

American Telegraphy.

AMERICAN TELEGRAPHY

AND

ENCYCLOPEDIA OF THE TELEGRAPH:

SYSTEMS, APPARATUS, OPERATION.

EMBRACING (2953

ELECTRICAL TESTING; PRIMARY AND STORAGE BATTERIES; DYNAMO
MACHINES; MORSE, DUPLEX, QUADRUPLIX, MULTIPLEX, SUBMARINE,
AUTOMATIC, AND WIRELESS TELEGRAPHY; BURGLAR-ALARM,
FIRE-ALARM, AND POLICE-ALARM TELEGRAPHY; PRINT-
ING TELEGRAPHY; MILITARY AND NAVAL SIGNALING;
RAILWAY BLOCK SYSTEMS; TELEGRAPH WIRES,
CABLES, AND CONDUITS; ETC.

BY

WILLIAM MAVER, JR.,

MEMBER OF THE AMERICAN INSTITUTE OF ELECTRICAL ENGINEERS; EX-ELECTRICIAN BALTIMORE AND
OHIO TELEGRAPH COMPANY; AUTHOR OF MAVER'S "WIRELESS TELEGRAPHY."

668 PAGES, - - - 490 ILLUSTRATIONS.

NEW YORK:
MAVER PUBLISHING COMPANY.

1909.

**COPYRIGHT, 1892, 1896, 1903, 1908,
BY WILLIAM MAVER, JR.**

PREFACE.

Somewhat less than twenty-five years ago the simple Morse system of telegraphy was the only one in general use in America. One or two printing telegraph systems were in operation, and attempts were being made to utilize, satisfactorily, chemical automatic telegraph systems. At that time, although the duplex system of telegraphy was in limited use, it had not been perfected, and in some quarters it was looked upon as a "scientific toy," "very beautiful in its way but quite useless in a practical point of view."

Since then the duplex and quadruplex systems, and the Wheatstone automatic telegraph system, have been extensively introduced into the commercial telegraph service of this country. Since then, also, multiplex, phonoplex, burglar alarm, police signal and other analogous systems of telegraphy have been invented and placed in successful operation. Many important improvements in printing telegraphy, submarine telegraphy, fire alarm telegraphy, etc., have, in recent years, also been introduced, and in numerous other ways the art of electrical telegraphy has been advanced.

While a number of the systems and improvements referred to have, at different times, and at more or less length, been described in electrical books and periodicals, the writer is not aware that even a majority of them has been fully described in any one book, and thus a knowledge of them placed within easy reach of the ordinary student of telegraphy.

Believing that such a book would be of value, the attempt has been made, in the present work, to supply a comprehensive account of the systems of telegraphy now in use in America, and as such an account naturally includes sources of electromotive force employed, line construction, line and apparatus testing, etc., those subjects have also been dwelt upon at some length.

As far as possible each subject has been treated from a practical standpoint, and the book, as a whole, has been written in a manner intended to be clear to novices in electrical matters, more especially those who are directly engaged in the practical working of electrical systems of telegraphy. To that end, where it has seemed essential to a proper understanding of a subject, full, and, it is hoped, accurate, explanations of laws and facts of electricity and magnetism involved in the operation of systems and methods described, have been given. In short, the object, however imper-

fectly carried out, has been to provide in this work a complete practical hand-book of telegraphy.

With but few exceptions the systems herein described are in actual operation. The exceptions relate to peculiar types of systems, a description of which was considered desirable for reference. In nearly every case the diagrams employed have been designed expressly for this book.

The author thankfully acknowledges his obligations to numerous friends for valuable practical information concerning a number of the systems herein described, and through their courtesy in that respect many details of certain systems are now given for the first time.

PREFACE TO FIFTH EDITION.

Advantage has been taken of the opportunity offered by the publication of the present new and much enlarged edition to add somewhat to the title of this work. This change has been suggested many times by friendly critics, it having been observed that the original title appeared to convey the idea, to those unfamiliar with its scope, that the work was confined to a treatment of Morse telegraphy, and perhaps some of its allied branches, whereas, in fact, the book is encyclopedical, treating not only of all that virtually appertains to telegraphy proper, but also of fire-alarm, police, burglar-alarm, and printing telegraphy; railroad block-signaling; manufacture of telegraph wire; electrical testing, etc., etc.

It was originally intended to limit this work to descriptions of systems in actual operation in this country, but in order that the book may now, as far as practicable, conform to its amplified title, descriptions of a number of telegraph systems, repeaters, etc., used in other countries have been added, together with descriptions of telegraph systems of recent application in this country and abroad, such as wireless telegraphy, etc. In many other ways, also, as by the sections on inductance, impedance, Gray's harmonic telegraph, the telantograph, etc., the author has endeavored to enhance the usefulness of the work as a book for students and as a work of reference, to which endeavor he has been in a measure prompted by the increasing use of the work by students generally, and as a text-book of Telegraph Engineering in colleges and other institutions of learning.

It may be noted that since the first edition of this work was printed over 90 pages of new matter (comprising about 60,000 words of text) and 60 illustrations have been added, mainly in the present edition. For synopsis of new matter see Supplemental Index, last page.

The author takes this occasion to express his appreciation of many kindly words which have reached him commendatory of this work, and would add that communications concerning subjects treated of herein are cordially invited.

*182 Arlington Avenue,
Jersey City, N. J.*

W. M., JR.

CONTENTS.

	PAGE
Introductory.	xii
CHAPTER I.	
ELECTRICITY.	
THEORIES, ELECTRICAL TERMS, ETC.	I
CHAPTER II.	
PRIMARY BATTERIES.	
Polarization.—THE GRAVITY or CALLAUD CELL.—The Care of.—The Use of Oil on.—Hydrometer.—THE LECLANCHE CELL.—THE FULLER CELL.—CHLORIDE OF SILVER CELL.—THE EDISON-LALANDE CELL.—THE BURNLEY DRY CELL.—THE GASSNER.—ARRANGEMENT OF CELLS IN BATTERIES.—Cells in Series.—Cells in Multiple.—Cells in Opposition, Etc., Etc.	9
CHAPTER III.	
THE DYNAMO MACHINE IN TELEGRAPHY.	
Introduction of in Telegraphy.—Joint Resistance of Circuits.—Distribution of Current In Divided Circuits.—THE DYNAMO-ELECTRIC MACHINE.—Theory of.—METHODS OF ARRANGING DYNAMOS IN TELEGRAPHY.—Western Union Arrangement.—Dynamo Reversing Switches.—Postal Arrangement.—Arrangement for Locals.—The Motor Dynamo.—The Storage Battery, Etc., Etc.	27
CHAPTER IV.	
THE MORSE TELEGRAPH SYSTEM.	
Theory.—Operation of.—Closed Circuit Method.—Open Circuit Method.—Telegraph Codes.—Steno Telegraphy, Etc., Etc.—Practical Notes for Beginners.	50
CHAPTER V.	
MORSE TELEGRAPH APPARATUS.	
KEYS.—Bunnell.—Steiner.—Victor.—Legless.—Self-Closing.—RELAYS.—Main Line.—Pocket.—Pony.—Box.—SOUNDERS.—Local.—Bunnell.—Western Electric.—Victor.—MAIN LINE SOUNDERS.—Winding of Etc.—THE MORSE REGISTER.—Ink Recording Morse Register.—AUTOMATIC PAPER WINDER.—AUTOMATIC TELEGRAPH SENDER.—TELEGRAPH TRANSMITTERS.—La Dow Transmitter.—Typewriter in Telegraphy.—BUNNELL SOUNDER RESONATOR.—SWITCH BOARDS.—Main Office.—Single Spring Jack Boards.—Way Office Switch Board.—Way Office Cut Out.—LIGHTNING ARRESTERS, ETC.	58
CHAPTER VI.	
THE CONDENSER.—STATIC CHARGE.—DISTRIBUTION OF, ETC.—INDUCTION, MUTUAL, SELF, ETC.—THE RHEOSTAT.	
Adjustable Condenser.—Standard Condenser.—Wheatstone Condenser.—Condensers Arranged in Multiple.—In Series.—Electrification.—STATIC CHARGE.—MUTUAL INDUCTION BETWEEN PARALLEL WIRES, ETC.—INDUCTANCE, CAPACITY, REACTANCE, IMPEDANCE, LOADED CONDUCTORS, RHEOSTAT.	90
CHAPTER VII.	
GALVANOMETERS.	
Theory.—THE TANGENT GALVANOMETER.—Parallelogram of Forces.—Western Union Tangent Galvanometer.—ASTATIC GALVANOMETERS.—DETECTOR GALVANOMETER.—THOMSON REFLECTING GALVANOMETER.—Shunts.—Directing Magnet.—D'ARSONVALL GALVANOMETER.—TABLE OF TANGENTS.	

CONTENTS.

CHAPTER VII.

ELECTRICAL TESTING.

122

THE WHEATSTONE BRIDGE.—Theory.—Post Office Pattern.—Siemens Pattern.—MEASURING RESISTANCES.—By Wheatstone Bridge Method.—By Substitution Method.—CAPACITY TESTS.—MEASUREMENTS ELECTROMOTIVE FORCE.—Internal Resistance of Batteries.—LOCATING FAULTS ON TELEGRAPH WIRES.—Locating Crosses.—A Wheatstone Bridge Method.—Locating Faults by Varley Loop Test.—By Capacity Test.—MEASURING INSULATION RESISTANCE OF WIRES AND CABLES.—Direct Deflection Method.—MEASURING PARTIAL INSULATION RESISTANCE OF TELEGRAPH WIRES.—TESTING INSULATORS, ETC.

CHAPTER IX.

THE DELANY LINE ADJUSTMENT.

150

CHAPTER X.

AUTOMATIC TELEGRAPH REPEATERS.

153

BUTTON REPEATERS.—Woods.—AUTOMATIC REPEATERS.—The Mayer-Gardanier.—The Neilson.—MULTIPLE.—The Milliken.—The Horton.—The Weiny.—The Atkinson.—The Ghegan.—Open Circuit.—Double Current.

CHAPTER XI.

DUPLEX TELEGRAPHY.

169

Differential Method.—Bridge Method.—THE STEARNS DUPLEX.—Continuity Preserving Transmitter.—Spark Coil.—Static Compensating Condensers.—Balancing Stearns Duplex.—THE POLAR DUPLEX.—Operation of.—Pole-Changer.—Polarized Relay.—Theory of Polar Duplex.—Balancing the Polar Duplex.—Terminal Connections, Etc.

CHAPTER XII.

THE QUADRUPLIX.

194

Theory of.—Operation of.—Edison Quadruplex.—Moment of No-Magnetism in Neutral Relay.—Smith Condenser Arrangement.—Ratio of Current Strength, Transmitter Closed and Open.—Action of Condenser as Static Compensator.—Terminal Connections W. U. Quadruplex.—W. U. Neutral Relay, Winding of.—Combination Rheostat --Repeating Sounder, Etc.—DYNAMO QUADRUPLIX KEY SYSTEMS.—W. U. or Field Dynamo Key System, Theory of.—Terminal Connections W. U. Quadruplex.—POSTAL TELEGRAPH COMPANY QUADRUPLIX.—QUOTATION COMPANY QUADRUPLIX.—GENERAL REMARKS.—Nomenclature.—Balancing The Quadruplex.—Causes and Symptoms of Faults on Duplex and Quadruplex Circuits and Methods of Detecting Them.—The Roberson.—The British P. O. Quadruplex.

CHAPTER XIII.

DUPLEX AND QUADRUPLIX REPEATERS.

241

Extended Locals.—Quadruplex-Short Wire Automatic Repeaters.—The Downer.—Gardanier—Emergency Repeaters.—Multiple Quad-Short Wire Repeaters.—Quad-Single Wire Automatic Repeaters.—The Edwards.—Waterbury.—Arrangement for Converting Short Wire into Main Line Wire.—HINTS ON THE MANAGEMENT OF QUADRUPLIX-SINGLE WIRE REPEATERS, ETC. ETC.

CHAPTER XIV.

BRANCH OFFICE SIGNALING DEVICES.

256

The Buzzer or Interrupter.—NEW YORK BRANCH OFFICE CALL WIRE.—CHICAGO BRANCH OFFICE SIGNAL ARRANGEMENT.—THE HURD BRANCH OFFICE CALL.

CHAPTER XV.

LOOP SWITCHES.

261

LOOP SWITCH CONNECTIONS.—POSTAL LOOP SWITCH.—DAVIS LOOP SWITCH.

CHAPTER XVI.

COMBINATION DUPLEX SYSTEMS, ETC.

264

THE EDISON-SMITH DUPLEX.—THE SIEURS DUPLEX.

CHAPTER XVII.

SUBMARINE TELEGRAPHY.

267

Mirror Receiver.—The Thomson Siphon Recorder.—The Cuttriss Magnetic Siphon Recorder.—Earth Currents.—Use of Condenser in Connection Therewith.—SIMPLEX WORKING.—DUPLIX WORKING.—Stearns Artificial Cable.—Muirhead Artificial Cable.—STEARNS CABLE DUPLIX.—MUIRHEAD CABLE DUPLIX.—Balancing Cable Duplex.—Rate of Signaling.—BROWN AND ALLEN RELAY.—THE JACOBS DUPLIX.—UNDER WATER TELEGRAPHY.—BROWN CABLE RELAY REPEATER.

CHAPTER XVIII.

AUTOMATIC TELEGRAPHY.

287

RAPID AUTOMATIC TELEGRAPHY.—Single Current.—Double Current Methods.—CHEMICAL AUTOMATIC TELEGRAPH SYSTEMS.—Theory.—Chemical Solutions Employed.—Effects, Etc.—ANDERSON CHEMICAL AUTOMATIC SYSTEM.—Page and Line Chemical Recorder.—THE WHEATSTONE AUTOMATIC SYSTEM.—Perforator.—Transmitter.—Theory of, Etc.—Wheatstone Receiver.—Wheatstone Duplex.—Terminal Connections, Etc.—Wheatstone Automatic Repeaters.—Condenser.—Repeater Relay.—Winding of.—Dial Rheostat.—“Extra Current” Neutralizer.—Balancing and Adjusting Wheatstone Apparatus, Etc.—AUTOMATIC FAC-SIMILE TELEGRAPHY.—Methods.—Electro-magnetic.—Chemical.—THE DENISON FAC-SIMILE SYSTEM.—Stevens Perforator.—Delany Rapid Automatic.—Electrograph.—Pollak-Virag Automatic.

CHAPTER XIX.

WRITING TELEGRAPH SYSTEMS.

WRITING TELEGRAPH COMPANY SYSTEM.—The Robertson Transmitter.—Receiver.—The Etheridge Transmitter.—Writing Telegraph Central Office.—The Telautograph.

CHAPTER XX.

WIRELESS TELEGRAPHY.

Phelps, Edison, Preece, Marconi, De Forest.

CHAPTER XXI.

SYNCHRONOUS MULTIPLEX TELEGRAPHY.

Theory of.—DELANY SYSTEM—Synchronizing Device, Etc. 336

CHAPTER XXII.

THE TELEPHONE.—SIMULTANEOUS TELEGRAPHY AND TELEPHONY.—VARLEY-ATHEARN DIPLEX-DUPLIX.—THE EDISON PHONOPLEX.

THE TELEPHONE.—Theory of.—SIMULTANEOUS TELEGRAPHY AND TELEPHONY.—Van Rysselberghe System.—Varley-Athearn Duplex-Diplex.—Superposed Currents.—THE EDISON PHONOPLEX.—The Phone.—Magnetic Coil, Etc.—Gray's Harmonic Telegraph.

CHAPTER XXIII.

TIME TELEGRAPH SERVICE.

356

Time Telegraph Signals.—Electrically Synchronized Clocks.—BARRAUD AND LUND REGULATOR.—HAMBLET SYNCHRONIZING APPARATUS.

CHAPTER XXIV.

HELIOGRAPHY.—MILITARY TELEGRAPH SIGNALING.

361

HELIOGRAPHY.—MacGregor's Heliograph.—Operation of, Etc.—MILITARY TELEGRAPH SIGNALING.—Field Equipment.—Flag and Flash Signaling.—UNITED STATES STATION AND FIELD KITS, CODE, ETC.

CHAPTER XXV.

THE AMERICAN DISTRICT TELEGRAPH MESSENGER SERVICE.

367

Call Boxes.—Central Office, Box Circuits.—RETURN SIGNAL CALL BOXES.—The Van Size.—District Service Magnet Bell.—Double-Pen Register.—Self-Starting Register.—Multiple Call Boxes.—Field and Firman.—DISTRICT SERVICE SWITCHES.—The Lockwood Battery.—District Service Time Slips.—FAULTS ON DISTRICT CIRCUITS.

CHAPTER XXVI.

AUTOMATIC BURGLAR ALARM TELEGRAPHY.

381

THE HOLMES BURGLAR ALARM SYSTEM.—Operation of, Etc.—THE WILDER DUPLIX AUTOMATIC BURGLAR ALARM.—Operation of, Etc.—Combination Call and Burglar Alarm Box.—The Double Balanced Relay.

CHAPTER XXVII.

PRINTING TELEGRAPHY.

300

Theory "Step by Step" Systems.—News Tickers.—"GOLD AND STOCK" TICKER SYSTEM.—Theory and Operation of.—Transmitter Key Board.—Shifting Device.—SCOTT TWO WIRE TICKER.—PHELPS STOCK PRINTER.—Operation of.—Paper Feed.—Shifting Device.—Key Board.—Type-Wheel.—Unison.—THE "UNIVERSAL" OR EDISON TICKER SYSTEM.—Operation of.—"Universal" Transmitter.—NEW YORK QUOTATION COMPANY TICKER SYSTEM.—Operation.—"Locker" Circuit.—Healy Clutch Device.—Shifting Apparatus.—Ticker.—Paper Feed.—THE PHELPS "MOTOR" PRINTING TELEGRAPH SYSTEM.—Printer — Motor Governor.—Transmitting Apparatus.—Receiving Apparatus.—Synchronising Device.—Unison Device.—Adjustment, Etc.—THE ESICK PAGE AND LINE PRINTER.—Theory.—Paper Carriage.—Printing Apparatus.—The Buckingham, Barclay, Murray, Hughes, Rowland, Baudot Systems.

CHAPTER XXVIII.

FIRE ALARM TELEGRAPHY.

437

Simple Fire Alarm Telegraph Circuit.—THE GAMEWELL FIRE ALARM TELEGRAPH SYSTEM.—Automatic Non-Interfering Repeater.—Theory of, Etc.—Gardiner Non-Interfering Street Box, with Auxiliary Fire Alarm Attachments.—Indicator.—Operation of.—THE GAYNOR FIRE ALARM TELEGRAPH SYSTEM.—Operation of.—Manual Repeater, Etc.—JERSEY CITY OR SPEICHER FIRE ALARM TELEGRAPH SYSTEM.—Operation of.—Tower Bell Circuit Connections.—Tower Bell Electro-Mechanical Striking Apparatus.—THE GAMEWELL AUXILIARY FIRE ALARM TELEGRAPH SYSTEM.—Operation of.—"Cross" Relay.—"Disturbance" Relay, Etc.—AUTOMATIC FIRE ALARM TELEGRAPHY.—THE BULEN SYSTEM.—Operation of.—Thermostats, Etc.

CHAPTER XXIX.

POLICE SIGNAL TELEGRAPH SYSTEMS.

471

THE GAMEWELL POLICE SIGNAL TELEGRAPH SYSTEM.—Central Office, Street Box Electrical Connections.—Operation of, Etc.—Stable Electrical Connections.—Automatic Transmitter, or Multiple Break-Wheel.—Street Boxes.—THE CHICAGO POLICE PATROL TELEGRAPH SYSTEM.—Operation.—Patrol Box.—THE PEARCE AND JONES POLICE PATROL TELEGRAPH SYSTEM.—Signal Box.—STOVER SPECIAL ALARM DEVICE.—THE MUNICIPAL POLICE SIGNAL TELEGRAPH.—Street Boxes.—Time Stamp.—Answer Back Signal, Etc.—POLICE PATROL BOXES.

CHAPTER XXX.

RAILWAY ELECTRIC BLOCK SIGNALING SYSTEMS, ETC.

494

THE UNION SWITCH AND SIGNAL ELECTRO-PNEUMATIC BLOCK SYSTEM.—Operation of, Etc.—THE UNION SWITCH AND SIGNAL "CLOCK" SYSTEM.—THE HALL RAILWAY SIGNAL SYSTEM.—Operation of, Etc.—HALL'S ELECTRIC SIGNAL FOR CROSSINGS.—OVERLAPPING BLOCK SIGNAL SYSTEM.—THE SYKES SYSTEM OF BLOCK SIGNALING.—THE STEWART-HALL TRAIN ORDER SIGNAL.—TRAIN SIGNALS.—The Hart Train Signal.—Motor Operated Semaphores.—Miller Cab Signal.

CHAPTER XXXI.

OVERLAND TELEGRAPH WIRE.

509

THE MANUFACTURE OF IRON AND COPPER WIRE.—Wire Drawing.—Galvanizing Iron Wire.—MECHANICAL TESTS OF TELEGRAPH WIRE.—Wire Gauges.—American Standard Wire Gauge.—Micrometer, or Pocket Gauge.—Tests for Breaking Strain.—For Ductility.—WIRE TESTING FOR RESISTANCE AND CONDUCTIVITY.—Effects of Impurities On.—Corrections for Temperature.—Table of Co-Efficients for.—Weight Per Mile Ohm.—Iron and Steel Line Wire, Terms, Etc.

CHAPTER XXXII.

UNDERGROUND CONDUITS.—UNDERGROUND, AND RIVER AND HARBOR TELEGRAPH CABLES, ETC.

524

UNDERGROUND CONDUITS.—"Drawing In and Out."—"Solid."—Rodding.—UNDERGROUND TELEGRAPH CABLES.—Cable Jointing.—Measuring Insulation.—Resistance of Joints.—RIVER AND HARBOR CABLES.—Cable Testing.—Remarks Concerning.—Electrification.—LOCATING FAULTS IN CABLES ELECTRO-MECHANICALLY.—Point to Point Method.—Locating Faults in Short Under-Water Cables.—Under-Running Method, Etc.

CHAPTER XXXIII.

CONSTRUCTION AND MAINTENANCE OF TELEGRAPH LINES.

524

LINE CONSTRUCTION.—Erection of —Tools, Etc.—Guying.—Pole Lightning Arresters.—Brackets.—Cross-Arms.—Pins.—Fetter Drive Screw.—Insulators.—**WIRE STRINGING.**—Wire Barrow.—Come Along.—Tying Wire to Insulators.—Joints on Aerial Wires.—“Sleeve” Joints.—Pliers.—**ANTI-HUM DEVICE.**—**HOUSE-TOP FIXTURES.**—**AFTER CONSTRUCTION.**—Maintenance of Lines —Tree Trimming.—Etc.—Line Repairing, Etc.—Trouble Hunting.—**AERIAL CABLES.**—Methods of Suspending.—Aerial Cable Hanger.—**CHIN-ROCK CABLE WINDER.**—Operation of, Etc.

CHAPTER XXXIV.

SPECIFICATIONS—ESTIMATES—MISCELLANEOUS—TABLES.

553

Specifications for Apparatus.—Battery Material.—Hard Drawn Copper wire.—Iron Wire.—Aerial or Underground Cable.—Short, River or Harbor Cable.—Emergency Cable.—Form of Contract Specification for Manufacturing and Laying of Underground Cable —**MISCELLANEOUS.**—Binding Screws.—Message Hooks Prices of Telegraph Apparatus, Material, Etc.—Effects of High Temperatures on Vulcanized India Rubber Insulation —**TABLES.**—Difference Between Principal Wire Gauges in Decimal Parts of an Inch.—Number, Diameter, Weight, Length and Resistance of Commercial Copper Wire.—Wages of Operators.

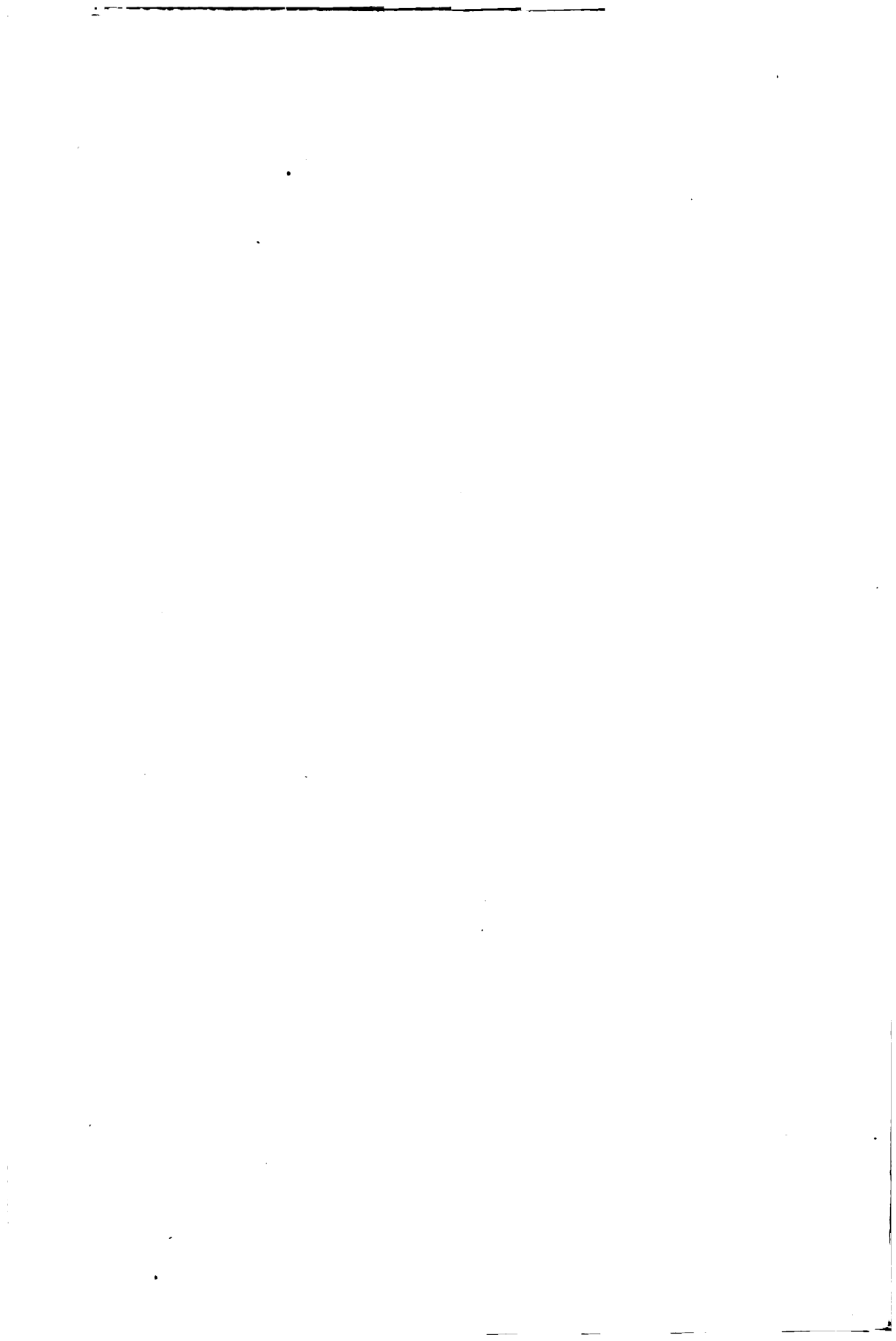

INTRODUCTORY.

THE word "telegraph" strictly defined means "to write afar off." In the modern practice of telegraphy, however, the term has a wider meaning and it is now used to signify any means whereby intelligence is conveyed to a distance by signs or sounds.

From remotest times methods of communicating intelligence to a distance have been employed for purposes of war, defence and extraordinary intercourse.

A brief review of some of the earlier methods may be of interest at the opening of a work of this nature, especially as such a review may be found to show that principles involved in the operation of very primitive methods of telegraphing have been applied in more or less modified forms in some of the modern electrical telegraph systems.

The ancient Greeks employed among other methods of telegraphing one which was, perhaps, the simplest of all the ancient methods. This method required the erection of towers on hill-tops and other elevations, suitable distances apart. In each tower a vessel capable of holding a given quantity of water was placed. Down the side of the vessels the letters of the alphabet were arranged. Each vessel was supplied with means for permitting the water to flow out of the vessel at a given rate. When ready for signaling the vessels were filled with water. The station desiring to signal the other, raised a torch, at night. This was responded to by a similar signal from a distant tower. At another signal the attendants in each tower withdrew the stops and permitted the water to flow out of the vessels, and when the water had fallen to a point opposite a desired letter the torch was again raised; the attendant in the receiving tower noted the letter; each attendant refilled the vessel and the operation was repeated until the message was completed.

Towards the latter part of the eighteenth century the semaphore system of telegraphy was introduced; the term semaphore signifying "A Sign I bear."

In semaphore systems of telegraphy one or more movable arms or levers supported on suitable posts are employed. By the manipulation of these levers messages may be transmitted with moderate rapidity. This method of telegraphing was very widely adopted, and, for many years, utilized, throughout Europe, especially in France and Russia, and is, in a modified form, in use to day on every railroad in the world.

In this country a semaphore system was for many years in successful operation between Sandy Hook and New York, before, and for a short time after, the introduction of the electric telegraph, or, as it was termed, the magneto telegraph.

The semaphore company had stations on this line at Sandy Hook; the Highlands, N. J.; at Staten Island and in the cupola of the Custom House, New York City. This line was intended chiefly for reporting the arrivals of vessels at Sandy Hook.

For some time after the establishment of the magneto telegraph between New York and Sandy Hook the semaphore system held its own, for, while in foggy and hazy weather both systems were useless, since passing ships could not be discerned, in wet weather, without fog, the semaphore system was often the first to convey marine intelligence to the city, owing to the poor insulation of the electric telegraph wires. The semaphore company, however, ultimately found it to its interest to unite with the electric telegraph company.

Another system of telegraphy, somewhat akin to the semaphore, and known as Washington's telegraph, was at one time employed in this country. It was presumably so called because of the fact that it was one among many similar telegraph systems used during the war of Independence in this country.

The apparatus used in the Washington telegraph system was easy of construction, and, it must be admitted, somewhat crude. It consisted of a portable mast, on the top of which was placed a tub, or barrel; also, on one side of the post, a movable flag was placed, and on the other side, near the top, a basket, which was suspended from a bracket or nail. By interchanging the position of the flag the barrel and the basket, and by moving the flag up and down, various signals could be sent,—about 60 different signals in all.

Although up to 1852 certain visual systems of telegraphy such as the semaphore, were in extensive use, electricity had been utilized, experimentally, long prior to that date, as a means of communicating intelligence to a distance.

For example, Lesage, of Geneva, had constructed a telegraph system consisting of 24 line wires, one for each letter of the alphabet. At each terminal of each wire pith balls were suitably suspended, and, taking advantage of the well-known repellant effect that follows the electrification of such light substances, Lesage had succeeded, by the use of frictional electricity applied to the wires, in transmitting intelligible signals over them.

In 1815 an "alphabetical" telegraph was invented by Francis Ronalds. In this arrangement, clockwork, operating a revolving dial, was used at each end of a wire. The dials rotated in unison. A notch was cut in each dial. Behind each dial the letters of the alphabet were placed in a circle, so that as the dial revolved one letter at a time was seen through the notch. Pith balls were electrically connected with the wire at each end. At a certain signal the clockwork was started, and as the

notch came opposite a desired letter the circuit was so operated that the pith balls were actuated. The letter at that time seen through the opening in the dial was noted and in that way messages were transmitted.

In 1839 a telegraph system was devised by de Heer in which a physiological effect of the electric current was employed. In this system ten wires were utilized between the sending and receiving stations. At the receiving station the operator placed his fingers and thumbs on the ten terminals of the line wires. Thus the passage of a current through one or more of the wires was felt in the fingers touching those wires, and signals were indicated by a pre-arranged manner of transmitting currents through the wires. For example, a simultaneous "shock" in the thumb of the right hand and forefinger of the left hand might signify the letter A, etc.

In 1774 Volta discovered that electricity could be generated by chemical means, and, availing of the "voltaic" current from a battery, efforts were made, more or less successfully, between 1806 and 1830, to utilize, in the transmission of telegraphic signals, its property for decomposing metallic salts, by causing electric currents originated at one terminal of a wire to decompose a chemical solution at the other terminal; these efforts were the pioneers of others more successful in later years.

In 1820 the discovery was made by Oersted that a magnetic needle would be deflected from its normal position when held parallel to a wire conveying an electric current, and, further, that the deflection was to the right or left according to the direction of the current. Taking advantage of these discoveries various needle telegraph systems came into existence and were at one time extensively employed in Europe, and are still in limited use there.

The needle systems were operated on the principle just referred to; namely: that a current flowing in a wire would deflect a magnetic needle. A magnetic needle was pivoted in the centre of a coil or coils of wire, and a pointer, attached to the needle, swung in front of a dial. Deflections to the right or left signified certain letters. These deflections were produced by sending over the wire pulsations of one polarity, or alternations of both, as required by the letter to be transmitted.

In 1824, Sturgeon, of England, discovered that when a current of electricity is caused to flow in an insulated wire surrounding a bar of well annealed iron, the latter becomes a magnet, and that when the current ceases to flow the iron at once loses its magnetism.

Availing of these electro-magnetic laws, Morse, in 1837, invented the telegraph system which bears his name, and which system, in one form or another, is, to-day, in almost general use.

The apparatus first used by Morse in his experiments bore but slight resemblance to the instruments now employed in Morse telegraphy. For instance, the modern Morse relay weighs about 3½ pounds. The first telegraph relay or electro-magnet con-

structed for Morse weighed over 300 lbs; and it was thought that the height of improvement was reached when a relay was made that weighed only 70 lbs. By degrees, however, the laws of electro-magnetism became more clearly understood, and, finally, the instruments reached their present shape and size.

Much of the subsequent work of telegraph engineers up to the present time has related to the improvement of apparatus and the development of means for increasing the capacity of the existing wires either by the use of "automatic" telegraph systems or by the aid of "multiplex" systems of telegraphy.

It is not, however, only as an agent in the transmission of commercial or social telegrams that electricity is now employed in telegraphy. It also performs an indispensable part in the operation of Fire, Police, and other analogous telegraph systems, many of which will be found described in the unabridged American Telegraphy.

AMERICAN TELEGRAPHY.

CHAPTER I.

ELECTRICITY.

THEORIES—ELECTRICAL TERMS; ETC.

As with but few exceptions the systems of telegraphy described in this book are electrical a reference to some of the theories of electricity may properly be made here. As, however, an extended review of the various theories of electricity (and magnetism) would be outside the scope of this work, such reference will be limited to what may be termed "working theories," and to those through which several of the common terms at present in use have been introduced.

Reference will also be made here to some of the more important laws of electricity involved in the operation of the systems to be described; reference to other electrical and also to certain magnetic laws and actions will be made elsewhere as may seem appropriate.

It may be premised that nothing is, at present, definitely known of electricity, except through its manifestations as a force, which manifestations are, it is assumed, the results of some mode of motion or disturbance of, or around the molecules of the substances in which the manifestations are exhibited. The same may be said, generally, of magnetism, with this, additionally, that magnetism is always either an accompaniment of, or a result of, electrical action.

It is well known that electricity may be manifested in many ways; for example, by rubbing a glass rod with dry silk, or by rubbing a stick of wax with dry flannel, when those substances become "electrified" and capable of attracting small, adjacent bodies. It is known, also, that when thus electrified, if the glass and the wax be lightly suspended they will attract each other, while, if two pieces of wax or two pieces of glass be thus electrified and similarly suspended it is found that they repel each other.

Since *force* may be defined "as any cause which moves a body that is at rest or stops it when in motion," or which retards or increases the velocity of a body in motion, the foregoing may serve as simple instances of electricity as a force.

Franklin considered that electricity was an imponderable "fluid," pervading everything, and which, in its normal condition, was uniformly distributed in all substances. He assumed that the electrical results obtained by rubbing glass were due to the production of an excess of the electric fluid in that substance, and that those obtained by rubbing the wax were due to a diminution of the fluid. The electricity manifested in the glass, when rubbed by silk, he called "positive;" that in the wax, when rubbed by wool, he termed "negative."

The Franklin theory was for many years entertained, but the idea of electricity as a "fluid" is now generally abandoned.

For practical purposes it may be assumed, that all substances possess an electric state which is normally zero or neutral, and that, while in that condition, no electrical phenomena are apparent; but if that normal electrical condition of the substance be disturbed, electrical manifestations result.

This assumption may be illustrated by analogy. For example, air, it is known, at any given portion of the earth's surface, is under a certain pressure, reckoned in so many pounds per square inch at sea level. Normally, so far as any given section of the earth's surface is concerned, if the air be left undisturbed, there is no visible evidence of its existence. If, however, by any means, as by the heating of the air particles at some one point of the earth's surface, the normal pressure is disturbed, a "current" of air, that is, *wind*, is the result, and the observed effects of wind are, obviously, manifestations of air in motion. Further, when, by suitable means, an excess of air is driven into an air chamber, the compressed air within the chamber acquires a tendency to escape therefrom by any available outlet, and, if such an outlet be provided, a perceptible current of air will flow until equilibrium is established, that is, until the pressure within the chamber is equal to that without. If, on the contrary, a vacuum be created in the chamber the reverse will be the case; the tendency will be for the air without to enter the chamber, until, as before, equilibrium, or zero pressure, is established. In either case, it will be observed, the direction of the current is from the point of higher to the point of lower pressure.

In the case of an "electrified" body, that is, one in which the normal, electrical condition may be supposed to have been disturbed, it may be assumed that the molecules of the substance resist or oppose the changed electrical condition, and, further, that, when thus displaced, the tendency of the molecules is to return to the normal condition of zero or neutrality; as, for example, an archer's bow resists bending, and, upon being bent, tends to restore itself to its normal condition.

If the electrified body be surrounded by an "insulating" medium, analogous, for instance, to the walls of an air chamber, a pressure is presumably exerted on that medium, which pressure will be relieved when the electrified body is, so to speak, given an opportunity to resume its normal condition of electrical equilibrium, as will be the case when a so called conductor of electricity is provided, for, example, an iron or copper wire.

If, reverting to the air analogy, means for maintaining the vacuum or pressure in the air chamber, and a suitable inlet and outlet, be provided, and if the inlet and outlet be then connected by a pipe, it is apparent that a current of air will flow from the point of greater to the point of lesser pressure, continuously.

Analogously, if means are taken to renew the electric stress or pressure of the electrified body as quickly as it may be relieved, what is termed, a "current" of electricity will "flow" continuously in the conductor.

Such a "current" is obtained when, for example, the terminals of a common voltaic cell are connected by an iron or copper wire. It is known that the terminals of the plates of such a cell are "positively" and "negatively" electrified as, for instance, in the case of rubbed glass and wax.

When the plates of such a cell are thus joined, it is found that the connecting wire now possesses peculiar properties; one of which is that a magnetic needle suitably sus-

pended parallel to the wire, is steadily deflected from its usual position. This deflection of the magnetic needle is one of the best known manifestations of the electric current.

More recently a theory termed the *electronic* theory has been developed, according to which theory, briefly stated, the material atom instead of being indivisible, as has been held for nearly a century, is made up of an equal number of positively and negatively charged electric units, termed electrons. In short, that electrons are electricity, and therefore the ultimate particles of matter are electrical. According to the theory of the ether as developed by Dr. J. Larmor, it possesses a rotational elasticity, the various parts of which resist complete rotation round an axis, yet may be displaced or sheared over each other. The strain by which this displacement is brought about is due to an electric force, and it disappears when the electric force is withdrawn. In such an ether the electron is the center of a permanent strain-point which can only be moved about in this ether as a kink can be moved in a rope. The ether can only be moved by the electrons and it only can move them. Hence it has been said that the electrons have a grip of the ether and by their rapid motion set up and are affected by radiation in the ether. The size of the electron as compared with the material atom is exceedingly small, there being, it has been calculated, about 700 in the smallest known atom, that of hydrogen, and about 140,000 in one of the densest, the mercury atom. These atoms are assumed to be in orbital rotation around each other, and notwithstanding that the diameter of the mercury atom is taken as the one one-hundred-millionth of a meter, the orbits of the 140,000 electrons constituting the atom are relatively as great, proportional to their size and to the space in which they move, as are those of the planets of the solar system. To account for the phenomena of current electricity by this theory it is supposed that in addition to the electrons composing the atoms of substances there are many so-called free negative electrons intermingling and interchanging with the electrons of the atoms. These free electrons under an electric force seem able to move unobstructedly through metals or other good conductors, giving rise to the electric current and its accompanying magnetic field, whereas the structure of non-conductors is apparently so complex the electrons cannot move freely through them. That which has hitherto been regarded as positive or negative electricity (constituting a charge of electricity) is due to the removal of a negative electron from an atom, which latter thereupon becomes positive; a theory which to this extent conforms to Franklin's fluid theory, the exception being that what he termed negative electricity is known to be positive electricity, and vice versa. By this theory, also, an alternating current in a conductor is due to oscillations of the electrons, and the electrons in rapid vibration in a conductor give rise to electrical waves in the ether.

The reader will find a more detailed treatment of this subject in the author's "Wireless Telegraphy." See also "Hertzian Waves," Chapter XX.

POTENTIAL; ELECTROMOTIVE FORCE; CURRENT; RESISTANCE.

For practical purposes it may be considered that when a body is "positively" electrified it has acquired an electrical condition above the normal, or zero, and

when it is electrified "negatively," that it has acquired an electrical condition below the normal.

It is then essential to adopt a standard by which to estimate the extent of that electrification, either above or below normal; as, for example, in the case of the measurement of temperature, zero may be taken as that degree of heat or cold which exists at the freezing point of water, temperatures above or below that point being referred to as so many degrees above or below zero.

In the case of electricity, the zero pressure or condition is taken as being equal to that of the earth; it being assumed that the latter, in common with other bodies, has at any given point, a normal electrical condition. Thus, when a body is said to be positively or negatively electrified it is assumed to be electrified above or below the normal electric state, condition or "level" of the earth.

The technical term used in relation to electric pressure is "potential," but the terms "potential" and "pressure," are now, almost generally, used interchangeably.

"Potential" is defined as "power to do work," or "capacity for doing work." For instance, if a weight be raised by any means from the earth's surface against the attraction of gravitation, say, one foot, it is said to have acquired and to possess a potential or capacity for doing work, equal to the energy which it was necessary to expend in raising it to that height. Analogously, when, by any means, whether by a voltaic cell, friction, or otherwise, electricity is excited in a substance, for instance, a wire, it is said to have acquired an electric potential, that is, a capacity for doing electrical work.

The force, whatever it may be, that produces this electric potential is frequently termed electromotive force, that is, the force which moves or drives electricity, and this force is measured by the extent to which the electric potential of a body is brought above or below zero; that is, again, the *difference of potential* or pressure existing in the electrified body. It is also said, disregarding the cause which develops this difference of potential, that the difference of potential, itself, constitutes the electromotive force, that is, the force which moves electricity, virtually as the flow or movement of water in a pipe connected with a high reservoir is said to be due to the "head" of water; that is, the difference between the pressure of water in the reservoir and that at zero level. It is, however, definitely known that when a so called "difference of electric potential" is established between any two points of a conductor, that which is termed an electric "current," flows, and will continue to flow as long as the difference of potential is maintained.

It is assumed, for convenience, that when a body acquires a "positive" potential, the tendency of the current is downwards towards zero, and that when it acquires a "negative" potential, the tendency of the current is from zero to the point of lower potential.

The more frequently used terms relating to electrical measurement are potential, electromotive force, current and resistance.

All substances are capable of conducting electricity. Some, however, possess this property so limitedly that, by comparison with certain other substances, they may be considered as not possessing it and are, consequently, termed non-conductors, insula-

tors or dielectrics, while those substances which are capable of conducting electricity freely are said to possess conductance, or conductivity, and are termed conductors.

There is, on the contrary, no material known which does not offer some resistance to the "passage" of electricity through it, the extent of which resistance varies in different materials, and it also varies with the size of the conductor of a given material: decreasing as the size or weight is increased, and increasing as the size is decreased.

In the case of all things that are measurable, units of measurement are necessary. Thus the unit of weight, English measure, is the pound; the unit of length is the foot or yard, etc.

As electricity is also measurable, instances of which will be noted later, suitable electrical units of measurement are necessary and have been provided. Thus, the "practical" unit of electromotive force is the volt; the practical unit of current strength is the ampere; the practical unit of resistance is the ohm. The derivation of these units will be alluded to subsequently.

The volt represents a certain potential to which electricity is brought, above or below zero potential, as, analogously, one foot may represent the difference of pressure between a volume of water at sea level and another volume raised one foot above sea level.

The difference of potential between the plates of a voltaic cell, such as the well known gravity cell, is slightly more than one volt.

The term electromotive force is frequently abbreviated thus: E. M. F., and in formulae is represented by E. These abbreviations will be occasionally employed herein.

The *ohm is equal to the electrical resistance of a column of pure mercury .00155 square inch sectional area (that is, the area of a section of the column taken directly crosswise,) and 41.73 inches in length at a temperature of 32°F.

Perhaps, to some, a clearer, if a less exact idea of the value of the ohm, as a practical unit of resistance, may be conveyed by considering that it is equal to the resistance of one mile of pure copper wire about twenty-three one hundredths of an inch, that is, slightly less than one-quarter of an inch, in diameter, at a temperature of 60°F.

One mile of ordinary galvanized iron, six-tenths of an inch in diameter, has a resistance of, approximately, one ohm.

With a given electromotive force the current which will flow when a conductor is provided will be proportional to the resistance or, as it is sometimes termed, the "opposition," which the conductor may offer to the passage of the "current."

The ampere is defined as the strength of current which flows in a conductor, or the amount of electricity that will be driven past any given point of a conductor, when the electromotive force is one volt, and when the resistance of the conductor is one ohm.

The resistance of a conductor of given dimensions is, generally speaking, constant, regardless of changes in the electromotive force or in the current.

OHM'S LAW.

The current strength in a conductor varies directly with changes in the electromotive force; it varies inversely with changes in the resistance.

This very important law of the electric current, now so well known, is termed, Ohm's law, after its discoverer. The law may also be thus stated; the current

* See Chapter XXXI.

strength, expressed in amperes, in any circuit, is equal to the quotient of the electromotive force in volts, divided by the total resistance of the circuit, in ohms. Hence, as the current strength is directly proportional to the electromotive force, if the electromotive force be increased the current strength is increased; if the electromotive force be decreased, the current strength is decreased.

The current strength being inversely proportional to the resistance, if the resistance be increased the current strength is decreased; if the resistance be decreased the current strength is increased.

Ohm's law is symbolically expressed thus:—

$$C = \frac{E}{R}$$

where c represents current strength in amperes, E the electromotive force in volts, and R the resistance in ohms.

For example, assuming a circuit of 10 ohms resistance, 10 volts electromotive force, the current strength will be one ampere, for $\frac{10}{10} = 1$.

Further, since the current strength is equal to the quotient of the electromotive force divided by the resistance, it is evident that the resistance multiplied by the current strength will give the electromotive force. Hence, if the current strength or, as it is sometimes termed, the amperage, and the resistance of a circuit be known, the electromotive force will be represented by the formula $E = C \times R$.

Again, if $C \times R$, be equal to E , then R must be equal to the quotient of E divided by C , or $R = \frac{E}{C}$.

Consequently, when any two of the three factors concerned in Ohm's law are known, the third may readily be found.

Thus, suppose it is desired to know the strength of current on a "circuit" between any two points, say, 250 miles apart, the resistance of the wire being 10 ohms, per mile, the resistance of the relays, say, 1,000 ohms, and the electromotive force at each end 50 volts.

The total resistance of the circuit will be 3,500 ohms; the total E. M. F. 100 volts, which, dividing the latter by the former, gives, $\frac{100}{3500}$, or $\frac{1}{35}$ of an ampere; that is, approximately, $\frac{28}{1000}$ of an ampere.

As in telegraphy the current strength rarely amounts to one ampere, the term milliampere, which is the one thousandth of an ampere, is frequently used. Thus the strength of current on a circuit such as that just referred to would be equal to 29 milliamperes.

Again, if, as in practice is the case at times, it is desired to learn the electromotive force necessary to obtain a current strength of 29 milliamperes on a circuit of, say, 3,500 ohms, the required information may be calculated thus: $E = .029 \times 3,500$ equal, in round numbers, to 100 volts.

DERIVATION OF ELECTRICAL UNITS OF MEASUREMENT.

The practical units of electrical measurement unlike, for instance, the pound for weight or pressure, and foot or yard for length, are not arbitrary, or, as it were, haphazard units, but are derived from certain, so called, absolute electrical units, which, in turn, are

based on certain fundamental units of length, mass and time; to which, brief and general reference will here be made.

The fundamental units referred to are the *centimetre* for length; the *gramme* for mass, that is, weight; and the *second* for time.

The centimetre is the one hundredth of a metre. The *metre* (equal to 39.37 inches) is the one ten millionth of an earth quadrant, estimated from the equator along a meridian to the pole. The *gramme* is equal to the weight of a cubic *centimetre* of water at its point of greatest density, namely, at 39.2°F. The *second* is equal to the time taken by a pendulum, beating at the rate of 86,400 beats per day, to make one beat.

The unit of *force* is termed the *dyne*. The *dyne* is equal to that force which is required to communicate a velocity of one *centimetre*, per second, to one *gramme* mass after acting upon it for a period of one *second*.

It may be here interpolated, although the subject will be referred to more at length

FIG. 1.

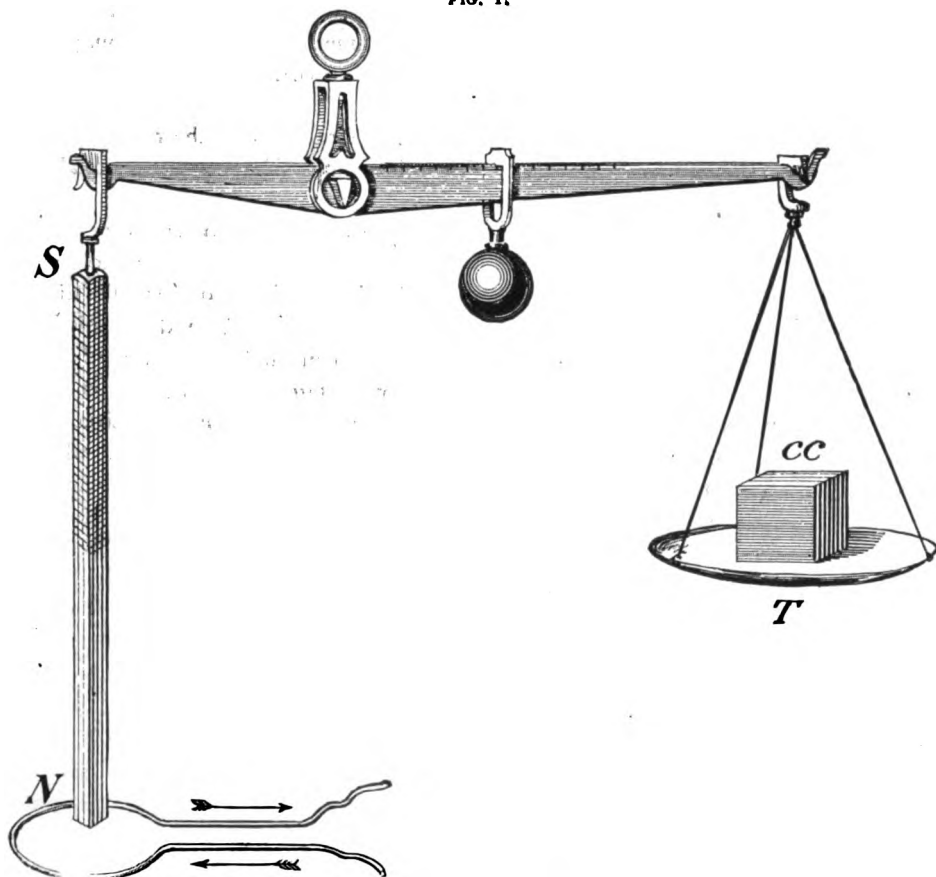

elsewhere, (*see* Chapter III,) that, when a current exists in a wire the neighborhood of that wire becomes magnetic, and the strength of the magnetism thus developed depends upon and varies with the strength of current in the wire. The magnetism thus

manifested attracts or repels ordinary magnets in the same way that like or unlike poles of magnets attract or repel each other.

A magnetic pole of unit strength is one such that when it is placed at a distance of one centimetre from another magnetic pole of unit strength and of opposite polarity, it attracts the other with a force of one dyne.

It is then said that the absolute unit of electromotive force exists in one centimetre portion of a circular conductor whose diameter is two centimetres, when it drives through that portion of the conductor a current of sufficient strength to develop at that portion a magnetic pole of sufficient strength to attract, with a force of one dyne, a magnetic pole of unit strength placed at the centre of the circle, namely, at a distance of one centimetre.

This is illustrated, theoretically, in Fig. 1.* in which N may be assumed to be a unit magnetic pole suspended in the centre of a curved wire of one centimetre radius. CC , in the tray T , may represent a vessel which in the figure is purposely drawn to correspond in dimensions, as accurately as may be, to one cubic centimetre. This vessel may be assumed to contain enough water, of the required density, to correspond in weight to the unit of mass, namely, one gramme.

The current so developed will be of absolute unit strength, and the resistance of the portion of the conductor between which this absolute unit difference of potential exists will represent absolute unit resistance.

As the absolute units of electromotive force and resistance are too small for ordinary purposes, the units of electromotive force and resistance previously referred to, namely, the volt and the ohm, have been chosen as practical units. On the contrary, the absolute unit of current strength is rather large for ordinary work and, consequently, a unit of less value, the ampere, has been chosen for practical measurements of current strength.

The value of the practical unit of electromotive force, the volt, is 100,000,000 times greater than that of the absolute unit; that of the practical unit of resistance, the ohm, is 1000 000,000 times greater than the absolute unit of resistance, while the value of the practical unit of current strength is one-tenth that of the absolute unit.

The absolute units of electrical measurement are frequently designated, the c. g. s. units, from the initials of the fundamental or standard units of length, time and mass, to which they are related.

UNIT OF ELECTRICAL ENERGY.

The practical unit of electrical energy is the watt; this is the product of the E. M. F. by the current, or $W = E \times C$. 746 watts are equal to one mechanical horse-power. One mechanical horse-power is equal to the work done in raising 33,000 pounds one foot in one minute. The electrical horse-power is the kilowatt, or 1000 watts. The electrical horse-power of a dynamo machine having an output of 25 amperes at 200 volts is 5 kilowatts. An electric motor taking 25 amperes at 200 volts should develop 5 kilowatts, or $\frac{5000}{746} = 6.7$ mechanical horse-power, less the loss in the motor, or, if the efficiency of the motor is say 80 per cent., 5.36 mechanical horse-power.

*Suggested by figure 40, Flemings "Lectures to Electrical Artizans."

CHAPTER II.

PRIMARY BATTERIES.

IN electrical telegraphy the electromotive force required is furnished chiefly but not exclusively, by primary, or chemical batteries.*

A simple voltaic cell may consist of a plate of copper and a plate of zinc placed in a suitable vessel containing a dilute solution of sulphuric acid. A number of such cells connected together is termed a battery.

Batteries such as the well known "gravity" or the Leclanché, are generally designated "voltaic" or "primary" batteries—sometimes "chemical" batteries.

A reference here to some of the chemical terms used in connection with the subject of primary cells may assist in the subsequent descriptions.

An atom is assumed to be an indivisible particle of a substance. A molecule is a combination or union of two or more atoms. For example, water is formed of molecules, each containing 1 atom of oxygen and 2 atoms of hydrogen, represented by the symbol H_2O . An "oxide" is, generally speaking, a combination of oxygen and some metal, for example, the oxide of zinc, which is a chemical combination of oxygen and zinc. The term peroxide is used to denote those oxides containing the highest number of oxygen atoms that will combine with a given metal, as, for instance, in the case of peroxide of manganese. "Chlorides," "perchlorides," etc., are combinations of chlorine and other substances, as chloride of ammonium, commonly known as sal-ammoniac, which is a combination of 4 parts hydrogen, 1 part nitrogen, and 1 part chlorine. An "acid" is, generally speaking, a combination of oxygen, hydrogen, and some non-metal. For instance, sulphuric acid is a combination of oxygen, hydrogen, and sulphur. Metals replace the hydrogen atoms of acids to form "salts," which are generally designated by the affix "ate," as, for instance, sulphate of copper, which is a chemical combination of sulphur, oxygen and copper; or sulphate of zinc, a combination of sulphur, oxygen and zinc.

It is known that when a metal plate is partly immersed in a liquid, for instance, dilute sulphuric acid, it becomes electrified. The extent and nature of this electrification varies in different metals, some metals being more highly electrified than others. This result is attributed to an electro-chemical difference existing between the different substances. For example, zinc is said to be electro-positive to copper; that is, its electric state is higher than that of copper. Thus, when those elements are arranged as, for instance, in a "gravity" cell, the difference of potential between the plates is found to be about 1.079 volts.

That plate in such a cell which possesses the higher electric potential is termed the "positive" plate; that which is at the lower potential, the "negative" plate.

* This statement is not quite exact to-day; dynamo machines and storage batteries having supplanted primary batteries in a large number of the main offices of this country.

When two such plates are connected by a wire a current is assumed to flow from the positive plate to the negative plate within the cell, and from the negative to the positive outside of the cell; the terminal of the positive plate of a cell is termed the negative "pole;" that of the negative plate the positive pole. Thus, in the "gravity" cell the positive pole is at the copper plate; the negative pole at the zinc plate.

The current will flow so long as the difference of potential is maintained. This difference is maintained in the voltaic cell at the expense of the positive plate, which is found to be dissolved more or less rapidly, depending upon the rate at which "current" is supplied. In other words, the cell may be said to give out electrical energy at the expense of the positive plate of the cell in a manner analogous to that in which a steam engine gives out mechanical energy at the expense of the fuel in the furnace.

Certain primary cells, when "short-circuited," as when the plates are connected outside the cell by a thick wire, or when placed in a circuit of moderately low resistance, for any length of time, are known to lose their effect quickly, which is made apparent by the rapid decrease of strength of current in the circuit. For instance, if a plate of zinc be placed with a plate of copper in a cup containing a dilute solution of sulphuric acid, it will be found, as has been stated, that a current will flow when the two plates are connected by a wire, but that, after a very short time the strength decreases.

Such cells are commonly termed "open" circuit cells. This term distinguishes them from such cells as the "gravity," which will maintain a current of almost uniform strength for a long period on a circuit of low resistance. Batteries, or cells of the latter class, are, consequently, called "constant" cells, or batteries.

POLARIZATION.—The cause of the rapid fall in the strength of current in "open" circuit batteries, is chiefly attributable to an action within the cell which is termed *polarization*.

This term, polarization, in this relation, may be taken to signify a counter-electromotive force that is set up in the cell; that is, a force tending to oppose the original electromotive force of the cell. The cause of polarization may be explained as follows:

The difference of electro-chemical potential between some of the metals, and some of the metals and gases is very slight. For example, the electro-chemical difference between zinc and hydrogen is very small; sometimes the hydrogen is found to be electro-positive to the zinc. When an electric current passes through the solution or "electrolyte," as it is also termed, of a cell, a chemical decomposition and recombination of the components of the solution takes place. Thus, in the case of a simple voltaic cell whose zinc and copper elements are placed in a solution of dilute sulphuric acid, it is assumed that the oxygen of the solution combines with the zinc, forming oxide of zinc, which, uniting with the sulphuric acid of the solution, forms sulphate of zinc, setting free hydrogen, which is deposited on the copper or negative plate.

The effect of this deposition of hydrogen on the negative, or copper, plate is to oppose to the zinc plate an element having an electro-chemical state or level nearly equal to its own, the consequence of which is that when sufficient hydrogen has ac-

accumulated on the copper plate, practically, no current flows in or from the cell. When this has occurred the cell is said to be *polarized*.

That the falling off in the current is due chiefly to this cause, namely, the accumulation of hydrogen on the negative plate, may be shown by removing the hydrogen bubbles which have gathered on the negative plate, by means of a brush, or by shaking that plate in the cell, when the current will be found to increase temporarily. Or, it may be further shown by removing the zinc plate from the solution, after the cell has ceased to act, and substituting, therefor, another copper plate. On joining the two copper plates together, it will be found that a current flows from the hydrogen-coated copper plate to the other one until the hydrogen has been dissipated, and this current will be opposite in direction to the former current, indicating that it was to this counter-electromotive force that the former inaction of the cell was due.

To prevent the hydrogen from accumulating on the negative plate of a cell, thereby to prevent polarization, many plans have been devised. When polarization is entirely prevented, "constant" cells are the result; when the deposit of hydrogen on the negative plate is only partially prevented, the cells are liable to be completely polarized if "short-circuited" for a time.

In many "open" circuit cells, however, substances are employed in connection with or adjacent to the negative plate which tend to absorb the hydrogen as it is set free during the operation of the cell, and that, while the battery is inactive or open, continue to absorb, or combine with, the hydrogen on the negative plate, so that after such cells have rested for a time they become entirely depolarized; the substances used for that purpose being termed depolarizing agents. Instances of depolarizing agents will be given subsequently. The manner in which polarization is prevented in "constant" cells will be referred to in the course of the description of the gravity and other cells.

THE GRAVITY OR CALLAUD CELL.

THE elements of the gravity cell are a copper and a zinc plate. The solution in which the copper plate is placed is, primarily, that formed by the dissolving of "bluestone" in water. Bluestone is known in chemistry as sulphate of copper. The zinc plate is immersed in water, but a solution of sulphate of zinc is, subsequently, formed around it.

In the Daniell cell, which was the first *constant* cell invented, and of which the gravity, or Callaud cell, is a modification, the copper plate is placed in a cell in a solution of sulphate of copper. In the same cell is placed a porous cup containing a dilute solution of sulphuric acid in which the zinc plate is immersed.

The chemical action assumed to take place in the Daniell cell when the circuit is closed may, in general, be stated as follows: oxygen attacks the zinc element, forming oxide of zinc which displaces the hydrogen of the sulphuric acid, forming sulphate of zinc; the hydrogen thus released attacks a molecule of the copper sulphate, displacing the copper of the sulphate, and forming with the sulphur and oxygen of the sulphate, sulphuric acid, which unites with a newly formed oxide of zinc, forming another molecule of sulphate of zinc and again releasing hydrogen which in turn displaces metallic copper, as before. This action, or an equivalent one, is supposed to take

place throughout the cell, or until the copper plate is reached, the result being that the hydrogen is not set free, but, instead, an atom of pure copper is deposited on the copper plate of the cell.

The chemical action that occurs in the gravity cell on closed circuit may be considered the same as that of the Daniell cell. Consequently, the elements of the cell remain as at first, copper and zinc, and a practically uniform, or constant electromotive force is thus maintained. In other words, since the hydrogen is diverted from the copper plate, *polarization* does not ensue.

The gravity battery is usually set up in glass cells about 6 inches in diameter by 8 inches in height. The copper plate is placed in the bottom of the cell; the zinc plate is suspended by a hanger from the rim of the cell, as seen in Fig. 2. An insulated copper wire is connected to the copper plate as shown.

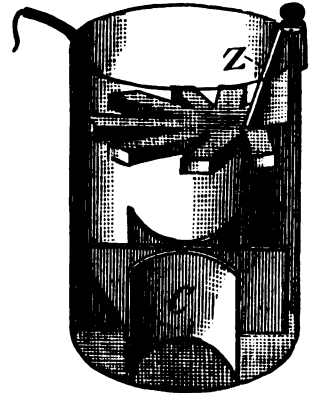

GRAVITY CELL,

The form of zinc plate shown in the figure is called the "crowfoot." This form of zinc, due to d'Infreville, is in extensive use in this country in gravity batteries. Occasionally, star-shaped zincs, which are suspended by a "tripod" resting on the top of the cell, are employed.

The bluestone, in crystals, is placed in the bottom of the cell, around the copper plate, and sufficient water is poured into the cell to cover the zinc. The bluestone dissolves quite rapidly, forming a solution of sulphate of copper.

After the cell has been in use for a short time a certain amount of sulphate of zinc is formed. This is also dissolved in the water of the cell, but, owing to the respective specific gravities of the two solutions, they do not speedily mix; the sulphate of copper, being the heavier of the two solutions, remaining at the bottom. Hence the name of the cell.

While, however, as just stated, the specific gravities of the respective solutions keep the copper sulphate below the zinc sulphate, the solutions will eventually mingle unless the action of the cell is sufficient to use up the sulphate of copper as speedily as it is dissolved. When this is not the case the copper sulphate solution diffuses through the cell and is decomposed by the zinc plate; the oxygen joining with the zinc to form oxide of zinc, and the copper of the sulphate being deposited on the zinc as a black mud, in appearance. From what has been said it is obvious that this action, will take place most rapidly when the cells are continuously idle, that is, open.

THE CARE OF GRAVITY BATTERIES.

The amount of bluestone to be placed in the cell depends somewhat on the work required of the battery. For "local" batteries, in which the sulphate of copper is rapidly consumed, about 3 pounds, per cell, are usually allotted. When this has been exhausted it may be assumed the cell requires cleansing. The bluestone crystals should be of such size as to pass through a sieve $1\frac{1}{4}$ inch mesh, and should not be so small as to pass through a $\frac{1}{16}$ inch mesh.

For "quadruplex" circuits the "long" end of the battery need not be supplied with

quite as much bluestone as the "short" end, since the former is not worked so continuously as the latter.

In some cases it is customary to put in a small supply of bluestone when the cell is set up and to renew the supply as required. This plan may prove satisfactory where very few cells are concerned, but in a battery room containing a large number of cells it will not answer, unless the staff of attendants is unusually large, too much time being required in the operation of replenishing. Another objection to this plan is that it appears to cause "caking" at the bottom of the cell.

The condition of a cell may generally be known by its appearance. In a cell in good order the solution is a bright blue color, the blue changing to water color before reaching the zinc. A very pale or a dirty brown-colored solution is indicative of a deteriorated condition of the cell. The average life of a local gravity battery is from 4 to 6 weeks. That of a main line battery, out of which 3 or more wires are supplied, about 8 weeks, and a quadruplex battery from 5 to 8 months.

HYDROMETER.—A hydrometer is often recommended as a useful adjunct to a battery room, and it certainly is convenient to have one on hand when required.

The function of the hydrometer, as its name suggests, is to indicate the density, that is, the specific gravity of the solution of the cell. Knowing the point of density of the solution at which the cell gives the best working results, the information furnished by the hydrometer can be availed of to keep the cell at the proper density point. But, again, these measurements require the attendant's time, and would not, on that account, work altogether satisfactorily on a large scale. For general purposes, as already said, the appearance of a battery will indicate to an intelligent attendant the time for renewal. The tendency of the battery solution is, of course, to become more dense, and when it is desired to withdraw some of the solution to replace it with water, a syringe such as shown in Fig. 3, may be employed.

FIG. 3



BATTERY SYRINGE.

The hydrometer commonly used for the foregoing purpose, consists of a glass bulb, about an inch in diameter, to which is attached a narrow glass stem, 5 or 6 inches in length. A quantity of small shot is inserted in the bulb—sufficient to sink it to a desired depth in pure water. A scale, somewhat similar to that of the ordinary

thermometer, is arranged on the stem. The scale is divided into 40 or 50 sections or degrees; zero being placed at that portion of the stem which is level with the surface of the water. As the density of the liquid is increased, the bulb and with it the stem rises; the density being indicated in degrees on the scale. An indicated density of 30° to 35° on certain forms of battery hydrometers has been found to be about the maximum consistent with the satisfactory operation of the cell.

THE USE OF OIL ON GRAVITY BATTERIES.—The utility of the use of oil on gravity batteries is questioned every now and again. This use of oil refers to the placing of a layer of oil on the liquid to prevent evaporation, etc. The objections generally offered to its use are that it makes the cell and the plates more difficult to clean; it cakes and falls to the bottom; it corrodes the insulation of the copper connecting wire; it does not prevent gathering of white salts on cell; it is dangerous as conducive to fires, etc.

The answer to these objections is that with proper precautions they need not be valid.

The cell in which oil has been used, and also the plates, are readily freed of any oil that may adhere to them, by the application of moistened waste, dipped in sand. Battery oil of the proper quality does not cake or flake. Ordinary oil is, it is known, a solvent of rubber compounds, and, but to a less extent, of gutta-percha, and when these substances are used as the insulating material of the copper connecting wires, they are soon softened, especially if the oil employed has even a trace of naphtha. But a compound composed of gutta-percha and paraffin withstands the oil very well. Good oil certainly does prevent evaporation of the water of the solution, and the gathering of "white salts" on the jar. This has been proved repeatedly. When the salts have started to "climb" before the oil has been applied, they will continue to do so, but to a more limited extent. The oil should be applied when the cell is newly set up.

The advantages of the use of oil arise from the fact that, preventing evaporation of the liquid and the formation of "creeping" or "white salts," a much more efficient battery is secured with a much smaller force of attendants than would otherwise be required. These white salts, or evaporated sulphate of zinc, when oil is not used, rapidly creep over the edge of the cell and down to the battery stand. This dry sulphate of zinc is a good conductor of electricity, and as it spreads from cell to cell is most liable to short-circuit them, in whole or in part; thereby, of course, wasting the battery.

By preventing evaporation the solution is kept constantly above the zinc, whereas, when oil is not used it is a common thing to find the battery open, due to the solution having fallen below the zinc. In one battery room of 5,000 cells, within the writer's knowledge, where oil was not used, one attendant was kept busy one day and a half to two days in the week replenishing the cells with water, and even this amount of attention did not suffice to obviate all trouble due to opening of batteries from the aforesaid cause.

As intimated, a good quality of oil should be used for this purpose. It should have the following requisites:—a color readily distinguishable from the solution, for instance, an auburn tint; should spread over the surface of solution readily, otherwise waste of oil and of time in applying it will ensue; should be odorless, non-inflamma-

ble under 400°F, and free from traces of naphtha or acid. A good lubricating oil, a product of petroleum, will meet all of these requirements.

Battery oil may, with care, be used over and over again and, therefore, should be carefully preserved when the cells are being cleansed or renewed. The best method for thus preserving the oil at such times is to pour the solution of the cells, oil included, into a barrel having a faucet at the bottom. The oil will float on the surface of the solution. When the barrel is full the solution is drawn off at the faucet until the oil is reached, when the latter is run into a separate vessel.

The evaporation of the solution and the formation of salts may be prevented by providing the cells with covers nearly air tight, but this is a difficult thing to do and to maintain on a large scale. In the hasty search for trouble in cells the cover will be removed and not put back, with the result that evaporation, etc., will go on. But when this plan can be properly carried out, as it may be in small battery rooms, it is a good and efficient one.

A method frequently employed to prevent climbing salts is to smear the upper edge of the cells with paraffin. Still another is to place a strip of oiled cloth around the upper, inside edge of the cell.

In a few more years it is quite possible that dynamo-electric machines will have so far replaced chemical batteries that the use of oil or any other preventive of evaporation, climbing salts, etc., will not be of so much importance. But as hundreds of thousands of gravity cells are at present in service in this country the question of improvement in their maintenance is still one of great interest.

GENERAL NOTES ON GRAVITY BATTERIES.—In setting up batteries, old solution from an exhausted battery is sometimes employed. This puts the battery in a working condition at once, as it reduces the internal resistance of the battery to nearly the normal point; sulphate of zinc being, as stated, a good conductor. At other times the battery is put on short circuit for twenty-four to forty-eight hours. This also brings the internal resistance down to a working basis, but at a loss of considerable material, since the reduced internal resistance is due to the presence of zinc sulphate in the solution, and this has been formed by the decomposition of a part of the zinc element as well as a part of the sulphate of copper of the solution. It has been the writer's experience, however, that much less black copper attaches to the zinc when the cells are short-circuited at starting, than when the old solution is used.*

The *internal* resistance of a battery may be explained thus: While a voltaic cell is a "source" of electromotive force, its elements, the plates, solution, etc., are conductors and, consequently, like other conductors, possess *resistance*. In a gravity cell this resistance is from 2 to 3 ohms, depending on the size of the plates, their nearness to each other, the nature of the solution, etc. This resistance is called the *internal* resistance of the cell, in contradistinction to the resistance of the rest of the circuit which is termed the *external* resistance. The internal and external resistances of the circuit comprise the *total* resistance of the *circuit*.

Much difficulty, delay, and loss, is frequently occasioned by the breaking of glass cells, apparently spontaneously, after they have been set up. The writer has known as high a breakage as 18% of the glass cells in use in an office in one month.

* An analysis of zinc scale from gravity battery, by Dr. C. M. Cressen, showed 45.06 parts of zinc, 2.98 of copper, .99 of lead, 1.87 of iron.

These breakages were traced to changes in temperature of the battery room. The remedy for this is an improved grade of cell. One that is better annealed.

It has been found of advantage to connect the copper connecting wire to the copper plate at a point near the bottom of the cell, and to bring the insulated covering of the wire close to that point.

The beaten copper and the scrapings from the zincs should be carefully gathered, as they may be sold at a figure considerably above the expense of handling.

Care should be taken in cold weather to maintain the temperature of the gravity battery above 65° or 70°F, for below that temperature the internal resistance of cells increases very rapidly, so much so that even at 50°F. the battery becomes much impaired.

It may be remarked here that the resistance of liquids decreases as the temperature rises.

A number of modifications of the Callaud cell have been designed, mainly, to prevent accumulations of black copper on the zinc. They differ from the ordinary gravity cell, chiefly in the manner of supporting or enclosing the zinc element. In some a porous cup with a flange, or rim, on its upper edge, which rests on the top of the glass jar, is employed and the zinc is placed in this cup with a few ounces of mercury, the latter for amalgamating purposes. In other respects the elements used are the same as those of the gravity battery, namely sulphate of copper and metallic copper. In other modifications such as that due to Mr. Delaney the zinc is enclosed in a cloth bag.

THE LECLANCHÉ CELL.

There are many modifications of the Leclanché cell. One form is shown in Fig. 4.

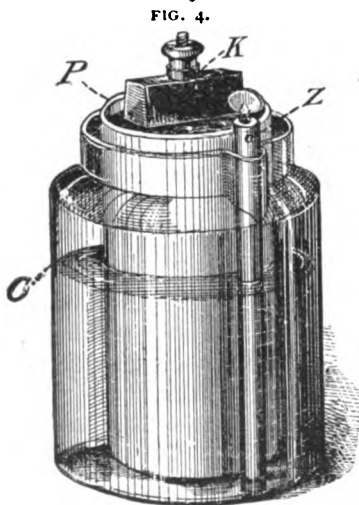

LECLANCHE CELL.

In this cell polarization is not altogether prevented, but it is measurably so. The depolarizing agent employed is peroxide of manganese, which is placed around the carbon element.

The plates of the Leclanché cell, Fig. 4, are zinc and carbon. The positive or zinc element generally consists of a rod z of that metal about half an inch thick, placed in a solution of sal-ammoniac contained in a glass cell c. The negative element of the cell consists of a rod or plate of carbon κ. This rod is placed in a porous cup p within the glass cell. The porous cup is filled with a mixture of small lumps of carbon and granulated peroxide of manganese. The porous cup permits the liquid to pass through and moisten the manganese and carbon.

Chloride of Ammonium, commonly known as sal-ammoniac, is a combination of chlorine and ammonia (ammonia being a compound of hydrogen and nitrogen); the molecule consisting, as previously intimated, of, hydrogen, 4 atoms; nitrogen, 1 atom; chlorine, 1 atom. In the action which is assumed to accompany

the passage of the current the chloride of ammonium is decomposed, the chlorine leaving the ammonia and hydrogen to unite with an atom of the zinc plate, forming chloride of zinc, and setting free ammonia and hydrogen. The ammonia is dissolved in the water of the cell; the hydrogen enters the porous cup and would very speedily polarize the cell by adhering to the carbon plate, thereby setting up a counter-electromotive force, but that it encounters the peroxide of manganese, which readily yields up a part of its oxygen, forming by the combination H_2O , that is, water; leaving what is termed a sesqui-oxide of manganese. This absorption or combination of the hydrogen prevents immediate polarization, but, apparently, hydrogen is evolved during the operation of the cell more rapidly than it can combine with the oxygen of the manganese, inasmuch as it is found that polarization soon takes place when the cell is short-circuited. When, however, it is left open for a time depolarization ensues and the cell recuperates; in a short time attaining its normal electromotive force.

An advantage of the combination of carbon granulations with the carbon plate is that it practically increases the surface of the negative element, and thus tends to increase the constancy of the cell, since, in addition to the counter-electromotive force set up by the hydrogen its presence on the surface of the carbon increases the internal resistance of the cell by reducing its conducting surface.

The Leclanché cell is extensively used in telephony, district messenger service, etc., etc., and in connection with other systems where open circuit batteries are available. Its electromotive force is 1.47 volts. Its internal resistance varies with the size of the elements and their distance from each other, but it is generally less than 1 ohm.

The contact with the carbon is generally made by drilling holes in the ends of the plate, into which lead is cast, and into which, at the same time, a brass contact screw is also inserted. The upper end of the carbon rod is thoroughly soaked in paraffin wax to prevent the rising of salts from the cell, but, notwithstanding this, the binding screw is frequently corroded by the action of the salts, after a few months use, and, as a consequence, the cell is rendered useless until a firm contact is re-established between the carbon plate and binding screw.

In setting up the Leclanché cell an excess of sal-ammoniac should not be used, as a saturated solution tends to a deposit of crystals on the zinc. On the other hand, the solution should not be allowed to become too weak, as in that case chloride of zinc will form on the zinc. Both of which causes materially increase the resistance of the cell. Some sal-ammoniac should be added to the cell from time to time depending upon the extent of its use.

The Leclanché cell has the advantage over the "gravity" and many other cells that when not in actual use, there is no waste of the materials of the cell.

THE FULLER CELL.

This cell is frequently employed in telegraphy where a strong current is required. It is in extensive use as a source of electromotive force for telegraph lines in Great Britain, taking there the place of the gravity cell in this country.*

The plates used in the Fuller cell are zinc and carbon. The zinc plate *z*, Fig. 5, is pyramidal, or cone shaped, and is placed within a porous cup *c* containing a dilute solution of sulphuric acid. The carbon plate *k* is placed outside of the porous cup, but

* This cell is now used very largely in telephony, in this country, as the transmitter battery.

within the glass jar *J*. The carbon is partly immersed in a solution composed of bichromate of potash, 3 parts; sulphuric acid, 1 part, and water 9 parts. This solution is generally known as *electropon*. In the bottom of the porous cup about two ounces of mercury are placed for the purpose of amalgamating the zinc. The necessity for amalgamating the zinc, which consists in coating the zinc with mercury, arises from this, that in commercial zinc there are more or less impurities such as lead, iron, tin, etc., and when such zinc is placed in a dilute acid, a local current, or local action, as it is called, is set up between the impure metals in the zinc and the zinc itself, which action wastes the zinc to no purpose.

The act of coating the zinc with mercury appears to form on its surface an amalgam, or alloy, which includes also the iron and other impurities of the zinc, that brings the entire surface of the zinc to a uniform condition. Consequently, there is no tendency to inequality of electrical condition so far as that portion of the zinc exposed to the acid solution is concerned, and hence, practically, no local action. As the zinc becomes decomposed, during the operation of the cell, the mercury passes to the next particle of zinc, and thus, automatically, maintains the amalgamation. The impure particles of the amalgam become detached as the zinc proper dissolves from around them, and fall to the bottom of the cell. Ordinarily, zinc is amalgamated by pouring or rubbing mercury over it, and wiping off any surplus. This is effective until the mercury wears or drops off, when local action again sets in. In the Fuller cell, as stated, the mercury is placed in the bottom of the porous cup, and by capillary action the mercury climbs the zinc, and keeps it permanently amalgamated. This is the chief advantage of the Fuller cell over other somewhat similar batteries.

Bichromate of potash is a combination of oxygen and the metals chromium and potassium. When the circuit of the cell is completed it is assumed that the sulphuric acid (the supply of which passes from the outer solution into the porous cup,) attacks the zinc, ultimately forming sulphate of zinc and setting free hydrogen; polarization being prevented by the combination of the hydrogen thus set free with oxygen of the bichromate of potash. The electromotive force of the Fuller cell is 2.028 volts. Its internal resistance, about .5 ohm. The internal resistance may be decreased still further by increasing the size of the carbon and zinc. When this cell is not overworked it will last four or five months without attention, but otherwise it should receive attention about once a month. Very little action takes place in this cell when the circuit is open. When the solution, originally orange, due to the bichromate crystals, acquires a bluish tint, it is evidence that additional crystals are necessary. Should the solution retain its orange color, but is, nevertheless, inoperative, fresh

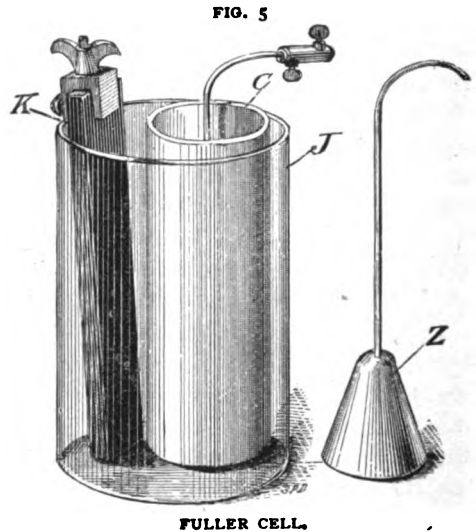

FULLER CELL.

sulphuric acid should be added. When the color of the solution is bright, and the battery still remains inactive, it may be assumed that it requires renewing.

CHLORIDE OF SILVER CELL.

This cell is shown in Fig. 6. Its elements are z, a rod of chemically pure zinc, the positive element, and c, a rod of chloride of silver, the negative element. A silver wire s, is cast into the chloride of silver element. The cell

itself is, in practice, generally, a small glass vessel v about two and a half inches long, by one inch wide. The "exciting fluid," or solution, is sal-ammoniac dissolved in water. After the solution has been added the vessel is closed by paraffin wax, which, practically, hermetically seals the cell.

This cell is often used as a standard of electromotive force. Its E. M. F., is about 1.03 volts. Its internal resistance is variable, and is at first about 4 ohms, but becomes much higher after ordinary usage.

Owing to its compactness and portability, a battery of these cells is much used in this country in measuring the insulation resistance of cables, etc. A form of this battery ex-

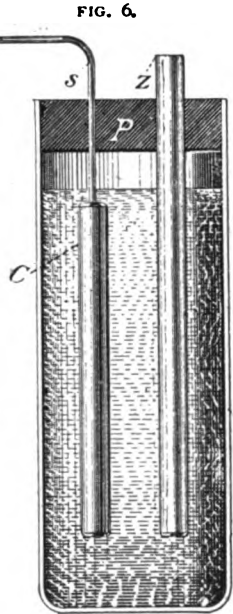

FIG. 6.

CHLORIDE OF SILVER CELL.

tensively used for this purpose, and known as the Barrett chloride of silver battery, is shown in Fig. 7. The cells are placed together as indicated in Fig. 8, in any desired number, in a frame, F, with compartments for each cell, and with one of the electrodes, or plates of each cell extending above the frame as shown. The entire battery is then surrounded by liquid paraffin wax, which speedily hard-

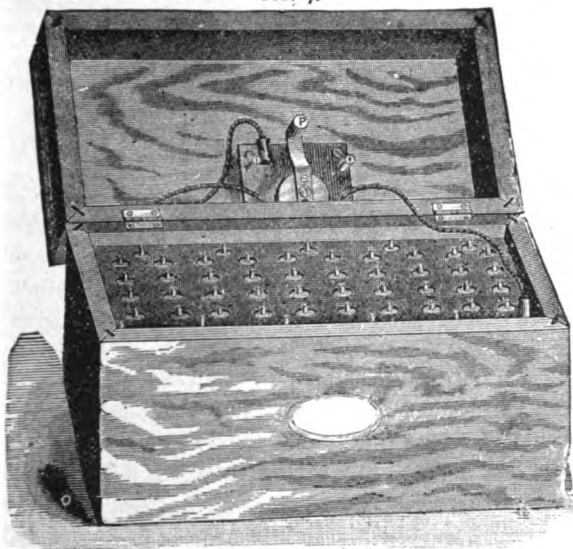
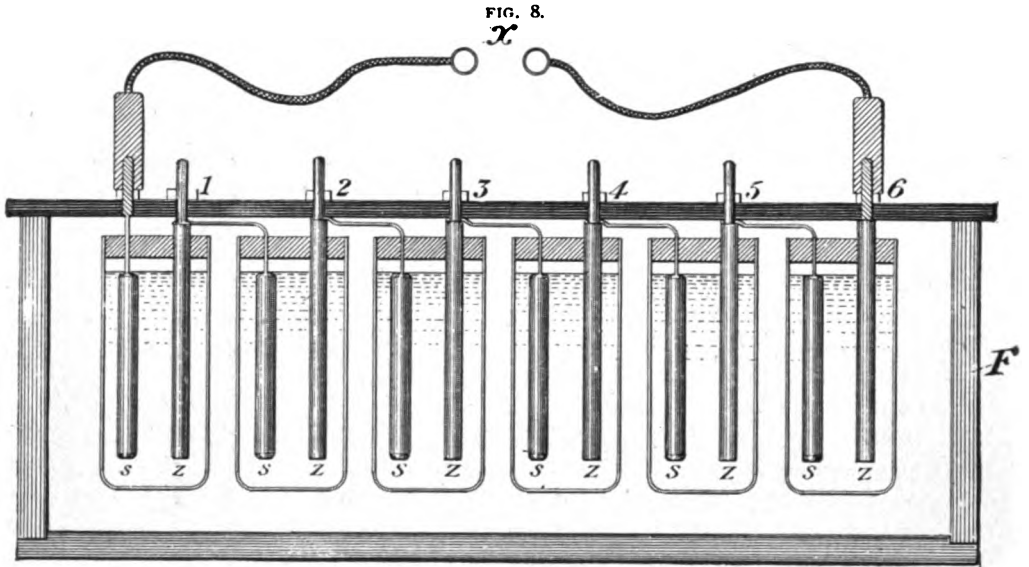

FIG. 7.

CHLORIDE OF SILVER BATTERY.

ens. This well insulates the battery. The cells are joined together permanently, as shown in Fig. 8, but until the electrodes are connected by a wire outside of the frame the battery does not become active. By the use of hollow metal plugs, which fit over the ends of the protruding electrodes, and to which plugs, insulated wires are attached, as shown in Fig. 7, any part or all of the cells may be brought into circuit. For instance, the cells in Fig. 8, between and including 1 and 6, are in circuit. A pole-

changing switch is placed on the cover of the box at x , by means of which the polarity of the battery may be reversed at will. This pole reverser is shown in Fig. 7.



A battery of one hundred chloride of silver cells can be readily placed within a box one foot square.

THE EDISON-LALANDE CELL.

This cell, which is a modification, chiefly as to mechanical construction, of the "De Lalande and Chaperon" cell, is illustrated in Fig. 9. Its elements are a zinc plate z and a block of copper oxide c , upheld by a frame f . The solution of the cell is oxide of potassium, or caustic potash, dissolved in water. The plates are suspended from the cover of the cell as shown.

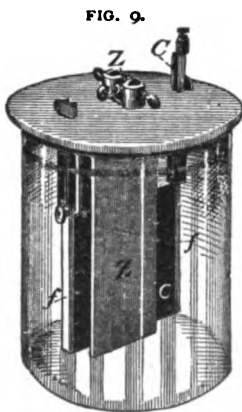

Polarization is prevented by the "decomposition of the water of the solution, the oxygen of the water combining with the zinc to form oxide of zinc, which in turn combines with the potash to form an exceedingly soluble double salt of zinc and potash." The hydrogen liberated from the water combines with the oxygen of the copper oxide, re-forming water and depositing pure, metallic copper.

The copper oxide of the "Edison-Lalande" cell is obtained by roasting copper turnings which are then ground finely and afterwards formed into blocks of suitable size.

To prevent evaporation and the formation of creeping salts, a layer of suitable oil is placed over the liquid. This, it is said, also prevents a combination of di-oxide of carbon from the air with the potassium of the solution.

The electromotive force of the cell is low, being at first about .98 volt, and after working for a short time it falls to .7 or .75 volt. The internal resistance of the cell is very low and varies with the size of the cell; the resistance of the largest cell being but .025; that is $\frac{25}{1000}$ ohm. The internal resistance decreases after the cell has been in operation for a few hours, owing to the substitution of the reduced metallic copper for the copper oxide; the former being a better conductor than the oxide. In the "Edison-Lalande" cell a film of metallic copper is deposited, in advance, on the copper oxide, thereby procuring a minimum internal resistance immediately the cell is connected in circuit. The manufacturers advise that, in setting up the cell, one-half the caustic potash sticks, which accompany the cell, should first be placed in the jar, after which the jar should be filled to within one inch from the top with water. The liquid should be stirred occasionally or until the caustic potash is dissolved, when the balance of the caustic may be added, the liquid being then stirred as before. This precaution is rendered necessary by the increase of temperature that accompanies the solution of the caustic potash. This solution is harmful to the skin. The hands should therefore be carefully guarded against direct contact with it.

It may be added that the Edison-Lalande cell is well adapted to purposes requiring strong currents. A cell of this kind having an E. M. F. of .75 volt and an internal resistance of .025 ohm would, on short-circuit, furnish a current of 30 amperes. A gravity cell having 1 volt E. M. F. and 2 ohms internal resistance would furnish a current of but .5 ampere under similar conditions.

DRY BATTERIES.

A form of zinc-carbon primary cell, known as a "dry," but which is more correctly a *moist* battery, is one in which the usual liquid solutions are dispensed with, and instead the cell is partly filled with substances which are capable of retaining moisture for a considerable time; or to which a small amount of liquid may be added from time to time. These substances hold the "exciting agents," such as sal-ammoniac, in solution. The freedom of these cells from climbing salts, accidental spilling of the solution, etc., has rendered them very desirable for use in telephony; call bell service, etc., and the demand for them has grown rapidly in recent years, with the result that there is now a large variety of such cells in the market.

Some forms of dry batteries, like the Leclanché liquid cell, have the advantage that they do not become inoperative at low temperatures, as do, for instance, the Daniell and "gravity" liquid batteries. Certain dry batteries have been found to perform satisfactory service when exposed to temperatures ranging considerably below zero, Fahrenheit.

THE BURNLEY DRY CELL.

One form of dry cell, known as the Burnley, is shown in Fig. 10, in cross-section.

In this cell the usual glass jar is replaced by a zinc tube, or cup *A* to which a clamping screw *B*, is rigidly attached. *C* is a solid carbon cylinder, forming the negative plate of the cell. It is provided with a connecting screw *D*. The zinc cup

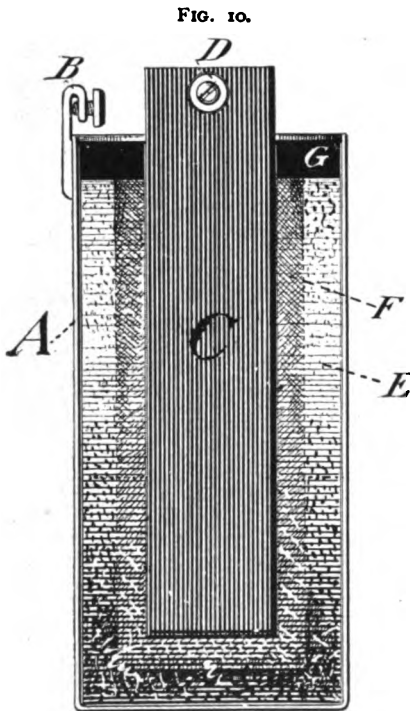

THE BURNLEY DRY CELL.

is lined with an exciting agent, *E*, which, practically, corresponds to the solution of the Leclanché cell, and is composed of sal-ammoniac, 1 part; chloride of zinc, 1 part; plaster, 3 parts; .87 parts of flour, and 2 parts of water.

In constructing this cell, the ingredients of the exciting agent are mixed together, forming a semi-liquid, which is poured into the cup *A* around a plunger that has been temporarily inserted in the centre of the cup, when the mass speedily stiffens. The plunger is then removed and the carbon rod is inserted in its place. The carbon, however, does not occupy all of the space left by the plunger, and the space around the carbon is filled with a semi-solid compound, *F* in the figure, consisting of sal-ammoniac, 1 part; chloride of zinc, 1 part; peroxide of manganese, 1 part; granulated carbon, 1 part; plaster, 3 parts, 1 part of flour and 2 parts of water.

After the ingredients are placed in the cell, it is sealed with bitumen, *G*, or any equivalent substance.

The main constructional feature of this dry battery is the manner in which the layers of the exciting and depolarizing agents are arranged within and around the zinc and carbon plates, respectively. The depolarizing agent in this cell, it will be noted, is also practically similar to that of the Leclanché.

This cell has an E. M. F. of 1.4 volt, and an internal resistance of 1 ohm. It gives a practically constant current during the life of the cell.

THE GASSNER DRY CELL.

In Fig. 11 is shown, in cross-section, the Gassner dry cell. In the figure *ZJ* is a zinc cup, to which a clamping screw *S*, is firmly attached. *CM* is a cylinder contained within the zinc cup, composed of carbon and manganese, to which is attached the binding post *C*. The space between the two cylinders, *ZJ* and *CM*, is filled with an exciting agent, in liquid form, which afterwards becomes comparatively solid. The whole is sealed in the cup by some suitable material, *M*. The ingredients of this exciting agent are compounded about as follows: 1 part by weight of oxide of zinc; 1 part sal-ammoniac; 3 parts of plaster; 1 part chloride of zinc; 2 parts water.

The claimed effect of the oxide of zinc upon the composition is to loosen and make it porous, and that the greater porosity thus secured facilitates the interchange of the gases and diminishes the tendency to polarization. The internal resistance of the cell is not increased by the oxide of zinc, inasmuch as the latter is a better conductor than the plaster of the compound.

FIG. 11.

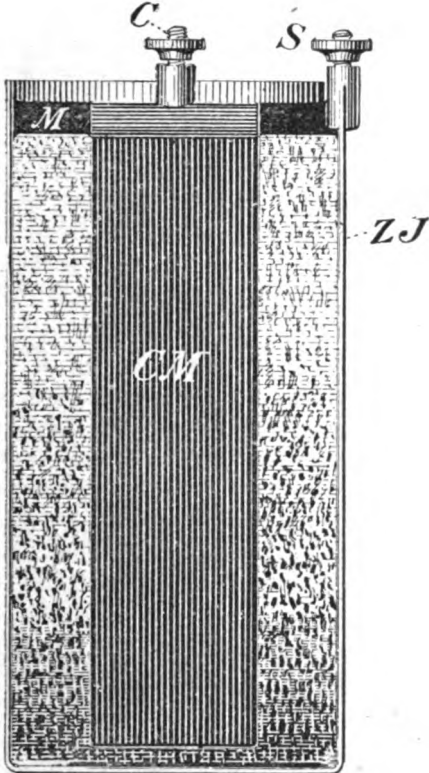

GASSNER DRY CELL.

FIG. 12.

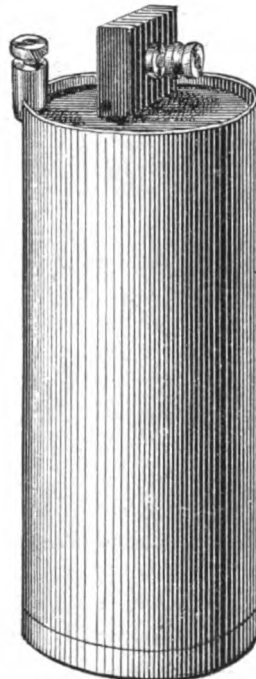

DRY CELL.

The general external appearance of a "dry" cell is illustrated in Fig. 12. The structure of the cell is, however, frequently varied both as to size and shape.

Used as a "call bell" battery, or for similar purposes, successful, dry batteries will last, without renewal, for from six months to two years, depending on the service performed.

ARRANGEMENT OF CELLS IN BATTERIES.

As already stated, a number of voltaic cells joined together is termed a battery.

CELLS IN SERIES.—When it is desired to obtain a greater electromotive force than that developed by one cell, a number of cells are connected, as in Fig. 13; the positive pole of the first cell being connected to the negative pole of the second cell; the positive of the second cell to the negative of the third cell, and so on.

Cells thus placed are said to be arranged in series. When thus arranged, the electromotive force of each cell is added to that of its neighbor, and the resulting electromotive force is equal to the sum of the electromotive forces of all the cells. Assuming the E. M. F. of each cell in Fig. 13 to be 1 volt, the total E. M. F. developed by the series will, consequently, be 6 volts, and, in the figure, the direction of the current in the external circuit is assumed to be from the positive pole at 6, to zero, as indicated by the arrows, that is, from the point of high to the point of lower potential. As each cell increases the electromotive force by 1 volt, the E. M. F. at any one of the cells, that is, the difference of potential between that cell and zero, will be found to be, practically, as indicated by the figures.

FIG. 13.

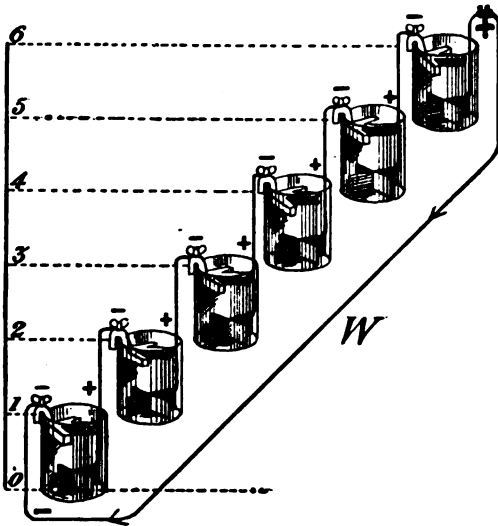

CELLS IN SERIES.

CELLS IN MULTIPLE.—When it is desired to obtain additional strength of current without increased electromotive force, the cells are connected as shown in Fig. 14, which represents two rows of 6 cells, each, with the negative pole of each row joined at A, and the positive pole of each row joined at B. When thus arranged the two rows of cells are said to be in multiple, or parallel.

FIG 14.

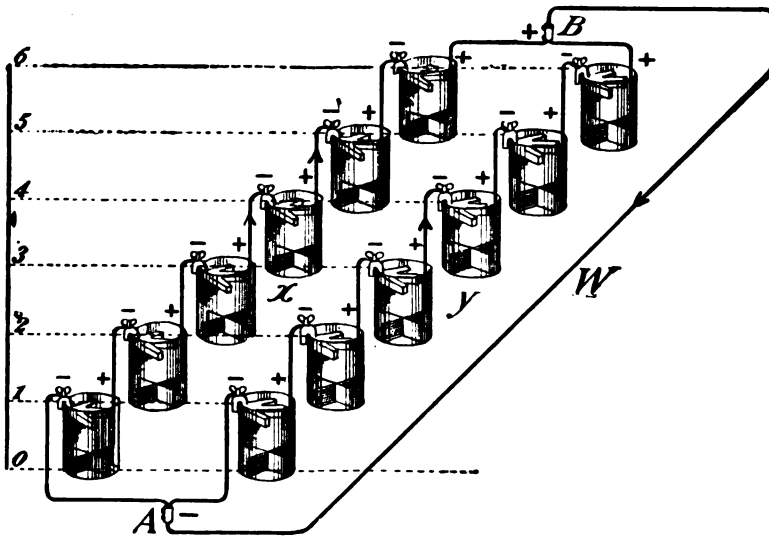

CELLS IN MULTIPLE.

Thus arranged, each cell of each row adds its E. M. F. to that of its adjoining cell, so that each row has at its terminals a difference of potential of 6 volts, as in the case of the separate row of 6 cells, Fig. 13. But, in the case of the cells in multiple, twice as much current will flow in the external circuit, wire w, Fig. 14, as in wire w, Fig. 13. A cell or battery whose terminals are thus connected by a wire of practically no resistance, is said to be "short circuited."

The doubling of the current in the case of Fig. 14, is due to the fact that the internal resistance of the cells has been reduced one-half, as may be shown:

Assuming, as before, (Fig's. 13 and 14) that each cell has an E. M. F. of 1 volt, and an internal resistance of 2 ohms; the "internal resistance" being, as already said, the resistance of the plates, the connecting wires in the cell and the liquid of the cell; which internal resistance varies inversely with the size of the plates, their nearness to each other, and with the nature and condition of the solution of the cell. The "external" resistance, as previously remarked, is the resistance of the circuit outside of the cell.

With 6 cells in series, therefore, we have 6 volts E. M. F., and 12 ohms internal resistance, which, according to Ohm's law, gives $\frac{6 \text{ volts}}{12 \text{ ohms}} = \frac{1}{2}$ ampere. In the case of Fig. 14, on the other hand, we have, by placing the cells in multiple, practically doubled the size of the cells and, consequently, have halved the resistance, so that, while the electromotive force is the same as before, the total internal resistance, that is the "joint" resistance of the two rows of cells, is 6 ohms, and the strength of current in wire w will be $\frac{6 \text{ volts}}{6 \text{ ohms}} = 1$ ampere. In other words, if instead of using two rows of cells we should reduce the internal resistance of the first row by increasing the size of the copper and zinc plates, and by bringing the plates in the cell nearer to each other, so that the internal resistance of each cell should be but 1 ohm, instead of 2 ohms, we would have, in the external circuit, virtually, the same result as with the two rows; that is, $\frac{6 \text{ volts}}{6 \text{ ohms}} = 1$ ampere.

If the 12 cells, Fig. 14, were placed in one series instead of in multiple, the resulting electromotive force would be 12 volts, and the strength of current would be $\frac{12 \text{ volts}}{24 \text{ ohms}} = \frac{1}{2}$ ampere. And, further, it will be found that as long as each cell has an E. M. F. of 1 volt, and an internal resistance of 2 ohms and the external resistance of the circuit continues low, the current will be the same in the external circuit whether we have but 1 cell or 1,000 cells in series, since, in that case, it will be evident that for every volt electromotive force added to the circuit there are added to the same circuit, 2 ohms resistance. For example, with 1 cell, $\frac{1 \text{ volt}}{2 \text{ ohms}} = \frac{1}{2}$ ampere, or with 1,000 cells, $\frac{1,000 \text{ volts}}{2,000 \text{ ohms}} = \frac{1}{2}$ ampere.

CELLS IN OPPOSITION.—In Fig. 15 is shown a set of 6 cells, 2 of which are placed in opposition, as regards their poles, to the other 4. This figure may be used to illustrate what is termed counter-electromotive force. It will be seen by

reference to the arrangement of the positive (+) and negative (-) signs over the cells, that cells 1 and 2 are opposed to cells 3, 4, 5 and 6. The effect of this is that the electromotive force of cells, 1 and 2, offsets, or neutralizes, the electromotive force of two of the remaining cells, and, as a consequence of this opposing, or counter-electromotive force, the available, or effective electromotive force of the circuit is only equal to that of 2 cells, or 2 volts. And, since each cell in the circuit retains its usual internal resistance, the current flowing in the circuit of the 6 cells, when thus arranged, will be $\frac{2}{12} = \frac{1}{6}$ of an ampere, as against $\frac{1}{2}$ ampere when the cells were connected in "straight" series.

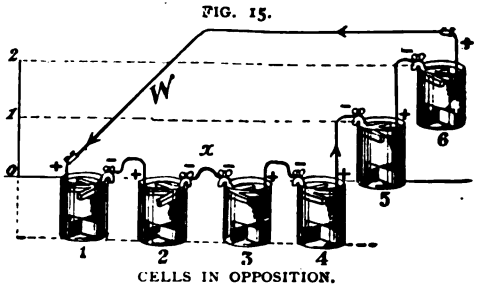

Further, if, in Fig. 14, the wire w be severed, no current will flow in the cells, inasmuch as the 6 volts of row x, will oppose the 6 volts of row y, thus presenting an equal potential, or pressure, at A and B, and thereby preventing any tendency to a flow of current between those points; the flow of current, as stated elsewhere, depending on a difference of potential, or pressure.

In all of the foregoing it has been assumed, as intimated, that the resistance of the connecting wires w, is so low as to be negligible; when, in practice, this is not the case, the resistance of those wires must be included, in calculating, by Ohm's law, the resulting strength of current, instances of which will be given later.

An improvement made recently by Mr. G. d'Infreville, in the form of the zinc of the gravity battery, is shown in Figs. 15 a, 15 b. "In d'Infreville's crow-foot battery the disadvantage exists that after the "feet" of the zinc have been consumed, the internal resistance becomes so great that a new zinc must be supplied. With the "wasteless" zinc the stub is used in the cell until none of it remains. Each zinc, as shown in Fig. 15 b, is furnished with a tapered post which is coned out underneath; the size of the socket thus formed corresponding to that of the tapered post. The post is forced into the socket as indicated in Fig. 15 b, in such a manner that two or more zincs, or portions of zincs, may be in use at once in the cell. The method of hanging the cell is shown. The doubled zinc reduces the internal resistance of the cell to .7 ohm."

FIG. 15a.

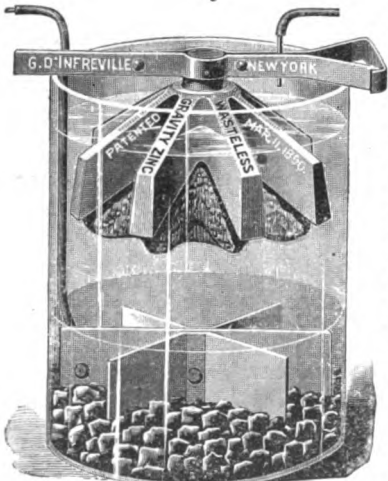
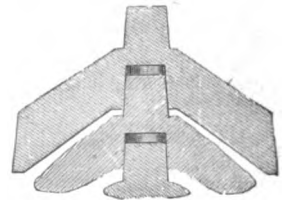

FIG. 15b.



CHAPTER III.

THE DYNAMO MACHINE IN TELEGRAPHY.

Ten or twelve years ago it would have been unnecessary to write a chapter devoted to the dynamo-electric machine in a book descriptive of electrical telegraphy, but to-day such a work would scarcely be complete without reference to that machine.

The dynamo machine was first extensively used in telegraphy in this country, to take the place of gravity battery previously used to furnish the current required in the main office of the Western Union Telegraph Company in New York City, 1880. It is now employed for a similar purpose in many other large telegraph offices in this country.

It is known that not more than 3 or 4 circuits at most can be advantageously worked from one gravity battery.

This is due mainly to the fact that the variation in the strength of the current furnished by this form of battery, when many line wires are being "fed" from one of them, renders signals unsteady. This variation of the current strength is due to a constantly changing external resistance, caused by the opening and closing of the wires in the act of operating them. When a source of electromotive force having a very low "internal" resistance is employed, the fluctuations of the external resistance do not materially affect the amount, or strength of current supplied to the various wires forming the "external" resistance.

An explanation may be useful here, of the causes which lead to this variation of current strength when gravity batteries are employed, and of the statement just made, namely, that, with a source of electromotive force having low internal resistance, this variation would not occur. But, as to a proper comprehension of the subject, a knowledge of the laws of the "joint" resistance of circuits, and of the distribution of current strength in divided circuits, is essential, reference will first be had to those laws before proceeding with the explanation. As those important laws are also concerned in the operation of certain systems, notably the Field key system, and in methods of testing described herein, they will be referred to at some length.

JOINT RESISTANCE OF CIRCUITS.—The resistance of a conductor of a given length decreases in proportion as its weight, or mass, is increased. Thus, if a wire 1 mile in length and weighing 200 pounds, be assumed to have a resistance of 6 ohms, per mile, a wire of the same length and material, weighing 400 pounds, will have a resistance of 3 ohms.

If, as in Fig. 15 *a*, a number of conductors be connected with a given battery, or other source of E. M. F., the whole may be classed as one circuit, the total resistance of which will be that due to the internal resistance of the battery and the exter-

nal resistance of the conductor; the external resistance in this instance being the "joint" resistance of the 3 conductors.

FIG. 15 a

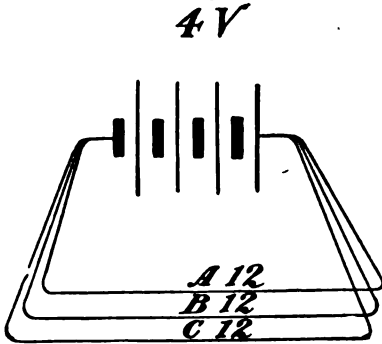

In Fig. 15 a, let A B C represent 3 copper wires of equal diameter and length, weighing 3 pounds each, and each having a resistance of 12 ohms. It is evident then that, as regards electrical resistance, these 3 wires are equal to 1 wire of similar length, weighing 9 pounds. Consequently, if the 3 wires be measured together, it will be equal to measuring 1 wire of 9 pounds weight, and hence, the joint resistance of the said 3 wires will be but $\frac{1}{3}$ of 12 ohms, namely, 4 ohms, and, if we neglect for the present the resistance of the battery, the total

resistance of the circuit will be 4 ohms. Conductors arranged as in Fig. 15 a, are said to be in "multiple" or in "parallel;" and such a circuit as that shown in the figure, is termed a "divided circuit."

If the weight, length and material, and, consequently, the resistance of each conductor of a circuit were the same, it would be easy to calculate the joint resistance of any number of circuits arranged in multiple. For instance, the joint resistance of, say, 20 wires of equal weight and length, each having a resistance of 20 ohms, would be equal to the resistance of 1 wire of similar length weighing twenty times as much as any one of the 20 wires; that is, the resistance of such a wire would be 1 ohm. Nor, is it necessary, to arrive at this conclusion, that each of, say 20 wires, should be of the same weight and length. If each wire has the same resistance, the joint resistance of the 20 wires will be 1 ohm. For, evidently, electrically considered, a wire measuring 20 ohms, whatever be its actual weight and length, will be the equivalent (as to resistance) of any other wire measuring 20 ohms. Thus, an easy way to find the joint resistance of a number of circuits of equal resistances, in multiple, is to divide the resistance of any one of the circuits by the total number of wires, as in the last instance: $\frac{20}{20} = 1$ ohm.

But when the respective resistances of the wires placed in multiple are not alike, the rule for finding their joint resistance may seem more complicated. In that case the rule is as follows:—*The joint resistance of circuits in multiple is equal to the reciprocal of the sum of the reciprocals of the respective resistances of the circuits.*

This statement is, not, however, as formidable as it may, to the novice, at first sight appear. Indeed, the plan previously described for finding the joint resistance of circuits of similar resistances, is, virtually, the result of the working out of that statement, as we shall presently see. We shall see, also, that the statement is merely the expression of well-known electrical laws.

The reciprocal of any number is the quotient obtained by dividing 1 by that number. And the sum of a given amount of reciprocals is obtained by simply adding those quotients together. Consequently, the reciprocal of the sum of any amount of reciprocals may be obtained by dividing 1 by that sum.

For example, the reciprocal of 20 is .05; that is $\frac{1}{20} = .05$. On the other hand, the reciprocal of .05 is 20; that is $\frac{1}{.05} = 20$. Thus, the reciprocal of a number may be called the converse of that number. Again, the sum of reciprocals may be shown thus: $\frac{1}{20} + \frac{1}{20} + \frac{1}{20}$ which is equal to $.05 + .05 + .05 = .15$. Hence, the reciprocal of the sum of the reciprocals of $20 + 20 + 20$ must be $\frac{1}{\frac{1}{20} + \frac{1}{20} + \frac{1}{20}}$ that is;

$$\frac{1}{.05 + .05 + .05} = \frac{1}{.15} = 6.66$$

Now, electrical conductance, or conductivity, is the reciprocal, or converse, of resistance, and, contrariwise, resistance is, of course, the reciprocal, or converse, of conductance. That which tends to increase resistance decreases conductance, and whatever increases conductance decreases resistance.

There is no generally adopted unit of conductance, as yet, but Sir Wm. Thomson has suggested the term mho, as such a unit. This word, it will be perceived, is the converse of ohm, and thus is suggestive of the converse of resistance.

The conductance of a conductor, obviously, increases directly as its power of conducting is increased. Thus, if we join up 2 wires in multiple, each having a conductance of, say, 6 mhos, the joint conductance of the wires would be the sum of their respective conductances, that is, 12 mhos. Or, if 3 wires of 6, 12 and 18 mhos, each, were thus connected the joint conductance would be 36 mhos. That is, the conductance of the 3 wires combined would be equal to the conductance of 6 wires of 6 mhos each, or to 1 wire of 36 mhos conductance. For example, assuming the case of any 3 wires having each a *resistance* of 6 ohms, it is clear, from what has been stated, that they would each have a conductance of $\frac{1}{6}$ mho.

Now, since the joint conductance of the wires is the sum of their respective conductances, their joint conductance would be $\frac{1}{6} + \frac{1}{6} + \frac{1}{6} = \frac{3}{6} = .5$. That is, .5 mho would be their joint conductance and, since, again, conductance is the reciprocal, or converse, of resistance, the resistance of a conductor having a conductance of .5 mho, would be $\frac{1}{.5}$ ohm, that is, 2 ohms. In other words, the joint resistance of the said 3 wires in multiple would be 2 ohms.

The foregoing would be stated, in accordance with the rule for finding joint resistance, as follows:

$$\frac{1}{\frac{1}{6} + \frac{1}{6} + \frac{1}{6}} = 2 \text{ ohms.}$$

Having the foregoing in mind then, the explanation of the law of joint resistance of conductors in "multiple" or "parallel" will become plain. It virtually resolves itself into this:—First, find the sum of the conductances of the conductors whose resistances are known, and then ascertain the reciprocal of the sum of those conductances, which will be the joint resistance of the conductors.

The formula for finding the joint resistance of *two* circuits, R and r, in multiple, is generally stated thus:

$$\frac{R \times r}{R + r} = \text{joint resistance,}$$

or, for example, assuming R to have a resistance of 20 ohms; r a resistance of 10 ohms, as follows:

$$\frac{20 \times 10}{20 + 10} = x = \text{joint resistance.}$$

This formula is simply the result of working out the foregoing rule, as we may see. For example, as before, the conductance of R will be $\frac{1}{20}$ mho; that of r , $\frac{1}{10}$ mho, consequently, their joint *conductance* will be $\frac{1}{20} + \frac{1}{10}$ or $\frac{1}{R} + \frac{1}{r}$ which, by addition of fractions, is found to be equal to $\frac{20 + 10}{20 \times 10}$ or $\frac{R + r}{R \times r} = \text{joint conductance.}$ Then, as joint conductance is the converse of joint resistance, the latter, for *two* circuits, will be represented by the formula just stated: $\frac{R \times r}{R + r}$. That is, *the joint resistance of two circuits is equal to the product of their respective resistances divided by their sum.*

The joint resistance of several circuits may also be ascertained, by aid of the latter formula, by first calculating the joint resistance of 2 of the circuits and then using that result as if it were the resistance of 1 wire wherewith to find the joint resistance of 3 wires, and the joint resistance of 3 wires may then be utilized to find the joint resistance of 4 wires, and so on.

THE DISTRIBUTION OF CURRENT IN DIVIDED CIRCUITS. The law of distribution of current in a divided circuit is, in effect, as follows: *The strength of current in the branches of a divided circuit is inversely proportional to the respective resistances of each branch.* In other words, the strength of current in each of such branches will be found by dividing the potential difference at its terminals by its resistance.

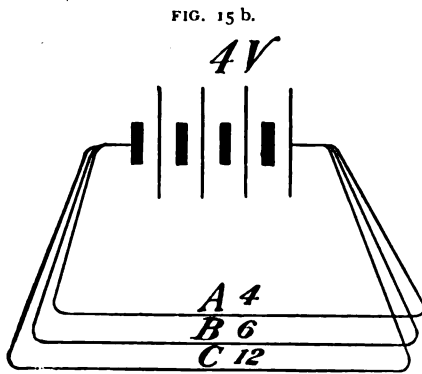

For example, if, in Fig. 15 *b*, we assume the E. M. F. of the battery to be 4 volts, and the resistances of branches A B C to be 4, 6 and 12 ohms, respectively, the joint resistance of which would be 2 ohms, the total current strength in the circuit at the poles of the battery (neglecting its internal resistance) will be, according to Ohm's law, $\frac{4}{2}$, that is, 2 amperes, which current will be distributed among A B C according to their respective resistances.

Thus A will get $\frac{4}{4} = 1$ ampere; B $\frac{4}{6} = \frac{2}{3}$ ampere, and C $\frac{4}{12} = \frac{1}{3}$ ampere, the sum of which fractions of the total current strength is, evi-

dently, 2 amperes.

DISTRIBUTION OF CURRENT IN TELEGRAPH WIRES, IN MULTIPLE.—The manner in which the foregoing laws are concerned in the explanation referred to will now be considered.

Suppose the case of a gravity battery of 100 cells, each cell having an internal resistance of $2\frac{1}{2}$ ohms, making in all 250 ohms, and 4 telegraph wires, each having a total resistance of 1000 ohms, connected up with the battery. The joint resistance of those wires, as may be ascertained by the rules given, is 250 ohms.

With all the wires closed at one time the total resistance of the circuit, including

the internal resistance of the battery will then be 500 ohms. The electromotive force of each cell of the battery being approximately 1 volt, or 100 volts in all, the resulting strength of current yielded by the battery at such times will be, according to Ohm's law, $\frac{100}{500} = \frac{1}{5}$, that is .2 ampere. Distributing this current among the four wires obviously gives each .05 ampere, since the resistance of each wire is the same.

With 3 wires open, and 1 closed, the total resistance of the circuit, including as before, the battery resistance, will be 1,250 ohms, which gives a strength of current of nearly, .08 amperes, that is, about $\frac{3}{100}$ more current than was furnished each wire when the other 3 wires were also closed.

With 10 wires of the same resistance connected to the same battery, the strength of current furnished each wire when all are closed, will be, not quite .03 ampere, or about one-third of that which would be furnished any 1 of the 10 wires with all the others open. Assuming that a strength of current of .03 ampere might be sufficient to operate the relays, it would be impracticable to keep them adjusted for this range of change of current strength.

With, however, a battery of the same electromotive force, but having a *total internal resistance* of only 1 ohm, it will make little difference, so far as the strength of current supplied each wire is concerned, whether 1 or all of the 10 wires connected to it, be open or closed.

For instance, again assuming each wire to have a resistance of 1,000 ohms. With but 1 wire closed the total resistance of the circuit, including internal resistance of battery, will be 1,001 ohms. The strength of current in the circuit will be, consequently, $\frac{100}{1001} = .099$ ampere. With the 10 wires closed, their joint resistance will be 100 ohms. Adding the battery internal resistance, we get a total of 101 ohms, which gives $\frac{100}{101} = .99$ ampere. This, distributed equally, gives to each of the 10 wires .099 ampere, as was the case with but 1 wire closed. If the decimals be carried out further, it will be found that each wire gets slightly less current when all are closed than any one would get with the other 9 open, but, practically, the amount is the same.

With a battery of still less internal resistance, a much larger number of wires could be fed without any perceptible change in the strength of current on any of the external circuits, regardless of the operation of the other circuits.

THE DYNAMO-ELECTRIC MACHINE.

It is easy to construct dynamo-electric machines, having an electromotive force, at least, equal to 100 cells gravity, the "internal" resistance of whose "armatures" is but a fraction of an ohm, and thus it is possible to "feed" from one dynamo machine, several hundred telegraph wires, without perceptible variation in the current strength furnished. It is this feature, among others, which gives the dynamo machine, as a source of electromotive force in telegraphy, so decided an advantage over gravity or other forms of chemical battery, in offices where many wires are operated.

Before entering upon a description of some of the methods by which the current established by the dynamo machine is utilized for telegraphic purposes, it will, perhaps, be advisable to state briefly, the theory of the operation of that machine; this will entail further allusion to some laws of electricity and magnetism.

THEORY OF DYNAMO MACHINES—It is well-known that when a magnet is placed beneath a piece of card-board or glass, on which soft iron filings have been strewn, if the card be lightly tapped, the filings arrange themselves in symmetrical lines, as outlined in Fig. 16. This singular arrangement of the iron filings in the presence of a magnet, such, for instance, as that shown in the figure—namely, a bar magnet—indicates the existence of a force to which the term, “lines of force,” has been applied.

FIG. 16

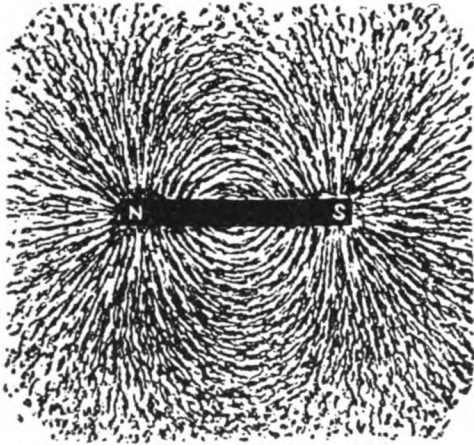
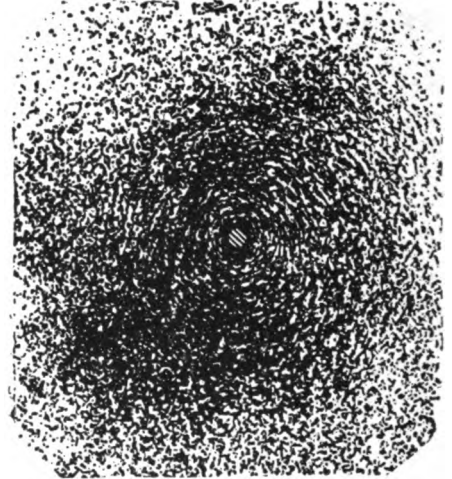

FIG. 18.



It is not meant that actual “lines” of force exist; the term being merely used as a convenient means of designating the phenomenon and the direction in which the force acts.

It is known also that when a current of electricity is caused to flow in a wire, similar magnetic “lines of force” are set up, concentrically, around it, as indicated in Fig. 17, and, as may be evidenced by passing a wire conveying a strong current through a cardboard on which iron filings have been thrown, as illustrated in Fig. 18.

These magnetic lines of force are set up by what is termed the magnetomotive

FIG. 17.

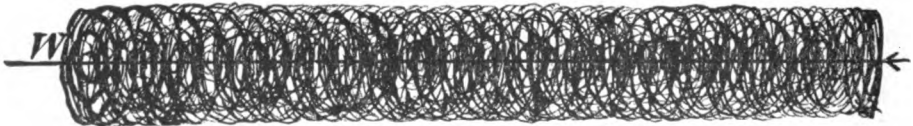

force. The space between the “poles” of a magnet, or wherever its magnetic influence is felt, or in the space around a wire conveying a current of electricity, is termed a magnetic “field.” The substances through which the lines of force pass, including the iron of a magnet, compose the *magnetic circuit*. The expression, *number of lines of force within a given space*, for example, a square inch, is at present generally used in practice as a measure of magnetic density, or strength, the term being frequently abbreviated to “lines per square inch.”

The total number of lines of force in a magnetic circuit is termed the magnetic flux, and is obtained by multiplying the total area of the field in square inches by the density of a square inch section of the circuit. The magnetomotive force is equal to the product of the amperes in the coil by the number of convolutions of the coils. This is also termed the ampere-turns. The magnetic flux may be increased by increasing the magnetomotive force, or by decreasing the resistance, or reluctance, of the circuit. Thus the insertion of a soft iron bar in a circuit previously consisting of air alone will largely increase the flux, soft iron being a much better conductor of magnetism than air (or is more permeable than air). For instance, if the permeability of air be 1, that of iron may be from 100 to about 350, depending on the quality of the iron. The reluctance of iron is not, like electrical resistance, a constant, but varies, in iron, with the magnetic density of the circuit. The relation between the foregoing terms is shown in the equation: $\text{Magnetic flux} = \frac{\text{Magnetomotive force}}{\text{Reluctance}}$. (See page 66.)

Many of the phenomena of electricity and magnetism are reversible, or convertible. For instance, it is known that when an electric current passes in a wire surrounding a soft iron core, the iron becomes a "magnet." On the contrary, when a wire is caused to cross a magnetic field, it is known that an electromotive force is developed in the wire, which produces a current of electricity when the ends of the wire are connected. It is, however, necessary to the development of such electromotive force, that the wire shall be caused to "cut" the lines of force, in passing through the magnetic field.

In order to assist in comprehending what is meant by "cutting" the lines of force, it is usual to *assume* that these lines are tangible and susceptible of being cut by a wire, in some such sense, for instance, as one might cut a falling shower of water with a rod. If the wire should be simply moved parallel to the lines of force, that is, moved back and forth between the poles of a magnet, no electromotive force would be developed in it for the reason that in such a movement no lines of force are cut in the sense in which it is found they must be cut to effect that result.

The electricity, that is, the electromotive force, developed in the wire under the conditions stated, may be considered to be proportional to the number of lines of force cut by the wire in a given time, or to the rate at which it cuts them. For instance, if a wire cuts 1 line in one second, and thereby has developed within it an electromotive force of, say, 1, if it be caused to "cut" 2 lines in one second; the electromotive force will be doubled; or, if the density of the magnetic field be so increased that, within the same area where before there was but 1 line, there are now 2, and the wire is caused to cut them in one second, the resulting electromotive force will be 2.

In the construction of dynamo-electric machines, the foregoing and other facts are availed of.

As it would be impracticable to secure a magnetic field of sufficient extent and density in which to move a wire continuously in a straight line, for the purpose of developing electromotive force, the expedient of rotating the wire in a magnetic field in such a way that it will cut the magnetic lines of force, has been most generally adopted. The manner in which this result is accomplished, may be explained by the aid of the diagrams following.

In Fig. 19, a wire loop mounted on spindle x in a uniform field of the magnet N S , is shown. This loop may be considered as belonging to one of the coils of the "armature" of a dynamo machine, such, for instance, as is used in telegraphy.

In the "field" the lines of force are always assumed to pass from N to S , in which case their direction is said to be "positive." As the field is, in this case, assumed to be a uniform one, there will be an equal number of lines in any given section of the field in which the loop is placed. In the figure the "lines of force" are, for purposes of illustration, supposed to be represented by the straight lines connecting N S .

Experiment has demonstrated that when the lines of force are "flowing" from right to left, or from N to S , if the loop be rotated on its spindle so that one side, s , of the loop, is caused to cut the "lines" from a to b a current will be set up in s in a direction away from the observer; while the current generated, at the same time, in the side s' , in cutting the lines from c to d , will be towards the observer. The direction of the currents in the loop, as a whole, will, however, coincide, as indicated by the direction of the arrows parallel to s

FIG. 19.

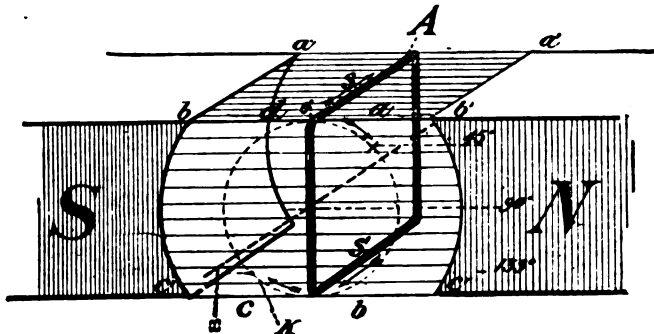

and s' . As the current is the result of an electromotive force established in the wire by the act of cutting the lines of force, it is plain that, upon the direction in which the wire cuts the lines, depends the polarity of the electromotive force.

As the loop continues its revolution, and the side s begins to cut the lines from c to d , while the side s' begins to cut from a to b , there is now set up a current in s in the direction opposite to that which existed before it completed the first half of its revolution; the same is the case with side s' of the loop; consequently, the direction of the current in the loop, as a whole, is changed at the half of the revolution. In other words, the direction of current is changed twice in each revolution, and it is, therefore, a so-called alternating current, within the loop.

Owing to the circular movement of the loop in the magnetic field, it will, in certain parts of its revolution, instead of cutting lines of force, simply slide through them. This will be when the sides s , s' of the loop are at right angles to the "faces" of the pole pieces of the magnet, or when parallel to the lines of force, as

in the figure, and as the electromotive force developed in the loop is due to the cutting of the lines, it is plain that when the loop is in that position no electromotive force is developed in it. Further, for a short distance from the vertical position the number of lines cut by the loop will be very small, as the motion of the sides of the loop is such that near that position it cuts but few lines compared with the number it cuts in moving an equal distance as it approaches the horizontal position. Consequently, the current not only changes in direction twice during every revolution, but it also rises and falls from minimum to maximum strength and vice versa, twice in every revolution, the latter due to the fact that the electromotive force rises from zero in the vertical position of the loop to maximum in the horizontal position, and falls from maximum in the latter position to minimum in the vertical position; or, to put it another way, because the coil cuts the minimum number of lines in or near the vertical position and the maximum number of lines in or near the horizontal position.

A further explanation of the increased or decreased *number* of lines cut as the loop approaches or recedes from the horizontal may be attempted by the aid of Fig. 19.

In that figure let the horizontal lines between x and s represent, as before, the lines of force passing from the north to the south pole of the magnet.

Since, as before, the magnetic field is assumed to be a uniform one, there will be an equal number of lines in any given section of the space occupied by the field. In the figure it is assumed that there are 12 lines from a^1 to b^1 , and 12 lines from b^1 to c^1 ; that is, 12 rows of 12 lines each, making, in the space between the faces of the poles x & s , 144 lines. Hence, in making a revolution, each side of the loop will cut 288 lines, and the loop, as a whole, will cut 576 lines each revolution. In making its revolution each side of the loop, of course, describes a circle, equivalent to k in Fig. 19.

By calculating, then, the number of lines cut by each side of the loop in different parts of its revolution, it is found that, in turning one-eighth of a revolution, or through an angle of 45° , the side s of the loop, only cuts 2 row of lines, that is, 24 lines, while from 45° to 90° it cuts, approximately, 4 rows of lines, that is, 48 lines. On the other hand, in continuing its revolution from 90° to 135° another 48 lines will be cut by s , and from 135° to 180° only 24 lines. Simultaneously, the side s^1 has been cutting an equal number of lines at a similar rate of increase and decrease in the different parts of its revolution, but in the reverse direction.

Since, as already said, the electromotive force thus developed in a wire is proportional to the rate at which the lines are cut, it is evident that the electromotive force developed in a loop, or coil, rotated in a magnetic field, may be increased in several ways in addition to those previously mentioned. Thus, it may be increased by increasing the speed at which the loop is rotated. Assuming the loop, Fig. 19, to have been rotated at the rate of one revolution, per second, if it be made to turn at the rate of three revolutions per second, the number of lines cut per second will now be thrice 576 lines, and the electromotive force will be trebled. The electromotive force developed may also be augmented by increasing the number of "turns" of the wire without increasing the area or density of the field. For example, if, instead of one

turn of wire, a coil of two turns be employed, each turn of the wire will cut an equal number of lines in the course of a revolution, hence, doubling the electromotive force, for this practically doubles the number of lines of force cut, per revolution, by the loop.

It is obvious that a current of electricity, constantly varying in strength, alternating in direction, and circulating in a closed coil, such as has been thus far shown, would not, generally speaking, be of much utility, and, therefore, means have been provided in the dynamo machine, whereby the current set up in the coil, is conducted out to an external circuit. In some machines the apparatus for this purpose is so arranged that the current is led out to the external circuit, alternating in direction. Such machines are termed "alternating" current machines. In others, and among them those used for telegraphic purposes, the apparatus employed is such that the current in the external circuit is in one direction. Machines of the latter class are termed "continuous," or "direct" current machines. The plan by which the current is led out from the coil in the magnetic field, and the direction of the current made continuous in the external circuit is indicated in the case of one coil in Fig. 20. It consists of separat-

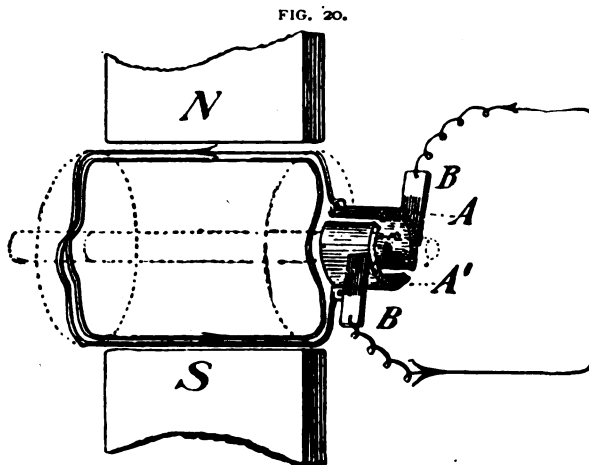

ing one end of the loops of the coil, the terminals of which are connected to curved metal segments *A*, *A'* on the spindle of the coil; the segments being insulated from the shaft and from each other. Metal "brushes" *B*, *B'* are caused to rest on the segments, to which brushes the external conductors, leading to any desired point, are attached. The brushes are placed on opposite sides of the shaft in such a way that, as the shaft rotates, each is always on a separate segment. They are also placed on the segments in a position corresponding nearly to the point at which the sides of the coil will be parallel with the lines of force, namely, at the point where the current is reversed in direction. Thus, as the coil is rotated, the segments pass from one brush to the other just as the direction of current is about to change in the coils and, consequently, each brush is always placed in connection with that side of a coil which is generating current in a given direction. Such an arrangement of segments on the shaft is termed a "commutator."

While a current thus "straightened" out would be, as regards the external circuit, uniformly in one direction, it is clear that it would still be very variable as regards strength, since it would fluctuate from zero to maximum twice in every revolution. In order that the current thus generated may be of practically constant strength, as well as continuous in direction, many such coils of insulated wire, wound on an iron core, somewhat as shown in Fig. 21, are employed in some forms of dynamo machines.

At one end of this core is a series of metal strips, or segments m , close together, but, as in the case of the segments seen in Fig. 20, also insulated from each other and from the shaft by suitable insulating material. These segments are arranged cylindrically on the shaft, and form the "commutator."

The manner in which the coils are connected to the segments and in which the coils themselves are wound over the core varies with nearly every type of dynamo machine, but the method of winding indicated in Fig. 21 has been frequently employed.

In that figure, for clearness, but five coils are shown, but the receptacles for others, on the core, may be seen. The terminals of the coils 1, 2, 3, 4, are, however, shown connected to the segments as though the coils lay in adjoining receptacles, as they do in practice. One terminal of coil 1 is brought to segment s^1 on the commutator. As

FIG. 21.

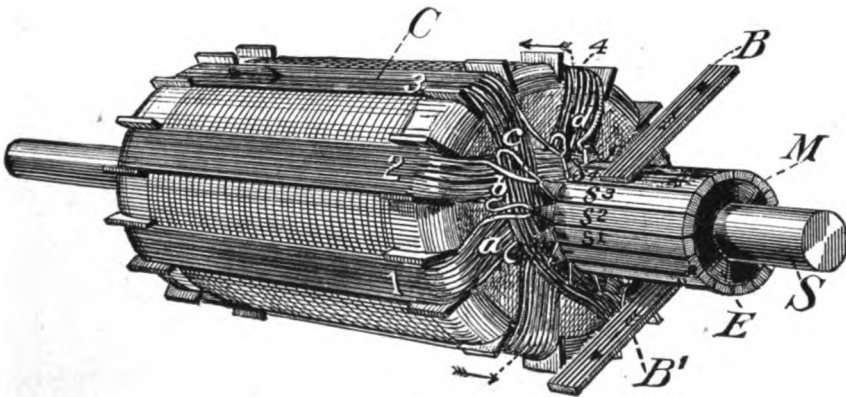

many turns of wire as may be desired are wound on the core and the other terminal of coil 1 is then brought to the next segment, s^2 , of the commutator. The terminal b of coil 2 is also connected to segment s^2 , wound around the core, and then brought to segment s^3 . A terminal c , of coil 3, is brought to segment s^3 , and its other terminal is connected with segment s^4 , and so on, around the commutator.

This arrangement places two terminals of different coils in contact with each segment, and starting from any one segment, puts all the coils in series with each other. But, as the brushes are placed on segments diametrically opposite each other, it will be obvious, on consideration, that so far as an external circuit from the brushes is concerned, one-half of the coils are connected in multiple with the other half. For example, it may be seen that when, say, segment s^4 , is under upper brush B , the coils 3, 2, 1, and the others to the left of that brush, will be in multiple with the coil 4 and the other coils to the right of upper B ; and the other end of each series

of coils will be at the segment on which the lower brush *B* may be resting. As, also, those portions of the coils on opposite sides of the brushes generate currents in opposite directions, it is evident that those currents will unite at the brushes and pass out to the external conductor. For instance, supposing a current to be flowing in the lower side of coil 3 from left to right, it will pass out of segment *s*⁴, to which its terminal is attached, in the same direction. In that case the current in the upper side of coil *c*, will be from right to left. Then, as the upper sides of coils 3 and 4 are on opposite sides of upper brush *B*, the current in upper side of coil 4, will be from left to right, and as the upper part of that coil is also attached by its terminal *d*, to segment *s*⁴, the currents from both coils will coincide in direction through the brushes.

The collection of coils and the core compose the "armature" of the dynamo machine. In practice the brushes are placed on the commutator at, or near the point where the reversal of polarity in the coils takes place. A shaft *s*, to which the armature is rigidly attached, passes through the centre of the latter. The shaft rests on the usual bearings, and in practice it is equipped at one end with a pulley by means of

FIG. 22.

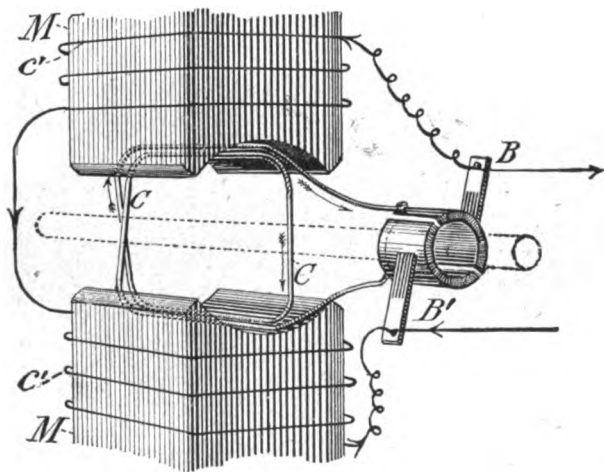

which the armature is caused to revolve rapidly between the poles of the magnet.

The magnet used to produce the magnetic field in which the armature rotates, is termed the "field magnet." Occasionally, permanent magnets have been used as "field" magnets, but ordinarily, electro-magnets are employed for the purpose.

A primary battery may be used to supply the current necessary to magnetize the field magnets but it is generally obtained by the simple device of "shunting" a portion of the current developed in the armature coils through the field magnet coils *c*¹, *c*¹, in the manner shown in Fig. 22, in which, for simplicity, only one coil *c* of the armature, is shown, and in which figure *M*, *M* are the field magnets, and *B*, *B'* are the brushes, on the commutator. The manner in which this magnetizing current is developed may be described as follows:

In the iron of the magnets there usually is some "residual" magnetism from previous magnetizing. When the iron is thus slightly magnetized a weak magnetic field is set up between the poles of the magnet. As the armature revolves slight electric currents are "generated" in its coils. These pass out to the brushes. Here the current divides, one portion passing to the external wire, and another through the coils of the "field" magnet. This current, in passing through these coils further increases the magnetism of the field magnets, and thus the magnetic field is increased. This still further increases the current in the coils of the armature and, consequently, a current of greater strength flows in the field magnet coils, which in turn still further increases the magnetic field, and so on, until the maximum electromotive force which the dynamo machine may be capable of developing is reached.

Machines of this class are termed self-exciting. Machines wound in this way are

FIG. 23.

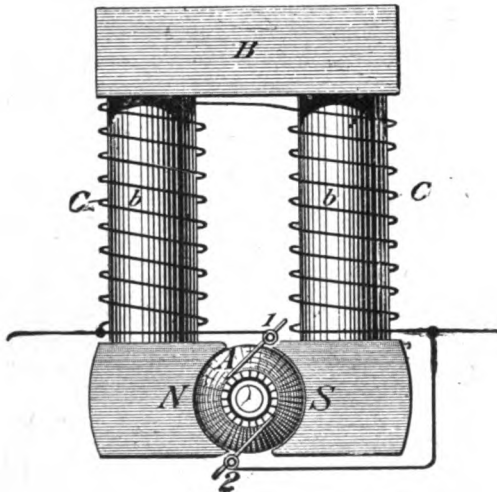

known as shunt-wound dynamos. In some machines the field magnets are excited by separate machines, an instance of which will be given later.

The essential parts of a dynamo machine are the field magnets, armature, commutator and brushes. These parts are shown in Fig. 23, which represents the "Edison" type of dynamo machine, referred to. *A* is the armature, one end of which only is seen. *1* and *2* are the brushes resting on the commutator. The coils of the field magnets are indicated by *c, c*. The cores of the field magnet by *b, b*, which are connected at the top by the cross-bar *B* of soft iron. The pole pieces of the field magnet *N S*, are curved as shown, and between the pole pieces the armature is placed. The curved faces of the pole pieces are so arranged that the armature is partly enveloped by them. This is to insure the passage of the coils of the armature through the maximum number of lines of force, and also to reduce the resistance of the magnetic

circuit by reducing the resistance of the "air space" between the poles. For the same reason, also, the core of the armature is made of iron, which, being a far superior conductor of magnetism than air, concentrates, or directs, the magnetic lines of force through the coils, or, it may be, adds its lines to the circuit. See page 66.

The practical, or working unit of electromotive force is developed when a conductor cuts 100,000,000 lines of force per second. This unit is termed the volt. In practice it is not uncommon to have "fields" of a density of 165,000 lines per square inch.

METHODS OF ARRANGING DYNAMOS IN TELEGRAPHY.

In practical telegraphy the lengths and resistances of circuits vary very materially, so that, when gravity battery is used as the source of electricity, the number of cells of which a battery is composed is usually governed by the length and resistance of the circuit to which it is to be assigned. For instance, a single wire from New York to Boston, 300 miles, might require 75 cells; one, New York to Buffalo, 430 miles, 150 cells; one, New York to Philadelphia, 150 miles, 50 cells, while quadruplexed circuits between the same points may require 150 cells, 350 cells, and 125 cells, respectively.

One method of arranging dynamo-electric machines to furnish varying electromotive forces, is shown in Fig. 24, which illustrates the plan of the original device for that purpose, as designed by Mr. S. D. Field. Practically the same arrangement is now in operation in some of the Western Union Telegraph Company's main offices.

The dynamo machines shown are known as the "Siemens-Alteneck." The field magnets are indicated by the letter *m* in each case; the armatures by *a*. The machine *e* is called the "exciter." It is self-exciting. Its function is to excite the field magnets of the machines *A*, *B*, *C*, *D*, which furnish the current for the wires. The circuit from machine *e* simply extends to and through the field coils of the other machines and returns to *e*. This machine is wound in what is termed "series"—that is, the field magnet coils are connected directly in the external circuit and with the armature coils, not shunted as in Fig. 22. Each of the machines *A*, *B*, *C*, *D*, is capable of developing an electromotive force of about 80 volts, and, therefore, as one machine is connected to the other in series, in the same manner as chemical battery cells might be connected, the total electromotive force developed by the four machines is 320 volts, as indicated in the diagram. The circuit of the machines *A*, *B*, *C*, *D*, is from earth *E*¹, thence to the lower brush of *A*, through the armature to the upper brush, thence to point *x*, where part of the current is diverted to the line wires of low resistance, (first passing through an artificial resistance *R*.) The other portion of the circuit leads to the lower brush of machine *B*, at which machine the *E. M. F.* is augmented to the extent of 80 volts, making 160 volts. From the junction *x*¹ a wire leads to the switch board to furnish current to such line wires as require 160 volts

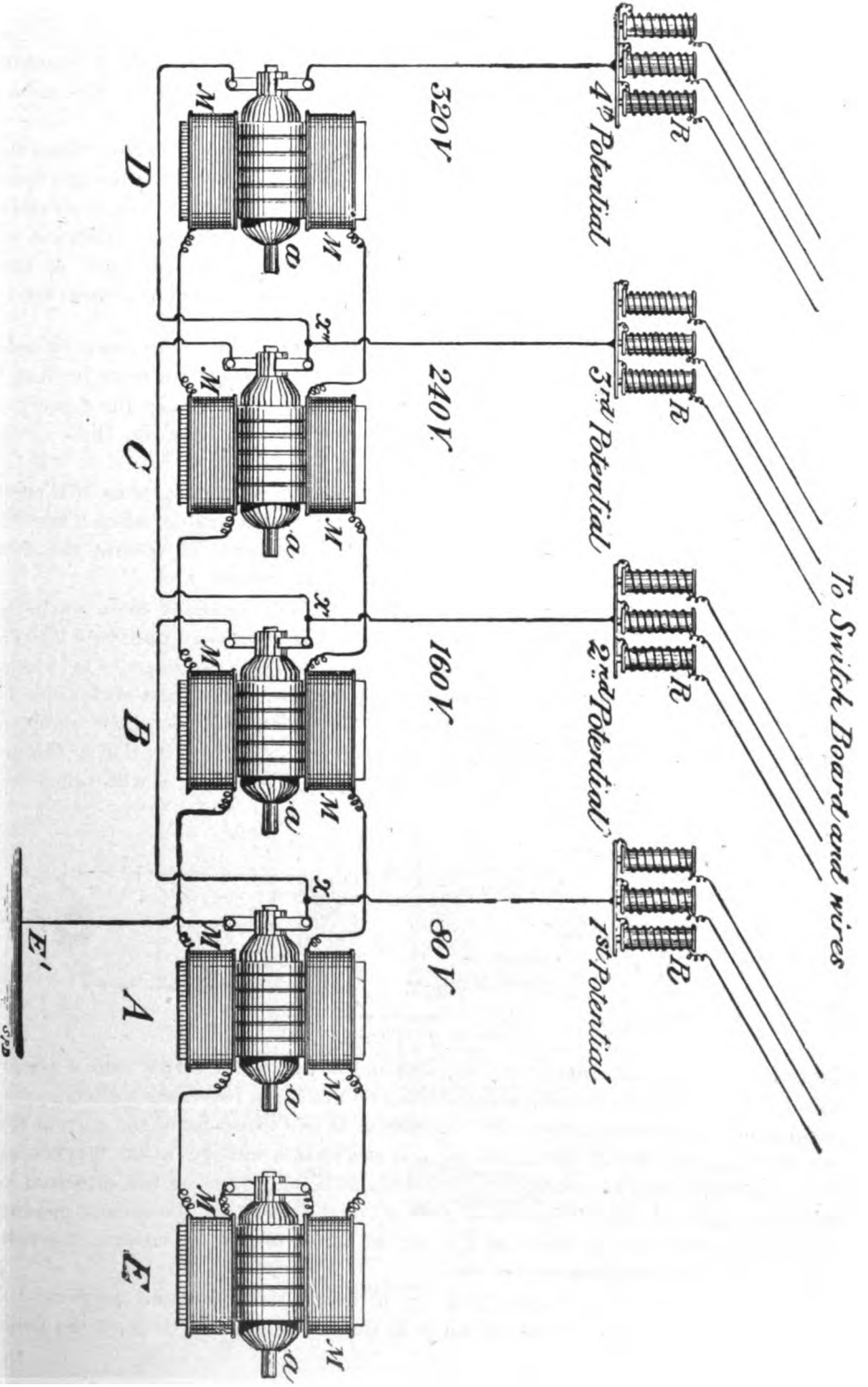

FIG 24.—THE "FIELD" ARRANGEMENT OF DYNAMOS IN SERIES.

potential. The circuit then, from x^1 , passes through, in the same way, the armatures of c and d, still further increasing the E. M. F., which is utilized as in the cases of A and B.

It is evident that machine A must furnish a larger amount of current than any of the other machines, since it supplies a share of the current furnished to the wires from the 2d, 3d, and 4th potential, as well as all the current supplied to the wires drawing from the 1st potential. This it does, owing to its low internal resistance, which is about $\frac{1}{3}$ of an ohm, without any appreciable variation in the strength of current furnished the wires, regardless of whether but one or several hundred wires are being "fed."

The resistances R R, etc, are of German silver wire coiled around a cylinder of plaster of Paris. Each coil rests on a plate of metal, to which the wire leading from the dynamo is attached. One of these coils is inserted in the circuit of every wire. The function of these coils is to diminish the current strength, thus avoiding sparking at keys, etc, in cases of short-circuiting.

As in the operation of the polar duplex and the quadruplex systems it is essential to have reversals of electric polarity, and as it is not practicable, when a machine is furnishing electromotive force for a large number of wires, to reverse the dynamo machines, means to provide for this essential must be devised.

This is accomplished by operating two series of 5 dynamos each, one of which series is caused to furnish positive polarity, the other series, negative polarity. To guard against failure of one of the series, a third series of 5 machines is held in readiness as a "spare" series. Suitable devices for converting the spare series into a positive or negative polarity series, are provided in the dynamo room, but as means for effecting this result will be described more in detail in the description of the present dynamo plant in the Western Union building, New York City, it will suffice to state

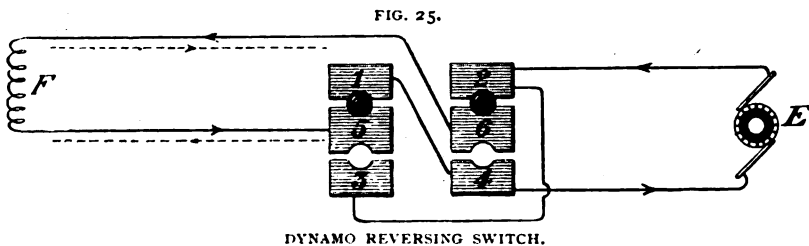

here that this result, namely, the conversion of the spare series into a positive or negative series, can be readily accomplished by placing a reversing switch in the field magnet circuit of the machines, since a change in the direction of the current through the field magnet coils of the machines will result in a change in the magnetic polarity of the field magnet, which change will, in turn, by reversing the direction of the magnetic lines of force in the field, reverse the direction of the current generated in the armatures of the machines A, B, C, D; the direction of the current through E, of course, remaining uniform.

Such a switch is outlined in Fig. 25, in which E is a dynamo machine. 1, 2, 3, 4, 5, 6, are metal discs. With the plugs as shown, the current through the field mag-

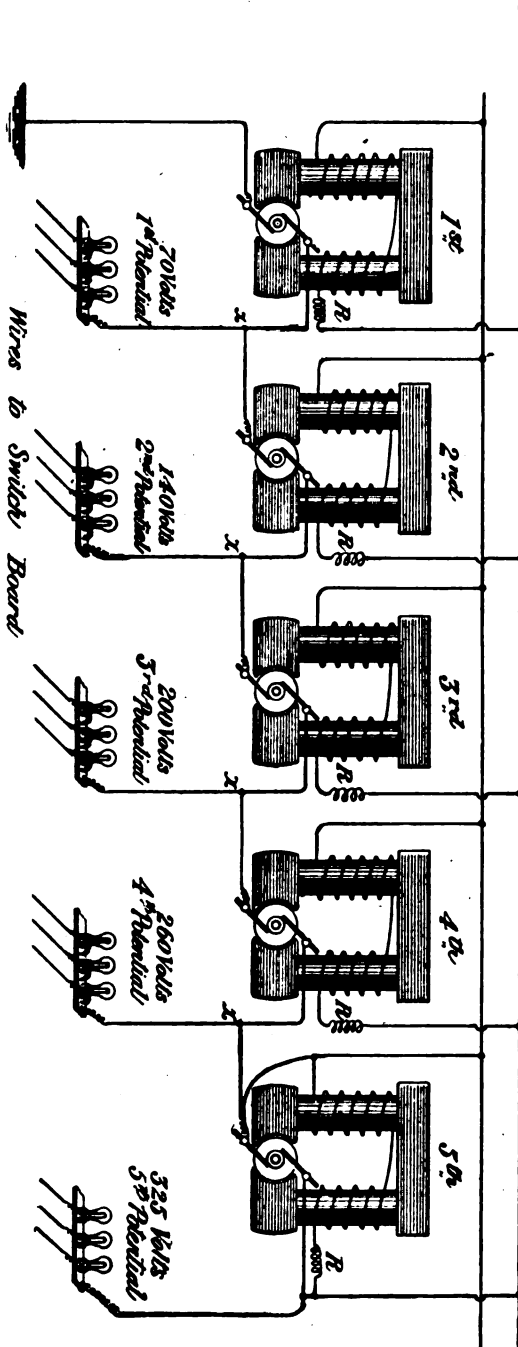
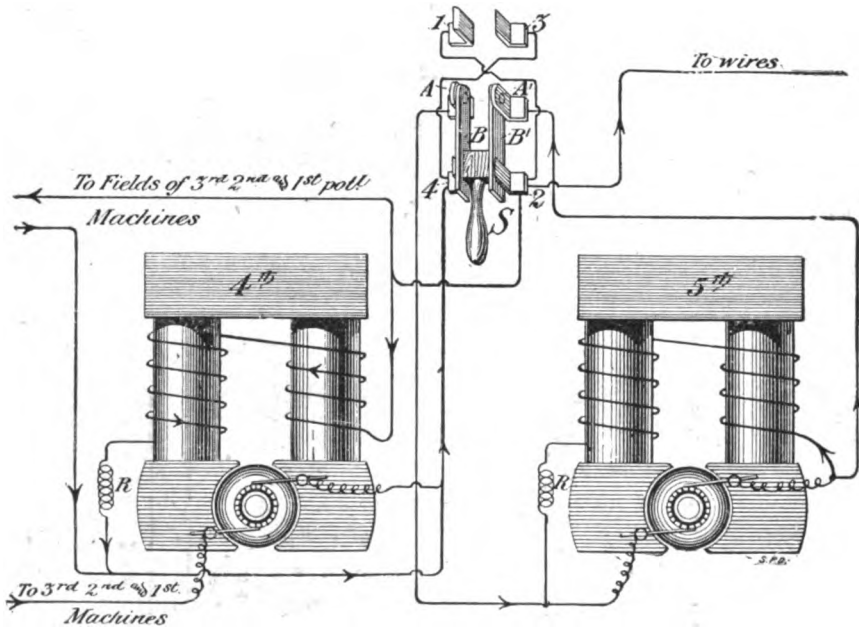

FIG. 26.—THEORY OF WESTERN UNION ARRANGEMENT OF DYNAMOS.

net circuit F is as indicated by the solid line arrows. With the plugs inserted at 3 and 4, instead of at 1 and 2, the current in the field magnet circuit would flow as shown by the dotted line arrows.

In Fig. 26 is shown, theoretically, the present arrangement of the dynamo machines employed in developing electricity for the wires emanating from the Western Union building, New York. It differs in several respects from the arrangement just described. In the former there are but four grades of potential, although five machines are employed. In this arrangement there are five grades of potential, each machine of a series being utilized to develop current for the line wires. These machines are of the "Edison" type and manufacture. The 1st and 2^d ma-

FIG. 27.



chines of each series, Fig. 26, supply 70 volts each; the 3d and 4th machines 60 volts each, and the 5th machine 65 volts; amounting in all to 325 volts for each series. Each machine is tapped at x, x , etc. as in the diagram, and a portion of the current is diverted to the artificial resistances, consisting of one or more incandescent lamps, and thence to the line wires at the switch board, practically as in Fig. 24.

The 5th machine in the figure is shunt wound; all the others are wound with separate field magnet coils. The 5th machine is self-exciting. The other four machines are excited by the 5th machine which, in addition to furnishing 65 volts for line wires, also supplies current for its own field magnet, as well as the field magnets of the other machines. The field magnet coils of the 1st, 2d, 3d, 4th and 5th machines are connected in multiple as shown. In the field magnet circuit of each of the five machines, a resistance R is placed. This resistance is varied to increase or decrease the field magnetism when it is desired to vary the electromotive force of a machine.

The resistance of each field magnet coil is about 30 ohms; that of each armature about .09 ohm.

As in the Field arrangement, previously described, there are also three series, of 5 machines each, in this arrangement; two of which series are permanently arranged to furnish positive and negative polarity, respectively; the third is a "spare" series, which, by means of a "reversing" switch may be caused to develop positive or negative polarity as required.

The manner in which this change is effected is shown in Figs. 27 and 28, in which figure but two machines of the spare series are shown, they being sufficient to indicate the plan. *s* is a switch consisting of the brass strips 1, 2, 3, 4—1, 2 and 3, 4 being metallically connected. *B* and *B*¹ are bars of metal, pivoted on the supports, *A*

FIG. 28.

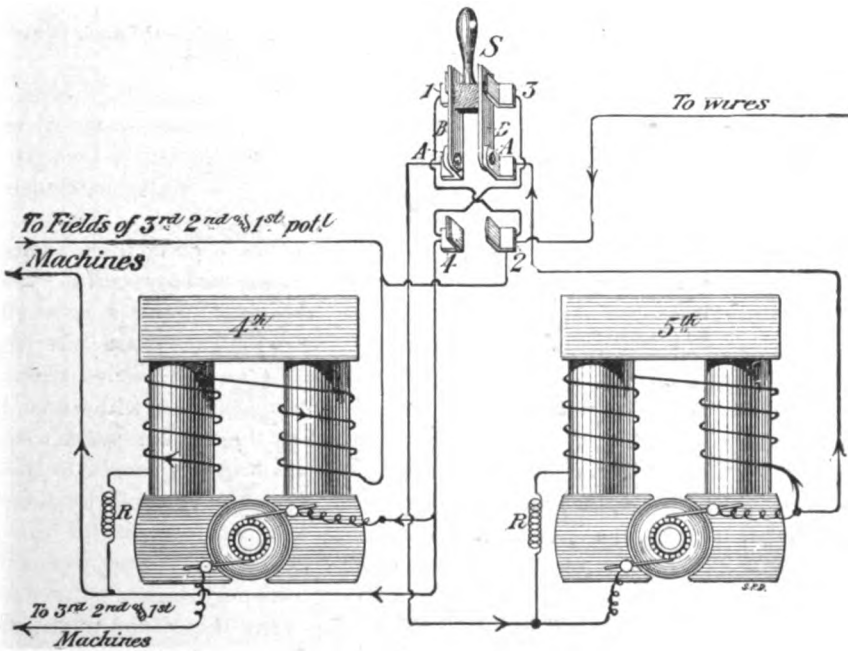

*A*¹, respectively. The wires from the 5th machine are led to *A*¹. The bars *B* *B*¹, are rigidly connected together by an insulated cross-bar and handle *s*, by means of which those bars may be turned over on their pivots, or hinges *A* *A*¹, from the lower strips, 2 and 4, to the upper strips, 1 and 3, and *vice versa*.

Upon the position of the bars *B* *B*¹ depends the direction of the current from the "spare" series. In the position shown in Fig. 27 it is assumed that the series is furnishing positive polarity.

When the bars are connected with strips 3 and 1, as in Fig. 28, it will be found that, while the current flowing from the 5th machine is still in a positive direction, the current which it supplies to the line wires, via strip 2, is in a negative direction. At the same time, owing to the change in the direction of the current flowing through the

field magnets of the other machines, due to the changed position of the bars $B B^1$, the current flowing from those machines to the wires is in a negative direction. This is assuming that the current flowing outwards from the upper brushes indicates a positive polarity, or direction of the current.

An amplification of this switching arrangement is shown in Fig. 29, which figure illustrates, besides, the practical connections of the machines, with the further means required to speedily change from either of the "permanent" series to the "spare" series. *sw* is a switch board. The discs 1, 2, 3, 4, 5, on *sw*, are large, metallic discs of ordinary form, with semi-circular notches to receive metallic plugs. Discs 1, 1, 1, 1, 1, are connected to the wires leading to dynamo machines of the regular positive series. Discs 2, 2, 2, 2, 2, are connected with the wires leading to switch board or line wires; discs 3, 3, 3, 3, 3, with the machines of the spare series (two of them via the commutators, or reversing switch *s*) and discs 5, 5, 5, 5, 5, with the "permanent," negative series, of machines. Discs 4, 4, 4, 4, 4, are also connected with wires leading to the switch-board in the operating room.

In the figure, discs 2, 2, 2, 2, 2, and discs 3, 3, 3, 3, 3, are connected together by plugs. So also are discs 4, 4, 4, 4, 4, and 5, 5, 5, 5, 5. This places to the wires the "permanent" negative series and the spare series furnishing positive polarity. If it is desired to release the "spare" series and to place in operation the permanent, or regular, positive series, plugs are first inserted between discs 1, 1, 1, 1, 1, and 2, 2, 2, 2, 2. This places the two series in parallel. When this has been done the plugs between 2, 2, 2, 2, 2, and 3, 3, 3, 3, 3, are then removed, freeing the spare series. Should it be required to release the regular negative series, the commutator *s* is so placed as to cause the spare series to become negative, after which plugs are inserted between discs 4, 4, 4, 4, 4, and 3, 3, 3, 3, 3. This also places the spare series in parallel with the regular negative series, whereupon the plugs may be withdrawn from between 4, 4, 4, 4, 4, and 5, 5, 5, 5, 5; thereby releasing the regular positive series. By thus running *like* series in parallel, momentarily, no break is caused in the line wire circuits. Resistances, amounting to about 2.5 ohms, per volt of electromotive force are placed between the dynamo machines and each wire circuit, for the reason already stated. These resistances are "incandescent" lamps. They were substituted for the coils of German silver wire because of the frequent breakages of the fine wire of the coils, which occasioned delays. The lamps have been found to give satisfactory service.

Another arrangement of dynamo machines for telegraph purposes, differing from those already described, is shown theoretically in Fig. 30. It is in use in the main offices of the Postal Telegraph Company, New York City and elsewhere. In this arrangement of the dynamos the machines are not connected in series, but each machine is operated separately, as shown in the figure. Each machine may be considered as the equivalent of a gravity battery of very low resistance, out of which a large number of wires are "fed." In the New York plant there are 16 machines furnishing eight grades of negative and positive potential, namely, 50, 70, 90, 110, 200, 250, 275 and 300 volts, respectively. In the figure, 6 machines are shown, 3 negative and 3 positive. One pole of each machine is connected to ground, the other pole is connected to a switch *s*, and thence to the wires. By means of this

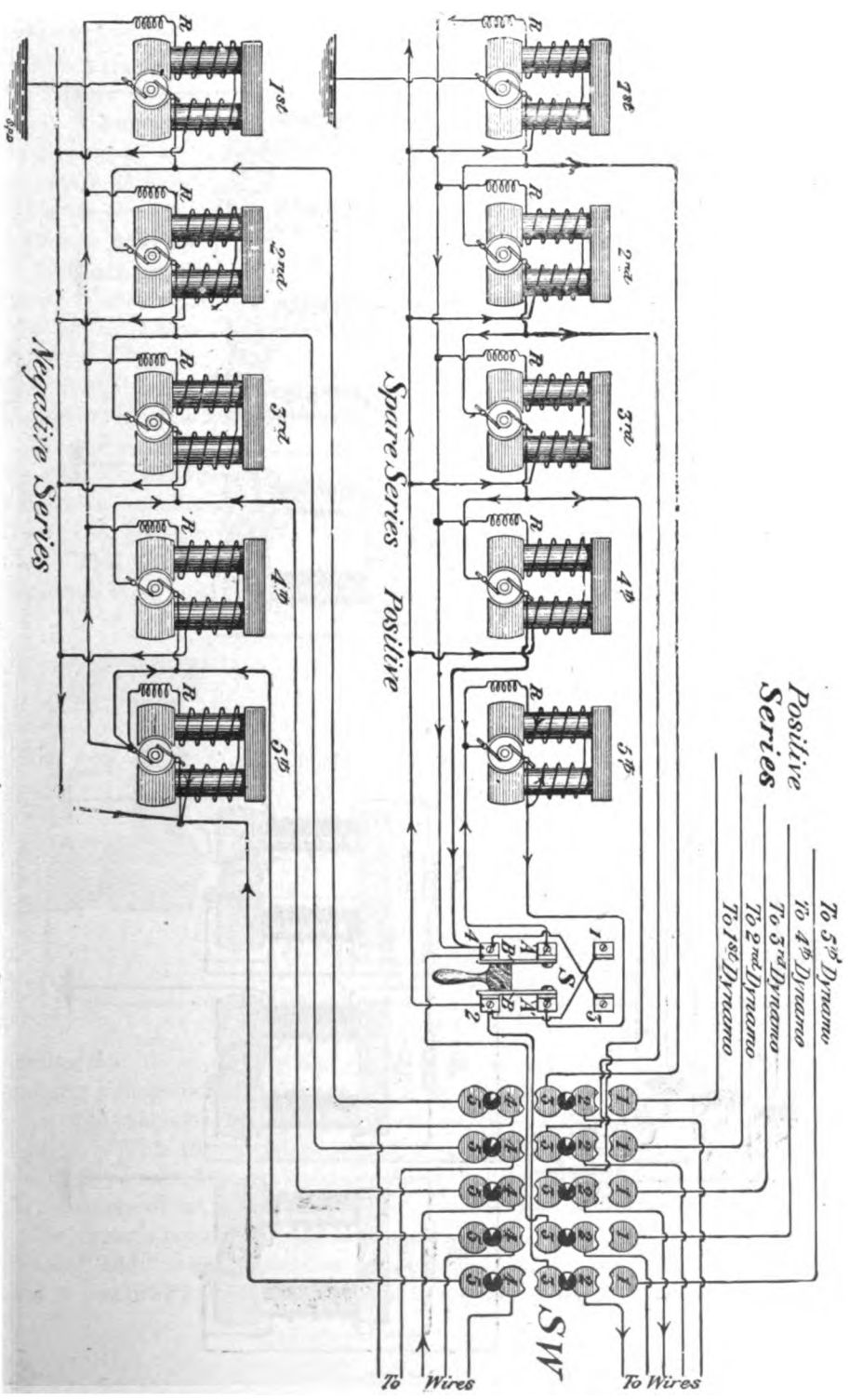

FIG. 29.—THE "WESTERN UNION" ARRANGEMENT OF DYNAMOS.

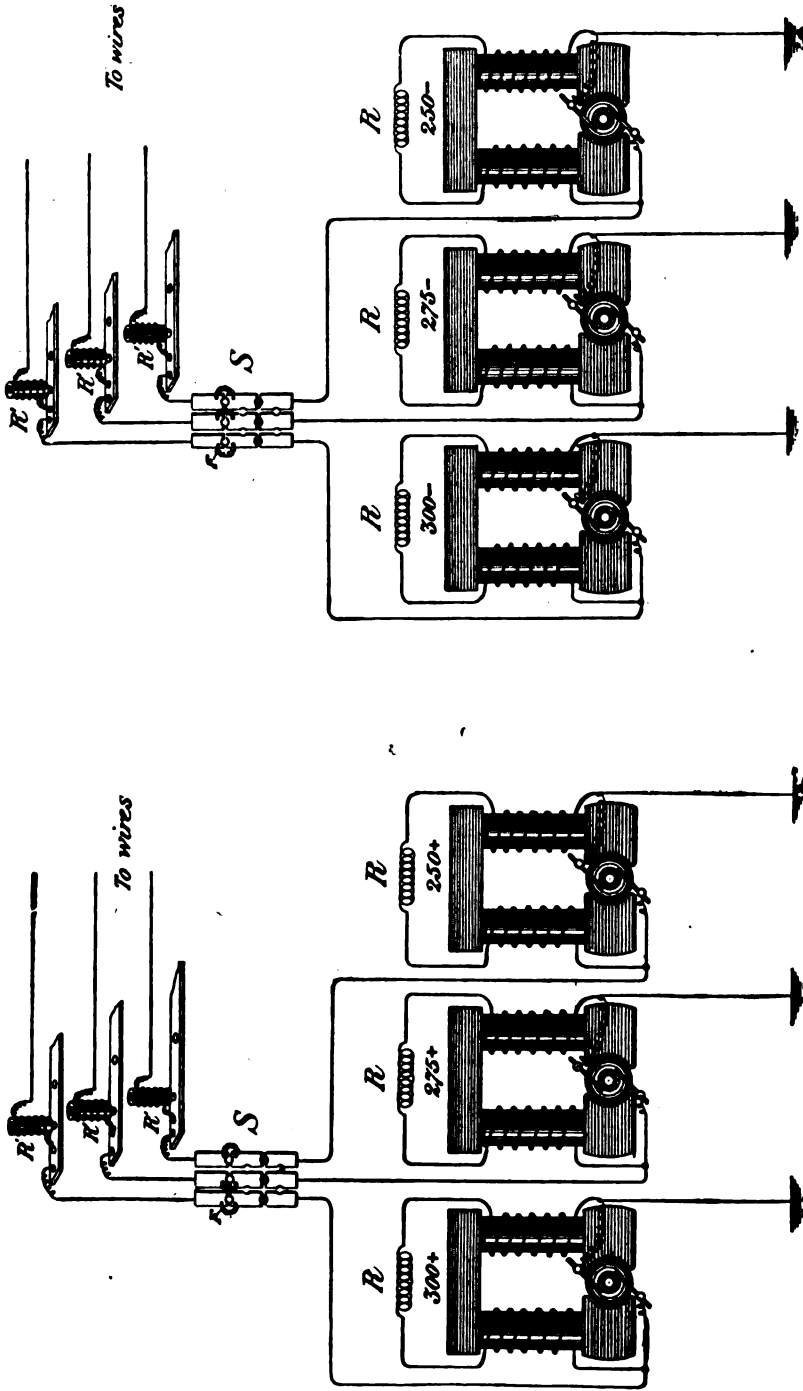

FIG. 30.—THE POSTAL ARRANGEMENT OF DYNAMOS.

switch any machine can be readily disconnected and another substituted. Two spare machines are provided and these have switches so connected that the line wire terminal and ground terminal may be readily transposed to furnish a desired polarity. A resistance $R^1 R^1 R^1$, consisting of German silver wire, is inserted in the circuit of each wire before the operating room switch is reached. The machines are of the “Edison” type, shunt wound. The electromotive force of each machine may be varied by the removal or insertion of resistance from the rheostat R in the field magnet circuit. The machines are driven by a suitable motor. To prevent injury to the apparatus, due to accidental short-circuiting, fuses F are inserted in each dynamo circuit at the switch s . These fuses “blow” out under a “heavy” current, thereby opening the circuit.

In several large telegraph offices the *local* circuits are now operated by current furnished by dynamo machines.

In some cases where this has been done, the sounders have been wound to about 40 ohms, and the dynamo machine has been designed to have a very low internal resistance, which is rendered necessary by the fact that all the sounders are connected in multiple and, hence, a very low, joint resistance of the combined external local circuits results. This will be clear upon a reference to Fig. 31, in which LB is the local dynamo machine, and c the combined local circuits with the sounders s in multiple.

FIG. 31.

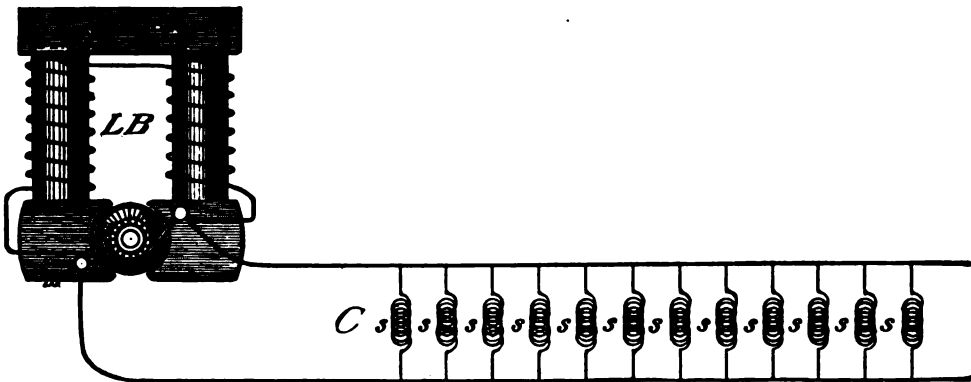

DYNAMO ARRANGEMENTS FOR “LOCALS.”

Assuming that there may be 800 sounders in a large office. This at 4 ohms each would give a range in the resistance of the external circuit c of, from 4 ohms, when all but one of the sounders are open, to five thousandths of an ohm when all the sounders are closed. With the sounders wound to 40 ohms, the lowest external resistance would be five hundredths of an ohm. The *internal* resistance of the dynamo machine is the resistance of the wire of its armature; (or the joint resistance of its wires).

The dynamo machine is also used quite extensively in large cities in the service of “stock” and “news” quotation companies. When that is the case, they are arranged in practically the same manner as in the case of the regular telegraph service.

MOTOR-DYNAMOS.—Since the foregoing was written what are termed motor-dynamos have come somewhat extensively into use in telegraph offices for the purpose of obtaining current for the charging of storage batteries as well as for the operation of main and local circuits direct. Philadelphia W. U. office is an instance of the latter use.

On page 33 attention is called to the fact that many of the phenomena of electricity and magnetism are reversible. Another instance of this reversibility is afforded in the case of the dynamo machine, which, when a current of electricity is sent through its coils from an outside source at once begins to turn around. The explanation of this may be considered as follows: Assuming that the dynamo machine is shunt or series wound, the current, or a shunted portion of it, which passes into its armature also flows through the field magnet coils, thereby setting up a magnetic field practically as indicated in Fig. 19. A magnetic field is also established around those coils of the armature through which the current is passing, and these coils will obviously be those upon which the brushes are resting. If, therefore, the brushes are set at such a point on the commutator that the magnetism set up around the armature coils does not coincide with the magnetism of the field, the tendency will be for the armature to be attracted into a position where the respective magnetic lines of force will coincide, but the moment the armature turns, the armature coils which were carrying the current from the brushes slip past the brushes and another set of coils is brought into action and the current dies out of the first set of coils. It is then clear that the same tendency of the lines of force from the new set of armature coils and those from the field, to coincide, still exists, and, hence, the armature continues to turn, with the result that another set of coils is called into play, and so on, a sort of tread-mill arrangement as it were.

If a belt be attached to the pulley of the dynamo machine it may be caused to do work and it is then termed an electric motor. In some cases instead of a belt being attached to its pulley, the shaft of a dynamo machine is attached to the motor and the latter in this way rotates the dynamo machine. When connected in this way the combination forms one type of motor-generator, or motor-dynamo.

Another form of motor-dynamo is one in which the armature coils of the motor and those of the dynamo machine are wound on one core. But in this case the armature is furnished with two commutators, one at each end, for the dynamo and motor coils, respectively, as in Fig. 31a. The current from the outside source enters the armature coils of the motor causing the armature to rotate as before. As now the dynamo coils are caused to rotate in the magnetic field of the field magnets, an electromotive force and current are established in those coils, which will be proportional to the density of the magnetic field, the number and length of the coils and also to their resistance, as well as the speed of rotation, as already explained, page 35. This being known, it is a comparatively easy matter to design a motor-dynamo to be operated at any stated voltage from the outside source applied to the motor, and to deliver at the dynamo terminals any desired electromotive force and current.

The utility of such a device in telegraphy and in other branches of electricity is that the electromotive force and current from an electric light or electric power plant may be availed of to drive a motor which in turn will drive a dynamo machine constructed to furnish a suitable electromotive force and current for telegraph purposes.*

STORAGE BATTERY.

STORAGE BATTERY.—The storage cell as now constructed and used in telegraphy and for many other purposes, consists of prepared plates of lead immersed in a liquid solution of sulphuric acid and water; about five parts of water to one of sulphuric acid. What are termed the positive plates are all connected together; similarly those termed the negative plates are likewise connected. The plates are placed side by side, one negative next one positive, and each plate is separated from the other by thin sheets of asbestos cloth. A metallic lug projects from each plate above the so-

* In Philadelphia one motor-dynamo, receiving current for the motor portion from the street electric mains, at about 220 volts potential, is set apart for each positive and negative potential required, practically akin to the arrangement shown in Fig. 30, but the Field Key system is used in the quadruplex systems as usual. Of course the machines in Fig. 30 are supposed to be belt driven.

lution, and by these lugs the positive and negative plates are respectively connected as stated, and virtually as shown to the right of Fig. 31a (chloride cell). The number and size of the plates in a cell depend upon the desired capacity of the cell. This capacity is rated in ampere hours. Thus if a cell should give out 20 amperes of current

FIG. 31a.

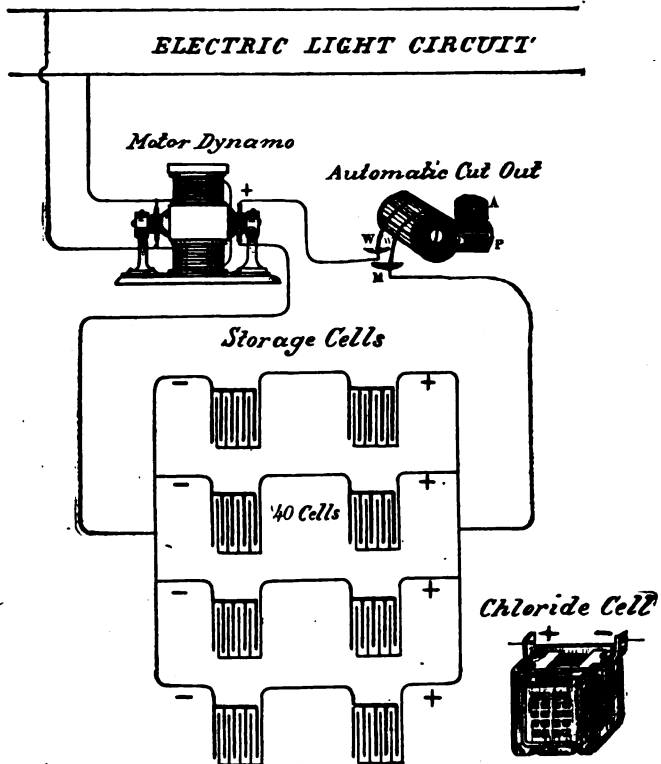

strength, without becoming unduly discharged, for one hour, it would be said to have a capacity of 20 ampere hours. This same cell, however, might give out 40 amperes for half an hour, or 10 amperes for 2 hours.

These batteries (sometimes called secondary batteries) derive their name from the fact that electricity is, so to speak, pumped into them and there stored until required. This is called charging the cells. In charging, the positive pole of a dynamo machine is attached to the "positive" plates of the cell and the negative pole of the same machine to the negative plates of the cell. When the dynamo is removed and the positive and negative plates are connected by a wire a current flows from the positive pole, in other words, in a direction opposite to that of the current which charged the cell. In reality the plates which were attached, in charging, to the positive pole of the dynamo are the negative plates, and those connected to the negative pole the positive plates, analogously as the zinc element in the gravity cell is the positive element of that cell, but it is the practice to refer to the plates connected to the positive pole of the dynamo as the positive plates, and, contrariwise. A battery of primary cells could be employed to charge a storage battery, but it would not be economical to do so on a large scale.

Although termed storage batteries it is, of course, known that, in fact, electricity is not stored up in these cells, but only the energy of chemical change. For, if after

the cells are charged, the plates should be removed from the solution of the cell, no indication of electricity would be perceived. The action that takes place in the cell during charging is a chemical one and a chemical action accompanies the discharge of the cell.

FIG. 316.

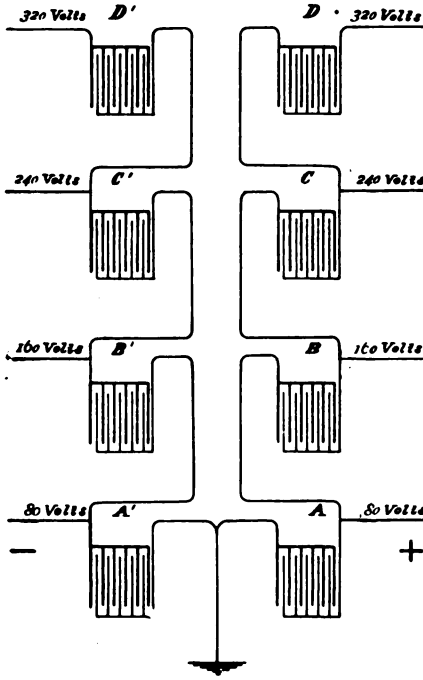

In the first storage cells which were experimented with, the plates consisted of ordinary thin sheets of lead placed in the solution mentioned. The effect of sending a current of electricity through the electrolyte (the solution) of these cells may be considered as follows, namely: the decomposition of the water, releasing oxygen and hydrogen; the oxygen at the positive pole of the charging current uniting with the lead to form peroxide of lead, and the hydrogen settling upon the plate at the negative pole. On removing the charging current and connecting the terminals of the plates a current flows from the positive pole, and during this time the peroxide of lead gives up its oxygen which reunites with the hydrogen, forming water. In other words the current flows until the plates and electrolyte resume their previous chemical condition. Measurements have shown that the difference of potential of these plates is about 2.4 volts. That is, the real positive plate is electro positive to the peroxide of lead plate to that extent.

After the cell is discharged it is found that a change has taken place on the surface of the "positive" plate, namely, that the metallic lead precipitated from the peroxide has become spongy, or porous, while but little change is noticeable on the negative plate. By reversing the direction of the charging current and repeating this procedure for a considerable time it is found that the capacity is considerably increased, but this method could not be continued indefinitely as it would obviously lead to the disintegration of the plates. Improvements in the construction of the plates have therefore modified this method of "forming" the plates. For example, in the type of cell known as the "chloride," which is now extensively used in telegraphy and otherwise in this country, the plates (Fig. 31*a*) consist of specially prepared granular or porous lead tablets, in square and circular form, surrounded by ordinary pure lead which has been moulded around these tablets under pressure, the whole forming a compact plate.* This cell derives its name from the fact that the porous lead used for the tablets is obtained from chloride of lead; there is no chlorine used in the cell after it is in actual operation. After the plates are thus compressed the plates which are intended to serve as positive plates are immersed in a solution of sulphuric acid through which an electric current is passed in one direction for about fourteen days, by which time the granular lead has been converted into peroxide of lead, or, as it is said, into active material, when the plate is ready for setting up with the negative plates in the cell. In this cell the tablets for the positive plates are made in circular form; those for the negative plates in squares. In a solution of sulphuric acid, lead is normally attacked by the acid, forming sulphate of lead ($PbSO_4$), and if the action is prolonged a higher sulphate, or "sulphating," as it is termed, which is indicated by a white scale on the lead, ensues, more or less impairing the cell's utility. Too strong solution and over-discharging also conduce to sulphating. According to some authorities, the simple sulphate of lead facilitates the operation

* In the latest type of this cell the tablets are formed out of a strip of corrugated lead about $\frac{1}{4}$ inch in width, which is rolled into a circular tablet about $\frac{5}{8}$ inch in diameter, the corrugations giving a larger surface.

of the cell. From this standpoint the chemical action that takes place in the storage cell is considered to be as follows: The lead sulphate during charging is broken up into peroxide of lead (PbO_2) which is deposited on the positive plate, and into metallic lead (Pb) which is deposited on the negative plate, while sulphuric acid (H_2SO_4) is liberated in the electrolyte. The action in discharging is the reverse of this, leading to the reforming of lead sulphate.

Hence, in charging the cell the solution increases in density as sulphuric acid is released, while, in discharging, it becomes less dense. Within certain limits the electrical resistance of sulphuric acid solution decreases as its density increases, and these limits are virtually maintained in practice. As, however, the electromotive force of the cell is highest when fully charged, and falls somewhat as it is discharged, it is considered advisable to allow the density of the solution to exceed the point at which it is the best conductor, so that as the electromotive force of the cell falls in discharging, the resistance may for a short time fall, whereby a better average electromotive force of the cell is obtained. The electromotive force of the cell, as stated, when fully charged is about 2.4 volts. In discharging it should not be allowed to fall below 1.9 volts. The average is about 2 volts. In all storage cells there is one more negative plate than there are positive plates; thus the positive plates are enclosed at both ends of the cells. It will be understood that, regardless of the number of plates in a cell, the voltage is practically the same. Consequently, to get a suitably high electromotive force, the negative plates of one cell are connected to the positive plates of another cell, or vice versa, as in the case of any primary battery.

One of the ways in which the cells are charged and utilized in telegraphy is outlined in Figs. 31*a*, 31*b*. In these figures it is assumed that the voltage on the electric light mains is not suitable for the charging of the cells and, consequently, a motor-transformer is operated by the current from those mains. The dynamo portion of the machine is arranged to generate an electromotive force of 110 volts. This then may charge several banks of cells, say, 4 banks of 40 cells each, in multiple. These cells may then be connected up in series by suitable switching devices and resistances to furnish electrical pressures for the main wires varying from, say, 80 to 320 volts as indicated in Fig. 31*b*; each series of cells A, B, C, D, and A', B', C', D', acting practically as the dynamo machines shown in Fig. 26.

Similarly a motor-dynamo may be utilized to charge cells for the local wires and instruments. In the latter case the dynamo coils of the machine would be designed to generate a much lower voltage, but much greater quantity of current. This in turn charges cells of greater capacity. The capacity of the main line cells may range from 72 ampere hours to 50 and 25 ampere hours, the cells A A' in the figure, for example, being called upon for more current than the cells B, B', for the same reasons as are given on page 42. The capacity of the cells for the locals is about 250 ampere hours. The manner in which the locals are connected in this service is analogous to the method shown on page 49, Fig. 31. Of course the actual capacity of the cells for main line and local service will vary with the special needs of each case. The internal resistance of these cells is obviously very low, to which is due the large current which they supply, and also the ability to supply many wires from one battery. (See page 31.) The internal resistance is readily calculated by Ohm's law, viz.: $R = E \div C$.

It is evident that after the storage cells are charged, or partly charged, they exert a counter electromotive force against the dynamo machine. Consequently it is essential that the potential of the machine shall always exceed the combined pressure of all the cells that are in series, otherwise the tendency would be for the cells to drive the dynamo as a motor, or perhaps to short-circuit themselves through its armature. To prevent such occurrences a simple automatic circuit-breaker, or cut-out, is used, as outlined in Fig. 31*a*. This consists of a soft iron core with pole-pieces P. Only one pole-piece is shown. The core is surrounded by a few turns of heavy wire w, the two ends of which dip into cups M containing mercury. The cups and heavy wire normally form part of the dynamo-circuit. The core, with its turns of wire, is suitably pivoted and the pole-pieces tend by gravity to fall away from armature A. While the normal current flows the pole-pieces are attracted, but when from any cause the current ceases, or very measurably diminishes, the pole-pieces drop, thereby lifting the wires w out of the mercury and the circuit remains broken until the cut-out is reset.

CHAPTER IV.

THE MORSE TELEGRAPH SYSTEM.

THEORY.—The Morse telegraph system and, with but one or two exceptions, the other electrical telegraph systems described herein, primarily depend for their successful operation upon the fact that when a current of electricity flows in a coil of insulated wire surrounding a soft iron bar, the bar becomes a magnet (termed an electro-magnet). When the current ceases to flow in the wire, the bar of soft iron ceases to be a magnet. Following that is the fact that when a piece of soft iron is presented near a magnet there is a mutual attraction between them which tends to bring them together. That the attraction is mutual is evident from the fact that if the piece of iron be free to move while the magnet is held, the former will approach the latter, while if the magnet be free to move and the iron be held, the reverse will be the case. The supposed cause of this attraction will be stated presently.

We have already seen (Chap.III.) that so-called magnetic “lines of force” exist in the presence of a magnet. Also that, surrounding a wire conveying a current, similar magnetic lines of force are found, and that these lines, in availing of the presence of a magnetic conductor, such as soft iron, permeate and give it the properties of a magnet.

Faraday, who discovered and named this phenomenon, assumed that the tendency of the lines of force is to coincide in direction, and to contract, or shorten themselves. This assumption may be used to explain the action of a magnet, such as a “relay” or a “sounder,” in attracting its “armature:” The lines of force emanating from the poles of the magnet enter the iron armature, the iron becoming, as it were, the vehicle of the lines of force. Then, as, according to the foregoing theory, the lines tend to shorten themselves, as does, for instance, a stretched elastic band, the armature is drawn and held towards the poles of the magnet, even against the pull of a retractile spring, as long as the iron continues magnetized.

In some of the following chapters reference will be made to the fact that there is mutual repulsion between the north poles of magnets when presented to each other, and that between south poles of magnets there is also repulsion under similar conditions. This effect, it may be added here, is also explained by the foregoing assumption, namely, that the “lines of force” tend to coincide in direction. It is, apparently, the attempt of the lines issuing from the similar poles of each magnet to so turn the lines of the other pole that they shall coincide in direction with its lines that gives the mutually repellent effect referred to.

In order to obtain the “flow” of current necessary to magnetize the iron bar surrounded by an insulated coil of wire, the “circuit” of the wire must be complete, and a source of electromotive force must also be provided.

A “circuit” may be represented, as in Fig. 32, by a line, or wire *w*, battery *B*

and a galvanometer, *G*, which is an instrument devised to indicate the presence of an electric current in a circuit. (*see Galvanometers*).

The source of electromotive force, in this case battery *B*, is represented by the thick and thin lines, the usual symbols of a voltaic cell, or battery, in electrical diagrams; the thin line representing the positive pole, the thick line the negative.

FIG. 32.

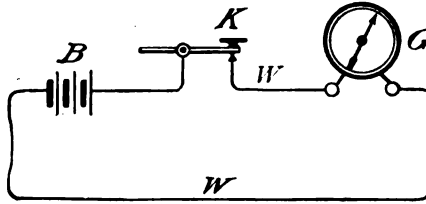

The course of the circuit is assumed to be from the positive pole of the cell, or battery *B*, and thence through the wire *w*, the galvanometer *G*, and back, through the battery, to the positive pole. When key *K* is down, or “closed,” as in the figure, the circuit is completed, and a continuous current flows; when the key is raised, or “open,” the circuit is open and the current ceases flowing.

An ordinary telegraph circuit without instruments is theoretically shown in Fig. 33. In this case the circuit comprises the battery *B*, the line wire and the ground. The course of the circuit is assumed to be from the ground at *x*, through the battery, and the line wire to the ground at *y*. When the wire is continuous from the ground at one end, to the ground at the other, the circuit is said to be completed, and a current will flow in the wire as indicated by the arrows.

FIG. 33.

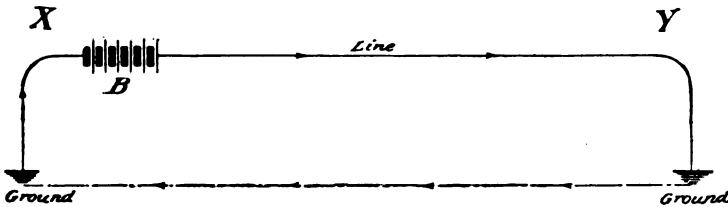

It has for years been a disputed point whether the earth acts as a conductor to “conduct” the current from the terminal at one station to the terminal at the other station, thereby completing the circuit in the sense that it would be completed by a wire; or whether the earth acts simply as a large reservoir out of which, so to speak, the electricity is pumped into the wire at one end, and out at the other end, as water might be, if, for instance, the wire were a tube with one of its ends in Boston harbor and the other end in New York harbor. In the latter case, obviously, with suitable pumping apparatus, there might be a constant flow of water through the tube from Boston to New York or contrariwise, without causing any perceptible flow of water in the ocean, between those points, as a result of the water pumped through the tube.

But, for practical purposes, this is immaterial, inasmuch as the fact remains that, when the wire is thus placed in the earth at both terminals, no matter how widely separated, the circuit is practically completed, virtually as though the circuit were completed by a return wire.

A circuit such as shown in Fig. 32, in which the circuit is completed by a wire, is termed a "metallic" circuit. One such as that shown in Fig. 33, in which the earth is used to complete the circuit is termed a "ground return" circuit.

OPERATION MORSE SYSTEM.—Since the Morse telegraph system is based on the foregoing facts, and since it employs them to transmit signals electrically by the opening and closing of a circuit for a longer or shorter interval, which acts operate apparatus designed to automatically record or to convey those signals to an operator at a remote station, it is evident that, to insure the successful operation of that system, there must be provided, among other things, a circuit capable of being readily opened and closed; a source of electricity; a magnet capable of being quickly magnetized and demagnetized, and a piece of soft iron free to move to and from that magnet; which provision we shall see has been made.

The essential apparatus of a Morse telegraph equipment, for one circuit, at one station, consists of instruments termed a relay, a sounder and key; besides a local battery to operate the sounder, and, if the station is a terminal one, a main battery consisting of from 10 to 150 cells or more, according to the length of the circuit.

A regular Morse circuit with battery, keys, relays and sounders, at two terminal stations, is shown in Fig. 34. R, R, are the relays, each of which is furnished with a bar s of soft iron, termed the core. This core is surrounded by a coil of small insulated, copper wire, which is generally protected from injury by a hard rubber sleeve.

FIG. 34.

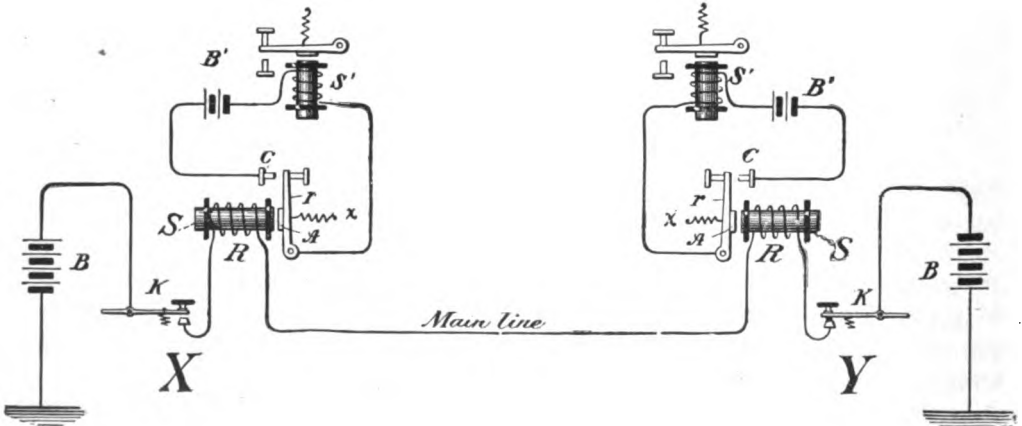

THEORETICAL MORSE CIRCUIT.

The poles of the core are at the ends next to A in figure. A is a small strip of soft iron, termed the "armature" of the relay, placed close to the ends of the core of the relay. This armature A is supported in its position by the upright rod, or lever, r, to which it is rigidly attached, and which is pivoted at its lower end.

The core, the insulated coil of wire, and the armature, with the contact points *c* on the upright rod *r*, compose the Morse relay.

The function of the battery is to provide the electromotive force of the circuit; that of the key is to open and close the circuit, thereby "stopping" and "starting" the flow of current in that circuit; the function of the relay is to attract and release its armature as the current flows or ceases to flow in the insulated wire surrounding its core.

In practice the core of the relay is generally formed in the shape of the letter *u*, or a horse shoe, and two coils of wire are used, one on each "leg" of the magnet, which coils are joined together, forming practically one coil.

The wire from the earth at *x*, Fig. 34, through the battery *B*, to the coils of the relay *R*, and thence via the wire to the earth at the distant station *Y*, forms the main circuit. The wire between the two stations is termed the line wire, or main line.

The retractile springs *x* of the relays must be so arranged that when the core becomes demagnetized they shall pull the armature lever sharply against its back stop. The pull of the spring must be so regulated as not to exceed in strength the attractive power of the cores when magnetized. The work of thus arranging the spring is termed "adjusting" the relay.

According as the current flows or ceases to flow in the circuit, and the core of the relay is, consequently, magnetized or demagnetized, the armatures *A*, *A*, are alternately attracted towards, or withdrawn from their cores by the retractile springs *x*, *x*.

An additional circuit is shown at *x* and *Y*. It includes the coils of a "sounder;" a small battery, *B*¹, of one or two cells, and the supporting rod *r* of the relay's armature *A*, and the relay contact points. This is termed a "local" circuit. The sounder is termed a "local" sounder, the battery *B*¹ a "local" battery.

The sounder is made on exactly the same general principles as the relay, but the wire with which it is wound is larger, and its armature and lever are heavier. The armature of the sounder is also attracted by the magnetism of its core, and withdrawn by its retractile spring when the core is demagnetized; the magnetizing and demagnetizing of that core being caused by the opening and closing of the local circuit at the contact point *c* of the armature lever *r* of the relay as the latter is alternately attracted and withdrawn from its core by the closing and opening of the main line; the lever of the relay, in this case, acting the part in the local circuit of the keys in the line circuit. Consequently, it is plain, that as the main line is opened and closed, the local circuit will be opened and closed at the same time.

The motion of the lever of the sounder, thus produced, causes the well-known clicking sound of the Morse system, and these sounds are converted into intelligible signals by the use of what is known as the Morse alphabet, which consists of long and short sounds, that are symbolized on paper as dots and dashes, a certain number of dots and dashes, or a certain combination of each being assigned to the letters of the alphabet, and to figures and punctuation marks, as will be shown presently.

When the duration of the opening and closing of a key is arranged to correspond to the time required to form dots and dashes of the Morse alphabet, the signals thus formed are repeated by the sounder and recorded by the receiving operator.

Plainly, the number of relays and keys in the main circuit may be largely increased above those shown in Fig. 34.

It is not uncommon, in this country, to have 30, 40 or more stations, with their keys and relays in one Morse circuit, and with but two main batteries, one at each end.

In Fig 35, are shown four such stations, A, B, C, D; A D being terminal, and B C "intermediate," or "way," stations. The keys at B, C and D are closed, the key at A open, consequently, as this opens the entire circuit, all of the relays in the circuit are opened, or demagnetized, as indicated by the position of the armature levers, which are against their "back stops," as the back limiting screws *x* are termed.

FIG. 35.

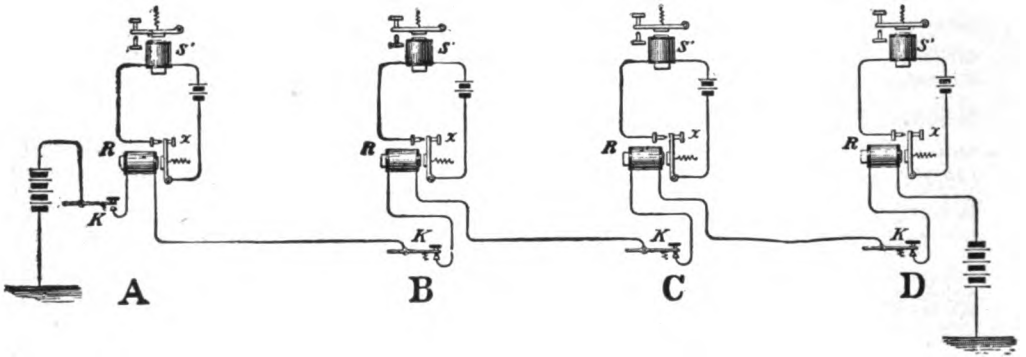

MORSE TELEGRAPH SYSTEM—CLOSED CIRCUIT METHOD—THEORY.

When any one of the keys in a Morse circuit is open, not one of the remaining keys can close the circuit, and when any key is operated, all the relays on the line, if they be adjusted, will be simultaneously operated, by reason of the alternate cessation and flow of the current, which alternately magnetizes or permits the demagnetization of their cores.

Since then but one key may be satisfactorily operated at one time on a Morse circuit, such as is shown in Fig's. 34 and 35, and which is termed a "single" circuit, to distinguish it from "multiplex" circuits, it is evident that this system is only capable of permitting the transmission or reception of one message over the circuit at one time.

The foregoing arrangement of circuits of the Morse system is termed the "closed circuit" arrangement, from the fact that the circuit is normally closed with "current" on the line.

THE MORSE "OPEN CIRCUIT" method.—In Europe the Morse circuits are generally operated on what is termed the "open circuit" plan. This consists, essentially, of so arranging the apparatus that the battery shall only be placed to the line when a message is to be transmitted; at other times it is open. The arrangement is outlined in Fig. 36. A C may represent two terminal stations, and B an intermediate, or way station. At rest, it is seen, the batteries *b* at each station will be open; while at such times the relays *R* are in the circuit. A main battery is thus necessary at each station—way stations included—whereas, in the "closed circuit" system employed in America, main batteries are only required at the terminal stations.

An advantage of the open circuit plan is that when not in use, the battery is not required to supply current to the line; another advantage is that the resistance of the relay is not always in the circuit, since the closing of a key "cuts" out the relay.

The relays are provided with local sounders or registers. In some cases a "tell-tale" galvanometer *G*, is placed in the main line at each station to indicate to the operator the condition of his transmitted signals, etc.

FIG 36.

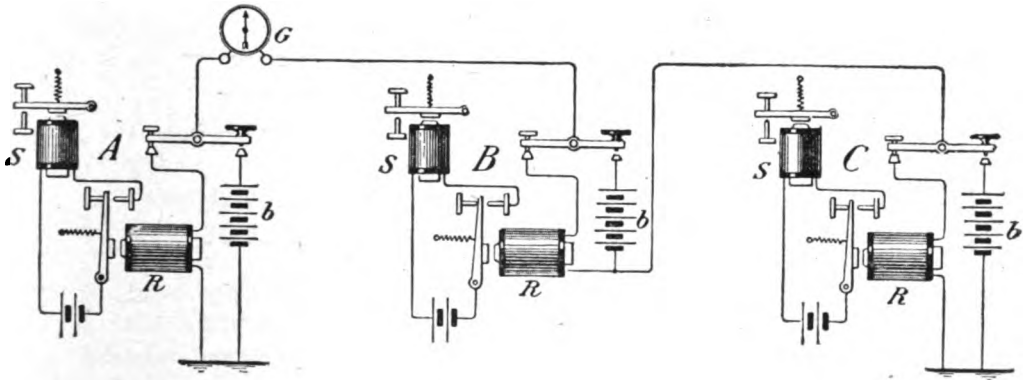

MORSE TELEGRAPH SYSTEM—OPEN CIRCUIT.

TELEGRAPH CODES.

The Morse telegraph code, which is in use exclusively on overhead lines in the United States and Canada, and modifications of which are in use in Europe and elsewhere is composed of dots, dashes and spaces.

These are formed by the length of time during which the key, or other transmitting instrument, may be held closed or open, the time of making a dot being taken as 1.

Some of the letters of the Morse alphabet are composed of dots, others of dashes, others again of dots and dashes, while others yet are composed of dots with spaces between. The latter are termed "spaced" letters.

In length, or duration, one dash is theoretically equal to three dots. The dots and dashes are separated by intervals of time. The space between the elements of a letter is equal to one dot; the space between letters of a word to 3 dots; the space between words to 6 dots; the interval in "spaced" letters is equal to 3 dots.

The code in use in Europe and other foreign countries is known as the Continental code.

The Bain alphabet or code was at one time in use in parts of Europe and this country in connection with the Bain chemical telegraph system, but is not in use at the present time.

The Morse, Continental and Bain codes are given below; also the Phillips code for punctuations, etc.; the latter of which is now much used in "press" work throughout the United States.

AMERICAN TELEGRAPHY.
TELEGRAPH CODES.

LETTERS	MORSE.	CONTINENTAL.	BAIN.
A	.-	.-	.-
B	---..	---..	---..
C	..-.	---..	...-
D	---..	---..	---..
E	.-	.-	.-
F	..--.	...--.	...--..
G	---..	---..	---..
H	---..
I
J	---..	---..	---..
K	---..	---..	---..
L	---.	---..
M	---	---	---..
N	---.	---	---..
O	...	---	---
P	..-..	---..	---..
Q	---..	---..	---..
R	.-..	---.	---..
S	...-	...	---..
T	---	---	---..
U	...-	...-	---
V	...--	...--	---..
W	---..	---..	---..
X	---..	---..	---..
Y	..-.	---..	---
Z	...-	---..	---..
&	-.---	---	---..

NUMERALS.

	MORSE.	CONTINENTAL.	BAIN.
1	.----	---..	---..
2	..---	---..	---..
3	...--	---..	---..
4-	---..	---..
5	-----
6	-----	---..

	MORSE.	CONTINENTAL.	BAIN.
7	-----	-----	-----
8	-----	-----	-----
9	-----	-----	-----
0	-----	-----	-----

PUNCTUATIONS, ETC.

	MORSE.	CONTINENTAL.	PHILLIPS.
. Period
: Colon	-----	-----	-----
;- Colon dash	-----	-----	-----
; Semi colon
, Comma
? Interrogation
! Exclamation	-----	-----	-----
Fraction line	.		.
- Dash			-----
- Hyphen		-----	-----
' Apostrophe		-----	-----
£ Pound Sterling		-----	-----
/ Shilling mark		-----	-----
\$ Dollars			-----
d Pence			-----
Capitalized letter		
Colon		
: "followed by			-----
Quotation. }			-----
c cents		
. Decimal point			-----
¶ Paragraph	-----		-----
Italics or }		-----	-----
Underline }		-----	-----
() Parenthesis	-----	-----	-----
[] Brackets			-----
" " Quotation marks		-----	-----
Quotation within }			-----
a Quotation			-----
" " " " }			-----

SOME ABBREVIATIONS IN COMMON USE.

(See, also Military Telegraph Signaling.)

Min.—Minute.	Bn.—Been.
Msgr.—Messenger.	Bat.—Battery.
Msk.—Mistake.	Bbl.—Barrel.
No.—Number.	Col.—Collect.
Ntg.—Nothing.	Ck.—Check.
N M.—No more.	Co.—Company.
O K.—All right.	D H.—Free.
Ofs.—Office.	Ex.—Express.
Opr.—Operator.	Fr.—Freight.
Sig.—Signature.	Fr.—From.
Pd.—Paid.	G A.—Go ahead.
Qk.—Quick.	P. O.—Post Office.
G. B. A.—Give better address.	R R.—Repeat.

STENO TELEGRAPHY.

The necessity for promptness in getting news by telegraph into the newspaper offices before the time of going to press has long been recognized by all concerned.

To secure such promptness Mr. W. P. Phillips has devised a system of steno-telegraphy in connection with an ink recorder, which has been found of much utility.

This system, or code, is a "short hand" method, arranged for telegraphic purposes. The Morse alphabet is employed to represent the sounds used. The code proper consists of single letters, double letters and contractions of words which represent, arbitrarily, figures, words and phrases. Examples of the use of single, and double letters and contractions are given below:

Single letters:—

- B; be.
- C; see
- D; in the, *or*, pence.
- F; of the.
- G; from the.
- K; out of the.
- Z; from which.

Double letters:

- Ac; and company.
- Ad; adopted.
- Cj; coroner's jury.
- Em; embarrass.
- Fb; of the bill.

Contractions:

- Abmn; abomination.
- Agum; argument.
- Ahr; add house regular.

Such words and phrases as occur most frequently are represented by the single and double letters. For market quotations the first letters of the words of frequently recurring phrases are used as one word. For instance:—

Abnqh; active but not quotably higher.

Aobfwos; absence of business for want of stock.

Cqas; closed quiet and steady.

In the "reporting" code such words as are most frequently used in congressional debates are given preference.

The Phillips code contains several thousand characters, or signals, each of which represents one or more words, all of which should be memorized by the operator before he can use the system to its full advantage, but even by the aid of the single, double and three letter contractions the ordinary speed of transmission may be much increased.

As it would not be possible for an operator to receive and transcribe in full, as quickly as received, matter transmitted by this code, an ink recorder, somewhat analogous to the "Wheatstone" ink recorder, is used by which to record the signals. The signals thus received are then written out by two or more operators.

Since the foregoing was written it has become customary to record this matter without the aid of an ink recorder, by means of the typewriter in the hands of skillful operators.

SOME PRACTICAL NOTES TO BEGINNERS ON SENDING AND RECEIVING BY THE MORSE CODE.

It is assumed that the student has thoroughly familiarized himself with the characters of the Morse Code. This is best done, perhaps, by separating from the rest of the alphabet, first, all of the "dot" letters—thus: E . , I . . , S . . . , H , P , G , afterwards, the letters and figures containing dashes only—thus: T — , M — — , 5 — — — , and L, long dash, ——— , Cipher, extra long dash, ————— ; and so on.

After the alphabet, figures, and punctuations have been completely mastered, or even before, the student may begin the practice of making the letters by means of the Morse key. In connection with this subject it may be said that while the exact manner of holding the key and the style of sending will vary more or less with each individual sender, still it is without doubt the case that much may be done by care at the beginning, in the matter of acquiring an easy, fluent, and correct style.

In words containing two or more spaced letters, space just enough, not so much as between letters. Still, do not underspace them. Avoid, for instance, making "meet her," "mother," or vice versa. The letter L should be long enough to distinguish it fairly from a dash. A double L, in such words as "skill," should not be transmitted as though it were "skim," and "skim" should not be sent as if it were "skill." The letter J is made as nearly as it may be explained verbally, like TF run closely together; the letter K like TA run together; the figure 9 like TV.

Each dot and dash should be firmly made, and always with the same degree of pressure, not changing from light to heavy pressure, or the reverse. On long lines the difference between senders is very marked. Light sending can be adjusted for,

somewhat, on single lines, but not so readily on duplex or quadruplex circuits. On long lines where there are several repeaters (see Automatic Repeaters) in circuit, skillful senders adopt a style which carries the signals through firmly and clearly. This is done by slightly lengthening the dots and dashes, and also by firmness and uniformity of contact at the key.

Avoid the habit of making P for H, or 6 for P, or of making seven or eight dots for the figure 6, a habit which it is said is more common of late than was formerly the case. This habit usually arises from carelessness in learning. In making these letters and figures it will be well to count them mentally as made until practice enables the student to make them accurately automatically.

The manner of holding the key in sending which is adopted by many of the best and speediest senders in this country is known as the Catlin method. According to that gentleman (Mr. Fred. Catlin), the key should not be held tightly. The end of the index finger should rest on the edge of the knob, using the thumb and second finger for steadying. The fingers should be arched and pliable, not straight or rigid. "The wrist and forearm should do the work, the finger tips and thumb being used as the end of the lever." The key should be so placed as to allow the elbow to rest easily on the table or desk. The degree of tension on the spring of the key will vary with the sender. Some of the speediest senders use a very stiff spring.

It is only by constant practice that the ability to receive the Morse characters by sound can be acquired. The student must either have some one to send to him, or he must listen to the Morse passing on some wire to which he has access. Very often the speed on such a wire will be too great for the student. In this case he must wait for slower sending. The ability to read Morse is acquired gradually, like a foreign language. First a letter is occasionally recognized. Then some word such as "you" will be caught by the ear. At other times a succession of words will be heard by the listener. It also sometimes happens when a "clear" sender is transmitting Morse over the wire that the student is delighted to find that he can read much of what is passing. Again, a "blind" sender will have possession of the wire and the student will fail to catch a word. Discouragement follows. This is, however, no good reason for discouragement. The time will ultimately come when the one-time student will be able to read all styles of sending.

It is obvious that it is at first a difficult matter to exercise one's faculties to the utmost in the act of translating the Morse characters into the characters of the more familiar English alphabet, and at the same time give much attention to the style of one's penmanship, in recording the translation. So long, however, as the use of the pen is permitted in telegraph offices (and the typewriter has not yet completely superseded that method of recording messages) great care should be exercised in acquiring a clear and legible style of penmanship, while writing at a high rate of speed. Ornate penmanship, although not to be belittled in the telegraph operator, is not an essential, but plain writing is very essential. Each letter should be accurately written, and the letters which, like *fine*, *fire*, *five*, in long-hand, are liable to be confused, should be very legibly written; even where words are not liable to be confused they may often be "blind," as it is termed, if each letter is not clearly defined.

By acquiring a habit of legibly forming each letter in the act of receiving by Morse, the operator will find that he will usually write far more clearly when receiving Morse than when writing at his own dictation, so to speak. This has been the experience of many operators.

When the sense of a message as transmitted is obscure, and the receiving operator has doubts as to a word, it is better to break and have the word or words repeated, than to risk possible subsequent chagrin or loss. If there is doubt as to a word after the sender has passed it for some time, the receiver may inquire at end of the message or even later, "Is that chignon?" indicating the message referred to, or simply "Chignon?" To which the sender may reply "ok," or by proceeding without comment let silence give assent. If the word thus repeated is inaccurate the sender will correct it. On the other hand, an intelligent receiver by the use of good judgment may often prevent an error by questioning a word as received. For example, if the following is received: "Your fine horses leave to-night," the receiver should inquire "Fine, not five?" In many cases of this kind the sender on thus having his attention particularly called to the word will say, "Please make it five." If not, it will be well for the receiver to make some private mark on the message, or, at least, a mental note of the matter for future reference. For, in such an instance as the above, unless the receiver can prove his own accuracy, it may be considered a case of divided responsibility between the sender and receiver. But in addition to that, and at least equally important, a diminution of errors as a whole is thus brought about, and hence added prestige to the employer, for it is the company, after all, that the public which supports the telegraph service denounces or looks to for redress, if errors are committed. It may indeed be pointed out that one of the important advantages of the Morse system over any automatic system is that the receiver is assumed to act as a check upon the sender in the matter of errors.

In the actual work of transmitting telegrams by the Morse method, the operator is required to "time" each message as it is sent. This is usually done with a pencil in the left hand while the right is engaged in transmitting the message. The ability to perform this double function is soon acquired by practice. The sender is also required to attach his allotted "initial" or "sign," as it is termed in shop phrase, to the message. This timing and signing are usually done on the back of the message. The number of each message as sent on a given wire or to a given office is also placed on the message by the sender, but on the face of the blank. Number sheets are generally placed on each desk with numerals placed in vertical rows. In large offices each operator is expected to mark off on this sheet the numbers corresponding to the messages transmitted or received, and to place his "sign" opposite the numbers thus marked off.

In receiving telegrams the operator is expected to place the initial of the sender, his own initial, and the hour of receipt of the dispatch on the spaces provided therefor on the receiving blanks.

CHAPTER V.

MORSE TELEGRAPH APPARATUS, ETC.

MORSE TELEGRAPH KEYS.

The function of the Morse telegraph key is to open and close, or "make" and "break" the circuit, as already stated.

That the Morse key is one of the most important instruments in the telegraph service is a fact which has frequently been recognized by the officials of the principal telegraph companies of this country, and the wishes of the operators in respect to the form of key desired, have generally been consulted, even to the extent of displacing keys already extensively in service. The wisdom of such action is evident when it is considered that, at a low estimate, an operator will transmit with the same effort from 5 to 10 more messages per hour with a key suitable to his style than with one not so suitable.

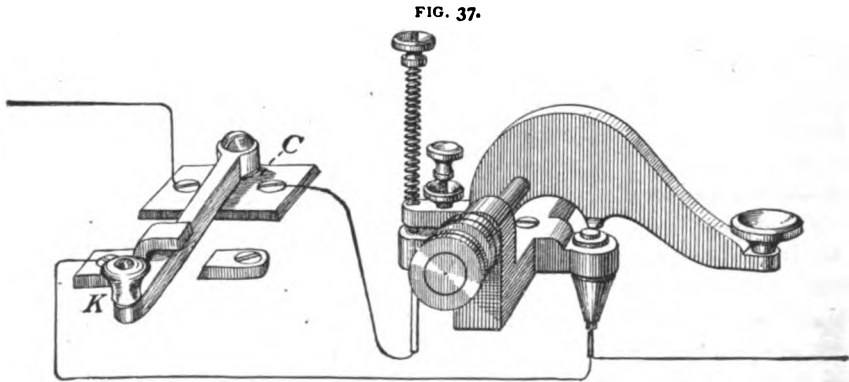

OLD STYLE MORSE KEY AND CONNECTIONS.

The tendency of the Morse telegraph key in this country has been from that of a heavy, cumbersome mass of brass, as outlined in Fig. 37, which represents a style of key in vogue twenty-five years ago, to those shown in Figures 38, 39, 40; weighing about $7\frac{1}{2}$ ounces, each.

The construction of the modern telegraph key may be readily understood from Fig. 38. In that figure, L and L^1 are metal extensions, termed "legs," projecting from an oval-shaped metal strip, or base. The leg L^1 is connected directly with the base. The leg L passes through the base, and is insulated from it by a bushing of hard rubber. On its top it is furnished with a cone-shaped cap c , termed the anvil, carrying a small platinum point. A small flat strip of metal, s , extends out a short distance from the cap. At a point on its under side, directly above the platinum point on c , the lever is also supplied with a projecting platinum point termed the hammer. The lever A of the key is supported at its trunnion by the set screws shown. A curved strip of metal,

FIG 38.

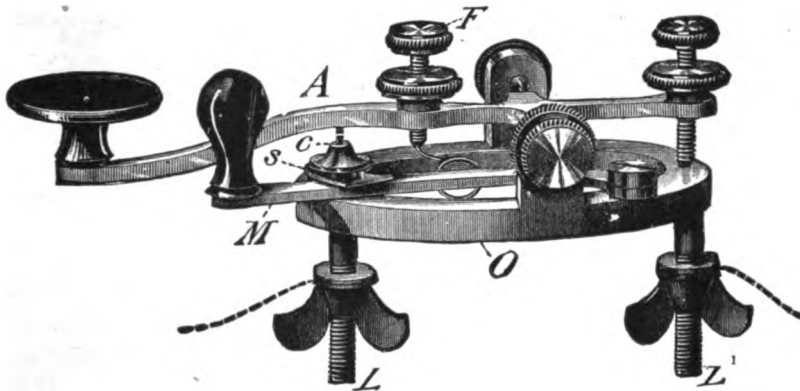

"BUNNELL" KEY.

M , termed the "circuit closer," is pivoted on the base, as shown. The lever A , and the circuit closer M , are each supplied with hard-rubber finger-tips, or knobs, by which they may be freely moved. A spring, adjustable by the set screw F , normally lifts the lever A from the contact point c . One terminal of the circuit, of which the key may form a part, is brought to leg L , the other terminal to leg L^1 . As the leg L is insulated from the base, the circuit would be open at c but that the circuit closer M slips between s and the base, thereby continuing the circuit from the oval to leg L .

When the operator is about to "send," the circuit closer must first be pushed out from s , so as to permit the lever A , when it is operated, to open and close the circuit.

Platinum contact points are employed because of the fact that, at each time an ordinary telegraph circuit is opened, a small spark occurs at the point of opening (see self-induction); the result being that if a metal, such as brass, were used, the surface would soon become *oxidized*, and, measurably, non-conducting. The points could be filed and thus temporarily made conducting, but at the cost of rapidly wearing the metal, etc. Platinum, being virtually non-oxidizable, is not affected in this way and further, its hardness renders it much more durable than a softer metal would be.

When the key, shown in Fig. 37, was first employed, it was not furnished with a circuit closer, but a special circuit closer, much resembling an old fashioned window catch, was used separately for that purpose, namely, to short-circuit the contact points of the key when the latter was not in use. This arrangement is also shown in Fig. 37, C being the circuit closer, the knob K of which was pushed to the right in sending.

Keys, almost as large as those introduced by Morse, are at the present day in use in the British Postal Telegraph service. The operators in that service have frequently expressed the opinion that they can "send" as speedily and with as little fatigue as the users of the lighter keys in this country.

FIG. 41.

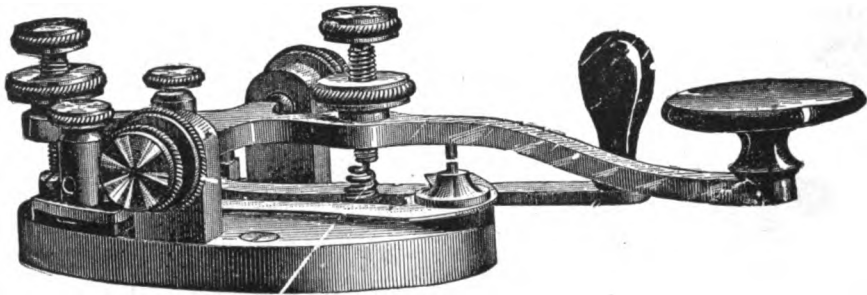

"BUNNELL" LEGLESS KEY.

The style of key shown in Fig. 38, is known as the "Bunnell" key. It may be said to have been the pioneer of the many light, "solid lever" keys now in service in this country. Fig. 39 illustrates the "Steiner" key. Fig. 40 the "Victor" key.

The keys shown in Figs. 38, 39 and 40, are known as "leg" keys. That in Fig. 41 as a "legless" key.

FIG. 39.

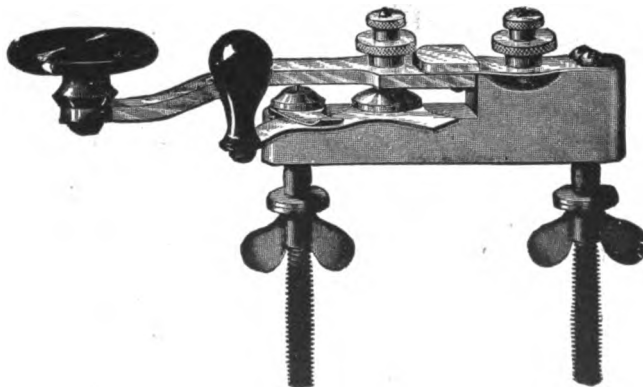

"STEINER" KEY.

Leg keys are held to the table, or desk by the pressure of the set screws against the under part of the table, the set screws also holding fast the wire terminals. It is understood that suitable holes are bored in the desk for the passage of the key legs. The legless key is screwed fast to the desk, while the line wire terminals are attached to the

key by means of the binding screws provided on the base of the key.

SELF-CLOSING KEYS.—Every one connected with telegraphy knows the vexation caused and time lost by the failure to close the keys. To avoid delays, etc., arising from this failure, many attempts have been made to devise a “self-closing key” which would be satisfactory in all respects, but apparently none such has yet been found— at least none has been adopted for general use.

FIG. 40.



“VICTOR” KEY.

Whether this is due to inherent lack of merit in the devices or to a lack of desire on the part of the telegraph companies to encourage negligence on the part of employes is, perhaps, debatable. It is, however, unquestionable that some of the self-closing arrangements devised would provide a “remedy” which would be rather worse than the complaint; as, for example, that one in which the operator's elbow, while he was sending, was to be caused to open a circuit closer which would be automatically closed when the elbow was removed.

Fig. 42 will illustrate the principle of one form of self-closing key which, after a brief trial, has seemingly fallen into disuse, and it is not known that any substitute

FIG. 42.

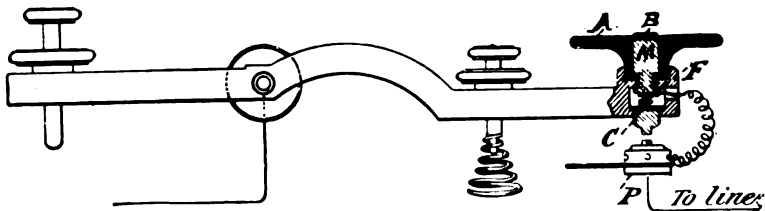

SELF CLOSING KEY.

has taken its place. The key resembles other modern Morse keys quite closely. Its peculiarity is that the finger-tip of hard-rubber is in two parts, A, B, one within the other. In size, A is about the same as the finger-tip of the ordinary key. At its centre a circular hole is cut, into which the smaller part B, loosely fits. B rests on a metal pin *m*, into whose lower end a pin, resembling a small, inverted screw, is in-

serted. A small, spiral spring, resting on an insulated cross-piece, *c*, gives *m* and, with it *b*, an upward tendency. When pressed upwards, the flange *f* of the inverted screw, makes contact with the metal of the lever. The tip *a* is suitably supported by the metal of the lever. The spiral spring below *f*, normally, raises the hard-rubber tip *b* slightly above *a*.

It will be seen that the inverted screw is electrically connected by a wire with the contact *p*, of the key. Thus, when the key is "open," the circuit is closed, at the key, via that wire, and the inverted screw below, *m*, is insulated from all other parts of the key lever, except at the flange. When the operator uses the key he places a finger on *b*, pressing its surface level with that of *a*. That action opens the circuit at the flange. When he further depresses the two discs and the lever, he closes the circuit at *p*. Care is necessary to remember to keep disc *b* level with *a* during sending. As soon, of course, as the operator removes his hand from the key, the spiral spring of *m* automatically closes the circuit. The act of depressing the tip *b* to a level with *a*, is equivalent to "opening" the key in the usual way.

Another suggestion in this direction was that the circuit closer of all keys should be removed; that the contact be made on the back instead of the front of the key, and that all the relay armature lever contacts be placed on the back stop, as, theoretically, shown in Fig. 43. This arrangement would give the signals on the front stroke. It

FIG. 43.

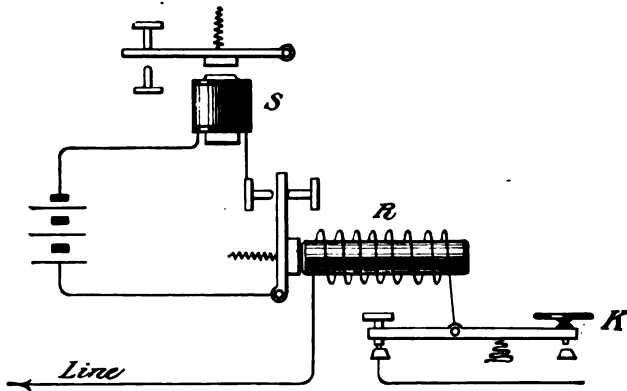

would also, besides insuring a remedy for "open" key delays, of the usual order, put the local batteries of the sounders on "open circuit," except when in operation. The disadvantage would be that the transmitted signals would probably suffer, owing to uncertain action of the spring of the key, upon which spring the actual making of the contacts would chiefly depend.

THE MORSE RELAY.

The Morse relay has also undergone many changes as to its shape, dimensions and resistance, since it was first invented. As stated in the introduction, it was thought that a remarkable advance was made when a relay, weighing only 70 or 80 pounds was produced. The Morse relay of to-day weighs but little over 3 pounds. As late as 1867, relays wound to 1,100 ohms, were employed in this country in regular telegraph service.

MAIN LINE RELAYS.—Specimens of Morse relays, now in general use on main lines in this country, are shown in Fig's. 44 and 45. These only differ as to details. For example, in Fig. 44, the armature is a part of the lever, while in Fig. 45 the armature is a separate piece of soft iron, carried by a brass or nickel-plated lever. Main line relays are, as a rule, now wound to 150 ohms resistance.

These relays may be "adjusted" in two ways; either by drawing the cores away from the armature by means of the adjusting screw, A, which is attached to the cores suitably for that purpose, or by the aid of the retractile spring R, attached to the armature. In wet weather, when, owing to "escapes" due to defective insulation, the current strength is much increased at the battery end, or ends, of the wire, the relay is best adjusted by withdrawing the coils, or cores from the armature, until the latter works freely. (The spring should not be adjusted more than to give the armature

FIG. 44.

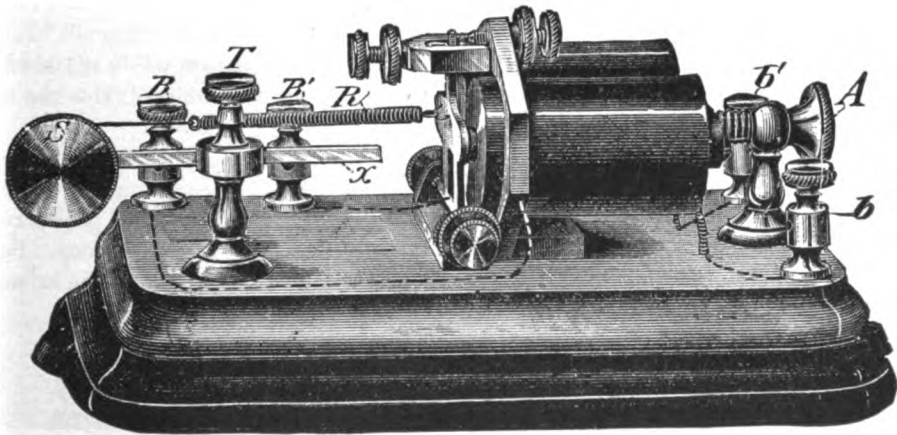

MORSE MAIN LINE RELAY.

prompt action. Thousands of retractile springs are wasted annually by turning them around the cross-bar of the winding screw s.) The explanation of the increased strength of current, at such times, is that the circuit is virtually shortened, and, consequently, the resistance offered to the battery is decreased. The actual resistance of the line wire itself, of course, remains the same. (See remarks in connection with Delaney line adjustment device.)

In Fig's. 44 and 45, the winding screw s is movable to or from the relay coils by aid of the "upright" T, through which the support, U of that screw passes. The screw

posts B, B^1 are for the local connections, and posts b, b^1 are for the main line connections. The dotted lines show the manner of connecting under the base-board of the relay.

As the object of the relay is merely to "relay," or "repeat" the signals passing over the main line to the "sounder" the play of its armature should not be large. This play is regulated by moving forward or backward the contact screw on the front stop (that is the screw next the coils), and the screw on the back stop. The "armature" proper consists of the strip of soft iron opposite the cores, but, generally speaking, among operators the lever which carries the armature, is included in that term. The armature

FIG. 45.

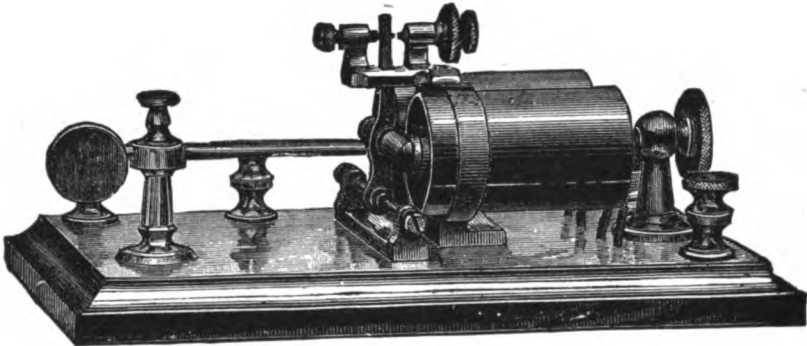

MORSE MAIN LINE RELAY.

lever is pivoted as shown. Care should be observed that the screws do not bind the movement of the lever. The armature and its supports are all insulated from the brass sockets, or "spectacles" into which the coils of the relay fit, as shown.

POCKET RELAY—This relay is designed for use in line testing, as, for instance, when a break may have occurred on several wires, and the foreman is taking orders or giving them, etc. It is placed directly in the main line. The pattern of pocket relay, shown in Fig. 46, is about 6 inches long by 3 inches wide, and $2\frac{1}{2}$ inches deep. Screw posts are provided at the left end for the line wires. The construction of the armature

FIG. 46.

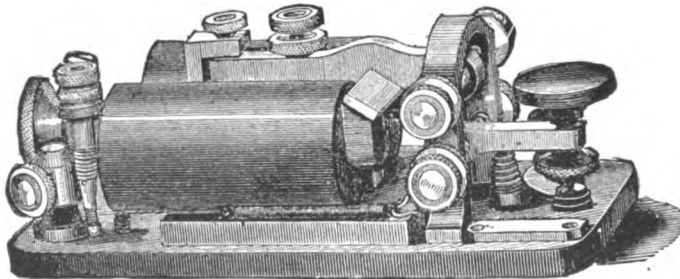

POCKET RELAY.

and lever of this instrument is such as to produce a very fair sound.

PONY RELAYS.—This is a name given to a relay which differs from the main line relay only in minor details of construction, and in the resistance, or winding of its coils,

which varies from about 20 to 100 ohms. It is mostly used on "private" lines. For lines up to 15 miles in length the "pony" is "wound" up to about 20 ohms. For lines 20 to 40 miles, about 45 ohms. For lines 70 to 75 miles, about 75 ohms. A specimen of a pony relay is shown in Fig. 47.

FIG. 47.

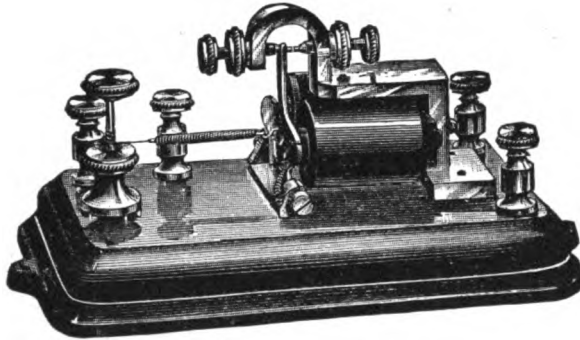

PONY RELAY.

THE BOX RELAY.—This is an ordinary Morse relay, the coils of which are covered by a square, or oblong, wooden box, as seen in Fig. 48. Holes are cut in the left end of the box opposite the front contact point of the amature lever, and opposite the ends of the cores of the relays, and at the right end of the box for the adjusting screw of the coils. The instrument is adjusted in the same manner as the unboxed relay. **The box relay is generally provided with a Morse key on the base-board.**

FIG. 48.

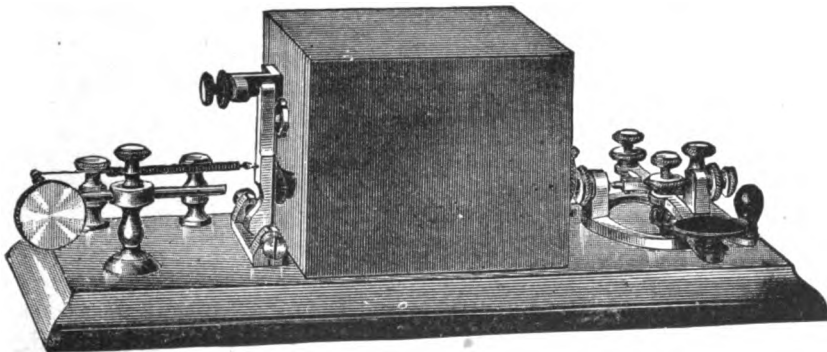

BOX RELAY.

This form of relay is mostly used by linemen, or others, in testing, or for temporary offices when a local battery is not to be had, or may not be desirable. The box over the coils acts as a sounding board, and increases the sound of the signals to such an extent as to make them clearly perceptible without the aid of a sounder, but a sounder may be connected in, if desired. The box relay, shown in the figure, is technically known as a "box relay with key on base."

SOUNDERS.

The object in using the "sounder" in Morse telegraphy is to obtain an increased sound as compared with that given out by the Morse relay.

The necessity for the sounder in Morse telegraphy in addition to the relay is primarily due to the fact that the strength of current with a given electromotive force is proportional to the resistance of the conductor; the strength of current decreasing as the resistance increases. As the resistance of a wire of a given diameter increases directly with its length, the longer the wire, the weaker will be the current.

The magnetism developed in a given electro-magnet, such as a relay, or sounder, increases with the strength of current in the coils, and also with the number of convolutions of wire in the coils; the resulting magnetism, being, within certain limits, directly proportional to the product of the strength of current multiplied by the convolutions or turns of wire. This product is termed the "ampere turns."*

FIG. 49.

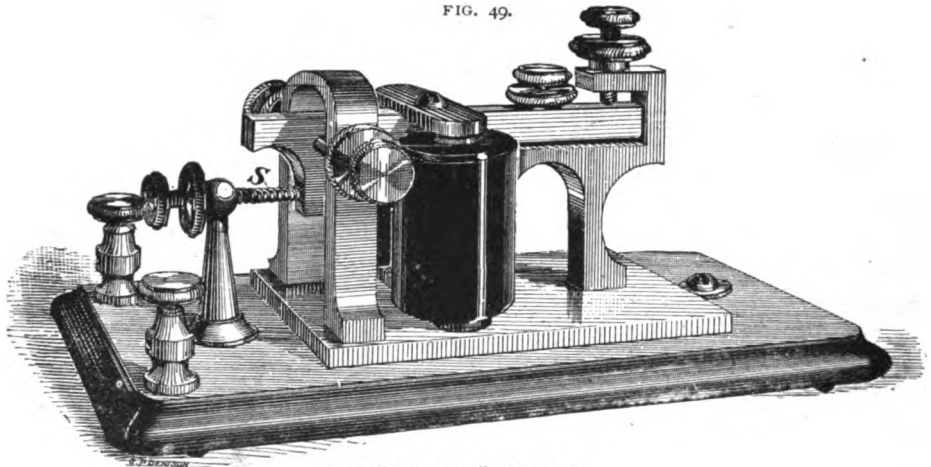

THE "BUNNELL" SOUNDER.

An instrument to produce sounds loud enough to be easily heard by the operator, requires that the apparatus should possess considerable mass, and as its moving parts require to be actuated quickly and without lag, the use of a strong retractile spring is entailed. This necessitates the use of a magnet of considerable strength.

It is found that, to produce the clear, loud "click" of the ordinary Morse sounder, about one quarter of an ampere is needed in its coils. Assuming the number of convolutions of the sounder to be, say, 900, the "ampere turns" of the sounder will be 225. Consequently, it may be said that 225 "ampere turns" are necessary to

* The limit referred to is when what is termed the point of magnetic saturation of the iron is reached. This statement should, however, be qualified. After this point is reached the magnetism increases directly with the magnetomotive force, but the lines of force in the circuit do not thereafter increase in the same ratio as before saturation. Saturation is, however, rarely reached in the magnets used in telegraphy. Hence it may be assumed here that the magnetism developed will be proportional to the ampere-turns as remarked. A hypothesis due to Ampère and amplified by Weber to explain the effect following the introduction of iron into a magnetic circuit, and to account for saturation of the iron, is, that each molecule of the iron is normally a magnet, but in the normal state each acts independently of its neighbor; the result being that one neutralizes the other, and no magnetism is apparent. When, however, an external magnetomotive force, due, for instance, to a current in a coil of wire, is brought to bear upon the iron, more or less of its molecules are turned so that their lines of force are added to the circuit. When the external magnetomotive force is such that all the molecular lines of force of the iron are brought into play, the saturation point of the iron is assumed to be reached. In a solenoid, that is, a coil of wire without iron, the resulting lines of force or magnetic flux are proportional to the ampere-turns without limit. See p. 33.

properly operate an instrument capable of furnishing the "sound" required for successful Morse telegraphy.

If a Morse sounder were placed directly in a line wire extending from, say, New York to Philadelphia, and having a resistance, including the internal resistance of the battery, of, say, 1200 ohms, which would, with a battery of 100 cells, give a current of about .08 ampere, (80 milliamperes) the "ampere turns" of the sounder would be 72, which is much short of the amount necessary. To secure the desired "ampere turns" a battery of, at least, 600 cells of "gravity" would be required on such a circuit. It is, therefore, evident, if for no other reason than the foregoing, that it would be unadvisable to attempt to supply sufficient current to operate an instrument such as an ordinary sounder on long telegraph lines. It is found more economical to employ a main line relay having a much larger number of convolutions, and a light armature, not designed to produce a large volume of sound, and then to cause this relay to operate a sounder by means of a local battery.

In fig's. 49, 50, and 51 are shown styles of sounders now in use in this country. The first is known as the "Bunnell" sounder; the second as the "West-

FIG. 50.

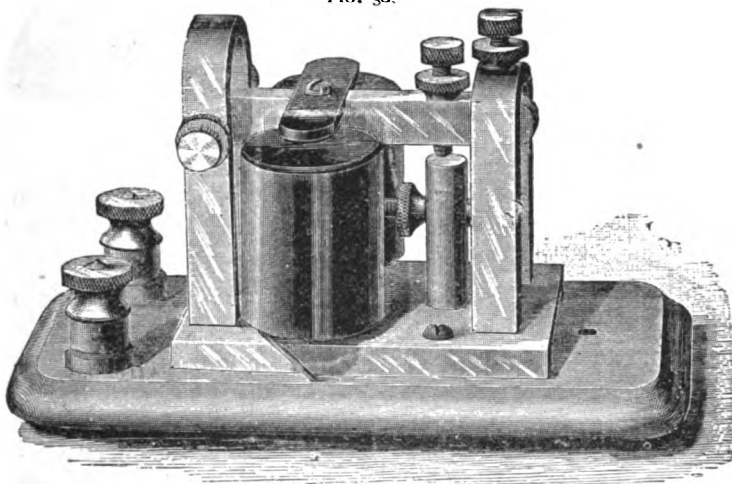

THE "WESTERN ELECTRIC" SOUNDER.

ern Electric" sounder. One point of difference between these sounders is that fig. 49 is supplied with a spiral spring *s*; that in fig. 50, with a retractile spring. Fig. 51, represents the "Victor" sounder. In this the trunnion of the lever rests on pins, or points, instead of the usual bearings. The pins project from above the coils near the right end of the armature lever, but are not seen in the figure. The usual resistance of a "local" sounder is between 4 and 5 ohms.

MAIN LINE SOUNDERS. Main line sounders are used on main lines when, for any reason, it is not desirable to have relays in the circuit. The resistances of these sounders is about 20 ohms. In other respects they resemble the ordinary sounder.

While the additional convolutions on the main line sounders add considerably to the total resistance of a line wire, already moderately large, yet the added resistance reduces the total strength of current but slightly, and, on the other hand, the increased number of convolutions, as compared with the ordinary local sounder of 4 ohms,

FIG. 51.

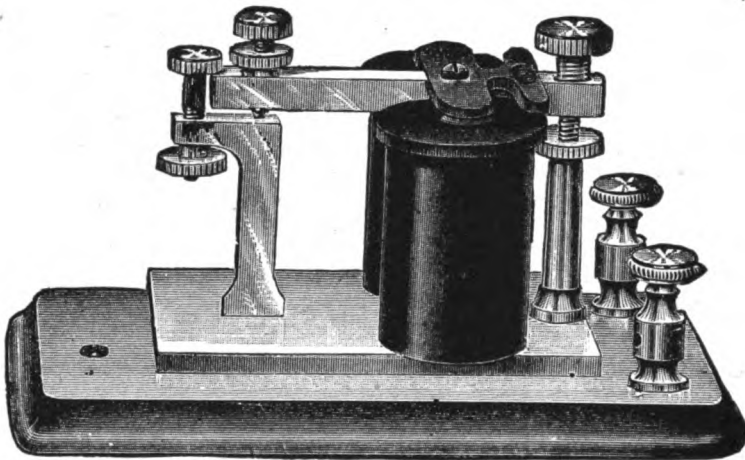

"VICTOR" SOUNDER.

augments the ampere turns, and, consequently the magnetism, of the magnet in greater proportion than the strength of current is reduced by the added resistance of the coils. An illustration of this will perhaps be useful.

Assuming a local circuit of 2 cells and 1 local sounder, the total resistance of the circuit will be:—

2 cells, 2 ohms internal resistance each,	4 ohms.
1 sounder, 4 ohms,	4 "
Total resistance of circuit,	8 ohms.

The resistance of the connecting battery wires may be neglected.

Electromotive force, 2 volts, divided by the resistance, 8 ohms, gives a current strength of .25 ampere. Ampere turns = $.25 \times 900 = 225$.

Assuming now it is desired to operate 4, 4-ohm sounders on a short wire having a resistance of, say, 100 ohms. If we increase the battery to, say, 30 cells, we have:

Internal resistance, 30 cells,	60 ohms.
Resistance of 4, 4-ohm sounders,	16 "
Resistance of line wire,	100 "

Total resistance, - - - - 176 ohms.

And a consequent strength of current of $\frac{30}{176} = .17$ ampere; giving 153 ampere turns, which is considerably less than required to operate the 4 ohm sounder satisfactorily—namely, as we saw, 225.

If now we substitute for the 4 ohm sounders, four 20-ohm sounders, we have:

Internal resistance of 30 cells,	-	-	-	60 ohms.
Resistance of 4, 20-ohm sounders,	-	-	-	80 "
Resistance of line wire,	-	-	-	100 "
				240 "
Total resistance,	-	-	-	240 ohms.

Which gives a strength of current of $\frac{30}{240} = .125$ ampere. As the number of convolutions of the main line sounder is about 1800, we thus obtain 225 ampere turns. In other words, the current strength of the circuit is reduced from .170 to .125 amperes, by the additional 64 ohms of the main line sounders, but the magnetic strength of those sounders is increased, by the additional convolutions, to a point virtually equal to that of the 4 4-ohm sounder in a local circuit.

The foregoing figures, relative to the number of convolutions, are approximately correct. The exact windings of sounders and relays as furnished by the manufacturers are as follows:

150 ohm Morse relay, 30 layers of No. 30, B & S wire on each core; 144 convolutions to each layer; 8640 turns in all. (See Wire Gauges.)

4 ohm sounder, 10 layers of No. 24, B & S wire on each core; 47 convolutions to each layer; 940 turns in all.

20 ohm sounder, 14 layers of No. 25; B & S wire on each core, 67 convolutions to each layer; 1876 turns in all.

In every case silk covered wire is now used in the coils of these instruments—relays and sounders.

Amount of current that is required for proper operation of 150 ohm Morse relay, about 40 milliamperes; for polarized relays on duplex and quadruplex circuits, about 25 milliamperes; for quadruplex neutral relays, about 70 milliamperes, depending on the ratio with transmitter open and closed (see page 207). The amount of current required to operate the Brown and Allen relay is about 7 milliamperes. A sensitive polarized relay on cable circuits of moderate length will work with 15 milliamperes.

THE MORSE REGISTER.

The Morse embossing "register" which was in extensive and almost exclusive use as a "receiver" in the operation of the Morse telegraph system, until the present method of receiving by sound was adopted, is now mainly used as a "call" recorder in connection with the District Telegraph Messengers service, Fire Alarm Telegraphy, etc.

The ordinary Morse embossing register consists of an electro-magnet, usually operated by the armature of a main line relay, which electro-magnet, placed in an oblong frame containing clock-work and a spring motor, by means of which two brass rollers are given a tendency to rotate. A strip of paper is passed between these rollers and is carried along by them when the instrument is in operation. An extension from

the armature lever of the electro-magnet carries a pencil which, in certain positions of the armature, is caused to impinge against the paper, indenting thereon long or short dashes, as the case may be, which indentations appear as embossings on the upper side of the paper strip.

As the electro-magnet is operated by the main line relay any signals transmitted over that line are recorded on, and may be transcribed from, the embossed strip of paper.

INK RECORDING MORSE REGISTER.

An ink recording register is shown in Fig. 52. The manner of its operation will readily be perceived. A disc *D* and an ink-roller *I* are placed on the outside of the register. The disc is caused to revolve by clock-work gearing within the box. The ink-roller is held lightly against the disc by a spring *s*, attached to the arm *A*, which

FIG 52.

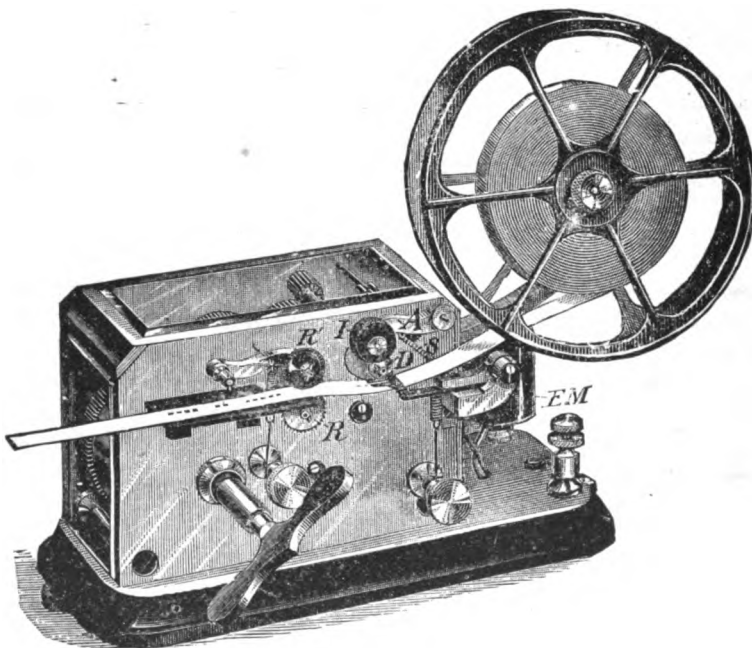

INK RECORDING MORSE REGISTER.

carries the roller. Thus the edge of the disc is kept wet with ink. The paper is pulled along by the rotation of rollers *R*, *R*¹; *R* being operated also by gearing within the box. The armature lever of the electro-magnet *EM* is extended to a point just under the disc *D*. This extension of the lever *EM* carries a flat sleeve, or guide, in the upper half of which a slot is cut. The paper is passed through the guide in the manner shown. Consequently, as the armature is operated, the paper is alternately lifted up against the disc and withdrawn from it, by which action a long or short mark is left on the paper according to the duration of the impact of the paper against the disc.

This ink recording instrument can be used in any place where the ordinary Morse register is applicable, the former having the advantage that the ink record is much more readily decipherable than the embossings of the Morse register.

(For a description of a self-starting and stopping Morse register, see District Telegraph Service).

AUTOMATIC PAPER WINDER.

This is a device, Fig. 53, used in connection with printing telegraph "tickers" or registers of any kind in which paper tape is employed. Its office is to wind up the paper as fast as it is delivered from the receiving instrument. The reel is turned by the clock spring *c*. The paper is held taut by the weight-roller *x*, as shown in the figure.

FIG. 53.

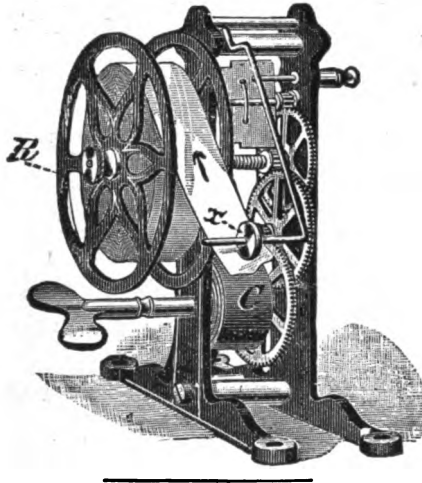

AUTOMATIC TELEGRAPH SENDER.

It is sometimes desirable to have a simple means whereby Morse signals may be automatically transmitted. This may be done by the Wheatstone transmitting apparatus, but that apparatus can hardly be classed as simple.

The principle of a device which has been availed of at intervals by different experimenters, probably first by Edison, is illustrated in Fig. 54. At the left of the figure the top of an ordinary Morse "register" with an extra attachment consisting of a delicately pivoted lever *L*, whose lower end rests easily on the paper *P*, are shown. The upper end of the lever carries a contact point and is close to a contact point *c*, which is part of a circuit, *x*, in which is included a sounder *s* and battery, *B*. The lever itself is also part of the circuit. The paper *P*, has previously been embossed by the stencil of a Morse register in the ordinary way. As the paper is drawn along by the rollers of the register, the embossings on its surface raise the lever *L*, and cause its

upper end to close the circuit at *c*, for a longer or shorter interval depending on whether the embossing is a dot or a dash. By a slight modification of the extra attachment the lever can be caused to *reverse* the polarity of the battery and thus be made to operate a "polarized" relay. As the motion of the lever *L* is necessarily limited a close adjustment is required at the contact points, but for moderate speed this is an easy matter.

FIG. 54.

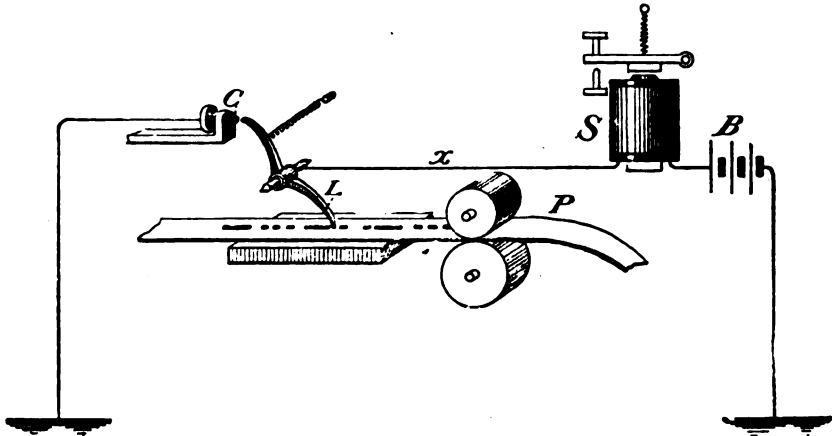

AUTOMATIC TELEGRAPH SENDER.

This apparatus has of late been much improved by Weiny and Phillips, and is now termed the Phillips-Morse automatic telegraph. In the new arrangement three rows of embossings are made on the transmitting paper to secure greater accuracy, at high speeds. The claim for this device is that messages may be prepared in advance by operators in case of wire trouble or of an abnormal increase of business, and be transmitted over the wires at a speed thrice that of the best speed by hand sending, or, say, 120 words per minute. Being embossed as received messages may be copied from the register by clerks, or sent through the automatic sender and received by a Morse operator at any desired speed, as the speed of the machine is variable at will.

TELEGRAPH TRANSMITTERS.

With the object of securing a simple and speedier method of transmitting the Morse alphabet than the manual key method, Morse devised several arrangements; one of the first of which is shown in Fig. 55. It consisted of a plate of metal *A* on which were several pieces of metal, the length, number and arrangement of which corresponded to the dots and dashes of the Morse alphabet. The spaces between the raised pieces of metal were filled with an insulating material, flush with the surface of the raised metal pieces to secure an even surface on the plate. The battery was connected to the plate by a binding post *c*, and a metal pointer *P*, having

an insulated handle, was connected with the line. Consequently, when the pointer touched any one of the raised pieces of metal the circuit was completed. The operator held this pointer in his hand and drew it over the surface of a desired character, closing and opening the circuit as he did so in a manner to correspond to that letter.

Another somewhat similar device, also by Morse, consisted of a metal cylinder on the surface of which the characters of the Morse alphabet were, in a practically similar

FIG. 55.

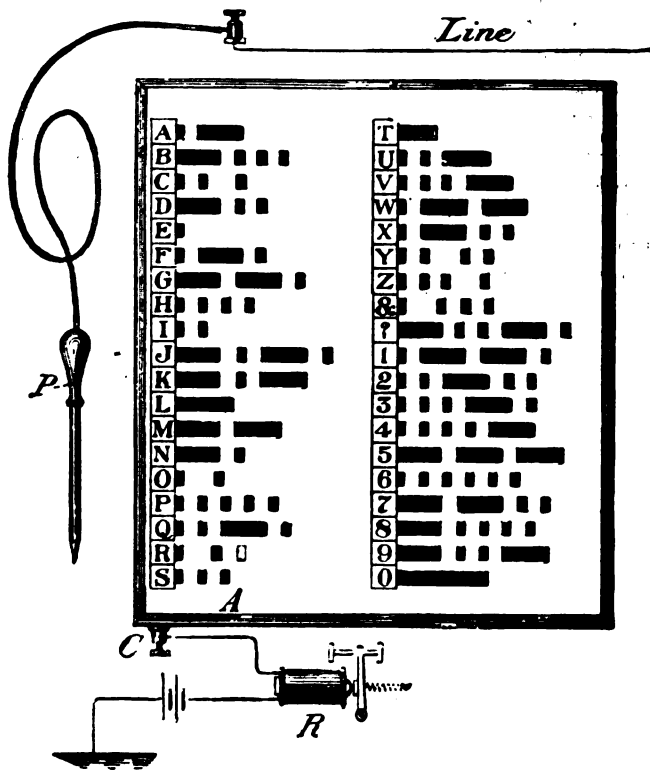

way, arranged. Above each of the characters representing a letter, a key, which could be readily depressed by the finger, was placed. This depression brought a metallic brush, connected to the under side of the key, into contact with the surface of the cylinder. The same act of depression of a key permitted the cylinder to make a partial revolution. The cylinder being connected to the battery, and the metal of the key to the line, the foregoing actions resulted in the transmission of Morse characters. These devices, however, did not get into extensive use, the reasons for which were stated to be that the signals were not transmitted uniformly by the pointer in the hands of the operator or by the depression of the key upon the insulated cylinder.

The complication of machinery, also, doubtless, had some bearing on the matter, as in those days the bulk of business was not great.

In explanation of the fact that these methods were not availed of to meet the

demands of increased business, later, it may be supposed that inasmuch as the average operator is able to "send" with an ordinary key, as fast as the average operator can receive, there was nothing to gain by increasing the speed of transmission.

THE TYPEWRITER IN TELEGRAPHY.—Within the past few years, however, the "typewriter" has been adopted by many telegraph operators as a means of recording received messages, and its use for this purpose is steadily increasing in this country. Indeed, the ability to manipulate the typewriter expertly is now virtually essential to employment as operator in the service of the various Press associations. Also, it may be added, in the Wheatstone automatic departments of the telegraph companies of this country the telegrams are in many cases "transprinted" from the "received" slip to the regular message blank, by means of a typewriter in the hands of the "copyist." It is very likely, also, that as soon as the means of adjusting the telegraph blanks to the typewriter has been simplified that instrument will be used generally in the large telegraph offices for recording despatches as they are received. An expert with the typewriter can write from 60 to 70 words per minute. It is therefore evident that there would be time and to spare for the insertion of "time received," the operator's "sign" etc., even when receiving at the rate of, say, 45 or 55 words per minute.

FIG. 56.

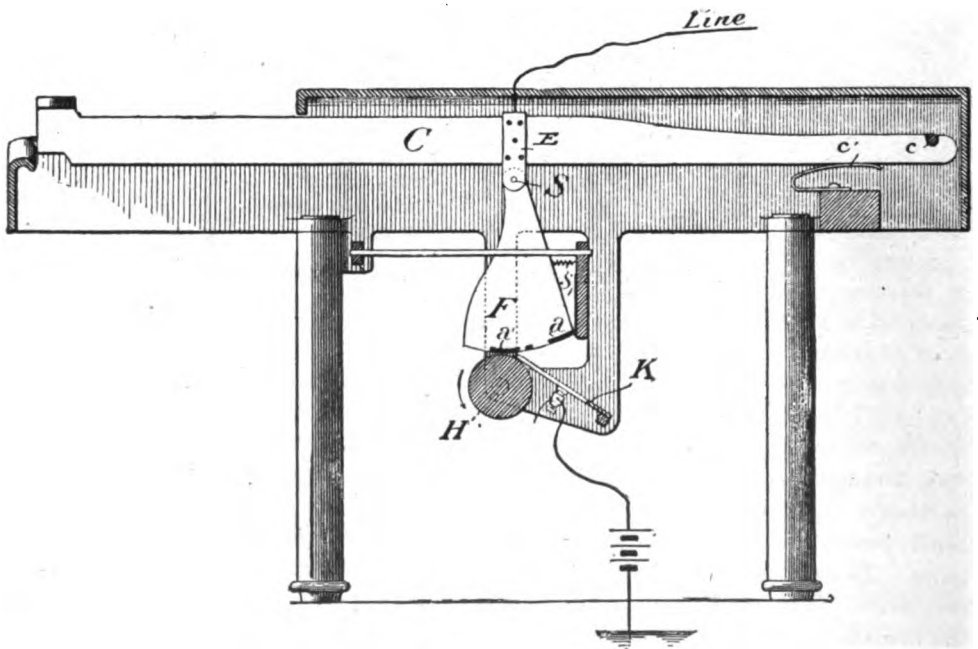

This use of the typewriter, with the accompanying gain of speed in transcription, has revived, in some quarters, the employment of means for increasing the speed of transmission of signals beyond that at which the ordinary operator can send, and this without resorting to the use of devices for especially preparing the despatch for

transmission. One of the devices having this object in view, namely, the La Dow Transmitter, will be described.

LA DOW TELEGRAPH TRANSMITTER.

The La Dow Transmitter, which aims to overcome defects of earlier transmitters, is shown in side view Fig. 56. It consists of a key-board arranged on the general plan of that of a typewriter. One key is shown at *c*. Each key is pivoted at the right hand end, as shown at *c*. It is held in its normal position by spring *c'*. Near the center of each key is attached a rudder-shaped, thin piece of metal *F*, having portions of its lower edge insulated, as shown by the thick lines. Each of these attached pieces of metal has a corresponding portion of its lower edge insulated, namely at *a'* in the figure. The rest of the edge is divided into sections corresponding to the

FIG. 57.

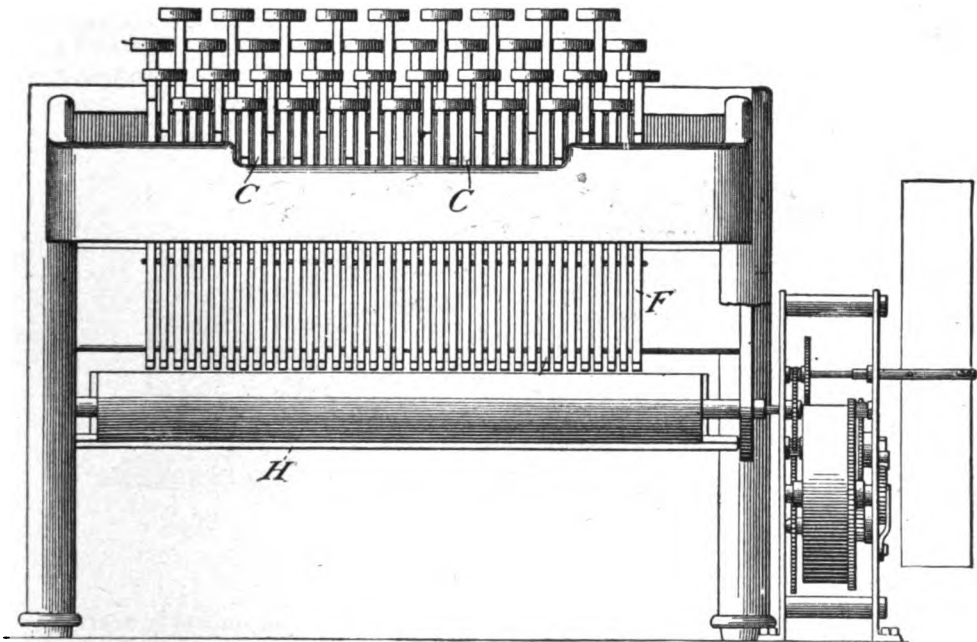

letters of the Morse alphabet. The insulated portion *a'* is directly over a metal cylinder *H* which extends under all of the keys, and which cylinder, when in use, is kept in constant rotation by a suitable spring or motor shown at the right of Fig. 57. A flat metal spring, or brush *K*, rests on the cylinder, and to this spring the battery is attached, the line being connected with all the keys at *E*, as shown. In Fig. 56 the key is assumed to be depressed. This places the insulated portion *a'* of *F*, on the cylinder, the result of which is that *F*, which is hinged at *s*, is carried to the left a certain distance, during which journey the metal portions of its lower edge, in turn, make contact with the cylinder, thereby completing the circuit for a period corres-

ponding to the lengths of the uninsulated portions. In the case of F it will be seen that the insulated portions, Fig. 56, are so arranged that the letter A will be transmitted. When the finger is removed from the key the spring *s*' immediately brings F back to its starting-point. In a similar way all the other keys will transmit signals according to the letter assigned to them. Suitable means are provided for holding the "rudders" in line. Although this arrangement is designed chiefly to increase the ordinary speed of transmission of signals, it is also intended for those who may have writers' cramp, or who may not be expert "senders." This transmitter is shown in front view in Fig. 57, in which F indicates the rudder-shaped pieces of metal. H is the cylinder.

THE YETMAN KEYBOARD TRANSMITTER.

This modification and improvement of the La Dow transmitter just described has been introduced into practice of recent years. By its use quite a high speed of transmission is obtained. The character of the signals is very good. As in the case

FIG. 57b.

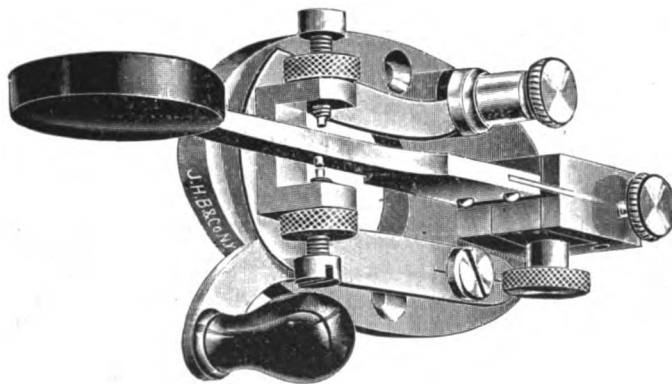

DOUBLE ACTION-KEY.

of the La Dow transmitter, the mechanism of the Yetman transmitter is so arranged that the depression of a key transmits the complete Morse letter. In the latest type of the Yetman keyboard transmitter it is combined with an ordinary typewriter so that the one keyboard serves as a typewriter and keyboard transmitter. This transmitter has been employed successfully on some of the longest circuits in this country, as, for instance, the New York-New Orleans duplex circuit.

DOUBLE-ACTION AND AUTO-TRANSMITTERS.

The desire to supply the demand for a type of key differing from the ordinary Morse key with its up-and-down motions, especially to enable operators afflicted with

loss of "grip" or loss of ability to transmit telegrams by the vertically operated key, as well as to afford operators generally an opportunity to vary the monotony of vertical sending, has led to the introduction of numerous laterally operated and automatic transmitting keys, two of which are shown below. Fig. 57*b* is known as the Bunnell double-speed key. At rest the lever is between two contacts. A movement of the lever to the right or left closes the circuit. It requires but one-half the motions of the ordinary key to form a character of the Morse letters, and these motions are made by a sidewise rocking motion of the hand, easily acquired. Keys combining a vertical and lateral motion of the key as desired have also been utilized. A key termed the "twentieth century" key employs this lateral motion. It is not a double-action key. Double-action keys have been tested a number of times within the past thirty years, but do not appear to have attained very extensive use.

In Fig. 57*c* is shown the "Vibroplex," a form of transmitter which exemplifies a number of more or less similar automatic transmitters, variously named the "auto-dot," the "mecograph," etc. The vibroplex consists of a pendulum arrangement *P* extending from one end of a key *K*. This key is pivoted at *N*. *c*, *c'* are contact posts. *L*, *L'* are the line posts. *L'*, *c'*, and *c* are insulated from the iron base of the key. *L* is in contact with the base and consequently is in contact also with the lever of the key *K*. Normally, spiral springs *R R* hold the lever *L* in a middle or

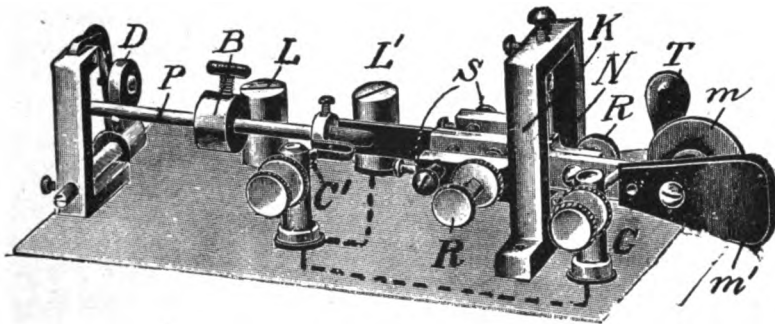
FIG. 57*c*.

VIBROPLEX TRANSMITTER.

"open" position between the stops *ss*. When key *K* is pushed to the left by means of knob *m* it closes the circuit at the dash contact *c*. When the key is pushed to the right by means of knob *m'*, the pendulum is set into vibration and the circuit is opened and closed rapidly at the dot contact post *c'*, contact with the lever of key *K* being made by a flexible U-shaped contact.

In the act of sending the operator moves the key lever to the left and holds it there for a time corresponding to a dash. To form dots the key is moved to the right and is held there while the pendulum automatically transmits one, two, three, four, five, or six dots, as the case may be. A braking device *D* dampens the vibration of the pendulum when a dash is being made. The circuit of the transmitter is

closed by means of a metal strip (corresponding to that of the Morse key), the knob *T* of which is seen in Fig. 57*c*. After a little practice the ability to rapidly transmit the characters of the Morse alphabet in this way is easily acquired. The speed of transmission is regulated by moving the bob *B* along the pendulum. It has been found that signals made by this transmitter carry over the longest circuits, and as the sending is done by an arm movement and the key is never grasped as in vertical sending the manual work of Morse signaling is much simplified to the operator.

Other transmitters of this general type employ a magnet controlling the pendulum, but while the operation of these transmitters is perhaps somewhat more accurate than that of the natural pendulum, the added cost of the magnet and of a local battery for its proper working appears to offset the advantage mentioned.

These automatic transmitters may readily be placed in a desired circuit by means of a flat metal plug which is inserted between the contact points of the ordinary Morse key. Flexible insulated wires connect the plug with the binding posts of the transmitter.

In order that the noise incidental to the operation of the typewriter should not interfere with the reception of the Morse signals by sound, an arrangement, illustrated in Fig. 57*d*, has been devised, whereby the signals emanating from the sounder are much amplified, and by which the sounder may be placed in any position:

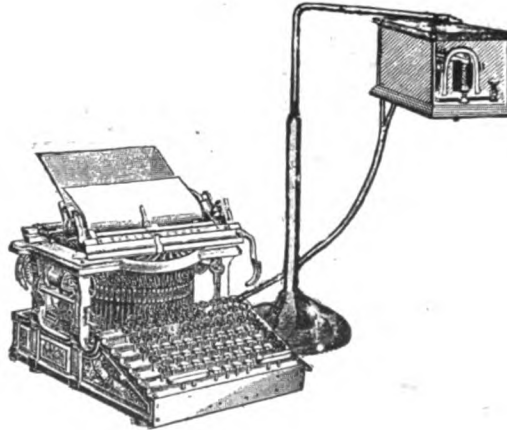
FIG. 57*d*.

SOUNDER RESONATOR.

desired by the operator. The device consists of a resonating box, suspended by an adjustable support, and within which the sounder is placed. The local circuit is conducted to the sounder by flexible wires shown. This arrangement, it is obvious, may also

be utilized to advantage in railway station offices, and in other places where confusing noises prevail. Another advantage gained by the adjustable feature of the support, apart from its use in overcoming the noise of the type-writer, is that the sounder may be placed so close to the ear that only the operator can hear the signals; the sounder itself being adjusted down accordingly. By this means complete secrecy is obtainable, when desired.

In connection with this subject, it may be noted that it has been customary for the attendants of quadruplex and duplex circuits, where the apparatus is "bunched" on one corner of a table, etc., (in consequence of which it is next to impossible to distinguish between the different signals, in the ordinary way), to employ a rod of wood of sufficient length to reach from the instruments on the table to the ear of the attendant, for the purpose of separating the signals. By placing one end of this rod on the base of the proper instrument, and the other end to the ear, the signals from that instrument can be heard with ease, regardless of the conflicting noises.

SWITCH BOARDS.

MAIN OFFICE SWITCH BOARD.

This useful piece of telegraph apparatus is shown diagrammatically in Fig. 58. It consists of a large board, or series of boards, of any desired size, on the face of which are arranged, vertically, narrow strips of brass, termed straps. On the back of the board are other strips of brass or copper running at right angles to the vertical straps. Metal discs connected with the horizontal strips at the back of the board, pass, through holes in the board, to the front of the board, flush with the surface of the straps. The discs on their sides nearest the straps, have semi-circular notches cut in them. Similar notches are cut in the straps immediately opposite those in the discs. "Pin" plugs, like that shown in Fig. 59, with a cone-shaped metal piece *n* and an insulated handle *r*, are made to fit in the hole formed by the two semi-circles, thus metallically connecting the strap and back strip together, for a purpose which will be stated presently.

A series of peculiarly shaped flat metal springs, termed "spring-jacks," are placed at the foot of the board, one spring-jack under each strap. In some cases two series of such spring-jacks are placed under the board, two jacks under each vertical strap. A board thus equipped is termed a "double spring-jack switch board with

straps." The number of straps gives a designating name to the board, as for instance, "a 40-strap-double-spring-jack-board."

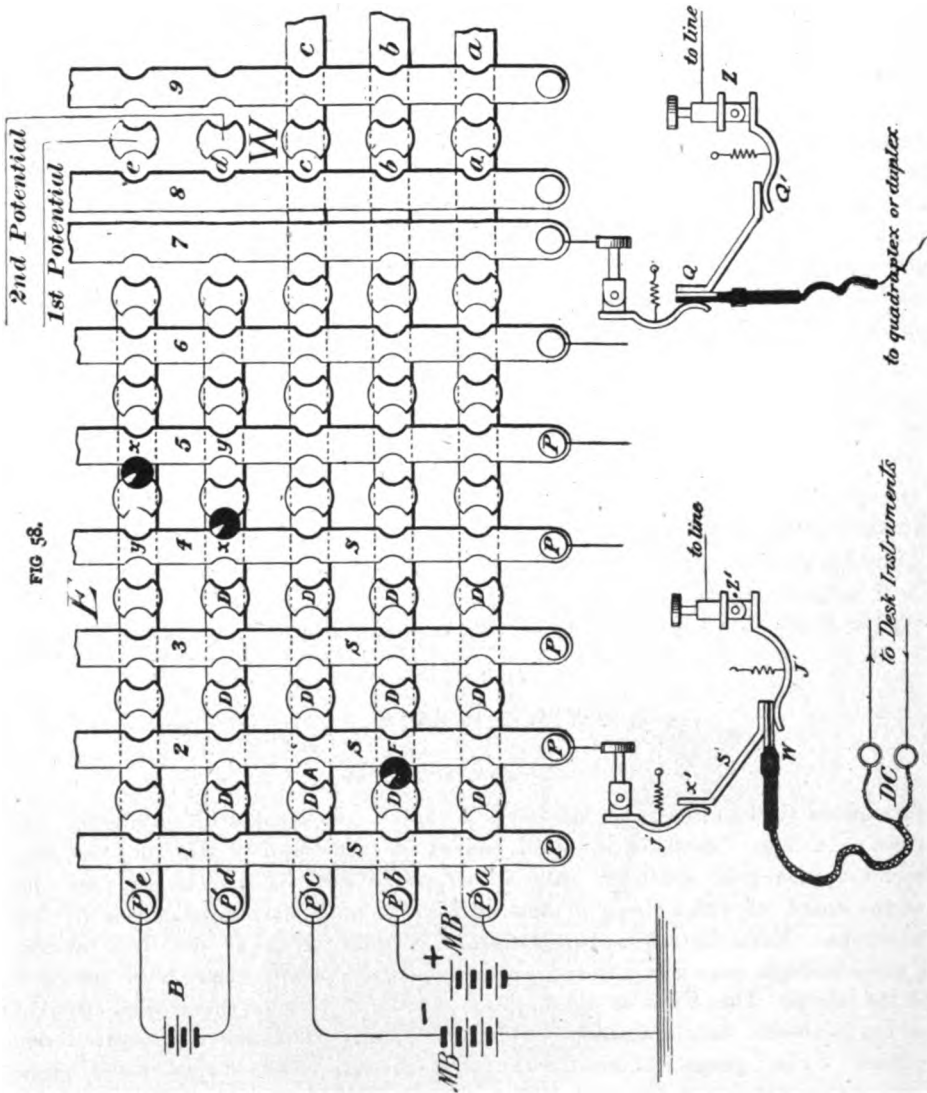

A series of such spring-jacks arranged on a separate board is shown in Fig. 60. In that figure a spring-jack "wedge" is shown in position. The wedge is usually formed of two flat, metal strips, insulated by a hard rubber strip from each other. The upper strip is shown at B; the under strip is directly beneath B. Two insulated, flexible conductors within one cover, C, are joined separately, by suitable means, each to one of the metal strips on the wedge. To take off some of the strain from the

flexible conductors a piece of stiff rubber tubing *R*, is placed over portions of the insulated handle *I* of the wedge and the conductor. The wedge proper is about 4 inches long, $\frac{1}{2}$ inch wide and $\frac{3}{8}$ inch thick.

Referring again to Fig. 58, *s, s, etc.*, represent the vertical brass straps. The dotted lines represent the horizontal strips behind the board, and which are metallica-ly connected with the discs *D*. Pin plugs are shown inserted at *F* and *x*.

FIG 59.



PIN PLUG.

J is a spring-jack, connected by "office" wire, (that is, a pliable, insulated wire) at *P*, to the strap *z*. *J*¹ is also a spring-jack. The jack is hinged as shown, and is capable of being moved, as at *w*, to permit the insertion of one or more wedges. At the end of the "double conductor" cord, remote from the wedge, the terminals are generally run into separate double connecting binding posts, as at *DC*, below the switch-board, and are thus connected to wires leading to any desired desk instrument in the operating room.

FIG 60.

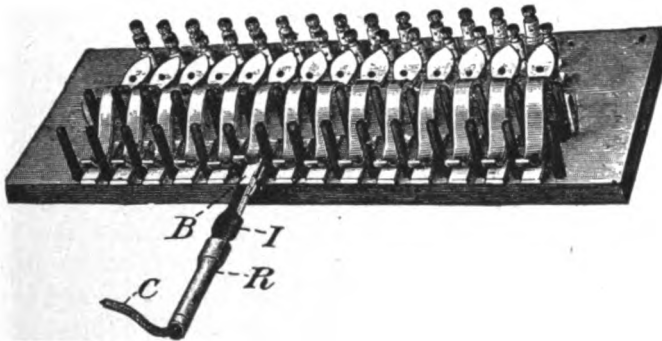

SINGLE SPRING JACK BOARD.

The double spring-jack arrangement allows of the insertion of additional sets of instruments into the circuit when desired. For instance, another wedge could readily be inserted at *x*¹; the space between the two jacks *J* and *J*¹ being, in practice, much wider than would appear in the figure. Other instances of the utility of the spring-jack and wedge will be found in connection with the "Davis" loop switch. Main batteries *MB, MB*¹ are connected to binding posts *P P*¹ attached to horizontal strips, as shown. Line wires are connected to binding posts *z* at the lower end of each spring-jack. It will be remembered that each vertical strip is equipped with a single or double spring-jack, as the case may be. For simplicity but two straps are shown thus equipped in Fig. 58.

By means of this switch-board and its attachments, the chief operator, that is, the attendant in charge, is enabled to make, with ease, rapid changes in the disposition of wires, desks and batteries.

In the figure the "positive," or "copper" battery is connected by a plug at *D F*, via strip *b* and disc *D*, to strap *z*, thus supplying electromotive force of positive polarity to the line wire at binding post *z*¹, via the spring-jack *J*, through one side of wedge *w*, to the desk relay, back to other side of wedge to spring *J*¹. In a similar way any other line wire may be connected with battery *M B*¹, by the insertion of a plug at the proper place.*

Should it be desired to put the "zinc," or "negative" battery to a line wire it is done by inserting a plug so as to connect any desired strap with a disc attached to the horizontal strip *c*. Thus if it should be required to put "zinc" instead of "copper" to the line wire now connected with spring-jack *J*¹, it would only be necessary to remove the plug from *D F* and insert it in the next aperture above, namely, *A*.

As each wire entering the office is attached to the binding post of some one strap, it is plain that by the removal of a wedge from one spring-jack to another any instrument on any desk may be speedily put into the circuit of any desired wire, since, as already said, each desk instrument is "connected up" with a wedge at the switch board.

For large offices these switch-boards are made in sections of 40 to 50 straps and 15 to 30 horizontal rows of strips and discs. In some cases also the straps are connected by office wire from screw post *r* to post *z* and the line wire is then connected to the post at the back of spring-jack *J*; but this does not appear to serve any useful purpose and is wasteful of "office" wire.

The battery, or *E. M. F.* for the operation of duplex and quadruplex circuits is brought directly to the operating room table or desk and is not "plugged" on at the switch. This being the case, "quadruplex" switch cords require but one conductor and one strip of metal on the wedge. An instance of that arrangement is shown at *Q*, Fig. 58, where, it may be seen, the circuit from the duplex or quadruplex set passes through the cord and thence to the spring-jack and line wire. By thus insulating one side of the wedge it leaves the strap *7* free to be used for other purposes without interfering in any way with the quadruplex circuit. To permit such use more effectually the quadruplex wedge in *Q* might be inserted at *Q*¹.

It is sometimes desirable to be able to insert an "intermediate" battery in a circuit which, as in the case of a "through" wire, does not terminate at the switch board. The intermediate battery *B*, attached to the horizontal straps *e d*, as shown, is placed in the circuit of the two wires desired, in this instance the wires attached to straps *4* and *5*, by the insertion of the plugs at *x, x*. Should it prove that this arrangement of the plugs does not cause the battery *B* to coincide in polarity with the batteries at the other end of the circuit, the battery *B* may be "reversed" by removing the plugs from *x x* to *y y*.

In some large offices as many as 5, 6 or more 50 strap sections are in use, placed side by side or in different parts of the room as required.

When placed side by side it is easy to connect together two remote circuits on

* Where dynamos are used the wires from the machines are brought to certain discs on the switch-board, as indicated at *e, d*, Fig. 58. These discs are not connected together by the horizontal strips behind the board. This is to allow of the insertion of the lamps, or other resistance, in each circuit, shown in Figs. 24, 26. Three or four horizontal rows of such discs are thus set apart. The top row is usually allotted to the first potential; the second and third rows to the second potential, on account of the greater number of circuits fed from that potential. The fourth and fifth potentials, being mostly employed on long quadruplex circuits, are not, as a rule, brought to the switch-board, but to the desks direct, as in the case of gravity battery. Otherwise the arrangements on the switch-board are not practically changed.

the switch board by joining the proper horizontal strips of the different sections, either by a suitably arranged plug or by a piece of wire. Thus, in Fig. 58, assuming the straps 1 to 7 to belong to one section E, and straps 8, 9 to an adjoining section W, the two horizontal strips, *cc* and *bb* are shown joined to carry battery to the adjoining sections. The lowest horizontal strip is the "ground" strip, by means of which, and a pin plug, any of the wires may be grounded without battery. This strip is also connected *through* to both sections E W.

WAY OFFICE SWITCH BOARD.

A form of switch much used in "way" offices, as distinguished from terminal or main offices, is shown in Fig. 61. The wires are, as a rule, led into the switch at the upper binding posts and into the instruments on the right hand side of the board. By means of pin plugs the desk instruments may be placed in the line or not, as

FIG. 61

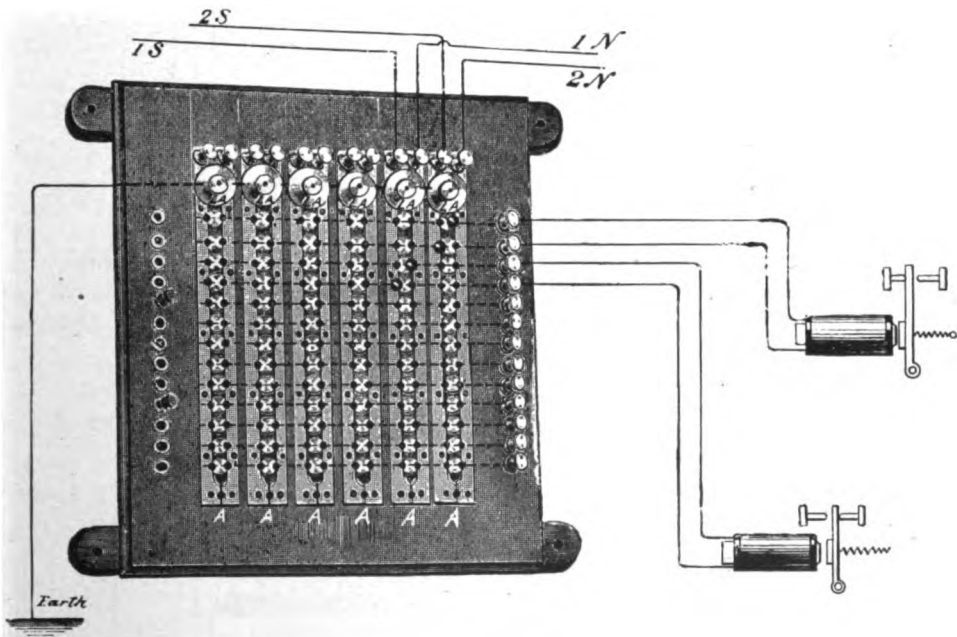

WAY OFFICE SWITCH.

desired, or the line may be caused to pass through the switch only, by inserting a pin in the corresponding aperture, A, between the two vertical bars at the lower end of the board. The vertical row of binding posts on the right are connected behind the board to the notched discs, as shown by the dotted lines.

Many different combinations will suggest themselves in connection with this switch; for instance, if, as is often the case, it is desirable to have a way office "cut" in on any one of the wires passing through the switch-board it may be quick-

FIG. 62.

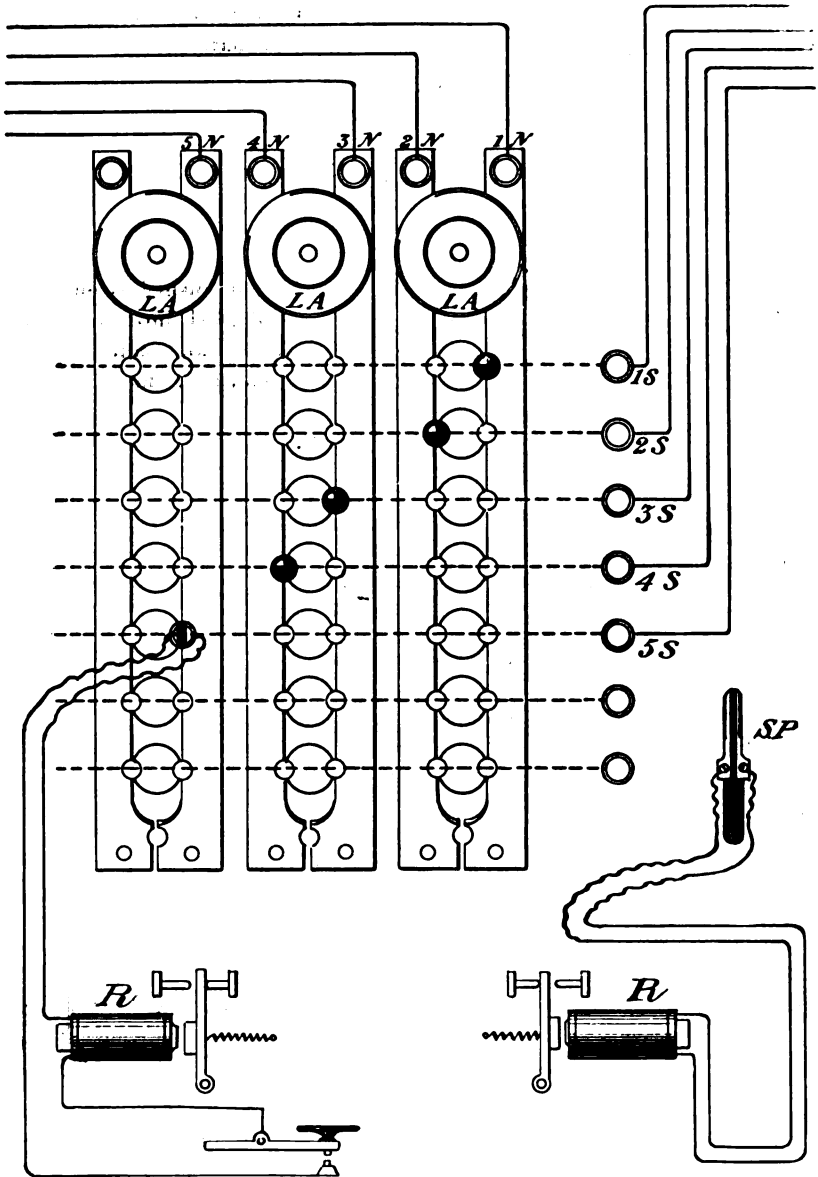

WAY OFFICE SWITCH.

ly done, if the line wires are arranged as in FIG. 62.

By the use of "split" plugs SP, the "testing" instrument, or any of the instru-

ments connected with one of the plugs, may be readily cut in on any of the wires. One such plug is shown "cut in" on wire 5, thereby inserting "test" instrument *x* in the circuit.

A split plug *sp*, is shown as attached to the relay at right of Fig. 62, and separately in Fig. 63. In the latter figure *c c*¹ are the insulated wires passing into the insulated handle *i* and which are connected to the brass segments *B B*¹, which latter are insulated from each other by the insulating material *i*'. Of course, care must be taken to turn the split plug in the aperture of the switch so that it will not "short circuit" the relay out of the main line circuit, as would result if one half of the plug touches both the strip and disc.

FIG. 63.

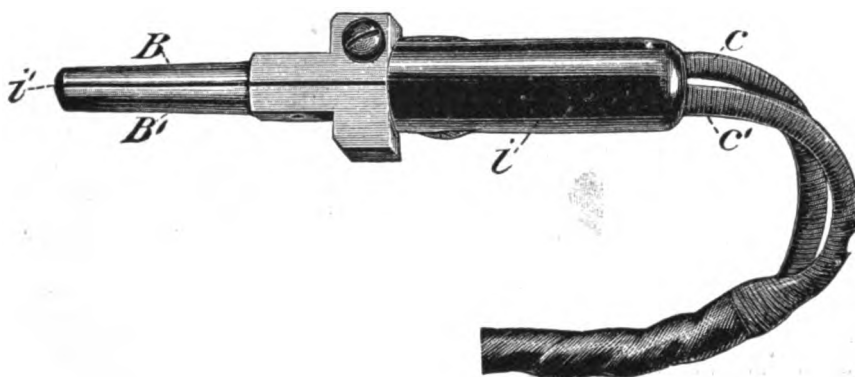

ROUND SPLIT PLUG.

Lightning arresters *L A*, Figs. 61 and 62, consisting of flat, metal discs, which are connected by a strip behind the board with the ground, are placed in close proximity to the upright straps. [See "Lightning Arresters"]

WAY OFFICE CUT OUT.

A common form of cut-out switch for one-wire way offices is shown in Fig. 64.

FIG. 64.

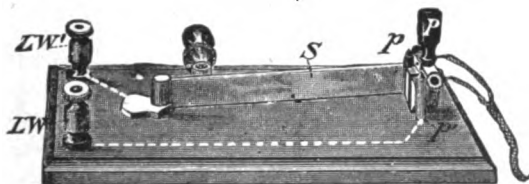

WAY OFFICE CUT-OUT.

It consists of a metal strap *s*, placed on a small base board. On one end of the strap a short pin *p* is attached. A similar pin *p*¹ is set in the base board. At rest, the tension given to the strap brings *p* snugly against *p*¹. The split plug

P, shown separately in Fig. 65, is grooved on its sides to fit the pins p p^1 , and it is capable of being pushed down between the latter. The office instrument is connected by suitable wires with the respective sides of the split plug; one half of the plug being insulated from the other half.

FIG. 65.

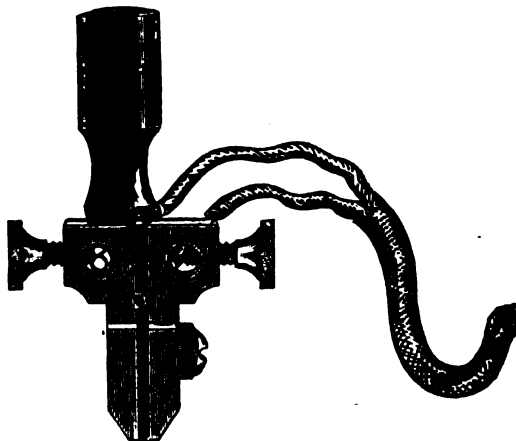

SQUARE SPLIT PLUG.

The line wire is brought to two binding posts LW LW¹, on the base board. LW¹ is connected under the base to the strap s. LW to the pin p^1 . Thus when the plug is inserted between the pins, the office instrument, or relay, is put in the line wire circuit. When the plug is withdrawn the relay is cut out and the line wire is closed automatically by the contact of the pins.

LIGHTNING ARRESTERS.

Many of the so-called lightning arresters in use on telegraph circuits might, perhaps, more correctly be termed lightning "deviators," since the object of their use is not so much to arrest the lightning as to cause it to deviate from the path leading to earth through the instruments to another path leading to the earth directly.

Such lightning "arresters" are those which are placed near to, but not in direct contact with the telegraph wire to be protected. They frequently consist of a strip of brass, Fig. 66, connected by a wire directly to the earth e . Right above, or beside this strip, but not touching it, is placed another strip of brass forming a part of the line circuit. The strips are separated by a small air space having high resistance. The intention is that when the line is highly charged by lightning the electricity will

jump over this short air space of high resistance in preference to following the, electrically, shorter route to earth through the instruments. And, taking advantage of the tendency of electricity to jump from sharp points, the side of the strip connected with the line is made with a serrated edge to facilitate the desired action.

FIG. 66.

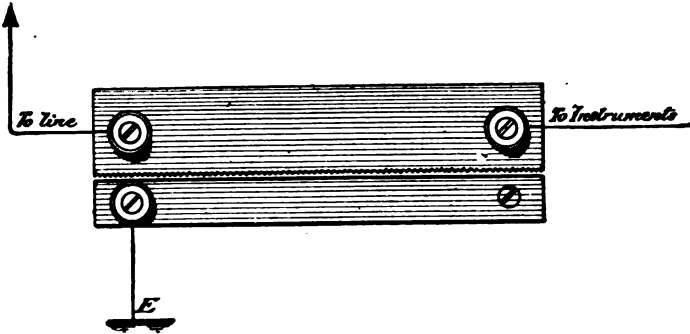

In other forms of lightning "arresters," the line strips, as indicated in Fig. 67, are placed upon a "ground" strip with only thin layers of paraffin paper intervening. In this form the lightning discharge, in passing to the earth, ruptures the paraffin paper. The manner in which the plates are separated by this paper is shown more clearly by the black line between plates P and E, in Fig. 70.

FIG. 67.

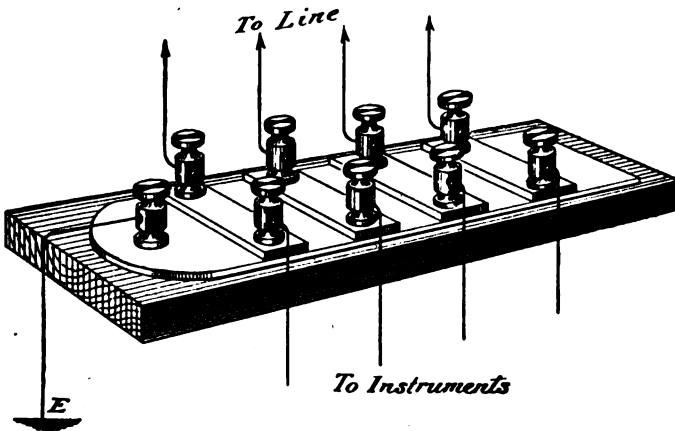

In many way-office and other switches, a disc form of "arrester" is used, one disc, connected to the earth, being placed over two strips. The discs D D, Fig. 68, are screwed on to the ground strip P (which runs horizontally the length of the switch-board, on the back of it) but do not touch the line strips s, s etc. on the front of the board. Fig. 68 represents a front view of the apparatus; a side view, or cross section of the same may be seen in Fig. 69.

In the latter figure the separation of the discs *D* from the strips *s s* is plainly shown.

COMBINATION PLATE AND "SPIDER" ARRESTER.—Another form of lightning arrester consists of a fine wire of some alloy, such as German silver, inserted in the line wire at the switch. This is generally placed as an auxiliary to the forms of "arresters" previously described. This wire has a high resistance as compared with the rest of the circuit and is either disrupted or fused by the passage of an unusually strong current of electricity. When this happens the "lightning" may fairly be said to be "arrested."

FIG. 68.

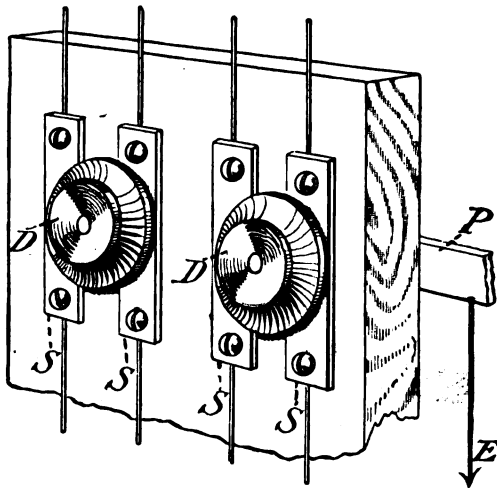

ARRESTER ON SWITCH-BOARD.

This combination arrangement of fuse and ground plate, shown in Fig. 70, or modifications of it, is now almost invariably used in "cable boxes" and "cable houses," and on the cupolas of telegraph offices, and it is being extensively introduced on switch-boards. The wire used has a diameter of about 5 to 7 mils, equal

FIG. 69.

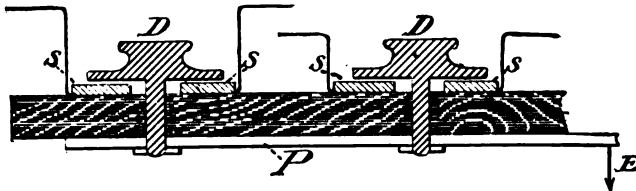

to No. 32 or No. 36 B. y. G. A mil is the one thousandth of an inch. The binding screws *B s*, to which the fine wire is attached, are specially constructed to hold the wire without injury. These screws have double connections, one for the line wire

proper at x , on the main body of the binding post, and the other, on the top, consisting of a set screw arrangement for the fine wire. Some care is necessary in connecting up the German silver wire. The connection may be facilitated by giving the wire a few spiral turns around a small roll of card paper, which will give the wire a slight tension, and, at the same time, provide a small surplus upon which to draw in tightening the set screws. The tension is useful in that it may assist in the disruption or separation of the wire under a strong current. This wire is known as the "spider" wire. It would now be used, even if not effective as a lightning arrester, as a *fuse* wire, to protect the office apparatus in the event of a cross with an electric light circuit.

The arrangement in Fig. 70 dispenses with the employment of one row of binding screws, three rows having been employed formerly. It will be under-

FIG 70.

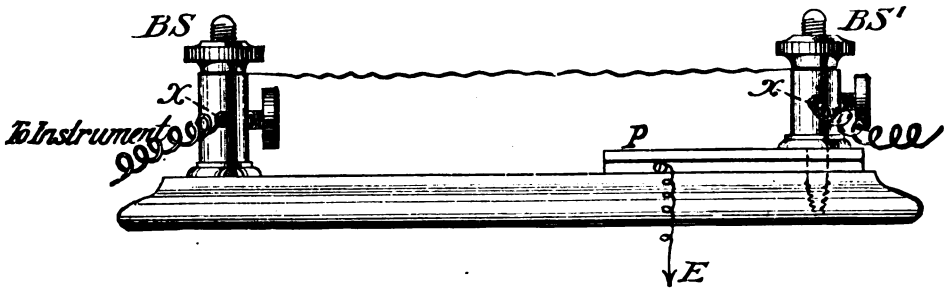

stood that the wood-screw of $B s^1$ is not connected with anything but the wooden base. The ground plate E and the brass plate P correspond to those shown in top view, Fig. 67, the brass plates P being separated from the ground plate E by paraffin paper.

MAGNETIC LIGHTNING ARRESTER.—Still another form of lightning arrester in use in the telegraph service of this country, and one which is used also as a protection against electric light or other strong currents, is shown in Fig. 71. It is a

FIG 71.

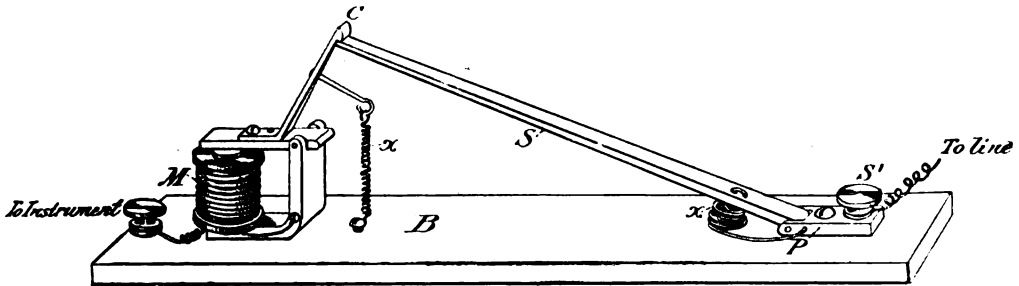

"magnetic" lightning or current arrester. The line wire is connected at screw post s^1 , with the apparatus, which is mounted on a narrow base board B . The screw

rests on a brass strip attached to the base board. A strip of brass *s*, hinged at *P*, extends to the catch *c* which is rigidly attached, as shown, to the armature of the electro-magnet *m*. There are but a few turns of wire on the electro-magnet. The strip *s* is given a constant tendency to spring away from *c* by the spiral spring at *x*. The spring *x* normally holds the catch on strip *s*. Ordinarily, the line circuit includes the strips *P*, *s*, the catch *c*, the armature and the coil of the electro-magnet. The adjustment of the retractile spring *x* is such that the armature is not attracted until an unusually strong current passes in the electro-magnet, when the latter attracts its armature. This act releases the strip *s* which springs away, opening the circuit at *c*, thereby, if the action has been prompt enough, preventing injury to the office instruments.

Objection is sometimes urged against this class of arrester on the ground that it is prone to open the circuit on slight cause, and does not always do so when it would be beneficial, which state of affairs is doubtless due to improper adjustment of the apparatus. It is also claimed that it is inoperative in the presence of accidental contact of an alternating current circuit since the rapidity of the alternations prevents the magnet from acting upon its armature.

ELECTRO-THERMIC ARRESTER.—An arrester shown in Fig. 72 has recently been devised to respond to either continuous or alternating currents. It operates in conformity with the laws that, when a powerful current, continuous or alternating, flows in a wire of high resistance its temperature rises and the wire expands.

FIG. 72.

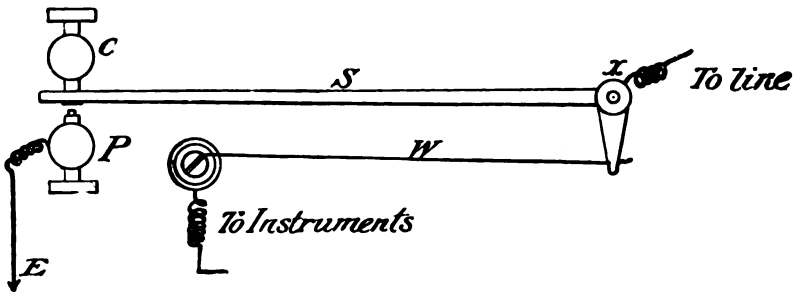

In the figure, *w* is a short wire of high resistance always in the circuit. *s* is a bent lever hinged at *x*, and normally held against the up-stop *c*, a short distance from *P*, by the tension of the wire *w*. When, however, the wire *w* is heated by a strong current it expands and permits the lever *s* to drop on the contact *P*, which is connected with the earth, thereby diverting the current from the apparatus to be protected.

THE ARGUS LIGHTNING ARRESTER.—This arrester, which is now largely used by the Western Union Telegraph Co., is shown in Fig. 73*a*. It embodies some features which have been found of advantage. It has but few metal parts, and these are mounted on a porcelain base, *B*. It employs a small coil of bare copper wire *w* wound in a spiral groove on a porcelain cylinder. A ground plate *G* is placed over the coil as indicated. This coil, as well as a fuse wire *F* *w*, is interposed between

the aerial line L and a cable or the office instruments A. The ground plate is adjusted over the coil so that the end nearest the line is about an eighth of an inch from the bare wire, while its other end is about the thirty-second of an inch from the wire. This is done for the purpose of distributing the lightning discharges over the whole of the coil, whereby no damage results to any one part of the plate or coil.

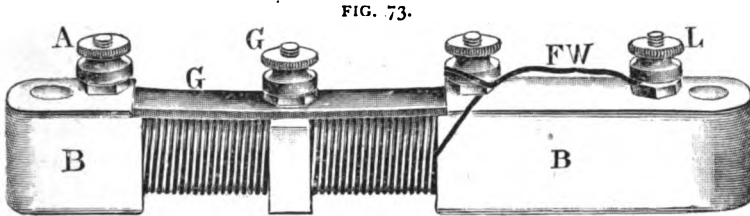

By this arrangement the line is freed of the lightning charge without interruption to the service, and without the necessity of frequent attention to the arrester. The fuse wire is mainly employed to prevent damage to the apparatus or cables, in case of contact with an electric light or power wire. The current-carrying capacity of the fuse wire is about 4 or 5 amperes; above that it fuses.

CARBON-BLOCK FUSE LIGHTNING ARRESTER.—In Fig. 73a is shown a form of arrester that has been used a good deal in telegraph and telephone practice. In the figure, F is a small fuse wire carried on a thin strip of mica m, tipped with metal at each end, and held by metal clips as shown. c represents two small carbon blocks separated by a thin sheet of mica. These blocks are held in position by the metal springs shown. The left-hand block is connected to ground at G; the right-hand block is connected to the wire or apparatus at A. A wire from A leads to apparatus.

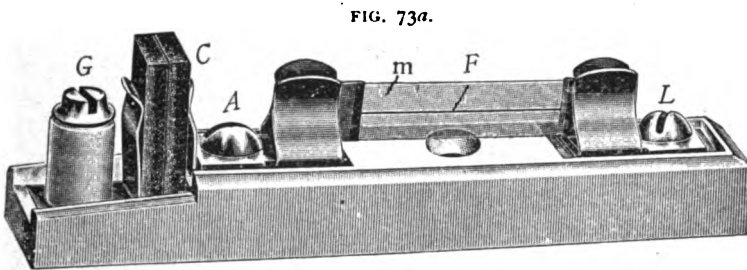

The line wire is connected to L. Thus a heavy current coming from the line wire will fuse F, and a lightning discharge will jump to ground by way of the carbon blocks. When the fuse is blown the mica strip is removed from the springs and a new strip is inserted. The effect of a lightning discharge through the carbon blocks is to create some carbon dust, to remove which the carbons are taken out of their springs and the dust brushed off, when the carbons are again ready for service. The carrying capacity of the fuse wire may also be about 4 or 5 amperes.

CHAPTER VI.

THE CONDENSER—STATIC CHARGE—DISTRIBUTION OF, ETC.—INDUCTION, MUTUAL, SELF, ETC.—THE RHEOSTAT.

THE CONDENSER.

Theory.—When by any means an insulated conductor is charged with electricity, whether by friction or by the application of a battery or other source of electricity, it is found that it will excite or, as it is said, “induce,” in any neighboring conductor a charge of electricity. It is further found that if the electricity in the first body be “positive,” that induced in the neighboring body will be “negative.” For example. In Fig. 74, if the insulated metal plate *A* be charged by the positive pole of battery *b* it will induce in the adjoining plate *B* a charge of negative polarity.

Such an arrangement of plates is termed a “condenser,” and one of the most useful and indispensable instruments employed in multiplex, printing, and automatic telegraphy, and in electrical testing, is based on the foregoing fact.

If the battery *b*, Fig. 74, be removed and the wire connecting it with *A* be in-

FIG. 74.

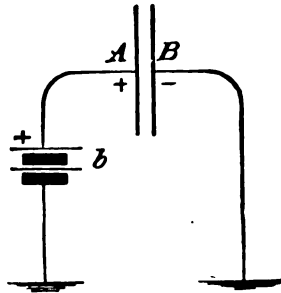

insulated, the plates will retain the charge for a certain time, depending on the degree of insulation of the plates. If that were perfect the charge would be held indefinitely. In practice this degree of insulation is not procurable, so that, even as regards the best of condensers, the charge is gradually dissipated. If, on the other hand, the battery be removed from plate *A*, and the two plates be at once joined by a wire, a momentary current will pass in that wire and it will then be found that both plates, by that act, have been discharged of their electricity.

The electricity induced and held in the plates of the condenser in the manner stated is termed “static” electricity.

The quantity of electricity thus accumulated in, or at the plates, is proportional to the electromotive force of the charging battery and to the "capacity" of the condenser.

The "capacity" of a condenser is its ability to contain, or accumulate a certain amount of electricity under a given electric pressure. The capacity may be likened, for example, to that of a gas meter which, under a certain pressure, will contain a certain number of cubic feet of gas. At such a time we may speak of the meter as being filled with gas while yet it may be capable of containing much more gas under a higher pressure; gas being a compressible fluid. Thus, we may say, in the case of such a meter, the space enclosed by which is, say, 1 cubic foot, that under a pressure of 1 lb. it will hold a cubic foot of gas. Obviously, a meter enclosing 2 cubic feet of space will contain double the amount of gas, at the same pressure.

Gas is measured, as to quantity, in terms of cubic feet. Water in terms of the gallon, etc. Analogously, electricity is measured, as to quantity, in terms of the *coulomb*; a coulomb being that quantity which will flow past a given point in a circuit in 1 second, when the current strength is 1 ampere. When an electrical condenser, under a pressure of 1 volt, holds, or accumulates, 1 coulomb of electricity, it is said to have a "capacity" of 1 farad; farad being the unit of electric capacity.

The capacity of a condenser varies with the distance between its opposite plates;

FIG. 75.

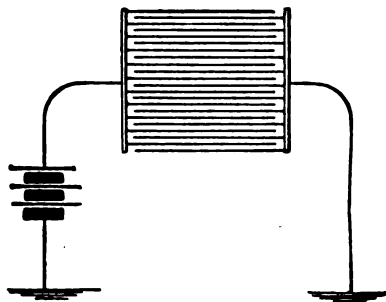

being greater the nearer they are together. It increases, other things being equal, as the size of the plates is increased. The capacity is also found to vary with the insulating material, or dielectric, employed between the plates; being greater, for instance, if the space be occupied by glass, india-rubber or gutta-percha, than if occupied by dry air.

This property of insulators, or dielectrics, which permits this so-called inductive influence to take place through them, or by which the inductive influence is effected, is termed "inductive capacity." The property which this inductive capacity of a dielectric imparts to conductors is termed "electro-static capacity."

The inductive capacity of air is taken as the standard by which that capacity in other dielectrics is compared.

Air being 1, the "specific inductive capacity" of paraffin is found to be about

2; india-rubber 2.5; glass 3.25. etc.

The electrical condenser, as employed in telegraphy, is generally constructed of thin sheets of tin-foil which are separated from each other by an insulating material such as paraffin paper or mica.

In order to secure a large area of conducting surface, thereby to increase the capacity, the alternate tin-foil plates are connected as outlined in Fig. 75, the plates of the respective series being connected. In that figure the horizontal lines represent the alternate sheets of tin-foil; the blank spaces, the insulating material.

The practical unit of electro static capacity is the microfarad (the one-millionth part of a farad.) The electro-static capacity of 3 miles of Atlantic cable is about 1 microfarad. The electro static capacity of an ordinary overhead wire is about three one hundredths of a microfarad, per mile.

FIG. 76.

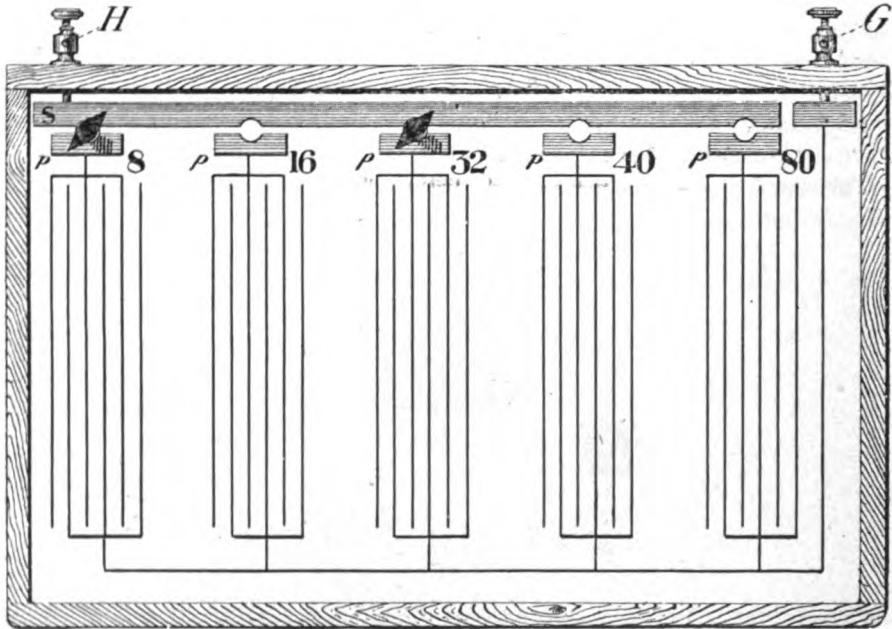

THEORY OF ADJUSTABLE CONDENSER.

In practice it is frequently necessary to be able to vary the capacity of a condenser. To permit this, "adjustable" condensers are so constructed that, by the insertion or removal of metallic plugs, more or less plates of tin-foil are brought into or cut out of service.

Fig. 76 indicates the manner in which this variation of the capacity of a condenser may be accomplished. A desired number of the sheets of one series of plates is connected in groups and each group is then connected, separately, to brass pieces *p*, as at 8, 16, 32, 40, 80, in the figure. A strip of brass *s*, provided with niches for metallic "pin" plugs, faces the pieces *p*. By the insertion of pin-plugs any one or all

of the groups can be connected with the brass strip *s*. In the figure, groups 8 and 32 are thus connected, the other groups being left inoperative. All the "ground" plates are joined together and brought to the screw-post *g*, but only so many of them as may be opposite the groups joined to the strip *s* will be "active." The external connections of the condenser are made at the screw posts *h* and *g*.

STANDARD AND COMMERCIAL CONDENSERS.—The form of "standard" condenser usually employed in testing is represented in Fig. 77. The capacity of such condensers is generally $\frac{1}{2}$ or $\frac{1}{4}$ microfarad.

FIG. 77.

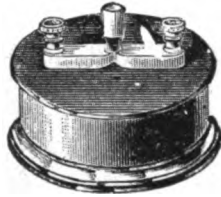

STANDARD CONDENSER.

The ordinary condenser used in telegraphy is illustrated in Fig. 78. The capacity of these condensers is generally stamped on their ends—it ranges from $\frac{1}{2}$ to 10 or more microfarads.

FIG. 78.

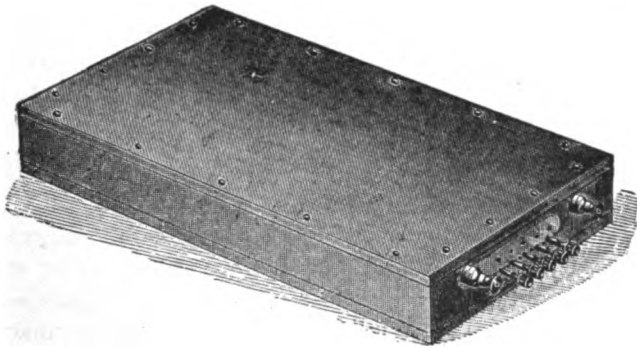

ADJUSTABLE CONDENSER.

Fig 79 is a form frequently employed in the Wheatstone automatic duplex system. A modification of this form also is shown, theoretically, in chapter on the Wheatstone automatic telegraph system.

Ordinary condensers such as are used in duplex and quadruplex telegraphy are required to have an insulation resistance of about 40 megohms, per microfarad, after one minute of "charging," or electrification. (See Chapter XXXI, and also remarks at end of this section.) For example, a condenser of 5 microfarads capacity, having a total insulation resistance of 8 megohms, will meet the require-

ments of 40 megohms, per microfarad. Condensers may be tested for capacity by the method described in connection with Capacity tests.

When a number of condensers are joined, in the manner, for instance, in which the plates 8 and 32 are connected in Fig. 76, they are said to be connected in multiple, and, thus connected, each set of plates adds to the total capacity proportionally to its capacity. In other words, each condenser adds to the total capacity virtually as each conductor connected with others in multiple adds to the total conductance of the circuit; hence the joint capacity of condensers in multiple is equal to the sum of the respective capacities of the condensers.

FIG. 79.

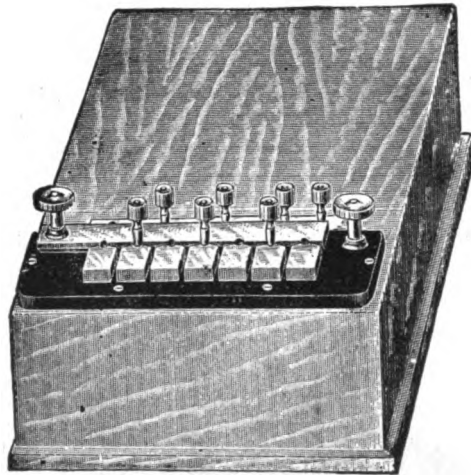

WHEATSTONE CONDENSER.

When condensers, as for example, c_1, c_2, c_3 , are connected as in Fig. 80, in which the inner terminal of one condenser is joined to the outer terminal of the other, throughout, they are said to be connected in series, or "cascade."

In telegraphy it is rarely necessary to connect condensers in series. In testing it is sometimes done to secure a greater variation of "capacities." The rule for finding the total capacity of condensers, in series, is similar to that for finding the joint resistance of conductors in multiple, namely.—

The total, or resulting capacity of condensers in series is equal to the reciprocal of the sum of the reciprocals of the respective capacities of the condensers, (See Joint Resistance.)

Condensers may be tested for insulation resistance by the direct deflection method of measuring high resistances.

The insulation resistance of standard condensers may be made very high, in some cases a resistance amounting to 8000 megohms, per microfarad, has been attained.

ELECTRIFICATION.—When a battery is applied to the terminals of a condenser, in which the dielectric is, for instance, paraffin, india-rubber or gutta-percha, it is noticed that the current does not immediately die out, but decreases gradually. In

some condensers indications of a decreasing current are still observable at the end of several hours, and on discharging such condensers the first strong current of discharge is followed by a gradually decreasing current in the opposite direction to that of the current of charge.

This phenomenon is termed electrification. It is referred to elsewhere as being very noticeable on gutta-percha, and india-rubber covered cables. It is not, however, noticeable, or but very slightly, in condensers in which the dielectric is air, and but to a slight extent in the best make of standard condensers; the currents of charge and discharge in such cases being of momentary duration.

FIG. 80.

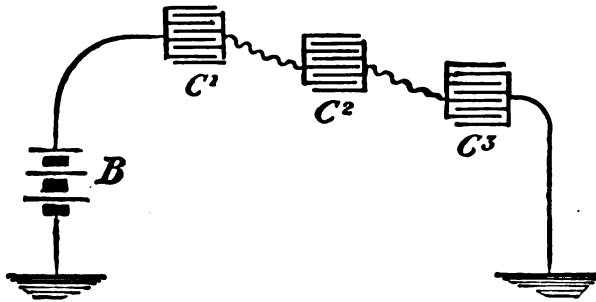

CONDENSERS ARRANGED IN SERIES, OR CASCADE.

This phenomenon, electrification, is supposed to be due to the gradual "polarization" of the dielectric, in other words, to the setting up of a counter-electromotive force in the dielectric opposed to that of the charging battery, the result being that the current through the dielectric is gradually reduced, in a manner, at least, analogous to that in which the current is reduced by the polarization of a voltaic cell. When electrification has ceased, or after it has progressed for a stated time, (*See* Chap. XXXI) the *resistance* of the condenser is calculated.

STATIC CHARGE, DISTRIBUTION OF, ETC.

When electric pressure is applied to the terminal of a conductor such as a telegraph wire, or cable, the latter receives a "charge" of electricity after the manner of a condenser. Such a wire or cable may, in fact, be considered a condenser, the conductor being one of the plates and the earth, water, or the armor of the cable, the other plate; the air or other insulating medium between the conductor and earth or the armor serving in the same capacity as the insulating medium, or dielectric, of the condenser.

Thus, such a conductor possesses, in addition to "resistance," the property of electro static capacity, by virtue of which it takes a static "charge."

The static capacity of a wire or cable varies with its length and, as in the case

of a condenser, with the area of the surface of the conductor, and with the nature and thickness of its insulating covering. The static "charge" of a wire or cable, varies directly with its static capacity and with the electromotive force.

When electromotive force is applied to the terminal of a long conductor, or cable, the other end of which is "open," there will be at first a sudden inrush of electricity due to the "charging" of the conductor, but afterwards the current diminishes more or less gradually, according to the extent that "electrification" takes place. When the electromotive force is applied to the terminal of a conductor, the other end of which is placed to earth, the first rush of current is partly due to its electro-static capacity; the normal current which follows is explainable by Ohm's law.

When a "steady" current is flowing in a circuit it is known that the potential, or pressure, falls in direct proportion as it "overcomes" resistance. For example, if, in Fig. 81, the line R represents the resistance of a wire of, say, 100 ohms, from x to y , and the perpendicular line A , the electromotive force, 100 volts, of the circuit, and if the wire be grounded at y , the fall, or "slope" of potential, as it is also termed, will be represented by the line F . If then the pressure, at x , is 100 volts, at a point along the wire, say, 50 ohms from x , that is, midway of the circuit, it will have fallen to 50 volts, and at any other selected point of the circuit it will be found that the pressure will have fallen in direct proportion to the resistance overcome.

The extent to which the potential has fallen at any point of a circuit may be graphically shown by a diagram such as Fig. 81, and as recourse to similar drawings will be frequently had in the course of this work to facilitate certain explanations, it may be well to dwell further on the subject here. (*see also* Wheatstone bridge.)

For example, assuming the vertical line A to be subdivided into 100 parts, each representing 1 volt, and the line R into 100 parts, each representing 1 ohm, if a vertical line be drawn from any point on R , say, at o (50 ohms) to the line F , and a horizontal line be then drawn from the intersection of that vertical line with the line F to the line A , the horizontal line will touch A at a sub-division corresponding to the potential on the wire at o , namely, 50 volts. (The wire being to earth at y .)

In practice the term electromotive force is now often used to indicate the total electromotive force in a circuit. The term "potential difference" is used in reference to the difference of potential, or pressure, that exists between any parts of a circuit. For instance, in the example just given, the "electromotive force" of the circuit is 100 volts; the "potential difference," or difference of potentials, between x and o is 50 volts; that between o and y 50 volts also.

A wire or cable also, like a condenser, takes a charge proportional to the difference of pressure at its respective plates; the plates, in this sense, being the conductor proper and the armor or earth. Consequently, as the potential, or pressure, falls in a conductor in direct proportion as resistance is overcome, it follows that the static charge of a wire or cable is not, under all conditions, the same at each point of its length; as will, perhaps be clear by further reference to Fig. 81.

For example, assuming first that the positive pole at x is placed to the line and that the latter is grounded at y , the slope of potential, as before, is represented by the line F . Hence, lines drawn from the point a on R to the line F and thence to A , will indicate the potential at that particular point to be about 66.6 volts. Other

lines drawn similarly from R at the point *b* will show the potential at *b* to be 33.3 volts, etc.

If then we should attach, as indicated in the figure, condensers *c*, and galvanometers *G*, of exactly similar capacities, respectively, to the wire *R* at points *x*, *a*, *b* and *Y* and should measure the potential difference at those points in the usual way* we would find that at *x* it would be 100 volts; at *a*, 66.6 volts; at *b*, 33.3 volts, while no difference of potential would be perceptible at *Y*.

Calling, for the purpose of illustration, the capacity of each condenser 1, the charge accumulated in the condenser at *x* would then be 100; that at *a* would be 66.6; that at *b* would be 33.3, while the charge of a condenser connected with the wire at *Y* would be nothing, since in that case the wire is at zero potential. The total charge of the condensers will be equal to the sum of their respective charges.

Since, then, a conductor in taking a charge acts like a condenser, it follows that, under the conditions of battery and wire stated, and assuming each portion of the conductor to have an equal electro-static capacity, the charge at point *x* of the conductor would be the maximum; at unit portion *a* it would be $\frac{2}{3}$ less; at unit portion *b* it would be $\frac{1}{3}$ less, while at unit portion *Y* the charge would be zero. Similarly, for any other particular portion of the conductor the charge will be found to vary with the potential of the conductor at that portion, and the total charge of the conductor will be equal to the sum of the various charges at each portion of the conductor.

As pointed out by Sir Wm. Siemens, the sum of those charges may be represented by the superficial area of the triangle *A F R*, Fig. 81.

FIG. 81.

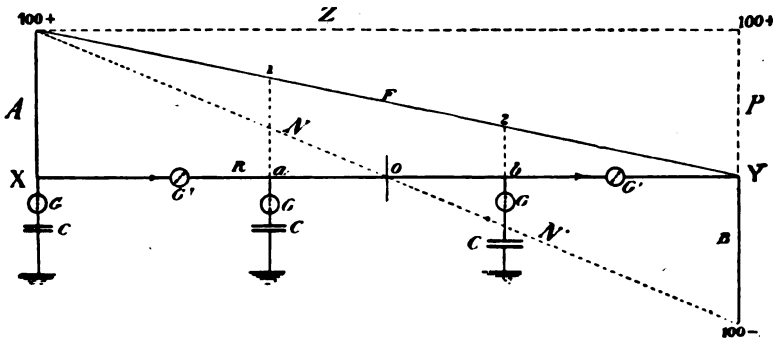

DISTRIBUTION OF "CHARGE."

The superficial area, or surface enclosed by a triangle is equal to one-half the product of the altitude of the triangle by its length; in other words, it is equal to one-half the superficial area of a square or parallelogram having similar altitude and length. Hence, if, for example, we assume the capacity of a conductor, say, 500 miles in length to be, in round numbers, 1 microfarad, per mile, its total charge, or quantity of electricity accumulated, with an electromotive force of 20 volts, would be $\frac{500 \times 20}{2} = 5000$, that is assuming the conductor to be "grounded" at one terminal. The potential of the same conductor with its distant terminal open, or with the

* (See Electrical Testing.) The condensers and galvanometers need not be of similar capacity unless the readings of the various galvanometers are to be compared to that at X, where the potential is known to be 100 volts. The potential at these points might also be determined by noting the deflection of a galvanometer due to a condenser charged by 1 volt from a gravity cell, for instance, and comparing that deflection with the deflection caused by the same condenser when attached to the line wire. If, for example, the deflection due to 1 volt should be 10 divisions and that due to the line 500 divisions, the potential of the line at that point would be 50 volts.

positive pole to line, would be equal at all points, and may be represented by the line, *z*, in Fig. 81. The total charge of the conductor in this case may be represented by the parallelogram *A Z P R*; in other words, the charge with the wire open is double that with one terminal to ground. In both of these cases, since the charging electromotive force is assumed to be positive, the charge would also be positive.

If a negative pole should be placed to the line at *γ*, Fig. 81, the fall of pressure along the conductor would be indicated by the line *NN'* and the charge from *x* to *o*, which would be positive, would be proportional to the area of the triangle *ARN*; while the charge from *o* to *γ*, which would be negative, would be proportional to the area of the triangle *BRN'*, and the total charge of the conductor would be equal to the algebraic sum of those charges, and these "charges," if allowed to unite, or mix, would nullify each other.

It may be noted here that although the "potential" at various points of the conductor, may, under certain conditions, be of different values, the current strength in a conductor is equal at all points, as may be proven by the insertion of similar galvanometers, *g g'*, at the opposite ends of the circuit *x*, when it will be found that, while a steady current is flowing in the wire, those galvanometers will each show an equal deflection.

STATIC CHARGE OF A CONDUCTOR.—The statement that the static "charge" of a wire or cable varies directly with the electromotive force may be illustrated by the aid of a diagram.

FIG. 81 a.

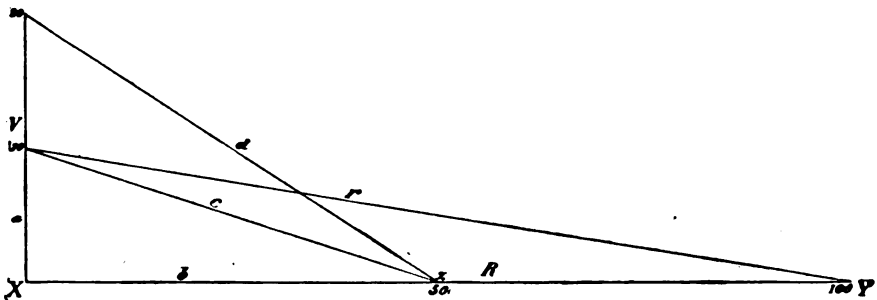

In Fig. 81 a, let *x* represent the resistance of a conductor of two sections of equal length, having a resistance of 50 ohms each; *v* the electromotive force at *x*.

First, taking the conductor from *x* to *x*, grounded at *x*, with an assumed electromotive force of 10 volts, the total charge, that is, the sum of the various charges at all the points, may be represented, as in the previous section, by the triangle *a b c*, namely, $\frac{10 \times 50}{2} = 250$.

Second, doubling the length of *x*, but retaining the electromotive force at 10 volts, the charge will now be represented by the triangle *a b r*, namely, $\frac{10 \times 100}{2}$

= 500.

Third, doubling the electromotive force, R remaining 50, the charge will be represented by the triangle $v b D$; namely $\frac{20 \times 50}{2} = 500$, micro-coulombs.

The total charge of a wire or cable with distant terminal "open" may be expressed by a formula, thus:

$Q = E \times K \times L$, where Q is the total charge in coulombs, E the electromotive force in volts, K the capacity of cable, per mile, in microfarads, and L its length, in miles.

With the distant terminal to ground the total charge may be represented thus:

$$Q = \frac{E \times K \times L}{2}$$

The manner of ascertaining the static capacity of a conductor is described under chapter on Electrical Testing. (See Capacity Tests.)

MUTUAL INDUCTION BETWEEN PARALLEL WIRES—SELF INDUCTION.

ELECTRO-MAGNETIC MUTUAL INDUCTION.—When an electric current flows in a wire it is observed that variations in the strength of current have the effect of "inducing" momentary currents in adjacent parallel wires.

For example, in Fig. 82 let A and B be two parallel circuits; b the battery or other source of electromotive force, in A .

If the key K be opened and closed at intervals it will be seen by the deflections of the galvanometer G that "current" is, at such times, set up in B , and that the current set up when the key is closed is opposite to that originated when the key is opened; and further, that the current originated in B , at the "closing," is opposite in direction to that of the current due to battery b .

This effect, or so much of it as may be electro-magnetic, and which is termed "mutual induction,"* is explained by the fact that the magnetic lines of force which emanate from a wire conveying a current, in rising and falling, "cut" the parallel wire and induce in it currents which vary in strength with the current flowing in the first wire.

The induction coil used so extensively, among other ways in connection with the telephone transmitter, is an instrument constructed to avail of the mutual electro-magnetic induction between parallel wires. The turns of the first wire, or the "primary," in which the battery is placed, being adjacent to the "secondary" wire, the makes and breaks, or rapid variations in the strength of current of the primary circuit, "induce" currents of opposite polarity in the secondary coil. A core of soft iron is embraced by the coils to increase the density of the magnetism and thereby to increase the strength of the induced current as the lines of force increase and decrease, in rising and falling

* Electro-magnetic

ELECTROSTATIC MUTUAL INDUCTION.—It has already been stated that when a conductor of electricity receives a “static” charge, it induces in a neighboring conductor, as, for instance, B in Fig. 82, a charge of opposite polarity to the charging battery or E. M. F. The charge in B is due to static induction. In the act of taking this charge a momentary current is established in B, and when the originating charge is withdrawn a momentary current in the opposite direction is set up in B. A and B are virtually plates of a condenser corresponding to A, B, Fig. 74. These

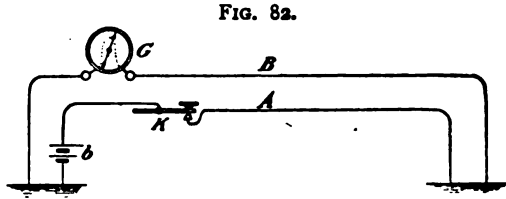

FIG. 82.

currents are due to electrostatic mutual induction.

INDUCTANCE, CAPACITY, REACTANCE, IMPEDANCE.—It is known that in a telegraph line or other conductor in which there are electromagnets, the current is retarded in rising when the circuit is closed, and that its fall is prolonged when the circuit is opened, thus producing a retardation of the signals. This is due to the inductance of the circuit, or self-induction. The explanation is that the magnetic lines of force which in rising and falling set up currents in a parallel conductor, also cut the wire in which the current that produced the lines of force is or was flowing. The sudden collapse of the magnetic lines of force at the opening of the circuit induces in the wire a momentary electromotive force which sets up an “extra” current or a prolongation of the original current; that is, the current of self-induction at the opening of a circuit is in the same direction as the original current. Reversely, when the circuit is closed and the lines of force are rising they tend to set up an E. M. F. opposed to that of the battery or dynamo, with the result that the current does not attain its full strength immediately.

The inductance of a given circuit (assuming a circuit without iron, *see* page 66), like resistance and capacity of a given circuit, is constant. As stated elsewhere (Hertz oscillator), inductance is analogous to mechanical inertia, while capacity is analogous to mechanical elasticity. With a continuous current, inductance and capacity have no effect upon the current, but when the current is varied, or alternated, their effects come into operation. In a circuit in which there is only resistance, the current rises and falls with the E. M. F., and is therefore said to be in phase with it. When there is resistance and inductance in a circuit the effect of inductance is, as stated, to retard the rise and fall of the current, so that it is said to lag behind the dynamo or battery E. M. F., by an angle depending on the inductance E. M. F., as indicated in Fig. 82a, in which the solid curve represents the E. M. F. wave, and the dotted curve

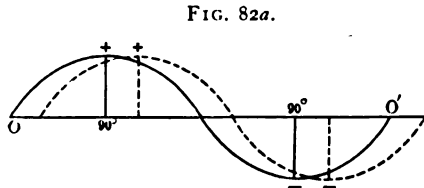

FIG. 82a.

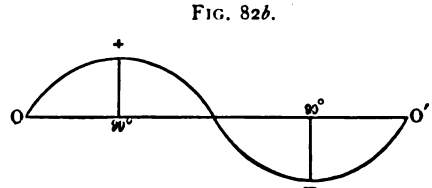

FIG. 82b.

the current wave, and as explained in connection with Fig. 82c. (A complete period or cycle of a current wave from zero, to positive maximum, back to zero, to negative maximum and back to zero constitutes two half cycles of 180° each, *o* to *o'*, Fig. 82b.) When there are only resistance and capacity in a circuit the effect of capacity is like that property of a spring which resists bending but assists in the restoring movement; hence it hastens the rise and fall of a varying current so that it precedes or leads

the dynamo E. M. F. by an angle depending on the capacity E. M. F., in which case the solid line in Fig. 82a would represent the current wave and the dotted line the dynamo E. M. F. wave. Therefore if the inductance and capacity effects of a circuit are equal the current will rise and fall with the dynamo E. M. F. (examples of which will be mentioned later), inasmuch as their joint effect upon the current is nil.

Capacity and inductance effects are termed capacity and inductance reactances respectively. Capacity reactance is also termed condensance. The inductance of a conductor depends largely on its form. Thus a coil of wire will have greater inductance than a straight wire of the same length, for the reason that the lines of force in each turn of the coil act upon all the other turns; whereas the lines of force circling around a straight wire cut the wire but once. Also, the capacity of a wire conductor depends upon its circumference, its dielectric, etc. (See page 98.)

In a circuit in which the current is alternating or varying and in which there is inductance or capacity, the effect is equivalent to having an opposing E. M. F. in the circuit. Hence to obtain a current equal to that which would flow if the current were continuous, the dynamo or battery E. M. F. must be increased to compensate for the opposing E. M. F.; otherwise the current will be less than with a continuous current. In such cases the dynamo or battery E. M. F. is termed the impressed E. M. F. In such a circuit there are to be considered an impressed E. M. F., an E. M. F. due to the inductance or capacity of circuit, and an energy or active E. M. F. In the case of a primary battery, if two cells of one volt E. M. F. each are placed in opposition to four similar cells (see page 26) in a circuit of, say, four ohms resistance, the resulting effective or energy E. M. F. is two volts, and the current strength, according to Ohm's law, is $\frac{1}{2}$ ampere. The energy E. M. F. referred to is that E. M. F. which, multiplied by the current, gives the electrical power, or watts, of the circuit. In connection with alternating current practice this E. M. F. is variously termed the free, effective, virtual, and power E. M. F., as distinguished from the impressed and reactance electromotive forces. In the example given the four cells in series constitute or are the equivalent of the impressed E. M. F. of the circuit.

In an alternating current circuit having inductance or capacity, the lag or lead referred to brings about a condition in which the inductance or capacity E. M. F. is said to be in quadrature with or acts at right angles to the energy E. M. F., and the impressed E. M. F. corresponds to the resultant, or what is termed the vector sum, of those forces (see parallelogram of forces, page 104), and not the numerical difference as in the case of the opposing electromotive forces, Fig. 15. (These effects of inductance and capacity which, so to speak, place them in quadrature with the energy E. M. F. are virtually due to the changes in the magnetic or electrostatic fields, or both, around the conductor, and may be considered as operating in a sense analogously to the magnetic lines of force in the coil and the earth's magnetic lines, respectively, Fig. 85.)

For example, let the line E' , Fig. 82c, represent the inductance E. M. F. of a circuit; the line E the energy E. M. F. Then e represents the impressed E. M. F.; E' and E being the components of the resultant e . In other words, e is the hypotenuse of the triangle with sides E' , E . The angle x formed by e and E is termed the angle of lag, which angle will vary if E or E' vary, as will be shown presently. By geometry the square of e is equal to the sum of the squares of E' , E , that is, $e^2 = E'^2 + E^2$, or $e = \sqrt{E'^2 + E^2}$ (that is, e equals the square root of the sum of the squares of E' , E). Hence the value of the components of e may be readily ascertained if the values of e and either of its components are known, and vice versa, numerical examples of which will be given. It is obviously not strictly correct to say that the impressed E. M. F. is the resultant of the energy and inductance E. M. F.'s, since these latter forces are brought into existence by the former, but it is convenient for the purpose to so consider it. By Fig. 82c it may be seen on consideration, and as indicated by

the dotted lines, that the greater the inductance E. M. F. E' , with a given impressed E. M. F. e , the less will be the energy E. M. F. E , and the greater will be the angle of lag x between E and e . For it is clear that E' cannot be increased without detracting from E if e remains unchanged. Also the less the inductance E. M. F. E' , the impressed E. M. F. remaining the same, the greater will be the energy E. M. F. E , and the less will be the angle of lag x between e and E . Hence when E' is entirely eliminated the impressed E. M. F. becomes the energy E. M. F. of Ohm's law, which law, however, it may be noted, is as operative in alternating as in direct current circuits when due allowance is made for inductance and capacity reactances, as will be shown in connection with subsequent remarks on impedance.

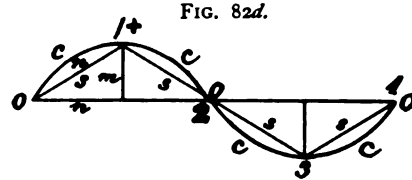
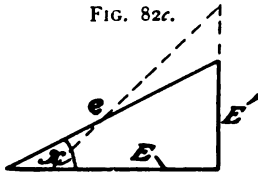

As stated elsewhere (page 207a), the unit of inductance is the henry, which is defined as the amount of inductance existing in a circuit that will develop one volt when the current varies uniformly at the rate of one ampere per second. From this it follows that the inductance E. M. F. or reactance in a circuit of given inductance will vary with the strength of current and with its frequency of variation. For example, given an inductance of one henry and a current of one ampere varying ten times per second, ten volts inductance E. M. F. will be developed, or if the current be ten amperes and varies once per second, ten volts inductance E. M. F. will be developed.

Hence, $E' = N \times C \times L$, and $L = \frac{E'}{N \times C}$,

where L is inductance in henrys, E' is the inductance E. M. F., N is the rate of variation (or, more correctly, the frequency or periods) per second, and c is the current. For reasons to be noted shortly, however, the preceding formulæ are expressed thus:

$E' = 2\pi NCL$, (and by substitution) $L = \frac{E'}{2\pi NC}$. (See page 335b.)

Taking a numerical example. Let the frequency be 50 per second, produced, for instance, by a Wheatstone transmitter sending 50 dots per second. In this case 50 positive and 50 negative pulsations, that is, 50 periods per second, are being transmitted, and as each pulsation rises from zero to maximum and falls from maximum to zero, there are really four variations of current in each period, or cycle (as variously termed), as indicated in Fig. 82d, which represents one period or two alternations. Thus there are $4 \times 50 = 200$ variations of current in such a circuit per second. Suppose that in this circuit there is a relay having an inductance of one henry, and that the current strength is one ampere, the inductance E. M. F. E' will then be represented by the formula,

$E' = 4N \times C \times L$, or $E' = 200 \times .1 \times 1 = 20$ volts.

This, however, is assuming that the rise and fall of the current might be indicated by the uniform lines s, s, s in Fig. 82d, which represent a current in which the increment or decrement varies at each step by a given or uniform amount.* But when, as in practice, the rate of variation of current is greater than this uni-

* In this part of the subject the author follows and amplifies somewhat an article by Mr. W. D. Weaver in *American Electrician*, Nov., 1897. Acknowledgments are also due to Mr. R. N. Inglis and Mr. Townsend Wolcott for useful suggestions hereon.

form variation, it may be indicated by the curve *c*, which, assuming a sinusoidal wave, indicates the form of curve that would result if the current or E. M. F. were measured at each instant of rise and fall, and which is termed a sine curve. If, therefore, it be also assumed that in varying from zero to maximum the current has to vary through an area represented by the quadrant *n n m*, Fig. 83*d*, of a circle, it is evident that this area of variation is greater than would be the case if it were limited to the area of the triangle inscribed within the quadrant by the straight or uniform lines. Thus there is a greater variation, four times repeated, in each period than is permitted by the rule defining the henry; and this excess is in the ratio of $\frac{\pi}{2}$ or $\frac{3.1416}{2} = \frac{1.5708}{1}$, which is the ratio that the area of a quadrant of a circle with a radius of unity bears to the area of the said triangle. (For example, $x = \pi \times r^2$, where x is the area of a circle, with a radius r of 1, π being the ratio of circumference to diameter. Then, in numerals, $x = 3.1416 \times 1^2 = 3.1416$. The area y of a triangle whose sides r equal 1 is, $y = \frac{r^2}{2} = \frac{1}{2} = .5$.)

Then the area of quadrant *q* of the circle is $q = \frac{3.1416}{4} = .7854$, and ratio of area *q* of quadrant to area *y* of triangle is $\frac{.7854}{.5} = \frac{1.5708}{1}$. Therefore, to ascertain the actual inductance E. M. F. of the circuit the result thus far obtained must be multiplied by 1.5708, giving the expression

$$(a) \quad E' = 1.5708 \times 4N \times C \times L, \quad \text{or} \quad E' = 1.5708 \times (4 \times 50) \times .1 \times 1 = 31.416.$$

As, however, 1.5708 is one half of 3.1416, the figure 4, representing the variations of current per cycle, is dropped, and the formula is simplified and abbreviated thus,

$$E' = 2\pi NCL,$$

which is the equivalent of formula (a), for, obviously, 2×3.1416 is equal to 4×1.5708 .

Hitherto in these remarks it has been assumed that the inductance of the circuit is known. By analyzing the preceding example the operation of the resultant or vector method of ascertaining the inductance, when unknown, may be utilized. For example, let a Wheatstone transmitter or an alternating current generator be arranged to send a current of .1 ampere and 34.8 volts (as measured by an alternating current ammeter and voltmeter) with a frequency of 50 per second through a Morse relay of 150 ohms resistance. By Ohm's law, $R \times C = E$, or $150 \times .1 = 15$ volts, which is the energy E. M. F. of the circuit (the component *E* of Fig. 82*c*). There is, then, in the circuit an energy E. M. F. *E*, of 15 volts in quadrature with the thus far unknown inductance E. M. F. *E'*, the vector sum of which is $15^2 + E'^2$. To maintain these forces an impressed E. M. F. *e*, in this case 34.8 volts, is required. As the square of the resultant *e* of two such forces is equal to the sum of the squares of such forces, by simple equations,

$$\text{Impressed E. M. F.,} \quad e^2 = E^2 + E'^2, \quad \text{or} \quad 34.8^2 = 15^2 + E'^2.$$

$$\text{Transposing, we get,} \quad E'^2 = 34.8^2 - 15^2, \quad \text{or} \quad E'^2 = 1211 - 225 = 986.$$

Hence, as the square root of E'^2 is obviously E' , then $E' = \sqrt{986} = 31.4$ volts, the inductance E. M. F. of the circuit (component *E'* of Fig. 82*c*). Or, having the impressed E. M. F. and the inductance E. M. F., it is easy to obtain the energy or power E. M. F. *E*, for $E^2 = 34.8^2 - 31.4^2 = 225$, and $E = \sqrt{225} = 15$ volts. Thus, with an alternating current in a circuit with inductance, instead of simply subtract-

ing a counter E. M. F. from the impressed E. M. F. to obtain the energy E. M. F., as in the case of battery cited, the vector difference between the impressed E. M. F. and inductance E. M. F. is taken.

It is known that the E. M. F. measured by an alternating current voltmeter is the virtual E. M. F. and not the maximum E. M. F., and to ascertain the latter the virtual E. M. F. must be multiplied by 1.41.

IMPEDANCE.—Every conductor offers a certain opposition to the flow of current in the shape of ohmic resistance or resistance reactance R . The reactances of inductance and capacity also by neutralizing more or less of the impressed E. M. F. virtually oppose the flow of current in a circuit, and may therefore be regarded as resistances. These reactances, however, act at right angles to the energy E. M. F., and also at right angles to the current, inasmuch as the current is in phase with the energy E. M. F. Since, also, the ohmic resistance is, so to speak, in phase with the current, it follows that the forces opposing the flow of current (ohmic resistance and reactance) are in quadrature with each other, and hence it is the vector sum of the ohmic resistance and inductance (or capacity) resistance (reactance) that is considered (namely, the square root of the sum of their squares), and not their arithmetical sum.

This vector sum, or joint effect, of these reactances is termed impedance, Z , or apparent resistance, and is expressed in ohms. As the apparent resistance due to inductance increases directly with the inductance and frequency, the impedance of a circuit having only ohmic resistance and inductance resistance is expressed by the formula

$$Z = \sqrt{R^2 + (2\pi N L)^2}.$$

But as the apparent resistance due to capacity decreases with the increase of capacity and frequency, and contrariwise, the reciprocal of capacity reactance is used. Hence, the impedance of a circuit having ohmic resistance and capacity resistance (or condensation) only, and when the capacity is in series with the ohmic resistance, is expressed thus:

$$Z = \sqrt{R^2 + \frac{1}{(2\pi N K)^2}}.$$

The latter formula will be clear when it is considered that the larger the capacity of a condenser the more current will flow into it, hence the less its apparent resistance, or the more its apparent conductance, conductance being the reciprocal of resistance, and vice versa. Since further, as already remarked, inductance reactance and capacity reactance act oppositely, so to speak, on the current, when there are ohmic resistance, inductance and capacity in an alternating circuit, the impedance is thus expressed:

$$Z = \sqrt{R^2 + \left(2\pi N L - \frac{1}{2\pi N K}\right)^2}.$$

That is, in this case, the impedance is equal to the resultant of the resistance component and a component consisting of the numerical difference of the inductance and capacity reactances. In the above formula the inductance reactance is supposed to exceed the capacity reactance. When contrariwise, the inductance reactance is subtracted from capacity reactance. The current in an alternating current circuit is then equal to the impressed E. M. F. e divided by the impedance, or $\frac{e}{Z}$. If the inductance and capacity reactances of a circuit are equal their effect upon the current strength is nil and the current is in phase with the impressed E. M. F. There is no impedance. For example, assume a circuit having capacity .000003 farads (3 micro-farads) and inductance 3.38 henrys, and neglecting resistance of circuit.

$2\pi LN - 2\pi NK$ represent inductance and capacity reactance. With a frequency of 50, $2\pi N$ in each case will be $2 \times 3.1416 \times 50 = 314$, and reactance will equal $314 \times 3.38 - \frac{1}{314 \times .000003}$, or $1061.3 - 1061.3 = 0$. Thus, if inductance and capacity of a circuit be so distributed that this condition prevails throughout, the current strength would be in accordance with Ohm's law.

A main-line Morse relay, 150 ohms resistance, with the armature adjusted for working, has an inductance of about 5 henrys; with the armature touching cores, 10.5 henrys; a polarized relay, 400 ohms, with armature within .004 inch of cores, about 2 henrys. Kennelly gives the inductance of a bare copper wire, No. 12 B. & S., on poles 23 feet above ground, as .003 henry per mile; a No. 6 B. & S. copper wire, about .029 henry per mile; a No. 9 B. & S. overhead copper wire has a capacity of about .01 microfarad per mile.

PUPIN'S LOADED CONDUCTOR.—It is known that a straight conductor, such as an overhead telegraph line or a cable, possesses very little inductance but considerable capacity, especially long cables. This tends to retardation of signals, the energy of the current being dissipated in charging the various parts of the cable. Attempts have been made to diminish the retardation due to capacity by placing inductance at the terminals of the cables, but as the capacity is distributed uniformly throughout the length of the cable, this arrangement of inductance was not successful. Dr. S. P. Thompson and others have pointed out that the effective way to counteract the retarding effects due to uniformly distributed capacity was to introduce into the circuit uniformly distributed inductance; and assuming a two-conductor cable, he proposed to insert at intervals between the two conductors inductance coils to offset the effects due to the capacity of the cable, since inductance acts oppositely to capacity. Dr. Pupin attacked the problem in a somewhat different way, and deduced mathematically the amount of inductance and the intervals at which it would be necessary to introduce inductance in series in conductors or cables of a given capacity, for electric wave-lengths of a given order, for instance, those that are utilized in telephony. This arrangement is described in U. S. patent No. 652,230, covering Dr. Pupin's invention, and the writer has drawn freely from the language of these specifications in the following description, which, however, is but an abstract of the same, and for further elucidation of the subject the reader may be referred to the patent in question. To illustrate the principle the inventor uses

FIG. 82e.



FIG. 82f.



the analogy of vibrating strings, the laws of which may be found in works on physics. In Fig. 82e a string is shown attached at B to the prong of a tuning-fork C and at the other end to a suitable support D. If the fork is made to vibrate the string will make forced vibrations with it, that is, vibrations which follow the period of the tuning-fork. When the internal and external frictional resistances may be neglected the waves travel with undiminished amplitude. Hence the direct wave coming from the tuning-fork and the reflected wave coming from D will have the same amplitude, and therefore stationary waves will be formed with fixed nodes at $a c e g$ D, and ventral segments at $b d f h$. When, however, there are external and internal frictional resistances the amplitude of the wave is continuously diminished in its progress from B to D. After its reflection at D the returning wave, having a smaller amplitude than the oncoming wave, cannot form with it, by interference, a system of stationary waves, but forms a wave curve as $a' b' c' d' e' f'$, with continually

diminishing amplitude due to attenuation, Fig. 82f, that is, a quickly damped series of waves. If the frictional resistance reactions are proportional to the velocity of propagation, the ratio of attenuation (namely, the ratio of amplitudes of two successive half-waves) will be a constant quantity. The velocity of propagation and the attenuation ratio depend on the density of the string, its tension, its frictional resistance, and frequency. For example, the greater the tension the greater the velocity, and consequently the greater the wave-length with a given frequency of the fork. Also the greater the density the slower the velocity, and hence the shorter the wave-length with a given frequency.

The greater the density of a string the less will be the attenuation ratio, and the lighter the string the greater the attenuation ratio. The energy which the string receives from the tuning-fork and then transmits toward D exists partly as kinetic energy and partly as potential energy or energy of deformation of the string. The process of propagation of a wave consists in the successive transformation of the kinetic part of the total energy into potential energy, and vice versa. During this transformation a part of the energy is lost as heat due to frictional reactances. These reactions are assumed to be proportional to the velocity, so that the rate of loss will be proportional to the square of the velocity; but since the velocity diminishes with the density the heat loss is inversely proportional to the density. From which it is deduced that dense strings transmit energy more efficiently than light strings, because the former require a smaller velocity in order to store up a given amount of kinetic energy, and smaller velocity means less dissipation into heat and therefore a smaller attenuation of the wave.

Dr. Pupin then points out that the coefficient of friction, the density, and tension of a vibrating string are an exact analogy of the ohmic resistance, the self-inductance, and the reciprocal of the capacity of an electrical conductor. The magnetic energy of the current corresponds to the kinetic energy of the vibrating string, and just as a dense string transmits mechanical energy more efficiently than does a light one, so a wire of large inductance per unit length will, under otherwise the same conditions, transmit energy in the form of electrical waves more efficiently than a wire with small inductance per unit length, inasmuch as a wire of large inductance can store up a given quantity of magnetic energy with a smaller current than is necessary with a wire of small inductance, hence with smaller heat losses and smaller attenuation and therefore with higher efficiency.

Dr. Pupin's further experiments with a vibrating string consisted in loading it with beads at certain intervals, thereby adding density to the string, and he found that the foregoing theory was borne out. By the analogy of the beaded string it was also shown that if the tuning-fork vibrate at such a rate as to produce in the beaded string a vibration the wave-length of which is equal to or greater than the distance between B and D, the vibration of the string will then be practically the same as that of a uniform string of equal length, tension, frictional resistance, and mass. This indicated that in the transmission of electrical energy in long conductors it would be feasible, by properly selecting the amount of inductance, in the shape of coils, and the intervals at which they should be placed, to obtain results for a given frequency, resistance, and capacity of conductor, similar to those in which the inductance is uniformly distributed in the conductor, assuming it were practicable to so distribute inductance, and this is the essential feature of Dr. Pupin's device, namely, that when the distance between the periodically distributed inductance is a fractional part of the wave-length of the current, the effect is equivalent to a uniformly distributed amount of inductance in the conductor, it being assumed, briefly, that when alternating currents of a certain frequency are transmitted in a conductor the waves are reflected back at the far end of the conductor or by a receiving apparatus in the system.

The denser the medium the slower the rate of wave propagation in that medium, hence Dr. Pupin termed his loaded conductor, consisting of inductance coils suitably placed, a slow-speed conductor. In working out the theory practically the inventor employs two constants, namely, the wave-length constant α and the attenuation constant β . When there is no inductance in the line these may each be expressed by the comparatively simple formula, namely, α and $\beta = \sqrt{\frac{1}{2}\rho\kappa R}$, where κ is capacity, R is resistance per mile, and $\rho = \frac{2\pi}{T}$, where T is frequency of the impressed E. M. F.

If $\lambda =$ wave-length, then $\lambda = \frac{2\pi}{\alpha}$. The following example is given in the specifications referred to: Suppose it is desired to transmit speech over a line 3000 miles overland, the wire having a resistance of 4 ohms per mile, and a capacity of .01 microfarad per mile.* The total attenuation factor of a similar wire from New York to Chicago, about 1000 miles, is $e^{-1.5}$ for the highest frequency in speech (e being the base of the Napierian logarithms, 2.71828), namely, 1500 periods per second. This, then, must be the total attenuation factor for the 3000 mile circuit. Then $e^{-3000\beta} =$ the attenuation factor $e^{-1.5}$ and $3000\beta = 1.5$. Assume resistance of added inductance coil is .6 ohm per mile, giving a total of 4.6 ohms per mile. When the reactance per mile is sufficiently great in comparison with the resistance as in this case, the following simplified formula may be used for the attenuation constant,

$\beta = \frac{R}{2} \sqrt{\frac{\kappa}{L}}$, and from this the inductance L may be calculated as follows:

$$3000\beta = 3000 \frac{4.6}{2} \frac{1}{1000} \sqrt{\frac{.01}{L}} = 1.5. \quad \text{Hence } L = .2 \text{ henry.}$$

Having obtained the inductance required per mile, the wave-length for the highest frequency used in speech, 1500 periods per second, is calculated

$$\lambda = \frac{2\pi}{\alpha} = \frac{2\pi}{\rho \sqrt{LK}} = \frac{1}{\frac{1.500}{10^3} \sqrt{.2 \times .01}}, \text{ or about 15 miles approximately.}$$

A sufficiently high degree of approximation to a uniform telephone line will be obtained in this case if 15 coils of .2 henry each per wave-length, or one coil per mile, be employed.

THE RHEOSTAT, OR RESISTANCE BOX.—In testing, and in duplex telegraphy, etc., the introduction of "extra" resistance into a circuit is frequently necessary. For instance, in testing, a coil of small wire, of known resistance, is often used to ascertain, by comparison, the resistance of a wire, the resistance of which is unknown; and, in duplex telegraphy, coils of wire are used to "balance" one wire against another, etc. The coils of wire used for such purposes are generally placed together in one box, termed a "rheostat." It is desirable that these coils should not occupy much space, and for that reason an alloy possessing high electric resistance is usually employed in this capacity, most generally German silver, the resistance of which is about twelve times greater than copper. For purposes in which rheostats are employed, it is usually undesirable that the coils should produce any magnetic effect due to the current.

FIG. 83.

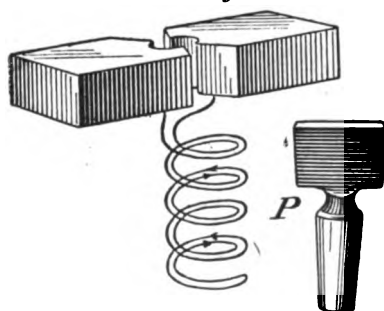

* The factor by which B has to be multiplied to get the amplitude at a given distance is termed the attenuation factor.

To prevent such magnetic effect the coils in rheostats are "doubled" back on themselves in the manner indicated, in Fig. 83. The result is that, as the same current passes through parallel portions of the coils in opposite directions, as outlined by the arrow heads, no perceptible magnetic effect is produced; the explanation being that any tendency of the current in one portion of the coil to set up magnetic effects is counteracted by a current of equal strength, in the opposite direction, in the parallel portion of the coil.

The coils of the rheostat are usually mounted on bobbins, and are connected up in the "rheostat," practically as shown in Fig. 83 *a*.

The brass plates numbered 3000, 2000, 1000, etc., are set in the ebonite cover of a box of suitable size to hold the coils; one terminal of a coil being connected to one brass plate, the other terminal to the next brass plate. The numbers indicate the resistance of the respective coils, in ohms.

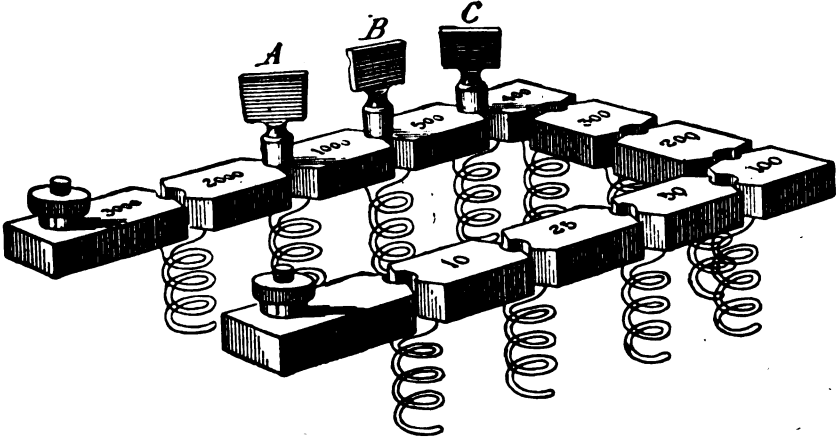
FIG. 83 *a*.

The brass plates have semi-circular openings cut in them into which metal plugs *P*, Fig. 83, and *A, B, C*, Fig. 83 *a*, can be inserted to connect any two brass plates for the purpose of "short circuiting" any coil whose terminals come to the particular plates into which a plug may be inserted. Thus, when the brass plates are connected by plugs, as at *A, B, C*, in the figure, the 2000, 1000 and 500 ohm coils are short-circuited out of circuit; that is, those coils will not be traversed by a current passing through the other coils because of the very low resistance of the metal plugs, as compared with the resistance of the coils, which low resistance of the plugs practically diverts all current from the coils short-circuited thereby.

By thus inserting or removing the plugs, obviously, more or less resistance can be inserted or withdrawn from a circuit at will.

Other forms of rheostats will be found described in chapters on Wheatstone bridge, the Wheatstone automatic system, the Quadruplex, etc.

CHAPTER VII.

GALVANOMETERS, VOLTMETERS, AMMETERS.

In the electrical tests required in practical telegraphy the instrument chiefly used is the galvanometer.

The term galvanometer, as the word implies, signifies an instrument for "measuring" electricity. The galvanoscope is an instrument designed to indicate merely the presence of electricity in a substance. In many of the tests necessary in telegraphy the galvanometer is used as a galvanoscope, or "indicator" of the presence of an electric current, and only rarely as a direct means of measuring the strength of current, but the results obtained are, nevertheless, indirectly due to the fact that the current is, so to speak, measured, as may be evident from the ensuing descriptions of certain forms of galvanometers.

The galvanometers mostly used in telegraphy are the tangent galvanometer,

FIG. 84.

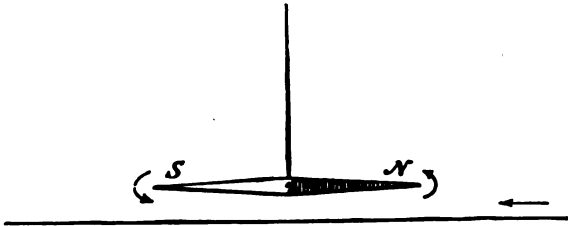

the "detector," and Thomson reflecting galvanometer.

THEORY.—It has been established that the earth is a magnet, having north and south "poles," between which magnetic "lines of force" are constantly passing. A magnetic needle freely suspended tends to point north and south because of the directive influence of the earth's magnetic lines of force; in other words, because the magnetic lines of force of the needle seek to obey the tendency of magnetic lines of force to coincide in direction. When in this position, namely, pointing north and south, the needle is said to be in the magnetic meridian.

When a magnetic needle is held parallel to a wire conveying an electric current the needle will be deflected. This deflection of the needle is due to the action of the magnetic lines of force, which, as stated more fully elsewhere, (Chap. III.) surround a wire in which an electric current is flowing. The direction of the deflection of the needle depends on the direction of the current in the wire. For example, assuming the needle to be freely suspended above the wire, as in Fig. 84, if the current in the wire be flowing towards the north pole of the needle, the south

pole will be deflected to the right of the wire. If the current be flowing toward the south pole of the needle the north pole will be deflected to the right of the wire. If the needle be placed beneath the wire the deflections will be in the reverse directions. The extent, or angle, of deviation of the needle will vary with the strength of current in the wire, but except for very small deflections will not be proportional thereto; which remark will be amplified later on.

Upon this action of the needle in the presence of a wire in which a current is flowing the operation of the galvanometer is based. As, however, the effect due to a single wire would produce a very limited deflection of the magnetic needle, unless the current in the wire were quite strong, or the needle very sensitive, or both, it is customary, in the construction of ordinary galvanometers, to arrange the wire in the form of a coil, or ring, of many convolutions, in the center of which the needle is suspended. By this means the effect is multiplied manifold and galvanometers capable of responding to very minute currents in the coil are thus obtained.

FIG. 85.

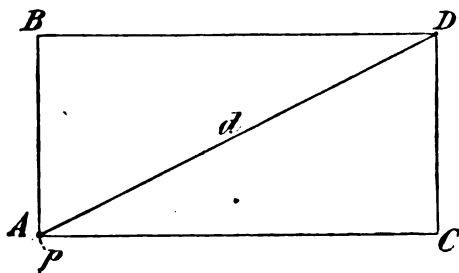

If the earth's magnetic influence upon a magnetic needle should be temporarily eliminated while the needle is at the center of a coil of wire carrying an electric current, what has been said relative to the effect of the earth's magnetic influence upon the needle would be true of the effect of the magnetic influence of the coil, namely, the needle would tend so to turn that its magnetic lines of force, and those of the coil, would be alike in direction, and, consequently, it would turn at a right angle to the plane of the coil. But the earth's magnetic influence upon the needle is not eliminated, except under special conditions to be referred to later. This being so, when a magnetic needle is so placed within a coil of wire that the earth's magnetic force tends to point it north and south, while that of the coil tends to point it east and west, it will point neither due north nor due west, but will, in fact, assume a position between those points.

In mechanics, when two or more forces act upon a point, the combined effect of those forces is termed the *resultant* force, and the forces thus producing that resultant are termed its *components*. Analogously, it has been found that the position which a magnetic needle will assume, when placed as stated, will be that due to a resultant force composed of the two magnetic forces.

THE TANGENT GALVANOMETER.

The tangent galvanometer depends for its operation as a current meter on the law that the currents which may flow in its coil, or coils, are proportional to the tan-

gents of the angles of deflection of the needle due to those currents. This law, it will be found, is derived, primarily, from a knowledge of the fact that the deflection of the needle is due to the resultant force of the earth's and the coil's magnetic forces.

The resultant of two such forces as those referred to can be graphically indicated by a diagram such as is shown in Fig. 85, which illustrates what is termed the parallelogram of forces; the principle of which may be stated as follows: If from the point p , on which two forces are assumedly acting, the lines $A C$, $A B$, be drawn, representing the direction and magnitude of the respective forces, and, from those lines, as sides, two other lines, $C D$ and $B D$, be drawn, to complete the parallelogram, then a diagonal d , from A to D , will represent, in direction and magnitude, the resultant of the two forces. This statement may be illustrated by the following well-known mechanical experiment. In Fig. 86 let the weights $x y z$ be suspended, as indicated, by light, flexible cords; the cords attached to $x z$ being passed over small pulleys in such a manner that friction may be neglected. The three weights, or forces, are then acting upon the point P , and the weights come to rest in a position where $x z$ exactly counterbalance y . In the actual experiment a slate, or black-board is usually placed immediately behind this arrangement of the weights, cords and pulleys so that the direction of the cords may be readily traced. The line $A B'$ will then represent the direction in which the force x is acting; the line $A C'$, that in which z is acting, and the line $A A'$, that in which the force y is acting. Divide a portion $A C$, of the line $A C'$ into as many units of length as there are units of weight in z , and a portion, $A B$, of $A B'$ into as many units of length as there are units of weight in x , and complete the parallelogram $A B D C$, by drawing the lines $C D$; $B D$. Then, accord-

FIG. 86.

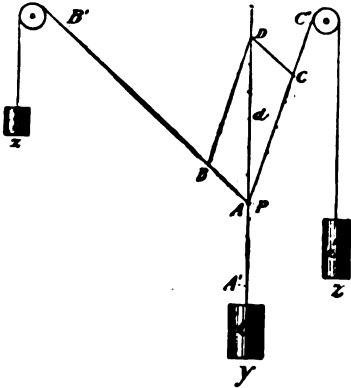

ing to the principle of the parallelogram of forces, the diagonal d is the resultant of the forces x and z , and, as this resultant force is, in strength, equal to, and, in direction, opposite to the force y , the diagonal d should contain as many units of length as there are units of weight in y , which will be found to be the case. Should the weights x or z be varied, the diagonal, or resultant, will also vary, but whenever equilibrium is obtained it will be found that the diagonal will always represent in magnitude and direction the resultant force. It may also be noted, in connection with the application of this principle to the case in point, that it will be found, that the length of the line $D B$, taken from the point of intersection with the diagonal, will also be a measure of the magnitude of the force which that line represents; the line $D B$, it is understood, being, in length, equal to the side $C A$, of the parallelogram. In Fig. 87 several such parallelograms are shown.

The two forces now to be considered are those due to the earth's magnetic field, and the magnetic field of the coil, and the object, or point assumed to be acted upon, is that of the end of a short magnetic needle, pivoted at P , at the center of

a coil, or ring of wire. The needle is assumed to be, normally, in the magnetic meridian BA' , and in the plane of the coil.

As it may be taken for granted that, in the space about the needle, the earth's magnetic field does not vary in strength, that strength may be called 1 . The direction in which that strength is exerted on the needle may then be indicated by the line AB , and the strength, that is, the magnitude, 1 , may also be indicated by the same line. The strength of the magnetic field of a coil, however, in the space about the needle, may be varied as desired, but we may begin by calling it 1 also. As the force of that field is exerted at right angles to AB , its direction may be represented by the line AC . A parallelogram $ABCD$ may now be finished by drawing, in accordance with the foregoing stated rule, the lines CD , and DB , as sides. The

FIG. 87.

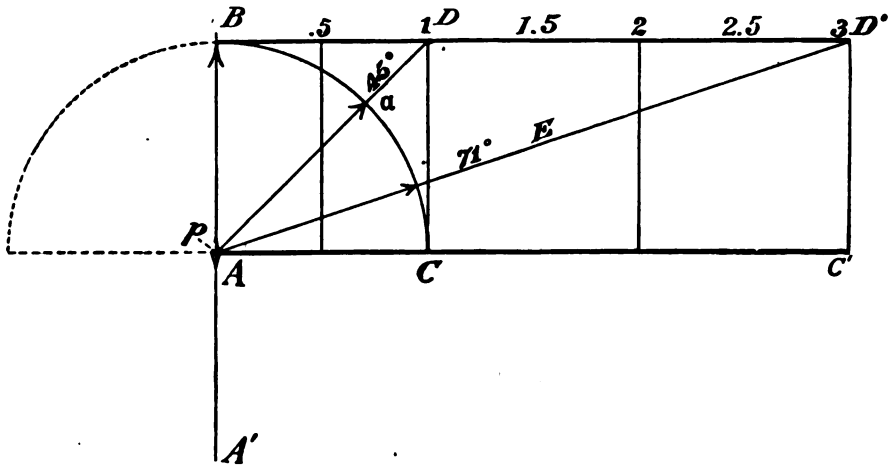

resultant of the two forces, each having a strength of 1 , will then be represented by the diagonal AD , and, since this diagonal represents, in direction and magnitude, the resultant of the two forces AB, AC , a needle acted upon by two such forces would be deflected to a position, or an angle, coincident with the resultant line AD .

If, now, the strength of the magnetic field of the coil be increased three-fold, its strength will be indicated in the figure by the line AC' . The strength of the earth's magnetic force remaining as before, namely, 1 , a new parallelogram is finished by the lines $C'D'$ and $D'D$, and the resultant force will be represented by the diagonal AD' ; and a needle acted on by two such forces would be deflected to a position coincident with that resultant.

A means of ascertaining the resultant force due to the earth's and coil's magnetic forces is then afforded by a knowledge of the fact that a magnetic needle will be deflected to a position, or angle, coincident with the diagonal representing the resultant of the component forces. For example, if it is found that a magnetic needle, capable of describing a circle having a radius equal to the line AB , is deflected to an

angle of, say, 71° , (see Fig. 87,) we know that the diagonal ϵ will represent the resultant of the two magnetic forces producing the deflection.

We have seen that a diagonal touching the line $B D'$ at the point 3, Fig. 87, represents the resultant force of a magnetic force of 3 acting against a magnetic force of 1, on the needle P . We may see further that a magnetic force, due to the coil, which would cause a deviation of the needle, against the magnetic force of the earth, to an angle, or degree, where a line continued therefrom would touch the line $B D'$, at 2, would have a strength of 2; and that a magnetic force due to the coil of $2\frac{1}{2}$, similarly acting against the magnetic force of the earth, would deflect the needle to an angle where the diagonal ϵ would touch the line $B D'$, midway between 2 and 3, namely, at 2.5, etc., the line $B D'$ lengthening, or shortening, directly as the strength of the magnetic force of the coil is increased or decreased. It thus follows, from

FIG. 88.

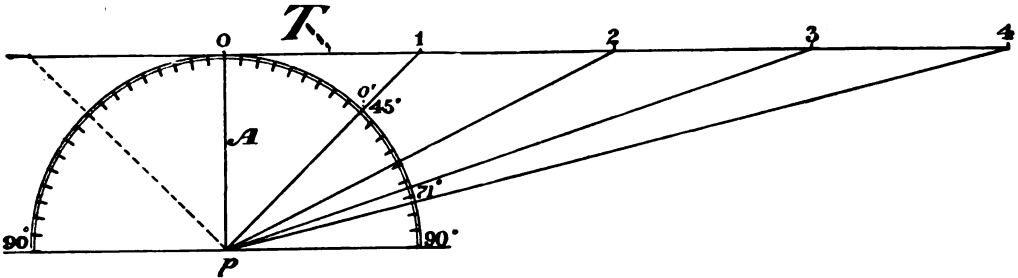

what has been said, that the length of the line $B D'$, reckoned from B , Fig. 87, to the point where it may be touched by a diagonal, or *resultant* line, is directly proportional to the strength of the coil's magnetic force. Further, as the magnetic force, or field, of a coil, surrounded by air, is proportional to the strength of the current flowing in it, it also follows that the strength of current in such a coil will also be proportional to a line similar to $B D$. For example, if a current of 1 ampere in the coil should originate a magnetic force at the needle, sufficient, when acting against the earth's magnetic force, to produce a resultant force, represented by the line $A D$, (Fig. 87,) then a current of 3 amperes will be required to originate that magnetic force which, also acting against the earth's magnetic force, causes a resultant represented by line $A D'$.

Assuming a circle with a radius A , to be drawn around P , Fig. 88, a straight line, such as T , (which corresponds to line $B D$, or $B D'$ in Fig. 87,) drawn from a point O on a circle, but not cutting it, is termed a *tangent*; and a line drawn from P , through any degree of the circle, less than 90° , will touch a tangent at a point which is termed the *tangent* of the angle. For example, the tangent of the angle of 45° is, in this case, $O 1$; that is, the line $O 1$ is the tangent of the angle $P O O'$. Analogously, the tangent of the angle of 71° is $O 3$, etc. In referring to the angle of deflection of a magnetic needle, its tangent is termed the "tangent of the angle of deflection." The tangent in this case, may, for the purpose of illustration, be said to correspond to

one of those sides of the parallelograms which represents the magnetic force due to the coil. Since, then, the "tangents" of the angles of deflection of the needle within a coil of wire, may be shown to be proportional to the strength of the currents in the coil the converse law is deduced, that such currents are directly proportional to the "tangents of the angles of deflection of the needle." This law, however, only holds when the needle of the galvanometer is acted on by the two forces uniformly at all points; which will only be the case when the lines of force of the coil are of sufficient length in a straight line to furnish a practically uniform field around the needle, regardless of the position it may assume.

FIG. 89.



Fig. 89 may be considered as representing the earth's magnetic lines of force; for while, taken as a whole, those lines of force are curved lines, any portion of them, of the length of an ordinary magnetic needle, is so slightly curved as to be practically straight. Hence, the earth's lines of force, in the vicinity of such a needle, may be considered as being of uniform direction and strength, and it only remains to insure that the magnetic lines of the coil shall also be practically uniform in direction in that portion of the field where the needle is placed, in order to secure the essentials necessary to the successful operation of the law referred to.

We have seen, (Chap. III) that a wire carrying a current is surrounded by magnetic lines of force, in concentric circles.

FIG. 90.

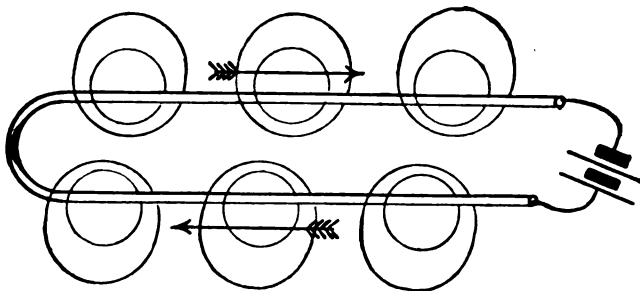

When wires conveying a current are placed parallel with each other, if the current in each wire is in opposite directions there is found to be repulsion between the "lines" of the respective wires, which may be represented as in Fig. 90. When the current is in similar directions in the respective wires there is found to be attraction between the lines of force, which then tend to coalesce and form larger circles, as outlined in Fig. 91. These actions are virtually similar to those of the poles of

magnets, which, when "unlike," attract each other, and, when "like," repel each other; the attraction and repulsion being due to the tendency of the lines to coincide in direction; this very tendency in the case of like poles, as stated, apparently producing repulsion.

When a wire carrying a current is formed into a ring, or circular coil, it is evident that at any two opposite parts of that ring the current will be flowing in opposite directions, and hence, the form of the lines of force within such a coil may be in-

FIG. 91.

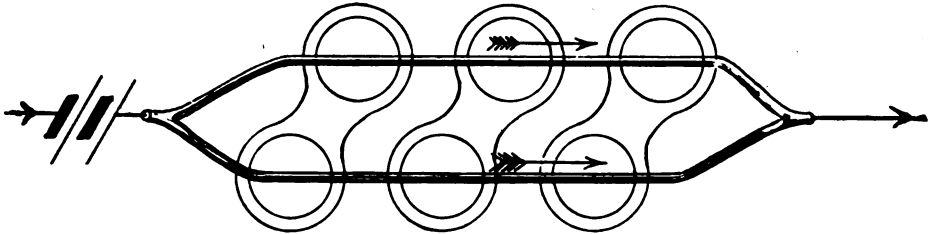

dicated as in Fig. 92. In that figure $c\ c'$ are sections of a circular coil of wire taken at diametrically opposite points. The space within the dotted lines l may represent

FIG. 92.

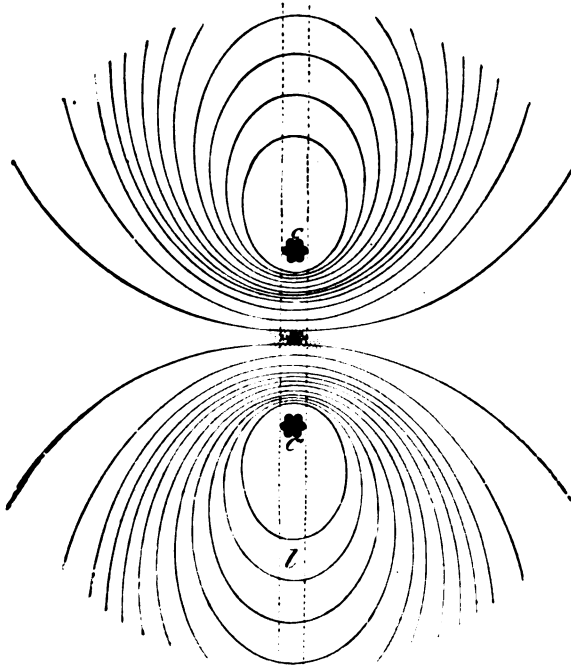

the plane of the coil, the small dots a section of the earth's lines of force, and the curved lines the lines of force that emanate from the coil. Similar curved lines may be

assumed to emanate from every other part of the coil. It is seen in Fig. 92 that the lines nearest the coil have a sharper curve than those more remote therefrom, and that those lines near the center of the coil are nearly parallel. Hence, if a magnetic needle be placed in the center of the coil, as at *x*, it will be in that portion of the field of the coil where the lines are most uniform and, if the needle employed be a very short one in comparison with the diameter of the coil, it may be moved to a position of right angles to the plane of the coil, (as shown in the figure) an angular deflection not obtained in practice, without emerging, very materially, from the uniform field. In constructing a galvanometer, therefore, which is intended to avail of the law that the currents flowing in a coil are proportional to the tangents of the angles of deflections of the needle, a needle whose length is from six to eight times less than the diameter of the coil, is generally used, which ratio is found to be quite sufficient for practical work.

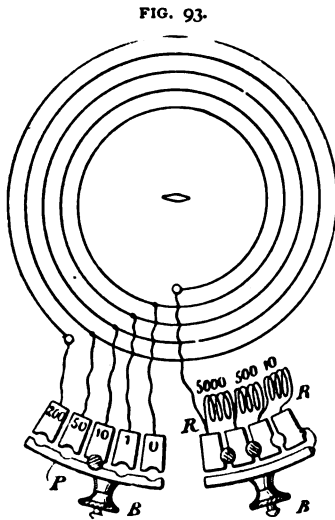

FIG. 93.

TANGENT GALVANOMETER (THEORY.)

A form of tangent galvanometer much used in telegraphy is shown, theoretically, in Fig. 93. It consists of coils of insulated wire, forming a circle, at the center of which a very short magnetic needle is freely suspended. One of the coils of the wire surrounding the needle consists of a ribbon, or band of copper; the other convolutions are wound and connected as shown. In order to obtain a variable effect upon the needle, as may be required, the convolutions are "tapped" at various points and led to the metallic discs marked 0, 1, 10, 50 and 200. If, for instance, it is desired to place in circuit all of the convolutions, a metallic plug is inserted between the brass plate *P* and the disc marked 200. All the other discs on the left hand side are left disconnected. If it is desired to use only the copper ribbon, the plug is inserted at the disc marked 0. If it is desired to include the convolutions 0, 1 and 10 the plug is inserted as shown in Fig. 93.

It is sometimes desirable to be able to reduce the deflection of the needle without altering the electromotive force of the battery. This may be done by placing in the galvanometer circuit one or more of the resistance coils *R R*, which may be short-circuited by metal plugs, in the usual way. In the figure the 5000 and 500 ohm coils are short-circuited and the 10-ohm coil is in circuit. The external wires are connected to binding screws *B, B*.

WESTERN UNION TANGENT GALVANOMETER.—This form of tangent galvanometer, as constructed for service, is illustrated in Fig. 94. It is known as the Western Union Standard. The coils of wire of the galvanometer are contained in the vertical, circular, grooved frame *R*. This frame is about six inches in diameter. The resistance spools are enclosed in a circular box, under the base of the instrument; the base is composed of hard rubber. The instrument is supported on three adjustable legs, by means of which it is levelled. The needle is balanced on a jewelled pivot; some-

times it is suspended from the arch of the coil or other suitable point. The length of the needle is $\frac{7}{8}$ inch.

As it would be inconvenient to read deflections from the needle itself, owing to the small circle which it would describe, there is fastened to it, at right angles, a long, light pointer of some non-magnetic material, such as aluminum, the ends of which extend to curved scales on the circumference of a dial placed immediately beneath the ends of the pointer. Any deflection of the needle deflects the pointer to an equal angle. On one half of the dial the degrees of a circle up to 90° , on each side of a zero, are marked. When normally at rest, the needle, being then under the directive influence of the earth's magnetism only, points north and south. When current is not flowing in the coil it is turned so as to be directly in line with the needle. Consequently, the pointer at such times will lie at right angles to the plane of the coil, and its ends will be over the zeros of the scales. When current is caused to flow in the coil the needle is deflected and the extent of this deflection is shown in degrees by the pointer.

. TABLE OF TANGENTS.—If the strength of currents flowing in the coil were directly proportionate to the angles of deflection of the needle we would know that if a given current deflected the needle to, say, 20° , a current which would deflect it to 40° would be of double the strength of the first current. But, as such is not the case, it is necessary, in using the tangent galvanometer, first to note the degrees of deflection of the needle, and then ascertain the tangent of the angle of the deflection.

To facilitate finding these tangents, a table of tangents, similar to that given at the end of this chapter, is usually employed. In this table it is assumed that the tangent of the angle of 45° is unity, or 1, and that the tangential line is divided into any number of divisions of equal length. For instance, the tangent of 45° , in Fig. 88, being 1, tangent 2 represents a space on the line from 1, equal to that which 1 represents from 0 to 1, and so on. These divisions are assumed to be divided again into 100 or 1000 parts. Thus, by reference to the table it is found that the tangent of 20° is 0.364, that is, $\frac{364}{1000}$ of 1.

These tables are then used in the following way:

For example, assume that the needle is deflected by a given current to an angle of 20° , and that a different current deflects it to an angle of 36° . By reference to the



W. U. TANGENT GALVANOMETER.

table of tangents it is found that the tangent of 20° is 0.364 and the tangent of 36° , 0.728. As the currents in question are proportional to these tangents it is evident that the last current has twice the strength of the first, since 0.364 is to 0.728 as 1 is to 2.

Knowing this law, then, and utilizing it in connection with Ohm's law, it is quite easy to avail of it in testing. For instance, if, with a given electromotive force and a given resistance in a circuit, a deflection of 36° is obtained, and with the same electromotive force, but a different resistance, 20° is obtained, we conclude that this last resistance is just double that of the former. For, as we have just seen, since the tangent of 20° is .364, namely, half that of the tangent of the angle of 36° , which is .728, it follows that the current strength must have been halved to cause the diminished deflection, and, by Ohm's law, it is known that with a constant electromotive force, the halving of the current strength in a circuit must be due to a doubling of the resistance, etc.

FIG. 95.

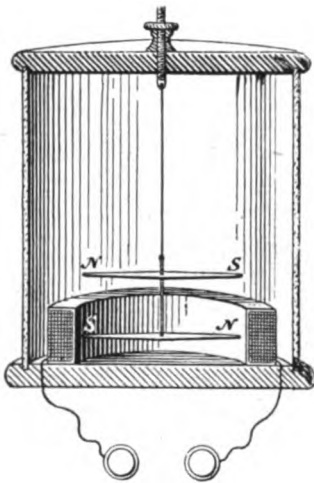

ASTATIC GALVANOMETER.

In some forms of tangent galvanometers one-half of the circumference of the dial is allotted to a scale on which the tangent of the angle, instead of the degree of the angle, is marked. This avoids reference to a table in calculating results, and when rough results only are desired it is a convenient arrangement but when greater accuracy is required the table should be referred to.

ASTATIC GALVANOMETERS.

In order to eliminate as much as desired the effect of the earth's magnetic influence upon the needle of a galvanometer, and thereby to make it more sensitive to the magnetic influence of the coil, at least, two devices have been employed. One of them consists of placing a "permanent" magnet sufficiently close to the needle and in such a position that the earth's magnetism is practically neutralized. In fact, it may not only be entirely neutralized, but, in addition, the permanent magnet may be caused to act as the directing force of the needle. Examples of this device are given in the description of the Thomson reflecting galvanometer, although it is also applied to other forms of galvanometer. The term "permanent" is applied to those magnets in which the magnetism is not maintained by an electric current. The common horse-shoe magnet is an example of this class. The metal of permanent magnets is usually hardened steel.

Another device for eliminating the effect of the earth's directive influence consists of the use of two magnetic needles, one above the other, supported at their centres on a common shaft. Fig. 95.

As it is difficult to make the needles equal in every respect, one of them will generally be slightly stronger than the other, or it may be made so purposely. The needles

are placed parallel with each other, the north pole of one being placed directly above the south pole of the other and *vice versa*; the consequence of which arrangement is that the tendency of one needle to point north is counteracted by that of the other to point south, with the result that the slightly stronger needle controls the direction of, but leaves the pair in a very unstable position, and one from which it will be very readily deflected by any external magnetic influence.

Such an arrangement of the needles is termed an astatic, or unstable, arrangement, that is, virtually, one in which the needles are indifferent to the position in which they may be placed.

This astatic arrangement is used extensively in galvanometers of the Thomson reflecting pattern. It is also used in a form of galvanometer called the detector, which is employed for testing purposes quite extensively in telegraphy. It may be made quite sensitive, and is useful in ordinary testing where a Thomson reflecting galvanometer might be too sensitive, and the ordinary tangent galvanometer not quite sensitive enough. It is used frequently in Wheatstone bridge testing, where it indicates the passage of current through the bridge wire.

DETECTOR GALVANOMETER.—A Detector galvanometer is shown with a section cut away for illustration, in Fig. 95. One of the needles of the astatic system is placed within the coil, the other above it. The upper needle carries a pointer, one end of which traverses a short scale, not shown in Fig. 95. The needles are suspended by a silk fibre from the top of the glass case, within which the galvanometer is enclosed.

In addition to the sensitiveness secured by the astatic arrangement of the needles, an additional advantage accrues from the placing of the needle within and above the coil, namely, that a greater deflecting force is exerted on the united needles than would be the case with a single needle, inasmuch as the lines of force acting on the lower needle, and those acting on the upper needle, both tend to turn the arrangement, as a whole, in the same direction. This remark may become clear by considering that, if a needle be placed above the coil and, looked at from above, should be turned to the right by a given current, the same needle, if placed below the coil, with the position of its poles reversed, would still be deflected to the right.

A form of the "detector" galvanometer used in practice, is shown in Fig. 96. It is placed on a tripod, with a ball and socket joint, to permit a ready leveling of the instrument. Small magnifying glasses are placed on the top of the case in order to assist in detecting slight movements of the needle. A device is also provided

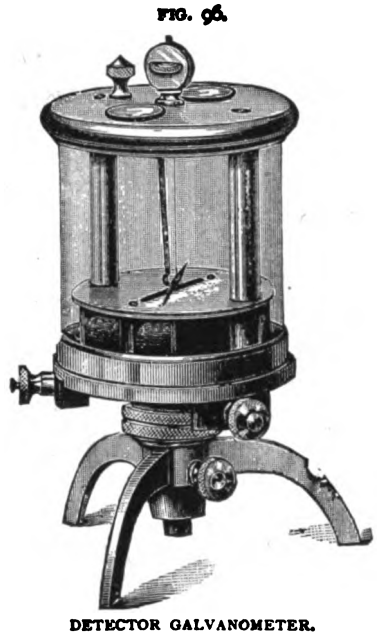

for holding up the needles when not in use, thus taking the strain off the silk fibre.

It will be understood from what has been said that the deflection of an instrument such as the "detector," is not proportional to the current traversing the coils, except for very small deflections, especially as the needles are generally much longer than the needle of the tangent galvanometer and, consequently, soon pass out of the more uniform field of the coils.

FIG. 97.

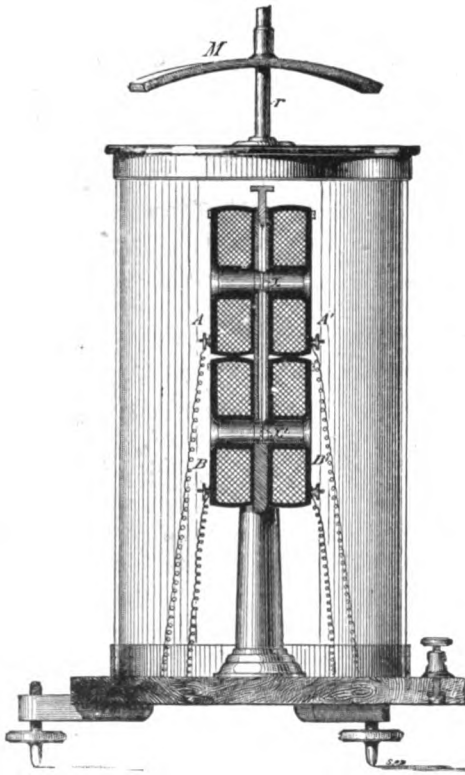

THOMSON REFLECTING GALVANOMETER.

The scale over which the pointer moves is provided chiefly to enable a "reading" to be taken when comparative results only are required. Of course, a given current passing through the coil will deflect the needles a given distance and, therefore, it would be quite practicable to calibrate the scale so that the instrument would act as an ampere meter, that is, a measurer of current strength.

THE DIFFERENTIAL GALVANOMETER.

The differential galvanometer was at one time in extensive use in telegraph testing in this country, but of recent years it has been replaced for that purpose by other forms of galvanometers.

It is now mostly used as a "tell tale," in Wheatstone automatic telegraphy.

In brief, the differential galvanometer is, in principle, similar to a differential relay, (*See Duplex Telegraphy*), a magnetic needle pivoted at its centre replacing the armature of the relay.

THE THOMSON REFLECTING GALVANOMETER.

This well known instrument is mainly used, in telegraphy, in the electrician's department, in tests of the resistance of insulating materials, insulated wires, cables, etc; electromotive force and internal resistance of batteries; electro-static capacity of cables; conductivity of wire, etc., the great sensitiveness of the instrument rendering its use for testing wires parallel with "live" wires somewhat unreliable. The instrument is also used as a "reading" galvanometer in submarine cable working, as described in Chapter on Submarine Telegraphy.

In the construction of the Thomson reflecting galvanometer, as a rule, four coils, wound on bobbins, are employed, which coils are placed in pairs, one pair above the other, and are supported by suitable frame-work, as in Fig. 97, where A A' are the up

per coils and $B B'$ are the lower coils, as seen sidewise; a section of the coils and frame being removed, in the drawing, for the purpose of illustration. The four coils may be readily connected together in series, or in multiple. Two magnetic needles are usually employed, one placed at the center of the two upper coils, as shown at x , the other at the center of the two lower coils, as at x' in the figure.

The needles are supported by a thin aluminum wire shaft a , shown more clearly in Fig. 98, forming, virtually as in the case of the "detector" galvanometer, an astatic needle system. Each "needle" is really formed of a number of small needles strongly magnetized, generally made out of watch spring. In the case of the upper needle these small magnets are attached to the back of a small, circular mirror, $\frac{1}{2}$ or $\frac{7}{8}$ of an inch in diameter, which is itself carried by the aluminum wire. The lower needle is also attached to the aluminum. A vane of light material, such as mica, is often placed at right angles to the needles for the purpose of retarding their swing. The needle system is upheld by a fine cocoon silk fibre attached to a movable pin P which fits into a slot in the top of the framework supporting the coils. The coils, needles, and their supports, are contained within a glass or brass case. Above the coils and outside of this frame, a curved magnet m is supported by and movable upon a rod r . This is termed a directing magnet, the utility of which will be mentioned later on. In some portable forms of the instrument the two lower coils are dispensed with and only the two upper coils are used.

FIG. 98.



The manner in which one form of the Thomson reflecting galvanometer is set up for use is shown in Fig. 99. The form there shown is the tripod. In the figure, L is a lamp, s a scale and s' a set of "shunts," or resistances. These shunts are used to divert certain portions of the current from the galvanometer coils in cases where, with the full current passing in the coils, the deflection would exceed the dimensions of the scale, or when, for any reason, a diminished deflection may be desired. (See end of section.) The object of the lamp and scale will presently be seen. A slit is made in the board below the scale s . The lamp is placed behind this slit and its beams fall upon the mirror N of the galvanometer, and are reflected back on the scale. Any deflection of the needle thus causes the reflected beam of light to traverse the scale to the right or left, according to the direction of the deflection of the needle. The scale is usually about 18 inches in length, and is divided into 720 divisions; that is, into 360 divisions each side of the zero, which is placed directly above the slit.

The scale may be considered as representing the tangent of the angles of deflection of the needle. For example, if the needle be deflected so that the beam is reflected on the scale as indicated in Fig. 100, it will be seen that the beam reaches the scale at a point where it would be intersected by a tangent τ , drawn from the semi-circle c at zero. Thus, by the use of this ingenious instrument, the practical equivalent of a pointer without weight, reaching from the needle to the tangent line, is obtained, and also one which, by its length, gives a considerable deflection with a scarcely perceptible motion of the needle, and a comparatively large deflection with an exceedingly feeble current.

Apart, also, from the fact that the scale line becomes, virtually, the equivalent of

the tangent of the angles of deflection of the needle, it is to be noted that with the needle at some distance, say 3 feet from the scale, a deflection of the needle of but 7° , would cause the reflected beam to traverse the scale to its limit, assuming the beam to have started from zero, as may be seen by an examination of Fig. 100. Therefore, if as, perhaps, is more frequently than otherwise the case in practice, the deflections do not exceed 50 or 100 divisions of the scale, it would be equal to working with deflections of 1° or 2° on an ordinary tangent galvanometer; in which case the currents would be, for practical purposes, proportional to the *angles* of deflection, so slight would be the variation between the angle and the tangent of the angle.

FIG. 99.

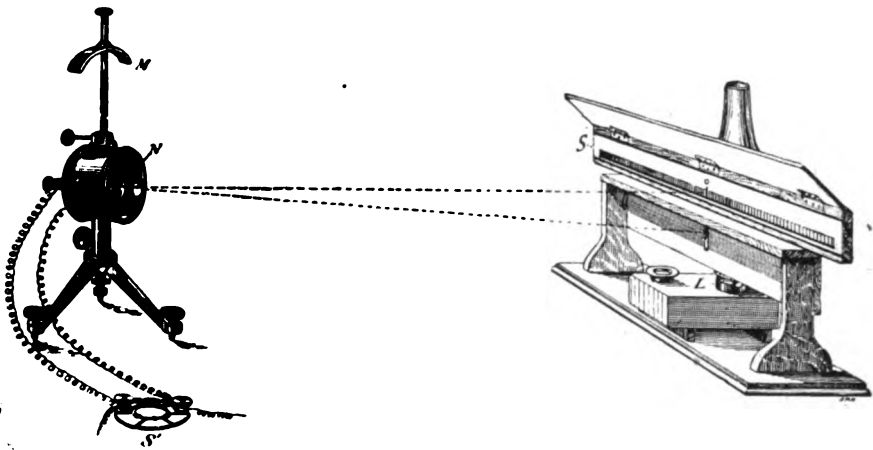

Since the scale line may be said to correspond to a tangent of the angle of deflection of the needle, it will be observed that the strength of current in the coil of the Thomson reflecting galvanometer will be proportional to the deflection of the needle as indicated on the scale. This deflection is not, however, strictly proportional to the current in the coil of the galvanometer, owing to the fact that the angle of deflection of the beam is double that of the actual angle of deflection of the needle. This may be understood, or verified, by observing that a hand-mirror, when held towards the sun at an angle of, say, 45 degrees, will cast a beam at a right angle, or 90° , to the direction in which the rays strike the mirror. But the variation due to this cause for very small deflections of the needle is not great, and even for larger deflections, unless where the strictest accuracy is required, it may be neglected, and the calculations made from the results of the actual reading of the scale.

GALVANOMETER SHUNTS.—The resistance of the coils of the Thomson reflecting galvanometer varies in different instruments, and with the purpose for which each instrument is designed, ranging from 5,000 to 50,000, or more, ohms, in instruments intended for measuring high resistances, to less than 2 ohms in instruments intended for measuring very low resistances. For example, certain ordinary instruments of

the former class, will give 1 division deflection with a current due to 1 volt through 100,000,000 ohms; that is, with a current of $\frac{1}{100,000,000}$ of an ampere; while instruments of the latter class will give perceptible deflections due to variations in the current strength, caused by minute variations in the length of the conductor under test, or by the minute variations of temperature of the wire caused by the momentary contact of the hand of the operator with the wire. Owing to this sensitiveness of the instrument it is essential, in order to enlarge its range of measurements, that means be provided for diverting certain portions of the current from the instrument; otherwise the limit of the scale would soon be reached. In practice the means used for this purpose are coils of wire termed "shunts," one of which, at a time, is placed across the terminals of the galvanometer coil; thereby forming with the latter a 'divided' circuit. It is thus obvious that the current which will flow in the respective branches of this divided circuit will be proportionate to the resistance of each branch, and may be calculated accordingly.

FIG. 100.

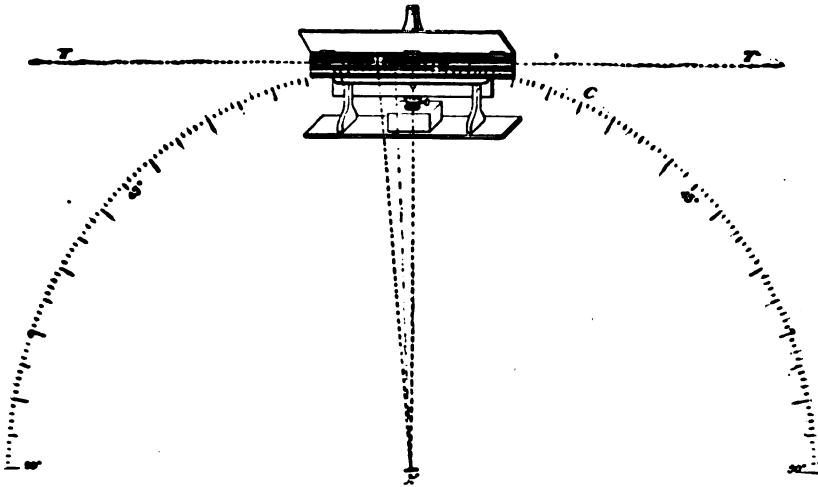

The "shunts" generally consist of three coils, termed the $\frac{1}{3}$ shunt, the $\frac{1}{9}$ shunt and the $\frac{1}{27}$ shunt. The resistance of each coil is arranged to bear a definite relation to the total resistance of the galvanometer coils, so that when, for instance, the galvanometer is shunted with the coil of the lowest resistance, namely, the $\frac{1}{27}$ shunt, a $\frac{1}{1000}$ part of the current flows in the galvanometer, the other $\frac{999}{1000}$ parts flowing through the shunt. When the $\frac{1}{9}$ shunt is used a $\frac{1}{100}$ part of the current flows through the galvanometer, the other $\frac{99}{100}$ parts flowing through the shunt, and when the $\frac{1}{3}$ shunt, namely, the shunt of highest resistance is used a $\frac{1}{10}$ part of the current flows in the galvanometer coil, the other $\frac{9}{10}$ parts in the shunt. Consequently, any deflection obtained when the $\frac{1}{3}$ shunt is used is multiplied 10 times, for the reason that, were the shunt not used, the current flowing in the galvanometer coils would be 10 times stronger and thus would deflect the needle to an angle whose tangent would be

practically 10 times greater than that of the angle obtained when that shunt is used. Similarly, when the $\frac{1}{100}$ shunt is employed, the deflection is multiplied 100 times, and when the $\frac{1}{1000}$ shunt is employed, 1000 times. On this account the various shunts are sometimes termed the tenth, hundredth and one thousandth shunts.

Without this arrangement of shunts the usefulness of the galvanometer would be much reduced, since, as stated, by its aid many measurements may be made which otherwise would be impracticable. This is especially the case where measurements by the "direct deflection," or "substitution," method of measuring high resistances, is concerned, for, without shunts of known multiplying powers, it would be necessary to utilize known resistances of a value equal to the resistances measured, which would be far in excess of those now employed or required.

FIG. 101.

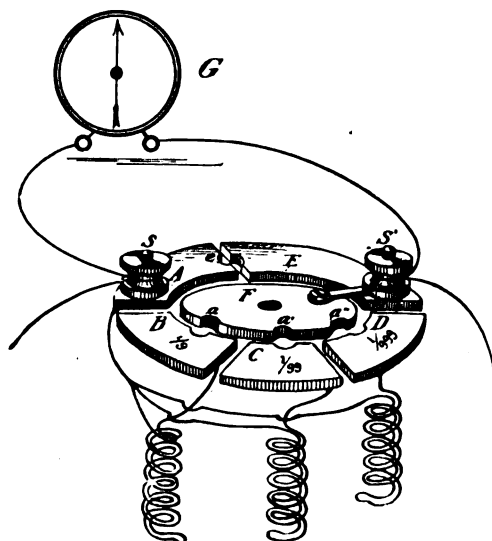

GALVANOMETER SHUNTS (THEORY.)

A form of "shunts" much used with the Thomson reflecting galvanometer is outlined in Fig. 101. A B C D E are brass segments and F is a brass disc. s s are binding screws to which the wires leading to the galvanometer etc., are attached. (In practice the disc F is connected by wire to segment E, under the disc, but, for clearness, it is shown connected on the top, in the figure.) The $\frac{1}{10}$ shunt coil is connected by one of its terminals to A, and, by the other, to B. The $\frac{1}{100}$ coil is also connected to A, and, by its other terminal, to C, and similar terminals of the $\frac{1}{1000}$ coil are connected to A and to D. When a plug is inserted in the aperture a the current diverted through the shunt follows the path from s, through the $\frac{1}{10}$ shunt to F and s', or contrariwise, and the insertion of a

plug at a', or at a'' brings into operation either the $\frac{1}{100}$ or the $\frac{1}{1000}$ shunt. Only one coil is supposed to be inserted at a time. It is seen that the coils are always open at one end except when connected in by a plug at a, a' or a''. The galvanometer may be short-circuited by inserting a plug at e. The shunt coils are "double" wound, as in the case of the ordinary rheostat.

When it is desired to obtain a multiplier different from any in the regular shunt the coils of an ordinary rheostat may be utilized, and the amount of resistance necessary for a given multiplier may be found by the formula:—

$$\frac{R}{M-1}$$

where R is resistance of the galvanometer coils, and M the multiplying power of shunt

desired. For example, if the resistance of galvanometer be 4000 ohms, and a shunt for a multiplier of 40 be desired, the resistance necessary to place in the shunt will be $\frac{4000}{40-1}$; that is 102.56 ohms.

DIRECTING MAGNET.—The Thomson reflecting galvanometer is generally set up with its needle or needles pointing north and south, and in this position the directing magnet may be raised on its supporting rod to a maximum height from the needle. It is not, however, absolutely essential that the needle should point north and south, since, by lowering the directing magnet, it, as it were, assumes control of the needle and by its use the latter may be caused to point to zero of the scale in almost any position. The sensitiveness of the galvanometer is, however, reduced when the magnet is in very active control of the needle. The closer the directing magnet is brought to the needle the more quickly does it resume its position of zero after the deflecting cause has been removed. It is often beneficial, indeed necessary, by the use of this device, to waive some of the sensitiveness of the instrument when external changes of magnetism, or the movement of iron in the vicinity, would tend to disturb the needle if directed chiefly by the earth's magnetism.

In testing with this galvanometer care should be taken not to carry knives, magnetized watches, etc., on the person, as erroneous results may be caused thereby. It is very important that the needles of the instrument should be perfectly level.

The form of instrument shown in Fig. 97 is always equipped with a spirit level. The tripod form may be levelled by a pocket spirit level.

Further allusion to this galvanometer will be found in connection with chapter on cable testing.

THE D'ARSONVAL REFLECTING GALVANOMETER.

This galvanometer differs from the Thomson (now Kelvin) reflecting galvanometer in that it employs a movable coil in a magnetic field, practically similar to the siphon recorder (page 269). The coil is suspended in virtually the same manner as the small magnets in the Kelvin instrument. There is also on the same suspension system a mirror which turns with the coil. This instrument is "dead beat," that is, it moves to its maximum deflection without oscillating back and forth. The scale *s* is read by means of a small telescope *t* focused upon the mirror *m*, Fig. 101a, the scale appearing to move past the hair mark on the mirror, the light from a lamp or window being thrown on the scale. This gal-

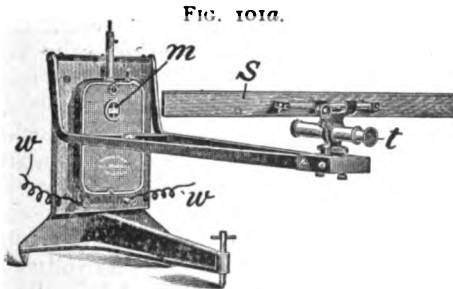

vanometer is not, as a rule, as sensitive as the Kelvin galvanometer, but is not readily affected by external magnetism, which with its dead-beat quality renders it advantageous where a portable instrument is required. The instrument is provided with the usual shunts; the lead or shunt wires are connected at *w w*.

VOLTMETERS, AMMETERS.

Voltmeters and ammeters are now extensively used for measuring voltage and current strength respectively, and for line tests. These instruments have the advantage that in measurements of E. M. F. and current strength the results are given upon a scale without further calculation. The instruments are also "dead beat," and the portable kind require no leveling and are not materially, if at all, affected by external magnetism. In Fig. 101*b* an ammeter is illustrated as it appears in practice. The voltmeter is practically similar in external appearance, Fig. 101*c*. In the type of instruments illustrated, a rectangular or oblate coil of wire pivoted on

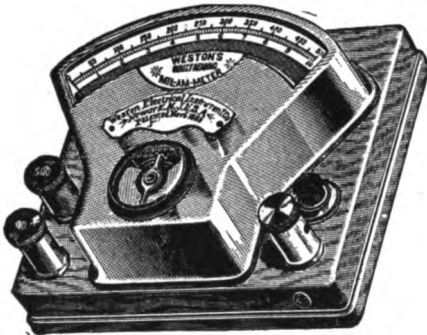
FIG. 101*b*.FIG. 101*c*.

jeweled bearings is placed in a strong magnetic field, also like the siphon recorder, which coil tends to turn when a current passes through it. The coil carries a light metal pointer, the outer end of which, when the coil turns, moves over the scale; the scale being calibrated to indicate, in the case of the voltmeter, the voltage at the terminals of the coil, and in the case of the ammeter, the strength of current, in amperes or milli-amperes, as the case may be, passing through the coil. The coil is moved by the current against the force of light springs, which springs return the coil to zero when the current is removed. Frequently the instruments are arranged for high and low readings in the one instrument. Thus Fig. 101*c* represents a voltmeter which will indicate up to 150 volts on the upper scale and up to 15 volts on the lower scale. For the 15 or 150 volt scale, one lead wire is connected with the right-hand post, and the other lead with the post marked 15 or 150, respectively. There are usually two resistance spools in the base of the double reading instrument, one or the other of which is placed in series with the moving coil, depending on which scale is used in the test. The small push button at the right, when depressed, closes the circuit in the instrument during tests. In stationary instruments, such as are used in connection with storage batteries, the instruments are permanently in the circuit. The voltmeter and ammeter are alike in general construction, but in the case of the voltmeter the coil is of thin wire of high resistance, while the coil of the ammeter is of thick wire of very low resistance. The voltmeter consequently diverts but little current from the circuit being measured for voltage, its resistance being very high compared to that circuit, and the ammeter consumes but little of the current, its resistance being very low relative to that circuit. The ammeter is placed in series in the circuit. The voltmeter is placed across the terminals of battery or instrument to be measured for E. M. F. or drop in voltage.

TABLE OF TANGENTS

TABLE OF TANGENTS.

DEG.	TANGENT	DEG.	TANGENT	DEG.	TANGENT	DEG.	TANGENT
1	.017	26	.488	51	1.23	76	4.01
1.5	.026	26.5	.498	51.5	1.25	76.5	4.16
2	.035	27	.509	52	1.28	77	4.33
2.5	.043	27.5	.520	52.5	1.30	77.5	4.51
3	.0524	28	.532	53	1.33	78	4.70
3.5	.061	28.5	.543	53.5	1.35	78.5	4.91
4	.070	29	.554	54	1.37	79	5.14
4.5	.078	29.5	.565	54.5	1.40	79.5	5.39
5	.087	30	.577	55	1.43	80	5.67
5.5	.096	30.5	.589	55.5	1.45	80.5	5.97
6	.105	31	.601	56	1.48	81	6.31
6.5	.113	31.5	.612	56.5	1.51	81.5	6.69
7	.123	32	.625	57	1.54	82	7.11
7.5	.131	32.5	.637	57.5	1.56	82.5	7.60
8	.140	33	.649	58	1.60	83	8.14
8.5	.149	33.5	.661	58.5	1.63	83.5	8.77
9	.158	34	.674	59	1.66	84	9.51
9.5	.167	34.5	.687	59.5	1.69	84.5	10.38
10	.176	35	.700	60	1.73	85	11.43
10.5	.185	35.5	.713	60.5	1.76	85.5	12.70
11	.194	36	.728	61	1.80	86	14.30
11.5	.203	36.5	.740	61.5	1.84	86.5	16.35
12	.212	37	.753	62	1.88	87	19.08
12.5	.221	37.5	.767	62.5	1.92	87.5	22.90
13	.231	38	.781	63	1.96	88	28.63
13.5	.240	38.5	.795	63.5	2.	88.5	38.18
14	.249	39	.810	64	2.05	89	57.29
14.5	.258	39.5	.824	64.5	2.09	89.5	114.59
15	.268	40	.839	65	2.14	90	Inf.
15.5	.277	40.5	.854	65.5	2.19		
16	.287	41	.869	66	2.24		
16.5	.296	41.5	.884	66.5	2.29		
17	.306	42	.900	67	2.35		
17.5	.315	42.5	.916	67.5	2.41		
18	.325	43	.932	68	2.47		
18.5	.334	43.5	.949	68.5	2.53		
19	.344	44	.965	69	2.60		
19.5	.354	44.5	.982	69.5	2.67		
20	.364	45	1.000	70	2.75		
20.5	.373	45.5	1.017	70.5	2.82		
21	.384	46	1.030	71	2.90		
21.5	.393	46.5	1.053	71.5	2.98		
22	.404	47	1.07	72	3.08		
22.5	.414	47.5	1.09	72.5	3.17		
23	.424	48	1.11	73	3.27		
23.5	.434	48.5	1.13	73.5	3.37		
24	.445	49	1.15	74	3.49		
24.5	.455	49.5	1.17	74.5	3.60		
25	.466	50	1.19	75	3.73		
25.5	.477	50.5	1.21	75.5	3.86		

CHAPTER VIII.

ELECTRICAL TESTING.

**THE WHEATSTONE BRIDGE.—MEASURING RESISTANCE; CAPACITY; ELECTROMOTIVE FORCE,
ETC.—LOCATING FAULTS ON TELEGRAPH WIRES, ETC.**

One of the most frequently used, as well as one of the most useful methods of testing, in telegraphy, is that known as the Wheatstone bridge method. The principle of the Wheatstone bridge has also been used in overland duplex telegraphy and is almost exclusively employed in submarine duplex telegraphy.

The operation of the Wheatstone bridge is, it may be said, based primarily on the fact that, when the potentials at two points of a wire are equal, no flow of electricity will take place in the wire.

In Chap. VI, it was stated that electric potential, or pressure, in a conductor decreases, or falls, proportionately as it "overcomes" resistance, etc. By the aid of a

FIG. 102.

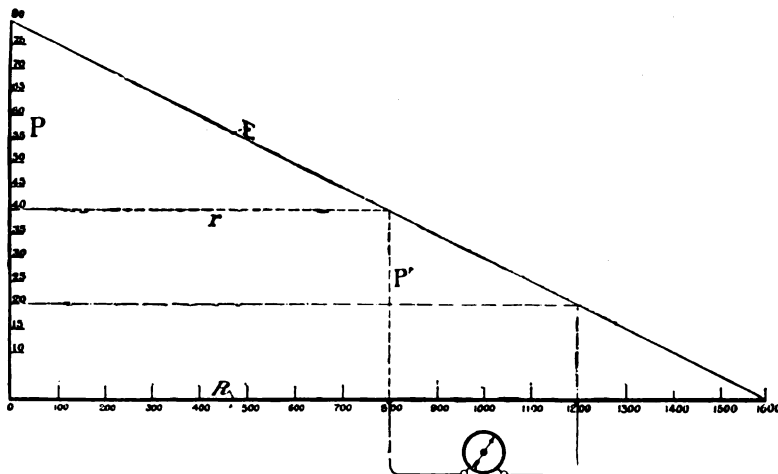
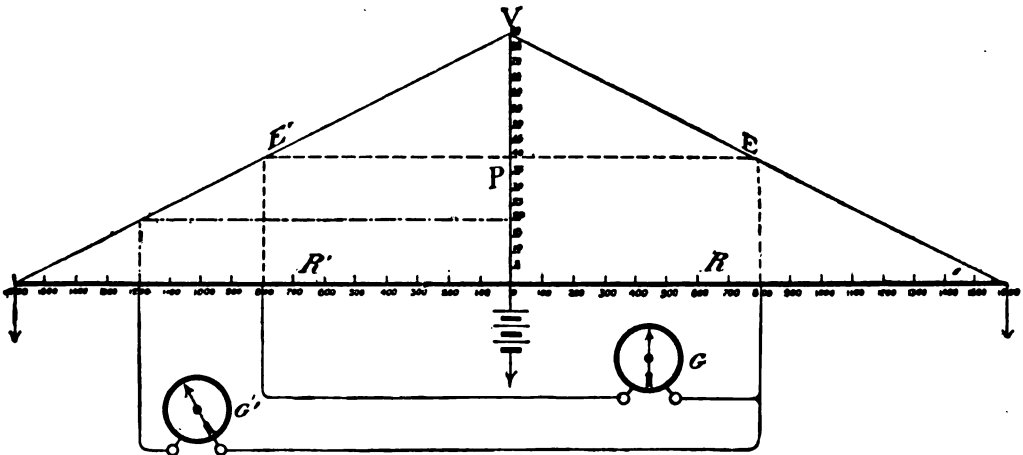

diagram similar to Fig. 102, the potential at any point of a circuit in which a current is flowing, (and of which the E. M. F. and resistance are known,) may be found, in the manner described in Chap. VI., and of which one or two additional illustrations may be given. It is assumed that the conductor is grounded at distant end.

Assume the resistance of the conductor represented by the horizontal line R to be 1,600 ohms and the E. M. F. by the vertical line P , 80 volts, as indicated. In the figure the vertical line P is divided into sections, each representing 5 volts; the horizontal line, R , into sections of 100 ohms each. By drawing a vertical line from any point of R until it intersects the line E and then by drawing, from that intersection, a horizontal line to P , the potential at that point of R will be indicated. Thus, in the figure the vertical, dotted line P' from 800 ohms on R , intersects, on E , the dotted line r , drawn to the 40-volt section on P , thereby indicating that the potential has fallen through, or overcome, one half the resistance of the circuit. Similarly, at any other point of the conductor, the potential may be found. In an analogous manner, also, the difference of potentials between any *two parts* of a conductor may be found when the total E. M. F. and resistance of the conductor are known. Thus, it will be seen, by reference to the dotted lines, that there is a potential difference of 20 volts between the 800 ohm section and the 1,200 ohm section of the conductor.

That this difference of potentials exists could be proven if the terminals of a suitable measuring instrument, such as a voltmeter, were connected between those points, as outlined in the figure. The direction of the current which would flow in

FIG. 103.



an instrument placed between those points, would be from the point of higher, namely, the 800-ohm section, to lower potential. If both terminals of the measuring instrument were connected to, say, the 800-ohm section, it would be found that no current would flow in the instrument. This would be, of course, because, in that event, there would be no difference of potential at its terminals; or, in other words, because the pressure at both terminals is equal.

In Fig. 103 an illustration is given of a means of producing this equality of electrical pressure at the terminals of a conductor*. In that figure there are two conductors, R , R' represented, each of 1600 ohms, connected at one terminal with a common source of electromotive force of 80 volts. The conductors, for the sake of

* Or an instrument, such as a galvanometer.

clearness, are shown as diverging to the right and left of the source of electromotive force; the lines E, E' , representing the slope of pressure along the conductors.

It is plain from what has been said that at a point, say 800 ohms from P , along each conductor, R, R' , the pressure will have fallen equally in each conductor, namely, to 40 volts. If then, the terminals of an instrument, such as a galvanometer G (or a relay) be placed, one at 800 of R , and the other at 800 of R' there will be no indication of current electricity in the instrument, and, as a matter of fact, none will flow. If, however, one terminal of the galvanometer G' be placed at 800 R and the other at 1200 R' , its needle will be deflected, indicating the "passage" of a current through its coils, and the "flow," which will be from R to R' , will be due to a potential difference of 20 volts, inasmuch as the potential at one terminal is 40 volts, and at the other terminal, 20 volts

FIG. 104.

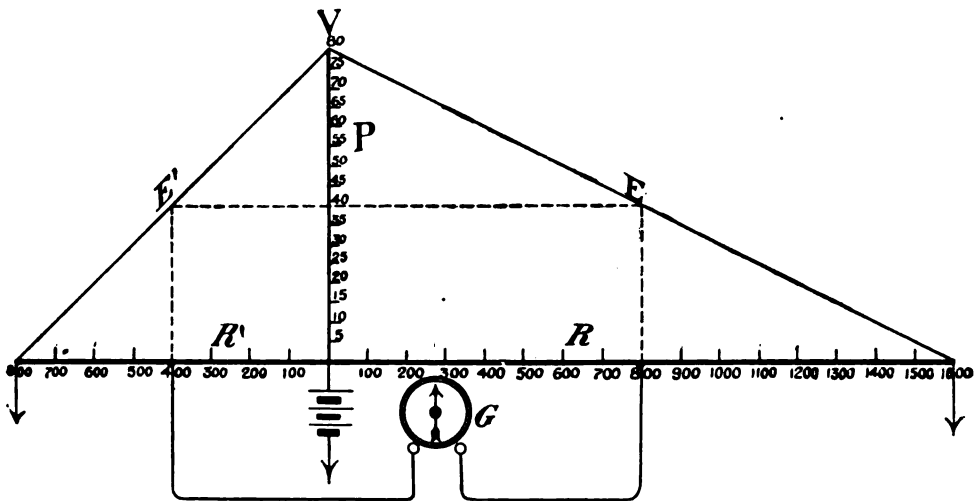

It is not necessary that the resistances of each conductor, or circuit, R, R' should be equal, in order that points of equal pressure may be obtained. For example, since it is known that the pressure falls directly as resistance is overcome, if we have one circuit of 1600 ohms, and another of 800 ohms, connected with a common source of electromotive force, as in Fig. 104, it is evident the pressure will have fallen one-half at the point 800 ohms in the longer circuit R , and to one-half at the point 400 ohms, in the shorter circuit R' . Hence, if we connect one terminal of a galvanometer to R at 800, and the other terminal to R' at 400 ohms, there will be no flow of current in its coils, the pressure at both terminals being equal and opposite.

The strength of current flowing in each circuit would, it is true, be unequal; for, by Ohm's law, in the case of R it would be .05 of an ampere, and in that of R' .1 of an ampere. But the current strength does not enter into consideration here, except in so far as its heating effect upon the wire might vary the resistance.

If then, we should arrange a combination of conductors, or circuits, of which we knew, and could vary at will, the resistance of one or more of the conductors, we could, by the use of suitable apparatus, ascertain the resistance of an unknown circuit by the introduction of resistance in the known circuit until we had brought about an equality of pressure at two given points, at one point on the known and one on the unknown resistance, which equality of pressure might be made evident by the failure of a suitable instrument to deflect its needle, or armature, when that equality has been reached. The principle aforesaid and a combination of circuits and apparatus for the purpose stated, are availed of in the Wheatstone bridge.

In Fig. 105, which is a theoretical diagram of the Wheatstone bridge, we have P , a battery exerting a pressure at A of, say, 80 volts. R R' are known resistances, consisting of coils of wire, each having a resistance of 800 ohms. B , is a resistance box, or rheostat, having adjustable coils. x is a length of wire the resistance of which it is desired to ascertain. R and R' , B and x , are termed "arms" of the bridge, and G is a galvanometer placed in a circuit, or wire, whose terminals are respectively connected as shown at T and T' .

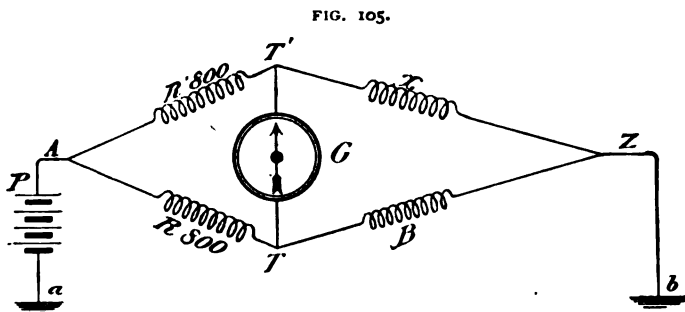

It has been stated that as long as there is unequal pressure at the terminals of a conductor, current will flow in its coils from the point of higher to the point of lower potential, but that, when the pressure is equal, and opposite in direction, at those terminals, current will not flow. The resistance of the arms R' and R being equal in this case, if we adjust the known resistance B until no deflection of the galvanometer needle is perceptible, we may know that we have rendered the pressure equal at its terminals T T' . When this result is accomplished the bridge is said to be balanced.

Supposing that, to bring about this equality of pressure, it was necessary to insert 800 ohms in the rheostat B , it will follow that the unknown resistance x must also be 800 ohms, and that such must be the case is evident from the fact that, in the case of the known resistance from A to Z , via R , T and B , the pressure at T has fallen one-half, or to 40 volts; consequently, since equality has been produced at T T' , the potential at T' must also be 40 volts, which indicates that half of the total resistance from A to Z via R' T , and x has been overcome and, since the first half, R' is known to be 800 ohms, the second half, or x , must be the same.

Ordinarily this conclusion is arrived at by considering that the arms of the bridge bear certain relations to each other when a "balance" has been obtained in the bridge wire, and that relation is expressed by the "rule of three" formula : $R : R' :: B : x$. Knowing then the resistance of any three of the terms it is an easy matter to ascertain the fourth. For instance, in the case given, we have

$$\begin{matrix} (R) & (R') & (B) \\ 800 & : 800 & :: 800 : x, \text{ which is equivalent to saying, } x = \frac{800 \times 800}{800}. \text{ That is, } x = \\ \frac{640000}{800} = 800. \end{matrix}$$

As stated in the case of examples already given, it is not necessary that the resistances of the arms R R' , Fig. 104, should always be equal—indeed, if that were the case the usefulness of the Wheatstone bridge would be much diminished—for by varying the resistances in R and R' it is possible to measure the resistance of an unknown wire very much greater than the combined resistance of all the coils of the rheostat B , or very much less than the resistance of its smallest coil.

FIG. 106.

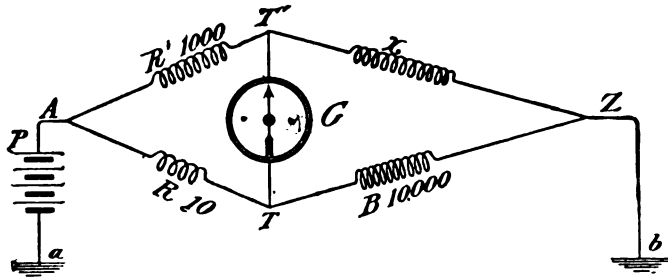

For example. It is desired to measure the resistance of a wire, or any other substance, which we find to be greater than the total resistance of the rheostat. If, in Fig. 106, we place in R a resistance of 10 ohms, and in R' 1000 ohms and find it necessary, in order to get a balance, to insert 10,000 ohms in B , it will follow that the unknown material x must have a resistance of 1,000,000 ohms for, since, at the point T , we know the pressure has fallen through $\frac{10}{10010}$ parts of the resistance from A to Z , via R and B ; at T' the pressure must have fallen through a proportional part of the entire resistance of the circuit from A to Z , via R' and x , which would be

$$\frac{1000}{1000 + x} \text{ parts, and, therefore, also by rule of three: } R : (R + B) :: R' : (R' + x), \text{ or}$$

$$10 : 10010 :: 1000 : R' + x \quad \text{That is, } \frac{10010 \times 1000}{10} = 1,001,000 = R' + x. \text{ Then,}$$

as we know that the resistance of R' is 1000 ohms, x must equal 1,001,000—1,000 ohms, that is, 1,000,000 ohms. Or, we may obtain this result, as before, by the formula :

$$\begin{matrix} (R) & (R') & (B) \\ 10 : 1,000 & :: 10,000 : x; \text{ that is, } x = \frac{1000 \times 10000}{10} = 1,000,000. \end{matrix}$$

Or the result may be obtained more easily yet by multiplying the known resistance of B by the ratio which R bears to R' . In this case the ratio is 1 to 100, consequently, the resistance of x is $100 \times 10,000$, or 1,000,000.

In Figs. 105 and 106, the terminals, a, b , are shown as placed to earth. It will be apparent that since the earth acts precisely as if it were a conductor, having practically no resistance, those terminals might be joined directly together in the Wheatstone bridge without affecting in any way the results.

FIG. 107.

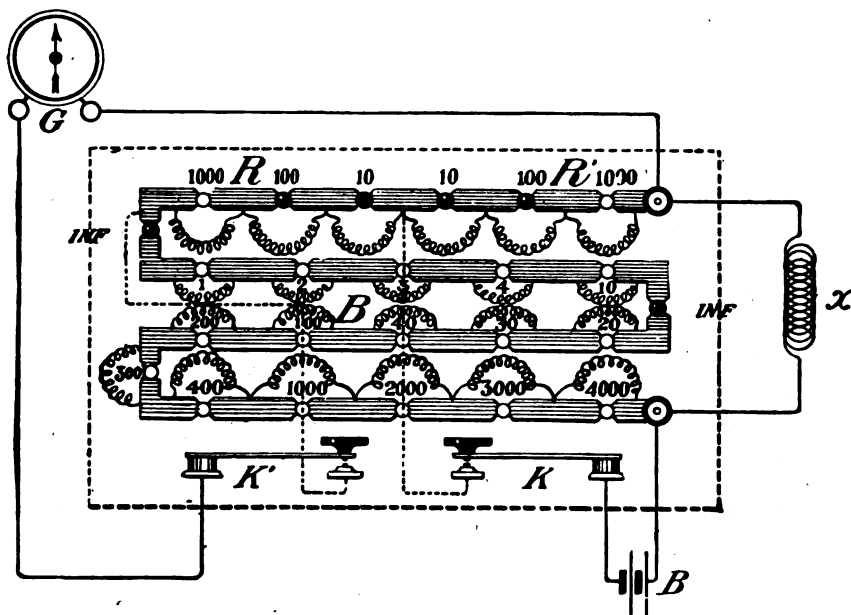

If it is desired to measure a conductor, the resistance of which is less than the smallest coil of the rheostat B , it is only necessary to reverse the arrangement shown in Fig. 106 and place the 1,000 ohms in the arm R , and the 10 ohms in R' . If then a balance is obtained by the insertion of, say, 20 ohms, in B , the resistance of the conductor x will be .2 ohms. For, as it is known that at T , the pressure has fallen through $\frac{1000}{1000+20}$ parts of the circuit from A to Z via R, B , so, at T' , the pressure must have fallen through $\frac{10}{10+x}$ parts of the circuit from A to Z via R', x . Or, as

$$\frac{(R)}{1000} : \frac{(R')}{10} :: \frac{(B)}{20} : x. \text{ Then } x = \frac{10 \times 20}{1000} = \frac{200}{1000} \text{ that is, .2 ohm.}$$

Or, in other words, the result may be obtained by dividing the resistance placed in B by the ratio which R now bears to R' ; that is, 100 to 1; that is, 20 divided by 100 equals .2.

If greater or less resistances than those above chosen are required to be measured by the Wheatstone bridge method, it may be done by still further increasing the ratio

between the arms R R' of the bridge, if the capacity of the apparatus will permit. In some forms of the Wheatstone bridge the arms of the bridge are so arranged that a ratio of 10,000 to 1 is obtainable.

POST OFFICE WHEATSTONE BRIDGE.—One form of the Wheatstone bridge as conveniently arranged for actual testing is outlined in Fig. 107. It is commonly known as the "Post Office" pattern. The bridge is contained in a box represented in the figure by the dotted lines. R and R' represent the arms of the bridge, which are, respectively, made up of coils of 10, 100 and 1,000 ohms, as marked. Any of these coils may be employed, at will, by the insertion of metal plugs in the ordinary way. In

FIG. 108.

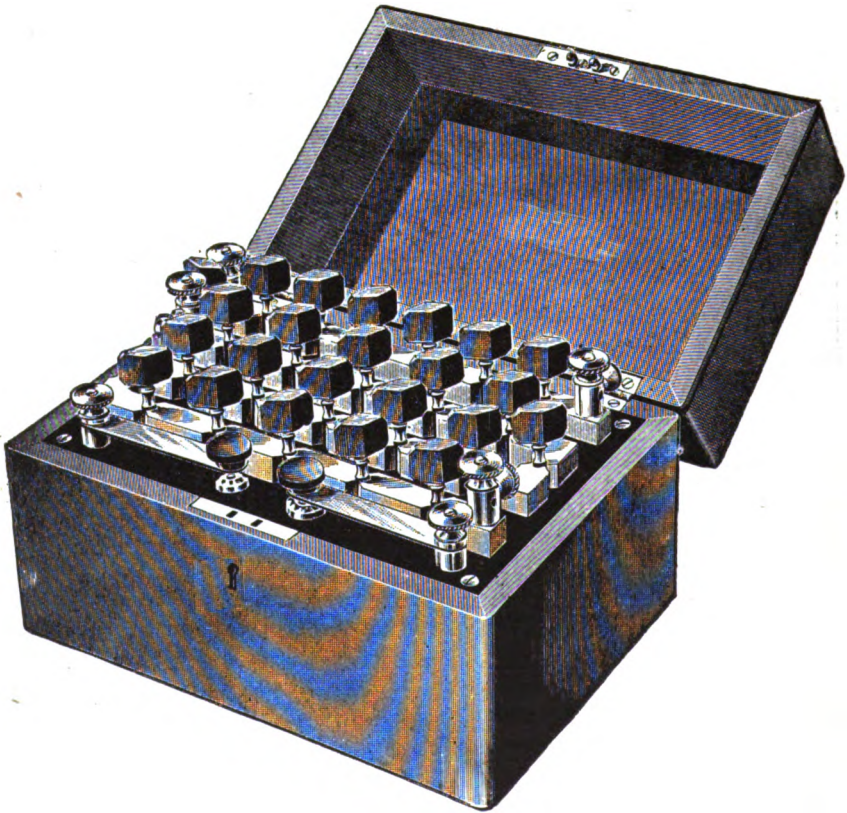
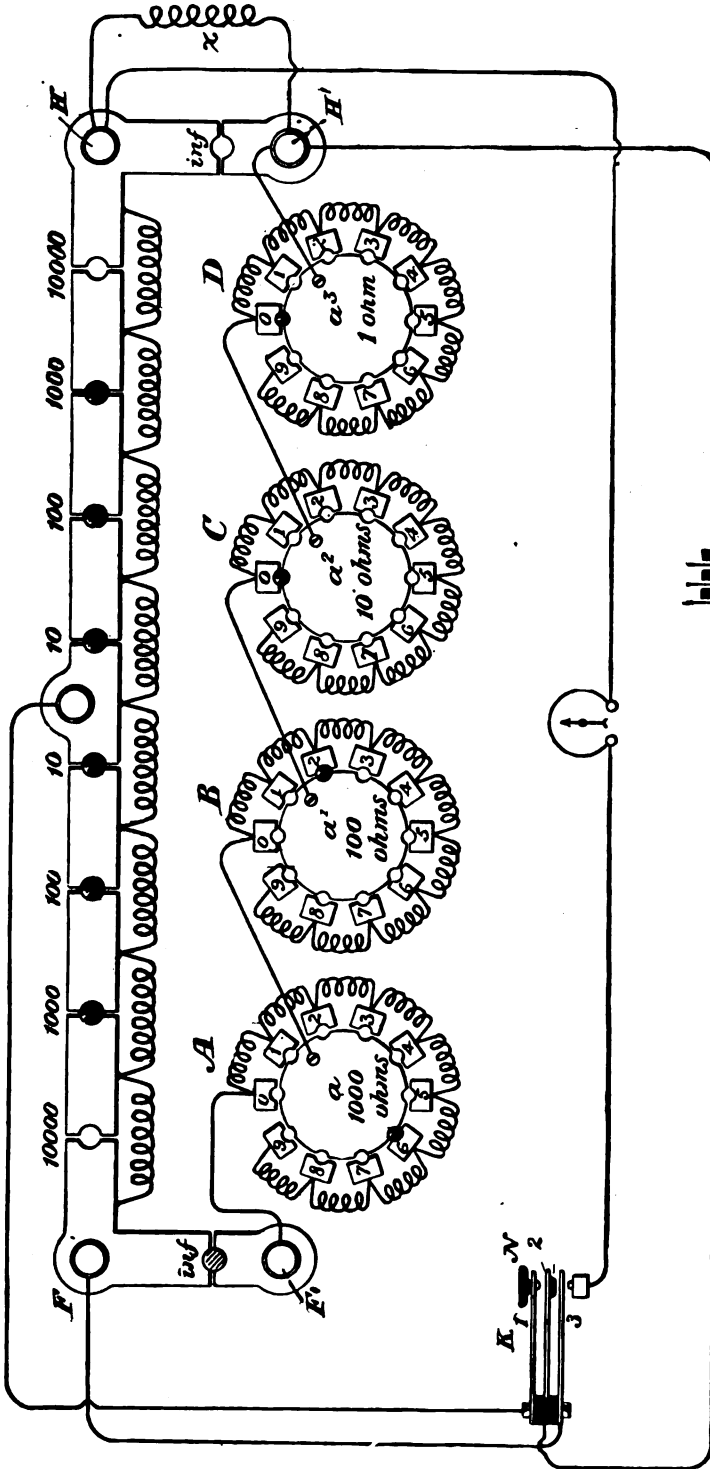

Fig. 107 the 1,000 ohm coils in R , R' , are shown as in use, making the "ratio" of those arms equal. B is an adjustable rheostat, having resistance coils amounting in the aggregate to 11,110 ohms. K , K' , are keys which, normally, keep the battery and galvanometer circuits open, but when depressed close those circuits. G is a galvanometer. B a testing battery. x is the unknown resistance to be measured.

The Post Office pattern of the Wheatstone bridge as used in practice is shown in Fig. 108, with box, plugs, keys, etc.

FIG. 109.



SIEMENS-WHEATSTONE BRIDGE, (THEORY.)

SIEMENS WHEATSTONE BRIDGE.—Another form of the Wheatstone bridge, known as "Siemens" pattern, is outlined in Fig. 109.

This form of bridge differs from the Post Office pattern chiefly in the arrangement of the coils of the adjustable rheostat; the general connections are practically the same. In the Siemens arrangement the coils are arranged in dial form as shown. The dial *A*, Fig. 109, is composed of 9 coils of 1,000 ohms each, so arranged that one plug inserted between the disc *a* and any one of the segments, (numbered from 1 to 9) will put into the circuit as many coils of 1,000 ohms each as may be marked on the segment. Dial *B* consists of 9 coils of 100 ohms each, dial *C* of 9 coils of 10 ohms each, and dial *D* of 9 coils of 1 ohm each; respectively connected to the discs *a'*, *a*², *a*³.

It will be seen that the metal strip *F'* is connected to segment *o* of dial *A*, and that the disc *a* of *A* is connected to segment *o* of dial *B*; *a'* of *B* to *o* of *C*; *a*² to *o* of *D*, and *a*³ of *D* to the strip *H'*. Apertures are provided between the disc and segments of the dials for the insertion of plugs, as shown. Assuming plugs to be inserted between the discs *a* and segments *o* of all the dials, it may be seen that all of the coils of those dials are simply short-circuited. Also that the complete removal of a plug from between any one of the discs *a* and the segments *o*, 1, 2, 3, etc., will open the circuit between *F'* *H'*. Or, if a plug be inserted between *a* and segment 6 of dial *A*, and another between *a'*, and 2 of dial *B*, and if the dials *C* and *D* be short-circuited by plugs between the discs and *o*, there will be in circuit, between *F* and *H'*, 6,200 ohms, namely, 6,000 at *A* and 200 at *B*.

This arrangement of the coils of the rheostat simplifies considerably the act of changing the coils to get a balance, and also the summing up of the resistances in circuit.

This form of instrument is frequently provided with a separate set of keys mounted on a common base, as at *K*, Fig. 109, whereby the battery and galvanometer circuits are, respectively, closed and opened.

The keys consist of three brass strips, having suitable contact points. The battery circuit is connected to the two upper strips; the galvanometer circuit to the lower strip and the lowest contact point. Strip 2 is insulated from 3 by a piece of hard rubber. The act of depressing the knob *N*, closes first the battery and next, the galvanometer circuit. When the finger is removed from the knob, the strips, of their own tension, rise, opening the circuits. This separate arrangement of keys has the advantage that they may be placed more conveniently for observing the deflection of the galvanometer than if permanently attached to the bridge box; it being understood that the resistance of the connecting wire of these keys may be neglected; of course, it should not be excessive.

In Fig. 109 the wire to be tested, *x*, is shown connected to the posts *H*, *H'*; the space, whose resistance is infinity, between the brass strips on which *H* and *H'* rest, being open. It is obvious that by opening the space between *F*, *F'*, and closing that between *H* and *H'* the resistance *x* may be connected at *F* and *F'*, instead of as shown, in which case the battery wire in the figure now attached to *H'* would require to be removed to *F'*.

MEASURING RESISTANCES BY SUBSTITUTION METHOD.

By the aid of the tangent or detector galvanometer an unknown resistance may be measured by what is called the "substitution", or direct deflection method.

It is known that with a given electromotive force and resistance the current in the coils of the galvanometer will cause a certain deflection of the needle.

When it is desired to measure, by the direct deflection method, an unknown resistance, x , it is placed in circuit with a galvanometer G and a battery B , Fig. 110. If the tangent galvanometer is used the deflection is brought to a suitable point on the scale by changing the coils of the galvanometer and, if necessary, inserting more or less resistance in the galvanometer circuit. The deflection is noted. The switch S is then turned to the right, which act cuts out the unknown resistance x and inserts the rheostat R . R is adjusted until a deflection similar to that obtained with the unknown resistance is shown. The resistance thus inserted in R is equal to the unknown resistance. Of course this method is only available when the unknown resistance is within the range of the resistance of the rheostat.

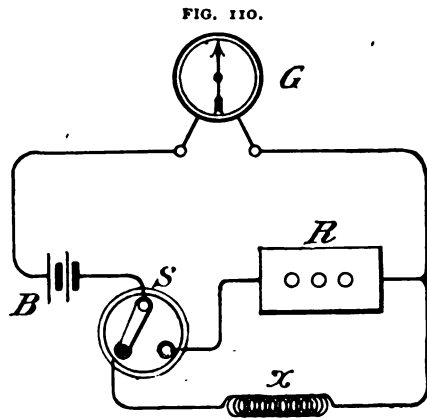

CAPACITY TESTS.

It is frequently desirable to know the electro-static capacity of a wire or cable. This capacity may be ascertained by the aid of a standard condenser and certain other apparatus, shown theoretically in Fig. 111, in the manner to be described.

As has been stated, the capacity of the standard condenser used for this purpose is generally $\frac{1}{2}$ or $\frac{1}{3}$ microfarad. In the figure K is an instrument termed a "discharge" key. It consists of a flexible metal strip R and rigid strips s s' ; all supported on suitable frames. R is supported at P and is given a tension which, normally, holds it against s' . There are contact points on the surfaces of R , opposite s' and s . B is a battery of any required E. M. F. SC is a standard condenser with an assumed capacity of $\frac{1}{2}$ microfarad. G is preferably a Thomson reflecting galvanometer. The first procedure is to obtain a *constant*. This is done by depressing R against s , by which action it is seen that the condenser SC is charged by battery B , via wires 1 and 2. The strip R is held depressed for a stated time, say 30 seconds,

when it is quickly let go, thus permitting it to break contact with *s* and make contact with *s'*, thereby opening the battery circuit and allowing the condenser to discharge through the galvanometer *G*

FIG. 111.

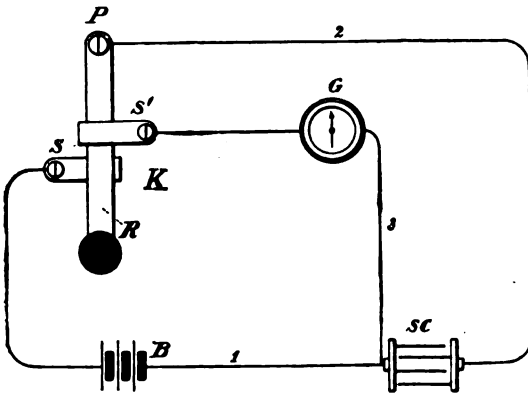

CAPACITY TEST.

and wires 2 and 3. The extent of the "deviation," "throw," or "swing" of the needle, as indicated by the movement of the spot on the scale, is duly noted. The foregoing action may be repeated several times in order to verify the "reading." If the capacity of the condenser or cable to be tested is known to be high, a low electromotive force, for instance, 1 volt, may be used in taking the constant. This, let us say, gives a deflection of 100 divisions on

the scale. The assumed capacity of the standard condenser being $\frac{1}{2}$ M.F. we may then say the constant will be 200 divisions deflections for 1 microfarad with 1 volt E. M. F. The standard condenser is then replaced by the condenser or cable to be tested (as in Fig. 112). Assuming it to be an "armored" cable, the wires 1 and 3 are connected to the conductor and wire 2 to the armor. If the cable is not armored, wire 2

FIG. 112.

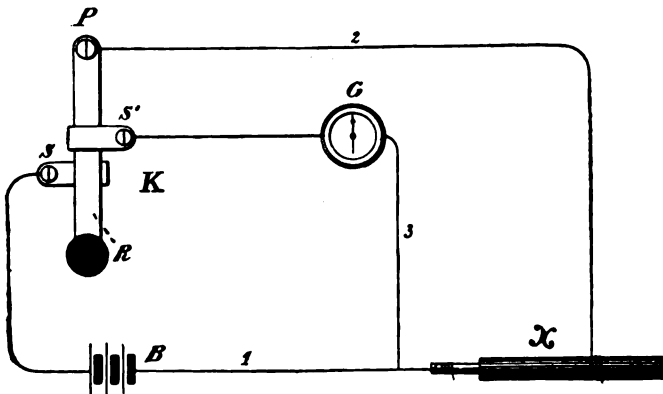

CAPACITY TEST.

is put to the earth direct. A preliminary test may be made to ascertain the approximate deflection due to the discharge of the cable. If the cable is a long one a "shunt" around the galvanometer will probably have to be used, even if but 1 volt be employed in the test. The strip *R* is then depressed for, say, 30 seconds, charging the cable. The cable is then discharged and the deflection is noted. Assuming that it is necessary to use the $\frac{1}{2}$ shunt and that a deflection of 100 is obtained, it is plain

that, without the shunt, the deflection would be 1000 divisions. Hence, as the deflection is proportionate to the strength of current and the current is proportionate to the potential to which the cable was raised, it follows that the capacity of the cable is ten times greater than that of the standard condenser, since, with the same E. M. F. it gives a discharge current ten times greater than the standard condenser. The total capacity, therefore, of the cable is 5 microfarads. The formula for this test is as follows: $x = \frac{D \times K}{d}$ where d is deflection due to standard condenser,

D the deflection due to unknown capacity of cable, K the capacity of standard condenser, and x the total capacity. Supposing the cable tested to be 20 miles in length the foregoing result would show the cable to have a capacity of .25 microfarad per mile.

MEASUREMENTS ELECTROMOTIVE FORCE.

The arrangement shown in Fig. 111 may also be used to measure the electromotive force of a cell or battery.

For this test a *standard* cell is used, that is, one, the electromotive force of which is known; for instance, a carefully prepared gravity cell, the E. M. F. of which may be taken as 1.079 volts.

This test is made virtually as in the case of a capacity test, except that the "reading" is generally taken at the moment of charge, and it is based on the fact that the "charge", or quantity of electricity which a condenser will accumulate, is proportional to the electromotive force of the charging battery. Thus, with the connections arranged as in Fig. 111, assuming that a deflection of 100 divisions is obtained with a standard cell B; then if we substitute for B, another cell, calling it B', and get a deflection of 200 divisions, the electromotive force of the second cell is evidently twice that of B.

The formula for this test would be $d : d' :: B : x$, where x is the E. M. F. of B'; B, the E. M. F. of cell B; d , the deflection obtained with B; d' , the deflection obtained with B'.

MEASURING INTERNAL RESISTANCE OF BATTERIES.

The following is a simple method of measuring the internal resistance of a cell or battery. It is termed the "half deflection" method. The arrangement for this test may be similar to that shown in Fig. 110. A tangent galvanometer is employed, the copper band of which is used. The cell or battery B to be tested is connected up with the galvanometer G and a rheostat R. The coils of the latter are at first short-circuited.

We have seen that the currents in the tangent galvanometer coils are proportional to the tangents of the angles of deflection of its needle. Also that, according to Ohm's law, current strength in a circuit is inversely proportional to the resistance. In this test the electromotive force is furnished by the cell, or cells to be tested. The current flowing in the circuit consisting of the galvanometer band and the cell itself, is then equal to the quotient of the E. M. F. divided by the resistance. This current deflects the needle a certain distance. It is immaterial in this test what the exact

strength of the current may be ; that is, within the limits of the galvanometer. The deflection is noted. Assuming it to be 21.55° of the scale, the tangent of the angle is .3889. It is understood that the resistance of the copper band is so little it may be neglected. The connecting wires should be so short or so thick that this statement may also apply to them. If now, by means of the rheostat, sufficient resistance is inserted in the circuit to bring the "pointer" to a place on the scale opposite 11.12° , we shall have, practically, halved the tangent of the angle of the first deflection, the tangent of 11.12° being .1944. Assuming that 2 ohms were inserted to thus reduce the deflection it is clear that the internal resistance of the battery is also 2 ohms. For, since we have halved the tangent of the angle of deflection, to which the current is proportional, and have not disturbed the electromotive force, it follows that we must have doubled the previously existing resistance of the circuit.

TESTING THE CONDITION OF BATTERIES.

The tangent galvanometer is also used to determine the condition of batteries, in the following manner :

The deflection of the needle due to the current from one cell taken from the battery, and known to be in good order, is noted. This deflection will serve as a *constant*. The current from the entire battery is then passed through the copper band of the galvanometer. The deflection should be the same if the entire battery is in good condition, for, in that case, the current flowing through the galvanometer should be the same as when but one cell was used. (*See Arrangement of Cells, etc.*)

In practice it is common to ascertain, by experiment with a given galvanometer, what the lowest deflection will be with a battery in good working condition, and, when the deflection falls below that point, to have the battery examined or renewed. If a newly set up battery should show an abnormally low deflection, or, in other words, an abnormally high resistance, the cause will doubtless be found in some one or two cells, which may be determined by testing the cells separately.

It may be noted that the uniform deflections obtained under the different, but proportionate, conditions of electromotive force and resistance, when the battery is in good order, are due to the fact that the resistance of the galvanometer band used during this test may, as already stated, be neglected. If a coil of high resistance were employed a different and not so simple a method of calculating the result would be necessary.

LOCATING FAULTS ON TELEGRAPH WIRES.

The "faults" that occur on telegraph lines are generally due to crosses, heavy escapes and grounds. The cross is caused by two or more wires coming together; the escape is caused by a partial contact of the wire with the ground, and the "ground" is occasioned by the actual contact of the wire with the earth.

On the occurrence of faults of the nature just mentioned, or analogous ones, the first step generally taken is to locate, or localize, the fault between two stations, or offices. This is done by the testing office asking some office located about the middle of the line to "cut" in on the defective wire. Call this office *F*. If the defect is a "break" the station thus called in, will put on his "ground" wire. If this closes the circuit the break in the wire is evidently beyond *F*. *F* is then told to take off his ground and "cut" out, and a more distant office is called in on the wire. Should the "break" be between the testing office and *F*, the putting on of the ground in *F* will have no effect, and that office reports the circuit open. In this case the testing office then calls up a nearer office and the same procedure is followed, until the trouble is located between two offices.

To locate a "ground" between two offices, intermediate office *F* is asked to open the defective wire. If by so doing he opens the wire at the testing office the ground is beyond him, and a more distant office, *G*, is called in. If the opening of *F*'s key does not open the wire at the testing station the "ground" is between *F* and *G* and in that case the testing office then proceeds to call in a nearer office. This plan also applies to the locating of "escapes."

In locating a "cross" between two or more wires the intermediate office is called in and requested to open one of the crossed wires. If, on his doing so, the testing office finds that wire now clear, the cross is beyond the intermediate office. If the cross still remains on the wire the trouble is evidently this side of the intermediate office, and a more remote office is next called in.

In making the foregoing tests the chief operator uses the ordinary main line relay; determining the extent of, or removal of the escapes, etc., by the pull of the retractile spring.

Having located the trouble between two stations the testing chief operator then decides whether a test for a closer location of the fault is necessary. This depends sometimes upon the whereabouts of the linemen and the distance apart of the stations between which the fault has been located. Should it be deemed best to locate the fault more accurately, either of the electrical methods to be described may be utilized. In the case of a "dead" open fault, as it is termed, since it is most probable that at least one end of the wire is grounded, the nearest testing office beyond the break and on the side of the "ground" is requested to locate it by an electrical test.

In ordinary practice, in this country, it is the custom to rely, almost entirely, on the "between office" test, especially when the line follows a railroad, in which case the lineman proceeds by train to the scene of the break and by keeping a close look-out can generally detect the trouble from the train. He may then, if fortunate enough, have the train stop to permit him to alight. If not it will be necessary for him to walk back, or to use a railroad velocipede from the next station.

Where offices are widely apart on highway lines the question of electrical tests to locate faults as accurately as possible becomes more important, since the fault may be within a few feet or yards of one of the offices. But even in the case of highway lines electrical tests are not always resorted to; the general rule being to

send out linemen from each office with orders to proceed until they meet; the first arriving at the fault to repair it if he can do so alone.

When it becomes imperative to test for the exact locality of a "break" in a wire, the only means of so doing is by a "capacity" test. (*See Locating Faults by Capacity test.*)

Another source of trouble on telegraph wires is that due to a high resistance caused by poor joints, loose connections, etc. Such faults are best located by measuring the resistance of the wire from point to point by means of the Wheatstone bridge.

LOCATING CROSSES ON OVERHEAD WIRES OR IN CABLES.

When wires, whether overhead or in cables, are "crossed", it is a comparatively simple matter to locate the distance of the cross if the wires crossed are of the same resistance throughout, and, also, if there be no resistance at the scene of the cross itself.

LOCATING A CROSS HAVING NO RESISTANCE—The procedure in that case is as follows: Suppose the wires A B, Fig. 114, each having a resistance of 10 ohms, per mile, to be crossed at the point x . The wires are first opened at z , and the loop formed by A and B via the cross is then measured from y , preferably by the Wheatstone bridge method. Assuming the resistance thus obtained to be 500 ohms, which will be the sum of the resistances of the two wires from y to x , it is an indi-

FIG. 114.

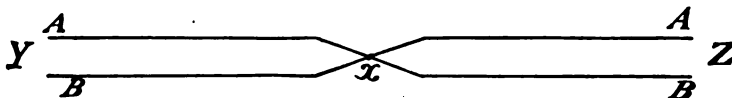

cation that the cross is distant 250 ohms along either A or B, and as the wires measure 10 ohms per mile, the fault is, evidently, 25 miles from the terminals at y .

It is not, however, safe to take it for granted that there is no resistance at the point of contact, x , of the wires, and, therefore, a method in which the resistance, if any, at that point, may be measured and allowed for, must be employed.

LOCATING CROSSES HAVING RESISTANCE.—One such method is as follows: A and B, Fig. 114, are shown crossed at x , as before. If not already known, the total resistance of A is first measured. This is done by opening wire B at both ends and grounding A at z . Assuming this resistance of A to be 1,000 ohms. It is also supposed that B has a similar total resistance. Next open A at y , and B at z , and measure the resistance of the circuit thus formed, from y to z via x , and call it 1,100 ohms. It is then plain that the resistance of the "cross" is the excess of

resistance over the normal resistance of either of the wires; that is, 1,100 minus 1,000, namely, 100 ohms.

The wires A and B are now measured as a loop, from Y to x and return. Assuming the resistance obtained to be 600 ohms, the resistance of the cross itself

FIG. 115.

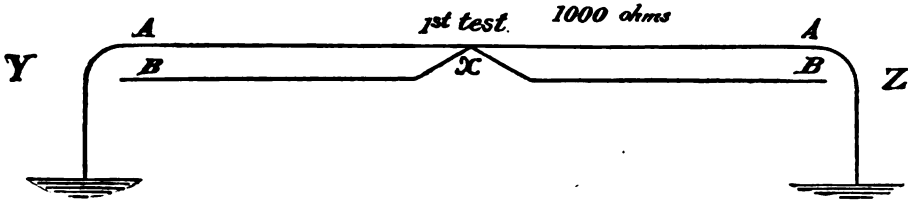

must now be deducted from that amount: namely, 100 from 600, leaving 500 ohms. The resistance of either of the wires from Y to the cross is, therefore, 250 ohms, and this places the cross 25 miles from Y.

It has been assumed in the foregoing tests that the resistance of the two wires is practically the same throughout. When this is not the case a different plan of testing is followed; namely, one in which the resistance of either of the wires is calculated from the measurements; or another in which, owing to the manner of the test, the resistance of but one of the wires is required.

The first of these methods to be described is quite simple and will be understood by the aid of the diagrams accompanying the following description: First, measure the resistance of A with B open at both ends, as in Fig. 115, and call it, as before, 1,000 ohms. Next measure A and B, as a loop, from Y to the cross x and return,

FIG. 116.

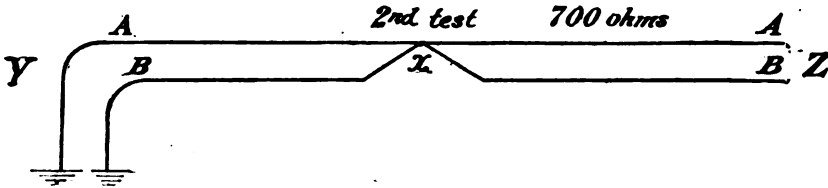

through and including the resistance of the cross, Fig. 116. Assume it to be 700 ohms. Next, open A at Y, and B at Z, as in Fig. 117, and measure A B from Y to Z, via x, and call the result 1,100 ohms. This latter test also includes the resistance of the cross. If we now add the results of the first and second tests together, making 1,700 ohms, and subtract from that amount the result of the third test, that is, 1,100 from 1,700, it will be observed that we have virtually cancelled the resistance of B from Y to x, (Fig. 116) including the resistance of the cross, and the resistance of A from x to z. This shows that the 600 ohms left after this cancellation is the sum of the resistance of A from Y to x, taken twice. (Figs. 115 and

116.) Hence it is plain that the cross is at a point 300 ohms from Y ; or, assuming the resistance of the wire A, to be 10 ohms, per mile, the fault is 30 miles from Y.

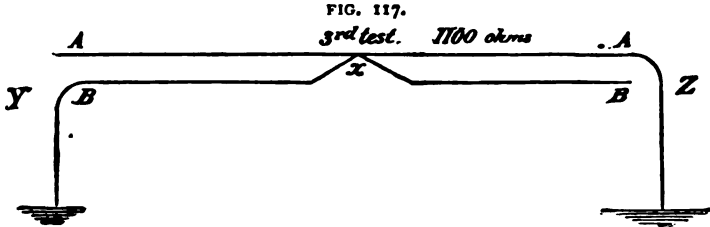

It is thus seen that the actual resistance, per mile, of the wire B is not required to be known.

The formula for this test would be

$$x = \frac{A + L - F}{2}$$

where x is distance of fault in ohms, A the result of 1st test, L the result of 2nd test, and F the result of 3rd test.

LOCATING A CROSS HAVING RESISTANCE—A WHEATSTONE BRIDGE METHOD.—Another method in which the resistance of one of the wires may be neglected is shown in Fig. 118, as usually outlined in the text books. In this figure x is the cross

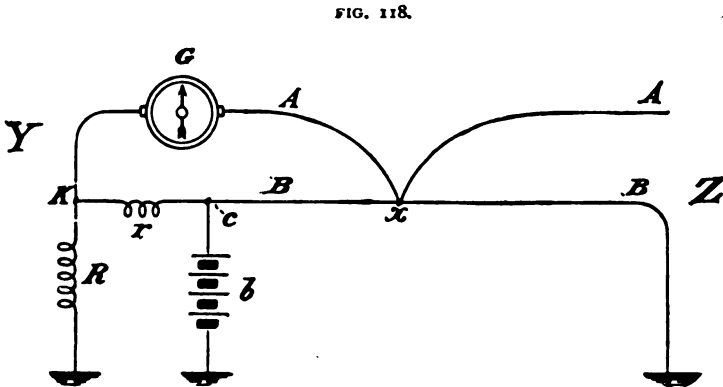

as before, the test being made from station Y. A and B are the crossed wires. G is a galvanometer, one terminal of which is attached to line wire A at station Y ; the other terminal to point K, also in station Y. r is a known, moderately low resistance, inserted between the line wire B at c , and the point K. R is an adjustable resistance, inserted between K and the ground. b is a testing battery attached to B at c , as shown. The distant end of wire A in Z office is insulated ; that of B is grounded.

At first sight the foregoing diagram may not be recognized as an arrangement of the Wheatstone bridge, but it is so, nevertheless, as will perhaps be more clearly seen by reference to Fig. 119, in which the arrangement of wires and apparatus is modified to conform more closely to the conventional Wheatstone bridge. B, between c and the cross x, forms one arm of the bridge; r, the known resistance, forms the other; A, between the galvanometer and the cross, forms the chief portion of the bridge wire, and B, beyond x, is balanced by the adjustable resistance R.

Since the wire A is in the bridge wire on one side of the cross and open on the other side of the cross it is easily understood that its resistance may be neglected, and since wire B is not tested *through* the cross the resistance of the cross may also be overlooked. Having made the arrangements as shown, a balance is obtained in the usual way, by adjusting R until equilibrium is established in the galvanometer.

FIG. 119.

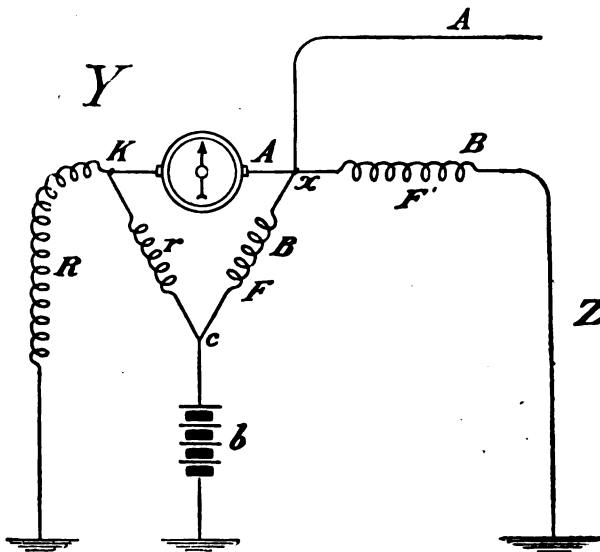

For example. Let us call the portion of the wire B, between c and x, F, and that portion between x and the earth at z, F'. When a balance is secured in the Wheatstone bridge it is known that r is to r + R, as F is to F + F'. Assume that the resistance of r is 20 ohms, and that it is necessary to insert 480 ohms in R to obtain a balance. We have, it is also assumed, previously ascertained that the total resistance of wire B, from Y to z is 1,000 ohms; that is, F + F' = 1,000 ohms. As the total resistance of r + R is 500 ohms, it is self evident that r is $\frac{20}{500}$ of that total resistance; that is, r is $\frac{1}{25}$ of 500. Then, as F is to F + F', as r is to r + R, F will

be $\frac{1}{25}$ of 1,000; in other words, 40; which is obvious from the fact that 20 is to 40 as 480 is to 960, which is the equivalent of saying that the arm r , of the bridge, is to F as the arm R is to F' .

The usual formula for this test is :

$$F = B \times \frac{r}{R + r}$$

where F is distance of fault in ohms ; B is total resistance of wire B ; and r and R are, respectively, resistances of bridge arms.

LOCATING FAULTS BY VARLEY LOOP TEST.

To locate a "ground" on a wire or cable would be comparatively easy if it were known that the ground itself had no resistance, for in that case it would only be necessary to measure the resistance of the wire from the testing end to the ground, and then, (as in locating a "cross" under similar conditions) divide the result by the known resistance of the wire, per mile. But, as in the case of "crosses" also, there is generally more or less resistance at the point of contact with the earth, and as the amount of this resistance is not known, some method of locating the "fault" must be employed in which the unknown resistance may be neglected.

The Varley loop method, the connections of which are shown in Figs. 120 and

121, is one such method of locating a ground. It will be seen that it utilizes the Wheatstone bridge. In making this test it is necessary to have two parallel wires, one of which is the defective wire. These two wires are first connected as in Fig. 120, forming a loop, the resistance of which loop is measured by the bridge method ; the presence of the ground, or fault F , not interfering with this measurement. It is assumed that the wires of the loop are of practically equal resistance per

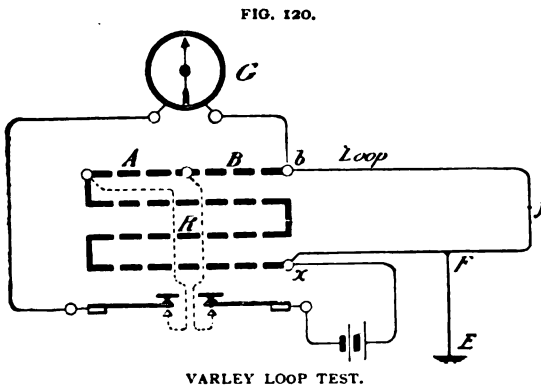

unit of length, throughout.

The "detector" galvanometer may be used for this test. It is placed in the "bridge" wire of the Wheatstone bridge.

The connections are next made as in Fig. 121 in which $A B$ are arms of the bridge; w is the "good" wire of the loop, and w' is the defective wire, connected, respectively, to the bridge box terminals at b and x ; w' being indicated by the curved line; the fault by F . The battery is connected as shown, one pole being placed to ground. R is the usual adjustable resistance of the bridge.

When these connections have been made the keys are depressed and resistance is inserted in R until a balance is secured. When this balance has been secured it may be seen by reference to Fig. 122, that the fault is moved, as it were, to the middle of the loop now formed by the wires w w' , and the resistance R , just added to w' to bring about the balance.

FIG. 121.

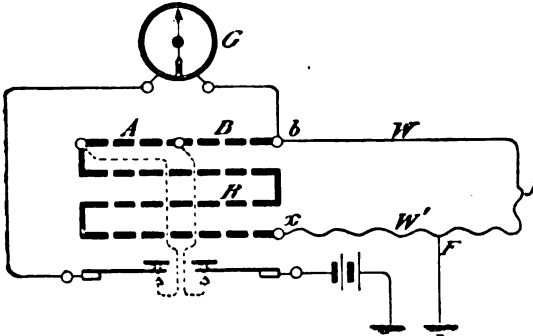

VARLEY LOOP TEST.

The distance of the fault F , from x , in ohms, is then found by the use of the formula, $F = \frac{L - R}{2}$

where F is the resistance of w' , between x and F ; L the known resistance. Or, it may be found by the formula, $F = w' - \frac{R}{2}$; w' being the resistance

of the defective wire; these formulae being the equivalent of each other. That such is the case will be obvious on considering that w' is one half of L .

These formulae may be reasoned out, aided by Fig. 122, as follows: Assuming that the resistance of the loop as first measured is 30 ohms, the resistance of each wire will be 15 ohms. Assume also that it was necessary to insert 12 ohms in R to secure the balance. We may see, Fig. 122, that in procuring the balance a certain portion of w' has been added to w , namely, that portion of w' between the

FIG. 122.

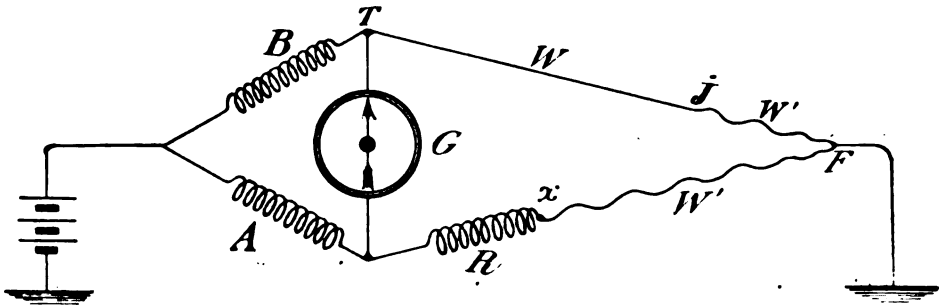

fault F and the junction j of w with w' . Therefore, it is plain that as much as has been added to w has been subtracted from w' . Hence, in obtaining a balance it must have been necessary to insert in R a resistance equal to the sum of that which has been added to w and subtracted from w' . In other words, the resistance R added to w' to procure a balance against the total resistance of w plus that taken from w' , is equal to twice the resistance of that portion of w' between F and j . Hence, the resistance of w' between F and j must be one-half of 12; the added resistance, namely, 6 ohms. That being so, it must follow that the resistance of the portion of w' , from x to F , will be equal to the total resistance of w' (namely, 15 ohms) minus the

resistance of w' from F to J , that is, 15—6, or 9 ohms. From which we may see that the formula $F = w' - \frac{R}{2}$, or $F = 15 - \frac{12}{2}$, is correct.

The resistance, per mile, or per foot, of the wire being known, it is then a simple matter to calculate the distance of the fault from the testing station. In the foregoing it has been assumed that the arms A , B , of the bridge have been equal. When such is not the case, the actual resistance of R should be calculated in the usual way before proceeding with the formula. In making this test, the faulty wire must always be connected to the bridge box at x , Figs. 121, 122, in order to get a balance, except when it happens that the resistance of the "good" wire used to form a loop with the defective wire is so much less than the latter that the resistance of the indefinite wire, added to that of the portion between x and F of the defective wire, is less than the resistance from the testing station to the fault, of the defective wire, in which case the position of wires, w and w' must be reversed; the wire of low resistance being connected to R at x , and the faulty wire w' , to arm B at b . The two wires are then measured as a loop as before. The battery is then "grounded," and a balance obtained by the insertion of resistance in B , also as before. But in this case the result of the second measurement is added to that of the first and their sum is divided by 2, which gives the distance in ohms from b at B , to the fault on the defective wire.

The formula for this latter test is $F = \frac{L + R}{2}$, where L is the loop and R the added resistance.

The foregoing method of testing is commonly known in the larger telegraph offices of this country as the "pig tail" test; perhaps due to the resemblance, in some diagrams, of the "fault" to a *queue*.*

In making these and similar tests, the probable existence of defective joints in the circuits should be taken into consideration, as such joints would, of course, impair the accuracy of the results, and possibly render them useless.

Regular electrical tests of circuits will, however, disclose in advance any abnormal resistance that may develop.

LOCATING FAULTS BY CAPACITY TESTS.

Breaks in wires are sometimes located by aid of the "capacity" test.

When the capacity, per mile, of the wire, or cable, is known, its total capacity, up to the break, is measured in the manner described (*see* Capacity tests) and from this the length of the conductor up to the break x is calculated. For example, assuming the capacity of a conductor to be .25 microfarad, per mile, and that the measured fragment of the conductor has a total capacity of 5 microfarads, the break is evidently 20 miles removed from the testing point; that is $\frac{5}{.25} = 20$.

When the capacity, per mile, of the cable is not known in advance, the capacity of a similar conductor, or cable, whose length is known, is measured, and the capacity, per mile, or per foot if need be, thus ascertained.

This capacity, per mile, or, per foot, is the more readily learned when the break has occurred in a cable composed of two or more conductors.

In this measurement a complete "break" is assumed.

* To test for a swinging cross the method known as the Diehl arrangement may be used. Take one of the swinging wires, and connect it at a point beyond the cross with a good wire, thus forming a loop, the resistance of which is measured. The second swinging wire is left open at the distant point, but is grounded at the testing station; a relay and a strong battery being placed in its circuit. The bridge is then balanced, as in Fig. 121, so that the galvanometer is not affected when the swing comes on. The relay in the second crossed wire will, however, click at each contact of the swinging wires, showing that the balance is obtained. The locality of the cross is then ascertained by the formulæ given for the Varley loop test.

INSULATION RESISTANCE OF WIRES AND CABLES.—MEASURING, ETC.

As already mentioned, those substances which possess very inferior electrical conducting qualities, are termed "insulators," and the material of the substances is spoken of as insulating material.

In order to insure the passage of a current throughout the length of a conductor, it is essential that no other conductor shall come in contact therewith. For example, if a "bare" telegraph wire should be allowed to come in contact with the earth at a number of places, it would be practically as useless to attempt to convey signals from one end of the wire to the other, as it would be to convey water from one end of a pipe to the other if the sides of the pipe were perforated with large holes at different points of its length, inasmuch as under the conditions stated the electricity would "escape" from the wire, virtually as would the water from the pipe.

In the case of the "escape" of the electric current under those conditions, the explanation is simple, namely: at the points where the bare wire touches the earth the potential falls to "zero" and, thus, as, normally, the electrical condition of the wire is zero, it is evident that such portions of the circuit as are beyond the point of earth contact can not be subjected to any difference of potential. For example, assuming a telegraph wire extending from A to B, with an electromotive force at A. If the wire be connected direct to earth at an intermediate point, x , the potential at that point falls to zero; hence, the remaining portion of the wire between x and B will remain at zero and, consequently, no current will flow between those points.

Hence, in the employment of aerial telegraph lines, the wires are strung on poles, and at each pole the wire is supported by a "glass" insulator, that the "current" may not "escape" to the earth via the wood of the pole; glass being a better insulating material than wood, more especially when the latter is damp. As air is one of the best known insulators the bare wire may be freely suspended in it without any danger of the current escaping to earth.

When wires are to be laid underground or underwater, it is necessary, for the same reasons, to cover them with some form of insulating material, as, for instance, gutta-percha, India-rubber, etc. As the working condition of telegraph wires, and, in fact, all electrical conductors, depends very largely upon the excellence of the "insulation" of those wires, it becomes very desirable to maintain the insulation practically intact, and in all large telegraph offices, regular tests are, as a rule, made to ascertain the condition of the insulation of the circuits. This is termed measuring the resistance of the insulation, or, for brevity, the "insulation resistance," of the circuits.

The total insulation resistance of an overhead wire depends mainly upon the "joint" resistance of all of the "resistances" at the various points of "escape"; for instance, at the insulators; at points where foliage touches the wire, etc. In the case of cables the total insulation resistance may be said to depend upon the joint resistance of the various resistances of each portion of the insulating material. For instance, there being 5,280 feet in one mile, if one foot of the insulating material of a cable has an insulation resistance of one million ohms, the total insulation resistance of one mile of such a cable would obviously be the joint resistance of 5,280 circuits in multiple, each

having a resistance of one million ohms. This subject is alluded to further in connection with the measuring of the partial insulation resistance of telegraph wires.

For measuring the insulation resistance of overhead telegraph wires or aerial cables when the "insulation" is not very high, a moderately sensitive galvanometer, such as the "detector," may be used, in connection with a Wheatstone bridge; the "detector" being placed in the bridge wire and the arms of the bridge suitably proportioned, as explained in chapter on the Wheatstone bridge. But, in general, for insulation tests the "direct" or "substitution" method is adopted, that is, the unknown resistance is compared with a known resistance and the resistance of the former is calculated from the results thus obtained, and a Thomson reflecting galvanometer or a sensitive tangent galvanometer is employed. In what follows the employment of the former is assumed.

Ordinarily, the *constant* for this test may be said to be the resistance necessary to be introduced into the galvanometer circuit, which, with 1 volt E.M.F., will give 1 division deflection on the scale. But, in practice, what may be termed a working constant is used. This working constant is obtained as follows:

Referring to Figs. 123, 124, a reflecting galvanometer G , and a shunt s , are placed in circuit with a battery B , of, say, 100 volts, and a known resistance R , say, of 100,000 ohms. The $\frac{1}{2500}$ shunt is generally necessary. When this shunt is employed, the *multiplier* is 1000. (See Shunts).

FIG. 123.

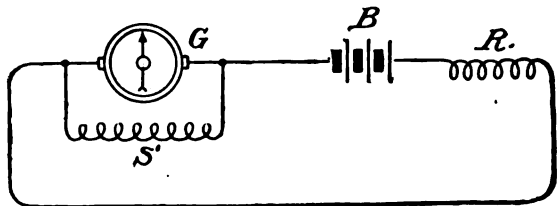

If the deflection obtained with this known resistance, electromotive force and shunt be, say, 250 divisions, it is plain that, without the shunt, the deflection would be 250,000 divisions. Therefore, since the deflections of the reflecting galvanometer are practically proportional to the current, and the current is inversely proportional to the resistance, it is clear that, to reduce the strength of current to such an extent that it would deflect the needle but 1 division, it would be necessary to introduce into the circuit 250,000 times 100,000 ohms. For, by simple proportion $1:250,000::100,000:x$, namely, 25,000,000,000 ohms—or 25,000 megohms; a megohm standing for one million ohms; consequently the "working constant" would be, with 100 volts, 25,000 megohms for 1 division deflection.

Having obtained this constant it is apparent that any resistance less than 250 megohms may be measured by this apparatus, and the unknown resistance will be equal to the quotient of the *constant* divided by the number of divisions obtained with the unknown resistance in circuit. For example, if an unknown resistance be substituted for R , Fig. 123, and a deflection of 50 divisions be obtained, without the shunt, the resistance would be $\frac{25,000,000,000}{50} = 500,000,000$ ohms. Or, this conclusion may be reached in another way. For example, assuming, as before, that, with 100,000 ohms in the galvanometer circuit, we get, by calculation, 250,000 divisions, without the shunt, and an unknown resistance gives 50 divisions, (without shunts) it is evident that the

unknown resistance is 5,000 times greater than 100,000 ohms, since it must have reduced the current 5,000 times, (as evidenced by the diminished deflection). Hence the known resistance, $100,000 \times 5,000 = 500,000,000$ ohms, as before.

The usual connections for this test are outlined in Fig. 124, in which *G* is the galvanometer; *r k* is a *reversing* key; *c* is a cable, or line wire (the unknown resistance); *R* is the known resistance. *B* is the battery and *s k*, a key for short-circuiting the galvanometer. *sw*, is a switch by means of which the cable or other conductor, and the

FIG. 124.

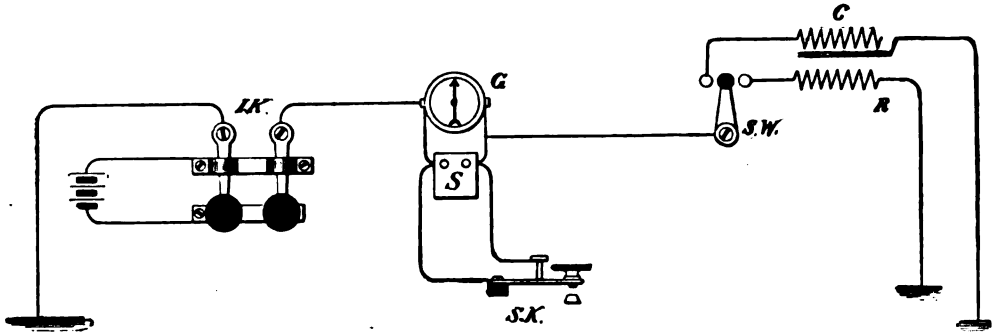

known resistance, may be alternately placed in circuit with the galvanometer, as desired. If it is a cable that is undergoing test the *conductor* of the cable is connected to the switch, as in the figure.

The reversing key has several functions, namely, to place the battery to the cable, to reverse the poles of the battery, according as one or other of its keys is depressed, and to "discharge" the wire or cable when both keys are up.

In making this test care must be taken to "short-circuit" the galvanometer before and for a few moments after the battery is placed to the cable and when the cable is discharged; otherwise the needle may be injured. Care should also be taken to connect the galvanometer between the battery and the cable, as by so doing any slight escape in the battery may be neglected.

If it is desired, and it is sometimes necessary, to begin by taking the *regular* constant for this test, (that is, the resistance necessary to introduce into the circuit, which with 1 volt will give 1 division deflection,) it may, of course, readily be taken, by placing 1 volt in circuit with the galvanometer and the known resistance, and noting the deflection. Having obtained this constant, a working constant is then found by multiplying the constant obtained with 1 volt, by the number of volts to be used in the test. Thus, if with 1 volt the constant is 1 division with 2,500,000 ohms in circuit, and it should be intended to make the tests with a battery of 100 volts, the working constant would be 1 division with 250,000,000 ohms in circuit. An advantage in using the full battery in taking a constant is that in case any of the battery cells are faulty the results will not be affected inasmuch as the fault will have affected the constant as well as the actual test and to a relatively similar extent.

In place of the resistance box *R*, containing the coils of resistance used to obtain a

constant, a plate of carbonized material set in glass, and measuring one million ohms from binding post to binding post, (See Fig. 125), is frequently employed. It is generally known as the "English" megohm plate.

FIG. 125.

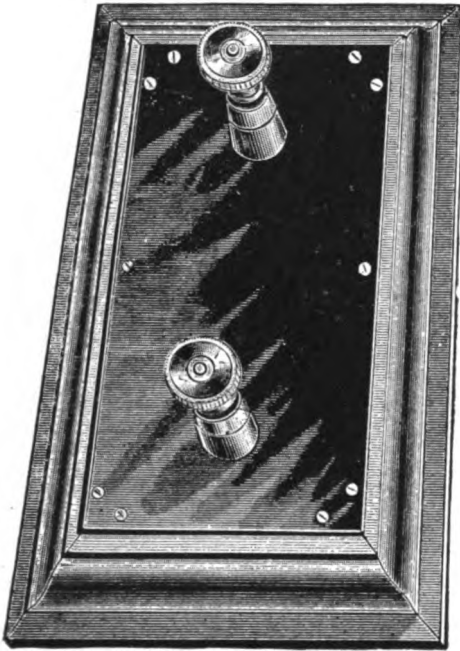

MEGOHM PLATE.

It may fairly be assumed, for the purpose of the test in question, that the sections of the wire A to B and B to C, are in multiple, as regards the testing office, and in so far as the insulation resistance of the two sections is concerned.

It is preferable to use large resistances when the unknown resistance is large; and also to employ for the actual test a battery of high electromotive force. In making this test the resistance of the galvanometer, like that of the copper band of the galvanometer in other tests, may be neglected, it being so low, relative to the total resistance of the circuit.

PARTIAL INSULATION RESISTANCE OF TELEGRAPH LINES.

It is quite frequently desirable to know the insulation resistance of a section of a circuit which is not directly accessible.

For example, Fig. 126, assuming a wire tested at A to have an insulation resistance of 600,000 ohms from A to C, and tested from A to B, to have an insulation resistance of 1,800,000 ohms, and that it is desired to know the insulation resistance of the wire between B and C.

FIG. 126.

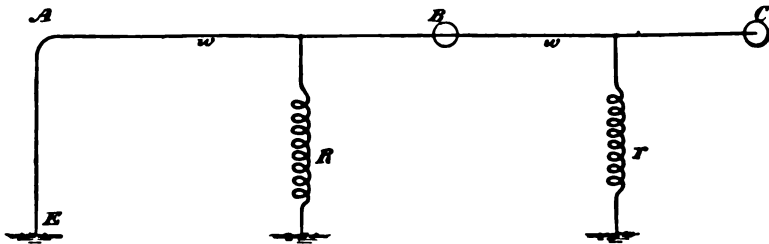

To illustrate: In Fig. 126, w w , is the wire; open at C; grounded at A; out through at B. R may represent the joint insulation resistance of the "escapes" between A and B, and r the joint resistance of all escapes from B to C.

Assume the distance from A to B to be 20 miles; B to C, 30 miles. Then

A to C will be 50 miles. The resistance of the *wire* itself may be placed at 250 ohms. It is then very evident that 250 in a total of 600,000 ohms may be easily neglected. Therefore, in making the test, the two sections, as represented by R and r, may be treated as though the terminal of each emanated directly from

A, as shown in Fig. 127.

FIG. 127.

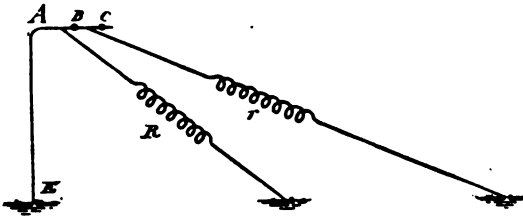

If then we test section R, with the wire open at B, and find, as stated, an insulation resistance of 1,800,000 ohms and, then, with the wire cut through at B and open at C, we find a total insulation resistance of 600,000 ohms, we know that the latter must be the joint resistance of both sections, namely, R, r.

Having, then, this data, and knowing the formula for obtaining the joint resistance x , of two circuits, R and r, namely, $x = \frac{R \times r}{R + r}$, (see Chapter III.) it is plain that we may state the resistance of the section from B to C, calling it r, (and, for the present, we may omit the ciphers) as follows:—

$$\frac{18 \times r}{18 + r} = 6$$

It only remains to calculate from this the value of r.

We can now clear the above equation of fractions if we multiply the right hand term, that is 6, by the divisor of the left hand term, and then we shall have, without having altered the value of the equation,

$$\begin{aligned} 18 \times r &= 108 + 6 r \\ 18 r &= 108 + 6 r \end{aligned}$$

Again, if we subtract 6 r from the right hand term of the equation, and 6 r, from the left hand term, we shall get, without yet altering the value of the equation, $12 r = 108$. Consequently, if $12 r = 108$; $1 r$ will equal $\frac{108}{12} = 9$, and, therefore, we find that the insulation resistance of the section between B and C is (adding ciphers again) 900,000 ohms.

To prove this it may be asked, what would be the joint resistance of the two sections, one having a resistance of 1,800,000 ohms, the other, 900,000 ohms.

$$\text{Obviously, } x = \frac{1,800,000 \times 900,000}{1,800,000 + 900,000} = 600,000 \text{ ohms.}$$

The formula for ascertaining the insulation resistance of the distant section is then as follows: $r = \frac{R}{R - J} \times J$, where R is the near section and J is the joint resistance of R and r.

But there is a simpler means than the foregoing of obtaining this information, if

the "direct" deflection method of measuring insulation resistance be employed. (*see* page 144.)

Assuming that a Thomson reflecting galvanometer having a working constant of, say, 36,000,000 ohms is used.

If the section from A to B gives, without a shunt, a deflection of 20 divisions, the insulation resistance is evidently $\frac{36,000,000}{20} = 1,800,000$ ohms. If the sections A to B and B to C, that is R and r, tested together, give a deflection of 60, their joint resistance must be, $\frac{36,000,000}{60} = 600,000$ ohms. Since we know that 20 divisions of the 60 thus obtained are due to R, the balance, 40 divisions, will be due to r, and, therefore section B to C, that is, r will be $\frac{36,000,000}{40} = 900,000$ ohms.

If a tangent galvanometer be used, it is only necessary to deduct the tangent of the angle of the deflection obtained by the first section from that of the tangent obtained by the joint resistance of both sections, in order to get the deflection due to the distant section, which latter, divided into the constant of the galvanometer, will give a quotient equal to the insulation resistance of the circuit.

The foregoing method of ascertaining the insulation resistance of remote sections is not limited to two sections, as will be readily seen, on consideration.

The average insulation resistance of the respective sections, per mile, may be ascertained by multiplying the total insulation resistance of the section by the number of miles in each section. Thus, the insulation resistance, per mile, of the section A to B will be $1,800,000 \times 20 = 39,000,000$. That of section B to C, will be, $900,000 \times 30 = 27,000,000$ ohms per mile; it having been assumed that those sections were 20 and 30 miles, in length, respectively.

Further remarks on electrical testing will be found in connection with the electrical tests of wire and insulated cables at the factory. (Pages 509 to 531.)

The voltmeter may be used to measure voltage between different parts of a circuit, and, in combination with the ammeter, to measure resistance. Thus the resistance of an instrument R may be measured by placing an ammeter in series with it and a voltmeter across its terminals. If in such a case a reading of .5 amperes is obtained, and 20 volts drop across the terminals of R, by Ohm's law (*see* page 6) the resistance of R is $\frac{20}{.5} = 40$ ohms. If, on the other hand, the resistance of R is already known, the current is calculated by Ohm's law $\frac{20}{40} = \frac{1}{2} = .5$.

To measure resistance or insulation resistance by the voltmeter, first measure the E. M. F. of testing battery, using that scale which is nearer the E. M. F. of battery. Then place the voltmeter in series with the battery and line or instrument to be tested, exactly as a galvanometer would be placed, and note the deflection in volts. It will of course be less than in the first case. The unknown resistance R will be found by the following formula,

$$R = r \times (V - V') \div V'$$

where r is the resistance of the voltmeter coil, V is the E. M. F. of battery, and V' is the second deflection in volts. The resistance of the voltmeter coil is usually marked on the instrument. When using the voltmeter to measure high resistance, the voltmeter is connected like G in Fig. 123; when used to measure the insulation resistance of a line or cable, it is connected like G, Fig. 124, omitting the shunts and reversing key. The voltmeter may also be used in place of G, Fig. 110, in measuring resistance by substitution method. (*See* page 120.)

MEASURING INSULATION RESISTANCE OF INSULATORS.

Since the total or "absolute" resistance of the insulation of an overhead wire depends upon the joint resistance of all the points of escape throughout its length, the insulation resistance of the "insulators" used on the poles to support the wires becomes an important factor in the maintenance of the "insulation" of the circuit as a whole.

The material of the insulators used in this country for telegraph and telephone overhead wires is almost exclusively glass, made in the well-known bell form.

The electrical resistance of glass varies very materially with the quality of the material, and specifications for insulators frequently stipulate that each insulator shall have a certain electrical resistance. The test to determine this resistance may be made practically as follows:

A trough τ , Fig. 128, is provided, in which metal supports i , resembling inverted tumblers, are placed. Into these supports the insulators x , to be tested, are inserted, upside down, as shown. The trough, the supports and the insulators are nearly filled with acidulated water, care being observed that the water does not get over, or upon, the edges of the inverted insulators.

Bent wires are then plunged into each of the insulators in the manner indicated and these are then connected with the galvanometer G . Another wire which includes a battery, B , is led into the trough to complete the circuit. This wire may be attached to a copper plate, as E . A reversing key may be employed as in other insulation tests. The constant of the galvanometer is taken as usual in the direct deflection method test.

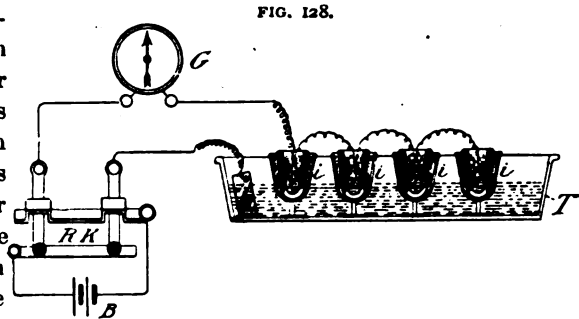

FIG. 128.

Assuming, as shown in figure, that four insulators are to be tested the result obtained in this case will be the joint resistance of the four insulators. The result should be multiplied by 4, and if the product is above the specified requirements, the test is satisfactory. If below, each insulator should then be tested separately until the cause of the low insulation is ascertained. Of course, in practice, the test is not limited to four insulators at one time.

Another arrangement for the same purpose is shown in Fig. 129. In this the insulators are suspended in the water in

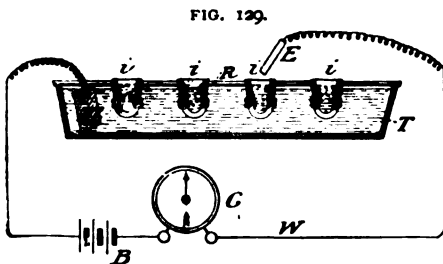

FIG. 129.

trough τ by means of a cover R . One terminal E' , of the wire w , terminates in the trough; the other end E , is held in the hand and is dipped into one insulator after another, thus completing the circuit through each. When the deflection of the galvanometer needle does not exceed an established point, the insulators are accepted, otherwise they are rejected.

CHAPTER IX.

THE DELAY LINE ADJUSTMENT.

During the prevalence of rainy weather much delay is frequently occasioned on poorly insulated wires and even on comparatively well insulated wires, by lack of proper adjustment on the part of operators at some of the "way" stations.

The cause of this is, generally, that the partial grounds formed by numerous "escapes" have sufficed to establish a current between the battery and a point beyond the unadjusted relay, which current flows, notwithstanding that a key at some point beyond may be open.

For example, in Fig. 130, a telegraph line is shown with batteries B B' at the terminals X , Y ; a relay, R_2 , at an intermediate station, and relays R_1 , R_3 , at X and Y . Escapes E , E , E , due to defective insulation, are indicated as between R_2 and the battery B , at X .

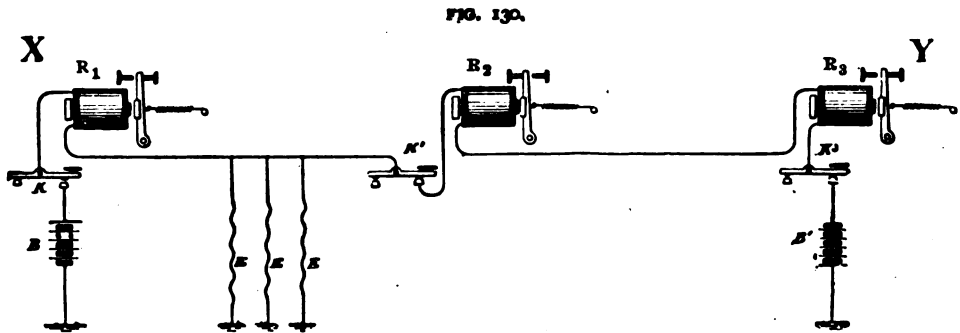

Assume those escapes to amount in the aggregate to a partial "ground", and that, when key K is closed, the major portion of the current from B will pass, by way of those escapes, to the earth, and only a small portion will assist battery B' , at Y , in operating relay R_2 .

Then, if the operator at the intermediate office R_2 has arranged his adjustment for the current due to B' at Y , it is plain that, as far as relay R_2 is concerned, it matters little whether key K , at X , be open or closed, inasmuch as only a trifling change in the strength of the current passing through R_2 will be effected by such action of key K . For, whether key K be open or closed, the current from Y will continue to flow as long as the partial ground is maintained at E , E , E . If, however, it were possible for the operator at X , by some means, when he opens his own key, to open the line at Y also, thereby cutting off the battery B' , the line would be cleared of all current for the moment, and the relay, R_2 , would respond.

This result is ingeniously accomplished by the Delany "line adjustment," or more correctly, perhaps, "escape" nullifier, in the manner illustrated in Fig. 131.

In this figure R_1 is a Morse relay at x , R_2 is a relay at A , and R_3 a relay at Y . This may be supposed to represent a railroad "way" telegraph line, with one station between the dispatchers' offices at x and Y .

FIG. 131.

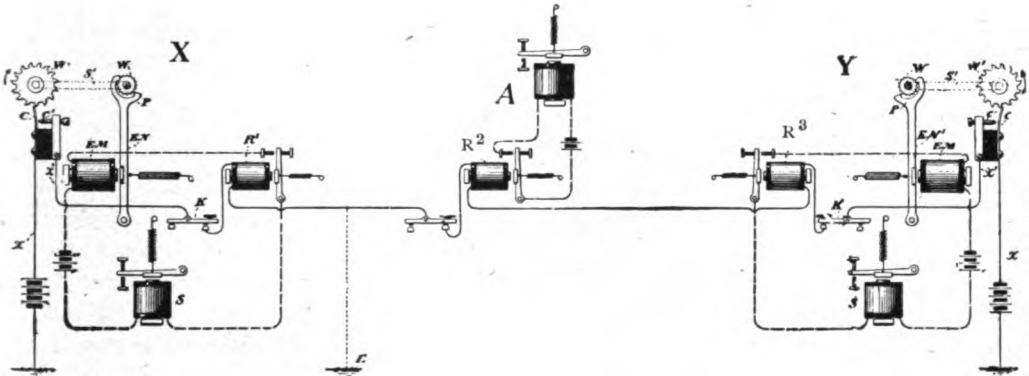

DELANY ESCAPE "NULLIFIER" (THEORY).

The apparatus used to open the circuit simultaneously at both ends of the line is shown to the left of relay R_1 at x , and to the right of R_3 at Y .

It consists of an "extra" electro-magnet EM , in addition to the usual sounder s , placed in the local circuits, of R_1 and R_3 . The armature lever EN of the extra magnet is pallet shaped at its upper end, as shown. This pallet P , operates an escape wheel w , mounted on a shaft s' . On the same shaft is carried a toothed wheel w' . Below the wheel w' is arranged a flat contact spring c , which, normally, rests against the contact screw c' . This spring c , and screw c' , are normally separated, except at, or near, the contact point, by insulating material. The main line wire, it will be seen, is led to and through c and c' by the wires x, x' , and that, when the contact at c, c' is broken, the main line is opened. The spring c is extended upward in proximity to the toothed wheel w' . When the armature lever EN is attracted to and withdrawn from the electro-magnet EM , the pallet P engages with the escape wheel w , and gives it and, consequently, the wheel w' , a "step by step" movement, in the direction of the arrow. The position of the spring c is so adjusted with relation to the wheel w' , that, when the armature lever is on its back stop, the end of spring c rests in the spaces between two of the teeth of w' . When the armature moves forward the pallet so moves w' that one of its teeth rests just behind c . When the armature falls back again that tooth engages with c and separates it from c' , opening the main line circuit. But, before the armature reaches its back stop, the tooth of w' releases c , and it snaps back against c' , again closing the main line at that point.

Thus the line wire is only opened between c and c' at the "break" of the main line circuit. The figure 131 represents the "line adjusting" apparatus at the moment of opening the key at x .

Now, if there should be an escape at E , Fig. 131, it will only be necessary for the despatcher at x to keep his relay adjusted so that it will be operated by the opening and closing of the key at x . When this is accomplished the batteries at x and x' , in addition to the regular opening at the key, will be momentarily opened at EN and EN' , and, in consequence, no matter how low a tension the operator at A may have on his relay, the armature of R_2 will fly back at the moment of breaks at EN , EN' .

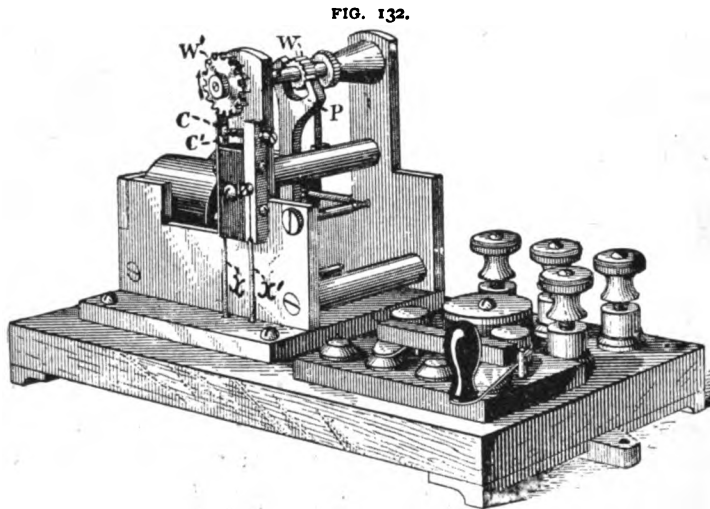

DELANY "LINE ADJUSTMENT," OR "BREAK" REPEATER.

The adjusting apparatus as it appears in practice is shown in Fig. 132. A switch, shown on the base board of the apparatus, is provided to cut out this portion of the "escape nullifier" from the main line and locals when the condition of the line does not require its use.

This apparatus is also designed for application to long underground circuits, on which it would be placed in way offices, and at the opening of the circuit would be caused to momentarily ground the line, thus facilitating "clearing" the circuit of its static charge, thereby permitting more rapid signaling.

The various parts of this apparatus are similarly lettered in Figs. 131 and 132.

CHAPTER X.

AUTOMATIC TELEGRAPH REPEATERS.

Automatic repeaters in telegraphy are used in intermediate offices to avoid relaying messages manually between points, when, for various reasons, it would be unadvisable or impracticable to transmit the messages over a continuous wire.

One such reason is that the strength of current on a wire, as already stated, decreases as the resistance increases, and as the resistance increases directly with the length of the wire, more than the ordinary amount of battery at the terminals would, therefore, be required to properly work very long circuits. Another reason is that there is more or less "escape" of current at every pole on a line, in addition to the places where the wire comes into contact with house-tops, foliage, etc., and this escape of current from the wire to the earth, via these numerous routes, is greater as the resistance of the wire itself is increased. This is in accordance with the law that the amount of current in the branch circuits of "divided circuits" is proportional to the resistance of each circuit. (*see* "divided circuits.") Hence, it is advisable to keep the length of the wire within certain limits to avoid undue waste of current from that cause. Again also, the speed of signaling, or, in other words, the rate at which the circuit can be charged and discharged in order to properly operate the receiving instruments, decreases as the static capacity of the wire is increased, and *that* capacity it is known, increases with, among other things, the length of the circuit. (*See* Distribution of Static Charge.)

The function of the "repeater" is to take, as it were, the message from one wire and "relay" it, automatically, to another wire, thereby dispensing with the necessity for manual reception and transmission at the intermediate office.

Morse, whose first electro-magnets for telegraphing were so constructed as to require for their operation a much greater strength of current than do the relays of today, was the first to employ "repeaters" for relaying messages from one wire to the other, in intermediate offices, and he appropriately named the instrument he employed for this service the "relay." Subsequently, Morse devised the local sounder to be operated by the "relay," and this name has clung to the latter instrument.

A name becoming necessary for the automatic "relaying" instruments, when they were first invented, and the term "relay" having been bestowed upon another instrument, the term "repeater," presumably came to be used as signifying apparatus which otherwise might have been termed a relay.

It may be mentioned that the term "repeater" was employed in Great Britain, as early as 1837, to designate "a mechanical circuit breaker, which consisted of a forked wire made to vibrate in and out of mercury cups alternately." It was used in connection with a magneto-electric machine. Subsequent modifications of this device were termed "electrepeters."

FIG. 133.

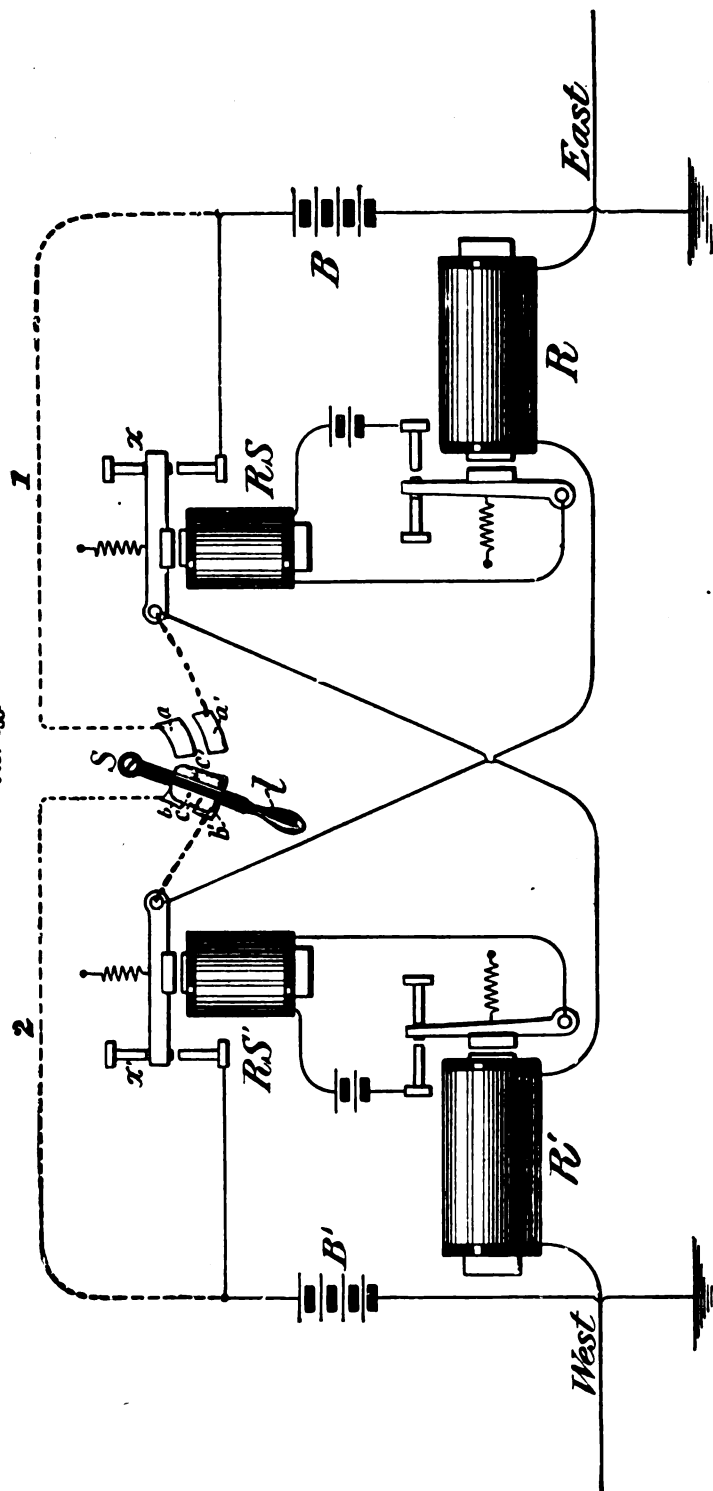

WOODS BUTTON REPEATER.

Although apparatus for repeating automatically is now so plentiful, instruments capable of performing that function, were, at one time, looked upon as something greatly to be desired; and, before the invention of the first "automatic repeaters," it was thought that a decided advance was made when "button" repeaters were introduced.

Button repeaters automatically repeat from one wire into another by means of a relay, but only in one direction, until a switch is manually turned at the repeating station, where an operator sits beside the repeaters, listening to what is passing, ready on the instant to turn a "button" over to permit one or other side of the repeater to break or send.

BUTTON REPEATERS.

About the first button repeater employed was the "Woods," a diagram of which is given in Fig. 133. Its operation is very simple.

The diagram represents the apparatus at the intermediate, or "repeating" office, only. *s*, is the button switch. The lever *l* is pivoted as shown. It is composed of ebonite, or other insulating material, and carries on its lower edges two metallic strips *c*, *c'*, one on each side, which are insulated from each other. On the base-board are four contact strips *b*, *b'*; *a*, *a'*. When the lever *l* is turned to the left, the contact strip *c*, on its left side, connects the contacts *b*, *b'*, and the contacts *a*, *a'* are separated. It may be seen that a short wire 2, shown in dotted lines, short-circuits the contact points *x'* of the repeating sounder *rs'*, when the lever *s* is turned to the left. A similar short wire 1 short-circuits the contacts *x* on the repeating sounder *rs*, when the lever *l* of *s*, is turned to the right, which act joins the contacts *a*, *a'* together.

The eastern wire passes through relay *R*, to the armature lever of *rs'* and thence, via the short wire 2, and via battery *B'*, to earth. The western wire passes through *R'*, to the armature lever of *rs*, and is there shown open in the figure; both relays *R*, *R'*, being open.

The switch lever *l*, in the figure, is turned to permit East to send to West, and thus every signal sent by the east will be repeated by the sounder *rs* into the western wire; the lever of *rs* acting as a key to open and close the western circuit. On the other hand, the repeating sounder *rs'* (in the present position of the button switch), does not open and close the eastern circuit, because of the wire 2 via the button switch, which gives that circuit a closed route to the earth regardless of the openings and closings at *x'* of *rs'*.

Should the West wish to "break" or to send, the attendant at the repeating office turns the switch *s* to the right, separating the contacts *b*, *b'*, and connecting contacts *a*, *a'*, which now gives the repeating sounder *rs'* control of the eastern circuit, and, at the same time, renders the repeating sounder *rs* unable to operate the western circuit, inasmuch as its contact points are short-circuited by the short wire 1.

The necessity for these short wires consists in the fact that but for their presence either of the line circuits, when once opened, would remain opened. To explain, suppose that, (as in Fig. 131, and ignoring, for the moment, the short wires 1 and 2,) the button switch, *s*, is turned to permit East to send to West. At the opening of relay *R*, repeating sounder *rs* will open. This will be followed by the opening of the western wire at the point *x*; then relay *R'* in the opening will open sounder *rs'*, which breaks

the eastern wire at x' . Thus, when the western operator again closes his key, he finds his circuit open and has no means of closing it.

When the button switch s is placed directly in the centre, the control of the respective circuits is removed from the armature levers of the repeating sounders, and, hence, the circuits are, by that act, made separate and independent circuits. In such central position the strip c' rests on the contacts a, a' and the strip c on the contacts b, b' .

AUTOMATIC REPEATERS.

It will be apparent to the reader of the foregoing that the chief function of an automatic repeater must be to automatically prevent the "opposite" transmitter* (as, for example, rs' , in Fig. 133, which controls the eastern circuit) from breaking, for instance, the eastern circuit, when that circuit is repeating into the western circuit.

We have seen that this is done in the case of the "button" repeater, virtually, manually, by the act of the attending operator in the repeating office in turning on the short-circuit 1 or 2 around the opposite transmitter, as required.

The same function is performed, entirely automatically, in various ways, by "automatic" repeaters, several of which may now be described.

THE MILLIKIN REPEATER.

This was one of the earliest repeaters introduced into the telegraph service, and it is still a standard repeater of the principal telegraph companies of this country.

This repeater may, perhaps, be termed an automatic, electro-mechanical repeater, for, while electricity is the controlling force in the performance of its automatic functions, the ultimate action is mechanical, as will be seen.

Fig. 134 is a theoretic diagram of the connections of the Milliken repeater. R and R' are the main line relays. EM and EM' are extra magnets, which, in practice, are supported on metal standards that hold them rigidly in their respective positions relative to the main line relays. The armature levers of the extra relays are pivoted at the top as shown. T and T' are transmitters. The levers L, L' of the transmitters are insulated from the tongues, x, x' , at points i, i' , and from screw posts F, F' , by small pieces of hard rubber.

The working of this repeater may, perhaps, be best described by assuming that the East is about to send. To that end he opens his key; that opens relay R' and its lever L' falls back, as in the figure, and opens the local circuit controlling the transmitter T' . As the latter instrument opens, it first breaks the local circuit of EM at a' ; the retractile spring s of extra magnet EM , at once pulls its lever against the lever L of relay R as in figure; presently the transmitter T' opens the western circuit at x' ; this demagnetizes relay R , and its spring *would* withdraw its lever L , from its front stop f , thereby opening the transmitter T , and, consequently, the eastern circuit at x , but that, as already said, the lever of EM is against lever L , holding it on its front stop and thus keeping the local circuit of T closed. When the East again closes his key, relay R' also closes, consequently, so does T' ; this action closes EM , and the lever of that instrument is withdrawn from its position against the lever R . This releases R 's lever, but, as now

* See Transmitter, (continuity preserving) Duplex Telegraphy.

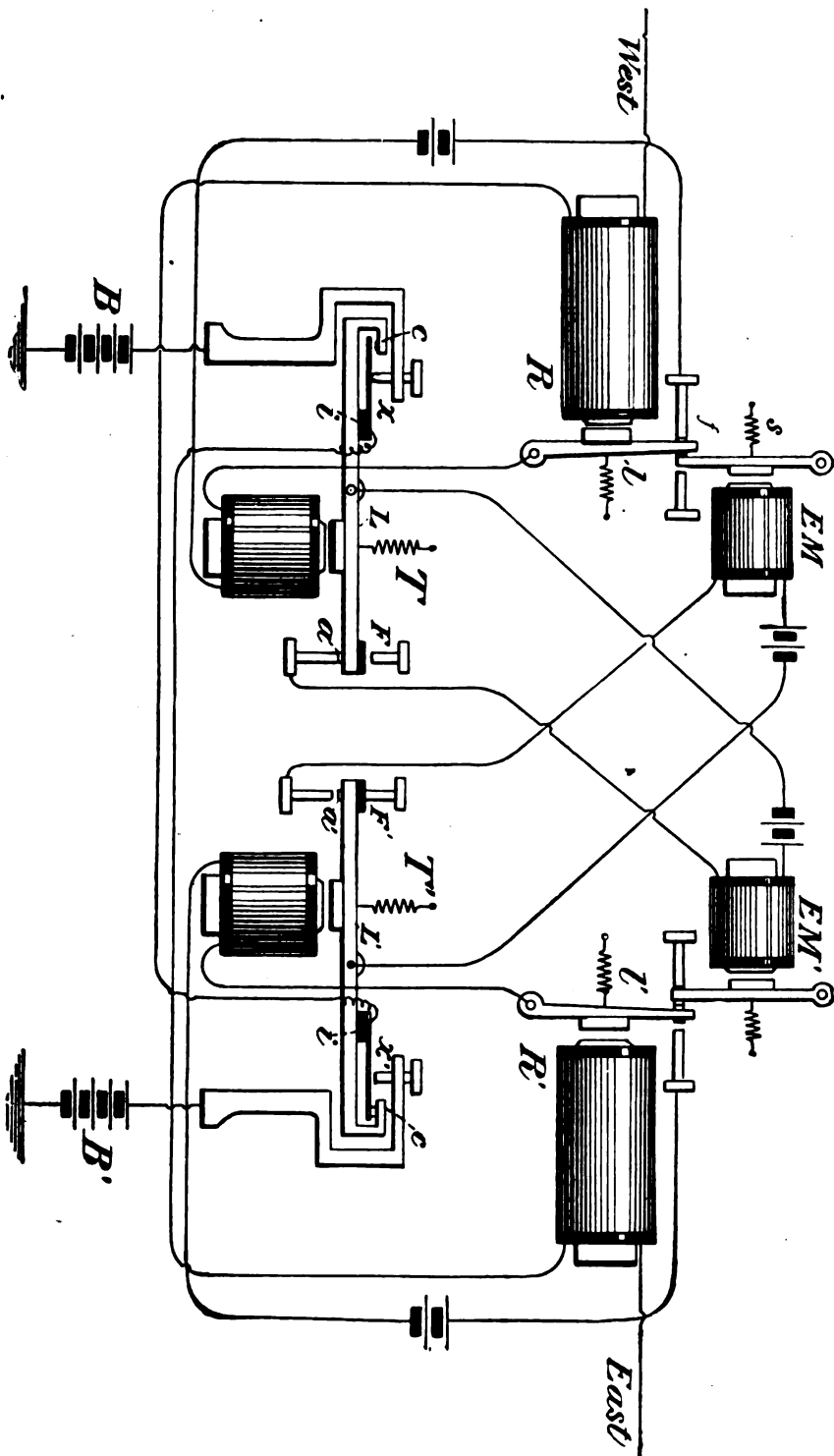

FIG. 134.

MILLIKEN REPEATER.

the western circuit is closed at x' , the lever l is held forward by its armature.

In this way the function of the repeater in keeping closed the opposite transmitter, and virtually also the circuit which is being "repeated" into, is performed.

Should the West now desire to "break," or send to the East he opens his key, which action, by opening the local circuit of transmitter τ , at f , opens the eastern circuit at x . The East finding his circuit now open, closes his key to await the remarks of the West, when the "repeating" actions just described are reversed.*

The Milliken repeater is considered by many to be one of the best repeaters known, if not the best. A drawback, perhaps, being that it is somewhat difficult to maintain in proper adjustment by the inexperienced. The local batteries which operate the extra magnets are termed "extra" locals. These require to be carefully looked after in order to secure the best results; but this, it may be said, is also true—perhaps not to the same extent—of all "locals" and other batteries for all purposes in telegraphy.

SIDE REPEATERS.—The Milliken repeater is also available as a "side" repeater. That is, assuming a through circuit between New York and Buffalo, via Utica, and that it is desired to repeat into a "side" circuit extending, for instance, from Utica to Ogdensburg; one side of the repeaters may be placed in the through wire and the other in the "side" wire, and thus whatever signals are transmitted on one wire are heard on both. To explain briefly how this is accomplished. If, in Fig. 134, we call the western wire the "side" wire, and imagine the main battery B , controlled by transmitter τ , to be cut off, and the wire running to ground at that battery to be "looped" out of the office instead, (as if it were the "through" wire) that will be all the change necessary.

THE TOYE REPEATER.

This repeater is quite extensively used in the United States and Canada. It is quite simple in its operation. In Fig. 135 is to be found a diagram of its electrical connections. τ and τ' are the usual transmitters. These transmitters differ, however, from those used in the Milliken repeater in that they are not insulated at the screw posts. R R' are the usual main line relays. MB , MB' , the main line batteries. rh , and rh' , are adjustable rheostats, the use of which will shortly be explained.

The manner in which the "opposite" transmitter is kept closed or passive, is as follows: (by "opposite" transmitter, it may be repeated, is meant the transmitter which is controlled by the relay in the circuit which is being repeated into).

Supposing again, that the East is sending to the West through the "repeaters." When the East opens his key, the relay R opens, as in the diagram; this opens transmitter τ and, consequently, the western circuit is opened at x . At the same instant that the western circuit opens at x , the circuit which includes the relay R' and battery MB' is closed via the lever of transmitter τ through the rheostat rh . The resistance of the rheostat is adjusted so that it equals the resistance of the western circuit. As this transposition of circuits maintains the current passing through relay R' at the same strength as before the change of circuit was made, that relay remains closed and, likewise also, the transmitter τ' .

West

East

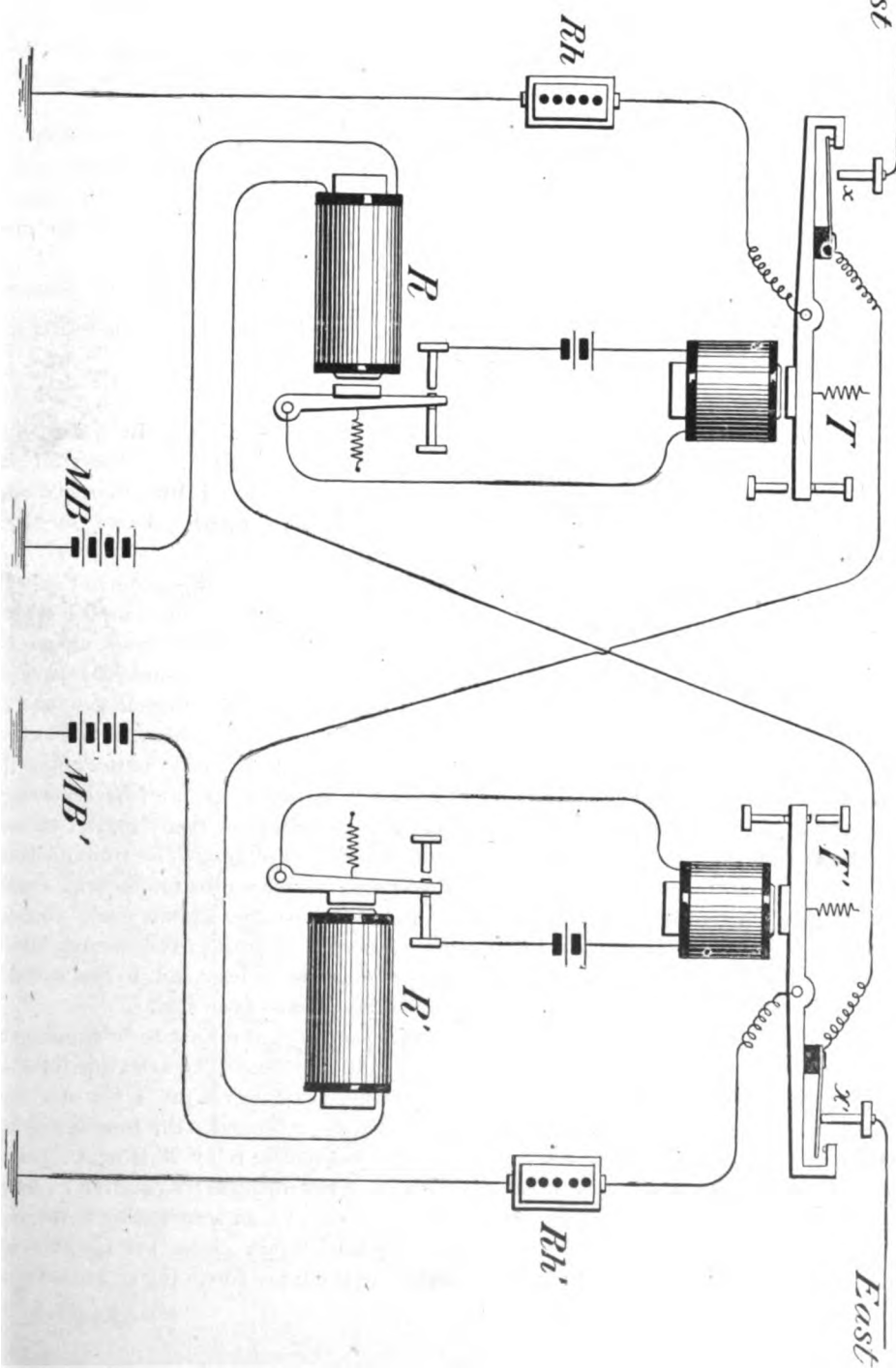

FIG. 135.—THE TOY REPEATER.

It will be noticed that this automatic method of keeping the opposite transmitter closed is exclusively electrical. It need hardly be said that when the West wishes to send to the East the foregoing action is reversed.

An advantage held by this repeater over the Milliken is that it dispenses with "extra" batteries and "extra" magnets. The Toye, however, is severe on the main battery as the latter is always kept closed in this repeater.

In the practical operation of this repeater care must be observed to keep the resistance in the rheostat about equal to that of the main line, especially in bad weather; otherwise the signals may be uneven, due to the variation in the strength of current traversing the relay as its circuit is changed from that of the line to that of the rheostat.

This repeater is not available as a "side" repeater, since it requires the presence of a main battery to keep the relay closed at the proper time.

MAVER-GARDANIER REPEATER.

The above was the title this form of repeater went under in the Baltimore and Ohio Telegraph Co., where a large number of them was in operation. The writer has since been informed that this repeater was previously invented by others, (whose names are unknown), and that it was in operation in the Montreal office of the Montreal Telegraph Company a number of years ago.

The "opposite" transmitter of this repeater, a diagram of which is given in Fig. 136, is automatically kept inoperative at the proper time by the use of a device which opens its local circuit. The main line relays operate their respective transmitters by the back contact points. Consequently, the signals, as heard on the transmitters, are on the "back" stroke. The main line connections, however, on the transmitters, are so arranged that, when the transmitter is open, the main line passing through its contact points is closed, and vice versa. This is done by connecting the main battery wire to the lever of the transmitter instead of to the post P, as in "front" stroke repeaters; hence, the signals are repeated from one line into the other on the "front" stroke, notwithstanding the "back contact" arrangement of the relays. The front contact point of each main line relay controls a local sounder, as shown in the figure; consequently, the operator in attendance can hear, not only how the signals come to him, but how they pass to the other side, without the necessity of going to the switch board to cut in and listen, which is an advantage not possessed, or at least not, to the writer's knowledge, utilized, in any of the repeaters herein previously described.

The operation of this repeater is as follows: Supposing the East to be sending to the West. He opens his key, which action opens the relay, R. The armature lever of that relay falls back, closing the local circuit of transmitter T, via the lever of T' and the switch s. When the transmitter T is closed its post P separates the tongue t from the lever L. This opens the western line at t; consequently, relay R' is next opened and its armature falls on its back contact. This does not operate transmitter T', however, as the local circuit of that instrument was opened, at x on transmitter T, the moment that T started to close, and, thus, when the East again closes his key, R is attracted, and T is opened. When the West wishes to send, the foregoing actions are, as

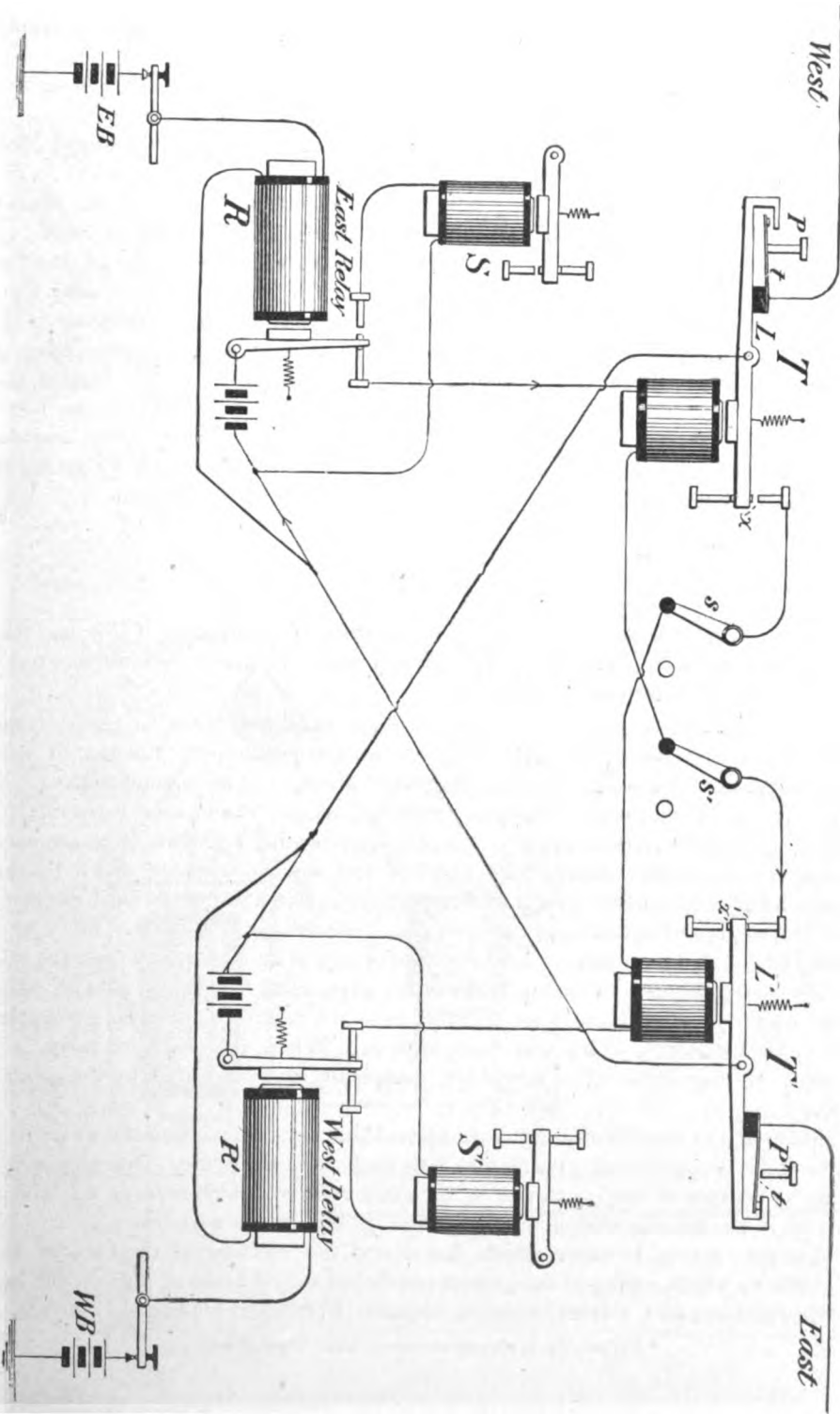

FIG. 136.—THE MAVER-GARDNER REPEATER.

in the case of the other repeaters described, simply reversed, the transmitter τ' keeping τ , passive, by the opening of the local circuit of the latter at x' .

The "3-point" switches s s' are used to put the repeaters "through," or to separate the sets.

In the management of these repeaters it is recommended that the adjustment of the relays be made by moving the magnets of the relays backward and forward. This insures a uniform stroke of the relay armature on its local contact in all kinds of weather. The local sounders s s' are utilized to give signals on the front stroke.

The best manner of adjusting these repeaters is to ask one or other of the "repeating" circuits to send. Suppose in this case it is the West. Listen at relay κ and adjust relay κ' , and transmitter τ' , until the signals are heard perfectly at relay κ ; this will show that the repeating apparatus is doing its work correctly. Then have the East write; listen at κ' and adjust relay, κ , and transmitter τ , until the signals pass ok, when the repeaters are adjusted. When not required as a repeater the instruments may be used for ordinary Morse telegraphy, by turning the 3-point switches to the right, (whereby the transmitters are rendered inoperative,) and by having the proper wires run from relays to switch board to facilitate cutting them in.

THE NEILSON REPEATER.

This repeater is in use in Canada.* It is deserving of description, if for no other reason than that of its uniqueness; it certainly bears no marked resemblance to any of the "repeaters" known to the writer.

At first sight the repeater may appear a little complicated, but in reality it may be quite easily understood, although, it must be said, it performs its function of keeping the "opposite" transmitter closed, in a round about, if in an ingenious way.

In Fig. 137, κ' and κ are the regular main line relays; κ'' and κ' are extra relays of about 30 or 40 ohms resistance, each. s' and s are repeating sounders, or transmitters; s' having control of the eastern wire and s of the western wire. κ' and κ , by their armature levers, have control of s' and s respectively. The wires of the local circuit LB' , it will be seen, are extended from the lever L' and contact point x' of the relay κ' to similar parts of the extra relay κ'' , and the local circuit of LB is extended from the relay κ to the armature lever and contact point of the extra relay κ' . It will also be noticed that the local circuits LB' and LB are shunted into the magnet coils of the extra relays κ'' and κ' ; the reason for which will soon be plain. When the main line relays κ' κ are closed the coils of the extra relays are completely short-circuited by the points x and x' .

Assuming the eastern office to have opened his key to send into the western circuit; the relay κ' opens and its armature falls back, as in the figure. This action opens sounder s' , because of the resistance of the extra relay κ'' , which reduces the strength of current in the sounder to such an extent that its armature is withdrawn.

The same action, however, which has caused the opening of the sounder s' at once closes κ'' , which, owing to the greater number of convolutions of its coil, and more sensitive armature and retractile spring, requires a smaller amount of current for

* It is now also in use quite extensively in the United States.

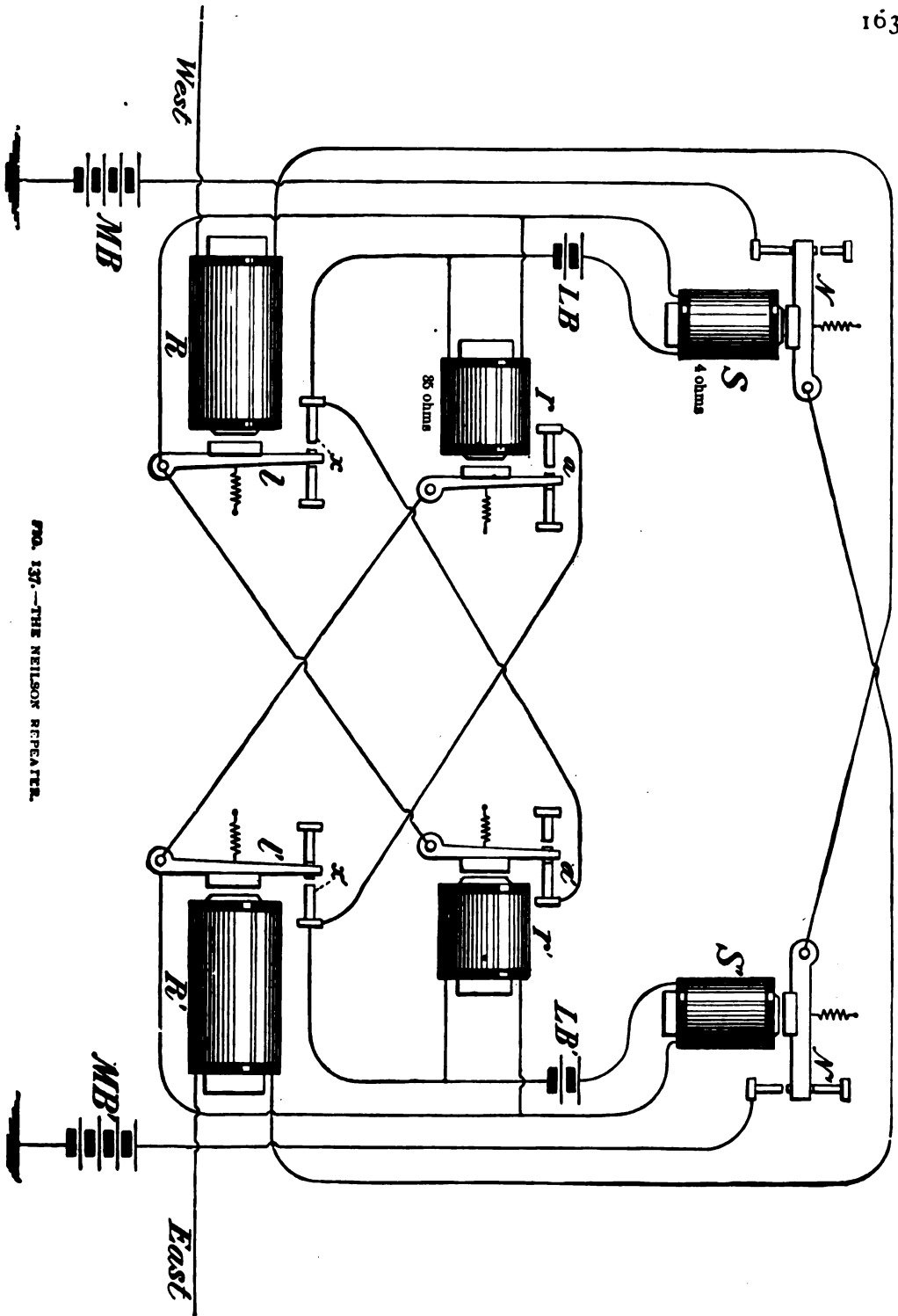

FIG. 137.—THE NEILSON REPEATER.

operation. The act of opening the sounder s' opens the western circuit at N' . Thereby, relay R , in the western circuit, is opened. When r' closes it is seen that its armature closes the local circuit LB at its armature contact point a' , so that, although the relay R is opened, as said, when its circuit is broken at the point N' of the sounder s' , nevertheless, the sounder s is kept closed, since the resistance of its circuit is unchanged, and it follows that the western circuit is kept closed at x ; all as in figure.

When the West wishes to send to the East he reverses the forgoing actions, and it will then be the sounder s , which is opened, and the sounder s' , which remains closed.

THE WEINY REPEATER.

This repeater is shown in Fig. 138. The opposite transmitter is kept closed at the repeating station by the action of an extra magnet added to the main line relays, the construction and operation of which are, briefly, as follows: The extra magnet is wound with two coils, through which a current flows from a local battery in opposite directions around the core, so that the latter is, normally, not magnetized.

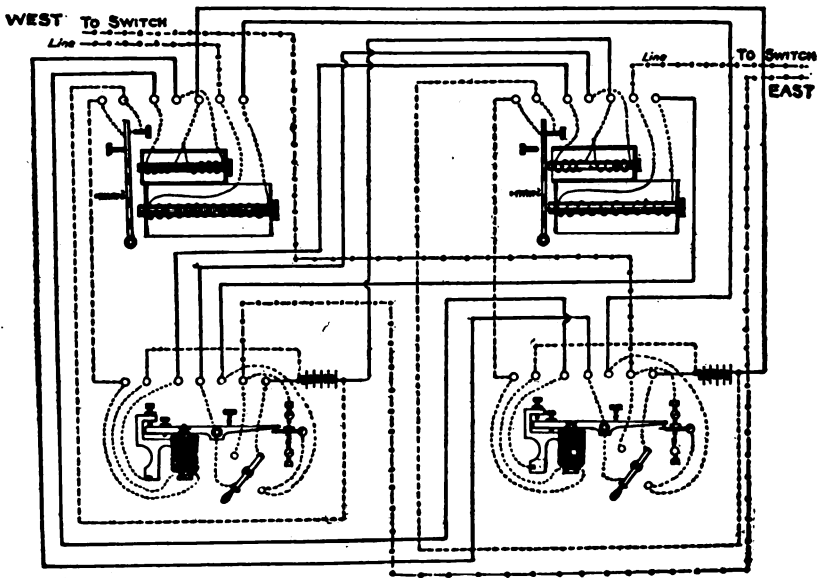

FIG. 138.—THE WEINY REPEATER.

When, however, one of these extra coils is opened the current in the other coil magnetizes the core. The wire which is joined to both coils of the extra magnet goes directly to the positive pole of the opposite local battery. The other end of each coil passes to the other pole of the same battery, one coil by way of the left-hand post, and the other by way of the lever of the opposite transmitter, as shown. This lever is insulated from the left-hand post when the transmitter is open. Consequently, when the left-hand transmitter is open, as in the figure, the circuit of the left-hand coil of the extra magnet of the eastern relay is open at the left-hand post of the western transmitter, and as a result thereof that extra magnet is magnetized by the current passing through the right-hand coil, and, hence, the armature lever of that relay is held against its front stop. Thus, for example, when, as in the figure, the

West sends to the East, and, thereby, opens his key, the western relay in the repeating office opens, and its armature lever falls back, opening the local circuit of the western transmitter. As this transmitter opens it, first, breaks, at its left-hand post, the circuit of the left-hand coil of the extra magnet of the eastern relay, and, next, opens the eastern main line circuit at the right hand post. As, however, the armature of the eastern relay is kept closed, in the manner stated, by its extra magnet, the eastern circuit remains unbroken in the repeating station.

The local battery, it will be seen, is also utilized to operate its respective transmitter. Often a local dynamo is used for this purpose. A button switch is placed on the base of each transmitter for the purpose of short-circuiting the main line contact points on the transmitter when it is desired to use the transmitter simply as a sounder for the relay.

THE HORTON REPEATER.

This repeater, Fig. 138a, has recently been introduced into practice. It is simple in operation and is said to be efficient. The sending circuit is held closed at the repeating station by the utilization of the force of gravity; the main line relays *R*, *R'*, being tilted, as shown in the diagram, for this purpose. Each relay is provided with an extra electro magnet, as shown, the local circuit of which is controlled by the opposite transmitter. Normally these local circuits are closed. Normally also the attractive force of the main line relay, aided by gravity, is superior to that of the extra magnet. Hence, so long as the main line is unbroken, the armature of each relay remains

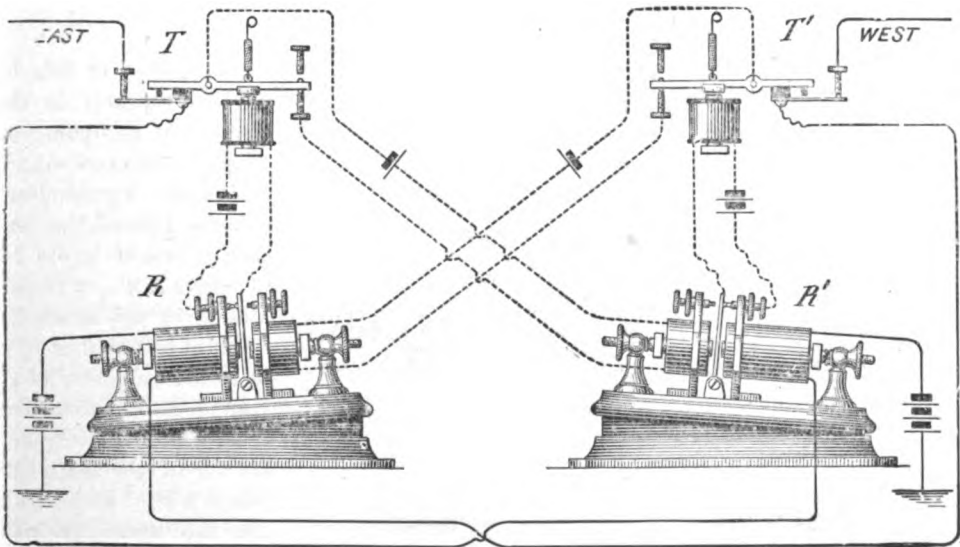

FIG. 138a.—THE HORTON REPEATER.

on its front contact point, which contact point controls the usual transmitter, as seen in the diagram. When, however, for example, the West wishes to send to the East, and, for that purpose, opens his key, and the relay *R* is thereby demagnetized, the extra magnet at once withdraws the armature, breaking the local circuit of transmit-

ter T. This transmitter at once opens, which act first opens the local circuit of the extra magnet R' and next opens the eastern main line at the left end of the transmitter. The opening of the eastern main line, of course, demagnetizes the relay R', but as the local circuit of its extra magnet is open, gravity retains the armature on its front stop and, hence, the local circuit of transmitter T' is not broken. Consequently, the western circuit is not broken at the repeating station. Of course, these actions will simply be reversed when the East wishes to send to the West. The adjustment of the relay and extra magnets, as regards their distance from the armature, is regulated by the screws shown at the respective ends of the relays and magnets.

THE ATKINSON REPEATER.

This repeater, Fig. 138*b*, which has been quite generally employed of late by the Western Union Telegraph Co., is somewhat like the Neilson repeater in the

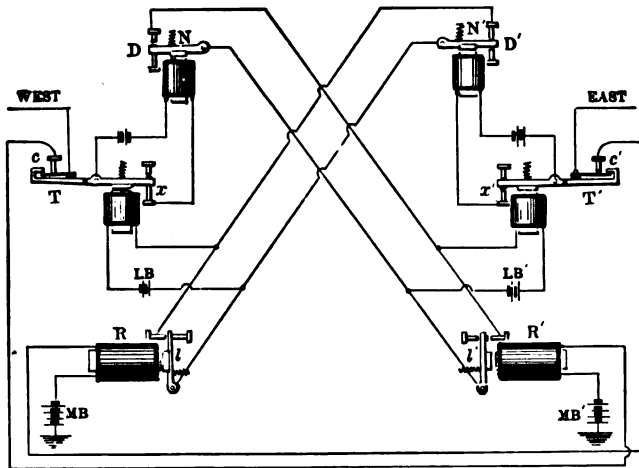

FIG. 138*b*. ATKINSON REPEATER.

manner of its operation. N and N' are extra sounders which control shunt circuits around the contact points of levers *ll'* of relays R R'. N is controlled by the local contact *x* of transmitter T, N' by local contacts *x'* of T'. T and T' are in turn controlled by armature-levers *ll'* of the main-line relays R R'. MB and MB' are the main-line batteries. The operation of the repeater is as follows: In the figure West is repeating to the East.

The act of opening the western line opens relay R' and its armature falls back, opening the local circuit LB' of transmitter T', whose lever in rising first opens at *x'* the local circuit of N', whose armature-lever at once rises and closes the shunt circuit of LB at D'. The next

instant the lever of T' opens the eastern circuit at c' . This opens relay R , whose lever l falls back, but this does not affect transmitter T , since its local circuit LB is closed at D' of N' . Thus the opposite transmitter is kept closed. When East sends to the West these actions are reversed, and the transmitter T' is kept closed by a shunt circuit at D on the sounder N .

THE GHEGAN REPEATER.

This repeater, which is employed on some of the large railroad telegraph lines and elsewhere, is of somewhat recent invention, and has given good service. It is unique in that the superposed extra armatures $a a'$, Fig. 138c, whose levers control

FIG. 138c.

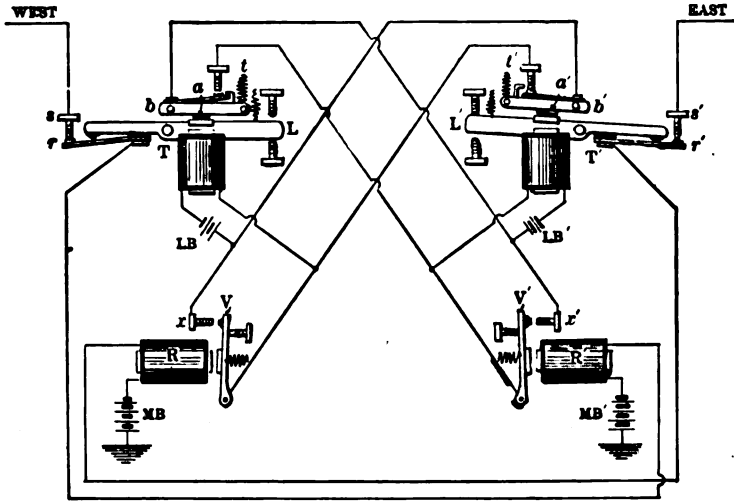

GHEGAN REPEATER.

the shunt circuits, receive their magnetism by induction from the armatures of transmitters $T T'$ respectively. These superposed levers are pivoted at $b b'$ independently of levers $L L'$. Owing to their position armatures $a a'$ are magnetized more slowly than the armatures of $T T'$, and also lose their magnetism more quickly. Further, when necessary, the levers of $a a'$ can be retarded still more in their downward motion by increasing the pull on their retractile springs $t t'$, and, in addition, the time of breaking the shunt circuit is increased by the flat springs on $a a'$, which rise somewhat until they reach their stop pin, as the lever descends, which features are found of much utility on heavily escaped lines.

The operation of this repeater is as follows: West is supposed to have opened his key to send. This has opened relay R' , whose armature v' falls on its back stop. This opens local circuit LB' at x' , and T' then opens. Immediately the superposed armature a' rises, closing shunt circuit of LB at the contact on lever of a' . Next, armature-lever L' of T' opens the eastern circuit at s', r' . This opens relay R , whose armature v falls back, opening circuit of LB at x , but this does not open transmitter T , as local circuit LB has been previously closed at a' . If East were sending to West the foregoing actions would be reversed, the superposed armature of T closing the shunt circuit of LB' at a , etc. MB, MB' are the usual main-line batteries.

OPEN-CIRCUIT REPEATER.

The theory of the open-circuit method of operating Morse circuits is shown in Fig. 36. Normally, on these systems there is no battery to the line. When it is desired to repeat from one such circuit into another an arrangement theoretically shown in Fig. 138*d* is frequently employed. This is a modification of the repeater as used in Europe, as to the apparatus, but the principle in each case is the same. The repeaters are also used by the United States Signal Corps on submarine cable on which the single-current, open-circuit method is employed.

In the figure, R R' are polarized relays, with a bias or retractile spring to keep them, when at rest, on the lower or "dead" contact.

Ordinary Morse relays could be used as in Fig. 36. T and T' are normally open repeating transmitters, operated by relays R and R' respectively. B B' and b b' are the main and local batteries. The operation is as follows: Assume that the East is to send to the West. He closes his key, putting his battery to the line. The current from

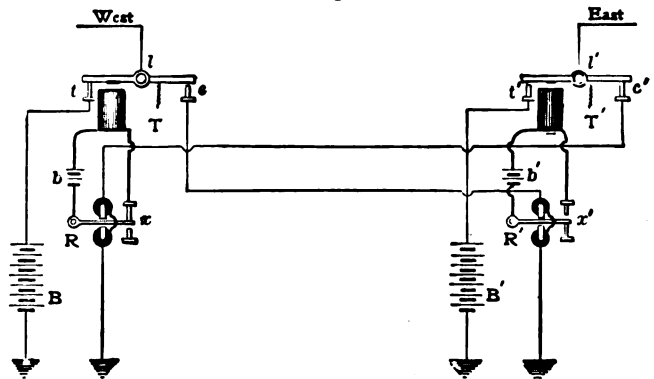

OPEN-CIRCUIT REPEATER.

his battery traverses relay R via lever l and contact c . This current brings the armature of relay R against contact x , thereby closing the local circuit of battery b , which closes transmitter T , thus putting main battery B to the western line, as shown in the figure, through contact t and lever l of T , and thereby operates the distant western relay. When the eastern operator next opens his key his battery is removed from that line. Consequently the bias or retractile spring of relay R brings the armature-lever to the dead stop, opening T , thereby removing battery B from the western line and opening the distant western relay. Thus the openings and closings of the eastern circuit are reproduced in the western circuit. It will be seen that when lever l of T was closed by its local battery b it opened the circuit of R' at c , but this had no effect upon that relay, as it was already "open."

Reversely, when the West desires to send to the East, and to that end closes his key, the current from his battery energizes relay R' , by way of lever l and contact c (for at such times transmitter T must be open), and thus closes the circuit of battery b' at x' , thereby closing transmitter T' , which puts the main battery B' to the eastern line by way of contact t' and lever l' , thereby operating the distant eastern relay. Ordinary reading sounders can be placed in series with the transmitter magnets, and switches are used to separate the sets when not used as repeaters, and to enable the repeating station to converse with either of the terminal stations. These switches and sounders are omitted to simplify the diagram.

DOUBLE-CURRENT SINGLE-WIRE REPEATER.

This repeater, a modification of the Varley repeater, is used on circuits where the double-current system (*see* page 287) is employed, chiefly in Europe. A single battery and a pole-changing key are generally used at the terminal stations, but a double or split battery like those shown at the repeater station *B B'*, Fig. 180, and operated by a pole-changing key, or by a single battery with an ordinary pole-changer, Fig. 151, could also be employed.

The advantages of the double-current system for single-wire working are that it is speedier, that the receiving instruments are more sensitive than the ordinary Morse relay, and that they require less attention than the latter, since any variation in current strength on the line affects both poles of the polarized relay similarly, whereas in the case of continuous current working a variation in the current

FIG. 138f. DOUBLE-CURRENT SINGLE-WIRE REPEATER.

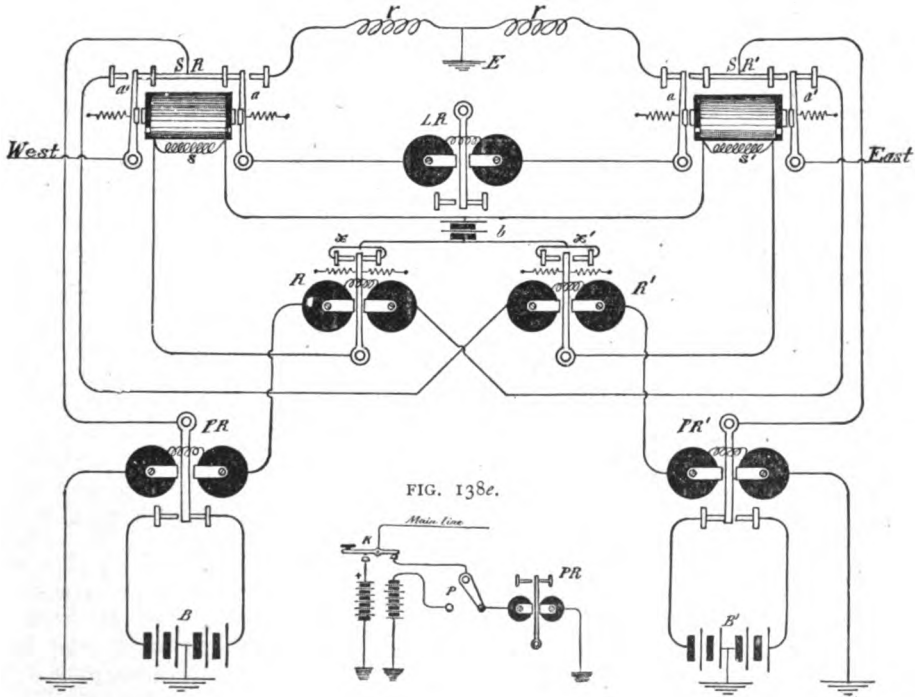

strength makes it necessary to increase or decrease the tension of the retractile spring of the Morse neutral relay.

In the double-current system, for ordinary working, the apparatus is set for sending and receiving by means of a manually operated three-point switch *P*, Fig. 138e, which, when turned to the right for receiving, places the main line directly to earth via the receiver *PR*, a polarized relay. At this time, key *K* being open, the batteries are open as shown. When the apparatus is to be set for transmitting, the same switch is turned to the left, which disconnects the receiver from the main line and also connects the negative battery to the back contact of the pole-changing key *K*, the positive pole of battery being permanently connected to the front contact of key. It is therefore evident that a double-current single-wire repeater must perform this function automatically at a repeating station. The manner in which this is done is

indicated in Fig. 138*f*, in which a double-current repeater is diagrammatically shown. $B B'$ are split or double batteries. $SR SR'$ are neutral relays, termed automatic switches, with armatures $a a'$ at each end. PR and PR' take the place of the pole-changing keys referred to. They are polarized relays whose levers control the batteries $B B'$ as shown, practically as do $PR PR'$ in the Wheatstone duplex repeaters, Fig. 232. $R R'$ are also polarized relays with retractile springs attached to their armature-levers, which springs hold the lever in a middle position between contact points as shown at x' , when no current is passing through the coils. LR is a leak or telltale polarized relay, used for the same purpose as the similar relays PR'' in the Wheatstone repeaters (page 308). Adjustable resistances $r r$ are interposed between the earth E and the leak relay. These resistances permit only a small portion of the line current to pass through the leak.

It may be seen that R and R' , in either position of their armature-levers, control the switch relays $SR SR'$ respectively. Normally the armatures $a a'$ of the latter are against their back contacts, as shown in the case of SR' . When a current passes through the coils of SR or SR' , both armatures $a a'$ are attracted, as at SR . For simplicity the switches for separating the eastern and western sets are omitted.

The operation of this repeater is virtually as follows: Assume that the East has started to send to the West. He has closed his key, which puts a positive pole of his battery to line, the current from which passes through and reverses the polarity of relays R and PR . This current in passing, by way of lever a' of SR' , through relay R has brought the armature-lever of that relay against a contact point x . This, by means of local battery b , attracts armatures a and a' of SR to their front contacts as shown. This action switches the western circuit from the relay PR' and puts the West in contact, via a' , with the lever of relay PR , which lever has just been brought into contact with the positive pole of battery B , as in the figure; the thin line of the battery conventionally representing the positive pole, the thick dash the negative pole, in these diagrams. At the same time the lever a of SR offers a branch circuit to earth via lever a of SR' and resistance r , through the leak relay LR , operating that instrument. It is obvious that the next opening of the eastern key will send a current in the opposite direction which will reverse the polarity of PR , causing its lever to move to the other contact, and thereby to place the negative pole of B to the western line. R is, of course, also reversed at the same time, and while its armature-lever is passing from one side to the other the local circuit of battery b will be open and the levers $a a'$ of SR will tend to fall back. But to prevent this action a shunt wire s , having a resistance about equal to that of SR , is placed across the terminals of that relay, whose current of self-induction discharges through the coil s while the armature of R is in transit, this sufficing to hold the armature-levers $a a'$ against the front contacts during that interval. Thus the switch relay SR is automatically kept in the desired position, while the East continues to send without intermission, or as long as he keeps his battery to the line. When he ceases sending he turns the switch P that places the receiver to line and removes the battery. When the West wishes to send to the East the foregoing actions are reversed, and SR' , which is also supplied with a shunt-coil s' , becomes the automatic switch relay, and PR' the transmitting relay, sending out reversals of polarity from B' via the front contact a' of SR' to the eastern line.

From what has been said it is evident that so long as the East or West is sending continuously the receiving terminal cannot break or interrupt, as at such times he has no control of the battery at the repeating station. At a pause of the transmitting station, however, the automatic switch gives the receiving station such control. Ordinarily, where these repeaters are mostly used it is not customary to break until the end of a message, at which time the transmitting operator is on the alert for interruptions, which he can detect by the telltale galvanometer usually placed in the circuit of such systems. (See *a*, Fig. 36.) At such times the trans-

mitting operator sets his switches for receiving. For high-speed working a condenser which is shunted by a non-inductive resistance of about 5000 ohms may be placed in series in each circuit between the receiving relay and the ground, or, for instance, between relays PR and R.

MULTIPLE REPEATERS.

It is occasionally necessary or desirable to be able to repeat from one wire into several wires, and automatic repeaters capable of performing this function are sometimes called "three cornered" repeaters. This can be accomplished, for instance, by the use of several sets of Milliken repeaters; causing them to act as "side" repeaters. In other cases where this is done button repeaters are employed. In still other instances the transmitters are furnished with extra contact points, tongues, posts, etc., which render those instruments capable of acting as multiple repeaters. Mr. R. T. Edwards invented a multiple repeater on this general plan, which he termed an "Octuplex" repeater, by which eight circuits could be repeated into.

The present writer has devised an automatic multiple repeater, shown in Fig. 139,

FIG. 139.

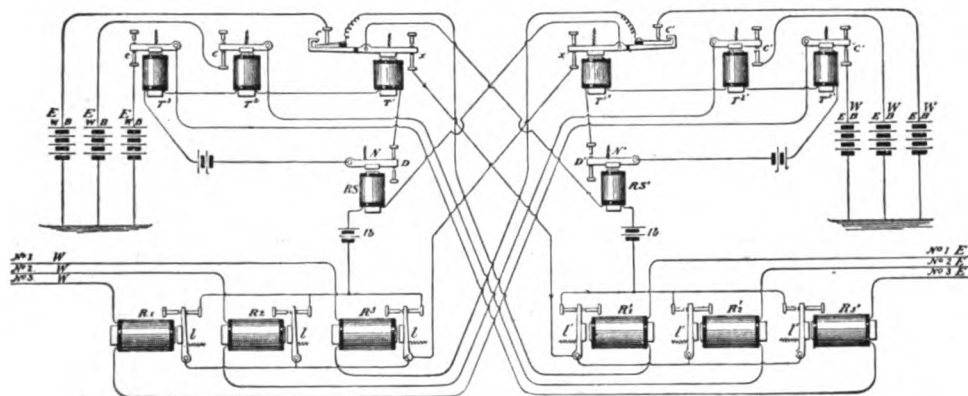

THE MAVER MULTIPLE REPEATER.

which dispenses with extra attachments on the transmitters, and which is practically unlimited as to the number of circuits to be repeated into; and each of the circuits thus repeated into is able by this arrangement to "break" the sending circuit, or to send into all of the others circuits of an opposite series.

The main line relays are operated on the backstroke, so far as the locals are concerned.

By the use of "repeating" sounders, RS, RS', similar to those used on the "second" side of the quadruplex, with contact point on the up stroke, the signals are converted into straight "stroke," before the transmitters are reached. It will be seen that the repeating sounder RS' is, by means of its armature lever N', given control of the transmitters T₁, T₂, T₃, and that RS is given control of transmitters T₁, T₂, T₃. Also, that main line relays R₁, R₂, R₃, are, through their armature levers, given control of repeating sounder, RS', and that relays R₁, R₂, R₃, in the same way,

have control of repeating sounder RS. That is assuming, in the case of the relays, that the local circuits controlled by their armature levers are not open at the points x or x' of the transmitters T_1' or T_1 , in which case, the control of the repeating sounders is taken from the relays, as in the figure at x' .

In the figure, three main line circuits, east, and three similar circuits, west, are shown. The main line circuits are controlled by the various transmitters, as shown. For instance, circuits No. 1E, 2E and 3E, being controlled by the levers of T_1 , T_2 and T_3 , respectively.

By the use of this multiple repeater, as already stated, any one circuit of the western series may repeat into all of the eastern series, and any one of the eastern series may repeat into all of the western series. It will, shortly, be seen that the operation is very simple.

Assuming that No. 1 east circuit is about to send to all of the western circuits. He opens his key, which action, by opening relay R_1 , closes the repeating sounder R_s' , as shown. The repeating sounder closing, opens the transmitters T_1' , T_2' and T_3' , and, consequently, opens also the western main circuits at $c' c' c'$.

It is seen that the transmitters T_1 and T_1' are somewhat different from the other transmitters, the former being furnished with tongues and a local circuit connection posts x, x' . T' and T_1 are termed the "master" transmitters.

At the moment the transmitter T_1' started to open, in response to the breaking of its local circuit at the point D' , the local circuit of the relays R_1, R_2, R_3 , was broken at x' . It thus follows that when, immediately afterwards, the western main line batteries are opened at c', c', c' , thereby opening said relays R_1, R_2, R_3 , the repeating sounder RS, is not affected, and it remains open as in the figure.

In this way the automatic portion of the repeater service is performed. As in the case of "single" repeaters, when the West wishes to send to the East the foregoing actions are merely transposed.

By the arrangement of the local circuits of the relays it may be observed that each of them has control of the repeating sounders, as already said, but, of course, they must exercise that control at separate times. It is clear that should either No. 2 or No. 3, east, desire to repeat into the western circuits it has equal control of those circuits with No. 1 circuit, as in the case described. It is also plain that not any of the western circuits hear what either of the other western circuits may transmit, and if one should break, the fact would only be apparent to the others by the cessation of the "sending," and the remarks in reply to the breaking circuit.

It will be obvious to the reader on consideration that the novelty of this repeater consists chiefly in the arrangement of the local circuits. The local contact of the relays being on the back stroke it may be seen that the local circuit could be extended almost indefinitely to include new relays of additional circuits. And an equal number of transmitters could be included in the circuit of the repeating sounders D and D' , to control the main batteries of such circuits. But, of course, it does not happen very often in actual Morse telegraphy that more than two or three circuits require to be repeated into. The repeating sounder can be dispensed with when desired and the transmitters would in that case be operated directly by the relays.

CHAPTER XI.

DUPLIX TELEGRAPHY.

By duplex telegraphy is meant the sending of two messages over one wire in opposite directions, that is, one from each end of the wire, simultaneously.

In this and other chapters throughout, the apparatus, battery, etc., at the near station will frequently be referred to as the "home" apparatus; that at the distant station, the "distant" apparatus. For instance, the "home" battery; "home" relay; "home" transmitter, etc.

It has been pointed out that in ordinary Morse, or single wire working, signals can only be transmitted by one station at any one time, because of the fact that the opening and closing of the circuit by any one of the keys operates all the instruments on the circuit.

FIG. 143

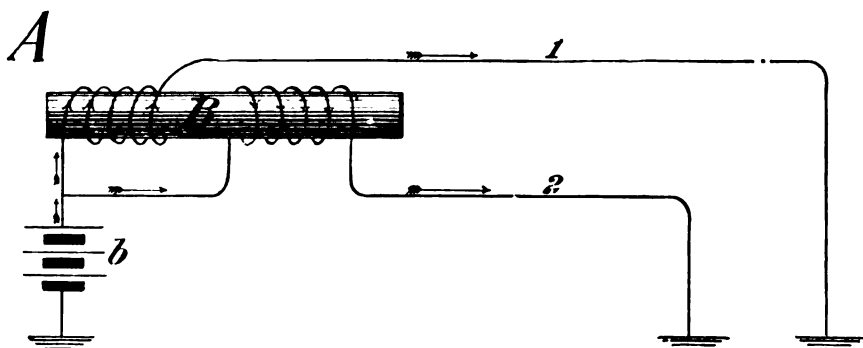

THEORY DIFFERENTIAL DUPLEX.

To make duplex telegraphy possible, therefore, it is essential that the signals transmitted from the home station shall not interfere with the signals to be received at the home station. The home receiving instruments at each station must, consequently, be so constructed, or so placed, that, while ready to respond to signals from the distant station, they will not be responsive to signals transmitted from the home end.

These requirements are met in several ways, but the two most important are known as the "differential" and the "bridge" methods.

The differential method will first be described:

DIFFERENTIAL METHOD.—We have seen that the effect of an electric current flowing in a coil of wire wound around a soft iron bar is to magnetize the bar. One end of the bar will be a north pole, and the other end a south pole, depending upon the direction of the current. We have also seen that the strength of the resulting magne-

tism in the bar is, within the requirements of electrical telegraphy, proportional to the strength of current in the coil.

In Fig. 140, B is a bar of soft iron, around which are wound two similar coils of insulated wire which, respectively, start from a common battery *b*, and are continued by wires 1 and 2 to the earth.

It is a law of electricity that when the current has a choice of paths in which to complete its circuit, it divides in proportion to the resistance of each path (*see* Divided Circuits). In Fig. 140 the coils are shown wound around the bar in opposite directions. The resistance of each wire, 1 and 2, attached to the coils, is the same, hence an equal amount of current flows through each coil from the battery to earth. Consequently, the current in coil 1 has a tendency to make one end of the bar a north pole, while the current in coil 2, being in the opposite direction around the bar, has an equal

FIG. 141.

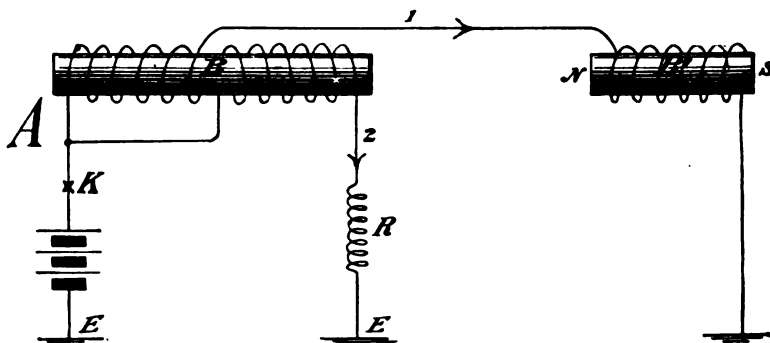

THEORY DIFFERENTIAL DUPLEX.

tendency to make the same end a south pole. Hence, the bar is not magnetized by either coil, as the effect of one is neutralized, or balanced, by that of the other; quite as effectively, for instance, as one pound weight in one tray of a scales would balance another pound weight in the other tray. Or, it is, virtually, as if we should suppose that the current flowing in each coil should, with equal strength, tend to rotate the bar in its direction. As the tendency of the current in one coil to rotate the bar in one direction would be opposed by that of the current in the other coil to rotate it in the opposite direction, obviously the bar would remain at rest.

Since, then, with equal currents flowing in these coils in opposite directions no magnetic effect is produced in the bar, it is clear that it is immaterial whether the current from battery *b* be flowing or not, so far as the bar is concerned. A bar of soft iron, or a relay, wound in the manner stated, is said to be wound "differentially," not because of the opposite winding but, rather, because, as we shall see, they are operated, that is, magnetized, by differences in current strength in the respective coils.

Suppose, now, that the bar B, in Fig. 141, represents a home relay of a duplex telegraph system, and that bar B' is the core of a distant relay, with but one coil shown. In order that equal currents from the battery at the home station shall still pass through the coils of B, a coil of wire R, equal in resistance to the line wire between B and B'

added to the distant coil around B', is placed in wire 2. The result is that, owing to the winding of its coils, B, at A, is not magnetized by the current from the battery at A, but as the current from that battery passes in one direction only around B' that bar is magnetized. If, now, a key were placed in the circuit at K, and it should be opened and closed, the bar B would remain unaffected, as before, but B' would be magnetized and demagnetized, as in the case of a relay in an ordinary Morse single circuit.

If then, differentially wound relays be placed at both ends of the wire, with a battery, key and resistance coils at both stations, it will be found that neither of the relays will be responsive to its home battery, but that each will respond to the movements of the distant key, or transmitter, in a manner which may be understood by the aid of the following figures.

In Fig. 142, B is an iron bar which may correspond to a duplex relay, at A. B' is a battery at a distant station in circuit 1. The resistances of wires 1 and 2 are supposed to be equal. Battery B' is so arranged that its current coincides in direction with the current from battery B. It is assumed that the electromotive force of each battery is the same. The effect is that, the electromotive force in wire 1 being doubled, the current in wire 1, and, consequently, in coil 1, of the home relay, is doubled, while, as the

FIG. 142.

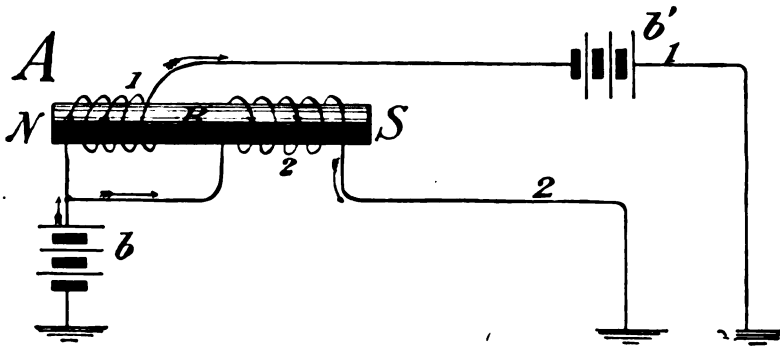

THEORY DIFFERENTIAL DUPLEX.

electromotive force in wire 2 has not been increased, the current in coil 2 remains as in Fig. 141. This "excess" of current in coil 1 magnetizes the bar virtually as if there were but one coil with a current from one of the batteries flowing in it. This action will be referred to again.

Should the battery at the distant end be so connected that its electromotive force opposed that at A, the result will be that no current will flow in wire 1; but, as there is no opposing electromotive force at the distant terminal of wire 2, a current will flow through coil 2 and wire 2 from the battery at A, and this will magnetize the core of the relay. From which it is seen that it is, in a sense, immaterial whether the batteries at the ends of the wire 1, assist or oppose each other. In either case the operation of home relay will be due to the operation of the distant key.

The main feature of the differential method just described is that it prevents the home battery from affecting the home relays, by securing, so far as the home battery is concerned, an equal flow of current through each coil in opposite directions around the core, but yet leaves those relays free to be actuated by the distant battery, which latter is, of course, essential.

There is, as already noted, another method employed for the same purpose, namely, the "bridge" method which depends for its success in preventing the effect of home battery upon the home relay upon the maintenance of an equal and opposite potential, or pressure, at the terminals of the bridge wire in which the relay is placed. This method, which will now be described, is founded on the principle of the Wheatstone bridge.

"BRIDGE" METHOD.—In Fig. 143 wires 1 and 2, and battery remain as before. The coil around the bar B, representing the relay, is now shown connected *between* wires 1 and 2. In this arrangement but one coil is necessary in the relay. *a'* and *b'* are resistance coils placed in the "arms" of the Wheatstone bridge. Assuming

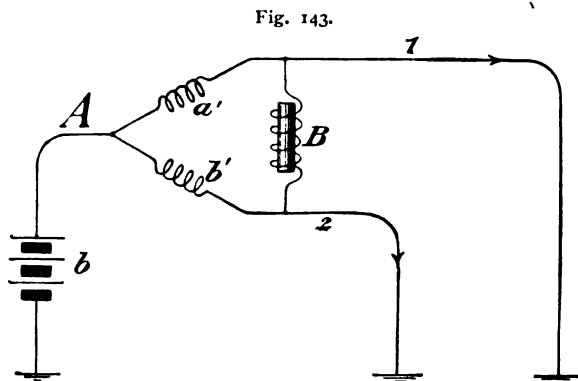

Fig. 143.

THEORY BRIDGE DUPLEX.

the resistance of these arms to be equal, and the wires 1 and 2 also equal, the electric pressure, or potential, due to battery *b*, at the terminals of the bridge wire must be equal and opposite, consequently, a current will, of course, not flow through the bridge wire, and hence the bar B, or relay, as in practice it would be, is not magnetized.

This action may be illustrated as follows:—Suppose in Fig. 143 the battery *b*, at A, to be a water pump; that the wires, or circuits, *a'* 1 and *b'* 2 are parallel pipes of equal diameter and length and that they are connected, at equal points remote from A, by a pipe B. It is then obvious that if the pump *b* is caused to force water through the parallel pipes, no water will flow through B, inasmuch as the tendency to such a flow from either end of B will be offset by an equal and opposite tendency from the other end. But, if, by any means, the pressure at one of the ends of B be made less or greater than at the other, a current will pass through that pipe from the end of greater pressure. Such a difference of pressure at one of the terminals of B might be brought about, for instance, by the use of another pump at the distant end of pipe 1, which could, by assisting or opposing the flow of water through that pipe, vary the pressure at B as desired.

Analogously, in the case of the bridge method, if a battery be placed in the circuit at the distant end of wire 1 it will cause the potential, or pressure, to vary so that a difference of potentials is brought about at the terminals of the bridge wire

and a current will flow from the terminal of higher to the terminal of lower pressure.

If then (as in the case of the "differential" method) each end of a duplex circuit be equipped with the bridge arrangement, etc., it is clear that the variation of pressure at the terminals of the bridge wire, due to the operation of the distant keys, will effect an analogous result to that of the excess of current in one of the coils in the differential arrangement of the coils of the relays, namely, a current will flow in the coil and the core will be magnetized.

In the single Morse system, as stated, when any one key is open it opens the entire circuit; consequently, during that time, no other key can "operate" the circuit. It is clear that such a result following the opening of one of the keys in a duplex telegraph system would be fatal to success. This result is avoided in duplex telegraphy by the use of keys, or transmitters, of peculiar construction, which will be described later on.

There are two systems of duplex telegraphy quite generally used in this country namely, the Stearns duplex and the polar duplex.

The Stearns duplex system is operated by "increase and decrease" of current on the line, or by placing the line to ground and to the battery, alternately.

The polar duplex is operated by "reversals of polarity," obtained by alternately placing first one pole and then the other, of a battery, or other source of electricity, to the line.

In the operation of these systems, as will be noted in the ensuing descriptions, distinctly different apparatus is employed. They may be arranged on either the "differential" or "bridge" plan. The differential is the one most frequently employed in overland telegraphy; the bridge plan is almost invariably employed in submarine telegraphy.

THE STEARNS DUPLEX.

The Stearns duplex is, broadly speaking, operated in practically the same way as is the ordinary Morse telegraph system; namely, by the placing of a battery in the line to actuate or magnetize the home relay, thereby attracting the armature, and by removing such battery from the line, thereby permitting the retractile spring of the armature lever to withdraw it from the core of the relay.

The home battery is prevented from affecting the home relay when the home key is opened and closed in the manner described as the "differential," namely by winding the relays "differentially." This duplex is sometimes termed the differential duplex.

In connection with Fig. 141 a coil of wire was shown inserted in the wire 2 to make the resistance of that wire equal to wire 1, in order to insure that the current flowing in each coil of \mathfrak{B} should be equal.

In actual duplex working in which the differential or bridge plan is utilized, it is similarly necessary that the resistance of the wires attached to the respective coils of the relays, or to the arms of the "bridge," should be equal, that an equal strength of current from the home battery should tend to flow in each coil, or wire.

In the arrangement of a "differential" duplex, as the *main line* wire is connected to one of the coils of the relay at each terminal station it is clear that considerable "resistance" must be connected up with the other coil to ensure that the current flowing in the latter coil shall be equal in strength to that in the former coil. It is clear also that, if, in duplex telegraphy it were necessary to provide a wire, similar in size and length to the main line wire, wherewith to bring about this equality of current in both coils, the main advantage of duplex telegraphy, namely, its ability to provide additional facilities for telegraphing without increased expenditure for wires, would be lost.

But such, fortunately, is not the case, for it is well known that, with a given electromotive force and a circuit of a given resistance, the strength of current will be the same, whether the conductor composing the circuit be one mile or one hundred miles in length, one inch or one foot in diameter.

Availing of this fact the resistance necessary to insure the equality of currents referred to is made up of "resistance coils," composed of small wire of high resistance, termed a "rheostat," or "resistance box," which is constructed in such a manner (*See Rheostat*) that the resistance may be varied until it is found to equal the resistance of the main line. When this result is obtained the duplex is said to be "balanced." The method of obtaining this balance will be fully described.

In Fig. 144 the connections and apparatus of a Stearns duplex system are shown, theoretically. Two stations x and y are represented and the instruments and apparatus at one station are duplicates of those at the other.

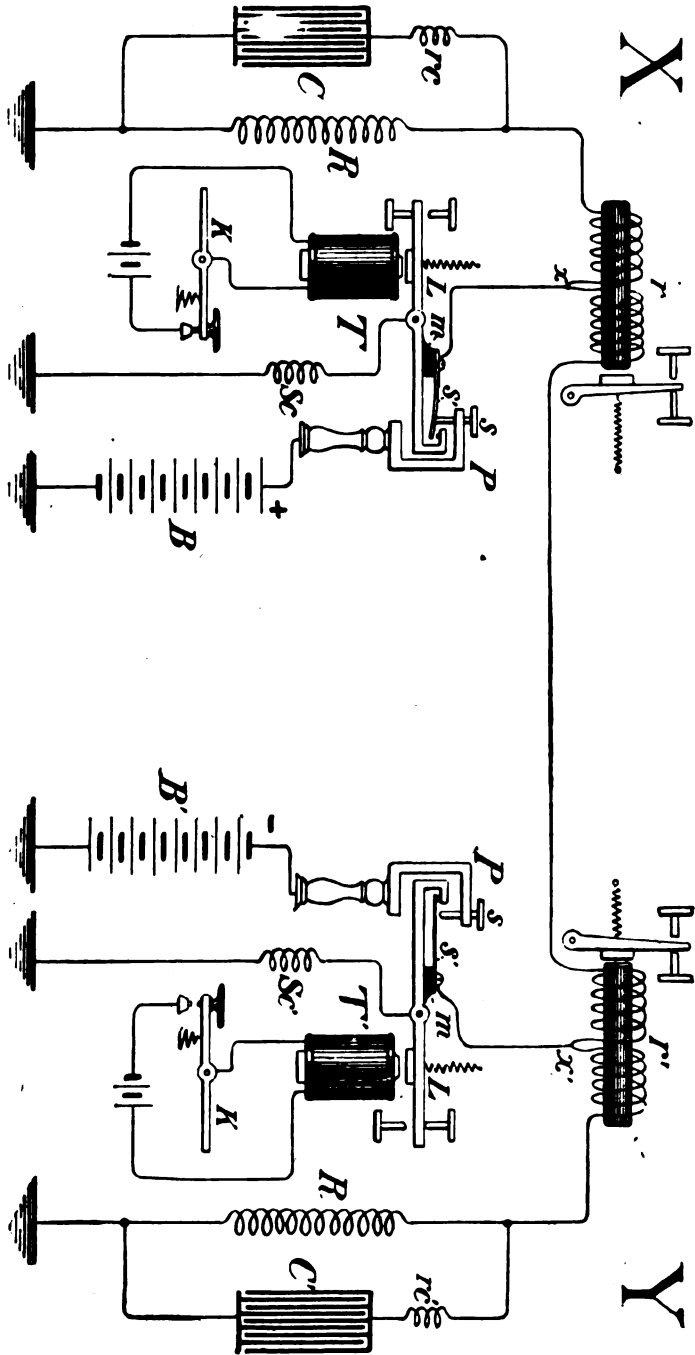

FIG. 144.—STEARNS OR DIFFERENTIAL DUPLEX, THEORY.

R and R' represent the resistance coils just referred to. In practice these coils are generally termed the "artificial" line; sometimes the compensating line.

The coil of the relay at either end which is connected to the main line is termed the "main line" coil; the coil connected to the resistance coils, the "artificial line" coil.

B and B' are the main batteries. T and T' are instruments known as "continuity preserving" transmitters but, ordinarily, termed simply, transmitters. These transmitters are operated by a local battery and Morse key, as indicated in the figure. Differential relays r and r' are placed at each terminal.

CONTINUITY PRESERVING TRANSMITTER.—The transmitter in the Stearns duplex takes the place of the key in the simple Morse system. It has, as may be seen (T, T' in Fig. 144) a lever L , which is bent at one end. The lever carries a piece of insulating material M on which is fastened a strip of metal s' , generally of steel, called the "tongue," which extends under the bent end of the lever L . A metal post, or standard P , is equipped with a screw s , the lower end of which is near to, and in certain positions of L , touches the tongue s' , making contact therewith, as at transmitter T .

A wire leading to the line is generally connected, as shown, to the tongue, the battery wire to the post P , and the "ground" wire to the lever L . Hence, when so connected, if the transmitter be "open" the line is placed to the ground, as at T' , and if it be "closed," battery is placed to the line, as at T .

The transmitter derives its name, "continuity preserving," from the fact that, by the arrangement of the tongue s' the screw s and the bent end of the lever L , the line wire which is attached to s' as shown, is transferred from the battery to the earth without any "break" in the "continuity" of the circuit. This will be apparent from an examination of the diagram. In the figure the transmitter at x is closed. When it opens the right end of the lever will descend, and, as it does so, the tongue s' will come into contact with the bent end of L , which will withdraw s' from s and leave it in the position shown at station y where the key controlling T' is open.

OPERATION OF DIFFERENTIAL DUPLEX.—In Fig. 144, as just stated, the transmitter T is closed and T' is open.

This places the positive pole of battery B to the line and leaves battery B' open, but places the line wire to the ground at y .

The current from x divides in equal parts at x , one part passing to the main line and ground at y , the other to the artificial line R and ground. The result is that, since the current from battery B passes around the coils of r in equal and opposite directions, no effect is produced upon that relay. At the distant end y , however, the current only passes through line coil of relay r' , to the ground, and, consequently, that relay is magnetized and its armature is attracted.

The statement that the current only passes through the line coil of the relay at y may be slightly qualified, since, while it is true that in the position of the transmitters in the figure the bulk of the current will pass through that coil to the ground

via transmitter τ' , it is the case also that a smaller portion of the current will pass through the artificial line coil of r' to the ground, via κ' ; but, as in doing so it passes around the core of the relay in a direction similar to that in which the current traversing the line coil passes around the same core it only assists in the further magnetization of the relay. The amount of current which will flow through the artificial coil at this time depends upon the respective resistances of sc' and κ' . The greater the resistance of sc' , the resistance of κ' remaining the same, the greater will be the strength of current traversing the artificial line r' . If there were no appreciable resistance at sc' , virtually no current would pass through the artificial coil.

When the conditions are reversed and transmitter τ' is closed and τ is open the relay at γ will not be affected by battery, B' , while the relay at x will be operated.

When both transmitters are closed simultaneously, thus placing a positive pole to the line at x , and a negative pole to the line at γ , the effect will be that practically twice the amount of current will pass through the main line coils of the relays as will pass through the artificial line coils.

This is due to the fact that the placing of both batteries to the line has doubled the electromotive force on the main line circuit, while, practically, only the electromotive force of one battery is placed to the *artificial* line at each station. This gives a preponderance of current in each main line coil, owing to which the cores of the relays are magnetized and their armatures are attracted.

Hence, since, as we have seen, with the distant key open and the home key closed or open, the home relay remains open, it is obvious that it is practically immaterial whether battery is to the line or not at the home station, so far as regards signals sent from the distant end. In other words, owing to the differential arrangement of the coils of the relays and the fact that each coil is part of a circuit of equal resistance, the home relay is only responsive to changes in the current strength due to the operation of the distant transmitter. The manner in which the changes are effected will be referred to at greater length in the descriptions of the polar duplex and quadruplex.

SPARK COIL.—In Fig. 144 sc is a small resistance coil (often termed the spark coil) employed to compensate for the internal resistance of the main line battery, when the transmitter is open. The object in using this coil is to maintain a uniform resistance on the line, in either position of the transmitter. For instance, assuming the internal of a battery to be 300 ohms. When the battery is to the "line" this 300 ohms is added to the resistance of the line, whereas when the transmitter is "open" it would not be, normally. Thus, without the resistance referred to, placed at sc it would likely occur that an unevenness of the signals would follow.

STATIC COMPENSATING CONDENSERS. c, c' are *condensers* which are employed in duplex telegraphy to impart to the "artificial" line a "static" capacity equal to that of the main line. (*See Static Charge.*)

The necessity for the employment of condensers in this respect may be explained as follows.

As has been shown elsewhere, conductors, besides possessing "resistance" also possess the property of electro-static capacity. The electro-static capacity of over-

head telegraph conductors is very much less than that of underground, or submarine conductors, about as 1 to 23. This is mainly due to the proximity of the latter to the earth, and also to the specific inductive capacity of the insulating material of the cable.

The effect of charging a conductor which has measurable electro-static capacity, is that, at the moment of charge a greater rush of current takes place into the wire than would be the case if the conductor were devoid of this quality. When the battery is removed and a route to the earth provided, the accumulated "charge" rushes out in a direction opposite to that of the charging current.

The German silver wire of which the rheostats employed as the artificial line are generally composed (*See Rheostat*) has, normally, no appreciable "static" capacity; the consequence is that, (unless capacity is furnished to the rheostat) at the moment when the home battery is placed to the main and artificial lines, and also when the battery is cut off, a greater quantity of current, for an instant, flows through the line wire coil of the relay than flows through the artificial line coil, and when the line wire is of sufficient length, this excess of current is ample to cause a momentary magnetization of the core of the relay which tends to attract the armature. Or, it might be that the excess of "charge" and "discharge" currents, due to the static capacity of the line, would tend to momentarily demagnetize the core and thus permit it to be withdrawn from its contact point. This will be discussed further under the "Quadruplex."

The effects of these momentary current of static charge and discharge of the line upon the home relays are, on long lines, of such an injurious nature as to entirely prevent the successful reception of signals in duplex telegraphy when both stations are simultaneously transmitting signals, and, were it not possible to compensate for this effect, not only duplex but also quadruplex telegraphy, and especially the latter, would be impracticable. It is especially true of quadruplex telegraphy, because of the much greater electromotive force used in that system than in duplex telegraphy; the static charge and discharge increasing in direct proportion with the electromotive force of the terminal batteries.

The instruments used to impart to the artificial line the quality of electro-static capacity are the condensers referred to, c, c' , Fig. 144. One terminal of the condenser at each end of the line is connected to the artificial line, R, R' , the other to the earth. The condenser is provided with an adjusting arrangement by means of which its capacity is increased or decreased until it is found to furnish current which exactly offsets that due to the static capacity of the line. When such is the case the line is said to be balanced for "static." In order to bring about this balance more accurately it is sometimes essential to use two, or even three, condensers, arranged in multiple and with a resistance coil inserted before each of them. In Fig. 144 such resistance coils sc and sc' are shown placed between condenser c and c' and the artificial lines.

Instances will be seen of two and three condensers in figures of the Wheatstone automatic system.

The effect of the resistance coil is to retard and diminish the condenser charge and discharge to conform more closely to the actual conditions of the main line.

TERMINAL CONNECTIONS.—The actual connections and apparatus of a “Stearns” duplex at one station are outlined in Fig. 145.

R is a “differentially” wound relay, each coil having a resistance of about 200 ohms. In practice this relay is somewhat larger than the ordinary Morse relay. *T* is the transmitter operated by key *K*, and local battery *b*. *Rh* is the rheostat for artificial line. *C* is the condenser. *rc* the retarding coil of condenser. *sc* is the resistance

FIG. 145.

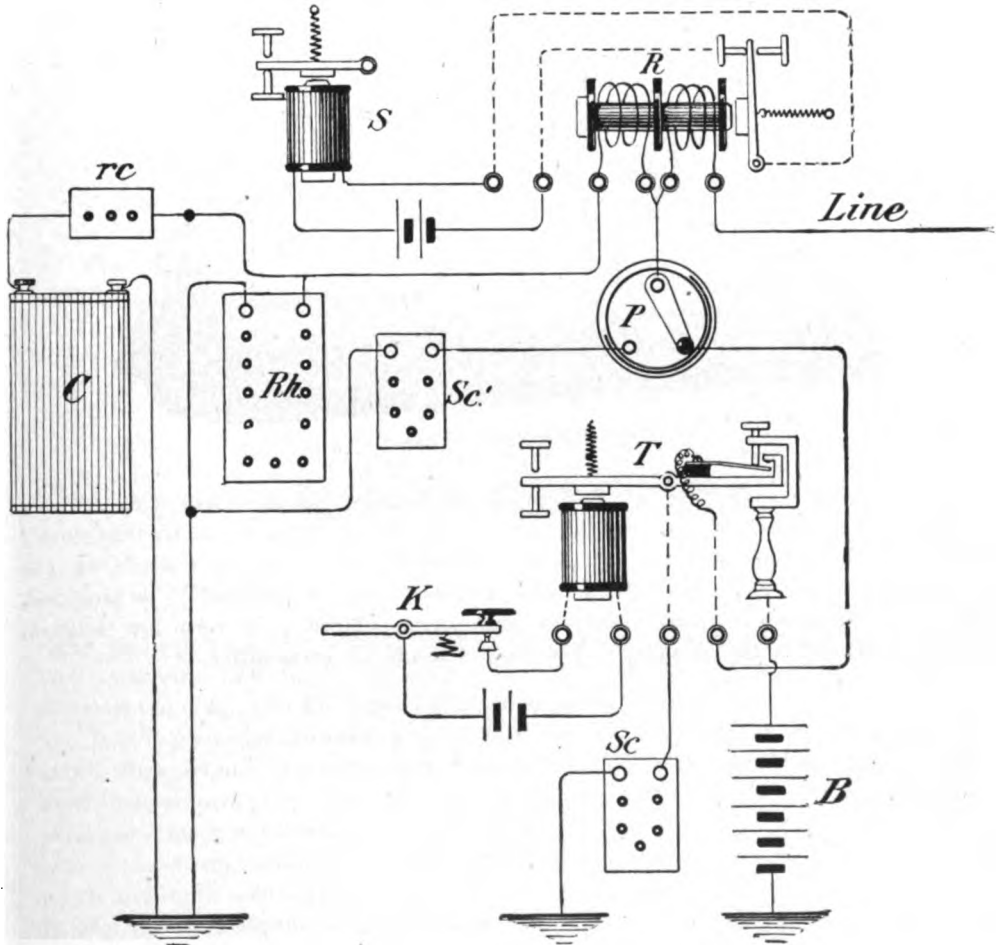

TERMINAL CONNECTIONS, STEARNS DUPLEX.

coil which compensates for internal resistance of the main battery *B*. *P* is a 3-point switch useful in “throwing” the line to “ground” when a balance is desired by the distant end, but it is not so essential in the Stearns duplex as it is in the polar duplex, inasmuch as if the transmitter be open the line is thereby grounded.

STEARNS TRANSMITTER.—In Fig. 146 the Stearns transmitter is shown as in practice. *L* is the lever; *i* is the insulating material on which the tongue, *t*, rests; *p* is the supporting post, insulated from the brass base plate on which the standard of lever *L* rests.

FIG. 146.]

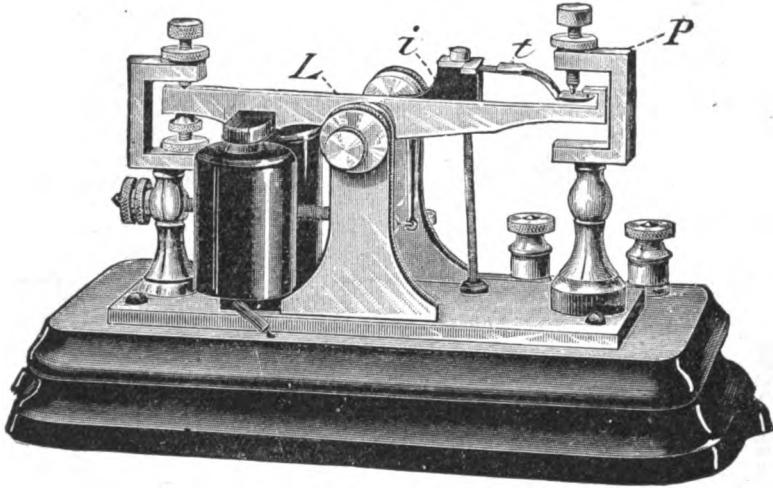

STEARNS TRANSMITTER.

BALANCING STEARNS DUPLEX.—In taking a “balance” on this form of duplex it is only necessary to ask the distant station to open his key. This opens his transmitter which places the distant end to “ground.” Dots and dashes are then made on the home key and the rheostat and condenser adjusted until a “balance” is procured, which will be when the home relay, its spring being placed at a very low tension, does not respond to the opening and closing of the home transmitter.

THE POLAR DUPLEX.

This duplex involves in its operation, among other principles, this one, that, when a current of electricity flows in a coil of wire surrounding a soft iron core, the iron not only becomes magnetized, but also that its magnetic *polarity* depends upon the direction in which the current flows in the coil around the core.

FIG. 147.

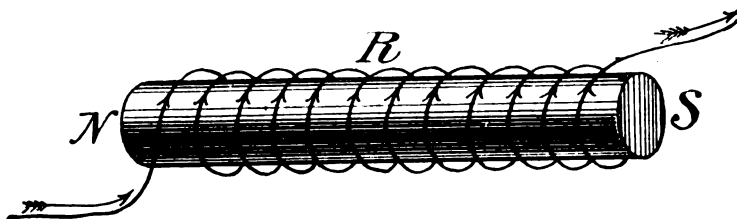

For instance, if, as in Fig. 147, the current circulates around the core from left to right, as indicated by the arrows, the left hand end will be a north pole and the

FIG. 148.

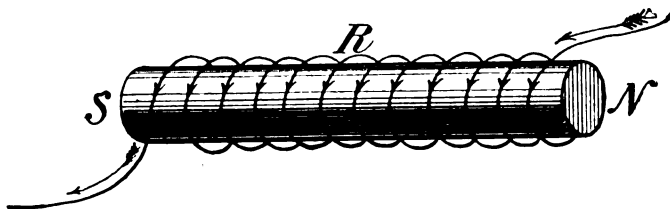

right end a south pole. If from right to left, as in Fig. 148, the right hand end will be a north pole and the left a south pole. This will be the case regardless of the shape of the core. (See *Polarity of Electro-magnets*, page 201).

It is known that the north pole of one magnet will attract the south pole of another magnet, and vice versa, and that the south pole will repel a south pole and a north pole a north pole. In Figs. 149 and 150 the *north* pole of a freely suspended permanent magnet *A* is placed between the poles of an electro-magnet *R*. The direction of the current around *R*, in Fig. 149 is, as indicated by the arrows, such that its north and south poles are as marked, and, consequently, *A* is attracted to the right. In Fig. 150 the current is in the opposite direction around *R*, and its poles, it will be seen, are the reverse of those of *R*, Fig. 149, with the result that *A* is attracted to the left.

Assuming the end of the permanent magnet *A* to remain of north polarity it is evident that, if the direction of the current around the coils be reversed repeatedly, *A* will vibrate from pole to pole in response to to the reversals. In such a case the permanent magnet may be considered the armature of the electro-magnet and, by having suitable means for reversing the direction of the current in a circuit of which

the coils in Figs. 148 and 150 might form a part, it would then be easy to cause armature Λ to operate a local circuit at each reversal of the current.

The instruments and apparatus presently to be described, for so reversing the direction of the current and for responding to such reversals, constitute the more important instruments of the polar duplex.

In this duplex, in overland telegraphy, the "differential" plan is generally adopted, to avoid interference with received signals by the operation of the home transmitter.

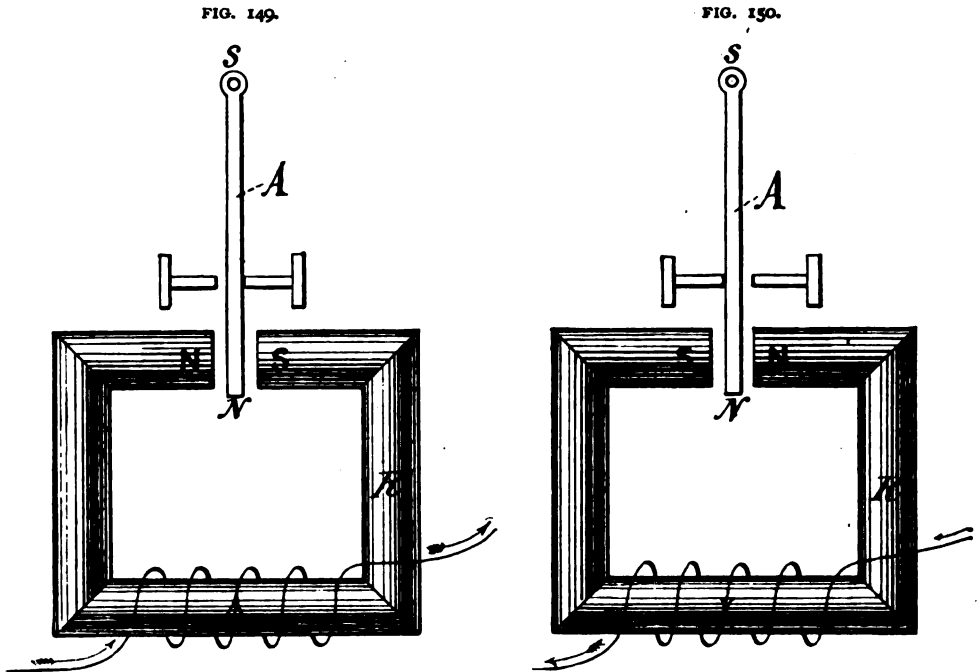

OPERATION OF POLE-CHANGER.—In Figs. 151 and 152 apparatus is shown for reversing the direction of the current. In those figures PC is a pole-changing transmitter, commonly termed a "pole-changer," designed to transpose the position of the poles of the battery as regards the circuit in which it is placed, and, consequently, to reverse the direction of the current in the circuit.

This pole-changer PC is of the class known as continuity preserving pole-changers, and which are designed to "reverse" the battery with the least possible break in the circuit. In Fig. 151 the contact points are purposely separated more widely than is customary in practice.

PC consists of a lever L carrying the armature Λ of an electro-magnet E ; the latter being controlled by a key, κ , and local battery b . The lever L is extended, as shown, and has a platinum contact point P at the end of the extension. Opposite P is another contact point P' , supported by framework, not shown in Figs. 151 and 152, but seen in

Figs. 157 and 158. Metal strips l, l' , with platinum contact points, are also supported on the framework and pivoted as indicated. l is given a downward tendency, l' an upward tendency, by springs or otherwise. P is fixed rigidly in its place. The poles of battery B are connected, respectively, to levers l and l' , as shown.

In Fig. 151 the pole-changer is shown closed. In that position the contact P is in contact with l , while P' is in contact with l' . This, it will be seen, places the negative pole of battery B to the line, and the current on the line is in the direction indicated by the arrow.

When the key, K , is opened, the extension of L is caused to descend. As it does so the strip l follows P until it is stopped by the contact point P' . P then severs connection with l and, descending still further, makes contact with l' , which it pushes away from P' , the whole assuming the position shown in Fig. 152. The positive pole of the battery is now placed to the line and, consequently, the direction of the current is reversed on the line, also as indicated by the arrow.

FIG. 151.

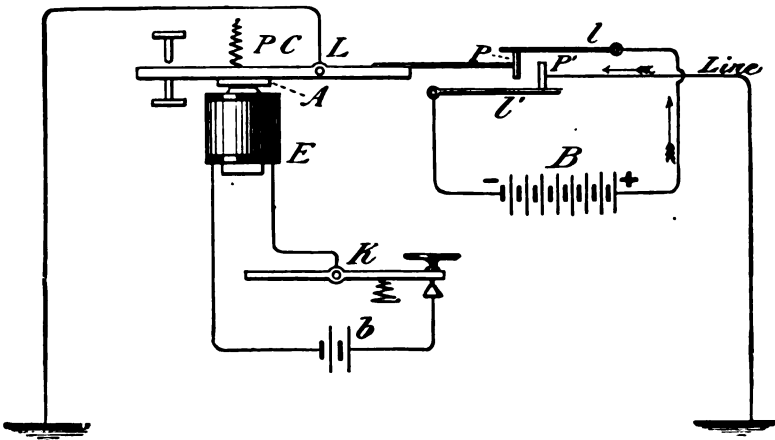

In Fig. 152 a relay, PR , corresponding to P in Figs. 149 and 150, is shown as at a distant end of the line. Its armature controls a sounder s . It is plain that as often as the battery is reversed by the pole-changer the direction of the current in the coil of R will also be reversed and, consequently, the armature A will be oscillated from one side to the other. Hence, by proper manipulation of the pole-changer, dots and dashes will be received at the distant station.

In some countries this method of transmitting signals is used almost exclusively on *single* wires. It is known as the "double current" method. The difference between this and the Morse, or single current method, is that, in the double current method, the spaces are made, in reality, by placing that pole of the battery to the line which will cause the withdrawal of the armature of PR from its local contact point, while, in the Morse method, the space is made by opening the circuit, thus cutting off the battery from the line. (See pages 287, 288).

POLARIZED RELAY.—The instrument corresponding to *R* in Figs. 149, 150 and *PR* in Fig. 152, and which is designed to respond, at a distant station, to the movements of a pole-changer at a home station, is termed a “polarized” relay, or, for short, a “polar” relay.

One form of this instrument, very generally used in duplex and quadruplex telegraphy, is shown in Fig. 153. It is known as the Western Union polarized relay.

FIG. 152.

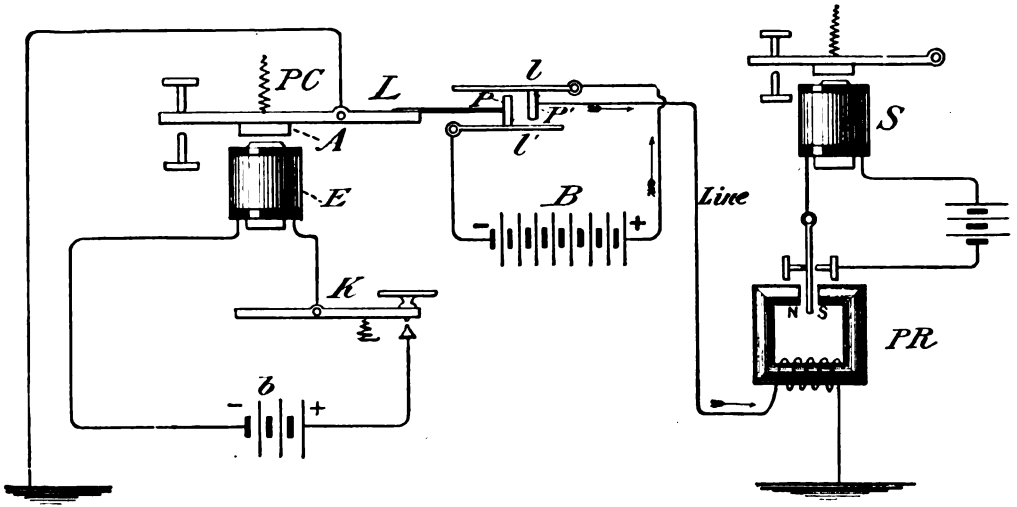

The polarized relay is a combination of a permanent magnet and an electro-magnet. The electro-magnet consists of short cores made of the best Norway soft iron, surrounded, (when intended for differential duplex working,) by “differentially wound” coils, each having a resistance of about 400 ohms. In some forms of polarized relays the core of the electro-magnet is extended beyond the edge of the coils so as to bring the poles face to face. These extensions, which are also of soft iron, are termed pole pieces, (*See P, P, Fig. 154.*)

A permanent magnet, *PM*, Fig. 153, bent to the shape shown, rests on the base board of the instrument. These permanent magnets are formed of steel and are very retentive of magnetism. On the lower end, *s p*, of the permanent magnet the cross-piece of the electro-magnet rests. The cross-piece of the electro-magnet is a strip of soft iron connecting the two cores of the electro-magnet in the usual way. To the upper end, *n p*, of the permanent magnet, is pivoted, at *x*, a soft iron tube, *A*, which extends between, and somewhat beyond, the poles of the electro-magnet. This is the armature of the polarized relay. This armature is constantly magnetized by its nearness to the permanent magnet *PM*. Assuming the end, *n p*, of the permanent magnet, to be its north pole, and *s p* its south pole, the armature *A* will be magnetized so that its end between the poles of the electro-magnet will be a north pole; and the ends of the cores of the electro-magnet, which are also magnetized by

contact with the permanent magnet, will be south poles; that is, during the time that no "magnetizing" current is flowing through its coils. The term magnetizing current is used here, advisedly, because of the fact that, in a "differential" relay, the current does not magnetize the core until an excess of current flows through one of the coils.

When, therefore, there is no magnetizing current in the coils of EM, the armature A, which, having no retractile spring, when placed exactly in the "centre" be-

FIG. 153.

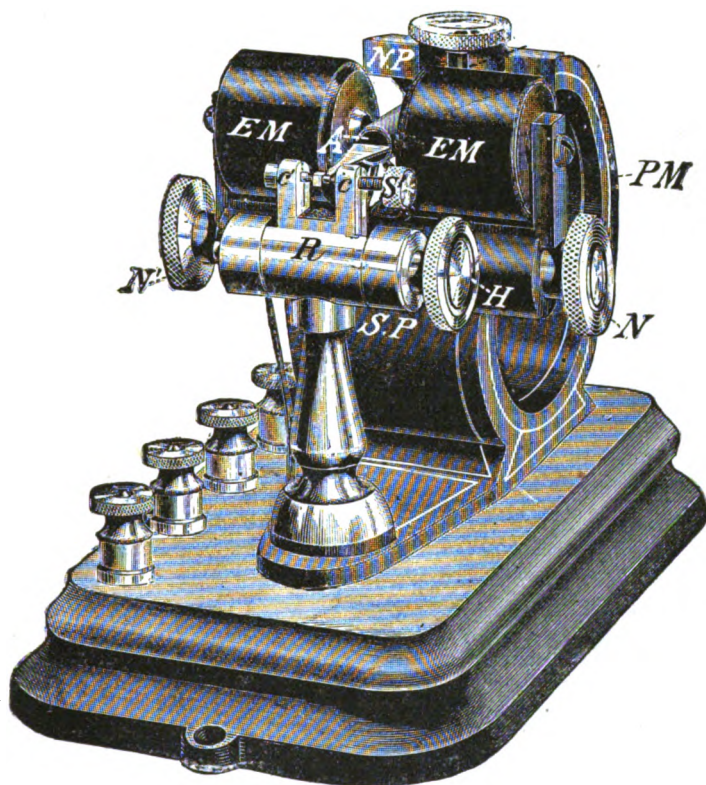

W. U. POLARIZED RELAY.

tween the two ends of EM, will be attracted equally by both ends, since a south pole on each side is "pulling" with equal strength, at a north pole.

But, if the armature be placed nearer one pole face of EM than the other, it will be held towards that face, or end. Consequently, under the conditions stated, the armature will stay on whichever side it is last placed. When, however, a magnetizing current passes through the coils of the electro-magnet, the magnetism in its core, (due to the permanent magnet,) is either increased or overcome and its ends become north or south poles according to the direction of the magnetizing current, and the

armature *A* is attracted by the south pole of the electro-magnet and repelled by the north pole.

The magnetism of the electro-magnet of the polarized relay changes in response to the reversals of the distant battery and the armature vibrates to and fro between its front and back stops in accordance with those changes.

It is obviously essential that the magnetism of the permanent magnet should not be reversed by the reversals of magnetism of the electro-magnet, otherwise the magnetism of the armature *A* would be reversed also and would fail, in that case, to respond properly to the reversals of the distant battery. Since the armature does respond properly, it is evident that the permanent magnet is not materially affected by the magnetic reversals of the electro-magnet. There may be a slight tendency to so change on the part, as it were, of the electro-magnetism of the electro-magnet, but, owing to the point at which the permanent magnet is connected to the cores or cross-piece, of the electro-magnet, that is, at its "neutral" point, namely, at the middle of the cores, on such effect is not perceived in practice.

The play of armature of the Western Union polarized relay is adjusted by means of the small screw *s*'. Its position between the cores of the electro-magnet is regulated by the position of the front and back contact points *c*, *c*'. These contacts ride in a carriage which is movable, within certain limits, in the cylinder, *R*. The carriage is movable, back and forth, by the screw *H*. The armature may be placed directly in the "center" between the two poles of the electro-magnet by the movement of the screw *H*. The cores of the relay may be independently moved to and from the armature by the screws, *N*, *N*'.

FIG. 154.

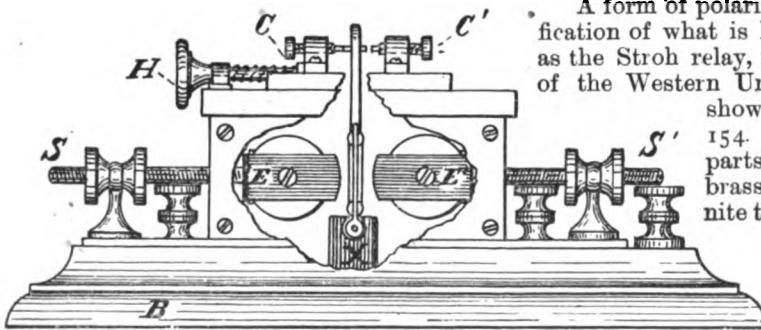

A form of polarized relay, a modification of what is known in Europe as the Stroh relay, now the standard of the Western Union Company, is shown in side view Fig. 154. Its chief working parts are enclosed in a brass case with an ebonite top in which there is an opening through which the armature lever comes. There is also a small

opening in the sides of the brass case through which the pole pieces of the electro-magnets can be observed for purposes of adjustment. In the figure this opening is enlarged in order to show more clearly the relative positions of the coils *E*, *E*', pole pieces, etc. In this relay an ordinary horseshoe magnet is employed as the permanent magnet. It lies horizontally under the base *B* of the relay, as outlined in Fig. 154 *a*, which is a top view of the relay. The relay has two electro-magnets with separate cores, practically similar to those of the Wheatstone relay shown and described, pages 303, 315, 317; the main difference being that in this form the electro-magnets lie horizontally, lengthwise, with pole-pieces facing, and the armatures are vertical, lengthwise, the lower ends of the armatures being loosely inserted in a recess in short iron extensions (*x* Fig. 154) from the respective ends of the permanent magnet by which the armatures are inductively magnetized. The pole-pieces extend across the ends of the coils, but

FIG. 154a.

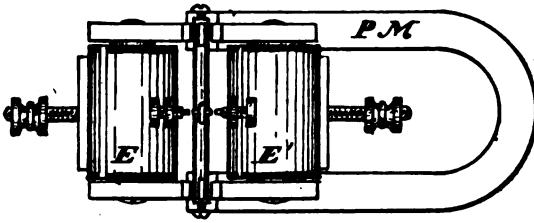
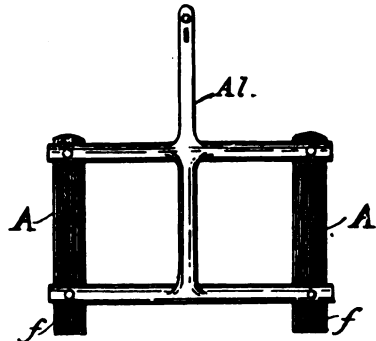

FIG. 154b.



are connected to the cores as indicated. The pole-pieces and coils are moved to and from the armature by means of the adjusting screws *s s*. The local contact point and back stop *c c'* are movable in a frame which is adjustable by the screw *h*. The moving parts of this relay are much lighter than in some of those previously in use by this company; the light, non-magnetic metal aluminum being used wherever practicable. As intimated, the relay has two separate armatures which, however, are carried on a common frame, which is outlined in Fig. 154 *b*. This frame is pivoted at *f f*. *A A* are the soft iron armatures. *Al* is the armature lever, also of aluminum.

THEORY OF THE POLAR DUPLEX.—The theoretic connections of a polar duplex at two stations *x* and *y* are shown in Fig. 155. In this, *P C* and *P C'* are the pole-changers. *P R* and *P R'* are differentially wound polarized relays. *B* and *B'* are main batteries.

R, R' are rheostats, or coils of insulated wire, adjusted to equal the resistance of the main line wires. This, it has been explained is necessary in order that, when the distant end is "grounded," the same amount of current shall flow through each coil of the differential relays, which will be the case when the resistance of the rheostats equals that of the main line.

In Fig. 155 the pole-changers at both ends of the line are open. This places the positive pole of batteries *B* and *B'* to the line. As these batteries are supposed to have an equal electromotive force no current flows over the main line. But a current from the respective batteries *B, B'* flows to "ground," via the artificial lines, in a direction which so magnetizes the cores of *P R* and *P R'* that their armatures are withdrawn from their local contact points, thus leaving the sounders open. It may, perhaps, be useful to explain these statements. It has been shown (Wheatstone Bridge) that when the terminals of a wire are at similar potentials, no current will flow in that wire. In the case in point, when positive poles of equal electromotive force are placed to the main line at each station it is plain that the terminals of that wire are at similar potentials. In the case of the artificial wires, on the other hand, the *distant* terminal of each is at zero, under which conditions, of course, a current will flow in these wires.

If now the pole-changer *P C'* at *y*, be closed, it will place a negative pole to the line.

That action should reverse the magnetism in *P R* but should have no effect on the relay *P R'* at *y*. That such is the case we shall see. It is here suggested to the student that he draw diagrams to show these changes, inserting arrows to indicate the changed direction of the current.

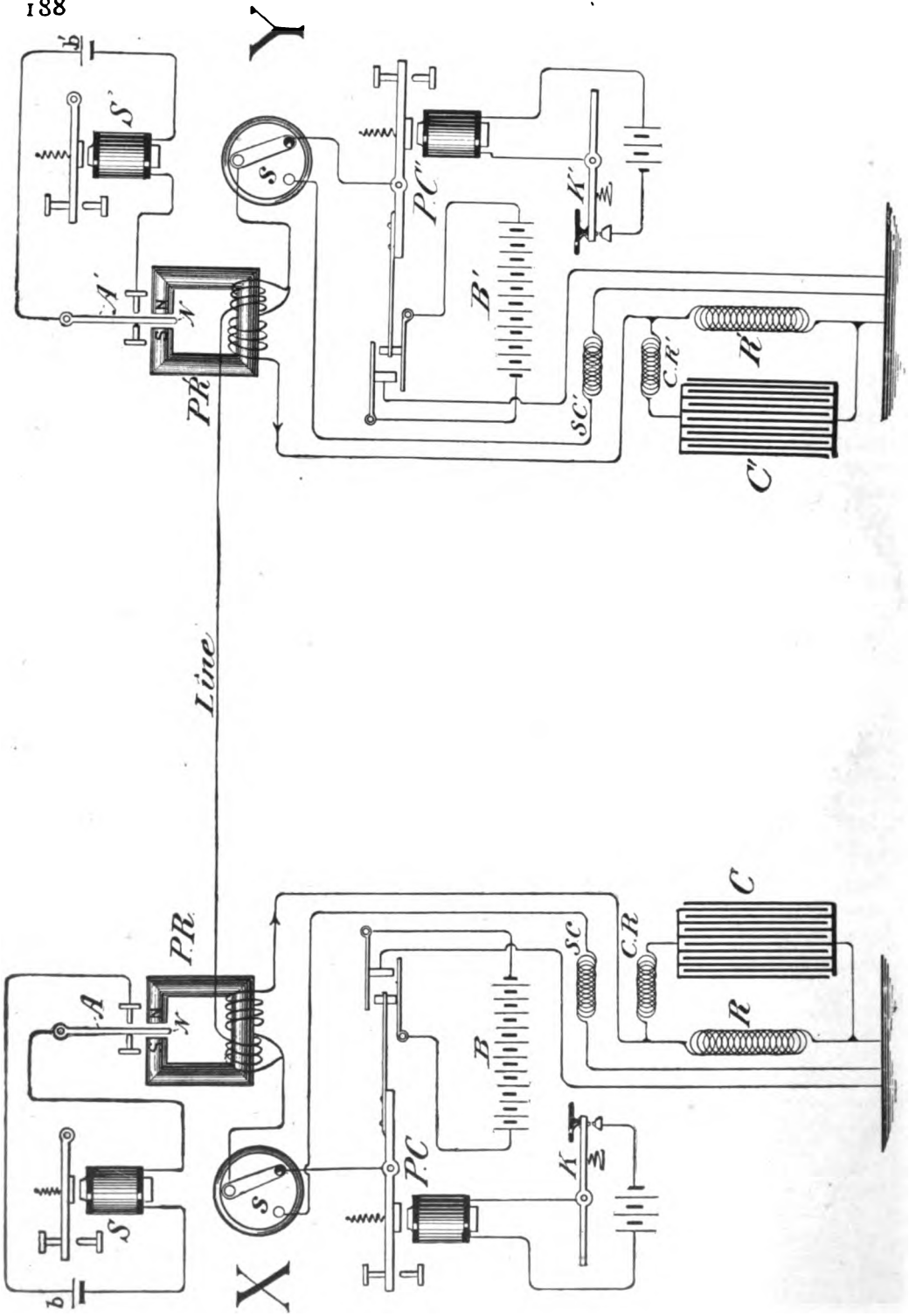

FIG. 15.—MOLAN DUPLEX (THEORY).

With the positive pole to the line at x and the negative to the line at y there will be twice the current flowing over the line wire that flows through the artificial lines. Before the reversal of $P C'$ the current was flowing only through the artificial line coil of PR , shown by the arrow, etc. After the reversal that current continues to flow, but now there is a current of twice its strength flowing in the main line coil around the core of PR in an opposite direction. The result is that the magnetism of the core of PR is reversed and the armature, A , is moved over against its local contact point, closing the local circuit. So far the result desired is brought about. Now let us see whether the polarized relay, PR' , at y , has been affected by the action which has reversed the polarity of PR at x .

Before the reversal of $P C'$ a current was flowing only through the artificial line coil of PR' in the direction shown by the arrow. After the reversal of battery B' twice the current flows through the main line coil that flows through the artificial line coil, but its course through the main line coil is in the same direction, *around the core* of PR' , as was the current which previously flowed through the artificial wire coil, so that the magnetic polarity of PR' remains unaffected and its sounder continues open.

If the pole-changer at x should also be closed that action will place a negative pole of battery B to the line. The result will be that, since the pole-changer at y is also closed, the negative pole of B' is to the line, consequently, no current will flow over it. But now the current through the artificial line coil is in an opposite direction around the core to that which had made its magnetism north and south as marked at its poles in the figure, and, hence, its magnetism is changed and the sounder is closed. It will also be found on examination that this reversal of the battery at x has not affected the relay at x although the magnetizing current has been transferred from the main line coil to the artificial line coil. From all of which it is evident that, with a proper "resistance" and "static" balance, the home relays will not have their magnetism changed by reversals of the home batteries, regardless of whether the poles of the batteries at the respective ends of the wire oppose or assist each other.

BALANCING THE POLAR DUPLEX.

The polar duplex is balanced by asking the distant station to "ground." This he does by throwing the 3-point switch s , Figs. 155 and 156, to the left. (Sometimes the left hand lower "point," or disc, is connected to the earth, via $s c$; sometimes it is the right hand lower point that is so connected.) This action disconnects the pole-changer and battery from the line and transfers the latter to the earth, via the resistance coil $s c$ or $s c'$. These resistance coils are inserted, as in the Stearns duplex, to compensate for the internal resistance of the battery at each end. When the distant switch has been turned the home switch is also turned similarly. The adjusting screw κ , Fig. 154, of the polarized relay is turned forward or backward until the armature remains on whichever side it may be placed. The home battery is then placed to the line by turning the switch s to the left. Then the pole-changer is opened and closed and the resistance in R or R' is adjusted until the armature

of the relay remains on either side, as before. This insures a "resistance" balance. The pole-changer is now closed and opened rapidly and if short clicks are heard the capacity of the condenser is varied until these disappear altogether. This shows that a "static" balance has been obtained. A static balance can also be got by asking the distant station to "cut" in, which he does by turning the switch to the right. When he has done so ask him to close his key so that the armature of the home relay will rest against its contact point. The armature may then be given a slight bias away from its contact point and the home pole-changer again operated. If clicks are still heard in the sounder, the condenser and its resistance coil are adjusted until they disappear, when the distant end may be asked to write a few words

FIG. 156.

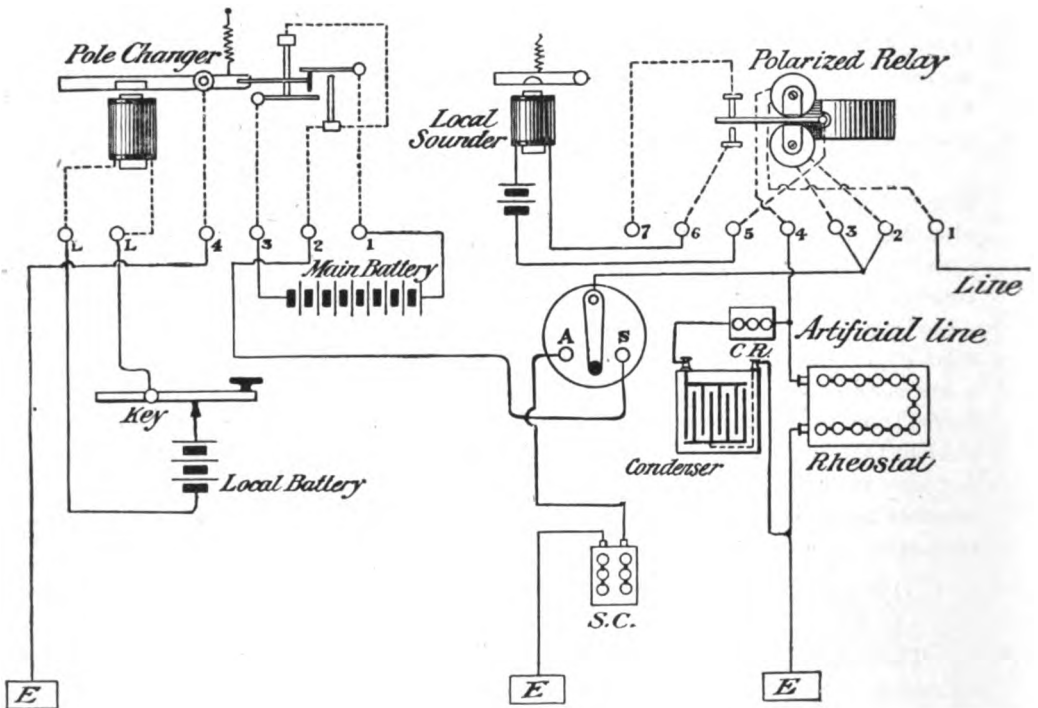

POLAR DUPLEX TERMINAL CONNECTIONS. (GRAVITY BATTERY.)

to give an opportunity to readjust the armature to its proper place. As a rule, however, a good, working static balance can be obtained on a polar duplex without giving the armature of the polarized relay a bias.

A diagram of actual connections of a polar duplex "set" at one station, is given in Fig. 156, with a gravity, or other chemical battery, as the source of electromotive force. The dotted lines represent the small wires connecting the apparatus to the binding posts. In the figure the polarized relay is shown with front and back local contact points, leading to screw posts 6 and 7, respectively. The polar relay is

not always equipped in this way; binding post 7 being generally omitted. But the former arrangement is often useful, as it affords an easy means of putting the sounder on the "front stroke" when the distant battery connections are reversed, which frequently happens in practice. *CR* is the condenser resistance. *AS* is a 3-point switch used in "grounding" the line. *SC* is a "spark coil," or resistance box, adjusted to equal the internal resistance of the main battery. The other instruments are as marked.

W. U. POLE-CHANGER.—The Western Union standard pole-changer for gravity batteries is shown in Fig. 157. The contact points of the instrument are enclosed in a circular, glass-encased box. The end of the lever *L* is seen extending into the box

FIG. 157.

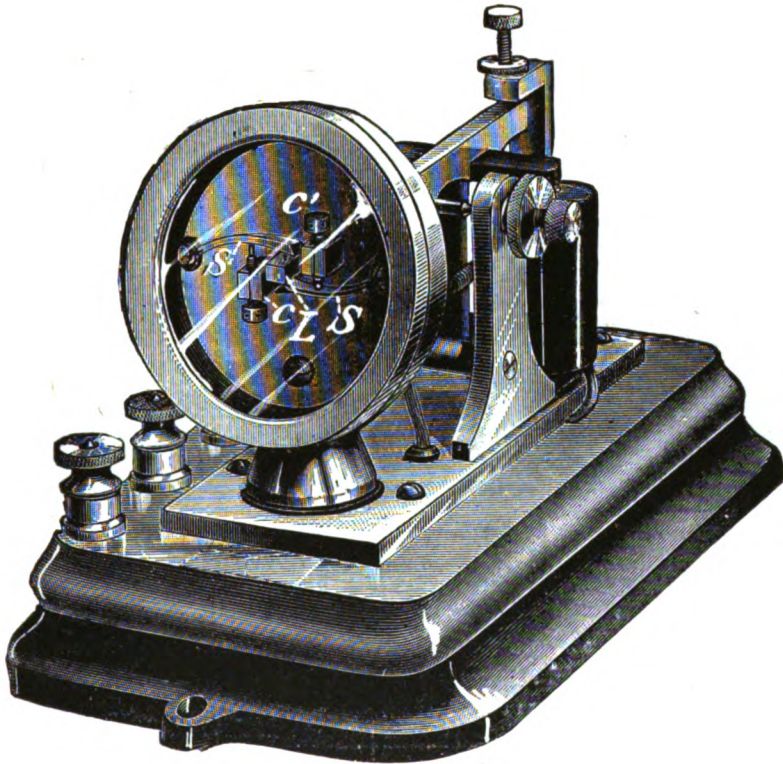

W. U. POLE-CHANGER.

through an aperture in the back of the framework. The tension springs *s*, *s'* are insulated from the box. The contacts *c* *c'* are attached to the framework. The poles of the battery are generally connected to the springs *s* *s'* by way of their respective binding posts on the side of the base board. The lever is connected to the earth, and the contact points *c* *c'* to the line, or vice-versa, as desired; also via the binding posts.

B. AND O. POLE-CHANGER.—In Fig. 158 is shown another form of pole-changer that has been and is extensively used. It was designed to afford ready access to the contact

points for cleaning and adjusting purposes. s , s' , c , c' , and L correspond to and perform similar functions to those of similar parts of Fig. 157.

TERMINAL CONNECTIONS AND APPARATUS OF POLAR DUPLEX WITH DYNAMOS AS SOURCE OF ELECTROMOTIVE FORCE.

Fig. 159 shows connections of duplex with dynamos as generators of electromotive force. A special form of pole-changer, PC , is employed when the electromotive force exceeds the point at which "sparking" would occur at the "continuity preserving" contact points of the ordinary form of pole-changer. PC consists of

FIG. 158.

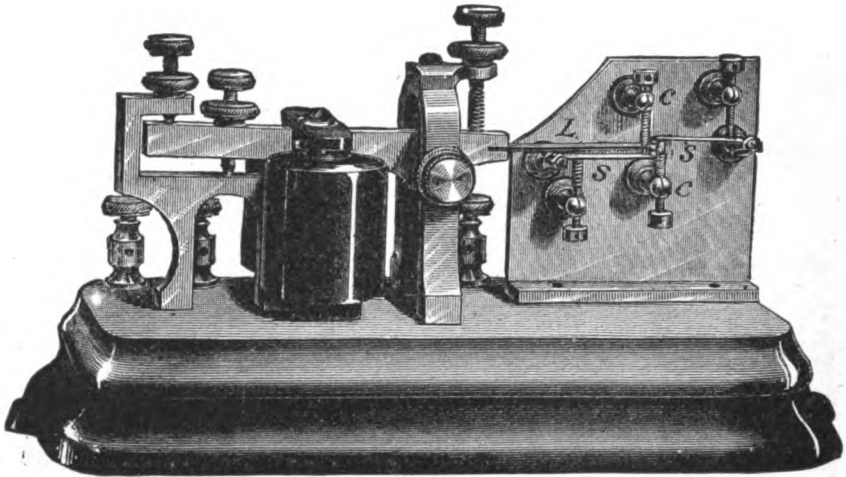

B. AND O. POLE-CHANGER.

the lever L , pivoted on trunnion bearings at x . P , P' , are brass standards connected, respectively, to the positive and negative dynamo machines. The line wire is connected to the lever. The lever rests on P when closed, and on P' when it is open. Between its opening and closing there is a brief break in the circuit, scarcely perceptible at the distant end, and yet sufficient to perceptibly diminish sparking at the contacts. In other respects the connections are practically the same as when gravity battery is employed.

PR is a polarized relay. CR is the condenser resistance. c is a static compensating condenser. R is the compensating rheostat, or artificial line, resistance. AS is a 3-point switch, used in going to ground for a balance. More frequently a special form of switch is used in connection with the cutting off of the dynamos. It is shown in the description of the Field quadruplex key system. D , D' , are dynamo machines, r , r' , are the resistances inserted to reduce spark at pole-changer, etc.

sc is a resistance equal to the resistance r , or r' .

FIG. 159.

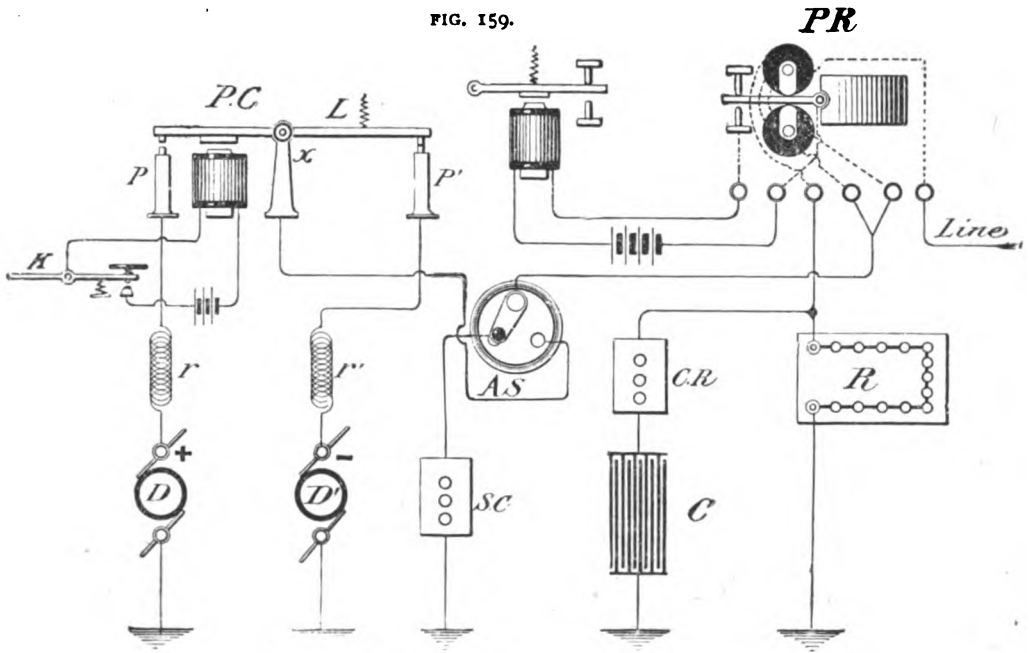

POLAR DUPLEX TERMINAL CONNECTIONS (DYNAMO KEY SYSTEM.)

CHAPTER XII.

QUADRUPLEX TELEGRAPHY.

A quadruplex telegraph system is one by which four messages may be transmitted over one wire at the same time, two from each end, simultaneously.

There are several "multiplex" systems extant by which two, four or more messages may be simultaneously transmitted over one wire, but as a rule the term multiplex is applied to systems of the multiplex synchronous order (*see* the opening remarks of chapter on synchronous multiplex telegraphy, page 336), while those multiplex systems in which dot and dash signals are transmitted on a practically unbroken wire, by comparatively continuous currents, and which are received by relays in a manner virtually similar to that in which signals are received by the Morse relays, are termed "duplex" or "quadruplex" systems. Of the latter, numerous different forms have been devised.

THE EDISON QUADRUPLEX.

In this system the principles of the Stearns duplex and the polar duplex are combined on one wire.

The Stearns duplex, as we have seen, is operated by the putting on and taking off of battery from the line at the home station, which action effects the operation of a relay at the distant station. The polar duplex is operated by the reversals of polarity of a battery at a home station, which reversals are responded to by a polarized relay at a distant station.

In the quadruplex system, the Stearns duplex relays respond to an increase and decrease of current on the line, regardless of the polarity of the current. The polar duplex relays respond to the reversals of polarity, regardless of the strength of current on the line. If, therefore, an arrangement be effected whereby instruments to cause, and respond to, an increase and decrease of strength of current, be combined, on the one wire, with apparatus for causing, and responding to, reversals in the direction of the current, it is evident that it would be possible to send two distinct sets of signals from one station; and then, by using, say, differentially wound relays to prevent interruption of received signals by the home transmitter, two messages could be sent at one time from each end of the wire.

The quadruplex referred to employs in its operation a combination of apparatus similar to that just outlined; the chief instruments used in the combination being the transmitter, and a modification of the Morse, or neutral relay, of the "Stearns" duplex, and the pole-changer and polarized relay of the polar duplex.

As herein stated, the differential winding of the relay prevents the operation of the home relays by the home battery, which is correct as far as signals transmitted from the home station are concerned, but it will be found that, in the beautiful and intricate actions that are continually occurring during the operation of the *full* quadruplex, the signals transmitted from the distant station are frequently made by the home battery. This will be alluded to in detail later.

THEORY OF THE QUADRUPLIX.—There are several ways in which the foregoing mentioned combination of the principles of the Stearns duplex and the polar duplex may be effected on one wire. One of these is shown, theoretically, in Fig. 160. *PC* is a pole-changing key; *NR* is a Morse relay; *PR* is a polarized relay; *T* is a transmitter, which, when open, inserts in the circuit, a resistance *R*; when closed, it short-circuits that resistance.

FIG. 160.

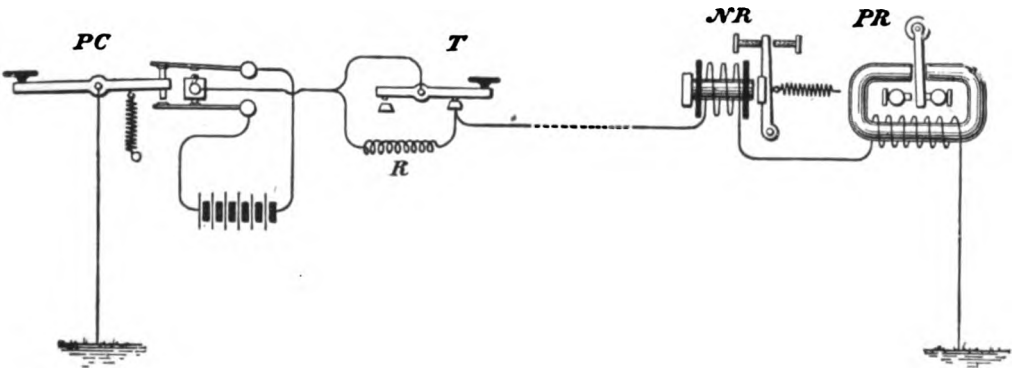

The result of introducing the resistance into the circuit is that the current strength is decreased. When the transmitter is open and the strength of current is thus decreased, the spring of the relay, *NR*, is so adjusted that its armature is withdrawn from the front stop, but when the resistance, *R*, is short-circuited, as in the figure, the consequent increased strength of current causes the armature to be attracted to the front stop. It is then apparent that if the transmitter be operated in the ordinary manner dots and dashes will be repeated by the relay *NR*.

When the pole-changing key *PC* is operated, a positive and negative pole of the battery are alternately placed to the line. This has the effect of reversing the magnetism of the polarized relay and of operating its armature in the manner described in the chapter on the polar duplex.

It is clear, that the only effect upon the polarized relay of increasing and decreasing the current passing through it is that its armature is attracted more or less strongly to whichever side it may be at the time of increase and decrease; it being understood that the minimum current is made sufficiently strong to properly operate the polarized relay.

On the other hand the armature of the Stearns relay is attracted by both poles of its core when the current is sufficiently powerful to overcome the retractile spring. Consequently, the transmitter and the pole-changing key may be simultaneously operated and the former will operate the relay NR, but will not operate the polar relay; contrariwise, the pole-changing key will operate the polarized relay, but not the Stearns relay.

It may be mentioned here that the reversals of magnetic polarity have a certain effect upon the armature of the Morse relay NR during the time that it is attracted by the full strength of current but, in practice, this effect is rendered harmless by various devices, some of which will be referred to subsequently, and, for the present, the effect may be overlooked.

The method just described, Fig. 160, has been chosen to illustrate the theory of the combination on one wire, of increase and decrease of current and reversals of polarity, because of its simplicity, but, in practice, the use of resistance thus inserted and removed, for the purpose mentioned, has not been very successful in quadruplexy. A more successful method is shown in Fig. 161, in which T rep-

FIG. 161.

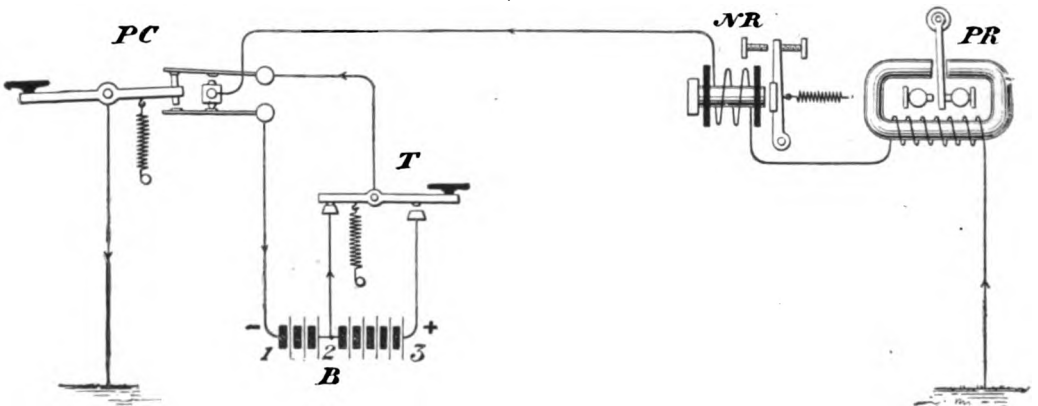

resents a transmitter; PC a pole-changer and NR and PR (as in Fig. 160), a Morse, or Stearns relay, and polarized relay, respectively.

In this arrangement the decrease of current is obtained by cutting off a large portion of a battery B, when the transmitter is open, as in the figure, and the increase of current is obtained by employing the entire battery, which it may be seen is done when the transmitter is closed. The connections of the system are so arranged that whether a portion only of the battery, or the full battery, be placed in circuit by the transmitter, that portion; or the full battery, will be reversed by the pole changer. For example, when the transmitter T is open, as in Fig. 161, it is seen that only that portion of the battery between 1 and 2 is in use and the negative pole of the smaller portion is to the line, the pole-changer being closed.

It is seen that whether the transmitter be open or closed there will be an available battery to the line. The object in so arranging the connections of the transmitter that, whether open or closed, there will be available battery at the terminal of the circuit, is to insure the working of the polar duplex feature of the system. since it is clear that, as it depends for its operation upon the reversals of polarity of a battery, or other source of electromotive force, there must be provided, in either position of the transmitter, a source of electromotive force to reverse. If then the relay NR be adjusted, as stated in connection with Fig. 160, so that, when the smaller portion of the battery is placed to the line its armature will be withdrawn by the retractile spring, we can see that, in Fig. 161, the relay NR will be "open," and the position of the armature of the polar relay will depend on the direction of the current in its coils, etc.

In Fig. 162, the key, or transmitter, T, is closed; consequently, the wire leading from 2 in battery B to the left hand contact point of T, is open, and the full battery is

Fig. 162.

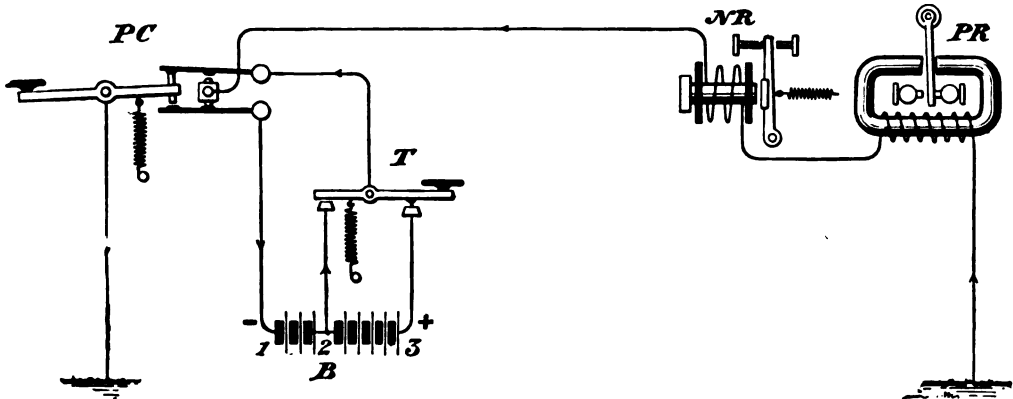

placed to the line. The result is that the armature of NR is attracted. As, however, the pole-changer has not been opened, the polarized relay has not been affected. It will be observed, however, that should the pole-changer be operated *now*, it will reverse the *entire* battery.

The relays NR and PR are supposed to be at the distant end of the line; PC and T being at the home station. Thus, as in the case of Fig. 160, the polarized relay will repeat only the signals transmitted by the pole-changer, and the Stearns relay those due to the variations in the strength of the current produced by the operation of the transmitter.

The electro-magnets of PC and T, the sounders and local circuits of NR and PR have been omitted to avoid complicating Figs. 160, 161 and 162.

In practice the smaller portion of the battery is termed the "short end;" the point at which the wire divides the battery, is termed the "tap;" the wire so tapping it the "tap wire;" the larger portion of the battery the "long end." In the Quadruplex, the Stearns, or Morse relay, is generally termed the "neutral" relay.

OPERATION OF THE QUADRUPLIX.—It may be doubted whether in the whole range of applied electricity there occur more beautiful combinations, so quickly made, broken up, and others reformed, as in the operation of the quadruplex. For example, it is quite demonstrable that during the making of a dash on the neutral relay at one station the distant pole-changer may reverse its battery several times; the home pole-changer may do likewise and the home transmitter may increase and decrease the electromotive force of the home battery, repeatedly. At the same time, and, of course, as a result of the foregoing actions, the home neutral relay may have had its magnetism reversed several times, and the *signal* will have been made, partly by the home battery, partly by the distant and home batteries combined; partly with current on the main line, partly without; partly by the main line "static" current, and partly by the condenser current, and yet on a well adjusted circuit it will have been heard on the quadruplex sounder as clearly as any dash on an ordinary "city line" sounder.

A theoretical diagram of the duplex, as arranged in practice, for the gravity battery "key system," with connections and apparatus at both ends, x and y , is given in Fig. 163, and by its aid a description of the manner of operation of the system, and of some of the combinations just referred to, will be attempted.

PC, PC' are pole-changers. T and T' are transmitters. MB, MB' are main batteries, divided as shown. NR and NR' are neutral relays, the main and artificial line coils of which have each a resistance of about 200 ohms. RS, RS' are "repeating" sounders, the function of which will be stated. s', s, s, s' are the "reading, or regular sounders. PR and PR' are polarized relays, each of whose coils has a resistance of 400 ohms. R, R' are rheostats of the artificial lines. c, c' are condensers which compensate for the static induction of the main line. cr and cr' are resistances to retard the currents to and from the condensers.

In the figure, PC and T , at station x , are shown closed, while, at y , they are open. Assuming the battery to be divided into two parts, as shown, and that the smaller part is one-fourth of the whole battery, the ratio of current from the small end as compared with the full battery will be as 1 to 4. The arrows indicate the direction of the current through the several coils of the relays. The figure under each coil may, for the purpose of illustration, be supposed to indicate the strength of current in the coils under the assumed existing conditions. For instance, in the left hand coil of NR and PR the strength is 5; in the right hand coils the strength is 4; while the strength of current in the left coil of PR' and NR' is 1, and in the right hand coils, 5.

Since these currents are flowing through the respective coils of the relays in opposite directions it is plain that the current available for producing the magnetic effect on the cores of those relays, NR and PR , is the excess of 5 over 4, namely 1; and in the cases of PR' and NR' the resulting magnetic effect is due to the excess of 5 over 1, namely, 4.

That such is the case may be ascertained by consideration of the following: The full battery MB at x is placed to the line. We assume that it gives a current strength

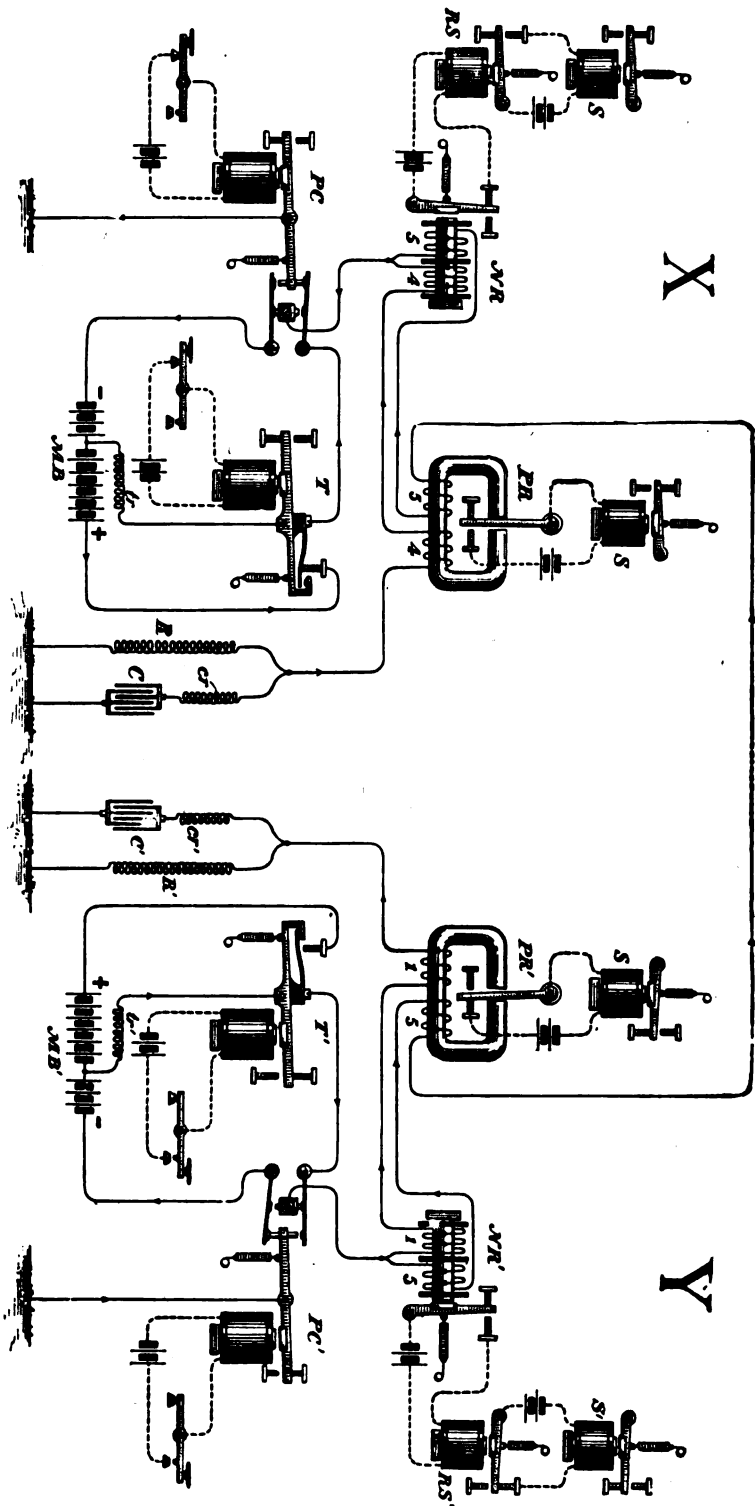

FIG. 103.—THEORY OF THE QUADRUPLEX (GRAVITY BATTERY KEY SYSTEM.)

of 4 to the right hand coils of NR' and PR', at Y. The transmitter T' at Y being open the small portion of the battery MB' is placed to the line; the "long" end of that battery being open. Thus a strength of but 1 passes to the artificial line R' from MB' and a similar current strength is added to the main line coils, making the strength in the main line coils of all of the relays, 5.

For convenience hereafter in this description the excess of current in one coil over the other may be termed "excess" current.

It will be premised that the springs of the neutral relays are so adjusted that when the excess current in one coil over the other is represented by 1, the armature will be withdrawn from the front stop, but that when the excess is represented by 4 the increased magnetism will overcome the pull of the springs and the armatures will be attracted.

Now, at X, the excess current in the line wire coil of NR is 1, consequently the armature is withdrawn and its sounder S, is open. But, at Y, the "excess" in the line wire coil of NR' is 4 and the armature is attracted and the sounder S' is closed. This should be expected since the transmitter at X is closed and the transmitter at Y is open. In both cases the polarized relay is irresponsive, the only effect, which is not a visible one, being that the armature will be attracted to its cores more or less strongly, as the case may be.

If now the transmitter T, at X, be opened, it will be found that only the short end of MB is in service, its long end being open. The result is that now a current strength of but 1 flows in the artificial coils of NR and PR, and a strength of 2 in the main line coils of NR and PR and NR' and PR'. This is plainly so since the current of 1 from battery MB' is added to that of MB in the main line coils. The excess of current, therefore, in the coils of the relays is now but, 1 and, hence, the armature of NR' is withdrawn; both neutral relays now being open. And it will also be found, on examination, that regardless of what poles of the batteries may be placed to the line the home neutral relays will be closed when the distant transmitter is closed and open when it is open. Of this an example will be given.

Let PC and T, at X, remain as in Fig. 163 and let PC' and T', at Y, be closed. This places the negative pole of the full battery at each station to the line. We should now find that this change closes the neutral relay NR at X, and reverses the position of the armature of PR, which is the case, as we shall see. A result of the changes referred to is that no current flows through any of the main line coils, inasmuch as the potential at each terminal of the main line is now equal and similar, but a current strength of 4 now flows in each artificial line coil. Thus the neutral relay at X is closed and the neutral relay at Y, which had been closed by the excess current of 4 in the main line coil, remains closed. Before the closing of the pole-changer at Y we saw that PR at X was magnetized by an excess current of 1 in the main line coil flowing in the direction indicated by the arrows, Fig. 163. It is now magnetized by an excess current of 4 flowing in the opposite direction around its core and, consequently, the magnetism of its core is reversed and its armature is moved over against its contact point, closing, thereby, its sounder.

As regards the effect of the closing of the pole-changer and transmitter at Y, upon the relays NR' PR', it will be found to be nil; for those relays had already

been magnetized by a current strength of 4, which had been flowing in their main line coils in a certain direction around their cores, which direction was similar to that of the excess current of 4 now flowing in their artificial line coils.

It is again suggested to the student desirous of following out the foregoing that he draw for himself diagrams to meet the changed positions of the apparatus and direction of the current. [Further allusion to the actions just referred to as well as other analogous actions occurring in the operation of the quadruplex will be found in connection with description of diagram, Fig. 166.]

POLARITY OF ELECTRO-MAGNETS DUE TO DIRECTION OF CURRENT AROUND CORES.

It may further aid the student to a comprehension of the electro-magnetic actions touched upon in the foregoing to understand what the polarity of a given end of an electro-magnet will be with a current around its cores in a given direction.

FIG. 164.

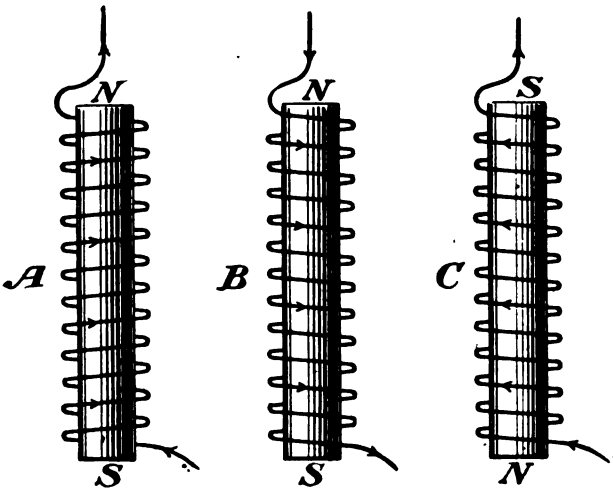

For example, referring to Fig. 164. If one is looking at a given end of a core, a current in the coil around the core from right to left *will make that end of the core a south pole, A and B, Fig. 164. If the current is flowing in the coil around the core from left to right, as in C, the end looked at will be a north pole.

It will be noticed that the winding of B is the reverse of that of A, and, although the direction of the current through the wires A and B is opposite, still, owing to the difference in the winding

of the coils, the direction of the current *around the core* is the same in each case and, hence, the poles of the cores are the same.

MOMENT OF NO MAGNETISM IN NEUTRAL RELAY.—In quadruplex telegraphy, as already mentioned, the differentially wound Morse relay is termed the “neutral” relay because of its *practical* neutrality to reversals of polarity of the current.

Since, however, the neutral relay NR, is in the same circuit, and subject to the same influences as the polarized relay PR, it is clear that whatever changes of magnetism take place in the polarized relay must also occur in the neutral relay. In other words, every reversal of the battery which reverses the magnetic polarity of the polarized relay must also reverse the magnetic polarity of the neutral relay.

* That is, as the hands of a clock move around the dial, as one is looking at it.

Between each reversal of magnetism, there is an interval when there is no magnetism in the core of the relays. At this moment of "no magnetism" the armature of the polarized relay simply retains its last position. When the armature of the neutral relay is on its back stop, it is immaterial whether the magnetism of the core be reversed or not. When, however, that armature is on its front stop, being held there by the full distant battery, against the pull of its retractible spring, it will, at the moment of "no magnetism," recede from the front stop. But the recession is only momentary, as, almost instantly, the relay is again magnetized, and attracts its armature. If, however, the local circuit of the sounder be connected to the front stop of the neutral relay NR, there is, at the moment of no magnetism, opportunity for that circuit to open, when the armature momentarily flies back, and thus produces a false signal, or "kick," in the local, or reading sounder S. This was found to be the case in practice and to overcome this defect, one of the first things done by Mr. Edison was to place the local circuit contact of the neutral relay on the back stop, as shown in Fig. 163, so that the effect of the reversal of the distant full battery upon the local sounders of that relay might be reduced to a minimum; for it is plain that the duration of contact of the armature lever of NR upon its back stop, will be but a fraction of the total time that it is away from its front stop during the moment of "no magnetism."

As this arrangement of the contacts would deliver the signals on the "back" stroke, a "repeating" sounder RS, Fig. 163, with local contacts on the up stroke, is used to convert the signals received on the reading sounder S, to the front stroke. The interpolation of the repeating sounder between the relay and reading sounder still further tends to prevent the false signals on that sounder, since the repeating sounder must first be fully magnetized before it will withdraw its armature from the upper contact.

It may be added that the use of the repeating sounders is not now imperatively necessary, and, in many instances, it is dispensed with, the connections of the quadruplex transmitter being transposed so that the "short" end of the battery is placed to line when the transmitter is closed, and the "full" battery, when it is open.

On very long lines the effect of the "kick" due to the reversal of the entire distant battery is much increased; in other words, the reversal of the magnetism of the relay is more gradual, and, consequently, a longer duration upon its back contact is allowed its armature.

To further diminish the period of no magnetism in the neutral relays, the contact points of the pole-changer are adjusted as closely as practicable and the neutral relay is, as a rule, constructed of the best soft iron, with very short cores, to facilitate magnetic reversals.

While, as intimated, the detrimental effect due to the recession of the armature of the neutral relay, at the moment of the distant reversal is, in many instances, practically, eliminated by placing the contact on the back stroke, it is known that the efficiency of the quadruplex system would be increased if the moment of no magnetism in the relay could be further diminished, or, so to speak, tided over.

To accomplish this result a number of ingenious devices have been brought out, some of which will be herein described.

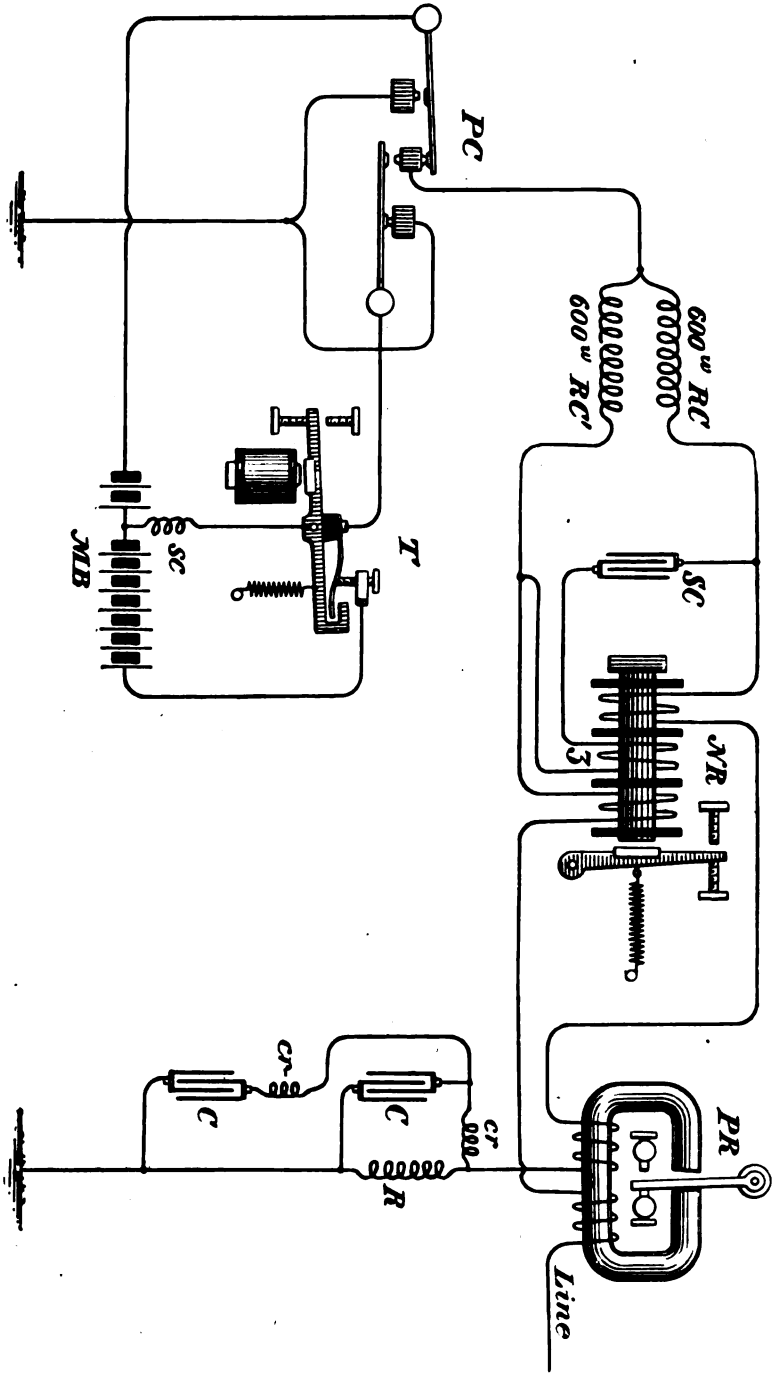

FIG. 165.—THEORY OF SMITH CONDENSER ARRANGEMENT FOR DISTANT REVERSAL; IN QUADRUPLIX.

SMITH CONDENSER ARRANGEMENT.—One of these, namely, the Smith condenser arrangement for diminishing the period of no magnetism in the neutral relay, is shown theoretically in Fig. 165, in connection with the other quadruplex apparatus at one station; namely, *PC* the pole-changer, *T* the transmitter, *NR* and *PR* the neutral and polarized relays, and *R*, *CR*, *CC*, the rheostat, etc., of the artificial line.

In the Smith condenser arrangement, which has been extensively employed on the quadruplex circuits of the Western Union Telegraph Company, the neutral relay *NR* is furnished with a third coil, *3*, as shown. This coil is in the circuit of a condenser *sc*, whose terminals are connected, respectively, to the main and artificial lines. *RC* *RC'* are resistance coils of about 600 ohms each, the object in using which is to obtain a difference of potential between the plates of the condenser when the distant battery is to the line, in a manner to be explained.

When the distant end of the line is "grounded," and when the balance between the main and artificial line is secured, no difference of potential will exist at the terminals of the condenser, and, consequently, it will not be charged. When the distant battery is to the line, a difference of potential is set up between the plates of the condenser, and a charge is accumulated which will be discharged at the moment of reversal of the distant battery. And it will be found, on investigation, that the current of discharge, which then flows in the third coil of the relay, is in an opposite direction to that of the "excess" current which had previously been circulating in the main or artificial line coils of the relay. The result is that the reversal of the magnetism of the relay is accomplished very rapidly; even before the effect of the actual reversal of the distant battery may be felt in the home relays. In this way the time of "no magnetism" in the relay is reduced and the tendency to a false signal diminished.

By the aid of diagram Fig. 166, the various changes of potential produced in the plates of the condenser by the reversals of the distant battery may be graphically illustrated. (For some explanatory remarks concerning diagrams of this kind the reader may refer to Chapter VIII. See Wheatstone bridge.)

In Fig. 166. The horizontal line *AL*, *ML*, represents the resistance of the artificial and main line circuits, respectively, each having a resistance of 3000 ohms from the junction at *J*, which may correspond to the junction of the main and artificial wires of the quadruplex at the home station.

In what follows the letters *AL* and *ML* will stand for artificial line and main line, respectively.

The vertical line *v* represents the E. M. F. of the home battery at *x*, with the full battery of 300 volts, positive pole, to the lines, *AL* and *ML*. This vertical line is subdivided into sections 10, 20, etc., indicating the E. M. F., at those points. Similarly, the distant battery at *y* is represented by vertical line *v'*; the portion of that line below *ML* representing the full battery with negative pole to line; the portion above *ML* representing the full battery with positive pole to line.

The horizontal line *z* may represent the potential along the main line when positive poles at *x* and *y* are to the line; at which time, assuming a thoroughly insulated line wire, there is no fall of potential along the wire. The inclined line *w* may represent the fall of potential on the wire when the negative pole of the full

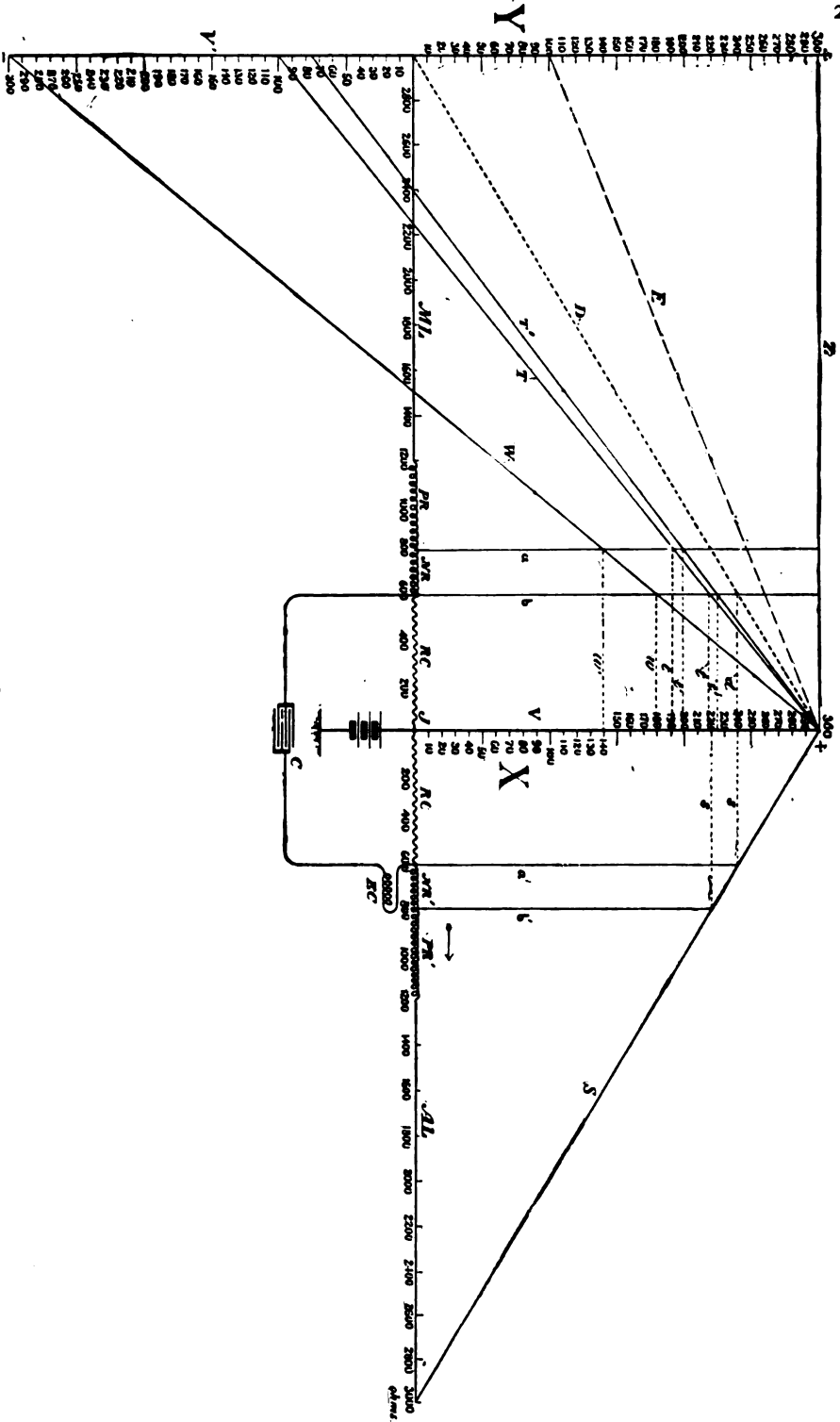

FIG. 165.

distant battery is to line; the line *s*, the fall of potential on the artificial line *AL*, regardless, practically, of the polarity or E. M. F. of the distant battery. The dotted line *D* indicates fall of potential on main line from *x* when the distant end is to ground, direct; the line *ε* the fall when the small end, positive pole, of distant battery is to the line.

The resistance of 3000 ohms is supposed to include the resistance coils, *RC*, of Fig. 165, the relay coils at the home and distant stations, and the internal resistance of the distant battery.

In the Smith condenser arrangement the terminals of the condenser are placed between the main and artificial wires, behind the 600 ohm coils. In Fig. 166 the terminals of *c*, are shown connected to *AL* and *ML*, at points 600 ohms removed from *J*. The wavy lines *RC* correspond to the 600 ohms resistance coils. The "turns," at *NR*, *NR'*, *PR*, *PR'* represent the main and artificial line coils of the home relays; *EC* the third coil of the neutral relay.

As the changes to be shown by this figure will be due to reversals of the distant battery only, it will be assumed that the "home" battery will remain constantly, at 300 volts positive potential, and, for the same reason, the artificial line at the distant end may be neglected.

Assuming, first, that the positive pole, 300 +, of the entire distant battery at *r* is to the line, the horizontal line *z* from *r* to *x* indicates the potential on the main line; that is, there is then no fall of potential along the wire. There is, however, a fall of pressure along the artificial line, as indicated by the line *s*.

At this time then, the main line terminal of the condenser is at 300 + volts potential as indicated by the point at which the vertical line *b* intersects the line *z*; and the *AL* terminal of *c* is at 240 + volts potential as indicated by the point at which the vertical line *a'* intersects the line *s*. Consequently, the condenser *c* will receive its charge, which will be due to a difference of potential of 60 volts at its terminals, from the point of higher potential, namely, the main line terminal; in the act of receiving which charge a momentary current will be set up in the third coil, around the core of the neutral relay in a direction assisting in the magnetizing of the core. This being so, it is evident that the discharge current of the condenser, which is always in the opposite direction to that of the current of charge, will pass through the third coil in a direction tending to reverse the previously existing magnetism of the relay, in which case it will curtail the moment of "no magnetism" in the relay, since, by tending to reverse the magnetism of the relay the condenser, by its discharge, does what is desired to be done by the ensuing reversal of the distant battery.

When the entire distant battery is reversed, thereby, in the case assumed, putting the negative pole to line, the line *w* will represent the fall of potential along the main line. In this case it is seen that the *ML* terminal of the condenser is at 180 volts potential, as indicated by the point at which the vertical line *b* intersects the line *w*, while the *AL* terminal remains, as before, at 240 volts—still leaving a difference of potential of 60 volts between the plates. The condenser now, however, receives its charge from the *AL* terminal and its charging current is opposite in direction to that of the previous charging current. Therefore, its next discharge current will be in the opposite direction to that of the previous "discharge" current.

And it will be found that the discharge currents of the condenser will always be in a direction, at the moment of "no magnetism," to deprive the relay of its previously existing magnetism, while the currents of charge will assist in magnetizing it to a polarity coinciding with that due to the ensuing reversal of the distant battery.

The effect of a reversal of the distant battery at the time the short end of battery is to the line has not thus far been considered. Inasmuch as the armature of the home neutral relay is on the back stop at that time, it is evident the distant reversals will not have any effect upon the armature. The charge and discharge of the condenser, of course, proceed as usual, but with much reduced effect. This will be seen by further reference to Fig. 166.

Assuming the short end of distant battery to be 100 — volts, the fall of potential will be as indicated by line T, which shows that the ML terminal of the condenser is now at say 220 volts potential, while the AL terminal is at 240 volts as before. But, now, there is only a difference of potential of 20 volts between the plates of the condenser, and since the magnitude of its current of charge and discharge depends primarily upon the difference of potential between its plates, it is plain that the current in the latter case will be much diminished. Nevertheless, this diminished current must be felt in the relay, and on fine working "margins" should tend somewhat to reduce the value of the device, since the pull on the spring of the relay must be increased, be it ever so little, to counteract the magnetic pull of the core due to the charge of the condenser when the short end of distant battery is to the line.

It may be asked what the effect upon the Smith condenser would be of reversing the home battery? Practically none. The reader may prove this to be the case by turning Fig. 166 upside down, and changing the + and — signs to meet any hypothetical conditions of the batteries required.

It has frequently been noticed in practice during stormy weather—also at other times—that the margin is increased on the neutral relay, by "short-circuiting" the condenser of the Smith arrangement. This is probably due, chiefly, to the fact that the third coil of the relay is now free to be acted upon by the "regular" currents of the system, set up by the action of the distant transmitter. It will be seen by reference to Fig. 165 or 166 that the third coil is, practically, in the bridge wire of a Wheatstone bridge, when the condenser is cut out, and that the relay itself is in a combination of the differential and bridge methods for preventing the effect of the home battery upon the home relays.

THE FRIER SELF-POLARIZING NEUTRAL RELAY.—This relay has been found to give the most satisfactory results in the Western Union service of any relay yet devised for the second side of the quadruplex, to the extent that it has become the standard form of neutral relay employed in that service. In this as in other forms of neutral relays there is, of course, a moment of no magnetism, but the results of its operation show that it is not so marked as in some other forms, which is most likely due to the form of construction whereby the self-induction of the instrument is lessened, the cores, as will be seen, not being connected by a yoke or cross-piece, and also to the lightness of the moving parts, whereby its responsiveness to weak currents is increased, and in consequence of all of which its "figure of merit" is increased. By

figure of merit is meant the reciprocal of the least amount of current necessary to operate the relay efficiently. For instance, if the necessary current should be .014 ampere the figure of merit would be $\frac{1}{.014} = 701$. Obviously the lower the current strength required the higher the figure of merit.

Another term used in connection with the operation of circuits and relays is "time constant," which is the time required for the current or the magnetism to reach a certain fractional part of its maximum strength, namely, the $\frac{2}{3}$ of that value*. The time constant is equal to the self-induction of the circuit or relay divided by its resistance. The henry is the unit of self-induction and it is defined as "the induction in a circuit when the electromotive force induced in this circuit is one volt while the inducing current varies at the rate of one ampere per second." For example,

FIG. 180a.

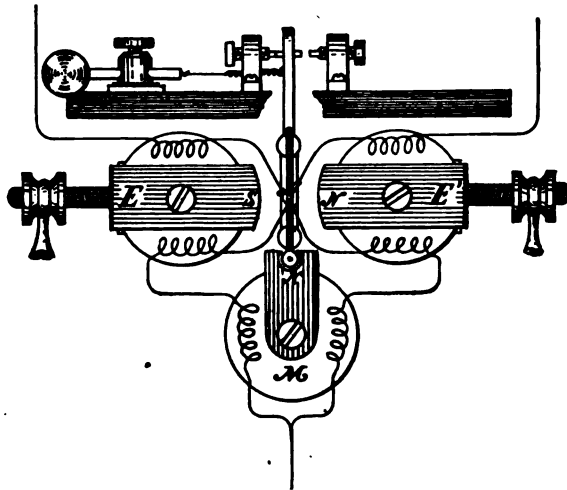

if a relay on short-circuit has a current of 1 ampere flowing through its coil and if the lines of force set up by this current fall from maximum to zero in 1 second and in doing so set up an electromotive force of 1 volt, the self-induction of the relay is 1 henry.

Referring to the time constant, if the self-induction of a relay be, say, 4 henrys, and its resistance be 300 ohms, its time constant is $\frac{4}{300} = \frac{1}{75}$ of a second. If the self-induction and capacity of a circuit or relay were nil the current or magnetism would attain its maximum strength immediately. (See Self-Induction, also Healy Neutral Relay, page 230; also foot-note, page 318, and Appendix.)

In form and external appearance the Frier relay is almost identical with the polarized relay shown in Fig. 154, but with the permanent magnet removed and an electro-magnet put in its place. The manner of its operation is practically as follows: Its armatures are pivoted adjacent to the pole-pieces of the extra electro-magnet M , Fig. 180a, and they vibrate between the pole pieces of the electro-magnets

* This subject is treated from this standpoint more fully, theoretically, in Fleming's "Alternate Current Transformer," page 103, Vol. I. Another definition of "time constant" is that it is the time the current takes to rise from zero to its maximum and to fall again to zero. Preece and Stubbs state that the highest speed in telegraphy requires that the time constant of the line shall not exceed $\frac{1}{2500}$ of a second. This is presumably at the rate of 450 words per minute.

$\epsilon \epsilon'$. In Fig. 180a the relay is shown in a side view and the description will for simplicity only consider the armatures and pole-faces as there shown.

The electro-magnet m , like $\epsilon \epsilon'$, is differentially wound and its coils are inserted in the main and artificial lines of the quadruplex circuit, in series with the respective coils of the electro-magnets $\epsilon \epsilon'$. A magnetizing current in the coils of m will, of course, magnetize its core, the result being that one of its ends will be a north, the other a south pole, and these poles in turn will, by induction, magnetize the armatures in proximity thereto, practically as if the pole-pieces of m were permanent magnets. If, with a given magnetizing current through m , the end of the core shown in the figure be a north pole, the end of the armature between the pole pieces $\epsilon \epsilon'$ will also be a north pole, and since the connections of the coils of $\epsilon \epsilon'$ are such as to ensure that the pole piece of the regular electro-magnets which are opposite each other will be of opposite polarities, the north pole of m will be attracted to that pole-piece which the same current has made a south pole, and repelled from that pole-piece which has been made a north pole. (See pages 303, 304, Wheatstone relay)

In the figure the south pole is shown at ϵ , and consequently the armature is attracted to that side. If now the direction of the magnetizing current be reversed in the coils, that end of the armature between the pole-pieces $\epsilon \epsilon'$ will become a south pole, while the pole-piece of ϵ will become a north pole and that of ϵ' will become a south pole, the total result being that the armature is still attracted to pole-piece ϵ . Hence it is evident that, regardless of the reversals of the distant battery, the armature will continue to be attracted to pole-piece ϵ . Since the armature lever of the relay is provided with a retractile spring, as in the case of the neutral relays already described, it will be obvious that it may be adjusted like the armature of that relay, in such manner that it will only be attracted towards the pole-piece ϵ' when the entire distant battery is to the line.

It has been found that the best adjustment of this relay is obtained when the armatures are close to the attracting pole of the electro-magnets and at some distance from the repelling pole. This is especially the case in fine weather, but is not so noticeable in bad weather when the magnetizing current in the coils is diminished.

RATIO OF CURRENT STRENGTH WITH TRANSMITTER CLOSED AS AGAINST TRANSMITTER OPEN.—We have seen that the polar duplex feature of the quadruplex requires that a certain amount of electromotive force should be on the wire when the transmitter is open. The amount of this E. M. F. is regulated by the minimum strength of current found necessary to properly operate the polarized relays. The maximum E. M. F. is regulated by the amount of current required to properly operate the neutral relays. This is generally in the ratio of 3 to 1 or 4 to 1 with key closed as against key open.

With a battery of 300 gravity cells the ratio of 3 to 1 would be secured by putting the tap wire at 100 cells; the ratio of 4 to 1 by placing it at 75 cells.

We may also utilize Fig. 166, or its equivalent, to graphically follow all of the changes that occur in the relays in the actual working of the quadruplex, among others, those by which, for instance, the operation of the transmitter effects the changes in the current strength flowing in the coils of the neutral relay. It is only necessary to remember that the current flowing in the coil, or coils, of a relay, as in any other conductor, is due to the difference of potential between its terminals, and that the magnetizing current of the differential relays is due to the "excess" of potential difference between the terminals of one coil, over that between the terminals of the other.

For example, take the case of the neutral relay, Fig. 166. First, supposing the distant station to have its full positive battery to the line. It is seen, by tracing the vertical lines $a b$ to line z , that the terminals of the main line coils of that relay are at equal potentials, hence no current flows in that coil. By lines $s s$ it is seen that the a' terminal of the AL coil of NR' is at 240 volts and the b' terminal at 220 volts; thus the current in the AL coil, which in this case is the magnetizing current of the core, is due to a potential difference of 20 volts. The strength of this current will be found by Ohm's law, namely the quotient of the E. M. F., or difference of potentials between the terminals of the coil, divided by the resistance of the coil—in this case = $\frac{20}{100}$, that is $\frac{1}{5}$ ampere.

Now, assuming the negative battery to be to the line at distant station \bar{y} , the fall of potential is shown by line w , and the b terminal of the ML coil of NR is at 180 volts while the a terminal of the same coil is at 140 volts, a potential difference between the terminals of 40 volts. The current in that coil is, therefore, due to that potential difference. The terminals of the AL coil of NR' remain as before, namely, with a potential difference of 20 volts between them. Consequently, twice the current flows in the ML coil at this time that does in the AL coil, but, as the currents flow in opposite directions, around the core, the "excess" magnetizing current is only what would be due to a potential difference at the terminals of either one of the coils of 20 volts. That current is, of course, in the opposite direction to the "excess" current which had existed in the AL coil before the distant reversal.

If now it is assumed that the short end and negative pole of the distant battery be put to line—and that it has an E. M. F. of 65 volts—the fall of potential on the main line will be represented by the line τ' . In that case the potential at the b terminal of NR will be 225 volts; that of the a terminal at 200 volts, a difference of 25 volts at the terminals. The potential difference at the AL terminals of NR' still remains as before, namely 20 volts, consequently, the "excess" current in the ML coil is due to a difference of 5 volts; that is one-fourth of what it was with full distant battery; thus showing that the ratio of current strength, as between transmitter closed and open, is as 4 to 1, which we know would be the case with the tap at 75 volts in a battery of 300 volts.

The resistance of the coils of the polarized relay being double that of those of the neutral relay, the potential difference between the terminals of its respective coils will be double that at the respective terminals of the neutral relay coils, but as the resistance of the polarized relay coils is twice that of the neutral relay coils the current that flows in the respective coils of both relays will always be the same.

That would follow from the well-known law that the strength of current is the same in all parts of an undivided circuit. The added convolutions of wire, other things being equal, would, of course, produce a greater magnetizing effect in the core with the same current strength.

The effect upon the home relays of placing the small end of the distant positive battery to the line when the full battery is to the line at the home station, may be studied by the reader, if desired, by aid of line E, Fig. 166.

ACTION OF THE CONDENSER AS A STATIC COMPENSATOR.

Even an outline description of the various combinations set up in the relays by the operation of the pole-changers and transmitters would be incomplete without a reference to the very pretty automatic action of the condenser as a "static compensator."

Unless the writer is mistaken this action is not generally understood. The text books, hand-books, and patent specifications which he has seen have generally united in describing the action of the condenser in its capacity of static compensator, in duplex telegraphy, when it is employed to give to the artificial line a static capacity equal to that of the main line, practically as follows:—

"The return current from the line," (as the static discharge of the line was formerly called,) "passes through one coil of wire of the electro-magnet, with the same strength and at the same time, but in a reverse direction to that of the return current from the condenser passing through the other coil of the wire. Thus the effects of induction are neutralized."

The impression conveyed, and in some instances distinctly stated, is that, at the moment the above described action is taking place, the electro-magnet, or relay, is without magnetism, and, consequently, the false signal due to the static discharge, or return current, is obviated.

The present writer thinks it can be shown that the only time when the foregoing explanation is strictly accurate is in the Stearns duplex when the distant end is to "ground," and the distant battery is, consequently, cut off. It can also be shown, in duplex telegraphy, with the condenser in the artificial line, that the line return current sometimes assists in producing the signals and that sometimes the condenser "return current" assists in producing them, and that, in the polar duplex and the quadruplex, it rarely, if ever, happens that the action of the condenser as a static compensator conforms to the action as stated in the quoted explanation.

The present writer's attention was first called to the insufficiency of the foregoing explanation by a consideration of this fact, namely, that it does not explain what it is that, in the quadruplex, retains the home neutral relay against its front stop, when the entire distant battery is to the line, at the time that the home transmitter, or home pole-changer, especially the latter, is being operated.

If the effect of the static induction be neutralized as indicated in the statement quoted, the armature should, at the instant of "neutralization," fly away from its front stop, but it does not do so. Some other explanation is, therefore, necessary; the following one will, it is thought, meet all the requirements.

Fig. 167 may represent a portion of a Stearns duplex system. The main line wire ML is shown as having the ground nearly adjoining it throughout its length. It may also be considered that the artificial line consists of a series of condenser plates along the length of the rheostat Rh , as in the manner of the "Muirhead" artificial cable. (See Submarine Telegraphy.)

With the positive pole at x and the negative pole at y , to the line, the excess current in ML coils of relay NR will be in the direction indicated by the arrows, and the core will be magnetized and its armature attracted by the current in that coil.

Without going minutely into the actual distribution of the static charge along the main line and artificial line, it will be sufficient, for the present purpose, and will simplify the explanation, to assume that the main line and the condenser have at x a static capacity rendering them capable of acquiring, under the given conditions, a potential of $100 +$ or $-$ volts.

FIG. 167.

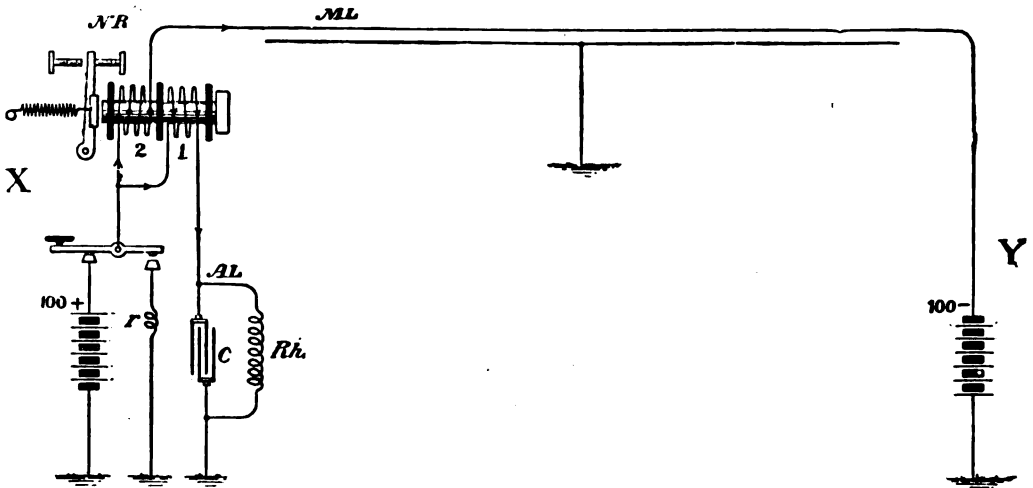

Now when the key at x is opened and the wire is thereby placed to the ground, as in Fig. 168, the currents of static discharge should be due to 100 volts positive potential, and as, at the moment of discharge, the main and artificial lines are at a higher potential than the earth, the current from both of those lines, if nothing opposed the action, should be towards x , and, in that event, as one current would oppose the other in the coils of the relay, demagnetizing it, the armature of NR would fall back at an inopportune time and make a false signal.

As, however, this false signal does not appear on a well balanced line, it is evident that something other than a simultaneous discharge of the condenser and the line, occurs at that moment; and this we may see is the case.

If the currents of static discharge from both the main and artificial line come towards x , the presence of the assumed $100 +$ volts, due to the static induction of the line, is evidently the equivalent of placing, momentarily, 100 volts of negative polarity in or to the main line and artificial line at x . Consequently, as the regular

battery of 100 volts negative polarity is already 'on' the main line at *y*, the result is a momentary cancellation, as it were, of all current on the main line, and, therefore, there is, for the time being, no current in the main line coil of the home relay *NR*. But, at that same instant, the condenser discharge takes place through the artificial line coil of the relay, and as its direction around the core of *NR*, (*see* arrows, Fig. 168), corresponds to the direction of the previous magnetizing current, (*see* *ML* coil, Fig. 167), the magnetism of the relay is maintained without interruption.

Fig. 168 is supposed to represent the conditions at the moment of putting the line to earth at *x*.

The action of the condenser may be considered practically instantaneous; before its current of discharge ceases to affect the relay, or simultaneously with such cessation, the line static discharge, which had been, as it were, holding back the distant battery current, also dies out, and the current from the distant end assumes control of the relay, its

FIG. 168.

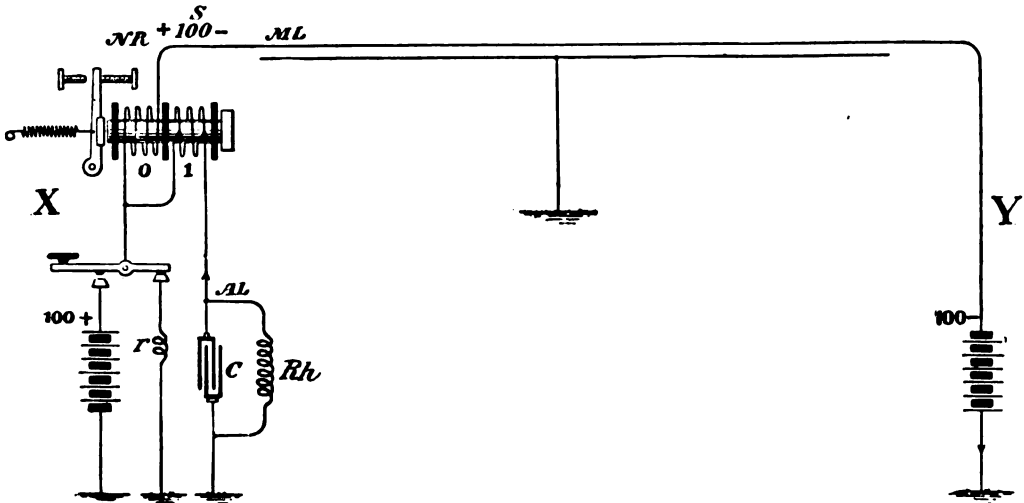

INSTANT OF STATIC DISCHARGE.

direction being such, again, that it flows in the main line coil in the same direction around the core as the current from the condenser had just been circulating. If it should seem to the reader that the act of cancelling, or nullifying, the current on the main line at the moment stated would tend to open the distant relay, it may be remarked that this would simply assist in accomplishing the object of opening the key at *x*, which object is, at that time, to open the distant neutral relay.

In the foregoing instance we see that the signal from the distant station is partly made by the condenser at the home station.

If now, for further illustration, the battery at *y* be reversed, placing the 100 volts positive pole, to the line, but retaining the 100 volts, positive, to the line at *x*, as in Fig. 169, there will then be no current on the main line, but the relay at *x* will be mag-

netized and held towards its core by the current from the battery at x through the AL coil.

When the key at x is again opened, putting the line to earth, we may see that the effect of the static discharge at x will be, as before, virtually, to place a battery of negative polarity of 100 volts to the line at x. But as now a battery of 100 + polarity is to the line at y, the effect will be, at the moment of static discharge, to momentarily double the current in the main line coil of the relay. The condenser, as before, also discharges, as shown by the arrow, but its current is overcome by the "excess" current in the main line coil; and as this excess current is in the same direction around the core, as that of the magnetizing current which has just been flowing in the AL coil, the magnetism of the relay is not affected.

In this latter case we have the signal from the distant station made partly by the

FIG. 169.

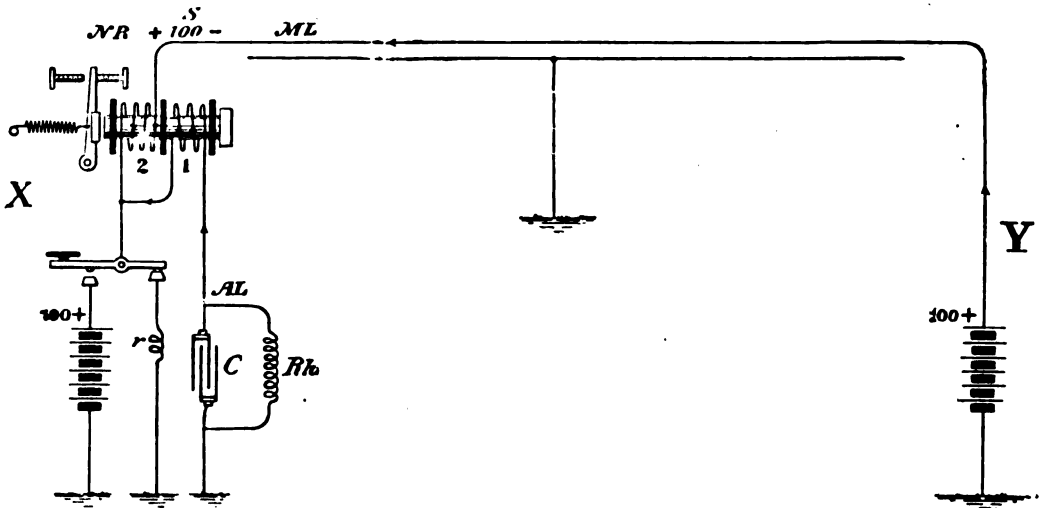

combination of the line static discharge and the distant battery; the effect of the condenser discharge being nullified.

While, for simplicity, the Stearns duplex has been chosen for the purpose of illustration, it will be found, on examination, that the foregoing will suffice to explain any of the conditions due to static charge and discharge occurring on the polar duplex or the quadruplex.

The foregoing may be amplified by means of Figs. 159a, 169b, showing the assumed effects of the line and condenser static effects upon the relay in the "bridge" wire when the "bridge" duplex is employed.

In these figures ML and AL may represent the main artificial line of, for the sake of simplicity of description, a Stearns duplex, each line having 3000 ohms resistance. v and v' will represent the home battery of 300 volts, positive and negative respectively; E and E' the positive and negative distant electromotive force; a a' the

resistances of the arms of the bridge, say 600 ohms each. The relay in the bridge wire is represented by R.

In Fig. 169a it is first assumed that the home battery has 300 volts positive polarity to the line, and that the distant battery of 300 volts negative polarity is to the line. In that case the sloping dotted line s will represent the fall of potential along the main line, while dotted line z' may represent the fall along the artificial line. In that case the potential at the z' terminal of relay R will be 240+ volts and at the s terminal 180+ volts, as indicated by the vertical dotted lines b b'. The direction of the current in R will, therefore, be from the point of higher to the point of lower potential, or from left to right, as indicated by the arrows.

In the explanation of this theory it is assumed, for simplicity also, that at the moment when the home battery is removed and the line is placed to ground, the

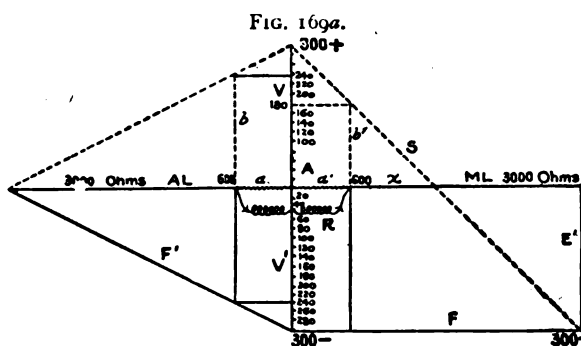

currents of static discharge from the line and condenser are due to an electromotive force practically equal to that of the home battery, but of opposite polarity, it being known that the current of static discharge is in the opposite direction to that of charge.

Let the solid lines in Fig. 169a, then, represent conditions at the moment of static discharge at the home station.

Then, the distant battery remaining unchanged, the electromotive forces of static discharge may be supposed to bring about momentarily the conditions represented by the horizontal line F and the sloping line F', in which case the artificial line terminal of the relay will yet be at the point of higher potential (240 negative being higher than 300 negative), and the current will continue to flow in the same direction through R, as shown by the arrows.

If now, as in Fig. 169b, it be assumed that the distant battery has been reversed,

as, for example, in the polar duplex, putting the positive pole to the line, the positive battery at A being to the line as before, the charge or potential on the main and artificial lines may be represented by the dotted lines zz'. In this case, the line terminal of the relay is at the point of higher potential, the result being that the current now flows through the relay from right to left, as should be expected from a reversal of the distant battery.

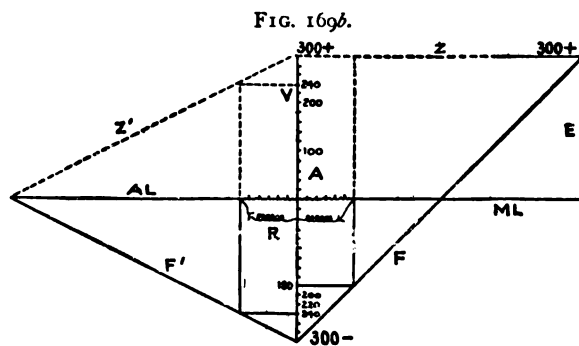

When now the line is next put to ground at A, the electromotive forces of static

discharge may be indicated by the solid sloping lines F and F', Fig. 169*b*, in which case the main-line terminal of it is at the higher point of potential, and a current still flows from right to left in that relay. Hence the combined effects of the distant battery and the static discharge of the main and artificial lines evidently is to maintain the magnetism of the relay at the same polarity as that due to the action of the distant battery, thereby preventing false signals in the home instruments at the moment of static discharge at the home station.

THE STUMM ADDED RESISTANCE ON DUPLEX AND QUADRUPLIX CIRCUITS.— This consists of placing a certain amount of resistance in the main line in wet weather, for the purpose of improving the working of the second side of the quadruplex. The author's theory of the admitted beneficial action of this device, as given to the U. S. Patent Office on behalf of the inventor, Mr. F. A. Stumm, New York, is that it diminishes the effect of rapid variations of the main line insulation resistance upon the "balance" of the relays. In other words, the imperfect working of the neutral side of the quadruplex is not due so much to an insufficiency of working current, as to the rapid variations in the main line insulation resistance which upset the line "balance." For example, it is obvious that if by placing, say, 900 ohms in the main line (which must be compensated by 900 ohms in the artificial line), thus increasing the apparent resistance of the line from 900 ohms to 1800 ohms, a variation of, say, 225 ohms in the main line will then act on the "balance" only in the ratio of 225 to 1800, as against the ratio of 225 to 900 without the added resistance.

It is sometimes stated that the merit of this device lies in preventing the line resistance from falling so low as to interfere with the proper operation of the resistances in the Field key system. Analysis, however, shows that this view is erroneous. Thus, assume a normal line resistance ML of 1800 ohms, and that wet weather has apparently reduced this resistance to 900 ohms. This presupposes a line escape (call it ML') equal to 1800 ohms. Assume also an E.M.F. of 225 volts and a ratio of 3 to 1 in current strength with key closed as against key open. Then with key closed joint resistance of AL (artificial line) and ML, ML' is 450 ohms, which with 600 ohms at dynamo (see Fig. 176) gives a total of 1050 ohms. The resulting current at J is $225 \div 1050 = .214$ ampère, of which AL takes .107 ampère, ML takes .0535 ampère, and ML' takes .0535 ampère. With key open the total resistance is $600 + 1200 +$ joint resistance from J of L, AL, ML, ML' (300 ohms) = 2100 ohms. Now $225 \div 2100 = .107$ ampère, of which AL takes .0359, ML takes .0179, ML' takes .0179, and leak takes .0359 ampère. Thus the proportion of current to line with key closed and open is respectively .0535 and .0179, or 3 to 1. With the Stumm added resistance of, say, 900 ohms in circuit, the artificial line balances against 1800 ohms, and analysis will show that now, with key closed, the total current at J will be .15 ampère, of which AL takes .075, ML takes .0375, and ML' takes .0375 ampère. With key open the current at J will be .1 ampère, of which L takes .05 ampère, AL takes .0250 ampère, ML takes .0125, and ML' takes .0125 ampère. Thus with key closed the current to line is .0375, as against .0125 ampère with key open; that is, a ratio of 3 to 1 in current strength. Hence in each case, with and without Stumm resistance, the proportion of current to main line is 3 to 1 with key closed and open respectively.

TERMINAL CONNECTIONS. W. U. QUADRUPLIX.

In Fig. 170 are shown the terminal connections of the Western Union Quadruplex when operated with gravity battery.

The local connections are shown by the letters //; T is a transmitter; PC the W. U. pole-changer; NR the 3-coil neutral relay; PR is the polarized relay; SC are the

FIG. 170.—WESTERN UNION QUADRUPLEX, TERMINAL CONNECTIONS—(GRAVITY BATTERY.)

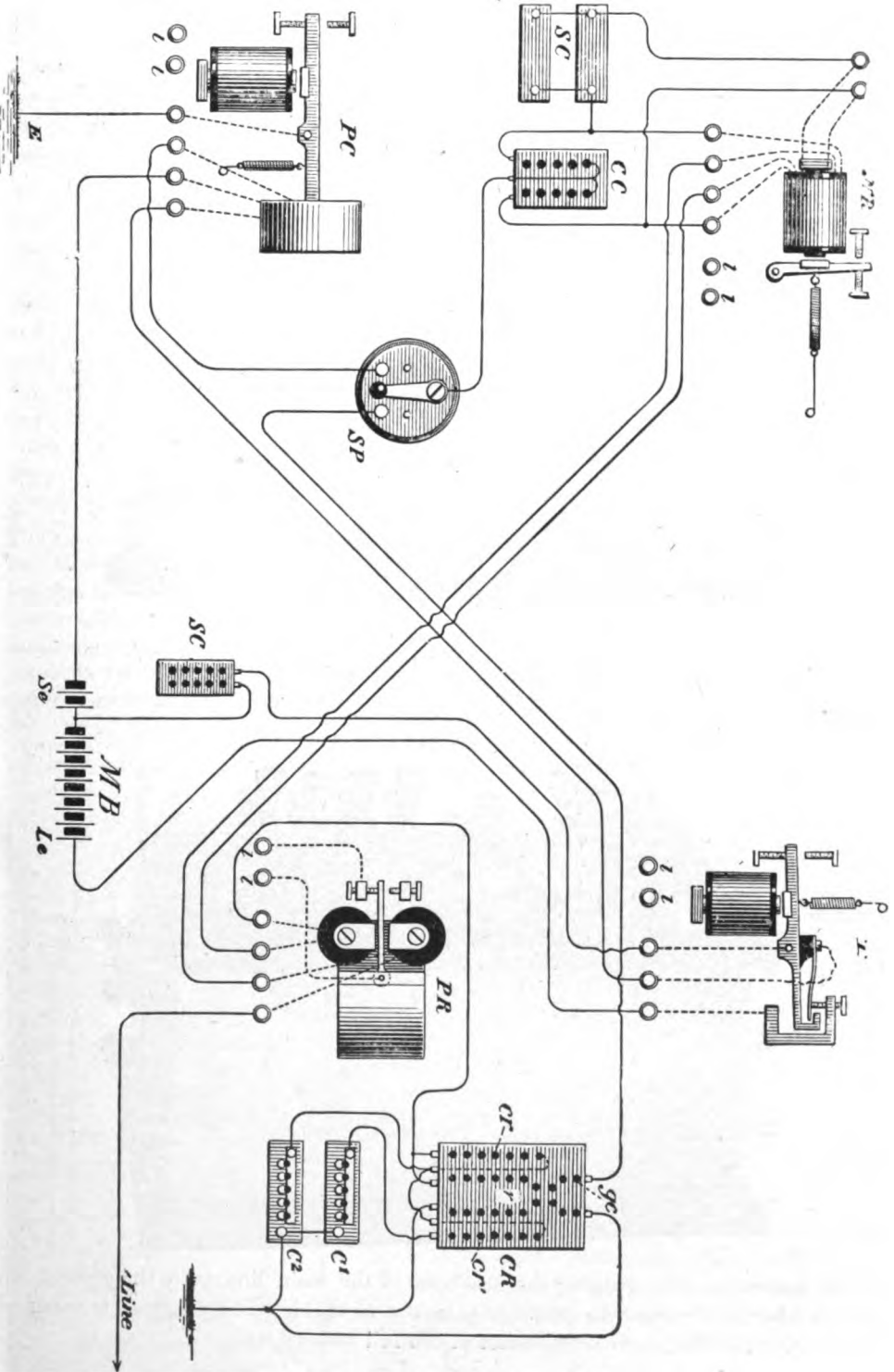

"Smith" condenser; c c are the boxes containing the 600 ohm coils; sp is the 3-point switch for putting line to ground at the desk; sc is the "spark-coil" with resistance equal to internal resistance of long end of the battery; se is the short end, le the long end of the main battery. cr is a "combination" rheostat, so called because,

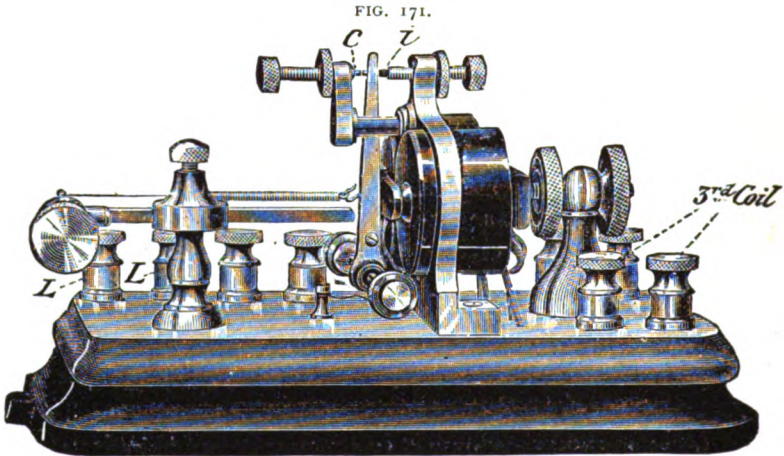

WESTERN UNION NEUTRAL RELAY.

within its covers, are contained several separate series of resistance coils; cr and cr' represent the retarding coils placed before the static compensating condensers c^1 c^2 ;

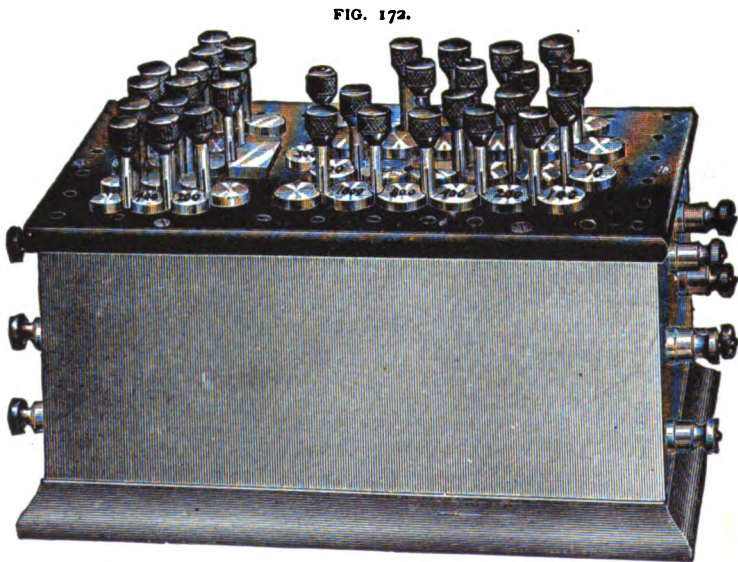

r is the resistance coil equalling the resistance of the main line; gr is the ground coil, thrown into circuit when the switch sp is turned to the right in the figure; its resistance is made to equal the internal resistance of the full battery mb .

The connections, as shown in Fig. 170, are, of course, apt to be transposed, in some respects, in practice, but they may be easily verified by following out the actual desk connections. It is always well in practice not to rely too implicitly on any diagram of such connections until they have been verified.

The three-coil neutral relay is shown as it appears in practice in Fig. 171. The combination rheostat in Fig. 172, and the quadruplex repeating sounder in Fig. 173.

THE THREE-COIL NEUTRAL RELAY—WINDING OF.—

The manner of winding the three-coil relay is shown theoretically in Fig 174; only a few turns of each coil being shown, for the sake of clearness.

A and B represent the "bobbins" of the relay. The bobbins are made of hard rubber, the cylinder or tube into which the iron core of the relay fits, being made very thin.

This serves as an additional safe-guard to prevent the wire short-circuiting with the core. The rubber tube is not shown in the figure. e e e e are the ends of the bobbin. The ends of the core c, c. cp is the iron cross-piece connecting the two cores. Three coils of wire, 1, 2 and 3, are wound on each bobbin. The first coil consists of about 1800 turns of wire. A sheet of tissue paper is placed over this coil. Then a second coil of 1800 turns is wound over the first; another sheet of tissue paper is then placed over the second coil, and a third coil of 1800 convolutions over that.

The wire used is about No. 36, B. W. G., silk insulation.

As it is very difficult to draw wire of this diameter which will have a uniform resistance throughout its length, the manner now to be described of connecting the coils on the bobbins has been adopted.

The coil 1 on A is connected to coil 2 on B; coil 2 on A to coil 1 on B. As these are the "differential" coils, it is very essen-

FIG. 173.

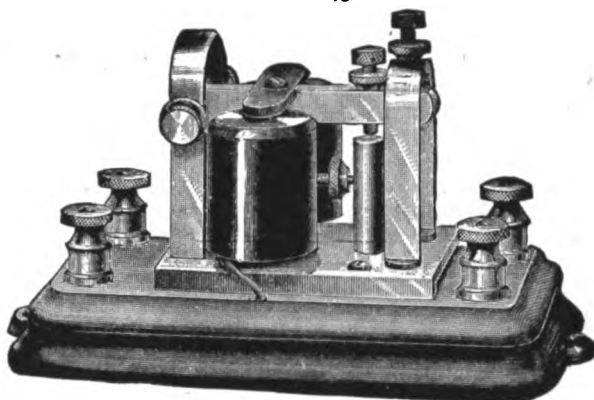

REPEATING SOUNDER.

FIG. 174.

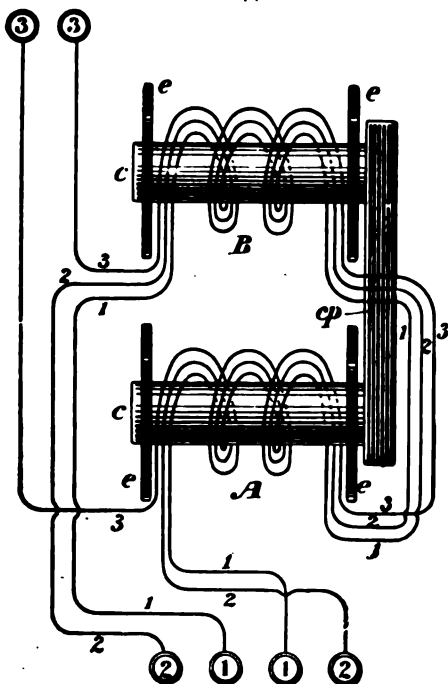

WINDING 3-COIL NEUTRAL RELAY.

tial that they should be of equal resistance, and have an equal magnetic effect upon the cores when an equal current is passing around each. This arrangement of the coils effects this desideratum in a high degree, by distributing the resistance of the two coils over the two bobbins.

Coil 3 on A is connected to coil 3 on B.

FIG. 175.

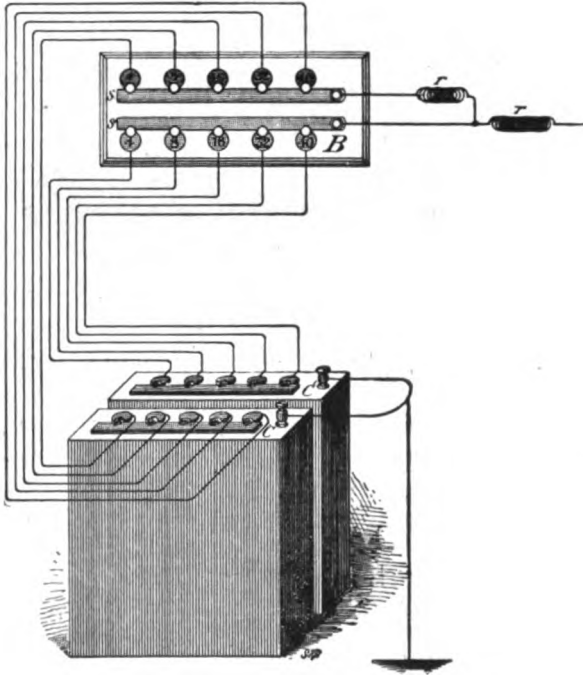

SMITH ARRANGEMENT OF CONDENSERS TO ECONOMIZE SPACE

The resistance of the coils 1 and 2 varies from 200 to 225 ohms. That of the third coil is nearly 400 ohms, which is due, of course, to its greater length, it being the outside coil on each bobbin.

SMITH ARRANGEMENT OF CONDENSERS FOR ECONOMIZING SPACE.—Especially in large offices the available room under the desks is frequently much diminished, to the discomfort of the operators, by the number of condensers, “leak” boxes, etc., employed in quadruplex telegraphy. In order to improve this condition, Mr. Gerritt Smith devised the arrangement shown in Fig. 175, by means of which the removal of the duplex or quadruplex condensers to a less crowded quarter is made feasible, without in the least detracting from the ease with which the instruments may be adjusted. This

device consists of a duplicate of the “adjusting” end of condensers, diminished in size, mounted on a suitable base-board B, and placed conveniently upon the desk. The crescent-shaped and numbered discs, on the base-board B are connected by insulated wires to correspondingly numbered discs, on the ends of the condensers, as shown, which latter, as previously intimated, may be in a separate room. The strips s, s' on B, are connected to the artificial line through the resistances r, r' ; the strips on the condensers c, c' , to the earth. Thus the act of plugging or unplugging a disc on the base-board is equivalent to plugging or unplugging similar discs at the condenser.

DYNAMO-QUADRUPLIX KEY SYSTEMS.

Owing to the difficulty that presented itself in the attempt to operate any system of telegraphy, requiring reversals of polarity, from dynamo machines which were also required to furnish, at the same time, current, of a stated polarity, to other circuits, it was necessary, if duplex and quadruplex circuits were to be supplied with current developed by such machines, that means should be devised to reverse the polarity on the circuits, without reversing the machines in the sense that a gravity battery is reversed in duplex and quadruplex telegraphy. It was also necessary that means should be provided to increase and decrease the strength of current on the quadruplex circuits.

The difficulty in utilizing reversals from dynamo machines when employed as stated, consists in the fact that if a dynamo be reversed for one circuit it will reverse the direction of current in all the other circuits that may be connected to it. This would, of course, be equally true if an attempt should be made to reverse, for one circuit, a gravity or other battery to which other circuits may be connected.

It was, comparatively, an easy matter to secure reversals of polarity by using a pole-changer, which, in one position, was connected with a series of dynamo machines furnishing positive polarity and, in the other position, to another series of machines furnishing negative polarity.

To secure the necessary increase and decrease of current for the quadruplex system, without changing the existing forms of transmitting apparatus, was not so easy of accomplishment. It was, of course, known that increased and decreased strength of current could be obtained by "cutting" resistance coils in and out of the circuit, but experience had shown that this method of securing the variation in current strength was not very successful; the resulting action of the relays being more or less sluggish.

To obtain a quick acting "increase and decrease" of current on the quadruplex circuits for the operation of the distant relays, without affecting the resistance of the main line and without changing the construction of the existing apparatus was the object in devising the dynamo quadruplex key system, (due to Mr. S. D. Field), which is in use in all the cities where the Western Union Telegraph Company has replaced gravity batteries by dynamo machines.

WESTERN UNION OR FIELD DYNAMO KEY SYSTEM.

This key system successfully provides an increased and decreased strength of current in the distant relays without any change in the previously existing transmitter, and with, in fact, a simplification of the pole-changer.

In the Field key system the desired ratio of current strength is secured by varying certain resistances in the main line and in a short branch circuit to earth; the combination of which, as will be shown, effects the desired result without any actual increase in the resistance of the main line circuit.

In the gravity battery key system, as has been shown, the decrease of current is secured by reducing the electromotive force at the sending end of the wire and this is effected by cutting out, by means of the transmitter, any desired number of cells.

In the Field dynamo key system the same result is accomplished, namely, the placing of the sending end of the wire at a lower potential, (but without cutting out, or off, any portion of the source of electromotive force,) by means of the combination of the added resistance and branch circuit to earth, just alluded to, which combination is under control of the transmitter.

In the operation of this key system the laws of "joint resistance" and of "divided circuits" are largely concerned; the reader, if not familiar with those laws, is therefore referred to Chapter on Dynamo Machines in which those laws are discussed. (Chap. III).

The theory of the Field key system is outlined in Figs. 176, 177 and 178.

Fig. 176 is a theoretic diagram of the key system at one station with main and artificial lines only shown.

In this figure *D, D* are dynamo machines each supplying 225 volts. *r r'* are resistances of 600 ohms placed between the dynamos and pole-changer *PC* to lessen the intensity of the spark at the contact points, etc. *R* is an "added" resistance of 1200 ohms. When the transmitter, *T*, is closed, as in Fig. 176, this resistance is short-circuited by the short wires *1* and *2*, via the post *P* and tongue *X* of the transmitter.

L is a resistance of 900 ohms, termed the "leak," between the lever of the transmitter and earth. When the transmitter is closed, *L* is open at the bend *B* of the transmitter lever.

Thus when *T* is closed, both *R* and *L* are virtually out of the main circuit and, so far

FIG. 176.

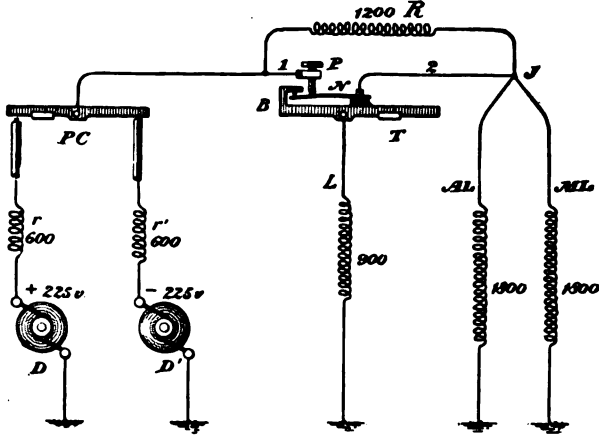
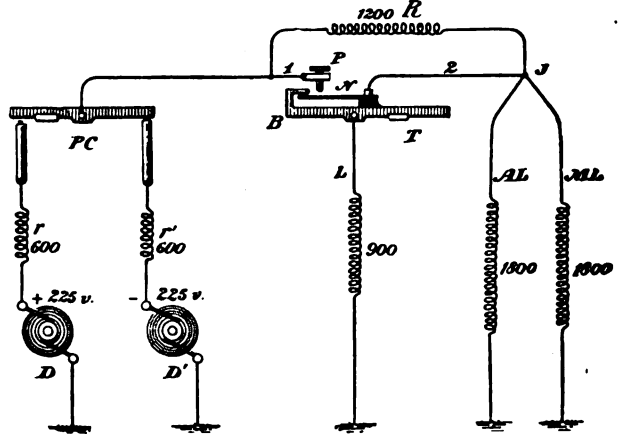

FIG. 177.



as those resistances are concerned, the full strength of the current goes to the main and artificial lines. When τ is open, however, R is put into the circuit and L is tapped on to the circuit, at J , via wire 2, as may be seen in Fig. 177.

The object of this device is to cause, at the distant station, a variation in the strength of current equal to what would be caused by cutting off two-thirds of the cells of a gravity battery; that is, to produce a ratio of 3 to 1 in the current, as between the key closed and open. This we shall see it does.

FIG. 178.

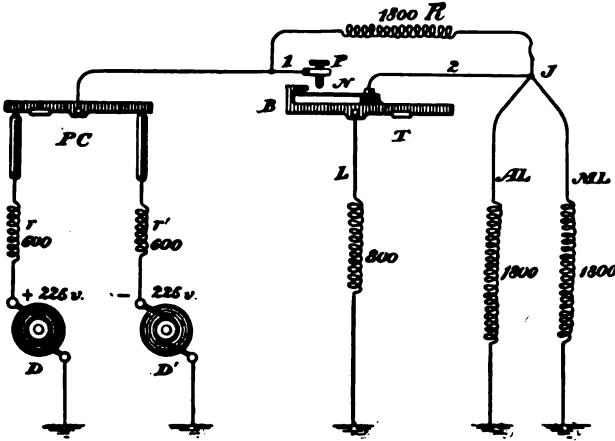

In Figs. 176, 177, 178 the main and artificial lines are supposed to have a resistance of 1800 ohms each. The joint resistance of those circuits from J would then be 900 ohms.

In Fig. 176 the only other resistance in the circuit is the 600 ohms, r' , at the minus pole of dynamo machine D' ; hence the total resistance of this circuit, with τ closed, will be $600 + 900 = 1500$ ohms. This gives a current strength in the

circuit, up to J , of .15 ampere (*i. e.* $\frac{225}{1500} = .15$). At J the current divides equally between AL and ML , each wire taking .075 amperes.

Counting from J to the ground, via r' and the dynamo D' , it is seen that the resistance is 600 ohms.

Referring now to Fig. 177, in which τ is open, we find that the resistance of the circuit from D' to J is $600 + 1200 = 1800$ ohms. The joint resistance of AL , ML and L , from J , is 450 ohms. The total resistance of this circuit is, therefore, $600 + 1200 + 450 = 2250$ ohms. This gives a strength of current up to J of $\frac{225}{2250} = .1$ ampere. This current is now divided between AL , ML and L in inverse proportion to the resistances of the branch circuits. As the joint resistance of AL and ML is 900 ohms and the resistance of L is also 900 ohms it is clear that the current will divide equally between AL and ML , and L . Hence L will receive $\frac{1}{2}$ of .1, that is, .05 and AL and ML will each receive $\frac{1}{4}$ of .1, that is, .025 ampere.

Or, this may be arrived at in another way. The total resistance of this circuit, Fig. 177, from dynamo D' is, as said, 2250 ohms. Between D' and J the resistance is 1800 ohms. Consequently, as the fall of potential is proportional to the resistance "overcome," the potential will have fallen, at J , $\frac{1800}{2250}$ of 225 volts, namely, 180 volts. Hence the potential at J will be $225 - 180 = 45$ volts. Thus the strength of current flowing in AL will be, by Ohm's law, $\frac{45}{1800} = .025$ ampere, and in ML the same; while, in the branch L it will be $\frac{45}{900} = .05$ ampere. We saw that with τ closed, ML and AL each received .075 ampere. It is evident then, from the

foregoing, that the ratio of 1 to 3, as between τ open and closed, is thus secured on the main line .075; since thrice .025 is .075.

Further, reckoning also from J to the ground, via the two routes, namely, the leak (L 900 ohms) and the dynamo ($1200 + 600$ ohms = 1800 ohms) we find the joint resistance to be 600 ohms. Thus, while the desired reduced strength of current has been effected on the main line and at the distant end, by the insertion of the resistances, etc., at the home station, the resistance from J to the earth at the home station has not been altered so far as regards the distant station.

At times, in practice, it is desired to increase the ratio of current strength, as, for instance, to make the ratio 4 to 1. In the Field key system this result is brought about by making the added resistance 1800 ohms and the "leak" L , 800 ohms. This change is outlined in Fig. 178.

With the transmitter closed it has been shown that the added resistance is not in circuit, and that the "leak" is cut off. Hence the current strength to line will be the same with transmitter closed in Fig. 178 as in Fig. 177, the *E. M. F.*, at the dynamo machine not having been altered. With the transmitter open, however, it is different, and it will be found (by a calculation similar to that made in the case of Fig. 178 of the varying joint and total resistances which exist under the conditions brought about by opening and closing the transmitter, Fig. 178,) that the variation in the current strength with key closed, as compared with it open, is now as 4 to 1. This result will be graphically illustrated in Fig. 179.

In practice when this ratio is increased the total electromotive force is also generally increased.

It has been noted that the total resistance presented to the distant station is not, in the Field key system, altered, in either position of the home transmitter, owing to the fact that, in either case, the total, or the joint resistance, from the point J to the earth at the home station is 600 ohms. But the resistance from J to the ground at the dynamo D' , in say, Fig. 176, is, with transmitter closed, 600 ohms, as against 1800 ohms, with that instrument open. And it is this change in the resistance in combination with the short route to earth via the leak, which, by lowering the potential at J , is chiefly instrumental in bringing about the aforesaid variation in the current strength at the distant station.

This effect will also be found graphically illustrated in Fig. 179; as will also the manner in which the variations of electromotive force at the home station affect the current strength in the distant neutral relay.

For the sake of simplicity the distant battery at γ is not included in the figure, it having already been shown, in the cases of the polar duplex and the "gravity" battery quadruplex key systems, that the presence of the distant battery in the circuit does not affect the result intended by the operation of the "home" transmitter or pole-changer, upon the distant relays. But any reader may construct for himself diagrams showing the varied conditions that will occur in the operation of this key system. It will be found an interesting study.

In Fig. 179, let x represent a home station and γ a distant station. The vertical lines D_1, D_2, D_3 , the electromotive force, under the varying conditions of the

key system at x . The horizontal line ML , may represent the resistance of the main line from x to γ , with the transmitter closed at x

The resistance of the main line from the junction J of the main and artificial lines at x , to the ground at γ , is assumed to be 1800 ohms, as in the case of Figs. 176, 177, and 178. The resistance of the artificial line from J to ground will, of course, also be 1800 ohms. The resistance from the dynamo D' at x , to γ , which includes the 600 ohms at the dynamo machine, is 2400 ohms, as marked, and this resistance is represented by the thick line ML . The thick horizontal line ML, AR , will represent the resistance from D' to γ with the transmitter at x *open*, when the key system is arranged for a ratio of 1 to 3, in which case the added resistance of 1200 ohms is placed in the circuit. The line ML, AR, AR' will represent the resistance from D' at x to γ , when the key system is arranged for a ratio of 1 to 4. The electromotive force at x is assumed to be 225 volts, negative polarity.

As already stated the electric pressure at any point of the main line, may be ascertained by drawing a vertical line from ML to any of the sloping lines, and by drawing, from the intersection of those lines, a horizontal line to the vertical lines representing the E. M. F. For instance, in Fig. 179, the vertical line a , drawn from ML to the line rc' , shows the pressure on the main line, 1600 ohms from D' , to be 60 volts.

With transmitter *closed* at x , (ratio 3 to 1) the total resistance presented to the dynamo at x would be 1500 ohms from D' ; that is, 600 ohms at the machine, plus the joint resistance of the main and artificial lines from J , namely 900 ohms.

If this resistance were contained in a single wire from D' to ground the fall of pressure could be represented by the line rc, kt . It may then be considered for illustration purposes, that the fall of pressure from D' to J is the same as if the circuit were composed of a single wire measuring 1500 ohms from D' to ground, and, hence, the pressure at J may be found by drawing a line w from vertical line J' and kt to the line D' —it is found to be 135 volts.

From the junction J , the fall to "ground," via the different wires, (main and artificial wires) is proportional to the resistance of each wire. The resistance of the main and artificial lines in this case being 1800 from J to the ground, the slope, or fall of potential may be represented by sloping line rc' .

As the main line to station γ is joined at J to the wire leading to the dynamo machine at x , the line rc' which indicates the fall of pressure along the main line, ML from J to γ , joins the lines rc and kt at w , in the figure.

The 200 ohms resistance of the main line coil of the neutral relay at γ is indicated by NR . This coil will be utilized to show the decreased current due to *opening* of the transmitter at x .

With transmitter at x closed it is seen that the coil of NR has, at its terminals a potential difference of 15 volts, which is indicated by lines $a b n n'$, the a terminal being at 60 volts, the b terminal at 45 volts. The current flowing in NR will, of course, be due to this potential difference divided by the resistance of the coil, namely, $\frac{15}{200}$ ampere.

With the transmitter at x open (ratio 3 to 1) the resistance of the circuit from the dynamo at x is increased, by the added resistance, 1200 ohms, which, as it were, places the machine back to AR .

The fall of pressure at J, reckoned from AR, is *now* due to the dynamo resistance of 600 ohms and the added resistance of 1,200 ohms AR to D', plus the joint resistance of the main and artificial lines and the leak of 900 ohms (See Fig. 177), which gives a total resistance of 2250 ohms.

The fall along a single circuit of that resistance would be indicated by the line KO, from line D². Hence, the potential at J, at this time, as shown by the intersecting line n from J, KO, is but one-third of what it was with the transmitter closed at x,

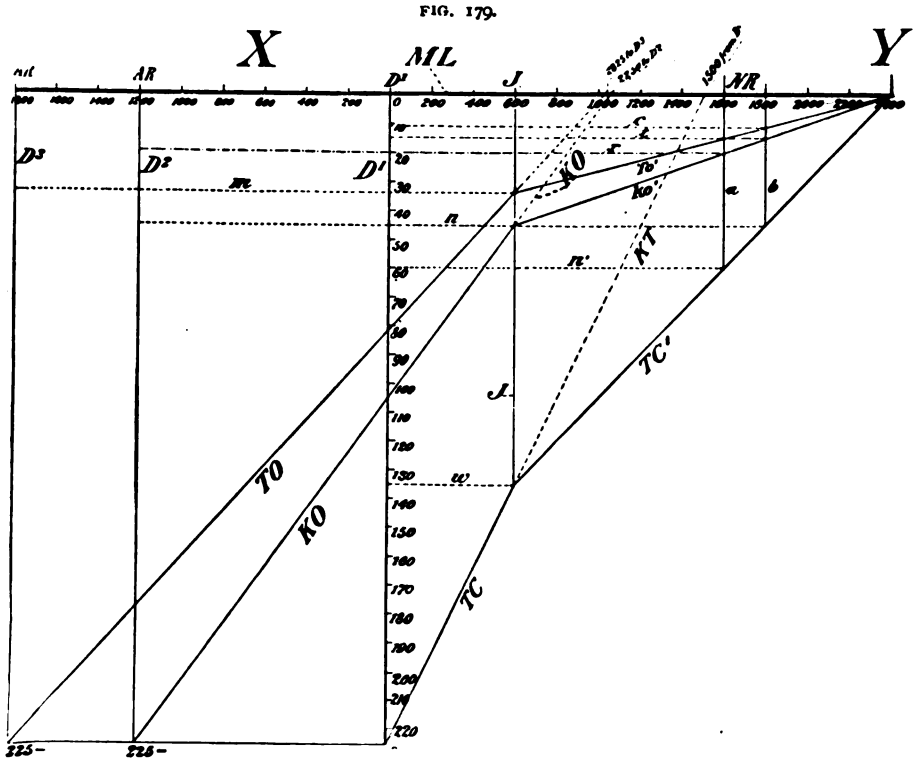

THE FIELD KEY SYSTEM (THEORY.)

namely 45 volts, and the line KO' now represents fall of pressure along main line ML; that is, with transmitter open at x.

Hence, the potential difference at the terminals of ML coil of NR is, as indicated by the lines *a b* and *r t*, 5 volts; the potential at *a* terminal being 20 volts, that at *b* terminal, 15 volts. Consequently, the current now flowing in that coil is equal to the E. M. F. of 5 volts, divided by the resistance 200, that is $\frac{5}{200}$ ampere, which is, obviously, one-third of $\frac{15}{200}$ ampere, which was the current strength in coil with transmitter at x closed.

When the ratio of 4 to 1 is desired, the 1,800 ohms added resistance is inserted and the "leak" is changed to 800 ohms. In this case, when the transmitter is open, the dynamo is virtually placed at AR' as in the figure.

The total resistance then offered to the dynamo from AR' at x would be 2825 ohms. The fall of pressure along a single wire having a resistance of 2825 ohms from D_3 at AR' is shown by the line RO .

As the point of joining the main and artificial lines to the wire leading to the dynamo has not been changed this places the junction J at a point where the pressure, or potential, is 33.75 volts, that is, one-fourth of what it was with transmitter closed, as may be seen by reference to horizontal line m drawn from intersection of vertical line J and sloping line RO to vertical line D_3 .

The slope of potential along the main line, ML , from J , with transmitter open, is now indicated by slope RO' , and it may be seen by the lines t c that the potential difference at the terminals of NR is now but $3\frac{3}{4}$, or 3.75 volts, the pressure at terminal a being 15 volts, that at b $11\frac{1}{4}$ volts. Consequently, the current now in the coil NR is $\frac{3.75}{100}$ ampere, which is one-fourth of $\frac{15}{100}$ amperes; the latter being the current strength in coil with key closed at x . Or, as in a previous case, the foregoing results may be proved in another way. Thus, for instance, since, with the transmitter at x closed, the potential at the junction J of the main and artificial wires is 135 volts, and as the resistance of ML is 1800 ohms, it is evident that, at the a terminal of NR , the potential will have fallen "through" $\frac{10000}{18000}$ of the total resistance of ML ; and, as, in doing so, the pressure will have fallen $\frac{10000}{18000}$ of 135 volts it evidently has dropped 75 volts at that point, making the pressure at terminal a , 60 volts, as in the diagram. (The a terminal being 1000 ohms from J .)

Thus, it is again seen that the same result is obtained by the opening and closing of the transmitter in this key system as is obtained by decreasing and increasing the number of cells, which is the office of the transmitter in the gravity battery key system; the function of the "added" resistance and the "leak" being, as intimated, to reduce the pressure at the junction J .

TERMINAL CONNECTIONS WESTERN UNION QUADRUPLEX.

In Fig. 180 is shown the terminal connections of the present standard quadruplex system and apparatus of the Western Union Telegraph Company. It will be seen that the Field key system is still employed, but that the Smith condenser arrangement has been dispensed with; the Frier self-polarizing relay taking its place. The oblong form of rheostat has also given way to the Varley rheostat v r with radial arms, the general principle of which is fully described in connection with the Wheatstone automatic system, page 317. The form of polarized relay PR shown in Fig. 154 is also used in place of the Phelps relay, and a somewhat new form of transmitter T in which the supports and lever are of tubular brass is now employed. The local connections are shown by the letters ll . P C is the dynamo pole-changer. The leak box L B is shown with the arrangements for varying the ratio from 1 to 3 to 1 to 4 or vice versa, as desired. The ratio is varied by cutting out or putting in the 600 ohm coil of the added resistance and the 100 ohm coil of the leak, which is done by inserting

FIG. 180.

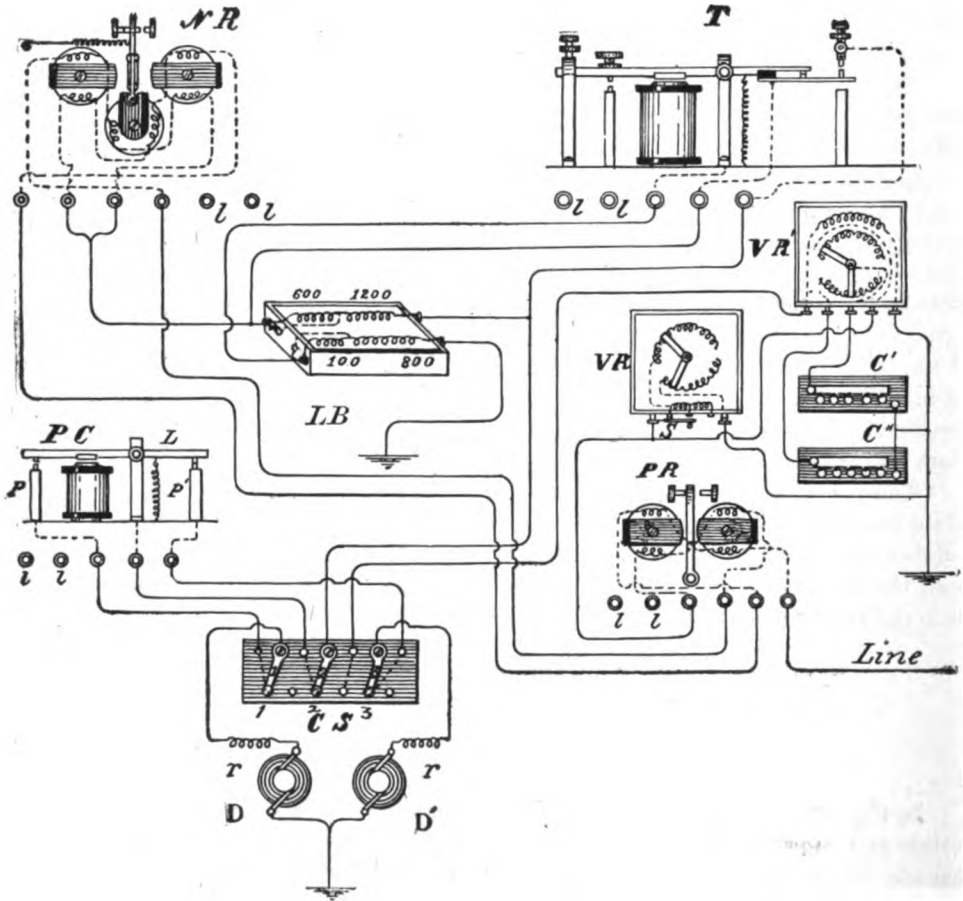

TERMINAL CONNECTIONS WESTERN UNION QUADRUPLIX.

pin plugs between the discs on the end of the box, or by removing them. In the figure a plug is inserted cutting out 600 ohms of the added resistance. No plug is inserted in the leak, hence the box is arranged for the ratio of 3 to 1. The cut-out switch *c s*, consists of three 3-point switches or arms on one base-board. Arm 1 when to the right opens the circuit leading to dynamo *D*. Arm 3, turned to the right opens circuit to *D'*. Arm 2 when turned to the right grounds the line wires through resistance in *v r'*. The Field pole-changer consists of a brass lever *L* supported on the usual bearings. *P* and *P'* are brass posts having contact points on their upper end. The lever is also equipped with contact points opposite these posts. The post *P* is connected to one dynamo machine via the cut-out switch *c s*. The post *P'* to another machine of opposite polarity. The line wire is connected to the lever of the pole-changer via the cut-out switch. Thus when the lever of *P c* is operated it presents to the line a different polarity at each change of position. This form of pole-changer was devised to diminish sparking at the contact points, this having been found a serious defect in the old style of pole changer when used in connection with high potential dynamos. The artificial line is connected to an arm *s* on *v r*, which arm according to its position on certain posts inserts or cuts out resistance coils of 3,000 and 6,000 ohms, respectively, in addition to the coils connected with the radial arms, practically on the principle of pin *P* Fig. 237. The box *v r'* contains the resistance inserted before the static compensating condensers *c', c''*. *rr* are the resistances placed in each circuit as described in Chap. III.

A condenser is now in many instances placed between the lever *L* of *PC* and the ground to reduce the spark at contact points. Mr. S. D. Field tested this device in 1882, but it was not found of utility, rather the reverse. Perhaps condensers of too high capacity were then employed. A condenser of about .5 m. f. is now found to be of decided advantage. The condenser is adjusted until the best results are obtained. Apparently the spark occurs at the making of contact, and it has therefore been thought that the sparking was due to the static discharge jumping to the lower contact point before the making of contact, but this does not seem likely in view of the high E. M. F. necessary to rupture cold air, say 4,000 volts for $\frac{1}{8}$ inch. Several theories might be advanced to explain the action of the "spark" condenser in this capacity. For example: In this form of pole changer there is evidently a rebound or a series of rebounds of the lever at the making of contact, and it is probably at the breaking of circuit during these rebounds that the spark tends to occur. If, for instance, the positive dynamo machine, Fig. 159, has been placed to line, the spark condenser and the line would both have a plus charge. Then when the lever *L* started to reverse polarity it would first open at *P*. Any tendency of the positive current of *D* to follow the lever would then be opposed by the positive charge in the condenser; it being assumed that the static discharge from the line might be held back momentarily by the opposing E. M. F. of the relays. When the contact is made at *P'*, one or several actions may follow. The spark condenser and line may discharge in multiple through the negative machine, and immediately take a negative charge. Whereupon if the break due to a rebound of the lever now occurs, the negative charge in the spark condenser will oppose the tendency of the negative current to follow the contact point at the rebound. Or the sparking may be reduced by the charge of the spark condenser holding back the line discharge while the lever is in transit between contact points, etc.

THE POSTAL TELEGRAPH COMPANY'S QUADRUPLIX.

The theory of the quadruplex system used by the Postal Telegraph Company, with the dynamo as the source of electromotive force, is shown in Fig. 182.* In the operation of this system the "increase and decrease" of current principle, in combination with that of reversal of polarity, is utilized.

When, in this system, gravity battery is employed the quadruplex key system already shown is used. When dynamo machines are availed of the ratio of current strength, as between transmitter open and closed, is obtained by transposing the circuits from one dynamo machine of, say, 225 volts to one of, say, 75 volts or *vice versa*—and the reversals of polarity are secured by transposing the circuit from a machine of, say, positive, to one of negative polarity.

The manner in which this is done will be plain by reference to Fig. 182, in which *pc*, *pc'* act as the pole-changing instruments. They are, for clearness, shown as having separate electro-magnets, but it is evident the contact points could be supported on one lever, thereby dispensing with one of the electro-magnets.

As the electro-magnets of *pc*, *pc'*, are in the same local circuit both will open and close together when the key *k* is operated. The contact point 1 of *pc* is connected by wire to a "negative" machine of 225 volts; contact point 2 with a "positive" machine of 225 volts. Contact point 1 of *pc'* is similarly connected to a negative machine of 75 volts; contact point 2 to a positive machine of 75 volts. The lever *l*, of *pc* is connected by a wire to post *p* of *t*; lever *l'*, of *pc'*, to lever *l*₂ of *t*. The tongue *x*, of *t*, is joined to a wire leading to the main and artificial lines. *r*, *r*, *r*, *r*, are the usual resistances inserted between dynamo machines and the office apparatus to diminish sparking. The operation of this key system may be described as follows:

When transmitter *t* and *pc* and *pc'* are closed the circuit from the earth passes via the 225 + volt machine to the lever *l* of *pc*, thence via post *p* of *t* to the line wire. When *t* and *pc*, *pc'* are open the circuit will be from the earth via the 75-volt machine to *l* of *pc'* and via the lever *l'* of *t*, to the line. Or, again, for example, if *t* should be closed and *pc*, *pc'*, open, the circuit will be from the earth via the 225 volts negative machine to the line. Thus, at every opening or closing of the transmitter *t*, the electromotive force, and consequently the current strength, is decreased or increased, and at every opening or closing of the pole-changer *pc*, *pc'*, the current is reversed; the strength of current "transmitted" from the home station depending on the position of *t*, regardless of the position of *pc* and *pc'*, and the polarity, or direction, of that current depending on the position of *pc*, *pc'*, regardless of the position of *t*.

The receiving instruments of this system are shown to the right of transmitter *t*.

NR is a neutral relay having three electro-magnets. Its electro-magnets *E*, *E'* are "differentially" wound and their coils are in the main and artificial lines, as shown. *EM* is a "singly" wound magnet which is in the circuit of the secondary wire of an

* This arrangement of the quadruplex, due to Mr. F. W. Jones, is being displaced by the Field-key system (see Fig. 176). Instead of the usual pole-changer and transmitter with horizontal levers, 16-ohm relays with vertical levers are employed, as outlined in Fig. 182a. *pc* and *t* (opposite page). The inductorium *ic* and extra coil *em* are also being replaced with a modification, due to C. E. Diehl, Fig. 182b, of the Edison repeating sounder device (page 202). In Fig. 182b, *NR* is the Jones neutral relay, coil *EM* of which is idle. Contact *x* of a 20-ohm relay *RS* is on front stop. When lever of *NR* is on back contact *c*, current from the 40-volt dynamo is shunted from coil of *RS* to earth by way of wire *aa*

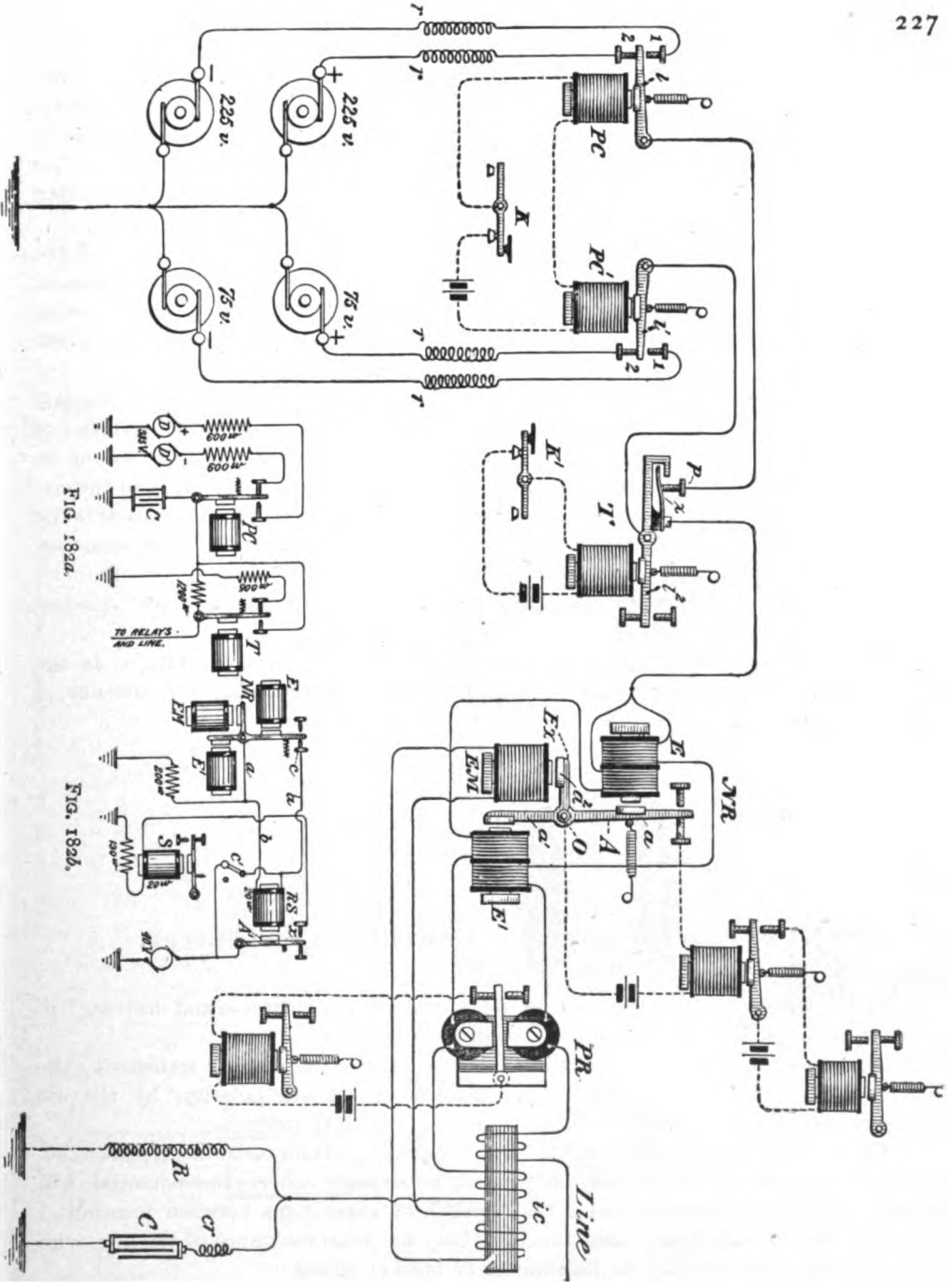

FIG. 182a.

FIG. 182b.

FIG. 182.—POSTAL TELEGRAPH COMPANY QUADRUPLEX—JONES ARRANGEMENT.

and 200-ohm resistance, at which times relay RS and consequently sounder s are open. When the lever of NR is on its front stop, shunt circuit a is open at c, and current passes through coil of RS, magnetizing it, and attracting its armature, closing circuit of s at x, whereupon s is magnetized. It will be seen that by this arrangement the magnetism of RS not only has to be brought to full strength (which consumes time) before its armature A' is attracted, but also that armature must travel from the back to the front stop before the reading sounder s will be at all affected, thus minimizing the opportunity for false signals at the moment of no magnetism in NR. c' is a cut-out switch.

induction coil *ic*. *ic* is a differentially wound induction coil having two primary wires, one of which is in the main line circuit, the other in the artificial line circuit. Consequently, the core of *ic* is only affected when an excess of current exists in either one of those coils, and a current is only induced in the secondary coil at the moment when the excess current is set up, or is subsiding, as when the distant battery is being reversed.

The lever *A*, carrying the armatures *a a'*, is pivoted at *o*; thus the cores of the different magnets, when magnetized, all tend to move the lever in the one direction. The object of the use of the two main and artificial line magnets *E* and *E'* is to obtain an increased effect upon the armature lever, thereby to secure a better working margin.

The extension, *Ex*, from the lever *A*, carries the armature *a²* of the extra magnet *EM*. At the reversal of the distant battery there is, of course, the usual reversal of magnetic polarity in the "home" relays. At that time an extra current is set up in the secondary wire of the induction coil, *ic*, and, as the extra magnet, *EM*, is in the circuit of the secondary wire, the core of *EM* is momentarily magnetized and attracts its armature, thereby tending to hold the armature lever, *A*, against its front stop during the moment of no magnetism in the cores of the magnets *E*, *E'*. In other respects the action of this neutral relay is practically similar to the ordinary quadruplex neutral relay.

PR is the ordinary polarized relay. *R* is the "artificial" line rheostat. *c* is the static compensating condenser and *cr* is the resistance for retarding its currents of charge and discharge.

"NEW YORK" QUOTATION COMPANY'S QUADRUPLEX.

This quadruplex also employs in its operation the "increase and decrease" of strength principle, in combination with reversals of polarity.

The reversals of polarity are obtained in the usual way, namely by transposing the line from a machine of one polarity to a machine of opposite polarity, by the use of a pole-changing instrument.

The decrease of strength is secured by "tapping" certain resistances, placed between the dynamo machines and the ground, at a point where the potential will be such as to give a desired ratio in the strength of current as between transmitter open and closed, and, at the same time, to keep the total resistance of the line wire at a uniform value whether the transmitter be open or closed.

The manner in which this is done is indicated in Fig. 183, which also shows in outline the form of pole-changer and neutral relay employed in this system, which is due to Mr. C. L. Healy.

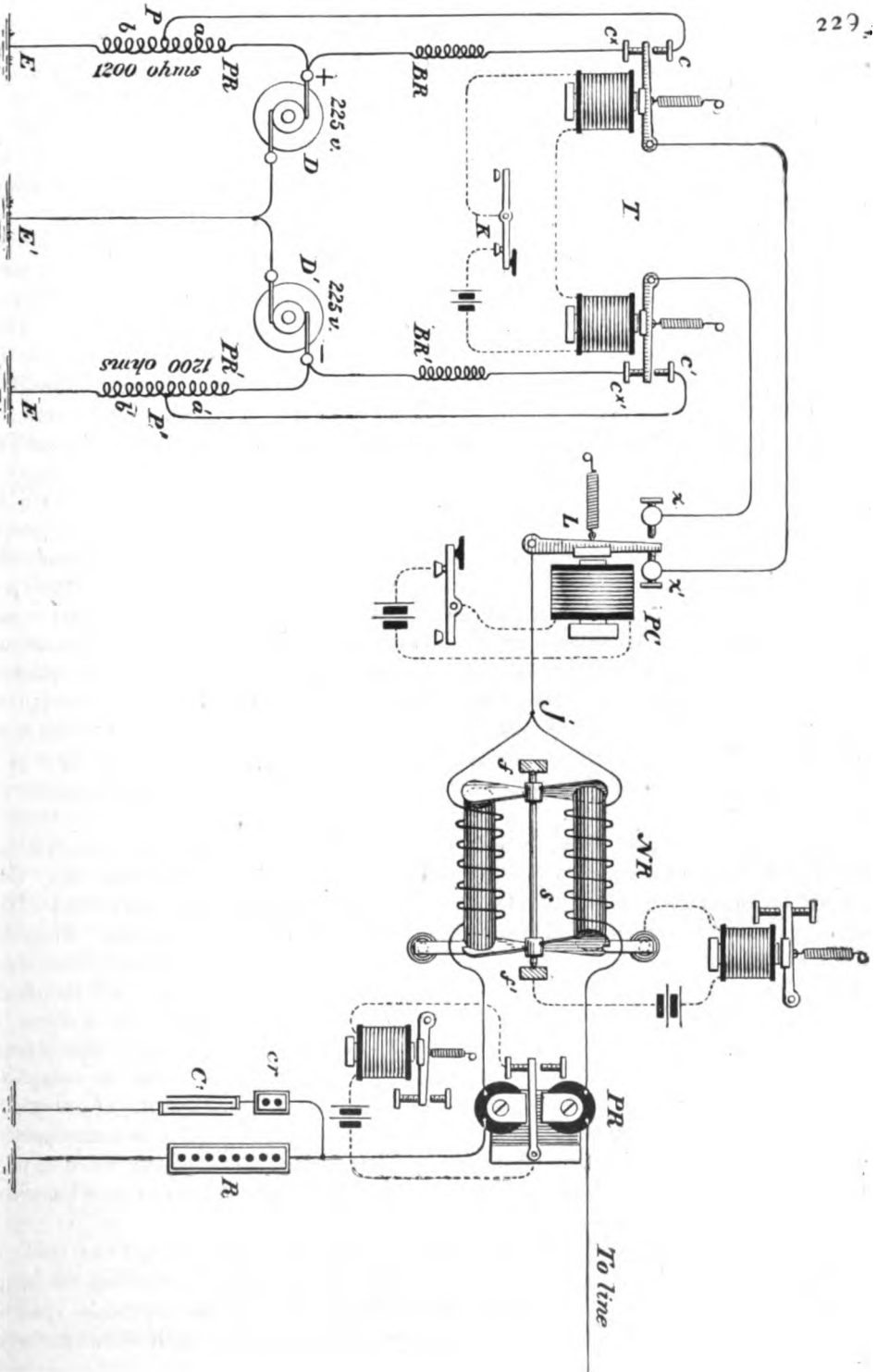

FIG. 183.—HEALY ARRANGEMENT OF QUADRUPLIX.

The resistances PR, PR' , are permanently connected, as shown, between the ground and dynamos D, D' . T is a "double" transmitter, the magnets of which, being in the one local circuit, are jointly affected by the key K . When K is closed the full current strength is to the line. The upper contacts c, c' , of the transmitter T' are led to a point in the permanent resistances PR, PR' where the potential has fallen to a desired degree.

For instance, if the total resistance of PR, PR' , be 1200 ohms, each, and it is desired to obtain the ratio of current strength of 3 to 1, and the electromotive force of each machine is, say, 225 volts, the "taps" P, P' would be placed at a point 400 ohms from the ground, where the potential will have fallen to 75 volts. Thus, when the transmitter, T , is open, an E. M. F. of but 75 volts is offered to the line, while, when the transmitter is closed, the full E. M. F. is virtually placed to the line.

It is obvious that the total resistance from, say, the contact c to the earth, via the tap P , would be the joint resistance of a and b , from the tap P ; that is, the joint resistance of 800 ohms and 400 ohms, which is $\frac{800 \times 400}{800 + 400} = 266$ ohms. This resistance may be considered as the equivalent of the internal resistance of a gravity battery. Therefore, to insure that the resistance from the junction J of the main and artificial wires to the earth at the home station shall be the same in either position of the double transmitter T , resistance, such as BR, BR' , equal to the joint resistances of a and b , is placed between contact points cx, cx' , and the dynamo machines D and D' , respectively, which resistance (BR, BR') in this case, would be 266 ohms.

The pole-changer PC consists of an electro-magnet whose armature is carried by a stiff, upright lever L , which plays between two contact points x, x' . When the pole-changer is closed, current is taken from the positive machine, D , via c or cx . When the pole-changer is open, current is drawn from the negative machine D' via c' or cx' .

The Healy neutral relay, NR in the figure, is of peculiar construction. It has two separate cores which are differentially wound. The cores are composed of small iron wires bundled together and insulated from each other. This arrangement of the cores is to facilitate reversals of the magnetic polarity. The relay has two armatures which are carried on a brass shaft s , passing between the cores. The shaft is pivoted on the bearings f, f' . The ends of the cores are cut slantingly, and the armatures, which are made of very light iron, are twisted into a form resembling the blade of a propeller, so that each end of an armature may face, evenly, the slanting end of a core. Thus the magnetic circuit of the cores is completed through the armatures. One of the armatures carries an extension, the upper end of which plays between two stops, one of which has a contact point, in the same way as does the lever of the ordinary relay, excepting, however, that, owing to the peculiar construction of the armatures, the lever moves at right angles to the length of the cores, instead of to and from them.

In the regular form of quadruplex neutral relay the entire length of core, including the cross-piece, is about 4 inches. This leaves about two inches on which to wind the coils. The cores of the Healy neutral relay furnish $2\frac{1}{2}$ inches space on each core on which the coils may be wound, and, also, a shorter length of iron to reverse

at the time of distant reversals, it being assumed that the cores of each coil will demagnetize simultaneously.

The polarized relay, PR, and the artificial line, in this quadruplex system, are similar to others already described.

GENERAL REMARKS ON THE QUADRUPLIX.

NOMENCLATURE—DETECTION OF FAULTS, ETC.

NOMENCLATURE.—Many of the following terms have been used, and, in some instances, explained, in foregoing chapters.

The "neutral" relay is often termed the No. 2 relay ; sometimes the "common" relay. The polarized relay is generally called the "polar" relay, or the No. 1 relay. That portion of the quadruplex which causes and responds to the reversals of polarity is often termed the No. 1 "side," that which causes and responds to the increase and decrease of current strength, the No. 2 "side." "Reversals" applies to changes in the polarity of the battery, or other source of electromotive force, and to the consequent changes in the direction of current, and of the magnetism of the relays, etc. The "tongue" of the armature of the "polar" relay is that part of it which extends between the "contact point" and "back stop." The "tongue" of the "single" transmitter is the flat spring, with contact point, which is fixed on the insulated block attached to the lever of the transmitter. The "leak" is the resistance used, in the Field key system, between the lever of the transmitter and the ground. The "added" resistance is that resistance which is connected between the tongue and post of the transmitter, and which is short-circuited when the latter is closed. The "tap" is at the junction of the "short" and the "long" ends of the quadruplex battery.

To "dot" on 1, and write on 2, is to open and close the pole-changer, and write with transmitter. To "close 1" or "2" is to close the pole-changer or the transmitter. As the instruments of many quadruplex sets are "bunched" on the table, it is a common thing for attendants to use one hand for dotting and the other for "sending."

A "margin" refers, practically, to the pull permissible on the armature of either of the relays without interfering with the working of the instruments. If this pull is very little, the "margin" is said to be small. If much, the "margin" is said to be large. An increased "margin" is obtained by increasing the ratio of current strength, as between key open and closed, and, also, by increasing the total amount of electromotive force used in the circuit. Also, of course, by decreasing the resistance or improving the insulation of the circuit, etc. The margin on the polar side of a quadruplex may be increased by increasing the number of cells on the small end of the battery.

The term "phantom" is frequently used to denote the circuits practically gained by the use of Multiplex systems. For example: One single circuit, say, from New York to Chicago, requires the use of one line wire, about 1,000 miles in length. This wire, "quadruplexed," gives, virtually, three additional circuits, between those points,

hence it is said those circuits are "phantom circuits," and that the gain is 3,000 miles of phantom wire; the latter being generally referred to as phantom mileage.

THE QUADRUPLIX PARADOX.—While it is true that the successful operation of a duplex or quadruplex circuit may be said to depend upon the obtainment of a practically perfect "resistance" and "static" balance, it is equally true that the successful operation of the duplex or quadruplex, consists in upsetting that balance. In other words, the rheostat and condenser of the artificial line balance the main line, as regards the resistance and static capacity of the latter; this balance insures that the action of the home transmitting instruments shall not operate the home relays; but the distant battery, or resistance inserted in the main line, upsets this balance, and, thereby, operates those relays.

BALANCING THE QUADRUPLIX.—The "resistance" balance, generally speaking, consists of placing in the artificial line, by means of the rheostat, a resistance equal to that of the main line wire, the distant relays and the distant battery.

The "static" balance consists in giving to the condenser attached to the artificial line a "capacity" equal to that of the main line. In some instances a condenser has been so connected with the main line and a third coil of the relays (for example the Gerritt Smith arrangement), as to compensate, fairly, for the static effects of the line. In other cases an induction coil has been placed in the main and artificial lines (for instance, the F. W. Jones device),* and so connected with a third coil in duplex relays as to compensate for the static effects of the line upon them. But, so far as known to the writer, the only device employed for the purpose at present is the Stearns arrangement of the condenser, shown in the figures illustrating the various duplex and quadruplex systems described in previous chapters.

To balance a quadruplex, ask the distant station to "ground." This he does by turning the 3-point switch to the "ground" point. The home station then "grounds" also, and proceeds to put the "tongue" of the armature of the polar relay on its "centre." When this is done the armature will stay on whichever side placed. The home station then "cuts" in his battery, by turning the 3-point switch to the "line" point. The No. 2 transmitter is then closed, and the pole-changer is opened or closed, and the resistance of the artificial line is changed until the armature of the polar relay remains on either side. It is well to see that this resistance balance is the same with both poles to the line. If it is not, and if the difference is not very marked, the average resistance of both poles may be used. The distant station may then be asked to cut in and to open his transmitter. This, as a rule, places the "short" end of his battery to the line. In some cases where a repeating sounder is not used on the No. 2 side, the short end is placed to the line when the transmitter is closed. It is sometimes found desirable to thus arrange the battery connections. When the short end of the distant battery has been placed to line, the home station may proceed to take a static balance. First, by putting his full battery to the line, and then by adjusting the condenser until the polar relay does not respond to the opening and closing of the home pole-changer. Afterwards, the home station lets down the spring of the neutral relay, until it rests lightly on its back contact point.

The opening and closing of the home pole-changer is resumed, and the condenser, or condensers, and their resistances, are adjusted until the "kick" on the neutral relay

* Neither of which is described here.

is eliminated.* It will be difficult to get rid of every trace of this "kick" when the armature lever is only held on its back contact by a very slight pull of its retractile spring, but, if the armature is passive on its back contact on a much slighter pull of the spring than is required to withdraw the armature from its core when the entire distant battery is to the line, it may be safely assumed that a good static balance is obtained.

The balance may be taken altogether on the No. 2 side, if desired, but, by taking the preliminary balance on the No. 1 side, it leaves the polarized relay ready for work without further adjustment.

It will be noted that with the *small* end of the distant battery and the *full* battery at the home end to the line, the nearly *maximum static* effects are compensated for at the time when the home relays are in their most sensitive condition, and, if the balance is maintained at that time, there will not be much likelihood of its being affected when the entire distant battery is to the line, since at that time the armatures of the home relays will be most strongly held in their respective positions towards their cores.

When the "resistance" and "static" balances have been obtained, the distant station should be asked to "write on both sides," while the home station does likewise. While this is being done, the neutral relay may receive any necessary adjustment.

CAUSES AND SYMPTOMS OF FAULTS ON DUPLEX AND QUADRUPLIX CIRCUITS, AND METHODS OF DETECTING THEM.—To insure the successful working of a quadruplex circuit, constant attention to details is essential. One radical defect in a quadruplex or duplex circuit, may be readily traced and eliminated, but many trifling defects, allowed gradually to accumulate, and not one of which, perhaps, by itself, would seriously interfere with the working of the system, may, jointly, cause trouble which will be much more difficult to locate than the one radical defect.

Frequently, on entering an office, while on an investigating tour of circuits, the writer has been met by the official in charge with the assurance that everything under his supervision was in excellent order. The writer having satisfied himself, by careful tests of the circuit from a distant station, that there might be ground for thinking otherwise, would usually proceed to overlook matters. An examination of the main battery would perhaps indicate that the major portion of that important element of a duplex or quadruplex system was in fair condition, but, possibly, on one of the top shelves, two or three defective looking cells would be discovered. The battery man on being questioned would probably admit that recently a local battery of an important circuit had suddenly given out, and he had, just temporarily, taken out two cells from the quad battery, and substituted defective "locals" for them. He had much better have left them out. Next, the local batteries would be investigated, and a suggestion of a change here and there would be acted upon. Possibly two or three of those cells had been allowed to become practically "short-circuited" by an accumulation of salts; or the insulation of the copper connecting wire had been abraded, permitting the wire to touch a zinc, etc. The "quad" instruments would next be inspected; a loose contact tightened in one place; a dirty contact point cleaned; in one instrument a worn out spring would be replaced; in another the points of contact would perhaps be more correctly adjusted, and a number of other different details, seemingly trifling, would

* It may also tend to a better balance if the distant pole-changer is opened and closed at intervals.

receive attention. The distant station would then be called up for a test with the quite frequent result that he would report a satisfactory working of the set.

If, after a careful "balance," the signals of the distant station are obscure on either "side" of the quadruplex, the symptoms should be noted, and steps taken to remove the cause.

The causes producing, or conducing to, imperfect signals, are many, and it would be difficult to mention all of them. Indeed, new causes of faults, that cannot well be foreseen, are every now and again developing, and it is only by tracing such faults to their source, step by step, that they can be located. There are, however, many frequently recurring troubles, which are manifested by well-defined symptoms, and a few of them will be alluded to here. (It will be understood that reference is now had to the gravity battery quadruplex key system.) Other faults of less frequent occurrence will be indicated subsequently.

As already mentioned, or intimated, in several places in this work, much of the trouble in the practical operation of duplex and quadruplex circuits, automatic repeaters, etc., is occasioned by the failure to look after, properly, the condition of the contact points, local and main, of the different instruments.

In addition to the high resistance introduced at the contact points by the production of oxide, due to sparking, (already referred to) dust, and pieces of feather dusters, at times get between the contact points. When this happens at the pole-changer, it will be indicated at the distant station by his failure to get one or both of your "poles" properly, or it may simply act to render his received signals unsteady. When it occurs at the transmitter, it may prevent the long or the short end of the battery from reaching the wire, or it may open the circuit altogether. Similar causes also frequently impair the working of local circuits.

If a general overhauling of your contact points, etc., fails to improve your signals at the distant end, the home battery should be tested. This may be done by the aid of the home quadruplex or duplex instruments, opening the main line to facilitate the test. The line wire may be opened at the switch-board, or by detaching the line wire at its point of connection with the desk apparatus. The currents from the home battery will now pass through but one coil of the home relays, and the effect upon those relays should be the same as that previously observed at the distant end.

Assuming the line wire to have been in proper working order, the home station, by opening and closing the pole-changer, with the transmitter open and closed alternately, may see and "feel" for himself, by the pull of the magnets, whether the currents pass with equal strength from both poles of his battery. He can also see whether the "long" and "short" ends of his battery pass to the line, by the action upon his neutral relay. If not, the reason may be definitely ascertained by tracing back from point to point. Sometimes the wire between the battery and switch-board is broken; sometimes a wire under the base-board of instruments; sometimes a loose screw exists. Again, it may be a broken wire in the battery, etc. Possibly it may be a faulty connection in or about the line coils of the relays. If so, the previous tests would not have shown it. To insure that such is not the case, the artificial line should be connected to the main line post on the polar relay, so as to test those coils, the artificial line coils being left open in the interval. Or, the line wire may be connected as usual,

and the artificial line wire disconnected; the line wire being grounded at "distant" station during this test. The writer has found this method very effectual, as it enables the attendant at the home station to determine for himself, by the various manipulations of the transmitter and pole-changer, what he would, otherwise, only ascertain by questioning the distant station as to the results of such manipulations.

Of course, if the attendant at the distant end is more expert than the one at the home station, it may be well to permit him to dictate as to the manipulations of the keys, and if possible, to locate the defect from the distant station.

A differential galvanometer in the circuit is very useful in making such tests, as it will show at a glance, whether, or not, each pole of the battery or of the dynamo machine is coming properly to the instruments, and also whether the proper increase and decrease of current is being effected by the transmitter.

Even after everything has been proven to be all right at the home station, it may be that signals are not satisfactorily received at the distant station. It being assumed that the attendant at the latter station has overhauled his own apparatus, it will then be well to change the wire for one known to be indefective. The trouble still remaining, another quad. set, also known to be in good working order, may be tested against the supposed defective one. Indeed, it is often desirable to do this immediately on the appearance of any not easily explained trouble, as it at once locates the fault in one set or the other, or in the wire.

When no amount of adjusting of the condenser will balance the line "static," the cause may be looked for in or around the condenser, especially if no noticeable effect is produced by alterations of the capacity of the condenser. It may be that the wires connecting that instrument to the artificial line, or to the ground, are loose or broken; or the plates of the condenser may have become crossed; this latter, however, unless the cross is only partial, and has a comparatively high resistance, would act like a partial ground, as there would only be the resistance of the "retarding" resistances between the battery and the ground, and, in that case, a balance of the line resistance would scarcely be possible. A somewhat similar effect would be caused by the burning out of coils of the "artificial line" rheostat.

Sometimes, also, a static balance is rendered difficult by the presence of a wire crossed at some point of the duplex or quadruplex circuit, and open at both of its ends, thereby adding its "static" charge and discharge to that of the regular line. To offset this trouble, a second or third condenser may be necessary, together with a careful adjustment of the retarding coils.

One obscure source of trouble is sometimes due to an abnormal variation in the resistance of one or other of the coils of the relays. It is a good plan to have some spare relays well "balanced," and known to be in perfect condition, ready to replace any corresponding relay whose faultlessness is suspected. The same is also advisable as regards pole-changers and transmitters.

In order to ascertain whether a relay is properly balanced, that is, whether, with equal currents passing through both coils in opposite directions around the core, its armature will remain passive, the relay should be tested by itself with a strong battery; for which purpose it may be connected up as indicated in Fig. 183a. The coils are connected at their respective binding posts by short pieces of wire *w*, *w*, and

the terminals of the battery are momentarily touched to those wires. This sends the current through the respective coils in opposite directions. With a well balanced relay there should not be more than a very faint movement of the armature; it being adjusted close up to the core and resting on its backstop with its retractile spring almost dangling. This refers to the neutral relay. When the polarized relay is to be tested its respective coils are connected and the battery terminals are applied in the same way, the cores being moved close up to the armature on both sides. When a decided movement of the armature is noticed under these conditions the relay should be sent back for correction or repairs.

When making these tests the movement of the armature, or its lever, should be free and easy on its bearings. The attendant

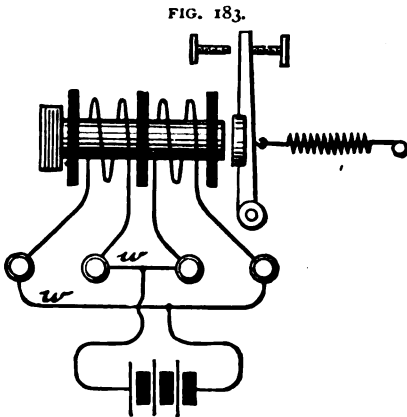

should also, of course, be on his guard to note that the terminals under the base of the respective coils of the relays are connected to the proper posts to produce neutrality in the cores when equal currents are passing through the coils. It sometimes happens that a relay connected up in an unusual way is permitted to pass the inspectors at the factory and thus becomes a marked source of trouble unless the cause is quickly discovered. This remark is equally true of unusual connections under the bases of pole-changers and transmitters.

The resistance of the coils should also be measured, although it will almost al-

ways happen that when the "balance" of a relay is found to be accurate, the resistance of both coils will be, within a very small fraction, equal. It is not, however, to be taken for granted that such is the case, since it is possible that a portion of one coil might be short-circuited to just the extent necessary to divert enough additional current through the remainder of the coil to compensate for the diminished number of convolutions due to the short-circuit.

Tests should also be made to determine whether any "cross" exists between the coils, or between either of the coils and the iron core. This is done by disconnecting all external wires from the posts of the relays and then applying the terminal wires of the battery to a binding post of two different coils; then to the binding post of a coil, and to the iron of the core. A "cross" will be indicated by a spark at the points of contact, or by a movement of the armature lever.

When the distant "reversals" break up the received signals on the No. 2 side, a new balance may be required; the distant pole-changer may need adjustment, or the retractile spring of the home neutral may require letting down. When the reversals caused by the home pole-changer interfere with received signals at the home station, a new general balance may be needed; possibly only a static balance. Or the trouble may be overcome by pulling up the retractile spring of the No. 2 relay, provided that this action does not bring the armature within the scope of the *distant* reversals. The advantage of a good working margin on the No. 2 relay is that

it permits a readily found happy medium, between these two "effects": namely, that due to the distant and to the home reversals, respectively.

Perhaps the writer cannot better illustrate some of the less frequent causes of trouble in quadruplex working than by quoting from his personal notes the results of an inspection of a series of quadruplex circuits extending over a distance of nearly four thousand miles.

The circuits were all newly established, and in one or two instances the attendants had never seen a quadruplex set previously. At the first station *A*, nothing radically wrong was discovered, but a number of minor details had been overlooked and it was evident from the report of the eastern station that improvement was observable after they had received attention. At the next station, *B*, the attendants were quite sanguine that the trouble was in *A*; that being a railroad office. Presently the writer chanced to see on one of the desks an instrument used in certain experimental tests with which he was familiar. It was a magnetic coil having a resistance of 500 ohms. On asking the number of the circuit allotted to the desk in question the reply confirmed the suspicion that it was the "defective" circuit. The coil was removed and the circuit was tested without it, whereupon station *A* reported, as was to be expected, that the circuit now worked admirably. The magnetic coil had been placed in the circuit during the experiments alluded to, and was allowed to remain therein subsequently, its detrimental effect upon the circuit not having been surmised.

Tests were then continued between *B* and *C*, with the result that an increased ratio of current strength was advised; the wires between *B* and *C* having high resistances as compared with other circuits working with similar electromotive force. At *C*, nothing was discovered except as to minor details. But at *C* the manager at *D* reported, over the wire, a complete failure of the circuit south of him. He stated that *E* office insisted that his, *D*'s, "tap" wire, was open. Tests made from *C* showed that this was not so.

It was raining heavily when the writer reached *D* and the No. 2 side of the quad. south, was useless. This was at first attributed to defective insulation due to the wet weather, and further action was delayed for one day to give time for the wires to "dry off." This the wires north did upon the appearance of clear weather, but the low insulation south, which almost amounted to a "ground," still continued, notwithstanding that the fair weather now extended all along the line. This being so, a close personal inspection of the line was determined on. It should, in fairness, be said, in advance, that this telegraph line had just been taken over from a "Construction" company and had not, previously, been inspected.

Three or four miles from the station, what seemed to be a very luxuriant vine, growing up one of the telegraph poles was perceived. Examination showed that this foliage had sprouted from the pole and was festooned around the wires for a distance of 3 or 4 feet in each direction. Several poles were found similarly sprouting. The poles were native saplings which had not been peeled and which grew wherever stuck in the ground. After these "decorations" had been removed the wire assumed a normal insulation resistance, and the manager at *D* was pleased to be

able to prove that his "tap wire" had not been broken, the more especially as he was not responsible for the "foliage."

At E, fair weather prevailed, and not much of importance was noted. At F, the batteries were in a deplorable condition, due to climbing salts, and, notwithstanding that water was difficult to obtain in large quantities, oil had not been used to prevent evaporation, owing to the belief that oil would "grease" things. Between F and G there was a radical defect. The insulation resistance of the line was fair and the resistance of the wire was also normal, but there was no working margin on the neutral side.

On reaching G investigation showed, as anticipated, that the "tap" was on the wrong end of the battery, so that, instead of having a ratio of, say, 4 to 1, there was a ratio of but 4 to 3, as between transmitter open and closed. When this fault had been removed the circuit worked perfectly between F and G.

GENERAL REMARKS:—When there is a number of parallel circuits in active operation the opening and closing of each circuit sets up induced currents in the other circuits, the strength of which depends upon the nearness of the other wires to the "inciting" wire, the distance it runs parallel with them, and the electromotive force of its battery.

In taking a balance on a duplex or quadruplex circuit, under such conditions, a very pronounced clatter is generally heard in the relays, especially in the polar relay, as long as there is no current on the circuit in question, at either end, and also after a balance has been obtained, but before the distant battery is placed to the line.

If, with the small end of the distant battery to the line, either of the relays should be affected by the currents induced by parallel circuits, and there is no reason to think that the battery is not in working order, it is fair to assume that higher voltage is needed on the short end, at the distant station.

In practice it has been found by the writer, repeatedly, that up to a certain number of circuits, say four or six, each additional circuit necessitates increased voltage on the other circuits, but that, after that number has been reached, the placing of still more circuits does not materially affect the working margin.

The high voltage used on quadruplex circuits, (which is from 3 to 4 times that needed on single or duplex circuits of equal length,) of course, necessitates that the minimum electromotive force used on the "short" end of each circuit should furnish current sufficient to hold the armatures of the relays firmly against their stops against the inductive effects due to the rise and fall of the maximum "currents" on parallel circuits.

The writer recalls the case of a polar duplex circuit, 432 miles in length, which was successfully worked with 40 volts at each end when first established, but which required, for its proper operation, 100 volts at each end, after a number of quadruplex circuits had been established parallel with it; the electromotive force of the latter circuits was about 370 volts at each terminal station. These, and similar results on other circuits, could not be attributed to surface leakage, that is, leakage from wire to wire, via the cross-arms, poles, etc., as the effects were, if anything, more marked in cold, dry weather, than in stormy weather.

These causes seemingly preclude the use of any hard and fast formulae as to the amount of current necessary to successfully operate such circuits, inasmuch as the laboratory "figure of merit" of an instrument would not hold where these counter electromotive forces have to be allowed for.

The ordinary resistance of the quadruplex neutral relay is about 225 ohms, but on very long circuits a resistance of about 400 ohms has been found advantageous; the added resistance, of course, being made up of increased convolutions of wire.

Any one who has had much to do with the practical working of duplex and quadruplex circuits will not have failed to observe the waste of time that is frequently caused during the prevalence of stormy weather, and at other times, by attempts to operate, to their full capacity, circuits that for various reasons are not in condition to be so operated.

Sometimes it is the case that, owing to the particular conditions existing at the time, one station may be able to work his set "all sides," while the other station may not be able to get more than a duplex or triplex, and it is not always easy in those cases to make it clear to the successful "attendant," who perhaps insists on working the circuit 4 sides, that the result at his end is not due so much to his expertness as to the circumstances.

These and other causes led to the formulation of the following rules by the writer for the government of an extensive duplex and quadruplex system, of which he had the supervision.

These rules, which are, perhaps, self-explanatory, were admitted by all concerned to be beneficial and it may be that they will serve as a basis of rules for others who may appreciate the need of somewhat similar systemization.

"RULES FOR THE MANAGEMENT OF DUPLEX AND QUADRUPLIX CIRCUITS IN CASE OF INSTRUMENTAL OR WIRE TROUBLE, OR DURING STORMY WEATHER.

When intricate trouble occurs on any duplex or quadruplex circuit that cannot be eliminated within 30 minutes, at the end of that time the circuit must be started as a duplex, if it will work as such, or, if not, as a single wire; unless the circuit can be readily dispensed with for a longer time.

When the attendant at either end reports to the distant station that a quadruplex circuit will not work as a full quadruplex this will be sufficient basis for the abandonment of so much of the quadruplex as may be thus rendered necessary, even although the other attendant may be able to work the circuit to its full capacity. The attendant ordering this partial abandonment of a circuit will be held responsible therefor, and must, if required, be able to show sufficient cause for the same in every case.

No time should be lost discussing the advisability of or necessity for balancing changing or testing wires, cutting through, as at repeating stations, etc. If one station asks another to balance, change or test wires, cut through, etc., the request should be complied with, at once. This rule will, however, not apply where the entire con-

trol of circuits has been conferred upon any one of the offices. But it will be the right and the duty of the subordinate office to report to the proper official any apparently useless requests for balance, etc.

Quadruplex attendants should carefully record the condition of the wires under which the various circuits in their charge will not work satisfactorily either during prevalence of very bad weather, or when a circuit is "patched" with an inferior wire, etc., so that no time may be wasted in futile attempts to obtain more service from a circuit than it is capable of performing, under recurrences of similar conditions. These records should be easily accessible to all concerned.

Attendants also, at terminal stations, should mutually inform each other of any changes in the weather that might necessitate alterations in the balance and adjustment, thus anticipating or explaining trouble.

THE ROBERSON QUADRUPLIX.

It is well known that on long lines, and especially in bad weather, the second or neutral side of the Edison quadruplex is not as efficient as the polar side. The chief object of the Roberson quadruplex is to secure a system both sides of which shall be equally efficient under all conditions. To secure this result, Mr. O. R. Roberson, to whom this arrangement is due, has found it necessary to employ current pulsations of positive and negative polarity in place of the comparatively continuous currents used on the polar side of the Edison quadruplex, and the nearly continuous currents used on the neutral side; it being known that the characters received on the latter side are somewhat broken by the signals transmitted on the polar side; not, however, to such an extent as to be observable or detrimental on a good working quadruplex. On the other hand, it has been noticed that the signals composed of a number of pulsations—as, for example, in the synchronous multiplex system described herein—have a wavering or fluctuating sound, not common to the single Morse or quadruplex system. This feature of rapidly pulsating systems, it is claimed, has been largely minimized in the system in question by the devices to be described, and, in any event, the bad-weather qualities of this system are so superior that it is now being put into operation on a number of the lines of the Western Union Telegraph Co.

The theory of the Roberson quadruplex is shown in Fig. 183*a*. To simplify the explanation, it may be noted that the first principles involved in the operation of this quadruplex are similar to those of the Sieurs diplex, described in Chapter XVI. In the application of these principles to the quadruplex and a dynamo key system, several difficulties were encountered which Mr. Roberson has successfully overcome.

The negative and positive pulsations which are transmitted to the line when one or other of the transmitters is closed, as well as the alternations of polarity which are transmitted to the line when both are closed, are generated by the dynamo, *N*, *S*, Fig. 183*a*, on the shaft of which are three rings, *b*, *c*, *d*, which revolve with it. One half of the rings, *c*, *d*, is insulated as shown by the black dashes. This insulated half of the ring is mainly of metal, to give a good wearing surface for the brushes. The

other half of these rings, which may be termed the conducting segment, is entirely of metal. The brushes 4 and 3 respectively rest on opposite sides of the ring *c*.

FIG. 183a.

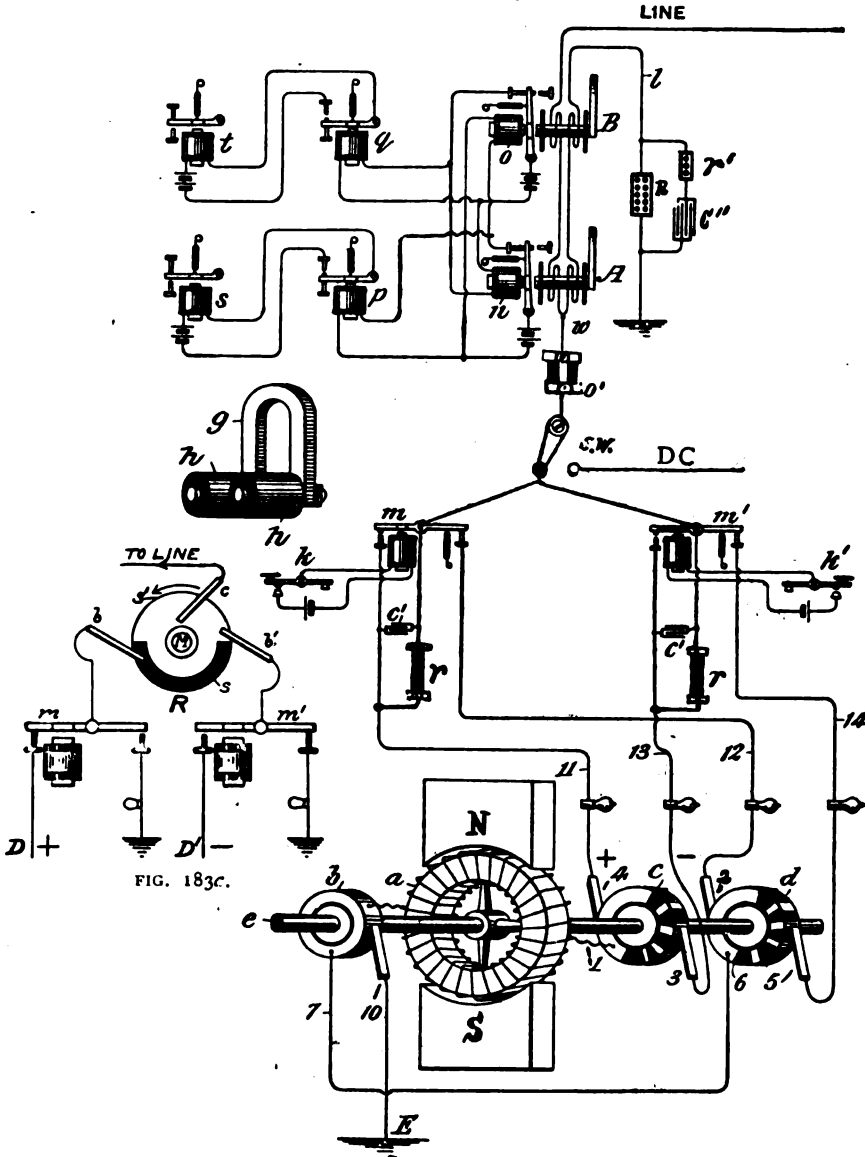

FIG. 183c.

THE ROBERSON QUADRUPLEX-THEORY.

The conducting segment of *c* is connected by wire *1* to one terminal of the armature *a* of *N S*; the other terminal of this armature is connected to ground by way of ring *b*

and wire 10. The conducting segment of d is also connected to ground by way of wire 7, ring b , and brush 10. Ring b is entirely of metal. Wire 7 and the wire 1 of course revolve with the shaft and are securely held in place close to shaft. Ring b is continuously connected to ground by the brush 10, and its function is to provide a ground connection for the other rings and armature.

Assuming now that in the position of the armature of the dynamo as shown in the figure, the brush 4 is receiving positive polarity from the conducting segment of c , it is well known that when the armature and segment have turned to the opposite side of their revolution a negative polarity will be received by brush 3 (see page 44). Hence the brush 4 will always collect positive, while the brush 3 will always collect negative polarity, and of course no current will pass into the brushes while resting on the insulating segment of c .

Referring now to the transmitters m m' , it will be seen that the lower left-hand contact point of m is connected by wire 11 with positive brush 4 on c ; the lower left-hand contact of m' is connected by wire 13 with negative brush 3 on c . Also, that the lower right-hand contact point of m is connected by wire 12 with brush 2 on ring d ; the lower right-hand contact of m' with the brush 5 of same ring by wire 14. Hence, when either or both of the transmitters are closed, negative or positive pulsations or alternations of both will pass to line, and when either or both are open the line is intermittently placed to ground direct via brushes 2, 5 and the ring b .

The conducting segments of c and d cover slightly more than half of the periphery of the ring, which insures that contact will be made by one brush before it is broken by the other; but as at the instant when both brushes are on the conducting segment the potential of the armature is zero (see page 44), no sparking will follow. At other times the insulated portions of the ring prevent short circuits between the brushes.

The lamps or other resistance shown in wires 11, 12, 13, 14, and a carbon rod resistance o' , are inserted for the usual purpose of avoiding injury to the relays and other apparatus in case of grounds. The resistance of the lamps in wires 11 and 13 is about 50 ohms; those in wires 12 and 14, about 100 ohms. It is clear that it is not advisable to place high resistances between the dynamo and transmitters, inasmuch as such resistances are placed in multiple when brushes 4 and 3 are on the conducting segment of c , and this would have the effect of varying the balance at the distant end. The resistance of the carbon rod o' may be from 500 to 1000 ohms, depending on the voltage used; on the longer circuits it is about 1000 ohms. Fuses, not shown here, are also placed between the dynamo and transmitters to protect the armature in case of short circuit at transmitters. The *E. M. F.* of dynamo $N. S.$ is about 200 volts. The resistance of armature a is about 50 ohms for long circuits. A non-inductive resistance—that is, a coil wound back upon itself (see Rheostat) or a carbon rod $r r$, of about 6000 ohms, is inserted around the front contact points of each transmitter. This permits weak current pulsations to pass to line when the transmitters are open, for a purpose presently to be explained. The condensers $c' c'$, and small resistances not shown in the figure, are employed around the front contacts of transmitters to diminish sparking at those points. It is found that very little capacity in the condenser is required to effect this result. It would not be advisable

in this quadruplex to use solenoids such as are shown at R, Fig. 24, as resistances, for, apart from their bulk, their magnetic effects would, owing to the rapid variations of current, produce an impedance that would be detrimental to the operation of the system. Hence the use of carbon rod resistances which have no noticeable inductance. (*See Self Induction, page 100.*)

In practice, as this quadruplex is operated by the differential method, the receiving relays A B are differentially wound. The relays are of the Hughes polarized form, this form having been found to be best adapted for this work. The Hughes relay differs from the well known form of polarized relay employed in the polar duplex and the Edison quadruplex, in which the cores of the electromagnet and its armature are joined to opposite ends of a permanent horseshoe magnet. The main difference is that only the cores *h h* of the electromagnet are connected to the permanent magnet, *g*, as shown more clearly at the left of Fig. 183*a*. This arrangement of the permanent magnet gives the cores *h h* a certain magnetism, one becoming a north pole, the other a south pole. The coils of relays A B are then so connected that a certain current, say a positive current, will assist the induced magnetism of one, let us say A, and oppose the induced magnetism of the other relay B; whilst a negative current will assist the induced magnetism of B and oppose that of A. The armature of each relay is provided with a suitable retractile spring as shown, the tendency of which is to withdraw the armature from its core, and the spring is so adjusted that it overcomes the induced magnetism of the cores (and the weak open transmitter currents to be referred to). When, then, a current passes through the coils in such a direction as to assist the induced magnetism of a relay, its armature is attracted; when the direction of the current is such as to neutralize the magnetism of the cores, the armature is not affected and remains on its back stop.

The permanent magnet of this relay is usually provided with a movable "keeper" (a strip of soft iron), which may be shoved up and down across the legs of the magnet, and in this way short-circuits or diverts more or less of the magnetic lines of force from the ends of the magnet, thereby increasing or decreasing the induced magnetism in the cores of the relay as desired. The nearer to the ends of the permanent magnet the keeper is brought, the less will be the induced magnetism in the cores. In practice the keeper is usually kept close to the cores, although in wet weather it is found advisable to raise it somewhat, in order to admit more lines of force into the cores, the proper distance being found by actual trial.

The chief advantage of the Hughes relay is its sensitiveness to weak currents and its quick action. Its sensitiveness, in common with that of the ordinary polarized relay, is largely due to the fact that the magnetic pull of a magnet on its armature is proportional to the square of the number of lines of force in action. Thus, if the induced lines of force in the cores due to the permanent magnet, number, say, 100, and if the number of lines due to the effective current flowing in the coil, be, say, 100, we have a pull in the first instance proportional to the square of 100, or 10,000; and in the second instance we have a pull proportional to the square of 100 + 100, or 40,000. Thus, in wet weather, when the received current is reduced by escapes on the line, the pull on the armature may be increased somewhat by increasing the induced lines of force, although the gain to be obtained by this means is limited by the

counter-effect of the added pull necessary to be given to the retractile spring to withdraw the armature of the relay when its distant transmitter is open.

The alternations of polarity generated by the dynamo N S are at the rate of 40 per second or 2400 per minute.

The armatures of relay A and B are each furnished with an extra magnet *o* and *n* respectively. The coil of *n* is in multiple with the repeating sounder *q*, and both are controlled by the lever of B. Similarly the coil of *o* is in multiple with the repeating sounder *p*, and both are controlled by the lever of A as shown. These repeaters act as so-called "bug" catchers, as in the Edison quadruplex, *t* and *s* being the ordinary sounders. In a later arrangement, the repeating sounders *p q* have been

FIG. 183b.

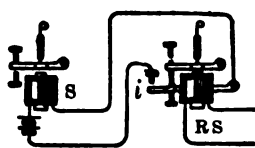

replaced by a repeating sounder of the form shown in Fig. 183b. In this, RS has two levers, the lower one of which has the local contacts of sounder *s*. The lower lever is operated by the upper lever, which itself is operated by the magnet. The object of this device is to make it necessary for the upper lever to traverse a considerable distance downward before it will push the lower lever away from the contact *i*, thereby to more effectually prevent false signals on

sounder *s* due to a momentarily prolonged contact of the lever of A or B on the back stop.

It may be seen by reference to Fig. 183a that when, for instance, the armature lever of A is on its back stop, the magnet *o* is magnetized by the local battery of *n*, and that when the lever of B is on its back contact point *n* is magnetized by the local battery of *o*. The object of using these extra magnets is to obtain a practically uniform forward pull upon the armatures of the relays at the times when but one or when both of the relays are in operation, for it is well known that successive pulsations of one polarity more fully charge the line and magnetize the cores of a relay than do rapid alternate positive and negative pulsations of current, and in this system, if this effect were not guarded against, signals varying in strength, or wavering, would result (see page 288). The effect of the operation of the extra magnets is to weaken the forward movement of the armature when but one relay is working. For example, if relay A, which we will say is responsive to key *k*, and thus to positive pulsations of current, is in operation alone, its forward movements will be weakened by the backward pull of *n*, whose local circuit is then closed at the back contact of B; and if B alone were in operation its forward movements would be weakened by the backward pull of *o*, whose local circuit is then closed at the back contact of A. When, on the other hand, both relays are responding to pulsations, namely, when both keys *k*, *k'* are closed, and in consequence their armatures are in rapid vibration, the time of contact on the back contact is so slight, the extra magnets *n o* as well as the repeating sounders remain inoperative, as mentioned in connection with the Sieurs diplex, page 266a. The purpose in sending weak currents to line when either transmitter is open is also to maintain approximately the same forward pull upon the armatures whether either or both of the relays are in operation, a weak positive current following a strong negative current, or vice versa, tending to accomplish the desired object. since by so much it clears out the previous charge (see double current, page 288).

The employment of these devices has been found to have a steadying effect upon the relays.

The coils of the relays A B are connected in multiple, there being two coils of 300 ohms each, thus giving a joint resistance of 150 ohms for the main and artificial line coils (*see* multiple wound relays, page 317).

It may be noted that by adding additional rings on the shaft of N S other Roberson quadruplex sets could be supplied with current from this machine.*

To BALANCE THE ROBERSON QUADRUPLEX—Mr. Roberson gives the following as the best method of balancing this system. The balance may be made with either relay, but as the rheostat and condensers are on the "A" side, that side is generally used for balancing. First, request the distant station to open both keys, which places the line to ground through the resistance o' and the lamps or fuses. Then open both of your keys, after which turn down the spring of A relay till the lever stays on either the front or back stop, or until it vibrates, by the line induction or weak distant pulsations between them. Then throw the 3-point switch sw to the left, which places a battery or dynamo D C, furnishing direct current of say 320 volts to the line. If the line is out of balance the armature of relay will now be attracted. Adjust the rheostat R in the artificial line l , as in the case of the Stearns condenser or the Edison quadruplex, until the armature remains on either front or back stop as before. Now throw the 3-point switch back to its left-hand point, and pull up a little on the retractile spring of the relay, until the lever rests lightly on its back contact point. Then close both your keys $k k'$, which puts alternations of full strength to line. If now the armature of relay is affected it shows that the static balance is out. Therefore now adjust the condenser or condensers c'' (if there are more than one) and the amount of resistance in the "retarding" coils r' until the lever stays on its back contact. Slight variations in the condenser or resistance will sometimes effect this result. Then have the distant station close his B transmitter and write on A transmitter, and adjust your A relay until the signals arrive satisfactorily. Then have him open transmitter A and write on B, when, if signals are not as clear as before, adjust the extra magnet on your A relay until signals are satisfactory. An adjusting screw practically similar to that used on the Morse relay (Fig. 44) is provided on the extra magnets for this purpose. If signals are light, screw the magnets back; if heavy, forward. Then, if necessary, do same on B side, but changes on that side of this quadruplex are not often required.

When signals fail to come properly after a careful balance has been taken, it is advisable to examine contact points of transmitters to see that they are in order; test line wire, apparatus, etc., as in case of the Edison quadruplex. The apparatus may be entirely disconnected from the dynamo by throwing a switch, similar to C S in Fig. 180, to the right, which switch is arranged on the desk for this purpose.

* A device shown in theory in Fig. 183c at left of Fig. 183a, has recently been introduced, whereby the alternating generator N S, Fig. 183a, is replaced by a commutating ring R, and brushes b, b', c , giving currents of different polarity from direct current machines, indicated by D, D'. Ring R is on shaft κ which is rotated by a motor. A segment s on one side of the surface of R is insulated, as shown. The brushes $b b'$ are so placed that while one is on the insulated surface s , the other is on the conducting surface s' of the ring. Brush c connected to line is always on the conducting surface of the ring. Consequently, when brush b is on s' , and transmitter m is closed, positive pulsations pass to line. When brush b' is on s' and transmitter m' is closed, negative pulsations pass to line; when m and m' are closed, alternations of polarity go to line; when m and n are open the line is grounded, etc., all practically as already described.

BRITISH POST-OFFICE QUADRUPLIX.

The quadruplex employed on the lines of the British Post-office telegraph is shown theoretically in Fig. 183c. This quadruplex is similar in principle to the Edison quadruplex, the only difference being in the construction of the transmitting and receiving apparatus. The pole-changer and transmitter, or reversing key RK, and increment key IK, as these instruments are respectively termed in Great Britain, correspond to the pole-changers and transmitters used here in battery-key systems except that they are operated manually by the Morse operator. The reversing key RK is shown in end view for clearness; the increment key IK in side view; the necessary contact points being carried on the end of the lever of the respective instruments as shown. (See Fig. 160, for example.) The tension contact pieces $a a$ and $a' a'$ of RK are metallically connected as indicated. The cross-piece $E L$ is insulated in the

FIG. 183c.

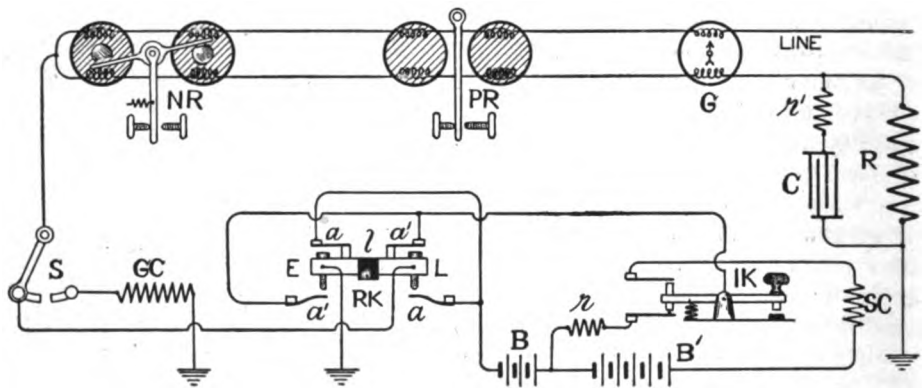

middle as outlined. E is connected to earth and L to line. It will be seen that as the lever l of RK is opened and closed, the entire battery $B B'$, or the short end B only, will be reversed, depending upon the position of the increment key IK. When IK is open, as in the figure, only the small end of the battery is to line; when closed, the entire battery, all in the manner described in detail in connection with Figs. 160, 161, 162. S is the usual 3-point switch for putting the line to ground for a balance, etc. SC is a spark coil of 100 ohms inserted to avoid sparking at contact points when the full battery is in use. GC is the ground coil, with a resistance equal to the entire battery and SC . r is a resistance in the tap wire, made equal to the resistances of SC and the long end B' of the battery, to preserve the balance when IK is open. NR is a differentially wound neutral relay of the construction indicated. PR is a differentially wound polarized relay. Each coil of these relays is wound to 200 ohms. G is a differentially wound galvanometer used as in the Wheatstone automatic system for line balancing, etc. R is the usual rheostat or artificial line resistance employed to "balance" the main line. C is the static compensating condenser, r' the condenser retarding resistance. The armature levers of PR and NR operate reading and repeating sounders in virtually the manner shown in detail in Fig. 163. The polar side of the system is termed the A side; the increment side, the B side.

When this quadruplex is used for repeating from one line to another, apparatus corresponding to that used in this country is employed, namely, a pole-changer and transmitter operated by their electromagnets and keys in local circuits. (See T and PC, Fig. 163.)

CHAPTER XIII.

DUPLEX AND QUADRUPLEX REPEATERS.

Although automatic repeaters of the class described are still much used in the telegraph service in this country, their employment has been largely circumscribed by the introduction of duplex and quadruplex systems, which latter, while also re-

FIG. 184.

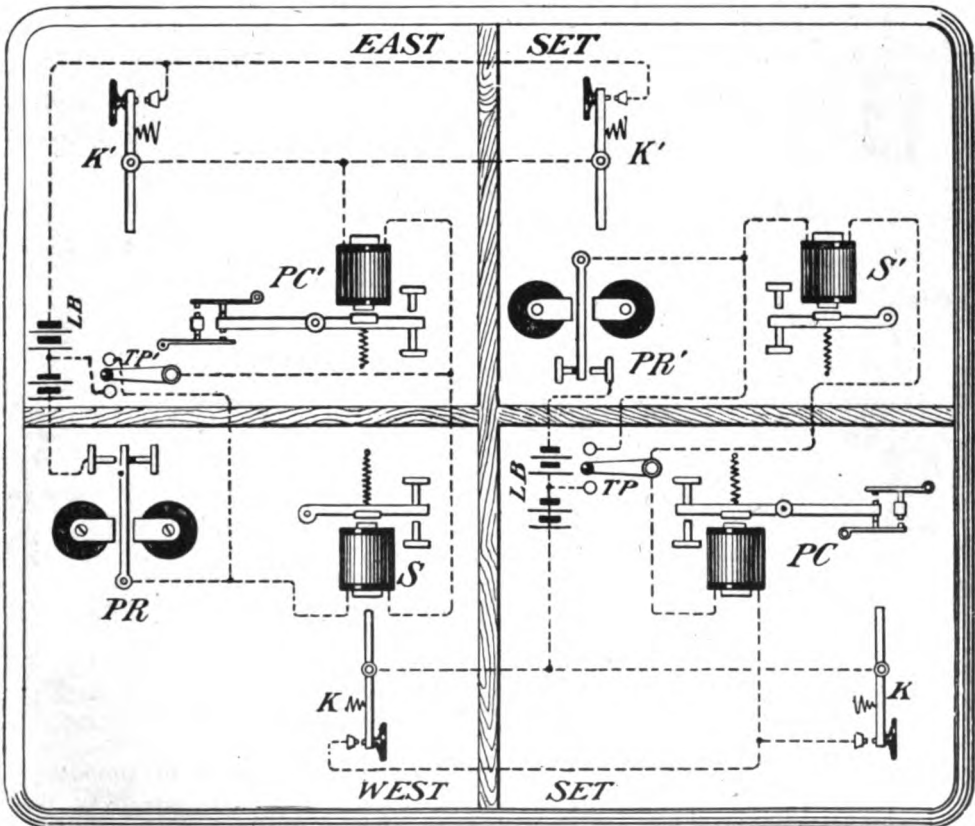

DUPLEX REPEATERS ARRANGED ON QUARTETTE TABLE.

peating automatically from one wire into another, operate in a more direct and simple manner than do the "single" wire, automatic repeaters.

This is explained by the fact that in duplex telegraphy the result is practically the same as though two single wires were used, one to send and the other to receive by continuously, and as if, when "breaking" is necessary, it should be done on the sending wire only. In such a case it is easy to understand that, at a repeating station, the relays of each wire could be made to operate a transmitter controlling the battery of another line. This, virtually, is what is done by duplex repeaters, as will be seen by reference to Fig. 184, in which PR' and PC' represent the polar relay and pole-changer, respectively, of one duplex set, at a repeating station; PR and PC represent similar instruments of another set at the same station, as generally arranged on a "quartette" table.

It is assumed that PR' and PC' are the terminal instruments of a duplex, working, say, east, and PR and PC similar instruments of a duplex, working, west, from the

FIG. 185.

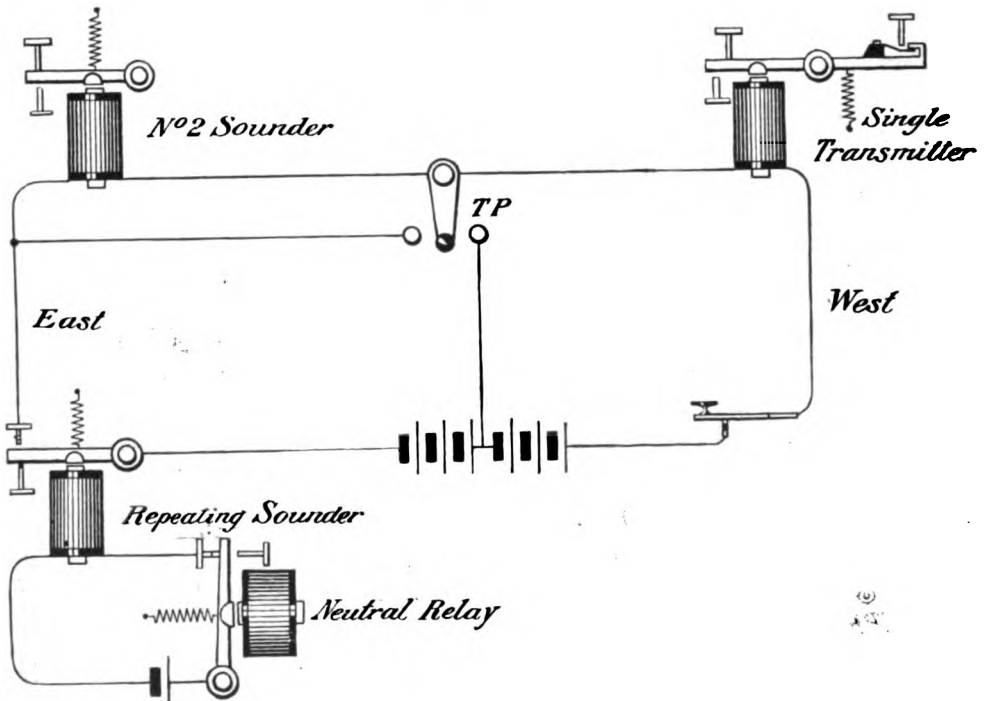

NO. 2 SIDE OF QUAD. REPEATING INTO QUAD. TRANSMITTER OF ANOTHER SET.

repeating station. The duplex connections are omitted for the sake of simplicity. Polar relay PR' by means of its armature lever has control of the local circuit of the pole-changer PC ; polar relay PR of the western set, has similar control of the pole-changer PC' , of the eastern set. By this means whatever signals are received on the respective relays are repeated by the respective pole-changers. When it is desired to increase the current in the pole-changer coils, the 3-point switch, TP or TP' , is turned to the left, which action diminishes the resistance of the local circuit by cutting

out the local sounder. When it is desired to separate the eastern and western sets the 3-point switches are turned to the right, which gives each pole-changer and polar relay an independent local battery.

A key is shown on each corner of the table. The key on the polar relay corners is placed there to afford the receiving operator facilities for breaking when the sets are not used as repeaters. Of course the keys are closed when working through.

It is plain that the No. 2, or "neutral" side of a quadruplex may be arranged in the same general way, for repeating, the only difference being that the contact points of the repeating sounder, instead of those of the neutral relay, are made the direct means of operating the "opposite" single transmitter. This is shown in Fig. 185, which, in view of what has been described, will not require further explanation.

When it is required to repeat from one quadruplex circuit into another, as, for instance, in the case of such circuits as those between New York and Chicago, the

Fig. 186.

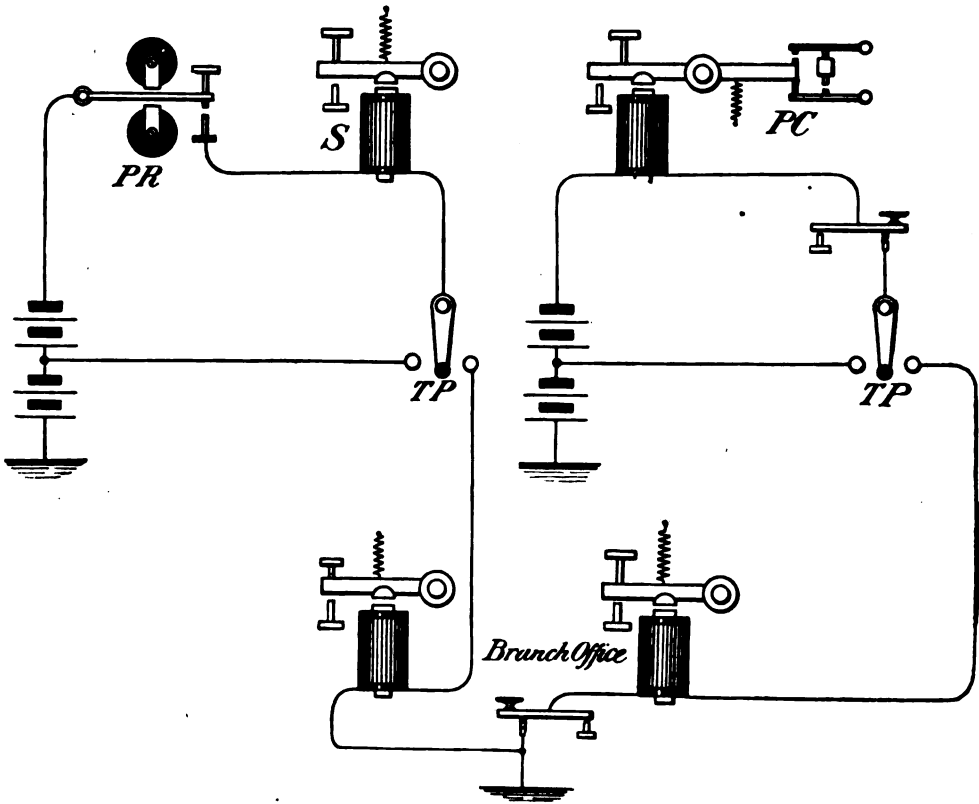

EXTENSION OF DUPLEX OR QUAD. LOCALS TO BRANCH OFFICE.

first side of each "quad" set is caused to repeat into the first or into the second side of the other set, according to the wishes of the "powers that be." There has been

some difference of opinion as to which is the better plan. It is well known that the polar side of a quadruplex has a higher working efficiency than the second side, especially in stormy weather. It has, therefore, in some cases, been assumed that, this being the case, if the good and the inferior sides of the system were interchanged at the repeating station, a better average result would be obtained. While this reasoning has seemed plausible, experience has convinced the writer, at least, that, on the whole, more satisfactory results are secured by repeating from the first into the first side and from the second into the second side, in all cases. For these reasons: that, in good weather, both sides generally work satisfactorily, and, in stormy weather, the first side works tolerably, well, while the second side, as a rule, does not. Therefore, by working the sides "straight," at the repeating station, one good duplex is reasonably assured, and, possibly, also one mediocre duplex, while, by interchanging the sides at the repeating station, the result, in stormy weather is, generally, two very indifferent duplexes.

EXTENDED LOCALS.—It is frequently desirable to extend the local connections of a duplex, or one side of a quadruplex set, to a branch office.

This is done, as shown in Fig. 186, by simply continuing the local wires to the branch office. Additional battery is employed to compensate for the increased length of wire and the added instruments.

The wires extending to the branch offices are termed a "loop," and the separate wires of the "loop" are known as the sending and receiving "leg" of the loop. When the 3-point switches, TP, are turned to the right, the "legs" are thrown on to the duplex or quad instruments, and are cut off therefrom when the switch is turned to the left. This still leaves a local battery for the duplex instruments. In the figure the instruments are shown idle.

The connections for this arrangement are shown and explained more in detail under the subject of "Loop Switches."

QUADRUPLEX—SHORT WIRE AUTOMATIC REPEATERS.

Sometimes it is not necessary to have more than one "leg" from one side of a quadruplex set to a branch office, as when one side of a quadruplex is leased to a broker who never uses the wire but one way at a time.

When this is the case it is evident that some means of keeping the transmitter closed, or inoperative, when the distant station is sending to the branch office, must be devised. This service can be performed by one-half of any of the ordinary automatic repeaters. It was first done, the writer thinks, by Mr. D. R. Downer, as shown in Fig. 187.

THE DOWNER QUADRUPLEX—SHORT WIRE REPEATER.

In this figure, PC, is the pole-changer; PR the polarized relay of a quadruplex set; RT is a repeating transmitter. When the 3-point switch TP is turned to the right the circuits are arranged for the working of the quadruplex instruments into the branch office.

In the figure the local contact of the polar relay is closed. This closes the circuit passing through the magnet of the pole-changer and the tongue *x* and post *P* of the transmitter *RT*, to the branch office. Should the distant station open his pole-changer, thereby opening the polar relay *PR*, it will open the repeating transmitter, which opens the branch office circuit at *x*. Just as this occurs, however, a local circuit is formed via the tongue and lever of the repeating transmitter and a small portion of the battery *B*, to and through the pole-changer magnet, keeping the pole-changer closed; this forming the automatic feature of the device. Otherwise the distant station would get his own writing back. The branch office operates the pole-changer by simply manipulating his key, which, of course, opens and closes the bat-

FIG. 187.

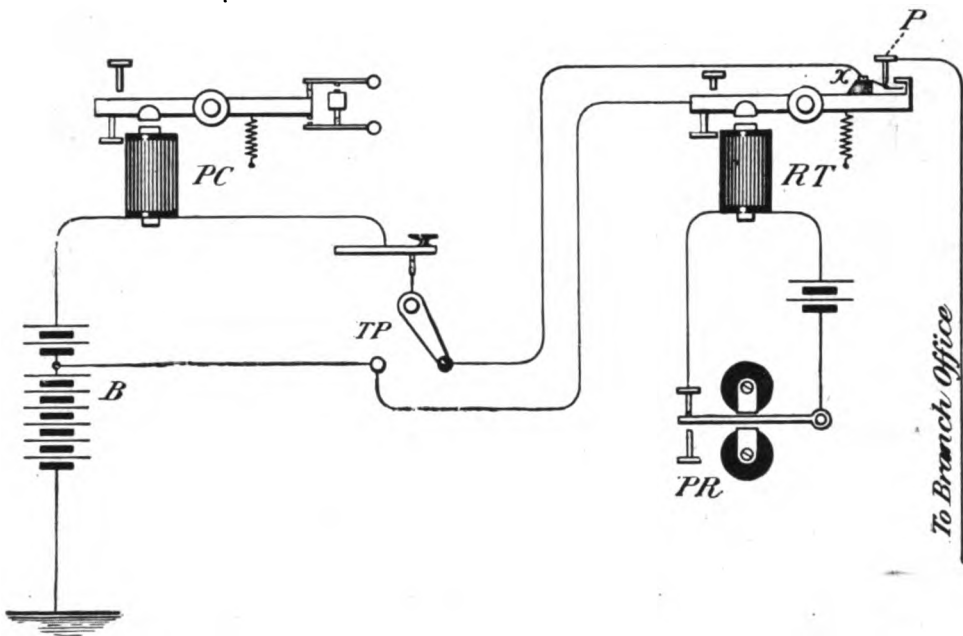

DOWNER QUADRUPLEX—SHORT-WIRE REPEATERS.

tery *B*. The "Downer" arrangement is generally employed on the Western Union Company's lines for short circuits.

THE GARDANIER QUADRUPLEX SHORT WIRE REPEATER.

A modification of this arrangement, known as the Gardanier arrangement, shown in Fig. 188, was much used on the lines of the Baltimore and Ohio Telegraph Company. The operation of this arrangement is easily understood. The larger portion *E* of the loop battery *B* and local battery *LB* unite to operate the pole-changer and the branch office instruments. The pole-changer is kept

closed automatically, when the polar relay is open, as in the figure, by a short circuit and the local battery, LB, through the lever and tongue of the repeating transmitter. The branch office operates the pole-changer when RT is closed; the same way as in the "Downer" arrangement.

"EMERGENCY" QUADRUPLEX-SHORT WIRE REPEATER.

The "Toye" repeating principle is frequently used as a means of utilizing one wire from one side of a quadruplex or a duplex, to a branch office.

FIG. 188.

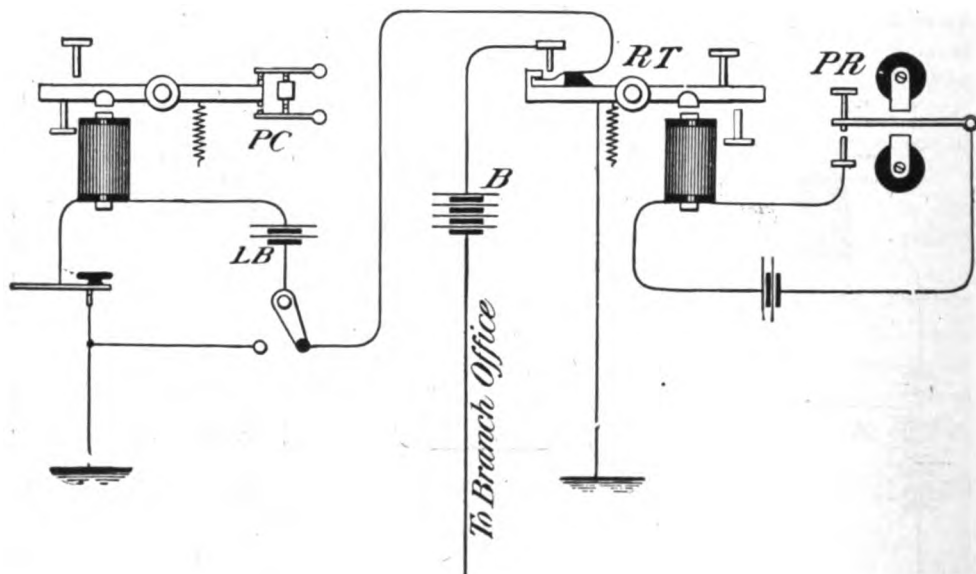

GARDANIER QUADRUPLEX-SHORT-WIRE REPEATER.

It is, perhaps, more especially used for this purpose in emergencies, as when, for instance, one of the legs of a two-wire loop connection, from a duplex to a branch office, gets into trouble. In such a case, unless a repeating arrangement is put in at the main office, the perfect leg, and, consequently, so far as the branch office is concerned, the entire duplex must remain idle until the defective leg is repaired.

Since this emergency occurs quite often a diagram illustrating the arrangement may be of use.

In Fig. 189 the necessary connections are shown.

The defective short wire, in this case the receiving leg, is indicated as open, or "thrown out," at the 3-point switch, TP. The dotted lines represent the temporary wires used in making the connections. The sounder, s, may be cut out of the circuit, if desired, by connecting the temporary wire to the left hand screw post, instead of the right hand one, as indicated. The wire w' is disconnected from the pole-changer and is connected to the temporary wire leading to the post of repeating trans-

mitter, RT. A wire is run also from the lever of RT to the rheostat, and thence to ground, and the polar relay is given control of the repeating transmitter, RT, in the manner shown. It will thus be seen that all the apparatus necessary to effect this temporary repeating arrangement is a spare single transmitter, five or six pieces of wire, and, for convenience in joining up, two thumb screws, and a rheostat. Sometimes the rheostat is dispensed with and in that case the wire from the lever of RT is

FIG. 189.

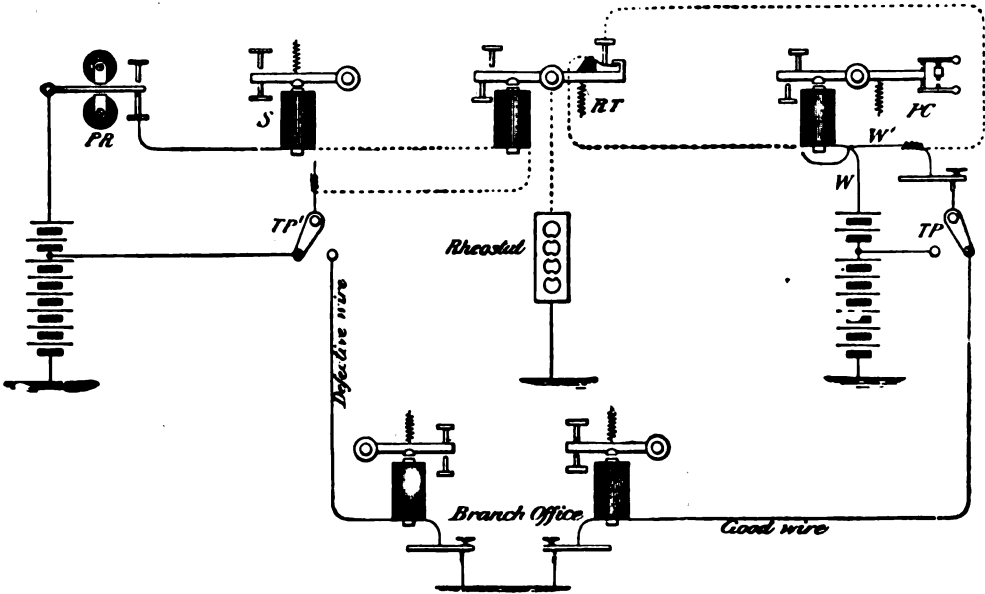

MOFFAT TEMPORARY REPEATER FROM DUPLEX OR QUAD. TO BRANCH OFFICE.

run directly to ground. As this arrangement can be put into operation by an expert in one or two minutes its value, in point of time saved, is apparent. This expedient is due to Mr. J. M. Moffatt. When the sending leg is in trouble the connections may be made as shown in Fig. 190.

The connections in Figs. 189 and 190 are given on the assumption that the battery wires, etc., are led to the various points assigned. If not, it will be necessary to change the connections to suit each case, which is a simple matter when the general plan is understood.

MULTIPLE QUADRUPLEX—SHORT WIRE REPEATERS.

Sometimes it happens that wire facilities would be increased were it feasible to repeat from two or more quadruplex sets into the same branch office at an intermediate station; or even to repeat from one side of a quad, to two or more sides of different quads, at a main or repeating office. To make this remark clearer an instance that occurred in actual practice may be stated. There were at Indianapolis, Ind., three quad sets—one to Chicago, one to St. Louis and one to Cincinnati. It was

desired to give a lessee direct communication from Chicago to Indianapolis, St. Louis and Cincinnati, using for the purpose one side of each of the above mentioned quad circuits, and it was necessary that each of those offices should be able to communicate with each other, exactly as though all the offices were on a single wire.

An arrangement devised by the writer to meet those requirements is to be seen in Fig. 191. All of the instruments and battery shown in the figure are supposed to be located in the main repeating office, except, of course, the loop, or branch wire, instruments at that point.

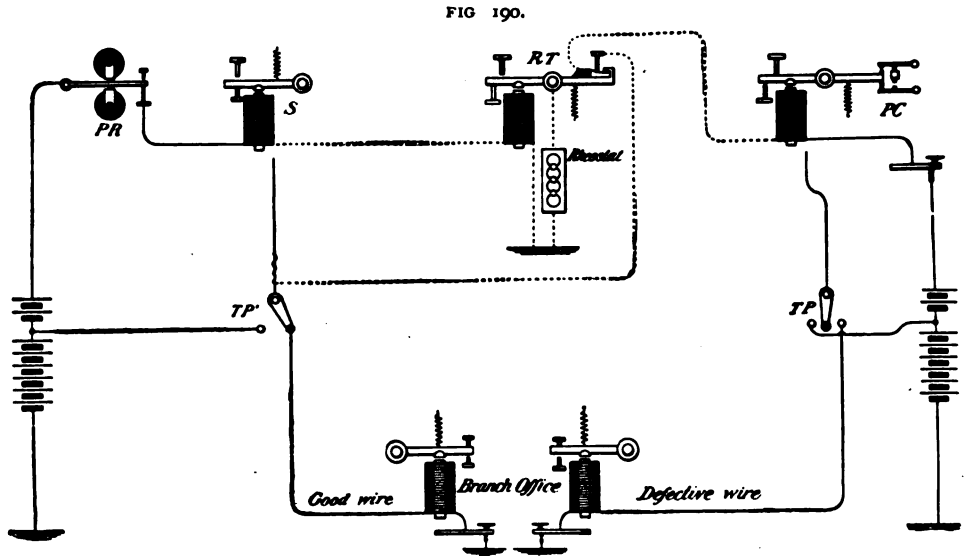

The first sides of the quads are supposed to be used in this instance, consequently the pole-changers PC^1 , PC^2 , PC^3 , and polar relays PR^1 , PR^2 , PR^3 , of the respective sets, only, are shown. In each case the polar relay controls a repeating transmitter RT^1 , RT^2 , RT^3 . In the figure, the polar relays being closed, the repeating transmitters are in the position indicated, and it will thus be seen that if the key at the branch office be operated, it will operate all of the pole-changers, since the loop or wire to the branch office passes also through the magnet of the pole-changers. On the other hand, should the operator, at Cincinnati for instance, desire to send to all of the other offices he may do so by operating his pole-changer which actuates PR^2 at Indianapolis. In turn PR^2 operates its repeating transmitter. This latter instrument, in opening, will open, at the point x , the circuit passing through pole-changer magnets PC^1 and PC^3 and to the branch office. The pole-changer PC^2 of the Cincinnati set is not opened, however, as, at the moment the repeating transmitter RT starts to open, a local circuit via the lever of RT^2 , including the local battery LB^2 , comes into play, and thus, automatically, keeps the magnet of PC^2 closed. The local batteries LB^1 , LB^2 , LB^3 are arranged so that they coincide with and assist the loop, or single wire, battery, when this wire is closed. It will be seen by a casual observation that, in the same way,

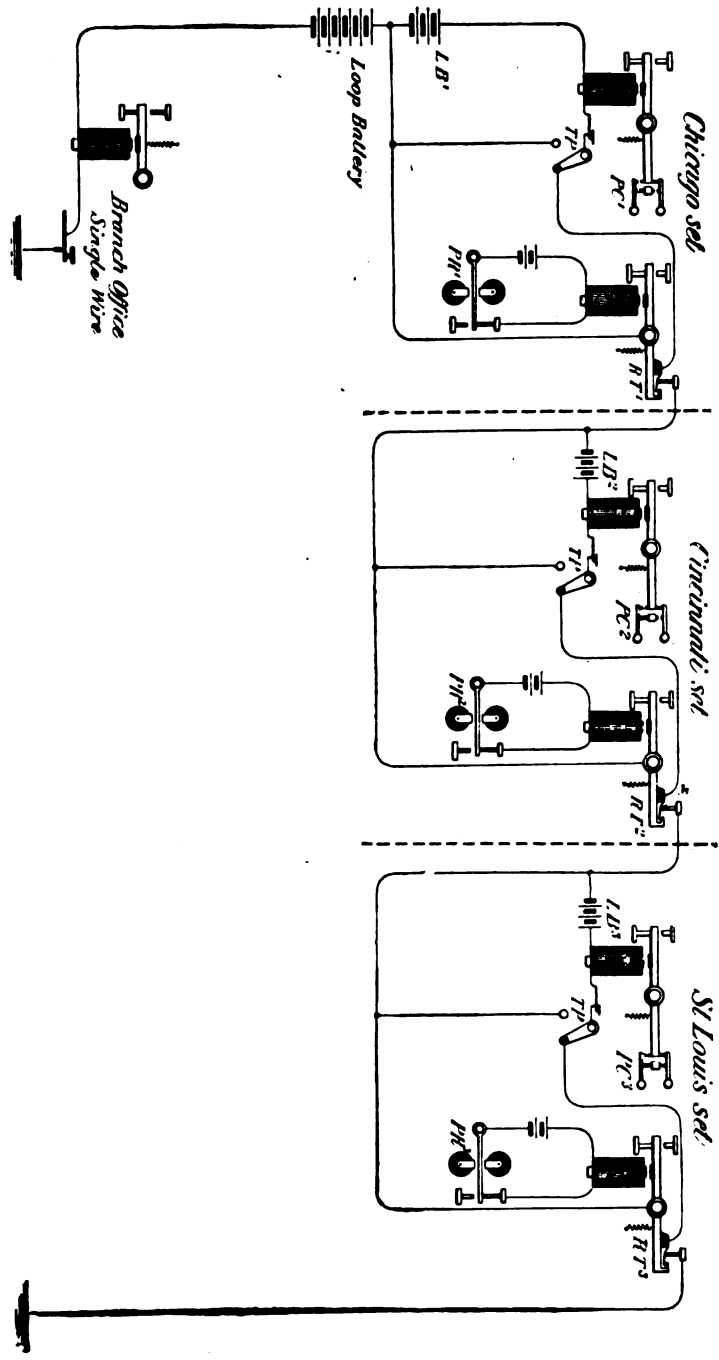

FIG. 191.—THE MAVER MULTIPLE QUADRUPLEX.—SHORT OR SINGLE WIRE REPEATER.

both the Chicago and the St. Louis sets have, through their polar relays, similar control of their respective repeating transmitters, and that each pole-changer is, at the proper time, kept closed, automatically, by its local battery, acting through the lever of its repeating transmitter.

When it is not desired to use the quad sets as repeaters, the simple turning of the 3-point switches TP to the left will separate the sets, and the repeating transmitters may then be used as sounders. It is plain that the number of quad sets brought together in this way is not limited to the number shown, and that more single wires could be looped in the series by the use of repeating relays, similar to R in Fig. 193 or 194, to operate the pole-changers or transmitters; it being understood that the introduction of single wires would unduly weaken the current so far as the operation of the local magnets of the pole-changers is concerned. Of course, the main and local batteries would have to be increased if additional wires were placed in circuit. An advantage of this arrangement is that, when any one of the quadruplex or single wire circuits in the series is operated, every other circuit hears the signals and thus there is no "breaking" in upon each other, unintentionally.

QUADRUPLIX-SINGLE WIRE AUTOMATIC REPEATERS.

One of the important advantages of the quadruplex is the use to which it can be put between points where there is a scarcity of wires. For example. Between New York and Albany there is a large demand for wires. There exists beyond Albany a large number of medium sized towns and cities which do a fair amount of business with New York, sufficient to warrant the assignment of a wire between those points and the latter city. In order to meet the demand for facilities between the cities named, many of the wires between them are quadruplexed and one or both sides of the quadruplex are operated into a single wire, or wires, west, north or east of Albany. To permit this, a repeating arrangement is necessary, as in the case of the combination of one side of a quadruplex and a branch or short wire, and, in fact, the main difference between them is, that, on the longer circuits, a relay has to be used to operate the pole-changer or single transmitter, as the case may be.

THE EDWARDS SINGLE WIRE-QUADRUPLIX REPEATING ARRANGEMENT.

It is evident that, as in the quadruplex-short wire repeating arrangements, the one-half of any of the successful repeaters is applicable to the single wire quadruplex single wire repeating arrangements. In Fig. 192 the "Edwards" repeater is shown adapted to this purpose. PC and PR are the pole-changer and polar relay, respectively, of the first side of a quadruplex. RT is a repeating transmitter and R is a main line relay. The main line relay is used to operate the pole-changer, instead of having the main line pass directly through the magnet of the pole-changer, because of the large amount of current required to operate the latter instrument, namely, about one-quarter of an ampere, as against about four one-hundredths of an ampere; that is, 40

milliamperes, required by the Morse relay. The operation of this arrangement is as follows:

The polar relay operates the repeating transmitter, which opens and closes the single wire at *x*. This, of course, also operates the relay *R* in the single wire circuit, but the pole-changer is prevented from opening in response to the break of its local circuit at the contact point *c* of relay *R*, by the formation of an extra local circuit, 1, 2, 3, 4, 5, 6, around the said contact points, via the lever of *RT*, at the moment when the main line is opened at *x*. When the single wire is operated from an outside point the polar relay is not affected, and, consequently, *RT* remains closed. This leaves the extra local circuit 1, 2, 3, 4, 5, 6 open at *B*. As the relay *R* is operated by the opening and closing of the single wire, consequently, the armature lever of that relay

FIG. 192.

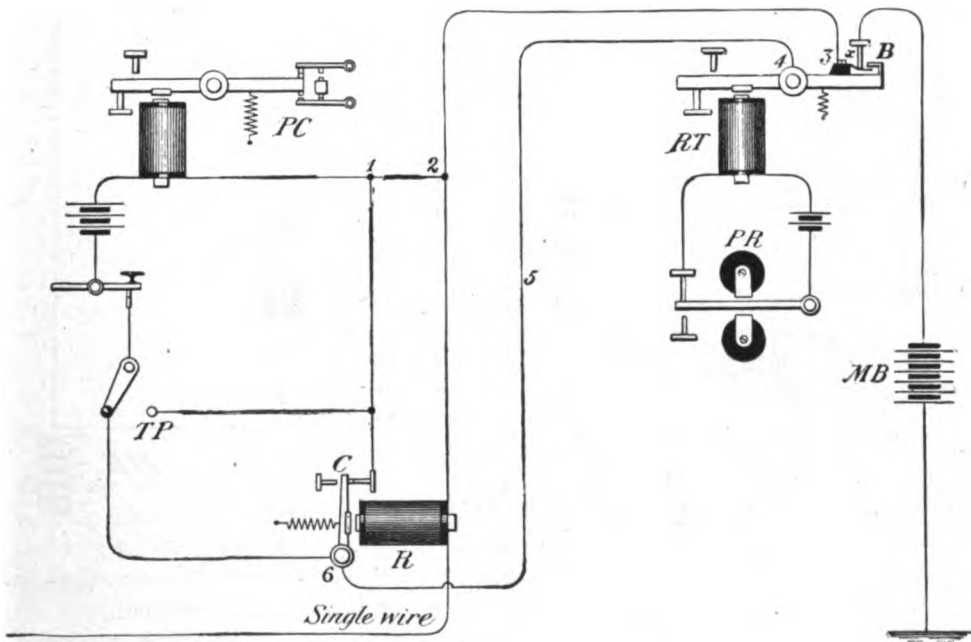

EDWARD'S QUADRUPLIX-SINGLE WIRE REPEATER.

operates the pole-changer, by opening and closing its local circuit, in accordance with the signals transmitted. The 3-point switch is used to cut off the relay *R* when the attendant at repeating station wishes to communicate with a distant end of the quadruplex circuit.

THE WATERBURY QUADRUPLIX-SINGLE WIRE AUTOMATIC REPEATER.

This arrangement, Fig. 193, like a number of other repeaters, goes by several different names, one of which is the McPherson.

It performs its allotted work in the following manner:

As in the repeater just described, when the quadruplex is sending to the single wire, the polar relay *PR* operates the repeating transmitter *RT*. This operates the single

wire by opening and closing it at the point *x* of the transmitter. This cuts off and cuts in the main battery, *MB*. The smaller battery *LB* in the local circuit, formed by the wires 1, 2 and the lever of *RT*, keeps the relay closed during the time that *RT* is open. When the single wire sends to the quadruplex, the polar relay being closed, so is *RT*, and, hence, the circuit via wire 1, 2 and the lever of *RT*, is open, and the relay *R* responds to the signals sent over the single wire, and its armature controlling the local circuit of the pole-changer, repeats the signals over the quadruplex circuit.

This arrangement has the disadvantage, in stormy weather, that, owing to increase of current through the relay *R*, due to the escapes on the line, the tension on

FIG. 193.

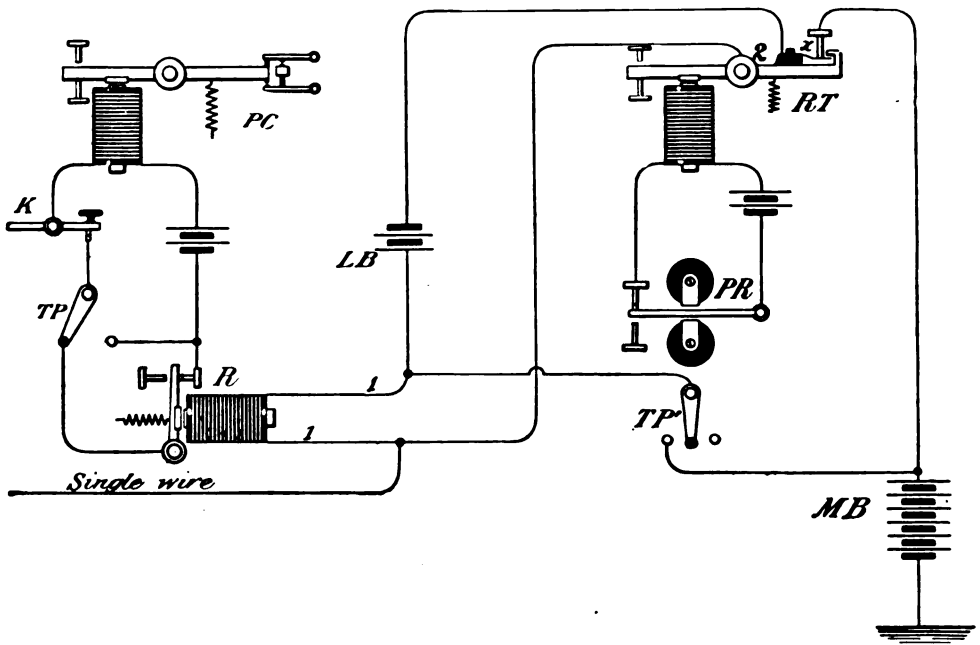

WATERBURY REPEATER.

the spring of its armature is so much increased that it is often beyond the current strength, due to the extra battery, *LB*, to keep the armature closed, when the polar relay opens. To remedy this the extra battery must be increased. Care should be taken to observe that this extra battery is connected up to coincide in polarity with the main battery, or a false signal will be occasioned.

It is, of course, obvious that the occasions are rare when it will be desirable to repeat from a duplex into a single wire, inasmuch as the addition of the single wire to the duplex reduces the capacity of the duplex to that of a single wire. It is, however, possible that occasions may arise when such a combination may be of use, as, for instance, when the business at a repeating office with the office at the other ter-

terminal of the duplex circuit may not be sufficient to warrant the assignment of a special wire between those offices. In that case it is practicable for the terminal stations of the duplex to utilize the duplex during the time that the "single wire" station, or stations, may be sending to, or receiving from, the distant terminal station of the duplex system.

It is rendered practicable by turning the 3-point switch TP, Fig. 193, to the right, when the duplex is sending to the single wire, at which time the repeating station may "receive" from the distant duplex station, and by turning the 3-point switch

FIG. 194.

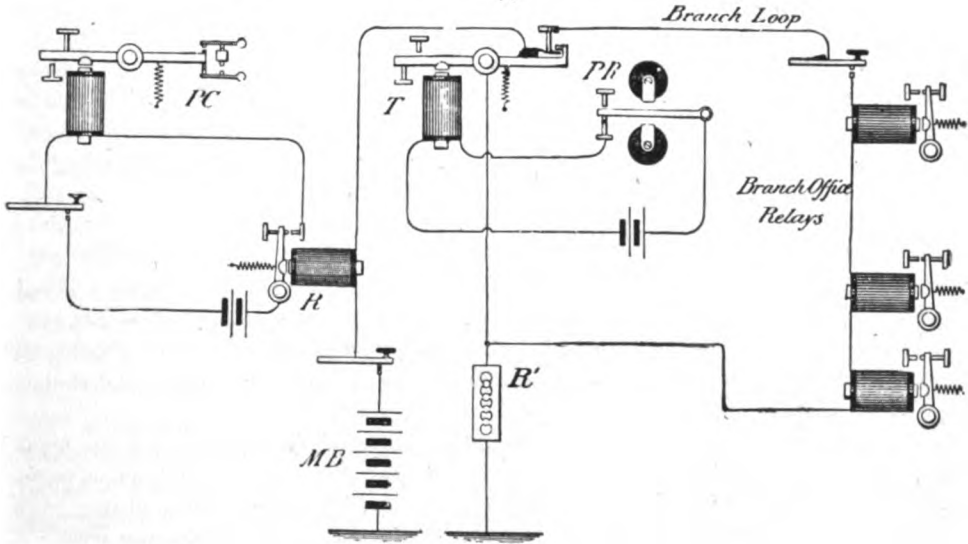

ARRANGEMENT FOR CONVERTING SHORT WIRE INTO MAIN LINE WIRE.

TP' to the left, when the single wire is sending to the duplex, at which times the repeating station may "send" to the distant duplex station. In the latter case the 3-point switch TP' cuts out the points of the repeating transmitter and, thereby, prevents the movement of the lever of that instrument from operating the single wire during the time that the latter is sending to the duplex station. In the former case the 3-point switch TP cuts out the contact points of the relay, with an analogous result.

It is clear that the same device may be made use of in the case of the combination of one side of a quadruplex and a single wire. As a matter of fact this device has been used repeatedly in the past to good advantage. One of the chief difficulties of the plan is that the operator at the intermediate station is apt to leave the 3-point switches out of position for the terminal stations.

ARRANGMENT FOR CONVERTING A SHORT WIRE INTO A "MAIN" LINE WIRE.

It is, at times, desirable to put a number of branch offices on one branch circuit, or loop, in connection with a duplex or one side of a quadruplex. The writer has known as many as nine offices to be thus placed in connection with one side of a quadruplex. When the quad circuit is a long one and, especially if the No. 2 side is assigned for this purpose, much trouble is often experienced by the quadruplex attend-

ants at repeating stations in keeping the instruments adjusted to suit the various styles of the different senders on the loop circuit. To remedy this difficulty, as far as possible, the arrangement shown in Fig. 194 was devised by the writer and was found of considerable utility in practice. The arrangement virtually consists in transforming the "loop" circuit into a *main* line by the addition of resistance furnished by the rheostat R' . The sounders in the branch office are replaced by relays, and the loop battery, in the main office, by a main battery MB, and, instead of running the loop circuit through the coils of the pole-changer magnet, it is put through a relay, R, which latter is given control of PC, as in the figure. The automatic repeating arrangement employed is, virtually, the "Toye." The rheostat R' , performs the double function of increasing the resistance of the loop and of keeping the relay R and, consequently, the pole-changer, closed, at the proper time. Should the number of relays in the loop be excessive, it would be advisable to use two rheostats, to avoid too great a variation in the resistance due to the cutting out of the relays in the loop circuit when the repeating transmitter is open, which variation might introduce a tendency to wavering in the repeating relay R. In the figure the apparatus is shown idle.

HINTS ON THE MANAGEMENT OF QUADRUPLIX—SINGLE WIRE REPEATERS.

To properly attend to repeaters of any kind or any telegraph apparatus, a small thin file for cleaning contact points is indispensable. Files for this purpose are procurable from many of the larger electrical supply companies. The file should be about $\frac{3}{4}$ inch thick, about $\frac{1}{4}$ inch wide, and from 2 to 2 $\frac{1}{2}$ inches in length, and should be provided with an insulating handle.

The attendant should see that all the contact points of the apparatus are in good order. Even if the dirt or oxide on a contact point has not become so thick as to be noticeable the circuit will, it may be taken for granted, work better without it.

One of the most common sources of trouble on quad-single wire repeating arrangements is that due to imperfect connections at the points of the repeating transmitter, caused by dusty contacts. This prevents the extra local battery, or other device, from holding the pole-changer or single transmitter closed during the operation of the polar relay or neutral relay, and if the single wire repeating device is in operation at both ends of the quad circuit, the result is that the single wire is opened. If the repeating device is only at one terminal of the quadruplex circuit the end remote therefrom gets his own writing back.

Other causes which may produce the same symptoms are those due to a weakening of the extra local battery; (or, what amounts to the same thing, an excess of strength of the "loop" battery and extra local combined, over that of the extra local alone), which may induce the attendant to increase the pull of the retractile spring of the quad pole-changer or transmitter when the branch office is sending; the consequence being that, when the polar relay operates the "repeating" transmitter, the pole changer also is operated, its strong retractile spring overcoming the pull of the magnetism developed by the extra "local" alone. This must be remedied by equalizing the strength of current passing through the pole-changer or transmitter in both positions of the repeating transmitter.

Still another cause which may give the sending operator at the distant end of

a quadruplex circuit his own writing back, is that of a stiff tongue on the quadruplex transmitter, combined with a weak extra local. This defect does not often occur, but it is sometimes puzzling when it does. The effect of such a combination is that the tongue of the transmitter will partly withdraw the armature from the magnet, until the tongue comes in contact with the bent-over end of the lever, when its power to further withdraw the lever will cease. This practically short-circuits the long end of the quadruplex battery, and thus by giving the operator at the sending end his own writing back, points to trouble in the points of the repeating transmitter. When the play is small on the quadruplex transmitter it is not at once detected that the lever is in motion.

DIRECT REPEATING RELAYS.—Of recent years the telegraph companies of this country have adopted on many of their long duplex circuits the direct polar relay arrangement, practically as described and illustrated in connection with the Wheatstone duplex repeater, page 308, Fig. 232. In the Western Union arrangement, as devised by Mr. J. C. Barclay, an extra lever is added to the relay armature. To this lever is attached a contact point controlling a local sounder, by means of which the nature of passing signals may be read. In the Postal Telegraph-Cable Company's arrangement of direct repeating relays for duplex circuits, the "leak" relay, as used in the Wheatstone duplex repeater, is employed for the purpose of ascertaining the nature of the repeated signals.

HIGH POTENTIAL LEAK DUPLEX.—When it is desired to operate a polar duplex set from a high potential dynamo, as is sometimes the case, the general principle of the Field dynamo key system for reducing the electromotive force at a given point may be availed of. (See page 218, 2d paragraph, and page 223, 4th paragraph.) In practice on the lines of the Postal Telegraph-Cable Company the added resistance employed is 800 ohms, which with 800 ohms resistance at the dynamo machine (consult Figs. 176 and 179) equals 1600 ohms. The leak resistance L is 2200 ohms. Assuming main line resistance ML and artificial line resistance AL to be 2200 ohms each, the joint resistance of L , ML , AL will be 733 ohms. Then calling the E.M.F. of dynamo machines 380 volts each, and with an added resistance of 800 ohms in circuit, the potential at J will be approximately 120 volts, for under these conditions the potential at J will have dropped $\frac{1600}{733}$ of 380 = 260, and 380 — 260 = 120 volts. With only 800 ohms resistance in circuit the E.M.F. at J will be about 182 volts, since in that case the potential at J will have dropped $\frac{800}{1633}$ of 380 = 198, and 380 — 198 = 182 volts.

In practice duplicate leaks and added resistances are interposed in the dynamo circuits between the dynamos and the contact points of the pole changer, instead of a single leak and added resistance as in the Field key system. A simple switching arrangement is provided for cutting out the added resistances and leaks when it is required to employ the entire E.M.F. of the dynamos.

CHAPTER XIV.

BRANCH OFFICE SIGNALING DEVICES.

In large cities where there are many branch offices, such as those of lessees of wires, etc., it is customary to "loop" in the branches from the main office; the charge and care of the line wire remaining in the hands of the main office.

In order to enable the branch offices to report wire trouble promptly, it has been found advisable to supply each office with an auxiliary short wire on which to communicate with the main office. The arrangement of the "short" wires has varied in different cities.

Several of these will be described presently, but the operation of a simple instrument used in connection therewith, namely, the buzzer, may first be explained.

THE BUZZER OR INTERRUPTER.—This is an ingenious device much employed to obtain a continuous vibration of the armature of an electro magnet, so long as a battery is permitted to act upon it. The principle of this arrangement is used in many systems of telegraphy.

The manner of its operation is as follows: In Fig. 195 *EM* is an electro magnet. *A*, is its armature, with contact on back stop. The front stop is insulated. *B* is a battery of any desired number of cells. The spring, *s*, naturally draws the armature, *A*, against the contact point, *CP*. The moment this occurs *EM* is magnetized, and attracts its armature. When this happens the circuit of *B* is broken, *EM* is demagnetized, and the spring draws the armature against its contact point again, thus closing the circuit. Again the *EM* is magnetized, attracts its armature, again breaking the circuit with the former result, and in this way the armature is maintained in vibration, causing it to set up a hum, or buzz—hence the name of "buzzer." Usually there is a push button or other contact point at some part of the circuit which keeps it open excepting when the button is

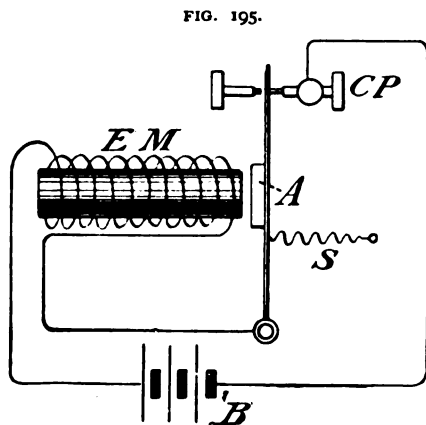

depressed.

Very frequently the armature is a part of, or is attached to, a tuning fork, or reed, in which case a spring is not needed, as the resiliency of the reed causes its withdrawal when the electro-magnet demagnetizes. In Fig. 196 is given an illustration of a "trembling" or "call" bell with buzzer connections. The armature, *A*, in this case, carries a flat, "tension" contact spring, which permits the retractile spring to be dispensed with.

NEW YORK BRANCH OFFICE "CALL" WIRE.

A branch office call wire arrangement is shown in Fig. 197. It consists of an ordinary metallic circuit with the branch offices BO, cut in.

A low resistance call bell, or buzzer, *CB*, (in a local circuit in the main office *MO*,) is controlled by the back contact of the lever of the sounder *s*, and operated by the local battery *b*, so that when either of the branch offices opens the circuit to report trouble, or for any other reason, the "buzzer" attracts the notice of the main office attendant. In the buzzer circuit is placed a key, *k'* which, when depressed, opens its circuit, thus enabling the attendant to clearly hear the message of the branch office.

By having the key thus arranged the bell circuit is not so likely to be left inoperative as it might be if an ordinary closing key were used to open the local circuit temporarily.

CHICAGO BRANCH OFFICE SIGNAL ARRANGEMENT.

This arrangement was used at one time in a Chicago main office, and is illustrated in Fig. 198.

At the main office *MO*, *k* is a switch or key with upper and lower contacts. When on its upper contact the call bell *CB* is in circuit. Normally the keys in the branch offices, *BO*, are open. When either of these keys is depressed the call bell, *CB*, is operated. The attendant at the main office hears the alarm and by depressing switch key *k*, he

FIG. 196.

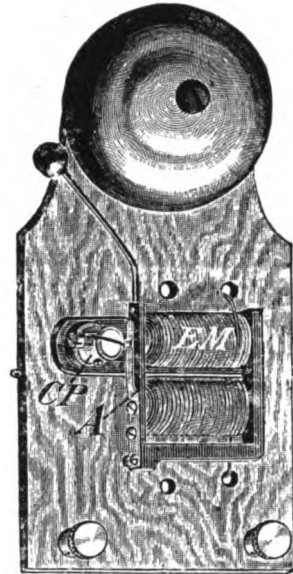
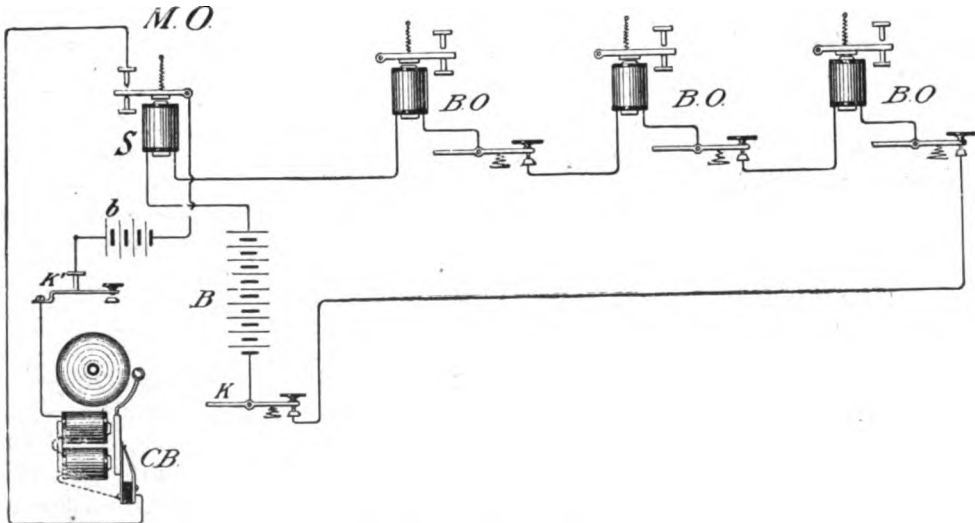

FIG. 197.



BRANCH OFFICE SIGNALING CIRCUIT.

opens the call bell circuit and throws his own sounder, *s*, and key, into circuit, by means of which he then communicates with the branch office. This arrangement has the ad-

vantage, if such it may be considered, that none but the main office can hear the remarks of the respective branch offices.

In the Western Union main office, New York, all of the single leased wire loops are brought into a spring-jack switch. Attendants at this switch are required to cut in

FIG. 198.

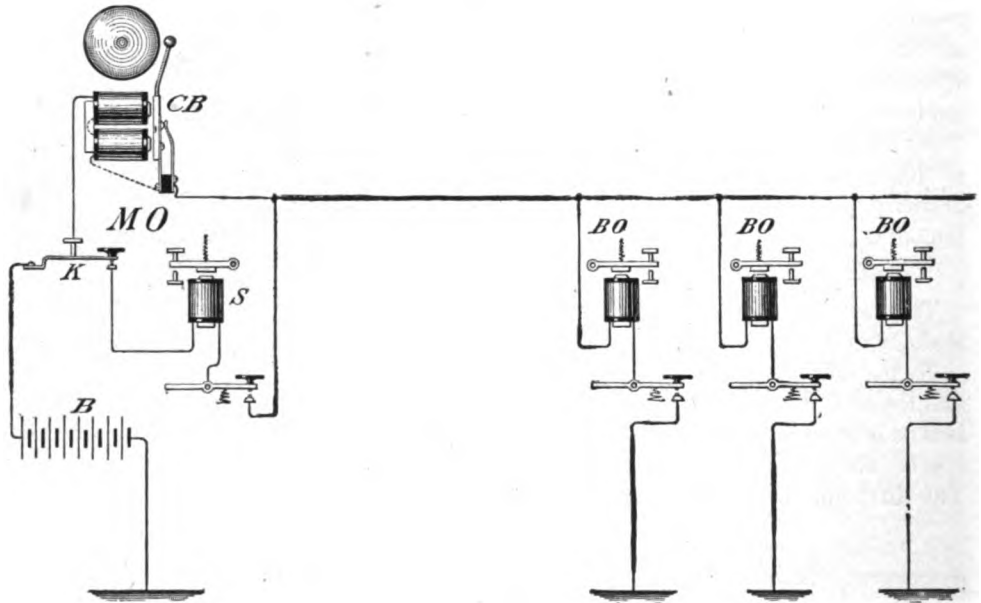

"CHICAGO" BRANCH OFFICE SIGNALING CIRCUIT.

a relay into each circuit at regular intervals to listen to the working of the wire, thereby to anticipate a complaint or "call" on the part of the branch office or lessee.

In addition to the foregoing measure to insure promptness in the detection of wire trouble, an alarm device is inserted in the branch office loop in the main office.

This device, due to Mr. J. B. Hurd, is shown in Fig. 199.

THE HURD BRANCH OFFICE CALL.

The branch offices are "looped" as indicated in the figure. MB is main battery in main office. A is a "drop" indicator of two or three ohms resistance. R, is the Morse relay in branch office. S' is its sounder. S, is a 3-point switch, the switch a, of which is connected to ground. Ordinarily, the current on the wire does not affect the drop indicator, A. When the branch office desires to attract the attention of the main office he throws switch a of S to the "ground" for a moment. This short-circuits the main battery through the coil of the indicator, the result of which is that its armature is attracted, releasing the drop. The name or call of the branch office is written on the indicator so

that, at a glance, the main office attendant can see which circuit requires attention. This device saves the time that would otherwise be consumed in answering the branch office to ascertain the identity of the caller. An electric bell is sometimes attached to

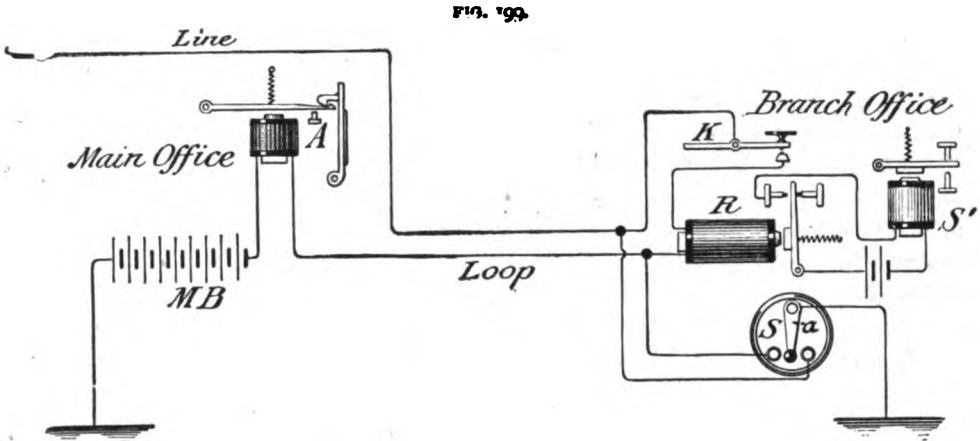

THE HURD BRANCH OFFICE CELL.

the drop to give an audible signal. By having the 3-point switch connected to both sides of the relay the cutting out of that instrument is insured in the event of a transposition of the sides of the loop in the main office. This device gives very satisfactory results.

CHAPTER XV.

LOOP SWITCHES.

The chief use of a loop switch is to facilitate the "switching" of loops and loop batteries, worked in connection with duplex and quadruplex sets.

Although the term "loop" would signify an unbroken wire from the main office to the branch office and return, and was and is so employed in such cases, it has adhered to the two short wires, or "legs," now employed in connecting a main office with a branch office from a duplex or one side of a quadruplex set; which "legs" are grounded at both the main and branch offices.

FIG. 200.

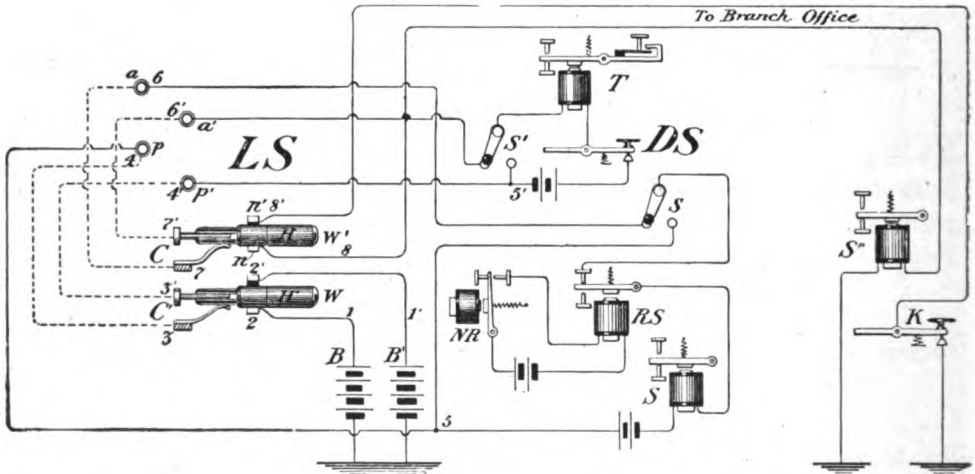

LOOP SWITCH CONNECTIONS.

In Fig. 200 a common form of loop switch and its connections are shown theoretically at L s.

The wires, binding screws, plugs, or wedges, connections, etc., for one duplex or quadruplex "loop," are outlined in the figure. The binding posts *a, a'* and *p, p'* are placed on the back of the board at L s. The binding posts and the spring-jacks are connected, behind the board, by wires represented by the dotted lines. The spring-jacks *c, c'*, project through to the front of the switch board, and are accessible for the insertion of the hollow plugs *w'* and *w*. These plugs, which are shown at their left ends in cross-section, in the figure, are of peculiar construction. They consist of an inner and an outer metallic tube, insulated from each other, as shown by the black line along a section of the tubes. The inner tube of each plug is connected to a small screw *n', 2'*; the outer tube to the small screw *n* and *2*. The small screws, *n', 2'*, do not touch the

outer tube, being insulated therefrom; nor do screws n, 2, come in contact with the inner tube. Thus, when the plug is inserted in a spring-jack, the inner tube is connected with a pin at 7' or 3', and the outer tube with the spring at 7 or 3. The handles n, n' of the plugs are made of insulating material.

The instruments to the right of the figure, at D S, are those of the No. 2 side of a quadruplex, the quadruplex main connections being omitted. T is the transmitter. NR

FIG. 201

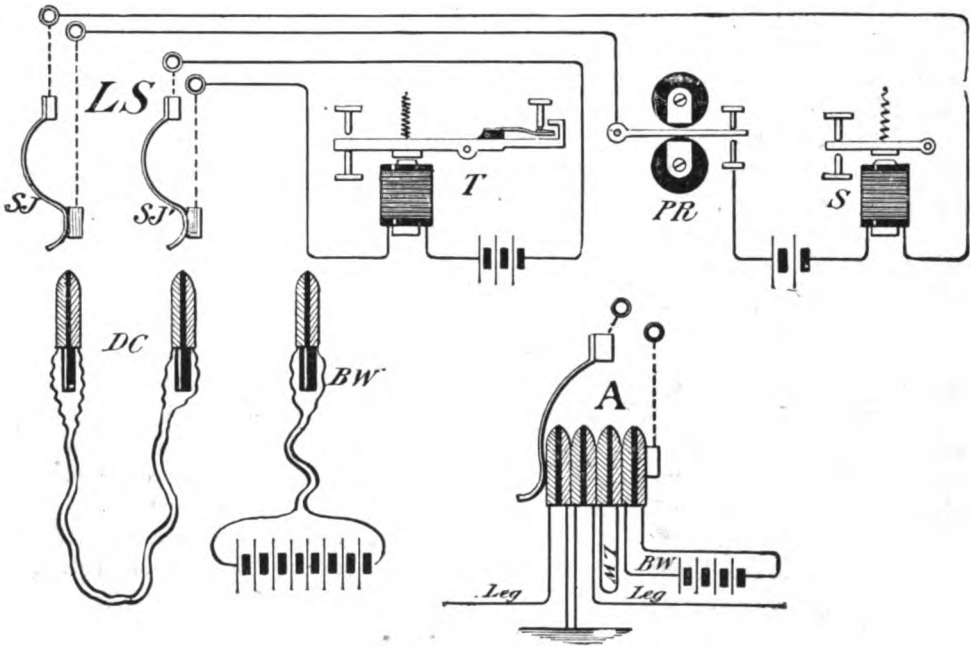

POSTAL LOOP SWITCH.

the neutral relay. R S the repeating sounder, etc. The tubes of w' are connected permanently to the wires running to the branch office. Wires leading from "loop" batteries B' and B are connected to the tubes of w. Wires leading from the 3-point switches s' s are connected to the binding posts a' a, respectively.

By means of these devices if either or both of the batteries, B' or B, should fail, it is only necessary to remove plug w, from spring-jack c', and insert in the same spring-jack a plug connected with batteries known to be good. Or, if either of the "legs" of the loop fail, it is only necessary to remove plug w' from spring-jack c', and insert in its place a "good" loop running to the same branch office. Or, if the duplex or quadruplex set fails, it is only requisite to withdraw plugs w, w', from the spring-jacks, and insert them in spring-jacks connected with a set known to be intact. The route of each circuit, from the battery at the main office to the earth at the branch office, may be readily traced on the diagram by means of the figures 1, 1'; 2, 2', etc.

The loop batteries are, or should be, arranged in a uniform manner so that every

battery of the loop switch system may coincide as to polarity with the local batteries of the different duplex and quadruplex sets. Each plug and each spring-jack is usually marked with the number of the battery, or loop, etc. with which it is connected.

When it is desired to cut off the loops from the duplex or "quad" sets it may be done by simply moving the 3-point switches at the desk, to the right.

POSTAL LOOP SWITCH.

The principle of this simple and efficient loop switch, for "gravity" battery circuits, is shown in Fig. 201.

Each duplex and quadruplex instrument is connected to a spring-jack and strap s_j , s_j' , at the loop switch, $L s$, as in the figure, without the intervention of 3-point switches.

If it is desired to repeat from one set into another in the main office, it is only necessary to put in a double-cord and double-end wedge, such as DC , in the spring-jacks; one wedge in each jack.

For instance, assuming T and PR to represent the transmitter and polar relay of two different "quad" sets, if one wedge of DC be placed in s_j , and the other in s_j' , PR will control T .

To insert a "loop" wire in the local circuit of either the transmitter or polar relay, it is only necessary to put in a loop-wedge (as LW , at A .) in the spring-jack. If more battery be needed the battery wedge BW may be inserted with LW .

To place a short leg of a loop in the circuits of T or PR , it is only needful to insert a leg-wedge, as shown at A . in the proper spring-jack. At A is also seen the manner in which two short "legs," a "loop" wire LW , and battery wedge BW , may be placed in the circuit of a polar relay or transmitter.

When it is found that the "loop" or "leg" batteries do not coincide with the "local" batteries the defect is remedied by simply reversing the position of the battery wedge in the spring-jack.

THE DAVIS LOOP SWITCH.

This arrangement, devised to facilitate loop and leg connections where the source of electromotive force is a dynamo, is outlined in Figs. 202 and 202 *a*.

In Fig. 202 T is a transmitter of a quadruplex set and P' is a spring-jack connected with same. NR is the neutral relay of a quad set, with spring-jack P connected therewith. s is the reading sounder of the neutral relay. D , is the dynamo machine assigned to local circuits and loops. s' and s are 3-point switches, one point of which is connected with the dynamo; the other point, viz x, x' , being connected to earth. These switches are usually turned to the right, thus connecting the transmitter, or the armature of the neutral relay, with the dynamo.

The brass plate upon which the jack rests, and which, in ordinary forms of spring-jacks, is in one piece, is in the one used in the Davis arrangement, cut in two, as at P, P' , and a resistance coil of 130 ohms is placed between the segments, as shown.

L , in Fig. 202, is a "leg" wedge. It has but one "live" face, that is, one metal face, the other side being insulated. The live face cuts out the 130 ohms when the wedge is inserted in the jack, as at P .

The magnet coils of the pole-changers, transmitters, sounders, etc., are wound to 20 ohms.

It will be seen, assuming the 3-point switches s s' to be turned to the right, that

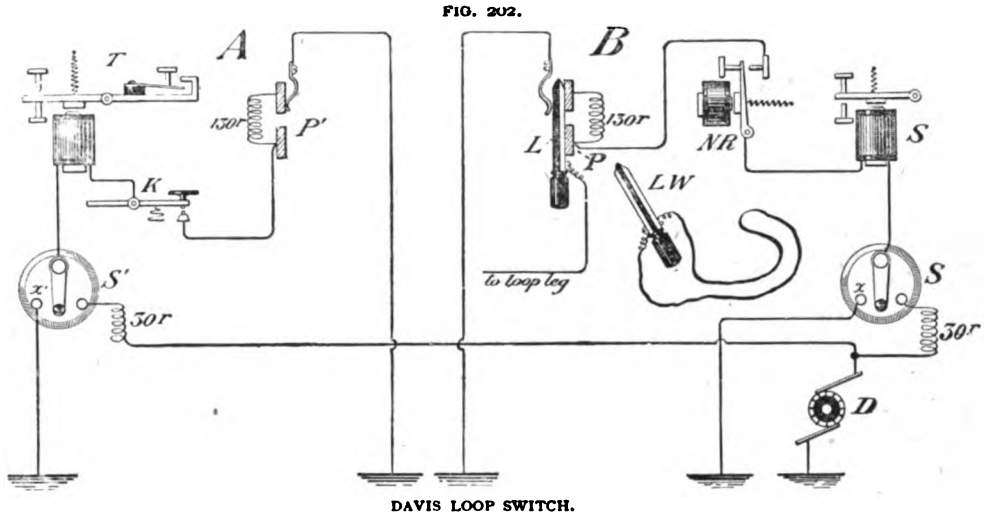

in the case of the apparatus at A, Fig. 202, the circuit has an added resistance of 160 ohms from D, while, in the case of the apparatus at B, the circuit has an added resistance of 30 ohms, and also the resistance of a loop leg which is inserted by means of the wedge L.

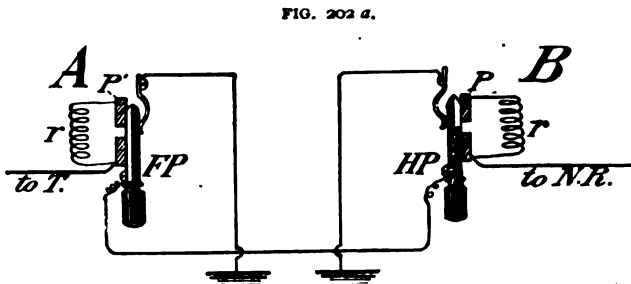

By withdrawing the wedge L the loop leg would be removed, and the neutral relay circuit would pass to earth in the main office, as at A, via the 130 ohms.

When it is desired to insert a loop or loops into the "repeating" circuit, a double

faced wedge, such as LW, is employed in the spring-jack.

For repeating from one quad set to another, as from A to B, in Fig. 202, a double-end cord, having a full brass plate, FP, (as in Fig. 202a) on one wedge, and a half plate HP, on the other wedge, is used; the full plate HP making contact, but leaving in the resistance r , as at P. In addition to the use of this double-end cord, either one of the 3-point switches, must be turned to the left to complete the circuit and to avoid introducing electromotive force at more than one point.

CHAPTER XVI.

COMBINATION DUPLEX SYSTEMS, ETC.

THE EDISON-SMITH DUPLEX.

This duplex is arranged to operate with battery at one end only. It may be classed as a combination of the Stearns duplex and the polar duplex. Such a duplex is occasionally of utility when it is not feasible to place a battery at both terminal stations.

The principle of the duplex is shown in Fig. 203.

PC is a pole-changer. NR is a neutral relay, at station X. At station Y, PR is a polar relay, and R is a rheostat; the latter capable of being short-circuited by the key K.

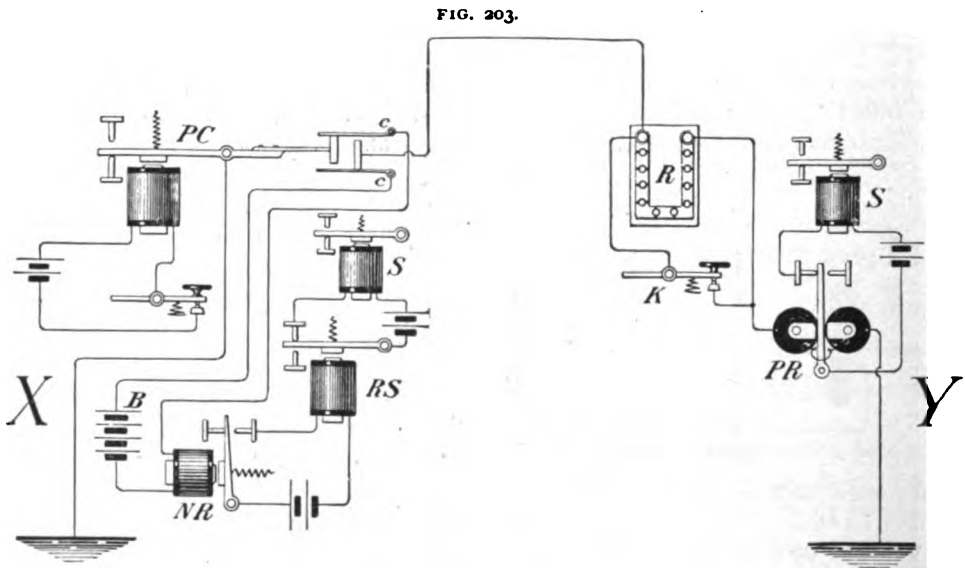

EDISON-SMITH DUPLEX.

The neutral relay is placed in the circuit of battery B, *within* the contact points, *cc* of the pole-changer, so that it is not affected by the "reversals" of the battery, the direction of the current between those contacts being always the same.

The relays NR, PR are wound "singly." The rheostat R, at Y, is so adjusted as to produce the variation in the strength of the current in the circuit necessary to operate the neutral relay at Y when the key K is opened and closed, care being taken to leave sufficient current on the line to operate the polar relay when the resistance

is included in the circuit. The polar relay PR is operated by the reversals of the battery due to the pole-changer at x, in the usual way. A repeating sounder PS may be used to offset any tendency to a "kick" in the neutral relay, due to the short-circuiting of battery B, at the moment of reversal.

THE MORRIS DUPLEX.

This duplex, due to Robert H. Morris, illustrated in Fig. 204, is somewhat of an improvement on and modification of the Edison-Smith duplex just described. It is modified at station A to operate from two separate batteries or dynamo machines D D'. The neutral relay N s. at A is so wound that currents from either machine, although of opposite polarity, pass around its core in the same direction and thus have the same magnetic effect upon the core; hence there is no reversal of magnetism in that relay.

FIG. 204.

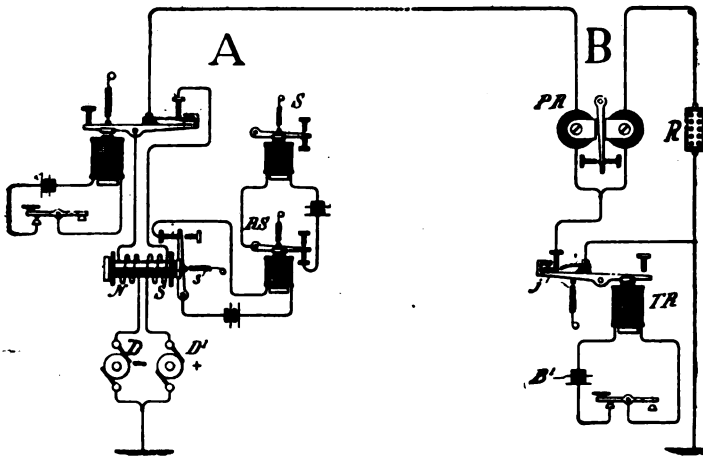

THE MORRIS DUPLEX.

At station B, the coils of the polarized relay PR are connected in series as shown, but are tapped in the middle in such a manner that when the transmitter TR is closed the right-hand coil and the rheostat, R, are short-circuited, leaving but one coil of the relay in operation.

The short circuiting of the rheostat and coil reduces the resistance of the circuit, thereby increasing the current and closing the neutral relay at A; it being understood that the spring *s* of this relay is so adjusted as to withdraw the armature when the rheostat at B is in circuit, as in the Edison-Smith duplex. On the other hand, when transmitter *rx* at B is open both coils of *pn*, as well as the rheostat, are included in the circuit, and thus, while the current is reduced as desired to cause the opening of the neutral relay at A, the core of the polarized relay is magnetized to practically the same extent as when but one coil with the stronger current is in use; this conducting, of course, to a more satisfactory operation of the relay.

The local contact point of the neutral relay in this duplex is placed on the front stop to avoid the effect of the short circuiting of the dynamo machines at the contact points of the pole-changer at A, when the distant key is open. A continuity preserving pole-changer is employed, this having been found more serviceable than the usual dynamo pole-changer. A repeating sounder, *rs*, also with contact on front stop, may be used as shown, to obviate any static effects where the line is of sufficient length to warrant its employment. The polar relay is of course caused to operate a sounder in the usual way.

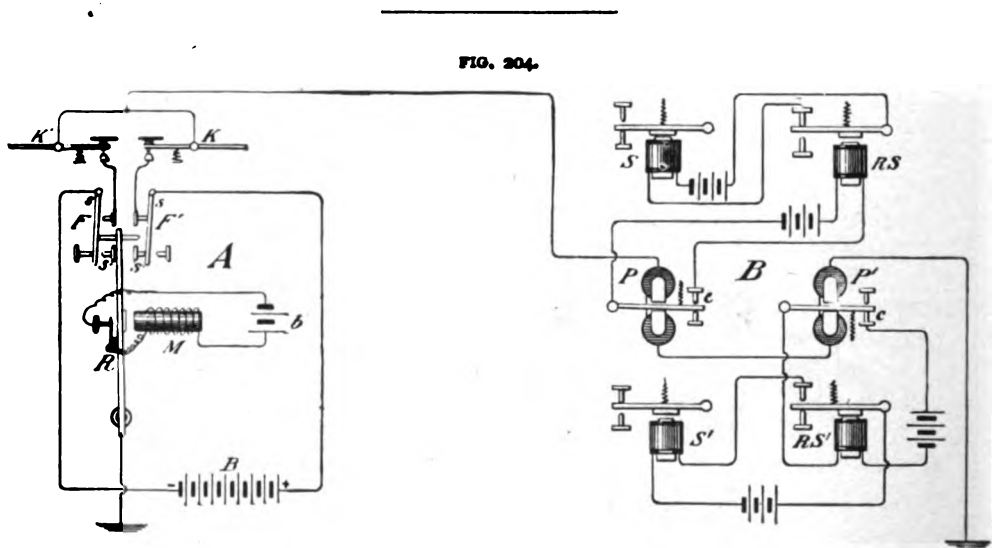

SIEURS DIPLEX.

THE SIEURS DIPLEX.

By duplex transmission is meant the simultaneous transmission of two messages in one direction over one wire.

The Sieurs duplex system is entirely different in principle from the duplex systems already described. The writer is not aware that it has ever been in continuous practical operation, but as it may be found of utility in some places, a description of it is here given. In Fig. 204 *R* is a reed, vibrating constantly while the duplex

is in operation, by the usual means, consisting of a local battery δ , electro-magnet m and the back contact shown.

The free end of the rod R plays between two metallic strips F, F' , which are given a tension towards the inner stops S', S . The reed R is grounded at one end. The apparatus at A represents the sending station; that at B the receiving station. It will be seen that when the rod R is against the strip F , as in the figure, and when key, K , is closed, the positive pole of battery B is placed to the line. So long as the apparatus remains in this position, with key K' open, only momentary positive currents will pass to the line. Should key K' be closed, and key K open, it will be found that only negative pulsations reach the line. Should both keys be closed, momentary positive and negative pulsations will pass to the line. When both keys are open no current gets to line.

At the receiving end B, P, P' are polarized relays, which, it is known, will respond to either positive or negative polarities.* In this diplex the armatures of those relays are provided with a light spring which causes the armatures to rest against the local contact points, c, c' , when both keys are open. The coils of the relays are so connected in the circuit that a current of a given direction will tend to move their armatures in a similar direction. It will be seen, however, that the local contact of each relay is on different sides. Each local circuit is furnished with a repeating sounder and a regular reading sounder. Thus, when the keys are open the reading sounder is open also, as in the case of the No. 2 sounder of the quadruplex when a repeating sounder is used. It is known that when rapid pulsations of electricity are sent over a circuit one instrument may be operated by them, while another instrument, not so sensitive, will not be visibly or audibly affected thereby. In the case in point either of the polarized relays may respond to pulsatory currents and may, by its armature lever, set up pulsatory currents in the local circuit which will not affect the repeating sounder RS , owing to the greater inertia of the armature of the sounder.

Assume that positive currents deflect the armatures of the relays, as shown, and that relay P' is responsive to key K ; relay P to key K' .

In the figure, when K is closed positive pulsations are sent over the line, the effect of which is to aid the spring of P' to hold the armature against c' ; the effect on P is to send its armature over to its back stop, away from c , but as the current is only momentary the spring tends to withdraw the armature to its contact point, and, as long as the positive pulsations continue the armature is kept in a state of rapid vibration, sufficient to open the local circuit of the repeating sounder, RS , which, it is seen, closes the reading sounder, S , thereby effecting the desired result of closing that sounder when key K is closed. If key K be open and key K' closed, negative pulsations are transmitted, the effect of which, on relay P , is to assist its spring in holding the armature against its contact point c . But its effect on the armature relay P' is to put it in a state of vibration, which also opens the local circuit of RS' , and thereby closes the reading sounder S' in the usual way. When both keys are closed, together, rapid alternations of positive and negative polarity ensue with the result that both relays are rapidly vibrated, thereby opening both repeating sounders and closing both the reading sounders.

This arrangement might be modified to dispense with the repeating sounders but the latter assist in making a more perfect signal than would be obtained without them.

CHAPTER XVII.

SUBMARINE TELEGRAPHY.

SIPHON RECORDERS—STEARNS DUPLEX—MUIRHEAD DUPLEX, ETC.

When the first Atlantic cable was laid the ordinary Morse method of telegraphing was employed, but it was soon discovered that the strength of current necessary to secure the operation of the Morse receiving apparatus tended to reduce the speed of signaling to a very low rate; namely, one or two words per minute.

The cause of this slow signaling may be illustrated by analogy:

Suppose a long, large pipe to extend from A to B, with a pump at the near end A, to drive water through the pipe, and a wheel at the distant end, B. Assume that it is intended to transmit signals by causing the wheel to turn out of a certain position when the water is flowing, and to resume a normal position by the pull of a spring or weight when the water ceases to flow. It is evident that if a cumbersome wheel is employed a larger volume of water must pass through the pipe to turn it, and this volume of water will require more time to flow in and out of the pipe, than if a small, light wheel should be employed, since the latter will respond to a much less volume of water, and thus may be operated more rapidly than the much larger wheel could be; in fact, by a volume of water so small that it would have no perceptible effect on the larger wheel.

In the case of a long submarine cable the employment of apparatus requiring considerable strength of current for its satisfactory operation is, perhaps, relatively, more detrimental than would be the employment of cumbersome apparatus in the case of the water-wheel analogy, for the reason that, owing to its static capacity, when such a cable is connected with a battery the charge at first arriving at the distant end is very small and only rises to its maximum, gradually, and, when the cable is disconnected from the battery the discharge is, approximately, as gradual as the charge; the static capacity, as it were, retarding the passage of the current to remoter parts of the conductor until the nearer portions have received their respective static charges. It is, it may be said, virtually, as if, in the case of the water-pipe analogy, small closed pipes should be run off from the sides of the main pipe, the filling, or charging and discharging of which, it is evident, would retard the arrival of the full volume of current at the distant end, and would also prolong the time of discharge of the pipe to a greater degree than would be the case were the small, lateral pipes absent.

It will be obvious, on consideration, that the static capacity of a long submarine cable, (as compared with an overhead wire of equal length) will be large, because of the nearness of its conductor to the earth throughout, and the high specific inductive capacity of its insulating medium, usually gutta-percha, both of which tend to increase

the total capacity of the cable and thus cause it, with a given electromotive force, to take a greater static charge than would be the case if, for instance, the conductor possessed resistance alone, or resistance with but a small capacity. (*See* Static Charge of Conductors). From the foregoing it is clear that a desideratum in submarine telegraphy is a receiving instrument which shall respond to very feeble currents, since the feebler the current required the shorter will be the time of charging and, consequently, discharging the cable, and, hence, the more rapid the signaling.

MIRROR RECEIVER.

The receiving instrument first successfully employed on long submarine cables was the Thomson reflecting galvanometer, an instrument which, as already stated, can

FIG. 205.

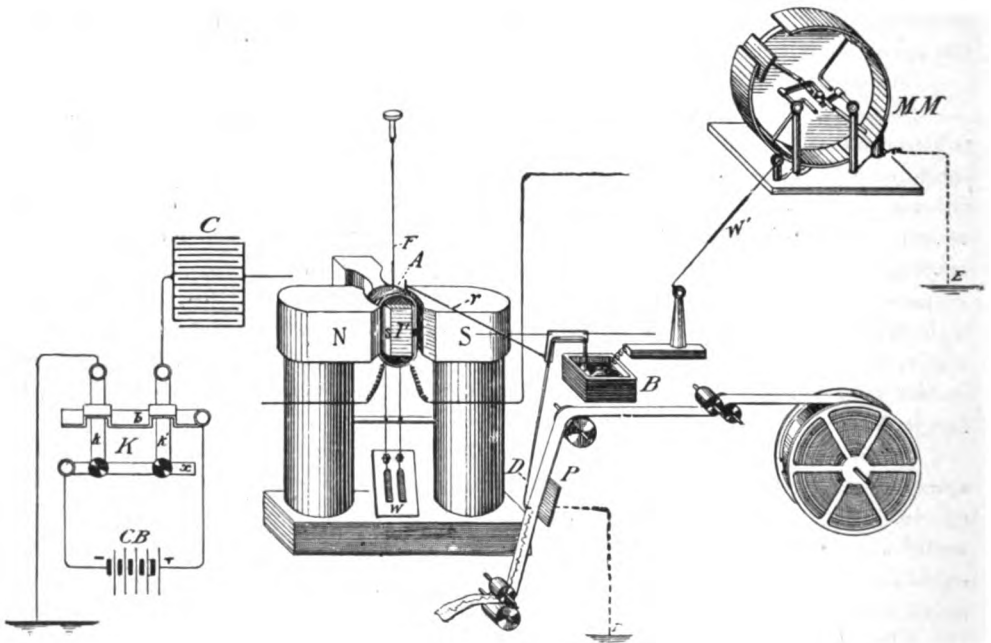

THOMSON SIPHON RECORDER.

be made responsive to very feeble currents. In the operation of this method the galvanometer is placed in the circuit of the cable and hence is responsive to signals transmitted over that circuit. The spot of light reflected from the mirror is thrown on a screen in a darkened room. The "International" code is employed. The dot and dash are distinguished from each other, not by the duration of the signal, but by the direction of the deflection of the spot of light on the screen. For instance, an imaginary zero being at any given point on the screen, a deflection of the spot to the left of the zero represents a dot, one to the right of the zero, a dash. The advantage of dispensing with the Morse "dash" is that it avoids filling up the line with a prolonged charge, and thus permits speedier signaling. The direction of the deflection depends

on the direction in which the currents pass through the galvanometer, and this is regulated by a reversing key or "tapper" κ , shown at the left of Fig. 205, at the sending station, which sends a positive or negative current to the cable as one, or other of the single keys, k or k' , of the reversing key, is depressed.

At rest, keys k k' press up against the brass strip b . When either key is depressed it leaves the strip b and makes contact with the lower strip x . The poles of cable battery CB are connected to strips b and x , as shown.

Assuming that a positive pole of the battery deflects the "spot" to the left, and that a negative current deflects it to the right, the letter A would be formed by depressing, first the key k , placing the positive pole to the cable; and then the key k' , placing the negative pole to the cable. The letter s would be signaled by three consecutive depressions of key k .

It is seen that every time both keys, k k' , touch the strip b the cable is placed to the earth direct, thus discharging the cable, more or less, between each signal. It is this partial discharge between each depression of the same key which causes the successive deflections on a given side of zero.

In the reception of signals by the foregoing method, two clerks are required; one to read out the letters or words as received, the other to write them down. Thus no automatic record of the signals is made. This defect was supplied by a subsequent invention of Sir Wm. Thomson's; namely, the siphon recorder, which is outlined in Fig. 205.

THE THOMSON SIPHON RECORDER.

In the operation of the siphon recorder advantage is taken of the fact that, when a current flows in a wire the vicinity of the wire becomes magnetic, the magnetic effect thus set up being at a right angle to the length of the wire. This is shown by the action of a magnetic needle, which, when freely suspended over such a wire will tend to place itself at right angles to the wire; or if, on the contrary, the magnetic needle be rigidly held while the wire is freely pivoted, the latter will tend to place itself at right angles to the needle. The magnetism thus developed in the vicinity of the wire will be north or south magnetism (or in a positive or negative direction), depending on the direction of the current traversing the wire; and thus, if the direction of the current be changed at intervals, it will cause an oscillation of the wire suspended under the needle or other magnet.

In Fig. 205 an oblong coil of fine wire A is suspended, by a silk fibre F , between the poles N S of a powerful magnet, in such a manner that, when a current passes through the coil the latter tends to place itself at right angles to the poles of the magnet. In other words, the coil becomes, for the time being, a magnet, with the equivalent of north and south poles, which change from side to side of the coil in accordance with changes in the direction of the current passing in it, with the result that its poles are alternately attracted or repelled by the poles of the permanent magnet, between which the coil is placed.* Or, if the strength of current in the coil be varied, its direction remaining uniform, the magnetic strength of the coil will vary also, allowing the coil to

* The coil is normally brought to and held at zero by means of the two small weights W , Fig. 205, which move up and down in grooves on the inclined plane; being suspended as shown from the coil by silk fibre. The weights do not much exceed one ounce.

advance or fall back, slightly, between each variation of current strength; thus giving the coil an oscillatory motion.

Another way of considering the immediately foregoing is to assume that the action of the magnetic needle is due to the tendency of magnetic lines of force to coincide in direction. Thus, as the lines emanating from the wire are at right angles to it, it is natural that the needle should tend to set itself at right angles to the wire, since, in that position, the lines of force of the needle will coincide with those of the wire magnet. Similarly, in the case of the magnet *N. S.* the lines of force pass from the north to the south poles, and hence are at right angles to those of the coil; consequently, in the effort, so to speak, of the "lines" to coincide in direction, the coil is deflected, as intimated. A piece of soft iron, *I*, is placed within the coil to concentrate the lines of force and "direct" them across the coil.

A siphon, *D*, consisting of a very small glass tube, is attached to the coil *A* by a fine, but rigid wire *r*. The siphon is so suspended as to be free to move in unison with the coil. The lower and bent end of the siphon is placed directly over the centre, or imaginary zero, line of a paper ribbon *P*. The end of the siphon remote from the paper dips in an ink well *B*, and, by means of an electric machine, termed a "mouse-mill," *M M*, outlined in the figure, very fine dots of ink are deposited or projected on the paper tape. The mouse-mill is driven by a suitable motor not shown.

There are two explanations as to the exact manner in which the ink is placed on the tape. One is that the electricity developed by the mouse-mill causes the ink to be spurted in minute drops across the air space between the end of the siphon and the paper. The other, due to Cuttriss, is that a static charge of electricity generated by the mouse-mill is collected at the end of the siphon; that this charge tends to unite with "opposite" electricity accumulated on the paper tape *P*, behind which, at that point, is a ground plate. The siphon is thereby attracted towards the paper, and, as the latter is kept in a slightly humid condition, the moment the ink on the point of the siphon touches the paper the charge of electricity escapes, whereupon the siphon returns to its normal position; but in an instant the charge is renewed, the siphon is again attracted to the paper, and in this way it is maintained in vibration at its fundamental rate. The amount of charge is regulated, as desired, by the insertion of a small piece of moist thread *w'* in the mouse-mill circuit. The siphon does not impinge on the paper and thus friction is avoided.

A reversing-key, *K*, similar to that used in the mirror system, is used in transmitting signals, and the momentary pulsations of positive and negative currents through the coil cause the lower end of the siphon to move to one side or the other of the zero line of the paper tape, thus leaving a zig-zag series of marks on the paper, readily recognized as dots and dashes by the cable operator. In this way the signals are recorded as received. Further reference to the siphon will be made shortly.

THE CUTTRISS MAGNETIC RECORDER.

The operation of the Thomson siphon recorder is sometimes delayed by the failure of the ink to flow, or by a failure of the siphon to vibrate to and from the paper tape. This is generally due to an accumulation of moisture on the mouse-mill or ink-well supports, which permits the charge to escape without passing through the siphon.

Some difficulty is also, at times, experienced in maintaining the paper tape in a proper degree of humidity.

Cuttriss sought to overcome these difficulties by the arrangement shown, theoretically, in Fig. 206.

In this arrangement, coil *A*; permanent magnets *s*, *s*; soft iron *I'* within the coil; an ink-well *I*, and siphon *s*, are used as in the Thomson siphon recorder. The mouse-

FIG. 206.

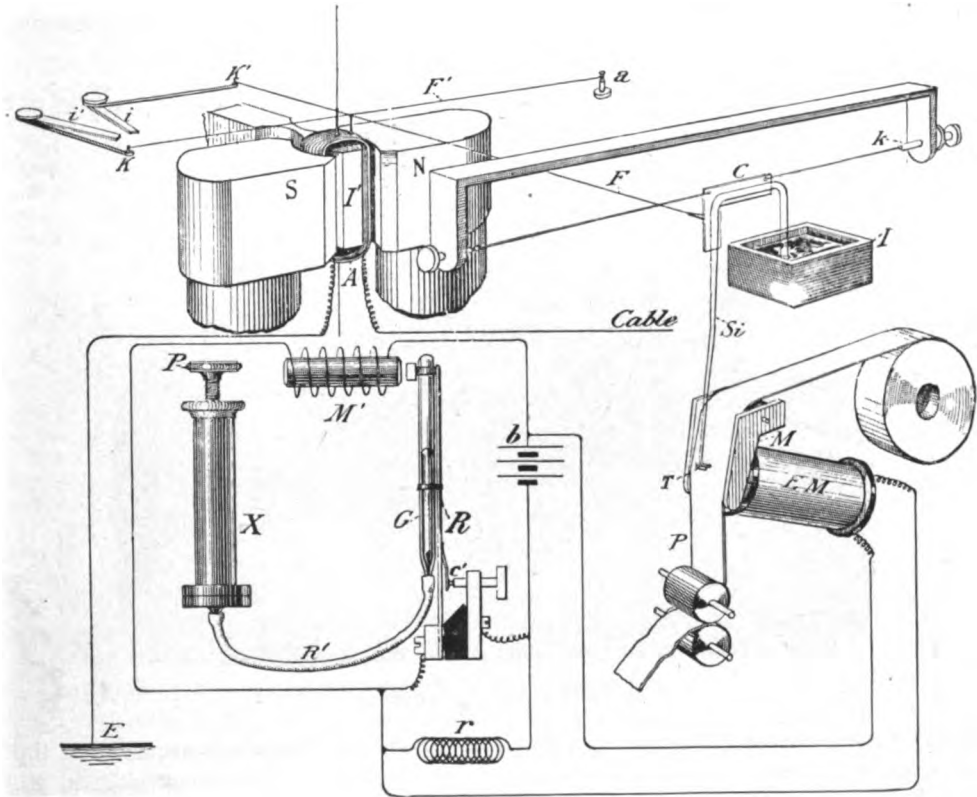

CUTTRISS MAGNETIC SIPHON RECORDER.

mill, is, however, dispensed with. The coil is pivoted on fine, agate bearings, and it is brought to a zero by the use of delicate springs κ , κ' . The siphon consists of a glass tube about one hundredth of an inch in outside diameter; the diameter of its aperture being about five one thousandths of an inch. On its lower end a very small piece of soft iron *T*, about one-eighth of an inch in length, is placed. This iron tip is placed close to the paper tape, *P*, but does not touch it. The paper at this point is caused to pass over a magnetic "table" *M*, which is magnetized by contact with the core of an electro-magnet, *E.M.* Magnetic vibrations are set up in the "table," by means of the vibrating rod, or reed, *R*, which so acts as to cut the resistance *r* in and out of the local circuit of battery *b*. This increases and decreases the current in the circuit

of EM , and thus varies its magnetism. The resistance of r may be increased until the strength of current in the circuit is practically nil, and until the effect is as if the circuit were "broken" while that resistance is in; the presence of r , however, diminishes sparking at the contact points c' of R . This momentary magnetism of EM tends to attract the iron τ on the siphon, and, if the rate of the magnetic vibrations of EM corresponds with the fundamental rate of vibration of the siphon, the latter will vibrate in unison with the vibration of the rod R ; otherwise it will not.

In order to secure a rate of magnetic pulsations in the electro-magnet EM corresponding to the fundamental rate of vibration of the siphon, the vibrating rod R is

FIG. 207.

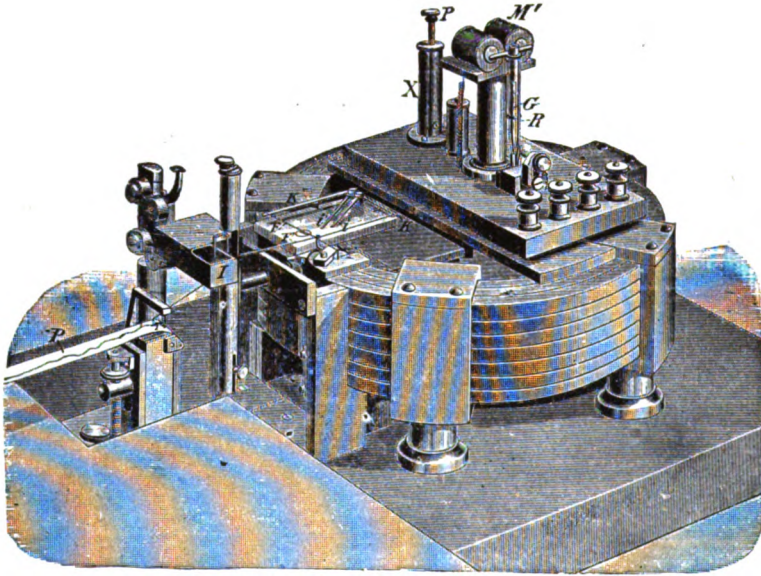

CUTTRISS MAGNETIC RECORDER.

made to carry a glass tube G , partly filled with mercury. The tube is attached to the steel rod as shown. At its upper end R carries the armature of the electro-magnet, M .

When the tube is set in vibration, it will continue to vibrate in the well-known way common to circuits connected up in the manner shown in the figure—which will be recognized as virtually the manner in which "buzzers" are connected. But the rate of vibration of the rod R may be varied by raising or lowering the column of mercury contained in G , and this is readily done by means of rubber tube R' connecting the glass tube with a reservoir X in which mercury is held. By adjusting the amount of mercury in the tube by means of the plunger P inserted in the reservoir X , a point is reached where the vibrating rate of the tube coincides with the natural rate of vibration of the siphon.

When this result has been secured it is indicated by the appearance of a fine line of dots on the moving paper tape, and signals are received by marks to the right and left of zero as in the case of the Thomson siphon recorder.

The siphon is attached by wax to the cradle *c*, which is composed of a light metal. The cradle is delicately suspended as indicated in the figure. A fine wire, or fibre *F*, reaches from the cradle to a pin projecting from the top of the coil *A*. A fibre from *A* extends to a very sensitive flat spring *κ*. Another fibre extends at a right angle to *F*. One end of this fibre is attached to a fine, flat spring *κ*; the other end is rigidly held by an adjusting screw *a*. The springs *κ*, *κ'* are adjustable by the indices *i*, *i'*. By this arrangement of fibres and springs it will be seen that any tendency of the coil *A* to place itself at a right angle to the permanent magnets will deflect the siphon to the right or left, as the case may be, of the imaginary zero. The Cuttriss recorder, as it appears in practice, is shown in Fig. 207. The permanent magnet is of nearly circular form. The letters in Fig. 207 refer to parts similarly lettered in Fig. 206. In the latest form of the Cuttriss recorder a small, curved iron cheek, movable in a groove, is placed on the top of the permanent magnets, one on each pole. These nearly embrace the upper part of the coil. A small iron pin is attached to the upper end of the coil. A slight movement of the movable cheeks assists in adjusting the position of the coil in the field and permits the removal of one of the adjusting springs alluded to. The presence of the iron in the coil affords a means whereby the attraction of the permanent magnet tends to, measurably, uphold the coil, thereby removing nearly all friction from the agate bearing; in fact the coil is, as it were, "floated" between the magnets.

An important advantage accompanying the siphon recorder and mirror methods of signaling is that a "variable" zero is not an obstacle to their successful operation. By that is meant that it is not essential that the "spot," in the mirror method, or the siphon, in the recorder arrangement, should come back to a stated zero between each pulsation. To indicate that the signals are either dots or dashes it is sufficient that one deflection should go, or "climb," beyond the other, in one direction, with but a slight fall between each character. A change in the character of the signal from a dot to a dash, or vice versa, is indicated by a more pronounced fall or rise beyond a preceding "peak" or valley. In Fig. 208 is shown a specimen of signals as received over a 1,000 mile section of an Atlantic cable by a Cuttriss recorder. The characters, as indicated by the underlining, represent the "International" alphabet. It may be seen that what would be an intermediate line between the dots and dashes, or the upper and lower peaks, varies considerably from a straight line. The same characters as they might be received on a very short circuit are shown in Fig. 208*a*.



FIG. 208

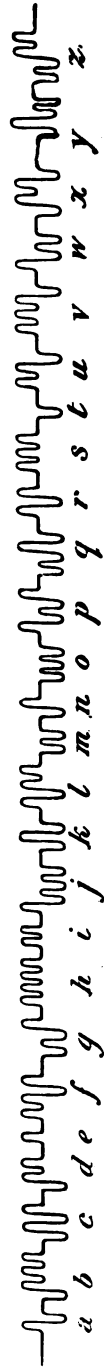
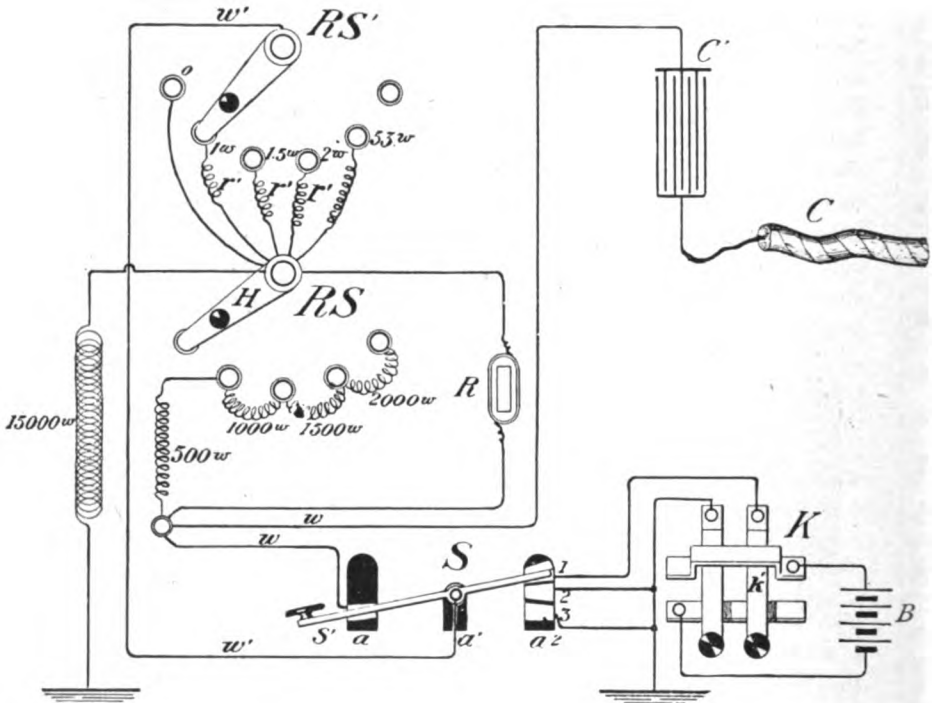

FIG. 208*a*.

EARTH CURRENTS.

When the terminals of a long cable are placed directly in the earth it is found that, so-called, earth currents, of sufficient strength to operate the sensitive receiving instruments used on such cables, are almost always observable. At least two causes have been assigned to explain these currents. One is that they are due to a difference of electric potentials of the earth at the terminals of the cable; the other is that the currents are due to variations in the density of the earth's magnetic lines of force,

FIG. 209.



CABLE TERMINAL CONNECTIONS—SIMPLEX WORKING.

which in "rising" and "falling," "cut" the conductor of the cable. Probably these currents are due to both causes, but for the present purpose it will suffice to consider them as only due to the former cause.

Ordinarily, these earth currents are neither very powerful nor very variable. During the prevalence of violent "magnetic" storms, however, they are very marked, so much so, indeed, as not only to disturb the sensitive cable apparatus but also the much less sensitive Morse apparatus on land lines.

It is, of course, essential that means should be adopted to avoid or minimize the effects of these earth currents in submarine telegraphy.

It is known that when the terminals of a condenser, of superior construction, are oppositely electrified, as by the attachment of a battery to one of the terminals, while the other terminal is grounded; or, by placing one pole of a battery to one terminal

and the other pole to the other terminal of the condenser, a current of momentary duration occurs in the wires leading to these terminals, after which, so long as a uniform difference of potentials is maintained, at the terminals, there will be no further indication of current in the connecting wires. Advantage is taken of this fact, in submarine cable telegraphy, to nullify the effects of earth currents, and, to that end, condensers are interposed between the terminals of the cable, and the battery or the earth, as, for instance, is shown at *c'* in Fig. 209. The capacity of the condensers thus used is varied with the requirements. Those employed on the Atlantic cable have a capacity of about 50 microfarads.

Inasmuch as the capacity of a condenser is, generally speaking, proportional to the number of its plates in service, and as its "charge," with a given difference of potentials at its terminals, decreases as the plates are diminished in number or size, it is clear that a tendency to an increase in the strength of the earth currents could be offset by a reduction in the capacity of the interposed condenser. This principle, it may be remarked, has been availed of frequently by the writer and others in experimental and regular work in connection with simultaneous telegraphy and telephony, and in other somewhat similar systems, in which sensitive apparatus, such as a telephone receiver, is used to receive "pulsatory" signals, and in which the pulsatory system is "separated" from the main line, by condensers. In those cases the capacity of the condenser is adjusted until the noises in the telephone, due to "induction" from parallel circuits, are silenced or, at least, rendered "harmless," when, if necessary, the pulsatory signaling currents are increased in strength by an increased E. M. F., to compensate for the diminished capacity of the condenser.

Assuming a practically constant difference of potentials at the terminals of a cable, it follows that, if a condenser be interposed in the circuit, no current, or, at most, a gradual rise or fall in its strength, such as would produce a large curved zero line on the paper strip, will be manifest in the receiving apparatus due to the electric potential of the earth, after the first momentary charge. This leaves the cable free to be charged by comparatively rapid variations in the charge of the condenser, which variations are set up by the battery and transmitting apparatus at the cable terminals.

It will be observed that the cable and condenser, Fig. 209, are virtually connected in "series," the conductor of the cable being one plate of an extensive condenser. Hence, as the "charge" is proportional (See Condenser) to the capacity, and as the total capacity of the cable and condenser is less than the condenser would be alone if its other terminal were connected directly to earth, a higher electromotive force is necessary for the transmission of signals when the interposed condensers are employed than if the battery were connected directly to the cable; the difference, in practice, being roughly, about as 3 to 1. The electromotive force employed on the Atlantic cables is about 30 volts, in duplex working. The "Fuller" battery is frequently used.

Another important advantage in using the interposed condenser is that, owing to the quick charge and discharge of the condenser, as compared with that of the cable when connected directly to the battery, the signals are much more clearly defined,

the deflections of the mirror and the of recorder coil being much more sharply curtailed.

SIMPLEX CABLE TELEGRAPHY.

Long submarine cables are worked both singly, or "simplex," as it is termed, and duplex. In either case currents of both polarities are employed in the transmission of signals.

One terminal of a cable with apparatus arranged for simplex working is shown also in Fig. 209. In this figure k is a double, or reversing key, similar to that shown in Fig. 205, in connection with which its function is explained. s is a switch which is used in changing from "sending" to "receiving," and vice versa. The metal strip s' , is pivoted on insulated block a^1 . There is a contact segment on a , and three similar contacts on a^2 . The upper segment on a^2 is connected to key k at k' . The two lower contacts on a^2 , to earth. The contact on a is connected by a wire with a switch rs . The block a^1 is connected by wire to switch rs' . R is the "recorder" or "mirror" galvanometer. c is the interposed condenser of large capacity. c is the cable.

When the switch s is set for "sending," as in Fig. 209, it may be seen that there is a direct route to the condenser and cable, via wires $w w$, for the sending current; but, if it is desired to observe the manner in which the signals are being transmitted a portion of the sending current may be diverted through the recorder, via wire w', w' , by means of the switch rs' ; the amount being regulated by the low resistance coils $r' r' r'$.

In some stations a large resistance, approximating to that of the cable, say, about 15,000 ohms, is so placed as to be readily attachable by a suitable "strap" to the switch rs . When thus connected the current from battery B divides between the cable and the high resistance, and, assuming the short-circuit coil o in rs' to be used, the terminals of the recorder R would be, practically, at equal potentials, so that no current would flow in it, but by the introduction of a resistance at rs' a small portion of the current from the home battery is diverted through the recorder. When the high resistance is used a resistance of 53 ohms inserted at rs' has been found to give satisfactory results.

When the apparatus is to be arranged for "receiving," the handle of lever s' of switch s is raised, by which act contact is broken between s' and the contact on a . Hence the "received" current is caused to pass through the recorder, thence to the middle block a^1 of s and to the earth, via a^2 . The full, received current may be caused to pass through the recorder or mirror coil by turning the strap n of rs to the vacant button at the left. The resistance coils in rs are employed to diminish the deflections of the receiving instrument should the "received" current, passing through the recorder, be too strong.

When "electrified" ink is used and when a tendency to lateral vibrations exists it has been found in practice that the 3,000-ohm shunt in rs sometimes exercises a steadying effect upon the siphon. These lateral vibrations are noticeable when the paper is not sufficiently humid; they are assumed to be due to the attraction of the electrified siphon by the metallic sides of the paper guide.

In order to discharge the cable before the switch *s* is set for receiving, thereby to prevent possible injury to the recorder, the metal contact on block *a*, switch *s*, is slightly extended, so that the strip *s'* makes connection with the contact *z* on *a*², for an instant, before connecting with contact 3.

DUPLEX WORKING.

When the cable is worked "duplex," the switch *s* is not used, as the effect of the inrush and outrush of current due to the charge and discharge of the cable, upon the "home" receiving instrument, is avoided by placing it in the bridge wire of a Wheatstone bridge; that method of rendering the home apparatus practically irresponsive to the operation of the home battery keys being the one most generally used in submarine duplex telegraphy.

The "artificial," or "false" cable corresponds to the "artificial" line in over

FIG. 210.

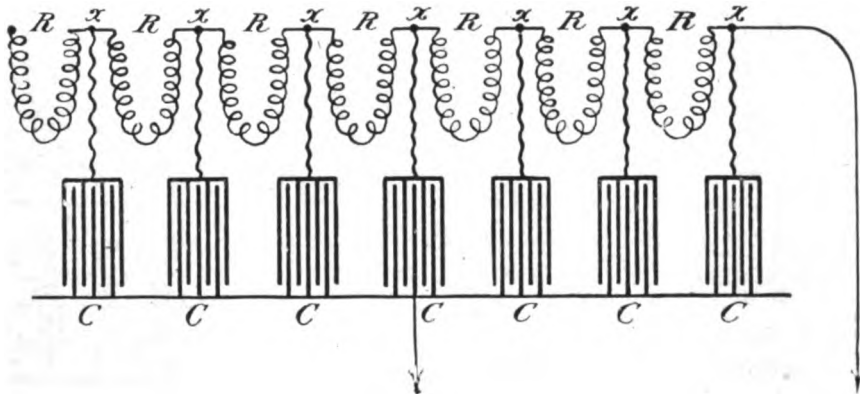

THEORY—STEARNS ARTIFICIAL CABLE.

land duplex telegraphy, but it is required to resemble the cable proper much more exactly, as regards resistance and static capacity, than does the artificial line in overland telegraphy.

The reasons for this are that in the case of the overland conductor the capacity is much less, and the insulation resistance is, generally speaking, much inferior, to that of a cable. Thus, in overland telegraphy, there are numerous external points at which the static discharge may escape, thus diminishing the amount that reaches the receiving station.

It has been found that the artificial cable must especially resemble the cable proper, the first few miles of its length.

There are two forms of artificial cables in practical operation in submarine duplex telegraphy, namely: the "Stearns," or "Varley," and the "Muirhead."

STEARNS ARTIFICIAL CABLE.—In Fig. 210 Stearns artificial cable is shown in

theory. This artificial cable consists of a series of resistance coils, R, R etc., to which condensers are attached at x, x , etc., as shown in the figure.

In practice the "artificial" cable is put up in large boxes and the terminals of the resistance coils are brought to the outside of the boxes. The terminals of the condensers are also made accessible, outside of the boxes, by flexible cords, to which are attached suitable plugs, and by means of which condensers may be added to the resistance coils to give them "capacity," until a "balance" is obtained, which will be

FIG. 211.

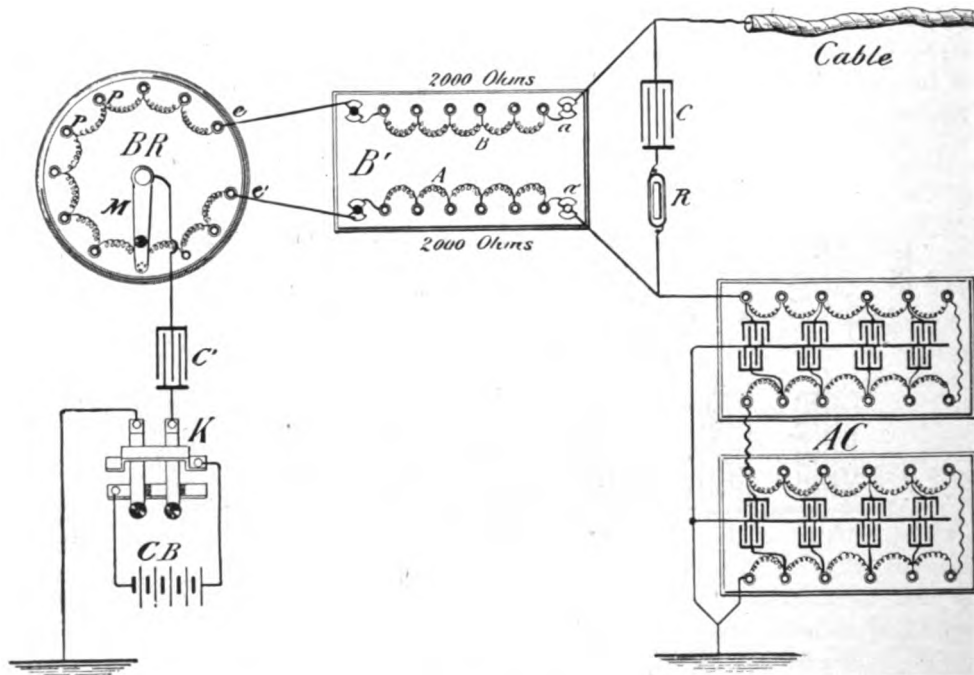

CABLE DUPLEX; STEARNS ARTIFICIAL CABLE.

when the artificial cable is equal in resistance and capacity to the "real" cable.

STEARNS CABLE DUPLEX.—A diagram is given, in Fig. 211, of a long submarine cable as arranged for duplex working with the Stearns artificial cable, at one end.

The transmitting and receiving instruments are the same as those employed in simplex working. The method employed to prevent the interruption of received signals by the home transmitter is that of the Wheatstone bridge. B' is a box containing the arms A, B , of the "bridge," consisting of about 1,000 ohms, each. The ends of the arms a, a , are connected to split discs, as shown, into which metal plugs are inserted for duplex working. This arrangement is provided to facilitate changing from "simplex to "duplex," and vice versa; the removal of the plugs disconnecting the recorder from the bridge arms. Condenser c , and the recorder or mirror, R , are in the bridge wire. AC are boxes containing the Stearns artificial cable. BR is a rheostat composed of about 40 small coils of wire, in series, each

coil, $\frac{1}{4}$ ohm; the terminals c, c' of the series are connected, as indicated, to the arms A, B of the bridge; the metal arm M is connected to a wire leading to the condenser c' . By moving the arm M around on the metal pins P, P, etc., resistance may be added to and taken from one or other of the bridge arms to complete the balance.

MUIRHEAD ARTIFICIAL CABLE.—The Muirhead artificial cable is shown theoretically in Fig 212. The object of this form is to make the artificial cable correspond exactly with the actual cable, both as to resistance and capacity, mile, per mile, of each. This is practically accomplished by using continuous strips of tin-foil, cut in ribbons of various widths, which are placed in proximity to, but separated from, other strips of tin-foil, which latter are, or may be, connected to the earth, at will. The tin-foil ribbon thus arranged is enclosed in a box with accessible terminals on the outside of the cover, virtually as indicated in the figure. The terminals x are those of the tin-foil strips R, used as a resistance; terminals x' are those of the tin-foil strips c adapt-

FIG. 212.

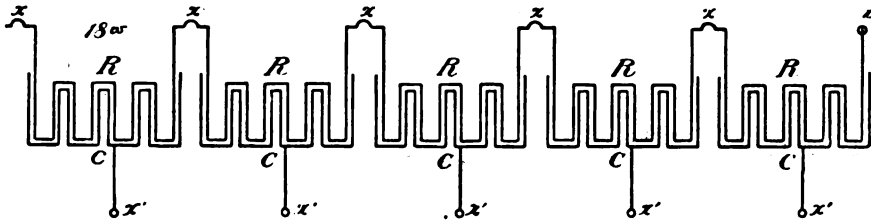

THEORY MUIRHEAD ARTIFICIAL CABLE.

ed to add capacity to the strips c when terminals x' are connected with "ground." As many boxes are added as may be required to equal the entire cable in both of said respects.

MUIRHEAD CABLE DUPLEX.—The connections and arrangement of apparatus now employed in duplex working on many of the longest submarine cables is shown theoretically in Fig. 213.

The transmitting keys K are the same as those used in simplex cable working. BR is the rheostat of small resistance bobbins used in procuring a "fine" balance on the cable. c, c' are condensers, placed in the bridge arms in place of the usual resistances. R is the receiving instrument, in the bridge wire. AC is a Muirhead artificial cable. The capacity of the condensers, c, c^1 is about 50 microfarads each; that of the small condenser c^2 , about 3 to 5 microfarads, sub-divided into fractions of microfarads. The bridge wire condenser c^3 has a capacity of about 50 microfarads.

This arrangement of the condenser in the arms of the bridge, in place of resistances, is termed the Muirhead "double-block." It is said to increase the signaling capacity of the duplex about 15 per cent. The average rate of signaling on long submarine cables is about 25 words per minute in either direction.

The arrangement of resistances between the "earth" plates, or foil, of the artificial cable, and the earth, is varied, both as to amount and as to location on the artificial cable, on different cables, but that shown in Fig. 213 may be considered as practically representative. R' is a small resistance intended to balance the wire leading from the cable office to the terminal of the cable; it may consist of but a few ohms. A short

section of the earth plates of the artificial cable, near the beginning, is attached, separately, through a comparatively low resistance, 180 ohms, to the earth. Another short section of earth plate is connected to earth through a resistance of about 1500 ohms; the remainder through a resistance of about 180 ohms, as indicated.

BALANCING A CABLE DUPLEX.

At one time the procuring of a "balance" on a long submarine duplex cable was a matter requiring much skill, but of recent years the actual cable is so closely duplicated by the artificial cable that it has become a comparatively simple operation.

In taking this balance the nature of the signal, if any, produced on the home recorder by depressing the home keys is an indication as to the location of that section

FIG. 213.

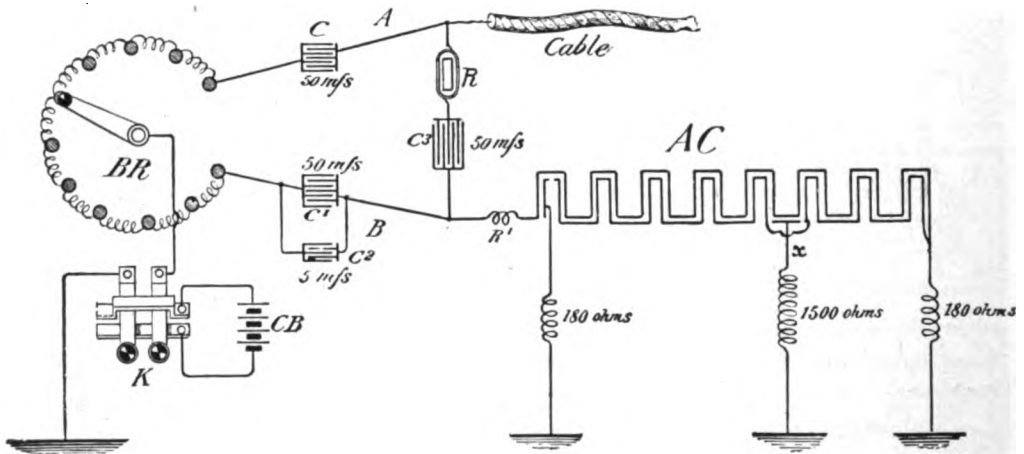

CABLE DUPLEX—MUIRHEAD ARTIFICIAL CABLE.

of the artificial cable which is not in "balance" with the "real" cable. For instance, if a sharp, well-defined signal, is returned, it may be expected that the near end of the artificial cable requires adjustment. If the signals, on the depression of the home key, are faint, the lack of balance is further on in the box, etc.

The balance is, of course, practically perfect when the home recorder is unaffected by the home keys.

As a rule, after the cable has once been balanced any slight changes that may occur are easily compensated for by the small condenser c^3 and the small coils in BR. In practice, these latter adjustments are made about once in twenty-four hours, and it is not necessary to stop the transmission of telegrams to effect the necessary changes.

In the case of the Commercial Cable Company's Atlantic cables, a change in the balance of the main artificial cable is only required about twice in the twelve months; namely, in March and October, and this only necessitates a slight alteration in the location of "ground" resistance in one of the boxes of the artificial cable, as at x , Fig. 213.

This change in the main balance, which occurs uniformly at the times stated, is doubtless due to variations in the temperature of the ocean.

The "static" or "inductive" capacity of an Atlantic cable is about one-third microfarad, per knot. Its resistance is about 3 ohms, per knot; for example, the total length of the Canso-Waterville Atlantic cable of the Commercial Cable Company is 2345.72 knots; its resistance, 6,997 ohms, and static capacity, 876 microfarads.

The speed of telegraphic signaling has been found to be inversely proportional to the product of the resistance of the conductor multiplied by its capacity. Hence, in its high resistance and capacity, a long submarine cable possesses elements conducive to slow signaling. The resistance of a wire conductor decreases inversely as the square of its diameter; its capacity increases directly as the area of its surface. Hence, by increasing the diameter of the conductor, its resistance may be decreased in a greater ratio than its capacity is increased, consequently, by increasing the diameter of a conductor of given length, the product of capacity and resistance (or, as it is termed, KR) may be reduced, and in that way the rate of signaling may be increased, other things being equal.

An example of this may be offered.

Assuming a cable of a given length having a total resistance of 15 ohms and a capacity of 1 microfarad, and having a diameter of 90 mils. The product of resistance and capacity will be $15 \times 1 = 15$. Let the diameter of the conductor now be made 100 mils. From the foregoing the resistance of the conductor will now be, $100^2 : 90^2 :: 15 : x = 12.15$ ohms, and the capacity will now be, $3.1416 \times 90 : 3.1416 \times 100 :: 1 : x$; that is, $282.744 : 314.160 :: 1 : x = 1.11$ microfarads, and the product of these will be $12.15 \times 1.11 = 13.48$, showing that, by the increase of diameter, the signaling has been increased in the ratio of 13.48 to 15.

THE BROWN AND ALLEN RELAY.

It has already been intimated that the time required to charge and discharge a long submarine cable to the extent necessary to operate ordinary Morse relays precludes the use of such relays for practical purposes in submarine telegraphy.

The result of charging, for instance, an Atlantic cable with the amount of current used on land lines, would be that the distant relay would simply remain closed, since the intervals during which the key would be open would not suffice to permit the cable to properly discharge. In other words a retarded current of ample strength to attract the armature would, while the key is momentarily open, continue to flow through the distant Morse relay. There would be, however, a diminution in the strength of current in the cable during those intervals, but only of a slight character—not enough, as just intimated, to allow the armature to yield to its retractile spring. These variations will, however, be somewhat more pronounced when the "double current" method of signaling is used, that is, the method in which the current is reversed in direction by the opening and closing of the key, in the manner previously explained.* To avail of these slight changes of current strength, a very sensitive instrument, termed the "Brown and Allen" relay, has been devised, and has been successfully employed on submarine cables of about 600 knots in length, in connection with the double current method of signaling.

See also Chap. XVIII, pages 287, 288.

This relay is shown in Fig. 214. It consists of a coil of fine wire wound around a core of soft iron. The ends of the core extend beyond the coil and pass between the poles of two permanent magnets N, S; N, S. A current in the coil tends to make one of the ends of the core a north pole; the other a south pole; consequently, the north end will be attracted to the south pole of its permanent magnet, while the

FIG. 214.

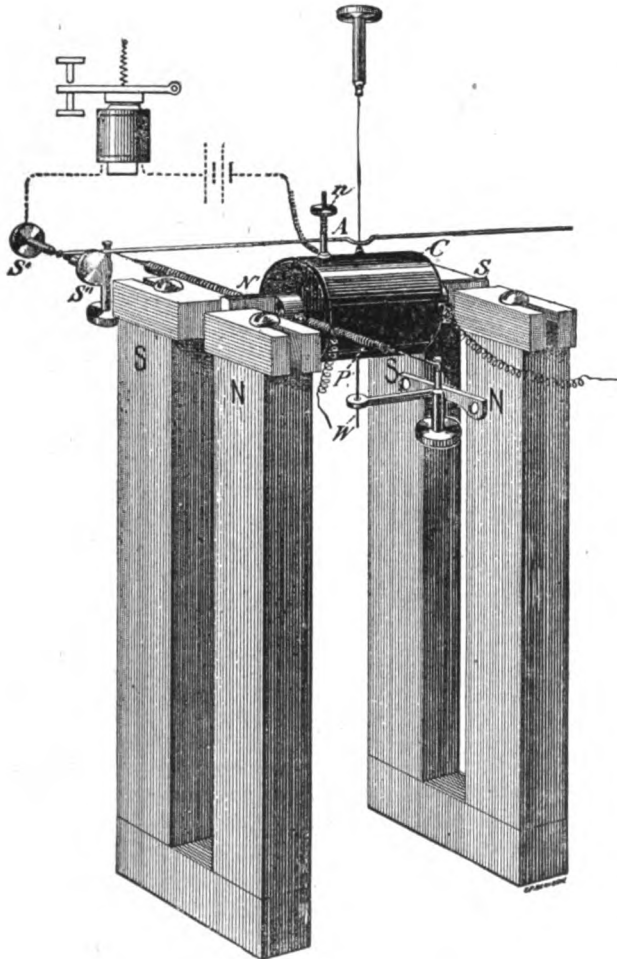

THE BROWN AND ALLEN RELAY.

to insure contact for the local circuit and to cause the pointer to follow, when unrestricted, the coil in its movements. But the pointer is not so rigidly attached to the coil as to check the motion of the latter when the jockey reaches its contact point or back stop. In other words, should the coil, for instance, be deflected to an angle of 1° or more, the "jockey" will not follow it more than $\frac{1}{1000}$ of an inch, and yet, on the slightest recoil, and subsequent slight advance, of the relay on its axis, the pointer will fall back and again advance with it, etc.

other end of the core will be attracted to the north pole of its permanent magnet. The coil is rigidly attached to the core, but is insulated from it, in the usual manner; and the whole is suspended by a fine fibre, as indicated. So far, the arrangement is virtually a form of polarized relay, delicately poised. There is, however, in addition, an attachment to the instrument which imparts to it, sensitiveness; namely, a light metal pointer, termed a "jockey," pivoted at A, somewhat in advance of the middle of the coil, and extending beyond its ends. One of the ends of the "jockey" is placed between the ends of the stops s', s'', one of which has a contact point and is part of a local circuit. The play of the pointer between these stops is very limited; about the one thousandth of an inch. A delicate spring, resting on the pivot of the jockey, and controlled by a small nut n, bears on the pointer just sufficiently

The coil is held, normally, in a central point between the permanent magnets, by the springs F, F' . The presence of a current in the coil overcomes this balance, by magnetizing the core. The local connections of the pointer are so arranged that a current in the coil will press the jockey against its contact point, closing the local circuit. A very slight diminution of the current allows the pointer to fall away from the contact point. In practice, frequently, several makes and breaks are made in the local circuit without any perceptible motion of the relay.

The relay virtually corresponds in its action to that of the mirror or recorder on longer submarine cables, the frictional connection of the jockey with the relay, permitting, as it were, a "shifting" zero; the minute changes in the magnetic strength of the coil, due to the transmission of signals, while not sufficient to allow the relay to return to its normal zero between signals, being, yet, sufficient to actuate the pointer, and thus to operate the local sounder, at a fair rate of speed.

THE JACOBS DUPLEX.

Submarine cables of moderate length, such as those referred to, on which the Brown and Allen relay may be used, are sometimes made up of two conductors.

It is apparent that if two conductors of a cable of any considerable length were

FIG. 215.

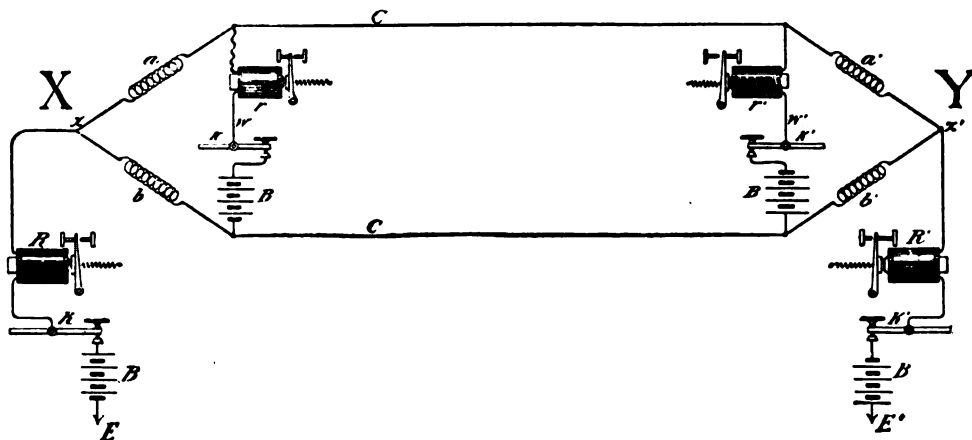

JACOBS DUPLEX.

operated separately, marked "inductive" effects from wire to wire might be expected, especially in view of the sensitiveness of the receiving instruments necessarily employed. To avoid these effects and yet retain the practical equivalent of two conductors, an arrangement known as the "Jacobs" duplex is used.

The principle of this arrangement is shown in Fig. 215, and, for simplicity the ordinary Morse method of signaling is there assumed. c, c' are the two conductors of the cable, which are joined at x, x' . Between x, x' and the ground E, E' instru-

* i.e. of a given direction.

ments and battery are placed at each end of the cable, x and y , respectively. Bridge wires w, w' , in which are placed instruments and batteries connect the two conductors at each end, as shown, forming a Wheatstone bridge arrangement, of which the resistances $a b$ and $a' b'$ are arms.

From what has already been stated relative to duplex telegraphy, it will be evident that, if the resistance of the conductors $c c$ from x to x' , and that of the arms a, a', b, b' , be equal, the opening and closing of the keys k, k' will produce no effect upon the instruments in the bridge wires, but will operate the relays $R R'$. Thus signals

FIG. 215 a.

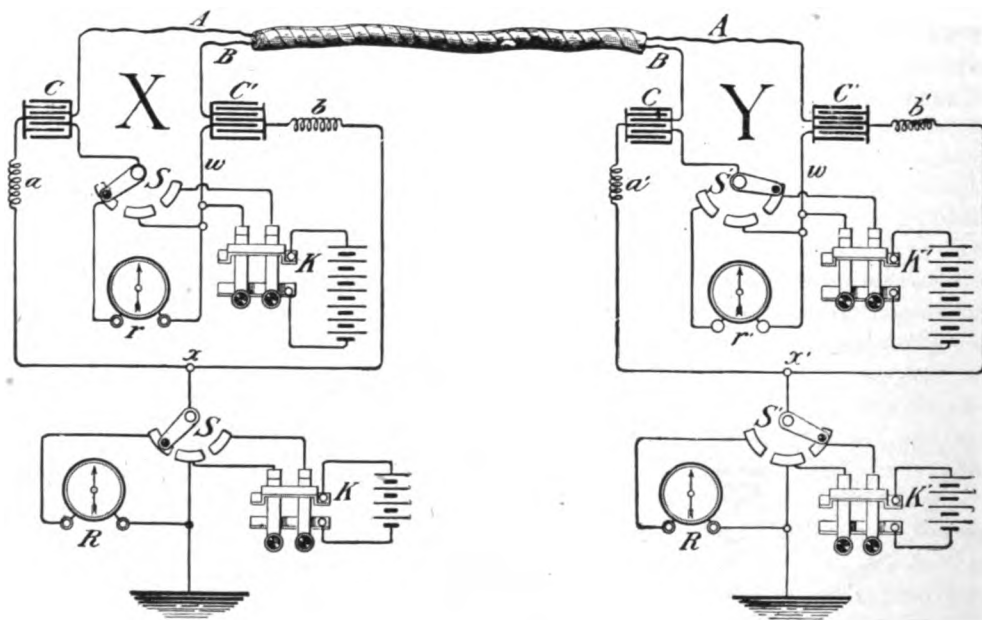

may be sent from K to R' and K' to R , without affecting the relays r or r' , in the bridge wires. On the other hand, the effect of opening and closing the key k or k' , in the bridge wires, will be to operate the relays r or r' , practically as if they were in a metallic circuit disconnected from the bridge arms and earth, except, of course, that, by the division of the current (due to the bridge wire batteries) between the conductors proper and the bridge arms, the current reaching the distant end of the cable is diminished somewhat; and this fact necessitates the placing of sufficient resistance in the bridge arms $a b, a' b'$ to avoid any tendency to short circuiting those batteries via the said arms. In the practice of this method condensers are sometimes placed in the bridge arms in place of, or in addition to the resistance coils $a b$. None of the current from the bridge wire batteries passes to earth via the relays $R R'$ and, consequently, those relays are not affected by those batteries. It thus results that signals may be sent from the instruments in the bridge wires which will not be noticeable on the instruments R, R' in the wires leading to earth, and, vice versa.

As this arrangement provides the equivalent of a metallic circuit there will be no "interference" from wire to wire during the transmission of signals from either end. It will be understood, however, that the same electrical action that would occur on a simple metallic circuit in the transmission of signals, or that would occur on two wires connected at x, x' , without the bridge wire batteries, does not take place in this arrangement when both "sides" are in operation, but, instead, there takes place a practically similar action to that described in connection with the operation of the polar duplex system, in which the batteries at the opposite terminals, whether opposing or coinciding as to direction, equally co-operate to produce the desired signals at the terminals by bringing about variations in the potentials which tend to that result.

This "duplex" as arranged for practical working is outlined in Fig. 215*a*.

A and B are the conductors of the cable. x, y are assumed to be the terminal stations. r, r' in the bridge wires and R, R in the "single" wire between x, x' and the ground, are "mirror" galvanometers or "recorders." c, c' and c, c' are condensers, placed in the bridge arms, as shown. Those condensers are of practically equal capacity. Small resistances a, b, a', b' may be placed in the arms. κ, κ' are the ordinary cable reversing keys. The 3-contact switches s, s, s', s' , are used to change from "sending" to "receiving," as may be desired. The switches s and s are set for receiving. s' and s' for sending. The middle contact on the switches is designed to allow the "charge" of the cable to escape to earth, or to equalize itself, before the recorder or mirror is placed in the circuit.

If the cable is not too long, "Brown and Allen" relays may replace the mirrors.

It will be observed that this arrangement furnishes greater facilities than one wire duplexed, since two messages may be simultaneously sent from either end or one message from each end, at the same time.

AUTOMATIC TRANSMISSION:—Two forms of automatic transmitters are in use in Submarine Telegraphy. One, the Wilmot transmitter, a modification of the Wheatstone transmitter. The messages are prepared for transmission on a paper ribbon on which, for this purpose, three rows of holes are perforated. These upper and lower holes control the polarity of the current sent into the cable; the middle row is employed as in the Wheatstone transmitter. The other transmitter is due to Cuttriss. This latter device is novel in that by an intermittent motion of the perforated ribbon it is practicable to vary the duration of current and earth contacts in any proportion, the one to the other. Another feature of this transmitter is that by means of a cam device the contacts are never opened while current is passing them. Hence sparking is avoided.

The main advantages of automatic transmitters for this work are that a greater speed is attained, and also a more uniform signal is transmitted than is possible in manual transmission. Hence the operators are enabled to translate the received signals with greater accuracy.

BROWN'S CABLE RELAY AND REPEATER.

Many attempts have been made to devise a long submarine cable relay, but until recently without success. The difficulty has been to secure an instrument that would respond to the very minute currents that reach the receiving end of such a cable, and especially one that would respond to the very slight variations of current that occur between the pulsations of similar polarity, as for instance in the letter *h*, at the ordinary rate of signaling on such cables. In the siphon recorders employed on long submarine cables friction is practically eliminated in the manner described, namely, by keeping the siphon in a state of vibration. The varying or wandering zero is not found to be a bar to easy reading of the ink record by expert operators. When the attempt is made, however, to utilize a relay operated by such currents to repeat the message on to another cable, it is necessary that the pointer or tongue of the relay come back to a fixed zero between signals.

An ingenious cable relay due to Mr. S. G. Brown, described in the "Journal of the Institution of Electrical Engineers," No. 157, 1902, has been found to meet these requirements. This relay is outlined in Fig. 286a. In this *c'* is the cable, *c* is

FIG. 286a.

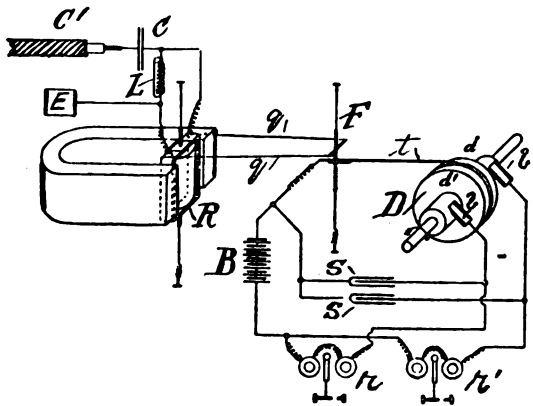

BROWN'S CABLE RELAY.

the interposed condenser, *R* is the coil of the ordinary siphon recorder, *F* is a pivoted rod which is joined to the coil *R* by two silk or quartz fibers *q q*. A tongue *t* is carried by the arm *F* as shown. The tongue is a fine siphon glass tube, through which runs a phosphor-bronze wire, to the right end of which is soldered an iridium contact-point which normally rests lightly on the middle segment of a drum *D*. This middle segment is insulated. Two other segments *d d'* of this drum are of metal, and are in metallic contact with the brushes *b b'*, each of which is part of a local circuit containing dot-and-dash relays *r r'* and a battery *B*, one or the other circuit being completed when the contact point of *t* rests on either segment *d d'*, or both will be open when *t* is on the middle segment, inasmuch as *t* is also a part of the said circuits. When the drum *D* is at rest the tongue remains on the middle segment

regardless of whether signals may be arriving or not, the strength of the currents in the coil κ not being sufficient to move the tongue against the friction of the point on the drum. But when the drum is rotated at the rate of about 150 revolutions per minute the friction is apparently eliminated and the pointer responds to each impulse of the coil. The condensers s s , of two microfarads each, which shunt the contact-point of t , are found to be of much utility in improving the contact, especially when the surface of the drum is very smooth, the reason for which result is not known.

This, however, does not get rid of the variable zero of the coil, which would render the operation of the relay of no utility, as the pointer would not get back to the insulated section between signals. To overcome this defect Mr. Brown has designed a "local correction," which, briefly, consists of setting up currents through an extra winding in the coil, not shown, of such character and strength that as the cable current dies out the local current increases at the same rate. This is brought about by means of the current from a local battery and the relays r r' , which is sent through a circuit, including the extra coil, "having considerable retardation, and made up of a condenser placed between two high resistances, condenser and resistances being made capable of minute adjustment. . . . L is a large inductive shunt of 30 ohms resistance joined across the terminals of κ ." This device suffices for comparatively short cables, but, as the inventor notes, on longer cables at high speed many of the originating impulses are obliterated from the received signals whenever successive impulses of the same polarity occur. There is no difficulty on the part of the operator in translating the characters on the tape, since he reads them by the space they occupy on one side or other of the zero line. When, however, it is desired to repeat from one cable to another it may be essential to reproduce the missing beats or "ripples." To this end Mr. Brown employs an interpolating device, "whose action resembles that of the automatic transmitter at the originating station, with this difference, that the movements of its transmitting levers, instead of being governed by the perforations in tape, are governed by the motions of the relay tongue." This interpolator consists of two rotating-cam arrangements, operated by suitable mechanism, which, under the control of the relay tongue, open a local dot-and-dash circuit as many times as there may be characters, dots, and dashes in a letter. So that, for example, "if, when the letter h is received, the tongue of the drum relay remains in contact with the dot side throughout the four beats of the letter, simply producing a long contact on the dot relay, this long signal is split up by the dot cam of the interpolator and transmitted as four dots." In a similar way a long contact on the dash relay, representing, say, the letter o , would be split into three dashes by the dash-cam of the interpolator. The speed of the interpolator mechanism must be synchronous with that of the transmitter.

This relay is now in operation on several long cables.

UNDER WATER TELEGRAPHY.

A number of experiments, more or less successful, have been made relative to the transmission of telegraphic signals, electrically, across water, without the aid of wires. One method for this purpose is to place in the water, at some distance apart, the terminals of a conductor connected with a battery and transmitting apparatus, on one side of a river or harbor; while on the other side of the river the terminals of a wire, connected up with receiving apparatus, are similarly placed in the water. When the distance across is not too great the signals transmitted may be received. Hitherto no very practical use has been made of the results thus obtainable.

The device illustrated in Fig. 216 is intended as a mechanical means of communication between vessels at sea, during fogs, but, so far as known to the present writer, it has not passed the experimental stage.

The manner of its operation will be apparent. A bell, *B*, is lowered into the sea, by means of a rope and pulley, into a position where it may be struck by the hammer *H*, which is movable from shipboard. The receiver is along, bent, trumpet-shaped tube *T*, which is lowered into the water from another vessel. Both vessels are assumed to be provided with receiving and transmitting apparatus, which may be placed at the bow or stern, as desired.

FIG. 216.

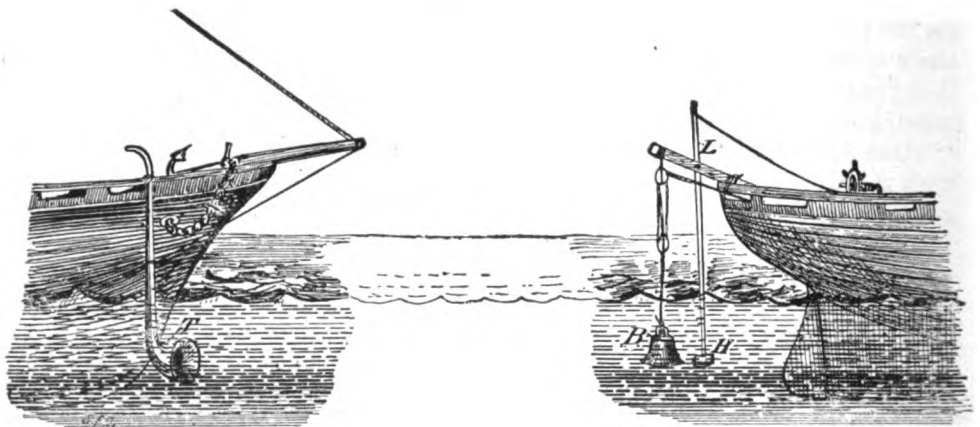

The sounds produced by the strokes of the hammer upon the bell are propagated by the water to the mouth of the tube and thence to the ear of a listener at the "receiving" ship.

Experiments have shown that signals can be transmitted in this way to a distance of about half a mile, but at a distance of 2200 yards the sound is not perceptible.

CHAPTER XVIII.

AUTOMATIC TELEGRAPHY.

THE WHEATSTONE AUTOMATIC SYSTEM.—ANDERSON CHEMICAL AUTOMATIC SYSTEM—

FAC-SIMILE TELEGRAPHY.

RAPID AUTOMATIC TELEGRAPHY.—The term Automatic Telegraphy, applied to the transmission and reception of telegrams, etc., is hardly sufficient to include definitely, the different practical systems of automatic telegraphy.

For instance, a system may be partly manual and partly automatic, as in the case of the Morse system when a recording register is used as receiver; or in that of the Phelps "motor" printing telegraph system, in which the manually transmitted messages are received in Roman letters on a paper strip. Nor does the term distinguish between those automatic systems in which the messages are recorded in ink, and those in which the signals are recorded by electro-chemical action. Elsewhere herein the term, "ink recording" automatic telegraphy, is applied to systems in which the signals are received by ink recorders, and the term, "chemical" automatic telegraphy, to systems in which electro-chemical decompositions produce the records of signals.

As, however, there are instances of both of these systems, in the operation of which the rate of transmission is comparatively slow, namely 30 to 60 words, per minute, the writer has chosen the term, "rapid" automatic telegraphy, to distinguish the systems by which the signals are transmitted at a rate of speed ranging from, say, 300 to 2000 words, per minute, from those by which the signals are transmitted at the first mentioned rate of speed.

In the transmission and reception of Morse or other code signals, rapid *chemical* automatic telegraph systems usually employ at the sending end, in a manner to be described, specially prepared, perforated paper, and contact *pens*, and, at the receiving end, chemically prepared paper, upon which the electrical pulsations corresponding to the signals transmitted are caused to record such signals, by decomposing the chemical solution in which the receiving paper had previously been immersed. Rapid ink recording automatic systems usually employ somewhat similar devices at the transmitting end, but, at the receiving end, an ink recorder or "register" is employed to record the signals.

In telegraphy, the term, "single current," is applied to systems in which currents of one direction only are employed; for example, the ordinary Morse system. The term, "double current," is applied to systems in which the direction of the current is

reversed at each opening and closing of the key, or pole-changer, as, for instance, in the polar duplex system.

Owing to the higher rate of transmission of electrical pulsations that can be attained over a telegraph circuit by means of the double current method of signaling, that method is almost invariably used, both in chemical and ink recording automatic systems; as, for example, in the case of the Wheatstone automatic duplex system, to be described presently, in which the *transmitter* acts as a double current "sender," or pole-changer.

At a high rate of speed of transmission, even on wires of only moderately high electro-static capacity, the signals tend to run together, causing prolongations of the characters and, in some cases, a continuous dash, on the paper tape. These prolongations are technically termed "tailings." This result is due to a cause similar to that described in connection with the attempt to operate the ordinary Morse apparatus on long submarine cables, namely, that the wire has not time, between signals, to clear itself of the previous charge before a succeeding charge again "fills" the line. This tailing effect, obviously, depends largely on the length of the circuit and upon its electro-static capacity.

When a charge of one polarity is followed by a current of opposite polarity on the wire, as in the double current method, the effect is to neutralize the previous charge, thus cutting short the tailings; and it is this which conduces to the higher speed of transmission by the double current method in rapid automatic telegraphy. It may be mentioned, however, that the same result, as regards tailings, will, of course, follow, even when the double current method is employed, when the rate of transmission exceeds the maximum carrying capacity of the wire or the instruments.

The manner of preparing messages for transmission by rapid automatic transmitters, has generally been to punch holes in a paper tape, either in a single row, when the single current method is to be employed, or in two rows, when the double current method is to be utilized. In some cases the messages have been prepared for transmission by the deposition of an insulating, quick-drying paint, or paste, upon a cylinder, in the shape of the Morse characters.

As a rule the perforations have been made hitherto by the depression of a "punch" which, at each depression, perforates the part of a letter. For instance, one depression of the instrument punches the symbol for a dot, the next depression that for a dash; this requiring as many depressions to compose a letter as there are characters in the letter. In other instances, punching apparatus has been devised by means of which all of the characters composing any given letter have been perforated at one depression of a key. Where the single current method is employed, and when but one row of perforations is required, the preparation of the paper has been accomplished with comparatively little difficulty, as, in that case, it is only essential that long and short holes, corresponding to dots and dashes, be perforated in a straight line. But, when the double current method is utilized, the machinery required to punch the required number of characters at one stroke in two rows is of a somewhat more complicated nature and, consequently, more liable to get out of order. For this reason, perhaps, the single character punching apparatus has been adhered to in the

most successful of the double current automatic systems, for instance, as in the Wheatstone automatic system.

In preparing messages for transmission by the "insulated" cylinder plan referred to, the paint is deposited on a revolving, and laterally moving, metallic cylinder, by means of a flexible spout in communication with a suitable reservoir containing the insulating paint; the spout being attached to the armature of a sounder, or relay, in a circuit controlled by a Morse key. In effect the operation of the punched paper and the "painted" cylinder is the same, unless when, as in the Wheatstone automatic system, the perforated paper is used to control the operation of the transmitter.

When the perforated paper is used to transmit directly, the electrical pulsations, it is caused to glide over a metallic cylinder, or wheel, which forms part of the line circuit. Above the paper, and resting on it, are placed one or two metallic brushes, or contact pens, according as it is the single or double current method that is employed. These pens also form a part of the line circuit. As the paper passes over the cylinder the pens fall through the holes in the paper and complete the circuit. In the double current method one pen may be connected with one pole of the battery; the other pen with an opposite pole, so that the opposite poles are placed to the line as the respective pens make contact with the cylinder. Analogously, in the case of the "painted" cylinder, a contact pen is caused to rest upon the cylinder, and as the latter revolves and moves laterally, the circuit is opened and closed according as the pen passes over insulated or non-insulated parts of the cylinder.

Systems which employ contact pens in the manner just stated may be termed "direct contact" transmitting systems, in contradistinction to those in which the prepared paper is caused to control the operation of the transmitting instruments, of which latter the Wheatstone automatic system is also an example.

CHEMICAL AUTOMATIC TELEGRAPH SYSTEMS.

At one time, both in Europe and in the United States, rapid chemical automatic systems were extensively employed in commercial telegraphy, but to-day it is questionable whether one such system is in practical operation. In many instances, it is true, electro-chemical methods of recording signals are now employed in police, fire alarm and similar telegraph systems, in this country.

In Europe, for various reasons, chemical automatic telegraphy has been practically superseded by ink recording systems, and, in this country, mainly by the ordinary Morse manual system.

Until within a few years chemical automatic telegraphy was the only method of *rapid* telegraphing attempted in this country, but, at present, as elsewhere remarked, the Wheatstone automatic system, with its ink recording apparatus, is now being operated quite largely.

The receiving apparatus of those chemical automatic systems in which the Morse code characters are recorded, so far as the actual recording of the signals is concerned, is practically the same in all cases. It is outlined in Fig. 217. A cylinder, or wheel D, with a flat periphery, composed of some metal not decomposable by

the chemicals used, forms part of the circuit. Metal pens, or styles *P*, form another part of the circuit. Between the cylinder and the pen, or pens, the chemically prepared paper *P'*, still damp from immersion in a chemical solution, passes.

The principle involved in the operation of chemical telegraphy is that of the decomposition of the *electrolyte* through which the current is caused to pass. The liquid chosen as the electrolyte must be one readily decomposable by the current. In other words, one in which the component parts are held together in a, chemically considered, somewhat unstable manner. At the same time the combination must be one which will not, in its normal condition, attack the parts of the apparatus with which it may

FIG. 217.

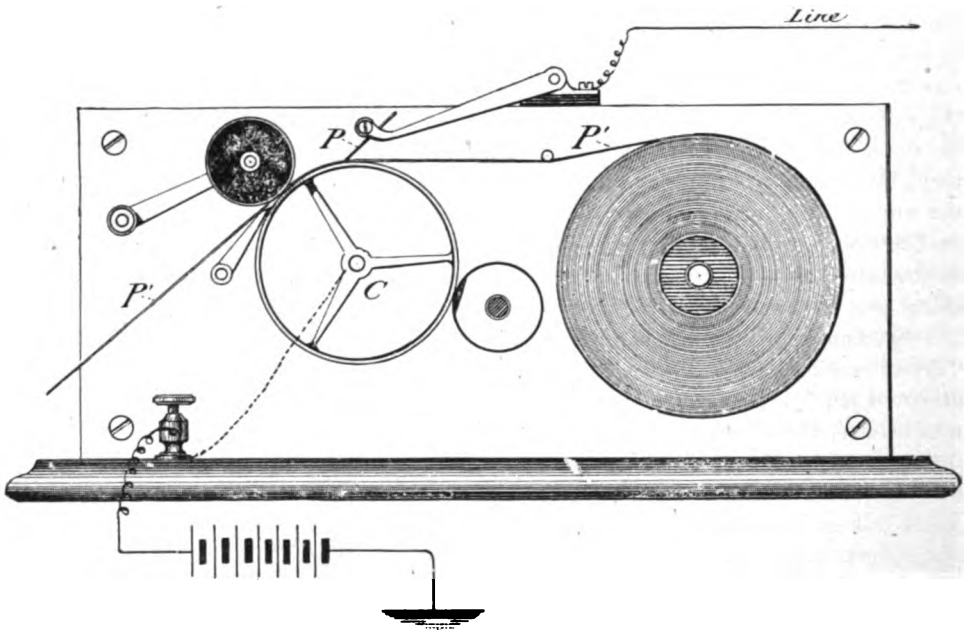

CHEMICAL AUTOMATIC RECEIVER.

come in contact, that is, the pen or cylinder of the receiving apparatus. But, at the same time also, the combination, or mixture, as in part the chemical solution sometimes is, must contain elements, or sub-combinations, which will either, when freed by the current, produce a mark on the paper or else combine with the metal of the receiving pen to produce such a mark during the progress of the current through the paper. For example, if the paper be saturated with a solution of potassic iodide dissolved in water, the action of the current will separate the iodine from the potassium, when the former will appear on the paper as a brown line.

Again, it is known that one of the most characteristic properties of iodine is the production of a clear blue color when combined with common starch. The iodine for this purpose must be free, or uncombined. If then the solution, or mixture, employed, be one containing potassic iodide, and starch dissolved in water, the action of

the current will set free, as before, the iodine, which, combining with the elements of the starch, will produce a blue mark on the paper.

The latter solution is, in practice, usually prepared in the following proportions: 1 part potassic iodide; 20 parts starch paste; 40 parts water. The stain produced by this solution, however, while very readily produced, that is, with a minimum of current, is very transient, fading almost as soon as exposed to the air. When this solution is used a platinum pen is employed to conduct the current to the paper.

Another solution from which the current sets free an acid that attacks the iron or steel pen, thereby forming a combination which appears as a blue-black mark on the paper, is composed as follows: 5 parts prussiate of potash; 150 parts ammoniac nitrate; 10 parts water.

The essentials of a solution for the sensitive paper used in chemical telegraphy are that it shall be easily decomposed; produce a permanent record; be retentive or accumulative of moisture, and a fair electrical conductor.

In the case of the last mixture given the object in using the prussiate of potash is to supply the acid radical cyanogen, which attacks the iron pen, forming "prussian" blue, permanent marks, on the paper. That in using the ammoniac nitrate is to maintain the paper in a moist condition, which it does by absorbing moisture from the air, the ammoniac nitrate being a deliquescent salt, that is, one which is accumulative of moisture. The conductivity of the solution is sometimes increased by adding to it dilute sulphuric acid, not of sufficient strength to attack the metal pen. The marking always occurs at the positive contact point.

Measurements of the resistance of the moistened chemical paper, between the pen and the periphery of the cylinder, have shown it to be between 250 and 300 ohms.

ANDERSON CHEMICAL AUTOMATIC SYSTEM.

So far as is known to the writer there is but one chemical automatic system now extant in this country, designed for the rapid transmission of telegrams, on which work of any kind, practical or experimental, is being done; namely that of the Machine Telegraph Company. The objects striven for by the inventor of this system, Mr. Frank Anderson, are maximum rapidity consistent with accuracy of transmission and simplicity of the apparatus. The Anderson system belongs to that class of automatic systems in which Morse characters are transmitted by means of perforations in a strip of paper and in which the characters are recorded either by ink recorders or by electro-chemical decompositions on chemically prepared paper; it is, however, best known as a chemical system.

In Fig. 218 the connections of the Anderson system are shown, theoretically. *B* is a main battery at a transmitting station. *x* is a metal cylinder rotated by suitable apparatus. *s* is a contact pen or brush. *P* is a perforated paper tape passing between the cylinder and brush. At the receiving station *y*, *T'* is a metal cylinder, also rotated by suitable mechanism. *P'* is a chemically prepared paper tape which passes between the cylinder and pen *s'*. *C* is a condenser and *R* is a rheostat "shunting" the condenser.

The transmitting strip is prepared by punching large and small holes in one row, as seen in Fig. 218.

Since but one row of holes is used in the perforated paper it will be evident that some means must be provided for obtaining the equivalent of the "double" current method of transmission previously referred to, otherwise a very high rate of speed could not be expected. This equivalent is furnished by the condenser *c*, at the distant station which, on discharging, gives out a current in the opposite direction to that of its charging current; the result of which is to cut off the "tailings."

The operation of the condenser in this system is based on the well-known fact that this instrument receives a "charge" when its poles, or terminals, are at different electrical potentials, and is immediately discharged when the charging battery, or electromotive force is removed and the condenser terminals are connected together,

FIG 218.

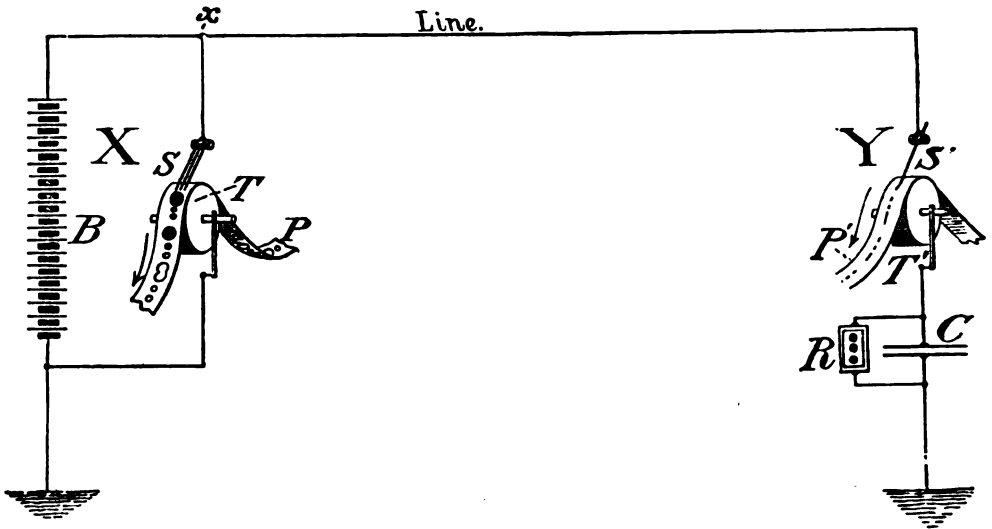

ANDERSON CHEMICAL AUTOMATIC SYSTEM.

or placed to earth; the current of discharge being in the opposite direction to that of the current of charge.

It will be seen, Fig. 218, that the pen *s*, paper *P* and cylinder *T*, at the transmitting station, form a circuit around the battery. This circuit is, however, only complete when the pen drops through one of the holes in the paper; the effect of which is to short-circuit the battery *B* and, consequently, to suddenly drop the potential on the line wire at *x*. Normally, therefore, as when the pen is resting on the paper, the full battery is to the line. At such times the condenser *c* at *Y* is charged with a certain polarity, the amount of charge measurably depending on the resistance *R*. At the moment when the transmitting brush falls into a hole in the paper and the potential on the line is dropped practically to zero, the condenser, *c*, at once parts with its charge, producing a current in a reverse direction to that of the charging current, thus interrupting the flow of marking current through the paper. The resistance of *R* is regulated so that the current from the condenser shall be sufficient to secure well defined and sharp marks on the paper; otherwise, in some cases, the marks would be imperfect, showing that the discharge current from the condenser was too strong.

Hence, by this means, there is obtained the equivalent of a double current at the transmitting end, with the advantage of a prompter action in the matter of the application of the reversed current, to diminish the tailings, by having the generator of the "double current" at the receiving end; an additional advantage consisting in the fact that the amount of charge and discharge may be readily adjusted at the receiving end without reference to the transmitting battery, excepting, of course, that the latter must have sufficient electromotive force to provide a working margin at the receiving end.

In the Anderson arrangement in the act of short-circuiting battery B, a direct path to earth via *x* is provided for the "static" discharge of the line, leaving a minimum to be neutralized by the condenser at *y*. In other chemical systems where a condenser has been used as at *y*, but in which the direct earth at the transmitting station has not been employed, it was frequently found that the condenser, not having sufficient opportunity to discharge between impulses, would become charged or, so to speak, "clogged," and would remain virtually inoperative after a few impulses.

Ordinarily, in chemical automatic systems of this class the battery has been placed to the line when the contact pen touched the cylinder, in the same way that the current passes to the line when the key is closed in the Morse system.

It has been shown that, in the Anderson system, the signals are transmitted by an opposite method, namely, that when the transmitter is in contact with the cylinder the battery current does *not* pass to the line. If, therefore, the holes in the paper were made in lengths to correspond to dots and dashes, signals would be received, as it were, on the "back" stroke. Hence it is clear that a special method of preparing the holes in the paper must be availed of. This method consists in so perforating the paper strip that the uncut paper between the holes represents the dots and dashes of the alphabet. Consequently, as, in the Anderson system, it is only when the transmitting contact pen is passing over the uncut parts of the paper that the charges pass to the line, the result is that "straight" dots and dashes are recorded.

A specimen of the punched paper strip used in this system is shown in Fig. 219.

In the figure, characters in dots and dashes are placed under the holes. The large holes produce the space between letters. Two large holes cutting into each other produce the space between words. The blank spaces on the paper between the holes produce dots or dashes, according to their respective lengths.

FIG. 219.

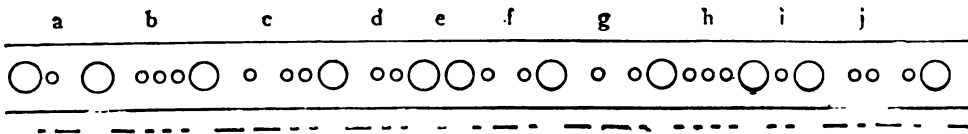

The holes represent letters of the alphabet from A to K. Spaced letters are not used in this alphabet. Such letters are assigned special characters. Thus:

C - - - - - O - - - - - R - - - - - Y - - - - - Z - - - - -

In experiments over actual circuits of about 2,500 ohms resistance and 1,000 miles in length, signals have been transmitted clearly by this system at a uniform rate of 600 words, per minute, during all kinds of weather and without any change in the adjustment of the apparatus. The electromotive force used was 250 volts. The condenser at the receiving end had a capacity of 4 microfarads and was shunted with

Fig. 220.

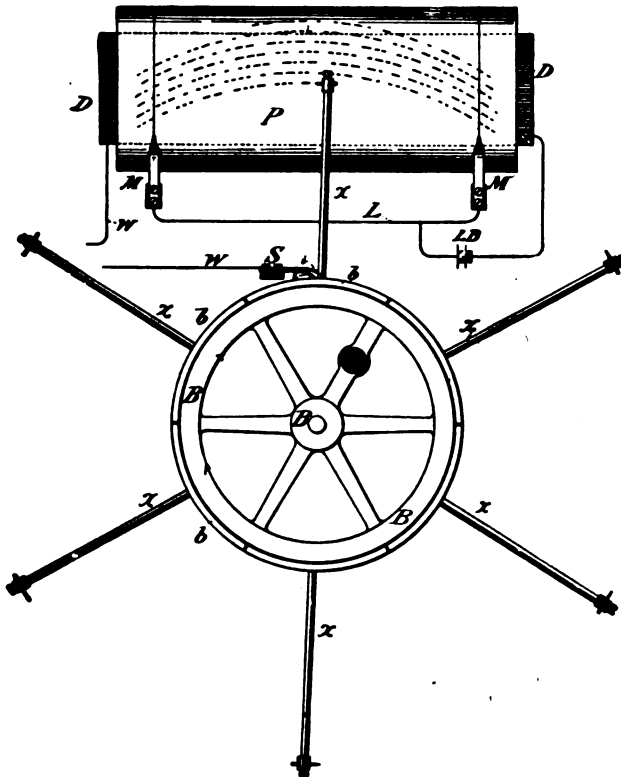

ANDERSON PAGE AND LINE CHEMICAL RECORDER.

10,000 ohms resistance. On a circuit 360 miles in length and having about 700 ohms resistance, 3,000 words, per minute, have been transmitted and clearly reproduced at the receiving end. In regular practice such a high rate of speed would hardly ever be necessary; probably 1,500 words, per minute, would suffice.

In the act of transmitting messages at high rates of speed, say, 2,000 words, per minute, the paper at both ends is shot over the respective cylinders at the rate of about 400 feet per minute.

It is very plain that at such a rate it is quite impossible for the attendant at the receiving station to follow intelligently the signals as they arrive and are recorded on the paper; everything appearing as a straight line or as a blank.

In regular practice this inability to follow up the received signals has frequently been a source of much vexatious delay owing to the fact that any confusion of signals due to the occurrence of momentary interruptions of the circuit has gone unnoticed until the dispatches reached the hands of the transcribing clerk. This has often necessitated the repetition of many messages in order that corrections might be made.

To avoid this defect of rapid automatic telegraphy in the Anderson system, a low resistance telephone is placed in the circuit. The effect of the rapid transmission of the signals is to cause a distinct hum in the telephone which is clearly heard, but upon the occurrence of wire trouble the instrument gives out a broken sound which serves as an instant warning to the attendant, who at once stops the instrument and takes any action necessary. The transmitting end may be similarly equip-

ped and thus the safeguards against errors are doubled. This device is peculiar to the Anderson system.

Another device which is useful in aiding the prompt detection of wire trouble consists of an arrangement whereby the signals are received on sheets of paper instead of on the ordinary paper tape. On the sheet, or page, the attendant can see at a glance, almost as soon as the signals are received, whether they are being recorded properly or otherwise.

The manner in which this result is effected in the Anderson system is shown in Fig. 220. The paper *P*, in page width, is shown passing over a long cylinder *D*, which is part of the line circuit *w*. The paper is chemically prepared in the usual way. Below the cylinder is a wheel *B*, having a metal periphery. This periphery is divided into 6 segments *b b* etc., as seen. The segments are insulated from each other. On this periphery rests a split contact pen, or spring, *s*, to which is attached another portion of the main line circuit. One of the tines of the pen is put slightly in advance of the other. Six metal pointers, *x*, project, at equal distances apart, from the periphery of the wheel, one from each segment of the periphery. On the end of each of these pointers a small metal pen, or needle, is placed, one of which is shown resting obliquely against the paper *P*.

As the wheel *B* is insulated from the cylinder *D*, it is obvious that the line circuit is completed through the periphery of wheel *B*, the pointer *x* and the paper *P*, to the cylinder.

The wheel *B* and cylinder *D* are caused to revolve by any suitable means. The pointers are so arranged that as one is *about* to move off the paper *P* the next one moves on it, but before one pointer moves off entirely the contact spring *s* will have moved off that pointer's segment, thus cutting the right hand pointer out of circuit. Similarly the current will not have passed through the left hand pointer until the contact spring has reached that pointer's segment.

At the same time, the paper, in process of winding, is passing the cylinder. The result is that the left hand ends of the lines of characters are slightly lower than the right hand ends, but the distance between each line is the same.

As it is essential that the contact spring *s* should not actually leave one segment until it has made contact with the next one, the spring contact is split in the manner stated and shown. In consequence of this there will be at the end of each line, on the page paper, a duplicate of the signals at the beginning of the next lower line. In order to avoid confusion from this cause two additional contact springs *m*, *m'*, are caused to touch the paper on the cylinder, as shown. These form part of a local circuit *L*, in which is included a local battery *LB*. The result is that two continuous vertical lines are electrolytically produced on each side of the paper. As the space between the points of the two contact springs *m m'* bears a fixed relation to the curves of the successive segments; all of the record to the right and left of the vertical lines is in duplicate. In reading the record the operator has simply to read all of the record to the left of the right hand line, ignoring all to the right of that vertical line, or all to the right of the left hand line, ignoring all to the left of that line.

The chemical solution for the recording paper used in the Anderson chemical automatic system consists of $1\frac{1}{2}$ ounces red prussiate of potash; $1\frac{1}{2}$ pounds nitrate of

ammonia and 1 pound of muriate of ammonia, all dissolved in a gallon of pure rain or distilled water.

According to Mr. D. H. Craig, to obtain the best results, paper intended for perforating in automatic telegraphy, should be made from pure white cotton and liner rags, without the use of chlorine, or, if that is used, it should be washed in good water until every vestige of the chlorine has been expelled. Such paper does not dull the punches, or cutters, of the perforator when they are properly constructed.

The pen used in the Anderson chemical automatic system is of very fine piano steel wire. The pen is so adjusted that it can be conveniently lengthened or shortened, even while recording at the highest speed.

The current, in its passage through the paper, decomposes the chemicals of the mixture, setting free an acid which attacks the steel wire, leaving, as a result of the action, permanent clear, blue-black dots and dashes on the paper. If a copper wire were used red dots and dashes would result. The wearing of the steel pen, thus occasioned, is provided for in the adjustment just referred to. Pure, soft iron wire is more sensitive than steel for this purpose but it has been found less reliable in practice.

THE WHEATSTONE AUTOMATIC TELEGRAPH SYSTEM.

Of the rapid, ink-recording, automatic systems of telegraphy, the Wheatstone is to-day, the best known. It has for many years been extensively used in Great Britain and has also been employed on a number of circuits in this country for several years.

FIG. 221,

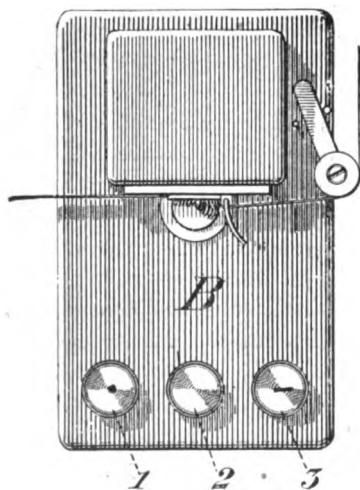

THE PERFORATOR, TOP VIEW.

The apparatus of the Wheatstone automatic system consists of a perforating machine, by means of which messages are prepared for transmission; a transmitter, which utilizes the perforated paper to transmit messages thus prepared, and a receiver which, being actuated by electrical pulsations set up by the transmitter, records them in ink, on stiff paper tape, as dots and dashes.

THE PERFORATOR.

The perforator is shown, as a whole, in Fig. 221. It consists essentially of a set of five metal tubes, or punches, each moving within a close fitting case, or guide, and which are capable of being pressed outwardly beyond the cases, by suitable mechanism. These punches, and the apparatus for operating them, are contained within the box B.

The hollow punches, at their outside ends, have keen edges, and the paper to be perforated is caused to pass, as seen in Fig. 221, close to the edges.

The inner ends of the punches are adjacent to three rods or levers, which connect with three keys or discs, 1, 2 and 3, Fig. 221, which latter are placed in a position

convenient for the operator. These keys are depressed by the punching operator who uses a rubber tipped mallet in each hand for the purpose. When a key is depressed certain of the cylinders are pushed outward through the paper strip. The keys 1, 2 and 3 are marked *dot*, *space* and *dash*, respectively. When the dot key is depressed three vertical punches marked 1, 2 and 3, in Fig. 222, are pushed outwards, and three vertical holes (\odot) are perforated. When the dash key is depressed four punches marked 1, 2, 4 and 5, are operated, and four holes $\left[\begin{smallmatrix} \circ \\ \circ \\ \circ \\ \circ \end{smallmatrix} \right]$ are punched. When the space key is depressed, but one punch, marked 2, is operated, and but one hole (\circ) is punched.

A small star-wheel, the edge of which is seen as a short dash to the left of punch 2, in Fig. 222, is so placed before the punches that the same action which pushes them out, also operates mechanism which causes that wheel to revolve, and as its teeth fit into the central, or space holes, just perforated, the paper is carried forward by that wheel with a regular motion. By depressing these keys according to the requirements of the Morse alphabet, a message, represented on the strip of paper by vertical and diagonal circular

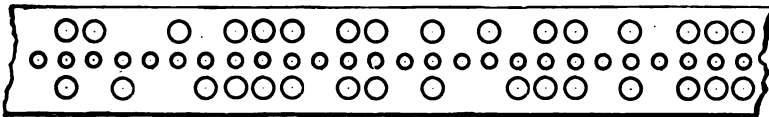
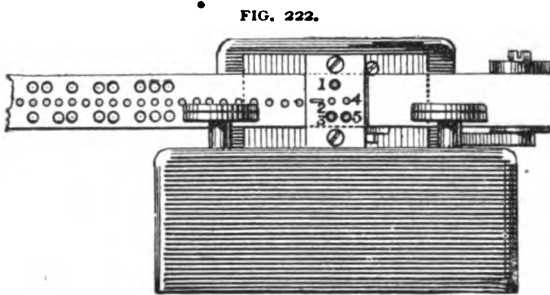

A B C D E

THE PERFORATOR—SIDE VIEW.

perforations, is prepared for transmission by the Wheatstone transmitter. When in perfect order,

or gauge, the perforator punches 120 space, or center, holes, to the foot. A portion of perforated paper is shown below the box in Fig. 222.

As the work of depressing the disc of the puncher is somewhat arduous, a pneumatic arrangement is sometimes employed.

In this arrangement the operator simply depresses a disc with his finger, which action opens a valve connected with an air tube, when a piston driven by the air pressure actuates the punches.

THE TRANSMITTER.

The actual transmitting parts of this instrument are outlined in Fig. 223. The rods, cranks, levers, etc., shown, are supported on the side of a box containing clock-work and gearing for driving the transmitter machinery. In the figure R is a "rocking beam" carried by a shaft which enters the box through the frame. The shaft is given a rotary motion by suitable machinery within the box. L' and L are vertical rods, which, at their lower ends, are attached to the crank levers A A'. The crank levers are provided with horizontal connecting rods H, H', the right hand ends of which pass through holes in the arms, or projections M M' from the disc D. H H, are

furnished with collets, or shoulders c, c' , which, in certain positions, engage with the arms $M M'$ and push the disc D back and forth. By means of adjusting screws F, F' the vertical rod L is set to the left of L' , a distance equal to the space between two consecutive horizontal holes in the perforated paper. The rods are, normally, held towards these set screws by light springs K, K' . The springs s, s give the vertical rods L, L' a constant upward tendency, but their upward motion is checked by the pins P, P' on the rocking beam R . For example, when the right hand end of the beam is making its upward motion the rod L follows the pin P upwardly. At the the same time the rod H , by its collet, pushes over the arm m of disc, D , as shown. Also, at the same time, the pin P' on R depresses the rod L' and this action withdraws the collet of connecting rod H' , and thus permits the rod H to act freely on the disc

F. G. 223.

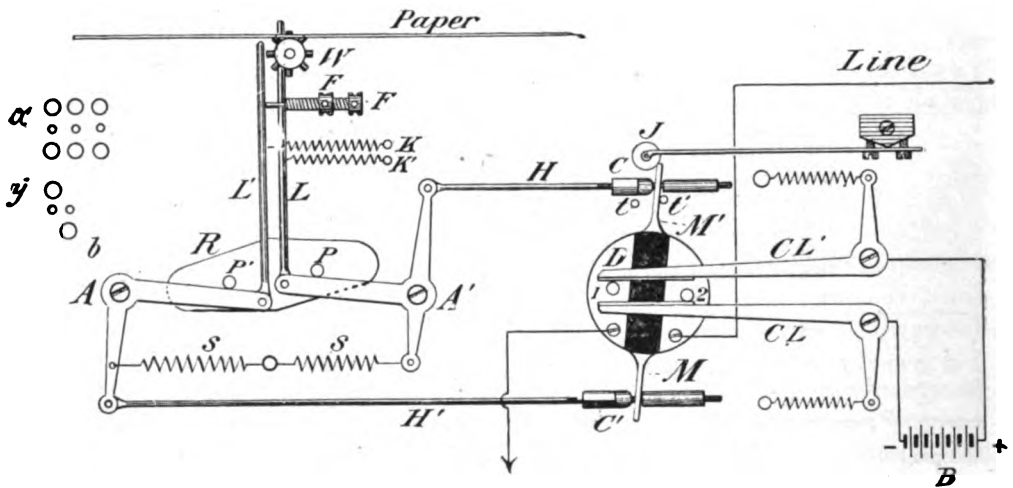

WHEATSTONE TRANSMITTER THEORY.

D by its arm m' . This disc is formed of two metal segments which are separated from each other by an insulating material. One of the segments is connected to the line, the other to the ground. A metal contact pin, 1, 2, juts from each segment. Two crank levers CL, CL' , connected with the battery B , are held against one or other of these pins by the springs shown. The movement of the disc D to the right or left is checked by limiting pins t, t' .

The disc D is virtually a pole-changer and these rods and levers simply replace the fingers of the operator in causing it to reverse the poles of the battery. In the position of the disc D , in Fig. 223, a negative pole of the battery is placed to the line. The perforated paper is shown by the line above the vertical rods L, L' ; and it is supposed that the rod L has passed through one of the perforations in the paper. Assuming that there is another hole in the paper immediately opposite that one through which L has just passed, then, when the next movement of the beam R permits the vertical rod L' to rise, it will, owing to its position to the left of L , as well as to the movement of the paper to the left, pass through that hole, as shown in Fig. 224. By the downward motion of the right end of R the rod L has been depressed. Conse-

quently, the collet *c* on *H* has been withdrawn, giving the collet *c'* on rod *h'* free scope to act upon arm *m* of disc *D*; thus placing the rod *cl'* in contact with the right hand pin *2*, on disc *D*, and the rod *cl* in contact with the left hand pin *1*, thereby reversing the polarity of battery *B*; for it will now be found that the positive pole of battery *B* is to the line. (Fig. 224.)

J, in Figs. 223, 224, is a small wheel, termed a "jockey roller," held above the arm *m*, of disc *D*. It is held in position by a flat spring. Its function is to assist in pushing over the disc *D*, when it passes the center, to either side, and it also insures a steady contact of the rods *cl*, *cl'*, with the pins on the disc.

The machinery within the transmitter box which actuates the beam *R*, also causes the star-wheel *w* to revolve, and its teeth, fitting into the central holes in the perforated paper urge it to the left a certain and regular distance at every up and down motion of the beam. As the central holes in the paper are perforated by the punching machine with precise uniformity as regards the position of the outside rows of holes in the paper, this stated motion of the paper insures that, whenever there is a lateral, or outside, perforation, it will always be in a position directly over one or other of the vertical rods *L* *L'* when they approach their maximum upward motion.

The bent levers *cl'* and *cl* were formerly provided with a small set screw opposite the disc *D* to keep the contact points apart at the moment of reversal of the disc and thus prevent short-circuiting of the battery. The set screw was insulated from the lower lever. This device has been dispensed with in the instruments of recent manufacture.

In Morse telegraphy the dots and dashes are distinguished from each other by a short or long duration of the signal. In the Wheatstone automatic system, if a series of vertical holes such as these \odot (see *x*, Fig. 223) were prepared on the paper tape and passed through the transmitter, the rods *L*, *L'* would make a full phase at every motion of the beam, and, inasmuch as this would cause regular reversals of the battery, a succession of dots would be recorded by the distant receiving instrument.

When, however, a set of holes, such as these, $\odot \ominus$ (see *y*, Fig. 223,) is passed through the transmitter, the result is different. Namely: at its first upward motion the rod *L* will pass through the upper, or further, hole as in Fig. 223, (that is the hole nearest the frame of the transmitter) pushing the disc *D* to the right. At the next motion of the rocking beam the rod *L'* meets the paper at a point opposite the hole through which *L* had just previously passed, and its further upward motion is obstructed; consequently, crank lever *A* does not follow pin *p'* the entire distance. The result is that the disc *D* is not pushed over and the battery is not reversed. In the next upward motion of *L* its phase is also checked by the paper, and the polarity of the battery, consequently, is still unchanged, until, at the next upward motion of *L'*, the latter comes opposite and passes through the hole *b* (*y*, Fig. 223,) and thus causes the arm *m* to push back the disc *D*, thereby reversing the poles of the battery. This delay in the reversal of the battery is sufficient to make quite an appreciable distinction in the length of the signal recorded and, in fact, constitutes a dash.

The effect of all this is that, depending upon the position of the perforations in

the paper, which have already been prepared for the purpose, dots and dashes are transmitted by the pole-changing disc *D*, in practically the same manner as the Morse operator would transmit them by an ordinary manual pole-changer, although, of course, at a greater speed.

A MODIFIED FORM OF TRANSMITTER.—A new form of transmitter now much

FIG. 224.

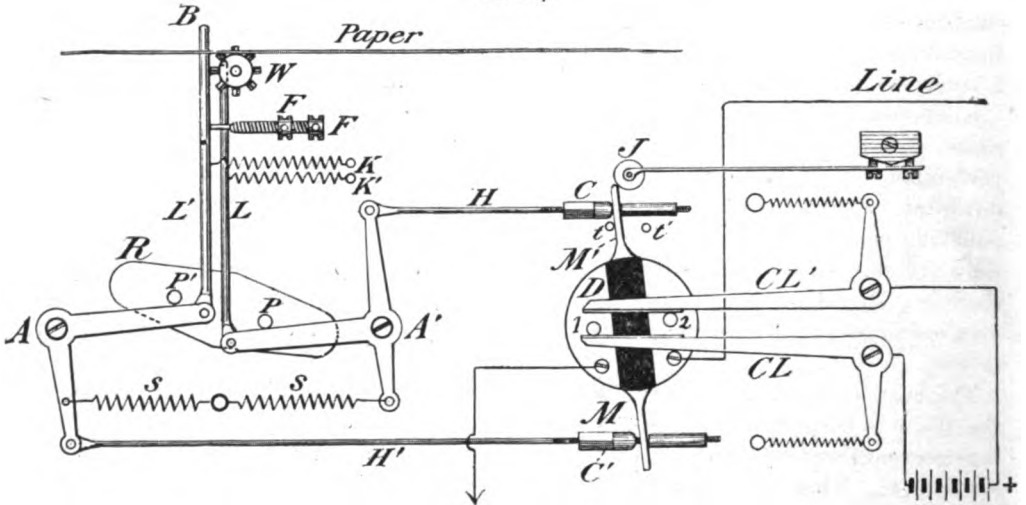

WHEATSTONE TRANSMITTER THEORY.

used in the British postal service, by which the speed of transmission is said to be increased very materially, is shown in Fig. 225. The change is chiefly in the arrangement of the battery reversing connections. The bent levers *CL*, *CL'*, Figs. 223, 224,

are dispensed with and in their place, two metal strips, having contact points at both ends, as shown, *P' N'* are supplied. To these the positive and negative poles of a battery are, respectively, attached. The line wire is attached to the insulated portion *P* of the vibrating lever *P, D*, which takes the place of the disc *D*, and is acted upon by the collets *c* and *c'* in the same manner as is that disc in the arrangement shown in Figs. 223, 224. In addition to the foregoing changes the ends of the rods *H* and *H'* are passed through holes in supports *x* by which means the motion of the lever *D* is not impeded by the weight of those rods.

FIG. 225.

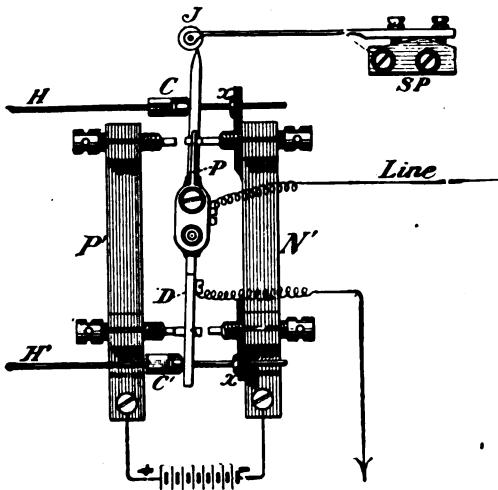

The "rider" wheel *J*, is also considerably reduced in size and its supporting piece, *SP*, is reversed. The "ground" is

connected to the lower portion of the lever *D*, as shown, the upper and lower portions of that lever being insulated from each other.

This style of transmitter has not been found very well adapted for circuits on which high electromotive force is employed, in this country, owing to the sparking which takes place at the contact points. There is also, in this form, some difficulty in maintaining a fine adjustment owing to the number of contact points to be considered.

FIG. 226.

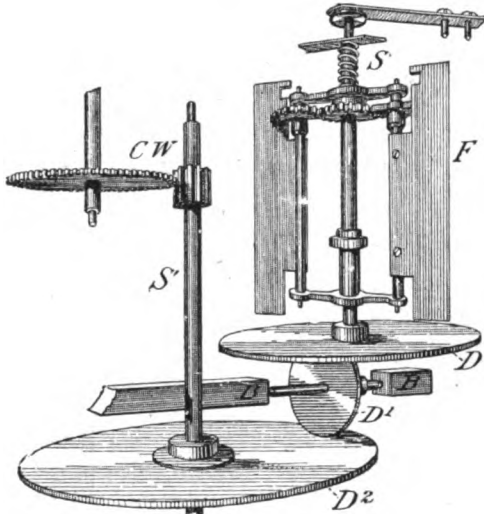

SPEED REGULATOR.

train, *cw*. When *D*² is revolved, *D*¹ in turn, revolves, and causes disc *D* also to revolve. As the disc *D* revolves, centrifugal force causes the arms of the fan to spread, in which position they encounter the resistance of the air (to an extent depending upon the speed) and thus retard the speed of the clock-work.

The speed at which the clock-work may run is regulated by the position of disc *D*¹ with regard to discs *D* and *D*² and this position is adjusted by the movement of the bearings *BB* of the disc *D*¹, from the outside of the box, by means of a lever, shown at the top of the receiver, (Fig. 228.)

When the disc *D*¹ is in the position shown in Fig. 226, that disc will turn quickly because of the large circumfer-

SPEED REGULATOR OF TRANSMITTER.— The speed of the clock-work of the Wheatstone transmitter (also of the receiver) is controlled by a "governor" consisting of a regulator contained within the case.

This apparatus is shown in Figs. 226, 227, in which a portion of a "fan" *F* is shown extending from the shaft *s*. At the lower end of *s* a disc *D* is rigidly attached. Below *D* is placed, at right angles to it a smaller disc *D*¹. The latter is mounted on an axle which has its bearings in a small, movable brass frame *B, B*, whereby it may be moved to the right or left. At its lower edge disc *D*¹ rests against a larger disc *D*², which latter is rigidly attached to the shaft *s*'. *s*' is directly connected with the clock-work

FIG. 227.

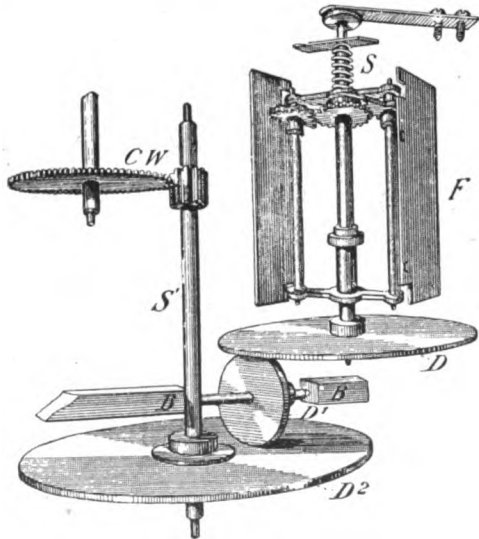

SPEED REGULATOR.

ence of D_2 as compared with D_1 ; while the large circumference of D_1 as compared with that of the surface at which it gears, by friction, with D , gives the latter a comparatively rapid motion. When D_1 is moved to the left so that it assumes the position indicated in Fig. 227, the circumference of r_2 , so far as disc D_1 is concerned, is reduced, while that of D is increased, with the result that a comparatively rapid motion of D_2 imparts but a com-

FIG. 228,

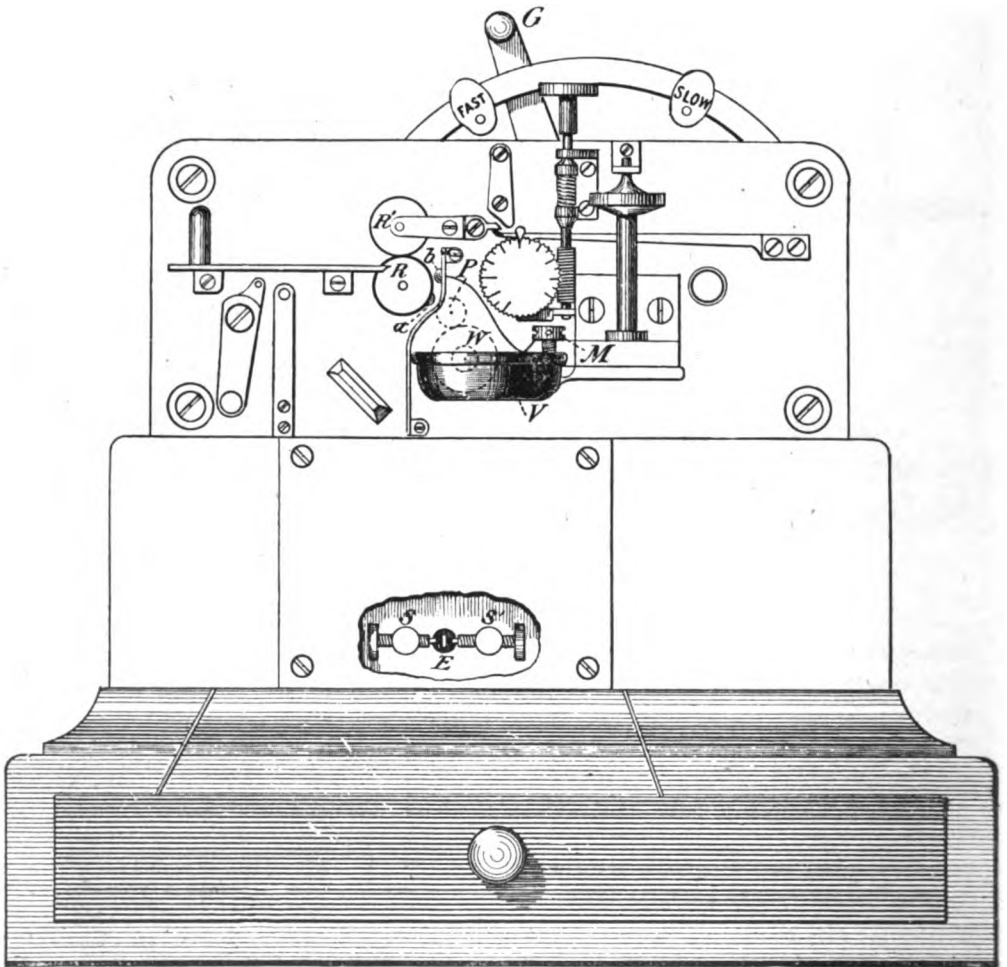

WHEATSTONE RECEIVER.

paratively slow motion to D ; thereby reducing the resistance at the fans, and thus permitting a more rapid movement of the clock-work.

THE WHEATSTONE RECEIVER.

The Wheatstone automatic receiver, or ink recorder, is outlined in Fig. 228. The electrical portion of the receiver consists of a polarized relay, not shown in Fig.

228. The mechanical portion consists of machinery devised to move the paper ribbon on which the ink records are made, as well as that employed in the production of the ink records. The moving force of this machinery is a weight on an endless chain. The clock-work and the polarized relay are contained within the frame of the receiver. The apparatus shown outside of the frame-work, Fig. 228, will be referred to later.

Fig. 229 shows the devices actually employed in producing the ink records. These consist of a polarized relay PR, an axle x , and a shaft B , pivoted, with its gearing, at one end r , and carrying a disc P , outside of the box, at its other end. This disc revolves in a groove on the periphery of the wheel w , but does not touch the latter.

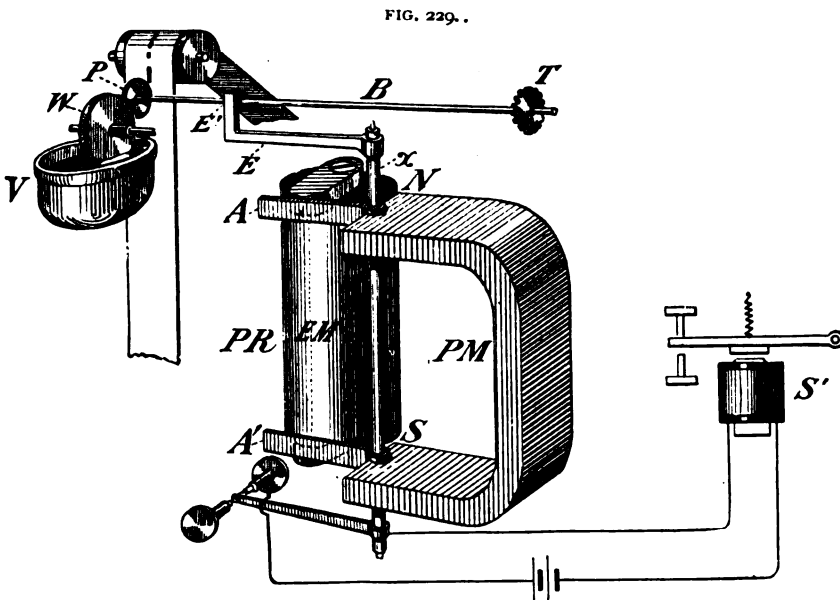

WHEATSTONE RECEIVER—RECORDING PARTS.

Wheel w is also placed outside of the box and is rotated by the shaft B , which latter is operated by the clock-work within the box. The lower portion of w revolves in an ink-well, V , attached to the frame-work of the receiver, as seen in Fig. 229. The paper ribbon passes in proximity to the edge of disc P , but does not touch it. It, at times, however, comes so close thereto that it leaves an ink mark on the paper and this record is a dot or dash corresponding to the character transmitted from the sending end. As, by this arrangement, friction is avoided, it will be readily understood that a much more sensitive receiving relay may be employed than would be the case otherwise. The manner in which the characters are caused to be imprinted on the paper will be described presently. The polarized relay consists of the permanent magnet PM , Fig. 229, electro-magnets EM , with two bobbins opposite each other, only one of which is shown here; the near bobbin being removed to show the armatures A, A' , more clearly. Armatures A, A' are rigidly attached to the axle x , and at the point of junction

with the axle they fit loosely into a curved notch in the ends of the permanent magnet. Thus the ends of each armature between the pole pieces of the electro-magnets are "inductively" magnetized to opposite polarity. For instance, that at A would be north; that at A' south. The coils of the electro-magnet are so wound that the pole-pieces facing one another are of opposite polarity. Thus each armature is attracted by one and repelled by the other pole-piece, and it also follows that both armatures will tend to move in the same direction when current flows in the coils of the electro-magnets. The axle *x* is loosely pivoted on suitable bearings within the box. At its upper end it is provided with an extension *E*, as shown, which does not extend outside the box. This extension is given an upward turn at *E'*, sufficient to bring it within the range of the shaft *B*. There is a notch in *E'* in which *B* rests very lightly.

A current intended to record a dot or dash on the paper is termed a "marking" current; one that is intended to permit a space on the paper, a "spacing" current. When a marking current is transmitted the armatures move slightly, their motion being very limited, in a direction which turns the axle *x* and, consequently, moves the extension *E* towards the paper, and a dot or dash is recorded. When a spacing current is sent the armatures reverse their positions and the disc is withdrawn from proximity to the paper. Thus at each change in the direction of the current, which is brought about by the action of the transmitter, the armatures are oscillated, and with each oscillation the disc *P* is either caused to approach or recede from the paper. The wheel *w*, revolving in the ink-well, brings with it sufficient ink to keep the disc *P* well supplied.

Reverting to Fig. 228. On the frame-work of the box are shown *c*, the "governor" lever, which regulates the speed at which the clock-work, and consequently, the paper, will run. *v* the ink-well. *R* the roller which, operated from within the box, by the clock-work, draws the paper along. The paper in passing the disc *P* is steadied by the rounded projections *a*, *b*. The marking disc *P* is shown by dotted lines. The paper tape is kept in a roll in a receptacle under the receiver. The ink-well is covered by a brass top which may be removed by loosening the screw *m*. The adjustment of the armature of the receiver may be accomplished by letting down the door, indicated by the screws on the frame of the box, thereby obtaining access to the relay. A portion of the door is assumed to be removed to show the contact points of that instrument. Two small screws *s s'* are suitably supported near the lower armature of the polarized relay. A small extension, *E*, from that armature plays between these screws, thus limiting the movements of the armatures.

ADJUSTING THE WHEATSTONE RELAY.—To adjust the relay the paper should be allowed to run at a moderate speed. The extension *E* is then held loosely against the left hand screw *s* and that screw is moved to the right until the "mark" line appears as dots. The screw should then be turned to the left until the marks appear as a straight, even line, when another slight turn of the screw should be given, for a margin. The extension *E* is then held in a similar way against screw *s'* and that screw is moved to the left until the marks appear as dots, when it should be moved to the right until the marks just disappear, when a slightly further movement should be given to *s'* to the right, also to insure sufficient margin. Care should be taken that the marking disc *P* is not clogged with ink as that would entail a larger space between

the ends of the screws *s s'* in adjusting, and an unnecessarily extended motion of the armature, with a probable reduction in the speed of reception of signals.

WHEATSTONE DUPLEX.

The Wheatstone automatic system in this country is almost invariably worked on the polar duplex plan.

This system as arranged for duplex working is shown theoretically, in Fig. 230. In the figure, *T* is the transmitter, with all but the pole reversing parts omitted. *TS* is a

FIG. 230.

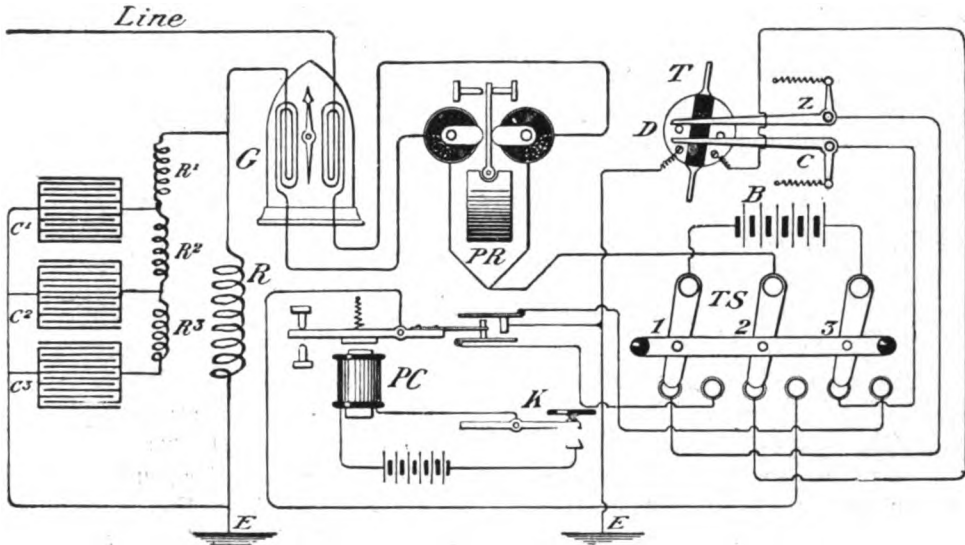

TERMINAL CONNECTIONS WHEATSTONE DUPLEX-THEORY

switch attached to the frame of the transmitter, used to change from the automatic to the manual system, in which latter case an ordinary pole-changer *PC*, operated by a key, *K*, is employed. When the switch is turned to the left, as at present, the automatic transmitter *T* is in use; when turned to the right, the manual pole-changer is placed in circuit. In the former case the circuit starts from *E*, passes to the disc, or transmitter *D*, thence, via lever *Z*, to the strip 1 on switch *TS*, to the negative pole of battery *B*, thence to the strip 3 of the switch, thence to disc *D*, via lever *C*, thence to the middle strip 2 on the switch, to the polarized relay *PR* of the receiver, where the circuit divides; one portion going to the rheostat *R* and ground *E'*, the other to the line and ground at the distant end.

G is a differentially wound galvanometer, one of whose coils is in the main line, the other in the artificial line. This instrument is used to balance by, inasmuch as the relay is not very accessible. When the balance is obtained the needle will stand at zero, if the distant end is to ground. This galvanometer, in the hands of experts, is also exceedingly useful for indicating, visually, the exact working condition of the circuit. It may be repeated here that the differential galvanometer is the equiva-

lent of a differentially wound relay, its coils being so wound that when currents of equal strength flow in them the needle will stand at a zero point.

The condensers c^1 c^2 c^3 are used, as in other duplexes, to obviate the effects of the static induction of the main line. In the very rapid transmission of signals, however, a more exact static balance is necessary than in ordinary Morse duplex working, and this is obtained by the employment of these additional condensers, each with a small resistance in its path. The first condenser has but the resistance of R^1 to encounter; c^2 has that of $R^1 R^2$; while c^3 has the combined resistances of $R^1 R^2 R^3$; the object being to so regulate the charge from the respective condensers that they shall equal the near, the middle and the remote portions of the line wire.

The actual connections now used in a standard Wheatstone duplex set are shown in Fig. 231, of which a detailed description is unnecessary. The switch DS is a different one from that shown in Fig. 230. It serves the purpose of placing the line to ground when a balance is desired and also acts as a battery reverser, as may be seen by imagining the strips 1, 2, 3, of the switch, to be turned to the right; assuming the strips to be pivoted at the top. The ends of the condensers only are shown. The local connections for a sounder are shown at the receiver. This is used when the system is being worked simple Morse. The connections are made at the set screws s , s' and extension E , shown in Fig. 228.

THE WHEATSTONE DUPLEX REPEATER.

This repeater is operated on the same general principle as the ordinary polar duplex repeater, in which the armatures of the polarized relays at the repeating station are caused to operate the pole-changer of an opposite set.

There are, however, several points of difference between the polar duplex repeater and the Wheatstone duplex repeater, as may be noticed in Fig. 232, which is a theoretical diagram of the latter repeater. In that figure PR , PR' are very sensitive polarized relays. G G' are the differential galvanometers usually employed in the Wheatstone automatic system. MB and MB' are main line batteries, each of which is grounded in the middle, as shown, (or they may, of course, be two distinct batteries) one having its positive pole and the other its negative pole, grounded. In each case, the poles of the batteries are led to the contact points of the polarized relays, and the lever of those relays is connected with the "opposite" line wire. Consequently, as the levers A A' are moved from side to side, an opposite pole of the battery is alternately placed to the "opposite" lines.

When the circuits are connected up for repeating "through," the western wire passes via F' , to the armature lever A of PR and the eastern wire passes via, F , to the armature lever A' of PR' , thence to the respective main batteries and "ground." The arrangement gives the western circuit control of the eastern circuit, and vice versa, inasmuch as the western distant station, having control of PR' , can reverse the battery MB' ; and the eastern distant station, having control of PR , can reverse the battery MB . It will thus be seen that the Wheatstone transmitter is dispensed with at the repeating station and that the armature levers of the relays PR and PR' are caused to act as pole-changers in their stead. In practice these armatures are adjusted very

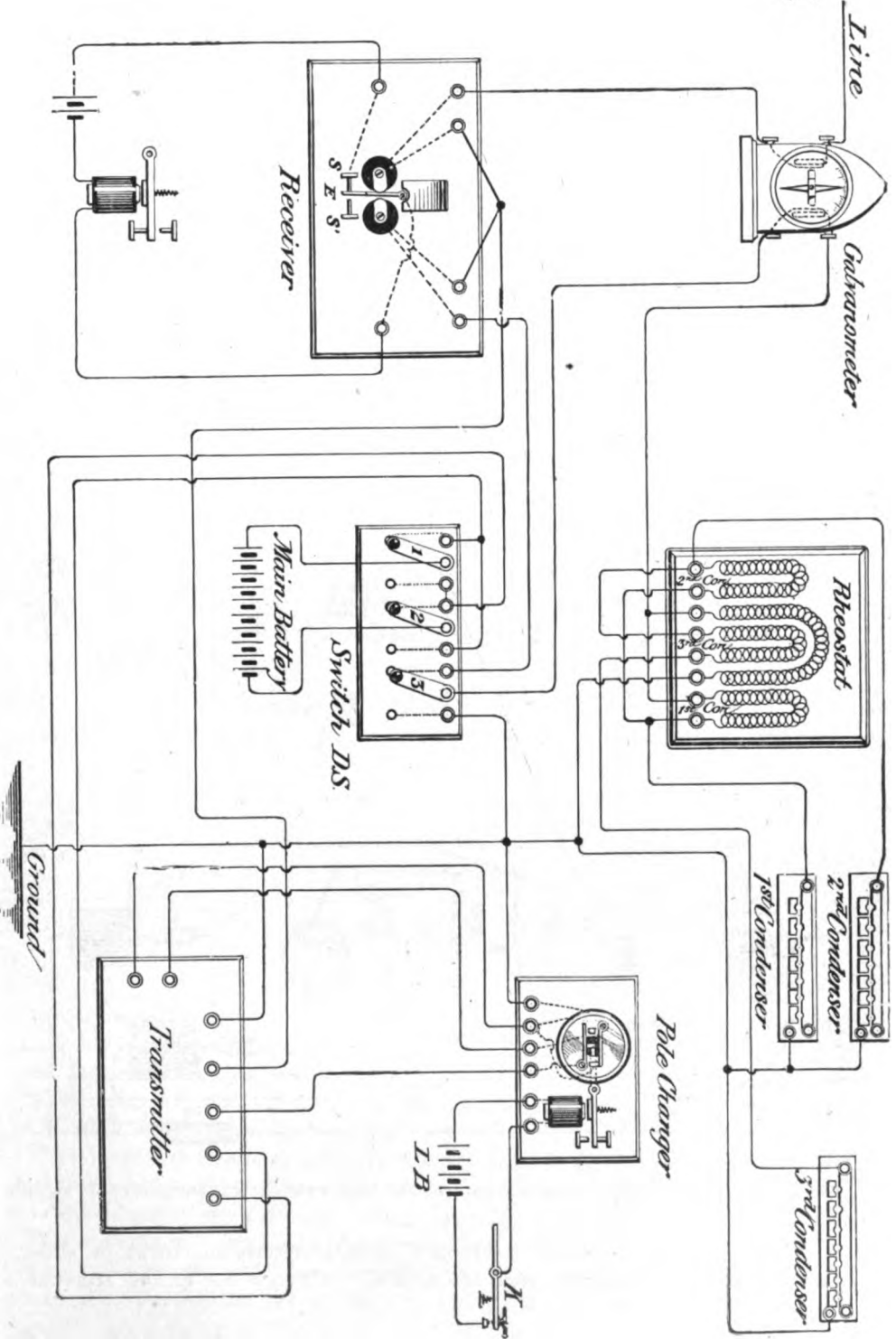

FIG. 231.—TERMINAL CONNECTIONS WHEATSTONE DUPLEX—ACTUAL.

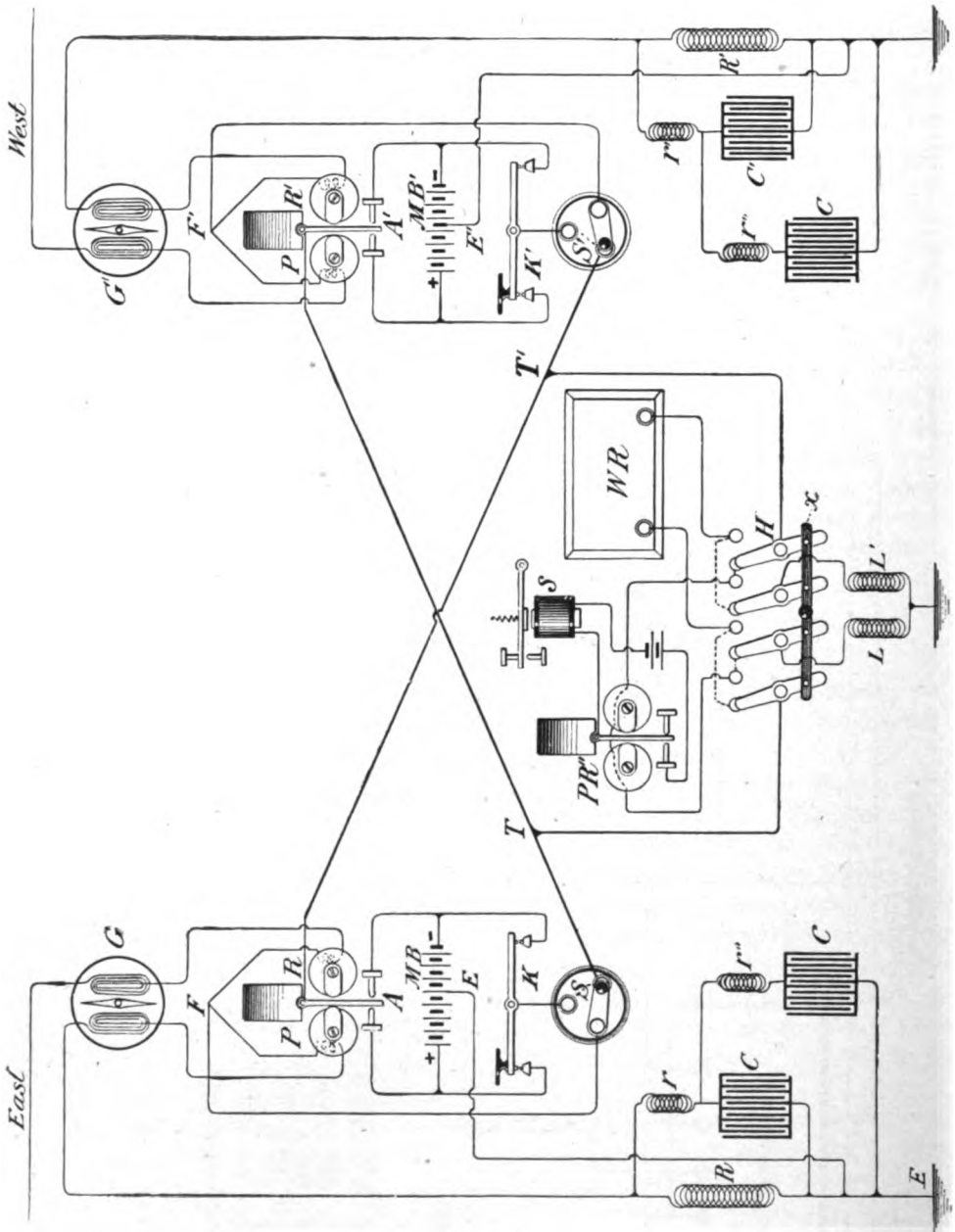

FIG. 232.—THEORY WHEATSTONE AUTOMATIC REPEATERS.

closely, and necessarily so, on account of the high rate of transmission of signals on this system.

When the circuits are cut "through," as in the figure, the circuit of either side may be traced, for instance, from the earth at E, through MB to the armature A of

PR; thence to the forked wires F' at relay PR', where the circuit divides in the way usual to polar duplex circuits, one wire leading to the rheostat R' and "ground," the other to the western wire.

When it is desired to separate the circuits for purposes of conversation, "balancing," etc., the 3-point switches S S' are turned, as indicated by the dotted lines. This, it will be seen, opens the wires leading to the armature levers of the polarized relays, and puts into circuit the double contact, or pole-changing, keys K, K'. These keys then act as pole-changers on their respective circuits; K reversing the battery MB, and K', MB'.

It is often desirable and essential to know the manner in which signals are passing through the repeaters. To obtain this information, readily, the arrangement of apparatus at the lower part of the figure is employed. It consists of a polarized relay PR', a Wheatstone receiver WR, a switch H, and high resistance coils LL'. These coils have a resistance of about 20,000 ohms each, and the receiver, WR, is wound to about 1,000 ohms. These relays and high resistances are tapped on to the main circuits as shown at T, T'.

The strips of the switch H are pivoted in the center and are mechanically joined together by the insulating strip x. As shown in the figure, the receiver WR is tapped on to the eastern wire; PR'' to the western wire. Should the strip x be thrown to the left it would connect WR with the western, and PR'' with the eastern wire.

Owing to the high resistance of the, so-called, "leak" resistances L, L', the

FIG. 233.

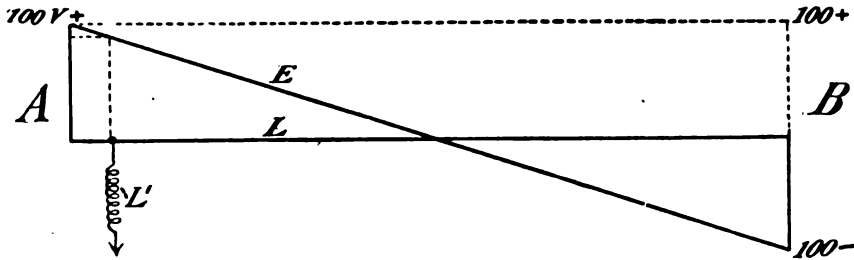

presence of the instruments PR and WR is not noticeable in the main circuit, but sufficient current is diverted from the main line to operate those highly sensitive relays.

PR'' is furnished with a local circuit and sounder and when the speed of transmission is sufficiently slow the signals are received on the sounder S, but when the speed is high the receiver WR' is brought into service.

The relays in the leak are not differentially wound, hence they are responsive to the reversals of polarity of the home battery, but are not responsive to the reversals of the distant battery even although it may be undergoing reversals.

This is due to the very slight change of potential effected by the distant battery at the point where the "leak" is connected to the line circuit. This statement may be rendered clearer by the aid of Figs. 233 and 233a. In these diagrams the re-

sistance of the line wire is represented by the horizontal line L ; the "slope" of potential along the wire by the line E . The E. M. F. at each end is assumed to be 100 volts. In Fig. 233, when the positive battery at A is to the line, and the negative pole is connected at B , the fall of potential may be shown by the line E . The leak L' is connected at the point indicated and a current flows through it in a positive direction. When the positive pole of the battery at B is placed to the line, the point to which the leak L' is connected at A is raised slightly, as indicated by the dotted lines, but the only effect of this is to increase the positive current flowing through the leak from the battery at A .

When, on the other hand, the negative battery is to the line as at A , Fig. 233a,

FIG. 233a.

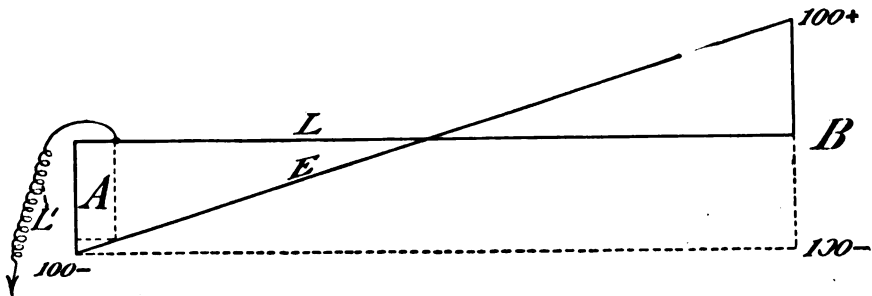

the direction of the current is obviously reversed through the leak, but the only effect of a reversal of the distant battery, which may be represented by the dotted lines, will be, as before, to increase, in a negative sense, the existing potential at the point to which the leak is connected, and thus again to increase current flowing through the leak.

Thus, as stated, the effect of the reversals of the *distant* battery on the instruments in the leak will only be to slightly increase or diminish the current flowing therein, while, at every reversal of the *home* battery, the direction of the current in the leak is completely changed.

The repeater "set" is provided with the usual duplex outfit of rheostats RR' , condensers CC' and retarding coils rr' . The batteries are sometimes provided with a device for ringing an alarm should they become short-circuited through the relays.

ACTUAL CONNECTIONS WHEATSTONE REPEATER.—The actual connections of the Wheatstone repeaters, as usually arranged, are shown in Fig. 234. The apparatus is generally erected on a large base-board, the binding posts being placed on one side of the board and the connecting wires under the board. This arrangement much simplifies the setting up of the repeaters, in repeating offices, as it is only necessary to bring the external, main and local batteries and line wires and ground wires, to the marked binding posts, when the repeater is, virtually, ready for service.

In Fig. 234, beginning at the binding posts 1 and 2, on the left hand side. A brass hook connects those posts together when the repeaters are working. When it is desired to work the apparatus by a separate Wheatstone transmitter the hook is thrown

1
2
3
4
5
6
7
8
9
10
11
12
13
14
15
16
17
18
19
20
21
22
23
24
25
26
27
28
29
30
31
32
33
34
35
36
37
38
39
40
41
42
43
44
45
46
47
48
49
50
51
52
53
54
55
56
57
58
59
60
61
62
63
64
65
66
67
68
69
70
71
72
73
74
75
76
77
78
79
80
81
82
83
84
85
86
87
88
89
90
91
92
93
94
95
96
97
98
99
100

WEST

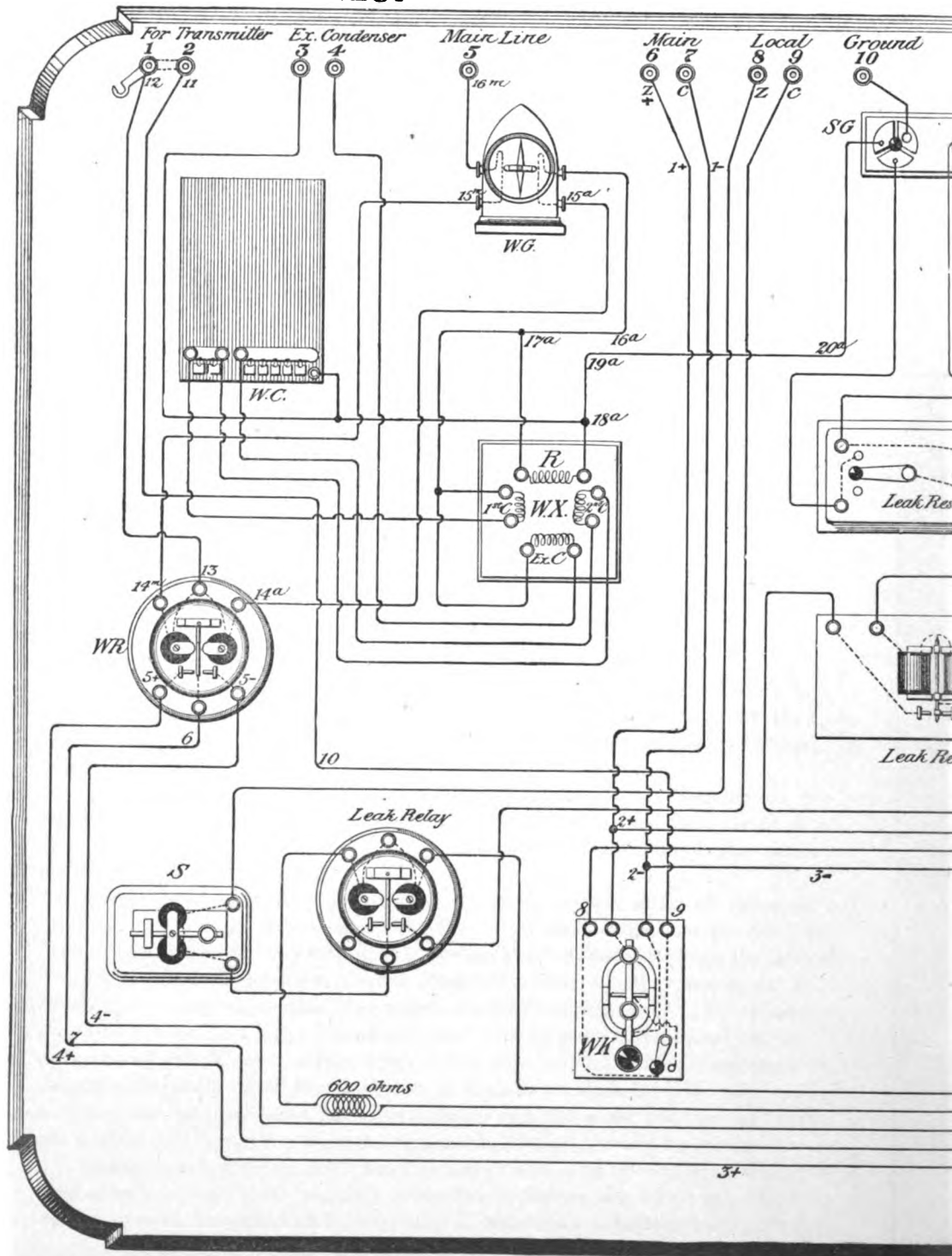

WHEATSTONE AUTOMATIC REPEAT

EAST

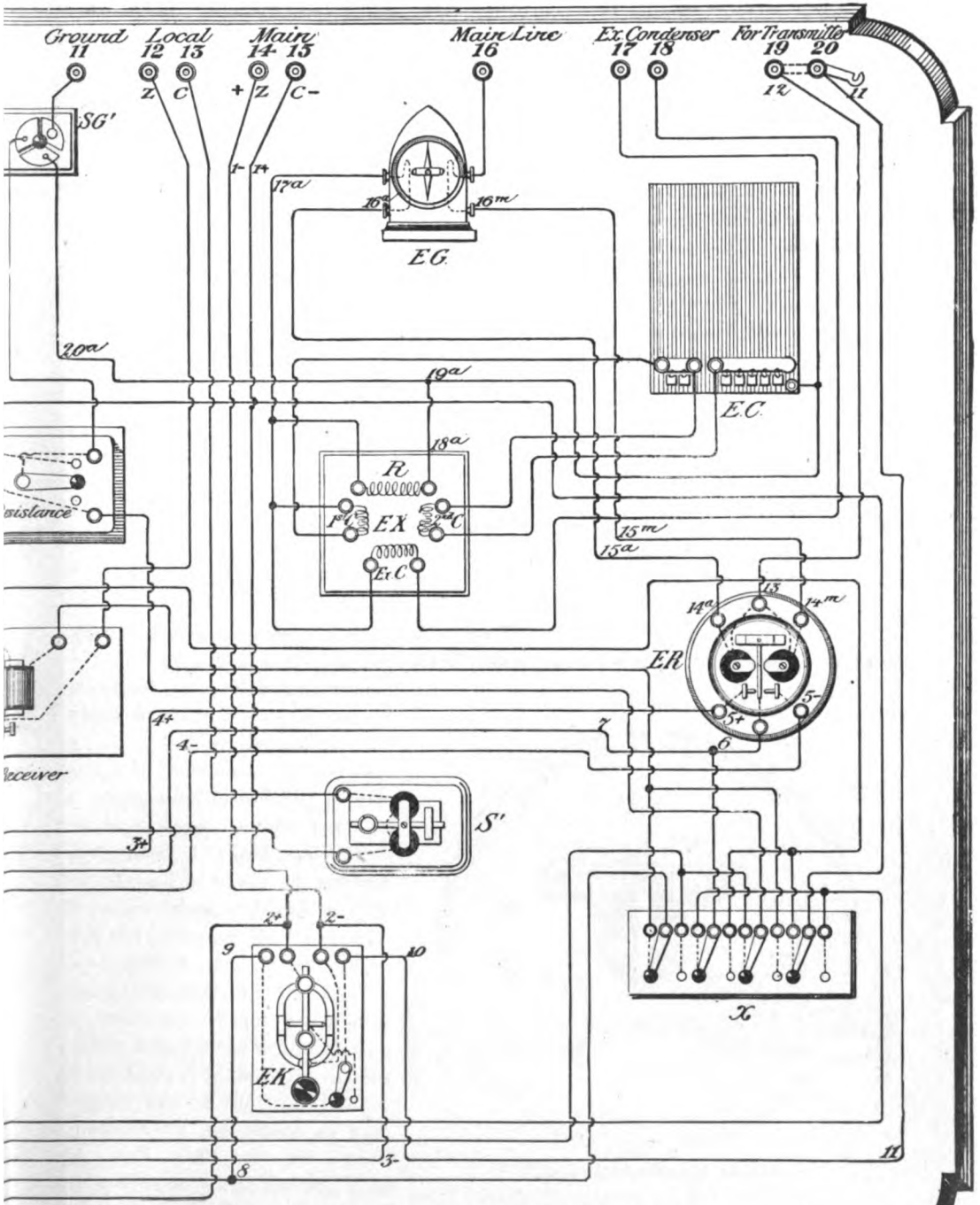

TERS—CONNECTIONS—ON ONE BASE-BOARD.

off, as in the figure, and the transmitter connections are attached to posts 1 and 2. Posts 3 and 4 are arranged for an "extra" condenser, if one should be necessary for a proper balance. In that case, wires from the condenser are led to posts 3 and 4,

FIG. 235.

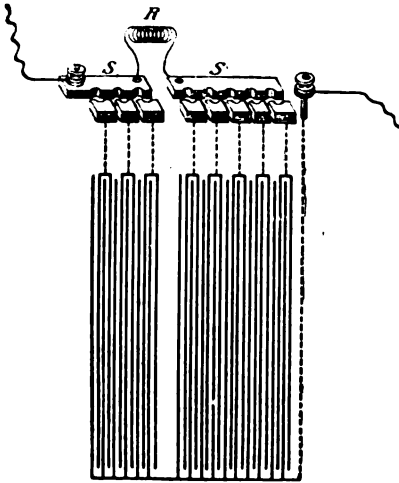

when the condenser will be found to be in the proper place, that is, practically as shown in Fig. 230. Post 5 is connected with the main line wire, in this case assumed to be the western wire. Posts 6 and 7 are connected, respectively, to the zinc and copper poles of the main line battery. Posts 8 and 9 to the zinc and copper poles of the local battery of the sounder *s* of the leak relay. Posts 10 and 11 are connected to the ground. Posts 12 and 13 are connected with the zinc and copper poles of the local battery of the sounder *s'* of the leak receiver. Posts 14 and 15 are connected, respectively, with the zinc and copper poles of the "east" main line battery. Post 16 is connected with the eastern line wire. Posts 17 and 18 are provided for an extra, or third, condenser. Posts 19 and 20 are provided for the insertion of a transmitter

in the same manner as posts 1 and 2, described.

It will be seen that the instruments of the western set are a duplicate of those of the eastern set. The leak relay, the leak receiver (*PR* and *WR* of Fig. 232) and the switch *x* are common to both sets. *EC* and *WC* are boxes, each containing 2 condensers arranged in one box for compactness. The leak resistances are contained in boxes as marked and are furnished with switches by which the coils may be "opened" when required. *EG*, *WG* are differential galvanometers. *WX* and *EX* are resistance boxes containing separate coils for the artificial line and condenser resistances. These rheostats are of the *dial* pattern and are shown separately in Fig. 237. *WK* and *EK* are small base boards on which are the keys

FIG. 236.

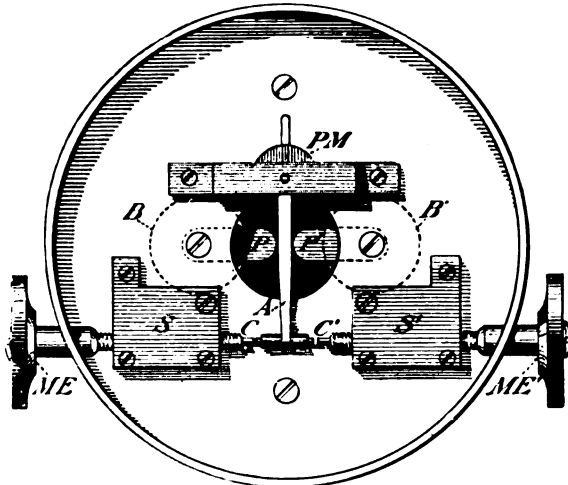

WHEATSTONE REPEATER RELAY.

used for conversation, and a 3-point switch for separating the western and eastern sets. This key and switch correspond to *KK'* and *SS'*, Fig. 232. *SG* and *SG'* are metal segments to which the ground wires are attached. By means of the plugs,

shown inserted in the center, the sets may be speedily disconnected from the ground.

WR and ER, Fig. 234, are the Wheatstone "repeater" relays.

FIG. 237.

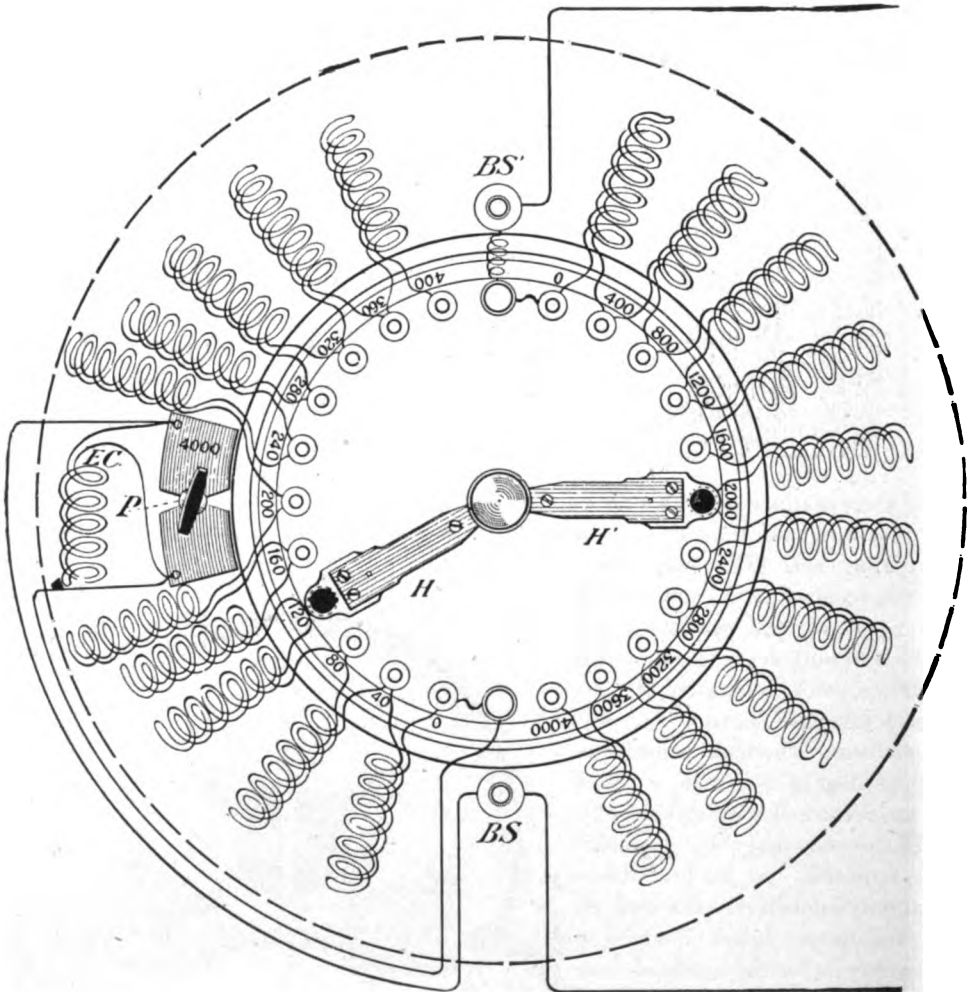

DIAL RHEOSTAT.

The routes of the circuits, when arranged for working "through," may be readily traced by the small figures 1+; 1-; 2+, 2-; etc., from the main battery posts, up to the split, or fork, that is the junction of the main and artificial wires, whence the circuits may be further traced by the numbers 13al, 13ml, etc., referring to "main line" and "artificial line," as will be seen on examination.

The arrangement of two condensers in one box, just referred to, is shown sep

arately in Fig. 235. In that figure the brass strip is in two parts, *s, s*, each part including a certain number of plates. Between the two strips the wires lead to a resistance which may be considered as corresponding to R^2 in Fig. 230.

WHEATSTONE REPEATER RELAY.—It is obvious that the “repeating” relays used in the Wheatstone automatic repeaters must be both sensitive and easy of adjustment. Such a relay is that shown in top view in Fig. 236. It is a polarized relay, wound for duplex working. *PM* is the permanent magnet, which magnetizes the armature *A* of the relay in the same manner as does the permanent magnet of the “receiver” relay. The tops of the two bobbins *B B'* are shown. The core of each magnet is supplied with pole-pieces *P P'* between which the armature vibrates. The armature is adjusted by means of the movable contact screws *ME, ME'*. The play of the

FIG. 238.

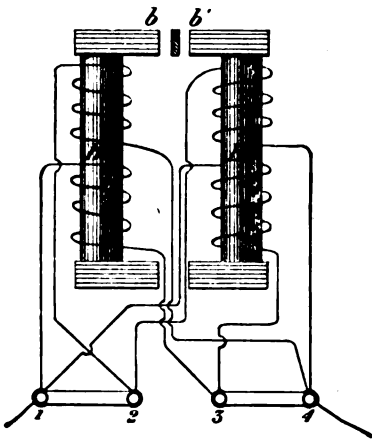
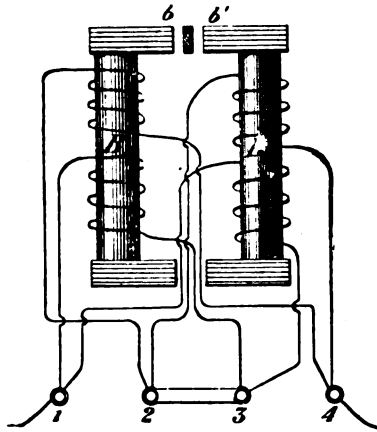

FIG. 239.



armature which is necessarily very small, is regulated by the distance between the contact points *c, c'*. These contact screws move in the brass supports *s, s'*. This relay is adjusted for a balance in, practically, the same way as the ordinary polar duplex relay. The bobbins and armature are contained within a cylindrical brass frame, except near the top, where a tight-fitting glass cover is attached to exclude dust, etc. The ends of the contact screws extend outside of the frame and thus are readily accessible for adjustment of the relay.

DIAL RHEOSTAT.—The adjustable rheostat generally used in the Wheatstone automatic system in this country, as well as in Europe, is of the dial pattern. It is shown, theoretically, in Fig. 237. *H* and *H'* are metal hands pivoted in the center of the dial like the hands of a clock, and movable in either direction. Around the dial are metal discs on any one of which an end of *H* and *H'* may rest. The terminals of the resistance coils are brought to these discs, as shown. The external connections are made at the binding posts *RS, RS'*.

The sum of the resistance coils on the left hand half of the dial amounts to 400 ohms, as indicated by figures, each coil being wound to 40 ohms. That of the coils on the right, 4,000 ohms, each coil being wound to 400 ohms. There is also an extra

coil ϵc , on the left of the dial which may be added to the circuit, when required, by removing plug P .

If, as in the figure, the hand H' rests on the 2,000 ohm disc, and the hand H , on the 120 ohm disc, there will be a total resistance of 2,120 ohms in circuit, as may be found by tracing the route, starting from the 2,000 ohm disc, from which the circuit then passes through the hands H' H and thence to the 120 ohm disc, thence to, but not through the extra coil ϵc , as it is short-circuited by the plug P , to the post BS .

FIG. 240.

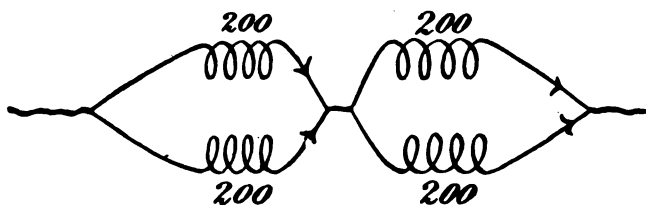

only necessary to slip the hands around from disc to disc in any desired direction until a balance is obtained.

WHEATSTONE POLARIZED RELAY. — The actual winding and arrangement of the Wheatstone relay is indicated in Figs. 238, 239.

This relay, as already stated, is composed of two separate, soft iron bars B , B' . Two coils of 200 ohms each are wound on each bar, the terminals of which coils are

brought to binding posts as shown. The winding is arranged to cause the poles that face each other, of the magnets, to be of opposite polarity. For example, a current which would tend to make one end, b , of bar B , a south pole, would make the end b' of B' , a north pole, and contrariwise. The manner in which the armature of the relay is placed between these poles has already been shown.

In "single" working the terminals of the coils are frequently arranged so as to permit placing portions of the coils in series or in multiple, for the purpose of minimizing the effects of "self-induction" which, as has been shown, conduce to slower signaling. (see Self Induction.)*

FIG. 240 a.

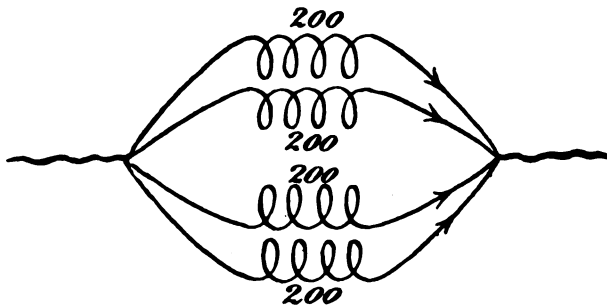

* Placing the coils in multiple effects this result, mainly, perhaps, by putting the electromotive forces of self-induction in parallel instead of in series, as indicated in Figs. 240 and 240a. It also decreases the ampere turns of the relay (See page 306), upon which, among other things, the self-induction depends. For example: if with one set of coils in series there are 500 turns of wire, and on the line .1 ampere, the ampere turns will be 50. Placing this set of coils in multiple gives, say, two sets of coils, each with 250 turns and each now carrying .05 ampere (assuming that the reduced resistance of the coils in multiple will not materially vary the line current), which gives 12.5 ampere turns for each coil and a total for both of 25 ampere turns. Of course, where a large number of relays are on one circuit (See other page), a change to the multiple winding might be expected to materially reduce the total resistance.

To connect the coils in multiple the binding posts 1, 2 and 3, 4 are joined by metal strips, as in Fig. 238. To connect in series the posts 2, 3, are joined, as in Fig. 239. When connected in multiple the joint resistance of the coils is 50 ohms. When in series the resistance of the coils from post 1 to post 4 is 200 ohms. When arranged in series, or more correctly, in this instance, multiple-series, the coils are connected, virtually as shown theoretically in Fig. 240; when arranged in multiple they are connected virtually as in Fig. 240a.

The resort to the multiple connections is more essential in the case of "single" wire working, especially when a large number of relays are in the circuit, inasmuch as the total "extra" current of the coils in series would materially affect the speed of signaling.

CONDENSER "EXTRA CURRENT" NEUTRALIZER.—Another device for diminishing retardation due to the "extra current" of self induction employed in single working in the Wheatstone automatic system, consists of a resistance in the main line circuit

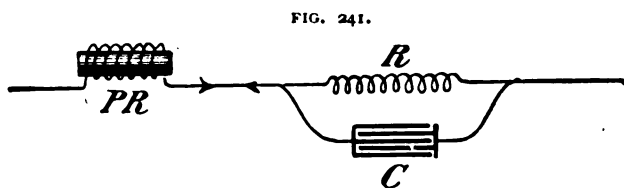

shunting the terminals of a condenser, as outlined in Fig. 241, in which PR may represent the polarized relay; R a resistance wound upon itself to prevent magnetic effects, and C a condenser.

The object, of course, in using this resistance is to get the necessary difference of potentials at the terminals of the condenser.

As the current of discharge from a condenser is in the opposite direction to that set up by the charging electromotive force it will be understood that the effect of the current of discharge from the condenser will be to neutralize the current of self-induction in the relay at the moment the circuit opens. This effect is indicated by the arrows in opposite directions in the figure.

This device has been found to very materially increase the speed of transmission.

BALANCING AND ADJUSTING WHEATSTONE APPARATUS, ETC.

In taking a balance on the Wheatstone duplex after the distant station has grounded, dot slowly on the key and alter the resistance in the rheostat until the galvanometer is not affected. Then, to get a static balance, after the distant end has cut in, run an alphabet or piece of old slip through the transmitter, at the same time having the distant office run his transmitter, and adjust the static compensating condensers and the retarding coils connected with them, until no effect is noticeable on the signals from distant end.

The part of the Wheatstone automatic apparatus requiring most care is the transmitter, which, to do successful work should be given close attention. The platinum pins and plates on the battery arms of the levers and disc D should be kept

thoroughly clean, as any imperfections of contact will unsteady the outgoing currents and cause signals to drop at the distant end. The slots in the brass extension from the framework of the receiver, which admit the star-wheel and the vertical rods, should be cleaned out occasionally, as they get filled up with paper dust. Should the distant office, or repeater station, complain of signals dropping, first inquire if there is any indication of "bias." A bias will be indicated by the needle of the differential galvanometer at the receiving station; that is, it will hang to one side or the other, of zero; or the bias may be indicated by "lines," or "drops," as the case may be, on the paper tape of the receiver. The bias is due to uneven duration of contacts at the disc of the transmitter. When the transmitter is working at high speed and the duration of contacts is practically uniform, the pulsations of current will, owing to their rapidity and uniformity of strength, not noticeably vibrate the needle of the galvanometer, for the simple reason that the inertia of the needle, that is, its disposition to remain at rest, is not overcome—or, in other words, before it can respond to the impulse to move in one direction it is met with an equal impulse to move in the other direction. But, when, by reason of an uneven contact at the transmitter, the current from one pole of the battery is of longer duration than that of the other pole, the needle obeys the more prolonged impulse and tends to hang to one side of zero, as before stated.

If the distant end reports a bias it can generally be remedied by moving the *top* collet to the right for marking, and to the left for spacing, or by moving the collet on the *bottom* rod, to the left for marking, and to the right for spacing. This is, of course, assuming that all transmitters are connected up alike which, as a rule, is the case. The collets can be adjusted by moving them forward or backward, on their respective rods or shafts, and to obtain their correct position a "blank" slip should be passed through the transmitter, when, if the collets are in correct position, they will not move the disc of the pole-changer. The collets are kept immovable after adjustment by tightening up the adjoining set screws on the collet rods.

If complaint of bias is still made, although reversals be properly received at the distant end, and if the home perforated slip is in gauge, that is, with the star-wheel, it is possible that the upright rods of the rocking beam may not be in proper position.

If your signals drop at the distant station, the stop screws, or pins, may be too far to the left, and one or both should be worked back a little to the right. Should the *distant station* complain of receiving "lines" or "markings," the stop screws should be moved to the left; or the jockey roller may require a little adjustment. The said dropping of signals may also be due to too much pressure of roller. If the signals run to lines the jockey roller may require letting down somewhat. Sometimes the springs *s, s*, Fig. 224, which push the collet rods *H, H'* forward, may require strengthening.

To all of the Wheatstone apparatus, as in the case of the quadruplex apparatus, and, perhaps, more so, on account of the greater speed at which the former is worked, as well as the greater complication of the machinery, much attention should be paid. The contact points especially should be kept bright and free from dust, etc., and the local and main batteries should be kept up to a high standard of excellence.

The E. M. F. found necessary on Wheatstone duplex circuits of say 400 to 500 miles is from 150 to 175 volts of each polarity. This system is still largely used in Europe (1903), but its employment in this country has been confined to the circuits of the Western Union Telegraph Co. The speed at which signals are transmitted over these long circuits varies with the conductivity and general conditions of the wire. Between New York and Chicago, a distance of 1000 miles, with repeaters at Buffalo, less than midway, a speed of 150 to 200 words in each direction is maintained.

The arrangement shown in Fig. 241 is used as stated, in single automatic working for the purpose of diminishing retardation due to induction. As it may be assumed that two currents cannot flow in the same direction in the same portion of a wire simultaneously, it is perhaps better to consider that in the figure, at the moment of cessation of the current due to the battery or dynamo, the E. M. F. due to the inductance of the relay and the E. M. F. due to the previous charge of the condenser oppose each other, and thereby prevent an extra current, or it is possible that the condenser performs its function of facilitating signaling, not only by neutralizing, but also by over-riding the extra current of the relay. In Fig. 241a is outlined the method of arranging the extra current condenser and also what are termed

FIG 241a.

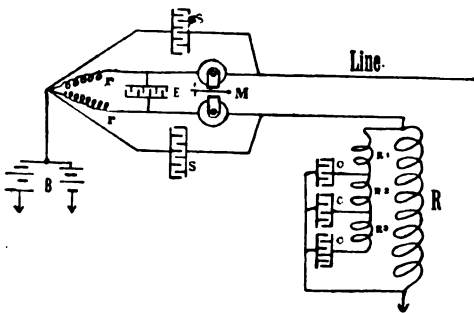

signaling condensers in automatic duplex working on mixed aerial and comparatively short submarine cables, as between London and Paris. E is the extra current condenser, which, it is seen, is in a bridge wire; *rr* are the arms of the bridge. This is virtually the F. W. Jones condenser arrangement for duplex telegraphy, which corresponds to the Smith arrangement with the third coil omitted, which is fully described on page 204. *ss* are the signaling condensers, which are placed around

the bridge arms and the relay coils *M*, as shown. The office of the signaling condensers, according to some authorities, is to neutralize the return static current from the cable, by which it is perhaps meant that the signaling condensers in discharging assist in neutralizing or "wiping" out the previous charge of the cable, and in charging assist in the prompt recharging of the line. It would seem also that the tendency of the condensers *ss* as thus disposed around the coils of relay *M* would be in discharging (that is, that portion of the discharge which would take this route) to prolong the extra current in the relay (see page 342), which in practice is the case, but this effect is offset by additional capacity in the condenser *E*. It is evident, on the other hand, that these condensers should facilitate the transmission of signals, inasmuch as they in effect cut out of the circuit the resistance coils *rr* and the respective coils of the relay, or, in other words, they tend to "switch" the rapid pulsatory currents past those coils (it being known that electromagnets are, as C. F. Varley pointed out, partially "opaque" to such currents), the ensuing diminution of received currents being compensated by condenser *E*. The use of this arrange-

ment has been found to increase the speed on the circuits referred to about 100 per cent. Preece and Sivewright's "Telegraphy" gives figures showing that on the London and Amsterdam circuit, consisting of 130 miles aerial wire on the British side, then 130 miles of cable and 20 miles aerial in Holland, without the signaling condensers the speed of working from London to Amsterdam is 48 words per minute, while 68 words per minute may be transmitted from Amsterdam to London, this difference being attributed to the nearness of the cable to Amsterdam. With the signaling condensers the speed of working on the same circuit is increased to 116 words per minute in each direction.

In the figure, R is the artificial line resistance. $R^1 R^2 R^3$ and condensers $C C C$ correspond to those used in compensating for the static capacity of the line in automatic duplex working. (See Fig. 230.) B is the usual battery or dynamo source of E. M. F.

THE STEVENS-WHEATSTONE PERFORATOR AND TRANSMITTER.

This is a device which is attached to a Wheatstone receiver in such a way that short and long dashes are perforated in a straight line on a paper strip instead of the usual ink records. The message can then be read by sight or it may be passed through a transmitter and received by sound or transmitted on to another station. The relay is practically similar to the regular Wheatstone receiver, except that a forked lever takes the place of the extension which in the latter carries the marking disc. The fork projects over a small bolt on the surface of which there is a small pin with which the fork engages. The punching devices consist of a vertical rod or plunger continuously moving up and down in suitable guides at a rapid rate by connection at its upper end with a crank-pin operated by a motor. A small foot-piece at the lower end of this rod moves up and down with it. The punch proper is also arranged vertically, its head being slightly to one side of and above the lower end of the plunger. In the head of the puncher there is a small vertical slot, the length of which is equal to the up-and-down motion of the plunger. The foot-piece works in this slot. The small bolt referred to is moved into and out of this slot through a hole in the side of the head of the puncher by the engagement of its pin with the forked lever. A marking current pushes the bolt into the slot, thereby shortening the length of the slot, with the result that the foot-piece depresses the cutter of the puncher through and withdraws it from the paper strip at a high rate of speed, a short hole or slot being punched for a dot, a longer hole for a dash. A spacing current withdraws the bolt from the slot, and at such times the puncher is passive.

The transmitter for retransmitting the messages thus prepared is more or less analogous to that shown on page 72, one end of a lever L being allowed to pass through the perforations in the strip, the other end playing between contacts which are connected to positive and negative poles of a battery or dynamo, the line being connected to the lever. A speed of over 180 words per minute has been attained by this device on circuits of about 250 to 300 miles in length in Great Britain.

THE DELANY RAPID AUTOMATIC TELEGRAPH.

In the Delany system a Morse key operates a punching-machine which cuts holes, representing dots and dashes, in a paper strip. Holes are punched in two rows on the strip, Fig. 241*a*. For dots the holes are punched slightly diagonally, as for E in the figure; for dashes the holes are punched considerably more aslant, as for T in the figure, like the holes for dashes in the Wheatstone perforated paper, page 297. In the operation of the punching-machine the closing of the Morse key causes a punching-magnet to perforate the upper hole, and the opening of the key causes another magnet to perforate a lower hole in the paper; and between these operations the paper is fed on, the longitudinal space between an upper and lower hole depending on the length of time the key is held closed, the necessary mechanism to regulate the amount of paper fed for dots, dashes, and spaces being provided. It will be obvious that an operator at one station may in this way prepare the paper by a punching machine at a distant station.

The double-current method is employed in this system. In the transmitter four brushes, Fig. 241*b*, are employed, two upper and two lower, which tend to press

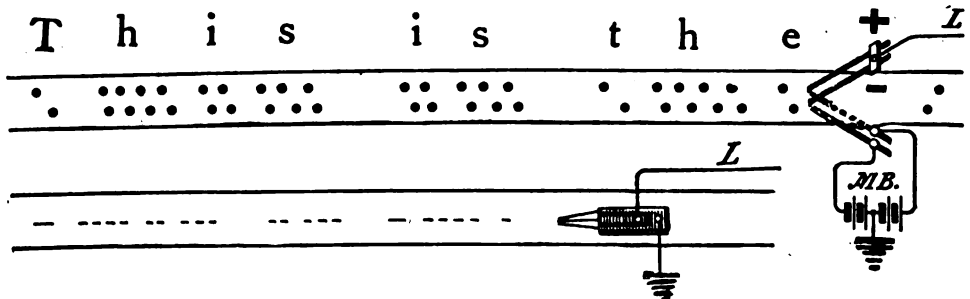
FIG. 241*b*. FIG. 241*c*.

against each other as indicated. Two of these brushes rest on the top of the paper strip, two below it. The positive pole of a battery is connected, as shown, to the brush opposite the upper row of holes in the paper strip; a negative pole to the brush opposite the lower row of holes. In the receiver three needles are used: the two outer ones are of platinum and are connected to the earth; the middle needle is of iron and is connected to line L, Fig. 241*c*. The base of the chemical solution with which the receiving-paper is dampened is prussiate of potash. A current in a positive direction leaves a mark on the paper under the iron needle; the platinum needles are not attacked. Reference has already been made to the effect of the static capacity of the line in producing tailings on chemically prepared paper (page 288). In the present system advantage is taken of this effect in the arrangement of the perforated holes for dots and dashes at the transmitter. In the operation of making a dot, when the upper or positive brush meets a hole and thereby makes contact with the brush under it, and completes the circuit, a positive current is sent to line. Almost immediately the lower or negative brush completes the circuit, although there has been a moment of no battery to line while the paper intervened. This negative potential clears the line of positive current, but in the meantime a dot had been recorded on the receiving-strip. When a dash is to be

sent the greater space of paper between the upper and lower holes allows the tailing current to exist longer before it is followed by the clearing-out current, and a dash is recorded on the chemically prepared receiving-strip. As the "space" character is always preceded by a clearing-out current, it follows that no current, or at most only negative tailings, which do not mark, will be on the line when a space is to be indicated.

The advantages of the Delany automatic system are somewhat akin to those of the Phillips-Weiny automatic telegraph, page 72, but a much higher speed is obtainable with the chemical method of transmission, some data on which have already been given, page 294. Of course it will be understood also, from what has been said, that the perforated strip may be used when desired to transmit signals at a rate receivable by Morse operators by sound. The receiving machine of the Delany system is self-starting and self-stopping (*see* page 373 for examples), and also stops automatically when the transmitting tape passes out of the sending machine.

AUTOMATIC FAC-SIMILE TELEGRAPHY.

Fac-simile telegraphy relates to the transmission and reproduction, at a distance, of characters, symbols, or pictures.

There are two general methods by which this has been accomplished, namely, an electro-chemical and an electro-magnetic method.

In electro-chemical methods the characters, etc., to be transmitted are, as a rule, prepared, in some form of insulating ink, upon a metallic base, such as a strip of tin-foil. At the receiving station a strip of chemically prepared paper, corresponding in dimensions with that of the tin foil, is used. The tin-foil and paper strips are respectively connected in a circuit, practically as are the paper strips of the chemical automatic systems, already described, and means are provided whereby the characters are reproduced on the prepared paper by the electrical decomposition of the components of the solution in which the receiving paper strip had been previously immersed.

In electro-magnetic methods the characters to be transmitted are sometimes embossed on card-board, which is then placed on a suitable cylinder. A blank card is placed on a similar cylinder at a receiving station. The cylinders at both ends of the circuit are, by any suitable means, synchronously rotated, spirally. A light lever, controlling the contact points of a circuit, is placed over the transmitting card. As the cylinder is rotated and, at the same time, moved laterally, the lever is raised and lowered as it passes over the embossings, with the result that, as it does so, the circuit is alternately made and broken. These makes and breaks of the circuit at the transmitter are caused to actuate a pen supplied with ink, attached to the armature of an electro-magnet in the circuit at the receiving station; the arrangement of the lever being such that when the circuit is broken the pen rests on the card on the receiving cylinder; while, when the circuit is closed, the pen is lifted from the card. Consequently, there is reproduced, in ink, on the receiving card, by these makes and breaks, a practical fac-simile of the embossings on the transmitting card. The embossings on the latter card may be made by a thick ink traced on the paper by a suitable pen or brush. Evidently, the arrangement described could be reversed, and

the openings and closings of the circuit be caused by holes, depressions or "etchings" in the paper.

THE DENISON FAC-SIMILE TELEGRAPH SYSTEM.

An electro-chemical fac-simile system now employed in this country is shown theoretically in Fig. 242, in which *T* is the transmitter, *R*, the receiver. These instruments, it is seen, are nearly similar in general construction. Each consists of a polarized relay *PR*, *PR'*, the function of each of which is to cause the vibration of the arms *a*, *a'*, which are attached, as indicated, to the armatures of the respective re-

FIG. 242.

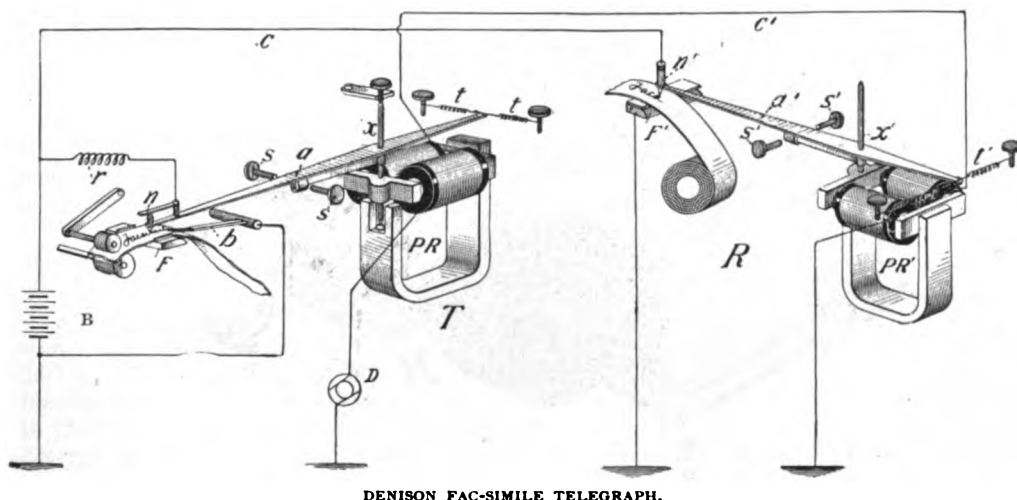

DENISON FAC-SIMILE TELEGRAPH.

lays. The amplitude of the vibration of the arms is regulated by the stop screws *s*, *s'*. These relays are in a common circuit *c'*, in which circuit rapid reversals of polarity are produced by a "generator" *D*; in this case a small alternating current dynamo machine, driven by any suitable motor. Being in the same circuit the relays will cause their armatures and, consequently, the long arms, *a*, *a'* to vibrate in unison.

At the transmitter, *T* is a strip of tin-foil on which characters are traced with insulating ink. The foil is caused to pass over and through a suitable roller and guide. The chemically prepared paper at the receiver is also passed over a roller and a platinum plate *F'*.

A circuit *c* is provided for the transmission and reproduction of the characters. The circuit passes from earth at *T* to the earth at *R*. A small contact needle *n* is arranged on the arm *a'* of the transmitter, as shown. This needle normally rests on the tin-foil. A stylus, or pen *n'*, is similarly arranged on the arm *a'* of the receiver. Delicate spiral springs, suitably arranged, hold the needle and pen snugly against the tin-foil and paper. The transmitting battery, *B*, at *T*, is normally short-circuited by the arm *a* and the tin-foil, via the needle *n*; consequently, at such a time, no current passes to line. When, however, the needle *n* rests on, or passes over, the insulated ink, the short-circuit is broken and a record is made on the prepared paper at the re-

ceiver. The operation of the apparatus will be readily understood. At a given signal the transmitter and receiver are set in motion. As before stated the arms are caused to vibrate synchronously. (The vibrations occur at the rate of about 1,500, per minute.) At the same time the tin-foil at the transmitter and the paper at the receiver are caused to move forward at a practically equal rate of speed. Since current will only flow in the circuit *c* when the needle of the transmitter is passing over the insulating ink, and as the record is only made at the receiver when current is flowing, and, further, as the pens at *t* and *r* are always at corresponding points of the tin-foil

FIG. 242 a.

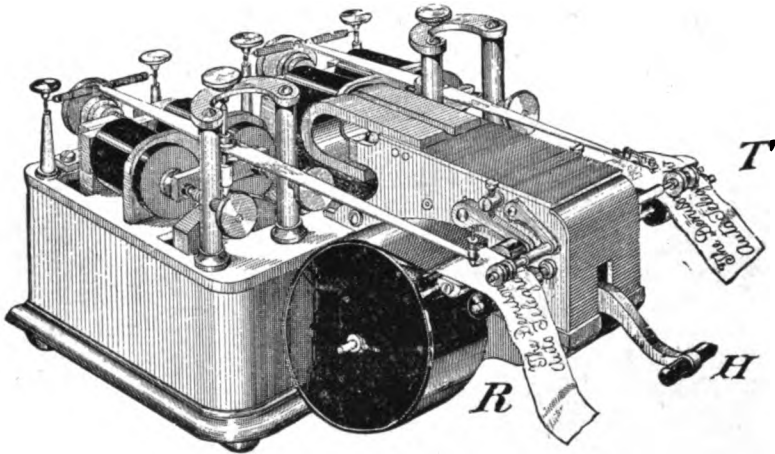

and paper, respectively, it results that there will be reproduced on the chemical paper a fac-simile of the characters placed on the tin-foil.

In Fig. 242a the transmitter *t* and receiver *r* are shown as, in practice, they are combined on one base. *H* is a switch which is normally in a middle position as regards the slot in which it moves. When in this position an electric bell is included in the circuit of the relays. The act of depressing the handle of *H*, at either end, by throwing in the battery, taps the bell, indicating that a message is to be sent, whereupon the distant station lifts up his switch, thereby placing his receiver in the circuit. When desired the bell may be operated for code signaling in the transmission of short messages.

THE PALMER-MILLS ELECTROGRAPH.

This is an electromagnetic system by means of which messages or pictures may be transmitted. It employs a transmitting and receiving cylinder practically similar to those already described, also a transmitting stylus and receiving pen. The method of preparing the message or picture for transmission and other details are, however, different. In this system the message or picture to be transmitted is, up to a certain

point, prepared in the same manner as a half-tone, on a zinc plate, but in the final preparation the etchings in the zinc are filled with an insulating wax, thus providing a smooth combined insulating and conducting surface, over which the transmitting stylus travels. The zinc plate is then bent over the cylinder and locked in position. It takes about twenty-five minutes to prepare the plate. The transmitting and receiving cylinders are revolved synchronously by suitable motors at the rate of about 40 revolutions per minute, and the stylus and receiving pen and its magnet are moved parallel with the axis of the cylinder by screws which have a pitch of 40 or 80 threads to the inch, as may be selected. Synchronism of rotation between the transmitting and receiving cylinders is maintained by impulses sent at certain parts of each revolution of the transmitting cylinder, at which moment the receiving-pen magnet is cut out. The receiving cylinder being set to revolve slightly faster than the transmitting cylinder, these synchronizing impulses operate magnets which apply a small friction-brake to the fly-wheel of the receiving cylinder. From the immediately preceding descriptions of other facsimile systems, the operation of this system will be readily understood without further explanation, it being understood that a suitable paper is employed on the receiving cylinder, the pen of which records at the rate of about 80 dots per second.

THE POLLAK-VIRAG AUTOMATIC TELEGRAPH SYSTEM.

This system employs a perforated paper tape somewhat similar to the Wheatstone, the holes on one side of the paper transmitting dots, those on the other side, dashes. This paper passes between two metal brushes and a metal cylinder. One brush sends current of one polarity, say, positive; the other sends negative polarity to the line. Two wires are used between stations. The receiver is a telephone, the diaphragm of which is set into oscillation by the current pulsations, the direction of the oscillation corresponding to the polarity of the current transmitted. These oscillations are communicated to a small mirror, which is attached to the diaphragm by a metal rod in such a way as to largely amplify the motion of the mirror; a

FIG. 242b.

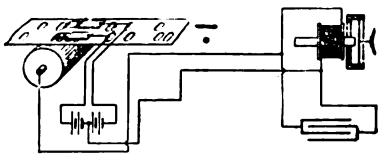

TRANSMITTING AND RECEIVING CIRCUITS.

FIG. 242c.

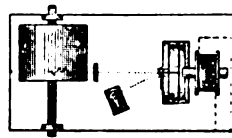

RECEIVING APPARATUS.

condenser is placed around the telephone to prolong the duration of the current impulses and to steady the oscillation of the mirror. A small incandescent lamp is caused to throw a beam of light on the mirror, which beam is reflected by the mirror through a slot in a cylinder within which is contained a moving roll of sensitized paper. When the system is in operation the beam or pencil of light is moved to the right or left, depending on the direction of the current, and a record is produced on the sensitized paper, which, when developed, resembles the record made by the siphon recorder. This system has been tested between Budapest and Vienna, a speed of 1500 words per minute being reported, on a metallic circuit 400 miles in length having a resistance of 4000 ohms. See Figs. 242b, 242c.

✓

CHAPTER XIX.

WRITING TELEGRAPH SYSTEMS.

Writing, or autographic, telegraph systems may be distinguished from automatic fac-simile telegraph systems in that the former systems electrically transmit and record fac-similes of letters, or characters, while they are being formed by the stylus, or pen of the transmitter, in the hands of an operator. Ordinarily, autograph telegraph systems

FIG. 243.

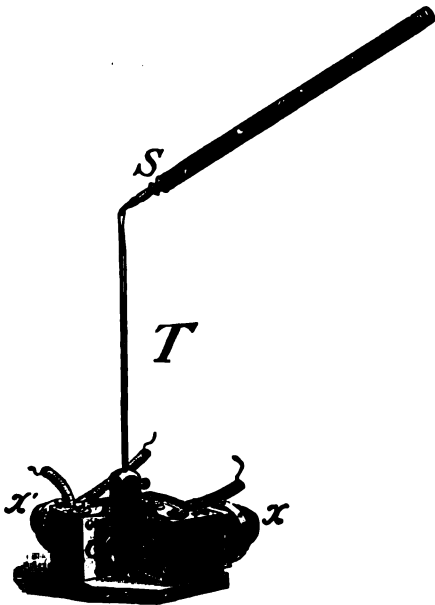

ROBERTSON TRANSMITTER.

FIG. 244.

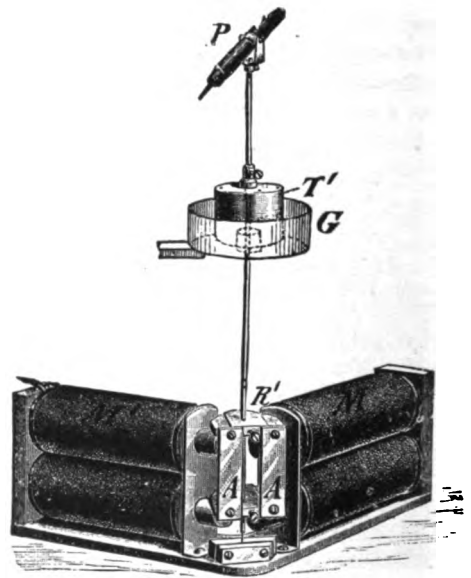

ROBERTSON RECEIVER.

simply reproduce in fac-simile the writings or sketches which have been previously prepared on a conducting surface; as in the case of the Denison fac-simile telegraph, herein described.

The first to invent a telegraph system which would reproduce electrically the hand-writing of the operator, simultaneously with the writing, was Mr. E. A. Cowper, of England.

The principle of operation of the writing telegraph is that of "compounding the movements of a point, in two directions, the one at an angle to the other, the actual movement of the point being the resultant of the two movements." (*See Galvanometers*).

The operation of the receiving pen depends, primarily, upon variations of the mag-

netic strength of two electro-magnets, placed at right angles to each other; which variations produce changes in their magnetic fields, in which an armature to which the receiving pen is attached, is placed, and to which changes the armature is free to respond. Each of said magnets is, in practice, placed in a separate circuit. The variation of the current strength in the circuits which effects the fluctuations in the magnetic fields, is brought about by means of a stylus which, when moved, as in the act of writing with an ordinary pen, causes variations in the resistance of the respective circuits. The transmitter employed by Mr. Cowper consisted of a stylus which was caused to slide over contact points, thereby cutting in or cutting out resistance coils.

Subsequently, Mr. J. Hart Robertson devised a transmitter which, when moved as in writing, varied the resistance of the circuit by varying the pressure on two series of carbon discs, each of which series was in a separate circuit.

This arrangement was adopted with a view to obtaining a more uniform and gradual variation in the resistance of the circuits than had previously been obtained, and was found to work successfully in practice. The receiver now used by the Writing Telegraph Company, now to be described, is also due to Mr. Robertson.

WRITING TELEGRAPH COMPANY SYSTEM.

The Robertson transmitter and receiver are shown in Fig's. 243 and 244. In practice these instruments are enclosed in one box.

THE ROBERTSON TRANSMITTER.—This transmitter, T in Fig. 243, consists of two series of thin discs of carbon placed at right angles to each other. Each series is made up of 30 discs, each disc one-half inch in diameter, and one-twentieth of an inch thick, placed side by side, within a hard rubber receptacle c or c'. R is a vertical rod which is supported at its lower end on a flexible wire. Apertures are made in the hard rubber receptacles through which an end of each series of discs may be reached by short projections from the rod R. The rod R extends upwards and passes through an opening in the cover of the box, not shown in the figure, where it is flexibly connected to an attachment resembling an ordinary stylus. The opening is of such a size as to permit only a limited motion of the point of the stylus in any direction. Any motion of the rod R causes a variation in the degree of pressure of the projections against the ends of the discs, the pressure increasing according to the extent of the motion towards the discs. The normal pressure of each series of discs is adjusted by screws x x'.

THE ROBERTSON RECEIVER.—The receiver, Fig. 244, consists of two electro-magnets M, M', also placed at right angles to each other. Each magnet has an armature A, A', of peculiar construction. The armatures are magnetically insulated from each other, being joined together by a brass strip. These armatures are supported by the rod R', which latter rests on a flexible wire, as shown. This rod also rises through an opening in the cover of the box and carries at its top loosely pivoted, hollow cylinder P, as shown. This cylinder holds an ink which supplies the pen at the lower end of the cylinder. The pen rests loosely on a strip of paper. The rod R' carries, about midway, an inverted thimble T', which moves freely in a pot c containing glycerine. The pot is supported by the framework. The function of this device is to steady the motion of the rod and, consequently, the pen. Without this device the writing is found to be wavering. The operation of the transmitter and receiver will be described presently.

ROBERTSON WRITING TELEGRAPH—CONNECTIONS.

A theoretic diagram of this writing telegraph system is given in Fig. 245. D, D' are the series of carbon discs of the transmitter T . M, M' are the electro-magnets of the receiver. The series of discs D is in circuit with the magnet M ; the series D' , with the magnet M' . Each circuit has a battery B, B' . The vertical rod of the transmitter is indicated by R ; the projections which reach to the ends of the carbon discs by e, e' ; the rod and armatures of the receiver by R' and A, A' .

It is well known that the electrical resistance of carbon varies under pressure, the resistance decreasing as the pressure is increased. This fact, as previously remarked, is availed of in this system, and the arrangement of the discs just described is chosen to obtain the greatest variation with a minimum of pressure. Each disc of each series

FIG. 245.

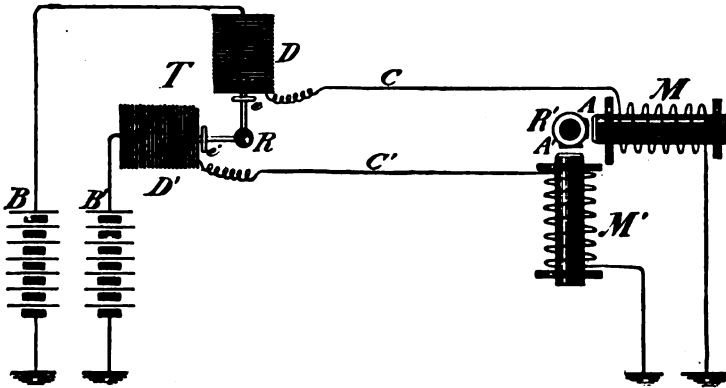

has a resistance, under a pressure of 8 lbs., of about 2 ohms.

The two circuits employed in this system are practically separate from each other.

When the apparatus is at rest the projections e, e' on the rod R of the transmitter (Fig 243) press equally against their respective discs. Consequently an equal current flows through both circuits and the magnets at the receiver are equally attracted. When the pressure is increased on each series of discs, equally, the increase of current in each circuit is uniform, and the attractive force of each magnet moves the armature forward diagonally between them. A uniform decrease of pressure permits an opposite backward motion of the armature. When one projection, say, e is caused to press more strongly against its disc D , by reason of a particular movement of the handle of the transmitter, the resistance of its circuit C is decreased, while that of the other circuit C' is augmented by the increase of resistance due to a reduced pressure on the discs D' . This produces a variation in the current strength and causes an increased attraction of the armature A of the receiver, which armature is attracted towards its magnet, carrying with it the rod R' and its pen; but as the magnet M' still continues to exert some attraction on armature A' the motion of the rod will be more or less in a curve, depending on the attractive power of the respective magnets.

FIG. 246.

In the act of transmitting a message by this system, the sender takes hold of the handle of the transmitter and proceeds to write in the ordinary way, except that the letters are, as it were, made one over the other. The movements of the rod

FIG. 247.

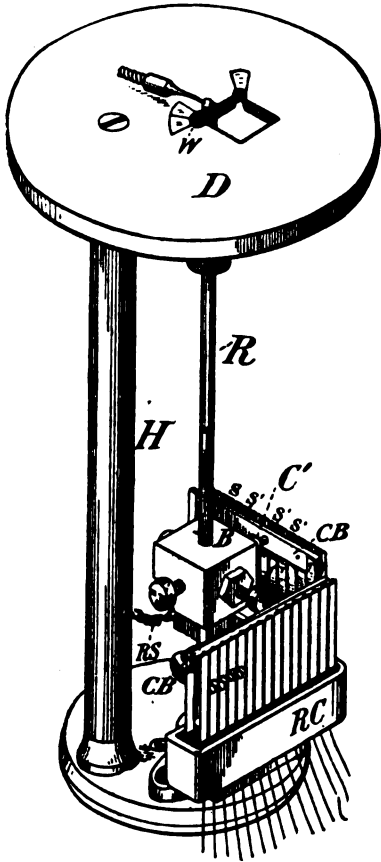

R, causing one or other or both of the projections $e e'$ to press against the end of the discs, or to be withdrawn therefrom, the resistance of the circuits is decreased or increased in the manner described; the result being that the motions of the transmitting rod R are repeated by the point of the pen of the receiver, which pen thus traces, on the paper moving under it, the letters formed at the transmitter

A specimen of the writing thus received is given in Fig. 246. It will be seen that the words are not separated by an actual break in the line. Arrangements could be devised to effect this result, but it is not thought of sufficient importance to warrant adding the necessary apparatus.

THE ETHERIDGE TRANSMITTER.—A later form of transmitter, due to Mr. Etheridge, which is, in a measure, a return to first principles, has recently been introduced. It is shown separately in Fig. 247. In this figure, D is a plate, even with the surface of the enclosing box and supported by the standard H . s is a portion of the pen, or stylus, that is held by the one using the instrument in writing. It is flexibly attached to the rod R , the latter being supported on a slender, flexible rod r , shown in Fig. 248. Normally, the upper end of the rod R , Fig. 247, is drawn into the notch w by a retractile spring RS . In this form of transmitter the carbon discs are replaced by two series of resistance coils contained within suitable receptacles RC . The terminals of one set of

coils are brought to upright metal strips $s s$, etc., and those of the other set to $s' s'$, etc. These sets of strips are placed at right angles to each other, as shown. The rod R carries a "pressure" block B , on whose sides are the set screws $c c'$. On the upper end of each terminal strip a platinum contact point is soldered; and opposite these contact points, narrow, flat contact bars CB and CB' are placed, and are so arranged as to be easily brought into contact with the terminal contact points, $s s$; $s' s'$ etc. by the movements of the pressure block B .

The theoretical arrangement of the coils and strips is shown in Fig. 249.

The flexible strips $CB CB'$ are supported at $x x'$, respectively. On each contact bar a sharp projection $p p'$ is fixed, opposite the set screw $c c'$, on the pressure block. R is the top of the rod which carries the block B . The resistance coils of the transmitter, whose terminals are connected with the contact tongues $s, s', etc.$, are shown as at $RC RC'$. The coils $BC, b, c, d, etc.$ are so arranged that when the contact

The letters are from one over another

bar cb is pressed by the block B against the contact tongues, the said coils are placed in multiple. Similarly, the coils bc' , b' , c' , d' , etc., are placed in multiple when the contact bar cb' is pressed against them.

This will, perhaps, be more evident by reference to Fig. 250, in which one set of coils is shown detached and theoretically. The coils of each series are graded from a higher to a lower resistance; the coils of least resistance being nearest the receiver; the coils of highest resistance being nearest the "ground."

Referring again to Fig. 249.

Normally, the end coils bc bc' and the end wires z z' are in the main circuit.

FIG. 248.

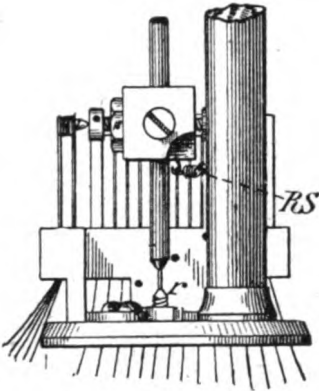

The object of this arrangement of the coils is to obtain a uniform and gradual change in the strength of current as the coils are cut in or out of the circuit by the movements of the pressure block.

To prevent sparking at the tongues the intermediate coils 1, 2, 3, etc.; $1'$, $2'$, $3'$, etc., are interpolated, as shown. The resistance of coil 1 is made equal to coil b ; coil 2 to coil c , and so on. Likewise the resistance of coil $1'$ is made equal to coil b' ; that of the coil $2'$ to coil c' etc. Thus when, for instance, the contact bar cb is pressed against the tongue contact s , the coil 1 is practically short-circuited by the contact bar, while, by the same contact, as just stated, the coils bc and b are placed in multiple. When the contact bar cb is released the contact is broken at s^2 and the coil

1 is again inserted in the circuit, thereby affording a path for "extra" current that may be set up in the coil at the moment of the break of contact.

In practice there are 14 contact tongues and 13 pairs of coils on each series, and these are found to be ample to provide a sufficiently gradual variation of current strength in the circuit for the proper operation of the receiver. There is also an extra coil, namely, bc or bc' , termed the balancing coil, the function of which will be seen shortly.

It having been found in the practice of this system that a variation of current strength from .032 to .090 ampere gives a very satisfactory movement of the receiving pen, the total resistance of the transmitter coils necessary to produce that variation is calculated and employed. For instance, assuming the resistance of a circuit, including the instruments, to be 100 ohms, and the internal resistance of a gravity battery to be 27.5 ohms, an electro-motive force of 11.77 volts will be necessary to give the required maximum current; that is, $\frac{11.77}{100 + 27.5} = 0.090$ ampere.

Having this maximum current on the circuit, the resistance necessary to reduce it to .032 ampere, is calculated. Thus, by ohms law $\frac{11.77}{.032} = 368$ ohms. Then, from this 368 ohms the resistance of the line and battery is deducted, giving 240 ohms; which will be the maximum resistance necessary to be introduced in the circuit by the transmitter. That is to say, the maximum resistance of the transmitter will be, in this case, 240 ohms, and it will vary from that to nothing.

The next step is then to so arrange the resistances of the coils of the transmitter,

that they shall give a gradual rise and fall of current from the maximum to the minimum, and *vice versa*.

To ascertain the respective values of the coils for this purpose Mr. Etheridge prefers the following method, which will doubtless be of utility to others in arriving at analogous results.

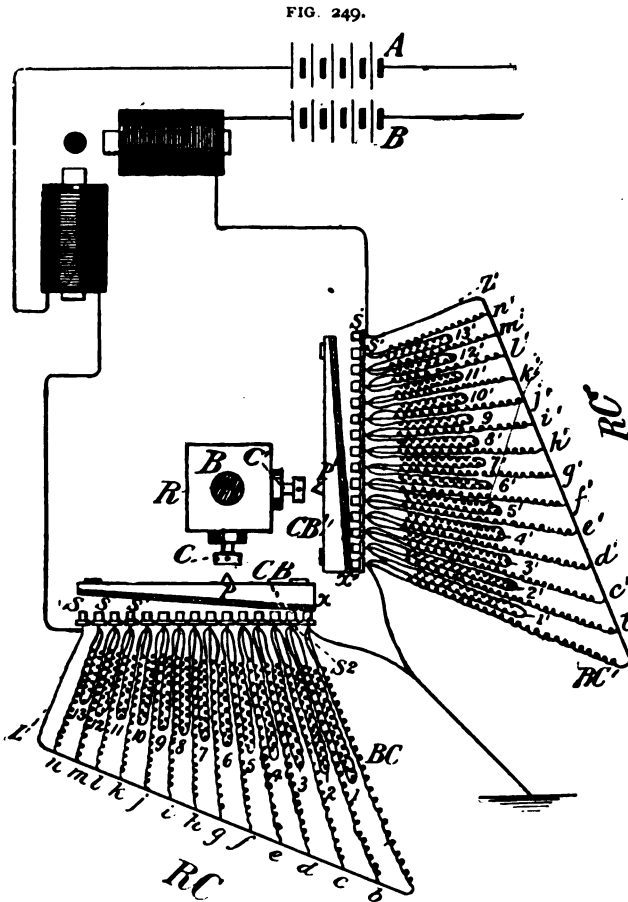

FIG. 249.

THEORY OF ETHERIDGE TRANSMITTER.

A true elliptic curve is constructed and its vertical line A, Fig. 250a, is divided into as many equal sections as there are contacts that go to make up the "rise and fall," that is, 13. The base line B is divided into as many sections as there are units of resistance in the transmitter, namely, in this instance, 240. Horizontal lines are then drawn from each section on vertical A to the curve c. Vertical lines are then dropped from the point of intersection of the horizontal lines with the curve, to the base. The points at which those touch B will indicate the gradual resistances necessary to be secured at the tongues of the transmitter.

For example, in a transmitter consisting of 240 ohms, to reduce the strength of current from maximum to minimum, the resistances necessary to be consecutively inserted in the circuit by the transmitter are found to be in

ohms, 0; 1; 3.5; 7.5; 14; 21; 32.5; 45; 60.5; 80; 106.5; 139; 240.

The resistances of the respective coils to produce the desired "gradual" resistance, is shown in Fig. 250. Thus the resistance of *b* is 240; that of *c* 330.25 ohms, and the joint resistance of *b* and *c* is 139 ohms. Again the resistance of *d* is 445.75 ohms and the joint resistance of *b c d* is 106.5 ohms, and so on to *n*, or zero.

As, however, for the reasons given, intermediate coils are placed in, so to speak, double multiple with the coils *b*, *c*, *d*, etc., the total resistance of the transmitter at rest is found to be more than 240 ohms, for it will be observed, by reference to Fig. 249 that the coil 1 is placed in the circuit *before* the coil *b*.

To ascertain what this total resistance is the circuit of the transmitter is measured from *x* to *z*; which, having been done the value of a resistance such as *bc*, which, when placed in multiple with the other coils will restore the resistance to 240 ohms, is calculated. In this case it is found to be 440 ohms, which is, consequently, the value of the resistance placed in the balancing coils.

FIG. 250.

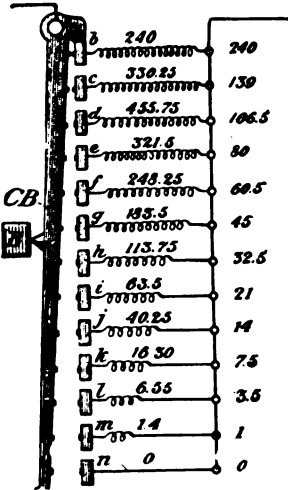

WRITING TELEGRAPH CENTRAL OFFICE.

In Fig. 251 a diagram of the central office and subscribers office arrangements of the writing telegraph system is given.

At a subscriber's office SO, the entire equipment is included in one box. *r* is the rod of the transmitter. *c* *c'* may represent the coils of the transmitter. *m*, *m'* are the receiver magnets. *A* is the rod carrying the writing pen, the armatures of which are not shown in this figure. *a a'* are extra armatures placed below the pole-faces *f f* of the cores of the magnets. *a a'* have a common lever *L*, pivoted at *x*. This lever has two extensions *E E'*. *E'* extends to the "fan" or "fly" of the clock-

work that operates the paper-feeding mechanism. The extension *E* is made a part of one of the circuits of the system and assists in opening or closing that circuit at the point *CP*, as will be explained, when its armatures *a a'* are attracted or released.

FIG. 250 a.

Normally the top of the transmitter rod *r* rests against two contact points *p, p*, being held there by a retractile spring *rs*. These contact points are respectively connected, electrical-ly, to one of the main circuits. There is another contact point *EP*, adjacent to *r* and against which it may be placed. *EP* is connected by a wire, *e*, with the circuit of magnet *x*, as indicated by the dotted line. Normally that wire is open at *EP*.

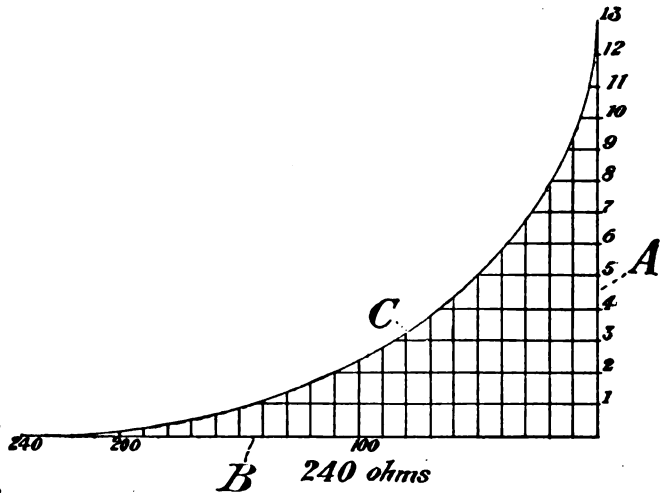

In the central office CO, *n', n* are annunciators. *w w'* are wedges capable of being inserted in the receptacles, or spring-jacks *J J*. The metallic tube *w* of the wedge is insulated from the rod *w'* as indicated in the figure. When thus inserted the metallic surface *w* makes contact with the metallic sleeve *j*; the rod *w'* making con-

tact with the horizontal jack. This arrangement, it will be seen, is the equivalent of the split plugs and tubular plugs shown in "loop switch" diagrams, elsewhere. The annunciators are connected by wire to the sleeve *j*; the metal pin *w'* with the horizontal jack. The wedges *w*, *w* are connected with batteries *B*, *B'* in the manner shown.

Each subscriber's circuit, which is a duplicate of that shown at *SO*, is similarly connected with a spring-jack *J* in the central office and, at rest, the apparatus and connections at the subscriber's office and the central office are as outlined in the figure.

FIG. 251.

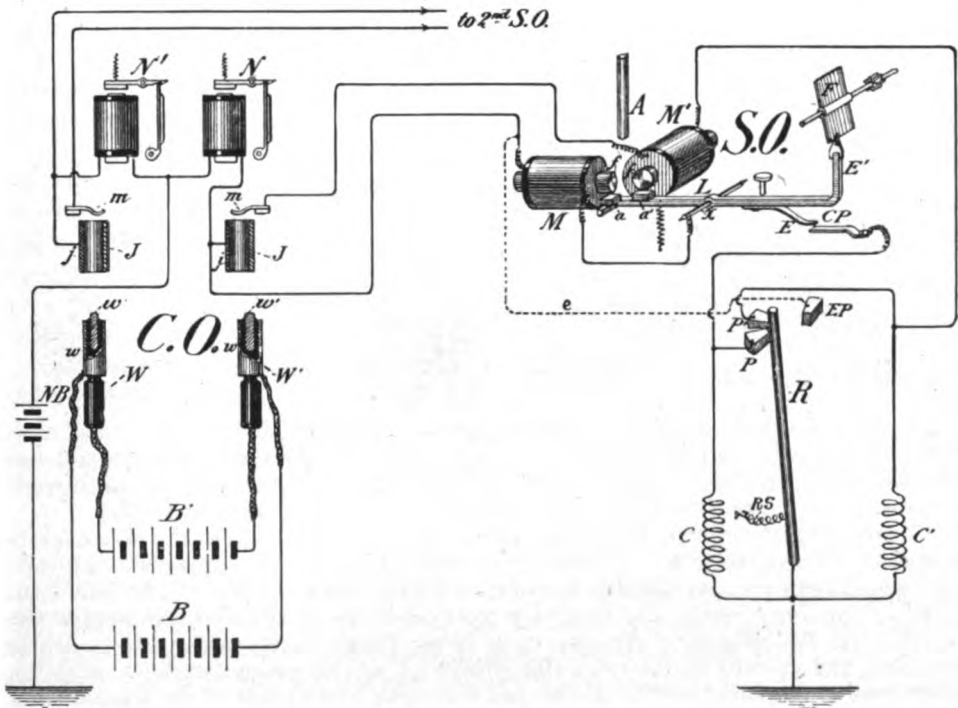

At such times it will be seen that the circuit of magnet *m*, *SO*, is open at *EP* and *CP* and the transmitter coils *c*, *c'* are short-circuited by the wires via the contacts *p*, *p'*, and the transmitter rod, which is connected directly to "ground."

When a subscriber desires to communicate with another subscriber on the same system he takes the handle of the transmitter and places it, for a moment, in the notch *EP* to the right. (Shown more clearly in Fig. 247.)

This completes a circuit from the ground at *SO* to the ground at *CO*, via the annunciator *x* and the small battery *NB*. This attracts the annunciator armature, releasing its shutter, and ringing a call bell.

The central office is, of course, equipped with a transmitter and receiver which he uses to ascertain the wishes of the subscriber. Having learned them, he inserts the wedges *w w* in the receptacles *J J* connected with the desired subscriber's office (as,

for instance, 2nd SO in the figure), thereby completing the circuit of M' via the pins w' and battery B' and jacks m , whereby the armature a' and the lever L are attracted. This act closes the circuit of magnet M at CP and also withdraws the extension E' from the path of the fly F , thus permitting the paper to run. A bell is also provided at the subscriber's office which can be actuated from the central office.

THE TELAUTOGRAPH.

This writing telegraph depends for its operation upon the resultant of two motions, like the original Cowper writing telegraph. The system has of late been much simplified and improved, now receiving its message on a sheet or roll of paper about 5 inches wide. It is in practical use by the United States army, etc.

Two wires are employed between the transmitting and receiving stations. The mechanism of the transmitter and receiver is outlined in Figs. 252, 252a. P is the pencil of transmitter, to the point of which are connected two light rods ll

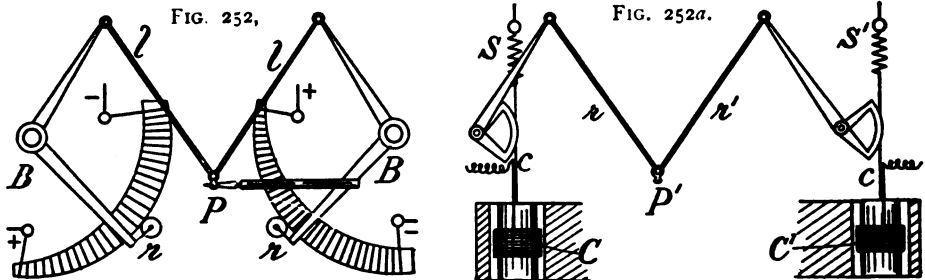

which are connected pivotally to one end of crank levers BB , at the other end of each of which is attached a metal roller r , which runs over the terminal of resistances, virtually similar to those shown in Fig. 249, with the similar result that the current is varied in each circuit as the pen is moved by the writer. (See page 327.)

The pen P' of receiver, Fig. 252a, is attached to the arms r r' of the crank levers as shown. These latter are in frictional contact with vertical supports c c' of coils c c' , which coils are suspended in a strong, uniform magnetic field. The coils form a part of the line circuits, and thus vary their positions in the magnetic field as the currents in the respective circuits vary, being drawn downward as the current increases, and upward by the retractile springs s s' as the current weakens, with the result that a compound motion of the pen corresponding to that of the transmitting pencil is brought about. The receiving pen is automatically lifted at the receiving end by the following devices. An induction coil at the transmitting end which has two secondary coils, one connected with each circuit, is caused to transmit pulsatory currents superposed upon the regular currents. The ordinary pressure of the pen in writing on the tablet opens a shunt circuit, which act increases the strength of the pulsatory currents on the line. These stronger currents in turn operate a relay, the lever of which closes a local circuit and thereby operates a pen-lifting magnet, whereupon the pen rests on the paper roll. When the pressure of the transmitting pencil is removed the said shunt circuit is closed, the strength of the pulsatory currents is decreased, the action of the vibrating relay is reversed and the pen-lifting magnet lifts the pen from the paper. These pulsatory currents also decrease the friction of the receiving pen on the paper by keeping the pen in slight continual vibration. The paper at the transmitter is advanced mechanically as desired by the motion of a "master" switch. This same motion of the switch sends a current over one of the wires which operates a magnetic device that advances the paper roll at the receiver a corresponding distance. Stations are called by pressing a button, virtually as in the case of the Etheridge system. This system requires but little attention other than to keep the ink fountain filled and the pen points clean.

CHAPTER XX.

WIRELESS TELEGRAPHY.

HELPS, EDISON, PREECE, MARCONI, DE FOREST SYSTEMS, ETC.

The term wireless telegraphy as now generally used refers to the recently devised electrical methods like Marconi's and others, in which the wire between the transmitting and receiving stations is dispensed with, and in which electric or ether waves in free space are utilized. These, however, are not the only electric wireless telegraph systems in which the connecting wires are dispensed with, for during the past fifteen or eighteen years there have been in limited use a number of electric wireless telegraph systems, which have sometimes, perhaps for want of a more apt name, been termed induction telegraph systems, and in which electromagnetic and electrostatic impulses of low potential and low frequency, as distinguished from electric waves of high potential and high frequency, are employed. It may be noted, however, that some of the later wireless telegraph systems have also availed of comparatively low tension and low frequency waves.

Electromagnetic and electrostatic induction wireless telegraph systems are based upon the phenomena of induction between wires (*see* page 100 and Fig. 82). Such systems were probably first employed practically as a means of communicating to and from moving trains. There are at least two fairly successful systems in which "induction" is thus utilized.

HELPS AND EDISON INDUCTION SYSTEMS.

The first method employed on railways in this country was an electromagnetic induction system, the Phelps, in which an insulated wire *c*, Fig. 253, is coiled in numerous convolutions longitudinally around a car. In series with coil *c* is the secondary wire *c'* of an induction coil *I*, also a telephone receiver *T*. *B* is the buzzer

FIG. 253.

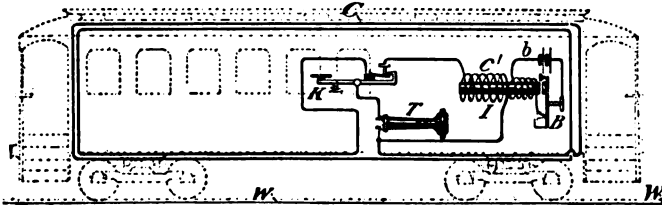

or vibrator of the induction coil, with the usual battery *b*. An insulated conductor *w* is placed between the rails of the track and is led into the stations as desired. This conductor is grounded at both terminals. An induction coil and transmitting and receiving arrangements are also placed in each fixed station in series with the track coil. When it is desired to establish communication from, for instance, a train to a

station, the "buzzer" in the train, is set in motion. This originates pulsatory currents which flow in the coil surrounding the car, and these pulsations are, by induction, transmitted through the air to the wire *w* between the rails. These pulsations are heard in the telephone at the station as a prolonged "buzz" when the key or transmitter *κ* is closed, but, when that key is opened, the buzz ceases, as, at such times, the secondary coil is open. Thus, by opening and closing the key *κ*, long and short noises corresponding to the dot and dash of the Morse alphabet, may be transmitted by the operator in the car and received by the operator in the station. In like manner the "buzzer" in the station may be set in operation, and the pulsations, in traversing the

FIG. 254.

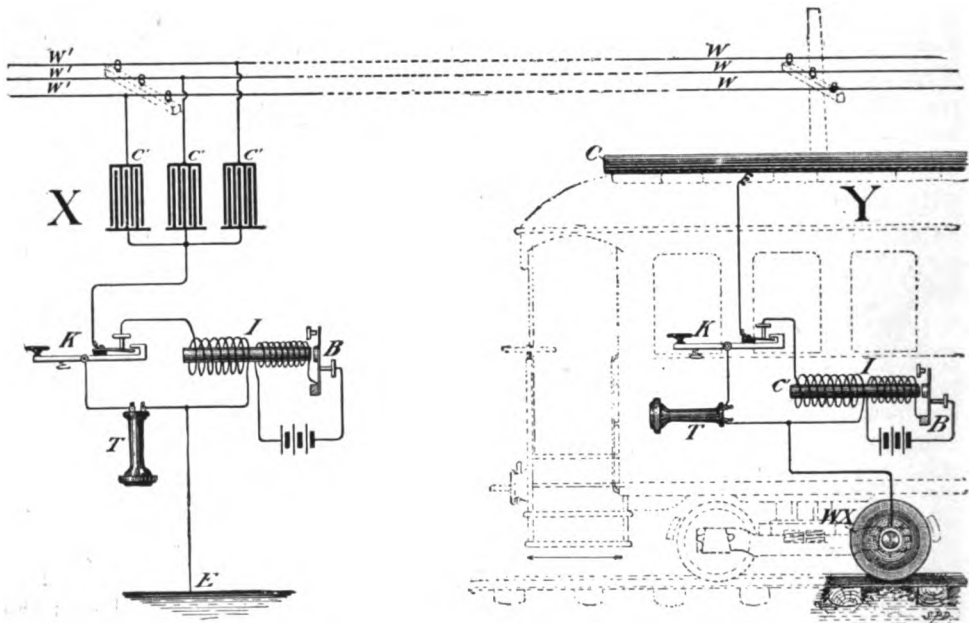

conductor between the rails, will induce pulsatory currents in the coil around the car, which may be broken into dots and dashes by the transmitting operator at the station, and received by the attendant in the car.

The contacts on the transmitter *κ* are so arranged that, when the key is closed, the telephone is cut out of, and the secondary coil is cut into the circuit; while, when the transmitter is open the reverse is the case.

Another method of communicating to and from a moving train, and a more successful one from a commercial stand point, is shown in Fig. 254.

The apparatus for setting up and receiving the "induction" currents is practically the same as in the method just described; but the huge induction coil around the car and the special conductor between the rails are dispensed with. In their places the metallic roofing *c*, of the car or cars, (Fig. 254,) of the train is used as one large plate of a condenser; the telegraph wires *w w w*, by the side of the railroad track, as the other plate; the insulating medium, or dielectric between the plates, being the intervening air.

X represents the apparatus and connections of the station. **Y** represents the apparatus, etc., in the car.

The metallic roofing *c* of the cars is connected as shown, via the key, or transmitter κ , to the earth ε , through the wheels of the car. At the permanent, or stationary office, **X**, several ordinary condensers, *c'c'*, are connected to adjacent telegraph wires *w'w'*, along the route of the car. One terminal of the condensers *c'c'* at **X** is grounded, via key κ , at ε ; the metallic roof of the car *c* at **Y** is grounded via κ and the wheel *wx* of the car—thus completing the "induction" circuit.

The consequence of this arrangement is that when the buzzer at either station is operated, the condensers in the one case, and the roofs and adjacent wires in the other, are alternately charged and discharged; the currents thus produced setting up in the telephone at the receiving office, whether in the car or station, a buzz similar to that referred to as established by the operation of the buzzer in the "coil and conductor" method.

The keys $\kappa \kappa$ are availed of to place the telephone and the secondary coil alternately in the circuit, as previously explained. By means of this arrangement of key κ the transmitting operator is not annoyed by the loud buzzing which would be set up in his telephone by the home induction coil, while, at the same time, he has an opportunity, at each opening of his key, to hear the "breaks" of the distant station, should any be made. In some cases a special wire on a pole line has been erected in closer proximity to the track than the ordinary pole line.

Both of these methods, the former of which is known as the "Phelps," and the latter as the "Edison," have been in actual operation on railroads in the country.

THE PREECE ELECTROMAGNETIC METHOD.

By an analogous method to that of the Phelps induction system, namely, the electromagnetic method, Sir W. H. Preece in 1892 succeeded in signaling to a distance of over three miles without intervening wires, between Penarth on the mainland and the island of Flat Holm in the Bristol Channel. Two parallel wires on poles were used, one on the mainland, the other on the island. The wires were from one to three miles in length. These wires served alternately as the primary or secondary wires, depending on which was employed as the transmitting or receiving wire. The respective wires were grounded at each end. Telephones were used as the receivers, as in the Phelps system. Instead of an induction coil to set up the electromagnetic

impulses, Mr. Preece employed a motor-driven make-and-break wheel **B**, Fig. 254*a*, by which means a sharper rise and fall of current is obtained, which in turn has a more pronounced effect upon the receiving instrument **T**. *r* is an adjustable resistance. The break-wheel is shunted by a condenser *c*. Battery *b* consists of about 100 dry cells.

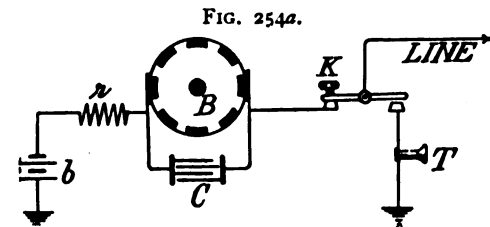

About 600 alternations per second were used. Mr. Preece states that the 100 cells

with this break-wheel give as good results at 3.3 miles as a $2\frac{1}{2}$ horse-power transformed into alternating currents by a transformer, owing to the smoother sinusoidal waves of the latter. When key K is closed, the pulsations from B are transmitted to the line; when open, the telephone T is in circuit for receiving signals from the distant station. "Calls" are received in this system by means of a very sensitive relay operated by a special transmitting device, the relay when operated ringing an alarm bell.

More recently Preece has succeeded in establishing a wireless telephone circuit, by means of which speech is transmitted between the Skerries lightship and the mainland of Anglesey, a distance of nearly three miles, the parallel wire on the Skerries Islands being 750 yards in length, and that on the mainland 3.5 miles in length, the ends of each wire terminating in the sea. On these systems both magnetic induction and electric conduction through the earth and water are utilized. The ordinary telephone transmitter and receiver are employed. It was suggested the vessels could hold speech with one another by this arrangement a considerable distance apart by having a copper wire carried from bow to stern and passing over the topmast, the ends of the wire being in the sea.

HERTZIAN WAVES.

Remarkable as these results are, however, they have been almost totally overshadowed by those wireless telegraph systems in which electric waves, or ether waves, are utilized, and several of which will presently be described.

When, in 1864, Clerk-Maxwell, who was, perhaps, the most noted mathematician of his day, made announcement of his celebrated electromagnetic theory of light, which theory involved the existence of electric waves in free space, many of the prominent physicists of the time set themselves the task of demonstrating by experiment the truth of this theory. It was not, however, until 1887 that the actual existence of electric waves in free space was demonstrated, the great honor of this accomplishment falling to Prof. H. Hertz, after whom such electric waves are now almost generally termed "Hertzian" waves. The old popular idea of electricity hardly conceived it as existing outside of a wire or other metallic conductor. The air was an insulator, and how, therefore, could electricity exist apart from a wire! Maxwell overturned this view, and told us that just as under the undulatory theory of light that which we call light is a result of ether vibration, so also is electricity a result of ether vibration, and that, in so far as light and electricity differ, it is only a question of the rate of vibration of the ether, those undulations of the ether which the eye recognizes as light occurring at a rate varying from 400,000,000,000,000 to 700,000,000,000,000 per second, while the frequency of the electric undulations of the ether vary from a few hundreds or thousands to over 200,000,000 per second.

According to the undulatory theory of light, the undulations of the ether, of the frequency just mentioned, are set up by any source of light. Similarly, according to Maxwell's theory, undulations are set up in the ether by any source of electric oscillations, analogously, for example, as waves are set up in the atmosphere by a source of sound. Also, as those ether waves which correspond in frequency to light affect an organ of sight when they fall upon it, and as sound waves affect an organ of hearing when they fall upon it, so, it was reasoned, should the electric waves of the ether affect a suitable electric "eye," or receiver, when they fall upon it.

The manner in which Prof. Hertz proceeded to show the existence of electric waves in free space was, briefly, as follows: It was already known that electric oscillations could be set up in a well-insulated wire or conductor; in fact, that the discharge of the Leyden jar is made up of a series of electric oscillations, as had been shown by Lord Kelvin in 1853. Hertz set up electric oscillations by means of an

electric oscillator, shown in Fig. 254*b*. This consists of an ordinary large induction coil, *I*, the terminals of the secondary coil being connected to brass balls, or knobs, *b b*, and to which short metal rods, or cylinders, *w*, are attached. The knobs are separated by a small air space or spark gap *s*, across which sparks jump when the coil is in operation. At such times electric oscillations are set up, the rate of which varies with the inductance, capacity, and resistance of the circuit, according to the formula, $T = 2\pi \sqrt{KL}$, where *T* is the time in seconds, π (Greek letter *pi*) is the ratio of circumference to diameter, *K* is capacity, and *L* the inductance of circuit, or $T = 6.2832 \sqrt{KL}$.

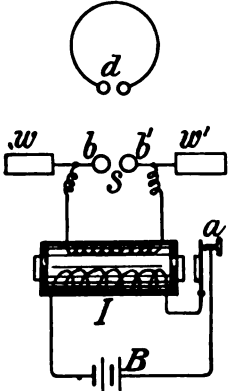
FIG. 254*b*.

It is assumed that inductance is the equivalent of inertia in mechanics, while capacity is the equivalent of elasticity. A charged condenser or other conductor possesses potential energy. In the act of discharging, the potential energy of the condenser decreases, while kinetic energy (momentum), due to the current accompanying discharge, will be acquired. Hence, when potential energy has fallen to zero (and assuming little resistance in the circuit) the current will still flow. This current charges the condenser oppositely and it again possesses potential energy, which, when the charging current ceases, will again set up kinetic energy, and thus electric oscillations are established and continue until dissipated by the resistance of the circuit, etc. The resistance of such circuits being comparatively small is neglected in the above formula. Certain Hertz oscillators are found by calculation to oscillate at the rate of ten millions per second; others at the rate of 300 millions, etc., varying with size of balls.

Hertz assumed that if the electric oscillations thus produced set up corresponding waves in the ether of free space, these waves should, in turn, set up electric oscillations of corresponding frequency in a suitable receiver, or "eye," within the range of their influence. He, therefore, adopted as a receiver of these waves, a circular copper wire, *d*, Fig. 254*b*, about 16 inches in diameter, but broken at one point. On the ends of this wire he placed small metal knobs, the distance between which could be easily regulated by a micrometer screw. This wire was held by an insulated handle, a few feet from the oscillator. With the room darkened, minute sparks were observed passing between the discharge knobs of the receiver; and the results of this simple experiment have been generally accepted as proof of the existence of electric waves in free space. Hertz, however, was not satisfied with this demonstration of the accuracy of Maxwell's theory, but also, in the course of his subsequent masterly experiments, showed that, like sound, heat, and light waves, the Hertzian waves could also be reflected, refracted, concentrated in parallel rays, etc.

By the Hertz receiver the distance at which electric waves could be detected was very limited, perhaps ten or twelve feet at most, and hence it is not likely that much would have been done in the utilization of Hertzian waves for telegraphic purposes had progress rested there. Fortunately, it did not. Shortly after the experiments of Hertz, Dr. Branly discovered that loose metal filings, which in a normal state have a very high electrical resistance, lose this resistance in the presence of electric oscillations and become practically conductors of electricity. This he showed by placing metal filings in a glass tube, *k*, and making them part of an ordinary electric circuit, Fig. 254*c*. When electric waves are set up in the neighborhood of this circuit, electromotive forces are generated in it which appear to bring the filings more closely together, that is, to cohere, and thus their electrical resistance decreases, from which cause this piece of apparatus—the tube and its filings—is termed a "coherer." Hence, the receiving instrument, *G*, in the figure, which may be a galvanometer or a telegraph relay, that normally would not manifest any sign of

current from the small battery, B, will be operated when electric oscillations are set up. Prof. Branly further found that when the filings had once cohered they retained

their low electrical resistance until shaken apart, for instance, by tapping on the tube.

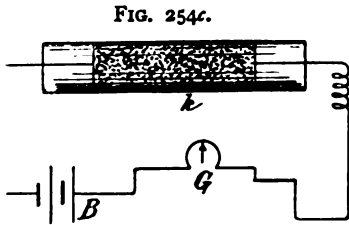

In 1894 Dr. O. J. Lodge showed that the Branly coherer could be employed to transmit telegraphic signals, and in order that the filings might not remain "cohered" after the cessation of the electric oscillations, he devised a mechanical "tapper," on the principle of the common electric door-bell, the hammer of which was caused to tap the glass tube as long as the elec-

tric oscillations continued. The filings thus virtually take the place of a key in the ordinary telegraph circuit. In the normal state the key is open; in the presence of electric oscillations the key is closed. Thus, by opening and closing the key for a longer or shorter period, signals corresponding to dots and dashes may be produced. In other words, by setting up electric oscillations for periods of time corresponding to dots and dashes, messages may be transmitted, and if at the receiving station a recording instrument (controlled by the coherer), such as is used, for instance, in the Wheatstone automatic telegraph system, be provided, a record of the message in dots and dashes is obtained.

In 1895-1896 Poppoff and others utilized the coherer to show the existence of atmospheric electricity, using for the purpose a vertical or aerial wire connected to the coherer, as shown in subsequent figures.

MARCONI WIRELESS TELEGRAPH.

In wireless telegraphy as at first operated by Marconi there were employed an electric oscillator *o*, Fig. 254*d*, with the primary and secondary coils *p* and *s* of an induction coil *i*, the discharge balls *b b*, and an aerial wire *A*, connected to the secondary coil and to earth by wires *w w'* as shown, forming the transmitter circuit. The receiving circuit comprised a filings coherer *k*, Fig. 254*e*, a tapper *T* in a local circuit *b'*, and vertical wire *A*. It was by modifying, improving, and perfecting these devices, and by adding others, that Marconi has been enabled to obtain practical results. The improvements and additions that perhaps conducted more than anything else to the first successful results obtained by Marconi were those that related to the coherer and the vertical wire. The sensitiveness of the coherer he increased greatly by diminishing its size, as indicated in Fig. 254*e*, compared with the Branly coherer, and by employing a mixture of nickel filings and silver—90 per cent. of the former and 10 per cent. of the latter metal. He also placed the few filings used in a vacuum. The other instruments shown in Fig. 254*e* are the relay, *R*, controlled by the coherer, and an ink-recording instrument, *E*, controlled by the relay. This figure illustrates the earlier arrangement of Marconi's devices. In it the coherer is directly connected with the lower end of the vertical wire by one of its terminals, and with the earth by its other terminal. The operation of the transmitting and receiving apparatus is practically as follows: The closing of key *K* of the primary circuit *p* of the induction coil sets up current of high potential in secondary circuit *s s*. When the potential is sufficiently high, sparks jump across the air gap between *b b* and electric oscillations are set up in *A* and *w w'*, and ether waves are emitted in space. By opening and closing key *K* to form dots and dashes, the sparks are correspondingly broken into short and long periods. Normally the lever *l* of tapper *T* is given a tension which holds it against the contact *c*. The armature-lever *l* of relay *R* is also normally on its back stop *x*. Hence at this time

local circuit of battery *b'* is open. When the filings cohere on the arrival of the emitted waves, relay *R* is magnetized by one dry cell *b* and its lever *l* moves over to contact *x'*, closing circuit of battery *b'*, and the electromagnet of *T* attracts its arma-

FIG. 254*d*.

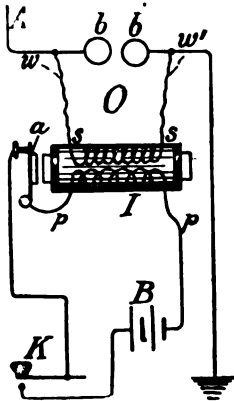
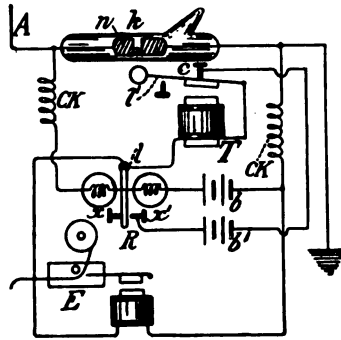

FIG. 254*e*.



ture, which opens the circuit of *b'* at *c*. At once the armature of *T* flies back on its contact point, at the same time striking the tube, decohering the filings, and opening the local circuit of *R* at *x'*. Immediately, however, the filings again cohere, assuming the oscillations to continue, with the result that *R* is energized, again closing circuit of *b'* at *x'*, whereby *T* is again magnetized, and the actions just described are repeated many times in a second. In addition to the apparatus outlined in Figs. 254*d*, 254*e*, a number of impedance or choke coils such as *ck*, and non-inductive coils essential to the practical operation of the system are employed. The choke coils are furnished with fine iron wire cores to increase the magnetic effect; the non-inductive coils are wound back upon themselves like rheostats, and are thus non-magnetic. In practice it is found necessary to enclose the coherer, the tapper, transformer coils (*j*, Fig. 254*i*) and the wires connected therewith in a box sheathed with iron. This sheathing is connected to the earth. *R* is usually a sensitive polarized relay of from 1200 to 10,000 ohms resistance. It is operated with one cell *b*. One reason for the use of a sensitive relay is that with more than one cell the coherer may act continuously. It is necessary that no sparks shall be developed at any of the contact points of *R* or tapper *T*. To prevent such sparks these contacts are shunted by non-inductive resistances of from 1000 to 4000 ohms, and in some instances with a condenser. The Morse register *E* is placed outside of the box, the wires leading out to it passing through a choke coil at the box to prevent external oscillations following the wire. A call bell is operated by the lever of the register *E*.

Beginning his experiments in Italy in 1895 with vertical wires twenty feet in height, Marconi found that he could get signals at a distance of one mile, and that by doubling the height of the vertical wire at both stations signals could be transmitted to four times that distance. Thus, with wires forty feet high, he could signal four miles, and with wires eighty feet high, sixteen miles. Since then Marconi has steadily increased the height and number of aerial wires until in his latest work these wires, over 250 feet in height, are numbered by the score, and the distance to which signals are transmitted through free space is over 2500 miles, as will be described in more detail subsequently.

To transmit and receive signals a distance of say 186 miles, with the apparatus outlined in Figs. 254*d*, 254*e*, about 150 watts (10 volts and 15 amperes) are necessary,

or nearly one fifth of a mechanical horse-power. The source of the electrical energy is a storage battery, which latter is sometimes charged by a number of dry cells in multiple. In passing, it may be remarked that an ordinary telegraph relay may be operated at a distance of 186 miles at an expenditure of three watts at the transmitting end of a telegraph wire, or with one fiftieth of the energy used in operating the electric oscillator in question. The actual energy required to operate the telegraph relay is about 0.24 of a watt, the rest of the energy being consumed in the wire itself. It must not, however, be assumed from this that the coherer is a less sensitive electric receiver than the relay; nor will it be, when it is reflected that the electrical energy expended in the case of the relay is, so to speak, mainly confined to the wire, as, analogously, sound waves are confined within a speaking-tube, whereas the electrical energy of the oscillator is radiated into space in every direction, and thus but a small portion of the total energy reaches the receiving vertical wire. It has been calculated that the electrical energy received on a surface one foot square at a distance of but one mile from the oscillator is less than one-three-hundred-millionth of the total energy radiated, and it may be noted, the energy actually radiated as electric waves is a mere fraction of the energy consumed in and at the oscillator.

From the results obtained by Marconi and others, it appears that the effect of increasing the length of the vertical wires is to give a greater radiating surface at the transmitting end and to present at the receiving end a larger surface upon which a greater number of circles of waves may fall, each circle of waves adding to the electrical energy set up in the receiving vertical wire.

The vertical wire or wires for ships and for short distances is usually of stranded copper, about $\frac{1}{4}$ inch in diameter, although Marconi for this purpose has used also

FIG. 254f.



strips of wire netting, about 2 feet broad. The wire or netting is supported by masts of proper height, securely guyed. It is not necessary that the wire be suspended strictly vertically so long as the desired vertical height is obtained. The wire is thoroughly insulated from the mast or tower at the top by sticks of rubber or ebonite, and is led in through an open window or hatchway to the room where the transmitting and receiving apparatus are situated. Although the discharge knobs are separated by an air space of only about half an inch, the induction coil used in connection with the oscillator is often capable of producing a spark that will jump ten or twelve inches through air. The actual appearance of the induction coil, discharge knobs, vertical wire, etc., is illustrated in Fig. 254f, which represents a military signaling outfit. The heavy current and high pressures in the circuits of the oscillator have led to the adoption of a much larger key for manipulating the oscillator than is used in ordinary Morse telegraphy.

The specimen of a dot and dash wireless telegraph record given in Fig. 254g is a facsimile of bulletins "caught on the wing" during the yacht races of 1899 in New York Harbor. Mr. Marconi had his apparatus on the steamship *Ponce*, and was sending bulletins of the progress of the race to the Mackey-Bennett cable ship, some miles away, when this specimen and many others were recorded by a set of Clarke wireless telegraph apparatus which the writer was supervising on the steam-

ship *La Grande Duchesse*. This was probably the first instance of tapping Hertzian wave signals, in the United States at least. It will be understood that Shr. is an abbreviation of *Shamrock*. Other abbreviations were used in these bulletins, as Col.

FIG. 254g.

--- --- ---
 S | H | R | D | R | A | W | S | A | W | A | Y |
 --- --- ---

for *Columbia*; abt. for about; bd. for board, etc. The present speed of signaling by wireless telegraphy is from ten to twenty words per minute. With the filings coherer as a detector of the receiver oscillations, but with the later type of detectors, known as anti-coherers, auto-coherers, etc., and by the use of the telephone as a receiver, a speed of 30 to 40 words per minute is attained. Instances of such detectors are those used by Marconi and De Forest, which will be described herein.

SYNTONIC WIRELESS TELEGRAPHY.

At an early period of the practical history of Hertzian wave telegraphy it was seen that the usefulness of this art might be considerably curtailed by the fact that but one message could be transmitted between any two stations within the sphere or "radius" of influence of a transmitter, since the attempt to transmit even two messages at one time would result in an unintelligible mixture of both messages. Several inventors have been more recently at work trying to overcome this defect, and, it is claimed, with success, notably Dr. Lodge, Sig. Marconi, and Dr. Slaby. The plan followed by these gentlemen has been that of employing a syntonic or tuning method; that is, the transmitting and receiving circuits are adjusted or "attuned" to a given rate of electrical oscillations.

It is a well-known experiment that when two tuning-forks, having an identical fundamental rate of vibrations, are placed in suitable proximity, either fork may be set into vibration by air waves set up by the other fork, and neither will be set into vibration by another fork of a different note. The tuning-fork is a persistent vibrator by virtue of two qualities which it possesses, elasticity and inertia. When struck a smart blow, it moves from its point of rest; directly its elasticity returns it to its point of rest, its inertia carries it past that point, its elasticity returns it to zero point, inertia carries it past, and so on, until the resistance of the air and other causes stop it. Analogously, an electrical circuit may be given, in almost any desired proportion, the equivalents of mechanical inertia, elasticity and resistance, in inductance, capacity, and ohmic resistance, respectively; and the rate of electric oscillation of a circuit may be varied by varying these factors—the smaller the factors, the higher the rate of oscillation. (See page 335b.)

When, then, the receiving circuit of a wireless telegraph system is accurately tuned to oscillate in harmony with the transmitting circuit, by giving the respective circuits practically equal inductance, capacity, and resistance, the receiving circuit will respond only to the oscillations set up by a transmitter correspondingly tuned. In experimenting, Marconi and others have, it is stated, found that perfect syntony between the respective stations is not absolutely essential, but that if there is a marked divergence of frequency of oscillation between them, the receivers will not respond to any but their correspondingly attuned transmitters.

The arrangement of Marconi's tuned transmitting and receiving circuits is outlined in Figs. 254h, 254i. It will there be seen that the oscillator and the coherer *k* are not connected to the earth, as in Figs. 254d, 254e, but that a small induction coil or transformer, *t*, is interposed. In Fig. 254h, *A* is the vertical wire which is

attached at its lower end to a coil of wire w . The end of the wire s , which forms part of the secondary wire of the induction coil T , may be connected to any desired turn of the coil w . By this means the inductance of the vertical wire circuit may be

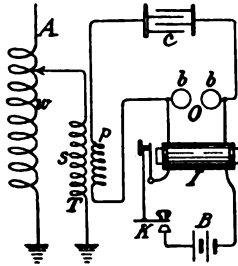
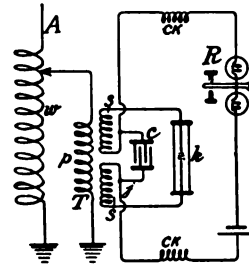
FIG. 254*h*.FIG. 254*i*.

varied, and its oscillation period thereby be made to correspond with that of the circuit o , of the oscillator, which includes the primary wire p of T ; c is an adjustable condenser of very small capacity, by varying which the oscillation period of the circuit may readily be varied. Leyden jars are frequently used for this service. A key K controls the primary circuit, as shown, and thereby, the oscillator circuit; I is the induction coil of the oscillator.

The tuned receiving apparatus is shown in Fig. 254*i*. In this figure, A is again the vertical wire with the turns of wire, w , to which is attached the primary wire p of the induction coil T ; ss is the secondary of the same induction coil; k is the coherer, and c is a condenser. The induction coil T acts virtually as a step-up transformer, which, it is claimed, materially enhances the electromotive forces of the received oscillations, and thus increases the signaling distance. In this case the condenser consists of a few sheets of tin foil or copper, the alternate sheets being separated from each other by thin sheets of paraffin paper.

Marconi has found it important that the oscillation period of the coherer circuit shall be the same as, or an octave of, the oscillation period of the vertical wire circuit. This can be done by making the secondary coil ss of the coil T equal the length of the vertical wire A . The transmitter circuit is then adjusted so that its oscillation period corresponds with that of the receiving circuit. This is brought about by varying the capacity of the condenser in Fig. 254*h*. The method of obtaining this "balance," as practised by Marconi, is to begin with very little capacity in the condenser, and adding to it until the best results are obtained at the receiving station. If, when the best results are obtained, still greater capacity is given to the condenser in the transmitting circuit, the signals fade away, showing that then the two circuits are out of harmony.

Marconi also found that by means of tuned apparatus a much greater distance may be reached, with a given source of electrical energy and height of wires. For example, a transmitter which would affect a tuned receiver thirty miles away would not affect a non-tuned receiver 160 feet distant. This, it may be assumed, is because in the case of the tuned receiver the faintest oscillations, or electromotive forces, set up in the receiving circuit by the incoming waves, are in unison with those waves, and successive incoming waves amplify the oscillations in the receiver circuit until they affect the coherer (in other words, resonance comes into play); whereas the oscillations which the same waves tend to set up in the non-tuned receiver circuit are, so to speak, out of step with the natural rate of oscillation of the non-tuned circuit, and thus as frequently oppose as assist the natural oscillations of the circuit.

In connection with the experiments carried on by Marconi, it is reported that two different messages have been received at one time on a vertical wire, two sets of

receiving apparatus, each attuned to a different rate of oscillation, being connected with the same wire. To those who have had experience with Gray's harmonic system of wire telegraphy, in which three and four instruments, attuned to transmit and to receive different rates of electrical current pulsations, have been successfully and separately operated on one wire, this will not appear astonishing, since it is quite conceivable, if it be granted that wireless transmitting and receiving apparatus can be successfully attuned, that two or more receiving instruments might be connected with one vertical wire, and each set of apparatus select and respond only to the particular rate of oscillations to which it is attuned. However, if by the use of tuned apparatus nothing else were gained than the ability, with a given amount of electrical energy and a given height of vertical wire, to transmit signals to a greater distance than is possible with untuned apparatus, it must be considered a decided advance in the art, and judging by the whole progress of electrical telegraphy, it is safe to say, when so much has already been achieved, that the necessary improvements to obtain at least practical freedom from interference between adjacent apparatus will ultimately follow. Tuned wireless systems are known as "closed," untuned as "open" systems. The one is a persistent vibrator, the other is quickly dampened. Compare Fig. 254*d*, Fig. 254*h*.

MARCONI LONG-DISTANCE WIRELESS TELEGRAPH.

From the more recent experiments it appears that, given a sufficiently powerful transmitter and a sufficiently sensitive receiver, there is no limit to the distance to which signals can be transmitted by electric waves. It was at first thought that this distance would be limited to within a few hundred miles by the curvature of the earth, it being impracticable to secure masts or other means of support for the aerial wires high enough to surmount the convex surface of the earth between points several hundred miles apart, and it being supposed that the earth would prove a barrier to the electric waves traveling in straight lines like light waves, which latter it is well known are obstructed by substances opaque to light. A number of theories have been advanced to explain the fact that signals are received at distances much beyond what would be possible did the earth intercept the waves traveling in straight lines. One, due to Kennelly, assumes that the atmosphere at a distance of say 50 miles from the earth's surface possesses an electric conductivity about 20 times greater than ocean water; further, that electric waves of the frequency used in wireless telegraphy, propagated through the atmosphere and the ether, are reflected by the electrically conducting surface of the ocean (the ocean as a conductor being opaque to electric waves of a frequency of millions per second). The conducting strata of air and the surface of the ocean thus give an upper and a lower conducting surface. The upper conducting surface may have little effect on electric waves that are transmitted a few miles only, but on waves that are transmitted to a distance that is large compared with 50 miles, the waves may find in the upper conducting strata of air another reflecting surface, and thus may move horizontally outwards in a 50-mile layer between the upper and lower reflecting surfaces, to a great distance. Another theory, advanced by Rankin Kennedy, is that the action upon the electric wave detector in long-distance wireless telegraphy is due to electric oscillations set up in the earth itself considered as a sphere or globe insulated in space. Nominally, the globe is electrically neutral, all parts of it being at equal potentials, but when the electrical condition is disturbed, as by an electric oscillator, the disturbance spreads over the whole globe and may be detected at any other part of its surface by a sufficiently sensitive electric wave detector. Still another theory, due to Taylor, is, in brief, that the waves travel over the earth's surface or that of the ocean, as they would over the surface of a conducting plate, in all directions horizontally from the vertical wire, the base of the waves following the contour of the earth or ocean, traveling over curved or round conducting surfaces, and being absorbed by precipi-

tous conducting surfaces, and passing through non-conducting substances, since the latter are transparent to these waves.

In the latest Marconi arrangement of the equipment for transatlantic and other long-distance wireless transmission, the aerial wires at the land stations are supported on high masts or towers, preferably the latter, in order to withstand storms, as shown in fig. 254j. These towers, of which there are four, are about 220 feet in height, and at South Wellsfleet, Mass., they stand on a sand cliff about a hundred and fifty feet above sea level. A multiplicity of vertical small copper wires are supported by horizontal wires strung from tower to tower as shown. The vertical

FIG. 254j.

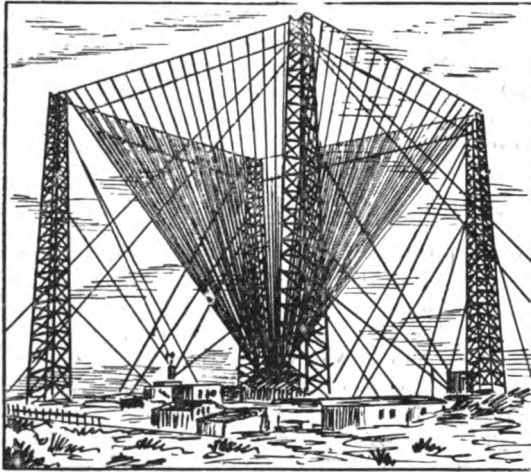

wires converge as indicated and are thence led into the instrument room. At the same station there is a windmill used to drive a dynamo to charge a storage battery. A gas engine is employed to run the generator used in setting up the powerful oscillations necessary for transatlantic signaling by this system. Details are not yet obtainable in full regarding these stations. At the Poldhu (Cornwall, England) station, it is understood that a 20-kilowatt generator developing 2000 volts was used. This voltage is raised by "step-up" transformers (a type of induction coil) to perhaps 100,000 volts on the aerial wires. Owing, however, to the

losses in transformation and at the spark gaps only a small fraction of the energy of the generator is radiated. It is clear that means must be provided for obviating danger at the opening and closing of the transmitting key, where strong currents and high potential are used. This is sometimes done by opening the circuit in oil, special keys being designed for the purpose.

THE FLEMING TRANSMITTING SYSTEM.—In Fig. 254k is outlined a transmitting system designed by J. A. Fleming, for the Marconi Wireless Telegraph Company, for long-distance signaling, the description herewith of which is condensed with slight changes from the British patent specifications. In the figure, D is a 20 or 25 kilowatt alternator, at 2000 volts more or less, with a frequency of 50 per second. T is a transformer the primary wire of which is in series with D. This transformer raises the E. M. F. to about 20,000 volts, charging condensers c, which discharge across spark gap s, in secondary of T, and oscillations are set up in the primary of T', which oscillations are again transformed to higher E. M. F. in T', charging condenser c', which discharges across s', setting up oscillations in T'', which still further increases the E. M. F. thrown upon the aerial wire, or wires A. By means of this double or treble transformation the E. M. F. at the aerial wires is sufficient to give a spark of about twelve inches, perhaps equal to over 100,000 volts. If oscillator circuit O' be omitted the secondary of transformer T' is connected to the aerial wire. Condensers c are of special construction, consisting of a number of stoneware boxes filled with double-boiled linseed oil, in which twenty glass plates, 15.5 inches square and coated with tin foil on both sides, are placed. Eighteen such boxes in parallel give a total capacity of about one microfarad. They are connected as shown at c, so that the length around

and through any condenser and the spark gap and primary of transformer T' shall be equal, to the end that all condenser discharges shall travel in the same time to spark gap s and all have the same frequency. The capacity of condensers c' is adjusted in such manner that oscillator circuit o' has an oscillation period equal to the

FIG. 254k.

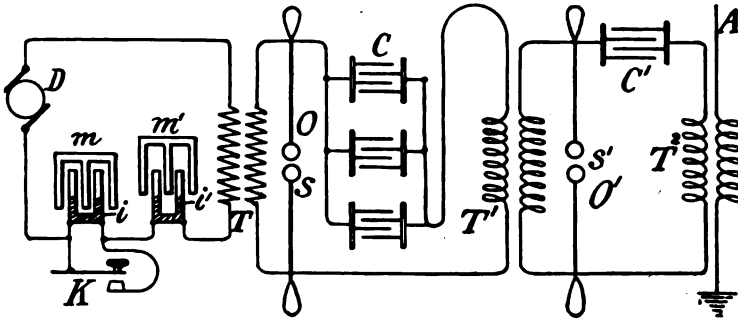

secondary of T' and the aerial wires. Analogously, the other oscillation circuit o and transformer circuits are suitably attuned to each other, by varying the inductance or capacity, for which provision is made in the apparatus.

To obviate opening and closing the primary circuit of D two choke coils i i' having movable iron cores m m' , are placed in the primary circuit of T and D . The iron core of m' is so adjusted that as much current as can safely be allowed to flow through primary of T shall normally pass. The core m of i is let all the way down, and it entirely impedes the flow of current in the primary of T . Coil i can, however, be short-circuited by key K , at which times the current in said primary attains full value. Thus the circuit of D is not opened in the usual sense. Key K is of the type that is opened at a number of places, ten or twelve, to render the spark harmless, and the switch is opened in insulating oil.

MARCONI LONG-DISTANCE RECEIVER—MAGNETIC AUTO-COHERER.—For wireless transmission in excess of a few hundred miles the filings coherer with a relay as receiver is not sufficiently sensitive, hence, as already intimated, recourse has been had to more sensitive detectors, termed auto-coherers and anti-coherers, in which the telephone is used as the receiver, that instrument, it is known, being responsive to exceedingly minute currents. In the auto-coherer no tapping back is required, the instrument resuming its normal electrical condition automatically directly the electric oscillations cease. An auto-coherer designed by Marconi, and known as the magnetic detector, has been used with much success in his transatlantic and other long-distance work. It consists of a primary and secondary coil of fine copper wire

FIG. 254l.



w w' , Fig. 254l, wound over a core c of fine iron wires. The inner wire w may be connected with the aerial wire in the manner described in the case of the filings coherer. The outer wire contains in its circuit a telephone receiver t , but no battery. A permanent magnet m is placed near an end of the core c . The magnet is revolved by clock-work at the rate of about thirty revolutions per minute.

This detector of electric waves is based on the observed fact that when a magnet, such as core c , is undergoing regular slow changes of magnetism (which slow magnetization, by reason of hysteresis, is retarded and lags behind the magnetizing force), electric oscillations produce rapid changes in the magnetization of the magnet, with the

result that currents are set up in the coils surrounding the core, which are heard in the telephone receiver as long and short sounds when signals are being received.

With electric wave detectors of the automatic type the action seems to be practically instantaneous, unlike the filings coherer, in which time is lost in cohering and in tapping back. A much higher rate of transmission with detectors of the Marconi and De Forest type (to be described) is therefore possible; a speed of thirty-five to forty words having already been attained. It is apparent that when detectors of this type are employed and the current is too weak to operate a relay there will be no automatic ink record of the received messages. Marconi, however, anticipates that it will be possible to find a suitable recorder in connection with the magnetic detector, in which event he predicts a speed of 100 words per minute. For calling, a coherer with alarm bell is used in connection with auto-detectors otherwise the attendant must keep the telephone at his ear continuously.

DE FOREST WIRELESS TELEGRAPHY.

This system, shown theoretically in Figs. 254*m*, 254*n*, is used successfully in the United States. In this system the usual induction coil for setting up oscillations is dispensed with and instead a motor generator *D* (see Fig. 31*a*) is employed, which receives direct current at 110 volts from any available source as a motor, and as a generator delivers an alternating current of 500 volts. Or where current is not available to operate an electric motor, an engine-driven generator is employed. *T* is a step-up transformer which transforms the current to 25,000 or 50,000 volts. This latter current charges a condenser *C*, or Leyden jars (a capacity equal to about five quart jars is used). The condenser discharges across the spark gap *S*, setting up electrical oscillations in aerial wire *A*. Instead of the usual balls at the discharge gap,

FIG. 254*m*.

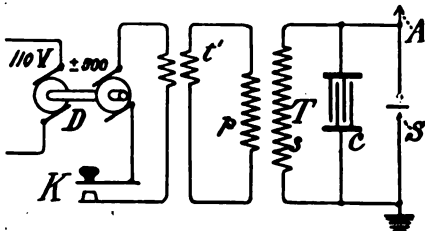
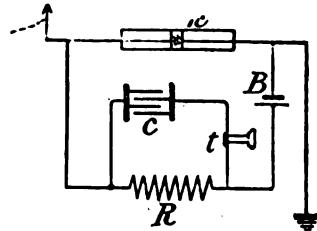

FIG. 254*n*.



a brass disc between two small brass balls is employed, the latter being adjustable, the disc stationary. The balls are supported in a vertical position on corrugated pillars of ebonite; *t'* is a choking or impedance transformer with a ratio of transformation of unity, that is, the primary and secondary have the same winding. Its function is to prevent the high potential currents jumping through to the armature of *D*; *K* is a Morse transmitting key, by means of which the train of oscillations is broken into dots and dashes of the Morse code. The contacts of this key, which are in the circuit of *D* and primary of *t'*, are opened in oil to prevent harmful sparking. The contacts of this key are so arranged that the aerial wire is automatically connected with the transmitting circuit when the key is closed, and with the receiving circuit when the key is open, which practice is also common to the Marconi and other systems. A general resemblance of the Fleming transmitter, Fig. 254*k*, and Fig. 254*m*, may be noted. By this arrangement of transmitting apparatus much greater power is obviously obtainable than by the ordinary induction coil.

One arrangement of the De Forest receiving circuits is shown theoretically

in Fig. 254*n*. The wave detector *k* used in this system is termed the "responder." It is an auto-coherer, and also an anti-coherer in that normally its resistance is low, but increases when oscillating currents traverse the receiving circuit. This detector consists of a tube in which two metal rods are placed, practically as in the case of the filings coherer. In the space between the ends of these rods a viscous liquid, such as glycerine, is placed, and in the liquid small pieces of metal, such as lead oxide, are suspended. When current from cell *B* alone is flowing, these filings build up bridges which close the gap, electrically considered, but when electric oscillations are set up in the circuit electrolysis takes place with an explosive generation of hydrogen gas, which destroys the bridges, thereby largely increasing the resistance of the circuit. On the cessation of the oscillations the bridges at once re-form automatically under the influence of battery *B*. The variations in the strength of current thus produced affect the telephone *T*, and a note or sound corresponding in length to the dots and dashes transmitted, is set up in that instrument. *R* is a resistance used to regulate the current in the circuit. In series with telephone *t* is the condenser *c*, which accentuates the sound in the telephone.

No attempt is made to utilize syntonny or tuning in the De Forest system, and apparently it has not thus far been deemed necessary, dependence being placed upon the transmission of powerful waves and the highly sensitive responder employed. Tests of this system have recently been made by the United States Navy Department, between Washington, D. C., and Annapolis, Md. At each station masts 180 feet high are used. From these masts five wires 200 feet in length are fanned out, and joined at the bottom. The "ground" consists of two copper plates, two by six feet each, buried six feet in the earth. It is understood that this company will shortly have constructed a 175 foot tower at Cape Hatteras, for communicating with passing ships and also with Block Island off Rhode Island, 300 miles distant, where a similar tower is being constructed. The power at these stations will be four kilowatts. For shorter distances, machines generating about one kilowatt are sufficient. Long distance signaling across the Pacific is also said to be contemplated by this system, with stations having a capacity of forty-five kilowatts.

The De Forest system has been utilized as a means of transmitting stock news from the street to brokers' offices in New York City. The street equipment is carried in an electric automobile, a rod from the vehicle supporting a comparatively short vertical wire. For this work an induction coil is used in setting up the electric oscillations, current being supplied by the storage battery of the automobile. The Branly-Kopp Company of France has a somewhat similar method of distributing news in operation in Paris. It may be noted that balloons and kites have been repeatedly used for upholding the vertical wire when masts have not been available.

Numerous other wireless telegraph systems have been invented within the past few years, among others the Braun or Siemens-Halske, the Slaby-Arco, the Fessenden, the Lodge, and the John Stone Stone. Of these, at least the Braun and the Slaby-Arco are in operation in Europe. It is, however, not within the present scope of this chapter to describe these various systems. From the fact that suits and counter-suits at law between a number of the prominent wireless telegraph interests are proceeding, for infringement, it may be assumed that there is a tendency towards the employment of more or less similar methods and apparatus. For a more complete treatment of the entire subject, as well as a detailed description of the systems mentioned and others, the reader may be referred to the author's work on "Wireless Telegraphy," for synopsis of contents of which see last pages.

CHAPTER XXI.

SYNCHRONOUS MULTIPLEX TELEGRAPHY.

In ordinary manual telegraphy the speed of transmission of the average operator is from 25 to 40 words per minute. Assuming that there are 25 pulsations to the average word, we get a total of, say, 600 electrical pulsations as the maximum number of dots which an operator is capable of making, per minute. It is known that 500 or more pulsations, per second, can be successfully transmitted on moderately long overhead circuits.

From the knowledge of these and other facts, the idea was conceived that, if means were provided whereby a telegraph wire could be distributed among four, six or more operators, giving each of them exclusive, momentary, use of the wire, in rotation, so rapidly that it would not be possible for any one of them to make a dot before the wire would be assigned to him, the same wire could be utilized to transmit 4, 6, or more messages at, practically, the same time on one wire.

In order that this might be done satisfactorily it was evident that the corresponding transmitting and receiving instruments at the near and distant stations should be placed in connection with the line wire at identical instants of time. This entailed devices for securing a certain synchronous action of the apparatus so that the aforesaid requirement could be met, and, hence, the title of this system of telegraphy.

The apparatus for securing this result consists of a revolving wheel, due to Paul La Cour, at each end of a telegraph line, the wheels revolving, as nearly as possible, at a precisely uniform rate of speed, and electrical and mechanical devices for the maintenance of this uniform rate of rotation.

The motive power of each wheel is an electric-motor, or, it may be said, the wheel is part of an electric-motor.

The motor is operated by electrical pulsations caused by a tuning fork, or vibrating reed, one at each station. These reeds are attuned to the same rate of vibration, as nearly as may be.

The motor, reeds, circuits, etc., at each station, are shown in Fig. 255. *cc* are the vibrating reeds. *AA* are electro-magnets, the poles of which face the soft iron teeth *T* rigidly attached to the periphery of the wheels *ww'*. These wheels revolve in a horizontal position, consequently they are meant to be shown in top, not side view, in the figure. Directly above the wheels *ww'* is placed a disc *D*, on which are shown certain segments, indicated by the numerals 9, 10. The teeth *T* are shown as extending beyond the periphery of the disc *D*. The shaft on which *w* revolves passes vertically through a hole in the center of disc *D*. On this shaft is rigidly fastened a strip of metal *R*, from the outer end of which droops a metallic brush, termed a "trailer." As the wheel revolves the trailer is swept over segments, 9-10, and also over other segments not shown in this figure.

The reeds *c c* are kept in vibration in a well-known way. That is, when the reed is placed against the contact point *P* the resistance *r* is cut out, or short-circuited, and battery *B* exerts its full strength. This magnetizes the electro-magnet *m*; hence the reed is attracted towards contact point *P'*. As now the circuit of *B* is broken at *P* the resistance *r* is again placed in circuit, diminishing the current, mag-

FIG. 255.

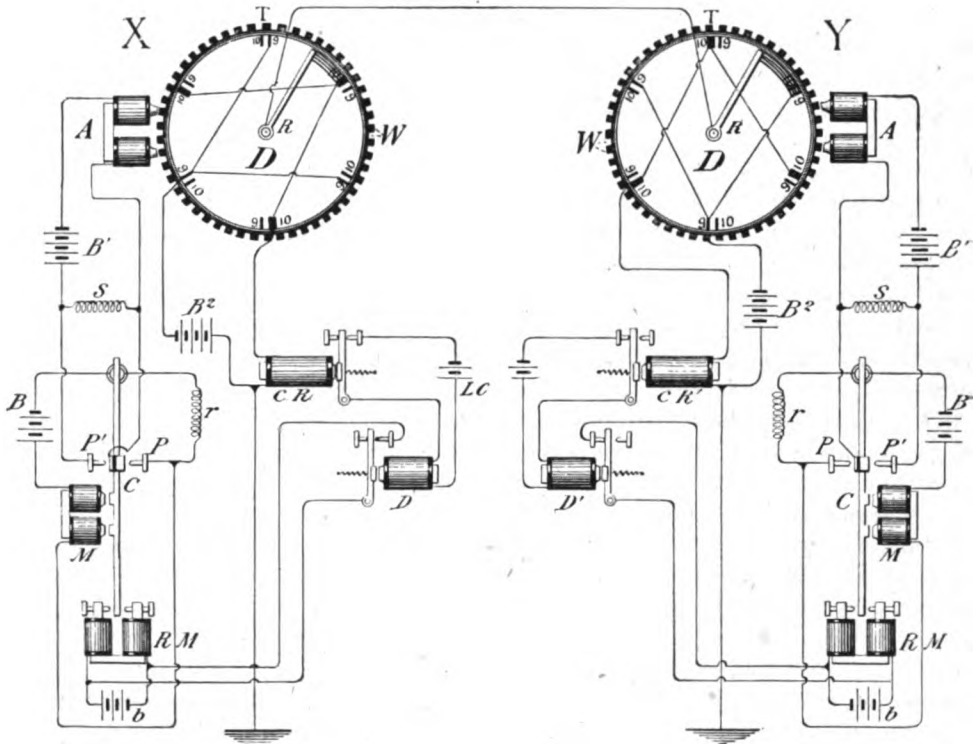

CONNECTIONS—DELANY MULTIPLEX TELEGRAPH THEORY.

net *m* loses its attractive force and reed *c* is withdrawn, by its own tension, to contact point *P*, and so on, thereby producing the well known "buzzer" action.

Whenever the reed makes contact with *P'* the circuit of battery *B'* is closed. This magnetizes electro-magnet *A*. When the reed leaves contact *P'* the circuit of battery *B'* is opened and *A* is demagnetized. *s* and *s* are high resistance coils, shunted like *r r'*, across or around the contact points to prevent sparking. The uses of the other apparatus will be referred to presently.

The wheels *ww*, not being self-starting, are first "flipped" into motion by an attendant. They are then maintained in motion as follows: (We may, for simplicity, consider only the case of one wheel, the action of both being similar.) The teeth on the wheel, as it rotates, pass in close proximity to the curved pole-pieces of the electro-magnet *A*, which is in the circuit controlled by the vibrating reed *m*. At each full vibration of the reed the electro-magnet is momentarily magnetized and

during the time it is thus magnetized, it attracts towards its poles two of the soft iron teeth of the revolving wheel. The momentum of the wheel carries those teeth slightly past the poles of the magnet and brings another pair of teeth up to the poles, ready to be acted upon by them when the electro-magnet is again momentarily magnetized. In this way the wheel is not only kept revolving but it is also kept revolving at a uniform rate of speed as long as the magnetic pulsations of the electro-magnet A are uniform; for, if the last magnetic pulsations should accelerate the momentum of the wheel to the extent that it should tend to pass by the poles of the magnet, out of its regular time, the magnet acts as a drag upon it, the wheel, holding it back slightly.

It would, however, be impossible to procure two reeds or tuning forks capable of vibrating in perfect unison, especially when at any distance apart, for any length of time, no matter how skillfully made, owing to variations in temperature, etc. Hence, in order to secure practical synchronism, some means, in addition to the ordinary natural vibration of the reeds, or tuning forks, must be employed.

The arrangement used for accomplishing this result in the system under consideration is shown in Fig. 255 also. The three segments marked 9, on disc D , at x , are, it will be seen, connected together and thence the circuit leads to a battery, B_2 and to earth. Three segments marked 10, are also joined together and thence are led to and through a relay CR , termed a "correcting" relay, to earth. Segments marked 9 and 10 are connected in a similar way on the disc at y , the only difference being that the "live" segments at the respective stations are at relatively different points of the disc, as shown in the figure. (The segments which are not connected to battery B^2 , or to relay CR , are termed "dead" segments; those that are so connected are termed "live" segments.)

Assuming the trailer at x to be on a "dead" segment, 9, while the trailer at y is on a "live" segment, 9, it is evident that no current can pass from battery B^2 ; and further, it will be found, on examination that, so long as the trailers are on corresponding segments at x and y , no current will pass from battery B^2 at either end, to the line. When, however, either of the trailers is driven faster than the other, as, for instance, if, as shown in Fig. 255, trailer at x should run so that it passes over a "live" 10, while the trailer at y passes over a "live" 9, a current from battery B^2 at y will pass over the line wire and through the correcting relay CR , at x , to earth; thus momentarily magnetizing that relay, which attracts its armature, opening the local circuit of LC , as in figure. This permits the armature of relay D to fall back, opening the shunt around the battery b and allowing that battery to magnetize the electro-magnet RM , between the pole-pieces of which the lower end of the vibrating reed c , oscillates. The effect of the introduction of this magnetic field in the path of the reed is to retard its vibration and, consequently, the rate of pulsations transmitted to the motor magnet A is diminished. From what has been said it follows that the speed of the revolution of the wheel at x is retarded until it is brought into unison with the wheel at y . When, on the contrary, the trailer at y runs ahead of the trailer at x , "correcting" currents are similarly transmitted, from x , to the correcting relay CR' , at y , with equivalent result to that just described.

In practice the "live" segments 10 are made somewhat broader than segments 9, so that corrections will always be sent out from one or the other end before the

FIG. 256.—DELANV SYNCHRONOUS MULTIPLEX SYSTEM, ARRANGED FOR POLARIZED RELAYS AS RECEIVERS.

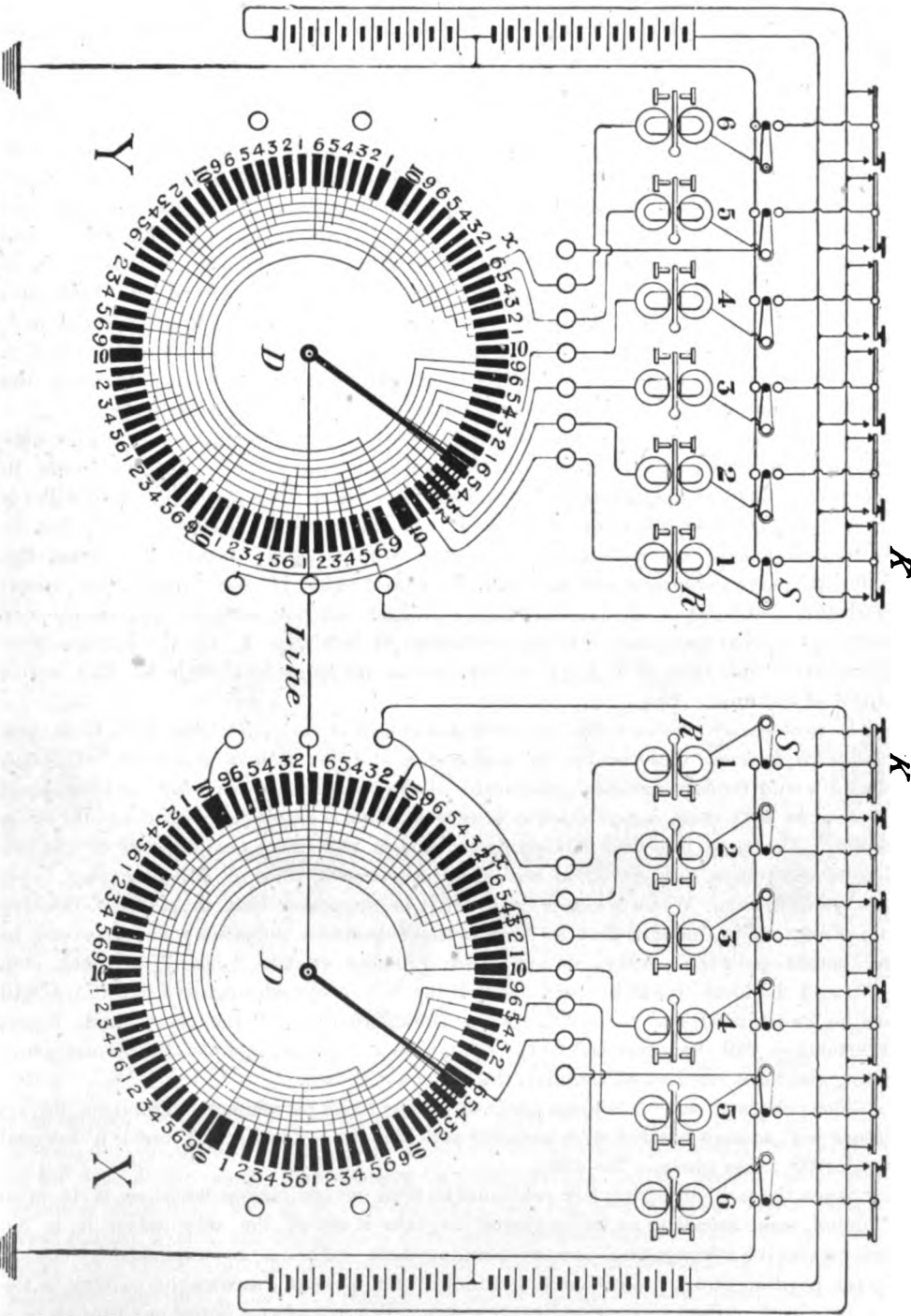

loss of synchronism of the trailers can proceed so far as to interfere with signals on the segments which, as will presently be shown, are assigned to the transmission of despatches.

This method of obtaining synchronism is adapted to the requirements of a multiplex telegraph system as shown in Fig. 256. In this figure the disc *D* is shown with 84 metallic segments, each insulated from the other. Assuming that it is desired to transmit six messages simultaneously, 72 segments are set apart for the purpose, and each of 6 desks at each end of the line is allotted 12 segments, as in Fig. 256. That is, starting, for instance, from a given point, as *x*, on the disc, the first segment is given to desk No. 1, the second segment to desk No. 2, at each end of the line, and so on, to the sixth segment. Here the two segments numbered 9 and 10 are skipped. A second and a third series of segments are then connected to desks Nos. 1, 2, 3, 4, 5, 6, when another two segments, 9 and 10, are again skipped and so on around the disc, as in the diagram, each desk being connected with different segments.

As the wheel *w* revolves the trailer is swept over the segments in rapid succession. The trailer makes about three revolutions, per second. It thus comes in contact with 216 desk segments per second and hence each desk at each end of the line is connected to the line 36 times per second. As an operator cannot make a dot in less time than, say, one-twelfth of a second, it follows that, during that time, the trailer will have given him contact with the line thrice. If, for instance, the operator at desk, No. 2, at *x* should hold his key closed for one second, 36 pulsations of electricity would reach the receiving instrument at desk No. 2, at *y*. In this way each of the 6 operators at each end may transmit messages as though he had entire control of the line.

It necessarily ensues from this arrangement that each character sent from any one desk is formed of a number of pulsations, and as such a condition of transmission would render signals unintelligible if the ordinary Morse relay and its local connections were used, a modification of that method is employed in this synchronous system. There are two such modifications used in practice. One consists of the use of polarized relays, *R*, Fig. 256, as receiving instruments, and of pole-changing keys, *K*, as transmitters. When a key is open, let it be supposed that it places a positive pole of battery to line and that so long as these positive pulsations are received in the distant polarized relay, its armature remains on the "dead," or back stop point, and the local circuit is open. When the key is closed, negative pulsations will then be transmitted, and these will reverse the magnetism of the relay, and, hence, its armature will be attracted to the other side and placed against the contact point, closing the local circuit and sounder, the latter not shown.

The polarized relay is chosen because, owing to its permanent magnetism, its armature will remain passive on whichever side it is last placed, and until a reversal of polarity takes place in the core.

Since the pole-changing key continues to send out pulsations whether it is open or closed, some means must be employed to take it out of the way when it is desired to receive messages on its corresponding desk. This is accomplished by changing the position of a 3-point switch *s*, which in one position, throws the battery to the line and, in the other, places the line to earth. When midway between either stop it

opens its particular desk circuit. A disadvantage of this method is that a sending operator has no means of knowing when he is being broken by the receiving operator until he switches in the polarized relay.

Another method of availing of these pulsatory signals is that shown in Fig. 257, in which the Morse neutral relay, NR, is employed, the contact point of which is placed on the back stop. In this case *no* pulsations are transmitted when the key is closed. But, when open, pulsations may pass from either end. This is due to the

FIG. 257.

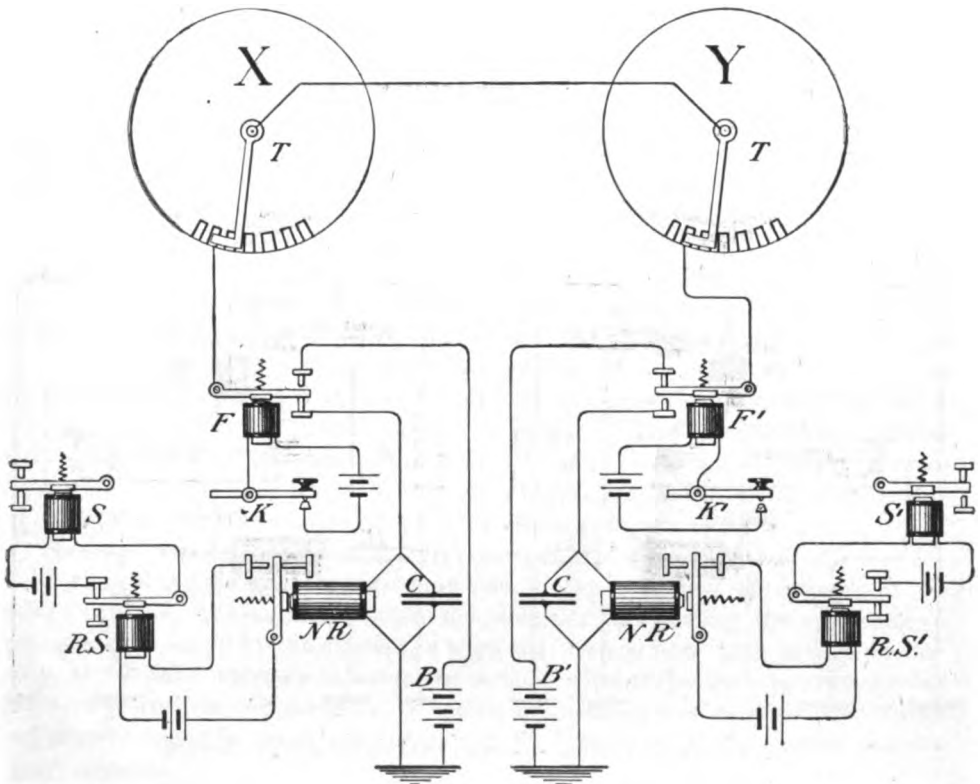

SYNCHRONOUS MULTIPLEX SYSTEM ARRANGED FOR "NEUTRAL" RELAYS.

arrangement of connections on the armature levers of F F'. Both ends, x, y, of the circuit, and the apparatus for one desk, are shown in the figure, also a few segments of the disc at each end. The trailers T T, are assumed to be passing over corresponding segments. Key k, at x, is shown closed, key k' at y, open. Thus pulsations from battery B' at x are transmitted over the line and are received in the neutral relay NR. These cause the armature of that relay to vibrate between its front and back stops so rapidly that the repeating sounder RS does not respond, but remains against its upper stop, thereby closing the local circuit of the reading sounder s. In

this way the pulsatory signals are caused to produce, at the receiving end, ordinary dots and dashes in the sounders.

The pulsatory currents received at the relays are augmented and prolonged by the condenser c or c' , placed around the relays. The action of the condenser in performing this function may be stated as follows: During the existence of a pulsatory current the condenser is charged and upon the cessation of the charging current the accumulated charge is discharged through the relay in a direction similar to that of the current which had charged the condenser.

FIG. 258.

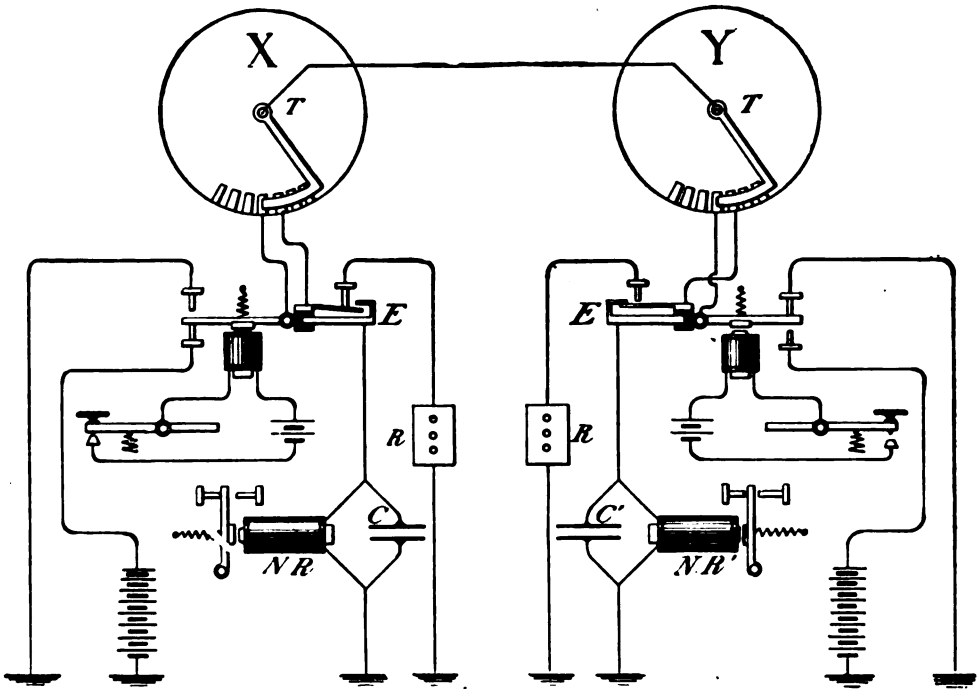

SYNCHRONOUS MULTIPLEX SYSTEM; ARRANGED FOR LONG CIRCUITS.

A very decided improvement in the working of the relay is noticed when the condenser is employed. The usual resistance of the neutral relays now used in this system is about 1,000 ohms. The arrangement of transmitters, F , F' is useful, inasmuch as it places the receiving relay to the line every time the operator closes his key, thus enabling him to hear breaks from the distant end.

As previously stated, it is well known that on long telegraph wires a perceptible time is required to discharge the wire of the electricity with which it has been charged in the transmission of signals. This conduces to retardation of signals, which, if not guarded against, would, in systems of the nature just described, tend to produce "false" signals in the receiving instruments, for, otherwise, the charge remaining in

the wire from one signal would be received in the instruments connected with the succeeding segments.

In the operation of the Delany synchronous system, just described, provision is made for dispersing the charge accumulated in the wire from previous signals, and which, if not dispersed, would not only tend to produce false signals in the signaling relays, but would also interfere with the synchronism, by sending currents through them at inopportune moments. The devices for carrying off the accumulated charges consist of metal segments, not seen in the diagrams, placed between each "desk" segment. These are all connected together and then grounded; thus permitting the residual electricity in the wire to escape harmlessly at both ends of the line.

On circuits of moderate length, say, about 100 miles of overhead wire, this device is found quite efficient, but on longer lines not to the same extent, owing to the greater delay in charging and discharging the wire.

To permit the use of the system on longer circuits, the arrangement of transmitters and segments shown in Fig. 258 has been devised, and has been found of utility.

In this modified arrangement advantage is taken of "retardation" in the following manner. In the figure x and y represent the terminal stations, with trailers $\tau\tau$, segments, etc. The electrical synchronizing devices remain as before. The chief change consists of a transposition of the segments by means of a specially constructed transmitter ε , so that, when the trailer at the sending end, say, x , in the figure, is on a segment connected with the battery, the trailer at the distant station is on a segment connected to the ground, as at y . This carries off so much of the charge as may have reached y . The next instant the trailer at x passes to a segment connected with the ground, via the transmitter ε , and through a rheostat r ; this cuts off all battery; at practically the same instant the trailer at y passes over a segment connected with the relay $\varkappa r'$, whereupon the retarded charge passes through the relay and actuates it. In the same way signals are also sent from y to x .

The local circuits of the neutral relays remain as before described.

In view of the fact that the chief drawback to the operation of systems of the synchronous order on long lines is due to the difficulty in adjusting the apparatus to meet conditions set up by the attempt to work the system from both ends, simultaneously, Mr. Delany proposes to assign one or more wires to be used in transmitting signals exclusively in one direction, by which arrangement it is believed the matter of adjustment would be much simplified and the efficiency of the system thereby largely enhanced.

The foregoing described system somewhat modified is in successful operation in Great Britain.

A feature in connection with synchronous telegraph systems, uncommon in other systems, is that, during foggy or rainy weather, they have been found to work much better than during dry weather; the inferior insulation of the wires during wet weather apparently aiding in the dispersion of the charge remaining from previous signals.

CHAPTER XXII.

THE TELEPHONE—SIMULTANEOUS TELEGRAPHY AND TELEPHONY.—VARLEY-ATHEARN DU-
PLEX OR DIPLEX.—THE EDISON PHONOPLEX.

THE TELEPHONE.

A detailed description of the telephone, in theory and practice; its apparatus, connections, etc., would furnish matter for a book of no small dimensions, if devoted exclusively to that purpose. It is, therefore, not feasible to enter into a lengthy account of the practical operation of the telephone, in this work, as to do so would unduly extend its proportions. A brief description of the principle of the telephone will, however, be given here.

FIG. 259.

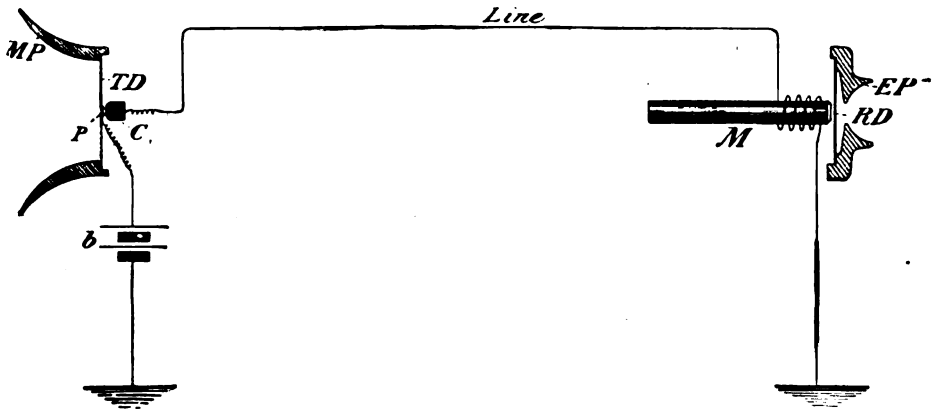

THEORY OF TELEPHONE.

In the act of speaking, air vibrations are set up by the voice. These vibrations consist of to and fro motions of the air particles, which vibrations so act upon the ear nerves as to produce the sensation of hearing.

The electrical telephone consists of a "transmitter," by means of which the air vibrations, originated by the voice, are caused to develop electrical vibrations in a conductor, or, stated in another way, variations of electrical current strength, which, in turn, establish corresponding variations in the strength of a magnetic field, which latter variations produce vibrations in a diaphragm which are practically similar to those originated by the voice at the transmitter.

A simple arrangement of apparatus for effecting the foregoing results is shown in Fig. 259. MP is the mouth-piece of a transmitter; TD represents a flat disc, or diaphragm shown end on. At its center a small platinum contact point P, is attached. C is a small piece of carbon, held lightly, by suitable means, against P. These con-

stitute the "transmitter" of the telephone. b is a battery. A line wire is connected to c . A magnet m is placed in the circuit at the receiving end. Opposite m a metallic diaphragm rd is placed within an ear-piece ep .

In the transmission of speech by this method the mouth of the speaker is placed adjacent to mp ; the ear of the listener to ep . Both of the diaphragms are held somewhat rigidly at their edges by suitable devices, and they tend to assume a certain position to which they return by their own tension if displaced by any means.

It is known that the electrical resistance of carbon varies under pressure; that the strength of current in a circuit varies with the resistance of the circuit; that the magnetic field of an electro-magnet varies with the strength of current in its coils, and that the armature (such as rd) of an electro-magnet tends to vary its position, when free to move, with variations in the strength of the magnet.

Remembering these points the principle of the telephone will be readily understood.

The circuit in Fig. 259 is from the ground at the left, through the battery b to the platinum point p , to and through the carbon to the line wire, thence to the magnet m and the ground, at the right of figure.

When speech is uttered into the mouth-piece air vibrations are set up which "strike" against the diaphragm rd . This gives the diaphragm a to and fro motion which alternately increases and decreases the pressure of p against the carbon c , with the result that the resistance of the carbon is varied to a greater or less extent, depending upon the amplitude of the vibrations of the diaphragm. Consequently, the strength of current due to the battery b is varied in accordance with the variations of the resistance at c . These variations of the current strength, again, vary the magnetic strength of magnet m in manner proportionally equal to the variations of the current strength; hence, the diaphragm rd , which in this case acts as the armature of m , is given a to and fro motion, of greater or less amplitude, corresponding with the variations in the field of the magnet m . These vibrations of the "receiving" diaphragm set the air particles in its vicinity into vibration, which air vibrations, in turn, entering the ear of the listener reproduce therein the words, or sounds, uttered at the mouth-piece of the transmitter.

In practice the transmitter battery is placed in circuit with the primary of an induction coil (as shown in figures following), the secondary coil being placed in the main line circuit. This arrangement is found to augment the volume of the received signals.

SIMULTANEOUS TELEGRAPHY AND TELEPHONY.

By simultaneous telegraphy and telephony is meant the dual transmission of telegraphic and telephonic signals over the one circuit.

If a telephone "receiver" be placed in an ordinary Morse telegraph circuit, a loud crackling noise, due to the rapid and, comparatively, powerful vibrations of the diaphragm produced by the makes and breaks of the telegraph circuit, is heard in the receiver.

It is therefore evident that, before simultaneous telegraphy can be rendered pos-

sible, the noises in the receiver, due to the causes stated, must be obviated; otherwise it would be impossible to hear, intelligibly, the telephonic signals. This requirement has been met in several different ways, but, probably, the most successful is that due to Van Rysselberghe, who gets rid of the noises in the telephone by the introduction of apparatus into the circuit which "graduates" the rise and fall of the "telegraph" currents at the time of make and break of the telegraph circuit. The effect of thus graduating the telegraph currents is to produce in the diaphragm of the telephone receiver a gradual movement, to and from its electro-magnet, which movement is not sufficiently rapid to cause an appreciable sound. Upon this gradual vibration, or inflection, of the diaphragm is superposed the rapid vibrations due to the vibratory currents originated by the transmitter of the telephone.

To obtain the desired gradual rise and fall of the telegraph currents Van R

FIG. 260.

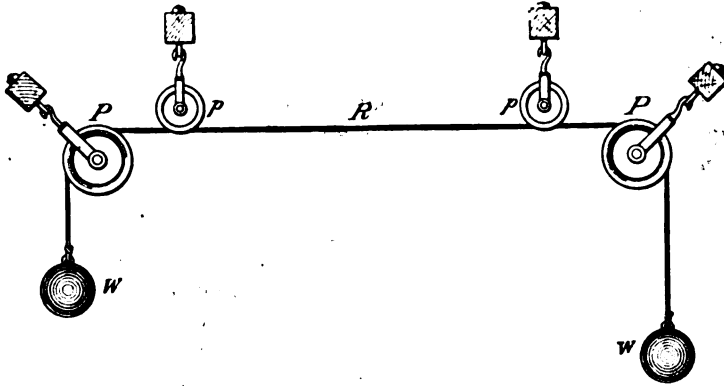

selberghe utilizes the retarding and prolonging effects of the self-induction of electro-magnets in an electric circuit, in a manner to be described presently.

An idea of the manner in which the vibrations due to the telephone transmitter are superposed upon the inflections of the diaphragm due to the telegraphic signals may be gained by a consideration of the ingenious mechanical illustration, Fig. 260, devised by C. F. Varley to show the principle of a simultaneous "telegraph and pulsatory" current system invented by him. In that figure R is a rope drawn over the pulleys P P, and stretched tightly by the weights w w. The smaller pulleys p p are held, loosely, over the rope R. It is plain that when the rope is moved to and fro, longitudinally, one weight will rise while the other falls, and that by a pre-arrangement of the frequency or duration of the movements of the weights, up and down, signals might be transmitted, during the transmission of which signals the small weights would be practically stationary. If, however, while the rope is being moved to and fro, as stated, the rope be hit with a hammer, it will be set into rapid vibrations which will cause the smaller pulleys to dance while the vibrations last; but these vibrations will not interfere with the reception of signals by the rise and fall of the weights. If, also, the frequency and duration of the strokes of the hammer upon the rope be pre-arranged, signals which would be due to the "pulsatory" motions of the rope might also be transmitted.

The Van Rysselberghe devices to effect the silencing of the telegraphic signals in the telephone receiver consist of condensers and electro-magnets, or magnetic coils, inserted in the telegraph line, *outside* of the telegraph instruments, as shown in Fig. 261. In this figure *R* is the relay, *A* the key, and *B* the main battery, of the Morse system. *G G* are magnetic coils, termed "graduator". In order to increase the retarding and prolonging effects of the coils, an outer shell of soft iron is placed over them, in addition to the usual iron core. To obtain absolute silence in the telephone receiver, so far as the telegraphic signals are concerned, the resistance of the magnetic coils should be about 500 ohms each, but practical silence can be obtained with half

FIG. 261.

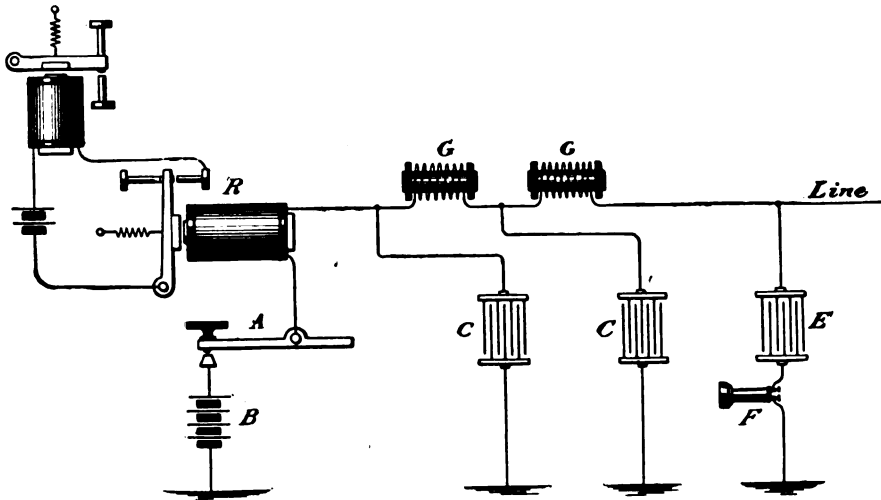

that resistance.* *c c* are condensers which assist in rendering the rise and fall of the telegraph currents gradual.

As it is necessary that the telephone circuit should not at any time "ground" the telegraph circuit, the telephone apparatus is "separated" from the main line, but yet electrically connected thereto, through the medium of condenser *c*, which acts, practically, as a separator and a "repeater," conveying or relaying, the telephonic signals, by induction, from the main line to the telephone receiver.

The general theory of the operation of simultaneous telegraphy and telephony may be briefly outlined as follows: Assuming, for example only, the strength of the "telegraph" current to be 2,000, and that of the telephone current to be 1. If, while the diaphragm of the telephone receiver is attracted, or in process of gradual attraction, by a telegraph current, of, say, positive direction, a "telephone" current of similar direction be transmitted, the current will be suddenly increased to 2,001 and the diaphragm will be given a sudden minute impulse towards its magnet. Should then a negative telephone current follow (the telegraph current remaining as before) the current on the line will be suddenly reduced to 1999, and the diaphragm by its own tension recedes rapidly from its magnet. In the actual operation of these systems, of course, many hundred pulsatory, or undulatory, currents, might be transmitted during

* With the new form of retarding coil now used, in which the core is a closed iron ring, 50 ohms suffice.

the time taken to transmit one telegraphic signal, and thus, while the diaphragm is being gradually attracted to, or is gradually receding from, its magnet, owing to variations in the telegraph current, at the same time it may be making several hundred intermediate forward and backward motions of less amplitude, due to the variations of the line currents caused by the telephone transmitter. Of course the minute additions to or subtractions from the telegraph current are not noticeable on the telegraph instruments.

In Fig. 262, *A* may be supposed to represent the undulatory or graduated telegraph current. *B* the quick and minute, or undulatory, current transmitted by the telephone transmitter, and *C* the combination of the two.

By the foregoing stated expedient of rendering the makes and breaks of the telegraph circuit gradual, to such an extent that they are not noticeable in the telephone

FIG. 262.

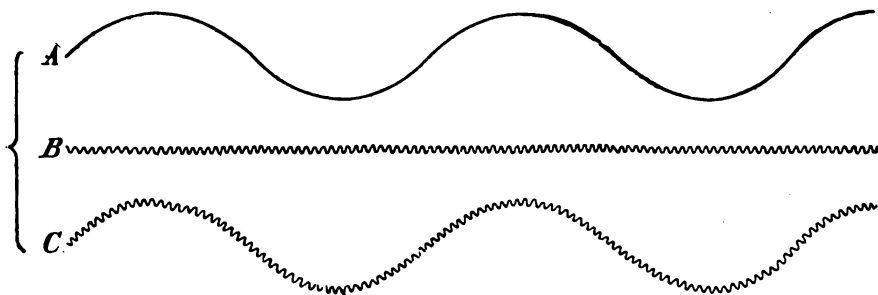

receiver, the telephonic signals may be, and in practice are, superposed upon the telegraphic signals and heard in the telephone receiver, virtually, as though on a separate circuit.

In Fig. 263 is given a theoretical diagram of the connections and apparatus at two stations of a combined telephone and telegraph circuit. The wires No. 1 and No. 2 represent two Morse circuits. R_1 and R_2 , and K_1 and K_2 are the relays and keys of those circuits, and MB , MB' are the main batteries feeding both of the Morse circuits, in the well known way. The "graduating" instruments are shown between R_1 and F in circuit No. 1 and between R_2 and F_1 in circuit No. 2. These instruments consist of condensers C , of about 6 microfarads each, as marked, and of the magnetic coils GC , of about 50 ohms each.

The "telephone" system, which comprises the transmitters TT ; receivers $T'T'$, batteries TB , etc., utilizes both of the telegraph circuits, as a "metallic," or round circuit. It will be seen that the circuits, No. 1 and No. 2, are not metallically connected by the wires of the telephone system, but are *electrically* connected through the "separating" condensers sc , which instruments, as already said, virtually act as repeaters of the rapid pulsations set up by the transmitter of the telephone; the minute and rapid variations of potential caused by that transmitter being reproduced at the terminals of the condensers and, consequently, also reproduced on the main line circuits on both "sides" of the condensers.

When it happens that there are "intermediate" relays in the telegraph circuits

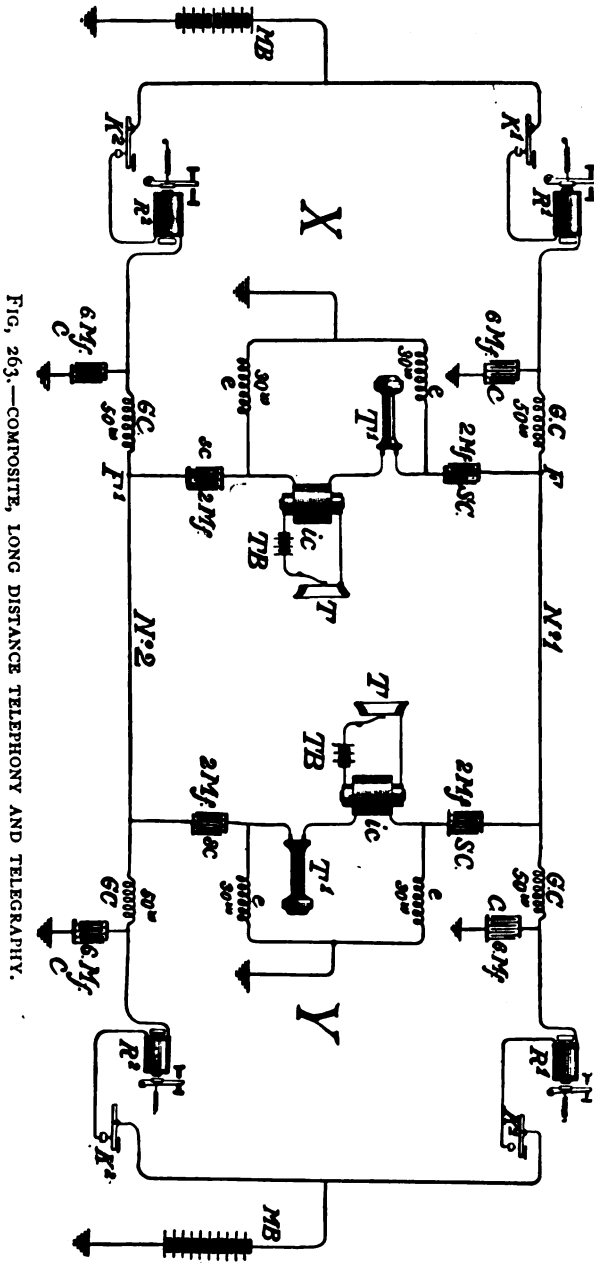

FIG. 263.—COMPOSITE, LONG DISTANCE TELEPHONY AND TELEGRAPHY.

it is necessary to “shunt” those relays with condensers, as shown in the case of the “Varley-Athearn” duplex and the “Edison” phonoplex, next described.

In Fig. 264 the actual connections of the graduating apparatus are shown. In practice the magnetic coils *GC* and condensers *C* of the gradulators, are, for convenience, placed in one box *G*, and the terminals are brought to the outside of the box, as indicated. The resistances and capacities of those instruments are plainly marked in Fig. 263.*

The arrangement of the telephone apparatus, as shown in Fig. 264, is virtually that used in “long distance” telephony in this country. The apparatus consists of an induction coil *ic*; an annunciator, or vibrating bell *I*, which operates in response to a distant “call,” a transmitter *T*; transmitter battery *TB*, about 2 volts; an automatic circuit closer and opener *F*; a telephone receiver *TR* and a small switch *s*, which, when depressed, short-circuits the secondary coil *m* of the induction coil, thus removing the “magnetic” resistance of that coil from the circuit and thereby

increasing the clearness and strength of received signals.

* Experiment will show whether one or more graduating coils and condensers are essential to a particular circuit, and also the amount of retardation and capacity necessary for best results. Inductance coils *ee* placed around *T T'* as shown are serviceable in preventing interference between Morse circuits.

For the purpose of "ringing up" the distant station, a vibrator or "generator" may be inserted at *x*.

The practical operation of the switching apparatus *K*, etc., in sending and receiving, may be briefly described: As shown in the figure, the telephone receiver weighs down the hook, or switch *K*, thereby opening the transmitter battery, and putting into circuit the annunciator magnet *I*, in readiness to receive a call. When the receiver is lifted from the hook, the latter, raised by the spring *h*, opens the an-

FIG. 264.

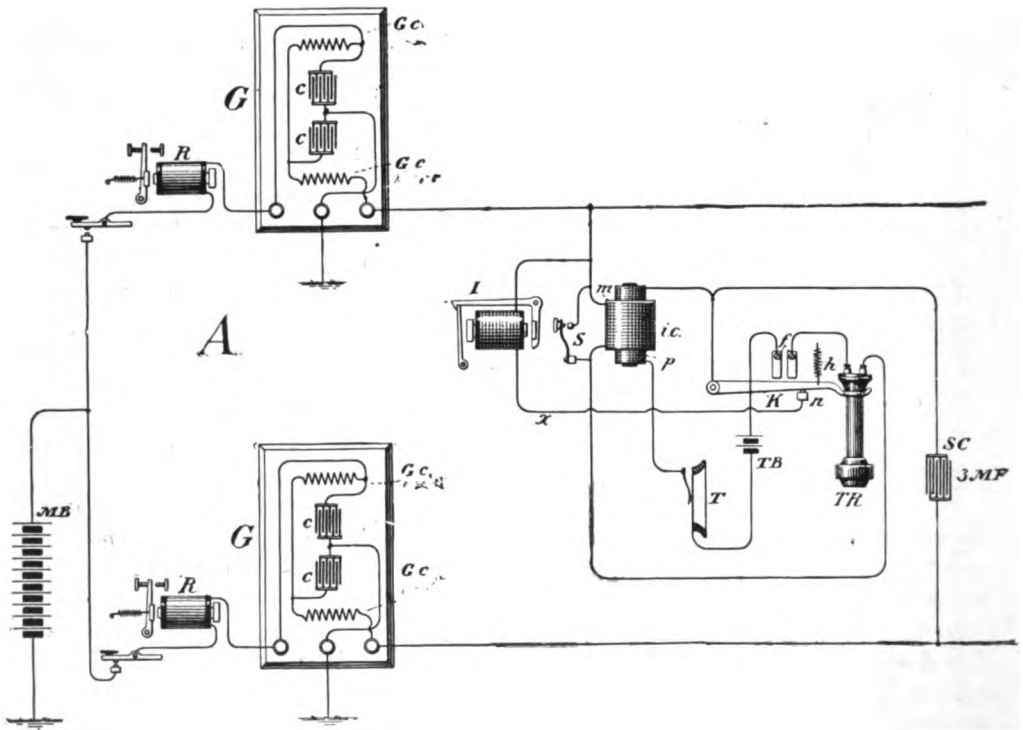

TERMINAL CONNECTIONS—TELEPHONE, ETC.

unciator circuit at *n* and closes the circuit of the receiver at the strips *f*. This, it will be seen, places the transmitter, and battery *TB*, in the circuit of the primary coil *p* of *ic*.

Simultaneous telegraphy and telephony has been in successful operation in different parts of Europe.* Prolonged experiments in this country have demonstrated that the combination of the two systems *can* be operated on circuits of 1,000 miles in length. In other words, on any circuit, where simple telephony is feasible, but it has been found also that the "graduating" apparatus is more or less detrimental to duplex and quadruplex telegraphy, especially the latter.

* Simultaneous telegraphy and telephony is now being successfully carried on in this country.

VARLEY-ATHEARN DUPLEX-DIPLEX.

This is one of several arrangements, of which the first was devised by C. F. Varley, to increase the capacity of a wire by superposing "pulsatory" current signals upon the regular Morse signals.

To accomplish this result successfully it is necessary, as in simultaneous telegraphy and telephony: First, that the pulsatory currents shall not be so powerful as to actuate the Morse relays. Second, that the pulsatory receiving apparatus shall not respond to the regular Morse signals.

FIG. 265.

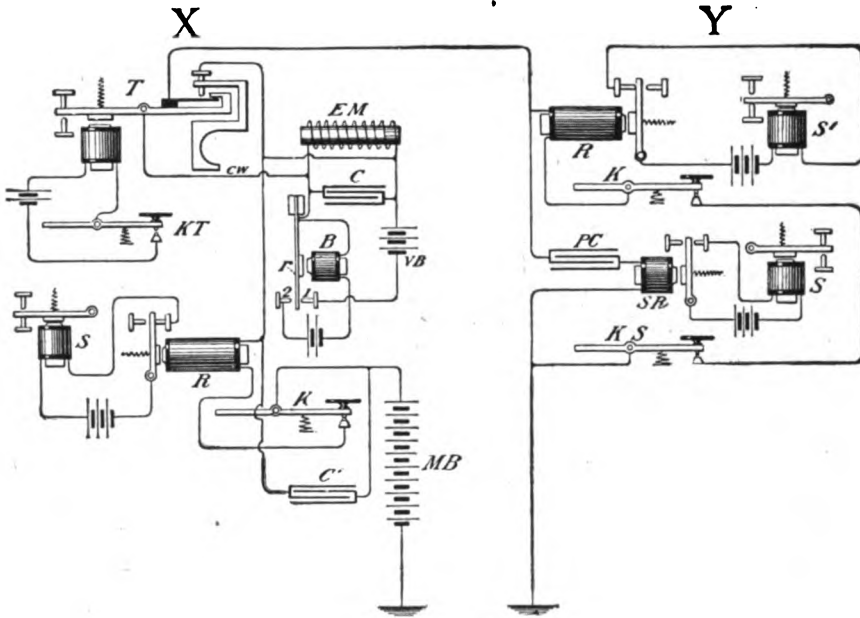

VARLEY-ATHEARN "SUPERPOSED" CURRENT SYSTEM.

The first requirement is met by the use of apparatus which sets up momentary currents of comparatively feeble strength. These currents may consist of a single pulsation for each character of a signal, as in the Edison "phonoplex" (next described), or each character may be composed of a number of such pulsations, as in the Varley-Athearn device, now being considered. The second requirement is met by the use of receiving apparatus of such a nature, or so placed in the circuit, that it will only respond to quick, momentary pulsations; and also by taking advantage of the fact, as is also done in simultaneous telegraph and telephone systems, that currents which would otherwise rise and fall abruptly, are retarded in passing through an electro-magnet, or a "magnetic" coil, and, consequently, rise and fall gradually, and thus do not affect the receiving apparatus of the pulsatory current system.

The Varley-Athearn arrangement, for the purpose stated, is shown, theoretically in Fig. 265, in which two terminal stations, x and y, are represented.

The Morse apparatus consists of the relays RR , keys KK , and sounders SS . MB is the Morse battery. The "pulsatory" apparatus at x consists of a magnetic coil EM , of a resistance of 15 or 25 ohms. The core of this coil is generally composed of a number of fine, soft iron wires. B is a vibrating reed, or buzzer. VB is a battery, which magnetizes the coil EM , in certain positions of the reed r . T is a transmitter, operated by key KT .

At y , the "pulsatory" apparatus consists of a sensitive, short core relay SR , with contact on back stop, and condenser, PC .

The "pulsatory" currents are set up by the action of the vibrating reed of the buzzer, which is kept in vibration in the usual way (*see* Buzzer). When the reed is against its contact r the coil EM is magnetized. When the reed leaves contact, r , the coil in demagnetizing "discharges" into the line λ , if the transmitter T is in the position shown in Fig. 265. When the transmitter is closed, the pulsations are cut off from the line, the wire cw , via which the pulsatory current set up by the coil would pass to the line, being then open. As long, therefore, as the transmitter is open, the vibratory currents pass to the line, and reaching the distant end (y) cause variations in the charge of the condenser PC , which "charges," in turn, cause the armature of SR in the condenser circuit, to vibrate, back and forth, against its stops. (In this case, also, the condenser SR may be supposed to act as a "repeater" of the pulsatory current).

While that armature is thus rapidly vibrating the local sounder s' is open, inasmuch as its comparative sluggishness prevents it from following the rapid vibrations of the armature. When the armature ceases vibrating it rests on its back contact point and closes the local circuit of s' . Since the pulsatory currents are only permitted to reach the line when the transmitter at x is open, and the sounder s' at y is closed only when the armature of SR is on its back stop, it is clear that the signals received on that sounder will be on the front stroke, and since, while the vibratory signals are passing in the relay SR , the sounder s' is closed, and vice versa, it is evident that the opening and closing of the transmitter will have the effect of producing the usual dot and dash signals in the sounder s' , (as, for example, in the case of the pulsatory signals of the synchronous multiplex system, when the Morse relay is employed).

The Morse signals from x are made comparatively gradual, or are "graduated," by being caused to pass through the Morse relay R , and, when the transmitter is open, through the coil EM ; consequently, SR , at y , is not actuated by the Morse signals, the currents thereby set up in the circuit of condenser PC not being of sufficient force to effect that result; and, on the other hand, the variations in the strength of the Morse currents, due to the coil EM , are not of sufficient strength to affect the Morse relays. The condenser c' , across key k' and R , at x , tends further to "graduate" the Morse signals and also, practically, keeps the pulsatory circuit closed when that key is open. Condenser c is employed chiefly to diminish the spark at the contact points r when the circuit of VB is broken. As the transmitter T is "continuity-preserving," the Morse currents pass to the line regardless of whether that instrument is open or closed.

This arrangement, it will be seen, is more than a duplex and less than a quadruplex, since two messages may be sent out from station x at once, or one from station x and one from station y , simultaneously. The operator receiving the pulsatory currents signals at y is furnished with a key, KS , whereby he breaks the dis-

tant sender, by way of the Morse circuit. It would be quite possible to equip γ with "pulsatory" transmitting apparatus similar to that at x , which would then give the practical equivalent of two single wires, but as the system requires somewhat expert attention, it has not hitherto been so arranged, chiefly, perhaps, because such attention is least available where the use of such a service would be most advantageous, as, for example, in branch offices.

Experience has shown that this device is much better adapted for short, than long circuits.

THE EDISON PHONOPLEX.

This system was also devised to extend the facilities of existing wires by superposing pulsatory signals upon regular Morse circuits. It is in service on a number of railroad wires in this country.

FIG. 266.

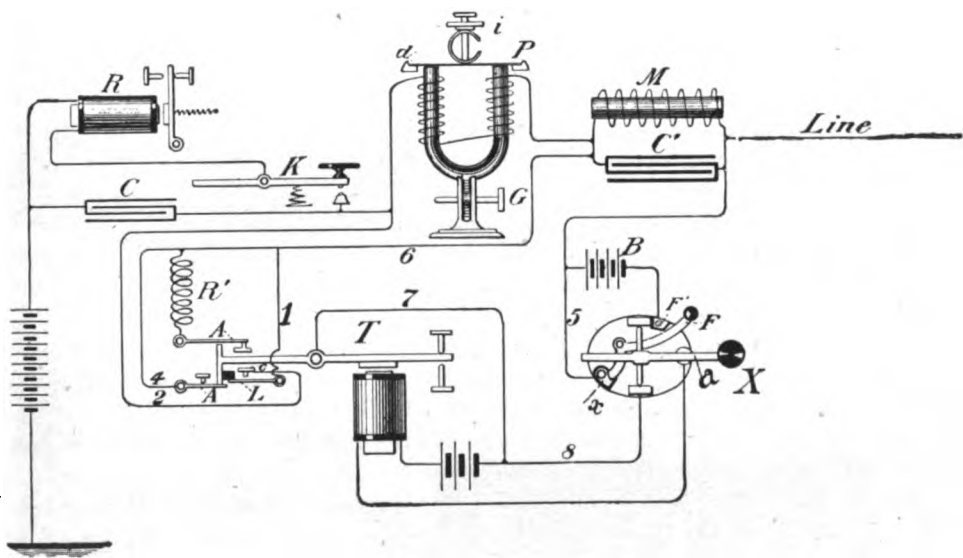

EDISON PHONOPLEX-THEORY.

A theoretical diagram of the system is given in Fig. 266. In that figure, R and K are the ordinary Morse relay and key. M is a coil of wire wound upon an iron core formed of a bundle of fine iron wires. It is employed to originate pulsatory currents when the phonoplex key x , is opened and closed. P is an instrument termed the "phone." It comprises an electro-magnet, opposite the poles of which is placed, in a horizontal position, a metallic disc d , somewhat similar to the diaphragm of the Bell telephone receiver. T is a transmitter of special construction, having several functions, one of which is to short-circuit the phone; the object of which will be mentioned presently. Key x operates transmitter T , and the latter opens and closes the phonoplex battery, B . When lever a of key x is open, in the sense that the ordinary telegraph key is open, the bent lever F is away from the contact F' , and the phonoplex battery B

is open, and the "magnetic" coil m is short-circuited via the wires 5, 6, 7, 8 and the lever of transmitter T , the latter instrument being also closed when key x is closed. When lever F of x is placed in contact with F' , it slips out of contact with x . The contacts F' and x are insulated from the metal framework of the key. The lever F is electrically connected with that framework.

When transmitter T is open, as in Fig. 266, the phone is thrown into the main line circuit, as may be seen.

c is a condenser placed around the key κ and the Morse relay R . A similar condenser is placed around the other relays in stations between the terminal stations of the phonoplex circuit. Its function is to keep the circuit practically intact for the transmission of the pulsatory signals during the operation of the key κ . It also facilitates the passage of those signals past the relay R (it being known that electro-magnets in a circuit tend to retard rapid pulsatory signals). A condenser is placed similarly around the other relays in stations between the terminal stations of the phonoplex circuit. The condenser c' , placed around the coil m , prevents excessive sparking at the contact points AA of the transmitter T . It also facilitates "incoming" signals on the phone.

In the operation of this system, also, it is necessary that the phone P should not be seriously affected by the makes and breaks of the Morse circuit. This is more or less successfully accomplished by the use of the condenser around the keys, which has a noticeable effect in diminishing the abruptness of the "rise and fall" of the Morse currents on the line. The relays in the circuit also aid in "graduating" the rise and fall of the telegraph currents.

The phone is provided with an adjusting gear G , by means of which the poles of the electro-magnet of that instrument are withdrawn from the diaphragm to a point just beyond the active, or harmful influence of the regular Morse signals, but not out of the influence of the pulsatory currents.

The "pulsatory" currents are originated by the charge and discharge of the coil m , brought about by the operation of transmitter T , which whether open, or closed, (and when the lever F of x is "open") charges the coil m by the battery B . Between the openings and closings of the transmitter the current of self-induction of the coil discharges into the line, thereby actuating the distant phone.

The pulsatory currents must be of such a strength as not to affect the Morse relays on the line, but at the same time must be sufficiently strong to quickly "flip" the diaphragm of the phone. The current set up by the magnetic coil gives, on the phone, a fairly loud signal, which is enhanced by attaching, close to the diaphragm a small, split metal ring i , which dangles loosely on the diaphragm.

It is obvious that it would be difficult to read these signals if something were not done to distinguish between the up and down "strokes." By the use of a small resistance coil R' , which, by means of the transmitter T , is placed in the circuit of the phonoplex battery B , at, or just before, the time corresponding with the signal made on the up stroke, and this has the desired effect of making quite a distinction between the two strokes. It does so by diminishing the strength of current in the magnetic coil circuit.

The battery B used for this purpose has generally been a "quick-acting" battery, such as a bichromate of potassium battery, of from 6 to 12 cells. Of late the Edison-Lalande battery has been successfully employed for this work.

It is further evident that, if the phone P were left in the circuit at all times, it would be operated by the home magnetic coil when the latter was being actuated by the home battery B, and would, in consequence, give out a disturbing sound at such times. Means are therefore provided for cutting out the phone to avoid this defect. These means consist of the lever L and contact pin c on transmitter T, which contacts, it is seen, are open in the figure, leaving the home phone in the main circuit, ready to be acted upon by the distant phonoplex, but, when the key x is closed, at which time the transmitter T closes also, L and c come together and short-circuit the phone by way of the wires 1 and 2, as stated.

FIG. 267.

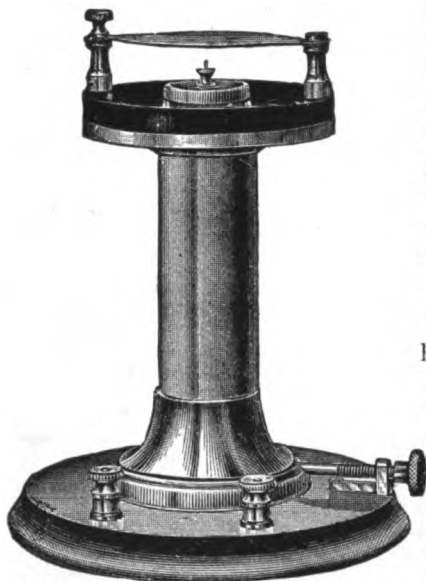

THE PHONE.

said, the variation is sufficient to operate the "phone." It may be added that having once "graduated" the Morse currents, or adjusted the phone, so that those currents are unfelt in the phone, it will make no difference in the practical working of the pulsatory system whether the Morse system is idle or working.

In Fig. 267 the phone is shown as it appears in practice. The magnetic coil is shown in Fig. 268. This system may be used on circuits of from one hundred to one hundred and fifty miles in length, and it is not limited to any stated number of intermediate stations. Neither is it necessary that a continuous Morse wire be used, as the pulsatory signals may be transferred from one wire to another by connecting any desired wires together by a condenser.

The regular Morse signals on the main circuit having been rendered of no effect upon the diaphragm of the phone, the effect of the pulsatory current of the phonoplex circuit is either to rapidly increase or decrease the Morse currents, virtually as in the case of simultaneous telegraphy and telephony, according as the pulsatory currents oppose, or co-operate with, the Morse currents. The variation in the strength of the Morse current thus produced will not operate the Morse relays, unless when the latter may be working on a very fine adjustment, but, as has been

FIG. 268.

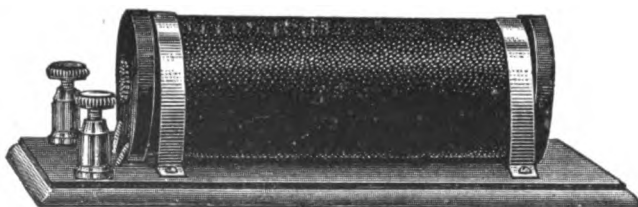

MAGNETIC COIL.

THE GRAY HARMONIC TELEGRAPH.

It is known that a steel rod or a tuning-fork held at one end will vibrate at a given rate when hit a smart blow, or moved out of the normal position and quickly set free. This rate of vibration of the rod or fork is termed the fundamental rate of vibration. If such a rod whose fundamental rate of vibration is, say, 10 per second, should receive a blow, in a direction coinciding with its motion, every one-tenth of a second, it would continue to vibrate indefinitely. If, on the contrary, it should receive blows at intervals not in accord with its rate of vibration, some of the blows would oppose its motion and it would practically come to a standstill.

In Gray's harmonic telegraph system this general principle is employed. The theory of this ingenious system is shown in diagram, Fig. 268*b*. F^1, F^2, F^3, F^4 , are circuit-breaking forks, fastened at one end x , which respectively pulsate the circuits of main batteries B^1, B^2, B^3, B^4 . These forks are attuned to given rates of vibration, say 264, 320, etc., vibrations per second. When these forks are set in vibration

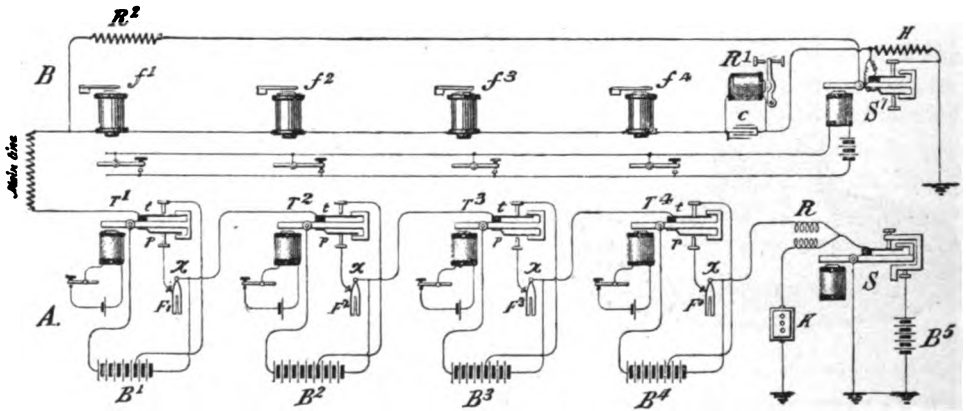
FIG. 268*b*.

they open and close the circuits of their respective main batteries at a rate corresponding with their fundamental rate of vibration. These forks are kept in constant vibration by well-known electromagnetic vibrating devices not shown in the figure (see pages 257, 272, 336, 357), while the system is in operation, but they can send out current pulsations to the line only when double transmitters T^1, T^2, T^3, T^4 are open, for it may be noticed that these forks short-circuit their respective main batteries at every vibration by way of the lower tongues p , etc., when their transmitters are open, and that the main battery is open at the lever of the transmitter when that instrument is closed, so far as the vibrator is concerned. In the figure T^1, T^2 are open and therefore forks F^1, F^2 are transmitting pulsations to line by way of the levers and tongues t of those transmitters. On the other hand, as transmitters T^3, T^4 are closed the main batteries B^3, B^4 are open at the levers of those instruments, and hence no pulsations pass from them to the line at this time, although, as stated, forks F^3, F^4 continue to vibrate as before. A weak current still goes to line, however, as will be explained shortly. The upper tongues t are insulated from the levers of transmitters T as indicated; the lower tongues are metallically connected therewith.

At the receiving station B four electromagnets, f^1, f^2, f^3, f^4 , are placed in the main line. The armatures of these magnets are reeds fastened at one end and attuned to vibrate at rates corresponding with their respective transmitting forks. Hence f^1 will only respond to current pulsations transmitted by F^1 , f^2 will only respond to those from F^2 , and so on. Each of the reeds is equipped with a light lever (not

shown) which rides loosely on the top of the reed. This rider is part of a local circuit in which there is an ordinary sounder. When the reed is at rest the local circuit and sounder are closed; when in vibration the sounder is open, as in the Varley-Athearn system, Fig. 265. Hence, by this arrangement, as the pulsations from the transmitting forks pass to line only when the double transmitters are open, the Morse signals transmitted by means of the keys controlling those transmitters are received on the front stroke.

The batteries B^1, B^2, B^3, B^4 are divided or tapped at a certain point such that when a transmitter is closed, as at $T^1 T^2$, the larger portion of each battery is open at the lever of the transmitter, and that only the smaller portion is in the main circuit. This arrangement was rendered necessary by the great reduction of current strength caused by the rapid vibration of the transmitting forks, probably due to imperfect contact at the forks, and also to the effects of inductance of the numerous magnets—in other words, to the high impedance of the circuit. This decrease of current strength amounted in practice to about 60 per cent. For instance, if 40 volts maintained a required strength of current on the line when a transmitting reed was at rest, about 100 volts were necessary when it was in operation.

With this system there is also combined a duplex telegraph system, employing the single transmitter s , a differentially wound relay R and rheostat K at A , and an ordinary Morse relay R , a double transmitter s' , and a resistance coil H at B . Transmitter s operates relay R' by cutting in and out main battery B^1 . Transmitter s' operates relay R by cutting in and out the resistance H . (See page 265.) As the transmitter s' at B is only used to interrupt the distant sending operators, each receiving operator on the harmonic system is placed in control of s' by means of the keys shown.

As it is found desirable in the operation of this system to maintain a nearly uniform current in the relays of the harmonic system, an adjustable resistance K^2 is attached to the line wire outside of f' , and this resistance is thrown into the circuit simultaneously with the throwing out of the resistance H and *vice versa*. This diverts as much of the increased current due to the removal of H as may be required to effect the desired result. Nevertheless, the removal of the resistance H disturbs the line balance at A and thus operates relay R . (See Chapter XVI.)

To prevent the operation of the relays R and R' by the pulsatory currents, their springs are adjusted to hold the armatures open over the maximum pull of those currents, and thus are only responsive to the additional battery B^2 , or to the variation in the balance of the line caused by inserting or removing the resistance H . Condensers are placed across the terminals of relays $R R'$, as shown at c , to permit the free passage of the pulsatory currents.

No graduators are used in this system, and apparently they are not essential, for the reed armatures of the receivers of the harmonic system, being exactly attuned to the note of the corresponding transmitting forks, are not readily affected by pulsations that are not in unison with their rates of vibration. Furthermore, the large number of electromagnets in the circuit tend to round off the Morse telegraph signals. Six messages were simultaneously transmitted by this system, which was for a considerable time in practical operation on the lines of the Postal Telegraph Cable Co. between New York and Chicago on wires of one and a half ohm resistance per mile. Its use, however, was limited, not only by the care required in its adjustment, but also by the marked inductive effects of its pulsatory currents on parallel lines, which made it difficult to operate to any great distance more than one circuit equipped with this system, and even on short circuits some difficulty was experienced in working the system on more than one parallel wire. All of the circuits on which this system was operated have been abandoned and the quadruplex system substituted therefor.

CHAPTER XXIII.

TIME TELEGRAPH SERVICE.

The "Time" Telegraph which is in quite extensive use in New York City and vicinity consists in the transmission of pre-arranged electrical signals over circuits controlled by a standard clock to various offices of railway companies, jewelers, etc.,

FIG. 269.

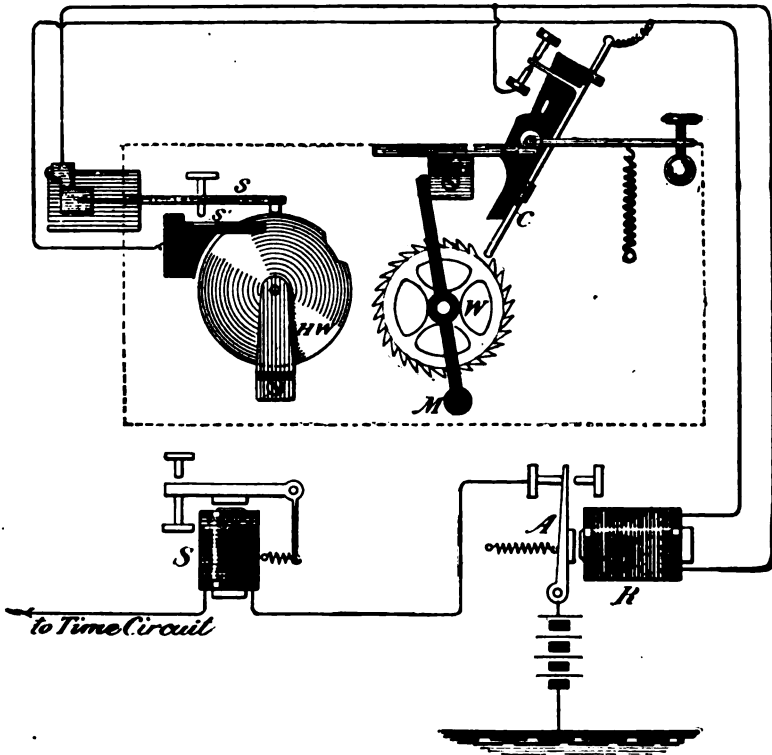

TIME TELEGRAPH SIGNALS-THEORY,

and which signals are so arranged that, to the initiated, they indicate, by a single stroke, or strokes, of a sounder, or electric bell, the time to a second.

These signals are sent out by the standard clock at the normal rate of one stroke every two seconds, excepting that, in each minute, the fifty-eighth second is omitted. Again, at twenty seconds before the beginning of every period of five minutes the signals cease, etc.

The arrangements for automatically transmitting these signals are outlined in Fig. 269.

In this figure M is the second-hand of the standard clock. Its wheel w has twenty-nine teeth, a thirtieth tooth being cut away, as may be seen. A delicately poised flat rod c is placed in the path of these teeth, and as each tooth passes under the rod, the circuit in which the relay R is placed, is broken. The result is that, during each minute, the circuit is broken 29 times, but at the fifty-eighth second it is not broken. This indicates that the first beat after the pause is the beginning of the next minute. The wheel hw is so geared as to make one revolution every five minutes. Its periphery is notched for a distance equal to one-fifteenth of its circumference. A contact spring s rides lightly on this periphery. Branch wires lead from this contact spring, and a fixed contact point s' , to the relay circuit. When the notch in the wheel

FIG. 270.

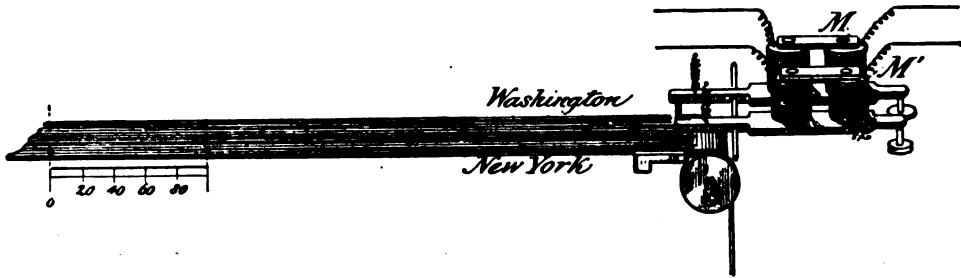

arrives at a certain point in its revolution the flat spring s drops into it. This completes, at s' , a circuit through the relay. Hence so long as the spring s remains in the notch the second-hand wheel w cannot open the relay circuit. The notch on hw is so arranged that it arrives at the point opposite the spring s at exactly 20 seconds before the beginning of a five-minute period; the notch is also so arranged that the contact at s' is again broken at the beginning of that period. In other instances additional apparatus is provided, and actuated, through mechanism set in motion by the standard clock, whereby strokes indicating the quarters, halves, three-quarters and hours, are transmitted over the time circuit.

The standard clock used for this service in New York City was devised by Mr. James Hamblet.

The clock is located in the Western Union building and is compared each day, at noon, with the National Observatory clock in Washington, D. C., by means of a special circuit set aside for that purpose.

When a comparison with the National Observatory clock shows a gain or loss in the twenty-four hours, if the discrepancy is sufficient to warrant it, the oscillation of the pendulum is varied by deftly adding to, or withdrawing from the "bob," a very small weight, which, by slightly increasing or decreasing the center of gravity of the pendulum, has the desired effect.

The standard clock is compared with the clock in Washington, or elsewhere, by means of an electric chronograph, shown in Fig. 270, in which M M' are the electromagnets of double pen registers which are in circuits controlled by the respective clocks.

A paper tape passes in proximity to the pens in the ordinary way. If the clocks are beating seconds, and each is in accord with the other, the dots recorded by the pens will be in vertical alignment; if not, one will be in advance of the other. The time in advance, in seconds, can be calculated to the one-hundredth of a second, or less, by knowing the rate at which the paper is running out. If, for example, it should be running out at the rate of one inch, per second, and a portion of the paper is divided into 100 parts by means of a suitable scale, the space between any two dots will indicate the extent of time by which the clocks vary. For instance, in Fig. 270, the upper row of dots assumedly representing the "Washington" clock and that of the lower row the "New York" clock, it is seen by reference to the scale that the New York clock is forty hundredths of a second behind the Washington clock.

ELECTRICALLY SYNCHRONIZED CLOCKS.

In addition to the service just described there are many instances in which clocks are corrected or synchronized at stated periods by pulsations of electricity transmitted by a standard clock. This correction is made by some form of electro-mechanical device which, when actuated by the standardizing clock, moves the minute hand to a given point, either backward or forward, depending on whether the clock to be corrected is running slow or fast, that is, within certain limits, as will shortly be obvious.

BARRAUD AND LUND REGULATOR.—One of the most frequently employed methods of synchronizing clocks by electricity is shown in Fig. 271. It is known as the

FIG. 271.

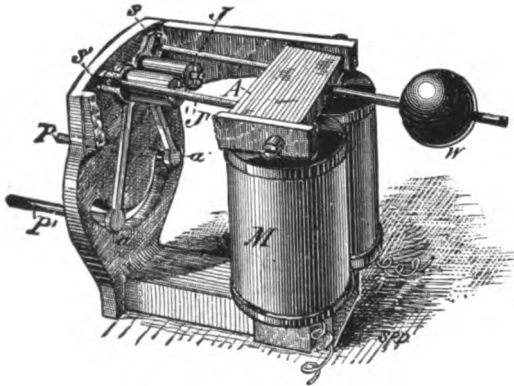

CLOCK SYNCHRONIZER.

Barraud and Lund "hour regulator." Its function is to actuate two arms *a a*, which, in coming together, engage with the minute hand of the clock, at, or near, XII, and after bringing it either forward or backward, as may be necessary, exactly to that point, immediately release it and withdraw out of its path.

The device consists of the electromagnet *M* to whose armature *A*, are attached two projections *J J'*. The magnet *M* is in the circuit controlled by the standard clock. Opposite the ends of the projections *J J'*, the two angular arms, or crank levers, *a a* are placed. There is a slot *s s'* in the upper arm of each lever, into which the ends of the projections enter. The armature is so pivoted as to raise the projections *J J'* up and down. The effect of this motion is to cause them to bring together and spread apart the lower ends of the levers *aa*. On the lower ends of *a a* there are two right angular pins *p, p'*, which extend through a curved slot on the top of the dial of the clock, as at *pp*, Fig. 271*a*, which represents the dial of a clock equipped with this correcting device. Normally the pins *pp'* are at the ends of the slot. Consequently,

as the minute hand approaches XII on the dial, it comes within the path of the pins p, p' , and if the clock should be either fast or slow as compared with the standard clock, the minute hand will be, at the first second of each hour, placed exactly at the hour.

The correcting apparatus is placed at the top of the clock within the case, as "dotted in," in Fig. 271*a*. The armature of the magnet m is counter balanced by

FIG 271 *a*.

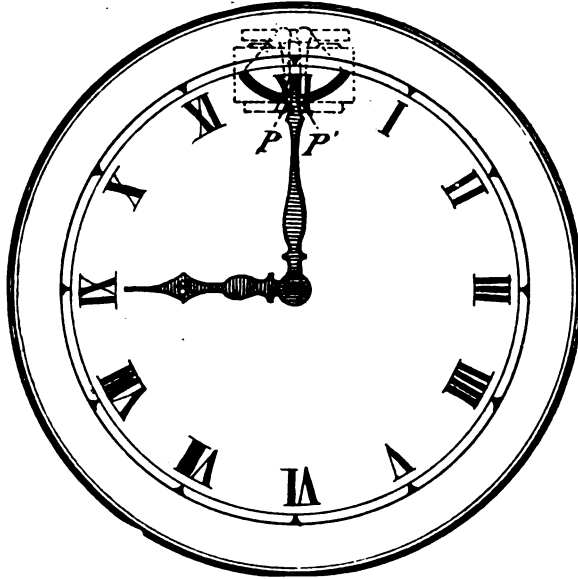

SYNCHRONIZING CLOCK DIAL.

the weight w . One advantage of this peculiar construction of the levers, etc., is a large amplification of the motion of the armature at the pins p, p' ; and a comparatively powerful leverage is also thereby obtained. The minute hands of the clocks to be corrected are adjusted so as to be readily moved by the correcting apparatus, when necessary.

THE HAMBLET SYNCHRONIZING APPARATUS.—Another clock synchronizing device, due to Mr. J. Hamblet, shown in Fig. 272, will be readily understood by reference to the illustration.

D is a clock dial. H is a minute hand. d and d' are pins projecting from the lower ends of arms A, A' ; the latter being mounted on the axles of pinions w' and w , respectively. The pinions w' and w gear into each other, as shown. The axial length of pinion w is greater than that of w' . This permits a toothed segment s to gear with a rear portion of w , without coming in contact with w' . The segment s is part of a lever L which carries the armature a of the magnet m in the synchronizing circuit. When the circuit is closed at the hours the lever L and the segment s

momentarily take the position indicated by the dotted lines. This action of *s* turns the pinion *w* in one direction, and that pinion, in thus turning, rotates *w'* in the op-

FIG. 272.

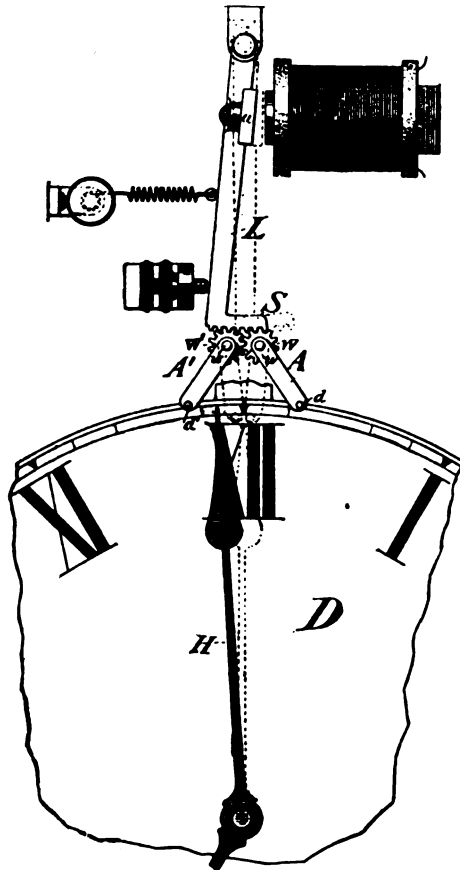

HAMBLET SYNCHRONIZING CLOCK.

posite direction. The result is that the arms *AA'* are brought sharply together, and if the minute hand is within their scope it is brought exactly to the hour of twelve, as indicated also by dotted lines. The return motion of the lever *L* restores the arms to their original positions.

CHAPTER XXIV.

HELIOGRAPHY—MILITARY TELEGRAPH SIGNALING, ETC.

HELIOGRAPHY.

The term heliography is derived from two Greek words—*helio*, the sun, and *graph*, to write. As ordinarily used, the word signifies a sun picture, or photograph. As employed in telegraphy the term heliography relates to the art of transmitting signals by reflections of the rays of the sun, the duration of the reflections being made to correspond to dots and dashes of the Morse or any other pre-arranged alphabet or code. The heliograph is a device designed to facilitate the transmission of such signals.

FIG. 273.

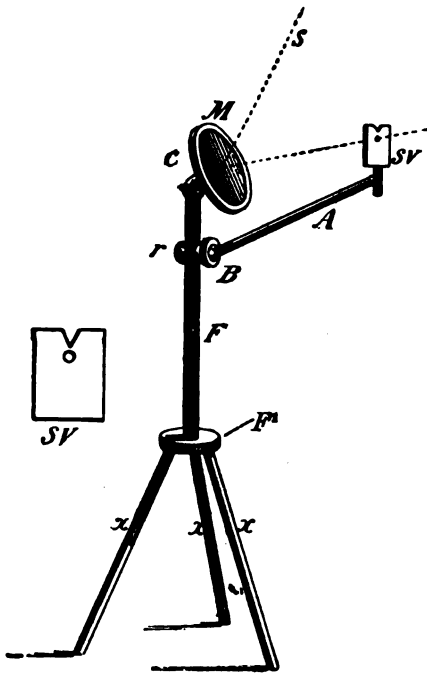

THE HELIOGRAPH.

Heliography is now quite extensively availed of by the military in this and other countries. In this country it is employed by the military and the meteorological signal service departments between outposts where communication by wire or otherwise would be difficult and in some cases impracticable, if not impossible. The average distance apart of such outpost stations is about 25 miles. A territory extending over 500 miles is covered by this system.

In Fig. 273 a portable form of heliograph, known as MacGregor's heliograph, is shown. In the figure *F* is a metal rod, resting on the base *F'*, which is itself supported by the legs *xx*. *M* is a small mirror, about three inches in diameter, attached to the upper end of *F* by a ball and socket joint. The mirror is freely movable in the socket. A small, circular portion of the mirror is left unsilvered and consequently

unreflecting. *A* is an arm, resting also in a ball and socket joint *B*. A clamping screw *r* is provided, by which the arm may be rigidly held in any position to which it may be adjusted. At the upper end of the arm *A*, a small, adjustable sight vane *SV* is placed. This vane is shown separately, and enlarged, at the left of the figure.

The instrument is adjusted and used as follows: The sight vane and the mirror are set facing the distant station when the sun *s* is in the direction of that station. The operator then looks through the clear glass in the centre of the mirror; and the v-shaped notch in the sight vane is placed in line with the distant station. The mirror,

and the arm carrying the sight vane, are then so adjusted that the hole in the centre of the mirror, and the hole in the sight vane, below the *v*, are in a straight line with the distant station. When so adjusted, the dark spot in the reflection, due to the clear spot in the glass, is thrown on the bottom of the *v* of the sight vane. By means of this guide the flash is directed on the distant station. Signals may then be transmitted by simply interposing the hand, or some other opaque substance, between the sun and the mirror; or between the sight vane and the mirror.

Fig. 274.

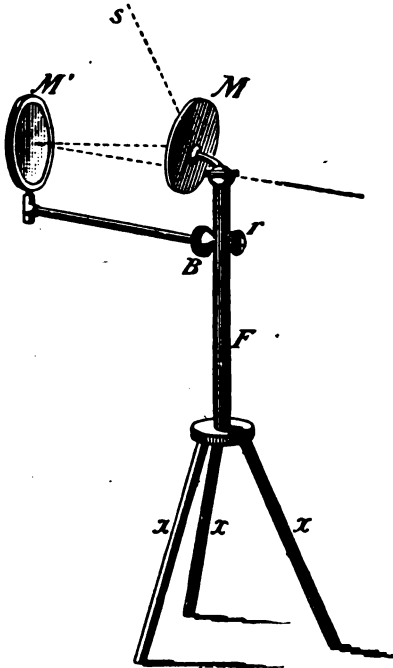

THE HELIOGRAPH.

When the sun is not towards the distant station, the arrangement shown in Fig. 274 is used. This consists merely of the addition of another mirror *m'*, which is placed over the sight vane. A piece of v-shaped paper is placed on the face of *m*.

The mirror *m* is now placed towards the sun *s*, with its back to the distant station; the second mirror *m'* is placed facing the distant station. The rays of *s* are reflected on *m'*, and, by the latter, reflected towards the distant station. The operator adjusts the mirrors by looking through the hole in the back of *m* and moving the mirrors until he sees the reflection of the distant station within the *v* on *m'*, and, at the same time, the dark spot, due to the clear glass on mirror *m*, on the bottom of the *v* on *m'*.

Signals are then transmitted as before.

It is occasionally necessary to re-adjust this instrument to allow for the displacement of the reflection caused by the earth's motion. In stationary heliographs a clock-work arrangement, which moves the apparatus automatically at a rate corresponding with the earth's motion around its axis, is sometimes provided.

It has been customary to transmit heliographic signals by "flashing" the light on the distant station, which was done by turning the mirror towards and away from that point. Such signals are now, however, generally transmitted, in military or naval operations, by obscuring the "reflection" by the interposition of some opaque substance before the mirrors, the said substance being interposed and removed at suitable intervals by means of an electro-mechanical arrangement controlled by an operator.

MILITARY TELEGRAPH SIGNALING.

In this country the Morse system of telegraphy was quite extensively employed as a field telegraph system during the late civil war, and its efficiency was highly commended by the Generals in command.

The telegraph equipment consisted of Morse relays, sounders and keys, or, frequently, a pocket relay with key combined; battery and wires, and construction tools.

For hurried construction, to open up communication with headquarters, reels of insulated wire were provided. The battery and the apparatus were generally carried in wagons or on pack mules. This method is still practiced in connection with military operations in this country.

Flag signaling, termed "wigwagging," and flash signaling have long been employed in military operations by all the European war departments, and by the war department of this country, where the electric telegraph is not available. Torches at night take the place of the flag, and lanterns the place of the heliograph.

In flag and torch signaling as well as in heliographic and lantern signaling the American Morse Code (page 57) is used by the United States war department, when a dot and dash alphabet is to be availed of. The United States Army and Navy Code, known as the Myer Wigwag Alphabet, and extracts from official instructions regarding same, and also for the use of the Morse code in wigwagging, etc., are given below.

U. S. ARMY AND NAVY SIGNAL CODE. (MYER WIGWAG ALPHABET.)

A.....22	G....2211	M....1221	S.....212	Y.....111	5....1122
B....2112	H.....122	N.....11	T.....2	Z....2222	6....2211
C....121	I.....1	O.....21	U....112	1....1111	7....1222
D....222	J....1122	P....1212	V....1222	2....2222	8....2111
E.....12	K....2121	Q....1211	W....1121	3....1112	9....1221
F....2221	L.....221	R.....211	X....2122	4....2221	0....2112

ABBREVIATIONS.

a....after.	h....have.	t....the.	w....word.	x x 3.. "numerals follow"
b....before.	n....not.	u....you.	wi....with.	or "numerals end."
c....can.	r....are.	ur....your.	y....why.	sig. 3..signature.
End of a word.....	3	Repeat last word.....	121, 121, 3	
End of a sentence.....	33	Repeat last message...	121, 121, 121, 3	
End of a message.....	333	Error.....	12, 12, 3	
Aye "I understand".....	22, 22, 3	Move to the right.....	211, 211, 3	
Cease signaling.....	22, 22, 22, 333	Move to left.....	221, 221, 3	

CODE CALLS.

A. S. U.	Action Signals Use.	C. B. U.	Cipher "B" Use, etc.
I. C. U.	International Code Use.	G. L. U.	Geographical List Use.
T. D. U.	Telegraph Dictionary Use.	N. L. U.	Navy List Use.
G. S. U.	General Signals Use.	V. N. U.	Vessels' Numbers Use.
C. A. U.	Cipher "A" Use.		

INSTRUCTIONS for signaling with flag, torch, hand-lantern, or beam of search light, by the Myer and Morse codes.

The motion "1" to the right corresponds to that of the Morse "dot" in the following instructions; the motion "2" to the left, to that of the Morse "dash"; the motion to "front," to that of the Morse "space."

Thus right (1), left (2), right (1), represents the letter C—that is "121," etc. Otherwise the instructions apply to both codes. For fog signals or fog horns, however, one (1) toot, about one-half second, will be "one" or "1", of the Myer alphabet. Two (2) toots in quick succession will be "two" or "2", and a blast about two seconds long will be "three" or "3". The ear and not the watch is to be relied upon for the intervals.

For signaling with flash lantern, heliograph or search-light shutter, same as in fog signals; substitute "short flash" for "toot", and "long steady flash" for "blast." The elements of a letter should be slightly longer.

TO SIGNAL WITH FLAG OR TORCH.

The flagman faces exactly toward the communicating station; staff is vertical in front of centre of body, but at height of waist. Fig's. 276, 277. The *dot* (·) is rep-

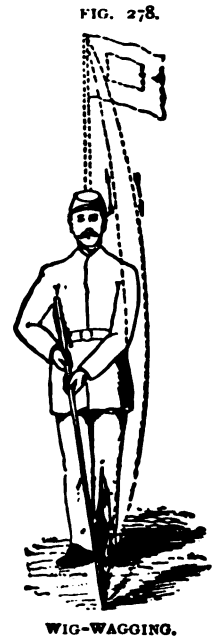
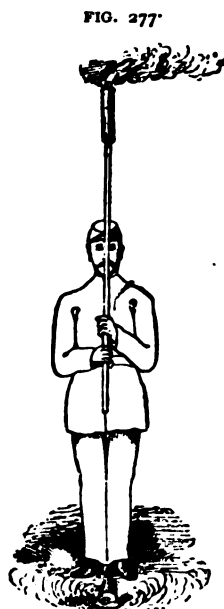
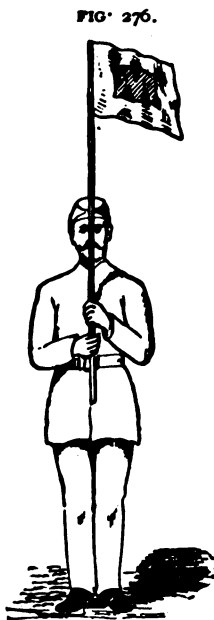

resented by a motion to the right, and the *dash* (—) by a motion to the left of the sender. The *space*, whether separating elements of *spaced characters* (C. O. R. Y. Z. and "&.") or separating *words*, will be represented by a "front" motion. Fig. 278.

Thus the motions:

Right right, front, right, represent C.

Right, front, right, represent O.

Right, front, right, right, represent R.

Right, right, front, right, right, represent Y.

Right, right, right, front, right, represent Z.

Right, front, right, right, right, represent &.

Each motion will embrace an arc of 90°, starting from and returning to the vertical.

The *long dash* (letter "L" and numeral "naught") is distinguished from the "T" dash by a slight pause at the lowest point of dip, and with this exception there will be no pause whatever between the motions required for any single letter.

A slight pause will be made between letters.

At the end of each word, abbreviation, or conventional signal the space signal, or "front" motion, is made, *preceded and followed by a pause* equivalent to that made between letters.

CONVENTIONAL SIGNALS FOR FLAG OR TORCH.

To call a station.—Signal the "call letter" of the station required, or, if the call letter be not known, signal "A" without pause until acknowledged. The calling station will then proceed with the message.

To acknowledge a call.—Signal "I" three times followed by "front" and the call letter of the acknowledging station.

To break or stop the signals from the sending station.—Signal "A" without pause until acknowledged. Fig. 279.

To start the sending station after breaking.—Signal "G A" followed by "front" and the last word correctly received: the sender will immediately resume his message, beginning with the word indicated by the receiver. If nothing has been received signal "R R," the sender will then repeat all.

Error in sending.—Signal seven dots (· · · · ·) rapidly followed by "front," and resume the message, beginning with the last word correctly sent.

End of address.—Signal the period (· — · — ·) followed by "front."

Signature follows.—Signal "sig" followed by "front."

To acknowledge receipt of a message.—Signal "O K" followed by "front" and personal signal or initial of receiver.

CONVENTIONAL SIGNALS FOR HELIOGRAPH OR FLASH LANTERN.

To call a station.—Turn a steady flash on the station and keep it there until answered by a steady flash. Both stations will then adjust each on the other's flash. When adjustments are satisfactory, the station called will acknowledge and cut off its flash, and the calling station will proceed with the message.

FIG. 279.

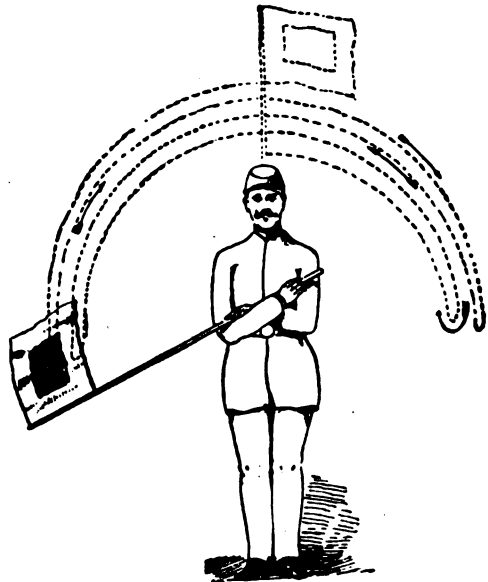

WIG-WAGGING.

To acknowledge a call.—Signal “I” three times, followed by the call letter of the acknowledging station.

To break or stop the signals from the sending station.—Signal “A” without pause until answered by a steady flash

To start the sending station after breaking.—Signal “G A” followed by the last word correctly received; the sender will immediately resume his message, beginning with the word indicated by the receiver. If nothing has been received signal “R R,” the sender will then repeat all.

Error in sending.—Signal seven dots (· · · · ·) rapidly, and resume the message, beginning with the last word correctly sent.

Adjustment.—If the receiver sees that the sender's mirrors needs adjusting, he will turn on a steady flash until answered by a steady flash. When adjustment is satisfactory, the receiver will acknowledge, and the sender will resume his message.

End of address.—Signal the period (· — — ·).

Signature follows.—Signal “Sig.”

To acknowledge receipt of a message.—Signal “O K” followed by personal signal or initial of receiver.

CONVENTIONAL SIGNALS FOR TELEGRAPH.

To call a station.—Signal the “call letter” of the station required until acknowledged, signing at intervals the “call letter” of the station calling.

To acknowledge a call.—Signal “I” three times followed by “call letter” of acknowledging station.

To break or stop the signals from the sending station.—Open the key.

To start the sending station after breaking.—Signal “G A” followed by the last word correctly received; the sender will immediately resume his message, beginning with the word indicated by the receiver. If nothing has been received signal “R R.” the sender will then repeat all.

Error in sending.—Signal seven dots (· · · · ·) rapidly and resume the message, beginning with the last word correctly sent.

End of address.—Signal the period (· — — ·).

Signature follows.—Signal “Sig.”

To acknowledge receipt of message.—Signal “O K,” followed by personal signal or initial of receiver.

MESSAGES BY FLAG, HELIOGRAPH, TELEGRAPH, ETC.

The following will be the order of transmitting the several parts of a message: 1st, number of message and “call letter” of sending station; 2d, operator's personal signal; 3d, the check; 4th, place from and date; 5th, address in full; 6th, period (address complete); 7th, body of message; 8th, Sig. (signature follows); 9th, signature.

Abbreviations should not be used in the body of a message, and numbers occurring therein must be spelled out in full.

It may be added that the foregoing conventional signals, for flag and torch signaling, are practically similar to those employed in commercial telegraphy in the United States and Canada.

THE UNITED STATES SIGNAL CORPS STATION KIT.

The connections of this "kit," or combined telegraph, telephone, and "buzzer" outfit, are shown in Fig. 279a. The kit comprises a buzzer *M*, the telephone receiver *R* and transmitter *T*, the key *K* for Morse and buzzer sending, the necessary switches *A*, *B*, *C*, *D*, for changing from one to another method of communication, and a battery of about 8 dry cells *B'*. The whole is contained in a box about nine inches square and nine inches deep. It is opened into two equal parts when in use. The telephone receiver is used for receiving the Morse and buzzer signals and for speech. When used for open-circuit Morse or double-current working, the sounds are heard in the receiver as clicks, corresponding to the sounds of the Morse sounder, the click at the closing being louder than that at opening the key *K*, as will be explained. When used for buzzer working the signals are received in the telephone receiver as a succession of pulsations which produce a buzz or tone that is broken up into dots and dashes, that is, short and long tones. The telephone system has the usual primary and secondary induction coils *I*. For the operation of the transmitter *T* only half of the battery *B* is used, as the full battery would perhaps produce "frying" in the transmitter that would impede speech. The buzzer *M* is the same in principle as that described on page 256, but its general construction is quite different. Its coils, of 10 ohms each, are connected in multiple to give sharper action. Its armature-lever or circuit-breaker *e* is of steel, and requires careful adjustment for best results. The contact *r* is mounted on a spiral spring carried on an adjustment-screw *a*; the armature-lever is also supplied with an adjustment-screw *b*, all strongly made. The key *K* is of special construction. In the drawing its under-contacts are projected in order to show the connections more readily. The key has one back contact and two front contacts. This outfit is used for station work as distinguished from the field outfit.

To simplify the ensuing explanation the buzzer arrangement may be considered as analogous to the Varley-Athearn device, and the Morse arrangement to that of the phonoplex described in Chapter XXII.

BUZZER WORKING.—Switches *A*, *C*, *D* are turned to the left, *B* to the right, for buzzer working. (It will simplify the study of these devices if the reader will draw, with a pencil, lines on the diagram to indicate the different positions of the switches.) When key *K* is closed a metallic circuit is formed as follows: From positive pole of battery *B* to post 11, to post 10, to switch *C*, to contact *t*, to key-lever, to trunnion *q*, to post 9, to the coils of *M* at *c*, through coils to armature-lever *e*, to back contact *r*, to posts 8, 12, and negative pole of battery. At this time it will be understood the buzzer is active and is sending out rapid pulsations to line by way of post 9, trunnion *q*, key-lever to contact *n*, to post 14, to posts 4 and 2; and to earth *E* by way of armature-lever *e* and post 1, which pulsations are heard as long and short tones in the distant telephone. When, on the other hand, key *K* is open the battery metallic circuit first traced is open at contact *t* and consequently no pulsations are developed at *M*. When key *K* is closed the receiver *R* is short-circuited, as may be seen, by way of posts 4, 14, trunnion *q*, post 9, switch *B*, and post 5.

For receiving buzzer signals key *K* is kept open, and the telephone receiver is then in the circuit from line, to post 2, to post 4, through receiver, to post 5, to top of switch *B*, to and through coils *M*, to post 1, to earth *E*.

MORSE WORKING.—Switches A, B, C, D are turned to the right. With switch A to the right, circuit-breaker *e* of M is short-circuited and therefore cannot act as a buzzer. There is then, when key K is open, a metallic circuit from the positive pole of B', to post 11, to switch D, to back contact *i* of K, to trunnion *g*, to post 9, to and through coils of M, to lever *e*, to *r*, and back by way of posts 8 and 12 to negative pole of battery. With K closed the metallic circuit is from the positive pole of B' to posts 11, 10, to switch C, to and through a resistance coil of 10 ohms, to contact *t*, to key-lever, to trunnion *g*, post 9, to and through coils of M, its armature *e*, and back by way of *r*, posts 8 and 12, to negative pole of battery. When,

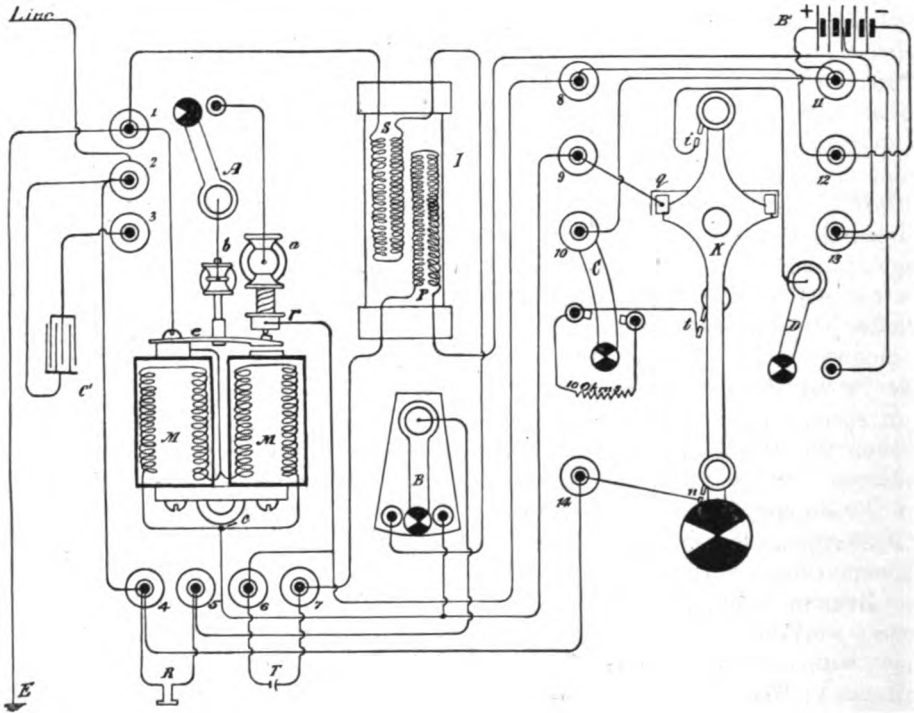

FIG. 279a.

therefore, the key is open or closed in buzzer sending the magnet M is charged by battery B'. When the key is in transit from open to closed, and vice versa, coils M discharge into the line by way of switch B, post 5, receiver R, and posts 4 and 2; and to earth E by way of post 1. The difference in the sound of the Morse characters is obtained by the use of the resistance at switch C. As this resistance is not in the metallic circuit of M when key K is open, but is in that circuit when K is closed, the sound is louder when the key starts to close (that is, when the circuit is broken at back contact *i*), and weaker when the key starts to open, thus giving the equivalent of the front-and-back stroke of the Morse sounder.

TELEPHONE WORKING.—Switch A may be open or closed; B is turned to the left; C may be on either contact; and D is open. The transmitter circuit may be

traced from the middle of battery B' to post 13, to and through primary P of induction coil I, to post 7, through transmitter T to post 6, to posts 8, 12, and negative pole of battery. The route of the received telephonic signals is from line, to post 2, to and through receiver R, to switch B, to secondary coil S, to post 1 and earth E.

When the buzzer or telephone system is superposed upon a regular Morse telegraph circuit the line wire is connected to post 3, which interposes the condenser c', through which of course the pulsatory and telephone currents pass unobstructedly as explained, page 347. Otherwise the connections remain the same as just noted.

FIELD KIT OF UNITED STATES SIGNAL CORPS.

Another arrangement of the U. S. signal corps buzzer and telephone circuits is shown in Fig. 279b. In this, for the sake of clearness, the switches are omitted.

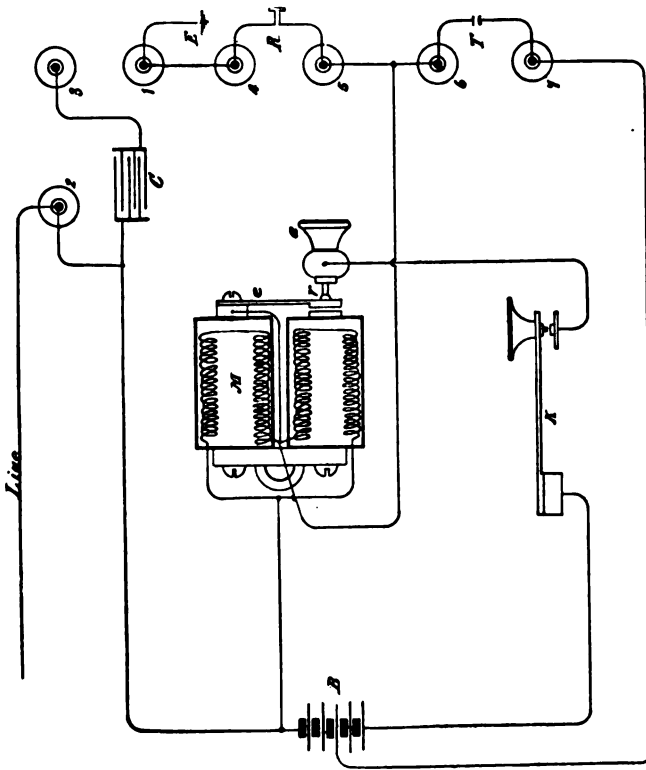

FIG. 279b.

When set for buzzer signals the operation is as already described. When arranged for telephoning the circuit-breaker *er* is short-circuited. No secondary coil is used in this case, the impulses in the coils of *x* caused by the variations of the resistance in the telephone transmitter (due to the voice) sufficing. The condenser *c'* is employed for the purpose already mentioned. The transmitter is connected to posts 6 and 7; the receiver to posts 4 and 5; the other connections are as marked. The field kit weighs about 5 lbs. and is about half the size and weight of the station kit. The field kit is not used for Morse working.

As the battery in use on this apparatus is of the open-circuit type, switch *D* should always be kept open when the apparatus is idle. The switches should always be set for Morse or buzzer working when not being used for telephone working. When it is desired to use a regular Morse system and the buzzer on the same line simultaneously, the buzzer apparatus is connected outside of the Morse apparatus virtually as in the case of simultaneous telegraphy and telephony, *E F*, Fig. 261.

In actual operations in the field, these and more or less similar outfits have been found of great utility in various countries, the lightness and compactness of the apparatus being a great advantage. The Morse method can be used over comparatively short distances; the buzzer for longer distances, and especially when the insulation of the line is low. On many occasions the buzzer method has been successfully used with the bare wire lying on fences, trees, and even in water. The Morse and buzzer methods are generally preferred for accuracy in the case of important correspondence. In some European military departments, however, a recording apparatus is preferred.

The foregoing description of these kit systems is based on data kindly supplied by Gen. A. W. Greely, Chief Signal Officer U. S. Army, and Capt. E. Russell.

CHAPTER XXV.

THE AMERICAN DISTRICT TELEGRAPH MESSANGER SERVICE.

This "service" relates to the supplying of messengers, policemen, firemen, etc., at the call of the "subscribers" in whose houses or offices an instrument termed a "call box" has been placed.

This call box, which is shown virtually as it appears in practice, in Fig. 280,

FIG. 280.

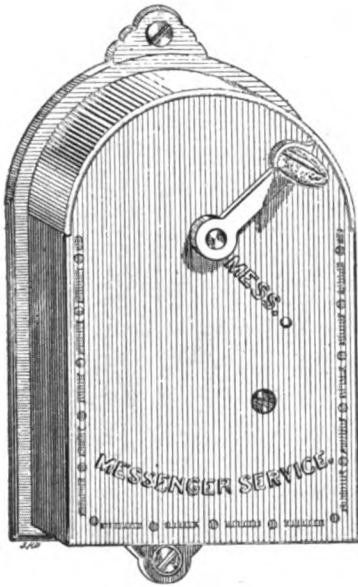

DISTRICT SERVICE CALL BOX.

is electrically connected with a central office, at which the messengers, policemen, firemen, etc., are located. Each box is supplied with "make and break" attachments which are set in motion by the turning of a crank on the cover of the box, and which attachments, when thus operated, transmit to the central office a specified number, which indicates to that office the location of the signaling box.

The electrical connections for this service, which are quite simple are outlined in Fig. 281. In the figure *R* is an ordinary Morse relay, wound to about 100 ohms. *B* is a single *stroke* electric bell, whose electro-magnet is wound to about 4 ohms; *G* is a single or double pen Morse register, the magnet of which is also wound to about 4 ohms. *B* and *G* are in the one local circuit, which, it will be seen, is controlled by the armature lever of the relay *R*; the contact point of the latter being on the back stop. *LC* is a local battery of 4 to 8 Leclanché cells. *c'* is the call-box-circuit battery, of 12 or more gravity cells, according to the length of the circuit. *s* is a switch used for testing and changing circuits, and is shown

and described more fully further on. All of those instruments and batteries are located in the central office.

CALL BOXES.—At the right of Fig. 281, *CB* represents the circuit-breaking arrangements and crank of a call box in a subscriber's office. The crank *c* is mounted, with a recoil spring, on a shaft, as indicated. A cog-wheel, *cw*, is also mounted, loosely, on the crank shaft. A "break-wheel" *w* is geared with the cog-wheel *cw* in such a manner that it receives a tendency to turn in the direction shown by the arrow, but it is normally prevented from turning by the engagement of the pin *p* on its side with the curved cam *k* attached to the prolongation of the crank arm. When however the crank lever *c* is pulled to the right, preparatory to sending in a call, the cam is moved out of the path of the pin *p*, and the wheel *w* is then free to move. By a

suitably arranged pawl and ratchet the cog-wheel *cw* is prevented from moving when the crank is pulled down. (A practically similar pawl and ratchet is shown in Fig. 282.) The effect of turning the crank shaft is to wind the recoil spring. When the crank is let go the spring unwinds and as it does so the wheel *w* begins and completes a revolution and the crank lever returns to its normal place. When the latter has done so the cam *k* is again in the path of pin *p*; hence the wheel *w* is stopped in its normal position.

The contact spring *a* is supported by the frame of the box, but is insulated therefrom. Normally, one end of *a* rests on the periphery of the break-wheel *w*, thus keeping the circuit closed. The periphery of the break-wheel is notched practically as shown in the figure, so that, as the wheel is revolved, the spring *a* alternately

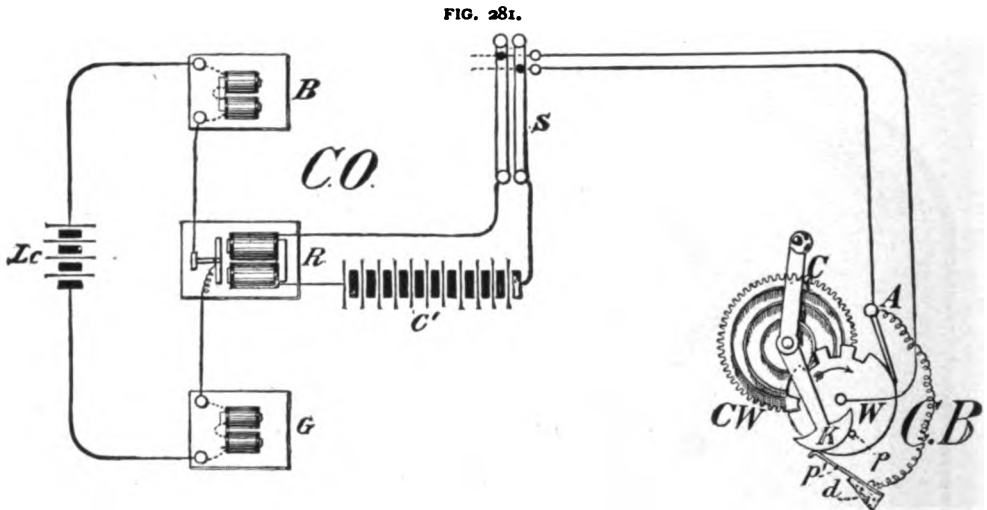

CENTRAL OFFICE AND CALL BOX—DISTRICT MESSENGER TELEGRAPH.

ly passes over the metal periphery and falls into the spaces between the "teeth," thereby opening and closing the circuit. In the figure, there are 3 notches a uniform distance apart, further on another notch. In turning once, therefore, the wheel will first break the circuit thrice, in comparatively rapid succession, and, after a longer pause, will again break it once. This will, of course, operate the electric bell and the register, in the central office, which instruments will, respectively, ring and record the number of the signaling box; in this case 31.

Although but one call box is shown in Fig. 281, it is plain that a large number of such boxes may be placed in one circuit. In practice it is not uncommon to have fifty or more call boxes on one circuit, but the maximum is about one hundred, it having been found that more than this number too largely increases the chances of signals clashing.

In order to guard against the opening of the circuit in any of the call boxes when the instrument is in its normal position, by a failure of the contact spring *a* to make perfect contact with the periphery of the break-wheel, a short circuit

is provided which is only complete when the cam k rests against the contact p' , which it normally does, but from which it separates when the crank lever is pulled, as will be obvious on examination, thereby leaving the circuit free for the operation of the break-wheel. The contact strip p' is suitably supported in the box on the insulated piece d .

Another form of "break-wheel" used in the district messenger service is shown in Fig. 282. In that figure k is the crank shaft. The crank lever is not shown. A coil spring s is attached at one of its ends to the crank shaft; its other end is rigidly attached to a rod f fastened to the framework of the box. The shaft k carries a wheel v , (indicated by the dark strokes) on the periphery of which are two detents d, d' opposite each other. w is a large flat wheel, loosely mounted on shaft k . The pawl, or "click" r , carried by the wheel w , is pressed against the periphery of v by the tension spring p . When the crank is turned to the right, a full turn, the coiled spring s is wound up more tightly, and, at the same time, the pawl r drops in behind the detent d . As a result the coiled

FIG. 282.

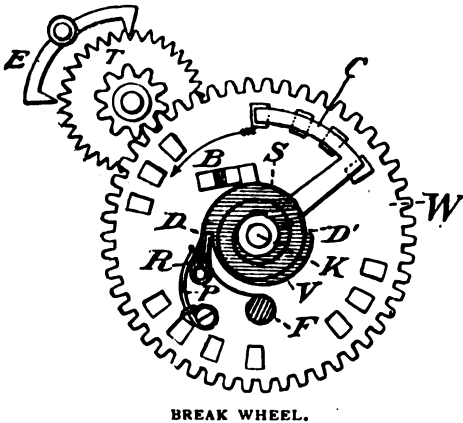

spring, in unwinding, revolves the crank shaft and wheel v , and, since the pawl r is then caught by detent d , the large wheel w is also revolved in the direction of the arrow, and the contact, or "trailer" c , alternately resting on the brass of the wheel w and suspended, as in Fig. 282, over the open spaces in that wheel (thereby opening and closing the circuit), sends in the regular number of the box. Owing to the size of wheel w there is room to cut the number of the box out twice, as in the figure, so that, if the crank is pulled a prescribed maximum distance, the number will be sent in twice, thereby indicating a special signal.

If pulled a less distance the number will be sent in but once. The movement of wheel w is always in the same direction.

The function of the small toothed wheel t , which is geared with the large wheel w , and the escapement e , is to regulate the speed of uncoiling of spring s . The coiled spring is prevented from running completely down by the extension b , attached to shaft k , which, at a suitable point engages with a check pin attached to the framework of the box.

For other examples of the "District" call boxes, see the "Fix" combination "call" and burglar alarm box.

RETURN SIGNAL CALL BOXES.

In the district service system described, it may have been noticed that there is nothing to tell the subscriber whether or not his "call" has been received in the central office. Perhaps it may be truly said that the average user of the call boxes does not care to know; preferring to have visual evidence of the fact that the call has been received, in the prompt appearance of the messenger.

But to meet the wishes of such as desire to have an immediate acknowledgement, from the central office, of the receipt of the call, various, so-called, "return" signals, to be actuated, automatically, or by the clerks in that office, have been devised, and, in some instances, put into service, one of which, the Van Size return signal box, will now be described.

THE VAN SIZE RETURN SIGNAL BOX.—"Return" signals are, generally speaking, either audible or visual. The Van Size return signal box gives an audible signal. This device and the necessary attachments for its operation are shown in Fig. 283.

FIG. 283.

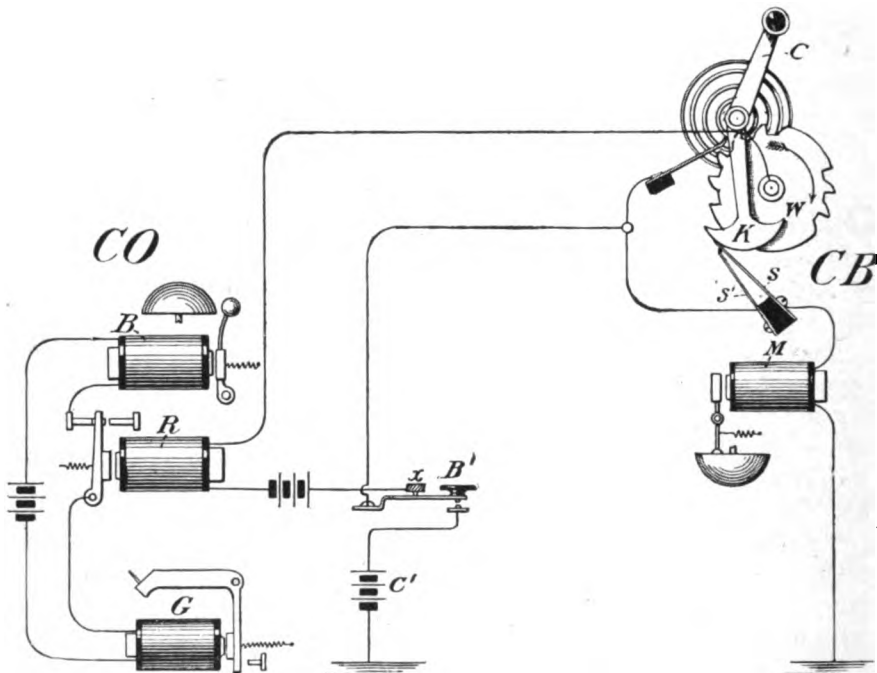

CONNECTIONS—VAN SIZE RETURN SIGNAL.

The mechanical and electrical portions of this box are nearly identical with the ordinary call box. The bell *B*, relay *R*, register *G*, etc., at the left of figure are assumed to be in a central office, *CO*. The return signal apparatus proper is placed in the bottom of the call box *CB*.

It consists of a small electro-magnet *M*, whose armature, when actuated by a current flowing in the magnet, taps a bell.

The operation of the return signal is as follows: In the first place the mechanism of the box is so arranged that every movement of the crank *C* causes the break-wheel *W* to make two revolutions. During the first revolution the number of the call box is sent in as usual. During the progress of the second revolution the thicker portion of the curved cam *K* impinges against the contact spring *S*, causing it, as in the figure, to press against the lower contact spring *S'*. These two springs are normally separ-

ated. When the cam passes the spring *s*, the latter resumes its usual position. A wire connects *s*, via the bell magnet *m*, with the earth. Another wire connects *s'* with a screw post in the box, to which is also connected one side of the main circuit, as indicated in the figure. At the central office, *B* is a "strap" key, which, when depressed, first opens the main line circuit at *x*, and next, puts a special battery *c'* to a portion of the main line circuit. It is then obvious that when key *B* is depressed at the time the cam *κ* has brought the two springs *s* and *s'* together, in the call box, that there is a circuit from the ground in the central office to the ground at the call box, via the bell magnet *m*, and the latter will ring.

Hence, in order to send the return signal, it is only necessary that the attendant at the central office, when he hears the first signal of the box, should depress the button *B* and hold it depressed for a few moments, or until the cam *κ* temporarily closes the circuit, thereby ringing the bell in the call box, which is evidence to the subscriber that his call has been received.

The successful operation of this return signal depends upon the promptness of the attendant at the central office, for, should he fail to depress the button while the cam is passing the circuit-closing contact springs, no return signal can be sent back until the subscriber repeats his call.

Another audible return signaling device will be shown in connection with the "Field and Firman" call box.

Visual return signal devices, as the name implies, consist of means, more or less analogous to the foregoing, whereby an electro-magnet in the call box brings into view some pre-arranged letter or character at an opening in the box.

Neither audible nor visual return signals are used very extensively in the district messenger service, but their use is increasing. It may be added that at one time an electro-magnetic arrangement was attached to the call boxes which permitted the customer to ascertain for himself, by depressing a button and listening, whether the line was being used by others. This was, however, to avoid clashing of signals.

When, as occasionally happens, two subscribers pull their call boxes simultaneously the signals are, of course, jumbled. There is at present no remedy for this but to wait until the subscribers call again, unless the central office clerk is able to separate the signals, which, from experience, he may be able to do. It is said, and may be noted in passing, that almost every call box has a characteristic of one kind or another in the manner of transmitting its signal, with which the central office clerk quickly becomes familiar, and this characteristic is frequently sufficient to enable him to determine from which box a call has emanated, even before it is completed. For instance, suppose a box to have the number 234. Perhaps before 2, 3, is signaled the "characteristic" will have identified the box so calling. This feature is occasionally of utility in enabling the clerk to distinguish a call when the entire signal may have been prevented from coming in by the cause just mentioned, or others, such as the crossing of the wire, etc.

DISTRICT SERVICE MAGNET BELL.—This instrument is shown as *B* in Fig. 283. It is an ordinary electric bell; the clapper being, by suitable means, attached to the armature of its electro-magnet. When the relay *R* is operated by a call box the clapper strikes the gong a number of times corresponding to the number of the box. The

object in using these bells, in addition to the double-pen register, is to guard against failure of the register to record, and also as an indication of the "arrival" of a call. As a matter of fact the "call" is more frequently taken from the bell than

FIG. 284.

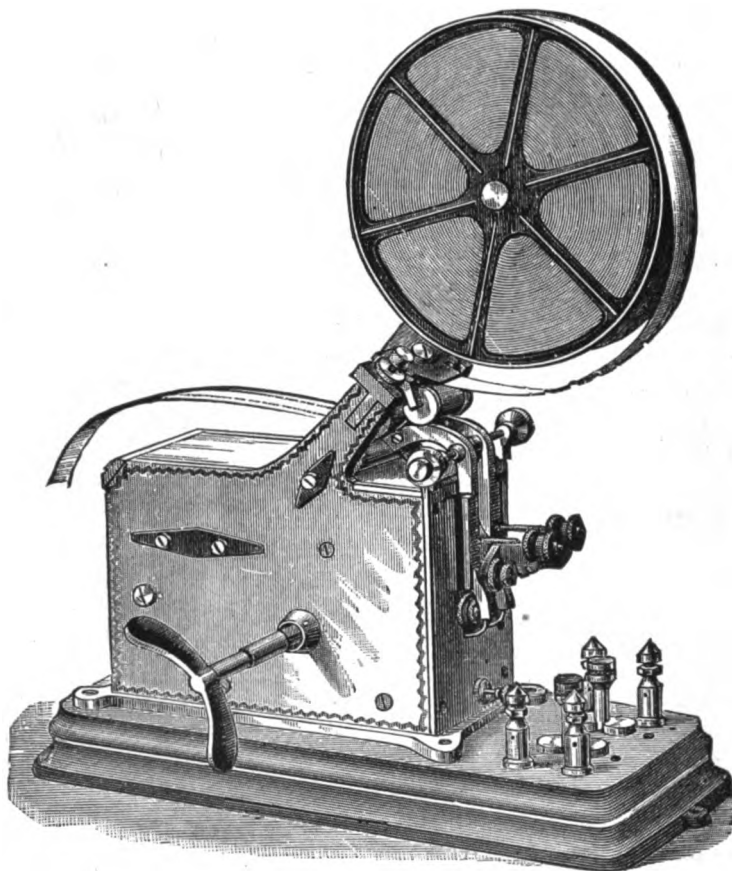

DOUBLE PEN REGISTER.

from the number embossed on the paper strip of the register, and the latter becomes, in time, more a means of securing a record of calls received, than otherwise. In some central offices the bell also is dispensed with, the clerk relying on the sound of the register to attract his attention to a call.

DOUBLE PEN REGISTER.—One of the forms of registers used in the district messenger service for recording "calls," automatically, is illustrated in Fig. 285. This is known as a self-starting, "double-pen" register. The action of this register is very simple. A reel carries paper tape which is passed between two rollers, as shown. These rollers are given a constant tendency to rotation by clock-work within the box. There are two magnets within the box, each magnet in a separate circuit. The arma-

ture levers of these magnets are extended to a point directly under the paper tape: each lever carrying a stylus (seen in side view in Fig. 285, at *x*.) When either of the magnets is operated the clock-work is started; (in a manner presently to be explained)

the paper is also started, and the stylus indents the paper as many times as the circuit is broken, and with intervals corresponding to those of the number of the box from which the call comes.

By the placing of two magnets and two pens in one frame the clock-work for one register is saved.

SELF-STARTING REGISTERS.—There are several kinds of self-starting registers in vogue. One such, which is in quite general use, is theoretically shown in

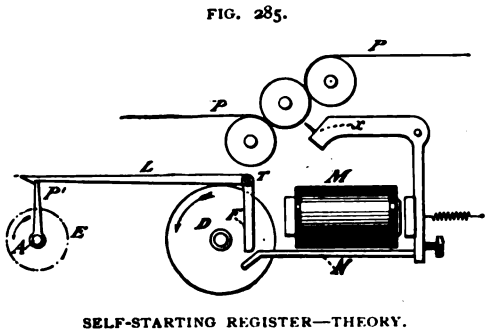

SELF-STARTING REGISTER—THEORY.

Fig. 285. Only one magnet and one pen, or stylus, is shown.

D is the drum containing the spring which drives the clock-work. E is the wheel most remote from the drum; it is connected with the clock-work by gearing, omitted in the figure. The shaft A of wheel E carries an arm P', as shown. L is a lever trunnioned at T. F is an extension from that lever. This extension rests easily against the flat end of the drum D. Consequently, as the drum revolves it tends to raise, by friction, the extension F. This action, when continued long enough, brings the left end of the lever L into a position where it engages with the extended arm P' of A. This at once stops the rotation of the wheel E and, therewith, the entire clock-work.

The armature lever of magnet M is provided with a horizontal extension, or arm, N. This arm, when the armature of M is attracted, pushes forward the extension F, thereby removing the left end of lever L from the path of the rotating arm P, which at once releases the clock-work. It will be understood that as long as signals follow each other in quick succession the extension, N, will continue to strike against F, thereby keeping lever L out of the path of the arm P'. The action of the drum in moving the extension F is so regulated that, when the signals cease, but a few inches of paper run out before the clock-work is stopped.

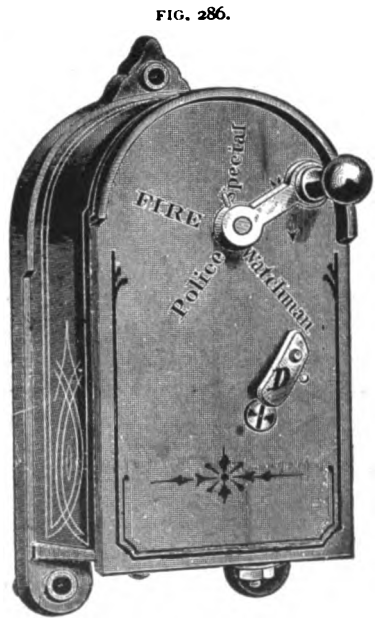

FIG. 286.

MULTIPLE CALL BOX.

“MULTIPLE” CALL BOXES.

When it is desired to furnish a subscriber with more than simple messenger ser-

vice, for instance, fire alarm, burglar alarm, calls for doctor, etc., a pre-arrangement may be made whereby, for example, the number of the call box once sent in, may signify that a watchman or messenger is wanted; twice sent in, police assistance; thrice sent in, a fireman; four times, a doctor, or other special want. Thus, in the latter case, the subscriber would be required to turn the crank of the box four times, consecutively.

But to avoid this trouble, and to avoid confusion due to errors in counting turns, a "special" or "multiple" call box is frequently provided, which may be set by the subscriber at a point signifying a call for messenger, police or physician, and one turn, or partial turn, of the crank then suffices to send in the desired signal, automatically.

One box of this kind resembles the ordinary single call box, save that it is furnished with 4 pawls, or clicks, by means of which, when the crank is turned beyond one, two, three or four of the pawls, the break-wheel is caused to make a corresponding number of revolutions, thereby sending in its number as many times as the wheel revolves. On the cover of such boxes the point to which the crank should be turned to secure the service desired is plainly marked, as shown in Fig. 286. The detent *D* on the cover of the box, prevents the crank from passing the messenger, or watchman, call, until it, the detent, is moved out of the way.

FIG. 287.



FIELD AND FIRMAN CALL BOX.

THE FIELD AND FIRMAN ELECTRIC CALL BOX.

The form of "multiple call" and "return signal" box illustrated in Fig. 287, is employed in district messenger service. It is also used, in slightly modified forms, in some police telegraph systems, as a means of transmitting special signals from patrol boxes. (*see Gamewell Police Patrol Telegraph.*)

The theory of this box is outlined in Fig. 288. *K* is the crank lever; *BW* is a break-wheel which transmits the ordinary box number. *sw* is a wheel used for transmitting special signals, in a manner to be described shortly. This wheel may be moved to the left by the pointer *P*; both being on the same shaft. A segment of a wheel, with cogs *GG*, is rigidly attached to the side of *BW*. A similar segment with similar cogs *G'G'*, is attached to the side of *BW*. The shaft of break-wheel *BW* is geared with the wheel *w*, which latter is mounted on the winding shaft *s*. Wheel *sw*

is *not* normally geared with any of the other wheels. A curved arm *c* on shaft *s* acts as a stop for the wheel *BW* by engagement with the pin *t*. When the crank lever *K* is pulled down, *c* is moved out of the path of the pin. This permits the wheel *BW* to make one revolution before the crank lever shaft *s*, in the process of unwinding, places *c* again in the path of pin *t*.

FIG. 288.

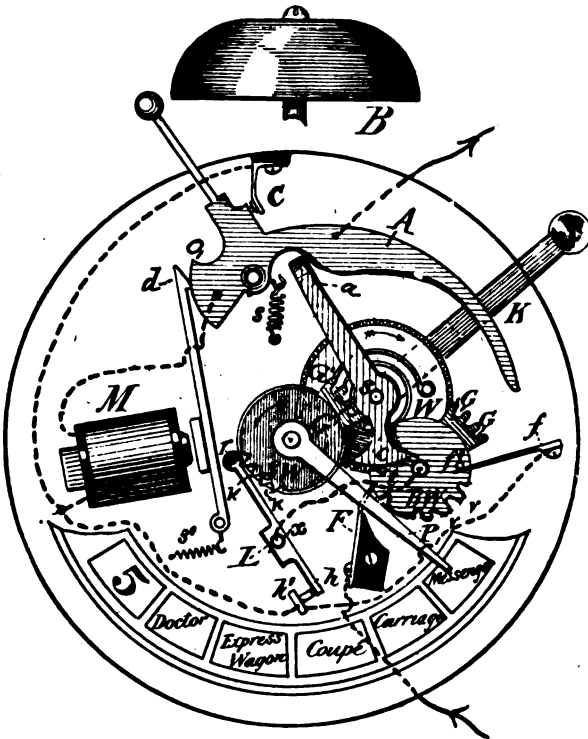

FIELD AND FIRMAN CALL BOX, THEORY.

In the present position of the wheels *BW* and *sw*, it will be seen that *BW* may rotate continuously without any opportunity being given for the cogs *g* on *BW* to engage with cogs *g'g'* on *sw*. When, however, the pointer *P*, controlling *sw*, is moved to the left, it brings, depending on how far to the left it is moved, one or more of the cogs *g'* into the path of the cogs *g*, with the result that, as the wheel *BW* rotates, the cogs *g* engage with the cogs *g'* and cause the wheel *sw* to resume its former position.

When, therefore, it is only desired to send an ordinary service call, the pointer *P* is not moved, and the pulling of the crank lever *K* simply effects the turning in of the box number by the medium of the spring contact *F* and the breaks *v v* on the break-wheel. When it is desired to send in a special signal, the pointer is moved over to the place, or "stop" corresponding to the desired service. For instance, if it is placed over "coupe," the lever will ride over two teeth *k*, as it does so opening the

By means of a pawl and ratchet, not seen in the figure, the wheel *BW*, which is loosely mounted on its shaft, is rotated in one direction only, and does not move when the crank lever is being pulled down in the act of winding the recoil spring; in which respect it resembles the break-wheel of the ordinary call box described.

A rod, or lever, *L*, pivoted at *x*, carries a roller *r* on its upper end. When *sw* is rotated the roller *r* rides in and out of teeth *k* on the periphery of *sw*. As it does so the contact between the points *h h'* at the lower end of *L* is broken. Ordinarily the contacts *h, h'* are short-circuited by the dotted wires and contact spring *f*. It will be seen, however, that as soon as break-wheel *BW* begins to revolve this short-circuit does not exist, as at that moment the spring *f* separates from the pin *f*.

contacts at $h h'$ twice, but as those contacts are still short-circuited via f and f' , the circuit is not affected. The pointer having been thus "set", the crank lever is operated, whereupon the break-wheel bw proceeds to make its revolution. In so doing it first sends in the box number by opening and closing the circuit between the spring F and wheel bw . This done, the spring contact F then rests steadily on the periphery of bw . The next moment the cogs G on bw engage with G' , moving sw back into its former position, which causes the roller r to ride back over two teeth k , thereby, (the short-circuit via $f f'$ now being broken) opening the main circuit twice at $h h'$. The signal, as thus sent, is recorded by the register or bell at the central office; the signals following the box number indicating the nature of the service.

A "return signal" arrangement, by means of which the subscriber may know that his call or signal has been received, is provided in the box. Its operation is as follows: The lever A , from which the "tapper" of bell B is extended, is normally held by the spring s in the position shown in the diagram; the armature lever of magnet M resting against one of the ends of A , as shown. This magnet is ordinarily short-circuited, as shown at the contact point c , which latter is insulated from the frame-work of the box. When the crank lever K is pulled down, the arm a , which moves with that crank, turns the lever A on its trunnion, opening the short-circuit at c and placing the catch o at a point where it is engaged by the detent d on the end of the armature lever, whereby the lever A is held in that position even after the arm a has been restored to its usual position. The spring s is of sufficient tension to hold the armature lever away from the magnet against the attraction of the core occasioned by the current due to the main battery in the central office. When, however, the attendant in that office hears the signal just sent in, he depresses a key, which action adds another battery, momentarily, to the circuit. The increased current has the effect of attracting the armature of M , thereby releasing the lever A , which quickly resumes its normal position, and, as it does so, the tapper strikes its bell B once, thus announcing the receipt of the signal or call; at the same time the magnet M is again cut out of the main circuit by the short-circuit via c .

The number of cogs $G G'$, on the segments attached to bw and sw , may, of course, be increased to correspond with any number of different, "special" signals, desired.

DISTRICT SERVICE SWITCHES.

As a rule metallic circuits are used in the district messenger service, mainly because such metallic circuits are not affected by one accidental "grounding" of the circuit, as would be a "ground return" circuit.

In order that one such accidental "ground" may not remain long unnoticed, it is customary to test each district circuit every hour, by grounding it at the central office, when, if any other portion of the circuit be grounded, a "test" instrument, placed in the "ground" wire in the central office, will ring; the circuit of the test instrument being thereby completed. To facilitate testing and switching of circuits each central office is equipped with one or more switch boards.

Fig. 289 represents a section of a central office switch, and the connections for one circuit. The figure also shows a spare relay and battery, and the manner of their connections, as employed in some central offices. The spare set is used in case of

trouble to the regular set, which is shown at *RS*. In the figure the regular set is shown as "cut in" by the plugs at *xx*. Should it be desired to displace the regular set and insert the spare set, the plugs are removed from *xx* to *zz*. A call box *CB* is placed in the circuits in the central office, to test the circuit. Any circuit may be grounded in the central office by use of disc and plug on the switch at *FF'*. In Fig. 290 is shown a somewhat different form of central office switch, with three call box circuits, and the manner in which the local and switch connections may be made. *BBB* are the bell magnets. *GGG*, the register magnets. *RRR*, the relays of the three circuits. The bell and register magnets of the different circuits are connected in multiple, thereby requiring but one Leclanché battery *LC*. Each call box circuit is, however, supplied with separate gravity batteries, *c c c*.

FIG. 289,

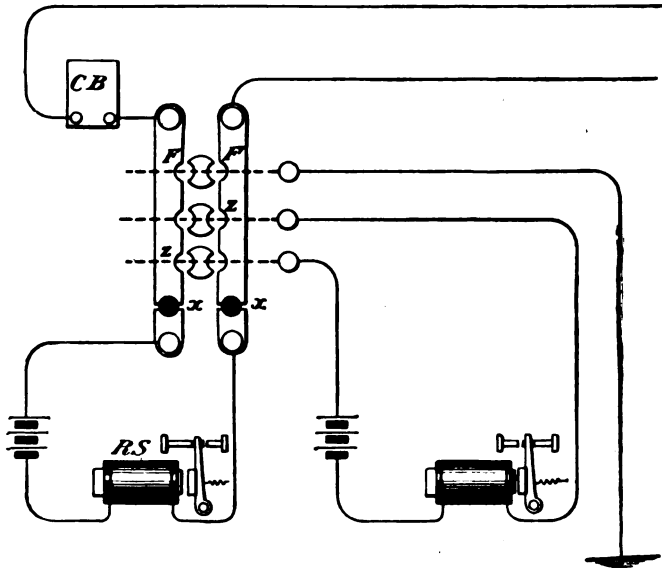

DISTRICT TELEGRAPH SWITCH.

BBB are the bell magnets. *GGG*, the register magnets. *RRR*, the relays of the three circuits. The bell and register magnets of the different circuits are connected in multiple, thereby requiring but one Leclanché battery *LC*. Each call box circuit is, however, supplied with separate gravity batteries, *c c c*.

A test instrument, for "grounds" is shown to the left of the switch *s*. By inserting a pin plug in both "straps" connected with any one of the circuits, one strap at a time, and by turn-

ing the crank of *r*, if a ground exists on any circuit, it will be indicated on the bell and register. When the line is clear the action of the "test" box will be without effect on the relays.

LOCKWOOD BATTERY.—The form of main line battery most generally used in the district service is that known as the "Lockwood," the elements of which are the same as in the Callaud gravity battery, namely, zinc, and copper in a solution of sulphate of copper. The only difference is in the shape of the jar and of the copper element. (see Fig. 291). The jar is about 12 inches high, by 5 wide. The copper element consists of two horizontal spirals of copper wire; one resting on the bottom of the jar, the other supported from the lower spiral by a copper rod, or a narrow upright spiral, about as shown. The bluestone crystals are placed between the upper and lower spirals. The object said to be gained by the use of the upper copper spiral is that, in some manner, the "blue" solution is prevented from rising above it, and, thereby, the deposit of "black" copper on the zinc element is minimized. But, perhaps, a better explanation, as regards the non-rising of the blue solution beyond the upper spiral, is that the battery, being on closed circuit the greater portion of the time, with a resistance of 150 to 250, or more, ohms, uses just about sufficient sulphate of copper to keep the "blue" line at the right height.

A slight modification has somewhat recently been made in the construction of the copper spirals. Formerly, the two spirals and the supporting rod were made separately and were held together by screw nuts. In the modification, the lower horizontal spiral is continued up from its centre as a narrow vertical spiral, equal in length to the

FIG. 290.

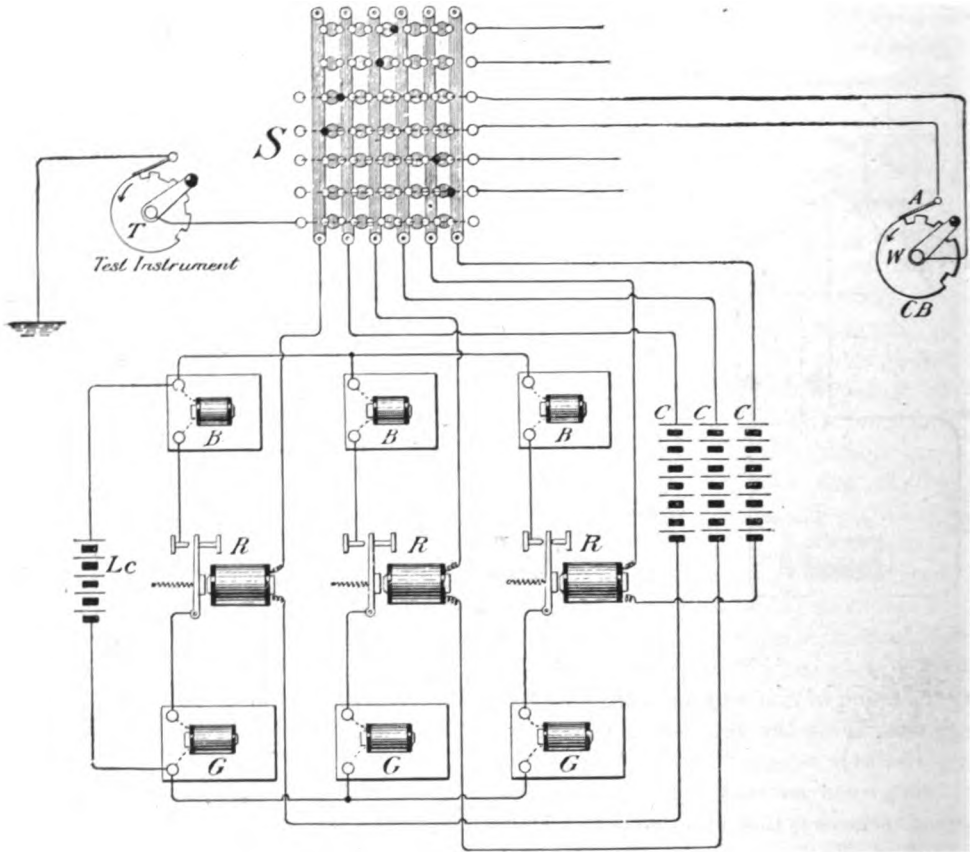

DISTRICT TELEGRAPH CIRCUITS—CONNECTIONS.

rod previously used. A short piece of straight wire is continued down, from the centre of the upper spiral, and is dropped loosely into the top of the narrow spiral rod, thus dispensing with all screws and screw nuts. In a very short time after the cell is set up, a firm connection between the spiral rod and the upper spiral is established by the deposition of metallic copper.

The spiral form of copper element is used until it becomes too bulky for the jar, when the copper is disposed of.

The Lockwood cell lasts from 10 to 12 months without removal, in this service. Callaud, or gravity cells, have been known to give satisfactory results for from 6 to 9 months without renewal, in the district service. The solution in the cases referred

to was prevented from evaporating and salts from forming, by the use of a thin layer of a good quality of battery oil, placed on the surface of the liquid.

It may be remarked, also, of the Lockwood battery, in connection with the district messenger service, that it has quite a presentable appearance and, therefore, it is frequently placed in central office window, or other conspicuous place, side by side with a register or two, thereby giving the office a "professional" look that it might not otherwise have; the full significance of which remark will be best appreciated by those who are familiar with some of the by-places in which District central offices are located.

FIG. 291.

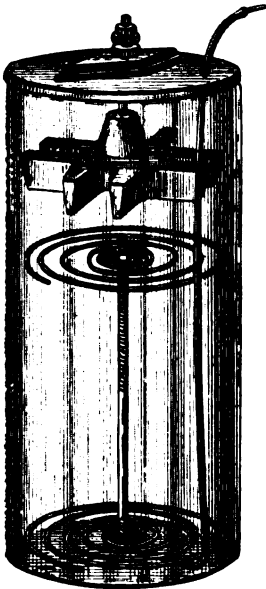

LOCKWOOD GRAVITY CELL.

DISTRICT SERVICE TIME SLIPS.—In Fig. 392 is shown a chest of small drawers, numbered. In each drawer are placed slips having printed on them the name and address of the subscriber whose call box number corresponds with the numbers of the drawer. Each drawer is partitioned, and thus affords space for two subscribers slips. The slip contains a space for the "number" of the messenger, the time the call is received, and the time the messenger returns.

When a "call" is received the clerk on duty takes out a slip from the proper drawer, and after marking the time upon it hands it to a messenger. This slip is signed by the subscriber, and it serves as a receipt for the service performed.

It will be noticed that the numbers on the drawers begin at 3, and that no figure higher than 7 is used. This is to minimize the number of breaks on the wheel in the call box, as well as to save time in the transmission of the "calls."

FAULTS, ETC., ON DISTRICT CIRCUITS.

Apart from "troubles" due to accidental line failure, which are many, in the district service, and which some of the companies have attempted to diminish by the use of insulated wire; and the troubles arising from the tempting nearness of the district wires, in many places, to the curious and meddling hands of messengers, porters, etc., there are also the troubles due to such causes as the opening of the circuit by the introduction of high resistance in the "call" boxes, due to rusting of the break-wheel, or to the accidental stoppage of the wheel with the contact spring over a "break," etc.

It is difficult to provide a remedy for the tampering referred to and almost equally so to provide an absolute preventive of the opening of the circuit within the box. Probably the latter cause might be diminished by improving the mechanism of the call boxes, or by occasionally oiling it, although the amount of labor involved in the latter suggestion would most likely preclude its adoption.

The use of relays of somewhat higher resistance and improved construction, thicker cores, etc.), has been found serviceable in reducing the number of "open" circuits due to the causes stated.

In "hunting" for line trouble on a call box circuit it is customary first to ground

the battery in the central office. The lineman then goes to the most centrally located call box and "grounds" the circuit at that point. This, if the trouble is an "open" circuit, puts in all the call boxes on one side of his ground. He then goes to a point somewhat closer to the central office and grounds that; if "OK," he then proceeds further from the central office, and so on, until the trouble is located between two or more boxes.

FIG. 292.

3	4	73	74	213	214	325	326	461	462
5	6	75	76	215	216	331	332	511	512
13	14	113	114	221	222	333	334	513	514
15	16	115	116	223	224	335	336	515	516
21	22	121	122	225	226	341	342	521	522
23	24	123	124	231	232	343	344	523	524
25	26	125	126	233	234	351	352	531	532
31	32	131	132	235	236	353	354	533	534
33	34	133	134	241	242	361	362	541	542
35	36	135	136	243	244	371	372	551	552
41	42	141	142	245	246	413	414	611	612
43	44	143	144	251	252	415	416	613	614
45	46	145	146	253	254	421	422	621	622
51	52	151	152	261	262	423	424	623	624
53	54	153	154	263	264	425	426	631	632
55	56	155	156	271	272	431	432	641	642
61	62	161	162	313	314	433	434	711	712
63	64	163	164	315	316	441	442	713	714
65	66	171	172	321	322	443	444	721	722
71	72	173	174	323	324	451	452	731	732

SERVICE SLIP DRAWERS.

The first District messenger service system was established in this country about eighteen years ago, on a small scale. To-day it is estimated that there are over 150,000 call boxes in operation. When the service was inaugurated, a rental was charged for the use of the box in addition to the charge for the messenger's service, but, in order to secure business, competing companies, in the larger cities, undertook to supply boxes free, and this is now the prevailing custom, except when "return signal" boxes, or other special signal boxes are supplied.

This "service" has quite recently and after much opposition been introduced in London, Eng.

CHAPTER XXVI.

AUTOMATIC BURGLAR ALARM TELEGRAPHY.

The object of automatic burglar alarm telegraph systems, or, as they are also frequently termed, "Electric Protective" systems, is to automatically announce, by the ringing of an electro-magnetic alarm in a central office, the presence of intruders in the building, or buildings, in which the protecting apparatus is installed.

FIG. 293.

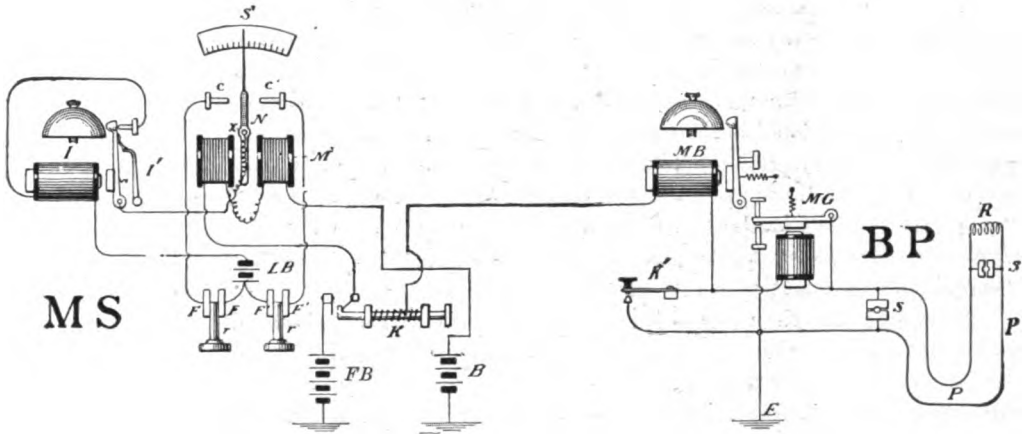

BURGLAR ALARM TELEGRAPH SYSTEM CONNECTIONS.

One of the plans on which such systems are arranged is the following: In the "protected" building a net-work of wires is run in partitions across doors, sky-lights, etc. These wires are a part of a circuit extending to the central office and the said wires, and the doors and windows of the protected building are so connected with the circuit that any interference with them after they have been "set," will cut out a high resistance, suitably placed in the circuit, which will so increase the current on the circuit as to operate an instrument at the main office; or, if the resistance is not "cut out," but, instead, the circuit should be broken, by accident or design on the part of intruders, the absence of current, or even a diminution of it, on the circuit, will likewise cause an alarm.

In Fig. 293 is shown a diagram of the electrical connections and apparatus employed to carry out the requirements of the foregoing plan, which is generally known as the Holmes burglar alarm system.

THE HOLMES BURGLAR ALARM TELEGRAPH.

The instruments, etc. shown at the left are supposed to be in the central or main

office **MS**. Those at the right, of the building to be protected, **BP**.

At **MS** **N** is a pointer carried by the needle or armature of a galvanometer or relay **M**; the pointer being pivoted at *x*. **I** is the magnet of an ordinary indicator; **FF**, **F'F'** are metallic strips, normally separated from each other, between which the metallic rods **rr'**, are placed when it is desired to close the local circuits shown, or from between which the same rods are withdrawn when it is desired to open those circuits. **B** is an ordinary gravity battery, **FB** is a special battery, much stronger than **B**.

At **BP** **MR** is a bell magnet. **MG** is an ordinary magnet. **P**, **P** may represent a net-work of wires running through a partition or elsewhere. **R** is a high resistance placed at some point in the building. **s**, **s** are arrangements of metallic strips connected, as shown, to the circuit, and attached to doors, windows, safes, etc., in such a manner that when the doors or windows are furtively opened the strips are brought together, thereby short-circuiting the resistance **R**.

The operation is as follows: When the circuit is in its normal condition, as shown in the figure, the resistance **R** is included in the circuit. This, with the resistance of the line and the magnets, gives a certain strength of current and, as a result, the pointer **N** at **MS**, is brought to a position midway between the contact points *c, c'*, in which position the local battery **LB** is open and the armature **I'** of the indicator **I**, remains at, or nearly vertical. The normal position of the pointer **N** is noted on the curved scale **s'**, so that any marked deviation to the right or left from that point is observed by the attendants. When there is no current whatever passing through relay or galvanometer **M**, the pointer, by its own weight, is arranged to fall; for instance, against contact *c'*.

Supposing that the resistance **R** in **BP** has become short-circuited, the effect is to largely augment the strength of current flowing in the circuit, and the magnet **M** now draws the pointer **N** against the contact *c*, which act closes the local circuit **LB**. The magnet of **I**, being thereby attracted, permits the indicator **I'** to drop, in the well known manner. This indicator carries or discloses the signal number of the building from which the alarm has come in. Concurrently with the falling of the indicator, a vibrating bell, which may be placed separately in the local circuit, or attached to **I**, as shown, is set in motion by the same battery and will continue to vibrate until one or both of the rods **rr'** is withdrawn, to open the circuit of **LB**.

If, instead of the resistance **R** at **BP** being short-circuited as described, the circuit should be cut or broken, all current would be removed from the line and the pointer **N** would fall against contact *c*, again closing the local battery **LB**; thereby permitting the indicator to drop and give the alarm.

It will be seen that the circuit is also led up to the armature of **MG** at **BP** and that the lower stop of the same instrument is connected to the ground. While the normal current is on the circuit the armature of this magnet is held back by its spring, which is adjusted accordingly, but when the current is increased, if only momentarily, the armature is attracted, short-circuiting the wire, thus giving an alarm. The bell-magnet **MB** is used as a "signal-bell," to give pre-arranged signals, transmitted from the main office, at the regular opening and closing of the store, or building. This magnet is so adjusted as not to be operated by the battery **B** at any time, otherwise intruders in the building would themselves be warned. When the main office de-

sires to ring that bell, the button, or key, κ is depressed, thereby putting battery RB to the line. The occupants of the protected building respond to these signals by depressing the key κ' , after a pre-arranged manner.

It will be understood that, in the system just described, a separate wire is run from the central office to each building to be protected and a separate set of alarm instruments is assigned to each of said wires in the central office. This insures that any tampering with the wire in that building, or at any part of it, will be at once perceived in the central office and an attendant will be sent to ascertain the cause. This may be termed a "separate wire" method. It may be said to insure as nearly as attainable, the absolute protection of the building against the entrance of burglars.

The actual resistance R , used in the protected building is unknown to any one, it having been taken at random from a number of unmarked coils; consequently, an attempt on the part of intruders to replace it, without varying the current of the circuit, prior to an entrance into the building, would be unavailing.

The chief objection to the employment of the separate wire method is an economical one; namely, the large number of wires necessary to be erected and maintained. The objection to the use of a single metallic circuit, or "omnibus" wire, on which all of the alarm apparatus in each protected building should be placed has, hitherto, been that, in the event of the omnibus wire breaking or grounding, the entire system would be rendered inoperative until the wire had been repaired.

A system recently introduced and now in practical operation in this country, known as the Wilder duplex automatic burglar alarm telegraph, employs an omnibus wire, and means to be presently described, for the transmission of alarms, regardless of whether the wire is grounded or broken, within, of course, certain limits.

THE WILDER DUPLEX AUTOMATIC BURGLAR ALARM.

The devices just referred to as being employed in this system whereby alarm signals are transmitted to the central office, regardless of whether the wire is open or grounded, form what is termed its "duplex" feature. In addition to these devices means are also provided in the protected buildings whereby attempts to ground or short-circuit the wires in the building will be announced in the central office; etc.

The apparatus and electrical connections of a central office and protected building are shown in Fig. 294, in which CO is the central office, BP is a "protected" building. In CO , BR , GR and MR are ordinary relays, termed, respectively, the "buzzer relay," "ground relay" and "metallic relay," because of the respective functions allotted to them. BR and MR are in the main line circuit. GR is in a circuit to ground, in which is placed a battery B' . The armature of BR controls a local circuit in which is placed a buzzer b , which is set in operation when relay BR is opened. By means of the 3-point switch s , the buzzer may be disconnected when desired. Relay MR may control, by its armature, an ink recording register g . By the use of the 3-point switch s' , the ground relay may be placed in control of that register; normally it is so placed. As the ground relay is not in the metallic circuit it would not, ordinarily, be responsive to signals sent over that circuit, but, by the operation of a peculiarly constructed break-wheel in the protected building, the signals sent in from that building are received in that relay. When a foreign "ground" comes

in on the metallic circuit the "ground" relay in CO is cut out by the attendant and the metallic relay is then caused to operate the register. The central office is also equipped with a telephone set which is tapped on to the metallic circuit, as shown, and is prevented from grounding that circuit by the use of the condenser c, in the manner described in Chapter XXII. (Simultaneous Telegraphy and Telephony). *t* is the receiver, *t'* the transmitter. By the use of the telephone the inspectors are able at any time to communicate with the central office from any point of the alarm circuit.

FIG. 294.

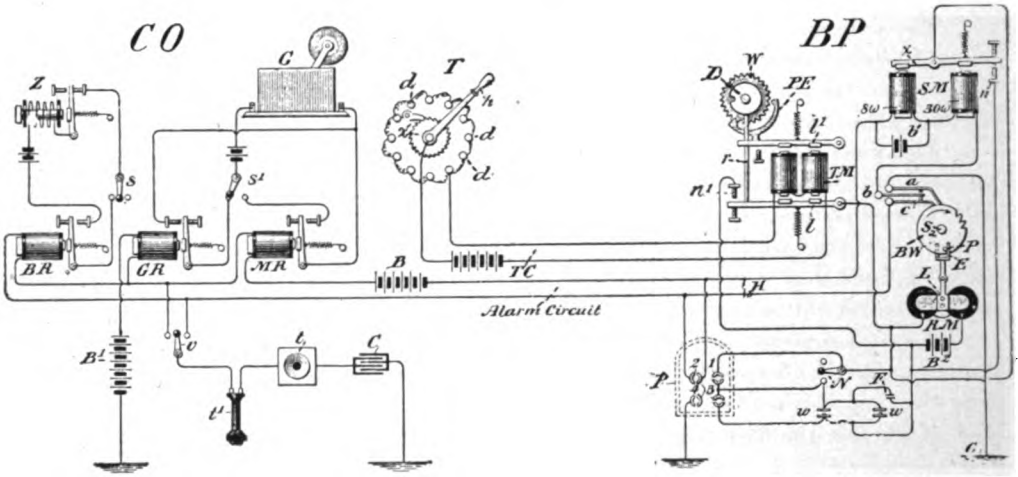

WILDER BURGLAR ALARM TELEGRAPH SYSTEM

t, in CO, is an instrument termed a "testometer". It controls a special, separate circuit running parallel with the alarm circuit and enters all the buildings of the system. By aid of the testometer and apparatus with which the protected building is equipped, an alarm may be automatically set up by the central office from any one of the protected buildings desired, or from all of them in rotation, in order to ascertain the condition of the wires in those buildings, and also to ascertain, speedily, the location of trouble on the omnibus wire. The manner in which these functions are performed will be described presently.

The apparatus in the protected building is contained in one box. It consists of a break-wheel BW, a "release" magnet RM, in control of the break wheel, a "safety" magnet SM, whose armature at certain times operates the release magnet, and TM the "testometer" magnet, supplied with two armatures, one of which *l*, also, at times, controls the release magnet, causing it to send in an alarm or signal; the other armature *l'*, controls, by a "push and pull" escapement PE, and escape wheel W, a disc D. On the periphery of D a small notch is cut. This notch is placed on different parts of each disc relative to the other discs of the systems, for reasons to be explained.

The wires distributed through the building, and the contact points at doors, windows, etc., are represented by *w*, etc.

Resting on the periphery of the break-wheel *bw* are two flat, flexible, metallic strips *a* and *c*. The break-wheel is composed of insulating material. Between *a* and *c*, a rigid, metallic strip *b*, not touching the break-wheel, is placed. The strips *b*, *c*, form part of the alarm circuit and, normally, they are in contact with each other, as shown. Strip *a* is connected to ground and, at rest, does not touch strip *b*. The break-wheel is operated by a clock-spring, which is wound up at intervals. This spring gives it a constant tendency to rotation, but it is prevented from rotating by the engagement of the escapement *E* with the pin *p* on the side of the wheel. The escapement *E* is attached to the armature lever *L* of the release magnet, as shown. When the release magnet is magnetized by the closing of its circuit at any point, the escapement *E* slips away from *p*, upon which the break-wheel is permitted to make one revolution, when it is held by the engagement of the other prong of *E* with another pin on the obverse side of the break-wheel. In making this revolution, the notches in the periphery of the break-wheel have come under the ends of the strips *a*, *c*. *c* falls first into the first notch, thereby separating *c* from *b* and opening the metallic circuit, which, by opening the buzzer relay in the central office operates the buzzer therein. Presently *c* rides again on the periphery of *bw*, closing the metallic circuit, and the next instant the strip *a* falls into the same notch, thereby making contact with *b* and placing its "ground" on the metallic circuit, with the result that the "ground" relay in *co* is closed by the ground battery *B'*, and the register *G* is operated. The next instant again, the strip *a* rises out of that notch thereby removing the ground, and then strip *c* falls into the next notch, again opening the metallic circuit by separating *b* *c*, as before. This opening is quickly followed, also as before, by a grounding of the circuit, and with a similar result, and these actions are repeated until the last notch has passed both of the strips. The number of notches on the periphery constitutes the "number" of the protected building. It is thus seen that, normally, at each alarm, or at each revolution of the break-wheel, two sets of, or "duplex" signals, are transmitted; one by the opening and the other by the grounding of the metallic circuit. When, however, it happens that the metallic circuit is broken at any point, it is obvious that the signal will only come in on the "ground" relay. In practice, it may be added, the main battery for the operation of the circuit is placed, in sections, at different points of the metallic circuit, in the protected buildings, and the ground battery *B'* in the central office is dispensed with; since by this distribution of the main battery throughout the circuit it is clear that it will not matter which side of a building the wire may be open; there will still be battery between the ground in that building and the ground relay in the central office with which to operate that relay at such times.

The release magnet will be closed if any of the doors or windows are opened after they have been set for an alarm. It will also be operated if an attempt should be made to short-circuit the wires of the building, as at *H*, *co*. This is due to the arrangement of the local circuits around the safety magnet *sm*, which is also in the metallic circuit. The coils of its magnets are so wound that, ordinarily, the small battery *B'* will hold the finely balanced armature lever *x* away from the contact

point *n*, but when the metallic circuit is short-circuited as stated, the division of the current that then takes place in the coils overcomes this balance and closes the local circuit of release magnet *RM*, thereby permitting the break-wheel to transmit the box number. Of course, the presence of the short-circuit at *H* would prevent the transmission of signals by the openings of the circuit at *b*, *c*, but the "ground" signals would be transmitted as before.

The operation of the "testometer," *T* in Fig. 294, may now be considered. It consists of a circular base, on which are placed small metal buttons *d*, *d*, etc. A handle *h*, pivoted at *x'*, may be passed over these buttons consecutively. As it passes from one disc to the next it opens the testometer circuit, in which one testometer magnet *TM* in *BP*, is indicated. The effect of these openings at *BP* is that the escapement *PE* is operated and the disc *D* is rotated. The lower armature *l* of *TM* is not, however, operated, although subjected to the same electrical action as lever *L*, partly because of an attachment, consisting of a vertical rod *r*, which, at its upper end, is normally in contact with the periphery of *D*; partly by its greater weight. When, however, the notch on *D* comes opposite the rod *r*, and if it is then desired to lift armature *l*, a stronger battery is put on the circuit in *CO*, and the lever rises into the notch the next time the testometer circuit is closed, and, in consequence, the local circuit of the release magnet *RM* is closed at *n'*, with the result that the box number is transmitted as before. Since then, as stated, the notch on each disc is at a relatively different position to that of every other disc, and, also, as the notch on each disc bears a certain relation to one of the flat buttons on the testometer in the central office, it is readily seen that an alarm, or signal may be brought in from any desired building.

In *BP* certain metal segments marked 1, 2, 3, 4 are shown. These form ordinary apertures for the insertion of "pin" plugs. They are contained in a small box located outside of the building. By their aid several functions can be performed. The 3-point switch *N* in *BP* is supposed to be turned to the left by the proper persons, on closing up the building for the night. Until this is done the door contact *F*, which is depressed as a signal for the closing of the building will not be operative. Hence in the absence of this signal, an inspector is sent to investigate the cause. He thereupon inserts a pin plug in aperture 1, which, it will be seen, closes the house circuit around the points of the switch.

By inserting a plug in 4, a pocket telephone, with condenser attachment, is connected to the metallic circuit, and, by its means, the central office may be communicated with. When it is desired to know the condition of the "safety" magnet, a pin plug, inserted by the inspector at 2, will elicit that information. A pin placed in 3 will test the condition of the door and window contacts.

BURGLAR ALARM AND DISTRICT MESSENGER CALL BOX COMBINATION.

Sometimes it is desired to utilize existing "district" service call boxes and the wires connected therewith, as burglar alarm circuits.

One of the methods employed in this combination, known as the "Fix" box, is shown in Fig. 295.

FIG. 295.

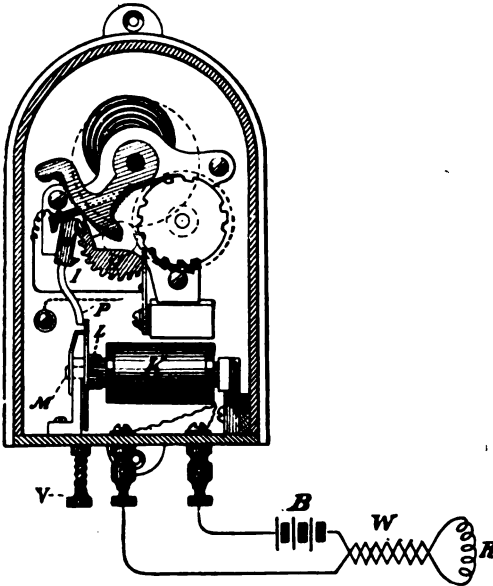

COMBINATION "CALL" AND BURGLAR ALARM BOX.

then sends in the "number" of the box to the central office; it being understood that the box signaling apparatus had been previously wound in the usual manner, by means of the crank lever *J*, seen in Fig. 295*a*, and that the pallet had then been set by pushing up the rod *v*. This rod, coming into contact with the pin *T*, which projects from the plate *N*, Fig. 295*a*, had turned that plate into the position shown in that figure.

The burglar alarm circuit in the building to be protected may consist of wires *w*, Fig. 295, arranged in the manner described in the first part of this chapter. The joining of those wires will short-circuit the resistance *R*, thus, by means of a suitable battery *B*, placed in the building, attracting the armature and releasing the pallet *P* in the way already described.

In some instances the current necessary to operate the magnet *K* is derived from a "shunt" taken from the main circuit, thereby dispensing with the necessity for a battery in the protected building, but the plan just described is considered more generally effective.

THE DOUBLE BALANCED RELAY.

Another arrangement for indicating any change in the condition of a burglar

The upper part of the box contains the usual signaling apparatus of a call box used in the district service. The burglar alarm attachment is seen in the bottom of the box. It consists of an electro-magnet *K*, having a peculiar armature *L* which moves on a pivot *M*, sideways, to and from the core of the magnet. This armature carries a flat metal plate *N* (shown more clearly in Fig. 295*a*), which plate has a notch on its upper portion. The pallet, or anchor *I*, which regulates the escapement, is provided with an extension *P*, which reaches down to the upper portion of the plate *N*. When the armature and, consequently, this plate, is in the position shown in Figs. 295, and 295*a*, the pallet *I* is held against the wheel *H*, preventing its motion. When the armature *L* is attracted and turns on its pivot, the notch is brought opposite the extension *P*, which, falling therein, thereby releases the signaling machinery, which

FIG. 295 a.

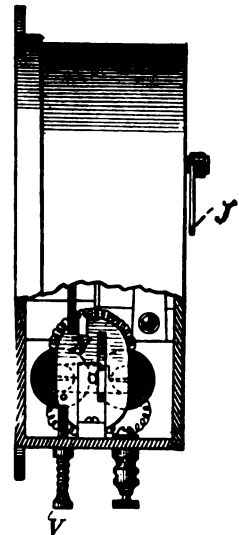

alarm circuit, known as a "double balanced" relay, is shown diagrammatically in Fig. 206. This instrument performs a practically similar office to that of the galvanometer,

FIG. 206.

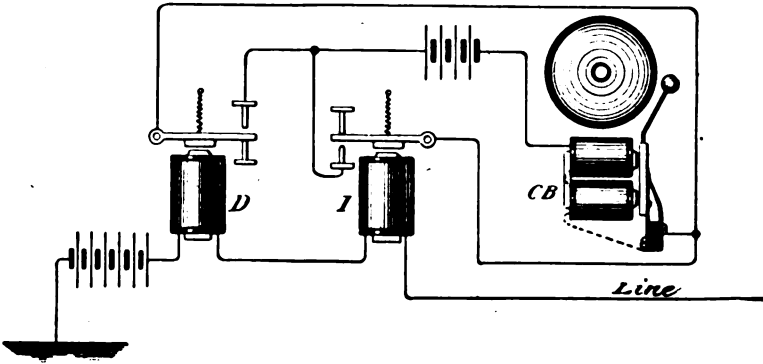

DOUBLE-BALANCED RELAY THEORY.

Fig. 293. The arrangement consists of two relays located in a central office of a "Protective" company. The main circuit is passed through each of these relays,

FIG. 298.

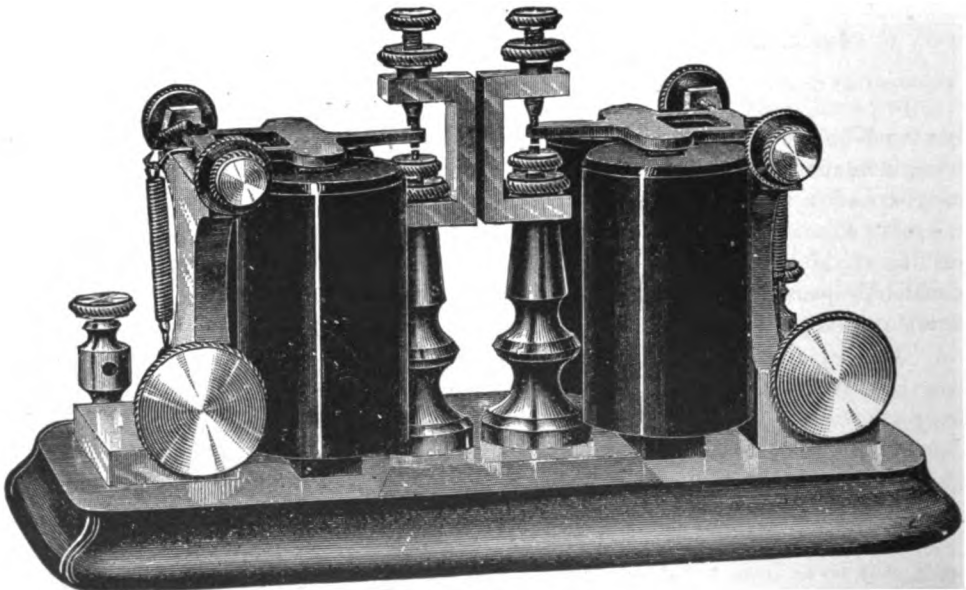

DOUBLE-BALANCED RELAY.

which are wound to about 150 ohms each. One relay, D, is so adjusted that the slightest decrease in the current will permit its armature to be withdrawn; the other I, is so adjusted that the least increase in the current will cause it to attract its arma-

ture. In the case of *D* the contact points are so arranged that the rising of its armature will close the circuit of an annunciator, or alarm bell, *CB*. The contact points of *I* are so arranged that the lowering of its armature will close the annunciator.

This arrangement makes it impossible to either "open" or "ground" the "protecting" circuit in the protected building, or elsewhere, without operating the alarm. In practice the relays are placed, for convenience, on one base, as shown in Fig. 297.

The connections in the protected store or dwelling may be the same as those already described.

CHAPTER XXVII.

PRINTING TELEGRAPHY.

THEORY "STEP BY STEP" SYSTEMS—NEWS TICKERS, ETC.

Printing telegraphy relates to those telegraph systems in which telegrams, etc. are "printed" as received.

Generally speaking, such systems depend, primarily, for success upon the uniformity of revolution of a cylinder or wheel at a transmitting station, with a type-wheel at a receiving station, virtually as in the instances of telegraph systems referred to in the Introduction.

FIG. 298.

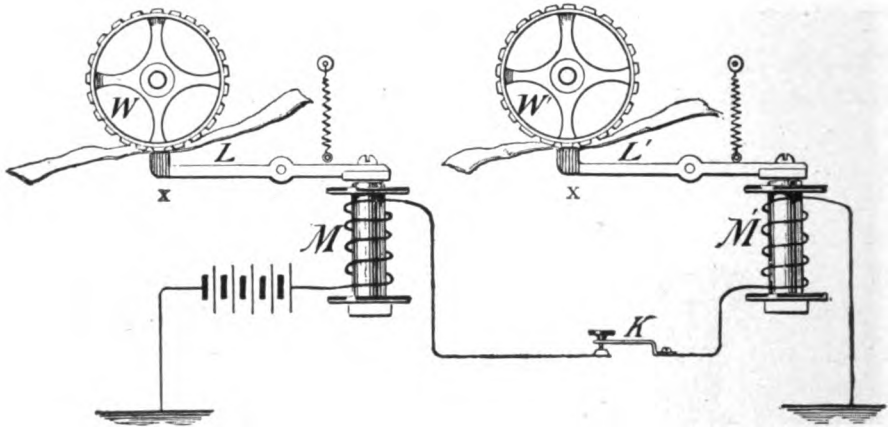

"STEP BY STEP" PRINTING TELEGRAPH—THEORY.

If, for example, two wheels of equal size, having on their peripheries "type" letters of the alphabet, are put side by side, and means are devised to cause them to rotate at equal rates of speed, it is evident that, if they start rotating, simultaneously, with a given letter at a given point, as long as the wheels rotate at equal rates of speed, each wheel will present a similar letter at the given point.

For instance, referring to Fig. 298. Suppose that below the wheels w w' are placed the electro-magnets m , m' , with armatures and levers L , L' and paper tape passing between the wheels and lever. Assuming the wheels w , w' to have been set in rotation with, in each case, the letter A opposite a given point x . In that case a similar letter on each wheel will always be opposite x , and if the wheels are suddenly stopped, and, at the same time, the circuit of the magnets m m' be closed, their armatures, will be attracted, and the upper end of the levers L L' will strike against the paper, impressing whatever letter may be opposite thereto. It will also be apparent that, in a similar manner, a dozen or more type-wheels of the same kind, similarly equipped with electro-magnets,

all in one circuit, might be caused to rotate synchronously, and, at a given time, suddenly stopped and a given and similar letter be printed by each type-wheel. It is, however, a difficult matter to obtain a synchronous movement of two or more such wheels, especially when rotating at a high rate of speed, unless their rate of rotation is under control of some "master" wheel or transmitter. Consequently, in electrical printing telegraphy, devices have to be resorted to which place the control of the type-wheels at the various stations, practically under control of a "sending" transmitter.

In printing telegraph systems such as are used in the transmission of stock quotations, general news items, etc., and which are generally known as "ticker" systems, the type-wheel of the tickers in the various offices are placed under control of a transmitter which maintains them in synchronism by a "step by step" movement, so called. In some other printing telegraph systems, such as the Phelps Long Distance, or "Motor," printing telegraph, the synchronous rotation of the transmitting and receiving wheels is maintained by a nearly synchronous rotation of the motors at each end of the circuit, and in addition by a "correcting" device, (operated, primarily, by the transmitter,) applied to the type-wheel.

The "step by step" movement is produced by a transmitter which sends out pulsating currents, generally of alternate polarity, and apparatus responsive thereto. The pulsations thus originated cause the armature of a polarized relay to oscillate from side to side. As it does so it operates an escapement which, in turn, permits an escape-wheel to rotate one "step" for each oscillation; in other words, one half tooth for each alternate pulsation from the transmitter. The transmitting apparatus being under the control of an operator, a desired number of pulsations may be sent out. If, then, there should, for example, be 13 teeth on the escapement wheel, 26 pulsations would permit it to perform one complete revolution, the revolution being made "step by step."

In practice a type-wheel having 26 or more letters on its periphery is placed on the same shaft as the escape wheel. If it should be started with, say, the letter A opposite a given point, it would be an easy matter to bring, say, the letter D, opposite that point by the transmission of 3 pulsations, by the transmitter. In the same way any other letter on the type-wheel could be brought to the same point by the transmission of the requisite number of pulsations. Ordinarily there are twice as many characters on type-wheel as teeth on escape-wheel.

In "step by step" ticker systems the transmitter is designed to send out, automatically, the requisite number of pulsations to bring any desired letter, on a distant type-wheel, opposite a given point, by the depression of a corresponding key of a keyboard at the transmitting station. A theoretical diagram of a simple step by step printing telegraph system is given in Fig. 299.

Several of the "ticker" systems now in use, for example, the Kiernan "news" ticker, is operated on, virtually, the principle embodied in that figure, excepting that the characters on the type-wheels and on the key-boards employed in the latter system are much more numerous than shown in the figure; in some cases as many as 50 such characters being employed, these characters being composed of letters, figures and fractions. This large number of characters, as will be obvious later, tends, however, to diminish the speed of transmission.

The transmitting apparatus of this system consists of a long cylinder τ Fig 299, resting on suitable bearings to permit rapid rotation. On the left end of the cylinder

shaft a metal segmental wheel *w* is mounted. At the right end of the same shaft there is an electric motor *M*, the shaft of which is connected by friction bearings to the cylinder shaft. This motor drives the cylinder. The object of the friction bearings is

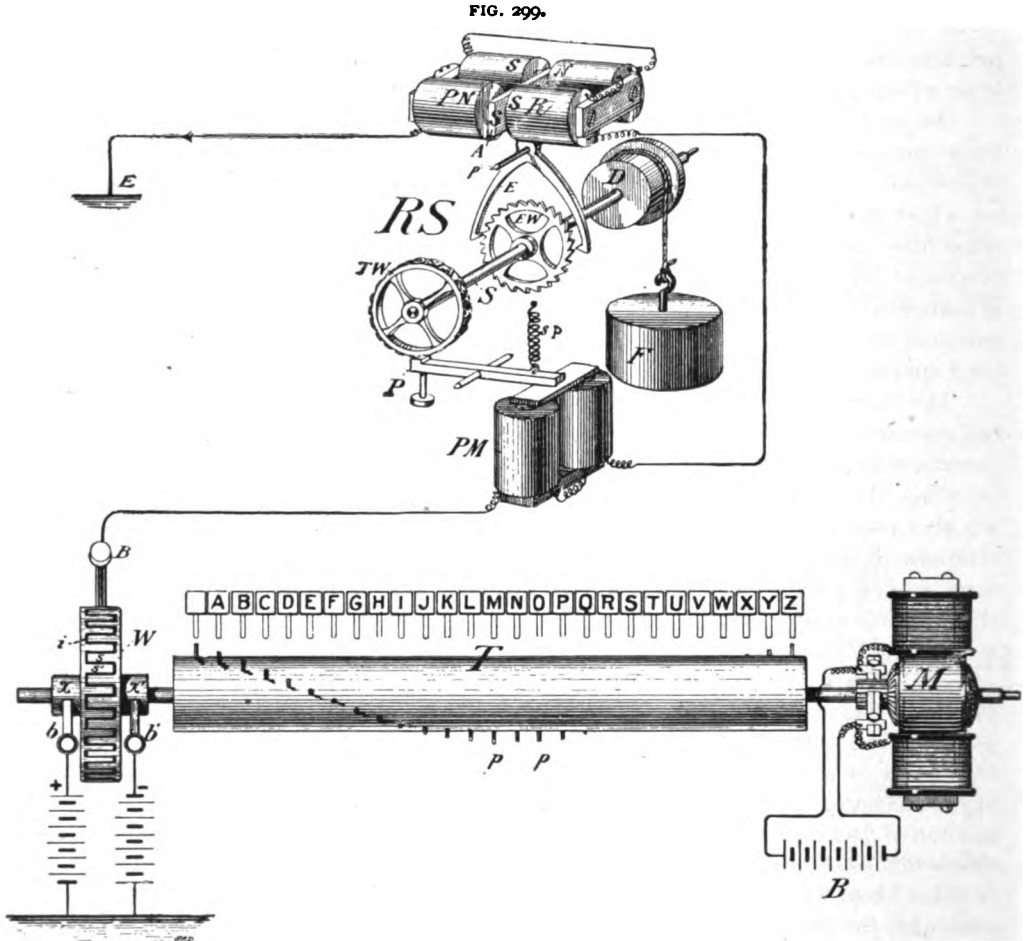

SIMPLE "STEP BY STEP" PRINTING TELEGRAPH.

to make it feasible to instantly stop the rotation of the cylinder without stopping the motor. The friction is so adjusted that, while, when the cylinder is rigidly held the motor may continue to rotate, the moment the cylinder is released the bearings insure the immediate starting (at, practically, its normal rate of rotation,) of the cylinder. A centrifugal governor, not shown, attached to the motor shaft maintains its speed at a uniform rate. The motor is driven by a strong primary battery *B*. Any other suitable form of motor could, of course, be used.

The cylinder *T* carries a set of blunt pins, or spurs, *p, p*, etc., projecting, spirally, from its surface. A key-board is placed above the cylinder with the keys directly over the pins, as indicated by the lettered discs. The pins project from the cylinder

at regular intervals from one another. There are as many pins as there are characters on the key-board. The keys are depressible and are provided with a catch, or spur, on their under sides. The cylinder is so placed with regard to the key-board that when any particular key is depressed, the projection under that key gets into the path of a certain pin on the cylinder, as it revolves, thereby instantly arresting the cylinder, at a given point in its revolution.

The wheel *w* may be made in a number of different ways. The one shown in Fig. 299 is divided in two portions, (each separated from the other, as at *s*, *s'*;) by a zig-zag strip of insulating material *i*. The portion on the right is electrically connected with the hub *x'*; that on the left with hub *x*. *x* and *x'* are also insulated from each other. A metal brush *b* rests on *x*; a similar brush *b'* on *x'*. *b* is connected, as shown, to a positive pole of a battery; *b'* to the negative pole of a battery. A brush *B* rests on the periphery of the wheel *w*. The brush is so placed that, as the wheel revolves, it only touches one portion of the wheel at a time. *B* is connected with the line circuit. Each half section of *w* may be supposed to have, say, 13 segments, making in all on the periphery, 26 segments.

As the wheel *w* is rotated one segment after another passes under the brush *B*. Since by this act the brush *B* is placed in connection first with, say, a positive pole of a battery and next with a negative pole of a battery, or vice versa, it must follow that, while the wheel is revolving, currents of alternate polarity will pass to the line, and, on the other hand, when the wheel ceases to rotate, a continuous current will pass to the line; the polarity of which will depend on which metal section of *w* the brush *B* comes to rest upon.

As the wheel *w* is caused to revolve at a high rate of speed, the pulsations must necessarily be very rapid, since for every revolution of the wheel, or the cylinder, there will be 26 electrical pulsations over the line.

The receiving apparatus, or "ticker" proper, *RS*, consists of a polarized relay *P R*; "press" magnet *PM*, which is an ordinary electro-magnet; a type-wheel *rw*, and an escape wheel *ew*, on the same shaft, *s*. A drum *D*, by means of a weight *F*, and intermediate gearing, omitted in figure, tends to rotate the shaft. The rotation of the shaft is regulated by the pallet, or escapement, *E*. The escapement itself is connected rigidly with an extension carrying the armature *A* of the polarized relay, and is pivoted at *P*. The relays *PM* and *PR* are in the same circuit, as shown. Each relay is, consequently, subjected to every pulsation of current passing on the wire. These pulsations are sufficient to oscillate rapidly the armature of the polarized relay, in consequence of which the pallet *E* permits a rapid rotation of the escape wheel and the type-wheel.

As the polarized relay *P R* shown in Fig. 299, differs in form from those which have previously been shown in this work a few words of explanation concerning it may be of use. The armature *A* is permanently magnetized. Hence, it will have a north and south pole. *P* and *R* are ordinary electro-magnets, set with the ends of the cores facing each other, in the manner shown. Each magnet is so connected that a current of either polarity will make the poles facing each other of opposite magnetism, as indicated by the letters *N S*, *S N*. These poles, of course, change with each change in the direction of the current. As, however, the magnetic polarity of the armature

remains constant, it will be attracted from one side to the other with every alternate pulsation. By this arrangement a strong movement of the escapement is secured.

It has been assumed that the wheel *w* of the transmitter sends out 26 electrical pulsations in one revolution. Consequently, one revolution of that wheel will cause 26 oscillations of the armature of the polarized relay; in short, it will cause one revolution of the type-wheel. Hence, if the transmitter be put in motion with the brush *B* resting on the segment which is in line with the space on the cylinder directly under key *A*, while the letter *A* on the type-wheel is opposite the platen *P*, on the end of the lever of the press-magnet *PM*, it will follow that, for every revolution, or part of a revolution, the transmitter may next make, just enough pulsations will be sent out to permit the type-wheel to make an equal number of revolutions or parts of revolutions, and thus, whatever key may be depressed, the type-wheel will present a corresponding letter to the platen *P*.

As the press-magnet is in the same circuit as the polarized relay, it might be expected that it also would be responsive to the pulsations sent over the line, in which case it is evident that the platen would be continually impinging against the paper tape. This, however, does not occur, the armature of the press-magnet remaining open and passive during the continuance of the rapid pulsations. This is due to the greater inertia of the armature lever of the press-magnet, held back as it is by the strong retractile spring *s*, and also to the fact that the strength of the current is more or less diminished by an increased resistance, at the points of contact of the brushes with the segment wheel, during its rapid rotations. As soon, however, as the pulsations cease, a stronger current passes to the line and the armature of the press-magnet is attracted, causing the printing of the desired letter, in the manner already indicated.

It is, of course, essential to the success of such systems that the letters on the type-wheel should always be in a certain given position relative to the pins on the transmitter. When such is not the case, misprints of letters follow. This action is termed "throwing out." This may be caused by the sticking of the escapement wheel; a momentary interruption of the line wire, etc.

When printing telegraphy, or rather, "tickers," were first introduced, this defect was remedied as often as it occurred, by despatching an inspector to "set" the instrument in the various offices. Subsequently, an ingenious device for automatically bringing the instruments on a circuit to a "unison" point was invented by Mr. H. Van Hoevenbergh.

Devices of this kind, termed "unison" devices, are now quite numerous. In general they consist of mechanism which, when permitted to do so, throws a pin or brake in the path of a pin on the shaft of the type-wheels, in practically the same manner as the catch on the self-starting and stopping Morse register is brought into the path of the pin on the shaft of the fly-wheel. The pin is placed at a point on each "ticker" shaft which brings the type-wheel to a stop with the dot, or unison, type opposite the platen of the printing lever. The unison mechanism is not, as a rule, permitted to get into the path of the shaft pin until the type-wheel has made two or three continuous revolutions.

Descriptions of "unison" devices employed in different ticker and other printing telegraph systems will be given subsequently.

As premised, the foregoing remarks concern the simplest form of a printing tele-

graph system. It would be known in practise as a "single," or "one," wire and "single" type-wheel system, in contradistinction to systems in which two wires and two type-wheels are used.

In stock quotations the use of figures is very frequent. Therefore, unless figures, as well as letters, were placed on the periphery of the type-wheels, it would be necessary to spell out the figures, which would be productive of slow working. When, on the contrary, the figures and fractions, as well as letters, are placed on a type-wheel, it adds many characters to the type-wheel and much reduces the rate of speed at which quotations, etc., can be sent, owing to the increased length of the circumference of the wheel.

To avoid the delay which accompanies the spelling out of the figures, without at the same time reducing the speed of transmission by an increased circumference, a figure wheel is, in many systems, placed side by side with a letter-wheel, and means are provided for printing from either the letter or the figure-wheel, at will. The manner in which this is accomplished varies with nearly every system. In some it is done by moving the type-wheels on the shaft so that either wheel desired comes over the platen, or printing pad, on the press lever. In others the platen is moved from below one wheel to the other, as required. In some systems, again, the platen is mechanically actuated; the result of an electrical impulse. In others a separate wire is provided to effect the result. The apparatus or wire employed for this purpose is termed the "shifting" mechanism, or wire.

While it is feasible to operate a two wheel ticker system on one wire, and many such systems are in successful operation, it has been found that when a large number of magnets are placed in the circuit the speed of transmission is diminished, which fact has led, in many instances, where fast working is necessary, to the use of a separate wire for the press-magnets.

GOLD AND STOCK TICKER SYSTEM.

The ticker system which is used by the Gold and Stock Company in New York, and in other cities, for the transmission of stock quotations, employs in its operation two type-wheels and two wires, one of which latter is used to effect the rotation of the type-wheel shaft and to effect the printing of the characters; the other wire is used to effect the "shifting" of a pad from below one type-wheel to the other type-wheel as required.

The transmitting or central office apparatus of this system is outlined in Fig. 300. The transmitting apparatus τ is quite different, as to details, from that shown in Fig. 298, but, in principle, it is practically the same. It consists of the motor bevelled wheels w, w' ; cylinder c ; reversing brushes b, b , etc.; shaft s with arm r ; a circle of magnets mc ; a key-board kb ; a "shift" relay sr , etc. The cylinder c , rigidly mounted on the shaft s , is formed of hard rubber, around the surface of which, flat strips of metal m, m , etc., are placed. Above these strips are placed the brushes b, b^2 , etc., which touch the strips in pairs, as shown. The brushes are attached firmly to the metal supports B, B^2 ; B^5, B^6 . Brushes b^1, b^2 , are connected to B . b^3 is insulated from B_2 , as indicated by the

black right angle; b^5 is similarly insulated from B^5 ; b^4 is connected to B^2 , while b^6 is connected to B^5 ; and b^7, b^8 are both connected to B^6 . Brushes b^4 and b^5 are connected together by a wire; brush b^3 and brush b^6 are similarly connected (via support B^5).

The poles of a battery, or dynamo machine, D , are connected to B^2 and B^5 , respectively. The terminals of a type-wheel-press circuit are connected to B and B^0 .

The eight brushes, with the strips $m m$, etc., on the cylinder, constitute the pole-changing, or current reversing, apparatus of a type-wheel-press circuit. In practice as many as 12 circuits are arranged for on one cylinder. The brushes for but 2 circuits are shown in Fig. 300.

The brushes b^1, b^3, b^5 and b^7 are, it will be seen, placed in advance of brushes b^2, b^4, b^6 and b^8 , on the cylinder, assuming it to rotate in the direction of the arrow. The strips $m m$, etc., are so placed that the long brushes shall always be on their respective strips, together. The short brushes are, likewise, arranged to be at one time on their respective strips. When the long brushes are on the metal strips the short ones are on the insulated portion of the cylinder, and vice versa. As indicated in the figure, the current through the press-circuit is, with the long brushes on the metal strips, in the direction outlined by the arrows. With the short brushes on the metal strips it will be found, on examination, that the current traversing the circuit will be in the opposite direction. Hence, as the cylinder is rotated, currents of alternate polarity are sent over each circuit connected with the metal strips on its surface, and it will likewise follow that all the "tickers" in the respective circuits, being actuated by currents of similar periodicity, will rotate in synchronism.

This system, so far as the rotation of the type-wheels and the printing of impressions are concerned, is practically similar to the single wire system previously described. That is, the rapid alternate reversals of polarity on the circuit operate the type-wheels, and the prolonged current, when the reversals are stopped, actuates the press-magnet, which is too "blunt" to respond to the quick reversals. The cylinders are geared to run at the rate of about 150 revolutions, per minute.

The cylinder shaft carries, loosely, on its left end, the bevelled wheel w . On each side of w , friction pads, or plates, r are caused to press, by suitable springs. Another bevelled wheel w' , gears with w . The shaft s' is driven by steam or electric motors, and is the means whereby cylinder c is driven. It is plain that as many cylinders as may be necessary could be similarly geared with wheels carried on shaft s' and when this is done, as it is in practice, all of the cylinders of the different circuits will be operated in unison.

It is apparent that in this system the method of stopping the reversals must be different from that described in the case of the single wire system, inasmuch as the radially projecting pins from the cylinder, shown in Fig. 299, are here dispersed with; and also as the key-board is removed from above the cylinder.

In place of the pins on the cylinder the device outlined at the right end of the cylinder c , Fig. 300, is employed. This consists of a series of 36 electro-magnets mc , arranged in a ring and termed the "magnetic circle." Each magnet is provided with a movable core, one end of which is normally kept a short distance out of the coil, or solenoid, by a stout spring s' , as shown at the right end of the magnets. The shaft

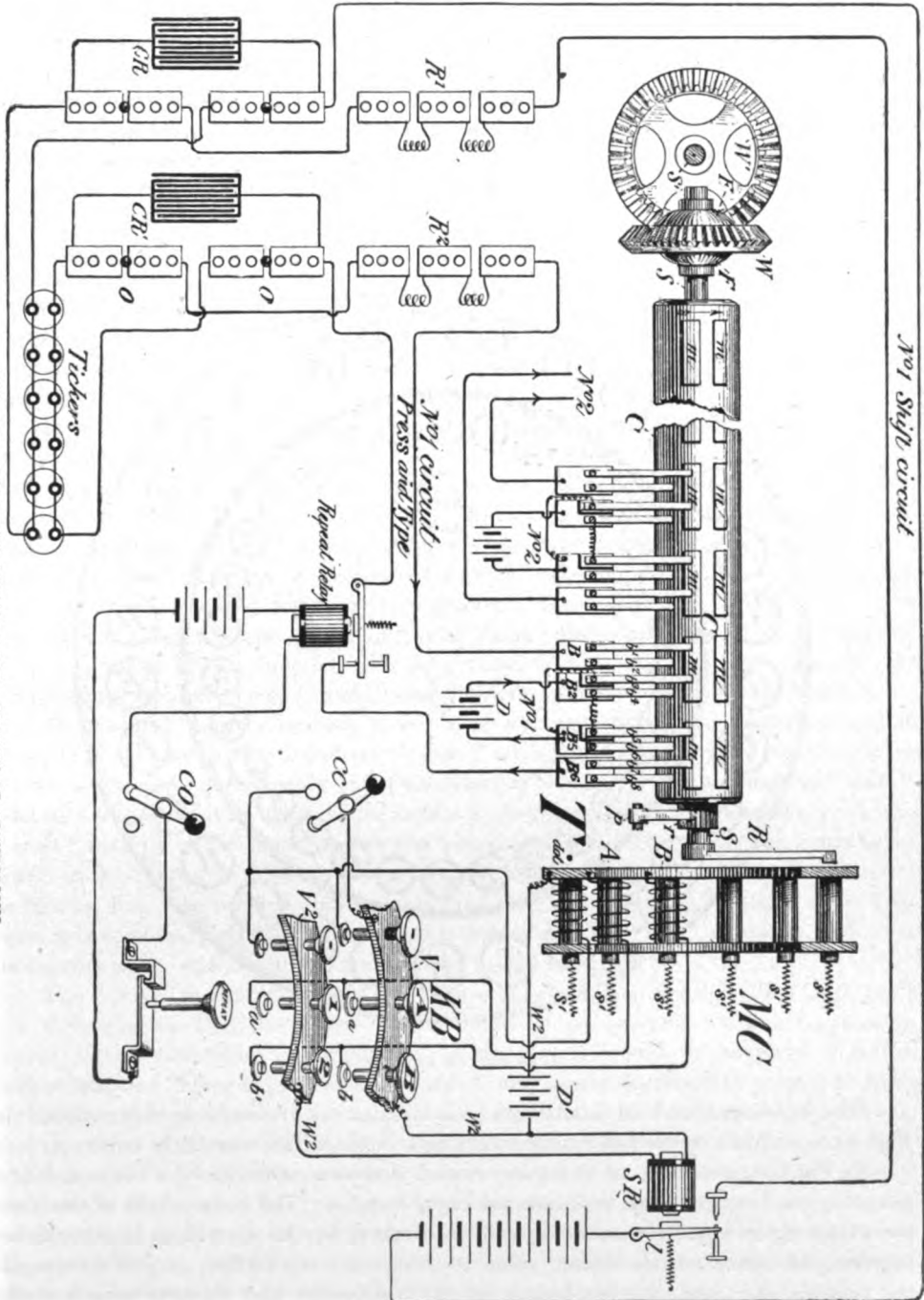
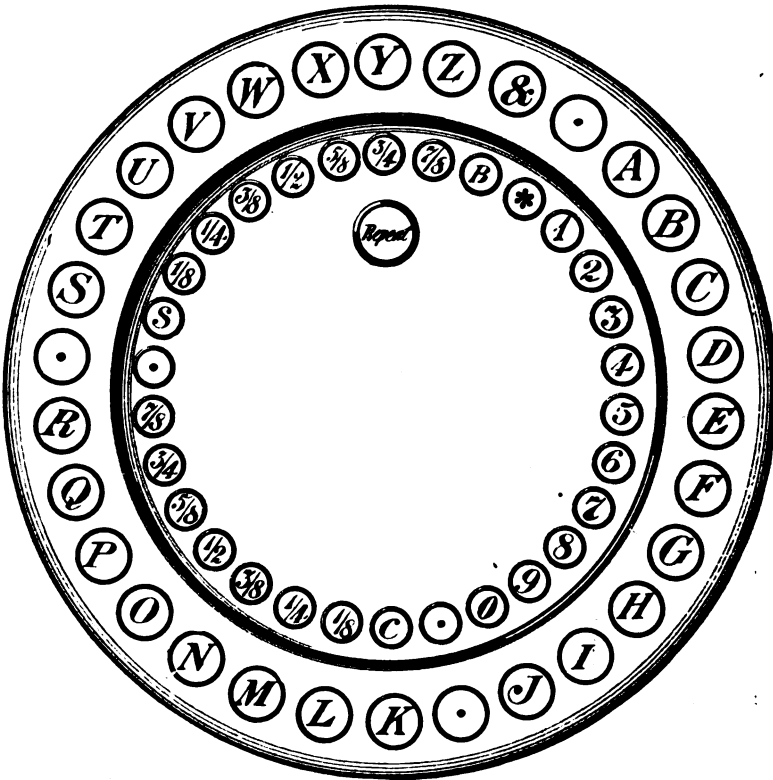

FIG. 300.—GOLD AND STOCK TICKER—THEORY OF CONNECTIONS.

s of the cylinder carries, in proximity to the magnetic circle, an arm *R*, the end of which revolves close to the left ends of the electro-magnets in such a way that when any one of the coils is charged with a current, and, consequently, draws in its iron core, against the pull of spring *s'*, an extension of the core, which is thereby caused to protrude from the left end of the coil, gets into the path of the arm *R*, arresting the motion of the cylinder, but, of course, not stopping the motion of the bevelled wheel *w*, which continues its motion against the pressure of the friction pads.*

FIG. 301.



TRANSMITTER KEY BOARD.

The key-board used in this system is a circular one (resembling that outlined in Fig. 301), with the figure and fraction keys in a circle within the letter keys.

In Fig. 300, a section, *KB* of the key-board, is shown; with the "dot" key, and keys *A B*; also the "repeat" key, and numeral keys, 1 and 2. The frame-works of the letter and of the figure keys are insulated from each other. In this system, as in other ticker systems, the tickers of the circuit come to "unison" with a dot, or period, opposite the printing pad; and the key-boards of the transmitter, and the type-wheels of the tickers are so arranged that corresponding letters on each follow in a certain order.

* The present practice (1899) is to employ a cylinder with spirally projecting pins; the magnetic circle being dispensed with. Electro-magnets operated by the keyboard are arranged over the cylinder in such a way as to throw an armature in the path of one of the pins, thereby stopping the cylinder at a given point. Relays are then employed to control the various circuits analogously to the manner shown in Fig. 300.

Thus, for instance, in Fig. 300, as the keys A B on the key-board follow the "dot" key, the letters A B will follow the "dot" on the letter type-wheel, of the ticker.

In Fig. 300, one terminal of the coil of each magnet in MC is connected to the frame-work supporting the circle, and that frame-work is connected, by a wire w^2 , with the frame-work V of the letter keys, and with a battery D' in the same wire. Wire w^2 is also connected to the frame v^2 , of the figure keys, via a relay SR. The other terminal of the coil of each magnet in MC is separately connected by a wire with a contact point a, b , etc., under each key. Consequently, when a letter key, for instance, A, is depressed, it completes a circuit through magnet A. This magnetizes that magnet, thereby causing the interposition of its core in the path of arm R and stopping the cylinder and, consequently, the type-wheels, with the letter A in readiness to be printed. In the same way, if the dot key, or any other key, be depressed, the magnet connected with that key will interpose its core in the path of the arm, stopping the cylinder at the proper point.

It will be seen that the contact points under the "figure" keys are connected with the contact point under some particular letter. For example, numeral 1 is connected with that of letter A, numeral 2 with B, and so on. It will be seen further that, when any of the *letter* keys may be depressed, it will complete a circuit including battery D' and its respective magnet, but will not include the relay SR; while, on the other hand, none of the *figure* keys can be depressed without including that relay, as well as the magnet in the circle with which it is connected. For instance, if "figure" key 1 be depressed it closes a circuit containing relay SR and circle magnet A. Relay SR is the "shift" relay. The function of this relay is to close an electro-magnet, by means of its armature lever L, in the "shift" circuit which runs through each ticker.

The "shift" magnet in each ticker is so arranged that when the shift circuit is open, as is the case, normally, when "letters" are being transmitted, its armature lever moves the printing pad directly under the letter type-wheel; while, when the "shift" circuit is closed, as it is when figure keys are depressed, the armature lever of the "shift" magnet in the ticker moves the printing pad directly under the figure type-wheel in the "ticker." The advantage of this device is that the shifting from letters to figures, and vice versa, is done automatically at the key-board, while in other systems it is customary, first, to bring all the type-wheels to "dot," or unison, and then to depress a key which actuates the shifting mechanism.

The "shift" magnet in the ticker will presently be shown and described (Fig. 302.)

Referring to Fig. 300 again. It is frequently necessary in "ticker" service to repeat letters and figures. Ordinarily, to do this, it would be required that the proper letter or figure key, should be raised and again depressed to permit another revolution of type-wheel to bring it back to the same letter. In practice, however, this repetition of figures or letters is generally done by means of a "repeat" key, which controls a relay whose armature lever is included in the circuit. Such a relay is shown, in Fig. 300, in the "press and type" circuit. In this system, as has been said, the impression on the paper tape is made by the attraction of the press magnet when the rapid alternations have ceased. Consequently, until the rapid alternations of current are again started, the "press" lever remains up against the pad. When then the repeat key is depressed and released at the key-board, it opens the "repeat relay,

thereby opening the "press and type" circuit, momentarily, which allows the press-magnet in the ticker to open and close, whereby the armature lever falls and rises, and as, in doing so, it also actuates the paper "feed" mechanism, the particular letter is repeated once or twice, as the case may be. When it is desired to hold the tickers idle,

FIG. 302.

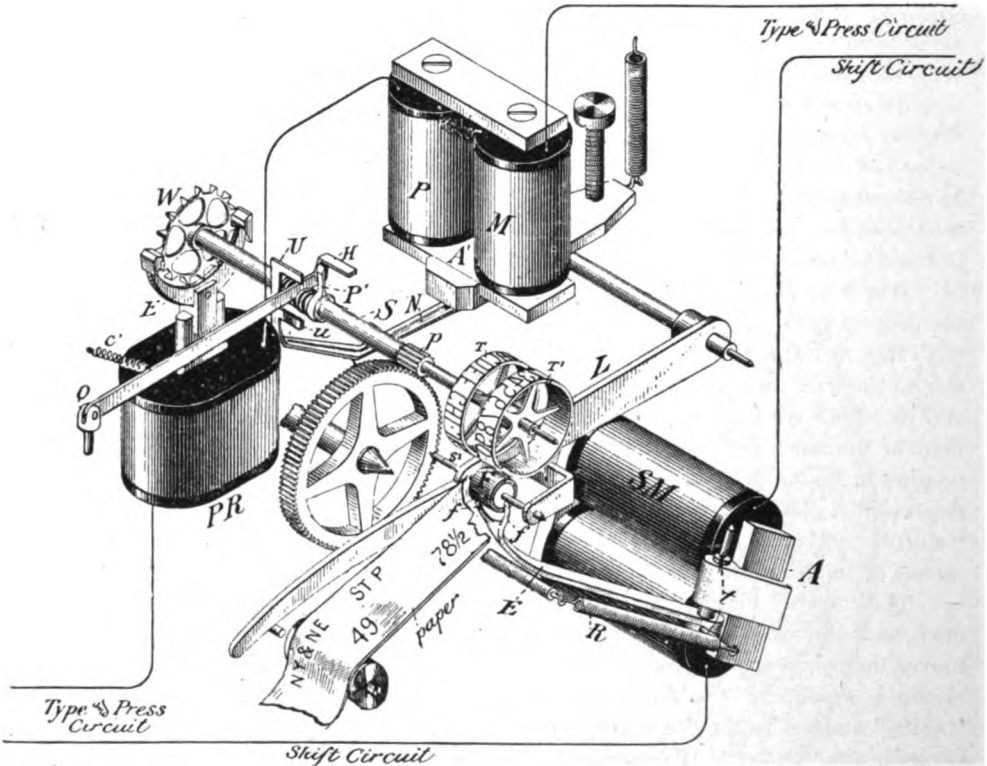

GOLD AND STOCK TICKER.

and at unison for a time, as when there is a lull in the market, the circuit closer *cc* around the dot key, may be closed, and the circuit opener *co* in the "repeat" key circuit opened, which will have the desired result.

By means of the bevelled gearing on shaft *s'*, in the central office, which insures a synchronous rotation of all the type-wheels in as many separate circuits as may be desired, and owing to the fact that coils of as many magnetic circles as there are cylinders employed may readily be connected in the local circuits controlled by the respective letter and figure keys, and also owing to the readiness with which shift relays for each circuit may be placed in circuit with *sr*, it will be seen that one operator with one key-board may control all the circuits emanating from a central office.

In the practice of this system dynamo machines are used in the central office as the source of electromotive force necessary. These are connected to the circuits in the usual manner, and resistances and fuses, not necessary to be shown in the figure, are employed.

Where many "ticker" circuits are thus operated simultaneously, some of them will vary as to length, number of instruments in operation, etc. It is found desirable, in order to obtain the best results, to bring about an equality between all of the circuits, as regards resistance, lag, etc., and in some offices a "standard" instrument is placed consecutively in each circuit at the morning test, when the resistance of the circuit is varied until the standard instruments respond in prescribed manner.

Adjustable resistances, as at $R^1 R^2$, are placed in each circuit to facilitate any desired change in that respect.

To avoid sparking at the transmitter, (which has always been more or less of a preventive of high speed in printing telegraphy), condensers are very usefully employed in different parts of ticker systems; as at $CR CR^1$, Fig. 300. A pawl p and ratchet r on the shaft of cylinder c are employed to prevent backward motion of the cylinder. The circuits may be opened at o , o , by the removal of plugs.

It may be noted that the circuits are operated in metallic circuit, as shown, it having been found preferable so to "work" them.

Duplicate, or spare cylinders and dynamos are at hand in the central office, and means are provided for quickly transposing from a regular to a spare set of apparatus in case of necessity.

SCOTT TWO WIRE TICKER—The Gold and Stock, or Scott, two wire "ticker," is shown in outline in Fig. 302.

PR is the type-wheel relay which is furnished with an escapement anchor E of the style shown. This escapement controls the escape wheel w , and, consequently, the shaft s and type-wheels T, T' , in the usual way.

The shaft s is given a tendency to rotate by a weight and train of gearing connected with pinion p . PM is the press magnet whose armature actuates the long printing lever L . The relays PR and PM are in the same circuit. The lever L carries, on its side, in the manner shown, a pad F , which is movable on the small shaft s' . The pad F is held by the fingers ff' of an extension E from the trunnion t of the armature A of the shift-magnet SM . When the shift circuit is open at the central office, as it is when letter keys are depressed, the retractile spring R withdraws the armature A of SM , from its magnet, which action turns the trunnion t of that armature so that the pad F is pushed under the letter type wheel. Thus, when the press lever L is operated, as it is when the rapid pulsatory currents are followed by a continuous current on the "type and press" circuit, and, also, when the repeat key is operated, only the "letter" wheel will make impressions on the paper tape.

When, on the contrary, a figure key is depressed, the shift relay in the central office closes the shift circuit, and, hence, the armature A of SM is attracted, whereupon the fingers on extension E are caused to pull the pad F under the "figure" wheel, and away from the "letter" wheel, so that, when the press lever L is next operated, only figures, fractions or dots, will be printed on the tape.

The unison device of this ticker is shown at u on the shaft s of the type-wheels.

It consists of a spiral groove on the shaft, as indicated; a metal strip H pivoted at o , normally resting in the spiral groove on the shaft; a spring c' , tending to pull this strip against a stop u ; a pin P' projecting from the shaft s , and a rod N connected

with the armature Λ' of the press-magnet PM . The rod N is curved so that it passes under the shaft s , and yet, when the armature Λ' is raised, gives the strip H an upward lift, out of the groove. The operation is as follows: When the shaft s is rotated the spiral groove in the shaft moves the strip H towards the pin P' , and in two or three turns the angular extension on strip H engages with that pin, checking the shaft s at a point where the "dot" characters on each wheel are opposite the printing pad. This, however, does not check the pulsations over the "type and press" circuit; hence, when the dot key at the transmitting station is depressed, (which act causes a continuous current to be sent over the press circuit), the armature of PM , at the same time that it lifts the press lever, also lifts the strip H out of the path of pin P' on the shaft s , permitting the latter to rotate as usual. It will be obvious that when the press-magnet is operated continuously the rod N will continue to lift the strip H out of the groove and permit its spring c' to withdraw it to its stop U before it can be drawn in to the path of pin P' .

The paper feed mechanism is also operated by the press-magnet lever, practically in the manner described in the chapter relative to the New York Quotation Company's ticker (which *see*).

THE PHELPS "STOCK" PRINTER.

This printer may be operated with one or two wires as desired. It employs two type-wheels; also two trains of gearing, one of which is assigned to the turning of an escapement wheel; the other to the turning of shaft s , which, when liberated, causes, in one revolution, the operation of the shifting and printing levers, and the paper feeding device.

An outline drawing of the mechanism of the printing and shifting apparatus of the instrument as arranged for one wire is given in Fig. 303.

In that figure PR is the polarized relay which, actuated by the rapid, alternate electric pulsations set up by the transmitter at the central office, controls the rotation of the type-wheels TW in the usual way. PM is a magnet, which may be termed the "press-magnet," although it does not directly effect the printing. Like the ordinary press-magnet, it is only brought into action at the cessation of the rapid alternate currents. It will be found that the operation of this "printer" is almost entirely mechanical.

The shaft s is given a tendency to rotation by the clock-work gearing alluded to. It is held in check by an arm a , rigidly mounted on that shaft, as long as the spring lever H stands in the path of a . H is kept in that path by the flat spring s' . When, however, the armature lever Λ of PM is attracted by a continuous, or prolonged, current, it lifts lever H out of the path of arm a which act permits that arm to begin a revolution; but the same act that takes H out of the path of a , places e of Λ in the way of arm a , at a point where it will have made about three-quarters of a revolution; for a purpose to be explained.

immediate withdrawal of the shifter out of the path of the pins $i i'$, on the shaft κ . The same motion of wheel w , after it has performed half a revolution, and before the shaft s is arrested by the extension ϵ , brings the projection t' into contact with t on lever PL , which projection t' gives that lever a quick momentary downward depression that throws the printing pad up against the type-wheel, thereby effecting an impression on the paper. The extent of the upward motion of PL , thus imparted, is regulated by an adjusting screw attached to the projection t , by which the latter may be raised or lowered. When the press-magnet PM is again released the arm a of shaft s finishes its revolution and again engages with spring lever H , until the armature of PM is again attracted.

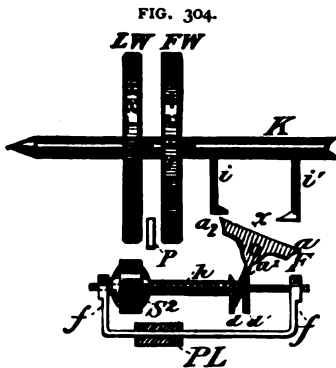

PHELPS SHIFTING DEVICE.

the Phelps printer is operated by the wheels pw and gs , Fig. 303. In the operation of these wheels the mechanical movement employed is the Geneva stop. Small pins p_1, p_2 , etc., are placed on the side of the wheel pw at uniform distances apart. gs is a notched wheel; the notches n_1, n_2 , etc., of which are somewhat closer together than the pins p_1, p_2 , etc., on pw .

The wheel pw , termed a "pause" wheel, is geared with the clock-work, but has only a limited continuous motion, namely, the distance between any two pins such as $p_1 p_2$. It is released to begin this movement simultaneously with the movement of the shaft s of the wheel w . The direction of the movement of pw , is, however, opposite to that of shaft s . The wheel gs is mounted on an independent shaft s_2 , and is turned by the wheel pw . A roller wheel, pr , is mounted on the shaft s_2 , with gs . A smaller roller r (also seen in Fig. 303) rests on pr . The paper tape is placed between pr and r , in the ordinary way.

The Phelps paper feed.—The paper "feed" of

THE PHELPS PAPER FEED.—The paper "feed" of

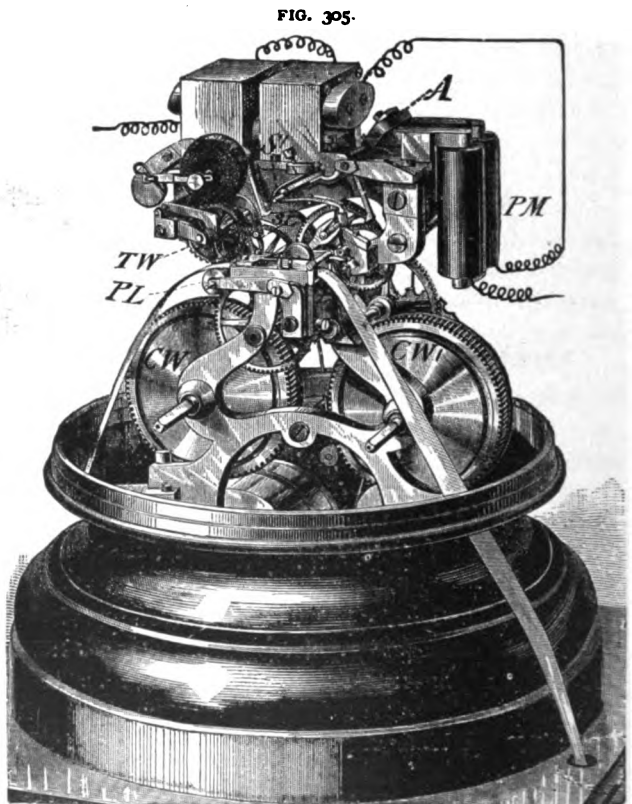

PHELPS "STOCK" PRINTER.

Normally, one of the pins say, p' , rests in one of the notches n' of gs , as shown. Consequently, when the wheel pw is turned, the pin p' pushes the wheel gs out of its path, a certain distance, turning with it, necessarily, the roller pr , and moving with it the paper an equal distance. Then the pin leaves the notch n' , while the wheel pw continues its movement. For a moment the wheel gs is at rest, and the mechanism is so arranged that just at that moment the printing is effected. The next instant, as the wheel pw progresses, the pin p_2 goes into the notch n_2 and moves the wheel gs with it to the end of its motion, thereby moving the paper forward another short space.

Thus at every movement of the wheel pw , which occurs simultaneously with the movement of the printing mechanism, the notched wheel is moved around the distance of one notch, by the consecutive action of any two of the pins on pw .

PHELPS SHIFTING DEVICE.—The shifting and printing parts of the instrument are shown in Fig. 304, in which fw and lw are the figure and type-wheels, shown end on. k is the type-wheel shaft. i and i' are the "shift" pins attached to the type-wheel shaft at points in alignment with the "unison" or shift dots, on the figure and letter wheels, which it may be said are necessarily placed diagonally to each other, as will be obvious later. Thus, looking at those pins from either side, along the shaft, it will be seen that one is slightly in advance of the other. F is the 3-arm shifter, pivoted as shown, directly under the shaft k , on an extension carried from the shift lever. Consequently, the shift arms rise and fall with that lever. d and d' are discs, between which is placed one arm a' of the shifter F . s_2 is a printing platen, or pad. The discs d, d' and the platen s_2 are rigidly mounted on a sliding shaft h , which is movable in bearings cut in the frame f, f , carried by the press lever pl .

The transmitter of the Phelps printer is practically similar to that of the "news" ticker, described. But to assist in accomplishing the additional work caused by printing from two type-wheels with the use of but one wire, the key-board of the Phelps transmitter is provided with two dot keys, termed the "letter" and "figure" key, respectively. These keys are placed directly over two consecutive pins on the transmitter cylinder, and each pin transmits a pulsation of different polarity. Hence, assuming that the "letter" dot pin is placed one "step" in advance of the "figure" dot pin, and that the "figure" pin i' , on the type-wheel shaft, is one "step" in advance of the letter pin i , (considered from the direction in which the cylinder and shaft respectively rotate) it is clear that the said shaft will be rotated one "step" more, when the figure key is depressed, than when the letter key is depressed.

It, therefore, depends upon the position of the type-wheel shaft whether the pin i or i' shall be in the upward path of the shifter F ; and this, as just intimated, is regulated by the transmitter at the central office.

It has been explained that F is momentarily raised with the lever sl , by the action of the crank roller r on wheel w .

If, as in the figure, the shaft k be stopped, with the pin i' over the arm a of the shifter, the lower arm a' , by engaging with disc d when the lever sl is thrown upwards, will throw the sliding shaft h , to the left and, with it, the platen s_2 under

the letter-wheel. If, on the contrary, the shaft κ be stopped with the pin i' over arm a_2 , the arm a will slide the platen under the figure wheel.

To prevent the paper from coming in contact with both wheels at the time of printing, a thin plate p is inserted between the type-wheels and so placed as to extend slightly below them.

KEY-BOARD, TYPE-WHEELS, UNISON.—There is but one set of keys on the key-board of the Phelps transmitter (and others of a similar nature) for both the letters and figures; each key being marked with a letter and figure (or fraction.) For example, key A is also marked 1 ; key B is also marked 2 , and so on. The characters impressed on the paper tape will, of course, then depend on whether the "figure" or "letter" key has been last depressed.

In the Phelps printer there are two parallel consecutive "dot" types on the "letter" and "figure" wheels respectively; the figure dot proper being placed diagonally to, and one step in advance of, the letter dot, as already intimated. This, it will be found on consideration, insures that the character printed on the paper tape, immediately after each "shift," shall be a dot.

The "letter" dot key on the key-board also serves as the "unison" dot key, (the unison device of the Phelps system being practically similar to those already described.) Consequently the unison stop pin on the type-wheel shaft is in direct alignment with the letter pin i over the shift arm. As the type-wheels of each ticker on the circuits are exactly alike and the unison pins on the type-wheel shafts are at corresponding points on each shaft, it follows that all of the tickers will come to unison at a given point and thus will be in readiness to rotate synchronously and each with a given character at a given point when the transmitter cylinder is again released. It is customary, in practice, to allow the tickers of a circuit to run to unison, at short intervals, to insure that if any machine has "thrown out," its synchronism may be rectified. The type-wheels are brought to unison before shifting.

The Phelps stock printer as it appears in service is shown in Fig. 305. In that figure cw, cw' are the winding wheels of the respective clock-works, to which reference has been made. tw is the type-wheel. Δ the armature lever of permanent magnet PM . sl the shift-lever, etc.

THE UNIVERSAL OR EDISON TICKER SYSTEM.

This ticker is in use in many American cities. It is a two wire system. It differs somewhat from those already described in several important respects. For instance, the type-wheel shaft is rotated by means of a "push and pull" motor,

operated by pulsatory, "straight" currents, set up by the transmitter. Thus, neither weights nor clock-work gearing is required in the "ticker". Again, the type-wheels (letter and figure) are "shifted" on their shaft so that either wheel may be printed from, at will.

FIG. 306.

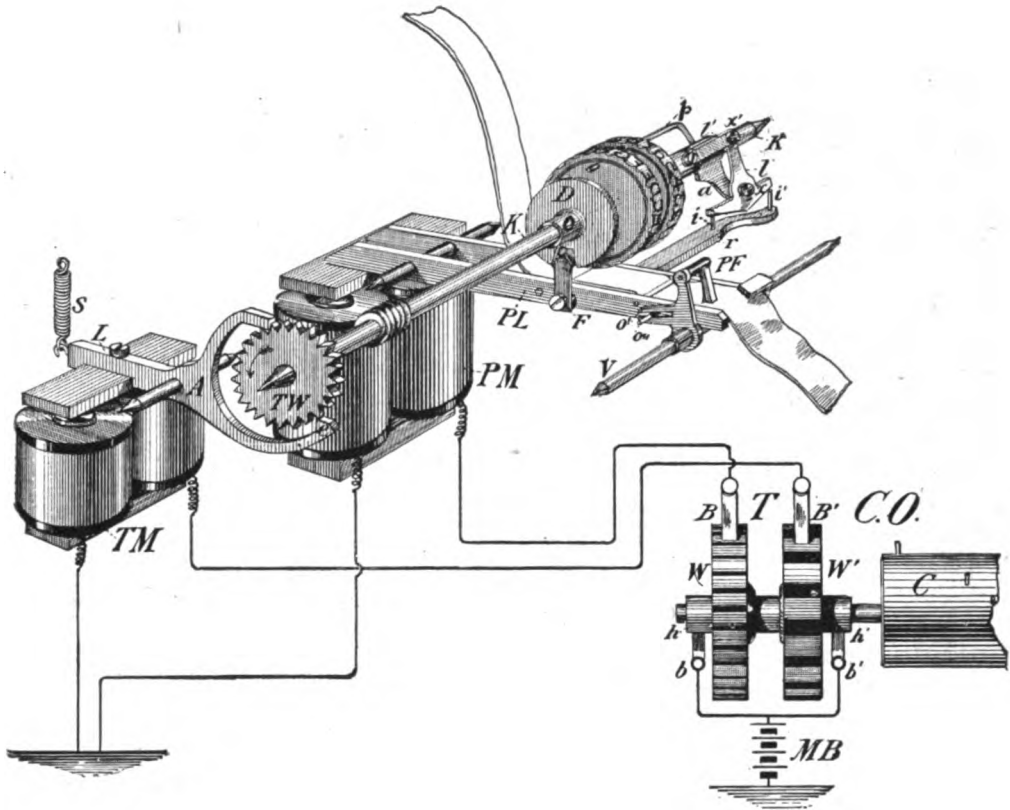

UNIVERSAL OR EDISON STOCK TICKER THEORY.

A portion of the transmitter τ at a central office CO and of a ticker at a branch office, with the parts somewhat separated and enlarged, for the purpose of illustration, are shown in Fig. 306; parts unnecessary to the description being omitted.

The transmitter consists of a cylinder c , a portion only of which is shown, at the right of the figure. This cylinder is driven by any suitable motor, and it is stopped at any desired point in the well-known way, by the depression of keys on a key-board, not shown. On the left end of the cylinder shaft two segmental wheels $w w'$ are placed. These wheels are made up of metal segments which are connected respectively with the hubs $h h'$. The segments are insulated from each other. b, b' rest on the hubs of w and w' , respectively. The other ends of these brushes are connected

with a common battery MB. Brushes B and B' rest on the wheels as shown. The brush B is connected with the press-magnet circuit. Brush B', with the type-wheel circuit.

The metal segments on wheel w are narrower, it may be seen, than those on w'. There are as many segments on w as there are pins on the cylinder, but only half as many segments on w'; or, in other words, half as many segments as there are characters on the type-wheels of the ticker.

As the cylinder rotates, the current from MB passes over both the "type-wheel" circuit and "press" circuit.

In the ticker, at the left, TM is the type-wheel magnet. PM is the press-magnet. The type-wheel magnet in this ticker has obviously more work to do than is assigned to that instrument in the tickers of other systems, inasmuch as it is required to revolve the type-wheels, by means of its armature lever and the "push and pull" gearing shown; but, notwithstanding this, it is more readily operated than the press-magnet PM.

Consequently, when the cylinder is rotated, while the current from MB passes over both circuits, only the type-wheel magnet is actuated. The inaction of the press-magnet at this time is aided by the narrowness of the segments on w, which, by diminishing the duration of the contact, tends to diminish the current passing over the press circuit. When, however, the cylinder is brought to rest the continuous current thereby permitted to flow over the press circuit operates the press lever.

As there are but half the number of segments on wheel w' that there are characters on each type-wheel, it is evident that half of the pins on the cylinder must be set opposite insulated sections of wheel w'. Therefore, when the cylinder is stopped with the brush B' resting on an insulated section of w', all of the battery from MB will pass over the press circuit. When, on the contrary, it stops with the brush B' resting on a metal segment the current from MB divides between both circuits. With a dynamo machine as the source of E.M.F. this would have no bearing on the working of the apparatus; nor does it when gravity battery is used except that it is necessary to maintain the current strength at a point where there is ample margin to operate the press magnet in either position of brush B'. It is, of course, apparent that two separate batteries may be used if desired; one for each wheel.

The "step by step" movement of the type-wheels in this ticker, although effected by the lever L of TM, as it rises and falls, is practically the same as in that of the other printers described. For example, it will be seen that when the brush B' is on an insulated section of w' the lever L of TM is withdrawn by the retractile spring s. In the act of withdrawal the upper tine of the anchor A moves the toothed wheel TW a space of half a tooth in the direction of the arrow. When, as the wheel w' rotates, a metal segment is next brought under brush B', the armature of TM in the ticker is attracted. This again causes anchor A to move the wheel TW a distance of one half tooth. There are half as many teeth on TW as there are characters on each type-wheel. Thus, since a "make" and a "break" of the press circuit moves the type-wheels forward two letters, or figures, it is plain that although there are on the wheel w' but half the metal segments usually employed, that wheel effects the same

result as the ordinary segmental wheel with alternating currents; that is, one revolution of w' effects one revolution of tw , and, consequently, one revolution of the type-wheels.

The type-wheels are mounted rigidly on a sleeve o , which is movable lengthwise on the shaft κ by the devices shown at the right of the type-wheels. These devices consist of a small 3-arm lever l pivoted at x , and a link lever l' , pivoted at x' . The link lever l' is attached as shown, to the type-wheel sleeve. Thus, if the 3-arm lever l be rocked on its shaft x , it will, through the intermediary l' , slide the type-wheels back and forth.

The shaft x , on which lever l is mounted, is supported by an arm a rigidly attached to the shaft κ , so that, of course, the levers l and l' rotate with the shaft κ .

The type-wheels, while free to move, within certain limits, to and fro on the shaft κ , are held in a definite relation to it by a bent pin p , connected at one end directly with the shaft and passing loosely through holes, or slots, in the frames of the type-wheels, as indicated.

The shifting of the type-wheels is brought about as follows:

A projection r from the press lever PL , carries two pins i, i' . One of these pins is behind the other a distance equal to that between any two characters on either type-wheel.

If the type-wheel shaft be stopped with the lower edge of lever l directly above the pin i' , it is seen that, when the lever PL rises to print, the lever l will be canted as shown in the figure, and the type-wheels will be pushed to the left. If, on the other hand, the shaft κ be stopped, with the lower edge of l directly above pin i , the lever PL , in rising, will cant the lever l in the opposite direction, thereby "pulling" the type-wheels to the right.

The apparatus is then so arranged that when the figure "dot" on the key-board is depressed it will cause shaft κ of the ticker to be arrested with the lever l immediately over the pin i , in order that the wheels may be slid upon the shaft to that point over the paper where the "figure" wheel only will make an impression on the paper. The same motion moving the "letter" wheel out of the way of the printing platen. (*See Phelps shifting device, page 405*).

When the letter "dot" key on the key-board is depressed the shaft κ will be stopped with the lower edge of lever l immediately above pin i ; and the letter wheel will, consequently, be placed in position for printing, while at the same time the figure wheel is removed from above the paper. Either wheel having, in this way, been "set," the printing of either letters or figures may be proceeded with in the usual manner. By a device such as that shown in the Phelps "ticker," the type of but one wheel is permitted to make contact with the paper tape when the press lever is raised.

The type-wheels are prevented from "sliding" lengthwise when the shaft is being rotated, by the pin F and disc D , in the following manner: D being mounted on the same sleeve as the type-wheels, when the type-wheels are brought into the position for shifting, the slot s on D is opposite the end of F . Consequently, in that position, D may be moved right or left, past F . But as soon as the wheels begin to rotate the pin F is either on one side or the other of the disc D , which, it will be seen prevents a lateral motion of the wheels at such times.

The unison device employed is practically similar to that described in connection with the "Gold and Stock" ticker and, therefore, need not be described here.

The paper "feed" apparatus is shown at the right end of lever PL. It consists of a push "dog," or pawl, which rests above a roller, over which the paper passes. The dog is operated by the bent lever PF, upon the shaft v, in such a manner that when the press lever is descending at the end under PF, the paper is urged forward. This action is brought about by the action of the pin *o*' on the side of PL, in the slot *o*' upon the lever PF.

It may be added that in many of the "Edison" tickers as now operated, the shifting apparatus just described has been replaced by that of the Phelps shifting mechanism, described in connection with the Phelps "ticker," the main difference

being that, in the modified Edison ticker the 3-arm shifter therein described is carried by the "press" lever instead of the "shift" lever.

The application of the Phelps shifter to the Edison ticker, it will be observed, dispenses with the sliding type-wheels on the shaft, the printing platen being moved instead.

The Edison, or Universal ticker, mounted on a base board and virtually as it appears in practice is shown in miniature in Fig. 307.

UNIVERSAL TICKER TRANSMITTER.—The principle of another form of transmitter used with the "Universal" ticker, whereby the same results are obtained as by the insulated segmental wheels, is shown in Fig. 308.

In this figure *G* is a cog-wheel on the shaft *s*, driven by an electro motor, weights, or a spring. On either side of *G* two smaller cog-wheels *w*, *w'*, of equal size, are geared. On the shaft with *w* a toothed wheel *A* is mounted. On the shaft with *w'* another toothed wheel, *A'*, is mounted. There are double the teeth in *A* that there are in *A'*. A lever *l* is caused to rest on the periphery of *A*; a lever *l'* is similarly placed on *A'*. The "press" circuit is connected with

FIG. 307.

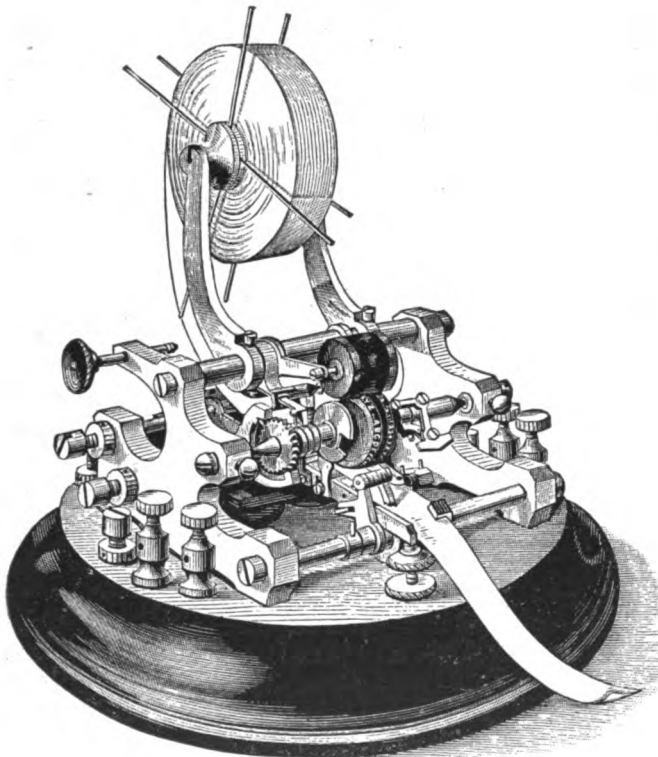

EDISON OR UNIVERSAL TICKER.

lever l ; the "type" circuit with l , as indicated. A contact point c is placed adjacent to l ; a contact point c' adjacent to l' . Owing to the manner in which w w' are geared to the wheel G , the rotation of each in the direction of the arrows is insured. As the wheels A A' rotate, it will be seen that lever l will make contact at c each time its end e falls into a notch between the teeth of A , and it will break contact when the end e rides upon a tooth, as in the figure. On the contrary, in the case of lever l' the contacts of the circuit are made at c' when the end e' is in a notch, and vice versa.

As wheel A has twice as many teeth and notches on its periphery as A' ; and since wheels w , w' rotate at a uniform rate of speed, it is evident that the "press" circuit

FIG. 308.

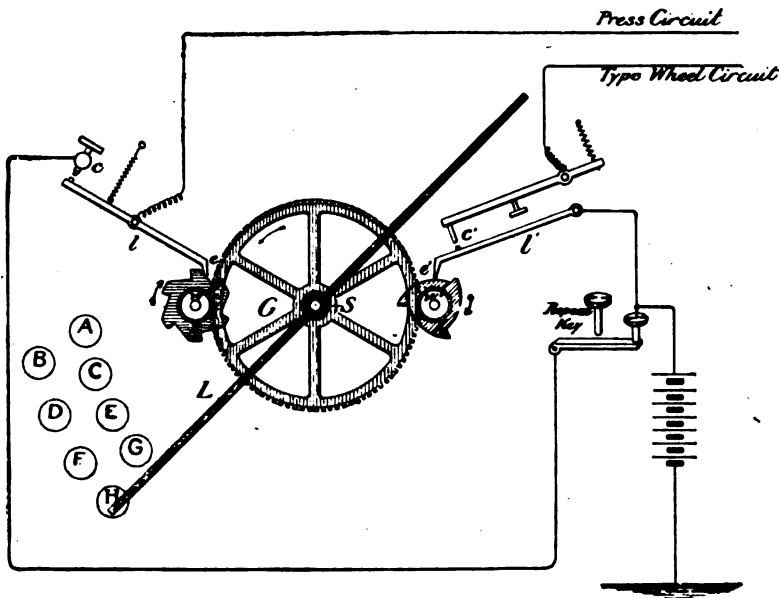

" UNIVERSAL " TRANSMITTER, THEORY.

will be broken at c twice as often as the "type" circuit at c' ; which, it will be noticed, is exactly the result obtained by the use of the two segmental wheels, Fig. 306, one of which has twice as many metal segments as the other. Consequently, the action upon the type and press magnets of the "ticker" is practically the same in both cases, as stated.

In connection with the transmitter, Fig. 308, a key-board, the keys of which may be arranged in a semi-circle, as indicated at the left of Fig. 308, is used. A rod, or lever, L revolves with the wheel G , and arms beneath the keys are so placed that, when a key is depressed an arm directly beneath that key is thrown into the path of the rod, or lever L , thereby stopping the wheel, and, of course, stopping the rotation of the wheels w , w' , and, thereby, effecting a similar result to that accomplished by the

depression of a key whose detent, or lower projection, intercepts a pin on the surface of the rotating cylinder of the transmitter, Fig's. 299, 306.

As the rod *L*, Fig. 308, extends an equal distance in each direction from the center of *G*, it may be seen that, as one end of the lever leaves one end of the semi-circle, its other end will be at the beginning of the semi-circle and thus there is no motion lost by the lever, as a whole.

THE NEW YORK QUOTATION COMPANY'S "TICKER" SYSTEM.

In this system two wires and two type-wheels are used. One of the wires is used exclusively to operate the press lever and the shift mechanism of the tickers. To operate the press lever the press circuit is simply closed momentarily; to operate the shift mechanism the polarity of the current on the press circuit is reversed at the transmitting station.

The central office transmitting apparatus and connections are shown in Fig. 309. *PT* is the "transmitter. It consists of a two-section shaft *s'*, *s*, on which are mounted a trailer *t*, a "clutch" wheel *cw*, and "pole-changer," *pc*. The shaft is driven by a belt on the pulley *p'*. The pole-changer is rigidly held on the shaft *s'*, but it also rests on the shaft *s* by a friction bearing. This friction is normally sufficient to cause the rotation of the shaft *s'* with *s*, but, when a "clutch" *c*, shown separately in Fig. 309 *a*, is advanced into the path of the teeth of the clutch wheel *cw*, the shaft *s'* is instantly stopped, while *s* continues to rotate.

At the end of shaft *s'*, opposite the trailer *t*, a "sunflower" *sf* is placed. It is shown side view in the figure. This "sunflower" is made in the usual way; being composed of a number of metal segments, which radiate from a common centre; the segments being insulated from each other. As the shaft *s'* is rotated the trailer passes over each segment in succession. A small section of the key-board used is shown at *kb*. A contact point *p* is placed under each key of the key-board, and each of those contact points, with the exception of those under the keys marked *F* and *L*, is, by a wire, connected direct to a separate segment on the sunflower. The keys *F* and *L* are connected, in a round-about way, to one segment on the sunflower. The "pole-changer" *pc* is composed of a cylinder on the periphery of which metal segments are placed, as shown. Resting on this cylinder are three brushes, one of which is connected to a positive pole of dynamo machine *D*; another to the negative pole of another machine *D'*, each through a safety fuse, and a resistance *r*; while the middle brush is connected with a wire leading to a series of polarized relays, *TR*, *TR*, etc., and thence to the ground at *E*². The arrangement of the metal segments on *pc* is such that the middle brush rests on a segment jointly with each of its neighboring brushes, alternately. The result is that rapid reversals of polarity are transmitted through the polarized relays so long as the pole changer continues to revolve; the consequence of which reversals is that the armatures of the polarized relays are kept in rapid oscillation while the pole-changer rotates. The right and left hand "local" contact points

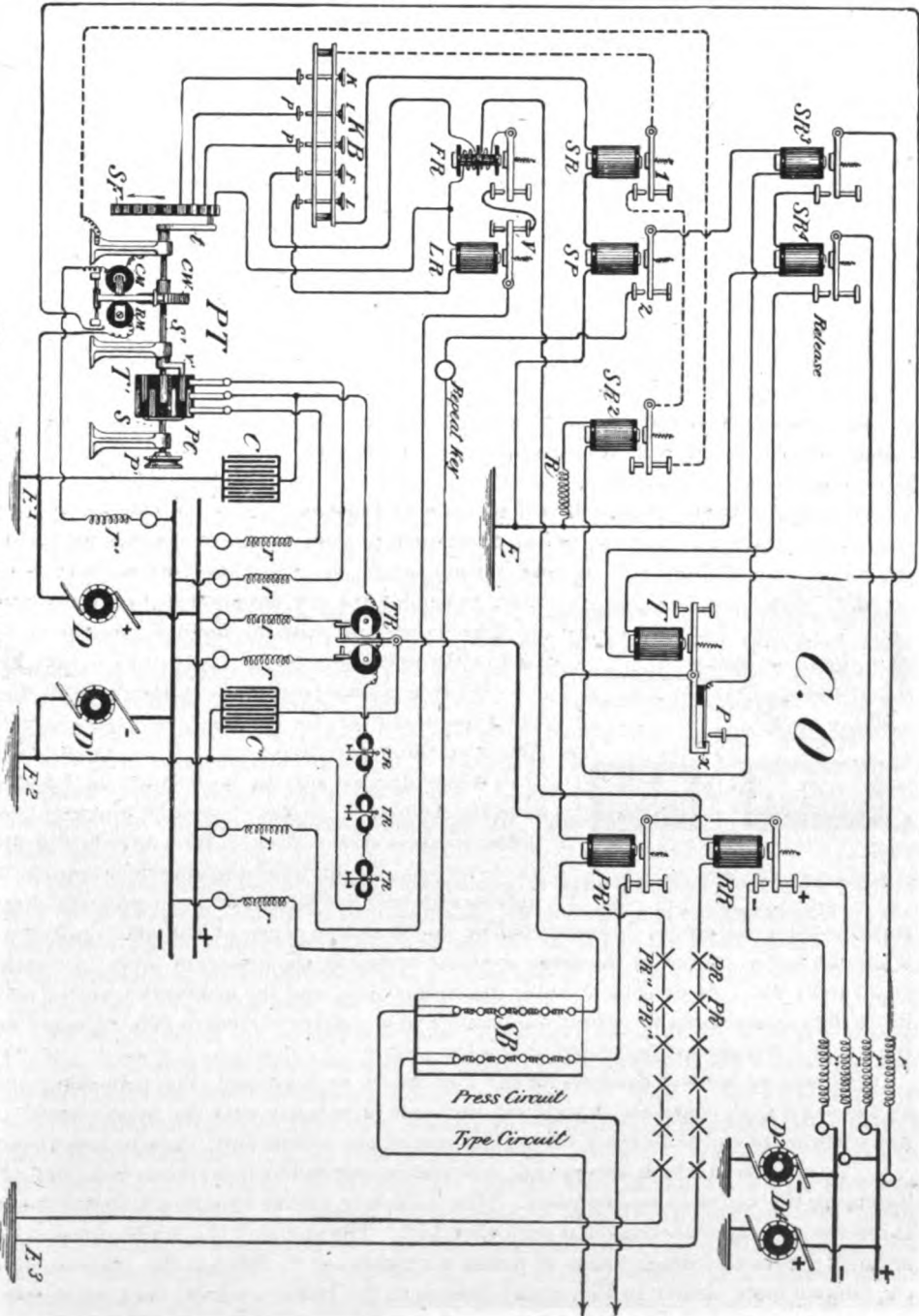

FIG. 309.—CONNECTIONS—QUOTATION COMPANY'S 'TICKER' SYSTEM THEORY.

of all of the polarized relays TR, TR etc., are connected, respectively, to dynamo machines of different polarity, as shown, for instance, in the case of the enlarged relay TR, whose contact points are in connection with dynamo machines D, D', respectively; the similar connections of the other relays TR, etc., being omitted for clearness. The armatures of TR, TR, etc., are connected, as shown in the case of TR, through a switch-board, SB, with the type-wheel circuits. Thus so long as the cylinder, or pole-changer PC, rotates, currents of alternate polarity will be caused to traverse the type-wheel circuits and will cease with the stopping of that instrument; these currents, in turn, rotating and stopping the type-wheel shaft in each "ticker," in the usual manner, by means of polarized relay, controlling, by its armature lever, the escapement and escape-wheel.

In printing telegraphy, in the transmission of signals at a high rate of speed, considerable skill is required on the part of the "operator" to accurately gauge the proper duration of his finger on the keys of the board, to insure sufficient time for the correct printing of each letter.

In the system in question a device has been introduced, by Mr. C. L. Healy, to "lock" the circuit of each key, the moment it is depressed, and keep it locked until after a letter or figure has been transmitted, when the key is, automatically, unlocked. By the use of this device, which will be described presently, it is only necessary that

the transmitting operator should depress his key for an instant, when the "locking" device comes into play, and holds the key circuit closed until the letter or figure is printed, without further thought on the part of the operator.

When a positive current is passing over the line, the type-wheels of the tickers are "set" to print letters on the paper tape.

When figures are to be printed, a negative polarity is placed to the "press" circuit. One press circuit is shown at SB. Its source of E.M.F. is at D₄ or D₂, (right hand top corner in figure). It may be seen that the *polarity* of the current which will

traverse the press circuit is controlled by the armature lever of the small relay RR; while the actual control of the press circuit is vested in the armature lever of another small relay PR'. At present it holds the circuit open, and the armature lever of RR is, in the figure, arranged to permit the passage of a positive current. The "press" and the "type" circuits are grounded at the far end.

So long as none of the keys on the key-board is depressed, the pole-changer PC, on the shaft s, s', continues to send out reversals of polarity over the type circuit, via the armature of the polar relay TR. (The case of one circuit only, need be considered).

The manner in which letters or figures are transmitted by this system is as follows: Assuming the key K to be depressed. The sunflower trailer t continues to rotate until it reaches the segment connected with that key. The moment the trailer reaches that segment a current from dynamo D' passes via resistance r', through the clutch-magnet CM, (shown more clearly in Fig. 309a), thence to the frame-work of the transmitter, to the trailer, through the trailer and the sunflower segment to the key-board, thence to

FIG. 309a.

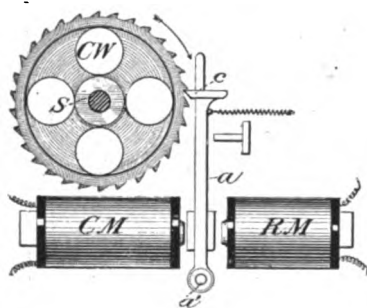

small relays SR , SP , to the "ground" at E . The completion of this circuit attracts the armature of CM , and its lever c (Fig. 309a) interposes a detent c before a tooth on the clutch cw , as in Fig. 309a, at once arresting the rotation of the shaft s , and holding the trailer on the segment connected with key K . At the same time the armature of small relay SR is attracted and closes a circuit, partly indicated by dotted lines, and termed the "locker" circuit. This locker circuit, it will be seen, follows a route from the earth E^2 , and dynamo D' , via the resistance r' , and through the clutch-magnet CM , to the frame of the transmitter $P T$, whence it passes through the armatures of SR_2 and SR , to the frame of the key-board, thence through the coils of SR and SP , to the earth at E . This circuit keeps the clutch-magnet closed, regardless of whether key K is now depressed or not. Hence the name, "locker" circuit.

The next action that takes place is the closing of the armature 2 of the relay SP , which completes a circuit from dynamo D' , through that armature lever, to the magnet of relay SR_3 , thence to the tongue and lever of an ordinary continuity preserving transmitter T , to the relay PR' , and the other "press" relays PR' , to the earth at E_3 . The completion of this circuit closes PR' , and permits a charge from D_4 to enter the press circuit, which charge actuates all of the press magnets on the ticker circuit, printing thereby the desired letter. Concurrently with the closing of relay PR' , the armature of SR_3 has been attracted. This, it will be seen, closes a circuit through the magnet of a "release" relay SR_4 . The closing of this latter circuit, by attracting the armature of SR_4 , completes a circuit through the magnet coils of transmitter T and the coils of the "clutch-releasing" magnet RM , at the "printing" transmitter PR . The closing of this circuit, by operating the clutch-releasing magnet RM , withdraws the "clutch" from the tooth of the clutch-wheel, with which it had been engaged, permitting the shaft s' , to at once resume its rotation. The "closing" of transmitter T , opens, at x , the circuit of the "press" relays PR' . At the same instant the current from dynamo D' is diverted momentarily through a resistance R , equal to the resistance of the "press" relay, (this to avoid sparking at x), and also through relay SR_2 , which again opens the "locker" circuit at armature SR_2 , thereby opening the small relays SR and SP .

The re-opening of relay SP causes the breaking at armature 2 of the circuit from D' , which opens relay SR_3 . This, in turn, opens SR_4 , which again opens transmitter T , the opening of which at P opens relay SR_2 , and puts the circuit of the press relays PR' , etc. into contact with x , at the transmitter T , in readiness to be again momentarily charged by dynamo D_2 or D_4 , when relay SP is again closed.

To relate in detail the foregoing actions necessarily occupies considerable space, but it may be stated that the actions of the different instruments occur so nearly simultaneously, that the ear can scarcely detect any lapse of time in the strokes of the levers. An idea of the rapidity of these actions will be gained by a consideration of the facts, that the shaft on which the pole-changer, clutch-wheel and trailer, are mounted, makes about 120 revolutions, per minute, and that the teeth of the clutch-wheel are less than one-half inch apart. Consequently, in order to stop the pulsations at a given letter, the armature of the relay CM must move into the path of a tooth in the $\frac{1}{3600}$ of a minute, there being 30 teeth on the wheel. The need, therefore, of a clutch which will respond without delay to the depression of a key, is obvious; hence, the object of

the Healy "clutch" wherein a retractile spring is dispensed with, in order to avoid hinderance to the quick forward motion of the clutch. By the successful operation of this clutch, *one* transmitter is made to operate all of the circuits of a system through "repeating" relays, as indicated by the marks at PR' and PR", each of which may respectively control a "press" and "type" circuit, simultaneously with relays RR and PR'.

The relay SR₃ is termed a "time" relay, its function being to delay, momentarily, the releasing of the clutch, and the closing of transmitter T, until the printing of the letter has been assured; to effect which properly the distance through which the armature of SR₃ should travel is regulated by experiment.

QUOTATION TICKER SHIFTING APPARATUS.—As already said, the "shifting" mechanism of the "ticker" of this system is performed by a polarized relay in the ticker. The mechanism by which this is effected will be described in connection with the "ticker" itself. It need only here be said that, with a positive pole to the press circuit, the armature of a polarized relay in the ticker is so arranged as to hold at unison the "figure" wheel, while permitting the "letter" wheel to rotate; while, with negative polarity to the press circuit, the same armature is so moved as to stop the "letter" wheel at unison, while permitting the "figure" wheel to rotate in obedience to the impulses sent over the type-wheel circuit.

The devices at the central office C O, whereby the desired "shifting" polarity is presented to the press circuit, are also shown in Fig. 309.

The "figure" and the "letter" keys are shown, respectively, as F and L at KB. The contact points under both of these keys are, as already stated, and as may be seen, connected with the same segment on the sunflower SF, but, in the case of key L, the circuit first passes through *the* coil of relay LR, while in the case of key F, the current first passes through *a* coil of relay FR. The segment on the sunflower, to which keys L and F are connected, corresponds, as to relative position, with the unison "dot" on the type-wheels. In the figure, a positive pole is ready for presentation to the press circuit, and, hence, the ticker is set to print letters. Supposing then, the figure key F, to be depressed, the "current" from D' passes through clutch-magnet CM, arresting the sunflower trailer *t* at "dot" segment, then passes through the lower coil of relay FR, to the key-board frame, thence through relays SR and SP. The effect of closing FR is to close a circuit from dynamo D to the armature of FR, thence to the upper coil of FR and through the shift relays RR, PR, etc., to the earth at E₃. This attracts the armature of RR, which changes the polarity from positive to negative. As long as the "letter" shift relay LR remains open the figure shift relay FR will be kept closed, by the upper coil on that relay. When, therefore, it is desired to shift back to letters, it is only requisite to depress the letter key L, which, it is seen, diverts the current from dynamo D', through relay LR, via the key-board frame, when that relay will be closed, breaking at *v* the circuit through relays RR, PR, etc., when the armatures of those relays will be retracted, and the positive pole will again be put to the "press" circuit. When a change from figures to letters or letters to figures, is to be made, it is, therefore, necessary to first bring the type-wheel to the unison dot. It may be stated that all of the apparatus shown in Fig. 309 is located in the central office.

Referring to Fig. 309*a* it will be observed that the arrangement of the "clutch" magnet CM and "release" magnet RM is such that the attraction of the lever A (which

is pivoted at a'), by cm , places the detent c in the way of the upper teeth, while the attraction of lever a by RM , withdraws it from those teeth. The small spring shown as apparently assisting RM is merely used to hold the lever loosely against its back stop when neither magnet is "active."

QUOTATION COMPANY TICKER.

The Quotation company's "ticker" is shown in Figs. 310, 311. In Fig. 310, r

FIG. 310.

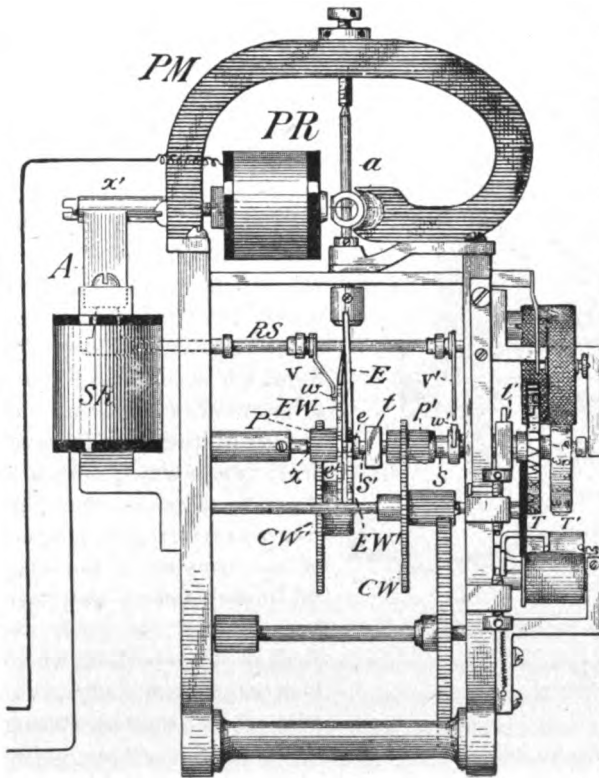

"QUOTATION" COMPANY TICKER—END VIEW.

and r' are the letter and figure type-wheels, respectively. The shafts s s' of these wheels are arranged one as a sleeve over the other; the figure type-wheel shaft being the inner one. The shaft s' of the figure type-wheel has its bearings at x and x' . Shaft s has its bearings in t and t' . The shafts do not touch each other. Shaft s is geared by means of a pinion p' with a large cog-wheel cw' , both of which cog-wheels are geared with a train of gearing driven by weights. These weights give the type-wheel shafts a constant tendency to rotate. EW is an escape-wheel attached to shaft s . EW' is a similar escape-wheel attached to shaft s' . These escape-wheels are placed side by side, as shown. E , seen in end view, is an escapement anchor, which engages with the escape-wheels. This escapement anchor is connected with the armature axis a of a polarized relay, PR , which is in the type-wheel circuit. The arma-

ture of PR is given a lateral, vibrating motion by the reversals of polarity in the type circuit. Consequently, a corresponding lateral motion is given to the escapement anchor E . The anchor is so arranged that when one end e of the anchor rests on a tooth on, say, escape-wheel EW , the other end, not visible in figure, rests on a tooth of EW' , and vice versa. Hence, accordingly as the relay PR is operated by the central office transmitter, the type-wheels will be permitted to rotate "step by step," in, practically, the usual way.

In this system, however, but one type-wheel is permitted to rotate at one time,

means being provided, as already said, whereby either wheel is held at unison, as long as desired, while the other is free to revolve. This constitutes the shifting device of this "ticker". The holding of the wheels, as desired, is effected by means of projections v and v' from a rocking shaft rs , which shaft is rocked by the armature lever of a polarized relay sr which is in the "shift and press" circuit, the latter controlled by the figure and letter keys of the key-board, in the central office.

FIG. 311.

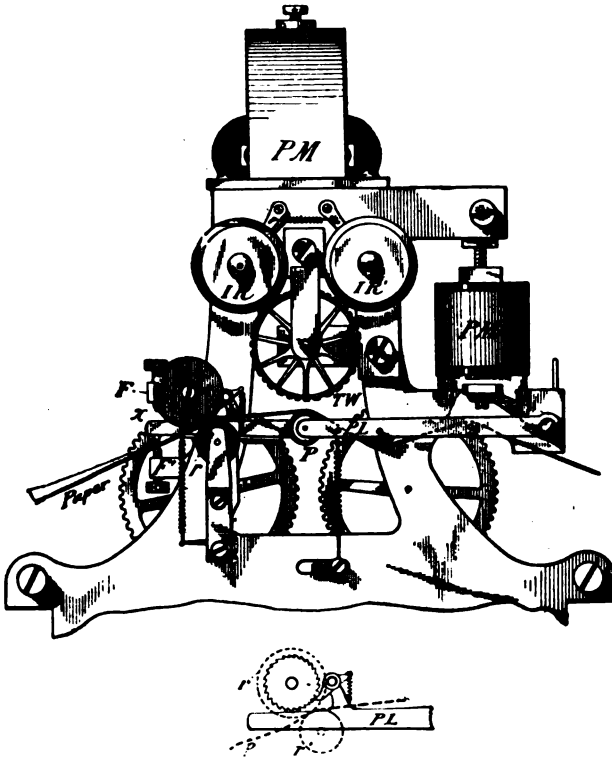

The projection v , when in a certain position, as in the figure, engages with a pin w on the side of the escape-wheel ew . The projection v' , in a certain position, engages with a pin w' on the letter wheel shaft s . In the figure v' and w' are clear of each other. Thus the figure wheel is held and the letter wheel is free to rotate. This indicates that the letter key has been last depressed. When next the figure key at the central office is depressed, it will cause the closing of the shift relay rr (Fig. 309) which places a negative pole to the line, thereby reversing the position of the armature of the relay sr , in the "ticker," and causing its lever to rock the shaft rs into a position where it clears pin w and engages v' with pin w' , thereby freeing

the letter wheel and holding the figure wheel.

In this ticker, therefore, the pad is not moved, but strikes both type-wheels at every impulse of the press lever. As, however, only one wheel is permitted to revolve at any one time, while, at that time, the other wheel is held at "unison," the only impressions which appear on the paper tape are made by the dot type of the stationary wheel, and the desired characters of the revolving wheel. After a few impressions from the stationary dot type it ceases to mark on the tape, the ink on the pad giving out. The press magnet is not shown in Fig. 310.

The manner in which the rocking shaft rs is operated will be evident on examination of Fig. 310. The polar relay sr , is supported by the framework of the ticker. Its armature A , which is pivoted at x' , is polarized by contact with the permanent magnet pm , and hangs down between the pole-pieces of sr . At its lower end it

engages with an extension from rocking shaft RS in such a way that, as it oscillates between the pole pieces, it gives the shaft RS the rocking motion to which reference has been made. No device other than that for holding the type-wheel shafts by the rocking shaft RS, is employed to bring the wheels to unison, none being required, and this arrangement brings either wheel to unison within *one* revolution of the type-wheel, which fact adds to the speed at which the system may be operated, it being necessary, in some ticker systems, to allow 3 or more revolutions of the type-wheel to bring it to unison.

This ticker is also shown, in side view, in Fig. 311, PM is the permanent magnet for relays PR and SR of Fig. 310. TW are the type-wheels. PM' is the press-magnet. PL is the press lever, which extends to *x* and vibrates between the stops F, F'. P is the printing pad, which, raised by PL, impresses the character of the type-wheel on the paper tape, at each closing of the press relay PR', Fig. 310. The paper is drawn along between the rollers *r*, *r*, which are turned a certain distance at every motion of the press lever. IR and IR' are two ink rollers, placed as shown, one roller being assigned to each type-wheel. This arrangement of the ink rollers is designed to impart steadiness to the type-wheels. The type-wheels rotate at about 130 revolutions per minute.

The paper "feed" is shown separately below Fig. 311 on the side of the upper roller *r*, a toothed wheel, between the teeth of which a pawl, carried on the printing lever PL, is placed. The pawl is so arranged that it slips past the teeth as the lever rises, while it engages firmly with one of them as the lever descends. The descent of the lever is thus caused to turn the roller, by which act the paper is drawn along only when the lever is descending, thereby leaving the paper at rest while characters are being impressed upon it.

This "ticker" as now developed is due chiefly to Messrs. Field, Healy and Mahnken.

THE BURRY SELF-WINDING TICKER.

This ticker is in quite extensive use in the reception of general and sporting news. The instrument, as a whole, is shown in Fig. 311*a*. As its name indicates it is self winding, a spring being used to operate the type-wheel. The winding of the spring and the regular rotation of the type-wheel is performed by the press-magnet, through the medium of several ingenious devices, which are shown in detail in top and side views in Fig. 311*b*. In these figures the respective parts are indicated by numerals. The main spring is enclosed in the drum 14, which is loosely mounted on the shaft 3. The spring itself is fastened at one end to shaft 3; its outer convolution pressing against the top of the drum, tending to turn it by friction. The drum is fastened to the side of the cog-wheel 12 which is also loosely mounted on shaft 3, and meshes into the cog-wheel 7. A fly-wheel 13 is also loosely mounted on shaft 3, and flexibly connected to that shaft by means of the spiral spring 15 which is fastened at the point 11 to the shaft 3, and at its other end to the pin 16 on the hub of the fly-wheel. A pin 17 which projects from the shaft into the path of pin 16 acts as a stop. This fly-wheel is the important feature of the self-winding process, as will be seen

later. The gear-wheel 7 is loosely mounted on the type-wheel shaft 2, but it is flexibly connected thereto by the spiral spring 8, one end of which is connected to the shaft, the other end to the wheel 7. This flexible arrangement is designed to avoid the jarring on this wheel due to the sudden stops and starts of the larger wheel 12.

On shaft 3 a ratchet wheel 9 provided with a detent *a*, is rigidly mounted. A pawl 20, on the end of an extra lever 19, attached to the trunnion 4 of the printing

FIG. 311a.

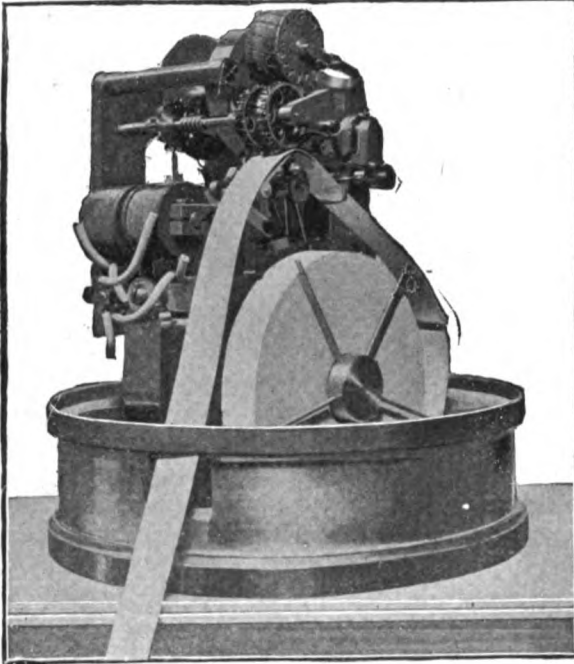

magnet, engages with the ratchet wheel in such a manner that, when the press magnet *p* is in the act of closing, the ratchet wheel is rotated one or more teeth. This action turns shaft 3, thereby moving pin 17 away from pin 16. It also, as it turns, winds spring 15 slightly. The inertia of the fly-wheel holds it back for a moment, but presently it responds to the tension put upon it by spring 15 and starts forward, causing the pin 16 to strike against pin 17 with a hammer-like blow, thereby rotating the shaft 3 to a much greater degree than is the case when the energy applied at the ratchet-wheel is alone relied upon, and thus the main spring on the same shaft is wound to a proportionately greater extent.

In order to secure prompt action of the press-magnets of tickers it is necessary to employ a stronger current than would be necessary to operate them could a tardy action be permitted. This current varies in different machines from about half an ampere to over one ampere. The Burry ticker employs half an ampere. It is also known that the action of the press-lever is accelerated as it approaches the magnets, the speed being greatest at the last, and the stroke generally being stronger than is necessary for the actual printing. Advantage of these facts is taken in this self-winding arrangement to so construct the apparatus that the pawl on the end of the lever 19 does not engage with the ratchet wheel until that lever nears the end of its stroke. Thus the self-winding arrangement not only does not obstruct the starting of the press-lever, but it also acts as a sort of cushion to the press-lever at an opportune time.

The rest of the apparatus will be readily understood. The tendency of the winding arrangement is to the over-winding of the spring, but when this happens the spring momentarily slips in the drum, and at such times the rotation of the type-wheel is kept up by the small spiral spring 8 on shaft 2.

Shaft 2 also carries the escapement-wheel 6, which is controlled in the usual way by the polarized relay, seen in Fig. 311a.

The keyboard and transmitter of the system on which this ticker is employed, are in a measure akin to those shown in Fig. 309, simplified, however, in some respects and modified in others; the sunflower trailer and the shaft, which in Fig. 309 are operated by a pulley driven by a belt, being operated in the Burry system by an electric motor attached to the end of the shaft, and, instead of the clutch magnet, a pair of curved, soft iron armatures are mounted on the shaft and normally revolve in the concaved recesses of a pair of coils, which, like the clutch magnet, have current sent through them when a key of the keyboard is depressed, with the result, in the present case, that the curved iron armatures instantly stop in the path of the magnetic field of the coils, thereby holding the shaft and sunflower in the desired position until the key is raised. The shaft is, of course, in frictional connection with the motor shaft.

FIG. 311b.

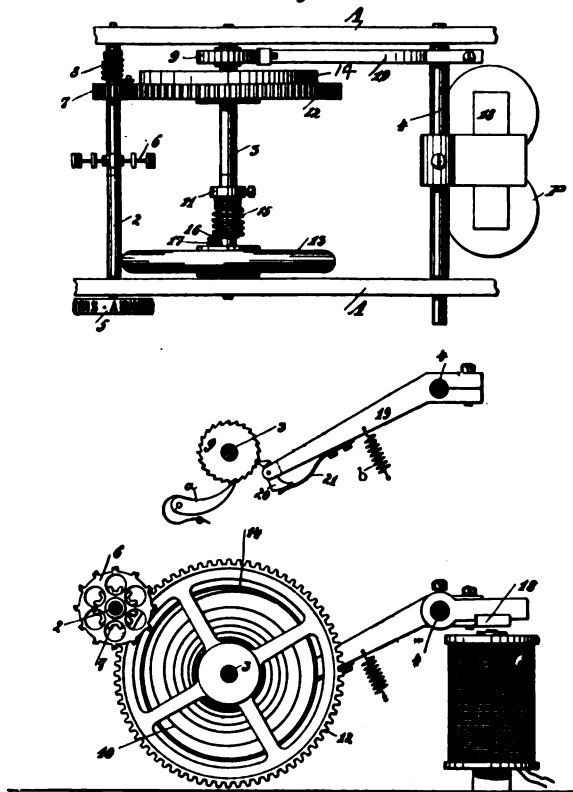

THE PHELPS "MOTOR" PRINTING TELEGRAPH SYSTEM.

This system is successfully employed on several long circuits of the Western Union Telegraph Company. This "printer," presumably, derives its distinguishing name from the fact that it was the first to be driven by an electric-motor in this country.

The message as received on this "printer" is printed on a strip of paper in Roman letters. No figures are placed on the type-wheel; the Roman numerals, such as VI. for 6, being employed.

This system, in common with other more or less similar ones, depends for its successful operation on synchronous rotation of the transmitter at one end, and the receiver at the other end of the circuit. As will be shown, the receiver is not actuated by the "step by step" movement, as in the case of the stock quotation instruments described.

The instruments, etc., employed in the operation of this system are shown, as ar-

ranged in practice, in Fig. 312, in which *T* represents the transmitter, which consists of a key-board, and mechanism controlled thereby to actuate a circuit breaker *PC*; a receiver *R*, which comprises an electro-magnet, or relay, controlling a type-wheel and printing mechanism. The key board is clearly seen. *M* is the case containing the motor, *MS* is the motor battery switch. The motor, by suitable gearing, causes the

FIG. 312.

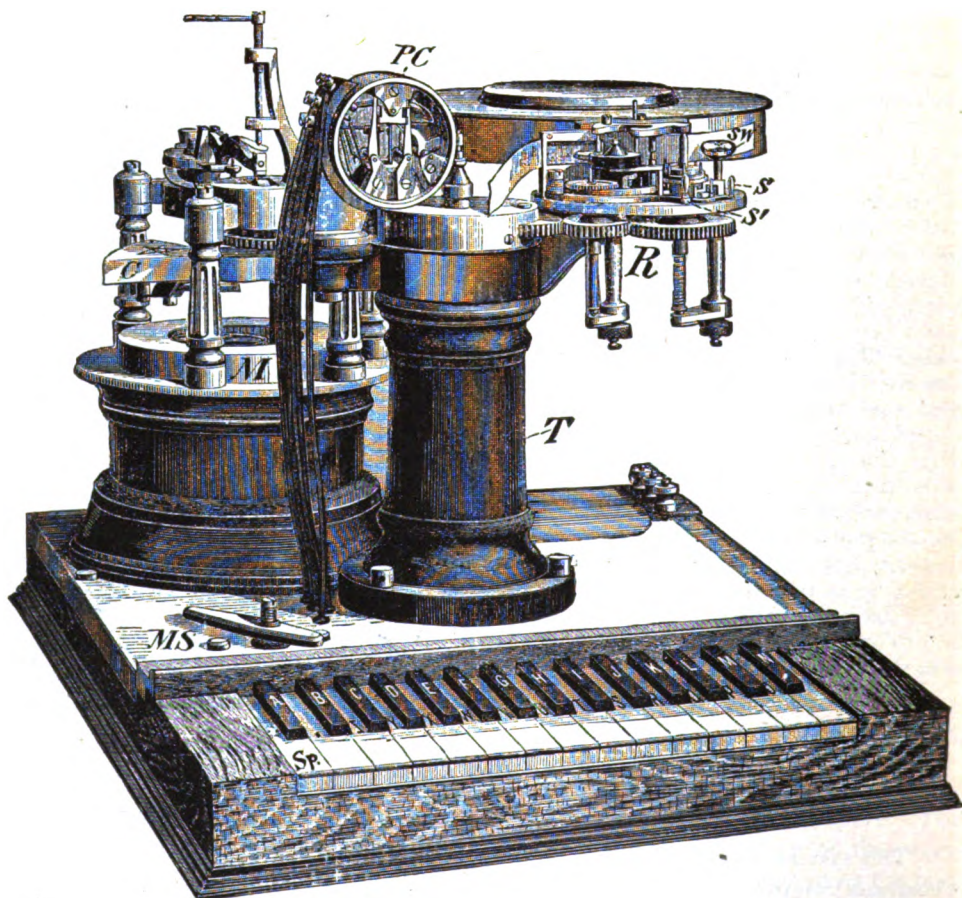

PHELPS "MOTOR" PRINTER.

rotation of both the transmitting and receiving mechanism.

Fig. 313 represents, theoretically, the electric-motor connections and those of the transmitter. The motor employed in this system, due to the late Mr. G. M. Phelps, is highly ingenious and efficient, but as a description of it is not essential to an understanding of the system proper, the motor is indicated in the figure as an ordinary drum armature. The route of the motor circuit may first be considered. Starting from the negative pole of battery *B*, it reaches, by means of an insulated wire, the insulated point *F*; thence it passes to the lever *F*, which is insulated from the framework. The circuit then passes to the wheel *FD*, which rotates in an oil pot *OP*; thence,

via the framework of the motor, to the motor brush and through the motor to the battery. The function of the shunt wire *w* via *R*, will be described presently. The lever *F* rests more or less lightly on the periphery of *FD*, according to the pressure applied to the spring *s* by the screw *H'* which may be turned up or down by the handle *h*.

MOTOR GOVERNOR.—In order that the rate of rotation of the revolving apparatus

FIG. 313.

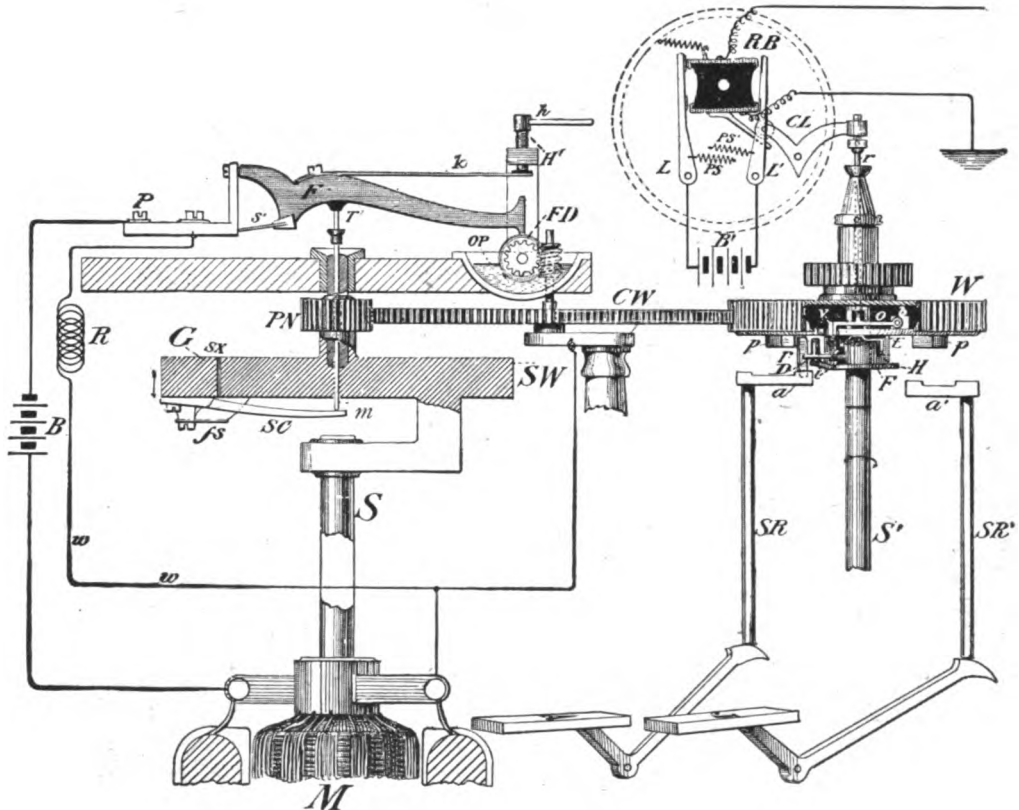

PHELPS "MOTOR" PRINTER, THEORY.

at each end of the wire shall be practically the same, it is necessary that the speed of each motor should be under control at each station. This control is effected by means of an electro-mechanical governor, shown as *G* Fig's. 312 and 313, and consists of the following parts: A nearly solid wheel *sw*, (Fig. 313), forming part of a shaft *s*, as shown. A strip *sc*, and a rod *m* which passes through and above the upper part of shaft *s*, where it reaches, but is insulated from the lever *F*. The wheel *sw* has a segment *sx*, which is fastened to the wheel by a stiff, flat spring *fs*. When the shaft is in rotation this segment tends, by centrifugal action, to fly outward at a tangent, but as the spring *fs* prevents it from doing so, it takes a downward movement, as indicated by the arrow. As it does this, the right end of the flat strip *sc* is given an upward tendency.

This causes the rod *m*, which is resting on *sc*, to raise the lever *f*. This latter action separates wheel *FD* from lever *f*, and thus diverts the entire current through resistance *R*, thereby at once weakening the current in the motor coils. As the motor has considerable work to do in driving the transmitting and receiving apparatus, which it does by means of pinion *PN* on shaft *s* and cog-wheel *cw*, its motion is at once retarded, and the "governor" section *sx* of wheel *sw*, resumes, under the pressure of its supporting spring, its former position, when contact is again made at *FD* and increased current is again supplied to the motor. In the operation of the motor this action is constantly taking place, but the governing mechanism is so prompt in its adjustment that the actual variation of the speed of rotation is not perceptible.

The motor shunt, *R*, also serves the purpose of preventing sparking at the point of junction of the lever *f* with the wheel *D*. The resistance *R* is regulated to obtain the best results, and requires to be varied at times to meet the varying condition of the motor battery.

TRANSMITTING APPARATUS.—The key-board of the transmitter, as shown in Fig. 312, contains the letters of the alphabet, a "dot" key and one "space," or blank key, that is one key which, when depressed, does not cause a letter to be printed, but yet has the effect of advancing the paper at the receiver. Each key is mechanically connected with one of a series of vertical slide rods, arranged in a circle within the hollow cylinder *T*. Two keys *A*, *J*, and their respective slide rods *SR*, *SR'* are shown to the right of the motor in Fig. 313. From the upper end of each rod an arm *A*, *A'* extends, at right angles to the rods, towards, but not reaching to the centre of the cylinder. The act of depressing a key elevates its slide rod a certain, short distance; the angular arm being of course raised with the rod. A vertical shaft *s'* (Fig. 313) rises through the centre of the cylinder. A hollow cog-wheel *w* is rigidly attached to the shaft. The shaft *s'* is tubular from the wheel *w*, up, and through this tube a small rod *r*, passes, as indicated by the dotted lines. One end of a bent lever *CL*, rests on the top of this rod. The other end of the lever carries a small roller which rests on an arm projecting from a rocking block *RB*, of the circuit breaking apparatus.

RB carries a contact point at each of its 4 corners. Its upper half is insulated from the lower half; the line wire being connected to the upper half, the ground to the lower half. The block is pivoted at its centre. The levers *LL'* each have two contacts capable of connecting with the contact points on *RB*. These levers are inclined towards *RB*, by springs *PS*, *PS'*. Normally, the springs attached to *RB* give it the position shown in figure. When, however, the rod *r* is raised, as it is by the action of depressing a key on the key-board, in the manner presently to be described, the bent lever *CL*, is caused to bear upon the projecting arm of *RB*; thereby partly turning *RB* on its axis. This action, it will be seen, transposes the contact points and reverses the battery *B'*; for, as thus arranged, the circuit breaking apparatus is really a pole-changing device. At the distant end is a polarized relay, whose armature controls a rotating printing wheel.

Hence, when the bent lever *CL* is operated it virtually controls the distant printing mechanism.

The mechanism by which the circuit breaking apparatus is operated, is

shown at the right in Fig. 313. It consists essentially of a small wheel *H* and its attachments, carried loosely by the shaft *s'*. (This wheel is also shown in Fig. 315). In shape it resembles somewhat a hat; having a flange *F* at the part corresponding to the rim. In Fig. 313 *a*, the wheel *H* is shown straightened out, for the purpose of

FIG. 313 *a*.

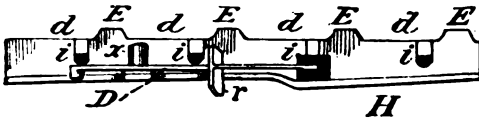

better illustration. Above the crown, on the side of the wheel, there are four small elevations or ridges, *E*. On the side of the wheel are four *u* shaped niches, *i*. The extensions *E* and niches *i* on the side of the wheel are in virtually the position indicated in the diagram, as regards each other.

On the rim of *H* an attachment *D*, termed a dog, is pivoted at *x*. *r* is a projection which may be termed an ear. The actual shape of *D* is better shown in top views, Fig's. 315, 316, in which *D* is the dog, *r* the ear, *t* the tail, *h* the head, and *P* a tongue extended within the wheel through one of the niches *i*.

Normally, *D* is in the position on the flange shown in Fig. 316, and it is held snugly in that position by means of the curved tongue *P* and the jockey roller *j*, attached to the inside of the wheel *H*.

When, at certain times, the head *H* is pushed out, as in Fig. 315, the tongue is slipped over the roller, and thus the head is held out until it is pushed back again in the course of the operation of the device. This roller may be said to perform a practically similar work in this device to that of the jockey roller in the Wheatstone transmitter.

Normally, the wheel *H* and its attachments revolve with the shaft *s'* and wheel *w*. It is caused to do so by the device shown in Fig. 314. This represents the sides of the wheels *w* and *H* opposite to those shown in Fig. 313. A portion of the hollow wheel *w* is cut away for illustration; *K* is a small projection from a spring rod *N*, the latter attached to the inside of wheel *w*; *K* passes out of the wheel *w* through a suitable slot, just above the outside edge of the periphery of wheel *H*. The spring rod *N* gives *K* a tendency to press against the outside of *H*. Thus, if the wheel *H* be stationary while *w* is moving, *K* will fall into that one of the four niches *i* on the side of *H* at which it first arrives, and will hold with sufficient tenacity to, at once, set *H* into rotation with *w*. If, however, the course of *H* be suddenly checked, *K* simply rises out of the niche, leaving the wheel *H* behind. But, again, if by the time *K* reaches the next niche, ear *r* has been released, *K* at once drops into that niche, and instantly draws the wheel *H* with it.

FIG. 314.

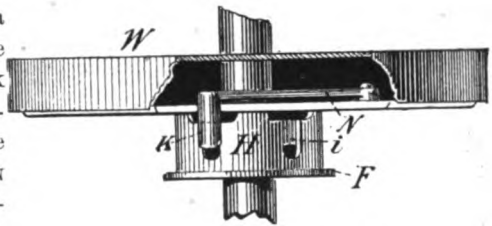

Reverting now to Fig. 313. The wheel *w* is supposed to be rotating in the direction indicated by the arrows; *H* being rotated with it. The angular arm *a* of the slide rod *SR* is shown as just having been elevated by the depression of key *λ*. It will be seen that the angular arm *a* is now directly in the path of the ear *r* of the dog which is

riding on the flange *F* of wheel *H*. The next instant the ear will strike against that arm and throw the tongue out of a hole *i* on the side of *H*. This act throws the ear between two of a circular row of teeth (Fig. 315) which teeth are fixed just outside of the normal path of the ear. These teeth are cut in a circular metal plate *z* supported from the inside of the cylinder. This contact at once stops the rotation of *H*, but the wheel *w* continues its motion, the projection *κ* having glided out of its niche. The result is that, in a moment, a small projection (*v* Fig. 313) carried on the end of a rod *o*, and which extends below the under side of the wheel *w*, normally resting in a depression *d* on the top of the side of the wheel *w*, slides up on an extension *E*. This raises the horizontal rod *o* on which the vertical rod *r*' is resting as shown, and by that act the circuit breaking, or current reversing apparatus, is operated in the manner above described. The length of time during which the rod

FIG. 315.

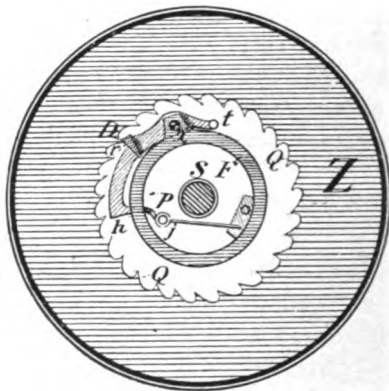

r' keeps the circuit open, or reversed, corresponds with the time taken by the projection *v* to ride over the extension *E*. The instant it has done so it falls into the next depression and the rod *r*' falls with it permitting the circuit breaking apparatus to resume its normal position.

FIG. 316.

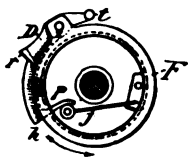

The pulsations necessary to print the letter corresponding with the key which had been depressed at the sending station, having been transmitted, it is now necessary that the dog should be promptly released from the tooth which is holding it, that it may be ready to engage with the next slide arm elevated for the purpose of sending another letter. This release is brought about by the device of suspending from the bottom of the under side of wheel *w*, four small wedge-shaped metal pieces, with the point of the wedge towards the shaft *s*. These are shown as *P, P, P, P*, in Fig. 317, looking at them from below. Two of these pieces, *p, p*, are also shown in Fig. 313. They are so placed with relation to the upper part of the ear *r* that, after the lower part of the ear has been struck by the angular arm *a* and the wheel *H* is, consequently, halted in its progress, the wheel *w* can only traverse a space equal to the distance between any two of the pieces, say, *ab*, when one of them will impinge against the ear *r*, thereby partly turning the dog on its pivot and detaching the ear from between the teeth *q*. At the very instant that this happens the extension *κ*, on the side of wheel

FIG. 317.

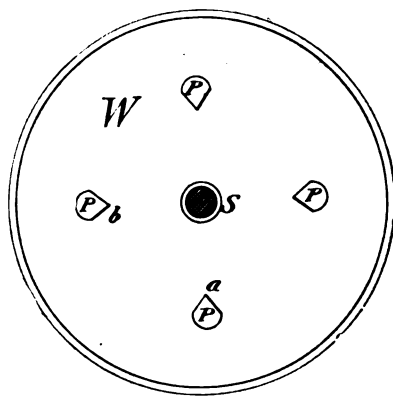

w opposite the dog, (Fig. 314) has arrived at and dropped into one of the niches *i* on the side of wheel *H*, which at once compels the latter wheel into rotation with *w*, when it is again ready to perform its part in the transmission of another letter. (In Fig. 315 the dog is shown as engaged with teeth *q*; in Fig. 316, free from the teeth.)

Thus the act of stopping the wheel *H*, by the action of the angular arm of the slide rod, and the act of starting it by the action of metal piece *P* must occur within a very short time of each other. The shaft *s'* rotates at about 180 revolutions, per minute. As there are but four pieces, *p*, etc., the actual time would be but the one-twelfth of a second, and as each of the extensions *E, E, E, E*, occupies but one-eighth of the circumference of wheel *H*, the time during which the rod *r'* is raised is, virtually, but the one-twenty-fourth part of a second.

Notwithstanding the speed of rotation of the shaft *s'*, and the high rate of transmission by this system, namely, 65 to 75 words, per minute, it is worthy of note that the actual number of pulsations transmitted over the wire is much below that necessary in simple Morse telegraphy. For example, in transmitting the word "Phelps," by the Morse alphabet, 19 pulsations are necessary, while but 5 pulsations are required in the transmission of the same word by the printing mechanism under consideration.

RECEIVING APPARATUS.—The chief parts of the "printing" apparatus of the Phelps printing telegraph system are shown in Fig. 318.

FIG 318.

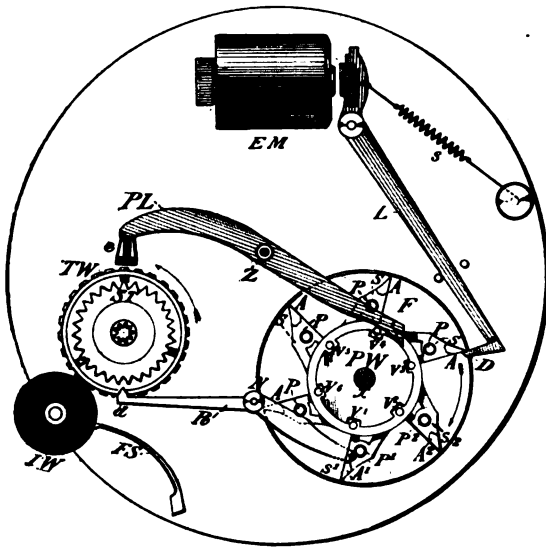

EM is an electro-magnet in a local circuit controlled by a polarized relay, L is a lever, to which is attached the armature of EM. This lever has, at its lower end, an angular arm, or detent, D, which engages with the spurs, or teeth, s,s,s, of a star-shaped wheel, PW. This is termed the printing wheel. Six such spurs project from PW. On the end of each spur is an angular arm A. At about the middle of each spur is a pin P. On the main body of wheel PW are six pins v_1, v_2 , etc., the use of which will be explained shortly. The wheel PW is loosely mounted on the shaft x.

The flat wheel F is rigidly mounted on the same shaft. PW is pressed snugly against F and when it is not restrained by the engagement of the detent D with one of its spurs, it revolves in unison with F. TW is the type-wheel, carrying the letters of the alphabet on its periphery. ST is a toothed wheel, rigidly fastened to the type-wheel, so that, when, by proper means, the detent *d* of the lever R, which is fulcrumed at N, is inserted between any two of the teeth of ST, the type-wheel TW at

once ceases to revolve. Normally, the type-wheel *tw* is caused to revolve at a rate equivalent to that at which the wheel *H* carrying the dog *D* at the transmitting station is rotated; for simplicity the train of wheels for the purpose is omitted in Fig. 318. *rw* is an ink-roller which is held by means of its flexible support *rs* and a suitable spring against the types of *tw*. *pl* is a lever, the effect of whose operation is similar to that of the press lever of the ordinary stock printers.

Normally the printing wheel *pw* is held at rest by reason of the fact that the local circuit controlling *em* is open and consequently its armature is withdrawn by springs, thus permitting the detent *d* to engage with and hold one of the spurs of *pw*.

FIG. 319.

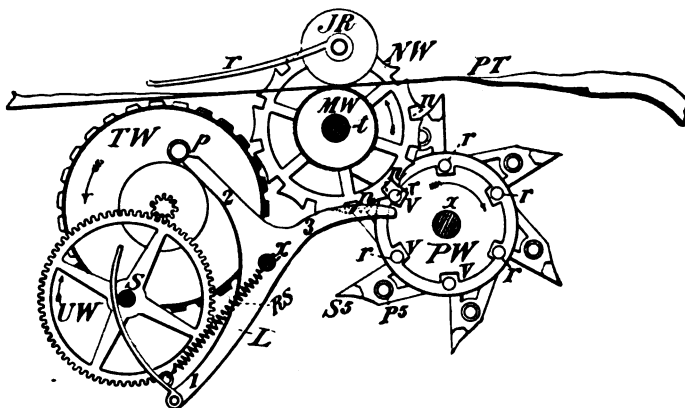

When however the electro-magnet is closed for an instant it results that the detent *d* is withdrawn from the spur. The printing wheel *pw* at once starts to rotate, but before it can move far the electro-magnet *em* is again demagnetized, and the detent *d* resumes its former position and engages with the next spur. Consequently, as there are but six spurs, at equal distances apart, the opening of the electro-magnet has only permitted the printing wheel to make the one-sixth of a revolution. But, in making this portion of a revolution the printing wheel has performed four important functions, namely: It has operated the lever *R*, which has stopped the rotation of the type-wheel *tw*; it has operated the lever *PL*, which has printed the desired letter. It has, by operating mechanism, shown in Fig. 319, advanced the paper tape a suitable distance, and it has again operated the lever *R*, causing it to withdraw the detent *d* from the teeth of *st*, permitting the type-wheel *tw* to resume its motion.

At rest, as in the figure, the angular arm at the end of lever *R* is nearly in contact with the pin *P'* on spur *s₁* of *pw*. When *pw* begins to move, this pin engages with the arm of *R* and pushes the detent *d* between the teeth of *st*. The pin *P'* then continues to glide along the curved edge of *R* still holding it so that detent *d* remains between the teeth of *st*, until the next spur *s₂* arrives nearly at the position just held by *s'₁*, when the projection *A₂* on *s₂* engages with the inclined end of *R*, pushing it towards the pin *P₂*, and, at the same time, withdrawing the detent *d* from between the teeth of *st*, which at once permits the type-wheel to resume rotation.

In the meantime, and during the same motion of the wheel *PW*, the pin *v*₄ on the main body of *PW* has come in contact with an end of the lever *PL*, raising that end, and, consequently, depressing the other end *c* against the paper, thereby printing a letter; having done which the lever resumes its former position, its lower end then resting on pin *v*₅, ready for the printing of another letter, at the next motion of the printing wheel *PW*. It will be seen from the relative position of the lever *R* to the pins *P*₁, *P*₂, etc., and the angular projection *A*, and that of lever *PL* to the pins *v*₁, *v*₂, etc., that the type-wheel will be arrested before the lever *PL* can have reached the paper, and that, further, the latter lever will have arisen from the paper before the detent *d* of the lever *R* has been withdrawn from the teeth of *ST*.

PHELPS SYNCHRONIZING DEVICE.—In the “step by step” printing telegraph systems we have seen that the rotation of the receiving apparatus is controlled by the transmitter and that the rate of rotation of the receiver is thus made to conform to that of the transmitting apparatus. In the Phelps system, however, such is not the case, the transmitter and the receiver being practically independent of each other, so far as the operation of the latter by the former is concerned.

It is therefore obvious that some means must be employed to secure synchronism between the Phelps transmitter and receiver.

The device by means of which the Phelps system is synchronized consists of the detent *d* attached to lever *R*, Fig. 318, which is caused to perform a double function, one of which has already been described (namely the arresting of the type-wheel). It performs its synchronizing function as follows: The shape of the detent is such that it fills the space between any two teeth, when it is placed therein. Hence, if the toothed wheel *SR* should be slightly in advance of the transmitting wheel *H*, Fig. 313, the detent *d*, which is actuated primarily by that wheel, cannot fully occupy the space between any two teeth except by pushing back wheel *SR*, and with it, of course, the type-wheel. Contrariwise if wheel *SR* should have lagged slightly the detent *d* will push it the necessary distance forward. Inasmuch as this action is repeated at the printing of each letter, a considerable variation from actual synchronism in the revolution of the receiving and transmitting apparatus might take place before the instrument will “throw-out.” Perhaps, this synchronizing action will be clearer to some if it is pointed out that it embodies the now well known clock synchronizing principle, in which the minute hand is pushed forward or backward if not keeping the correct time, by the action of the armature of an electro-magnet. The function of synchronizing the type-wheel, or, as it is called, correcting the synchronism of that wheel, may, therefore, fairly be added to the other functions specified of the printing wheel of the receiving apparatus.

UNISON DEVICE.—The mechanism of this system by which the type-wheel is brought to unison, is shown in Fig. 319.

In brief, the unison device may be said to consist of means whereby the type-wheel is brought to rest at a certain point after a few revolutions, when the printing wheel is not in operation, and of additional means whereby the action of the device which would thus bring the type-wheel to rest, is prevented from acting upon that wheel so long as the printing wheel is in operation. In the figure, *TW* is the type-wheel. (This wheel has 26 letters and one blank space on its periphery.) *CW* is a

small cog wheel, or pinion, on the same shaft as *rw*. *uw* is a toothed wheel, meshed with *cw*. The shaft *s*, on which wheel *uw* is mounted, extends beyond the wheel. *w* is a curved rod pivoted on an end of arm 1 of a 3-arm lever *L*, which is pivoted at *x*. The left end of *w* rests on the shaft *s* and it is caused to rest snugly against the shaft by the pull of a spring *rs*. Consequently, when the type-wheel and the wheel *uw* are rotating, the latter in the direction shown by the arrow, the rod *w* is given a gradual upward movement. This movement of *w* turns the lever *L* on its axis and, if nothing prevents this forward motion of the rod *w*, the arm 3 of the lever *L* will, after a few revolutions of *rw*, be interposed in the path of a pin *p* projecting from the side of the type-wheel.

When this occurs, as shown in the figure, the type-wheel is held fast, with the blank space on its periphery opposite the pad of the printing lever *pl*, Fig. 318.

It will be seen, however, that the arm 3 of *L* is now directly in the path of pin *p*, on a spur of the printing wheel-*pw*. Hence, at the moment a distant key is depressed and the detent, on the armature lever of *em*, Fig. 318, is withdrawn, the pin *p* throws arm 3 of lever *L* out of its path, which instantly throws arm 2, of *L*, out of the path of pin *p* on *rw*, thus permitting the latter wheel to rotate. Inasmuch as, in the act of printing the letters, the printing wheel is kept in almost continual motion, it will be evident that the arm 3 of lever *L* will be constantly set back by contact with the pins on the spurs of that wheel and, consequently, the arm 2 cannot, while the printing operation is in progress, get into the path of the pin on the side of the type-wheel.

When the type-wheel has been brought to unison it is necessary that the transmitting operator should depress his "blank" key before proceeding with his message. This starts the type-wheel at once and as the "blank" key corresponds in position with the blank space on the type-wheel, which is below the printing platen at that time, the transmitting apparatus and the receiving apparatus will rotate with corresponding letters in, as it were, proper alignment.

PAPER FEEDING MECHANISM:—The paper feeding apparatus of this system, which is also shown in Fig. 319, is virtually similar to that of the Phelps stock printing instrument. In the operation of this apparatus the small pins *r r* on the printing wheel *pw*, and the notches *n n* in the wheel *nw*, are utilized. The wheel roller *mw* and the wheel *nw* are on a common shaft *t*. *jr* is a smaller roller, supported by a flexible rod *r'*, and resting lightly on the paper strip *pt* which passes between *jr* and *mw*. Normally, one of the pins, *r*, is in one of the notches *n*, of wheel *nw*. When the wheel *pw* is allowed to move the distance between any two of the spaces, the pin *r* engages with the edge of the notch and pushes the wheel *nw* a short distance out of its path. As the wheel *nw* is turned the paper tape is urged a short distance to the left. The pin then leaves the notch, and the next pin moves into the next notch, ready to give the wheel *nw* a further turn at the next movement of *pw*. Thus, at each partial revolution of *pw*, the paper is moved a certain distance, sufficient to properly separate the letters, and the arrangement of the printing lever *pl*, Fig. 318, is such that the printing is not done until the advance movement of the paper tape has been effected.

It will be understood that the parts of the receiver shown separately in Figs. 318, 319, are suitably placed on a common base to permit the necessary co-operation between them.

ADJUSTMENT, ETC.—The motors of this system are adjusted in the following manner: The distant station depresses the blank, or space key (sp, Fig. 312). At the same time the home station permits his motor to run.

If the instruments are in synchronism nothing will be printed. If the letter A, or A B C should be printed, it shows that the home instrument is running too fast and the handle *h*, Fig. 313, of the governing apparatus, is raised. This permits the lever *F* to recede further from the disc wheel and thus slackens up the speed of the motor. If, on the contrary, the letters x y z, should be printed, it is evidence that the home motor is lagging, and the speed is increased by the pressure of the lever *F* on *FD* by which action more current passes through the coils of the motor.

FIG. 320.

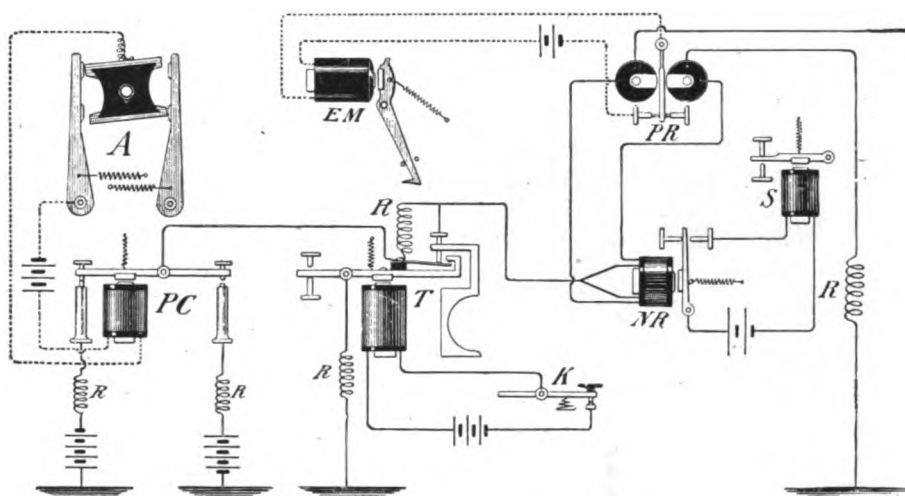

CONNECTIONS OF PHELPS MOTOR PRINTER.

To secure a space between words on the paper tape, the sending operator depresses the blank key between each word. This operates all of the printing mechanism at the distant end and moves the paper forward, but, as the blank space on the periphery of the type-wheel is opposite the platen at that moment, nothing is printed.

This system is now worked exclusively on a quadruplex circuit. The polar side of the quadruplex is utilized solely for the transmission of messages, each way. The "second," or neutral side, for "breaks" By this arrangement but one sending operator is interrupted; each receiving operator doing his own breaking.

A diagram of the connections as arranged for quadruplex working is given in Fig. 320.

The circuit breaking apparatus of the Phelps motor printer is shown at A. Owing to the tendency to sparking at its contact points when applied directly to a quadruplex it is caused to operate a pole-changer *PC*, as shown. *T* is the transmitter, *NR* the neutral relay and *PR* the polar relay of the quadruplex. The polarized relay controls the printing magnet *EM*. Breaks are sent by operating the transmitter which causes the sounder *S* in the local circuit of the neutral relay to give a "break" signal.

THE ESSICK PAGE AND LINE PRINTER.

The printing telegraph systems thus far described have all used a paper fillet, or strip, on which to print the letters and figures.

FIG. 321.

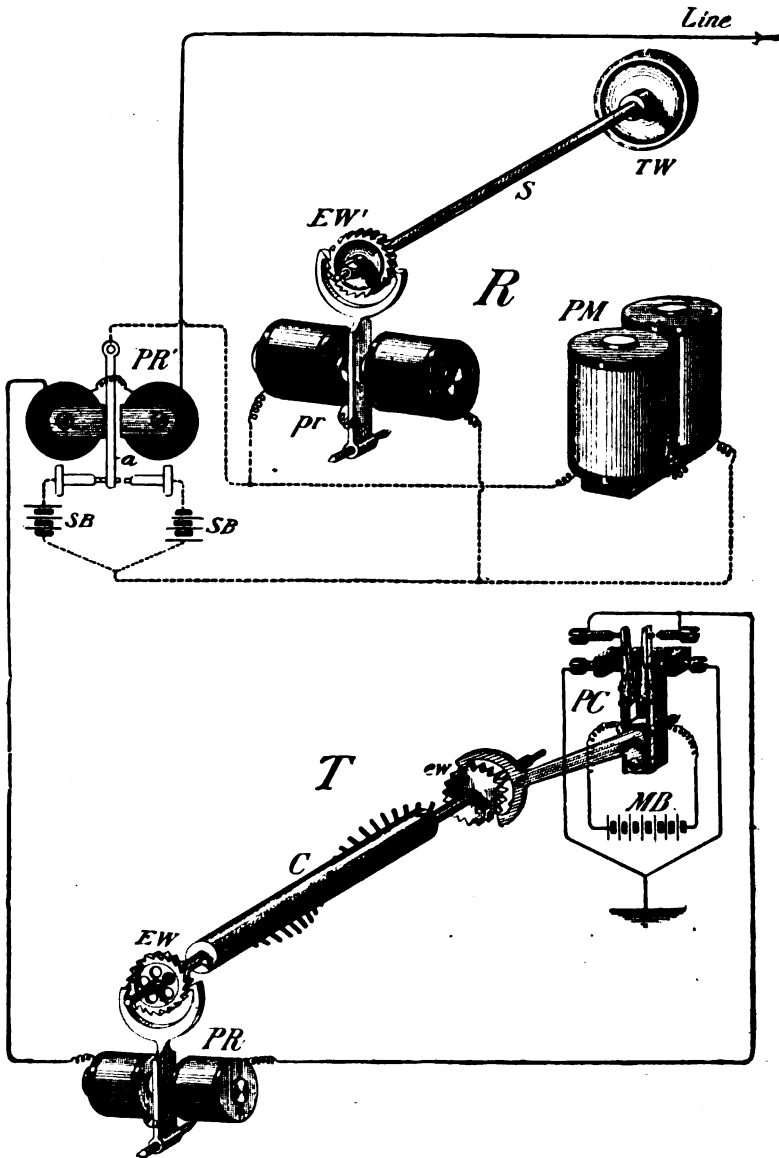

ESSICK PAGE AND LINE PRINTER, THEORY.

The Essick "Page and Line" printer, as the name implies, departs from this method and furnishes a record of messages received on a page of paper.

This necessitates, of course, means for moving either the paper, or the type-wheel, suitable distances, laterally, as each letter is printed, and also means for moving the paper upward or forward a suitable distance at the end of each line. In the Essick printer it is the paper that is moved laterally and upward, and the type-wheel is held in a given position where it rotates on its shaft in the usual way.

In addition to the special apparatus entailed by the page and line feature of the Essick printer, the transmitting and receiving devices of this system differ from any of the systems thus far described; in several respects quite materially.

The Essick printing telegraph system is intended to be used either as a local or long distance printer.

The theory of the transmitting and receiving apparatus is illustrated in Fig. 321. τ is the transmitter, κ is the receiver at one station. Each terminal is, of course, similarly equipped. The transmitting cylinder c and the type-wheel shaft are rotated by spring motors with which they are connected by clock-work gearing. The speed of rotation is governed by escape wheels ew , ew' , and polarized relays PR , PR' .

Reversals of polarity are used to effect the rotation of the polarized relays. These reversals are produced by a pole-changer pc , under control of an escape wheel ew on the right end of the cylinder c of the transmitter. Ordinarily the rotation of escape wheels is governed by the escapements, as in the case, for example, of ew , ew' . This procedure is reversed in the case of the escape wheel ew and the escapement e , (which latter is attached to what corresponds to the lever of the ordinary duplex pole-changer,) that escape-wheel actuating its escapement, thereby producing a motion of the levers of the pole-changer which rapidly reverses the battery MB . These "reversals," in turn, pass through the polarized relay PR , in consequence of which a mutually governing action, as between the pole-changer and the cylinder c , is secured; and by which also serious interruptions on the line wire immediately serve, either to hold the cylinder shaft, or to indicate to the attendant the presence of "trouble" on the wire.

The rotation of the cylinder c is, itself, controlled by the keys of the key-board in a manner practically similar to that of cylinders of the same type already described; but the actual construction and some of the details of the key-board of the Essick transmitter differ from the others referred to. These features will be explained separately.

The type-wheel shaft s of the receiver κ is controlled by a local polarized relay PR , which is operated by reversals of polarity of the split battery SB ; the said reversals being caused by the armature a of the main line polarized relay PR' . As the latter relay is under control of the distant transmitter it follows that the reversals of polarity controlling the receiver will correspond with those caused by the transmitter.

The press magnet PM of the receiver is in a branch circuit with the polarized relay pr . Owing to the rapidity of the pulsations this press magnet is normally open, but on the cessation of reversals its lever is immediately attracted. This magnet does not effect the printing directly, but it releases mechanism which does. The same mechanism, when thus released, also acts to move the paper carriage, laterally, and to throw off the unison device, in a somewhat analogous manner to that of the printing mechanism of the Phelps stock printer.

A front view of the paper carriage of the receiver is shown in Fig. 322. The frame of the carriage is indicated by *ff*. The frame is carried and guided by wheels *w w w*. The rack-bar *R* is also carried by the frame. An endless screw *w* rests normally in the teeth of the rack. *w* is mounted rigidly on the shaft *A*. At its right the same shaft supports a pinion *p*; which is geared with a large cog wheel *cw*. A pin *r* projects from the right end of shaft *A*. This pin is normally held by the upper tine of a double detent *d*, Fig. 323, carried by the lever *L* of the press-magnet. When the armature of lever *L* is attracted the pin *r* is released. This permits shaft *A* to make one revolution, at the end of which revolution the pin *r* is held by the lower tine of detent *d*, until the armature again rises, when the pin *r* is again held by the upper tine of *d*. The act of turning the shaft *A* once, moves the carriage laterally a distance equivalent to the width of one letter of the type-wheel, against the pull of a recoil spring contained within the pulley *P*. The left end of the shaft *A* rests in a movable bearing *B*. This

FIG. 322

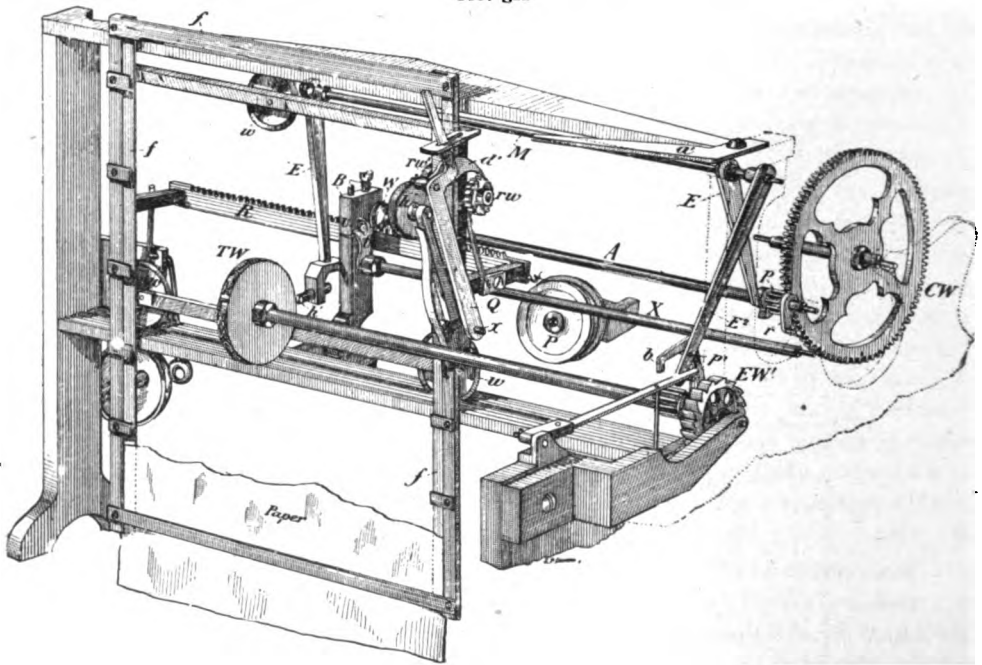

ESSICK PAPER CARRIAGE, FRONT VIEW.

bearing may be raised or lowered by shaft *x*. When this shaft *x* is oscillated, as at certain times it is, it operates an eccentric *t* which raises the endless screw *w* out of the rack; thereby allowing the recoil spring to withdraw the carriage to the starting point.

When the carriage has been moved forward to the extreme left a small bell is automatically sounded, as an indication thereof; whereupon the operator depresses a key which allows the escape wheel *EW'* of the receiver to run continuously for a few revolutions, which action brings into play a device, to be shown subsequently, that lifts the endless screw out of the rack. It is not necessary, however, that the carriage should be moved to the extreme left before bringing this mechanism into play; it may be returned, in the same way, to the starting point at any part of its trip.

The device whereby the paper is moved upwards at the end of a line, is indicated in Fig. 322, at *rw'* and *a'*. *a'* is an arm set out at an angle from the frame, and forming, with the frame, a horizontal *v*. The vertical rod, or lever, *Q*, is pivoted

at *x* on the frame of the carriage. This rod, *q*, carries a pawl *d'* which rides on a small ratchet wheel *rw*. On the same shaft with *rw* is a roller *rw'* the upper edge of which is seen. Opposite *rw'* is a roller *h*, suitably pivoted, which presses against the paper. The act of pushing forward the rod causes the pawl *d'* to engage with its ratchet wheel and thus rotates the rollers. In returning, the pawl simply slips past the teeth on *rw*. A suitable spring holds the rod *q* out from the upper part of the

FIG. 323.

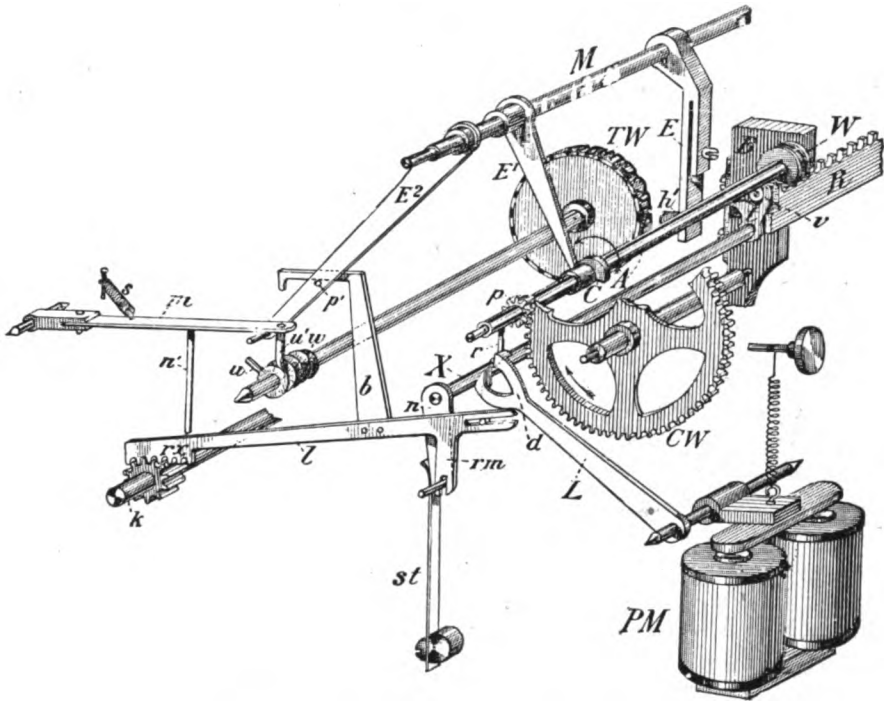

ESSICK PAGE AND LINE RECEIVER—THEORY PRINTING DEVICES.

frame a certain distance. Thus when the carriage is being returned to the starting point the rod impinges against the arm *a'* and is quickly pushed forward, thereby causing the pawl *d'* to turn the rollers, which effects the desired upward movement of the paper. The paper is outlined at the bottom of the carriage frame.

A side view of the principal actuating parts of the printing and carriage-moving mechanism, just referred to, is given in Fig. 323.

In this figure *PM* is the press magnet. *L* is its lever extending to the double detent *d*. *cw* is the large cog-wheel which imparts the rotary motion to the shaft *A*, and with which the pinion *p* on shaft *A* is geared. Shaft *A* also carries an eccentric, or cam, *c*. Opposite *c* is placed an extension *E*₁ mounted rigidly on a shaft *M*. *M* also carries extensions *E* and *E*₂. *E* is placed directly behind the type-wheel *rw*. The shaft *x* which carries the eccentric *t* also carries at its left end the depending arm *n*. The arm *rm* of the lever *L*, at its lower end is slotted, as shown, and a pin projecting from the arm *n*, fits in the slot. Another bent projection *b* from *L* rests, normally, on a

pin, p' , on the side of extension E^2 . The left end of lever l is provided with a short rack rx which, normally, rests in the pinion k . This pinion is in constant rotation when the receiver is in operation. Consequently, if the rack rx were allowed to rest continuously in the teeth of k , it would be quickly drawn to its limits, against the pressure of the tension spring st . This act would push the extension n to the left, thereby oscillating shaft x and causing the eccentric t , Figs. 322 and 323, to lift the endless screw w out of the rack R , for the purpose stated.

As long, however, as the rack rx of lever l is prevented from resting continuously in the teeth of k , the oscillatory movement of shaft x does not take place; and as it is imperative that this action should only take place at desired intervals, a device analogous to that used in printing telegraph systems for preventing the action of the "unison" device during the regular printing operation, is employed.

This device consists of the bent arm b , attached to l , which operates to insure the desired effect as follows:

At every downward motion of the armature of the press magnet we have seen that the shaft A is permitted to make one revolution. In making that revolution the cam c on that shaft strikes against the extension E' . This action oscillates the shaft x and, consequently, the extensions E_1 and E_2 with it. Thus, at every stroke of the cam c the extension E_2 by means of pin p^1 , is caused to lift the rack rx of lever l out of the teeth on the pinion k , thus preventing it from oscillating shaft x .

The unison device is shown in Fig. 323. It consists of the endless screw w of the type-wheel shaft and the pins u and u' . The operation of this device is practically similar to others already described. Normally the pin u' would rest in the thread of the endless screw w . The rotation of the type-wheel shaft would bring the pin u' into a position where it would engage with the pin u , thus stopping the type-wheel at a certain point, that is, with the "space," or dot, opposite the hammer h' . In the operation of the printing mechanism, however, the pin u' is continually lifted out of the screw threads and brought back to its starting point by the pull of the spring s .

The office of the projection n' from the strip m is to insure the operation of the rack rx when desired. For instance, it was found that *sometimes* the rack rx would rest on the top of the teeth k before meshing, for a sufficient time to permit the type-wheel to come quickly to unison, thereby preventing the desired return of the carriage to its starting point. The projection n' is so placed that it holds the unison pin u' out of the screw threads until the rack meshes with the pinion teeth.

It will be understood that the press-magnet is only operated when it is desired to print a letter, or to effect a motion of the carriage for spacing. Since then the extension E from shaft M is urged forward, at each motion of the press-magnet, by the action of the cam c , it will be seen, the hammer h' attached to the lower end of E will strike against the type-wheel, or rather the intervening paper, and impress thereon the letter desired to be printed.

It is thus obvious that the various actions of the printing and moving mechanism are, almost entirely, mechanically performed, the press-magnet merely serving to set free the mechanism at the desired instant, the result of this release being to permit the rotation of shaft A , by which act the carriage is moved laterally, the unison device

is held out of contact with the pin *u*, the lever *l* is prevented from operating eccentric *z*, and the printing is effected.

FIG. 324.

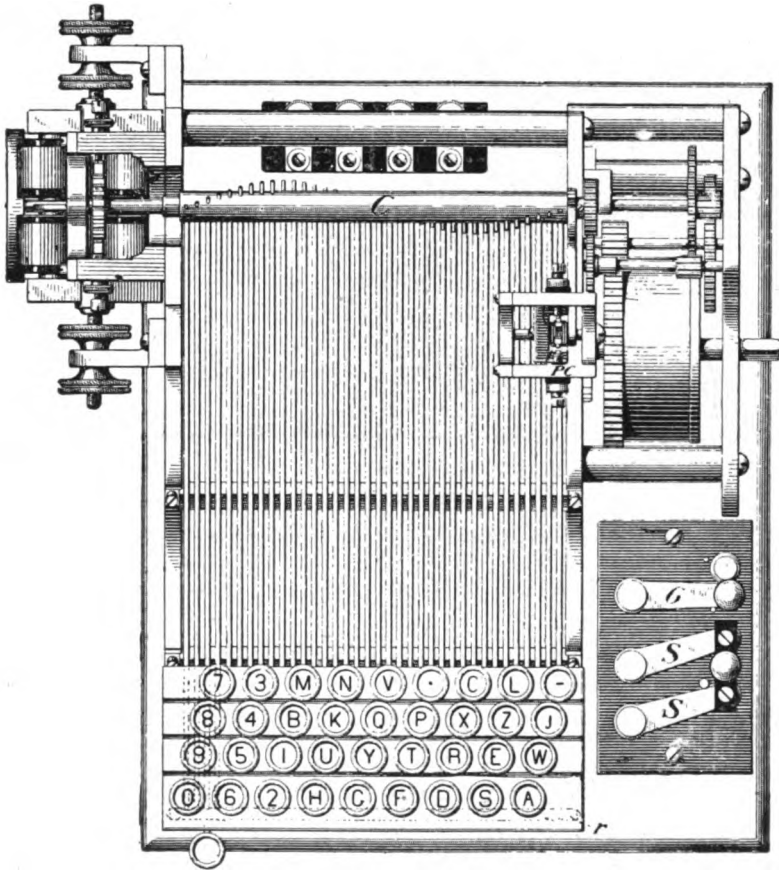

ESSICK PRINTER, KEY-BOARD AND TRANSMITTER.

The transmitter and key-board are shown, top view, Fig. 324. *ss* are switches whereby the necessary change from "sending" to "receiving" is effected. *pc* is the pole-changer, *c* the "pin" cylinder. Each key on the key-board is provided, as shown, with a lever extending to the cylinder; which lever is furnished with a detent, (outlined in side view of the transmitter, Fig. 325,) by means of which it engages with its corresponding pin on the cylinder.

A device, whereby any key depressed is held down until another key is depressed is shown also in Fig. 325. It consists of the bent lever *b*, which carries a rod *r* (shown in cross section in the figure) placed at the lower ends of the key levers, as

outlined in Fig. 324. The rod *r* is cut away on its under side, so that, when a lever is depressed, its end passes under the rod and is held there until the depression of the

FIG. 325.

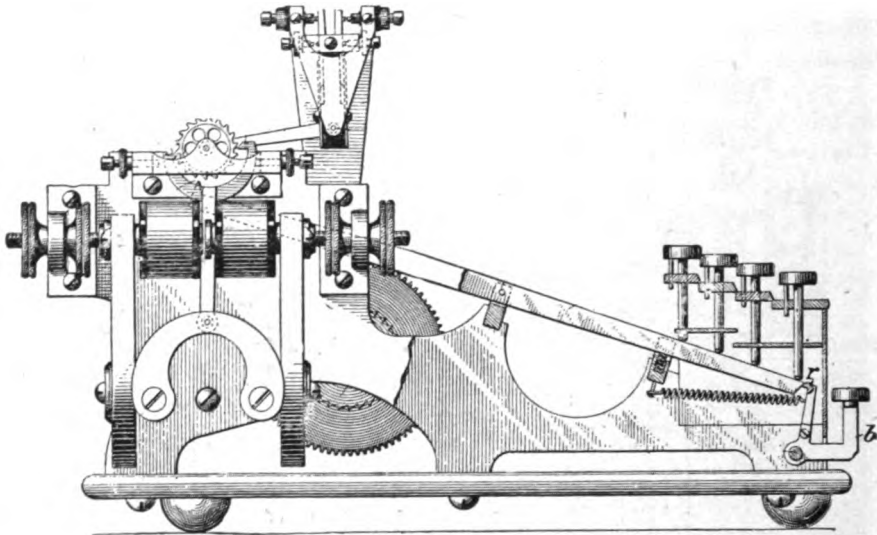

next key lever pushes the rod back, allowing the first lever to rise. This device, if not desired may be readily dispensed with by holding it out of the path of the levers.

FIG. 325a.

EXCHANGE BR PR KIN
 486.488 39. $\frac{3}{8}$ 80.1 11.14.

In Fig. 325a, specimen of printed slip as received by a two type-wheel ticker, is shown in fac-simile. The initials on top lines stand for the name of the stock; the figures on lower lines, for the market quotations.

THE HUGHES PRINTER.—This printer is quite largely used in Europe, and to a limited extent in Great Britain. The Phelps Motor Printer described herein embodies the essential features of the Hughes, and may be considered an improvement thereupon, especially as regards rate of signaling, which by the Hughes system is 30 to 35 words per minute, the message being received on a paper tape. The Hughes relay, described on page 240c, is employed as the main-line relay of the Hughes printer. Up to a recent period the mechanism of this printer was spring driven, but an electric motor analogous to that of the Phelps is being applied to the Hughes system.

THE BUCKINGHAM AUTOMATIC LONG-DISTANCE PAGE-PRINTING TELEGRAPH.

IN the step-by-step and the synchronous printing telegraph systems already described, it is evident that a considerable loss of time ensues, from the fact that it is frequently necessary to rotate the type-wheel the greater part of a revolution in order to print one letter. Thus, if the letter A follows B in a given word, it will require 31 pulsations of current to print A. If R follows C, 15 pulsations will be necessary. This gives an average of about 15 pulsations for each letter, and for the space between words as well, and hence conduces to a low rate of speed, an average of perhaps 25 to 35 words per minute. In addition the message is printed as received on a paper strip, which is not an acceptable form for delivery to the public. When also it happens that the transmitting wheel, or cylinder, and a type-wheel on these step-by-step systems get out of unison, or throw out, it is necessary to let the transmitter run free for two or three revolutions, until a unison device is actuated, this often requiring 60 or more pulsations of current. In the case of the synchronous systems described it is frequently necessary to allow the apparatus to run free for several minutes to obtain unison. In the Phelps system, for instance, synchronism is obtained as follows: The sending-station regularly depresses a pre-arranged letter, for example, the letter A. If then the letter B is received, and subsequently the letter C, the receiver is running too fast. The speed is then reduced until the given letter is printed, and vice versa. It may also be noted in this relation that quite a high degree of skill is required on the part of the operator of the Phelps and similar keyboards to secure the best results. Probably for the foregoing reasons the use of the Phelps printer is gradually being discontinued in this country (1902).

The Buckingham Long-Distance Page-Printer is the successful outcome of the work of the inventor, Mr. Charles L. Buckingham of New York, assisted by Mr. E. Germann, to produce a rapid page-printing telegraph system adapted to operate on the longest circuits, and to avoid the paper strip and other objectionable features of previous printing telegraph systems.

It is evident that to attain these ends it was necessary to diminish largely the number of pulsations required for the transmission of letters and spaces below that requisite on the ordinary printing telegraph. As a first step in this direction the Buckingham printer employs 4 octagonal type-wheels, each less than one-half inch in diameter and one-eighth inch thick, fixedly mounted on one shaft side by side. On the periphery of each wheel are placed 8 letters and other characters, 32 in all. The shaft on which this combined type-wheel is mounted is so disposed that by an ingenious arrangement of 5 arms or levers attached to the shaft the type-wheel may be given a lateral or rotary motion, such that any one of the 32 characters on its periphery may be placed before a given point for printing, by 5 pulsations of current, that is, two and one-half alternations of polarity, from the transmitting-station. It may also be noted here that the Buckingham receiving-apparatus is so arranged that a succession of short pulsations must always bring the escape-wheel of the receiving-apparatus, and with it the type-wheel, to the zero or unison position and lock it there, in a manner to be explained subsequently. For the actual printing of the

letter, in the Buckingham system, the interval corresponding to the space between letters and words in the Morse and Wheatstone systems is utilized. Hence the selection and printing of any character is brought about by a cycle of 6 pulses of current in all that is to say, 3 reversals of polarity. These pulses are, however, of varying lengths, akin in this respect to the Morse alphabet. For example, the letter A will be selected by a dash and two dots. B, by a dot, space, dash, space, dot; the space, as in the Wheatstone system, being made by a negative current, and, since it is known that a succession of 5 short and long pulses can be arranged in 32 different ways, a different combination is readily obtained for the 26 letters of the English alphabet and 6 other characters.

These combinations form what is termed the Buckingham alphabet or code, given herewith:

A	I	Q	Y
B	J	R	Z
C	K	S	&
D	L	T	,
E	M	U	.
F	N	V	?
G	O	W	-
H	P	X	Space

BUCKINGHAM ALPHABET.

Inasmuch as the prolonged negative or positive pulse of this alphabet, like that of the Morse dash, is theoretically equal to three short pulses, that is, as the dash is to the dot, the letters of the English alphabet that are known to occur most frequently in the English language, are, in the Buckingham alphabet, allotted the combinations which contain the least number of prolonged impulses. The figures in this system are transmitted by the use of the Roman numerals, as in the case of the Phelps system.

In the feature of preparing the messages for transmission, and in the actual transmission of the messages, the Buckingham system is almost identical with the Wheatstone automatic system. Consequently, the messages are prepared for transmission by being perforated in a double row on a paper strip, which is then passed through the Wheatstone transmitter, and if the Wheatstone receiver were employed at

the receiving-end the messages would be recorded on the paper strip as dots, dashes, and spaces, differing from the Wheatstone records only as the Buckingham alphabet differs from the Morse alphabet.

The transmission of the six pulses of alternating polarity thus arbitrarily arranged for each character results in the operation of a Wheatstone polarized relay in the main line at the receiving-end of the system, which relay by its armature controls local circuits in which are a governing-relay, a unison-magnet, and an escapement-magnet, which latter imparts, by means of an escapement, a step-by-step motion to a "sunflower," or distributor, of peculiar construction, to such purpose that, with the co-operation of the governing-relay, and depending on the duration of the incoming pulses and the order of their arrival, one or more selecting-relays are operated, and these in turn, by actuating certain type-magnets, cause the operation of the type-wheel-moving levers, which bring a desired letter on the type-wheel to the printing position.

The Buckingham printer is thus a positive or "step-by-step" system, in which an escape-wheel, and with it the sunflower, or distributor, is caused by a cycle of six pulses of current, one or more of which is prolonged, to undergo a cycle of six steps for each letter or other character printed. The term "prolonged pulse" is a relative one, as will be understood if it is considered that when the system is operating at the rate of 100 words per minute the length of a prolonged pulse is about the one-fortieth of a second.

Before considering the receiving-apparatus further, the manner of preparing messages for transmission by the Buckingham system will be described.

As already noted, the ordinary method of preparing messages for transmission by the Wheatstone system is a somewhat tedious and arduous process. The rate at which a Wheatstone puncher can prepare messages by the mallet method (page 297) is from 20 to 40 words per minute. One of the important features of the Buckingham system is that it dispenses with this mallet method of preparing messages, in which every element of a letter has to be punched separately by the operator, and instead it employs a method in which all the elements of a given letter, and the space between letters, are perforated by the depression of one key on a keyboard corresponding to that of the Remington, and by means of which messages can be prepared for transmission by the Buckingham system at a maximum speed of about 80 words per minute. The keyboard of this perforator is outlined in Fig. 325a, and its operation may be described as follows: Under and at right angles to the levers K of the keys a number of fine piano-wires, $h h$, are stretched at intervals of about .25 inch. These wires are fixed at the left end, while at the right end each wire is attached to a separate crank-lever contact o , which controls a circuit in which is an electromagnet. There are in all 24 of these wires, 15 of which, through their crank-levers, control an equal number of punching-magnets, and 9 of which control 9 paper feed-magnets. The key-levers are provided with inverted stirrups on their under edges (the actual number and position of which are different for each key or letter), and when a given key-lever is depressed these stirrups engage with certain of the piano-wires, which latter operate the crank-levers with which they are connected, and thereby close the circuits of their respective electromagnets.

The punch- and feed-magnets and their circuits are shown diagrammatically in Fig. 325*b*. *o*' indicates the actual type of crank-lever operated by the piano-wire. For simplicity the remainder of the crank-levers are represented as at *o o*. They are pivoted as shown at *n n* on the same metallic base *M*. Their lower contact points are indicated by *l*. The 16 punch-magnets are represented by letters *B*; the 9 feed-magnets by *H*. *B' B'* are two magnets termed "assist" magnets, which are employed to assist in withdrawing the punches after the paper has been perforated, in a

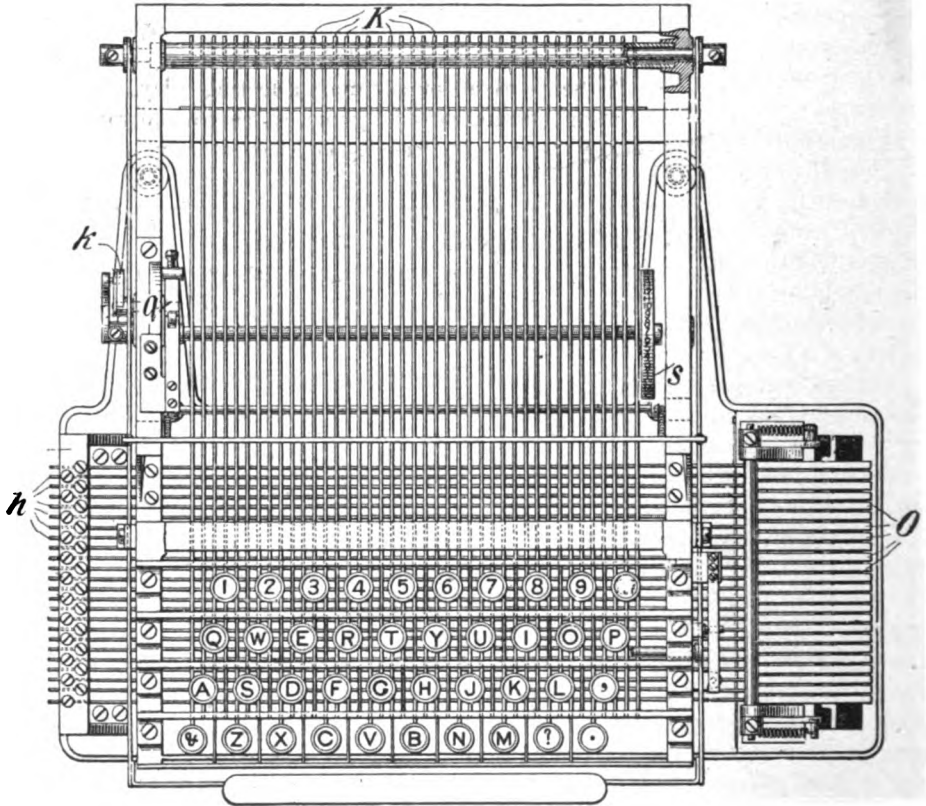
FIG. 325*a*.

BUCKINGHAM KEYBOARD PERFORATOR.

way shortly to be explained. *I* is a magnet termed the "knock-down" magnet, the use of which will be described in connection with the paper feed-wheel of the perforator. It is controlled by the circuit-closer *ii*, which is carried on the armature-lever of an assist-magnet *B'*, as shown on the left side of Fig. 325*c*. Normally the circuit of magnet *I* is open, but when the assist-magnets are attracted it is closed. By suitably adjusting *ii* the action of *I* may be hastened or delayed. Inasmuch as every letter of the Buckingham alphabet begins with a positive pulse, the magnet which punches the first hole of each letter is always operated without the need of a

piano-wire. This magnet is shown as B at the right top corner of the figure. This explains why 24 piano-wires suffice for 25 magnets. The circuit-closer *qq'* is a common closing point for all the other contact points. It is operated by all of the keys of the keyboard by means of a horizontal bar, shown in previous figure. It is so arranged that whenever any key is depressed it closes before a piano-wire can operate a crank-lever *o*, and it is opened before the wire releases its crank-lever. In this way any sparking at the opening of the circuit occurs at the common contact point, which is made of suitable material to withstand such sparking. In Fig. 325*b* the key of letter A is assumed to be depressed, with the result that all the contacts connecting with the proper punch- and feed-magnets for this letter are closed. The source of E. M. F. is indicated by a battery MB, but in practice a dynamo machine is utilized. The route of the circuits may be readily followed by means of the figures 1, 2, 3, etc.

A side view of the punching apparatus and punch-magnets is given in Fig. 325*c*. The punches *a* in this perforator are 16 in number, of the same diameter as those used in the Wheatstone mallet perforator. They are arranged in two rows in a box or punch-head *g g*, 8 being arranged on one side of the box and 8 on the opposite side. Thus they punch the paper strip from the opposite sides; the right-hand

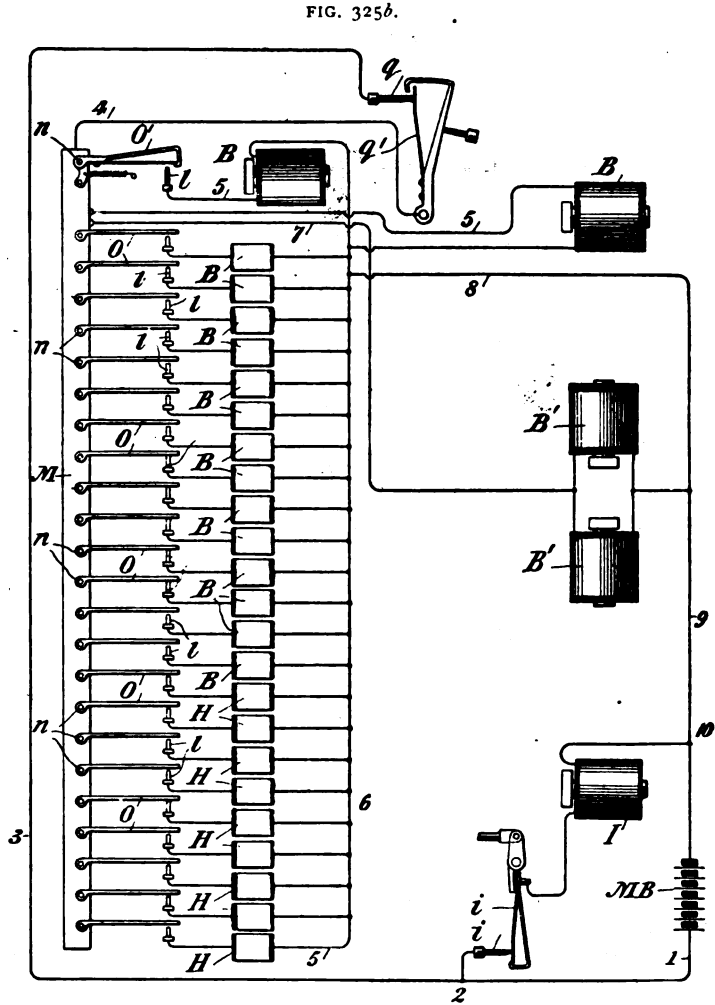

THEORY OF KEYBOARD PERFORATOR.

Fig. 325*c*. The punches *a* in this perforator are 16 in number, of the same diameter as those used in the Wheatstone mallet perforator. They are arranged in two rows in a box or punch-head *g g*, 8 being arranged on one side of the box and 8 on the opposite side. Thus they punch the paper strip from the opposite sides; the right-hand

series of punches making the necessary upper holes in the paper, the other series the lower holes, the latter series being set lower for that purpose. The paper strip is caused to pass in a small space between the punches. The punch-magnets are represented by *B*. They are compactly arranged in four vertical rows, two of which are seen in the figure. Behind each punch *a* there is placed a crank-lever *d d* (pivoted at *ss*), one for each punch. Pivotaly attached, as shown, to each of the armature-levers of the magnets *B*, there is a narrow metal arm *y*, which has on its upper end a hook that fits over a curved portion of the crank-levers *d d*. Hence,

FIG. 325c.

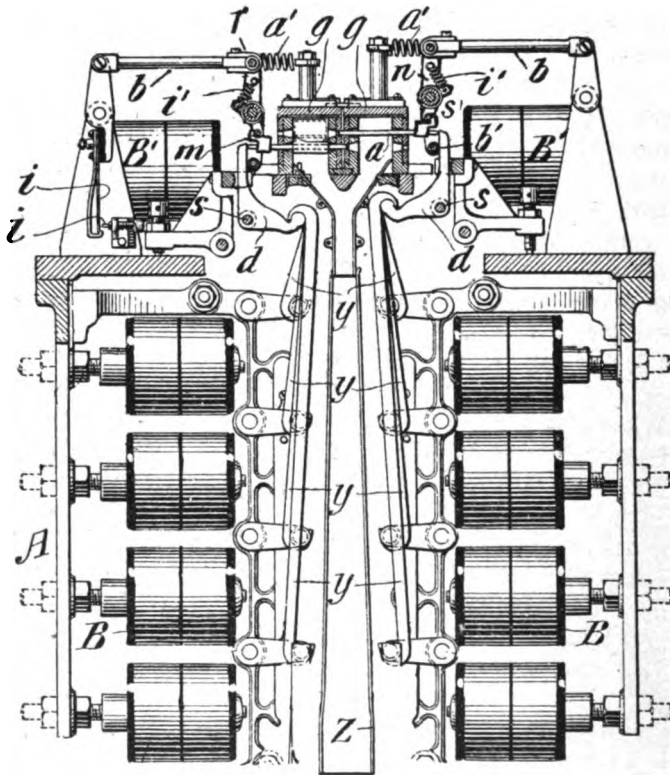

when a magnet is attracted, the hooked arm pulls down the lower end of its crank-lever *d*, driving the punch opposite its upper end forward through the paper strip. Thus when any given key is depressed it will close a certain six of the circuits containing punch-magnets, which in turn will operate the punches connected therewith, thereby perforating three upper and three lower holes in the exact order required for the transmission of the letter represented by the key so depressed. From what has been said it will be understood that these holes are differently arranged for each letter or other character, in order to bring about the variation in the duration of the six pulses for each letter.

To prevent the cuttings or chips from the perforated paper clogging up the apparatus, a chute or conduit *z* is provided into which the chips fall, their downward passage being facilitated by the jarring of the arms *y* against suitably arranged pins while the punching is in progress.

The assist-magnets *B'B'* are shown at the top of framework, one on each side of the punch-head. *bb* are two arms which extend at right angles from the upper end of the armature-levers of the assist-magnets. This armature is not seen in the figure. There are in fact two such extension arms *b* from each assist-magnet, although but one can be seen in this side view. To the inner ends of each of these extension pieces *bb* two downwardly extending levers *n* are pivotally attached, as at *r*. These levers are mounted on a shaft *s'* near their center, and are connected at their lower ends by a cross-bar *b'*. There is also a small crank-lever on a sleeve-shaft which is mounted over the shaft *s'*. These small crank-levers are also connected at their lower ends by a cross-bar *m*. They are connected to levers *n* by the small retractile springs *i'i'*. When the armatures on *B'B'* are attracted they put a tension on the springs *a'a'*, and at the same time loosen the tension on the springs *i'i'*. Also at this time the downwardly extending levers *n* are rocked inwardly, thereby moving the cross-bars *b'* away from the tops of the crank-levers *dd*, and concurrently the cross-bars *m* of the small crank-levers are moved away from a projecting block attached to the outward ends of the punches *a*, thus giving crank-levers *dd* and the punches a clear path in which to perform their respective functions. When the punches have acted and the assist-magnets are released their armatures are withdrawn, with the result that the cross-bars *b'* engage with the upper arm of crank-levers *dd* and return them to normal position. Also the cross-bars *m* on the small crank-levers engage with the projecting block on the punches, and the latter are withdrawn from the paper.

THE PERFORATOR PAPER FEED.—In the Wheatstone punching device the small central holes are punched simultaneously with the other perforations. In the Buckingham the central holes are prepared in advance by a special machine at a high rate of speed. The device for this purpose is shown in Fig. 325*d*, in which *L* is a reel holding the uncut paper strip, and *B* is a wheel having small cutting-pins *D* on its periphery. Under this wheel is a smaller one *H*, which has holes or dies set in its periphery in which the pins on *B* mesh. *B* is rotated by an electric motor as indicated. The paper strip is suitably guided through a chute between *H* and *B*, and is wound on the receiving-reel *M*, the speed of which is automatically regulated by the loose-fitting belt *X*, the operation of which is easily understood. An endless metal strip or band *F* with a continuous row of central holes corresponding to the pins on wheel *B* is placed loosely over wheel *H* and on the idler-wheels *G*. As the paper strip *K* passes between wheel *B* and the endless band, the cutting-pins perforate the central holes in the paper. The wheel *B* is operated at the rate of about 80 revolutions per minute, and as it has 150 cutting-pins on its periphery, 12,000 or more central holes may be cut per minute.

In the Wheatstone perforated strip, and also in the Buckingham strip, there are 10 central holes to the inch. If the upper and lower holes as well as the spaces between holes in space letters are termed "time units," and the "dot" is taken as

the unit, then the short space between the elements of a letter will consume, or occupy, 1 time unit; the dash will equal 3 time units; the long space in letters will equal 3 time units; the space between letters will equal 3 time units; and the space between words will equal 5 time units. It is then easily calculated how much space on the paper strip must be allowed for a given letter, and consequently the amount of paper that must be fed for each letter. As already intimated, the first pulse of a letter in this and the Wheatstone systems is always of positive polarity; the last, of negative polarity. In both systems this last pulse does not count in the letter itself,

FIG. 325d.

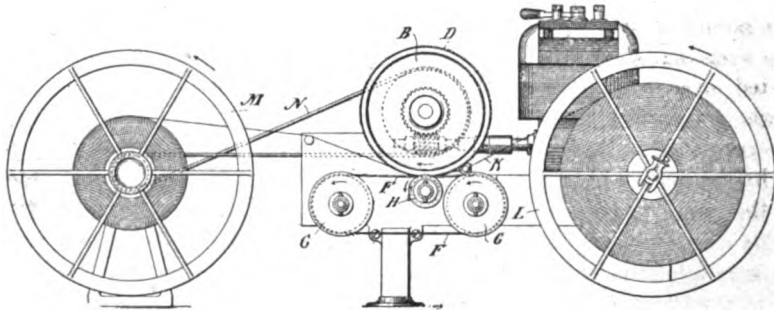

CENTRAL-HOLE CUTTER.

inasmuch as it performs an act exactly equivalent to that of the Morse operator's fingers when he withdraws them at the end of a letter. Obviously, at the end of a letter or word the key must be restored to normal, and the time so occupied counts in the Buckingham alphabet as one of the three time units between letters and words, during which the printing of the letter is effected. In the Buckingham system the paper is fed the distance required for the letter, and also by the one operation the distance of the space between letters. Thus, in Fig. 325e it is seen that to letter A 5 central holes are allotted (or, in the actual strip, .5 inch), which are equal to 10

FIG. 325e.

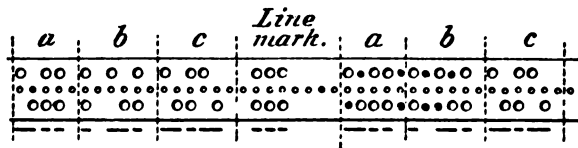

time units (7 for the letter A and 3 for the space between letters). For the letters B and C, 6 central holes are required, or 12 time units (9 for the letters and 3 for the letter space). These time units may be counted on the right half of Fig. 325e, if the large holes and the black dots are each counted as one time unit. The length of a time unit of course varies with the speed of transmission, but the number of time units in a given character does not vary. The line-mark which is made by the keyboard operator at the end of each line by the depression of a key is also indicated in this figure.

There are six different lengths of characters in the Buckingham alphabet, hence the amount of paper fed varies with different letters. The variable feed action is automatically performed in this perforator in a simple manner. The device for the purpose is outlined in Figs. 325*f*, 325*g*. It consists of a drum-shaped wheel 1.6 inch in diameter, on the periphery of which are placed small teeth *d* of the proper size, and so placed as to mesh into the central holes of the perforated strip. This wheel is carried on a vertical shaft *D'*, frictionally driven by a motor-wound spring *D*, Fig. 325*f*, from which it may be manually disconnected by raising it from the clutch *E*, a suitable lifting device being provided for that purpose.

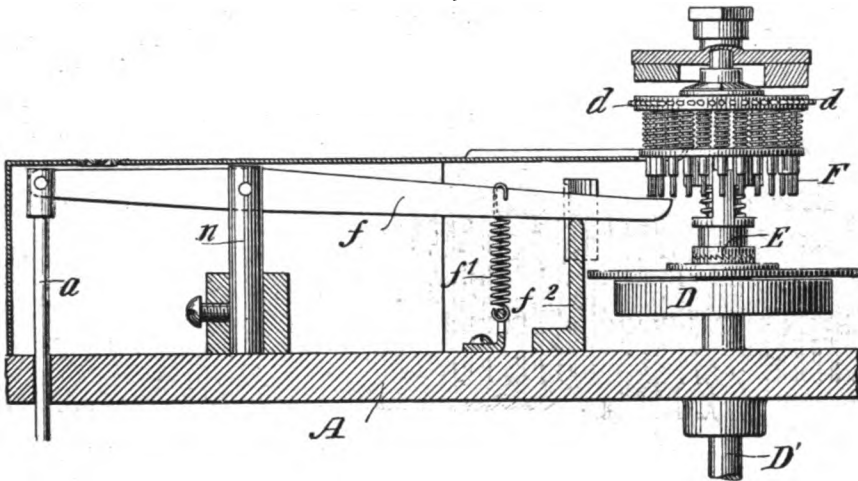
FIG. 325*f*.

THEORY OF FEED-WHEEL PERFORATOR.

There are arranged vertically around the edge of the feed-wheel a number of movable pins *F*, frictionally held in any position by the close-fitting spiral springs shown. These pins normally project below, but may be raised above the upper surface of the feed-wheel by lever *f* pivoted on post *n*; *f* extending from the armature-lever *a* of a feed-magnet. Lever *f* is withdrawn by spring *f*¹; *f*² is a stop for the lever. Normally some one of the movable pins *d* is always raised as at the left of Fig. 325*g*, and while so raised it engages with a fixed stop *c* placed above the wheel, whereby the wheel's rotation is stopped. When a key of the keyboard is depressed, one of the feed-magnets referred to is operated, and through its connecting-lever *f* it drives up another of the movable pins as shown, which pin is distant from the fixed stop a space equal to the length of the letter represented by the key so depressed, together, as stated, with the letter space. Simultaneously with the raising of this latter pin, the proper punch-magnets have also been actuated and have punched the paper strip. At nearly the same instant the hammer end *h* of the armature-lever of the knock-down magnet 1, Fig. 325*b*, has been placed above that pin which is now raised at the fixed stop *c*. When the operator removes his

finger from the key, allowing it to ascend, the circuits of the punch-magnets, feed-magnets, and assist-magnets are opened, the punches are withdrawn from the paper, and nearly simultaneously the hammer of the knock-down magnet hits the pin under it, depressing it below the fixed stop, whereupon the feed-wheel quickly turns until the pin last raised arrives at the fixed stop, when the wheel is again halted, and the apparatus is ready for the punching of another letter. Suitably arranged metal guides bring the movable pins into exact alignment before they reach the levers *f*. When the punched paper strip passes the feed-wheel it enters a curved chute, which strips it from the teeth of the feed-wheel, and it is then "run" through the Wheatstone transmitter.

In the operation of this keyboard perforator the operator depresses the keys precisely as in the case of the ordinary typewriter, depressing a space key once for the space between words. To prevent the operator overrunning a line in preparing messages for the Buckingham system, an escape-wheel, termed an indicator, is provided, which is rotated step by step with each key depressed. At the zero point of this wheel, which corresponds with the end of a line, there is a slot into which a pawl drops and locks the apparatus. To unlock it the operator depresses the line-space key, which at one operation throws the pawl out of the slot and punches a line space. On the periphery of the indicator there is a white mark which comes into view as the end of a line is approached, giving the operator visual warning to that effect. When a message or any part of it ends in the middle of a line, the operator manually turns a knob on the axle of the indicator, which brings it at once to the zero or locked position, ready for the beginning of a new line. *k* is a device which insures the operation of the common break *q* in unison with the indicator, Fig. 325*a*.

As intimated, all the business transmitted by the Buckingham system is prepared by this keyboard perforator, and it may be added that two thirds of all the business transmitted over the regular Wheatstone automatic circuits from the New York office has also been prepared by this keyboard perforator; it being understood that it is only a question of arranging the necessary combination of feed- and punch-magnets to adapt the keyboard to any dot-and-dash alphabet. Fig. 325*a* represents a keyboard perforator arranged for the Morse alphabet and numerals, in which case no indicator is necessary.

As intimated, all the business transmitted by the Buckingham system is prepared by this keyboard perforator, and it may be added that two thirds of all the business transmitted over the regular Wheatstone automatic circuits from the New York office has also been prepared by this keyboard perforator; it being understood that it is only a question of arranging the necessary combination of feed- and punch-magnets to adapt the keyboard to any dot-and-dash alphabet. Fig. 325*a* represents a keyboard perforator arranged for the Morse alphabet and numerals, in which case no indicator is necessary.

DETAILS OF RECEIVING-CIRCUITS AND APPARATUS.—Details of the receiving-circuits and apparatus of this system are shown in Fig. 325*h*. The current for the operation of these circuits is furnished by a dynamo *D*. To simplify the diagram

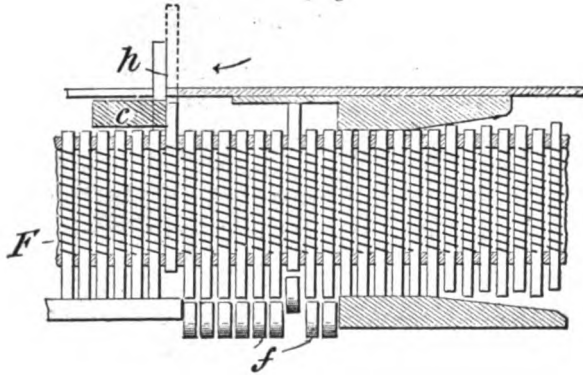
FIG. 325*g*.

prevent the operator overrunning a line in preparing messages for the Buckingham system, an escape-wheel, termed an indicator, is provided, which is rotated step by step with each key depressed. At the zero point of this wheel, which corresponds with the end of a line, there is a slot into which a pawl drops and locks the apparatus. To unlock it the operator depresses the line-space key, which at one operation

throws the pawl out of the slot and punches a line space. On the periphery of the indicator there is a white mark which comes into view as the end of a line is approached, giving the operator visual warning to that effect. When a message or any part of it ends in the middle of a line, the operator manually turns a knob on the axle of the indicator, which brings it at once to the zero or locked position, ready for the beginning of a new line. *k* is a device which insures the operation of the common break *q* in unison with the indicator, Fig. 325*a*.

As intimated, all the business transmitted by the Buckingham system is prepared by this keyboard perforator, and it may be added that two thirds of all the business transmitted over the regular Wheatstone automatic circuits from the New York office has also been prepared by this keyboard perforator; it being understood that it is only a question of arranging the necessary combination of feed- and punch-magnets to adapt the keyboard to any dot-and-dash alphabet. Fig. 325*a* represents a keyboard perforator arranged for the Morse alphabet and numerals, in which case no indicator is necessary.

DETAILS OF RECEIVING-CIRCUITS AND APPARATUS.—Details of the receiving-circuits and apparatus of this system are shown in Fig. 325*h*. The current for the operation of these circuits is furnished by a dynamo *D*. To simplify the diagram

the circuits are shown as having ground returns, the negative pole of the dynamo being indicated by the minus mark and the conventional symbol of an earth connection. In fact, metallic circuits are employed. *M L* is the main-line polarized relay. Its armature controls two branch circuits *c c'* (fed by dynamo *D*), in which are a polarized escapement-magnet *E M*, a unison-magnet *U M*, and a governing-relay *G R* of the neutral type. These each have two coils reversely wound as indicated. In the case of the escapement-magnet the effect of a current alternating in the coils is to oscillate its armature from side to side in common with the armature of the main-line relay, this permitting the step-by-step movement of the escape-wheel *E W*. The unison-magnet is polarized and its coils are so connected that a current through one of them corresponding to a negative current on the main line tends to assist the induced magnetism, while a current in the other coil (corresponding to a positive current on the main line) opposes the induced magnetism of the magnet. The adjustment of the armature-spring of this magnet is such that short pulsations of either polarity will not attract the armature, neither will prolonged positive pulses attract it, but the armature will be attracted by prolonged negative currents, the result of which is that when short and long positive and short negative currents are being transmitted on the main line, the hook *h* on the end of the armature *a* of the unison-magnet is always in the path of, but between, the teeth of the unison-wheel *U W*, which latter is on the same shaft *s* as the escape-wheel *E W*; but when a long negative pulse is received, the armature of *U M* is attracted and the hook is withdrawn from the path of the teeth. There are 15 teeth on the unison-wheel and 45 on the escape-wheel *E W*.

The space between any 2 of the teeth on the unison-wheel is equal to the space between any 3 of the teeth on the escape-wheel. Six pulses of current will move the escape-wheel a distance of 3 teeth; therefore 6 pulses will also move the unison-wheel a distance equal to that between 2 of its teeth. Hence, so long as the unison-wheel is in proper step with the received pulses of a letter, the hook *h* will always be drawn out of the path of its teeth, since each letter of the Buckingham alphabet is followed by a long negative pulse; but whenever the apparatus gets out of unison 5 short pulses of either polarity will, as already stated, operate to hold the unison-wheel at the zero point, which is the point at which the apparatus is in the correct position to receive a new cycle of pulses.

The teeth of the unison-wheel also perform another important office. There are six circuit-closing levers, indicated at *k* and pivoted and numbered as shown, of which levers five are on the one metallic support *s*; the sixth is on a separate metallic support *s'*, insulated from *s*. These circuit-closers with the unison-wheel comprise the sunflower, or distributor, of this system. The arrangement of these levers relative to any seven of the teeth on *U W*, is such that when the unison-wheel moves a distance equal to the space between two of its teeth, these levers ride over one or other of the teeth, thereby closing their respective circuits at 1, 2, 3, 4, 5, 6 in quick succession, beginning at 1. In other words, each cycle of six pulses, whether of long or short duration, will bring about a brief consecutive closing of the circuit controlled by these levers, for a purpose presently to be mentioned. Of course a long pulse will cause a circuit-closer to dwell longer on its contact than a short pulse, and, as will be understood later, the sixth lever rests normally on a tooth.

The armature-spring of the governing-relay *G R* is so adjusted that its armature will not respond to short pulses of current, but will respond to prolonged pulses of either polarity. This feature is utilized in connection with the circuit-closers of the sunflower, and certain polarized relays, termed selecting-relays *s R*, of which there are 5, numbered 1, 2, 3, 4, 5, respectively. These relays also have two coils, also reversely wound. One of the coils of each relay is connected to the correspondingly numbered contact post of the sunflower, but as the support *s* of these circuit-closers is connected to a contact point of the governing-relay, this circuit cannot be fully completed until the armature of that relay is attracted. The other coil of each selecting-relay is in series in a circuit *r c*, termed the restoring or resetting circuit. This circuit is controlled by the armature *a'* of a neutral relay termed the "throw-back" or restoring-relay *R R*, as will be explained more fully. The selecting-relays by their armature-levers control certain magnets, indicated at 1, 2, 3, 4, 5 in Fig. 325*j*, which latter by their armatures mechanically move certain arms connected with the type-wheel-moving devices, Figs. 325*i*, 325*j*. These magnets are termed the type-wheel magnets, and by their aid any character on the type-wheel is brought to the printing position.

Whenever, in the course of an incoming six pulses that represent a character, one or more of the pulses are prolonged, there will be a prolonged pulse or pulses in the circuit of the governing-relay *G R* which will attract its armature, as in Fig. 325*k*. Assume, for example, it is the first pulse. At this moment circuit-closing lever 1 is on a tooth of the unison-wheel, and its circuit is closed at contact post 1 of the sunflower. Hence at this instant the selecting-circuit *s c* of selecting-relay No. 1 is completed, and being thereby actuated by current from dynamo *D*, its armature is attracted to the right, closing the circuit of and operating type-magnet No. 1, Figs. 325*i*, 325*j*. This magnet by its armature-lever will move the type-wheel into a position for printing the letter *A*, and if there be no other prolonged pulses in the cycle up to the sixth pulse, that letter will be printed. Had the third and fifth pulse of the cycle also been prolonged, the third and fifth selecting-relays would have been operated, with the result that letter *K*, and not *A*, would have been printed.

The circuit-closing lever No. 6 is the last to act (it may be said to be the first and the last, for, as stated, it rests normally against its contact point, but it leaves it at practically the instant that circuit-closer No. 1 makes its contact). This lever, No. 6, when it closes, completes the circuit (from dynamo *D*) of two relays, one of which, the sixth-pulse relay *s P*, by its armature-lever closes the circuits of the press-magnet *P M*, the printer escape-magnet *M'*, an ink-ribbon magnet *R F*, and a dogging-magnet *M*; the other is the restoring or resetting-relay *R R*, which closes the restoring-circuit *r c*, and thus resets the selecting-relays and type-magnets to normal position after the selection and printing of a letter, by means of the restoring-coils of those instruments. It need not be said that these operations follow each other very quickly. It is obvious that the apparatus actuated by relay *s P* must operate before the restoring-apparatus performs its part. This is insured by giving the armature-lever of relay *R R* a longer distance to travel before it makes its contact, and also by suitable adjustment of the springs of the armatures. The ink-ribbon feed-magnet *R F* actuates a step-by-step ratchet and pawl which moves the inking

ribbon (not shown) so that a new surface is regularly brought under the type-wheel of the printer. The functions of the dogging-magnet *m*, printer escape-magnet *m'*, and press or printing magnet will be described subsequently.

In series with each of the selecting-coils *s c*, and in series with the restoring-coils *r c* of the selecting-relays, Fig. 325*h*, there are two coils of another relay, termed the non-print relay *N P*, the office of which will now be described. Being in series with each of the selecting-coils of those relays, the armature of *N P* will be thrown to the right when any one or more of the armatures of the selecting-relays are thrown to the right. The armature of *N P* will also be thrown to the left when the restoring-circuit is closed. It may be seen that the circuit of the press-magnet *P M* is led to the armature contacts of *N P*. The object of this is to avoid operating the press-magnet *P M* when the cycle of pulses representing the *space* between words is transmitted, the space cycle also being terminated by a long negative pulse, which of course will operate the sixth-pulse relay and restoring-relay, and therefore, *normally*, the press-magnet *P M*. As, however, during the space cycle none of the selecting-relays has been thrown to the right, the non-print relay is not actuated, and hence the press-magnet will not be operated, its circuit being open at the contacts of *N P*. Lest, however, the circuit of the press-magnet should tend to be opened at *N P* before it has finished printing, a branch or extra circuit is provided around the contacts at the armature of *N P*, by way of the tongue and contact point *x y* on the press-magnet lever, which, when the latter is once closed, keeps it so closed until the circuit is next opened at the sixth-pulse relay *s P*. The rod *m* is a manually operated device. In addition to other offices which it is caused to perform, and which will be mentioned further on, it closes and opens the circuits of the dogging-magnet *m* and the ink-ribbon feed *R F* (which are in multiple), at the spring contacts *m' n* respectively. When the rod is pulled to the right the contacts separate, and vice versa. The object of opening these circuits is to free the printer apparatus so that the paper blanks may be inserted or removed at will in a way to be described.

The E. M. F. of dynamo *D* is 110 volts. The resistance of each coil of the selecting-relays is 200 ohms. Sufficient extra resistance is inserted in the circuits at *r r'* to bring the current strength to about .055 amperes. Condensers are placed around contact points to reduce sparking when necessary; *f f* represent the usual fuses. A differential galvanometer *G*, similar to that used in the Wheatstone automatic system, is employed to facilitate the adjustment of the armature-lever of *M L*, when required. The apparatus, however, needs but little adjustment, and it will operate without change over a variation of speed of between 50 and 100 words per minute.

As already intimated, the tension of the armature-spring of the restoring-relay *R R* and the play between its contact points should be greater than that of the sixth-pulse or printing relay. Adjustable tension springs are used on these relays. When a marked variation in the speed of transmission occurs, some adjustment of the governing-relay is of course necessary. The lower the speed the stronger the pull or push of the spring should be to secure prompter action of the armature-lever, since otherwise the lever would perhaps be drawn to its contact point by a short pulsation. Contrariwise, when the speed of transmission is high the pull of the

spring must be reduced in order that the armature may get forward to its contact point at the proper time. The selecting-relays each have two electromagnets, but have no retractile springs, as the reversed winding of their coils effects the same purpose, and with the advantages that the effect of the armature-springs has not to be overcome, and that the repelling magnetism of one of the cores assists in the movement of the armature-lever. It also insures that the relays will stay in a given position until the current that reverses the position of the armature actually passes through the coils.

TYPE-WHEEL SETTING APPARATUS.—The manner in which the type-wheel is brought into any one of the 32 possible positions is perhaps the most unique of the

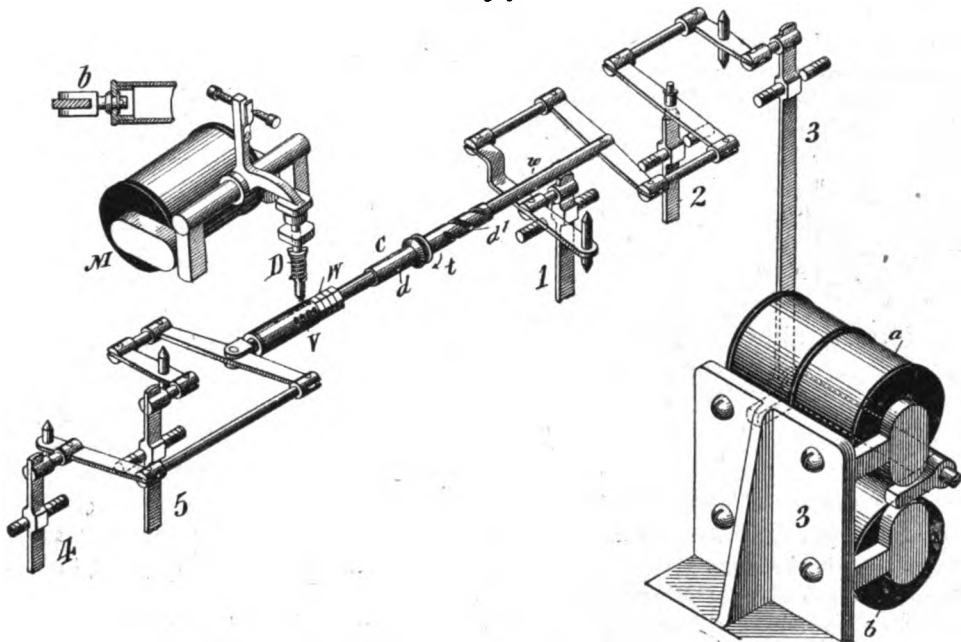
FIG. 325*i*.

THEORY OF TYPE-WHEEL-MOVING APPARATUS.

numerous novel and ingenious features of the Buckingham printer. The electro-mechanism for this purpose is schematically outlined in Fig. 325*i*. The type-wheel *w* is securely mounted with a dogging-cylinder *v* on a horizontal shaft. This shaft receives an endwise motion from the horizontal levers on the left, and a rotary motion from the horizontal levers on the right.

Type-magnet No. 3, which is operated by selecting-relay No. 3, is shown as *a b* at the right of Fig. 325*i*. The means by which its arm 3 is connected to the type-wheel levers and to the armature is clearly outlined in the figure. The other arms are similarly connected to their respective type-magnets, which latter are also operated by their respective selecting-relays (which likewise act as the type-magnet restoring-relays), as indicated in Fig. 325*j*.

In shop phrase, these horizontal levers are termed whiffletrees. The vertical arms 4, 5, connected with their type-magnets 4, 5, move the horizontal levers which give the endwise motion to the type-wheel. The arms 1, 2, 3, connected with type-magnets 1, 2, 3, move the right-hand levers, which impart, by suitable intervening mechanism, rotary motion to the type-wheel. The type-wheel shaft is attached by a swivel connection to the left-hand levers. This swivel is shown separately at *b* above dogging-magnet *M*.

The whiffletrees are connected by suitable links and pins to their respective arms, and, as indicated in Fig. 325*i*, are so pivoted and interlinked that a movement

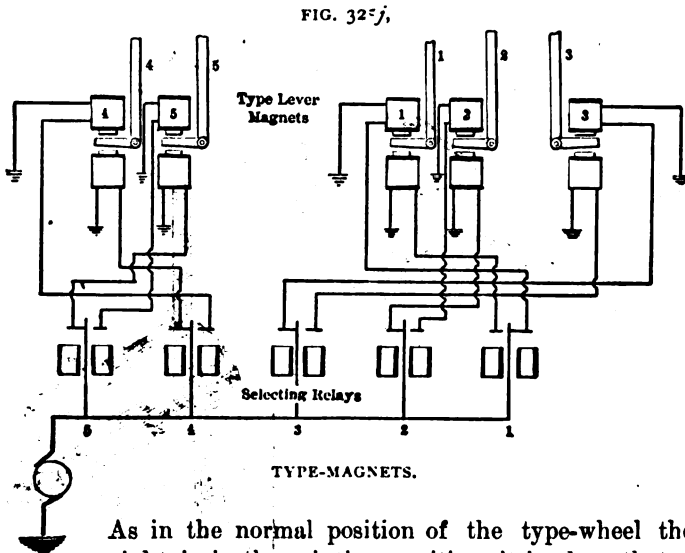

of arm 5, for example, to the right will move the type-wheel a distance equal to the width of one of the type-wheel rings to the left. When arm 4 only is moved it shoves the type-wheel shaft lengthwise a distance of 2 rings of the type-wheel to the right. When both arms are moved together the type-wheel is moved a distance equal to one ring to the right.

As in the normal position of the type-wheel the second ring from the right is in the printing position, it is clear that either of the three other rings may be brought into a printing position by the single and combined effect of the two endwise adjusting-arms.

The movements of the right-hand levers to the right or left impart a rotary motion to the type-wheel shaft by the intermediary of the spiral slot in a sleeve *c* through which a pin *d'* attached to a rod *w* projects. This rod is connected by a link to the right-hand whiffletrees. The type-wheel shaft enters the left end of the same sleeve, in which it moves freely lengthwise. The sleeve itself turns on suitably supported ball bearings (not shown) in the groove *t*. A pin *d* on the type-wheel shaft projects through a straight slot in such a manner that when the sleeve rotates in either direction, the pin compels the type-wheel shaft to turn with it. The rotating levers are so adjusted that arm 1, when moved alone to the left, by its magnet will turn the type-wheel, as a whole, one half of a revolution in the direction of the arrow shown at *t*. Arm 2, when moved alone to the right, turns the type-wheel two eighths of a revolution in an opposite direction. Arm 3 moved alone to the right turns the type-wheel one eighth of a revolution in the same direction as arm 2. Arms 2 and 3, acting together, turn the type-wheel three eighths of a revolution in

a direction opposite to the arrow, while arms 1 and 2 acting at the same time, but oppositely, will turn the type-wheel two eighths of a revolution in the direction of the arrow; and by these means, as already intimated, any one of the characters on the type-wheel may be placed in the position for printing with a maximum of five prolonged pulses, apart from the final prolonged negative pulse for printing and restoring the apparatus to normal after printing.

The dogging-magnet *M* shown above the type-wheel plays an important part in adjusting and steadying the type-wheel for and during the process of printing. This it does by means of the small cylinder *V* on the same shaft as the type-wheel, on the surface of which cylinder 32 small holes are arranged to correspond as to number and relative position with the characters on the type-wheel. When the dogging-magnet is operated, which will be after a desired letter is in the printing position, its armature drives a pin or dog *D* having a cone-shaped point into one of these holes, thereby adjusting and locking the type-wheel in the desired position, until the printing is effected, when it will be released by the opening of the circuit at the armature of the sixth-pulse relay. The spiral spring shown retracts the pin after printing.

It may be noted that each of these various movements of this apparatus is effected with a strong positive motion, the pull of the electromagnets upon their respective armatures being equal to several pounds. Nevertheless, the different operations are carried out with almost mathematical precision, and any slight deviation from such precision is corrected by the dogging-pin *D* in the manner stated.

As previously noted, the letters and other characters of most frequent occurrence in the English language are allotted the least number of prolonged pulsations in the Buckingham alphabet. It will also be observed that the arms which have to move their levers the greatest distance are placed the nearest to the beginning of a cycle of operation of the circuit-closing levers *k*, Fig. 325*k*, in the formation of the combination of a letter. For example, type-magnet arm 1, Fig. 325*l*, which is required to rotate the type-wheel a half of a revolution, is primarily operated by No. 2 circuit-closer, etc. Further, to insure correct action, the arm 1 is furnished with a retractile spring which accelerates its setting movement and retards its restoring movement. Arms 4, 5 also have springs that hasten their setting and retard their restoring movement. By these various devices the action of the different adjusting and rotating arms is assured before the printing and restoring apparatus can come into play.

THE BUCKINGHAM PAGE PRINTER.—Details of this apparatus are shown in Figs. 325*k* to 325*o*, similar parts having the same reference letters, and these figures may be considered together. The general appearance of this printer is outlined in Fig. 325*k*. In the page-printing telegraph system previously described, page 430, the paper carriage is moved back and forth in a manner practically similar to the ordinary typewriter. That is, at the end of a line the carriage is six or eight inches away from the starting-point of a new line. To avoid the loss of time due to this arrangement, and to simplify the mechanism generally, the telegraph blank of the Buckingham printer is arranged in the form of a tube, which is placed over a fixed tubular support (*a*, Fig. 325*k*), which is firmly upheld by the bracket *b*. *M* is the dogging-magnet, *D* is its armature-lever. The press-magnet *P M* is placed at the

right end of the supporting-tube *a*, as shown. Its lever is connected with the crank-lever of the printing-platen within the tube, directly under the type-wheel, by means of a strip of rattan *t'*, which substance, singularly enough, has been found the most suitable for this work. *m* is the manually operated rod referred to in connection with Fig. 325*h*. This rod is provided with a frictional locking device at its left end *A*, which holds it in a given position, either forward or back.

The paper tube is slid over the left end of the tube *a*. A row of small holes (*h*, Fig. 325*m*) is perforated in advance along the margin of the paper tube, and the

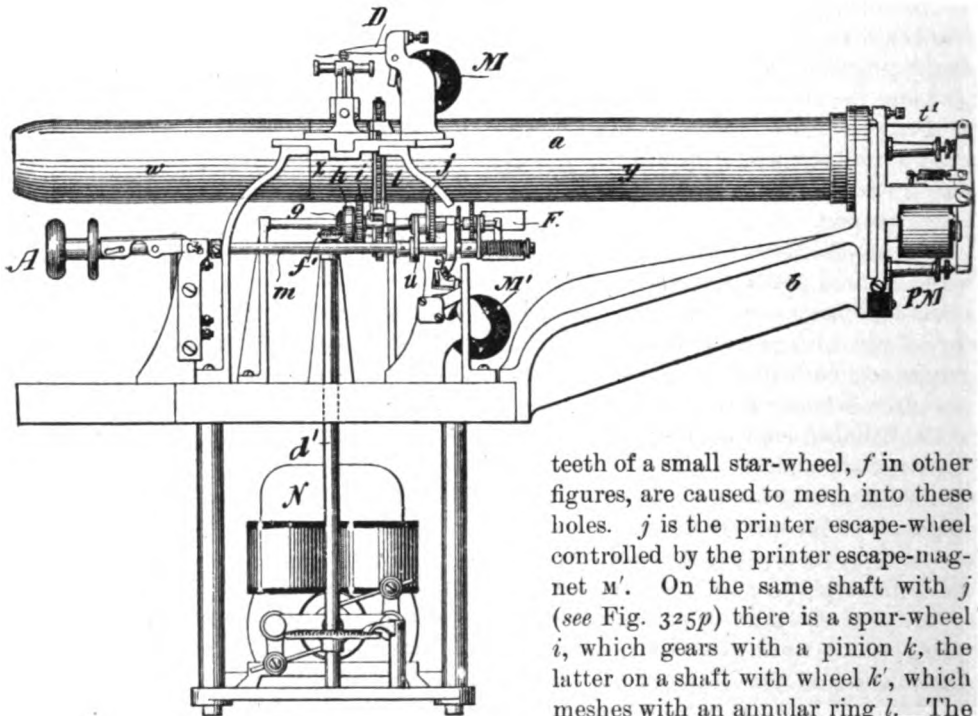
FIG. 325*k*.

BUCKINGHAM PRINTER—SIDE VIEW.

teeth of a small star-wheel, *f* in other figures, are caused to mesh into these holes. *j* is the printer escape-wheel controlled by the printer escape-magnet *M'*. On the same shaft with *j* (see Fig. 325*p*) there is a spur-wheel *i*, which gears with a pinion *k*, the latter on a shaft with wheel *k'*, which meshes with an annular ring *l*. The driving power of this train of gearing is furnished by an electric motor

N that turns a vertical shaft *d'*, which shaft by means of a bevel gear *f g* tends to wind up a recoil-spring *h*, one end of which is attached to the shaft *d*, the other end to the shaft on which the printer escape-wheel *j* and spur-wheel *i* are mounted. When the spring is fully wound the motor stops, the force employed permitting this without injury to the mechanism.

The star-wheel is carried on the inner side of the annular ring *l*, Fig. 325*o*. The clock-work gearing operated by the motor-wound spring gives the annular ring a tendency to rotation, which, under control of the printer escape-magnet *M'*, becomes a step-by-step movement. Thus, while a message is being printed letter by letter, this annular ring and with it the star-wheel are moved around the supporting-tube

(the star-wheel being held in one axial position at this time by the engagement of some of its teeth in three circumferential grooves, *t, s, r*, on the supporting-tube, Fig. 325*m*), until at the end of a revolution the star-wheel is almost at the place of beginning. Since the star-wheel teeth are, as stated, meshed with the perforations in the paper, the latter is also carried around the fixed support step by step, and thus, as printing goes on, a new surface of the paper is uniformly fed below the type-wheel. On the annular ring there are 74 teeth (sufficient to carry the ring once around the tube), which corresponds also with the number of letters and spaces on one line of a telegraph blank. The annular ring *l* is upheld by grooved roller bearings *n n*, which run on flanges on the periphery of the ring, the teeth of the latter being placed on the centre of the periphery (Fig. 325*o*).

It is seen that the grooves *t, s, r*, on the tube *a*, turn off at an angle or incline *v' w' x'*, at a point, Fig. 325*l*, which corresponds with the end of a line on the paper. When the star-wheel in its course passes through these inclined grooves it perforce turns on its axis, causing its teeth to mesh with new perforations in the paper, and advancing the paper tube thereby the distance of one line along the supporting-tube. This action is brought about quickly as follows: Near the zero point several teeth are omitted from the escape-wheel *j*. At the time when the star-wheel *f* arrives at the entrance of the angular grooves, that portion of the wheel *j* from which the teeth are omitted reaches the escapement-pawls 4 and 5 (Figs. 325*o*, 325*p*), whereupon that wheel and with it the annular ring jump a corresponding distance, with the result that the paper, as just stated, is advanced a line, with but one step of the escape-wheel—in other words, with but one pulse of current.

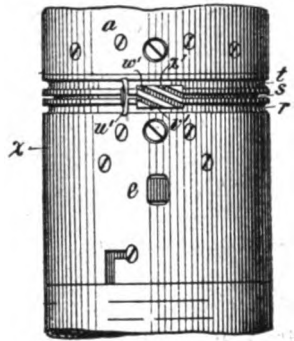
FIG. 325*l*.

In Fig. 325*m*, which is a top view, *τ* is the paper tube, *a* is its tubular support. The perforations *h* in the margin of the paper tube are prepared in advance. *w* is the type-wheel, and at its left *v* is the dogging-cylinder. The printing-platen is within the tube, and in printing it strikes the paper through the aperture *e* in *a* (Fig. 325*l*). Normally a slot *u'* is directly below the star-wheel *f*, so that when the attendant slips a paper tube over *a*, the first holes *h h* in the paper easily mesh with the teeth of the star-wheel. In order that after the star-wheel has passed the angular grooves *v', w', x'* (shown in previous figure) its teeth may not catch in the edges of the grooves at the slot *u'*, at the commencement of a new line, the slot is placed a short distance to the left of the angular grooves. There is, however, another device to insure that the teeth of the star-wheel *f* shall always be in the position to clear the edges of the grooves at this slot, namely, the pin *o*, Figs. 325*n*, etc. This pin is normally in such a position that just before the star-wheel enters the slot the pin enters a space between two teeth of the star-wheel, and puts those teeth in positive alignment with the grooves *t, s, r*. Inasmuch, however, as when the paper tube is being placed in position for printing its perforations have to mesh with the star-wheel, it is evident that the pin *o* would be in the way of this action. Therefore at this time it is moved

out of its normal position by the extension *s'* (carried on a slide-bar) by means of the small chain and pulley, *d i*, Fig. 325*m*, and *p*, Fig. 325*o*, which are actuated each time

FIG. 325*m*.

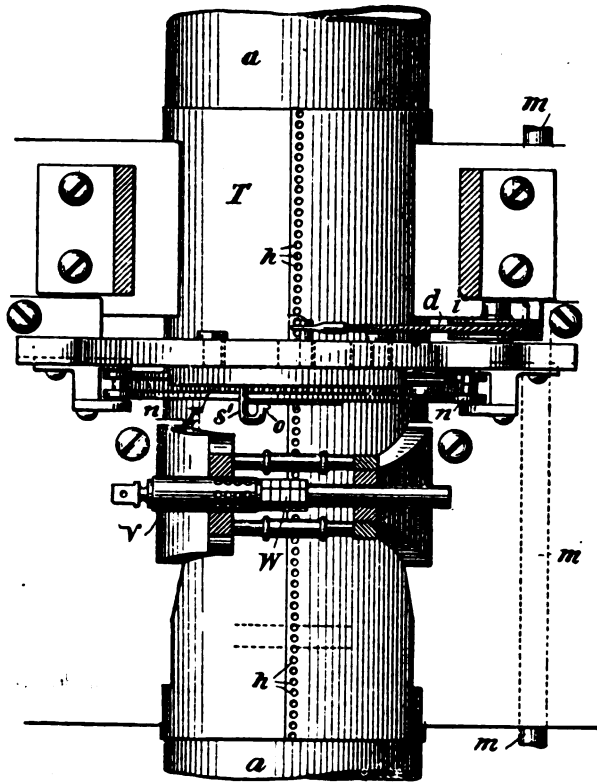

the attendant manually pulls out the rod *m* (see Figs. 325*h*, 325*k*). When this rod is pushed in by the attendant the pin *o* is returned to its normal position, placing the teeth of the star-wheel into alignment with the said grooves, assuming that the act of inserting the paper tube might have placed the teeth out of alignment.

A section of the paper tube with the holes *h h*, and the manner in which the star-wheel *f* meshes into these holes and with the grooves *t, s, r*, are also indicated in Fig. 325*n*; also the middle section *x* of the tubular support. The tubular support *a* is divided into three sections, *w, x, y*, Fig. 325*k*. The left-end section is of slightly less diameter than the right end, to facilitate passing the paper tube over it. The end sections *w* and *y* are of

brass tubing; the middle section *x* is of iron, and is of sufficient thickness for the circumferential and angular grooves cut in it, as indicated in Fig. 325*n*.

Fig. 325*o* is an end view of the tube *a*, printing-platen *p*, the star-wheel adjusting-pin *o*, and the pulleys and chain which operate it by the manually operated rod *m*, etc. When this rod *m* (shown in end view in this figure) is pushed in, that is, to the right, it engages with a stop *p* on pulley *p'*, which causes the chain to move the pin *o* out of the path of the star-wheel. When the rod is withdrawn the bent spring *h'* restores the pin to its normal position for the purposes just noted. *n n* are the roller bearings on which the annular ring turns; *b'* is the bracket by which the star-wheel *f* is attached to the annular ring. A device which is employed to cushion

FIG. 325*n*.

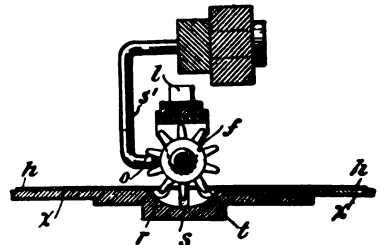

the star-wheel *f* is attached to the annular ring. A device which is employed to cushion

the blow of the printing-platen on the type-wheel is also shown in this figure. It consists of an endless rubber band *b*, which runs over two small wheels at the top and a pulley *c* at the bottom of the tube. A ratchet-wheel is mounted on the pulley shaft; *d'* is its pawl. An arm *a'* extends from the printing-lever *P*, as shown, and at every downward movement of the lever this arm engages with a tooth of the ratchet-wheel, thus turning the rubber band to present new surfaces to the platen, thereby preventing undue wearing of the rubber at any one point. The wearing process is, however,

FIG. 325o.

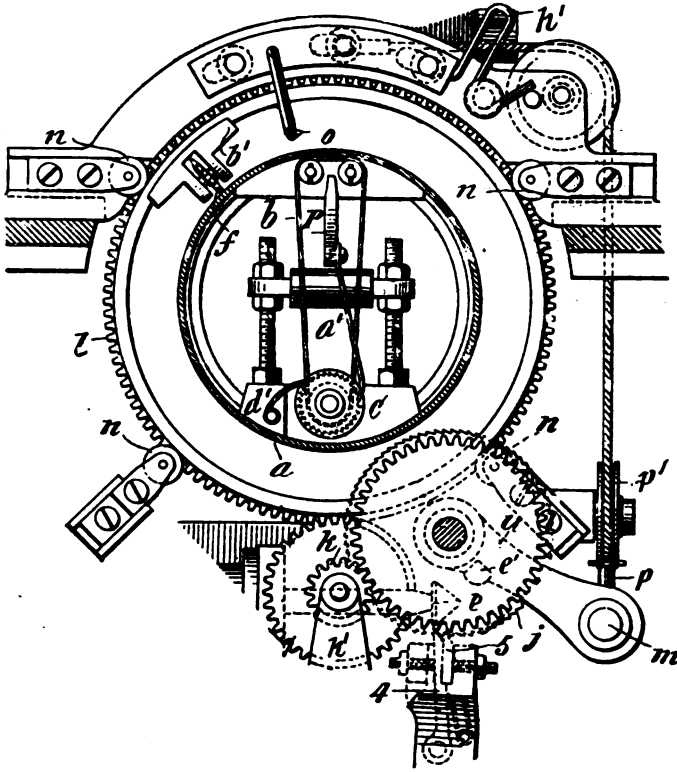

very slow, and the pawl and ratchet can be detached if desired.

A side, end, and sectional view of the step-by-step and the printing and related apparatus are given in Fig. 325*p*. In this *P* is a side view of the printing crank-lever. Instead of the conventional curved escape device shown at *j*, Fig. 325*h*, the escape-wheel *j* in practice is provided with two pawls, 4, 5. These pawls are supported by a vertical arm *R'* from armature *R* of printer escape-magnet *M'*, and are shown just below *j*. Pawl 5 is fixed on *R'*; pawl 4 is movable on an axis *b'*. It will be seen that when armature *R*

is attracted pawl 4 is disengaged from a tooth of the escape-wheel *j*, and that at the same time pawl 5 moves to the right in the path of a tooth. This only permits a very slight movement of the escape-wheel. When, however, pawl 4 is disengaged it is turned on its axis by the spring *q*, a short distance in a direction opposite to that in which the escape-wheel *j* rotates, so that it comes into line with the space between the teeth next back of that in which pawl 5 now rests. Hence, when the armature *R* is retracted and pawl 4 disengages from the wheel *j*, the wheel will advance one step before it is held by pawl 4. This peculiar movement insures that the paper tube will not be fed until after the letter is printed; that is to say, when the armature of escape-magnet *M'* is attracted by the closing of the sixth-pulse relay of the system

(at which time the printing is effected), the escape-wheel does not make a full movement, and consequently the paper tube is not advanced, but when the letter is printed and the armature R of M' is retracted, the paper is then fed.

In the operation of receiving messages by this system, the attendant places the telegraph blank in its tubular form over its support a until it meshes with the star-wheel as stated. The reception of a message then proceeds. At the end of the first line, which contains the number, originating station, and date of the message, also at

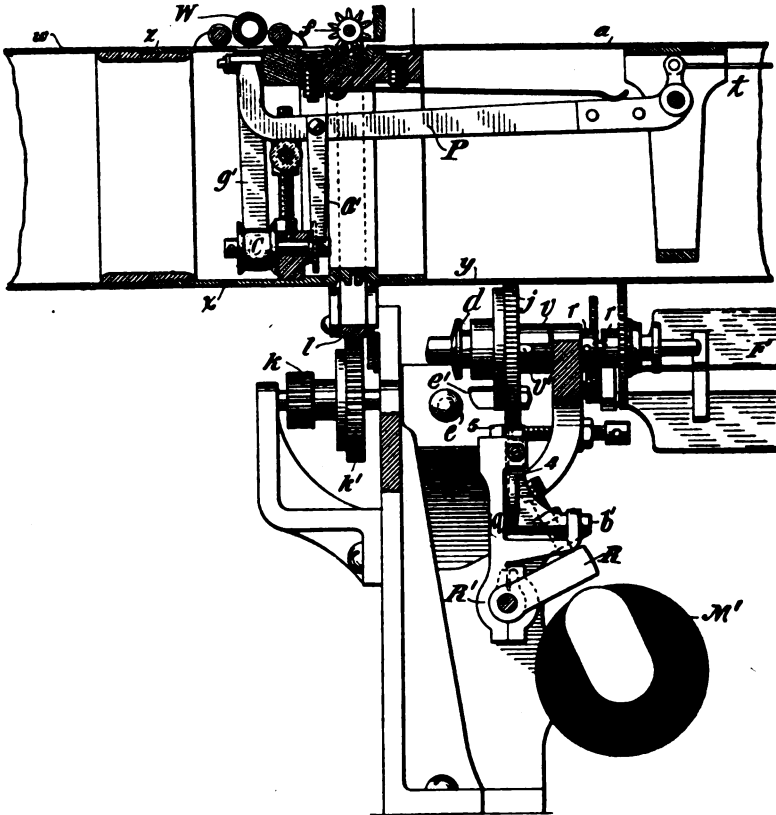
FIG. 325*p*.

the end of the address, and at the end of the message, a double or line space is provided in the perforated strip at the transmitting end. At these intervals the attendant operates the manual device m by the knob A , and advances the paper tube one line.

It is essential at such times that means be provided whereby the pawls 4, 5 may be readily disconnected from their escape-wheel j , so that it, as well as the annular ring l , and with it the star-wheel f and the paper tube, may be quickly brought to the zero or unison position. The apparatus for this purpose is shown in Figs. 325*k*, 325*p*.

It consists of an arm u attached to the right end of the manually operated rod m , which engages with a groove d cut in the hub of the escape-wheel j . On the right end v of this hub is cut a slot, through which a pin v' projects. This permits the escape-wheel to be moved a certain distance endwise on its shaft. Upon an auxiliary disc attached to j there is a flat tooth e' , whose end normally clears a fixed stop e . When, however, the rod m is pulled to the left, thereby drawing with it the escape-wheel j , and freeing the latter from its pawls, the stop e is in the path of tooth e' and holds the wheel j at a point which corresponds to the unison point, namely, the point at which star-wheel f will be in line with the slot u' , Fig. 325*l*. In order to avoid the shock which would ensue to the apparatus if the gearing were allowed to run without check of any kind, when the escape-wheel is thus released from its pawls, a fly r is caused to make a clutch connection at r with the shaft of j at the instant of said disconnection, which effects the desired result. It is also essential for the proper working of this paper feed apparatus that when it is thus allowed to run to zero or unison position, the fixed pawl 5, and not the movable pawl 4, shall be in the path of a tooth of j . Hence, when disengagement of the escape-wheel j with its pawls is made, armature R is assumed to be attracted, which will bring pawl 5 in the path of a tooth.

An expert attendant quickly detects any imperfect signals, such as might be caused by wire trouble of any kind, by a break in the rhythm of the working of the receiving-apparatus of this system; and in the event of any appearance of error he signals to the transmitting operator accordingly. In this way incipient errors due to line and instrument troubles are detected with practically the same facility as is the case on the regular Morse circuits.

The rate at which messages are regularly transmitted between New York and Chicago, a distance of 974 miles, by the Buckingham printing telegraph on a duplex circuit, averages over 80 words per minute in each direction. This is equal to 200 messages of the average length per hour on one wire. The ordinary Wheatstone repeaters are inserted at Buffalo, which is 444 miles from New York and 532 miles from Chicago. The wires used are the ordinary overhead copper wires of the company, measuring about 5 ohms per mile, and the system is of course operated under all the prevailing conditions of capacity, self-inductance, and induction effects from other lines to which the contiguous circuits may be subjected. On several occasions the system has been worked at full capacity, to test its accuracy of transmission and reception. The matter transmitted on these occasions consisted of ordinary newspaper press reports, and were received on sheets of foolscap. On the first test, from Chicago to New York, 2429 words were transmitted in 23 minutes 54 seconds; on the second test, 6073 words were sent and received in 60 minutes 13 seconds; on still another occasion 9126 words were sent in 91 minutes 18 seconds, without error in the printed copy. This is at an average rate of 100 words per minute. These figures include time lost in changing the sheets, which required six seconds for each change. By improvements in the apparatus this time has been reduced to one second.

The writer desires to express his obligations to Mr. Buckingham for facilities afforded him in gathering the foregoing data concerning this interesting and ingenious system.

THE BAUDOT MULTIPLEX PRINTER.—This system is employed by the French Government on all of its most important lines. For its multiplex feature it employs synchronism and a trailer and segmental wheels or discs, practically similar to that shown in Fig. 256, certain segments being set apart, in series of 5, at intervals around the wheel, for each transmitting and receiving instrument, of which there are usually 4 to each circuit. On short circuits 6 sets of apparatus may be thus operated. Hence 4 or 6 messages may be sent practically simultaneously by this system. For each letter transmitted a combination of 5 positive or negative pulsations of equal duration is employed. A letter is transmitted by depressing a certain key or keys of a key-board, which thus sends out the desired combination of pulsations for a given letter. At the receiving station these pulsations operate one or more of five polarized relays corresponding to the keys depressed, and these relays in turn, by their armature-levers, close certain local circuits which control mechanism whereby the given letter is selected and printed on a paper tape. While this given letter is being printed on one receiving instrument the line is being utilized for the transmission of another letter on another instrument. Synchronism is maintained by suitable correcting devices. The rate of signaling by this system is about 30 words per minute on each set of instruments, or, for a circuit, 120 words or 180 words per minute, depending on whether it is arranged for quadruplex or sextuplex transmission. (Described at length in Thomas's *Traité de Télégraphie Electrique.*)

THE ROWLAND MULTIPLEX PAGE PRINTER.—This printer in its latest form is arranged to transmit 8 messages at once, 4 in each direction, the circuit being worked duplex. For the multiplex transmission a segmental wheel or cylinder and trailer are used, certain segments being disposed in series of 11 around the cylinder for the respective transmitting and receiving instruments. In this system 11 pulsations of alternating polarity are utilized for the transmission of a letter, two given pulsations out of the cycle of 11 being omitted for a given letter. Selecting-magnets in a local circuit operated by a main-line relay select the letters transmitted, the message being printed in page form. A manually operated key-board transmitter is employed for each set of instruments, the depression of one key setting up the necessary combination of omitted pulsations for a given letter. The alternating currents for the operation of this system are set up by a dynamo machine. A motor at each end of the circuit is employed to drive the trailer, and these motors are governed by the pulsations from the dynamo machine, by which means synchronism between the sending and receiving apparatus is secured. The rate of signaling by this system is given as 30 words per minute on each printer, or a total of 240 words per minute. This printer is in successful operation (1908) in Germany and Italy as an octoplex, and on several circuits of the Postal Telegraph Cable Company in this country. For instance, as an octoplex between New York and Boston, New York and Philadelphia, Chicago and St. Louis, and as a quadruplex between New York and Chicago, with repeaters at Meadville, Pa. Details of this printer will be found in a paper by Mr. Louis M. Potts (*Trans. Am. Inst. El. Engineers*, April, 1907).

THE BARCLAY LONG-DISTANCE PAGE PRINTER.

This printer, due to Mr. J. C. Barclay, is now employed extensively on the lines of the Western Union Telegraph Company and has been adopted by that company. The messages are received on a telegraph blank by an ordinary typewriter. Fig. 325*g* is a theoretical diagram of the system. Up to a certain point this printer corresponds to the Buckingham printer, already fully described in the immediately preceding pages. Thus it employs a perforated tape (perforated by a keyboard perforator) by means of which the elements of a letter are transmitted and the selection and printing of the characters are effected by a cycle of six pulses of varying lengths, the Buckingham alphabet being used. The transmission of these pulses results in the operation of a polarized relay R, Fig. 325*g*, in the main line. This relay by its armature controls local circuits in which are a governing or separator relay GR, a unison or synchronizer magnet UM, and an escapement magnet EM, which latter magnet imparts the step-by-step motion to the sunflower or distributor D on shaft *s*, thereby actuating the circuit closers 1, 2, 3, 4, 5, 6, with the result that, as stated on page 436*c*, one or more selecting, or distributing relays, DR¹, DR², DR³, DR⁴, DR⁵, are operated. It is at this point the Barclay printer deviates from the Buckingham. In the case of the last named printer the selecting relays, by energizing certain type-magnets, cause the operation of certain levers that in turn bring a desired letter on the type-wheel to the printing position.

In the Barclay printer it will be seen by reference to Fig. 325*g* that the armature levers of the selecting relays control the operation of a series of contact switches CS¹, CS², etc., which switches, depending upon their respective positions, close a given circuit to one of the printing magnets PM. Each of these printing magnets is, by means of its armature lever, not shown in the figure, in mechanical connection with the type-wheel of a Blickensderfer or other suitable typewriter, and when the circuit of a given printing magnet is completed by the closing of the sixth circuit closing lever 6 on the sunflower, or distributor D, that printing magnet is operated and a given letter is printed exactly as if the key of the typewriter had been depressed manually. A given letter or other signal is selected for printing by the routine in which the long and short impulses of a given series of six pulses arrive (see pages 436*b*, 436*k*). When none of the pulses of a series is prolonged none of the distributing relays is affected, and the position of the switches CS¹, etc., controlled by those relays is as shown in the figure, in which case only the sixth pulse relay SP, the type release magnet TR, and the spacing magnet SM are energized, as may be seen by tracing the circuit from the battery B¹ through lever 6 of the sunflower D, to wire W, to the armature lever of the sixth pulse, or restoring relay SP, to and through the armature levers of the distributing, or selecting relays, thence to the type release magnet TR, to and through the spacing magnet SM to earth. The sixth pulse, or restoring relay SP, controls the restoring circuit of the selecting, or distributing relays, DR¹, etc. Relay SP, it will be seen, is in a multiple circuit with a printing magnet when any one of them is selected, but

by a suitable adjustment of the spring of the armature-lever of relay SP and the distance through which the lever travels, the selection and printing of a given letter are assured before the armature levers of the distributing relays are restored to normal position by the closing of the contact c of relay SP. (See reference to governing relay, page 436*m*, as to adjustment of spring for a somewhat similar purpose.)

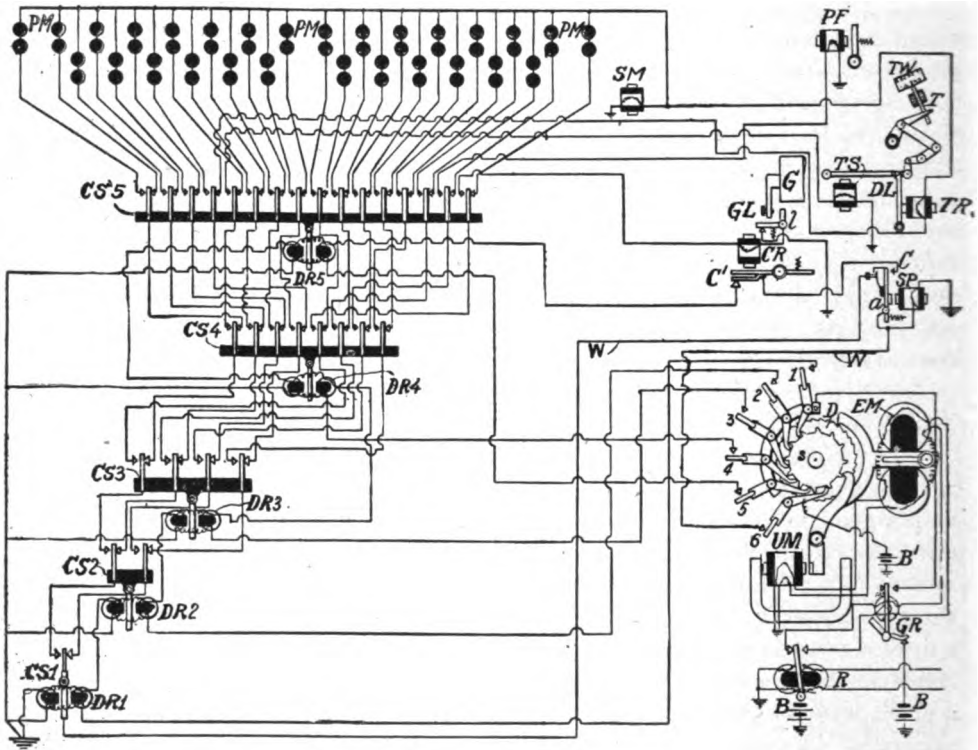
FIG. 325*q*.

BARCLAY PRINTER, THEORY.

The spacing between the printed letters on the typewriter is done automatically, and practically concurrently with the printing of the letters, by the operation of the spacing magnet SM, which it may be seen is normally in the common return circuit of the printing magnets and consequently is operated each time a printing magnet is energized. The spacing between words is effected also by the spacing magnet SM, which is then operated by a "spacing" signal consisting of six short pulses. As stated, these short pulses will not operate any of the selecting relays DR. Hence the position of their armature levers will be as in the figure, at which time the circuit, as previously noted, is completed from battery B' by way of circuit closer 6, to and through contact switches CS, to and through type release magnet TR, to spacing magnet SM which operates the spacing mechanism of the typewriter.

In the Blickensderfer typewriter employed for printing in the Barclay system, the type-wheel TW is somewhat like the type-wheel of the Buckingham printer. It has two parallel rows of type on the surface of a small cylinder. One of these rows consists of letters, the other of figures and punctuation marks. Normally the type-wheel of the Barclay printer is set for letter printing. When figures and certain punctuation marks are to be printed the position of the type-wheel is shifted by moving a shaft T on which it is fixedly mounted. This shaft is moved the desired distance for printing figures by means of a system of levers actuated by the armature of the shift-magnet TS as outlined in the figure. To select and operate the shift-magnet a shift-signal consisting of two long impulses of current followed by one short and three long impulses is transmitted and consequently certain armature levers of distributing relays DR', etc., are moved to the left, thereby completing a circuit from the sixth pulse circuit closer 6 to the shift relay TS. To insure that the armature lever of the shift-magnet TS shall remain shifted until properly released, its armature lever is held down by a detent lever DL, actuated by the type release magnet TR. This continues until a spacing signal is sent, whereupon the type release magnet, which is in series with the spacing magnet SM, withdraws the detent from the armature lever of shift relay TS. When the shift-magnet has been operated any desired figure or punctuation mark may then be selected and printed by the

A - ---	H £ ---	O 9 -- -	V ; --- -
B @ . - -	I 8 ---	P 0' - ---	W 2 - - -
C : ---	J ' ---	Q 1 - ---	X / - - -
D # ---	K (---	R 4 ---	Y 6 ---
E 3 ---	L) - - -	S # ---	Z " ---
F % ---	M ? ---	T 5 - --	• --- - -
G ^ -- -	N # - --	U 7 - . .	, --- - -
SPACE ---		PAPER FEED - - -	
TYPE SHIFT - - -		CARRIAGE RETURN - - -	

BARCLAY COMBINED LETTER AND FIGURE ALPHABET.

transmission of the proper signals, which, it will be seen by the accompanying alphabet of the combined letter and figure code, correspond to the letter code. For instance, when the shift-magnet is set for figures the transmission of the code signal for the letter 'T' will print the figure 5, etc.

As the typewriter used in this system is an ordinary page printer it is necessary to employ magnets to operate the carriage return, the line spacing, and paper-feed apparatus. When the proper signal is transmitted, at the end of a line, for instance, magnet CR operates the carriage return apparatus. In order that magnet CR may not be de-energized during the return of the carriage by the action of the restoring relay circuit upon the distributing relays, the restoring circuit of those relays is opened at this time at the armature contact c' of magnet CR and continues open at

that point until the carriage, indicated by *G*, reaches its starting-point, where a lever *GL* engages with a lever *l* and thus mechanically opens the circuit of magnet *CK*. This allows its armature to fall back and close the restoring circuit at point *c'*. As soon as the carriage begins its movement to the left the contact at point *l* closes automatically. The paper line feed mechanism, which may consist of a variety of devices, is operated by the magnet *PF*, which is selected for operation by a prearranged signal. The mechanical operations, such as the carriage return of the typewriter, are facilitated by electric motors practically as used in the Blickensderfer electrically operated typewriter.

The local batteries used are indicated in Fig. 325*g* by the conventional symbols, but in practice the source of E.M.F. is a dynamo machine or storage battery. In practice also certain auxiliary apparatus, for example a paper-feed assist magnet and a shift assist magnet, are employed, but for clearness are not shown in the figure. Condensers around contact points and resistances and fuses are also employed practically as shown in Fig. 325*h*. The time taken in changing the message blanks on the typewriter is from one to two seconds. According to Mr. Barclay the rate of transmission by this printer is approximately 100 words per minute in each direction, the system being usually operated as a duplex. On long circuits Wheatstone repeating relays are employed at the repeating stations (see Fig. 232).

This system has been operated experimentally through seven duplex automatic repeaters between New York and San Francisco. It is now in regular successful operation between New York and Chicago, New York and Boston, New York and Atlanta, Chicago and St. Louis, and numerous other points on the lines of the Western Union Telegraph Company, and its use is being rapidly extended upon those lines.

THE MURRAY PRINTING TELEGRAPH.

This system is due to Mr. Donald Murray. It was for some time in experimental operation on the lines of the Postal Telegraph-Cable Company of this country, and is now in practical operation in the British Post Office telegraph service and elsewhere.

The characters representing messages to be transmitted by this system are perforated on a paper strip by a keyboard perforating-machine. This prepared strip is caused to send given combinations of electrical pulsations for each letter over a main line, which pulsations, or the omission of pulsations, operate or control receiving apparatus at the receiving station. This apparatus in turn is caused to perforate another strip of paper, which paper is then passed before a set of metal strips that in their operation, and depending upon the position of the perforations on the paper, select a certain letter of a typewriter; the message being thereby printed in page form. Fig. 325*r* is a theoretical diagram of the apparatus and circuits at the transmitting and receiving stations of this printer. The Murray transmitter somewhat resembles the Wheatstone transmitter, but employs only one vertical rod, 1. This rod is carried by a thrust lever 9 on lever 3 and finally receives its vertical movements from the lever 3, pivoted at 4. Lever 3 is caused to oscillate by the lever 6, attached to the cam 21, which cam, with star-wheel 15, receives motion from a phonic wheel 26 (see Fig. 255, page 337). Lever 2 carries a tooth 7 that rests against the pin 8 on lever 3. When the transmitter is in operation the rod 1 makes a complete or partial upward stroke, depending on the presence or absence of holes in the paper strip 20. When the paper strip does not limit the upward movement of rod 1, the end 9 of lever 2 impinges on lever 11, pushing lever 13 against contact point 18. When the rod 1 is restrained from making a complete stroke by the uncut paper strip, the end 9 of lever 2 is forced upward against lever 10, pushing lever 13 against contact 19; thereby either reversing the battery or putting the line to ground, as may be prearranged. A succession of holes in the paper merely results in holding lever 13 against contact 18; whereas the effect of a succession of unperforated parts of the paper is to hold that lever against contact 19. The jockey rider 17 holds lever 13 firmly in either position. The paper strip is moved forward by the star-wheel 15 by means of the small central row of holes in the paper, which are punched in advance of and separately from the regular message perforations (see, for instance, Fig. 325*d*).

Unlike the characters of the Morse alphabet or of the Buckingham code, the elements forming the letters, figures, and other signals of the Murray alphabet are of equal length; there being five units for each letter, or other characters of that alphabet. This fact admits of the use of a perforator that does not require a variable feed device, in which respect it differs from certain other keyboard perforators (see page 436*i*). These five units occupy half an inch lengthwise of the paper strip, as indicated by the transverse lines shown in the figure. The location and number of the perforations within this space vary with each letter, and upon the position and number of these perforations depend the length of and routine in which pulsations of current shall pass over the line, which pulsations in turn determine or select the letter or other signal to be printed. Thus in the figure the last five com-

binations of holes in the paper strip at the collector represent the letters forming the word PARIS. To indicate the quality of the positive and negative pulsations passing to line the following device is provided. An eccentric wheel 5 makes one revolution for each positive and negative pulsation. If the index carried by wheel 5 points to a given division on the scale 22 when the negative or the positive contact is broken, equal currents are going out to line. If not, the contacts are adjusted accordingly, practically as in the Wheatstone automatic system to correct a bias (see page 319).

In the Murray printer there is no space between letters, hence the signals run into one another at times; but as the operation of the receiving part of the system depends on the time of arrival of letter and other signals, this, as we shall see, does not affect the proper selection and printing of such letters, etc. This printer does not require synchronous movement of parts at the transmitting and receiving stations, but it does require isochronism, or identity of speed of operation between the transmitting and receiving apparatus, which isochronism is maintained by the action of arriving signals upon certain apparatus in a local circuit at the receiving station, in a way to be described subsequently.

The perforated strip at the transmitting station and the transmitter are termed the Collector. The apparatus which effects the maintenance of isochronism and the punching of the paper strip at the receiving station is termed the Distributor. The mechanism which selects and prints the letters and figures is termed the Translator, all as in Fig. 325^r.

In actual practice the transmitter is caused to send out positive and negative pulsations of current. These pulsations operate a polarized relay at the receiving station, and this relay actuates a "punching" relay and a "governing" relay in a local circuit. To simplify the description the polarized relay is omitted in Fig. 325^r, and the punching relay and governing relay are shown as operated directly by makes and breaks of the main line circuit at the transmitter; the positive pole being placed to line at contact 18 and the earth to line at contact 19, according to the position of lever 13. The punching relay and governing relay are identical in construction, and consequently their armature levers move synchronously in response to arriving currents. The punching relay controls the operation of a punching magnet, which by means of armature lever 29 and punch 30 perforates the "recorder" paper. The governing relay 28 controls the rate of vibrations of the vibrator 35. This vibrator performs two functions: it operates a spacing magnet by means of contact 32, and the punching magnet by means of contact 33.

The rate of vibration of the reeds of the respective vibrators at the transmitting and receiving station may be varied by moving the small weights *w**w*, in the well-known way. These vibrators are operated on the well-known "buzzer" principle (see page 256). In practice the reed 34 at the receiving station is given a tendency to vibrate at a rate 2 or 3 per cent. higher than the transmitting vibrator, but the respective vibrators are maintained at a practically equal rate of vibration, by an ingenious retarding device applied to vibrator 35, as follows. The reed 23 of the transmitting vibrator has an unretarded phase of vibration. Hence any change in the strength of current more or less increases the amplitude of vibration, the rate of vibration

remaining practically uniform. The reed 34 of vibrator 35, however, is provided with buffers, 36, 37, against which it impinges at each oscillation. These buffers limit the amplitude of vibration of the reed, and (as Mr. Murray has pointed out) as the energy imparted to the reed must find some outlet, it becomes very susceptible to variations in current strength through its coils. Normally, when makes and breaks of the

FIG. 325r.

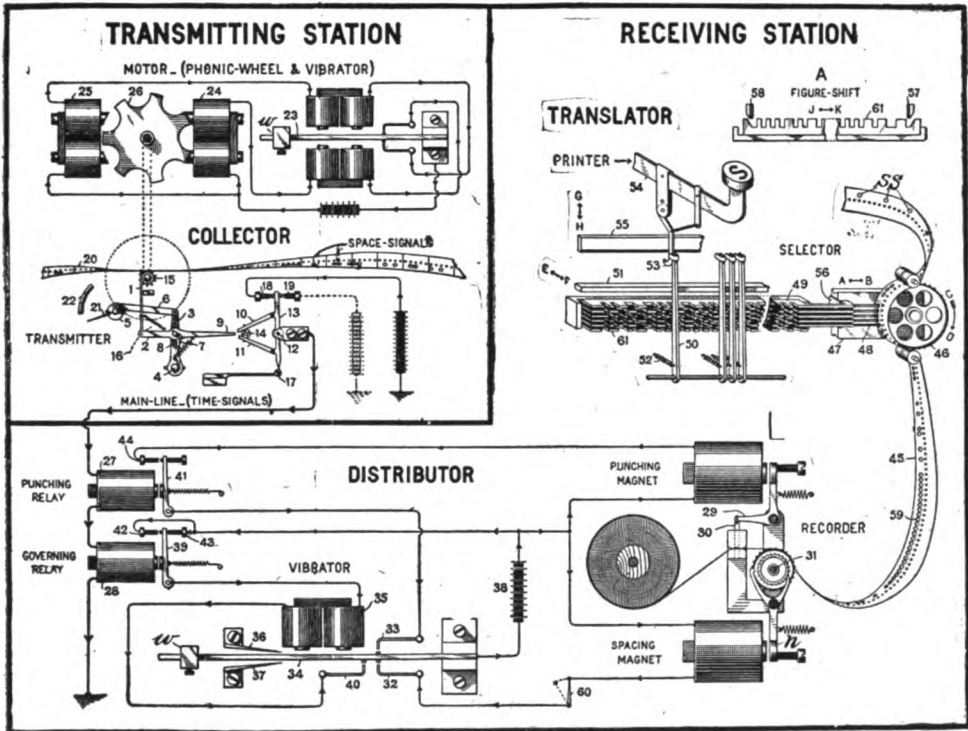

MURRAY PRINTER, THEORY

circuit or alternations of current are being transmitted, the armature levers 41, 39, and the reed 34 would oscillate synchronously, but for the slight tendency of the reed to outspeed the levers. When synchronism exists lever 41 will be on contact 44, lever 39 will be on contact 42, and reed 34 will be on contact 33, at the one time. If, however, reed 34 tends to exceed the said normal oscillation of lever 39, there will be times when the lever 39 will be between its contacts 42, 43; consequently a decrease of current strength through magnet 35 ensues, and the rate of vibration of the reed is thereby retarded sufficiently to keep it in step with the relays. Further, as long as signals continue to arrive over the line more or less uniformly, the reed 34 effects a regular succession of breaks of the spacing magnet circuit at contact 32, with the result that the recorder paper strip is drawn along at a uniform rate by the star-wheel on shaft 31. The perforations made in the recorder paper strip are identical with those of the perforated paper at the transmitting station. The punch 29

therefore must only be actuated when the rod 1 at the collector passes through a hole in the tape; and when the rod 1 meets a section of uncut paper, the punch 29 must be quiescent. These requirements are met in the following manner. When the rod 1 passes through, say, 3 holes in the paper in succession, a continuous current passes to the line during that time. Hence, during the same time, the lever 41 of the punching relay is attracted to its contact 44, but during this time also the reed 34 of the vibrator has thrice opened and closed the punching magnet circuit at contact 33, which punches three holes in the recorder paper corresponding to those in the collector paper. Obviously, if a section of uncut paper equal to, say, 3 units passes before rod 1, no current will pass over the main line during that time. Consequently the lever 41 will be on its back stop during that interval, thereby opening the punching magnet circuit at contact 44. Therefore punch 30 is at rest during this time, notwithstanding that reed 34 continues to open and close its contact 33. Clearly, when lever 41 of the punching relay is on its front or back stop, the lever of the governing relay will at the same time be on its front or back stop, and for equal intervals. As already noted, however, the armature lever 39 of relay 28 has a contact on its front and back stop. Hence whether lever 39 is on contact 42 or 43, the circuit of vibrator 35 is closed at either point. Thus the reed 34 will continue to open and close that circuit at contact 32 at regular intervals, thereby operating the armature lever n of the spacing magnet, which by actuating the star-wheel 31 effects a regular step-by-step movement of the recorder paper. By these means an exact reproduction of the original perforated paper is obtained at the receiving station. When signals cease to arrive over the main line a device not shown in the figure automatically opens the spacing magnet at the switch 60 to prevent unnecessary running out of the paper.

The manner of translating the perforations in the recorder paper into printed characters will now be described. It may simplify the explanation if it be noted that in the operation of the various parts of the translator (Fig. 3257) the process of the perforating machine at the transmitting station is here virtually reversed. In the operation of the perforating machine the depression of a letter key projects forward a certain group of punches that perforate holes in the paper strip corresponding to the key depressed. In the selector the action of the mechanism presses backward by means of the uncut paper a certain group of rods, which act effects the depression of a key of a typewriter, and the printing of a desired letter. The selector includes a star-wheel 46, carried on a shuttle 47, which oscillates in the directions indicated by the double arrow A—B. The shuttle also carries a curved die plate which is coincident with the surface of star-wheel 46. The die plate has holes punched in its surface corresponding with five consecutive units or holes of the perforated paper. At each reciprocation of the shuttle the star-wheel 46 is rotated a distance CD, corresponding to five units of the paper strip, and as the star-wheel is thus rotated the paper strip is advanced a distance equal to one letter. The right ends of the five rods 48 are suitably held in proximity to the die plate. These rods are attached to combs 49 having teeth 61. As the shuttle moves toward A the die plate is pushed toward the rods 48, and depending on the location and number of perforations in the paper strip a certain number of the rods will enter the holes in the die plate and the combs attached to such

rods will not be affected. But the rods which come against the uncut parts of the paper are pushed back a distance of about one-sixteenth of an inch. This moves corresponding combs a similar distance, thereby bringing a certain group of teeth or slots into alignment with a vertical bar or latch, for instance, 50 in the figure. There are in all 56 of these latches; one for each of the letters, figures, etc., of the typewriter or printer. These latches are held in front of, but just removed from, the teeth, or slots, by a universal bar 51, which, however, at a given instant is moved back in the direction F—E, allowing that latch, and no other, which is opposite the slots that have been brought into alignment as stated, in this case latch 50, to move into the space thus provided; being drawn thereinto by its spring 52. This latch pushes the hook 53, which is attached to a given type key, under a bar 55 that is oscillating rapidly in the directions indicated by double arrow H—G, with the result that the key s (in this instance) is sharply depressed, printing the corresponding letter. Similarly any other letter thus selected will be printed. The moment the hook 53 engages with the bar 55 the universal bar 51 on its excursion E—F restores the latches to their normal position, and the shuttle on its return by means of the plate 56, which engages with projections from the combs, restores the rods 48 to zero position. All of these actions are effected at the proper instants by a battery of cams operated by suitable machinery, not shown in the figure. As one letter of a word is being printed while the next letter is being selected for printing, no actual time is lost in the printing.

As the combinations of the five units of the Murray alphabet give only 33 permutations, a "shift" signal is provided by which a shifting device is operated on the typewriter, whereby figures or punctuation marks in place of letters are printed, or *vice versa*. The figure shift is operated by means of a sixth comb 61, not attached to any of the rods 48. This device is shown separately at A, Fig. 325r. When the figure shift signal is transmitted the latch 58 is selected and is drawn into the slot, its wedge-shaped edge engaging with a sloping tooth of the figure comb and moving it to the left one-sixteenth of an inch, whereby the figure locks are opened and the letter locks are closed. Reversely, a letter shift-signal selects the latch 57, thereby opening the letter locks and closing the figure locks. The letter shift-signal consists of five holes in the paper strip. Obviously this permits the rods 48 to enter holes in the die plate. Hence no letter is selected and the printer remains idle. Advantage is taken of this arrangement to correct errors in the perforated strip at the perforating machine. Thus when the operator finds that he has perforated a wrong letter or figure, he punches the letter shift-signal over the erroneous characters, which constitutes a "rub-out," and then repeats the desired letter. A rub-out of five letters is indicated at 59 on the recorder strip.

The letter feed of the Murray printer or typewriter is accomplished automatically as each letter is printed. The line feed is accomplished by a "line" signal, which is made by the depression of a line signal key on the perforator by the operator at the end of every seventieth letter, the occurrence of which is indicated to him by a letter-counting device at the perforator. This line signal operates a special latch at the typewriter which releases mechanism that automatically moves the paper the distance of a line. At the end of a message the operator perforates a "stop"

signal. This signal runs the printer carriage back to the starting position and stops the printer. The attendant thereupon tears off the message and presses a button which starts the printing of another message. If it should be desired to repeat the messages thus recorded on the perforated paper to a distant station, the strip is passed through a transmitter precisely as if it had been punched by the original perforating machine.

It is essential that the recorder paper should always present the space on the paper representing a given five-unit signal before the five holes of the die plate. To insure this result, which is termed maintaining unison, the punching operator makes several space signals before starting a batch of messages. The space signal, as already intimated, is represented by a middle or third hole in the five-unit space, as shown at the collector and as indicated by ss at the selector. Every fifth tooth of the star-wheel 46 is omitted. The attendant can thus see at a glance if the space signal coincides with the missing tooth. If not, he retards the paper by the rotation of a unison arm, not shown, which speedily brings it into unison. The mechanism of the printer is driven by a small electric motor which consumes about 40 watts for a speed of 140 words per minute.

According to Mr. Murray the maximum capacity of this printer is about 150 words per minute, but for various reasons the speed in practice is maintained at about 100 words per minute. For additional details of this printer the reader is referred to a paper by Mr. William B. Van Syze on "A New Page Printing Telegraph" (Transactions American Institute of Electrical Engineers, Vol. 18), and to a later paper by Mr. Murray descriptive of his printer (Journal British Institute of Electrical Engineers, Vol. 34), from which paper the accompanying diagram is with some minor alterations reproduced.

CHAPTER XXVIII.

FIRE ALARM TELEGRAPHY.

GAMEWELL, GAYNOR, SPEICHER SYSTEMS.—AUXILIARY AND AUTOMATIC FIRE ALARM TELEGRAPHY, ETC.

The importance of electricity as a time saver in announcing the existence of a fire can scarcely be over-estimated, since it is self-evident that the more promptly a fire can be attacked by the firemen the more easily it can be subdued and that with the minimum of loss.

There are but few cities of any importance in this country to-day that are not equipped with a fire-alarm telegraph system. The days of the fire observation tower, with a watchman patrolling its topmost platform on the lookout for signs of incipient conflagrations, have, it may be said, passed, although in several cities the old towers still remain, and in some instances are utilized as a support for a "fire" bell, which now is rung, either to announce, by the number of its strokes, the location of an alarm box, or to "strike" certain hours of the day and night; the strokes of the hammer being caused by impulses of electricity in a manner to be described subsequently.

An especial advantage of a fire alarm telegraph system is that it not only gives the alarm of fire with the minimum loss of time but also indicates to the firemen the location of the fire within a very short distance.

A simple fire alarm telegraph system consists of a central office, or station, in which alarm apparatus and battery are located, and of signal boxes in the street and elsewhere, by which to transmit alarms to the central office, and a wire connecting the central station with the various signal boxes in the streets, in fire-engine stations, and elsewhere.

Such a "system" is outlined in Fig. 326, in which *R* is a relay and *G* a bell, controlled by *R*, in the central office. *MB* is the main battery for the circuit. *SB* are street signal boxes. Normally, the fire alarm circuit is closed.

In each street box is placed a "make and break" wheel resembling that used in the call boxes of the district messenger service already described. In fact, the ordinary fire alarm telegraph systems and the district messenger systems are practically similar in principle; the main difference between them being that, in the fire alarm telegraph service, owing to the exposed positions of the street boxes, and the greater importance of the service as a whole, more substantial boxes and additional testing apparatus, etc., are employed than is necessary in the district service.

The mechanism of the fire alarm signal boxes is set in motion in various ways. In some boxes a lever or crank is used, which, on being "pulled," winds up a weight, or a spring, within the box, the unwinding or falling of which spring, or weight

causes the break-wheel to open and close the entire circuit a pre-determined number of times, depending upon the construction of the break-wheel. These makes and breaks of the circuit open and close the alarm apparatus in the central office and, as will be described, in bell towers and elsewhere, and the bells and gongs are struck a number of times corresponding to the breaks in the wheel of the signal box. As in the case of district call boxes, each fire alarm box is assigned a designating number. One form of a street fire alarm box with doors open is shown in Fig. 327.

In general these signal boxes are now supplied with an outer and inner door, as indicated in that figure, to protect the electrical apparatus from the elements.

The signaling mechanism of the box shown in Fig. 327 is operated by the falling of weight *w*; *w* being first raised by the depression of the left end of lever *u*. This lever is depressed as follows: When the inner door of the box is shut a starting

FIG. 326.

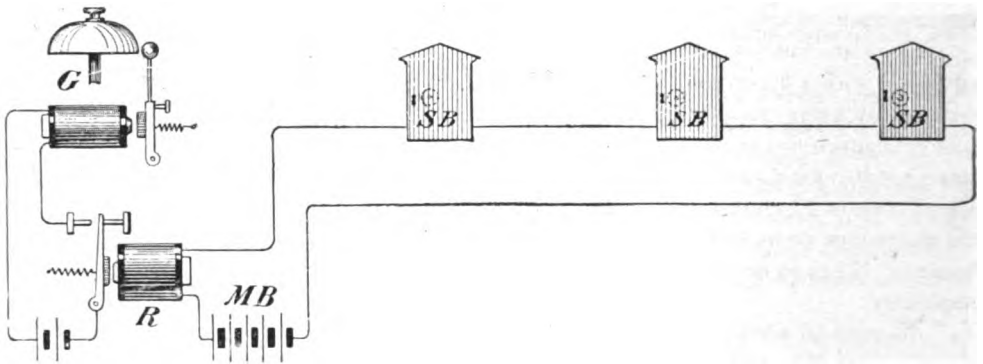

SIMPLE FIRE ALARM CIRCUIT.

hook *u*, which extends to the front of the inner door, is placed directly over the end of *u'*, in such a manner that when the hook is pulled down from the outside of the inner box, the weight is raised. The weight in falling is caused to operate the break-wheel, as a recoil spring would do. The object in using the weight has been to avoid the delays and annoyance due to the breaking of springs, but recoil springs are now used almost exclusively.

Each signal box is provided with a "testing" switch, a lightning arrester, and a signaling key (shown at the bottom of the box) by means of which an inspector may communicate from the box to the central office. Each box is also equipped with a small electric bell, or gong, as *G*, in Fig. 327, upon which the strokes of the alarm are heard. This serves two purposes. It notifies the one giving the alarm, that the signal has been transmitted properly and it also warns others who may have opened another box elsewhere, for the purpose of sending in another alarm that a prior alarm is in process of transmission over the circuit. The electrical connections within the box are, as a rule, so arranged that when the outer door is closed the gong magnets are cut out of the circuit. The advisability of this will be obvious when it is considered that there might be 15 or 25 such magnets in a circuit, the combined re-

sistance of which would, otherwise, be unnecessarily added to the circuit. The electrical connections of this signal box will be shown more in detail in subsequent diagrams.

What has been thus far said relates almost entirely to the sending in of alarms to a central office; and the simplest apparatus required for the reception of an alarm has been shown in Fig. 326.

Much more than this, however, is generally used in practice. For instance, it is desirable that a record be made of the alarm received, and for this purpose recording devices are provided. Again, in the large cities, the number of signal boxes is greater than is deemed advisable to place on one circuit and, therefore, a number of separate circuits emanate from the central office. This necessitates the employment of devices to repeat alarms received on any one circuit over all of the other circuits. These repeaters may be either manual or automatic.

When tower bells or church bells are rung from the central office on independent circuits, special apparatus is furnished for the purpose.

In the later forms of improved fire alarm signal boxes the spring is wound up after the manner of a clock-spring and the mechanism is started by simply pressing a button, or by pulling upon a hook.

Also the break-wheel, in improved boxes, is caused to revolve four times, instead of once, as formerly. This is done in case the firemen should mistake the first "round"; or lest an accidental grounding of the circuit should momentarily confuse the signals, etc. The recoil springs are capable, when fully wound up, of sending in forty or more alarms, and an index is placed in each box to indicate to the inspectors, or others having access to the box, the total number of "rounds" sent in, and the need or otherwise of re-winding the spring.

Experience has shown that it rarely happens that two fire alarms from different boxes are started over the same circuit at exactly the same time. The result of such an occurrence would, of course, be to confuse the signals.

In order, however, to minimize the chances of such an occurrence, many devices designed to preclude the sending in of an alarm from one box while an alarm is being transmitted from some other box, have been introduced into the boxes. Boxes equipped with such devices are termed "non-interfering" boxes.

FIG. 327.

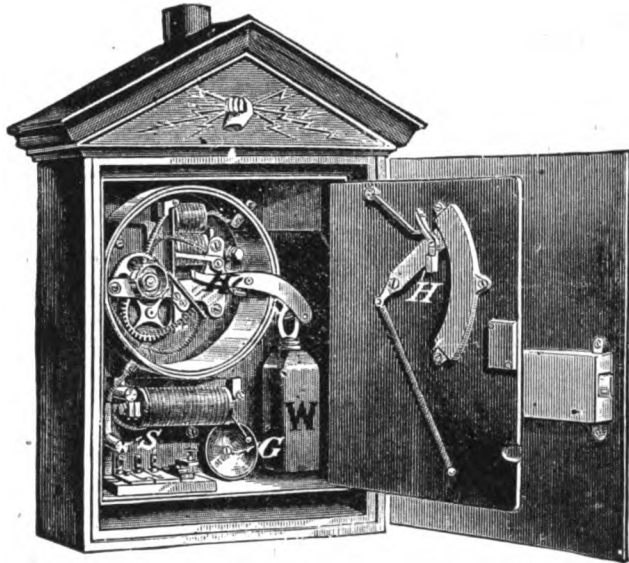

FIRE ALARM STREET BOX.

It is often thought desirable also to extend city fire alarm circuits to buildings, factories, etc., without, at the same time, clogging up the main circuits with additional magnets, break-wheels, etc., and without running the main circuit into comparatively inaccessible places where line "troubles" might be frequent and difficult of repair. To effect the desired result with the minimum of complications to the main circuit, a number of different arrangements, consisting of auxiliary box connections, and of circuits extended from the regular street signal boxes, have been devised.

Illustrations of boxes and diagrams of circuits in which these improvements have been introduced will be found in the succeeding pages together with detailed descriptions of the same.

THE GAMEWELL FIRE ALARM TELEGRAPH SYSTEM.

The "main" alarm circuit of this system includes the usual street signal boxes and central office apparatus.

The central office apparatus consists essentially of a relay in each circuit, a "multiple pen," or other form of register, for each relay, to record the alarms as received, and an automatic or manual repeater by which signals received on any one circuit are repeated over all of the others.

In the most improved repeating apparatus for central offices of the Gamewell system an alarm received on any one circuit is automatically repeated over all the other circuits, and, to prevent interference with the repetition of those signals, by incoming signals on any one or more of the other circuits, suitable mechanism is provided. The apparatus by means of which this is accomplished is termed a non-interfering automatic repeater.

THE GAMEWELL AUTOMATIC NON-INTERFERING REPEATER.

This repeater, as arranged for three circuits is illustrated in Fig. 328.

The repeater is provided with "locking" mechanism whereby all the armatures of the relays of the different signal box circuits, excepting the one on which the alarm has originated, are "locked," and are thereby prevented from responding to any new alarm that may be started, or from sending in confusing signals (due, perhaps, to accidental breaks of the wires, crosses, etc.) during the transmission of an alarm. One of the features of this repeater is that no local batteries are needed in connection with it.

In Fig. 328, R_1, R_2, R_3 , are the relays of the fire alarm circuits. w', w' are wires leading to contact strips resting on an insulated cylinder at c , on certain parts of which cylinder are placed metal segments m , (shown separately in Fig. 329.) The trains of wheels, etc., on the left, are operated by the weights w, w, w . s is a shaft, geared by means of beveled wheels bw , with one train of wheels. This shaft carries downward-hanging rods r_1, r_2, r_3 . These rods are loosely mounted on *eccentrics* at c, c , which latter are rigidly attached to shaft s . When that shaft is given a partial turn the eccentrics push the rods downwards. At the next half turn of the shaft the rods are restored to their original positions. These rods assist in locking the armature

A pin p' projects from one side of r , virtually as indicated. When the armature lever a is attracted, all the circuits being closed, this pin projects a short distance above the flat spring fs , as in figure. The lever h extends out to the rod r . Normally the right end, or tip, of h is just under the break b in r . Fig. 329 represents the position of the levers, armatures, rods, etc., of all the relays, when at rest.

FIG. 329.

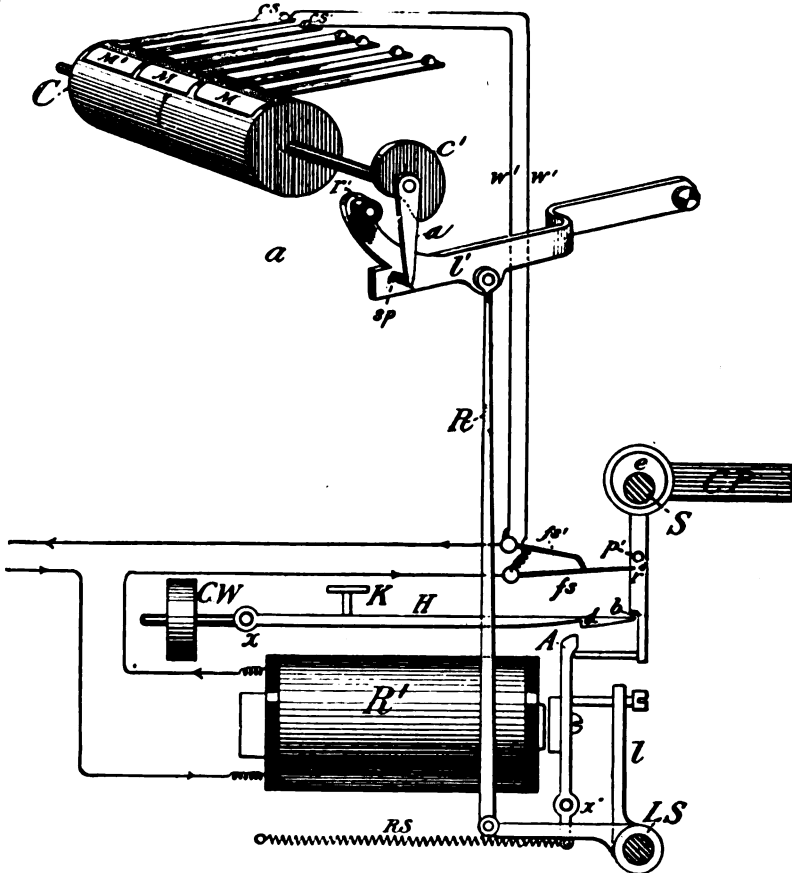

GAMEWELL AUTOMATIC REPEATER, THEORY.

It may be seen that the main circuit in Fig. 329, after passing through the relay, passes to the flat strip fs , thence to another flat strip fs' which rests against fs , and thence out to the line again, as indicated by the arrows. Two short wires w', w' , lead from the flat springs fs, fs' , to two flat springs cs, cs' , which rest, normally, on an insulated portion of the cylinder c , in such a manner that the short circuit via wires w, w' , is usually open. m' on this cylinder is a short metallic strip, curved to conform to the surface of the cylinder. All of the relays are similarly provided with short wires $w'w'$, which are led to separate strips resting on cylinder c , and opposite each pair of such strips is placed, on the cylinder, a similarly curved metal strip m . The different strips $m m$ are insulated from each other.

Assuming that an alarm is now to be sent over the circuit in which relay R_1 is placed, Fig. 329.

The first breaking of the circuit permits armature lever λ to fall back. The latter, in falling back, throws aside the rod r and the rod l . The rod r simply turns to the right on its eccentric e , but the rod l turns also the shaft LS . This movement of LS , by actuating the long rod κ removes the pin sp from the path of the arm a , and thus, by means of mechanism not seen in Fig. 329, permits the shaft s to make a portion of a revolution; and the cylinder c to make one revolution. The same mechanism likewise causes the cam c' , which is mounted on the same shaft as c , to quickly depress the lever l' by contact with the roller r' . The depression of lever l' places the pin sp again in the path of arm a , and also, at once, by the medium of long rod κ , resets the rod l on the shaft LS , thus pushing back the armature lever λ of relay R' to its magnet.

It is this mechanical assistance extended to the return of the armature which allows the employment of the strong retractile spring RS on the armature lever, for, without this assistance, the magnetic strength of the relay would not serve to attract its armature when the latter had fallen back sufficiently to throw aside the lever l and rod r .

The act of turning the shaft s causes the eccentrics to quickly lower all the rods r , and, excepting that of relay R^1 , each rod engages with the tip of lever h of its respective relay and depresses that lever, as shown in the case of R_2 , Fig. 330. This depression of lever h puts each detent d in the path of each armature lever λ , thus "locking" it, also as in Fig. 330. At the same time the lowering of rod r has engaged its pin p' with the flat strip fs and has separated it from fs' ; thereby opening the main circuit. This act, being duplicated at all of the relays, of course, opens all the main circuits (excepting, as before, the circuit of relay R') at fs fs' . The next instant, however, the cylinder c , in the act of revolving, brings the various flat strips, cs, cs' , over their respective curved metal strips m , thus closing the circuits for a short time, and making a stroke on all of the gongs, etc., on the various circuits. The gongs, etc., on the circuit of relay R' will, of course, already have been operated by the break caused by the street box in sending in its alarm.

The cam c' , Fig. 329, as just said, at once returns the pin sp into the path of arm a , checking the motion of the cylinder at the end of its revolution; but the shaft s remains as first placed, namely with its revolution incomplete, and with the rods r all lowered, until the completion of the alarm, and for the space of about fifteen seconds thereafter, by which time self-setting mechanism, outlined at the left of Fig. 328,

FIG. 330.

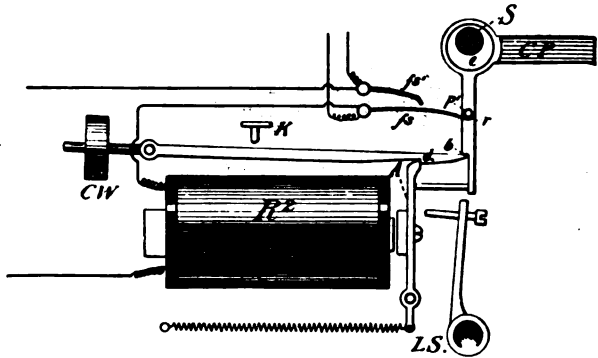

permits a detent lever to fall into a slot, thus enabling the shaft *s* to complete its revolution and at the same time to lift the rods *r* away from levers *h* and from the flat springs *fs*, thereby allowing *fs* and *fs'* to come together, closing all of the circuits as before.

In the case of relay *R*¹, (which we have assumed to be in the circuit where the alarm has originated,) since its armature *A* had moved before the rod *r* had received its downward motion, there was nothing to stop its normal backward motion, the result being that its rod *r* is thrown to the right, out of the way of the strip *fs* and the tip of lever *h*, and, when, the next instant, *r* is lowered, it falls to the position shown in Fig. 331,

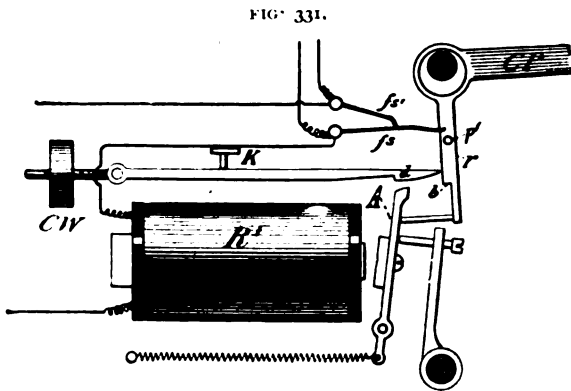

which, it is seen, leaves the flat springs *fs*, *fs'* intact, and leaves the catch *d* on lever *h* out of the path of armature lever *A*. Consequently, that lever is left free to continue its back and forth motions in response to the makes and breaks of the break wheel in the signal box, striking, at each backward motion, the upright rod *l* which, as we have seen, by turning shaft *ls*, re-

leases the arm *a* of the cam *c'*, thus allowing the cylinder *c* to make one revolution for each break of the circuit, for the purpose mentioned.

In the event of a wire of any of the circuits breaking, the armature of the relay of that circuit will be released. This will cause one "stroke" to be sent over all of the other circuits. Simultaneously all of the other relays are "locked," as described. In the course of a few seconds, however, the mechanism of the shaft *s* unlocks the armatures of the other relays and thus leaves the unbroken circuits free to send in signals regardless of the broken circuit; the armature of whose relay simply rests on its rod *l* until it is again attracted by its magnet when the circuit is repaired. The advantage of this arrangement is that in the absence of attendants none but the broken circuit is affected. To insure the prompt "locking" of the armature levers, the rod *r* is assisted by a cam *K* over each lever, *h*, which descends on the levers concurrently with the first partial rotation of the shaft *s*; the mechanism for the operation of this cam it is not deemed requisite to show.

In addition to the apparatus described in connection with this automatic repeater, an annunciator is so placed with regard to each relay that the opening of its circuit lets the "drop" fall, disclosing the number of the circuit. A glance at the repeater thus shows on which circuit the "break" has occurred, whether it be due to a regular alarm or to a broken wire.

NON-INTERFERING STREET SIGNAL BOX.

Fig. 332 is a theoretical diagram of a Gamewell fire alarm signal box, in which a four "round" break-wheel and a non-interfering device are employed; there are also

shown in the same figure the connections for an auxiliary fire alarm attachment and, at the right, an "auxiliary" alarm box.

In Fig. 332, SB is a street signal box, with both doors removed, and the frame of which is indicated by dotted lines. *m* is the electro-magnet which actuates the non-interfering apparatus. *bw* is the four-round break-wheel. *s* is the recoil spring, or motor, which drives the signaling mechanism. *w* and *w'* are wheels, suitably geared with the motor shaft. *L* is a lever, pivoted at *x*, which lever, in conjunction with wheels *w* and *w'*, performs an important part in causing the starting and stopping of the break-wheel.

BW, *s*, *w*, *w'*, *m*, and the clock-work gearing, are contained within a small circular case with a glass cover. *AM* is the auxiliary magnet which, through the medium of the apparatus *A* and the rod *R*, releases the break-wheel *BW* when a signal is sent in from the auxiliary box. *GM* on the upper right corner of SB is the signaling gong, or bell, already mentioned. Switch *H* and wires 1 and 2 form a short-circuit around the gong bell magnet when the outer door of the box SB is closed, thus cutting out that instrument. In the figure switch *H* is open. *H'* is a switch devised to cut off the auxiliary circuit when it is in trouble. This is done by throwing *H'* to the left, when the auxiliary circuit will be opened at *a a'*; at the same time the regular circuit will be preserved intact through metal strip *b*. *H'* is moved by the ebonite cross-piece *E*. *T* and *T'* are the auxiliary box terminals. The strap-key *SK'* to the right of *T* is for signaling on the auxiliary circuit. *F*, *F* and *SK* are the cut outs, lightning arresters and signaling key ordinarily employed in such boxes.

The main circuit from the central office CO, as indicated by arrows, enters SB at the post *F'*, passes through the key *SK* and magnet *GM*, to the binding post *BP*; to and through the contact springs *CS*, to the post *BP'*; thence to and through the auxiliary box AB; back to *H'* in SB; thence to the post *F'* and back to the central office. The circuit has not been traced through the auxiliary magnet *AM* because it is shunted out by the auxiliary box wires; consequently, that magnet is normally "open." The manner in which this magnet is caused to operate the alarm apparatus in SB will be described further on.

The non-interfering apparatus, the general principle of which is shown in Fig. 332, is known as the "Gardiner." It consists of the electro-magnet *m* and its armature lever *SI*. The lever *SI* is hollow at its lower end and in the tube a rod *NI* is inserted. The rod *NI* is held out by a small spiral spring, as shown, but may be readily pushed further into the tube.

To *NI* is attached a flat brass disc *D* about $\frac{3}{8}$ inch in diameter. Normally, this disc has a portion of its surface *under* the pivoted bar *L* and an equal portion over one end of the starting hook, or lever, *SH*, the end of which only is shown in the figure, by a dotted square. This lever *SH* does not extend under the lever *L*. Its other end terminates in a hook outside of the inner door of the signal box. The lever *SH* is so pivoted that when the hook outside the box is pulled down the end within the box, is elevated. When the end *SH* of the lever is thus raised it comes in contact with the disc *D* which it lifts up. The disc in turn lifts the lever *L* up, and away from the pin *p*, on the periphery of *w*, permitting the train of wheels to start. This leads to a break in the main circuit, which demagnetizes *m*, whereupon its armature lever *SI* is withdrawn, taking with it the disc *D* from below the lever *L*. Hence the

starting hook might now be pulled indefinitely without bringing its end *SH* in contact with the lever *L*. When the outer door of a signal box is closed it thrusts a rod against the lever *SI*, which rod holds that lever towards its magnet, regardless of whether the circuit is open or closed. When, however, the outer door is opened, if the circuit be then opened, as it might be, for instance, by the act of transmitting a signal from some other box, the spring *SI* at once withdraws *NI* and the disc *D*, away from the magnet *M* and out of the reach of the attractive force of the latter, so that it is impossible to start the train of wheels by means of the starting hook until the main circuit is closed and the outer door has again been closed. When the inner door is opened it is possible to place the lever *SI* in its normal position by depressing the rod referred to. In the manner described, therefore, signals are prevented from interfering with one another. It will also be found as the description is proceeded with that when once any one has started an alarm signal, which is done, according to the directions plainly cast into the outside of the cover of the inside door, Fig. 333, "Pull the hook down once and let go," it is not possible for him to interfere with that signal until it has been transmitted four times to the central office, and until he has again closed the outer door to push the lever *SI*, Fig. 332, up to its magnet. This arrangement was rendered necessary because of the fact that people in their excitement would continue to pull the hook repeatedly, thus confusing the signal. In Fig. 333, *F* is the end of the rod which pushes the lever *SI* towards its armature by contact with the pin *F'*, when the outer door is closed. *S* is the rod which short-circuits the gong magnet when the outer door is closed.

The manner in which the four rounds of the break-wheel are obtained may now be described.

Referring again to Fig. 332. As already said, *w'*, *w* and *BW* are geared up with the recoil spring shaft *s*. There is a slot *s* on the lower edge of lever *L*, and a pin *j* extending from its side. On the other hand there is a pin *p* extending from the side of wheel *w*, and a dent *d* in the circumference of *w'*. The dent may be assumed to be of the shape shown in the figure, although, to avoid complicating the drawing, the exact appearance of the arrangement is somewhat departed from.

The wheel *w'* revolves once while *w* revolves twice and while *BW* revolves four times, each in the direction indicated by its arrow. When at rest pin *p* is in the slot *s* and the pin *j* is in the dent *d*; the pin *p*, consequently, holding the train of wheels in check. The moment, however, that the lever *L* is raised the pin *p* moves out of the path of *s* and, for a short space, the lever is held up by the pin *p*, but, presently, the periphery of *w'* comes into contact with the pin *j*, thus keeping the lever *L* elevated, until, in the course of its revolution, the wheel *w'* brings the dent *d* opposite pin *j*, which act permits lever *L* to fall on to pin *p* of *w*, but only for a short distance when pin *p* arrives at *s* permitting the lever to fall to its normal place, thus again stopping the clock work. In the meantime the wheel *w* had performed two revolutions and *BW* four, with the result that the under contact spring of *CS* had fallen into the breaks on the periphery of *BW*, thereby opening and closing the circuit as many times and with as many intervals as there were breaks on the wheel; which breaks correspond with the number assigned to the box; in this case 25. It will be understood that the

lower spring of cs recedes from the upper spring every time the former falls into the notches on the break-wheel.

To the right of Fig. 332 is the auxiliary box AB. It is known as the Speicher auxiliary box. In that box are placed two break-wheels, aw and aw' . In practice they are mounted on one shaft, although shown separately in the figure, and they are operated in the same manner as is the break-wheel of the ordinary district messenger box. The wheel aw' , in rotating, actuates its metal strips ms ms' , which are in con-

FIG. 333.

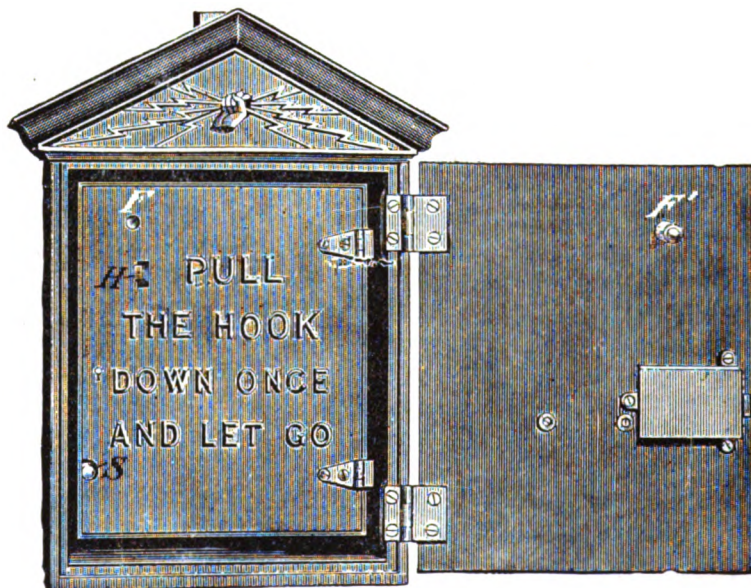

GAMWELL FIRE ALARM BOX.

nection with the wires leading to SB. Normally these strips are touching, thus short-circuiting the magnet AM in SB, as stated. There are about 10 or 12 "breaks," or notches on the wheel aw' . As it rotates, the lower strip ms' falls into the breaks on the wheel and rises out of them, alternately opening and closing the auxiliary circuit at f_2 , as many times as there are breaks on the periphery of aw' . The object thereby sought will be explained presently. The wheel aw in rotating actuates, in a similar manner, its metal strips ms , ms' , which strips are connected with wires leading to the indicator in the nearest fire-engine station. On the periphery of aw the number of teeth correspond to the number assigned to the particular auxiliary box, so that, when an alarm is sent in from that box, the nearest fire station is at once apprised of the exact location of the fire.

In AB a common compass, c^1 , is placed above a small magnet m' . This magnet would be in the auxiliary circuit but that it is normally cut out by the short-circuit via c . When, however, the button v is pushed in, the contacts at c are separated and the main line current flows in the magnet m' , which causes a deflection of the

compass c' , thereby showing the person in charge, at the factory or other building in which the auxiliary box may be located, that the auxiliary circuit is intact.

In addition to the starting hook SH in SB , it will be observed that, if the vertical rod R is raised high enough, it will come in contact with lever L and start the clock-work. The lower end of R rests on the cam K . The cam is rigidly attached to the peculiarly shaped lever A , so that, as the right hand end of A descends the cam K ascends, raising, as it does so, the rod R . The end K , of A , is given an upward tendency by its spring. On the surface of A , at the right, 14 small flat spurs are set,

FIG. 334.

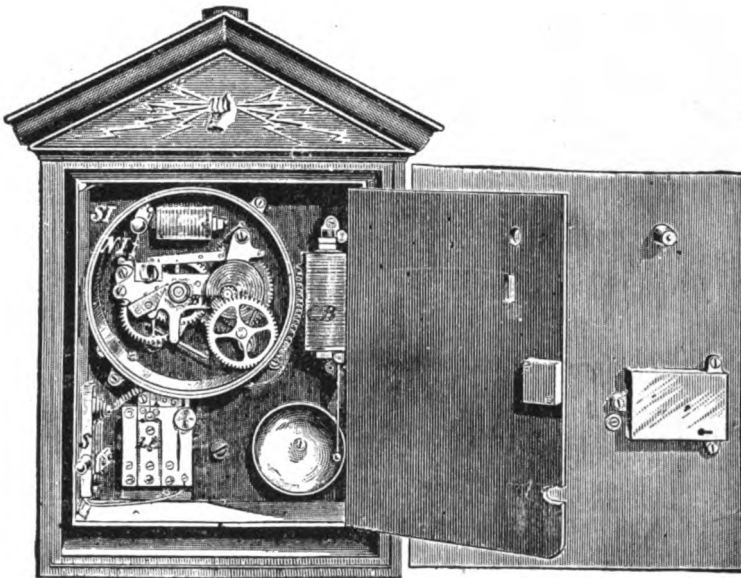

GAMEWELL GARDINER NON-INTERFERING FIRE ALARM STREET BOX, WITHOUT AUXILIARY ATTACHMENTS.

as shown. On the lower end of the armature lever, L' , is a small cross-piece cp facing the spurs on A . At rest, namely when AM is demagnetized, as, owing to the shunt around it, normally, it is, the lowermost spur on A rests on the cross-piece on the bottom of L' . When the magnet AM is alternately opened and closed, however, (as it is when the break-wheel AW' , in the auxiliary box, is set in motion, and the shunt around AM in SB is, in consequence, broken and closed at f_2 in AB), one spur after another on A rests on the cross-piece on L' until the last but one is reached, by which time the cam K has lifted rod R until it has reached and raised the lever L and thus has started the train of clock-work. On passing the next and last spur on A , the spring pulls the lever A into a vertical position, which act places the "cut away" edge of the cam opposite the lower end of rod R , whose upper end is thereby at once withdrawn from the vicinity of the lever L , by the spiral spring shown. The lever A then remains down until it is reset by an inspector of the fire department.

After the usual four rounds have been sent in the lever *L* resumes its normal position in readiness for another signal.

The object in having the auxiliary box directly connected with the nearest fire engine station is that the engines in that station may proceed by the nearest possible route to the scene of the fire, as it is evident that, in this way, valuable time may be saved.

GARDINER NON-INTERFERING BOX, ETC.—In Fig. 334 the “Gardiner” non-interfering box of the Gamewell system is shown with doors open, and without the “Speicher” auxiliary attachment. In that figure *CB* is the gong or bell magnet, *BW* the break-wheel, *NI* the non-interfering device, *SI* the knob whereby *NI* is reset after an alarm.

FIG. 335.



In Fig. 335 the Gamewell fire alarm street signal box is shown as it appears with doors closed. To transmit an alarm the outer door is opened by a key, which gives access to the starting hook.

GAMEWELL FIRE ALARM INDICATOR.—The indicator of the Gamewell fire alarm and police patrol systems is placed in very many of the fire engine houses and elsewhere, to give a visual record of a fire alarm or police wagon call corroborative of the strokes of the gong to be found in the majority of such stations.

This indicator is illustrated in Fig. 336.

The operating mechanism is seen within the case. The number of the box whence the alarm originated is presented at small windows in the door of the indicator case. An electro-mechanical gong is shown on the top of the case.

In Fig. 337 so much of the mechanism of the indicator as may be necessary to show the principle of its operation is outlined. *EM* is an electro-magnet in the fire alarm or other circuit. *C, C₁, C₂*, represent three cylinders on each of which numerals from 0 to 9 are imprinted, one above the other, as outlined. Each cylinder is given a tendency to turn on its axle in the direction of the arrow, but is prevented from so doing by arms projecting from extension rods *E, E₁, E₂*, which, normally, engage with one of the pins *p* projecting from the side of the cylinders.

The dotted lines may be supposed to represent the windows on the door of the case.

When either of the fingers *F, F₁, F₂*, is lifted momentarily it pushes back its corresponding extension rod. This act moves the upper end of the extension rod out of the path of its projecting pin *p*, thus permitting the cylinder to turn the distance of one numeral, when the extension rod again engages with a pin and holds the cylin-

der. Consequently, as often as any one of the fingers is lifted the corresponding cylinder is released. For instance, in the case of cylinder B, as the figure 5 is presented before the window, the finger F has evidently been lifted five times.

The manner in which this figure is presented before the window will shortly be described, as well as the manner in which the numerals on the different cylinders are caused to appear.

The mechanism seen at the left of the magnet EM, and the clock-work gearing (only a portion of which latter is seen in the figure) is held or liberated by the armature lever A of the magnet. A spring operates the mechanism. As shown in Fig. 337 the mechanism is arranged to operate in connection with a normally "open" circuit. The armature lever A of M is bent as shown. It carries an extension T. W is a small disc wheel on a shaft s'. The periphery of w is not circular, being cut away as shown. The left end of extension T, rests on this periphery for a useful purpose. On the same shaft, s', the arm or projection w' is also rigidly mounted. The gearing gives this arm a constant tendency to rotate in the direction of the dotted arrow; but it is normally checked by a pin P' on the side of the armature lever A'. Normally, also, the lever AA' is held in the position shown in the figure, by the bent lever K. K is mounted quite loosely on its trunnion Z, and, when not upheld by the pin P', on the upper end of A', will drop.

The rod Q is pivoted on the wheel w at x. The upper end of Q passes loosely through a pivoted sleeve which is carried by the 4-arm lever L. Normally, the upper end of rod Q is directly under finger F. L is loosely mounted on an axle x', which latter carries the gear wheel N whose tendency to rotate is in the direction indicated by the arrow. The 4-arm lever L moves also with this wheel, but it may be moved in either direction on its shaft. It may be held more or less firmly against wheel N by a flat spring f' which latter may be tightened at will.

It requires a closing and opening of the circuit of EM to release this mechanism. Assuming the circuit to be at present open, the spring RS is prevented from pulling the upper end of armature lever A' further to the right by the bent lever K. When, however, the circuit is closed, and the armature is attracted, the movement of A' to the left permits K to fall. Consequently, at the next opening of the circuit of EM the spring RS pulls A' far enough to the right to move the pin P' out of the path of arm

FIG. 336.



GAMEWELL INDICATOR.

w'. This releases that arm, which, with w, at once makes a revolution, with the following results: First, wheel w at the middle of its revolution pushes the rod q up against finger F, thereby permitting the cylinder c to turn the distance of one figure. When w has completed its revolution q is in its usual position. Second, owing to the snail-shell shape of the periphery of w the extension T from A' is pushed to the left, bringing with it the upper end of A' also to the left. At the same time, a pin a, on the arm w', engages with the lower arm of the bent lever k, raising the end of that lever into a position where it is again hooked by the pin t', as before. The same action brings the pin p' on A again into the path of arm w', hence, holding it at the end of its revolution. Further, immediately upon the release of the arm w' the clock-work, which is self-starting, begins to move the arm I of lever L to the right, but not sufficiently to bring it past finger F before the rod q strikes F; and, furthermore, whatever advance the rod q may make to the right is lost by the fact that, as wheel w performs its revolution, the small roller v' on the side of that wheel, hits the prong h at the lower end of arm 3 of lever L and pushes it back to its starting point, which it is enabled to do by reason of the fact that the lever L is, as stated,

FIG. 337.

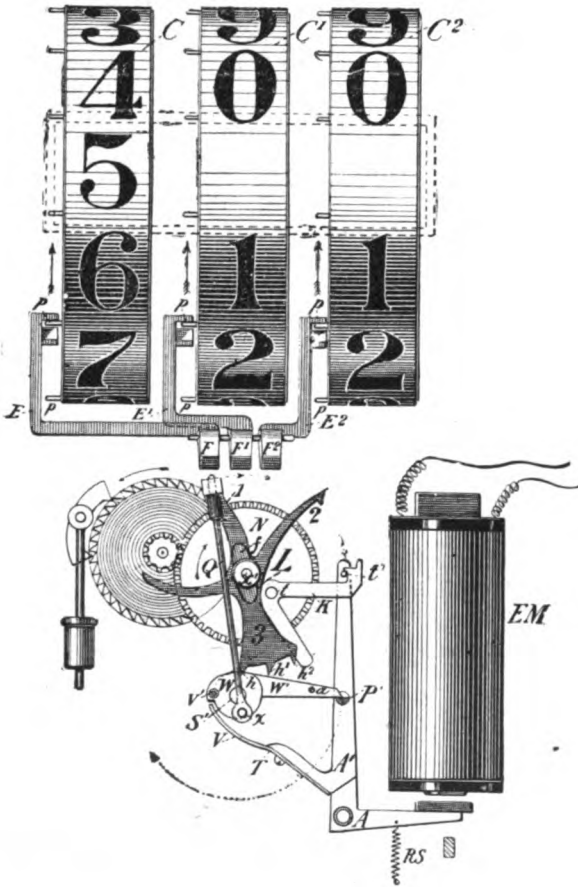

GAMEWELL INDICATOR, THEORY.

only held to the wheel x by friction. As long as the electro-magnet EM continues to be opened and closed regularly the foregoing operation is repeated at each opening and closing, and hence, at each revolution of wheel w a figure will be advanced on the indicator.

When, however, a longer interval occurs in the breaks of the circuit, as happens between the figures of a signal box "number," the mechanism of the indicator is so "timed" that, during that interval, the rod q is moved forward under the second finger F; and, thus, when the revolutions of w are resumed, the prong h is now out of the path of the pin v', while, on the other hand, the second prong h' is now in the path

of the periphery of w the extension T from A' is pushed to the left, bringing with it the upper end of A' also to the left. At the same time, a pin a, on the arm w', engages with the lower arm of the bent lever k, raising the end of that lever into a position where it is again hooked by the pin t', as before. The same action brings the pin p' on A again into the path of arm w', hence, holding it at the end of its revolution. Further, immediately upon the release of the arm w' the clock-work, which is self-starting, begins to move the arm I of lever L to the right, but not sufficiently to bring it past finger F before the rod q strikes F; and, furthermore, whatever advance the rod q may make to the right is lost by the fact that, as wheel w performs its revolution, the small roller v' on the side of that wheel, hits the prong h at the lower end of arm 3 of lever L and pushes it back to its starting point, which it is enabled to do by reason of the fact that the lever L is, as stated,

of v' , and, in the same manner as before, the rod q is held under f' , and will lift up that finger, releasing cylinder c' at each revolution of w ; so long, again, as the signals come in at regular intervals. If the box from which the signal emanates has a three-figure number the space between the second and third figure is sufficient to allow the rod q to be brought under finger f_2 ; which brings the prong h_2 in the path of pin v' ; with a similar result. When the full number has been transmitted once the numerals making up the number are shown at the window of the indicator.

When the first alarm has been received, the further motion of the 4-arm lever l is unchecked until its arm 2 reaches the pin t of armature lever λ' , with which it engages, thereby locking that lever, so that any further signals sent over the circuit of EM will have no effect on the indicator until it has been reset for a new signal. This is accomplished by pulling down a rod x at the bottom of the indicator case, shown in Fig. 336.

THE GAYNOR FIRE ALARM TELEGRAPH SYSTEM.

The street box of this system is shown in Fig. 338. The break-wheel, actuated by the clock-work mechanism, transmits the number of the box in the usual manner.

The clock-work is set in motion by the depression of the lever k which releases the rod r . The lever k is depressed by the act of turning the key to open the door, by means of a catch on the outer door, which, when pushed down, engages with the lever k which projects through the slot in the inner door. The rod r is geared with the clock-work in such a way that it makes but one revolution while the break-wheel makes four. Thus, at each "alarm," the box number is transmitted to the central office four times. At the end of its revolution the rod r is again held by the lever k .

When lever k is pulled down the gong-magnet m is automatically switched into the circuit at x , to the left of rod r , by the lever a and b , and when that rod resumes its normal position, after completing its revolution, the gong-magnet is again cut out of the circuit.

FIG. 338.



GAYNOR FIRE ALARM STREET BOX.

The pointer *I* on dial *D* turns 1 point with each round sent in, and thus indicates the total number of alarms sent in and shows the inspector at a glance whether or not the spring needs re-winding.

The spring is wound by means of the stem-winding apparatus shown at *s w*.

FIG. 339

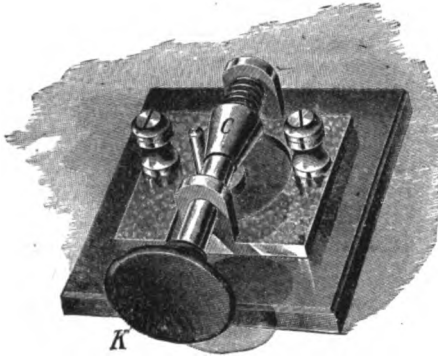

A suitable lightning arrester, and means for cutting the box in and out of the main circuit, and also means for grounding the circuit, when desired, are provided within the box, at the lower left corner.

The hand signaling key used in this box is shown separately in Fig. 339. The contact is made between the pin at the left and the cone-shaped piece of metal *c*. A spiral spring normally keeps the cone and pin in contact. When, however, the knob *K* is pushed upon, the contact is broken. The knob, and with it the cone, may be turned to secure new contacts, without breaking

the circuit.

The alarms received from the various circuits are recorded in the central office

FIG. 340.

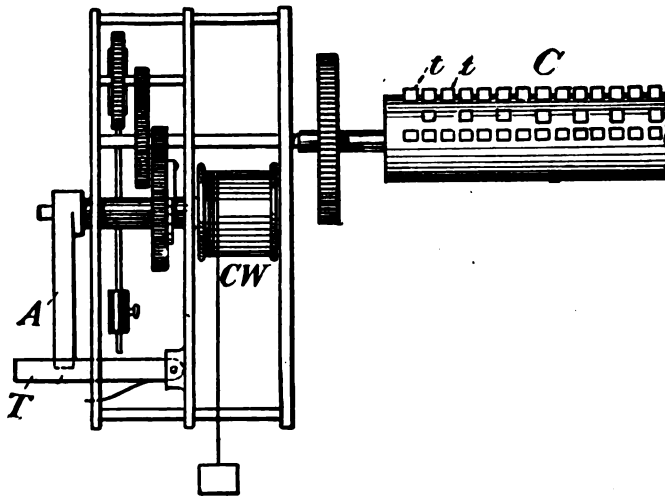

by a multiple pen register ; one pen being provided for each circuit.

In this system a manual repeater is used in the central office for the purpose of repeating the signals received on any one circuit over all of the others.

This repeater is shown, theoretically, in Figs 340, 341, and 342. It consists essentially of a cylinder *c*, Fig. 340, which may be termed a multiple break-wheel. On

its surface, teeth, or indentations, *t, t* are arranged, side by side, to correspond with the numbers of boxes in use on the various circuits. This cylinder is caused to revolve one or more times by the depression of a trip *T*, which releases the arm *A* controlling the clock-work gearing *cw*.

An end view of the cylinder and contact tongue is given in Fig 341. The spring *c'* is carried by an insulated block *B* to which is attached a handle *H*, which extends outside of the "repeater" case, as shown in Fig. 342. By sliding the handle in one direction or another, the contact tongue is placed under any desired set of teeth on the cylinder. When the handle has been properly placed the clock-work is started, with the result that the box number corresponding to the set of teeth on the cylinder opposite the contact tongue *c'*, is transmitted over all the circuits excepting the one on which the alarm has originated, which is temporarily disconnected from the manual repeater.

FIG 341.

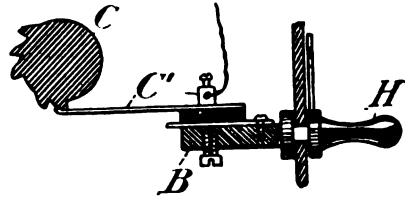
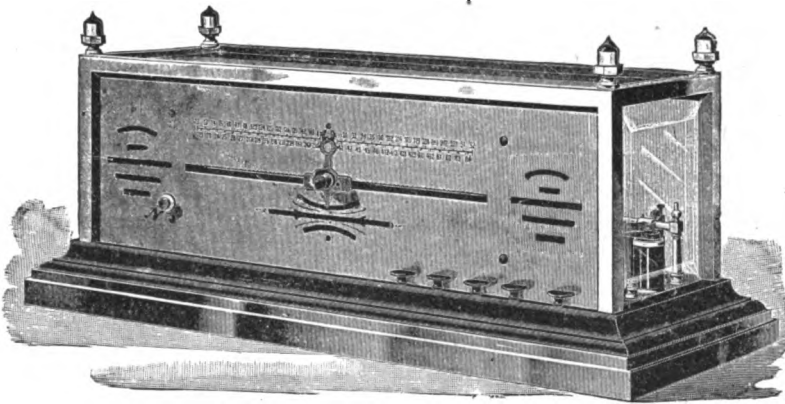

FIG. 342



GAYNOR MANUAL REPEATER.

The electrical connections of the repeating arrangement are shown in Fig. 343. In this, *c* is the cylinder, or multiple break-wheel, shown end on. *c'* is the contact tongue. The tongue *c'* normally rests on the cylinder. As thus arranged it will be observed that the cylinder controls a local circuit in which are a battery *B* and electro-magnet *M*. The armature lever of *M* carries a number of pairs of contact springs. Each pair of contacts controls a main alarm circuit—as indicated, with batteries *MB*. Thus, as often as the multiple break-wheel circuit is opened, all of the main line circuits will be similarly opened, in the usual manner, by the operation of the armature lever of *M*.

The numbers shown on the rear of the repeater case, Fig. 342, represent the numbers of the street boxes. The act of placing the index opposite a given number places

the contact tongue beneath the corresponding break-wheel on the cylinder within the case. The clock-work is tripped by pushing upon the button κ .

FIG. 343.

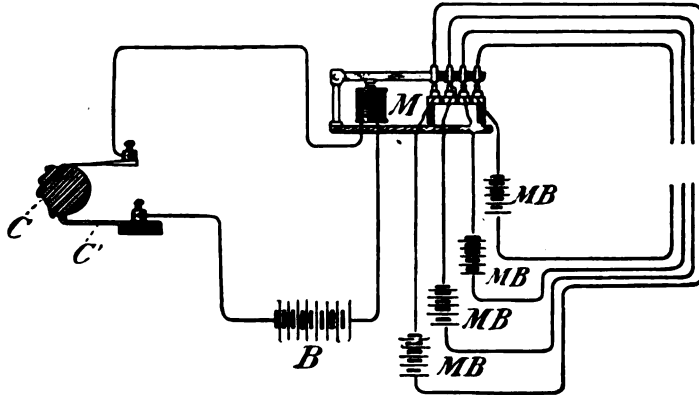

MANUAL REPEATING TRANSMITTER—GAYNOR.

The knobs at the right control circuits communicating with the various officers of the Fire department.

JERSEY CITY OR SPEICHER FIRE ALARM TELEGRAPH SYSTEM.

Where tower bells are struck to announce fire alarms, unless the speed of the gearing of the signal boxes is much reduced, special apparatus for regulating the speed of the strokes is necessary, since the box numbers can be transmitted much more rapidly by means of the "break-wheels" of the street box than it is feasible to transmit them over a "tower bell" circuit controlling the ponderous hammers of the bell.

Tower bells which are rung in connection with the alarms from signal boxes are useful in at least two respects. For example, in some cities where a large regular force of firemen is not kept, a number of extra men are employed, subject to call, in certain districts. These men are attached to certain stations, but are supposed to sleep at their homes and to respond to the alarms of fire as sounded from the tower bells. Again, it gives business men and others interested, who are furnished with a directory of the location of the various signal boxes, a general idea as to the nearness of a fire to their places of business, etc.

A tower bell system is quite extensively employed in Jersey City, N. J.

The apparatus of the Jersey City fire alarm telegraph system, including the electro-mechanical apparatus for automatically actuating the tower bell circuit, is shown theoretically in Fig. 344, in which $R^1 R^2 R^3 R^4$ are relays in the signal box circuits No. 1, 2, 3 and 4. o, o, o, o , may represent signal boxes in those circuits. B, B, B, B , are the main batteries for those circuits. The street boxes used are the Gamewell non-interfering.

In many fire alarm systems the alarm signals received in the central office are recorded by an ink recording register; the number of the box being represented on the

paper by so many dashes; the figures of the number being separated by a larger space between the dashes. In the Jersey City central office system, due to J. W. Speicher, the records of alarms are made by punching, in the paper tape, holes corresponding in number to that of the signaling box. These holes in the tape, besides acting as a permanent record, are also caused to perform another function, to be presently described, in connection with the striking of the tower bells.

RR is the automatic repeater by means of which an alarm received on any one of the signal box circuits is repeated over all of the others. In the figure, four such circuits are indicated. c, c, c, c , at RR are flat, steel strips, having platinum contacts at their right hand ends. Immediately above the latter are other contact points $c'c'c'c'$, attached at $p p p p$ to the insulated cross-piece r , of the lever L , which is fulcrumed at K . Each of the circuits is caused to pass through one of the strips c and contacts c' . Normally, a flattened portion of the circumference of wheel w on shaft H , rests on the lever L and thus the spring s holds the contacts c' against strips c , and hence, the circuits remain closed at those points. By means of a weight, not shown in the figure, the wheel w is given a strong tendency to rotate in the direction of the arrow, but, generally, it is prevented from revolving by the presence of the long rod LR , which holds in check the extended arm A which is rigidly attached to shaft H . When, however, LR is withdrawn from the path of arm A , the wheel w rotates, and the round portion of its circumference coming in contact with the lever L , the right end of that lever is depressed and its left end is raised, which act opens all of the signal box circuits at the various contacts c' .

The right hand end of rod LR is connected with wheel w' through the medium of the crank-rod to which LR is hinged at F . LR is caused to slide in bearings b, b' . When the wheel w is caused to make a revolution in the direction of the arrow, the rod LR is momentarily withdrawn from the path of arm A of shaft H . The wheel w' is, itself, held in check by the contact of the arm A' , which is firmly attached to w' by a bent extension, E , of the armature lever AL of the local magnet M . On the same shaft, s' , with w' , is arranged an *eccentric*, upon which is mounted a hollow head h of a "puncher" T . The eccentric is so constructed as to give the puncher a quick down and up motion, through the paper tape, when the shaft s' is rotated. This shaft, like the shaft H , is given a strong tendency to rotate by means of a weight.

The paper reel, r , on which the unpunched paper tape is wound, is automatically started to unreel when the magnet M attracts its armature, and the clock-work is rendered self-starting and self-stopping by well known mechanism, not shown in figure. Thus the magnet M controls the entire apparatus thus far described, for, when it is attracted, the extension E of armature lever AL is withdrawn from the path of A' ; this permits the rotation of shaft s' which causes a hole to be punched in the paper tape; at the same time the rotation of wheel w' withdraws LR from the path of A , allowing w to rotate, thereby opening all of the circuits at c', p , etc.; and reel r starts to feed out the paper tape.

The local circuit of magnet M is connected to the back contact and to the levers of all of the relays, so that, normally, it is open. When, however, a signal is transmitted over any one of the circuits, say, No. 3, it causes relay R^3 to open, which act closes the local circuit of magnet M , starting the mechanism, as just described. Pres-

ently the relay R^3 is closed again, thus opening local circuit of x and at once arresting the motion of the mechanism. Thus, almost concurrently with the first break of circuit No. 3, all of the other circuits are broken at c^2 , and, in quick succession (at the rate of about one break, per second) the breaks are received on relay R^3 and repeated to the other circuits. In the same manner an alarm coming in over any one of the other circuits is transmitted over all the remaining circuits.

It may be remarked that the wheel w' makes its revolution in much less time than one second, but, by a very simple escapement device attached to extension x , not seen in the figure, the wheel is arrested at the end of its revolution until the magnet x is again attracted. (A practically similar escapement device will be seen illustrated in connection with the receiver of the Essick page and line printer, *d*, Fig. 323).

The "tower" circuit is seen to the right of the figure. The paper tape after being punched passes in a suitable guide to a paper winder PR . The tape between the reel r and PR is held taut by means of a weight w , the handle of which, on which is fastened a small roller, is hung over the paper as shown.

As already stated, the paper tape is punched at the rate of one hole per second. The breaks sent over the tower bell circuit are transmitted at the rate of one in two seconds. Consequently, the reel r is caused to feed out the tape at twice the rate at which PR takes it up; the surplus paper is carried down between r and wx until the three or four rounds of signals, as may be, have been sent in, when the reel PR gradually brings the weight up to its former level. The clock-work of the tower bell circuit at wx is held in check by a catch, on the lower end of lever cx , which is brought in contact with a pin on the shaft of wx when the paper at w is almost at a level with the guides. There is a small counter-weight on the upper end of lever cx at v . As soon as the paper is started at r , the weight w begins to sink, which permits the counter-weight v , attached to the catch-lever cx to fall, withdrawing the lower end of cx from the gearing. This comprises the self-starting and self-stopping mechanism of the tower circuit mechanism, wx .

The breaks on the "tower" circuit are made in a very simple fashion. The circuit is led to a contact point c^2 and to a flat contact spring fs . Normally, these contacts are together, being held thus by the small, round, projection r on the under side of fs , which projection rests on the paper tape. When, however, a hole in the paper passes under r it drops into it, thus opening the tower circuit at c^2 . It is then easy to see that there will be as many "breaks" of the tower bell circuit as there may have been holes punched in the paper.

In this system devices have also been provided to prevent interference with an alarm which may have been started on any one of the circuits. These devices consist of mechanical attachments to the levers of the relays R^1 , R^2 , R^3 , R^4 , controlled by a "locking" relay operated by an additional contact on those relays, but as in practice it has not been necessary to use these attachments they have not been shown in the figure. The employment of the non-interfering signal boxes referred to practically prevents confusion of signals on any of the circuits, since, while an alarm is in progress over a circuit, (whether emanating from a box on that circuit, or from a box on some other circuit, via the repeater in the central office,) the signal box non-interfering apparatus will at once be put into operation upon the opening of the outer door.

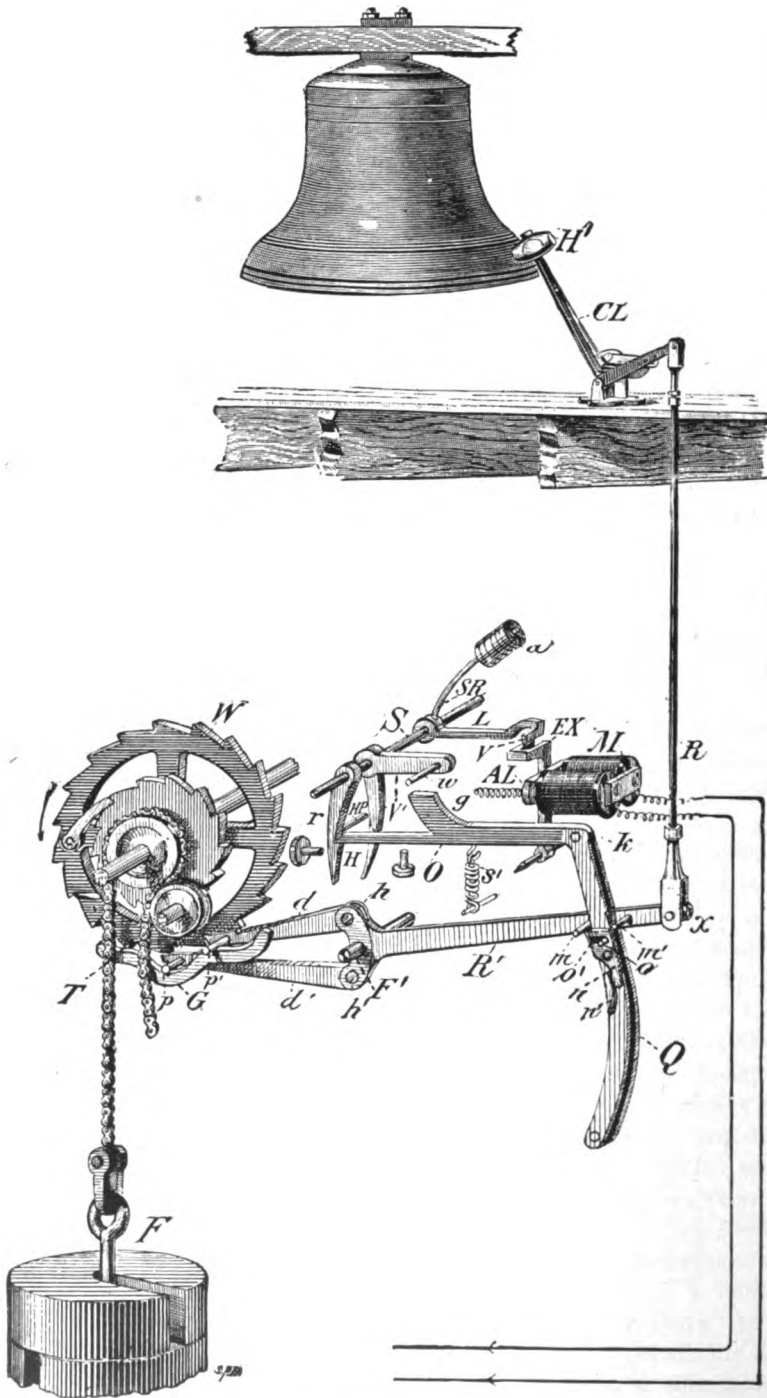

FIG. 345.—TOWER BELL AND ELECTRO MECHANICAL STRIKING APPARATUS.

TOWER BELL ELECTRO MECHANISM.

The tower bell striking mechanism and electro-mechanical starting devices are illustrated in Fig. 345.

In the normal position of the apparatus the hammer h' of the bell is as shown in figure. A bent lever cl , forming a handle for the hammer, is connected by the rod r , at x , with the rod r' . r' whose trunnion r' is pivoted on framework not shown in figure, carries at its other end two pawls, or dogs, d d' , which are hinged to it at h h' . These dogs are held against, or near, the teeth of a ratchet wheel w , by a peculiarly curved support G , on which the pins pp' , projecting from the side of the dogs, rest. The object of this peculiar support will be noticed presently. The dogs are so arranged that only one of them at a time engages with a tooth of the ratchet wheel. The ratchet wheel w is given a strong tendency to rotate by ponderous weights F , (which weigh from one ton to one ton and a half), but it is, normally, prevented from turning by the engagement of dog d with one of its teeth, as in figure. A pressure is, of course, constantly exerted on the rod r' , giving it a downward tendency, but it is prevented from yielding to the pressure by the pin m on its side which rests on the pawl n pivoted on the side of bent lever oq . The movement of the pawl n is limited by a pin o , on the side of Q , in slot o' ; n is normally held in its present position by the flat spring n' . The bent lever oq , which is pivoted as indicated at k , is provided with a strong spring s' , which would pull the vertical arm Q into a position to the right, where the pawl n could slip from under the pin m of rod r' , but that it, oq , is held in check by a hook h on the lower end of a pawl r . r is loosely mounted on a shaft s . Thus as long as the hook h is held under the left end of arm o of lever oq , the ratchet wheel w will not move.

On the same shafts with the pawl r is a bent lever Lsr one of whose arms L rests on a short extension ex from the top of the armature lever AL of the relay x , which is in the tower bell circuit. The arm sr carries at its upper end, a weight a which gives the arm L of the lever a constant downward tendency. The extension ex , looked at from the top, is of a U shape. There is also an extension v from the lower arm of lever Lsr . These extensions are so arranged that, normally, the extension v rests on the outside leg of ex in such a manner that when the armature lever is released and is withdrawn from its magnet the extension v of L slips off ex and thus L has an unobstructed path in which to fall.

On the shaft s , also, is another lever v' . Both L and v' are rigidly mounted on shaft s , so that when lever L falls it turns with it that shaft which, in consequence, throws the lower end of v' to the left. Assuming the tower bell circuit to have been broken, thus allowing the armature of m to fall back, the extension v of arm L is released and it falls. At the same time the arm v' is thrown to the left which brings it sharply against a pin, hp , on the side of the pawl r . This knocks the hook h from under the end of o , which latter then, in response to its spring s' , falls. This act removes the pawl n from the pin m , freeing the rod r' . At once the weight F acts on the dog d , causing the rod r' to move downwards, which act causes the withdrawal of the hammer h' from the bell. The motion of the ratchet wheel which accompanies that act brings d' into sudden contact with the next tooth t and this shakes the upper dog d

from the tooth with which it was engaged. The result is that the pressure of the weight is now put upon the dog d' ; the rod r' is caused to reverse its previous motion; the hammer h' is thrown violently against the bell, and the pawl d' again engages with a tooth, as in the first place. At the same time, and while r' is thus caused to rise, its pin m pushes back the pawl n until it gets above it, when the flat spring n' pushes n again under pin m . At the same time also, the rod r' , in rising, throws the arm o of oq up, so that its spur g , coming in contact with the pin w , on v' , raises that arm, and, in consequence, the arm l , so that the extension v slides above ex , (the latter yielding slightly), and then settles down upon it, the magnet in the meantime having been attracted. The arm o of oq having been raised above the hook h on pawl r is caught and held as before.

At the next and subsequent openings of the circuit the foregoing actions are repeated.

It will be seen that as dog d is moved to the right, in the figure, the pin p' gets above a hollow in the curve of G , while the simultaneous forward motion of d' brings it on a ridge of the curve. Thus, in the first case, d is given room in which to fall clear of its tooth, while, in the second, d' is raised up into the path of its next tooth.

It is, of course, understood that the whole process of raising the hammer and striking the bell is comparatively rapid, since it must be accomplished in less than two or two and one half seconds, which is the rate at which the signals are transmitted over the tower bell circuits.

In some cities, for example, Newark, N. J., the tower bell magnets are placed in the signal box circuits, and the mechanism of the break-wheels in the boxes is somewhat reduced in speed.

THE GAMEWELL AUXILIARY FIRE ALARM TELEGRAPH.

It has already been pointed out (*See Gamewell fire alarm telegraphy*) that the object of an auxiliary fire alarm system is to increase the utility of the main fire alarm telegraph by increasing the number of places from which alarms may be transmitted, etc.

The chief features of the Gamewell auxiliary system are illustrated in Fig. 346; namely, the auxiliary box and the auxiliary mechanism in the street box. It is well known to those concerned that, as a rule, municipal fire departments strenuously object to the introduction of any apparatus into the street signal boxes, or elsewhere, that may tend in any way to complicate or hamper the operation of the existing systems. To meet this objection the Gamewell auxiliary system has been designed. It avoids any electrical connection whatever between the auxiliary alarm circuit and that of the regular circuits of the fire department. This being the case a special battery is obviously necessary in the auxiliary circuit.

In the figure, $A B$ is an auxiliary box, located at any desired point of the auxiliary circuit. This box serves the double purpose of causing the operation of the street fire alarm box, and of giving an "answer back" signal, signifying that the alarm has been started over the regular or main alarm circuit. B and b are the batteries used in con-

nection with the auxiliary circuit. The smaller battery *b* is used only for testing purposes, as will be explained.

SB shows a portion of the street fire alarm box. BW is the usual break-wheel. AM is the auxiliary magnet placed within SB. When this magnet's armature AL is attracted the rod R is raised, lifting the lever L, and thus starting the clock-work which operates the break-wheel in the usual manner.

The auxiliary box AB is provided with an accessible hook H attached to a lever L'. Three strips of metal 1, 2, 3, insulated from each other and from the box are placed as shown. Normally lever L' rests on strip 1. In this position of lever L', the auxiliary

FIG. 346.

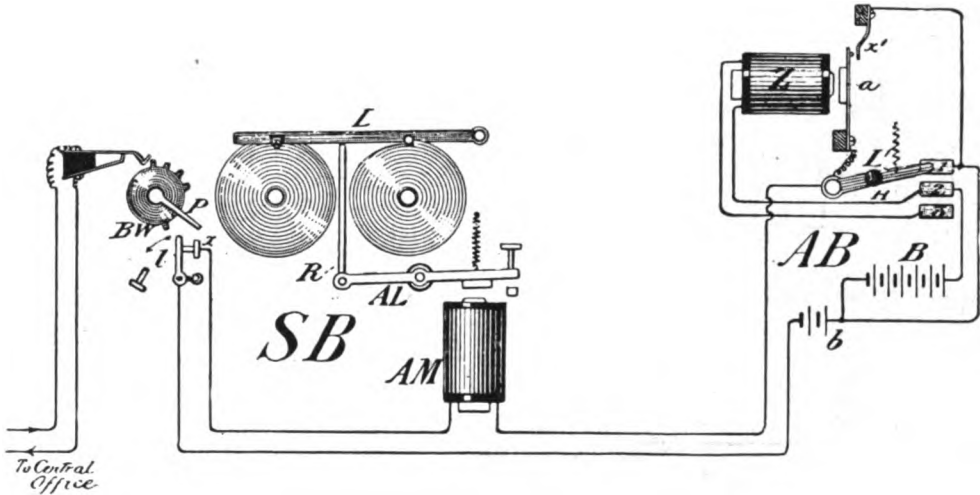

GAMEWELL AUXILIARY FIRE ALARM CIRCUITS.—THEORY.

circuit is completed through the small battery *b*. The current from this battery is, however, too weak to operate the auxiliary magnet AM in the street box. When the lever *L'* in the auxiliary box is pulled down, as in case of fire, the moment it touches strip 2, the large battery *B* is brought into the auxiliary circuit. The strength of the current thereby added to that circuit operates the auxiliary magnet AM, in the street box, and, in consequence, the clock-work of that box is set in motion, precisely as if it had been started by a pull on its own lever.

When the lever *L'* at AB is still further pulled down, it makes contact with strip 3. This, it will be seen, diverts the current of battery *B* through the "buzzer" *z*, thereby attracting its armature *a*, and, for the moment, holding it there. Within one or two seconds, however, an arrangement provided in the street box, in connection with this auxiliary system, consisting of the projection *p* attached to the break-wheel BW, engages with the small lever *l*, moving the latter away from the contact point *x*, and thus opening the auxiliary circuit at that point. The small lever *l* is held against *x*, normally, by the counter poise shown.

It being assumed that the one giving the alarm from the auxiliary box has been instructed to hold down the lever *L'* on contact 3 for a few seconds, the result is that the opening of the auxiliary circuit at the street box permits the armature of the buz-

zer to spring back against a contact point x' , thus momentarily completing a circuit through the buzzer, battery B, strip 3, lever L' and armature a ; whereupon the usual action of a buzzer ensues, thus announcing that the street box has been started; for as we have seen, the "buzzer" z only acts as a buzzer, when the auxiliary circuit has been broken by the break-wheel in the street box in the act of turning to transmit its number over the main fire alarm circuit. This buzzer acts somewhat differently from the ordinary, in that, normally, it rests away from its back contact and depends for its start upon the rebound of its armature lever from the magnet, when the auxiliary circuit is broken.

FIG. 347.

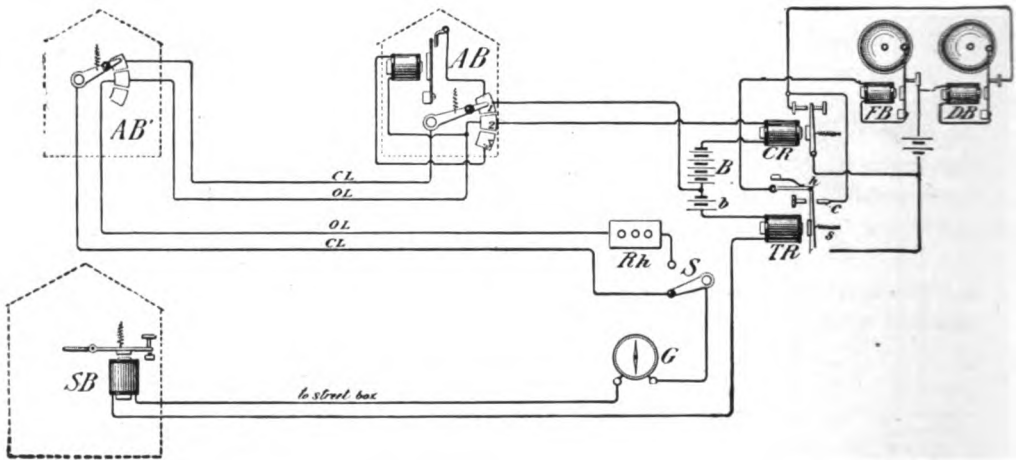

GAMWELL AUXILIARY FIRE ALARM.—CONNECTIONS.

The auxiliary circuit is not only broken at the lever l in SB by the projection from the break-wheel BW , but the lever is also thrown by that projection to a point where it remains until reset by some one duly authorized to open the street box. This, in addition to facilitating the transmission of the "answer back" signal, insures that when an alarm has been started from that circuit no other alarm shall be sent in until the lever l has been reset.

In many of the buildings, such as factories, warehouses, etc., equipped with auxiliary fire alarm apparatus, it is desirable that the officials of the building should be apprized, simultaneously with the giving of an alarm to the street box. As, also, in some buildings auxiliary boxes are placed on every floor and in every room, to the number of one hundred and more, it is evident that means must be provided at some suitable point in the building for testing, etc.

In Fig. 347 apparatus and connections to effect the foregoing results are shown.

This apparatus is generally located in the manager's or superintendent's office in the building.

B and *b* are the batteries shown in Fig. 346. CR is termed the "cross" relay; TR the "trip" relay; FB the "fire" bell; DB the "disturbance" bell; Rh is a rheostat of about 500 ohms resistance; G is a common galvanometer, or indicator; AB and AB' are auxiliary boxes in any desired part of the building. AB is shown with cover off and, enlarged, the better to show the connections. The "trip" relay TR is equipped with a hook lever; *insulated* at the hook *h*.

Normally, the auxiliary circuit is closed, as shown in Fig. 346 and in Fig. 347. As has been said, the current from small battery *b* is insufficient to operate the auxiliary magnet AM in SB. The adjustment of the retractile spring *s* of TR is such that its armature is just attracted to the hook *h* and held against it, as in the figure, by battery *b*. The circuit in which CR is placed is normally open at switch *s*. The local circuits of the alarm bells FB and DB are also normally open.

When any one of the auxiliary boxes is pulled, the first effect, as explained, is to bring into the circuit the large battery B. This not only operates the auxiliary magnet in the street box, but also the relays CR and TR in the building; the increased current strength being sufficient to attract the lever of TR *past* the insulated hook *h*, which hook at once "locks" that lever. The effect of the attraction of those relays is that the local circuits of FB and DB are closed, and both of those bells are caused to ring.

As we have seen, the auxiliary circuit is broken at the street box within a second or two after the auxiliary box has been pulled. The consequence is that the relays TR and CR are at once demagnetized and the disturbance bell DB, controlled by the lever of CR, stops ringing. The trip relay, however, is still held towards its armature by the hook *h*, and the fire bell continues to ring until the hook *h* is removed by the depression of a suitable knob, not shown in figure, when the spring *s* retracts the armature lever and (as the auxiliary circuit is now open at SB), holds it against its back contact point *c*. Hence the disturbance bell circuit is again closed by a new route, and this bell continues to ring until the auxiliary lever *l* in the street box is reset, which act, by closing the circuit, again brings the small battery *b* into service and thus, again, the armature lever of TR is attracted, up to the hook *h*.

FIG. 348.



AUXILIARY FIRE ALARM BOX.

As the galvanometer G is always in the auxiliary circuit its needle assumes a uniform deflection due to the small battery. Thus a glance at that instrument indicates the general condition of the circuit. Should the auxiliary circuit open by an accidental break, or otherwise, the trip relay falls back, operating the disturbance bell. Should the wires OL and CL in the building become crossed the relay CR is at once attracted and again the disturbance bell is rung. The normally open wire OL and battery B may be tested by turning the switch *s*, at which time the presence of the resistance Rh, by temporarily reducing the current strength, prevents any effect being felt in the relays CR, TR, or the magnet AM, by undue increase of current during such tests.

An auxiliary fire alarm box is shown in Fig. 348, as it appears in practice. Very frequently a small pane of glass is inserted in the frame to prevent meddling with the hook. When an alarm is to be transmitted the glass is broken to give access to the hook.

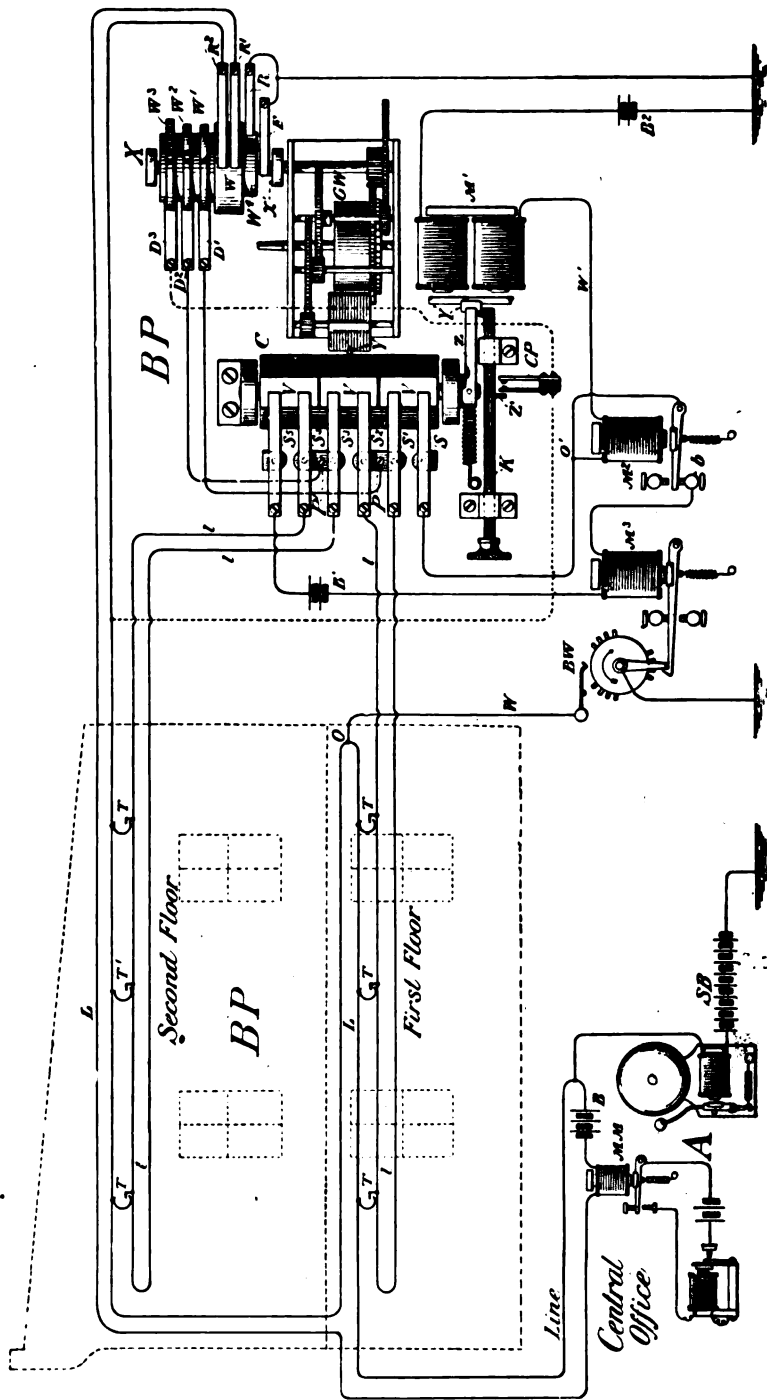

FIG. 349.—AUTOMATIC FIRE ALARM TELEGRAPH.—THEORY OF CIRCUITS, ETC.

AUTOMATIC FIRE ALARM TELEGRAPHY.

In many of the large cities of the United States an auxiliary to the regular fire alarm system is to be found in the use of automatic fire alarm telegraph apparatus, which on the occurrence of fire in a building transmits a signal to a central office, the attendants at which either immediately send their own firemen to the building from whence the alarm emanates, or make a call upon the regular fire department.

The means most frequently employed for thus automatically transmitting fire alarms is some form of thermostat which is so constructed that at a certain temperature its expansion will be sufficient to complete an electric circuit, which act sets in motion apparatus that transmits to the central office a specified "number" of the building, as well as, in many cases, the number of the floor of the building on which the fire has originated. This system is also somewhat analogous to that of the American district messenger telegraph, the chief difference being that, in the latter service, the subscriber operates the signaling box manually, while, in the case of automatic fire alarm systems, the increased temperature due to fire causes sending in of the alarm.

One such system, due to George F. Bulen is illustrated, diagrammatically, in Fig. 349.

The instruments used in this service, at the central office, A, are a call bell, inking register, and electro-magnet MM, whose function will be noted later; a small battery B and the main battery SB; and, at the building to be protected, BP, a transmitter, comprising a multiple break-wheel X; a cylinder C, partly insulated, and carrying raised metal segments V, V, V, on which the contact strips $s, s^1, s^2, s^3, s^4, s^5$, normally rest, and the various electro-magnets M^1, M^2, M^3 , and other contacts and apparatus to be specifically described shortly.

A metallic circuit L, L, extends from the central office A to the protected building BP; the same circuit is extended to every floor in the building, or to as many floors as may be desired; in this case being looped into the first and second floors as shown. This circuit is also brought to the break-wheel X at the periphery W, but, when that wheel is at rest, the circuit is merely continued through the metal of the periphery. This circuit L is grounded at the central office as indicated, but, ordinarily, it is not grounded in the protected building. In addition to the line circuit, a local circuit L', L' is looped through every floor in the building. The local circuit, before passing to the respective floors, is first passed through metal strips s^1, s^2, s^3, s^4 . The same circuit also passes through the strips s_1 and s_5 and small local battery B', thence through the magnet M_3 and through the armature lever and back stop of magnet M_2 . Normally this circuit is closed and, consequently, the armature of M_3 is on its front stroke. When thus attracted the armature of M_3 holds a projection from a normally, rapidly revolving break-wheel BW, having notches corresponding to the designated number of the building. A wire W from the main line at O leads to the contact spring of break-wheel, and the frame of the latter is connected with the earth. This ground circuit is open except when the break-wheel is revolved. The local circuit L' is tapped at O' by a wire W', which, after passing through the magnets M^2, M^1 , and battery B² is connected to the earth. Ordinarily this has no effect on the local circuit L'.

The cylinder C is given a tendency to a partial rotation by a retractile spring, as

shown, but it is prevented from making this movement as long as the projection z , attached rigidly to c , rests on the top of the lever y' of the armature of magnet m^1 . When the armature of m^1 is attracted the projection z is released and the cylinder c performs its allotted motion. This movement of c removes the raised contact pieces $v.v.v$, on the cylinder and permits the flat spring contacts s,s' , etc., to fall on contact points P and P' . These contact points are connected to the flat spring contacts D^1 and D^2 , which latter rest near, but do not touch, certain of the peripheries of the "multiple" break-wheel x ; this break-wheel having a number of separate wheels, as hereafter described. The shaft of these wheels, when free to rotate, is actuated by clock work cw . The wheels w^1w^2 of x are connected metallicly with the shaft x' of that wheel, which shaft in turn is connected to the earth by way of the flat spring contact F . w^1w^2 carry, on their peripheries, a number of projections corresponding to the floor with which, as we shall presently see, they are respectively connected. Wheel w has a wider periphery than w^1,w^2 . It is furnished with breaks, or indentations, corresponding to the "number" of the building. These breaks on w^4 are at a different point of its periphery than are the notches on w^1,w^2 or w^3 . The wheel w^4 is a smaller wheel side by side with w . w and w^4 are metallicly connected, but are insulated

FIG. 349 a.

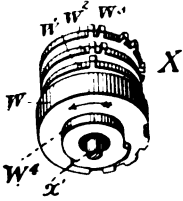

from the common shaft x' of the multiple break-wheel. w^4 has one portion of its periphery raised, as shown (Fig. 349 a) so that at a part of its revolution it comes into contact with the flat spring contact R , which is in connection with the earth. The result is that, (when wheel x is rotated), during the time that the contact R rests on the raised portion of w^4 , the line L is placed to earth, excepting when the flat contact springs r^1, r^2 are disconnected from the periphery of w by the presence of the notches (seen in Fig. 349 a) which equal the "number" of the building. This suffices to send in to the central office the regular number of the building. The raised portion of w^4 is sufficiently prolonged to permit the transmission of the building "number" at such times. When the raised portion of w^4 passes R the line circuit is disconnected from the earth at that point during the rest of the revolution of x .

It may be seen that the main line L and the local circuit I are, at several points on each floor, separated from each other only by thermostats T,T,T . When, therefore, the temperature in any of the floors exceeds the "safe" temperature of the thermostat, the space by which the two circuits are separated is closed, and thus they are electrically thrown together; it is then the function of the transmitting apparatus to communicate to the central office, not only the building number, but the floor in the building on which this has occurred; and this it does in the following manner:

Suppose that this connection takes place at r' on the second floor. The result is that the current from the main battery SB at central station A passes from the line wire L to the local circuit wire I , and through the flat contact strips s^4 and s^5 to magnets M^3, M^2, M^1 and earth. This current has the effect of attracting the armatures of the magnets M^2, M^1 , but the most important work is performed by M^1 , which withdraws the catch y' from arm z . This permits the spring to draw down the arm z , thus partly turning the cylinder c . This movement of c releases the catch x attached to the fly-wheel of the multiple break-wheel x , which latter starts to rotate (in response to

the clock-work spring with which its shaft x' is geared), in the direction indicated by the arrow, Fig. 349*a*. The same action of the cylinder c which released the catch y , holding the break-wheel x , permitted the flat contact springs s^1, s^2, s^3, s^4 connected with the floor local circuit L, L' , to drop down on the contact points p, p , connected by wires with the flat contact springs resting near the break-wheel x . This now puts the flat contact spring D^2 in contact with the line wire L , via the local wire at contact T' on the second floor. Contacts s, s^5 , also drop on suitable stops.

Assuming now that the break-wheel x has started to rotate. Presently the contact k touches the raised portion of w_4 . This completes a main line "ground" circuit via the periphery w and contacts R^1R^2 ; the next moment the contacts R^1R^2 come opposite a notch in the periphery, "opening" the line L again, and this is repeated, say 4 times, assuming that to be the "number" assigned to the building. This indicates, both on the bell and register at the central office that an alarm is in from building 4. Having sent in this signal the main line is momentarily open, but, as the break-wheel x rotates still further, the raised points on the periphery of w_2 meet flat spring contact D^2 and close the "ground" circuit twice in succession, via the thermostat at T' , thus indicating to the central office that the alarm has originated on the second floor of building 4. The actuating clock-spring of break-wheel x is wound sufficiently to cause that wheel to perform a number of revolutions; consequently, the building number and floor number are sent in, over and over, until the spring runs down.

If it should be desired to protect more than two floors it is only necessary to add the necessary segments and flat springs on cylinder c , and peripheries on the multiple break-wheel x , to meet the requirements.

In order to insure the proper working of the line and local circuits at all times, and to prevent false alarms of fire, it is necessary, when either of those circuits "open" or "ground" from any cause, other than the operation of the thermostat, that a distinguishing sign, or signal, should be forthcoming.

It is the office of the electro-magnet MM and the small battery B , at A , and that of the electro-magnets M^3 and M^2 , and the small break-wheel BW , at the protected building, to "announce" such opens, or breaks, which they do as follows:

As already said, the local circuit L in BP is normally closed; hence M^3 is magnetized and its armature is attracted. Assuming the circuit L to be, in some way, broken, the armature of M^3 falls back, thus releasing the "fan" of the small break-wheel BW , which rotates rapidly, grounding the main line repeatedly, and "sending" the number of the building over the main line. This indicates to the central office that there is a defect in that building in the local circuit.

If, on the other hand, the local circuit L should become grounded at any point, a short-circuit is formed from that ground, through M^2M^1 , short wire w' and the small battery B^2 to the ground. This battery is not strong enough to attract the armature of M^1 , but does attract that of M^2 . This opens the local circuit L at the back stop of b of M^2 , also with the result of releasing the fly which holds the clock-work of the small break-wheel, and again the building number is transmitted to the central office.

If the line wire L should open, the effect is to demagnetize the electro-magnet, or relay, MM , at A , that instrument being in a metallic circuit. Or, if either of the line wires forming the metallic circuit should ground, it will be announced by a closing of the bell magnet and register in the central office.

In practice the building numbers are recorded by an ink register, as dashes, the floor numbers, as dots. Thus a signal from building 4, floor 2, would be recorded on the paper as — — — — . . This is due to a greater length of contact on wheel w.

Self-starting and self-stopping registers are used in this service.

Reverting to Fig. 349, when an inspector in making his tour of the circuit desires to announce his presence at a certain building he simply pushes in the plunger κ . This, it will be seen, first closes the dotted line circuit at cr and then removes the armature lever y' of M' from the path of the catch z which allows the cylinder to turn; this, in turn, releasing the break-wheel x , which also turns. The first action of the break-wheel is to send in the building number, as before, and afterwards to make contact with flat strip D^3 which then causes a series of 2 makes and breaks of the main line circuit, which is evidence that the signal has been sent by the inspector.

The form of thermostat, T , Fig. 349 b used in this system consists of a bi-metallic

FIG. 349 b .

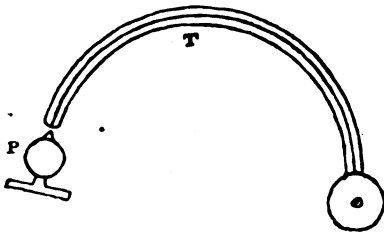

BI-METALLIC THERMOSTAT.

spring which is bent normally into the shape of a crescent, one end being securely fastened to a standard, while, opposite its free end, a platinum point P is adjusted. The spring is made of steel and copper. The more expansive of the two metals under heat, namely copper, is on the outside of the spring. When the spring is subjected to heat it tends to coil into a smaller crescent. The coiling is soon retarded by the platinum point, which completes the circuit between the local and main line circuits, as previously

stated. The coil is normally adjusted for a temperature of about 130 F.

In some systems, easily fusible alloys are employed as thermostats.

In some systems also, two thermostats are used, conjointly, in a circuit, or in two circuits; one being arranged to originate an alarm slightly in advance of the other; this to prevent false alarms that may be due to accidental contacts between the terminals of a thermostat.

Other forms of thermostats consist of a flat box containing substances which expand readily under increased temperature and thus "bulge" out the sides of the box, which action is caused to close or open a circuit.

CHAPTER XXIX.

POLICE SIGNAL TELEGRAPH SYSTEMS.

It has been said, perhaps truthfully, that in no other department of municipal government, has there been so little progress as in the police department; "for the old system, coming down from the time when watchmen patrolled the streets with lantern, bill-hook and rattle, has been substantially followed." The policeman, after leaving headquarters with the platoon, to go upon his beat, has been free to exercise his own will, virtually unseen, and often out of reach. And, while this state of affairs may have been satisfactory, in some respects, to the policeman, it also had its drawbacks in that it frequently left him at the mercy of any quickly gathered mob, without ready means of obtaining assistance. In cases of accident also, the means at hand for speedy assistance from the police were lacking.

The fact that, as in the Fire department service, electricity could be successfully utilized as an ally in the police service has, of course, long been recognized by the proper authorities of many municipalities, but until within the past few years no very general active measures were adopted to avail of that fact.

At the present time, however, many of the cities of this country have introduced electric signaling systems which have, admittedly, much increased the efficiency of the police force.

In the operation of these systems, electric signal boxes, connected by a wire with headquarters, are located at stated points along the routes of the police. In some cases the boxes are simply placed against an available wall, or in a niche provided in a lamp post. In others, specially constructed houses, or booths, somewhat similar to "sentry boxes," are placed on the curbs or the corners of streets, and in these the signal boxes are placed.

Each signal box is provided with a telephone by means of which the policeman can communicate with headquarters, and in some systems that instrument is used nearly exclusively, the policeman as he arrives at the signal box sending in a signal which intimates to the attendant at headquarters the number of the box at which he has arrived, whereupon the attendant communicates with the policeman and takes his name; thus getting a record of the movements of the policeman at each section of his route.

In other systems when the policeman merely wishes to announce his arrival at a certain point he opens the box with a specially constructed key which sends in the number of the box. This number is recorded automatically on a slip of paper and the time of receipt of the signal is automatically stamped on the same slip; thus showing that the officer has been at that part of his route at a given time. If the policeman desires to send in a special signal of any kind, as for an ambulance or wagon, or to obtain assistance to quell a disturbance, etc., he can do so by the use of

a special arrangement within the box. If, on the other hand, headquarters wishes to communicate with the officer, the apparatus is set in such a way that an intimation to that effect will be given to the policeman, when he opens the signal box, whereupon he brings the telephone into requisition; or, if the policeman should desire to confer with the attendant at headquarters, he can, by a pre-arranged signal notify the former over the wire to that effect. All of this service is performed over one wire in manner to be described.

Again, in some cities, keys for the signal boxes are given to citizens, watchmen, etc., who are empowered to send in signals for police assistance in cases of emergency, and thus the police force is practically augmented by a volunteer service. In order that the use of the keys in such hands should not be abused, the keys furnished to citizens are numbered and the "citizen's" lock of the box is so constructed that the key, having once been inserted in the key-hole, and turned to send in a signal, cannot be withdrawn until a policeman arrives and releases it. In this way the user of the key is identified.

THE GAMEWELL POLICE SIGNAL TELEGRAPH SYSTEM.

The police signal system of this company affords facilities for the sending of an ordinary patrol signal by the policeman on his "beat," or special signals for ambulance; assistance, etc. Means for telegraphic or telephonic communication between the signal, or patrol box, and the central office, or police headquarters, and vice versa, are also supplied. The apparatus and electrical connections employed to effect these results are shown theoretically in Figs. 350, 351.

In Fig. 350 SB is the signal box. CO is the central office. The arrangement by which "on duty" and special signals are transmitted from the signal box is a modification of the "Field and Firman" electric call box. In SB, bw is the break-wheel, carrying only the "number" of the box on its periphery. sw is a wheel which is only actuated when a special signal is to be sent in. When the latter wheel is moved around, a roller, carried by a lever *r*, rides in and out of the notches *n* in the periphery, separating the contacts *c, c'*. It will be seen that, normally, these contact points *c, c'* are short-circuited by wire *w* and flat spring *s'* which rests on a pin *p* projecting from one side of bw. P is a pointer rigidly attached to the shaft of sw. When the pointer is opposite the numeral 1 the "on duty" call only is sent in. That is, the crank lever controlling bw is merely pulled and let go. This allows the break-wheel to make one revolution, in the course of which it sends in the box "number." This number arrives at the central office and operates the relay R, in whose local circuit, controlled by lever *l'*, is a register RG. This register is provided with chemically prepared paper which records the number of the box as received. If the central office should desire to speak to the policemen sending in an "on duty" signal, the double contact key DK is depressed. The key is so arranged that when it is thus depressed it first closes a circuit around the relay R and battery B, and then

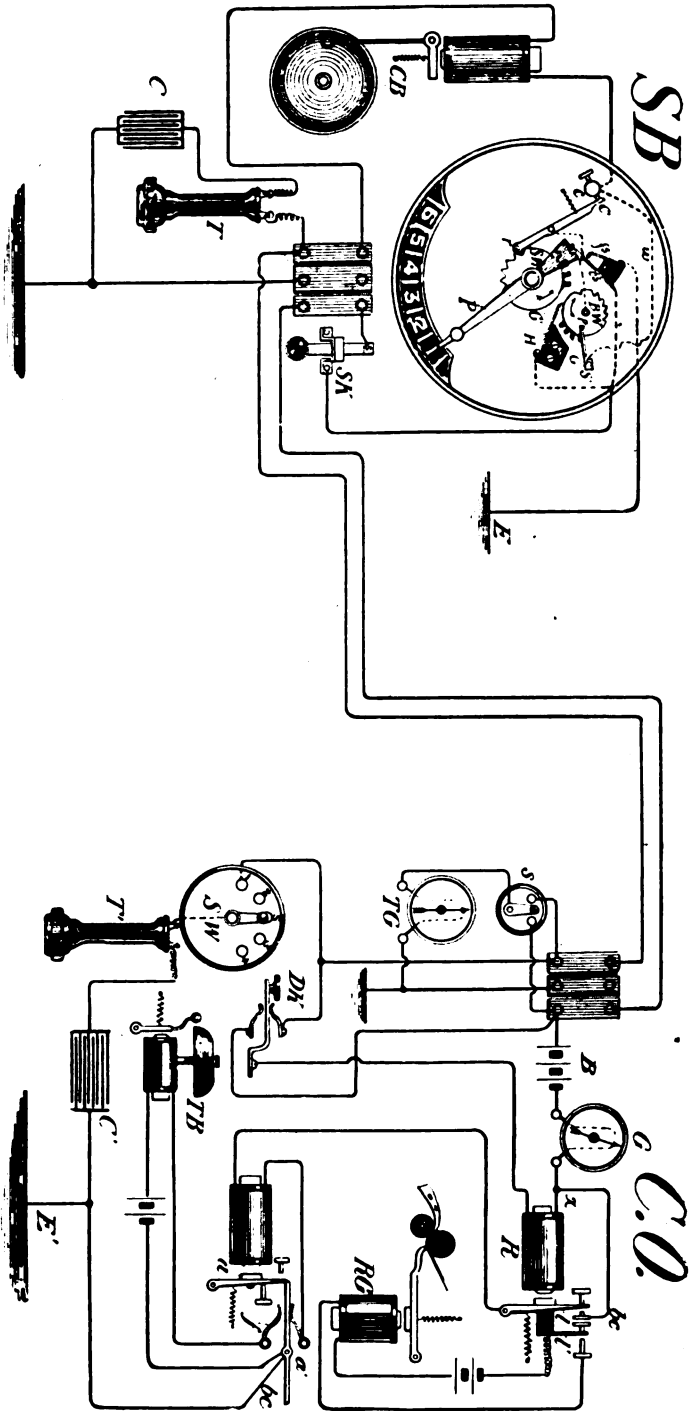

FIG. 350.—GAMEWELL, POLICE PATROL, SIGNAL SYSTEM.—THEORY.

opens the main circuit, which actuates the call bell in the signal box. The act of forming a new circuit around the relay r avoids operating the register uselessly while the policeman is being signaled. Upon hearing the bell, after sending in an 'on duty' signal, the telephone is used; or the strap key sk may be operated according to a pre-arranged code.

The telephone is shown in outline as r' in CO and r in SB. The telephone is connected with the earth, through a condenser c, c' , to avoid grounding the main circuit. At central office the telephonic apparatus is connected with the index of a switch sw , by means of which it may readily be placed in connection with any of the main circuits or with the stable s , Fig. 352. The only connection shown in Fig. 350 is with circuit No. 1. When a policeman, or a citizen furnished with a key, desires to send in the signal for an ambulance wagon, fire, riot, or any other special call provided for among the number of special calls, he moves the pointer to the desired number and pulls the crank. The action of moving the pointer to the left brings in one or more of the cogs on the under side of sw , into the path of the cogs on the under side of bw , in the manner described in the explanation of the operation of the "Field and Firman" electric call box. The result is as follows: In the first place the act of turning the pointer to the left, although it opens the contacts cc' as the rod r rides over the teeth n, n of sw , does not break the main circuit, which still remains closed via the short wire w and the pin p on bw . When, however, the wheel bw begins to make its revolution, the flat spring s' slips off pin p , opening the wire w . Presently the cogs g on bw engage with the cogs g' and cause sw to resume its normal position, in doing which the rod r retraces its motion over the teeth nn , opening the contacts cc' and, this time, opening the main line. The openings of the circuit, thus produced, are made at a comparatively low rate of speed and appear on the chemical paper in the central office as dashes. These are soon followed by the signals due to the passage of the contact h over the notches in the periphery of the break-wheel, which represent on the chemical paper the "number" of the signal box from which the call emanates. In this instance 51. It should be said, however, that these police signals are transmitted and received at a very high rate of speed by the apparatus employed—much more so than those of fire alarm signals, which is explainable by the fact that in the police system no heavy gongs are operated, as is the case in fire alarm systems. An electric "time" stamp, placed over the paper tape in the central office, is at the same time actuated, and the hour at which the signal has been received is recorded. This time stamp, it may be noted, records the time of the receipt of simple "on duty" calls as well as special calls.

A specimen of a special call, with the time stamp, is shown in Fig. 351, in which the four dashes represent the special call and the shorter dashes the box number 51.

When a simple "on duty," call is sent in, it is, as stated, automatically recorded on the chemical paper, and it is not necessary that an attendant should be on the alert to receive it at the central office.—nor, unless the attendant has noticed the whirr of the register, need he be aware of the arrival of such a signal. It is different, however, when a "special" signal is sent in, as when the officer, for any reason, wishes to arrest the attention of those in the central office. In that case the act of moving the pointer in SB brings an insulated block momentarily against the contact spring

cs, bringing that spring into contact with *fs*: This momentarily grounds the main circuit in SB at *E*. As, however, there is, at present, no other ground on the circuit, this has no effect. When the wheel *sw* opens the main circuit, as just described, the relay *r* is opened. [That relay carries two levers on its armature, insulated from each other. A branch circuit *bc* from the main circuit at *x* passes via the lever *l* of *r*.] In returning to its normal position the insulated block momentarily presses again, *cs* against *fs*. The moment that this happens a circuit from the ground at *E*, to the ground *E'* in the central office is formed, through the relay *r'*, which magnetizes that relay. The attraction of the armature *a* which normally holds up a lever *a'*, releases the latter, which falls on the contact *f*, thereby closing a local circuit through a bell magnet *tb*, which rings out an alarm calling attention to an incoming special signal, the nature of which is then seen by reference to the record. In falling on the contact *f* the lever *a'* separates from the lever *a*, thus removing the ground from the main circuit at *x*. The central office attendant resets the lever *a'*.

FIG. 351.

When a special signal requiring the attendance of a wagon at a certain box, has been received, the apparatus, shown as connecting the central office with the stable, in Fig. 352, is employed.

The galvanometer *G* in the central office *CO*, is always in the main line and indicates, by the deflection of its needle, the general condition of the circuit, and the strength of current. The galvanometer *TG*, by the turning of the switch *s*, will indicate the side of the circuit on which a ground may have occurred.

In Fig. 352 the stable electrical outfit is shown at *S*. The apparatus at the central office consists of a double contact key *k*; a call bell *cb*; a telephone equipment *t, c*; batteries *B, B'*, and a "multiple" break wheel *mw*. In the stable, the outfit comprises a double contact key *k'*; a call box *cb'*; an indicator *I*, with gong *G*; telephone outfit *t', c'*, and battery *B''*. The keys *k* and *k'* are so arranged that when either of them is depressed it actuates both call bells, but does not operate the indicator *I*, in the stable, which instrument is only operated from the central office by the multiple break-wheel *mw*. On the top, *D*, of the case of the multiple break-wheel, numbers, corresponding to those of the signal boxes, are marked, as shown in Fig. 353.

When a call for a wagon or ambulance is received the attendant at the central office places the pointer *P*, Fig. 352, at the number corresponding to that from which the "call" has proceeded, and then pulls upon the crank lever *L*, whereupon that number is automatically transmitted over the indicator circuit to the stable and is

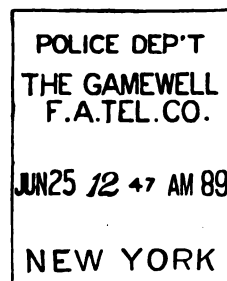

struck by the gong and recorded visually by the "indicator." The manner of operation of the indicator is described in connection with the Gamewell fire alarm telegraph.

AUTOMATIC TRANSMITTER, OR MULTIPLE BREAK-WHEEL.—The general principle of the multiple break-wheel or transmitter, will be readily understood by reference to Fig. 354, in which *P* is the pointer and *L* the crank lever seen in Fig. 352. *MW* is the multiple break-wheel, mounted on a shaft *s*. This shaft extends above the cover *D* of the box in which the wheel is encased; and the pointer is rigidly attached to it. Conse-

FIG. 352.

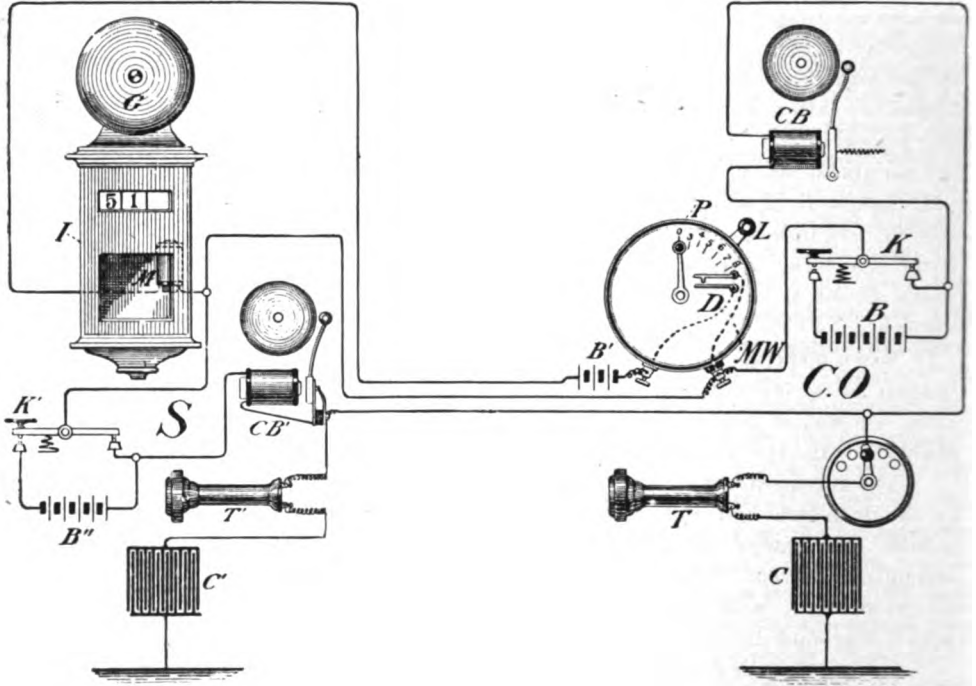

GAMEWELL CENTRAL OFFICE.—STABLE ELECTRICAL CONNECTIONS.

quently, as the pointer is moved around, the break-wheel is turned with it. The break-wheel consists of concave strips of metal, on the outer edge of which, teeth corresponding in number and arrangement to the numbers of the signal boxes, are projected, as indicated in the figure. *s, s'* are contact strips, supported as shown, by a shaft *λ*. Normally, these strips are separated. The effect of pulling the crank lever to the left is to give the shaft *λ* a half turn, or more, which act gives the contact strips a downward sweep, indicated by the dotted line. In making the downward sweep the small lever *l* on the end of *s'* comes into contact with the teeth that may be in its path and rides over them, without moving the strip *s'*. When the crank lever *L* is released a recoil spring, not shown in the figure, returns the shaft *λ* to its normal position. In its return sweep the small lever *l* on the end of *s'* again engages with the teeth, but, as now it cannot yield, it forces the strip *s'* down upon *s* thereby closing the "indica-

tor" circuit. This act is repeated at each tooth with the result that the box number is transmitted. In the illustration the box number transmitted would be 23.

In the transmitter box as actually used, an arrangement is provided whereby the circuit is kept open at another point during the downward sweep of the contact strips, lest by any means the contacts should be thrown together at that time; but immediately on the commencement of the upward sweep the extra opening is closed. Means are also provided whereby, when the crank lever has been pulled, the pointer P is locked until the box number has been transmitted. These devices have been omitted in the figure for the sake of clearness.

As the element of "time" enters largely into the successful operation of the "indicator," care is, of course, taken that the teeth representing figures shall be separated by equal distances in every case.

FIG. 353.

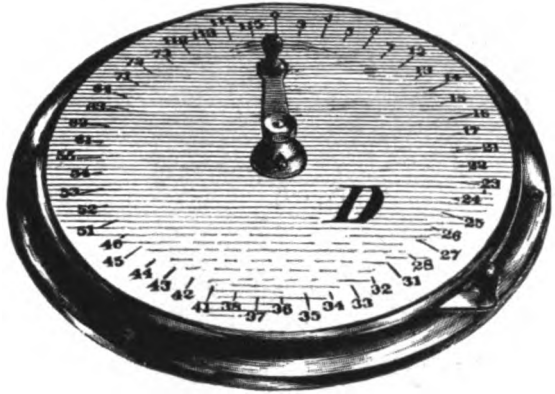
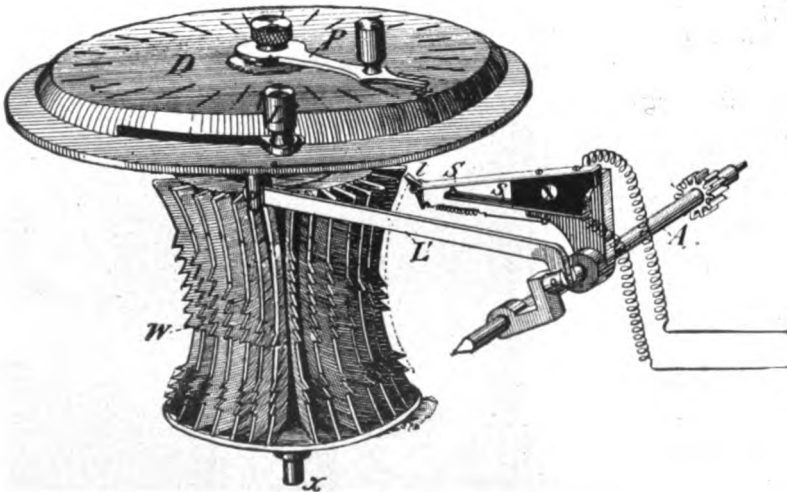

FIG. 354.



MULTIPLE TRANSMITTER OR BREAK WHEEL.

GAMEWELL POLICE TELEGRAPH BOXES.—The Gamewell police telegraph box is shown in its three positions in Figs. 355, 356 and 357: namely, with both doors closed, with the outer door open, and with both doors open.

In the practical operation of this system a signal can be transmitted by inserting

FIG. 355.



and turning a key in a key-hole provided for the citizen's key. The turning of this key has a similar effect to pulling down the crank lever by its handle. When the key has been inserted in the "citizen's" key-hole and turned, it cannot be withdrawn until the outer door has been opened, but, immediately upon its release, a special wagon signal is transmitted to headquarters and the nature of the special signal, which appears on the paper strip as a long dash preceding the box number, indicates to the attendant that the "call" has been transmitted by a "citizen's" key. This is accomplished by a device within the case, c, on the inside of the inside door, Fig. 357, which opens, and, at the same time, "grounds," the main circuit for a short time, just prior to the sending in of the box number by the break-wheel *bw*. At the same time, also, the special wheel *sw* is cut out of the circuit, so that it is immaterial at what point of the dial the pointer *p*, Fig. 356, may be inadvertently left

when the outer door is closed; the citizen's signal only will be transmitted. The grounding of the circuit operates the central office bell as described.

Normally, the gong magnet *g*, within the box, is cut out of the circuit, when the outer door is closed, by the pressure of that door upon a knob *n*, Figs. 356, 357. When, however, the "citizen's" key is inserted in its key-hole the gong magnet is placed in the main circuit and becomes operative.

Ordinarily, the police officer in pursuing his rounds, opens the outside door and places the pointer at "report," after which he pulls the crank, which, by transmitting the signal, announces to headquarters his presence at a certain box. An "answer

FIG. 356.

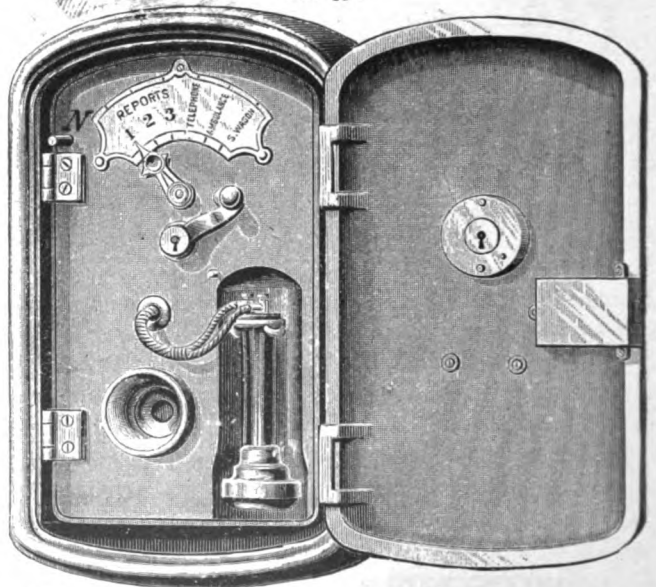

back" signal on the bell, within the box, informs him that his report has been received and he may proceed on his "beat." If the policeman should be wanted for any reason by the central office, a pre-arranged number of strokes on the bell notifies him to use the telephone. Should the central office attendant require to leave his desk he may

FIG. 357.

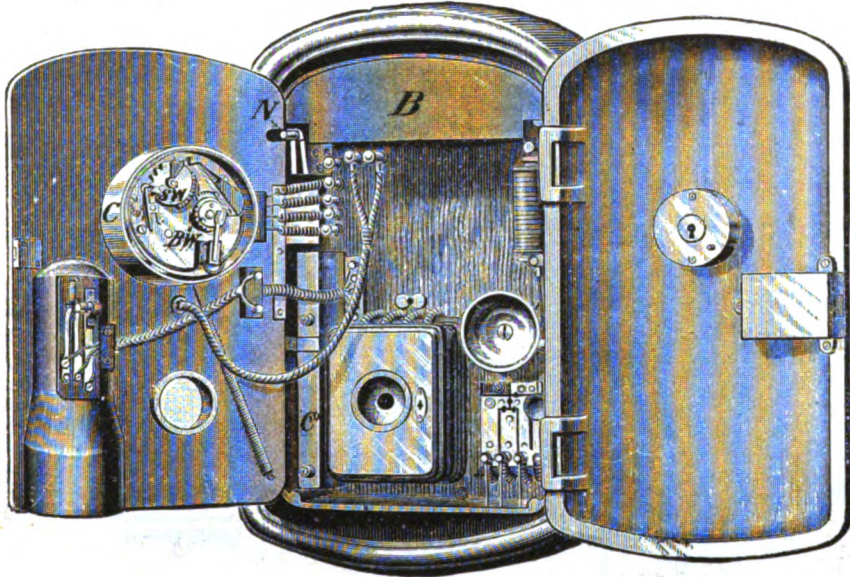

set a device which will automatically transmit this pre-arranged signal immediately after the completion of the officer's signal, thereby holding him. One means by which this is accomplished is shown in connection with the municipal patrol system. The arrangement of the telephone apparatus is shown clearly in Figs. 356 and 357. The "transmitter" battery is held in a receptacle *B* under the roof of the box. The condenser, which is used to complete the telephone circuit, as outlined in Figs. 350, 352, is shown as *c'* in Fig. 357.

THE CHICAGO POLICE PATROL TELEGRAPH SYSTEM.

In the operation of this system it is the practice to have an attendant constantly at the "cabinet," (as the desk in, or on, which the central office apparatus is placed, is called) in Police headquarters. It is the duty of the attendant to note and acknowledge receipt of every signal. Consequently, it is not considered necessary to employ "alarm" apparatus in the signal box when a special signal is to be sent; nor apparatus in the central office to respond to the same. With this exception the signal box and central office apparatus of this system is virtually similar to that of the "Gamewell" already described; therefore, only such features of the Chicago system as differ from those of the Gamewell system need be here described.

The electrical connections of the Chicago police patrol telegraph are outlined in Fig. 358. SB is the patrol, or signal box apparatus. bw is the "number" break-wheel. sw the "special" signal wheel. CB is an "answer back" bell. T, c' the telephone apparatus. SK is an ordinary strap-key, on which code signals may be tapped out by an officer.

The apparatus at the central office, CO, is shown at the right of the figure. It consists of the relay R, register RG, a "push-jack" H, magnetic coil MC, line galvanometer G, main battery B, local batteries *b* and *b'*, lightning arrester LA and telephone outfit T, C. A stable outfit, similar to that employed in the Gamewell police telegraph system, but not shown in Fig. 358, is employed.

FIG. 358.

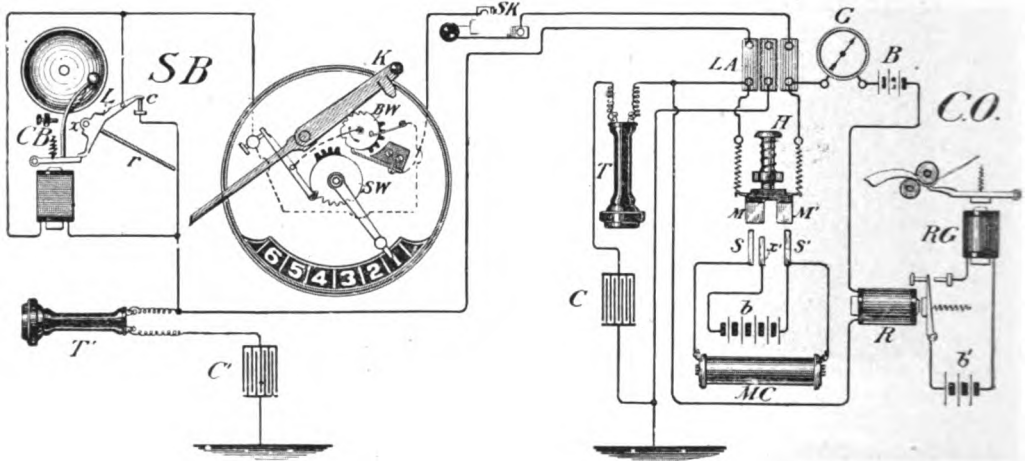

CHICAGO POLICE PATROL CIRCUITS—THEORY.

When a signal is received, it is, as stated, acknowledged by the attendant in the central office, either by the telephone, or by means of the push-jack. The function of the push-jack, when depressed by the hand and withdrawn by a spring, is, first, to charge the coil *mc* by the battery *b*, and, next, to permit its discharge through the main circuit. It will be noticed that the metal strips *M, M'* on *H*, when the latter is pushed down, form a circuit for battery *b* through *mc*, and that, on the withdrawal of the push-jack, the connection with the battery is broken at *x'* before the longer strips *s, s'* sever connection with the strips *M, M'* on the push-jack. This gives the magnetic coil an opportunity to discharge through the main circuit, thereby momentarily increasing the current on that circuit, and operating the "answer back" bell in the signal box from which the signal had emanated.

The manner in which the "answer back" bell is operated is as follows: Referring to Fig. 358, it will be seen that that bell, *CB* in *SB*, is cut out of the main circuit by the short-circuit via contact *c*. The bent lever *L*, pivoted at *x*, at its upper end keeps the contact *c* closed, while, at its lower end, it holds down the armature lever of *CB*, which otherwise would be drawn up by the strong pull of its retractile spring; and this would occur even when the contacts at *c* are separated and the main line current is thereby permitted to flow in the coils of *CB*.

When the crank lever κ of the signal box, shown also in Fig. 359, is pulled, its left end engages with the rod r , lifting the lever L so that the contacts at c separate, putting cb into the main circuit and releasing its armature lever, which is then withdrawn by its retractile spring. As soon as the crank lever κ returns to its normal position, the rod r falls, but is prevented from resuming its former place by the armature lever cb . Thus the bell cb still remains in the main circuit. The attendant at the central office CO now operates the push-jack and the extra current generated thereby attracts the armature of cb , striking the bell once and permitting the lower end of the lever L to move over the armature lever again, locking it as before, and also closing the contacts at c . The stroke on the bell is termed the "answer back" signal, which indicates to the policeman at the box that his signal has been received and that he may now use the telephone.

The object in using this "push-jack" and magnetic coil, it will be understood, is to avoid the necessity for a large extra battery to furnish an extra current to close the bell magnet; since it is not desired to open the circuit for any other purpose than the transmission of "on duty" or special signals. It will be understood also that the di-

rection of the extra current thus set up by the magnetic coil is arranged to coincide with the current from the main battery; otherwise the "counter" current would be apt to momentarily release the relay R when the push-jack is operated.

The signal box SB is shown as it appears in actual service, with the door open, in Fig. 359, in which r is the telephone receiver Tr the transmitter; c the condenser; cb the "answer back" bell; sw the special signal wheel; bw the box "number" break-wheel; κ the crank lever and P the pointer.

The battery, of one dry cell, for the operation of the telephone from the signal box, is contained in a receptacle under the roof of the box. The actual connections of the telephone apparatus, with the condenser omitted, are shown in the Pearce and Jones system, next described.

The signal box with inside door closed is illustrated in Fig. 360. The pulling of the lever κ , shown on the outside of the door D , by reason of the engagement of a projection P' within the door, (shown in Fig. 359) with a projection κ on the crank lever, pulls down the latter in the usual way to operate the signaling mechanism.

FIG. 359.

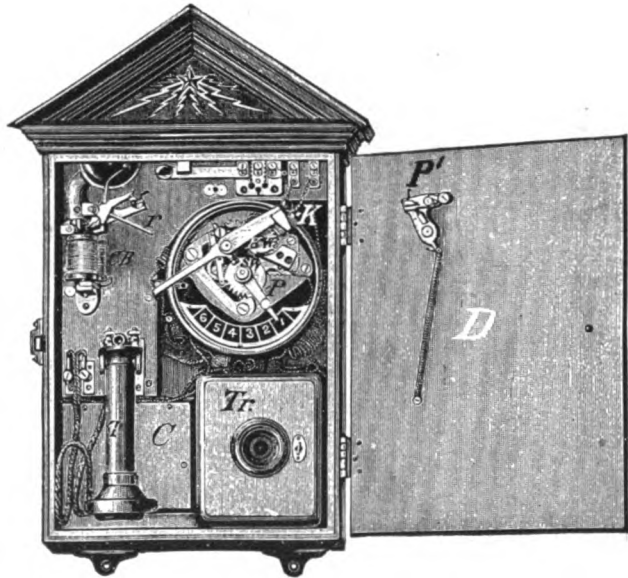

CHICAGO POLICE PATROL BOX.

Special signals are transmitted by the police officer, or others having access to the boxes, by moving the pointer *p*, Fig. 359, to the designated point on the dial; which

FIG. 360.

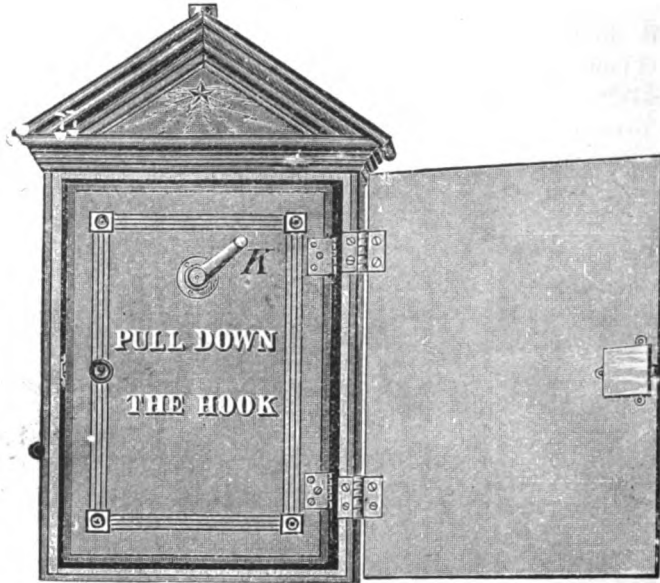

CHICAGO POLICE PATROL BOX.

signals are recorded on the register in the central office.

THE PEARCE AND JONES POLICE PATROL TELEGRAPH SYSTEM.

This system is in successful use in several of the large cities of the United States. It is quite simple in its operation.

In this system means are provided in the street signal box whereby the policeman on his beat may send in the box number to indicate his whereabouts to headquarters, or whereby he may hold telephonic or telegraphic communication with that office, or send in special calls for assistance; for ambulance wagons, etc.

Apparatus is provided at the central office for receiving, automatically, on a register, the number of the box, the nature of the call, etc., and also the means for holding telephonic and telegraphic communication with a policeman at any of the signal boxes.

In Fig. 361 is shown in general outline the apparatus and connections of a central office of this system. The connections for two patrol circuits are shown in the figure.

It will be understood that as many more circuits as may be necessary can readily be added. In the figure DR is a double-pea register, one magnet of which is included in the local circuit at relay R¹; the other in that of R². The register is self-starting and

FIG. 361.

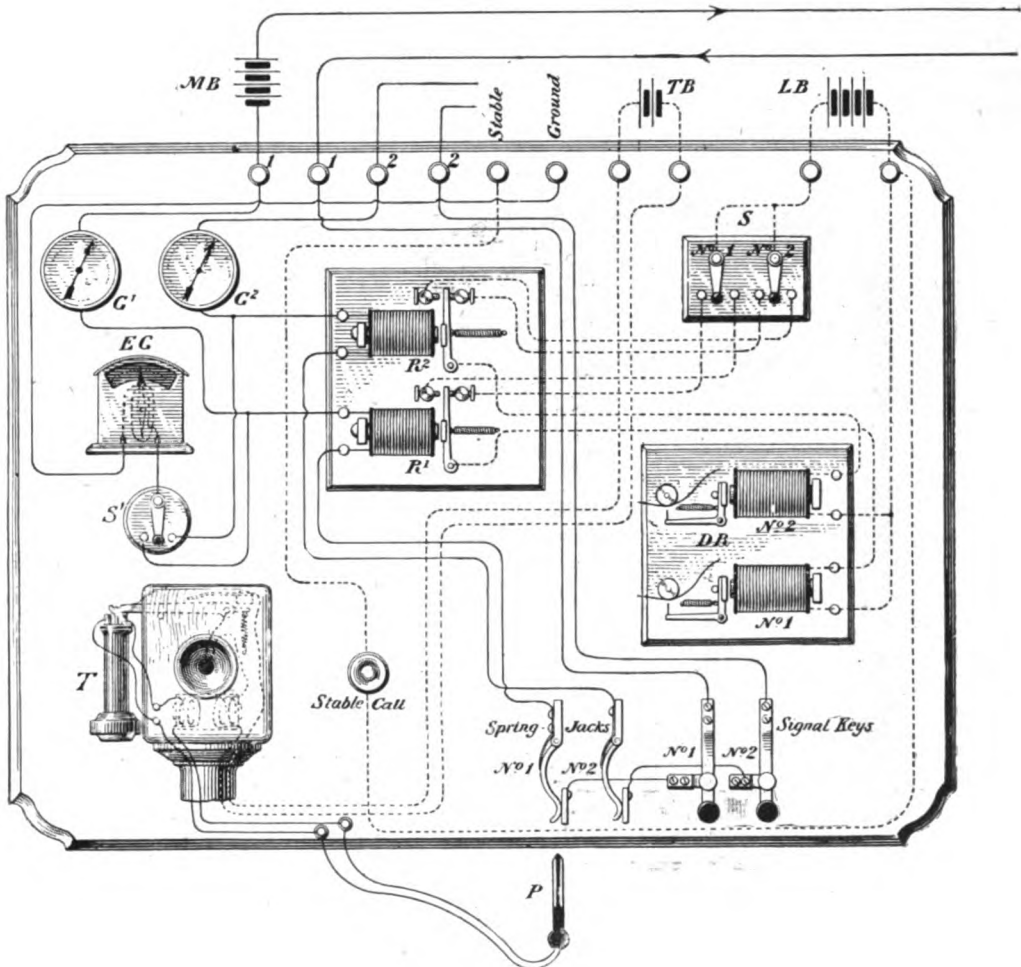

PEARCE AND JONES POLICE PATROL SYSTEM.—CONNECTIONS.

self-stopping. Ordinarily the telephone T is not in any circuit. Its terminals are connected with a "wedge" P, by means of which it may readily be introduced into either circuit, at the spring-jacks, in the well known way. This telephone is inserted in a circuit by the operator at headquarters whenever a signal is received from a street signal box. Relays R¹ R², having a resistance of about 80 ohms each, are always in the respective circuits. These, by means of their armatures and local batteries, operate the registers DR. These relays are furnished with back and front contact points, and, by means of the switch S, the register may be operated on either front or back contact.

This arrangement is valuable when the alarm circuit is broken by accident at any point, for, at such times, the local circuit may be switched from the back to the front contact, and, as soon as the line is repaired, the armature will be attracted and the register operated, thus automatically announcing that the repair has been made; when the local circuit is again switched over to the back stop. The "signal keys" are normally

FIG. 362.

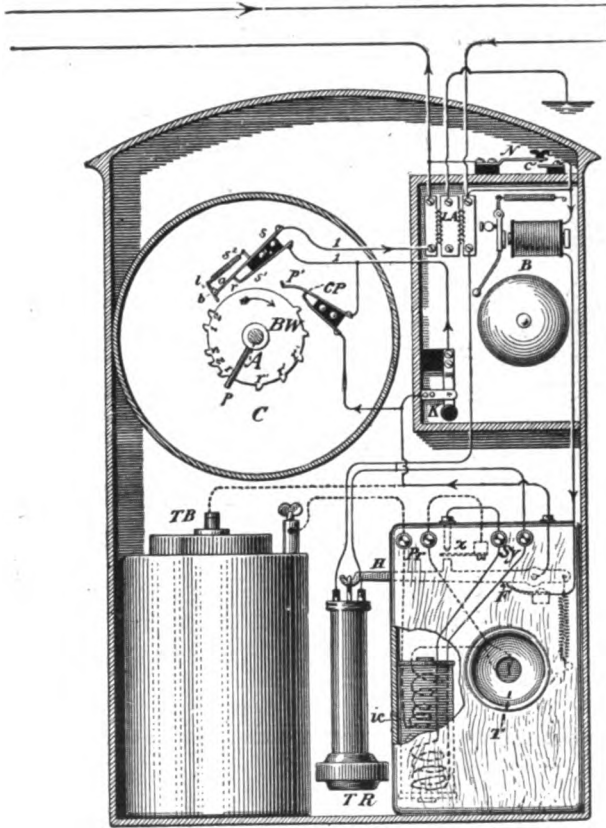

PEARCE AND JONES SIGNAL BOX.

closed. They are actuated when it is desired to operate the bell in the signal box, as will be explained. In each circuit is placed a galvanometer $G^1 G^2$. The normal current strength of the circuit deflects the needle of this instrument to a certain angle. When the deflection is out of the normal it indicates either an open circuit, a ground, or an escape. The galvanometer EG, by means of the three-point switch S' , may be cut in on either No. 1 or No. 2 circuit. One terminal of EG is permanently connected to ground so that, when a circuit is connected to its other terminal, the presence of an escape or ground on the circuit will be indicated. The "stable call" is used in announcing to the ambulance people that their services are required.

The connections and apparatus of a street signal box are shown in Fig. 362. It is about the size of the usual street fire alarm box, and is similarly provided with

tight doors, etc. In this figure BW is a break-wheel of peculiar construction, by means of which regular and special signals are transmitted. K is a strap, or signal key by which, as in the manner of the ordinary Morse keys, signals may be "tapped" out. As, however, expert operators are not available, this key is only used for the purpose of sending in code signals, according to a printed blank attached to the inside of the door of the box. The bell B is operated by the central station when such code signals are being transmitted to the policeman at the box. A telephone receiver TR is contained within the box, also a telephone transmitter T, and the usual induction coil, ic, and the

transmitter battery TB. Usually the telephone receiver is suspended from a hook H, at which time the telephone battery is out of the circuit, being open at x , and the bell, B, is then in the circuit, but, when the telephone receiver is in use, the hook is pushed up against x and the telephone battery is put into the circuit by way of contact x , while the bell B is cut out of circuit at the contact F, as will be easily understood by examination of the connections. The "cut out" N at the top of the box is operated by an attachment on the outer door of the box, which forces the contacts c' together, thus cutting out the apparatus within the box, as is customary in the case of many fire alarm signal boxes, and for the same purpose, namely, to diminish the resistance of the circuit by short-circuiting the induction coils, magnet coils, etc.

The break-wheel BW, within the large box, is enclosed in a metallic case C, from which the cover is, in the figure, removed. The apparatus, BW, consists of a brass wheel, on the periphery of which are projections 1, 2, r , r' , etc. This break-wheel, mounted on a shaft A, to which is attached a recoil spring, is revolved in the usual manner. The main line circuit 1, 1, is led, by insulated wire, to two flat contact strips s, s' ; the upper of which extends somewhat beyond the lower at a . A small lever l pivoted at b is held in the position shown by a light spring s^2 . When the wheel BW is turned, by the crank handle, in the direction of the arrow, the lever l simply slides over the projections without separating the contacts s, s' , which are normally together. But, when, in obedience to the recoil spring, the wheel BW reverses its motion the lever l cannot yield, but, instead, rides over the projections r', r' , etc., and, consequently, the upper contact s is forced to rise, breaking the circuit at r . The number of such breaks will depend on the number of projections over which the lever may be caused to ride. In practice, in this system, the projections representing the number of the signal box are set nearly together, as 1,2 and 1,2,3. Further along the periphery, similar projections r', r', r' are placed, at greater intervals. These latter are the means by which emergency calls are given. For instance, if the wheel BW is turned so that the lever l passes the projections 1,2 and 1,2,3, and is then stopped, only the number of the box, assuming it to be, in this case, 32, will be sent in, but, if the wheel is turned until, for example, the projection marked "fire," on the dial, Fig. 363, is reached, the signal sent in would be 3 slow strokes, and then the number, 32, as before. This would indicate to the central office that a "fire" signal had been sent in from box 32. Had but 2 slow strokes and the "number" been received, it would have indicated that an ambulance was desired at the box 32.

In practice there is placed on the outside of the cover of the case, shown in Fig. 363, in which the break-wheel is enclosed, a depressible projection P, which, normally, stops the downward motion of the crank lever K at a point at which it will have turned the break-wheel to a position where only the ordinary number of the box will be sent in. Thus it is only necessary in ordinary circumstances to pull the crank lever as far as it is free to move. When, however, an emergency call is to be made, a knob, N, which also extends outside of the cover of the case C, is pressed in. This action removes the obstruction P out of the path of the crank lever and allows it to be pulled to any desired point on the dial, whereupon the crank is let go and is returned to its starting point by the recoil spring; the break-wheel, at the same time, sending in the desired signal.

Inasmuch as one of the objects of a police patrol telegraph system is to provide a means whereby the policeman may announce his exact whereabouts, thus showing that he is faithfully patrolling his "beat," it is evident that means should be devised to prevent him from outwitting the box, which he might do by tapping off the number of a box located at some other point than that at which he has arrived. In other words, to prevent him, for example, from remaining at any one box and from that box sending in signals corresponding to the various boxes at which he should have arrived, at given times. This he might do, if not thwarted, by imitating by means of the signal key k in the street box, the action of the break-wheel in sending in the box number.

FIG. 363.

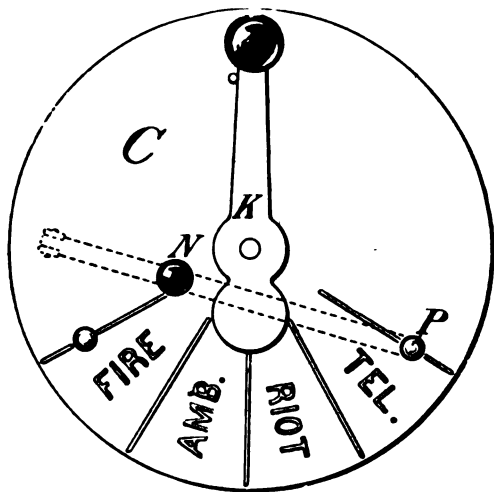

To avoid this possibility, in the "Pearce and Jones" "patrol" box, the signal key k is normally cut out by means of the contact points ϕ , Fig. 362, contained within the break-wheel case c . These contacts are only separable by turning the break-wheel until the insulated piece p attached to the shaft λ , reaches the contact strip at p' , when the contacts are separated. p is so placed that it does not break the contact at ϕ until the wheel bw has reached a point where, on its being released, it will automatically send in the number of the box. Consequently, when the officer

desires to communicate by means of the signal key k , he must first turn the crank of bw to its ordinary extent, and then hold it there until he taps in his code signal. It would, of course, then be useless to send in a false box number, by means of the signal key k , inasmuch as it would be immediately followed by the correct number, upon the release of the crank lever.

The lightning arrester LA , shown in Fig. 362, is of the usual form.

In the cities where this system is in operation the officer on reaching a patrol box is required to use his telephone to converse with the attendant at headquarters to receive instructions, etc. In case the telephone is not in working order the emergency call is used, or the emergency call may be used in addition to the telephone message.

No means are employed on this system to prevent the passage of box number signals over the circuit from interfering with the use of the telephone; the interruption, if any, being only of momentary duration. Should two officers open different boxes simultaneously, they hear each others conversation and one refrains until the other has completed his conversation with the central office.

Where it is desired to announce a special call by an extra alarm in the central office, additional devices may be added to those shown at CO in Fig. 361. One such device, due to Mr. J. W. Stover, is outlined in Fig. 364.

In this figure CO represents the central office in which G is the recording register

and R is the main line relay, which, by its armature lever, operates G. MB is the main battery. B is a street patrol box. The apparatus employed to give the special alarm in the central office consists of a magnet RM in the patrol circuit, and a vibrating bell CB, whose local circuit is controlled by the armature lever of RM. The armature of RM is so adjusted that the usual current on the main circuit will not attract it. At such times it retains in a vertical position, by means of its hook end E, the upright rod L. When, however, by any means, the current on the line is increased, the armature of RM is attracted, upon which its lever releases the rod L which falls over on the contact point P, thereby closing the local circuit of CB, vibrating its bell.

FIG. 364.

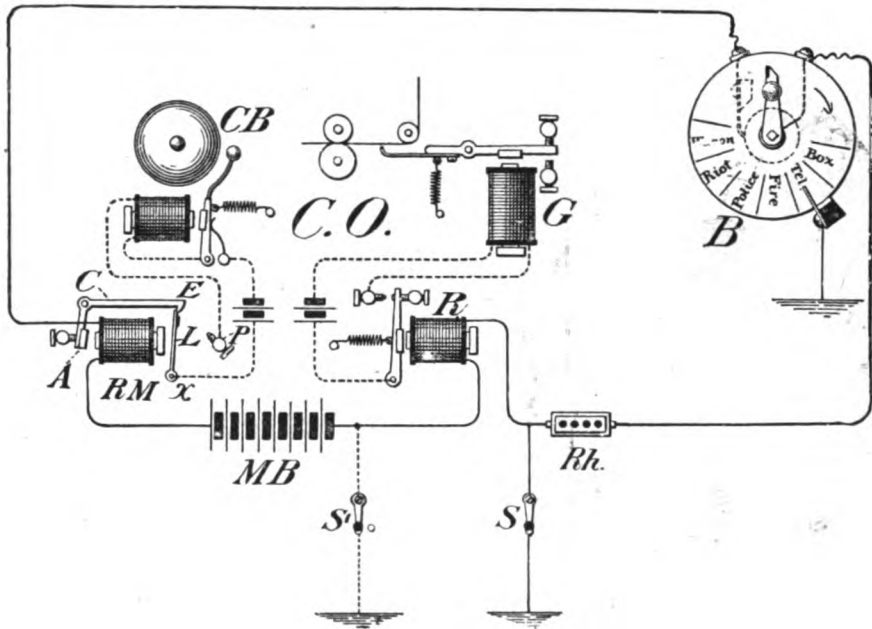

STOVER SPECIAL ALARM DEVICE.

To produce this increase of current on the line, special arrangements are provided in the signal box B and in the central office. In the signal box a spring connected with the "ground," is so placed that, when the crank lever is turned beyond the ordinary stopping point, it momentarily grounds the main circuit. A "ground" is permanently put on the main line in the central office by either the switch S or S'. S is used when the rheostat Rh of moderately high resistance is employed. The effect of grounding the circuit at the signal box is to "short-circuit" the rheostat. When the switch S' alone is employed and Rh is dispensed with, the act of "grounding" the main circuit in the signal box short-circuits the relay R. Either operation increases the current flowing in the relay RM and actuates it, thereby calling the attention of the attendants in the central office to the fact that a special signal is to be sent in. The lever L of RM requires re-setting manually,

after each special signal. One side of the crank lever of *B* is insulated, as shown, so that the line wire is not grounded on the return trip of the crank.

THE MUNICIPAL POLICE SIGNAL TELEGRAPH.

This police patrol system varies somewhat in its arrangement from those already described.

The apparatus employed consists of the usual street signal box for the transmission of signals, and, in the central office, relays, registers, time stamp, etc.

FIG. 365.

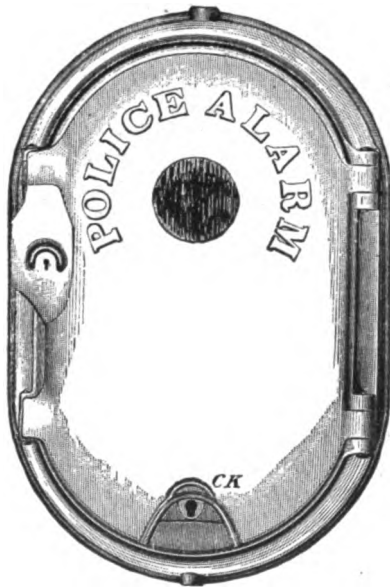

The signal box is shown with both doors closed in Fig. 365. In Fig. 366 it is shown with the outside door open. It will be noticed that the pointer is arranged somewhat differently from those shown in the systems previously described; being placed, when at rest, at the center of the dial. The handle of the pointer is made in such a way that the act of shutting the outside door insures that a knob *k* shall place the pointer in its normal position.

Signals may be sent in by the act of turning a key in the key-hole, shown at the bottom of the door, Fig. 365, or, by pulling down the hook, shown in Fig. 366.

The arrangement of the apparatus within a patrol box is shown in Fig. 367; in which *B* is the telephone battery and *C* is the condenser used in connection with the telephone. The special signal apparatus and the box "number" break-wheel are contained within the case *w*. The winding shaft of the break-wheel, etc., is connected

with a long strip *s*, the pulling down of which, by the turning of the key, or by the pulling of the hook referred to, operates the signaling wheels. The "answer back" magnet *G* at the side of the case *w*, is a polarized magnet which is only responsive to reversals in the direction of the current on the main line, which reversals are caused by a pole-changer in the central office.

A multiple pen register, and time stamp, employed in the central office, are shown in Fig. 368. The register case contains, on one side, the multiple pen apparatus, and, on the other side, apparatus used in connection with "answer back" signals, or for the automatic transmission of signals to indicate to an officer that he is desired to use the telephone.

In the operation of this system "special" signals are indicated by an "alarm," or annunciator "drop," in the central office.

In Fig. 369 is shown a theoretical diagram of circuits and apparatus in a central

office, and signal box, by means of which the various signals mentioned may be transmitted and received. CO is a central office, in which are placed a relay R, controlling, by its armature, a register G; an ordinary duplex pole-changer PC, which, when operated, reverses the main battery B in the usual way. A is an annunciator magnet, or electric bell. ∇ is a grooved screw, geared with the clock-work and started by the register lever; this screw tends to bring a lever l into connection with a contact point x controlling the annunciator circuit. This piece of mechanism may be considered as analogous in its operation to that of the self-starting and self-stopping apparatus of Morse register. In this case the lever l is normally

FIG. 366.

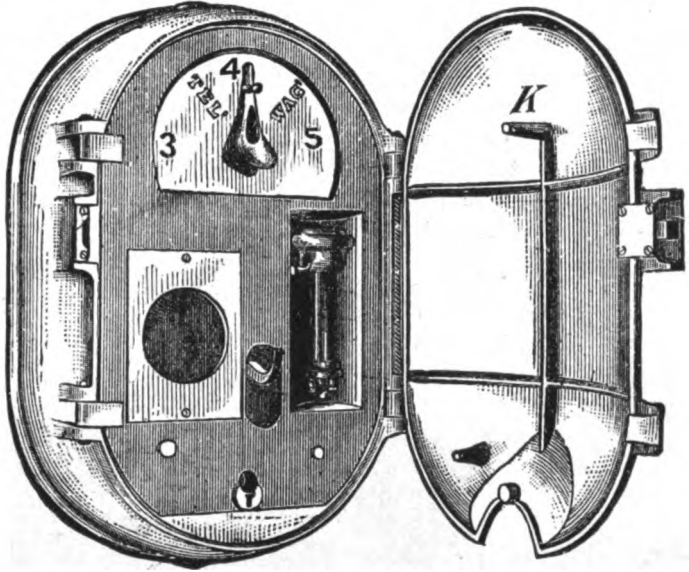
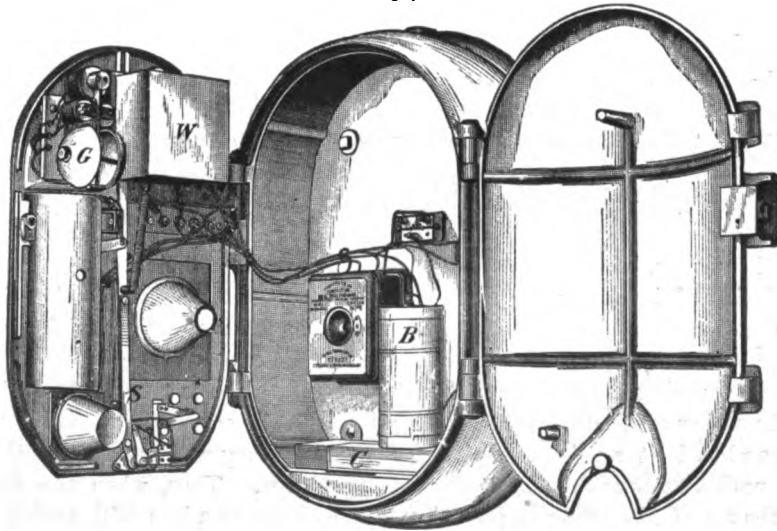

FIG. 367.



held out of the groove of ∇ by the armature lever l' of the register. When the latter is closed the knife edge of the lever l is placed in that groove ∇ , whereupon it

quickly starts to complete the local circuit at x , and, if the register's armature lever is not at once raised it will do so, thereby ringing the annunciator bell. If, on the contrary, the armature lever is only momentarily depressed the lever l is thrown out of the screw thread and the spring s draws that lever to its back stop x' . Hence a dot, or series of dots, sent over the police circuit, from a street box, will not operate the annunciator drop, but a more prolonged signal, such as a dash, will. It will, therefore, be plain that if ordinary signals, such as may be used to note the arrival of an officer at a box, are composed exclusively of "dots," the "alarm" in the central office will not ring; while, if a special signal is made up of one or more dashes, time will be afforded to close the alarm circuit.

It will be seen presently how these long and short signals are automatically transmitted, as desired, from the signal box.

FIG. 363.

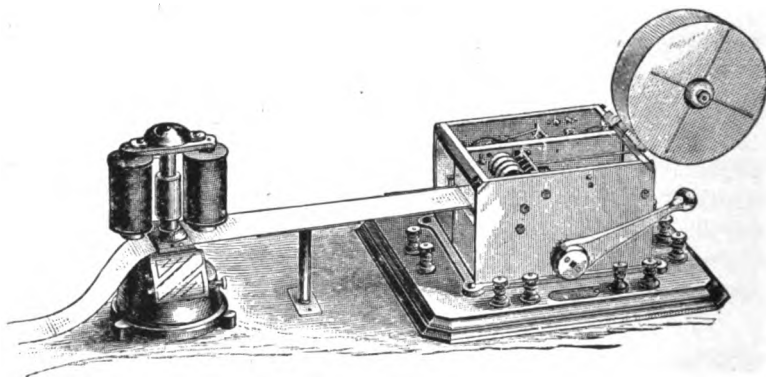

As has been intimated, means are provided in the central office for calling up an officer on his arrival at the patrol box in the absence of the attendant at the central office. This consists of an arrangement of the gearing in the register box, whereby a wheel m , at the recurrence of each signal, is caused to make a revolution. On its periphery are three teeth over which a contact spring fs rides, thereby making contacts with the contact cs and closing the local circuit of the pole-changer pc at those points. Normally, however, this local circuit is open at a switch s , so that the fact of the closing of the circuit at fs , cs , on receipt of every signal coming in on the circuit does not affect the pole changer. But, if, as when an officer is desired to use his telephone at the signal box, the attendant in the central office closes the switch s , the effect of closing the local circuit of pc at fs , cs , will be to operate the pole-changer a stated number of times, corresponding to the teeth on the periphery of m . These teeth are placed at a point on the periphery where they will not affect the contact strip fs until almost at the end of the revolution of m . Thus, when the switch s is closed the act of the officer in reporting his presence at a box will eventually cause the pole-changer to reverse the direction of current thrice on the line, which reversals, by ringing the bell in the signal box an equal number of times, will signify to the policeman that he is required to communicate with the central office.

The theory of operation of the pole-changer and polarized relay will be found described in the chapter on the polar duplex.

In Fig. 369 also, SB is the street signal box, in which are shown only a multiple break-wheel BW; a pointer P; a cylinder C, with spirally arranged projections *p*; the "answer back" bell, G; the telephone T, and condenser C'.

The multiple break-wheel shown consists of a shaft on which a number of break-wheels, w^1, w^2, w^3, w^4 , are placed, as indicated. Over these wheels flat contact strips

FIG. 369.

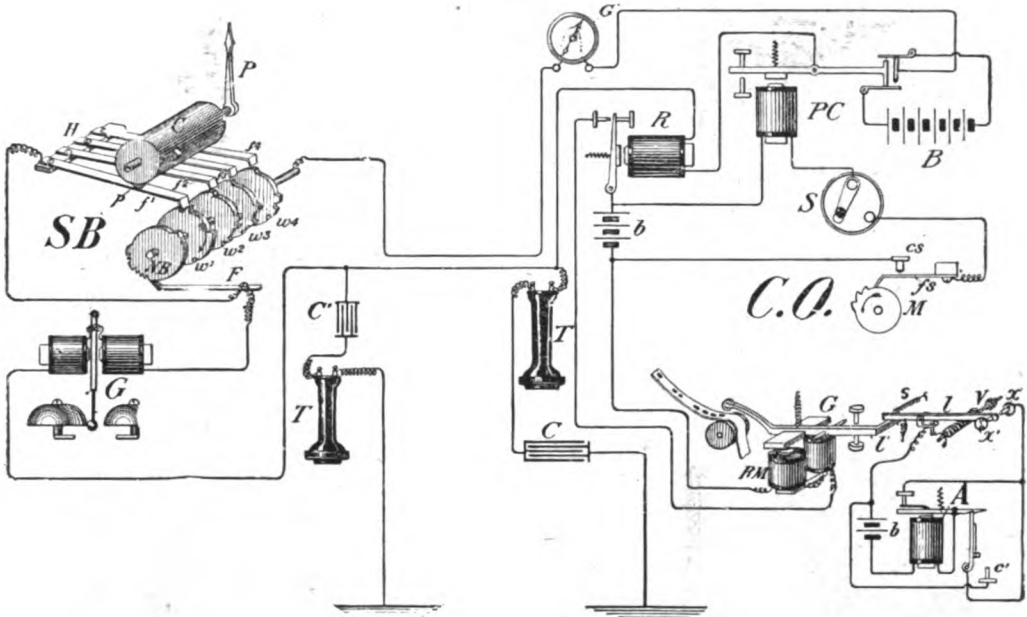

POLICE PATROL SIGNAL CIRCUIT.—SHOWING AN ARRANGEMENT FOR "ANSWER BACK" SIGNAL IN CENTRAL OFFICE.

f^1, f^2, f^3, f^4 , are held, by a common support H. Above these flat contacts the cylinder C is placed. The pointer P is attached rigidly to the shaft of C. Thus, when the pointer is turned to the right or left the cylinder C is moved a corresponding distance to the right or left. When thus turned the effect is to cause one or other of the pins *p* to depress and push a flat contact strip into contact with the periphery of its respective break-wheel. The box "number" break-wheel, NB, is shown on the end of the multiple break-wheel. It has a separate contact strip F. The main line circuit is connected to the break-wheel cylinder; and to the strips F and H, as shown.

The break-wheels f^1, f^2 , etc., are, in the figure, arranged to transmit "wagon," "telephone" and "report" signals. For example, the telephone signal may be represented by a dot, dash, dot, followed by the number of the box, thus: - - - - -; the wagon signal by two dashes, followed by the box number, thus: - - - - -, etc., assuming the box number, in each case, to be 24. Hence the "telephone" break-wheel w_3 will be equipped with three breaks, corresponding to dot, dash, dot, and the

“wagon” signal wheel w_2 , with two breaks, corresponding to two *dashes*. Other break-wheels may be arranged, as desired.

Owing to the spiral arrangement of the pins on cylinder c only one special signal strip will be depressed at one time by the turning of the cylinder.

FIG. 370.



FIG. 372.



It may be seen that the long break in the periphery of the number break-wheel NR is placed at a point where the continuity of the circuit is taken up by one or other of the flat springs f_1, f_2 , etc., by contact with a break-wheel; and that a similar long break is made in the periphery of the other break-wheels at a point where the continuity of circuit is taken up by the box number wheel.

When an ordinary signal, such as a “report for orders,” which might be represented by one *dot* preceding the box number, is transmitted, the special alarm in the central office is not operated, for the reason that the break has not been of suffi-

cient duration to permit the closing of the "annunciator" circuit. When, however, a "wagon" or "telephone" signal is transmitted, the spaces on the break-wheels assigned to those signals allows the lever / at CO to be moved over to x, thereby closing the annunciator circuit, with the result stated. In Fig. 368 the break-wheel at SB is represented as just having transmitted an ordinary box number signal, as indicated at CO.

There is, in addition to the apparatus shown in Fig. 368, at SB a device whereby, when a signal is transmitted by a citizen's key, from the key-hole on the outside door, a dash twice the ordinary length is recorded on the register. This not only gives the "alarm" of a special signal, but also indicates that the special signal has been actuated by a citizen's key.

Galvanometers for testing circuits, multiple break-wheels for transmitting the calls for wagon to the stable, and rotating switches for connecting up any circuit with the telephone, etc., practically similar to those already described in connection with other patrol systems are also used in the central office of the system just described.

POLICE PATROL BOXES.

As previously stated the signal or patrol boxes of the various companies are placed on walls, in booths or on lamp posts and telegraph poles, as may be most convenient.

In Fig. 370 is shown a lamp post box. This box is provided with signaling apparatus virtually as described in connection with patrol boxes; but has, in addition, an attachment known as the Tooker "keyless door." This door may be opened without a key, by any citizen, by turning the handle until the door opens, but, as the handle is turned, a loud gong is struck repeatedly, giving notice to adjacent policemen, or others, that the box is being opened.

The same box with the outside door opened is shown in Fig. 371; the gong being contained within the round case c. The door may

be opened from the outside by a policeman with a key without ringing the gong.

A booth and box are shown in Fig. 372. The door of the booth is normally closed.

FIG. 371.

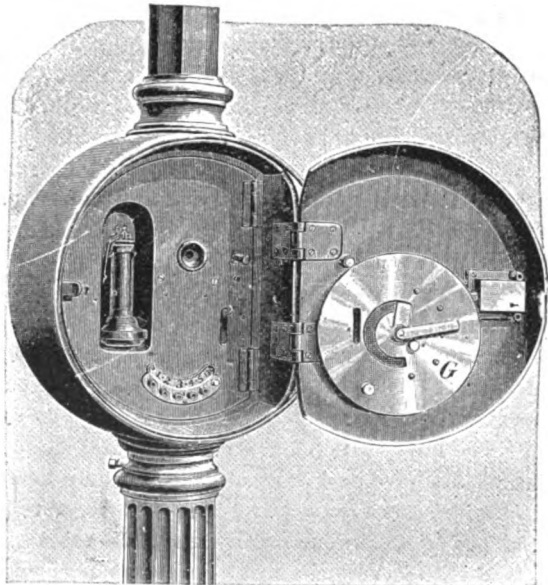

CHAPTER XXX.

RAILWAY ELECTRIC BLOCK SIGNALING SYSTEMS, ETC.

A "block" system, in brief, consists of a plan for the showing of signals, manually, or automatically, which indicate to the engineer of an approaching train that a certain section of the track in advance of him is "clear" or "occupied." That is, either that there is or is not another train on the section before him. These "sections" or "blocks" are divided into various lengths, depending in a great measure on the topography of the road or the amount of traffic over it. In some cases, the sections do not exceed 1,000 feet; in others they may be several miles in length.

Electricity performs a very important part in many of the "block" systems now in operation on railroads of this country.

Block systems are of at least two kinds. Namely the "absolute block" and the "permissive." In the absolute, but one train is allowed at one time on any one block; and the signals displayed at the entrance to such a block is either "safety" or "danger." In the permissive system, a second, or even a third, train is allowed on the one block, under certain conditions. The signals employed on the block systems are either "safety," "caution," or "danger."

The "safety" signal consists of a white sign or white light. The "danger" signal of a red sign or red light. The "caution" signal of a green sign or green light.

In automatic electric block systems the circuits and mechanism are generally so arranged that the entrance of a train into a "block" sets the "danger" signal, and that signal is continued until the train passes out of that block into the next, when the danger signal is lowered and the safety or caution signal, shown.*

The part assigned to electricity in the operation of these signals, when that agent is employed, consists, as a rule, in actuating electro-magnets which are placed in circuits capable of being opened, closed, or short-circuited, by the engine or cars of a train. These electro-magnets in turn are caused, either directly or indirectly, to operate the various signals.

The laws, or facts, of electricity and magnetism involved in effecting the foregoing results have been fully stated elsewhere herein, but, for convenience of explanation may be repeated here. They are, briefly, as follows: A rod or bar of soft iron surrounded by an insulated coil of wire becomes a magnet when a current of electricity is caused to flow in the coil. The current of electricity may be set up by any suitable source of electromotive force. As long as the current circulates in the coil the bar remains a magnet; when the current ceases, the iron ceases to be a magnet. While the iron continues a magnet it will attract its armature; when it ceases to be a magnet the armature is released. The current through the magnet coil may be discontinued by opening the circuit at any point; or it may be diverted from the coil

* In some block signal systems, what is termed the "normal danger" plan has been somewhat recently adopted, whereby the "danger" signal is normally shown until the approach of a train, when, if the immediately preceding sections are clear, the signals go to "safety." This plan is intended to lessen, among other things, the likelihood of signals standing abnormally at "safety," due to mechanical defects, or other causes, such as sleet storms.

by providing a shorter circuit for the current than that offered by the coil. Both of these methods of demagnetizing electro-magnets are availed of in railway electric signaling.

In some electrical systems of block signaling, for instance, the Union Electric Switch and Signal system, the rails of the tracks are used as part of the electric circuit, in the manner to be described. In other systems, as, for example, Hall's railway signal system, the wheels of the train operate a mechanical "circuit maker" or "breaker" which causes the desired movements of the signals.

THE UNION SWITCH AND SIGNAL ELECTRO-PNEUMATIC BLOCK SYSTEM.

In the block system of the Union Switch and Signal Company, one of the methods of signaling employed is a combination electric and pneumatic system.

In Fig. 373 are shown, theoretically, the electrical circuits and connections of this system as arranged for one track of a double track road. In the figure the position of the armatures of the relays and magnets, and the position of the semaphores, in four different blocks, are shown as they would appear in practice under the conditions described further on.

Compressed air is employed to effect the downward movement of the semaphores against the weight of a counter poise. The compressed air is conducted from compressors placed at suitable points along the road, by a large pipe, indicated as *r*, Fig. 373, to reservoirs *r*, as shown at *A*, from which it is conducted by smaller pipes to air chambers on the posts supporting the semaphores. The electrical portion of the system is utilized to open valves which admit the compressed air into the air chambers.

The semaphores, of which there are two at the entrance of each block, are placed one below the other on the supporting post. The upper semaphore is square at its end and is painted red. The lower semaphore is fish-tail shaped and is painted green. The upper one is termed the "home" semaphore; the lower one, the "distant" semaphore.

FIG. 372 a.

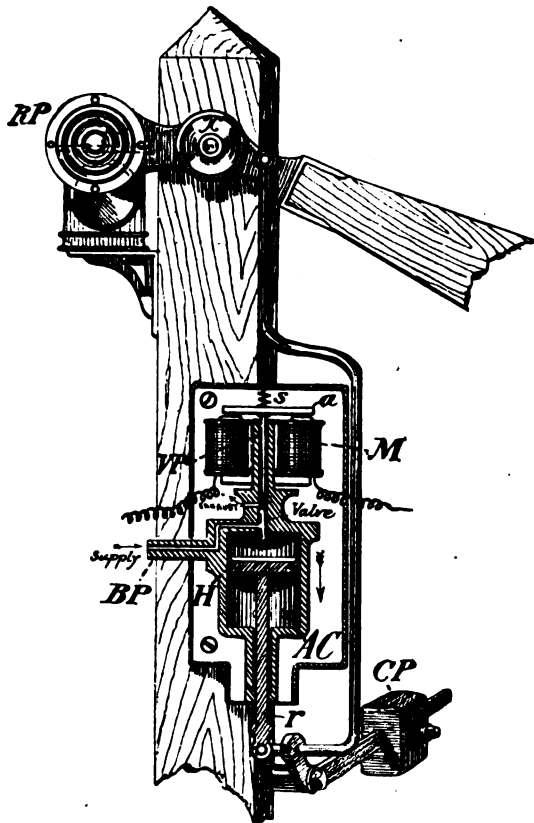

When both semaphores are set at right angles to the supporting post, as at C, in the figure, it is an intimation that a train is on the "block" guarded by those semaphores, and when thus set they are said to be in the "danger" position.

When the "home" semaphore is down, or at "safety," while the "distant" semaphore is up, or at "danger," as at B, it is an intimation that a train is one block in advance of that post, and when thus set the signal is one of "caution."

When both the "home" and the "distant" semaphores are down, as at A and D, they are said to be at "safety," and in this position it is an indication to the engineer that, for at least two "blocks" in advance, the track is unobstructed.

The arrangement of the apparatus of this system is such that whenever any part of the electrical connections becomes impaired the semaphores are automatically "set" in the danger position. As the description proceeds the manner in which this result is accomplished will appear.

Each semaphore (*see* also Fig. 372*a*) is pivoted at x on its supporting post and it is furnished with a counterpoise cp , which, when not prevented from so doing, tilts the semaphore at right angles to the post.

Each semaphore is equipped, on its short end, that is its left end in the figure, with a circular glass pane, rp . In the case of the upper semaphore the color of the glass is red, for danger; that of the lower, or distant semaphore, is green, for caution. At night, lamps are placed in such positions on the post that, when both semaphores are at "safety," two white lights are shown, one above the other. When both semaphores are at danger, a red light is shown above a green light. When the upper, or home, semaphore is at safety, and the lower, or distant, semaphore is at right angles to the post, a green light is shown below a white light, signifying "caution." These results, it will be readily understood, are due to the simple fact that, when the semaphores are at right angles to the post, the colored glasses rp on the ends of the respective semaphores are interposed between the lamps and the observer.

A view of one semaphore, with a portion of the air chamber cut away for purpose of illustration, is shown in Fig. 372*a*. The air chamber ac in which the piston head h with its rod r , works, is placed on the post below the semaphore which it operates. A branch pipe bp , leading from the reservoir (r Fig. 373) is led into the air chamber, from which, however, it may be cut off by a valve rod vp , within the air chamber, which valve rod is held in control by the armature a of an electro-magnet m . The valve rod is attached as shown, to the armature a . On the lower part of the valve rod is a small *port* through which, when the armature is attracted, air passes, from the branch pipe bp , into the chamber. This compressed air acts on the piston head h and depresses it. The piston rod r , being attached, at its lower end, to a rod connecting with the semaphore, as outlined in the figure, it follows that the act of depressing the piston head lowers the semaphore to the safety position.

When the air pressure is removed, as it will be when the armature a is withdrawn by its spring s , and the "supply" port hole is again closed, the counterpoise cp , will raise the semaphore to the danger point; the air remaining in the air chamber escaping at the "exhaust" port.

As already stated, for a portion of the electrical circuits required in the opera-

tion of this block system, the iron rails of the tracks are used. For another portion separate wires are employed. The rails of one block are insulated from those of the

FIG. 373.

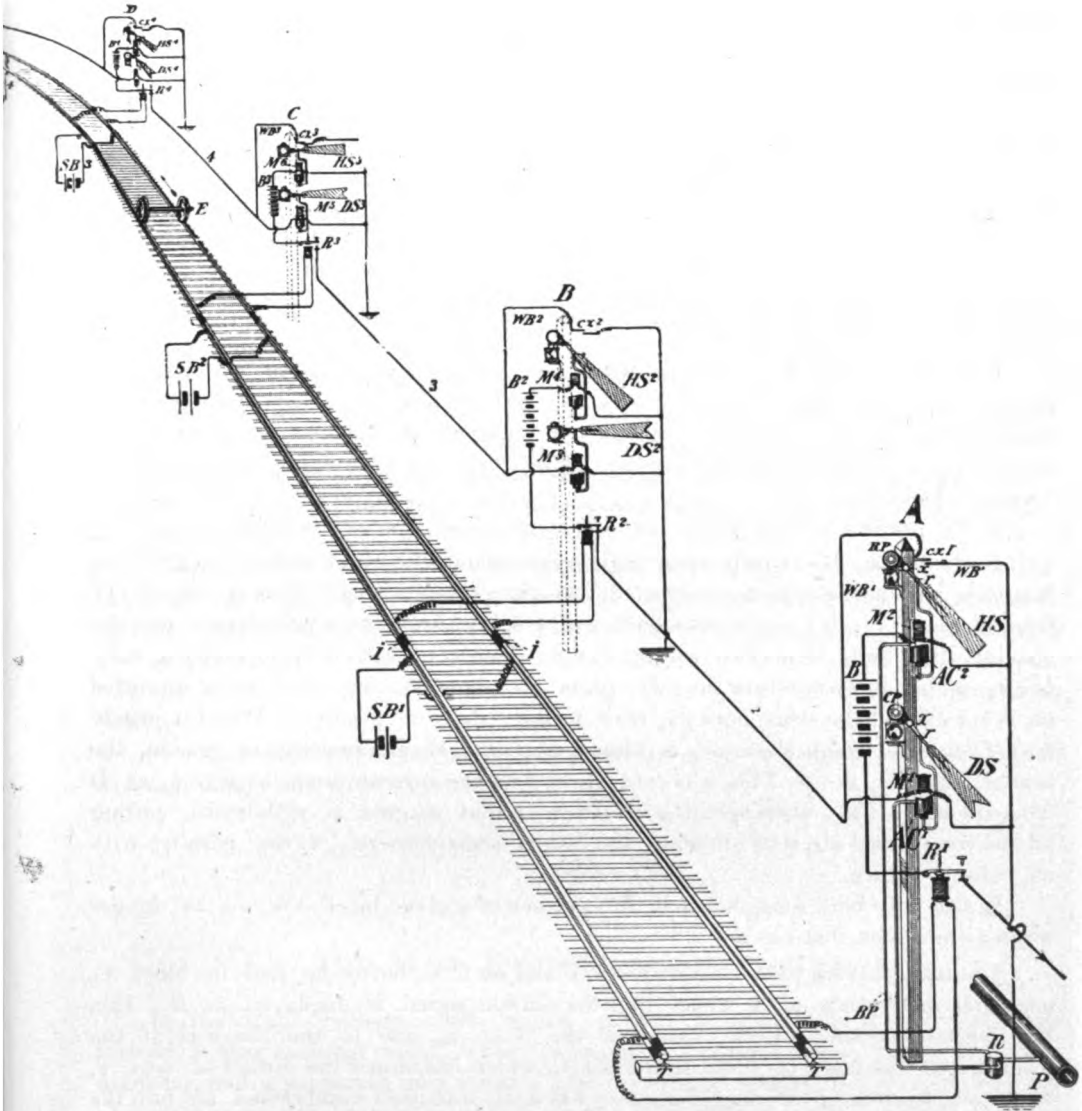

ELECTRO-PNEUMATIC RAILWAY SIGNALS—THEORY—UNION ELECTRIC SYSTEM.

next block by the insertion of an insulating medium between the end rails at the dividing points of the blocks, as at 1,1, in Fig. 373, in which T,T are the rails. To insure a thorough connection between the rails of each block a piece of galvanized iron wire is connected by a rivet, across the fish-plate, or junction plate, of each rail.

A small battery SB of two cells, "gravity," is connected to the rails as shown; one such battery for each block. In each block a relay R_1, R_2, R_3, R_4 , is inserted into the circuit formed by the rails. As long as the "block" in which any relay is placed, is clear, as at A, B and D, current from battery SB flows through it, and holds its armature on the "front" stop. When the track is short-circuited, however, as by the wheels E of an engine or car, as shown between C and D, Fig. 373, the current is diverted from the relay and its armature is withdrawn by its retractile spring.

It may be seen that a circuit, via wire 3, from the earth at C to the earth at B, includes a large battery B_3 , the magnet M_6 at C, the magnet M_5 at B, and the armature of relay R_3 . A branch wire WB_3 leads from wire 4, via a circuit closer cx_3 , which latter is so placed as to be closed when the home semaphore HS_3 is at right angles to the post, and to be open when that semaphore is at "safety."

A circuit similar to 3 formed partly by wire 2, passes through magnet M_4 at B, battery B_2 , the armature of R_2 magnet M_1 at A, to ground; and a branch wire WB_1 leads from wire 2 at A to circuit closer cx_1 .

In the same manner a similar circuit (and branch wire) connects one block with the next, throughout the system. Normally, these circuits are closed, and the branch circuits WB_1, WB_2 , etc., are open, in consequence of which, magnets M_1, M_2 , etc., are closed, the valves in the air chambers are open, and the semaphores are forced to a "safety" position.

In the practice of this system the home signal rises first and falls first.

In the figure, the wheels of an engine E are assumed to be on block C to D. This, it is seen, has short-circuited, or diverted, the current from small battery SB_3 at D, from magnet, or relay R_3 , in consequence of which its armature is withdrawn, thereby opening the circuit, formed by wire 3, at R_3 . This permits, first, the opening of magnet M_6 , which, in turn, closes the valve of its air chamber, whereby the compressed air is cut off, and the semaphore HS_3 rises to the "danger" position. When it reaches this point the circuit closer cx_3 is closed, as shown, short-circuiting, to ground, the branch wire WB_3 at C. This, it is evident, diverts the current from battery B_4 at D from the magnet M_5 , whereupon the armature of that magnet is withdrawn, cutting off the compressed air, thus allowing the distant semaphore DS_3 to rise parallel with HS_3 , also as shown.

In this way both semaphores at the entrance of a given block are set at danger when a train is on that block.

The train having passed out of block B and on to C, but being still in block C, one block in advance of B, we see that the caution signal is displayed at B. This has been accomplished by the closing of the relay R_2 , due to the removal of the wheels from the track of block B to block C, which has closed the circuit of wire 2, which act, by closing the magnet M_4 at B has again admitted compressed air into the air chamber at M_4 , thereby depressing semaphore HS_2 . The distant semaphore DS_2 at B, however, which had been raised to danger, by the short wire WB_2 which had been closed at cx_2 by the semaphore HS_2 , still remains up, owing to the fact that the circuit 3 of magnet M_3 is now open at relay R_3 at C, and, consequently, the valve controlled by M_3 is still closed.

The engine E having passed out of block B into C, and being now two blocks in advance of A, the circuits of relays R_1 and R_2 , and magnets M_1 and M_2 , are all closed; hence the valves of air chambers AC_1 and AC_2 are open, and the semaphores at A have been forced to "safety."

The batteries used for this system are kept, when convenient, in any adjoining building, but, otherwise, in a vault beside the track

The rails of the track, when the distance is not too great, are found to possess sufficient insulation to work the system in all weathers; but the heavy "escapes" necessitate the use of a low electromotive force on the rail circuits. This use of the tracks in connection with railroad block signaling was introduced by Mr. F. L. Pope.

When this system is arranged to set the signals at "danger" when a track switch is opened, the operation of the switch "short-circuits" the relay R of whichever block it may be in, with the result just stated.

THE UNION SWITCH AND SIGNAL "CLOCK" SYSTEM OF BLOCK SIGNALING.—There is another method of electrical block signaling known as the Union Switch and Signal Company's clock system, which may be described briefly.

In this system a rotating disc in place of a semaphore, is used. The disc is given a tendency to rotate in one direction by a heavy weight suspended in the hollow of the supporting post. This weight actuates clock-work which, when permitted to do so, gives the disc a motion equal to one quarter revolution. The disc shows "white" on one side, and "red" on the other.

The clock work is released by the opening of a relay as a train enters the block practically as in the manner already described in the case of the electro-pneumatic system. The act of opening the relay releases the clock-work, which turns the disc to "danger" until the train moves off the section, when the closing of the relay permits the clock-work to make another "step," which "turns" the disc around to "safety."

The mechanism employed in this service is especially arranged and constructed to act promptly and without jarring.

THE HALL RAILWAY SIGNAL SYSTEM.

In the Hall railway block signal system a semaphore is not used, but instead, a disc, enclosed within a case, is employed. The case is about 3 feet in diameter, and is supported on a suitable post. The disc consists of a light ring of aluminum across which a piece of fine, red silk is stretched. The apertures in the sides of the case are glazed to correspond in size and shape with the disc. A lamp is placed outside of the case, at the side remote from the disc. At night the lamp is held directly behind the disc; during the day it is dropped below it to permit daylight to enter the case. The post and case is shown in connection with the Stewart-Hall "train order" signal.

The disc *D* and electro-magnet *EM*, which operates it, are shown within the case *C* in Fig. 374, one side of the case being cut away for the purpose of illustration. In the figure the disc is shown as at safety; it having been turned to that point by the action of the electro-magnet, which instrument and the manner of its operation will be more clearly understood by reference to Fig. 375. In that figure *EM* is the electro-

FIG. 374.

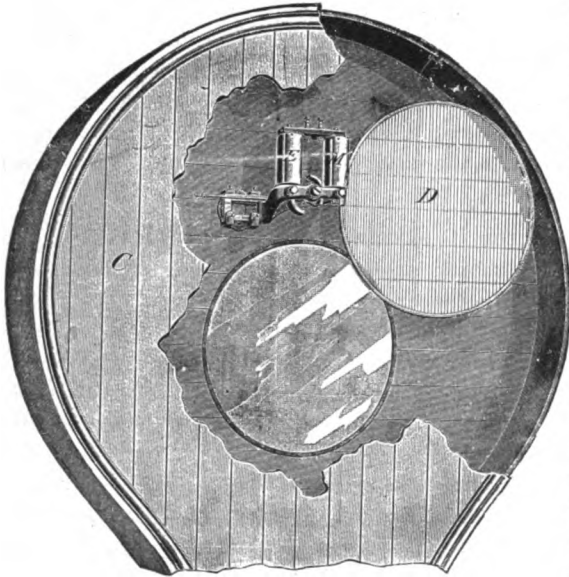

magnet, *A* its armature and *D* the top of the disc. The armature is pivoted at its center. The electro-magnet has curved pole-pieces *P*, *P'*. The armature is of peculiar construction, as may be seen, having two rounded "wings" *w*, *w'*. The disc is rigidly attached to one of the wings. A rod *R*, which acts as a partial counterpoise to the disc is connected to the other wing. When the electro-magnet is not magnetized the disc drops by gravity and the danger signal is shown. This is the position of the disc in Fig. 375. When the circuit is completed and the electro-magnet is magnetized the wings of the armature are attracted, up and down respectively, by their pole-pieces,

which causes the armature, as a whole, to be turned, with the result that the disc is removed from before the aperture of the case. As long as current is caused to flow through the coils of the magnet the disc will be held out of the way of the aperture. When the current ceases to flow, the disc, as just stated, drops by gravity.

A diagram of the circuits of the Hall signaling system is given in Fig. 376. As already stated, the changes from "open" to "closed" circuit are made in this system by the use of so called "track" instruments, which, upon the passage of a train, open the circuit at the entrance to the block, and close it at the end of the block. The instrument at the entrance is termed the "block" track instrument; that at the end of the block, the "clear" track instrument. In Fig. 376, *BT* is the "block" track instrument, *CT* the "clear" track instrument. *EM* is the disc magnet, *D* the disc. *R* is a magnet, or relay, the office of which will be explained. *B* is the working battery. The connections between the "block" and the "clear" instrument are made by wires *w*, *w*, strung on poles alongside the track. The relay *R* may be placed at any point along the route of the block. Normally, the contacts *c* at the "block" instrument are closed. At *CT* the contacts *c'* are normally open. At such times *EM* and *R* are in the one circuit, part of which is completed through the armature *A* of *E*. Consequently, the disc *D* is at "safety"; the armature of *EM* being attracted. When a train enters the block, the wheel of the engine depresses one end of the "track" instrument *BT*, which raises a piston *P* in such a manner against the spring contacts *c* as

to separate them. This has the effect of opening the present circuit of EM and R. The result is, the disc D falls to "danger," and the armature A of R drops, opening the circuit at a second point x. After the train has passed BT the piston P falls down, permitting the contacts c to come together again. But now the circuit passing through EM is still broken at x; thus the disc remains at "danger." When the engine reaches CT, which may be placed somewhat beyond the end of the block, it depresses one end of the lever L', raising the piston P', which, in this instance, closes the contact springs c'. This completes a circuit through the relay R, via wires w,w. This attracts armature A, thereby again completing the circuit through EM and R; but, inasmuch as there are now two circuits for the current, and as the one through R, via wires w,w, has much less resistance than that through EM, the latter still remains open, holding the disc at danger. When, however, the last car of the train passes over the "clear" track instrument CT, it resumes its former position, opening the circuit at c' again, whereupon a larger portion of current traverses the magnet EM, which is again magnetized, and attracts its armature, placing the disc at safety.

By this arrangement, if the battery fails, or if any of the connections wear out, or the wires break, the disc sets itself, automatically, at danger. Or

FIG. 375.

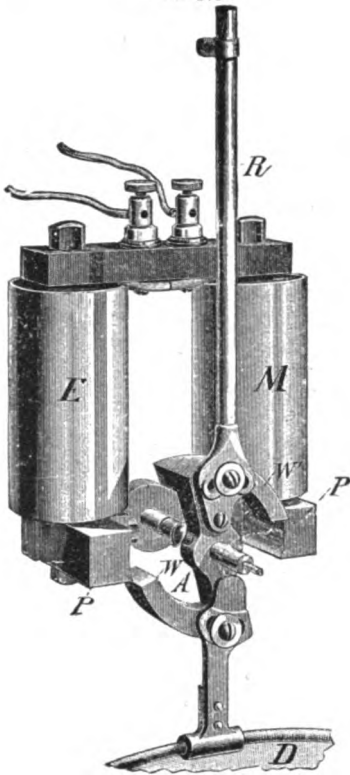
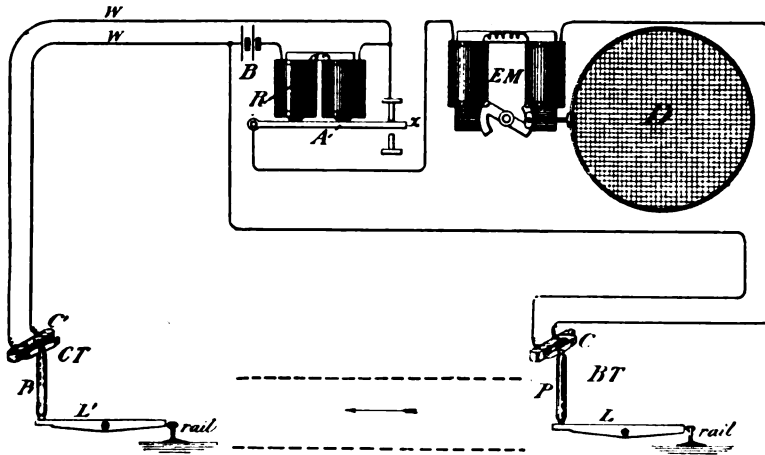

FIG. 376.



HALL RAILWAY BLOCK SYSTEM—THEORY.

if the wires w,w become crossed, that will, by diverting current from EM, place the signal at "danger" also.

The relay R and the magnets are placed in any suitable place.

One of the "track instruments" is shown in cross section in Fig. 377. In this, r is the rail, L is the lever, fulcrumed at x . p is a piston, contained within the upright

FIG. 377.

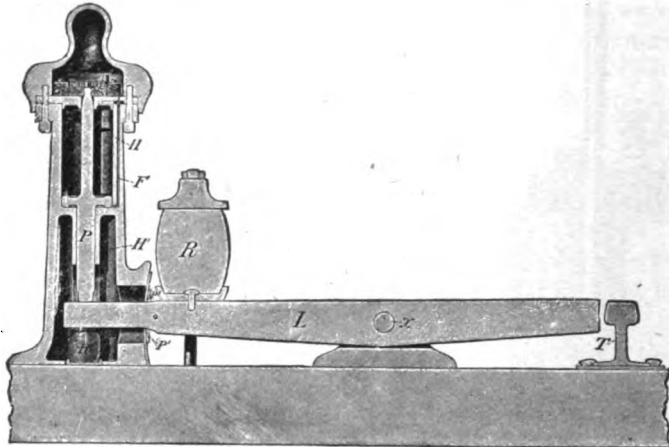

HALLS TRACK INSTRUMENT.

tube. R, R' are india-rubber "buffers" above and below the lever, placed there to ease the up and down motion due to the action of the wheels, and also to prevent anything short of a heavy weight from moving the lever. Normally, the end of the lever at the tube is down, owing to the greater weight of that end. The up and down motion of the piston P is retarded by the air within the tube, which acts as a cushion. The tube, or cylinder, is divided into an upper, middle and lower portion, which are connected by a small air port at r . Consequently, as the piston begins to rise, the air in the upper part passes into the lower chamber. But when the piston rises sufficiently to cover the hole h there is no further escape for the air out of the upper chamber and it therefore acts more quickly as a stopper of the piston. On the other hand, when the piston falls, the air which is driven through the *port* hole also acts as a cushion, retarding the fall. The amount of this air pressure is regulated by a valve. The lower end of the lever L moves in a closed chamber h' . The opening through which the lever L enters the chamber is kept closed by the slide plates $P'P'$ which move up and down with the lever.

FIG. 377 a.

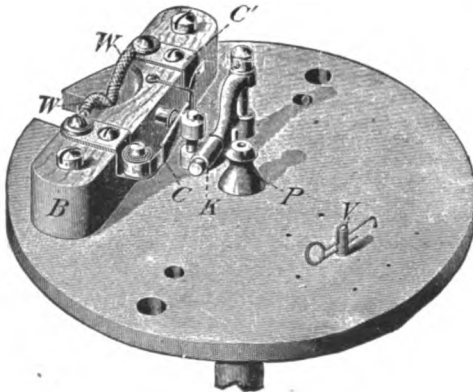

The manner in which the piston tends to operate the electrical portion of the circuit is shown in top view, Fig. 377a.

Here P is the top of piston; w,w are the wires of the circuit, connecting with the contact springs c,c'. When the piston is raised it pushes the key κ over so that the springs, in this case, are brought together and the circuit completed. In the "block" track connections the strip c may be placed between the insulating block B and the contact c' so that, when the piston is raised, the contacts are separated, as in the case of "break" track instruments. The screw v controls the valve by which the air pressure is regulated.

When switches occur in a "block," the levers connected with the switch are caused to operate a set of contacts properly enclosed, which operate the disc signal in a manner similar to that of the "track" instrument.

HALL'S ELECTRIC RAILWAY SIGNAL FOR CROSSINGS.

By the aid of two track instruments, electric circuits, and a method of "interlocking" magnets, a gong is caused to ring at railway crossings on the approach of a train, and is stopped automatically by the same train, after it has passed the crossing.

FIG. 378.

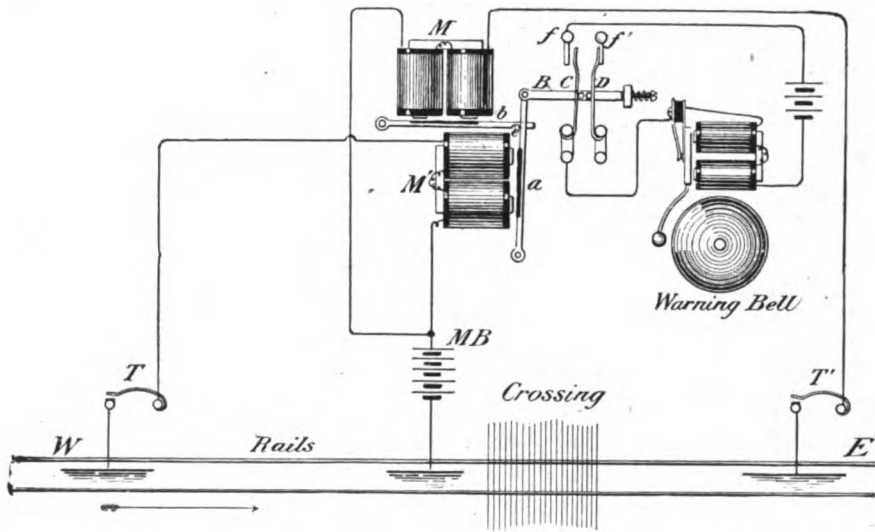

HALL'S RAILWAY CROSSING SIGNAL.

The interlocking magnets and circuit connections for this purpose are shown in Fig. 378. M,M' are ordinary electro-magnets provided with armatures a, b as shown. One end of armature lever b of M passes through a slot c in the armature lever of M'. A bar B is pivoted at the upper end of a in the manner shown. Two flat springs c,c' pass near two pins projecting from B. Near the upper ends of these springs are two contact f,f' to which latter the terminals of a local circuit are brought. At rest these contacts are separated, as in the figure. Contacts f' in this figure being idle, when the armature a of M' is withdrawn a pin on B pushes flat spring D against f'. When the armature a is attracted contact is made at cf and broken at df. At the same time, the end of the armature b of M, which is cut away at c near the end, on the inside,

falls down and "locks" the armature of m' so that, even should the latter magnet be demagnetized, armature a cannot be retracted until the magnet m is magnetized, and thus, by attracting its armature, (thereby unlocking armature a ,) permits it to recede.

The interlocking magnets and "warning" bell and batteries are located at the crossing. The figure shows the circuit arranged for trains coming from west to east, (w to e) as indicated by the arrow. The track instrument τ' , whose office is to cause the warning bell to ring, may be located at any desired distance from the crossing. The track instrument τ' , which causes the ringing to cease, is placed at a point sufficiently far removed from the crossing to permit the longest trains to pass before the bell ceases.

A wire composing the circuit which passes through m' , leads, from the ground at τ , to the contact points in the track instrument, thence to the ground at the crossing; or, if desired, a metallic circuit may be employed, instead of a "ground" at each end. Another wire leads from the track instrument τ' to the magnet m , thence to "ground," at the crossing. The battery MB serves for both track instrument circuits, as only one is used at a time. When the instruments are at rest this battery is open.

The operation of the apparatus is as follows:—On the arrival of a train at the track instrument τ , the circuit through m' is completed. This magnetizes that instrument and causes it to attract its armature a . This action forces the flat strip c against the contact f , which completes the circuit of the gong magnet. This circuit is arranged on the well-known plan of the "call bell" or "buzzer" circuit; consequently, as long as the contact at $c f$ is maintained the gong will ring; which, since a is now locked by b , will be until the train, after passing the crossing, reaches the track instrument τ' at e , when the circuit through m will be completed by the operation of that instrument. This then magnetizes m which attracts its armature b , thereby unlocking armature a , which falls back, allowing the contacts $c f$ to separate, breaking the gong circuit at that point.

OVERLAPPING SYSTEMS OF AUTOMATIC BLOCK SIGNALS.

The term "overlapping" is applied to those systems in which the signals, operated by a train as it enters a section, are placed at a considerable distance behind the entrance of that section. A plan of one such overlapping system is shown in Fig. 379, in which four sections of one track of a double track road are shown. The rails are used as part of the circuit, as in the case of the electro-pneumatic system, previously described.

The semaphore (or the disc signal) for each section is placed about twelve or fifteen hundred feet from the entrance of the section which it is to guard. For example, Fig. 379, the signal for section B is set about the middle of section B, and so on.

Thus, assuming a train to be moving in the direction of the arrow, when it enters section B it will short-circuit the relay b , thereby setting the signal b at danger, thus showing the officials of any other train that the immediately preceding section (B) is occupied. When the train arrives at section C and leaves the rails of section B, the signal d' is set at danger, while signal b is restored to "safety," by any suitable

means, such as pneumatic pressure or magnetic attraction. In this way each signal is caused to overlap its own section.

FIG. 379.

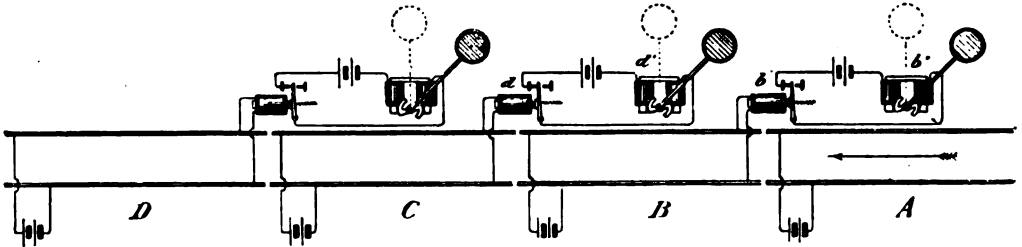

OVERLAPPING BLOCK SIGNAL SYSTEM.

The overlapping system is also applied to single track roads in a practically similar way to that just described; signals being placed on each side of the track to indicate from which direction trains may be approaching.

THE SYKES SYSTEM OF BLOCK SIGNALING.

The "Sykes" system is of the manual-electric order, as distinguished from the systems previously described, which are mainly electro-mechanical in their action.

The "Sykes" block system is in use in England and is also employed in this country.

The signals used in this system are of the double semaphore pattern, which signals are actuated by means of levers, by an operator located in an adjoining tower. The towers are connected by wires for telegraphic intercommunication. Normally all signals in this system are set at "danger" and, when thus at danger, the levers are locked by the armature of a magnet, the latter being in a circuit controlled by the operator in the tower in advance. Consequently, when a signal is placed at danger it cannot be set at safety until the operator in the tower in advance presses on an instrument termed a "plunger" which opens the circuit in which the locking magnet is placed. The operator in the "forward" tower will not plunge for the "tower" behind him until all trains have passed out of his block. Similarly the operator in each tower has control of the block behind him.

When an operator in one tower has "plunged" to allow a train to enter his block, that act locks the lever of the semaphore controlling the block in advance so that he cannot set his own signal clear for the approaching train until he has telegraphed to the tower in advance to plunge for him.

The construction of the "plunger" is such that when it has been plunged once it cannot be plunged again until the lever controlling the signal has been completely reversed and then restored to its normal position. Thus, for instance, when B plunges to allow A to admit a train he cannot repeat the operation until he first reverses his own lever and thereby clears the signal for C's train to proceed. This, however, re-

quires the consent of the "tower" in advance of B, namely C, who controls the lock to B in the same manner that B does to A".

As the operator in the first tower A of this block system has not any one behind him to "plunge," thereby to necessitate the placing of his own signal at "danger," a portion of the track opposite, or near, the tower is insulated, and made a portion of a circuit which latter controls a relay and magnet in such a manner that when a train enters the insulated section it automatically sets A's signal at danger. Hence, when A wishes to place the signal at safety he must first ask the tower in advance to "plunge," that he may do so.

The operators in the different towers communicate telegraphically, (over the wire referred to) with each other, by "bell" taps, a certain number of taps signifying, "plunge," "OK," etc.

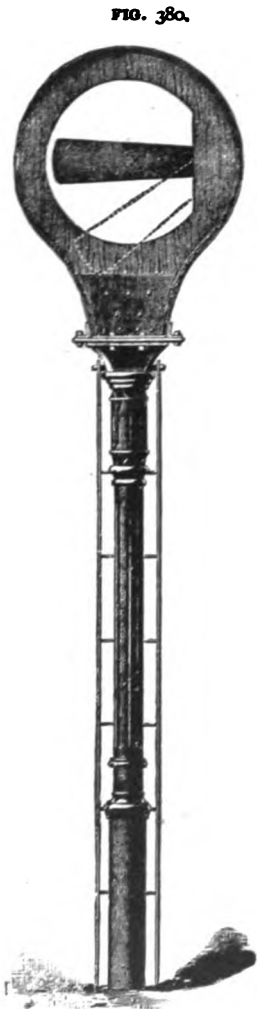

TRAIN ORDER POST,

In connection with the Hall railway signal system, a recent device, termed a "train order" signal, has been introduced. One of its objects is to hold trains at any station where an order may be awaiting them. The "train order" semaphore is shown in Fig. 380. The Hall disc might be used if desired.

The train order signal posts are designed differently from the ordinary semaphore, or disc, posts, in order that the train men may be apprised of the exact reason for the display of the stop, or danger, signal.

The electrical connections of this device are outlined in Fig. 381. The switch *s* annunciator *A* and battery *B* may be located in a station. The semaphore *s'* and electro-magnet *x*, are in the signal post case.

Ordinarily the circuit is completed through the switch *s*, and the annunciator magnet, and thus the signal is held at "safety" by the action of its magnet. When, however, the station agent or operator has an order for an approaching train he moves the switch in such a way as to break the circuit, which action permits the counterpoise *CP* of the semaphore to raise it to danger, as shown in Fig. 380. The opening of the circuit also permits the annunciator drop to fall which, it will be seen, opens the circuit at a second place, viz. *x*, and it also reveals the words "train order," as shown at the right of Fig. 381. The object of this latter arrangement is to assist the station agent or operator in remembering that he holds a train order for a particular train which it does by making it necessary on his part, in order to reset the signal at safety

THE "STEWART-HALL" TRAIN ORDER SIGNAL.

not only to move the switch back to its normal position, but also to push back the

FIG. 381.

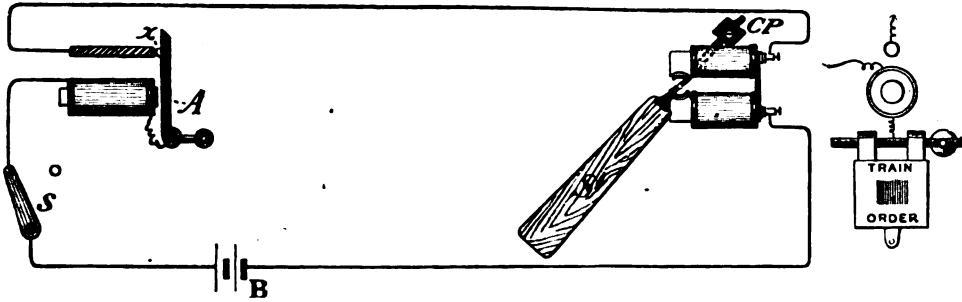

STEWART-HALL TRAIN ORDER SIGNAL.

“train order” annunciator. In practice the annunciator boxes are marked “west bound,” “south bound,” etc.

TRAIN SIGNALS.

Many electrical devices have been tried to take the place of the bell cord on trains but the latter still, almost exclusively, retains its place.

The objections to the use of electrical devices for the purpose of permitting train men to communicate with the engineer have been that when, in the operation of such devices, “open circuits” have been used, frequent occurrences of short-circuits, whereby false signals have been turned in, have resulted; and, when closed circuits have been employed, the rapid wasting of the battery necessitating constant attention, has militated against the system.

A system of train signaling known as the “Hart” train signal has been devised to obviate both of these objections. It is shown in Fig. 382. It is, in effect, a combination of the open and closed circuit systems of train signals.

In the figure, *c* is a large signal bell of high resistance. *c'* is a small signal bell, or buzzer, of low resistance, both located in the cab of the engine. *A* is a switch, within easy reach of the engineer. *B* is the operating battery, which is placed under the engineer’s seat. Press buttons, with double contacts, are located in each car, as at *P, P, P*, for operating the call bells.

The system requires three wires, 1, 2 and 3, as shown. Ordinarily, as in the figure, the device is set for the open circuit arrangement. When thus set the depression of any of the buttons will complete a circuit, via the wires 2 and 3, through the large bell *c*, ringing it.

Should the circuits 2 and 3 become crossed or short-circuited at any point, as at *x*, a circuit is formed through both the signal bells, but as the resistance of bell *c'* is

much less than that of *c*, the signal is only received on *c'*, which indicates to the engineer the presence of trouble on the circuit. He then turns switch *A*, which puts the battery on closed circuit, via the wires 1 and 3, and cuts out bell *c'*. It also places the large bell *c* in the battery circuit, but the circuit formed by wires 1 and 3 shunts that

FIG. 382.

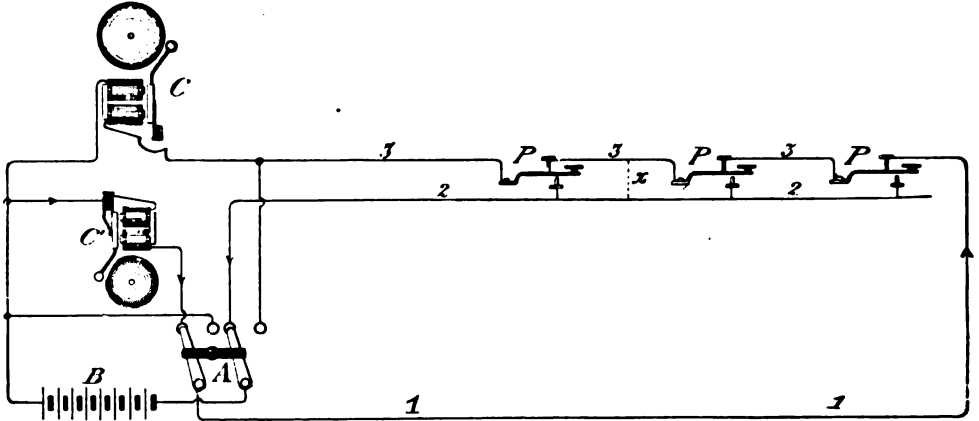

"HART" TRAIN SIGNAL.

bell. When, however, any of the buttons are depressed the shunt circuit 1 and 3 is opened, thereby permitting all the current to flow through the large bell *c*. Thus this arrangement affords opportunity for the removal, at leisure, of the "cross" between wires 2 and 3.

The coupling used in connecting the wires between the cars has knife-edge sliding contacts. The "coupling" is so arranged that when pulled apart it joins together the wires 1 and 3 and leaves wire 2 open. When the coupling is "made," wires 1 and 3 and 2 pass, separately, through it.

Since the foregoing was written (1892) some changes have been made in the arrangement and operation of the semaphores, and in the connections of the track circuits of many of the roads more recently equipped with block signaling apparatus. It is, of course, desirable, where possible, to dispense with the two- or three-inch iron pipe used to convey the compressed air in the pneumatic system, together with the expense of the compressor plant, etc. To this end different signal companies are availing of electric motors to bring the semaphore blades to safety against gravity. Wooden poles for sustaining the semaphores are being generally displaced by hollow iron poles, in an enlarged base of which are placed the electric motor and battery. Iron rods within the poles communicate motion from the motor to the semaphores. In the Union Switch and Signal Company's system the iron rods *RR'* are raised by the engagement of a pivoted toe *t* (on the end of an arm *aa'* which extends from the lower end of the rod) with a knob on a sprocket-chain *hh'*, which is rotated vertically by the sprocket-wheel *s*, which is operated by motor *M*, through wheel *c'* and pinion *p*, as outlined in Fig. 382*a*. In this figure the rods *aa'* are shown in

shown at c. One terminal t of these circuits is connected to the wheels of the engine, the other terminal t' is attached to one of the trucks of the tender, which truck is insulated. TT' and relays RR' each have two armatures, as indicated. The armatures of RR' are really pole-changers for batteries BB'. When no trains are on a block, relays TT' are closed by track batteries $b\delta$, and at such times circuit of battery B, for instance, is completed via lower armature of R to lower armature of T, to line wire x , to upper armature of T' (T' being closed, as said), to and through relay R', to rail, to upper armature of R back to B. When an engine passes from a regular

FIG. 3826.

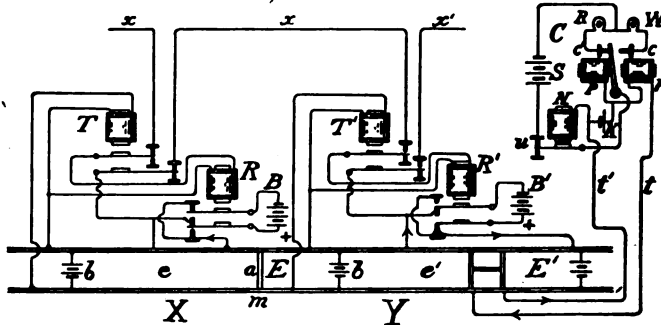

MILLER CAB SIGNAL.

block to a short block, a circuit is provided from battery B or B' through the cab circuit. The direction of current at this time (assuming no engine on block ahead) is such that the armature A of a polarized relay P is attracted to contact c , completing a circuit through a white lamp w and a 5-cell battery s. When, however, an engine is on the block E, as at m , track relay T' is short-circuited and its armature contacts are open as in figure. When at this time also an engine passes from block E' to short block e' , the wheel of locomotive and wheel of the tender together bridge, by means of terminals $t t'$, the space between the said blocks, and current from B' traverses the cab circuit and polarized relay P in an opposite direction, and armature A is drawn against contact c' , putting the red lamp R instead of white lamp w in circuit with battery s, as in figure. As long as the track ahead is clear, therefore, the white light is continuously shown, and when the red light is shown it continues to burn until the engine passes into a "clear" block, inasmuch as relay P remains on the contact on which it is last placed, until a current in reverse direction passes through it. Small battery K comes into play when the cab circuit to the track is broken. Normally its current passes through both coils of P equally, but when the circuit on either side is broken it passes through but one coil. When circuit to track is open the red light is shown. When circuit to small relay N is broken that relay opens, opening both lamps at u , in either case calling for attention. Battery K, consisting of one cell, does not materially affect the operation of batteries B B'. The front insulated joints of the short blocks are set at such a distance apart that one or other rail maintains contact between the rail terminals $t t'$ of the cab circuit as required. It will be observed that inasmuch as line wire x' is open at the lower armature of T', the line-wire circuit extending to and through the pole-changing relay to the right of R' (not shown in figure) will also be open, reversing its respective battery. In this way the block behind that on which a train is passing is also guarded.

CHAPTER XXXI.

OVERLAND TELEGRAPH WIRE.

IRON AND HARD-DRAWN COPPER WIRE.—MANUFACTURE OF, ETC.—MECHANICAL TESTS

AT FACTORY.—CONDUCTIVITY TESTS.—WIRE GAUGES, etc.

Until within a few years past, iron was almost exclusively used for "overland" telegraph wires, although it was well known that copper possessed electrical qualities far superior to iron. But the former high price of copper, added to inherent mechanical defects, combined, for years, to keep the latter metal out of the market, as a competitor of iron for such purposes.

On this point the following language from an advertisement which appeared in an electrical periodical in 1868, may be quoted: "The superiority of copper as a conductor, over other metals, is well known, and but for its ductility rendering its permanent suspension in a pure state impracticable it would always have been used on telegraph lines."

The tensile strength of "soft" copper is about one-tenth that of iron. The ductility of soft copper is such that it becomes attenuated by its own weight between poles; and having no elasticity, when elongated it has no tendency to resume its previous form. As an electrical conductor, copper is seven times better than iron. Again, self-induction is much less marked in copper than in iron; thus, apart from its superior conductivity, copper is better adapted for rapid signaling than iron.

There is no comparison as between copper and iron in the matter of durability under exposure to, and without artificial protection from, the elements. Indeed, copper may be said to be, under ordinary atmospheric conditions, practically incorrodible; whereas it is known that iron even when protected by galvanizing, will succumb to the attacks of moisture and acids within ten or twelve years; in some places in less than one year, as, for instance, in the vicinity of factories and railroad yards. Copper wire, exposed to the same conditions, simply takes on a coating of oxide and soot and is not further attacked.

About 25 years ago the price of copper was at least 10 times greater than iron. More recently, however, the discovery and development of large deposits of comparatively pure copper in this country conduced to a very material reduction of the cost of that metal, and a marked improvement in the manufacture of copper wire also soon followed.

This improvement consistéd in providing a wire known as "hard-drawn" copper wire, of much greater purity, and one possessing a much higher tensile strength, than

formerly ; although the added strength was obtained at the cost of pliability, which however, is not found to be seriously, if at all, detrimental.

Prior to this improvement in the manufacture of copper wire, an effort had been made to provide a telegraph wire which should have the strength of iron and much of the conductivity of copper. This resulted in the production of a "compound" wire of iron or steel, and copper, many miles of which were strung in this country. In some instances the copper was placed over the iron wire by electrolytic deposition ; in others, by placing the copper, in strips, spirally around the steel core, the edges being run together so that the seams were not perceptible.

Siliconized copper wire and phosphor-bronze wire were also introduced for the same purpose, but neither these, nor the compound wire, has, in this country, given anything like the satisfactory results obtained by the use of hard-drawn copper wire, which is doubtless explainable by the fact that the tensile strength given to hard-drawn copper wire, in the process of "drawing," having been found ample for the purpose of overland lines, it was evident that it would possess, practically, all the mechanical advantages of the compound wire and siliconized wire, with, in addition, superior electrical qualities. Its cost also, is probably below either of the foregoing mentioned wires.

In some instances it was found that the durability of the compound wire was impaired by a separation of the two metals.

In silicious bronze wire, which is an alloy of copper and tin, the silicon is mainly used to aid in the removal of impurities, especially oxides and sub-oxides, and is not intended as a part of the alloy. The tensile strength of silicious bronze wire is somewhat greater than that of hard-drawn copper, but the former appears to lose in conductance as it gains in tensile strength. Silicious bronze wire has been somewhat extensively used in Europe, but in this country it has not been employed, other than experimentally, for telegraph purposes.

In the year 1884 the extensive employment of hard-drawn copper wire for overland telegraph purposes was begun in this country.

Although some misgivings were felt that the experiment, (for such its employment at first was conceded to be), would meet with failure, yet the advantages to be derived from its use, if it should prove successful, were so numerous, and decided, that the experiment was tried, and with such abundant success that to-day, in this country, it may be said that copper wire for overland telegraph lines is rapidly superseding iron. Indeed, iron wire is now, by some companies, only employed on new lines as a means of strengthening the lines.

This successful use of copper has apparently shown that the high percentage of elongation always formerly called for in the specifications for telegraph wire was unnecessary ; the percentage of elongation of hard-drawn copper wire not exceeding, on an average, 2.5 per cent. and in many cases falling below .5 of 1 per cent., without any marked prejudicial results following.

THE MANUFACTURE OF IRON AND COPPER WIRE.

The iron mostly used in the manufacture of wire is Swedish iron. It is brought to this country in the shape of pig iron, which, after passing through various processes to remove impurities is rolled into rods of any desired size. It is then prepared for the process of "drawing," by which it is made into wire. This preparation consists of first thoroughly cleansing the rods by washing, or "pickling," them in acids, after which they are covered with a flour paste, which is then dried hard by baking in an oven. The process of "drawing" consists of pulling the rods, while cold, by powerful machinery, through a steel die, in the manner indicated in Fig. 388. In the figure,

FIG. 383.

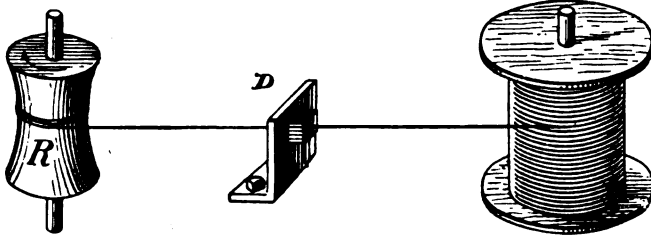

WIRE DRAWING.

D is the die, *R* is a revolving drum, around which the wire is wound as it comes attenuated through the die. The rod is started through the die by filing the end for a short distance, when a clamp is attached to it. This clamp is fastened to a chain, and

the latter to the drum *R*. *R* is revolved by machinery not shown in the figure. The drawing is repeated until the wire is reduced to the desired size, a smaller die being used at each drawing. During the drawing process the wire becomes hardened and, consequently, it is necessary to anneal it between each drawing, and as the drawing wears off the flour coating, the wire must be re-coated between each drawing. It is said to be a curious fact that the wire in passing through the die does not come into contact with it at all, the flour acting also as a lubricant.

The dies are made of the hardest obtainable steel or specially prepared cast iron.

When iron wire has been drawn to the size required it is then annealed to the desired degree of softness. Each coil of the wire is then carefully inspected by the workmen to detect flaws or defects of any kind; coils containing which are rejected.

The next process to which the iron is subjected is that of galvanizing. This consists of covering the wire with a thin coating of zinc. The object of this is to protect the iron from rusting, that is, from oxidizing. This the zinc does by combining with the oxygen of the air and thus forming a covering of oxide of zinc over the wire, which is not further assailed by air, unless in the presence of a gas, such as sulphuric acid gas, set free from burning coal, etc., when the acid combines with the oxide of zinc, forming sulphate of zinc. The latter, being soluble in water, is soon washed off the wire, leaving the iron to be quickly attacked by the oxygen of the air, and in a short time corroded.

It is very essential that the surface of the wire should be chemically free from all impurities, such as sand, scales, cinder, oxides, etc, before it is galvanized, otherwise the zinc will not properly adhere to the iron. To insure this essential, the wire is again "pickled" by immersion in a vat containing a solution of dilute sulphuric acid, for from six to twenty-four hours, after which it is flushed in water to remove the acid.

To still further cleanse the iron it is immersed in muriatic acid which removes oxides that form (after the pickling process) when the wire is exposed to the air.

The act of galvanizing the iron wire consists in momentarily immersing the wire in a bath of molten zinc. One of the methods employed for this purpose is shown in Fig. 384. The wire is brought on reels to the vicinity of a sort of oven κ ,

FIG. 384.

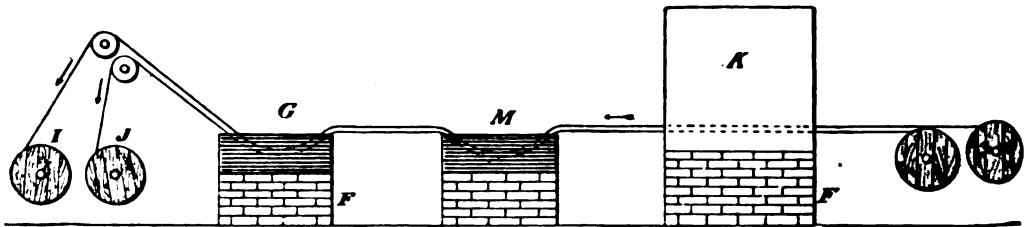

GALVANIZING IRON WIRE.

which has, running through it, horizontally, a number of fire brick tubes, which are kept at a white heat by a furnace F , extending under the oven. M is a trough containing a solution of muriatic acid. G is a bath of molten zinc. The zinc is kept "boiling" by a furnace under the trough. Several reels of wire may be run simultaneously through the tubes of κ . The wire in passing through these tubes at a moderate rate of speed becomes heated to redness. On its exit from its tube the wire falls into the acid, where all traces of grease, oxides, etc., are removed, and the next moment the wire passes through the molten zinc and emerges therefrom galvanized.

The wires are automatically wound on the reels I, J , after leaving the zinc bath.

The iron being heated to a high temperature in passing through the tubes any acid that may adhere in passing through the solution is at once evaporated and the distance between the acid vat M and the zinc bath G is so short that but little time is given for the iron to oxidize. It is very important that the zinc should be kept at a fixed temperature; the best results are said to be obtained with a bath heated to about $740^{\circ} F$.

The effectiveness of the galvanizing is tested, generally, as follows: A piece of the galvanized wire is immersed for one minute in a saturated solution of sulphate of copper. The affinity of the sulphuric acid of the salt for zinc is well known. The effect of this immersion is that some of the zinc combines with the sulphuric acid of the sulphate setting free copper. When iron is immersed in such a solution the copper is set free on the iron. The foregoing action is repeated three or four times, as may be called for in specifications. If at the end of the fourth immersion there is no appearance of a copper deposit on the wire thus repeatedly immersed, but, on the contrary, it remains black, as after the first immersion, the galvanizing may be considered effective. The presence of a copper deposit would indicate that the iron had become exposed and that, consequently, the galvanizing was imperfect.

Copper rods are prepared for drawing into wire in the same general way as iron. The manner of drawing the copper rods into wire and that wire into still finer wire is

also similar to that by which iron is "drawn." When, however, the copper wire is intended to have a high tensile strength it is not annealed so frequently between the different drawings as in the case of iron.

Experiments have shown that the ductility of copper wire decreases as its tensile strength increases, but the experiments were not continued to an extent sufficient to show the exact ratio. A specimen of copper wire, thoroughly annealed, .128 inch in diameter, was found to have a tensile strength of 330 lbs., and elongated 36 per cent. A sample of the same wire, on being drawn twice, to reduce its diameter to .104 inch, had a tensile strength of 330 lbs., and elongated 23 per cent. Another specimen, from the same piece, on being drawn thrice to bring it to the same diameter, namely .104 inch, was found to have a tensile strength of 415 lbs. and elongated but 3 per cent. Still another specimen from the same wire, drawn four times to reduce it to .104 inch, had a tensile strength of over 550 lbs. and elongated but 1 per cent. The average of a number of like experiments indicated that, in obtaining an elongation of 2.5 per cent. to 3 per cent., a reduction of 130 to 140 lbs. in the tensile strength would follow.

The term "hard drawn" is applied to distinguish the unannealed from the annealed copper wire; the only difference between soft copper wire and hard drawn copper wire being that one is annealed after drawing while the other is not. The process of drawing the wire through the die forms a thin, hard, polished crust, or shell, not exceeding the one thousandth of an inch in thickness, over the wire. Inside of this crust the metal is, seemingly, comparatively soft. The tensile strength of hard drawn copper wire appears to rest in this outside shell, for the slightest indentation made around the circumference of the shell with a sharp instrument will at once lower its breaking strain; and while, with an undented surface, the copper wire may withstand 5 or 6 bends on itself, with such a dent it will break in one bend.

WIRE JOINTING AT FACTORY.—At one time it was quite customary to require, in specifications for telegraph wire, that the wire should be delivered in continuous lengths of one half mile or more, *without joints*. This was when it was the habit to make the large twist joint (shown Fig. 420). In ordering hard drawn copper, also, the same requirement was inserted; the "sleeve" joint being then used. The objections to such joints were that the tensile strength at those points was considerably less than that of the main wire; that they retarded the work of uncoiling the wire in the act of stringing, and that, when the wires were strung, the joints frequently, by engaging with parallel wires, caused steady crosses, which would otherwise have been but momentary wind crosses. Hence, it was very desirable to reduce the total number of such joints, to a minimum.

As it is not an uncommon occurrence for wire to break in the act of drawing, the matter of jointing such broken wires in such a manner as to avoid the objections referred to, was one which received much attention from the manufacturers, and various attempts were made to weld the joint, mechanically, without materially increasing its bulk, or decreasing its tensile strength; but only with indifferent success. Of late, however, electric welding has been resorted to, for this purpose, with marked satisfactory results. In making joints, or welds, by this process, the ends of the broken wires are brought together, and are fastened to separate clamps. Wires connected with a dynamo machine are brought to these clamps, and a very strong current is then caused to pass through the tips of the broken wires, which speedily produces a heat sufficient to form a perfect union between them. For ordinary telegraph wire the time of application of the current is but a fraction of a second, but the time of application of the current, the extent of the wire exposed between the clamps, and the pressure with which the ends are brought together, varies with different wires. Welds made in this way have scarcely a perceptible burr, and tests have shown that the tensile strength of the weld is practically similar to that of the wire proper.

MECHANICAL TESTS OF TELEGRAPH WIRE.

The purchasers of copper and iron wire almost invariably have it inspected by a representative, at the factory, in order to ascertain before acceptance of the wire, whether it meets the requirements of the specifications.

The mechanical tests to which iron and copper wire are subjected and the manner in which the tests are made are practically as follows:

TESTS FOR GAUGE OR DIAMETER.—The diameter of the wire is generally stated in the specifications as so many mils.

In drawing long lengths of wire through the dies in the manner previously described, it very seldom happens that the wire is of exactly uniform diameter throughout. It is generally slightly thicker near the ends than in the middle. This is supposed to be due to a gradual clogging up of the die hole at the beginning of the drawing, which clogging seems gradually to disappear and thus the die hole resumes its normal size towards the end of the drawing. The disparity, however, between the ends and the middle of the drawing is not ordinarily very great, not amounting to over 1 or 2 mils, at most. But, to guard against a too marked discrepancy between the various parts of the wire, the coils are "gauged" at the ends and center by means of a "micrometer," or other suitable gauge.

WIRE GAUGES.—In this country and Great Britain the diameter of wires is measured in mils. The diameter of insulation of wires in "32ds" of an inch. There are nearly 31.2 mils in the $\frac{1}{32}$ of an inch.

In order to distinguish the different sizes of wires it has been customary to designate wires of specified diameters by a given number of an arbitrary gauge. Thus a wire having a diameter of .083 inch, that is, 83 mils, would be No. 14 Birmingham wire gauge, or B.W.G. One having a diameter of .080 inch would be No. 12 Brown and Sharp, or B and S, gauge, and wires ranging from a few mils to an inch in diameter, have been classified in those "gauges," in numbers ranging from 1 nought (o), 2 nought (oo) 3 nought (ooo) etc., up to 36 and 38. The smallest wires being allotted the highest numbers of the gauge, and vice versa. (*see* wire tables).

Since the numbers of the gauge only include wires of 40 or 42 different diameters, it is plain there will be many sizes of wires in use, and necessary, which do not coincide with any of the many arbitrary gauges. The various wire gauges also differ very materially from each other and much confusion is, consequently, occasioned.

These causes have led many large users of wire to designate the size of the wire desired by its diameter in mils, or by the square of the diameter in mils, which is termed circular mils, or by its sectional area in square inches. Sometimes by its weight per mile, disregarding altogether any reference to the arbitrary wire gauges.

For instance, if a wire measuring 83 mils in diameter is desired, it may either be designated as a wire 83 mils diameter; or as one of .005567 square inches, cross section.

Instruments for measuring the diameter of wires, or for at once ascertaining the gauge of a wire in terms of some one of the numerous "standard" wire gauges, are also termed "wire gauges."

A specimen of one of the latter is shown in Fig. 385. It is known as the "American standard wire gauge." It consists of a thin, flat, circular piece of metal, having

indentations, or slots, on its periphery, as shown. Each of those indentations is numbered, as in the figure. The apertures of the various indentations are of a size corresponding with the diameter of the wire of a certain number of the Brown and Sharp wire gauge. Consequently, when it is desired to know the gauge of a wire, in terms of the Brown and Sharp gauge, without being any wiser as to the actual diameter of the wire, unless by reference to a Brown and Sharp wire gauge table, the said wire is placed sideways into the apertures, or openings, on the edge of the wire, as at *x* until it reaches the aperture closely fitting it, when reference to the figure stamped on the disc will indicate the number of the wire in the Brown and Sharp gauge.

FIG. 385.

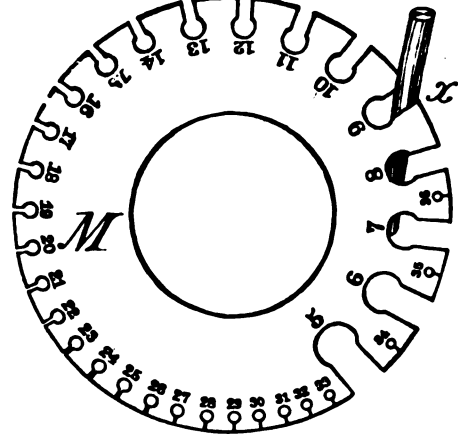
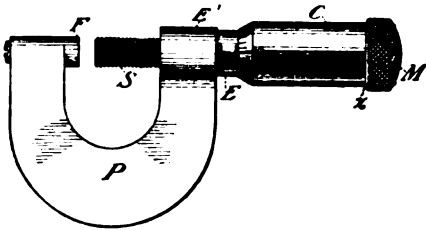

Fig. 386 represents a "micrometer," or "pocket," wire gauge. It is constructed to measure from the one thousandth of an inch up to its maximum capacity; which may be $\frac{1}{2}$ inch, one inch, or more. The manner of its construction and use is as follows: The instrument is made of polished steel. The screw *s* is attached to the milled cap *M*, at the point *x*. *c* is a sleeve, over *s*, also rigidly attached to the cap *M*. The left end of sleeve *c* is bevelled, as shown, and on this beveled edge 25 horizontal, short, equal divisions are cut. *F* and *E* are extensions of the U-shaped metal piece *P*. A hole having a thread suitable for the screw *s*, runs lengthwise through *E* and *E'*. A number of vertical divisions are cut, as shown, on the extension *E*; also one horizontal line. When the screw *s* is screwed into the thread until it meets the extension *F* the sleeve *c* covers the extension *E*, up to the perpendicular mark, *o*. The threads of the screw are so arranged that in one revolution of the screw it moves to

FIG. 386.



MICROMETER WIRE GAUGE.

or from the extension *F*, the .025 of an inch, that is, the one fortieth of an inch. The perpendicular marks to the right of zero on *E* are so arranged that, starting from zero, each of them measures one complete revolution of the screw. Thus, when the screw has made one revolution from *F* the zero mark on the sleeve *c* will be opposite the horizontal mark on *E*, and the bevelled edge of *c* will be opposite the first perpendicular mark to the right of zero, on *E*. Consequently, a wire which would fit into the opening between *E* and *F*, when zero on the bevelled edge of *c* rests directly over the first vertical mark from zero, on *E*, will have a diameter of 25 mils. Each of the other perpendicular marks on *E* will also indicate that the screw has travelled an additional 25 mils. Now, since the bevelled edge of *c* travels with the screw, being rigidly attached to it at *M*, any fraction of the 25 mils between the vertical marks on *E*

or from the extension *F*, the .025 of an inch, that is, the one fortieth of an inch. The perpendicular marks to the right of zero on *E* are so arranged that, starting from zero, each of them measures one complete revolution of the screw. Thus, when the screw has made one revolution from *F* the zero mark on the sleeve *c* will be opposite the horizontal mark on *E*, and the bevelled edge of *c* will be opposite the first perpendicular mark to the right of zero, on *E*. Consequently, a wire which would fit into the opening between *E* and *F*, when zero on the bevelled edge of *c* rests directly over the first vertical mark from zero, on *E*, will have a diameter of 25 mils. Each of the other perpendicular marks on *E* will also indicate that the screw has travelled an additional 25 mils. Now, since the bevelled edge of *c* travels with the screw, being rigidly attached to it at *M*, any fraction of the 25 mils between the vertical marks on *E*

will be indicated by the horizontal marks on the edge of *c*. For instance, in the figure there are five perpendicular marks exposed. Therefore, up to the mark under the figure 1, on *E*, which stands for 100 mils, the screw will have made four revolutions, and the space between that mark and the bevelled edge indicates that it has performed part of another revolution, and the extent of that part of a revolution is shown to be $\frac{1}{10}$, since the tenth division on the bevelled edge is opposite the horizontal mark on *E*.

In other words, a wire which would fit snugly into the space between *s* and *r* while the gauge is in the position stated, would have a diameter of one hundred and ten one thousandths of an inch.

TEST FOR TENSILE STRENGTH OR BREAKING STRAIN.—A sample, about 16 inches

FIG. 387.

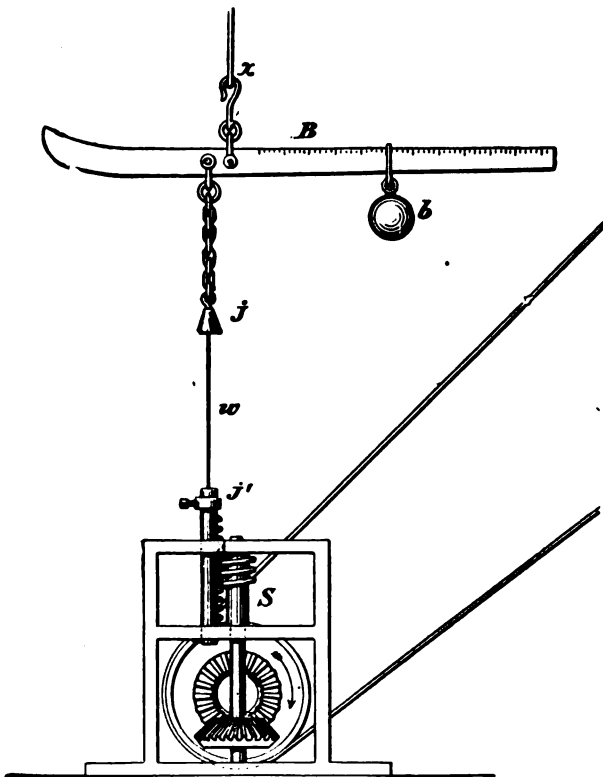

TESTING FOR TENSILE STRENGTH.

in length, is taken from the ends of a coil. Each bundle, or coil, of wire may be tested, if desired, but as this would be a very arduous task in the case of very large lots one coil in about ten may be selected. The specimens of wire actually tested may be any determined length; generally a piece 10 inches long is specified.

One form of apparatus for making this test is shown in Fig. 387. It consists of a beam and scales *B*, suitably supported at *x*; a screw *s* and a means for turning the screw up or down. Sometimes this consists of a crank; at other times a belt and pulley is provided, as shown in the figure. The wire *w* to be tested is placed in the jaws *j* and *j'*. Care must be taken to see that, while the jaws hold the wire rigidly

they do not cut it in any way. The exact length of wire to be tested should be placed in the jaws so that when everything is ready for the test the jaws of the machine will be just 10 inches apart. The machine should then be slowly started and always at as nearly a uniform rate of speed as possible, for each sample tested. The screw in descending puts a pull on the wire and this tends to raise the scale end of the beam, just as if a weight had been attached to the jaw *j'*. To meet this pull and to bring

the beam back to a balance the bob *b* is moved along the scale. This is continued until the wire breaks, when the number of pounds indicated on the scale is noted. This will be the tensile strength of the sample.

TEST FOR ELONGATION.—The test for elongation or, in other words, the stretching qualities of the wire, is partly arranged for while the wire is in position for testing for breaking strain. The wire just outside of the jaws having been carefully marked with a pencil, after the wire has broken and its breaking strain has been tested the fractured ends of the wire are placed as closely together as possible and the length of the wire from mark to mark is measured. From this measurement the percentage of elongation may be readily calculated. For example, if, after breaking, the length of the wire is found to be 10.1 inches, the percentage of elongation would be 1 per cent.

TESTS FOR DUCTILITY.—Tests for ductility are made in at least two ways. One of these is illustrated in Fig. 388. In this *v* is a stationary vice, supported on a table. *v'* is a vice, or clutch, capable of being rotated by the wheel, or crank *κ*. The wire *w*, generally six inches in length, is placed, as shown, in the jaws of the vices, which are then tightened. In some cases a streak of ink is placed on the upper surface of the wire. The vice *v'* is then rotated by means of the crank *κ*, at a uniform rate of speed, until the wire breaks. The number of twists which the wire has withstood will have been equal to the number of complete turns of the wheel, or the twists may be ascertained by counting the spiral now formed by the ink streak.

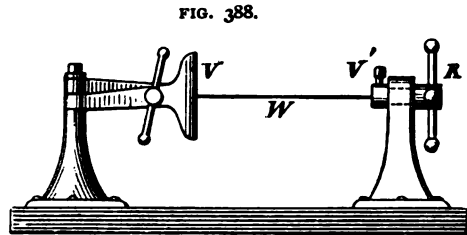

DUCTILITY TEST.

This test is sometimes varied by bending the wire back and forth upon itself. For copper this test is perhaps more valuable than the twist test, since it shows how many bends and kinks it is likely to withstand without breaking. For making the latter test a device somewhat resembling a lemon squeezer, without the receptacle for the lemon, has been used. The "squeezer" is first laid open, when the wire is placed upon it and clasped there. The device is then closed and opened until the wire breaks. (See specifications for wire.)

WIRE TESTING FOR RESISTANCE AND CONDUCTIVITY.

In the natural state, iron and copper are found, mixed more or less, with oxides carbon, arsenic, phosphorous, etc., to remove which impurities is the object of the various refining, smelting and hammering processes to which the metals are subjected, but not always entirely successfully, by the manufacturers.

As stated elsewhere herein, electrical resistance is the converse, or reciprocal, of conductance. Whatever, therefore, tends to increase the conductance, diminishes the

resistance of a conductor, and contrariwise. A very small percentage of either of the named, or other impurities, in iron or copper, has a marked effect in reducing the electrical conductance of these metals.

Matthiessen and Holzman, who examined particularly the effect of foreign substances in copper, placing the conductivity of silver at 100, and hard drawn copper at 93.08, found the percentage conductivity of

Copper containing	2.5 per cent. phosphorous	to be	7.24
"	" .48 per cent. iron	"	34.56
"	" traces arsenic	"	57.80
"	" 1.22 per cent. silver	"	86.91
"	" 3.5 per cent gold	"	65.36

from which it is seen that a very small percentage of foreign substance affects largely the conductivity of copper, even when the foreign substance is, itself, a better conductor than copper. Iron and other conductors are affected analogously.

It also happens, sometimes, that the conductivity of conductors is decreased by imperfect treatment in the course of wire drawing, etc., and from both of these causes, namely, the presence of impurities in the metals and imperfect manufacture, occasional batches of defective wire result.

To detect any wire that may be defective, as well as to ascertain the exact specific conductivity of the wire, electrical tests are mainly resorted to. The terms, specific conductivity and specific resistance of a material, refer, of course, to the conductivity and resistance of that material, as compared with some standard; as analogously, we speak of the specific gravity of a substance—meaning its gravity as compared with an equal bulk of water, etc. In the case of copper wire the standard is pure copper, which is considered as having a conductivity of 100. The specifications for copper wire intended for electrical purposes, often referred to as commercial copper, generally call for a material having a specific conductivity of 96 or 98, or a conductivity equal to 96 per cent. or 98 per cent. of that of pure copper. For example, if it is known that a wire of pure copper of a given diameter has a resistance of 5.76 ohms per mile, at 75° F., a commercial copper wire of the same diameter, required to have a conductivity equal to 96 per cent of pure copper, should have a resistance of 6 ohms, per mile, at the same temperature.

This will be clear when it is considered that, conductance being the converse, or reciprocal of resistance, the conductance of the pure copper wire will be $\frac{1}{5.76}$, while that of the commercial wire is but $\frac{1}{6}$. It is then apparent that $\frac{1}{6}$ is 96 per cent. of $\frac{1}{5.76}$.

For the purpose of ascertaining the percentage conductivity of wires, samples of the wires, one-fiftieth or one-hundredth of a mile in length, are usually chosen and tested for resistance; a method frequently employed being that of the Wheatstone bridge. The lengths mentioned are chosen to facilitate the calculations, and this is evidently an object when hundreds of samples may have to be tested.

The Wheatstone bridge* and other apparatus, and the connections for such tests, are outlined in Fig. 389. In the figure R and R' are the adjustable arms of the bridge. B is the adjustable rheostat, with coils ranging from 1 ohm to 4,000 ohms. T and T' are the points to be brought to equal potentials for a balance. X is the unknown resistance, in this case the wire to be tested, which is connected at T' and W, and is coiled

* Fully described in Chapter VIII.

around an insulated support *D*. *B'* is a battery. Keys *κ κ'* are inserted in the galvanometer and battery circuits, respectively. *G* is a Thomson reflecting galvanometer. If very accurate results are not required a detector or tangent galvanometer may be used in the bridge wire. The Thomson reflecting galvanometer is described in a separate chapter. It may be added here that the beam of light should rest on the zero of the scale when no current is flowing through its coils. It may be brought to zero by manipulating the directing magnet *M*, for which purpose an endless screw is conveniently provided on the instrument. The sensitiveness of the needle to currents in the coil may be increased by raising the magnet *M*, and decreased by lowering it.

FIG. 389.

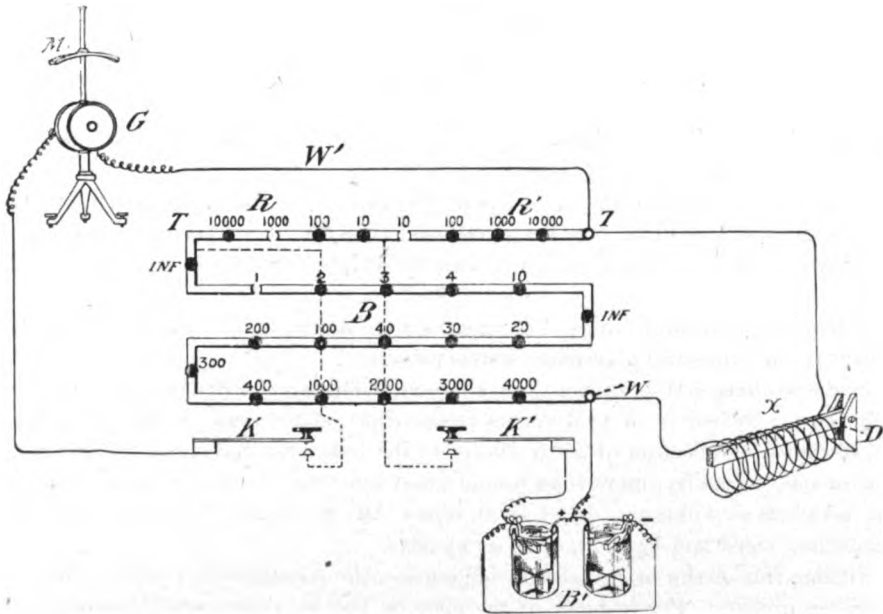

For measuring pieces of wire of very low resistance, the 10,000 ohm coil of *R*, and the 10 ohm coil of *R'* of the bridge arms are used. This, of course, gives a ratio of 1,000 to 1. Or a ratio of 100 to 1 may be obtained by using the 1,000 ohm coil in *R* and the 10 ohm coil in *R'*. In making the test the wire is coiled around the support *D*, care being taken not to permit the coils to touch each other. If the approximate resistance of the wire to be tested is known, the ratio of the arms *R, R'*, may be arranged accordingly, and a resistance may at once be placed in *B*, equal to the approximate resistance. The depression of *κ'* places the battery in circuit, that of *κ* the galvanometer. Key *κ'* is depressed first and then key *κ*. A shunt around the galvanometer may be used if, at first, the deflection is too large. The keys are depressed at intervals, and resistance inserted in *B* until a balance is secured at *T, T'*, that is, until the galvanometer is not affected by the depression of the keys. If the approximate resistance is not known, it must be ascertained by experiment; by inserting and removing resistance until a balance is obtained. In the latter case the result is facilitated by "shunting" the galvanometer with the $\frac{1}{2}$ shunt, until an approximate resistance is found.

An instance of the practical utility of this testing arrangement is to be found when measuring the one-hundredth part of a mile of wire, (the ratio of the arms R, R' of the bridge being as 1,000 to 10, or as 100 to 1), in which case the resistance inserted in the rheostat B to procure a balance, while, in reality, one hundred times greater than the resistance of the piece of wire x , is, at the same time, the actual resistance of one mile of the same size of wire. To explain: Assuming that the resistance thus inserted in B is 10 ohms. The resistance of x is, therefore, one hundredth of this, namely $\frac{1}{10}$ ohm. But, as x is only the one hundredth part of a mile in length, it is necessary to multiply $\frac{1}{10}$ by 100 to get the resistance for one mile, which, of course, brings the figures back to 10 ohms. The resistance, per mile, having been thus ascertained, the specific conductivity of the wire may be calculated by a comparison of its resistance with that of pure copper or iron wire, as the case may be.

To get the best results in the foregoing tests the resistance of the galvanometer coils should be very low, and a battery of one or two cells, having low internal resistance, should be used. Two gravity cells, joined up in multiple, as shown in Fig. 394, will, as a rule, suffice for such tests.

If the sample to be tested is not connected directly to the bridge box terminals, the connecting wires should be very large, in order that their resistance may be neglected, or, otherwise, their resistance should be ascertained, and deducted from the results of tests.

When it is impossible to get an exact balance by the aid of any of the coils of the rheostat B , the following plan may be availed of.

Suppose that, with 9 ohms in the adjustable rheostat, and with the arms of the bridge *even*, a deflection of 10 divisions to the right on the scale is obtained, and that, with 10 ohms, a deflection of 20 divisions, to the left. In that case, the resistance of the wire x is, evidently, more than 9 ohms, and less than 10 ohms, that is, it is $\frac{1}{10}$ of an ohm, in excess of 9 ohms, or $\frac{2}{10}$ of an ohm less than 10 ohms. In other words, the resistance is 9 ohms and $\frac{1}{10}$ of an ohm, or $9\frac{1}{10}$ ohm.

If the arms of the bridge should be uneven, the resistance in B must be divided by the proper divisor. For instance, if the ratio be 100 to 1, the actual resistance of x would be, in the case just cited, .0933 ohm.

CORRECTIONS FOR TEMPERATURE. The electrical resistance of metal conductors varies with the temperature of the metal; the resistance increasing as the temperature rises, and vice versa. It is, therefore, important to note the temperature of the room at the time of testing. The test should not be made until the wire has been in the test room long enough to acquire its temperature. The variation of resistance, due to temperature, is not the same for all conductors, but is approximately so for pure metals.

Matthiessen found by experiment that the resistance of pure copper increased at the rate of about $\frac{2.1}{10000}$ for each degree Fahrenheit increase of temperature. Thus, if a wire at 60° F. has a resistance of 6 ohms, at 61° it will measure $6 + (6 \times .0021)$ ohms = 6.0126 ohms. The same wire at 62° F. will measure $6.0126 + (6.0126 \times .0021) = 6.025$ ohms, and, at 63° F. the same wire will measure $6.025 + (6.025 \times .0021) = 6.038$ ohms; the rate of increase, it will be seen, and as pointed out by Culley, being similar to that of money at compound interest, the degrees F , corres

ponding to the number of years in the former. As it would be onerous to calculate, in this way, the corrections for variations of temperature, tables of co-efficients, or multipliers, are made up, based upon the increase in unit resistance for a certain number of degrees variation of temperature. For example, the increase of resistance for 1 ohm for 1° F. increase temperature would be 1.0021; for 2°, $1.0021 + (1.0021 \times .0021)$, which is equal to 1.0021×1.0021 , or, 1.0021 squared. For 3°, the increase would be 1.0021^3 , and so on. Consequently, since the increase for 1 ohm is as stated, the corrected resistance for, say, 3° increase of temperature, in a wire measuring 6 ohms, would be $6 \times 1.0021^3 = 6.038$ ohms.

A table for a variation of 20° Fahrenheit is subjoined.

CO-EFFICIENTS FOR CORRECTIONS FOR TEMPERATURE.

1°	1.0021	.9979
2°	1.0042	.9958
3°	1.0064	.9937
4°	1.0085	.9916
5°	1.0106	.9895
6°	1.0128	.9874
7°	1.0149	.9853
8°	1.0170	.9832
9°	1.0193	.9811
10°	1.0214	.9790
11°	1.0236	.9769
12°	1.0258	.9749
13°	1.0280	.9728
14°	1.0301	.9708
15°	1.0323	.9689
16°	1.0345	.9666
17°	1.0367	.9646
18°	1.0389	.9626
19°	1.0411	.9605
20°	1.0433	.9585

To correct from low to high temperature take the co-efficient in the left hand column opposite the degrees representing the difference between the observed resistance and that to which it is desired to correct to, and multiply the observed resistance by that co-efficient. To correct from high to low apply same rule but using right hand column of co-efficients.

As the resistance increases with increased temperature and decreases with decreased temperature the left hand column of figures should be used when it is desired to correct from a lower to a higher temperature; if from a higher to a lower temperature the right hand column should be used.

The right hand column of figures represents merely the "reciprocals" of those on the left, advantage being taken of the fact that, to multiply by the reciprocal of a number is equivalent to dividing by that number.

Where strict accuracy is not required the following formula will give an approximately correct co-efficient for commercial copper, namely: $1 + (.0021 \times 1^\circ)$ where

t° is the number of degrees Fahrenheit between the observed temperature and that to which it is desired to correct the resistance for temperature.

If it is desired to correct the observed resistance to a higher temperature, the observed resistance should be multiplied by the co-efficient; if from a higher to a lower temperature the observed resistance should be divided by the co-efficient. Thus assuming a certain wire to have at 60°F . a resistance of 6 ohms, and that it is desired to correct it to 70°F . The difference in degrees being 10, the co-efficient would be $1 + (.0021 \times 10) = 1.021$; hence, the corrected resistance of the wire in question would be $6 \times 1.021 = 6.126$ ohms. Similarly the co-efficient for any ordinary number of degrees variation of temperature may be obtained.

WEIGHT PER MILE OHM.—The standard for telegraph and telephone wires in this country is a cylindrical wire, one mile in length, measuring one ohm, at 60°F . Thus a standard wire of pure copper would weigh, virtually, 871.177 lbs.; a standard wire of pure iron about 4,000. This is termed the ohm mile. From this is derived the expression "weight per mile ohm," or "pound-mile-ohm," a term applied to the product of the weight, per mile, of a wire, multiplied by its resistance, per mile. It is a useful term in several respects. Thus having obtained a "standard" pound-mile-ohm, at a given temperature, for pure iron or copper, it affords a convenient means for calculating the percentage conductivity of a "commercial" wire of either metal. For example. If the pound-mile-ohm for pure copper be 871.177 at 60°F ., and it is found that the pound-mile-ohm of a commercial copper wire is 888.59, at the same temperature, its percentage conductivity will be 98. That is, $\frac{871.177 \times 100}{888.59} = 98+$.

Again. Knowing the pound-mile-ohm of a metal, and having the resistance of a wire of that metal, per mile, its weight, per mile, may readily be determined by dividing the pound-mile-ohm of the same metal, by the resistance, per mile. Or, if the weight, per mile, is known, the resistance, per mile, may be ascertained by dividing the pound-mile-ohm by the weight, per mile.

For instance, if a wire of 98 per cent. commercial copper weighs 200 lbs., per mile, its resistance, per mile, will be $\frac{888.59}{200} = 4.44$ ohms. Or, if the resistance, per mile, of a similar wire is 4.44, per mile, its weight, per mile, will be $\frac{888.59}{4.44} = 200$ lbs.

Again, in testing wire, the weight of the sample or coil may be carefully ascertained and from that, its weight, per mile, may be calculated, from which the "weight per mile ohm" may be obtained, and from that the percentage conductivity. Otherwise the resistance of the wire would first have to be compared with a pure copper or iron wire of the same weight or diameter, per mile, to ascertain the conductivity.

Numerous experiments have been made to determine the exact value of the practical unit of resistance, the ohm. For many years the unit known as the B. A., or British Association unit, was extensively employed. Subsequently another determination of the ohm was made by a committee, authorized by the Paris Congress of Electricians, the result of whose work was the introduction of a unit, termed the Legal ohm, having a value 1.12 per cent. higher than that of the B. A. ohm. In the fore-

going remarks concerning "weight per mile ohm," the B. A. ohm is assumed. The "ohm mile" for pure copper would be, in legal ohms, 861.142 lbs., approximately. Standard resistance boxes are made up in value of legal or B. A. ohms, as desired; the boxes being stamped accordingly.

IRON AND STEEL LINE WIRE.—In view of the foregoing explanations the following trade terms and items concerning iron and steel wire, compiled from Washburn and Moen's pamphlet, will be readily understood.

I. EXTRA-BEST BEST.

II. BEST BEST

III. BEST.

1. "*Extra-Best Best*," by improved continuous processes from very best iron. This grade stands highest of any known telegraph wire in conductance, with a "weight per mile ohm" of from 4,600 to 5,100 lbs. Very uniform in quality, pure, very tough and pliable.

2. "*Best Best*." Less uniform and tough than the above named, but stands a good mechanical test. "Weight per mile ohm," 5,500 to 5,800 lbs. Is largely used by some telegraph companies, and in railway telegraph service.

3. "*Best*." A term almost indiscriminately applied to the lower grades of wire designed for electric service. A harder and less pliable wire, about 6,500 weight per mile ohm.

4. "*Steel*," or homogenous metal, more expressly designed for short-line telephone service, where a measure of conductivity can be exchanged for greater tensile strength in a very light, strong wire, 6,600 to 7,000 weight per mile ohm.

The first named, or "Extra-best best," is almost exclusively employed in the best telegraph service, though there are instances in line construction where long spans call for a wire of greater tensile test strength, and steel is employed for that purpose.

The standard breaking strain of superior galvanized wire is two and one-half times its weight per mile.

CHAPTER XXXII.

UNDERGROUND CONDUITS.—UNDERGROUND, AND RIVER AND HARBOR TELEGRAPH CABLES, ETC.

CABLE TESTING.—ELECTRO-MECHANICAL METHODS OF LOCATING FAULTS IN CABLES., ETC.

UNDERGROUND CONDUITS FOR CABLES.—The evident desideratum in an underground conduit system is the maintenance of the insulation of the conductors placed therein.

This may be accomplished in two general ways. Namely: By using, for the conductors, an insulating covering impervious to gases and moisture; the duct to serve simply as a mechanical protection for the covering. Or, by the employment of bare conductors, or an insulating covering of inferior quality, in a conduit which shall be so constructed and maintained as to provide conditions under which the insulation of the conductors shall remain intact.

The first method requires the construction of a substantial conduit, but one not necessarily water or gas proof. The second requires the construction and maintenance of a conduit which shall be gas and moisture proof—at least the latter.

It thus becomes a question as to whether the expense shall be incurred of providing a conductor insulated with a gas and waterproof material; or of providing and maintaining a conduit, moisture and gas proof.

Of the underground electrical conduits which are now in active operation, there are at least two types. The “solid” conduit and the “drawing in and out” conduit.

The “Edison” underground conduit is an instance of a solid conduit. It consists of a wrought iron pipe, in which, copper rods, forming the conductors, are placed. These conductors are wound with rope, and the pipe is filled with an insulating compound of resin, paraffin, linseed oil, and Trinidad asphaltum. These iron pipes are laid directly in the earth. Once laid in the trench the conductors are practically immovable and can only be got at by digging down to the pipe. Terminal boxes are, however, employed at stated intervals along the route of the conduit by means of which direct access may be had to the conductors, by the removal of a cover.

The drawing in and out conduit generally consists of wrought or cast iron, wooden or cement pipes, placed in trenches. The diameter of the pipes is generally from two to three inches. The method commonly adopted in laying the iron pipes is as follows: The bottom of the trench is first levelled to grade; planks are then set

against the side of the trench to sustain it. A layer of concrete is then laid and rammed in the bottom of the trench. On this is placed a row of iron pipes, (if more than one duct is required), next a layer of concrete, then another row of pipes, and so on, until the desired number of pipes is laid. In order to add strength to the mass and to protect the ducts from mechanical injury, the concrete is applied more thickly on the bottom, top and sides of the conduits, than between the pipes. There is placed, over all, a two-inch yellow pine planking, heavily creosoted, to further protect the conduits against injury from picks, crow bars, etc., in the event of future excavations in the streets.

The iron pipes are joined end to end by a coupling screw joint with a tapering, or vanishing, thread.

FIG. 390.

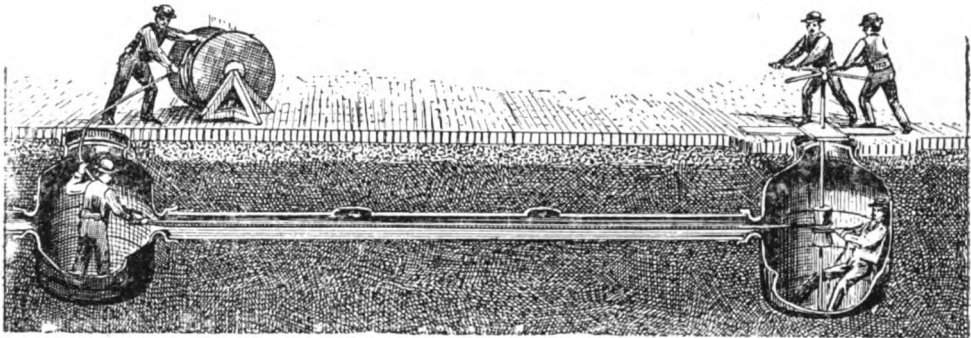

Access is had to the conduits of the drawing in and out system by means of manholes placed at an average distance apart of about one twenty-fifth of a mile. The manholes are generally of brick or cast iron. Access is had to the manholes from the street through a cast iron head, which is provided with double covers.

Into the ducts thus provided insulated cables, or separate conductors, are drawn, from manhole to manhole, by the use of a winch, in the manner indicated in Fig. 390.

When the cable is not very heavy it may be drawn into the duct by hand.

Before the cable can be drawn into the duct a rope has to be passed through the duct by a process termed "rodding." Rods, about three feet in length, with a screw thread and screw socket on their respective ends, are shoved into the duct, one rod after another, until the distant manhole is reached. The work of attaching the rope to a large cable requires considerable skill and care. The connection is generally so made as to put the strain chiefly on the conductors.

In case of a defect to a cable, or a conductor, it is drawn out and another substituted: hence the distinguishing name of the conduit.

When it is desired to make exit from the underground conduit to a pole line, or to a house top, a "subsidiary" duct is run from the nearest manhole to the pole or to the side of the building chosen; up which a tube, in which the cable is placed, is continued, until the actual distributing point is reached, when the conductors are "fan-

ned" out on the cross-arms, as indicated in the figure representing house-top fixtures in chapter on "Construction."

UNDERGROUND TELEGRAPH CABLES.—The average number of conductors in a tele-

FIG. 391.

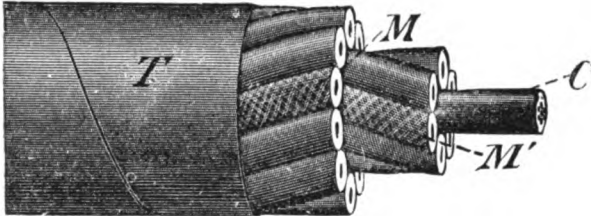

graph underground cable, in large cities, is about 50, although much smaller cables are also used. In Fig. 391 a specimen of an 18 conductor cable is shown. *c* is the central wire. *M* and *M'* are "marking" wires for the separate layers, which are useful in identifying the conductors in testing, jointing and numbering. *T* is the tape

covering. The size of the wire used is, as a rule, No. 16 B. W. G. and the outside diameter of its insulated covering is $\frac{9}{32}$ inch. This outside diameter includes that of the conductor.

The types of cables more generally used by the telegraph companies of this country, for underground service, are those known as the "Kerite," "Okonite," "Safety" "Standard" and "Paterson."

The insulation resistance of the "Okonite" insulation is given as about 2500 megohms; that of "Kerite," about 800 megohms; that of the "Safety," about 2000 megohms, and that of the "Standard" and "Patterson," about 1500 megohms, each, per mile, all for the thickness of insulation just stated.

Gutta-percha is not in extensive use in this country in underground service, owing to its low melting or softening point, which is about 135° F., a temperature which is frequently met with in the streets of large cities, at the points where boilers and furnaces encroach on the streets, in vaults and elsewhere.

CABLE JOINTING.—After having been drawn into the ducts the conductors of the cables are then jointed. In Fig. 392, which represents a manhole of the Johnstone conduit system and in which the ducts are more clearly seen, the ends of a telegraph or telephone cable are shown in readiness for jointing. Care is, of course, taken to keep the ends dry. The manner of making the joints depends upon the nature

FIG. 392.

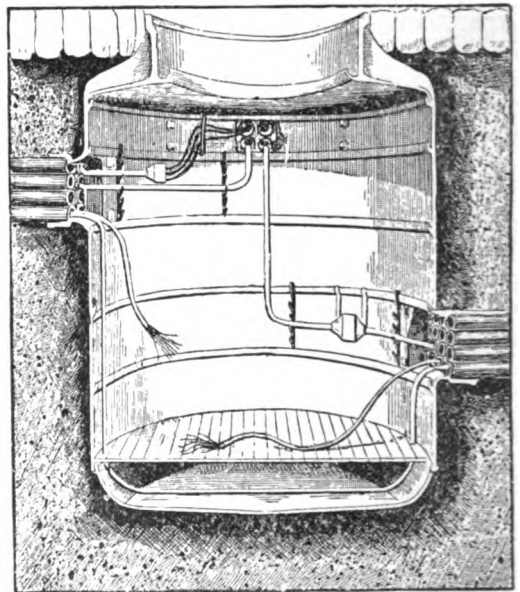

SUBWAY MANHOLE.

of the cable. If of fibrous material the cable will, as a rule, be lead covered, to exclude moisture. In that case joints are generally made by carefully connecting the ends of two conductors together by a twist joint, which is soldered, lightly. The joint is then covered with a semi-insulating tape. After all the conductors have been thus jointed a lead sleeve is placed over the joints. This sleeve is next soldered on to the lead covering and one or two holes are punctured in the sleeve. Into the sleeve, a hot, insulating liquid, such as paraffin, is then poured. This liquid subsequently hardens. The holes in the sleeve are then soldered.

If the cable be insulated with India rubber compound it is not always lead covered when used underground for telegraph purposes. Several thicknesses of tape are, however, generally placed around the cable and, also, in some cases, a padding of jute. Joints on this type of cable are made as follows: First, about one inch of the insulation is removed from the ends of the conductor; the ends of the conductor are then "sweated" together, a small, split, copper sleeve being usually placed over the ends. When the sleeve is not used, the ends of the conductors are filed and then placed together and wrapped with fine wire. No acid is used in soldering; resin being commonly used as a flux. After the wire has been spliced the insulation is then scarfed, that is, tapered off, for about three-quarters of an inch. A layer of pure rubber strip is then wrapped around the wire, spirally, back and forth, about three times, and each time the rubber is brought further up the scarfed insulation. A few layers of white, or unvulcanized, rubber strip is then wound above the pure rubber layers, and after that one or two layers of a pink rubber strip is put on. A layer or two of fibrous tape, with a rubber coating, is then placed over all. Between each layer of rubber strip a small quantity of rubber solution is applied to make the rubber adhesive and, practically, homogeneous. If the cable should be lead covered, a few inches of the lead is stripped off prior to proceeding with the joint making. After the joints have been made a lead sleeve is then shoved over all, and "wiped" on to the lead covering.

MEASURING INSULATION RESISTANCE OF JOINTS.—In underground and submarine cables it is very necessary that great care should be used in making joints, inasmuch as they are conceded to be the weak points of all cables. When joints are made in the factory it is easier to test them than when made under the conditions accompanying the laying of the cables underground or underwater, and, except in the case of very important, long cables, a joint is rarely tested outside of the factory.

When it is desired to test a joint for its insulation resistance it may be done as indicated in Fig. 393, in which *v* is a vessel filled with salted water; *rk* is a reversing key; *B* is a battery of 50 or 100 volts or more. *G* is a galvanometer, the constant of which has been ascertained in the usual way. *c* is the cable, having one of its ends connected to galvanometer, and its other end free, and insulated. The joint *x* is

FIG. 393.

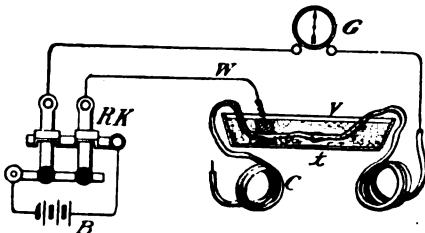

TESTING JOINTS.

immersed in the water of the vessel. The wire *w* is placed directly in the water. Thus when the key is depressed any current flowing in the circuit must pass from the joint through the water to the wire *w*. Hence, the deflections of the needle, if any, obtained, furnish data from which to calculate the resistance of the joint.

RIVER AND HARBOR CABLES.—As a rule, but one conductor is used in long ocean cables, as, for example, in the case of the Atlantic cables. Gutta-percha is chiefly used as the insulating material. The conductor of such cables is of the purest copper obtainable and is generally composed of 7 copper wires. The strand thus formed is covered with three or four separate layers of gutta-percha, and between each layer a compound is placed which unites the different layers into practically one

FIG. 394.

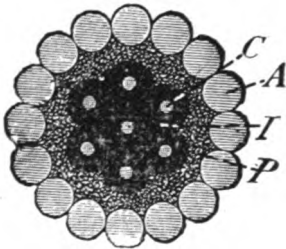
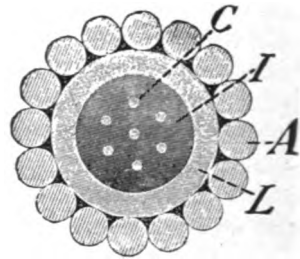
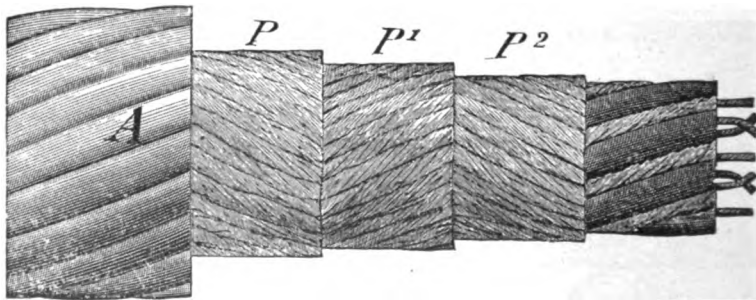

FIG. 395.



covering. One object in using several layers of gutta-percha, in the construction of the cable, is that, in the process of covering the wire with that material, air holes are liable to occur. If but one layer were used it is evident that the development of an air-hole into a "fault" would speedily follow the immersion of the cable. By putting on the different coatings of gutta percha any air-holes that may exist in any one layer are rendered practically of no effect. Tared hemp is then placed over the

FIG. 396.



gutta-percha, and, over the hemp, a number of twisted galvanized iron wires, forming the "armor," is finally placed.

For crossing rivers and bays in this country, cables containing from 1 to 7, or more, conductors are employed. The insulation employed is mainly india rubber or gutta-percha, while, for short crossings, lead covered and armored, fibrous cables, are

also used. The thickness of the armor and particular construction of the cable depend upon the nature of the river or harbor bottom and the general conditions likely to be met.

In Fig. 394 is shown a cross-section of a 7-conductor, fibrous, lead covered cable. *c* being the conductors, *i* the insulating material, *L* the lead covering, *A* the galvanized iron armor. Fig. 395 represents the section of a 7-conductor rubber compound or gutta-percha, jute padded, and armored cable; *c* representing the conductors, *i* the insulating material, *P* the padding and *A* the armor. In Fig. 396 is shown a 7-conductor india-rubber compound cable intended to withstand severe strains and abrasions, as where ice might be expected on river beds, etc. Each conductor is cushioned by a thick, jute cord, while between the conductors and the heavy armor *A*, three layers of jute packing *P*, *P*¹, *P*², are interposed.

CABLE TESTING, REMARKS CONCERNING, ETC.

The arrangement of apparatus for measuring the insulation resistance of wires and cables has already been shown and described in Chap. VIII.

In making such tests, if the cable is a long one, the galvanometer, as previously remarked, should be momentarily short circuited when the battery key is first depressed. It will be found, after the short-circuiting key has been raised, that a large deflection is still observable. If the insulation of the cable is perfect the deflection will diminish rapidly at first, and more gradually afterwards, until it reaches a point where for practical purposes, it may be said to be permanent, although, in reality the effect will continue indefinitely. This phenomenon, as has been stated, is due to *electrification*.

With a given cable, in good condition and after the previous charge has been entirely dissipated by "grounding" the cable, it will be found that at a given time of taking the readings, the deflections will be the same with either pole of the battery to the cable. For instance. Assuming that it is intended to take 1 and 3 minute readings; that is to say, after the key which places the battery to the cable has been closed for one minute, a note of the deflection is made; at the end of 3 minutes another reading is taken. If a deflection of, say, 200 is observed, after the first minute, and 100 after the third minute, with, say, the positive pole to the cable, exactly similar deflections should be observed, after 1 and 3 minutes, respectively, with the negative pole to cable. If such is not the case, and if careful examination shows that the variation is not due to imperfect connections or apparatus, a defect may be looked for in the cable. It will generally be found in such cases that the copper pole of an increased battery applied steadily for a time to the cable will develop, or "break down" the fault.

When, however, the deflections are *even* the insulation resistance of the cable is computed from the readings taken at the first or third minute, as may be preferred; the one minute reading generally being specified.

The action, or effect, of electrification varies markedly in cables of different insulating materials, being more pronounced, according to the experience of the present writer, in india rubber and gutta-percha cables, than in fibrous, lead-covered cables. It also varies in different rubber compounds.

In certain types of rubber compound "insulations," of which the writer has tested many hundreds of miles, it was noted that, in faultless cables, the electrification proceeded with such unvarying uniformity that, after the first reading, the deflection at the subsequent readings could be unfailingly predicted successfully. It was found, for instance, that the deflection at the third minute would always be one half that of the deflection at the first minute, etc.

In taking readings it will be found advantageous to "tap" the short-circuiting key, momentarily, until the deflection comes within the limits of the scale, which, as a rule, will be within a few seconds after the battery key has been depressed. Then the short-circuiting key may be "clamped" down, or held down by the fingers, until the close of the readings.

For insulation tests it is, in some cases, preferable to use high electromotive force, as it is more searching, that is, the pressure is greater and, consequently, the tendency to a disruptive charge is greater and also, with a given electromotive force and resistance, the current will be greater. As the chemical action of a current is proportional to the current strength, it follows that a strong current might develop a defect that would remain unnoticed under a weaker current. Nevertheless, the actual insulation resistance of a material, in the absence of the conditions necessary for electrochemical action, may be as accurately measured, with one cell, and a sufficiently sensitive galvanometer as with a battery of 100 cells. Of course the E.M.F. should not be so high as to break down the normal resistance of the insulating material.

LOCATING FAULTS IN CABLES, ELECTRO-MECHANICALLY.

The following, so to speak, "rule of thumb" electro-mechanical methods of locating faults in cables in which the defect is not a pronounced one, such as a dead "ground" or "break," have been adopted by some experienced repairers of short submarine cables in this country, in preference to the electrical methods which might be employed to locate the defect, and which methods are, in many instances, rendered more or less uncertain by the lack of data concerning the exact resistance and length of the conductors, (especially when the latter are "laid" up spirally) and other information essential to satisfactory results. It should, however, be said that, in the hands of experts, the "Varley loop," and other methods of locating such faults, have been found to give quite accurate results in numerous instances of defective submarine and underground cables.

POINT TO POINT METHOD.—Imperfectly developed defects in unarmored cables in the factory or store-house may frequently be located by tests made from "point to point" of the insulation, in some such manner as the following, (*See Fig. 397*).

The cable is placed in a tank T, or on a damp floor and well wetted. One end of the cable is connected to the terminal of a sensitive galvanometer G, the other end is kept well insulated; the other terminal of the galvanometer is connected to ground, via a battery, as shown in the figure. The galvanometer will be deflected by the current due to the, comparatively, low resistance of the defect. The cable is then slowly coiled on to insulated stand I. If the deflection of the galvanometer needle is closely watched it will be found that when the defective portion of the cable leaves the tank there will be a drop in the deflection. Much of the success of this method depends on keeping the

stand *I* thoroughly insulated. Care must also be observed that the "defect" does not get a "ground" after it is on the insulated stand, by way of the wet surface of the cable. Whether it has done so can be determined by occasionally drying off a few inches of the surface of the insulating material of the cable, between the tank and stand, as at *J*. The insulating material may be readily dried by the judicious use of the heat from a spirit lamp. If the cable is juted or taped this must be removed and the insulation proper exposed and dried. If the defect, after one of these dryings, is found to be on the stand, the cable is then coiled slowly back into the tank until the defect leaves the stand. The vicinity of the defect is thus ascertained, and by using care and gradually shortening the length of cable operated on, the defect may be located to within a fraction of an inch. Sometimes, on inspection of the insulation, the defect is visible when it first leaves the tank.

With armored cables it is not thought advisable to cut the shield in the manner suggested in the case of jute and therefore it would be useless to coil the cable on to the insulated stand with any hope of finding the defect. When faults occur on lead-covered or armored cables the defect is sometimes located by running the cable over a "drum" and observing any change in the deflection that may be caused by the variation of the resistance of the defect in passing on to the drum. When such an indication is manifested the suspected spot is beaten with a wooden mallet to further develop the defect if it exists at that point.

LOCATING FAULTS IN SHORT SUBAQUEOUS CABLES.—In locating faults in subaqueous cables, laid across moderately narrow bays or rivers, a method called "under-running," which is practically similar to the last described, is employed.

FIG. 397

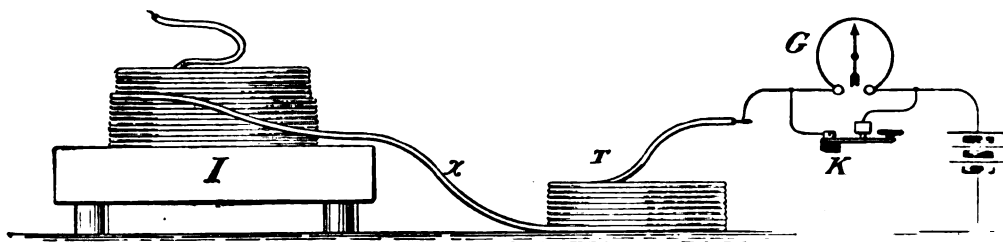

A "shore" end of the defective conductor of the cable is connected with a galvanometer and battery, as in Fig. 397. A flat boat, with a set of rollers or pulleys on its deck, having been provided, a portion of the cable near one of the shores is lifted on the boat and placed in position on the rollers. The boat is then started across the bay, the cable rising out of the water on one side of the boat and falling into it on the other side. This, of course, eventually takes every portion of the cable out of the water, for a few seconds, and the change of position almost invariably alters the resistance of the defect as it passes over the boat. When this variation of the resistance is observed by the attendant, the boat is signaled to that effect. The boat is then moved back and forth until the exact location of the defect is found.

CHAPTER XXXIII.

CONSTRUCTION AND MAINTENANCE OF TELEGRAPH LINES.

AERIAL CABLES, ETC.

Generally speaking, it may be said that in building a telegraph or telephone line in this country no regular survey of the route is made. It is, however, customary, after the general route of the line has been selected, to prospect for the shortest and best route. In the performance of this duty the official engaged is expected to note whether the digging will be medium or rocky and to designate the height of poles necessary to clear the trees to be encountered at certain points, etc.

After the route has been thus selected it is important to obtain the right of way, or, as it is termed elsewhere, "way leave"; in other words, permission to erect the line on public and private property, along the route selected.

If the line is to follow and be constructed on the property of a friendly railroad, the question of right of way is quickly settled. But, if it is a "highway," or "pike" line, the question of right of way is one requiring much attention.

The mode of procedure for obtaining rights of way is different in almost every state in this country. In some states it is necessary to apply to the road supervisors for permission to set poles in their districts. In others, the town selectmen, of whom there are generally three to five, furnish necessary authority for the purpose. It has happened that lines have been constructed semi-surreptitiously along country roads, but in the end it has often proved an expensive undertaking.

Rights of way should be obtained, in writing, if possible, for every pole set. This will frequently save trouble and the expense of moving the poles, as well as litigation expenses, after the line has been built.

The poles and other materials are brought to the route of the line by the most available means. If it is a railroad "route," the poles, wire, etc., are placed on a truck car and thrown off at the proper intervals, as the train moves slowly along. If the line follows a highway the material must be brought to the nearest point by rail or boat and thence to the route of the line by teams. The number of poles, per mile, is, of course, determined in advance; 35 to 40, per mile, being the average. In some cases no more than 25 poles, per mile, are used.

POLES.—In choosing poles for an overhead telegraph line the locality of the line is taken into consideration. For use in cities, Norway pine is generally selected. For this purpose the poles should be from 50 to 80 feet long. In some special cases even longer, as when very high buildings are to be surmounted. Other timber used for poles in this country includes cedar, chestnut and cypress. The average life of Norway pine may be placed at 6 years; that of chestnut, 15 years; cypress 12 years; cedar 10 years, according to Mr. J. A. Helvin, to whom I am much indebted for information on this subject.

The poles should always be well seasoned. The process of seasoning consists, essentially, in promoting the evaporation of the sap. In some instances this is done by a resort to drying rooms, but the best results are obtained by exposing the poles to a free circulation of air, in a sheltered place, until the sap has evaporated.

Before seasoning the poles should be peeled, and the knots should be shaved smooth.

Poles are said to be more durable if peeled when the sap is down, but are more readily peeled when the sap is up. The first place at which, as a rule, poles begin to decay is close to the ground, at the point termed the "wind and water" line. To prevent, as far as possible the "wind and water" effect, it is sometimes customary in this country to coat the butt end of the pole, that is, the end which goes in the earth, with pitch, to a distance of 6 feet from the end.

The length and thickness of the poles required will, of course, vary with the number of wires to be carried, and, also, with the conditions existing along the route of the line. For instance, if there is much shrubbery along the route, for a line of, say, 22 wires, an average length of 30 feet will suffice. This will allow of "setting" the poles to the depth of 5 feet in the ground, and yet leave considerable space between the lowest wires and shrubbery. For a line of 40 wires the poles should average 40 feet and should be set 5 to 5½ feet in the ground. If, in this case, there are trees along the route, it is expected that the wires will pass under the foliage, where thickest. For a line of from 40 to 200 wires, (there is a telephone line of over 300 wires in present existence in New York City) the poles should average 75 to 80 feet in length, and, depending on the nature of the ground, should be set 7 to 9 feet therein. In this latter case it is assumed that the wires pass over the foliage of trees.

In all cases where wooden poles are to carry "cross-arms" (See "cross-arms") they should not be less than 7 inches in diameter at the top end.

IRON POLES.—Iron poles are used in some places in this country for telegraph purposes, but not very extensively. They are used chiefly by the United States government, more especially in the far west, and along the coast, in the Signal service; being considered preferable, in that they withstand, in the one case, the prairie or forest fires, and, in the other, at least to a greater extent than wooden poles, the heavy surfs and storms that prevail. In "commercial" telegraphy, and in telephony, iron poles are rarely employed; the fact that the breaking of an insulator or the slipping of a pin will cause an immediate ground, should the wire touch the pole or cross-arm, militating against their use.

ERECTION OF POLES.—The principal tools used in digging the hole for the pole and in handling and raising it into position, are the spoon shovel and long shovel, (Figs. 398, 398a) tamping bar, Fig. 399; round-face tamping bar; the "paddle," Fig. 400; "deadman," Fig. 401; cant hook, Fig. 402. A post-auger, Fig. 403, is sometimes used to bore holes when the nature of the ground will permit; that is, in sandy or clayey soil, but, in general, the "long" and "spoon" shovels, and pikes, are employed in hole-digging, the latter to loosen the earth.

The depth of the hole varies with the length of pole and nature of the ground. For 30-foot poles the hole should be 5 feet deep in soil, and, at least 4 feet in solid rock; for longer poles the holes should be proportionately deeper.

The hole having been made, the "paddle" (shaped as indicated in figure) is

placed in it, on one side, to serve as a rest for the "foot," or butt, of the pole. By the aid of cant-hooks the pole is rolled with its butt end over the hole. It is then raised slightly and its butt slipped into the hole where it rests against the paddle,

FIG. 38.

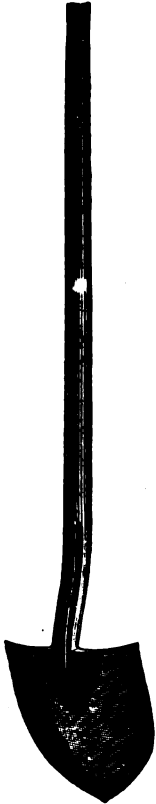

SPOON SHOVEL.

FIG. 398 a.

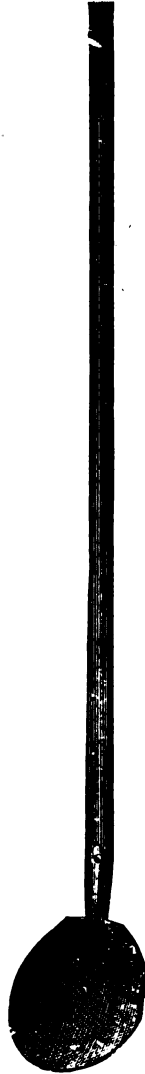

LONG SHOVEL.

FIG. 399.



TAMPING BAR.

FIG. 400.



THE PADDLE.

which prevents crumbling down of the earth from the side of the hole. The pole is then raised higher, and the "deadman," or "butt-prop," as it is also termed, is put under it. This supports the pole until a new hold is obtained, whereby the pole is raised still higher, which accomplished, the prop is moved nearer to the butt. The

“deadman” consists of a short wooden bar on one end of which are two iron tines, U-shaped, with a small sharp spike between them. The tines partially embrace the pole, while the pike prevents slipping.) Sharp pikes at the end of long poles, Fig. 404, are then thrust into the upper part of the pole, on both lower sides of it, by

FIG. 401.

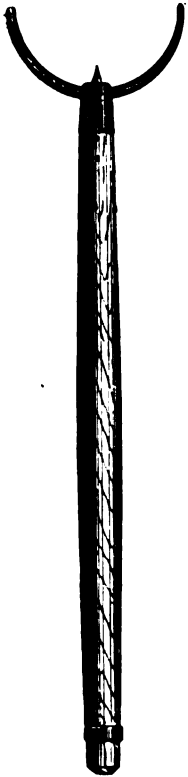

“DEAD-MAN.”

FIG. 402.

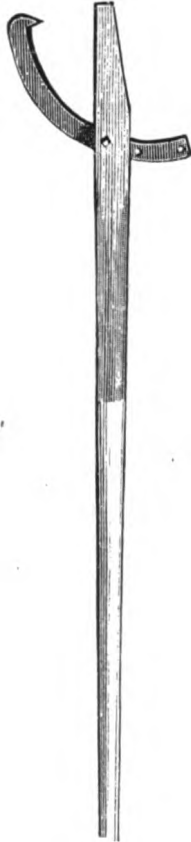

CANT HOOK.

FIG. 403.



POST AUGER.

means of which it is raised to a vertical position, when it slips down into the hole. The cant-hook is again used to turn the pole in the hole, so that the “gains,” or notches, which have been cut in its side for the cross-arms, will be at right angles to the wires, as they run. The hole is then carefully filled, the soil, stones, etc., being tamped, or beaten down, by the “tamping” bars, in process of filling. The work of tamping should be well performed, as, upon that much of the future stability of the poles depends. In places where the ground is soft, a foot-plate, somewhat similar to that shown in Fig. 405, is placed under the butt of the pole to increase the stability of its foundation.

Poles placed on curves or corners should be set sloping, to an extent depending on the sharpness of the curve, and against the pull of the wires. Where the line under construction is to cross an existing line the poles should be of sufficient height to carry the lowest wires well over those of the line crossed; or, if that course should prove to be impracticable, owing to the height of the other line, a guard wire should be placed on the top of the new line to ward off lower wires of the existing line.

GUYING.—A very necessary part of telegraph line construction is the “guying” of the poles. Guying consists in attaching to the pole, at a desired point a wire, or

FIG. 404.

strand of wires, termed the guy wire (which, at its further end, is suitably fastened, or “anchored”) for the purpose of strengthening the pole in its position. Guying is especially necessary in the case of “heavy” lines, that is, those carrying a large number of cross-arms and wires. Such lines should be well guyed, both “head” and “side,” before the wires are strung. A “double-head” guy is made by fastening a heavy guy wire to the top of a pole, or at about the fourth cross-arm from the top, and running the wire to the next pole, in either direction, and then fastening it to the latter pole, say, ten or twelve feet from the ground; and then running, from the top of the latter pole, to near the base of the former, a similar, strong wire. This forms a horizontal  between the two poles. The double head guy should be placed every fourth or sixth span, where the line is exposed to heavy winds.

A “side” guy is formed by attaching a “guy” wire, of suitable dimensions, to

FIG. 405.

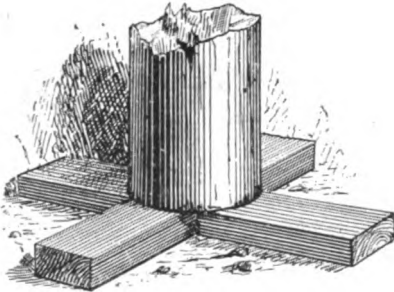

“FOOT” PLATE.

the top of a pole, as in the case of the “head” guy, and thence running it to an adjacent tree, to a house top, or to a guy “stub,” placed some distance from the side of the pole. A “guy stub” consists of a stub of a pole set in the earth at an angle away from the pole to be guyed. “Side” guys should be put on each side of the pole, laterally, so that the wind may not have an advantage either way.

An “anchor” guy is constructed in the following way: The guy wire is fastened under the bottom cross-arm, or, if there are more than 4 arms, under the fourth arm. A hole is then dug in the earth, 5 or 6 feet deep, at a distance of about 10 or 15 feet from the pole. An “anchor,” consisting of a heavy stone, or even green wood, is then placed in the hole, first having attached to it the other end of the guy wire. The hole is then filled up with earth which is well tamped down. The anchor guy is used where a “stub” can not be employed or where a tree is not available.

No. 8 or No. 6 B.W.G. galvanized iron wire, single or formed into a strand by twisting together as many wires as may be necessary, is generally used as guy wire in telegraph construction work.

It is sometimes necessary to span rivers or ravines of moderate width. In such cases the poles at the banks require extra guying and "strutting." "Struts" consist of poles or "stubs," bearing against the regular pole in a direction contrary to the strain.

When a span would exceed, say, 300 feet, at a river crossing it will be advisable and, in the end, economical, to use a subaqueous cable. There are, however, spans of from 200 to 800 feet of iron, and of hard-drawn copper, wire in existence in this country to-day which were erected over 8 years ago. Probably one of the longest spans in this country was one near Trenton, N. J. This span was about 1700 feet in length. It was made up of a No. 12 steel wire and a No. 14 hard-drawn copper wire.

POLE LIGHTNING ARRESTERS.—By some superintendents it is deemed desirable to equip a certain number of poles per mile, with lightning rods. This rod is formed of a length of iron wire twisted repeatedly around the butt of the pole and thence continued up the pole to the top, and 6 inches beyond.

BRACKETS, PINS, CROSS-ARMS.—The wires are suspended on the poles in two ways: Namely, by means of brackets and cross-arms.

Brackets (Fig. 406) are simply pieces of wood sloping on one side and straight on the other, with a screw thread on the upper end to carry the insulator.

Brackets are not often used when more than two wires are to be strung on the poles. The bracket is nailed to the pole with the straight side out, to leave a space between the pole and insulator. Where a "bracket" line is to carry two wires, one bracket should be put on one side of the pole and the other on the opposite side, one about 15 inches above the other, to prevent the wires from crossing, in the event of one of the brackets breaking off and falling. Further, if it is necessary to put more than one bracket on one side of a pole, the wire should be "tied" on the inside of the bracket, so that, if the insulator be broken or pulled off, the wire will rest on the bracket until the insulator is replaced.

The "cross-arm" is composed of an oblong piece of wood of varying length and thickness, according to the weight it may have to support, placed cross wise on the poles. On the cross-arms are placed "pins," Fig. 406*a*, for the insulators. In Fig. 407 is shown a pole P, with cross-arms A, pins P', brackets B with insulators *i, i*, and wires in position. Notches, or "gains," are made in a side of the pole to afford a flat surface for the cross-arms. The gains should not be less than two inches in depth and should be cut to hold the cross-arm snugly. The top gain should be about eight inches from the top of pole; the other gains should be twenty-four inches apart. The cross-arms are placed in the gains after the poles are in position, and are fastened to the poles by means of spikes of desired size, similar to those shown in Fig. 408,

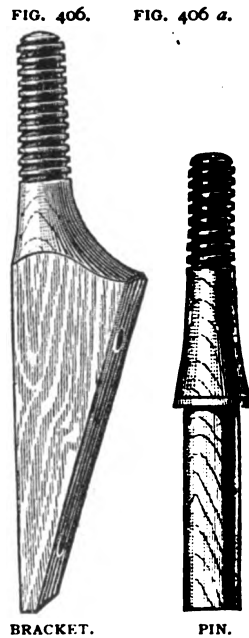

known as Fetter drive screws. The pins for the support of the insulators are placed on the cross-arms in advance. Locust pins are the most durable and most capable of

withstanding heavy strains. The cross-arms and pins should be painted before their erection on the poles. In some cases they are simply dipped in paint, but this has not been found a durable method of applying the preservative. Specifications generally state the exact manner in which these details are to be executed.

The number of wires to be strung on the poles having been determined in advance the desired size and the number of cross-arms is arranged for. For telegraph purposes 2, 4, or 6-pin cross-arms are most frequently used, as arms of those sizes allow a larger space between the wires. In putting up cross-arms on lines of all kinds the arms should be reversed on every other pole; that is, the "gains" should be on one side of one pole, and on the other side of the next pole, as one looks along the line. This tends to keep a uniform strain on the poles.

INSULATORS.—Some of the essentials of an insulator, for aerial purposes, are that it shall have high electrical resistance, shall possess strength, permit a good hold upon the wire, shed rain freely, have no dark

recesses for the accommodation of insects, and be reasonably cheap.

As these requirements are found but rarely in any one substance it is evident that the available materials are limited. For instance, iron would possess strength,

FIG. 407.

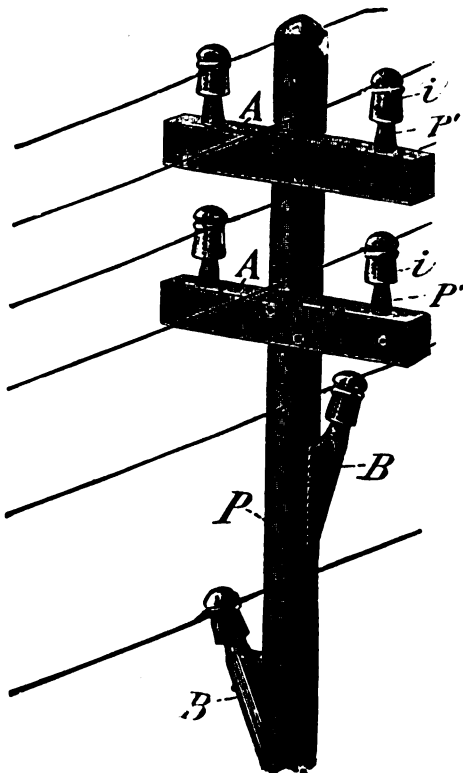

FIG. 408.



FETTER DRIVE SCREW.

but it is not an insulator, and glass possesses non-conducting qualities but is more or less brittle. A combination of both might possess strength and high insulation but would be opaque.

In Europe, porcelain and earthenware insulators are very extensively employed and are highly esteemed. They have also been used in America, but at the pres-

ent time and for many years past a glass insulator is and has been practically the only one employed in the telegraph, and, it may be added, the telephone service.

It is claimed for porcelain and earthenware insulators of the higher grades that, besides possessing, normally, higher electrical resistance than glass insulators, in moist and damp weather, they do not accumulate, on their surfaces, moisture, to the same extent as glass and, therefore, that they are a much superior insulator than glass at such times. On the other hand, it has been observed, in this country, that vermin are more apt to build in the recesses of the porcelain insulators than in the glass, (presumably owing to the greater opacity of the former), and, also, that, apparently, soot adheres more firmly to the former than to the latter, both of which, it is well known, tend to reduce the insulation, especially in wet weather. Doubtless, however, the greater cost of porcelain and earthenware, especially the former, as compared with glass, has been an important factor in preventing a more general use of those materials as insulators, in this country.

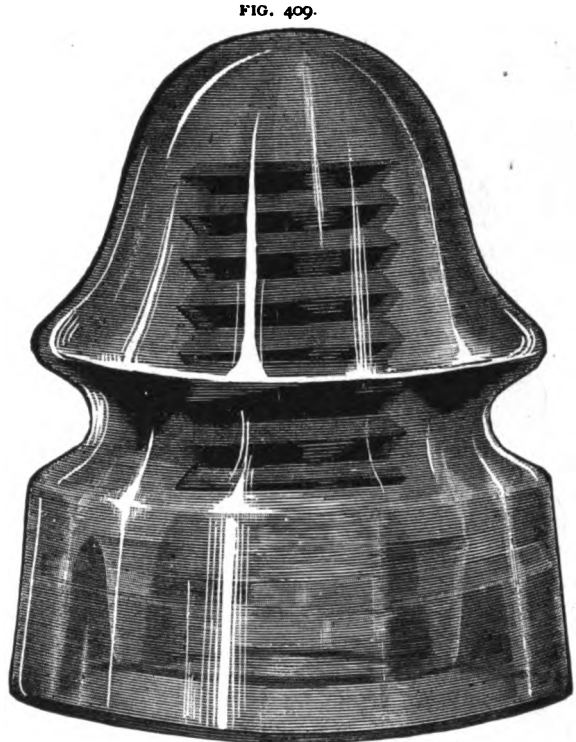

GLASS INSULATOR.

Experience has, however, also shown, in this country, that, given a wire free from foliage, kite tails, etc., the occasions are rare when a line well insulated with glass will not work fairly successfully in ordinary wet weather.

On repeated occasions the writer has found that certain long overhead circuits which, within city limits, were practically useless, owing to low insulation, when tested outside of those limits were found to be in good working order.

The styles of the "American" glass insulator vary in numerous ways, namely: as to its shape, the location and depth of the groove for the wire, the depth of the hole for the pin, the number and depth of the screw-threads within the insulator for the pin, etc., but its general appearance will be seen in Fig's. 409, 410. The latter is known as the "B and O" insulator; its weight is about 22 ounces.

A smaller insulator of the same general form, termed a "pony" insulator, Fig. 411, is much used for No. 12 B. W. G. hard-drawn copper wire.

The location and depth of the wire groove requires consideration. If it is too shallow, the "tie" wire slips out easily. If too deep, the strain of the tie wire is apt to crunch the glass, thereby impairing the insulation; in fact, introducing a source of

defective insulation, often very difficult to discover. The lower the groove on the insulator the less is the strain on the supporting pin, but at that point the glass is thinnest.

The bell shaped form gives a good water shed and tends to throw the "drip" away from the pin.

In order, further to keep the pin dry, some insulators are made with a double

FIG. 410.

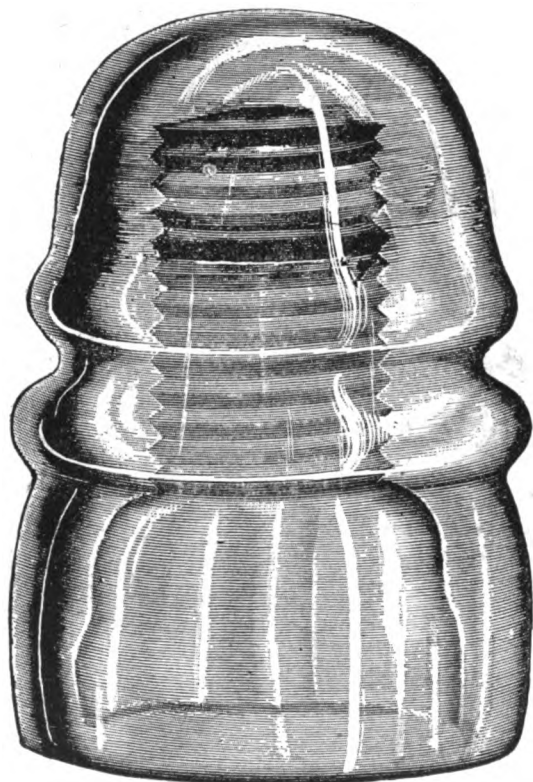

B. AND O. INSULATOR.

FIG. 411.

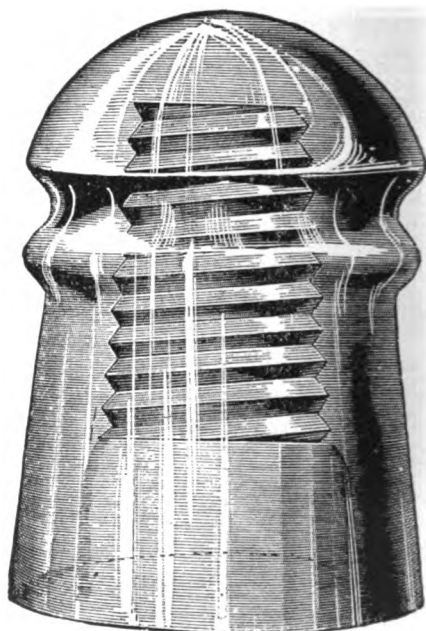

PONY INSULATOR.

"petticoat," as seen in Fig. 412, in which a section of the lower part of the insulator is removed to show the double petticoat. This insulator is known as the W. U. "double petticoat" insulator. In Fig. 413 is shown a form of insulator designed to still further increase the insulation of the insulator by decreasing its surface where it would come in contact with the line wire and "tie" wire. It also facilitates the cutting of the tie wire; that is, the piece of wire which ties the line wire to the insulator. Economy is also aimed at by reducing the weight of the glass without materially decreasing its strength. The manner in which both of these results are designed to be effected will be obvious on examining the illustration. In Fig. 410 the tie wire is passed around the upper groove. The bulge above the upper groove

is designed to throw off the water from the wire and pin. The object sought in running the pin so far up in the bell is that, in case of the breaking of the glass, the tie

FIG. 412.

FIG. 413.

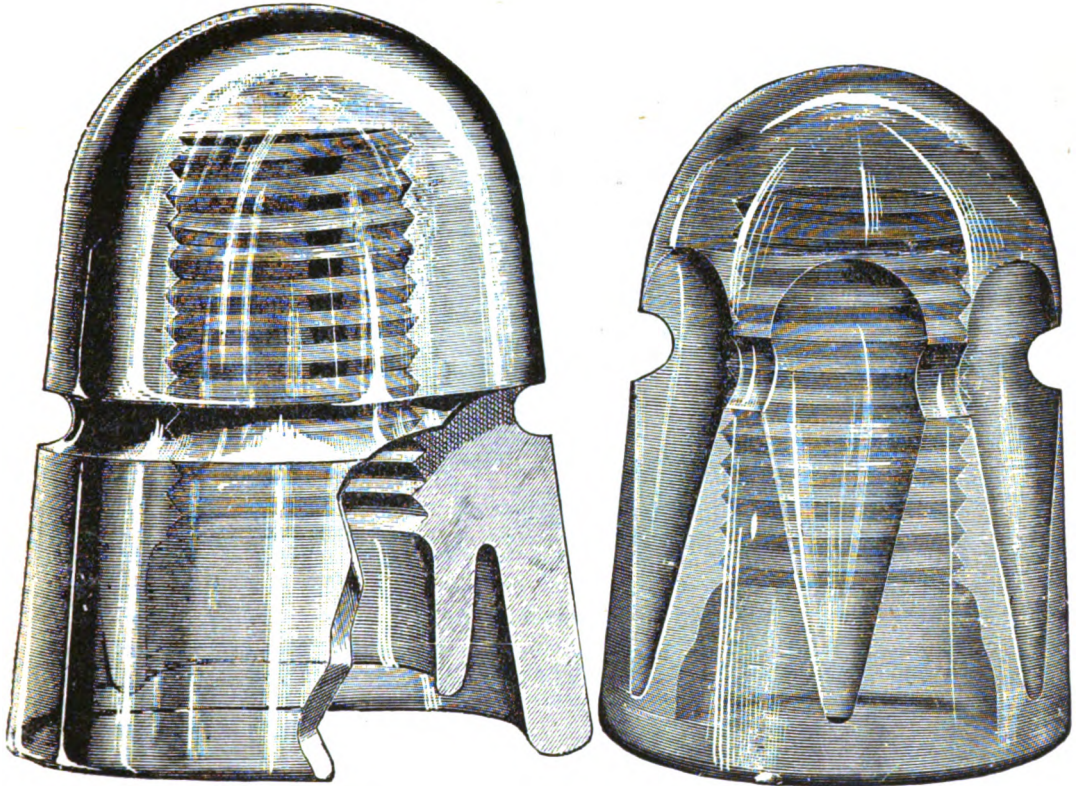

W. U. INSULATOR.

wire may still be held by the pin upon the cross arm.

FIG. 414.

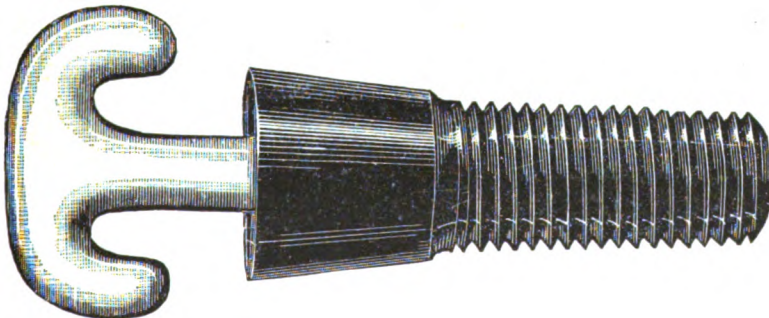

RUBBER INSULATOR.

A rubber insulator in which an iron hook is inserted, as shown in Fig. 414, is used

extensively on the underside of cross-arms, in cities, especially on house-top fixtures.

TREE INSULATOR.—When from any cause whatever it is found impracticable to pass beneath or to surmount a grove of trees so as to avoid the foliage, it will be necessary to use insulated wire through that portion of the route.

FIG. 415.

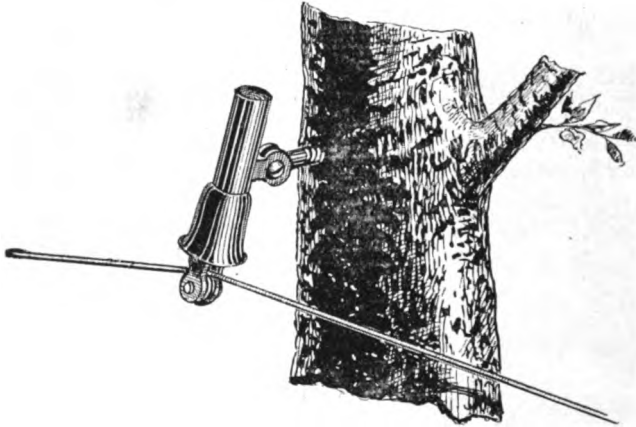

In isolated cases, where the owner will not permit the placing of insulators on trees to ward off the wires from the trunk or boughs, a tube of vulcanized rubber placed over the wire has been found of much utility.

An insulator designed for attachment to trees is shown in Fig. 415. It may be fixed at any desired angle. The manner of its application will be obvious by a glance at the drawing.

WIRE STRINGING.

Although hard-drawn copper wire has been found to give very satisfactory service as an aerial telegraph wire, it is still thought advisable by some telegraph engineers, in the construction of a line of that wire, to strengthen it by the use of one or more iron wires.

As to the manner of placing the iron wires to obtain best results, opinions differ. When but one iron wire is used, however, a No. 6 or 8 B.W.G. iron wire is generally placed on a pin on the top of the pole. When more iron wires are used, it is, by some, considered advantageous to erect, first, a 4-pin cross-arm, and on this to string a No. 6 B.W.G. iron wire, each side of the pole, stringing the copper wires on the adjacent pins. If the line is a heavy one this process may be repeated, say, every third or fourth cross-arm.

Assuming the copper wires to be No. 14 B.W.G., No. 6 iron wire could be used, in wire "patching," interchangeably with the copper wire, the electrical resistance of each being nearly alike, namely, about 8.5 ohms.

The poles, cross-arms, etc., having been placed in position and the poles thoroughly guyed, the men engaged in stringing the wire follow up, closely. This force con-

sists of "climbers," that is, the men who, by the aid of linemen's "spurs," climb the poles to attach the wire to the insulators; and the men who "pull" the wire

taut, for the climbers. The wire, put up in coils of the length that may be specified, is generally carried on a barrow-reel, Fig. 416. Great care should be taken to prevent the wire from kinking, or from being bruised. When kinks occur they should be cut out and the wire jointed. This is especially

FIG. 416.

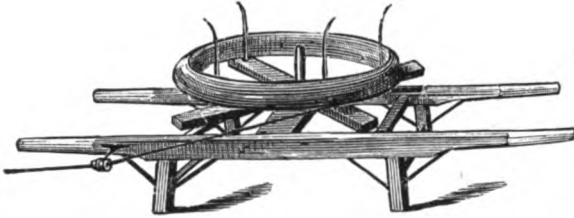

WIRE BARROW.

necessary in the case of hard drawn copper wire.

In stringing the wire it is first pulled loosely over the desired cross-arm for a number of poles. The "pullers" then haul on the wire until it is taut; a "block and

FIG. 417.

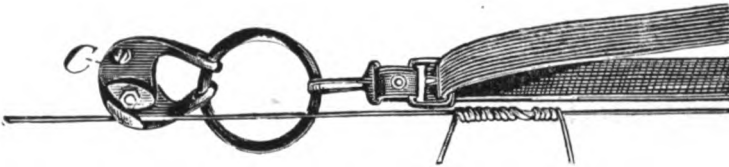

"COME ALONG."

fall" may be used to pull up iron wire, but copper wire should be drawn up, level with the iron wire, "hand tight," as construction men term it; that is, without the use of vices or "come-alongs."

FIG. 418.

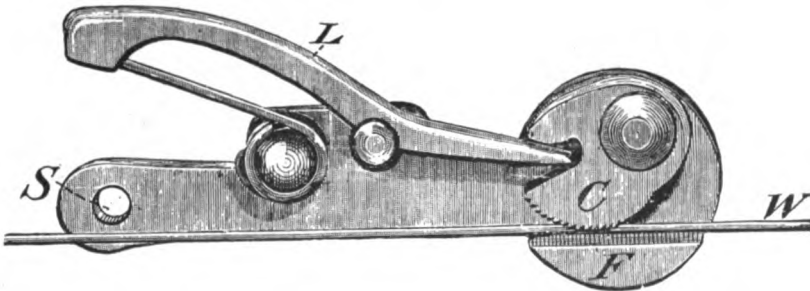

COME-ALONGS.—A "come-along" is shown in Fig. 417. It consists of an eccentric clamp *c*, supplied with a ring and strap, as shown. The wire is placed in the clamp, and the lineman gets a purchase for one end of his strap on the pole. He pulls on the loose end which causes the clamp to tighten on the wire. As the wire comes in the buckle secures the strap in the well-known way.

Another form of wire "grip" is shown in Fig. 418. It has the advantage that a

grip on the wire can be obtained with the use of but one hand. The operation is simple; the wire *w* is placed between the cam *c* and the flange *f*. The strap is attached at *s* and the pull on the strap tightens the hold of the cam on the wire. The wire is released by depressing the lever *L*, which raises the cam.

When a wire is drawn up to the tightness desired it is then fastened to the insulator.

TYING WIRE TO INSULATORS.—In tying iron wire to the insulator the line wire is

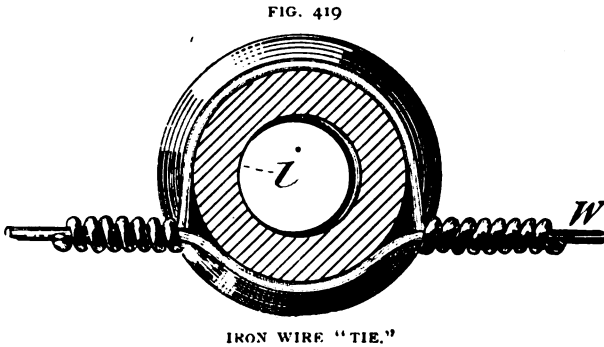

placed in the groove of the insulator. The tie wire, a piece of iron about 16 inches in length, is wound around the line wire close to the glass. The other end of the wire is passed around the insulator and back to and also twisted around the line wire. The pull on the wire is such as to give the line wire a bend at the insulator

which prevents slipping.

This tie, as seen from above the insulator *i*, is shown in Fig. 419; a section of the insulator being removed for clearness.

In tying copper wire to the insulator, soft or annealed copper is used.

Owing to the sensitiveness of hard-drawn copper wire to scratches or kinks it has been found desirable to depart from the method usual in tying iron wire to the insulator. Instead, the tie wire is first wound around the groove in the insulator and is then given a twist around itself, with the ends left parallel with the line wire; the latter is then placed in the groove in the insulator, when the ends of the tie wire are wound around the line wire a number of times, spirally; thus giving it a snug, but not rigid, resting place, in which it is, at the same time, free to move longitudinally. This "tie" is shown in Fig. 419*a*.

FIG. 419*a*.

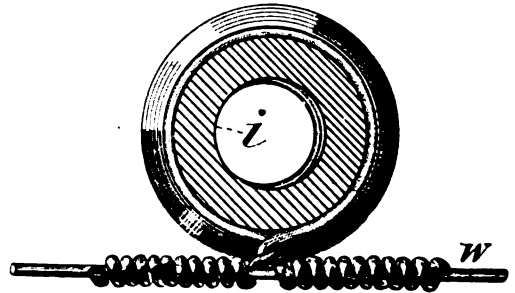

HELVIN TIE.

SAG.—As regards the amount of "sag" to be allowed between poles, (a feature of line construction which is considered of great importance in other countries) it may be said that, in much of the recent construction work in this country, the "sag" has been virtually dispensed with, both in the case of iron and hard-drawn copper the wire being drawn up virtually level with its cross-arms. This is in cases where the poles are comparatively numerous to the mile, say, 40; thus making

a stretch between poles of but 130 feet. It has been found that the percentage of "breaks" in the case of tightly strung wire has been no greater than in the case of wire erected with a "specified" sag. Further, the after work of taking up "slack," due to expansion, is rendered almost unnecessary in the case of "tightly" strung wire.

Where strict regard is paid to a definite amount of sag, the strain on the wire, in pulling it "tight," is limited to one-third of the "breaking strain" of the wire. Thus, for instance, assuming the breaking strain of No. 6 B.W.G. iron wire, to be 2100 lbs, a strain greater than 700 lbs. would not be permissible and, inasmuch as the strain increases the tighter the wire is drawn, it is obvious that, with a given span of wire, if the maximum tension stated is adhered to, a considerable "dip" will be noticeable. The dip in the case of the wire cited would be about two feet in a span of 300 feet.

JOINTS ON AERIAL WIRES.—As the work of stringing the wire progresses, the jointing of the ends of the coils, etc., becomes necessary.

In the case of iron wire, the joint is made by bringing together the two ends of the wire to be joined, and causing them to overlap each other, 6 to 8 inches. One end is then wound around the other wire spirally, several times, which operation is next repeated with the other end of the wire; this making a jointure such as that seen in Fig. 420. This joint is then soldered; soldering tools being carried for that purpose.

FIG. 420.

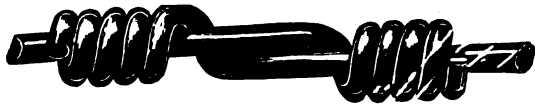

IRON WIRE JOINT.

With copper wire the joints are made differently, and it is necessary to exercise much greater care than in the case of the iron wire.

JOINT SLEEVES.—In making a joint on hard-drawn copper wire a "sleeve" is almost invariably used.

At one time a sleeve, known as the "Helvin," was extensively employed, and hundreds of them are in use to-day. It consists of a brass cylinder, through which two chambers are run, lengthwise. These chambers are of sufficient size to admit the wire. One end of the wire is run into and through one of the chambers; the end of the other wire through the other chamber, from the opposite end of the sleeve. The end of each wire is then wrapped 3 or 4 times around its adjacent wire, close up to the sleeve, and soldered at the ends of the chambers; the object of which is to prevent corrosion, etc., by excluding moisture from the chambers.

FIG. 421.



A sleeve, now much used in hard-drawn copper wire jointing, is known as the McIntyre sleeve. It is practically similar to the Helvin sleeve, having two chambers also, but, as a rule, no solder is used in connection with it, and the ends of the wire are not twisted; instead, the sleeve itself is twisted; one lineman holding one end of the sleeve with his pliers, while another lineman twists the sleeve several times. The sleeve, before and after twisting, is shown in Figs. 421, 421a. This joint has the

advantage that it can be quickly made, and it gives satisfactory results. Holes are sometimes cut in the side of this sleeve, into which solder may be run if desired.

FIG. 421 a.



MCINTYRE SLEEVE JOINT.

PLIERS.—Since the general introduction of electric lighting, the use of pliers, with insulated handles, in any kind of construction or repair work, is advocated as a precaution against accidents. In one style of insulated pliers, thick rubber bands are wound spirally around the handles. Another style is illustrated in Fig. 422. In this the insulation, *i, i*, is shaped to conform to the handle, and drawn over it.

FIG. 422.

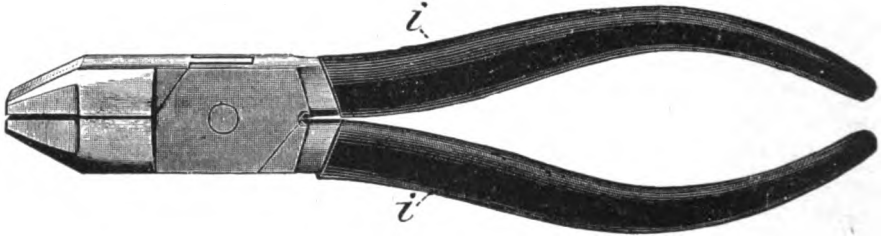

“ANTI-HUM” DEVICE.—In many places it is necessary, in order to retain possession of right of way, to obviate the humming noise due to the vibration of the wires. This can be accomplished by the use of a device known as the “anti-hum,” which is shown in Fig. 423.

FIG. 423.

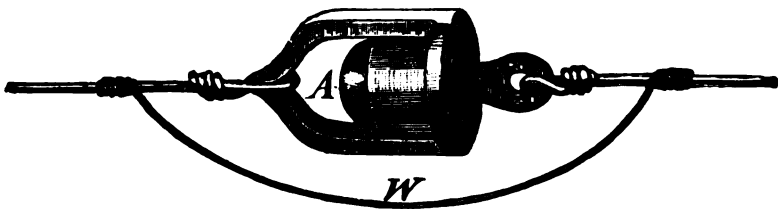

A is a galvanized iron shackle, inserted directly in the line wire, near the pole, and provided with a washer, or cushion, of rubber, or other suitable material, to take up the vibrations.

As this would break the circuit as well as the vibrations, a piece of wire, *w*, termed a “bridle” or “jumper,” is passed loosely around the “anti-hum,” in the manner shown, and is soldered to the wire on each side of *A*.

CITY CONSTRUCTION WORK.—The general method of constructing a telegraph line in a city does not vary much from that in the country, except that, as a rule, the work,

owing to the crowded condition of the streets, the presence of paved sidewalks, etc., is much more difficult. The work is also rendered more onerous by the more frequent objections of owners of property to the presence of poles in front of their premises. These objections may be diminished if the sites chosen for the poles are located on the house, or lot, lines.

FIG. 424.

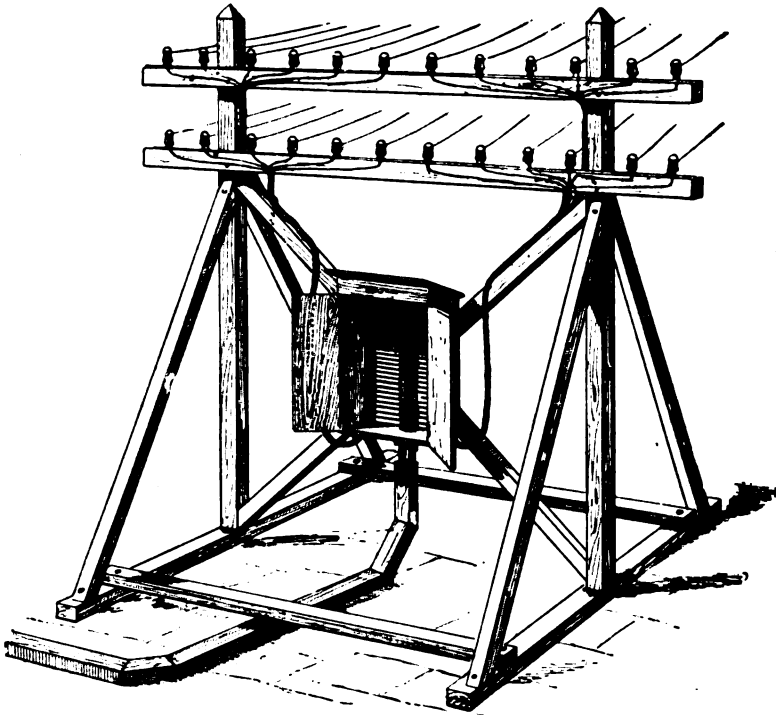

HOUSE TOP FIXTURE, "DOUBLE," WITH CABLE BOX, ETC.

HOUSE-TOP FIXTURES.—In the larger cities a great many wires are supported on what are known as "roof" or "house-top" fixtures. There are "double" and "single" house-top fixtures. They are composed of stout scantling, and have perpendicular frames with lateral cross-pieces, on which the pins and insulators required are supported. These fixtures, in some instances, carry as many as 150 wires. A standard form of a "double" house-top "fixture" is shown in Fig. 424. The uprights are propped, and frequently guyed, in every direction, to withstand strains due to high winds, etc. The privilege of placing these fixtures on roofs must first be obtained, and the rental for this privilege ranges from \$1 to \$500 or more, per annum, per fixture. This does not include the expense of keeping the roof in order, which devolves on the company owning the fixture. Owing to the expense attendant upon the maintenance of house-top lines, added to that of ordinary maintenance, and of renewals necessitated by severe sleet storms, etc., the telegraph and telephone companies in several of the largest

cities of this country, have voluntarily resorted to the extensive use of underground conduits, but there, of course, still remain points at which the house-top fixtures are required in connection with the underground service.* In this case the cables from the underground conduits are brought to the roof in pipes or enclosed boxes, and led up to a "cable box" on the fixture, whence they are distributed to the cross-pieces, or arms, of the fixture, also as indicated in Fig. 424, in which figure the doors of the box are arranged to show the general disposition of the wires within it. Each conductor is provided with a lightning arrester within the box, as outlined.

AFTER CONSTRUCTION.

The strain due to contraction of the wire, caused by decreased temperature, finds the weak spots in the wire, and the number of breaks due to this cause is sometimes excessive. These breaks, it has been observed, are more noticeable along railroad lines than along pike lines, which may be owing to the fact that, in the former case, the position of each pole being taken at a certain distance, laterally, from the rails, the poles are in much better alignment than in the case of the highway line. In the case of highway lines, in the absence of surveyor's stakes, and, although care is exercised to erect the poles in strict alignment, they are found to be in a more or less zig-zag line. The result, apparently, being that, in the case of the railroad line, there is nothing to give way and the faulty wires break; whereas, in the case of highway lines, the contraction of the wires brings the *tops* of the poles in alignment, by which action the strain is relieved.

Experience has shown that, at least, as high a percentage of breaks, due to sudden frosts, occurs in the case of iron as in copper wires.

The writer remembers the interest with which, by all concerned, the first cold "snap" was awaited, along the route of the West Shore Railroad, after the completion, in the fall of 1884, of the first mixed iron and hard-drawn copper wire line of the Baltimore and Ohio Telegraph Co., from New York to Buffalo. This line was a new departure in, at least, two respects. It was the first instance of the extensive use of hard-drawn copper wire for aerial telegraph purposes in this country; and the wires had been advisedly strung without any perceptible sag. The temperature, during one night, fell to 30° below zero throughout the Mohawk valley, and the breaks were quite numerous, but the record showed that, mile for mile, the breaks in the iron wire exceeded those in the copper. However, the number of breaks was sufficient to cause misgivings, and orders were issued to put some "slack" in the wires at different points, but before much could be done in this direction, another equally cold snap followed, when it was found that the breaks were almost nil, showing that the excessive number of breaks in the first instance was due to flaws, kinks and other injuries, occasioned by the lack of proper handling and jointing on the part of the linemen, who were, of course, at the time, untrained in the stringing of hard-drawn copper wire. Similar favorable results were afterwards obtained in other sections of the country, and, as already intimated, a wide-spread use of hard-drawn copper for aerial telegraph purposes, followed.

* Roof fixtures have still further been dispensed with by the device of running the insulated wires from house to house in cellars and along the walls of houses in a block. This plan has been largely adopted in New York City.

MAINTENANCE OF LINES.—So much depends upon the maintenance of a telegraph line in good condition that it would almost seem superfluous to call attention to the necessity for maintaining it in that condition. But it is a well known fact that there is no expense quite so begrudgingly incurred by some Telegraph directors as that for repairs to their lines.

Shrubby, if not cut down, will grow up into the wires, trees if not trimmed will grow up through them; insulators will be broken and will slip off the pin; pins will rot and break; cross-arms will go awry, and poles will lean, in the course of time. All of these details, and many others, require constant supervision, and if not attended to the result will be shown in deteriorated service.

Whenever permission can be obtained it is always best to cut down trees out of the way of the wires, once for all; and along railroad lines this is nearly always feasible. But, of course, it is not, elsewhere. The next best thing is to obtain the consent of the property owners to trim the trees. For this purpose a "tree trimmer" is very useful, and its employment dispenses with the need of a step ladder to reach the boughs and limbs of trees. Such a tree trimmer, provided with a saw and knife, is shown in Fig. 425. These tools are attached by a suitable socket to a long pole. The method of using the saw is clear. It is used for cutting off large limbs of trees. The knife is operated by means of a stiff wire, extending from the upper end of lever *L* to the lower end of the pole, the wire being guided by screw eyes as shown. The lower end of the wire is furnished with a handle. The bough to be cut is placed in the cavity between *E*, *C*, and the wire is pulled upon. This brings the sharp edge of the knife-edged eccentric against the bough and forces it, at the same time, against the fixed cutting edge *E*. The saw may be readily removed by unscrewing the screws *s*.

Great care should be exercised by linemen not to disfigure trees abutting private property. The ruthless manner in which such trees have, in the past, been disfigured, has perhaps done more to incur the opposition that now exists to the presence of overhead telegraph lines along country roads, than any other cause.

LINE REPAIRING, ETC.—To facilitate repairs to lines, in well regulated companies, linemen are stationed at intervals along the route. It is the duty of these men to patrol their sections for the purpose of replacing insulators; renewing pins; straightening cross-arms; guying poles, etc. In case of line trouble occurring, such as breaks in the wire; crosses between wires, etc.; the chief operator, after locating the trouble between two stations, starts the linemen from each end of a section with orders to proceed until they meet each other, or until they find the trouble. When, as already noted,

FIG. 425.

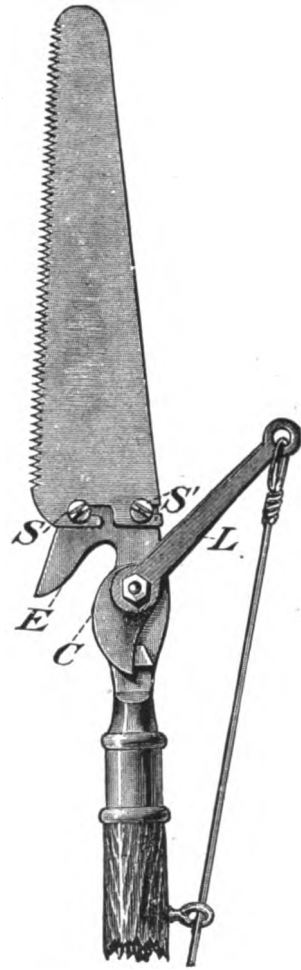

TREE TRIMMER.

(See Locating Faults on Telegraph Wires, Chap. VIII, page 135) the line follows a railroad, the linemen generally have permission to board a train, from which they keep a sharp look-out for the trouble. If they descry it, and are not permitted to stop the train between stations, a railroad velocipede is generally brought into service, from the next station. This machine, or vehicle, is constructed with three wheels, two of which, of similar size, run on one rail; the third, a smaller wheel, on the other rail. The two larger wheels are connected like the wheels of a bicycle. The third wheel has an axle which extends across the track to the truck of the larger wheels. The axle and smaller wheel are removable from the larger. The machine is propelled by pedals, like an ordinary road velocipede. Sufficient room is provided for a lineman's necessary working tools and supplies, in a receptacle under the seat. One man can readily lift this vehicle on and off the track out of the way of trains, and by its aid a fault is much more rapidly reached than otherwise.

On highway lines a horse and wagon are essential to speedy repairs.

TROUBLE HUNTING.

The most troublesome faults to find are often those which are of but short duration; as, for instance, a swinging cross, caused by the wind blowing two wires together momentarily.

Other sources of obscure trouble are those which occur only under certain conditions, as, for example, when a switch, or semaphore arm, or street gate, touches a wire, at intervals, and may be out of touching distance when the lineman passes. Many such causes of trouble are on record.

A rather peculiar case of obscure trouble which came to the writer's notice was occasioned in the following manner: The operator in a way office, whose duty it was to perform certain wire service each Sunday, was given the key of the outer door of the building, to afford him access to his office. He carried the key with him and placed it, for safe-keeping, on the top of the switch board. A short while after his arrival the chief office of the Division called him for a test of certain wires which were crossed. The trouble was located between the way office in question and a more distant office. The way office received orders to "clear" the trouble. He engaged a "team" to traverse the line but found no trouble, and so reported on his return, and a test disclosed that the wires were clear. This same proceeding was repeated twice before it dawned on the operator that the cross was occasioned by the presence of the key on the top of the switch-board.

AERIAL CABLES; METHODS OF SUSPENDING, ETC.

It frequently happens that it is more convenient to suspend a cable, containing a number of conductors, on poles than to string the same number of conductors separately on the cross-arms. In some cases it is imperative to employ cables in this way. For example, the writer has knowledge of an instance in New York city where the

only means of making connection from one office to another, was by the erection of three fifty-conductor cables, each 8,000 feet in length, upon poles which would not have accommodated 10 wires strung in the usual way. Again, there are hundreds of instances in large cities where cables are suspended for distances varying from 50 yards to 8 and 10 miles, as in the case of those under the elevated railroads in New York and Brooklyn.

Generally speaking, the insulation of aerial cables is some rubber compound surrounded with jute and tape. Light armored cables and lead covered cables are sometimes used for aerial purposes, but not frequently. In the case of some lead covered cables suspended under the elevated railroad in New York city a singular effect upon the lead covering was noticed after 6 or 8 months use, namely: minute crevices appeared throughout the length of the cable, to the extent that the insulation, which depended upon the lead covering for protection from moisture, was rendered defective. The cracks in the lead were probably occasioned by the mechanical vibration of the elevated structure.

The first act in erecting aerial cables generally consists in placing in position, between the supporting poles or other structure, a "guard" wire, which usually consists of one iron wire, or several iron wires stranded, securely fastened at the supporting points. This having been arranged, the cable is then raised, and is passed through a suitable pulley, near the guard wire. If it is a long cable, pulleys are placed along the proposed route at proper intervals, say at every other pole, if poles are the supports. The cable is then, by means of a rope attached to one end, hauled through the pulleys to any designated point. When thus drawn there is always more or less sag in the cable. The next operation consists in "hitching" the cable up to the guard wire. This is done in several ways; one of which is to provide a second wire, under the guard wire, on which a lineman walks, and from which he proceeds to tie the cable up to the guard wire, by marline, at every few feet. As he does so the slack is taken up by other linemen.

Sometimes a metal clamp or hook, Fig. 426, is used, by which to suspend the cable from the guard wire. This "hanger" is, however, mostly employed for suspending cables from an easily accessible structure, in which case the guard wire may be dispensed with, the clamps being attached directly to the structure. In other cases the cable to be suspended is tied to the guard wire while both are on the ground, after which both are raised together, to the supports.

FIG. 426.

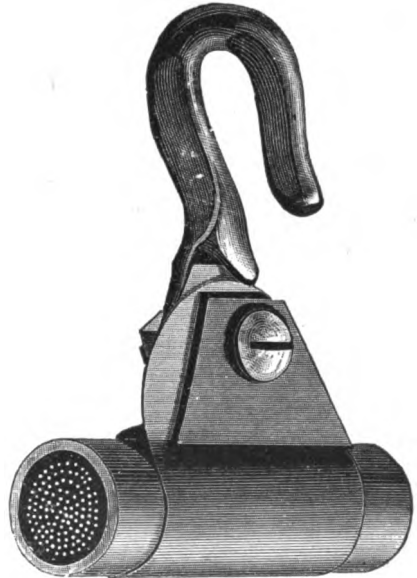

AERIAL CABLE HANGER.

CHINNOCK'S CABLE "WINDER," OR "SPINNING JENNY."

A much more expeditious means, than those described, of drawing a cable up to the guard wire, is the Chinnock cable "winder," popularly termed the "spinning jenny." It is shown in cross-section in Fig. 427. The device consists of a bobbin *A*, split in two parts, lengthwise, and having a hole through the center as indicated. An end view of the bobbin is given at *B*.

The device is employed as follows: The two parts of the bobbin are first separated and are then put over the guard wire and the cable to be drawn up to the guard. The parts are then fastened together by hooks on the ends of the bobbin, or

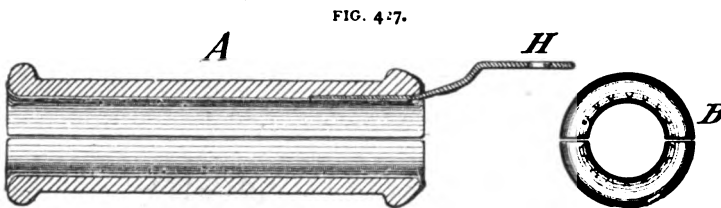

otherwise. The bobbin is now free to be moved along the guard wire *w* and cable *c*, as indicated in Fig. 428. Strong marline is then wound on the bobbin in layers, from one end to the other, and thence back to the starting point, and so on. The marline is then attached to a support, as at *p*. A larger rope *r* is connected to the hook *h* on one end of the bobbin. This rope is then hauled by linemen stationed at suitable points in advance. The effect is that, as the bobbin is thus pulled along the guard wire, the marline is unreeled from the bobbin and twists itself spirally around the guard wire and cable, and, as it progresses, draws up the cable in proximity to the guard wire, pushing before it the slack of the cable, which is taken up by linemen as it accumulates.

This arrangement is extensively employed in this country for this purpose. The operation of winding the bobbin has, of course, to be repeated, between every two points of support. In some instances the process is repeated, as from *p'* to *p*, to give added security to the cable.

The inside of the bobbin is sheathed with copper to prevent wearing. The copper is attached to the ends of the bobbin, as indicated in end view, *B*, Fig. 427.

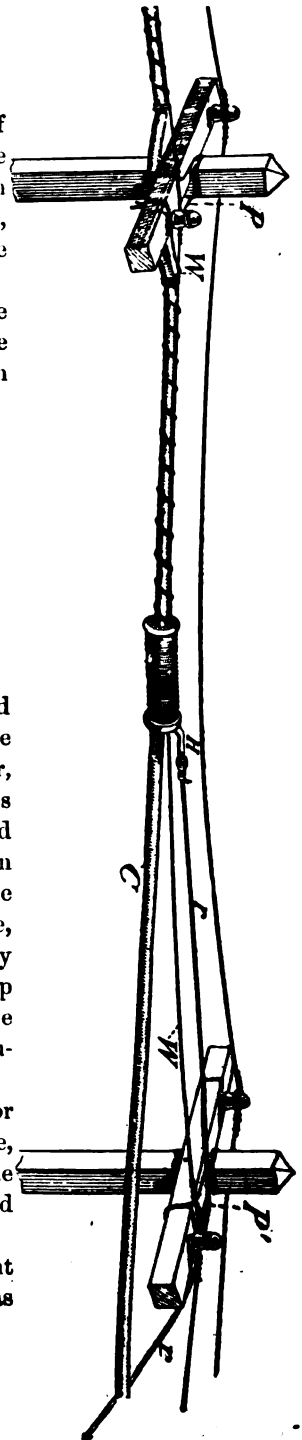

FIG. 428.

CHAPTER XXXIV.

SPECIFICATIONS—ESTIMATES—MISCELLANEOUS—TABLES.

SPECIFICATIONS, APPARATUS, ETC.

The following specifications have been found of service in practice and may, with such modifications as changing conditions may require, be of some value as a basis for others:

TELEGRAPH KEY.—(Maker, as may be stated.) Legs two inches long, having 40 well-cut threads to the inch, with thumb-screw and two washers for each leg, to match.

MORSE RELAY—Resistance 150 ohms. Silk insulation on copper wire of coils. Oiled base, with iron rim around the edge. Screw-posts all on one side. Length of core $2\frac{1}{4}$ inches. Diameter of core $\frac{7}{16}$ inch. Length of helix $2\frac{1}{2}$ inches. Length of lever of armature $2\frac{1}{2}$ inches. Diameter of helix $1\frac{1}{8}$ inches. Iron core must be of the best soft iron. The copper used in winding same must have conductivity of at least 97 per cent. of pure copper.

MORSE LOCAL SOUNDER.—Resistance 4 ohms. Short spiral spring. Sounder must give good, clear, snapping sound, without a "ring" following the stroke. Silk insulation on helix. Iron used for cores of magnets and wire wound on them, same as for relay.

REPEATING SOUNDER.—Resistance 4 ohms. Interchangeable contact points. Short spiral spring. In other respects same as for ordinary sounder.

MAIN LINE SOUNDER.—Resistance, 20 ohms. Similar in other respects to the Morse local sounder.

POLE-CHANGER.—Contact points and levers well separated, to prevent the current forming an arc between them. Resistance of electro-magnet, 4 ohms. Silk insulation. Iron of electro-magnet to be of best quality soft iron, and wire for winding the same to have a conductivity of, at least, 97 per cent. of pure copper. Screw posts all on one side. Base, same as for Morse relay.

SINGLE TRANSMITTER.—"Shovel-nose" contact tongue. Resistance of magnets, 4 ohms. Silk insulation. Iron for electro-magnet and wire for winding same, similar to pole-changer. Screw posts all on one side. Base, same as for Morse relay.

RHEOSTAT, (COMBINATION.)—Sets of coils in rheostat sub-divided (as may be desired). The 3,000, 2,000 and 1,000 ohm spools to be wound with, at least, No. 34 B. W. G. wire, and no wire smaller than No. 34 to be used in any of the spools. Length of rheostat, 10 inches. Width $5\frac{1}{2}$ inches. Height 5 inches.

SPARK COIL.—Total resistance of coils 1,110 ohms, sub-divided as follows 400,

300, 200, 100, 50, 35, 20, 10 ohm coils. Wire used must not be smaller than No. 34 B. W. G.

3-POINT SWITCH.—Length of legs, 2 inches. Well-cut threads on legs, 40 to the inch, with thumb-screw and 2 washers to each leg. Polished base.

REGULAR RHEOSTAT.—Total resistance of coils 11,110 ohms, sub-divided as follows: 4,000, 3,000, 2,000, 1,000, 400, 300, 200, 100, 50, 30, 20, 10. No wire smaller than No. 34 B. W. G. to be used in any of the coils.

POLAR RELAY.—Differential—400 ohms each side. Wires of different coils must not be crossed over each other inside the ebonite covering. Permanent magnet, semi-circular in form, $3\frac{1}{4}$ inches in diameter at the widest point. Length of armature $2\frac{1}{4}$ inches. Iron for electro-magnets must be of the best quality of soft iron, and wire for winding same to have a conductivity of at least 97 per cent. pure copper. Silk insulation over copper wire. Screw posts all on one side. Base same as for Morse relay.

QUADRUPLIX NEUTRAL RELAY.—Differential—200 ohms each side. Cores of magnets $\frac{1}{2}$ inch in diameter, and $1\frac{3}{16}$ inches long. Light retractile spring. Lever of armature $2\frac{3}{4}$ inches long. Length of helix $1\frac{1}{16}$ inches. Diameter of helix $1\frac{1}{2}$ inches. Quality of iron for electro-magnets and wire for winding same to be as called for in the polar relay. Screw posts all on one side. Base same as for Morse relay.

SPRING JACK SWITCH CORD AND PLUG—DOUBLE CONDUCTORS.—Length of "cord" according to directions of each requisition. Conducting wires of cord to be composed of strands of tinsel wire of good quality, each conductor well separated from the other, throughout. The conducting wires must be neatly and firmly soldered to the metal on handle end of plug, and then covered with strong twine. A piece of flexible rubber tubing, 4 inches long, must cover the junction of the cord and the plug. The surfaces of the brass on the plug must be well insulated from each other, the plug itself to be of good insulating material, such as hard rubber.

BATTERY MATERIAL.

BATTERY OIL.—Must be, non-volatile, non-inflammable, odorless, not capable of crusting, and must be of a color readily distinguishable from the solution, and have the quality of spreading well upon the battery solution. Reddish color preferred.

BATTERY JAR.—Extra well annealed, clear, flint glass. Weight of jar, 3 lbs. Size $6 \times 7\frac{1}{2}$ inches.

BATTERY COPPER.—Made of 98 per cent. pure, well-annealed, Lake Superior copper, .01 inch thick. Three "leaves," $5\frac{1}{2} \times 2\frac{1}{2}$ inches, concaved on lower edge, fastened together by a rivet in the middle. Well annealed copper connecting wire, .049 inch diameter, covered with a gutta-percha compound insulation, $\frac{1}{32}$ inch diameter, except for $1\frac{1}{2}$ inches at the top, which must be removed without scratching the wire. Lower

end of wire doubled on itself for $\frac{3}{4}$ inch—well fastened to the “copper” by a rivet, half way between bottom and top of one leaf of the copper, near the end. Total length of connecting wire, 12 inches from top of copper leaf. Weight of copper, with connecting wire, $2\frac{1}{4}$ ozs. (The “insulation” of this copper wire should not be pure gutta-percha, as, in that case, it is liable to crack, outside of the solution, in a comparatively short time; nor a rubber compound, because of the demulscient effect of the battery oil upon it.)

BATTERY ZINC.—Crowfoot pattern. Impurities not to exceed $\frac{1}{4}$ of one per cent. Hole in “hanger,” for connecting wire, $\frac{5}{32}$ inch diameter, and smooth, to prevent scratching the wire. Zinc to be smooth throughout. Thumb-screw of brass. Well cut screw, 20 threads to the inch. End of screw blunt and smooth. Distance from inside of hanger to bottom of zinc $2\frac{1}{2}$ inches. Weight 5 pounds. Hole for thumb screw to be well threaded, and must match the screw exactly.

ZINC AND COPPER SCRAPER.—One foot in length. Material, steel. Handle and blade one solid piece. Handle 5 inches long, 1 inch in diameter. Blade 7 inches long, flattened out in middle and tapering towards end. Middle of blade $1\frac{1}{4}$ inches wide. Diameter of blade near handle $\frac{7}{8}$ inch, at middle $\frac{3}{4}$ inch, at point $\frac{3}{8}$ inch. Blade to be double-edged. Edges about $\frac{1}{4}$ inch thick.

SPECIFICATIONS FOR HARD-DRAWN COPPER TELEGRAPH WIRE.

Weighing 170 lbs. per mile.

Weighing 110 lbs. per mile.

	No. 12 B. W. G.	No. 14 B. W. G.
Gauge		
Resistance per mile, ohms at 60°F.	5.23	8,078 ohms
Weight per mile ohm, at 60°F.	888.59	888.59
Diameter, in inches	.104	.083
Conductivity	98 per cent.	98 per cent.
Elongation	1 to 1.5 per cent.	1 to 1.5 per cent.
Twists in 6 inches	40	40
Tensile strength	550 lbs.	355 lbs.
Bends	$3\frac{1}{2}$	$3\frac{1}{2}$

One bend and straightening out counts 1.

(Note. The tensile strength for other sizes of wire may be placed at three and two-tenths times the weight, per mile, of the wire. The resistance or the weight, per mile, for other sizes of wire, may be calculated from the weight-per-mile-ohm, as explained elsewhere.)

All wire furnished to be smooth, bright and polished, round in cross-section, and without kinks of any kind. Length of coil at least $\frac{3}{4}$ mile, without splice, for 170 lb. wire.

After having been passed by the purchasers Inspector, each coil to be tied with four bands; then thoroughly covered with burlaps, or sacking, and wound with 15 turns of wire, outside.

SPECIFICATIONS FOR GALVANIZED IRON TELEGRAPH WIRE.

1. "The wire to be soft and pliable, and capable of elongating 15 per cent without breaking, after being galvanized.
2. Great tensile strength is not required, but the wire must not break under a strain less than three times its weight, per mile.
3. Tests for ductility will be made as follows: The piece of wire will be gripped by two vices, 6 inches apart, and twisted. The twists to be reckoned by means of an ink spiral, formed on the wire during torsion. The full number of twists must be distinctly visible between the vices on the 6-inch piece. The number of twists in a piece of 6 inches in length not to be under 15.
4. The electrical resistance of the wire in ohms, per mile, at a temperature of 60 Fahrenheit, must not exceed the quotient of the constant number 4844 when divided by the weight of the wire in pounds, per mile. Examples: A wire weighing 550 lbs., per mile (No. 6) should have a resistance not exceeding $4844 \div 550 = 8.8$ ohms, per mile. A wire of 388 lbs. per mile (No. 8) should have a resistance not exceeding $4844 \div 388 = 12.48$ ohms, per mile.
5. The wire to be cylindrical and free from scales, inequalities, flaws, sand splits and all other imperfections and defects.
6. It is desired to obtain the wire in coils, all of one piece, of about 150 lbs. each.
7. The wire must be well galvanized and capable of standing the following test: The wire will be plunged into a saturated solution of sulphate of copper, and permitted to remain one minute, and then wiped clean. This process will be performed four times. If the wire appears black after the fourth immersion, it shows that the zinc has not been all removed, and that the galvanizing is well done; but if it has a copper color the iron is exposed, showing that the zinc is too thin."

SPECIFICATIONS FOR A TELEGRAPH CABLE FOR AERIAL OR UNDERGROUND USE.

- No. of conductors as desired. Insulating material as desired.
 Conductors to be No. 16 B.W.G. copper wire. Conductivity 98 per cent. 6—32ds insulation. Conductors to be in exact center of insulation.
 Electro-static capacity not to exceed .35 microfarad, per mile.
 Insulation resistance of cable not to be less than 500 megohms, per mile, after

1 minute electrification; test to be made after at least 48 hours' immersion in salted water, at temperature of 75° F.

Cable to stand, without deterioration, variations in temperatures ranging from 5° F. below, to 150° F., above, zero. The whole to be enclosed in jute covering, finished with two thicknesses of rubber tape.

Outside diameter not to exceed — inches.

Cable to be warranted, by the manufacturer, for 3 years, to withstand electrical pressure of 500 volts; also to be warranted for same period against injury from gas or water, if laid in underground ducts.

SPECIFICATIONS FOR SHORT CABLE FOR RIVER OR HARBOR CROSSING.

Seven or more conductors, each to be No. 16 B.W.G. copper wire; or of 3 wires No. 18 B.W.G. stranded, as may be stated by purchaser. Conductivity, 98 per cent. Outside diameter of each conductor 9-32ds inch.

The whole, after cabling, to be well juted and armored with 18 No. 9 B.W.G. galvanized iron wires, or a less number of No 4 B.W.G., depending on conditions to be met.

Insulation resistance of each conductor 500 megohms, at 75° F. after 1 minute electrification, and after at least 48 hours immersion in water.

Electro-static capacity, .35 microfarads, per mile.

SPECIFICATIONS FOR EMERGENCY CABLE.

(In cases of breaks in the pole line, due to floods, railroad wrecks, etc., a small, easily handled cable is of much value in opening up communication pending repairs of the break.)

Length of cable about $\frac{1}{2}$ mile.

Number of conductors, say, 12. (18 B.W.G.)

Nature of insulation of each conductor to be some tough, pliable material, utterly impervious to moisture, such as a rubber compound. Thickness of insulation of each conductor, 4-32ds.

Insulation resistance to be at least 500 megohms, per mile, after 1 minute, electrification, and after 48 hours immersion in water, at 75° F.

Cable to contain 1 taped or tracing wire.

Two extra heavy tapes outside.

Outside diameter of cable to be about 17-32ds.

Cable to be placed on a light reel.

FORM OF CONTRACT SPECIFICATION FOR THE MANUFACTURE AND LAYING OF UNDER-GROUND CABLES.

"The cable is to be laid from — street, — city, along — street to — Avenue under right of way furnished by the — Telegraph Company.

The length of trench required is about — feet.

The cable to contain — conductors of copper, — of which are to consist each, of a single wire, having a diameter of — of an inch (No. — gauge,) and one conductor to consist of a copper wire having a diameter of — of an inch (No. — Gauge) and a conductivity not less than — per cent. of that of pure copper.

The insulation to be of the material commonly used by the — Insulated Wire Company, and to have a diameter of at least — thirty seconds of an inch on the small wires, and at least — thirty-seconds of an inch on the large wire, and shall in all cases offer a resistance of not less than — megohms per mile.

The — Insulated Wire Company warrants the conductors to maintain the above insulation resistance for one year, against an electromotive force of — volts on the small conductors and — volts on the large conductor.

If one or more of the — conductors in the cable shall not meet the requirements of this agreement then a proportionate amount shall be deducted from the price of the whole cable, and cost of laying thereof for such wire or wires, and thereupon, the wire or wires so rejected shall be and remains the property of said — Insulated Wire Company, and the said — Telegraph Company shall have no right or title in or to such wires. It is hereby agreed and understood that the — Insulated Wire Company does not warrant against mechanical injury, that is, such injury as might result from accidents, excavations, or malicious tampering, etc., and any repairs or replacing of cable made necessary, by such causes, shall be made by them at the expense of the — Telegraph Company, at the actual cost of such repairs and replacing.

The cables are to be laid in a box — inches square on the inside, to be made of lumber at least — inch thick, and filled in with earth; said box to be laid in a trench — feet deep; the cable to be reeled in the box, joints made, excavation refilled and all displaced paving replaced, by the — Insulated Wire Company; said work to be done in a manner satisfactory to the city authorities.

It is understood and agreed that the price of the above cable shall be — cents per foot, and that the trenching and repaving shall be done at — cents per yard, and the box containing the cable shall be — cents per foot; and an additional sum of — dollars per mile shall be allowed on each mile of cable laid in said trench or proportionately for any fraction of a mile to cover cost of joining and reeling the cable in the trench. All the expenses connected with the opening of the streets, laying the cable and repaving the streets to be paid as soon as the work of laying the cable and repaving the streets shall be completed. And, within — days after notice from the Insulated Wire Company that the line is ready for use said cables shall be tested by an electrician appointed by the — Telegraph Company, and, if found in accordance with these specifications, shall be turned over to them for their use, and after — days trial, if the cable still continues in perfect order

as per these specifications, then — — per cent. of the price of the cables shall be paid. And if said cable shall continue in perfect working order during the further period of — — days, then at the end of — — days, said — — days, said — — Telegraph Company shall pay the remaining — — per cent. of the price of said cable.”

MISCELLANEOUS.

BINDING SCREWS.— In Fig. 429 are shown several types of binding posts such as are used on switch boards, relays, etc.

FIG. 429

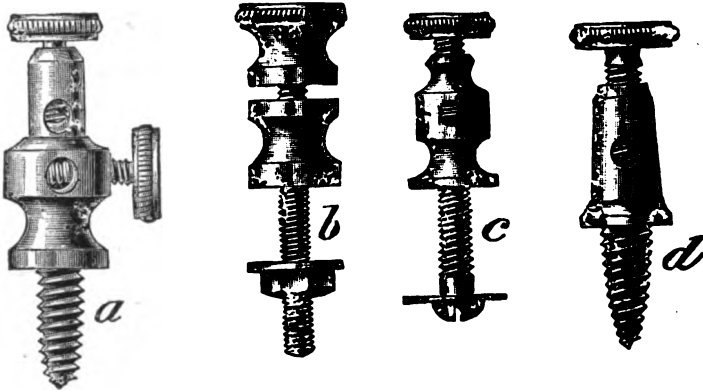

BINDING SCREWS.

a is a “double connector”; *b*, *c* and *d* are “single connectors.” *b* is known as the

FIG. 430.

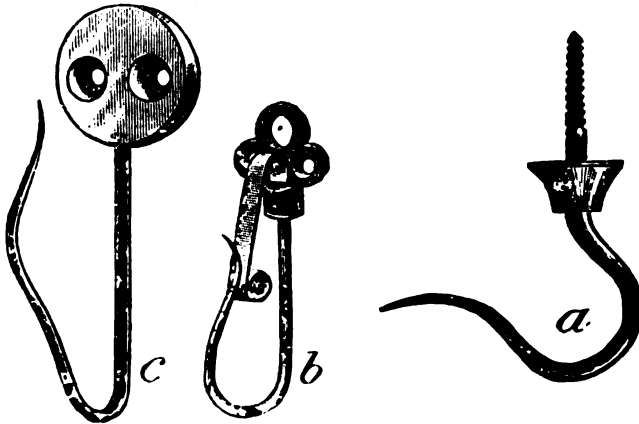

MESSAGE HOOKS.

“English” binding post; it affords a firm contact with the wire and is very suitable for permanent connections.

To prevent loosening of the contact upon the wire, as frequently happens in the forms *a c d*, a “set” screw is generally provided in addition to the ordinary screw.

MESSAGE HOOKS.—"Message" hooks for holding telegrams prior to transmission are generally provided on each desk in operating rooms. The style shown at *a* in Fig. 430, is the one most frequently employed. Hooks *c* and *d* are designed to prevent the accidental removal of messages from the hooks: by drafts of wind, etc.

PRICES OF TELEGRAPH APPARATUS, MATERIAL, ETC.

The following figures, while taken from actual quotations and estimates, can only be considered as approximately correct; the prices constantly changing. The figures, however, will serve to give a fair general idea of present prices.

Morse key,	\$1.50
Sounder, 4 ohms,	2.40
Morse relay, 150 ohms,	4.00
Neutral relay, double winding, 200 ohms,	11.50
Polar relay,	11.50
Transmitter, single,	6.75
Fole-changer,	11.25
Repeating sounder, 4 ohms,	2.75
Rheostat, 11,100 ohms,	15.00
Combination rheostat,	35.00
Spark coil, 1,100 ohms,	6.00
Condenser, 3 to 4 MF, adjustable,	18.00
3-point switch,	0.65
1 zinc, crowfoot, 3 lbs.,	0.20
Bluestone, 1 lb.,	0.03 to .04
1 battery jar, 6 x 8 inches.	0.14
1 battery, copper,	0.08 to .12
Rubber tape in rolls,	about \$1 per lb.
No. 6 iron wire,	about 4 $\frac{3}{4}$ cents per lb.
No. 12 copper wire,	14 cts. per lb.
Cross-arms,	40 cts. each.
Insulators, 22 oz.,	4 cts.

Creosoted wooden subways, about 16 cts. per foot, per duct, exclusive of excavation, back filling and repaving.

Estimated average cost of maintenance of 1 gravity cell, per annum, \$1.16. This includes zinc, bluestone, labor, rent, breakage, supervision.

Carefully estimated average cost of maintenance of a telegraph line places it at \$25 to \$30 per mile, per annum.

EFFECTS OF HIGH TEMPERATURES ON VULCANIZED INDIA RUBBER INSULATION.

The effects of high temperature on vulcanized India rubber is to harden it, and, eventually, to carbonize it. Vulcanized rubber will ignite when brought into moderately prolonged contact with flame.

Tests made by the writer, of India rubber cables which had an insulation resistance of 1,500 megohms, per mile, at 60° F., gave the following average results at the temperatures stated.

Degrees Fahrenheit	Insulation, resistance megohms.
110	220.
120	200.
130	180.
140	160.
150	131.
170	62.
180	49.
190	29.7
200	18.6
212	11.4

The same cables showed the following increase of electro-static capacity:

Between the temperatures of	100° F and	110° F	5 per cent.
" " "	" 110°	" 125°	5 "
" " "	" 125°	" 140°	6 "
" " "	" 140°	" 150°	6 "
" " "	" 150°	" 160°	6 "
" " "	" 160°	" 170°	8 "
" " "	" 170°	" 180°	12 "
" " "	" 180°	" 190°	16 "
" " "	" 190°	" 200°	18 "
" " "	" 200°	" 212°	25 "

AVERAGE SALARIES OF TELEGRAPH OPERATORS IN DIFFERENT COUNTRIES. COMPILED BY CARROL D. WRIGHT, UNITED STATES COMMISSIONER OF LABOR, 1901.

COUNTRY.	Wages per Day.	Hours per Week.	COUNTRY.	Wages per Day.	Hours per Week.
Australia	\$.80 to \$2.67	—	Japan	\$.15 to \$.25	—
Belgium	.98	—	Mexico	1.92	60
Canada	1.32 to 3.60	56	Netherlands	.50 to .99	56
China	.79	—	Russia	.26 to 3.00	56 to 84
France	.99	—	United States	1.95	70
Germany	.68 to .98	63	" in large		
Great Britain	1.11 to 1.95	56	offices	2.20	50
Italy	.90	60	" maximum	3.00	54

In 1850 the highest salaries paid operators in the United States was about \$35 per month. The superintendents of telegraph received about \$125. In 1860 the salary for operators was about \$55 per month. During the war, 1862 to 1865, these latter salaries were doubled.

TABLES.

DIFFERENCE BETWEEN PRINCIPAL WIRE GAUGES IN DECIMAL PARTS OF AN INCH.

New British	American. or Brown & Sharp. (B. & S.)	No. of Wire Gauge	Birmingham or Stubs. (B. W. G.)	Washburn & Moen.
.....	00000046
.....	0000043
.4	.46	0000	.454	.393
.372	.40964	000	.425	.362
.348	.3648	00	.38	.331
.324	.32495	0	.34	.307
.3	.2893	1	.3	.283
.276	.25763	2	.284	.263
.252	.22942	3	.259	.244
.232	.20431	4	.238	.225
.212	.18194	5	.22	.207
.192	.16202	6	.203	.192
.176	.14428	7	.18	.177
.16	.12849	8	.165	.162
.144	.11443	9	.148	.148
.128	.10189	10	.134	.135
.116	.090742	11	.120	.12
.104	.080808	12	.109	.105
.092	.071961	13	.095	.092
.08	.064084	14	.083	.08
.072	.057068	15	.072	.072
.064	.05082	16	.065	.063
.056	.045257	17	.058	.054
.048	.040303	18	.049	.047
.04	.03539	19	.042	.041
.036	.031961	20	.035	.035
.032	.028462	21	.032	.032
.028	.025347	22	.028	.028
.024	.022571	23	.025	.025
.022	.0201	24	.022	.023
.02	.0179	25	.02	.02
.018	.01594	26	.018	.018
.0164	.014195	27	.016	.017
.0148	.012641	28	.014	.016
.0136	.011257	29	.013	.015
.0124	.010025	30	.012	.014
.0116	.008928	31	.01	.0135
.0108	.00795	32	.009	.013
.01	.00708	33	.008	.011
.0092	.006304	34	.007	.01
.0084	.005614	35	.005	.0095
.0076	.005	36	.004	.009
.0068	.004453	370085
.006	.003965	38008
.0052	.003531	390075
.0048	.003144	40007

NUMBER, DIAMETER, WEIGHT, LENGTH AND RESISTANCE OF COMMERCIAL COPPER WIRE.
PERCENTAGE CONDUCTIVITY 98.

Gauge	Diam.	Weight. Sp. Gr.—8.89			Length.	Resistance at 70° Fahrenheit. B. A. Ohms.			
		In mils.	Grs. per ft.	Lbs. per 1000 ft.		Lbs. per mile.	Feet per lb.	Ohms per 1000 ft.	Ohms per Mile.
0000	460.000	4475.33	639.33	3375.66	1.56	.051	.2692	19605.69	.0006798
000	409.640	3549.07	507.01	2677.01	1.97	.064	.3379	15547.87	.000127
00	364.800	2814.62	402.09	2122.93	2.49	.081	.4276	12330.36	.000202
0	324.950	2233.28	319.04	1684.53	3.13	.102	.5385	9783.63	.000320
1	289.300	1770.14	252.88	1335.20	3.95	.129	.6811	7754.66	.00051
2	257.630	1403.79	200.54	1058.85	4.99	.163	.8606	6149.78	.000811
3	229.420	1113.20	159.03	839.67	6.29	.205	1.0824	4876.73	.001289
4	204.310	882.85	126.12	666.00	7.93	.259	1.3675	3867.62	.00205
5	181.940	700.10	100.01	528.05	10.00	.326	1.7212	3067.06	.00326
6	162.020	555.20	79.32	418.60	12.61	.411	2.1700	2432.22	.00518
7	144.280	440.27	62.90	332.11	15.90	.519	2.7973	1928.75	.00824
8	128.490	349.18	49.88	263.05	20.05	.654	3.4531	1529.69	.01311
9	114.430	276.94	39.56	208.87	25.28	.824	4.3507	1213.22	.02083
10	101.890	219.57	31.37	165.70	31.88	1.040	5.4912	961.91	.03314
11	90.742	174.15	24.88	131.50	40.20	1.311	6.9220	762.93	.05269
12	80.808	138.11	19.73	104.20	50.69	1.653	8.7278	605.03	.08377
13	71.961	109.52	15.65	82.74	63.91	2.084	11.0035	479.80	.13321
14	64.084	86.86	12.41	65.51	80.59	2.628	13.8758	380.51	.2118
15	57.068	68.88	9.84	51.95	101.63	3.314	17.4979	301.75	.3368
16	50.820	54.63	7.81	41.27	128.14	4.179	22.065	239.32	.5355
17	45.257	43.32	6.19	32.72	161.59	5.269	27.820	189.78	.8515
18	40.303	34.35	4.91	25.96	203.76	6.645		150.50	1.3539
19	35.390	26.49	3.88	20.58	264.26	8.617		116.05	2.2772
20	31.961	21.61	3.09	16.36	324.00	10.566		94.65	3.423
21	28.462	17.13	2.45	12.94	408.56	13.323		75.06	5.443
22	25.347	13.59	1.94	10.27	515.15	16.799		59.53	8.654
23	22.571	10.77	1.54	8.14	649.66	21.185		47.20	13.763
24	20.100	8.54	1.22	6.45	819.21	26.713		37.43	21.885
25	17.900	6.78	.97	5.12	1032.96	33.684		29.69	34.795
26	15.940	5.37	.77	4.06	1302.61	42.477		23.54	55.331
27	14.195	4.26	.61	3.22	1642.55	53.563		18.68	87.979
28	12.641	3.38	.48	2.55	2071.22	67.542		14.81	139.893
29	11.257	2.68	.38	2.02	2611.82	85.170	x5.28	11.73	222.449
30	10.025	2.13	.30	1.60	3293.97	107.301		9.31	353.742
31	8.928	1.69	.24	1.27	4152.22	135.402		7.39	562.221
32	7.959	1.34	.19	1.01	5236.66	170.765		5.86	894.242
33	7.080	1.06	.15	.80	6602.71	215.312		4.64	1421.646
34	6.304	.84	.12	.63	8328.30	271.583		3.68	2261.82
35	5.614	.67	.10	.50	10501.35	342.443		2.92	3596.10
36	5.000	.53	.08	.40	13238.83	431.712		2.32	5715.36
37	4.453	.42	.06	.31	16991.06	544.287		1.84	9048.71
38	3.965	.34	.05	.25	20854.65	686.511		1.46	14320.26
39	3.531	.27	.04	.211	26302.23	865.047		1.16	22752.6
40	3.144	.21	.03	.158	33175.40	1091.866		.92	36223.59

SUPPLEMENTAL INDEX.

A M

Alphabet, Myer, 363.
 " Buckingham, 436b.
 Aluminum armature levers, 187.
 Ammeters, 120, 148. Ampere hours, 49b, 49c.
 Ampere turns, 33, 318.
 Angle of lag, 100a.
 Automatic cut-out, 49d.
 " telegraphy, Delany, 321b, 322.
 " " Pollak-Virag, 323b.
 " transmission, 72, 285.
 " embossed tape for, 72.
 " switches, 166d.
 Battery, dry, 335; Edison, 355b.
 Block signals, railway, wireless system for, 508a.
 " Miller cab signal, 508a.
 Branly coherer, 335b.
 Buckingham alphabet, 436b.
 " printer, 436a.
 Burry self-winding ticker, 419.
 Buzzer working, 366a.
 Capacity uniformly distributed, 100c.
 Catch magnets, 508a.
 Choke coils, 335d.
 Code, *see* Alphabet.
 Coherer, anti, auto, 335b, 335f, 335f.
 Condensers in bridge duplex, 212, 321.
 Conductors, loaded, Thompson, Pupin, 100c.
 Counter E. M. F., 100a.
 Current for relays, 69.
 Dead beat swing, 119.
 De Forest wireless telegraph, 335k.
 Delany automatic telegraph, 321b.
 Diehl test for crosses, 142.
 Double current method, repeaters, 166c, 167, 321b.
 Duplex, high potential leak, 255.
 Electric "eye," waves, undulations, 335a.
 Electrophotography, 323.
 Electromagnetic theory of light, 335a.
 Electromotive force, counter; impressed, 100a.
 Electronic theory, electrons, 3.
 Energy, E. M. F. 100a; kinetic, 100f; radiated, 335c.
 Ether, 3, 335a.
 Field key system, 226.
 Fleming wireless transmitting system, 335d.
 Frequency, 100b.
 Fuses, 87, 89.
 Galvanometer, D'Arsonval, 119.
 Gray's harmonic telegraph, 335a.
 Ground for vertical wire, 335f.
 Henry, unit of inductance, 100b, 207a.
 Hertz experiments, oscillator, waves, 335a, 335b.
 Horse-power, 8.
 Hughes printer, relay, 240c, 436.
 Impedance, 100b.
 Increment key, 240b.
 Inductance, *see* Self-induction.
 " of relays, etc., 100f, 318.
 " uniformly distributed, 100f.
 Induction telegraph, 335.
 Interpolator, 285b.
 Interrupter, 335.
 Iridium contact, 285a.
 Iron poles for semaphores, 508.
 Keeper, 240c.
 Key or transmitter, reversing, increment, 240b.
 Leak box, 223.
 Leak relay, 166d.
 Lightning arresters, carbon, argus, fuses, 89.
 Lines of force, 33.
 Local correction device, 285b.
 Magnetic lines of force, 400.
 " flux, saturation, permeability, 33, 66.
 " pull, 240c.
 Magnetism, Ampere theory of, 66.
 Marconi wireless telegraph, 335c.
 Master switch, 342.
 Miller cab signal, 508a.
 Morris duplex, 268.
 Morse sending, notes to beginners, 57b.
 " manual transmission, advantages of, 57d.
 Motors, motor dynamos, motor generators, 49a.
 Myer alphabet, 363.

O Z

Ohm's law, 100d, 100e.
 Oscillations, rate of, 335b.
 Oscillators, Hertz, 335b.
 Penmanship, 57c.
 Perforator, keyboard, 321a, 436a.
 Photographic receiver, 323b.
 Polarized relay, 186.
 Poles, iron, for semaphores, 508.
 Pollak-Virag automatic telegraph, 323b.
 Preece induction telegraph, 335.
 Printing telegraph, Buckingham, 436a.
 " " Hughes, 436.
 " " Baudot, Rowland, 436x, Barclay, 437.
 " " Burry, 419; Murray, 437d.
 Punch magnets, 436d.
 Pupin loaded conductor, 100c.
 Quadruplex, British post-office, 240f.
 " Roberson, 240.
 Railway block signals, 508.
 Reactance, 100, 101, 101a, 100d.
 Receiving pen, 332.
 Relay, *see* Repeater. Direct repeating relays, 255.
 " current for, 69.
 " Hughes, 240c.
 " polarized, 335d.
 " Stroh, 186.
 " vibrating, 332.
 Repeater, Brown cable relay, 285a.
 " Atkinson, Chagan, open circuit, ~~166b~~ current, 166b, 167.
 Repeating sounder, 240d.
 Resistance, carbon, non-inductive, 240b.
 Retardation of signals, 100.
 Rheostat, Varley, 223.
 Self-induction, 100, 100b, 100c, 100f, 318, 321, 335f.
 Semaphores, compressed gas for, 508a.
 " motor operated, iron poles for, 508.
 Sieurs duplex, 240.
 Signal corps "kit," 366a.
 Signaling between vessels, distance, 335a.
 " speed of, 323b, 321a, 436w.
 Solenoid, 66.
 Stevens perforator and transmitter, 321a.
 Storage battery, 49a; chloride cell, 49b.
 " in telegraphy, 49d.
 Stroh relay, 186. Stamm added resistance, 217b.
 Sunflower, 436a.
 Tappings, 322.
 Tapper, 335c.
 Telergraph, 332.
 Telegraph and telephone working, 366a.
 " automatic, 322.
 " Gray's harmonic, 335a.
 " wireless, 332.
 " writing, 332.
 Telegraphing pictures, 323a.
 Telephone receiver, 323b, 335.
 " long distance, 335a.
 Tests by ammeter, voltmeter, 148.
 Time constant, 207a.
 Transmitter, Stevens automatic, 321a.
 Unit of electrical energy, 8.
 United States signal corps kits, 366a, 366c.
 Varley, opacity of magnets, rheostat, 223, 321.
 Vector sum, 100c.
 Velocity of wave propagation, 100e, 100f, 101.
 Vertical wires, 335c, 335e.
 Vibrating relay, 332.
 " strings, 100c.
 Voltmeters, tests by, 120, 148.
 Wages of operators, 561.
 Watt, kilowatt, 8, 100a.
 Wave, attenuation factor, constant, 100e.
 " propagation, 335f, 335i.
 Wig-wag telegraph, code, 363.
 Wireless telegraphy, 333; syntonic, 333f.
 " " De Forest, 335k.
 " " Lodge, Marconi, 335c, 335a.
 " " masts for, 335f.
 " " Preece, 335.
 " " tuned circuits, 335g.
 Zero, wandering, 285.
 Zinc, wasteless, 26.

INDEX.

A B

Absolute block signals, 494.
 Absolute units, 7.
 Action of condenser as static compensator, 209.
 " Added " resistance, 231.
 Adjusting Morse relay, 63.
 " Wheatstone relay, apparatus, 304, 319.
Aerial cables, 550.
 " hanger, 551.
 " methods of suspending, Chinnocks, 551-552.
Aerial wires, joints on, 545.
Alphabets, Morse, Continental, Bats, Phillips, etc., 56, 57, 268, 273, 363.
 Alternate current machine, 36.
 Amalgamation of zinc, 18.
 American district telegraph messenger service, 367.
 American standard wire gauge, 514.
 " for telegraph wires, 522.
Ampere, 5.
 " turns, 66, 37, 68, 69, 318.
 Anchor guy, 536.
 Anti-hum device, 546.
 Answer back signals, 370, 374, 376, 464, 480.
 Apparatus, Morse telegraph, 58.
 " prices of, etc., 560.
 " specifications for, 553.
Armatures, 38, 51, 499.
 Arrangement of dynamo machines in telegraphy, 44.
Arresters, lightning, See Lightning Arresters.
 Artificial Hue, 176.
 " cable, Stearns', Muirhead's, 276, 279.
Astatic galvanometer, 112.
 Atlantic cable, 281.
Automatic answer back, 490.
 " burglar alarm telegraphy, *See Burglar Alarm Telegraph.*
 " fac-simile telegraph, 321.
 " fire-alarm telegraphy, *See Fire alarm Telegraph.*
 " multiple transmitter, 476.
 " telegraph repeaters, *See Repeaters.*
 " telegraph sender, 71.
 " telegraphy, Anderson, chemical, Wheatstone, 289, 293, 296.
Auxiliary fire alarm telegraph, 445, 461.
Balancing cable duplex, 280.
 " polar duplex, 189
 " quadruplex, 232.
 " relays, 236.
 " Stearns' duplex, 179.
 " Wheatstone duplex, 319.
Barrand and Lund clock synchronizer, 353.
 Barrett chloride of silver battery, 18.
 Batteries, *See Cell.*
 " testing condition of, 134.
Battery, arrangement of cells in, 23.
 " copper, 554.
 " copper, zinc, 80.
 " gauge, Bunnell's, 119.
 " internal resistance of, 15.
 " intermediate, 80.
 " jar or cell, 12, 554.
 " Lockwood, 377.
 " material, 554.
 " oil, 14, 21, 238, 554.
 " primary, 9.
 " zinc, 554
Bi-metallic thermostat, 470.
 Banding posts, 79, 559.
Block-system, See Railway Electric Block Signals, 494.
 " instrument, Hall's, 507.

B O

Bluestone, 11, 12.
Box relay, 65.
Brackets, 537.
 " line, 537.
Branch office signaling devices, Chicago, New York, Hurd, 257, 258.
Brush, dynamo, 36.
 Breakage of cells, 15.
 Breaking strain, 516, 522.
 Breaks in copper wire, 545
 Break-wheels, 368, 468.
Bridge arms, ratio of, 519.
 " duplex, 172.
 " Wheatstone, 122, 519.
Bridle or jumper, 546.
 British association ohm, 522.
 Brown and Allen relay, 281.
 Bulen automatic fire alarm telegraph, 467.
 Bunnell key, 59.
 " sounder-resonator, 76.
Burglar alarm and district call box combination, 386.
Burglar alarm telegraph, 380,
 " " " Holmes', 380.
 " " " Wilder, 383.
Cable, artificial, 276.
 " box, 548
 " duplex, 280.
 " emergency, 557.
 " hanger, 551.
 " jointing, 526.
 " winder, Chinnocks, 552.
 " working, duplex, simplex, 277, 276.
Cables, aerial, See Aerial Cables.
 " river and harbor, 528, 557.
 " specifications for, 556, 557.
 " underground, *See Underground Telegraph Cables.*
 " underground, form of contract for construction and laying of, 558.
Callaud or gravity cell, care of, 11, 12.
Call box, 367.
 " Field and Firman, 472.
 " Fix, 387.
 " multiple, 373.
Cant-hooks, 535.
Capacity, electric, 91.
 " constant of, 132.
 " electro-static, 91.
 " of condensers, joint, total, 94.
 " Atlantic cable, 92.
 " overland telegraph wires, 92.
 " specific inductive, 91.
 " tests, 131, 142.
Carbon, resistance under pressure, 326, 345.
Caution signal, 494.
Cell, (primary), 9.
 " dry, 21.
 " Burnley, 22.
 " bi-chromate of potash, 18.
 " Callaud or gravity, *See Gravity Cell.*
 " chloride of silver, 19.
 " constant, 10.
 " Daniell's, 11.
 " Edison-Lalande, 20, 534.
 " Fuller, 17.
 " Gassner, dry, 23.
 " Leclanché, 16.
 " open, closed, circuit, 10.
Cells, arrangement of in batteries, in multiple, in opposition, in series, 23, 24, 25.
Charge, static, See Static.
 " distribution of in conductor, 97.

- Chemical automatic telegraph, *See* Automatic Telegraphy.
- " action of current, 530.
 - " recorder, 294.
 - " solutions, 290, 295.
 - " terms, 9.
- Chemically prepared paper, resistance of, 291.
- C. G. S. units, 8.
- Chicago police patrol telegraph system, 481.
- " branch office signal, 257.
- Chlorides, of zinc, 9, 16.
- Chinnock's cable winder, 552.
- Chronograph, electric, 357.
- Circuit, 51.
- " closed, open, methods, 54.
 - " ground return, 52.
 - " local, 53.
 - " magnetic, 32.
 - " metallic, 52.
 - " Morse, 52.
 - " phantom, 231.
 - " short, 10.
- Circuits, joint resistance of, 27, 30, 146.
- Citizens key, 472.
- City construction work, 546.
- Climbers, 542.
- Clock block signal, 499.
- Clocks, electrically synchronized, 358.
- Codes, telegraph, 53, 363.
- Coil, spark, 177.
- Coils, German silver, 42, 101, 178.
- " differential induction, 231.
 - " magnetic, 351, 460.
 - " resistance, 174.
 - " retarding, 177.
- Combination duplex systems, 264.
- " rheostat, 214.
 - " plate and spider lightning arrester, 86.
- Come-alongs, 543.
- Commutator, 37.
- Compensating line, 176.
- " condensers, *See* Condenser.
- Component forces, 103.
- Condenser, 90, 274, 275.
- " adjustable, 93.
 - " as static compensator, action of, 177, 209, 306, 307.
 - " as neutralizer of reversal effects, 204, 206.
 - " as neutralizer of extra-current effects, 319.
 - " capacity of, 91, 93.
 - " in automatic telegraphy, 293.
 - " in induction telegraphy, 334.
 - " in multiplex telegraphy, 342.
 - " in printing telegraphy, 401.
 - " in simultaneous telegraphy and telephony, 348.
 - " in submarine telegraphy, 275.
 - " Wheatstone automatic, 306, 315.
- Conductivity, conductance, 29.
- " percentage, 518.
 - " specific, 518.
- Conduits, *See* Underground Conduits.
- Constant cells, 10.
- " of capacity, 182.
 - " of galvanometer, 144.
- Construction and maintenance of telegraph lines, 532.
- " after, 548.
- Continental alphabet, 56.
- Continuity preserving transmitter, 176.
- Convulsions of wire in relays and sounders, 69.
- " effect of increased number of, 36, 69.
- Copper, manufacture of, etc., 511.
- " battery, scrapings of, 554, 16.
 - " connecting wire, 554.
 - " wire, hard-drawn, *See* Hard-Drawn Copper
 - " tables concerning, 563.
- Cord, double conductor, 79, 554.
- Core, 37, 52.
- Correcting devices, 338, 391.
- " relay, 338.
- Corrections for temperature, 520, 521.
- Coulomb, 91.
- Counter, E. M. F., 10, 11.
- Creeping salts, 14.
- Crosses, locating, 134.
- Cross-arms, 537.
- Crow-foot zinc, 12.
- Current, alternating, continuous, direct, 36.
- " distribution of, 30.
 - " "excess," 200.
 - " magnetizing, 185, 208.
 - " single, double, methods, 183, 267.
 - " strength, 5.
 - " ratio of, 207, 217.
- Currents, earth, 274.
- " pulsatory, 265.
- Cutting lines of force, 33.
- Cuttriss' magnetic siphon recorder, 271.
- Cut out, way-office, 83.
- "Danger" signal, 494.
- Daniells' cell, 11.
- Davis loop switch, 262.
- Dead-man or butt-prop, 534.
- Decrease of current method, 196.
- Delany line adjustment, 150.
- Delany synchronous telegraph, 336.
- Denison automatic fac-simile telegraph, 322.
- Derivation of electrical units, 6.
- Detector galvanometer, 113.
- Dial rheostat, 316.
- Diameter of wire, tests for, 514.
- Dielectric, 91.
- Difference of potentials, 4, 5, 10, 208.
- Differential duplex, 169, 176.
- " galvanometer, 114, 305.
 - " induction coil, 228.
 - " relay, 170.
- Diplex, Sleurs, 265.
- Direct current machines, 36.
- " deflection method of testing, 131, 145, 529, 530.
- Disc signal, 499.
- Discharge key, 131.
- Distribution of current in divided circuits, 30, 219.
- District telegraph service, American, 367.
- Divided circuits, 30, 219.
- "Dot" key, 395.
- Double-balanced relay, 387.
- " block, Muirhead's, 279.
 - " conductor cord, 79, 554.
 - " binding posts, 79, 559.
 - " current method, 183, 267.
 - " petticoat insulator, 540.
 - " spring-jack, 79.
- Drawing in and out conduit, 524.
- Dry batteries, Burnley, Gassner, 21, 22.
- Duct, *See* Underground Conduits.
- Ductility tests, 517, 555.
- Duplex telegraphy, 169.
- " telegraph, bridge, 172.
 - " cable, 277, 280.
 - " differential, 169.
 - " Edison-Smith, 264.
 - " Jacoba, 263.
 - " polar, 174, 181, 184.
 - " Stearns', 173.
 - " Varley-Athearn, 351.
 - " Wheatstone, 305.
- Duration of gravity cells, 13, 378.
- Dynamo machine (in telegraphy), 27.
- " essential parts of, 39.
 - " methods of arranging, 40, 44, 46, 49.
 - " theory of, 32.
 - " loop switch, Davis, 262.
 - " pole-changer, 194.
 - " reversing switch, 42.
- Earth currents, 274.
- Earth's magnetism, 103.
- " directive influence, 112.
- Edison conduit, 524.
- " dynamo machine, 39.
 - " Lalande cell, 20, 354.
 - " phonoplex, 353.
 - " Smith duplex, 265.
 - " ticker, 406.
- Effects of impurities in metals, 517, 518.
- " of temperature on conductors, on liquids, 520, 16.
 - " of high temperature on vulcanized India rubber, 500.

E F G

Electrical units, 8.
 Electric block signals. *See* Railway Electric Block Signals.
 Electrical testing, 122.
 " tests of telegraph wire, 517, 519.
 Electrically synchronized clocks, 368.
 Electrification, 94, 529.
 Electricity, 1.
 " positive, negative, 3, 91.
 " static, 91.
 Electro-chemical difference of potential, 10.
 " magnet, 50.
 " magnetic mutual induction, 99.
 " motive force, 4, 34, 35.
 " " measurement of, 133.
 " pneumatic block signal, 495.
 " static capacity, 91, 95, 267.
 " mutual induction, 99.
 " thermic lightning arrester, 87.
 Electrolyte, 10, 290.
 Electropoion, 18.
 Elongation of wire, 510, 517.
 English binding post, 559.
 Escapes, locating, etc., 134, 142, 150, 153.
 Esbeck page and line printing telegraph, 430.
 Etheridge transmitter, 327.
 Extra current of self-induction, 100.
 " " neutralizer, 319.
 Extended locals, 244.
 Fac-simile telegraphy, 321.
 Fall of potential, 96.
 Farad, 91.
 Fault indicating apparatus, 461.
 Faults, breaking down of, 529.
 " in cables, locating electro-mechanically, 530.
 " in quadruplex, locating, etc., 232.
 " in telegraph wires, locating, 134, 142, 379.
 Fetter drive screw, 542.
 Field and Firman electric call box, 374, 472.
 " key system, 217.
 " magnet, 38.
 " magnetic, 32.
 Figure of merit, 307.
 Fix call box, 387.
 Fire alarm indicator, 450.
 " " telegraph, 437.
 " " " auxiliary, 445.
 " " " boxes, 438.
 " " " Bulen's automatic, 467.
 " " " Gaynor's, 453.
 " " " Gamewell, 440.
 " " " Jersey City or Speichers, 456.
 " " " non-interfering boxes, 438.
 " " " repeaters. *See* Repeaters.
 Flag signaling, 362, 363.
 Flash " 365.
 Flour as a lubricant, 516.
 Foot-plate, 535.
 Force, 1.
 Force, electromotive, 4, 34, 35, 133.
 " lines of, *See* Lines of Force.
 " magnetizing, 32.
 " resultant, 103.
 Forces, parallelogram of, 103.
 Four-round fire alarm boxes, 439, 447.
 Freir neutral relay, 307.
 Full r cell, 17.
 Fuses, 46.
 Gains, 535, 537.
 Galvanometers, 103, 144.
 " astatic, 112.
 " constant of, 144.
 " detector, 113.
 " differential, 114, 305.
 " readings, 529.
 " shunts, 116, 519.
 " tangent, 103.
 " Thomson reflecting, 114, 519.
 " W. U. tangent, 110.
 Galvanoscope, 103.
 Gamewell automatic repeater, 454.
 " auxiliary fire alarm telegraph, 461.
 " fire alarm telegraph, 453.
 " police signal telegraph, 472.
 Galvanizing iron wire, 511, 512.

G H I J K

Gardiner non-interfering fire alarm box, 445.
 Gassner dry cell, 22.
 Gauges, wire, 514, 515, 562.
 Gaynor fire alarm telegraph, 453.
 " signaling key, 464.
 Geneva stop, 404.
 German silver resistance coils, 42, 101, 178.
 Gold and stock ticker, 395, 398.
 Governor, Phelps motor, 420.
 " Wheatstone, 304.
 Gravity cell, battery, 11.
 " care of, life of, 12, 12, 16, 378.
 " modification of, 16.
 " use of oil on, 14.
 Gramme, 8.
 Ground return circuit, 52.
 Grounds, locating, 134.
 Guard wire, 551.
 Gutta-percha, 526, 528, 529.
 Guying poles, 536.
 Guy, anchor, double-head, head, side, stub, wire, 530.
 Hall's "block" instrument, 500.
 " electric signal for railway crossings, 503.
 " railway signal system, 494.
 " " track " instrument, 500.
 Hamblet clock synchronizer, 3-9.
 " time telegraph, 356.
 Hard-drawn copper wire, 510, 513, 535.
 " " " breaks in, 548.
 " " " first extensive use of, 548.
 Hart's train signal, 507.
 Head guy, 536.
 Healy arrangement of quadruplex, 228.
 " " clutch," 414.
 " locker circuit, 414.
 Hellograph, MacGregor's, 361.
 Hellography, 361.
 Helvin sleeve joint, 545.
 " tie, 544.
 Holmes burglar alarm telegraph, 386.
 House-top fixtures, 547.
 Hydrometer, 13.
 Impurities in metals, 518.
 Indicator, electro-mechanical, 450, 475.
 Induction coil, 99.
 " " differential, 228.
 Induction, electro-magnetic electro-static, self, 99, 101.
 " telegraphy, 333.
 Inductive capacity, specific, 91, 267.
 India rubber. *See* Rubber.
 Ink recording Morse register, 70.
 " automatic telegraph, 287.
 Insulation, 524, 530.
 Insulation resistance of wires and cables, measuring, etc., 142, 145.
 Insulators, essentials of, 538.
 " B. & O., double petticoat, pony, rubber, W. U., tree, 539, 540, 541, 542.
 " measuring insulation resistance of, 149.
 " tying wire to, 544.
 Intermediate battery, 80.
 " " or way stations, 54.
 Internal resistance of batteries, 15.
 International, or Continental code, 368.
 Interlocking magnets or relays, 503.
 Iron and steel wire nomenclature, 523.
 Iron poles, 531.
 Iron wire joint, 545.
 " manufacture of, 511.
 Jacobs duplex, 283.
 Jersey City, or Speicher fire alarm telegraph, 456.
 Jockey roller, 299, 423.
 Johnstone conduit, 526.
 Jolt resistance, 27, 142.
 " sleeve, 545.
 Joints, cable, 526.
 " iron wire, 545.
 " measuring insulation resistance of, 526.
 Jones' arrangement of quadruplex, 226.
 " three-magnet neutral relay, 226.
 Jumper, 546.
 Kerite cable, 526.

K L M

Key, citizens, for fire alarm boxes, 472.
 " discharge, 131.
 " Gaynor signaling, 454.
 " pole-changing, 341.
 " Morse telegraph, Bunnell, legless, self-closing.
 steiner, Victor, 59, 60, 61, 553.
 " reversing or tapper, 269.
 " board transmitters, 392, 398, 407, 411, 430.
 " systems, dynamo, quad, 217, 226, 230.
 " " gravity battery, 198, 212.

La Cour wheel, 326.
 La Dow telegraph transmitter, 75.
 Lalande-Edison cell, 20.
 Law, Ohm's, 5, 25, 26, 31, 68, 112.
 " of tangent galvanometer, 104, 109.
 " Leak," 231.
 " resistance, 309.
 " relay, 309.
 Leclanché cell, 15.
 Legal chm, 522.
 Legless key, 61.
 " Letter " key, 398.
 Lightning arresters, 84.
 " combination plate and spider wire, 86.
 " electro-thermic, 88.
 " magnetic, 87-
 " pole, 537.
 " quadruplex,
 Line adjustment, Delany's, 150.
 Line repairing, 549.
 Lines of force, 32, 33, 40, 51, 105, 109, 270.
 Local battery, circuit, sounder, 53.
 Locating faults in telegraph wires, *See* Faults and
 Electrical Testing.
 " " cables, 530.
 " " point to point method, 530.
 " " under-running method, 531.
 " Locker " circuit, Healy's, 414.
 Lockwood battery, 377.
 Loop switches, 260.
 " Davis, 263.
 " postal, 261.
 " test, Varley, 140.

Machine, dynamo electric, *See* Dynamos Machines.
 MacGregor's heliograph, 361.
 Main line, 53, 67.
 " relay, 53, 63.
 " sounders, 67.
 " office switch boards, 77.
 Maintenance of telegraph lines, cost of, 532, 549, 561.
 Manholes, subway, 526.
 Manual repeaters, *See* Repeaters.
 Magnet, electro, 33, 50.
 " directing, 119, 519.
 " interlocking, 503.
 " permanent, 112, 184.
 " polarity of, 181, 207.
 " press, 393.
 Magnetic circuit, 32, 33.
 " "circle," 396.
 " coil, 351, 480
 " field, 32, 33.
 " lightning arrester, 87.
 " needle, VII, 103.
 " saturation, 66.
 " storm, 274.
 " strength, 69.
 Magnetism, Earth's, 103.
 Magnetizing current, 185, 208.
 Manufacture of iron and copper wire, 511.
 Margin, quadruplex working, 231.
 Marking current, 304.
 Mechanical tests of telegraph wires, 514.
 Measurement by Wheatstone bridge, 126, 519.
 " of electromotive force, 133.
 " of joints, 527.
 Measurements, internal resistance batteries, 134.
 " insulation resistance of wires and
 cables, 142, 529.
 " partial insulation resistance of tele-
 graph wires, 150.
 " resistance, by substitution method, 130.
 " " Wheatstone bridge me-
 thod, 126, 519.
 " resistance of insulators, 142.

M N O P

Megohm, 144.
 " plate, 146.
 Message hooks, 559.
 Metals, impurities in, effects of, 517, 518.
 Metallic circuit, 52.
 Methods of arranging dynamos in telegraphy, *See*
 Dynamo Machines.
 " suspending aerial cables, 550
 " telegraphing, open, closed circuit, 54,
 55.
 " telegraphing, single, double current,
 183, 287.

Microfarad, 92.
 Micrometer gauge, 515.
 Mile-Ohm, 522.
 Military telegraph, 363.
 Milliampere, 6.
 Miscellaneous, 559.
 Mirror receiver, galvanometer, 268.
 Mixed iron and hard-drawn copper wire lines, 548.
 Moment of no-magnetism, 201, 225.
 " " methods of obviating,
 204, 228.
 Morse telegraph system, 50.
 " alphabet, 56.
 " apparatus, 58.
 " keys, *See* Keys.
 " operation of, 52.
 " registers, *See* Registers.
 " relays, *See* Relays.
 " single circuit or wire, 54, 173.
 " sounders, *See* Sounders.
 Motor governor, Phelps, 420.
 " printing telegraph, Phelps, 419.
 " push and pull, 408.
 Municipal police patrol telegraph, 488.
 Muirhead artificial cable, 279.
 " double block, 279.
 Multiple break-wheel, 468, 480.
 " call boxes, 373, 472, 485.
 " cells in, 24.
 " telegraph wires in, 30.
 " transmitter, automatic, 476.
 " repeaters, *See* Repeaters.
 Multiplex telegraphy, synchronous, 336.
 Mutual induction between wires, electro-magnetic,
 electro-static, 99, 100.

Negative electricity, 3, 91.
 " plate, pole, 10.
 " potential, 4.
 Neutral relay, Freir's, 225.
 " Healy's, 228.
 " Jones', 226.
 " resistance of, 239, 574.
 " three-coil, winding of, 213.
 New York Quotation Co., ticker system, 412.
 " " quadruplex, 228.
 Nomenclature, quadruplex, 231.
 " iron and steel wire, 522.
 Non-interfering automatic repeater, (Ganewell,
 440.
 " fire alarm telegraph boxes, 439,
 444, 446, 449, 453.

"Office " wire, 79.
 Ohm, 5, 522.
 " weight per mile, 522.
 Ohm's law, 5, 25, 26, 31, 68, 112.
 Oil, battery, 14, 21, 238, 554.
 Okonite cable, 526.
 One wire ticker system, 395, 402.
 Open circuit cells, 10.
 " method of telegraphing, 54.
 Overland telegraph wire, *See* Telegraph Wire.
 Overlapping block signal system, 504.
 Oxides, peroxides, 10.

Pad or platen, printing, 395.
 Paddle, 533.
 Page and line chemical recorder, 294.
 " " printer, Eselck's, 430.
 Paper, chemically prepared, 291.
 " feeds, 404, 418, 428.
 " perforated, 295, 459.
 " winder, automatic, 71.
 Parallel quad. circuits, 238.

P Q

Parallelogram of forces, 105.
 Partial resistance of telegraph wires, measuring, 145.
 Paterson cable, 526.
 " Pause " wheel, 404.
 Pearce and Jones police patrol telegraph, 482.
 Percentage conductivity, 518.
 Perforated paper, 288, 299, 459.
 Perforator, Speilcher's, 457.
 " Wheatstone, 297.
 Permanent magnet, 117, 184.
 Permissive block systems, 494.
 Phantom circuits, 231.
 Phelps' motor printer, 419.
 " paper feed, 402.
 " shifting device, 405.
 " stock printer, 402.
 " synchronizing device, 427.
 " unison device, 406, 427.
 Phillips steno-telegraphy, 57a.
 Phone, 353.
 Phonoplex, Edison, 363.
 Physiological telegraph, VII.
 Pin plug, 79.
 Pins, 537.
 Pikes, 535.
 Plate, positive, negative, 10.
 Platinum contact points, 59.
 Pliers, 546.
 Plug, pin, split, 79, 83, 84.
 " Plunger," 506.
 Pocket wire gauge, 515.
 " relay, 61.
 Point to point method of locating faults, 530.
 Polar duplex, 181.
 " balancing, 189.
 Polarity of magnets, 181, 262.
 Polarized relays, 184, 318, 393, 554.
 Polarization, 10, 12, 17, 20.
 Pole, positive, negative, 10.
 Pole-changer, 182, 412, 431, 553.
 " dynamo, 192, 225.
 Pole-changing keys, 341.
 Poles, 532.
 " erection of, etc., 532.
 " iron, 532.
 " lightning arrester, 536.
 Police signal telegraph, 471.
 " " Chicago, 479.
 " " Gamewell, 472.
 " " Municipal, 468.
 " " Pearce and Jones, 482.
 " " boxes, 477, 481, 493.
 Positive electricity, 3, 91.
 " pole or plate, 10.
 " potential, 40.
 Post-auger, 533.
 Post office pattern Wheatstone bridge, 128.
 Postal arrangement of dynamo-machines, 46.
 " quadruplex, 226.
 Potential, negative, positive, 4.
 " electro-chemical, 10.
 " fall or slope of, 96, 122.
 Press-magnets, 393.
 " relays, 415.
 Prices of telegraph apparatus, etc., 560.
 Printing telegraphy, 391.
 " telegraph circuits, adjusting, 401, 429.
 " " Edison, or universal, 406.
 " " Essick page and line, 430.
 " " Gold and Stock or Scott, 395.
 " " Phelps' motor, 419.
 " " New York quotation, 412.
 " " step by step, 391, 408.
 Printing pad or platen, 395.
 Pulsatory currents, 265.
 " current signals, 351.
 " Push and pull " motor, 384, 407.
 " Push " Jack, 480.
 Quadruplex telegraph, 194, 225, 228.
 " balancing the, 232.
 " lightning arrester.
 " locating faults in the, 232.
 " New York Quotation Co., 228.
 " nomenclature, 232.
 " Postal, 226.
 " repeaters. See Repeaters.

Q R

Quadruplex, working of, etc., rules concerning, 230.
 Railway crossing signal. Hall's electric, 503.
 " electric block signal system, 494.
 " " " clock, 499.
 " " " electro pneumatic, 495.
 " " " Hall's, 499.
 " " " overlapping, 504.
 " " " Sykes, 506.
 " " " Union Switch and Signal, 495.
 Railroad velocipede, 550.
 Ratio of bridge arms, 519.
 " current strength, etc., 207, 217.
 Readings, galvanometer, 529.
 Receiver, Denison, 322.
 " mirror, 268.
 " Robertson, 326.
 " telephone, 344.
 " Wheatstone, 393.
 Reciprocals, 28, 518, 521.
 Recorder, siphon, 269, 271.
 " chemical, 294.
 Reflecting galvanometer, 114, 519.
 Register, double-pen, 372.
 " ink recording, 69.
 " Morse, 69.
 " self-starting, 373, 488.
 Regular rheostat, 554.
 Relay, Brown and Allen, 281.
 " correcting, 338.
 " differential, 170.
 " double-balance, 387.
 " interlocking, 503.
 " Morse, box, main-line, pocket, pony, 63, 64, 65, 533.
 " " adjusting, 63.
 " neutral. See Neutral Relay.
 " polarized, 184, 225, 318, 393, 534.
 " press, 415.
 " repeating, 416.
 " " shift," 395, 401.
 " " time," 416.
 " Wheatstone, adjusting, 304.
 " " polarized, 3-8.
 " " repeater, 317.
 " winding of, 69, 215.
 Release magnets, 384, 416.
 " Repeat " key, 398.
 Repeaters, automatic telegraph, 153.
 " " " Maver-Garlanier, 160.
 " " " Milliken, 156.
 " " " Neilson, 162.
 " " " " Side," 158.
 " " " Toye, 158.
 " " " multiple, 166.
 " duplex and quadruplex, 241, 263.
 " quadruplex—short wire, Downer, 244.
 " " " Garlanier, 245.
 " " " Maver multiple, 248.
 " quadruplex—short wire, Moffatt emergency, 247.
 " quadruplex—single wire, Edwards', 250.
 " " " hints on management of, 254.
 " quadruplex—single wire, Waterbury, 262.
 " fire alarm telegraph, Gamewell, 440.
 " " " manual, 454.
 " on one base-board, 167.
 " Wheatstone duplex, 307, 315.
 Repeating sounder, 215.
 Resonator, Bunnell sounder, 75.
 Resistance, 5.
 " added, 231.
 " box, coils, 42, 101, 174.
 " external, internal, total, 15.
 " inversely proportional to square of diameter, 281.
 " joint, 27, 142, 146.
 " measurement of, See Measuring Resistance.
 " of batteries, internal, 15.
 " specific, 518.
 Resultant force, 103.
 " line or diagonal, 104.
 Retardation of signals, 283, 342.

Retarding coils, 177.
 Return signal boxes. *See* "Answer Back" Signals.
 Retractable springs, 63.
 Reversals, distant, 201, 231.
 Reversing key, 269.
 " switch, 42.
 Rheostat, 101, 114, 318.
 " combination, 214, 553.
 " dial, 317.
 " regular, 554.
 Rights of way, 532.
 River and harbor cables, 528.
 Robertson writing telegraph, 325.
 Ronald's alphabetical telegraph, VI.
 Rodding underground conduits, 525.
 Rubber compound insulations, 529, 530.
 " India, effects of high temperatures on, 560.
 Safety underground cable, 526.
 " magnet, 384.
 Sag, 544.
 Salts, 9.
 " creeping, white, 14.
 Scott ticker, 395.
 " unison device, 401.
 Scrapings, copper, zinc, 16.
 Second, 8.
 Segments, live, dead, 338.
 Segmental wheel, 392.
 Self-closing key, 61.
 " exciting machines, 39.
 " induction, 100, 318.
 " starting, self-stopping mechanism, 373.
 " " register, 459.
 Semaphores, XII, 495.
 Sender, automatic telegraph, 71.
 Series, cells in, 23.
 " condensers in, 94.
 Shift relays, 393, 401.
 Shifting devices, 395, 401, 405, 416, 418.
 Short-circuit, 10.
 Short-circuiting key, 530.
 Shovels, long, spoon, 533.
 Shunts, galvanometer, 116, 519.
 Shunt wound machines, 39.
 Side-guy, 526.
 " Repeaters, 158.
 Siemens-Wheatstone bridge, 130.
 Sleurs duplex, 266a.
 Signal, train order, 506.
 " branch office, 256.
 Signaling, speed of, 153, 267, 281, 287.
 " torch, 363.
 " wig-wag, 363.
 Simplex cable working, 276.
 Simultaneous telegraphy and telephony, 345.
 Single current method, 183, 287.
 " transmitter, 176, 553.
 " wire or circuit, 54, 173.
 Siphon recorder, Thomson, 269.
 " Cuttriss, 270.
 " alphabet, 273.
 Slack in telegraph wire, 548.
 Sleeve joints, Helvin, McIntyre, 545, 548, 549.
 Slope or fall of potential, 96, 122.
 Smith arrangement of condenser, 204, 216.
 Solid conduits, 524.
 Sounders, Morse, Bunnell, main line, Victor, West-
 ern-Electric, 66, 67, 69, 553.
 " ampere turns of, 69.
 " local, 67.
 " repeating, 215.
 " winding of, 69.
 Special signal apparatus, police signal telegraphs,
 475, 487.
 " wheel, 480, 485.
 Spacing current, 304.
 Span, wire-span, 537.
 Spark coil, 177.
 Specific gravity, 518.
 " inductive capacity, 91, 267.
 " resistance, 518.
 Specifications for apparatus, cables, wire, 553, 557.
 Specimen slip, siphon recorder, 273.
 " ticker, 437.
 " writing telegraph, 327.
 Spelcher's auxiliary fire alarm box, 445.
 " fire alarm telegraph, 176.

Split plug, 83.
 " condenser, 315.
 Spider wire, 87.
 Spinning jenny, Chinnocks, 552.
 Spring-jack, 78, 554.
 " switch-boards, 79.
 Stable outfit, police telegraphy, 475.
 Standard breaking strain, 522.
 " for telegraph wire, 522.
 " underground cable, 526.
 " wire gauge, 514.
 Static capacity, 91, 267.
 " charge, 94, 97, 210.
 " compensating condensers, 177, 209, 301.
 " electricity, 90.
 Stearns' arrangement of condenser, 232.
 " artificial cable, 276.
 " duplex, 174.
 Step by step printing telegraph, 391, 408.
 Steiner key, 60.
 Steno-telegraphy, 57 a.
 Stewart-Hall train order, 506.
 Stock printer, Phelps, 402.
 Stover's special signal, 487.
 Straps, switch, 77.
 Strap keys, 484.
 Struts, 537.
 Sub-aqueous cables, 531.
 Submarine telegraphy, 267.
 Substitution method of measuring resistance, 13.
 145.
 Subsidiary ducts, 525.
 Subway manholes, 526.
 Sulphate of copper, 12.
 " zinc, 14.
 Sunflower, 412.
 Switch, dynamo reversing, 42.
 " loop, 261.
 Switch boards, 77.
 " main office, 78.
 " way-office, 81.
 " district service, 376.
 Synchronized clocks, 358.
 Synchronizing devices, 358, 427.
 Synchronous telegraphy, 336.
 Syringe, battery, 13.
 Tables, 121, 521, 562, 563.
 " concerning copper wire, 563.
 Tailings, 288.
 Tamping bar, 533, 535.
 Tapper key, 269.
 Tangent, tables of, 104, 121.
 " galvanometer, 103.
 " " law of, 104, 109.
 Telegraph alphabets and codes, *See* Alphabets.
 apparatus, Morse, 58.
 " cables, 526.
 " lines, construction and maintenance of,
 532.
 " military, 363.
 " Morse, *See* Morse Telegraph.
 " physiological, VII.
 " repeaters, *See* Repeaters.
 " Ronald's alphabetical, VI.
 " sender, automatic, 71.
 " service, American District, 367.
 " systems, *See* Telegraphy.
 " transmitters, 72, 75.
 " Washington's, VI.
 " wire, impurities in, 518.
 " " manufacture of, 511,
 " " mechanical tests of, 511, 516, 517.
 " " overland, etc., 509.
 " " specifications for, 556.
 " wires, escapes on, 150.
 " " joint resistance of, 30, 146.
 " " in multiple, 30.
 " " locating faults in, *See* Electrical
 Testing.
 " " measuring partial insulation resist-
 ance of, 146.
 Telegraphing from moving trains, 333.
 Telegraphy, automatic, *See* Automatic Telegraphy.
 " automatic burglar alarm, *See* Burglar
 Alarm Telegraphy.
 " duplex, *See* Duplex Telegraphy.
 " fac simile, 321.

T

Telegraphy, fire alarm, See Fire Alarm Telegraphy.
 " multiplex, *See* Synchronous Telegraph Systems.
 " police signal, *See* Police Signal Telegraph Systems.
 " printing, *See* Printing Telegraphy.
 " quadruplex, *See* Quadruplex.
 " steno, 57a.
 " submarine, 267.
 " synchronous multiplex, 336.
 " typewriter in, 74.
 " under-water, 285.
Telephone, the, 344.
 " " in automatic telegraphy, 294.
 " " " police signal telegraphy, 474.
 " terminal connections of, 350.
 " transmitter, receiver, 344.
Temperature, effects of on liquids, on conductors,
 16, 520, 560.
 " corrections for, 520.
Tensile strength, 516, 522, 514.
Terms, chemical, 9.
 " electrical, 3.
Test, Varley loop test, 140.
Testing, electrical, 122, 519.
 " the condition of batteries, 134.
 " " relays, 236.
 " insulators, 148.
Testometer, " 386.
Tests, capacity, 131.
 " mechanical, *See* Mechanical Tests.
 " of telegraph wire, *See* Electrical, Mechanical Tests.
The quadruplex, See Quadruplex.
Thomson's reflecting galvanometer, 114.
 " "Throwing out," 394.
Tickers, 394.
 " Edison, two wire, 406.
 " Essick, 436.
 " Gold and Stock, or Scott two wire, 401.
 " Kiernan " news," 391.
 " New York Quotation Co., 412, 416.
 " Phelps, one wire, 405.
 " slip, specimen of, 436.
Tie, Helvin, 544.
 " wire, 544.
Time slips, 379.
 " stamp, 471, 474, 480.
 " telegraph service, 356.
Tools used in construction of telegraph lines, 533.
Tooker keyless door, 493.
Torch signaling, 365.
Tower-bell circuits, 456.
 " striking mechanism, 461.
Track instrument, Hall's, 500.
Train order signal, 506.
Train signal, 507.
Traller, 336, 341, 412.
Transmitter, continuity preserving, 176, 553.
 " Denison, 322.
 " Etheridge, 327.
 " Healy, 412.
 " key-board, 392.
 " multiple automatic, 476.
 " Morse telegraph, 72.
 " Phelps' motor, 422.
 " phonoplex, 353.
 " printing telegraph, 392, 398, 407, 411,
 412, 421, 430.
 " Robertson.
Tree insulator, 542.
 " trimmer, 549.

T U V W Z

Trouble " hunting," 551.
Two type-wheel tickers, 395.
Tying wire to insulators, 544.
Type-wheels, 391, 395.
Type-writer in telegraphy, 74, 76.
Underground conduits for cables, 524.
 " " drawing in and out, 524.
 " " Edison, sold, 524.
 " " Johnstone, 526.
 " telegraph cables, Kerite, Okonite,
 Paterson, Safety, Standard, 526.
Under-running of cables, 531.
**Union Switch and Signal electro-pneumatic block
 system, 495.**
Union Switch and Signal clock block signals, 499.
Unit, B. A., 522.
Units, electrical, 7.
 " C. G. S., 8.
United States signal and telegraph code, 363.
Union devices, 393, 401, 406, 427.
Universal ticker, transmitter, 406, 410.
**VanRyselberghe simultaneous telegraphy and
 telephony, 345.**
VanSize return signal box, 370.
Variable zero, 273, 283.
Varley loop test, 140, 530.
Varley-Athearn duplex, 351.
Velocipede, railroad, 550.
Victor key, 58.
**Vulcanized India rubber, effects of high tempera-
 tures on, 560.**
Way leaves, 632.
Way office, 54.
Weight per mille ohm, 522, 523.
**Western Union arrangement of dynamo machines,
 44.**
Wheatstone automatic telegraph system, 296.
 " bridge, 122, 126, 128, 519.
 " circuits, lengths of, 321.
 " condenser, 93.
 " duplex, 305.
 " perforator, receiver, relay, repeaters,
 transmitter, 296, 298, 308, 306.
White salts, 14.
Wig-wag method of signaling, 363.
Wilder "duplex" auto. burglar alarm, 383.
"Wind and water" line, 533.
Winding of three-coil neutral relay, 215.
 " " relays and sounders, 65, 69.
Wire barrow, 543.
 " method of placing on poles, 542.
 " compound copper and steel, etc., 510.
 " diameter of, 261, 514.
 " drawing, 511.
 " elongation of, 510.
 " gauges, 514, 515, 562.
 " "office," 70.
 " overland telegraph, 509.
 " stringing, 542.
Wires, See Telegraph Wires.
Working constant of galvanometer, 144.
W. U. insulator, 539.
Zero, variable, 273, 283.
Zinc and copper scraper, 555.
 " crowfoot, 12.
 " scrapings, 16.
Zincs amalgamation of, 18.

