



# TELEPHONY.

---

## PART IV.

### THE CONSTRUCTION OF AERIAL LINES.



# TELEPHONY

*A MANUAL OF THE  
DESIGN, CONSTRUCTION, AND OPERATION  
OF TELEPHONE EXCHANGES.*

IN SIX PARTS

PART IV.  
THE CONSTRUCTION OF AERIAL LINES  
WITH 140 ILLUSTRATIONS

BY  
ARTHUR VAUGHAN ABBOTT, C. E.

---

NEW YORK  
McGRAW PUBLISHING COMPANY.  
1903



**COPYRIGHT, 1903,**  
**BY THE**  
**McGRAW PUBLISHING COMPANY,**  
**NEW YORK.**

1381151

75684  
JAN 14 1904

TR  
AB2  
4

## CONTENTS.

### *PART IV.*

---

CHAPTER.	PAGE.
I. INTRODUCTION . . . . .	1
II. THE LOADED LINE . . . . .	8
III. ROUTES AND RIGHTS OF WAY . . . . .	22
IV. POLES . . . . .	39
V. STRESSES AND THE STRENGTH OF POLES . . . . .	57
VI. WIRE SUPPORTS AND WIRE . . . . .	88
VII. DISTRIBUTION . . . . .	113
VIII. THE COST OF AERIAL LINES . . . . .	125
IX. DISTURBANCES ON TELEPHONE LINES . . . . .	144
X. SPECIFICATION FOR THE CONSTRUCTION OF AERIAL LINES.	159



# LIST OF TABLES.

## PART IV.

TABLE.	PAGE.
1. WEIGHT OF POLES . . . . .	58
2. CRUSHING STRENGTH OF TIMBER . . . . .	60
3. TENSILE STRENGTH OF TIMBER . . . . .	67
4. WIND DATA . . . . .	69
5. DIMENSIONS OF ANCHOR PLATFORM . . . . .	81
6. DIMENSION OF POLE LATTICES . . . . .	82
7. DATA FOR GUY ROD BANDS . . . . .	83
8. POSITION OF GUY ROD BANDS . . . . .	84
9. DATA FOR POLE BANDS . . . . .	85
10. MAIN GUY RODS . . . . .	86
11. BRANCHES FOR GUY RODS . . . . .	86
12. GUY ROD EXTENSION PLATES . . . . .	87
13. TABLE RESISTANCE PER MIL-FOOT OF COPPER WIRE IN LEGAL OHMS AT VARIOUS TEMPERATURES FAHRENHEIT.	101
14. RESISTANCE OF A MIL-FOOT OF VARIOUS METALS COM- PARED WITH COPPER . . . . .	101
15. COMPARISON OF WIRE GAUGES . . . . .	103
16. GALVANIZED IRON WIRE . . . . .	106
17. CHARACTERISTICS OF COPPER WIRE . . . . .	107
18. PROPERTIES OF COPPER WIRE . . . . .	108
19. HARD-DRAWN COPPER WIRE. BRITISH POST-OFFICE SPECI- FICATIONS . . . . .	109
20. HARD-DRAWN COPPER WIRE. TELEPHONE SPECIFICATIONS.	110
21. TENSILE STRENGTH OF COPPER WIRE . . . . .	111
22. PROPERTIES OF BI-METALLIC WIRE . . . . .	112
23. COST OF POLES AND COST PER WIRE MILE OF WIRE ERECTED . . . . .	126
24. DATA FOR ESTIMATING COST PER MILE OF POLES SET READY FOR ARMS (CITY STYLE) . . . . .	129
25. DATA FOR ESTIMATING COST PER MILE OF POLES SET READY FOR ARMS (COUNTRY STYLE) . . . . .	133
26. COMPLETE COST OF POLE LINES . . . . .	135
27. COMPARATIVE COST OF AERIAL AND UNDERGROUND LINES.	138

TABLE.	PAGE.
28. COMPARISON BETWEEN UNDERGROUND WIRE PLANT, AERIAL CABLE, AND OPEN WIRE PLANT . . . . .	140
29. SCHEDULE OF OPEN WIRE LINE MATERIAL . . . . .	168
30. POLE DATA . . . . .	171
31. STANDARD CROSS ARMS. . . . .	177
32. LIGHT CROSS ARMS . . . . .	178
33. PROPERTIES OF GUY STRANDS . . . . .	194
34. PROPERTIES OF HARD-DRAWN COPPER WIRE . . . . .	200
35. PROPERTIES OF GALVANIZED IRON WIRE . . . . .	201
36. SCHEDULE OF CONSTRUCTION . . . . .	203

# LIST OF ILLUSTRATIONS.

## PART IV.

FIGURE.	PAGE.
1. POLE LINE, AMSTERDAM AVENUE, NEW YORK CITY . . .	2
2. ANOTHER VIEW ON AMSTERDAM AVENUE . . . . .	4
3. POLE LINE IN CHICAGO . . . . .	5
4. COMPENSATING COILS FOR CABLE WIRE . . . . .	15
5. COMPENSATING COILS FOR OPEN WIRE . . . . .	16
6. CURVES SHOWING CURRENT TRANSMITTED BY LOADED AND UNLOADED LINES; FREQUENCY, 400 PER SECOND . . .	17
7. CURVES SHOWING CURRENT TRANSMITTED BY LOADED AND UNLOADED LINES; FREQUENCY, 900 PER SECOND . . .	18
8. CURVES SHOWING RELATION OF NUMBER OF COILS PER MILE AND CURRENT TRANSMITTED; LOADED AND UNLOADED LINES . . . . .	19
9. CURVES SHOWING RELATION BETWEEN NUMBER OF COILS PER WAVE LENGTH AND CURRENT TRANSMITTED ON LOADED LINES . . . . .	20
10. A TRIPARTY RIGHT OF WAY . . . . .	30
11. POLE-CARRYING ELECTRIC LIGHT AND TELEPHONE CIRCUITS . . . . .	34
12. STRUCTURAL IRON POLE TOP . . . . .	43
13. BELGIAN POLE LINES . . . . .	44
14. BELGIAN POLE CONSTRUCTION AT BASE . . . . .	45
15. FUNGUS DESTROYING RED FIB TIE . . . . .	48
16. CURVES SHOWING RELATIVE LIFE OF TREATED AND UNTREATED WOODS . . . . .	51
17. PLAN OF POLE LINE . . . . .	62
18. PLAN OF CORNER IN POLE LINE . . . . .	64
19. GUY DIAGRAM . . . . .	70
20. VARIOUS STYLES OF GUY ANCHORS . . . . .	73
21. WRONG METHODS OF GUYING . . . . .	74
22. STRUCTURAL IRON POLE . . . . .	76
23. COMPOSITE ANCHOR POLE . . . . .	77
24. ELEVATION AND PLAN OF COMPOSITE ANCHOR POLE . . .	78
25. DETAILS OF LATTICE . . . . .	79
26. CROSS SECTIONS AND SIDE ELEVATIONS OF BANDS . . .	80
27. DETAILS OF GUY RODS . . . . .	82
28. CLAMPS . . . . .	113

LIST OF ILLUSTRATIONS.

FIGURE.	PAGE.
29. DISTRIBUTING POLE TOP . . . . .	114
30. DISTRIBUTING POLE TOP, WITH OPEN WIRE AND CABLE . . . . .	116
31. DISTRIBUTING POLE TOP, WITH PLATFORM . . . . .	116
32. POLE TOP, WITH STERLING HEAD . . . . .	117
33. DISTRIBUTING POLE IN CENTER OF BLOCK . . . . .	118
34. CONSTRUCTING A DISTRIBUTING POLE TOP . . . . .	119
35. A BAD EXAMPLE . . . . .	120
36. LATTICED DISTRIBUTING POLE . . . . .	120
37. DETAILS OF CHANNEL IRON POLE TOP . . . . .	121
38. DETAILS OF POLE TOP FOR CABLE DISTRIBUTION . . . . .	121
39. AERIAL CABLE TERMINAL . . . . .	122
40. A COMMON CASE . . . . .	122
41. ORNAMENTAL IRON DISTRIBUTING POLE . . . . .	123
42. ELECTROMAGNETIC DISTURBANCE; OPEN CIRCUIT . . . . .	148
43. ELECTROMAGNETIC DISTURBANCE; TRANSPOSED CIRCUIT . . . . .	149
44. DIAGRAM OF STATIC INDUCTION . . . . .	151
45. ELECTROSTATIC DISTURBANCE; OPEN CIRCUIT . . . . .	153
46. ELECTROSTATIC DISTURBANCE; TRANSPOSED CIRCUIT . . . . .	154
47. DIAGRAM OF COMMON RETURN SYSTEM . . . . .	157
48. SAMPLE OF SKETCH MAP . . . . .	161
49. POLE ELEVATION . . . . .	170
50. POLE TOP . . . . .	170
51. WOOD BRACKET . . . . .	175
52. IRON BRACKET . . . . .	175
53. YELLOW PINE CROSS ARM . . . . .	176
54. ALLEY ARM LOCATION . . . . .	179
55. CABLE ARM . . . . .	179
56. CABLE CROSS ARM . . . . .	180
57. CABLE STRAND U BOLT . . . . .	180
58. WOODEN PINS . . . . .	181
59. CORNER PIN . . . . .	182
60. IRON PINS . . . . .	184
61. INSULATORS . . . . .	185, 186
62. FRONT CROSS ARM BRACE . . . . .	187
63. BACK CROSS ARM BRACE . . . . .	188
64. ALLEY ARM BRACES . . . . .	188
65. CROSS ARM BOLTS . . . . .	189
66. CARRIAGE BOLTS . . . . .	190
67. FETTER DRIVE SCREW . . . . .	190
68. DOUBLE ARM POLE . . . . .	191
69. POLE STEP . . . . .	191
70. POLE RINGS . . . . .	192
71. PROTECTION STRIP . . . . .	192
72. WHEEL GUARD . . . . .	193
73. GUY ROD . . . . .	193
74. THIMBLES . . . . .	195
75. TWO-BOLT CLAMP . . . . .	195
76. THREE-BOLT CLAMP . . . . .	195

LIST OF ILLUSTRATIONS.

xi

FIGURE.	PAGE.
77. STRAND CLAMP DETAILS . . . . .	196
78. ROCK EYE BOLT . . . . .	196
79. STAPLE . . . . .	196
80. FUSE . . . . .	197
81. CONNECTOR . . . . .	198
82. BOLT PROTECTION . . . . .	208
83. CONCRETE FOUNDATION . . . . .	211
84. LOG FOUNDATION . . . . .	211
85. PLATFORM FOUNDATION . . . . .	212
86. PLATFORM AND PILES . . . . .	212
87. POLE RAISING . . . . .	213
88. POLE DERRICK . . . . .	214
89. SETTING POLES WITH DERRICK WAGON . . . . .	215
90. ATTACHMENT OF FRONT BRACES . . . . .	217
91. ATTACHMENT OF REAR BRACES . . . . .	217
92. DOUBLE ARMING . . . . .	219 (a, b, and c).
93. EXAMPLE OF DOUBLE ARMING . . . . .	220
94. PLAIN GUY . . . . .	221
95. GUY ANCHOR . . . . .	223
96. GUYS OVER OBSTACLES . . . . .	223
97. UNANCHORED GUY STUB . . . . .	224
98. GUY TO TREE TRUNK . . . . .	224
99. GUY TO TREE BRANCH . . . . .	224
100. ROCK GUY . . . . .	225
101. ROCK EYE BOLT . . . . .	226
102. HEAD GUYING TO LINE . . . . .	226
103. SINGLE BRACE . . . . .	227
104. DOUBLE BRACE . . . . .	227
105. DOUBLE POLE . . . . .	228
106. CURVES AND CORNERS . . . . .	229
107. CURVE AND CORNER DETAILS . . . . .	229
108. CURVES AND CORNERS OVER HIGHWAYS . . . . .	230
109. CORNERS AND CROSSINGS . . . . .	231
110. HIGHWAY CROSSING WITH SIDE GUYS . . . . .	231
111. WIRE REEL . . . . .	232
112. REEL CART AT WORK . . . . .	233
113. RUNNING BOARD . . . . .	232
114. PULLING UP WIRE . . . . .	234
115. LINE DYNAMOMETER . . . . .	235
116. SAGS AND TENSIONS . . . . .	237
117. LOCATION OF WIRE ON PINS . . . . .	239
118. TYING OF WIRE . . . . .	240
119. McINTYRE JOINTS . . . . .	241
120. SINGLE McINTYRE SLEEVES . . . . .	240
121. COMPLETED JOINT . . . . .	242
122. WESTERN UNION JOINT . . . . .	242
123. METHOD OF DEAD ENDING . . . . .	243
124. TRANSPOSITIONS OF TWENTY-WIRE LINE . . . . .	244



FIGURE.	PAGE.
125. TRANSPOSITIONS OF TWELVE-WIRE LINE . . . . .	245
126. TRANSPOSITIONS OF FORTY-WIRE LINE . . . . .	245
127. DETAILS OF TRANSPOSITION . . . . .	247
128. RECENT METHODS OF TRANSPOSITION . . . . .	248
129. SUBSCRIBER DROP-WIRE . . . . .	248
130. ANTI-HUM DEVICE . . . . .	250
131. FIXTURE A . . . . .	253
132. FIXTURE B . . . . .	253
133. FIXTURE C . . . . .	254
134. FIXTURE POLES . . . . .	254
135. POLE STEP . . . . .	255
136. CROSS ARM FOR FIXTURE A . . . . .	256
137. CROSS ARM FOR FIXTURE B . . . . .	256
138. CROSS ARM FOR FIXTURE C . . . . .	256
139. SECTION OF CROSS ARM . . . . .	256
140. POLE BASE FOR WOOD ROOFS . . . . .	257
141. POLE BASE FOR IRON ROOFS . . . . .	257
142. GUY AT POLE . . . . .	258
143. GUY ATTACHMENT AT ROOF . . . . .	258

## P R E F A C E.

---

To write a treatise on the building of Pole Lines, the earliest and most venerable form of electric circuit, that for half a century has been a familiar object in the landscape, whether urban or rural, would seem to be an attempt to present matter that was painfully *réchauffé*, but within the past decade the art of Aerial Construction has been confronted with new, and in many respects peculiar conditions, and has had to adapt itself to changed circumstances. With the advent of Independent Telephony, circuits of all descriptions have been multiplied enormously, and with the coming of the conduit the type of overhead work has largely changed, from the main line to the distributing line, at least in so far as urban installations are concerned. At the outset an impression prevailed among Independent Telephonists that anything would do for a circuit, all that seemed to be considered necessary was to set up a pole, any kind of a stick, string a wire, any kind of a wire, in any kind of a fashion, and lo! a complete plant was ready to be financed by the unwary capitalist. As a result much line work has already been rebuilt, much more must be soon reconstructed, and all must undergo that somewhat painful sifting process that seems inevitably necessary to teach experience to the inexperienced, who cannot seem to perceive how dangerous a thing a *little* knowledge is. Fortunately many telephone constructors have been quick to perceive the errors of their adolescence and are rapidly learning to

construct in the most praiseworthy manner, and setting an example that it behooves all to follow. Owing to the present increase in quantity of Pole Line and the great decrease in the ratio of wire mileage to line mileage the design of the Pole Line of 1903 differs radically from that of 1893, and this volume is an effort to deal with the conditions of the present, with the idea of devoting little space to descriptive matter that is chiefly academic in its nature, or the rehearsal of methods now largely obsolete. Following the plan of the previous parts the subject is treated in a manner that it is hoped will be of value to the man who is bearing the heat and burden of the day, particularly by supplying much needed information as to costs of construction and the proper rates of maintenance and depreciation.

Finally, a specification is framed on lines that it is hoped are broad enough to cover all but the exceptional case.

ARTHUR VAUGHAN ABBOTT.

NEW YORK, August, 1903.

# TELEPHONY.

---

## CHAPTER I.

### INTRODUCTION.

THE pole line is the oldest form of electrical circuit and is so familiar as seemingly to merit but slight attention. Owing to its cheapness the pole line is universally adopted where but a few circuits are needed, and as it is subjected to destructive forces of greater number and intensity than those which prey upon conduit lines, there is more opportunity to exercise ingenuity in the construction of the best line for the least expense.

Two general types of pole lines are now commonly accepted — the city type and the country type. Few towns of less than 35,000 or 40,000 inhabitants require electrical circuits to be placed in underground conduits. In the environs of the largest cities exists a zone of too low a telephonic density to warrant conduit construction, and in which the pole line is the not only permissible, but is the only economic expedient. Pole lines for such locations will necessarily carry, comparatively, a large number of circuits. They must be so designed and built as to be substantial and secure, and must present as neat and trim an appearance as is possible under the circumstances. The restrictions of city streets are such as to render it difficult to secure space for anchoring and guying, which would be common in the open country. These

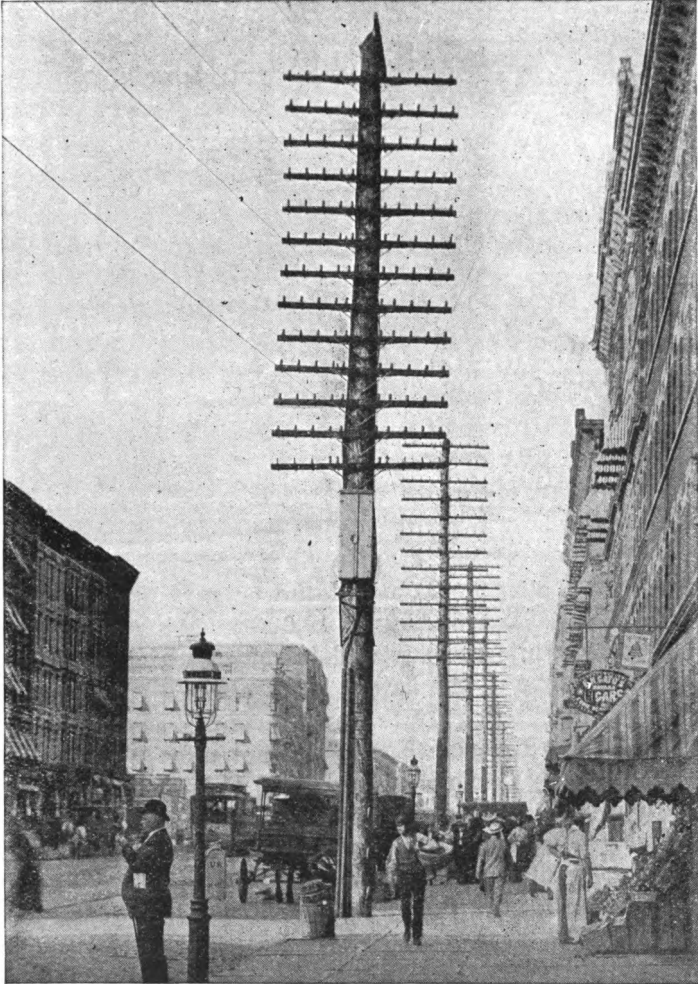

FIG. 1.—POLE LINE — AMSTERDAM AVENUE, NEW YORK.

conditions impose so many limitations upon pole line construction as to make the city line require considerable engineering, and that of no mean order. Examples of well-constructed city lines are shown in Figs. 1, 2, and 3. Fig. 1 is the beginning of the long-distance pole line on Amsterdam avenue, New York. The pole in the foreground is the terminal pole on which all of the open wires terminate, and are here connected by bridle wires to the underground cables, which are carried through iron pipe along the side of the pole to about 15 feet above the sidewalk. The cables run into the cable box and thence are bridled to the open wire lines. Such a pole must withstand the entire stress due to the tension of all the open wires. Fig. 2 is another view of the Amsterdam Avenue line taken further north, and shows the line as it passes over some of the hilly portions of the city. Fig. 3 is portion of a pole line in Chicago, running south on Indiana avenue, carrying a branch line running east and west and is a good example of the best type of city construction.

The average city line is expected to carry from 50 to 100 wires. It must be high enough to give ample room beneath the lowest of its circuits, for the most extraordinary city traffic. Such a line is in addition often burdened with the weight of half a dozen aerial cables, so that the stresses which it is called upon to resist, particularly during a winter blizzard, are considerable. City lines, therefore, must be designed from an entirely different standpoint from 'cross country ones; they must be higher, stronger and better appearing. 'Cross country lines average half or less than half as many wires, they extend along rural highways or over private right of way where there is ample room for guying and staying at corners and curves, and owing to sparsity of settlement it

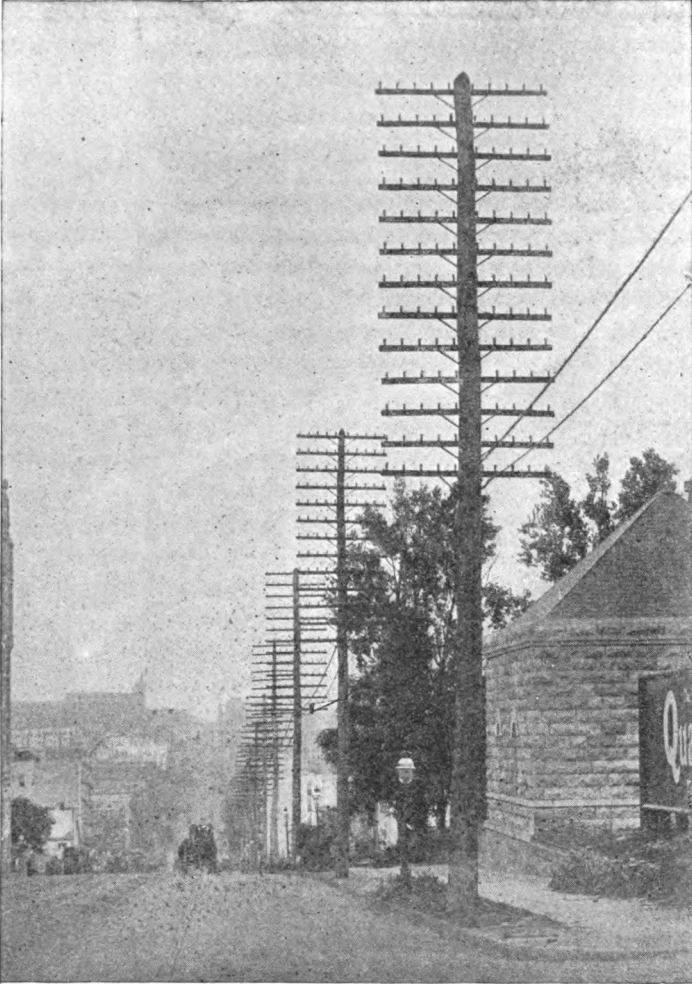

FIG. 2.— ANOTHER VIEW — AMSTERDAM AVENUE.

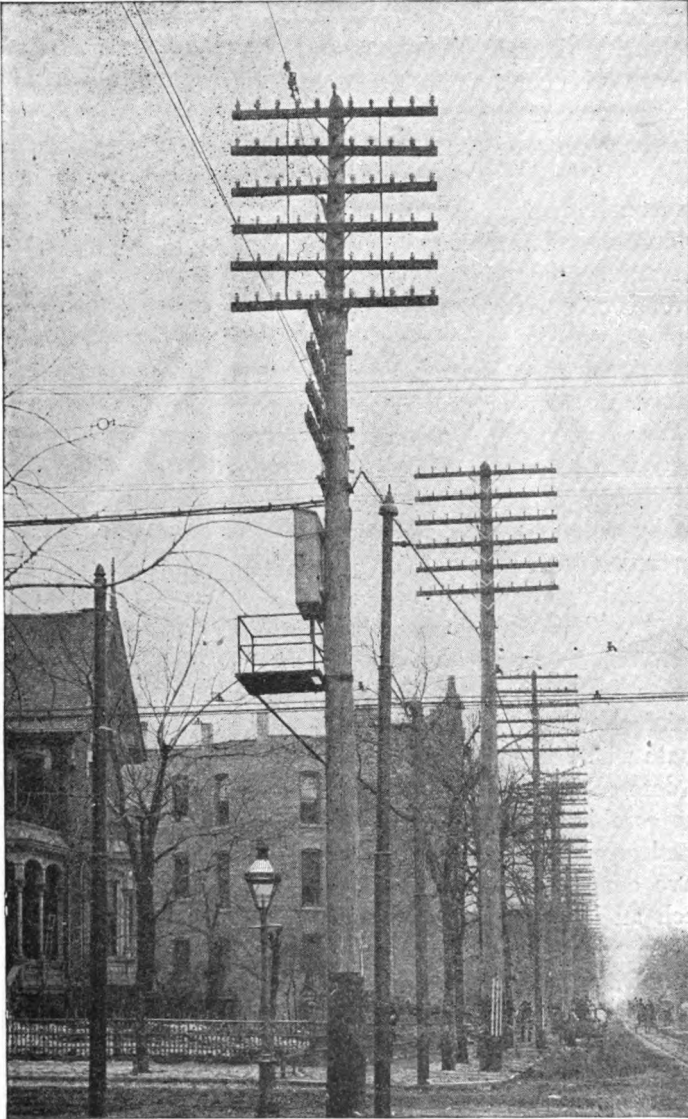

FIG. 3.—POLE LINE IN CHICAGO.



is unnecessary to pay as much attention to appearance as in a town.

During the recent marvellous development of telephony a very erroneous, though equally plausible idea of the requirements of the telephone plant has arisen. For example, a few of the inhabitants of some rural district, decidedly in advance of average in intelligence, activity, and enterprise, perceive the advantages of mutual intercommunication. They buy half a dozen telephones and installing them, themselves, in series on possibly the strands of a barb wire fence, can, under favorable circumstances, succeed in talking with each other. Encouraged by this success, they proceed to gather in their neighbors, imagining that because half a dozen telephones *sometimes talk* an exchange of perhaps 200 or 300 subscribers can be served in a somewhat similar fashion. But now the conditions are completely changed. A man who is riding a hobby will accept with delight annoyances and discomforts that he will not for a moment tolerate in a service rendered to him by others, and for which he is expected to *pay*. The difficulties and expenses of a telephone system vary nearly with the square of the number of instruments installed. A service, which might be perfectly satisfactory to a few co-operative owners, is totally inadequate when applied to a larger number, from whom rental is demanded. Many telephone companies are created by the combination, and amalgamation of a number of isolated groups of stations, that in a greater or less degree have come into being by the process described. When such an incorporation occurs, it has been the universal experience that it is necessary almost immediately to rebuild the entire plant, particularly the aerial portions thereof, in order to render a service that shall be even

remotely acceptable to subscribers who are now expected to pay a fair remuneration for the service rendered to them. In a rural district the wire plant is on the whole the most important part of the entire installation. The switchboard may be compressed within a few square feet of surface in the rear of an office or drug store. It is of comparatively simple construction, easily supervised and not liable to many difficulties, but the pole line ramifies through all the surrounding country and unless it is built in a strong and substantial manner so much time will be spent in clearing trouble, and there will be so much complaint and dissatisfaction from subscribers that the debit side of the profit and loss account will, at the end of the year, assume most alarming proportions. "What is worth doing at all is worth doing well" is one of the truest aphorisms, and is truer of a pole line than almost anything else. But like every other structure the pole line is subservient to the laws of design, and that line is the best, which, while entirely adequate to the purpose, requires both the least investment and least annual expense.

## CHAPTER II.

### THE LOADED LINE.

TELEPHONISTS have always been exceedingly averse to the use of cables in any form for telephone lines, on account of the impairment in the transmission of speech which takes place when long cable lines are used to unite the talking instruments. If a long conductor, such as a telephone or telegraph wire, be connected to a battery or other generator of electromotive force, electrification is not immediately manifested at the distant end of the conductor, but a perfectly measurable, though very small interval of time elapses between the actual contact of the conductor with the poles of the generator and the exhibition of electricity at the remote end, and if the conductor be suddenly disconnected from the generator the electrification does not immediately and absolutely instantaneously cease, but it persists for a fraction of an instant after the conductor has been physically severed from the generator. Furthermore it is found that when a conductor is thus joined to a source of electromotive force, a certain amount of electrical energy is used up, and apparently (for the time being at least) lost before electrification can be manifested at the remote end.

It is a familiar fact that all bodies, some more and some less, offer a certain opposition to the transfer of electric energy from place to place, and experience has shown that in addition to this quality of resistance two other factors are involved in the transmission of electrical energy from place to place, that are particularly important in the consideration of the transmission of speech

over distances of magnitude. It is found that when an electric current traverses a conductor it in some mysterious manner creates what is termed "magnetic field" around the conductor; that is to say, that as long as the current traverses the wire, the space about it possesses exactly the same properties as are exhibited by a magnet. To create this magnetic field requires an expenditure of energy on the part of the generator.

The intensity of the magnetic field which is thus created depends upon the amount of electricity passing, and the geometrical shape that is given to the conductor. This property of exciting and maintaining a magnetic field in the vicinity of any conductor is termed "*Inductance*," and as long as the electrical state of the conductor is changing, that is to say, whenever the current is increasing or decreasing in value, the magnetic field surrounding it will be correspondingly changing. So long as the current is growing in strength the magnetic field is increasing in volume and intensity, and this demands an expenditure of energy from the conducting wire. Conversely, if the current be dying away, the magnetic field is decreasing, and during this period of time is returning to the conductor the energy which it previously absorbed from it. Thus the energy expended in creating the magnetic field is not really lost, but is, for the time being, absorbed and stored up in the dielectric which surrounds the conductor. This is quite the reverse of the phenomenon which accompanies the more familiar ohmic resistance. To overcome this form of opposition to the transfer of electricity, requires an expenditure of electromotive force, which is accompanied by a more or less intense heating of the conductor, and the energy thus transformed from electricity into heat is radiated away

from the wire and so far as any electrical results are concerned is entirely lost.

It is also found that in addition to the property of inductance every conductor has the power to apparently absorb and retain intimately connected with itself a certain amount of electricity. The most familiar example of this is displayed by the ordinary condenser, such as is used at the sub-stations of subscribers. The condenser consists of two sheets of tin foil, which are separated by a layer of paraffine paper. Now if the terminals of the condenser be attached to a dynamo or other generator, a certain quantity of electricity will flow into the condenser and be retained thereby, and it is a familiar experiment to charge such a condenser and to take a shock by subsequently touching its terminals. The wires of every electrical circuit act in precisely the same manner; that is to say, one wire is equivalent to one of the strips of tin foil, while the other wire is equivalent to the second one, and the air in the case of an aerial circuit, or the insulating material of a cable forms the counterparts of the paper strips in the ordinary condenser. Now it is found by experiment that the quantity of electricity which any conductor can thus absorb and store, is proportional to the surface of the conductors, the kind of insulating material used, and inversely proportional to the distance between them. This principle easily explains the method adopted for making the sub-station condenser. The two strips of tin foil contribute the largest surface within the smallest bulk, while the strip of paper, as an insulator, is the thinnest thing that can be used to insulate them, so by rolling up a pair of sheets of tin foil, separated by a strip of paper, one obtains the greatest surface with the least intervening thickness of any imaginable contrivance. It

is now easy to understand why a cable should possess very much greater capacity than an aerial line, for in the cable the wires are twisted closely together and are only separated by a thin strip of paper, and in this condition quite closely approximate to the design of the substation condenser.

In the aerial line the component wires of any circuit are rarely set nearer each other than 10 in., the minimum distance between pins, and it is not difficult to arrange circuits so the wires may be separated by the entire length of a cross arm by placing each side of the line on the outer pins. It is found moreover that air as an insulator can absorb *less* electricity than any material, or to use the scientific phrase "*its specific electrostatic capacity*" is the smallest of any substance. Thus the open wire line shows a less electrostatic capacity than any other form of wire plant now in use.

It is the function of the telephone transmitter to impress upon the line an undulating or alternating electromotive force which produces in the line a correspondingly variable current. Upon the impression of such electromotive force and resultant current three things happen. First, a certain proportion of the energy transmitted disappears by ohmic resistance, is changed into heat, radiated away from the conductor, and is thus, so far as speech transmission is concerned, entirely lost. The effect of this is to reduce the amplitude of the waves which are transmitted, and conversation seems less loud, but ohmic resistance has no effect upon the shape of the wave which is sent. Second, the operation of inductance in creating the magnetic field, surrounding the conductor is to store therein a certain portion of energy. So long as the wave is increasing the energy absorbed by the magnetic field

is deducted from that impressed upon the line, but as soon as the electromotive force begins to wane, the magnetic field gives up its energy, which returns to the conductor and acts to prolong the flow of the current from which it previously derived energy. Third, the capacity of the line absorbs a certain amount of energy which is in some similar manner stored, and when the electromotive force wave commences to die away, the line, acting as a condenser, begins to discharge, and thus increases and reinforces the current. Thus it will be perceived that the operation of inductance and capacity are both similar in so far as they absorb, store, and return energy to the circuit, but are dissimilar inasmuch as inductance appears to cause the current wave to lag behind the electromotive force wave, and capacity to make the current wave advance in front of the electromotive force wave. Now if the energy taken by inductance and capacity were abstracted and returned by the conductor in such a manner as not to change the shape of the current wave there would be no injurious effect upon the transmission of speech, but merely a slight delay between the transmitting and receiving end which would not be of the slightest consequence. Unfortunately this absorption of energy *does* take place in such a manner as to flatten out the electrical waves, so that crests are smoothed off and reduced, and the hollows filled up and leveled. This changes the shape of the wave, and as our ability to understand articulate speech depends almost entirely upon the shape of the sound wave, this "*distortion*," as it is called, operates to make speech unintelligible. As both inductance and capacity abstract from the line a certain amount of energy it is quite conceivable that if either or both of these exist in excess, it might be impracticable over a very

long line to transmit any current whatsoever. Transmission plants, operating at high voltage, in which there is considerable capacity, sometimes absorb several hundred H.P., that is, expended solely in charging and discharging the lines with every wave impulse from the generators.

It has been shown that inductance and capacity in some respects are the opposites of each other, and so it would seem possible to make such a combination of these two elements as would enable one to neutralize the effect of the other, and thus leave the line burdened only with the ohmic resistance which is relatively but of little moment. This possibility was first perceived by Heaviside more than a decade ago, and at the International Congress of Electricians at the World's Fair in 1893, Dr. S. P. Thompson pointed out that the obstacle in transoceanic telephony was chiefly due to the distorting action of the great capacity offered by rubber insulated cables, and suggested the possibility of adding inductance coils in such a manner as would balance and neutralize this capacity. Neither the suggestions of Heaviside nor Thompson were developed, and little progress was made in the improvement of the wire plant from a transmission standpoint, until about four years ago when Dr. M. I. Pupin made an exhaustive and far-reaching study showing that it would be possible to add impedance coils to telephone lines in such a manner as to vastly improve their transmitting quantities by mutually neutralizing capacity with inductance. By this means existing lines could be made to talk much better, the radius of possible telephonic conversation greatly extended, and new lines could be built of smaller and cheaper wire, and give results equal to those attained by circuits now in operation. Shortly after Dr. Pupin's invention was announced his patents



were acquired by the American Telephone & Telegraph Co., and while it is reported that many of long-distance lines have been equippd with compensating coils, few statistics, as to results, have appeared. The European patents covering this invention have been secured by Siemens & Halske, who have made some exhaustive tests, both upon cable and aerial lines that are extremely interesting, as showing the improvement that may be made by the proper employment of compensating inductances. The German experiments were tried both upon underground cables and upon open wire lines. For the cable tests the line between Berlin and Pottsdam, a distance of about 20 miles, was selected.

This is a cable of the well-known paper type, buried in the earth outside of city limits, but extending through the conduit system in Berlin. The cable consists of 28 pairs of conductors each approximately, No. 18, B. & S. The resistance of the cable wires is 38 ohms, the capacity .06 m. f. and the inductance .0012 henrys per mile. The compensating coils were constructed to have resistance of 4.1 ohms and an inductance of .062 henrys. Sets of coils were located along the cables at distances of about 2,000 feet. The coils were arranged in a cast-iron box, somewhat similar to the old-fashioned distributing box. The method of installing coils is shown in Fig. 4, from which it appears that the cable is carried through a sleeve somewhat resembling that of a Y splice, to which the ends of the cable sheath are soldered. The cable conductors are then led into the box that contains the coils and fanned out in the usual manner and soldered to the coils. The whole apparatus is made water-proof by a cast-iron cover secured with a rubber gasket. Fourteen pairs of the cable were selected for the test, seven of which were

equipped with the compensating coils, while the remaining seven were left uncompensated for comparison.

Comparative tests upon a loaded and unloaded pair, 20 miles in length, showed that conversation could be heard nearly twenty times as far away from the receiver when connected to the loaded pair as when connected to the unloaded one. Tests were made by connecting pairs together in series. When five successive pairs, equipped with com-

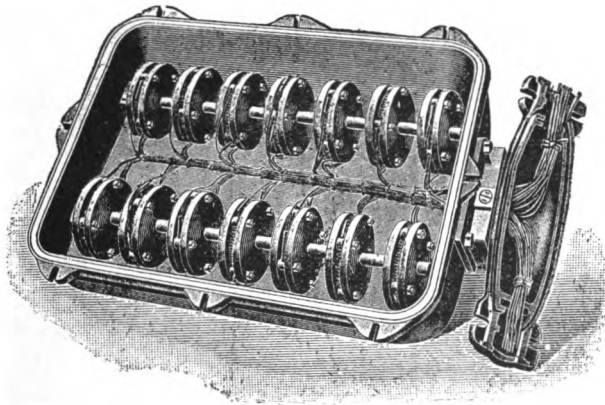

FIG. 4.—CABLE COMPENSATING COILS.

pensating coils, were joined, it was found that the transmission was about equal to that over a single pair unequipped with coils. Finally experiments were tried over 13 pairs equipped with coils, giving nearly 250 miles of cable, and over this line conversation was clear and understandable, though faint. In a general way this investigation shows that the addition of balancing inductance will extend the radius of transmission about fivefold.

The next set of experiments was a set of similar trials

upon aerial lines. The ordinary line insulator was replaced by a double insulator, on which the compensating coil is supported, shown in Fig. 5. The line upon which the trial was made extended from Berlin to Magdeburg and was composed of bronze wire of two sizes approximately, No. 9 and 12, B. & S. The No. 12 line was equipped with compensating coils, in order to favor the unloaded line. The length of the line was a little short

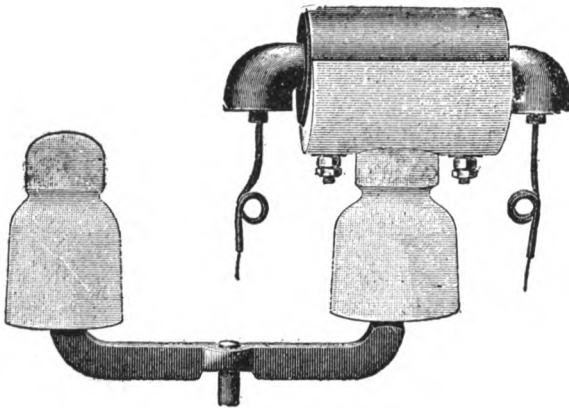

FIG. 5.— AERIAL LINES — COMPENSATING COILS.

of 100 miles. The results of the aerial tests were qualitatively about the same as those obtained when using the cable; that is to say, conversation over the loaded line could be carried on over about five times as long a line with equal facility.

While the conversational test thus described left no doubt in the minds of the investigators as to the superiority of the loaded conductor it is impossible in a test by talking to get accurate quantitative results, and some fur-

ther trials were made by sending alternating currents of different frequencies, approximately within the ranges of those of articulate speech, over the loaded and unloaded lines, and measuring the volume of current, both at the transmitting and receiving ends. The first test was made with a frequency of 400 and the results are shown by curves in Fig. 6. The horizontal scale is the distance in miles, while the vertical scale is the number of mil-amperes, measured at the *receiving* end. In all cases the current was 3 mil-amperes at the sending station. Curve 1

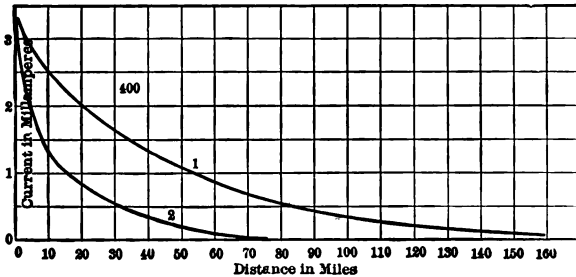

FIG. 6.—CURVES SHOWING CURRENT TRANSMITTED BY LOADED AND UNLOADED LINES—FREQUENCY 400.

shows the amount of current measured at the receiving end over the loaded conductor, while Curve 2 gives the amount obtained over the unloaded conductor. Fig. 7 is a record of similar tests made with a frequency of 900, the horizontal and vertical scales are the same as in Fig. 6, and Curves 1 and 2 are respectively results obtained with the loaded and unloaded conductor. These quantitative experiments demonstrate very conclusively that the results stated by all observers in the talking tests are fully substantiated. When Heaviside first suggested the possibility of compensating capacity with inductance, trials

were made by inserting compensating coils, but the early experimenters fell into the error of locating the balancing inductances at but few points along the line. Dr. Pupin's success is due to his ability to point out the necessity of distributing the balancing inductance all along the length of the conductor, and of devising a mathematical formula which should show the distance between the coils and what the electrical proportion of each coil should be. To test the correctness of the mathematical deductions, the German experiments included some trials upon loaded

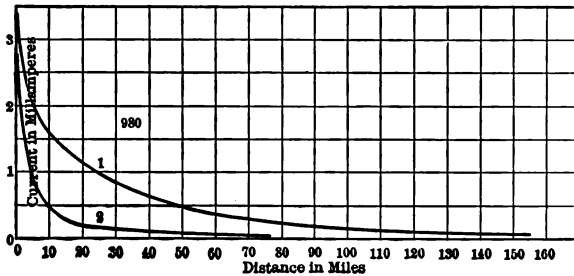

FIG. 7.—CURVES SHOWING CURRENT TRANSMITTED BY LOADED AND UNLOADED LINES — FREQUENCY 900.

lines with a varying number of coils per mile, and the results of these experiments are given in Fig. 8. The lower scale shows the spacing of the coils in miles, while the left hand vertical scale is the current in mil-amperes at the receiving station. In all cases three mil-amperes were transmitted at the sending station. The curves 400, 600, and 980 show the current at the receiving station measured in mil-amperes in proportion to the distance between coils as given on the lower scale, thus with 4 miles between coils the current at the receiving station was zero with a frequency of 980, .8 of a mil-ampere with a fre-

quency of 600 per second and  $1\frac{1}{2}$  mil-amperes at a frequency of 400. When the coils were spaced 1 mile apart 2.1 mil-ampere was received, when a frequency of 980 was used 2.45 with a frequency of 600 and 2.6 with a frequency of 400.

The investigations of Dr. Pupin show that in the telephonic transmission of speech a series of waves traverses the line, and that if balancing inductances are concen-

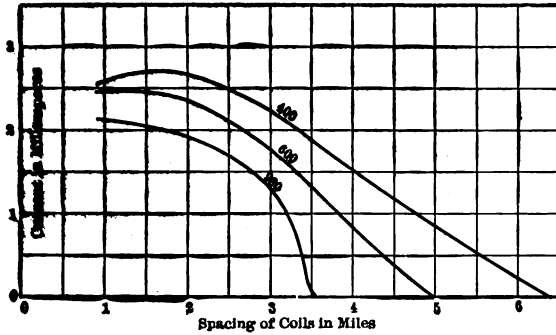

FIG. 8.— CURVES SHOWING RELATION BETWEEN NUMBER OF COILS PER MILE AND CURRENT TRANSMITTED.

trated at a very few points, they act to choke the line and to cause the advancing electric speech wave to be reflected back upon itself, exactly in the same way as a water wave, reaching an obstacle, dashes against it and rises as spray. One can, in a similar fashion, imagine that the electric wave meeting a heavy impedance coil would be dissipated, and the addition of coils in such a manner would be a detriment and not an improvement to the talking properties of the line; such was the experience of the early investigators in this direction.

To prove the correctness of this theory a number of experiments were made during the preceding tests to ascertain influence of the number of balancing coils in relation to the electrical wave length that was traversing the line. In these tests three different frequencies representatives 400, 600, and 980 per second were adopted. At the sending station 3 mil-amperes were transmitted in each case. The horizontal scale of the curves in Fig. 9 shows the number of coils per wave length, while the vertical scale is the number of mil-amperes received at the

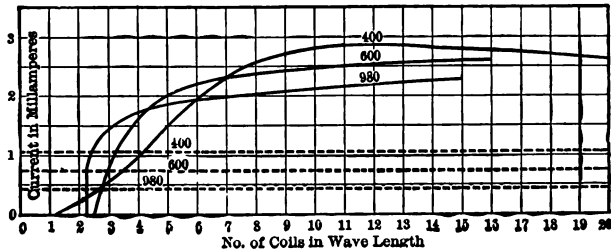

FIG. 9.—CURVES SHOWING RELATION BETWEEN NUMBER OF COILS PER WAVE LENGTH AND CURRENT TRANSMITTED.

receiving station. The horizontal dotted lines marked 400, 600, and 980 show respective amounts of current measured at the receiving station for an unloaded line, while the heavy-line curves, marked respectively 400, 600, and 980, give the amount of current measured at the receiving station, referred to the number of coils per wave length as given on the bottom scale. These curves indicate conclusively that success can only be attained by using a large number of coils in proportion to the wave length to be transmitted. With two coils almost no im-

provement is obtained, but with three or more the increase in current at the receiving station is very rapid and very marked. The electrical properties of telephone lines have, in recent years, received so little attention, that it is encouraging to perceive how much may accrue from a careful and intelligent study of their properties. The method invented by Dr. Pupin is by no means the only possibility of improving transmission, for both Mr. C. J. Childs and Dr. S. P. Thompson have shown other arrangements of balancing inductance that certainly, theoretically, appear to be promising, and with Dr. Pupin's success as an incentive, other inventors should not be slow to take up the problem in an endeavor to equal or possibly surpass the results already attained.



## CHAPTER III.

### ROUTES AND RIGHTS OF WAY.

THE selection of a pole line route is a difficult matter, because a wise choice of the best route depends far more upon the exercise of judgment, and the experience of a long education in pole line construction, than upon the application of any specific set of rules or formulæ. There are two general principles which must never be lost sight of. These are that the shortest line and the straightest line is the best line. The selection of routes for city lines is governed by the location of the subscribers that it is desired to reach, and by the streets, alleys, or other thoroughfares along which rights of way can be obtained. A city line is best located by plotting upon a good map, showing all available streets and alleys, the location of the subscribers, and then reaching the various groups by such routes as will give the straightest and shortest lines. A large number of western cities have long blocks which are split centrally by alleys. These are hardly thoroughfares in the true sense of the word, as they are rarely wide enough to allow passage of two vehicles abreast, but they serve as means for the delivery of goods to both dwellings and stores, and afford an additional access for light and air. There is usually little objection to the erection of pole lines in alleys, so where such opportunities exist the designer has comparatively an easy task to select the most favorable wire route, compatible with urban topography. In older and eastern cities, alleyways are less frequent, and, of necessity, lines must be located along the traveled thoroughfares. It is rare to find a city so hilly that any special designing is needed to

accommodate pole lines to vertical changes in alignment, so that this question may be dismissed from the consideration of city pole lines.

The selection of a proper route for a cross country line is in some respects easier, and in others more difficult than the choice of a city route. While in general aerial lines follow the highways, there is always the chance of cutting across private property and thereby either saving distance or avoiding ugly and dangerous corners, and from this aspect the choice of the country line requires more consideration, and a more careful examination of a proposed route, than is necessary in a city. In the location of city lines the obstacles presented by forests or the crossing of wide streams are seldom encountered, but country lines frequently meet these, each one of which must be dealt with according to the circumstances presented. In rural districts the line must necessarily follow the contour of the country, and must be built "up hill and down dale," accommodating itself the best it may to surface configuration. For this reason it is customary to proportion the height of poles to meet, as far as possible, the requirements of hilly territory by using the shortest poles on the summits and the longest poles in the valleys.

In both city and country lines questions of rights of way play an important part in the selection of pole line routes. In many States the courts have held that the erection of a pole carrying telephone wire imposes an additional burden upon the highways, and that, therefore, telephone companies cannot condemn right of way under eminent domain laws, but must purchase, or otherwise obtain leave to erect poles, specifically from each abutter. Municipal franchises have been construed from a similar point of view. Further, most telephone companies have

found it on the whole to their interest to resort entirely to pacific measures to obtain necessary consent for the erection of lines, rather than to appeal to the courts. Partially, this is due to a fear on the part of telephone companies, that if the right of eminent domain (where legal) is exercised, appraising jurors will establish such a measure of damages for the occupancy of either highway or private property, as to set a dangerous and undesirable precedent, which, if established, would incite all property-owners to make such a charge for every pole as they might conceive the jury would allow — thus, on the whole, raising the cost of construction above that which now obtains even when burdened by such damages as are occasionally demanded by avaricious owners.

It is to the last degree desirable that questions of right of way should be fully and thoroughly settled prior to the commencement of work. If this is not done, the pole line gang, as it proceeds, is hindered and delayed, and the cost of erection enormously increased by objections which are sure to be interposed by property-owners who feel that their just rights are being unwarrantably invaded. Again, it is relatively an easy matter to secure the right of pole erection, or tree trimming from an owner if approached by a polite and tactful right of way agent. If construction is commenced in the absence of a definite and well-understood agreement, the owner is likely to be raised to such a pitch of, what appears to him, warrantable indignation as to render it impractical to subsequently secure from him any consents whatsoever, and a resort to the courts, or a change in location, is the only remedy. Moreover, it is very greatly to the interest of the telephone company owning a pole line to secure the "good will," cordial friendship and assistance of all persons along the line of its

routes. It must be remembered that the wire plant is an exceedingly exposed structure, that the poles or circuits may be injured, or even destroyed maliciously with the greatest facility in such a manner as absolutely safe against detection.

There is no pole line that is always exempt from accident, and when the day of disaster arrives, the hearty cooperation of each abutter is of the greatest value as an aid toward the repair of the wreck, remission of possible claims for damages due to falling poles and wires, and, if a subscriber, a greater tolerance of impaired service. To quarrel with an abutter, on anything short of overbearing injustice on his part, is in the end folly. So by throwing away a few sprats, the telephone company is likely to catch a great many herrings. Fair and square business dealings, the prompt and honorable fulfillment of all obligations on the part of the telephone company, with a manifest endeavor to be a little more than just to the property-owners, are sure to win out in the long run.

In securing rights of way there is nothing more important than an explicit and definite contract with each property-owner, stating exactly where and how poles and guy stubs shall be set, and to what extent tree trimming is permitted. For each location the right of way agent should secure a sketch, which may be conveniently made in a manifold copy book. This sketch should show the location of all poles and guy stubs with reference to the property lines of the owner. A brief contract should be drawn, specifying the number and location of poles and guy stubs, for which permission is given as shown upon the sketch; finally, the contract should contain a clause stating specifically the trees for which trimming permission is given, and how much trimming is to be allowed.

All such contracts should be made in duplicate on regular forms (of which the following is a model), one copy to be retained by the company, and the other given to the owner. Occasionally property-owners are met with who will grant right of way, but will not sign any contracts. In negotiating for right of way, therefore, it is always desirable to make a party of two men, so that there are at least two witnesses to every transaction.

In securing rights of way the right of way agent should plainly and honestly explain to each property-owner exactly what the telephone company proposes to do, so that subsequently there may be no misunderstanding in the instructions given to the foreman for the erection of the line. When construction is actually undertaken, the foreman must be supplied with a copy of each contract, and instructed to be particularly careful that all poles and guy stubs planted are entirely within the specified height, diameter and location recorded in the contract with each owner; and ordered to take the utmost pains that tree trimming is done in such a manner as to injure in the least possible degree all trees or shrubberies; and that, under no circumstances, without additional special permission in writing, should tree trimming exceed that specified in the contract. It is only by means of dealings which are perfectly honorable and above board, and in which the telephone company is clearly within the rights that it has secured *prior* to commencement of work, that it is possible to establish any tolerable *modus vivendi* with property-owners along the lines of open wire routes.

While all legal questions of importance should be referred to counsel, general managers and superintendents can gather valuable information, and inform themselves in a general way, as to right of way questions, by consult-

ing Keasbey, on "Electric Wires;" Crosswell, on "The Law Relating to Electric Wires," or Joyce, on "The Law of Electricity."

**RIGHT OF WAY CONTRACT.**

(Form . . . .)

*The . . . . . Telephone Company:*

In consideration of the building by the . . . . . Telephone Company, of a telephone line from . . . . . to . . . . ., to be located . . . . .

And the further consideration of . . . . ., the receipt of which is hereby acknowledged, well and truly paid to, and received by . . . . ., the undersigned, hereby agree.. both for . . . . ., jointly and singly, and for . . . . . heirs, assigns, and legal representatives, jointly and singly, to permit the said Telephone Company, and its assigns, to erect and perpetually maintain the following specified poles, guys, guy stubs, and attachments; and also to cut, trim, or remove the following specified trees and shrubbery, as may be necessary to permit of the free and unobstructed passage of all the wires, cables, and other attachments that said poles may now, or in the future, carry. And . . . . . agree said trimming may be repeated from time to time in the future, whenever the growth of said trees or shrubbery may render it necessary.

If said telephone line is not completed within . . . . . years from the above date, or if in the future said company, or its assigns, shall abandon its line, or shall discontinue the use thereof for a period of one year or more, then this contract shall be null and void, and all rights there-

under shall revert back to ..... or .....,  
 heirs, assigns, or legal representatives.

In witness whereof ..... hand .....,  
 are affixed this ..... day of .....

Witness .....

.....  
 .....  
 .....

Circumstances often arise that require two or more companies to share the same right of way, for it may happen that two electric light companies, two telephone and two telegraph companies are all seeking, in a single town, the privilege of planting circuits, and each desires to reach the principal thoroughfares by the shortest and most direct route. As streets and highways are only built with two sides, it is physically impossible for each of the six companies to secure one side of the road to itself, and, therefore, either some mutual compromise must be adopted, some of the companies must abandon the field, or other routes be selected. Even when only two companies desire aerial lines municipalities may restrict construction in such a manner as to compel both to build on the same side of the street, or indeed specify joint occupancy of all poles. Even when franchises authorize circuits to be built on both sides of the highway the consent of abutting property-owners must be obtained for the erection of each pole, and it is usual that decided objections exist to the placing pole lines on both sides of the street, and often much dissatisfaction is expressed when more than one pole is planted on one side. Fig. 10 shows the appearance of a highway occupied by modern lines where three companies have strung circuits independently of each other. Such an

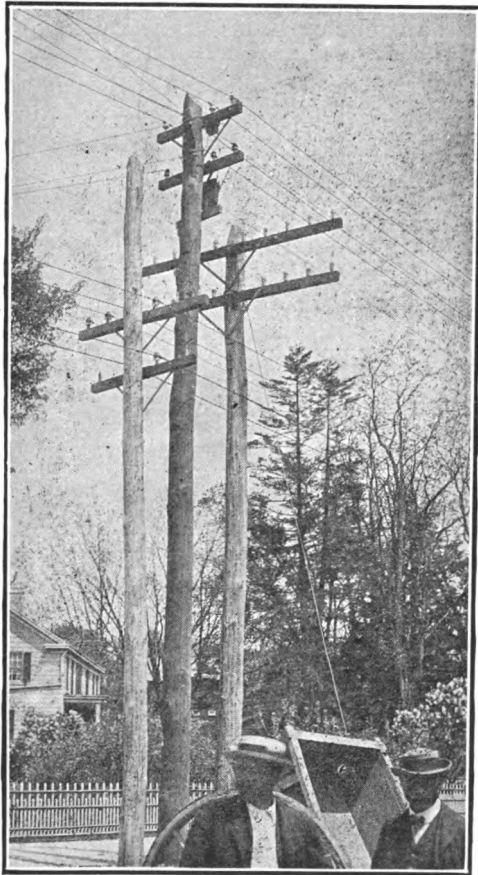

**FIG. 10.**—A TRIPARTY RIGHT OF WAY.



example is offensively repugnant even to the most uneducated artistic perception, and it is not strange that property-owners and municipalities are daily becoming more and more reluctant to grant permission for the erection of more than one set of poles on one side of the road.

From an operating standpoint there are many objections either to joint occupancy of poles or the construction of more than one set of circuits on the same right of way, and electric companies are undoubtedly wise in using all honorable and reasonable means to secure individual rights of way; but no company should for a moment take the position that it is *impracticable* to operate electric circuits of all descriptions even under the restrictions of joint pole occupancy, nor is any company, under any circumstances, justified in resorting to tactics to secure or hold rights of way, that are in the slightest unfair or unreasonable or which *it* would *consider unfair* and *unreasonable* if applied to *itself*. The occupancy of one side of a highway does not confer upon a company holding the same the exclusive right to all space above or beneath its pole lines, and when, in the ordinary course of events, a second corporation desires the privilege of extending circuits along the same right of way, the first company should meet it fairly and openly, and accord to the newcomer the same welcome which it would desire in case it was the one to build lines last.

The objections to joint occupancy either of poles or rights of way are many and obvious. It is argued that it is more expensive and difficult to work on the first line after the second one is in operation. This is as true as it is more expensive to increase capacity on an existing line after it is in service than it is to build of sufficient size at the outset; but as electric companies of all descriptions

are constantly augmenting wire facilities, it is absurd to advance such a reason as final argument to estop the erection of a second set of circuits when one already exists. Companies occupying the same location usually lay great stress upon the hazard and difficulty to which linemen are probably exposed, due to the proximity of the other set of circuits, but it is obviously no more difficult for a lineman to climb among foreign circuits than it is to climb among his own circuits. If an electric light company wishes to string its circuits below those of a telephone or telegraph company there is strenuous objection on the ground of danger to linemen by being compelled to crawl through the high potential circuits in order to reach the lines above. This is a good argument for placing high tension wires on the tops of joint pole lines, but it by no means demonstrates the impracticability of operating high tension wires beneath other circuits. For there are thousands of high tension circuits in operation that carry several cross arms, and many circuits through which linemen must daily crawl in order to perform repairs. Some casualties occur, but in proportion to the danger to which workmen are seemingly exposed the number of accidents is exceedingly small. There are other reasons that render it desirable to place high tension circuits above telephone and telegraph wires. The high tension circuits are usually much fewer in number. They are invariably constructed of much larger and consequently stronger wire, and it is customary to string them with a greater center deflection. Thus each line is not only intrinsically stronger, but is subject to less stress proportionately, than the telephone and telegraph wires, and it is, therefore, better prepared to resist breakage. Statistics show not only that annually there is a less number of broken electric light and

power wires than of telephone and telegraph wires, but the per cent. of broken high potential wires in proportion to the total number is far smaller than the same per cent. in the case of telephone and telegraph lines. If high potential circuits are placed below telephone and telegraph wires a broken low potential wire will almost invariably fall across circuits beneath, such a wire will then become a menace to the central office at one end, and to the subscribers' station at the other, and is also a source of danger to the street beneath, for if a broken line comes in contact with high potential circuits (as is usually the case), it is immediately charged to the same potential, and may inflict a possibly fatal shock upon any one touching it, and is likely to convey sufficient current to destroy terminal apparatus. A similar result may occur when high tension wires are above low tension ones, for if the high tension wires break and drop upon circuits beneath they will charge them with equal hazard to all concerned. It has been shown that this contingency is less likely to occur, and consequently the safer construction is to place high tension lines upon the tops of the poles.

From a maintenance standpoint joint occupancy of pole lines is objectionable. It is more expensive and difficult to care for circuits that are above another set, but so far as the lower circuits are concerned the expense and difficulty of repairs remains unchanged, and it is only in the case of broken wires in the upper lines that there is any probability of injury accruing to the company occupying the lower cross arm from the presence of circuits above them. The linemen of the company occupying the top arm must climb through the wires of those which are lower and this obviously increases the cost and difficulty of making repairs and may cause some injury to the lower cir-

cuits due to the carelessness on the part of repair-men seeking the circuits above. These objections to joint occupancy of pole lines are real and vital, but they should not be advanced to prove that joint pole lines are impracticable or even seriously objectionable. The injury to the appearance of the streets and highways caused by construction of several pole lines, and obstruction to traffic on those which are in any way crowded, is far greater than any inconvenience inflicted on electrical companies by requiring them to occupy joint poles.

Telephone and telegraph companies usually assume that the presence of high tension wires upon the same pole will interfere with service because high tension wires will leak electricity, but this is not an argument against joint occupancy of pole lines but only an argument for good construction. The modern methods of insulation have been so far perfected that there is no excuse for any electric company that constructs aerial lines in such a manner that there could be sufficient *actual* leakage to affect any of the telephone and telegraph lines that are built in accordance with the best practice.

As a last resort telephone companies object to joint occupancy of rights of way on the ground of either electrostatic or electromagnetic induction. Herein lies the strongest argument which can be advanced against a common right of way. That in the past much injury has been inflicted upon telephone companies by the presence of other circuits cannot be denied, and it is unquestionable that in a general way telephone companies had better be as far from all other circuits of any description as possible. But with increased experience the laws of inductive disturbances are becoming far better understood, and methods to remove such trouble more common, and applied with

greater success, so that now it is possible to operate extensive telephone systems including important trunk lines in which the wires are placed on the same poles with those

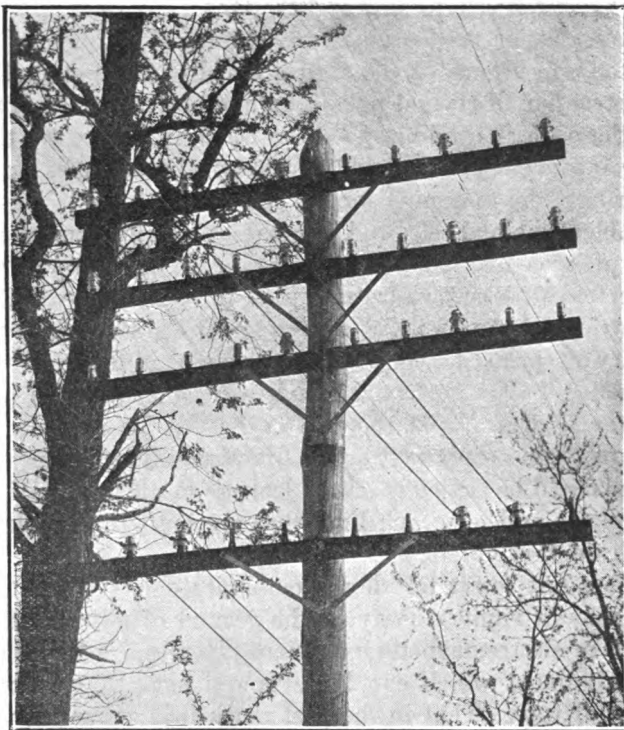

FIG. 11.—POLE CARRYING ELECTRIC LIGHT AND TELEPHONE WIRES.

of electric light circuits. Many such instances can be cited from actual practice. For example Fig. 11 is from a photograph of a pole top upon which a telephone company use the three top arms carrying 30 wires some of which

form trunk lines. At the time the pole was photographed an electric light company had two active circuits on a cross arm 24 in. below the telephone wire. For several months the electric light company had occupied the gain above, and during this time no injury to the service had been reported. The lighting wires were moved down again to allow the telephone company to place a fourth cross arm and erect 10 more wires. Now while this instance forms no argument for the desirability of joint occupancy of poles when it is possible for each company to secure individual rights of way it is conclusive in showing the unwisdom displayed by any electric company in assuming the position that such joint occupancy is impracticable, from either a maintenance or service standpoint, nor can it be said that such joint occupancy inflicts upon either company any serious hardships, and when questions of joint rights of way arise a very slight application of the "Golden Rule" will in nine cases out of ten solve all difficulties.

The selection of right of way and the decision of the question of joint occupancy of pole lines will depend somewhat upon the capacity in number of circuits, for which the line must be built. It was formerly the custom to build very large and heavy aerial lines, and in some cases miles of poles carrying 20 or 30 cross arms, each holding 10 or 12 wires, have been constructed, but with the advent of the conduit, and the development of the telephone cable such lines have become only matters of history and would not, at present, be undertaken. From a telephone standpoint aerial lines possess one feature that makes them superior to any other design of wire plant now known, and which has caused telephone companies to tenaciously cling to this form of circuit. An aerial

line talks better than any other circuit because it possesses much less electrostatic capacity. For this reason it has always been a favorite form of construction with telephone companies, and has been regarded as the only feasible method of working long trunk lines. So for this purpose the aerial line has held its own, and even now, in the larger cities, the trunk line leads are brought as near as possible to the exchange by means of overhead wires. The opinion has long prevailed that the aerial line was much cheaper than the underground circuit, but as will be subsequently shown the relative cost of circuits depends entirely upon the number of wires that are to be used. Where only a few circuits are necessary, the open wire construction is undoubtedly much cheaper than any form of cable or underground line, but it is impossible to build a pole line of large capacity, and the time soon arrives when it is cheaper to put up an aerial cable than it is to add cross arms, and as the number of circuits increases the cost per wire mile, of either aerial cable or underground line, falls, until presently an underground cable in a conduit becomes cheaper than any form of open wire line or aerial cable. Experience has shown that the maintenance and depreciation of an open wire line is very much larger than for an aerial cable, and that the aerial cable is annually more expensive than the conduit line. The designer of the wire plant should carefully recognize this fact, for neglecting the consideration of reliability of such service, as impossible to estimate in dollars and cents, it is obvious that when the annual costs of depreciation and maintenance of open wire lines and aerial cable are capitalized and equated against, the investment for the same number of circuits when placed underground, a comparatively small number of circuits will show really a cheaper installation when placed in conduit.

It is difficult to assign any standard type to aerial construction, because each electric company has ideas of its own. One can recognize at a glance the difference between an electric light line, a telephone line and a telegraph circuit, and it requires but a little experience to pick out a Western Union pole from that of the Postal Telegraph or any one of the telephone companies. The process of manufacturing supplies for aerial work has, however, tended toward certain standards and at present 2-pin, 4-pin, 6-pin, 8-pin and 10-pin cross arms are usually recognized as the preferred capacities for arms, occasionally a 12-pin arm is seen, but these are rare and experience has not encouraged their use. Where 4 wires or less are needed the cross arm is dropped and the circuits supported on the sides of the poles by means of brackets; 2-pin cross arms are chiefly used for electric light and railway work, and rarely make their appearance in telephone or telegraph practice. The 6-pin and the 10-pin arms are most frequent, and present practice tends strongly to the adoption of the 10-pin arm in all cases. When the capacity of the pole line will probably be always limited to 5 circuits; the single 10-pin arm produces a line somewhat top heavy in appearance, and the long cross arm tends, especially at the corners, to pull the line over. In such cases it is preferable, although slightly more expensive, to erect two 6-pin arms instead of one 10-pin arm. If the capacity of the line is, however, to exceed that of one cross arm, it is preferable to adhere to the 10-pin standard, erecting in the beginning one cross arm and subsequently adding others as fast as additional lines are needed. For urban and suburban plants the present tendency is, particularly for distributing systems, to limit open wire construction to three



10-pin cross arms or a capacity of 15 circuits. When these arms are filled it is considered advisable to erect a 50-pair cable to which the working lines may be transferred and the cross arms set free for local growth. The 50-pair cable provides a sufficient margin for a considerable increase, and if development should extend sufficiently to exhaust the capacity of this cable, it is then advisable to reinforce the line by adding a 100-pair cable. Generally speaking, when the second cable is full it is advisable to seek underground conduit, for by that time the line will be carrying 180 wires, and considering annual expense, practice has shown that the advantages of underground construction with lines having 200 or more circuits are so great as to justify any slight difference in installation expense that there may be between the conduit and the pole line.

## CHAPTER IV.

### THE POLE.

It is difficult to assign a standard to size of poles either in height or in diameter. For country lines and in the outskirts of villages and small towns it is customary to require that the lowest portion of any line shall be at least 18 ft. above the highway or sidewalk. Railway companies invariably specify at least 22 ft. between the lowest point of the line and the top of the rail. In large towns and cities from 22 to 25 ft. is frequently demanded. It has become customary to space cross arms 24 in. center to center, and the specifications for distance between the lowest point of the line and the highway, in connection with the number of cross arms and the spacing thereof, will necessarily determine the minimum height of poles. It is exceedingly desirable to avoid changes of level in circuits, for any variation inflicts upon the insulator and pin a stress in addition to weight of the line and snow load that they may be called upon to carry. Poles which are placed upon the apex of a hill are thus subjected to an additional vertical stress, acting downward, due to the tension of the circuits, which tends to break the arms, while the resultant of the tension in the wires of those poles which are set in valleys acts to lift the insulator away from its pin, and one may often see an insulator swinging in midair, suspended from the wire, which it was designed to support. Therefore, in hilly country it is customary upon rising ground to set the lowest poles, and in the valleys to use longer ones in order to equalize changes in line level. Poles are customarily rated by

length over all, and diameter or circumference of top, and by diameter or circumference 6 ft. from the butt. Experience has shown that it is expedient to use nothing less than a 7-in. top. Occasionally lines are built of smaller timber, but such lines are of the bean pole variety, generally used on the so-called rural or farmers' lines, and can hardly be regarded as legitimate aerial construction. It is rare to load them with more than six wires, and even under such circumstances few winters pass that do not inflict serious injury. By the best opinion even the 7-in. pole top is considered light, and is only used where circuits are few and low, and the line never expected to carry more than one or two cross arms. Such poles are too light for large and important lines. The 8-in. top pole represents more nearly the highest engineering standard for aerial lines, and it is rare to find good and important open wire work constructed of anything less substantial. From the requirements of height, underneath the lowest point of circuits, a pole carrying one cross arm must be at least 18 to 22 ft. in length above the ground. Practice has shown the desirability of setting light poles at least 5 ft. and heavy poles from 6 ft. to 8 ft. into the earth, thus a pole 25 ft. over all is about the shortest which can be used in regular work. Longer poles customarily vary by 5 ft. upwards to 70 ft. When the exigencies of construction require still higher poles recourse must be had to splicing. Fortunately, this necessity is rare, as it is a difficult job, and it is next to impossible to build a line of spliced poles that will not at an early date succumb to a fall of sleet, accompanied by a wind storm. As a makeshift, however, it is possible to splice poles, and this is best accomplished in the following manner: For the pole butt a solid, substantial and

as long a stick is selected as can be obtained. The upper end is scarfed for a distance of about 6 ft. to 8, and a second pole of sufficient length when added to the first stick to secure the required height, is chosen. This pole should be as slim and straight as possible. The butt of the second stick is scarfed to match the first one. Then the two sticks are halved, together bolted in place by three  $\frac{1}{2}$ -in. bolts only intended to hold them in place until the work is completed. A series of six iron rings, about 2 in. wide and of  $\frac{1}{4}$ -in. stock, are forged of such a size that when heated red hot and driven onto the pole they will form a series of bands extending over the splice. These bands are then heated and shrunk into place exactly after the fashion of wagon tires. A spliced pole made in this manner is about as strong as anything short of the natural wood, or a structural iron pole, and there are many instances on record where 70-ft. or 80-ft. lines, carrying 8 to 10 cross arms have been built in exposed locations and have rendered for many years faithful and efficient service. Nevertheless such lines sooner or later surely go down, and sooner or later such circuits go under ground, as maintenance and depreciation soon becomes an onerous burden.

In the construction of aerial circuits European and American practice presents one point of striking dissimilarity. In America the use by telephone and telegraph companies of iron poles is so rare that their occurrence is remarkable. In Europe the use of poles of structural iron, constructed along the best of engineering designs for aerial lines is not only common but in all the important towns and cities it is the rule. In America wood is much more plenty, wooden poles consequently much cheaper and much easier to be obtained than in

Europe, and as a result telephone and telegraph companies have almost without exception adhered to the employment of wooden poles, but the electric light and railway companies have from the first largely adopted iron poles as being in the long run the cheaper and more satisfactory form of building when permanence and durability were taken into consideration; and there seems to be little reason why telephone and telegraph companies, who wish to continue the use of aerial circuits, should not follow this example and erect something which is really a structure, durable and substantial, and which is not so unredeemably offensive to the eye as is the ordinary wooden pole line. A modern example of excellent design in structural iron poles is given by the Belgian toll line, shown in Fig. 12. The poles, as will be seen from Fig. 13, are composed of four angle irons, which are latticed together in such a manner as to form a support of exceeding strength. The cross arms are constructed of transverse angles which are bolted to the vertical angles, and upon which the pins and insulators are carried. Each cross arm is usually made double; that is, of two angles placed back to back, between which the pins are inserted and bolted into place. The base of the pole forms a hollow iron column into which enameled tile is inserted, as shown in Fig. 14. Evidently such a method of building open wire line is much more expensive than the slip-shod American practice, but it possesses features of durability and of artistic effect that will forcibly appeal to the general manager, who has an eye to the permanence of his plant, desires means which shall reduce annual charges to a minimum and wishes to secure additional franchises to extend aerial lines; for the adoption of such a form of construction would go far to remove the repugnance which

municipal bodies of all kinds now evince to granting franchises for open wire lines. It is exceedingly easy to build a pole line upon such design of almost any capacity, and

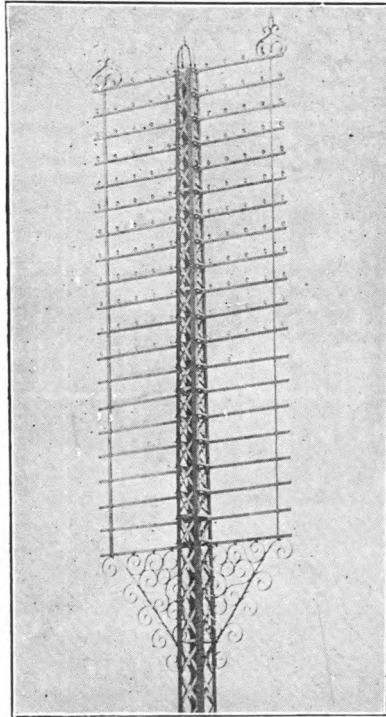

FIG. 12.—STRUCTURAL IRON POLE TOP.

to so design the poles that they may be capable of standing up under the severest wind and sleet storm that it is possible for winter to inflict. It is also evident that very little modification of design will enable the constructor to

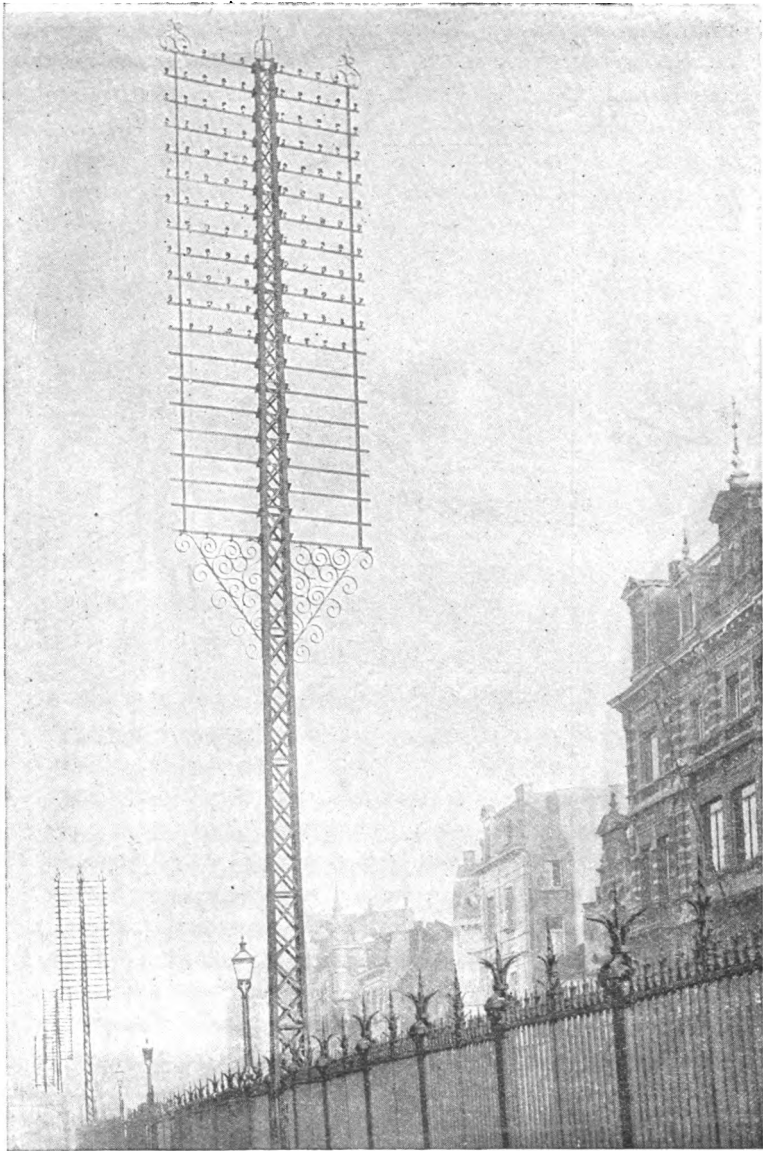

FIG. 13.— BELGIAN POLE LINE.

plan a pole which may serve as a terminal pole or anchor pole, in such a manner as to entirely avoid the unsightly guys that now terribly burden any streets upon which

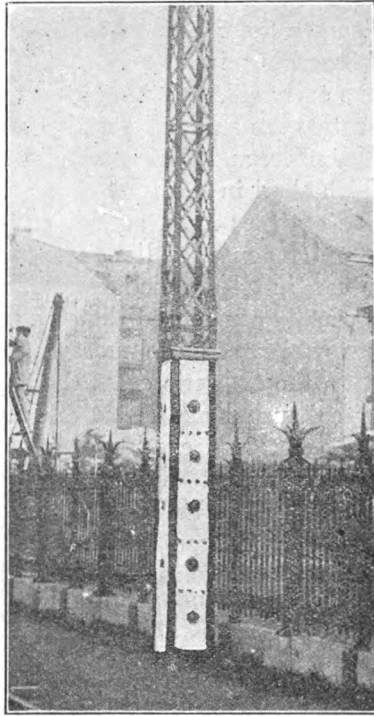

FIG. 14.—BELGIAN POLE CONSTRUCTION  
AT BASE.

there is even but a moderate traffic. Against the iron pole no possible objection, excepting that of expense, can be urged, and it is gratifying to perceive that a few of the Independent Telephone companies have at last recognized



the value of permanence in construction and have begun to equip their urban lines with structural iron poles of a neat and excellent design.

The rapid extension of telephone and telegraph plants and the demands upon the timber resources of the country by other wood-absorbing industries, raise so serious a probability of the early exhaustion of the supply of poles, that line constructors are anxiously casting about for both new supplies of timber, and for methods to increase the life of those which shall in the future be erected. Year by year the price of poles rises, and so rapidly that this factor in the cost of open wire lines is now becoming a most serious problem in telephonic installations. Of available woods it is usually considered that cedar or northern pine yields poles which are the most durable and the strongest. But on the Atlantic coast the supply of such timber is nearly exhausted and cedar and northern pine poles can rarely be obtained except by importation from the forests of the Northwest. In lieu of pine and cedar a great deal of chestnut is being used in New England and the Central Middle States. On the whole chestnut is a fairly good wood for poles, but it lacks the strength and solidity of pine and cedar. The chestnut as a tree is much slimmer than the pine or cedar and consequently the butt of the pole has considerably less resistance than with the other woods. As chestnut can be obtained in fair quantities at reasonable prices throughout Massachusetts, Connecticut, New York, Pennsylvania, Delaware, and Maryland, a very large proportion of lines recently constructed, particularly those of moderate height, say 35 to 40 ft., are built of this material. The Southern States should apparently afford an inexhaustible supply of pole line material in yellow pine timber. But experience has shown

that notwithstanding the pitchy quality of that wood, yellow pine rots with most alarming rapidity when cut and set in the ground. It is commonly believed that yellow pine poles unprotected will not last more than four or five years. From the District of Columbia southward to and including all of the Gulf States, southern cedar, so called, usually really a juniper or cypress, is chiefly employed for pole lines. In the Middle West, Norway pine cut in the forests of the Northwest, or on the edges of Canada, is common, and makes excellent timber for open wire lines, but is now rapidly rising in cost.

The exhaustion of timber supply and consequent rise in price and increasing scarcity is bringing the question of the treatment of wood in some manner to retard the ravages of decay, prominently to the foreground. A study of causes that lead to the destruction of timber shows that rotting is due to a fungus which attacks all varieties of wood when placed in situations to be alternately wetted and dried, coupled with a temperature favorable to the development of parasitic growths. Fig. 15, in an illustration photographed by the United States Department of Agriculture, shows how this fungus attacks a railway tie. The fungus in question attacks the wood and destroys the fibre, cell by cell, until the entire stick is reduced to a spongy mass. As the growth of this fungus can only take place under favorable conditions of moisture its action is localized at the point where the pole enters the ground, and rotting is chiefly confined to the space about a foot above and a foot below the earth, and when the pole fails by breaking close to the butt, it is often discovered that the upper part of the pole is perfectly sound. Railway companies are confronted with the same problem in an aggravated form, for in the use of wooden ties

to support rails, timber is placed under the most trying conditions, for it is partially bedded in the earth and kept in an environment of temperature and moisture conditions most favorable to its destruction, and the railways have spent many years and much money in an endeavor to discover some satisfactory preservative process. The results of all that has been done with preservative proc-

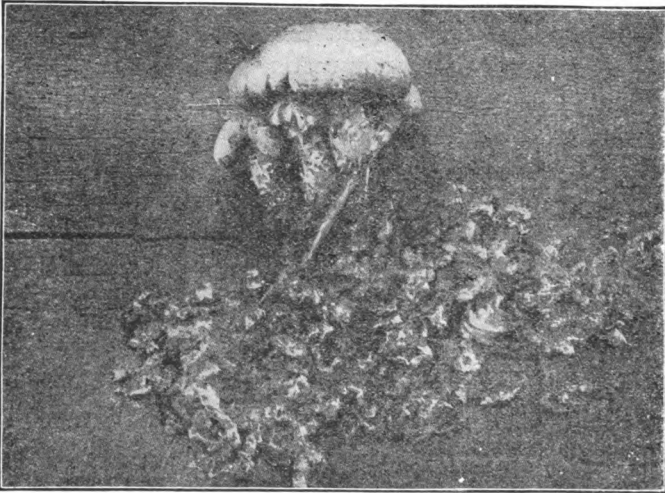

FIG. 15.—FUNGUS DESTROYING A RED WOOD TIE.

esses inclines to the belief that any method to be successful must have the following two requirements: First. After the timber is felled and *seasoned* it must be thoroughly sterilized, and the only way in which sterilizing can be carried to the heart of every stick is to raise the temperature of every part of it to at least 250° F. Second. After sterilization all the pores of the wood must be sealed

with some compound which will prevent the subsequent entrance of any fungus germs. If these conditions are faithfully carried into effect the process of decay is retarded for a very long period. A great many experiments have been tried in an endeavor to cheapen preservation, but all such methods omit sterilization and are based only upon the injection into the timber of various chemical solutions, designed either to coagulate the albumen of the sap or be antagonistic to the development of fungus germ. As all of these processes have lacked the essential qualifications of sterilization prior to the application of the preservative solution they have been only partially successful.

Of these various methods the only one which has attained a sufficient measure of success to be worthy of serious consideration is that which involves treating the timber with a solution of zinc chloride. This is accomplished by placing the seasoned timber in a vat, capable of sustaining considerable pressure, filling it with a solution of chloride of zinc and then putting the whole mass under hydrostatic pressure in order to force the solution into the pores of the timber. Experience with railway sleepers treated in this manner is on the whole favorable, as the life of ties is markedly prolonged, and of all preservative processes the zinc chloride treatment is decidedly the cheapest when relative costs are taken into account. Some observations have shown the following life for railway ties of different woods treated with zinc chloride: oak ties, 19 years; fir, 14; pine, 8, and beech, 15 years.

The only process which is fully worthy of consideration, and which on the whole is admitted by all opinion to be the most satisfactory, is that of creosoting; and that this process is apparently superior to others appears largely due to the

thoroughness with which sterilization may be accomplished. The process of creosoting consists in placing the timber to be treated in a vat which can be hermetically sealed. Superheated steam is then applied and the timber cooked for such a length of time as may be necessary to thoroughly heat every stick and raise its temperature to at least 250° F., then an air pump is attached and a vacuum maintained in the tank so long as there is any discharge of moisture or sap from the timber which, as fast as it oozes from the wood, is pumped out of the tank. As soon as the timber is thus artificially seasoned the tank is filled with dead oil of tar, which by means of steam coils, placed inside of the vat, is kept at a high temperature, and hydrostatic pressure again applied to the tank until the timber absorbs such a quantity of oil as may have been previously decided upon. The vat is then opened and the timber may be used at once, though some weeks' exposure in the open air is considered advantageous. Experience has shown that the life of wood treated in this manner, even under the most unfavorable circumstances, is very markedly prolonged. In Fig. 16 six curves are given, showing the average of a large number of observations upon treated and untreated wood. The horizontal scale shows number of years of life, while the vertical scale on the left-hand side gives the percentage of decay. Curves 1 and 2 are for beech, 1 being untreated wood and 2 being creosoted timber; Curves 3 and 4 are for oak treated and untreated, and Curves 5 and 6 applying to pine. The table is used as follows: For example, after 5 years' life 40 per cent. of pine had decayed and 100 per cent. of beech, while after 18 years' life 9 per cent. of creosoted beech had decayed and 38 per cent. of creosoted pine. Two salient lessons are to be drawn from this table. First, by all ob-

servations, the process of creosoting prolongs the life of woods from three to tenfold. Second, the poorest and consequently cheapest woods, which decay most rapidly, receive the greatest benefit from preservative treatment because they can absorb the most oil.

But when all is said, the general question of whether telephone poles shall be treated or not depends solely upon relative expense, and the matter should be viewed solely from the cost standpoint. If the annual cost of an

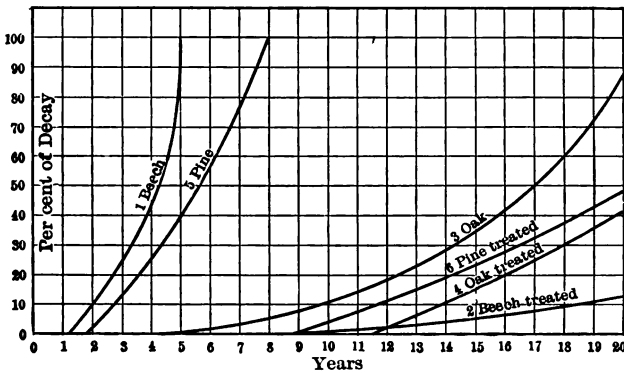

FIG. 16.—CURVES SHOWING RELATIVE LIFE OF TREATED AND UNTREATED WOODS.

untreated pole, perpetually maintained, is less than the similar annual cost of a treated pole similarly maintained, the preservative process is of little value. An example will perhaps best show how the matter should be regarded. Suppose a pine pole to cost \$8.00 and the erection of the pole to cost \$2.00, the total cost of the pole in place will then be \$10.00. The annual charge against this pole must be such an amount as will pay current rate of interest upon the capital invested on the pole, plus such an amount

as will provide a sufficient sinking fund, so that at the end of the life of the pole there may be funds to provide for its replacement. Suppose the pine pole in this example to last for 18 years; as its original cost was \$10.00 a sinking fund of \$1.25 per year must be provided in order to replace the pole at the end of its life. Strictly speaking compound interest should be allowed upon the sinking fund, but to explain the method of reasoning it is unnecessary to burden the discussion with such refinement. As the cost of the pole in place is \$10.00, current interest at say 6 per cent. must be allowed, making 60 cents, and consequently the total annual charge will be \$1.85. Now assume that the pine pole be creosoted, that the cost of treating be \$8.00, and that the preservative process will cause the pole to last for 25 years. The total cost of the pole in place will be \$8.00 for the pole, \$8.00 for treating, and \$2.00 for erection, or \$18.00. If the life of the pole be 25 years, the annual charge for depreciation is 72 cents, and the annual charge for interest \$1.04, a total annual charge of \$1.76. As the untreated pole annually costs \$1.60 and the treated pole costs \$1.76, the preservative process is not expedient. But assume that a cheaper pole, say a yellow pine or a cypress, could be used instead of the pine pole and by treatment could be endowed with an equivalent life, and let us assume that the cost of this pole is \$5.00, and the cost of treatment \$8.00, then the total cost of pole set would be \$15.00; the annual depreciation charge is 60 cents, the interest charge, 90 cents; total, \$1.50, which is 94 per cent. of the cost of the untreated pine pole. Thus there is an annual saving of 6 per cent. and treatment will pay.

This calculation has been based only on costs that can be calculated and does not recognize the many and mani-

fest advantages that will arise from a more uninterrupted service.

The cost of creosoting varies chiefly with the amount of oil forced into the pores of the wood. It is considered that creosoting is valueless for the softer woods unless at least 8 lbs. of oil per cubic foot of timber is injected, while for the harder woods 3 to 5 lbs. is sufficient. To thoroughly preserve the softer varieties, under severe conditions, from 12 to 16 lbs. of oil per cubic foot are considered essential. The cost of creosoting will then vary from \$12.00 to \$20.00 per 1,000 ft. board measure. Treatment with zinc chloride is found to cost from one-third to two-thirds as much per 1,000 ft. board measure, but the amount which this process is able to prolong the life of telephone poles is so much less than that attained by creosoting that its adoption is of doubtful value.

But decay is not the only destructive force which operates against the pole. The impact of passing wheels may damage a creosoted pole as much as an untreated one. The sleet storm is no more a respecter of a preserved pole than one unpreserved, nor does creosoting materially strengthen the pole except in so far as it may prevent a decay which weakens; and in city lines the progress of urban development may render the substitution of underground lines for aerial ones imperative long before even an untreated pole will fail through natural causes. In 'cross-country lines the normal increase of business may demand so many additional circuits as to necessitate rebuilding the line from the standpoint of required increased capacity before its lifetime is over. Thus in considering the relative advantages of treated and untreated line material, it is necessary to remember that rotting pure and simple is by no means the only reason that compels a re-



construction of the wire plant, but a pole line built of creosoted timber, wisely designed in a location where it is likely to remain undisturbed for a considerable period, of sufficient strength to resist the elements, and with capacity to meet all probable demands, is a sagacious investment, and where it is possible to realize such conditions, the treated pole is by far the best material to select. As decay takes place most rapidly close to the ground level, about one foot above or below this point, it would seem superfluous to treat the whole of a large pole in the endeavor to save such a small portion from rotting. Many attempts have been made to invent a local treatment which would be satisfactory, but so far none of these efforts have succeeded in accomplishing their object, for all forms of local treatment which have been sufficiently efficacious to prevent decay at the ground surface have been attended by so much greater expense as to nullify the attempted saving. As yellow pine poles can be obtained at a considerably less price per pole than northern timber, the expense of creosoting is not so burdensome, when yellow pine is used as in the case of the other woods. So, for all these reasons the process of creosoting is steadily making headway, and within the last few months more than one telephone company has installed its own plant for the treatment of pole-line material and report favorable results.

One or two suggestions for local treatment, which involve very little expense, are worthy of some consideration. Poles, which are carefully shaved, then thoroughly charred over a hot fire, and while hot soaked in tar, last perceptibly longer than those which are set without such precautions. A plan has just been suggested that involves setting the pole in a kind of socket, slightly larger than

its diameter, which may be made of either a piece of iron or vitrified pipe or a cylinder of concrete, and filling the space between the socket and the pole with an asphalt concrete. By allowing the socket to extend a few inches above the ground it is hoped that the surface decay will be prevented. This idea looks hopeful, but there is as yet no experience therewith.

An ingenious inventor has suggested a plan for repairing pole lines, which decay has already rendered insecure. He proposes to saw off the pole square, as close to the ground as possible. Then to extract the rotten stub and to replace it with an artificial butt of concrete, to which the pole is subsequently bolted, by means of 4 or 6 iron straps. Certainly this is a novel expedient, and where lines are not subjected to great bending moments, may have some value, but it will be shown that the greatest stress on the pole occurs at the ground surface, hence the impossibility of designing any kind of splice at this point which will confer any sensible amount of strength.

But omitting from consideration all preservative processes, the telephone company should exert strenuous endeavors to secure the best possible timber for poles. There is no better method than to have the standing trees examined by an inspector, somewhat skilled in forestry, and withal a good lineman, with a knowledge of the kind of poles necessary for the particular job under consideration. The accepted pole should be marked, and only felled during the three winter months when the wood carries the least sap, for poles cut in spring and summer decay much more quickly. As soon as on the ground the poles should be trimmed, cut to the required length, peeled and roofed. They should then be stacked up on skids, away from the earth and allowed to season at least for a year, prior to

setting. Unfortunately, only the largest telephone companies can afford to carry a sufficient stock to justify so careful a selection, and the majority must content themselves with poles purchased from a dealer, who probably does not endeavor to do anything beyond supplying poles, which approximately correspond to the specifications for length and top and butt circumference, and cases are on record where standing poles have, within a week, been doing duty in a working line. Consequently, a lot of very poor material is creeping into pole lines.

## CHAPTER V.

### STRESSES AND THE STRENGTH OF POLES.

THE foundation of the pole line is the pole and it must be sufficient to the burden imposed upon it, therefore, from an engineering standpoint the first consideration is the stress inflicted on the poles, in order that they may be designed to be adequately resistant.

The poles of an open wire line are subjected to four stresses. First. Each pole must, as a column, support the weight of all the wires, cables, cross arms, pins, insulators, etc., with which it is burdened, plus all the weight of snow and sleet, which may accumulate on its circuits. Second. Each pole may be subjected to longitudinal strain, due to the tension of the wires and cables forming the circuits which it supports. In well-constructed pole lines the tension upon the various circuits should be neutralized before the wires or cables are fastened on the cross arms, by allowing each to slip to and fro until it adjusts itself in such a position as to bring nothing but vertical stress upon the cross arm. But either from carelessness in adjustment, or from subsequent changes in tension due to various causes, upon the spans on either side of the pole, it is not uncommon to find the poles subjected to quite a severe longitudinal strain. Third. Wherever there is any change in direction in circuits, such as is required by a curve, or the turning of a corner in the location of a route, all of the resultant tension of the circuits will fall upon the poles, planted along such portion of the line as is included in this change in direction, and must either be met by the actual resistance to bending

offered by the pole or cared for by proper guying. Fourth. Each pole will be subjected to a lateral stress due to the wind pressure against the surface of the poles, cross arms, circuits, etc., due to the heaviest gale that may blow. It is this stress that usually wrecks a pole line, for it is very rare that either of the other causes suffices.

First. *Vertical stress.*—The vertical stress to which poles are subjected due to the weight of the line and snow is the least important of all they are called on to resist, and while lines have been known to fail by the simple crushing of the poles such cases are rare. Each pole must carry its own weight plus that of its cross arms, pins, insulators, etc., half the weight of each span of wire and cables on either side of it, plus any burden of snow and sleet. The weight of various sizes of poles will average about as in Table 1.

TABLE 1.

*Weight of Poles.*

Height in feet.	Weight, lbs.	Height in feet.	Weight, lbs.	Height in feet.	Weight, lbs.
25	400	40	650	55	1,500
30	450	45	1,000	60	2,000
35	550	50	1,250	65	2,700

A 10-pin cross arm in place with half the weight of the wire in either adjacent span (allowing 42 poles per mile) will be from 80 to 100 pounds for .080 or .104 copper wire. Iron wire lines are from 10 per cent. to 15 per cent. heavier as larger gauges are common. The weight of aerial cable per pole, including messenger wire, will be about 650 pounds for 25-pair cable, 800 pounds for 50-pair, and 1,000 pounds per 100-pair. Snow load is the

most difficult to estimate. Ice coatings on a No. 10 wire, 6 in. in diameter, are veraciously reported, but are fortunately of the rarest occurrence. One and 2 inches of sleet are by no means unknown, though from an eighth to a quarter of an inch is the average coating produced by a sleet storm, so there are many instances annually when the sleet load is sufficient to rupture the wire itself. Probably 150 to 200 pounds per wire and 700 to 2,000 pounds per cable are well within the range of each winter's possibilities. Thus each pole of 25-ft. line with two 10-pin arms is burdened as follows:

Pole .....	400 lbs.
Arms .....	200 "
Snow .....	3,000 "
	<hr/>
Total .....	3,600 "

A 65-ft. line with 12 10-pin arms and 4 cables might impress on each pole base the following load:

Pole .....	2,700 lbs.
Arms .....	1,200 "
4 Cables .....	3,450 "
Snow .....	20,800 "
	<hr/>
Total .....	28,150 "

The pole is column fixed at one end (the base) and unsupported at the other (the top). Hodgkinson shows that the strength of such a column made of white pine is given by the formula:

$$W = 4 \frac{d^4}{l^3}$$

in which  $W$  equals the supporting power of the pole in tons of 2,000 pounds,  $d$  the diameter of the pole in inches

at the base, and  $l$  the length between the ground and the lowest arm in feet. For a 25-ft. line,  $W = \frac{4 \times 8^4}{20^3}$  (approximately) 40 tons. This is the ultimate strength; and a factor of safety of at least 10 should be allowed, so the working crushing strength is 4 tons or 8,000 pounds, a little over double the load imposed as shown above. Similarly for a 65-ft. line.

$W = \frac{4 \times 12^4}{80^3}$  (approximately) 92 tons, or say 10 tons for working load, which is two-thirds of the line load by the preceding calculation. Tall, heavy lines, therefore, have much less safety factor than low, light ones. This deduction corresponds with experience, for the large lines are usually the sufferers. If any other wood be used the formula may be corrected by the data of Table 2.

TABLE 2.

*Crushing Strength of Timber.*

Variety.	Crushing Weight in lbs. Per square Inch.
Ash .....	5,000 to 8,000
Cedar, red .....	4,500 to 5,900
Chestnut .....	..... 5,350
Elm .....	6,000 to 10,000
Oak .....	4,000 to 9,000
Pine, yellow .....	5,300 to 6,500
Pine, red .....	6,000 to 7,500
Pine, white .....	5,000 to 6,000
Spruce, white .....	4,500 to 6,000

Thus white pine is allowed a crushing strength of 5,000 pounds per square inch, and yellow pine 5,300 pounds; hence a yellow pine pole will be  $\frac{53}{50}$  as strong as a white pine one.

Second. *Longitudinal tension*.— It is common practice in building pole lines to pull each wire up to a tension of about 150 pounds at an average temperature of say 60° F. The messenger strands of aerial cable carry a tension of from 3,000 to 4,500 pounds. If, therefore, a wire or cable is dead-ended, or so secured by the tie or other fastening that it cannot slip, the cross arm and pole may be subjected to this stress. So neglecting snow and sleet load a 10-pin arm on which all wires are dead-ended carries a stress of 1,500 pounds. In straightaway work, even when lines are dead-ended for transposition, the tension of one span practically balances that of the succeeding one, and the arm and pole are released, but where a wire or messenger actually stops, the entire tension must in some way be taken up, as will presently be shown.

Third. *Tension due to curves or corners*.— When a pole line changes its direction, as at curves or corners, the longitudinal tensions of the circuits manifest themselves in a most striking manner. Problems in pole line stress are most conveniently solved by graphical method. Fig. 17 is a plan of a line with one 10-pin arm *BC* attached to the pole, *A*. Suppose the various wires represented by 1, 1, 2, 2, etc., to be dead-ended on the pins and to be drawn up to a tension of 150 pounds each, what is the force exerted on the pole, and which way does it pull? Evidently each wire pulls 150 pounds in the direction it runs. If, therefore, a scale of pounds be assumed (in this example 350 pounds to the inch) and such a distance be laid off along each wire as represents the pull of the wire according to this scale, a series of lines are obtained which represent in magnitude and direction the tension of each wire on its pin. These lines are represented at 1, 2, 3, 4, etc. As the wires are parallel all the tensions are parallel, and a



line,  $A D$ , parallel to the wires, whose length is the sum of all the separate tensions, represents the total tension, and further as all the separate tensions are equal the resultant is applied at the middle of a line drawn through all the pins, or at the point  $A$ , where the arm is bolted to the pole, and the pole is pulled in the direction  $A D$  with a force of 1,500 pounds. Suppose that only eight

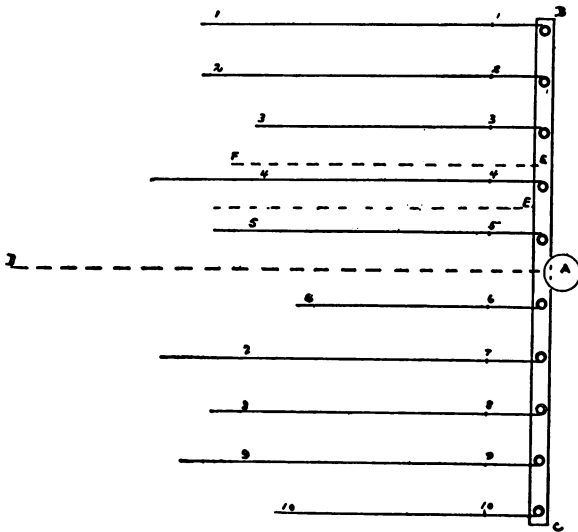

FIG. 17.—PLAN OF POLE LINE.

wires had been placed on the cross arms of Fig. 17, wires 9 and 10 being omitted. The point of application of the resultant will be midway between wires 4 and 5, at  $E$ ; that is, at the middle point of the line drawn through the center of the pins to which the wires are attached. The magnitude of this resultant evidently will be the

sum of 1, 2, 3, etc., up to and including 8, or 1,200 pounds. As all the wires are parallel to each other the direction of the resultant will be parallel to the direction of the wires. But now the resultant does not pass through the center of the pole but is 16 in. away from it, and hence tends to twist the pole in its hole. As the resultant is 16 in. away from the center of the pole, this twisting effect is found by multiplying the intensity of the resultant, 1,200 pounds, by 16, the distance that it is away from the center, giving a force of 1,500 foot-pounds as the tendency to turn the pole around in its socket. The only thing in practice that *does* keep the pole from twisting, under such circumstance, is the friction of the earth about the butt, and indeed in wet, clayey soils, when the circuits are thus unbalanced, twisting does take place. If we assume the pole to average 10 in. in diameter at the butt the friction of the soil will have a lever arm of 5 in. As the twisting moment is 1,500 foot-pounds the friction of the soil must be  $\frac{1500 \times 12}{6} = 3,000$  pounds.

A sheet of cross-section paper is most convenient for plotting stress diagrams, for the lines of the paper enable one to draw and read results directly. Fig. 18 is an example of a corner in a pole line. The various wires, 1, 2, 3, etc., to 10, are assumed to reach the pole, *A*, in direction parallel to the lines in the paper and to turn on the pole and depart in the direction 1', 2', 3', 4', etc. The tension on each wire is assumed at 150 pounds. As already described, the resultant of the tension in all the circuits leading to the pole is represented by the line *AB*. Similarly the resultant of the tension of the lines leading away from the pole is represented in magnitude and direction

by the line  $A C$ . Draw the line  $A D$  a continuation of, and equal to  $A B$ , and draw  $A E$  a continuation of, and equal to  $A C$ . Complete the parallelogram,  $A E F D$ , by drawing the line  $E F$  equal and parallel to  $A D$ , and the line  $D F$  equal and parallel to  $A E$ , draw the line  $F A$ , then  $F A$  represents in magnitude the resultant of all the

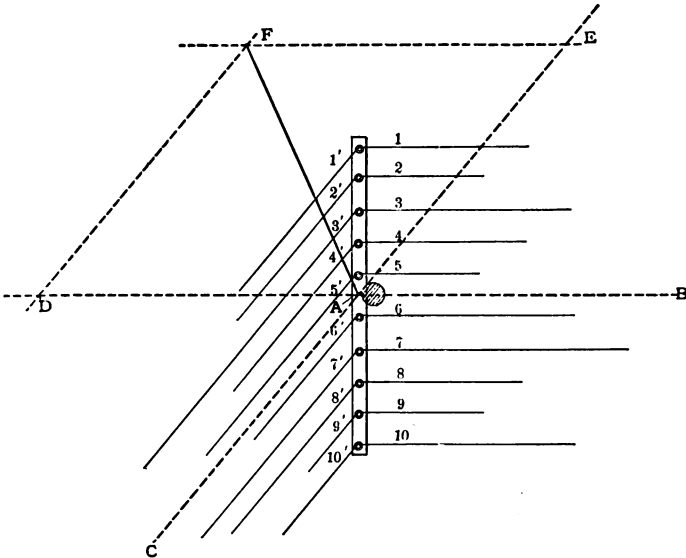

FIG. 18.—PLAN OF CORNER IN POLE LINE.

tension in such a corner pole. This stress the pole must resist either by its own intrinsic stiffness or by the aid of a guy. The tension of the circuits tends to pull the pole toward the inside of the curve or corner, hence to resist this the guy must be set away from the corner in the line  $A F$ . Such a diagram then shows both the tension on

the guy and the direction in which it must be placed. It is easy to see that by making an elevation drawing of a pole line the same method may be used to determine the magnitude, direction, and point of application of the resultant of the forces that act on the line in a vertical plane. In a line carrying open wire only, the resultant in a vertical plane will, if the arms are all filled, and carry the same number of wires, bisect a line joining the centers of all the arms. If there are aerial cables the resultant will still intersect and be at right angles to a line drawn through the center of the arms, but will divide this line into two segments, that are inversely proportional to the stress on all the open wire arms and the stress on the cable arms.

*Resistance to bending.*—When a pole is subjected to a horizontal force, in any direction, it tends to bend in the direction toward which the force is directed, the fibres of the wood lying on the side of the pole toward the direction of the force are compressed, while those on the opposite side are stretched. If the pole be cylindrical it can be shown that the section along which rupture will take place will be at the surface of the ground, when the diameter of the pole, at the point at which the resultant of the force is applied, is equal to, or greater than two-thirds of the diameter at the ground surface. When the diameter of the section at the point of application of the force is *less*, rupture takes place above the surface of the ground at that point where the diameter of the pole is two-thirds of the diameter at the point of application of the force. The horizontal stress, which will cause rupture, when the section of rupture coincides with the ground level, is given by the formula,  $F = \frac{\pi R^3 T}{4 L}$  where

$R$  is the radius of the section at the surface of the ground,  $L$  is the height above the soil to the point of application of the force,  $T$  the resistance to rupture per unit of section of the material composing the pole, and  $F$  the force causing the rupture. To find the diameter of a pole to resist any given tension, with say a factor of safety of 10 this formula may be transformed and will appear as follows:

$$R = \sqrt[3]{\frac{40 FL}{\pi \times T}}$$

In case the diameter of the section of the pole at which the resultant of all the forces acting upon it is applied is less than two-thirds of the diameter at the level of the ground, the section at which rupture will take place will be above the ground, and the force,  $F'$ , necessary to break the pole, can be found, but the formula is much more complicated and is given below:

$$F' = 27 \frac{\pi R_1^2 (R - R_1) T}{16 L}$$

in which  $R_1$  is radius of the section at which the force is applied, while the other symbols have the same meaning as before. The values of  $T$  in the preceding formulæ are the tensile strengths of the various kinds of wood used for poles. The values shown in Table 3 are averages from many tests on timber, selected as useful in calculating pole strength:

TABLE 3.

*Tensile Strength of Timber.*

Variety.	Breaking Weight per Square inch in lbs.
Ash, American .....	5,500 to 17,000
Cedar, American .....	4,000 to 11,400
Chestnut .....	7,000 to 13,000
Cypress .....	3,000 to 6,000
Elm .....	6,000 to 10,000
Oak .....	8,000 to 10,000
Pine, yellow .....	5,000 to 12,000
Redwood, California .....	6,000 to 10,800
Spruce .....	5,000 to 10,000

As a practical illustration assume a 30-foot line with two 10-pin arms all full.

*Case first.*— Suppose all wires to be dead-ended, the tension of the line will be 3,000 pounds; the point of application of the resultant is in the center of the pole midway between the two arms, or say 28 ft. from the ground. The radius of the point of application of the resultant is about  $3\frac{3}{4}$  in. (7-in. top pole), the radius at the ground (standard pole) about 5 in., hence the upper diameter is more than three-fourths of the ground diameter and the pole will break at the ground. Assume a cedar pole, then

$$F = \frac{3.14 \times 3.75^3 \times 11.400}{4 \times 28} = 16,800 \text{ lbs.}$$

As the stress applied is 3,000 pounds the pole would hold, under normal conditions, but would have so little margin as to probably fail with the first sleet storm.

*Case second.*— Assume a similar line, but with only one cross arm to turn a corner, as shown in Fig. 18. For

one cross arm the resultant stress tending to bend the pole is shown by Fig. 18 to be 1,275 pounds. The strength of the pole is the same as previously found, thus showing a factor of safety of 13. Such a pole in a sheltered location would be sufficient, but would be better if reinforced with a guy. From these examples it is easy to see that when a number of wires are dead-ended, or when there is an angle or curve of any magnitude, the horizontal stress soon rises to such proportion as to be far beyond the resistance to flexure presented by any ordinary pole.

*Wind stress.*—Of all the forces operating against a pole line wind is far the most difficult to evaluate, and the very best estimates frequently go astray. Some lines which have withstood the attacks of the elements for years will suddenly, and under seemingly slight provocation fail. Recorded tests on wind pressure are fragmentary and misleading. Some well-received data show that a gale blowing 70 miles per hour exerts about 25 pounds per square foot of area normal to the wind. On a sleet-covered line of 50 wires this would amount to about 4,500 pounds. But it is common experience for lines that should successfully withstand a greater stress to fail at presumably less wind velocity. Two explanations have been advanced, one that occasional gusts cause far greater instantaneous pressures, the other that such gusts set the line swinging and vibrating in a manner to hasten its destruction. Probably both of these causes operate, and very possibly to a far greater extent than is usually imagined.

The best data on wind pressure is that gathered by Professor Langley in his "*Experiments on Aerodynamics.*" Langley's formula is  $P = .0036 V^2$ , in which

$P$  is the pressure per square foot of surface in pounds, and  $V$  the velocity of the wind. By means of this formula Table 4 is calculated. The pressures here

TABLE 4.  
*Wind Data.*

Pounds per sq. ft.	Velocity.
5	37
10	53
15	65
20	75
25	83
30	91
40	105
50	119
60	130

given are such as would be exercised against a flat surface set perpendicularly to the direction of the wind. For a cylindrical surface like a pole or wire the effective pressure is two-thirds of what it would be for a square surface of the same area as the cylinder. Common practice in designing bridges and roofs allows 50 pounds per sq. ft. of area for wind pressure. But as pole lines are

near the ground where the wind velocity is modified by the friction of the earth, fences, trees, etc., it is considered that from 20 to 30 pounds is an ample allowance.

Wind pressures attack the line from every conceivable direction, but in a general way they may be relegated to the category of the horizontal forces that act transversely to the line. Thus intensity is so difficult to estimate that in exposed locations about the only method is to build as strongly as possible, and then rebuild when the line goes down. Thus it is shown that all the forces acting on a pole line may be either resolved into vertical or horizontal ones. For the vertical ones strong straight poles form the only resource; but the horizontal stresses, particularly those which are developed at curves, angles, and terminal poles, must be treated by other methods.

From the preceding investigation it appears that the pole is least able to resist the horizontal stresses inflicted



upon it. Fortunately it is possible to reinforce poles against such stresses by the various methods of "guying" now to be described.

Let  $A B$ , Fig. 19, be the vertical elevation of a pole, entering the ground at the point  $B$ , and let  $A C$  repre-

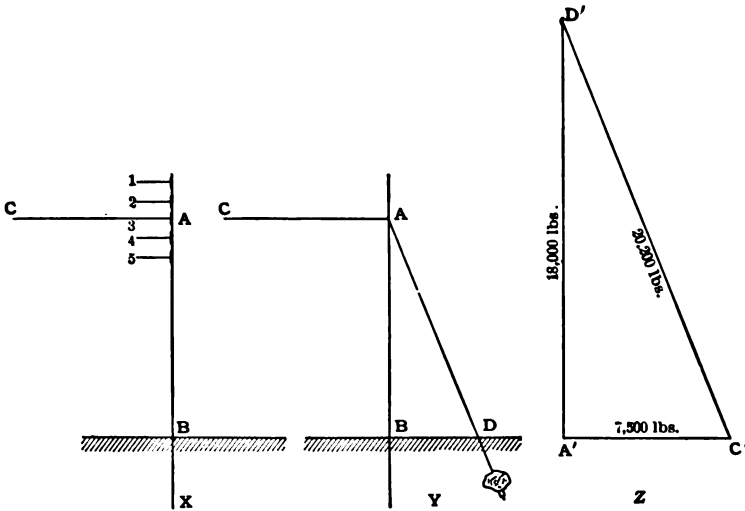

FIG. 19.—GUY DIAGRAM.

sent the resultant of all the stresses due to the tension of the circuits acting in the direction  $A C$ . To resist this tension it is customary to reinforce the pole by attaching a wire rope, or iron rod, in the neighborhood of the point

$A$  extending to the ground, or to some other point of attachment at a convenient distance from the pole at say  $D$ , as is shown at  $Y$ . It is now required to determine the stresses on the guy  $A D$ , and on the pole  $A B$ , under the action of the force  $A C$ , in order that such a pole may be properly designed. The height of the pole  $A B$  is known, also the distance  $B D$  from the base of the pole to the point of attachment of the guy, and the stress,  $A C$ . To any convenient scale of pounds draw  $A'C'$  parallel to  $A C$ , and make  $A'C'$  equal to the resultant  $A C$  of all the tensions on the pole. From  $A'$  erect the perpendicular  $A'D'$ . Make the length of  $A'D'$  bear the same proportion to  $A'C'$  that  $A B$  does to  $B D$ , or in other words, divide the length of the pole  $A B$  between the application of the resultant and the ground by the distance  $B D$  from the base of the pole to the point at which the guy is attached, and multiply  $A'C'$  by this quotient to find the length of  $A'D'$ . The length of  $A'D'$  measured by the same scale as  $A'C'$  gives the compression in the pole. Connect the points,  $C'D'$ , then the length of the line  $C'D'$  to the same scale as  $A'C'$ , and  $A'D'$  will give the tension in the guy rod. For example, assume a 30-ft. pole line, carrying 5 10-pin cross arms, or 50 wires, each stretched to a tension of 150 pounds. The resultant  $A C$  of the tension in all the wires will be 7,500 pounds, and the point of application, midway between the top and bottom arm at say 25 ft. from the ground. Suppose the guy to be set 10 ft. away from the base of the pole, then  $A B$  divided by  $B D$  gives 2.5. Fig. 19  $Z$ , shows  $A'C'$  drawn to represent 7,500 pounds (scale 4,000 per inch).  $A'D'$  is made 2.5 times as long as  $A'C'$ , showing the compres-

sion in the pole to be 18,750 pounds, and  $C'D'$  is found to be 2.69 times as long as  $A'C'$ , giving 20,200 pounds (approximately) as the tension on the guy. The necessary size required for the pole is readily calculated by remembering that the pole is a column supported at the base, and the diameter may be obtained by the use of the preceding formulæ. As guys are always in tension it is usual to make them of wire rope, or iron rods, but it is necessary to remember that not only must the material of the guy itself be sufficiently strong to resist the stress applied upon it, but its attachment both to the pole and to the ground, or other object, must be sufficient to withstand all of the force applied. It is a common practice to fasten guys by bolting the end of the strand to a log of wood termed a "dead man," and burying it in the earth. Another, more modern, and in some respects more mechanical method, employs a device resembling an enormous auger, which can be screwed into clay or loam, and makes an excellent fastening in such soils. A still more recent device consists of a pointed iron pipe, which can be driven into the earth, and after it is set, one or more sharp, spur-like grappling irons can be projected through the wall of the pipe into the earth. These devices are shown in Fig. 20.

Sometimes, especially in soils that are marshy or contain quicksand, the pole is bolted to two long timbers, that form a base on which it may stand, and to the end of which the guy is attached. Now the pole and platform may fail by overturning, and the timber foundation must be large enough to hold a volume of earth whose weight shall prevent this. Take the example of Fig. 19. The tendency

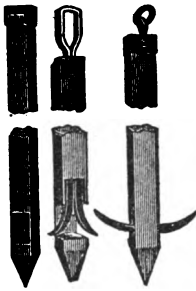

of the pole to tip over is measured by multiplying the height of the pole to the resultant (25 ft.) by the resultant of the line tension ( $7,500 \times 25 = 187,500$  foot-pounds). This is called the moment of the force tending to overturn the pole. On the timbers bolted to the base of the pole rests a quantity of earth; the moment of which (its weight multiplied by the distance of its center of gravity from

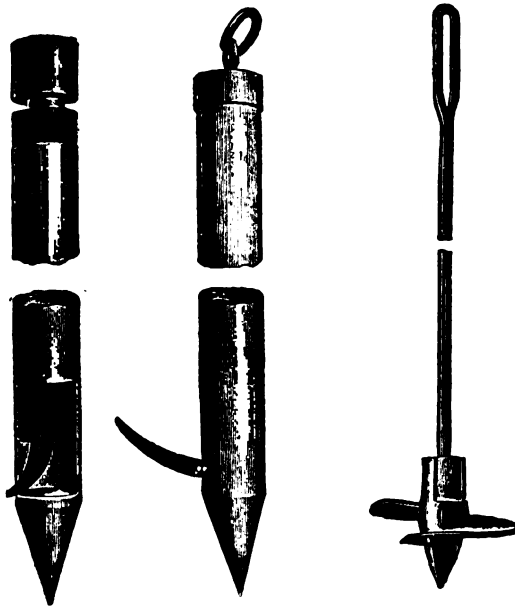

FIG. 20.— VARIOUS STYLES OF GUY ANCHORS.

the pole) must be equal to or more than the overturning moment. The distance of the center of gravity of this earth from the base of the pole is half the distance of the guy from the pole, or in this example 5 ft., then the weight of the earth must be  $\frac{87500}{5} = 35,500$  pounds. Earth weighs about 100 pounds per cubic foot, hence

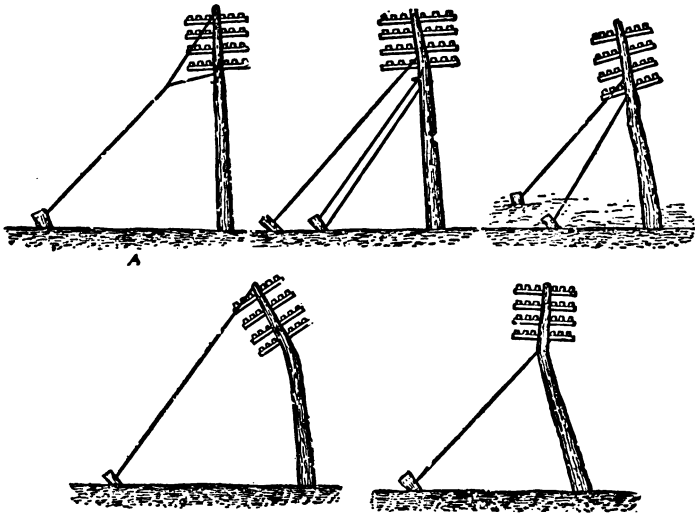

FIG. 21.—WRONG METHODS OF GUYING.

$\frac{35,500}{100} = 355$  cubic feet of earth are needed. Suppose the timbers to be 10 ft. long and buried 6 ft. below the surface, then the width of the timbers or the planking they carry must be  $\frac{355}{10 \times 6} = 5.9$  ft. This will exactly balance the pole, but in addition a sufficient amount must be allowed to provide a fair factor of safety.

There are few parts of a wire plant in which as many mistakes are made as in guying. Fig. 21 is an illustration of some of the methods in which guying has been done. At *A* the well-known form of Y-guying is illustrated, which is probably the best device of this nature. Here the upper portion of the guy is split into two parts, one of which is attached to the top of the pole and the other directly beneath the lower cross arm. By this means there is less tendency for the tension in circuits to bend the top of the pole than by any other method. Erroneous methods of guying are shown in the other four examples of this illustration, the difficulties to which they give rise being so self-evident that further explanation is unnecessary.

City lines are frequently called upon to carry large numbers of wires and cables, and it is often necessary either to turn very sharp corners or to terminate an entire line, at say its entrance to the underground system, so that poles must in many instances resist very severe longitudinal stresses. A line upon which 80 or 100 wires terminate, carrying three or four cables, will be subjected to a stress at the pole top of 30,000 to 35,000 pounds, and poles designed for such purposes are termed "anchor poles." By far the neatest solution of this problem lies in the erection of a pole built of structural iron, similar to that shown in Fig. 22. It is easy to design such a pole to carry any desired line stress, suitable for the most restricted location of city streets and, withal, present even a pleasing architectural appearance. But poles of this kind are expensive. As a compromise it is possible to reinforce a wooden pole in such a manner as to make it both structurally strong and of good appearance. This is accomplished by fitting the top of the pole with a lattice

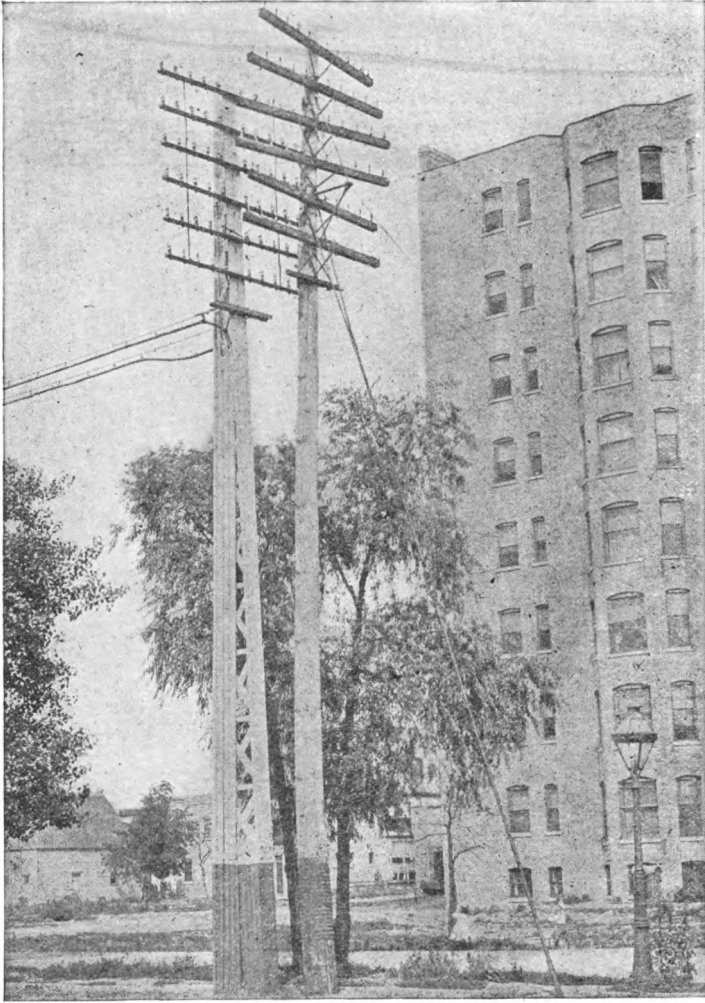
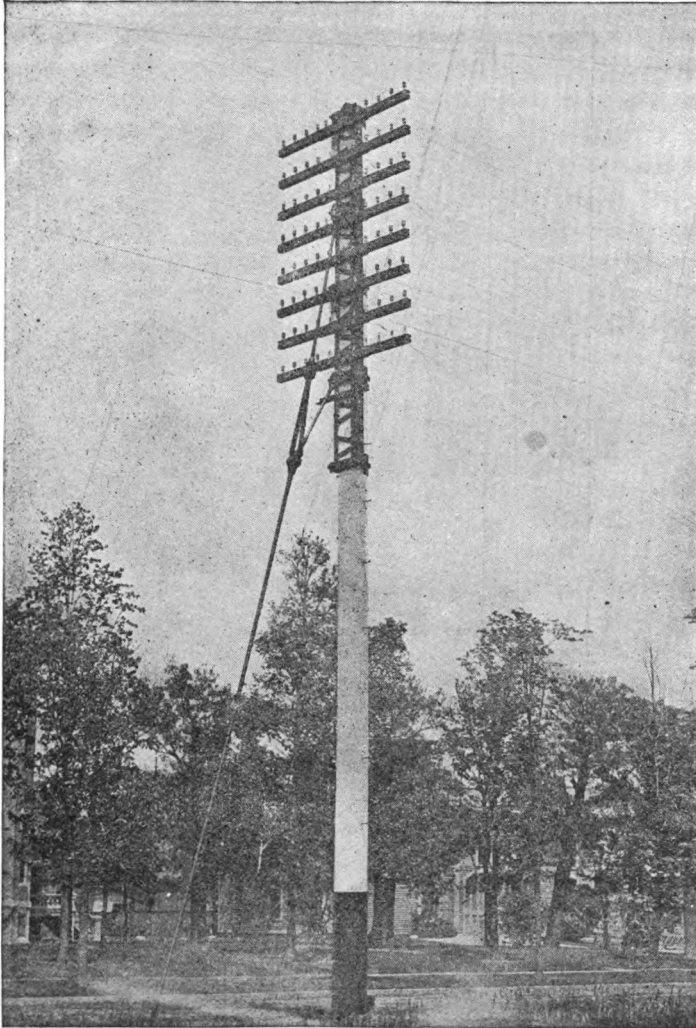

FIG. 22.—STRUCTURAL IRON POLE.



**FIG. 23.— COMPOSITE ANCHOR POLE.**



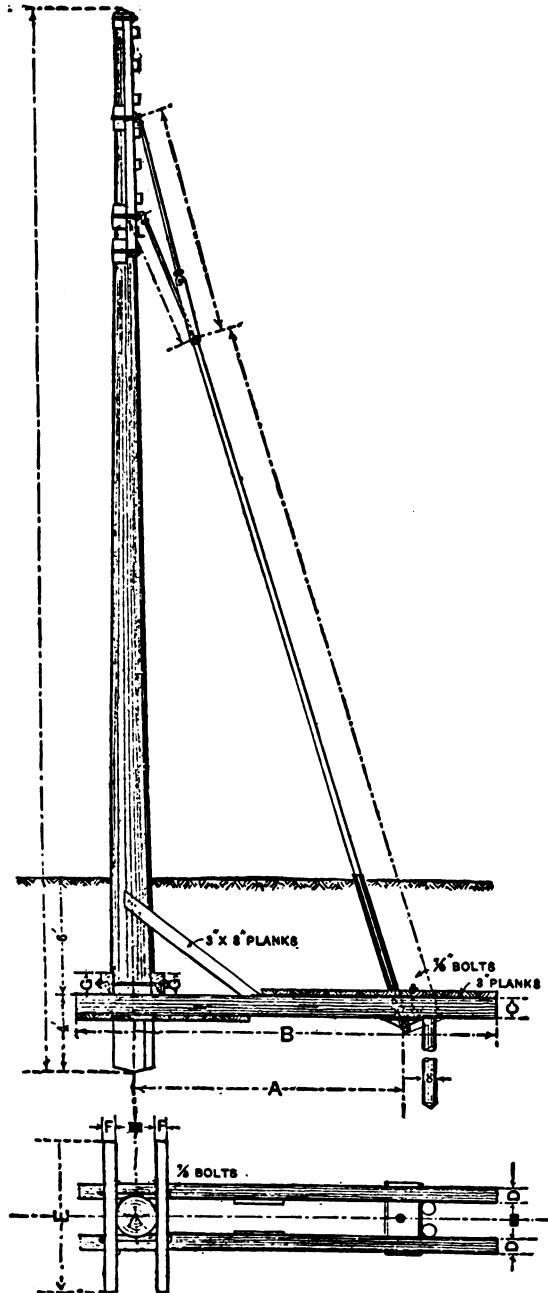

FIG. 24.—ELEVATION AND PLAN OF COMPOSITE ANCHOR POLE.

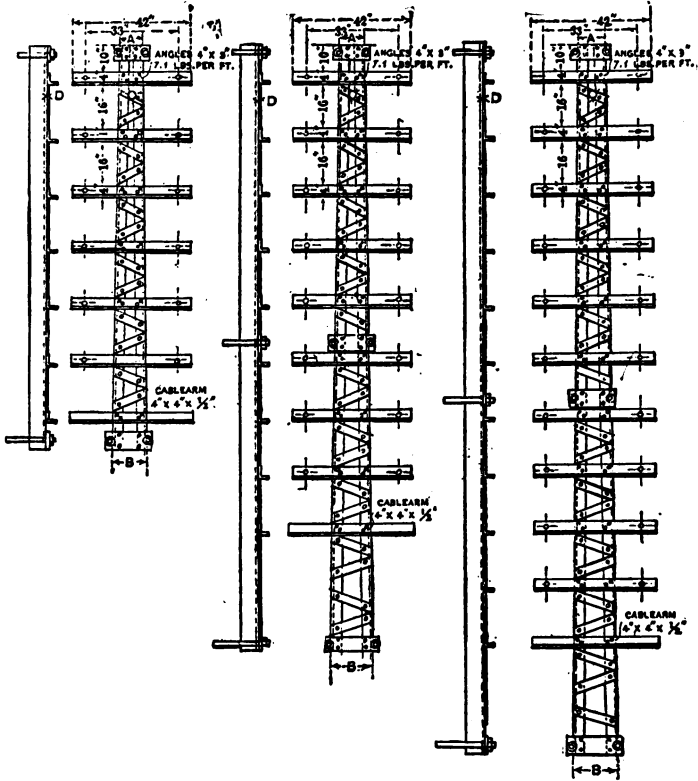

FIG. 25.—DETAILS OF LATTICE FOR COMPOSITE POLE TOP.

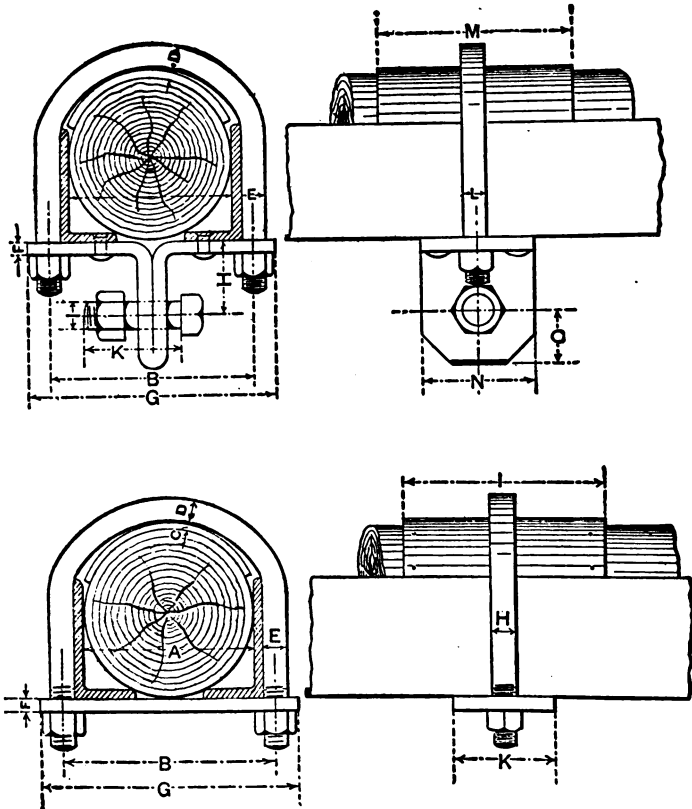

FIG. 26.—CROSS SECTIONS AND SIDE ELEVATIONS OF BANDS.

work of angles, stiff enough to transmit all the tension of the circuits to the guy rod without bringing an undue bending moment on the top of the pole. An illustration of the "composite anchor pole" is, as this device is termed, given in Fig. 23 and the details of construction shown in Figs. 24, 25, 26, and 27. Fig. 24 is the general elevation and ground plan of the entire structure. The pole may be any suitable stick of sufficient height, say

TABLE 5.

*Dimensions of Anchor Platform.*

Number of Cross Arms.	Number of Cables.	A	B	C	D	E	F	G
4	0	12' 0"	20' 0"	12"	8''	6' 0"	6"	12''
6	0	11' 0"	10' 0"	12"	8''	6' 0"	6"	12''
8	0	13' 0"	22' 0"	12"	10''	8' 0"	8"	12''
10	0	13' 0"	22' 0"	12"	10''	8' 0"	8"	12''
4	1	12' 0"	20' 0"	12"	8''	6' 0"	6"	12''
6	1	3' 0"	12' 0"	12"	10''	8' 0"	8"	12''
8	1	13' 0"	22' 0"	12"	10''	8' 0"	8"	12''
10	1	14' 0"	24' 0"	12"	12''	10' 0"	10"	12''
4	2	13' 0"	22' 0"	12"	10''	8' 0"	8"	12''
6	2	13' 0"	22' 0"	12"	10''	8' 6"	8"	12''
8	2	14' 0"	24' 0"	12"	12''	10' 0"	10"	12''
10	2	14' 0"	24' 0"	12"	12''	10' 0"	10"	12''
4	3	13' 0"	22' 0"	12"	10''	8' 0"	8"	12''
6	3	3' 0"	22' 0"	12"	10''	8' 0"	8"	12''
8	3	14' 0"	24' 0"	12"	12''	10' 0"	10"	12''
10	3	14' 0"	24' 0"	12"	12''	10' 0"	10"	12''

40 ft. to 60 ft., to carry the lowest circuit at the requisite elevation above ground level. The top diameter should not be less than 10 in. and the diameter at the ground from 18 in. to 24 in. As is shown in Fig. 24, the pole is framed into two yellow pine sticks shown in elevation at *B* and in plan at *D D*. These sticks carry a platform of 3-in. plank, as shown in the elevation. This platform serves to carry sufficient weight of earth to keep the pole

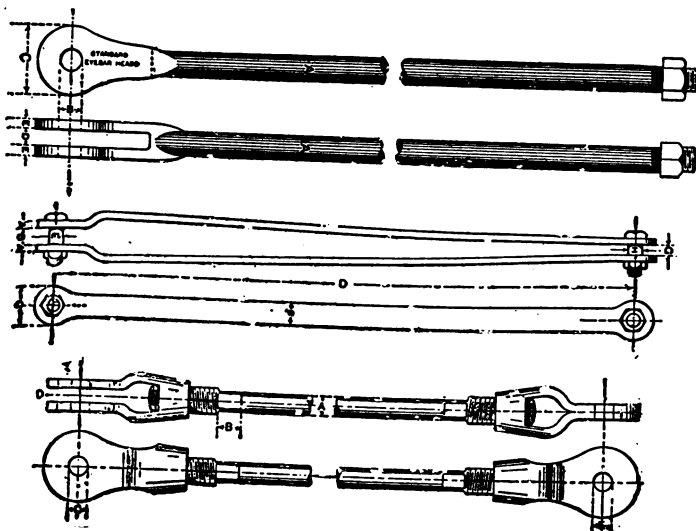

FIG. 27.—DETAILS OF GUY RODS.

TABLE 6.

Dimension of Pole Lattices.

No. of Cross Arms.	No. of Cables.	Size of Angle Iron.	Weight of Angle Iron in lbs. per Foot.	No. of Angles.	Length of Angles.	LATTICE.			
						Wide.		Thick.	
						A.	B.	C.	D.
4	0	6"x3 1/2"x3 1/2"	11.7	2	12'0"	.....	.....	3'	3 1/2"
6	0	7"x3 1/2"x7-16"	15	2	12'0"	.....	.....	3'	3 1/2"
8	0	6"x3 1/2"x3 1/2"	11.7	2	18'0"	.....	.....	3'	3 1/2"
10	0	7"x3 1/2"x7-16"	15	2	21'0"	.....	.....	3'	3 1/2"
4	1	7"x3 1/2"x7-16"	15	2	12'0"	.....	.....	3'	3 1/2"
6	1	6"x3 1/2"x3 1/2"	11.7	2	12'0"	.....	.....	3'	3 1/2"
8	1	7"x3 1/2"x7-16"	15	2	18'0"	.....	.....	3'	3 1/2"
10	1	7"x3 1/2"x7-16"	15	2	21'0"	.....	.....	3'	3 1/2"
4	2	6"x3 1/2"x3 1/2"	11.7	2	12'0"	.....	.....	3'	3 1/2"
6	2	6"x3 1/2"x3 1/2"	11.7	2	12'0"	.....	.....	3'	3 1/2"
8	2	7"x3 1/2"x7-16"	15	2	18'0"	.....	.....	3'	3 1/2"
10	2	7"x3 1/2"x7-16"	15	2	21'0"	.....	.....	3'	3 1/2"
4	3	6"x3 1/2"x3 1/2"	11.7	2	12'0"	.....	.....	3'	3 1/2"
6	3	7"x3 1/2"x7-16"	15	2	18'0"	.....	.....	3'	3 1/2"
8	3	7"x3 1/2"x7-16"	15	2	18'0"	.....	.....	3'	3 1/2"
10	3	7"x3 1/2"x7-16"	15	2	21'0"	.....	.....	3'	3 1/2"
4	3	6"x3 1/2"x3 1/2"	11.7	2	12'0"	.....	.....	3'	3 1/2"
6	3	7"x3 1/2"x7-16"	15	2	18'0"	.....	.....	3'	3 1/2"
8	3	7"x3 1/2"x7-16"	15	2	18'0"	.....	.....	3'	3 1/2"
10	3	7"x3 1/2"x7-16"	15	2	21'0"	.....	.....	3'	3 1/2"
4	3	6"x3 1/2"x3 1/2"	11.7	2	12'0"	.....	.....	3'	3 1/2"
6	3	7"x3 1/2"x7-16"	15	2	18'0"	.....	.....	3'	3 1/2"
8	3	7"x3 1/2"x7-16"	15	2	18'0"	.....	.....	3'	3 1/2"
10	3	7"x3 1/2"x7-16"	15	2	21'0"	.....	.....	3'	3 1/2"
4	3	6"x3 1/2"x3 1/2"	11.7	2	12'0"	.....	.....	3'	3 1/2"
6	3	7"x3 1/2"x7-16"	15	2	18'0"	.....	.....	3'	3 1/2"
8	3	7"x3 1/2"x7-16"	15	2	18'0"	.....	.....	3'	3 1/2"
10	3	7"x3 1/2"x7-16"	15	2	21'0"	.....	.....	3'	3 1/2"



from overturning. Table 5 shows the dimensions of the timber needed for various capacities of pole lines, the sizes given in the columns headed *A B*, etc., refer to the dimensions of Fig. 24 designated with the same letter. On the top of the pole a simple lattice of angle iron is placed, made as shown in Fig. 25. This lattice should reasonably fit the top of the pole and be long enough to cover the entire space occupied by the cross arms. At

TABLE 8.  
*Position of Guy-Rod Bands.*

Upper Band.	Lower Band.	No. of Clamping Bands.
Midway between 2d and 3d arm . . .	.....	2
Midway between 3d and 4th arm..	.....	2
Midway between 2d and 3d arm....	Midway between 6th and 7th arm.	3
Just above 3d arm.....	Just below the 8th arm.....	2
Just below 3d arm.....	.....	2
Midway between 2d and 3d arm . . .	Just below 6th arm.....	2
Just below 3d arm.....	Just below 8th arm.....	3
Midway between 3d and 4th arm..	Midway between 9th and 10th arm	3
Just above 2d arm.....	Midway between 4th and cable arm	2
Midway between 3d and 4th arm..	Midway between 6 h and cable arm	2
Just below 3d arm.....	Just below 8th arm.....	3
Just above 4th arm.....	Just above 10th arm.....	3
Just above 2d arm.....	Just above cable arm.....	2
Midway between 3d and 4th arm..	Midway between 6th and cable arm	2
Midway between 3d and 4th arm..	Just below 8th arm.....	3
Just above 4th arm.....	Just below 10th arm.....	3

proper intervals a transverse angle iron is rivetted to the lattice to hold the cross arm. Fig. 25 is a detail drawing of the various sizes of lattice needed, while all dimensions are given in Table 6. As is seen in Fig. 23 the lattice is placed on the back of the pole, *i. e.*, is away from the direction in which the circuits extend and secured by iron bands. The guy is a Y-guy and also secured by iron bands which encircle both pole and lattice. An enlarged cross





TELEPHONY.

TABLE 10.

Main Guy Rod.

Number of Cross Arms.	Number of Cables.	A	B	C	D	E
4	0	15 1/2"	21 1/2"	7"	11 1/2"	3 1/2"
6	0	17 1/2"	21 1/2"	7"	13 1/2"	3 1/2"
8	0	2 1/2"	21 1/2"	7"	11 1/2"	3 1/2"
10	0	2"	21 1/2"	7"	11 1/2"	3 1/2"
4	1	17 1/2"	21 1/2"	7"	13 1/2"	3 1/2"
6	1	2 1/2"	21 1/2"	7"	11 1/2"	3 1/2"
8	1	2"	21 1/2"	7"	11 1/2"	3 1/2"
10	1	2 1/2"	21 1/2"	7"	11 1/2"	3 1/2"
4	2	2 1/2"	21 1/2"	7"	11 1/2"	3 1/2"
6	2	2"	21 1/2"	7"	11 1/2"	3 1/2"
8	2	2 1/2"	21 1/2"	7"	11 1/2"	3 1/2"
10	2	2 1/2"	2 1/2"	7 13-6"	13 1/2"	1 1/2"
4	3	2"	21 1/2"	7"	11 1/2"	3 1/2"
6	3	2"	21 1/2"	7"	11 1/2"	3 1/2"
8	3	2 1/2"	3"	7 13-16"	13 1/2"	1 1/2"
10	3	2 1/2"	3 1/2"	9 1/2"	2 1/2"	1"

TABLE 11.

Branches for Guy Rod.

Number of Cross Arms.	Number of Cables.	A	B	C	D	E
4	0	15 1/2"	21 1/2"	7"	11 1/2"	3 1/2"
6	0	17 1/2"	21 1/2"	7"	13 1/2"	3 1/2"
8	0	2 1/2"	21 1/2"	7"	11 1/2"	3 1/2"
10	0	2"	21 1/2"	7"	11 1/2"	3 1/2"
4	1	17 1/2"	21 1/2"	7"	13 1/2"	3 1/2"
6	1	2 1/2"	21 1/2"	7"	11 1/2"	3 1/2"
8	1	2"	21 1/2"	7"	11 1/2"	3 1/2"
10	1	2 1/2"	21 1/2"	7"	11 1/2"	3 1/2"
4	2	2 1/2"	21 1/2"	7"	11 1/2"	3 1/2"
6	2	2"	21 1/2"	7"	11 1/2"	3 1/2"
8	2	2 1/2"	21 1/2"	7"	11 1/2"	3 1/2"
10	2	2 1/2"	3"	7 13-16"	13 1/2"	1 1/2"
4	3	2"	21 1/2"	7"	11 1/2"	3 1/2"
6	3	2"	21 1/2"	7"	11 1/2"	3 1/2"
8	3	2 1/2"	3"	7 13-16"	13 1/2"	1 1/2"
10	3	2 1/2"	3 1/2"	9 1/2"	2 1/2"	1"

section and side elevation of the bands appears in Fig. 26. Table 7 gives dimensions for guy rod bands, and Table 9 data for pole bands. The guy rod consists of an iron rod with a nut at the lower end to attach it beneath the earth platform, and a clevis at the upper end, to which the guy rod bands are attached, as shown in Figs. 23 and 24. Fig. 27 gives a detail drawing of each piece; Table 10 the dimensions of the main rod; Table 11 the sizes of the branches, and Table 12 data for extension plates. Poles of this description can be built at a cost of from \$100 to \$150, depending on line capacity. Their strength seems ample, for the author has known several blocks of a hundred-wire line with five cables to go down, leaving an anchor pole of this description the solitary sentinel at the end of the line.

TABLE 12.

*Guy Rod Extension Plates.*

Number of Cross Arms.	Number of Cables.	A	B	C	D	E	F	G
8	0	3 $\frac{1}{2}$	3 $\frac{1}{2}$	7	54	2 $\frac{1}{2}$	3	11 $\frac{1}{2}$
10	0	3 $\frac{1}{2}$	3 $\frac{1}{2}$	7	54	2 $\frac{1}{2}$	3	11 $\frac{1}{2}$
6	1	3 $\frac{1}{2}$	3 $\frac{1}{2}$	7	48	2 $\frac{1}{2}$	3	11 $\frac{1}{2}$
8	1	3 $\frac{1}{2}$	3 $\frac{1}{2}$	7	54	2 $\frac{1}{2}$	3	11 $\frac{1}{2}$
10	1	3 $\frac{1}{2}$	3 $\frac{1}{2}$	7	54	2 $\frac{1}{2}$	3	11 $\frac{1}{2}$
4	2	3 $\frac{1}{2}$	3 $\frac{1}{2}$	7	48	2 $\frac{1}{2}$	3	11 $\frac{1}{2}$
6	2	3 $\frac{1}{2}$	3 $\frac{1}{2}$	7	48	2 $\frac{1}{2}$	3	11 $\frac{1}{2}$
8	2	3 $\frac{1}{2}$	3 $\frac{1}{2}$	7	54	2 $\frac{1}{2}$	3	11 $\frac{1}{2}$
10	2	3 $\frac{1}{2}$	3 $\frac{1}{2}$	7 13-16	54	3	4	13 $\frac{1}{2}$
4	3	3 $\frac{1}{2}$	3 $\frac{1}{2}$	7	48	2 $\frac{1}{2}$	3	11 $\frac{1}{2}$
6	3	3 $\frac{1}{2}$	3 $\frac{1}{2}$	7	48	2 $\frac{1}{2}$	3	11 $\frac{1}{2}$
8	3	3 $\frac{1}{2}$	3 $\frac{1}{2}$	7 13-16	54	3	4	13 $\frac{1}{2}$
10	3	3 $\frac{1}{2}$	4 $\frac{1}{2}$	9 $\frac{1}{2}$	54	3 $\frac{1}{2}$	5	13 $\frac{1}{2}$

## CHAPTER VI.

### CROSS ARMS, WIRE, AND ACCESSORIES.

*Cross arms.*—Next to the pole the cross arm is the most important wooden portion of the pole line. For many years the standard cross arm has been a bar  $3\frac{1}{4}$  in. wide by  $4\frac{1}{4}$  in. deep, 10 ft. long, bored with 10 holes, into which the insulator pins are placed. The customary spacing was 12 in. between centers of pin holes for all pins excepting those at center, where the cross arm intersects the pole, where a spacing of 16 in. is given. The top of the cross arm is roofed by milling it to a more or less semi-circular form in order to provide drainage. Recently there is a tendency to use for telephone circuits a lighter cross arm  $2\frac{3}{4}$  in. x  $3\frac{3}{4}$  in., but this appears to be a doubtful economy. Cross arms are frequently broken by weight of the circuits and accumulated snow load. In performing repair work it is necessary for line men to stand upon the cross arms and must frequently inflict upon them considerable stress when raising material or performing avocations necessary to maintenance, and unless cross arms are amply strong to support the line-man and withstand all the shocks which he may inflict upon it by jumping, many accidents will occur, and with the present tendency of the courts to award high damages for all injuries to employees the cost of a single suit will overbalance the saving of a multitude of light cross arms.

Norway pine, yellow pine and sometimes cypress are the woods usually employed for cross arms, and it is essential to subject them to a rigid and careful inspection to assure that arms are sound and substantial in every

respect, and that they do not contain knots which will weaken them and cause them to break under slight provocation. Cross arms are usually secured to the pole by bolting with a machine bolt and bracing by two arm braces that extend a distance of  $18\frac{1}{2}$  in. on either side of the center and run to and are screwed to the pole. The braces are universally fastened to the cross arms by means of  $\frac{3}{8}$ -in. carriage bolts. In the past there has been considerable discussion as to the relative merit of fastening cross arms and braces to the poles by lag bolts or by machine bolts. The advocate of the lag bolt has shown that the prime cost of the lag bolt is considerably less than that of the machine bolt and that it is quicker, easier, and cheaper to place. Those who favor machine bolts have shown that the machine bolt is intrinsically much stronger, because it passes completely through the pole and is supplied with a washer under both head and nut. It forms a more reliable method of attaching either cross arms or braces, and the replacement of cross arms, when secured by machine bolts, is much more certain and reliable, for with the lag bolt rotting sooner or later sets in and it is impossible to remove the lag bolt more than two or three times from the poles without entirely destroying thread in the wood. It appears quite certain that on the whole the machine bolt has the balance of advantage, from a structural point of view, and the difference in expense between lag bolts versus machine bolts is too small to be worthy of extended discussion.

*Pins.*—The cross arm supports the pin. Until recently pins have been universally constructed of wood, having a shank from  $1\frac{1}{4}$  in. to  $1\frac{1}{2}$  in. in diameter which is driven into cross arm and there secured by driving a wire nail directly through the arm and pin shank. The

top of the pin is supplied with a screw thread, cut to fit the moulded thread in the insulator. All opinion agrees in accepting the use of locust as a preferable wood, considering cost, from which pins should be constructed. Pains should be taken to see that the wood is sound and solid, without splits and other defects, and that it is carefully and accurately machined. Subsequent to all machining the pin should be boiled in oil or preferably in paraffine in order to not only thoroughly season it and prevent it from rotting, but to increase insulation by obviating absorption of moisture. There is no better means of preserving pins than the thorough boiling in paraffine, but to successfully accomplish this process some precautions are necessary. In heating and boiling care should be taken not to raise the temperature of the paraffine too high, or else it may be decomposed and injured. The pins should be weighted, in order that they may not float in the liquid, and the cooking should continue until all bubbling or exudation of moisture or air from the pins has entirely ceased. It is then advisable to allow the pins to cool in the kettle until the paraffine has solidified. By this means the contraction due to a lowering of temperature will force an additional amount of the preservative into the pores of the pin. Subsequently the paraffine may be melted and the pins removed.

Recent practice in pin construction, it is reported, initiated by the Western Union Telegraph Co., points to the employment of iron and steel instead of wood, and certainly there is every reason to consider that this material would be preferable. The iron pin can be made very much stronger than the wooden pin, and at the same time very much smaller. Consequently the necessary hole in the cross arm for the iron pin can be largely

reduced in diameter over that required for wood, so the cross arm is either made much stronger or can be made lighter with the same proportionate resistance. The iron pin is best made of a piece of  $\frac{1}{2}$  or  $\frac{5}{8}$ -in. steel or iron rod, upon which a shoulder is forged to bear against the top of the cross arm, while the bottom of the pin is supplied by a screw thread, nut, and washer to secure it in the arm. To attach the insulator the pin is placed inside the bell and thick plaster of paris poured in, thus holding the insulator firmly on the pin. As the iron pin can be made much less in diameter than the top of the wooden pin the insulator may be made smaller and lighter, and a gain in insulating properties results. The chief objection to iron pins is their expense; but, considering the decreased maintenance of such pins, it is doubtful whether they are as expensive as wood is in the long run. But, in an endeavor to cheapen iron pins, error has been made in using too light iron, which is likely to bend under the horizontal stress in the circuits and allow the insulator to tear away from the plaster and set the circuits free.

*Insulators.*— In the past legions of different forms of insulators have been proposed for the support of the line wire and a multitude of different materials suggested from which they should be constructed. In America practice has until very recently universally adopted glass for the purpose, and has finally settled down for telephone work into the well-known poney type, which is of all but universal usage. The successful insulator should have a high specific insulation resistance. It should present a surface upon which dust and dirt do not readily collect, in order that the specific insulation may not be impaired by the presence of foreign matter, and as no known surface is absolutely free from a deposit of impurities from

the atmosphere, the insulator should be so designed that it may be readily and frequently washed clean by rain storms. It should possess the highest amount of mechanical strength in order that it may withstand the severe usage to which every line is subjected. The form of insulator should be such as to hold the wire securely in its place and lend itself readily to the attachment of the line by means of the tie, or of some equivalent device. Further, the wire should be located upon the insulator in such a manner that the stress delivered by the wire may be transmitted through the insulator without producing objectionable stresses in the body of the insulator. Lastly, as lowering of insulation is often due to insects who find that the protecting petticoats of the ordinary insulator furnishes an admirable location in which to spin cocoons, the design of the insulator should afford such intruders as little temptation as possible, and its material should be as transparent as practicable, for the cocoon loves not the light. For all these reasons American practice has tended entirely to the use of glass, though in many respects it is not an ideal material. Glass is brittle, does not possess high tensile strength, its surface easily condenses a film of moisture, which is difficult to get rid of, and so exhibits many points of desirable improvement. On the other hand, glass is easily workable in a molten state, and so insulators may be made of great cheapness; has very high specific insulation; is transparent, and offers little temptation to insects. In Europe the varieties of porcelain moulded into insulators have secured a much wider recognition than in this country, though recently porcelain insulators have appeared in many localities, and seem in some cases to be gaining ground. They are more expensive and unless carefully glazed with proper vitreous

material are likely in a short time to roughen and present a lower insulation resistance than is found with glass. White porcelain insulators are open to another serious objection, in that they present a shining target for the small boy newly armed with a rifle or shotgun, and every holiday is likely to afford a crop of porcelain insulators that have fallen victims to the target practice of the mischievous. To remedy this the glaze of the porcelain has been colored a dark brown, and while this succeeds in decreasing the attractiveness of the insulator as a target it also darkens the interior and exposes a greater temptation to cocoon-building insects. Many other materials, such as ebonite, india rubber, moulded mica, lava, steatite, etc., have been proposed as insulating material and have gained some currency, but their use is largely confined to special locations, such as the support of subscriber's drop wires, sustaining interior circuits, and so-called tree insulators, designed to be placed on trees, or to prevent tree limbs from chafing circuits, which are otherwise supported. All such insulators are so much more expensive and appear so rarely as to be of little consideration in the construction of open wire lines. The insulation of open wire lines is important and has received too little consideration. The best experiments agree in the opinion that insulation is lowest after a drought when insulators are covered with dust and dirt and also during a mist when the super-saturated atmosphere deposits upon the insulator a condensed film of water. On the other hand, insulation is highest just after a brisk rain, succeeded by a bright sun, when the insulator is washed clean and quickly dried. The open double petticoat insulator is found to dry more rapidly than the closed single petticoat, but during actual rainfall the double petticoat shows a



much higher insulating value, while in fine weather both forms give identical results. The true value of any design of insulator can only be properly measured when the actual size of the insulating bell has been eliminated and attention concentrated upon the possible cross section of conducting material, such as moisture or dirt that may be deposited upon the exterior. Insulators should, therefore, be evaluated by taking the mean circumference and the conducting length between the point at which the wire is secured to the insulator and the point of attachment to the pin. The section of conducting material is then ascertained by multiplying the mean circumference by the distance over the insulating surface, and evidently that design which gives the greatest length in proportion to mean circumference will have the highest insulating power. In a general way the engineer should not be satisfied unless a new open wire line should show insulation resistance of several megohms per mile, while an old line should be considered decidedly below standard if the insulation resistance fall below one megohm.

*Accessories.*— The remaining accessories used in open wire line construction, such as the necessary bolts for securing the braces, cross arms, etc., together with pole steps, protection strips, wheel guards, etc., are matters of relatively minor detail and will be found so fully described in the Specifications for Open Wire Construction — Chapter X — as to render further description here superfluous.

*Lightning protection.*— The telephone line forms an attractive temptation to the thunder storm, which may not only strike poles and seeking the circuits run to the central office or sub-station to the injury or destruction of the apparatus, but in the light of our present knowledge

of electrical oscillations, the line plays to the electric waves set up by every thunder shower exactly the same part as the vertical mast does to the Marconi wireless telegraph stations and intercepts Hertzian waves, which, traveling along the conductor thus provided, may do considerable damage either to the sub-station or the central office by puncturing the insulation of unprotected apparatus. It has been customary to frequently equip the poles of an aerial line with a lightning rod, by nailing to the pole a piece of No. 6 B. W. G. iron wire, so arranged as to project a foot or more above the top of the pole and burying the same at its base. That such protection is of value is unquestioned, but directions for installing lightning rods formerly specified that the buried end of the wire should have three or four hand turns in order that a good ground might be secured. Nothing could be more fallacious than to introduce coils into a conductor designed to relieve the line of the infinitely rapid oscillations of a lightning flash. A lightning guard, to be of any value, should be as straight as possible and its earth secured by driving an iron rod to permanently moist earth and attaching the wire to the end thereof. Such lightning rods are valuable to produce a "silent discharge" of an overloaded cloud, and so protect the line from an actual, so-called lightning stroke, but are of little efficiency to relieve it from the electrical oscillation which may be set up by Hertzian waves. For this purpose it is desirable to frequently equip a line with a spark gap, and nothing can be better than a modification of the carbon plates, which now form an adjunct to the protection of every central office and many sub-stations. For open wire lines, the gap may be considerably larger, namely,  $1\frac{3}{8}$  or  $1\frac{5}{8}$  of an inch, so that danger from accidental grounding of

the lightning arrester by dirt is not imminent. The fusible metal button may be omitted as it is only static discharges that this protection is designed to meet. It is exceedingly difficult to say how often such spark gaps are necessary in order to afford adequate protection. The electrical disturbances that accompany a thunder storm invariably set up electrical oscillations in open wire lines, which, like all other forms of wave motion, have modes and crests, and in order to thoroughly protect a line there must be a sufficient number of spark gaps, so that the crests of the waves may always be permitted to discharge harmlessly, but it is impossible to predict where such crests will appear, and with every shower they may appear in a new place. In a general way it is pretty safe to say that lightning protection should be introduced as often as four times a mile, and preferably even somewhat more frequently.

*Wire.*—The best material out of which to construct the circuit of open wire lines has always been a point of discussion. Early telephone circuits were invariably made of iron, but its rapid rusting, objectionable resistance, and more detrimental magnetic qualities have caused this material to be largely discarded, excepting for inferior installations. Iron wire has the advantage of a superior tensile strength, and is cheaper in the first instances, but in all other respects it is much inferior to copper or the bronzes. Considerable misapprehension exists as to the relative costs of copper and iron. It is often argued that as iron wire costs  $3\frac{1}{2}$  cents a pound and copper wire 15 cents, the investment in telephone lines may be decreased four-fifths by the employment of iron wire; but it must be recollected that wire cost is but a fraction of the total cost of the line. The expense of

erecting wire and providing insulators, pins, cross arms, poles, etc., is exactly the same whether the line is strung of copper or iron. As will be subsequently shown the wire cost is about two-fifths of the total mileage cost of open wire lines, and, therefore, the maximum possible saving would be two-fifths of four-fifths or about eight-twenty-fifths. The maintenance cost of iron wire line is much greater than that of one built of copper, for even with the best galvanizing iron wire rapidly rusts in most localities. In cities whose atmospheres are burdened with gases from soft coal corrosion is exceedingly rapid, and iron wire lines fail in three or four years. In particularly exposed locations the wire may not last even a year. In small towns and rural districts, where the atmosphere is pure, iron wire lines will last a much longer period of time, but under the most favorable circumstances the depreciation of iron wire cannot be reckoned at less than 10 per cent., while copper can be safely placed as low as 4 per cent. Hence if the depreciation fund be capitalized the saving by the use of iron wire at 3.5 cents per pound versus copper at 14 cents is 9 per cent. of the total line cost, and when difference in service is considered this is too small a saving to be taken into account.

There have been many attempts to devise some other form of wire, which would be preferable for telephonic purposes. A number of alloys, chiefly combinations of aluminum and copper in the aluminum bronzes, have been tried. These wires possess considerably greater strength than hard-drawn copper, but are always burdened with two or three times the resistance. For drop wires, alley lines, and other distributing purposes, wire of this description has a value, and its use in this direction is likely to increase, but it seems to be limited to such special loca-

tions. In times past many attempts have been made to form what is termed a bi-metallic wire or center of steel, surrounded by a coating of copper, upon the theory that the steel would contribute the necessary strength and the copper the desired conductivity. Theoretically all this is true, but practically the increased cost of manufacture does not enable such wires to show economy over regular hard-drawn copper, except for special cases, and from no other standpoint is their use desirable. Prior to the application of hard drawing to the manufacture of wire, there was much greater need for the use of iron, as ordinary annealed copper could not be made of sufficient strength to support itself over desirable spans under a snow load. But when Mr. Doolittle showed how greatly the tensile strength of copper could be increased by the process of passing it through a die, without subsequently annealing, the fate of iron wire was sealed, as the increased tensile strength thus secured to the copper made it capable of sustaining itself under all ordinary conditions of span and load. In using hard-drawn copper, however, it must not be forgotten that the value of the material lies in the surface skin, and that nothing should be done which in any way interferes with its integrity. Thus all tools or hard objects must be kept away from the surface of hard copper wire. It must under no circumstances be nicked or scratched, or bent at a sharp angle. Anything which disturbs its surface vitally injures its cohesive power. Any form of annealing will perform the same result, and, consequently, no soldering must be done upon hard-drawn wire, but all joints must be made with clamps — McIntire joints, or by some other mechanical method.

Good telephonic practice now uses copper wire having a diameter of .080 in. for all ordinary work, and .104 in.

for toll lines and important trunk lines. For toll lines that do not exceed 10 to 15 miles .080 wire gives satisfactory service while for long distance work .104 is superior. Formerly wire of .165 in. in diameter was widely employed for trans-continental lines, but in the future such large wire, if used at all, will probably be exclusively limited to the lines of the most important circuits, but before passing to a further consideration of telephone wire it is well to review some of the general principles that apply to all wire.

Wires are usually specified by stating in diameter in thousandths of an inch or *mils*, as this dimension is designated. The area of wire may be expressed as a fraction of a square inch, but it is becoming more and more common to state the area of wire in circular *mils*, the circular mil being the area of a wire  $\frac{1}{1000}$  of an inch in diameter. In some respects the circular mil as a unit is preferable to the square inch, because the area of wire in circular mils may be at once obtained by squaring the diameter in mils, and in case it is desirable to reduce the area in circular mils to area in square inches, this may be at once done by multiplying the area in circular mils by .7854.

A wire 1 mil in diameter will have an area of 1 circular mil, and a piece of such a wire 1 ft. long may be termed a *unit wire* for it will have a unit diameter, a unit area, and a unit length. If all the mechanical, electrical, and economic properties of such a wire be determined it is easy by simple multiplication and division to determine the properties of any other wire. It is convenient to use the following symbols:

$$\begin{aligned} M &= \text{Diameter in mils.} \\ CM &= \text{Area in circular mils} = M^2. \\ L &= \text{Length in feet.} \end{aligned}$$

$R$  = Resistance in ohms.  
 $W$  = Weight in pounds.  
 $T$  = Tensile strength in pounds.  
 $C$  = Cost in cents (unit cost reckoned at 15 per cent. per pound).  
 $P$  = Percentage variation of current market price from unit cost.

For the unit wire the following constants are found:

$M = 1$ .  
 $CM = 1$ .  
 $L = 1$ .  
 $R = 10$  ohms at  $50.4^\circ$  F.  
 $W = .00000302$  lbs.  
 $T = .0275$  lbs. for soft copper and  $.0510$  lbs. for hard copper.  
 $C = .0000453$  cents.

Then for any other wire:

- (1)  $CM = M^2$ .
- (2) Area in square inches =  $.7854 CM = .7854 M^2$ .
- (3)  $W = .000003 \times L \times CM = .000003 M^2 L$ .
- (4)  $T = .0275 CM$  (soft copper) and  
 $T = .051 CM$  (hard copper).
- (5)  $R = 10 \times L = 10 L$ .  
 $\frac{CM}{M^2}$ .
- (6)  $C = .000045 \times L \times CM \times \frac{P}{15} = .000045 \times L \times M^2 \times \frac{P}{15}$ .

The resistance of all conductors changes with variation in temperature, for copper the rate of variation is given by the expression

$$R_t = R_o(1 + .00387t + .0000597t^2)$$

in which  $R_o$  is the resistance at  $0^\circ$  centigrade, and  $R_t$  any other temperature on the same scale. Table 13 gives the resistance per mil foot over the ordinary temperature ranges on the Fahrenheit scale. The figures in the second column of this table are so near the true percentage change in resistance that for all commercial work they may be taken as the per cent. of change of resistance due to temperature.

The cost of wire given by (6) is the cost at 15 cents per pound; for any other price it is simply necessary to multiply by  $P$  the per cent. change in price, thus for 18 cents  $P=120$  per cent. and for 12 cents  $P=80$  per cent.

TABLE 13.

*Resistance Per Mil Foot of Copper Wire in Legal Ohms at Various Temperatures F.*

Temperature.	Rest. in Ohms.
0	8.967
10	9.164
20	9.364
30	9.568
40	9.776
50	9.988
60	10.202
70	10.420
80	10.643
90	10.868
100	11.096

By finding the ratio between any of the preceding constants given for copper and the same constant for any other substance, the preceding formulæ may be used for a wide range of calculation by simply multiplying by the ratio thus found. Table 14 gives the ratio of electrical resistance between a mil foot of copper and that of many other metals.

TABLE 14.

*Resistance of a Mil-Foot of Various Metals Compared with Copper.*

Silver, annealed .....	9.44
Copper, annealed .....	10.00
Silver, hard drawn .....	10.25
Copper, hard drawn .....	10.25
Gold, annealed .....	12.93
Gold, hard drawn .....	13.15
Aluminum, annealed .....	18.55
Zinc, pressed .....	37.20



Platinum, annealed .....	56.80
Iron, annealed .....	61.00
Nickel, annealed .....	78.20
Tin, pressed .....	82.90
Lead, pressed .....	122.60
German silver .....	131.20
Antimony, pressed .....	222.50
Mercury .....	582.00
Bismuth .....	823.00

Another convenient constant is the mile-ohm; this is the product of the weight per mile and the resistance per mile, or what is the same thing, the weight of a piece of wire one mile long which has a resistance of one ohm. For soft copper wire the mile ohm is approximately 866 pounds at 68° F. and 892 pounds for hard-drawn copper. This constant furnishes a very easy way to compare relative resistances. If the copper mile-ohm is 866 and that of some other wire is 6,320 the relative resistance is  $\frac{6320}{866} = 7.5$ .

The sizes of wire are frequently specified in accordance with certain arbitrary gauge numbers, which have in the past grown up as matters of trade convenience. There are a number of such different gauges more or less in current use, but the majority of reference is made either to the B. & S. gauge, which is devised by Brown & Sharpe, and is almost exclusively used in America, or the B. W. G. gauge, used in England and adapted to suit the convenience of the Birmingham wire manufacturers, from which it derives its name of the Birmingham gauge. The Brown & Sharpe system is so designed that each size or number of wire has half the area of the third number larger and twice the area of the third number smaller. To illustrate, a No. 10 wire has an area of 10,381 circular mils, while a No. 7 wire (third number larger) has an area of 20,817, and No. 13 (third number smaller) has an

area of 5,178. In other words, all the sizes of wires by Brown & Sharpe gauge vary in a geometrical progression, of which the constant ratio is 1.123, or the sixth root of 2. A tabular comparison between these two wire gauges is shown in Table 15.

TABLE 15.

Comparison of Wire Gauges.

Number.	B. & S. GAUGE.			B. W. G. GAUGE.		
	Diam. in Mils.	AREA IN.		Diam. in Mils.	AREA IN.	
		C. M.	Sq. Mils.		C. M.	Sq. Mils.
0000	400	211,600	169,791	454	206,116	161,888
000	369	187,805	151,790	425	180,825	141,862
00	364	183,070	104,590	380	144,400	113,411
0	324	105,534	82,8-6	340	115,800	90,722
1	299	88,694	65,733	300	90,000	70,586
2	277	66,373	53,129	184	80,856	63,347
3	229	53,633	41,338	919	67,081	59,685
4	204	41,743	32,784	238	59,644	44,488
5	181	35,103	25,998	230	49,400	38,013
6	162	26,350	20,617	203	41,809	32,365
7	144	20,817	16,949	180	32,400	26,449
8	128	16,509	12,967	165	27,225	21,883
9	114	13,094	10,284	148	21,904	17,308
10	101	10,381	8,153	134	17,956	14,102
11	90	8,284	6,467	120	14,400	11,309
12	80	6,529	5,123	109	11,881	9,381
13	71	5,173	4,067	93	9,025	7,088
14	64	4,106	3,2-5	85	6,989	5,410
15	57	3,356	2,557	72	5,184	4,0-1
16	50	2,523	2,023	61	4,225	3,313
17	45	2,043	1,608	53	3,364	2,642
18	40	1,624	1,275	49	2,401	1,885
19	35	1,238	1,011	42	1,764	1,335
20	31	1,021	802	35	1,225	968
21	28	810	636	22	1,024	804
22	25	643	504	23	781	615
23	22	509	400	25	625	490
24	20	404	317	22	484	380
25	17	330	251	20	400	314
26	15	254	199	18	324	254
27	14	201	158	16	256	201
28	13	159	125	14	196	153
29	11	135	99	13	169	132
30	10	100	78	12	144	113
31	8	79	62	10	100	78
32	7	63	49	9	81	63
33	7	50	39	8	64	50
34	6	39	31	7	49	38
35	5	31	24	5	25	19
36	5	25	19	4	16	12

*Iron wire.*—The only excuse for the use of iron wire is its cheapness, from every other standpoint it is to the telephonist objectionable. It corrodes so rapidly that unless protected by a coating of galvanizing its life would be measured by months, even in favorable locations. Under exceptional circumstances galvanized iron wire has been known to last 25 years, but considering the atmospheric contamination of most towns from four to six years is its probable life, so that in reckoning with iron wire lines one must allow a depreciation of 10 to 25 per cent. per annum on the wire part of the wire plant; and when it is remembered that copper wire, unless exposed to the particularly destructive atmosphere of chemical works, is almost everlasting and need not be burdened with more than 3 or 4 per cent. depreciation, the iron wire line is seen to be an expensive investment. In the trade there are several varieties of iron wire, whose names are somewhat misleading, excepting to the manufacturer. Iron wire is largely referred to as "Extra Best Best," "Best, Best," "Best," and "Steel." These terms are often abbreviated to "E. B. B.," "B. B.," and "B." "Extra Best Best" is made from the best grade of soft stock and has the best highest conductivity of any iron, averaging from one-fifth to one-sixth that of copper wire. Its breaking strength is usually about 2.5 to 3 times its weight per mile, and the mile ohm varies from 4,500 to 4,800, with an average of 4,700. "Best Best" wire is from a poorer quality of stock, it is less uniform but stronger than the preceding grade, having a breaking strength of 3.3 times its weight per mile; the mile ohm varies from 5,000 to 6,000, averaging 5,500, showing much lower conductivity. The "Best" grade is the poorest quality of wire; it is hard and apt to be brittle, and has a break-

ing strength of about 4 times its weight per mile, while the mile ohm varies from 6,000 to 7,000. Steel wire is usually made from one of the cheaper varieties of Bessemer steel. It is stronger than any of the iron wires but has poor conductivity. Its tensile strength is from 4 to 5 times its weight per mile, while the mile ohm is from 6,500 to 7,500, averaging 6,800. There is a proper and legitimate sphere for iron wire in open wire line construction. For short lines in rural districts, where the plant must be installed with the greatest economy, where there is no important toll-line business, where rapid growth is to be expected and life of the wire plant necessarily short, and where subscribers fully understand that a second class service is provided, iron wire lines are justifiable. But in the larger cities for pole lines of consequence wherever telephonic business is of magnitude and importance the engineer is no more justified in building an iron wire line than he would be to construct a horse railroad in these days of electric propulsion.

Table 16 gives the properties of iron wire.

TABLE 16.  
*Galvanized Iron Wire.*

Numbers, B. W. G.	Diameters in Mils.	WEIGHTS, POUNDS.		BREAKING WEIGHTS, POUNDS.		RESISTANCE PER MILE IN OHMS.		
		1,000 Feet.	One Mile.	Iron.	Steel.	E. B. B.	B. B.	Steel.
0	340	804	1,607	4,821	9,079	2.93	3.42	4.05
1	300	237	1,311	3,753	7,068	3.76	4.4	5.2
2	284	213	1,121	3,363	6,383	4.19	4.91	5.8
3	259	177	932	2,736	5,668	5.04	5.9	6.97
4	233	149	787	2,361	4,449	5.97	6.99	8.26
5	220	127	673	2,019	3,807	6.99	8.18	9.66
6	208	109	573	1,719	3,237	8.21	9.6	11.35
7	180	85	440	1,350	2,545	10.44	12.21	14.48
8	165	72	378	1,134	2,138	12.42	14.53	17.18
9	148	58	305	915	1,720	15.44	18.06	21.35
10	134	47	250	750	1,410	18.88	22.04	26.04
11	120	38	200	600	1,131	23.48	27.48	32.47
12	109	31	165	495	938	28.46	33.8	39.36
13	95	24	125	375	709	37.47	43.85	51.83
14	88	18	96	288	541	49.06	57.44	67.83
15	72	13.7	72	216	407	65.22	76.33	90.21
16	65	11.1	59	177	332	80.03	93.66	110.7
17	58	8.9	47	141	264	100.5	120.4	139
18	49	6.8	38	99	199	140.8	164.8	191.8

*Copper wire.*—For the last decade and a half the use of iron wire has been steadily decreasing, is now essentially abandoned by all telephone companies of magnitude and in its place copper wire is universally employed. The constants for copper wire are for tensile strength 3.2 times its weight per mile, while the mile ohm for good commercial wire is 866 pounds, at 68° F. Dr. Perrine gives the following table, as representing present good American practice in the manufacture of copper wire :

TABLE 17.

*Characteristics of Copper Wire.*

WIRE.	Conduc- tivity.	Tensile Strength in Pounds per Square Inch.	Percent- age Elong- ga tion.	Twists in Six Inches before Breaking.	Right Angle Bends before Breaking
Hard No. 8, B and S. and larger.....	98%	60,000	1½	25 to 35	4 to 6
Hard No. 10, B. and S. and smaller.....	97%	67,000	1	40 to 45	6 to 8
Soft .....	99%	34,000	40	30 to 60	10 to 20

The following Table, No. 18, gives the chief proportion of copper wire and is condensed from data published by J. A. Roeblings Sons Co. :

TABLE 18.  
*Properties of Copper Wire.*  
 Brown & Sharpe Gauge.

Numbers.	Diameter in Mils.	Areas in Circular Mils. $C.M.=d^2$ .	WEIGHTS.		RESISTANCES PER 1,000 FEET IN INTERNATIONAL OHM.	
			1,000 Feet.	Mile.	At 60° F.	At 75° F.
0000	460	211,600	641	3,782	.018 11	.049 66
000	410	168,100	509	2,687	.0260 56	.063 51
00	365	133,225	408	2,129	.0376 42	.078 87
0	321	105,625	320	1,686	.0536 31	.099 48
1	289	83,521	258	1,385	.0712 19	.126 8
2	258	66,564	202	1,064	.0912 9	.157 9
3	229	52,441	159	838	.114 1	.200 4
4	204	41,616	126	685	.141 6	.254 5
5	182	33,124	100	529	.170 4	.317 2
6	162	26,244	79	419	.207 9	.400 4
7	144	20,736	63	331	.251	.506 7
8	128	16,384	50	262	.312 4	.641 3
9	114	12,996	39	208	.383 4	.806 5
10	102	10,404	32	166	.467 5	1 01
11	91	8,281	25	132	1.229	1.269
12	81	6,561	20	105	1.552	1.601
13	72	5,184	15.7	83	1.961	2 027
14	64	4,096	12.4	65	2.495	2.565
15	57	3,249	9.8	52	3.133	3.234
16	51	2,601	7.9	42	3.914	4.04
17	45	2,025	6.1	32	5.028	5.189
18	40	1,600	4.8	25.6	6.363	6.67
19	36	1,296	3.9	20.7	7.855	8.108
20	32	1,024	3.1	16.4	9.942	10.26
21	28.5	812.3	2.5	13	12.53	12.94
22	25.3	640.1	1.9	10.2	15.9	16.41
23	22.6	510.8	1.5	8.2	19.13	20.57
24	20.1	404	1.2	6.5	23.2	26.01
25	17.9	320.4	.97	5.1	31.77	32.79
26	15.9	252.8	.77	4	40.27	41.55
27	14.2	201.6	.61	3.2	50.49	52.11
28	12.6	158.8	.48	2.5	64.13	66.18
29	11.3	127.7	.39	2	79.73	82.29
30	10	100	.3	1.6	101.8	105.1
31	8.9	79.2	.24	1.27	128.5	132.7
32	8	64	.19	1.02	159.1	164.2
33	7.1	50.4	.15	.81	202.	208.4
34	6.3	39.7	.12	.63	256.5	264.7
35	5.6	31.4	.095	.5	324.6	335.1
36	5	25	.076	.4	407.2	420.3

Tables 19, 20, 21, gathered from the same source, show the characteristics and specifications particularly applicable to telephone wire.

TABLE 19.  
*Hard-Drawn Copper Wire.*  
 British Post-Office Specifications.

DIAMETERS.			WEIGHTS PER MILE.			Minimum Breaking Strain. Pounds.	Minimum Twists.	Maximum Resistance per Mile at 60° F. International Ohms.
Required.	Maximum.	Minimum.	Required.	Maximum.	Minimum.			
224	226	220½	800	820	780	2 400	in 6 in. { 15 20 25	1.098
194	196	191	600	615	585	1 800		1.464
1.8	160¼	155½	400	410	390	1,300		2.195
112	113¼	110¼	200	205	195	650	in 8 in. { 20 25 30	4.891
97	98	9 ½	160	158¼	146¼	490		5.855
79	80	78	100	102½	97½	380		8.782

“ The wire shall be capable of being wrapped in six turns around wire of its own diameter, unwrapped and again wrapped in six turns around wire of its own diameter in the same direction as the first wrapping, without breaking; and shall be also capable of bearing the number of twists set down in the table, without breaking.

“ The twist test will be made as follows: The wire will be gripped by two vises, one of which will be made to revolve at a speed not exceeding one revolution per second. The twists thus given to the wire will be reckoned by means of an ink mark previously drawn which forms a spiral on the wire during torsion, causing the full number of twists to be visible between the vises.”

According to above table, the mile-ohm of copper required is 878 pounds. This corresponds to a conductivity of 97.8 per cent., taking the value of the mile-ohm of 100 per cent. copper as 859.



TABLE 20.  
Hard-Drawn Copper Wire.  
Telephone Specifications.

NUMBERS.	DIAMETERS IN MILS.			WEIGHTS PER MILE.			BREAKING WEIGHTS.			WEIGHTS OF COILS.		CONDUCTIVITY.		Twists in Six Inches.	Per Cent. Elongation in Five Feet.
	Required.	Maximum.	Minimum.	Required.	Maximum.	Minimum.	Actual Required.	Actual Minimum.	Per square Inch.	Maximum.	Minimum.	Required.	Minimum.		
8 B. W. G. ....	175	166	164	436.4	44 7	451.1	1,928	1,801	62,100	216	152	97	96	90	1.14
10 N. E. S. G. ....	104	104.9	108 1	173 4	176.4	170.4	549	538	64,800	219	153	97	96	40	1.00
12 B. & S. G. ....	101.9	102.8	101	165	168	162	540	519	64,800	216	152	97	96	44	.84
14 B. & S. G. ....	80	81.2	79 8	102.6	105.7	100.8	354	327	66,500	72	52	97	96	47	.64
14 B. & S. G. ....	64	65	63	65	67.5	63	2.0	212	66,500	....	....	97	96	47	.51

TABLE 21.

*Tensile Strength of Copper Wire.*

Numbers, B. & S. G.	BREAKING WEIGHT, POUNDS.		Numbers, B. & S. G.	BREAKING WEIGHT, POUNDS.	
	Harddrawn.	Annealed.		Harddrawn.	Annealed.
0000	8,310	5,650	9	617	349
000	6,580	4,480	10	489	277
00	5,226	3,553	11	388	219
0	4,558	2,818	12	307	174
1	3,746	2,284	13	244	138
2	3,127	1,772	14	193	109
3	2,480	1,405	15	153	87
4	1,967	1,114	16	131	69
5	1,559	883	17	97	55
6	1,237	700	18	77	43
7	980	555	19	61	31
8	778	400	20	48	27

The strength of soft copper wire varies from 32,000 to 36,000 pounds per square inch, and hard-drawn wire from 45,000 pounds to 65,000 pounds. The preceding table is calculated on 34,000 pounds for soft wire and 60,000 for hard wire, excepting that 50,000 pounds is taken for Nos. 0000, 000, and 00; 55,000 for No. 0 and 57,000 for No. 1.

As telephonists must sometimes swing a long span of wire and need for this purpose something stronger than hard-drawn copper the properties of bi-metallic wire, which is designed for this purpose, are given in Table 22.

TABLE 22.

*Proportion of Bi-Metallic Wire.*

Numbers, B. & S. G.	Diameters in Mils.	Weights per Mile. Pounds.	Breaking Weight. Pounds.
0000	460	3,200	10,500
000	410	2,587	8,600
00	365	2,022	7,000
0	325	1,620	5,700
1	289	1,264	4,600
2	258	1,008	3,800
3	229	797	3,200
4	204	629	2,600
5	182	490	1,790
6	162	398	1,500
7	144	314	1,210
8	128	246	1,020
9	114	203	800
10	102	157	660
11	91	127	520
12	81	100	410
14	64	63	260
16	51	40	160
18	40	25	100

This wire consists of a steel center with a cover of copper. Its conductivity is about 65 per cent. of that of pure copper. The percentage of copper and steel may vary a trifle, hence the strength and weight must be approximate.

## CHAPTER VII.

### DISTRIBUTION.

THE pole line has always been a favorite with the telephonist from the ease with which it enabled him to reach sub-stations. The customary method of distribution has been to drop off a pair of wires at each station. For single lines this is usually accomplished by dead-ending the pair and attaching each side of the drop wire to a corresponding side of the line by a McIntire joint at the insulator or by clamping the drop wire to the line wire by means of a brass or copper clamp, such as is shown in Fig. 28. Neither of these methods has proved entirely

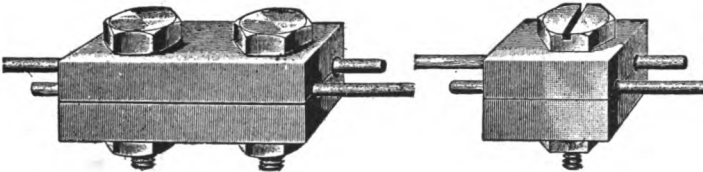

FIG. 28.— CLAMPS.

satisfactory, although both are commonly applied. The drop wires are usually more loosely strung than the line wires are, greatly affected by the wind and constantly swaying. This tends to twist off the McIntire or else to turn the clamp upon the line wire. Both of these actions operate to rupture either the line wire or the joint between the line and the drop; so broken house connections are a constant "bug-bear" to the wire chief.

To bridged party line stations the line wires are not

dead-ended till the last station is reached, and the drop wires must be secured to the line wires in some other

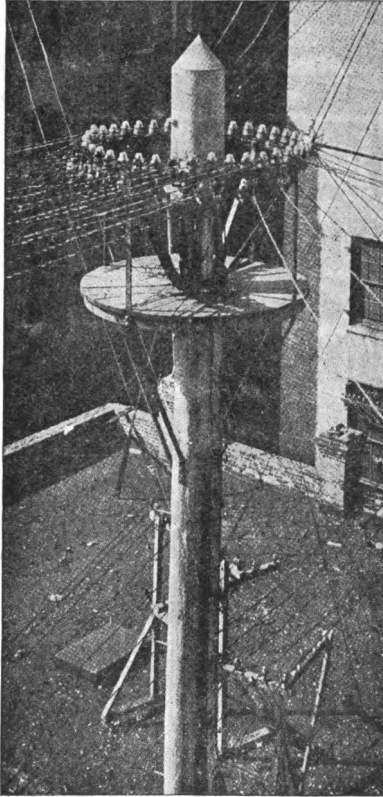

FIG. 29.—DISTRIBUTING POLE TOP.

fashion. The clamp is the best method, though it is prone to loosen and open the subscriber's circuit or even cut

the line wire in two by constant swaying in the wind. Sometimes the drop wire is twisted about the line wire and soldered. If the line wire is hard drawn the soldering weakens it, and in any event the swaying of the drop is likely to break it at the junction. Series party line stations are looped in by dead-ending and opening one side of the line, and securing the drop wires to the line wire by clamps or McIntire joints. By all methods yet devised the connection of the drop to the line is a weak point, and the trouble man impatiently awaits the invention of the perfect house connection.

Present practice tends strongly in the direction of limiting the open wire plant to two or three cross arms and the substitution of aerial cable whenever there are from 15 to 20 circuits. There are few blocks even in the smaller towns, at least in the business portions, that will not demand a score of telephones. A 50 or 60-pair aerial cable is erected, a distributing pole is placed as near as possible to the center of each block, and from 10 to 20 pairs of the cable looped through a distributing box, cable head, or pole terminal placed thereon. Formerly it was customary to terminate these pairs on the respective poles, but now they are always *looped through several terminal poles*. This is termed "*multiple distribution*," and confers a far greater flexibility on the wire plant, and is in reality much cheaper in the end than the older plan. A very slight consideration will show this, for subscribers are constantly moving about, and a wire once terminated can only be extended (if in cable) at great expense. Whereas, on the multiple plan, subscribers may move along the entire length of a long cable and cause absolutely no change in the wire plant, except that needed to rerun the drop wires. Again, when the time arrives for

a general increase in a lead, it is very much easier and cheaper to utilize a long uniform cable than to patch together a lot of short lengths of heterogeneous sizes. This change in design is rapidly multiplying the distributing

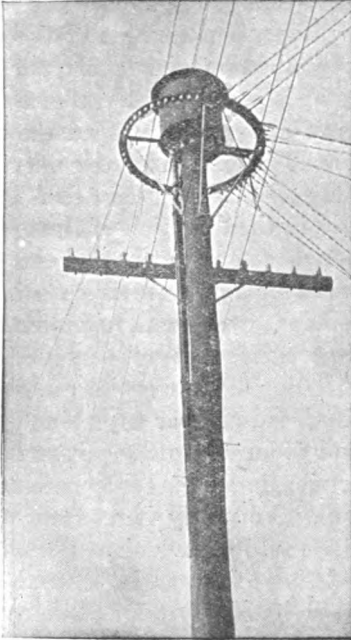

FIG. 30.— DISTRIBUTING POLE TOP,  
OPEN WIRE, AND CABLE.

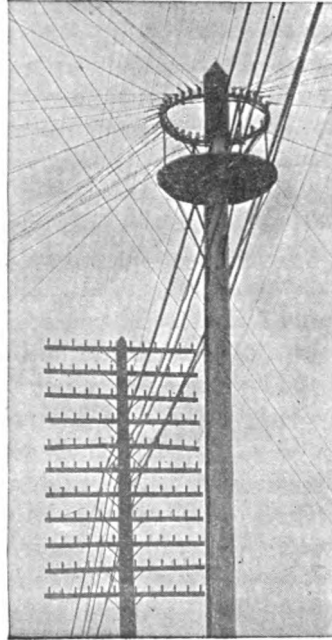

FIG. 31.— POLE TOP WITH  
PLATFORM.

pole, and there seems to be no reason why the distributing pole should not be used as a method of distributing open wire as well as aerial cable. As its name indicates, the line wires converge to the distributing pole, and from it the drop wires run to the subscribers. Present practice

tends to a distributing pole, provided with a circular ring, some five or six feet in diameter, that is placed upon the

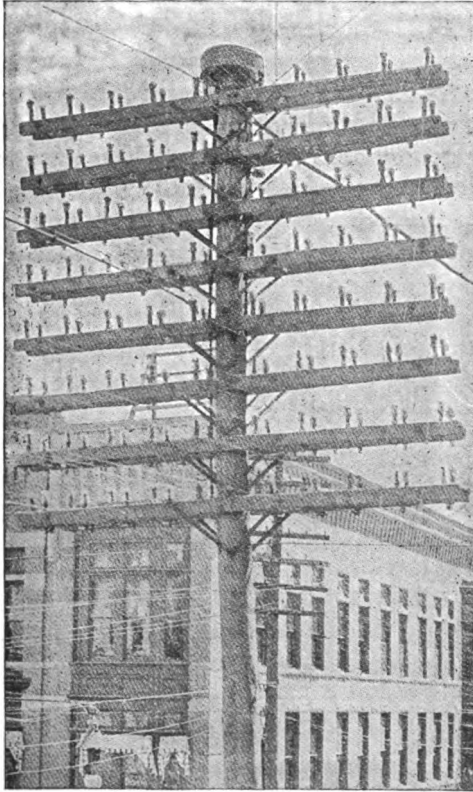

FIG. 32.— DISTRIBUTING POLE, STERLING HEAD.

top of the pole. This ring is supplied with a number of insulators, to which the line wires run and are there dead-ended. Drop wires are made usually of a twisted pair of



double-braided okonite or similar material. Each drop is attached to its pair of insulators and then swung in a single span to the premises of the subscribers which it is intended to serve. Samples of the tops of distributing poles are shown in Figs. 29, 30, 31, 32, and 33, while Fig. 34 shows the pole in process of construction; that is to say, the pole is erected, the ring in place, and the linemen are engaged in attaching the line and drop wires. Figs. 29, 30, 32, and 33 are examples of good construction, 29,

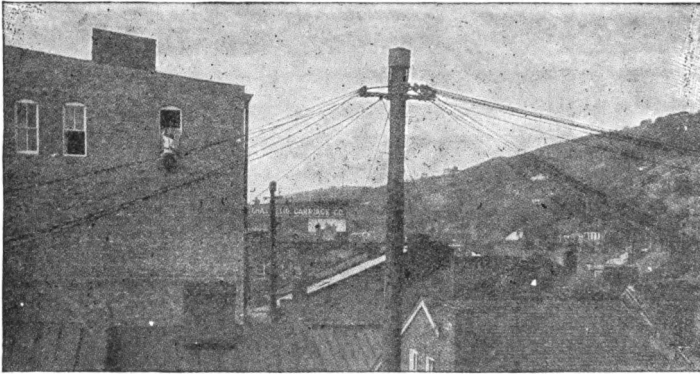

FIG. 33.—DISTRIBUTING POLE IN CENTER OF BLOCK.

31, 32, and 33 being particularly commendable, while Fig. 35 is an illustration of what not to do. The pole, as will be seen, is top-heavy and badly proportioned, having a top of greater diameter than that of the pole some feet beneath it, and, in general, is in an exceedingly disorderly and untidy condition. Formerly it was customary to construct the pole ring, carrying the insulators, of seasoned hard wood, supported upon iron braces, but recently designs, which are much more mechanical and

substantial have appeared. Thus Fig. 37 shows a pole top which is constructed by bending a light channel into

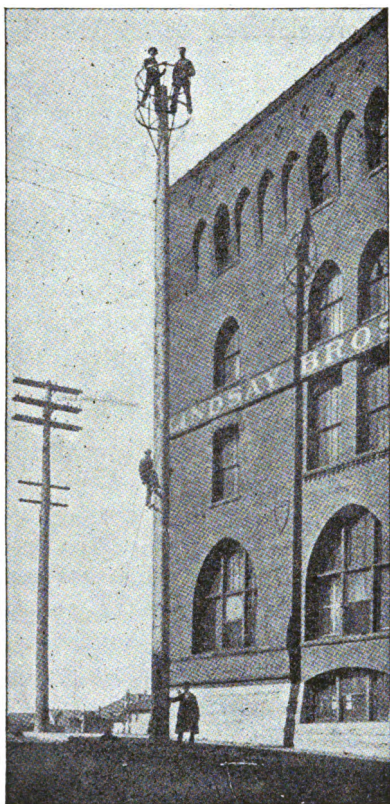

FIG. 34.—CONSTRUCTING A DISTRIBUTING POLE TOP.

a ring, to which the insulators are attached by bolting to the ring a bracket pin, upon which the insulator is placed.

The whole top is then secured to the pole by bolting both by diametrical braces in the inside of the ring, and by the vertical braces extending from the circumference to the pole. A still more elaborate design is shown in Figs. 38

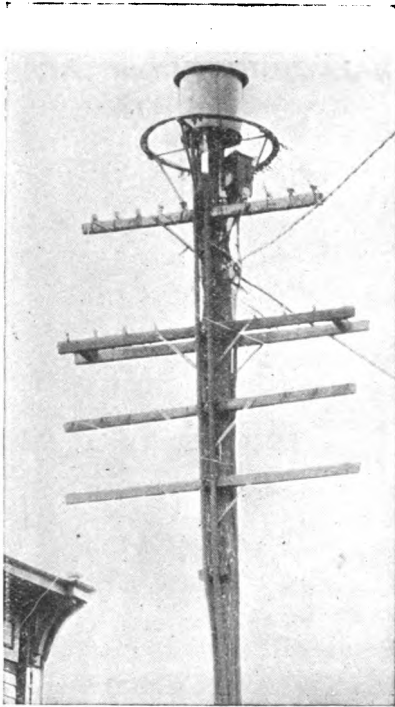

FIG. 35.— A BAD EXAMPLE.

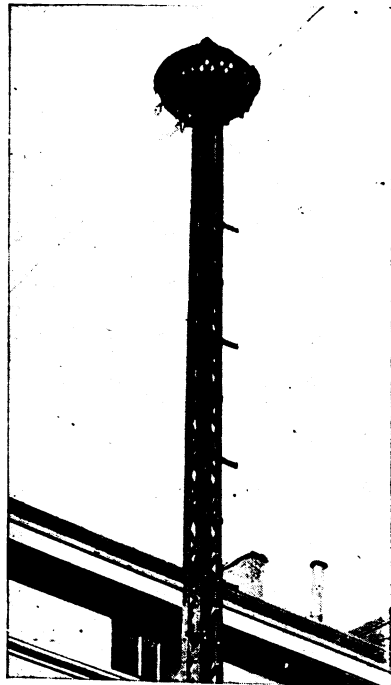

FIG. 36.— LATTICED DISTRIBUTING POLE.

and 39. The pole is provided with a kind of cable terminal, the 10 and 25-pair size being shown in Fig. 38, and 50-pair size complete erected upon the pole, in Fig. 39. The ring is composed of a circular flat iron secured to

the pole by two transverse pipe braces. Upon the circumference of the ring insulators are bolted, one of each pair being respectively on the top and the bottom of the

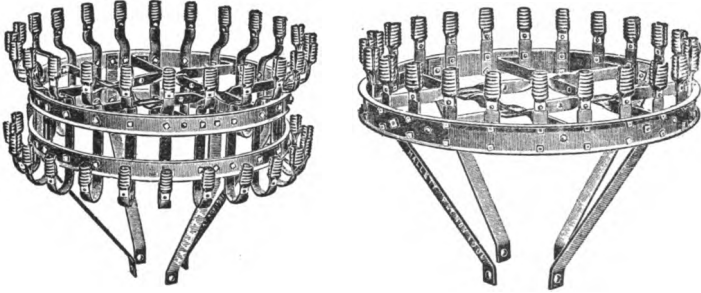

FIG. 37.—DETAILS OF CHANNEL IRON POLE TOP.

ring. Upon the top of the pole the cable box is placed, which consists of vertical strips, as shown in the illustrations, which are mounted between two parallel rings.

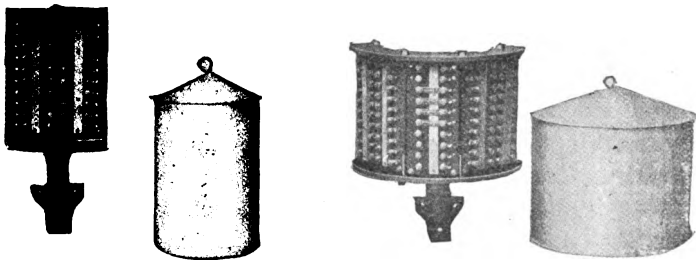

FIG. 38.—DETAILS OF POLE TOP FOR CABLE DISTRIBUTION.

The strips are made of hard rubber and carry cable terminals, to which the protecting fuses are attached and from which the bridle wires run downward to the dis-

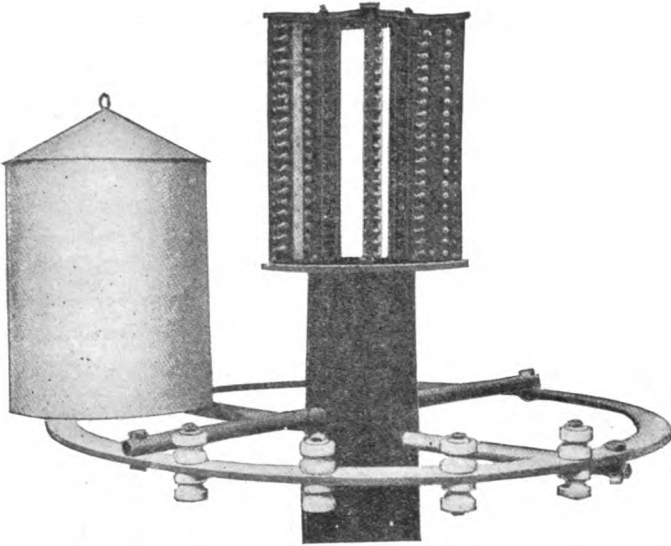

FIG. 39.—AERIAL CABLE TERMINAL.

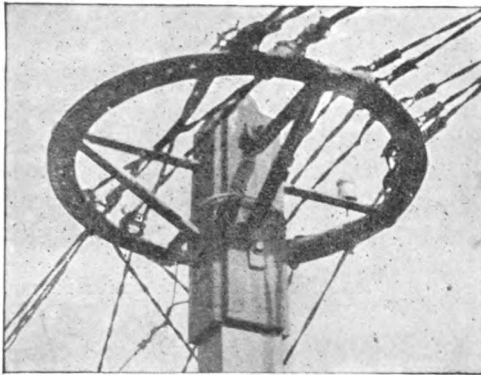
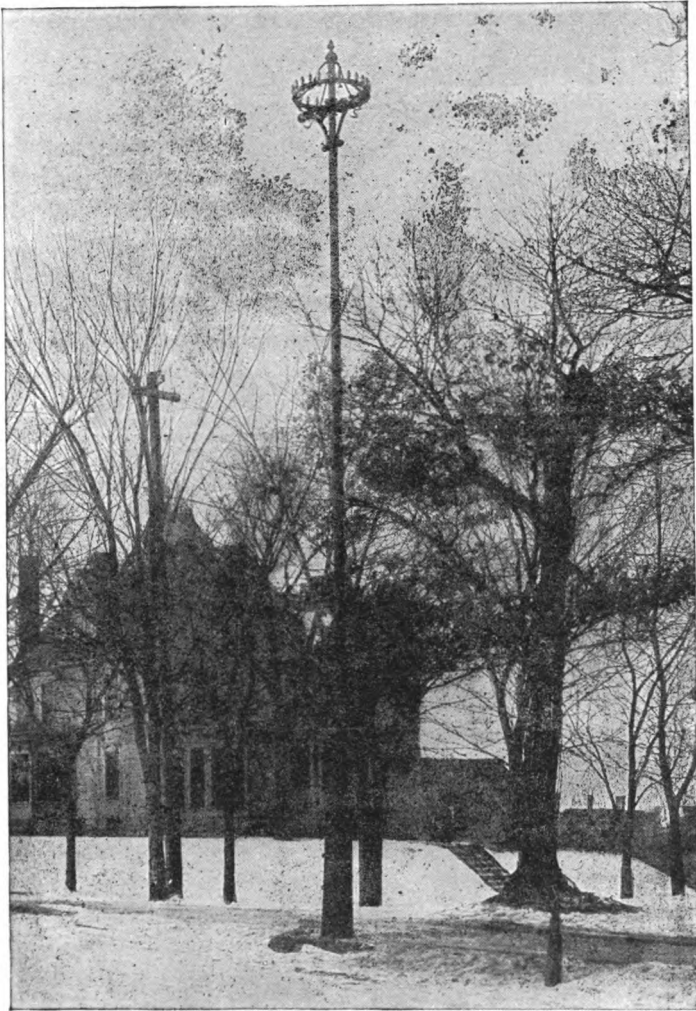

FIG. 40.—A COMMON CASE.



**FIG. 41.— ORNAMENTAL IRON DISTRIBUTING POLE.**

tributing ring. A metal cover surmounts the whole of the terminal and protects it from the weather. A near view of the top of a distributing pole of this kind is shown in Fig. 29, while Fig. 40 shows the top of a ring-distributing pole, carrying wires from an open wire line. Owing to their importance, it is necessary to be more careful in the construction of distributing poles than those in the ordinary line, and the writer is glad to note that the use of iron poles is beginning to make some headway. Figs. 25 and 26 show two poles of this nature. Fig. 36 is a light distributing pole of four angles, latticed together and used by the New York and New Jersey Telephone Company in Brooklyn. Fig. 41 is a much more pretentious, elaborate, and handsome pole, and is erected by the Twin City Telephone Company in Minneapolis. To structures of this description no exception can be taken.

## CHAPTER VIII.

### THE COST OF AERIAL LINES.

THE cost of constructing open wire telephone lines is probably the most difficult item to estimate of all the various portions of the telephone plant. This is partly owing to the absence of any real and definite standard type of construction, and partly to variation in prices that obtain in different districts of the country for the various materials used. The city line must be built to carry a greater number of wires than is usually necessary in cross-country lines, and must be designed with the view, ultimately, of carrying perhaps several aerial cables. In addition to greater strength, city lines must present a much better appearance than is demanded in country work. Wages and prices of materials in cities are often considerably higher than in country districts. Rights of way are more expensive and more difficult to obtain, and greater delays are frequent during construction. For such reasons the city line is considerably more expensive than that constructed in the country. The chief items composing open wire line cost are poles, cross arms with pins and insulators, wire, and labor of erection. To aid in the estimation of open wire costs six tables in graphical form are prepared. Table 23 gives the cost of single poles, and the cost per wire mile of various sizes of copper wire (at various prices of copper per pound) erected in place, including cross arms, hardware, pins, insulators, and labor of erection.

Holding this table with the point *A* in the lower right-hand corner, a scale marked "Pole Cost in Dollars" is



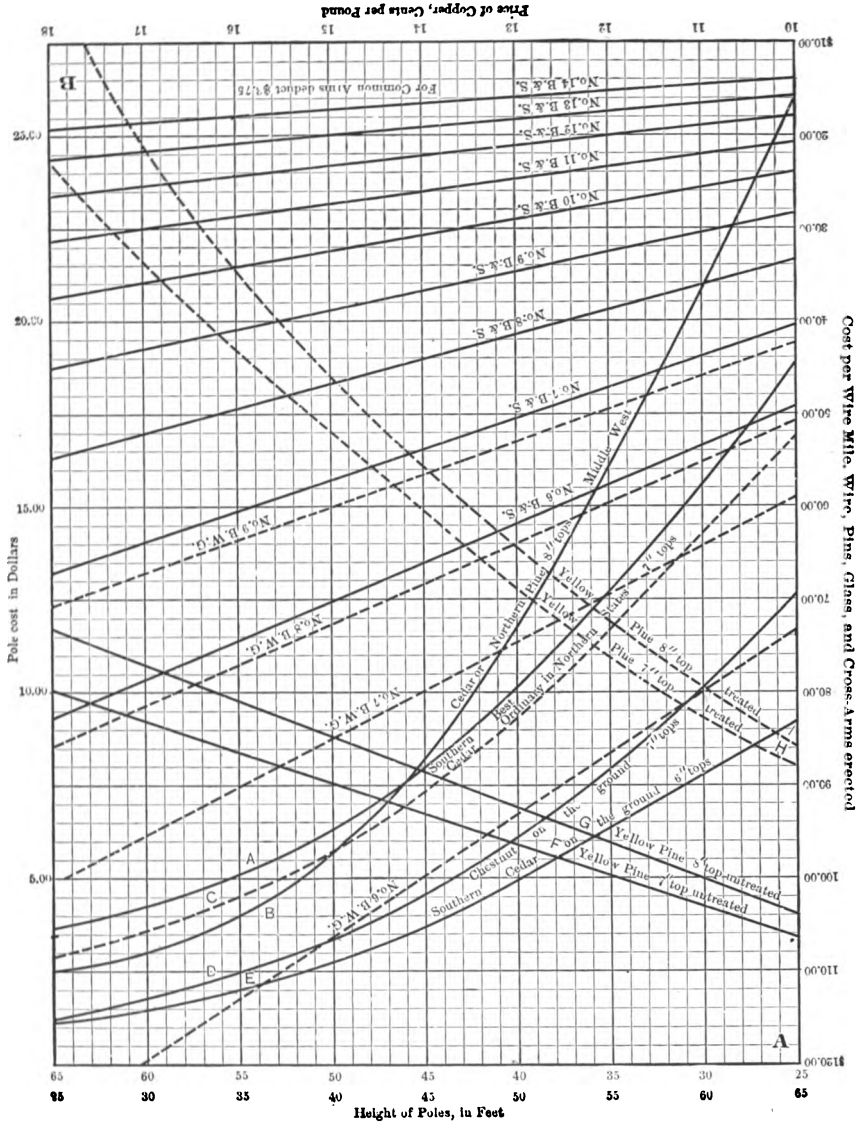

**TABLE 23.**  
*Cost of Poles and Cost Per Wire Mile of Wire Erected.*

found on the left hand. On the bottom there are two scales reading from 25 to 65 in both directions, denominated "Height of Poles in Feet." In the body of the table there are nine curves, *A, B, C, D, E, F, G, H,* and *I*, by means of which the cost per pole of various kinds, sizes, and lengths can be calculated. The kinds of poles to which these curves apply are as follows:

*A* Southern cedar, delivered in Northern States, 7-in. top, best quality.

*B* Northern pine or cedar 8-in. tops, delivered in Middle Western States.

*C* Southern cedar, 7-in. tops, delivered in Northern States, ordinary quality.

*D* Chestnut, 7-in. tops, delivered within wagon haul of point of cutting.

*E* Southern cedar, 6-in. tops, delivered in Southern States.

*F* Yellow pine, 7-in. tops, delivered in Northern States, untreated.

*G* Yellow pine, 8-in. tops, delivered in Northern States, untreated.

*H* Yellow pine, 7-in. tops, delivered in Northern States, creosoted.

*I* Yellow pine, 8-in. tops, delivered in Northern States, creosoted.

Example: To find the cost of a chestnut pole 40 ft. high, 7-in. top, follow a vertical line from 40 on the lower scale, reading left to right, to Curve *D*, thence a horizontal to the left-hand vertical scale, finding \$3.40. To find the cost of a treated 8-in. top yellow pine pole 60 ft. high, follow a vertical line from 60 on the *upper* bottom

scale, reading from *right* to left, to Curve *I*, thence a horizontal line to the left-hand vertical scale, finding \$24.60. The "Height of Poles" scales should be read from left to right for Curves *A* to *E*, inclusive, and from right to left for Curves *F* to *I*, inclusive.

By turning the sheet around so that the point *B* is in the lower right-hand corner, the curves for cost of wire can be read. The lower horizontal scale is "Price of Copper per Pound," and should include delivery at nearest railway stations. The left-hand scale is "Cost per Wire Mile for Wire, Pins, Glass, and Cross Arms Erected." Carriage bolts, lag screws, braces, etc., are included and labor of stringing, putting up, and tying. Two sets of curves are given, one set for copper wire and from Nos. 6 to 14, inclusive, B. & S. gauge, indicated by full lines, and one set in dotted lines for Nos. 7, 8, and 9 B. W. G. The best quality of standard 10-pin yellow pine cross arms (untreated, but painted) is assumed. If common pine arms are used, deduct \$3.75 from the cost of any mile of wire. Thus the cost of a mile of No. 8 B. & S. wire at 14 cents per pound is found by following a vertical from 14 on the lower scale to the curve headed No. 8, B. & S., thence a horizontal to the left hand, finding \$44. If common arms are used, deduct \$3.75, giving \$40.25 per mile.

Tables 24 and 25 contain the data for estimating cost of poles set, ready for cross arms and wire. Table 24 is calculated for city lines, and Table 25 for country lines. Holding Table 24 with *A* in the lower right-hand corner, the lowest scale is "Height of Poles in Feet," while the left-hand scale gives the expense of the various items comprised in the cost of a mile of poles ready for arms. These curves are based on wages at \$1.75 per day, and

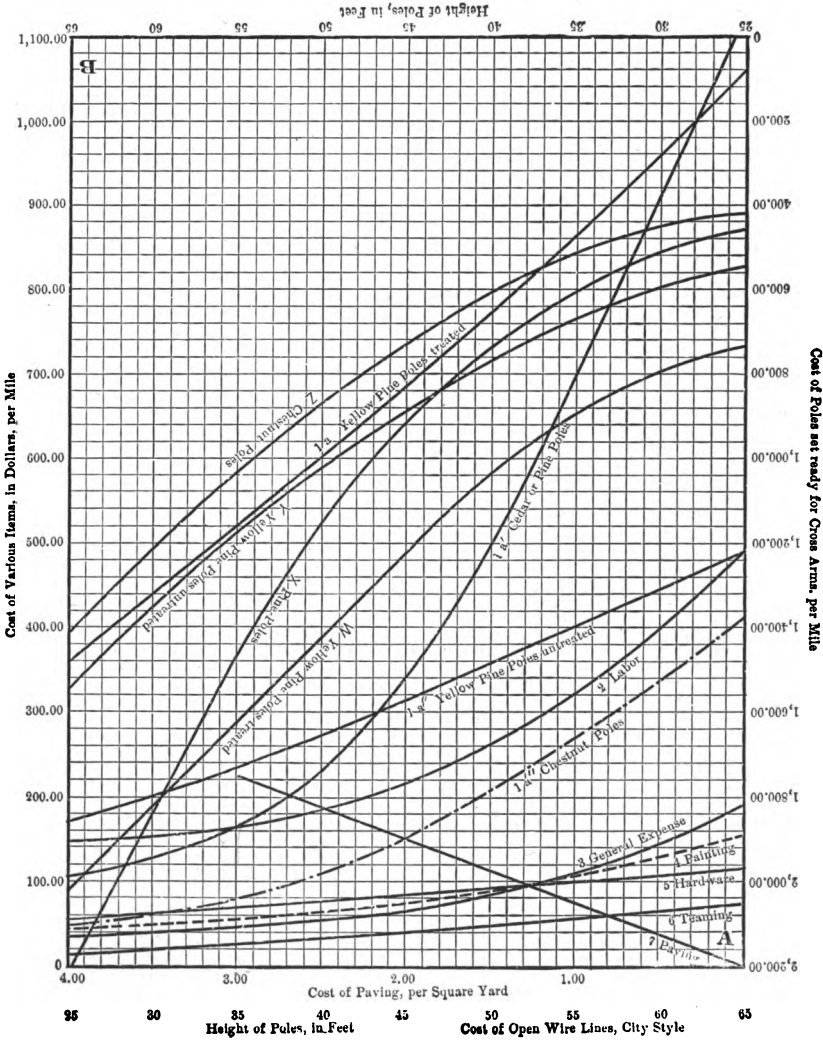

TABLE 24.

Table of Data for Estimating Cost Per Mile of Poles Set Ready for Arms.

\$3.25 per day for teaming. The expense of poles set, ready for arms, is divided into 7 parts.

- 1st. The cost of poles.
- 2d. Labor.
- 3d. General expense.
- 4th. Painting.
- 5th. Hardware.
- 6th. Teaming.
- 7th. Paving.

Curves  $1a$ ,  $a'$ ,  $1a''$ , and  $1a'''$  give the total cost per mile for poles only. Curve  $1a$  shows the cost of creosoted yellow pine poles,  $1a'$  northern pine or cedar,  $1a''$  yellow pine poles uncreosoted and  $1a'''$  chestnut poles. Curve 2 gives the labor expense. This includes pole inspection at point of delivery, shaving, framing, and other carpenter work to prepare the pole for setting; labor of loading and unloading from teams; the removal of pavement and digging the necessary holes; the refilling of the hole and tamping of the pole after setting and the temporary replacement of the pavement. Curve 3, "General Expense," includes all items which cannot be properly classified under any of the other headings, such as cost of supervision, car fares for workmen employed, office expenses, etc. Curve 4 is devoted to painting, giving the cost of painting the poles two coats of lead in linseed oil with a coat of black paint, 6 ft. high from the ground. Curve 5, headed "Hardware," is the cost of pole steps, protection strips, butt guards, wheel guards, etc. Curve 6, headed "Teaming," is the cost of all teaming, including hauling of poles, tools, machinery, etc., to and from the line location. Curve 7, headed "Paving," gives the cost of necessary repaving around the excavation made in which to place the pole. As the cost of paving is itself

variable, this curve must be read by aid of the supplementary horizontal scale, headed "Cost of Paving per Square Yard." The prices on this scale run to \$4, and the cost of repaving per mile of poles is found by taking the cost of paving per yard on the lower scale, following a vertical to Curve 7, and thence a horizontal to the left-hand scale. For example, at \$2 per yard the cost of paving for one mile of poles is found by following a vertical from \$2 on the lower horizontal scale to the Curve 7, and thence a horizontal to the left-hand scale, finding \$150. By inverting Table 24 so that *B* appears in the lower right-hand curve a set of four summation curves are found showing the complete cost of all the preceding items per mile of poles set ready for arms. Four curves are given — *W*, *X*, *Y*, and *Z* — respectively, applying to *yellow pine poles treated*, *northern pine or cedar*, *yellow pine poles untreated*, and *chestnut poles*. To find the cost of a mile of poles, ready for cross arms, select the height of the pole on the lower horizontal scale, follow a vertical till the curve of the kind of pole to be used is found, and thence a horizontal to the left-hand scale. Thus a mile of 50-ft. poles of yellow pine, creosoted, will cost \$1,420; of northern pine, \$1,150; of yellow pine, untreated, \$1,020; of chestnut, \$868.

Table 25 is arranged in precisely the same manner, but applies to country style pole lines. Holding this table with *A* in the lower right-hand corner, the lower scale is "Height of Poles in Feet" and the left-hand scale "Cost of Various Items in Dollars per Mile." For country lines there are only four items:

1. Poles.
2. Labor.
3. Teaming.
4. General expense.

Curves for three varieties of poles, 1a northern pine or cedar poles, 1a' for chestnut poles, and a curve for yellow pine treated, are given. Curve 2 gives the labor cost, Curve 3 that for teaming, and Curve 4 the general expense, and for these the same explanations apply as have been already given for Table 24. By inverting Table 25, so that *B* is in the lower right-hand corner, the total cost per mile of poles, ready for cross arms, is found. Three curves are here given — *X*, *Y*, and *Z* — applying respectively to lines constructed of yellow pine treated, northern pine or cedar and chestnut poles. Thus a mile of 45-ft. chestnut poles is seen to cost \$435, a mile of 45-ft. pine poles, \$628, and a mile of treated yellow pine \$960.

The information thus presented in Tables 23, 24, and 25 will enable the reader, by selecting such items as may be desired, to calculate with great rapidity and by means of a few simple additions the cost of almost any kind of open wire line in any location.

The preceding tables analyze the cost of open wire lines, but many cases arise when the cost of a typical line is desired without entering into a detailed consideration of the various component items. Tables 26 and 27 contain summary curves for such representative lines, constructed by adding the various items previously enumerated.

In Table 26 two kinds of poles are shown — chestnut, pine — and two sets of curves are given, one for iron wire and one for copper. For both sets the height of poles is found on the lower horizontal scale, reading from left to right for the iron wire line, and from right to left for the copper wire lines. The total cost per mile is found upon the left-hand side of the sheet for iron wire lines, and on the right-hand side for the copper lines. The basis of



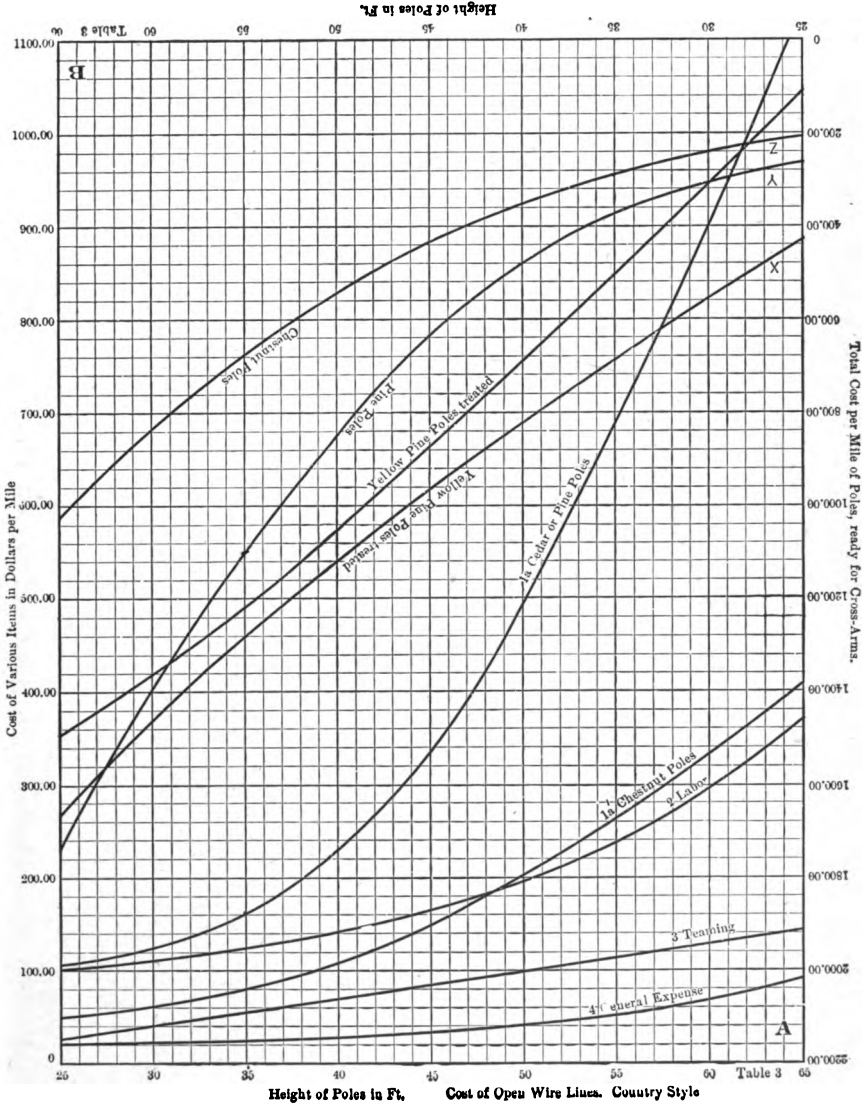

TABLE 25.  
Data for Estimating Cost Per Mile of Poles Set Ready for Cross-Arms.



estimating the total costs allows 3 standard 10-pin arms to a 25-ft. line, 4 to a 30-ft., 5 to a 35-ft., 7 to a 40-ft., 9 to a 50-ft. line, 12 arms each to a 55-ft., a 60-ft., and a 65-ft. line. Each arm is supposed to be fully equipped with a wire on each pin, but no knobbing is included. For iron wire lines No. 9 iron wire is assumed. There are two curves, one for pine poles and one for chestnut poles. For the copper wire lines three sets of two curves each are shown, one for .080 B. & S. copper, one for .104 B. & S., and one for .165 B. W. G. For each size of wire a curve for pine and a curve for chestnut poles is shown.

The open wire line has long been a favorite on account of a partially erroneous idea that it involved a less initial cost. But a *well*-built aerial line is by no means a cheap affair, and one poorly constructed is the most expensive luxury in which a telephony company can indulge. Neglecting for the moment the question of annual expense, and the effect of capitalizing the difference between the maintenance and depreciation on an open wire line, one in aerial cable, and one placed in conduit, it is interesting to consider the difference in *first installation cost*. Actual experience shows that first cost per wire mile depends on the *number of circuits* to be placed. For a very small number of wires the open wire line is beyond question the cheapest of all forms. But when the number of circuits increases somewhat a point is soon reached where aerial cable is less expensive per wire mile, and if still more are needed, the time arrives when the conduit is the most economical form now known.

In Table 27 a comparison between the cost of aerial and underground lines is made. Holding the sheet with *B* in the lower right-hand corner the lower scale is height of poles in feet, and the right-hand scale is the cost per

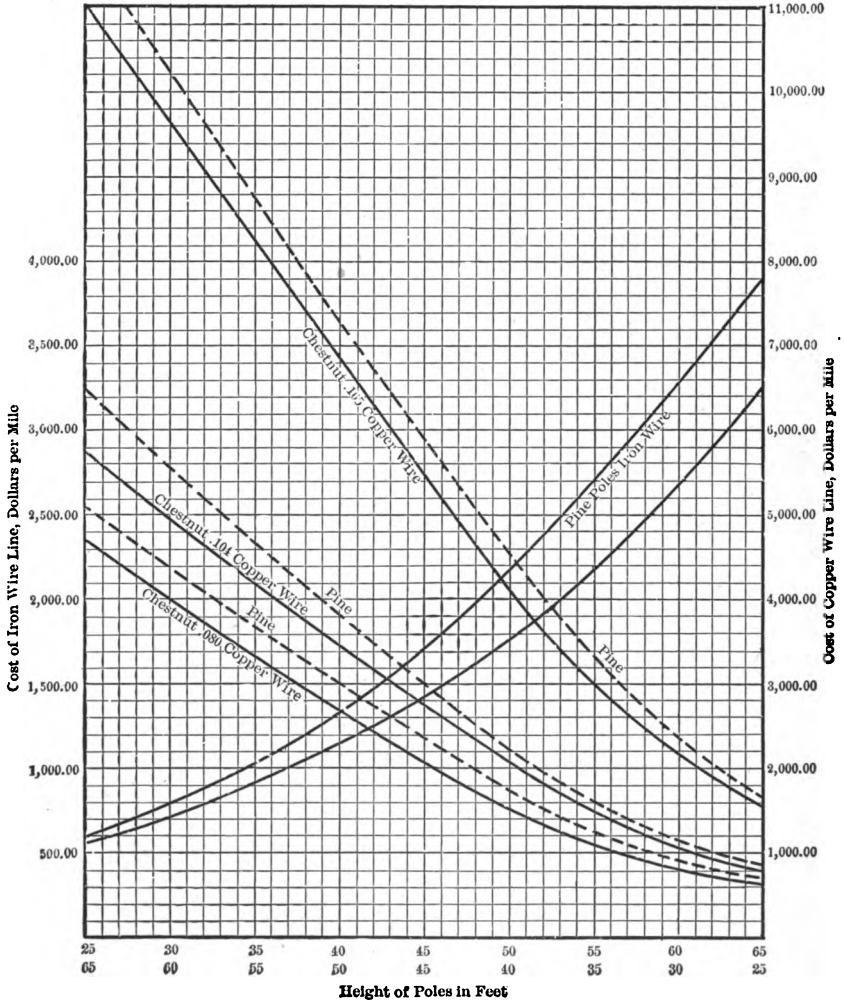

TABLE 26.  
Complete Cost of Pole Lines.

mile of entire line using creosoted pine poles. There are two curves — *C* for .104 copper and *D* for .080 copper. These curves are a continuation of the curves in Table 26. Holding the table so that *A* is in the lower right-hand corner, there are on the bottom of the sheet two horizontal scales, one devoted to the height of poles in feet, reading from left to right, while the other is the cost of conduits per duct foot, from 15 cents to 55 cents, reading from right to left. The cost per mile of completed line of either kind is found on the right-hand scale. Ten comparative curves are shown upon the sheet. No. 1, headed "Open Wire Only," gives the total cost per mile for lines carrying only open wire and no cable. No. 2 includes 1 25-pair aerial cable, No. 3 1 25-pair cable and 1 50-pair, No. 4 1 25-pair cable, 1 50-pair, and 1 100-pair, and No. 5 adds a second 100-pair cable. Curves Nos. 6, 7, 8, 9, and 10 give the cost per mile of cable installed in conduit of various prices as per the lower scale. Thus a mile of 100-pair cable in conduit at 20 cents per duct foot will cost \$3,900 — \$39 per circuit mile. The cheapest open wire line to carry 100 circuits would be a 30-ft. line with 2 cables and 3 cross arms, and would cost \$4,400 or \$48 per circuit mile. On the other hand, a 25-pair cable in 35-cent conduit will cost \$3,940 per mile, or \$157.50 per circuit mile, while a 45-ft. open wire line (Curve *D*) will only cost \$2,600 — \$104 per circuit mile. It is, therefore, obvious that when many circuits are needed, underground lines are by far the cheapest in original construction, to say nothing about annual decreased cost, but when there are few circuits the open wire or aerial cable is the cheapest to install.

It is manifestly impossible to realize the full efficiency of all parts of an aerial line, because many causes compel

COST OF AERIAL LINES.

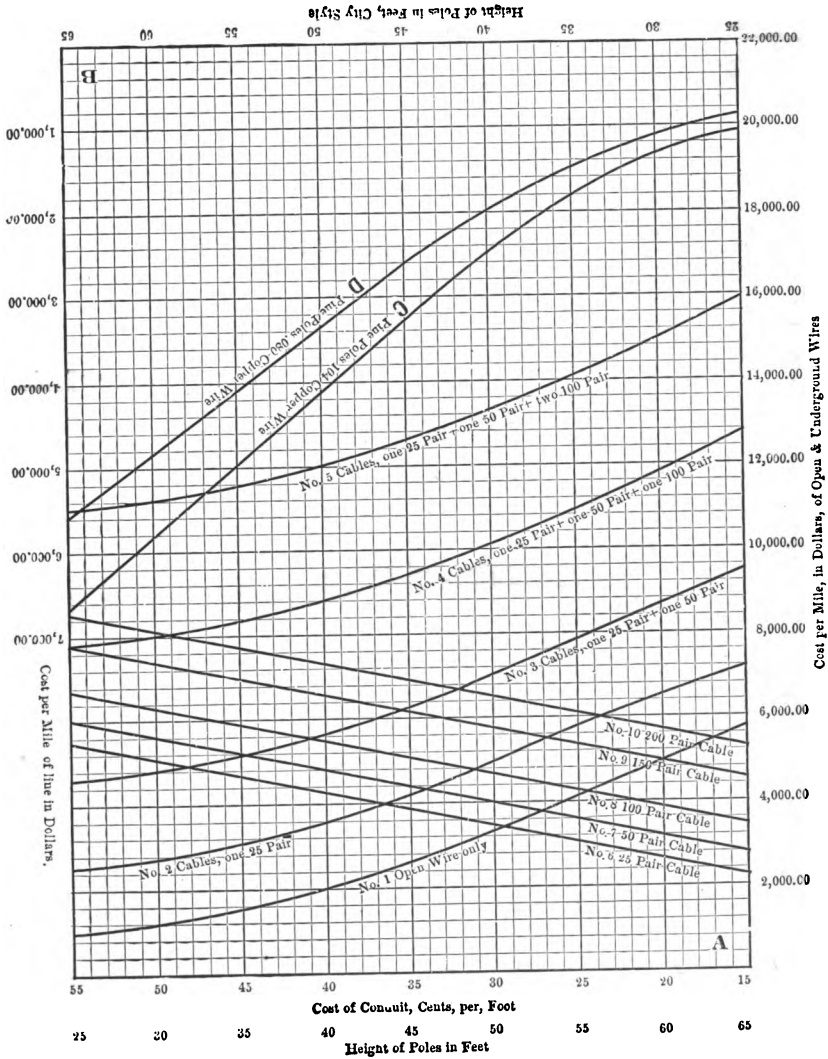

TABLE 27.

Comparative Cost of Aerial and Underground Lines.

a greater or less waste of facilities. Thus when a pair of wires is dropped off to a subscriber, the corresponding pins in the cross arms of the subsequent poles must, in the nature of things, remain unoccupied, and, therefore, a certain proportion of all the rest of the poles and arms be useless. It is inevitable, owing to changes in the location of subscribers, that more or less dead wire should exist, and when a large fraction of the circuits are in aerial cable the unused wire amounts to a notable percentage of the total plant. It is relatively easy to put up or take down an open wire and its insulators, while this is impossible with cable, consequently the dead plant of open wire can be much more closely controlled than is possible with any form of cable, for only as many insulators and as much wire need be erected as can actually be put in service. Thus the working efficiency of the pole line is somewhat greater than that of the conduit or aerial cable, and in large exchanges carefully planned, 85 per cent. efficiency has been achieved. Taking probable inefficiency into consideration, Table 28 gives a comparison between underground wire plant, aerial cable, and open wire on the circuit mile basis. On the bottom of the sheet there are two scales, one reading from left to right, showing the number of pairs per cable, applicable to both aerial and underground cable; the other from right to left for open wire. The left-hand scale shows the cost per available pair mile for all kinds of wire plant. There are three sets of curves. The full lines show the cost of underground wire in cables from 20 to 200 pairs. There are four curves, one for conduit of 4 ducts, one for 8 ducts, one for 12 ducts, and one for 16 ducts; the cost of these various sizes of conduit being the same as given in the volume on "Conduit Construction." The dotted curves on

the left hand of the sheet give the cost of aerial cable on 30-ft., 40-ft., 50-ft., and 60-ft. pole lines; the cable cost being that shown in the volume on "Cable Plant." On the right hand of the sheet there are five "dot dash" curves, giving the cost of open wire on 25-ft., 30-ft., 40-ft., 50-ft., and 60-ft. pole lines, calculated by the preceding data. These curves show very conclusively that when from 25 to 100 circuits are needed the aerial cable is the cheapest form of wire plant so far as original cost only is concerned. For less than 25 circuits the open wire line is cheaper, while when there are more than a hundred circuits underground conduit is cheaper. But this comparison applies only to original cost.

In succeeding paragraphs it will be shown that the annual cost of maintenance and depreciation is for all forms of aerial line at least twice as great as for underground, to say nothing of the more reliable service rendered by the latter. Suppose now that a telephone company builds its plant from the proceeds of a bond issue, bearing say 6 per cent. interest. To cover depreciation and maintenance on underground plant, 7 per cent. per annum must be allowed, while on an aerial plant 19 per cent. is necessary for the same items. The total annual charges will then be 13 per cent. for the underground plant and 25 per cent. for the aerial, and hence about \$200 can be invested in underground plant to every \$100 in an aerial one, and make annual expense exactly the same. In any such calculation it is impossible to value the additional advantages that accrue from the better service that the underground system offers in securing an immunity of interruption to service to which the aerial line is always liable. For many similar reasons, therefore, it is safe to assume that whenever during the lifetime of the plant

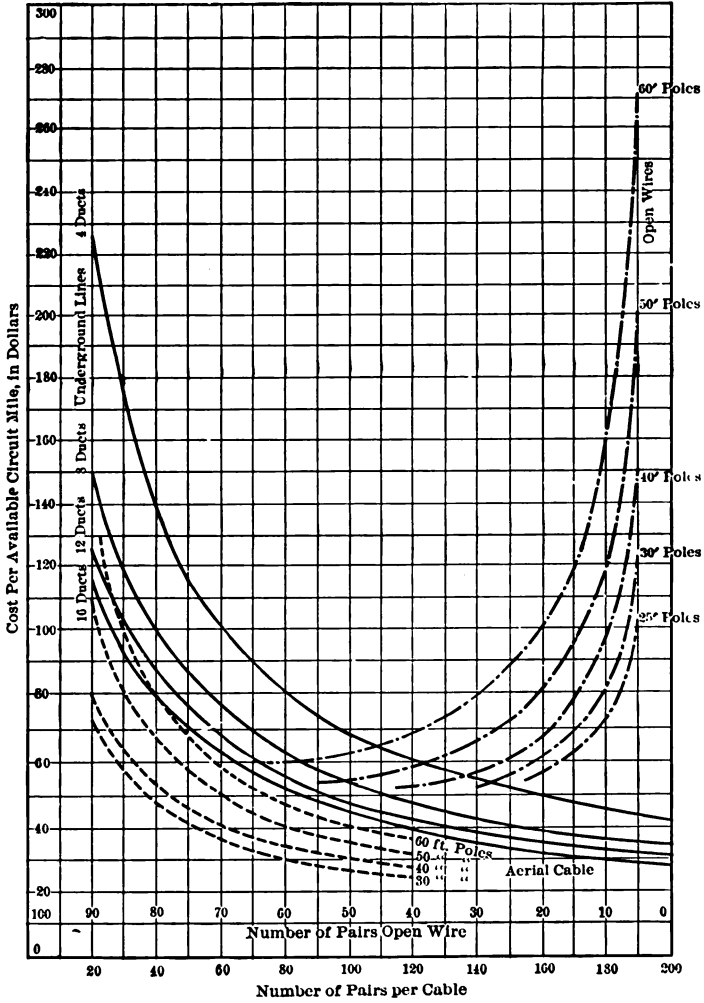

TABLE 28.

*Comparison Between Underground Wire Plant, Aerial Cable, and Open Wire Plant Working Efficiency.*

more than a hundred circuits may be expected the underground plant is the cheapest and best in the long run.

The annual expense of open wire lines is more variable and higher than on any other item in the telephone plant, for the pole line is subjected to a greater number of destructive forces, and those of greater intensity than any part of the plant.

*Depreciation.*—The causes producing depreciation are four: First. The gradual rotting of all the woodwork. Second. The growth of the territory served, so that sooner or later the pole line capacity is exhausted beyond the possibility of increase. Third. The constantly increasing demands of city authorities to substitute underground conduit for open wire. Fourth. The sleet storm.

First. *Decay.*—Experience has shown that the rotting of poles takes place close to the ground level, within about a foot above and below it, where the pole is most exposed to air and moisture. Few forms of preservative treatment, except creosoting, seem to have any sensible retarding effect on the rot, and on the average poles must be replaced in about 8 years. Cross arms and pins last longer, though the point of attachment of the arm to the pole is a weak spot and soon rots. The base of the pole is also constantly exposed to all sorts of extraneous attacks; the impact of wheels, the nibbling of horses, the mischievous ingenuity of the street urchin; all conspire to shorten the life of the pole.

Second. *Growth of territory.*—Increase in the number of subscribers has a marked effect on the depreciation of pole lines. A certain number of subscribers is estimated for a given territory, but within a few years this number has possibly quadrupled. By no possible means can the original line be made to carry so great an increase; either



a new line must be built on the old route or the new plant must go underground; in either case the old line must bear entire depreciation.

Third. *Change in city requirements.*—The regulations of all cities are each year growing more and more hostile to the employment of open wire, and almost universally the telephone companies are being urged to go underground, or to enlarge the territory of the underground plant they already have. This becomes a very potent cause of depreciation. Fifteen years ago there was little wire underground; now few cities will tolerate aerial lines except in the outskirts, and even the smaller towns are pushing toward the underground goal.

Fourth. *Sleet storms.*—But of all the forces that prey on the open wire line the sleet storm is the most destructive, and most to be dreaded. No winter passes that does not wreck many miles of telephone and telegraph wires; few in which the havoc is not widespread; and the telephonic isolation of some of even the larger cities is more than occasional. Witness the “big storms” of 1888 and 1890 in New York and New England, and those of 1895, 1896, and 1900 in Chicago and St. Louis. A few specific instances may be of value. In the sleet storm of February, 1901, one telephone company operating along the Atlantic coast lost not less than \$250,000, while five companies in Pennsylvania and New Jersey suffered more than \$300,000, and about the same time so far south as Lexington, Ky., half of the poles in the county went down. Mr. Ellicott, city electrician of Chicago, reports a storm that required 75 miles of new wire; and the author has a very vivid recollection of a couple of sleet storms that cost a telephone company in the aggregate at least \$60,000.

When all these items are carefully considered, in the

light of experience over a considerable period of time, it is found that an allowance for depreciation of 12.5 per cent. on first cost is the least that can be considered sufficient for open wire lines. It is probable, nay certain, that as large a percentage is not needed every year, but unless unexpended balances are carried to "Deferred Depreciation" the time comes when a very few hours' work of the wind will not only wreck the pole line, but wreck the treasury in the absence of such a safeguard.

The annual maintenance of aerial lines is equally onerous. Cross arms rot, insulators pull off, or boys break them with a rifle ball. A falling tree branch may tear open half a dozen lines. An extra frosty night will pull a lot of lines out of the McIntires, or even rupture the wire itself. A fire alone may be the knell of many circuits, for firemen are ruthless when a pole opposes the hose. Even a waste-paper basket fire will spoil all the aerial cable on a pole line, for the lead melts like butter under the least blaze. The ordinances of many towns contain provisions requiring the removal of lines to permit of house moving, for which the owner does not always pay. While even copper wire from its inoxidizable qualities is seemingly immune from maintenance, it yet falls sometimes a prey to those in whom enterprise is greater than their respect for the commandments, for there are instances recorded where many miles of working circuits have been stolen. For these and divers other reasons the maintenance of aerial lines will average at least 6 per cent. on original cost.

## CHAPTER IX.

### DISTURBANCES ON TELEPHONE LINES.

FOLLOWING the example set by the telegraph, telephone lines were at first constructed with only one wire, the earth being used as a return path for the current. It was immediately perceived that the telephone receiver was extraordinarily sensitive to electrical disturbances of all descriptions, that lines so constructed were rarely free from noises of an extraneous character, and were often so seriously affected thereby as to render conversation almost impracticable. As other electrical industries multiplied, causing the extension of circuits, carrying large amounts of current at high potentials to ramify along the majority of roads and highways, and particularly after the advent of the street railway that insisted upon using the earth as a return circuit for very large volumes of current, the perturbation of telephone lines became so great that telephonists were confronted with an exceedingly serious problem in an endeavor to render their circuits commercially quiet.

A careful study of the origin of extraneous noises upon the telephone lines reveal them to be universally due to one of three causes:

First. Leakage.

Second. Electromagnetic induction.

Third. Electrostatic induction.

These three causes will now be considered separately and the possible remedies to be applied pointed out:

First. *Leakage*.— Experience has shown that few instruments have been invented which form as sensitive a

detector for a varying electric current as the telephone receiver. Experiments by many careful investigators have shown that a current of less than a millionth of an ampere will readily affect a receiver, and so markedly as to render its operation almost uncommercial. If, therefore, a telephone line is so situated in respect to other electrical circuits that there can be an actual leakage of electricity to the telephone line, it is certain to produce so much disturbance as to render the use of the line impracticable. When telephones are operated as grounded circuits, one end of the line is connected to the earth at one station and the other at some distant point. If there is any difference of potential between the earth at the two stations, there is a tendency for foreign electricity to pass over the telephone wire in an endeavor to equalize this potential difference. A difference of potential between two earth points may arise from a great variety of natural causes, as well as the operation of other electrical plants. Frequently the earth is visited by magnetic storms (that astronomers believe to have their origin in solar disturbances) which create magnificent exhibitions of the aurora, affect compass needles all over the globe, and occasionally produce so serious electrical disturbances as to render even telegraph lines inoperative. Apparently the effect of such a magnetic storm is to create a considerable difference of potential between various localities. Under such circumstances telegraphists often notice earth currents flowing over their lines great enough to render the use of an office battery unnecessary, and messages may be transmitted by the use of such telluric currents alone. It is no wonder that under such circumstances all telephone lines are rendered so extremely noisy as to be thrown entirely out of commission. Even a summer

thunder shower will often produce so considerable a variation in potential over a few miles of country as to render conversation impracticable over short toll lines, and in almost any thunder shower the listener at a telephone receiver can usually hear a snap or click with every flash of lightning. Such disturbances particularly affect grounded lines, for the differences of potential created inevitably tend to equalize themselves over the telephone wires.

With the invention of the electric light came circuits carrying considerable volumes of current at relatively high potentials. These circuits designed to supply electric light to all, ramified over various streets and highways that would afford access to consumers. Naturally much had to be learned in the art of insulation, and consequently the early electrical circuits were more or less leaky, and permitted a sensible fraction of their current to escape. In its attempt to find its way back to the generator which gives it birth every such electrical current selects the grounded telephone lines as furnishing an easy path to travel. Next came the street railway that avowedly discharged into the earth volumes of current amounting, in many instances, to thousands of amperes. While the ground makes a fairly good conductor so far as the small currents of the telephone and telegraph are concerned, it presents a very marked resistance, when it is proposed to use it for the enormous amounts of electricity employed by railways, and no sooner did the electric railway become fairly launched, then telephonists found that it was utterly impractical to continue the use of grounded circuits. The only remedy was to build telephone lines completely metallic, and to insulate them with the utmost care, so that all parts of every line shall present

so great a resistance as not to invite the actual introduction of even so small an amount of electricity as will affect the sensitive receiver. The only reason for the grounded line is a less installation cost, but poor service is the most expensive luxury to which a telephone company can be addicted. In secluded parts of the country, where no electric railways exist, where subscribers are few, lines short, and business to be transacted not momentous, grounded lines may be tolerated, particularly by co-operative companies where the subscribers own and run the plant, and must blame themselves for any deficiency in service in which they wish to indulge. Such instances are of isolated character and are by no means representative of the telephone art as an industry. It is safe to say that no telephone company of magnitude can now for a moment consider the installation, or operation of grounded lines under any circumstance, and, on the contrary, it must use the utmost vigilance to see that its entire wire plant is constantly maintained in the very highest and best state of insulation. If, therefore, a telephone line becomes noisy the first step to be taken is to ascertain whether or not the line is leaky. It should, therefore, be carefully tested from end to end, and the remotest suspension of low insulation immediately taken in hand and cured. It is by no means safe to assert that a grounded telephone line *will* be noisy, and on the contrary it is equally unsafe to predict that a well insulated one *will* be quiet, but low insulation is frequent and prolific source of disturbance, it is easiest of all possible cause of noise to detect and remedy, and, therefore, comes first upon the list of diseases to be cured. It is exceedingly difficult to define what adequate telephonic insulation should be, because an amount that is sufficient in

one case will be inadequate in another. A new cable plant should show an insulation resistance of not less than 500 megohms per mile, while an old one may fall to 10 megohms per mile and yet render very fair service, but it is quite certain that less than 10 megohms per mile is likely to give trouble. Open wire lines always show lower insulation than cable circuits, but should never be allowed to fall below 1 megohm per mile even in bad weather, and usually should show much higher insulation.

*Electromagnetic induction.*—In Chapter 2 it has been shown that the passage of an electric current through a conductor is accompanied by a magnetic field surrounding that conductor. If a telephone wire is in proximity

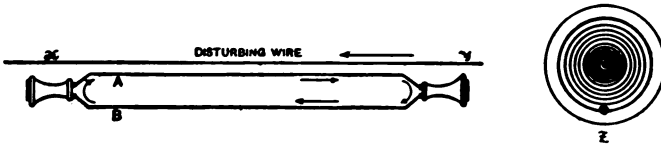

FIG. 42.

to a line carrying a varying current the corresponding magnetic field will surround and envelop the telephone wire. This causes a difference in potential in different parts of the telephone wire, and consequently a current is set up therein which inevitably produces noises in the receiver. This is termed "electro-magnetic induction," and is diagrammatically represented in Fig. 42, in which  $X Y$  is a foreign wire carrying a varying current of electricity, and  $A B$  a diagrammatic representation of a telephone line with its receivers. At  $Z$  a cross section is shown taken through the plane  $A B$ , the concentric circles around the wire  $X Y$  representing the magnetic field. From this diagram it will be perceived that more lines

of force of the field encircle the wire  $A$ , than inclose the wire  $B$  and consequently there is a greater electromotive force induced in  $A$  than in  $B$ . The result is to cause a current to flow in the direction of the arrows. Now, if by any means the wire  $X Y$  can be moved and so placed with reference to the circuit  $A B$  as to be exactly equi-distant from all points of both sides of the  $A B$  circuit, and if, furthermore, the  $A B$  circuit is exactly balanced, namely, that there is exactly the same resistance, inductance, and capacity along the side  $A$  and side  $B$ , it is evident that as electromotive force induced by the wire  $X Y$  is equal in  $A$  and in  $B$ , and as there is a perfect balance no current will be produced in any part thereof, because equal oppo-

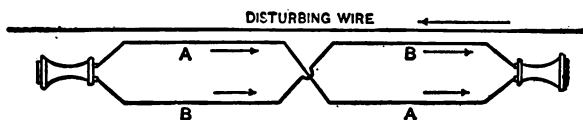

FIG. 43.

site electromotive forces will be acting over all parts of a line having similar electrical properties. Such an ideal condition, however, can very rarely be secured, although it is sometimes possible to approximate thereto by setting the wire  $X Y$  vertically above or below  $A B$  and along its center line. Another cure, however, presents itself. Refer to Fig. 43. Suppose the wire  $A$  and wire  $B$  be interchanged at the center of the circuit in such a manner that half the length of  $A$  is placed nearest to the disturbing wire  $X Y$  on one side of the center, and half the length of  $B$  is nearest to the disturbing wire on the other side. It is evident from this diagram that the disturbing electromotive forces induced in  $A B$  will oppose each other, and



if the line will be reasonably well balanced no current flow will take place. This method of entwining or twisting the sides of circuit in order to neutralize the effects of electromagnetic induction is called "Transposition."

It is easy to see in the case here illustrated that one transposition at the center of a balanced line affected by electromagnetic induction, due to a neighboring wire carrying an alternating current of uniform volume, is sufficient to render it quiet, but such conditions rarely prevail. Both telephone line and perturbing wire may suffer more or less from leakage, so inducing and induced currents are not constant over long stretches, and very few telephone circuits are sufficiently carefully designed and well built as to be so perfectly electrically symmetrical that sensitive receivers will detect no perturbing current under the conditions indicated in Fig. No. 43.

The amount of electromagnetic disturbance depends upon five factors:

1. Volume of current in the perturbing wire.
2. Actual distance of the perturbing wire from telephone circuit.
3. The relative distance between disturbing wire and two sides of the telephone circuit.
4. The distance that the inductive circuit parallels telephone circuit.
5. The amount of asymmetry of the telephone circuit.

On general principles telephone lines should be placed as far away from all other circuits as possible. They should be so designed as to be symmetrical with reference to other circuits, and when it is necessary for them to parallel other circuits the distance between circuits should be made as great as possible. It is very obvious that these conditions are in many respects antagonistic to each other

and can only be in practice carried out to a very limited extent, yet such are the ends for which design should strive in an endeavor to secure the least noisy lines.

*Electrostatic induction.*— The disturbances caused in a telephone line by electromagnetic induction are shown to be due to the presence of a varying magnetic field, for the lines of force of cutting the telephone wire, set up in that circuit, a difference of potential which causes a current to flow through the telephone line. Experiment shows that in some mysterious way the mere presence of electricity upon one body is capable of producing, or, as it is scien-

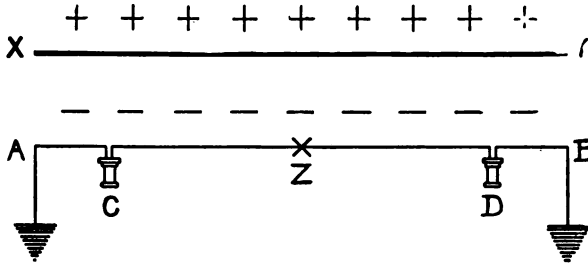

FIG. 44.

tifically stated, *inducing* a charge of electricity of equal quantity but of opposite polarity on other neighboring bodies. Consider Fig. 44, in which  $X Y$  is a wire of an electric light or other circuit and  $A B$  a telephone line connected to ground at the ends  $A B$ , containing two receivers,  $C$  and  $D$ . If the wire  $X Y$  becomes charged with electricity from any source, say positively, as shown by the plus signs along the top of the wire, the presence of this charge will induce or create a similar equal negative charge in the telephone line  $A B$ . So long as the electrical state of the wire  $X Y$  does not change the negative

charge in  $A B$  will remain quiescent, but if the electricity in  $X Y$  passes away or is removed in any manner, the charge which has been accumulated in  $A B$  will pass to the earth, and inasmuch as the electricity will travel along the lines of least resistance it is evident that half of the charge will pass to earth by  $A$  and the other half to earth by  $B$ , assuming that  $Z$  is the center point of the circuit and that two halves,  $Z A$  and  $Z B$ , are equal in all electrical properties. If the wire  $X Y$  is carrying an undulating current, it alternately becomes positive and negative, and consequently negative and positive charges are induced in the wire  $A B$ , following the changes in  $X Y$  with the same rapidity. Consequently there will be a series of moving charges in the two halves  $Z A$  and  $Z B$  of the line  $A B$ , and these moving charges will create noises in the receivers  $C$  and  $D$ . But as half the charge on  $A B$  passes toward  $A$  and the other half toward  $B$  there will be no electricity traversing the point  $Z$ , and if a receiver were placed at  $Z$  no sound would be heard; and further, if the line were cut at the point  $Z$  it would make no difference with the noises perceived in  $C$  and  $D$ , whereas if the noise be due to electromagnetic induction, opening it at  $Z$  will stop the noise. Mr. Carty's\* investigation proved this state of affairs in a telephone line, and he showed by many experiments that much of the noise to which telephone lines were subjected was due to electrostatic induction rather than to electromagnetic induction. Consider now what happens in a metallic circuit from the electrostatic standpoint. Refer to diagram Fig. 45, in which  $X Z$  is the disturbing wire and  $A B$  a metallic telephone circuit.

\* Transactions of American Institute of Electrical Engineers, Vol. V II, p. 100.

The presence of electricity along  $X Y$  will induce an opposite charge in the  $A$  side of the circuit  $A B$ , and the charge on  $A$  will induce an opposite charge on  $B$ . As soon as the electrical state of the disturbing wire changes these charges will seek each other in an effort to neutralize and will flow along the lines of least resistance. Evidently half the charge upon  $A$  will flow toward the left-hand side, to meet the corresponding half of the charge on the left-hand side of  $B$ , and the charge on the right-hand side of the center of  $A$  will flow toward the right in an effort to meet the half of the charge on the right-hand side of  $B$ , which will also move in the same direction.

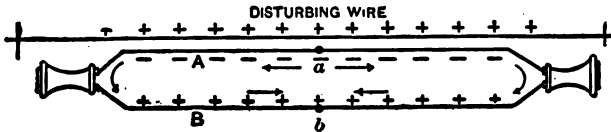

FIG. 45.

These charges will consequently move in the direction of the arrows and produce currents in the telephone receivers at the ends of the line. If such a theory be true, cutting the line at the points marked  $a$  and  $b$  should make no difference in the sound in the receivers, and also if a receiver should be inserted at  $a$  or  $b$  no sound would be heard. This can easily be verified by experiment and can be proved true. To cure electromagnetic induction it was shown that it was only necessary to transpose at the center a telephone circuit so that the current flowing along one-half the wire should neutralize that flowing along the other half. But such a remedy while it will mitigate electrostatic disturbance will not cure it unless the dis-

tance between the receivers is very short. Refer to Fig. 46, in which a line affected by electrostatic induction is shown transposed at the center. The charge on *A* now has two paths along which it can seek neutralization with the corresponding charge on *B*. One path is from *c* to *d* through the receiver and the other is along the line *c A a A' f*. Now the center points *a* and *b* are no longer neutral, and a receiver cut in there will sing, but there are four neutral points, *c*, *d*, *e*, and *f*, at any one of which a receiver will emit no sound, and where the line may be cut without effect on the end receiver or those at

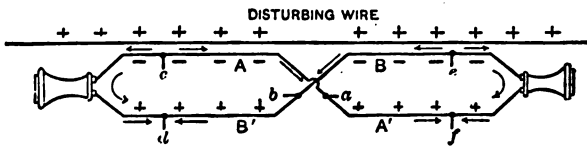

FIG. 46.

*a* or *b*. If at the points *a* and *b* impedance be placed equal to that of the end receiver the neutral points *c*, *d*, *e*, and *f* will be in the middle of each half of the line. In the diagram such is not assumed and hence the neutral points are shown moved toward the receivers until the portion of the line *c A b B' d* balances the part *c d*. The other half of the line must be regarded in the same light. In Fig. 45 all the charge induced in the complete circuit passed through the two end receivers, but in Fig. 46 only half the charge, hence the noise is lessened.

Now, if the number of transpositions be multiplied very greatly, it is evident that the telephone circuit may be broken up into so many small portions that the charge upon each one of the individual portions will be so minute that it will be unable to create a perceivable disturbance

even in the most delicate receiver. Therefore, by inserting a great number of transpositions it is usually possible to so completely neutralize electrostatic induction as to render telephone lines entirely satisfactory.

For specific details as to how transpositions are practically made and used, the reader is referred to the next chapter. It is impossible to give a fixed rule as to how often it is necessary to introduce transpositions, for the frequency will depend upon the local conditions, proximity of other circuits, etc. Figs. 124, 125, and 126 show different schemes for transposition; the first is for a 12-wire two-arm system, and the second for a 40-wire 4-arm line. It is usually customary to insert transpositions at intervals of about 1,300 ft., and, therefore, the length of these diagrams is in the neighborhood of about 8 miles. An examination of the scheme indicates that transpositions of similarly spaced lines are not placed at the same cross arms, and the arrangement is such as to make all lines repeat the same plan in each 8-mile section. The theory of the transposition is simply to cause each half of each circuit to frequently interchange position with reference to all other neighboring circuits, and with this principle in view the ingenious telephonist can work out any number of transposition schemes that may be necessary to enable him to cure the most difficult case of induction. In a general way the oftener transpositions are made the better. The 1,300 ft. interval is sufficient for most cross-country circuits, but it frequently happens that in towns and villages it is necessary to transpose every line at every pole, or indeed the perturbing cause may be so severe that it is necessary to have recourse to a cable or a twisted pair, for by such means a transposition is intro-

duced once in every 3 or 4 inches, and it is indeed a difficult case which will not succumb to such treatment.

The greatest bugbear of the telephonist is cross talk, namely, the ability of persons listening on one circuit to overhear the conversation of those who are talking on neighboring lines. That cross talk may occasionally occur from electromagnetic induction is unquestioned, but it is reasonably safe to assert that most causes of cross talk are due to electrostatic causes. This is one of the most perplexing difficulties that the telephonist has to encounter, because, while it is exceedingly easy to detect the presence of cross talk, it is very difficult to determine the exact cause, and when found a remedy may be hard to devise and expensive to apply, and one may have to experiment for weeks before he can cure a switchboard or wire plant in which this difficulty exists.

A summary of the whole subject of telephonic disturbances and the cures therefor is embraced in good insulation, careful balancing of all circuits under all circumstances, and the introduction of a sufficient number of transpositions. An exploring coil is a valuable aid in the study of the cause of noisy lines. Such a piece of apparatus is conveniently made by taking the wooden rim of a bicycle wheel and winding its groove with a few hundred turns of No. 30 silk-covered wire, to which a telephone receiver is attached by a flexible cord. Armed with such a coil the investigator may walk along a noisy aerial line and by exploring the neighborhood of its circuits with the test coil, he is almost sure to discover the location of the perturbing field by listening to the receiver. Then by walking back and forth and holding the coil in different positions one can presently trace the disturbing action to its source and will usually find a

grounded generating plant, a leaky light circuit; possibly the rotary converter of a street railway station, or an unbalanced phase of an alternating circuit.

*The common return.*— When the grounded line was found to be utterly impractical, it was proposed to compromise with foreign noises by running a common conductor other than the earth to all substations, or in the case of large exchanges to subdivide the stations into groups, each one of which should have its own wire. Such systems are known by the term “Common Return” or

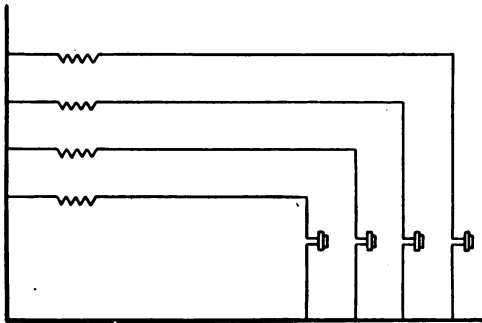

FIG. 47.

McClure systems, from the original inventor thereof. Fig. 47 is a diagrammatic representation of the general features of this device. That the common return system was an improvement over the dead grounded line is unquestioned, but it was only a compromise and not a remedy. Under some circumstances in small towns where the telephone service is not of highest importance and where street railway and lighting plants are not too aggressive a common return system may afford a fair service and is cheaper to install than complete metallic lines. The size of the wire



for the common return system and the question whether it should be grounded at the central office or completely insulated have been points over which many a telephonic battle has been fought. A common return wire may be made too large. The best experience inclines to the opinion that a No. 8 wire is amply sufficient under all circumstances, and that the employment of a larger conductor is probably an injury. To ground the common return at the office might seem to invite disturbance. That in some cases the ground is an injury is unquestioned, but in other cases the conditions are such that a ground at the office will materially tend to quiet subscribers' lines, and it is impossible, theoretically, to say whether a given common return system should or should not be grounded. For example, in a poorly insulated wire plant some lines may leak foreign current into the system that in an endeavor to find an outlet will distribute itself over all lines. A ground at the office will afford the desired relief, and while such an expedient will increase the noise on some poor lines, it may render a great many others satisfactorily quiet. As the matter is so easily demonstrated by experiment, those who are operating a common return can easily test it for themselves, by applying and removing ground either at the office or at other points of the line and determining under what conditions the most satisfactory service is obtained.

**CHAPTER X.**  
**SPECIFICATIONS FOR THE CONSTRUCTION OF AERIAL  
LINES.**

[NOTE.—The construction of aerial lines is rarely performed by contract, as each telephone company usually builds its own lines. For this reason no form of contract is embraced in the "*Specifications for Aerial Line Construction.*" If contract work is desired, the form of contract used, for either conduit or cable construction, can with slight modification be employed.]

**SECTION 1.**

**General Characteristics.**

Aerial lines shall be embraced in three types:

- A — Bracket lines.
- B — Cross arm lines.
- C — Aerial cable lines.

**A — BRACKET LINES.**

Bracket lines are those of small capacity, in which the circuits are carried on brackets placed on the side of the poles to which they are attached. Lines of this type shall be limited in capacity to six wires, three being placed upon each side of each pole.

**B — CROSS ARM LINES.**

Cross arm lines are those using cross arms for the support of the circuits. The maximum capacity of cross arm lines shall be limited to 10 arms of 10 pins each; thus, the maximum capacity of a cross arm line is 100 wires.

**C — AERIAL CABLE LINES.**

Aerial cable lines shall be those which use dry core paper cables, suspended by messenger strands to the poles. The number of aerial cables shall be limited to four, and the maximum size of each cable 150 pair.

**SECTION 2.****Routes.**

Prior to commencing construction, a careful examination and general survey of all desirable routes shall be made. From this survey a sketch map shall be prepared for the use of the right-of-way agent. A sample of such sketch map is shown in Fig. 48. This shall indicate the route which it is considered, on the whole, most desirable to follow, and the approximate desired location of all poles, guy stubs, etc., and other attachments of whatsoever nature. Wherever it is feasible to select more than one location, all of the desirable locations shall be indicated, in order that the right-of-way agent may have alternative routes in securing permits. No construction shall be commenced until rights of way have been finally and formally secured by the authorized right-of-way agent, in definite written form, upon the approved blanks of the company.

**SECTION 3.****Location.**

Aerial lines shall be located only on permanent rights of way. These rights of way shall include the necessary permission to erect all poles and guy stubs, to make any and all attachments to buildings or other property, to string necessary wires, and trim such trees and shrubbery as may be required to secure the proper working of the

circuits. Rights of way shall be secured by the right-of-way agent, and shall be in accordance with all of the laws of the country traversed, and in conformity to all

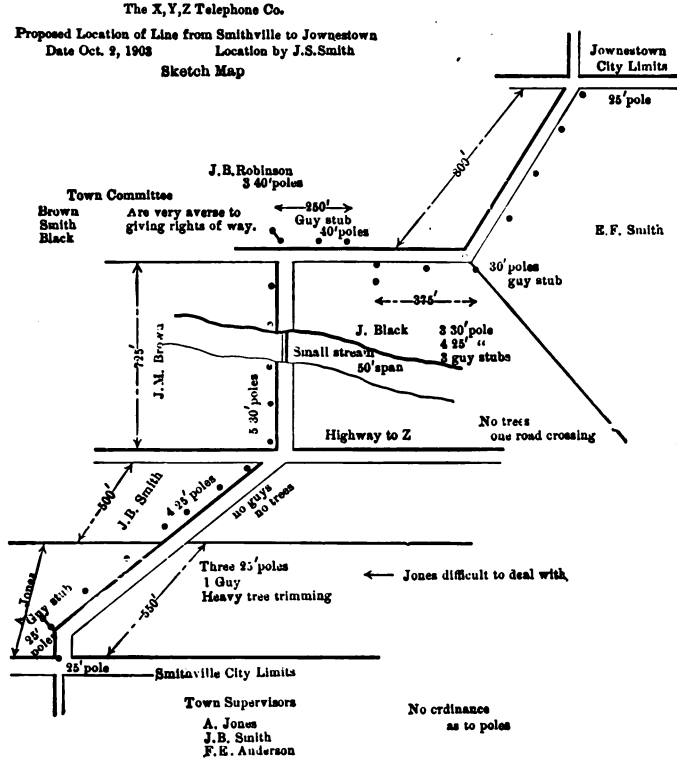

FIG. 48.— SKETCH MAP.

municipal regulations of all towns or villages traversed. The right-of-way contracts shall be examined and approved by the general council of the company, and recorded prior to the commencement of construction.

## SECTION 4.

**General Instructions to Foremen.****1. Work to be done according to right-of-way contract.**

Prior to commencing any construction, each foreman shall be supplied with a blue-print map, showing the location of all rights of way, and copies of contracts with all property-owners. The maps and contracts shall be sufficiently explicit so that the location for all poles, guys, guy stubs, or other attachments, and the permission to string wires and trim trees and shrubbery, shall be so specifically described that foremen shall have no difficulty in proceeding with construction in exact accordance with each permission received. Foremen shall be responsible to see that all poles, anchors, guy stubs, or other attachments are placed in exact accordance with the contracts, and that the erection of wires and trimming of trees and shrubbery is done as the permissions specify.

**2. Objections.**

In case any person shall offer any objections to the prosecution of any part of the work that seems to be clearly within the obtained permissions, or shall endeavor to hinder the erection of any poles, guy stubs, wires, or other attachments, or the trimming of any trees or shrubbery, the foreman shall courteously call the attention of such objecter to the copies of the contract permissions which he holds. In case the objection is still persisted in, the foreman shall stop work on the portion of the line in question, and shall refer this objection at once to the general manager or superintendent, and wait for further instructions. All foremen shall be rigidly responsible to perform all operations exclusively within the written

contracts of rights of way. Foremen must under all circumstances take particular pains that no contract is exceeded in any single particular, and they must be responsible to treat and to see that all employees reporting to them do treat all persons with the greatest politeness and courtesy, and that all work of construction is so prosecuted as to interfere with, damage, or inconvenience all persons in the smallest amount.

### **3. Accidents.**

During the prosecution of all work herein called for, foremen shall conduct all operations with all possible care for the safety and security of the general public, that of all of their employees, and of all property. Foremen shall not assume any risks whatsoever of any nature or description, not absolutely entailed by the nature and character of the work under construction. During the raising of poles, the stringing of wire, or the erection of cables, particular pains shall be taken to secure the public from injury. Poles, wire, and cable shall not be raised during the passage of teams or pedestrians, without giving due warning by stationing a watchman, with a red flag, at each end of the portion of the highway occupied, and no work shall be done in such manner as to endanger the safety or convenience of those using the highway more than is absolutely necessary. All material shall be so distributed along the highway as to produce a minimum of inconvenience to the public, and shall be arranged in such a manner as not to become a source of danger. In all cases where material sensibly obstructs the highway, a lighted red lantern shall be placed as a warning each evening at sunset. Each lantern shall be capable of burning all night. As fast as construction is completed, all

surplus material and tools or debris of whatsoever nature shall be removed and the highway left in its normal and proper condition.

In all operations in any way connected with the work herein specified, foremen shall carefully observe and comply with all of the laws of the land, and with all municipal rules, ordinances, or regulations of the towns traversed that shall in any way affect the conduct of those employed, or the method of doing work specified, or in the use of any materials, tools, appliances, or machines. Particular pains shall be taken not to interfere with or trespass in any respect upon the rights of way of any railway, telephone, or telegraph company, or other electrical company, whether such rights of way are upon the ground or in the air, and in all cases foremen shall confine all operations strictly within the written rights-of-way contracts with which they are supplied.

In case of any accident that can in any way be attributable to the prosecution of the work herein specified, the foreman shall immediately take the following steps:

#### A — ACCIDENTS TO PERSONS.

*First.*— Dispatch a messenger immediately for the nearest physician, and report the occurrence to the police if within corporate limits.

*Second.*— Take all possible local steps that will in any way conduce to the comfort and welfare of the injured.

*Third.*— As soon as practical make a written report to the company upon authorized blanks, stating the names and addresses of all injured, the nature and cause of the injury, the names and address of the attending physician, and of any or all witnesses of the accident.

**B—ACCIDENTS TO PROPERTY.**

*First.*— Take all possible local steps that shall prevent any extension of damage, and that shall in any way protect the property injured, and notify the police if within corporate limits.

*Second.*— Notify all owners that may be unaware of the occurrence of the character and probable extent of injury, and that a report will at once be sent to the company who will take immediate, proper action thereon.

*Third.*— Forward accident report to the company as under A—3.

**SECTION 5.****Inspection.**

All classes of material called for under these specifications shall be subject to inspection by an authorized inspector, duly appointed by the company. The company shall have liberty to select as the place of inspection, either the point of manufacture or shipment, or the point of delivery specified by the company for each class of goods. A reasonable number or amount of samples of each kind of goods herein called for shall be supplied to the inspector free of charge for the purpose of making such examinations as are herein called for. Any and all material which does not entirely fulfill the requirements of the specifications, all and singular, shall be rejected by the inspector. If any goods shall be rejected which the company elects to inspect at the point of delivery, the company shall notify the vendor as soon as the inspector completes the examination thereof, and, as soon as the notification is sent of the rejection of any goods, the vendor shall remove the same, and the company shall be no longer responsible in any way, shape, or manner for the care or preservation of



such rejected articles. The vendor shall, under no circumstances, institute against the company any claim for injury or damage to such goods.

#### SECTION 6.

##### **Shipments.**

Each of the various kinds of goods herein specified shall be properly and suitably packed for shipment by the vendor. The packing shall in all cases be such as is adequate to protect and guard each of the several classes of goods from the ordinary contingencies of transportation, and to enable them to be delivered to the company in proper order without loss or damage, or injury in any respect. Each individual package, box, or bale, shall be properly and plainly marked with the name of the company, the destination to which the goods are to be forwarded, and the route they are to pursue, together with a statement and description of the kind of article, and number of pieces which each package is to contain. The vendor in all cases shall properly deliver the goods to the transportation company by which they are to be forwarded, and shall take the customary freight receipt and bill of lading, and shall forward to the company suitable evidence of proper shipment. In all cases the responsibility of the company for goods shall not commence until after the company shall have received them from the transportation company in good order, and in no case shall any vendor advance any claim for damages against the company until the company shall have received in good order the goods in question from the transportation company.

## SECTION 7.

**General Qualifications of Iron and Steel.**

All articles made of iron or steel under these specifications, except wire, shall be of a first-class quality of wrought iron, or preferably of mild steel. The quality of the metal used shall in all cases be equal to that employed in bridge or structural iron work. All wrought iron shall have a tensile strength of not less than 50,000 pounds per square inch of area, an elastic limit of not less than 25,000 pounds per square inch, shall elongate not less than 15 per cent. in a test piece of eight inches in length, and shall have a reduction in area of not less than 25 per cent. All mild steel shall have an ultimate strength of not less than 55,000 pounds per square inch, an elastic limit of not less than 32,000 pounds per square inch, an elongation of not less than 28 per cent. in eight inches, and a reduction of area of not less than 45 per cent.

The fracture of wrought iron test pieces shall be fibrous, with not over 25 per cent. of white or granular spots. The fracture of mild steel shall be cup shaped and silky, and absolutely homogeneous in texture. All pieces of wrought iron or steel shall be capable of being bent, cold 180°, around a mandrel having a diameter not to exceed their least thickness.

## SECTION 8.

**Galvanizing.**

All iron and steel used in building open wire lines shall be galvanized, unless *distinctly specified* to the *contrary*, and all galvanizing for each specific case shall be done in such a manner as to stand the following test:

From each shipment of each kind of goods the inspector

shall select such a reasonable number of samples as shall, in his judgment, fairly represent the consignment in question. Each sample shall be immersed in a saturated solution of sulphate of copper for one minute. At the expiration of this minute it shall be removed and wiped dry. This process shall be repeated four times. If after the fourth immersion and wiping any deposit of copper can be found upon the sample, or if any red spots can be detected, or if the galvanizing shall be seen to be corroded and removed, it shall be considered defective, and the goods represented by this sample shall be rejected. All galvanizing shall be smooth and clean. There shall be no superfluous spelter or drops of zinc, or rough places, or other imperfections. All holes, grooves, recesses, and threads shall be entirely clean and free from zinc, and shall be fully up to the dimensions required of them, and in all cases galvanizing shall be so performed that the parts intended to fit together can be readily and easily assembled.

## SECTION 9.

**Material Specifications.**

The bulk of material required for the construction of aerial lines is comprised within the following schedule :

TABLE 29.

*Schedule of Open Wire Line Material.*

- SECTION 10. Poles.
11. Creosoted poles.
  12. Guy stubs and anchor logs.
  13. Wooden pole braces.
  14. Brackets.
  15. Cross arms.
  16. Pins.
  17. Insulators.
  18. Cross arm braces.
  19. Cross arm bolts.

- SECTION 20. Carriage bolts.  
21. Fetter drive screws or lag bolts.  
22. Double arm bolts.  
23. Pole steps.  
24. Pole rings.  
25. Pole protection strips.  
26. Pole wheel guards.  
27. Guy rods.  
28. Guy strands.  
29. Thimbles.  
30. Strand clamps.  
31. Rock eye-bolts.  
32. Staples.  
33. Fuses.  
34. Ground rods.  
35. Connectors.  
36. Copper line wire.  
37. Iron line wire.  
38. Bridle wire.  
39. Weather-proof wire.  
40. Tie wire.

## SECTION 10.

**Poles.**

All poles shall be of the best quality of live green timber, free from rot, sound and substantial in every respect. The grain of every pole shall be close and hard, with the annular rings closely pitched, and the heart sound and firm. Every pole shall be straight and well grown, free from all objectionable bends. Each pole shall contain the natural butt of the tree, squarely sawn with no trimming to reduce size. Poles shall vary in length by increments of 5 feet from 20 to 70 feet, and shall have an approximately uniformly decreasing cross section from butt to top; shall be true and well proportioned, and shall be cut and felled between the 1st of November and the 1st of March. From each pole all the bark and soft wood shall be carefully removed, all knots trimmed closely and smoothly, and the butts squared. The top of each pole shall be roofed and such a number of grains for cross

arms cut in each pole as may be specifically directed for the pole in question. The first gain shall be cut 10 in. from the top of the pole, and the center of each subsequent gain shall be 24 in. below that of the preceding one. Each gain for standard cross arms shall be  $4\frac{1}{4}$  in. wide

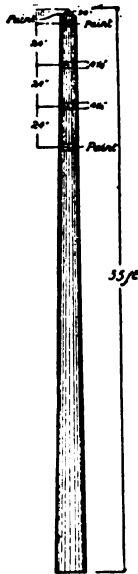

FIG. 49.— POLE ELEVATION.

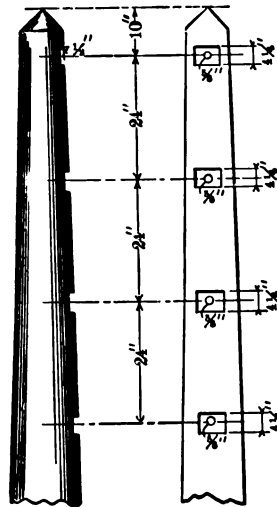

FIG. 50.— POLE TOP.

and  $\frac{1}{2}$  in. deep; for light cross arms the gain shall be  $3\frac{3}{4}$  in. wide and  $\frac{1}{2}$  in. deep. All gains shall be cut true and square with the axis of the pole, smoothly and evenly, in such a manner that all cross arms shall accurately fit the gains, and shall stand at right angles with the pole in all directions. Each gain shall be bored with two  $\frac{9}{16}$ -in. holes for two  $\frac{1}{2}$ -in. bolts, or with one  $\frac{11}{16}$ -in. hole for one  $\frac{5}{8}$ -in. bolt, as may be directed. If

two bolts are specified, the holes shall be spaced  $1\frac{1}{2}$  in. on each side of the center of the gain. If one bolt be specified, the hole shall be bored directly through the center of the pole, all holes shall be at right angles to the

TABLE 30.

*Pole Data.*

Length Feet in.	CIRCUMFERENCE IN INCHES.		Price Delivered per Pole-Ax.	Approximate Weight Each.	Approximate No. per Car.
	At Top.	6 ft. from Butt.			
20	12 $\frac{1}{2}$	24	(To be filled in at time of purchase.)	100 lbs.	200 1 car
20	16 $\frac{1}{2}$	25		130 lbs.	175 1 car
25	12 $\frac{1}{2}$	24		150 lbs.	150 1 car
25	16 $\frac{1}{2}$	25		200 lbs.	120 1 car
25	17 $\frac{1}{2}$	26		250 lbs.	110 1 car
19	22	27		350 lbs.	100 1 car
23	22	30		350 lbs.	100 1 car
25	25	34		275 lbs.	100 1 car
30	19	30		275 lbs.	1 0 1 car
30	22	34		350 lbs.	100 1 car
30	25	37		450 lbs.	80 1 car
31	22	37		450 lbs.	120 2 cars
31	25	40		600 lbs.	110 2 cars
40	22	40		625 lbs.	100 2 cars
40	25	43		800 lbs.	90 2 cars
45	22	43		885 lbs.	82 2 cars
45	25	46		1,000 lbs.	60 2 cars
50	22	46		1,085 lbs.	40 2 cars
50	25	50		1,250 lbs.	25 2 cars
55	22	50		1,000 lbs.	30 2 cars
55	25	54		1,500 lbs.	25 2 cars
60	22	54		2,000 lbs.	20 2 cars
65	22	58		2,000 lbs.	20 2 cars
70	22	64		2,700 lbs.	15 2 cars
				3,400 lbs.	12 2 cars

gain and at the axis of the pole. The general appearance of all poles and pole tops shall be as in Figs. 49 and 50. Each pole shall be sound, strong, and free from objectionable cracks, rot, or other defects, and shall be sub-

ject to inspection either at the point of shipment or at the point of delivery, as the company may elect, and all poles which do not strictly conform to all requirements of the specifications shall be unqualifiedly rejected.

The sizes and dimensions of poles, and the price per pole of various dimensions, shall be in accordance with Table 30.

#### SECTION 11.

##### **Creosoted Poles.**

The process of creosoting poles and cross arms shall be in accordance with the following requirements. Prior to treating, all mill work shall be done, and all holes bored, so that subsequent to the completion of the preservative process there shall be no cutting of timber. Creosoting shall be done by placing the lumber to be treated in a closed tank and steaming it with steam at a pressure of not less than 45 pounds gauge, for a period of not less than 4 hours. At the end of the steaming a vacuum of not less than 20 in. of mercury shall be applied to the tank, and all drainage from the timber pumped away. The vacuum shall be continued so long as there is any sensible discharge of sap or moisture from the timber. Pure dead oil of tar shall be then pumped into the tank, and an hydraulic pressure shall be applied sufficient to force into the timber at least 12 pounds of oil per cubic foot of timber treated. The absorption of oil by the timber shall be determined by measuring the total quantity of oil pumped into the tank, and comparing this with the known volume of the timber and the known volume of the tank. All oil used shall be pure dead oil of tar, and, if required, shall be subjected to a chemical analysis, and shall possess the following characteristics: It shall be

liquid at 100° F. It shall contain at least 25 per cent. of constituents that do not volatilize at a temperature of 600° F. It shall not contain over 5 per cent. of tar acids. It shall contain no admixture of any substance not derived from the distillation of coal tar.

After the process of creosoting is completed, all timber shall be stacked at least 6 inches away from the ground, shall be so piled as to permit a free circulation of air around all pieces, and shall be allowed to season in this manner for not less than three months prior to being used.

Prior to setting, the butts of all *untreated* poles, guy stubs, and anchor logs shall be charred and tarred. Each pole shall be placed on a skid and slowly revolved over a hot fire until the entire butt, to about 1 ft. above where the ground surface will intersect the pole, is thoroughly charred. While hot the butt shall be thoroughly painted with melted first-class coal tar, rubbed into the charring with a stiff brush.

## SECTION 12.

### **Guy Stubs and Anchor Logs.**

The timber used for guy stubs and anchor logs shall correspond in all respects with the specifications for poles, and shall be creosoted whenever creosoted poles are employed. Anchor logs shall not be less than 24 in. in circumference at the smallest point, and shall be at least 4 ft. in length.

Guy stubs shall not be less than 22 in. in circumference at the smallest end, and of such a length as shall enable the stub to extend 6 ft. into the earth, and at the same time support the top of the guy at such a point as may be re-



quired above the ground. Untreated guy stubs and anchor logs shall be tarred as specified in Section 11.

#### SECTION 13.

##### **Wooden Pole Braces.**

The timber to be used for wood pole braces shall fall under the same specifications as given for poles. No pole brace shall be less than 18 in. in circumference at the smallest end, and of such length as may enable the brace to be set 6 ft. in the ground, and to extend to the proper point required for supporting the pole. At the point at which the brace is attached the pole shall not be mortised more than three-fourths of an inch, but the brace shall be trimmed to fit the pole. Wherever creosoted poles are used, pole braces shall be creosoted; if untreated they shall be tarred as specified in Section 11.

#### SECTION 14

##### **Brackets.**

Brackets shall be of two kinds:

*A* — Wood brackets.

*B* — Iron brackets.

##### **A — WOOD BRACKETS.**

Wooden brackets shall be of the general form and dimensions as shown in Fig. 51. They shall be made of the best quality of oak; sound and perfect in every respect; fully up to the dimensions specified; neatly and carefully machined, with the bolt holes accurately spaced, carefully bored with sharp tools and with the insulator thread perfectly and truly cut, and a good fit for standard telephone insulators.

**B — IRON BRACKETS.**

Where more than two wires are to be placed on one pole, an iron bracket shall be used. There shall be two styles of iron brackets, namely, 2-pin and 4-pin brackets, as shown in Fig. 52. The bracket strip shall be of a first-

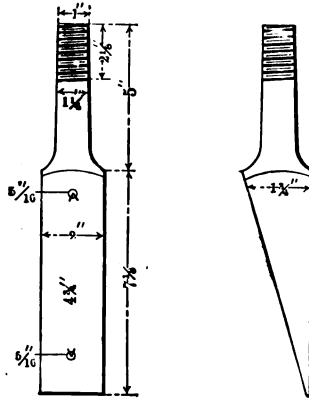

FIG. 51.— WOOD BRACKET.

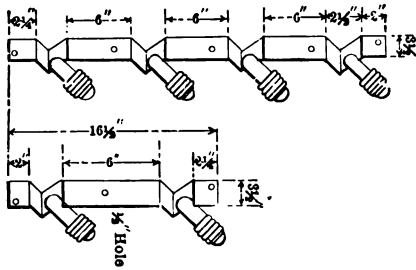

FIG. 52.— IRON BRACKETS.

class quality of flat-iron, or steel, to which the pins shall be solidly and substantially attached, as shown, and the pins shall in all respects correspond to the specifications for wooden pins — Section 16 — otherwise iron brackets shall have the form and dimensions of Fig. 52.

## SECTION 15.

**Cross Arms.**

There shall be four kinds of cross arms:

- A* — Standard arms.
- B* — Light arms.
- C* — Alley arms.
- D* — Cable arms.

**A — STANDARD CROSS ARMS.**

All cross arms, except cable arms, shall be made of thoroughly-seasoned, straight-grained wood — either Norway pine or Southern pine, as may be directed. The timber used shall be free from sap wood, and from any

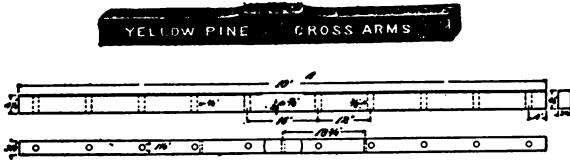

FIG. 53.—YELLOW PINE CROSS ARMS.

knots which may weaken it. Every arm shall be solid, sound, and substantial, free from bad cracks, dry rot, or any other imperfections whatsoever, shall be smoothly and accurately milled, with all dimensions full, as hereinafter specified. All holes shall be bored of the sizes specified, and at right angles to the respective faces of the cross arms, true and straight, and with sharp tools to avoid tearing or injuring the wood. All sides of every cross arm shall be straight and true, and at right angles to each other, and without warp or wind. Cross arms ordered creosoted shall be treated as specified in Section 11. In case cross arms are not treated, each arm

shall be thoroughly painted with a brush, and given two coats of Prince's metallic paint, color red, mixed in the ratio of 2 pounds of dry paint to 1 gallon of linseed oil. A drawing of the standard 10-pin cross is shown in Fig. 53. The dimensions for standard cross arms shall be as in Table 31.

TABLE 31.

*Standard Cross Arms.*

Finished size, 3¼ in. x 4¼ in.

\* Bored for 1½ in. or 1¼ in. pins, two ¾ in. carriage bolts and one ⅝ in. or two ½ in. bolts, as may be directed.

Length.	No. pins.	PIN SPACING.			Approximate weight.
		Ends.	Sides.	Centers.	
3 ft.	2	4 in.	.....	28 in.	10 lbs.
4 ft.	4	4 in.	12 in.	16 in.	14 lbs.
5 ft.	4	4 in.	15 in.	22 in.	17 lbs.
6 ft.	4	4 in.	11 in.	22 in.	21 lb.
6 ft.	6	4 in.	12 in.	16 in.	21 lbs.
8 ft.		4 in.	16¼ in.	22 in.	28 lbs.
8 ft.		4 in.	12 in.	16 in.	28 lbs.
8¼ ft.	10	3 in.	10 in.	16 in.	29¼ lbs.
10 ft.	8	4 in.	15 in.	22 in.	35 lbs.
10 ft.	10	4 in.	12 in.	16 in.	35 lbs.
10 ft.	12	4 in.	9¾ in.	16 in.	35 lbs.

\* Pin holes shall be a driving fit; carriage bolt holes 7/16 in. diameter; ½ in. machine bolt holes 9/16 in. diameter; ⅝ in. machine bolt holes 11/16 in. diameter.

**B — LIGHT CROSS ARMS.**

For light lines or those which are to be erected in particularly protected and in exposed situations, it is permissible to use a slightly lighter arm. The dimensions for light cross arms shall be as in Table 32.

TABLE 32.

*Light Cross Arms.*

Finished size, 2¾ in. x 3¾ in. (See note to standard cross arms.)

Arms bored for 1¼-in. pins, two ⅝-in. carriage bolts, and one ⅝-in. or two ½-in. bolts, as may be directed.

Length.	No. Pins.	PIN SPACING.			Approximate Weight.
		Ends.	Sides.	Centers.	
24 in.	2	8 in.	.....	18 in.	5 lbs.
30 in.	2	8 in.	.....	24 in.	7 lbs.
42 in.	4	8 in.	10 in.	16 in.	11½ lbs.
63 in.	6	8 in.	10 in.	16 in.	14 lbs.
82 in.	6	8 in.	10 in.	16 in.	18 lbs.
102 in.	10	8 in.	10 in.	16 in.	23½ lbs.
4 ft.	4	8 in.	18 in.	16 in.	11 lbs.
6 ft.	6	8 in.	12½ in.	16 in.	16½ lbs.
8 ft.	8	8 in.	12½ in.	16 in.	22 lbs.
10 ft.	12	8 in.	10 in.	14 in.	27½ lbs.

*C— ALLEY CROSS ARMS.*

Where pole lines are erected in alleys, a special arm is required, as it is usually impossible to center the arm upon the pole, but it must be placed as shown in Fig. 54. This requires that the square portion of the arm, fitting the gain, shall be in the center between the second and third pin holes from the end of the arm; that the holes for the arm braces shall be bored between the first and second pins, and the fourth and fifth pins, and that a special hole 9/16 in. in diameter, for a vertical brace, shall be bored between the seventh and eighth pin on each arm, as shown in Fig. 54. In other respects the dimensions of the arm, of the pin holes, and bolt holes, shall be as already specified for standard arms. Arms for terminal poles or corners and all exposed locations shall be bored for 1½-in. insulator pins. Cross arms to

be used with iron pins shall have all pin holes bored for  $\frac{5}{8}$ -in. bolts, driving fit, but in all other respects shall have the same dimensions as above specified.

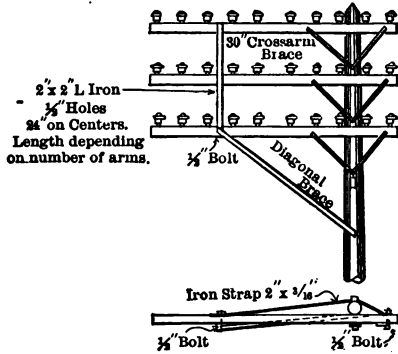

FIG. 54.—ALLEY ARM LOCATION.

*D* — CABLE CROSS ARMS.

The cross arms for supporting aerial cable shall be made of angle iron. Each arm shall be fitted to receive 4 cables,

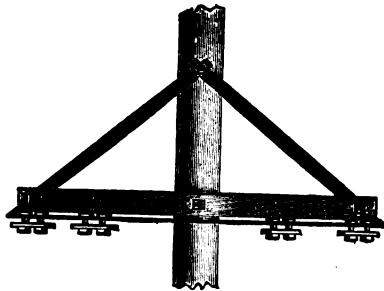

FIG. 55.—CABLE ARM.

and shall be attached to the pole 1 ft. below the lowest open wire arm, as shown in Fig. 55. Cable arms shall consist of

a piece of angle iron, weighing not less than 12 pounds to the foot, 36 in. in length — shown in detail in Fig. 56. The angle shall have a  $11/16$ -in. hole bored in the center thereof, for the purpose of attaching the same to the pole.

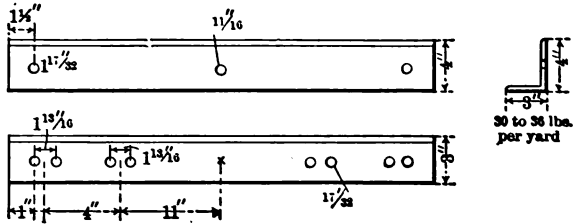

FIG. 56.— CABLE CROSS ARM.

On either side of the center, respectively at 11 in. and 15 in. away from the center, the fixtures for supporting the aerial cables shall be placed, which shall consist of steel U-bolts, as shown in Fig. 57. At a distance of  $1\frac{1}{2}$  ins. from

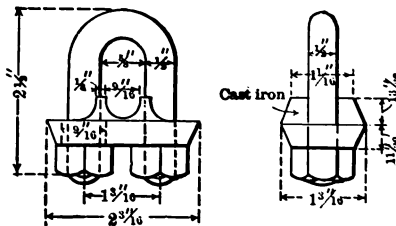

FIG. 57.— CABLE STRAND U-BOLT.

each end of the cross arm, a  $17/32$ -in. hole shall be bored for the purpose of attaching the cross-arm brace. Each cross arm shall be furnished with four steel U-bolts, as shown in detail in Fig. 57.

(NOTE.— For additional specifications for aerial cable lines, see Specifications for Aerial Cables, Vol. III.)

SECTION 16.

Pins.

There shall be two kinds of pins:

1. Wooden pins.
2. Iron pins.

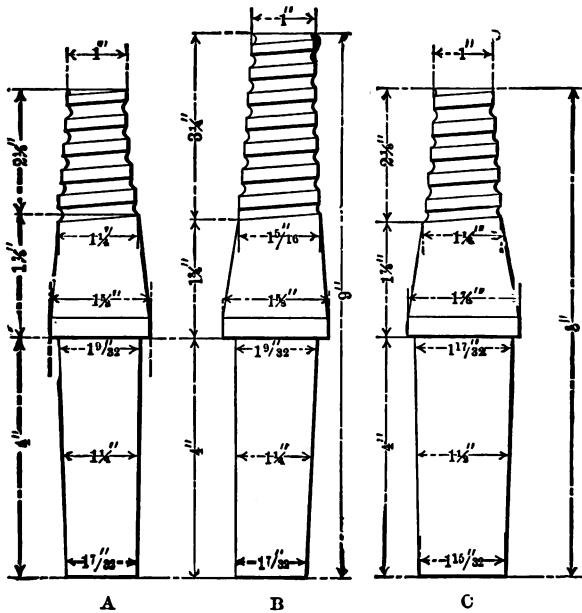

FIG. 58.—WOODEN PINS.

1. **Wooden Pins.**

There shall be three sorts of wooden pins, respectively known as

- A — Line pins.
- B — Transposition pins.
- C — Terminal pins.



**A — LINE PINS.**

The general form and dimensions of the line pin is as shown at *A*—Fig. 58. The shank shall be 4 in. long, and have an average diameter of  $1\frac{1}{4}$  in., being  $1\frac{9}{32}$  in. under the shoulder, and  $1\frac{7}{8}$  in. at the bottom of pin. The insulator thread shall be  $2\frac{1}{8}$  in. long, 1 in. in diameter at bottom, with a pitch of 4 threads per in., and shall fit a standard pony insulator. In all respects the line pin shall correspond to the dimensions of Fig. 58.

**B — TRANSPOSITION PINS.**

The transposition pin shall be of the form and have the dimensions shown in Fig. 58—*B*. It shall differ from the line pin only in having the insulator thread  $3\frac{1}{4}$  in. long instead of  $2\frac{1}{8}$  in.

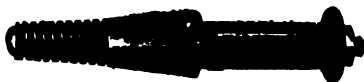

FIG. 59.—CORNER PINS.

**C — TERMINAL PINS.**

The terminal pin shall be of the form and have the dimensions shown in Fig. 58—*C*. It shall differ from the line pine only in the diameter of the shank, which shall be  $1\frac{17}{32}$  in. under the shoulder,  $1\frac{15}{32}$  in. at the bottom of the pin, and average  $1\frac{1}{2}$  in. In particularly exposed locations the shank of terminal pins shall be supplied with an iron bolt, nut, and washer, as shown in Fig. 59. This bolt shall be  $\frac{1}{4}$  in. in diameter,  $1\frac{1}{2}$  in. long outside the pin shank, and shall be secured in the shank firmly and solidly. The thread of the bolt and the nut shall be U. S. standard. The washer shall be

$\frac{1}{2}$  in. thick, 3 in. in diameter, and closely fit the bolt. All pins shall be made of the very best quality of thoroughly seasoned locust wood, sound, clear, free from knots and sap wood, subsequently boiled in paraffin or oil. All pins shall be cut of exactly the dimensions specified in Fig 58 in all respects. They shall be solid, substantial, free from all cracks, shakes, soft wood, or other defects, and shall be machined with sharp tools, smooth and fully up to all the dimensions specified.

## **2. Iron Pins.**

The general style and method of making iron pins is shown in Figs. 60—*A* and *B*. Each pin shall consist of an iron or steel bolt, not less than  $\frac{5}{8}$  in. in diameter, supplied with a U. S. standard thread, nut, and washer. The thread shall be at least  $1\frac{1}{4}$  in. long. The bolt shall be securely fastened into a cap, made of locust wood, which in all respects shall conform to all the requirements and match all the dimensions, specified in *A* and *B* of this section, for wooden pins. There shall be two sizes of wood caps — one with an insulator thread of  $2\frac{1}{2}$  in. long, to correspond to the line pin, and one  $3\frac{1}{4}$  in. long, to correspond to the transposition pin. The distance between the shoulder of the iron pin and the inner face of the washer, when the nut is so screwed on the bolt as to allow 2 full threads to project outside of the nut, shall not be less than 4 in.

## **SECTION 17.**

### **Insulators.**

#### **1. Glass Insulators.**

Insulators shall be of two kinds:

*A* — Line insulators.

*B* — Transposition insulators.

## A — LINE INSULATORS.

Line insulators shall be used for ordinary line work, and shall be of the type known to the trade as the



FIG. 60.— IRON PINS.

“Standard Pony” insulator. The general form of the pony insulator is illustrated in Fig. 61—*A*, and a section and dimensions are given in Fig. 61—*B*.

**B — TRANSPOSITION INSULATORS.**

The transposition insulators shall only be used where transpositions are to be made. There are four varieties of transposition insulators on the market, either one of

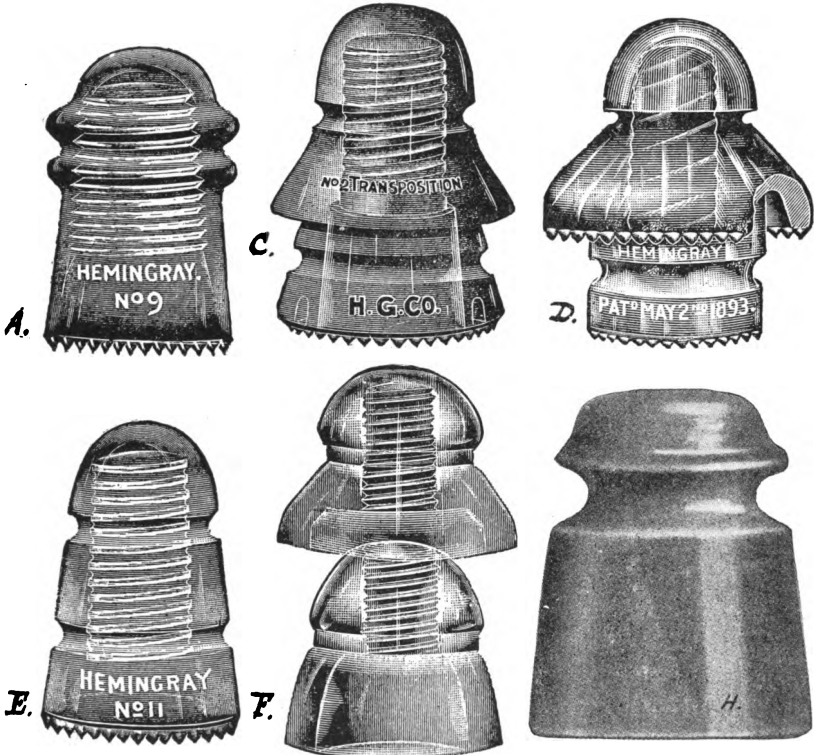

FIG. 61. A, C, D, E, F AND H. — INSULATORS.

which will answer the purpose, and are illustrated in Figs. 61—C, D, E, and F, standing in the same order of excellency. At G a section, with dimensions of F, is

given, and that portion of all transposition insulators which receives the pin shall have the dimensions of Fig. 61—*G*. All insulators shall be made of standard white or green glass — which shall not decompose under the weather — carefully and accurately finished with smooth surfaces, free from cracks, seams, flaws, sand spots, flat places, or any other imperfections whatsoever. They shall be molded full and true, and shall show a minimum die-seam. Screw threads shall be carefully and accurately molded, and shall be free from fins or sharp edges, and shall accurately fit the threads of the standard pins.

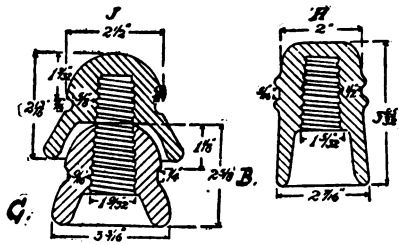

FIG. 61. B AND G.—INSULATORS.

## 2. Porcelain Insulators.

Insulators may be made of porcelain, the porcelain line Pony being shown at Fig. 61—*H*. Porcelain is somewhat stronger than glass, is a little less likely to crack in handling, and has somewhat better insulating characteristics, so is preferable on these accounts. The porcelain insulators shall be made of a first-class quality of highly-glazed brown porcelain, and shall in all respects possess all of the characteristics specified for glass insulators. Porcelain insulators shall be fully and thoroughly glazed, and hard burnt, and the enamel shall show no cracks, and shall be insoluble in any of the mineral acids.

## SECTION 18.

**Cross Arm Braces.**

There shall be three kinds of cross arm braces, made of iron or mild steel:

*A* — Front braces.

*B* — Rear braces.

*C* — Alley arm braces.

**A — FRONT BRACES.**

Front braces are those which shall be placed on the same side of the pole as the cross arm. Front braces are shown

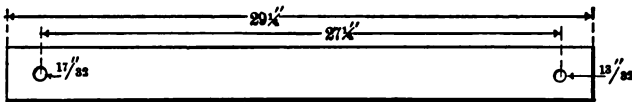

FIG. 62.— FRONT CROSS-ARM BRACE.

in Fig. 62. They shall be made of flat iron, 28 in. long,  $1\frac{1}{4}$  in. wide,  $\frac{1}{4}$  in. thick, and shall have 1  $\frac{17}{32}$ -in. hole drilled 1 in. from one end, and 1 hole  $\frac{13}{22}$  in., drilled 1 in. from the other end.

Braces for cable arms shall have bolt holes drilled  $\frac{17}{32}$  in. in diameter.

**B — REAR BRACES.**

Rear braces are those which shall be placed on the opposite side of the pole from the cross arm. Rear braces are shown in Fig. 63. They shall be made of flat iron,  $1\frac{1}{4}$  in. wide,  $\frac{1}{4}$  in. thick,  $29\frac{1}{4}$  in. long, and shall have 1 hole  $\frac{17}{32}$  in., drilled 1 in. from one end, and 1 hole  $\frac{13}{32}$  in., drilled 1 in. from the other end. Each rear brace shall have an offset, as shown in Fig. 63.

C — ALLEY ARM BRACES.

1. *Vertical brace.*—The vertical alley arm brace is shown in Fig. 64—A. It shall consist of a piece of  $2\frac{1}{2}$  in.  $\times$   $2\frac{1}{2}$  in. angle, weighing  $2\frac{1}{2}$  lbs. per foot. One inch from

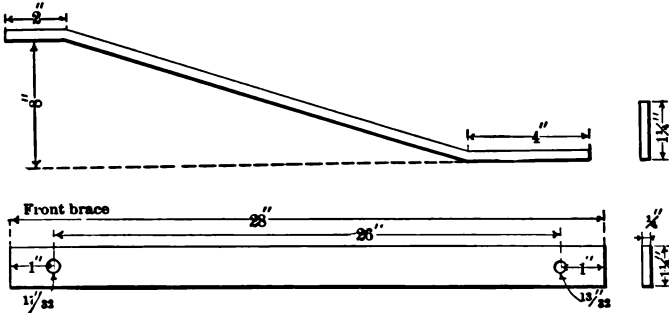

FIG. 63.—BACK CROSS-ARM.

each end of the brace a hole  $1\frac{1}{32}$  in. in diameter shall be drilled. The length of this brace will depend on the number of cross arms for which it is to be used, and an

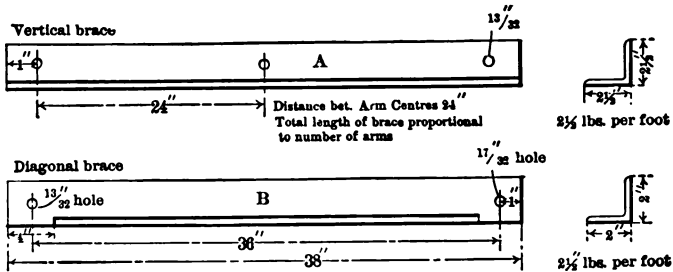

FIG. 64.—ALLEY ARM BRACES.

allowance of 24 in. in length for each arm shall be made, and for each arm 1 hole  $1\frac{1}{32}$  in. shall be drilled, as shown.

2. *Diagonal alley arm brace.*— The diagonal alley arm brace, Fig. 64—*B*, shall be 38 in. long over all, and shall be made of a piece of  $2\frac{1}{2}$  in.  $\times$   $2\frac{1}{2}$  in. angle,  $2\frac{1}{2}$  lbs. per foot. For a space of 4 in. on each end, the flange of the angle shall be removed. One inch from one end a hole  $\frac{17}{32}$  in. in diameter shall be drilled, and one inch from the other end a hole  $\frac{13}{32}$  in. in diameter.

## SECTION 19.

## Cross Arm Bolts.

Cross arm bolts shall be of steel, and supplied in two sizes,  $\frac{1}{2}$  in. and  $\frac{5}{8}$  in. in diameter, and of each size there

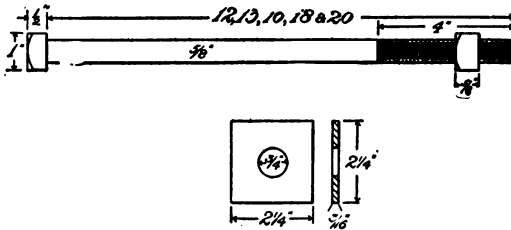

FIG. 65.— CROSS-ARM BOLTS.

shall be five lengths of bolts, measured under the head, respectively, 12 in., 13 in., 15 in., 18 in., and 20 in. long. Each bolt shall have a thread 4 in. long, cut on its end, supplied with a nut and square washer. All threads and nuts shall be U. S. standard. Fig. 65 shows the details of the  $\frac{5}{8}$ -in. bolt and washer. The  $\frac{1}{2}$ -in. bolt and washer shall be the same in all respects, except that the diameter of the bolt shall be  $\frac{1}{2}$  in., and that of the hole in the washer  $\frac{17}{32}$  in.



## SECTION 20.

**Carriage Bolts.**

All carriage bolts shall be standard trade carriage bolts of iron,  $\frac{3}{8}$  in. in diameter,  $4\frac{1}{2}$  in. long under head, and having a nut and washer as shown in Fig. 66.

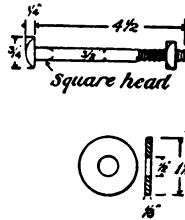

FIG. 66.—CARRIAGE BOLT.

## SECTION 21.

**Fetter Drive Screws or Lag Bolts.**

All fetter drive screws shall be standard trade fetter bolts, made of iron,  $\frac{1}{2}$  in. in diameter, and 5 in. long over all. They shall correspond to the dimensions of Fig. 67.

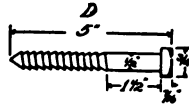

FIG. 67.—DRIVE SCREW OR LAG BOLT.

## SECTION 22.

**Double Arm Bolts.**

Double arm bolts shall be made of  $\frac{1}{2}$ -in. steel rod. There shall be four sizes, respectively, 17 in., 20 in., 23 in., and 26 in. over all. On each end of each bolt a U. S. standard thread shall be cut for 12 in. Each bolt shall

be supplied with 4 U. S. standard nuts, threaded to fit the bolt, and 4 steel washers,  $\frac{1}{4}$  in. thick, and  $2\frac{1}{2}$  in. square, each drilled with one  $17/32$ -in. hole in the center. The double arm bolt is shown in Fig. 68, and each bolt shall be shipped assembled in accordance therewith.



FIG. 68.— DOUBLE-ARM BOLT.

### SECTION 23.

#### Pole Steps.

Pole steps shall be of steel, as shown in Fig. 69,  $\frac{5}{8}$  in. diameter, 10 in. long over all, turned up for  $1\frac{1}{2}$  in. at



FIG. 69.— POLE STEP.

the outer end, and provided with a lag bolt thread for 3 in. on the other end.

### SECTION 24.

#### Pole Rings.

Pole rings shall be of iron or mild steel. They shall be 24 in. in circumference inside, 1 in. wide,  $\frac{1}{4}$  in. thick, made of  $\frac{1}{4}$ -in. by 1-in. bar, and otherwise according to Fig. 70.

## SECTION 25.

**Pole Protection Strips.**

Protection strips are shown in Fig. 71, and shall be made of sheet iron or steel, not less than 18 B. & S. gauge, 2 in. wide, 24 in. long, and shall be punched with 14 holes for tenpenny wire nails. All strips shall be concaved longitudinally to approximately fit the pole.

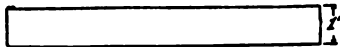
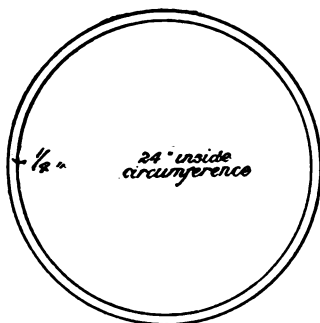

FIG. 70.—POLE RINGS.

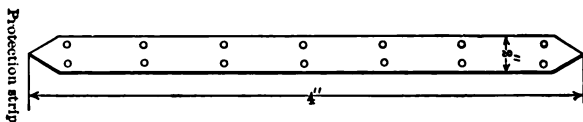
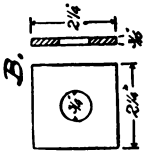

FIG. 71.—PROTECTION STRIP.

## SECTION 26.

**Wheel Guards.**

Wheel guards are shown in Fig. 72. They shall be made of  $\frac{3}{16}$ -in. iron or steel plate, of two sizes, re-



spectively, 15 in. × 18 in., and 18 in. × 20 in., and shall be bent to a radius of 7 in. Each plate shall be punched with 14 holes, 1/4 in. in diameter, or for sixpenny nails.

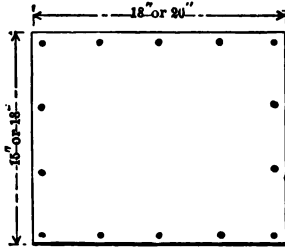
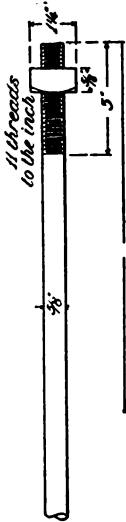

Wheel Guard

FIG. 72.— WHEEL GUARD.

SECTION 27.

Guy Rods.

Guy rods shall be made of wrought iron or mild steel. They shall be 5/8 in. in diameter, 18 in. to 60 in. long over all by increments of 6 in. furnished with an eye welded at one end, and a U. S. standard thread, and nut at the other end, and shall be of the dimensions and according to Fig. 73 — A. Each guy rod shall be supplied with one iron washer of the style and dimensions shown by Fig. 73 — B.



FIG. 73.— GUY ROD.

## SECTION 28.

**Guy Strands.**

All guys, from the end of the guy rod to the pole, shall be made of a first-class quality of wire rope. The wire used in making guy strands shall be the best quality of Bessemer or Siemens-Martin steel. It shall be uniform in quality, of an even cylindrical section, free from all die marks, scales, splits, flaws or other imperfections. Each wire shall be double galvanized. Every strand shall contain at least 7 wires, and in case wires are spliced the tensile strength of the strand shall not be reduced thereby. All strands shall have the physical characteristics given in Table 33.

TABLE 33.

*Properties of Guy Strands.*

DIAMETER IN INCHES OF		Lay in Inches.	ULTIMATE STRENGTH - LBS.	
Wire.	Strand.		Bessemer.	Siemens-Martin.
.072	1/4	3	2,500	3,050
.109	5-16	3 1/4	4,200	4,860
.120	3/8	3 3/4	5,700	6,800
.134	7-16	4	7,600	7,000
.165	1/2	4 1/2	9,800	11,000

## SECTION 29.

**Thimbles.**

Thimbles shall be made of wrought iron or mild steel, and shall correspond in all respects to the form and dimensions of Fig. 74.

SECTION 30.

Strand Clamps.

Strand clamps shall be of two sizes; the 2-bolt and 3-bolt clamp. Two-bolt clamps shall be used for  $\frac{1}{4}$  in. strands only; 3-bolt clamps for all strands over  $\frac{1}{4}$  in. The general

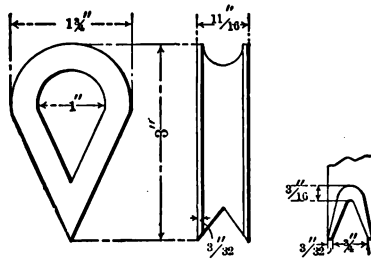

FIG. 74.— THIMBLE.

appearance of strand clamps is shown in Figs. 75 and 76, detail dimensions of a 3-bolt clamp at Fig. 77, to which all 3-bolt clamps shall correspond. Two-bolt clamps may be proportionately smaller. The clamp grooves shall ac-

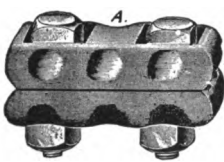

FIG. 75.— TWO-BOLT CLAMPS.

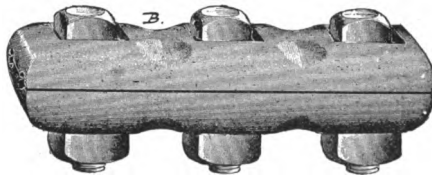

FIG. 76.— THREE-BOLT CLAMPS.

curately match the strand specified in Section 28. All clamps shall be of the best quality of malleable iron or soft steel casting. The bolts shall be special steel, having a breaking strength of not less than 80,000 pounds per

square inch. All castings shall be smooth, fully formed and carefully finished.

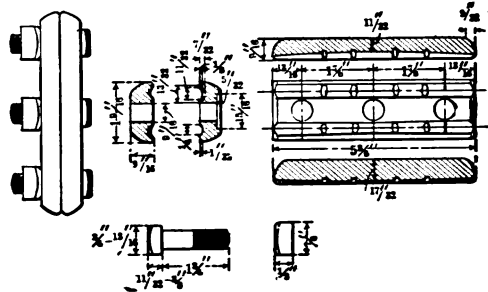

FIG. 77.— STRAND CLAMP DETAILS.

SECTION 31.

Rock Eye Bolts.

Eye bolts for rock guying shall be of the style, dimensions, and construction as shown in Fig. 78. The sides

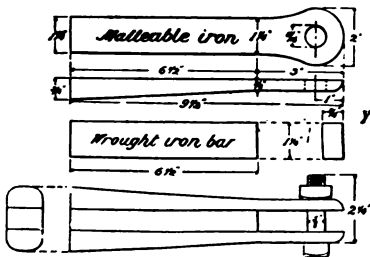

FIG. 78.— ROCK EYE-BOLT.



FIG. 79.— STAPLE.

shall be made of the best quality of commercial wrought iron or mild steel. Bolts shall be steel and shall have a breaking strength of not less than 70,000 pounds per

square inch. Bolts for rock guying shall be made accurately to the dimensions shown, shall be carefully finished, and shall correspond to all dimensions given. Rock eye bolts shall be assembled and wired together in sets, and then shipped either in boxes, barrels, or bags.

### SECTION 32.

#### Staples.

Staples shall be made of galvanized wire, approximately No. 6, B. W. G. They shall be  $2\frac{1}{2}$  in., and otherwise of the style and dimensions as shown in Fig. 79. All staples shall be galvanized. and shall be packed and shipped in boxes.

### SECTION 33.

#### Fuses.

Line fuses shall be of the general style shown in Fig. 80. Clamps shall be capable of being attached to any



FIG. 80.— FUSE.

wire between Nos. 5 and 12 B. & S., as shall be specified. Fuses shall blow at 3, 5, or 7 amperes, as may be specified in each case, and each fuse shall be plainly marked with its capacity. The fuse gap shall be not less than 3 in. The fuse case shall be of water-proof material, and each terminal provided with lock nuts.



## SECTION 34.

**Ground Rods.**

Ground rods shall consist of  $\frac{1}{2}$ -in. steel or iron rods, 6 in. long. Each rod shall have one end drawn to a point, and the other cut square. One inch (1 in.) from end that is squared, a  $\frac{3}{16}$ -in. hole shall be drilled through the rod perpendicular to its axis.

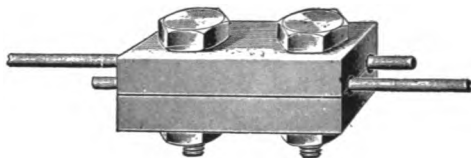

FIG. 81.—CONNECTOR.

## SECTION 35.

**Connectors.**

Connectors shall be made of copper, and designed according to Fig. 81. Each connector shall be not less than  $1\frac{1}{4}$  in. long, and provided with 2 bolts, each not less than  $\frac{1}{4}$  in. in diameter. Each bolt shall have a lock nut or other approved method of securing the nut. Connectors shall be designed for wire from No. 5 to 12, B. & S.

## SECTION 36.

**Copper Line Wire.**

All copper line wire shall be hard drawn. It shall be cylindrical in section, uniform in quality, with smooth surface, free from all die marks, scales, splints, flaws, fractory joints, or other imperfections of whatsoever

nature. The inspection of all wire shall be done at the factory of the manufacturer, who shall at all times afford the authorized inspector of the company full and free access to all processes of manufacture through which the wire, to be delivered under these specifications, shall pass. The manufacturer shall also provide adequate testing machines for making any and all of the mechanical tests hereinafter provided. The inspector shall have the privilege of inspecting all of raw material from which the wire is made. The inspector shall cut a sufficient length from each end of each coil of wire to make all of the mechanical tests hereinafter specified. Each coil of wire shall be drawn from one bar in one continuous length, and shall be free from all joints or splices. The diameter of the eye of each coil shall not be less than 20 in. or more than 22 in. When shipped, each coil shall be bound with 4 lashings of twine, and shall be so protected by burlap that there may be no danger of mechanical injury during transportation. Each coil shall be plainly marked by two tags, one of which shall be attached inside of the burlap, and the other on the outside. These tags shall state the weight and length of the coil in question. The mechanical and electrical properties of hard-drawn copper wire shall be as in Table 34.

TABLE 34.

*Properties of Hard-Drawn Copper Wire.*

Numbers B. & S. Gauge.	Diameters in Mils.	Areas in Circular Mils.	WEIGHTS IN LBS. PER		RESISTANCES IN INTERNATIONAL OHMS AT 66° F.		Tensile Strength—lbs.
			1,000 Ft.	Mile.	Per 1,000 Ft.	Per Mile.	
5	182	33,124	100	529	.3199	1.689	1,570
6	163	26,244	79	419	.4033	2.180	1,285
7	144	20,736	63	332	.5085	2.685	980
8	128	16,384	50	262	.6418	3.376	778
9	114	12,996	39	206	.8088	4.277	617
10	102	10,404	32	166	1.0199	5.384	489
11	91	8,281	25	132	1.2874	6.789	388
12	81	6,561	20	104	1.6218	8.563	307
13	72	5,184	15.7	84	2.0448	10.794	244
14	64	4,096	12.4	65	2.5779	13.612	193
15	57	3,249	9.9	52	3.251	17.165	133
16	51	2,601	7.8	41	4.099	21.646	103
17	45	2,025	6.2	33	5.169	27.294	87
18	40	1,600	4.9	25.6	6.518	34.416	77

All samples of hard-drawn copper wire shall elongate not less than 1 per cent. or more than 2 per cent. in test pieces 5 feet long. Samples of No. 5 hard-drawn copper wire, 6 in. in length, when tested for torsion, shall show not less than 20 twists in a length of 6 in. Each successive smaller gauge shall show at least 5 additional twists.

All wire shall be full in section, and shall not vary more than .001 in. on either side of the diameters specified in Table 34, and the weights per mile of wire shall not vary more than  $3\frac{1}{2}$  per cent. on either side of the weights specified in Table 34. The conductivity of all wire shall be at least 97 per cent. of Matthieson's standard.

SECTION 37.

**Galvanized Iron Wire.**

Iron wire shall in all qualifications, regarding size, finish, method of manufacture, inspection, etc., correspond to the specifications in Section 36, given for copper wire. There shall be three kinds of iron wire, respectively known as E. B. B., B. B., and Steel. The properties of the various kinds of wire are given in Table 35.

Samples of iron wire shall elongate not less than 15 per cent. in lengths of 1 foot, and when tested for torsion there shall be at least 15 twists in pieces 6 in. long. All wire shall be thoroughly and carefully annealed and double galvanized.

TABLE 35.

*Properties of Galvanized Iron Wire.*

Numbers, B. W. U.	Diameters in Mils.	WEIGHTS, LB., PER		BREAKING STRENGTH, LBS.		RESISTANCE PER MILE IN OHMS		
		1,000 Ft.	Mile.	Iron.	Steel.	E. B. B.	B. B.	Steel.
2	28	212	1,121	3,363	6,335	4.19	4.91	5.8
3	25	177	931	2,796	5,261	5.4	5.0	6.97
4	23	149	787	2,361	4,449	5.97	6.99	8.26
5	22	127	673	2,119	3,811	6.60	8.18	9.66
6	2.3	109	573	1,719	3,237	8.21	9.6	11.35
7	1.11	85	451	1,350	2,545	10.44	12.2	14.43
8	16	72	378	1,131	2,138	12.42	14.53	17.18
9	148	58	3.5	915	1,720	15.44	18.66	21.35
10	134	47	251	750	1,410	18.88	22.64	26.04
11	120	38	200	601	1,131	23.48	27.48	32.47
12	109	31	165	495	933	27.46	33.3	39.36
13	95	24	125	375	7.9	37.47	43.85	51.82
14	83	18	96	288	541	49.68	57.44	67.88

SECTION 38.

**Bridle Wire.**

Bridle wire shall be of No. 19, B. & S. gauge (36 mils in diameter), copper, insulated with okonite. The wire

shall be first tinned, and then thoroughly and uniformly covered with rubber compound to a thickness of  $\frac{3}{32}$  in. The composition shall be homogeneous in composition, and shall be evenly applied to a uniform thickness, and concentrically with the wire, and shall have the following electrical properties: After 48 hours' immersion in water at a temperature of  $60^{\circ}$  F., all wire shall show an insulation resistance of not less than 2,500 megohms per mile, when tested with the negative pole of a 100 volts battery to the wire, after an electrification of 1 minute. The dielectric strength of the insulation shall be tested by immersing a sample of the insulated wire in water for 72 hours, and then placing it in a conducting liquid in a metal trough. All wire shall under these conditions be capable of withstanding an alternating current of 18,000 volts with a frequency of 133 per second, applied to the test sample for 5 minutes.

#### SECTION 39.

##### **Weather-Proof Wire.**

Weather-proof wire shall be made of thoroughly tinned copper wire, insulated with three separate, closely-woven braids of cotton. Each braiding, as applied, shall be completely saturated with a dense moisture-repellant compound, applied in such a manner as to drive from the cotton any moisture contained. The thickness of the finished insulation shall not be less than 1-16 in., and the surface shall be hard and smooth. The covering shall retain its elasticity at a temperature of  $10^{\circ}$  below zero, F., and shall not drip at any temperature below  $180^{\circ}$  F.

## SECTION 40.

**Tie Wire.**

Tie wires shall be of same size and material as the line wires they are to secure, and shall be made of wire that is carefully annealed, and is as soft as possible. The length of the wire shall be as follows:

Size of Line Wire.	Length of Wire, Inches.
.080	16
.104	19
.165	22

## SECTION 41.

**Construction Specifications.**

For the purpose of description, it is convenient to subdivide the work of building open wire lines into the following sections:

TABLE 36.

*Schedule of Construction.*

- SECTION 42. Location of poles.  
*A* — Country lines.  
*B* — City lines.
43. Distribution of poles.
44. Fitting of poles.  
*A* — Gaining and roofing.  
*B* — Stepping.  
*C* — Ringing.  
*D* — Protecting.  
*E* — Lightning rods.
45. Setting poles.  
*A* — Foundations.  
*B* — Erection.
46. Cross-arming.  
*A* — Straight line work — single bracing.  
*B* — Straight line work — double bracing.  
*C* — Double arming.  
*D* — Alley arms.  
*E* — Cable arms.

- SECTION 47. Setting of pins.  
 48. Painting.  
 49. Guying.  
 50. Bracing.  
 51. Curves and corners.  
 52. Highway crossings.  
 53. Erection of wire.  
 54. Tension of wire.  
 55. Location of wire on pins.  
 56. Tying of wire.  
 57. Wire joints.  
 58. Dead-ending.  
 59. Transposing.  
 60. Distribution.  
 61. Protection.  
 62. Prevention of humming.  
 63. House top lines.  
     *A* — Right of way.  
     *B* — Construction.  
         1. Connection to main wire plant.  
         2. Fixtures and circuits.

## SECTION 42.

**Location of Poles.****A — COUNTRY LINES.**

Prior to the commencement of actual work, all pole locations shall be fixed by measuring off the proper distances along the route selected, which shall be in all cases within the limits granted in the rights-of-way contracts. At the points thus indicated stakes shall be set to mark the location of poles; in ordinary level country poles shall be set at uniformly equal distances of 130 ft., or in other words, there shall be 40 poles per mile of line. Stakes shall be planted irrespective of obstacles and poles set as near each stake as possible. Wherever guying or bracing is necessary, a stake shall be planted, indicating the location of the guy or brace, which shall be carefully arranged in such a manner as to completely absorb the horizontal stresses inflicted

upon the poles by the circuits. On curves, at corners, and other exposed locations, such a number of poles shall be placed as is necessary to secure proper strength, and the best alignment of the work. Heavy lines of 7 to 10 arms need more poles than light ones of 2 or 3 arms, and city lines must have more than country lines. It is rarely necessary to set poles closer together than 100 ft. and seldom expedient to build spans of more than 150 ft. These are the limits for good regular work, but as it is impossible to specify the arrangement of poles to meet all contingencies, the design and location of the various portions within the above limits shall be left to the discretion of the foreman. If special obstacles arise, a careful sketch showing all the details (with dimensions) of the portion of the route in question, shall be submitted to the manager with request for instructions.

In lines constructed along railway rights of way, no poles shall be set at a distance of less than 12 ft. from the edge of the nearest rail, unless the lowest cross arm that the line shall ever carry shall be more than 22 ft. from the top of the rail. In such cases, with the consent of the railway company, the pole may be set to within 7 ft. of the edge of the rail. Along all railway rights of way all wires, cables, strands, or other fixtures shall be placed so that the lowest portion of the line shall be at least 22 ft. from the top of the rail.

Poles shall be located upon the edge of the highway in such a manner as to interfere with its use as little as possible. Whenever any portion of the line is vertically over any road or highway, all wires, strands, fixtures, or cables shall be placed so that there shall in all cases be at least 18 ft. head room between the lowest portion of the line and every part of the highway.



Wherever a route shall intersect the lines or property of other telephone or telegraph company, or when two companies shall occupy the same poles, such a design shall be made as to allow the lowest wires of the line running over to clear the highest wire of the line running under by a space of at least 4 ft. This rule shall also apply to the clearance of all obstacles of whatsoever nature except trees.

**B — CITY LINES.**

The location of poles for city lines shall be made in all respects as specified in *A*. In addition, care shall be taken to place poles on the corners of streets to render guying easy. Poles shall be located just at the edge of the curb line, and as far as possible the center of each pole shall be set on a dividing property line, thus interfering with each owner as little as possible. All poles shall be placed away from driveways, gates, entrances, crosswalks, and the like.

**SECTION 43.**

**Distribution of Poles.**

The heaviest and most substantial poles shall be placed at corners and curves, and the straightest and best poles shall be selected for city work, and of these the best appearing shall be placed in front of residences. As far as possible, poles shall be selected for length in such a manner as to balance the changes in contour of the country, and to keep the lines as nearly level as may be. Thus, short poles shall be used upon high ground and tall poles in the valleys. It is essential to always so proportion poles that the circuits shall not pull upwards, tending to lift the insulators from their pins.

## SECTION 44.

**Fitting of Poles.**

- A* — Gaining and roofing.
- B* — Stepping.
- C* — Ringing.
- D* — Protection.
- E* — Lightning rods.

**A — GAINING AND ROOFING.**

All poles shall be roofed, gained, and bored for cross arms as specified in Section 10. The required number of gains shall be specified for each pole separately. If poles are not treated, the roof and each gain shall be painted with 2 thick coats of Prince's metallic paint, mixed in the proportion of 7 lbs. dry paint to 1 gal. pure linseed oil.

**B — STEPPING.**

Each cable pole, all painted poles in towns or in cities, and all poles 50 ft. in height and over, shall be equipped with galvanized pole steps, as is illustrated in Section 23. These pole steps shall be driven on alternate sides of the pole in line with the cross arms. Poles that are less than 63 in. in circumference shall have steps spaced 18 in. between centers on each side; poles which exceed 63 in. in circumference shall have the pole steps spaced 12 in. on each side.

**C — RINGING.**

Corner poles, or those in exposed locations, shall be ringed if in the judgment of the foreman this is desirable. Pole rings are specified in Section 24. Ringing shall be accomplished by shaving the top of the pole so that the ring can be driven on to the pole to 1 in. below the base of the roof. The ring shall be secured by four sixpenny

galvanized wire nails driven on top of the ring spaced equally around its circumference.

*D* — PROTECTION.

On all the principal streets of towns and cities, at all street corners, and in other exposed locations, where in



FIG. 82.— POLE PROTECTION.

the opinion of the foreman protection is desirable, poles shall be supplied with protection strips or wheel guards, or both, as the foreman may deem necessary. Protection strips and wheel guards are described in Sections 25 and 26. Protection strips shall be applied to the base of the pole and secured thereto, as shown in Fig. 82, with ten-

penny galvanized wire nails. Wheel guards shall be applied as shown in Fig. 82, but shall be secured with sixpenny galvanized wire nails.

#### E — LIGHTNING RODS.

Every tenth pole of country lines only shall be equipped with a lightning rod. This lightning rod shall consist of a piece of No. 6 galvanized iron wire, which shall extend not less than 12 in. above the top of the roof of the pole, and shall be attached to the sides thereof by means of galvanized steel staples (Section 32), spaced 1 ft. apart. Each lightning rod shall extend the entire length of the pole, and shall be soldered to a ground rod, driven into the earth below the surface at the base of the pole. The lightning rod shall be kept as straight as possible, and in no case shall any turns or coils be introduced therein.

### SECTION 45.

#### Setting of Poles.

- A — Foundations.
- B — Erection.

#### A — FOUNDATIONS.

Under ordinary circumstances, where the ground is of normal consistency, poles shall be set to the following depths:

Poles 30 ft. or less, 5½ ft. on straight lines and 6 ft.	
on corners and curves.	
35 ft. poles, 6 ft.	40 ft. poles, 6 ft.
45 ft. poles, 6½ ft.	50 ft. poles, 7 ft.
Poles 50 ft. or over, 8 ft.	

All poles on straight lines shall be set perpendicularly. Poles on curves shall incline slightly outward, enough so that the tension of the circuits shall pull them nearly per-

pendicular. All holes shall be dug large enough to admit the pole without stabbing or hewing, and shall be full size at the bottom, to permit the use of iron tampers. After the pole is placed in position, only one (1) shovel shall be used in filling the hole. Three (3) tampers shall be employed to pack in the filling continuously until the hole is completely filled. Soil shall then be piled up above the surface and firmly packed around the pole. In filling in holes, use the coarse soil or gravel at the top of the hole. Where the ground is sandy or marshy, additional precautions are necessary to keep the pole from settling out of line. Where the soil is fairly firm a sand-barrel may be used. The sand-barrel is a strong barrel or cask, which shall be set at the bottom of the hole, and into which the pole shall be placed, and the barrel packed with firm loam, clay, gravel, or sand, the barrel serving to distribute the pressure of the pole over a greater area of soil. When soil is only slightly soft a temporary sand-barrel may be used. This is an iron cylinder, about 3 ft. in diameter, and 4 ft. or 5 ft. in length, split longitudinally and provided with hinges and clasps. The cylinder is set at the bottom of the pole hole, the pole placed inside of it, and loam or clay rammed in place until the pole is solidly supported. The cylinder is then drawn from the excavation by a fall on the pole, and can be opened and removed. With a weaker soil the best method is to surround the pole with 6 in. or 8 in. of concrete, made of one part of Rosendale cement mixed with 2 of sand and 5 of broken stone. In such cases, place a layer of concrete 8 in. thick on the bottom of the hole. The concrete pole foundation is shown in Fig. 83. As the object of the concrete is to give a larger bearing surface against the soft soil, as much concrete may, within reasonable limits, be used as is neces-

sary. Where concrete is not available, or the soil seems so soft to require an excessive amount, a foundation may be secured by bolting transverse logs to the pole butt, as shown in Fig. 84. Such logs shall be from 4 ft. to 6 ft. long, not less than 6 in. in diameter at the smallest end,

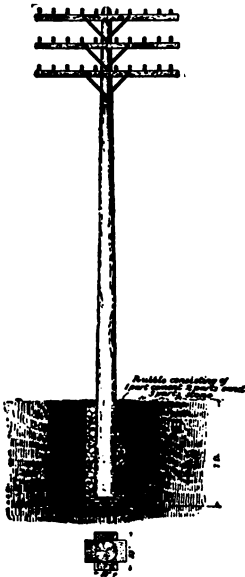

FIG. 83.— CONCRETE FOUNDATION.

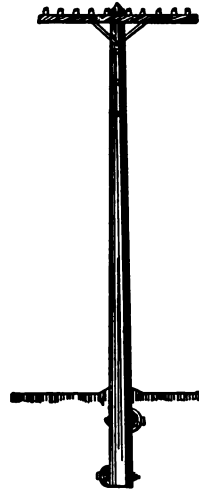

FIG. 84.— LOG FOUNDATION.

and secured to the pole by one  $\frac{1}{2}$ -in. bolt. When the soil is a veritable bog or marsh, poles shall be set on a platform, Fig. 85, or a platform and piles, Fig. 86. These methods are so obvious from the illustrations that further specification is unnecessary. The construction of Fig. 85 shall be used for 30-ft. pole, and that of Fig. 86 for larger

and heavier lines, or when the ground is very soft. If hard pan or rock shall be encountered, the only precaution to be observed is to make holes large enough to receive the butt without hewing, and to excavate the hole so that the pole can stand perpendicularly. If it shall

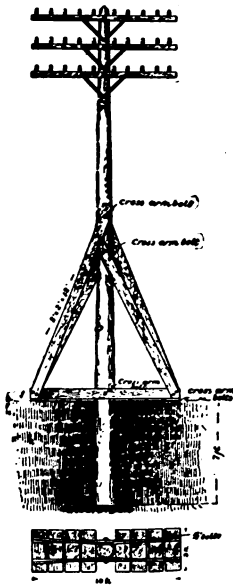

FIG. 85.— PLATFORM FOUNDATION.

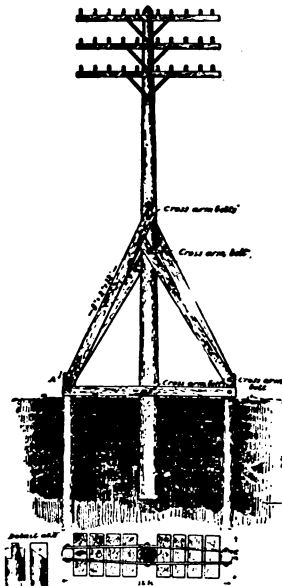

FIG. 86.— PLATFORM AND PILES.

be necessary to blast pole hole, this part of the work shall only be intrusted to those who are skilled in the use of explosives.

#### B — THE ERECTION OF POLES.

Poles which are 45 ft. or less may be erected with pike staves, as shown in Fig. 87. Care shall be taken to dis-

tribute the gang on each side of the pole, so that it may be held securely while in the air, yet so that in case of an accident no one shall be injured. To raise poles over 50 ft. a tripod derrick may be employed, as shown in Fig. 88. The derrick shall be built of three 30-ft. poles.



FIG. 87.—POLE RAISING.

The top of the derrick spars may be equipped with a universal swivel hinge and ring, to which the fall may be hung, or a simple lashing may be used. In the butt of each pole a solid spike, not less than 1 in. in diameter and 3 in. long, shall be placed to prevent the butt from slipping. A 4-part 3-in. fall is sufficient for hoisting.



For heavy poles, a winch clamped to one leg of the derrick can be employed. The pole should be slung just above its center of gravity, so that the butt will drag on the ground and slide into the hole. As soon as the butt



FIG. 88.— POLE DERRICK.

has entered the hole, the sling can be shifted and the pole hoisted upright. Better than either of the preceding methods is the use of a derrick wagon for all pole setting. Fig. 89. A heavy two-horse truck is equipped with a

small derrick, having a capacity of two tons, and a reach of 20 ft. in all directions. The mast is hinged at its base

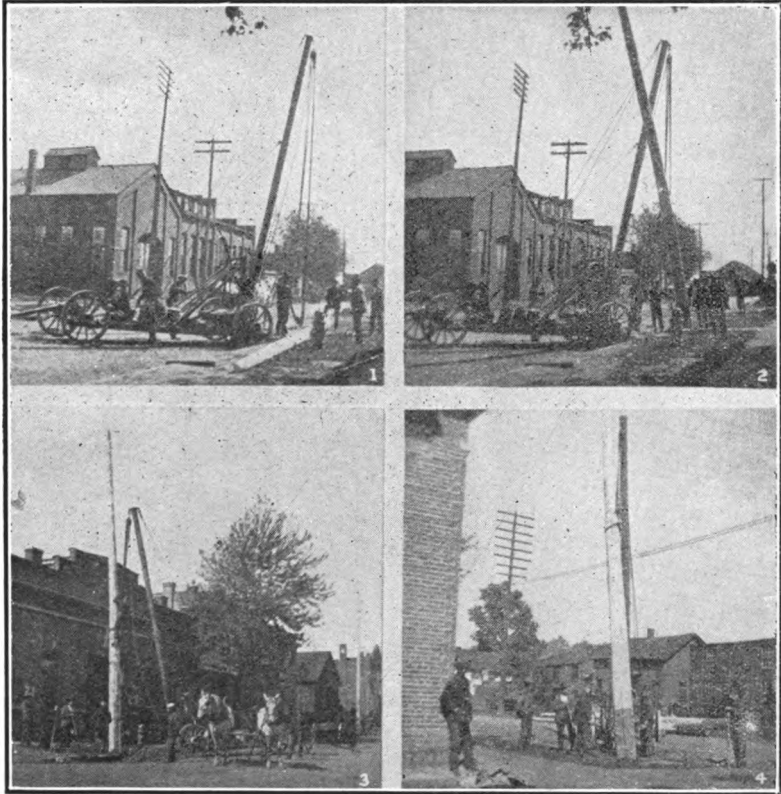

FIG. 80.—EXAMPLES OF USE OF POLE DERRICK.

on the truck, so that it can be laid down for transportation. Power is best supplied by a gasoline or electric

motor. With such an apparatus, poles can be set as fast as the wagon can drive.

Prior to raising, a guide cross arm shall be placed on each pole, to show which way the gains set. Before the refill is rammed about each pole, the pole shall be turned to bring all gains to their proper positions. On straight lines gains shall be perpendicular to the line, and on curves and corners set radially.

#### SECTION 46.

##### **Cross Arming.**

- A* — Straight line work — single bracing.
- B* — Straight line work — double bracing.
- C* — Double arming.
- D* — Alley arms.
- E* — Cable arms.

All cross arms shall be bolted to the pole, either with one  $\frac{5}{8}$ -in. machine bolt, or two  $\frac{1}{2}$ -in. machine bolts (Section 19), as may be specified in each case.

##### **A — STRAIGHT LINE WORK — SINGLE BRACING.**

In straight-a-way work each cross arm shall be braced with two galvanized mild steel braces of the style and dimensions shown in Section 18 — *A*. Each brace shall be attached to its arm by one 4-in. carriage bolt (Section 20). Both braces shall be secured to the pole by one  $\frac{5}{8}$ -in. fetter drive screw (Section 21). The method and dimensions for cross arming are shown in Fig. 90.

##### **B — STRAIGHT LINE WORK — DOUBLE BRACING.**

Whenever the line is exposed more than under normal conditions, back cross arm braces shall be used in addition, unless double cross arms are specified. The back

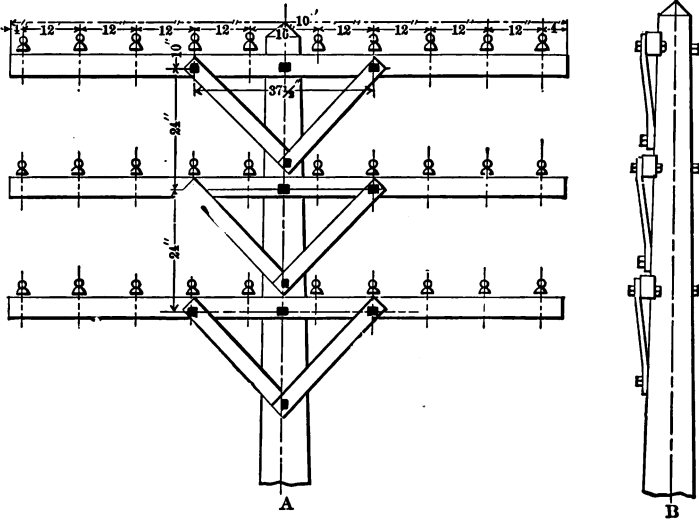

FIG. 90.— ATTACHMENT OF FRONT BRACES.

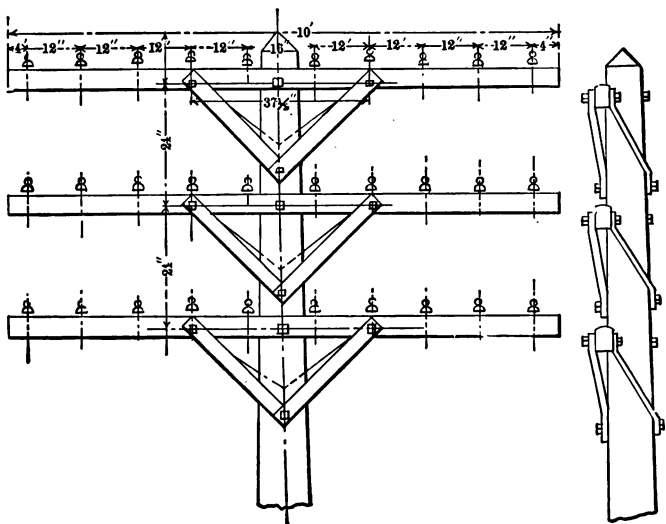

FIG. 91.— ATTACHMENT OF REAR BRACES.

cross arm brace shall be of the style and dimensions as shown in Section 18 — *B*. Each pair of black cross arm braces shall be fastened to the pole by one 5-in. fetter drive screw (Section 21). Each brace shall be attached to the cross arms by one carriage bolt (Section 20). The method and dimensions for double bracing are shown in Fig. 91.

#### *C* — DOUBLE ARMING.

Where many circuits are dead ended—on all bad corners; in particularly exposed locations; when circuits run in several directions from a distributing pole; and at such other points as the foreman shall deem necessary—poles shall be double armed. Double arms shall consist of two arms, one placed on each side of the pole and braced in the manner already specified in *A* of this section. In addition, each 10-pin double arm shall be secured by 4 blocks and double-arm bolts (Section 22). The blocks shall be of pine 4 in. x 4 in., and of such thickness as may be necessary to fill between the arms. The double-arm bolts shall be placed, and double-arming done, in accordance with Fig. 92 — *A* and *B*. An example of double arming is given in Fig. 93.

#### *D* — ALLEY ARMS.

Alley arms shall be erected as specified for straight line work, and, in addition, on each pole the two special braces shall be attached, as shown in Section 18 — *C*, Fig. 7. The vertical brace shall be attached to each arm with one carriage bolt (Section 20). The diagonal brace shall be attached to the pole with one fetter drive screw (Section 21) and to the arm with the same carriage bolt used for the vertical brace.

*E* — CABLE ARMS.

Shall be attached to the pole and braced as specified in *A* of this Section, and according to Fig. 55.

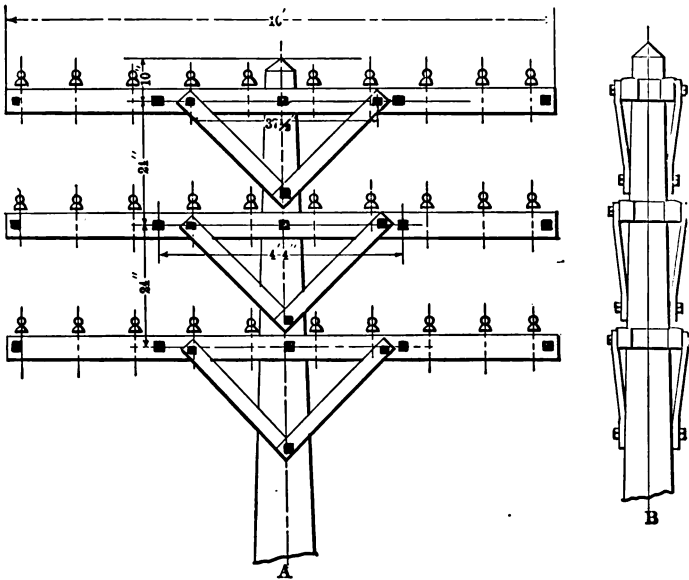

FIG. 92 A AND B.—DOUBLE ARMING.

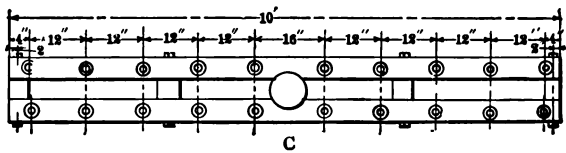

FIG. 92 C.—DOUBLE ARMING.

SECTION 47.

**The Setting of Pins.**

Wooden pins shall be placed at the time the cross arms are erected. Each pin shall be driven firmly into its hole

in the arm and nailed with one galvanized sixpenny wire nail, driven through the arm in the center between the top and bottom.

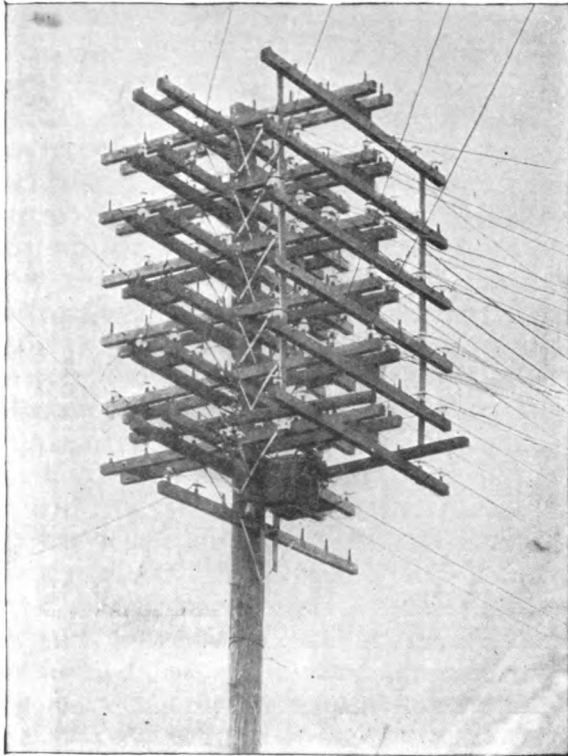

FIG. 93.— EXAMPLE OF DOUBLE ARMING.

Iron pins shall not be erected till the line wires are strung.

## SECTION 48.

**Painting.**

In cities and larger towns poles shall be painted after the line is completed. Each pole shall receive two coats of first-class lead and linseed oil paint, of such a color as may be directed by the company. After painting, the butt of each pole shall receive two coats of black paint for a distance of  $6\frac{1}{2}$  ft. above the ground.

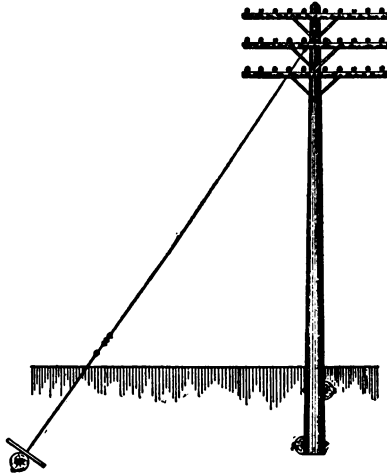

FIG. 94.—PLAIN GUY.

## SECTION 49.

**Guying.**

The various methods of guying are illustrated in Figs. 94 to 102, inclusive. Wherever possible, guying shall be done as shown in Fig. 94. The butt of the pole to be guyed shall be reinforced by two logs, 4 ft. to 6 ft. in



length, and not less than 8 in. in diameter at the smallest end. These logs shall be bolted to the butt of the pole, as shown. A guy rod (Section 27) shall then be planted at an appropriate distance from the pole; the greater the distance of the foot of the guy from the pole, the more valuable it is. The anchor log shall not be less than 8 in. in diameter at the smallest end and from 4 ft. to 6 ft. in length. Through the center of the log the guy rod shall be set and bolted. In place of the anchor log and rod, a guy anchor, as shown in Fig. 95, may be used, but can only be employed in loamy or clayey soils, where no rock or coarse gravel is encountered.

The guy shall be made of strand, as specified in Section 28. It shall run from a thimble in the eye of the rod to the pole, and be secured by two hitches around the pole, and a strand clamp, both at the pole and at the thimble. Where obstacles prevent running the guy, as shown in Fig. 94, guy stubs shall be used, as shown in Figs. 96 and 97. Of the two methods indicated for guy stubs, the one in Fig. 96 is the preferable one and should be used wherever possible. In all cases guy stubs shall be reinforced by two logs, as shown. Sometimes it is possible to use trees as anchors for guys. Wherever this can be done, under private right-of-way authority, the methods used in Figs. 98 and 99 shall be adopted, the one shown in Fig. 98 being the preferable one. Guys shall not be attached to limbs of trees, unless the limbs are at least 5 in. in diameter. In all cases, trees shall be protected with proper lagging, as shown. Where rock exists, guying shall be accomplished as shown in Figs. 100 and 101. Guys shall be secured to the rock by means of a rock eye-bolt (Section 31). A taper hole shall be drilled in the rock and the rock and eye-bolt set as shown

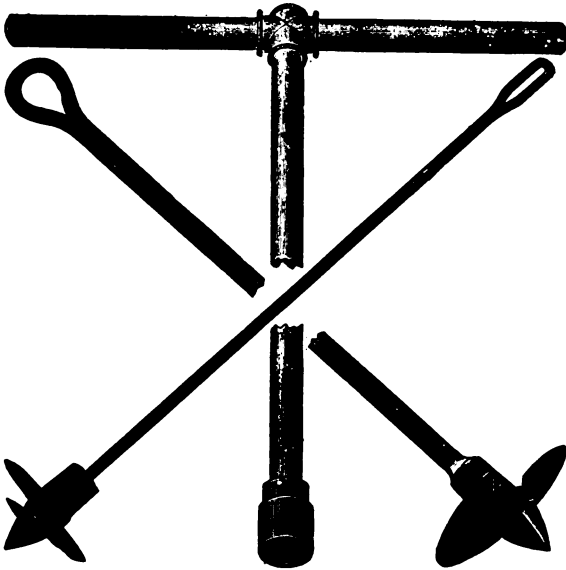

FIG. 95.—GUY ANCHOR.

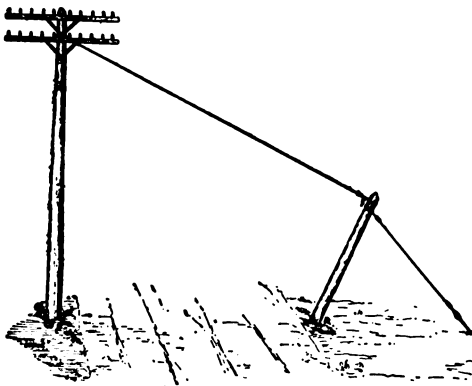

FIG. 96.—GUYS OVER OBSTACLES.

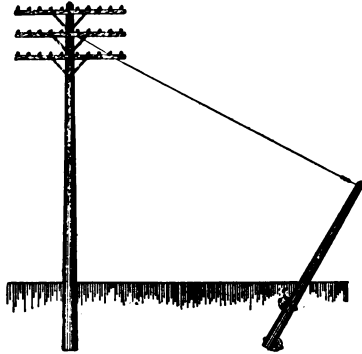

FIG. 97.—UNANCHORED GUY STUB.

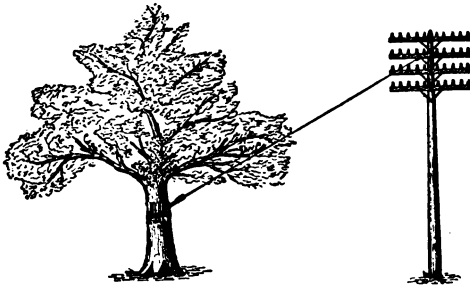

FIG. 98.—GUY TO TREE TRUNK.

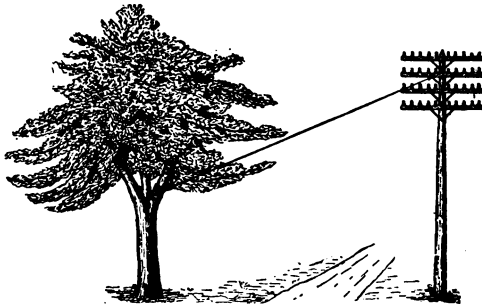

FIG. 99.—GUY TO TREE BRANCH.

in Fig. 101. From the rock eye-bolt the guy strand shall be extended to the pole. All attachments shall be made with strand clamps. As often as once in each mile in straight country lines — wherever turns, crossings, or corners occur — and as often as may be considered advisable in city lines, poles shall be head-guyed and double head-guyed, as shown in Fig. 102.

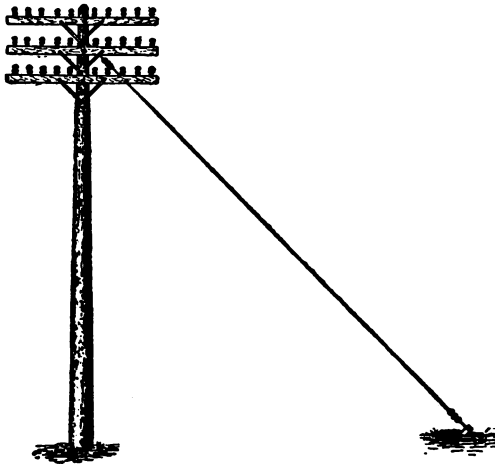

FIG. 100.— ROCK GUY.

#### SECTION 50.

##### Bracing.

To counteract side strain upon poles, braces may be used wherever it appears preferable, either from economy or convenience, to use a brace instead of a guy. The various forms of braces are illustrated in Figs. 103, 104, and 105. The single brace is shown in Fig. 103 and the double brace in Fig. 104. These figures are self-explana-

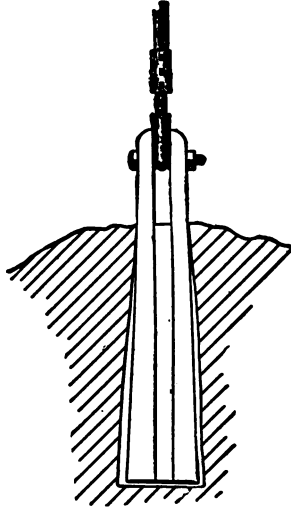

FIG. 101.— ROCK EYE-BOLT.

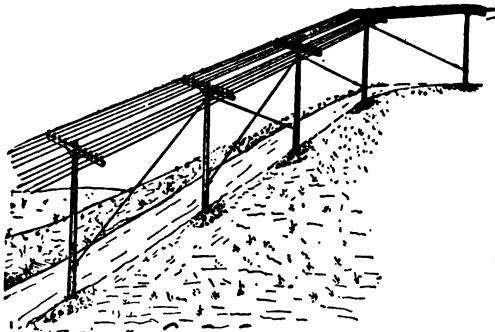

FIG. 102.— HEAD GUYING TO LINE.

tory. In Fig. 105 the double pole is shown. This is an exceedingly economical and desirable form, and should be employed in all exposed locations where right-of-way conditions will permit. An extension of this design, making a tripod pole, may be used at particularly bad

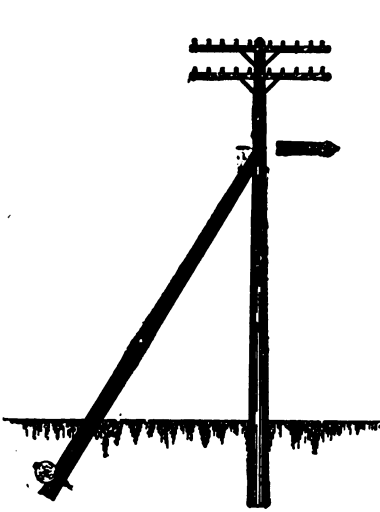

FIG. 103.— SINGLE BRACE.

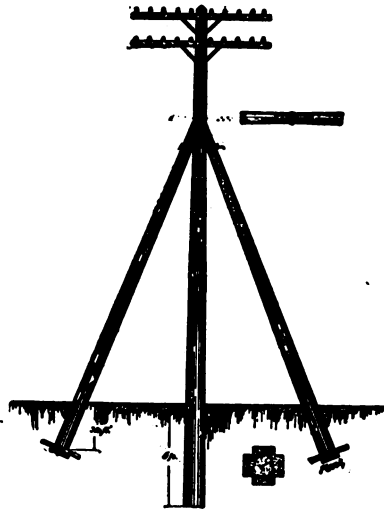

FIG. 104.— DOUBLE BRACE.

corners, and will provide a strut that will successfully withstand any gale.

#### SECTION 51.

##### Curves, Corners, and Crossings.

Where it is necessary to make any change in direction in a line, care shall be taken to make such change as gradual as possible, or, in other words, to spread the curve over as many poles as may be. Where sharp bends

are unavoidable, proper guys or braces, or both, must be provided to receive all the horizontal stresses of the circuits. Figs. 106 and 107 are examples of methods of curve and corner work. Fig. 106—*A* is the method of making a gradual bend, which should be adopted wherever possible. At Fig. 106—*B* a right angle corner, with side guys is shown. In Fig. 107—*B* a similar corner is shown, but this design is much stronger than Fig. 106—*B*,

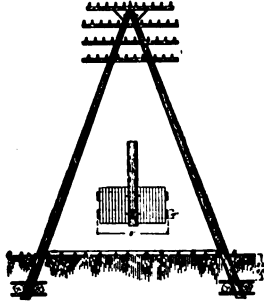

FIG. 105.— DOUBLE POLE.

as there are two more head guys and a brace suitable for poles, which are double armed. Fig. 106—*C* is a corner without guys, suitable only for light lines where guying is impracticable. Poles 3 and 4 should be double poles if possible. Fig. 107—*A* illustrates a design suitable for the sharpest kind of a corner. At Fig. 107—*D* a corner is shown made by dead-ending on the terminal poles and cutting the circuits into cable over the corner itself. Fig. 107—*C* shows a design for two intersecting lines. As it is impracticable to specify details for all curves, corners, and crossings, foremen shall build all ordinary cases as herein specified, and shall submit to the manager, for ap-

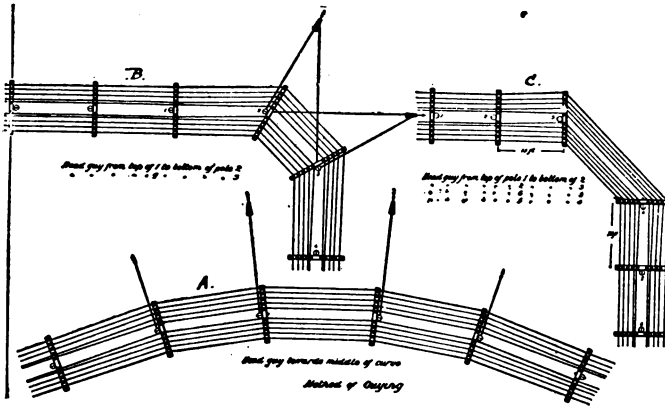

FIG. 106.— CURVES AND CORNERS.

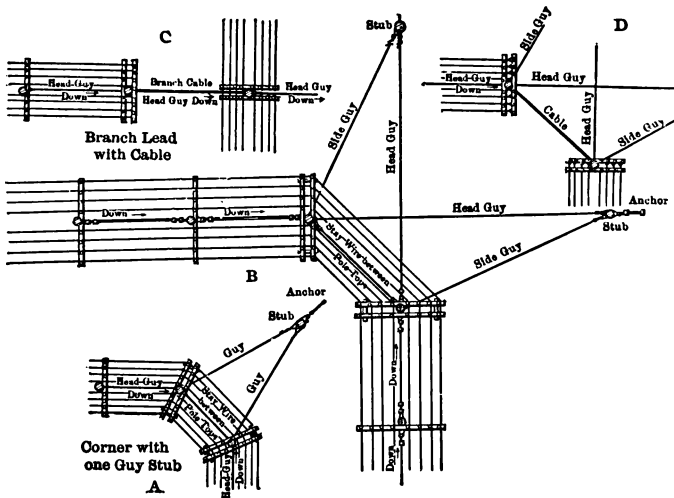

FIG. 107.— CURVE AND CORNER DETAILS.



proval, a sketch with full dimensions and all other information for all cases which are not hereunder comprised.

#### SECTION 52.

##### Highway Crossings.

Whenever a line must change from one side of a road or street to the other, the crossing shall be made so that the circuits make as near a  $45^\circ$  angle with the highway

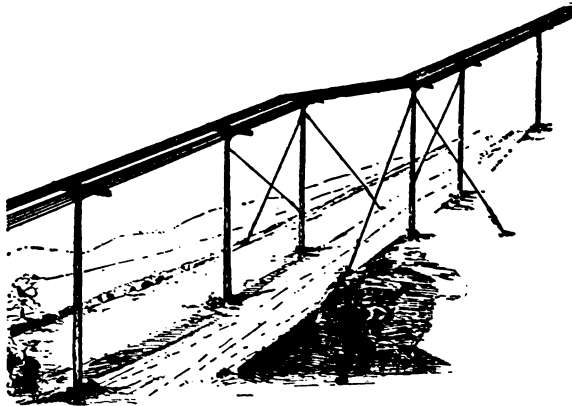

FIG. 108.— CURVES AND CORNERS OVER HIGHWAYS.

as possible. Pains shall be taken to select locations where the crossings can be made as in Fig. 108, with side guys at each terminal pole, as shown. If it is impossible to realize the condition, the crossing shall be made as in Fig. 109 or 110. If the line contains more than two cross arms the head guys shall be carried three poles from the end of each line, and the first two poles shall be double-head guyed.

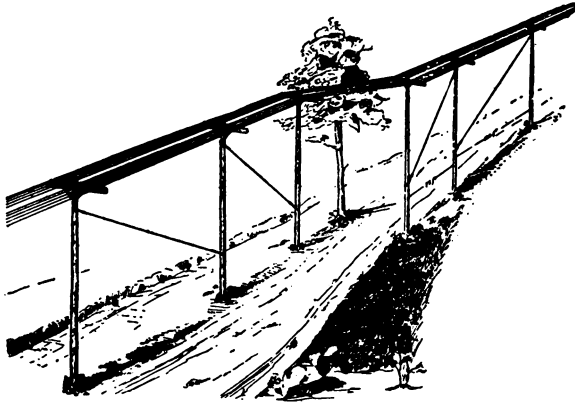

FIG. 109.— CORNERS AND CROSSINGS.

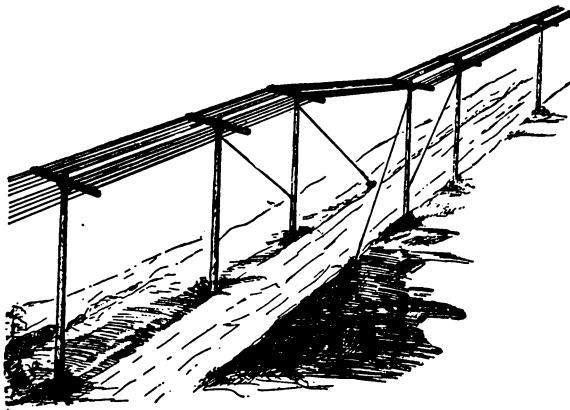

FIG. 110.— HIGHWAY CROSSING WITH SIDE GUYS.

## SECTION 53.

**Erection of Wire.****A — COUNTRY LINES.**

In open country or in thoroughfares not densely crowded, where a number of wires are to be strung simultaneously, a cart shall be provided, on which shall be

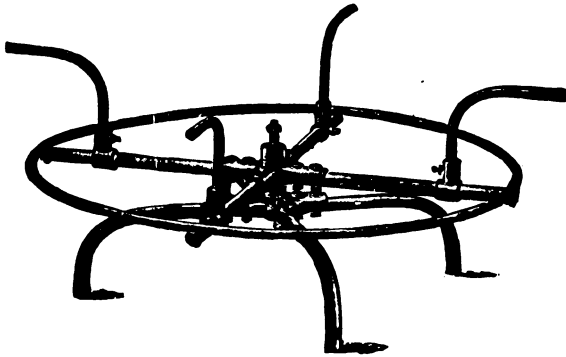

FIG. 111.— WIRE REEL.

placed as many reels as there are pins upon each cross arm. A good form of reel is shown in Fig. 111, while Fig. 113 shows the reel cart in use stringing wire. A



FIG. 112.— RUNNING BOARD.

running board shall be provided, as shown in Fig. 112. This is a piece of tough timber 4 x 6 in. as long as the cross arm, having holes bored as shown, spaced the same distance apart as the cross arm pins. Where there is

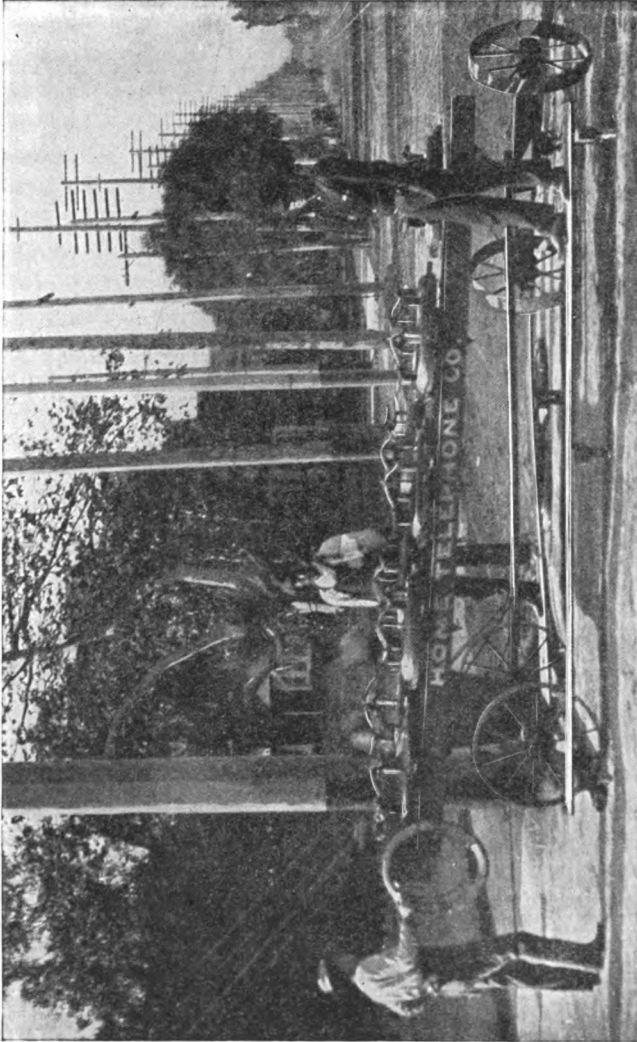

**FIG. 113. — REEL CART AT WORK.**

more than one arm a split running board shall be used. A running rope shall then be carried over the cross arms of the poles for 1,500 ft. or 2,000 ft., and the running board attached to the end thereof. A team of horses shall then be attached to the rope, and the running board, with the wire attached, hauled over the cross arms. At each pole a lineman shall be stationed, whose business it is to guide the running board and wires over the cross arms. As soon as the running board arrives at the last pole over

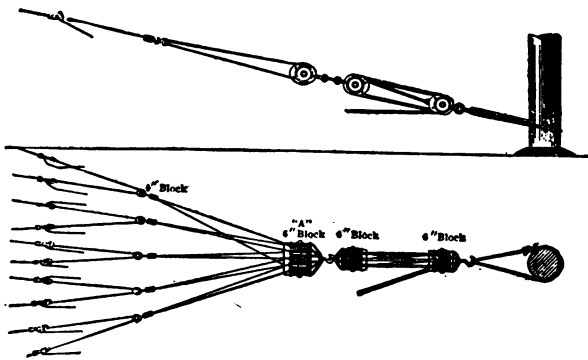

FIG. 114.—PULLING-UP WIRE.

which the running rope passes, the wires shall be temporarily secured and the process repeated until the line is completely strung. After the wires are in their places they may be drawn up by the method shown in Fig. 114, and the sags adjusted in the center of each span to the amounts prescribed in Section 54. A better method is to adjust the final tension on each wire by means of a come-along and dynamometer, shown in Fig. 115. The dynamometer is attached to the cross arm by its fall, and the wire gripped by the come-along. By means of the fall

the wire may be drawn in or paid out till the dynamometer shows the tension specified in Section 54. When the wires are finally in their places and adjusted to the

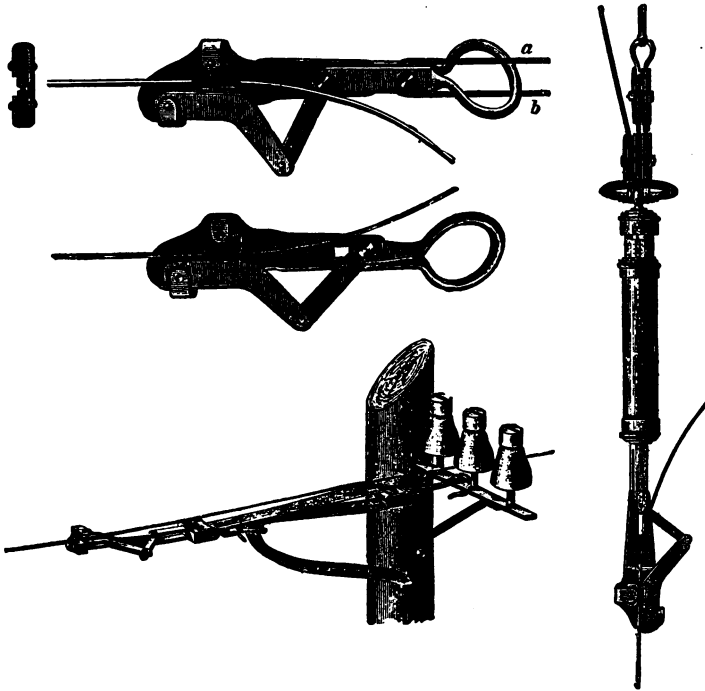

FIG. 115.—LINE DYNAMOMETER.

proper tension and sag, they shall be tied to the insulators, as specified in Section 56.

#### B — CITY LINES.

In crowded city streets it is rarely practical to employ the running board and erect a number of wires simultaneously, and it is usually only possible to erect a single

wire at a time. The method of erection consists in stringing a running rope over the cross arms of as many poles as possible, without seriously interfering with city traffic. A reel shall be mounted at the beginning of the line containing the wire, to which the running rope is attached, and then the wire, by means of the rope, hauled over the cross arms and lifted into place. At each cross arm the wire shall then be adjusted in proper tension and sag, as specified in "A", and tied to its insulators. This method may also be employed in country lines where but one or two wires are to be strung and the use of the running board is inexpedient.

## SECTION 54.

**The Sag and Tension of Wires.**

Before wires are tied to their insulators they shall be adjusted for tension. The proper tension depends on the length of the span, the temperature of the wire at the time of erection, and the size of the wire. There are two methods of adjusting wire: one is by means of a dynamometer, as specified in Section 53; the other is by adjusting the deflection of the wire in the center of each span below a horizontal line. In cold weather the wire contracts and the tension increases. All wire shall be so adjusted that in the coldest weather the tension shall not exceed one-third of the breaking strength. The relation between the deflection of any wire, the span between the poles, and the tension produced on the wire is given by the following expression:

$$\text{The tension} = \frac{\text{Span}^2 \times \text{weight per foot}}{8 \times \text{the deflection.}}$$

In this formula the span and deflection are measured in feet, and the weight of the wire in pounds per foot. In

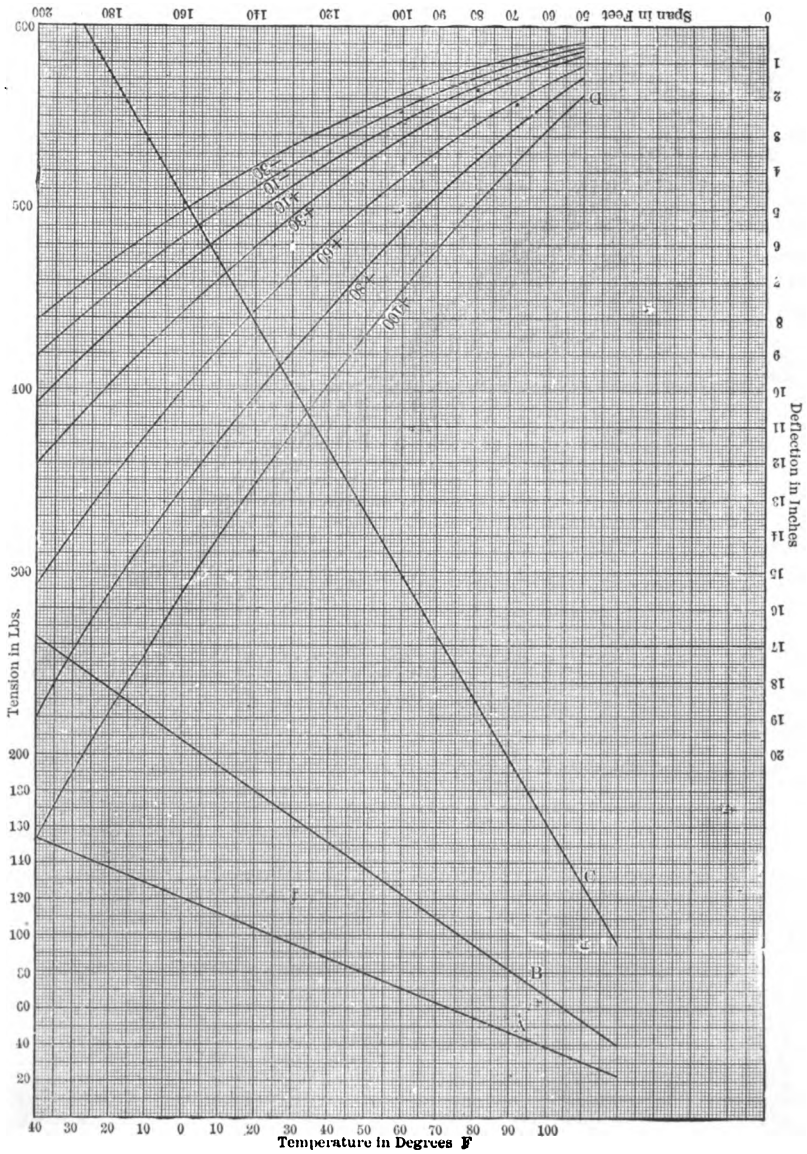

FIG. 116.—SAGS AND TENSIONS.



Fig. 116 a table is prepared from this formula, giving all requisite information regarding sags and tensions.

First. If wire is erected by dynamometer the proper tension is found by referring to curves *A*, *B*, and *C*. Curve *A* is for .080 copper wire, curve *B* .104 copper, and curve *C* .165 copper. Curves *B* and *C* may be used for iron wire of similar or nearly similar sizes. Find on the lower scale the temperature at which the wire is being strung, follow a vertical line up to the curve of the proper size of wire, then a horizontal to the left-hand scale, finding the tension to which the wire shall be strung. *Example*.—A No. 12 wire is to be strung at 60° F., what is the tension? From 60 follow a vertical to curve *B*, thence a horizontal to the left, finding 124 pounds, and with the dynamometer the wire should be pulled to 124 pounds, no matter what the span between the poles may be.

Second. If wire is strung by center deflection, turn the table over so the curves marked *D* are at the bottom, find on the lower scale the span between the poles, follow a vertical line to the curve marked with the temperature at which the wire is being strung, thence a horizontal to the left-hand scale, finding the deflection in inches at the center of the span. *Example*.—What deflection shall be given to any wire strung at 60° F. between poles 100 ft. apart? From 100 ft. on the lower scale follow a vertical to the curve headed + 60° F., thence a horizontal to the left-hand scale, finding 4.15 in. the proper deflection at the center of the span.

## SECTION 55.

**Location of Wire on Pins.**

In all straight lines wires shall be placed on the insulators, as shown in Fig. 117—*A*. At all corners, curves, or whenever the line is not perfectly straight, wires shall be located as shown at *B*, Fig. 117.

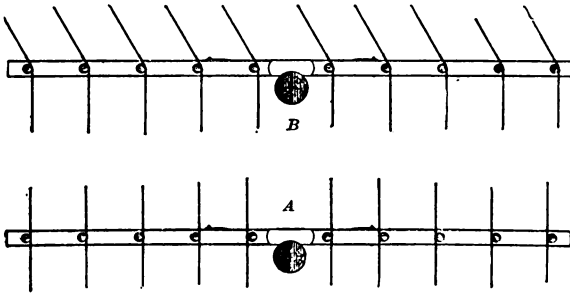

FIG. 117.—LOCATION OF WIRE ON PINS.

## SECTION 56.

**Tying Wire.**

Each wire shall be secured to its insulator by means of a tie wire of the same metal as the line wire. The qualities and dimensions of the tie wires are as specified in Section 40, and the method of applying the tie wire shown in Fig. 118.

## SECTION 57.

**Wire Joints.****A — COPPER WIRE.**

All joints shall be made in copper wire, with McIntire sleeves. There are two forms of the sleeve, the double form, illustrated in Fig. 120, and the single form, illustrated in Fig. 119—*A*. There is little choice between these

forms, though the single one is less likely to split. All sleeves shall be drawn of a single piece of the best annealed copper. Sleeves shall be supplied for each differ-

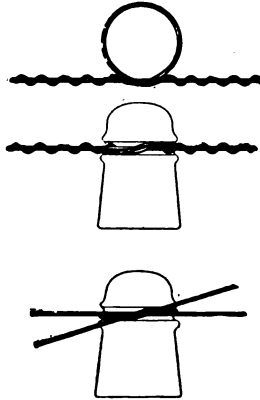

FIG. 118.—TYING OF WIRE.

ent size of wire, and no sleeve shall be more than .01 in. larger than the wire to which it is to be applied. Joints shall be made by slipping the ends of the wires to be

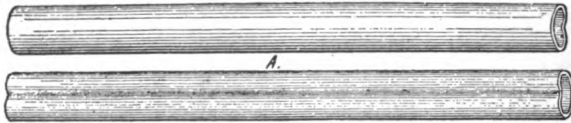

FIG. 119.—SINGLE M'INTIRE SLEEVES.

joined into their respective halves of the sleeve, so that the end of each wire shall project  $\frac{1}{4}$  in. through the sleeve. This end shall then be turned over, as shown in Fig. 121, and by means of the special McIntire pliers, illustrated

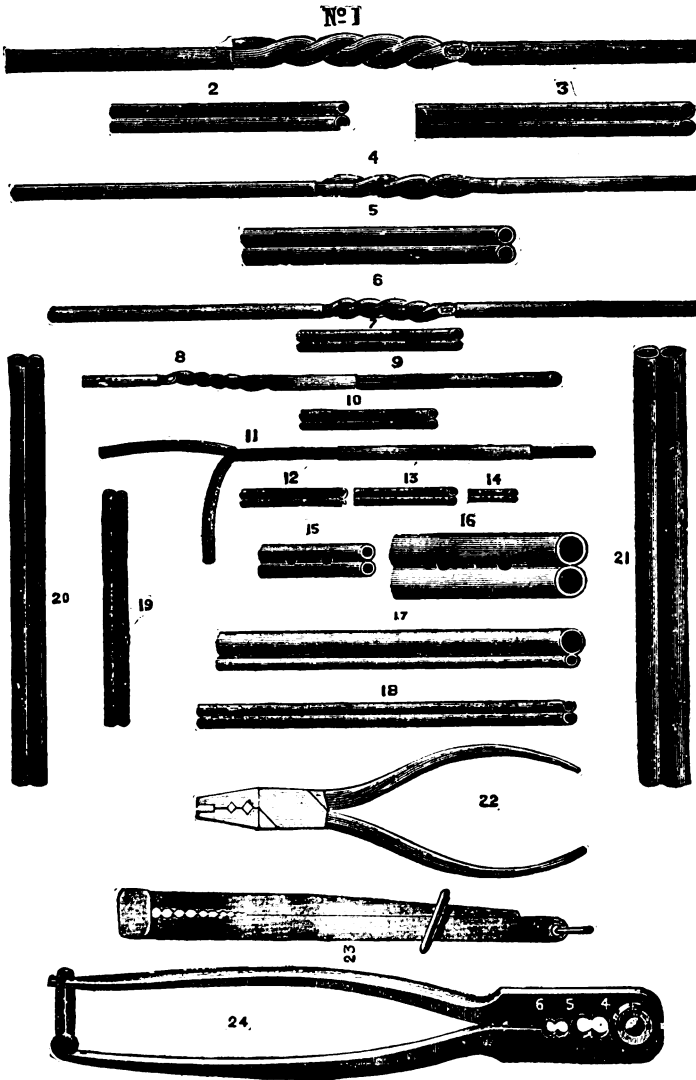

FIG. 120.—M'INTIRE JOINTS.  
16

in Fig. 120, the joints shall be twisted as shown in Fig. 121.



FIG. 121.— COMPLETED JOINT.

**B — IRON WIRE.**

All joints of iron wire shall be made with what is known as the Standard Western Union joint, as illustrated in Fig. 122.



FIG. 122.— WESTERN UNION JOINT.

**SECTION 58.**

**Dead Ending.**

In every case where a wire shall be terminated on a pin the method adopted at the last insulator shall be that shown in Fig. 123. A half McIntire joint shall be slipped over the wire. The wire shall then be turned around the insulator, the end slipped into the McIntire, and the joint made up, all as shown in Fig. 123.

**SECTION 59.**

**Transposing.**

**A — LOCATION OF TRANSPOSITIONS.**

Transpositions are introduced into the line at frequent intervals, in order to avoid inductive disturbances. The location of transpositions on twenty-wire lines shall be made in accordance with the diagram of Fig. 124. To

locate transposition poles, proceed as follows: Measure a distance of 1,300 ft. from the first open wire pole and mark the pole nearest the point so located as *A*. Measure a second distance of 1,300 ft. from the first 1,300 ft. pole, mark the nearest pole *B*. Proceed in the same manner to measure off poles at intervals of 1,300

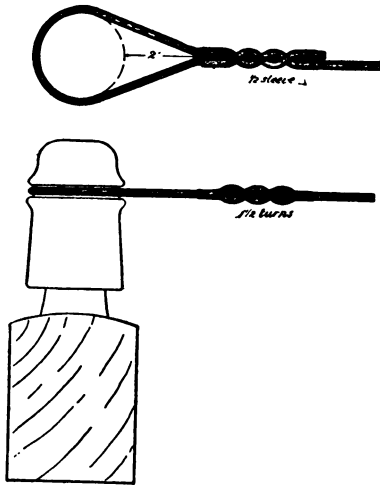
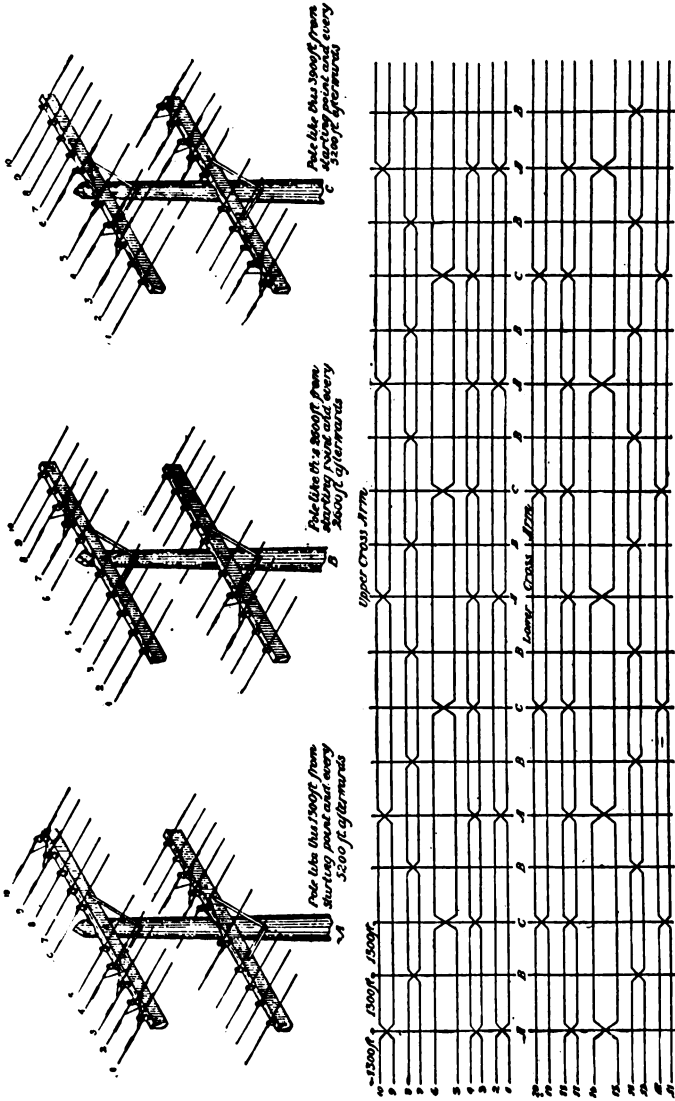

FIG. 123.—METHOD OF DEAD-ENDING.

ft. for the entire length of line. Poles so marked are designated respectively *A*, *B*, *C*, etc., in the diagrams, and are the poles upon which the wires shall be transposed, as shown by Figs. 124, 125, and 126. The diagram of Fig. 125 indicates the method of making transpositions on a twelve-wire line, consisting of two 6-pin cross arms. Diagram in Fig. 126 indicates another method of arranging transpositions on a 4-arm 40-wire



After 1700 ft the Pole Line contains more than two Cross-Arms. Transpose the 3rd, 4th, 5th, 6th, 7th, 8th, 9th, 10th, 11th, 12th, 13th, 14th, 15th, 16th, 17th, 18th, 19th, 20th, 21st, 22nd, 23rd, 24th, 25th, 26th, 27th, 28th, 29th, 30th, 31st, 32nd, 33rd, 34th, 35th, 36th, 37th, 38th, 39th, 40th, 41st, 42nd, 43rd, 44th, 45th, 46th, 47th, 48th, 49th, 50th, 51st, 52nd, 53rd, 54th, 55th, 56th, 57th, 58th, 59th, 60th, 61st, 62nd, 63rd, 64th, 65th, 66th, 67th, 68th, 69th, 70th, 71st, 72nd, 73rd, 74th, 75th, 76th, 77th, 78th, 79th, 80th, 81st, 82nd, 83rd, 84th, 85th, 86th, 87th, 88th, 89th, 90th, 91st, 92nd, 93rd, 94th, 95th, 96th, 97th, 98th, 99th, 100th.

FIG. 124.—TRANSPOSITIONS OF TWENTY-WIRE LINE.

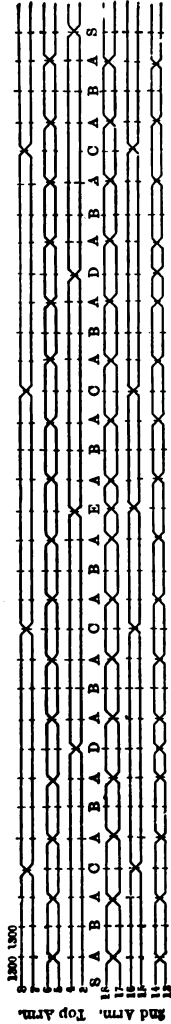

FIG. 125.—TRANSPOSITIONS FOR TWELVE-WIRE LINE.

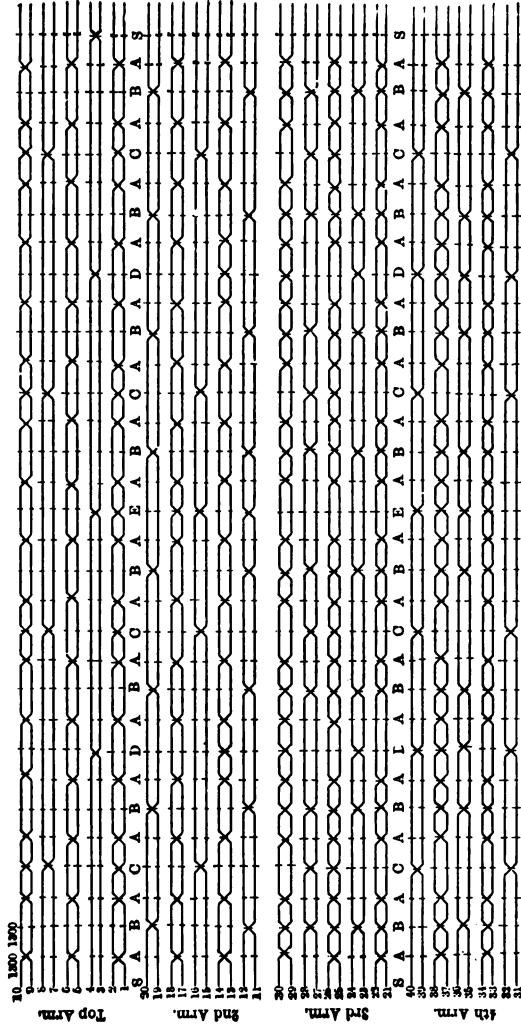

FIG. 126.—TRANSPOSITIONS FOR TWENTY-WIRE LINE.



line. These diagrams may be extended to any number of 6-pin or 10-pin arm lines.

#### B — TRANSPOSITION DETAILS.

There are two methods in common use for making transpositions. Each method requires the use of two transposition pins and two transposition insulators for each pair of wires to be transposed.

The first and older method is illustrated in Fig. 127 at *Y* and *Z*, *Y* showing a plan of the lines transposed, and *Z* a perspective view, including the cross arm. This diagram is self-explanatory. It is impracticable to use this form of transposition between the two wires nearest the pole, as the cross wires from one line to another would intersect in the middle of the pole. For the two wires nearest the pole transposition shall be made as shown in Fig. 127 at *U* and *V*. The only difference is that the line wires are bent backward around the back of the insulator to avoid the pole.

#### STOCK LIST FOR TRANSPOSITION SHOWN IN FIGURE 127.

- 2 Transposition pins.
- 2 Transposition insulators.
- 2 Whole McIntire joints.
- 6 Half McIntire joints.

The more modern method of making transpositions are shown in Fig. 128. To make this transposition, cut the wires *A* and *C* of such a length as to enable them to be dead-ended on their insulators, slip over each wire a McIntire sleeve, and run it back about 2 ft.; carry each wire to its insulator and dead-end it with a half sleeve.

Cut the wires *B* and *D* about 5 ft. longer than is necessary to reach their insulators, carry each to its insulator, turn it around the insulator and dead-end it with a

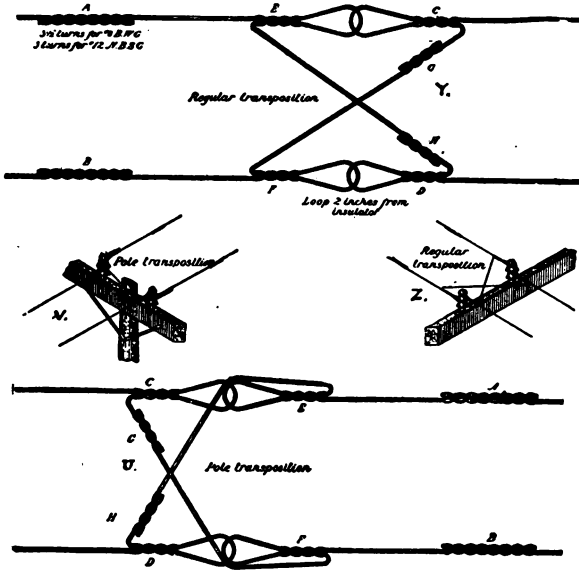

FIG. 127.—DETAILS OF TRANSPOSITION.

half McIntire; then carry the slack over the wires *A* or *C*, introduce it in the McIntire joints previously specified, and twist the same into a joint.

STOCK LIST, FIGURE 128.

- 2 Transposition pins.
- 2 Transposition insulators.
- 2 Whole McIntire joints.
- 4 Half McIntire joints.

## SECTION 60.

**Distribution.**

Where distributing poles are used to reach subscribers' sub-stations, the open wire lines shall be terminated on their appropriate insulators and bridled to the pole ring. From this point the drop wires shall be swung to

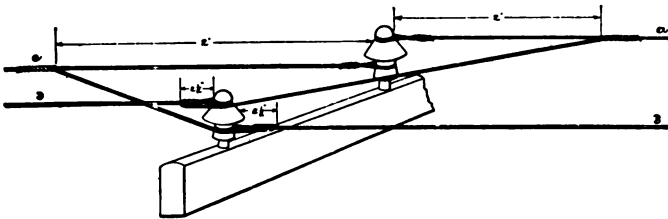

FIG. 128.—RECENT METHOD OF MAKING TRANSPOSITIONS.

the sub-stations. Drop wires shall either consist of twisted pair of okonite or weather-proof wire, as specified in Sections 38 and 39. Where the distribution is made from open wire cross-arm lines the methods shown in Fig.

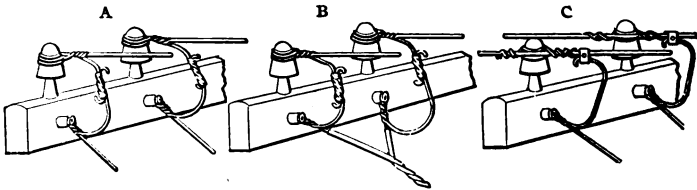

FIG. 129.—SUBSCRIBER DROP WIRES.

129 shall be used. In all cases the wires shall be dead-ended on their appropriate insulators, as shown. A pair of knobs shall then be attached to the cross arms, directly beneath the circuits, to which the drop wires shall

be attached. The drop wire may be either a pair of open wires, as at *A*, or a twisted pair of okonite or weather-proof, as shown at *B*. The attachment on the open wire to the open wire circuit may be made by McIntires or connectors, as at *B* or *C*.

#### SECTION 61.

##### **Protection.**

Whenever open wire lines run into a building or a cable, each wire shall be protected by a fuse. If the sub-station is supplied with any one of the approved forms of protection, having fuse, heat coil, and spark gap, and if the cable is terminated in a similarly protected head at the open wire, no further protection shall be introduced. But in case either the cable or the sub-station is unprotected a fuse such as is specified in Section 32 shall be introduced at the unprotected end of the line. At the cable pole the fuse shall be clamped to the open wire close to the insulator and the bridle wire attached to the other end of the fuse. At the sub-station the fuse shall be attached as close to the wall brackets as possible.

#### SECTION 62.

##### **Prevention of Humming.**

In case of difficulty with humming, the wires causing complaint shall be tied to their insulators, as shown in Fig. 130. The line wires shall be wrapped with a piece of soft rubber about 8 in. long, and then inclosed with a piece of sheet lead. The tie wire shall be treated in a similar manner, and then the wrapped line secured to the insulator with the wrapped tie.

## SECTION 63.

**House Top Lines.****A — RIGHT OF WAY.**

House-top lines shall be confined to accomplishing distribution, and only be used for extended circuits when it is impractical to reach sub-stations by regular routes. Prior to the construction of any house-top lines, all necessary rights of way shall be obtained in writing upon the regular blank forms provided by the company. Before rights of

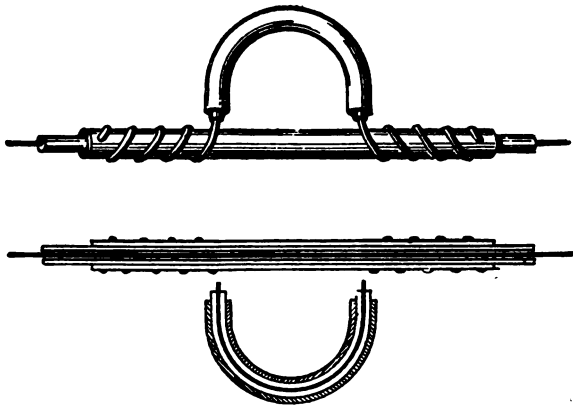

FIG. 130.—“ANTI-HUM” DEVICE.

way are negotiated a careful examination shall be made of each building to ascertain that its construction is amply sufficient to carry all the weight and stress that the contemplated line will impose. Rights-of-way contracts shall comprise a permission from the owner of each building to erect the necessary fixtures, guys, attachments, cables, and wire; shall state the amount of compensation to be paid therefor, and the length of time for which the permission

is granted. Whenever buildings are not occupied by the owners, an additional permission in writing shall be obtained from each and every tenant whose premises shall in any way be affected, either by the placing of any fixtures, wires, cables, etc., or during the process of construction. Such permissions shall be on authorized forms, and shall grant to the company leave to pass through and occupy such portions of the premises of the tenant as may be necessary for the purpose of construction and repairs, and shall state any compensation to be made therefor. Rights of way shall include and describe the methods, locations and means of extending cables or other circuits from such manholes or distributing poles in the general wire plant system of the company, as may be required to reach and serve the house-top line under consideration, and shall cover permission to occupy and use the premises of the grantor of the right of way for this purpose.

#### B — CONSTRUCTION.

The actual construction of house-top lines shall consist of two parts:

1. The connection to the main wire plant.
2. The fixtures and circuits.

1. *Connection to the main wire plant system.* The connection to the main wire plant system shall consist in running a cable from the nearest wire plant route of the company, to the point selected for the commencement of the house-top line. For this purpose a standard cable, having a sufficient number of pairs to supply the house-top line in question, shall be run from the selected manhole or distributing pole to the roof of the building on which the house-top line shall commence. If connection is to be

made with the underground a lateral shall be extended to the building, and either enter the cellar, or run upward along the outer wall to a sufficient height to protect the cable from external interference. If the lateral ends in the basement, the cable shall from its end extend to the roof through a light or elevator shaft, or such other passage-way in the building as may be found suitable for the purpose. If the cable is to run along the outside wall, it shall be placed near a leader, down spout, cornice, or moulding, so as to be as inconspicuous and protected as far as possible. In all cases the cable shall be fastened carefully and securely, as often as once in 18 in. All fastenings shall be so made as to prevent any injury to the sheath, and to support the cable in such a manner, that the sheath shall not be unduly strained. On the roof of the building, where the house-top lines commence, the cable shall be terminated in a pot-head, or cable-head, as may be directed for each case, and by means of bridle wires each cable conductor shall be carried to its specified pin on the house-top fixtures. (See Specification for Aerial Cables, Vol. III.)

2. *Fixtures and circuits.* House-top lines shall be carried on house-top fixtures, which shall consist of supports built of iron pipe, constructed as shown in Figs. 131, 132, and 133, specified as Fixture *A*, Fixture *B*, and Fixture *C*. Each fixture shall consist of wrought iron pipe set in a socket placed on the building roof, and carrying one or more cross arms. There shall be 3 standard sizes of pipe poles, as shown in Fig. 134, at *A*, *B*, and *C*. Pole *A* shall be made of 3-in. lap-welded tube, from 10 ft. to 15 ft. long, and shall be used for single pole fixtures, *A* and *B*, as shown in Figs. 131 and 132, when no more than 3 arms are needed. Pole *B* shall

be made of 4-in. pipe, from 12 ft. to 18 ft. long, and shall be used for fixtures *A* and *B*, Figs. 131 and 132, when more than 4 arms are needed, and always when Fixture *C* shown in Fig. 133, is used. Pole *C* may be used for any fixture, in case conditions are such as to imperatively demand the use of a very high pole, and

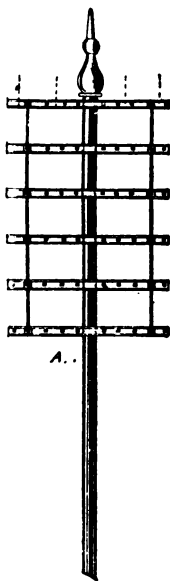

FIG. 131.—FIXTURE A.

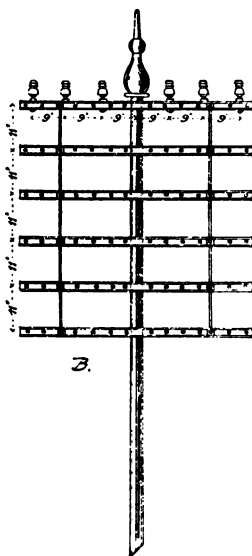

FIG. 132.—FIXTURE B.

shall be made of one piece of  $3\frac{1}{2}$ -in. pipe, 10 ft. long, telescoped and welded into one piece of 4-in. pipe, 15 ft. long, making a pole 23 ft. over all. Fixtures *A* and *B* should be limited to 5 cross arms, and Fixture *C* used when no more than 30 wires are needed. Fixture *C* can be used to carry 100 wires when built with pole *C*,



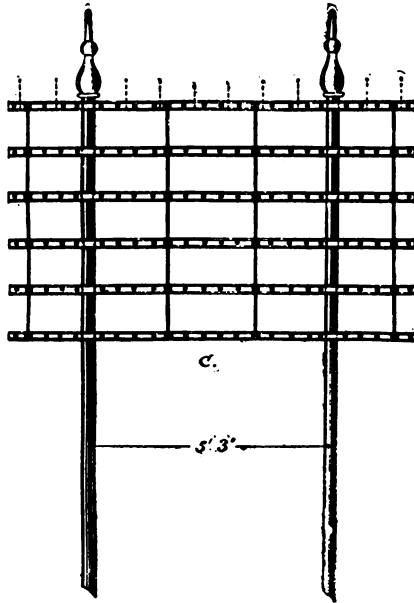

FIG. 133.— FIXTURE C.

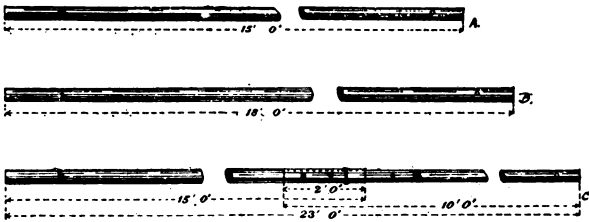

FIG. 134.— FIXTURE POLES.

but it is never expedient to build house-top lines of this capacity. Poles shall be secured in their bases either by leading, or by calking into place with a rust joint, made by calking around the end of the pole a freshly-made mixture of fine iron turnings, or filings, and sal ammoniac in the proportion of one part of sal ammoniac to two parts of iron. Pole steps shall be made of  $\frac{1}{4}$ -in. x  $1\frac{1}{2}$ -in. flat iron bent to fit each size of pole, as shown in Fig. 135. All poles shall be made of standard lap-welded ordinary iron pipe. All pipe shall be of regular sizes and thicknesses, and shall be first-class merchantable quality in all respects.

*Cross arms.* For each of the respective fixtures the cross arms shall consist of two  $1\frac{1}{2}$ -in. channels set back to

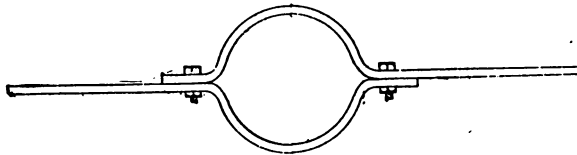

FIG. 135.—POLE STEP.

back, and fastened by  $5/16$ -in. bolts. To secure the arms to the pole and to hold the insulator pins in position, each channel shall be bent into an approximate semi-circle of 3-in. diameter for the pole, and 1-in. diameter for the pins. The channels shall be formed by heating and forging in a die. One  $5/16$ -in. bolt shall be placed on each side of each pole, and on each side of each pin. The details and dimensions of each arm are given in Figs. 136, 137, and 138, while a cross section is shown in Fig. 139.

*Pins and insulators.* Shall be standard pins and insulators as specified in Sections 16 and 17.

*Attachment to roof.* Each pole shall be set in an iron base placed on the roof. In case of a wooden roof, the



A.



FIG. 136.— CROSS-ARM FOR FIXTURE A.



B.

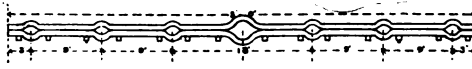
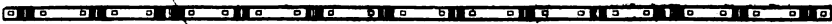

FIG. 137.— CROSS-ARM FOR FIXTURE B.

C



C.



FIG. 138.— CROSS ARM FOR FIXTURE C.

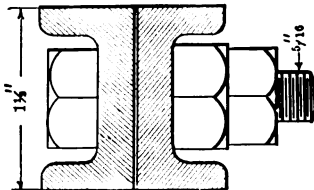

FIG. 139.— SECTION OF CROSS ARM.

base shown in Fig. 140 shall be used, and each pole shall be set over the principal roof timbers, so that no weight

shall fall on mere rafters or boarding. If necessary, a supplementary timber foundation shall be built to carry the load to the main timbers. The base shall be placed on

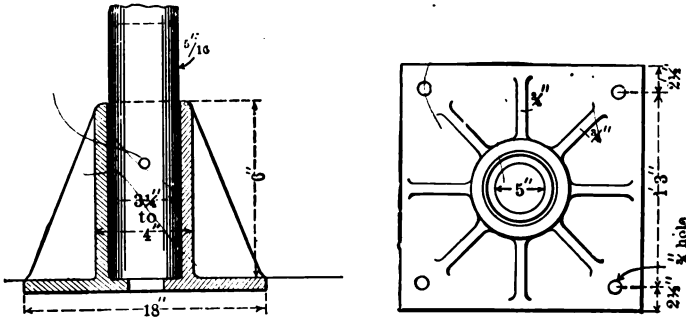

FIG. 140 — POLE BASE FOR WOOD ROOFS.

not less than 4 layers of roofing felt, and secured by 4  $\frac{5}{8}$ -in. lag bolts. For iron roofs the base shown in Fig. 141

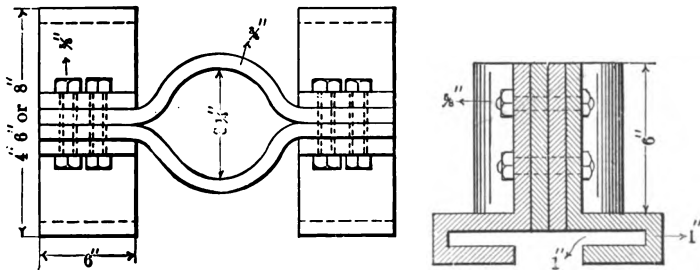

FIG. 141.— POLE BASE FOR IRON ROOF.

shall be used. This base shall be made to fit 4-in., 6-in., or 8-in. eye-beams, and shall be clamped on to the flanges of the beams of the principal roof system. By placing

shims between the casting and the pole pieces, both the pole and the beam can be clamped tightly. After each fixture is in place the roof shall be made tight by flashing around the base, rubber packing, or in any other manner satisfactory to the building owner.

*Guy.* Each fixture shall be stayed by not less than 4 guys, and as many more as may be required in special cases, each made of  $\frac{1}{4}$ -in. steel strand. At the pole each

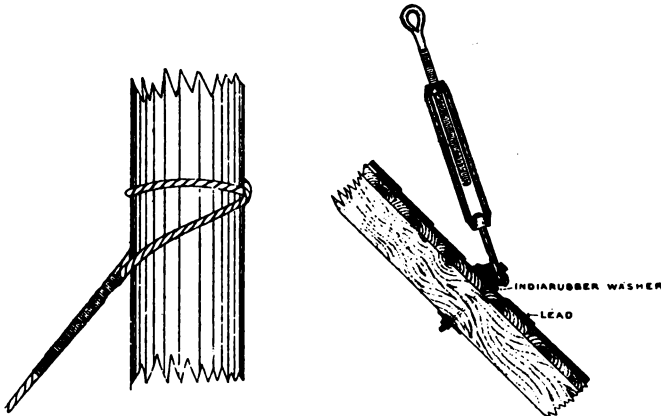

FIG. 142.—GUY AT POLE.

FIG. 143.—GUY ATTACHMENT TO ROOF.

guy shall be secured by a round turn and lashed eye, as shown in Fig. 142. Guys should be located as near the middle of the cross arms as possible. At the roof the guy shall, whenever possible, be fastened as shown in Fig. 143. A  $\frac{1}{4}$ -in. turn buckle or strand clamp shall be used, and the tension on all guys so adjusted to brace the pole equally in all directions. Care shall be observed to so locate the guys on each roof as to best protect the fixtures from the severest winds. If it is impossible to se-

cure guys to the roof, they may be attached to other portions of the building. The main wall, several feet below the cornice, is the next best place, and the guys secured by driving a wall iron into the brickwork. In this case the turn buckle or clamp must be placed above the roof and out of sight. Attachment to chimneys and cornices should be avoided as dangerous.

*Finishing.* After the fixture is complete, all the metal work shall receive two good coats of best metallic paint, slate color or light brown. All debris, tools, or materials shall be removed, the roof carefully examined and left in perfect and neat condition. In all other respects house-top lines shall be constructed of the same materials, and in the same manner as specified for regular open wire construction.



# INDEX.

## NUMBERS REFER TO PAGES.

- Accessories, 94.  
Accidents, 163-165.  
Aerial Cable Lines, 160.  
Aerial Lines, Cost, 125, 126, 127, 159.  
Alley Arm Braces, 188, 189.  
Alley Arms, 218.  
Alley Cross Arms, 178.  
Anchor Logs, 173.  
Arm Bolts, 189.  
Arm Bolts, Double, 190.  
Arm, Cross, Braces, 187.  
Arming, Cross, 216.  
Arming, Double, 218.  
Arms, Alley, 218.  
Arms, Cable, 219.  
Arms, Cross, 176, 177, 255.  
Attachment to Roof, 256.  
Bending Resistance, 65.  
Bolts, Carriage, 190.  
Bolts, Cross-Arm, 189.  
Bolts, Double Arm, 190.  
Bolts, Fetter Drive Screw or Lag Bolts, 190.  
Bolts, Rock Eye, 196.  
Bolts, U, 180.  
Brace, Vertical, 188.  
Braces, Cross-arm, 187, 188.  
Braces, Wooden, 174.  
Bracing, 225.  
Bracket Lines, 159.  
Brackets, Wood and Iron, 174, 175.  
Bridle Wire, 201.  
Cable Arms, 219.  
Cable Lines, Aerial, 160.  
Carriage Bolts, 190.  
Change in City Requirements, 142.  
Circuits and Fixtures, 252.  
City Lines, 206, 235.  
City Requirements, Change, 142.  
Clamps, Strand, 195.  
Common Return, 157.  
Connection to the Main Wire Plant System, 251.  
Connectors, 198.  
Construction, 251.  
Construction Specifications, 203.  
Contract, Right of Way, 27.  
Copper Line Wire, 198.  
Copper Wire, 107.  
Copper Wire Joints, 239.  
Cost of Aerial Lines, 125-127.  
Cost of Poles, 51-53.  
Country Lines, 204.  
Creosoting, 172.  
Cross-arm Bolts, 189.  
Cross-arm Braces, 187, 188.  
Cross-arm Lines, 159.  
Cross Arming, 216.  
Cross Arms, 255.  
Cross Arms, Standard, 176, 177.  
Cross Arms, Wire and Accessories, 88.  
Crossings, Corners and Curves, 227.  
Crossings, Highway, 230.  
Curves, Corners and Crossings, 227.  
Dead Ending, 242.  
Decay, 141.  
Deferred Depreciation, 143.  
Depreciation, 141.  
Details of Transportation, 246.  
Diagonal Alley Arm Brace, 189.  
Distribution, 113, 248.  
Distribution of Poles, 206.



- Disturbances of Telephone Lines, 144.  
 Double Arm Bolts, 190.  
 Double Arming, 218.  
 Drive Screws or Lag Bolts, 190.
- Electromagnetic Induction, 148.  
 "Electrostatic Capacity," 11.  
 Electrostatic Induction, 151.  
 Ending, Dead, 242.  
 Erection of Poles, 212.  
 Erection of Wire, 232.  
 Expense, General, 130.  
 Experiments by Langley, 68.  
 Eye Bolts, 196.
- Fetter Drive Screws or Lag Bolts, 190.  
 Finishing, 259.  
 Fixtures and Circuits, 252.  
 Foremen, Instructions to, 162.  
 Foundations, 209.  
 Fuses, 197.
- Gaining and Roofing, 207.  
 Galvanized Iron Wire, 201.  
 Galvanizing, 167.  
 Ground Rods, 198.  
 Growth of Territory, 141.  
 Guying, 75, 221.  
 Guy Rods, 193.  
 Guys, 258.  
 Guy Strands, 194.  
 Guy Stubs and Anchor Logs, 173.  
 Guards, Wheel, 192.
- Highway Crossings, 230.  
 House-top Lines, 250.  
 Humming, Prevention of, 249.
- Induction, Electromagnetic, 148.  
 Induction, Electrostatic, 151.  
 Inspection, 165.  
 Instructions to Foremen, 162.  
 Insulators, 91.  
 Insulators and Pins, 255.  
 Insulators, Glass, 183.  
 Introduction, 1.  
 Iron and Steel Qualifications, 167.  
 Iron Wire, 104.  
 Iron Wire, Galvanized, 201.
- Joints, Wire, 239.
- Langley's Experiments, 68.  
 Leakage, 144.  
 Light Cross Arms, 177.  
 Lightning Protection, 94.  
 Lightning Rods, 209.  
 Line Disturbance, 144.  
 Line Insulators, 183-185.  
 Line, Loaded, 8.  
 Line Pins, 182.  
 Line Wire, Copper, 198.  
 Line Work, Illustrations, 3-5.  
 Line Work, Straight Double  
 Bracing, 216.  
 Line Work, Straight, Single  
 Bracing, 216.  
 Lines, 125, 159, 160.  
 Lines, City, 206, 235.  
 Lines, Country, 204.  
 Lines, House-top, 250.  
 Lines, Specifications for Construction of, 159.  
 List Stock, 247.  
 Loaded Line, 8.  
 Location, 160.  
 Location of Poles, 204.  
 Location of Wire on Pins, 239.  
 Logs and Stubs, 173.  
 Longitudinal Tension, 61.
- Main Wire Plant System Connection, 251.  
 Material Specifications, 168.
- Objections, 162.
- Painting, 221.  
 Pins, 89.  
 Pins and Insulators, 255.  
 Pin Setting, 219.  
 Pins, Wire Location on, 239.  
 Pins, Wooden, 181-183.  
 Poles, 39, 169, 172.  
 Pole Braces, Wooden, 174.  
 Pole Distribution, 206.  
 Pole Erection, 212.  
 Poles, Fitting of, 207.  
 Pole, Location, 204.  
 Pole Prices, 51.  
 Pole Protection Strips, 192.

- Pole Rings, 191.  
 Pole Setting, 209.  
 Pole Steps, 191.  
 Pole Strength and Stresses, 57.  
 Porcelain Insulators, 186.  
 Preface, xiii.  
 Prevention of Humming, 249.  
 Protection, 208, 249.  
 Protection, Pole Strips, 192.  
 Pupin's Experiments, 17-19.  
  
 Qualifications of Iron and Steel, 167.  
  
 Rear Braces, 187.  
 Resistance to Bending, 65.  
 Return, Common, 157.  
 Right of Way Contract, 27.  
 Rights of Way and Routes, 22.  
 Ringing, 207.  
 Rings, Pole, 191.  
 Rock Eye Bolts, 196.  
 Rods, Ground, 198.  
 Rods, Guy, 193.  
 Rods, Lightning, 209.  
 Roof Attachment, 256.  
 Roofing and Gaining, 207.  
 Routes, 160.  
 Routes and Rights of Way, 22.  
  
 Sag and Tension of Wires, 236.  
 Screws or Lag Bolts, 190.  
 Setting of Pins, 219.  
 Setting of Poles, 209.  
 Shipments, 166.  
 Sleet Storms, 142.  
 "Specific Electrostatic Capacity," 11.  
 Specifications, 168.  
 Specifications, Construction, 203.  
 Specifications for Construction of Aerial Lines, 159.  
 Staples, 197.  
 Steel and Iron Qualifications, 167.  
 Stepping, 207.  
 Steps, Pole, 191.  
 Stock List, 247.  
 Storms, Sleet, 142.  
 Straight Line Work, Double Bracing, 216.  
  
 Straight Line Work, Single Bracing, 216.  
 Strand Clamps, 195.  
 Strands, Guy, 194.  
 Strength and Stresses of Poles, 57.  
 Stress, Wind, 68.  
 Stresses and Strength of Poles, 57.  
 Strips, Pole Protection, 192.  
 Stubs and Anchor Logs, 173.  
  
 Tension, Longitudinal, 61.  
 Tension and Sag of Wires, 236.  
 Terminal Pins, 182.  
 Territorial Growth, 141.  
 The Common Return, 157.  
 Thimbles, 194.  
 Tie Wire, 203.  
 Timber for Poles, 46-49.  
 "Transposition," 150.  
 Transposition Details, 246.  
 Transposition Insulators, 185, 186.  
 Transposition Pins, 182.  
 Tying Wire, 239.  
  
 U Bolts, 180.  
  
 Vertical Brace, 188.  
  
 Weather-proof Wire, 202.  
 Wheel Guards, 192.  
 Wind Stress, 68.  
 Wire, 96, 104, 107.  
 Wire, Bridle, 201.  
 Wire, Copper Line, 198.  
 Wire, Cross Arms, and Accessories, 88.  
 Wire Erection, 232.  
 Wire, Iron, Galvanized, 201.  
 Wire Joints, 239.  
 Wire Location on Pins, 239.  
 Wire Plant System Connection, 251.  
 Wire Sag and Tension, 236.  
 Wire, Tie, 203.  
 Wire Tying, 239.  
 Wire, Weather-proof, 202.  
 Work, Double Bracing, 216.  
 Work, Single Bracing, 216.  
 Wooden Pins, 181.  
 Wooden Pole Braces, 174.

