















THE  
NEW YORK

COACH-MAKER'S MAGAZINE,

DEVOTED TO THE  
LITERARY, SOCIAL, AND MECHANICAL INTERESTS OF THE CRAFT,

---

EDITED BY E. M. STRATTON.

---

VOLUME SEVEN,  
JUNE, 1865, TO MAY, 1866.

---

NEW YORK:  
E. M. STRATTON, Publisher,  
5 LUDLOW STREET.  
MDCCCLXVI.

TS2001

N48  
MHT/PD

24,250





## P R E F A C E .

---

EIGHT years have flown—one volume was two years in publishing—since we sent abroad the first number of THE NEW YORK COACH-MAKER'S MAGAZINE. During this period we have been making history at a rapid pace. Our political horizon has exhibited sunshine and storm, such as has never before been seen by any people; but out of it all has come a purification, which, if continued, will make this the greatest nation that time has ever seen. We have crowded into the period above mentioned events which have involved in their result the liberties of thousands yet unborn. Thanks to an overruling Power, right has come off victor, and to-day our national escutcheon is an untarnished one. May it thus ever remain.

When we take a retrospective view of our own personal labors in behalf of the special department of trade to which we have been educated, we are led to wonder and rejoice—to wonder why we did not despair during the four darkest years of our existence; to rejoice that we find our Magazine once more in a prosperous condition. The sales of the present volume have far exceeded our most sanguine expectations; the entire edition being nearly disposed of. Very soon the Seventh Volume will be pronounced "scarce," which, in the language of book-sellers, implies dearness. As the Magazine is not electrotyped, this is now unavoidable, the excessive costs of printing presenting obstacles we cannot overcome.

There are some features in the present volume which, in our judgment, renders it unique. The full account of the London Journeyman Coachmaker's Industrial Exhibition; the Report of Carriages in the Dublin International Exhibition of 1865; the American Dictionary for Coach-makers, and a great variety of other important articles, constitutes this volume one of great value. That the forthcoming one may not suffer in comparison with any of the preceding, we have taken special pains to make the proper preparation, in the trust that, as in the past, we shall have the pecuniary as well as the literary co-operation of our friends. In view of which, we remain,

Yours, decidedly,

NEW YORK, *April 8th*, 1866.

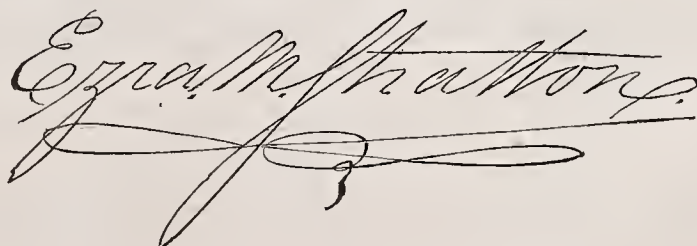

## INDEX TO PLATES IN VOLUME SEVEN.

DIRECTIONS TO THE BINDER.—The Portrait of Oren E. Miles, Esq., to face the title-page. All other Plates should be placed at the back end of the volume, in the order as numbered, for the convenience of reference when showing them to customers. All advertisements bound up with the volume should be placed after the Plates.

PLATE	PLATE	PLATE
Portrait of Oren E. Miles ( <i>Frontispiece</i> ).	15. Pony Sleigh.	32. Skeleton-front Coupé.
1. American Victoria.	16. German Sleigh.	33. Physician's Phaeton.
2. Duplex Tilbury Phaeton.	17. Park Phaeton.	34. Bracket-front Buggy.
3. Servant-seat Buggy.	18. Depot Buggy.	35. Original Monograms (3 figures, O. L. G., A. O. T., and H. I. Q.).
4. Original Monograms (3 figures, C. L. W., D. G., O. W.).	19. Newport Cart.	36. Extension-top Rockaway.
5. Open Beach-wagon.	20. Berlin Caleche.	37. Two-seated Phaeton.
6. Moulded Side-spring Buggy.	21. Cut-under Turn-out Seat Buggy.	38. Sporting Phaeton.
7. Stivers' Buggy.	22. Moulded Elliptic-spring Buggy.	39. Road Buggy.
8. E. Lane's Undulating-spring Buggy (2 diagrams).	23. Original Monograms (3 figures, W. T., L. W. C., F. E. L.).	40. Clarence Coach.
9. Excelsior Coupé.	24. Round-front Six-passenger Rockaway.	41. Extension-top Phaeton.
10. Tilbury Dog-cart.	25. Physician's Phaeton.	42. Excelsior Buggy.
11. Family Buggy.	26. Philadelphia Buggy.	43. Original Monograms (3 figures, L. R., F. S., A. M. B.).
12. Original Monograms (3 figures, A. W. P., L. D. S., H. I. S.).	27. Tandem Sleigh.	44. Juvenile Hearse.
13. Booby Hut (sleigh).	28. New York Caleche.	45. Triangular Rockaway.
14. Pony Sleigh.	29. Thresher's Combination Coal-box.	46. Hartford Buggy.
	30. Moulded Tilbury Buggy.	
	31. Road Buggy.	

## INDEX TO ILLUSTRATIONS.

	PAGE		PAGE		PAGE
Diagrams Illustrating the Strength of Axletrees (4 <i>Illustrations</i> ),	2, 49, 82, 83, 84	Ancient Roman Carriage part,	67	View of the Owl Creek Tire-setting Company's Establishment (humorous).	133
Cab Phaeton, with Turn-over Seat and Cant-board (English),	21	Eccentric Carriage-part,	89	Cupid in a Chariot Driving Goats (2 <i>Illustrations</i> ).	146
Machine for Preventing Ruts in Roads,	23	Cylindrical Wheel,	99	Armenian Cart Wheel,	147
Specimen of Coach Lace from Messrs. Horstmann & Son's Establishment, Philadelphia,	26, 58, 74, 123, 153	Conical Wheel,	99	Portuguese " "	147
Mechanical Grasshopper,	36	Caleche Body with Cant-board (English),	101	Sham-caning Apparatus,	152
Two Plans for Drawing Sweeps, Wheel,	51	Coupling Perches to Axles (2 <i>Illustrations</i> ),	106	Cupid in a Chariot Driving Swans,	163
The Syctalve, Illustrated,	51	Egyptian Chariot Wheel,	115	Bird Chariot from a Pompeian Design,	163
Ancient Roman Wheel,	52	Assyrian " "	115	Adams' Circular Spring Wheel,	164
		Inside View of Thrasher's Buggy,	120	Chariot Drawn by a Griffin,	179
		Pompeian Grotesque Illustration of a Chariot Race,	131	Skelley's Patent Wheel,	180
		Cupid in a Chariot, with a Team of Lion and Tiger Combined,	131		



NOTICE

AFTER CAREFUL EXAMINATION OF THE  
INNER MARGIN AND TYPE OF MATERIAL  
WE HAVE SEWN THIS VOLUME BY HAND  
SO IT CAN BE MORE EASILY OPENED  
AND READ.



## INDEX TO VOLUME SEVEN.

TO THE READER.—Under the separate heads of "THE HOME CIRCLE," "SPARKS FROM THE ANVIL," "PAINT ROOM," "TRIMMING ROOM," and "EDITOR'S WORK-BENCH," will be found the matter appertaining to those special departments. The departments here named are themselves all placed in alphabetical order with the remaining articles.

	PAGE		PAGE		PAGE
Advertising Cuts,	185	Coach-making in Africa,	54	Estimates for the Consideration of Car-	
American Artisan,	30	Coach-wheel, Driving a,	186	riage-makers,	168
Announcement,	39	Conical Rims, 134; Cylindrical,	134	Every Saturday, 142, 157,	186
An Innovation,	100	Coupé, Excelsior, 39; Skeleton Front,	137	Expensive Stable,	30
A Novel Invention,	62	Designs for May,	173	French Odometers,	163
Aristocracy, English and Russian,	185	Dog-cart, Tilbury,	39	Ginzrots, Wagen und Fahrwerke,	186
A Road Preserver,	23	Dog Carting in New York,	30	Hack-coach, Costs of,	168
Atlantic Monthly, 13, 30, 44, 109, 143,	158, 186	Drive, The Bloomingdale,	173	Hackmen, The, Looked After,	29
Beach Wagon,	24	Drosky, The,	157	Hearse, Juvenile,	180
Buggy, Bracket-front, 137; Cut-under		EDITOR'S WORK-BENCH:		HOME CIRCLE:	
Turn-out Seat, 88; Depot, 72;		A Chat with the Reader,	11	Aunt's Story, The	7
Excelsior, 168; Family, 39;		Advertising Cuts,	185	Babies, Natural History of,	136
Hartford, 181; Molded Elliptic,		Apprentice System, Need of,	77	Blacksmith's Toast, A,	7
88; Molded Tilbury, 121;		Carriage-making, Progress in,	184	Evening Thoughts (poetry),	69
Philadelphia, 105; Road, 121,		Carriage Museums,	141	Horse Feeding,	84
151; Road-molded Side-spring,		Carriages, Costs of, 171; Public,	171	Horse Market, New York,	29
24; Top Buggy, average costs of,	168	Charts, 172,	185	Horses, Detaching from Vehicles,	
Butts on Keeping Tires Tight,	45	Cincinnati, The Way they do		Help for Fallen, 94,	102
Caleche, Berlin, 88; New York,	120	Things in,*	156	Horses and Carriages, Draft	
Capital and Labor,	55	City Matters.	13	applicable to, 98,	113
Cart, Newport,	72	Correspondents, Considerations		Inventions, American, 14, 30, 46,	
Carriage Architecture (English), 21,	101	for,	154	62, 79, 110, 143, 168, 173.	
Carriage-manufactory, Largest in Maine,	157	Day's-work, Eight Hours a Fair,	28	Canadian, 31, 187; Foreign,	
Carriage-makers, Estimates for the Con-		Despicable Cupidity,	76	15, 31, 79, 111, 143, 159,	173
sideration of,	168	Editorial Viatory,	41	Jane North, the Story of, An Au-	
Carriage making, Eccentricities in, 23,	37	Exhibition of 1867, French,	156	tobiography, 103,	118
Carriage Materials, Current Prices in,		Governmental Mistakes,	43	Lincoln (poetry),	6
16, 32, 48, 64, 80, 96, 112, 144,		Important Trifles,	17	October (poetry),	86
160, 176,	187	In Memoriam (Mrs. L. H. Sig-		President Lincoln's Favorite Poem,	6
Carriage-part, Ancient,	67	ourney),	28	Rebellion, Pencilings of the,	6
Carriage-springs, Lane's Vulcanized		Intelligent Mechanics,	75	Revenge, The wild justice of, a	
Rubber "Undulating," 29; Man-		Internal Revenue Laws, Decis-		Sketch from personal reco-	
ning's Improved.	13	ions in, 142; Proposed Chan-		lections of Life in Ireland,	69
Carriage-wheels, Critique on, 147, 164;	180	ges in,	158	Snobbish,	7
History of,	51	Labor, The Day of Eight Hours,	108	Song of the Wind (poetry),	118
Carriage, Replevin of a, 157; For Inva-		Laboring to Advantage,	184	Story, Two Ways of Telling a,	87
lids,	173	Mechanism, Longevity of,	44	The Dandy and a Toll-gate Keep-	
Carriages, Report of, In the Dublin In-		Modern Travel,	66	er,	71
ternational Exhibition of 1865,		Other Days, Relics of,	185	The Past (poetry),	85
115,	129	Personal Matters,	59	Thoughts of Earth (poetry),	136
Chariots in Ancient Times,	172	Road Steam-carriage in India,	142	We shall meet in Heaven (poetry),	136
Chariots and Horses, Ancient Price of,	44	Stop their Mouths,	141	Young Smartness,	88
Chart, our new, Have you Seen?	78	Timber Selecting,	77	LETTER BOX, The Coach-maker's:	
Charts,	185	To the Public,	10	Letter from Alabama,	158
Coaching,	17	To our Patrons and Friends,	183	" " California	45
Coach-makers, American Dictionary		Trade, Review of, 60, 109, 126,		" " Illinois	95
for, A to B, 21; C to D, 37; D		172, 184		" " Indiana,	45
to E, 54; G to L, 69; M to Q,		Turn-out, A Political, under the		" " London,	14
102; R to S, 132; S to W, 161;		Hammer,	27	" " Massachusetts	13
Estimates for the consideration		Visit to our Western Friends,	91	" " Ohio,	173
of,	168	To a Wheel Manufactory,	156	Literary Notices, 13, 30, 44, 79, 110,	
Coach-makers' Industrial Exhibition,		Effects which different shaped Rims		143, 157, 186	
London Journeymen, 3, 18,	38	(tires), have on Roads, 99, 133, 165		London Omnibus System,	176
Coach-maker's Portfolio, Waifs from a,	113	English Cabs and other Vehicles,		London, Seven Deadly Sins of,	158
		Novelty in,	78	Long and Short Screw-drivers,	148



	PAGE		PAGE		PAGE
Lyrics of Life,	110	PEN ILLUSTRATIONS OF THE DRAFTS, 8, 24,		Welding Iron, 89; Steel and	
Mail-coach, The First English,	30	24, 39, 56, 72, 88, 105, 120, 137,		Cast, or Malleable,	106
Man-Odometer Wanted,	186	150, 167,	181	Spectacles for Horses,	30
Manufactory, Largest in the world,	157	Planks, To Check the Warping of,	30	Special Notices, 176,	187
"    New Wheel,	44	Pompeii, Pictures from, 131, 146, 163,		Stage-coaches, and Concord	
Mechanical Grasshopper,	36	178; Streets of,	50	Hacks out West,	257
Mexican Amusement,	117	Pony, Lost, The Bungay,	186	Steam Omnibuses, 13,	62
Miscellaneous,	150	Popular Errors, 1,	17	Squeezemhard's Mistake,	113
Modern "Gentleman,"	79	Phaeton, Duplex Tilbury, 8; Extension-		Strength of Iron,	100
Money, How to send,	78	top, 167; Park, 72; Physician's,		Team, What Constitutes a,	24
Musical Boxes, Jeff's,	13	105, 137; Sporting, 151; Two-		The Axle Discussion,	162
New York, Dog-carting in, 30; Horse		seated,	150	The Coach-maker's Lament (poetry),	114
Market, 29; Hack Inspection,	29	Railway Cars and Omnibuses, Weight of,	78	The Flour-market,	79
Omnibus System, London,	177	Relics of Other Days,	185	To Readers and Correspondents,	160
Oren E. Miles, Biography of,	65	Reviewer Reviewed, 49, 81,	97	To Subscribers, 32, 48,	64
Our Young Folks (notices of), 44, 79,	143,	Reviewed, How I was,	82	To Whom it may Concern,	78
	186	Rims, Conical, 99; Cylindrical,	99	Trade Unions,	30
<b>PAINT ROOM:</b>		Rockaway, Extension-top, 150; Round-		<b>TRIMMING ROOM:</b>	
About Brushes,	57	front Six-passenger, 105; Tri-		Afghans for Carriages,	171
Cleaning Stick Seats,	57	angular,	181	Black Japan,	40
Compounded Oils,	9	Screw-drivers, Long and Short,	146	Carriage-top Prop-block,	183
Body Coatings, Receipt for,	57	Simplicity in Rhyme,	44	Coach Lace, 26, 58, 74, 123,	153
Finger Marks,	57	Sleigh, Booby-hut, 56; Pony, 56; Ger-		Color vs. Tannin,	140
Green Cinnibar,	26	man, 56; Tandem,	105	Hammercloths, About,	140
Medley, A Painter's,	57	Soap on Arkansas stone,	66	Leather, Black Varnish for, 40;	
Oil and Oil-cake Factory, Dub-		<b>SPARKS FROM THE ANVIL:</b>		Cement for, 40; Cheating	
lin, 106, 122,	139	American Orders for English		in, 90; Making Water-proof,	
Original Monograms, 9, 40, 90,	140,	Iron,	169	74; Mixture for Preserving,	
Ornamentation,	40	A New Blow-pipe,	72	74; Tanning with Turpen-	
Painter, Hints for the,	72	Axles—An English Notion,	57	tine, 107; To Fasten on	
Painters' Brushes,	182	Anvil, Monstrous Cast-iron,	72	Metal, 10, 90; Varnish for,	40
Painters, Good news for,	40	Friction of Iron,	181	Lining Carriages in Olden Times,	170
Painting, 1805, 1865,	26	Browning Iron and Steel,	40	Lining Cloths,	170
Paint Peelings,	57	Case-hardening,	57	Machine Thread, 58,	154
Paints, Experiments with,	8	Eccentric Carriage-part,	89	Prop-block, Carriage-top,	183
Parisian Turn-outs,	61	Miscellaneous Scintillations,	169	Thread, Silk, Machine,	182
Poison vs. Poison,	58	Perch-coupling in Indiana, 152;		Saddlery and Harness in the	
Putty,	89	Literature, 25; Thrown out		Dublin Exhibition,	124
Sham-caning, 153; More about,	170	of Court,	89	To Trimmers,	107
Striping Pencils,	169	Perches, New mode of Coupling		Trimmings, Blue Cloth,	9
Turpentine, Spirits of,	58	to hind Axles,	106	Valuable Receipts,	40
Varnish, Hard as stone, 26;		Screw-bolt Screwers,	169	Warranted not to Fade,	90
Manufacture of,	9	Steel and the Bessemer Process,		Turnpike, The First,	2
Varnishes, Mixed English,	182	121, 137,	151	Turnpikes,	62
<b>PATENT JOURNAL:</b>		Steel and Iron, 39; Varnish for,		Victoria, American,	8
Inventions, American, 14, 30 46,		8; Browning,	40	Wagon, Steam, Ahead,	44
62, 79, 110, 126, 143, 158,		Steel, Constitution of, 8; Homo-		Wagons, Wide Tire,	173
173,	186	geneous for Carriage-tires,		War with the Hackmen,	44
Inventions, Canadian, 15, 31,	187	169; Producers and Steel		Water-cure Institution for Loose Tires,	133
"    Foreign, 31, 79, 111,		Consumers,	181	Windy,	44
127, 143, 159, 175,	187	Testing Springs,	169	Wood-workmen, Practical Suggestions	
		Vise, Parallel and Taper,	169	for,	177





AMERICAN VICTORIA.— $\frac{1}{2}$  IN. SCALE.

*Designed expressly for the New York Coach-maker's Magazine.*

*Explained on page 8.*



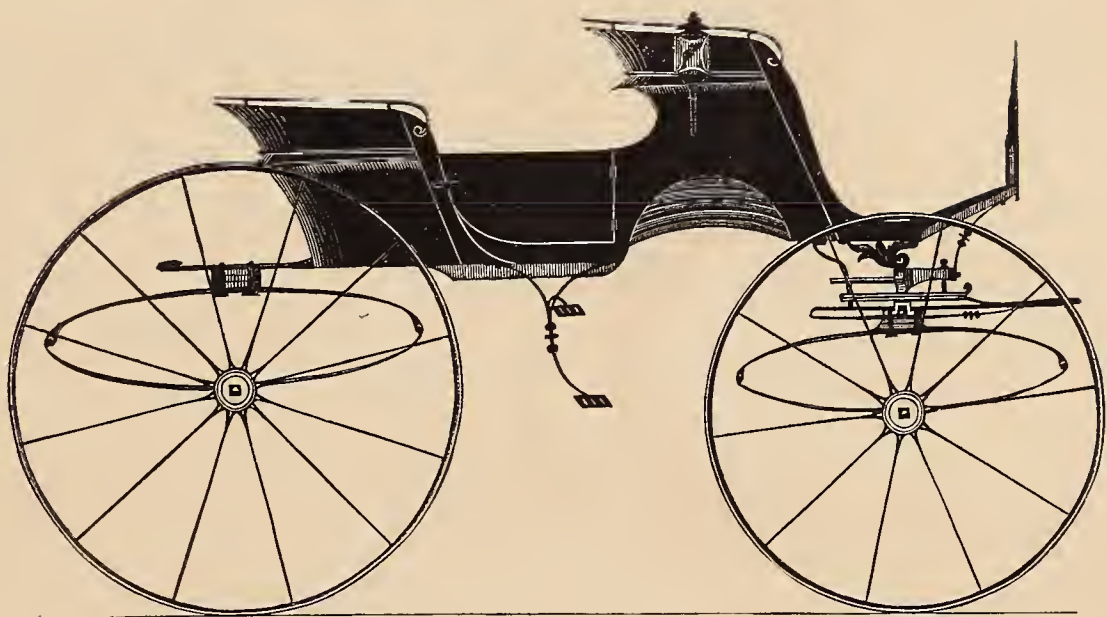

DUPLEX TILBURY PHAETON.— $\frac{1}{2}$  IN. SCALE.

*Designed expressly for the New York Coach-maker's Magazine.*

*Explained on page 8.*





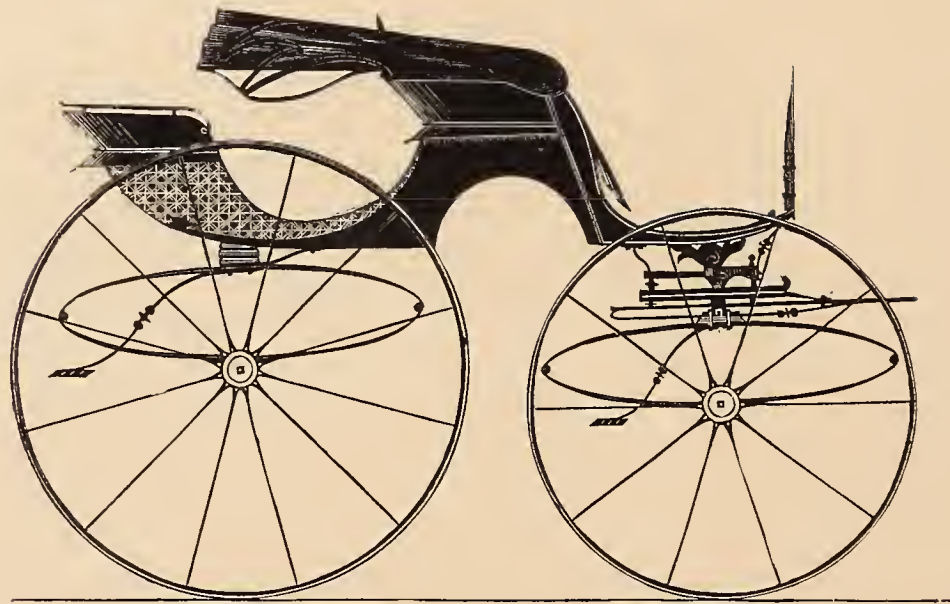

SERVANT SEAT BUGGY.— $\frac{1}{2}$  IN. SCALE.

*Designed expressly for the New York Coach-maker's Magazine.*

*Explained on page 8.*



C. E. W.



D. G.



O. W.

ORIGINAL MONOGRAMS.

DESIGNED BY J. G. D.



Faint, illegible text below the drawing, possibly a title or description.



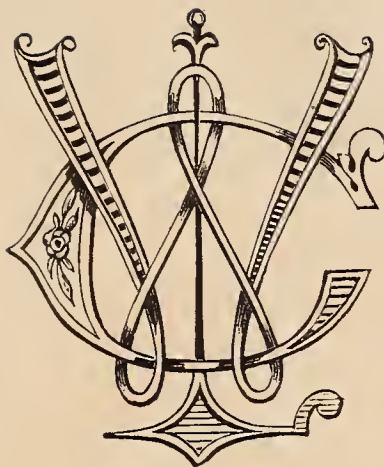

C. L. W.



D. G.

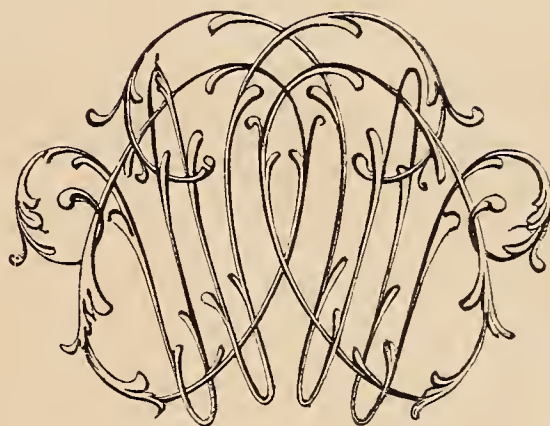

O. W.

ORIGINAL MONOGRAMS.

*See remarks on page 9.*







DEVOTED TO THE LITERARY, SOCIAL, AND MECHANICAL INTERESTS OF THE CRAFT.

Vol. VII.

NEW YORK, JUNE, 1865.

No. 1.

## Mechanical Literature.

### POPULAR ERRORS.

BY O. E. MILES.

How would the thousands of pages of reading which constitute the daily food of millions of readers who pay for and consume it be produced, and the lettered host who edit and contribute for it be maintained, and their presses be supplied with oil and steam, together with the multitude who earn their honest greenbacks in the manufacture of presses and paper, if only truth were printed, and every political, religious and philosophical fallacy were exposed and passed over to the bats and owls of dark oblivion the moment its character is discovered? Let all effort cease to make black look white, to make weakness look like strength—in a word, to make wrong seem right—and what millions of gifted brains and powerful muscles and machinery would at once be set at liberty to be applied to some useful purpose. But the wheel of Destiny has for long centuries yet to encounter the blocks which are all the time being forged by the enemies of progress. We must endure the presence of every error so long as money can be coined out of it. In proportion as such errors have been long-lived and powerful in their hold upon public favor, do we see the number large and influential who, having staked their all upon them, desire to see them perpetuated, and that they may fatten as long as possible out of the old carcass the means to this end are all made use of. The State, the Pulpit and the Press are made platforms upon which the lifeless body is dressed and paraded and by all means made to look like a living thing, though long since deserving the grave over which the ever-living foundations of truth are already laid.

It is often that we of the mechanical world are assigned the duty of exploding some giant heresy in the shape of a half developed idea or mechanical abortion, the perfection of which, however, was never doubted by its dotting parents and their friends who have lived to see it come into very general use. Patents by the score

have perhaps been issued, or improved processes in its manufacture and divers improvements in its details, all of course dependent for its patronage upon the real or supposed genuineness of the original substructure, and each enlisting a new squad to swell the number of its defenders. Like the side shows which cluster round a menagerie, they all stake their success upon the popularity of the great, grand and terribly awful *skyfungarorum* in the big tent. Especially in the enginery of war do we see the most far-reaching damage resulting from this state of things. It is by no means certain the best ordnance or the best small arms or the most healthful and convenient camp equipage is to be adopted, unless we can establish the fact that the individual or company offering it to the Government has at command the most money and the best lobbyists. These qualifications are generally possessed by the oldest plan, whether the best or not. It is humiliating in the extreme to confess that our country abounds in powerful combinations wielding vast amounts of capital who knowingly array themselves against the best means of destroying the enemy.

But I am wandering from the first intention of this article. I have been led to these general remarks upon popular errors from having observed with what tenacity some still cling to iron axles for wagons and carriages. Ten years ago the popularity of iron axles in this part of the country (Illinois) was at its height. Very few would have wooden axles who were able to pay for iron. About the same time I built the first thimble-skein wagon ever made here (Aurora) for Messrs. Boutwell & Anderson, since which time they have gradually gained upon iron till the latter have all left the track to the universal thimble-skein. So completely are the iron axles outlawed that merchants here having a few left on hand offer to sell them at the price of the rough bars; and I am informed on good authority that the Pittsburg axle-makers are melting up the remnant left on hand.\*

Why has this been? Is it because the makers of iron axle wagons have not observed the same correct principles in setting their axle-arms that the makers of wooden axles have? Not at all. The evidence cannot be pro-

\* Although we cheerfully admit this article to our columns for the sake of discussion, still we wish it understood that we do not endorse all the writer advances in favor of wooden axles over iron. Our readers have already in these columns had our opinion on this subject, and as this conflicts with those of our correspondent, we judge this notice necessary in order to escape the charge of inconsistency which otherwise might be brought against us.—Ed.



duced which would set aside that which I have had from hundreds who have brought their iron axles to this place to be re-welded and re-set. Why, it may be asked, are buggies still all made with iron axles? I answer, that as far as my observation goes, they give no better satisfaction there than in wagons, but a wooden axle to stand as much strain as the iron has to be so large as to look clumsy, so they are tolerated for their light appearance. There are very few of any observing faculties who will not agree with me that it is seldom that a buggy is seen in the streets with two persons in it but that presents the sorry spectacle of sprung axles. Take a bar of iron—an axle if you please—lay each arm on a horse thus :

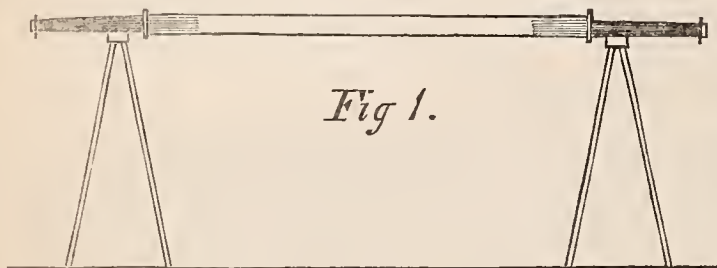

*Fig 1.*

In the position that it rests upon wheels. Lay a straw on the centre of it, and instruments are made which would show that the straw has sprung the iron bar, and every straw that is added increases the deflection till the end cometh, which in unscientific language would be a break-down.

Now, take the same bar, or one like it, and split in two, horizontally—thus figure 2 represents an end view :

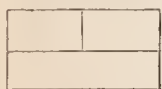

Then divide the lower half vertically, as shown, and we have three pieces all containing just the stock that the one axle did between shoulders. We then draw the two

*Fig 2.* small bars so as to make them long enough to occupy the position shown in figure 3 :

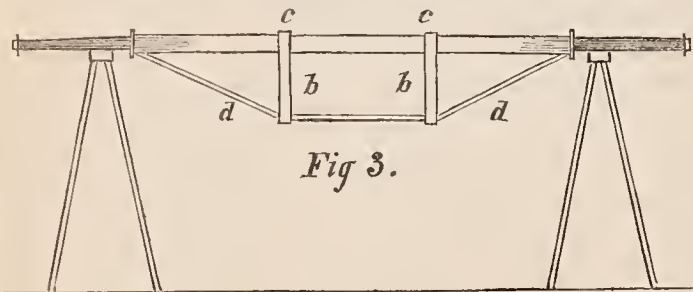

*Fig 3.*

With blocks between at *b b*, and all connected by elip *c c*. Now, it will take many hundred times the weight to seriously affect the position of the arms to this axle that was necessary to destroy the other, both weighing the same. There is no spring possible in this case, supposing the parts to be perfectly connected. The first appearance of give is the break-down, which is done by pulling the rods *d d* in two, endwise. Your readers have seen the plan by which I construct an unyielding axle embracing this principle. (See page 85, volume 6.) What I saw of the performance of my trial wagon, and heard of the opinions of the public concerning it, I have scarcely any more doubt that this is soon to be the universally recognized principle in the construction of wheeled vehicles, than I have that it has for a long time been the universal practice in the construction of railroad car trucks. Now,

this unyielding property in iron to endwise strain was created by the Maker of this abundant metal that we might thereby support great weights in an unerring position. The exceeding flexibility of the same metal to lateral pressure was instituted for equally wise purposes. Now, what looks very strange to me is that the makers of wheel vehicles, the machine of all machines which has to support the greatest burdens in proportion to its own weight, and jolts the hardest, will still ignore this principle, the great value of which has so long been acknowledged and used by other artisans under similar circumstances, and persist in the assumption that iron should not bend under lateral pressure. Suppose the axles in a new wagon to be set by the gauge to an exact nicety; every philosopher of reputation in the world will tell you that the first pound of load will move them out of position, which must inevitably be multiplied by every pound added to it, and will tell you further that after long-continued pressure they will refuse to regain their original position. In the light of these facts, how futile to talk of invariable plans for setting axles, or the established track for a carriage, or the correct position a spoke should occupy, or anything else which is based on the immutability of iron under lateral pressure.

#### THE FIRST TURNPIKE.

EXACTLY five hundred years have elapsed since a hermit, weary of the labor of having nothing to do, and tired of sitting the dull day through by the side of the stone which supported the sun-dial in front of St. Anthony's Chapel, on Highgate Hill—that stone which subsequently became known as Whittington's—resolved to mend the ways between the summit of the hill and the low part of the vale ending in Islington. This hermit was a man of some means, and he devoted them to bringing gravel from the top of the hill and laying it along the unclean track, which, then, as now, bore the name of "Hollow-Way." By digging out gravel, he gave a pond to the folks on the hill, where it was greatly needed; and he contributed cleanliness and security to the vale, where neither had hitherto been known. Travelers blessed the hermit who had turned constructor of highways; the pilgrims to St. Anthony's found their access to the shrine of the saint made easy and pleasant by him; and as for the beneficent hermit himself, his only regret was that, in accomplishing his meritorious act for the good of his fellow-men, he had entirely exhausted all his fortune. The king, however, came to the rescue. He set up a toll-bar, and published a decree addressed to "our well-beloved William Phelippe, the hermit," that he and the public might know wherefore. The king declared that he highly appreciated the motive which had induced the hermit to benefit "our people passing through the highway between Highgate and Smethfelde, in many places notoriously miry and deep." And in order that the new way might be maintained and kept in repair, the king licensed the hermit to take toll, and keep the road in order, and himself in comfort and dignity. This was the first road-bar created in England; and William Phelippe, the hermit, was the father of that race of turnpike-keepers whose sovereignty of the roads, within fifteen miles of London, came to an end, after a reign of five centuries, on the first day of the month of July of the past year 1864.



## LONDON JOURNEYMEN COACH-MAKERS' INDUSTRIAL EXHIBITION.

THIS Exhibition, of which we gave a notice in our last volume, was duly opened in London on the first of February, and appears to have attracted much attention from the press and public. Our correspondent, the Secretary, has kindly supplied us with printed notices of this first exhibition of the kind ever instituted, from which we select copious extracts for our pages. Should our readers feel half the interest in them which we do, the space we devote to the purpose will not be altogether lost. The first is from the *London Times* of January 31:

It would seem that competitive Industrial Exhibitions have become almost necessary to the healthy existence of all large and varied manufacturing trades. The North London Industrial Exhibition was, last November, one of the most successful of the year. The South London display, which opens to-morrow in Lambeth, promises to be equally fortunate. The Painters' Company, by the establishment of yearly exhibitions, have given a wonderful stimulus to excellence in their trade, and now the guild of Coach and Coach Harness-makers have followed the example, and have commenced an exhibition at the Coach-makers'-hall, near St. Martin's-le-Grand, which will be open to the public on the 1st proximo. The chief object of this exhibition is, of course, to encourage the workmen in the almost endless branches of the coach trade to exhibit the best specimens of manufacturing skill, the best working drawings of the vehicles now most in vogue, and, above all, the best designs for improving their general convenience and simplifying their mechanical contrivances. Mr. G. W. Hooper, of the Haymarket, has taken a most active share in the management and arrangement of this exhibition, and in connection with the Society of Arts, who, with their usual liberality, have given their cordial co-operation to the plan, a small but very interesting collection has been brought together, which will be opened on Wednesday by the Marquis of Lansdowne, who is the chief patron of the display. The nature and scope of the exhibition will be best judged of by the objects for which prizes will be given. The Society of Arts give prizes to the amount of 20*l.* for working drawings for a private carriage, showing the construction of its various parts; heraldic or ornamental chasing in silver, brass, or copper, suitable for carriage or harness; and heraldic or other metal ornaments produced by electro deposit suitable for carriage or harness ornamentation. Prizes are given by the Worshipful Company of Coach and Coach Harness-makers and others for open and close carriage combined; town barouche on under and C-springs; model of a light hospital carriage, to convey the sick poor; stuffed and quilted carriage cushion in blue morocco leather; drawing in pencil upon paper (half the full size) of an under fore-carriage for elliptic springs of usual or original design; landau pillar hinge; specimen of panel of carriage painting, either plain or ornamental; finished pad and bridle for pair-horse harness; the best covered carriage dash-iron, sewed by hand; working drawing of ornamental state lamp suitable for a coach or chariot; model of brougham or barouche lamp; full-size working models of furniture for pair-horse harness; working drawings of furniture for pair-horse harness; working drawings of bridle fronts; working drawings of bridle rosettes, of new design; working drawings of carriage door-handles, of new design; hard and soft solder plating.

Minor prizes are to be given for working drawings for improved street cabs; heraldic painting; decorative coach carving; drawings for an improved under fore-carriage for a brougham, combining lightness and strength; ornamental carriage painting, imitation pedestal painting, sham caning; also for harmonious combination of colors and perfection of surface; for the best method of detaching fallen horses quickly, either in front or rear; cushion stuffed and quilted in any material; new mode of trimming a carriage door; design for a hammer-cloth, combining a good effect and economy in cost, and others. The judges appointed are the Marquis of Lansdowne, Viscount Torrington, Mr. R. C. Mansell, South-Eastern Railway; Mr. Hall, of Long-acre; Mr. Holway, of Mount-street; and Mr. Rock, of Hastings.

The collection, as the first attempt of the kind, is not large, though what there is is perfect of its kind as to workmanship, and in its old relics and models is in the highest degree interesting. In models, as might be expected, it is unusually fruitful, and so also in good working drawings. Here one may see side by side the old conventional mail coach, with its cumbrous mechanism for securing the mail bags, and a model of the present railway mail vans, which are perfect little post-offices in themselves, and move all over England at the rate of 45 miles an hour. Here, too, are models and drawings of almost all the chief State carriages of Europe, including, of course, that of Her Majesty. The latter is still, though now nearly a century old, one of the handsomest and most regal-looking of them all, though the clumsy adaptation of its springs is said to impart such sudden and violent jerks to its illustrious occupants as to make it very difficult to sit upright in it at all even when drawn at the slowest pace. It was built for George III.; its beautiful panels were painted by Cipriani, and its cost is said to have amounted to the immense sum of 27,000*l.* Its carved work, which, with the rest of its form, was designed by Sir William Chambers, is remarkably fine, and as good in preservation now as the day it was made. Some exquisite wood carvings are also shown by Messrs. Peters which were executed for a new State carriage for George IV. The only four recognized State carriages in the kingdom are those of the Queen, the Lord Chancellor, the Speaker of the House of Commons, and the Lord Mayor. Of what are called "dress carriages" there are plenty of beautiful drawings, including those of the Dukes of Wellington and Devonshire. Among these sketches is one by William IV. for an invalid carriage for his own use, and with his scrawling autograph on the corner of the paper; and another, a fine pencil drawing, is a design for a sledge for the Queen by the late Prince Consort. In armorial and panel painting there are some exquisite specimens of workmanship, and a design for a brougham lamp, which gives a light as bright as a railway signal. A curious old engraving, which depicts the procession of the two Houses to St. Paul's to return thanks for Marlborough's victories, shows the quaint and most incommodious fashion of Queen Anne's days, when coaches were quite as uneasy and even less graceful to look at than those of a century before her reign. In coach-fittings, in embroideries, and linings, there are some very beautiful patterns shown. In these matters, however, the present age seems far behind in real value and richness of material the decorations that adorned the chariots of a century since. A specimen of the coach lace of Nelson, with its grim, roughly-designed picture of



the stern of the San Josef, contains more silk in a yard of its fabric than would now be given to almost the lining of a carriage. The whole exhibition, as a first attempt, is well designed, and future annual displays may be looked forward to with still greater confidence of success.

The Exhibition was opened by the Marquis of Lansdowne, K. G. His lordship, on arriving at the hall of the Coach and Coach Harness Makers, in Noble-street, Cheap-side, was received by Mr. Howe, the master of the company; Messrs. Powell, Thorne, Blake, and others of the wardens, and by the committee appointed to carry out the undertaking. Mr. Henry Cole, C. B., and Captain Fowke, representing the Science and Art Department, and several members of the Council of the Society of Arts, were present; and a guard of honor formed of the 24th Middlesex (Coachmakers), under the command of Captain Goodall, lined the entrance to the hall. The noble Marquis on arriving was warmly cheered. The proceedings were commenced by Mr. G. N. Hooper reading the following address:

OPENING ADDRESS.

On the occasion of publicly opening the first Industrial Exhibition of the Operative Coachmakers of London, in this Corporate Hall, every one must feel that a striking contrast is presented between the present state of the Coach-making Trade, and the position it occupied when the company of Coach and Coach-harness Makers received its Charter from the hands of King Charles 2nd, May 31st, 1669. At that period trades were mysteries and their processes secret. The present Exhibition, however, illustrates a vast change, not only in the processes employed, but in the altered state of feeling on the part of employers and workmen, who now court inquiry, comparison, and inspection of their work, hoping to interest the public by showing how much ingenuity, patience, and care are necessary for the production of a first-rate carriage. Carriages of a rude and uneasy description were invented at a very early date, and were in use among the Israelites, Egyptians, and Assyrians, as recorded in the sacred writings and upon their sculptured monuments. The Greeks and Romans made very little improvement upon the Egyptian Carriages, beyond inventing four-wheeled vehicles, and the art seems to have slumbered for many centuries. It revived at length and attained great excellence in Italy in the 15th and 16th centuries, and became spread over other countries. In the time of Queen Mary, 1556, we find mention made of a coach suspended on leather braces; this may have been sent to her from Italy, by her relations, who then ruled over that country. This was the commencement of the improvements in the Art of Coach-building in England, and which art was soon so extensively patronized that the writers of the times foretold that the use of carriages would enervate and enfeeble the people, who ought to be satisfied to travel on horseback as their forefathers had done. We may congratulate ourselves, however, that although carriages are now in daily use by all classes of society, we see no signs of that enervation which our ancestors predicted. Since the introduction of railways, the number of carriages has multiplied to an extraordinary extent, assisted by the reduction of the tax upon them, by Mr. Gladstone, in 1853. This increase has moreover stimulated industry and invention. The sound and honest character of English carriages has long been appreciated throughout Europe and every country in the world, and for many years has secured a preference for

the English trade. Our carriages have, for upwards of half a century, been considered the best in the world, both in design and durability.

The present Exhibition is intended, by its originators, to develop the wants and aspirations of the times we live in. Education has reached most working men, and assisted them in attaining a high degree of manipulative skill, they are now desirous of obtaining a more scientific knowledge of the laws and principles which govern their work. The French, German, and Belgian coachmakers (desirous of rivaling the English), have availed themselves largely of the technical schools and schools of design in their respective countries, and they have already much increased their skill in construction, and are approaching us closely in the art of ornamentation and finish. Our English mechanics are equally desirous of improving themselves, and by comparing their *own* work in its various stages in such exhibitions as the present, and by planning out their work beforehand as may be seen in the drawings around us, desire to extend their knowledge of the technicalities of their art, and obtain new ground on which to set their feet preparatory to a higher development of their craft.

The idea of rewarding *working men* for great *skill*, as well as master manufacturers, is not new; like many other seeds, destined to bear good fruit, this idea arose during the organizing of the Great Exhibition of 1851, and the exhibitors, who were prize holders, were furnished with printed forms in which to enter the names of the workmen who had actually been engaged in making the prize articles; but it was probably found to involve too great difficulties in completing the scheme to continue it, for we know that the workmen received no acknowledgment at that time. The principle, however, is now being fully recognized, and in this Exhibition we distinctly hold out the prospect of a reward to encourage the workman in showing his utmost skill and industry, not in the toys of his leisure hours, but in the business of his life, in the due fulfillment of that sphere of duty in which for the present time, at least, his Heavenly Maker has placed him. It is a matter of regret that we have not been able to promise protection and full security for inventors of new and useful improvements. The patent law, as it at present exists, is both an evil and a good, the dread of exhibiting before the invention is secured, often prevents the very exhibition in which hints for perfection might be gathered on one hand, and beneficial sale for the improvement be secured on the other by this sort of publicity.

These Exhibitions specially offer encouragement for young journeymen to make known their own original ideas by drawings and models, they can thus gain opportunities for advancement and becoming known; but no workman should neglect to visit, or when opportunity offers, to contribute to these Exhibitions for his own sake, if for no other reason; none are too old to improve, or too clever to learn. On the success of the present Exhibition will depend how soon another will be projected, and if it is possible to hold them periodically as the committee consider desirable.

The effect of bringing together exhibitors, even in keen competition, has had a tendency to encourage friendly feelings among the competitors. As one instance, may be mentioned the foundation of the Master Coachbuilder's Benevolent Institution, by the English Coachmakers who exhibited at Paris, in 1855, the idea was mooted and immediately adopted at a celebration dinner among the exhibitors.



rest, I expect soon to be ready for the saddle again. There are always some moments of our lives we find it pleasant to recall. Sitting under an old elm in the orchard with an extended bay in the distance, dotted with a thousand sail, these pencilings were suggested to me as a fit subject for whiling away a leisure hour.

It was during the midsummer of the year, when the loyal people of the North were feeling despondent over repeated disasters, that new hopes were created by the appointment of a new General for leading our army onward to victory. McClellan's badly handled, but still heroic forces had just come out of a disastrous battle on the peninsula, leaving thousands of their companions to fertilize the soil of hard-fought fields, when the battles of the Seven Pines, Fair Oaks and Malvern Hills were fought, making these sacred and historical grounds to all patriotic Americans. Up to this period, no better material for an army had been brought together under one banner than for this of the Potomac. It largely contained within itself every requisite to success; it was brave, patriotic, heroic. In physique it was of superior order, an improvement on the Anglo-Saxon, with energy sufficient to make them terribly effective in field movement. They were endowed with those rare qualities so expressively conveyed in the French word "*elan*"—rendering them as irresistible in charge and as strong to withstand attack as the waves of the Atlantic—an army which, if headed by a Napoleon, would have been led on to victory over the legions of half the globe!

Following this *psuedo* General's abuse of a glorious opportunity came the call from the President for 200,000 more men. The Government had now become terribly in earnest. This was the high-noon of the Rebellion, its tide was at the flood, traitors being eulogized at home and feasted abroad, by men who were a disgrace to the land giving them birth. Suddenly the scene in this fearful drama began to shift. The dark wave of treason was then ebbing, but now as I write is sinking in oblivion. Our Government had become persuaded, that among the laws by which the Great Jehovah governs the universe, is one recognizing equality for all.

Among the myriads of worlds which revolve in the trackless regions of space, the most perfect harmony prevails. This once destroyed would cause eternal ruin. Such being true of the material world is much more injurious when applied to the moral and spiritual world; "as ye mete out to others, so shall it be meted to you again." "I have placed the dark-faced children of Ham in thy care. As ye treat them so shall ye be rewarded in the day of your tribulation." It is curious in this stage of the war to note how it affected the minds of men in those days and led them to enlist, arm and equip in vast numbers. Indeed, the organizing in so short a time of 300,000 men, was a marvel, even in this marvelous age. It showed plainly the effects of those principles which have their foundation laid in eternal justice and liberty. That mighty power in the people, which had so long been slumbering, was aroused. Dragon's teeth were sown all over the North, from which seed an armed host sprang up as if by magic.

A few days after this call, business of a military character took me to Washington. There I fell in with an old and honored friend of my father. I recollect distinctly his words. They find an echo in thousands of loyal hearts to-day. He was so strongly impressed with the

weight of the coming struggle, and the heroic manner in which the nation was sending forth its best and bravest men to meet it, that he, in a tone of voice which affected me strangely, exclaimed: "I thank God that I am alive this day to see before I die the glory of this country, and though we are to be baptized with fire, it will be unto a purer and happier life. So go forth, do thy duty, cherish a strong heart, and the God of battles will bless thee." I have often thought of this circumstance, in the changes that have since taken place. In the bivouac beneath the unclouded stars, or in my lonely rounds of duty by night on Southern posts, or on the toilsome march, the words and manner of this dear "old Simeon" have ever sounded in my ears. We have as a nation swung clear of many of those political and military arrogancies existing in Europe and have begun an experiment of our own; we have organized a grand army of almost fabulous numbers, laid down new principles and carried out new ideas. We have likewise improvised with unprecedented rapidity a navy of gigantic power, founded in new principles, completely revolutionizing science as applied to naval warfare. This is no less a wonderment to the old, than a matter of joy to the new world.

With me the first excitements of the strife had died away, and the fever of enthusiasm created by the attacks upon Sumter had in some measure abated; calmness and reason had returned; it was an hour of cool deliberation—the calm that precedes the tempest. That firm and settled purpose which knows no defeat, had taken possession of the minds of all classes, and the busy hum of preparation was going on throughout the loyal States. A host was gathering in arms, strengthening our Government every day, for the purpose of crushing out treason and sending traitors to their deserved doom. To this host it was my privilege to join.

"I rose when other men had calmed  
Their anger in the marching throng—  
I swore that when I drew this sword  
And joined the ranks and sought the strife  
I drew it in thy name, Oh Lord,  
For Humanity."

My affairs were soon arranged. A coupé body half finished I got my old friend Wilmarth to complete for me. To see that my wife and child were cared for during my absence, and devote a day to leave-taking, were all that was necessary before I cast loose from the ties that bound me to social and domestic life. With a secret pleasure I care not to reveal, I threw myself again into the exciting tide of adventure. Having the advantage of a previous military experience, and auxiliary to this a good friend high in the red-tape order, I found no difficulty in getting a commission and being assigned to Company — in the — Regiment. A few days after this found me surrounded with all the duties, pleasures and disadvantages of a camp life, at Arlington.

(To be continued.)

SNOBISH.—A London paper says, there are no equipages in Sydney or Melbourne so gorgeous as those of the descendants of convicts. The glitter of the gold, it is thought, may blind men to the original defects of the escutcheon.

A BLACKSMITH'S TOAST.—An ignorant son of Vulcan, mindful of his forge, offered the following toast at a public dinner: "Here's success to forgery."



## Pen Illustrations of the Drafts.

### AMERICAN VICTORIA.

*Illustrated on Plate I.*

EVER since the first London Exhibition this vehicle has been deservedly popular among the higher classes of pleasure riders. We find satisfaction in being able to present a design, by our own artist, in which some new features will be observed. The construction of these has been so often described in these pages, that we find it unnecessary to enter on this occasion into details. It has become quite fashionable to paint the under carriages of some lively color, say cream or clay, and stripe broadly, with a narrow stripe or two, parallel therewith, through the middle.

### DUPLEX TILBURY PHAETON.

*Illustrated on Plate II.*

IN this design we have combined all the important points now in fashion, as applied to Phaetons, among others the bowl-shaped cut-under. This arrangement gives some advantages in turning as well as relieves the front quarters somewhat of its heavy appearance. The remark above made in regard to painting the carriage-parts of the Victoria, apply equally well in this case.

### SERVANT SEAT BUGGY.

*Illustrated on Plate III.*

WE observe, in our wanderings through the Central Park, that there is a growing disposition on the part of "Young America," to ape the follies of Europeans. Without offering any apology for our course, we have taken the pains to present our subscribers with an original design, intended to meet the wants of the class above referred to. The Manhattan Buggy on plate XX, volume Six, is still the most *fashionable* buggy on the road. This was published in our October number.

## Sparks from the Anvil.

### CONSTITUTION OF STEEL.

EVERYTHING calculated to render the workman acquainted with the nature of the material he takes in hand, we take to be legitimate matter for our pages. With this object in view we have from time to time presented articles of much practical utility, to which we now add another.

The Belgian Academy of Sciences having proposed to give a gold medal for the best essay on the constitution of steel, at a meeting on the 16th of December last, awarded a prize to a paper bearing the device "*Citius emergit veritas ex errore quam ex confusione.*"

This memoir is due to Captain Caron, to whom the committee awarded 800 francs [\$149], in addition to the medal, as an extraordinary recompense for the superiority of the essay. Mr. Stas, the Chairman of the committee

appointed to examine the treatise, reports that the author, Mr. Caron, proves satisfactorily that Mr. Fremy's opinion of the essential presence of azote in steel is untenable, and demonstrates that iron when passing into the state of steel, does not contain a particle of azote more than it had before the conversion, or more than it contained in the alkalis, through the intervention of which the carbon enters into the iron. [Fremy's opinion on this subject will be found on page 48, volume Four of this work.] He considers that the presence of azote in some steel is due to the traces of the azotide, or the azoto-carburet of titanium, which is to be met with in both cast and wrought iron used in the manufacture of steel. That steel is essentially composed of iron and carbon; that it owes its good qualities or its defects to two different causes acting in unison: 1st. To the state of the carbon in the metal. 2nd. To the nature of extraneous substances which deteriorate it. When steel becomes bad after being heated several times, this proceeds from its carbon having been burned or separated from the iron, a separation which no tempering can remedy, and which is due to the presence of extraneous matter, principally silicium, which impedes the perfect union of the two substances, and gives to the steel different properties or defects, according to the nature or quantity of such impurity.

### VARNISH FOR STEEL AND IRON.

FOR preventing rust in iron and steel, a fine varnish may be prepared by dissolving ten parts of clear grains of mastic and mixing them with five parts of camphor, fifteen parts of sandarach, and five of elemi, in a sufficient quantity of alcohol. This varnish may be applied without heating, when it will not only preserve metal from rust, but will retain its transparency so that the metallic brilliancy will not be obscured.

## Paint Room.

### EXPERIMENTS WITH PAINTS.

JOHN EWEN, Jr., of Williamsburg, L. I., has given an interesting account and proofs of experiments conducted by him to test the comparative durability of certain pigments, and the vehicles employed with them as applied in house painting. During the last twenty-three years, he has been practically engaged in house and sign painting, and in that period many questions had been asked of him regarding the best paints to use. "To these," he says, "I gave the best answers that a general and superficial observation would warrant; but not being reliably answered, they increased fourfold as the zinc paint came to be generally used. It was at this time (September, 1851) that a method of demonstration suggested itself. I forthwith procured two strips of board, and marked them into compartments, and after numbering them 1, 2, up to 11, I coated them in the following manner:—No. 1 received two coats of white lead mixed with raw linseed oil, and no dryer; the paint was laid off or finished with the brush, stroked up and down. No. 2 received the same coating of material as No. 1, but was finished with the brush passed right and left, crosswise. No. 3 was given two coats of white lead, raw linseed oil, and considerable spirits of turpentine in the first, but only a little in the last coat. No. 4 received



two coats of white zinc and raw linseed oil—all mixed with what is called 'patent dryer.' No. 5 the same as No. 4, but with no patent dryer. No. 6 received a first coat of white lead and Paris white, equal parts, and clear white lead for the last coat, with raw linseed oil as the vehicle. No. 7 was given two coats of white lead, with *boiled* linseed oil. No. 8 three very thin coats of white lead, with raw linseed oil. No. 9 got a very heavy prime coat of white lead, and a very thin second and last coat, with raw linseed oil. No. 10 the reverse of No. 9, namely, a thin prime coat and a heavy finishing one. No. 11 received two coats of Paris white and white lead, equal parts, with raw linseed oil. After this was accomplished, and the paints well dried, the two pieces of board were placed in a position where they were exposed to the weather—its sunshine and its storms—for years."

The following are the results obtained:—"The white lead paints exhibited a decided superiority for durability over the zinc, and the squares finished with the brush up and down in vertical lines are decidedly superior to the one laid with the brush right and left. [This is undoubtedly due to the moisture being allowed to flow down more freely than in the square finished with the brush run transversely, which left small cross ridges of the paint.] No. 9, which received a very heavy prime coat, is white and chalky; No. 10 is darker in color, but not so chalky; No. 11 is superior to the two preceding numbers. Of all the squares, however, No. 7, consisting of two coats of white lead, with *boiled* linseed oil, is by far the best—the smoothest and closest."

These experiments are valuable, because they afford positive data regarding paints, and the manner of applying them to the outside of buildings, so as to obtain the best effects. The coating of white lead, with raw linseed oil and a little spirits of turpentine, looks well, and strikes us favorably. Raw linseed oil, in white lead, without turpentine, imparts a greasy appearance to white paint when first put on; a little turpentine, therefore, improves its appearance, but care must be exercised not to add too much, because when in excess, it imparts a saponaceous character to the paint, which makes it become chalky, and scales off rapidly by exposure to rains and winds.

#### MANUFACTURE OF VARNISH.

SOME attention has lately been given in Europe to the use of acetone in the manufacture of varnish, by M. Wiederhold, according to whom acetone rendered anhydrous by rectification over chloride of calcium, readily dissolves cold copal which has been previously heated to the point of fusion. Only 2-8 of acetone are required for one part of copal, and a copal varnish thus obtained which dries almost instantaneously, leaving a hard, brilliant and durable coating. A more concentrated and almost syrupy solution is obtained, without separating any copal, by expelling part of the acetone by distillation. Evaporated to dryness, the remaining copal is more soluble in acetone than when in its original state. The solubility of gum lac in acetone varies according to the species of the gum; one part of artificially bleached gum lac required only 1-5 of acetone to form a thick solution like syrup; another, a colored specimen of gum lac, was almost insoluble; and a third required 3-5 times its weight of acetone to dissolve it. Acetone dissolves with especial facility, and in considerable quantities, mastic and sandarach; dammar, yel-

VOL. VII.—2.

low amber and india-rubber, are, on the contrary, almost insoluble. The solution of acetone and mastic produces a very beautiful and brilliant varnish. M. Wiederhold is of opinion that acetone might be employed for the restoration of oil paintings deteriorated by the alteration of the varnish which often becomes opaque from the effect of a molecular modification, and which, from a vitreous and transparent state, becomes crystalline or pulverulent. By carefully applying acetone the opaque varnish may be momentarily dissolved, and will then redispense itself, but in a vitreous state.

#### COMPOUNDED OILS.

OUR readers have doubtless from time to time observed among our patent lists, mixtures intended as substitutes for linseed-oil in paints. Perhaps it is needless for us to say that we have no faith in any of these compounds—that they are merely made to sell to such as will suffer imposition at the hands of unprincipled or avaricious men. Carriage-makers as a class may think themselves too intelligent and careful for such impositions, and yet we are informed that many in the West are *so weak* as to experiment with these "oils" in the hope of saving a penny. About all the penny advantages they ever realize is found in the "penny wise and pound foolish experience" they hoard. Our friends who would avoid trouble and economize time, are advised to give all these *speculators* the cold shoulder. The manufacturers and the manufactured article are both "humbugs," and should be "let alone." We give notices of these as we do other matters relating to carriage-making, for the purpose of perfecting our list, with no idea of endorsing them.

#### ORIGINAL MONOGRAMS.

*Illustrated on Plate IV.*

WE take pleasure in again presenting our subscribers with another installment of monograms, designed expressly for this Magazine, by one who is considered an expert in this line of business. They exhibit in a remarkable degree the power of combinations, and will serve as excellent lessons for practical instruction to young painters. The artist who is qualified to perform this kind of labor well, will always find employment in good shops. We intend to continue them occasionally through the volume, and trust they will be favorably received, and supply a want daily on the increase in this country. Other designs have already been published in numbers 9 and 11 of Volume Six. These can be purchased separately, for fifty cents each, through the mails.

#### Trimming Room.

#### BLUE CLOTH TRIMMINGS.

WE scarcely need tell our readers that with the fall of the premium on gold, the prices of cloths—these being mostly imported—have fallen likewise. If they examine our present prices current and compare the rates there quoted with those of the previous month, the fact will appear. As we some time ago observed, it is fortunate for us that cloth is generally now used for linings, for—costly as cloth was—leather as now held would have been still more expensive had to use it been the prevailing



fashion. Leather continues yet firm, its home production protecting it from the fluctuations in gold, as seen in all foreign goods.

Blue cloths are still the favorite colors in this market as they are likewise in Boston, as reported by our correspondent Telemachus, whose letter will be found in our "Box" this month. He appears to have adopted the idea that blue is fashionable, because that is now the fashionable color of the ribbons to the Boston ladies' bonnets. What connection there exists between the ladies' ribbons and carriage trimmings is a point we are not qualified to discuss, and must therefore leave *that* subject with our speculative-minded readers. Since, however, blue cloths were used for carriage linings long ago, we suspect our Yankee Telemachus is a little out of his "reckonings" this time. We suspect that the ladies are just as likely—perhaps more so—to have adopted blue ribbons from finding carriages lined with blue cloth, as otherwise. At any rate, Telemachus should employ his time in listening to the sermon while in church, instead of running his "eye over the congregation" and descanting on the "blue ribbons floating in graceful curls over the heads of our handsome women." It is said that "love makes the poet," and no doubt it has made our friend a little *flighty* in this instance. A lady at our elbow says that "pink" is the prevailing color among the New York ladies. On the theory maintained by Telemachus, this accounts for the "queer color" now fashionable among us for striping carriages.

#### TO FASTEN LEATHER ON METAL.

Our readers will find the following information very useful sometimes in trimming carriages: Steep the leather in a hot solution of gall-nuts, and wash the metal with a hot solution of gelatine. After this has been done press the leather on the metal, and allow it to cool, when it will be found firmly fixed.

### Editor's Work-bench.

#### TO THE PUBLIC.

WE fear our friends would weary were we to enumerate all the difficulties publishers have had to contend with during the four years the nation has struggled to maintain intact its political existence. We shall, therefore, omit such detail, and seek consolation in the hope that a more prosperous and more profitable career awaits us in the future. As far as regards the cost of publishing, very little diminution is found. It is true, paper is a trifle cheaper than it was six months ago—about the same price it was when we laid in a stock for the whole of our last volume. The additional tax laid on magazines by the last Congress would warrant us in raising our price of subscription still higher; but, with the expectation that our circulation will be larger this year, we have concluded to keep it for this volume at \$5. It will afford us the highest pleasure, when the time comes, to lower our subscription rates to the original figures. That, however, must not be expected while gold remains at a premium.

The six volumes of this work already in the hands of the public sufficiently attest our ability to perform all we have engaged to do, and, besides, convince the craft that our highest ambition is more to present them with a good journal than to make money. This being so, it only remains for us to say that we intend to unite uniting industry to an experience of several years in an effort this year to exceed all our former volumes, and produce, in the best sense of the idea, a Magazine devoted to the interests of the craft in its literary and mechanical aspects. We are not without hope for assistance from many of the correspondents who formerly contributed to our pages, but whose favors have been prevented by the circumstances of war. Mr. O. E. Miles, whose communications are received with much favor, has promised us his monthly contributions; added to which "Telemachus" (his extreme modesty forbids giving his real name) will present the readers with a series of papers under the head of "Pencilings of the Rebellion," the first of which appears in this number, to be continued.

In connection with the foregoing, permit us to say that we are still able to supply complete sets of the volumes from the commencement. How much longer we can do this is a questionable matter, since our stock is getting low. Those, therefore, who want the work had better send us their orders at once. That the worth of these volumes may be in a measure understood, we give here some of the peculiar features of each. The first volume, among other varied subjects, furnishes the craft with a series of diagrams and accompanying explanatory letter-press, teaching the most important principles contained in the so-called French Rule. This was originally written expressly for this Magazine, by a practiced artisan, and is the only correct series ever presented to the public in any literary work, as applied to American coach-building. Examples of each variety are given. The same volume contains another series of lessons—with letter-press and diagrams—in drafting carriages to scale. The reader will, besides, find several chapters devoted to the history of carriage-making in all ages, and in chronological order, beginning as far back in time as the days of the Pharaohs. Several drawings from a real chariot, now deposited in the Egyptian Museum department of the New York Historical Society of this city, are there shown, truthfully suggestive of the value of mechanical science at that primitive period in the world's history. One single comic illustration in this volume is of greater value in a pecuniary light, as an antidote against the blues—to which disease we find carriage-makers are prone—than the sum charged for the entire volume. This volume, bound and sold separate from the others, will cost, by express, three dollars and fifty cents; by mail, postage paid, four dollars.

There are still further examples in the French Rule



included in the second volume, besides additional chapters treating of the history of carriage-building, both in the old and new world, down to the present day. Under the head of "Autobiography of Caleb Snug, of Snug-town, Carriage-maker," is presented the personal history of one of the craft, strikingly illustrative of the trouble and difficulty under which apprentices received instruction in carriage-making years ago. This has not only been well received in this country, but received commendation from European mechanics. This series is completed in eleven chapters, running into the third volume.

Besides the subject alluded to above, the third volume is enriched with a number of examples, showing the English manner of constructing carriage-bodies. These, studied in connection with parallel examples of American carriages, as furnished in our first and second volumes, will prove profitable instructors in mechanical science. This volume likewise gives a detailed description of the largest coach-manufacturing establishment in England—that of the Messrs. Holmes, at Derby, Coach-makers to the Royal Family, accompanied by a fine engraving of their buildings. Two very interesting stories run all through this volume, but are there completed. The first is by one of the most humorous and vigorous writers of the age, James Scott, under the title of "Siftings from the Diary of a Coach-maker;" the second by H. S. Williams, entitled "Clarence Clifford; or the Experience of a Tramping Jour. in the Western Country," which one of our own correspondents, at the time these chapters were publishing, pronounced equal in merit and interest to anything written for and furnished by the more pretentious literary Magazines. This article, under the disguise of fiction, happily narrates the genuine adventures of the writer. The painter will, in this volume, likewise find, under the title of "Gossip for the Paint Shop," the best instructions in carriage painting ever written. Its practical worth has induced an English journal to pirate and publish it in London, but without giving credit.

Our fourth volume contains another life-like history, under the title of "Halford Cruff; or, what a Travelling Jour. saw 'Out West;'" besides several chapters devoted to a treatise on "The Rise and Progress of Carriage-making in England." "The Motive-power of Wheel-Carriages," by our friend Harper, also graces this volume. The value of this article will never be known until attentively read. A full report of the evidence taken in the suit of Brewster & Co. *vs.* Miner & Stevens, in relation to the "Saddle-clip," will be found in this volume; likewise "A Brief Treatise on the Mechanics of Wheel-carriages," and a condensed history of the several trials had on the Haussknecht Perch-coupling, with the decisions of the courts. Several "Lessons in Coach Painting" also enrich this volume.

In "The Tireville Miscellany," to be found in the

fifth volume, the carriage manufacturer will find (in daguerreotype) much of his own experience narrated. The articles relating to the "Composition of Paints," are the most valuable series on that subject ever penned, and are at least worth all we charge for a set of this Journal. Several chapters on "Ancient Roman Carriages," with illustrations; "The Effects of Wheel-carriages on Roads and Horses," "Carriage Wheels—their Mechanical Construction and Use Considered," and a great variety of other matter fill the pages of the volume.

The sixth volume, just completed, contains a valuable treatise on "Mechanical Power and Friction," written—as, indeed, the most of our matter is—expressly for this Magazine, and can be had in no other form. The dissection of the perch-coupling question, amply illustrated, is likewise given, and will be found indispensable to all who have been sued for infringements by any adventurer. They will here ascertain the merits of the subject in all its ramifications.

We have said very little about our engravings in this hasty synopsis, nor need we say much; they speak for themselves. These number nearly three hundred, all different, and are furnished at about six cents each, with about twelve hundred quarto pages of letter-press thrown in, gratis. Such a variety of valuable matter upon a special subject, so well embellished, and offered at so low a price, has been a matter of surprise to many. Indeed, was it not that the publisher is satisfied with the pleasure it affords him to edit, it would have ceased to exist three years ago.

Our article has become so lengthy that we can only find space to say that a uniform set, nicely bound in muslin, gilt—six volumes—can now be had for \$18 when all bought together, the purchaser paying for transportation by Express. When bought singly, the sixth volume will be four dollars; either of the first five, three dollars and fifty cents. When purchased in numbers, a reduction of one dollar in a volume of twelve parts will be made. Please send along your orders, and secure the work, before our stock is exhausted.

#### A CHAT WITH THE READER.

THOSE of our readers who have complete sets of this Magazine from the commencement, seven years ago, will find by comparison of those designs with these we are now publishing, that a vast improvement has been made in American carriages, so that we risk nothing in saying that now they are the most perfect specimens of *the art* to be found in any country. Who will dare to deny that this improvement is in no small measure due to the influence of this periodical? Here month after month are spread before the public every new feature which appears in the different departments of the trade. This is carried as it were "on the wings of the wind" to the most distant



towns of this Republic. Should a new style of buggy be got up in New York, but a few days intervene before it is laid before the pioneer carriage-maker in distant Oregon. Indeed, this very fact—that we spread the New York fashions over the whole country as soon as they appear—(often before they get out of a shop) is one of the strongest objections a leading house in this city puts forward as a reason why they will not patronize us. Perhaps a little reflection may convince our country friends that this circumstance is a strong reason why *they* should not fail to take our monthly. The house we allude to when it can be done, never fails to take any publication relating to carriage-making published in Europe, and should a new idea be obtained it is put forth here as an original one with them.

To show how far these European publications *are original*, we will state that the *Mercuré Universal*, three years ago, stopped exchange, and thinking we might not be aware of it, began copying our drawings and publishing them as “*Americaine*” without crediting us. The Carriage-builder's Art Journal carried its piracy in this respect so far while it did live, that long before it died we refused to exchange. The German “*Wagenban Zeitung*” takes the largest kind of liberty with our designs, copying in its last two issues the eight designs there given entirely from our pages and gives not a word of credit to us. These facts—we might give more—show strongly the great influence this journal is exciting in improving the carriage architecture of this and other countries. We make these assertions without fear of successful contradiction, because the evidence can be had by producing copies of these foreign journals, largely made up from our periodical.

These facts, although flattering to one's vanity, are still provokingly painful when viewed in the light of honesty. They prove one of two things, either that these foreign editors are not carriage-makers themselves and consequently unable to write experimentally, or else are so far degraded in character that they have become habitually *piratical*, from choice. But we have no hope of reforming these incorrigibles and therefore will here drop this subject.

How very pleasant is the meeting of old friends after a long separation. For four years has this journal been deprived of the assistance we were wont to receive from friends in other days, in consequence of our civil war, now about ended. Released from the excitements attendant upon camp life we expect this year to find a return to our pages of many old correspondents as well as subscribers to the work. Need we tell them they are cordially welcomed back; that the anticipated renewal of old associations affords us much satisfaction. But this is not all. We cannot but think that there are *some* diamonds which have not yet been discovered—some literary carriage-

makers that have never yet let their talents appear, and perhaps never would in a warlike atmosphere. Now that peaceful times have dawned, we invite them to favor us with their communications, and although these may not be *planed* to as smooth a surface as the panels of your carriages, a few *smoothings* from the editor will set all right. We are more strenuous for ideas, than finely turned sentences, although of course these are desirable. Many mechanics are found throughout the land, whose literary education, from various circumstances, has been sadly neglected, but whose mechanical genius has received the highest culture. From this class of minds we expect much and trust we shall not hope in vain.

In other days we have offered to furnish our periodical regularly to those who favored us with their communications. We here renew that offer, and will go still farther and present a complete set to such as will give us a monthly article of mechanical literature. Who will accept this proposition?

We are happy to find that our Magazine is gaining friends every day. Is it asking too much when we invite them to make up clubs for us as soon as they receive this number and send them in at once. Nothing better can be done to encourage us on, and render us better qualified to look after your “literary, social and mechanical interests.”

#### CITY MATTERS.

IN our notice under this head the past month we omitted mention of a few changes in business which were about to take place. Our friend B. W. Tilton, Esq., has removed his salesrooms from No. 614 to No. 616 Broadway, into more convenient quarters, where he will be happy to see all who are in want of carriages, of which he has a great variety of approved styles and workmanship. The manufactory has been removed from No. 207 Greene street, to the village of Mount Vernon, a short distance from this city, and on the line of the New Haven Railroad.

The “Broadway difficulty,” before alluded to, has been settled, we believe, to the satisfaction of all parties, who, we think, find as much business in selling carriages as they can well attend to. Success appears to attend all the repositories here, and we learn that the sales thus far this season have exceeded even those of last year, which in the judgment of old firms, was considered the most prosperous of many preceding it. Of course, prices have somewhat fallen, but this is the natural consequence of the decline in the premium on gold. The manufacture of new work is confined chiefly to the large establishments, very few orders finding their way to the smaller shops now. This disadvantage, however, is much relieved by the business they find at repairing. Indeed, the craft in this city are literally overrun with business at present, and find the greatest difficulty they have to encounter in



getting help to do the work offering. The return of our victorious armies from the battle-field to their homes will doubtless remedy this inconvenience very soon. Whether, as has been predicted, a return of peace will bring with it a stagnation in business, remains to be proved. It may be well to remember that false prophets have been plenty for the past four years, and may still be active.

#### EDITORIAL CHIPS AND SHAVINGS.

**MANNING'S IMPROVED CARRIAGE SPRING.**—The attention of the reader is called to the advertisement relating to the above on the third page of the cover to this Magazine. We have been shown a letter from a gentleman who has a buggy in use with these springs applied, in which the writer highly recommends them. An examination of their merits is solicited.

**JEFF'S MUSICAL BOXES.**—This was a name humorously bestowed by boys and the colored population on the wagons belonging to the Confederate Quartermaster's Department in Richmond, and which, before the evacuation, kept up a continual roar and din in the streets. They were long, low street wagons, apparently constructed, not for purposes of transportation, but to make as much noise as could possibly be gotten out of a given amount of wood and iron. Every piece of timber, every screw and bolt about them, had an average play of two inches, and as they dashed along the pebble-paved streets, they made an uproar equal to the rolling of a hundred thousand barrels of rocks down a steep hill. All the citizens must have missed the music of these discordant machines, but we question if many know what has become of them. Their ultimate fate is unknown to us, but we have little doubt that they have long ago been gobbled up by Sheridan. On the night preceding the evacuation, Major John C. Maynard, Quartermaster, who had charge of all local transportation under the Davis regime, loaded them with property belonging to his department, and moved with them across James River, ahead of Ewell's corps, in the direction of Burkesville. When last heard from he and his train had not been captured, but were still moving on toward Danville.

**JEFF. DAVIS' CARRIAGE.**—In his recent hegira from Richmond Jeff. Davis either forgot, or else thought more of the "stuff" and so left the carriage presented to him by his "admirers" behind, for the "hated Yankees" to seize.

**STEAM OMNIBUSES.**—An omnibus drawn by a locomotive, instead of horses, is now running at Chautenay, in the south of France. It can be turned and stopped with ease; and both inside and outside passengers travel by it without fear.

**NEW JERSEY TRADE.**—The neighboring State, New Jersey, has just opened a new trade with South America. Twenty-five tons of white oak spokes have just been shipped from Sussex County for that market.

#### LITERARY NOTICE.

THE ATLANTIC MONTHLY for May presents us with an unusual variety of interesting articles, under the following heads: With the Birds; Gold Egg—A Dream Fantasy; Out of the Sea; My Student Life at Hofwyl; Ice and the Esquimaux; Notes of a Pianist; Diplomacy of the Revo-

lution; Our Battle-Laureate; Doctor Johns; The Chimney Corner; Needle and Garden; Castles; Reviews and Literary Notices. The Atlantic has from the beginning of our troubles been conducted in the most decidedly loyal spirit, and is worthy the patronage of every true friend of republican institutions.

#### The Coach-maker's Letter-box.

BOSTON, MASS., April 20th, 1865.

MR. EDITOR:—Business is very dull at the Hub this month, so far, caused principally by the glorious news from the "front." The toppling and speedy downfall of the rebellion is now quite apparent. It has created no little excitement on State St., among the gold and stock speculators. The marking down has commenced on all merchandise, carriages not excepted. The "Bulls" are very much discomfited at the energetic manner in which Grant, Sherman and Sheridan are kicking gold down. Their idol is losing caste and fast becoming plebeian.

The stock of carriages this spring in the market is very large, and of better quality than the average of former years—yet the demand at present is less. I am inclined to the belief that consumers are merely holding off, waiting to see the market firm and steady. Why, I have had several gentlemen, after looking through our salesroom and selecting a carriage to suit them, hesitate on the price and tell me they would rather wait a month, in the expectation of getting it twenty per cent. less. But that idea may prove delusive, there will be no such reduction as that. The feeling among the dealers here is to hold on, be firm, and fair prices will be had, and fair sales effected. As the prices go down—as go they certainly must—let us see that they keep pace with the cost of manufacturing. For, if, when I sell a carriage for a certain sum that will enable me to replace the same, I really lose nothing of intrinsic value. The price that is taken off is merely nominal.

Judging from outside appearance, Mr. Editor, I should think that New York builders are either selling very little or have become uncommonly enterprising from the strong efforts they are making to introduce their work into the Boston market. I see advertisements in our daily papers of John C. Parker & Co., Mott & Co., and J. C. Ham, all of Broadway, and there is considerable work sent here from Wood Brothers, and the Brewsters. Their carriages, I think, give the greatest satisfaction, especially their heavy work. New York light carriages as a rule, do not give very great satisfaction here; what will suit in New York will not suit the tre-mountain city. Boston has still some puritanical ideas clinging to it which makes an extensive introduction of light work—as New York builders make it—no easy matter. It does not stand the test.

It is interesting to a thinking mind to notice how often the public taste, in the question of color, does change. Blue just now is a favorite color, our striping and trimming partake largely of it. I believe that the ladies' bonnets afford a good criterion as to the favorite color of any particular season. Last Sunday, when in church, I noticed that blue was the predominant color in running my eye over the congregation, blue ribbons floating in graceful curves o'er the well formed heads of our handsome women were as thick as the leaves in autumn.



Rich striping, which a short time ago was considered in bad taste, is now all the fashion. We stripe everything, but make our iron-work as plain as possible; it takes the paint better, and is more serviceable.

But change is necessary; we cannot pursue one routine long. We seek new devices, new ways. The laws of our being require it. All improvement in science and art is traceable to this cause. The great improvement made in carriage-building during the past fifty years is truly wonderful; it is a true exponent of the progress of the times. The magnitude of the business, the amount of brain and capital invested in it is surprising; so much so, that the *Scientific American* has classed it as the second mechanical business of the age—next to engineering. There has been quite a novelty in the shape of a carriage just turned out by one of our city builders. It was built for an eminent surgeon in the city, and destined to carry himself only. It is hung on two five-foot wheels, with a crank axle, thorough braces and wooden springs—a *la Chaise*—strapped on the shafts in a peculiar manner. It has a buggy body, with a top, and a place for the doctor's instruments behind. It makes a singular looking carriage, and is easy riding. It is called a *Monautos*. The name is taken from the Greek word *μόναυτος*—or *monos-aulos*—signifying being or living alone, as only one person can ride in it at the same time. The name, you see, is very appropriate.

The man who invents anything new and useful, confers a blessing on the age. But how often some foolish and absurd thing of the past is raked up by some aspiring noodle longing for inventive honors. A coach-maker of the last century—a Mr. Hatchet, of Long Acre, London—built a three-wheeled carriage, which was called by him a Tim Whiskey, because of its irregular or drunkard-like motion. Its impractical nature soon being demonstrated, it was thrown aside, until our antiquarian hunter in the West brought it to light again, for what purpose I never could learn, unless it was the love he had for the name.

But here is another specimen of inventive genius—the brilliant Sir Sydney Smith, one of the few men who opposed Napoleon successfully; a man who was decorated with crosses and badges of honor from half the crowned heads of Europe. Yet he had such love for carriage-building that he invented a Six-Wheeled Coach. Upon what principle it was built, at this moment of writing I am unable to state. It did not amount to much, however, for when he was living in Paris, to get an invitation to his rooms to have him explain it, was considered the greatest bore of the season. Adieu, TELEMACHUS.

[The date of the foregoing letter proves its publication a little behind time. This was occasioned by a lack of space in making up our index number the last month. Its importance as a record of passing events demands, however, that we give it to our readers, although a little stale.]

CARRIAGE MANUFACTORY, HAYMARKET, }  
LONDON, April 28th, 1865. }

*My Dear Sir:*—We in England have heard with the greatest abhorrence of the assassination of your chief magistrate, President Lincoln, and I take the earliest possible opportunity of condoling with you and your friends on such a national calamity. However much Englishmen may be divided in opinion on the subject of the war in America, their feelings at once most sincerely revolt from

a crime of so deep a dye as has just been enacted in your country.

I am sure I speak the feelings of all English coach-makers in thus expressing my own, and trust you will receive these hurried lines as an earnest of the good feelings that I think should exist between Englishmen on both sides of the Atlantic, by whatever name they are called. Joining my brother's good wishes with my own to you and yours, I remain, my dear sir, yours faithfully.

GEO. N. HOOPER.

E. M. STRATTON, Esq.

## Patent Journal.

### AMERICAN INVENTIONS.

Feb. 14. (46,792) BLACKSMITH'S FORGE.—J. H. Gould, Cincinnati, O.:

I claim, *First*, The combination with a forge of the sprinkling apparatus O, connected with a water-tank G, or its equivalent, arranged and operated substantially as and for the purpose described. *Second*, I also claim the combination of the sprinkling apparatus O, with the escape-pipe of a water-tank, or water-tweel of a forge, arranged and operated substantially as and for the purpose above set forth.

(46,796. HARNESS SNAP.—Horace Harris, Newark, N. Y. (Ante-dated March 1, 1865):

I claim the mode herein described of preparing the back end of the spring D, to be attached to the hook E, substantially in the manner specified.

(46,834) WAGON BRAKE.—F. L. Tripp, Prescott, Wis.:

I claim the bar F, and shoe or brake levers G G, connected with the rod I, in combination with the panels J, and ratchets K, all arranged and applied to the wagon, substantially as and for the purpose herein set forth.

Feb. 21. (46,904) DOUBLE-TREE FOR CARRIAGES.—John Hoover, Manchester, Md.:

I claim the elastic double and single-trees, when arranged, constructed and combined, as herein described and set forth.

(46,951) MACHINE FOR SHARPENING SAWS.—Reuben Sparks, Buffalo, N. Y.:

I claim the combination of the grinding wheel B, sliding saw table C or C', and adjustable guide-bar D, for the purposes and substantially as set forth.

April 4. (47,063) OIL FOR PAINT.—Roberts Bartholow, Cincinnati, O.:

I claim the manufacture and preparation of a new and improved kind of oil for mixing and compounding with white lead, zinc, white, and other mineral paints and pigments, in lieu of linseed oil and other paint oils, and for other purposes, composed of the ingredients above-named, and compounded, manufactured and prepared in the manner and for the purposes substantially as set forth above.

(47,154) SHAFT-COUPLING FOR CARRIAGES.—Francis B. Morse, New Haven, Conn. (Assignor to Frederick C. Dayton, Jr.):

I claim as a new article of manufacture a shaft-coupling, composed of a jack or stationary part, forged with two eyes, and a cavity for retaining an elastic presser, and a plain head with one eye, when constructed, combined and fitted for use, substantially as herein described.

11. (47,211) CARRIAGES.—Lewis N. Mason, Shelburne Falls, Mass.:

I claim my peculiar arrangements of two sets of shafts, A B C D, and a cross-bar E, with the whiffle-trees F A, whereby the cross-bar carrying the whiffle-trees is brought in rear of the draft animals when they are between the shafts. I also claim



the combination and arrangement of the connector K, and the two sets of shafts A B C D, and the cross-bar E. I also claim the combination and arrangement of the two mud guards L L, with the two sets of shafts and their cross-bar E.

(47,244) HARNESS SADDLE.—Oliver B. North (assignor to O. B. North & Co.) New Haven, Conn. :

I claim the use of studs or pins upon the frame, for the purpose of holding or of aiding to hold the skirts, jockeys, back or tug straps of the harness thereto, substantially as described. I also claim casting the bolt or projection *e*, on the underside of the seat, as and for the purpose herein described.

(47,245) CARRIAGE BOLT.—Alvin Pond, Hamden, Conn. :

I claim manufacturing bolts from round iron by means of dies formed so as to produce sharp corners at the ends of the squared portion, as set forth.

18. (47,276) HARNESS SADDLE.—Politorus Bottyear, Newark, N. J. :

I claim inserting the rein-hook in and securing it to the saddle with the rod *a*, or its equivalent, and with the trip leather B, or inclined planes B', or their equivalents, and with the governor A, substantially as and for the purpose described.

25. (47,408) CARRIAGE JACK.—Austin W. Field, Vergennes, Vt. :

I claim the stock or standard A, perforated sliding bars B B, and lever D, in connection with the pin E, all arranged substantially as shown and described, to form a new and improved carriage jack.

(47,473) VEHICLE.—Zalmon B. Wakeman, Rockford, Ill. :

I claim, in combination with the tongue C, the swiveled box or bearing F, having an eye or aperture increasing in size from front to back, and employed to receive and support the end of the brace rod E, substantially in the manner and for the purpose explained. *Second*, I claim the combination of the coiled spring E', and nut I, with the supporting rod E, the nut permitting the spring to be contracted and expanded at will, for the purpose of varying the position of the tongue. *Third*, I claim the tongue L, employed in combination with the spring E, rod F, tongue C, nut I, substantially as herein set forth. *Fourth*, I claim the adjustable springs K K, adapted to operate in connection with the knuckles L L, in the manner and for the purposes set forth. *Fifth*, I claim the spring or springs J, wrapped around the tongue rod, and with their ends secured under the tongue hounds, and the forward axle or sand board adapted to adjustment in any manner, and employed for sustaining the tongue C, as set forth.

(47,500) FASTENING FOR HARNESS.—Josiah Shepard, New Britain, Conn. (assignor to himself and Richard Butler, New York City) :

I claim a strap fastening for harnesses and for similar purposes, composed of two curved side pieces *a a*, connected at their ends by cross pieces *b b'*, placed relatively with each other as shown, and the center cross piece *b'* provided with a central piece *c*, substantially as described.

May 2. (47,520) COUPLING FOR THILLS.—E. E. Clapp, Auburn, N. Y. :

I claim the thill-iron constructed in two parts, and with conical perforated bearings, the said two parts being pivoted together and made to overlap one another under the thill, in combination with the clip-iron constructed and arranged, as described, all operating in the manner and for the purpose set forth.

#### FOREIGN INVENTIONS.

August 18, 1864. AXLES AND AXLE-BOXES.—F. Swift, Manchester Street, London.

This invention refers to a former patent, dated January 1st, 1856 (No. 2). In constructing axles according to the present

invention the inventor forms a frame, by preference of metal for the sake of lightness, but it may be of wood, extending across the underside of the carriage, if in section an inverted  $\Omega$  circular or other convenient shape. At or about the center of this frame and midway between the wheels he places an axle-box, constructed as hereinafter described. Each wheel has its separate and distinct axle, which he prefers to make somewhat conical or tapering, that is, smaller near the center than at the wheel end. Each axle is supported and is free to revolve in the box before-mentioned, and the outer ends pass through beams or bearings, outside of which the wheels are keyed; or the spokes of the wheels are inserted in lumps formed on the ends of the axles. Hence it will be seen that each wheel revolves with its axle, which being supported at each end, as before stated, renders the motion of each wheel steady without the possibility of any shaking or the wheel becoming loose. When the axles, constructed as before described, are applied to railway carriages, the axles traverse a tubular frame, and each wheel being fitted to a separate and distinct axle, great facility is afforded for passing around curves. The central axle-box is formed in two parts, with the sockets or receptacles to receive an enlarged portion or lump formed on the inner end of each of the axles. To insert the axles in the box one-half of the box is removed, and the enlarged portion of the axles are laid in the receptacles formed therein; the second half of the box is then laid on the first and over the axles, and a plate is laid on it and secured to the frame by nuts. The nuts are prevented from moving by a second plate inserted between the nuts, and which it partially embraces, the second plate being secured to the first by screws. The plate which partially embraces the nuts, after being removed acts as a key for securing the nuts. Plates similar to those just described are also employed for securing the outer boxes of the axles. Lubricating apertures or receptacles being closed by slides or otherwise after the oil or other lubricating material has been introduced. *Patent abandoned.*

Aug. 26, 1864. IMPROVEMENTS IN CARRIAGE-WINDOWS. R. Marshall.

For the purposes of this invention, the framing of a window of a carriage is near its upper end, provided with two spring catches or bolts, one on each side. The catches or bolts are formed at the outer ends of two rods which pass through holes formed in the top of the window, and the rods are acted on by a knob or handle in the following manner: On the stem of the knob or handle is a cam which acts on two short levers, which are in connection with the rods. These levers are constantly pressed on by springs in such manner as to force out the catches or bolts, and when the springs are free to act on the two levers, the two bolts or catches will be caused to project beyond the two side rails of the windows, and enter recesses or ratchets formed in the inner sides of the carriage-door or frame, wherein the window slides. The cam and the levers are recessed in the upper rail of the frame of the window, and they are covered over by a suitable plate. The window is raised by means of the knob or handle, and the window will be retained in the position desired by the two bolts or catches. When it is desired to lower the window, the bolts or catches by a partial rotation of the handle, will be withdrawn, and the window will be free to be slid down. At the lower part of the window of a carriage the patentee also places two springs, one on each side, which, when the window is fully raised, tend to press the lower rail of the window inwards; a projecting lip on the door or other frame in which the window slides. When the window has been fully raised the lip on the lower edge of the window is, by forcing out the lower part of the window, moved beyond the lip on the frame, and then, when the window has been lowered a short distance, the springs at the sides of the window will force the lip on the lower edge of the window inwards against the lip on the frame, and thus a trap will be formed which will shut out rain. Other springs also press the bottom of the window inwards, so as to clear the lip on the frame when the window is slightly raised, in order that it may be again lowered. *Patent completed.*



## CURRENT PRICES FOR CARRIAGE MATERIALS.

CORRECTED MONTHLY, BY MR. CHAS. WEEKS, FOR THIS MAGAZINE.  
NEW YORK, May 25, 1865.

Apron hooks and rings, per gross, \$2.00.  
Axle-clips, according to length, per dozen, 75c. a \$1.40  
Axles, common (long stock), per lb, 9½c.  
Axles, plain taper, 1 in. and under, \$6.50; 1½, \$7.50; 1¾, \$8.50;  
1¾, \$9.50; 1¾, \$10.50.  
Do. Swelled taper, 1 in. and under, \$7.00; 1½, \$8.25; 1¾, \$8.75;  
1¾, \$10.75; 1¾, \$13.00.  
Do. Half patent, 1 in. and under, \$9.50; 1½, \$10.75; 1¾, \$12.50;  
1¾, \$14.50; 1¾, \$16.25.  
Do. Smith's New York half patent case-hardened malleable iron  
box, 1 in. and under, \$10; 1½, \$10; 1¾, \$12.  
Do. Smith's Homogeneous steel, case-hardened mall. boxes, ¾ in.,  
\$12; ¾, \$12; ¾, \$12.50. Long draft, \$2 extra.  
Do. Saunders' improv. taper, ¾ in., \$12.00; ¾, \$12.00; 1, \$12.00;  
1¾, \$13.00; 1¾, \$15.  
Do. do. Homogeneous steel, ½ in., \$15.00; ¾, \$15; ¾, \$16.50;  
long drafts, \$4 extra.  
☞ These are prices for first-class axles. Makers of less repute, cheaper.  
Bands, plated rim, under 3 in., \$2.50; over 3 in., \$3.  
Do. Mail patent, \$3.00 a \$5.00.  
Do. galvanized, 3½ in. and under, \$1; larger, \$1 a \$2.  
Basket wood imitations, per foot, \$1.25.  
☞ When sent by express, \$2 extra for a lining board to a panel of 12 ft.  
Bent poles, each \$1.25.  
Do. rims, under 1½ in., \$2.25 per set; extra hickory, \$2.50 a \$3.50.  
Do. seat rails, 50c. each, or \$5.50 per doz.  
Do. shafts, \$7 per bundle of 6 pairs.  
Bows, per set, light, \$1.25; heavy, \$1.50.  
Bolts, Philadelphia, list.  
Do. T, per 100, \$3 a \$3.50.  
Buckram, per yard, 25 a 30c.  
Buckles, per grs. ½ in., \$1.15; ¾, \$1.40; ¾, \$1.70; ¾, \$2 10; 1, \$2.80.  
Burlap, per yard, 30c.  
Buttons, japanned, per paper, 30c.; per large gross, \$3.  
Carriage-parts, buggy, carved, \$4 a \$5.50.  
Carpets, Brussels, per yard, \$2 a \$3; velvet, \$3.75 a \$4.50; oil-cloth,  
60c. a \$75.  
Castings, malleable iron, per lb, 23c.  
Clip-kingbolts, each, 50c., or \$5.50 per dozen.  
Cloths, body, \$4.50 a \$5.50; lining, \$3 a \$3.50. (See *Enamelled*.)  
☞ A Union cloth, made expressly for carriages, and warranted not to fade,  
can be furnished for \$2.50 per yard.  
Cord, seaming, per lb, 45c.; netting, per yard, 5c.  
Cotelines, per yard, \$4 a \$8.  
Curtain frames, per dozen, \$1.25 a \$2.50.  
Do. rollers, each, \$1.50.  
Dashes, buggy, \$1.75.  
Door-handles, stiff, \$1 a \$3; coach drop, per pair, \$3 a \$4.  
Drugget, felt, \$2.  
Enamelled cloth, muslin, 5-4, 65c.  
Do. Drills, 48 in., 95c.  
Do. Ducks, 50 in., \$1.40.  
No quotations for other enamelled goods.  
Enamelled linen, 33 in., 75c.; 5-4, \$1.00; 6-4, \$1.20.  
Felloe plates, wrought, per lb, all sizes, 28c.  
Fifth-wheels wrought, \$1.75 a \$2.50.  
Fringes, festoon, per piece, \$2; narrow, per yard, 18c.  
☞ For a buggy top two pieces are required, and sometimes three.  
Do. silk bullion, per yard, 50c. a \$1.  
Do. worsted bullion, 4 in. deep, 50c.  
Do. worsted carpet, per yard, 8c. a 15c.  
Frogs, 75c. a \$1 per pair.  
Glue, per lb, 25c. a 30c.  
Hair, picked, per lb, 55c. a 72c.  
Hubs, light, mortised, \$1.25; unmortised, \$1.00—coach, mortised  
\$1.75.  
Japan, per gallon, \$3.  
Knobs, English, \$1.38 a \$1.50 per gross.  
Laces, broad, silk, per yard, \$1.20 a \$1.50; narrow, 15c. to 20c.  
Do. broad, worsted, per yard, 50c.  
Lamps, coach, \$20 a \$30 per pair.  
Lazy-backs, \$9 per doz.  
Leather, collar, dash, 28c.; split do., 18c. a 21c.; enamelled top,  
30c.; enamelled Trimming, 28c.; harness, per lb, 50c.; flap, per  
foot, 25c.  
Linen, heavy, a new article for roofs of coaches, 90c. per yard.  
Moquet, 1½ yards wide, per yard, \$9.00.  
Moss, per bale, 12½c. a 15c.

Mouldings, plated, per foot, ¼ in., 14c.; ¾, 16c.; ½, 18c.; lead, door,  
per piece, 40c.  
Nails, lining, silver, per paper, 12c.; ivory, per gross, 50c.  
Name-plates.  
☞ See advertisement under this head on 3d page of cover.  
Oils, boiled, per gallon, \$1.60.  
Paints, White lead, ext. \$15, pure \$16 p. 100 lbs.; Eng. pat. black, 35c.  
Pekin cloth, per yard, \$5.  
☞ A very good article for inside coach linings.  
Pole-crabs, silver, \$5 a \$12; tips, \$1.50.  
Pole-eyes, (S) No. 1, \$2.10; No. 2, \$2.90; No. 3, \$3.10; No. 4,  
\$4.50 per pr.  
Sand paper, per ream, under No. 2½, \$5.00; Nos. 2½ & 3, \$5.65.  
Screws, gimlet.  
☞ Add to manufacturer's printed lists 20 per ct.  
Do. ivory headed, per dozen, 50c. per gross, \$5.50.  
Serims (for canvassing), 20c. a 30c.  
Seats, buggy, pieced rails, \$1.75; solid rails, \$2.50.  
Shaft-eyes, (M. S. & S.'s), No. 1, \$2.75; 2, \$3.25; 3, \$3.50.  
Shaft-jacks, common, \$1.40 a \$1.60 per pair.  
Do. tips, extra plated, per pair, 37½c. a 56c.  
Silk, curtain, per yard, \$2 a \$3.00.  
Slat-irons, wrought, 4 bow, \$1.12½; 5 bow, \$1.25 per set.  
Slides, ivory, white and black, per doz., \$12; bone, per doz., \$1.50  
a \$2.00; No. 18, \$2.50 per doz.  
Speaking tubes, each, \$8.  
Spindles, seat, per 100, \$1.50 a \$2.50.  
Spring-bars, carved, per pair, \$1.75.  
Springs, black, 22c.; bright, 23c.; English (tempered), 28c.;  
Swedes (tempered), 30c.; 1½ in., 1c. per lb. extra.  
If under 36 in., 2c. per lb. additional.  
☞ Two springs for a buggy weigh about 28 lbs. If both 4 plato, 34 to 40 lbs.  
Spokes, buggy, ¾, 1 and 1½ in. 8½c. each; 1½ and 1¾ in. 8c. each;  
1½ in. 9c. each.  
☞ For extra hickory the charges are 10c. a 12½c. each.  
Steel, Littlejohn's compound tire, 3-16, 11½c.; 1-4, 10½c.; heavier  
sizes, 10c. currency.  
Stump-joints, per dozen, \$1.60 a \$2.25.  
Tacks, 9c. and upwards per paper.  
Tassels, holder, per pair, \$1 a \$2; inside, per dozen, \$5 a \$12;  
acorn trigger, per dozen, \$2.25.  
Terry, per yard, worsted, \$4; silk, \$9.  
Top-props, Thos. Pat. per set 62½c.; capped complete, \$1.38.  
Do. common, per set, 40c.  
Do. close plated nuts and rivets, 75c.  
Thread, linen, No. 25, \$1.30; 30, \$1.45; 35, \$1.65, gold.  
Do. stitching, No. 10, 95c.; 3, \$1.15; 12, \$1.28, gold.  
Do. Marshall's Machine, 432, \$2; 532, \$2.30; 632, \$2.60, gold.  
Tufts, common flat, worsted, per gross, 20c.  
Do. heavy black corded, worsted, per gross, \$1.  
Do. do. do. silk, per gross, \$2.  
Do. ball, \$1.  
Turpentine, per gallon, \$3., (fluctuating) with an upward tendency.  
Twine, tufting, per ball, 35c.; per lb, 60c. to 75c.  
Varnishes (Amer.), crown coach-body, \$6; nonpareil, \$7.50.  
Do. English, \$6.25 in gold, or equivalent in currency on the  
day of purchase.  
Webbing, per piece, 70c.; per gross of 4 pieces, \$2.60.  
Whiffle-trees, coach, turned, each, 50c.; per dozen, \$5.50.  
Whiffle-tree spring hooks, \$3 per doz.  
Whip-sockets, flexible rubber, \$4.50 a \$6 per dozen.  
Do. hard rubber, \$10.50 per dozen.  
Do. leather imitation English, \$5 per dozen.  
Do. common American, \$3.50 a \$4 per dozen.  
Window lifter plates, per dozen, \$1.50.  
Yokes, pole, each, 50c.; per doz, \$5.50.  
Yoke-tips, extra plated, \$1.50 per pair.

**TO SUBSCRIBERS.**—Our friends who have heretofore left with us a standing order for the continuance of the Magazine until they direct its discontinuance, will please take notice that the present number begins a new volume, as well as a new subscription to many into whose hands it now comes. While we return our heartfelt thanks for their constant patronage, and consequent encouragement, permit us to remind such as have not yet sent us the money for this volume, that our rules are **PAYMENT IN ADVANCE**, and that we expect to receive their remittances (\$5) before the next number is published. Please be punctual and oblige us. Office, 5 Ludlow Street, N. Y.



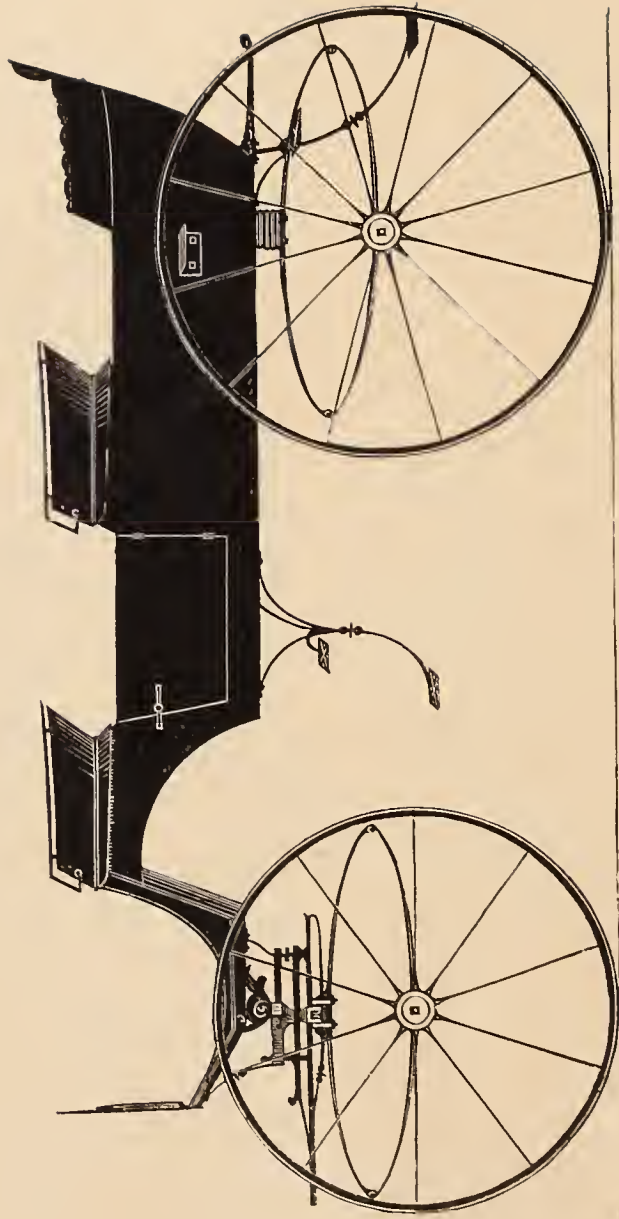

OPEN BEACH-WAGON.— $\frac{1}{2}$  IN. SCALE.

*Designed expressly for the New York Coach-maker's Magazine.*

*Explained on page 24.*



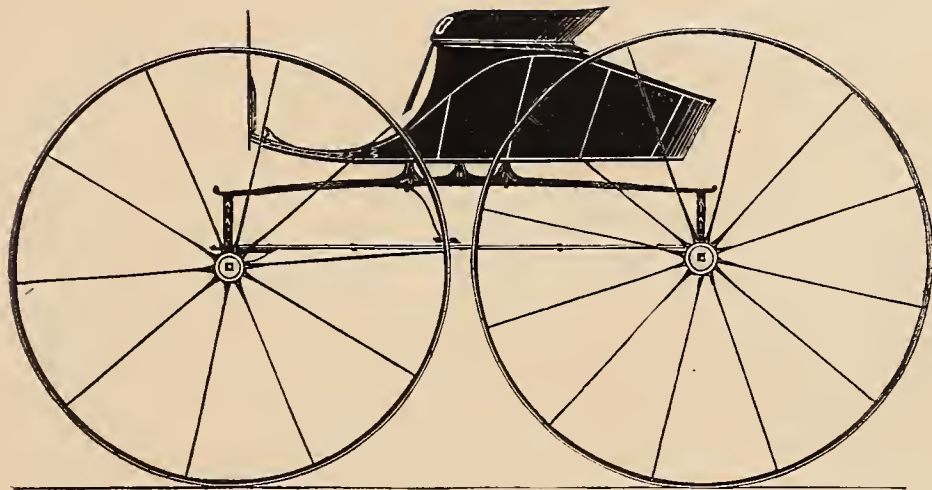

MOULDED SIDE-SPRING BUGGY.— $\frac{1}{2}$  IN. SCALE.

*Engraved expressly for the New York Coach-maker's Magazine.*

*Explained on page 24.*







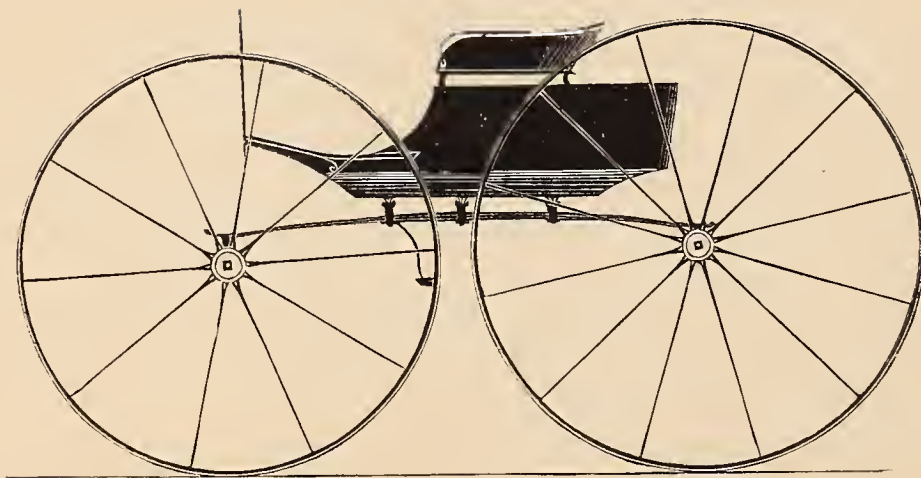

STIVER'S BUGGY.— $\frac{1}{2}$  IN. SCALE.

*Engraved expressly for the New York Coach-maker's Magazine.*

*Explained on page 24.*

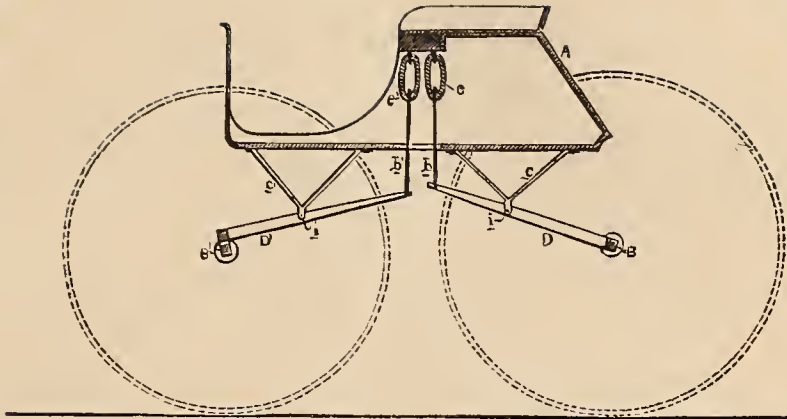

E. LANE'S "UNDULATING" SPRING BUGGY.—SCALE UNCERTAIN.  
(PROFILE VIEW.) *Explained on Page 24.*

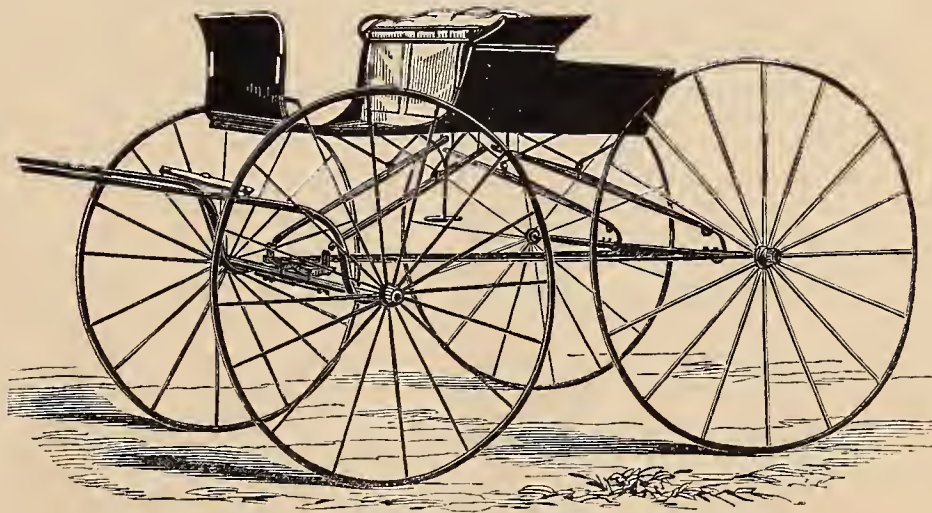

E. LANE'S "UNDULATING" SPRING BUGGY.—SCALE UNCERTAIN.  
(PERSPECTIVE VIEW.) *Explained on Page 24.*







DEVOTED TO THE LITERARY, SOCIAL, AND MECHANICAL INTERESTS OF THE CRAFT.

Vol. VII.

NEW YORK, JULY, 1865.

No. 2.

### Mechanical Literature.

#### LONDON JOURNEYMEN COACH-MAKERS' INDUSTRIAL EXHIBITION.

(Concluded from page 6.)

THE Marquis of Lansdowne, in reply to the address relative to the opening of this exhibition, said—I believe the exhibition will be productive of the most beneficial results, not only to the coach-makers throughout the country, but also to the public at large. It is only by making the public feel that they have an interest in exhibitions of this kind that such undertakings can receive that support which will lead to that which we all desire to see—viz., the permanent establishment of displays of this character. On the score of the usefulness of these exhibitions, I may say there never was an epoch when institutions such as these were destined to have so large an influence on the general welfare of the country. Formerly the use of carriages was confined to such a limited number of persons that the public could scarcely be said to be interested in their manufacture. But now, thanks to the prosperity which so generally exists, to the spread of civilization, which has led to a more extensive command of the luxuries and comforts of life, this special branch of industry is much more appreciated than was formerly the case. There now exist many more opportunities than before for talent to develop itself, and especially is this the case in regard to carriage-building. I can hardly enumerate the various classes of vehicles and the various conveniences which exist to testify to the increased demands on the part of the traveling portion of the public. I might almost say that too much is required on the part of coach-makers. The public want to have carriages subservient to every use; they require a vehicle to run on two wheels and upon four wheels; they want some too light, and others too heavy. The requirements of the public have gone almost too far. At the same time, it is no doubt desirable that we should have lightness in the vehicles; but it is also necessary that they should have strength also. Very great improvements have already been made in this combination of lightness with strength, and I believe that further improvements

are still to be made in this direction. (Cheers.) With respect to the awards of the prizes which have been made, I most entirely concur in the regret expressed by those who have had the management of the undertaking, that a greater amount of protection could not be afforded to those who are the exhibitors. It would have been very desirable if we could have given greater protection to inventors. (Cheers.) I do not wish to enter into the wide question of patents, and the difficult questions which they involve; but there can be no doubt that it would have been desirable if we had had the power of affording protection to the inventor. I believe, however, that those of the exhibitors who are inventors will, in the end, be much better in consequence of this exhibition, by being known as clever and talented men, and having been taken in hand by their employers, and they will thus benefit considerably in their after life by this exhibition. (Cheers.) I could point to various inventions and designs upon these walls which attracted notice, when the judges were going through their awards, as deserving of the highest praise. Some of them are the work of very young hands, and I trust that the young men among the exhibitors will be encouraged, as they deserve to be, for the talent which they have displayed. This exhibition will give them the opportunity of becoming better known by a large number of persons. Their names are placed in an honorable position before those who will have the opportunity of recognizing and rewarding their abilities. (Cheers.) A very just allusion is made in the address to the benefits which previous great exhibitions have conferred upon trade. It is now a perfectly well recognized fact that trades have much more to gain than to lose by competition. (Cheers.) The recognition of that great fact has already done good service to the country, and it cannot fail in the end to benefit all classes of the community. (Cheers.) A very long time has elapsed since the discovery of the value of competition was made. Some time since I was reading a work, to which I referred at a previous meeting in connection with this exhibition, in which a short extract was introduced from the work of Sir William Davenant in 1640. It is curious as illustrating the fact that then, more than 200 years ago, opinions were entertained which have only lately received general assent in this country. In the work of Sir William Davenant a supposed dialogue between a Frenchman and an Englishman is given. One, a bourgeois of Paris,



the other a citizen of London, are supposed to be discussing the respective merits of the two cities. The bourgeois is supposed to be speaking, and he says, "You of this noble city are yet to become more noble by your candor to the plea between me, a bourgeois of Paris and opponent of London, being concerned in honor to lend your attention as favorably to a stranger as to your native orator, since 'tis the greatest sign of a narrow education to permit the borders of rivers, or the strand of the sea, to separate the great consanguinity of mankind, though the unquiet nature of man hath made them bounds to divide Governments." (Cheers.) I was rather surprised to read such liberal sentiments as these from a writer of that date. It is now generally recognized that there ought to be an end to foolish jealousy, though rivalry should of course continue to exist. I draw a great distinction between those two feelings. I should be very sorry, indeed, to say anything which would tend to prevent a spirit of rivalry between those who are engaged in any branch of industry. Anything which would tend to diminish the spirit of rivalry would be productive of nothing but evil. A little opposition is a very excellent thing in its way. (Cheers.) It tends to keep people up to the mark; and this applies equally, in our constitutional government, to the Ministers in power, and to the Opposition out of office, as it does to every trade and occupation. One word or two on the subject of prizes. The judges went very minutely through the whole of the articles exhibited, and with such pains as they could bestow upon their task. At a later period the result of their awards will be made known. A suggestion was made, which I think a very good one, that in awarding the prizes or premiums, the judges should lay down as a law for themselves that they should not give prizes in cases where there was nothing of sufficient merit to reward. I think it is of great importance that such a rule should be observed as far as possible. I have suggested, in reference to my own small prize, that if there was no reason to award, the amount should be employed in some different form, or should be left available for further exhibitions of this kind. I think it is for the interest of the operatives themselves that these prizes should not be made too common. If persons should come to form an opinion that these prizes are not well bestowed, the whole of the halo which would otherwise attach to anything of the kind is taken away. (Cheers.) I confess, therefore, as far as my own opinion goes, that I fully concur in opinion with those who suggest that the prizes should only be given in cases where they were really deserved. The operatives themselves would, I am sure, rather not have a prize at all than that it should be open to the imputation of not having been awarded on sufficient grounds. (Cheers.) I wish I was one of those who, by their eloquence, could throw a luster upon everything on which they touch. It is difficult, on occasions of this sort, to say anything which would kindle the enthusiasm of those who are present. I trust, however, that I have explained sufficiently clear my own views with respect to these exhibitions, and that I have said sufficient to assure you of the warm sympathy which I feel in the objects of the exhibition, and which, I hope, will be not only a successful, but a permanent one. (Cheers.) Very great credit is certainly due to those who have undertaken and carried out the work; and I should be sorry, indeed, if those gentlemen who have taken so much pains themselves, and given

so much time and attention to the subject, should not be supported out of doors as fully as the merits of the exhibition deserve. (Cheers.)

On motion of Mr. Thrupp, a vote of thanks was given to the noble marquis for his attendance. The choir, principally operative coach-makers, sang the Old Hundredth Psalm, the Rev. Dean Milman offering up a prayer.

The choir then sang the anthem (Weldon) "O praise God in His holiness;" one by Kent, "Blessed be Thou, Lord God of Israel;" and the National Anthem. The Marquis of Lansdowne, the master and wardens, preceded by the beadle of the company, walked round the exhibition, and examined the models, drawings, and various articles of interest, a notice of which appeared in the article of the *Morning Post* on Tuesday.

From the *Athenæum* of Feb. 4, we take the following:—The Operative Coach-makers' Industrial Exhibition opened on Wednesday last, in the Hall of the Coach-makers' Company, Noble Street, Cheapside. For the most part devoted to technical objects, there is very little of general interest in the gathering, so far as its recent materials are concerned. Examples of fine manufacture in most of the crafts connected with vehicular construction and fittings predominate; ingenious devices for adding to the comfort and security of riders and drivers abound, with a considerable number of decorative works, such as are supplied by lace-makers, joiners, painters and others, whose trades relate immediately to the special object in view. Whatever might be said of the skillful manipulation of most of these matters, it is certain that very little praise can be awarded to them from an Art point of view. We find small, if any, attention has been paid to improving the design of our vehicles, so as to render them elegant and worthy of an Art-loving and Art-understanding people. This is the more to be regretted, because there is no class of modern domestic articles so much in need of improvement, or offering such facilities for the development of graceful design, as that of the coach-builder. It cannot fail to have struck every student that exhibitions of this order direct attention to the practice of a sort of decoration which is not mechanical. The managers, not only of this Exhibition, but of that produced by the Painters and Paper-Stainers' Company, offer prizes for imitative graining, "sham eanework," and other fallacies, as if these things were not in themselves violations of the laws of Art, and calculated to induce a belief that there is something creditable in creating things which are unintelligent, inasmuch as they deal with falsehoods, and are intended to supplant genuine, artistic and thoughtful design. Putting aside the obvious improvement of recent works of the class in question in respect to their convenience, our coaches contrast painfully with those of a hundred, or even fifty years ago. The visitor who is curious in the details of such works may compare, to the end suggested by our remarks, the beautiful coach-lace, exhibited by Messrs. Woodhall (No. 122), with that of more modern design which surrounds it. In frame 122 is the most generally attractive item of the Exhibition—a strip of lace made for Nelson's coach, and bearing the stern of the ship San Josef alternating with a cipher; below this strip is more beautiful lace, some of which looks as if it had been designed by Stothard. There is plenty of good carpentry and cunning joiner's work here; but very little that will interest one who



looks for something better. Let us hope a future occasion of this sort will show that attention has been given to artistic design in coach-building.

Mr. Hooper takes the following notice of the above in the next issue of the *Athenæum*:

As first proposer, and one of the promoters of the Operative Coach-makers' Industrial Exhibition, I am very glad to see you have noticed the undertaking, and begun to take it to pieces, and see what it is made of, and what it can be made into—in fact, we want discussion and criticism on the part of the public and the public press.

We are, like other manufacturers, bound to produce things that people will buy, and the rage for some time past has been, 1st, for cheapness; 2dly, lightness; and, 3dly, for one carriage to do duty for two, three, and sometimes four. You may guess what is the result in attempting to do so much; you must sometimes sit back to back, sometimes crab fashion, and at others with only a very slight interval between your nose and your knees.

In this age of wealth, luxury, and general comfort, carriages, from having reached the acme of comfort for traveling, and elegance for court use, are reduced to mere makeshifts; in fact, if you happen to be in the West End of London while Her Majesty is holding a levee, you will see nearly as many dirty cabs taking the company, as of private carriages, and those mostly of a mean description. Is the company so much poorer than that which attended levees in former times? or is it the same sort of inattention to details that would lead a slovenly man into a ball-room with muddy boots and dirty gloves?

While Art is so much valued in connection with architecture, pictures, goldsmiths and silversmith's work, pottery, book illustration, and numerous other professions and handicrafts, it requires public attention to be drawn to the vehicles of the present day, whether to convey a Duchess to a drawing-room or a workman to his suburban dwelling.

GEORGE N. HOOPER,

*Chairman of the Committee of Management.*

Another London Journal takes a more favorable view, and says:

The Operative Coach-makers, following the lead given at the Lambeth and Islington working-men's exhibitions, have collected a good many specimens of their art, both useful and ornamental, at Coach-makers' Hall, Noble Street. The idea was, we believe, first suggested by Mr. Hooper, and has since received warm support from Mr. Woodall and other members in the trade; but the object is, we understand, to leave the matter as much as possible in the hands of the working coach-makers themselves, and to leave to them whatever amount of public approbation may be bestowed on the exhibition.

The working coach-makers have, we think, wisely devoted their ingenuity to the production of specimens coming within the circle of their own highly skilled handicraft; and considering that the present is the first attempt, the result is very creditable. There are drawings and designs for carriages by working-men which will certainly be seen rolling in Rotten Row before long, and various models of improvements in splinter bars, steps, roofs, and other details of carriage-building. Elegant models of the Queen's and other state carriages form an attractive feature in the exhibition, and there are also some wonderful specimens both of heraldic and ordinary coach-painting. Some of the imitations of "basket"

bodies are exquisite. In another department the harness-makers are excellently represented, and there is an immense variety of coach lamps, including one which generates its own illuminating vapor, and produces a most powerful and continuous light. Cushions, hammer-cloths, lace, in short the whole *utile et dulce* of the trade are exhibited in great variety, forming, altogether, we will not say a perfect, but at least a very promising exhibition, one that even now, in its infancy, is well worth a visit, and which will, no doubt, if properly supported by the public, be the forerunner of a great many future ones, got up on a much more extensive scale.

Perhaps our operative friends will forgive us for observing on the paucity of evidence of the exercise of the inventive faculty in the working men amongst the articles exhibited. As a matter of fact, nearly all of our great mechanical inventions which have revolutionized manufactures and converted small masters into millionaires originated with working-men; and, therefore, is it a matter of regret to us when we see these latter wasting their cash and ingenuity in the construction of mere models, which, being entirely without novelty, are little elevated in character above the toy shop. There are several coach-making desiderata unsatisfied at this moment, and the working coach-maker who should supply any one of them would at once make his own fortune and confer an important benefit on the community. We want, for example, an omnibus not too large for the crowded streets of London, and at the same time with so much interior space as will enable the sixth passenger on each side to settle down in his seat without the assistance of a hydraulic ram. We should be very glad, also, of a "Hansom" into which the passenger could get without breaking his shins against the doors, and get out or lower the window without the imminent risk of nasal abrasion. Another model which would be immensely popular would be one of an improved "four-wheeler," which, while it ostentatiously exhibited its license to carry "four inside," should at least be able honestly to accommodate three of the number. We understand that the committee offered prizes for all the above matters, but that as yet the operatives have not been persuaded to turn their attention in so useful a direction. One very original model is seen of a traction engine, which struck us as being an immense advance on any at present in use. If it be entirely the invention of the exhibitor we should recommend him to register it without delay, as, if not, there will be great danger of piracy when the exhibition is thrown open to the general public. The ceremonial inauguration of the exhibition takes place to-morrow (Wednesday), when the Marquis of Lansdowne and several other notabilities have promised to "assist."

The Exhibition having been open several weeks, the distribution of the prizes was made to the successful contributors in the Theater of the Society of Arts, John Street, Adelphi, on the evening of April 3d, under the presidency of Lord Truro.

The proceedings opened with an address, read by the Secretary, announcing, on the part of the Committee of Management, that the exhibition had met with a success beyond their most sanguine expectations. It had (they say) given an opportunity for employers and operatives to become better known to each other, and opened a new era to the employers and operatives of the coach-making



trade, inasmuch as the welfare of the working-men will doubtless be much enhanced by periodical comparisons of skill and ingenuity, such as the one recently taken place. The award of prizes has taken place under circumstances of greater independence of any influence of the committee than they ever contemplated at the commencement of their labor. With the judges rested the entire responsibility of the award of prizes, except in so far as the committee strongly advised that, of the prizes offered, as many as possible should be awarded where there was merit, although in several instances there was only one article lent in competition for each prize: as these, however, were creditable specimens of what was expected, the exhibitors had the benefit of the absence of competition on the occasion of a first exhibition, it having been considered desirable, for the sake of encouragement, to distribute the awards liberally. On a future occasion it is expected that the competition for the prizes will be of a keener description, and that few who enter for a race will be allowed to walk over the course. We esteem it one of the most pleasing results of the exhibition that all classes have joined to encourage, praise, or reward those who have deserved well of their country, by freely showing the result of their knowledge, experience, and handiwork as examples for others to copy, or surpass. Meeting as we do in the house of the Society for the Encouragement of Arts, Manufactures, and Commerce, we are reminded that a work small at its commencement may grow in the course of years to national importance. We cannot look forward to benefit the nation so extensively as this great and noble society; but at a humble distance we have endeavored to follow their examples, and originate what we hope may confer great benefit on the carriage operatives, and indirectly the whole nation to which they belong.

Lord Truro then proceeded to distribute the prizes, which consisted of money—varying in amount from half-a-guinea to five guineas—the Coach-makers' Company's bronze medal in twenty-three instances, and in thirty others certificates of merit. The recipients of these latter were, as a general rule, more loudly applauded than those who took the money prizes. Whether this was intended as a reflection on the judges, or simply as an expression of sympathetic encouragement to future exertion, it was difficult to determine. His lordship having performed this part of the presidential duties, spoke in terms of regret at the absence of the Marquis of Lansdowne, who had opened the exhibition, and his hope that the award of the prizes had given universal satisfaction. He urged those who had not succeeded to persevere, in the confidence that the display of their ingenuity on the present occasion was but the germ of future success. These exhibitions were but the commencement of a new career in trade, of vast importance as exciting intellect and ingenuity, combined with manual skill and vigorous enterprise, and enabling the operators in this branch of industry to compete with the world in the race of free trade, and to maintain that position which they had during the last half century held. He was gratified to find that, of the prizes and certificates distributed that evening, 21 had been awarded for artistic merit, evidencing the importance attached to art on the one hand, and the artistic proficiency of the exhibitors on the other; while 13 had been given for mechanical contrivances, and 17 for manual skill. (Hear, hear.) After expressing a hope that the number

of competitors would increase at future exhibitions, he adverted to the great loss the country had sustained within the last forty-eight hours in the death of the acknowledged leader of free trade—Richard Cobden—(hear, hear)—to whom this country was undoubtedly indebted for the adoption of the free trade principle—a man who had won for himself immortal honor, and a name which the highest in the land might well be proud of, that of the benefactor of his country. (Cheers.) No title, no rank you could bestow upon a public man—no record that could gratify his feelings so much as to say of him that he died one of the greatest benefactors of his fellow-men that ever lived. Though others might have advocated the cause before him, there could be no question that it was to Richard Cobden we were indebted for free trade—it was his achievement that would incite our future exertions and compel us to leave no stone unturned in the struggle with foreign competition—it was he who had put the strain upon us to test the future merits of the British workman, amongst whom, from what he (the Chairman) had seen at the recent exhibition, he was satisfied that the coach-makers would not hold the lowest place. (Cheers.)

Lord Truro then presented the prizes as follows:

The Society of Arts prize for the best specimen of chasing, to J. Corbett; the Coach-makers' Company's bronze medals, to F. Humphreys, John Adcock, H. Pilbeam, and J. Bassett; the Master of the Coach-makers' Company (Thos. How, Esq.), for the best design of an open and close carriage combined, W. T. Allam; Mr. G. N. Hooper's prize of three guineas for a drawing of a barouche, W. C. Bolt, and of two guineas for a drawing of a hospital carriage, James Robinson; Mr. G. A. Thrupp's prizes of two guineas for the best stuffed cushion in morocco, Henry Headford, and for the best drawing of an under-carriage, Henry Semon; Messrs. Woodall's prizes of two guineas for the best panel of carriage-painting, John M. Dean, and for the best finished pad and bridle, Edward Spendlove; and of one guinea for the best hand-sawn dash-iron, Wm. Wood; Mr. Barlow's prize of two guineas for the best set of harness furniture, new design, to H. Birch; of half-a-guinea for the best working drawings of bridle-fronts, R. Burgess; for the best specimen of hard-solder plating and soft-solder plating, D. Jones and W. Sheldon. The Committee's prizes—of two guineas, for the best specimen of heraldic painting, to J. J. Cowens; for the best specimen of decorative coach-carving, J. Wyatt; for the best set of working drawings for an improved brougham carriage, A. Brewer; for the best specimen of sham caning, C. H. Fuller; for the best seat, the border sewn by hand, T. Robinson; for the best method of detaching fallen horses, J. Hammerton; for the best cushion, stuffed and quilted, A. Townsend.

Certificates of merit were next presented:

For drawings of carriages, to Joseph Butler; model of a landau, J. J. Norcott; drawing and improved hinge, Charles Toogood; model of improved hinge, a photograph and rule, John Weckes; apparatus for drawing C springs, Alfred Brewer; machine for drawing off fast-set axle-boxes, J. Smith; painted spokes, sham caning and striping, W. Hewitt, Jr.; a plain varnished panel, J. Gibbs; imitation basket-work, &c., W. Ninham; six spokes painted, W. Simpson; panels of various colors, Henry Smees; a spring cushion, Carl Moller; a carriage-seat,



caned beneath and improved cushion, William Stephens; a model of hammer-cloth, William Woolford; an improved awl, saving prick-marking, Henry Wyatt; specimens of soft silver plating, George Coster; a case of lamps, the workmen at Mrs. Salisbury's; a panel of monograms, F. V. Hadlow; chased door handle and harness ornaments, Joseph Little; drawings, of drag, barouche, &c., S. H. Birch; colored drawing of dress coach, J. Hewitt, Jr.; various drawings of carriages, P. Roduwart; models of railway carriages, William Hacker; brass model of carriage with portable railway, James Henwood; model of a state hammer-cloth, a straining joint, W. J. Murlis; a self-acting step to fold up under when carriage-door shuts, H. S. Dobson; model of a Brougham, J. T. Brown; new and inexpensive Venetian blind, J. J. Tattam; drawing of state harness, C. Muckersie; driving-cushions of new design, J. W. Berriff.

The prizes having been distributed, the Chairman said he regretted the absence of the Marquis of Lansdowne, who was much more intimately acquainted with the subject than himself. He hoped some of those who had been unsuccessful would not feel discouraged, for many of the articles now not successful might contain the germs of inventions likely to be valuable in future. These exhibitions were but the commencements of whole series of such gatherings, which we owed to the blessings of peace. Free trade had given us the whole world to contend with, and we must not be left behind in the race. The coach-making trade required as much skill and ingenuity as any branch of industry. There was a time when the English operative was content to earn his daily living, but he was not now satisfied without progressing. He observed with pleasure that the largest number of prizes had been given for what argued a high standard of education in the recipients. Twenty-one prizes for artistic merit had been awarded, thirteen for mechanical contrivances, and seventeen for manual skill. In conclusion, the Chairman urged the need of vigorous efforts under the system of free trade, and took occasion to refer to the great loss the country had just sustained in the decease of Richard Cobden, to whom the country was indebted for that great benefit. The mention of the deceased statesman's name and services was received with loud cheers.

After some further remarks the meeting concluded with the usual compliments to the Chairman.

We cannot dismiss this subject without expressing our thanks to Mr. Geo. N. Hooper, of London, who, in the kindest manner, has put it in our power to spread before our readers the interesting history of the first Operative Coach-makers' Industrial Exhibition with which the world has been favored. In a subsequent number we design to transfer to our pages an article on "Coaching," from *All the Year Round*, incited by this Exhibition.

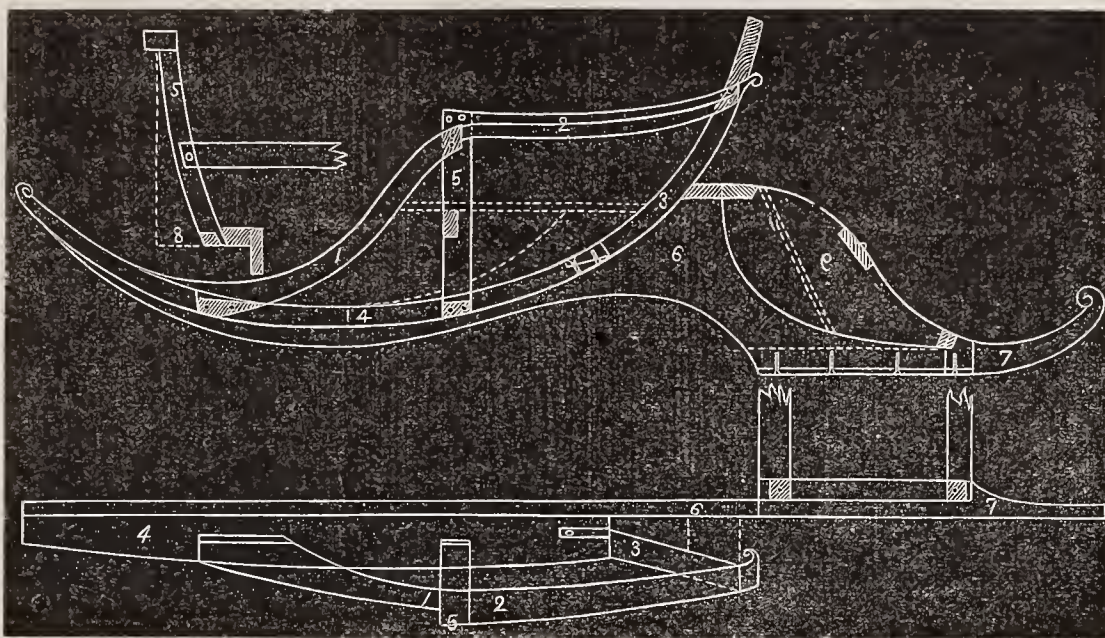

CAB PHAETON, WITH TURN-OVER SEAT, AND CANT-BOARD— $\frac{3}{4}$  INCH SCALE.

#### ENGLISH CARRIAGE ARCHITECTURE—No. XVI.

FIRST ascertain the extreme length of the body, and then proceed to draw the bottom-side on the black-board, as shown in the engraving; next the sunken-bottom and back pillar, &c. 1, shows the front pillar; 2, the arm or elbow; 3, the back pillar; 4, the bottom-side; 5, the standing-pillar; 6, the rocker and boot side; 7, the mock pump-handle or scroll; 8, the diagram, showing the turn-under of the standing-pillar; 9, the turn-over seat. The dotted lines drawn horizontally through the body represent the lines for the seats. The figures repeated in the "cant" below, refer to the like parts in the frame work already named in detail above. The further elucidation of this subject will be seen in vol. iii. pp. 126, 170.

#### AMERICAN DICTIONARY FOR COACH-MAKERS.

WE have two objects in view in compiling this Dictionary. One is to *draw out* information from the craft; the other to *enlighten* the public, so that when they visit a shop they can the more readily make their wishes known. Since many portions of a carriage differ in name, in different localities, we hope to hear from those who detect any variation on our part, that we may embody their communications in the future supplement we intend to publish.

A.

**AXLE-ARM** (Saxon, *earn*). That portion of the axle imbedded in the *hob* or hub, on which the wheel turns.

**AXLE-BED** (Saxon, *bed*). The timber added to support the iron axle-tree, or in which the axle is let or imbedded.

**AXLE-BOXES** (Sax. *box*). The cylindrical iron tube, or case, fitted around the arms of an axle or axle-tree, and which in a carriage are let into the hubs of the wheels. In ancient times no such protection for the hubs (or naves) was known. (See the chariot illustrated on p. 42, vol. i.)

**AXLE-CLIP** or **HOOP**. The strap or ring which is put around the axle and its bed to secure them firmly and strengthen both.



**AXLE-NUT** (Sax. *hnut*). The piece of iron used to secure the wheel on the axle, in the absence of linch-pins. The only apology for the term as we understand it, is, that it is allied to *knot*, a bunch or lump. In its general sense, it means a piece of iron in which a thread or screw is cut for a bolt.

**AXLE SET.** The inclination forward or downward (from a straight line) given to the axle, ostensibly, for two purposes: one to throw the top of a wheel out, the other to make the wheels "hug" the shoulder, or incline the wheels in from parallel lines, by some called *gather*, which see. (P. 2, vol. vi.)

**AXLE-SKEIN.** Strips of iron bedded in the top and bottom sides of a wooden axle-tree arm, to protect the same against wear from the hub-boxes.

**AXLE-TREE** (Saxon, *ax* and *tree*). The piece of timber, or the iron arm on which the wheels revolve. These are distinguished in our day as plain, taper, half, full or mail patent axles. Some of these, as the Collinge, are very complicated and expensive.

**AXLE-WASHER.** An iron or leather ring on an axle, placed between the outer end of the hub and the linch-pin. As understood by Felton and the craft seventy-five years ago, it was "an iron collar or shoulder fitted to the body or large end of the axle-tree, against which the back end of the wheel wears, for the purpose of keeping in the grease."

#### B.

**BAROUCHE** (ba-roosh). A four-wheeled carriage, with a falling-top to the back-seat, and a driver's seat in front, isolated. Not as fashionable as formerly. It was introduced into England from Germany, about 1802. (See vol. iv. p. 175.)

**BAROUCHET** (ba-roosh-a). A barouche with one of the seats omitted. This vehicle stands in the same relation to the Barouche that the Landalet does to the Landau. The term is expressive of *diminution*; a reduced barouche, a demi-barouche, carrying only half the number of inside passengers.

**BARs.** The crosspieces of shafts (thills), bodies, clips, &c. The general import of the word is to designate anything long in proportion to its width; by the craft, security.

**BATENS** (Russ. *batayn*). The strips of wood used as cross-pieces to panels, to prevent their splitting. The word, as formerly used by the craft, meant the strips of wood fixed on the outside of panels to form the framing, and were afterwards moulded. The word "stretcher" applied to the strips of wood *inside* of panels as a support in our times, has, in a certain sense, the same meaning.

**BEADS** (Germ. *bethe*). The mouldings used to ornament a carriage. (See MOULDINGS.)

**BENT STUFF.** Shafts, poles, rims and other wood steamed and bent to give elegance or strength to the natural timber. The use of bent timber by the craft is very ancient. (See the rims to the chariot wheel in vol. i, p. 42.)

**BLINDS.** Frame-work of wood, intended for use in excluding the passengers from outside observation, known as Venetian blinds. In some cases they are mere imitations, and then used as ornaments on the side-panels of carriage bodies.

**BLOCKS** (French, *bloques*). Wooden or iron raisers, placed under or above the springs, and other portions of a

carriage. These are generally made of hard wood, and are either carved or beaded for ornamentation.

**BODY** (Sax. *bodig*). The box for containing the passengers. The main *trunk* of a carriage, adjectively, under various names.

**BODY LININGS.** The materials of cloth, leather, &c., used for trimming a carriage body.

**BODY LOOPS.** The irons used in hanging up the body, and are generally applied to the bottom corners and secured by bolting.

**BODY VARNISH.** Varnish made expressly for varnishing carriage bodies of the purer gums, hence its greater expense. Among Americans, the domestic article is used for all except the finishing or last coat, this generally being of English manufacture, and considered more durable. A good imitation, at much less cost, is furnished by Messrs. Valentine & Co., of Boston, Mass. For carriage parts it advantageously takes the place of the foreign article.

**BOLSTERS.** The supports to a lumber-wagon body, generally constructed without springs. See STANDARDS.

**BOLTS** (Sax. *bolta*). Iron pins of various lengths, headed at one end and serewed at the other, which Felton tells us are "about half an inch thick." This is what an American carriage-maker would call "a *little too much* of a good thing," when applied to *his* carriages generally.

**BOOTS OR BUDGETS** (French, *botte*). Boxes covered with leather, and placed in the front end of a coach or carriage body, or as an apron to protect the person from rain or mud. This latter application Webster says is improper, but we think custom makes it admissible. Boots and budgets (covered boxes) were formerly known as Salisbury, platform or trunk in England. *Budgets* are unknown, as such, in this country. A drawing of one will be seen in vol. vi. p. 43.

**BOODGE.** In England another name for sword-case, which see.

**BOTTOM OR PANEL BARS.** "The bottom end framings of the body on which the end panels rest."—*Felton*, vol. i, p. 12. In America, "bottom bars."

**BOTTOM BOARDS.** The boards used as floors to carriage-bodies.

**BOTTOM SIDES.** The sills or main side-pieces of a carriage-body. These are like the keystone to the arch, the most important timbers of the structure, in which are embodied the chief points of beauty and of strength.

**BOWLS.** The concave-shaped pieces of wood inserted in the sides of buggies, &c., to facilitate short turning and add beauty to the vehicle.

**BOWs.** The arched strips of wood, used as supports to the covering of all "falling-top" (calash), and in some cases of "standing-top" wagons.

**BOXES.** These are the axle and carriage-seat closets for traveling conveniences.

**BOX LOCKS.** "Locks used for the doors of the body."—*Felton*, vol. i. p. 161.

**BRACES.** The leathers on which carriage-bodies swing, generally known as "thorough-braces." Thorough is derived from the Saxon *thurh*, and means, extending from end to end.

**BRACKETS** (French, *braquer*, to bend). The supports to the foot-board of carriage bodies. "The carved or-



naments fixed on each side the top of the coach-box foot-board."—*Felton*.

**BRASS BEAD EDGINGS.** This was the name given to the brass plates formerly screwed to the edges of doors for them to shut on. These are now known among us as mouldings, and are made of lead. The name is derived doubtless from the fact that they are *cast in a mould*.

**BRETT.** A contraction of the Russian name *Britzka*, and generally used in this form by American carriage-makers. Should this not be "Brit"?

**BRITZKA (Bris-ka).** The Russian name for a carriage with a calash top, so contrived as to accommodate the traveler at night with a place for sleeping, or reclining during the day. Very fashionable in Northern Europe.

**BROUGHAM.** An English name for the coupé, when made heavier and longer. The name was originally given in compliment to Lord Brougham. See *COUPÉ, ultra*.

**BUDGET.** A small box made to hang by straps under the hind part of a carriage, for the purpose of carrying a few spare bolts, nuts, lynch-pins, nails, &c., and tools, such as a wrench, hammer, chisel, pincers, &c., in earlier times, when carriage-makers were "few and far between," to repair the *breaks* on the road when traveling. It was also called a "Tool Budget." See *Felton*, vol. i., p. 223.

**BUDGET BOOT.** In America the term is obsolete. "The inner cross-bars to the front of the carriage on which the fore-spring and budget rest."—*Felton*, vol. i. p. 48. (See *HORNBAR, ultra*.)

**BUGGY (from Bug).** A very light vehicle, confined to carrying one or two persons. Among Europeans understood to mean a small phaeton or chaise, made to carry one person only. According to Webster it means a light vehicle to be drawn by one horse. *Felton* says, "A buggy is a cant name given to phaetons, or chaises, which can only contain one person on a seat; they are principally intended for lightness in draught, for the writer to sit snug in, and to preclude the possibility of an associate. Mostly used by outriders."

**BUTTONS.** Frequently used in America in place of tufts in trimming. Formerly, in carriage-making, it meant the nails or screws with large brass heads, used for hitching on the straps. Sometimes these were plated with silver and otherwise made ornamental.

**BUTTON-HANGERS.** "Small ornamented tassels, which are placed on the fringe."—*Felton*. These are now confined to the ornamentation of large coach tassels for outside holders. Very little used.

(To be continued.)

## ECCENTRICITIES IN CARRIAGE-MAKING.

NUMEROUS attempts have been made by men of a speculative turn of mind, for the purpose of taking the construction of carriages out of the ordinary mechanical channels, and substituting in the place thereof something bearing more decidedly the impress of originality. That this has generally been done by individuals not practical carriage-makers is evident. That they have proved failures is just what might have been expected. This fact, however, will not lessen the interests attached to their history. This conviction has led us to undertake the

publication of a series of articles under the head of "Eccentricities in Carriage-making," which properly illustrated, we intend to introduce to our readers, as opportunities present themselves. To do this the more effectually we invite contributions from such of our friends as may be in possession of originals in this line. Should such be sent us we promise to carefully return after we have copied them.

### I.—A ROAD PRESERVER.

The first example we introduce to our readers was *contrived* in 1796, and presents "A simple contrivance for preventing the wheels of carriages making ruts in Roads; By Robert Bealson, Esq., member of the Society for the encouragement of Arts, Manufactures and Commerce, Honorary Member of the Board of Agriculture," &c. The inventor says:

"Although several machines have at different times been invented for facilitating the repair of roads, and filling up ruts made by wheel-carriages, yet no method has ever been proposed, so far as I know, to *prevent* the

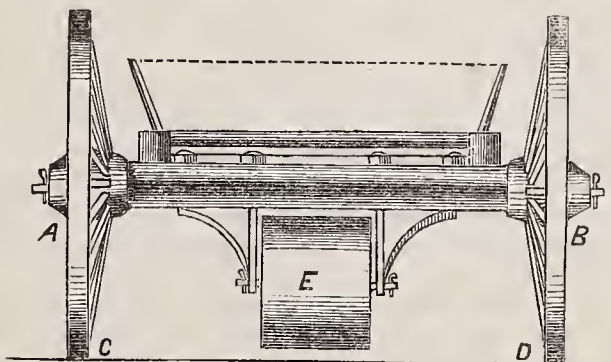

wheels of carriages *making* ruts; it being taken for granted that, however hard and solid the road may be, such ruts must unavoidably be made in it. But, in my humble apprehension, the common observation that it is easier to prevent an evil than to cure it afterwards may justly be applied in this case, for it appears to me that a method may be devised which will in a great measure prevent ruts being made, and thereby save much expense, not only in keeping roads in repair, but in their original construction.

"Broad wheels have long been in use; but although they are a great safe-guard to the roads when properly constructed, yet, while they are allowed to be shod in the convex manner in which most wagon wheels are to be seen, and with so many rings detached from each other, and with the heads of the large nails projecting so far, it is impossible for even the largest road to withstand the crush of the largest engines, especially when loaded with so enormous a weight as is sometimes contained in a large wagon. Besides, as broad wheels are very expensive, and cannot, therefore, become general for agricultural purposes, it would be of the greatest consequence to the community at large if some other method of protecting the roads were pointed out that could be more easily attained, and of more general utility. The following method is, therefore, with deference submitted to the public, not only as being very easily attained, but as being applicable to any wheel carriage without altering its present wheels. Suppose the figure to represent the head view of a cart or wagon. The wheels A and B, when heavily loaded, aided by a succession of carriages



which have preceded it in its track, will make ruts such as we find upon every road, while the horse path in the middle of the way remains entire. However, this central way not infrequently gives way too near the lines in which the wheels sink, owing to the additional force it requires to draw them out again and not, perhaps, to the road being softer there than in any other place; consequently, whenever any obstacles comes in the way to impede the draught, or to occasion a greater exertion to draw the carriage forward, the road will in that place sooner fail. This must always be the case where there are deep ruts, which often requires a greater exercise of power to get through them than even to surmount the most hilly roads. To prevent wheels forming these ruts or sinking into those already made, let a small broad-roller be placed between the pairs of wheels, as at E. It must be fixed directly under the axle-tree, and so strongly secured thereto as to be able to support the whole weight of the carriage when necessary, which it will always do when the wheels come to any deep ruts formed by other carriages. The lower part of the circumference of this roller, (which may with propriety be called a protector) should be about an inch and a half above the level of the line C D, the upper part about the same distance from the axle-tree, to which there should be a scraper fixed in order to keep it always clean. The size of the wheels will accordingly regulate the size of the protector, but in general about twenty-two inches, or two feet, in diameter will do for single carts; for double carts or wagons it may be larger or broader. By keeping the protector a little higher than the lower level of the wheels, it is evident that on good hard roads or streets the wheels will always bear the weight of the load, nor can they make any ruts, or sink into old ones, however deep they may be, while the middle of the road remains firm, for the protector will roll upon the middle which will certainly be a much easier draught for the horses than if the wheels were in deep ruts. For large carts or wagons there might even be more than one of these protectors between each pair of wheels; but in general one will be sufficient. It may by some be objected that even one will occasion too much additional weight; but this can by no means be the case if it be properly constructed, for then the weight will be absolutely inconsiderable when compared to its utility in saving the roads and lessening the first expense of making them; again, the wheels and other parts of the carriage may be made a great deal lighter, as they will never jolt so violently from side to side in bad roads, which motion is not only a great strain upon every part of the carriage, but the horses also."

At the present day such speculations as these would provoke laughter rather than serious reflection, but let us remember that this was many years ago, when science as applied to coach-making was comparatively in its infantile state. But these puerile "contrivances" *crop out* occasionally in our time, to amuse more than to benefit the world. Can we then wonder at these exhibitions of folly? Rather let us rejoice that we have (some of us at least) grown wiser.

WHAT CONSTITUTES A TEAM.—A case has been tried in England, which turned upon the question whether the word "team" meant a wagon and horses or the horses only. It was decided to mean the latter, and the Duke of Marlborough, who was the plaintiff, lost the suit.

## Pen. Illustrations of the Drafts.

### OPEN BEACH-WAGON.

*Illustrated on Plate V.*

OUR design represents a carriage adapted to the wants of visitors to Newport, Rockaway, Long Branch, and such other sea-side summer resorts as are found in our country. We have hung it upon elliptic springs, with a perch, as being stronger than on platform. Sandy roads are not only "hard on horses," but impose great strain upon the hind portion of the under-carriage, such as no-perch vehicles are unable to endure without damage. The popular *bowl* is given to facilitate short turning.

### MOULDED SIDE-SPRING ROAD BUGGY.

*Illustrated on Plate VI.*

ON this Plate we give another design of the New York buggy, with the latest *additions*—we can scarcely call them improvements—we allude to the side mouldings represented by the white lines on the side-panel. This singular application of moulding finds favor only with the "bloods" of Young America. Buggies of this pattern require gay colors in painting to set them off to advantage.

### STIVERS' BUGGY.

*Illustrated on Plate VII.*

THIS design is original—we believe—with Mr. R. M. Stivers, of this city, who has the reputation of being second to none in mechanical ability. At any rate, his styles just now are very popular with the public, and he finds as much business as he can well attend to, in consequence. The reader will find his shifting rail for tops, and fifth-wheel attachment described in an advertisement for the second page of the cover to this number.

### LANE'S PATENT "UNDULATING" CARRIAGE SPRINGS.

*Illustrated on Plate VIII.*

THESE springs, the invention of E. Lane of West Philadelphia, and patented June 2d, 1863, have been pronounced by those who have tried wagons with them applied, "the lightest, most durable, and easiest to ride in," they have ever used. Indeed, one admirer, who has others, says he has "repeatedly loaned his Lane wagon to carry invalids and wounded men who could not bear the jarring of ordinary carriages, and could fill many pages repeating the grateful praises sufferers have lavished upon the new style of wagon." In the side elevation of the first figure given in Plate VIII. are shown two wooden side bars, D D (connected with the axles B B), attached by the rods *b b*, to the oblong, oval-shaped, vulcanized rubber rings *e e*, these last being secured to the body cross-bars under the seat, and the iron triangles *c c*, secured to the body and working in pivots at *i i*, serve as hanging-off-irons."



The next engraving on the same plate shows a perspective view of one of Lane's buggies, to which perches are applied, rendering them still more perfect.

A little attention to the subject must convince the carriage-maker that this kind of vehicle may be built at much less expense than the ordinary wagon; and a little experiment satisfy the public that the "undulating" motion found in this arrangement imparts to the passenger the most gentle and pleasurable emotions ever experienced, however rough and uneven may be the road traveled. In many respects rubber is preferable to steel—that will not break, steel will. In a word, these wagons, thus constructed, when tried "speak for themselves" in such forcible language that the hitherto skeptical must be convinced of their superiority over others in every particular required in a pleasure wagon.

Those who wish to purchase State, county or shop rights, will address the patentee, E. Lane, No. 3040 Market Street, West Philadelphia. Mr. Lane, unlike most other patentees, is a practical carriage-maker, and knows whereof he speaks.

The rights for the States of New York and Pennsylvania have been disposed of to H. J. Perkins, of Williamsport, Pa., to whom all inquiries from those States for shop and county rights must be addressed. The terms offered will be reasonable, and accommodated to the extent of the business carried on by the applicant. We will cheerfully negotiate for parties desiring to purchase rights to this invention.

## Sparks from the Anvil.

### PERCH-COUPLING LITERATURE.

EDITORS of public journals frequently receive rare specimens of composition from correspondents, but we fearlessly defy any of our cotemporaries to produce one equal, in abuse, bad spelling, and faulty grammar, with that given below, and which we have lately received from "a distinguished character." If this specimen does not satiate the reader, we can assure him we have a file of missiles from the same hand, sent us from various quarters, which will. This particular letter has amused us so much, that we have determined to give it to our readers, that they may have an opportunity to laugh too. If any carriage-maker ever entertained a doubt respecting the usefulness of this journal, we think he will dismiss it when he discovers the "smell" we have stirred up in certain quarters, and receive it as one of the strongest arguments why he should make an effort to increase its circulation. We can assure him that although he disparages, yet Mr. H. thinks our success too great for his own. But here is the—"show," the only part of it *passable*.

VOL. VII.—4

No. 358 Canal

New York May 30th 1865.

Sir! Recently I saw an obscure publication called Coach Makers Magazine published by the self styled editor E M Stratton an article appearing therein headed the desecration of patent coupling which is so completely mixed up and statements falsely or erroneously given that no person can understand it, the self styled editor makes use of his meanness by expressing his views in very highly libelous manner agst persons who stand a great deal above him in character and, that the letters patent in question was granted by the Com. of Patent through some process by a member of Congress not according to law, Query: Does the self styled Editor know what the law is, from the writing or scribbling of said Editor it appears he does not

The self styled Editor of Cart Makers Magazine, it must be presumed that the said Editor made a mistake when he entered in the publishing of the Coach Makers Magazine, as well as when he tried Carriage, making instead of cart making.

The only thing I wish is the self styled editor may be improved, but he is a church member it can hardly be expected that he would confine himself to the truth in the case, which he has undertaken to dissect, without having the qualification of understanding necessary, but instead of facts he draws on the imagination and states untruths.

I would offer you assistance in the publication and assist you in correcting errors.

Respectfully yours, G. L. HAUSSKNECT.

E. M. STRATTON.

The author of the above letter accuses us of mixing up matters and making false statements in regard to his and other perch-couplings in our last volume. Since *his* side of the story is given as he has told it himself, in several published accounts—that portion may contain untruths—nearly in his own words, perhaps. Our business character, we think, is sufficiently established—without calling in *doubtful* testimony in its defence.

Unfortunately for himself, as well as the public, the "self-styled" inventor has more than once undertaken the difficult "business" of establishing a legal claim to the perch-coupling, but has thus far *failed* in every instance. This does not evince a very *good business* tact, and makes us distrustful; therefore, before closing with his offer of assistance—the position being one of great responsibility—we have concluded to present our readers with another specimen of literary composition from the same source, that by the perusal, they may have further opportunity for judging of his "qualifications" for discharging the duties he aspires to, both in a literary and ethical point of view. This last "specimen," as the date proves, was written only a few days after the Cincinnati trial, as recorded on page 93 of our last volume, and sent to a friend in Indiana.

Dayton O Novbr. 18th 1864.

Dear Sir! Please inform me whether you intend to stand by the agreement made between us yesterday, or



whether you hold yourself bound to hold any agreement you was led into by unfair means by Peter ———. —fraudulent transactions are to reprehensible and impossible to be morally or legally proper or just, the simple truth in the case is that C wishes to keep others out of their just dues, and with that end in view, has been trying to devise some means to accomplish his nefarious purposes, in such a manner as making in appear not to grate to harshly on his conscience (if he has any such thing?)

My advice to you is that you give up any partnership or association whatever with a man who is after exploring some means for wipping the devil round the stump and settle your affairs in a straightforward christian manner, whereby you save your good reputation legally and morally instead of being implicated to deprive others of their just dues by a combination to which you can not honorably be bound any longer.

With due respect I send you these lines for a fair consideration, the same respect I hope you will wish to be continued I therefore hope that you will not fail to send me a reply directed to No. 358 Canal Street stating which of the two agreements you can honorably keep—Your Most obedient servant  
G L HAUSSKNECHT

## Paint Room.

### VARNISH HARD AS STONE.

A new varnish for wood has recently been introduced in Germany; the ingredients of which, are forty parts of chalk, forty parts of rosin, four of linseed oil, to be melted together in a pot. One part of native oxide of copper, and one of sulphuric acid are then to be added, after which, the composition is ready for use. It is applied hot to the wood with a brush, in the same way as paint, and on drying is said to become as hard as stone.

### PAINTING—1805—1865.

As in the material so in the mechanical world like causes appear to have produced like effects. In 1805 Felton thus wrote, "Oils, turpentine, &c., has been materially advanced in price, of course the varnishes and japans has also risen; the fashion of painting has not been materially altered, only in the picking out [painting with various colors, the mouldings, &c.] which, instead of fine lines on the mouldings, they are now done with broad stripes of strong contrasted colors, and so full that it is sometimes difficult to know the ground from the picking out." This was at a time when everything was excessively dear, just as it is now, and all caused by war too. Could a writer in our day describe the cost of material and the fashions in striping nearer than our ancient craftsman has done? We think not. The fluctuations in the price of spirits of turpentine are singular. One year since it was sold as high as \$4. per gal. During March and April last we quoted it as low as \$2 $\frac{1}{4}$ , the same price as now given. Last month it was \$3 "with an upward tendency." We state these facts to show our readers how little reliance can be placed in human "speculations" as to the future. From the present stand-point the facts would warrant us to say, that the article *must* be brought down in price, and yet to do so *might* prove false prophecy.

## Trimming Room.

### COACH LACE.

THE importance of lace in trimming carriages, has long been felt and candidly admitted. Indeed, we remember the time when no substitute was tolerated, and

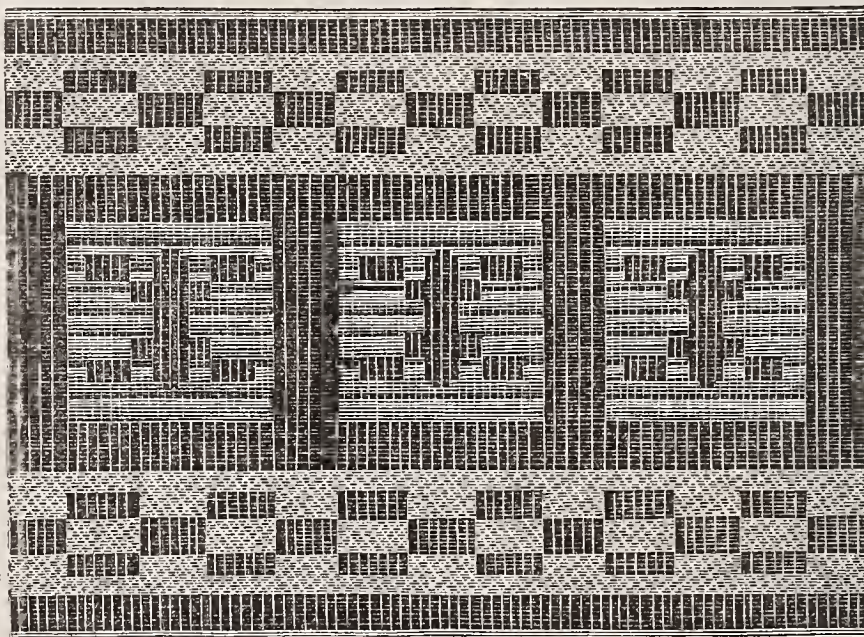

SPECIMEN OF COACH LACE, FROM MESSRS. HORSTMANN & SONS' ESTABLISHMENT, PHILADELPHIA.

it is even now questionable whether our present omission of it is not in bad taste. Leather and cloth have taken the place of laces, but in using them have we not sacrificed elegance to expediency, and beauty to fashion? When we consider the vast improvement made in the designs, and the superior texture of the fabric as it comes from the modern loom, and contrast the same with the productions of former days, we are rather surprised that anything else has ever been thought worthy to fill its place.

We have been led into the above reflections by receiving from the Messrs. Wm. H. Horstmann & Sons, the beautiful original design which our engraver has endeavored to show in the engraving which accompanies this article, the drawing for which was made from the manufactured lace, of the exact size and pattern. The lace itself is in two colors—crimson and black broché. In the engraving the crimson shades are represented by the lighter tinting; the black by the darker lines. The crimson material in the original is silk, the black colors worsted. This lace is of the very best quality, for producing which, the Messrs. Horstmanns' are justly celebrated.

### GREEN CINIBAR

A new color under the above name has recently been invented in Europe. It is prepared as follows: Prussian blue is dissolved in oxalic acid; chromate of potash is added to this solution, which is then precipitated with acetate of lead. The precipitate, well washed, dried, and levigated, gives a beautiful green powder. By varying the proportions of the three solutions, various shades of green may be procured. Chloride of barium or nitrate of bismuth may be used in place of sugar of lead.



## Editor's Work-bench.

### IMPORTANT TRIFLES.

PARADOXICAL as it may appear to a superficial thinker, yet it is nevertheless true, that in carrying on the carriage business there are some comparatively small matters which require the most careful attention from those who are desirous of obtaining—as well as maintaining—a reputation for manufacturing first-class work. Indeed, unlike the details in nearly all other kinds of business, particular attention to small things in this are, in their consequences, of the greatest importance. We speak from actual experience when we say that no mechanical occupation demands of the conductor a closer attention to the manipulation of his workshop in order to succeed, than carriage-making. That careless woodworkman—it seems as though a great many are of this class—in “getting out stuff” goes to work without any regard to the dictates of prudence, and “marks off his patterns” without in the first place sawing off the end of the plank to ascertain if it be free from checks or sound, and so in many instances after the sawing-out has been performed, had to throw all aside because of the *trifling* neglect. The same lack of care applies to getting-out his “panel stuff,” and then, when he comes “to warp” it for his body, he finds “a split,” rendering it wholly unfit for the purpose intended. He may even have to wait several days for a second panel to dry (season) before he can proceed with paneling his job because of his thoughtlessness.

The blacksmith, too, he earns—is entitled—to a large share of censure for his carelessness, to give it no harder name. Because it took a little more time, or made a little extra work, he put in an unsuitable bolt, one made from poor iron and badly fitted, in a part where the best ever made is scarcely good enough, and consequently it soon gave out and jeopardized the life of a good customer; or he sets a tire not half welded, or fitted an axle to the bed with a serious defect—perhaps a flaw in the iron—which “trifling matter,” had he paid stricter attention to, would have prevented a vast amount of *loud* talking from the purchaser, and not lost the boss a customer. This same lack of attention to “important trifles” may be detected in the remaining branches of the trade, patent to every observing mind, without necessarily being mentioned here.

These truths have never been more strongly exemplified than during the past four years. The great scarcity of skilled workmen, caused by the enlistment of a large body of mechanics in the army of the republic, has left but little room for choice in selection; so few, indeed, that the urgencies of necessity has forced upon us too many of that class who have never possessed a legitimate claim to the honored name of being called coach-makers. They are more properly *butchers*, whose chief aim appears

to be to *kill* time and get their wages for committing the murder! We are sorry to admit it, but the fact is so undisguised that truth obliges us to notice that at the present time there are more inexperienced mechanics among us than was ever known before in this country, and then, too, chiefly of foreign importation. Once there was some chance for selection, now this advantage appears to have vanished. The exigencies of the times demand men, and these must be obtained *at any rate*. We have hope that matters in this respect will improve with the return of our victorious armies from the field of battle; but we very much fear that many of these have so changed in their mechanical *status*, as to prove for some time of little worth.

Nor is this state of affairs likely to improve very soon. Many American parents are unfavorable to mechanical education, deeming it not sufficiently respectable to suit their views, and so they put their children into a store or the lawyer's office, to *worm* along through life respectably. Doubtless this action on the part of parents is one reason why there are so many “shabby genteel” individuals in the community, struggling against poverty by their wits, their gentility at a discount.

### A POLITICAL “TURN-OUT” UNDER THE HAMMER.

THE carriage, horses, and other “fixins” purchased a short time ago for presentation to President Johnson, but which proved *no go*, were sold in front of the Custom House, Wall Street, by Leeds & Miner, on the 2d day of June, at 12 o'clock precisely. The published announcement of the sale brought together a heterogeneous mass of good, bad, and indifferent citizens, who indulged in a free expression of their “opinions” regarding the would-be Presidential donors, the coach, horses, &c., to the evident amusement of the crowd. We heard one gentleman affirm that it was made by J. R. Lawrence, one of our best builders, and was no doubt a good one. Another, with much vehemence, declared that he considered Brewster & Co., of Broome Street, the best builders in this country. A third, at his elbow, said he had just bought a carriage of Demarest, on Broadway, which he considered equal to any. The fourth man, evidently from New Jersey, spoke very highly of a celebrated Newark firm, as being very good builders, alluding to Messrs. J. M. Quimby & Co. It was really amusing to hear some extol, while others spoke triflingly, of the value of “the turnout.” Our private opinion is, *that* carriage was never built expressly for our Chief Magistrate. In fact, some others thought the President showed good taste in rejecting the proposed gift, while others spoke pointedly disparaging of the “whole concern.”

Mr. Leeds, having seated himself on the driver's box, went on to that “this superb establishment was now of-



ferred to the highest bidder without reserve, the coach, horses, harness, &c., being offered separately." The horses, of a brown bay color, sixteen hands high, six years old, and well matched, were started at \$1,000, and soon run up to \$1,900, at which figures they were knocked down to Dr. Ferguson. The auctioneer said they originally cost the Presidential friends \$3,500. The coach—the body close paneled and trimmed with red satin, hung on C-springs, with a crane neck and Salisbury boot, and plainly finished—was the next article put up, and also started at one thousand dollars, and was finally sold, after much labor, to Mr. French, the gentleman in Chatham Street who is famed for "knowing how to keep a hotel," for fourteen hundred dollars. Mr. Leeds told us it cost twenty-one hundred dollars—which we don't believe.

The next thing offered was the harnesses, "without the pole-straps." Here Dr. Ferguson claimed the pole-straps as his, and belonging to the coach, which he had bid-off. An appeal to the auctioneer's Man-Friday, who happened to be a "contraband," soon settled the Doctor's claim, and the harness was sold, at four hundred and thirty-five dollars, to Mr. Banker. Mr. L. said the original cost was six hundred and seventy-five dollars. The woolen blankets, with A. J.'s "signet"—Mr. L. said—"thereon," sold for twenty-nine dollars each, to Mr. E. Powell. The first bid was fifteen dollars. A pair of summer sheets sold for twenty dollars each, to Mr. Talcott, and a pair of linen ones at six dollars and a half; a woolen stable blanket brought seven dollars; two blue girths, five dollars; a surengle, two dollars and twenty-five cents; and a silver-bound whip went for twenty-five dollars. The pole-straps were now announced as being up, and here the man who had bought the harness "put in" his claim, unsuccessfully, however. Can any one tell us whether the straps belong to the pole, or the harness? Has this knotty question ever been decided? The straps, however, "went" for eleven dollars to a *sovereign*. The last of this lot—a white sheepskin rug—sold for ten dollars. The full sum of these sales amounted to four thousand nine hundred and twenty dollars and fifty cents.

Immediately following, and similar to the *Presidential* coach—by the same maker, run three times—was put up another which was bid off by an American *sovereign*—William Pease, Esq., of this city, for \$825. Perhaps the friends of a republican government may discover in these facts an illustration of the *value* at which a representative, chosen by the popular will, is estimated in this country, over those to the "manner born."

#### EIGHT HOURS A FAIR DAY'S WORK.

WE see from perusing the public journals that a committee of the Massachusetts Legislature have made a report favorable to the reduction of a day's labor to eight hours. Mr. Ide, the chairman of this committee, appears

to have bestowed much thought upon the subject, and from a recapitulation of the evidence presented to them from various sources, the committee have come to the conclusion that a reduction of the standard of a legal day's labor to eight hours, so far from being a loss or injury to industry or wealth, would be beneficial to both, and greatly aid in the social, moral and intellectual condition of the industrial classes. In view of these advantages, the committee have recommended the appointment by the governor of a commission to collect information and statistics in regard to the hours of labor, the condition and prospects of the laboring classes, and to report the result to the next Legislature, all which has been agreed to. We have no doubt that this question, which is being agitated in other States, will end in a reduction of the ten hours labor now given as a day's work to eight.

It is with a certain class of the community a question whether this reduction will be productive of good to the working man, and we must confess that the fears of an unfavorable result are, in some degree, well founded. Not many days ago we saw the sentence we have adopted as the heading to this article, standing as the motto to a notice of a party invitation for a day's carousal in Jones' Woods, situated in the suburbs of New York city. Now, if no better use can be made of the two hours taken from the present ten hours work, than going to a place of debauch for the benefit of rum-sellers, then we think a change had better not be inaugurated. We have fears that the "moral and intellectual" faculties will suffer—especially the moral—while the intellectual will not be much improved. The great difficulty is, the laboring classes, as a rule, read but little—scarcely ever study. Could they by any means be induced to engage in so delightful an employment, the meditated change in the period for a day's work would be productive of good. We have no doubt the experiment will be made, however, and the result seen very soon. For this the public might as well be prepared.

#### IN MEMORIAM.

DEATH has again laid his icy hand upon one of our respected correspondents. This time he has taken from our circle, the amiable and talented Mrs. Lydia H. Sigourney, generally known as the "Hemans of America," and favorably celebrated throughout the world as a poetess of much literary strength and vigor. Her health had been failing for the past year or two, seriously interfering with her literary employments. Mrs. S. was born in Norwich, Conn., Sept. 1, 1791, and died at her residence in Hartford, June 10th, 1865, having attained an age of nearly 74 years.

The maiden name of this lady was Huntley. Before her marriage she was employed as school teacher in Nor-



wich, in 1810. She opened a select school for young ladies with much success, in Hartford, in 1814, about which time she attracted the attentions of Mr. Charles Sigourney, a hardware dealer in that place, and a man of much culture and literary taste. The offspring of this marriage, which took place in 1819, was Mary, now the wife of the Rev. Francis T. Russell, of Geneva, N. Y.; and Andrew, whose death, a few years ago, was the subject of a poem, entitled "The Faded Hope." After her removal to Hartford, her literary talents, which she lent extensively to the press of the day, attracted the admiration of the late Daniel Wadsworth, a gentleman of wealth and literary taste, through whose benevolence and assistance she was enabled to publish her first volume, under the title of "Moral Pieces in Prose and Verse," in 1825.

In 1840, Mrs. H. visited Europe, and, in 1842, gave to the world her "Pleasant Memories of Pleasant Lands." Her literary publications number nearly fifty volumes, and have received a wide circulation. Our readers have been favored with occasional effusions from her pen, contributed gratuitously as an offering of respect to an enterprise calculated, like ours, to advance and elevate the mechanical interests of her native land. Though these are not a fair specimen of her poetical abilities in younger years, still we refer to them with pleasant memories of one who always felt a kind regard for all her countrymen of whatever occupation, especially for the mechanical portion.

She is said, during life, to have made it a point to give at least one-tenth of her income to charitable objects. May her virtues find imitation from others.

#### EDITORIAL CHIPS AND SHAVINGS.

LANE'S VULCANIZED RUBBER "UNDULATING" CARRIAGE SPRINGS.—The attention of our readers is called to an article in another part of this journal referring to the above-named improvement. We have been favored with a ride in one of Mr. Lane's buggies over the roughest kind of road, and are happy to say, without experiencing any of the sudden jolts usually attendant upon the travel in other spring-wagons, the sudden tension and contraction of the rubber ring providing a remedy against such occurrences. Should our friends desire we will undertake to negotiate for shop or county rights between parties when requested.

THE INTERNAL REVENUE TAX.—We stated in our late notice of this Tax, that the law applicable to new work remained the same as last year; but it now seems we were mistaken; instead of five it is now 6 per cent. on gross sales of new work, and, as before stated,  $3\frac{6}{10}$  per cent. on repairing. A daily paper of this city charges the "tax gatherers" with insolence and ignorance in collecting the amount of monthly dues from this source, and we think with good reason. In our report for April, the larger sum was for repairs to carriages, but the blundering *Gaul*, who can scarcely make himself understood in English—*smuggled* in as clerk—reported the entire sum (a large one) at Washington all at 6 per cent. tax. When

we came to settle the deputy would give but little satisfaction for his servant's ignorance of duty, and tried to turn us off and make us pay unjustly a large sum. We paid under protest, and intend to contest our rights.

NEW YORK HACK INSPECTION.—During the past month the Twenty-sixth Precinct police, under the direction of Capt. Brackett, have inspected 251 hackney coaches, and of these 60 have been rejected as unfit for use, on account of broken springs, ragged upholstery, &c., necessitating the owners to cause their rejuvenation before soliciting fares or procuring an extension of their license. The number passed upon, however, is only a fraction of that class of vehicles in the city, the whole number being something over 2,100. A license is required for each one and the number of the coach must be conspicuously displayed upon the coach lamps, in figures of not less than two inches in length. Officer McWaters is especially detailed to look after this matter, and report all violations of the above rules, and he bears the title of Inspector of Hacks. A numerous class of vehicles, too, are those owned by the licensed venders. Each owner of a wagon is required to take out a license, for which he pays \$5, and must also have the number of his wagon painted in a conspicuous place, in clear legible figures. Of this class 213 have been passed upon and registered, and 29 rejected; and, in addition, 60 venders have been arrested and fined for having neither license nor number. The above work has been done in addition to attending to the ordinary work of the precinct—attending to the various steamboat landings and railroad depots, boarding newly-arrived steamers and vessels, and an infinity of work that none but those connected with the Police Department have any idea of.

THE HACKMEN LOOKED AFTER.—The police keep a close watch upon these gentlemen, whose conduct has in more than one sense rendered them notorious. Large numbers of hackmen having failed to comply with the provisions of the law requiring them to exhibit the rates of fare in a conspicuous place in their hacks, and neglected to have the number thereof on the lamps, have been lately hauled up and fined \$10 each: The parties offending were named, respectively, Patrick Callahan, James Maloney, James Hendrickson, McDonald and Sodin, these last fined \$20, for being minus badge and number.

NEW YORK HORSE MARKET.—JUNE 10, 1865.—The Twenty-fourth Street Sales Stables are well filled with horses. The supply exceeding the demand. There is a marked difference in the trade since the Government ceased buying for the army. Now the city railroads and stage lines are the principal buyers, paying, generally, \$125 to \$135, in some cases \$150, and even \$160. During the war they bought sparingly, and their stock run down, both in quantity and quality, requiring free purchases now to bring it up. A few work and carmen's horses are sold at \$175 to \$250, but next to the demand for railroad horses is the inquiry for good road teams for citizens going into the country, and who have a particular aversion to being passed on the road. Teams which suit this class of customers command \$700 to \$1,200; one span, 15 hands 1 inch high, bays, six years old, well matched; selling at the former prices, while a splendid pair of black horses, 15½ hands, good steppers, brought \$1,400, going to New Haven. Among the trotters there were no very marked animals, and few sales are reported of late. We noticed a "Hambletonian" horse, 5 years, 16 hands high,



reputed to trot in 2.50, held at \$2,000, with a bay Patchen horse at the same price. Some fancy spans have brought \$1,500 to \$2,000. Really good horses, particularly the "fancy," have not fallen off in price, but common horses are lower. Government sales of army horses are quite frequent at Washington, but it is not likely that many of them will be brought here, being needed in that vicinity and further South.

**DOG-CARTING IN NEW YORK.**—On our way to this office the other day, we saw one of the most *animated* "turn-outs" it was ever our fortune to contemplate. A sturdy Dutchman holding the shafts of his hand-cart was struggling with all his might to prevent his quadruple team of stout dogs from running away with his "institution," the canine "assistants" the meanwhile keeping up an intolerable bark, and vying with each other in an exhibition of strength. As it passed the Cooper Institute its ludicrousness made it a subject worthy of the pencil of a Hogarth. Industry and Idleness were both in striking contrast. Indeed, we believe the "boss" had to work harder to retard the progress of his cart than he would to have drawn it alone. We wish our readers could have seen this decidedly rich affair, for no pen can do the matter justice.

**THE FIRST ENGLISH MAIL COACH.**—An historical and descriptive account of the British Post Office, recently published in England, informs us that John Palmer, in 1783, was the first to advocate the conveyance of letters by mail-coaches, under much opposition from the post-office officials; but that continued perseverance installed him controller-general of the mail coaches. Under his management the receipts were largely increased, and the mails were much more expeditiously carried than previously, so the three hundred and eighty towns which in the olden time had only three deliveries a week, had, in 1797, a daily delivery. Palmer's coaches were so efficiently guarded that it is stated they were never robbed. The transmission of the mails from Edinburgh to London was accomplished under the new arrangement in six hours less time than it had been done before.

**SPECTACLES FOR HORSES.**—A cotemporary tells the following story: A gentleman had an old and valued horse whose sight had become defective from age. For some time past the animal evinced a tendency to stumble, and to strain his sight at objects close to him, in a manner that set the kind-hearted owner to devising a remedy. The owner judged that with a pair of spectacles, the horse would do as well as when in his prime. An optician ground to order a pair of pebble glasses, about the size of the object glasses of a large sized lorgnette. They were fixed in a frame over the horse's eyes. That animal is now a horse in "specks," and not an elderly gentleman ever yet showed greater appreciation of the convenience. When in the stable the spectacles are removed.

**TO CHECK THE WARPING OF PLANKS.**—The face of the planks should be cut in the direction which lay from east to west as the tree stood. If this be done, the plank will warp much less than in the opposite direction. The strongest side of a piece of timber is that which in its natural position faced the north.

**EXPENSIVE STABLE.**—A Hartford gentleman has expended \$20,000 on a stable, which is said to be "fitted up as nicely as a gentleman's residence," and in which there are \$20,000 worth of horses—among them Prince, Gen. Meade, Lady Littlefield, Girt, and other famous trotters.

**TRADE UNIONS.**—Those who put themselves under the ban of trade unions, have the satisfaction of knowing that they are subject to the petty tyranny of glib-tongued delegates, and the cajolery of those who, either unable or unwilling to work honestly for their own living, prey upon those who are simple enough to be gulled by them.

#### LITERARY NOTICES.

**THE AMERICAN ARTIZAN**, is the name of a very ably edited and well printed journal, of the same size and form as our own, and devoted to Science and Art. Every mechanic should patronize it. It is conducted in a more liberal spirit towards its cotemporaries, than some we might mention. Published by Brown, Coombs & Co., N. Y.

The June number of *The Atlantic Monthly* is an unusually interesting one. The principle articles are: A Letter about England; A Prose Henriade; Harpocrates; Dely's Cow; Needle and Garden; Going to Sleep; Doctor Johns; The Great Lakes; John Brown's Raid; Richard Cobden; Modern Improvements and our National Debt; The Chimney corner; and several other interesting chapters. Yearly subscriptions, \$4. Boston: Ticknor & Fields.

### Patent Journal.

#### AMERICAN INVENTIONS.

May 2. (47,576) MACHINE FOR BORING HUBS.—Peter Schutler, Chicago, Ill.

I claim, *First*, The employment in combination with a machine designed for boring taper eyes or holes in hubs of a horizontal pivoted bed C, or its equivalent, substantially in the manner and for the purpose described. *Second*, The employment in combination with a machine designed for boring taper holes or eyes in hubs of a laterally adjustable carriage E, and a longitudinal movable carriage D, and a pivoted bed C, all constructed, applied and operating substantially as and for the purpose set forth. *Third*, The employment of rack and pinion *r p*, in combination with a feeding screw B and contrivances, for throwing this screw into and out of gear with the carriage D, substantially as described. *Fourth*, The vertically sliding half-nut *h*, toe-lever *i*, weight *w*, shaft *j*, feeding-screw B', in combination with the tool-carriage of a hub-boring machine, substantially as described. *Fifth*, In combination with the lever *i*, and half-nut *h*, I claim the adjustable stop H, substantially as described. *Sixth*, The boring tool E, constructed with a cutter *f*, spiral flange, and a shoulder cutter *g*, substantially as described.

(47,580) SLED OR CARRIAGE.—Henry Smith, Naubuc, Conn.

I claim, *First*, The combination of the lever segment gears *h* and *g*, pawl and ratchet-wheels *k i*, and creaper-wheel *m*, with the carriage, substantially as described. *Second*, With the above I claim the combination of the guide *n*, plate *o*, and foot-lever *g*, with the carriage substantially as described.

9. (47,628) CARRIAGE-JACK.—Reuben Fink, Batavia Illinois.

I claim, *First*, the lever C, in connection with a fixed bearing or a sliding one F, bar D, and notches *b*, in the base A, all arranged substantially as and for the purpose specified. *Second*, The cord or chain E, connected to the bar D, and lever C, substantially as and for the purpose set forth.

(47,647) HARNESS SADDLE-TREE.—Adolph Roeler, Holyoke, Mass.

I claim securing the check-rein hook G, between the seat C, and tree A, by means of the lug or projection *a*, combined with



the screw E, as described. I also claim, in combination with the screw E, the screw D, passing through the lip *b*, and into the pendant projection *c*, for the purpose of securing the rear part of the seat to the tree, as described.

(47,674) LINC-PIN.—George Wright, Washington, D. C.

I claim, *First*, the safety or embracing arm D; *Second*, the arm D, in combination with the pin A, constructed and operated substantially as described for the purpose set forth.

16. (47,718) TIRE-FASTENER.—Robert Hatrick, Paterson, N. J.

I claim, *First*, the arrangement of the felly A, tire *c*, and bolt E, as described; that is to say, the bolt passing or extending into a notch in the edge or cheek of the tire, and extending obliquely through the felly of the wheel, thereby securing the tire in position, as herein above set forth. *Second*, so constructing the tire C, and the head of the bolt E, that the latter shall be dovetailed into the former so as to resist lateral pressure in either direction, as set forth. *Third*, the combination of the longitudinally wedge-shaped section of the bolt E, with a wedge-shaped recess in the tire, substantially as and for the purpose set forth.

(47,719) AMBULANCE.—John M. Hayward, Boston, Mass.

I claim attaching the stretcher C, to the saddle by means of the wedge-shaped legs *b*, and corresponding sockets *a*, substantially as set forth.

(47,735) HAME-FASTENING.—W. W. Kittleman, Bloomfield, Iowa.

I claim, *First*, the link D, with oblique slots through or in it, in the manner and for the purpose described. *Second*, the combination of the groove *d*, shoulders *e*, and holes *c c*, in the manner and for the purpose described. *Third*, the loop-catch C, constructed and described for the purpose set forth. *Fourth*, the combination of the hames loop-catch and link D, constructed, applied and operating substantially as herein described.

(47,762) HAME-FASTENER.—J. B. Woolsey, Bloomfield, Iowa.

I claim combining the spring *c* with the catch C, in the manner and for the purpose as described.

(44,765) METALLIC THILL-HOLDER.—Ebenzer Brown, assignor to S. E. Brown, South Boston, Mass.

I claim, *First*, casting the tug-strap loop and shaft-girth loop in one with the thill-holder, substantially as and for the purpose described. *Second*, casting the tug-strap buckle in the metallic thill-holder, substantially as set forth, and for the purpose described.

23. (47,781) BRUSH.—ALBERT ALDEN, New York City.

I claim the notched segmental plates B, in combination with the head A, handle C, and with the pivot *a*, and spring-catch *b*, all constructed and operated in the manner and for the purpose set forth.

#### FOREIGN INVENTIONS.

Sept. 17. CERTAIN IMPROVEMENTS IN CARRIAGE AXLES.—R. Richards.

The object of the first part of this invention is to secure the bush upon the axle in a simpler manner than formerly, though quite as effectual a mode. Hitherto a right and left-handed screw and a collet have been used, but the patentee purposes instead thereof to employ a single button. He also tightens the bush, as the leather washer in the collar wears away by means of a slot with which the button is fitted, and through which slot a linch-pin is adjusted when the bush is projected to its proper tightness. The second part of the invention has for its object to make the collar of a reduced size, which he does by altogether dispensing with the usual inner flange, and instead thereof he pro-

vides a perfectly flat bearing for the axle. In this manner strength is given where it is needed, but at the same time no greater weight of metal is employed than is absolutely necessary. The third part of the invention relates to the lubrication of the axle. Formerly the oil or other lubricating material has been supplied from the front of the nave (hub), but in this invention an aperture is constructed in the back part of the wheel, and this being the highest point of the axle, the oil by its own gravity runs down into the cap and parts where it is required. *Patent completed.*

Sept. 22, 1864. RELEASING HORSES FROM VEHICLES.—J. R. Hoffman.

This invention consists in the employment of a set of double rings or snugs, with bolts and springs proper to be applied to all sorts of harness and carriages, carts and vans by means of which the horses can be instantly released from the vehicle in case of danger. To attain that object, the inventor uses instead of the roller, bolts or hooks ordinarily fixed on the splinter-bar of the carriage, a series of double rings or snugs between which the loops of the traces are fastened by bolts, of which the driver has full command by means of a strap or chain to remove instantly, thus releasing the horses from the vehicle when required. He uses the same system of double rings or snugs to the end of the pole of the carriage, then they are kept in their place by a spring, which becomes disengaged by the pressure of the rings or snugs when the horses go forward. *Patent abandoned.*

Sept. 29. BRAKE BLOCKS.—G. Lindsley.

This invention consists in introducing at intervals into the surface of the ordinary wooden brake-block a gritty composition, which not only increases the durability of the block, but also affords additional biting or gripping power or increases the friction between the block and wheel. *Patent completed.*

30. IMPROVEMENT IN VEHICLES.—N. Clark.

The objects of this invention as applied to railway carriages are, *first*, to dispense with the connection between the wheels without losing the advantages of journals of fixed bearings. *Second*, to diminish the amount of friction on such journals or pivots by doubling their number. For ordinary vehicles the patentee substitutes journals turning in fixed bearings for boxes rotating on fixed journals. *Lastly*, for both kinds of vehicles he first does away with or lessens the lateral play that is caused by the angular motion of the axle; *second*, he applies high wheels to low vehicles; *third*, he pivots each fore wheel on an independent vertical axis, so as to admit of the vehicle being turned without displacing the centers of support of the fore wheels. *Patent completed.*

#### CANADIAN INVENTIONS.

Aug. 17. 1864. CARRIAGE SPRINGS.—Wm. Taylor, of Mahalide, County of Elgin, clerk.

For an improved carriage spring, termed, The Taylor Carriage Spring.

Oct. 4. SAFETY CARRIAGE SPRING.—Wm. C. Donnelly, of the township of Walpole, County of Haldimand, physician, and Jesse Parker of the same township, yeoman,

For a safety carriage spring.

24. TIRE UPSETTING MACHINE.—Henry Teager, of the township of Flamboro, county of Wentworth, wheelwright.

For an invention he terms a Tire Upsetting Machine.

26. CAST-IRON AXLE-ARM.—John Askew, of the township of Raleigh, county of Kent, millwright.

For a cast-iron axle-arm to apply to wrought-iron axle-trees.

Nov. 24. WHEEL HUB.—Richard C. Honey, of the village of Newtonville, in the township of Clark, county of Durham, coach-builder,

For a new and useful improvement in wheel hubs.



## CURRENT PRICES FOR CARRIAGE MATERIALS.

CORRECTED MONTHLY, BY MR. CHAS. WEEKS, FOR THIS MAGAZINE.  
NEW YORK, June 24, 1865.

Apron hooks and rings, per gross, \$2.00.  
 Axle-clips, according to length, per dozen, 75c. a \$1.25.  
 Axles, common (long stock), per lb, 9c.  
 Axles, plain taper, 1 in. and under, \$6.50; 1½, \$7.50; 1¾, \$8.50; 1¾, \$9.50; 1½, \$10.50.  
 Do. Swelled taper, 1 in. and under, \$7.00; 1½, \$8.25; 1¾, \$8.75; 1¾, \$10.75; 1½, \$13.00.  
 Do. Half patent, 1 in. and under, \$9.50; 1½, \$10.75; 1¾, \$12.50; 1¾, \$14.50; 1½, \$16.25.  
 Do. Smith's New York half patent case-hardened malleable iron box, 1 in. and under, \$10; 1½, \$10; 1¾, \$12.  
 Do. Smith's Homogeneous steel, case-hardened mall. boxes, ½ in., \$12; ¾, \$12; ¾, \$12.50. Long draft, \$2 extra.  
 Do. Saunders' improv. taper, ¾ in., \$12.00; ¾, \$12.00; 1, \$12.00; 1½, \$13.00; 1¾, \$15.  
 Do. do. Homogeneous steel, ½ in., \$15.00; ¾, \$15; ¾, \$16.50; long drafts, \$4 extra.  
 These are prices for first-class axles. Makers of less repute, cheaper.  
 Bands, plated rim, under 3 in., \$2.50; over 3 in., \$3.  
 Do. Mail patent, \$3.00 a \$5.00.  
 Do. galvanized, 3½ in. and under, \$1; larger, \$1 a \$2.  
 Basket wood imitations, per foot, \$1.25.  
 When sent by express, \$2 extra for a lining board to a panel of 12 ft.  
 Bent poles, each \$1.50.  
 Do. rims, under 1½ in., \$2.25 per set; extra hickory, \$2.50 a \$3.50.  
 Do. seat rails, 50c. each, or \$5.50 per doz.  
 Do. shafts, \$7 per bundle of 6 pairs.  
 Bows, per set, light, \$1.25; heavy, \$1.50.  
 Bolts, Philadelphia, list.  
 Do. T, per 100, \$3 a \$3.50.  
 Buckram, per yard, 25 a 30c.  
 Buckles, per grs. ½ in., \$1.15; ¾, \$1.40; ¾, \$1.70; ¾, \$2 10; 1, \$2.80.  
 Burlap, per yard, 30c.  
 Buttons, japanned, per paper, 30c.; per large gross, \$3.  
 Carriage-parts, buggy, carved, \$4 a \$5.50.  
 Carpets, Brussels, per yard, \$2 a \$3; velvet, \$3.75 a \$4.50; oil-cloth 60c. a 75c.  
 Castings, malleable iron, per lb, 23c.  
 Clip-kingbolts, each, 50c., or \$5.50 per dozen.  
 Cloths, body, \$4 a \$5; lining, \$3 a \$3.50. (See *Enamelled*.)  
 A Union cloth, made expressly for carriages, and warranted not to fade, can be furnished for \$2.50 per yard.  
 Cord, seaming, per lb, 45c.; netting, per yard, 5c.  
 Cotelines, per yard, \$4 a \$8.  
 Curtain frames, per dozen, \$1.25 a \$2.50.  
 Do. rollers, each, \$1.50.  
 Dashes, buggy, \$1.75.  
 Door-handles, stiff, \$1 a \$3; coach drop, per pair, \$3 a \$4.  
 Drugget, felt, \$2.  
 Enamelled cloth, muslin, 5-4, 65c.  
 Do. Drills, 48 in., 95c.  
 Do. Ducks, 50 in., \$1.40.  
 No quotations for other enamelled goods.  
 Enamelled linen, 38 in., 75c.; 5-4, \$1.00; 6-4, \$1.20.  
 Felloe plates, wrought, per lb, all sizes, 28c.  
 Fifth-wheels wrought, \$1.75 a \$2.50.  
 Fringes, festoon, per piece, \$2; narrow, per yard, 18c.  
 For a buggy top two pieces are required, and sometimes three.  
 Do. silk bullion, per yard, 50c. a \$1.  
 Do. worsted bullion, 4 in. deep, 50c.  
 Do. worsted carpet, per yard, 8c. a 15c.  
 Frogs, 75c. a \$1 per pair.  
 Glue, per lb, 25c. a 30c.  
 Hair, picked, per lb, 55c. a 72c.  
 Hubs, light, mortised, \$1.10; unmortised, \$1.00—coach, mortised \$1.50.  
 Japan, per gallon, \$3.  
 Knobs, English, \$1.38 a \$1.50 per gross.  
 Laces, broad, silk, per yard, \$1.20 a \$1.50; narrow, 15c. to 20c.  
 Do. broad, worsted, per yard, 50c.  
 Lamps, coach, \$20 a \$30 per pair.  
 Lazy-backs, \$9 per doz.  
 Leather, collar, dash, 28c.; split do., 18c. a 21c.; enamelled top, 30c.; enamelled Trimming, 28c.; harness, per lb, 50c.; flap, per foot, 25c.  
 Linen, heavy, a new article for roofs of coaches, 90c. per yard.  
 Moquet, 1½ yards wide, per yard, \$9.00.  
 Moss, per bale, 12½c. a 15c.

Mouldings, plated, per foot, ¼ in., 14c.; ¾, 16c.; ½, 18c.; lead, door, per piece, 40c.  
 Nails, lining, silver, per paper, 12c.; ivory, per gross, 50c.  
 Name-plates.  
 See advertisement under this head on 3d page of cover.  
 Oils, boiled, per gallon, \$1.60.  
 Paints. White lead, ext. \$15, pure \$16 p. 100 lbs.; Eng. pat. blk, 35c.  
 Pekin cloth, per yard, \$5.  
 A very good article for inside coach linings.  
 Pole-crabs, silver, \$5 a \$12; tips, \$1.50.  
 Pole-eyes, (S) No. 1, \$2.10; No. 2, \$2.90; No. 3, \$3.10; No. 4, \$4.50 per pr.  
 Sand paper, per ream, under No. 2½, \$5.00; Nos. 2½ & 3, \$5.65.  
 Screws, gimlet.  
 Add to manufacturer's printed lists 20 per ct.  
 Do. ivory headed, per dozen, 50c. per gross, \$5.50.  
 Serims (for canvassing), 20c. a 30c.  
 Seats, buggy, pieced rails, \$1.75; solid rails, \$2.50.  
 Shaft-jacks (M. S. & S.'s), No. 1, \$2.75; 2, \$3.25; 3, \$3.50.  
 Shaft-jacks, common, \$1.40 a \$1.60 per pair.  
 Do. tips, extra plated, per pair, 37½c. a 56c.  
 Silk, curtain, per yard, \$2 a \$3.00.  
 Slat-irons, wrought, 4 bow, \$1.12½; 5 bow, \$1.25 per set.  
 Slides, ivory, white and black, per doz., \$12; bone, per doz., \$1.50 a \$2.00; No. 18, \$2.50 per doz.  
 Speaking tubes, each, \$8.  
 Spindles, seat, per 100, \$1.50 a \$2.50.  
 Spring-bars, carved, per pair, \$1.75.  
 Springs, black, 22c.; bright, 23c.; English (tempered), 28c.; Swedes (tempered), 30c.; 1¼ in., 1c. per lb. extra.  
 If under 36 in., 2c. per lb. additional.  
 Two springs for a buggy weigh about 28 lbs. If both 4 plate, 34 to 40 lbs.  
 Spokes, buggy, ¾, 1 and 1½ in. 8½c. each; 1½ and 1¾ in. 8c. each; 1½ in. 9c. each.  
 For extra hickory the charges are 10c. a 12½c. each.  
 Steel, Littlejohn's compound tire, 3-16, 11c.; 1-4, 10c.; heavier sizes, 10c. currency.  
 Stump-joints, per dozen, \$1.60 a \$2.25.  
 Tacks, 9c. and upwards per paper.  
 Tassels, holder, per pair, \$1 a \$2; inside, per dozen, \$5 a \$12; acorn trigger, per dozen, \$2.25.  
 Terry, per yard, worsted, \$4; silk, \$9.  
 Top-pros, Thos. Pat, per set 62½c.; capped complete, \$1.38.  
 Do. common, per set, 40c.  
 Do. close-plated nuts and rivets, 75c.  
 Thread, linen, No. 25, \$1.30; 30, \$1.45; 35, \$1.65, gold.  
 Do. stitching, No. 10, 95c.; 3, \$1.15; 12, \$1.28, gold.  
 Do. Marshall's Machine, 432, \$2; 532, \$2.30; 632, \$2.60, gold.  
 Tufts, common flat, worsted, per gross, 20c.  
 Do. heavy black corded, worsted, per gross, \$1.  
 Do. do. do. silk, per gross, \$2.  
 Do. ball, \$1.  
 Turpentine, per gallon, \$2.25  
 Twine, tufting, per ball, 35c.; per lb, 60c. to 75c.  
 Varnishes (Amer.), crown coach-body, \$6; nonpareil, \$7.50.  
 Do. English, \$6.25 in gold, or equivalent in currency on the day of purchase.  
 Webbing, per piece, 70c.; per gross of 4 pieces, \$2.60.  
 Whiffle-trees, coach, turned, each, 50c.; per dozen, \$5.50.  
 Whiffle-tree spring hooks, \$3 per doz.  
 Whip-sockets, flexible rubber, \$4.50 a \$6 per dozen.  
 Do. hard rubber, \$10.50 per dozen.  
 Do. leather imitation English, \$5 per dozen.  
 Do. common American, \$3.50 a \$4 per dozen.  
 Window lifter plates, per dozen, \$1.50.  
 Yokes, pole, each, 50c.; per doz, \$5.50.  
 Yoke-tips, extra plated, \$1.50 per pair.

**TO SUBSCRIBERS.**—Our friends who have heretofore left with us a standing order for the continuance of the Magazine until they direct its discontinuance, will please take notice that the present number is the second of another year's subscription to many into whose hands it now comes. While we return our heartfelt thanks for their constant patronage, and consequent encouragement, permit us to remind such as have not yet sent us the money for this volume, that our rules are **PAYMENT IN ADVANCE**, and that we expect to receive their remittances (\$5) before the next number is published. Please be punctual and oblige us. Office, 5 Ludlow Street, N. Y.





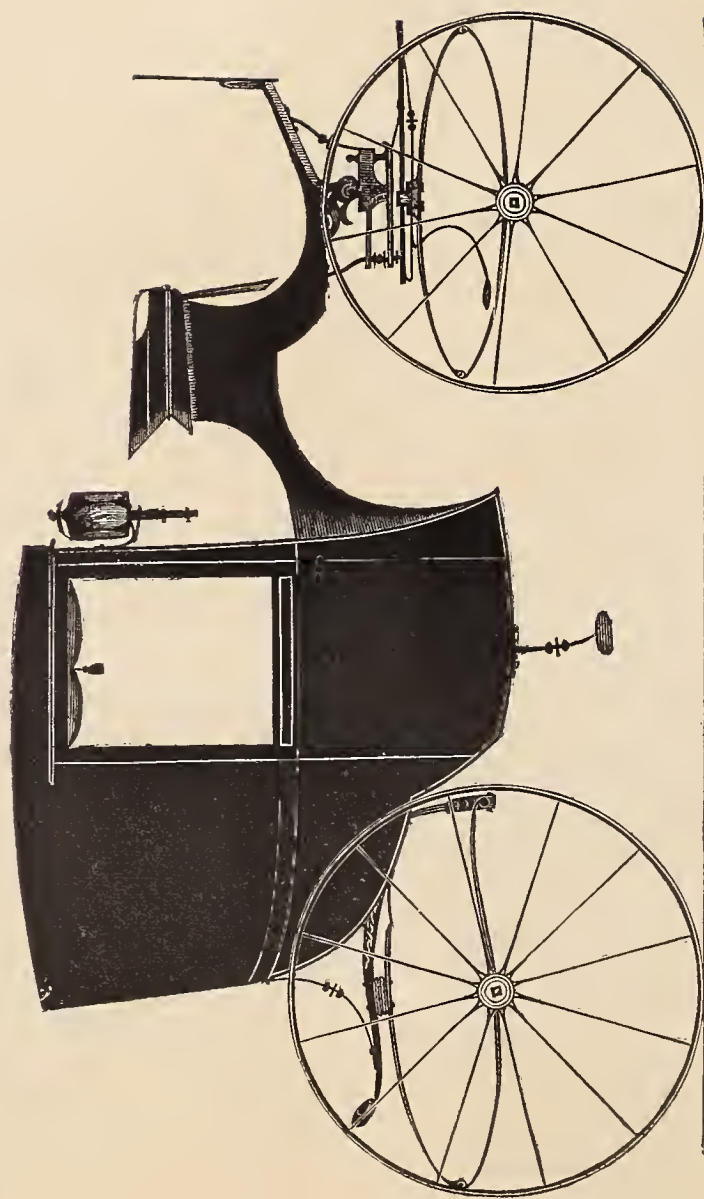

EXCELSIOR COUPÉ.— $\frac{1}{2}$  IN. SCALE.  
*Designed expressly for the New York Coach-maker's Magazine.*  
*Explained on page 39.*

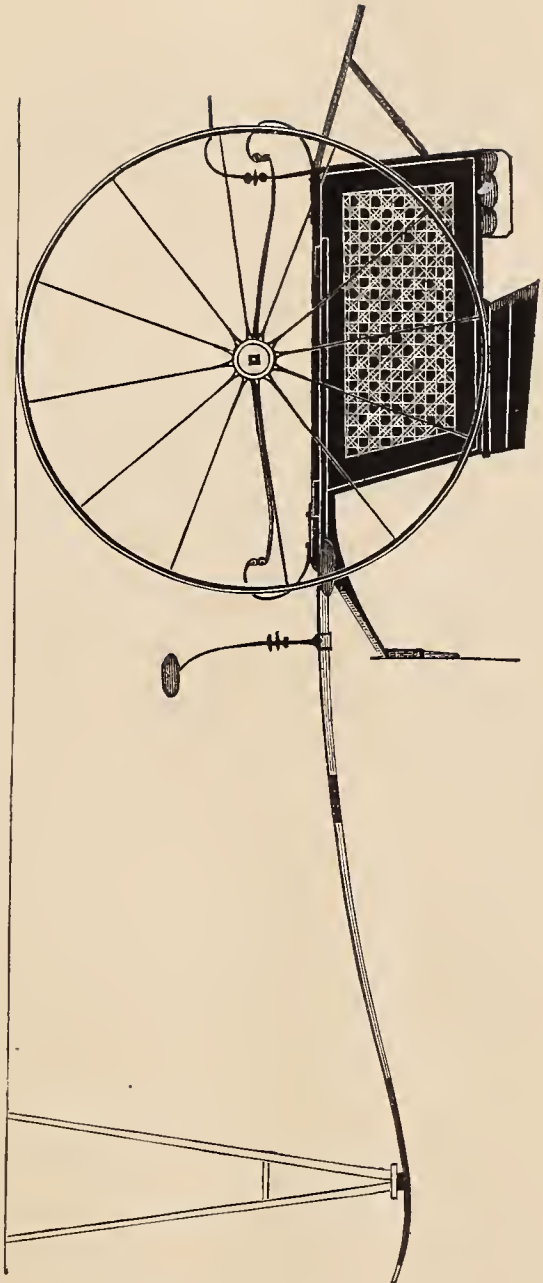

TILBURY DOG-CART.— $\frac{1}{2}$  IN. SCALE.

*Designed expressly for the New York Coach-maker's Magazine.*

*Explained on page 39.*









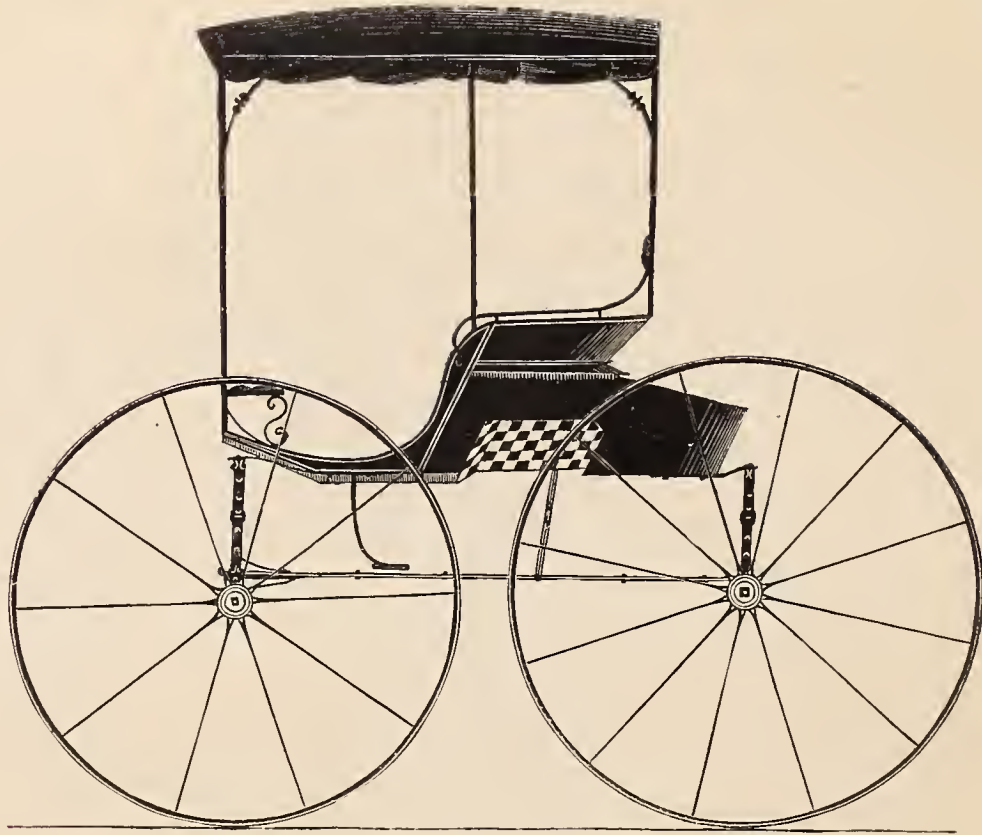

FAMILY BUGGY.— $\frac{1}{2}$  IN. SCALE.

*Designed expressly for the New York Coach-maker's Magazine.*

*Explained on page 39.*



A. W. P.

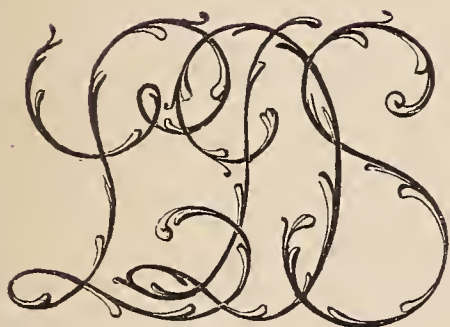

L. D. S.

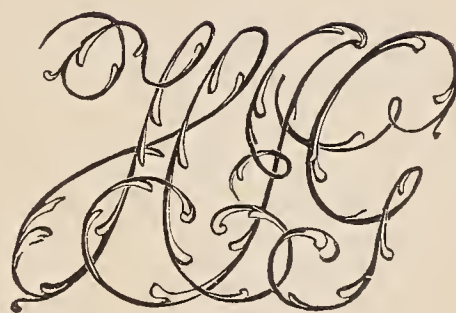

H. I. G.

ORIGINAL MONOGRAMS.

*See remarks on page 40.*



1872

1873

1874



DEVOTED TO THE LITERARY, SOCIAL, AND MECHANICAL INTERESTS OF THE CRAFT.

Vol. VII.

NEW YORK, AUGUST, 1865.

No. 3.

## Mechanical Literature.

### POPULAR ERRORS—II.

BY O. E. MILES.

IN the June number I pointed out certain philosophical errors which long ago found their way into carriage architecture, and which still live by the combined forces of the twin powers of darkness—prejudice and avarice. I spoke severely, though fairly, I think, of the men and motives which compose the recruits, equipments and supplies of these allied enemies of mechanical, as well as all other reform. Since penning the article referred to, I have thought I may profitably extend my reflections under the same heading, at least till I succeed in removing all erroneous impressions of what I desire the mechanical reader to comprehend. In our editor's foot note, under said article, he defines his position, in language that might lead the reader to the conclusion that I have undertaken the advocacy of wooden axles as superior to iron. He "does not indorse all the writer says in favor of wooden axles over iron," &c. Now, all I say in favor of wooden axles in said article may be found in the third paragraph on page 1, which is simply a plain statement of the history of the two in this section, as illustrative of popular opinion as to their respective merits. These statements, I would respectfully represent, are historical *facts*, from which the reader may deduce his own conclusions. I next explain my own interpretation of this state of things, though not as fully as I might and should have done. I repeat that Nature furnishes no material which can be placed in the position of figure 1, page 2, and loaded between the supports, without the *certainty* of changing its position in proportion to the load. In this respect be it remembered that I estimate one just about as good as the other, philosophically speaking; though financially, *good* hickory or maple timber may be made to yield more strength with the same or less money, when placed in this absurd position, though at the sacrifice of that neat appearance of the iron axle with the smaller hubs required for their boxes. With carriages, as with female dress,

public opinion has decreed that economy and utility must both be sacrificed to appearance, which accounts for the continued use of a costly and worthless article; while with wagons economy and convenience have had their more perfect work.

It is of the first importance to know the difference between the wrong and the right application of iron, to the end of securing the greatest possible strength in a correct position, under all grades of pressure short of breaking. At no point short of this should the scientific maker of vehicles be satisfied to stop, as it is most assuredly the least with which those who use them will ever be satisfied. The time has come when it is not enough to know that the wheels of a carriage occupy the correct position while standing empty in its maker's repository. This fact is of small consequence to the customer who intends to *load* his vehicle, especially that class who are fools enough to ask questions. We must not be surprised these days to hear from the impudent purchaser the question, "Will they stay put?" "Stay," says Spokeshave, "why my axles are all steel converted." The customer very perceptibly shakes his head. He evidently fears this case may terminate like many other conversions. Then, to clinch matters, he is informed that "all axles at this shop are set to a particular gauge!" "I don't see the gauge," says he. O, I mean a gauge we keep to set the arms by that can never vary." "Gauge your granny. Did you ever hear tell of the man that biled his water over night to scald hogs with? All right, you know, if it would only stay biled."

Dialogues like these remind us that no fallacy can always live. The outside world are watching us. The wagon or carriage which will carry the biggest load and *keep its place* is the one that wins. We shall yet see the Monitor before Norfolk was to the navies of the earth.

### COACHING.

NERO doubtless thought himself a smart young fellow, a fast man of the Roman type, when he drove through the streets of his capital in his decemjugis, or chariot drawn by ten horses. It was not, however, a comfortable affair after all. Those chariots must have been shaking, jolting, rumbling, inelastic, bone-tormenting vehicles; for they had no springs whatever. The chariots which Pharaoh



lost in the Red Sea, and those which Egyptians, Greeks, and Romans alike used, had the body or platform so connected with the framework of the wheels, that every shock received by the wheels was transmitted to it; and the charioteer could only bear these shocks by standing, and making the best he could of the elasticity of his feet. Some of the vehicles were strong, to override the enemy in battle; some were elegant, with an arched covering decked with costly trappings; but easy to the drivers or occupants they could not have been. Not until the makers devised springs, could any such vehicles be pleasant to ride in. Thin laths of wood, as we all know, are very elastic, if not very strong, while resting horizontally on two supports at the ends; and many forms of vehicles have derived a certain degree of comfort from being placed on such wooden springs. Another arrangement is to pass strong straps or thongs underneath the body of the vehicle, and fasten them at the ends to standards raised upon the carriage to which the wheels are attached. Much later and much more efficacious was the adoption of steel springs, in which a perfectly elastic substance, disposed in various ways, gives to the body of the vehicle a luxurious ease of movement. When four wheels began to be used instead of two, the vehicles were very difficult to turn, because the front pair would not and could not move except in harmony with the hind pair; but by degrees the ingenious plan of *locking* was adopted, which enables the front pair to turn round independently on a vertical axis, and to accommodate the vehicle generally to the curves and windings of the road.

Beckmann and a host of other learned pundits have dived into musty old records to discover when and where these various improvements were invented or first adopted. If they have not fully succeeded in their search, they have, at any rate, collected a curious amount of gossip. In the feudal days men were, or professed to be, scornful of riding in carriages, deeming such a mode of traveling too effeminate; but great ladies, after indulging in the luxury, taught their husbands to do likewise. The queen of Charles of Anjou, towards the close of the thirteenth century, entered Naples in a *caretta*, resplendent in velvet and gold; but what kind of vehicle this *caretta* was, is not clearly told. Chariot, charat, charotte, chariette, caretta, car, chare, chair, carriage—all are supposed to have been derived from some one word, modified in different ways and in different countries. Froissart speaks of charettes used by the English in the days of Edward the Third. There are many reasons for thinking that these vehicles, however gorgeous they may occasionally have been, would have woefully failed to realize modern ideas of comfort; for, even if supplied with leathern springs, they rocked to and fro when driven at anything beyond a walking pace, and tumbled the riders about in rather sea-sick fashion. As to the first *coach*, closed in on all sides, there have been almost as many claimants to the honor of inventing it, as there were cities which claimed to be the birthplace of Homer. The palm, however, seems to be due to Hungary, which possessed a *kotzee*, or *cotzse*, in the fifteenth century, sent as a present from the King of Hungary to the Queen of Bohemia. About the year fourteen hundred and seventy, the Emperor Frederick the Third came to Frankfurt in a covered coach; the novelty was commented on at the time, because it enabled his imperial Majesty to brave a shower of rain without needing lacqueys to hold

a canopy or covering over his head. In the next following century, Germany, with its army of princes and electors, was especially rich in dazzling gilded coaches. France was not so fortunate; Henri Quatre had only one coach; and one day he wrote, "I cannot come to you today, because my wife is using my coach."

There is a wordy war as to the first coach, properly so called, seen in England. Stow says that Walter Rippon made a coach for the Earl of Rutland, in fifteen 'fifty-five, being the first ever seen in this country; and that nine years afterwards, he made the first "hollow turning coach" (whatever that may mean) for Queen Mary, "with pillars and arches." Another account states that the first coach in England was brought over from the Netherlands by William Boonen, in the seventh year of Elizabeth's reign. Possibly Boonen was the first importer, but Rippon the first English maker. One of Rippon's coaches had "a chariot throne with four pillars behind, to bear a crown imperial on the top, and before two low pillars, whereon stood a lion and a dragon, the supporters of the arms of England." This coach had no coach-box for the driver; and indeed such an appendage seems to have been of more recent introduction. About this time the French coaches had a canopy supported by ornamental pillars, and stuff or leather movable curtains all round. A curious record is in existence of the cost of a dashing turn-out in Elizabeth's time. In the household book of the Kytson family, dated fifteen 'seventy-three, there is a sum of 34*l.* 14*s.* set down for a "coche and furniture;" 2*s.* 6*d.* for painting the family arms upon it; and 11*l.* 19*s.* 9*d.* for horses to draw it. The English ambassador to Scotland, two years before the close of the century, astonished the gude folk of Edinburgh by bringing his coach with him. Five years later, when James the Sixth of Scotland became James the First of England, he rode on horseback from the northern capital to the southern; but his queen "came to Sanct Geill's Kirk, well convoyit with coches, herself and the prince in her awin coche, guhilk came with her out of Denmarke, and the English gentlewomen in the rest of the coches." While King Jamie was on the English throne, Taylor the Water Poet heartily abused all street vehicles, inasmuch as they lessened his trade—that of a waterman. He characterized the coach as "a close hypocrite; for it hath a cover for knavery, and curtains to vaile and shadow any wickedness. Besides, like a perpetual cheater, it wears two bootes, and no spurs; sometimes having two pair of legs to one boote, and oftentimes (against nature) it makes faire ladies weare the boote; and if you note, they are carried back to back, like people surprised by pyratts, to be tyed in that miserable manner, and thrown overboard into the sea. Moreover, it makes people imitate sea-crabs, in being drawn sideways as they are when they sit in the boote of the coach; and it is a dangerous kind of carriage for the commonwealth, if it be considered." This allusion to persons sitting back to back, and others sitting sideways, points to modes of construction not much adopted in later years. Early in Charles the First's reign there was a satirical account of a battle between the sedan and the coach, with a beer cart as umpire; each trying to prove that the other was not well adapted to the streets of London. The umpire's decision is worthy of all note: "Coach and sedan, you both shall remove and ever give way to beer cart, wherever you shall meet him either in city or country, as your ancient and elder



brother"—which he unquestionably was. About the middle of the same century, the Empress of Germany had a glass-paneled coach, through which she and her subjects could see each other; it was called the "imperial glass coach." Germany could produce such a vehicle better in those days than England, owing to the greater development of its glass manufacture. Peter the Great's carriage, about the time of our George the First, was a close coach, made of deal stained black, with four wheels, and windows of mica or talc.

How the construction of pleasure carriages improved during the last century, as exhibited in the "state," "dress," "town," and "family" carriages of royalty and nobility, it is not here to tell; nor of the later advancements which have rendered English carriages the best in the world. The progeny is a numerous one, blessed with names derived from all sorts of etymological sources. Of these the Great Exhibition of eighteen hundred and fifty-one contained about a hundred and forty specimens of constructive skill in the form of coaches and other road vehicles; and the jury who reported on them remarked on the entire absence of those old symbols of luxury—family traveling carriages. They were surprised at the deficiency, but they regarded it "as accounted for in a great measure by the demand for carriages of this description having been so materially diminished by the general introduction of railways." The jury praised the coach-makers for the strength rather than the tasteful design of the exhibited carriages. "Comparing," they said, "the state of the art of carriage-building in former not very distant times with that of the present, we consider the principles of building in many respects greatly improved, and particularly with reference to lightness and a due regard to strength, which is evident in carriages of British make, and especially displayed in those contributed by the United States." But: "We regret to remark, under the head of elegance of design, that we find in the exhibition of carriages a great deficiency. While we admit, therefore, that there has been considerable progress in the principles of carriage-building, we are of opinion that the style has been injured by injudicious innovation."

Eleven years later, when the International Exhibition called for another series of Jury Reports, the coachmakers came in for their share of comment. If the cab-owners would attend to what the jury said on this occasion it would be more pleasant for all of us: "As regards its street-cabs, London is worse supplied than many European cities (with the exception of a few clean and well turned-out Hansoms), and far worse than most of the English provincial towns. There is no necessity to vary the size and build of such vehicles, as they exist here in only two types—the 'Hansom' as an open-air, the 'four-wheeler' as the close one. They might be produced in great numbers by machinery; all the parts might be duplicates one of another; the wheels, axles, springs, bodies, seats, &c., might be made of one size and gauge, to interchange; the rapidity of manufacture, facility of repair, and general economy of production, would appear to be advantageous to all parties. Those of the public who cannot afford to keep carriages of their own, might be carried in vehicles that should be, at least, clean, safe, and comfortable. With very little care in machinery, they (the cabs) might be brought into use without that very pungent smell of the stable which is probably dis-

agreeable to every one except the owner and the genuine London cabman. For many years the public omnibuses in Paris have been made on this plan; the various parts are made alike, and to interchange. The facility and rapidity of repair in such cases is more advantageous than may at first sight appear; seeing that every day the vehicle remains under repair is a loss to its owner, whose profit depends on its being at work and earning money."

A tiny exhibition, just now occupying a few paragraphs in the newspapers, has grown out of the larger international displays. As thus: At Paris, ten years ago, the English coach-makers, thrown into each other's company as exhibitors, came to know each other in ways apart from mere rivalry in business; and they formed a "Master Coach-builders' Benevolent Association," which has done much good among those who can't turn the wheel of fortune exactly in the proper way. Then the workmen took up the idea, and founded an "Operative Coach-makers' Benevolent Institution." Then, knowing that the arts of design have a good deal to do with the beauty of a coach, the masters and the higher grade of workmen gave their support to a Coach-builders' Art Journal, in which photographs as well as hand-drawings are brought to the aid of the coach-designer. It was at the last annual dinner (we *must* have annual dinners in England) of the Operative Coach-makers' Association, when employers and employed were assembled at the same board, that the question was mooted—"Shall we have an exhibition?" The ornamental painters, and grainers, and marblers, under the old designation of painter-stainers, had set the example in two or three successive years, by holding an exhibition of their craft at Painter-stainers' Hall: and there seemed no reason why an analogous attempt should not be made by the coach-makers. There has been for two centuries a "Worshipful Company of Coach and Harness-makers," with a hall in Noble street, Cheapside; but this is one of the old City companies which have, now-a-days, very little to do with the crafts to which they nominally belong. The company did not start this exhibition, but it agreed to lend its hall, and to give prizes to the exhibitors; and the leading coach-makers offered other prizes, and so did the Society of Arts: insomuch that there seemed no reason to doubt that the idea could be carried out.

And it has been carried out. On the first of February in the present year the "Operative Coach-makers' Industrial Exhibition" opened, for the display of drawings, designs, plans, models, and specimens of actual work in all the branches of coach-making. Exhibitors were tempted to do their best by prizes offered for heraldic and ornamental chasing, electro-plated chasing, working drawings for private and public vehicles, stuffed and quilted carriage cushions, under carriages for elliptic springs, pads and bridles, carriage dash-irons, carriage lamps, coach door handles, hard and soft-solder plating, panel painting, heraldic painting, sham caning, &c. This sham caning is so curious an affair, that we may as well say in a few words what it means. It is a manufacture of wood panels to imitate interlaced basket-work. The invention originated in France, where it was due to a retired soldier of the First Empire, named Fert. He not only made large quantities for the French coach-builders, but for some time exported a considerable quantity to England. By improved processes it is now made in England more accurately, and in a greater variety of patterns, than in



France. It is much used to give a light appearance to small carriages, principally for country use. It forms a neat and durable substitute for the real wicker-work formerly used, which became rapidly deteriorated by mud and moisture.

The exhibition in Noble street was exactly what we might have expected it to be—an illustration of the handicrafts concerned in the building of a coach or other vehicle. There was thus a unity of purpose about it, not possible in the miscellaneous exhibitions springing up all around us. The coach-body makers sent models and drawings and specimens of all sorts of carriages, especially landaus, which seemed to be in high favor; and one of them sent a model of a "hospital carriage, to be drawn by hand, to go through any ordinary door, and to stand in the hall of the hospital ready for use;" while another specimen was "a hospital carriage to be drawn by a horse, for longer journeys, or for use in bad cases, to avoid jolting as much as possible." The under-carriage makers showed and told us all about axles, carriage springs, pole and box, swingle-trees, &c. The coach painters exhibited many specimens of panel painting, sham cane-work, striping, and spoke painting. One of them sent a panel which had been cut out from a shelf or workshop door where the painters had been wont to rub their brushes after using; when the surface was lowered, leveled, and polished, the play of colors and the intricacy of curls and waves was extremely curious—*only* curious as yet, but possibly suggestive to an ingenious workman of something practically useful. The heraldic painters sent resplendent specimens of those lions and unicorns, knights and barbarians, which they are supposed to know so much about, but which are so mysterious to other people. The trimmers did their duty in the forms of silk curtains, lace fronts, quilted morocco cushions, spring cushions, hammer-cloths, and glories for coach roofs. The leather and harness-makers exhibited tugs and harness, pads and bridles. The coach metal-workers had plenty to do, for there is a large amount of beading and ornamental metal work, in silver plating and other metals, in and around a well-built private carriage. And then other persons sent a multitude of objects, more or less illustrative of the main object in view. The workmen of the Brighton Company's railway carriage works sent very good models of the three classes of carriage on that line; and the authorities at Euston-square sent models of those post-office railway carriages, or traveling post-offices, which are peculiarly a type of the go-ahead age in which we live. But the visitors would have liked to see the inside of these model carriages, with model clerks sorting model letters and putting them into model bags. Then there was a model of the Queen's state coach, that sumptuous affair which cost eight thousand pounds some time in the last century.

The committee of the exhibition threw out a useful hint to the Worshipful Company of Coach-makers, respecting the desirability of "establishing a collection of ancient models and drawings of carriages, to be preserved as memorials of past times, together with the names of those who made them; forming an interesting illustration of our domestic history, in connection with the art of coach-making. Possessors of such articles would doubtless cheerfully contribute to such an object." And if the

Company would also form itself into a Benevolent Association for the Improvement of Third-class Railway Carriages, it would call down blessings on its venerable head from those who do not exactly see why, as coals are carried for a half-penny a ton per mile, free born Britons should be charged (weight for weight) thirty times as much, for riding in dirty boxes or in open pens. The Operative Coach-makers could not, perhaps, develop this reform; but we thank them for their interesting little exhibition nevertheless.—*All the Year Round.*

## ECCENTRICITIES IN CARRIAGE-MAKING.

### II.—A MECHANICAL GRASSHOPPER.

THIS curious contrivance for "a wheel-carriage or machine which may be used as a wagon, cart, or dray, in a more perfect or expeditious manner, and with fewer horses than usually and heretofore done," was patented in 1797,

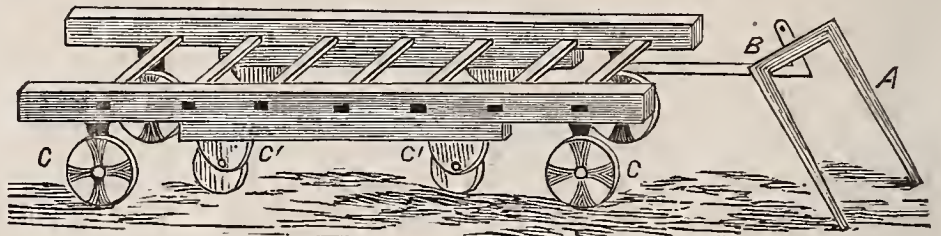

by Henry Overend, gentleman, of the city of Bristol, England. The inventor, contrary to the practice of modern times, is not very verbose in explaining his invention, and consequently we have very little in explanation of its assumed or intrinsic value over other vehicles then in use, but assures us that when complete the above is a correct drawing of his machine. We are told that the machine hung about "a foot from the ground; but that it could be made either higher or lower"—a *little* higher would be *some* improvement no doubt—"as the occasion may require, upon the same principle and proportion."

A denotes the shafts in which the horse works, and which may be removed from one end to the other of the machine. B is the iron receiver into which the ends of the shafts fit, and is applicable to both ends. C C are the front and hind wheels, both of which exactly correspond, and may be used as the one or the other. C' C' are patent castor wheels, fixed on the center of the bars of the machine; like the others, neither project outside nor inside of the bars, but ride in the center. How such a vehicle as this could be supposed to move in "an expeditious manner" is something we do not understand—we cannot readily see, nor do we think any one else can. It evidently is not the labor of a mechanical mind—and "did not take."

## AMERICAN DICTIONARY FOR COACH-MAKERS.

(Continued from page 23.)

C.

**CAB.** A covered carriage drawn by one—sometimes two—horses, most frequently hung on two wheels. The Hansom cab is a favorite in England, but has never become popular in America.

**CABRIOLE OR CABRIOLET** (kab-ri-o-là.) A sort of one-horse chaise with a falling top, with a boat or covering for



- the legs and feet, of French origin. Several kinds will be found in the preceding volume of this work.
- CASH** (French, *Caleche*). A light carriage, with a falling top to the hind seat, and low wheels, intended as a summer vehicle for airing in parks—as the Central.
- CANT**. A technical term denoting an inclination, or throwing out from a horizontal line, as *canting* the standing pillar to a body, generally performed by changing the set of a gauge in laying out.
- CANT-BOARD**. The black-board on which a diagram of the sweeps for a carriage body are drawn in chalk by—generally—the foreman, before it is framed, to guide the builder in his work. A sort of mechanical map or plane of curved lines. Many examples will be found in the first and second volumes of this Magazine, under the head of Carriage Architecture.
- CAP-BOX**. A long leather case, attached to the carriage eighty years ago, for carrying therein the fashionable head-dresses of the ladies.
- CAPS**. The pieces of leather used to hide the lower ends of the bows to take-off-curtain top carriages. The copper shell used in plating nuts, rivets, &c. “Leathers used to confine temporary pins or bolts, such as pole pin caps, &c.”—*Felton*.
- CARRIAGE** (French, *charriage*, to carry). In the restricted application by the craft, the part on which the body of a carriage is placed; the under-carriage, technically, the carriage-part. In some instances it is understood in a plural sense, as meaning the fore and hind portions in no-perch coaches.
- CAR**. Now confined to railroad vehicles. In England it formerly was applied to a small vehicle drawn by one horse. (See Johnson's Dictionary). The Irish jaunting-car, is a relic of the past age, and a fitting representative.
- CART** (Saxon, *cræt, crat*.) In America the term applies more particularly to a two-wheeled conveyance drawn by oxen, used in husbandry. When drawn by a horse it is invariably called a horse-cart. The term is sometimes applied to two-wheeled pleasure vehicles, but generally without dignity—in a degrading sense.
- CARPETING**. Coverings for the floors of carriage bodies, either of wool, or oil-cloth.
- CHAIN-BELT**. According to *Felton* (1805) “a thin wire chain, covered with leather and made in the form and to answer the use of a stop, for the purpose of securing trunks, &c., behind a carriage.
- CHAIR**. A name for the gig among our Puritan ancestry; vulgarly pronounced “cheer.” “A light chaise without panels, for the use of parks, gardens, &c.; a name applied to all light chaires.” [*Felton*, vol. ii. p. 121.] Literally, an elevated seat.
- CHARIOT**. The ancient name of a vehicle, for drawings of which see vol. i. pp. 23, 24 *et alii*. Among moderns a sort of demi-coach.
- CHECK BRACE**. A single strip of leather, which is looped through a ring at the corners of the body to check it from swinging too much endways. [*Felton*, vol. i., p. 211.]
- CHECK LOOP**. See **BODY LOOPS**.
- CHECK RING**. An iron screwed into the corner pillars of a body to receive the check-braces, or straps.
- CHECK STRAPS**. The straps made of leather and used in checking the upward movement of perch wagons in passing over uneven roads, mostly extending from the perch to a loop fixed to the bottom-side.
- CHECK STRINGS**. The cord by which the passenger gives notice to the driver when to stop.
- CLIP-KING BOLTS**. A combined clip and king-bolt now generally used for coupling the perch to the front axles of all light wagons. An excellent substitute for the old king-bolt. For an illustration, see vol. i., page 71, of this Magazine.
- COACH**, (French, *coche*). A close vehicle with seats before and behind, inside the body, and a seat for the driver in front; differing from the chariot in having an extra seat. In the term *coach*, is embodied all the dignity pertaining to this branch of the fine arts. Literally, a bed, on wheels.
- COACH-BOX**. An elevated seat in front, whereon the driver sits.
- COAL-BOX**. A name originally contemptuously applied, but now popularly designating the most fashionable buggies of the day. See vol. iv, plate 32 *et infra*.
- COLLAR**. The raised and turned portion made for ornamentation in the iron stays of steps, futchells, &c., of carriages.
- COLLAR BRACE**. The old term for check-strap, which see.
- COLLAR BRACE RING**. An ancient name for the modern Body-loop, designed to receive the ends of “check-straps.”
- COLLAR WASHER**. The ring separating an axle arm from the shank.
- CONCEALED HINGES**. A modern invention, taking the place of the old-fashioned butt hinge, in coupés, and other carriages, where such unsightly protruberances would be avoided. They are not as strong and durable as the butt hinge.
- CORK LEDGE**. Done away with. In earlier times it meant a strip of cork, nailed on the foot-board, against which the coachman placed his feet. A wooden substitute takes its place in modern carriages.
- CORNER PILLARS**. The corner *supports* used in framing carriage bodies. The second timber in importance, connected with the structure, the bottom-side being first.
- CORNICE RAILS**. The top framing of all standing-top carriage bodies.
- COTELINES**. A woven fabric of silk, much used in lining the finer carriage-bodies. From *cote*, a sheepfold, and lines, extending (?). A modern French production, about which the dictionaries are silent.
- COUNTER-SUNK BOLTS**. Bolts with heads let in level with the surface of the plates, or parts they fix.
- COUPÉ** (koo-pa). The name of a vehicle of French invention. Originally this term was applied to the front boot of the French Dilligence, a mail stage, and means from *couper*, literally to cut in two. Any one who surveys this vehicle, critically, perceives that the boot and body are connected by a small ligature always.
- CRADLE** (Saxon, *cradel*). In disuse now. A leather platform attached to opposite bearings in front of the carriage to receive or support the driver's seat. This was fastened to the loops on the seat irons, and either tied or buckled thereto, so as to be loosened or tightened at pleasure. “By those cradles the seating for the coachman is made comfortable, and is generally adapted to their several conceits.”—*Felton*, vol. i, page 130.
- CRAMP-WORK**. An obsolete American technical term, for the under carriage of all four-wheeled carriages with a perch.



**CRANE** (Saxon, *cran*). A strong iron bar crooked something like a swan's neck, to let the front wheels pass under; used like the perch to couple the front and back axles. See vol. i, p. 190 of this Magazine.

**CRANE-NECK CARRIAGE.** A carriage constructed with a crooked perch—crane—which see. In modern times bodies of a peculiar form—an example may be

seen in vol. ii, plate 30—hung on fore and hind carriages without a perch have been termed among us "crane-neck," or swell-arched carriages.

**CRANE SHAFT.** Wood instead of iron, bent or "worked out," and taking the place of "iron cranes."

**CURRICLE.** An ancient carriage, the fashion of which revived in England seventy years ago. A carriage drawn by two horses abreast. See vol. iv, p. 143, figure 30, for an illustration.

**CURTUERS OR CUTTOS.** The ends of axle-beds projecting over the hubs, either for ornament or screening the axle from gravel and dirt. Some American carriage-maker's call these "dubs."

**CUSHIONS** (French, *coussin*). A pillow for a seat, stuffed with moss and hair to render it soft and comfortable. In *cheap work*, hay generally supersedes the articles named above, as stuffing. The public may understand from this the *real* value of *cheap* carriages.

**CURTAIN ROLLERS.** Tin barreled cylinders with spiral springs on which the curtain rolls.

**CURTAIN FRAMES.** The frame used for glass lights in curtains.

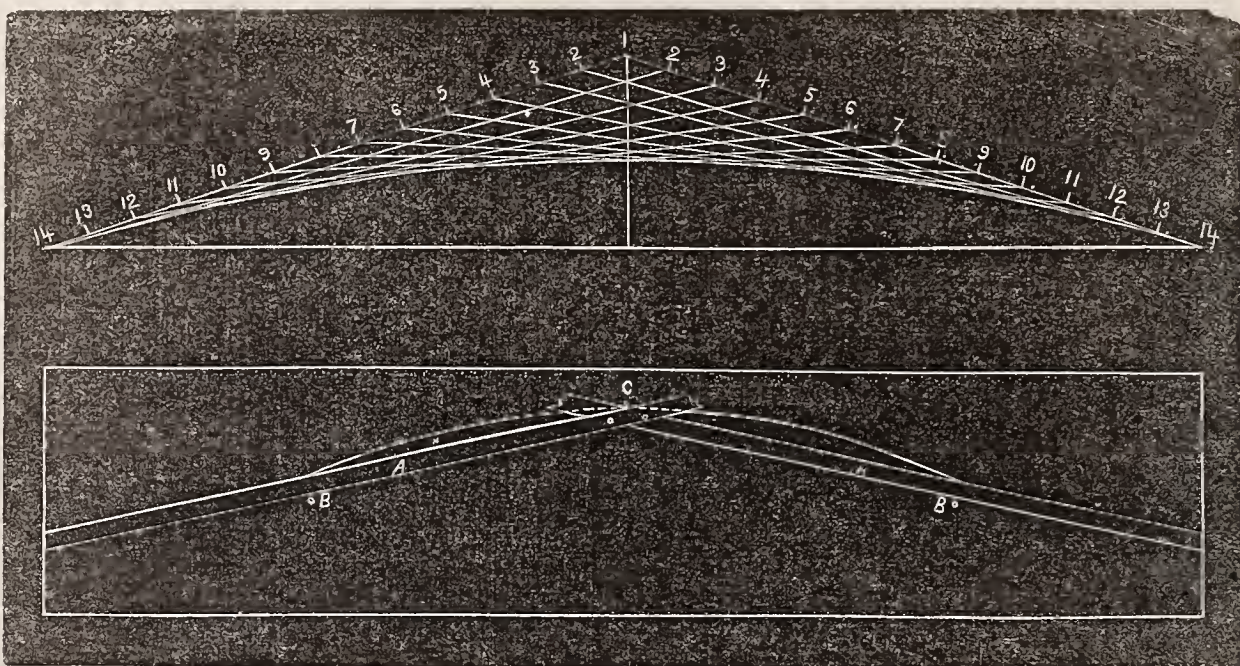

TWO PLANS FOR DRAWING SWEEPS.

## TWO PLANS FOR DRAWING SWEEPS.

THE accompanying illustration presents two different modes of obtaining sweeps. Figure 1 sufficiently explains itself. Figure 2 shows two slips of wood, A A, screwed together at the angle. Now, in order to describe the curve at B B, it will be observed are two fixed pins or points for A A to slide against C, the pencil or marker to be carefully slid from B to B, which will produce the desired curve. By this operation a true curve will be obtained by the intersection of a combination of straight lines. Several examples in geometrical, oval, and spiral figures are given in Volume i., pp. 192 and 207 of this Magazine.

## THE LONDON JOURNEYMEN COACH-MAKERS' INDUSTRIAL EXHIBITION.

THE following account of some of the most interesting articles in the late exhibition, not before published in this work, we take from the London *Morning Star* of Feb. 2nd:

The contributions of Messrs. Hooper will attract great attention. Among them are an engraving of the Queen's State coach; colored drawing of a pony chariot, made for and approved by the late King William the Fourth; an elegant sketch of a snow sledge, with swan heads at the ends of the shafts, with pencil alterations by the late Prince Consort; lithographic sketches of the carriages of Henri Quatre, Louis Treize, Quatorze, and Quinze, and the First Napoleon; colored drawing of the Emperor of Austria's sledge; and prints and photographs of all the different styles of carriages in the civilized world. Through the agency of Mr. Edward Page, Inspector-General of Mails at St. Martin's-le-Grand, the Postmaster-General is a contributor, sending an exact model of the old mail-coach, which is now known to the present generation but through the medium of Messrs. Fores' sketches. The London and North-Western Railway Company also exhibit two large models of railway post-office carriages. In these days of deserved outcry against the want of communication on railway trains visitors will inspect with special interest the movable "gangway" con-

## D.

**DASH (SPLASH?)** An iron frame covered with leather and placed on the fore part of the body to shield the passengers against water and mud, thrown by the horse's heels when in motion. Sometimes a simple board is substituted and termed a *splash-board*.

**DEE.** A sort of iron ring, in shape like the letter D, used for straps to *loop* through in some vehicles.

**DOG CART.** A vehicle much used by sportsmen so contrived as to transport the *canine fixtures* in the same box with the principals. The term is likewise applied to four-wheeled road wagons, in our day.

**DOOR-MOULDINGS.** The T shaped strips of lead or brass secured to the sides of carriage doors, to hide the joints created thereby in the side panel.

**DOOR PILLARS.** The pillars next the side door in the frame of a carriage-body, in other words the standing pillars.



necting the railway post-office with what is technically known as the "sorting tender," which is a perfect communication, and found to work admirably. Some splendid wood carvings, exhibited by Messrs. Peters, and made (but apparently not used) for a State carriage for George the Fourth, should be noticed; as should some really wonderful panel and spoke painting, sham carving, and imitation basket-work, in the "painter's" class. There are several specimens of methods for facilitating the release of horses from a carriage in the event of their falling. Among them, No. 13, an invention by Alfred Lewer, a working man, by which on simply unscrewing the top the roller-bolt falls forward and the trace is at once removed, seemed the simplest and most likely to be effectual. Mr. Henwood's brass working model of a carriage intended to overcome some of the objections to Mr. Train's tramway system, by which the carriage lays down and removes its own tram as it progresses, is ingenious, but its weight would probably prove an insuperable obstacle to its introduction. The walls are hung with drawings representing all kinds of carriages, but among them is a grim old engraving showing the procession, in carriages, of the Houses of Lords and Commons to return thanks at St. Paul's for Marlborough's victories. Nothing could be more hideous or more cumbrous than the coaches here depicted: they look like sedan chairs set top-heavily on wheels.

On the whole, this exhibition, unique in its kind, is most interesting, and well worth a visit.

## Pen Illustrations of the Drafts.

### EXCELSIOR COUPÉ.

*Illustrated on Plate IX.*

COUPÉS have, among the élité of this city, become extremely fashionable; scarcely a family of means being content without at least one composing a part of their establishment. Our design represents a contracted front coupé of the latest style. For an explanation of the term coupé, see the word on page 37 of this volume. For directions in building—these vehicles differ but little in this respect—see remarks on page 153, volume V.

### TILBURY DOG-CART.

*Illustrated on Plate X.*

Now that a peace has been conquered, we suppose the attention of the public will be turned to making *war* upon the game in which our country abounds. That we may encourage this more *manly* exercise and advance *civilization*, we offer this design for the benefit of our readers. The drawing is sufficiently instructive without further detail to enable any carriage-maker to construct one.

### FAMILY BUGGY.

*Illustrated on Plate XI*

This buggy is more particularly designed to suit the requirements of a small family—a gentleman, his wife,

and one or two little ones—having attached a front seat, to accommodate the children. Of course, this kind of buggy requires to be a little stronger made, and necessarily somewhat heavier than most others—those merely intended for the road. In our design we have included the most fashionable features of the present day. We have seen "the cut-under," to some buggies, as in our example, elegantly painted in plaids of different colors.

ANNOUNCEMENT.—The September number of this Magazine will be devoted to several original designs for sleighs. Any reader who will contribute, will be entitled to a copy when the number is published.

## Sparks from the Anvil.

### STEEL AND IRON.

THE difference between common iron and steel is in the carbon in the latter, but if iron be heated to a white heat and plunged in cold water it becomes very hard. Mechanics take advantage of this in making axles and collars for wheel-work, for it is easily filed and turned in a soft state, and afterward hardened; this is most commonly practiced in the machine-shop. Moulders who make wheels are often embarrassed by this chemical property in iron; for, as the metal is poured into the mould of moist sand, the evaporation of the water carries off the heat, and cools the iron so quick as to make it extremely hard. This is common in such portions of the metal as have to run the greatest distance from the aperture of reception. The only remedy for this, is to have the sand as dry as possible, and as many apertures as are convenient.

The harder the steel the coarser the grain; fine steel has the closest grain. A neat curved line and grey texture denote good steel; threads, cracks and bright specks denote bad. The management of the forging may indeed modify these indications, and steel good for some purposes may be bad for others. Very small articles heated in a candle are found to be perfectly hardened by whirling them in the cold air; and thin plates of steel such as the needle of a compass, are hardened by being ignited and laid upon a plate of cold lead and quickly covered with another.

"Case-hardening" is that property of iron by which it becomes very hard on its surface. Articles of iron may be case-hardened by smearing their surface with a paste of the prussiate of potash, then heating them to a red heat, and dipping in cold water.

In making tools, the artist is directed by the colors of the steel while heating. The different colors direct, in tempering, to a standard. When steel is too hard, it will not do for steel to have a very fine edge, because it will soon become notched, and if too soft, it will too easily bend. Purple is the color for gravers, or tools used to work in the metals; when the color appears in heating, it is immediately plunged in cold water. A very hard temper will be made if the steel is taken at a yellow color and dipped. Blue is the color for springs and instruments for cutting soft substances, such as leather, &c.



### BROWNING IRON AND STEEL.

A FRENCH paper, the "*Moniteur des Interets Materiels*," gives the following receipt for imparting a brown color to the surface of polished iron or steel: Mix four parts of water by weight, one part gallic acid, two parts chloride of iron, two parts chloride of antimony. The chloride of antimony (butter of antimony) should contain the least possible acid in excess. Dip a sponge in the mixture, and rub the metal to be colored. By repeating the process, the color can be deepened at will. Wash thoroughly with water, and when the surface is dry, cover it with a light coating of boiled linseed oil.

## Paint Room.

### ORNAMENTATION.

THE cultivation of artistic taste forms one of the most striking features in the character of the present age. It is visible in almost every undertaking, and particularly so in the articles turned out from our workshop. In these, artistic beauty and practical utility are happily blended.

Probably no mechanical pursuit can offer a more favorable field for the cultivation or display of genius than that of carriage-making, and it gives us much satisfaction to feel that among no class of artisans in our land is there a greater amount of practical knowledge generally diffused. The chisel of the wood-workman imparts a beauty to portions of the carriage worthy of the reputation of the old masters in carving; the smith with consummate skill forges from the rough bar, stays, collars and other beauties, rivaling the figures on the "Shield of Hereules," as poetically formed by Homer's pen; the trimmer,—though circumscribed—yet manages "to lend enchantment" to the eye, while he imparts comfort to the limbs of his customers and the painter—he is both a chemist, artist and a mechanic, all blended in one. He scientifically mixes his colors and produces a combination of paints, which not only protect the other departments from the destructive influences of the weather, but impart to them a beauty and finish they would never present without its aid; in reality like charity covering all their natural (sometime *unnatural*) defects.

It is true there are many "old fogies" yet, who are as devoid of taste as of reason, who are continually crying out about the folly and extravagance of ornamenting work, simply because it costs something to do it; but, however much we may advocate plain work, the fact is patent to every particular salesman, that it sells harder than the same grade with a little ornamentation. We have tried plain and striped work side by side in our sales-room, and found that out of ten persons, nine preferred—and would have none other—than "striped" carriage-parts. In view of these facts our friendly advice to our young friends is—early turn your attention to the uses of the pencil, not only in practicing striping, but in acquiring a practical knowledge of ornamenting the panels of carriages. Much will be accomplished by a determined perseverance. Many examples for practice will be found in these volumes with ample directions how to proceed. The monograms we have already published and those to come after, open one of the best schools for study in this department of art ever instituted.

### GOOD NEWS FOR PAINTERS.

DURING our civil war, the costs of spirits of turpentine were enormously high, as our Prices Current show. We now learn that great preparations are making in North Carolina for the manufacture of this necessary article, by repairing the works destroyed, and by the addition of many new ones. It is stated that when the farmers become able to leave their growing crops, which will be in a few weeks, the work will go on in good earnest. In order to encourage our long suffering readers, we may state here, that a few days since we saw reported in a Boston journal, that the schooner Sarah A. Hammond had arrived at that port, bringing, among other things, fifty barrels of spirits of turpentine, consigned to the celebrated varnish manufacturers, Messrs. Valentine & Co., whose business advertisement appears on the second page of the cover to this month's issue. It is added, in making this announcement, that formerly there was some sixty arrivals annually from Wilmington, N. C., and that "we welcome this first vessel [the Sarah A. Hammond] as the harbinger of the revival of the former business." We expect to soon find the prices of turpentine much reduced.

### ORIGINAL MONOGRAMS.

*Illustrated on Plate XII.*

WE again furnish our patrons with a fresh installment of monograms, or interwoven letters, for their study. These are from the same hand as those which we have before published, and which we hope will be as equally well received. We have more in preparation, which we shall give as opportunity offers.

## Trimming Room.

### VALUABLE RECEIPTS.

**CEMENT FOR LEATHER.**—A mixture of india rubber and shellac varnish makes a very adhesive leather cement. A strong solution of common isinglass, with a little diluted alcohol added to it, makes an excellent cement for leather.

**BLACK JAPAN.**—Take asphaltum three ounces, boiled oil four quarts, burnt umber eight ounces, and mix them by heating, and while cooling thin with turpentine. Next take amber twelve ounces, asphaltum two ounces; fuse by heat, add boiled oil half a pint, resin two ounces; when cooling, add sixteen ounces oil of turpentine. Both are used to varnish metals.

**LEATHER VARNISH.**—Durable leather varnish is composed of boiled linseed-oil, in which a dryer, such as litharge, has been boiled. It is colored with lamp-black. This varnish is used for making enameled leather. Common leather varnish, which is used as a substitute for blacking, is made of thin lac-varnish, colored with ivory black.

**BLACK VARNISH FOR LEATHER.**—Digest shellac twelve parts, white turpentine five parts, gum sandarach two parts, lamp-black one part, with spirits of turpentine four parts, alcohol ninety-six parts.

The above receipts will be found very useful in the trimming shop, and it would be a good plan to copy them out and post them for convenient reference.



## Editor's Work-bench.

### EDITORIAL VIATORY.

No class of men need the invigorating benefits of country air more than that unfortunate one called editors, and yet none find so few opportunities for enjoying that privilege. Doomed as they are to continual drudgery in brain labor while confined to the office, a chance for escape to the country is a treat which ought not to be neglected. Under such impressions—carpet-bag in hand, well filled with a stock of "mental food"—on the afternoon of July 8th we left this sweltering city, dirty streets, and yet more dirty politicians, for the Hudson River Railroad Station, on a journey up the Hudson, and eastward through some of the richest districts of this great and prosperous country. A few hours by rail, and we stood on the shores of the noble Hudson, beneath those frowning heights known as the Rhine-cliff. Here we found our old friend, Captain Morrow, awaiting our arrival with his "Lark," who, like his illustrious predecessor, Charon, of old, soon transferred us—not across the Styx—but over that more pleasant stream, the noble Hudson; setting us ashore in those classic grounds, called in vulgar parlance Rondout. We need not here undertake to describe the beauties of this place, a sensitive writer having already done this very graphically in a communication found on page 63 of volume I. From thence a short stage-ride set us down at the door of a hospitable friend in the ancient city of Esopus, known in modern times as Kingston.

Kingston was at one period of our history the capital of the State of New York, and this circumstance, during the revolutionary war, after Sir Henry Clinton had gained possession of the forts, in the Hudson Highlands, induced him to wreak his vengeance upon the rebellious inhabitants, by burning the place on the 13th of October, 1777. Lossing, in his "Field-book of the Revolution," thus describes this event:

"The frigates [British] were anchored a little above the present landing on Kingston Point, and a portion of the invaders debarked in the cove north of the steamboat wharf. Another division, in small boats, proceeded to the mouth of the Esopus (now Rondout) creek, and landed at a place a little northeast of Rondout village, called Ponckhocken Point. The people at the creek fled, affrighted, to Marbletown, seven miles southwest of Kingston, and their houses were destroyed. The two divisions then marched toward the village, one by the upper road and the other by the Esopus Creek Road. Near the house of Mr. Yeoman, who was in the army at Stillwater, they seized a negro, and made him pilot them directly to the town. The detachments joined upon a gentle eminence near the village, a few rods south of the Rondout Road, and, after a brief consultation, proceeded

to apply the torch. Almost every house was laid in ashes, and a large quantity of provisions and stores situated there and at the landing was destroyed. The town then contained between three and four thousand inhabitants, many of whom were wealthy, and most of the houses were built of stone. Warned of the approach of the enemy, a few saved their most valuable effects, but many lost all their possessions, and were driven back upon the interior settlements upon the Wallkill. Governor Clinton, with the members of the Legislature, was there, and efforts were made to raise a sufficient number of militia for the protection of the town, but without success. The enemy, however, fearing their wanton cruelty would bring the people in mass upon them, hastily retreated after destroying the village. A detachment crossed the River and marched to Rhinebeck Flats, two miles eastward, where they burned several houses; and, after penetrating northward, as far as Livingston's Manor, and burning some houses there, they rejoined the main body, and the fleet returned to New York." This wanton transaction cost the British the loss of Burgoyne's entire army four days afterwards!

There are two carriage shops in this place—Messrs. Curtis, Bowen & Co.'s, and I. T. Merritt & Co. There is some very good work made at both the shops we have named. Of course (we would say it with great modesty) such must always be the certain effect of industrious habits and the regular reading of "THE NEW YORK COACH-MAKER'S MAGAZINE."

From Kingston we traveled on to Hudson, and having waited upon our friends, Messrs. Burger & Kidney, we next proceeded onward to Mellenville, Chatham, Pittsfield, Palmer, Belchertown and Worcester. At Pittsfield, situated among the hills of Berkshire county, Mass., we had the pleasure of introducing ourself to Messrs. Van Valkenburg & Blinn, a young and enterprising firm, and that veteran coach-maker, Mr. Jason Clapp. In this establishment we found Mr. Wm. A. Osborne, the gentlemanly foreman, from whom we received encouragement for our Magazine. Belchertown was once a celebrated place for carriage-making, but very little is done there now.

In Worcester we renewed our acquaintance with Messrs. A. Tolman & Co., Wm. C. Whiting, George T. Atchinson and Messrs. O. Blood & Sons, who all—considering the times—appear to be prospering in business. An inspection of the work in the establishment of the Messrs. Bloods, gave us a very favorable impression of their mechanical abilities. Mr. Whiting also showed us some very fine evidences of his skill as a mechanic. For the first time, on this occasion, we made the acquaintance of Messrs. Rice & Richmond, who have a very respectable carriage-repository in the place, and who entered heartily into the object of our visit and made us feel



entirely at home. Mr. Whiting also placed us under renewed obligations, by introducing us to Mr. A. Walker, a gentleman dealing in carriage stock and carrying on the plating business. Upon the whole, our visit to Worcester lost nothing in attractions since last year. An hour in the Antiquarian Library, with our esteemed friend, Mr. Hamant, finished our business in this very pleasant city, full of objects of interest, not the least of which—in the public square—is a monument to the memory of Timothy Bigelow, an active officer in the war of the Revolution. To the stranger who reads is left the difficult task of determining in his own mind, whether or not this monument was designed to immortalize the name of the donor more than to perpetuate the fame of the hero. That our readers may judge for themselves in this respect we present the inscriptions upon it, as copied from our notebook:

(West side) Timothy Bigelow—(South) Born August 12, 1739; Died March 31, 1790—(East) In memory of the Colonel of the 15th Massachusetts' Regiment of the Continental Army in the War of Independence. This monument is erected by his great-grandson, Timothy Bigelow Lawrence, Anno Domini 1861—(North) Quebec, Saratoga, Valley Forge, Monmouth, Verplanck's Point, Yorktown.

Next to Boston—this city is claimed by the enterprising inhabitants, to be "the Hub of the Universe." Without stopping to dispute the claim, we cheerfully concede the fact that more of the peculiarities of English customs *centre* in this, than in any other place in the United States. Among these has been the importation of more European-made carriages than elsewhere. Indeed, it is apparent that there are more "old-fogy" notions in regard to styles among the people than in any other city in this Union. It saying this we would be understood as stating a historical truth, not as performing the part of a censor.

There are still to be seen many relics of English and French manufacture, in the shops, and in the streets. Our friend, Mr. Chauncey Thomas, informs us that the last importation (with the exception of an Irish Jaunting Car, last season), was made about ten years ago, by Abbot Lawrence, Esq., our minister to England, on his return home. Since that time our models have been so much improved that the effect is to stop the importation altogether. Fifteen years ago, Dr. H. J. Bigelow brought over a French Cabriolet, which we had the curiosity to inspect. It was at that time very common to find imported carriages running through the streets of Boston. In 1848, the last French full caleche was imported by Henry P. Sturges, Esq. It is claimed for Boston, by its admirers, that the tastes of the people favor a plain style of finish, and that, in this respect, we in New York, are

but copyists. With a consciousness detracting a little from the originality claimed by our Yankee friends, we suggest that *plainness* in this respect is evidently but a plagiarism, imported from abroad.

Our next calls were upon Messrs. Mitchell & Raymond, Russ, Easland & Co., Danielson & Johnson, Isburgh & Rowland, Thomas Goddard, E. W. Hale, and others. Mr. Hale keeps constantly on hand a great variety of carriages from different manufacturers, suited to the tastes of all grades. We judge that he is doing a very good business.

Messrs. William P. Sargent & Co., have a more extensive establishment than we were before aware of, occupying no less than five buildings, and selling about \$400,000 worth of stock in a year. They have constantly on hand from 200 to 300 vehicles of all kinds, from manufacturers in Bridgeport, New Haven, Portland, Saco, and Amesbury, having a stock interest in the manufactories in the two last mentioned places. Besides this, they keep on hand about 700 saddles, harnesses, and a stock of springs, axles and other material for the trade. For an opportunity to examine this establishment we are under obligations to Mr. Charles H. Bradstreet. Our friend, Mr. J. P. Whittier, near by, is evidently also doing a very fine business.

Our space forbids noticing in detail all the shops we visited, but this is scarcely necessary to be done here, as less than a year ago we gave ample proof of our friendship towards them in an article found in volume vi. Suffice it to say that we found but one firm out of humor with us in the city, and in this case it seems the displeasure arose from the circumstance that we had neglected to notice them at all—committed *the great sin of omitting to puff*. Puffing being entirely out of our line, we despair of ever being able to *sugar* them sufficiently well to reinstate ourself in their good graces.

In our homeward progress we stopped in Providence, renewing our acquaintance with friends there, to the satisfaction, as we trust, of both parties. An absence of six days completed our visit, and heaped upon us a pile of letters, to do justice to which, by answer, and meet the calls of the printer in time, hurries this article to a conclusion with less perfection than is desirable.

This visit to the craft confirms the prediction made by us some time ago—that the enormous tax imposed upon the small manufacturer would, if continued, ruin his prospects, and very much impede the progress of trade. Formerly, when a buggy could be bought for a small sum, even clerks, and others of light income, were able to indulge in the luxury of riding out, but now, their salaries not having been much increased, their small means admonish them to forego that pleasure, to the serious disadvantage of those engaged in the manufacture. Indeed,



the excessive amount of taxation eats up the entire profits of the country manufacturer, and will continue to do so until Legislative aid, by reduction, comes to his relief. Estimating the tax as now imposed, it amounts to—instead of six—about thirteen per cent., a great many items comprising the carriage paying a tax, two, three, and even four times over. This is all wrong, and evinces a lack of judgment in those forming the laws, singularly impolitic and short-sighted. Nor was this tax laid in ignorance of its effect—that having been shown to those in authority before it was fixed—that while the more popular manufacturers would obtain the price they asked, the smaller ones, for lack of popularity, would be compelled to sell so low as to discourage them from manufacturing altogether, or if they continued, ruin them. Events prove the truth of the prediction.

#### GOVERNMENT MISTAKES.

GOVERNMENTS, like individuals, often commit serious mistakes, a strong evidence that “assembled wisdom,” so denominated, is not always such by any means. This has been often shown in the legislative bodies of all nations, and doubtless will be continued down to the end of time. Measures taken to secure a large fund in the form of revenue from an exorbitant taxation of what we consider the luxuries of life, we consider as bad policy. It works very well for the interests of the State a year or two, but in the end ruins the interests of manufacturers and its own.

Any one acquainted with history knows that England has for a long time been overwhelmed with debt, created principally by her determined endeavors to maintain her aristocratic few at the expense of the many. This has kept her in constant “hot water” with her neighbors, and quarrels are always expensive. To pay some of these expenses, years ago, just as our Government has recently done, a heavy *draft* was made upon the pockets of all who either built or used carriages, so great was the injury inflicted, that Felton says: “Had the tax continued in the partial way it was imposed, the use of carriages would have been soon discontinued by most gentlemen in England. Indeed, so great was the pressure on the trade, that more than half the members belonging to the different branches thereof, felt a necessity of retiring to some other calling, or entering into the King’s service as soldiers or followers, and from which cause is to be attributed the present scarcity of hands.”

Precisely such effects have followed like causes in our day. That which we foresaw and predicted three years ago, has come upon us. The carriage business—except in a few instances—is now in a deplorable state. In fact, building new work has about stopped, and even jobbing has become, under some circumstances, a losing busi-

ness. All these disasters are directly chargeable to the spirit which conceived the grand idea of “putting it on” to luxuries. We have no disposition to find fault with legislative bodies, or magnify troubles; but how can we, as observers of “the signs of the times,” avoid complaining when we see the best houses in the trade compelled to advertise their made-up stock in the daily papers, as the readiest way in which to accomplish sales. Proof of “serious times” are still further illustrated by comparison of the costs in building, with the prices now obtained for finished carriages. While our monthly Prices Current show a very small reduction in the costs of the raw material, the Ledger tells a different tale—that the sales—if made at all—are at very low figures; so low, that it has and will ruin many.

But it is not alone in its pecuniary aspect that we would examine this subject—it has a moral bearing. Can there be any justice—any *fair* dealing—when Legislators heavily burthen with taxes the business of some while that of others is left comparatively untaxed, simply because one is a luxury and the other the necessary of life? We think not; but some others judge differently. These conclude that in taxing luxuries, the class is reached best able to bear it. This argument may appear very plausible on superficial examination. It is true the wealthy are bled, but while they are suffering from a slight hemorrhage, that other class, the carriage-builders, are being judicially assassinated!

But we are told if such be the case, then turn your attention to some more remunerative business where you can make a living. Why not, *is it not easy for a person to leave the business he was bred to, and slip into another!* Perhaps that other business is already overdone, and the new addition to its ranks will crush the entire life out of it. No matter, your labor panders to luxury, and the law but imposes a just penalty for the offence you have unwittingly committed by engaging therein. Such is the poor consolation we obtain from the administrators of Government enactments, while we are left to suffer.

There is a very strong reason why we cannot readily change our business. Most of us have from choice engaged in it, and its pursuit has made us infatuated with its artistic elements; its architectural beauties. What else induces us to continue therein? Surely it cannot be its remunerative bequests; for probably there is no business where so much capital is invested, that returns so diminutive a revenue. Indeed every one in the trade who walks with his eyes open, sees plainly his neighbors getting rich, while he is getting poorer and poorer—and still he goes like a carriage-maker—to the poor house! The only consolation we have remaining is, that we suffer for the good of our country, and patriotism is strengthening to some minds. As a body we are certain that carriage-makers yield to none in loyalty.



## LONGEVITY OF MECHANISM.

COMPLIMENTARY to the times in which we live is the fact, that the prejudices of former days against the mechanical classes are fast disappearing from among us. Very few can now be found ready to receive Dr. Johnson's odious definition, that "mechanic" means "a low workman." The majority would more likely define the term as meaning the *higher* and more useful class of society among mankind. As society is constituted, the merchant is not altogether a useless member, nor is the historian worthless; but without the mechanic, their occupation—if not like Othello's, entirely gone—yet would be greatly circumscribed. Some of the greatest men of ancient as well as modern times, have been mechanics. Even the Saviour of our race did not consider it beneath his dignity to work at the carpenter's bench. The Great Architect, the Father of us all, is himself, in more than one sense, the Chief of mechanics. Shall man, then, the creation of His mind, despise His handy-work? Away with such foolish ideas as those we have named! They are unworthy of thinking mortals—of beings claiming to be civilized.

Go back in the world's history some thousand years, and we find nothing remaining but a few fragments from some mechanical hand—monuments to posterity—evidences of the Longevity of Mechanism. We may, as has long been done, call Necessity the mother of invention, yet the fact remains that mechanism is eternal.

## LITERARY NOTICES.

THE late hour at which our recent visit to the craft puts the publication of this number off, affords us the opportunity to notice the August number of *The Atlantic*. We give the titles of the principal articles as indicative of the character of the work: Among the Honey-Makers; Countess Laura; Strategy at the Fireside; Around Mull; John Bright and the English Radicals; Needle and Garden; My Second Capture; Doctor Johns; Letter to a Silent Friend; The Chimney Corner; Reconstruction and Negro Suffrage, Reviews, &c., on the whole an excellent number.

We are also in receipt of a file of *Our Young Folks*, from the same publishers, concerning which it is only necessary to say that its popularity at the end of six months, has run its circulation up to 40,000 copies monthly, and it is daily largely on the increase. We can only find room here to say that its popularity is duly commensurate with the intrinsic value of the publication.

## EDITORIAL CHIPS AND SHAVINGS.

NEW WHEEL MANUFACTORY.—The attention of our readers is called to the advertisement of Mr. S. C. Crane, in the second page of our cover.

CITY AND COUNTRY WAGONS COMPARED.—A friend of ours carrying-on carriage-making in the country, claims that their wagons have a harder trial on the roads than ours in the city.—There they "go it" with a perfect loose-

ness—two passengers in—country wagons not being as frequently washed-off are more exposed to decay. City wagons on the other hand are washed-off every time they come in, and put under cover, are seldom used with more than one passenger in at a time, are kept well screwed up all around, and great care is taken in going out over pavements to walk the horses carefully.

THE STEAM-WAGON AHEAD.—The people in Poughkeepsie, N. Y., had a novel race for their amusement on the 14th of July. A man pitted himself against a steam wagon, the wagon coming out eight seconds ahead. The next race was between a trotting horse and the wagon. The wagon made one mile in two minutes twenty seconds; the man ran the same distance in five minutes and twenty seconds; the horse one mile in two minutes and thirty-seven and a-half seconds.

WINDY.—A violent tornado passed over Red Wing, Minnesota, a few days ago. It picked up a house and demolished it, killing an old man who had taken refuge in it. A gentleman riding in a buggy saw the storm approach, sprang out, and seizing a young sapling, lay flat upon the ground. No sooner had he done so than his horse and buggy were literally carried away. The buggy was torn into splinters, and the horse was carried forty rods and lodged in the tops of some small trees, so entangled in the brush and harness as to be unable to extricate himself. The gentleman saved himself by clinging to the sapling, and, as it was, he was blown straight into the air, and for a moment hung only by his hands.

ANCIENT PRICE OF CHARIOTS AND HORSES.—In King Solomon's day it is mentioned that the price of a chariot from Egypt, the chief place of manufacture, was 600 shekels of silver, or about \$275 (1 Kings, x, 29). Solomon himself had fourteen hundred chariots.—The price of a horse was 150 shekels, the king keeping about forty thousand, mostly raised in Egypt. The Egyptians trained their horses so skillfully that they were made to perform the most importance services. The Israelitish King, in a splendid chariot drawn by four Egyptian steeds, made as splendid an appearance probably as any Prince in more modern times.

SIMPLICITY IN RHYME.—The following lines by a poet named James Smith (cousin of the ubiquitous John), is a capital hit-off of the childish simplicity and mockish affectation of Wordsworth:

"The chaise in which poor brother Bill  
Used to be drawn to Pentonville,  
    Stood in the lumber room—  
I wiped the dust from off the top,  
And Molly mop'd it with a mop,  
    And brushed it with a broom!

"Well, after many a sad reproach,  
They got into a hackney-coach,  
    And trotted down the street;  
I saw them go; one horse was blind,  
The tails of both hung down behind;  
    Their shoes were on their feet!"

WAR WITH THE HACKMEN.—In the absence of other excitements, the city dailies are again "down on" the hackmen, because they make such high charges for their *low* accommodations, and are now advocating the adoption of some expeditious and cheap mode of single-horse vehicle to take passengers to different points about the city. As the like agitation of this subject has been carried on once in two years, for a long period, unsuccessful



fully, we have very little hope of there being anything accomplished now.

**BUTT'S ON KEEPING TIRES TIGHT.**—In the *Tinman's Manual*, by J. R. Butts, we find the following greasy receipt for keeping tires tight on wheels: "Before putting on the tires fill the felloes with linseed-oil, which is done by heating the oil in a trough to a boiling heat, and keeping the wheel, with a stick through the hub, in the oil, for an hour. The wheel is turned round until every felloe is kept in the oil one hour." We hope no one will try this because we reproduce it here.

### The Coach-maker's Letter-box.

SAN JOSE, CAL., June 17th, 1865.

EDITOR COACH-MAKER'S MAGAZINE:—"Time and tide wait for no man." My subscription expired long since, yet, in many shops in different cities, I have glanced over the shoulders of the craft into the Magazine and borrowed items of information, valuable, and long to be remembered, and now, after a space of ten years, as these silver threads attest, I return at the eleventh hour to your patronage, laying all blame to that naughty individual called Procrastination, and ask to be enrolled once more in the ranks of the favored few.

Since I used to read the Magazine regularly, and wondered if my apprenticeship would really ever terminate, my barque has quietly floated down the stream of "Fashion and Famine," [Dangerous stream, that] navigated the Alkali, [Where is that located?] and cut my teeth on "Feel" and "He,"—[Singular]—have laid aside the blouse for the epauletts; cleared the foot-lights and taken a squint behind the scenes; and after long sober thought, have come to the conclusion that there is no place like home—in the shop.

The pretty and thriving little village of San Jose is situated near the southern extremity of San Francisco Bay, in Santa Clara Valley; one of the most productive districts, with perhaps the finest climate in the world, where Ranchers and everybody else are fast learning the use of pleasure vehicles, as well as where they are made. Among a great many other *good things*, we are blessed with a branch of the Pacific Railroad, and when that "institution" is completed, I am going to America on the first train to see you—until then, adieu!

Yours, Respectfully,

W. T. ADEL.

LAPORTE, IND., July 11th, 1865.

FRIEND STRATTON:—You will undoubtedly be surprised to hear from one of your old subscribers, whom you may have forgotten. If you have, your memory is not as long as his, for he has not forgotten you. The reason that I have not written to you sooner is, because I set out upon one of those renowned tramps, and a "*glorious*" time I had of it, made up of hard-knocks, hard-work, love-scrapes, &c., incident to the life of a roving jour. If I only had the pen of a Cooper, or Dickens, I would write out its history, for there is stuff enough in a two years' tramp to make twenty novels, but I cannot do it, so what is the use of telling you what you know already, or ought to, at least.

My object in writing this is to find out your correct address, and see whether you are still alive, and conduct-

ing the *ne plus ultra* of magazines, and if so let me know by return of mail. I have five complete volumes, and want the sixth, and as much of the seventh as is out. The Magazine was a great deal thought of in the different shops in which I have worked, and most of the jours. took your address, but whether they ever wrote you, I cannot tell. I have found some true and noble hearted fellows among the Craft, and some who ought to be castigated and driven from the ranks, but I think I have already troubled you enough with my nonsense.

Business was quite brisk out here last year, but is rather dull at present, still we manage to get along pretty well.

Your friend, H. T.

[We publish these letters, not so much because of the information they give relating to the trade, but as showing the kind feeling existing among the journeymen toward this Magazine and its Editor. We will add that these gentlemen are unknown to us, except by correspondence, and, therefore, their testimony has the more value attached thereto. We might multiply the number by publishing more of the same nature, did we think it necessary.]

AURORA, ILL., July 19th, 1865.

MR. E. M. STRATTON—*Dear Sir*,—As I have before told you, our town has been running wholly to wagons since the war, hence the slim patronage our magazine gets from this quarter. It would be preposterous to suppose a wagon-maker to be so silly as not to patronize a scientific paper. Talking of scientific principles to the majority of wagon-makers is an unthankful task. It reminds us often of the man who introduced the subject of French etiquette to the man in the moon, using his telescope for a speaking trumpet. That strange notion which attaches to a wagon, and places its maker among the hewers of wood and the drawers of water, must be dispelled. The veil of fog which envelops the wagon-maker and his art so thickly as to wall them out from the scientific world, is to be lifted. Though obscured with mud from the unclean medium which it navigates, and its beauties hidden beneath unclean burdens, it moves in obedience to just as pure philosophy, just as inflexible laws as those which govern the movements of the chronometer. The harmony of these principles cannot be disturbed by the innovations of art, or the encroachments of self interest, though most seriously do these agencies turn the course of those interested in their development from the path of truth.

Though the manufacture of carriages in the west, is at present mostly confined to the large cities, there are many carriage-makers in the large towns who, though temporarily stooping to the coarser work, still know a buggy from the Declaration of Independence, and are longing to see the time when orders from the repentant Southrons will come, as of old, for Yankee carriages. We are holding our breath here, as all over the North, to see whether traitors are to be punished or pardoned; whether the strong arm of the new Executive is to push the car of progress on in the direction of true greatness and glory, or whether it is not in fact turning back to salve the wounds, and revive the hopes of the aristocratic chivalry. We wait and hope.

You ask, what are business prospects in the West?



I wish I were only prophet enough to tell you. Of late the frontier trade in wagons has received a very material check, I am informed, from Indian depredations having discouraged emigration to a great extent. Again, the downward tendency of material discourages the accumulation of work beyond the present demand, which being light, a very general stagnation of business is apparent; yet, as I have said, we feel quite sure of a heavy Southern demand soon for all kinds of work.

I am glad you think of coming West, and will be most happy to welcome you here. We rejoice always to see the faces of our Eastern friends, especially those of the press and prominent business men, who are in any wise afflicted with Eastern institutions on the brain. We always send such visitors back with a flea in their ear. I tell you the strides with which the star of mechanical empire is marching westward, is truly astonishing, and the time is soon coming when eastern operators, who come here to spend their money, will be perfectly satisfied to leave their fogysm behind, and accept the situation as they find it; in other words, judge of ideas as we do according to their value, regardless of birthplace. The same species of sectional jealousy which formed no small element in the struggle just closing, has by far too much to do with our intercourse as a nation of mechanics. We have learned to judge of a citizen according to his qualifications for true citizenship, leaving nativity out of the question. Let us learn the same lesson, to qualify ourselves to judge of mechanics and mechanical ideas.

Yours, truly,

O. E. MILES.

## Patent Journal.

### AMERICAN INVENTIONS.

MAY 16. (47,769) MACHINE FOR MAKING THE SPINDLES OF WAGON AXLES.—James M. Jay, Canton, O. (Assignor to W. H. Alexander & Co.):

I claim, *First*, a machine for turning the journal or spindle, for cutting the gain therein, and for boring the lynch-pin hole of wooden axles, the same being combined and arranged to operate in the manner and for the purpose substantially as set forth. *Second*, In a machine for cutting journals or spindles for axles, I claim the revolving tapering cutter-head, with its cutters *e*, *e'*, as and for the purpose described.

(47,832) SHEARS FOR CUTTING IRON BOLTS.—Geo. N. Hyatt, New York:

I claim the shear-bars B B, pivoted to the bar A, as shown for the purpose already described.

(47,894) WHIFFLE-TREE IRON.—Wm. M. Bryant, Washington, D. C. (Assignor to himself and John B. Wheeler, and John R. Elvans):

I claim, *First*, constructing the ferrules A, for wingle or whiffle-trees with the stops or shoulders *d e*, and inclined or bevel *f*, substantially in the manner and for the purpose described. *Second*, In combination with the subject-matter of the first clause of my claim, I claim the turning stem B, with its locking-pin *j*, substantially as described. *Third*, In combination with the subject matter of my first and second clauses of claim, I claim the screw-fastening *k*, substantially as herein described.

(47,903) THILL-TUG.—William H. Noyes, Homer, N. Y. (Assignor to himself and Charles H. Wheaton):

I claim a metallic thill-tug composed of two parts *a a*, connected by a joint *b*, and provided with a chaffing ring E, substantially as herein shown and described.

June 2d. (47,949) HARNESS.—Emery E. Hardy, New York City:

I claim, *First*, The plate A, constructed in the form and manner shown, and connected to the other parts as herein set forth. *Second*, In combination with plate A, I claim the blocks B and B', when so arranged as to form the channel of the strap C, and otherwise constructed as described. *Third*, The crupper plate E, when constructed and fastened in place, as shown and described. *Fourth*, The slotted-plate *e*, screw *h*, and nut *f*, or their equivalent, when constructed and arranged to operate as and for the purpose set forth. *Fifth*, The method of securing the tenet F, as shown, whereby an open space or channel is left underneath it for the strap C. *Sixth*, The self-adjusting back strap C, when arranged to operate in connection with the other parts as herein shown. *Seventh*, In combination with the strap C, I claim the slotted plate *e*, clamp *f* and *i*, and screw *h*, constructed and operating substantially as described. *Eighth*, The hook G, provided with the square shank U, and used in combination with the bolt *l*, and crupper-plate *t*, as and for the purposes herein set forth.

(47,957) COMPOSITION FOR BLACKING LEATHER.—Paul W. Keating, Norwich, Conn.:

I claim the composition of matter of the ingredients, in the proportions, and mixed in the mode above described.

(47,959) ATTACHING AND DETACHING TOPS OF VEHICLES.—D. A. King, and V. N. Gardner, Lexington, Ky.:

We claim the mode herein described, of attaching the top of vehicles to the movable piece *d*, resting on the false bottom *e*, and sustained by the bearers *f*, and with the movable piece *d*, held in position by the buttons K K, or their equivalents, all constructed and operated as above described, and for the purposes set forth.

(47,992) AMBULANCE.—William Slatter, Alleghany City, Pa.:

I claim attaching the thills to the under side of the axle, and bracing the thill and axle together by traces running from the centre of the springs to the thills, constructed, arranged, and operating substantially as herein described and for the purpose set forth.

6. (48,040) SLEIGH-BELL ATTACHMENT.—Wm. E. Barton, East Hampton, Conn.:

I claim, *First*, The within-described metallic bell-holder, cast of brass, or suitable malleable metal, having a hole through it to secure the strap, impinging points on the strap side, and on the bell side prongs adapted to enter the bell through suitable holes therein, and hold the same by bending or clenching, substantially as set forth. *Second*, The said bell-holder strap and bell in combination, when put together so as to hold the bell loosely, and away from the straps, substantially as described.

(48,110) UPSETTING TIRE.—Albert Stedman, Homer, New York:

I claim the machine or apparatus as a whole, when used in connection or combination with any vice, as and for the purpose above set forth.

(48,111) CARRIAGE AXLE.—George Hayward Thomas, New York City:

I claim the mode herein described of securing a wheel upon its axle, the same consisting in the use at the outer end of the axle of a detachable or moveable collar or ring, in connection with a nut, the two being arranged together, and operating substantially in the manner herein above set forth.

(48,114) AXLE FOR WHEEL VEHICLES.—Jonathan S. Tibbets, and W. M. Merrill, Jeffersonville, Ind.:

We claim *First*, A divided axle, or one composed of two parts, A A', connected by a bridge or skeleton hub, composed



of the heads B C D, and brace-rods E, arranged and applied to the axle in the manner substantially as and for the purpose herein set forth, and the ends of the parts A A' fitted together by a cone joint. *Second*, Providing the heads B D with radial openings, or oil passages, and having said heads bushed with babbitt metal, substantially as herein described.

13. (48,163) WHIFFLE-TREE.—James Elder, Carthage, Ill. :

I claim the combination of the adjustable lever G, lever J, and rod K, with the treble-tier D, for equalizing the draught upon the horses of the team, substantially as described.

(48,169) WAGON BRAKE.—Willis Glaze, Rochester, Ind. :

I claim, *First*, The connecting of the whiffle-trees Q to a bar *o*, pivoted to a rod *e*, which is connected with the lever J, for the purpose of relieving the rear wheels of the pressure of the shoes G, under the pull of the team, as set forth. *Second*, The arrangement of the slide K, fitted in the guide-plate L, lever *j*, and rods *e* M and thimble N, all arranged to operate in connection with the levers E E, substantially as and for the purpose specified. *Third*, The combination of the levers E E, rod S, lever J, rod *e*, slide K, rod M, and thimble N, with the bar O, connected by rods P P, to whiffle-trees Q Q, for the purpose set forth.

(48,178) BOY'S SLED.—David G. Hussey, Nantucket, Mass. :

I claim, *First*, The constructing or forming of the sled of a plurality of parts, attached respectively to the separate frame-pieces, *a* and *a'*, alternately arranged in one plane, as represented in the drawings, so as to constitute a level floor or bed, and in such a manner that said parts may be extended in a greater or less degree, to increase the capacity of the sled as may be required. *Second*, The combination of the pivoted steering frame E, (mounted on a pair of runners C C,) and the levers F and H, constructed, arranged, and operating, as described, in connection with levers I, or equivalent means for actuating the lever H. *Third*, The combination of the sliding foot-piece L R, rod K, and elastic brake-teeth *h h*, all constructed, arranged, and operating substantially as and for the purpose set forth.

(48,181) WOOD-BENDING MACHINE.—Samuel Keeler, Lancaster, Pa. :

I claim the arrangement and combination of the devices O, D, E, H, L, M, and N, as herein described, and for the purpose set forth.

(48,207) CARRIAGE-WHEEL.—John Reddin, Lynn, Mass. :

I claim, *First*, The thimble O, in combination with the screw N, and elastic packing M, applied to the spokes and felly of a carriage-wheel, substantially as and for the purpose described. *Second*, The metallic thimble P, applied to the felly end of a wooden spoke, in combination with the screw *g*, packing M, thimble O, and fixed screw N, substantially as shown in Fig. 3, and for the purpose described. *Third*, The fixed screw J, in a wooden hub, operating in combination with an internal screw cut in the end of a spoke, substantially as and for the purpose described. *Fourth*, The socket W, provided with a elasp entirely surrounding the felly, when used in combination with a spoke rendered adjustable by means of a screw, and the elastic packing M, substantially as and for the purpose specified. *Fifth*, The flanged socket 2, in combination with the adjustable screw-thimble T, and packing M, applied to the spokes and felly of a wheel, substantially as and for the purpose described. *Sixth*, The combination of a hollow metallic spoke with a thimble O, screw N, and elastic packing M, substantially as and for the purpose described.

(48,213) HARDENING AND TEMPERING STEEL.—Elliot Savage and Henry Stratton, West Meriden, Conn. :

We claim the use or employment in hardening steel of metallic solutions, in the manner and for the purpose substantially as set forth.

(48,228) WAGON LOCK.—John F. Bates, Mooresville, Ind. :

I claim the combination of the tongue K, the tongue-bolt *k*, the stop-bolt *x*, the front rod N, the lever M, king-bolt *h*, brace O, rear rod P, the rob-bars *g* and H, with their connecting pulleys *a a*, and slides R R, the hounds D D, the drop-lock *i*, with the snake-iron *h*, all arranged and operating substantially as described and for the purpose set forth.

(48,245) MACHINE FOR UPSETTING WAGON TIRES.—Gideon Huntington, Norwichville, C. W. (Ante-dated June 7, 1865.) :

I claim, *First*, The self-acting keys or wedges, acting in the loops or bevelled mortices, as above described. *Second*, The combination of the keys and mortices with the various parts of this machine, and for the purposes herein set forth.

June 20. (48,310) CARRIAGE.—Elisha Robbins, Worcester, Mass. :

I claim, *First*, The application of the thills or their equivalent, to the axle by hangers, or a crank shaft, as described, and so as to bear against the wagon body, under circumstances and for the purpose substantially as described. *Second*, The combination of the conical rollers F G, with the thills, their hangers, and the carriage-body, arranged and applied together substantially as and so as to operate as specified.

(48,313) CONNECTING THILLS TO CARRIAGES.—Blaney E. Sampson, Boston, Mass. :

I claim the application of the thills to the arms or journals of the axle, by means substantially as described, whereby they may be supported by, and turn on such arms while in use.

(48,315) TRUCK FOR PULLING STONE.—Gilbert L. Sheldon, Hartsville, Mass. :

I claim the combination of the secondary truck A', and wheel B, with the truck A, frame K, windlass I, sheave L, and chains M N, constructed and operating substantially as and for the purpose described.

27. (48,353) STOP-WASHER FOR NUTS.—H. N. Armstrong, Erie, Pa. :

I claim cutting the edges of the fixed washer, and turning up the corners thus formed to hold the nut from being forced back on its thread.

(48,364) ATTACHING TRACES TO WHIFFLE-TREES.—Ezra Caldwelwood, Portland, Maine :

I claim the sliding bars B B, provided with the pendant tips *e' e'*, to receive pins and rods *a a*, at the ends of the whiffle-tree, in connection with the sliding slotted-plate C, operated by a lever E, all being arranged and applied substantially in the manner as and for the purpose specified.

(48,373) CARRIAGE-KNOB.—R. P. Cowles, New Haven Conn. :

I claim the herein-described knob as a new article of manufacture.

(41,381) WAGON.—James Dowd, Boston, Mass. :

I claim the combination of the oil-holding channel *f'*, with the tubular pivot *d*, and step *e*, applied to the rock or plate, and the transom-bolt as specified. Also the combination of the slide L, with the spring and wagon body or truck, in manner and so as to operate substantially as described. Also the combination and arrangement of the auxiliary or tie-bars *e e*, with the truck F, and the springs H H, and their slides I I, applied thereto, substantially as described.

(48,386) CARRIAGE TOPS.—Joseph Enders, Louisville, Ky. :

I claim, *First*, The pillars E, and open rings F, or their equivalents, formed by the rear ends of the rail B, in combination with braces I, lazy-back D, and top C, constructed and operating substantially as and for the purpose set forth. *Second*, The hooks *d*, and catches *e*, in combination with the rail B, and straps *j*, secured to the seat A, substantially as and for the purpose specified.



## CURRENT PRICES FOR CARRIAGE MATERIALS.

CORRECTED MONTHLY, BY MR. CHAS. WEEKS, FOR THIS MAGAZINE.  
NEW YORK, July 25, 1865.

Apron hooks and rings, per gross, \$2.00.  
Axle-clips, according to length, per dozen, 75c. a \$1.25.  
Axles, common (long stock), per lb, 9c.  
Axles, plain taper, 1 in. and under, \$6.50; 1½, \$7.50; 1¾, \$8.50; 1¾, \$9.50; 1½, \$10.50.  
Do. Swelled taper, 1 in. and under, \$7.00; 1½, \$8.25; 1¾, \$8.75; 1¾, \$10.75; 1½, \$13.00.  
Do. Half patent, 1 in. and under, \$9.50; 1½, \$10.75; 1¾, \$12.50; 1¾, \$14.50; 1½, \$16.25.  
Do. Smith's New York half patent case-hardened malleable iron box, 1 in. and under, \$10; 1½, \$10; 1¾, \$12.  
Do. Smith's Homogeneous steel, case-hardened mall. boxes, ¾ in., \$12; ¾, \$12; ¾, \$12.50. Long draft, \$2 extra.  
Do. Saunders' improv. taper, ¾ in., \$12.00; ¾, \$12.00; 1, \$12.00; 1½, \$13.00; 1¾, \$15.  
Do. do. Homogeneous steel, ¾ in., \$15.00; ¾, \$15; ¾, \$16.50; long drafts, \$4 extra.  
☞ These are prices for first-class axles. Makers of less repute, cheaper.  
Bands, plated rim, under 3 in., \$2.50; over 3 in., \$3  
Do. Mail patent, \$3.00 a \$5.00.  
Do. galvanized, 3½ in. and under, \$1; larger, \$1 a \$2.  
Basket wood imitations, per foot, \$1.25.  
☞ When sent by express, \$2 extra for a lining board to a panel of 12 ft.  
Bent poles, each \$1.50.  
Do. rims, under 1½ in., \$2.25 per set; extra hickory, \$2.50 a \$3.50.  
Do. seat rails, 50c. each, or \$5.50 per doz.  
Do. shafts, \$7 per bundle of 6 pairs.  
Bows, per set, light, \$1.25; heavy, \$1.50.  
Bolts, Philadelphia, list.  
Do. T, per 100, \$3 a \$3.50.  
Buckram, per yard, 25 a 30c.  
Buckles, per grs. ½ in., \$1.50; ¾, \$1.50; ¾, \$1.70; ¾, \$2 10; 1, \$2.80.  
Burlap, per yard, 30c.  
Buttons, japanned, per paper, 30c.; per large gross, \$3.  
Carriage-parts, buggy, carved, \$1 a \$5.50.  
Carpets, Brussels, per yard, \$2 a \$3; velvet, \$3.75 a \$4.50; oil-cloth 60c. a 75c.  
Castings, malleable iron, per lb, 20c.  
Clip-kingbolts, each, 50c., or \$5.50 per dozen.  
Cloths, body, \$4 a \$5; lining, \$3 a \$3.50. (See *Enameled*.)  
☞ A Union cloth, made expressly for carriages, and warranted not to fade, can be furnished for \$2.50 per yard.  
Cord, seaming, per lb, 45c.; netting, per yard, 5c.  
Cotelines, per yard, \$4 a \$8.  
Curtain frames, per dozen, \$1.25 a \$2.50.  
Do. rollers, each, \$1.50.  
Dashes, buggy, \$1.75.  
Door-handles, stiff, \$1 a \$3; coach drop, per pair, \$3 a \$4.  
Druggot, felt, \$2.  
Enameled cloth, muslin, 5-4, 75c.  
Do. Drills, 48 in., \$1.  
Do. Ducks, 50 in., \$1.40.  
No quotations for other enameled goods.  
Enameled linen, 38 in., 75c.; 5-4, \$1.00; 6-4, \$1.20.  
Felloe plates, wrought, per lb, all sizes, 28c.  
Fifth-wheels, wrought, \$1.75 a \$2.50.  
Fringes, festoon, per piece, \$2; narrow, per yard, 18c.  
☞ For a buggy top two pieces are required, and sometimes three.  
Do. silk bullion, per yard, 50c. a \$1.  
Do. worsted bullion, 4 in. deep, 50c.  
Do. worsted carpet, per yard, 8c. a 15c.  
Frogs, 75c. a \$1 per pair.  
Glue, per lb, 25c. a 30c.  
Hair, picked, per lb, 55c. a 72c.  
Hubs, light, mortised, \$1.10; unmortised, \$1.00—coach, mortised \$1.50.  
Japan, per gallon, \$3.  
Knobs, English, \$1.38 a \$1.50 per gross.  
Laces, broad, silk, per yard, \$1.00 a \$1.25; narrow, 15c. to 20c.  
Do. broad, worsted, per yard, 50c.  
Lamps, coach, \$20 a \$30 per pair.  
Lazy-backs, \$9 per doz.  
Leather, collar, dash, 27c.; split do., 18c. a 21c.; enameled top, 29c.; enameled Trimming, 27c.; harness, per lb, 50c.; flap, per foot, 25c.  
Linen, heavy, a new article for roofs of coaches, 90c. per yard.  
Moquet, 1½ yards wide, per yard, \$9.00.  
Moss, per bale, 12½c. a 15c.

Mouldings, plated, per foot, ¼ in., 14c.; ¾, 16c.; 18c.; ½, 1 ead, door, per piece, 40c.  
Nails, lining, silver, per paper, 12c.; ivory, per gross, 50c.  
Name-plates.  
☞ See advertisement under this head on 3d page of cover.  
Oils, boiled, per gallon, \$1.60.  
Paints. White lead, ext. \$15, pure \$16 p. 100 lbs.; Eng. pat. blk, 35c.  
Pekin cloth, per yard, \$5.  
☞ A very good article for inside coach linings.  
Pole-crabs, silver, \$5 a \$12; tips, \$1.50.  
Pole-eyes, (S) No. 1, \$2.70; No. 2, \$2.90; No. 3, \$3.10; No. 4, \$4.50 per pr.  
Sand paper, per ream, under No. 2½, \$5.00; Nos. 2½ & 3, \$5.65.  
Screws, gimlet.  
☞ Add to manufacturer's printed lists 20 per ct.  
Do. ivory headed, per dozen, 50c. per gross, \$5 50.  
Serims (for canvassing), 20c. a 30c.  
Seats, buggy, pieced rails, \$1.75; solid rails, \$2.50.  
Shaft-jacks (M. S. & S.'s), No. 1, \$2.75; 2, \$3.25; 3, \$3.50.  
Shaft-jacks, common, \$1.40 a \$1.60 per pair.  
Do. tips, extra plated, per pair, 37½c. a 56c.  
Silk, curtain, per yard, \$2 a \$3.00.  
Slat-irons, wrought, 4 bow, \$1.12½; 5 bow, \$1.25 per set.  
Slides, ivory, white and black, per doz., \$12; bone, per doz., \$1.50 a \$2.00; No. 18, \$2.50 per doz.  
Speaking tubes, each, \$8.  
Spindles, sent, per 100, \$1.50 a \$2.50.  
Spring-bars, carved, per pair, \$1.75.  
Springs, black, 22c.; bright, 23c.; English (tempered), 26c.; Swedes (tempered), 30c.; 1½ in., 1c. per lb. extra.  
If under 36 in., 2c. per lb. additional.  
☞ Two springs for a buggy weigh about 28 lbs. If both 4 plate, 34 to 40 lbs.  
Spokes, buggy, ¾, 1 and 1½ in. 8½c. each; 1½ and 1¾ in. 8c. each; 1½ in. 9c. each.  
☞ For extra hickory the charges are 10c. a 12½c. each.  
Steel, Littlejohn's compound tire, 3-16, 10c.; 1-4, 9½c.; heavier sizes, 9c. currency.  
Stump-joints, per dozen, \$1.60 a \$2.25.  
Tacks, 9c. and upwards per paper.  
Tassels, holder, per pair, \$1 a \$2; inside, per dozen, \$5 a \$12; acorn trigger, per dozen, \$2.25.  
Terry, per yard, worsted, \$4; silk, \$9.  
Top-props, Thos. Pat. per set 62½c.; capped complete, \$1.38.  
Do. common, per set, 40c.  
Do. close-plated nuts and rivets, 75c.  
Thread, linen, No. 25, \$1.30; 30, \$1.45; 35, \$1.65, gold.  
Do. stitching, No. 10, 95c.; 3, \$1.15; 12, \$1.28, gold.  
Do. Marshall's Machine, 432, \$2; 532, \$2.30; 632, \$2.60, gold.  
Tufts, common flat, worsted, per gross, 20c.  
Do. heavy black corded, worsted, per gross, \$1.  
Do. do. do. silk, per gross, \$2.  
Do. ball, \$1.  
Turpentine, per gallon, \$2.25  
Twine, tufting, per ball, 35c.; per lb, 60c. to 75c.  
Varnishes (Amer.), crown coach-body, \$6; nonpareil, \$7.50.  
Do. English, \$6.25 in gold, or equivalent in currency on the day of purchase.  
Webbing, per piece, 55c.; per gross of 4 pieces, \$2.10.  
Whiffle-trees, coach, turned, each, 50c.; per dozen, \$5.50.  
Whiffle-tree spring hooks, \$3 per doz.  
Whip-sockets, flexible rubber, \$4.50 a \$6 per dozen.  
Do. hard rubber, \$10.50 per dozen.  
Do. leather imitation English, \$5 per dozen.  
Do. common American, \$3.50 a \$4 per dozen.  
Window lifter plates, per dozen, \$1.50.  
Yokes, pole, each, 50c.; per doz, \$5.50.  
Yoke-tips, extra plated, \$1.50 per pair.

TO SUBSCRIBERS.—Our friends who have heretofore left with us a standing order for the continuance of the Magazine until they direct its discontinuance, will please take notice that the present number is the third of another year's subscription to many into whose hands it now comes. While we return our heartfelt thanks for their constant patronage, and consequent encouragement, permit us to remind such as have not yet sent us the money for this volume, that our rules are **PAYMENT IN ADVANCE**, and that we expect to receive their remittances (\$5) before the next number is published. Please be punctual and oblige us. Office, 5 Ludlow Street, N. Y.





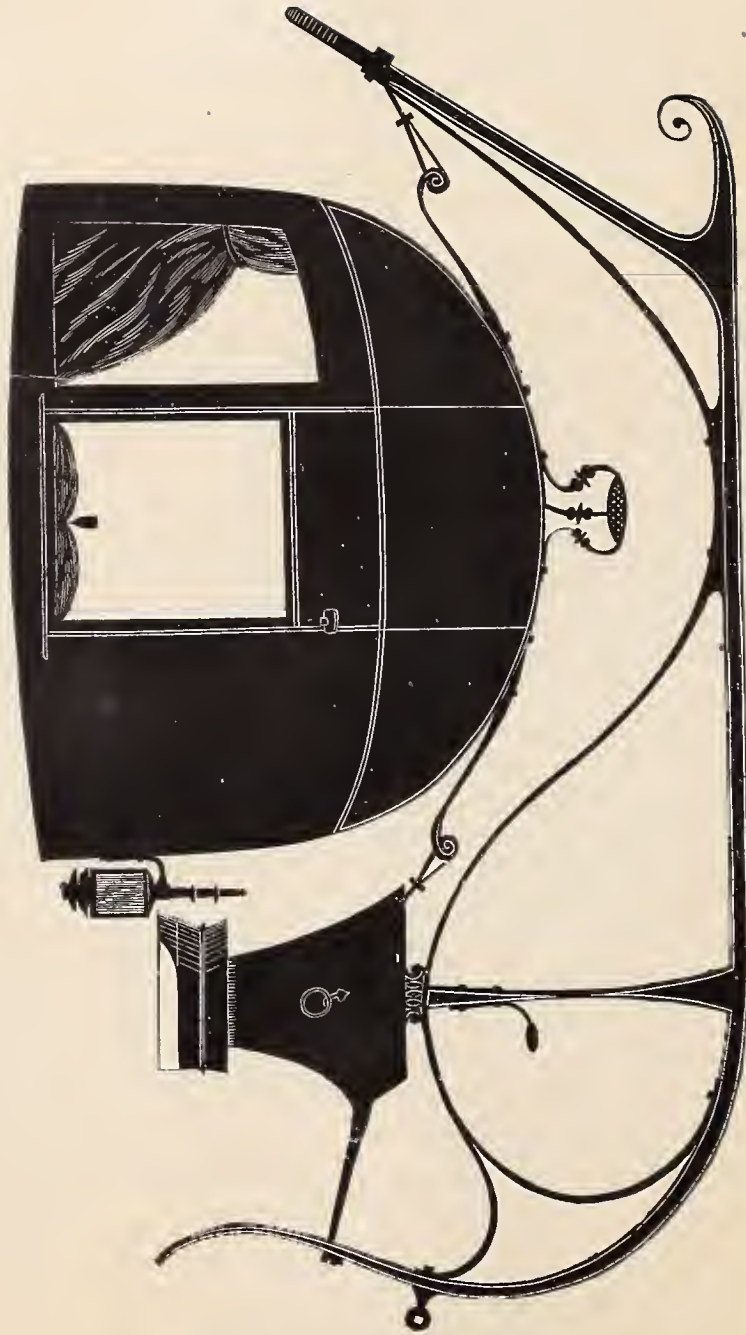

BOOBY-HUT.— $\frac{1}{2}$  IN. SCALE.  
*Engraved expressly for the New York Coach-maker's Magazine.*  
*Explained on page 56.*

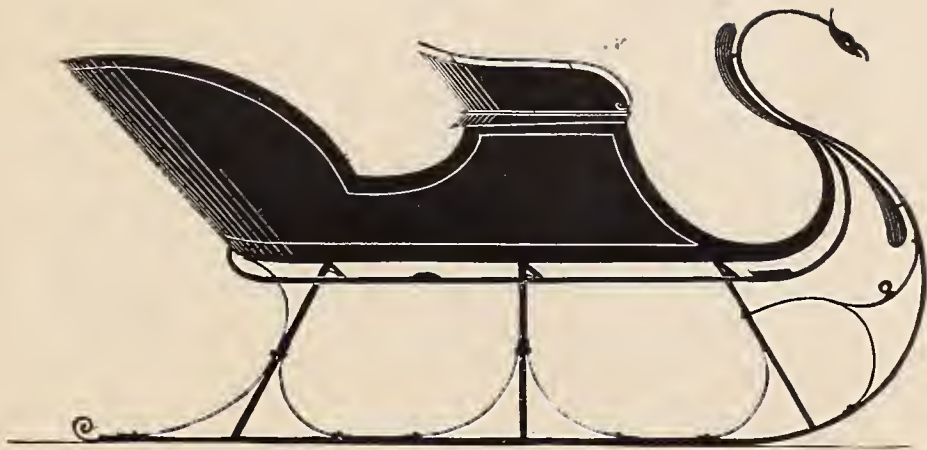

PONY SLEIGH.— $\frac{1}{2}$  IN. SCALE.

*Designed expressly for the New York Coach-maker's Magazine.*

*Explained on page 56.*



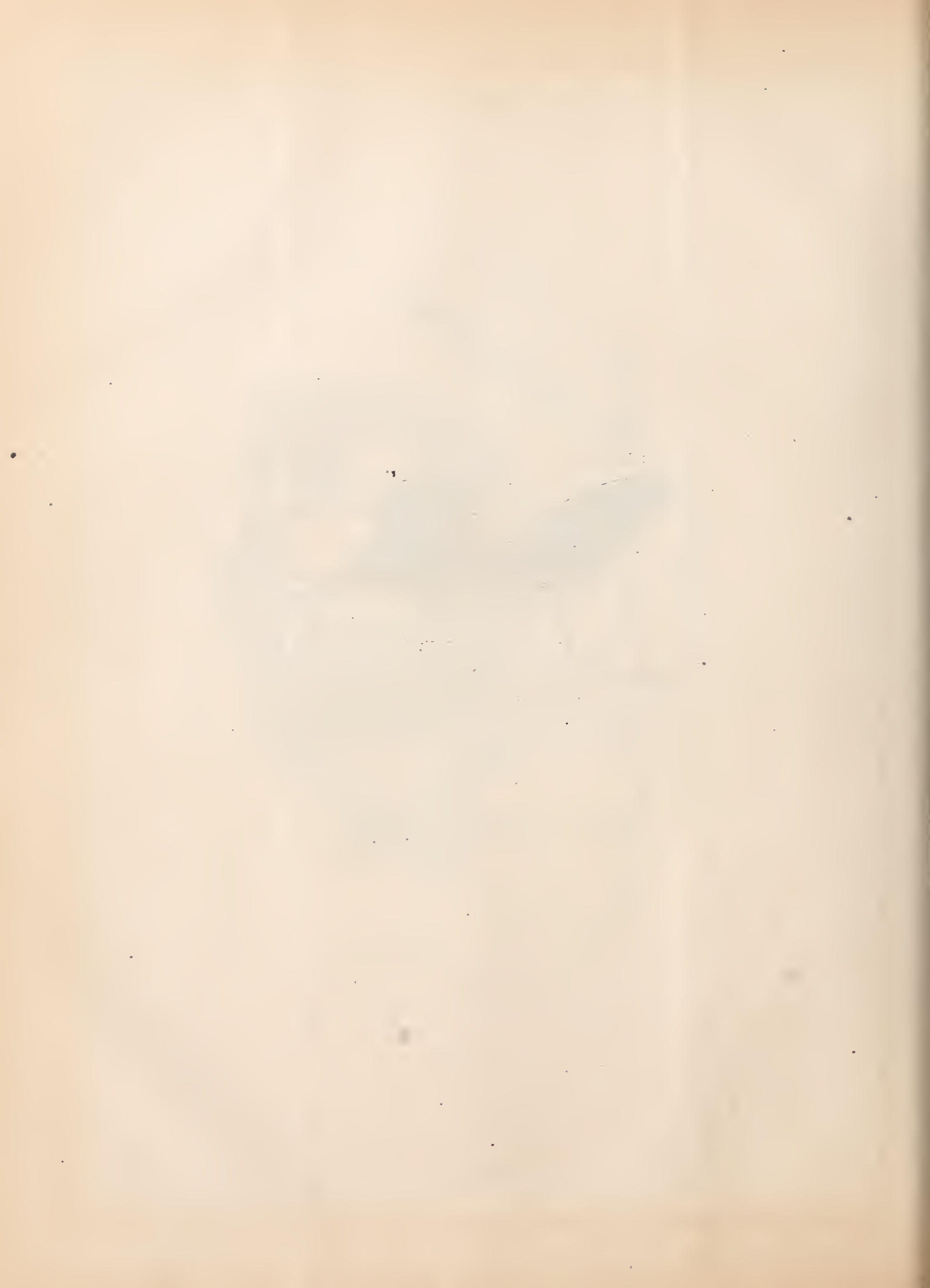





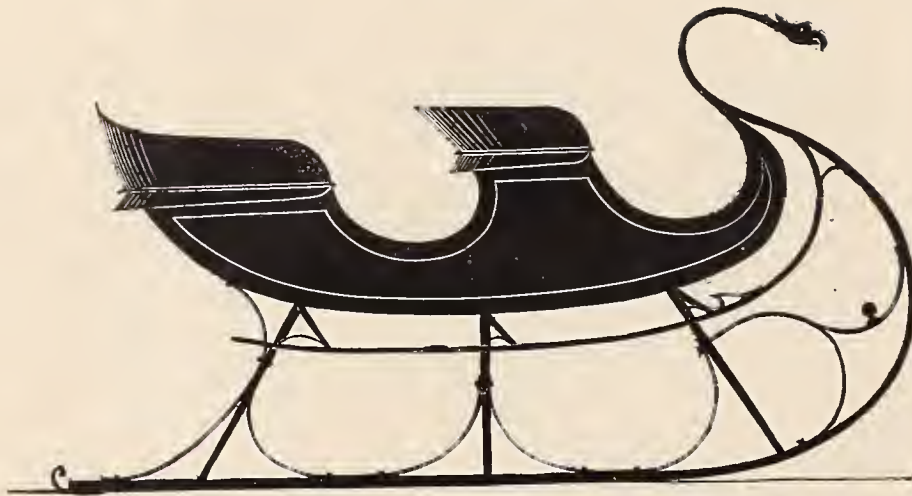

PONY SLEIGH.— $\frac{1}{2}$  IN. SCALE.

*Designed expressly for the New York Coach-maker's Magazine.*

*Explained on page 56.*

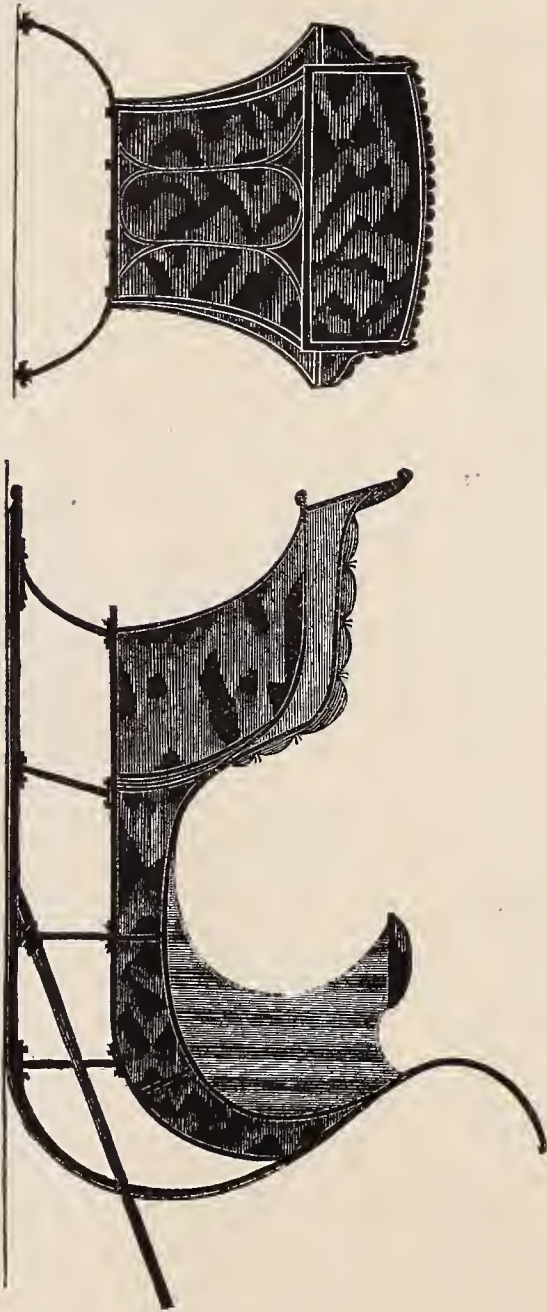

GERMAN SLEIGH (SIDE AND BACK VIEWS).— $\frac{1}{2}$  IN. SCALE.

*Engraved expressly for the New York Coach-maker's Magazine.*

*Explained on page 56.*







DEVOTED TO THE LITERARY, SOCIAL, AND MECHANICAL INTERESTS OF THE CRAFT.

Vol. VII.

NEW YORK, SEPTEMBER, 1865.

No. 4.

## Mechanical Literature.

### THE REVIEWER REVIEWED.

BY HENRY HARPER.

It would be expected, after reading Mr. Miles' bold denunciation against the prevailing effort to propagate "philosophic fallacies,"—"to make wrong seem right,"—"to develop mechanical abortions," &c.,—that in his reasonings he would at least steer clear of the thing of which he complains. For one, I am disappointed, and perhaps there are many others in the same condition.

To the scientific mechanic this subject—which are the best kind of wagon axles?—is an important one, affecting the whole community more than it does the individual manufacturer; therefore, any erroneous theory promulgated by the mechanic, should be controverted without hesitation. What Mr. Miles says about merchants in his vicinity—selling wrought iron axles at the same price that they do the rough bars—or about the Pittsburgh manufacturers discontinuing to manufacture them—does not affect the question in a mechanical point of view.

To the constant readers of *THE NEW YORK COACH-MAKER'S MAGAZINE* (which every wagon-maker who makes pretention to skill ought to be), the relative mechanical power that smaller sized axles have over the larger ones, have been so clearly elucidated, that it would be a waste of time to go over the same ground again; therefore, without any regard to what Mr. Miles' unmechanical neighbors may think of the subject, I shall only consider what seems to be set forth with the most prominence in the article on "Popular Errors,"—that is the improvement which he claims to have made on strengthening the axle.

Let us consider first, what he calls an "immutable law of nature,"—that is, that iron will sustain a greater strain lengthwise than it will laterally.

This result depends altogether on the amount of lever power that is thrown on to iron; not on the length or lateral direction of the iron. Thus in figure 1, let the line A be considered the middle of the axle on which one hundred pounds weight rests. Of this, fifty pounds would

rest on each extremity of the axle. Now, if we consider the wagon to be on a track of fifty-four inches, and the axle A to be one inch thick, the lever-power which would be concentrated from the extremities of the axle to the centre A, would be fifty-four times fifty from each end of the axle, which would make 5,400 pounds strain, drawing the under half of the axle apart, and a compression of 5,400 pounds pressing the upper half of the axle together. If the strain separated the under half of the iron, the fulcrum of the lever is changed so that it doubles the strain on the remaining amount of iron, and there is a

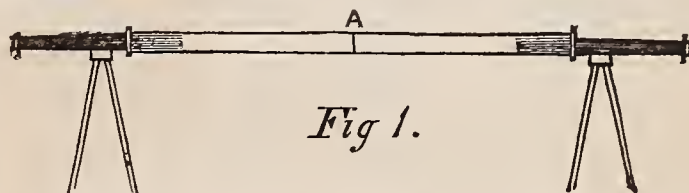

strain of 10,800 pounds lengthwise on the under half of the part which has been already weakened by the separation. The leverage will increase in the same ratio every time the original thickness of the iron is reduced. On the other hand, we lessen the lever-power, and consequently the strain, by increasing the thickness of the axle. Thus, if it is two inches thick, the strain would be one-half of the 5,400 pounds, and if three inches thick, it would be one-third of the same amount, and so on decreasing the amount of strain as the thickness increases.

Now Mr. Miles proposes to increase the thickness, by the use of the truss-stay (see Figure 3, on page 2), which is found of such use in the support of long stringers in every department of architecture. There is no doubt but what it would decrease the leverage of the strain just as many times as the distance from B to C doubles the thickness of the axle; but it by no means increases the strength of the iron as he supposes it will. It is merely an operation of lever-power, which can be mathematically calculated when the proportions are known.

The objection to his plan would be, that the stay reaching down, so near to the ground would be caught by stumps or stones, while the wagon was passing over them, disarranging the stays. Other objections might be enumerated, but this is enough, as long as the required reduction of leverage has been gained in another way, not subject to the above objection, or any other that I am aware of.



The required object is effectually provided for in the axle stock, which is securely fastened by clips or bolts to the upper side of the axle, so that it becomes a part of the axle. In addition to this, lumber-wagons have the hind bolster fastened so as to secure strength, freeing the axle from the lever strain. The compression of the upper half of the axle, comes on the top of the bolster, crowding it together, and the strain which draws it apart comes on the iron axle, which performs exactly the office of the proposed stays that reach so near to the ground. If the bolster reaches ten inches above the axle, one hundred pounds left on the middle of it would create a strain of 540 pounds towards drawing the whole iron axle apart.

Buggies are not so strongly fortified, but unless the usual plan is carried out by a working man who has never paid any attention to mechanical laws; or one who claims a divine right to "politely ridicule" mechanical principles, we do not see the "sorry spectacle" that Mr. Miles complains of when two men are seated in it, that is, a spring axle.

Mr. Miles lays claim to an improvement on wagon axles on account of the truss to the axle, as he has represented in the cut on page 85, Vol. VI., of THE NEW YORK COACH-MAKER'S MAGAZINE, compared with that which he presents in Figure 3 of his article on "Popular Errors." According to his own showing, it falls to the ground, for it is entirely devoid of the principle of the truss-stay, which he claims—and with very good reason to be absolutely necessary to the strength of an axle. His axle there represented, revolves with the wheels, and the stay cannot be applied to it. Neither can it be applied to the railroad axle. The latter, when compared with the ordinary wagon-axle, is positively defective in strength. One of them will weigh ten times as much as a two-inch wagon axle. One wagon axle of that size, will bear one ton on an ordinary road. A car axle, to be equal with its strength, should bear up ten times as much, and as they have four axles to a car, forty tons would be an equal load. I cannot give the exact amount of a load which is put on a car, but will venture to say, that ten tons would be the greatest amount ventured. If Mr. Miles' improvement equals that in proportion, then he has got the strength of one-fourth part of an ordinary wagon embodied in it. It would be gratifying for me to hear the man who ignored any principle in setting axles by gauge, state positively how much he gained in draught with his model wagon. I conclude that is not a strong point in his improvement, or he would have presented it more prominently.

The depreciation of the gauge for setting axles, which he hugs into his article, I sincerely thank him for—the gauge is founded on mathematical principles, and it is fun to see such men butt their heads against it. If it will not stand against their fallacious reasonings, let it go.

UNCLE SAM SELLING OUT.—Our Great Uncle, having kicked his rebellious children into submission, is now, tri-weekly, selling off his stock of horses, at the rate of 200 per day, to the highest bidder. Some good bargains have been obtained by the knowing ones in Gotham. Apparently very good horses were sacrificed for fifty-five dollars, and none on the day we attended the sale went higher than \$180. A Bull's Head robber would demand \$300 at least for one not as good.

## STREETS OF POMPEII.

In the fifth volume of this Magazine, we gave several examples of the carriages used by the people of Pompeii. As still further illustrative of the habits and customs of an extinct province of Rome, we are induced to say something more in relation to the carriage-ways. In doing this, we have in some measure, availed ourselves of the remarks of M. R. Phéné Spiers, recently read before the London Architectural Association, without, however, confining ourselves to what he says.

Pompeii, according to the historian, was destroyed by an earthquake in the year 63. In A. D. 79, a great eruption of Vesuvius took place, which covered the entire city with ashes. As many as eight layers of ashes and scoriæ have been counted over Pompeii, and it is only the lower one which has yet been disturbed. Excavations have been going on for one hundred and twenty years, and only about one-third of the city yet excavated. Tombs for the ashes of the dead were built along the sides of the public roads leading from, and frequented by the town's people: thus the Via Appia at Rome, is fringed on either side with tombs for upwards of thirteen miles away from the city. These have inscriptions on them according to the virtues and exploits of those buried there.

The walls surrounding the town have been traced throughout their whole extent. They are not more than two miles in length, and the space enclosed, about one hundred and sixty acres, is of the form of an egg, at the apex or smaller end of which is the amphitheatre. The walls are of great solidity and width. They had a double parapet and terrace, the latter about fourteen feet wide, sufficient to admit of two chariots passing abreast. It was environed by two walls, the outer one by a slight inclination, forty feet, and occasional flights of steps on the city side, to admit of easy access to the terraces. The walls are built of large blocks of *tufa* and *travertine*, in horizontal courses, with inclined joints; and in some of the stones are found Oscan inscriptions, so that these date, probably, from the formation of the city. The tombs are placed at intervals along the walls. The battlements seem to be of later date, being built in that kind of work called *opus incertum*, the noble work of the ancients. There are eight entrance gates, the five now facing the gate of Herculaneum being the most preferred of the three others.

The streets are for the most part straight, and run at right angles to one another; they are not wide, many of them not admitting of the passage of more than one chariot at a time, and probably these were not much used, taking into account the small extent of the city (only three-quarters of a mile in length and half a mile in width), though the deeply worn ruts in the stones would seem to indicate the contrary. The roadway is composed of huge polygonal masses of lava, from nine to eighteen inches in diameter, and nine inches in depth, closely fitted together; the stones were worked in a wedge shape, so that they spanned the roadway like a vault, each stone resembling the voussoir of an arch. All the streets have pavements for foot passengers, even those where chariots could not pass, consisting of curb stones of lava, with the pavement composed of bits of marble and stone set in cement, the whole rubbed flat; in places where the curb stones have broken away they



have been clamped together with iron. These foot pavements are elevated, sometimes more than a foot above the roadway; it is supposed that the latter, in times of rain (which falls very heavily in these countries), become a kind of sewer, as all the streets are slightly inclined one way or the other; and this supposition seems well founded, because there exist everywhere huge stepping stones from pavement to pavement, the wheels of the carriages and the horses (always two) passing on either side of the stone.

The way in which the solid refuse of the city was carried away is still a mystery, scarcely any traces of sewers having been found. Mazois gives us a drawing of one, the position of which he does not state; but it seems only to have served to carry the waters from the street under the walls to outside the town. It is just possible the streets may have been the only sewers, as they are still in some towns in the East. Though traces of aqueducts are found in the country around, it is not known with any great certainty from whence Pompeii was so plentifully supplied with water, there being no wells. A very large number of leaden and earthenware pipes have been found, the former of which supplied the numerous fountains which were placed in all the principal streets. They consisted of a cistern formed of blocks of lava clamped together with iron, the water falling into them through a pipe fixed in one of the back stones of the cistern, which rises higher than the rest.

The following reflections from Gautier may appropriately close this subject:—"Tired to death, the tourists who saw it yesterday [Pompeii] yet linger in their beds, and the morn that illumines the mummy city shines there upon no human face. Strange is it to see by her rosy and azure light this carcass of a city death-stricken in the midst of its pleasures, its labors, and its civilization, and which has not undergone the tardy dissolution of an ordinary ruin. You stand expecting that the masters of these perfect houses will come forth in their Greek or Roman dress; you listen for the roll of the chariot whose track is still upon the pavement; you look for the reveler to re-enter the tavern where his cup has marked a ring upon the counter. We walk in the past as though we were dreaming of it; we glance at the corners of the streets, and there an inscription in red letters announces the spectacle of the day. Only the day has gone by more than seventeen hundred years since!"

## HISTORY OF CARRIAGE WHEELS.

BY THE EDITOR.



AS our readers know, perform the most important office in all descriptions of carriages; and, therefore, everything illustrating their history must be deeply interesting to the public—particularly so to the carriage-making portion. Indeed, in modern days there is more vital interest and importance centered

in the wheel than in any other part of a vehicle, as every manufacturer soon learns on entering into business for himself. So very important it is to have wheels "stand,"

that upon "starting a shop" no effort or expense can be too great, if thereby a reputation—lasting as business life—may be secured. With knowledge in mind, it has always puzzled us to account for that strange infatuation which leads the carriage-maker in our times to sacrifice every mechanical law to the dictates of that erratic goddess, fashion. Where there should be the *most* strength, fashion puts the *most* weakness. Of all the great follies, taught by the same leader, this is the most foolish. But we did not set out with any intention of penning a practical treatise in the art of wheel-making, having already done this in the earlier volumes of this work; but, with the express design of presenting to our readers some thoughts relating to their progressive history.

Many speculative theories have been presented to the world, more or less plausible, respecting their origin. About all which we know with certainty is found in the fact, that the wheel and axle have been in existence for at least three thousand years; indeed, so old is its invention that its historical origin is buried in the *debris* of antiquity, while its mechanical power has placed it only second in the lists of six. We think its importance would justify its being placed first. Adams, in his history of "English Pleasure Carriages," makes a rolling log the inceptive idea for the framed wheel. A rolling stone is just as likely to have suggested the mechanical power hidden within, and perhaps more likely, since it was more readily obtainable for experiment. Presuming that one man's theory is of as much value as another's in a matter of this kind, we give a few speculations, and then pass on to notice the more authentic portions of history relating to this subject.

The annexed diagram may convey to the mind of the reader some idea of the inceptive origin of the conversion of the sledge to a wheeled vehicle. This

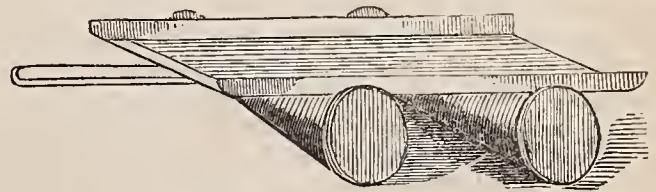

among the ancients was termed a *sycalæ*, and was employed in moving heavy columns, &c Aristotle has shown that this mode of conveyance has many advantages over carts with wheels and axles, and concludes that the axis impedes the progress by pressure in the hub. But to discuss this question here is foreign to our purpose.

In the infancy of the world, sledges are supposed to have been in general use, and that the wheel was an after consideration or contrivance. The author before referred to has indulged in a long speculation in reference to this very subject, but as these are not essential matters of inquiry here, we omit them, and merely state that whether the idea of a *rolling* wheel was suggested by a *rolling* log or some other object the fact is well established, that a framed wheel has been in use many thousand years. Indeed, contrary to the prevailing opinion of most persons, the bent rim (as distinguished from the sawed out felloe) was used at a very early period. Even the rotation of the wheel on an axle was known among the ancient Egyptians. Proof of this is seen in the illustration of an ancient chariot wheel on page 42, volume I, now



preserved in the Historical Society's building in New York. The hub of this wheel is not only nicely turned—apparently in a lathe—but is of sensible length to cause it to run steadily on an axle, a principle constantly ignored among us, and the spokes tenoned on both ends are worked out with much mechanical skill with a view to being ornamental. These last are six in number. The rim, although likewise in six portions, yet are evidently bent from straight timber and are rather skilfully lapped just where the point of the spoke intersects, in such a way as to give the greatest support to a naturally weak spot. The circle, doubtless used as a substitute for tire, contains all the principles evolved in the short-felly rimming of modern wheels, the whole when bound together forming a structure of considerable strength. This circle, which we take to be the part answering to the modern tire, is likewise divided into six sections, joined together by the use of mortise and tenon, known among modern mechanics as a male and female joint. But we have not space to enter into all the details, and must therefore refer those who would learn more about this wheel to our first volume, where they will be able to gratify their wishes to the fullest extent.

Although, as we have seen, wheel-making had made great advancement in Egypt at an early age, as the old wheel found in a mummy pit clearly proves, yet a very poor substitute has often been in use since among nations of less refinement. These have been of the rudest structure imaginable; some from cross sections of timber; others from planks sawn laterally. Even as late as our own times, wheels of this sort, as being cheaper, are in use in Italy, Chili, and even in China, the nation claiming to have a record running into a more remote antiquity than any other:

The wheel of an improved form would evidently be such as might be made from a wide plank, or two joined together and strengthened by cross-pieces, or batten. We are credibly informed by those trading to Buenos Ayres and some other South American States, that the carts and business-wagons of the natives have wheels of the rudest kind, the felloes—if such we may call them—being simply the rough branches of the forest trees, bored through for the ends of the spokes, put on and hewed a little at the ends to give them a form somewhat cylindrical, and yet after all, in the expressive language of an old sea captain, "they are neither round, square, nor oval." A wheel thrown together after this model is evidently the weakest at points where the strength is most required, as the accompanying illustration shows. This kind of wheel can only find favor among semi-barbarians, in a low state of mechanism.

The state of advancement in civilization may be readily seen by looking at the carriage wheels in any country. The more savage, if they have any, make them of the most diminutive size; the most refined, the largest. We have only to present this fact to the mind, to convince the most skeptical on this point.

The time when felly-rims arrived at perfection, or were adopted as we find now the case, has thus far escaped our research; but this evidently was many years ago. In the finer vehicles of antiquity the mechanic exercised (or tried to) considerable skill and taste in the formation of his spokes, &c. This, weighed by modern opinion, was not always with the greatest success either in taste or strength. Take, for instance, the old Roman wheel

here illustrated. The scientific mechanic sees at a glance

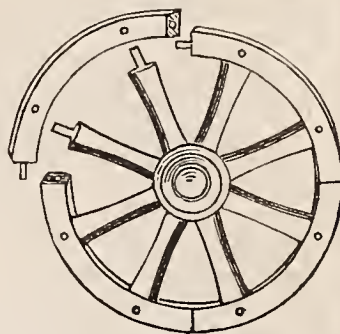

that the spokes are the weakest at the centers, a defect no one in our times will undertake to deny. Indeed, the modern spoke is just the reverse of the ancient one—stoutest, and consequently strongest, in the center. In another article we intend to extend our inquiries on this subject.

## AMERICAN DICTIONARY FOR COACH-MAKERS.

(Continued from page 23.)

- DOOR STYLES.** The middle rails, or framings of the doors.
- DOVETAIL KETCH.** A small iron ketch, fixed on the side of the door, to prevent it from settling. *Felton*, vol. i, p. 162.
- DRAGON TONGUES.** The peculiarly formed irons screwed into the ends of wooded whiffle-trees, to hitch the traces to, for drawing the wagon.
- DRAG-CHAIN.** A strong chain with a large hook at one end, to hitch on the hind wheel, and keep it from turning when descending a hill. This ancient drag-chain is now superseded by the Brake. See Fig. 23, vol. iv, p. 92.
- DRAG-STAFF.** "The staff is to stop the carriage, and to give rest to the horses when descending a hill; the chain (see *ante*) is fixed to a hook about the middle of the perch or crane, with a hook or shoe at the end for the wheels; the hook is more handy for use, but the shoe is preferable, as it preserves the iron of the wheel from injury, when dragging on hard strong ground; the chain being covered with leather, prevents it from rattling; the drag-staff is fixed nearer the hind part of the carriage, with jointed iron-work, and is made of strong ash, with iron ferrules on the ends, and a spike at the bottom, to make it hold secure in the ground; they are both fastened up with straps when out of use." *Felton*, vol. i, p. 221.
- DRIVING CUSHION.** A cushion made expressly for the accommodation of the driver; generally deeper so as to elevate him the higher.
- DROP-BOTTOM.** This portion of the body among American coach-makers, is usually termed the "sunken-bottom," and is that part *dropped* below the framing, to give more leg-room, and avoid heavy appearances at the same time. Some call it a rocker, properly so, as it assimilates to the shape of the cradle rocker.
- DROP HANDLE.** The handles of carriage doors, which droops or drops. Door handles are distinguished as the "stiff" and "drop" handles.
- DROP-SEAT BOX.** [*Not in use.*] According to *Felton*, "a box which is made to hang between the seat rails to carry luggage."

E.

**EAR CUSHION.** A muff-shaped, hair-stuffed, leather or velvet-covered article, suspended in the back corner of a coach to rest the head against.



**ELBOW.** (Sax. *elnboga*.) The arm-pieces on which the fixed cushion is raised for resting the arms, sometimes called "the resters."

**ELBOW CASE.** A cavity formerly made in the inside of the body, at the "elbow" part, for carrying bottles, and other conveniences, in such carriages as were intended for long journeys. In these days of railroads they are not required.

**ELBOW-RAILS.** (American, *arm-rails*.) The middle part of the framing to a coach or chariot, and the upper part to a chaise or phaeton body, on which the elbow rests. Inside elbows are projections within the body, for the elbow to rest on." *Felton*, vol. i, p. 12.

**ELBOW SPRINGS.** The original prototype of the elliptical spring, in use seventy years ago. The single elbow-spring is known now as the cradle, or grasshopper spring.

**EMBOSSING.** Raising figures in relief, in leather. [Nearly gone out of fashion.]

**ENAMELLED CLOTH.** Unbleached cotton cloth, (duck, &c.), coated with a mixture, the principle ingredients of which are linseed oil, lamp-black and turpentine. For particulars, see vol. vi, p. 134.

**ENAMELED LEATHER.** This leather is commonly made from calf, sheep-skins and the *green* hides. For particulars about the preparation, the reader is referred to vol. vi, p. 109.

**ENGLISH POLE PIECES.** This is the original name for pole straps among the English. *Felton*, vol. i, p. 212.

## F.

**FALLS.** (Sax, *feallan*.) That portion of the lining of a carriage seat which drops down in front, or hangs loose from the seat.

**FALSE LINING.** Another name for "slip-lining." A linen cover intended to hide a soiled carriage lining, or to preserve it clean.

**FANTAILED BODY.** In contradistinction to the "tub-body," which see, *ultra*. Bodies having the lower corner of the back in the shape of the swept edge of a fan; like the end of birds' tails. *Very seldom made now.*

**FELLY.** (Saxon, *fælge*.) The divided parts in the rim of a wheel. In earlier times the small part of a circle fixed on the futchells of a carriage, to support the half or full fifth-wheel, was termed a felly also. See *Felton*, vol. i, p. 110. The American custom of spelling the word "felloe," would seem to be altogether incorrect. See RIMS, *ultra*.

**FELLY BAND.** A band used to cover the joints where bent rims meet in a carriage wheel.

**FELLY PLATE.** The plate applied to the joints of rims, and used for the same purpose as felly or rim-bands.

**FENCE.** (Fr. *reboter*.) A rubber round the edges of the lights, to prevent the weather [water] getting between it and the glass or shutter-frame. *Felton*. We have never heard it so termed among us.

**FIFTH-WHEEL.** The technical name for the circle immediately surrounding the king-bolt; that portion which allows the fore axle to cramp or turn. The word is ignored in all the vocabularies, and this probably has led many "outsiders" to deny its existence, and say, by way of illustrating the uselessness of a

thing, "as useless as the fifth-wheel of a coach." The facts are, *we* know it is the most necessary thing in a pleasure-carriage; that without it a carriage would be comparatively useless.

**FILLET.** (French, *fillet*.) As applicable to coach-making in former times, this word meant a narrow painted border, never exceeding an inch, used in ornamenting a panel.

**FOOT-BOARD.** That portion of the front of a body on which the feet of the driver rests, or against which they brace.

**FOOT-BOARD LEDGE.** The strip of wood nailed or screwed to the foot boards, against which the driver's feet are placed when mounted on his box.

**FOOTMAN CUSHION.** A wooden frame stuffed and covered with stout leather, to ease and elevate the servant behind the carriage. *Felton*, vol. i, p. 123.

**FOOTMAN HOLDERS.** The laces with tassels hanging on the outside (back part) of a carriage, by which the footman steadies himself. Among us it is "more for ornament than use," and probably will soon fall into disuse altogether.

**FOOTMAN STEPS.** The iron steps fixed to the hind part of the carriage for the convenience of the footman in mounting. Seldom applied to an American carriage.

**FORE-BAR OR BLOCK.** An ornament fixed on the top end of the fore hooping piece, supporting the boot or budget in the middle of the front to which it is bolted, generally united to the side-blocks or raisers of the boot. [Not now used.]

**FORE-CARRIAGE.** The under portion of a no-perch carriage to which the front wheels are attached. This term can only be properly applied to *four-wheeled* carriages, in contradistinction to the *HIND-CARRIAGE*, which see *ultra*.

**FORE-PILLARS.** The front corner pillars of coupés, chariots, and such like carriage-bodies.

**FORE OR FRONT RAILS.** The rails framed across the front ends of bodies to *tie* the sides together.

**FORE TRANSOM.** The timber which crosses the perch, on which the springs are placed, and through which the centre pin or king-bolt passes to couple the upper and under portions of the fore-carriage. Only applicable or needed where two springs are used in front in hanging up the body. By some improperly called a bolster. Transom is from the Latin word *trans*, over, across,—that is, extending across;—whereas, bolster is a purely Saxon word, meaning to hold up or support something. Conceding that the bar under consideration does *bolster* up the springs it supports, still, its primary use is to carry them over to the outsides of the body.

**FRAME HEAD.** The head of a chaise or phaeton, made on an iron frame, for the purpose of taking off occasionally. *Felton*, vol. i, p. 98.

**FRENCH BASKET-WORK IMITATIONS.** These basket-work imitations are produced by machinery in mahogany, and used for panels of carriages. They were formerly imported from France at a high price; but are now made in New York, and sold comparatively cheap.

**FRINGES.** The fringes used in carriages are distinguished as bullion, festoon, and carpet. The festoon soon went out of use. An illustration may be found on page 11, vol. v, of this Journal.



**FROGS.** An ornamental device of wood and silk, made to set off lace holders in lining carriages.

**FUTCHELLS.** Crooked timbers framed through the front axle, intended to receive the back end of the pole, and support, in some instances, the fifth-wheel. In some portions of the United States they are termed "hounds," probably from the fact that they, in some respects, resemble the projecting parts of the head of a ship's mast,—in nautical language termed *hounds*.

### CAPITAL AND LABOR.

WE are glad to see that the workmen at different trades and handicrafts are meeting together extensively to discuss their interests, and are taking council one with another. The question of wages, the question of hours of work, the question of apprenticeship, the question of the relations of labor and capital, and other questions, temporary and permanent, will all be helped to a satisfactory solution by wise discussion, and by a comparison of views and notes on the part of all concerned. We think it would be well if those Societies and Unions which are composed mainly of the working craftsmen, would secure the attendance at their meetings of those who are employers, "bosses" and capitalists. Many misunderstandings would thus be prevented, many mistakes corrected, many theories tested at both ends. It seems from the proceedings of some of these societies that many of their members cannot get out of their heads the notion that capital is everlastingly and necessarily at war with labor, that employers are the natural enemies of the employed, and that it is the duty of one to organize for perpetual resistance to the other. It is curious enough that such opinions should exist in this country; but that they do, it needs but that one should attend any of these trade meetings to be satisfied. Freedom of discussion, however, if it be permitted, and a comparison of views between employers and employed, if it could be had, would soon rectify all such damaging errors.

The meeting of the "Journeymen Horseshoers' Protective Union, held on Monday night, deserves commendation for the freedom of argument on these points. It was addressed by the President of the Horseshoers' Association, the President of the Plumbers' Association, the President of the Plasterers' Association, and the President of the Painters' Union. One of the speakers "eloquently" delivered himself of the old absurdities concerning the enmity of labor to capital, the anxiety of capital to crush labor, etc., etc., and announced that "the capitalists were about to put forth their strength this Winter to crush down the workingmen's associations." Another of the speakers, however (Mr. McDermott, President of the Plasterers' Association), had clearer and sounder views upon the subject, and it is only by such intelligent discussions on the part of intelligent men that the members of these societies can be benefited.

"We fall into a grievous error," said he "by abusing capital and capitalists, and calling them hard names. All this abuse never amounts to anything. Capital is as necessary for us to live as the air we breathe. What creates labor but capital? And in the same manner labor is the parent of capital. Nothing on earth is valuable to man until the stamp of labor is imprinted on it. Now, a mania for strikes pervades all organizations. No sooner

is a society formed than its members, without ever asking themselves if they owed any duties toward employers, at once wish to announce its existence to the world by a strike. Societies possess rights which they should unflinchingly maintain, and owe rights to the employer which they should never refuse. Wages are like the ocean—thus far and no further can they go. Suppose a strike succeed, what then? One strike puts up prices in every branch of business, and, of course, reacts on labor. Rather let us profit by experience; keep wages at a certain level and preserve our moral character. That is enough for any workingman's society to attend to. Let each man be proud of his vocation, and commune with his fellow-workmen about everything relating to it. Disorganized, how can we know anything about our trade, about the state of the market affecting it? Organized, we learn the exact statistics of our respective trades, and regulate our ways accordingly. A certain class of growlers and quarrelers in societies force them to adopt arbitrary measures into unjustifiable strikes, and then they are the very first to back out, when brought face to face with the consequences of their rashness. Growlers are the drones in the workingmen's hive; they are ever snarling at the measures of others, ever complaining of cliques, ever breaking up confidence in a society."—*Times*.

### COACH-MAKING IN AFRICA.

CAPTAIN LYONS has given an odd narrative of an attempt at coach-building by a North African potentate, the Bey of Fezzan. "I was consulted," says the Captain, "respecting the construction of a real English coach by Mukni, and I solemnly promised him that, if he could manage to procure as good wood as must be used for the purpose, I would induce Belford to make it, while I would train four horses to run in it. I anticipated much pleasure and great amusement in this new occupation, for I knew no more of coach than of house-building. But I had nothing to do, and so I was foreman over Belford in constructing a coach for old Mukni. Belford set to work with an old shibbia and some boxes, and with these he made a body six feet in length, three in breadth, and four in height. This was the commencement of our carriage. This we covered over like a higgler's cart, with an arched top, and we put in something a little like a door behind. At all events, it opened and shut, though it must be confessed that, when it was closed, it had a tendency to remain so, and while, if open, it took unheard-of objections before it was quietly latched. But Mukni, when he saw this door, was disgusted. His argument was that the door had been made for him to enter the carriage, but it was large enough for a man bigger than himself to enter at. Therefore he contended that though the vehicle was made for him, it had the appearance of being made for somebody else, and this apparent fault too cruelly hurt his dignity. Well, we set to work again, and this time we made the precious door so narrow, that Mukni had to be helped and pushed into his state carriage, and his Majesty, in descending from that vehicle, had to be shot out like a troublesome sack of coals. However, the Sultan found the new arrangement very much to his satisfaction, and so we did not find it interfere with ours. The body of the carriage being completed, and springs being quite out of the question, it was mounted on two very strong poles, which actually we called the shafts, and to these



precious shafts we fixed two wheels from one of our field-pieces, so that the carriage stood about three feet from the ground. We got on pretty well, but should have done better had his Majesty the Sultan been kind enough to keep away a little time. But this he resolutely refused to do. From first to last his eye was on that precious carriage. Nor was this all; he took a mad, an unspeakable delight in trying it at every stage, and was pushed into the vehicle and shot out of it again so many times, that I hesitate to publish the number, and therefore leave the figure to look after itself. His delight at its progress was immense; and as toadies are to be found the world over, all the courtiers about his Majesty were in raptures of delight, and continually poking about Belford and me, and asking the most rapturous questions. I could not state how many times I was asked if our carriage was not an exact model of that in which the Queen of England rode with her crown on. I really could not say yes; for though Belford and I had done our best, and though, considering we had nothing with which to do any part of our work properly, we had worked wonders, our manufacture very much resembled a donkey-trap. However, the rapture rose to an unspeakable height when we covered it with red serge and put a feather bed on its floor. In order to throw up the red still more, we painted the body, shafts, and wheels of the very brightest green we could find; but as this performance was in distemper, I am afraid the bright green did not last long. Mind, we had tried oil, but the failure was awful; the green was verdigris, and part of our stock we mixed in the first place with olive oil; but I do not think that oil ever would have dried. The King's patience was soon exhausted, and he had the color violently rubbed off with dry grass, he himself assisting at the operation, and coming away from it with the air of having taken a dive in a duck-pond, and come up all the better for the weed on its surface. We then applied the distemper color, made with vinegar, and certainly the effect was as awful as the delight of his Majesty was great when that potentate discovered the paint was as dry as a bone. It answered his fondest expectations. The carriage was now as gaudy as even the Sultan could wish, and he became the sole and delighted possessor of this marvellous machine. But unfortunately his Majesty could not use it. He could be pushed through the narrow door into the carriage, and then be pushed out again, and there was an end of the matter; for the fact is that we had forgotten to make a seat for the driver. The Sultan was nearly reduced to despair, and he had cursed me very much indeed when I hit upon a plan; it was to convert the machine into a gig, or rather something like one in the eyes of his Majesty. Accordingly, a jack of all trades amongst my men, a very ingenious fellow, for Belford had given up the entire business in the very blackest of despair, made, under my weary directions, a set of harness, which he turned out of hand tolerably well, if I except that the *little* pad on the horse's back weighed forty-nine pounds and a half. However, we tried again and reduced it to twenty-five, when I came to the conclusion that we were about as near perfect as we should be without a practical coach-maker to help us through the difficulty, of which I was getting heartily sick; and, indeed, I had felt several mad determinations to make an end of the affair by converting the machine into a bonfire, and swearing it was an accident, and I was only saved from this performance by the feeling that his Majesty

would have vengeance upon somebody, and in all probability have off the head of some obnoxious courtier as some kind of a comfort under such trying circumstances.

"So far so good; our harness was complete, but unfortunately we found that when a horse was put in the shafts, the carriage was so low as to form at least an angle of twenty-five degrees to the ground, and that, consequently, were the wretched Sultan lying back in his state carriage, his Majesty's head would be about a foot below both of his Majesty's feet. His Majesty, however, got over this difficulty in the most seraphic manner, by deciding upon turning about and lying with his head to the horses. However, at the very first go off at a trot, his Majesty was immediately shaken down to the lower end of his carriage, where he remained kicking and uncomfortable to the end of the drive, but a great deal too dignified to utter a sound, or call for the least help, though he must have been nearly stifled. After this first attempt Mukni proved to us that had he been born in England, and an Anglo-Saxon, he would, by his perseverance and brickiness, have conferred an honor on the land of his birth. He would not give in, and he would use the carriage. I could suggest no improvements, and, indeed, I felt that all along the more the machine had been meddled with the worse it had grown. The Sultan, therefore, hit upon this happy expedient: he was tied up to the front of his carriage after he had lain down, and so became comfortable, as I suppose, for he always seemed, after the date of this application quite to enjoy his rides, in many of which he indulged in the space near our encampment. On each occasion the awful machine came rumbling and rolling along under the exertions of a number of slaves, who seemed almost dead with the exertion of pulling our manufacture along. At last his Majesty determined to venture upon a ride into the country with his horse to draw him. The animal, being put into the vehicle, took the alarm, I think it was the light green and the bright vermilion. However, he submitted, and the horsed vehicle was slowly led through one little gate to where Mukni stood. Suddenly the horse bolted. The thing was altogether too much for him. The man who was holding his head let go (he lost his own head that very day for his negligence), and off the carriage was borne at a tremendous speed. A gate, however, soon stopped the run, and the wheels being good, down went one of the gate-posts and a part of the wall, while the carriage bore the shock bravely. This proof of its strength—and, truth to tell, it was the only good quality it had—delighted every one. But the Sultan would allow his beloved vehicle to suffer no further dangers of that kind, and, being a man of genius who was not to be deprived of his dignity, he abolished the horse, and patronized a mule, on whom, on all occasions, *two* of his Majesty's subjects were to sit, with strict injunctions whenever the mule showed the least peevishness, to jump up and down on his back, and so *bump* him into submission. With this arrangement his Majesty was perfectly satisfied, and so was I, having grown heartily sick of carriage-building. When we left Mukni's territory his Majesty was present in his carriage, and the very last we saw of the equipage was the two attendants bobbing up and down on the mule as though they were at sea, the animal having kicked about, owing to the cheers my men, and especially myself, had thought fit to indulge in, while his Majesty held on like grim Death, deplorably shaken I felt sure, but, I was



equally certain, determined never to give up the use of the machine till either he or it came to a final end."

## Pen Illustrations of the Drafts.

### THE BOOBY HUT.

*Illustrated on Plate XIII.*

This family sleigh, called by the Bostonians a Booby Hut, is a great favorite among them for winter sleighing. The running part, although not new, possesses novelty sufficient to recommend it to the greater portion of our readers. The body—as some might suppose—is not an extemporized affair from some family carriage, but is generally made expressly for the purpose, much cheaper than the ordinary coach body, and trimmed with less expensive material. The boot panel, as shown in our engraving, is an addition made by our friend, Mr. C. Thomas. We saw, in our late visit to the "Hub," several "turnouts" of this kind stored away awaiting the advent of King Frost, when no doubt these notions will leave their hiding-places and once more be found among the merry crowd which, during good sleighing, line the celebrated "Neck." What can equal a sleigh-ride for wild excitement, delight of ear and eye—aye, of heart and soul, if you are young and have the one for whom you would barter so much nestling beside you, with her rosy face beaming from sable boa and shaggy buffalo-robe. In such case, if your horse is swift, you can shoot ahead of the party, and while the glittering meadows are made radiant by the full moon or glow with purple, crimson, and gold, as they reflect the mystic Aurora, you may well feel all that one has sung of this rarest experience of the poetic Northern life :

### THE SLEIGH-RIDE.

Hark! the jingle,  
Of the sleigh-bells' song!  
Earth and air in snowy sheen commingle;  
Swiftly throng,  
Norseland faucies, as we sail along.

Like the maiden  
Of some fairy-tale,  
Lying, spell-bound, in her diamond-laden  
Bridal veil,  
Sleeps the Earth beneath a garment pale.

High above us  
Gleams the ancient moon—  
Gleam the eyes of shining ones that love us;  
Could their tune  
Only fill our ears at Heaven's noon.

You and I, love,  
With a wild delight,  
Hearing that seraphic strain would die, love,  
This same night,  
Straight to join them in their starry light!

Closer nestle,  
Dearest to my side:  
What enchantment, in one magic vessel  
Thus to glide,  
Making music, on a silver tide.

Jingle! jingle!  
How the fields go by!  
Earth and air in snowy sheen commingle  
Far and nigh;  
Is the ground beneath us, or the sky?

Heavenward yonder,  
In the lurid North,  
From Valhalla's gates that roll asunder,  
Red and wrath,  
Balder's funeral flames are blazing forth.

O, what splendor!  
How the hues expire!  
All the elves of light their tribute render  
To the pyre,  
Clad in robes of gold and crimson fire.

Softly fusing,  
Every color rare,  
Half its own prismatic brilliance losing  
Grows more fair,  
Blending with the lunar glory there;

Even so, love,  
All my yearning heart  
In ethereal passion is a glow, love,  
And thine art  
To its hues new luster shall impart.

Jingle! jingle!  
Let the earth go by!  
With a wilder thrill our pulses tingle;  
You and I  
Will shout our loves, but aye forget to sigh.

### PONY SLEIGH.

*Illustrated on Plate XIV.*

WE present this as being an original design of our own, trusting that it will meet the approbation of our readers. The round corners to the seat and body are in harmony with the prevailing style of carriage construction. For the proper dimensions in building sleighs, see below.

### PONY SLEIGH.

*Illustrated on Plate XV.*

LIKE the preceding, this also represents an original design for a pony sleigh. The dimensions of sleighs of this kind may be given as follows: track about 3 feet 3 inches apart. The front ends of raves should be left about 6 inches wide, and the back 9 inches; thickness 1 inch. After bending, saw them apart, when you will have a better opportunity of forming a swept-back. Place your body raves from 2 feet 8 inches to 2 feet 10 inches apart on the beams, giving them a side swell 7 or 8 inches. The remaining directions are left to the practical workman.

### GERMAN SLEIGH.

*Illustrated on Plate XVI.*

This singular looking drawing we find in a German work devoted to carriage-making. It possesses some peculiar features, recommending it as a subject for study, although, as we think, far behind our graceful designs in both design and convenience. We re-produce it for the sake of variety.



## Sparks from the Anvil.

### AXLES—AN ENGLISH NOTION.

A GENTLEMAN of the name of Rydill, at Dewsbury, England, has communicated to *The Engineer* his ideas of improvement in axles. It is to place on the part subject to wear—in other words, the rubbing surface—on each side thereof, a nut or convex projection in form of a wheel, about three-parts of an inch in height, and one or two inches in thickness or breadth, this projection to form a solid, immovable mass to form part of the axle. On the outer periphery of this convex projection he places the half of a concavity absolutely of the same dimensions in the interior as the projection; this is to be fixed firmly by its two ends to the second angle fixed to the springs, or to the side framing of the carriage; next he places the lower half of the projection on the movable axle on the other half of the concavity, and attaches or fixes them by the two ends, as directed in respect to the first moiety. By this arrangement he expects to diminish at least one-third of the rubbing surface in the axle and box, and fix in the most secure manner the carriage to the movable box, without danger from lateral or other shocks. To facilitate the lubrication of this movable axle, there is to be an opening in the upper convex part, so that should the carriage be heavily loaded, still it could be easily lubricated.

It is evident that this improvement is peculiarly applicable to carriages running on straight or slightly curved roads, but to render the system applicable to all kinds of road, he proposes to add the following arrangement to the ends of the axle, in the nave or box of the wheel. With the part of the axle entering in the nave of the wheel, he makes a screw, with its end firmly fixed to the nave, and then makes a channel for the screw. Mr. R. observes, that the box need be no longer than is necessary to allow the formation of this channel for the screw. At both ends of the axle there is a small square end, destined to receive a nut secured in position by a pin. The reason for placing this nut is, that it stops any excessive unscrewing of the wheel, and prevents its leaving the axle. It also prevents the channel of the screw from being driven in, and consequently broken. The wheel being fixed upon the axle, and the nut in its place, he covers the end with a cap to hide the said nut and pin. The arrangement will, in turning, permit the wheel on the inside of the curve to unscrew of itself, and either to remain still, or, better, to turn slowly while the opposite wheel advances to obtain this result, a right and left hand screw must be used. The wheel will operate without shock if care be taken to leave the screw to work easily in its channel. He adds, without fear, the screw forming the end of the axle to stop the wheel, or hinder it from making four or five turns, according to the length of the screw channel. The turning finished, the unscrewed wheel resumes its course, the screwing and unscrewing taking place mechanically or without assistance.

### CASE-HARDENING.

Put the articles required to be hardened, after being finished, but not polished, into an iron box in layers, with animal carbon, that is, horns, hoofs, skins, or leather, partly burned, so as to be capable of being reduced to

powder, taking care that every part of the iron is completely surrounded; make the box tight with a lute of sand and clay in equal parts, put the whole into the fire, and keep it at a light red heat for half an hour or two hours, according to the depth of hardened surface required, then empty the contents of the box into water, care being taken that any articles liable to buckle, be put in separately and carefully, end in first.

## Paint Room.

### A PAINTER'S MEDLEY.

RECIPT FOR BODY COATINGS.—The following has been recommended for filling-up stuff: Take about four pounds of keg-lead, ground in oil, then add two ounces of japan, without shellac, a small portion of lamp-black, light or dark, according to fancy, and then thin the whole with turpentine. Four coats of this will be sufficient to fill up, when put on a good ground work of lead color. In the priming coats, use more oil in proportion than in the above. An article of English filling is better for those willing to go to the expense of purchase. Where time is an object, such will be found the cheapest, as a job can be hurried through quicker.

PAINT PEELING.—Various theories have been presented, going to show why paint peels off. Some of these look plausibly enough to the unpractised mind, but do not bear the test of experience. Some examples are, doubtless, caused by the action of the atmosphere, some from bad cleaning, but much more from using too little oil in the preparation of the coatings. Turpentine, or even japan, have not the adhesive qualities which oil has, naturally, and when, with this deficiency, their superior drying qualities are considered, we have at once the solution of the whole question. The quick drying properties of turpentine and japan do not give the different coats time to *fix* themselves to each other, and, of course, they must in time separate. It is evident that painting cannot be well done in a hurry.

ABOUT BRUSHES.—Much depends upon the brushes a painter uses on his work, not only the shape and size, but in the material of which it is made. Instead of camel-hair, the most approved for body-work are those made of fitch-hair for varnishing. The camel-hair brush does very well for spreading the under coats, but requires skill to succeed in spreading the paint evenly. The bear-hair brush is a favorite with many.

FINGER MARKS.—In hanging up bodies, it is next to impossible to avoid marring the beauty of the varnish, especially where the varnish is "tacky." To entrust this business to the blacksmith is sufficient to insure his *sign manual* in bold outline on the glassy surface. Premising that in all cases "prevention is better than any cure," yet where the mischief has been done, the "water cure" may prove beneficial. In applying the water, use a sponge very lightly, and dry the parts saturated by using a chamois skin immediately thereafter. In some instances the entire job will require washing to obtain a uniform beauty for the job. Even this last resource, if it accomplishes its purpose, will prove economical, generally.

CLEANING STICK SEATS.—In some parts of our extensive country, stick seats are still in fashion, although long ago "played-out" in our large cities. For the benefit of



those of our readers who are "behind the age," we give the following instruction: Rubbing off with sand-paper is a hard and tedious job. A more expeditious and effectual way is to use a long, narrow strip of coarse cotton cloth, by wrapping it around the stick, and then drawing it one way and then the other, by alternate hands. When this is rapidly done, it softens the paint on the stick, and suffers the cloth to reduce the surface to the proper smoothness very readily.

**POISON vs. POISON.**—We all know that what is called the painter's colic, is a very bad disease. Whether the following vile prescription will cure it, is more than we can say. The remedy may be more fatal than the disease; we present it for what it is worth: A late writer recommends every painter or varnisher to chew tobacco, while spreading white lead and its kindred poisons. He says: "It is the most powerful check to a substance acting to produce spasms by suspending the muscular action in the stomach. In short, tobacco possesses, in this respect, the advantages, without the danger, of opium, and has been found of the greatest service to persons using paints which contain poison. At the same time, persons who use it for the purpose I have here stated, should be careful not to indulge in the practice too freely, for the excessive chewing of tobacco will not only occasion a feeling of stupid languor, which unfits a man for exertion, but may, in time, bring on a disease almost as much to be dreaded as the evils which it is intended to guard against." We think a better remedy will be found in our "Gossip for the Paint Shop," vol. iii, p. 34.

(To be continued.)

### SPIRITS OF TURPENTINE.

WE have heretofore mentioned that our Canadian neighbors had undertaken the manufacture of spirits of turpentine from the pines found growing in their forests. This, the *Trade Review*, says, has appeared in our market, and observes that it "is very different from the Wilmington; it is not equal in any respect, and is more properly a spirit of Tar Wood or Naptha. This is sold at \$1.20 in this market, and meets with ready sale. For the ordinary uses of turpentine, this spirit, which is distilled from the wood and roots of the pine, will, no doubt, be useful; but for the manufacture of varnishes and paints, it will never come into general use, as its want of uniformity of strength and of specific gravity will render its employment inconvenient, and frequently will occasion serious loss. The Wilmington turpentine has peculiar properties as a solvent and drier, which will always render it the best to use."

In answer to the above, a Canadian cotemporary observes that not all the turpentine made in Canada is from the wood and roots of the pine, but that "Mr. Irish, of Brighton, taps the living tree for the gum, the same as in Carolina, and from it obtains the spirit of the resin: Messrs. Connell & Cotter, of Hastings, obtained it in the same way. Each of these is a good article having a proper smell; the boiling point of one is 154 °C, specific gravity 0,865, of the other we have not the analysis."

## Trimming Room.

### COACH LACE.

#### SECOND ARTICLE.

It is with no ordinary degree of satisfaction that we, this month, present the accompanying specimen of elegant coach lace to our readers. This is from the same celebrated manufactory—the Messrs. Horstmann & Sons' of Philadelphia—as the pattern illustrated on page 26 of this volume, and is not only creditable to their ingenuity as

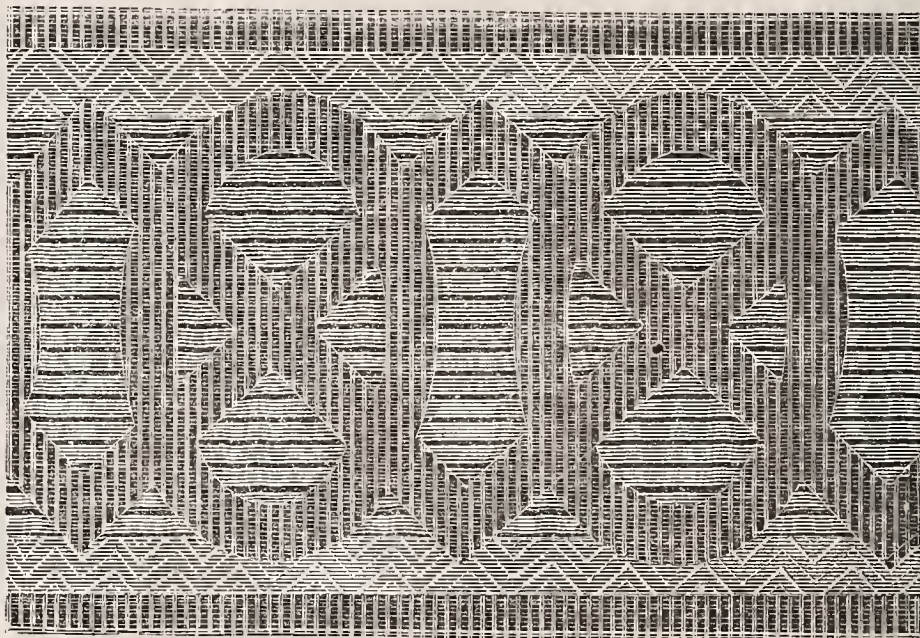

SECOND SPECIMEN OF COACH LACE, FROM MESSRS. HORSTMANN & SONS' ESTABLISHMENT, PHILADELPHIA.

designors, but likewise serves to prove that when the figures are judiciously combined and skillfully interwoven in the lace, it is far more ornamental and more tasty than any other substitute ever yet used in carriage trimming.

In this example—numbered 628—the artist has given us the raised figures in black in a deeper shade, while the blue ground-work is represented in lighter tint—the black being worsted and the ground-work silk. The engraving represents the lace of the exact size as originally woven. In our judgment, this pattern is not in any respect inferior to the beautiful specimen above alluded to, in artistic make-up.

### MACHINE THREAD.

SHOULD the reader consult our Prices Current for Carriage-materials, he will find under the title of machine thread, three numbers specified, viz: Nos. 432, 532 and 632. A few practical remarks in relation to this thread will not be out of place here. In the early history of sewing-machines as used by manufacturers, it was thought that nothing but silk would answer the purpose for stitching, and some of the sewing machine companies would fain make us think so still, because they have it to sell at an extravagant price, and probably can make more by the operation than they can, by selling hempen



thread. Be this as it may, the cheaper article answers every purpose. The hempen thread is not quite as glossy to the manufacturer's eye, but very few customers will notice the difference, especially after the trimmed carriage has stood a few days in the ware-room.

The hempen thread we have under consideration, is manufactured by Marshall & Co., at Shrewsbury, England, and is sent to this country in balls of half a pound in weight, put up in packages of three pounds—6 balls—of different colors, such as black, white, red, yellow, &c. No colors (except white and black) can be purchased of us in smaller quantities than three pound packages. The lowest of the three numbers used by carriage-makers, is the coarsest, and the medium number the most popular among the manufacturers of light work. The prices may be seen in our monthly reports, and the amount to be invested must accompany all orders for less quantities than a three-pound package. Larger quantities will be forwarded with C. O. D. bills, with the charges for collecting them added thereto, when required.

## Editor's Work-bench.

### PERSONAL MATTERS.

THERE are some matters connected with the publication of this Magazine which, if adverted to, may be of interest to the reader, and of service to the publisher.

No inexperienced person can comprehend the difficulties which an Editor has to contend with, when he undertakes to cater for a mixed multitude of mechanical and scientific readers. These difficulties are found to increase in the making up of a work for the treatment of a special mechanical business, like that in which we are engaged.

In the first place it is requisite that the Editor have an experimental knowledge of *the* business himself, so as to be able to winnow the chaff from the wheat, and to know when it is well winnowed. In the second place it is expected of him, that he will be well versed in general literature, and possess, likewise, a taste for his position, or he will not succeed in an age of intelligence, like the one in which we live. Nothing but the most indomitable perseverance and unceasing industry will supply the necessary copy as it is called for monthly by the printer, and the most studied thought, clear him from the censure which will most assuredly overtake him should he make but a single *faux-pas*. Even the eccentricities or errors of his mechanical correspondents are charged to his responsibility; so much have we in certain cases felt the weight of this, that in more than one instance we have been constrained to disavow our accordance with the opinion expressed, even at the risque of offending a sensitive writer.

In connection with the above, allow us to remark, that an Editor ought not to be so illiberal towards his correspondents as to reject an article because it teaches what is

by some considered an error—perhaps a small one, while the remainder of the article is all truth—simply because others differ in opinion from him. The most important scientific facts have been brought out by the free discussion of what some have denominated errors. To reject an article, therefore, because we do not happen to coincide with the writer, in opinion, we think bad policy. If, then, we admit to our pages an author with singular ideas—thought such by some—don't thrust aside nor condemn him until you have shown wherein he is wrong. To condemn a man unheard in these times of scientific discoveries is certainly an unwise procedure. It is much better to give his premises a close examination, and, if still thought erroneous, to try and *reason* him out of them, if possible. But in doing this, never suffer yourself to indulge in personal invectives, as in adopting such a course you only exhibit the *weakness* of poor humanity, without accomplishing any good object—perhaps only secure your own defeat by winning a life-long enemy, and discourage others from the investigation of scientific subjects.

While talking to our readers thus advisedly, we would not neglect a certain class who would be such could they obtain this journal on their own conditions, that is, without paying for it. This class of patrons we do not expect to reach at once, but in time. Any person who looks at our terms, will observe that they are published as being strictly in advance, and yet to this day there are those who still persist in asking us to send the Magazine to their address—including, perhaps, five or six back numbers—on receipt of which they will forward us the price of subscription for a year. Need we say that our experience goes to prove that the greater portion of these—strangers to us, have no intention of ever paying, and are only scheming to get the Magazine “free gratis for nothing.” These questionable customers write us as a reason for not complying with *our terms*, that they do not know them; This, to say the least, is a very thin covering for apparent dishonesty. Any one capable of giving the knowledge of our existence, ought to know enough about our subscription price to tell others how much will cover the costs of the numbers they write us for. We are convinced that *nothing but wilful ignorance dictates such action*, and *such ignorance* has no effect upon us. The only terms upon which *we can* send the Magazine without being paid in advance is, through your Postmaster or by Express, with a bill for collection, the subscriber to pay the extra charge for such collection, which is never less than twenty-five cents, and frequently is one dollar. This amount we shall always add to the bill, hereafter.

There is another thing we must mention. We have a long list of patrons who have kindly said to us, “We wish you would continue our Magazine, and not stop it at the



end of the year, and when you want the money send along the bill, and it shall be promptly paid." Most of these we have found noble men; but there are some so *forgetful* of their promises and our kindness, that they make us the trouble of dunning them for three or four months, and then, perhaps, compel us to send the bill by express, at a cost to us of fifty cents, which leaves but four dollars and fifty cents to be applied to their yearly subscription. Ought we to suffer by such delinquencies? We think not, and intend hereafter to protect the interests of our *good* subscribers and our own, by *cutting short* their term of receiving the Magazine—in other words we intend to charge for these collections, and keep back sufficient numbers to repay us our dues.

Again, there are many men at a distance—well meaning persons, too—who seem to think because they take and pay for this journal, that we are under obligations to answer *any* questions they may propound to us, by correspondence, without charge. We would disabuse such minds, and state once for all, that the five dollars we charge *only* pays for the Magazine. All beyond that is *new* business, altogether, and must be paid for, in some way; either in commissions from those of whom we purchase goods for the questioner, or by enclosing twenty-five cents to pay as for time spent in answering. There are many other things we ought to state, to set some people right on many points, but must defer until another time. Meanwhile, we trust what we have said will be heeded, and our precious time be not unnecessarily taxed, unrewarded.

#### MODERN TRAVEL.

WE read in the legends of imagination and tales of other days, how that by the peculiar properties of a magical wand, bestowed upon mortals who, by some fortunate circumstance, had obtained the good offices of some individual belonging to that mysterious fraternity generally known as fairies, or genii; that a merely human personage could, at pleasure, have his corporeal part instantly transported to any location his fancy might select, where he might find agreeable entertainment in the society of celestial companions, untrammelled by the gross cares which now hedge-in our pathway wherever we move. But for us in this day, has been reserved the happy realization of more than fancy has ever promised in her highest reveries, for quicker than thought are we borne along "the silent highways" of our beautiful country—swifter than the winds the iron-horse conveys persons and products to their appointed destination, and man even seems to play with the waves of an angry sea, as he defiantly skims along its surface in his steam driven vessel. Indeed, fast men, fast horses, fast roads—all abound in this fast age, quite throwing into the shade

every remembrance of the ancient "flying machines," and all contributing to substantiate the truthfulness of the general charge, that the present is a *very* fast age!

About fifty years ago, a visitor who left New York for a summer tour in Canada, when steam navigation was in its infancy, thus wrote: "I left New York in the Paragon or Car of Neptune, I forgot which, but any of these steamboats of the North River are justly entitled to either of these proud appellations, since they proceed, not *wind and weather permitting*, like all anterior navigators, but against wind and tide, at the rate of seven or eight miles an hour." The voyage to Albany was made in just twenty-two hours; a quick trip it was then thought, and so it was when compared with those made by sailing vessels, which, if accomplished in a week was considered a good one. But what would our traveler say of the voyages now made by the new Steamer Dean Richmond, just put on the same route—which are perfected in eight hours' time!—over twenty miles an hour?

Such have been the improvements in facilities for travel—including the railroad smash-ups—that Dr. Johnson, who asserted that "life had few things better to boast than riding in a post-chaise," is not only shown to be an "old-fogy;" but, that his, when compared with our times, must have been *very slow*, and matters in bad taste. But, as we said before, ours is confessedly a fast age, and having annihilated distance almost entirely, and rendered mankind himself nearly ubiquitous under the advancement of science, opening new sources for the increase of comforts, perhaps we ought not to judge the Doctor too harshly, nor twit him with old-fogyism, at this time in the world's history. Doubtless, our successors will, fifty-years hence, with good reason, say the same of us.

#### REVIEW OF TRADE.

THE laws governing trade are often an inexplicable riddle. The gains of to-day may, perhaps, be lost tomorrow, notwithstanding operations may each day be conducted in like manner, as far as human wisdom may devise. In the monetary world, like causes *do not* appear invariably to produce like effects; nor are the fondest anticipations of business men always realized.

Our reflections have been directed in this channel on finding that our civil war, now fortunately brought to a close, has not, as was anticipated, made us a nation of bankrupts, as our croakers and copperheads at home fondly declared it would, and our foreign *friends* falsely predicted. The business-world—if we except a few *fast* men therein—moves along in its regular course, to the evident surprise of many, and the satisfaction of every loyal heart.

It gives us pleasure to say, that although the early



spring wore a gloomy aspect for the city carriage-maker, yet the settled weather of the advancing year brought with it an extensive demand for pleasure-vehicles. Indeed, such was this demand, that it effectually emptied the shops and ware-rooms of the accumulated stock of a comparatively dull winter. It is reported that many of the leading houses have sold more carriages in this than they did the season preceding. Whether this has been done with as much pecuniary profit is another question. The prices obtained, have, certainly, ruled much lower than they did last year; and, in view of the high prices charged for labor and material against the builders, and the calls of the tax gatherer, we do not anticipate that the income of our friends will become so much inflated as to tax the carriage-builders' purse hereafter. The view here taken applies especially to New York and a few other leading cities.

Turning our attention to country affairs, quite a different picture presents itself. There manufacturing—except in a few localities where orders are filled for metropolitan salesrooms—has virtually ceased; because the more new-work our rural friends undertake, the more certain they are to lose money. This they have learned by sad experience. The advantages of the city over the country carriage-maker, may be seen in the following contrast:

Suppose, for example, our city friend obtains four-hundred and fifty dollars for a buggy, while our country cotemporary is obliged to sell his for two-hundred and seventy-five, although the latter is not far behind the former in the expenses of manufacture. The profits on the first may be fifty, in the latter fifteen dollars. The manufacturers' tax, in one instance, is twenty-seven dollars, in the other, sixteen and a half. According to this exhibit—we think it is a fair one—while the city builder *makes* twenty-three dollars, the country builder *loses* one dollar and fifty cents on every job he undertakes.

To the superficial observer these statements may seem drawn from false premises; but we are fully convinced from a free interchange of thought with many in the trade, in different States, that the position here assumed is mainly correct. Certainly these facts are not calculated to stimulate extensive operations in carriage-building generally throughout the country. Consequently, the traveler, as he wanders around, hears mournful complaints of the hardness of the times among carriage-makers, and an expressed determination from those engaged therein, that they intend to sell out as soon as possible. Poor fellows! Who will buy them out? Have we any men in these times, who—Micawber like—are waiting to invest their funds in business, and “wait for something to turn-up,” before indulging the hope of realizing any profit from it. No, gentlemen, we fear you are so completely “stuck in the mud” that to get out you must call—not on Jupiter, he can't listen—but on *short-sighted* legisla-

tors to step forward and do all they can to remedy the errors of the past, and lift you out of this “Slough of Despond.”

There remains no question, that the laws as applied to the fixing and collecting the Internal Revenue, require a thorough revision, and especially that portion applicable to the building of carriages. As it now stands—as we have elsewhere observed—while the more popular manufacturers ask and obtain a high price for their carriages, the less popular are compelled to sell at so low a figure that the more they build, the sooner they will be ruined. These facts are the best evidences of defective legislation, and that a speedy remedy is demanded both by policy and justice. Shall it be had?

#### EDITORIAL CHIPS AND SHAVINGS.

PARISIAN TURN-OUTS.—The Champs Elysées has presented the most aristocratic appearance during the past week. Omnibuses have long been prevented from thrusting their lumbering forms “betwixt the wind” and the “gentility,” but cabs have not been expelled, “*par ordre de M. Le Perfect.*” Their voluntary disappearance, however, has given us leisure to study the immense progress there has been made of later years toward perfection in the style in which the great world of Paris turn out their equipages. Prince Paul Demidoff drives a phaeton and a pair of magnificent Russian steppers, jet black, and of the peculiar race so celebrated in Russia, for carrying off all the prizes at the trotting matches which are as common in that country as in America. The Prince's barouche with four bays, is very perfect, the harness not showing too much silver, the liveries dark green and orange, with the Russian cockade, which is black, orange and white. The Prince's dark green drag, picked out with orange, which he tools himself, excites even English admiration. I dare not tell you what he paid for his team, which is matchless. His mines in the Ural mountains are, as you are aware, almost as productive as Monte Cristo's island. At one of the fancy balls of last season the costume His Highness had chosen was remarked on—a plain buff coat being a singular contrast to the dresses of the rest of the company. “Have you seen the Prince's cap?” was the reply; “His cap; it's black velvet.” “And the button?” “Ah! what is it?” “The Sancy diamond, worth half a million.”

The Duke de Montmoreney's sister, Princess de Sagan, with her dark blue barouche, picked out with red, attracts attention, from the fact that she drives one grey and one chestnut, perfectly matched, however, and good steppers. The liveries of her husband's ancient house have been for centuries light blue and red, and powder, which is not *sine qua non* here, as it is in London. The Comtesse Mercy Argenton's turn-out is English. The Comte drives in his phaeton a pair of grey ponies from Tarbes, capital goers, but I venture to suggest to M. le Comte the advantage of learning how to handle the ribbons before endangering our valuable lives by his deviations from the straight line. The Comtesse rides better than any other woman in Paris, and dresses well besides. M. de Lastrade's horses are Norman, and would make capital hunters. The Duke de la Rouchefoucauld drives



his phaeton and pair of dark bays at a slapping pace, while the great M. de Rothschild may be daily seen in his unpretending wagonette quietly tooling along his black ponies unremarked by any one who does not happen to know him by sight.

The late Lord Pembroke's coachman drives the magnificent equipage of Mme. Musard, whose husband's concerts we have all enjoyed. Vicomte Aguado sold her his splendid team of light bays for £1,700 (30,000 francs), and last Sunday her Victoria, the horses *à la Daumont*, the postillions wearing jackets of vert d'Isly satin, attracted great attention. A Russian droschky was the novelty yesterday—the coachman a true Mujik; the horses trotting at a wonderful pace.

**STEAM OMNIBUS.**—An omnibus drawn by a steam engine, has commenced running regularly on the high-road between Nantes and Nivot. The road from Nantes to Nivot presents several rather steep hills, which the engine, with its omnibus, according to *Galignani*, ascends and descends with the utmost facility and safety. The engine called the *Avenir* weighs about seven tons, with its provision of water and coals; it is 16 ft. 5 in. long, and 6 ft. 11 in. wide.

**TURNPIKES.**—These were erected, as early as 1267, as we find a grant of a penny for each wagon passing through a manor; and, subsequently it was a common custom to levy tolls for the repair of various thoroughfares. The derivation of the word turnpike is somewhat curious, namely: In early times it was the custom to fasten a pike or spearhead loosely to the top of a post, in order to prevent the intrusion of travelers not duly authorized to pass; the turning round of this pike, presenting a point on every side, gave rise to the name of turnpike.

**A NOVEL INVENTION.**—The *Chemical News* states that M. Pelon has invented a new heating apparatus adapted to the warming of railway carriages, and called a "heat generator." It consists of a cone of wood, which is covered with hemp, and which is made to revolve with great speed within a hollow cone of copper. These are inclosed in a metallic vessel, through which the air is passed, and becoming heated in the passage, is then conveyed to the carriage. The inventor proposes to place a generator outside each carriage; motion will be given to the wooden cone by one of the axles of the carriage, and the heated air will be admitted to the vehicle by an arrangement under the control of the passengers. The "heat generator" is, indeed, in actual use in Paris, and seems to be really efficacious. The machine is turned by a force equal only to about the twentieth of a horse power, but, after rotating for about eight or ten minutes, the air escaping from the apparatus was found to have attained a temperature of 70 deg. C.

## Patent Journal.

### AMERICAN INVENTIONS.

June 27. (48,404) **AMBULANCE.**—Benjamin Howard, New York City:

I claim the combination of transverse seats and sliding litters or beds resting on a frame placed within the body of the vehicle, supported and balanced by counterpoise springs within the body of the vehicle; this I claim, together with the compartment of the beds beneath the main floor of the body of the

vehicle, in which the litter or beds may be placed for convenience when not in use, as in the above described manner.

(48,416) **WHIFFLETREE.**—Joseph H. Littlefield, Cambridge, Mass.:

I claim the combination of the ferrule B, having its guard *h*, and socket *k*, the hook C, having its lever *l*, spindle *j*, and pin *p*, the spring D, and the cord and chain F and E, or their equivalents, all arranged substantially as described and for the purpose set forth.

(48,444) **CARRIAGE-SPRINGS.**—Andrew J. Ritter, Rahway, N. J.:

I claim the double-side spars A A a, or their equivalent, in combination with the thorough braces K K, cross-bars J J, axle *c*, and axle-bars F F, for the purposes herein set forth and specified.

(48,498) **BENCH-HOOK AND CLAMP.**—E. P. Wood, Lowell, Mass., and E. Blood, Lynn, Mass., assignors to Wood, Sherwood & Co., Lowell, Mass.:

We claim, *First*, The jaws A B, in combination with the hook E, and connecting bar C, substantially as and for the purpose set forth and described. *Second*, In combination with the jaws A B, and hooks E, we claim making the apparatus adjustable for thick or thin material by means of the rack D, and pin *c*, or equivalents therefor, substantially as and for the purpose herein set forth and described.

July 4. (48,513) **BREECHING-HOOK FOR VEHICLES.**—Edwin Brown, Leominster, Mass.:

I claim, *First*, The construction of a breeching-hook by combining with a fixed standard, a rigid hook swinging upon said standard, as described, so that the breeching straps shall be released by the displacement of the hook, substantially as herein described. *Second*, In combination with the fixed standard and movable hook, I claim a spring actuating the hook, and located in relation to the hook and standard as described.

11. (48,653) **COUPLING FOR CARRIAGES.**—John Bundy, Irondequoit, N. Y.:

I claim the combination of the coupling with the reach from the rear axle, by means of an arm or rod extending through the upper circular plate, in such form that the plate may revolve around it, substantially as above set forth.

(48,687) **MACHINE FOR MAKING WAGON-WHEELS.**—J. M. Howe, Portland, Oregon:

I claim the annular slide G, with the ring H, attached, and the latter provided with the arms *f*, and the slides *g*, in connection with the shafts C C, all arranged substantially as and for the purpose herein set forth.

(48,688) **CARRIAGE-TOP.**—K. Thomas Hurlburt, Lyons, N. Y.:

I claim, *First*, The combination of the pivoted socket D, guide *a*, and plate C, so arranged as to allow the carriage-top to be easily applied or removed, and to be turned half-way back, substantially as described. *Second*, The construction of the top, consisting of the jointed bows E E E E, single toggle-levers G G, and suitable covering A, the whole so arranged as to be compactly folded up, substantially as herein set forth. *Third*, The arrangement of the pivoted socket D, and guide, *a*, of the seat, and the bows E E, toggle-levers G G, and covering A, of the top, substantially in the manner and for the purpose herein specified.

(48,699) **METHOD OF FORMING BLANK-CLIPS FOR SINGLE-TREES.**—Michael Loughran, assignor to himself and James Loughran, of Pittsburgh, Pa.

I claim, as a new article of manufacture, a bar of iron having a raised brad running longitudinally on one or both sides, whether said brads are in the centre of the bar or near one edge, and with flattened spaces on one or both sides at regular intervals along the body of the bar, made by depressing



the brads, so as to form clips and clevises, in the manner herein shown.

(48,736) SLEIGH.—J. E. Stevenson, Marranett, Wis.:

I claim, *First*, Hinging the end of the runners to each other substantially as herein set forth and shown. *Second*, The guide-bars and traversing pieces, constructed and operated as herein recited and shown, in combination with the hinging of the runners to each other, as herein described.

18. (48,790) HARNESS.—Jerome Caulkins, Hudson, Mich.:

I claim arranging and connecting the straps D D, with the rings E E, straps C C, ring *a*, and with the ring F, substantially as and for the purpose specified.

25. (48,895) AXLE FOR VEHICLES.—Wheeler Beers, Bridgeport, Conn.:

I claim the application of the springs to an axle in connection with the tube or thimble, the circumferential projection in the interior of the box, and the nut on the outer end of the axle, substantially as and for the purpose set forth.

(48,928) GAUGE FOR SETTING THE PITCH TO WAGON-AXLES.—John Gorton, Providence, R. I.:

I claim the adjustable gauge described as Fig. 2, or its equivalent, in combination with the machine, described as Fig. 1, or its equivalent, the whole substantially as described, for the purposes as set forth.

(48,963) TUYERE.—Daniel S. Loy, Graceham, Md.:

I claim the blast-plate C, having a deflected slit opening, and capable by change of position, of directing the blast in the direction required as described and represented.

(48,984) JACK FOR HOUSE-COUPLING.—A. J. Settle, Schoharie, N. Y.:

I claim a tool composed of two jaws A B, formed and connected substantially as herein described, for the purpose set forth.

(48,998) FORGE TUYERE.—Ralph Platt, Florence, Ind.:

I claim so constructing the tuyeres that the longitudinal axes of the elongated orifice may be rotated in either direction, as and for the purpose specified.

(49,005) AXLE-BOX.—John Stephenson, New York City:

I claim, *First*, The combination of the yielding or self-adjusting collar B, with the chamber A, at the rear of the axle-box, and the collar C, the collar being fitted and controlled by the axle, and all arranged substantially as and for the purpose set forth. *Second*, The method of confining the bearing in the box, in order to provide for the facility of its extraction as set forth.

(49,054) MANUFACTURING AXLES AND WHEELS FROM IRON AND STEEL.—Henry Bessmer, London, England. (Patented in England, March 16, 1859.)

I claim, *First*, The manufacture of Locomotive and other crank axles from a plain slab or rolled or hammered ingot of cast malleable iron, cast-steel, or cast semi-steel, by sawing or otherwise, cutting away such parts of the mass as will leave a piece of metal having the general form or configuration of the intended crank axle. *Second*, In the manufacture of locomotive and other crank axles made of cast malleable iron or cast-steel, or cast semi-steel, I claim the twisting of the axle was to alter the angle of the different throws from the common plane in which they are formed with any desired angle or relative position to each other.

Aug. 1. (47,090) CARRIAGE-JACK.—George L. Cummings, New York City, Ante-dated, July 26th, 1865:

I claim, *First*, The combination of the frame A B, elbow-lever D, friction-roller *e*, and sliding bar C', all constructed,

arranged, and employed in the particular manner herein described, so that the short arm of the lever can be thrown into or beyond a vertical position, and thus sustain the weight without fastening the hand lever. *Second*, The combination of the adjustable rest E, and vertically-moving slide C, when constructed and arranged to operate as herein specified.

(49,094) VICE.—H. B. Dart, Westfield, Mass.:

I claim a vice provided with the usual paneled jaws, and with the oblique-faced or V-recessed jaws, combined and arranged substantially as set forth.

(49,108) TEMPERING STEEL SPRINGS.—William Hughes, Bloomington, Ill.:

I claim, *First*, The within described process of hardening cast-steel springs by first coating them with soap, or its equivalent, before heating and cooling them off, as before described. *Second*, The hydrated solution above set forth and composed of the ingredients herein specified, for the purpose of hardening springs of either cast or spring steel.

(49,109) WOOD-BENDING MACHINE.—Philip Hume, Hamilton, O.:

I claim the former A, stirrups E, key F, shear-bars D I, bolt J, pins G, and wedges O, arranged and operating together substantially as described.

(49,110) TRACE-TRIMMER.—William L. Hutchinson, Burlington, Iowa.:

I claim a device for trimming traces and other straps, constructed and operating substantially as herein shown and described.

(49,112) LIGHT-WAGON.—H. L. Isham, Plattsburg, N. Y.:

I claim, *First*, The securing of the ends of the levers *a*, of the springs of the bolster and axle, in the manner substantially as herein set forth. *Second*, In combination with the levers *a*, secured as hereinbefore specified, I claim the safety-straps G, attached to the bolster by dove-tail plates *d'*, and grooves C', in the manner described.

(49,128) SCREW-WRENCH.—Horace W. Love, Brooklyn, N. Y.:

I claim a single diagonal adjustable-screw wrench, constructed and capable of operating substantially as described.

(49,143) BREACHING-STRAP FASTENING.—A. W. Olds, Green Oak, Mich.:

I claim, *First*, Securing the breaching-straps to shafts of carriages, by means of a hook, in one end of which the strap is looped, in combination with a fixed pin or staple of the shaft on which the hook is hung, arranged together and operating substantially in the manner described, and for the purpose specified. *Second*, In combination with the above, the use of a spring, substantially as and for the purpose specified.

(49,158) MACHINE FOR UPSETTING, CUTTING AND PUNCHING IRON.—J. J. Rose, Elmwood, Ill.:

I claim combining in a complete and portable machine, a device for shearing metal, a device for punching metal, and a device for upsetting tires; the several devices being constructed and arranged substantially as described.

(49,173) SLED-BRAKE.—Levi H. Thomas, Waterbury, Conn.:

I claim, *First*, The vibrating, self-adjusting bar attached to the sliding frame, the same being connected with the levers, and so operating the prongs or dogs, that they adjust themselves to the density of the substance they come in contact with. *Second*, Placing the pins *f f*, in such a position, with the movable hooks *c c*, as to always insure their taking hold to break the force of the load when pressing forward.

(49,208) WRENCH.—James White, Cleveland, O.:

I claim the stop L, operating as described, in combination with the disk F, and adjustable jaws of the wrench, whereby they can be used at any desirable angle, and in either way, without removing the wrench from the nut, as specified.



## CURRENT PRICES FOR CARRIAGE MATERIALS.

CORRECTED MONTHLY, BY MR. CHAS. WEEKS, FOR THIS MAGAZINE.

NEW YORK, Aug. 22, 1865.

Apron hooks and rings, per gross, \$2.00.  
 Axle-clips, according to length, per dozen, 75c. a \$1.25.  
 Axles, common (long stock), per lb, 8½c.  
 Axles, plain taper, 1 in. and under, \$6.50; 1½, \$7.50; 1¾, \$8.50; 1¾, \$9.50; 1½, \$10.50.  
 Do. Swelled taper, 1 in. and under, \$7.00; 1½, \$8.25; 1¾, \$8.75; 1¾, \$10.75; 1½, \$13.00.  
 Do. Half patent, 1 in. and under, \$9.50; 1½, \$10.75; 1¾, \$12.50; 1¾, \$14.50; 1½, \$16.25.  
 Do. Smith's New York half patent case-hardened malleable iron box, 1 in. and under, \$10; 1½, \$10; 1¾, \$12.  
 Do. Smith's Homogeneous steel, case-hardened mall. boxes, ½ in., \$12; ¾, \$12; ¾, \$12.50. Long draft, \$2 extra.  
 Do. Saunders' improv. taper, ¾ in., \$12.00; ¾, \$12.00; 1, \$12.00; 1½, \$13.00; 1¾, \$15.  
 Do. do. Homogeneous steel, ½ in., \$15.00; ¾, \$15; ¾, \$16.50; long drafts, \$4 extra.  
 ☞ These are prices for first-class axles. Makers of less repute, cheaper.  
 Bands, plated rim, under 3 in., \$2.50; over 3 in., \$3  
 Do. Mail patent, \$3.00 a \$5.00.  
 Do. galvanized, 3½ in. and under, \$1; larger, \$1 a \$2.  
 Basket wood imitations, per foot, \$1.25.  
 ☞ When sent by express, \$2 extra for a lining board to a panel of 12 ft.  
 Bent poles, each \$1.50.  
 Do. rims, under 1½ in., \$2.25 per set; extra hickory, \$2.50 a \$3.50.  
 Do. seat rails, 50c. each, or \$5.50 per doz.  
 Do. shafts, \$7 per bundle of 6 pairs.  
 Bows, per set, light, \$1.25; heavy, \$1.50.  
 Bolts, Philadelphia, list.  
 Do. T, per 100, \$3 a \$3.50.  
 Buckram, per yard, 25 a 30c.  
 Buckles, per grs. ½ in., \$1.50; ¾, \$1.50; ¾, \$1.70; ¾, \$2 10; 1, \$2.80.  
 Burlap, per yard, 30c.  
 Buttons, japanned, per paper, 30c.; per large gross, \$3.  
 Carriage-parts, buggy, carved, \$4 a \$5.50.  
 Carpets, Brussels, per yard, \$2 a \$3; velvet, \$3.75 a \$4.50; oil-cloth 60c. a 75c.  
 Castings, malleable iron, per lb, 20c.  
 Clip-kingbolts, each, 50c., or \$5.50 per dozen.  
 Cloths, body, \$4 a \$5; lining, \$3 a \$3.50. (See *Enameled*.)  
 ☞ A Union cloth, made expressly for carriages, and warranted not to fade, can be furnished for \$2.50 per yard.  
 Cord, seaming, per lb, 45c.; netting, per yard, 5c.  
 Cotelines, per yard, \$4 a \$8.  
 Curtain frames, per dozen, \$1.25 a \$2.50.  
 Do. rollers, each, \$1.50.  
 Dashes, buggy, \$1.75.  
 Door-handles, stiff, \$1 a \$3; coach drop, per pair, \$3 a \$4.  
 Drugget, felt, \$2.  
 Enameled cloth, muslin, 5-4, 75c.; 6-4, \$1.  
 Do. Drills, 48 in., \$1; 5-4, 90c.  
 Do. Ducks, 50 in., \$1.40; 5-4, \$1.35; 6-4, \$1.55.  
 No quotations for other enameled goods.  
 Felloe plates, wrought, per lb, all sizes, 25c.  
 Fifth-wheels wrought, \$1.75 a \$2.50.  
 Fringes, festoon, per piece, \$2; narrow, per yard, 18c.  
 ☞ For a buggy top two pieces are required, and sometimes three.  
 Do. silk bullion, per yard, 50c. a \$1.  
 Do. worsted bullion, 4 in. deep, 50c.  
 Do. worsted carpet, per yard, 8c. a 15c.  
 Frogs, 75c. a \$1 per pair.  
 Glue, per lb, 25c. a 30c.  
 Hair, picked, per lb, 55c. a 72c.  
 Hubs, light, mortised, \$1.10; unmortised, \$1.00—coach, mortised \$1.50.  
 Japan, per gallon, \$3.  
 Knobs, English, \$1.50 a \$1.75 per gross.  
 Laees, broad, silk, per yard, \$1.00 a \$1.25; narrow, 15c. to 20c.  
 Do. broad, worsted, per yard, 50c.  
 Lamps, coach, \$20 a \$30 per pair.  
 Lazy-backs, \$9 per doz.  
 Leather, collar, dash, 27c.; split do., 18c. a 21c.; enameled top, 29c.; enameled Trimming, 27c.; harness, per lb, 50c.; flap, per foot, 25c.  
 Moquet, 1½ yards wide, per yard, \$9.00.  
 Moss, per bale, 12½c. a 15c.

Mouldings, plated, per foot, ¼ in., 14c.; ¾, 16c.; 18c.; ½, 1 ead, door, per piece, 40c.  
 Nails, lining, silver, per paper, 12c.; ivory, per gross, 50c.  
 Name-plates.  
 ☞ See advertisement under this head on 3d page of cover.  
 Oils, boiled, per gallon, \$1.60.  
 Paints, White lead, ext. \$15, pure \$16 p. 100 lbs.; Eng. pat. blk, 35c.  
 Pole-crabs, silver, \$5 a \$12; tips, \$1.50.  
 Pole-eyes, (S) No. 1, \$2.70; No. 2, \$2.90; No. 3, \$3.10; No. 4, \$4.50 per pr.  
 Sand paper, per ream, under No. 2½, \$5.00; Nos. 2½ & 3, \$5.65.  
 Screws, gimlet.  
 ☞ Add to manufacturer's printed lists 20 per ct.  
 Do. ivory headed, per dozen, 50c. per gross, \$5.50.  
 Serims (for canvassing), 20c. a 30c.  
 Seats, buggy, pieced rails, \$1.75; solid rails, \$2.50.  
 Shaft-jacks (M. S. & S.'s), No. 1, \$2.75; 2, \$3.25; 3, \$3.50.  
 Shaft-jacks, common, \$1.40 a \$1.60 per pair.  
 Do. tips, extra plated, per pair, 37½c. a 56c.  
 Silk, curtain, per yard, \$2 a \$3.00.  
 Slat-irous, wrought, 4 bow, \$1.12½; 5 bow, \$1.25 per set.  
 Slides, ivory, white and black, per doz., \$12; bone, per doz., \$1.50 a \$2.00; No. 18, \$2.50 per doz.  
 Speaking tubes, each, \$8.  
 Spindles, seat, per 100, \$1.50 a \$2.50.  
 Spring-bars, carved, per pair, \$1.75.  
 Springs, black, 22c.; bright, 23c.; English (tempered), 26c.; Swedes (tempered), 30c.; 1¼ in., 1c. per lb. extra.  
 If under 36 in., 2c. per lb. additional.  
 ☞ Two springs for a buggy weigh about 28 lbs. If both 4 plate, 34 to 40 lbs.  
 Spokes, buggy, ¾, 1 and 1½ in. 8½c. each; 1½ and 1¼ in. 8c. each; 1¼ in. 9c. each.  
 ☞ For extra hickory the charges are 10c. a 12½c. each.  
 Steel, Littlejohn's compound tire, 3-16, 10c.; 1-4, 9½c.; heavier sizes, 9c. currency.  
 Stump-joints, per dozen, \$1.40 a \$2.  
 Tacks, 9c. and upwards per paper.  
 Tassels, holder, per pair, \$1 a \$2; inside, per dozen, \$5 a \$12; acorn trigger, per dozen, \$2.25.  
 Terry, per yard, worsted, \$4; silk, \$9.  
 Top-props, Thos. Pat, per set 60c.; capped complete, \$1.38.  
 Do. common, per set, 40c.  
 Do. close-plated nuts and rivets, 75c.  
 Thread, linen, No. 25, \$1.30; 30, \$1.45; 35, \$1.65, gold.  
 Do. stitching, No. 10, 95c.; 3, \$1.15; 12, \$1.28, gold.  
 Do. Marshall's Machine, 432, \$2; 532, \$2.30; 632, \$2.60, gold.  
 Tufts, common flat, worsted, per gross, 20c.  
 Do. heavy black corded, worsted, per gross, \$1.  
 Do. do. do. silk, per gross, \$2.  
 Do. ball, \$1.  
 Turpentine, per gallon, \$2.25  
 Twine, tufting, per ball, 50c.; per lb, 85c. a \$1.  
 Varnishes (Amer.), crown coach-body, \$6; nonpareil, \$7.50.  
 Do. English, \$6.25 in gold, or equivalent in currency on the day of purchase.  
 Webbing, per piece, 55c.; per gross of 4 pieces, \$2.10.  
 Whiffle-trees, coach, turned, each, 50c.; per dozen, \$5.50.  
 Whiffle-tree spring hooks, \$3 per doz.  
 Whip-sockets, flexible rubber, \$4.50 a \$6 per dozen.  
 Do. hard rubber, \$10.50 per dozen.  
 Do. leather imitation English, \$5 per dozen.  
 Do. common American, \$3.50 a \$4 per dozen.  
 Window lifter plates, per dozen, \$1.50.  
 Yokes, pole, each, 50c.; per doz, \$5.50.  
 Yoke-tips, extra plated, \$1.50 per pair.

**TO SUBSCRIBERS.**—Our friends who have heretofore left with us a standing order for the continuance of the Magazine until they direct its discontinuance, will please take notice that the present number is the Fourth of another year's subscription to many into whose hands it now comes. While we return our heartfelt thanks for their constant patronage, and consequent encouragement, permit us to remind such as have not yet sent us the money for this volume, that our rules are **PAYMENT IN ADVANCE**, and that we expect to receive their remittances (\$5) before the next number is published. Please be punctual and oblige us. Office, 5 Ludlow Street, N. Y.





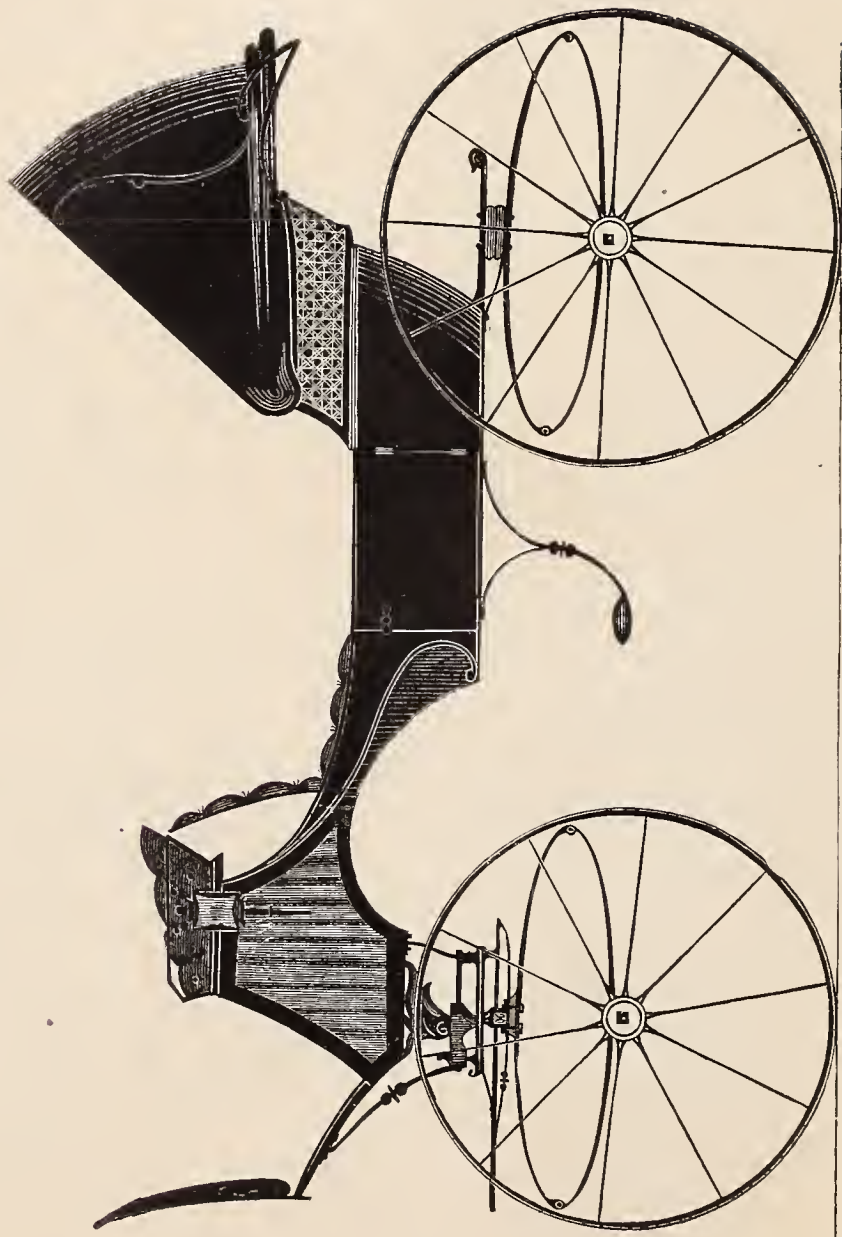

PARK PHAETON.— $\frac{1}{2}$  IN. SCALE.  
*Engraved expressly for the New York Coach-maker's Magazine.  
Explained on page 72.*



DEPOT BUGGY.— $\frac{1}{2}$  IN. SCALE.

*Engraved expressly for the New York Coach-maker's Magazine.*

*Explained on page 72*









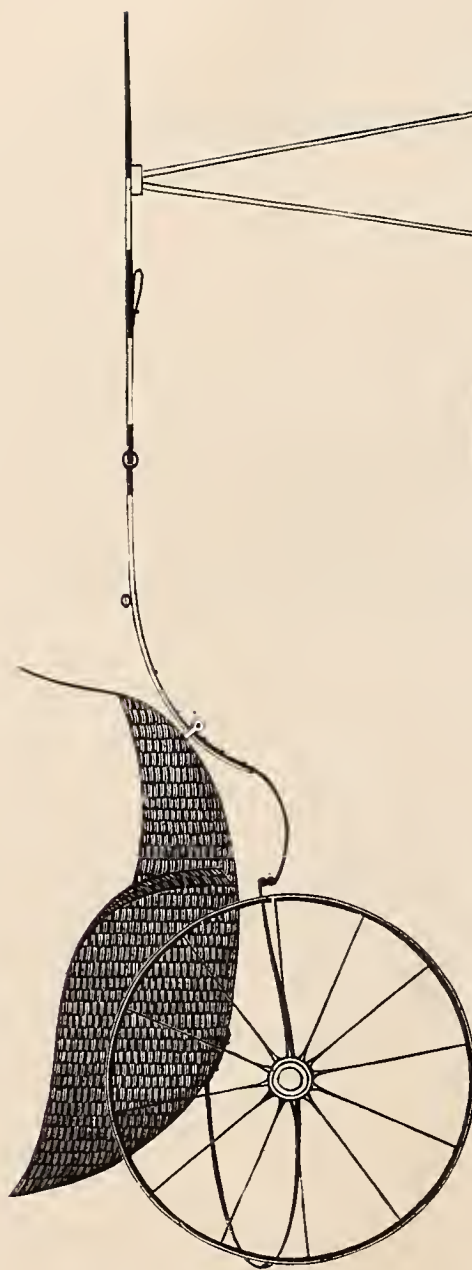

NEWPORT CART.— $\frac{1}{2}$  IN. SCALE.  
*Engraved expressly for the New York Coach-maker's Magazine.*  
*Explained on page 72*



*Yours truly*  
*O. J. Miles*

*Engraved express'y for the New York Coach-maker's Magazine.*

October, 1865.







DEVOTED TO THE LITERARY, SOCIAL, AND MECHANICAL INTERESTS OF THE CRAFT.

Vol. VII.

NEW YORK, OCTOBER, 1865.

No. 5.

## The Coach-Maker's Portrait Gallery.

### BIOGRAPHY OF OREN E. MILES, ESQ.

(WITH A PORTRAIT.)

OREN E. MILES, the subject of this sketch, was born in Watertown, Jefferson County, New York, March 11th, 1831, being at the present time a little over thirty-four years of age, half of which he has been a member of the coach-making fraternity. From a volume entitled "Personal Sketches and Recollections, in a Series of familiar Letters to a Friend," by Mrs. Eloise M. Abbott, a sister of Mr. Miles, we gather the following facts relative to his parentage and early life:

"Mr. Jonathan E. Miles was born among the spruce woods of New Hampshire, in June, 1782. His parents had a numerous family, and, like most of the people of the Eastern States, they were under the necessity of practicing the most rigid economy, and of requiring every member of the family to contribute to the general stock by habits of industry.

"At the age of eighteen, he obtained the consent of his parents to strike out in the world on his own account, and seek for himself such a fortune as might result from unaided efforts—with a kind expectation, however, that he would not venture much beyond the atmosphere of his native mountains, if indeed he lost sight of the old familiar chimney. But, having in possession some ten dollars in cash, the avails of a 'clearing out sale' of muskrat and mink skins—which were the result of his skill in trapping for those animals—he formed the resolution, as expressed by language at the time, of 'seeing how large the world was,' or at least of ascertaining 'where the sun went down.' With something of this kind in view, he set his face to the west, and went steadily and courageously on day by day, crossing the 'Granite State' to the Connecticut River, below Dartmouth College, and then, nothing daunted, right across the 'Green Mountain State,' and down its western slope to 'York State,' and so on, by the way of Albany and Schenectady, up the Mohawk River to Whitestown. Not finding the 'jumping-off place' yet, neither the place 'where the sun went down,' though

nearly out of money, he made arrangements to work the balance of the season at wages, with a view of replenishing his purse for another tramp westward.

"But about this time nearly the whole of the eleven original townships comprising the Black River tract, south of that river, were opened and offered for sale, and emigrants were flocking in and making purchases. The accounts given of the beauty of the country were such as to interest a mind like young Miles', and he forthwith sought and obtained the approbation of his employer in the resolution he had formed to push his way at once again towards the 'setting sun.'

"By the advice of his kind employer, he now set himself about an equipment, in the shape of apple-seeds for a large apple nursery, as soon as he could find the beau ideal of his ambitious day dreams. Leaving Whitestown, with his knapsack on his back, containing apple-seeds and a fair supply of provisions, together with a somewhat scanty wardrobe, and with a gun on his shoulder, he put his face toward the setting sun again, and proceeded to Fort Stenwix (Rome). Soon after leaving Rome, he entered a dense and tangled forest, and following a rough road, which led to Turin, on the Black River, where there were a few settlers, he passed on through Martinsburg, which was entirely uninhabited, to Lowville, which was called the 'eleventh town,' where there were a good many families. On the eighth, ninth, and tenth townships not a human face or habitation was to be seen. He saw but one family in the fifth township (Denmark); two families, Hubbard's and Harris', on the fourth (Champion); two, Keyes' and Miller's, on the third (Rutland), near the pond. From here the road was so indistinct and difficult to follow to the residence of Johnson and Andrew Hawk, in the present Col. Hungerford neighborhood, that he lost his way, and did not find their clearings, which, so far as he had any purpose, was to have been the end of his journeyings for the present.

"Passing on, he went to Dry Hill, and not finding inhabitants, or any clue to the Howks, he began to feel in a hurry, and urge on 'shanks' mare' into her fastest gait, lest peradventure his camp might have to be made in the woods, with 'no accommodation for man or beast.' For his dinner he shot a partridge, and striking a fire, he dressed and cooked it, after which he renewed his search; and finally, along towards night, discovered a smoke ahead, which proved to issue from the shanty of Eliphalet



Edmonds, on Sandy Creek, in the town of Adams, which he was occupying with a little daughter, long enough to clear four acres of land and sow it to wheat. They were just ready to return to their eastern home, having expended their provisions, except a salmon or two caught in Sandy Creek, and a little unleavened bread. They gave him particular directions how to make bread of this kind, which is here transcribed for the benefit of others who may at any time be similarly situated; viz.: 'Take of wheat flour and "Adam's ale" in due proportion, and bake on a chip before the fire!'

"Leaving these hospitable quarters next morning, he retraced his steps, and found the clearings of the Messrs. Howk without much difficulty. Mr. J. Howk furnished land, and assisted in sowing the apple-seeds, and he soon began to feel like having an investment on his own account which might prove the germ of a fortune in the future. He was not disappointed in his hopes, for the trees grew apace, and in due time were sought for far and near by those who would 'take time by the forelock' in cultivating fruit for their new homes."

Mr. Miles' father married for the second time Lucinda Sheldon, by whom he had eleven children, of whom the subject of this biography was the youngest but one. When the old gentleman was asked how many children he had, he would answer, "Six boys and half a dozen girls," one daughter being the child of his first wife. These twelve children all lived to mature years, and each contributed a fair proportion with their thrifty parents of the Herculean labor which has turned one of the most densely wooded and stony forests into what the Agricultural Society of Jefferson County has twice decided to be their best cultivated farm, by a premium of six silver spoons at each time. One of these bright souvenirs to each, as a reminder of the thorough management of their parents, with a portion of the extensive library the father accumulated during his life, constituted nearly the entire legacy of earthly goods he left to his children. "Excelsior" was clearly the old man's motto to the letter, and in which spirit he seems to have lived, and the impression is that so large a fund of mental and moral wealth as he accumulated seldom falls to the lot of so large a family. At the advanced age of sixty-five years, he became interested in, and prosecuted with the vigor of a young student, the science of astronomy. He made himself familiar with the text-books of Herschel and Dick, of European fame, and of Burritt, Olmsted, Mitchell, and others, of our own country. Not satisfied with reading of their observations upon the heavens, he procured the glasses for a telescope from Liverpool, through the assistance of his son Pliny, then in England, at a cost, when mounted, of three hundred dollars. With the aid of this instrument and his books, he soon became familiar with many of the more abstruse astronomical problems, able to calculate eclipses for years ahead, &c. Such men as he are not the best proof for the assertion that farmers and mechanics have no time to be scientific.

Ten of this family have been successful teachers of the young, and several have figured more or less conspicuously in the literary world. The oldest of the sons, Fabius, has been a member of the Legislature of Michigan, where he resides. The lectures, travels, and writings, as well as the public services of Pliny Miles, the third son, lately deceased, have rendered him quite eminent.

Oren is the only one of the family who chose a me-

chanical career for a livelihood, and in this he seems to be controlled by the same irresistible desire to arrive at the truth which seems to be a family characteristic. He says: "I commenced work at this business at the shop of Tuttle & Seovil, in my native town, on the day I was seventeen years old, and I suppose there have very few as blundering, absent-minded boys ever cumbered a wagon shop as I was for the first nine months. During this time about all I learned was to carry a saw perpendicularly through a plank, and hew to a mark. Generally when called upon for a job, I was found conning upon a more direct method of doing it. I thought I had cultivated muscle long enough, and that I was really getting no more food for ingenuity (of which I thought I had a great deal) than I was the year previous in the corn-field. So I struck out for better work and bigger pay, which I had no difficulty in finding fifteen miles distant, at the shop of J. M. Freeman, of Belleville. Here I worked a year at a great variety of work, and made much progress in the use of tools. I took my next degree in North Watertown, where I took a room adjoining the blacksmith shop of a brother-in-law, and did a small repairing business in connection with him on my own account. Here I built a foot-power turning-lathe, a hub-mortising machine, and in various ways accumulated the necessary tools and apparatus to drive a small business. In the fall of 1852, I boxed my kit, and set sail for Michigan, determined to see more of the country before sticking my stake permanently. I remained in Michigan only till the next February, during which time I did nothing at my trade. I next turned up at this place, which, with short intermissions, has been my abiding place ever since. During the twelve years I have lived in this place, I have once attempted to do business, which was abandoned for the development of some new principles (new to the carriage-making fraternity), for which I trust I may receive the approbation and support due to successful invention."

Mr. Miles, as our readers know, has contributed several articles to our pages, of more or less merit. His ideas appear to run in an original channel, and it may be that they will yet ripen in something that may astonish the world. Pliny Miles, who recently died at Malta, was a brother of our friend, and ranked as one of the best correspondents in the world, next to Bayard Taylor.

#### SOAP ON ARKANSAS STONES.

THE employment of sweet oil for the purpose of keeping Arkansas and other stones in proper condition for sharpening instruments is so general as to be used almost, if not entirely, to the exclusion of every other substance. The tendency, however, to become gummy, and clog the surface of the stone after it has been on a short time, along with the liability of soiling the fingers, and imparting an unpleasant odor to them, make the use of oil objectionable. All this can be readily obviated, however, by using soap in place of oil, as follows: Rub a piece of toilet soap and a little water over the surface of the stone until a thick lather is formed, and then allow this to dry. When occasion arises for putting an edge on an excavator, a few drops of water will moisten the soap, and place the stone in proper condition for use at once. This plan is one we have employed for years, and would recommend a trial of it on the part of others, in place of the substance generally used.



## Mechanical Literature.

### ANCIENT CARRIAGE-PARTS.

AMONG the ancients, strength in preference to beauty was the principal study in everything comprising a carriage. The frame-work of every four-wheeled vehicle shows such to be the case. As in our example, these consisted of the two axletrees connected together by a pole or perch, generally straight, and fixed firmly in the fore-axle, where it was secured by iron plates and bolted. The back end was mortised into the back axle, and strengthened by two wing-braces, as is sometimes done in modern carriages, and the whole was made additionally strong by two wooden bars, as shown in the engraving. Between the center of the perch, and under the floor of the body two props were placed as a support to the center.

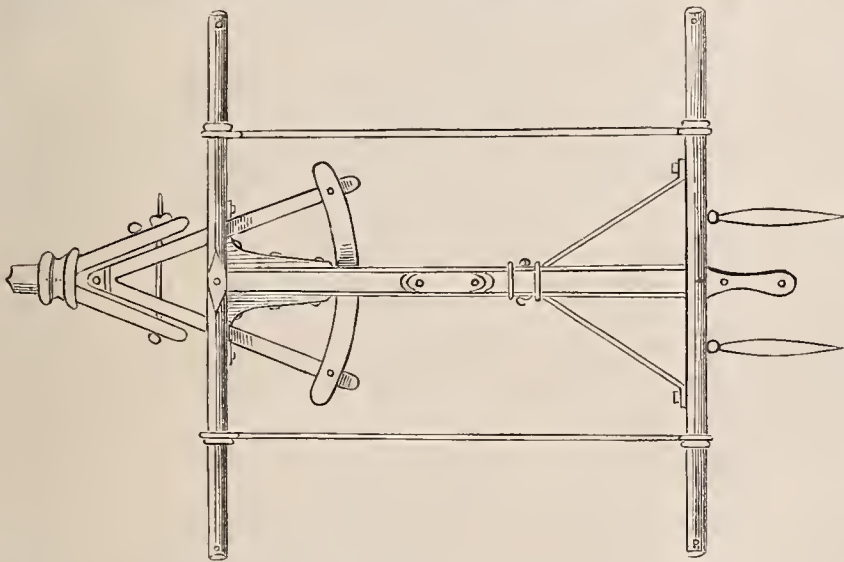

To these ancient carriages spring poles were sometimes applied, and often in the better class supported on the ends of elastic poles, where they were secured by iron rings or sockets. These poles were attached to the axles, and as the weight was not directly on them, but on the ends of the poles, the motion of the carriage was thereby relieved. Sometimes a greater number of poles were combined with the same view. These primitive springs may at first sight appear to have had little value; when we consider, however, that many kinds of hard wood preserve their elasticity for a long period, we may believe that when tapered and properly arranged, both the motion and the draught would be much easier than in carriages made without them. The poles were bound to the axles by iron bands called axle-girdles. The axletrees in inferior carriages were mostly made of wood, and sometimes strengthened with iron. In the better class, the tree was fitted into an iron bush which entered the hub, and again the entire axle was made of iron. On this axle the wheel was invariably secured by a linepin. The underside of the fore-carriage was coupled to the upper portion by a sort of king-bolt, which aided the turning about of the vehicle, as in modern times. By splitting the ends of the pole, and attaching it to the futchells by a bolt, as in our example, is shown one of the earliest modes of coupling poles to a carriage. The pole was not fixed, as in the two-wheeled carriages, at the end, but worked on a long bolt, in order to relieve the horses of the weight, was

kept in its place by a support fastened at the end of the forked frame or futchells. On the back of the frame two chains or straps were placed, that when passing over precipitous ground, if necessary, force might be applied to break the quick pace. Many of the Roman carriages were exceedingly strong and heavy; intercourse with distant countries was continually kept up by them, and goods, materials of great weight and value, were daily passing to and from the different cities; so that it was necessary to provide such appliances as would under all circumstances be requisite.

### AMERICAN DICTIONARY FOR COACH-MAKERS.

(Continued from page 54.)

**GATHER.** The technical term for the "set" given by carriage-makers to axles.

**GIB.** [Obsolete.] A small piece of wood, made flat on the bottom and round on the top, to fit the staple formerly used with the pole, intended to prevent the pole from flying up, which Felton tells us "was nailed on by a loose strap to the futchells, and was kept in its place by another strap nailed on the opposite side, which is hitched on a brass or plated button."

**GIB STRAPS.** The two straps above referred to, used to confine the "gib" in its place.

**GIG.** (French, *Gigue*.) As originally given, this word meant "lively motion," it being the lightest as well as the shortest-turning vehicle then used as a pleasure carriage, hung on two wheels. See vol. iv., p. 125.

**GLASS ROLLERS.** "A brass machine, which eases the weight of the glass when it is being drawn up."—*Felton*. Are not our window lifter plates a modern substitute for these *glass rollers*?

**GLASS STRINGS, OR HOLDERS.** The lace nailed to the window frames, to draw the windows up from their beds.

**GRASSHOPPER SPRINGS.** The spring generally known among us as the "cradle," and applied between the body and axle of dog-carts, gigs, &c. One of the earliest forms of the steel spring.

### H.

**HAMMER-CLOTH.** The ornamental covering to the dickey or coachman's seat. It is usually considered an aristocratic appendage, scarcely consistent with our republican notions. Among European "lords" it is an indispensable "institution."—See, vol. vi., p. 76.

**HANDLES.** This term includes not only the part taken *in hand* when opening and shutting the door, but the parts formed as *helps* for getting into carriages, often doorless.

**HEAD-BLOCK.** The *block* which receives the fore-ends or *heads* of perches, and on which the front spring rests.

**HEAD PLATES.** Metal ornaments fastened to the sides and back end of a coach, near the top. Very seldom used in America, and conflicting with good taste in every instance.

**HEAD-PLATE PINS.** Such small nails as are used to fasten the head-plates, generally with plated heads.

**HEADS.** The falling tops of buggies, gigs, or any vehicle



having a half top. The term seems to have been given to that portion of the carriage the *most* elevated; the topmost portion.

**HEARSE.** A carriage for the conveyance of the dead.

**HEEL-BOARDS, OR HEEL-LEATHERS.** Boards or leathers nailed under the seat to shelter the coachman's legs from the cold, and cover the vacant space between the foot-boards and the framed cross-bars, to each of which they were secured. These are now seldom used.

**HEDGEHOG.** A leather stuck full of nails, to buckle on the pole with the points upward, to prevent the horses from gnawing it.—*Felton*.

**HIND CARRIAGE.** The portion of the under-carriage not included in the fore-carriage, which see.

**HIND STANDARDS.** The ornamental risers of the platform, on which the footman stands behind, in full-dress carriages. Very seldom applied to American coaches. See plate 8, vol. ii.

**HOLD'-BACK.** The iron to which the breeching of the harness is attached when the horse is harnessed to a wagon, and which enables him to hold it back on inclined planes. Sometimes a staple is employed for the purpose, and then it is properly called a "breeching-staple."

**HOLDERS.** Broad lace with tassels (or stitched leather), attached to the back of a carriage for ornament, or placed in the inside as *resters*, or secured to the glass frames to draw them up by.

**HORN-BAR.** This term, as used in America, is frequently applied to the double whiffle-tree, generally made crooked for pleasure carriages. The crooked cross-bars *over* the "fifth-wheel." See BUDGET-BOOT, on page 23 of this volume.

**HOOD.** An extended addition to the front or head of a carriage top. The bonnet.

**HOOP STICKS.** An old name for the roof curves of a standing top body.

**HOOPS.** Iron rims or bands employed as tires; or, to fasten, strengthen, or mite some portions of the carriage together.

**HOOPED WHEEL.** A wheel with the tire in one piece, as distinguished from a straked one. See STRAKED TIRE, *ultra*.

**HOOPING PIECE.** "A strong timber, which unites the perch to the fore-end of the carriage."—*Felton*, vol. i., p. 46.

**HOUNDS.** Another name for the futchels.

**HUG-OF-THE-WHEEL.** A technicality, by which is meant, the back of the hub *hugs* the shoulder of the axle-tree; fits close.

#### I.

**IMPERIAL.** "A leathered case, which is placed occasionally on the roof of the body, for the purpose of carrying clothes, &c., safe."—*Felton*.

**ITALIAN LAMPS.** Lamps made of an oblong form. Lamps were once distinguished as globe, Italian, and oval.

#### J.

**JACK.** A contrivance used to shorten or lengthen the "thorough-braces." The term is often erroneously applied to the shaft couplings, in this country.

**JAPAN.** A mixture chiefly used as a dryer of paints.

**JAPANNING.** Painting, with a black glossy preparation; the leathered part of the body and carriage.—*Felton*.

**JEW'S-HARP STAPLE.** An iron staple chiefly used in chaises, or where the body is hung up on "grass-hopper-springs," to connect the spring with the axle, through which it passed. Not now in use.

**JOINTING.**—An old technicality for cleaning the mouldings, leveling the joints, &c., of old carriages previous to re-painting.

**JOINTS.** The crooked supports to all calash tops. *Mock-joints* are sometimes attached to standing-tops as ornaments. This is certainly in bad taste.

**JOINT PROPS.** The T-shaped irons which, screwed on to the top, receive the ends of the joints.

#### K.

**KNEE BOOT, OR KNEE FLAP.** The leather which protects the knees from the storm, when riding in an open carriage. Sometimes called the apron, but as we think incorrectly.

**KNEE-BOOT CREEKS.** The flaps on the sides of the knee boots.—*Felton*. These are now made *into* the boot, or, in other words, sewed thereto.

**KNEE-BOOT FALL.** An ancient strip of cloth covering the top of the knee-boot, but made of the same material as the linings of the carriage.

**KNEE-BOOT STRAP.** The straps used to fasten the knee-boot in place, when not in use. The "apron" straps.

**KNOBS.** The *buttons* for the curtains.

**LAMP.** (Fr., *Lampe*.) The vessel for producing artificial light; in some cases, "more for ornament than use."

**LAMP BARREL.** The lower end or tube in which the lamp or a candle is inserted.

**LAMP PROP.** The iron employed to sustain or fix the lamps to the carriage. These are made of both wrought and malleable iron.

**LAMP SPRING.** A spiral wire inserted in the lamp barrel to raise the candle as it consumes.

**LAMP STRAPS.** These are not now in use. Formerly, small straps which extending from the lamp to the body rendered it steady. Its purpose is now more securely accomplished by a socket, ingeniously connected to the stay.

**LANDAU.** A carriage built something in the manner of a coach, with a top opening at the center and falling forward and backward. A very expensive vehicle, named after a town in Germany, where it is supposed to have originated.

**LANDAULET** (Lan-del-lay). The diminutive of the Landau. A chariot body, with a top, something like the Landau, thrown back entirely when let down.

**LAYS.** (Saxon, *Lecgan*.) A strip of leather, which is sewed on the top of another that is broader for the purpose of additional strength, or to confine a smaller buckle; also, particular stripes in the lace, which are always of silk, called silk lays.—*Felton*.

**LAZY-BACKS.** The wooden elevated rail extending across the backs of buggy and other seats to rest the passenger's back against. See vol. v., p. 42.

**LIFTERS.** The lace or other material employed to *lift up* or let down the windows of carriages.

**LINCH-PIN.** (Saxon, *Lynis*.) The pin in the end of the axle, employed to secure the wheel on the axle-tree.



**LINING.** The inside trimming of carriage bodies, tops &c. The *within* covering.

**LIGHTS.** Strictly, the small windows in the flexible tops or heads of carriages. In a more general sense, the windows of every description.

**LOCKING PLATES.** This was the ancient term for our modern "wear-irons." So called because in turning around they are *hugged closely* by the wheel.

**LOCKING STOP.** A piece of timber fixed to the fore-bed, to prevent the wheel striking at all against the perch.—*Felton.*

**LOCKS.** A contrivance for *locking* or confining the doors of carriages.

**LOOPS.** See **BODY LOOPS**, on page 23 of this volume.

**LUGGAGE BOOT.** A sort of boot, with a loose covering, in which to store the *luggage* of travelers.

**LUGGAGE IRONS.** The iron frame giving form to the luggage boot. The framing of luggage boots.

**LUGG PLATE.** An iron plate, which Felton tells us has "a part branching from the side, to unite or hang two things by." Among us the *wear-irons* are improperly sometimes called lugg-plates. The original word means to *pull*, whereas it is all *push* with the "wear-iron."

## Home Circle.

### EVENING THOUGHTS.

BY ANNIE ROSE.

O! my heart, to-night is lonely—  
Well-loved friends are far away,  
And I sit in misty shadows,  
Waiting, longing for the day.  
O! my heart would hold sweet converse,  
With the friends I love so well,  
Friends, whose memory throngs around me  
Sweeter far than words can tell.

Stars shine out like sparkling diamonds,  
From the far-off azure sky,  
And my soul adores their beauty,  
Yet, I sadly sit and sigh.  
For I think of one who wandered  
Through the dim celestial blue,  
Long ago, when life was sweetest,  
And our hearts were young and true.

Angel sister; gone before me,  
Lost in bliss to mortal sight;  
But her memory still cheers me,  
With a holy calm delight—  
And I know when life is ended,  
And the things of earth are past,  
We shall meet in holy gladness,  
Such as will forever last.

O! the raptures of that meeting,  
Mortal tongue can never sing,  
Where the choir of holy angels  
Makes the Heavenly arches ring—  
Holy Saviour! shed thy blessing  
On this sad and weary heart:  
Fit it for that joyful meeting,  
Where loved friends shall never part.

### THOUGHTS OF EARTH.

BY FRANCES LAMARTINE.

How vain are earthly hopes!  
How soon our bright dreams die!  
They vanish like the dews of morn—  
Like cloudlets in the sky.

How fleeting, too, is life!  
Aye, swifter than the wind!  
It hastens on to realms unknown,  
And leaves all earth behind.

How transient are man's works—  
His monuments of clay!  
'Tis but a breath ere they grow old,  
And crumble, and decay.

And laurel-covered brows,  
And loudest notes of fame,  
Leave not a shadow here on earth,  
Nor echo of a name.

Then mortal, bow no more  
To earth's dissolving dust,  
Where all is eaten by the moth,  
Or eankered by the rust.

But let your soul aspire  
To that which *never dies*,  
And gain a home that God hath made—  
*Eternal in the skies!*

### THE WILD JUSTICE OF REVENGE.

(A SKETCH FROM PERSONAL RECOLLECTIONS OF LIFE IN IRELAND.)

BY WILLIAM HILL.

DANIEL O'CONNELL first applied the designation of "the wild justice of revenge" to those "deeds of blood" which have so frequently grown out of the relations between landlord and tenant in Ireland, and left their stain upon the pages of that country's history. Those unacquainted with the "relations" between the owners and occupiers of the soil, the wide and antagonistic social extremes which they respectively represent, the scope for oppression upon the one hand, and incentives to retaliation upon the other, will naturally find it difficult to reconcile the word "justice" with any combination of terms applying to the shedding of human blood by the hands of an assassin; and in the absence of this knowledge, it is equally difficult to understand why it is that, as in the case of Ireland, popular sympathy should be invariably found upon the side of the "criminal," provided that the deed which has marked him for that unenviable distinction appeals for its justification to the *real* or *imaginary* "oppressions" of a "landlord," or the often more intolerable arrogance of his subordinate or representative, usually called an "agent."

Indignities and oppressions based upon the usages of society, and practically illustrating its recognized distinctions, when aggravated by an appeal to the "rights of property," and even justified by the laws of the land, constitute a test of moral forbearance often too severe for the ethics of the Irish peasant. There is, as he regards it, but little to inspire him with a faith in the remedial appliances of the "Statute Book," and hence he raises his hand without



compunction against the life which he charges with a reckless disregard of his own, and against the laws which take as little account of his grievances or of himself. The traditions of his race, if they do not actually exclude even a *belief* in his legal right to protection, he learns from them at least that for *him* there is but one desperate redress, and Heaven help the victim whose destiny has marked him for the wild justice of revenge!

Under this latter name (or perhaps misnomer) there are atrocities upon the records of the past which can lay no claim to whatever of justification may be advanced for the outrages of a goaded people—outrages which for time immemorial have presented an unfortunate preponderance in connection with the Irish calendar.

One of these atrocities, attended by a singular and melancholy retribution, forcibly recurs to the memory of the present writer. It was one of those cases in which, so far as the tribunals of this world are concerned, the murderer went "unwhipped of justice," but it also exhibited an instance of those mysterious avengements of a guilty conscience which, could their visitations only be revealed, would be often found more terrible than any which the severest human laws have the power to inflict.

Some twenty years have elapsed since, upon a wild and stormy December night, the little household of Johnny Boland, of Ballinahown, were drawn closely around the newly trimmed fire that blazed upon his humble hearth. They were unconscious that the hours of their earthly communion were fast drawing to a close. The group consisted of a hale and jovial man, just turned of sixty, his wife, of a more delicate frame, and still further advanced in years, and a young girl of about twenty, a servant of the family. The residence of Johnny Boland occupied one of the angles of a lonely "cross roads," upon the outskirts of an extensive old domain, surrounding a time-honored family mansion—it was that of the Malones of Ballinahown, in the County of Westmeath.

At the period we now speak of, this noble Irish residence was in a condition bordering upon decay. A detachment of local police were quartered in the very finest apartments of the structure, and the herdsman of a stranger was domesticated in a scarcely less luxurious department of this once palatial mansion.

Ballinahown had for years been the subject of a suit in the Irish court of chancery. During the pendency of this prolonged litigation, the neglect which it naturally involved was followed by the necessary consequences—ruin, dilapidation and decay; and the faithful old retainers of the Malones—and "their name was legion"—regarded with feelings of jealousy and indignation these constant inroads of destruction upon the ancient homestead of their hereditary and still honored masters.

The domain of Ballinahown was at length brought to the "hammer." The property was "knocked down" to a Dublin merchant, and the name of the old family was known no more, except in the recollection of their faithful followers, and in connection with the date-stone of a fabric within whose halls they were never again to enter, except in the capacity of strangers. This change of owners involved a trying appeal to those feelings of attachment with which the tenantry of the Malone estates had been wont to look up to the now excluded family of their *rightful* "lords."

The new possessor was a gentleman of more practical and business education and habits. He at once set about

such changes and "improvements" as a shrewd "down-east Yankee" would be likely to inaugurate if suddenly coming into possession of the "hanging gardens" of the Alhambra or the Holy Sepulchre at Jerusalem. These changes and "improvements" necessarily included a total disregard, if not a wholesale obliteration of everything not immediately conducive to the intrinsic value of the domain, no matter how detrimental to the natural or artistic beauty of a landscape in which both were united in producing an effect of no common loveliness. These innovations also included the threatened removal, by process of summary legal ejections, of certain families whose fidelity to their former manorial lords had rendered them specially obnoxious to the Dublin merchant, and even to more than a few of their own neighbors, who had been ingeniously brought over to the interests of a new master by such preferences and favors as a wealthy but unpopular landlord might deem it necessary to bestow. Unfortunately for Johnny Boland, his tact and pliancy had early recommended him for favor (!) Johnny was as early employed upon the estate as superintendent and paymaster of a gang of laborers. Although honest in the abstract, Johnny had a sort of "ambition" to be really "suspected" of being intrusted with the secret of every movement of his master. But he found it much easier to open the door of suspicion than to close it. In short, he was not only "suspected" of knowing what evil was to come, but of secretly advising it beforehand.

On the night of which we have already spoken, there was not within the borders of Westmeath a family more free from the apprehension of danger than that of Johnny Boland. His sons—two in number, and both nearly full grown young men—were absent at a neighboring village. It was past nine o'clock, the night was dark and boisterous, and the old man had begun to experience some anxiety for the return of his boys. There is a footfall at the threshold! The friendly latch is about to answer to the pressure of a familiar finger, and the father's eye brightens with the joyous flush of that fond parental welcome with which it was his nature to hail the return of his beloved children. Again that mistaken footfall is heard upon the wayside pavement; its receding sound grows ominously dull, and there is something of mystery, although nothing of suspicion, in the cautious withdrawal of that stealthy tread. The expecting father pulls open the door, and with a hand resting against either of its rough jambs, he peers out into the gloom and storm through which the keenest eye could scarcely have traced the outline of a human form at a yard's distance. Suddenly he relaxes his hold on the door-jambs, reels back, and with a dismal groan, preceded by the report of an assassin's gun, falls dead into the fire. His murderer had taken aim literally at point blank, and at least a dozen slugs had made a riddle of the old man's heart.

Arrests upon suspicion—the public offer of "rewards"—all that vigilant police and zealous magistracy could effect or dream of—proved ineffectual for the discovery of the murderer of poor Boland.

Two years passed away—two years to the day and hour—and a scene invested with more indescribable terrors than those which had surrounded the murder of Johnny Boland might have been witnessed in a solitary cabin, not half a mile distant from the spot then owing a ghastly notoriety to the latter outrage. A poor, emaciated human form, in the wild contortions of a last agoniz-



ing struggle, lay writhing in the embrace of the "King of Terrors." It was that of a young man who had scarcely numbered twenty summers. A number of the comrades and neighbors of the sufferer stood grouped around the scene of his expiring agonies; but it was the impress of a paralyzing horror—not the emotions of a natural regret—that spoke for these awe-stricken mourners, as if they regarded his release from life as a deliverance from certain mysterious earthly horrors which had scarcely a parallel in the darkest realm beyond the grave.

Death was fast setting his seal upon the forehead of his victim. A deadly ordeal—not that of any known disease that "flesh is heir to," but that of an unbalanced mind, haunted by the ghastly creations of an unresting brain and guilty conscience—had left but little for the final separation of soul and body. But, as if gathering strength from every struggle that marked the near extinction of its vitality, expiring nature seemed to have reserved its most terrible efforts for the throes of final dissolution. The human skeleton—for the spectacle was reduced to that—seemed imbued with the concentrated power of a struggling giant. Strong men, coping in vain with the exhibition of supernatural energy which lent its horrors to the death scene of Tom Hickey, had given up the task, unmanned by a feeling of mysterious awe in the presence of so violent a form of mortal dissolution. In spite of their most powerful efforts, the dying skeleton sprang to its feet, raised itself up to its full height, and with an eye fast glazing into a dim and icy crystallization of death, gazed, or seemed to gaze, for a moment upon father, mother, friends, comrades, who made up the mute and terrified group that surrounded him. A wild hysteric shriek—"There! there! Don't ye see him?"—broke from the livid lips, now covered with the foam which betokened both the violence and the close of a last terrible struggle. He lifted his fleshless arm, as if to threaten away some invisible speeter of the imagination, then wildly swung himself out of the hands of his supporters. The dull sound of a lifeless corpse rang with a hollow crash upon the cabin pavement, and the murderer of Johnny Boland stood before the judgment seat of his God!

Young Hickey had been one among the number arrested, as already stated, on suspicion for the murder. He, with others, was on that occasion confronted with the corpse of the victim; but in spite of all that superstition can avouch, it will be true forever that "dead men tell no tales."

Evidence, under the circumstance, was out of the question, and an acquittal was necessarily the result. The young offender thus liberated had been betrothed to a girl about his own age, a daughter of one of the most faithful retainers of the old and venerated house of the Malones of Ballinahown. The fidelity of Tom Hickey's intended father-in-law to the name and interests of his old masters was known to have marked him for the vengeance of a new one—one of whom the unfortunate Boland was said to be no favorable advisor. The fate of the latter was sealed! Boland was secretly "arraigned" under the inexorable "code" applying to the charges against him. There was no appeal from the midnight sentence that doomed him to summary execution, and a notion, as false as it was unfortunate, of the duty which he owed to his loved one, induced the young and ardent Hickey, entirely without her knowledge, to become the voluntary assassin of her father's enemy.

A few months, and the excitement created by the

murder had in a great measure subsided. The recollection of the deed had never for a moment been permitted to slumber in the bosom of Tom Hickey. The pale and wasting cheek, the eye timidly averted from every human observer, the habitual start at the sound of a footstep or even the flutter of a leaf, all betokened a marked and unaccountable change. The habits of cheerfulness which had previously distinguished young Hickey among his associates distinguished him no more forever.

One evening—it was in the early spring—he was escorting his betrothed by a secluded pathway which took a sweep through one of the thickest plantations which then gloomily adorned the extended domain of Ballinahown. The sun had long set upon their evening ramble, when the young lovers found themselves alone in a sort of sylvan chamber formed by the natural festoonery of over-arching forest foliage, through whose shadowy entanglements even the beams of a mid-day sun could not have entered. This chamber had a record—one of a deeper darkness than its own. It was in this spot that a midnight tribunal had pronounced the sentence of Johnny Boland; and it was here that Tom Hickey, two years before, had sworn the black oath that bound him to its execution. The whole scene struck like an electric shock upon the recollection of the guilty one. He stopped short, as if his further advance were barred by some object invisible except to himself. The pallor of death overspread his countenance, and his frame, literally steeped in a flood of perspiration, shook and trembled under the influence of an undefinable terror. Uttering a shriek that awoke an unearthly echo in the gloom of the surrounding forest, and fixing an agonized stare upon his helpless companion, he dropped powerless at her feet. The living had quailed before the accusations of the dead. Johnny Boland, in his bloody shroud, stood that night before his murderer, and the vengeance for which he appealed to heaven seemed foreshadowed in the horror which had paralyzed a guilty and terror-stricken soul. The young girl was but a short survivor of the scene. It brought with it startling revelations of long-hidden crime. Tom Hickey!—she could never—never—be his! In three short months the churchyard verdure was luxuriant upon her grave.

From this first ghastly hallucination within the bowers of that sylvan chamber, until his latest hour, the apparition never deserted Tom Hickey. By night and by day, whether alone or in the midst of his companions,—whether at his daily toil or in his nightly slumbers—that vengeful visitant and shroud of blood were ever before him, and that selfsame sweat of a mortal agony was still wasting his young life, and bringing him down by slow degrees to the grave. It was an ordeal of mystery and torment, and we have seen both fearfully exemplified in the circumstances of his final release.

The fate of Tom Hickey is perhaps even now forgotten at Ballinahown. It is time to give it a written place in the dark annals of earthly retribution—a record of the past, whose pages, so far as they relate to Ireland, have not been unfrequently replenished from sources connected with "the wild justice of revenge."

THE DANDY AND A TOLL-GATE KEEPER—An English dandy lately riding in his "trap" thought fit to show off to a toll-keeper, and flung a shilling on the ground, saying, "There, take your toll out of that." "And there's your change," said the other, as he flung the balance into the mud.



## Pen Illustrations of the Drafts.

### PARK PHAETON.

*Illustrated on Plate XVII.*

This very fine design is contributed to the Magazine by Messrs. Neidig & Co., No. 74 West Twenty-Fifth Street, New York City. It is quite different from anything of the kind before illustrated in this Journal, having the drag-front, a sharp fore-quarter, round-back, &c. Sham-caneing the back seat makes the carriage look much lighter than it otherwise would. The drag-front, which we have striped, would likewise be improved by caneing, as such a process would present the side panel more in relief. The price of these carriages is \$1,000.

### DEPOT BUGGY.

*Illustrated on Plate XVIII.*

WE are indebted to an Eastern friend for the original sketch from which this engraving is made. It is a very popular vehicle at present among the people of Boston, Worcester, &c., and is there called a depot wagon, from the circumstance that it is much used as a conveyance for "persons and things" to and from the depots, on arrival of the trains. A dash—not shown in the drawing—is placed between the two front pillars, about 12 inches high. The wheels are front, 3 ft. 11 in.; back, 4 ft. 3 in. The side curtains are made in two halves, and knobbed together. We present this as being more useful than ornamental, trusting that in so doing we are contributing to the benefit of the public.

### NEWPORT CART.

*Illustrated on Plate XIX.*

ALTHOUGH a little late for practical purposes this season, yet we present this design as one of the latest in use. The body is *real* cane—nothing sham about it—with even the rings (dusters) formed of the same material. The originality in this instance is found in the application of the springs, and the attachment of the shafts by the use of shackles. This job may be profitably contrasted with those of the same description given on plates XXXI and XXXIV, in volume Five.

## Sparks from the Anvil.

### MONSTROUS CAST-IRON ANVIL.

THE Liverpool *Albion* thus speaks of a huge cast-iron block weighing 200 tons:—"The engineering science in its giant progress is constantly needing increased power in its appliances; and the massive forgings now required in ship-building necessitates steam-hammers of corresponding proportions. Many huge hammers have been made, but none have yet reached the size of the one now in process of erection at the Bolton Iron and Steel Works. This hammer is being made by Messrs. Nas-

myth and Company, of Patricroft, and is of gigantic proportions, and will strike a blow equal to 75 tons. This, of course, will require an immense anvil block, and the process of casting one for it, weighing 200 tons, on Wednesday last, was a work of unusual interest. The iron was smelted in two large patent upper-tweereupola furnaces, 24 feet in height and 7 feet in diameter. The molten metal was run into the molding in a constant stream, supplied alternately from each furnace. The process occupied ten hours. The metal was kept in a state of fusion by means of burning charcoal, until the whole quantity was poured in. The anvil block measures 12 feet square at the base, and 12 feet 6 inches in depth. The figure is pyramidal, and it is cast base upwards. The metal contains a certain proportion of Bessemer steel. The casting was performed under the superintendence of Mr. Ireland, of Manchester. Large numbers of visitors were at the works during the day, and were entertained at luncheon. The huge casting is not likely to be perfectly cold three months hence, and it will certainly not be reduced to a sufficiently low temperature to be dealt with under two months. When cool enough, it will be turned over, as already explained. The bed for the reception of the block will be enclosed in a large circular wrought-iron cylinder, measuring 20 feet in depth, and 18 feet diameter. This will be sunk in the ground and filled with concrete, and when finally deposited in its bed the anvil will appear about 2 feet 6 inches above the ground."

### A NEW BLOW-PIPE.

A novel blow-pipe is thus described in a foreign journal:—"Hendy's blow-pipe is an instrument which combines simplicity and efficiency in a great degree; it consists of an ordinary blow-pipe nozzle, supplied from an India rubber reservoir. The main portion of the blow-pipe is made with a joint, at which a valve is placed, which is opened when the operator blows, and closed immediately when he ceases. By this arrangement the little bag or bladder is readily filled at a single breath, and with very little exertion. When so filled a continuous current of air is forced from the nozzle of the pipe by the mere contractive force of the gutta percha. The force is uniform until the air is nearly exhausted. The current may be easily varied or entirely cut off by gently pressing the fingers upon the neck of the bladder above the nipple to which it is attached. Mr. Hendy has recently made a further improvement by attaching a rubber hose between the mouth-piece and the pipe, enabling the blower to change his position without disturbing the direction of the current on the object upon which it is turned.

## Paint Room.

### HINTS FOR THE PAINTER.

BY AN OLD PAINTER.

OF all the troubles which painters are subjected to, none are greater than the selection of paints, oils and varnish good and suitable for their work. There are so many ways of manufacturing, so many new kinds introduced, and so great a difference in the qualifications of the



manufacturers, all having the object of gain in view, with more or less conscientious scruples about the way of obtaining their object, that it is not strange that a combination of difficulties are presented that are hard to surmount. Another difficulty proceeds from the difference in experience of the painters who are to use the paints, oil and varnish. A painter that is endowed with a more than ordinary share of artistic skill in the ornamental branches is generally considered as the most competent by those who cannot comprehend the knowledge necessary experience required to make a painter. Often on account of artistic precocity such becomes a painter without learning even the first rudiments of the trade.

But by far the greatest trouble is derived from the everlasting desire with which many are endowed of getting the thing a little *cheaper*, without any inquiry as to its value. As the matter now stands, it is next to an impossibility to get a good quality of varnish, at the just price, of a second-hand retail dealer, or from a manufacturer whose success in business is not wholly derived from his just and honorable dealing. Perhaps there is not so great a chance for cheating without immediate detection in other articles, but in all cases it is prudent to get these directly from the original manufacturer, and always reward honesty by continuing our patronage.

The practice of adulterating flax-seed oil with other oils has become so common that the pure oil is seldom found in the shops. Boiled oil from the stores has become a worthless article for out-door painting. The secret of the failure in that once favorite article may be found in the patent record of the first volume of this Magazine, for manufacturing "meloine oil," as it is called. Its ingredients are shellac, dissolved in water by means of alkali, and then mixed with raw oil, so that it gives it the color of boiled oil, and a good drying quality. The water enables the manufacturer to sell it at the small advance of five cents per gallon over raw oil.

What may appear inconsistent to the painter, is, that the small advance of five cents on the gallon would scarcely pay for the work of drawing the oil off and boiling it and re-barreling it again, not to say anything about the cost of the drier to be used. If the patentee of this article had explained his process to the painter, who is more directly responsible for the quality of the oil, he would have been told that the alkali will destroy the quality of the oil by chemically changing it to soap, and it could never have come into general use in that way. The more artful course had been to persuade the dealers in oil, by presenting the gain to be made out of its sale. A few may have entered into it at first, and painters may have been pleased with the oil; but it required time to expose the cheat. The time came, however, and the painter was charged with the fault of the paint. It scaled and wore off as readily under the influence of the weather as though it was composed of glue. In the mean time the low price that *this* boiled oil was furnished at, and the quick sales, induced the trading fraternity to search out the way of preparing it, which they soon discovered was covered by a patent, although the secret had long before been known to painters, and condemned as worthless.

At one time boiled oil could be furnished in the place where the writer worked, for almost any price, by one dealer, who, as slick as his oil, made pretensions to about all the honesty and morality to be found in that section of country. A person who had found out the cheat through

THE NEW YORK COACH-MAKER'S MAGAZINE, showed him a copy of it treating on the subject. His garrulousness, for which he was noted, forsook him on that occasion; he could not say a word, but appeared as if thinking that his "occupation was gone." At the present time few good painters will use boiled oil, unless they have prepared it; yet it has a place in the shops for those who occasionally do a job for themselves.

The adulteration of raw flax-seed oil by mixing in other oils does not show injurious effects on the wear of paint. I should be somewhat backward in pronouncing its quality inferior to that which I have known to be pure flax-seed oil. The reason that one vegetable oil is not as good as another for painting is the absence of glue generally found mixed with the oil. Flax-seed has this glue in excess, so that the meal cake, after the oil is pressed out, if dissolved in water, forms a thick mucilage or gluey substance. If other seed, that is defective in glue but abounds in oil, is mashed with the flax-seed, may it not take up enough of the glue that would otherwise be left in the oil-cake, to give it the requisite qualification? This is theory, that *may* or *may not* be correct, but one thing is certain—that we have no statistical proofs that the raw oil we now use will not last just as long as that which is made of pure flax-seed.

The mixture found in the Western country, and sold for oil, is in about equal parts German rape and flax-seed. The German rape is different from what is called the wild rape, and has become a considerable article of commerce, for the purpose, as oil-makers say, of making a lubricating oil. It sells for about the same as flax-seed, therefore if there is any gain by using it, it is on account of its having a more oily nature.

Corn oil might be mixed with flax-seed, and perhaps produce a good *drying* oil, yet, from the fact that there are different processes for making, these would have to be mixed after they were made, which would be a loss of the requisite glue. But if there is money to be made by it, and it can be palmed off on the painter without immediate detection, it will be done. With all these difficulties surrounding the painter, he must be something more than a machine to produce a certain result; he must use his own reasoning powers in combination with that of others, as well as experience, to prevent him from committing many mistakes.

Deception in paints is generally practiced by forging the trade-mark of such as have acquired a reputation. For instance, Chinese vermilion is put up in small papers, of like appearance from time immemorial, and it has a preference in market above any other vermilion. The painter often finds the poorest quality of vermilion in papers exactly resembling the genuine article, and generally lays the cheat to the Yankee rather than the pagan. French zinc has become so unreliable that we care but little about buying it of retail dealers before it has been tried.

Many of the real foreign paints are preferable to our own from the fact that the manufacturers are subjected to the inspection laws that specify the amount of mixtures that may be combined, while our own is only regulated by the ambition of the manufacturer for gaining a reputation that will command the highest price in market. The foreign inspection laws are of little avail to us, because trade-marks can be tampered with without subjecting offenders to a criminal prosecution as easily as they would be if our own were transgressed.



My experience in varnish for carriages would give our best American manufacturers the preference where the real article can be produced. We have the advantage of producing some of the ingredients that go into them cheaper and better than foreigners can, therefore our manufacturers can sell it cheaper than they can. The difference in the price has led many to think there was a corresponding difference in the quality. Again, when carriage-makers and painters are presenting an estimate of the cost of their work, they naturally would be led to say the highest price material was the best, and the one they had used. Some who know nothing about the real state of the case, honestly buy foreign varnish, and as honestly proclaim it to be the best. Others who never would use it, on account of the price, say they do so, and say that it is the best. Rogues take the advantage of all this discord, and prepare a most villainous compound that can hardly be made to dry, put on an English trade-mark, and sell it for the real article. This may be a theory without foundation, but if it is, they act different in this case from what they do in others where they have the same opportunity.

I can better afford to buy American varnish and use it in carriage painting, than use English varnish and have it given to me, on account of its slow drying and the process of "sweating it out," which is simply washing off a part of the oil which does not dry so readily as the other part. We can manufacture exactly the same thing, but cannot sell, other than in the way pointed out, which respectable dealers will not stoop to.

## Trimming Room.

### MIXTURE FOR PRESERVING LEATHER.

THE *Shoe and Leather Reporter* gives the following preparation for insuring the durability of leather, and making it pliable. It consists of four articles, tallow, soap, rosin and water. These ingredients are prepared as follows:—Twenty-one parts of tallow are melted in a vessel, three parts of rosin added, and the two when melted mixed well together. In another vessel seven parts of good washing soap are dissolved in seventy parts of pure rain water; after it is dissolved and the mass heated to the boiling point, we add the parts prepared before, let it boil once more gently, and the preparation is ready for use. It is especially adapted to boots, harness, leather and belting.

### MAKING LEATHER WATERPROOF.

PARAFFINE is finding constantly new uses. A Dr. Stenhouse has invented a process of mixing with oil and applying it to leather, whereby the latter is made perfectly waterproof. After a coating of the mixture is applied the leather is heated, and a second coating can be put on. The leather, it is said, will wear double the usual time after passing through this process.

## COACH LACE.

### THIRD ARTICLE.

AGAIN we come before our readers with another specimen of beautiful lace from the popular manufacturers of the Quaker city—Messrs. William H. Horstmann & Sons. The design is numbered, in their list, 619. The original of this pattern is woven in two colors; black broché figures on a blue silk ground.

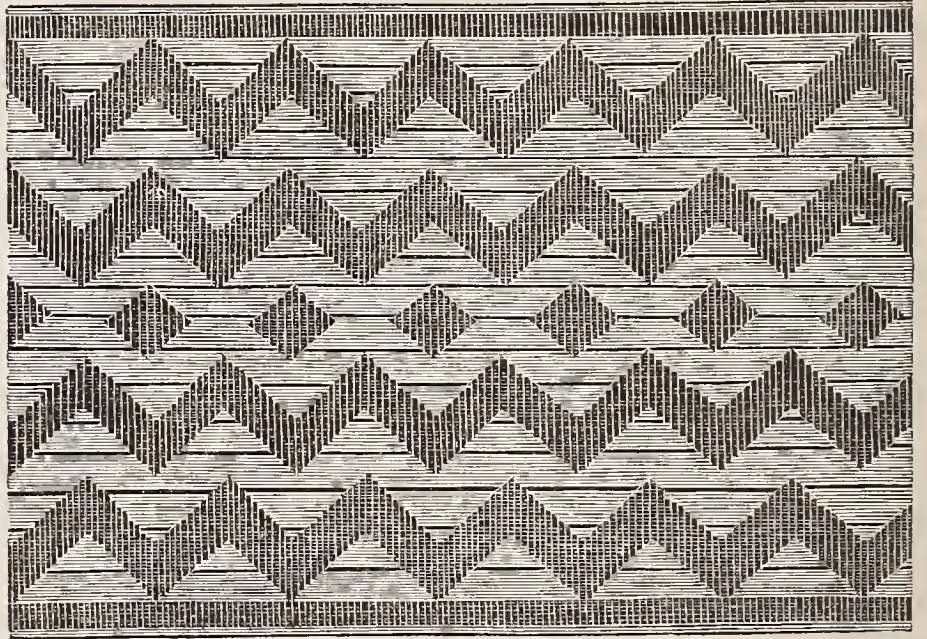

THIRD SPECIMEN OF COACH LACE, FROM MESSRS. HORSTMANN & SONS' ESTABLISHMENT, PHILADELPHIA.

The manufacture of coach lace is much more extensive at the present time than we had supposed, with indications that its use is largely on the increase. The census of 1860, shows that in the States of Connecticut, New York, and New Jersey alone, there were six establishments in operation. The total capital as exhibited by the new census, was \$42,800; paying for the material over \$28,737; employing 80 male and 16 female hands at an expense of \$32,364, and yielding for the year ending June, 1860, a product of \$89,200. As the establishment from which *our* specimen comes is the largest in the United States—but not included in the above enumeration—the reader may imagine how much greater the amount would be with its products added. The next census will doubtless show increasing popularity, and revival of taste for using it.

HELP FOR FALLEN HORSES.—A London cotemporary says, that when a horse in shafts falls down, he nearly always falls with some or all of his legs under one of the shafts, and his body over the other, and there is the greatest difficulty in getting him up again, in many cases the weight of the loaded cart being thrust forward and pinning the horse to the ground. If the shafts, however, were fastened by bolts and pins to the cart, they could be easily removed and the cart drawn back by a few bystanders, who could easily preserve its equilibrium, and then the horse could easily get up.



## Editor's Work-bench.

### INTELLIGENT MECHANICS.

KNOWING; understanding; well-informed; skilled; these are the acquirements of an intellectual mechanic. To reach this point, intellect and industry are indispensable, for a person may have a good intellect, and yet never attain to even a moderate degree of intelligence, without *industrious* study. The Great Supreme has created us with intellects, but has left it to our own choice to become intelligent. "Laziness" and "ignorance," in a certain sense, being synonymous terms. Such being the case, how important it is for those who would become distinguished mechanics, and succeed in business, that they make the best use of the mental faculties, in connection with skillful hands. These are doubtless the prerequisites to a successful result.

Ruskin tells us that "it is a no less fatal error to despise labor when regulated by intellect, than to value it for its own sake. We are always in these days trying to separate the two; we want one man to be always thinking and another to be always working, and we call one a gentleman and the other an operative; whereas *the workman ought often to be thinking, and the thinker often to be working; and both should be gentlemen in the best sense.* As it is, we make both ungentle, the one envying, the other despising his brother; and the mass of society is made up of morbid thinkers and miserable workers. Now it is only by labor that thought can be made healthy, and only by thought that labor can be made happy, and the professions should be made liberal, and there should be less pride felt in peculiarity of employment, and more in excellence of achievement."

There are obviously many good reasons why mechanics should cultivate their intellectual faculties. The hours of relaxation may be so industriously occupied in mental study, as to win for them an enviable position in life. We have abundant proofs of this in the history of our own country. There are a thousand evidences that study will reward its votaries, and pay its laborers, not only pecuniarily, but in that which is of more value, respect from our fellow-men.

It has been often and well said, that in this land of freedom, the road to honor and happiness is open to all. Here, no titled birthright clogs our way—all, however poor, may, beneath the folds of our glorious, starry flag, by industry and study, win their way "to fortune and renown." There is no earthly reason why a mechanic's fireside may not be blessed with as much intelligence and refinement as that of the most ardent "professor" among us. After admitting that some have a more apt or natural taste for research than others, still, we claim that *labor*

*omnia vincit* that labor *will* overcome every thing. As there is no "royal road to learning," so there is no exclusive path to fame or honor. All are admitted to the Halls of Science on their own merits, not on those of ancestry.

Once in possession, how satisfactory are the results. An awakened intellect will never find any moment hang heavy. There is that in an educated mind, which affords its possessor a rich mine of enjoyment all along through life, and how much intensified and enlarged such find matters in old age. They find themselves conversing with the spirits of the past, and never are at a loss for society or amusement. Give them books and they are happy—or in the absence of books, previous culture renders communion with their own thoughts an occupation sufficiently delightful to light-up the hours, which to an illiterate and barren mind, brings only weariness and pain.

It is a matter worthy of attention, that the members of any mechanical trade, if they so will, may, by united effort in cultivation, greatly increase their own respectability, wealth, and influence. By providing a library of their own, a reading-room, museum, and the necessary apparatus for scientific experiments, the intellectual faculties may become so stimulated to exertion in science and art, that bosses, journeymen, and apprentices, may soon be recognized as a scientific body, whose influence will shed a lustre all around them; receiving the grateful acknowledgment of their fellow-citizens, and the applause of the world. Such has ever been the rich reward of mechanical and intellectual cultivation. In proof of this examples are not wanting. Have not Watt, Arkwright, Harvey, Franklin, and many others, given us examples of what may be done by study? Have they not won for themselves a name, lasting as time?

In our own special business—that of carriage-building—never was so much intelligence shown (we say it fearlessly) as in our day. This happy state of things has come over us gradually but surely, and is no doubt justly attributable to the free interchange of thought among us, by means of periodicals devoted to our especial business. In our own sphere we have labored for the advancement of a business we have always loved, and should there be any doubt of our success, we invite the skeptical to compare the drawings of our first with those we have given to the world in our last volume. If such are not true indications of progress in every department of trade, including that uncertain something known as taste, then we must give up in despair. The idea for which we contend is very strongly illustrated in the *model* of our vehicles. Instead of crooked and irregular lines as formerly, we now find the "line of beauty and of grace" running all through the productions of our shops, and although our heavier carriages are built a little more *solid* than for-



merly, they evidently show more grace and strength than ever before. Who will have the hardiness to deny that this in a great measure is due to the study of periodical and mechanical literature, the few past years, specially devoted to the business?

We have come to believe—some may say we are blinded by self-interest—that no person can peruse our journal regularly as it comes monthly from the press, without being profited, and granting that some “can not see it,” yet a great many acknowledge that those who are so penurious as to neglect it altogether, and plod along in their old course, are not only left behind in art, but are yearly greater losers pecuniarily, than we are, in not having their patronage. This subject is worthy of a more extended consideration than we have space to devote to it now, and therefore we must await another opportunity of returning to it again.

#### DESPICABLE CUPIDITY.

FROM the old world into the new has been imported a custom as despicable as it is judged dishonest by every right thinking mechanic. The custom we allude to is that of making presents to the coachman and livery-stable loafers, in order to secure the custom of the “bosses.” This has now become so great a nuisance—it is in plain English nothing else—in all our larger cities, that a reform in this particular is loudly called for. Unless some steps are taken in this direction, the carriage-maker must either allow himself to still be robbed for the benefit of runsellers and *their* customers, or else submit to the loss of his mechanical *status* among his contemporaries, for the motto of these pests is, “you *must* give me or suffer;” and unless their wishes are complied with, the next you hear of the matter is, a bolt has failed in the new carriage you turned out the other day, or a strap has broken, or an axle bent, or a perch out of shape, or something else is wrong; all tending to lessen the reputation for good work you have spent so many watchful and laborious hours in building up. We speak from experience in this matter; for, never believing myself justified in robbing the boss for the benefit of his “lackey,” we have uniformly declined doing so, and on more than one occasion suffered the consequences. We will mention one instance of many.

Last year we sold a very light buggy to a gentleman, who took it to a stable not far from Union Square, in this city. Said buggy had not been in use many days before both perches were broken in the centre *on the top*, and the plates bent, showing that the mischief had been done with a lever from the underside. This could not possibly have resulted from ordinary use. This we made good *at our expense*. A few months afterwards one of the axles—Sanders’ best—broke down *from the underside*,

about six inches from the hub, with no apparent reason, except that a contemptible Irishman, whose name we might give, had called upon our foreman for his “wetting,” as he termed it, and been “bluffed off.” We are aware that some men are *liberal* enough to fee these thieves by *robbing* their customers in the charges they add to the bills, and justify themselves by charging honest men, who act otherwise, with being mean and stingy. Let such go on; they only sink themselves to the level with their dupes.

There is no reason why these livery stable men, especially, should be fed in this way, in this country, for if the keeper will not pay them sufficiently remunerative, they have only to turn to the thousand and one other occupations to find *honest* employment and adequate wages. The whole matter is this, the practice of giving is the consequences of poor pay in Europe, and the effect of bad rum in America, and whoever gives to these beggars, contributes directly to the making of drunkards and demoralized politicians. These facts are so evident that it were useless to go into the proof here.

To plead the antiquity of this custom for its continuance, is no reason why such a bad habit should not be abated. Felton tells us, about one hundred years ago, that “a practice had been introduced, and for a long time continued, that the gentleman of the whip received *doncers* from the tradesmen employed in building or repairing of carriages, no doubt with the original intention of encouraging the coachman to take good care of the carriage, and preserve his interest with his employer. It is very likely the zeal and activity of the coachman will, in a great degree, be proportionate to the encouragement given him; very extravagant expectations are formed by many, which, if not complied with, are sure to draw the resentment of the disappointed coachman upon the tradesman, and if complied with, he has no other method of reimbursing himself for this very unfair transaction, than by charging an exorbitant price for his workmanship, so that ultimately his employer suffers a manifest injury.

“If a coachman be honest [how rarely is such the case], attentive to his master’s interest, and a tolerable judge of his business, he will discover when *any* repair is necessary [it were well did they confine their discovery to *necessary* repair], and in some measure to what extent that repair ought to be carried; but, if swayed by sinister motives, and the tradesman should happen to be of the same complexion, a wide field opens for collusion between the two, and the proprietor is sure of being egregiously imposed upon, especially as coach-makers’ bills are generally given in technical terms not understood by their employers.”

How frequently have we seen these “thirsty suckers” urging the necessity of repairs to a vehicle where none



were called for, simply because they wanted the carriage-maker to have a job, so that they could get an extra "wetting." Any demur to such dishonesty from an honest mechanic is met with the customary remark, "Oh, it's all right, the boss has plenty of money, and is able to pay for it," meaning the repairs the coachman suggests having done, *however unnecessary*. Gentlemen who leave such matters to their hostler or coachman in this and other cities, without ever giving personal inquiry, or taking time to examine the subject, have no idea how extensively this system of robbery is practiced upon them, and never will until by some chance the fact is discovered.

And in buying new vehicles—there, too, is robbery. A business man wishes to purchase a new carriage for his family, but instead of hunting up one himself, to save time, sends his hostler. The hostler, true to his instincts, goes a little further than his authority warrants, and bargains for a certain sum from the manufacturer as a reward, provided he induces "the boss" to purchase at a stipulated price, the price often increased in view of the bargain. Many have paid their coachmen twice over for practicing duplicity against them in the past, and doubtless will continue to do so, until some men come to love honesty more, and *rum* less. But, perhaps, we have told enough for the present, to arouse those interested. If so, our end is accomplished, and a reform inaugurated.

#### SELECTING TIMBER.

In addition to being a good mechanic, it is highly important that a carriage-maker be a good judge of the qualities of the timber he uses. To do this readily and effectually will require more experience than most people will admit. The natural pride of the human heart often compels men to deny facts, in order to bolster up ignorance. We have found many instances where this ignorance was so deep that the subject could scarcely distinguish between oak, ash and hickory, much less select good timber from bad, especially among amateur builders, of which there are many in this country. To remedy this ignorance, as far as it can be done, on paper, is our object here.

Much in our time is said in relation to preserving and hardening timber, by the periodical press. Such information will not do our readers much good. We shall try to supply a lack of knowledge from the experience of a long mechanical life-time.

Presuming that the timber has been felled on high ground and from second growth—two essentials of the greatest importance—during the months of October and November, we have thus far gone prudently to work, and very likely secured timber of the best kind. But this can not always be done. Most men have to buy as the timber is offered them, in the plank, and as poor

plank is *never* offered, the wonder is that any is *ever* bought! Good timber presents an anomaly in contrast with general merchandise. Instead of fineness, look for coarseness in the outlines of the different yearly growths. These are more defined and distinct in trees grown on upland, in a dry soil, than in swamps or low lands. Wet lands invariably produce the finer grained timber—especially is such the case in ash—more yellowish in color, and brittle in the quality, than that grown on higher ground. In such cases, sunlight has but little chance to operate. So absolutely necessary are the rays of the sun in perfecting the growth of trees, that, as is the fact, the wood from the south side of the body of a tree is much tougher and stronger than that grown on the north side of the same. This strange circumstance can only be explained by the theory which physiologists inculcate: that as the warm blood in man, just purified by the introduction of fresh air into the lungs, is sent by the action of the heart through the arteries in his right side, making that side the strongest, and the left, where it becomes more impure, the weakest; so the tree, visited by the warm rays of the vernal sun, causes the sap to flow earlier and fresher on the southern side than it does on the northern, less favored in this respect, and more exposed to the chilling winds of March and April.

Some reader, who has never studied this subject as thoroughly as we have, may feel disposed to cavil at our theory; but, can they give a better reason? That the timber from the south side of a tree is always the best, cannot be successfully denied, and, of course, there is some cause for this difference. *We* have never yet heard any from others, and it will give us much pleasure to do so now.

#### NEED OF AN APPRENTICESHIP SYSTEM.

THE following article from the *Chicago Workingmen's Advocate*, commends itself to the candid attention of the mechanical public. The evil complained of is not only found in the Western country, but all through the United States:

"There is no evil from which the laboring classes of the Western States are suffering to a greater extent than the want and enforcement of a thorough apprenticeship system. We believe there is not a mechanic of this city, possessed of ordinary intelligence, who has not experienced the want of such a law, and we are sorry to say this evil is increasing every day. That a reform is demanded, and that such reform must ultimately be effected through a legislative enactment, must be a self-evident fact to any one who has given the subject the consideration its importance demands. That a subject fraught with such momentous results to the industry of the country should have been so long neglected, is a matter of surprise, and the sooner effective steps are taken to remedy the evil the better, both for employer and employé.



"One of the greatest drawbacks with which our mechanics have to contend, is the employment of inferior workmen—who have served no apprenticeship, who are always ready to work for a nominal compensation, and whose labor is invariably brought into competition with their own whenever the iron hand of necessity compels them to demand a remuneration at all equivalent to the value of the services performed. Now there is no class in the community so loud in their complaints of the prevalence of inferior mechanics as those men who employ them. They complain, and very truly, that there are too many who are jack of all trades, and too few who are masters of any; but they do not say that they, and they only, are responsible for the existence of such a state of affairs. The fact is, that in the absence of any legal enactments union organizations alone have attempted to foster that system, as the *sine qua non* of membership is invariably the credentials of an apprenticeship; and if that rule has ever been violated, it has been for the purpose of self-preservation or thwarting the intention of some unprincipled enemy or enemies of labor.

"The advantages to be derived from the passage of an apprenticeship law, are too patent to require any lengthened comments. When such a system is enforced, a stipulated time is required in which the apprentice is compelled to learn his calling; thus allowing him no opportunity of leaving until his practical education is completed, and a finished workman turned out. Under these circumstances there would be no inducement for any one to become the "tool" of an employer. The period devoted to the knowledge of his business, the most eventful of his life, would in all probability be the means of inculcating the principles of sobriety, independence of character, and a respect for the rights of others that could be acquired in no other school. Moreover, a business which demanded years of intelligent, laborious study to acquire, would present stronger claims to receive a proper valuation than where no such course has been pursued. As the case stands at present, those who have served no apprenticeship, and their name is legion, feel unable to compete with skilled, competent workmen, and consequently are willing to sell their labor for what it may bring. The system of working one year at one business and a second year at another, would also receive its *quietus*, and the alternative be presented of working under instructions till the business was learned or leaving it altogether.

"What we need at present is the co-operation of employer and employé, in obtaining the passage of a law which will do justice alike to the interests of both. The truth is, there is far too much estrangement existing between them. We are sure if employers would look at this matter in the right light, and throw prejudice to the dogs, they would be convinced such a movement would inure to their own benefit. None know better than they do, that, although they may use these men as temporary expedients, they are eventually the losers, and by employing them they adopt the 'penny-wise and pound-foolish' policy.

"We have been led to these remarks, because we are credibly informed a reactionary feeling is fast gaining ground in those firms who have persistently refused to acknowledge the claims of superior workmen. They find, by bitter experience, they cannot compete with those establishments who employ first-class men. We think the times are auspicious for the agitation of this subject, and

believe, if the proper steps are taken, employers and employés may become co-workers in the same cause."

#### EDITORIAL CHIPS AND SHAVINGS.

**HOW TO SEND MONEY.**—We would call the special attention of those sending us money for subscriptions, to the facilities offered by the Government, in issuing Post-Office money orders for their accommodation, in all our larger towns. This is not only a perfectly safe, but a cheaper mode of transmitting small sums, than by registering. Directions how to proceed will be learned of your Postmaster.

**HAVE YOU SENT FOR OUR NEW CHART?**—The charts numbered three, in our catalogue, containing twenty-four cuts of buggies, have all been sold. In its place we have got up a new one, much larger and handsomer; embracing cuts of 15 top and no top buggies; and 13 others—Phaetons, Victorias, &c.—making altogether the handsomest and best thing for a coach-maker's office ever published. The price is \$1, either at the office of publication, or by mail.

**NOVELTY IN ENGLISH CABS AND OTHER VEHICLES.**—A "Patent Carriage Company, Limited," has been formed in Birmingham, England, for the purpose of bringing into use sundry novel improvements in cabs, &c. The framework is of angle iron, welded. By using this, several inches of space are saved and added to the accommodation. The panels, which in ordinary cabs are of wood, in these new ones are of papier maché. The paper resembles leather, but is stiffer and very tough. Every part of a cab usually of wood, indeed, is in this instance made of paper. The springs are beneath the body, which brings the wheels five inches nearer than in the ordinary vehicle, and yet also gives additional room in the width. The window runs along the roof on the inside, and draws down like a sash, and there is a sash door which may be pushed down, and coils itself below the body of the vehicle. The ventilation, also, is more perfect than in the common cab.

**WEIGHT OF RAILWAY CARRIAGES AND OMNIBUSES.**—The *London Mining Journal*, thus speculates: "It is certainly worth considering whether railway engines and carriages need necessarily be such ponderous affairs—at any rate for passenger traffic. The Americans accuse us, with some justice, of being wedded to weight and massiveness in all manufactures, comparing, for instance, our crawling broad-wheeled trains and elephantine horses, with their express wagons and small-boned cattle. There is a curious comparison between a first-class railway carriage and an omnibus: carriage weighs five tons, carries eighteen people weighing twenty-two cwt.; omnibuses weigh one ton, carries thirty people weighing thirty-seven cwt. Consequently the railway carriage weighs five times as much as all the passengers put together, the omnibus only half as much. If omnibuses were proportionately as heavy as railway carriages, they would only carry three people; if, on the other hand, railway cars were as light as omnibuses, each carriage would carry one hundred and eighty people."

**TO WHOM IT MAY CONCERN.**—We are in the constant receipt of requests from country manufacturers, asking us to look up journeymen for them; or find a customer for their establishment, they wishing to sell out; or something else of a kindred nature. In future we must decline such orders, except they come in the form of



an advertisement for the Magazine, for which we expect, of course, to be paid. Any *spongy* gentleman will in future, therefore, understand, that *we* don't want *his* favors except they come in a remunerative shape. Our time is worth something—to us especially.

THE HORSE MARKET.—The Government sales still take place every Tuesday, in this city, the prices ruling much higher than it did in August, in consequence of the farmers from the country, attracted by the expectation of "bargains"—having come in, in great numbers, bidding freely. These Government sales have seriously affected business at the sales stables. Person who purchase the "fast horses," have been out of town, and, of course, *that* has had its influence on city trade. A few work horses have been sold, at the Twenty-fourth street stables, chiefly from Canada, that being at present the principal source of supply. The prices for such horses vary from \$75 to \$150, the extreme for good strong animals being \$300. Roadsters are occasionally sold at from \$600 to \$1,200, but there are evidently more sellers than buyers (the 10th of Sept.), now.

MODERN "GENTLEMEN."—Mrs. Swisshelm says, the young gentleman of our time have "little breeding and less sense, ripens fast, and believes himself to be an exceedingly nice young man. He chews and smokes tobacco, swears genteelly (!) coaxes embryo imperials with bear's grease, twirls a rattan, spends his father's money, rides fast horses—on horseback and in sulkeys, double and single,—drinks catawba, curses the Maine Law, and flirts with young ladies, hundreds of which are just like himself, though of a different gender; and *this* is the fashionable education of our day. The fathers and mothers of these fools were once poor [such was the father of the forger, Ketcham]. Good fortune has given them abundance. Their children will run through with an inexhaustible fortune in a few years, and die in the poor house." True, every word of it, and all traceable to that "pride and prejudice," which leads *some* parents to bring up their children in idleness and hatred of labor. We hardly know which to blame most, the parents or their children.

#### LITERARY NOTICE.

THE favorite of *Our Young Folks*, for September, exhibits a table of interesting articles, the principal of which are Lights on the Bridge, by Lucy Larcom, short and sweet; Apologising, by Gail Hamilton, beautiful; Margery Gray, by Julia C. Dow, a domestic tale in verse; The Cloud with the Silver Lining, by Mary N. Prescott, teaching that *all* happens for the best; Farming for Boys; The Swallow, by Charlotte K. Chanter, inculcating obedience to parents; Lessons in Magic, by P. H. C.; Winning His Way, by Carlton, showing how *good* poor boys may rise in the world; A few Plain Words to my Little Pale-faced Friends, by Dio Lewis, M. D., inculcating rules for the improvement of health; Half-hours with Father Bright-hopes, by J. T. Trowbridge, teaching lessons in wisdom; Aunt Esther's Rules, by Mrs. Stowe, for the prevention of cruelty to animals; Among the Studios, by T. B. Aldrich, who gives his account of a visit to the painters; Stars at Bedtime, by Anna M. Nells, poetry; and The Boy of Chancellorville, by Edmund Kirke, interesting to all Union boys and girls; also "a lot" of Charades and Rebuses, things we never trouble our heads with. This is decidedly the most interesting work ever placed in the hands of "our young folks."

## Patent Journal.

### AMERICAN INVENTIONS.

Aug. 8, (49,285) WHIFFLE-TREE.—Thomas R. Mar-killie, Winchester, Ill.:

I claim *First*, The levers C and F, combined with each other, and with braces D and E, constructed and operated substantially as and for the purposes specified. *Second*, In combination with devices for working three horses abreast; I claim the braces G, constructed and operated as and for the purposes specified, substantially as described.

(49,289) VEHICLES.—O. E. Miles, Aurora, Ill. (antedated Aug. 7, 1865):

I claim the spring D, in combination with the truss A, short axle *b*, and wheel B, fixed on the latter, all arranged relative to each other, and to the other parts E, etc., of the vehicle, substantially in the manner and for the purposes herein set forth.

(49,341) SPOKE MACHINE.—Junius Foster, assignor to himself and John Slocum, Long Branch, N. J.:

I claim the arrangement of the cutter G, attached to the reciprocating block C, the adjustable gauge-bar H, and slotted plates I I', J J', all constructed as and for the purposes herein specified.

22. (49,545) CARRIAGE SPRING.—Henry H. Olds, New Haven, Conn.:

I claim a spring composed of cross-arms A A, hinged caps B, and elastic block D, connected together substantially in the manner and for the purposes set forth.

(49,552) ADJUSTABLE THILL.—William P. Robinson, Bloomfield Ill.:

I claim the combination of the thills A B, and cross-bar C, pivoted together at *c c*, with the arcs E F, perforated as described, and the removable pins *m n*, arranged and operating substantially as and for the purposes herein shown and described.

### FOREIGN INVENTIONS.

NOV. 23, 1864. APPARATUS FOR INSTANTLY RELEASING HORSES FROM CARRIAGES.—G. Priolean, Perry street, Fitzroy Square, London:

To effect the object of this invention, the patentee employs a buckle, which is provided with mechanism by which the tongue is moved forward and backward. For buckling, the tongue is carried forward, and is held in that position by a spring. For unbuckling, an elbowed lever, acted upon by a cord (the end of which is within the reach of the driver), presses against the spring and relieves the tongue, which being no longer held forward, recedes from the hole of the strap. It will be then easily understood that, if the horse runs on, the traces will be released from the collar, the shaft tugs will glide away on the shafts, and the horse will be completely disconnected.

NOV. 29, 1864. INDICATOR OF TIME AND FARES.—J. Pinand, Paris:

This improved apparatus is intended to be fitted to cabs and other public vehicles, for the purpose of affording means of checking the amount of money received by the driver during the day. The chief feature of the apparatus is a movable card or dial, which is printed or marked in a special manner. The card or dial is moved by clock-work, and receives on its face opposite the passenger marks or indications of stoppages, journeys, when engaged by time, and by the "course" or distance. —*Not proceeded with.*

January 21, 1865. CARRIAGE-STEP ARRANGEMENTS.—H. A. Dobson, Marylebone, London:

This invention consists in certain mechanical arrangements whereby in the act of opening the door of the carriage, the steps are drawn forward in position ready for use, and when the door is shut, it is pushed back underneath the body of the carriage, so as to be out of the way. To the underside of the door is attached, by a moveable joint, a lever, connected by a



slide working in a curved slot underneath the body of the earriage. At any convenient point, either in the before-mentioned lever, or slide, a connecting lever is attached by a movable joint, acting upon the rod which carries the step in such a manner that, when the door is opened, the step is thrust forward, and *vice versa*. The rod or bar which carries the steps is supported by two short movable connecting pieces attached to the body of the earriage by moveable joints, so as to fold close up under the body of the earriage, the one at the hinder end having a double joint, so that any pressure on the step will prevent it from riding back of its own accord, and so closing the door upon any person in getting in or out of the earriage.—*Not proceeded with.*

## CURRENT PRICES FOR CARRIAGE MATERIALS.

CORRECTED MONTHLY, BY MR. CHAS. WEEKS, FOR THIS MAGAZINE.

NEW YORK, Sept. 20, 1865.

Apron hooks and rugs, per gross, \$2.50.  
 Axle-clips, according to length, per dozen, 75c. a \$1.25.  
 Axles, common (long stock), per lb, 9c.  
 Axles, plain taper, 1 in. and under, \$6.50; 1½, \$7.50; 1¾, \$8.50; 1⅞, \$9.50; 1⅝, \$10.50.  
 Do. Swelled taper, 1 in. and under, \$7.00; 1½, \$8.25; 1¾, \$8.75; 1⅞, \$10.75; 1⅝, \$13.00.  
 Do. Half patent, 1 in. and under, \$9.50; 1½, \$10.75; 1¾, \$12.50; 1⅞, \$14.50; 1⅝, \$16.25.  
 Do. Smith's New York half patent case-hardened malleable iron box, 1 in. and under, \$10; 1½, \$10; 1¾, \$12.  
 Do. Smith's Homogeneous steel, case-hardened mall. boxes, ⅝ in., \$12; ¾, \$12; ⅞, \$12.50. Long draft, \$2 extra.  
 Do. Saunders' improv. taper, ⅜ in., \$12.00; ⅞, \$12.00; 1, \$12.00; 1½, \$13.00; 1¾, \$15.  
 Do. do. Homogeneous steel, ⅝ in., \$15.00; ¾, \$15; ⅞, \$16.50; long drafts, \$4 extra.  
 These are prices for first-class axles. Makers of less repute, cheaper.  
 Bands, plated rim, under 3 in., \$2.50; over 3 in., \$3.  
 Do. Mail patent, \$3.00 a \$5.00.  
 Do. galvanized, 3½ in. and under, \$1; larger, \$1 a \$2.  
 Basket wood imitations, per foot, \$1.25.  
 When sent by express, \$2 extra for a lining board to a panel of 12 ft.  
 Bent poles, each \$2.00.  
 Do. rims, under 1½ in., \$2.25 per set; extra hickory, \$2.50 a \$3.50.  
 Do. seat rails, 50c. each, or \$5.50 per doz.  
 Do. shafts, \$7.50 per bundle of 6 pairs.  
 Bows, per set, light, \$1.25; heavy, \$1.75.  
 Bolts, Philadelphia, list.  
 Do. T, per 100, \$3 a \$3.50.  
 Buckram, per yard, 25 a 30c.  
 Buckles, per grs. ½ in., \$1.50; ⅞, \$1.50; ¾, \$1.70; ⅞, \$2.10; 1, \$2.80.  
 Burlap, per yard, 30c.  
 Buttons, japanned, per paper, 30c.; per large gross, \$3.  
 Carriage-parts, buggy, carved, \$4 a \$5.50.  
 Carpets, Brussels, per yard, \$2 a \$3; velvet, \$3.75 a \$4.50; oil-cloth 60c. a 75c.  
 Castings, malleable iron, per lb, 20c.  
 Clip-kingbolts, each, 50c., or \$5.50 per dozen.  
 Cloths, body, \$4 a \$6; lining, \$3 a \$3.50. (See *Enameled*.)  
 A Union cloth, made expressly for carriages, and warranted not to fade, can be furnished for \$2.50 per yard.  
 Cord, seaming, per lb, 45c.; netting, per yard, 5c.  
 Cotelines, per yard, \$4 a \$8.  
 Curtain frames, per dozen, \$1.25 a \$2.50.  
 Do. rollers, each, \$1.50.  
 Dashes, buggy, \$1.75.  
 Door-handles, stiff, \$1 a \$3; coach drop, per pair, \$3 a \$4.  
 Drugget, felt, \$2.  
 Enameled cloth, muslin, 5-4, 85c.; 6-4, \$1.05.  
 Do. Drills, 48 in., \$1.20; 5-4, 90c.  
 Do. Ducks, 50 in., \$1.40; 5-4, \$1.35; 6-4, \$1.55.  
 No quotations for other enameled goods.  
 Felloc plates, wrought, per lb, all sizes, 25c.  
 Fifth-wheels wrought, \$1.75 a \$2.50.  
 Fringes, festoon, per piece, \$2; narrow, per yard, 18c.  
 For a buggy top two pieces are required, and sometimes three.  
 Do. silk bullion, per yard, 50c. a \$1.  
 Do. worsted bullion, 4 in. deep, 50c.  
 Do. worsted carpet, per yard, 8c. a 15c.  
 Frogs, 75c. a \$1 per pair.  
 Glue, per lb, 25c. a 30c.

Hair, picked, per lb, 60c. a 90c.  
 Hubs, light, mortised, \$1.10; unmortised, \$1.00—coach, mortised \$1.50.  
 Japan, per gallon, \$3.  
 Knobs, English, \$1.50 a \$1.75 per gross.  
 Laces, broad, silk, per yard, \$1.00 a \$1.25; narrow, 15c. to 20c.  
 Do. broad, worsted, per yard, 50c.  
 Lamps, coach, \$20 a \$30 per pair.  
 Lazy-backs, \$9 per doz.  
 Leather, collar, dash, 28c.; split do., 18c. a 21c.; enameled top, 30c.; enameled Trimming, 28c.; harness, per lb, 50c.; flap, per foot, 25c. a 28c.  
 Moquet, 1½ yards wide, per yard, \$9.00.  
 Moss, per bale, 12½c. a 18c.  
 Mouldings, plated, per foot, ¼ in., 14c.; ⅜, 16c.; 18c.; ½, 1 ead, door, per piece, 40c.  
 Nails, lining, silver, per paper, 12c.; ivory, per gross, 50c.  
 Name-plates.  
 See advertisement under this head on 3d page of cover.  
 Oils, boiled, per gallon, \$1.80.  
 Paints. White lead, ext. \$15, pure \$16 p. 100 lbs.; Eng. pat. blk, 35c.  
 Pole-crabs, silver, \$5 a \$12; tips, \$1.50.  
 Pole-eyes, (S) No. 1, \$2.70; No. 2, \$2.90; No. 3, \$3.10; No. 4, \$4.50 per pr.  
 Sand paper, per ream, under No. 2½, \$5.00; Nos. 2½ & 3, \$5.65.  
 Screws, gimlet.  
 Add to manufacturer's printed lists 20 per ct.  
 Do. ivory headed, per dozen, 50c. per gross, \$5 50.  
 Serims (for canvassing), 20c. a 30c.  
 Seats, buggy, pieced rails, \$1.75; solid rails, \$2.50.  
 Shaft-jacks (M. S. & S.'s), No. 1, \$2.75; 2, \$3.25; 3, \$3.50.  
 Shaft-jacks, common, \$1.40 a \$1.60 per pair.  
 Do. tips, extra plated, per pair, 37½c. a 56c.  
 Silk, curtain, per yard, \$2 a \$3.00.  
 Slat-irons, wrought, 4 bow, \$1.12½; 5 bow, \$1.25 per set.  
 Slides, ivory, white and black, per doz., \$12; bone, per doz., \$1 50 a \$2.00; No. 18, \$2.50 per doz.  
 Speaking tubes, each, \$8.  
 Spindles, seat, per 100, \$1.50 a \$2.50.  
 Spring-bars, carved, per pair, \$1.75.  
 Springs, black, 23c.; bright, 24c.; English (tempered), 27c.; Swedes (tempered), 31c.; 1½ in., 1c. per lb. extra.  
 If under 36 in., 2c. per lb. additional.  
 Two springs for a buggy weigh about 28 lbs. If both 4 plate, 34 to 40 lbs.  
 Spokes, buggy, ⅞, 1 and 1½ in. 8½c. each; 1½ and 1¾ in. 8c. each; 1¾ in. 9c. each.  
 For extra hickory the charges are 10c. a 12½c. each.  
 Steel, Littlejohn's compound tire, 3-16, 10c.; 1-4, 9½c.; heavier sizes, 9c. currency.  
 Stump-joints, per dozen, \$1.40 a \$2.  
 Tacks, 9c. and upwards per paper.  
 Tassels, holder, per pair, \$1 a \$2; inside, per dozen, \$5 a \$12; acorn trigger, per dozen, \$2.25.  
 Terry, per yard, worsted, \$4; silk, \$9.  
 Top-props, Thos. Pat, per set 60c.; capped complete, \$1.38.  
 Do. common, per set, 40c.  
 Do. close plated nuts and rivets, 75c.  
 Thread, linen, No. 25, \$1.30; 30, \$1.45; 35, \$1.65, gold.  
 Do. stitching, No. 10, 95c.; 3, \$1.15; 12, \$1.28, gold.  
 Do. Marshall's Machine, 432, \$2; 532, \$2.30; 632, \$2.60, gold.  
 Tufts, common flat, worsted, per gross, 20c.  
 Do. heavy black corded, worsted, per gross, \$1.  
 Do. do. do. silk, per gross, \$2.  
 Do. ball, \$1.  
 Turpentine, per gallon, \$1.75  
 Twine, tufting, per ball, 50c.; per lb, 85c. a \$1.  
 Varnishes (Amer.), crown coach-body, \$6; nonpareil, \$7.50.  
 Do. English, \$6.25 in gold, or equivalent in currency on the day of purchase.  
 Webbing, per piece, 55c.; per gross of 4 pieces, \$2.10.  
 Whiffle-trees, coach, turned, each, 50c.; per dozen, \$5.50.  
 Whiffle-tree spring hooks, \$3 per doz.  
 Whip-sockets, flexible rubber, \$4.50 a \$6 per dozen.  
 Do. hard rubber, \$10.50 per dozen.  
 Do. leather imitation English, \$5 per dozen.  
 Do. common American, \$3.50 a \$4 per dozen.  
 Window lifter plates, per dozen, \$1.50.  
 Yokes, pole, each, 50c.; per doz, \$5.50.  
 Yoke-tips, extra plated, \$1.50 per pair.





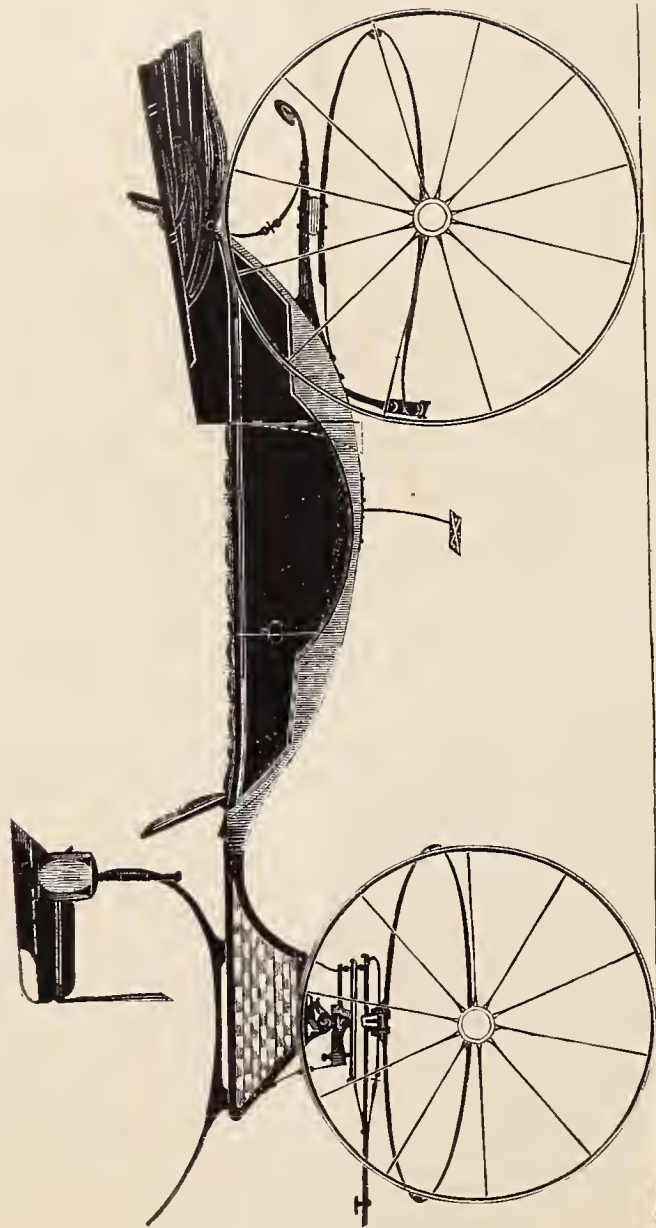

BERLIN CALÉCHE.—1 IN. SCALE.

*Engraved expressly for the New York Coach-maker's Magazine.*

*Explained on page 88.*



CUT-UNDER TURN-OUT SEAT BUGGY.— $\frac{1}{2}$  IN. SCALE.

*Designed expressly for the New York Coach-maker's Magazine.*

*Explained on page 88.*









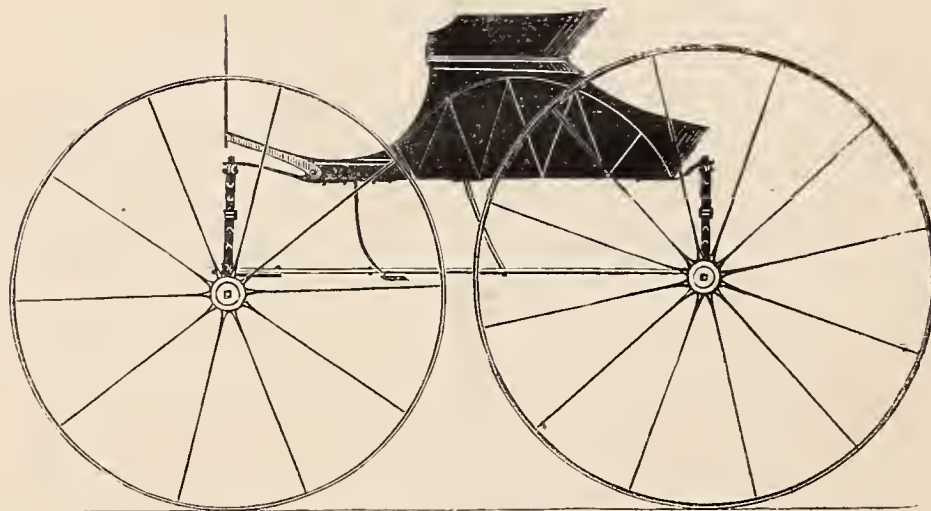

MOULDED ELLIPTIC-SPRING BUGGY.— $\frac{1}{2}$  IN. SCALE.

*Designed expressly for the New York Coach-maker's Magazine.*

*Explained on page 88*

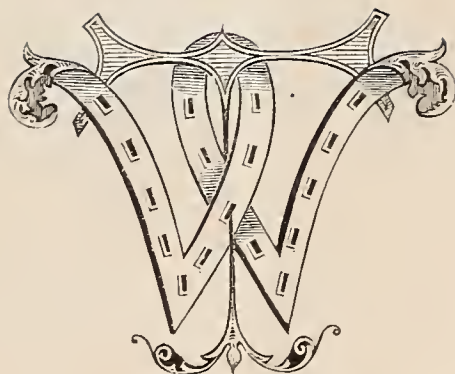

W. T.

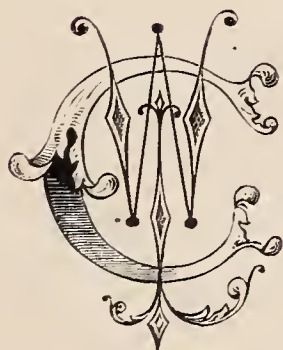

L. W. C.

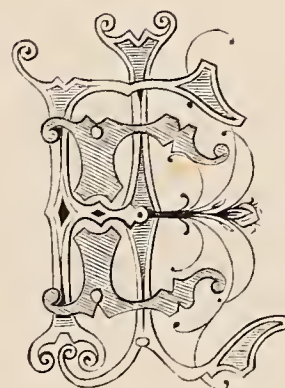

F. E. L.

ORIGINAL MONOGRAMS.

*See remarks on page 90.*







DEVOTED TO THE LITERARY, SOCIAL, AND MECHANICAL INTERESTS OF THE CRAFT.

Vol. VII.

NEW YORK, NOVEMBER, 1865.

No. 6.

## Mechanical Literature.

### THE REVIEWER REVIEWED.

BY HENRY HARPER.

MR. O. E. MILES, after due deliberation, has thought his article on "Popular Errors"—which is to be found on page 1 of this volume—could be "profitably extended." On page 33 we have a rehash of the same thing. Here he explains the "fact" that the Pittsburg axle manufacturers worked up their iron axles; but this was not, in the former article, given by him as a mechanical argument, but as historical fact. Those who are regularly buying axles in that market, and have found the prices quoted continually on the rise with labor, will not be apt to draw deductions any more favorable to him as a *historian* than they did as a mechanic.

What motive he has in view in writing these articles is not very clear; yet two things seem more prominent than anything else: *First*, That by introducing a truss stay to his model wagon, in the way described on page 85, volume vi., he wishes to show that he has given additional strength to his revolving axle which other wagons did not have. *Second*, Since he found that it was impossible, with his axle, to make the bearing come equally on the bearing surface, he now wishes to show that there is no use of it and that it will immediately spring out of place with the old axle.

His stay brace has been examined in the September number of this Magazine; and, it is there shown, that instead of being a stay to the axle it is in effect abandoning a perfect principle that long since had been in practical use; therefore we may proceed to the second part of his subject—his objections to the Axle Gauge. He attempts to carry his point by ridicule—a species of argument always looked upon as suspicious, and seldom resorted to where anything else can be said.

If axles are properly set he thinks they are only of use while they are in the repository. He takes it as a foregone conclusion that he has discovered a way of staying axles in their places, and that we have been deficient in that important item heretofore. Come to present the fact as has been done in the September number of the Magazine—which shows that we have always had a per-

fect stay to the axle—the tables are turned, and he stands with his improvement in the untenable position that he wished to place the Axle Gauge. Mr. M. does not deny that the Gauge is all that it claims to be; that is, that it will set the axle arms to their proper place, according to the dish of the wheels and taper of the arms; but says the difficulty is to keep them there. Why need it trouble him so much if it does not make any difference how an axle is set, as he argues? Here is the difficulty: if it is necessary to set an axle so that the bearings are equal throughout the length of the arm his model wagon is not practicable. It requires the bearing to be made as close to the spokes on the convex side of the wheel as can be. In addition, he loses the advantage derived from the natural tendency lubricating matter has of flowing downward to the point of bearing. He has to rely on the packing to convey the oil upwards towards the bearing of the axle-box. The gain he gets is a certain amount of leverage which cannot be disputed. The question is whether his gain is greater than his loss? In deciding it will be just to use his own testimony.

On page 86, volume vi., in describing his wagon and accounting for some unfavorable results he says; "I committed an error in making the boxes too narrow, under the mistaken notion that by this means I diminished friction. I had not then learned the fact long since familiar to mechanics that increased width in the journals adds nothing to the friction, but greatly to its durability. In addition to this mistake two of the boxes proved to be very soft porous iron, and the result was that after running four months they commenced cutting and were soon ruined."

If I understand the object of setting an axle it is to make the bearing equal throughout the length of the box. It will make little difference how wide the box is if the bearing comes on one edge of the box. Thus, in Figure 1. let B represent a box, and A an axle, C the edge where the bearing comes. They are held firmly to their respective places. No matter how wide the box is, the point C is the only part that will touch. Mr. M. should understand that his boxes will wear out under any circumstances unless the axle is set right.

Two of his boxes proved to be soft porous iron, he says. Exactly so. Concentrating the bearings on one edge would crowd the oil from between the bearings, so

Entered, according to Act of Congress, in the year 1865, by E. M. STRATTON, in the Clerk's Office of the District Court of the United States for the Southern District of New York.



that the rubbing iron coming in contact, heat would be the inevitable result; and that would make iron so soft that it would cut out just as quick if the boxes had been hard as if they were soft. Where wagon axles are not set right the boxes and axles *always* "prove to be soft." There are some other facts in the case which should be stated to give us some idea how unsafe it is to ignore properly setting the axles.

Mr. M., desiring to compare the draught of his wagon with another reputed to run very easy, procured a dynamometer and loaded the two wagons as nearly equal as he could by guess. The dynamometer showed the draught of his wagon to be forty pounds more than the other. Yet, he tells us, "many men loaded and tried *his* wagon in a variety of situations, and the trial was, with scarcely an exception, highly satisfactory." That may be true; but, when we put men's opinions and the test of an actual measurement together, it shows how different *opinions* may be from *actual* measurement.

Wagons have a lever power that propels them, and frictional power that retards them. The lever power is determined by actual measurement; and there is no necessity of one wagon having less than another if the maker understands true principles. Friction has no principle whereby the amount could be restricted to the least possible quantity, in one and the same amount, in different wagons. A long experience has satisfied my mind that this depends mostly on the set of the axle. To overcome the difficulty it is necessary to have complete control of the axle, so that the bearings can be brought to any desired angle with mathematical precision and facility. My humble efforts in that direction have finally culminated in the axle gauge and scale. The scale shows the exact pitch the axle should have to accord with the dish of the wheel, and the gauge supplies an exact pattern to pitch it to. Years of patient study have been consumed in the invention. Years of sickness and poverty have been endured in my humble efforts to present the craft the range of thought through which my mind traveled in consummating the invention. Had Mr. M. read what I said, and believed it, he certainly would not have been put to the expense of testing his mechanical notions by building the wagon that did only four months service. Nor would he build the one he has in contemplation with friction rollers. Instead of profiting by my labors he spares no powers of mind in his possession to deprecate them. Notwithstanding all this, I would like to compare the fruits of our labors. The axle gauge enables the craft to reduce friction sixty times lower than it was on his model wagon. The workman has such control of the matter that he makes all wagons alike perfect in draught. Well authenticated tests, in wagons that have run for two years, carrying heavy loads, show that, at the rate they wear, the axles will last twenty years used under the same circumstances. This shows that Mr. M.'s wagon wasted sixty times more power by friction than wagons that have the axles set properly. I do not rely on peoples' *opinions* to prove this fact, but can give actual measurements.

I think that four years constant use, with heavy loads, is full as long as the wear of ordinary wagon axles will average. This will be, in time, varying all along from one hour to eight years. As many will be destroyed in one hour as will last eight years. Taking this estimate as a standard axles set perfectly will last five times as long as ordinary axles will average, and every one last alike. It

will not be by *chance* that a perfect running wagon is made. It will earn five times the cost of the wagon, and more than the ordinary wagons, with the same amount of motive power applied.

Are the fruits of such labors of any use to the public? One individual, who is, or wishes to be, renowned for skill and mechanical acumen, said "Gauge your granny! Did you ever hear of the man who boiled his water over night to scald hogs with?" Another, who has no malice at heart, and not enough care about it to investigate the subject, may say "the Gauge is a first-rate thing, and if you can make the public believe it your fortune is made." Both this malice and apathy are of use in the world or they would not be permitted. The difficulty with me is that I do not understand the philosophy of its working out a good to the public.

The history of the introduction of every improvement has complication about it, has this invariable feature, it sinks the inventor into the lowest depths of poverty, and, often, contempt. He must rise from that degradation as he best can. In time all rise from the contempt; some—as in the case of our Charles Goodyear—go up in the scale almost to adoration, yet are sunk in poverty or the grave. Others, more fortunate at the close of life, have both riches and honors conferred on them just when they have no use for it. Others, still more favored in "catching at straws," get hold of a real substantial help, and a nation's wealth is born of their inventive genius. Of this last class Watt is an example. History says that Bolton expended over \$300,000, without compensation, on Watt's steam engine improvement; yet the public could not appreciate it. He even offered to furnish the engines, gratuitously, to those who would use them, and keep them in repair at his own expense; asking, as the sole indemnity, one third of the money saved in fuel by the new engine. This noble and earnest man, with his wealth, was the midwife to England's greatness. About the same time John Fitch presented the same improvement to America. It was contemptuously declined, and he left to die in poverty. The past shows us that he who steps ahead of his time will be pelted by purse-proud insolence, stupid indifference, and malicious ignorance. Although we know the conditions the mind is still on the march, even though Death's icy finger has palsied the physical frame.

#### HOW I WAS REVIEWED.

BY O. E. MILES.

THE little Napoleon achieved a name for grand reviews while pretending to lead the army of his country against its enemies, but practically operating toward a very different result. In like manner a gentleman out west assumes the role of the great reviewer; and some of his reviews and interpretations remind us strongly of a "democratic" review of the constitution and human rights in general. The great reviewer's military politics and political generalship, had it had its perfect work, would have worked a perfect finish on our National prospects. The little reviewer, while professing to treat broadly upon mechanical principles, and give his readers an impartial view of current mechanical ideas, passes in silence the most palpable errors, abuses those who would expose them, and would, were he allowed his own way, put an eternal quietus upon all mechanical progress, were this result necessary to secure the success of his patent.



And so has poor humanity been handled from its earliest history. The names of saints, patriots, and philosophers have ever been made to falsely adorn the dark blue flag of fogysim; and thus the mercenary speculators in played-out sophistries, under pretense of being the sage conservators of everything good and useful, have constantly feathered their foul nests from the fruits of progressive toil.

The great exponent of "democracy," and his "conservative" organs, raised repeated cries of warning to the people and press that they were sapping the foundations of our domestic institutions, interfering with State and personal rights, &c.; but the people "didn't see it" any more than they will be able to see the pith of this patent gentleman's caution to discard all efforts at prevention and apply his remedy. And right here, before I forget it, let me suggest to this reviewing patentee to add to his stock of remedies a universal unabridged mechanical dictionary of his own make. It will interrupt his operations but briefly to prepare it, there being only three words in it, with a table of contents, viz:

LEVERAGE.—The universal and only force in nature.

HEFT.—The only resistance ever opposed to the above force (vulgarly called gravitation or weight).

GAUGE.—The infallible remedy for a universal disorder or ailment called by the doctors spinal curvature; mechanically termed spring axle (see advertisement).

Now let us examine how Mr. Harper fixes up a reply to my explanation of the truss principle as I apply it to the support of axles; and which, as Mr. H. himself says, "is found of such use in the support of long stringers in every department of architecture." Mark you, after admitting its great use in architecture, he attempts to make it appear that the truss stay is, in effect, but the deepening of the beam or girder to the extent that the stay reaches below the same. Wonder if he has ever seen a beam, or the side of a freight car, with a truss stay reaching just the depth of it, as in Fig. 1. If the iron has no supporting strength

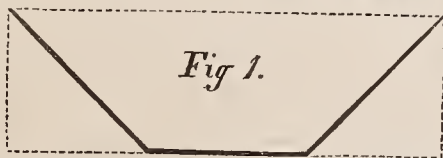

by reason of its peculiar position, as he clearly maintains, what a loss to the railroad companies that they did not long ago have the benefit of his counsel!

He says, in his very sage consideration of my first position, to wit: that iron has more supporting strength endwise than laterally; that "this result depends altogether on the amount of lever power that is thrown on to iron" (meaning weight, I suppose). You are right for once, Mr. Harper. None of us will dare deny that the result depends altogether on whether the experiment is tried or not! We are constrained to attribute the reaching of this important conclusion to a scientific sagacity and a depth of research absolutely incredible! But I do dare Mr. H. to deny that a one-inch square bar of iron will support 70,000 pounds weight, or "heft," as he would have it, on an endwise pull. I have not the authority by me, but I am confident that this is inside of the true figure. I will further dare him to deny that just before the "last straw" is laid on, said bar will measure just the length that it did before any tension was applied; and I will further dare him to deny that the first straw that is

laid on his axle at page 49 will spring his bar *appreciably*, and that 100 pounds so placed will seriously interfere with its functions as an axle. I learn from Mr. H.'s extraordinary review that the principal objections to my plan would be that the stays reaching down so near the ground would be caught by stumps, stones, &c. If your readers will lay a rule on Figure 1, page 85, volume vi., they will perceive that the nuts on the lower ends of the clips, which hold my truss together, are no lower down than the nuts on the lower side of a wooden axle; or, certainly, that no necessity exists for their doing so. A little further on in Mr. H.'s article we see that "by Mr. M.'s own showing it falls to the ground, for it is entirely devoid of the principle of the truss stay, which he claims, &c. His axle there represented revolves with the wheels, and the stay cannot be applied to it." You would have all smiled to see my trial wagon "fall to the ground" under 5,000 pounds weight, which it repeatedly carries without the least appreciable spring. Comment on this point is needless. Still a little further on he accuses me of ignoring any principle of setting axles by gauge, of depreciating his gauge, &c., when he knows that I have more than once, during our discussion, taken special occasion to indorse heartily his plan for setting axles. It would be quite as sensible for one of the Medical Faculty to accuse me of desiring to murder him because I had tried to teach his patient how to avoid disease. "That's what's the matter." *Cure*, is Mr. H.'s hobby. *Prevention*, is mine. Here I have nailed at least three flat mis-statements in the short space of less than a column of this impartial review. He goes into an elaborate calculation of the great absurdities embodied in the axles of railroad cars, leaving out of his premises, as usual, the chief peculiarity which characterizes railroad cars, viz: the great speed with which they travel necessitating a great disproportion of strength to the load carried, as compared to wagons, and makes out of his foolish fudging the important result that Miles' wagon was probably one-fourth as strong as a common one! I must candidly confess that I never read an article of scientific pretensions so innocent of one intentional truth as this same review.

Now let us ventilate his "leverage," by which he makes the axle stock in buggies and the bolsters of wagons answer every purpose of a truss girder. We will

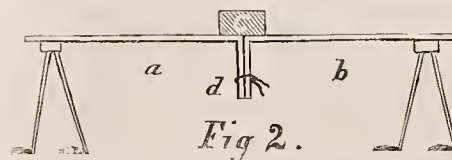

place two angled levers *a* and *b* (Figure 2), with the angles together, the long arms resting on trundles, and the short ones pointing downwards tied together with a cord, *d*. Here we have the three essentials of the lever located as they exist in the truss as I build it, and in a simple stick of timber, which Mr. H. says is the same thing. Now here is just how near they resemble each other, remembering, always, that the lower down from the fulcrum *c* the cord is placed the greater weight is required at *c* to break it (see Figure 3). Now every fibre of the stick of timber, *d*, below the top layer, is subjected to the same tension that the cord in Figure 2 is when

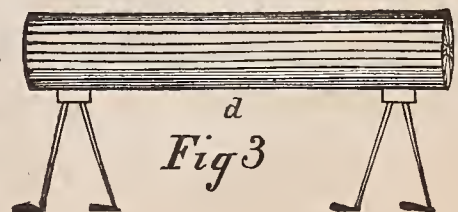



tied close up to the fulcrum *c*. To be sure "In union there is strength." Each fibre of the stick or bar has the additional support given by the cohesion of those lying round it, which soon fails under a jolting strain, as we have all seen axle arms and bolsters literally transformed into basket stuff—when the sad moral of Æsop results. The bundle of sticks has been separated. "Divided we fall."

Place the cord down to the lowest limit that the length of the short arms will admit, and we have its greatest advantage right where all the pulling strain comes in (Figure

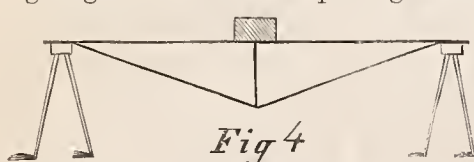

4). Then securely anchor this stretcher at the ends of the long arms of the two levers, right

where the bearing comes in my axle truss, on the top of the hub. Then let the crushing strain be properly fortified against kinking, which is effectually done by the clips *a' a'*, Figure 1, page 85, before referred to, and I feel safe in saying that no more perfect support can be constructed in the present stage of mechanical development out of the same weight of material. It will also be seen by Figure 1, page 85, that what little strain does come on the inner ends of the revolving arms *a a*, is a direct end-wise pull on an iron bolt; therefore, literally unyielding, as experiment proved, besides being perfectly supported upon my truss—*Mr. H. to the contrary notwithstanding*. If we choose to dispense with the rubber spring the bolster itself serves for the truss girder, dispensing also with the square bars, *c c*, making it a little less expensive, but harder even to ride upon than a common wagon, being totally rigid.

The springing which interferes so seriously with the easy and durable operation of common axles is of two kinds. The first is the simple operation of the property of elasticity, from which the axle recovers itself *almost* when the load is removed. I believe all known elastic solids refuse to quite regain their original positions after long continued flexure. As the mischief is always present while the axles are loaded, what a consolation to know that it stood in a correct position *before* it was loaded! This continual elastic springing of iron axles causes a continual, though slight, slipping of the joint, between the axle and stock, which cannot be prevented by loading it with clips from shoulder to shoulder. This tendency in an unsupported beam, especially one exposed to a jolting strain, to draw the fibres by each other, is so immensely powerful as to disintegrate the best of timber or iron, after a time, so that its stiffness is gone forever.

The other kind of spring of which I have spoken is a permanent bend which occurs at the shoulder, generally caused by a sudden jolt under a heavy load. This is one of that class of wounds which we sometimes wish might have proved fatal. In other words it is better for an axle to break, as a good weld is much safer than a replaced bend. After an axle has been once bent and straightened it requires this process thereafter, regularly, once a day (Sundays excepted). If Mr. H. will please tell us, in his next, how the axle stock or bolster operates to prevent this occurrence, he will place us all under lasting obligations.

Mr. H. calls for a report upon the draught qualities of my trial wagon, for which I must refer him to page 86,

volume vi., for the only satisfactory report I am able to give, which was the unanimous report of the many who tried it, to wit: highly in its favor. A dynamometer trial, applied after two of the boxes had commenced cutting, resulted against me a few pounds as compared with the easiest running wagon I could find. My arrangement, as then developed, showed a very large gain of power, which proved to be just about exactly canceled by a like increase of friction. I intend, in a wagon I am now building, to retain the same increase of power while I expect to develop much less friction than in a common wagon. Mr. H. may be surprised to find me ready to expose every point, whether for or against my preconceived views. The *truth* is what I am after; and I would be gratified to discover some slight evidence of a like disposition in him. I feel that I cannot afford to lose or misapply a jot of the evidence which any experiment may develop, or which mechanical or commercial operations around us may bring out or foreshadow. It is hypocrisy, as I am taught, to bow in august reverence to a law which is written while we strive to put out of sight or grossly misrepresent the more indelible characters which reflect upon the human intellect from the strata, the crucible, the forge. To my understanding our first duty, our best interests, and our highest privilege, all lie in the same direction—that of the deepest and most impartial research into, and the most purely honest interpretation which we are capable of, the glorious mechanical laws which it is our mission to expound; and if there is to be an endless punishment, a loss which an eternity of penitence cannot restore, it will be in the ever-recurring reflection that many a step in the eternal flight still lies ahead of us which might long ere this been left behind had we pursued with a more abiding faith, and more honesty of purpose, the harmonious code laid down by the Divine Architect, of whom the earthly artisan is the feeble yet ever unfolding type. Mr. H. affecting to ignore and put away the significance of the gradual, and, finally, almost total, cessation of the iron axle trade for wagons, is simply foolhardy and preposterous. He has invented a genuine instrument, and he or his heirs may grow rich out of it long after the article to which it is applied has become obsolete; but, if it were my case, the way the mechanical horizon now looks I should feel in a hurry; for the iron axle, as at present made, is as surely about to take its exit from the mechanical theater as that Slavery has gone "to pot," or "Little Mac" to Europe. Then, Br. Harper, we will "hang our harps upon the willows" and be resigned.

#### HORSE-FEEDING.

HENRY & MARSH, long livery keepers in Springfield, Mass., feed as follows: At 6 A. M., four quarts of oats, then long hay is offered; at noon eight quarts of oats; at night, a scoop shovel full of cut feed, consisting of chaffed hay and straw, intermingled with wheat shorts and meal. The night feed is always the heaviest. They use two hundred pounds of shorts a day for forty horses, and only about a ton of hay a month. They like oats ground with corn, but think clear corn too hearty. Rye makes a horse weak and stumble. Rye straw is the best of straws for feed, but all horses do not love it. The horses are fed regularly, a little food this way being considered better than a larger quantity at random. Water is given three times a day, the two last times with a pail



in the stall. Wheat shorts alone are medicinal, and may be safely used for a sick or idle horse. E. H. Patch, a well known boarding stabler, prefers cut feed and meal three times a day, and long hay the last thing at night. Farmers usually feed too much hay. Likes corn meal ground fine. Would not feed on shorts alone. Hogs can live on horse manure when horses have coarse meal. Rye and carrots weaken a horse. Horses vary in their needs, but fifteen pounds of hay and meal each, a day, or a hundred pounds each a week, is enough for most horses. A peck of corn meal weighs about fourteen pounds. A man that gives six quarts of meal at one feed usually has a poor horse, and shows his ignorance of feeding. Severe exercise retards digestion, hence a horse should have less than usual just before and after a hard drive. Water sparingly; half a pailful at once being ample. Too much water scours a horse and deranges digestion. Regularity conduces to thrift, and the cleaner a horse the healthier. Grooming saves feed. George Kibbe, the confectioner, who always keeps good horses, and knows how to improve them, believes in a variety of food, as well as regularity. He would have no two meals in a day alike. Likes a clean manger and a sharp appetite. Fasting sharpens the appetite. Uses very little long hay, and never more at a time than can be carried with one hand. Prefers oats first in the morning, corn meal and shorts in equal quantities, wet, at noon, and cut feed at night. Cracked corn or corn in the ear is desirable once a week. Uses a thin blanket in the stable. A horse treated in this way generally looks and feels well, and is ready for service. At Quincy, Ill., where Mr. Kibbe spent the last winter, they feed horses twelve ears of corn three times a day. Nearly one-third of their horses are blind or have white eyes, caused, doubtless, by their giving corn to colts. Mature horses can bear corn better. William Pynchon, a thrifty farmer of this city, feeds his work-horses thus: at 5 A. M., four quarts of oats, then a little dry hay; at noon, four quarts of oats again, then dry hay; at night, cut feed in which is three quarts each of cob corn meal and oats, water is given three times a day, but only after eating. Colts and idle horses get long hay morning and noon, and cut oat straw on which is four quarts of wheat bran, at night. They are watered at ten A. M., and only once a day. At a Boston livery stable of thirty horses, where hay costs \$43 a ton, and oats \$1.08 a bushel, twelve quarts of oats and ten pounds of hay is the daily allowance. The heaviest feed is given at night. Cut feed and meal is used only summers, because it does not freeze. Likes wheat shorts to regulate sick horses. Prefers loose hay to baled, because it has less chance to heat. At the Boston city stables where fifty-seven large horses are kept, under the superintendence of C. R. Cutler, they feed cut hay and meal at half-past four A. M., nine quarts of cracked corn and oats at noon, and cut feed at night. On an average, the horses eat \$4.50 worth of meal a week. Their hay comes in three hundred pound bales from Maine, is heavily bound with birch withes, and costs \$42 a ton. Here is a large new brick stable, conveniently situated for drainage into the back bay, and other systems more theoretical than practical. The horses face each other, and have a generous feeding passage between. They are separated from each other on the sides, in part, by an iron lattice. This allows them to see each other, makes them uneasy and wasteful, and has many of the disadvantages of feeding

at a picket rope. The mangers are of iron, which at times must be cold and uncomfortable. The floors are sparred, ostensibly to take away the urine, but really damaging the horse's foot by making it dry and crackly. Back of the horses is an iron crib, for holding and drying the nightly bedding. The crib is bad to back against, and has been known to trip an awkward beast. The solid manure of these horses brings \$6 a head per annum. Collecting swill and garbage is their chief business, which, solidified and drained, brings \$8 per cord, or about \$6,000 per annum. It costs about \$20,000 to collect it, the improved health of the city making up for the deficit. The old-fashioned way of feeding horses is to give them all the hay they will eat, all the water they will drink, and on rare occasions a little grain. Experience proves this to be neither politic nor economical. A horse lacks judgment, and it is here that human reason comes in. A limited quantity of choice food, fed regularly and judiciously, is better for the health and flesh of a horse than a larger quantity at random. Cleanliness and comfort are essential. Circumstances may vary the style of feeding, but for economy we have seen nothing better than the practice of the Boston livery stable, where horses are kept at a first cost of about fifty cents a day.—*Springfield Republican.*

## Home Circle.

### THE PAST.

BY FRANCES LAMARTINE.

Like a beautiful picture, it hangs on the wall  
Of my heart's sacred chamber, in memory's hall;  
Put safely away  
From the dust and decay  
Of Time's gathering rubbish, of earth's rise and fall.

Like a painting embellished by rare gems and flowers,  
It is locked safely there, in my soul's mighty towers;  
No earth-power can stain  
It's bright beauty again,  
For it heeds not the moments, the days, nor the hours.

Like a ling'ring reflection on Time's flowing stream,  
Where the shadows sweep o'er it, yet hide not it's gleam,  
Oh! thus 'tis arrayed,  
And it never will fade  
Like the beauties of summer, or thoughts of a dream.

It's white sails are flutt'ring o'er life's lovely sea,  
And the wavelcts are dancing in wild, merry glee;  
No storm clouds arise  
In the blue, ether skies,  
For oh! twas a beautiful life-dream to me.

The happiest faces, the cherished of yore,  
Are peacefully smiling in Memory's store;  
But their mist-covered eyes,  
Like stars through dim skies,  
Gleam mournfully out from the shadowy shore.

Let others talk ill of the beautiful Past;  
Let them say it was dark and its sky was o'ercast,—  
'Twas a joy to *this* heart,  
And it ne'er will depart,  
Till the angel of Death shall have called me at last.



## OCTOBER.

BY MARY A. E. WAGER (MINNIE MINTWOOD).

OCTOBER'S sombre presence slips  
 From out the year's unloving hand  
 She touches all things with her lips,  
 And trails her wierd robe o'er the land;  
 Beneath her gaze the apples blush,  
 The leaves grow crimson at her breath,  
 The hills to purple glory flush—  
 All royal-hued, to welcome Death!

Oh Death! a fitter presence thou,  
 Than sad October's tearless eyes,  
 That need to tell no gazer now  
 How pensively the Autumn dies.  
 She fruited Spring-time's smile's and tears,  
 She garnered all the summer toils—  
 Now sad and lone sinks in the years  
 The past uptreasures as her spoils.

Oh Heart! upon thy crimson fields  
 The life's October lieth low;  
 Hope's golden grain no harvest yields—  
 A desert, fleeced with hints of woe.  
 Within thy vales, where ealm content  
 Outflung her banner pure and fair,  
 Distrust a troop of shadows sent  
 That laugh to scorn her presenee there.

\* \* \* \* \*

'Tis well. I know a promise reads:—  
 "All who my precepts firmly keep,  
 And seed their lives with righteous deeds,  
 In heaven will full fruition reap.  
 Faint not! my hand will bear thee up,  
 And lead thee where distrust, and wrong,  
 And every dreg of sorrow's eup,  
 Give way to one triumphant song."

## THE AUNT'S STORY.

BY MARY A. E. WAGER.

It was early in September, and for several days the air had been hot and stifling, and, in the large towns, unusually oppressive. Annette Ray sat at one of the windows of a grand hotel, idly toying with a heavy tassel that nearly swept the floor, while around her ripe lips a slight sense of weariness was visible. She was spending a few weeks with her aunt, but was growing weary of town life and longed for the cool shady places with which her country home abounded.

"I think I must go home to-morrow," she said, as the two sat down in the luxurious parlor, after dinner. "I am tired of being ringed in and ringed out, and this everlasting routine of etiquette. Your rooms are elegant, your wardrobe unexceptionable. But, after all, Auntie, I don't believe I would give you in exchange my little rag-carpeted chamber at home, and calico dresses that I'm not afraid of spoiling even in a blackberry scramble."

The ealm face of Mrs. Ray was turned toward her niece with a smile, and, after a moment, she said, musingly:

"I hope you will always think so, Annette. I have an acquaintance in town who lives very quietly; and, as you seem so rustieally inclined to-day, what do you say of going with me to take tea with her?"

Annette was much pleased, and an hour later found them knocking at the door of a plain but respectable

dwelling in the outskirts of the town. They were greeted with a hearty welcome by the hostess, Mrs. Dunbar, who led them into a pleasant apartment that bore evidence of being the best room. A tasteful ingrain covered the floor; a number of easy chairs, a few choice prints, and fresh, airy muslin curtains were the other best points.

The usual gossipy conversation ensued until tea was announced and the guests were invited into an adjoining room to partake of the repast. The table was spread with nice linen, the china bright and glistening, and the eatable palatable enough to satisfy an epicurean of the first water. After tea was over and they were back in the parlor, Annette exclaimed, as she sank in an easy chair by the open window:

"How cosy and pleasant it is here! It really seems home-like!"

As she made the remark the bitter, discontented expression she had noticed on the face of Mrs. Dunbar visibly deepened, as she answered:

"We might have things pleasant if Mr. Dunbar would only get things—I am really ashamed to have my friends visit me when I have no better way to entertain them. My daughter has been feeling badly all the evening because we set no better table. But we've talked to Mr. Dunbar until I'm tired of it, and have about made up my mind to let things go and be content to be nobody."

Annette's brown eyes filled with surprise at her remarks, and tinged her voice, as she said:

"Why, I am sure you need not wish for anything better. Fine furniture does not make people happy. And you have things so nice and comfortable I see no need of complaint."

Her remarks did not seem to pacify her hostess at all; for, she continued in her strain of fault finding, contrasting her surroundings with those of her richer neighbors with whom she was on terms of intimacy.

From the conversation in the afternoon, which had been of an easy, confidential nature, one could easily infer that her husband was a mechanic who supported his family by day wages, their house a rented one, the wife and daughter extravagant in many ways. Making no effort, with their own hands, to lighten the care and labor of the husband and father, or cheering him with kindly, hopeful words. Their complaint was based upon the ground that they might live better if it were not for the penuriousness of Mr. Dunbar. The desire for fine living was merely to be able to have a better show of furniture for visitors, without regard to the comfort or feeling of him who should have been held as their best guest—the husband and father. Annette felt that *his* hold on the purse strings was their only safety, and longed so to tell them; but, being so much a stranger, forbore; but not without looking at her aunt, from whom she eagerly desired some comment. She was not disappointed.

"Laura," said Mrs. Ray, "there is a sad page in my life that I never read to any one; but, if you will listen, I will tell it to you."

Laura Dunbar signified her assent and her friend began.

"I was very young when married—only nineteen—and my husband was the only being I loved—my mother died when I was an infant, and my father was so stern and harsh that I married to free myself from the constraint his presence imposed upon me. I loved my husband with an idolatry that was almost a sin—I would have died for



him had it been to save him. I would suffer cheerfully for his sake. But, alas! at length a foolish sinful pride embittered my life and made us both wretched. We began life with little wealth, aside from our hands, and our cottage was a very humble home. But, for a year or two, it was a heaven to me and a haven of peace and rest to him. As time passed his business increased, our circle of acquaintances enlarged, and with it a desire for a better style of living took possession of me that only would be satisfied by the refitting and refurnishing of our house that would swallow up all we had been able to save from our living. My husband endeavored to convince me that, as we had been happy before, we could be happy still, and it would be better to have something laid up for a 'rainy day.' But my heart was set upon having things as good as my neighbors, and he finally yielded to my entreaties. As I glanced through the rooms, after they were arranged, a feeling of pride thrilled me that might have been justifiable under more favorable circumstances. My husband missed the easy couch, finding in its stead a staid sofa; and the room was never so bright and sunny after the new carpet was put down and the crimson curtains hung. He felt like a stranger in his own house, he said; and he came to spending an occasional evening away as I wearied of my new furniture and began again to ask for more. One new article only made way for another; and but a year or two had elapsed before my importunities became so habitual for increased expenditure that his leisure hours were all spent away from home in order to be free from his wife's increasing discontent.

Affairs grew no better as time progressed. Being deprived of my husband's society I looked elsewhere for sympathy, choosing, for companions, women in better circumstances than myself. I was continually endeavoring to possess what I did not have, failing to be happy with what I had. I thought my husband really unkind and selfish that he would not gratify me. At length, either from over-persuasion or a desire to have peace at any cost, he rented a larger house, furnished it with elegance, and said, after we were settled:

"I hope now you will be satisfied, Maria. I wish from my soul we could live our first year over—it was the only really happy one I have known. Heaven knows I can't support this style of living."

He seemed thenceforward to abandon himself to reckless extravagance. I questioned his ability, but he cut me off with:—

"'Tis your own act, Maria. You gave me no peace."

He came home late at night. His business was neglected. His eyes grew restless and wandering; family devotion was no longer held. The awful truth burst upon me—*my husband had become a gambler*; gambling for money to drown my incessant cry of 'give, give.' He took to drinking, borrowed money, staked heavily, and lost all. Then our goods were sold, and we were homeless and penniless. The trouble, with his habits of dissipation, brought on a fever from which he but scarcely recovered. I watched him through the long, weary illness; and, when life triumphed over disease, I thanked God, as I never had before, that my husband's life was spared and I was not a murderer!—for I felt that I had periled both his body and soul by my sinful, foolish ambition; and, God helping us, we would begin life anew, and never, by word or deed, would discontent fall upon my husband's heart, if my life could but be blessed with

his presence. So we began anew—poor in worldly goods, but rich again in each other's love and confidence. Our simple parlor was made pleasant by cheerful, loving words. There were always smiles or pleasant words for my husband or friends. We made no apologies to guests, for our circumstances, but gave them what God gave us. Those were happy days again, but purchased at a most fearful cost. We are now rich, and have long been surrounded by the luxuries wealth imposes upon its possessors, but we are no happier now than when our best room boasted of nothing costlier than a chintz-covered lounge and home-made carpet. It is not our surroundings that make us happy, my dear Laura. Honor your husband's judgment as your highest law, and hold his love of home and happiness as your most sacred talisman."

Tears stood in the eyes of both women as she closed; and, as she took the hand of her friend at parting, Laura Dunbar said with an attempt to smile:

"I will not forget what you have said. May God bless you, dear friend, and help me to profit by your warning."

HILDALE FARM (near Ludlowville), N. Y.

## TWO WAYS OF TELLING A STORY.

IN one of the most populous cities of New England, a few years since, a party of lads, all members of the same school, got up a grand sleigh-ride. The sleigh was a large and splendid one, drawn by six gray horses.

On the day following the ride, as the teacher entered the school-room, he found his pupils in high merriment, as they chatted about the fun and frolic of their excursion. In answer to some inquiries which he made about the matter, one of the lads volunteered to give an account of their trip and its incidents.

As he drew near the end of his story, he exclaimed: "O, sir, there was one little circumstance that I had almost forgotten. As we were coming home, we saw a queer looking affair in the road. It proved to be a rusty old sleigh, fastened behind a covered wagon, proceeding at a very slow rate, and taking up nearly the whole road.

"Finding the owner was not disposed to turn out, we determined upon a volley of snow-balls and a good hurrah. They produced a right effect, for the crazy machine turned out in the deep snow, and the skinny old pony started on a full trot.

"As we passed, some one gave the old jilt of a horse a good crack, which made him run faster than he ever did before, I'll warrant. And so with another volley of snow-balls pitched into the front part of the wagon, and with three times three cheers, we rushed by.

"With that an *old fellow* in the wagon, who was buried up under an old hat, and who had dropped the reins, bawled out, 'Why do you frighten my horse?' 'Why don't you turn out then?' says the driver. So we gave him three rousing cheers more. His horse was frightened again and ran up against a loaded team, and I believe almost capsized the old creature, and so we left him."

"Well, boys," replied the instructor, "take your seats, and I will take my turn and tell you a story, and all about a sleigh-ride, too. Yesterday afternoon, a very venerable old clergyman was on his way from Boston to Salem, to pass the residue of the winter at the house of his son. That he might be prepared for journeying in the



spring, he took with him his wagon, and for the winter his sleigh, which he fastened behind the wagon.

"His sight and hearing was somewhat blunt by age, and he was proceeding very slowly and quietly, for his horse was old and feeble, like his owner. His thoughts reverted to the scenes of his youth, of his manhood, and of his riper years. Almost forgetting himself in the multitude of his thoughts, he was suddenly disturbed and terrified by loud hurrahs from behind, and by a furious pelting and clattering of balls of snow and ice upon the top of his wagon.

"In his trepidation he dropped his reins, and as his aged and feeble hands were quite benumbed with cold, he could not gather them up, and his horse began to run away. In the midst of the old man's troubles, there rushed by him, with loud shouts, a large party of boys in a sleigh drawn by six horses. 'Turn out! turn out, old fellow! Give us the road, old boy. What will you take for your pony, old daddy? Go it, frozen nose. What's the price of oats?' were the various cries that met his ear.

"'Pray do not frighten my horse!' exclaimed the infirm driver. 'Turn out, then, turn out!' was the answer, which was followed by repeated cracks and blows from the long whip of the 'grand sleigh,' with showers of snowballs, and three tremendous cheers from the boys that were in it. The terror of the old man and his horse was increased, and the latter ran away with him, to the imminent danger of his life. He contrived, however, to secure his reins, and to stop his horse just in season to prevent his being dashed against a loaded team.

"A short distance brought him to his journey's end, to the house of his son. His old horse was comfortably housed and fed, and he himself abundantly provided for. That son, boys, is your instructor, and that *old fellow*, and *old boy* who did not turn out for you, (but who would gladly have given you the whole road, had he heard your approach,) that *old daddy* and *old frozen nose*, was your master's father."

Some of the boys buried their heads behind their desks, some cried, and many hastened to the teacher with apologies and regrets without end. All were freely pardoned, but were cautioned that they should be more civil for the future to inoffensive travelers, and more respectful to the aged and infirm.

#### YOUNG SMARTNESS.

"DAD," said a hopeful sprig, "how many fowls are there on that table?"

"Why," said the old gentleman, as he looked complacently on a pair of finely roasted chickens that were smoking on the dinner table: "Why, my son, there are two."

"Two!" replied the young smartness, "there are three, sir, and I'll prove it."

"Three?" replied the old gentleman—who was a plain matter-of-fact man, and understood things as he saw them. "I'd like to have you prove that."

"Easily done, sir, easily done. Ain't that one?" laying his knife upon the first.

"Yes, that's certain," said his dad.

"And ain't that two?" pointing to the second; "and don't two and one added together make three?"

"Really," said the father, turning to the old lady, who was listening in astonishment at the immense learning of

her son, "really, wife, this boy is a genius, and deserves to be encouraged for it. Here, old lady, do you take one fowl, and I'll take the second, and John may have the third for his learning."

## Pen Illustrations of the Drafts.

BERLIN CALECHE.

*Illustrated on Plate XX.*

WE find a drawing—we have slightly altered it—in an exchange, of a Caleche, by the celebrated builder Mr. Neuss, of Berlin, which possesses so many peculiar features that we are induced to present it to our readers. The arrangement of the diekey-seat, giving it a very light appearance, will strike the American coach-builder as being something of a novelty. Whether or not it be an improvement our readers will judge.

CUT-UNDER, TURN-OUT SEAT BUGGY.

*Illustrated on Plate XXI.*

ALTHOUGH this drawing possesses no very novel features, still it represents a very useful buggy for business purposes in large cities with narrow streets. For those in the country, who have a long distance to travel to church, it will be found very useful where there are juveniles in the family. The idea, however, of carrying two or four passengers, on the same elliptic springs, with equal comfort, must not be entertained for a moment.

MOULDED ELLIPTIC-SPRING BUGGY.

*Illustrated on Plate XXII.*

THERE appears, at present, to be a disposition among some manufacturers, as well as customers, to gratify their fancies for mouldings on the sides and backs of vehicles, to the great annoyance of the painter. This fact has led us to produce the example given on the plate above numbered. The outlines of the body present the reader with the very latest features of the New York buggy. It will be noticed that the bowl is omitted. Perhaps we may as well say to our friends in the country that *that* article, as applied to buggies, has about "played out" among Metropolitan carriage-builders.

## Sparks from the Anvil.

### THE PERCH-COUPLING THROWN OUT OF COURT.

THE perch-coupling man has several times been defeated in court, after a fair trial, but the following phase in his history will be news to our readers.

It appears that G. Haussknecht, in the course of business, filed a bill of equity against Elias and James D. Driscoll, of Springfield, Ohio. When the matter came up in the October term of the court, at Cincinnati, in 1864,



defendants, under the advice of S. S. Fisher, Esq., their legal adviser, filed a plea of the statute of limitations—that the offence, if any, had been committed over six years when this suit was brought—under which proof was taken, showing that the defendants had made a few carriages under the Everett patent more than six years previously. The court held that the point was well taken, and dismissed the bill at the plaintiff's cost—understood to be about \$80. The great importance of these trials to our readers is the only excuse we have to offer for publishing the result in this case at this late hour. Had our Cincinnati friends shown their usual alacrity our readers would have received the benefit long since. It may not be too late, however, for the benefit of some unfortunate individuals, should they receive a call from the pretended patentee—whose indefatigable exertions appear to surmount the discouragements of defeat.

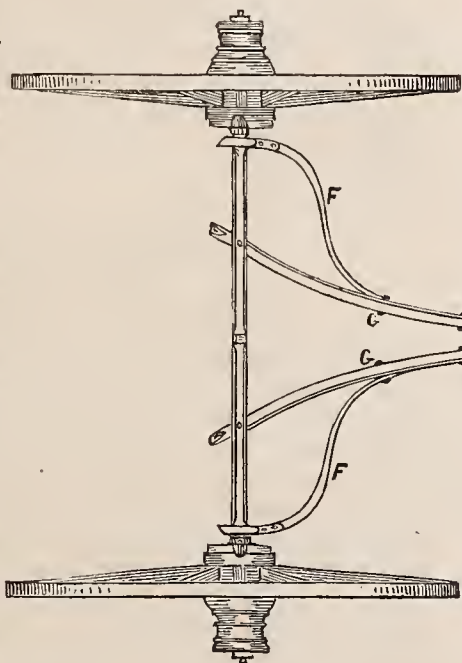

While we are giving some facts in reference to the perch-coupling, which—as we have shown in our sixth volume—was originally patented by the Everetts, one year and seven days in advance of the date when Haussknecht first filed his caveat, we will add some information given us by Robert H. Graham, Esq., of Washington, in our late visit to said city, going to prove that neither were the Everetts or Haussknecht the original inventors.

It seems that the then existing firm of Hook, Lochery & Thomas, in 1849, at Washington, had built a Phaeton for a worthy son of Esculapius, which, after using, he found would not turn short enough to answer his purpose. To obviate this difficulty the junior partner, Anthony W. Thomas, who appears to have been a very ingenious blacksmith, set his inventive mind at work and contrived the coupling; which he suffered the Everetts to patent, and which has ever since been the Pandora's Box of much evil to numerous members of the craft in various sections of the country. We understand that Mr. Thomas, who, as our story shows, has innocently been the cause of this trouble, is still alive and residing on a farm in Bedford, Laurence County, Indiana.

**WELDING IRON.**—An invention has been provisionally specified by Standley & Prosser, of Cockspur Street, London, which consists in the employment of hydrogen or its compounds, alone or mixed with oxygen, or atmospheric air projected from blow-pipes, for the purpose of welding plates or masses of iron, or other metals. They prefer to mix the gasses in a reservoir at the base of the blow-pipe.

### ECCENTRIC CARRIAGE-PART.

THE accompanying design has been reduced from a print published in England, some years ago, by Atkinson, of London. By giving it a place in our journal we hope thereby to prevent the speculations of such foreign adventurers as may in time undertake to maintain themselves in idleness, while they fleece the craft out of their hard

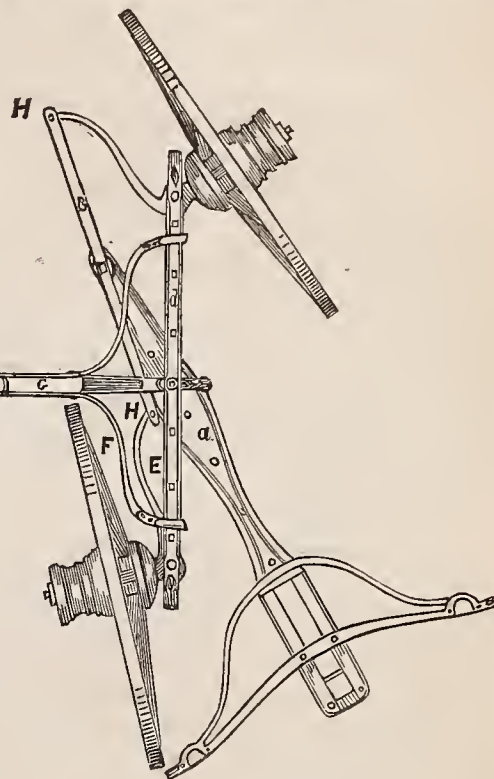

ECCENTRIC CARRIAGE-PART.

earnings. Although somewhat complicated, still, upon the whole, we think it a little ahead of the Everett coupling, in many respects. The axle-arm, being crooked, works on a pivot at H; E is the axle-bed; B the evener, and a the swivel-tree, which, receiving a pole, serves as the lever for turning the wagon in a very short compass. It, however, has a very serious defect in the mechanism—it places the wheel in such a position that it still will interfere with the perch and body of the vehicle.

### Paint Room.

#### PUTTY.

A CENSORIOUS public has often accused us of having hidden all defects in our work by the use of putty and paint, making in effect, putty the principal and paint an accessory to crime. Like many other things if an evil—it must be acknowledged a necessary one, in more than one sense, and it, charity-like, hides a multitude of—defects. These defects, however, are not necessarily weakening or serious. So much by way of introduction. Let us now turn to the practical part of our subject.

Some carriage-makers are careless enough to buy ready-made putty from the shops; but this is done to their injury, the greediness for gain in the dealer leading him to use more whitening and poor oil than is beneficial or useful to us. Taking this matter in every light, perhaps nothing better than putty made from dry lead can



be found to answer our purpose, since in its nature are combined firm and hard-drying qualities, less swelling and shrinking than when made of other material. The process of making we give in detail:

Take a quantity of dry lead, the purest to be found; and, having placed it on the paint stone, proceed to mash it up very fine, and afterwards lay-by on one side of the stone say about one-third of the quantity pulverized, and into the other two-thirds pour enough brown-Japan to make it into a soft mass; then roll it into the reserved third until it gets well thickened, after which pound it well with a large hammer until it is made very soft and pliable, repeating the operation until the entire mass is made in nature like the finest dough, and every lump has disappeared; this will be readily known by taking it in the fingers and feeling. Next take the mass in the hand and, holding it under water, work and knead it well for some ten minutes, when you will have a stock of putty superior to any other whatever. If there is one thing more necessary than another to produce good putty it is the hammering, which, being a little tedious, in the hands of an apprentice—to whose manipulation the matter is often consigned—regardless of consequences, on the score of economy in time.

Some go so far as to add to the made up putty Lamp-black, and sometimes a little varnish; but always to its detriment—the coloring matter from its oily nature injuring its drying qualities, and the varnish causing it to swell and “push out” of the holes where it is used. For *plastering* the sides of felloes, &c., a little varnish, and even a few drops of turpentine, may hasten the drying, with advantage. One great complaint among painters is, that by handling putty, they lose the strength and elasticity of the fingers. This probably arises from the injudicious habits some painters practice of working a lump of putty between their fingers while engaged in puttying—to not only the injury of the limbs, but the entire system. If we were to call some persons “dirty” they would resist it as insulting; but, in fact, we have seen those *worse than dirty*—their hands all plastered over with one of the most deadly poisons—whitelead—which they are so injudicious as to swallow with their dinner—one of the best means in the world to bring on the Painter's Colic. If dirty habits do not end quite so disastrously, still it leaves the poisonous article to work into the pores of the skin, and under the nails of the fingers, to the great injury of the delicate hand. When “plastering,” the putty should be used from a board, or other suitable article, in such a way as to avoid the direct handling through the fingers. A little practice in our plan would not only look more cleanly, but preserve the health of our painters. Indeed, water and soap are the best remedies we have to recommend to *all* who work in paints, as well as putty. To such as have been injudicious, and are suffering from the painful consequences, we offer the following remedy for injured hands:

Procure a pair of old buckskin gloves and fill them with a mixture of corn-meal and potash—say half an ounce of the potash to a pint of meal, making it into a pudding by the addition of common whiskey. These gloves, thus filled, should be put on to the hands and tied at the wrists every night for at least one week, until a happy result is accomplished. This operation will very likely make the hands tender for use during the time of cure, but perseverance will bring relief, the mixture drawing every par-

ticle of poisonous lead from the pores of the skin. We give this for the benefit of the suffering, but at the same time recommend “prevention,” (cleanliness) as the best cure in this case—the painter's occupation.

#### ORIGINAL MONOGRAMS.

*Illustrated on Plate XXIII.*

WE have this month furnished our subscribers with a new supply of monograms, the former, as we have reason for thinking, having given much satisfaction to those for whom they were published. These are designed expressly for us by a new contributor. By this arrangement we hope to give a varied character to our engravings, and supply the public with useful combinations in alphabetical studies.

### Trimming Room.

#### CHEATING IN LEATHER.

GREAT complaint is now made against the manufacturers of enamelled leather, that they impose on the carriage-manufacturers short measure. Since the price of the article has advanced to about double its former price, this has become a very serious matter and calls loudly for reform. There ought to be—as is the case with shoe-leather—an inspector appointed to see that full justice is done. This is the more necessary, since the purchaser has no instrument at hand to measure for himself, anything like accuracy. Until this is done, the dealer should be held responsible for his actions, and when he sells short, reductions in bills should be claimed. A few *lessons* in this respect would no doubt effect a cure where it is much needed. Who will move in this business?

#### WARRANTED NOT TO FADE.

NOTWITHSTANDING that the importers of cloths assure us that they can furnish the trade with a Union cloth—that is a fabric composed of cotton and wool—“warranted not to fade,” still, in our late visit to the West, we found many skeptical minds in relation to this matter. They find it difficult to believe that cotton will receive a dye sufficiently fixed so as not to change; or, in other words, that such will receive a “fast color.” Now, we are not sufficiently versed in this business as to convince them that their doubts are groundless; but, knowing the respectability of the parties making the offer to furnish it, we are bound to receive their assurances as being true, especially as in our own use of the article we have never found any complaint on this score. Although not quite as good for the finest carriages, yet its extensive use is commended by its comparative cheapness—about half the price asked for cloths *all* wool.

#### TO FASTEN LEATHER ON METAL.

AN adhesive mixture to cement leather, India-rubber, or other soft material, to iron and other metals, for which a patent has been taken out in Europe, is made as follows: Dissolve 112 pounds of glue with 7 pounds of ammoniac, by fire or steam heat; stir them well, and then add 7 pounds of nitric acid. The mixture may be applied in either the liquid or solid state, and it can be applied in the same way as common glue. If the metal is oily it does not prevent its adhesion. Directions for accom-



plishing the same object will be found on page 10 of this volume.

### Editor's Work-bench.

#### VISIT TO OUR WESTERN FRIENDS.

WE have just made a journey of about twenty-five hundred miles, through some of the most interesting sections of our country, embracing eleven states, and visiting the chief northern cities of the Union. It is scarcely necessary to say that this has been done at considerable expense, although the result, on the whole, has proved very satisfactory. Everywhere we received the most marked attention, and on all sides the wonder seemed to be that we had not visited the West earlier. Our visit convinces us that we have lost much by the delay. But we must not take up our space with too long an introduction, but enter at once upon details.

At 10:45 o'clock, in the forenoon of the 11th of September, taking the steamer Jesse Hoyt from Pier 3, North River, a two hours' sail landed us at Port Monmouth, on a pier extending far out into the lower bay of our noble harbor, in the State of New Jersey. A dusty and uncomfortable ride in one of the hottest days of the year, over the track of the Raritan and Delaware Bay Railway, took us to Camden, a place in New Jersey, whose chief importance seems to be borrowed from the city of Philadelphia, opposite which it is situated. Of course we paid our early respects to our friend Mr. C. S. Caffrey, of whom our readers have heard before. Mr. C. is celebrated for building good work, and is about making some additions to his shop, in order to meet the pressing wants of his customers. After partaking of some refreshments, supplied by his generosity, we crossed the Delaware river into the goodly city of brotherly love, Philadelphia.

The next morning we found our way to the shop of our esteemed friend Wm. D. Rogers, Esq., and were amply paid by the visit. Mr. D. is evidently prospering in business, giving his personal supervision to all the details and a pleasant reception to all visitors. Indeed, no one can stay long in his company without feeling perfectly at home, and it is not to be wondered at to find that he has a host of warm friends. Near by, in an adjoining street, is the repository and workshops of another fellow-craftsman, Mr. S. W. Jacobs. There we found some very excellent made carriages, and it gives us much pleasure to find him, too, doing a good business. A short stroll took us to the establishment of Mr. J. George Lefler, who, with some success, has introduced a cast iron recess into the sides of carriage bodies, which facilitate short turning, and, at the same time answer for wear-irons.

We next visited our friends Messrs. Willis & Blackiston, M. W. Allen, the gentlemanly foreman in the Watson establishment, and Mr. William Dunlap. During the past four years Mr. D. has rented the larger portion of his premises to the Government, for the quartering of Union soldiers; Mr. D. informs us that he has many Southern orders, and intends soon to occupy his entire shop himself.

From Philadelphia, we continued our journey unto Wilmington. This city is now, when its size is considered, the greatest carriage-making place in the United States. Many changes have been made within the past year. Messrs. Sullivan & Thompson have dissolved, and the firm is now Sullivan & Lane. A new firm—Messrs. McLear & Kendall, occupying the old Merrick shop, together with additional buildings on the same street, opposite. Mr. Merrick has erected, higher up town, the finest manufactory and sales-rooms in this country. In the building he has placed a sixteen horse-power engine, at an expense of some \$1,600, which blows, through suitable apparatus, his twelve smith's fires, and furnishes the motive power in drilling, grinding, &c., for the entire establishment. The smith-shop is the best arranged we have ever seen, and will well repay the visitor to take a look at. In the center is a nicely laid plank floor, while on the outside it is nicely bordered by a *ground* standing-place. Mr. J. N. Cooling, is also about taking a partner and moving into new quarters; and Mr. Klund, who was merely a foreman at the time of our last visit, is now his own boss, and our old friends, Messrs. Pretschner, and Wright & Co., are pursuing the even tenor of their way in business. There is, besides these, the large shop of the Messrs. Gregg & Bowe, where good work and an extensive business is done in carriages. It is from Wilmington that our Baltimore, Washington, and Pittsburgh friends obtain large quantities of the ready-made carriages they dispose of outside of their own manufacture.

The citizens of this place, who are without proper market accommodations, are supplied with stores direct from the country producers, whose wagons, backed up all the morning on one side, against the side-walk of the principal street, presented a picturesque show, an inspector, the meantime, with the scales of justice in his hands, moving among the venders, for the detection of lightweights, should such be found. A circumstance occurred reminding us of that passage in Scripture where it speaks of crying in the market places. An old gentleman, with a peculiar drawl in his speech, was crying at each corner, "A meeting—of the citizens—of Wilmington—will be held this evening—in the City Hall—for the purpose—of banding themselves together—to purchase coal—at first cost. Come one!—come all!!" This custom of ancient times greatly amused us. In Newcastle we visited the



shop of Mr. Wm. H. Rump, the only one in that place. This, although an old and pretty town, seems to grow very slowly.

Our next movement was *on* Baltimore. We found the friends very friendly, and enjoyed this visit very much. To mention them all would swell this article to a great length, and be merely going over the same story as told last year. We must, however, find room to thank Mr. Curlett for his kindness shown on this special occasion. Since our last year's visit, Messrs. Duncan, Wright & Co. have established a new manufactory on Jay Street, and are apparently doing a good business.

We had a very agreeable visit to our friends in Washington. Messrs. McDermott & Hall take a warm interest in our success, and as a consequence, we feel under many obligations to them. On this occasion we made the acquaintance of Mr. R. H. Graham, who has sales-room for carriages on D-Street. This gentleman put us in possession of some new facts in relation to the origin of the perch-coupling, which the reader will find narrated elsewhere in this issue of the Magazine. The Capitol is a noble edifice, built of white free-stone in the Corinthian order, but when it will be completed would puzzle the "oldest inhabitant" to decide. The work has been going on a number of years, and is likely to continue so for some years to come. Those who have visited the Capitol will remember the groups of statuary which adorn the east front of the edifice. While gazing upon the statue of Columbus, who is represented by Persico, as giving a new world to Civilization, we heard a contraband, who happened to be near, assure his female friend that it represented "Old General Jackson." We could not but think the "darkey's" *imagination* about as near correctness as the artist's, perhaps.

From Washington, returning to the Relay House, we took the cars on the Baltimore and Ohio Railway through Virginia to Ben Wood on the Ohio River, a distance of 375 miles—a tedious ride through grounds rendered classical in our late civil war. Burned bridges, the ruins of buildings, and fenceless farms, all gave evidence that something extraordinary had occurred. The inhabitants bore in their countenances a filthy, lazy look, different from any other class of beings we ever saw. But we must not dwell upon this melancholy subject.

Columbus, the capital of the State of Ohio, is beautifully laid out, and bids fair in time to become a place of much interest. There are at present three carriage shops in the place. The largest of these is that of the Messrs. Booth; who, at the time of our visit, were erecting additional accommodations for their workshops. The two other shops were those of Messrs. P. M. Gutches and Henry Moore's. As Cincinnati has received so much of our attention in the preceding volume of this work, we

may very properly pass over the details of our late visit to give room for observations elsewhere.

To Hamilton, the Capital of Butler County, we paid our next visit. This place is located on the Miami River, 25 miles north of Cincinnati, and 90 miles southwest from Columbus. It is situated in the center of a fertile district, and has many advantages for encouraging manufacturers. Carriage-making, however, seems not to flourish. Probably it is too near Cincinnati, a reason which applies with equal force to other places. That which was formerly the best shop in the place is now a livery-stable, kept by the same gentleman, Mr. Rump. The two remaining shops are doing very little.

We next proceeded "on to Richmond," Indiana. This city is situated on the east bank of the White Water River, on the Indiana Central Railway, 70 miles northwest from Cincinnati and 68 miles east of Indianapolis. Valuable water power is found in the vicinity, taking advantage of which numerous mills and manufacturing establishments have been erected. There are about six carriage and wagon shops in the place. By the term "wagon shop" in the West is meant such shops as build farm and other business wagons, to the neglect of finer work. Of carriage-makers there are but four—Messrs. Crocker & Brother, S. R. Lippincott, J. S. Hunt, and S. S. Strattan. We passed a very agreeable hour with our friend Mr. Peter Crocker. His attentions to us, a stranger in a strange land, will never be forgotten. Our namesake, too, we found a very sociable gentleman. Mr. Lippincott has the reputation of being "leagued in" with a certain perch-coupling adventurer, of whom our readers have before heard. True or not true, such a reputation is not calculated to increase one's popularity among the craft. For this reason we shall be happy to find the rumor disproved.

Our next move was *on* Indianapolis, by the Columbus and Indiana Railway. Indianapolis, the capital of Indiana, has a population of over 30,000 inhabitants. Situated in one of the richest agricultural valleys in the world, its natural advantages must secure for it a steady and increasing growth. There are four carriage shops in this city. Mr. Samuel W. Drew is the oldest carriage-maker now in the business. He is from Dover, New Hampshire, and has resided in the West about fourteen years. Col. B. C. Shaw, who has a very large manufactory in the city, rendered our visit very agreeable by his kind attentions. Ordering his horse harnessed to his buggy, he not only introduced us to the other bosses, but showed us the principal objects of interest in the city and suburbs; and, to crown all, took us to his home and treated us to the best dinner we partook of in our Western journey—the hotels not excepted. We will say for the Colonel that, among all the clever men it has been



our fortune to find in our rambles, he is one of the cleverest. We hope to meet him again. Mr. George Lowe is at the head of another carriage manufactory. To give the present generation some idea of the labor and toil undergone in days past by some of the older members, we add a few facts in Mr. Lowe's history. He informs us that for twenty years, from four A. M. to eleven o'clock at night, he toiled for 87½ cents per day. The price for a wooden axle being only 62½ cents. When he undertook to better his circumstances by going into business, his aged father, living in Pennsylvania, thought George was going a little too fast by leasing premises at \$400 five years ago. Some idea of the rise in the value of property may be gathered from the fact that Mr. L. has lately been offered \$1,800 per annum for a lower room fronting on the public street.

Lafayette, the capital of Tippecanoe County, is a flourishing city with a population of about 12,000 inhabitants. There are two carriage shops in the place. Mr. E. C. Jones' and J. H. Marsteller's. Mr. Jones, formerly a member of the firm of Cram, Hine & Co., is providing himself with a new shop, with water-power. He is a native of Connecticut, and gets up a very creditable buggy from good stock, which he sells for \$325.

Our journey from Lafayette to Chicago was undertaken before daylight, and when it broke, we were on the borders of the prairies. Never did we see so glorious a sight before—optical delusion and real sight, applied to prairie, mist and tree-tops in the distance, blending with the red clouds of the rising sun, and these again mixing with the fleecy cumulus of a darker hue, higher up, presented us with a picture indescribable. Stopping at a place called Haskell's, our attention was attracted by an unearthly rattling. Turning our head in the direction of the noise, we read over the door of a cabin, "Smith's Hotel;" observing an athletic Hoosier energetically banging a large tin pan against the door-post to let the hungry wayfarers know that breakfast was ready. Not a soul obeyed the summons. The ludicrousness of the affair produced the most intense fit of laughter from the passengers we have ever enjoyed.

Chicago people *imagine* that New York would be something of a place were it nearer Chicago. Be this as it may, there is certainly no room for doubting the fact that Chicago is a *fast town*. Among other things "fast" there is a wagon shop said to turn out twenty-two wagons a day. To verify this, and gratify our own curiosity, a friend took us in his buggy to a building 80 feet wide and 180 long, several stories high, where, chiseled in marble high up in the gable-end, we read, "Peter Schutler's Wagon Manufactory Establishment." Making our errand known, the clerk in attendance very coolly gave us to understand that Mr. Schutler did not wish the public to

know his business. This being decidedly the *coolest* reception we had experienced—we left. An "outsider," however, has supplied us with a few facts.

Some years ago Peter's brother joined the Mormons, and for fifteen or twenty years this brother has been supplied with wagons, all after one pattern, which, being sent over the plains to St. Joseph, were there re-sold to the deluded emigrants bound for Nauvoo City, at good prices. Besides this, he had a lively home trade among the Western farmers. A short time since Peter took it into his head to erect himself a villa of princely dimensions, but died before its completion. When he died, he is reported to have left \$200,000, with debts, in the aggregate, amounting to only \$70.

There is another "wagon shop" in Chicago, where, it is said, they "turn out" one dozen per day. These wagons sell for \$110 and \$125 each, according to the finish.

There are several carriage shops in Chicago. These we will mention in the order of our visit to them. Messrs. Henry Willett's, Thomas H. Brown's, A. MeFarland's, Coan & Tenbrocke's, J. H. Kline's, Kimman & Malefuyt's, Geo. N. Bohanon's, E. Ford's, John Lacey's, F. Mitchel's, R. J. Beal's, and Albert Card's. Messrs. Willett, Brown, and Ford, placed us under many obligations by their special attentions to us in a strange city. The extensive patronage this Magazine has in Chicago, is due, in a great measure, to the kindness of Mr. Ford.

The visitor to Chicago will be attracted by the almost continual sounding of steam whistles and turning of bridges over the Chicago River, running in a filthy stream through the city, into Lake Michigan. This constant turning of the bridges, for the accommodation of commerce from the lake, very much discommodes city travel—connected with which we will relate a somewhat amusing story. Previous to the turning of a bridge, there is always a bell rung, as a notice to travelers to keep off; but, heedless of this warning, we saw a farmer in haste drive his hay-loaded wagon on, no doubt imagining that he would gain time by so doing when the bridge resumed its previous position. Instead, however, of placing it as it stood before, those in charge—doubtless as a punishment—replaced the bridge with the ends reversed, to the great inconvenience of the countryman. This obliged the transgressor of the law to double his track back again some distance before he could find room to turn around in, at a great loss of time, he having barely time to make his way over before it was again turned.

An incident, illustrative of the great danger to property arising from this frequent displacement of bridges in a large city, was related to us by an eye-witness as having occurred but a few days previous to our visit. Our informant was sitting in a horse-car, awaiting the replacement of a bridge, when he observed a frightened



span of horses harnessed to a coach, dashing down the street at a fearful rate, with the owner in full chase. Approaching the open draw, the animals plunged down into the river, at least twenty feet below, taking the coach after them. Whether or no Pat imagined that he might possibly be able to save his coach by seizing hold of the hind-wheels as it went over the parapet, we did not learn; but, true it is, that having done so, over he went, head-first, into the filthy stream *after* his property. Emerging from the mud and slime, clambering up the side of a barge near by, his eyes and mouth filled with the refuse of the river, a fellow-countryman of his from the bridge sang out with much concern, "Patrick, are you hurt?" Answering, he exclaimed, "Ah, be jabers, Barney, and didn't I do well?" This answer, in view of the fact that the coach and horses were lost, created great merriment among the bystanders.

By the Michigan Central Railway we went on to Kalamazoo, which we reached on the 28th of September. This place is situated between Lakes Erie and Michigan, causing the atmosphere to become quite damp and chilly in the evening, rendering it very unhealthy to other than bilious constitutions. The scenery along this route reminds the New Englander of the hills in the Eastern States, which all the surroundings very much resemble. There are four carriage shops in Kalamazoo, the proprietors of one of which have lately "gone in." The two best remaining are those of J. B. Cornell & Co., and Russell & Burrell. Both of these firms appear to be thriving. Battle Creek is another busy place for carriage-makers. There are four shops in Jackson, among them Messrs. A. A. Pierce & Co's., Hewitt Bros., and S. S. Wellings'. To Mr. Pearce we are indebted for many kind attentions during our stay. There are also two or three shops in Ann Arbor, and one at Ypsilanti. This last place was originally called Woodruff's Grove, but since named in honor of a distinguished hero figuring in the Greek Revolution. We had the pleasure of introducing ourself to Messrs. Batchelder & McIntosh, who not only carry on the carriage business, but likewise are engaged in turning spokes by machinery quite extensively.

We reached Detroit on the 30th. This is a very pretty city, situated on the west bank of the Detroit River, about three and a half miles in extent. Some of the streets are 200 feet wide, the principal of which are Jefferson and Woodward Avenues. An early call upon our worthy friend, Hugh Johnson, Esq., rendered our visit extremely pleasant. This gentleman, at some sacrifice to his own affairs, drove us in his buggy around and introduced us to the proprietors of the chief shops in the place. By this voluntary favor, our labor was much facilitated. Our visit extended to the shops of Messrs. F. Reichle, John J. Patton, William Hartman, A. Ochsenhirt, Joseph Kengel, John Shaffer, Wm. M. Lyons, and

C. Dreher—about all of any note in the city. We shall long remember our pleasant sojourn in Detroit.

On the Monday following we traveled on to Monroe, where we found one respectable shop, presided over by Messrs. Younglove & Reynolds. Next to Adrian. There are four or five carriage shops in this place, one of which is owned by our friend Wm. A. Stowe, Esq., and another is occupied by Smith, Kaiser & Co. At this last shop we were shown some native timber of the very best quality. Both firms appear to be doing a good business. Prince Albert's are in much demand here, and sell for about the same price as a top buggy. Mr. Stowe is a practical mechanic, taking much interest in this Magazine, of which he has been for sometime a patron.

Toledo may be called a miserable place for the craft, the principal inhabitants being Yankees, who send eastward for their supply of carriages. Fremont—formerly known as Lower Sandusky—situated on the River Sandusky, boasts of two very respectable shops, those of Messrs. J. P. Moore's and A. Och's. Cleveland, another place in our route, has one good shop, kept by Messrs. Lowman & Warden. At Ravenna we formed the acquaintance of Messrs. Merts & Riddle, and Furry & King, who conduct the only two shops in the place. A call upon our friend H. Walser, at Alliance, and Werts & King, in Canton, finished our visit until we came to Pittsburg. Of course we could not pass through that *village* and expect forgiveness without paying our respects to Messrs. West & Co. These gentlemen not only made our stay very pleasant while there, but accompanied us to the *dépôt* on our departure for home, late in the evening. To duly appreciate such kindness, one needs be "a stranger in a strange place" late in the night.

We have thus hastily and briefly, for lack of space, narrated the chief points of any interest to our readers, in this visit. It certainly has proved not only a very pleasant, but a more profitable one, on the whole, than we have ever made in any direction before. We trust, health and time permitting, to go over the ground again, soon. We have, in this journey, learned, with much regret, that the carriage-business has very much declined from what it was a few years ago, although for the past two years those establishments still remaining have found sales for all the carriages they have been able to build. Prospects of a good business in the future are very favorable *now*, all through the Western country. We hope such will be realized.

The foregoing story has been told in the briefest manner possible consistent with the subject, and yet after all we have been forced, for want of room, to lay over a very interesting trade review, our usual literary notices, and a variety of other matter, including the Patent reports, until we issue the December number.



## The Coach-maker's Letter-box.

AURORA, ILL., October 2d, 1865.

DEAR FRIEND STRATTON: Having just returned from a business trip to the "Black River country," and narrowly escaped a visit to your headquarters, I think—though it may not be quite time for me to write a book of travels—I may presume upon space enough in your columns for a brief "diaree" of my expedition. Though I saw or heard little of especial interest to the craft, yet that little may serve to season the medley of topics I may offer. I arrived in safety at Chicago, Ill., a little station thirty-six miles east of here—at the end of our railroad,—where the Green Bay shingle-makers send their scows to exchange that staple for calicoes and quinine. Having with me some specimens of workmanship for exhibition at a fair which I had understood was to be held near this place, for the benefit of the peculiar institution styled the "State Agricultural Society," a combination got up for the especial encouragement of the detestable race known in respectable circles as "mudsills," I proceeded at once to embark by horse-railway, *via* State Street, to the fair grounds. And here, for the benefit of strangers who desire to see all the curiosities and superior conveniences, and taste all the good things of this great country, I will give one peculiarity of this particular street. Every building in it has a beer sign hung out, "Sands' Pale Ale," "Lill's Premium Ale," "Milwaukee Cream Ale," and the next another beverage, and so on for two miles and a half—longer or shorter. In all other streets the beer signs are interspersed with others indicative of groceries, dry goods, and other trade, but in State Street never; at least, if there are any, they are so eclipsed by this all-pervading traffic as to be invisible. I could only think of Doesticks when at Niagara, and wanted a glass of beer, but couldn't get it. I advise every one when going on "a bender," to commence at one end or the other of State Street, Chicago, and should he get a glass down of poor quality, and want a glass of beer to take the taste out of his mouth, he has only to try the next door.

Arrived at the fair grounds, and armed with a membership ticket, I felt that I was one of 'em, and boldly stepped into the inclosure; when such a sight met my gaze as no one can duly appreciate who has never seen one hundred solid acres of "mudsills," and more constantly arriving, each with his machine under his arm or on his cart, the whole comprising the entire catalogue, from a hog-tamer to a hay-press. The rain, on Tuesday, interfered seriously with preparations, but the invincible Yanks shook their vile plumage in defiance. One after another of the evidences of the march of Genius wheeled into its nook, and planted, staked, or belted up for movement, when the word should come from its dotting inventor to "do its best." The mechanics, farmers, manufacturers, ladies, the admiring and patronizing public, all did the requisite thing to make this what, with adequate shelter, would have been immensely successful and satisfactory to all concerned; but, after all the expenditure upon collecting and showing this vast amphitheatre of industrial wonders, the rain spoiled all. When the Agricultural Society of the great and growing State of Illinois has seen enough of itinerant fairs, and *locates* these exhibitions, we care not whether it is in the big woods or in a

big city, and erects suitable buildings for the protection of its patrons with their goods and wares, we can and will get up exhibitions which it will pay you for coming from New York to see; but till then we say, as we do to our own neighbors, stay at home. As for your unassuming correspondent, he had the best of facilities while the rain poured down upon his patent wagon stake, for showing how the socket thereof, being open at its lower end, can never fill, freeze, and burst. We dwelt with eloquence upon this point, while our facilities lasted—which was nearly all Tuesday and Thursday,—but how could we get glorious while so many were wretched? Think of showing fine carriages or testing the operation of grain separators *in the rain!* The ladies had a better time of it in floral hall, which was really well adapted to the occasion, yet the poor creatures, led by a pardonable curiosity, must traverse the grounds and see it all. Hence an immense display of variegated embroidery not mentioned in the premium list. We wept, still we could admire the luxurious waterfalls so in keeping with the season, and so strikingly suggestive of a half cabbage head hung to a whole one.

The Novelty Carriage Works of Chicago erected a shed at the expense of its agent, Thos. H. Brown, in which was displayed a great variety of superbly finished work. He gives particular attention to buggies and sulkeys, for the trotting course. We recommend him to the fast men and fast horses of this fast country. We were somewhat interested in a wagon built upon a patented plan called the hinge-axle. Its advantages are the ability to turn on a small space, and the absence of all tendency to the lateral motions of the pole when passing over obstructions, which, in other wagons, is so annoying to the team. The conclusion was, however, forced upon me, that the objects gained are reached through far too much and too costly machinery. Another wagon, furnished with rubber springs under the body, showed really obvious advantages gained, though cancelled by disadvantages equally great—that of raising the body too high for convenience, and the weakening of the hind axle by bolt-holes, in that part which is already the weakest. Competition was lively in tire-shrinkers; and one exhibitor, having a portable forge, was prepared to upset any one who needed it. As a full report of the exhibition was not our intention, we must pass over much of interest and take the State Street cars for the St. Joseph Dock, whence we embark for the land of peaches and shingles. Reached St. Joseph at daylight, on Friday, and a journey of twenty-one miles in a wagon brought us to the residence of a brother, with whom we sojourned till the next Tuesday, when, by staging to Decatur, fourteen miles, we took the cars of the Michigan Central Railroad to wake up in Detroit. Having to lie over a few hours, we called at two shops—those of Joram Priest and Hugh Johnson.

Mr. Priest is devoted, mainly, to making express wagons, and work of this class. Mr. Johnson is a live carriage-maker, takes the Magazine, and entertained us most agreeably. The interminable rattle-ty-bang of railroading hurried us on to Kingston, Canada, whence another water trip landed us at Cape Vincent.

While on the boat we had a little leisure to reflect upon the abominable hocus-pocus which gives the independent Britishers the right to call our greenbacked dollars worth sixty cents a piece.



Very well, Johnny, said I, we can afford it if you can. "Thee can proceed with thy elephant," and if we don't go back through the States it will be because all the railroads in Yankeedom blow up in the next few days. In Jefferson County, New York, the land of our birth, again; and, as my letter is already too long, I will give you some items of the back trip at some future time.

M.

## CURRENT PRICES FOR CARRIAGE MATERIALS.

CORRECTED MONTHLY, BY MR. CHAS. WEEKS, FOR THIS MAGAZINE.  
NEW YORK, Oct. 24, 1865.

Apron hooks and rings, per gross, \$2.50.  
Axle-clips, according to length, per dozen, 75c. a \$1.25.  
Axles, common (long stock), per lb, 9c.  
Axles, plain taper, 1 in. and under, \$6.50; 1½, \$7.50; 1¾, \$8.50; 1⅞, \$9.50; 1⅝, \$10.50.  
Do. Swelled taper, 1 in. and under, \$7.00; 1½, \$8.25; 1¾, \$8.75; 1⅞, \$10.75; 1⅝, \$13.00.  
Do. Half patent, 1 in. and under, \$10.50; 1½, \$12.50; 1¾, \$15.00; 1⅞, \$17.50; 1⅝, \$21.25.  
Do. Smith's New York half patent case-hardened malleable iron box, 1 in. and under, \$10; 1½, \$10; 1¾, \$12.  
Do. Smith's Homogeneous steel, case-hardened mall. boxes, ⅝ in., \$12; ¾, \$12; ⅞, \$12.50. Long draft, \$2 extra.  
Do. Saunders' improv. taper, ¾ in., \$12.00; ⅞, \$12.00; 1, \$12.00; 1½, \$13.00; 1¾, \$15.  
Do. do. Homogeneous steel, ⅝ in., \$15.00; ¾, \$15; ⅞, \$16.50; long drafts, \$4 extra.  
☞ These are prices for first-class axles. Makers of less repute, cheaper.  
Bands, plated rim, under 3 in., \$2.50; over 3 in., \$3  
Do. Mail patent, \$3.00 a \$5.00.  
Do. galvanized, 3½ in. and under, \$1; larger, \$1 a \$2.  
Basket wood imitations, per foot, \$1.25.  
☞ When sent by express, \$2 extra for a lining board to a panel of 12 ft.  
Bent poles, each \$2.00.  
Do. rims, under 1½ in., \$2.25 per set; extra hickory, \$3.25 a \$4.00.  
Do. seat rails, 50c. each, or \$5.50 per doz.  
Do. shafts, \$7.50 per bundle of 6 pairs.  
Bolts, Philadelphia, list.  
Do. T, per 100, \$3 a \$3.50.  
Bows, per set, light, \$1.25; heavy, \$2.00.  
Buckles, per grs. ¼ in., \$1.50; ⅜, \$1.50; ½, \$1.70; ⅞, \$2.10; 1, \$2.80.  
Buckram, per yard, 25 a 30c.  
Burlap, per yard, 30c.  
Buttons, japanned, per paper, 30c.; per large gross, \$3.  
Carriage-parts, buggy, carved, \$4 a \$5.50.  
Carpets, Brussels, per yard, \$2 a \$3; velvet, \$3.75 a \$4.50; oil-cloth 60c. a 75c.  
Castings, malleable iron, per lb, 20c.  
Clip-kingbolts, each, 50c., or \$5.25 per dozen.  
Cloths, body, \$4 a \$6; lining, \$3 a \$3.50. (See *Enameled*.)  
☞ A Union cloth, made expressly for carriages, and warranted not to fade, can be furnished for \$2.50 per yard.  
Cord, seaming, per lb, 45c.; netting, per yard, 8c.  
Cotelines, per yard, \$4 a \$8.  
Curtain frames, per dozen, \$1.25 a \$2.50.  
Do. rollers, each, \$1.50.  
Dashes, buggy, \$1.75.  
Door-handles, stiff, \$1 a \$3; coach drop, per pair, \$3 a \$4.  
Drugget, felt, \$2.  
Enameled cloth, muslin, 5-4, 85c.; 6-4, \$1.10.  
Do. Drills, 48 in., \$1.25; 5-4, \$1.20.  
Do. Ducks, 50 in., \$1.45; 5-4, \$1.40; 6-4, \$1.60.  
☞ No quotations for other enameled goods.  
Felloe plates, wrought, per lb, all sizes, 25c.  
Fifth-wheels wrought, \$1.75 a \$2.50.  
Fringes, festoon, per piece, \$2; narrow, per yard, 18c.  
☞ For a buggy top two pieces are required, and sometimes three.  
Do. silk bullion, per yard, 50c. a \$1.  
Do. worsted bullion, 4 in. deep, 50c.  
Do. worsted carpet, per yard, 8c. a 15c.  
Frogs, 75c. a \$1 per pair.  
Glue, per lb, 25c. a 30c.  
Hair, picked, per lb, 70c. a \$1.

Hubs, light, mortised, \$1.10; unmortised, \$1.00—coach, mortised \$1.50.

Japan, per gallon, \$3.

Knobs, English, \$1.50 a \$1.75 per gross.

Laces, broad, silk, per yard, \$1.00 a \$1.50; narrow, 15c. to 20c.

Do. broad, worsted, per yard, 50c. a 75c.

Lamps, coach, \$20 a \$30 per pair.

Lazy-backs, \$9 per doz.

Leather, collar, dash, 31c.; split do., 18c. a 21c.; enameled top, 32c.; enameled Trimming, 31c.; harness, per lb, 50c.; flap, per foot, 25c. a 28c.

Moquet, 1½ yards wide, per yard, \$9.00.

Moss, per bale, 12½c. a 18c.

Mouldings, plated, per foot, ¼ in., 14c.; ⅜, 16c.; 18c.; ½, 1 ead, door, per piece, 40c.

Nails, lining, silver, per paper, 12c.; ivory, per gross, 50c.

Name-plates.

☞ See advertisement under this head on 3d page of cover.

Oils, boiled, per gallon, \$1.88.

Paints. White lead, ext. \$18, pure \$19 p. 100 lbs.; Eng. pat. blk, 35c.

Pole-crabs, silver, \$5 a \$12; tips, \$1.50.

Pole-eyes, (S) No. 1, \$2.70; No. 2, \$2.90; No. 3, \$3.10; No. 4, \$4.50 per pr.

Sand paper, per ream, under No. 2½, \$5.00; Nos. 2½ & 3, \$5.65.

Screws, gimlet.

☞ Add to manufacturer's printed lists 20 per ct.

Do. ivory headed, per dozen, 50c. per gross, \$5.50.

Scrims (for canvassing), 20c. a 30c.

Seats, buggy, pieced rails, \$1.75; solid rails, \$2.50.

Shaft-jacks (M. S. & S.'s), No. 1, \$2.75; 2, \$3.25; 3, \$3.50.

Shaft-jacks, common, \$1.50 a \$1.65 per pair.

Do. tips, extra plated, per pair, 37½c. a 56c.

Silk, curtain, per yard, \$2 a \$3.50.

Slat-irons, wrought, 4 bow, \$1.12½; 5 bow, \$1.25 per set.

Slides, ivory, white and black, per doz., \$12; bone, per doz., \$1.50 a \$2.25; No. 18, \$2.75 per doz.

Speaking tubes, each, \$8.

Spindles, seat, per 100, \$1.50 a \$2.50.

Spring-bars, carved, per pair, \$1.75.

Springs, black, 24c.; bright, 25c.; English (tempered), 28c.; Swedes (tempered), 32c.; 1½ in., 1c. per lb. extra.

If under 36 in., 2c. per lb. additional.

☞ Two springs for a buggy weigh about 28 lbs. If both 4 plate, 34 to 40 lbs.

Spokes, buggy, ⅞, 1 and 1½ in. 8½c. each; 1½ and 1¾ in. 8c. each; 1¾ in. 9c. each.

☞ For extra hickory the charges are 10c. a 12½c. each.

Steel, Littlejohn's compound tire, 3-16, 10c.; 1-4, 9½c.; heavier sizes, 9c. currency.

Stump-joints, per dozen, \$1.40 a \$2.

Tacks, 9c. and upwards per paper.

Tassels, holder, per pair, \$1 a \$2; inside, per dozen, \$5 a \$12; acorn trigger, per dozen, \$2.25.

Terry, per yard, worsted, \$4; silk, \$9.

Top-props, Thos. Pat, per set 65c.; capped complete, \$1.50.

Do. common, per set, 40c.

Do. close-plated nuts and rivets, \$1.

Thread, linen, No. 25, \$1.30; 30, \$1.45; 35, \$1.65, gold.

Do. stitching, No. 10, 95c.; 3, \$1.15; 12, \$1.28, gold.

Do. Marshall's Machine, 432, \$2; 532, \$2.30; 632, \$2.60, gold.

Tufts, common flat, worsted, per gross, 20c.

Do. heavy black corded, worsted, per gross, \$1.

Do. do. do. silk, per gross, \$2.

Do. ball, \$1.

Turpentine, per gallon, \$2.

Twine, tufting, per ball, 50c.; per lb, 85c. a \$1.

Varnishes (Amer.), crown coach-body, \$6; nonpareil, \$7.50.

Do. English, \$6.25 in gold, or equivalent in currency on the day of purchase.

Webbing, per piece, 65c.; per gross of 4 pieces, \$2.40.

Whiffle-trees, coach, turned, each, 50c.; per dozen, \$5.50.

Whiffle-tree spring hooks, \$4.50 per doz.

Whip-sockets, flexible rubber, \$4.50 a \$6 per dozen.

Do. hard rubber, \$10.50 per dozen.

Do. leather imitation English, \$5 per dozen.

Do. common American, \$3.50 a \$4 per dozen.

Window lifter plates, per dozen, \$1.50.

Yokes, pole, each, 50c.; per doz, \$5.50.

Yoke-tips, extra plated, \$1.50 per pair.





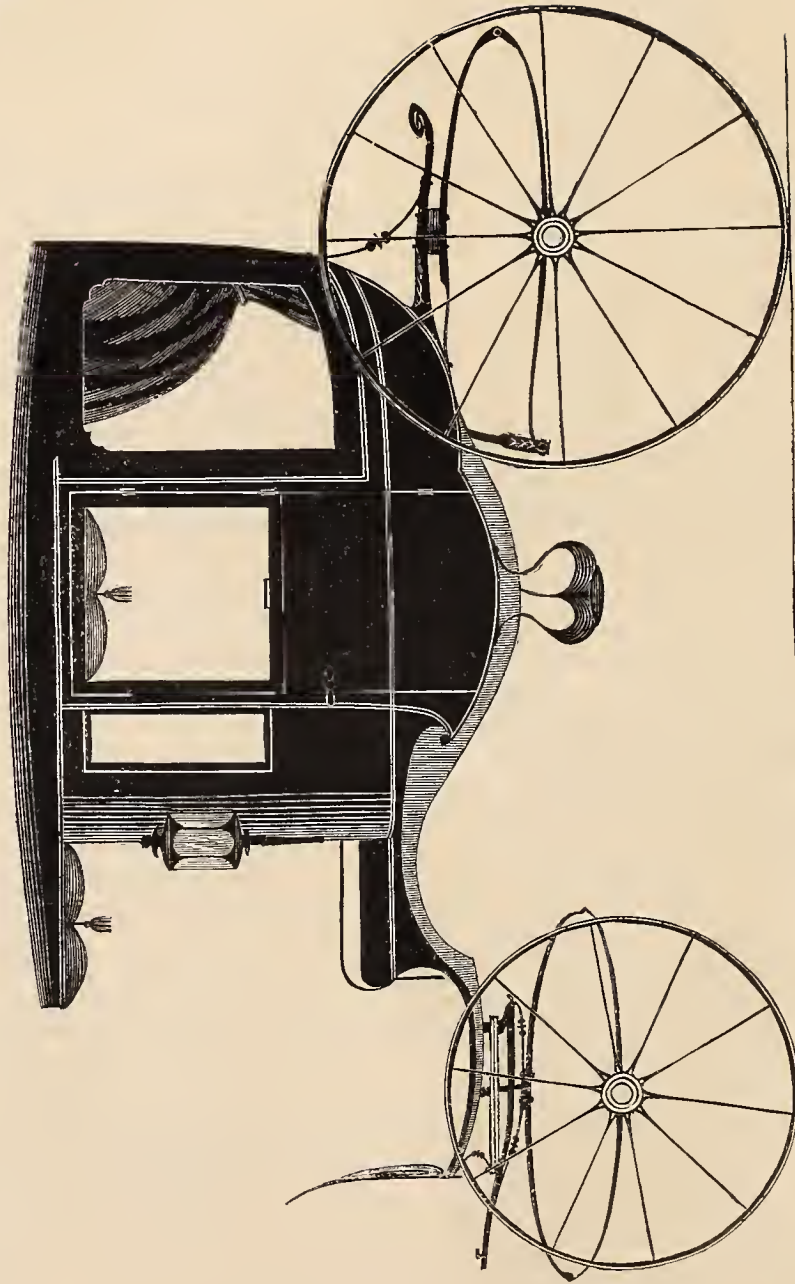

ROUND-FRONT SIX-PASSENGER ROCKAWAY.— $\frac{1}{2}$  IN. SCALE.

*Engraved expressly for the New York Coach-maker's Magazine.*

*Explained on page 105.*

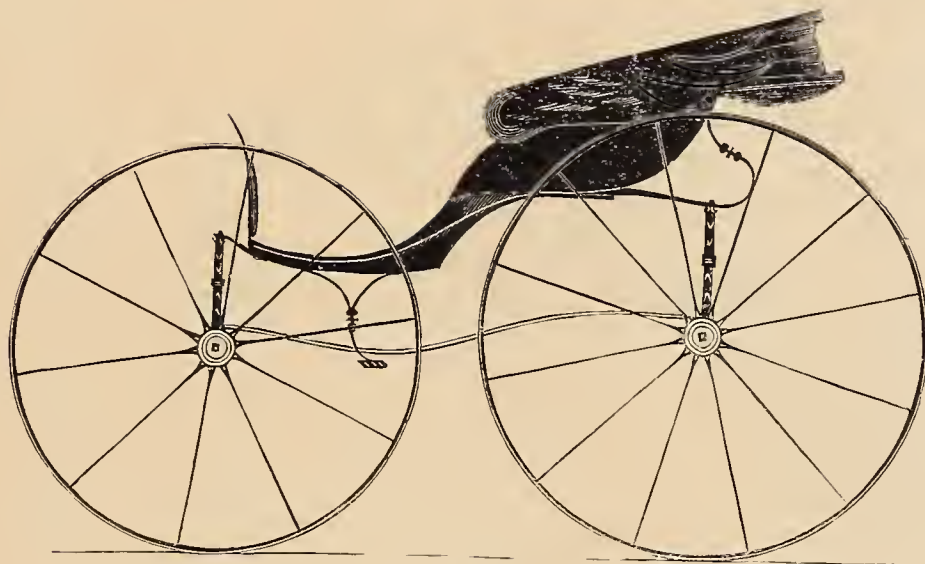

PHYSICIAN'S PHAETON.— $\frac{1}{2}$  IN. SCALE.

*Designed expressly for the New York Coach-maker's Magazine.*

*Explained on page 105.*









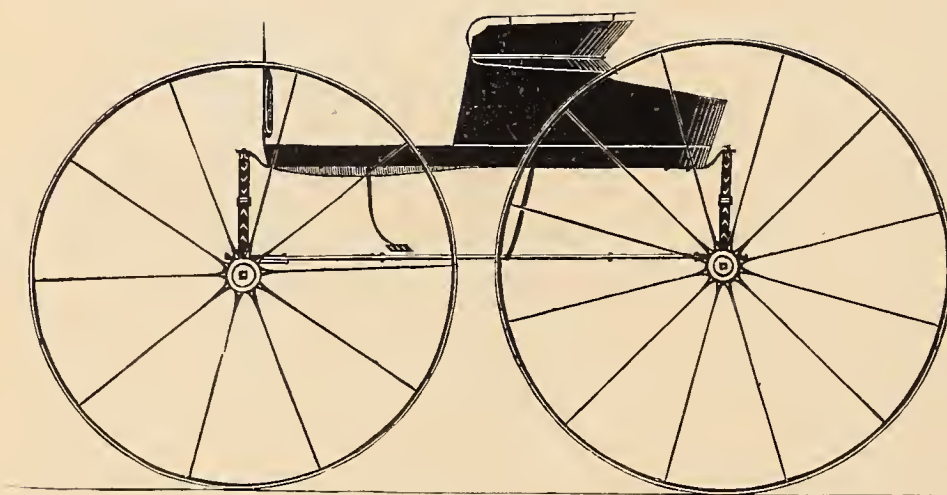

PHILADELPHIA BUGGY.— $\frac{1}{2}$  IN. SCALE.

*Engraved expressly for the New York Coach-maker's Magazine.*

*Explained on page 105.*



TANDEM SLEIGH.— $\frac{1}{2}$  IN. SCALE.

*Engraved expressly for the New York Coach-maker's Magazine.*

*Explained on page 105.*







DEVOTED TO THE LITERARY, SOCIAL, AND MECHANICAL INTERESTS OF THE CRAFT.

Vol. VII.

NEW YORK, DECEMBER, 1865.

No. 7.

## Mechanical Literature.

### THE REVIEWER REVIEWED.

BY HENRY HARPER.

I do not intend to be drawn from the subject under consideration by Mr. Miles' "spread eagle" declamation, nor his insolent charges of falsehood preferred against me, or any other subterfuge he may adopt. If it is necessary for him to employ "slang" in place of argument, let him do so.

Mr. M., after saying that I have admitted a truss-stay is of great use in supporting long-stringers, then comments as follows: "Mark you, after admitting its great use in architecture, he attempts to make it appear that the truss-stay is in effect but deepening the beam, or girder, to the extent that the stay reaches below the same." Just so, Mr. M., and I am sorry for the man who never noticed how much more unyielding a board is edgewise than sideways to a strain, and who has never studied enough to understand the reason of its being so.

Mr. M. is equally stupid about the ability of iron to resist the power of a strain endwise and sideways. He thinks a strip of iron an inch wide, cut lengthwise from band-iron, is infinitely stronger than the same width cut from the other way; at least he argues to that effect. The explanation on page 49 is of no use to him; his silly twaddle about the "immutable laws of iron," are not in the least abated. He "dares me to deny that a one-inch square bar of iron will support 7,000 pounds weight." Every person who makes pretensions to mechanical science enough to consult a table of the strength of materials used in mechanical constructions, knows that the tensile strength of iron is put down at only 60,000 pounds to the square inch bar, and that it will not do to rely on more than one-fifth of that amount; that is, 12,000 pounds to the square inch bar, in practical operation. Again, he "dares me to deny that just before the last straw is laid on, said bar will measure just the length that it did before any tension was applied." It is mortifying to be placed in a position where it is necessary to

argue against such absurd talk; it must be done, and my friend must know how, in the plainest way that it can be expressed. Mr. Miles, in his extensive mechanical experience and investigation, has seen a bar of iron bent into a hoop for the tire of a wagon-wheel. When the bar was straight the sides formed lines of exactly the same length. When it was bent into a hoop the inner and outer circumference of the hoop would be of different lengths, which could not be unless one side of the bar was compressed or the other expanded. Mr. M. did not read the article on page 49, Vol. vi. of THE NEW YORK COACH-MAKER'S MAGAZINE with any degree of profit, or he would not have shown himself so pitifully ignorant on this subject. There it is explained that the force of a lever operated to expand the outer, and the force of the fulcrum to the same lever operated to contract the inner circumference. His table of the strength of iron would have shown him that the resistance to compression was 10,000 and to expansion 12,000 pounds to the square inch, and that it will yield to either of the forces until they have reached five times that amount, when they would give away by breaking. This would have shown him that one side of the hoop became shorter and the other longer by contraction and expansion, and that the operation commenced long before they reach the 70,000 pounds. In fact, ductility is one of the prominent qualities of iron, and a man cannot be considered "*compos mentis*" who acts in a mechanical department without reference to the fact. We have a striking illustration of this in Mr. M.'s model wagon, presented on page 85, Vol. vi. In the centre of the axle-stock or frame, (e, Fig. 1,) he has placed a rubber spring. This spring, of course, cannot operate unless the upper part of the axle-stock or frame approaches nearer to the bottom of the axle-frame by the pressure of the load. If the upper half of the axle-frame is bent down towards the lower, it necessarily shortens the upper half of the frame, and bends it at the joint between the two axles every time the elastic rubber yields to the pressure of the load. This would throw the bottom of the wheels out, and present the difficulty of a sprung axle. This is the model wagon, the axles of which are made so firm that there is no possible chance of their being sprung, as the inventor asks us to believe! and this is the genius to whom the writer of that article is indebted for endorsing his Axle Gauge, as he tells us he has done!! and who, at various times, has undertaken to make us believe that there is



no use of setting an axle right, because it will, as soon as loaded, spring out of the place that it was set to !!!

Lastly, he dares me to deny that "the first straw that is laid on his [my] axle, at page 49, will spring his [my] bar *appreciably*, and that 100 pounds will seriously interfere with its functions as an axle." Talking about a straw's-heft springing a bar of iron the size of an ordinary wagon-axle, *so that it can be perceived*, is sheer nonsense, notwithstanding Mr. M.'s assertion to the contrary. What if 100 pounds would spring the bar of iron, it does not follow that a bar of iron is used for an axle unsupported by the axle-stock, bolster, &c., as is described on page 50 of the present volume. Years of experience has shown us that there is no difficulty in giving the wheels the necessary support in their proper position. To be sure, Mr. M. can point out exceptions to this, as a general rule; but I can point out as many exceptions in the members of the craft who pass for men of common sense, yet who, from some mental defect, are not capable of comprehending the reason why it is so, and therefore they imagine it is not so, and consequently throw away their time and money through a defect of their intellect. Is this not reason enough why in some cases axles should not have sufficient strength when such men build them?

Mr. Miles refers us to fig. 1, page 85, to illustrate the strength of his model wagon which is represented in another volume. Turn to the other volume of *THE NEW YORK COACH-MAKER'S MAGAZINE*, and you find no resemblance between the two axles. This one on page 85 is our ordinary axle, with the support (inconveniently) placed on the under side of the axle, which, in common use, has always been placed on the upper side; and that in his model wagon the axle revolves and has no stay to support it; but that its only merit is that the frame that the axle is attached to has a rubber spring in the centre, the elasticity of which will make a good spring for the load whenever the axle-frame springs and the wheels are thrown out of position. The result or consequence of this spring to the axle, is shown by throwing the whole weight of the load on one edge of the box, which makes it heat and cut out in the short space of four months, as Mr. M. tells us his experimental wagon did. All the benefit that can be derived from Mr. Miles' experiment is, that it is a demonstration added to the many that we had before of the impracticability of using wheeled vehicles without making the bearing surface, on an average, equal throughout the whole length of the axle-arm.

Mr. M. may try to construe this into a jealousy on my part; that I am afraid his invention will do away with the ordinary iron axle; but it will not look very probable as long as he tells us that he tried the experiment on only one wagon, three years ago, and that that cut out the axles in four months after it was used. Had he read *THE NEW YORK COACH-MAKER'S MAGAZINE* about the time he conceived the idea of building it, he would have been told the result and the reason why.

#### DRAUGHT APPLICABLE TO HORSES AND CARRIAGES.

MR. E. M. STRATTON, — *Dear Sir*: I do not recollect of reading in your valuable magazine, anything in regard to the line of draught most proper for horses in wheel-carriages, and if a few extracts from my notes of experiment can be of any service in elucidation of the matter,

they are very much at the service of your readers. Your most obedient servant,  
JOHN B. PEEK,  
COLUMBUS, O., October 24th, 1865.

A HORSE, considered as a machine, is admirably constructed either for draught or sustaining weight. His limbs form an assemblage of levers, which it would require a volume to point out. Look, however, particularly to the formation of his shoulders, at the place where the neck rises from the chest; the shoulder-blades form the resting place for the collar, or tugs, slopingly, and as this slope or inclination forms an angle perpendicularly with the horizon of about fourteen or fifteen degrees, it is clear that the line of his draught should be at the same angle. Why? Because the horse will then pull perpendicular to the shape of his shoulder, and all parts of the shoulder will be equally pressed by the collar. The horse, considered mechanically as a lever, has in this draught a manifest advantage over all obstacles opposed to it. In comparison with a horizontal draught, its power is in fact doubled.

We may, therefore, conclude that single horse-carts are preferable to teams; and that four single horses in single horse-carts will draw more than when the four horses are yoked together in one cart (a thing very often seen in Philadelphia and New York, but very seldom if ever in the Western cities; in fact, I have never seen such a case)—the reason is, because, in the latter case, three of the horses must draw horizontally, and therefore in a manner inconsistent with their mechanism. The truth of this has been proved by practice. The small horses or mules of this country, draw larger weights than the largest wagon horses, and go longer stages. A good mule will draw 15 cwt., while our best and largest horses do not draw on an average more than 10 or 12 cwt. In the case of our eight-horse wagons (often seen in this country ten or fifteen years ago), at least six out of the eight horses draw to a great disadvantage, so that much exertion is misapplied. The horse-collar is also drawn against his throat, and his breathing much impeded.

In cart teams, where the horses are not marshaled as in wagons, one horse is standing still while another is wasting his strength in pulling him forward. One horse leans one way out of the line of draught, whilst another is leaning a contrary way—their strength, in short, being scarcely ever united. A horse has the momentum of his draft increased by having a portion of his weight on his back, as in a sulkey or Boston chaise. Hence low wheels are not so disadvantageous as is generally supposed; for low wheels cause the line of draught to incline agreeably to the natural draught of the horse. To prove that a horse should have something to lift in his draught, and to give that draught a greater momentum, I have made the following experiments:

I constructed a model of a four-wheeled carriage, whose weight was 82 ounces; the fore-wheels  $8\frac{1}{4}$  inches high, the hind ones  $10\frac{1}{2}$  inches. This was drawn on a horizontal board by a line over a pulley; an obstacle  $1\frac{1}{2}$  inches high being placed before the fore-wheels, and the splinter-bar raised on the futchels so as to be even with the top of the fore-wheel—the line of draught then being horizontal. When things were so disposed, the weight necessary to draw the fore-wheels over the obstacle was forty-two ounces—two ounces over half the weight of the carriage. On lowering the splinter-bar so as to be three-



fourths the height of the wheel, the weight required was only thirty ounces. By lowering the splinter-bar still further so as to make the line of draught from the axle, the weight required was twenty-four ounces. On changing the point of draught to the splinter-bar one inch below the front axle, the weight was only twenty-two and a half ounces. It was seen by this, that the disadvantages of drawing from above the centre are as the line of the respective arcs passing through the splinter-bar; and the advantage of drawing from below the center also as the lines of the respective arcs.

Now, as the splinter-bar, or point of draught in most of our carriages, is placed about one-fourth the diameter of the fore-wheel *above* its center, it is evident that a fortuitous pressure, equal to one-fifth of whatever weight lies upon it, is actually added to the natural weight by this unnatural situation of the point of draught. Therefore, I argue that the splinter-bar should be placed low.

I have a wagon weighing 156 pounds, that I shall try some experiments on in the same way, as soon as I can make the necessary arrangements, and will hereafter make them known to the readers of the Magazine.

### EFFECTS WHICH DIFFERENT SHAPED RIMS (TIRES) HAVE ON ROADS.

BY ALEXANDER CUMMINGS, ESQ., F. R. S.

THE following article was written in 1779, and printed among the transactions of the British Agricultural Society. Some readers in this country—among them our Mr. Harper—have had serious doubts whether such an absurdity as a conical wheel was ever made. But such is the fact, and at one period in English history the subject elicited much debate, and produced intense excitement. We give it more as a curiosity, than for any practical worth. Mr. Cummings says:

“Although the following observations are applicable to wheels of every denomination, they more particularly apply to the broad wheels of wagons and other heavy carriages, because in them the effect is greater and more perceptible.

“The properties of all wheels, so far as regards the inquiry, depend upon their affinity to the cylinder or to the cone; and in order to show the nature and tendency of each class, it is necessary briefly to state such properties as unavoidably arise from the shape of these bodies.

“The cylinder, having all its parts of equal diameter, will, in rolling on its rim, *have an equal velocity at every part of its circumference, and necessarily advance in a straight line.*

“And as all the parts of the rim have an equal velocity, no one can have a tendency to drag forward or to retard the progress of the others. They all advance with one consent, without the rubbing of any part on the surface on which they roll.

“As there is no rubbing there can be no friction, and consequently a cylinder perfectly round, hard, and smooth

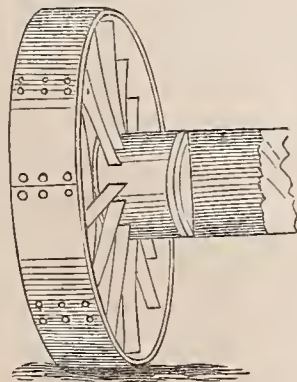

CYLINDRICAL WHEEL.

would roll on a surface perfectly level, hard, and smooth, *with the least possible resistance*, however great the weight or the pressure on its tire.

“It, therefore, follows that all the power that is employed in drawing forward a cylindrical body in a straight line on a compressible substance is ultimately applied in compressing, smoothing, and leveling the substance on which it rolls.

“The rolling of a cylindrical body, therefore, can have no tendency to alter the relative situation or position of the parts of the materials on which they pass, nor any how to derange them, but by a progressive *dead pressure* to consolidate, level, and smooth them.

“And the binding materials over which they pass being thus brought more within the sphere of mutual attraction, and into a contact nearer approaching perfection, are in a state more favorable to concretion and induration than they have been, and are in every respect better qualified to resist violence, and to protect from rain the softer materials which they cover, and they, being thus left dry, are the better able to support the crust that protects them; and thus the internal and external parts of the road derive a mutual advantage.

“These qualities of the cylinder are practically confirmed by the effect which frequent rolling with a cylinder has on gravel walks. It renders them compact, hard, smooth, and impervious to rains, and consequently secure against the devastations of hard frosts. Nor does it break or grind the gravel, more especially after the first time of rolling, when all the parts are laid flat and smooth.

“If a cylinder be cut transversely into several lengths, each part will possess all the above properties; and if the rim of a carriage-wheel be made exactly of the same shape, it must necessarily have the same tendencies, and its rolling will have the same effect on the roads that cylindrical rollers are observed to have on garden walks.

“When wheels with cylindrical rims are connected by an axis, the tendency of each being to advance in a straight line, they proceed in this connected state with the same harmony and unity of consent that exist in the parts of the same cylinder with the same facility of motion so favorable to the horse, and with all other properties that have been stated as favorable to the roads, *there is no more friction or resistance in this connected state of the pair of wheels than is applied to the same, and than if each rolled separately or unconnectedly.*

“All these properties of the cylinder, depending wholly upon the equality of every part of its diameter, and consequently upon the equality of the velocity of every part of the circumference, are peculiar to the cylinder; and it is impossible to gain equal advantages with any other shape of the circumference of a wheel.

“But as *conical rims* have been universally preferred for a series of years, it is natural to suppose that there were obvious reasons for such a preference; let us then endeavor to investigate the properties that must necessarily arise from the shape of the cone, and see from them

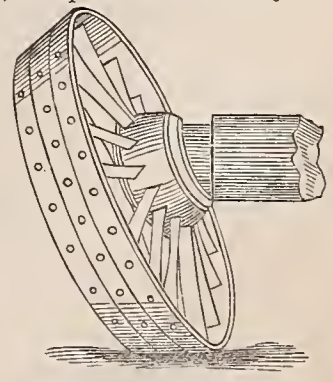

CONICAL WHEEL.



how far the *consequent effects* can justify the preference so long given to the conical rim.

"The cone, diminishing gradually from its base to its point, the velocity of every part of its circumference in rolling on an even plane will be diminished as the diameter, and at the *very point* where there is no visible diameter, there will be no perceptible motion, the cone revolving around it as a fixed point or centre; we shall, therefore, call it the *conical centre*, to distinguish it from the axis of the cone.

"Let a cone have races or circles marked on its circumference, dividing the whole length into ten equal spaces. If it be made to roll on a smooth regular horizontal surface, the circles that are on the circumference of the cone will trace on that horizontal surface other circles also at equal distances; the circumference of each representing the space described by the part of the cone that passes over it in one revolution round the conical centre, and the comparative spaces in any number of revolutions.

"But the circumference of each circle is as its distance from the centre, and the velocity of each point of the cone is also as its distance from the centre; therefore the space described by each part of the cone in rolling round its point is as the velocity of such part; and the cone will roll *in this direction* without rubbing or friction, and with the same facility that a cylinder does in a straight line.

"But if the cone be made to advance in a straight line, the natural velocities of its several parts will *not* be as the distance they are compelled to advance; therefore, a rubbing and friction will take place at its circumference from the different velocities of its parts, which must render the draught heavier.

"Let a straight line be drawn from the centre of the circles formed by the revolutions of a cone, as above described, to the outer circumference of them all, and let this line be divided into a number of equal parts—suppose 100—and numbered progressively from the centre. Each part of this scale will express the velocity of that part of the cone which rolls immediately over it; and thus may be found the difference of the velocity of any two parts of the cone.

"Here is an example. If the difference of velocity of the greatest and smallest parts of the circumference of that piece of the cone which is marked 10 be desired, the scale shows the velocity of the greatest part to be 100, and of the least part 90; and if each part were to advance according to its natural velocity (16), the greatest would run ten miles, whilst the smallest part would only advance nine, which, in fact, happens when they roll round the conical centre; *but when made to advance in a straight line*, the smallest part of the nine is necessarily dragged one mile in ten to keep pace with the largest part.

"And if the cone be supposed to be cut and separated at the several races marked on its circumference, and each part to form the rim of a broad wheel, the separated parts will regard their conical centre as when united with the others, and if rolled in this separated state, on a level plane, each part of the cone would roll in the same circle round the conical centre that it did when all the parts were connected. And the difference of velocity of the parts of each wheel, and consequently the friction and resistance at its rim, when advancing in a straight line, may easily be determined. And it will clearly appear that the rubbing at the rim of each will, in passing through

a given space, be increased as its diameter is diminished, and as its breadth is augmented.

"Here is an example. In the part of the supposed cone marked 5, the greatest velocity is 50, the least 40; so that, with these velocities, the larger part of the wheel would advance five miles whilst the smaller would only advance four; but *when moving in a straight line*, the smaller part of the conical rim must necessarily advance as far as the greater part, and must consequently be dragged *one-fifth* of all the way it goes.

"If we take yet a smaller part of the cone, say No. 3, its greatest and least velocities are to each other as 40 to 30, or as 4 to 3; so that as a wheel of this shape and proportion must have the smallest part of its rim dragged on the surface of the road *one-fourth* of all the way it goes, and daily experience shows how much the *dead drag* of one wheel retards the progress of the carriage, by analogy we may judge of the effect of a constant, although only partial, drag on all the wheels of a heavily laden wagon.

"But the evil arising from the rubbing at the rim of conical wheels is not confined to the increased labor of the cattle only; the *greatest efficacy is also given to their increased exertions* in destroying the hardest and most valuable materials of the road—the largest part of the wheel dragging forward the smallest, and with equal force resisting, there arises an action and counter-action; and the largest and smallest parts of the rim, advancing with different velocities and pressed by the weight of a heavy load, become alternate fulcrums to each other for the destruction and grinding of the hardest materials that can be produced.

"Whoever takes the trouble of inquiring into the requisites of a well-constructed pulverizing mill will find them combined in the conical broad wheel of the heavily laden wagon.

"The impalpable powder that is thus formed on the surface of roads when in a dry state is, by the least agitation, raised into clouds of dust, to the great annoyance of the traveler and all who live near road-ways. To remedy this in some degree, watering is used near the metropolis, by which the roads, being kept moist, they more readily admit water, and thereby the bad effects of wet seasons are anticipated and much increased."

(To be continued.)

#### MISCELLANEOUS.

AN INNOVATION.—The Low Moor Iron Company in England employ an omnibus to go round an out district every morning for the purpose of collecting their workmen and bringing them direct to their work. By this means the men are prevented from dropping into public houses on the way, and so losing much time. The plan has succeeded so well that it is intended to carry it out on a wider scale by employing more 'busses.

STRENGTH OF IRON, &c.—It is a remarkable fact that one of the most abundant materials in native iron is the strongest of all known substances. Made into best steel, a rod one-fourth of an inch in diameter, will sustain 9,000 lbs. before breaking; soft steel 7,000 lbs.; iron wire 6,000 lbs.; bar iron 4,000 lbs.; inferior bar iron 2,000 lbs.; cast iron 1,000 lbs. to 3,000 lbs. A rod of iron is about ten times as strong as a hempen cord of the same size.

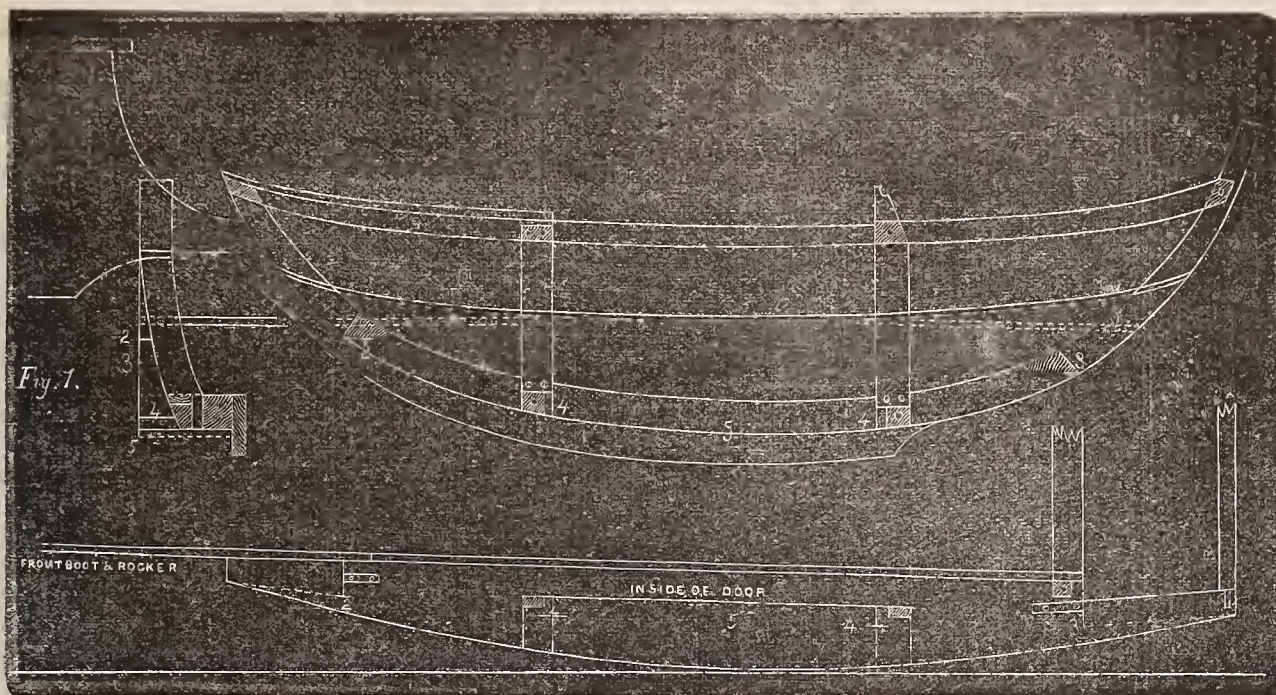

CALECHE BODY WITH CANT-BOARD.— $\frac{3}{4}$  INCH SCALE.

## ENGLISH CARRIAGE ARCHITECTURE.—No. XVII.

In this kind of body, the turn-under is in the same proportion from back to front, so that, in order to show the turn-under of the hind standing-pillar, make, in the first place, the drawing as in figure 1, and from that mark off the points of the turn-under as shown on the cant-board, and figured respectively 2 2 2, 3 3 3, 4 4 4 4, and 5 5 5, thus giving the outside the bottom-side line throughout.

Figures 2 2 2 show the front corner pillars. Figures 3 3 3 represent the hind corner pillars. Figures 4 4 4 4 the front and hind standing pillars; and figures 5 5 5 show the bottom side.

## AMERICAN DICTIONARY FOR COACH-MAKERS.

(Continued from page 69.)

## M.

**MAIN BRACES.** The long stitched braces, on which gig or other bodies are hung-off. A different thing from check braces. See CHECK STRAPS, vol. vii., p. 37.

**MANTLE.** The painted ornament in heraldry, in the form of a curtain, in which the arms, crest or cyphers are placed.

**MIDDLE-PIECE OR PILLOW.** The partition piece dividing the front windows of vehicles into two. This term is in some cases appropriately applied to the side-pillars in the framing of a body.

**MIDDLE-RAILS.** The middle framing of the body, sometimes termed the BELT-RAIL.

**MOCK-JOINTS.** Joints without a hinge, intended merely for ornament, sometimes applied to coaches.

**MONOGRAMS.** An ingenious interwoven combination of the initial letters of a person's name, being much in fashion among us at the present time. See numerous examples in this volume.

**MORTISE.** (Fr. *Mortaise*.) This word, formerly spelled "mortoise," means any hole made in one piece of

timber, intended to receive a tenon, usually formed on the end of another in framing.

**MOULDINGS.** So called, as projecting. They are chiefly used for additional ornamentation on carriage bodies, or to more effectually relieve the otherwise monotonous appearances of the panels.

## N.

**NAME-PLATES.** The ornament used as a card to the public by the manufacturers of carriages, in modern times.

**NAVE.** (Saxon, *nafa*, *nafu*.) An Englishman's term for hub. The central piece of timber or stock, in which all the spokes are driven, and through which the axle arm is inserted.

**NECK-PLATES.** Thin iron plates, fixed on the flats or woodwork of chaise heads, which move by means thereof. [*Felton*, vol. i., p. 107.]

**NETTING.** The crossings of chord, placed as a convenience for articles on the *inside* of carriages.

**NOSE-PLATE.** This was the name formerly applied to the plate extending from one to the other futchell, on the underside, to support the pole *in rest*. It received its name from its being attached near the "nose" of the futchells.

**NUNTERS.** Short timbers, framed across the beds, or transoms of the carriage, to strengthen them. [*Felton*, vol. i., p. 49.]

**NUTS.** (*Knots*.) (Saxon, *knut*.) Square pieces of iron, in which the ends of bolts are inserted, and held there by a female screw or thread.

## O.

**OIL-SKIN.** Oil-dressed linen, used chiefly as a protection to the linings of dickey seats, &c.

**OIL-SKIN PATENT.** An ancient woolen cloth, peculiarly prepared, and used for the same purposes as the "oil-skin."

**OMNIBUS.** A passenger stage with the seats running lengthwise, for carrying fares short distances. Literally a carriage for everybody.

**ORNAMENTS.** Metallic figures of different forms, added to the sides of a coach, or other body, merely "for show."

**OVAL LIGHTS.** The small windows inserted in the curthens and o

tains and o



## P.

- PANELS.** (Fr. *Panneau*.) The outside coverings to the framework of carriage bodies, generally inserted in a groove. These are distinguished as side, door, or back and front panels.
- PASTING LACE.** This is distinguished from "seaming," in that it is a narrow lace, nailed on, and *pasted* over the nailed edges of the cloth linings, instead of being sewed.
- PERCH.** (Fr. *Perche*.) The stick of timber uniting the fore and hind axles together. In America it is frequently called a "reach," perhaps with the greatest propriety, since it reaches from one axle-tree to the other, in the sense of extending.
- PERCH BOLT.** The bolt connecting the head-block and front axle together; the pivot on which the fifth-wheel revolves; the pin on which the fore-carriage turns; the king-bolt. See in this connection **CLIPPING BOLTS**, on p. 37 of this volume.
- PERCH-CARRIAGE.** Carriages built or made with perches, as distinguished from no-perch carriages.
- PERCH-COUPLING.** The name improperly given to a contrivance invented some years since, which has been the cause of more trouble to the craft than anything else ever used on a carriage. The means used to obtain a patent; the apathy shown afterwards in allowing the public to use it; the after prosecutions for infringements, and the espionage over the American shops in order to pounce upon all found using it, have now become matters of history, which after generations will look upon in utter disgust, for *all* in anyway connected with the imposition.
- PERCH-BOLT KEY, OR COTTERELL.** A thin piece of iron, fixed through the eye of the perch-bolt, to keep it from rising.—*Felton*.
- PERCH-BOLT NUT.** The square piece of iron in which a *thread* is cut, and which is screwed on to the lower end of the king-bolt for additional security.
- PERCH HOOP.** The hoop used in certain carriages (stages, principally) to unite "the wings" and perch together for greater security.
- PHAETON.** An open four-wheeled carriage, intended to be drawn by two horses. The term is often applied to a gig-bodied vehicle hung-up on four wheels. *Felton*, who wrote about one hundred years ago, says: "Phaetons, for some years, have deservedly been regarded as the most pleasant sort of carriage in use, as they contribute, more than any other, to health, amusement, and fashion, with the superior advantage of lightness over every other sort of four-wheeled carriages, and are much safer, and more easier to ride in, than those of two wheels." The name comes from the Greek word *Φαίω*, to shine; a very proper one, too, as those who use them are supposed to be "*cutting a shine*."
- PICKING OUT.** The technical phrase for the different colors used in stripping, coloring the mouldings, ornamentation, etc.
- PINNING.** The nailing with small headed iron nails, called pins, used only to the leather or lining.—*Felton*.
- PIPE-BOX.** The long box *in* which the axle-arm is inserted, as distinguished from short boxes; a tube of iron.
- PLATING.** Strengthening the timber with iron plates; covering iron with silver plating.

- POINT-STRAPS.** Small straps which buckle down the points of the main braces.—*Felton*.
- POLE.** A long lever, intended for harnessing two horses thereto, for the purpose of conducting the carriage over roads.
- POLE-CRAB.** The iron at the small end of the pole, for hitching the horses to by means of straps.
- POLE-EYES.** A modern invention intended for coupling the pole to the axle-jack.
- POLE-PIN.** The pin used in lumber wagons to secure the pole between the furchells, (improperly called "futehells,") when draught is applied. A *stop* supplies its place in modern pleasure carriages.
- POLE-PIN CAP.** The leather strap designed to keep the pole-pin in its place.
- POLE-RINGS.** The rings fixed on the ends of some poles to receive the pole straps.
- POLE-STAPLE.** The staple formerly driven into the back end of a pole, to receive a wedge in order to keep the pole tight. This wedge was called a **GIB**, which see on page 67.
- POLE-STRAPS.** Leather straps used in harnessing the horses to the pole, formerly known as "Pole Pieces." See **FRENCH POLE-PIECES**, *ante*.
- PRIVATE LOCKS.** Those fixed in the standing pillars by which the doors are occasionally locked up.—*Felton*.
- PROPS.** See **TOP-PROPS**.
- PULL CORD.** The cord used for communication between the passenger and the driver; a substitute for the "speaking tube," which see.
- PUMP-HANDLE.** This was sometimes anciently termed a "plow-handle," and its purpose was quite different from the present. Instead of being used for hanging up the body by, they served as *blocks* under the hind-board, on which the footman stood, the handle-formed-end sticking out behind, serving as "*a handle*" for "the servant to help himself up by, and to keep the horses of other carriages from coming too near, to do injury to the panels."

## Q.

- QUARTERS.** (Fr. *Quartier*.) In a restricted sense the term is applied to the panel between the standing and the end pillar, back and front; in an extended sense, it is applied to all sectional panels. The panel over the door is generally termed the door panel. The sides *within* the body are frequently called quarters, likewise. See **PANELS**, *ante*.

DETACHING HORSES FROM VEHICLES.—We are completely disgusted at finding in our patent record every few weeks, the details of some "Stiekemures Safety Harness," contrived for letting a horse slip out of the shafts of a vehicle while running away. Common sense dictates that the passengers will be more safe in *sticking* to the carriage until the horses are brought to a stand in some more safe way, for dropping the shafts on a common road, while the wagon is in motion, is certainly very dangerous. We wonder some "rare genius" does not set his brain to work and invent something which will prevent a horse from ever running away "at-all-at-tall," and so get at the root of the evil. We think he would be far more *usefully* employed in so doing.



## Home Circle.

### THE STORY OF JANE NORTH—AN AUTOBIOGRAPHY.

BY MARY E. WAGER.

THE character of some individuals and the name they bear seem to harmonize. Although we have numberless examples to the contrary there *is* much in a name, and from it we almost invariably build up an individual to correspond with it. We would never think to give the gentle name of Alice, Ellen or Evangel to a great, overgrown, gaunt woman; neither would we apply the stately Josephine, Isabella or Catharine to a milk-and-water maiden, who sleeps in curl-papers or plasters down spit-curls over a coating of *rouge*.

Jane North! You draw your inference at once; a staid, sober, precise, pink-of-propriety maiden of twenty-eight, who wears a gray straw bonnet trimmed with tan-colored ribbon, a lead-colored dress, a lace veil, and always carries a bible and hymn-book with her to church. She lives with her mother, who is a widow, in a little brown house opposite the parsonage; has charge of a class in Sabbath school, and is looked upon by the villagers as a model. The girls tire of hearing mother say, "How I wish you were as steady and thoughtful as Jane North!" while the boys wonder if Jane North ever laughed and romped and climbed fences as other girls.

I do not contend that you all would receive this impression from the name. I give it merely from my own standpoint, as I should feel if I were some one else, and you were Jane North.

In writing your own story you hardly know how to begin. You think at first you will write it as the Russians read their books; then it must read straight through as English. Again, it has all the tackings of a ship against the wind, or some important predicate, like a verb in Latin, upon which all hinges—so you advance and retreat, and finally wonder if there will be a great void in literature if you leave it unwritten.

But to return. I must dispossess you at the outset of the impression you have received from my name. A greater incongruity never existed between a cognomen and its owner, than between me and mine. Most names are heirlooms and worn by little children because grandfather or grandmother were so called. It was not so with me. I had no relative named Jane. Jane was short and respectable enough, and as I must be called something, my parents labeled me forthwith. I think I have honored their choice more than most women, for I have neither *eanned* it, or *ied* it, or *y'd* it.

My father was a New Englander by birth, who, after leaving college, went South to learn Southern manners and customs. To facilitate this he engaged as teacher in a private family where there were two girls to be taught. The youngest, Harriet, died at the expiration of two years. The elder, Frances, at the expiration of a third, became the wife of the New Englander. These were my parents: the one reared amid the free, clear air of New Hampshire hills and taught the maxim of equal rights; the other heiress in prospect to a plantation worked by a hundred slaves.

These inharmonious elements were not long at va-

riance, for when I had arrived at my twelfth year I was an orphan. I write this now with an apathy that may seem heartless, but as it is but remotely connected with my story I pass it as lightly as I can. Before my father died he freed his slaves, sold his plantation, and disposed of me in the following manner: His best friend, Owen Willis, was a farmer among the hills of his native State, and with him I was to find my home. In the meantime I was to attend school until I should be eighteen, and obey my guardian in all things. He had a son, Philip, a few years my senior, and if I carried out my father's dearest wish, it would be that sometime I would be the wife of the son of his best friend. There was nothing particularly displeasing in his arrangements except, perhaps, the last clause; for I think women universally prefer their own style of love-making to having a husband selected by some one else, as though a husband could be cut and fashioned and brought together to fit a woman's idea, as an india-rubber shoe does the foot.

But as troublesome a clause as this might have proved, I thought but little of it until I left school and settled down in Owen Willis's home on Chestnut Hill. The place was my idea of an old family homestead vitalized. The house was a two-story one, with large airy rooms, and a wide hall that ran through it like a channel. The lawn in front was spacious and sloping, not cut up with avenues for gravel or beds for flowers, but large and free, where the children could run without fear of crushing blooms, unless they were the golden-haired dandelions that gleamed amid the grass like gems in emerald setting. A row of chestnuts fringed the outward inclosure, and across the entire lawn ran a stream that flowed from a cool spring farther up the hill.

My guardian, Mr. Willis, but too often reminded me of the very excellent judgment my father displayed in selecting him for my protector. But Philip, he was farthest from my ideal of a husband, and then it is the most unromantic thing for lovers to live in the same house together. He was stout built—not much poetry in that, but excellent prose that strengthens life. He was a library of wisdom I thought for so young a man—only twenty-three. Such heaps of books and papers—and then to think of him settling down in his father's farm-house as a country physician, grooming his own horses, and sometimes actually appearing at dinner in his shirt sleeves! But so it was, and it was my father's dearest wish that I should marry him. If nothing of the kind had been designated, I should have been a hundred times more apt to fall in love with him. But as it was, I had been at the hill a year and as yet failed to be impressed with anything farther than that Philip's moustache was very airy and gossamer-like. I thought he must sit up nights to nurse it. His face, to me, was not at all handsome, and the idea of sitting opposite that three times a day all my lifetime was unendurable. He demeaned himself toward me with the utmost deference, but lavished no compliments or urged any attentions. I think, perhaps he thought I was not pleased with him, for one day as I was sitting idly under the chestnuts, curling the stems of dandelions, he sauntered that way, and doffing his hat with something of courtliness, said:

"May I claim audience with you a little time, Jane?"

"Oh yes; this is neither the abode of the gods or of love," I answered, tossing away my ruined flowers.

"Not of the latter I am quite well aware, Jane, and



this brings me to what I have to say to you. We are both acquainted with your father's wish, but I have been thinking you would be glad to avoid it if you could do so conscientiously. Whatever may be *my* lot in life, my earnest wish is that *you* may be happy. And so I ask you to be very candid with me, Jane, and we will be so frank with each other that there will be no room for misunderstanding," and he paused as if for me to speak, so I said: "You have always been so kind and good, Philip, I am sure what you have to say to me will all be right. And do not fear but that I, too, will be very open-hearted with you." So he went on.

"I am twenty-four now, Jane, and you nineteen. I never believed in early marriages. I always thought it so holy a sacrament that only the strongest love should bind it—love purified and strengthened by mature years. You may think this strange and unnatural, but having said it, you will think better of what I have to submit to you. It is this: if, when you shall become twenty-five, you can trust me above other men you will be my wife. But if another heart leads you to a more perfect faith, I will bless you and thank you for having been so frank as to tell me."

"Oh, Philip!" I cried; "it doesn't seem right some-way. I should hate you forever if I thought you could be so base as to marry me simply because my father wished it, unless your heart plead so too!"

"You do not know me, Jane," he said, almost sadly; "you do not know my heart. I hardly know it myself. Our casual interviews do not reveal the fullness and richness of character. Good qualities are not alone essential. There must be harmony as well as power. I never could fetter my soul with so base a crime as to ask your heart if mine had not already gone out wholly to you. This life is too sacred, too precious, to blaspheme against its sanctity. So, Jane, what I say to you must come from my very soul. I must speak as I would in the presence of the angels. Six years is a long time to wait, but I will not ask you to question your soul for me until then. But until then, I want you to feel free from any love of mine, and free to love wherever your heart may lead you. Will you promise me this?"

He took my hands in his, frightening me with his earnestness, so that I hardly knew my reply, until he said: "Bless you! you will do right I know." Then he went away. It all seemed so strange, and matter-of-fact, too. It was nothing like to what I had imagined love and lovers to be. His real manliness and sincerity for my happiness made me feel more kindly toward him. But I was satisfied I never should love him—not as I understood it to mean. I could trust him, for I knew he was the soul of honor. I could confide in him for he would keep faith.

My life passed very pleasantly at Chestnut Hill, and my twenty-fourth birthday had passed, and the year more than half told. Until then I hardly realized how the days had slipped away, and I was growing old. I remember the morning so well—a May day. As I opened my window it seemed as if heaven and earth had met in a close embrace. A gentle mist hung low over river and uplands, so that trees and dwellings appeared so softened and shadowy-like one might expect them to quite vanish. At length the mist gathered up her gossamer tresses, and shimmering through lattice and leaves came the glad sunlight. A hundred musical throats filled the air with

melody. A thousand inspirations from the great throbbing heart of Nature made one glad to be alive.

Only a few weeks and I should be twenty-five, and with it my promise to Dr. Willis. The years had changed us—him more than me. He had but once alluded to our relation—our possible future. That was one night as we were standing on the porch, talking of one who that day had died, and moralizing on the shortness of human life.

"Yes," he said, "the years swiftly build us a bridge upon which we pass to immortality. You will soon be twenty-five, Jane, do you find life hollow and unsatisfying?" I knew he would judge something from my reply, and so I tried to answer lightly, "Sometimes it seems cold and heartless, and then again I am glad I am alive, and so happy it seems almost a pain—but then 'tis said pain is only pleasure intensified."

Philip was a man in every sense of the term. He was not brilliant and flashing, but steady, strong and persevering. He stood high in his profession. Old physicians came to him for counsel, and trusted to his skill sooner than their own. Women were not fascinated by him; he won their respect; but among men he stood pre-eminent. I never understood it so plainly as afterward, that men have two characters, and those who please and fascinate women are never held in high repute among men. Their best side is all for women, and men find only a barren one left for them. Wondering why men *they* so little esteem, find such gracious favor in woman's eyes. And it is just so with the other side. Women fascinate men only as they lack attractions for their own sex.

I respected Philip profoundly. I esteemed him more highly than any other I knew, but it seemed all *head-love*. There was no debating his qualifications. I could hardly tell how I would have him different. I sometimes wished something would happen to test my feelings for him—how I should feel if I were to lose him. I knew his worthiness, but withal he did not satisfy me. Perhaps I had learned love wrongly.

But I was speaking of that May-day morning. We had a quiet breakfast. Soon after Katie Hays came laughing in, her cheeks all aglow with her morning walk.

"We want your help, Jane, and Dr. Willis," said she. "We are all going over in the Tilden Woods next Thursday for a pic-nic. We propose leaving our parlor manners at home, and have a genuine boy and girl frolic. Now, will you join us?" She subsided, and Philip turned to me for an answer. So, woman fashion, I asked who the "*we*" of the party were to be?

"Oh," said Kate, "the Harlans, and Daytons, and Danforths, and, by the way, a Mr. De—De—something, I don't recall the name, who is stopping for a time at the R—House, will be one of the company. I haven't seen him, but the girls all say he is splendid."

"For what is he stopping at the R—House?" I asked.

"Oh, they say he is an artist, and has just come from a tour among the mountains, and being pleased with the scenery hereabout designed, I suppose, to transfer some of our hillocks upon canvas. I hope he isn't so stiff and dignified that he will spoil all our fun at the pic-nic with his august majesty, so that we will have to sit up just so prim." And she straightened back, folded up her arms, and drew her dimples as nearly out of place as possible.



Philip joined in a hearty laugh at this, and said he would go, as his skill might be needed if the artist's presence had such an elongating effect upon Katie.

The intervening days passed pleasantly enough, like the others, and Thursday morning dawned cloudily, foreboding rain. But we went, notwithstanding, supplying ourselves with umbrellas, &c., in case we should need them.

Philip and myself were the last to arrive, as he was called away in the morning and did not return until late. As we rode up, Katie Hays greeted us with:

"I'm glad you've come. We were just saying there was no one to sing with Charley Danforth, and then we want your opinion about arranging the tables. Will it be too undignified to have them on the ground? We can sit *a la Turk*, you know," she added, thereby showing her preference. At this the feminine voices came in like an avalanche, pro and con, but the cons carried the day, at which triumph Charley Danforth essayed to cheer, and ended by coming round to me.

"I don't like to do it much, Jane," he began, "but Mr. Demun has been smitten with your pretty face, I suspect, as he has asked for an introduction. Excuse my compliment, but I didn't well know how else to bring it about!" and throwing off one of his significant gestures he sauntered away, soon returning with Folsom Demun, whom I saw for the first time.

After the ceremony was over, and Mr. Demun and myself were standing apart, engaged in light conversation, he suddenly threw the light of a pair of magnificent black eyes upon me, and said, in a low, earnest way, while his voice had a mellowed richness in it that made one quite envy its possessor:

"You will believe me, Miss North, when I tell you that I am very glad that I have met you here. The remembrance of your face has been a pleasant vision with me for many months."

"Why, have we met before?" I stammered, a little puzzled.

"Yes, unconsciously to you, perhaps; but I can never forget it. It was a year ago upon one of the Hudson steamers. Were you not going to New York with your guardian, Mr. Willis?"

"Yes, but it is strange you should remember me."

"There are some faces we cannot easily forget. Others we may pass a score of times and never know that we have seen them before. Do you not think it a beautiful theory that the soul fashions its temple in a great degree? I believe a beautiful soul never lies back of a thoroughly ugly setting," he added, in a dreamy way.

I could not refrain from looking at him, then, as I had not dared to before. If his theory were true, his soul must be marvellously beautiful. There was no soft, effeminate dandyism about him, but a bold outline of a grand man—too grand, I thought, with his fine muscular hands, to wield a brush all the years of his life. I would know if it were his *forte*, his passion—painting. I pointed out a fine view at our left; a plain with fringe of trees and the mountains beyond, and then asked if he sketched.

"Yes, a little, for recreation. I could hardly be content to wed myself to the profession, so I devote a few weeks each year to little excursions to transfer what suits me."

Then he talked of other lands and other years, all the time showing me some new beauty in a flower or fern,

leading me farther and farther away, until we were startled by the booming of thunder, and before we could join the others the rain came down in torrents.

(To be concluded next month.)

## Pen Illustrations of the Drafts.

### ROUND-FRONT SIX-PASSENGER ROCKAWAY.

*Illustrated on Plate XXIV.*

WE feel great satisfaction in being able, this month, to present so fine a drawing of a very useful carriage to our readers. The original design was furnished us by Mr. J. N. Cooling, of Wilmington, Del., and gives good evidence that the gentleman is a man of taste, a credit to the craft. This body has a round front with seat in front, capable of carrying four inside, and, besides the driver, another outside. The drawing so well tells its own story that we need not swell the description with further detail.

### PHYSICIAN'S PHAETON.

*Illustrated on Plate XXV.*

COMPARED with former practice, modern science has rendered the building of this vehicle a simple matter. The side quarter is worked out of the solid two-inch whitewood plank, and secured to the rocker by screwing; the most difficult portion of art being the proper adjustment of the corner pillars for receiving the grooving for the back panel. This is something, however, which cannot easily be taught here—it can be learned by practice only. Concerning the word "phaeton," consult the chapter of our dictionary on page 100 of this volume.

### PHILADELPHIA BUGGY.

*Illustrated on Plate XXVI.*

IN our late visit to Philadelphia, we saw several buggies similar to the one here presented; but as we only took an eye sketch, we are not quite sure of correctness. Be this as it may, this drawing will commend itself to the public, and this is saying a good deal, doubtless more than is necessary.

### TANDEM SLEIGH.

*Illustrated on Plate XXVII.*

WE intended to finish the sleigh business for the year in the September number of this Magazine, as far as our duty extended; but, since that was published, we have received from Mr. A. C. Lariviere several photographs of sleighs built by him in Montreal, from which we have selected the one here given as possessing the greatest novelty. Mr. L. says this sleigh "is very well liked in Montreal; that the back seat is made to change to be



used as a dog-cart sleigh, and then there is a water-deck to form a back for the back seat when they sit back-to-back; and when they want to use it with only one seat they shut all the seats and the water-deck, and then it makes a very nice one-seat sleigh."

## Sparks from the Anvil.

### NEW MODE OF COUPLING PERCHES TO HIND AXLES.

WE have been favored by Messrs. Merts & Riddle, of Ravenna, Ohio, with sketches of a new mode of coupling perches to the hind axles, which we have endeavored to show in the accompanying engravings. The novelty in

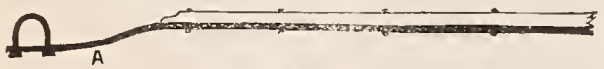

FIG. 1.

this case, is seen in Fig. 1, at A in profile, and is still further illustrated in the birds-eye view, Fig. 2.; the goose-neck being represented at A, and the wooden perch at B.

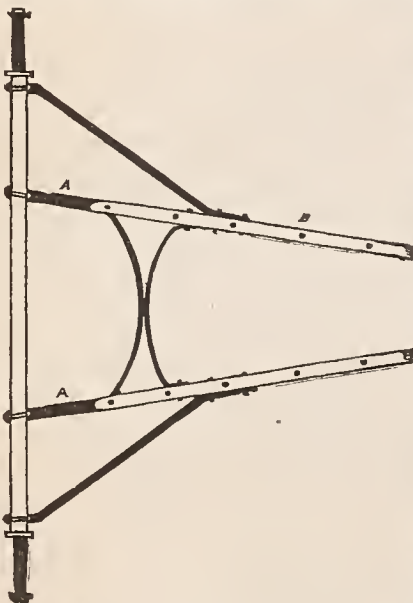

FIG. 2.

These goose-necks are about six inches long, shaped something after the manner of the common shaft irons, in order to raise the back ends of the perches on a level, nearly, with the front ends. Perches coupled in this way are pronounced less liable to break at the axle, from vibratory motion, than when arranged on the old plan. Mr. R., in sending these sketches, observes: "We sometimes make these double perches without any irons across the middle, letting them run straight with the body. The back ends will be considerably lower than the front, unless you put the reaches on the top of the axles. We let the irons take an easy curve [sweep] from where they leave the reaches to the bottom of the hind axles. These double reaches are pronounced perfect by those who use our carriages, as they will stand much more twisting than when the wood extends back to the hind axletree." We may add, in conclusion, that, if properly done, the job, when finished, is a great improvement in this portion of the vehicle—far more graceful than in the common mode.

**WELDING STEEL AND CAST OR MALLEABLE IRON.**—Mr. Carson, of Sheffield, England, has provisionally specified the use of a composition, consisting of borax, fifty parts; calais sand, thirty parts; emory, ten parts; and magnesia, ten parts, in the welding of steel and cast or malleable iron; but he does not restrict himself to these proportions.

## Haint Room.

### OIL, AND OIL CAKE FACTORY, DUBLIN.

OIL and wine, the two first discovered panaceas for a wounded spirit and wounded body, have lost none of their importance with the advance of civilization and the consequent discovery of new agents. Since the time when the rich juice was first trodden from the grape and the unctuous liquid first expressed from the olive, these two commodities have played an important part in the world's commerce. Yet the primitive uses of either have not been lost sight of. Our physician still "pours in" the one, if he does not the other, and oil is still an important agent of light, though not, as in earlier days, the only one.

Though oil and wine have almost ceased to be associated with each other, we do not consider the present subject unsuited to follow immediately after our last chapter, which took the reader through the interesting intricacies of the vaults belonging to one of the most extensive wine dealers in the kingdom.

In stepping across the Irish Channel to view the process adopted by grape and linseed oil crushers to obtain the natural oil from those seeds, we do not ignore the fact that oil mills of a like character are to be found at home. Desirous, however, of making "Our Business Houses" complete in descriptions of representative manufactories in every branch of our trade, we are also desirous of selecting the material from sources as widely as possible apart, so that individual examples of commercial enterprise may not be lost sight of, or indications of each country's manufacturing progress remain unnoticed. It was for these reasons we visited a Cork biscuit factory, a Scotch coal oil distillery, and a Lancashire soap house; and for these reasons, also, we take the subject-matter of our present chapter from the Ashtown Oil Mills, Phoenix Park, Dublin.

As Ireland promises to become a renowned flax-growing country, there is a prospect for oil crushers in that country which has never hitherto been presented.

The Ashtown Mills were built by Messrs. McGarry & Sons, under the superintendence of Mr. Robert McGarry, the present manager of the works, in the year 1831. At that time the McGarry's owned 130 acres of the adjoining land, and probably cultivated the seed crushed at their mill. At any rate, they were well known for their endeavors to develop the natural resources of their country; for, in addition to their extensive farming operations, they established lead mines at Clontarf, which, for want of the immense capital required for such operations, were closed many years since. The Ashtown Oil Mills, after having been successfully worked for over thirty years by the founder and his sons, passed, a short time since, into the hands of the present owners—Messrs. McMaster & Hodgson, the old-established and well-known drysalters and general merchants, of Dublin.

On communicating our errand to that firm, we were at once handed over by the active partner, Mr. Hodgson, to the tender mercies of the manager of the mills. Having procured an "outside car"—Ireland's own peculiar vehicular luxury—we at once set our faces towards the finest park in the world, for a long and pleasant drive past the Vice-Regal Lodge, Sir Robert Peel's and the Under Secretary's snug residences, through groves of elms and



herds of deer, and through all those lovely scenes which are calculated to make the most contented amongst cockneys long for a lord lieutenancy and a residence in Phoenix Park.

We remarked the fact that no delay occurred in the granting of our request, and "our card to view" was made use of the moment it was received. This we mention because there are many manufactories, the whole internal mysteries of which have never been laid bare to the world, and many there are the proprietors of which act strictly upon the terms of the gate sign—"No admittance except on business." Arrived at the mills, which adjoin the park on the north side, we take an external survey of the buildings, which are ordinary, good-sized, substantial affairs, with walls four feet thick, of stone, so close grained and durable that it appears likely to serve the purposes of many succeeding McMasters and Hodgsons, even should the present ones hold it until they are as aged as the patriarchs. A water-course has been cut from the Royal Canal, with a pond and mill-race, and a fall of 18 feet upon an immense wheel, 28 feet in diameter and 10 feet wide, which, without ceasing day or night, turns monotonously upon its axle for the good of the oil trade and consumers of oil, oil cake, and linseed and rape meal. The stream of water that supplies so much power to the machinery within having performed its important task, enters an arched channel and listlessly returns to its original source through a "tail race" about 1,200 feet long.

We notice that the buildings are well arranged, and that in their erection economy of space and the comforts of the workpeople have been well studied. The present works cover three acres of land, and clearances are being made for additional buildings.

Entering a good-sized room, we observe several men emptying sack after sack of linseed into an immense funnel-like wooden vessel, that appears to engulf all with extraordinary rapidity, and gape for more. This, our obliging guide informs us, is the "hopper"—why, we did not inquire, but proceeded to examine the means by which it disposed of so many sacks of seed in so short a space of time. We discovered that in this work the hopper had the assistance of an "elevator," consisting of an endless band of leather, supplied, at intervals of one foot, with buckets, which, as the belt revolves, dip into the mass of seed, and carry it aloft. The motion of the belt is so rapid that the little buckets, on reaching the top cylinder, pitch out their burden to a considerable distance from the shaft which, through a height of five extensive floors, protects the belt. It will be wondered how so much seed can be carried away in so short a time by vessels holding only about seven pounds each; but there are two hundred of them, and they never cease to ascend and descend in rapid succession. This is the process adopted for storing the grain on the various lofts, which is considered a much easier method than hoisting sacks with a crane. For those who are fond of familiar comparisons, we may add that the belt and buckets are on the same principle as those used on board mud-barges to clear the beds of foul rivers. While watching the grain disappear from the hopper, we receive the information that, in the absence of home-grown linseed, Dutch and Bombay seeds are used, the two kinds being mixed together. The home-grown seed is, however preferred; for it is brought to the mill in a fresh state while that from abroad is chiefly what is left after sowing.

(To be continued.)

## Trimming Room.

### LINING CARRIAGES IN OLDEN TIMES.

OUR progenitors experienced very few of the luxuries which modern science has placed within our reach. The *fine* linen of the ancient Egyptians would make a rather sorry show beside the silken fabrics produced by the looms of France. There is scarcely a single textile fabric now woven that is not much finer and more elegantly finished than ever before. The older carriage-makers yet among us well remember how tame and indifferent the inside linings of the carriages built thirty years ago appeared when compared with those now made. It is not alone in the artistic manipulation, but in the quality of the material also, that we excel. Both combined have evidenced to the world a remarkable degree of advancement.

Seventy-five years ago, according to Felton, instead of using broadcloth—considered by us rather common—in many of the better class of vehicles, "second cloth," which seems to have been a cheaper article, was more generally employed, even among the comparatively wealthy. Nor was such a luxury as sitting upon cushions stuffed with curled hair known. Such were filled with the wool of sheep—"flock," as it was called, even for the finest vehicle. Even kings, lords, and such *questionable* people, had no other choice. As for the middle classes "swinging-tow," or even hay, was thought to be *good enough for them*. Matters have since changed. Now, since labor has risen in value, *the poor* ask for the best. *O tempora, O mores!*

### TANNING LEATHER WITH TURPENTINE.

WE learn from a French journal that M. Picard has invented a process by means of which, with turpentine instead of bark, leather is perfectly tanned in twelve hours, and more effectually than by the old method. The process, though called tanning, is not, in reality, even a modification of it. Leather is a chemical compound of tannin and gelatin; in the new process the fatty substances are merely dissolved out by the turpentine; and though a material having somewhat the appearance of leather results, it is difficult to believe that it possesses the durability and other good qualities of leather, properly so called. The product may, however, answer well for many purposes; it is fifty per cent. cheaper, and its manufacture is far less laborious than the ordinary tanning process.

### TO TRIMMERS.

WE have repeatedly appealed to the trimming fraternity for contributions to this special department of our Journal; but thus far in vain. We are invariably put off with the declaration that very little can be said on the subject, as a quite sufficient excuse for non-compliance. Granted that such *is* the case, yet we think it strange there has not been found some one with sufficient spirit to give us *the little* in some shape. Suppose some one tries his hand, and let us see what can be done for this interesting department of our Magazine.



## Editor's Work-bench.

### THE DAY OF EIGHT HOURS' LABOR.

UNDER the head of "Eight hours a fair day's work," six months ago, we told our readers that the ten hours then given as a day's work, would, we thought, soon be reduced to eight, and that for this change the public might as well be prepared. Since that time the question has not been suffered to rest, but has now assumed something of a political nature in many of the States. As this subject is of the gravest importance; coming home to every fireside in our country; affecting all branches of industry, and calculated to change our entire system of labor, it demands the most serious examination on the part of the agitators themselves, lest, under the impression that they are promoting self-interest, they find themselves worse off by the change when, perhaps, it is too late to return.

Although we are friendly to any movement calculated to better the condition of those compelled to labor, yet it is questionable whether the present intended reduction will do it. If, as is generally believed, *labor is the poor man's capital*, how, when twenty per cent. of that capital has been withdrawn, can he be benefited? We assume that when eight hours constitute a legal day's work the laborer himself will be obliged to pay twenty per cent. more than at present for provision, fuel, house rent, etc., completely neutralizing the advantages expected from the change; for, to suppose that one's own labor will be well paid for, while a neighbor's is not enhanced in a like ratio, is mere folly. The reduction in the hours of labor will unquestionably render it more difficult to conduct business than under the old régime, and increase that hostile spirit which has for ages warred between capital and labor, fed by ignorance and prejudice. Modern agitators seem to have ignored the fact that in all these contests the poor man has suffered the most; and, in a great many instances, been obliged to appeal to the clemency of the rich to save himself and those dependant upon him for support from starvation. The journeymen ship-joiners of New York, who, on more than one occasion, have thus in our memory appealed, have lately

*Resolved*, That, in justice to ourselves and to our families, and for the improvement of such intellect as God has given us, we consider eight hours for labor to be a fair and just division of the twenty-four, and we shall use all honorable means to obtain legislative sanction to making eight hours' labor a legal day's work.

*Resolved*, That, as the merchant and capitalist work but five or six hours per day, and in that space of time accumulate millions, principally by our manual labor, we believe that the noble, just, and generous will not, and the proud, oppressive, and ungenerous should not, refuse to grant our just demands."

A cotemporary rightly observes that "the former of these resolves embodies a simple and every way proper

demand, which the second stultifies by assertions which are widely known to be false. It is perfectly notorious that successful employers and business men work too intently, too constantly, and they should be urged to shorten the working day for their own sake and that of their families, who are too often deprived of their society by their incessant absorbing devotion to money-making. To tell these men that *they* work but five or six hours per day, as an argument for shortening the day's work of their employes is the very way to set them inflexibly against you. If there be indeed merchants and capitalists who *accumulate millions* they do it by working far more than 'five or six hours per day;' if there are business men who work "but five or six hours per day," they are very unlikely to "accumulate millions."

We remember the time when, as an apprentice, we labored fifteen, and as a journeyman, ten hours a day, and yet had an easier time of it, and less exacting, than in after life when we set up business for ourself. We have known journeymen who have gone into business, afterward affirm that they experienced more happiness when their minds were free and their hands busy, than since their altered circumstances. But the greatest absurdity yet promulgated is found in the platform put forth by the workingmen's mass meeting lately convened in Faneuil Hall, Boston, Massachusetts. We produce an extract:

*Resolved*, That the great *material* advantage to the laborer of the Eight-hour System is, that it is the only way by which his wages can ever be permanently increased without increasing the price of the article produced—that this increase in the laborer's wages will be at the expense of the vast wealth of individual capitalists, and not at the expense of the laboring consumer—that the simple increase of wages means the first step on that long road which ends at last in a more equal distribution of the fruits of industry, in which the producer and the capitalists will be one. That, as the vast fortunes of individuals must melt back into the hands which produced them, under a higher standard of intelligence, so also must the abuses, monopolies, and illegitimate burdens which the people unconsciously impose upon themselves; that this means the downfall of a corrupt moneyed aristocracy, and of its natural counterpart, extreme poverty and pauperism—foreing children, and wives, and maidens, who would be wives if men were better paid, into the labor market, to elbow down each other's wages to a point which makes prostitution a necessity, and furnishing a theater for the demagogue in times of financial revulsion—perpetuating the system which makes such periods inevitable, and which furnishes to traitors at home and enemies abroad the only basis upon which to found a hope for Northern votes in favor of repudiating the debt of the nation.

How any sane man expects to have his wages increased—the eight hour system doing it effectually—without a corresponding increase in the costs of the article produced by his hands, is strange. If this can be



done, it is something hitherto incomprehensible to cultivated minds, and patentable. Suppose, for example, I hire a journeyman who is able to do the work required in building a carriage in sixty days, under the old system, for which I pay him three dollars a day; it then costs me \$180 to do the labor. Under the eight-hour system—unless as much work is done in eight as was formerly done in ten—but all history negatives such a conclusion—the same carriage, built by the same man, will cost me \$216. Then there are a great many more items used in the construction on which the same ratio of advance has been made. Is there any capitalist, now living, so *dead* to his own interests as to experiment with these theorists? If such are found they have more money than brains, and the experiment will soon leave them in possession of neither.

Journeyman mechanics, be not deceived. No capitalist will hire and pay you when he finds he can make nothing by so doing. Nor will you need ask him for work when you are in a situation to do better by being your own "boss." You may rest assured that the "long road" mentioned above as "ending *at last* in a more equal distribution of the fruits of industry, in which *the producer and the capitalist will be one*, is "the road from which no traveler returns"—the place where every man will reap according to his sowing. We have not space to enter more fully into this subject here, and if we had we fear that argument would only be thrown away, in discussing a subject so plainly understood by all minds not deeply steeped in ignorance.

#### REVIEW OF TRADE.

OUR readers will learn from an article found in the last number of the Magazine, that we have been visiting the craft "out west." It will naturally be expected that we give our observations on the state of trade in different localities. This we will endeavor to do as briefly as possible.

In Philadelphia, Wilmington, Washington, Cincinnati, Indianapolis, Chicago, Detroit, and Pittsburg, and some smaller towns, we were told by the manufacturers that they found sales for all the carriages they could build. Indeed, the only place where dissatisfaction seemed to prevail was among our Baltimorean friends. It will be recollected, by those familiar with the details of the late civil war, that this city set the first example of cruelty, in firing upon the Massachusetts soldiers while they were marching through the streets to the defence of our national Government. This great crime, although, in its execution, confined to a few rebellious spirits, has had a depressing effect on trade, and struck a blow from which it must suffer for some time to come. This is very much to be regretted; for, as a general thing, Baltimore is today as loyal a city as any other in this Union.

The chief complaint in Washington now is that they cannot get from Wilmington a sufficient supply of carriages to stock the repositories, and that "the prices are a little too stiff"—a natural consequence of great demand. The manufacturers too, complain that *they* cannot get material in sufficient quantities to supply their needs. To those interested we would say that we know of no place more inviting to an industrious and energetic dealer in carriage materials, than the city of Wilmington, Del.

Perhaps we cannot better illustrate the state of trade at this time, in the section of country over which our late visit extended, than by quoting some of the prices for which top buggies are selling. In no city—not even this—are so high prices obtained as in Cincinnati. Messrs. Gosling & Miller sell them for from \$500 to \$525 each, and it is no unusual thing for other makers to sell for \$450. These prices, considering that there are so many country shops in the vicinity, interfering with the trade in cities, are sure indications that there must be intrinsic value to warrant them. At Indianapolis, buggies sell for \$390 and \$400. At Lafayette the same sell for \$325. In Chicago there are several repositories where eastern-built buggies are sold for about \$325. City made top buggies sell there as high as \$425 and \$450. In Detroit, top buggies can be bought for \$300 to \$325; no-tops, for \$175 and \$200. In Adrian, a very well made top buggy is sold for \$300. The same price rules in Toledo.

The universal complaint is, not that any difficulty exists in effecting sales, but that when sold, and taxes paid, there is nothing made. With materials high, and workmen scarce, this is not very strange; but the most singular thing is, that since our soldiers have returned still the same scarcity of hands, and the difficulty in obtaining them, continues. This is contrary to the predictions of many on the return of peace, and is an additional proof that historical results in our case differ from those of all other nations. There are, evidently, more workmen seeking employment now than during the war; but, the fact that these very workmen, by their presence, make increased calls for supplies, seems to have been lost sight of in the blaze of national rejoicings. In almost every department of trade, the demand is much greater than the supply. This makes business brisk, and, consequently, the laborer demands higher prices now than ruled during the war. When this state of things will change no man can divine; but *our* customers may as well make up their minds that while they continue "those who ride must pay," and pay a very high price too. A close examination convinces us that at the present moment there are less ready-made carriages in the shops than there have been at any time during the past ten years.

Coming nearer home, it affords us great pleasure to find that in New York trade has been unusually brisk



upon the whole. It is true that the early spring seemed discouraging; but, after it had fairly opened, the repositories and manufacturing shops were soon emptied. We think there have been more carriages sold the past season than in any one year for a long period preceding it. Whether this has been done with profit to the manufacturer is another question. Were we to judge from the affirmation of the trade, generally, the answer must be a negative one, chargeable to the demands of the Revenue Tax gatherer. We are not, however, without hope that when Congress again meets this onerous demand will be in some degree modified. Until this is done, some exercise of patience will be necessary.

#### LITERARY NOTICES.

THE ATLANTIC MONTHLY, for October, is a very interesting number. It will sustain the reputation of this creditable American periodical. The leading subject is, Saints who have had Bodies. The other most important articles are, No Time like the Old Time; The Author of "Saul;" John Jordan; Noël; Wilhelm Meister's Apprenticeship, II.; Down the River; &c. The enterprising publishers, Messrs. Ticknor & Fields, have recently established an agency for their publications at 823 Broadway, N. Y.

The same publishers have issued *The Lyrics of Life*, by Robert Browning, and *National Lyrics*, by John G. Whittier, both works containing the best poems of the distinguished authors named; being additions to their Illustrated "Companion Poets for the People." Each may be purchased for 50 cents the volume, in stiff paper covers.

### Patent Journal.

#### AMERICAN INVENTIONS.

August 29th. (49,611) CARRIAGE-TOP.—Lewis Z. Dodds and Robert Walsh, Three Rivers, Mich. :

We claim, *First*, the combination of the top with the seat of a carriage, in the manner described, for the purpose set forth. *Second*, Fastening the top to the seat of the carriage in the manner substantially described, for the purpose set forth. *Third*, The skeleton frame, constructed as described for the purpose set forth.

(49,651) SECURING LYNCH-PINS.—Caleb M. Risley, Woodbridge, N. J. :

I claim the washer in combination with the sliding spring and slotted ears C C, all constructed and arranged as described, substantially as and for the purpose set forth.

(49,670) TRY-SQUARE.—John Williams, Shelburne, Mass. :

I claim the mode of attaching the tongue B, to the beam A, by means of the rod *g*, and nut *a*, arranged and combined in the manner set forth.

Sept. 5. (49,726) AXLE-BOX.—Charles Cook, Winsted, Conn. :

I claim, as an improved article of manufacture, a box for the axles of vehicles constructed of wrought-iron, with a true or finished interior surface, and hardened by the usual "case-hardening" or "steel converting" processes, substantially as set forth.

(49,734) RELEASING THE TAIL-BOARDS OF WAGONS.—Casper Dreher, Detroit, Mich. :

I claim, *First*, the rock-shaft E, provided with the tappets

*b*, and lever *a*, or their equivalents, substantially as and for the purpose specified. *Second*, The combination of the rock-shaft E, tappet *b*, lever *a*, and spring-catch D, substantially in the manner shown and described. *Third*, The tappet *b*, when connected to a suitable rock-shaft, and arranged to operate substantially as herein shown and described.

(49,771) WAGON-BRAKE.—Nelson Lezat, New Baltimore, N. Y. :

I claim the cross-bar *h*, carrying the fulcrum *i*, of the secondary lever *k*, in combination with the horizontal levers *d d*, and brake-blocks or shoes *g g*, as and for the purposes specified.

(49,772) AXLE-BOX.—Edwin Lockwood, Bordentown, N. J. :

I claim the construction and use of the packing C, composed of two parts E E, one part E, being fixed, and the other part E, being adjustable and regulated by a screw E', or its equivalent, in combination with the chamber B, at the rear of the bag, and the plate D, which, with the packing, is fitted in said chamber, and secured in position by bolts H, substantially as and for the purpose set forth.

(49,786) SPRING.—J. C. Plumer, Boston, Mass. :

I claim *First*, a spring which is constructed of two or more arms or levers, united by joints, and which derives elasticity from a piece or pieces of rubber fixed in or between the arms, as described. *Second*, The plates applied to the exposed surface of the rubber and connected by a bolt, in combination with the described spring, both as and for the purposes as described.

12. (49,872) FOLDING SEAT FOR WHEEL VEHICLES.—Henry A. Gilbertson, N. Y. City :

I claim a folding or hinged seat for wheel vehicles, provided with a back and sides, either both arranged and applied in such a manner as to admit of folding automatically, by the folding or turning up or down of the seat, all constructed substantially as herein shown and described.

(49,948) BRAKE-SHOE.—James Christie, assignor to himself, Rudolph Dicks, and E. H. Bitsman, Philadelphia, Pa. :

I claim *First*, the holder A, with its lugs *c e'*, and the sole E, with its lug *c*, constructed and secured together by the key F passing through the lug, substantially as described. *Second*, The key F, for securing the sole E to the holder, the said key being curved, as and for the purpose specified.

19. (50,067) PAINT BRUSH.—Samuel B. Faught, Foxboro' Mass., assignor to himself and Wm. T. Cook, Boston, Mass. :

I claim the double socket A, provided with a partition *a*, in combination with the conical wedge D, and screw *e*, substantially as set forth.

26. (50,114) BRACE FOR CARRIAGE SPRINGS.—Christopher C. Gleason, Wauconda, Ill. :

I claim the specific arrangement and adjustment as described, to wit, attaching the revolving lever to the bottom of the carriage-box, and attaching the braces to said lever and the front and rear axles, substantially as described.

(50,124) NECK-YOKE AND WHIFFLE-TREE SOCKET.—Chester C. Holman, Clayville, N. Y. :

I claim the mode of securing the angle lever D *e* in its place, by casting the chamber socket B *b*, on to it, so that the joint and spring E, which hold the lever D, closed against the hook C, will be protected, all constructed as and for the purposes herein described.

(50,130) MACHINE FOR DRESSING WAGON-WHEELS.—Silas T. Jackson, Sheboygan Falls, Wis. :

I claim the combination of a bearing wheel D, planers G, and smoothing discs I, operated and operating substantially as and for the purpose set forth.

(50,132) MANUFACTURE OF SPIRITS OF TURPENTINE.—John Johnson, Saco, Maine :

I claim, *First*, The use of water, steam, air, or gasses and



solvents, when circulating around, amongst, and through wood, timber or lumber, in proper receptacles, at a temperature sufficiently low to receive the exparture terebinthinates and resins free from empyreumatic odors, substantially as described. *Second*, The mode of procuring resin and spirits of turpentine by heating the lumber or wood placed over a stratum, or sheet of water which condenses the volatile products of the wood therein, and fixes the resin when the same is used in combination with the steaming of lumber, substantially as specified. *Third*, the mode of using two boilers successively, for economizing the heat and avoiding waste of terebinthene products, substantially as specified. *Fourth*, The mode of increasing the temperature of the liquid for extracting exudable and volatile products from wood, by the use of any suitable soluble salt, substantially as specified. *Fifth*, Passing heated air over the surface of a liquid to aid in taking up the volatile products for condensation previous to their entry into the condenser, substantially as specified. *Sixth*, Compressing wood after steaming to eliminate oleo-resins, substantially as specified.

(50,145) WAGON-BRAKE.—A. B. Mattoon, Niles, N. Y.:

I claim the pully fulcrummed levers E P N E P N, the revolving brake-block B, the short single levers S, and the rod T, combined and arranged as described.

(50,171) TIRE-SHRINKING MACHINE.—Melchi Scott, Fairfield Iowa:

I claim *First*, The caps C C, dogs 2 2, and the cranks 1 1, constructed and arranged as described, *Second*, The rods p p, evener O, and clevis R, in combination with the lever P, for operating the clamping device, as described.

(50,189) THILL [SHAFT] COUPLING.—H. K. Waterhouse, Factory Point, Vt.:

I claim the spring-catch composed of a spring C, provided with a beveled projection b, and applied to the coupling-pin B, in connection with the recess c, in the ear E A', substantially as and for the purpose herein set forth.

(50,209) CARRIAGE-SPRING.—Alexander Selkirk, assignor to Eliza J. Selkirk, Albany, N. Y.:

I claim the levers D and E, formed as described, and fitted with india-rubber springs S and t, in combination with the elliptic springs C 1 C 2, substantially as set forth.

Oct. 10. (50,335) MANUFACTURE OF ANILINE RED.—Charles Clemm, Philadelphia, Pa., and August Clemm, Mannheim, Grand Duchy of Baden.:

What we claim is the treatment of salts of aniline and its homologues by the arseniates of the alkalies, substantially as above described, for the production of aniline red.

(50,340) CASTING SKEINS OF WAGON-BOXES.—Thomas Considine, Chicago, Ill.:

I claim, *First*, The screw C, connected with a plate-form F, and placed in a suitable framing A, in connection with the rotary block a\*, in platform F, all arranged substantially as shown, for raising and lowering and for rotating the pattern, for the purpose specified. *Second*, The mold K, for the core of the skein and socket, having a pattern a', to form the mold for the inner end of the exterior of the socket J, when used in combination with the match-board or box K, and flask L, as described.

(50,347) WHIFFLE-TREE.—Isaac D. Flanagan, Ceresco, Mich.:

I claim the employment of crossed traces connected to a short adjustable equalizer E, when used in combination with the equalizing whiffle-trees B B, at double-tree A, and constructed and arranged substantially as and for the purposes herein described and set forth.

(50,355) COMPOSITION FOR WELDING.—George Harpst, New Hamburg, Pa.:

I claim the within-described composition, made substantially as set forth for the purpose specified.

17. (50,456) ODOMETER.—H. R. Coburn, Lowell, Mass.:

I claim rendering the space passed over by the pawl carrier lever O, adjustable substantially as set and for the purpose described.

#### FOREIGN IMPROVEMENTS.

JAN. 25, 1865. IMPROVEMENT IN THE CONSTRUCTION OF CARRIAGES.—S. L. & A. Fuller & C. Martin.

This invention is applicable to the carriages which are called or known as Landau's, and other carriages provided with removable fronts, consisting of framing and glass plates or lights arranged therein. In such carriages, when constructed in the ordinary way, great inconvenience is occasioned by the great difficulty in raising and lowering, or removing the framing lights contained therein, and by which the fronts of such carriages are formed in consequence of such parts being disconnected and entirely independent of each other by means of these improvements—the said operations can be easily performed by one person. The framing of which the front portion of the carriage-head is formed, is provided with hinges or joints at the angles thereof, so that the frame immediately behind, and parallel with the driving seat, shall be capable of falling toward the same in a sloping position. The top part of the carriage front, which is usually covered with leather, is jointed to the said last-mentioned frame, and is capable of falling and resting upon the same, thus protecting the glass, while those portions of the frames which form the front sides of the door framing, hold down in a horizontal, or nearly horizontal position upon the sides of the body of the carriage. The last-mentioned portions of the framing or door pillars are so constructed that the glass plates or lights at the sides of the front portion of the carriage can be slid behind or through the door pillars (which may be constructed with suitable slots therein for such purpose), and lowered into the door casings, the latter being made of sufficient capacity to contain the same. When the framing is raised and placed in its upright position, the side windows or lights are raised from the door casings, and slid behind or through the door pillars, as before mentioned in the other portions of the framing, which are suitably grooved to retain them, so as entirely to close the front part of the carriage.—*Patent completed.*

MARCH 2, 1865. APPARATUS TO BE APPLIED TO VEHICLES DRAWN BY HORSES TO RESTRAIN AND PREVENT THEM FROM RUNNING AWAY.—P. Rothwell, Denton, Lancashire:

This invention has for its object the restraining or pulling up of one or more horses when harnessed to vehicles running on common roads, and it is arranged so that if the vehicle is standing the horse will be pulled up if it attempts to move, and should the vehicle be in motion, and the horse attempt to run away, the improved apparatus can be instantly brought into operation to pull the horse by putting a powerful strain on the bit in its mouth, till it is compelled to stop; the apparatus, at the same time acting, to some extent, as a brake upon the wheels. The apparatus is such that the pulling strain can be modified instantly when applied and in action to any required extent. These improvements consist in suspending a horizontal shaft across the vehicle parallel to the axle-tree. Upon each end of a shaft a pulley is fixed, which may be covered with leather to give adhesion, and each pulley is formed so that it can come in close contact with the hoop or other part of the inside of the nave of the wheel. To the middle of the shaft a part is fitted in which the shafts can rotate, and to this part a rod, chain, rope or strap, is secured, which, at its other end, is attached to, or connected with a lever, wheel, or screw, or a combination of them. By means of this lever, wheel or screw, the shaft can be pulled forward so as to press the leather surfaces of the pulleys in close and firm contact with the naves of the wheels, and consequently the shaft will be rotated when the wheel is in motion. To the shaft end of a belt, a chain or rope is secured on each side, the other ends of which are attached to the bit in the horse's mouth, so that when the shaft turns it acts



as a windlass to wind up the belts, chains or ropes, and pull up the horse. When the lever, wheel or screw is turned back, or released, the shaft and pulleys will fall or be pushed back by the movement, or by springs or weights, out of contact with the naves of the wheels. It will be seen that any required amount of strain or pull can be put and kept upon the bit in the horse's mouth while the wheel is in motion, as the pulley according to pressure will slip when sufficient strain or pull has been obtained.

### CURRENT PRICES FOR CARRIAGE MATERIALS.

CORRECTED MONTHLY, BY MR. CHAS. WEEKS, FOR THIS MAGAZINE.

NEW YORK, Oct. 24, 1865.

Apron hooks and rings, per gross, \$2.50.  
 Axle-clips, according to length, per dozen, 75c. a \$1.25.  
 Axles, common (long stock), per lb, 9c.  
 Axles, plain taper, 1 in. and under, \$6.50; 1½, \$7.50; 1¾, \$8.50; 1⅞, \$9.50; 1⅝, \$10.50.  
 Do. Swelled taper, 1 in. and under, \$7.00; 1½, \$8.25; 1¾, \$8.75; 1⅞, \$10.75; 1⅝, \$13.00.  
 Do. Half patent, 1 in. and under, \$10.50; 1½, \$12.50; 1¾, \$15.00; 1⅞, \$17.50; 1⅝, \$21.25.  
 Do. Smith's New York half patent case-hardened malleable iron box, 1 in. and under, \$10; 1½, \$10; 1¾, \$12.  
 Do. Smith's Homogeneous steel, case-hardened mall. boxes, ⅝ in., \$12; ¾, \$12; ⅞, \$12.50. Long draft, \$2 extra.  
 Do. Saunders' improv. taper, ¼ in., \$12.00; ⅜, \$12.00; 1, \$12.00; 1½, \$13.00; 1¾, \$15.  
 Do. do. Homogeneous steel, ⅝ in., \$15.00; ¾, \$15; ⅞, \$16.50; long drafts, \$4 extra.  
 ☞ These are prices for first-class axles. Makers of less repute, cheaper.  
 Bands, plated rim, under 3 in., \$2.50; over 3 in., \$3  
 Do. Mail patent, \$3.00 a \$5.00.  
 Do. galvanized, 3¼ in. and under, \$1; larger, \$1 a \$2.  
 Basket wood imitations, per foot, \$1.25.  
 ☞ When sent by express, \$2 extra for a lining board to a panel of 12 ft.  
 Bent poles, each \$2.00.  
 Do. rims, under 1½ in., \$2.25 per set; extra hickory, \$3.25 a \$4.00.  
 Do. scat rails, 50c. each, or \$5.50 per doz.  
 Do. shafts, \$7.50 per bundle of 6 pairs.  
 Bolts, Philadelphia, list.  
 Do. T, per 100, \$3 a \$3.50.  
 Bows, per set, light, \$1.25; heavy, \$2.00.  
 Buckles, per grs. ½ in., \$1.50; ⅞, \$1.50; ¾, \$1.70; ⅞, \$2 10; 1, \$2.80.  
 Buckram, per yard, 25 a 30c.  
 Burlap, per yard, 30c.  
 Buttons, japanned, per paper, 30c.; per large gross, \$3.  
 Carriage-parts, buggy, carved, \$4 a \$5.50.  
 Carpets, Brussels, per yard, \$2 a \$3; velvet, \$3.75 a \$4.50; oil-cloth 60c. a 75c.  
 Castings, malleable iron, per lb, 20c.  
 Clip-kingbolts, each, 50c., or \$5.25 per dozen.  
 Cloths, body, \$4 a \$6; lining, \$3 a \$3.50. (See *Enameled*.)  
 ☞ A Union cloth, made expressly for carriages, and warranted not to fade, can be furnished for \$2.50 per yard.  
 Cord, seaming, per lb, 45c.; netting, per yard, 8c.  
 Cotelines, per yard, \$4 a \$8.  
 Curtain frames, per dozen, \$1.25 a \$2.50.  
 Do. rollers, each, \$1.50.  
 Dashes, buggy, \$1.75.  
 Door-handles, stiff, \$1 a \$3; coach drop, per pair, \$3 a \$4.  
 Drugget, felt, \$2.  
 Enameled cloth, muslin, 5-4, 85c.; 6-4, \$1.10.  
 Do. Drills, 48 in., \$1.25; 5-4, \$1.20.  
 Do. Ducks, 50 in., \$1.45; 5-4, \$1.40; 6-4, \$1.60.  
 ☞ No quotations for other enameled goods.  
 Felloe plates, wrought, per lb, all sizes, 25c.  
 Fifth-wheels wrought, \$1.75 a \$2.50.  
 Fringes, festoon, per piece, \$2; narrow, per yard, 18c.  
 ☞ For a buggy top two pieces are required, and sometimes three.  
 Do. silk bullion, per yard, 50c. a \$1.  
 Do. worsted bullion, 4 in. deep, 50c.  
 Do. worsted carpet, per yard, 8c. a 15c.  
 Frogs, 75c. a \$1 per pair.  
 Glue, per lb, 25c. a 30c.  
 Hair, picked, per lb, 70c. a \$1.

Hubs, light, mortised, \$1.10; unmortised, \$1.00—coach, mortised \$1.50.  
 Japan, per gallon, \$3.  
 Knobs, English, \$1.50 a \$1.75 per gross.  
 Laces, broad, silk, per yard, \$1.00 a \$1.50; narrow, 15c. to 20c.  
 Do. broad, worsted, per yard, 50c. a 75c.  
 Lamps, coach, \$20 a \$30 per pair.  
 Lazy-backs, \$9 per doz.  
 Leather, collar, dash, 31c.; split do., 18c. a 21c.; enameled top, 32c.; enameled Trimming, 31c.; harness, per lb, 50c.; flap, per foot, 25c. a 28c.  
 Moquet, 1½ yards wide, per yard, \$9.00.  
 Moss, per bale, 12½c. a 18c.  
 Mouldings, plated, per foot, ¼ in., 14c.; ⅜, 16c.; 18c.; ½, 1 ead, door, per piece, 40c.  
 Nails, lining, silver, per paper, 12c.; ivory, per gross, 50c.  
 Name-plates.  
 ☞ See advertisement under this head on 3d page of cover.  
 Oils, boiled, per gallon, \$1.80.  
 Paints, White lead, ext. \$17, pure \$17½ p. 100 lbs.; Eng. pat. bl'k, 35c.  
 Pole-crabs, silver, \$5 a \$12; tips, \$1.50.  
 Pole-eyes, (S) No. 1, \$2.70; No. 2, \$2.90; No. 3, \$3.10; No. 4, \$4.50 per pr.  
 Sand paper, per ream, under No. 2½, \$5.00; Nos. 2½ & 3, \$5.65.  
 Screws, gimlet.  
 ☞ Add to manufacturer's printed lists 20 per ct.  
 Do. ivory headed, per dozen, 50c. per gross, \$5.50.  
 Serims (for canvassing), 20c. a 30c.  
 Seats, buggy, pieced rails, \$1.75; solid rails, \$2.50.  
 Shaft-jacks (M. S. & S.'s), No. 1, \$2.75; 2, \$3.25; 3, \$3.50.  
 Shaft-jacks, common, \$1.50 a \$1.65 per pair.  
 Do. tips, extra plated, per pair, 37½c. a 56c.  
 Silk, curtain, per yard, \$2 a \$3.50.  
 Slat-irons, wrought, 4 bow, \$1.12½; 5 bow, \$1.25 per set.  
 Slides, ivory, white and black, per doz., \$12; bone, per doz., \$1.50 a \$2.25; No. 18, \$2.75 per doz.  
 Speaking tubes, each, \$8.  
 Spindles, seat, per 100, \$1.50 a \$2.50.  
 Spring-bars, carved, per pair, \$1.75.  
 Springs, black, 24c.; bright, 25c.; English (tempered), 28c.; Swedes (tempered), 32c.; 1¼ in., 1c. per lb. extra.  
 If under 36 in., 2c. per lb. additional.  
 ☞ Two springs for a buggy weigh about 28 lbs. If both 4 plate, 34 to 40 lbs.  
 Spokes, buggy, ⅞, 1 and 1½ in. 8½c. each; 1½ and 1¾ in. 8c. each; 1¾ in. 9c. each.  
 ☞ For extra hickory the charges are 10c. a 12½c. each.  
 Steel, Littlejohn's compound tire, 3-16, 10c.; 1-4, 9½c.; heavier sizes, 9c. currency.  
 Stump-joints, per dozen, \$1.40 a \$2.  
 Tacks, 9c. and upwards per paper.  
 Tassels, holder, per pair, \$1 a \$2; inside, per dozen, \$5 a \$12; acorn trigger, per dozen, \$2.25.  
 Terry, per yard, worsted, \$4; silk, \$9.  
 Top-props, Thos. Pat. per set 65c.; capped complete, \$1.50.  
 Do. common, per set, 40c.  
 Do. close-plated nuts and rivets, \$1.  
 Thread, linen, No. 25, \$1.30; 30, \$1.45; 35, \$1.65, gold.  
 Do. stitching, No. 10, 95c.; 3, \$1.15; 12, \$1.28, gold.  
 Do. Marshall's Machine, 432, \$2; 532, \$2.30; 632, \$2.60, gold.  
 Tufts, common flat, worsted, per gross, 20c.  
 Do. heavy black corded, worsted, per gross, \$1.  
 Do. do. do. silk, per gross, \$2.  
 Do. ball, \$1.  
 Turpentine, per gallon, \$1.35.  
 Twine, tufting, per ball, 50c.; per lb, 85c. a \$1.  
 Varnishes (Amer.), crown coach-body, \$6; nonpareil, \$7.50.  
 Do. English, \$6.25 in gold, or equivalent in currency on the day of purchase.  
 Webbing, per piece, 65c.; per gross of 4 pieces, \$2.40.  
 Whiffle-trees, coach, turned, each, 50c.; per dozen, \$5.50.  
 Whiffle-tree spring hooks, \$4.50 per doz.  
 Whip-sockets, flexible rubber, \$4.50 a \$6 per dozen.  
 Do. hard rubber, \$10.50 per dozen.  
 Do. leather imitation English, \$5 per dozen.  
 Do. common American, \$3.50 a \$4 per dozen.  
 Window lifter plates, per dozen, \$1.50.  
 Yokes, pole, each, 50c.; per doz, \$5.50.  
 Yoke-tips, extra plated, \$1.50 per pair.





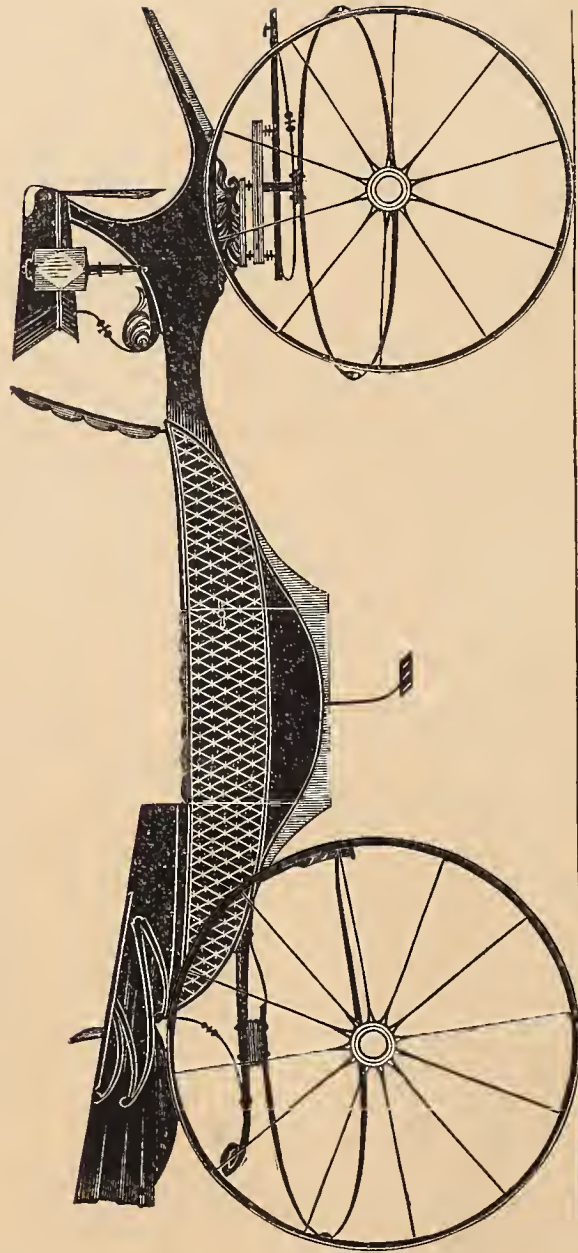

NEW YORK CALECHE.— $\frac{1}{2}$  IN. SCALE.

*Designed expressly for the New York Coach-maker's Magazine.*

*Explained on page 120.*



THRASHER'S COMBINATION COAL-BOX BUGGY.— $\frac{1}{2}$  IN. SCALE.

*Engraved expressly for the New York Coach-maker's Magazine.*

*Explained on page 120.*









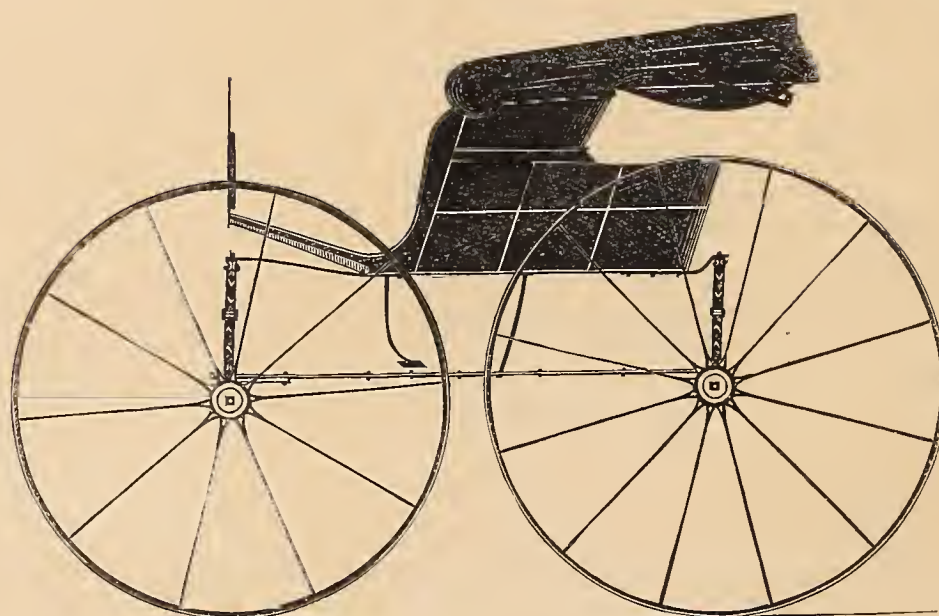

MOLDED TILBURY BUGGY.— $\frac{1}{2}$  IN. SCALE.

*Engraved expressly for the New York Coach-maker's Magazine.*

*Explained on page 121.*

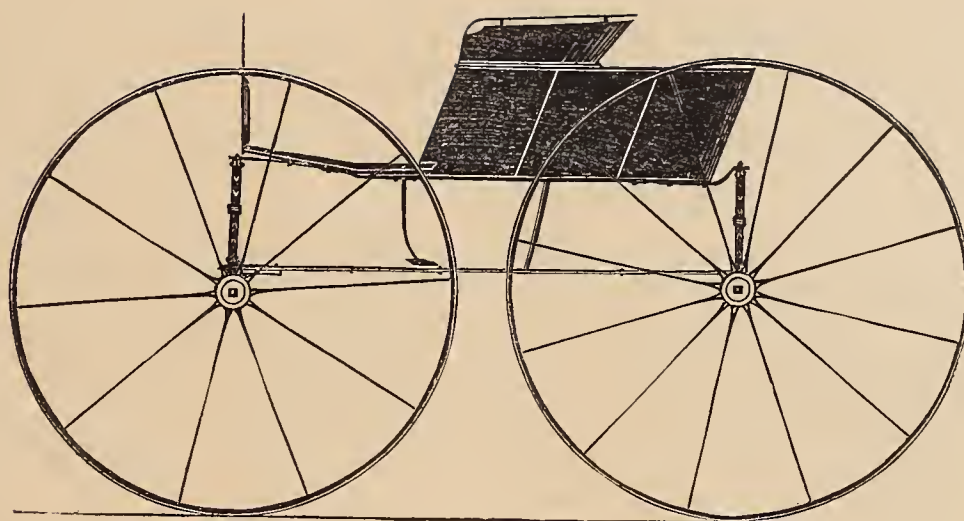

ROAD BUGGY.— $\frac{1}{2}$  IN. SCALE.

*Designed expressly for the New York Coach-maker's Magazine.*

*Explained on page 121.*







DEVOTED TO THE LITERARY, SOCIAL, AND MECHANICAL INTERESTS OF THE CRAFT.

Vol. VII.

NEW YORK, JANUARY, 1866.

No. 8.

### Mechanical Literature.

#### DRAFT APPLICABLE TO HORSES AND CARRIAGES.

BY JOHN B. PEEK.

ACCORDING to promise (see page 98), I have gone through another course of experiments before several livery stablemen, on a light buggy, weighing 156 pounds. The fore-wheels of the buggy were four feet, and the hind-wheels four feet three inches in diameter, with an obstruction placed in front of the fore-wheels, six and a quarter inches high. When the line of draft was perfectly horizontal, or even with the top of the fore-wheels, it required—to draw it over the obstruction—a weight of sixty pounds.

When the line of draft made an angle with the horizon of seven degrees, by lowering the point of draft six inches below the wheel, the weight required was forty-eight pounds.

When the end of the line of draft was lowered till the direction of it was at an angle of eleven degrees with the horizon, it got over the obstruction with forty-one pounds.

When the end was lowered in the center of the wheel, and the line of draft was at an angle of fifteen degrees with the horizon, the obstacle was surmounted with thirty-three and a half pounds.

When the end of the line of draft was lowered to six and a quarter inches below the center, or axle, so that the angle with the horizon was seventeen degrees, it was drawn over with thirty and a half pounds.

When it was lowered to twelve and a half inches below the center of the wheel, so that the angle was eighteen degrees, it was drawn over with thirty and a half pounds.

When it was lowered to eighteen inches below the center (being only six and a quarter inches above the road, and exactly level with the height of obstruction), the angles being twenty-three degrees, the weight necessary to draw it over the obstruction was twenty-seven pounds.

These experiments, though made upon a much larger scale than the former, produced exactly a similar result,

VOL. VII.—14

so that the fallacy of putting the jack-clip on top of the axles of light buggies or working wagons, or the splinter-bar of coaches, three-fourths the diameter of the front-wheel (sometimes the full height) above the ground, can be easily seen.

It is singular that—so far as we know—the application of the laws of draft to the motion of carriages has scarcely ever been investigated. Among all the new projects and inventions with which this age teems, there certainly is not one which opens up such boundless prospects for improvement as this. The above are my humble ideas on the subject; and, what is more, if we can lessen the draft of that noblest of the brute creation—the horse—we shall have done something for the carriage-maker. An excellent saying is ascribed to Aristipus, after he had paid a visit to Dionysius. When the tyrant asked him why he visited his court, the reply was (and let it be impressed on the minds of my brother tradesmen), “To give what I have, and to receive what I have not.”

#### WAIFS FROM A COACH-MAKER'S PORTFOLIO.

##### IV.—SQUEEZEMHARD'S MISTAKE.

THE public have heard of some *rich* things in connection with the perch-coupling movements; but it is doubtful if anything we have published will please our readers better than the tale we here unfold, from which it appears that one Squeezemhard “cut off his own nose” in a recent transaction, and for once at least, “upset his own dish.”

It would seem that “Squeezem,” through his secret spies, or his own searchings through Gotham, came upon a carriage-maker's shop, where a vehicle with his “so-called” patent *running gear* had been applied, for the use of an *esculapian*. True to his indefatigable instincts, he early made a visit to *that* shop, demanding damages, “or recourse of law” in equity. This unexpected intrusion came very near depriving the medical man of the great benefit he expected to derive from the use of this “greatest improvement of modern times,” and no doubt would have done so, had not the doctor, just in the nick of time, stepped forward to the relief of the affrighted “knights of the drawing-knife,” and secured a privilege



by planking down twenty-five dollars in "greenbacks." In filling out a legal document, however, our genius worded it in such a manner, that to a superficial reader, like the oracles of the ancient Pythian priestess, the meaning is rather ambiguous and obscure. A little study, however, shows that "the parchment gives a life-long shop-right to *that* shop. Squeezemhard says he made a mistake in the wording of the paper. Perhaps so; but that mistake will no doubt debar him of any further *speculations* in that locality, and it may afford him some relief to hear that a great many *smarter men* than himself have made "serious mistakes" before now. His case is but another instance of the fatal effects of one's undertaking to "play lawyer" on his own account.

#### V.—THE COACHMAKER'S LAMENT.

BY ONE OF 'EM.

This "Pome" was published in an obscure and badly edited Magazine some years ago, with so many absurd and miserable alterations, that the author scarcely recognized the "bantling," as being one of his own offspring when it came from the press. It is here produced in its original form, with a few additions:—

Now is the winter of our discontent  
Made still more wintry—BY SAD LACK OF WORK.  
SHAKE-SPOKE.

A COACH-MAKER sat in his office one day,  
A disconsolate wight—time musing away;  
He fumbled his pockets, no "tin" could be found—  
Says he (to himself), "I must 'shin it' around;  
I have promised this day two notes to redeem,  
So 'must come to the scratch,' or be ruined I ween.  
'Tis dreadful hard times, they are awfully tight,  
Not 'a shiner' have I, to cheer or delight.

"The protest approaches, O what shall I do?  
I am lacking in funds five hundred and two—  
Unless I can borrow, my credit is gone;  
My 'paper' dishonored; my prospects undone!  
'Tis a miserable trade—this business"—he said;  
"I wish I'd been 'prenticed to the tailoring trade;—  
I envy the Jew with his sickle-like nose,  
Who doubles his 'monish' on second-hand clothes.

"No ease-seeking 'b'hoys' are now seen to ride;  
The 'upper-crust' turnouts are all laid aside;  
No customer now e'er darkens my door—  
How wretched and miserable thus to be poor!—  
(The storm that is raging in fury without,  
Has a counterpart surely within my own heart);  
For my coaches and buggies in warehouse must stand,  
'Till the breezes of Spring revisit the land.

"Has nobody died?—I *could* furnish a hearse—  
Will nobody living replenish my purse?  
Must I sit like a beggar from day unto day,  
With nobody calling to purchase or pay?  
'Tis sad to confess, but one better be dead,  
Than to linger in want, when the 'needful' has fled—  
I've half a mind now to kill myself right,  
For in 'tipping the bucket,' I shall profit some wight."

#### MORAL.

'Tis thus that half the people feed  
On borrowed trouble, without need;  
For prudence, care and industry  
Are sure to bring a full supply  
For all the *real* wants of man—  
Is this not so?—dispute who can!

#### VI.—"GREASING THE JOB"—AN ANCIENT TRICK.

MANY years ago, when tar-kettles and 'prentice boys were more plenty than now—wooden vices being in fashion—it was the common practice of those bent on mischief—plenty such being generally found in every shop—that whenever they could catch "a greeny" leaving his bench with anything screwed between the jaws of the vice, in his absence, to daub the underside with the contents of the tar-kettle in the most effectual manner, so that on his return, in handling said article, he would get his fingers well *payed* (to use a longshoreman's phrase), with tar and grease.

Bemus, a lad "from a rural district," who had had his wits sharpened by a trick of this kind, played upon him by Shallifut, a journeyman from New York, was determined to obtain "satisfaction" for this insult offered to his dignity, and to do this the more effectually, resolved to make the workshop the theater of operations. With this resolve, Bemus, one morning, went to the shop a little earlier than usual, and removing the chips and shavings from around the foot of the journeyman's vice, at the head of the bench, carefully "slushed" the floor, replacing the rubbish to hide his doings. As usual, Shallifut the same morning, went to his work at the bench, "dressing up stuff." He had not, however, been long engaged, before a thundering noise was heard, and the journeyman found *sprawling* on the floor on his back, his feet having slipped from under him. This occasioned a tremendous outburst of laughter from the entire shop's crew, and turned the tide of ridicule, when the facts became known, so strongly against him, that the city journeyman was glad to pack his "kit" and "skedaddle." Bemus had become master of the situation, and fairly appeased his wounded feelings.

#### HISTORY OF CARRIAGE-WHEELS.

BY THE EDITOR.

SOMETIME ago (see page 51, *ante*), under the foregoing head, we furnished our readers with some observations on carriage-wheels, in which we took occasion to examine the history and construction of these essential improvements in locomotion. We design making this article an appendix to the one alluded to, in continuation of the subject, to do justice to which may require one or two papers more.

We have previously remarked that among the more barbarous nations of antiquity, carriage-wheels were made much smaller in diameter than among the more civilized. This, too, was done without much attempt of ornamentation. The chief examples in the way of ornament have been supplied in carriages intended for royalty or special use otherwise, but in nearly every instance to the great injury of strength. This will become apparent as we proceed with our investigations.

From a critical examination of the sculptures and other relics of antiquity, we discover that the ancient Egyptian wheel had, in some instances, four, and in others, six spokes; six, doubtless, being found an improvement over the earlier practice in wheel-making. A fine example of an *improved* Egyptian chariot-wheel of the time of the later Pharaohs is here engraved from actual manufacture, it being made up of the perfect fragments found in the museum of the late Dr. Abbott, now



the property of the New York Historical Society, whose building is located on the Second Avenue, in this city. This wheel has heretofore been presented to our readers in separate portions, in the First Volume of this Magazine, at page 42.

This wheel, with the wooden shoe attached, originally measured three feet three inches; without it just three feet of our mea-

sure in diameter. This, as every practical carriage-builder knows, is about the smallest size that should ever be applied in any way to a pleasure vehicle. The shoeing or wooden tire was secured to the felly-rim by using

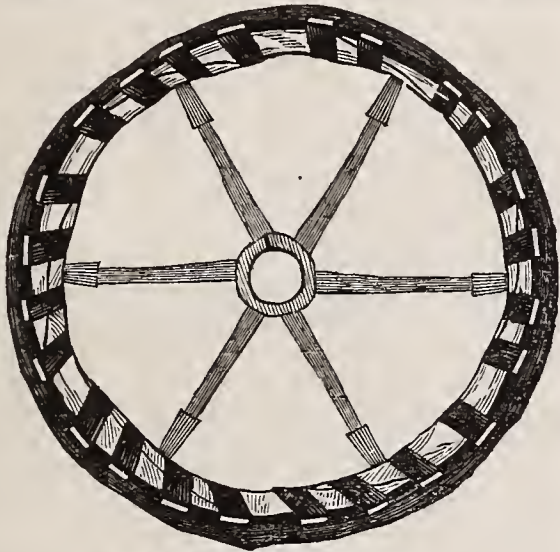

EGYPTIAN CHARRIOT-WHEEL.

strips of raw-hide, as is shown above, the fact going to prove that iron-bolts had not yet been invented. Indeed, we cannot detect, on critical examination, the least evidence of the use of iron in any part of this wheel. It evidently never had any substitute for a box, as the wear of the axle upon the inside of the hub sufficiently proves. Having already described this unique wheel in the volume before mentioned, we shall dismiss it with simply remarking that we have *tyed* the tire on with thongs, and that, unlike Sir Gardner Wilkinson, we have *set* it in a mechanical manner, so as to have the joints placed to bear the greater pressure uninjured.

The Tokkaie, a nation cotemporary with the Egyptians, by whom they were conquered in battle, being less civilized had their cart-wheels made solid, as is proven from an engraving in Sir G. Wilkinson's work, previously mentioned, these being secured to the axletree, around which they revolved by a linch-pin.

The Ninevites evidently made much improvement on the Egyptian wheel. They added eight spokes and secured its durability otherwise, more in conformity with mechanical laws, as our second illustration proves.

This eight-spoked chariot-wheel appears to have continued down to Homer's time, four hundred and fifty years before Christ. As our illustration shows, there is very little attempt at ornamentation, except about the central portion. From a critical examination of various drawings in Layard's "Ninevah and its Remains," we are led to believe that wheels, among the Assyrian

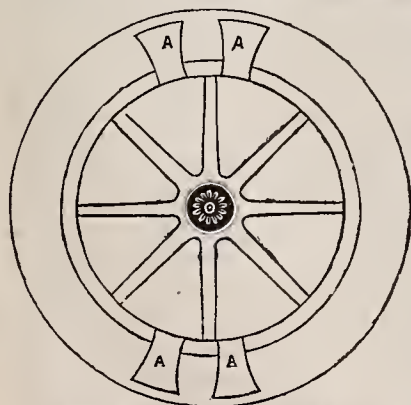

ASSYRIAN CHARRIOT-WHEEL.

nations, were secured to the axletree without a box, and made to revolve, axle and box together. There is no sign of a linch-pin in any instance, nor anything which looks like a hub. In some examples short fellows are shown, but such is not the case in the one we have under consideration here. In the absence of other proof one might suppose the spokes, rim, &c., with the rim-clamps, AAAA, to be made of cast-iron, and the outer circle or tire to be wood secured to the wheel by the afore-mentioned clamps. This, however, is mere conjecture.

#### REPORT OF CARRIAGES IN THE DUBLIN INTERNATIONAL EXHIBITION OF 1865.

WE are indebted to our friend, George N. Hooper, Esq., of London, for the interesting report of carriages in the late Dublin International Exhibition given below. The whole number of carriages exhibited was 40. Of these, 36 were British, 1 French, 1 Norwegian, 1 Zollverein. The exhibition consisted of 6 Phaetons, 5 Landaus, 11 Broughams, 2 Sociables, 5 Wagonettes, 1 Sleigh, 1 Barouche, 1 Private Hansom Cab, 1 Cariole, 1 Outside Car, 3 Town Cars, 1 Clarenee, 1 Private Cab on four wheels, and 1 Pony Cart. Some of these carriages belonged to firms from which the jury was selected; their carriages were thereby prevented the competition for prize medals. The awards were 10 medals and 6 certificates of merit. The jury say:

Before proceeding to offer any remarks on the carriages shown at the Dublin International Exhibition, a glance at their position and mode of exhibition may be worth consideration.

Their locality, as regard convenient access to visitors, is much better than at the former Dublin Exhibition; they are, however, still treated as articles of very moderate importance, considering the great amount of care and minute supervision that is necessary for their proper proportion, construction, and finish. They should, therefore, be shown to advantage, in order to give exhibitors every chance of doing business, as a return for the expenses they inevitably incur in taking part in Industrial Exhibitions.

The building to receive carriages should be well lighted from the sides, care being taken that the rays of the sun, in hot weather, are not allowed to injure them; it should also be proof against rain and dust; in addition to this there should be good ventilation, to prevent the accumulation of heated air in the department, which destroys the brilliancy of the varnish.

Experience seems to show that the most favorable manner of showing carriages together, is in parallel rows or avenues, each carriage being set obliquely; this is the arrangement followed in all the newest and best-arranged show-rooms for carriages in London and elsewhere. The reason appears to be this—that in order to see a carriage properly, and to judge of its proportions and merits, visitors should be able to retire to a distance to see the whole carriage at a glance; by placing them obliquely this is possible, even in a limited space, and in no other way, within a given area, can a number of carriages be properly inspected.



In more than one instance the jurors have been informed that the carriages shown were not prepared for exhibition, but were merely ordinary carriages selected from the stock on hand. This can hardly be considered complimentary to the numerous visitors who come from afar, and at great expense, with the expectation that each manufacturer will show the best article he can produce; it is also hardly just to the exhibitor himself, who in each department or class is supposed to compete for a prize; he thereby much reduces his chance, in being surpassed by an enterprising and careful manufacturer, who uses every effort to raise the standard of his work, and for which purpose competitive exhibitions offer excellent opportunity.

On occasions like the present it is very desirable to mark the changes that are taking place not only in the construction of carriages, but the causes that have brought about these changes.

The first incentive has been the demand, on the part of the public, for lighter carriages, in consequence of the use of a smaller, lighter, and a more active breed of horses. The demand for such horses has been produced by the fashion for riding that is now so general; horses of the size used, averaging fifteen and a half hands, are suitable for draft and for the saddle; they can be driven at greater speed, and do a longer day's journey than the large coach-horses of former times.

A mode of construction that has opened the way for great and striking changes was introduced about the time of the first International Exhibition in 1851; it is technically known as the "cut through doorway," and its first constructor probably little thought of the numerous improvements that would follow the use of the plan.

In order to understand the new system, it is first necessary to explain the old one. All carriages require a strong and sound foundation proportioned to their size and their proposed use; this consisted of a massive piece of timber generally cut out of planks six inches thick, on it were framed the uprights, to carry the doors, &c., and below it was fastened the locker or well, for the feet of the occupants.

The disadvantages of this plan were, a high projection to step over in entering the carriage; if for a landau, the panels were obliged to be made deep, to contain the glasses; the number of years it was necessary to keep the planks before they were thoroughly seasoned and fit for use; and if the panels were made shallow and graceful for a barouche, the folding steps, when not in use, projected in an unsightly manner above the doors.

By the new plan, which consists in so framing the bottom sides as to leave a gap in the center for the door to reach down to the real bottom line of the body, the timber used need not be more than three and a half inches thick, instead of six inches, thereby much reducing the time necessary to season it; the framing is also so reduced in depth at the doorway, that it is much more easily stepped over, especially by invalids and elderly persons; the doors are then made so as to reach to the bottom line of the carriage, enabling the glass to fall so much lower, and thereby allowing the panels to be made shallower by depressing the elbow or waist line of the body; in the case of barouches, where fashion and good taste require the most graceful lines that grace and sound construction allows, the folding steps are concealed from view when not in use, instead of causing a break in

the top line of the body by their projection upward; the new plan has further the advantage of enabling many carriages such as formerly required double folding steps for persons to get into them, to be built in such a manner that an ordinary single step with its cover, acting like those used for broughams can be used; whereas, each of such carriages formerly was, of necessity, accompanied by a footman, to let down and fold up the steps; it is now optional whether a footman shall accompany the carriage; a point of much importance in small establishments. A minor advantage is, that the doorway which always becomes somewhat untidy by the chafing of the feet of persons entering and leaving the carriage, is concealed by the door, which, when closed, covers and conceals all such chafed parts from sight.

Other inventions affecting the mode of constructing the heads of landaus, especially in enabling them to fall low, and to avoid unsightly notches and breaks in the line of the head when open, have been made since the opening of the London Exhibition of 1862. Among these plans should be noticed "Morgan's Ingenious Patent," for opening and closing carriage heads, by means of a screw acting on a series of cranks and levers, so that by turning a handle fixed to the coachman's seat, the head is opened or closed without further interference.

The use of tough steel instead of iron gradually increases, and were its advantages and mode of treatment in working more generally known, would, doubtless, obtain much public favor. Attempts are being made to use it for carriage axles; and in the hands of skillful and careful manufacturers it would be a most useful addition to the aids for reducing still further the weight of carriages. The general manufacturer of coach-bolts, nuts and screws of this useful and valuable metal, would also be a step in the right direction; they would have the advantage of great strength and toughness, and only small holes would be necessary to receive them; their use is almost solely delayed by there not being a constant supply in the ordinary course of trade. It would not answer the purpose of a coach-builder to set aside his iron bolts unless he could feel sure that in changing his sizes he could have a supply of steel bolts at his command, and so prevent his work being stopped or delayed by a short supply in the market, or by any difficulty in replenishing his stock of such articles at short notice. There is here a good opening for a useful branch of trade.

It is pleasant and cheering to be able to refer to the increased skill and ingenuity of the coach-workmen, especially among the rising generation of operatives. This fact was elicited by the recent Industrial Exhibition of the Operative Coachmakers, held in February last, in the Hall of the Worshipful Company of Coachmakers of the City of London; not only were there then shown several excellent working drawings of carriages, drawn to scale, and difficult of execution, and showing that there are forthcoming more highly educated and more competent men, well acquainted with the details of their crafts, and of the proper and scientific manner of setting out their work, now that frequent change of construction so much requires this knowledge; but there were many very ingenious models of proposed improvements, showing that their originators were men of thought and energy. The Exhibition gave promise that at some future time (should a similar one be held), talent would be more fully developed, and the competition for prizes would lead to



never knew that he played before. The music came low and plaintive, and so full of sadness that it depressed me. I begged him to stop; but, scarce heeding my entreaty, he played on, tears filling his eyes as he began chanting the Lord's prayer. Entreaty, pardon, and forgiveness rose one above another, and as his voice sounded at the close, it seemed as if the holy presence was visibly shadowed in our midst, so hushed was the earthiness, and so present the celestial.

"Music, Jane! It is the voice of angels around us! What a glorious thought that at our touch they come and sing to us! If I die, Jane, you can send messages upon the inspiration of music—it will rise to heaven!"

"But you will not die, Folsom!" I said, chokingly.

"Death is preferable to this life I lead. Do you know I love death—I invoke death! Oh! it is beautiful to lie in its marble embrace, calm, peaceful, at rest. Here I but chase a phantom, Jane. May I hope that at last I have found rest? I love you as I never before loved woman. Will you take this love?"

I cannot write what followed. The thought of it surges across my brain, and bewilders me even now. I could have died then for very joy, so intense was my happiness. We parted under the chestnuts at my home. He went away, leaving his blessing with me.

Love beautifies, it is said. It may be but the reflection of inward happiness. It was so with me, I think. Philip noticed it, and smiled. He translated it favorable to himself.

The next day opened as one closes a book. A volume in my life was finished, and the interim had come ere the second begins.

After breakfast, Dr. Philip drew my arm within his, and led the way into the library. He was very pale and haggard. I felt alarmed, and asked if he were ill.

"No, not ill—only worn out. You know how the fever is raging, and I am giving too much time and strength to sufferers. I need rest. But let me know if the sweetest and dearest of earthly rest is to be mine! You are twenty-five to-day, Jane!"

Twenty-five! It came like a thunderbolt, paralyzing me for a moment. I had forgotten it in the last few days. He drew his chair near to my own, and taking both my hands, he said: "Let your heart answer for you, Jane. I offer you my life, poor as it is; it is the best I have. Will you trust me in the future as you have in the past? Only let me call you by the dearest, holiest name out of heaven—*wife!*"

Only those who have passed through a like gate can know the pain it cost me! I would have given my immortality never to have known him! It gives no joy to any woman's heart to wound a soul that loves her. Philip had been so much to me, I could not lose him! But I must speak him the truth. It came at last—short, quivering a moment.

"I can trust you always, dear friend, but cannot be your *wife!*"—and we were separated. He drew away his hands, covered his face, and wept.

"Oh, Philip! do not hate me!" I cried; "you have been so good and true I shall always love you;" and bursting into tears, I threw myself at his feet, longing for a kind word; but he sat still, as if death had chilled him. It was unendurable. I arose and went to my room. I could not stay in the house with him. I felt I would go away. An hour later a messenger came for Philip, and

he was gone. He did not return to dinner, and I arranged with Mr. Willis to take me to the depot for the afternoon train.

"But this is a sudden move, Miss Jane," he said, smilingly. "You haven't caught a fever, have you?"

"No, no; only feeling a little dull, and think I will go and spend a few days in Boston with Mary Stone. She has been urging me some weeks. If anything happens, you can send for me, you know."

It was not a long ride, and the next afternoon found me safely ensconced in the pretty home of my friend. As we sat in the gathering twilight, recounting what had happened to us since we last met, I incidentally mentioned the name of Folsom Demun. "Oh! has he been lionizing in your little town?" said she. "His wife was here last evening, saying she was to meet him in New York this week. She is an insipid creature, and he is a notorious flirt! I don't know but I should have yielded allegiance to his magnificent sovereignty, had I not known of his '*twin soul.*' Did he create much of a sensation among the feminines of your place?"

*His wife!* I felt life die out in a moment, and a terrible calmness, that pride only breeds at such times, gave me strength. "He was very much admired by some, I think. But why does he flirt so? He seems too grand a man to stoop like that." I wondered how I controlled myself. My face would have told a different story, but the twilight with its kindly hands covered my shame.

"I don't think he means wrong, or sees it in the light others do. I attribute it wholly to his selfishness. One heart does not satisfy him. He wants every beautiful woman he meets to love him, and so far as his love is worth anything, he returns it. His wife cares more for laces and silks, and so long as he gives her gold, she little cares where he lavishes his affections. He is most badly mated, and seeks outside of his marriage for the sympathy he imagines he needs, regardless of results."

With her last words she arose to send for lights, which request I countermanded, pleading preference for twilight. Then she sang some pleasant melodies that she used to sing at that hour when we were school girls together.

"How happy those days were!" she exclaimed. "I believe one's school days are the only ones stored full of happy reminiscences."

I was very tired, I said, and begged to be excused. As she gave me a good-night kiss at the door, she said: "How haggard and pale you are, Jane! Let me do something for you!"

But I knew sleep was the best restorative, and she went away. I was now alone—no further need of mockery. All human love was gone. That I would have bartered my soul for was spurious. That which was pure and strong as the Divine life I had recklessly put from me. Down in the abyss of nothingness I sank lower and lower, until at length I felt the hand of the Father bearing me up; and, like a solitary star in the gloom of night, came the blessed assurance—*God is left!* God! I thanked him. Our friends die, and for a day or two lie in our dwellings. Sharp, intense the pain that cuts our hearts, as we feel the cold hands and marble brow; but it is only when the burial is over, and we come back to find our home desolate, that we fully realize how much was carried out by the pall-bearers.

So when morning came, there was a sense of some-



thing gone forever. The experience I had learned made me intensely practical. There was never aught gained by repining. Folsom Demun had shown me a new phase in human nature, for which, I reasoned, I should be thankful. I neither blamed him nor invented excuses for him, as women are so apt to do. I accepted it very philosophically as a judgment direct for placing the flimsiness of his soul above the gold of Philip's love.

A jilted woman becomes either melancholy or stoical. It destroys the nice equipoise of right, and she swings to one extreme or the other. I felt as though I had been embalmed in stoicism—hard, careless, and heartless. Philip was lost to me. It became my soul dirge, that short sentence. What is the use of being emotional or susceptible, when people care so little about spearing our soft places? If a boy falls and hurts himself, we tell him, if he cries, it is unmanly. Little girls hurt themselves and cry, for that is womanish, and we kiss the hurt, bind up the injured feelings with soft words of comfort and little bandages of sootherness. I made a practical use of the first. That I had been a fool once was no reason I should remain one all my days. I held to this theory a whole week. Land living is very much like ocean life, in one sense. A change of wind upsets our plans much sooner than it required to form them. A telegram sent me adrift. Philip had taken the fever, and would I come immediately? The dispatch came a day too late; it had been delayed by some means.

A carriage was awaiting me at the depot. I had no heart to ask after Philip, and the driver said nothing, as though I knew as much of him as he. The rows of chestnuts, the carriage drive, the grass, the dandelions—everything in my range of vision told me a sad message. My guardian met me at the door, grave and sorrowful.

"Philip!" I gasped, asking no more.

"Come and see him; he asked for you." And he led me toward the room in which Dr. Willis lay. The breath came freer then, but so fast I thought it would choke me. I had not wept since that morning I left him in the library. Tears came again now. They oil the machinery of feeling, that would otherwise wear out from friction. Mine were hot and dry, and scorching me to death, and so the tears came. Men go crazy oftener than women, because their brains whirl themselves into red heat, and they know nothing of letting on this irrigation. When I had grown calm again, I went in to Philip. He recognized me, and attempting to signal to me to come closer, I bent over him, and he drew his arm around my neck, whispering:

"Oh, Jane! I could not die without seeing you again! Kiss me once for the old times' sake!"

"For all time's sake, Philip," I sobbed. "You will not die!"

How it flashed through me, that little sentence spoken once before!

I never left him; he could not bear me away. Next morning, as the sun was just rising, he said, softly:

"Jane, see! How glorious! Heaven is opening! Come! I love you. Christ loves. Kiss me. Good-by." These were the last words he said.

I remember there was a funeral, and crape, and slow steps to the burying-ground, then a heavy fall of earth, and after a terrible blank in life. It passed at last, and the years lie between then and now.

I am an old woman now, and oftentimes people laugh, and ask me why I never married. Their words sound as

the earth did when it fell upon Philip's coffin. I have written my story, poor and meager as it may be, hoping it may help some one to see her way clearer than I saw mine.

## Pen Illustrations of the Drafts.

NEW YORK CALECHÈ.

Illustrated on Plate XXVIII.

THE drawing we give on this plate is from a design originating in this office, which we think possesses sufficient novelty to recommend it to the notice of our readers. The arrangement of the drop-bottom supplies plenty of leg-room, and the formation of the door quarter is such as to give the greatest possible lightness to the entire body at the same time. The sham-netting is another feature tending to the same end. The observer will not fail to note the new formation of the boot, which is peculiarly European, and known in New York as the "Metropolitan Boot."

THRASHER'S COMBINATION COAL-BOX BUGGY.

Illustrated on Plate XXIX.

WEST LIBERTY, O., December 6, 1865.

MR. E. M. STRATTON—*Sir*: Inclosed you will find a draft of what I term a "combination coal-box," an invention of my own. I did intend to get it patented, but have concluded to give it to the craft. It is so arranged as to combine four different vehicles in one by using my style of shifting-top, or any other shifting arrangement. We have one of these now finishing in our establishment [J. E. Thrasher's], and it is considered the most perfect thing of the kind ever invented. It shows no perceptible joint where the seat folds over the sliding arrangement, it being so constructed as to allow the slide-seat to work very near the upper edge of the panel. A fine moulding on the lower edge of the seat-riser, projecting beyond the side-panel, completely obscures the joint made by the seat in sliding from front to back.

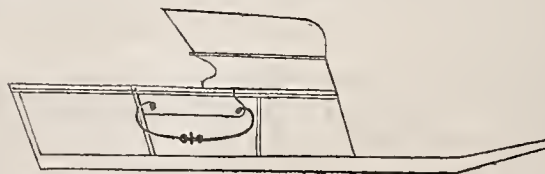

INSIDE VIEW OF THRASHER'S COMBINATION COAL-BOX.

These are the dimensions: Sill  $1\frac{3}{4} \times 1\frac{1}{2}$  inches; entire length of sills, 4 ft.  $5\frac{1}{2}$  in.; front part and edge of seat from the front end of the body,  $20\frac{1}{2}$  in.; width of turning-point of front seat,  $10\frac{3}{4}$  in.; width of the space cut out for the turn-over seat, from the turning-point,  $10\frac{3}{4}$  in.; from the front side of the back-seat, to the front side of the back corner-post, 13 in.; depth of panel, 9 in.; slide-rail below the edge of the panel,  $1\frac{5}{8}$  in.; slide-rail ( $\frac{1}{2} \times \frac{3}{4}$  in.) extends from post to post, and is disconnected at the



joints, except when the seat is turned in. The slide-irons should be trued to slide easy. Width of body at side of the sills, 2 ft. 5 in.; depth of cut-out and turn-over seat, 3 in.; depth of back-seat riser, 3 in.

Hoping this may prove beneficial to the craft,

I am yours, truly, EDWARD THRASHER.

#### MOLDED TILBURY BUGGY.

*Illustrated on Plate XXX.*

THIS design represents a style of buggy which has lately appeared in the streets of this city. It answers very well for a business vehicle, but is too heavy to ever become popular with the mass of pleasure-seekers on the road. With a Tilbury front, the sides of the body are set off with molding, as represented in the drawing. We have added a close top, such being the best suited to a business buggy.

#### ROAD BUGGY.

*Illustrated on Plate XXXI.*

SINCE moldings on buggies are getting very fashionable we are induced to offer our patrons another specimen of this kind of finish. The drawing explains itself sufficiently well without further remark. In explaining the term "buggy," on p. 239 of this volume, we quoted from Felton this explanation: "A Buggy is a cant name given to phaetons and chaises, which can contain only one person on a seat; they are principally intended for lightness of draught, for the *writer* to sit snug in," &c. For *writer*—as the printer makes us say—please read *rider*, as we wrote it.

## Sparks from the Anvil.

### STEEL, AND THE BESSEMER PROCESS.

From a paper read by Mr. A. L. Holley, before the Polytechnic Association of the American Institute, on October 12th, 1865.

ALTHOUGH the general composition and nature of steel are well understood by the members of the Polytechnic Association, it may not be inappropriate to refer briefly to these subjects, as preliminary to a consideration of the Bessemer process and its results.

It is well known that cast-iron is substantially iron with five per cent. of carbon and one or two per cent. of silex and some other impurities. Steel is iron with one to one-tenth per cent. of carbon and a trace of silicium, and traces of some other substances. Wrought iron is substantially pure iron—iron from which all but a trace of carbon has been eliminated. These are the three commercial forms of iron. Steel is subdivided, first, according to its quality, that is to say, substantially according to the high or low degree of its carbonization; second, according to its method of manufacture.

*First*, as to carbonization. High steel, or hard steel, is that which contains a large amount of carbon and a low specific gravity. Its distinguishing properties are

extreme ultimate tenacity, hardness, and capability of extension, without permanent change of figure; but its extensibility beyond the elastic limit is small, and it is therefore brittle under concussion. It will harden when heated and immersed in water; it is with difficulty welded, because it deteriorates under high heat and because its welded heat is very near its melting point, and it is melted at a low temperature as compared with wrought-iron on account of its excess of carbon.

Low steel, also called mild steel, soft steel, homogeneous metal, and homogeneous iron, contains less carbon and has a higher specific gravity. It can be welded without difficulty, although it deteriorates by overheating, and it more nearly resembles wrought-iron in all its properties, although it has much greater hardness and ultimate tenacity and a somewhat lower range of ductility, depending on its proportion of carbon. It has less extensibility within the elastic limit than high steel, but greater extensibility beyond it; that is to say, greater ductility.

The grand advantage of low steel over wrought-iron, for nearly all purposes, is that it can be made liquid at a practicable heat, and run into solid, homogeneous masses, however large; thus avoiding the great defect of wrought-iron—want of soundness, due chiefly to welds. It is also harder, more elastic, and more tenacious.

*Second*. Steel is named according to the processes by which it is manufactured.

What is called "puddled steel," or, by some of its makers, "semi-steel," ought not to be called steel at all. The idea of steel involves the idea of casting from a liquid state, and of consequent homogeneity. Puddled steel, so called, is high wrought-iron. It is wrought-iron puddled in the ordinary way, except that the process is stopped before the product is quite decarbonized. And the product possesses not only the ordinary defects of wrought-iron in the usual degree, but the defect of want of uniformity in a much higher degree. It is not easy to guess at a minute chemical quantity through the flame of a puddling furnace. Puddled steel, however, is stronger than wrought-iron.

Crucible steel, or pot steel, is made from cast-iron by making cast-iron into wrought-iron, *i. e.*, entirely decarbonizing it by the puddling or charcoal refining process, and then melting the wrought-iron with carbon in crucibles, to recarbonize it to the proper degree. Or, wrought-iron bars are covered with charcoal and baked for some days in a converting oven. By this process the bars are somewhat carbonized, but still possess the structural defects of wrought-iron. The product, called blister steel, is used in this state for the cheaper kind of springs, etc.; but its chief value is for remelting in the crucible, with additional carbon, to form cast-steel. Crucible steel is also made from scrap Bessemer steel—the spillings from ladles, etc., and ingot and bar ends; also from cast-iron decarbonized to the required degree in the Bessemer converting vessel, and then poured into water. The product is fine shot of perfectly uniform steel, which are remelted with or without additional carbon. The Bessemer process, in addition to making ingots, thus furnishes, directly or indirectly, the material for a large quantity of the best tool steel as well as low crucible steel now produced in Sheffield.

A little manganese, or some substitute for that metal, is always put into the crucible with the carbon. Chem-



ists do not agree as to the precise chemical office of the manganese or its substitutes; but the results is to increase the ductility of the steel, in both the heated and the cold state.

*Bessemer* steel is just as much *cast-steel*, both structurally and chemically, as steel made in crucibles; because it is poured from a melted state into masses of any size, and because it is definitely and uniformly carbonized.

By the Bessemer process steel is made in two ways from cast-iron. 1st. As in Sweden, by blowing air through melted cast-iron, the oxygen of the air uniting with the carbon in the cast-iron, and so removing all but the amount required in steel, say one-half to one-tenth of one per cent. The oxygen also removes all but a trace of the silic, and the other impurities are burned out. By this process a certain definite number of cubic feet of air are blown through a certain weight of iron, and the blowing is stopped before the iron is quite decarbonized. 2d. By the Bessemer process it is more usual and more convenient to blow the air through the melted cast-iron until *all* the carbon and silic are removed, after which a small amount of melted crude cast-iron is mixed with the decarbonized metal, thus giving it the proper quantity of carbon, silic, and manganese; or, instead of cast-iron, artificial mixtures, containing carbon, silic, and manganese, or some substitute for manganese are poured into the decarbonized iron.

The steel thus produced is cast into ingots, which are then ready for the hammer or the rolls. The apparatus employed is, first, a large melting furnace to melt the cast-iron to be converted; second, a converting vessel, into which the melted iron is run, and where the air is blown into it to decarbonize it; third, a small melting furnace where the small quantity of cast-iron or other material for recarbonizing is melted; fourth, a ladle, ladle-crane, etc., into which the steel is poured from the converting vessel, and from which it is let out into the ingot molds.

The melting furnaces used in England and on the continent are reverberatory furnaces, that is, furnaces in which the flame of the fuel is thrown down upon the iron, instead of the iron being mixed up with the coal. Thus the impurities of the coal do not mix with the iron. The furnaces are similar to common puddling furnaces. They were at first used in this country, but the cupola has now been substituted.

The converting vessel is a cylindrical vessel of plate iron with rounded or dome ends. It is (for making two tons of steel at a charge) about five feet in diameter and ten feet high. It is mounted on trunnions, so that it may be turned either end upward. On one end is an inclined mouth or spout, and on the other a tuyere box, to which air is admitted from the blowing engine by means of a hollow trunnion and pipes connected with it. The converter is lined with a refractory material about a foot thick—any silicious stone ground fine and rammed in; and the air is carried through this lining, from the tuyere box, by means of six fire-clay tuyeres, each tuyere having a dozen holes about a quarter of an inch in diameter. To the other trunnion is attached gearing and a crank to revolve the converting vessel.

The ladle is a plate-iron vessel some three feet high and three feet in diameter, lined say two inches thick with refractory material, chiefly molding sand. In the bottom of it is a hole in which is set a fire-clay nozzle. A

fire-clay stopper, lifted and lowered by a hand-lever fastened to the outside of the ladle, fits into this nozzle, and thus forms a valve by which the hole in the bottom of the ladle is opened and closed.

(*To be continued.*)

## Paint Room.

### OIL, AND OIL CAKE FACTORY, DUBLIN.

(*Continued from page 107.*)

IMMENSE quantities of seed having been stored on the various floors, it is conducted back again to the ground floor—as required for crushing—by means of wooden shoots. In the first process a small stream falls through the roof between two bright steel rollers placed within one eighth of an inch apart, and revolving toward each other. In passing between these the seed is merely broken, displaying afterward the rich yellow grain, but little indication of the stores of oil to be extracted from it by future operations. The stream of broken seeds descend upon the floor in one corner, and to this heap a man with a wooden malt-shovel makes periodical visits, transferring about six bushels at a time to beneath two pairs of ponderous vertical grinding stones weighing four tons each, and chasing one another upon edge around the metal pan which contains the broken seeds. The grinding soon destroys what remains of the original form and color of the seeds, for as it changes into a damp, heavy flour, the color of the mass also undergoes alteration, by the equal mixture of the outer skin and inner germ of the grain. The heap of broken seed is of a brown color when viewed at the distance of a few feet; but after the same has been submitted to the grinding-stones it has a much lighter yellowish tinge. It is one man's duty to attend to the devouring wants of these enormous stones, and when a "charge" has been sufficiently crushed, he "draws" it, and supplies another, without for a moment arresting the progress of the machinery. To effect the first object, a trapdoor is taken from the metal pan upon which the stones travel, and a sweeper descends at the will of the attendant and brushes all the flour into the wake of the hole, while a wooden bar occasionally shifts the mass toward the hole, through which it falls to the floor.

The seed is not allowed much rest in its new condition, but is at once seized by a number of men and boys, who transfer it to the "kettles"—a series of iron vessels holding about two bushels each, and surrounded by a hollow chamber filled with steam from an immense boiler in an adjoining building. Each vessel has a "stirrer," which being interpreted, means an iron rod with radiating arms, placed in the center. These rods, being connected with the water power, are kept in constant motion, by which means the contents of each vessel are constantly stirred and an equal amount of heat imparted to all portions of the meal. The object of this stage in the treatment is to liquify the oil previous to submitting the crushed seed to hydraulic pressure. When made quite hot it runs more freely from the grain than when pressed in a cold state. We keep our eyes upon one particular knight of the kettle to ascertain by what means he shall repossess himself of the hot contents, and presently we observe him place upon the lips of five mouths, opening at the base of the



vessel, as many long, stocking-like worsted bags. He then opens a trap-door, and out comes the charge and descends into the bags, which are instantly removed, and the door closed to make room for a repetition of the same programme.

We now come to the fourth and most important stage in the process, and not having yet tired our patient guide with our very minute examinations and inquiries, we stand with him before one of a number of oil presses all similar in construction and mode of action. One at a time the workman brings forward the worsted bags, and after manipulating them into an uniform shape—half round and half flat—by sundry vigorous applications of the fist, arm, and elbow, the five are placed between the five divisions of the hydraulic press, which no sooner receives them than it commences an affectionate hug, increasing its intensity by slow degrees until it culminates in the delightful squeeze of two hundred and fifty tons power. It is said that the younger workmen use this simile in their moonlight conversations with the Irish lasses, but for the truth of the statement we cannot vouch, as it did not come from our guide.

Along the side of each division that contains a bag, run small channels to receive the oil, and a series of pipes placed at the corner, convey it to where we shall in due course arrive. The first pressure merely flattens the bags, but presently bright drops of oil appear here and there, and fall into the channel; the drops now become more numerous, and, after a time, all join together and dribble rapidly into the pipes. As the pressure nears its utmost limits we see the oil gush out in such quantity that we begin to wonder how the small, dry-looking seeds we looked at in the hopper could have obtained so much oleaginous liquid. But we have been witnessing the performance of but only half of the press, which is a double one with alternate action. Another series of five shelves, with oil channels and pipes, alternates in its operations with that just described, and while one is being filled the other is emptied. The bag full of meal having been rendered literally as "flat as a pancake," the press gradually relaxes its hold, and meanwhile the water power transfers its attention to the second series of bags, which is now ready for the squeeze. While this is taking place, we alter our position to the opposite side of the press and watch the men draw out the long cakes of flat, hard, dry, uninteresting-looking stuff. The bags are stripped off, and the soft edges of each cake planed on a knife fixed in the front of a wooden bench. The refuse thus accumulated goes through the press again. Upon each cake we find the brand "M. H.," which is impressed by placing a piece of leather inside each bag with the initials cut out with a knife. The usual plan adopted for branding oil cake is to work the design with worsted upon the bags. Mr. McGarry has, however, adopted the simple and much more effective plan of placing the design, cut in leather, inside the bags.

We must now see what becomes of the oil after it leaves the several presses engaged in expressing it from the seed. Each little pipe from each division of each press communicates with one common channel, which conveys the oil to a monster under-ground reservoir capable of

containing about two tons of oil. The liquid, however, does not remain here long. A force-pump, from which numerous pipes proceed to all parts of the premises, conducts it to such places and in such quantities as are required. For the present we will follow those which carry the oil in its raw state to the stores. Here we find, in a building about 200 feet long, a series of immense tanks, ranging in capacity from 3,500 to 10,000 gallons. From these cisterns the oil is drawn by means of taps into the barrels in which it is sent to our shops. Outside the stores stands an immense pair of scales, and in these the barrels are weighed, and the quantity painted upon them. One of the out-buildings is set apart as a cooperage, and all the barrels used at the mills are made and repaired on the premises.

*(To be concluded next month.)*

## Trimming Room.

### COACH LACE.

#### FOURTH ARTICLE.

WE have been favored with another beautiful specimen of coach lace from the extensive and popular manufactory of Messrs. Wm. H. Horstmann & Sons, Philadelphia. The engraving shows the design to be perfectly unique, and, for this description of lace, the figures are elegant.

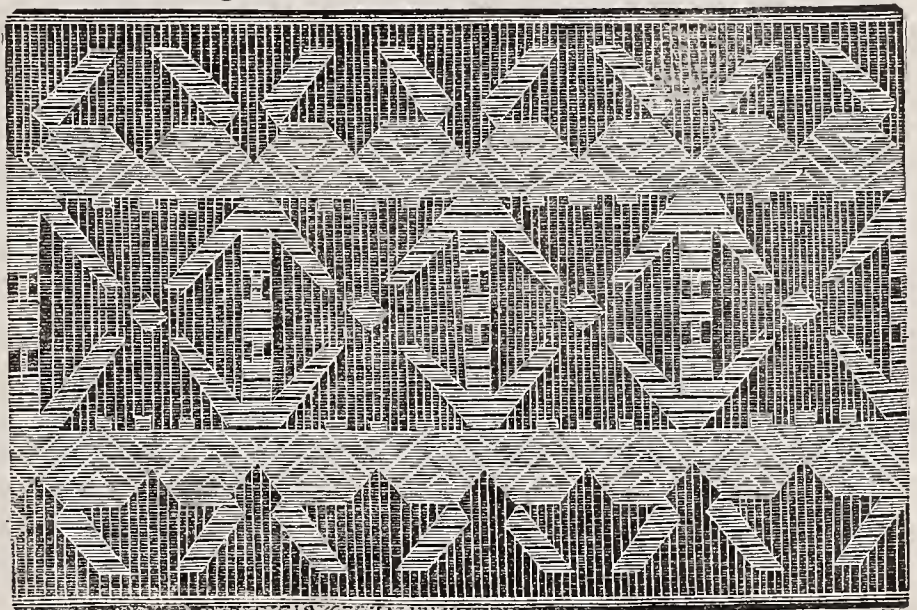

FOURTH SPECIMEN OF COACH LACE FROM MESSRS. HORSTMANN & SON'S ESTABLISHMENT, PHILA.

The number by which the manufacturers distinguish this pattern, is 622; so that in ordering, a customer has only to mention it to obtain the desired pattern. Our specimen is intended to represent a black figure on a blue ground, this last being designated by the lighter shades. In our late travel it gave us much satisfaction to find that lace is more extensively used now than formerly, and, for a great many jobs, it is certainly more appropriate and handsomer than anything yet used as a substitute. This fact is becoming more apparent every day, and we expect ere long to find it in general use.



## SADDLERY AND HARNESS IN THE DUBLIN EXHIBITION.

ALTHOUGH harness-making is not with us considered as a part of the trimmer's occupation, yet the general interest attached to this subject induces us to present the following report from the Dublin International Exhibition to our readers, in the absence of anything more important this month:

It is pleasing to be able to refer to the department of harness and saddlery as very creditable, both as regards the skill displayed and in the quality of the materials used. It must, however, be remarked, that in most cases the leather is procured from England; the manufacturers in this have shown their judgment, in procuring what is excellent, irrespective of the place of production. The workmanship in nearly all goods shown by Irish exhibitors is the production of native workmen. Not only is some of the harness and saddlery excellent of its kind, but the makers seem to be alive to the necessity for progress. Many plans and inventions are shown to add safety and comfort to the rider as well as to the driver, and confidence to the horse.

All persons accustomed to horses must have observed that much of what is technically called vice is in reality timidity; and if, by improved processes of breaking young horses, they can gradually be accustomed to the bit and strapping, many a promising colt may be trained to become a useful and valuable animal and friend of man, instead of being rendered an ill-tempered and vicious brute that none care to ride or drive lest life be endangered.

Much remains to be done before harness can be considered perfect. The young saddlers and harness-makers should take opportunities of traveling, and everywhere notice the mode of harnessing horses. They would see in the south of France the breeching carried beyond the collar and attached to the pole-piece, easing the strain on horses traveling in hilly countries when descending hills. In parts of Germany they would notice the horses drawing with breast-collars; again, they would see horses at work with very serviceable and inexpensive rope-harness. In Russia the horses would be noticed driven without blinkers and without traces, the shafts of the sledges and droskys being lashed to the collars; the harness would also be noticed to be so light as to seem for show and not for use; this, however, is owing to the excellence of the preparation of the leather, it being quite double the strength of the best English harness leather. In the United States of America he would see the fast-trotting horses drawing the light carriages used there almost entirely by the reins. These and many other customs and systems may be noticed by those who travel to collect information, experience, and new ideas in aid of their special calling.

The artistic ornamentation of harness is another matter that merits attention. It is in this case desirable to look to the export as well as the home trade. In many foreign countries people will not use the excellent and plain style of harness preferred by English, Scotch, and Irish gentlemen; they want something that will harmonize with their brilliant vegetation, clothing and sunshine; and it is useless to offer them harness they at once reject as not approaching their ideas of beauty.

The drawing schools of the country should here aid the manufacturer. Many years have passed since their establishment; the boys who attended the first classes have become full-grown men, and there ought to be results even in the manufacture of saddlery. In France, Italy, Spain, Russia, and other countries, richly ornamented and costly harnesses are used on occasions of state, and the men who make them are in a better position to execute such work for exportation than those who have given little or no attention to the subject. The public and merchants apply to those who are most likely to execute their orders with fidelity, taste, and accuracy, rather than let one unaccustomed to the work try experiments of which they may become the victims, while a manufacturer is learning a new branch of trade.

Much may be done in the reduction of cost by the use of ornaments produced by the electro-deposit process, the copper deposit being filled with melted brass, and afterward silvered or gilt. The invention is a French one, and deserves to be widely known. Not only are the most chaste and exquisite ornaments thus produced, but they have the finish and beauty of the most exquisite hand chasing. The system is already carried out extensively in the ornamentation of the beautiful furniture exported in such large quantities from Paris.

In singular contrast to the harness and saddlery department of the Exhibition held in Paris just ten years ago, no exhibitor of harness now shows any plan for detaching runaway horses, and for which purpose such numerous inventions were then submitted. It seems to have become a sort of settled opinion among Englishmen that a strong pair of reins pulled by a strong arm is the safest and best plan of treatment. In the case of timid or vicious horses, a good contrivance is some arrangement of bit or bridle to pain or impede the breathing, which can be used with horses that are known to be troublesome, and likely to cause danger.

---

## Editor's Work-bench.

---

### THE WAR AGAINST CAPITAL.

THOSE who are acquainted with the movements of the age have recognized the fact that, in the minds of the laboring classes, so called, there has recently been rekindled a decided hostility against another class in the community known as capitalists. It is true there is nothing new in this. It is but the spasmodic return of that which has taken place in past years—the outbursts of ignorance against enterprise—the exhibition of a spirit which shows itself in opposites everywhere. This ought not so to be. Capital has its demands as well as labor, and each is dependent upon the other, with this difference, that when capital is withdrawn labor suffers the most.

Laborers generally have come to believe that the division of the joint product of capital and labor is unjust to the latter. The journeyman carriage-maker, whose co-operative hands produce a vehicle worth, say, \$1,000, thinks *he* ought to have a greater share of the profits than his wages entitle him to. He compares the smallness of



his income as wages with the magnitude of the sum for which the carriage is sold, and argues therefrom that injustice has been done him, and jumps at the conclusion that his boss is getting rich at his expense by an undue appropriation of the profits. He does not take into consideration the costs of the material, for which the employer has to pay in addition to that paid for his labor in producing a carriage, nor does he count in the losses that are unavoidably made in all trade transactions; oh no, these matters never trouble him. This is the capitalist's business; let him provide against such contingencies!

Owing to the vicissitudes of trade and credit, in this country at least, many of the employers of labor, at fifty years of age, are poorer than their provident employes at the same age. Notwithstanding the howlings of labor against capital, so lavishly bestowed by the speakers at trade gatherings in our times, without fear of successful contradiction, we assert that the earnings of many are much greater when working for wages than they have afterward been when working on their own account; because, in the latter case, they did not have the expensive machinery and other necessary conveniences which capital provides, the benefits of which they share in the form of enhanced wages, and not from any generosity on the part of employers.

There is another advantage, the fruits of which fall to the laborer; it is the competition among employers, which leads them to offer the highest possible wages, in order to secure the co-operation of reliable and skilled workmen, without which capital would be unproductive, if not a serious loss. It is thus seen that the co-operation of capital and labor is beneficial, not only to one, but to both, and also to the community, who thereby find at their hand productions whenever they require them—all those things which contribute to the enjoyment of life.

There is an important point in this question, which the enemies of the capitalist persistently ignore. It is this: the road to wealth is open to all in this country. Every healthy, industrious and prudent man may become his own capitalist—his own manager. If he does not, whose fault is it? Certainly not the fortunate capitalist's. It is the laborer's own fault; because, in nine cases out of ten, he prefers spending—often without weighing the matter—at the corner grocery the chief portion of his income from labor, instead of laying it securely by where it increases by degrees from wages to a capital. It is evident that the relations of capital and labor are misunderstood by the mass of laborers at the present day. Were it not so, they would see that labor is more benefited by the accumulation and the protection of capital than the capitalist himself. For this reason, instead of crying out against the capitalist, the working man ought to be glad that there are some forehanded enough to hire and pay

him wages. Without his agency, the laborer's case would be pitiable indeed.

A cotemporary observes: "The capitalist has the trouble of administering the capital, which places at the disposal of the laborer whatever enjoyments he attains. The laborer who possesses no capital can only blame himself. He cannot have labored as perseveringly and as intelligently as those who do, or their ancestors. Every man can now accumulate property much more easily than the generations that preceded us, because we now control the natural forces, which labor gratuitously, their only cost being that of the means by which they are controlled. Those who do not possess property have only themselves to blame. They cannot in justice be permitted to enjoy that of others. By reducing the hours of labor, and by increasing wages, the world will certainly not become richer, for there will be less produced and more consumed for a short time, until the truth becomes apparent that only that which has been produced can be consumed."

We are conscious that in penning this article we are touching upon a delicate subject, in the opinion of some portion of our readers; yet, notwithstanding this, a sense of duty impels us to give it an examination. Those then who differ in opinion from us will make the proper allowance. We are fully satisfied that the hostility of capital to labor exists only in the imagination, and believe that the community will never enjoy the full benefit attainable through labor, until the great truth be fully recognized, that "there is no antagonism between capital and labor, so long as that great and constant spur to industry and progress, unfettered competition in all things, is permitted to exist in full activity everywhere." This is a matter which no legislative law will ever reach by enactments, but must be regulated by the more potent laws enforced by supply and demand.

#### CARRIAGES IN THE LATE CANADIAN EXHIBITION.

THE details of this exhibition, as relates to the carriage department, have been crowded out until this late day by more important matter. We cannot, however, pass them by without some notice.

The twentieth exhibition of the Agricultural Exhibition of Upper Canada for 1865, was held in London, on the 19th and the three succeeding days in September. We find in a cotemporary the following critical remarks respecting the vehicles there on exhibition: "In carriages and sleighs there was much to admire in the neat workmanship and light draft of the various vehicles exhibited; but we did not admire the style of the carriages ('buggies,' as they are termed), and there was more varnish and shining black leather than comported with our perhaps old-fashioned opinions—in fact, there was more of



show than of utility all through the room; but there were some good samples of plain work, in the shape of machine-made hubs, rims, fellys, and spokes, exhibited by several parties." These criticisms, coming as they evidently do from one blinded by European prejudices, are anything but flattering to the mechanical tastes of our Canadian friends. They are evidently making progress, proof of which is seen in departing from the stereotyped styles or old-fogyisms of England, as we in America term it.

Prizes were awarded as follows: For the best trotting buggy, to W. & J. McBride, of London, \$10; 2d best do., to J. B. Armstrong, of Guelph, \$4. For the best single-seated buggy, John Campbell, of London, \$8; 2d do., estate of H. H. Dart, of same place, \$5. For the best double-seated buggy, John Campbell, \$10; and for the 2d do., estate of H. H. Dart, \$6. For the best one-horse pleasure carriage, the Dart estate received \$10; and for the 2d do., John Campbell, \$6. For the best two-horse pleasure carriage, Thos. Todd, of Galt, \$12; 2d do., John Campbell, of London, \$8. Best one-horse sleigh, J. B. Armstrong, Guelph, \$10. As we miss many good names in the foregoing list, the presumption is that the exhibition of carriages was limited and local.

#### REVIEW OF TRADE.

WE learn from various quarters that trade is dull, with the exception of a few orders for the coarser kinds of work for the Southern trade. We notice a few old faces on the streets from the late Confederacy, but while they are chary in their purchases, the dealers here, as a general thing, insist on selling for cash only, having from past experience discovered that it is much better not to sell at all than to part with their goods on mere promises to pay on paper. A correspondent writes us, on the 17th of November, from San Francisco, that "the auction rooms have been crowded with vehicles of fair appearance, but poor work, sent there to be sold in that manner, and we have been unwilling to put good work in competition with them at the very low prices at which they have sold." The effect is that a large stock of buggies sent out for sale the past year must remain on hand until the coming spring at an extravagant expense on the part of the shippers and dealers for storage awaiting better times.

#### LITERARY NOTICES.

THE ATLANTIC MONTHLY for December presents the reader with a rich literary repast, and completes the sixteenth volume of this entertaining periodical. With the January number a new volume begins. The enterprising publishers promise, during the year 1866, to give passages from Nathaniel Hawthorne's Diary, stories by Bayard Taylor and Mrs. L. Maria Child, and other interesting articles, and to continue Mrs. Stowe's Chimney Corner and Mitchell's Dr. Johns. The terms will continue the same, \$4 a year.

Messrs. Ticknor & Fields are also the publishers of *Our Young Folks*. The next number, for January, will be the first of the second volume, presenting a good opportunity for *paterfamilias* to entertain his juveniles and himself too with interesting reading another year. We know of no periodical so richly worth the money (\$2) charged for it as this.

Mr. B. H. Ticknor, of 823 Broadway, agent for the house named above, has placed in our hands the Humorous Poems of O. W. Holmes, a uniform volume with others in the series known as "Companion Poets for the People." Dr. Holmes is one of the most humorous and talented writers of the day. The forty poems, some of which are illustrated by original designs, are very cheap at 50 cents, the price for the volumes of the series.

### Patent Journal.

#### AMERICAN INVENTIONS.

Oct. 17. (50,425) WHEEL.—Joseph Stoliker, assignor to himself and J. H. McKenzie, Pine Run, Mich.:

I claim, *First*, A metallic wheel for vehicles and for other purposes, provided with spokes, arranged or applied to the rim or tire so as to pass through a flange of the same, and connected at their inner ends to adjustable nuts or boxes on the hub, arranged in such a manner that the spokes may be strained or brought to a proper state of tension by spreading apart the nuts or braces, substantially as described. *Second*, The crossing of the wires forming the spokes, and the securing of the inner ends of the same to rings E, on the nuts D D, in the manner substantially as set forth. *Third*, The combination of the rim or tire A, spokes B, hub C, nuts D D, rings E, and plates E, with the nuts G G, all arranged substantially as and for the purpose specified.

31. (50,672) CUTTER SLEIGH.—Alfred Arneiman, Guttenberg, Iowa:

I claim the combination of two pairs of S-shaped runners, of different heights, with a sleigh, the body of which is constructed of the form substantially as described.

(50,682) ATTACHING TRACES TO WHIFFLE-TREES OF VEHICLES.—Edwin Brown, Leominster, Mass.:

I claim, as a new article of manufacture, spring-bolts for attaching to and detaching traces from whiffle-trees, arranged within a casing which is provided with bearings and a protecting cap for operation, substantially as shown and described.

(50,700) SHAFT COUPLING.—George H. Fox, Boston, Mass.:

I claim the coupling constructed substantially as described, that is to say, with the central and elongated key-hole in the coupling, and the central key-holes in the shafts, the shaft ends being made of tapering form, and the keys wedge-shaped, as specified.

(50,707) CARRIAGE JACK.—Aaron Higley, South Bend, Ind.:

I claim the forked arm E, pivoted to the plates F, resting and turning upon the shoulder g, and the lever B, when jointed to and constructed with the pedestal A, arranged so as to operate conjointly in the manner and for the purpose specified.

(50,716) TIRE-SHRINKING MACHINE.—J. M. Kellogg, Duguvin, Ill.:

I claim, *First*, The construction of the immovable slotted jaw A, side abutment A', slotted bed-plate A 3, and end abutment A 2, in combination with a movable slotted jaw B, substantially as described. *Second*, The combination with the subject matter contained in the first claim of the hooked tenon b', and tenon guide b, and wedge J, substantially as described. *Third*, The



combination of the movable back-support G, in the side abutment B, in the side abutment A, and jaws A B, substantially as described. *Fourth*, Adapting the concave-faced back-support G, to serve for tires of different diameter, substantially as described. *Fifth*, The use of forked and wedged keys C C, for securing the tires to the jaws A B, substantially as described.

(50,762) WAGON BRAKE.—Jesse F. Wilson, Lewisville, Ind. :

I claim, *First*, The toggle H, connected with the rod G, at the under side of the draft-pole, and which rod is attached to the shoe-bar C, and cranks *c c*, of the shaft K, in combination with the bar M, pivoted in the draft-pole, and connected with the toggle, and all arranged to operate in the manner substantially as and for the purpose set forth. *Second*, The lever O, connected by a rod N with the bar M, in combination with the toggle H, as and for the purpose specified. *Third*, The cross-head P, connected with the rod N, in combination with the arm *e* of the bar M, and toggle H, substantially as and for the purpose set forth.

(50,763) WHIFFLE-TREE.—Gallus Woeber, Davenport, Iowa :

I claim the socket C, attached to the cross-bar of the tbills, and provided with the bar *d* and slot *e* to form a guide in connection with the plate E, attached to the whiffle-tree B, fitted in the socket C, and provided with an arm D, to fit in the slot *e* of C, all being arranged and used in connection with the bolt F, substantially as and for the purpose set forth.

(50,768) MACHINE FOR TENONING SPOKES.—L. A. Dole, assignor to himself and Albert R. Silver, Salem, Ohio :

I claim, *First*, Constructing the cutter or boring shaft C' with a circular rack *e*, and arranging the toothed feed-lever G, to gear with the said rack, substantially in the manner and for the purpose herein described. *Second*, the arrangement of the arm E, on the vertically adjusted standard B, said standard serving to adjust and support the cutter or boring shaft C', and said arm being adapted for sustaining the holding and centering devices for the spoke in front of the cutter *w*, borer, substantially as herein described. *Third*, The construction of the adjustable centering plate *g*, with a notch in its upper end to receive the spokes, in combination with the pressure lever J, said parts being arranged in front of a rotary tenon-cutter, substantially as described. *Fourth*, The arrangement of the rod *j*, having a shoulder *i* formed on it, the binding-plate *l*, and nut *k*, in combination with the rack *a*, and pinion *b*, in the manner and for the purpose herein described. *Fifth*, The construction of a frame of a spoke-tenoning machine with a slotted standard B, a slotted tubular bearing C, and an arm E, substantially as described.

NOV. 1. (50,785) SPRING SEAT FOR WAGONS.—Thomas J. Alexander, Nesterville, Ohio :

I claim the spring seat, consisting of the boards *f f*, united by the cleat *i*, and attached to the knees E E, combined with the links C C, and slats B B, arranged and operating substantially as and for the purpose set forth.

(50,886) CARRIAGE SPRING.—William Taylor, East Zora, Canada :

I claim the compound bow and scroll-spring B, in combination with the elliptic spring D, constructed and applied for the purposes and substantially as described.

14. (50,918) WAGON SHAFT-SHACKLE.—Ferdinand Dickerson, Jr., Hartford, Conn. :

I claim a tapering bolt *c*, having the screw cut entire length, in combination with the hinge straps *a b*, washers *e x*, and nut *i*, substantially as and for the purpose described.

21. (51,118) PAINT OIL.—William W. Nichols, assignor to himself and Daniel Price, Lockport, N. Y. :

I claim a compound of vehicle for painting, composed of the ingredients herein set forth, combined substantially in the manner and proportions described.

28. (51,196) CARRIAGE, WAGON, ETC.—Edward Lane, Philadelphia, Pa. :

I claim the body A, its four springs, the levers D D, connected directly to the cross-piece E, and levers D D', connected to the rear axle through the medium of links F F, when the whole is arranged and operated as set forth, and is applied to a carriage in which the said cross-piece E is connected by a perch G to the rear axle, as specified.

(51,232) SELF-ACTING BRAKE.—C. A. Smith, Charleston, Ill. :

I claim, *First*, the shaft K, provided with the cranks *e f f*, and shoes L L, placed on the bar J, in relation with the wheels C, as shown, in connection with the slotted reach D, and the front bolster H, connected by a pivot bolt *a\** to the wagon bed or body near one end, fitted on the king-bolt G, as a fulcrum, and connected to the shaft K by the rod *g*, all arranged to operate in the manner substantially as and for the purpose set forth. *Second*, The slotted shoes L L, placed on the cranks *f f* of the shaft K, for the purpose of admitting the shoes to rise under the reverse motion of the wheels C, in backing, substantially as set forth.

(51,251) CARRIAGE-WHEEL.—Edward S. Winchester, Boston, Mass. :

I claim providing wheels with projections, arranged to operate substantially as set forth.

## FOREIGN INVENTIONS.

10. VENETIAN BLINDS FOR CARRIAGES.—T. Startin, Birmingham.

The following is a description of the improvements as arranged in connection with a Venetian blind suitable for a carriage-window, in which case the strips or laths forming the screen or blind are fitted between the sides of a thin frame for sliding down. The strips or laths are united to the rails of the frame by small wire, or other centers or axes projecting from each end, working in corresponding holes in the inner edges of the side rails of the frame. All this is common in the construction or making of such kind of Venetian blinds, whether for windows or other purposes. The improvements are entirely confined to the means of actuating the strips or laths of such blinds for the purpose of opening and closing the same, and consist in the use of a strip of metal, or other suitable material long enough to extend at right angles to the series of movable laths, which strip of metal is formed with a series of small eyes, not only equally divided, but exactly the same distance apart from eye to eye as the axes of the strips or laths, and into these eyes small metallic pins work, secured on the flat or face of each lath. From this it will be seen that, by pulling down or elevating the strip of metal, all the strips or laths will be simultaneously opened, closed, or set in any desired angle. For the purpose of protecting the action of the laths from undue force, the vertical strip is attached to a compound hinge-joint and plate at the bottom end, as may be desired, which plate, with the compound or double hinge or joint, is secured to the rail of the frame in which the laths work. *Not proceeded with.*

APPARATUS FOR IMMEDIATELY DISCONNECTING HORSES FROM CARRIAGES.—P. Marvand, Paris.

This apparatus is constructed as follows: The ends of the furchells of the fore-carriage are forked, that is to say, they have each two branches, and between the branches a ratchet or key-piece, is securely maintained by a spring or other side pivoting on a bolt. At the end of each shaft is a strong bolt which is introduced between the branches of the furchells, and secured by the above-mentioned key-piece. Adapted on the branches of each furchell is a can or nut, which is at the command of the driver, and on causing these cans or nuts to press against their respective springs, the ratchet or key-piece above mentioned is at once liberated, which permits the escape of the bolt of the shafts, splinter-bar, or carriage-pole, as the case may be, and thus immediately disconnects the horses from the carriage.



The coachman works the cams or nuts just mentioned by means of a lever conveniently disposed for that purpose, and connecting with an armature having the form of, and placed beneath the furchells of the fore-carriage, a connecting rod transmitting the action to the cam or nut; the lever being also connected with the fore carriage, the vehicle may be deviated as desired, the impetus carrying on the carriage a short distance. *Not proceeded with.*

### CURRENT PRICES FOR CARRIAGE MATERIALS.

CORRECTED MONTHLY, BY MR. CHAS. WEEKS, FOR THIS MAGAZINE.

NEW YORK, Dec. 26, 1866.

Apron hooks and rings, per gross, \$2.50.  
 Axle-clips, according to length, per dozen, 75c. a \$1.25.  
 Axles, common (long stock), per lb, 10½c.  
 Axles, plain taper, 1 in. and under, \$6.50; 1½, \$7.50; 1¾, \$8.50; 1⅞, \$9.50; 1⅝, \$10.50.  
 Do. Swelled taper, 1 in. and under, \$7.00; 1½, \$8.25; 1¾, \$8.75; 1⅞, \$10.75; 1⅝, \$13.00.  
 Do. Half patent, 1 in. and under, \$10.50; 1½, \$12.50; 1¾, \$15.00; 1⅞, \$17.50; 1⅝, \$21.25.  
 Do. Smith's New York half patent case-hardened malleable iron box, 1 in. and under, \$10; 1½, \$10; 1¾, \$12.  
 Do. Smith's Homogeneous steel, case-hardened mall. boxes, ½ in., \$12; ¾, \$12; ⅞, \$12.50. Long draft, \$2 extra.  
 Do. Saunders' improv. taper, ¾ in., \$12.00; ⅞, \$12.00; 1, \$12.00; 1½, \$13.00; 1¾, \$15.  
 Do. do. Homogeneous steel, ½ in., \$15.00; ¾, \$15; ⅞, \$16.50; long drafts, \$4 extra.  
 ☞ These are prices for first-class axles. Makers of less repute, cheaper.  
 Bands, plated rim, under 3 in., \$2.50; over 3 in., \$3  
 Do. Mail patent, \$3.00 a \$5.00.  
 Do. galvanized, 3½ in. and under, \$1; larger, \$1 a \$2.  
 Basket wood imitations, per foot, \$1.25.  
 ☞ When sent by express, \$2 extra for a lining board to a panel of 12 ft.  
 Bent poles, each \$1.75.  
 Do. rims, under 1½ in., \$2.25 per set; extra hickory, \$3.25 a \$4.00.  
 Do. seat rails, 50c. each, or \$5.50 per doz.  
 Do. shafts, \$7.50 per bundle of 6 pairs.  
 Bolts, Philadelphia, list.  
 Do. T, per 100, \$3 a \$3.50.  
 Bows, per set, light, \$1.25; heavy, \$2.00.  
 Buckles, per grs. ½ in., \$1.50; ⅞, \$1.50; 1, \$1.70; 1¼, \$2.10; 1½, \$2.80.  
 Buckram, per yard, 25 a 30c.  
 Burlap, per yard, 30c.  
 Buttons, japanned, per paper, 30c.; per large gross, \$3.  
 Carriage-parts, buggy, carved, \$4 a \$5.50.  
 Carpets, Brussels, per yard, \$2 a \$3; velvet, \$3.25 a \$4.50; oil-cloth 60c. a 75c.  
 Castings, malleable iron, per lb, 20c.  
 Clip-kingbolts, each, 50c., or \$5.25 per dozen.  
 Cloths, body, \$4 a \$6; lining, \$3 a \$3.50. (See *Enameled*.)  
 ☞ A Union cloth, made expressly for carriages, and warranted not to fade, can be furnished for \$2.40 per yard.  
 Cord, seaming, per lb, 45c.; netting, per yard, 8c.  
 Cotelines, per yard, \$4 a \$8.  
 Curtain frames, per dozen, \$1.25 a \$2.50.  
 Do. rollers, each, \$1.50.  
 Dashes, buggy, \$1.75.  
 Door-handles, stiff, \$1 a \$3; coach drop, per pair, \$3 a \$4.  
 Drugget, felt, \$2.  
 Enameled cloth, muslin, 5-4, 85c.; 6-4, \$1.10.  
 Do. Drills, 48 in., \$1.25; 5-4, \$1.20.  
 Do. Ducks, 50 in., \$1.45; 5-4, \$1.40; 6-4, \$1.60.  
 ☞ No quotations for other enameled goods.  
 Felloe plates, wrought, per lb, all sizes, 25c.  
 Fifth-wheels wrought, \$1.75 a \$2.50.  
 Fringes, festoon, per piece, \$2; narrow, per yard, 18c.  
 ☞ For a buggy top two pieces are required, and sometimes three.  
 Do. silk bullion, per yard, 50c. a \$1.  
 Do. worsted bullion, 4 in. deep, 50c.  
 Do. worsted carpet, per yard, 8c. a 15c.  
 Frogs, 75c. a \$1 per pair.  
 Glue, per lb, 25c. a 30c.  
 Hair, picked, per lb, 70c. a \$1.

Hubs, light, mortised, \$1.10; unmortised, \$1.00—coach, mortised \$1.50.  
 Japan, per gallon, \$3.  
 Knobs, English, \$1.50 a \$1.75 per gross.  
 Laces, broad, silk, per yard, \$1.00 a \$1.50; narrow, 15c. to 20c.  
 Do. broad, worsted, per yard, 50c. a 75c.  
 Lamps, coach, \$20 a \$30 per pair.  
 Lazy-backs, \$9 per doz.  
 Leather, collar, dash, 32c.; split do., 18c. a 22c.; enameled top, 32c.; enameled Trimming, 30c.; harness, per lb, 50c.; flap, per foot, 25c. a 28c.  
 Moquet, 1½ yards wide, per yard, \$9.00.  
 Moss, per bale, 12½c. a 18c.  
 Mouldings, plated, per foot, ¼ in., 14c.; ⅜, 16c.; 18c.; ½, 1 ead. door, per piece, 40c.  
 Nails, lining, silver, per paper, 12c.; ivory, per gross, 50c.  
 Name-plates.  
 ☞ See advertisement under this head on 3d page of cover.  
 Oils, boiled, per gallon, \$1.80.  
 Paints, White lead, ext. \$17, pure \$17½ p. 100 lbs.; Eng. pat. bl'k, 35c.  
 Pole-crabs, silver, \$5 a \$12; tips, \$1.50.  
 Pole-eyes, (S) No. 1, \$2.70; No. 2, \$2.90; No. 3, \$3.10; No. 4, \$4.50 per pr.  
 Sand paper, per ream, under No. 2½, \$5.00; Nos. 2½ & 3, \$5.65.  
 Screws, gimlet.  
 ☞ Add to manufacturer's printed lists 20 per ct.  
 Do. ivory headed, per dozen, 50c. per gross, \$5.50.  
 Serims (for canvassing), 20c. a 30c.  
 Seats, buggy, pieced rails, \$1.75; solid rails, \$2.50.  
 Shaft-jacks (M. S. & S.'s), No. 1, \$2.75; 2, \$3.25; 3, \$3.50.  
 Shaft-jacks, common, \$1.50 a \$1.65 per pair.  
 Do. tips, extra plated, per pair, 37½c. a 56c.  
 Silk, curtain, per yard, \$2 a \$3.50.  
 Slat-irons, wrought, 4 bow, \$1.12½; 5 bow, \$1.25 per set.  
 Slides, ivory, white and black, per doz., \$12; bone, per doz., \$1.50 a \$2.25; No. 18, \$2.75 per doz.  
 Speaking tubes, each, \$8.  
 Spindles, seat, per 100, \$1.50 a \$2.50.  
 Spring-bars, carved, per pair, \$1.75.  
 Springs, black, 24c.; bright, 25c.; English (tempered), 28c.; Swedes (tempered), 32c.; 1¼ in., 1c. per lb. extra.  
 If under 36 in., 2c. per lb. additional.  
 ☞ Two springs for a buggy weigh about 33 lbs. If both 4 plate, 34 to 40 lbs.  
 Spokes, buggy, ⅞, 1 and 1½ in. 9½c. each; 1½ and 1¾ in. 10c. each; 1¾ in. 9c. each.  
 ☞ For extra hickory the charges are 10c. a 12½c. each.  
 Steel, Littlejohn's compound tire, 3-16, 10c.; 1-4, 9½c.; heavier sizes, 9c. currency.  
 Stump-joints, per dozen, \$1.40 a \$2.  
 Tacks, 9c. and upwards per paper.  
 Tassels, holder, per pair, \$1 a \$2; inside, per dozen, \$5 a \$12; acorn trigger, per dozen, \$2.25.  
 Terry, per yard, worsted, \$4; silk, \$9.  
 Top-props, Thos. Pat. per set 65c.; capped complete, \$1.50.  
 Do. common, per set, 40c.  
 Do. close-plated nuts and rivets, \$1.  
 Thread, linen, No. 25, \$1.30; 30, \$1.45; 35, \$1.65, gold.  
 Do. stitching, No. 10, 95c.; 3, \$1.15; 12, \$1.28, gold.  
 Do. Marshall's Machine, 432, \$2; 532, \$2.30; 632, \$2.60, gold.  
 Tufts, common flat, worsted, per gross, 20c.  
 Do. heavy black corded, worsted, per gross, \$1.  
 Do. do. do. silk, per gross, \$2.  
 Do. ball, \$1.  
 Turpentine, per gallon, \$1.35.  
 Twine, tufting, per ball, 50c.; per lb, 85c. a \$1.  
 Varnishes (Amer.), crown coach-body, \$5.50; nonpareil, \$6.50.  
 Do. English, \$6.25 in gold, or equivalent in currency on the day of purchase.  
 Webbing, per piece, 65c.; per gross of 4 pieces, \$2.40.  
 Whiffle-trees, coach, turned, each, 50c.; per dozen, \$5.50.  
 Whiffle-tree spring hooks, \$4.50 per doz.  
 Whip-sockets, flexible rubber, \$4.50 a \$6 per dozen.  
 Do. hard rubber, \$10.50 per dozen.  
 Do. leather imitation English, \$5 per dozen.  
 Do. common American, \$3.50 a \$4 per dozen.  
 Window lifter plates, per dozen, \$1.50.  
 Yokes, pole, each, 50c.; per doz, \$5.50.  
 Yoke-tips, extra plated, \$1.50 per pair.





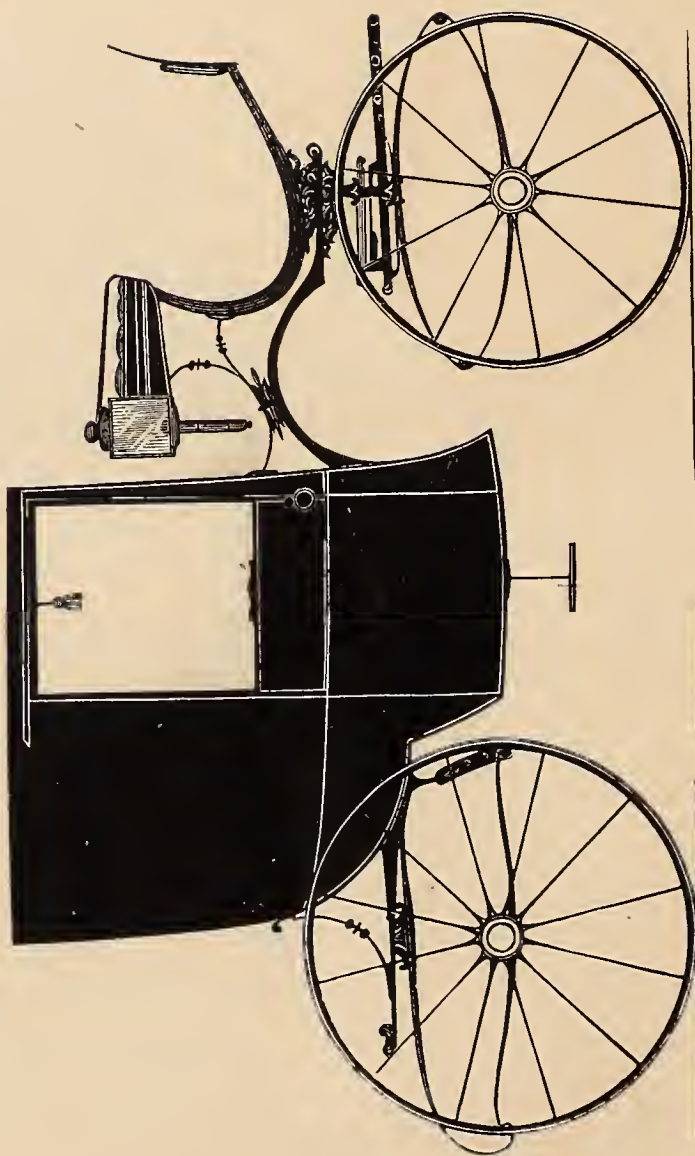

SKELETON FRONT COUPE.— $\frac{1}{2}$  IN. SCALE.

*Designed expressly for the New York Coach-maker's Magazine.*

*Explained on page 137.*

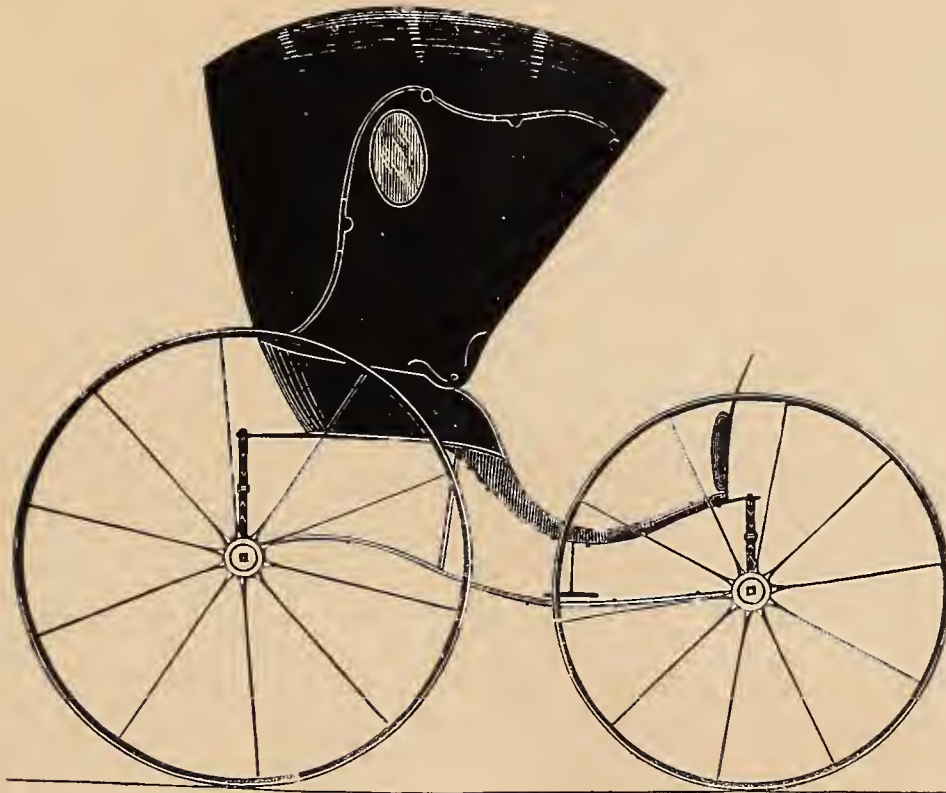

PHYSICIAN'S PHAETON.— $\frac{1}{2}$  IN. SCALE.

*Designed expressly for the New York Coach-maker's Magazine.*

*Explained on page 137.*









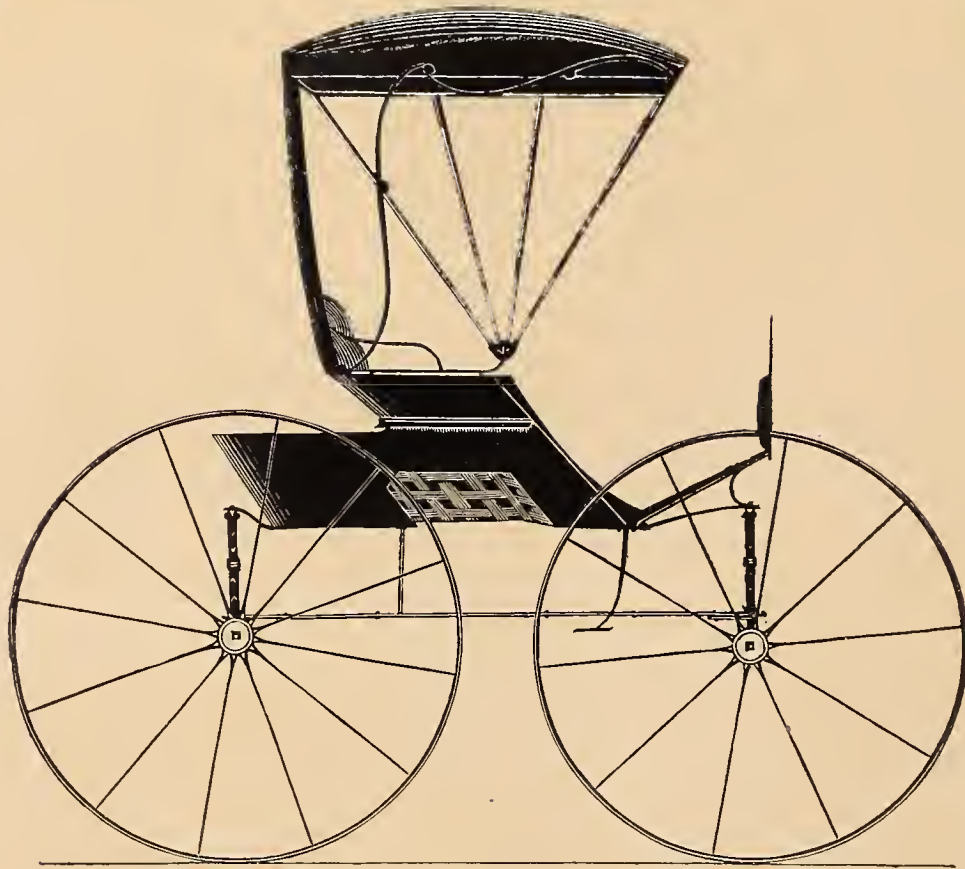

BRACKET-FRONT BUGGY.— $\frac{1}{2}$  IN. SCALE.

*Designed expressly for the New York Coach-maker's Magazine.*

*Explained on page 137.*



O. L. G.



A. O. T.

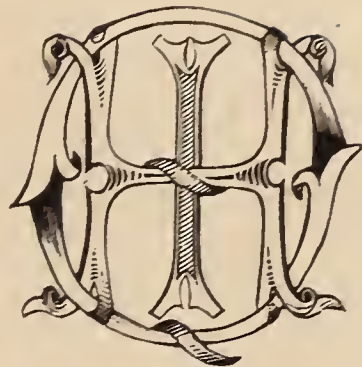

H. I. Q.

ORIGINAL MONOGRAMS.

*See remarks on page 140.*







DEVOTED TO THE LITERARY, SOCIAL, AND MECHANICAL INTERESTS OF THE CRAFT.

Vol. VII.

NEW YORK, FEBRUARY, 1866.

No. 9.

### Mechanical Literature.

#### REPORT OF CARRIAGES IN THE DUBLIN INTERNATIONAL EXHIBITION OF 1865.

(Concluded from page 117.)

THE art of the coach-maker being an intricate one, inasmuch as he has to combine in one harmonious whole a number of most varied products—wood, iron, steel, brass, paint, silver, cloth, leather, silk, ivory, hair, carpet, glass, &c., &c., each worked by a separate trade, but generally in one manufactory, and each of which may be spoilt or injured by carelessness or improper treatment in any process—it behooves all engaged on the production of carriages to work in harmony, that their united labors may approach perfection. It would add much to this desirable end, if in each manufactory, large or small, were issued a series of printed "general directions" for conducting the work; not rigid rules that would, if strictly enforced, reduce men to mere machines, instead of free and intelligent operatives, but such as would so guide each worker in the execution of his work, as not only to give satisfaction to his employer by its excellent and honest execution, but bring equal satisfaction and credit to himself. This state of feeling would be a very desirable one to bring about; it would beget mutual trust and respect between the employer and employed, and lead the way to a more cordial appreciation of each other's wants and difficulties; at the same time it would lessen the incessant watchfulness and anxiety necessary to insure the work being executed in such a manner that it may be depended on for accuracy and excellence when completed.

Under the new law regulating friendly societies, the London Coach Operatives have recently established a benevolent fund, which is supported by themselves as well as by the employers—such a fund destined for charitable purposes only, and not for trades-union purposes. There is thus being awakened a more united feeling of sympathy between employers and workmen, who are becoming more fully aware that they must rise or fall together. As the goods of the best manufacturers generally fetch the best prices, so the employers would naturally be desirous to attract to themselves the best workmen, and pay them well for a high standard of skill and energy.

A feature in the financial department of coach-making must not be overlooked, as it has much influence on an important trade. In former times a large proportion of carriages were built to order for the owners; the reverse is now the case—most persons select a finished carriage, which pleases their taste, or an advanced one, and get it completed to their favorite color. This, of course, necessitates the employment of large capital to meet the altered state of trade, which now requires so large a stock of carriages to be kept ready for use.

The excessive competition of recent years has so reduced the profit on each carriage, that, in order to carry on his business without loss, the builder has to require prompt payment from his customer, instead of leaving the time of payment uncertain. In fact, many manufacturers who have not been able to adapt their system of business to the necessities of the present time, have been obliged to give up the trade, which has fallen into other hands that have realized the obligation of change, and fallen in with the wants of the great body of carriage buyers.

The modern system enables a coach builder to make his purchases for ready money, and so buy not only better in quality, but at less cost than for extended credit, in order that he might, in his turn, give long credit to his customers, so that he is now obliged to depend on small profits and quick returns by turning over his capital more rapidly. He is not now, as much as in former times, the agent of the persons who supply the materials that he and his workmen convert into a carriage; but rather the designer, capitalist, and director of those who seek his service or custom, whether to supply labor or materials.

If the number of exhibitors really represents the trade of a locality whence they come, Dublin seems to be the chief manufacturing city in Ireland for carriages, as the whole of Ireland give 15 exhibitors, of whom 12 are of Dublin, showing 9 carriages; the remainder of Ireland giving 3 exhibitors, with 3 carriages. Scotland gives 4 exhibitors, of which number 1 is from Edinburgh, with 1 carriage; and 3 from the remainder of Scotland, with 4 carriages. England gives 17 exhibitors, of whom London has 9, with 8 carriages; the remainder of England, 8 exhibitors, with 12 carriages; so that all the English provinces together furnish rather more than the number sent from London; although in the latter city are made, and from it are sent, a very large number of



carriages to all parts of England, Ireland, and Scotland, as well as to most parts of the world where the duties on carriages are not excessive.

In close connection with the art of carriage building should be considered that of road making. This latter is much indebted to the genius and energy of Englishmen, who, within the present century, laid out and established on a sound basis the great system of English roads. They made a reputation by their ability, of which Englishmen may be proud. However, since the introduction of the railway system, the art seems to have slumbered in England. Not so, however, in France, and many parts of Continental Europe, where foreign engineers have taken up the art where English engineers left it.

In England, the roads are only half made, or at least unfinished, and it is left to the feet of horses or the wheels of vehicles to crush together and compound the loose stones into a smooth mass as best they may. The result may be guessed; this uncouth and rude treatment, although, in the course of time, it effects its object, leaves the road uneven, with depressions that hold the water, and loose stones that obstinately refuse to mate with their fellows.

In France the roads, when prepared with the last surface-dressing of hard, broken stones, are treated so as to finish them fit for traffic. Fine gravel is thrown on the broken metal, and slightly watered; a smooth, wide, and heavy roller is then drawn over it till the surface is compact and smooth enough for ordinary traffic—saving horses much unnecessary toil and suffering, besides avoiding the strain and injury to carriages and carriage-wheels.

It is desirable to direct attention to the proper horseing of carriages, that the owners of horses and carriages may adapt their plans so as to get the most satisfactory result from their arrangements. Not unfrequently a carriage is ordered for one horse only. When it is partly made, or perhaps finished, fittings are ordered for two horses; and it sometimes happens that the two horses put to the light one-horse carriage are coach-horses, between sixteen and seventeen hands in height. Such horses, although well adapted to a heavy family carriage, are quite out of their proper place attached to a light one. Although they can draw it at a good pace, and over almost any obstacle in the road, and do their journey without fatigue, the carriage suffers sooner or later. The lounging of such horses against a light pole, the strain thrown on the pole in case of a horse tripping, the certain breakage that must occur in case of a fall, and the risk of overturning the carriage, should all be considered before putting a very light carriage behind very large horses. It also sometimes happens that miniature broughams, and other very small carriages, built as light and as slight as safety will allow, are afterward used with a pair of horses. In such cases, if accidents do not occur through the great strain of a long pole acting as a lever on a very light mechanism, the parts become strained, do not work as they were intended to do, and necessitate constant repair from not being adapted for the work put upon them. Carriage owners should, in their own interest, have their carriages and horses suited to what they ought and can undergo, bearing in mind that there are advantages and disadvantages both with heavy and light carriages. The former are easier and more comfortable to ride in; they are safer for horses, drivers, and riders, and the necessary

repairs are less frequently required. The lighter carriages follow the horses more easily, and can, therefore, do a longer day's journey; and although the necessary repairs may come more frequently, the saving of the horses may be an advantage that many persons will consider of the utmost importance. Such light carriages should, however, be made of the choicest materials and workmanship, that they may do the work required of them.

A custom has arisen of late years of driving horses without breechings. Although this may be quite satisfactory with light carriages and on level roads, it is attended with much risk and danger in other cases; in descending hills, the breeching brings the strain on the horses' hind-quarters, besides relieving the strain on the pole. If the hind wheels are retarded by an ordinary drag-shoe, or by the friction of a lever brake, the chances of accident are considerably reduced. In the plan now so common of using horses for all purposes without breechings, the pressure of a pole in descending a hill is thrown on a horse's neck, and thereby on his front legs. Everything now depends on the pole bearing the extreme strain without breaking, and the horses trotting steadily; for if a horse trips, shies at any object in the road, becomes scared by a railway whistle, or terrified by a flash of lightning, he gives a sudden snatch or jerk at the pole, and sometimes even the best of timber gives way, just as, under certain conditions of wind and storm at sea, the best of masts may go overboard. Carriage owners and drivers should be aware of the means of safety within their reach. In hilly countries, nothing equals the screw or lever break, by which a graduated pressure is applied to the circumference of the hind wheels; in most circumstances, a carriage can be stopped when descending a hill, should the necessity arise for so doing. And when it is considered that the precipitous slopes of the Alps are daily traversed at a trot by this contrivance, it may readily be perceived in how many cases it is not only a means of convenience (being worked by a driver), but of necessity for the safety of a journey.

It is a source of regret that public carriages were unrepresented in 1865; at the last Dublin exhibition, 1853, one of Mr. Bianconi's compact and inexpensive four-wheel outside cars was shown, than which contrivance few are more suitable for conveying a large number of passengers on a minimum weight of carriage. Though somewhat unsuitable as regards shelter in bad weather, they possess many advantages over the conveyances known in London and elsewhere as omnibuses. The weight was kept low, thereby affording safety in case of collision or breakage of any part, and the seats being low, were easily accessible for passengers to mount and alight quickly. If the passengers got wet, they at least had what is of infinite importance to human beings—fresh air. These conveyances have been copied and used with much success on the temporary railway annually laid down at the volunteers' camp at Wimbledon. As regards omnibuses, the chief defect is the wretched ventilation for the inside passengers, and the difficult and dangerous means of access for the outsiders. If it were known how much ill-health and pain were caused by inattention to these matters, all persons who cannot afford to keep private carriages of their own would feel interested in having them improved.

The interiors of omnibuses are, in fact, "hot-air baths," in which heat and foul air are generated to a most injurious



extent. Thousands of business men of London pass daily an hour of their lives in this pernicious atmosphere, and the medical men of London could probably account for much of the low state of health of many of their patients from this cause. The means of ventilation are most simple, and police regulations should enforce their adoption in all this class of public carriages. The mere passing of the carriage through the air creates a current, and were openings made, front and back, allowing a stream of fresh air to pass along the inside of the roof, taking care that the current is led upward, and not to the faces and necks of passengers, the arrangement would be a great public benefit; fresh air might also be easily admitted under the seats. The outside passengers deserve more consideration than they get as regards their safety; many a sprained joint and injured limb is due to the defective arrangement of steps to mount and descend; and seeing that such passengers afford a large profit to the owners, they should receive that which is so essential to their comfort and safety. The introduction of the French plan of suspension is at last being adopted, much to the comfort of all omnibus riders in London, who, at least, should ride on as good springs as their Parisian friends and allies.

There seems to be at all industrial exhibitions a backwardness in sending public carriages for inspection and competition for prizes, probably from their solid and comparatively rough finish not being considered sufficiently attractive; it is, therefore, very desirable that such vehicles should be represented, the general public being deeply interested in their improvement. It is even worth a consideration if, in such cases, it would not be politic to offer one or more special prizes at future exhibitions, in order to attract exhibitors in this particular trade, for it is in reality a trade almost distinct from coach-making as generally understood. It is not usually desirable to interfere with the course of trade; but when public interests are neglected and thereby suffer, it is desirable to recall public attention to its wants, and bring out men from the crowd who have intelligence and energy to meet such cases.

In support of the preceding remarks, the "Instructions from the Council of Chairmen to the Carriage Jury," in 1851, expressly directed their attention to "carriages for the public service" (*Official Reports*, page 192). As His Royal Highness, the late Prince Consort, had so much to do in the general scheme of that exhibition, if the special direction did not emanate from him, it may reasonably be supposed that he approved it, and that the comfort and convenience of carriages for the public service was by him considered to be of importance. Not only did he personally direct the construction of some of the carriages made for Her Majesty, but, in his wide and thoughtful care, he desired that the public should have the benefit of improved and more suitable conveyances.

## PICTURES FROM POMPEII.

### FIRST ARTICLE.

FORTUNATELY for mankind, art has presented us with the outlines of the artisan's ingenuity, in spite of the destroyer Time. This fact is strikingly illustrated in the histories of Pompeii and Herculaneum. These cities

were overthrown by an extraordinary eruption of Vesuvius, in Anno Domini 79, burying them several feet beneath a covering of stones, cinders, and ashes. In this condition they were hidden for many centuries. Meanwhile, art as well as nature was undergoing change, over and around the buried sleepers of a former age. Pliny, to whose pen we are indebted for a detailed description of the eruption of the first century, has left us a mournful history of its effect. Our object, chiefly, is to present the reader with a series of drawings from the frescoed walls of exhumed Pompeii, in doing which, we hope to throw additional light on the carriage-maker's art, as practised in that unfortunate city. These designs have been copied from a very rare and costly work, published at the expense of the French Government.

Apprising the reader that we have already given several specimens of these pictures in the Fifth Volume of this Magazine, we now introduce to notice (Fig. 1.) a grotesque design of a racing chariot. To produce this

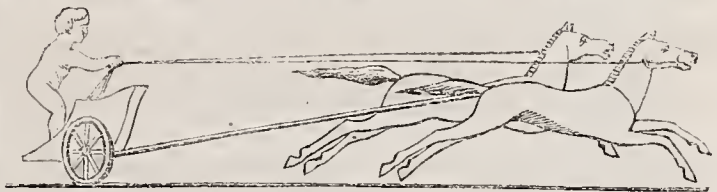

FIG. 1.

the more effectually, the artist appears to have exhausted his ingenuity, in order to provoke the laughter of the beholder. Every line in the picture is in direct opposition to the rules of perspective. An extravagantly long draught-pole, to which the long-legged animals are hitched, suggest difficulties in the way of such a team ever winning a race. Indeed, the design of the artist in executing these pictures, appears to be an attempt to illustrate various phases of married life. This we intend to point out as we proceed with the series.

In the next figure, we have a very interesting illustration of the matrimonial state, as in certain cases exemplified among other nations, as well as among the Pompeians. In the picture we find a lion and a tiger both

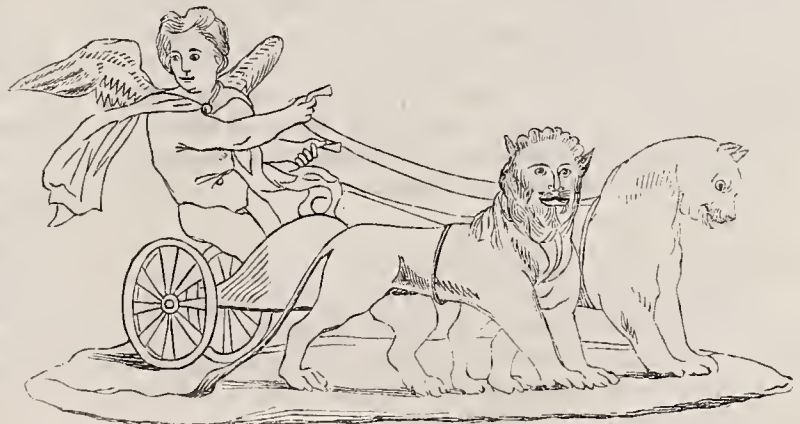

FIG. 2.

yoked together in the same chariot, with a winged cupid as driver. We may readily see that his is no very pleasant task. Indeed, notwithstanding the firm foothold provided for him by an ingenious placement of the axles and wheels at the rear end of the car, we imagine, that with such a singular team to drive, his skill will be sorely taxed. The lion is supposed to represent the



male, and the tiger the female. They both act out their natures on the start—aye, before starting—and it is very evident that with this pair “love will never run smooth.” In the male representative’s countenance we see pictured defiance, in that of the female, self-will. The one intends to lead, the other not to be led—a pretty yoke of contraries—the result is soon shown.

As to the model of this chariot, it is unique, unlike anything we have ever seen, certainly very much like the draught-team in character, faulty. In some circumstances this might be considered a great defect; in the present instance it speaks volumes in favor of the artist’s intelligence and skill, proof that, before painting, he had studied and understood his subject well. It is characteristic throughout.

### AMERICAN DICTIONARY FOR COACH-MAKERS.

(Continued from page 102.)

#### R.

- Rabbet.** (French, *rebattre*.) The channel *plowed* with a plane in the edge of a board, to receive the grooved edge of another board, thus forming a joint in architecture.
- RAISER OR RISER.** The blocks, or strips of wood under seats, &c., to raise them higher than the sides of the body proper. They are sometimes used for other purposes in carriages.
- ROCKAWAY.** A term peculiarly American, applied to certain classes of vehicles of light construction carrying four or more passengers. The name appears to have been given in consequence of their popularity at a celebrated watering place on Long Island, in the vicinity of New York city.
- ROCKERS.** The flat pieces of timber fixed within the bottomside, on which the bottom boards are nailed, for the purpose of sinking the bottom, to give more height within the body.—*Felton*. These are frequently termed the sunken-bottom, in this country.
- ROLLERS.** See CURTAIN ROLLERS, p. 38, *ante*.
- ROOF-RAILS, OR CURVES.** The framings of standing-top bodies, supporting the roof, and to which it is nailed.
- ROSES.** A small trimming, through which the head holders were formerly fixed. Tufts, which see.
- ROUND ROBBINS.** Broad rims (bands) fixed to the ends of the axle-tree bed, to cover the back of the fore-wheel, and for preventing dirt falling in to injure the arms of the axle-tree.—*Felton*.

#### S.

- SADDLE-CLIP.** The technical name for a peculiarly-formed clip used in securing the back springs of buggies, &c., to the back axle-tree. A patented article.
- SAFETY BRACES.** Braces so adjusted as to support the body of such carriages as were formerly hung upon braces, in case the latter broke.
- SALISBURY BOOT.** A box of a peculiar construction placed under the dickey-seat of pleasure carriages, in imitation of those originally used in Salisbury, England, to post-coaches; used now only in aristocratic coaches.
- SAND-BANDS.** Bands driven in or secured by screws to the back ends of hubs, and projecting over the ends of the axle-beds, to protect the axles against sand and dust.

**SAND-PAPER.** Paper on which sand is secured by glueing.

**SASH-HOLDERS.** Leather or lace loops for raising the window-sashes.

**SCREW-BOLT.** A bolt used without a nut, on the end of which a suitable thread is cut, to hold in the wood, into which it is turned.

**SCREWING UP.** Turning up, or tightening such nuts as by usage have become LOOSE in a carriage. Technical.

**SCRIMS.** A thin, sleezy kind of linen fabric, used for glueing to the inside of thin carriage-panels in order to strengthen them and prevent splitting.

**SCROLL.** (Fr. *ecroul*.) Spiral or convolved ornaments formed on the ends of bars, beds, &c., for carriages.

**SEAMING LACE.** The narrow lace to which the linings are stitched or seamed. It is distinguished from “pasting lace” in that it is woven with two selvages, instead of one. A round lace which is sewed in the corners and round the edges of the linings. *Felton*, vol. 1, p. 142.

**SEAT-BOARDS.** The boards forming the seat on which the cushions rest.

**SEAT-BOX.** A box formed of the space under the seat for storing luggage, &c. Formerly it was usually made to slide in and out.

**SEAT-FALL.** The cloth or other material placed in front of the seat in trimming, which, being ornamented with lace or other devices, completes the finish.

**SEAT-IRONS.** Irons used as strengtheners to the joints or other portions of a seat.

**SEAT-RAILS.** This term formerly meant the frame-work on which the seat-boards were nailed. In America the word is applied to the top rails of stick seats, &c.

**SEAT-ROLLS.** Strips of cloth, inclosing a cord or other substance, nailed along the edges of seats, to keep the cushions in position.

**SEAT-STICKS, OR SPINDLES.** Turned sticks for *open* seats.

**SEAT-STRAPS.** Straps for securing cushions. Cushion straps.

**SHAFTS, OR THILLS.** The timbers between which the horse travels singly. It is derived from the Saxon word *scaeft*, to extend.

**SHAFT-JACKS.** Irons employed to couple the shafts to the front axles of carriages.

**SHAFT-T'S.** The bracing irons on the under side of the shaft and bar to strengthen the joint.

**SHAFT-TIPS.** Irons let on the small ends or tips of shafts to protect them against injury.

**SILLS.** The foundation timbers in the carriage body.

**SLATS.** Thin pieces of timber up and down the sides or across the bottoms of wagon bodies; also, the roof-rails.

**SLAT-IRONS.** The irons that secure falling-tops to the pivot on which the bows hinge.

**SLIDES.** Fixtures of bone or ivory, intended to prevent the wear of the hinges in raising or lowering door windows.

**SLEIGH.** The American term for sledge. A runner vehicle for carrying passengers and goods on snow or ice.

**SLIDING SEAT.** Seats which slide in changing position. Formerly, according to *Felton*, “a seat, which occasionally moves higher or lower, to accommodate ladies in their head-dress; also, a small seat that draws out to accommodate a third person to sit in.” To properly appreciate the necessity of the sliding-





VIEW OF THE OWL-CREEK TIRE-SETTING COMPANY'S ESTABLISHMENT.

seat the reader has only to look at the fashions of the eighteenth century, as shown in *The Saturday Magazine*, vol. xiv., p. 81. The wonder is that the seats of carriages were ever put *low* enough to admit such *high* heads.

**SCROLL SPRINGS.** Springs, the ends of which are bent in the form of a scroll.

**SOCIABLE.** (Fr. *vis à vis*.) A vehicle so contrived as to seat the passengers face to face for social conversation.

**SPEAKING TUBES.** An India-rubber hollow tube employed to facilitate conversation between the passenger inside the coach and the coachman on the box or seat outside.

**SPINDLES.** See Seat-sticks, *ante*.

**SPLINTER-BAR.** The cross-bar, to which a pair of horses are hitched in drawing the heavier carriages, such as coaches, caleches, &c. Webster improperly tells us that it is the "cross-bar in a coach which supports the springs," which proves that even learned men sometimes exhibit much ignorance on certain subjects.

**SPLINTER-BAR SOCKETS, OR FERRULES.** The iron bands for the ends of a splinter-bar.

**SPLINTER-BAR ROLLER-BOLTS.** Bolts with large heads, through a roller and the splinter-bar, around which the traces *loop*, or are fastened for drawing the vehicle.

**SHACKLE.** Sax. *sceacul*.) Iron loops at the ends of springs to allow of greater freedom in operation, or to receive a brace from a body-loop.

**SPOKES.** The timber braces radiating from the hub [nave] of a wheel, and supporting the fellys or rim.

#### WATER-CURE INSTITUTION FOR LOOSE TIRES.

MR. EDITOR: Knowing that you feel a deep interest in all improvements relating to carriage-making, I take the liberty of sending you a few particulars of what is doing in this community. You will see by the sketch herewith inclosed, that a *one-horse idea* has been *expanded* into a mammoth concern. The patrons of this establishment are some of the most *enterprising* land-owners hereabouts. The *runners* inform the public that theirs is not only *the cheapest*, but likewise *the tightest*, possible way in which loose tires may be *cured*. How *the greenies* have been influenced by this doctrine may be inferred from the large amount of business so graphically shown in the drawing. Our carriage-making friends may judge from this that one of their most profitable sources of income—that of setting tires—is in danger of being curtailed.

A FRIEND OF PROGRESS.

OWL-CREEK, Jan. 10, 1866.

#### EFFECTS WHICH DIFFERENT SHAPED RIMS (TIRES) HAVE ON ROADS.

BY ALEXANDER CUMMINGS, ESQ., F. R. S.

*Continued from page 100.*

WHEN the roads are moist, pliant, and compressible, the effect of the *conical rim* is altered, but is not less destructive. On the approach of wet seasons the body of pulverized matter which lies upon the more solid gravel, and which supports the wheels, is soon fixed by water, and forms a body of sludge which excludes air and keeps the roads in a constant state of moisture. This



calamity soon renders the road so moist and pliant that the pressure of a heavy wagon-wheel will make the whole breadth of its *conical rim* to apply flatly, and bears hard upon the more solid materials which lie under the sludge, the parts of which, being now in a state more susceptible of altering their relative positions, comply with the motion of such parts of the wheel as immediately press upon them, and the relative situations of the parts that form the crust of the road are as much altered among themselves as the velocity of the parts of the rim differ from each other; and thus all former connection is destroyed, induration is prevented, and the materials which form the crust of the road are left in a broken unconnected state, ready to imbibe the water which the sludge on its surface supplies constantly and abundantly; and by this means the most destructive effects of wet seasons and subsequent hard frosts are introduced in a manner as destructive as certain, as it is deeply concealed from observation. How different is this from the consolidating effects of cylindrical rims under the same circumstances.

In rolling on paved streets nothing can be conceived more calculated for their destruction than the conical rim of a broad wheel. Let us suppose the largest part of the circumference of the broad wheel of a wagon to bear upon one stone of the pavement, and the smallest part of it upon the adjoining stone. The one will be pushed backward, and the other dragged forward, by force of the horses that draw the carriage, and if the force is sufficient to open the joint between them so as to admit water, the mischief is done. A wet joint will imbibe more water, and this softening the gravel in which the paving is laid, it becomes less able to resist the next effort. Thereupon the joint gets more loose, and admits sufficient water to float and transport the gravel; and thus ultimately the whole road paving is undermined, and the streets are furnished with that copious supply of ever-increasing soil which is always seen after heavy rains. This effect of conical wheels acts in so latent a manner that it appears to have totally escaped notice; but the cylindrical rim will not only prevent all this mischief, but will also improve the streets, by producing the effect of the rammer wherever the wheel passes.

Several other disadvantages of less importance attach to the conical rim. A constant divergency from the rectilinear direction causes the wheel to press continually against the linchpin, and also causes it to fly off the axis when the linchpin is lost or broken. The same divergency occasions a twisting in the nave on the axis, which increases friction. And if the box is gulled or badly fitted on the axis, it will occasion the hind part of the wheels in running to be closer each to each than the front portions. The effect of this is to make the rims of the wheels rub hard against the *inside* (inside here means the side next the carriage) of deep ruts, and throw up much dirt toward the middle of the road. All this greatly obstructs the progress of the carriage, and increases the labor of the cattle. Not one of these inconveniences attaches to the cylindrical wheel.

It may be thought extraordinary that no good qualities should here have been imputed to the conical shape of the wheel, since it has been sanctioned by custom for so many years; but if any advantages do belong to it, beyond the *flat bearing of its whole width*, the author of this essay has not been so fortunate as to discover them. He will, in a subsequent part, attempt to show the rea-

sons that first introduced them, and that first occasioned the preference so long and so unjustly bestowed upon them. Here such an exposition would divert the attention from what is of more moment to the immediate inquiry.

Let us then, to assist the memory and to bring the comparative merits of cylindrical and conical rims into one point of view, briefly recapitulate the properties that *inseparably* belong to each. First, of

#### CYLINDRICAL RIMS.

1. Naturally advance in a straight line.
  2. Have no friction or rubbing at the circumference.
  3. No rubbing against the sides of deep ruts.
  4. No throwing up of dirt by the hind part of the wheel.
  5. Do not increase friction on the axis.
  6. Have no pressure against the linchpin.
  7. The only resistance to their rolling in a straight line is from compressing, smoothing, and leveling the substances on which they roll.
  8. They have no tendency to displace, derange, break the texture of, or retard the concretion or induration of the parts on which they roll.
  9. Their frequent rolling on compressible substances renders them more compact, smooth, hard, and impervious to water, and leaves them in a state more favorable to concretion and induration; and, by keeping the *interior* and softer parts dry, they are better enabled to resist violence, and to support the crust that protects them.
  10. They have no tendency to open the joints in paved streets, but, on the contrary, to improve them, by producing the effect of ramming the stones over which they pass by the *dead pressure* produced by the uniform velocity of all the parts.
  11. And they advance in a *straight course* with the least possible resistance, and with advantages superior to any other possible shape.
  12. They serve equally to improve the roads, to relieve the cattle, and to preserve the tires of the wheels.
- And all these properties are as peculiar to and inseparable from the cylindrical shape as they are favorable to the roads and to the cattle.*

#### CONICAL RIMS.

1. They naturally roll in a circular direction round their conical center.
2. A constant force is required to confine them to a straight course.
3. When constrained to move in a straight direction, a rubbing and a friction takes place at the rim.
4. They increase friction on the axis.
5. They occasion a rubbing against the sides of deep ruts.
6. And a throwing up of dirt from the hind part of the wheel.
7. In dry weather they pulverize the best materials.
8. Which occasions much sludge in wet seasons and much dirt in dry.
9. In a compressible state of the roads they derange and break the texture of the parts, and leave them in a broken state ready to imbibe water; and thereby are introduced all the ruinously bad effects upon roads of wet seasons and severe frosts.
10. They promote the destruction of paved streets and causeways, by forcing open the joints and admitting



water under the stones, which ultimately floats and discharges the gravel, loosens the stones, and sinks the pavements into holes.

11. They increase the labor of the cattle.

12. And promote the wearing of the tires of the wheels by their constant dragging and grinding on the roads, none of which take place with the cylindrical wheels.

*Such are the effects that unavoidably arise from the conical shape, and they seem as much calculated for the destruction of the roads as those of the cylindrical wheels are for their preservation and improvement.*

In the preceding essay the effects of such wheels only as have an equal bearing of their whole width have been considered, as all the laws that have been made for regulating the breadth of wheels by the weight of the loaded carriage have supposed and intended that all the wheels should have; but, as various means have been devised to evade these wise regulations of the Legislature, by using wheels that have not an equal bearing of their whole width, the object of the following observations and experiments is to show in what manner such wheels as bear only a narrow part of a broad rim operate to the destruction of the roads, and to the manifest disadvantage of those who persist in using them.

#### *Observations on High Roads.*

If earth, sand, gravel, or any other material, or combination of materials of which roads are usually made, be laid on a flat pavement to the depth of some inches, and confined at the sides so as to be of a regular and equal breadth and depth, and of some considerable length; if the boards or other substance by which the sides are confined be removed, and a flat wheel of the whole breadth of the bed or stratum of materials, be made to roll on it lengthways, the pressure of the wheel will not only consolidate such parts as remain immediately under its track, but will also distend and spread a part of the materials to each side of the wheel, when it meets with no lateral resistance, and by this means a part of the compressive force of the wheel is lost in forcing the materials *sideways* from under it.

If a wheel that is quite flat, and bears equally on its whole width, has this tendency of forcing the materials sideways, a wheel that is roundish across the fellys, or that has a high *streak* in the middle, must have a much greater tendency to spread or force them *sideways* from under the pressure of the wheel.

This lateral motion of the materials is always the greatest on that side where it meets the least resistance, and the resistance will be the least on that side where there is the highest body of materials; and although this lateral motion of the materials in the road is not discernible to the eye, its effects become evident from the shape into which convex roads wear by frequent and long usage. Convex roads become flat or hollow in the middle, and swell towards the sides. Although, in repairing, the ballast is always laid in the middle, it is soon found to have shifted to the sides and the extremities.

But, in order to comprehend more clearly the manner in which this lateral motion takes place by wheels of an improper shape, and more especially on convex roads, where the resistance is always less toward the sides than toward the middle, let us suppose a wheel whose circumference of fellys are sloped off on each side, so as to

form a right angle, or square with each other at the lowest point, or sole of the felly. If this wheel be made to roll on a flat impenetrable pavement, it will only bear on a point, and move with the least possible resistance. But, on substances that yield with pressure, it acts like a wedge, penetrates deeper than a flat wheel of the same breadth, and partakes of the friction of a double cone, and its pressure tends as much to force the substance on which it acts *sideways*, as to compress them downwards; and this *lateral action taking place under the crust or surface*, tends to blow up the crust of the road on both sides the wheel as far its pressure extends; and, although no wheels are made exactly of this shape, every wheel that has not an equal bearing of its whole width partakes of this destructive effect, more or less, in proportion as it deviates from a flat smooth circumference.

The conical broad wheel, rounded across the fellys, or that has a high streak in the middle, adds this *lateral pressure* to the evils that are inseparable from the conical shape. The one forces up the crust, the other grinds the hardest materials. No rate of toll can compensate for the damage they do to the roads; and it is to be remembered, that in all cases the *immediate* increase of exertion required of the cattle is in proportion to the damage done to the road; and as even a heavy carriage with wheels of this description that travels the road, renders it worse for the vehicle which follows it, how much it would be to the interest of all to use no other wheels than those which improve the roads!

We now come to apply these preliminary observations in determining the most advantageous form of road (so far only as regards the effect of carriages upon them). As such ample information on this point and every other matter regarding the laying out, making, repairing, and managing roads, has been given in various communications to the Board of Agriculture, I should be precluded from any further observations on the subject, did not an earnest desire of contributing to so important an object of public improvement demand every exertion and supersede every other consideration.

*Convex or barrelled roads* have been generally preferred to the present time for several reasons. First, they are supposed to lie drier than flat roads, from the declivity on each side giving a greater current to the water than could be obtained if carried in the direction of the road. Secondly, as its *external form* resembles an arch, it is supposed to partake of the same property of sustaining pressure more thoroughly than any other form of sustaining structure. But it must be remembered that if the abutments, which sustain the lateral pressure and prevent the extension of the best constructed arch, give way, it will no longer sustain its own weight. If then, the *convex road* be less calculated to resist the *lateral pressure* already described, and to prevent the extension or spreading of the materials, it can derive no advantage from its apparent affinity to the arch. The advantage of carrying off the water toward the sides is obvious, when the roads are just finished, and have their surface of that perfect smooth form which the theory always supposes them to have; but so soon as any ruts are formed they obstruct the running of the water towards the sides, and retain or conduct it longitudinally on the road, contrary to the original intention; and, as no proper means have been used in the formation of roads to carry off the water from those ruts, it remains in them, and is mixed deeper



and deeper with the materials of the road by every wheel which passes, till at last the hard protecting crust is worn through.

(To be continued.)

## Home Circle.

### WE SHALL MEET IN HEAVEN.

BY ROSETTE ANNIE ROSE.

We shall meet in Heaven  
When this life is o'er;  
When our Father calls us  
To the Heavenly shore,  
Where the waters glisten  
With the golden light,  
Shining from the glories  
Hid from mortal sight.

We shall meet in Heaven  
Friends that we have lost;  
Friends, who in life's morning,  
O'er death's river crossed;  
We shall hear the music  
Of the angel band;  
We shall see the beauty  
Of the Heavenly land.

We shall meet in Heaven!  
O what joys untold  
Shall we feel when wandering  
Through the streets of gold.  
There no cares can enter;  
There no sin can come;  
Perfect bliss reigns ever  
In that Heavenly home.

We shall meet in Heaven!  
Let the blessed thought  
Make our spirits stronger—  
Make our fears forgot.  
'Tis not long we'll linger  
On this earthly shore;  
Soon we'll meet in Heaven,  
Meet to part no more.

### NATURAL HISTORY OF BABIES.

BABIES are of two kinds—male and female—and are usually put up in a package of one, though sometimes of two, in which case they are called twins, when nearly of the same age. They are not confined to any particular locality, but are found plentifully distributed over all parts of the inhabited countries. Their ages are various and have a wide range. We have known them as young as it is easy to calculate time on a watch dial, and then again we have seen them where they have acquired the healthy age of twenty-five, with a fair prospect of advancing still further in babyhood. Their weight depends a great deal on their heft; but as they have twenty-one years to grow in before it costs them anything, it don't matter so much how big they happen to be when they commence.

Probably babies have more pet names than any other known article of their size. In the tender years of their life—say the first two—they are lovingly addressed by such endearing names as Old Beautiful, Sweetness, Honeycomb, Him Darling, Papa's Hope, Old Blessed, Mamma's Joy, and hundreds of other appellations which we could never translate.

For several years, until they get old enough to play out of doors and soil their faces, their lives are one long

continuous game of Copenhagen, everybody laboring under the delusion that all babies are good for is to kiss, consequently to see one is to kiss it. We cannot recollect of ever finding ourself in the presence of a baby but what the fond mother would say to it, "Now be a good little deary, and give gentleman a nice sweet kiss."

The monotony of babies' lives is varied by such little incidents as an attack of the measles, mumps, or croup, and we would not neglect to speak of cutting teeth. A baby that has got safely through all these infantile troubles is considered worth some seventy-five dollars more than one who has them in prospect. The diseases are, however, easily treated, and, in a case of measles, all that is necessary is to have them "break out" well, and to see that they don't "strike in." With mumps, just let them "mump" round a day or two, and they will come out all right. With the croup it is necessary to "strike ile," generally "goose ile," and, if applied in season, 'twill soon lubricate the throat without much trouble. Cutting teeth runs longer than either of the other diseases, yet, by a timely investment in a rubber ring and rattle you get rid of a doctor's bill. When we were young we cut our teeth on a silver dollar; but as dollars are now made of paper, they wont stand the wear and tear of a whole set of teeth, and 'tis cheaper in the end to invest in the rubber ring.

Learning to walk and talk are two achievements about which too much cannot be said. The walking, though, is a mere nothing compared to talking, yet is more dangerous, and accidents oftener occur; still they usually acquire the art with the necessary breaking of some furniture, which they frantically clutch at in order to save a fall. During the season of practicing nothing can drop in the house, or the least noise be made, but what mother will drop whatever she has in her hand and cry out, "There goes Willie! what has he done now?" and rush to the scene of action, to find, perhaps, a flowerpot on the floor, and Willie engaged in scattering the contents about the room. After clearing up the debris mother returns to her work, thanking her stars that it was only a choice verbena that was ruined, and not Willie's neck.

Their conversation, in the beginning, is a little difficult to understand. They abbreviate a great deal, and throw aside all pronouns as perfectly useless. Listening to their talk is like attending an Italian opera; one hears the noise but cannot understand what it means. The first "papa" or "mamma," distinctly spoken, is worth five dollars to either of those delighted parents. Babies must not only talk themselves, but must be talked to, and the amount of baby-talk used in a common-sized family is prodigious. Baby's appearance opens a new field to all. The old hands who have seen babies before converse in the language quite fluently, but 'tis ludicrous to hear a beginner undertake to master this difficult tongue. Talking baby-talk is an art which few ever acquire to perfection, though by constant practice the most stupid can partially acquire it; yet it takes two or three generations of babies to make a perfect linguist.

The effect a baby produces on a family, no matter how sober said family may be, is wonderful to behold. It completely turns the heads of all. If any one in particular behave more insanely, or is carried away more than the rest, we think grandma will bear off the palm. We think the mother acts the most sensibly, though even she has her failings and weak points in regard to baby, and



will occasionally exhibit a trace of insanity when dilating upon his charms and accomplishments.

The effect on babies of the law of progression is self-evident. No one ever knew of a baby inferior to any other preceding baby. On the contrary, each one is a little in advance of any yet born; and when we think of the vast number yet to be, and how every one will be a trifle superior to its predecessor, what a glorious future awaits us! We shall eventually reach perfection. How can those persons who believe that we retrograde, instead of progress, reconcile this fact with their absurd theory?

Some people, a little enthusiastic, look upon a baby as "a thing of beauty and a joy forever." Now we have seen some whom we thought had a liberal discount on their beauty, and their "joy forever" would quickly vanish on having it commence to cry and refuse to be comforted when left in our charge, and we busily engaged in reading or writing.

It must be comforting to a man, no matter how ugly or despised he may be, to think that he was once a baby, beloved by a large circle of relatives and friends. It is a comfort we would not deny him. There are quite a number of this world's people who were not lovely babies a great while; quite early in life they arrived at years when people ceased to love them, and have never been babies since.

Babies resemble wheat in many respects. Firstly, neither are good for much till they arrive at maturity; secondly, both are *bred* in the house, and also the *flower* of the family; thirdly, both have to be *cradled*; fourthly, both are generally well *thrashed* before they are done with.

## Pen Illustrations of the Drafts.

### SKELETON FRONT COUPÉ.

*Illustrated on Plate XXXII.*

WE feel great satisfaction in presenting this original design for a coupé to our readers. Our artist has done himself credit in the execution of the details. The novelty in this case consists in the peculiar construction of the front, which we have called "skeleton," in deference to its lightness. Wheels, 3 ft. 2 in. and 3 ft. 6 in.; hubs, 5 × 7½ in.; spokes, 1⅓ in.; felloes, 1¼ × 1¼.

### PHYSICIAN'S PHAETON.

*Illustrated on Plate XXXIII.*

THIS is an original drawing, differing in several particulars from the one given on Plate XXV. of this volume. Not only does it differ in the quarters, but the body is made with round back corners, which, while it affords ample room for the seat, gives to the job a light form. Wheels, 4 ft. 2 in. and 3 ft. 6 in. high.

### BRACKET-FRONT BUGGY.

*Illustrated on Plate XXXIV.*

A NEW contributor favors us with this drawing. We hope to be remembered by him often hereafter. There are several points in this design worthy of notice. The

connection of the pillar with the bracket toe-board is quite novel. The cut-under in this job is not only required to make room for shorter turning in narrow streets, but necessary to impart a lighter look to the side panel. Indeed, these two requisites are happily combined in this ingenious arrangement; and in our reflections we are led to wonder why this thing was not done years ago. Upon the whole, we think that our readers will, with us, pronounce this a very pretty vehicle.

## Sparks from the Anvil.

### STEEL, AND THE BESSEMER PROCESS.

From a paper read by Mr. A. L. Holley, before the Polytechnic Association of the American Institute, on October 12th, 1865.

*(Continued from page 122.)*

THE ladle is mounted on a crane, which allows it to move up and down and to swing round in a fixed circle, that is, to swing under the converter to catch the steel, and then to be hoisted and moved over the ingot molds in succession. The process is as follows:—Two tons of pig-iron are melted in the large furnace—time one hour and a half; meanwhile the converter has a fire made in it, and two or three pounds per square inch pressure of blast let in, to heat the lining red hot, and the ladle is turned bottom upward over a little furnace, to heat. By means of another crane the ingot molds are also ranged in the pit in a half circle, so that the ladle can swing over them. When the iron in the large furnace is nearly melted, a small quantity of pig-iron or other recarbonizer is set to melting in the small furnace. When the iron in the large furnace is melted, the converting vessel is turned on its axes, spout downward, and the coal emptied out. It is then turned into a horizontal position, and an iron trough, lined with loam, suspended on rollers, is swung one end into the mouth of the vessel, and the other under a spout leading to the tap-hole of the furnace. The furnace is then tapped, and the iron runs through the channel thus formed into the converting vessel. The air blast is then let on, and the vessel turned spout upward, the tuyeres or air passages thus being underneath the melted cast-iron. The air is blown up through the cast-iron at about fifteen pounds pressure per square inch. Combustion, first of oxygen and silex, and then of oxygen and carbon, and a violent boiling, at once ensue. In from six to ten minutes, the flame, blowing out of the mouth of the converter into the chimney, changes from a dull red, full of sparks, to an intense white, with splashes of cinder. After five to ten minutes more, the flame gets thinner, shows purple streaks, and finally drops away, not entirely, but very obviously, to the practiced eye. At this instant the metal is entirely decarbonized. More air blown in would begin to burn the iron itself. At this instant, then, which is so clearly defined that a dozen men, tolerably familiar with the process, would cry "stop" at the same second, the converter is turned down into a horizontal position, and the air blast shut off. The recarbonizer from the little furnace is then run into the converter by the same means, thus restoring to the metal the exact quantity of carbon, silicium, and manganese, or its substi-



tute, required—the liquid cast-iron being only the vehicle for conveying these ingredients. The chemical mixture of the recarbonizer with the decarbonized iron is complete and almost instantaneous. It causes a momentary boiling of the mass in the converter.

The ladle is then swung under the mouth of the converter, and, the latter being lowered, the steel pours out into the ladle. While the ladle is being raised over the ingot molds, the mouth of the converter is still further lowered to let the slag run out. Some of the slag runs out with the steel, and forms a coating over it in the ladle, thus keeping it hot. The slag consists of such impurities of the iron as have not passed off in a gaseous form.

The ladle is then moved over the tops of the molds successively, and the steel let into them by the stopper and lever above mentioned. When a mold is full, a plate of thin sheet-iron is laid on the top of the steel, then a shovelful of sand, then a thick plate which is wedged down. In ten to sixty minutes, depending upon their weight, the ingots, still red hot, are removed from the molds, and may be hammered or rolled into rails, plate, shafting, or other forms, without reheating, except to warm the exterior, chilled by the molds. Usually the ingots are allowed to cool before hammering; this cooling changes their crystallization and improves their ductility. The ingot molds are usually of cast-iron, from two to three inches thick. Some of them are solid, and widest at the bottom, so that the ingot will slip out there. Others are made in two halves, held together by hoops, and are taken apart to let the ingot out.

Ingot are cast in the forms most convenient for hammering or rolling into the desired shapes, and of all weights, from 100 to 5,000 pounds. The loss of iron in the whole process is from 12 to 18 per cent.

Such are the machinery and the process as put in operation by Messrs. Winslow, Griswold & Holley, at Troy, N. Y., early in the present year, and by which the specimens of steel recently on exhibition by them at the Fair of the Institute were produced. The product is 10 to 12 tons per 24 hours. Early next year, this firm will have in operation a new work capable of turning out 50 tons of ingots per 24 hours. A brief description of these new works, now partially completed, may be of interest. The converting house is a building 110 feet long by 70 feet wide, with walls 22½ feet high and a ventilated roof. About 15 feet from one side of the building, and 15 feet apart, are two converting vessels, 14 feet high and 9 feet in diameter, suspended on trunnions. The outer trunnions, and the frames and standards supporting them, are hollow, and conduct air from the blowing engine to the tuyere boxes. Upon each inner trunnion is a pinion of 3 feet diameter and 12-inch face, which is operated by a steel rack that forms the piston-rod of a hydraulic cylinder. The converters are thus rotated and held in any position by simply turning a cock. The hoods and chimneys into which the converters discharge are built with the walls of the house. The weight of the converters, including 12-inch lining of refractory material, is 25 tons each. Their capacity is 5 to 7 tons of steel at a charge.

In front of the converters, and arranged to serve them both, is a 15-ton hydraulic crane, with a 14-foot jib, carrying either a 7-ton or a 15-ton ladle, to take the product of one or both converters. This crane is fitted with proper gearing to revolve the ladle in a circle over the ingot

molds, to tip the ladle, and pour from the top in case the fire-clay valve should chill; and to move the ladle radially, so as to pour into an outer and an inner circle of ingot molds. On either side and in front of the ingot pit (which is sunk about 3 feet below the general level) are three 8-ton hydraulic cranes, with 22-foot jibs. These three cranes handle the ingots and molds, and pass the ladles and vessel bottoms from the places where they are used to the places where they are lined, and the ovens where they are heated. These ovens are in the corners of the building, on the same side with the converters. A railway runs in front of the pit, throughout the building, with branches to the coal and iron yards.

The melting house is joined to the main building in the rear of the converters, and is large enough to receive four 5-ton cupolas and four recarbonizing cupolas. A railway runs through the lower story of this building, and the coal and iron cars are lifted from it to the charging floor by another 8-ton hydraulic crane. The melted iron from the cupolas is run into a ladle hung on trunnions, and located on a platform scale, so that it may be exactly weighed and then quickly tipped into a trough which leads it into the converter. The recarbonizing furnaces are similarly arranged.

The hydraulic machinery is driven by a Worthington duplex pump, specially constructed for this purpose.

The blowing engine consists of two 42-inch blowing cylinders and two 36-inch steam cylinders on the same rods, the stroke being 4 feet. The working air-pressure is 25 lbs. per square inch, and the working horse-power 350. The valves of the blowing engine are bands of india-rubber encircling the cylinder and covering and uncovering numerous small holes, thus giving a larger area with little stretching. This kind of valve is durable and noiseless under high pressure. The common flap-valve would obviously be inadequate.

The air is admitted to the converters, and the water to the various hydraulic cylinders and cranes, by cocks and handles situated on an elevated platform, where they may all be worked by a boy. Thus one boy accomplishes the work of *fifty* men.

The pair of vessels of the same size, as arranged in England, will produce only 25 to 30 tons per 24 hours. It has been the object of the writer, in arranging the new works described, to double the production, with a small addition to the cost of plant, and to economize labor and heat by more rapid working.

The first improvement on the English practice was in facilities for repairing the more perishable parts of the converter. The tuyeres endure but 6 or 8 charges. In England they are renewed by knocking them out of their seats from the mouth of the converter by a long rod, putting in new ones from the tuyere-box, and setting them with lining material, made semi-fluid with water, and poured round them from the mouth of the vessel. These wet bottoms are 10 or 12 hours drying, and are not solid when dry. In the works at Troy, the system of duplicate bottoms has been adopted. When the tuyeres are worn out, the whole bottom of the vessel is uncottered, lowered by a hydraulic lift, and removed by a crane for repairs. A duplicate bottom, hot from the oven, and in which tuyeres have been set in dry material and rammed, is by the same means attached to the converter. The vessel, still red-hot, is thus made ready for a new succession of charges in less than an hour.



Further improvements have been made in doubling the capacity of the casting-pit, by causing the ladle to travel over two circles of ingot molds; in the addition of another ingot crane; in making more room, within reach of the cranes, for the repairs of ladle linings, stoppers, nozzles, etc., and in more convenient access to ovens and depositories of fire materials.

But the grand American improvement in the Bessemer process is the adaptation of the cupola for melting the iron. In the reverberators, a pound of best bituminous coal will melt but 2 lbs. of iron. In the cupola, a pound of best anthracite will melt from 7 to 10 lbs. of iron. The sulphur, if any, communicated by melting with best anthracite, has not been discoverable in working some 50 tons of the material into boiler plates, rivets, pistol and rifle steel, and other forms that put its malleability and soundness to the severest tests. The structure and arrangement of the cupola, to better adapt it to this particular service, is the subject of experiments now going on at Troy. It is expected that from 9 to 12 charges of steel, of from 5 to 7 tons each, will be made per day. In the old works 4 charges have been made per 12 hours.

*(To be concluded next month.)*

## Paint Room.

### OIL, AND OIL-CAKE FACTORY, DUBLIN.

*(Concluded from page 123.)*

WE next follow the course of a four-inch pipe leading from the force-pump to a distance of about thirty yards, and entering the roof of a separate building. This is the boiling-house, where "drying" oil is boiled and fined for painters' use. An immense cauldron, holding 1,000 gallons, is filled with the crude oil, which is boiled for about seven hours, and when cold transferred to a sheet-iron tank, the necessary purifying agents being added. In this tank there are three taps at different elevations. The oil becoming clear near the surface first, is drawn off, and after a further settling down, the second tap is used, and finally the sediment is taken away through a tap in the base of the tank. So much care is not taken with the oil sent out from some mills. Manufacturers are not blind to the fact that the less pure, the more weighty the oil, so that the fining down does not occupy much of their attention. During the boiling the oil is kept in constant agitation by means of a shaft turned by a man, who takes up his position in a sort of pigeon-house near the roof outside the building. This precaution is taken in order that the health of the worker may not be affected by the fumes from the oil. The building is also well ventilated from the roof, and is separated by a distance of about 120 feet from any portion of the building. In case of fire, the danger or loss would be confined to the boiling-house.

Having traced the production of the oil cake through the various stages of manufacture to its final distribution to the dealer and consumer, we devote half an hour to a general survey of the storehouse for the oil cake and the lofts where the raw material is housed. But first we are invited to see the large kiln used for drying rapeseed. This is on the same principle as the malting floor at a brewery. Entering a long building of three stories, we are shown piles upon piles of cakes ready for the market. The cakes are laid edgeways, and one row is piled above

another to the ceiling. Each rank holds about 350 cakes, which are calculated to weigh together one ton. Twelve ranks can be accommodated one on the other, so that each complete pile contains say twelve tons. A clear space is left within a center archway, into which the wagons and carts are backed for loading; and, as linseed cake is piled at one end and rapeseed cake at the other, both kinds are easily reached. The floors above are similarly occupied, with the exception of a portion set aside for miscellaneous purposes.

Crossing the court-yard once more, we ascend, by steep and very greasy steps, to the first floor of the main building; and this performance we find requires the powers of a mountebank to accomplish with good grace. Every particle of wood about the immediate neighborhood of the machine-room is so thoroughly saturated with oil that neither the hands nor feet of an inexperienced traveler in these slippery regions will retain their hold. Some portions of the woodwork—such as the railings to the stairs—are dyed a rich, light, glossy, mahogany color, with the oil, and the explorer must ascend several flights of stairs before he escapes the dangerously smooth and narrow passages. But our devotion to the task we have taken in hand carries us in safety from one floor to another, until we reach the summit of the building, and stand on the fifth loft, where we examine the ponderous wheels of the workmen's clock, with the pulleys and ropes that move a minute hand three feet long round a dial six feet in diameter. On each of the floors nothing is to be seen but enormous heaps of seed, some of them receiving additions from the untiring revolutions of the belt and buckets previously described, and others giving out, through well-contrived shoots, gradual supplies to the machinery below. On the first and principal floor, a good-sized sifter, worked by the unseen agency that turns the machinery below, suffers the very extreme of nervous agitation. Through this sieve every grain of seed is made to pass before it enters the mill; and the miscellaneous collection of odds and ends it gathers from what previously appeared to us very clean seed indeed would astonish any one but those who have become accustomed to the sight. Rope ends, morsels of twine, scraps of correspondence in various languages, pieces of wood, small masses of damaged seed, and dust galore. Before commencing our perilous descent, we note down some figures respecting the capacity of the immense rooms we have passed through, and find that they are capable of storing six hundred tons of seed, an amount equal to ten thousand quarters, or eighty thousand bushels. We ponder a while to reduce these figures to amounts representing the manufactured article, and the result of our calculation is five hundred tons of oil and twelve hundred tons of cake. Of course, these store-rooms are not always full; but at the time of our visit there was a very large stock, upon which the workmen were operating most actively.

As we again mount our car, and enter the Park, we pass a row of very neat cottages, occupied exclusively by the workmen belonging to Ashtown Mills, and their families. There is an air of comfort about the dwellings that tells of satisfied occupants, and the occasional remarks let fall by our guide confirm this opinion. Some work by the side of their fathers, who, in their turn, buzzed about the heavy machinery with *their* fathers. Good air and plenty of it, with regular earnings and proper treatment, seems to chain them to the spot. There may be seen one



hale and hearty fellow who has seen ninety-three summers—forty of which were spent on this very estate, and we are assured that he is more active than many average-lived workmen in their prime.

In conclusion, and for the information of dealers, we are glad to be able to remark that, after inspection of the Ashtown Mills, we are satisfied that the best description of raw material is employed—that both the brown and refined rape oil, as well as the linseed and boiled oil, are prepared with the greatest care, and without mixture or adulteration. It is as satisfactory to us, as it no doubt must be to the trade, to know that it is the intention of the new proprietors to sustain the well-earned reputation enjoyed by the founder of these mills. Mr. Hodgson—if we may judge from the present and past position of the firm of McMaster and Hodgson—is not content, like Pughwash, in the "Chronicles of Clovernook," to saunter through life with his hands in his pocket and a daisy in his mouth—dying with just enough in his house to pay the undertaker.—*Oil Trade Review, London.*

### ORIGINAL MONOGRAMS.

*Illustrated on Plate XXXV.*

THE monograms we give this month are the combinations of one who has never before appeared in our columns in this capacity. We trust that they will prove useful to our friends, although not so complicated as some we have published. As we intend to give another plate, from original designs, in this volume—this being the fourth—the present may be accounted an extra installment.

## Trimming Room.

### ABOUT HAMMER-CLOTHS.

MAKING or trimming hammer-cloths is very little practiced among us, for the simple reason that our aristocracy have not yet reached the point which demands such useless gew-gaws as these. It is true that we occasionally see one in the streets, but they are the property of some imported fossil, upon whose carcass republican institutions and customs have no salutary influence. This class of population see nothing worth learning in this busy Union, which they manifest in such disgustful terms that the wonder is they do not leave at once for 'ome. But they do not; consequently we infer that, after all, their preferences are stronger than their prejudices. But we are digressing.

Those who are curious in this matter will find the origin of the word "hammer-cloth" ingeniously discussed on page 107, volume vi., of this work. Our special purpose here is to analyze their construction and examine the material of which they are and have been made. It is undoubtedly true that the original conception of the hammer-cloth originated from the desire for display in heraldic devices, or coats-of-arms. This passion led to the use of the best and most showy textiles which money could purchase, hence, from the very first, very little improvement could be made in richness and show.

The seat, four yards around, required "six breadths of six-quarter broad-cloth, cut in lengths of  $\frac{7}{8}$  or  $\frac{3}{4}$  of a yard," to give the proper fullness when sewed together. The usual six-breadth hammer-cloth took nine yards of each trimming to go around the cloth, and four yards for the

top. In execution of work and beauty of design the modern hammer-cloth is far in the shade when brought by the side of those made a century ago. Then, a hammer-cloth bound top and bottom with a lace two and a-half inches broad, had a row of velvet placed above the fringe, which was bound with narrow lace. A row of velvet was "Vandyked" at the top, and bound in the same way, and a fringe added to the bottom nine inches deep, set off with silk ornaments, which completed the job proper. On the sides or ends of this hammer-cloth was worked the silk-embroidered arms, crests, and "foliage mantles" of the lordly owner, for the admiration of the gaping, cringing multitudes around them.

Among us the ornaments have disappeared, and blue cloth, with modest lace and tassels, are made to do unnecessary duty, where once all was pomp and show. The coat-of-arms—that, too, now hides its diminished features behind a simple monogram, or a plain A. S. S. There we leave the hammer-cloth for the present.

### COLOR vs. TANNIN.

CONCEDING, as all tanners do, the presence of coloring matter and tannin in the usual extract from bark, it may be worth while to press the inquiry a little farther and ascertain the office of each. Do we really comprehend the fact that coloring matter is distinct from tannin? Sometimes I doubt whether tanners really do comprehend this. But it is important that we not only admit the fact, but that we fully realize its significance. For the purpose of coming to a conclusion let me recommend a little experiment as follows: Dissolve, say one pound of glue; make the glue-water as rich (strong) as possible, and then take the same quantity of pure tan liquor; let it be rich both in color and in tannin; precipitate them together, stir them for a moment, then let them stand until the leathery substance all settles to the bottom. If there shall remain an excess of tannin, draw it off and precipitate more glue-water, until the glue is in excess, and then there will remain the coloring matter. Now take this coloring matter and try to tan leather, and then you will, for the first time, comprehend the idea that lies at the bottom of the tanner's art. This coloring matter will color the leather and penetrate the fibers, but it will not combine with the gelatin or glue of the hide. This will be proven by trying it on a piece of sheep or calf-skin parchment. After coloring it will weigh practically the same as before submitted to the process; whereas if put into tan liquor it will increase its weight and expand its fiber and become leather—while in the first case you will have colored parchment—nothing more, nothing less. When this idea is fully understood, one of the causes of the variable gain in weight will be explained. Coloring matter is permitted to do the work of tannin. Then, too, we shall all understand how it is possible to tan leather with almost any vegetable extract—almost any weed will produce a coloring matter—which, with plenty of terra-japonica, will make a very good leather. Hence the thousand-and-one patents on all these plants. Any experiment, however simple, that will convince tanners that coloring matter is not tannin, will do, in my judgment, great service, and lay the foundation of other inquiries which will be valuable. Who can suggest a better practical form than the above? Let him speak.—*Correspondent of the Shoe and Leather Reporter.*



## Editor's Work-bench.

### STOP THEIR MOUTHS.

WE learn, through a creditable channel, that some traveling vagabonds from this quarter are circulating the report through the West, that the publisher of this Magazine has sold himself; in other words, bound himself to the carriage manufacturers of New York city, not to publish anything fashionable which may come out until it becomes a year old, lest, by so doing, injury may result to the trade of the metropolis; and we find there are some individuals silly enough to believe it. A moment's reflection ought to convince any one that all such stories are miserable fabrications. Those who are conversant with the craft and us know that such a collusion as this could not possibly occur. In the first place the principal carriage-makers of this city, to whom we are personally known, are gentlemen of nobler sentiments than to ever ask of us such a thing. In the second place, our own interests are too much involved, and would be seriously jeopardized, were we to enter into such a foolish arrangement. So far from this being true, we fearlessly state, that in several instances we have illustrated the fashions in our pages before they have made their appearance in the streets; and surely nothing new ever presents itself in public without coming under our notice. So far as we know—and we think we ought to know—there is not a carriage-maker here who would object to our publishing anything he might originate, did we but give proper credit therefor. Should any, however, object it would make no difference. This is decidedly an independent journal, and its editor a practical wood-workmen at the trade of forty years' experience, whose eye Prof. Fowler says needs no rule in order to obtain correct measurements. In addition to this—we would modestly mention it—we know it all “like a book;” every measurement and proportion about a carriage, and are thus enabled to furnish our readers with the latest fashions *on sight*. Besides this, we have several attentive friends in other cities who are interested in keeping us posted, but who yet are too modest to have their names emblazoned before the world.

Our patrons may rest satisfied that our heart is bound up in this publication—that our days and nights are given to its interests and theirs—and that no opportunity slips unimproved in gathering for these pages such matter of interest as is in any way calculated to benefit our friends. Indeed, had we not labored—*con amore*—from love of the thing, the past four years, *your Magazine* would now be among the things that were—would not now exist. Having survived the storms of war, it gives us much pleasure to say to our generous friends, that our circulation for the past year has been steadily on the increase, so that to-day we have more than twice the num-

ber of subscribers we had one year ago. Lately we have received subscriptions from many of our old friends, South, to the mutual satisfaction, as we trust, of both parties. The only drawback we have to record is the fact that paper and press-work is excessively dear. Instead of eleven cents we are now paying twenty-eight cents per pound for book-paper, which, as will be readily seen, is far in excess of the rise in our subscription rates. When matters in this respect will improve we know not, but until they do, we must bear and suffer—all, except the lying tongues of these shameless vagabonds, to whom this article chiefly refers. If they do not stop, we intend to publish their names and doings.

### CARRIAGE MUSEUMS.

WHILE almost everything beside has been collected and preserved for the study of the curious, in this country, thus far wheel vehicles appear to have been totally neglected. Why such should be the case we cannot tell. Surely it cannot be for lack of subjects suited to the requirements of such a purpose, for these are found in abundance in almost every city and town of our broad-spread land; nor is it owing to a want of enterprise on the part of the public. We entertain not the least doubt that, was the attention of the wealthier coach-makers called to this matter, and their present indifference disturbed, something might be done in organizing a society having for its object the perfection of this desirable work.

We know of some “old relics,” both American and foreign, quite sufficient with which to begin, and these would serve as the nucleus to others of which we have had reports, that would be secured in time and added to them. This collection need not be confined to old carriages entire, but may be extended so as to embrace improvements in the different parts thereof, including both those covered by patents, and such as have now become the common property of the public from different causes. The utility of such a collection as we have referred to, will not admit of a doubt. It would prove the best school extant for the younger members of the craft to study art in, and beside offer advantages to the older practitioners, such as they have never yet possessed.

A museum of this description has been for some time established in St. Petersburg, Russia, and judging from the accounts we have from that city, is an object of much interest to the citizens as well as strangers visiting it. As we have already printed a detailed description of the building and the contents, in our last volume, we need not here further notice it. In Paris, too, a building has lately been erected, having in view the foundation of a collection of Italian and probably other carriages of the sixteenth century. A few have already been secured to put therein. This question is now being agitated in England, and doubtless, be-



fore long we shall hear that a museum has been formed. Not at all behind the old world in scientific research, why should we remain behind them in this matter; the establishment on a grand scale of an institution alike creditable to the community it is to benefit, and the country it will honor, is demanded by the spirit of the age. Will not some gentlemen of wealth and influence take the initiatory step in this movement? Its situation seems to point to New York as the best location of such a building. We are persuaded it is only to resolve, and the thing will be speedily accomplished.

#### INTERNAL REVENUE DECISIONS.

THE Commissioner of the Internal Revenue has recently decided that "the term 'other articles,' used in the 94th section of the act of March 3, 1865, was clearly intended to include all manufactured articles subject to an excise tax under the several clauses of that section. All goods, wares, merchandise, and articles, therefore, which are subject to an excise duty when manufactured, or made and sold, or consumed, or used, are liable to be assessed for a tax on increased value, when the same are so repaired as to increase their value ten per cent. and upwards. To determine when a tax accrues in case of a repair, three distinct points are to be considered:

*First*—The precise article or thing repaired.

*Second*—The amount of value added.

*Third*—The ratio or per cent. of such added value to the entire value of the article after having been repaired.

"It is clear that the law contemplates levying a tax on the engine, the boiler, the car, the carriage, or other article, whatever it may be, as a unit upon its entire value, though many of the parts which enter into their structure are manufactures in themselves, and a tax may have been paid upon them before they were incorporated into the engine, boiler, car, &c., such as axles, tires, springs, wheels, castings, &c. If any of these parts which the law regards and treats as manufactures in themselves become broken or worn out, and entirely new parts are made and substituted in the places of the old, the broken or worn out parts, such parts are to be taxed as new work, the same when used in repairs as when made for a new car, carriage, boiler, engine, or other article, machine or instrument."

If, then, a carriage-maker makes a new set of wheels, shafts, pole, axles, or body, for an old job, these must be taxed according to the value, as if they were not parts of the carriage, but jobs independent of the other old parts. This is giving a new interpretation to what we have always denominated repairs, and charged for as such. The considering as a unit different parts, as the axles, springs, &c., incorporated in a carriage, and taxing these twice or thrice over, we have never thought the fair thing; but this last attempt of Commissioner Rollins to deprive the poor carriage-maker of all his earnings, is going a little too far for human nature, and calls for a decided remonstrance from the craft. The carriage-making fraternity must possess less selfishness and have more patriotism than any other

class of mechanics, or else long before this they would have clamored at somebody's door so loudly that ere this the burthens which are laid upon *their* industry would long since have been lightened. As long as they stand still, calling upon Jupiter, and not lay *hold of the wheel* in earnest themselves, nothing will be done.

#### ROAD STEAM-CARRIAGE IN INDIA.

A SMALL steam-carriage for ordinary roads has been put in operation in Calcutta. It is built for a private carriage, having ample room for four or five persons in front, and a stoker behind, and is arranged to run at an average speed of ten miles an hour; indeed, on good roads, sixteen miles per hour could easily be attained. The carriage is mounted on three wheels, each having independent springs; the small wheel in front for guiding, and the two behind, one or both of which are used for propelling, one of them being fixed on the shaft, and the other engaged by a clutch, so that, when disengaged, the carriage may turn round in its own length without stopping. It is easily guided by a handle from the fork of the front wheel, which is central with the outside seat. A brake is applied to each driving wheel, worked by a lever from the seat, so that the engine is entirely under the control of the driver.

The engine is built upon a tank, which forms a strong tubular framework, the boiler being placed above; and the whole of the machinery is contained in the space between the boiler and the tank, entirely protected from dust and dirt, and within reach of the stoker for oiling. The tank contains 35 cubic feet, or 210 gallons, which would enable a run of 20 miles to be made without taking in fresh fuel or water. The boiler is made of steel, and so constructed that it is not injuriously affected by variations of level. The diameters of the cylinders are 3½ in.; the length of stroke, 7 in. The diameter of the driving-wheel is 3 ft. 6 in. The number of revolutions is 16 per minute. From a trial made with this carriage it has been pronounced a complete success.

#### LITERARY NOTICES.

EVERY SATURDAY is the expressive name of a weekly journal of choice reading, selected from foreign current literature, containing each week thirty-two large octavo pages, handsomely printed in double columns. This publication "is intended for town and country, for the fireside, the seaside, the railway, and the steamboat. Its plan embraces Incidents of Travel and Adventure; Essays, Critical and Descriptive; Serial Tales; Short Stories; Poems; Biographies; and Literary Intelligence, in connection with judicious selections from the admirable popular papers on science, which are constantly appearing in foreign periodicals." The first number is dated January 6, and the work is published at \$5 a year, by Ticknor & Fields, 124 Tremont Street, Boston, Mass.

Messrs. Ticknor & Fields also publish *The Atlantic*



*Monthly and Our Young Folks*, both works entering upon new volumes with the January numbers. Those partial to polite literature should, by all means, read "the Atlantic," and those blessed with children ought, for their amusement and instruction, to place "Our Young Folks" in their hands. No better school can be found in which to learn to read.

## Patent Journal.

### AMERICAN INVENTIONS.

Dec. 5. 1865. (51,339) SPOKE-SHAVE.—Silas S. Mowry and Albert G. Bates, R. I. :

We claim the use of the two trimming wedge-form pieces E E, for the purpose of holding the cutter of a spoke-shave in its stock, arranged and operating in the manner substantially as described.

12. (51,456) TIRE-UPSETTING MACHINE.—Hiram L. Howard, Mendon, Mich. :

I claim the combined arrangement of the clamping and upsetting jaws A B, cam-lever M L, anti-friction roller R and stays S S, constructed and connected substantially as described, and the several parts arranged relatively with each other, and with the bench-plank C, or other bed-sill, in the manner and for the purpose herein specified.

(51,457) THILL-COUPLING.—James W. Innis, Milroy, Ind. :

I claim a thill-coupling for wheel vehicles, composed of an eye E, in which the thill-iron F, is secured by a pin *b*, the eye being provided with a pendant rod D, which is fitted in a protuberance C, on a clip A, and secured therein by a spring-catch G, substantially as and for the purpose set forth.

19. (51,585) WAGON-SHOE LOCK.—Alexander Hamilton, D. C. :

I claim the combination of the rods and levers described, by which the circular and rectilinear motion is given to the shoe-bar, for the purpose of bringing the shoe to the required position. I also claim the rod H, hog *k*, and the perforated plate J, arranged and operated substantially as described.

(51,597) ROTATING WHIFFLE-TREE.—Charles C. Lee, Washington, D. C. :

I claim the right and left strap socket B B, they having a curved finger or prong *b*, a hooked underlip *c*, and straight upperlip *a*, with their reversed inclined edges, as described in combination with a thimble-socket E, pintle F, spring *e*, supporting brace *f*, all constructed, arranged and operating in the manner substantially as and for the purpose herein set forth.

(51,620) FELLY-CLAMP AND SPOKE SUPPORT FOR CARRIAGE-WHEELS.—J. C. Plumer, Boston, Mass. :

I claim, *First*, The introduction of a spring or springs in the pulley or clutch for the purpose of relieving the jar or concussion when one portion of the clutch is brought in contact with the other portion, substantially as and for the purpose set forth. *Second*, The disk C, with its inclines D, and dogs F, in combination with the pulley A, and springs G, substantially as described.

(51 636) DEVICE FOR SHRINKING TIRE.—C. Wietman, Hazeltown, Iowa. :

I claim the combination of the hooked lever, B *b*, hook C, arm D, chain E, bed-plate A, and fulcrum *a*, all constructed, arranged and employed in the manner and for the purposes herein set forth.

26. (51,684) WAGON-BRAKE.—George and William Bench, Auburn, N. Y. :

We claim the combination of the locking device, with the

wagon-brake, when constructed and operated in the manner above described.

(51,688) MACHINE FOR BORING WAGON HUBS.—Frederick Bremerman, Indianapolis, Ind. :

I claim the tool-guide for boring out wheel-hubs for boxes, when the same is constructed and operated substantially as and for the purpose set forth.

(51,692) TUYERE.—W. P. Cain, Moravia, Iowa :

I claim as a new article of manufacture, the tuyere herein described, consisting of the spherical body A, nozzle B, tube D, plug E, and valve *e*, arranged and employed in the manner and for the purpose described.

(51,697) RUBBER SPRING FOR WAGONS.—Samuel G. Clough, Waupun, Wis. :

I claim the combination and arrangement of the cups, E E, the axle M, and bolster L, with the double-headed piston F F, and crossbar G, all constructed and operating substantially as set forth for the purpose described.

(51,712) WHIFFLE-TREE ATTACHMENT.—John C. Garner, Ashland, Pa. :

I claim the plate C, provided with the lips as shown and secured to the bar A, by the bolt D, in combination with the tube E, fitted in the whiffle-tree and the plate F, at the front side of the latter, the bolt D passing through the tube E, and all arranged to operate in the manner substantially as and for the purpose herein set forth.

(51,728) COMPOUND FOR TEMPERING STEEL SPRINGS, ETC.—L. W. Kelly, Brunswick, O. :

I claim the chemical compound as herein set forth for the purpose described.

(51,747) WAGON-WHEEL.—Benjamin Pearson, Salem, Mass. :

I claim a metallic crown felly supporter, constructed and applied substantially as described, in combination with the rim and spokes of a wagon-wheel at the point or points where the segments of the fellys meet, substantially as and for the purpose set forth.

(51,756) CARRIAGE-WHEELS.—John Scott, Ocala, Florida :

I claim, *First*, The making of a cast-iron hub as described, with protecting flanges from the box, which flanges are covered with a wrought-iron band, thus forming the oil-chamber with openings I and H, as shown and described. *Second*, In combination with the hub, band and oil-chamber as above described, I claim the double set of spokes with the cleats, constructed and arranged as set forth for the purposes specified.

### FOREIGN INVENTIONS.

April 11, 1865. CARRIAGE AND OTHER WHEELS.—S. Wright, Smethwick, Staffordshire :

The patentee claims making metallic hubs of the said wheels of a hollow cylinder or barrel which is fixed on the axle-box, upon which hollow cylinder or barrel is situated a fixed and movable plate or check, between which plates or checks the spokes of the wheel are fixed by the screwing home of the said movable check or checks, or making the said checks or plates upon the axle-box instead of upon a hollow cylinder or barrel. Also making the ends of spokes fixed in the said hubs of a taper or wedge figure, and of greater strength at the said taper or wedge part than at any other part, also making the said hubs of bars of iron or steel, having flanges on one or both sides, substantially as described.

21. INVALID CARRIAGES.—H. E. Newton, Chancery Lane, London :

The object of this is so to construct carriages, omnibuses and other vehicles as to make them impervious to the exterior air, and thus to preserve in the interior air more or less compressed, as may be thought advisable for the transportation of



certain classes of invalids. To effect this the carriage is made of strong and tenacious wood, the different parts of which are strongly jointed and screwed together, and then covered with sheet-iron of a sufficient thickness to resist a considerable pressure. When the iron and wood join, caoutchouc or other like suitable material may be introduced so as to render these parts completely air-tight. Caoutchouc or other suitable material is also put around the doors and windows of the vehicle for the same purpose.

### CURRENT PRICES FOR CARRIAGE MATERIALS.

CORRECTED MONTHLY, BY MR. CHAS. WEEKS, FOR THIS MAGAZINE.

NEW YORK, Dec. 22, 1866.

Apron hooks and rings, per gross, \$2.50.  
 Axle-clips, according to length, per dozen, 75c. a \$1.25.  
 Axles, common (long stock), per lb, 10½c.  
 Axles, plain taper, 1 in. and under, \$6.50; 1½, \$7.50; 1¾, \$8.50; 1⅞, \$9.50; 1⅝, \$10.50.  
 Do. Swelled taper, 1 in. and under, \$7.00; 1½, \$8.25; 1¾, \$8.75; 1⅞, \$10.75; 1⅝, \$13.00.  
 Do. Half patent, 1 in. and under, \$10.50; 1½, \$12.50; 1¾, \$15.00; 1⅞, \$17.50; 1⅝, \$21.25.  
 Do. Smith's New York half patent case-hardened malleable iron box, 1 in. and under, \$10; 1½, \$11; 1¾, \$12.50.  
 Do. Smith's Homogeneous steel, case-hardened mall. boxes, ½ in., \$12; ¾, \$12; ⅞, \$12.50. Long draft, \$2 extra.  
 Do. Saunders' improv. taper, ¾ in., \$12.00; ⅞, \$12.00; 1, \$12.00; 1½, \$13.00; 1¾, \$15.  
 Do. do. Homogeneous steel, ½ in., \$15.00; ¾, \$15; ⅞, \$16.50; long drafts, \$4 extra.  
 These are prices for first-class axles. Makers of less repute, cheaper.  
 Bands, plated rim, under 3 in., \$2.50; over 3 in., \$3  
 Do. Mail patent, \$3.00 a \$5.00.  
 Do. galvanized, 3½ in. and under, \$1; larger, \$1 a \$2.  
 Basket wood imitations, per foot, \$1.25.  
 When sent by express, \$2 extra for a lining board to a panel of 12 ft.  
 Bent poles, each \$2.00.  
 Do. rims, under 1½ in., \$2.25 per set; extra hickory, \$3.25 a \$4.00.  
 Do. seat rails, 50c. each, or \$5.50 per doz.  
 Do. shafts, \$8.00 per bundle of 6 pairs.  
 Bolts, Philadelphia, list.  
 Do. T, per 100, \$3 a \$3.50.  
 Bows, per set, light, \$1.50; heavy, \$2.00.  
 Buckles, per grs. ¼ in., \$1.50; ⅓, \$1.50; ½, \$1.70; ⅞, \$2 10; 1, \$2.80.  
 Buckram, per yard, 25 a 30c.  
 Burlap, per yard, 30c.  
 Buttons, japanned, per paper, 25c.; per large gross, \$2.75.  
 Carriage-parts, buggy, carved, \$4 a \$5.50.  
 Carpets, Brussels, per yard, \$2 a \$3; velvet, \$3.25 a \$4.50; oil-cloth 75c. a \$1.  
 Castings, malleable iron, per lb, 20c.  
 Clip-kingbolts, each, 50c., or \$5.25 per dozen.  
 Cloths, body, \$4 a \$6; lining, \$3 a \$3.50. (See *Enameled*.)  
 A Union cloth, made expressly for carriages, and warranted not to fade, can be furnished for \$2.40 per yard.  
 Cord, seaming, per lb, 45c.; netting, per yard, 8c.  
 Cotelines, per yard, \$4 a \$8.  
 Curtain frames, per dozen, \$1.25 a \$2.50.  
 Do. rollers, each, \$1.50.  
 Dashes, buggy, \$1.75.  
 Door-handles, stiff, \$1 a \$3; coach drop, per pair, \$3 a \$4.  
 Drugget, felt, \$2.  
 Enameled cloth, muslin, 5-4, 85c.; 6-4, \$1.10.  
 Do. Drills, 48 in., \$1.25; 5-4, \$1.20.  
 Do. Ducks, 50 in., \$1.45; 5-4, \$1.40; 6-4, \$1.60.  
 No quotations for other enameled goods.  
 Felloe plates, wrought, per lb, all sizes, 25c.  
 Fifth-wheels wrought, \$1.75 a \$2.50.  
 Fringes, festoon, per piece, \$2; narrow, per yard, 18c.  
 For a buggy top two pieces are required, and sometimes three.  
 Do. silk bullion, per yard, 50c. a \$1.  
 Do. worsted bullion, 4 in. deep, 50c.  
 Do. worsted carpet, per yard, 8c. a 15c.  
 Frogs, 75c. a \$1 per pair.  
 Glue, per lb, 25c. a 30c.  
 Hair, picked, per lb, 80c. a \$1.

Hubs, light, mortised, \$1.25; unmortised, \$1.00—coach, mortised \$2.00.

Japan, per gallon, \$3.

Knobs, English, \$1.50 a \$1.75 per gross.

Laces, broad, silk, per yard, \$1.00 a \$1.50; narrow, 15c. to 20c.

Do. broad, worsted, per yard, 50c. a 75c.

Lamps, coach, \$20 a \$30 per pair.

Lazy-backs, \$9 per doz.

Leather, collar, dash, 32c.; split do., 18c. a 22c.; enameled top, 32c.; enameled Trimming, 30c.; harness, per lb, 50c.; flap, per foot, 25c. a 28c.

Moquet, 1½ yards wide, per yard, \$9.00.

Moss, per bale, 12½c. a 18c.

Mouldings, plated, per foot, ¼ in., 14c.; ⅜, 16c.; 18c.; ½, 1 ead, door, per piece, 40c.

Nails, lining, silver, per paper, 12c.; ivory, per gross, 50c.

Name-plates.

See advertisement under this head on 8d page of cover.

Oils, boiled, per gallon, \$1.80.

Paints. White lead, ext \$17, pure \$17½ p. 100 lbs.; Eng. pat. bl'k, 35c.

Pole-crabs, silver, \$5 a \$12; tips, \$1.50.

Pole-eyes, (S) No. 1, \$2.70; No. 2, \$2.90; No. 3, \$3.10; No. 4, \$4.50 per pr.

Sand paper, per ream, under No. 2½, \$5.50; Nos. 2½ & 3, \$6.25.

Screws, gimlet.

Add to manufacturer's printed lists 20 per ct.

Do. ivory headed, per dozen, 50c. per gross, \$5.50.

Serims (for canvassing), 20c. a 30c.

Seats, buggy, pieced rails, \$1.75; solid rails, \$2.50.

Shaft-jacks (M. S. & S.'s), No. 1, \$2.75; 2, \$3.25; 3, \$3.50.

Shaft-jacks, common, \$1.50 a \$1.65 per pair.

Do. tips, extra plated, per pair, 37½c. a 56c.

Silk, curtain, per yard, \$2 a \$3.50.

Slat-irons, wrought, 4 bow, \$1.12½; 5 bow, \$1.25 per set.

Slides, ivory, white and black, per doz., \$12; bone, per doz., \$1.50 a \$2.25; No. 18, \$2.75 per doz.

Speaking tubes, each, \$3.

Spindles, seat, per 100, \$1.50 a \$2.50.

Spring-bars, carved, per pair, \$1.75.

Springs, black, 24c.; bright, 25c.; English (tempered), 28c.; Swedes (tempered), 32c.; 1½ in., 1c. per lb. extra.

If under 36 in., 2c. per lb. additional.

Two springs for a buggy weigh about 23 lbs. If both 4 plate, 34 to 40 lbs.

Spokes, buggy, ⅞, 1 and 1⅞ in. 9½c. each; 1½ and 1¾ in. 10c. each; 1½ in. 9c. each.

For extra hickory the charges are 10c. a 12½c. each.

Steel, Littlejohn's compound tire, 3-16, 10c.; 1-4, 9½c.; heavier sizes, 9c. currency.

Stump-joints, per dozen, \$1.40 a \$2.

Tacks, 9c. and upwards per paper.

Tassels, holder, per pair, \$1 a \$2; inside, per dozen, \$5 a \$12; acorn trigger, per dozen, \$2.25.

Terry, per yard, worsted, \$4; silk, \$9.

Top-props, Thos. Pat, per set 65c.; capped complete, \$1.50.

Do. common, per set, 40c.

Do. close plated nuts and rivets, \$1.

Thread, linen, No. 25, \$1.30; 30, \$1.45; 35, \$1.65, gold.

Do. stitching, No. 10, 95c.; 3, \$1.15; 12, \$1.28, gold.

Do. Marshall's Machine, 432, \$2; 532, \$2.30; 632, \$2.60, gold.

Tufts, common flat, worsted, per gross, 20c.

Do. heavy black corded, worsted, per gross, \$1.

Do. do. do. silk, per gross, \$2.

Do. ball, \$1

Turpentine, per gallon, \$1.30.

Twine, tufting, per ball, 50c.; per lb, 85c. a \$1.

Varnishes (Amer.), crown coach-body, \$5.50; nonpareil, \$6.50.

Do. English, \$6.25 in gold, or equivalent in currency on the day of purchase.

Webbing, per piece, 65c.; per gross of 4 pieces, \$2.40.

Whiffle-trees, coach, turned, each, 50c.; per dozen, \$5.50.

Whiffle-tree spring hooks, \$4.50 per doz.

Whip-sockets, flexible rubber, \$4.50 a \$6 per dozen.

Do. hard rubber, \$10.50 per dozen.

Do. leather imitation English, \$5 per dozen.

Do. common American, \$3.50 a \$4 per dozen.

Window lifter plates, per dozen, \$1.50.

Yokes, pole, each, 50c.; per doz, \$5.50.

Yoke-tips, extra plated, \$1.50 per pair.

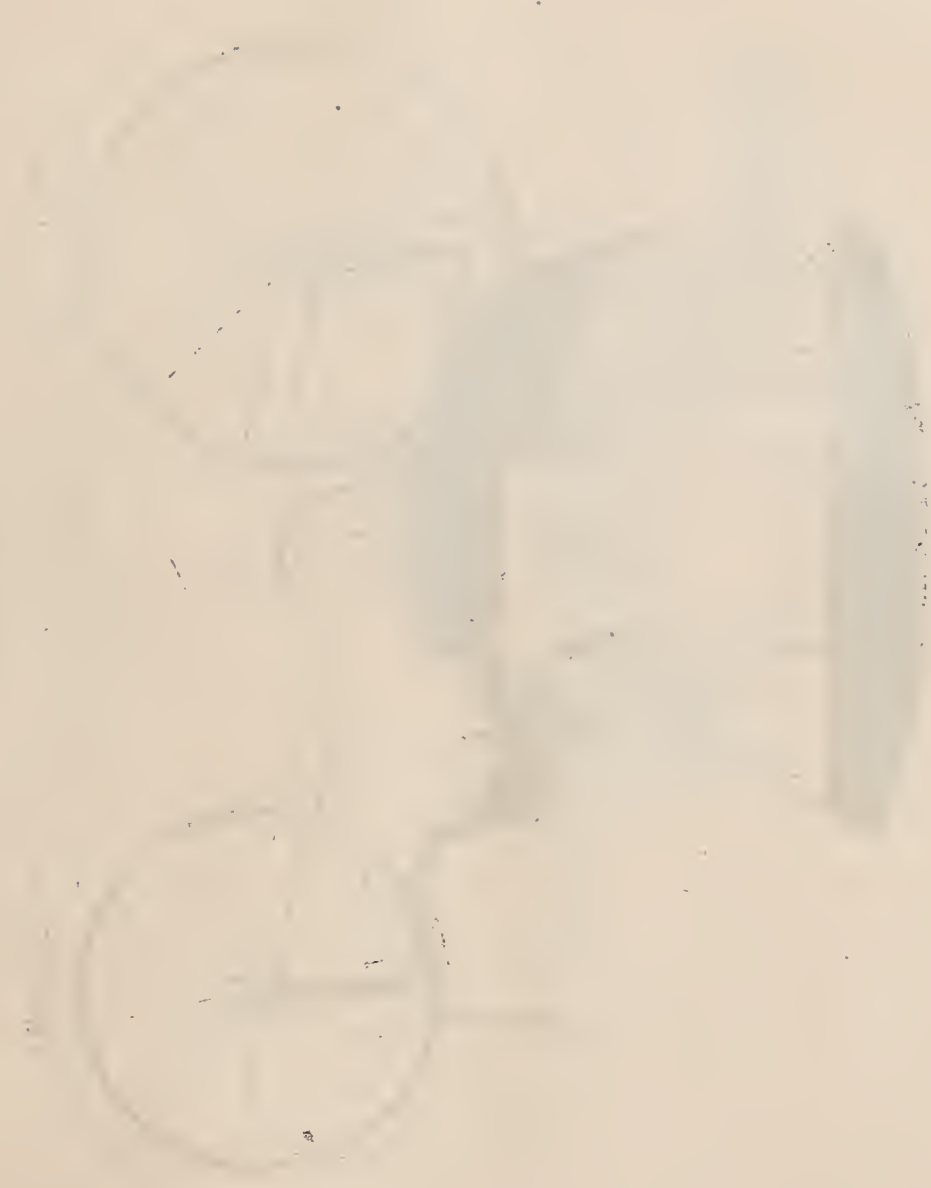

100  
100



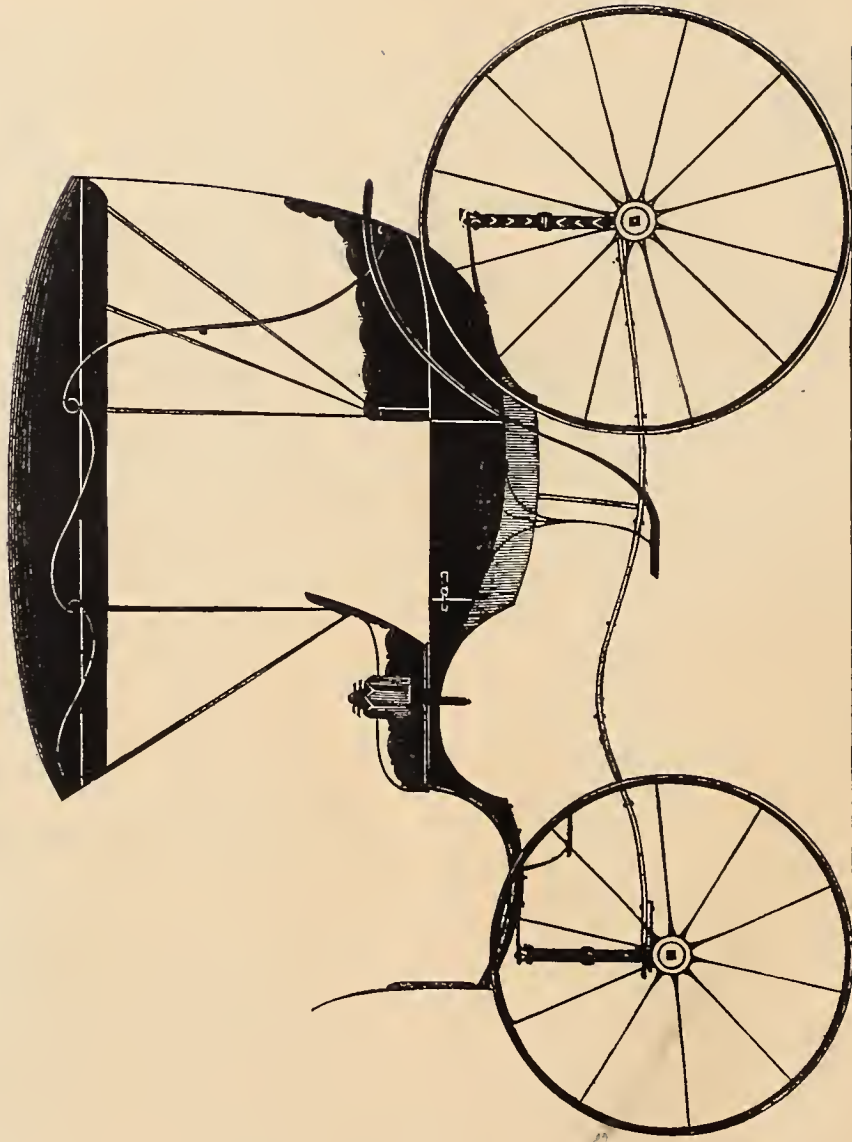

EXTENSION-TOP ROCKAWAY.— $\frac{1}{2}$  IN. SCALE.

*Engraved expressly for the New York Coach-maker's Magazine.*

*Explained on page 150.*

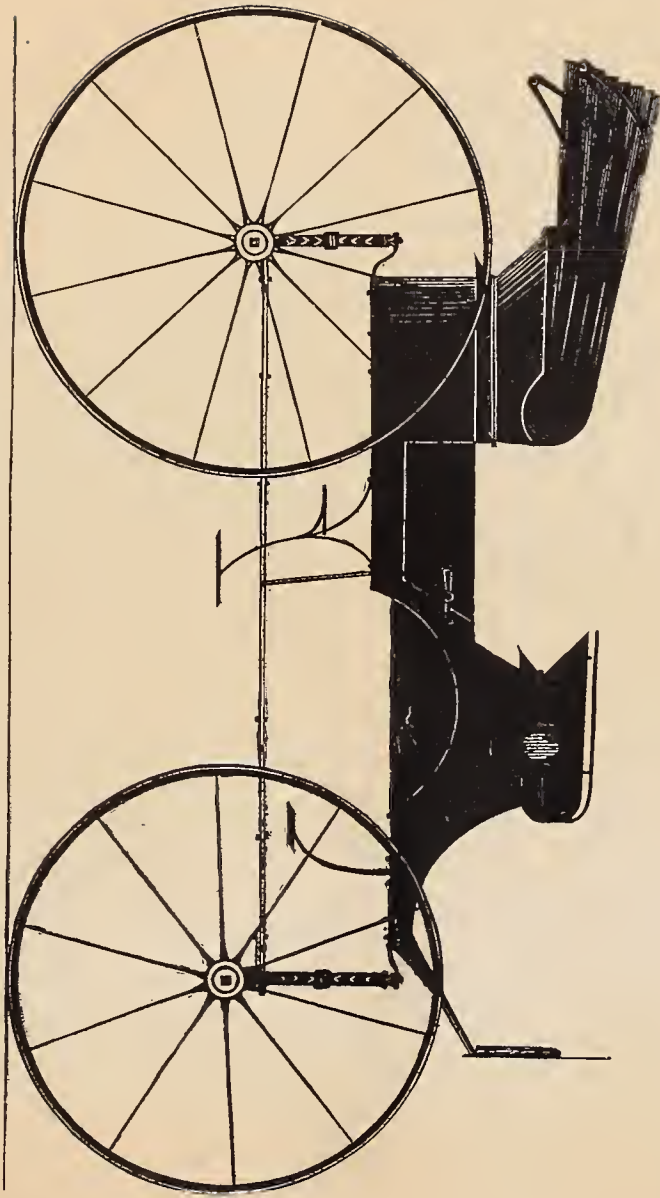

TWO-SEATED PHAETON.— $\frac{1}{4}$  IN. SCALE.

*Engraved expressly for the New York Coach-maker's Magazine.*

*Explained on page 150.*









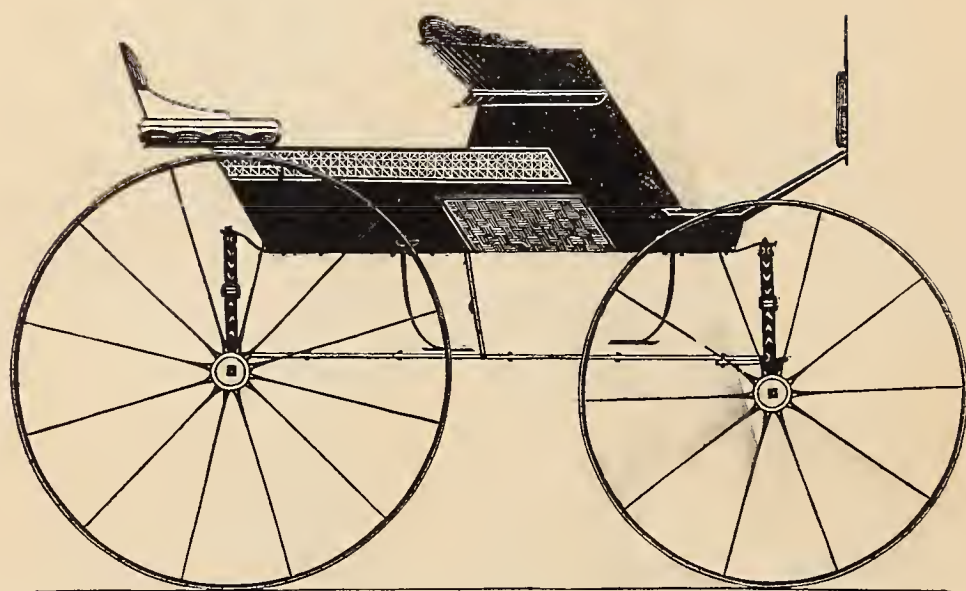

SPORTING PHAETON.— $\frac{1}{2}$  IN. SCALE.  
*Engraved expressly for the New York Coach-maker's Magazine.*  
*Explained on page 151*

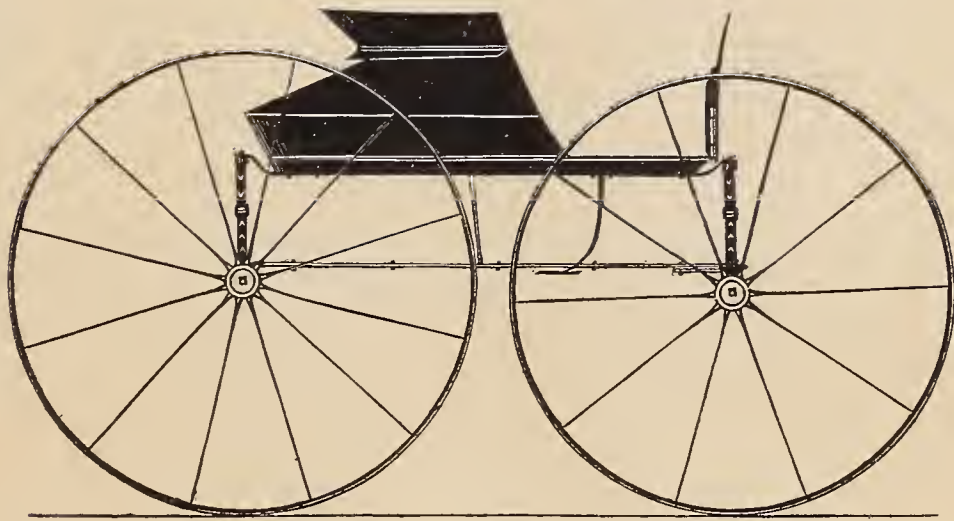

ROAD BUGGY.— $\frac{1}{2}$  IN. SCALE.

*Engraved expressly for the New York Coach-maker's Magazine.*

*Explained on page 151.*







DEVOTED TO THE LITERARY, SOCIAL, AND MECHANICAL INTERESTS OF THE CRAFT.

Vol. VII.

NEW YORK, MARCH, 1866.

No. 10.

## Mechanical Literature.

### LONG AND SHORT SCREW-DRIVERS.

BY JOHN B. PEEK.

THE acknowledged superiority of a long over a short-handled screw-driver I have experienced to be this: a very small error in the direction of the short-handled one permits the point to slip out of the nick in the head of the screw more easily; but it is obvious that the greater the deviation of the screw-driver from the axis or direction of the screw, the greater must be its power, that power being proportionate to the sine of the angle of deviation, or, in other words, the distance between the end of the handle and the line of direction of the screw acts as a *lever*.

A screw-driver may be called either a double lever or a single one. In the first case, the length of each lever will be equal to half the width of that part of the driver which fits into the head of the screw, or is equal to the radius of the circle formed by the revolution of the screw-driver, the center being the imaginary fulcrum. In the other case, the length of the lever will be equal to the whole width of that part of the driver which fits into the head of the screw. The power will, of course, be the same in each; for if we call it a double lever, each will have half the power of the single, and if we call it a single lever, it will have twice the power of each double one, the effect being always regulated by the distance between the acting power and the fulcrum.

It seems to me most convenient to consider a screw-driver as consisting of two levers, because in this case the imaginary fulcrum in the center is quite distinct from the acting and resisting parts of the instrument, while in the case of a single lever, the situation of the fulcrum will correspond with the place where the acting power is applied, each extreme point of the driver forming in its turn the fulcrum to the acting power and the acting power to the fulcrum. The resistance is also applied to the same place, and this is likely to cause confusion. I shall therefore suppose a screw-driver to consist of two levers of the third kind, where the power is between the weight and the fulcrum. In such a case, we all know that power is lost as time is gained; that is, if A, of two pounds will only raise B, of one pound, B will go twice as far as A, or the same distance in half the

time. Now as power is here lost, because the acting power travels slower than the resistance. So in all cases where the acting power travels faster than the resistance, power will be gained in the same proportion, and it is, of course, quite true *in practice* that the elasticity of a long screw-driver will cause it to yield or render (as a long lever will bend under a pressure that a short one would easily sustain), and thus, by giving way to the resistance, the lower end, or that which is applied to the screw, will hang back a little, and will not therefore go quite as far or as fast as the upper end of the driver or hand. If then we suppose that the upper part of the driver would in one revolution pass through three inches, while the lower part should only pass through two and a half, the power will be as much greater than it would be if the driver were non-elastic as 3 is greater than  $2\frac{1}{2}$ , or the power of the driver would be increased by its elasticity as 6 to 5. Now a screw-driver whose width at the lower end is one inch consists of two levers of half an inch each, having their fulcrum just over the center of the head of the screw, and as in one revolution each lever will pass through  $1\frac{1}{2}$  inches, the whole distance passed through would be three inches, and if the driver were non-elastic, the power and resistance would be to each other inversely as their respective velocities; and as the screw or resistance would only move through a space equal to the distance between two spirals (and this in one revolution must be the case), if the distance be stated at one-eighth of an inch, then this power would travel three inches, or twenty-four times as far, in the same time as the resistance. The power would therefore be mechanically multiplied twenty-four times. But as the effects of the elasticity have been stated to be one in six in favor of the velocity of the power, it will be one in six in favor of its efficacy, and instead of the power being as twenty-four to one, it will be nearly as twenty-nine to one. The first part of every mechanical operation is the most difficult to be performed, from causes which could be easily explained, but which would be out of place here. In driving a screw the resistance is the greatest at first, and this very circumstance renders the elasticity of the driver more particularly serviceable at this moment than any other, for the increased resistance causes the screw to remain stationary for a short time after the handle has begun to move, and therefore is the means of increasing the power by diminishing the velocity of the resistance, and this too at the very moment when such relief is most



needed—the beginning of the operation. Elasticity therefore, practically speaking, will be *one* cause of the increased power of a long screw-driver, though I take it to be unphilosophical in estimating the power of a machine (*unless, for practical purposes, we are expressly desired so to do*), to consider any imperfections that may have arisen in the construction or from the physical properties of the materials from which such machine may be composed. The smallness of the angle of deviation from a perpendicular, being as the length of the driver, is another cause (*in practice*), but this also arises from supposing the operation to be performed in an imperfect way, for if a man hold his hand steady (which in all operations we *suppose* him to do, unless expressly *told* to make allowance for the contrary), there would be no such angle of deviation at all.

A short spud of a driver is sure of disfiguring the face of a screw, and of bearing it unequally against one side or the other, as well as of tearing and defacing the bed prepared for it. I think I have now said sufficient to demonstrate the truth of what I have advanced, and shall only add that I hope all scientific and finished workmen as well as apprentices) will discard the spud screw-driver.

## PICTURES FROM POMPEII.

### SECOND ARTICLE.

In the pictures which accompany this article, we see that Cupid, the god of love, acts the part of charioteer. This genius, we learn from ancient authors, was the son of Venus, and took the direction in all love affairs. Figure 3 exhibits him in a strongly constructed chariot, endeavor-



FIG. 3.

ing to force along an unruly pair of male goats. What is symbolized by the artist in this team, research thus far has failed to teach us. No doubt there is a depth of meaning in the design which would edify us, could we unravel it.

In the next engraving (Fig. 4), we have a similar representation, except that the draught animals are evidently females, and the chariot body is of strikingly different design. This, although very graceful, appears to be of a more fragile form, and less fitted to undergo hard usage.

To manage the team, in the first instance, appears to require the best efforts of the teamster, while in the latter case it



FIG. 4.

is a comparatively easy matter. May we not read in these two examples the contrast existing in the nature and dispositions of mankind, especially when the two sexes are compared?

A few observations in regard to chariots will finish this article. In a previous volume we have shown that chariots were invented at an early period of the world's history. Sacred as well as profane writers confirm this truth, yet, strange as it may appear, Virgil asserts that Erichonius, who was educated by Minerva at Athens, being deformed in his feet, first invented the use of chariots, in order to hide the defect. This may be excused when taking advantage of the license awarded poets, but which certainly is an unpardonable anachronism when viewed in the light of sober history. That art had reached a high standard of perfection at Pompeii is proved by the specimens which have rewarded research since its destruction. This is seen in the drawings which, at considerable expense, we have reproduced in our pages. The gracefulness in which they are executed would be creditable to any painter of the present day.

## CRITIQUE ON CARRIAGE-WHEELS.

BY THE EDITOR.

On page 115, we gave an illustration of a chariot wheel from the ruins of Nineveh, with some critical observations on its structure and form. Another specimen of a wheel from the land of the Great King, as those of Assyria are called, will be found attached to the war chariot, as shown on page 103, volume I., of this journal. It is very true that for this specimen we are indebted to an exhumed slab from the long-slumbering ruins of an ancient city, but still this fact leaves little room for doubt of its being the correct delineation of a real wheel, as made in that remote age. The wheel to which we here refer differs materially from the one represented on page 115 of this volume, as



it has but six spokes, and these much out of proportion with the other parts. As we have elsewhere remarked, these bas-reliefs go to show that the rims were formed of two superposed circles, the external one being united by broad flaps to the internal one, in nearly every instance. There are a few, however, which present us with no clew as to how the one was united or secured to the other. These last are evidently of a more rude construction, and perhaps belong to a more remote age.

The more modern Roman wheel seems to have been formed after a studied pattern, a very fine specimen of which may be seen attached to the Rheda, on page 67, volume V. The wine-cart, illustrated on the seventh page of the same volume, presents us with a wheel in several respects equal to those in modern times—in the proportions of the hub much ahead of us. The modern fashion of sacrificing all the practical value attached to the hub to a silly whim seems never to have met with much favor among the nations of antiquity, when the same was made of wood.

The Armenians at the present time carry the produce of their harvests, not on the backs of animals, as in most other parts of Asia Minor, but in carts made entirely of wood, no iron being used, even in the wheels, which are in general built of walnut, oak and *kana-agatch* (literally, black tree-thorn), the stronger wood being used for rough spokes let into the wood. There certainly is much mechanical ingenuity displayed in this wheel, and no practical workman will dispute that it possesses great strength.

This, however, is gained at much seemingly unnecessary labor and clumsiness; still this, compared with the wheel on the ancient British war chariot, figured on page 185 of our First volume, is a very light affair, and in many respects far superior to many of the modern cart-wheels daily used in the South American States.

The most simple framed wheel with which we are familiar is the one used on the ox-carts of Portugal, and employed alike in agriculture and in commercial affairs. Although we find here the most economical use of a little material, yet such a wheel is, in the very nature of the case, very defective. It is true that the two sections composing the rim are employed to the best advantage, the joints meeting just where they will be the most effectually supported by the

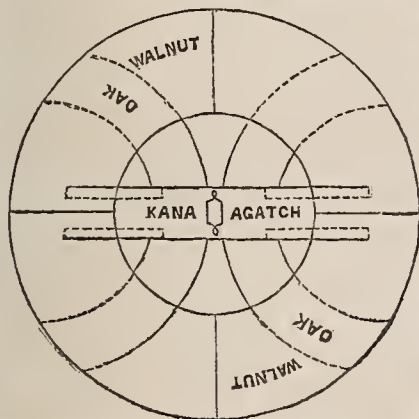

ARMENIAN CART-WHEEL.

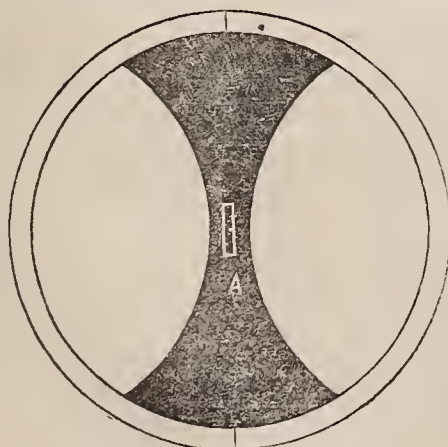

PORTUGUESE CART-WHEEL.

cross timber; but the other points in the circumference require more bracing in order to render them lasting, and the place in the center, where the axle naturally should be placed, is too weak for the application of an axle on which to revolve. This circumstance, as we see, necessitates the application of a *revolving* axle-tree, connected by mortise and tenon, as at A in the engraving. Notwithstanding these drawbacks here pointed out, still a friend who has frequently visited the Buenos Ayrean Provinces assures that those there employed are still more rude and much more inefficient when made by native workmen. Not intending to exhaust this subject here, we shall return to it again soon.

## Home Circle.

### A DREAM OF MY YOUTH.

BY ROSETTE ANNIE ROSE.

STAY, beautiful dream! O leave me not yet,  
Now while your whispers sweet visions beget;  
For my soul it is sad  
When I fain would be glad;  
Then beautiful dream, O leave me not yet.

Sweet dream of my youth, spread over my soul  
Pictures that mem'ry shall warmly extol;  
From the long-buried past  
O bring those that shall last  
When dark waves of sorrow around me shall roll.

O show me once more the days of life's morn,  
Where visions of rarest effulgence were born;  
All the friends that were mine,  
That their mem'ry may twine  
Sweet tendrils around where I wander forlorn.

My spirit is thrilled when I dream of the joy  
That Heaven shed o'er me all pure from alloy,  
In those days of my youth,  
When bright pictures of truth  
Graced the chambers of mem'ry which naught can destroy.

And ever and aye will that beautiful dream  
Give peace to my soul when life's rippling stream  
Is darkened by storms;  
Then its beautiful forms  
Will shine o'er my heart like the morning's bright gleam.

### VISITING A RICH RELATIVE.—A STORY OF WESTERN LIFE.

BY MARY A. E. WAGER.

"WELL, I *did* think I would write a little!" and the scarlet lips of the girl gave a leer of discontent, as she closed her pretty rosewood writing-desk with a despairing gesture.

"Well, what's to pay now, sis? Broken your Morton? out of paper? lost your wits?" and the handsome mouth of brother John subsided into equilibrium.

"If they are *not* lost, they will be! Here you are thundering away at 'Tennyson's Light Brigade Charge;' George and Mary giggling over something sharp in the 'Drawer;' Ben junior in the full blast of a two-year-old squall, and Ben senior trying to bring the keys to the merits of 'La Favorita.' One might as well try to write in Bedlam."



"Oh! if that's all," said the imperturbable John, "I think 'tis about time for me to care for the horses. And you, Master George, are aware that it devolves upon your lordship to administer the staff of sheep-life to that very estimable flock of merinos; so, old boy, put on your hat, and out with me." So the boys went out, and Mary took Ben junior in the dining room, and Ben senior played out his favorite air, and quiet reigned supreme. But the girl had forgotten her key-note, and so sat down before the grate, and told over in her mind the story she had heard in the last September from the lips of her friend Miselle Reynolds. At length she arose, and reopening her desk, she wrote this story:

Miselle had been a dear friend of mine since the first time I saw her, which was three years ago, when we were both members of the senior class in — College. She was never popular for her intellectual attainments, and barely passed the ordeal of examination at the close of each term; but she had the faculty of loving and being loved, so that at the close of commencement she not only carried away her sheep-skin most triumphantly, but the blessing and kindest regard of teacher and classmates.

It had been over a year since we parted at the depot, she to her home in Philadelphia, and I to my quiet one in Central New York. It was early in September when I read in the delicate Italian strokes of Miselle's that she would spend a fortnight with me at my country home. So on a bright afternoon the steamer put her off at the pier below us, and an hour later found her ensconced in my snug little sanctum.

Miselle was just the same gay, genial soul as ever, and the play of her lips and mouth was as arch and beautiful as one could wish. A day or two after her arrival, while enjoying a *siesta* in the back parlor, Miselle said:

"I think, Mintwood, if you will toss me a dozen or two of the largest of those peaches, I'll give you my experience in visiting a rich relative. You know 'the mind depends much on the state of the stomach' (I remember so much theory!), and you remember I ate but little dinner—only half a peach pie and a 'flank of beef.' That was Holmes' expression—poor fellow! He lost one of his fine eyes at Atlanta. There—that will do," she said, with one of her arch smiles, after catching two or three delicious rareripes.

"It was about a year ago—will be next month—that I packed my 'Saratoga,' and started off on a raid, with the one purpose of recruiting my bodily health by a change of climate. My mother's eldest brother resided somewhere in Southern Illinois, and was reputed to be very wealthy. He had no children, and undoubtedly would be very glad of the society of his niece for a few months. I remembered having seen him when a child, but retained no tangible recollection of his looks and appearance. He seemed quite inclined to ignore the existence of his eastern friends, and it was only in indirect ways that the impression had been received that he had held public offices of trust, and having amassed a large fortune, was now living in retirement upon his princely income. After due advices from father and mother and the elder stock of Reynoldses to behave myself, and keep in the good graces of my half-uncle, Josiah Newton, I bade home and friends good-by for a three and perhaps six months' absence. I stopped at Wooster a week or two with some friends, and then went to Cincinnati by way of Crestline. At the latter station the trains failed to connect, and the passengers

were doomed to a six hours' wait, or avail themselves of a caboose.

"While pondering upon my tedious position (for you know, Mintwood, there is nothing under the sun and moon more tedious than waiting in a depot), I espied a pair of shoulder-straps passing to and fro upon the platform around the depot. Having a great passion for such appendages, I watched their owner until he turned his face toward me, when, without a thought of caution, I exclaimed, 'Forcythe Greyson!' And, sure enough, it was he! looking ten-fold handsomer, and perhaps vainer, in his bright uniform of blue and gold, with two bars. Those are very becoming colors to put men or books in.

"Of course he was profuse in his protestations of delight at meeting me, and as his destination was Cairo, he was my *compagnon du voyage* the remainder of my journey, and not at all loath to accept my invitation to stop and partake of the hospitality of my rich relative.

"You know the Greysons pride themselves upon their high connections, and support a style of living perhaps not always fully warranted by their income, so I was very anxious to have Captain Greyson know I had high connections as well as rich ones.

"It was a little after noon when we arrived at my station, which proved to be a rudely built town, with two or three churches, and a dilapidated building that outflung its sign of 'Hotel.' We found our way into the parlor. Bless me! what a disconsolate room!—but no matter for that. Greyson went out to procure a conveyance to take us to 'Squire Newton's,' as the natives familiarly and respectfully called my uncle. He had great difficulty in procuring one, as nearly all went on horseback in that region. But we couldn't take a trunk on a horse, although I actually saw that done before I left the State.

"A half hour elapsed when our Jehu made his appearance. 'Where's your carriage?' asked Greyson.

"'Why thar 'tis? Whar's your woman's trunk?' responded the freckled-faced man.

"We could neither of us refrain from laughing outright at the pre-Adamic cart presented to our view. But it was evident from the town we could do no better. We could well dispense with fashionable equipage in view of the luxury we were so soon to inherit. So Greyson pointed out my trunk to the man, who, with wonder in his eyes, exclaimed, 'Do you call that a *trunk*? I should a' took it for a corn-crib! My old cart won't stand up under sich a load as that nohow, and ye'll be as much as my hoss will want to haul.'

"After some parleying, we concluded to leave the 'corn-crib,' and stepped in the Illinois barouche. I think we laughed until the tears coursed down our faces, wondering what Philadelphians would think to see us traveling in that style, and the surprise my uncle would experience to see people alight at his residence from such a vehicle.

"I imagined my uncle lived in a large, roomy old house, with wide halls running through it, antique furniture, but of a superior quality and finish. But I was *not* prepared for velvet tapestries and rosewood furniture, marble-fronted fire-views, pier-glasses, and paintings blushing in frames of massive gilding. No, Mintwood, I was *not* prepared for such. We were very free to criticise the quiet inhabitants we passed. One old man, in a field at work, received a most unmerciful review.

"We were interrupted in our conversation by hearing



the driver exclaim, 'Here's the Squire's house,' reining up at an ancient looking dwelling. He had evidently driven up at the back door, for no bell-knob was in view; so I thumped away with my parasol, and succeeded in bringing to the door a short, thick-set article in petticoats, who, putting her hand over her eyes in a horizontal position, greeted us with, 'Will ye walk in, strangers?'

"Well, we walked in and sat down. I immediately inquired for Josiah Newton, whereupon the aforesaid petticoats, after informing me he was 'diggin' pertaters,' went without, and began calling, 'Uncle Josh! Uncle Josh! Come tew the house!'

"During her brief absence I ventured a look around the room. At one end was an enormous cavern, intended for a fire-place, as a few coals were giving forth a feeble glow. The joists overhead were bare, black and smoked. The walls evidently had been some time hung with newspapers, which now hung in dingy scraps and ends from the walls. There was but one window, and the door must be thrown wide open to admit sufficient light to reveal the entire room. I can convey to you no idea of how I felt! There sat Greyson, as immovable as a statue. I touched his arm with my parasol to ascertain if he still lived, proof of which he gave me in eye-flashing. 'Don't scold!' I whispered. 'May be we have jumped in the wrong box!'

"Presently the woman returned (whom I soon learned was my deceased aunt's niece, named Lucy), and close in the rear the old man we had ridiculed or the way. He wore a red woollen blouse, and the original pattern of his pantaloons was quite hidden by the particolored patches with which they were covered.

"After ascertaining that he was really Josiah Newton, and that his home, I said:

"I am Miselle Reynolds, your sister Fanny's daughter, from Philadelphia; and this gentleman is a friend of mine, Captain Greyson, of the — Pennsylvania Volunteers."

"Wall now, Miselle, I am right glad to see ye;' and he put out a hard, dirt-soiled hand, into which I must lay Alexandre kidded ones! Then, turning to Greyson—

"And the Cap'n here—won't he have his horse put out?"

"How the eyes of Greyson flashed out. 'No, sir; the nag and cart were hired at the station; a boy drives them back.'

"Wall,' said Uncle Josiah, 'I guess we'll go up stars. And see here, Lucy, you get some dinner, for the friends here must be powerful hungry.'

"I was only too glad to follow up the narrow stairway that brought us into the best room. This had at least the luxury of a rocking-chair. A home-made carpet covered the floor. It had never been sewed together, the strips being laid down loosely. A few wooden chairs, an uncushioned settee, a table with a cloth of unbleached factory, a high cupboard, with window-framed front, and a really modern and presentable dressing bureau comprised the furniture. A very good portrait of Washington, framed in finger-marks, was pasted upon the wall. There were two moderate sized windows in the room, and, taking it 'all in all,' one *could* live in it.

"In front of the house was the wood-pile, and in close proximity the cow-yard. The one idea of having things near at hand seemed to overwhelm any esthetical ones. I endeavored to be cheerful, and tried to appear uncon-

scious of the extremely unpleasant surroundings. Greyson was completely *mum*. At the expiration of a couple of hours Lucy announced that dinner was ready, and we were invited to go below again in that horrid old room to eat! There being no *stove* in the house, the cooking had been performed over the fire-place. The table was loaded with eatables—about twenty varieties—and all to be eaten off one plate—that is, no side dishes were used. I confess I was nonplussed. The idea of having jelly, and sourkrout, and sweet potatoes, and chicken, with numerous condiments, mixed up on one plate, was entirely novel. As for Greyson, he prospered better than I, for he had had the benefit of camp life.

"It was late in the day when dinner was finished. Noticing that the scenery in the rear of the house was fine—for nature is beautiful everywhere—I invited Greyson to take a stroll. Oh! if I had not been so consummately unfortunate as to ask him to partake of the hospitality of my *rich relative!* But I had, and so must make the best of it. Greyson caught up his hat with a species of desperation unknown under other circumstances, and followed me out.

"For mercy's sake, Miselle, you don't intend staying in that hut over night?"

"When Greyson said that, I burst into a genuine woman cry. I could not endure it any longer. There I was—and such a place! such a realization! At the depot was my trunk, containing my fine dresses, that I had anticipated so much pleasure in wearing—my music also, for of course there would be a piano in my rich uncle's mansion. But instead, Mintwood, it was the horrid old place I was ever in! To think of staying there three months was quite unendurable, and to return home immediately would be giving the Philadelphians a bone for picking, as it was well known I was to be absent several months.

"There—there! don't cry, Miselle. But what *will* you do?" put in Greyson, consolatorily.

"Do? Why, I'll tell you; I'm going to stay here. That dirty old tavern at the station is no better. If *they* can endure it here *all the time*, I'm sure I ought for the present, at least. Of course you will do as you please. I know you would be welcome here—they seem kind-hearted enough—but as for *me*, I'll brave it out like a soldier!"

"Bravo, Miselle! No one knows what you women are made of until you are tried!"

"I could not refrain from smiling at this, and half forgot the house and its appointments in admiring the grand old forest at hand. On our way back Greyson signified his intention of returning to the station and boarding the ten o'clock train. I extorted from him a promise *never* to reveal his visit at that place.

"After a time I was shown to my sleeping room. The bed *ought* to have been comfortable. There were three feather beds on top of each other, and no less than half a dozen home-made 'kiverlids.' A strip of carpeting was spread on the floor in front of the bed. There were no washing or bathing conveniences—no mirror or toilet arrangements whatever—and the absence of these was worse than all. I wished I might waken in the morning and find myself back in my own room at home; but the dreary, half-whitewashed walls stared me in the face when I awoke.

"I inquired for water, when Lucy said, 'You can wash



out at the trough!"—a log hollowed out for that purpose. You can imagine how I looked performing my morning ablution! But I will pass over the little items of my stay, for I *did* stay, Mintwood, six long months. After a day or two I began a course of renovation. The rooms were cleaned, papered anew; the carpet taken up, sewed together; furniture cleaned and varnished, and with a rearrangement of articles, the purchase of a few new ones, and a few fancy ornaments of my own conjuring, was wrought a very decided improvement. My uncle was well pleased with the course I pursued, and gave me all the liberty I desired.

"The young people began to call at Squire Newton's, and went away with wonderful stories about the city miss who dressed so finely, and had fixed up the old house in such grand city style!"

"Well, was your uncle really wealthy, Miselle?"

"Yes, more so than I supposed. He owned several hundred acres of land, and was one of the most extensive stock growers in the State."

"Why did he live so then?" I queried again.

"Why, bless you, Mintwood, nearly everybody there lived so. He thought he had things *very* comfortable. 'To be sure,' he used to say, 'I haven't so many fine fixin's as sister Fanny has; but they don't amount to much in the long run, and so long as people have enough to eat and wear, I can't see the good that grows out of such extravagant notions.' And indeed, to hear him relate incidents of his early privations, his present comforts were indeed quite luxurious.

"I experienced all the discipline of frontier life, I think. I became accustomed at seeing huge 'back-logs' rolled in the fire-places, and *nearly* resigned at having my eyes *smoked shut*, my face *roast* and my back *freeze*. I learned how to cook and bake over a fire-place, to sand the floor beautifully, and to make the most of nothing, which is a greater achievement than it may at first thought seem. I learned to say 'allow' for 'agree,' 'right' for 'very,' 'bucket' for 'pail,' and 'right-smart-chance-of-a-place' for 'prosperous town.' I learned to ride on horseback, and could 'pitch in' and play 'blindfold' and 'charades' with as much gusto as a native.

"The young 'suckers' thought I was a 'right smart girl,' and during my stay no less than five or six of the most promising offered to become my liege lord and master.

"Bless me, Mintwood! allow me to picture to you my last 'lover.' He was about six feet and three inches tall, gaunt and crooked; a bright-colored yellow neck-tie; a large-figured vest, home-spun coat and pantaloons—the latter well enough, however, as I favor home manufactures. A row or swath of whiskers around under the chin from ear to ear, a brass finger ring, watch guard ditto, and silver watch, perhaps. He would usually come on the Sabbath afternoon, pull out his bandana, cross and recross his legs, tell how much per pound his pork brought, and descant upon the probable sale of fat cattle."

"But did you never write home how you were situated, Miselle?"

"Never—never, Mintwood. Our folks don't know until this day but that I had a really splendid time. And the fun of it is, about half of them intend to go there this winter. I'll give my curls if they only will!" and Miselle went off into one of her irresistible laughs.

"But what became of Greyson? Did you hear from him again?"

"Oh, yes! He wrote to me often, and I don't know what I should have done without my letters, which were quite numerous—and—and—I might as well own up to you, Mintwood, for I'll have to make a clean breast of it sooner or later. You see *that*, Mintwood!" and Miselle held up her fingers, upon one of which glittered a tasteful cluster of diamonds.

"Greyson put that on my finger three months after that memorable stop of his at Uncle Newton's; for, strange to say, he ventured there a second time, and was so pleased with the changes wrought that he remained a few days—long enough to tell me of his plantation farther west, where he intended to settle at the close of the war; and being so well satisfied that I would make a capital wife for a *new settler*, invited me to assume that post some time, and I—well—no matter, Mintwood, I'll take a few more rare-ripenes."

"Then your visit to a 'rich relative' did not turn out so disastrously after all?"

"No. I acquired more real useful discipline than in all my previous life. I learned how happy one may be, if he only will, even in very humble circumstances, and now can better appreciate to some degree the privations and discomforts of pioneers, and the real genuine goodness and heartiness that lies under the rough exterior of the backwoodsmen. I came home with a great fund of anecdotes, and in most admirable equipoise condition. The fact is, Mintwood, Western people are vastly better than we Eastern folks. They are twice as social, and are not half as selfish or given to sham notions of *caste*.

"I happened to perch down among rather an uncouth set, but then I never found better, kinder hearts than I did there; and after all I feel remarkably well paid for my *grit* in staying. But just one word of advice, Mintwood: Never invite a friend to partake of a 'rich relative's' hospitality until you have first enjoyed it yourself. And now I think I'm ready for that gallop along the Lake which you proposed this morning. You know I had fine drill in equestrianism when I was out West." And shaking out her curls with a merry laugh, we arose, one of us feeling exceedingly glad of the companionship of Misselle Reynolds.

HILDALE, 1866.

## Pen. Illustrations of the Drafts.

EXTENSION-TOP ROCKAWAY.

*Illustrated on Plate XXXVI.*

ALTHOUGH a good design, we do not claim that this is particularly new. It is, however, likely to be popular for years to come as a one-horse family carriage, its lightness and convenience serving to promote its manufacture. This body is intended to be paneled work, as it can be made much lighter in weight. The side panel being narrow, obligates the necessity of a deeper drop-bottom than usual. Perches to this kind of vehicle are a great support to the body against strains from use.

TWO-SEATED PHAETON.

*Illustrated on Plate XXXVII.*

WE give this as the varied plan of a very fashionable



carriage. As a summer vehicle for the Central or any other park it cannot be surpassed, especially should the owner be sportingly inclined. The call for this kind of carriage is increasing, and they are not likely to get out of fashion very soon. The round corners to the body and seats is a great improvement, since it makes a long body look much more neat and compact than when left square.

#### SPORTING PHAETON.

*Illustrated on Plate XXXVIII.*

THIS unique design is well calculated to supply the sportsman with a vehicle for the pursuit of his pleasures. While the body near the top is supplied with real cane for ventilation, there is ample room within for storing his "traps" and dogs. If intended for a family carriage, the panel need only be sham-caned, as described in another part of this Magazine. The pladding in the "cut-out" is done in various colors by striping, as indicated by the engraved lines. The back seat is made to turn in. The high cushion for a driver is seen projecting above the front seat.

#### ROAD BUGGY.

*Illustrated on Plate XXXIX.*

WE do not give this design as representing the fashions. What the fashion in buggies will be is difficult to determine just now. Perhaps the buggy on Plate XXXIV., published last month, is as nearly fashionable as any other we can offer. No doubt, as tastes differ, some will approve the one here given. It is far more likely to find admirers among plain people than the one we have above alluded to.

## Sparks from the Anvil.

### STEEL, AND THE BESSEMER PROCESS.

From a paper read by Mr. A. L. Holley, before the Polytechnic Association of the American Institute, on October 12th, 1865.

*(Concluded from page 139.)*

THE Bessemer process is, to the casual observer, almost ridiculously simple. It is, in fact, very simple; and it is conducted without any risk or difficulty, always providing that the irons used are of good quality, as most American irons are. In fact, it is almost impossible to make bad steel, or steel that is not uniform, out of good uniform irons, if ordinary attention is paid to the manufacture and the machinery, because the quality of the steel is not in a great degree dependent on the skill or judgment of the operator. The ingredients are mixed by weight. Bessemer steel cannot be economically made, however, without first-rate blowing apparatus, and constant vigilance on the part of the two or three skilled operatives who have charge of the tuyeres and linings.

The great commercial advantage of the Bessemer process over all other steel processes, and, considering the

quality of the product, over puddling, is its cheapness. The only fuel used is that for melting the pigs in a cupola, for heating the converter at the commencement of a series of charges, and the small amount for heating ladles, etc. The fire materials cost something more than in iron-making. The pig-iron required is more expensive than the average irons used in puddling. Very little skilled labor is required. Some steel products are produced at about the cost of wrought-iron products of the same shape and weight.

The great *advantage* of Bessemer steel over wrought-iron, especially in large masses, is its perfect homogeneity—the absence of welds and consequent imperfections, such as the laminations of rails, blisters in boiler plates, and cold-shuts in heavy forgings. Its tenacity is double that of wrought-iron, considering the above-mentioned and unavoidable defects of wrought-iron in welded masses. In the bar, it is one-half greater than that of wrought-iron, or from 90,000 to 120,000 lbs. per square inch, according to the degree of carbonization required for different purposes. The nature of the Bessemer process renders the product more uniform than wrought-iron can be, in all its qualities. The stiffness of this steel, proportionate to its tenacity, adapts it to girder and ship building, and peculiarly fits it to resist compressive as well as tensile strains, as in piston-rods. While the elasticity, and hence the safe working load, of the lowest steel is much greater than that of wrought-iron, its ductility is equal to that of the best wrought-iron. Two-inch bars may be bent double, when cold, under the steam-hammer. This property insures its safety in the form of axles and tires. The hardness of the material, as well as its homogeneity, increases its durability in the form of rails, guns, and parts subjected to abrasion. It is peculiarly adapted to plates requiring intricate flanging, and subjected to the immediate contact of fire. For a given strength it may be thinner than wrought-iron; it does not blister, and the carbon in it protects it against corrosion.

The kind of products now regularly ordered and produced at Troy are, railway axles, marine crank-pins, and small shafting, connecting-rods, piston-rods, locomotive crank-axles, boiler-plate, machinery steel-forgings, such as lathe-spindles, etc.; rolled and tilted bars for pistols, rifles, hammers, and agricultural machinery, wagon axles, and bars and rods for miscellaneous purposes. The old works produce ingots up to two tons weight; the new works will produce ingots up to fifteen tons weight.

A few experimental rails and tires without welds have been produced, but the present machinery is not nearly heavy enough for regular service. A heavy plate mill, a heavy mill to roll ingots into blooms, a tire mill requiring three hundred horse-power, and several steam-hammers, will be soon added to the works.

This process of making steel was brought out by Mr. Bessemer in 1856. English and European manufacturers began to adopt it in 1859 and 1860, and at the present writing not less than 100,000 tons of Bessemer steel are produced per year.

The idea of blowing air into melted cast-iron is at least three hundred years old. The fusing furnace for partially decarbonizing cast-iron, preparatory to puddling, has been worked on this principle for more than one hundred years. Since Mr. Bessemer's patents were issued, and since his practice began, claims have been made by two or three other persons for making steel by the Besse-



mer process; but not a pound of steel, or malleable iron was ever made by either of these processes; and it is physically impossible to make steel or malleable iron by either of them.

Mr. Bessemer spent a large fortune in his effort to carry the process away beyond the highest stage of decarbonization that could be reached by the fusing or any of its modifications; and I can say, from personal experience, that in his process the use of air, as a mechanical agent, is quite as indispensable as the use of air as a chemical decarbonizer. The attempt to completely decarbonize cast-iron without the use of the apparatus for which Mr. Bessemer has not only one but many distinct patents in England and in the United States, will result in the production of nothing but *scrap*, unequally decarbonized, and incapable of being either cast, balled, or utilized in any way.

Mr. Bessemer was also the first to suggest and to patent the process of *re-carbonization*, both by running cast-iron into a decarbonized iron and by other means, and the process of alloying manganese in connection with the pneumatic process. There are now seventeen extensive Bessemer steel works in Great Britain. At the works of the Barrow Steel Company 1,200 tons per week of finished steel can be turned out, and when their new converting-house, containing twelve more five-ton converters, is completed, these magnificent works will be capable of producing weekly from 2,000 to 2,400 tons of cast-steel. There are at present erected and in course of erection in England no less than sixty converting-vessels, each capable of producing from three to ten tons at a single charge. When in regular operation these vessels are capable of producing fully 6,000 tons of steel weekly, or equal to fifteen times the entire production of cast-steel in Great Britain before the introduction of the Bessemer process. The average selling price of this steel is at least £20 per ton below the average price at which cast-steel was sold at the period mentioned. With the present means of production, therefore, a saving of no less than £6,240,000 per annum may be effected in Great Britain alone, even in this infant state of the Bessemer steel manufacture.

#### THE PERCH-COUPLING IN INDIANA.

WE have received from Messrs. Barbour & Jackson, of Indianapolis, attorneys for the defendant, the following report of Haussnecht's late attempt to establish the validity of his claim to the perch-coupling in Indiana. Unless our friend exhibits better fighting, we are inclined to think his case hopeless elsewhere.

UNITED STATES.

*District of Indiana.—Circuit Court.*

HAUSSKNECHT

v.

ALVAH F. WOODCOCK.

The plaintiff, Haussnecht, claimed that he had made a new and useful improvement in the coupling of buggies and other carriages, and commenced several suits against carriage-makers in this State for an infringement of his supposed right. He admitted in his claim that others had used the improvement so far as to place the king-bolt back of the fore-axle, and the circular irons which he calls the fifth-wheel, long before his supposed invention; but he

claimed that he had a different combination, without explaining in any manner what his combination was. He had collected considerable sums of money from several of the carriage-makers of this State for a supposed infringement of his right, who would rather submit to the imposition than to be dragged into court, and subjected to the loss of time and payment of lawyers' fees; but the defendant in this case, and some others who were threatened with like suits, chose to make a stand, and contest the plaintiff's right to these demands. The defendant employed attorneys, who investigated the case, and advised him that the plaintiff had no legal claim upon him, and that he should defend.

Preparations for a defense were accordingly made, and the plaintiff was ruled to give security for costs. As these were likely to run up to a large bill, the plaintiff declined giving the security, but in the place of it prepared a long constitutional argument to show that the court had no right to rule him to give security for costs, which being unsatisfactory, the suit was dismissed.

As the plaintiff has learned some useful lessons upon the liability to pay costs in his suits in other States, it is not likely this suit will be revived. A defense to some of these actions in this State will put an end to farther demand upon carriage-makers in Indiana for any such infringements.

#### Paint Room.

##### SHAM-CANING.

SHAM-CANING in this country is comparatively a new business, and those who are in the secret are extremely careful to keep it to themselves. The object of this Magazine, however, is, among other things, to promote the mechanical interest of the craft. True to this principle, we intend, in answer to numerous inquiries, to let—*the paint out of the bag*. This we are enabled to do, as the result of laborious toil, in finding out.

To begin, then: the painter must provide himself with an apparatus, of which the engraving here given is a representation. This cannot be found at the shops, and must be made by the operator himself, in the following man-

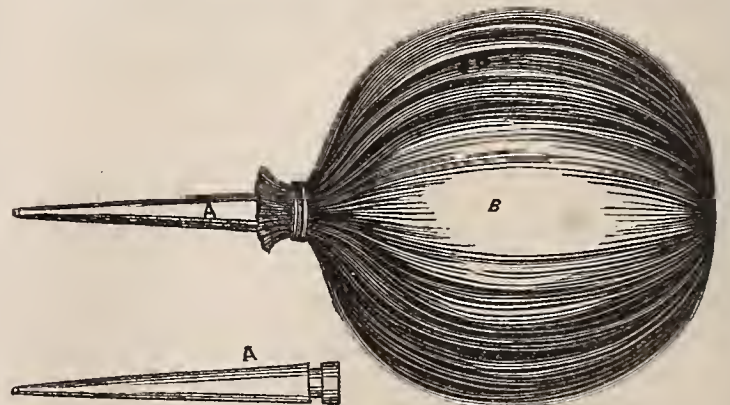

ner: Have the tubular end, A, made by a tin-smith, of zinc or stout tin, with a very small hole in the point, and the other end formed after the shape given, so that the bag—this bag, B, is made of sheep-skin—may be tightly tied with a string to the tube, after filling it with paint. This paint must, of course, be mixed of white and yellow colors to match the natural color of the cane, and of the



proper consistency to work well. (See volume III., p. 191.) We have now our instrument and the color ready.

Before we proceed further: we must cut out a stiff paper pattern the exact shape—in this pattern the full size of a panel, including the swell, must be taken—of the surface to be eaned, and lay it out with a pencil in lines as formed in the real cane, on the outside. Those who have our third volume will find examples already given on page 192, in which the lines are marked out. When these lines have all been drawn according to mechanical laws, this entire pattern must be pricked off in every line. To do this the more effectually it is necessary to have a small wheel full of points, inserted in a handle, after the manner of the trimmer's tool, known as the "pricker." Supposing that our panel has already been painted black, so as to fit it for striping, we next lay our pricked-off pattern thereon, and then *hammer* away at it throughout with a bag of tied-up whiting or pulverized chalk, just as the trimmer does to obtain a pattern for his white ornamental stitching. On removing this paper pattern we find the entire panel laid out in white dots. If the color of the paint in the ground work is red, some color in contrast must be substituted for our chalk, above named, and *vice versa*. Next, a rest-stick must be improvised, of a tapering form, and of suitable length, with a ball of cotton or soft leather at the end, to prevent scratching.

Everything being now ready for manipulation, seizing the tube and rest-stick in the left, with the right hand we press the paint-bag B, which pressure makes the paint exude from the end of the tube in the proper quantity to form the raised cane-strings, as with the left hand—guided by the rest-stick—the apparatus is moved toward the operator's body, leaving a *string* of paint behind it.

If we have succeeded in making ourself understood in this article, then our readers are in possession of the entire process of the *real* sham-caning, which narrow-minded men endeavor to envelope in mystery, that while their shop-mates are in ignorance they may flourish. It must, however, be apparent to all, that to succeed, requires much practice. The amateur ought therefore to do his *caning* on a *fugitive* panel, when he can do little damage should he make *faux faux*.

As a substitute for the above eaning, an article of merchandise has been imported from Europe by one or two manufacturers in this city. This, too, has been kept a secret by the knowing ones, and well it might be—*on the score of dishonesty*. It is a poor thing at best. We have examined the article. It appears to be nothing more than, oil-cloth *printed* in imitation of cane. It is prepared similar to the oil-cloth carpets, on a fine quality of muslin, a little more pliable. This *sham* article is fitted in, *over* the panel, and secured there by a preparation of white-lead while in a sticky state. A *little* glue in the lead would perhaps improve it. But this *shaming* is very liable to get loose in time, and prove more *shamable* than is required for one's fair reputation. We have heard of paper imitations of cane, but thus far we have not traced them to a reliable source. Lest we may be flooded with letters of

inquiry, we would state, once for all, that we cannot supply any of the materials referred to in this article.

A translation, in which much valuable information about eaning is given, was made from a French publication, for the third volume of this Magazine, and published five years ago, accompanied with engravings. This our practice forbids reprinting. The volume containing it, however, may be had, bound, for four dollars, by any who want it.

## Trimming Room.

### COACH LACE.

#### FIFTH ARTICLE.

WE this month present our readers with another specimen of coach lace from the Philadelphia manufactory of Messrs. Wm. H. Horstman & Sons. These gentlemen furnish a large proportion of the laeces made in this country, and it gives us great pleasure to find that there is daily an increasing demand for this beautiful adjunctive to cloth linings.

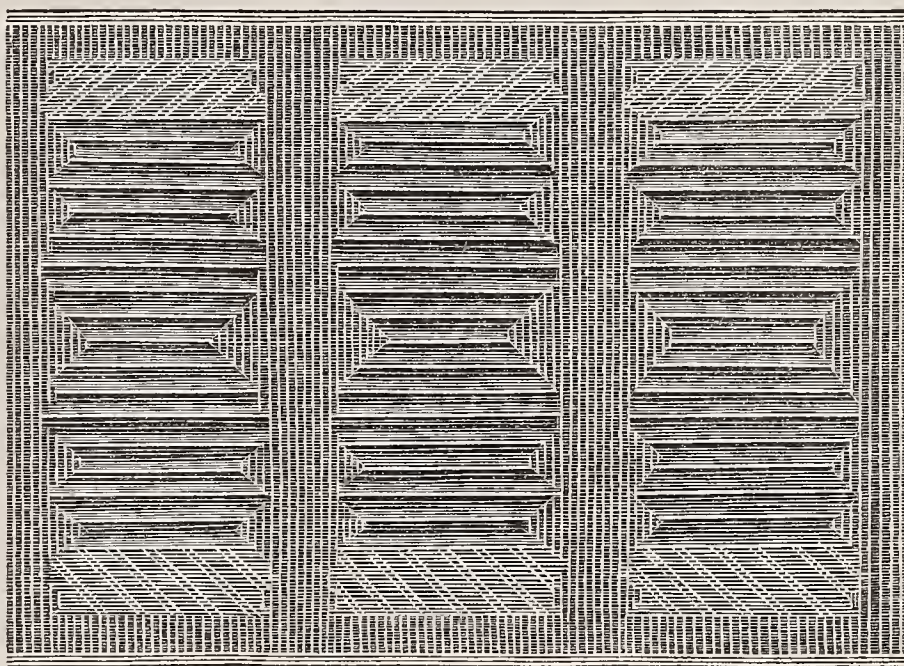

FIFTH SPECIMEN OF COACH LACE, FROM MESSRS. HORSTMAN & SONS' ESTABLISHMENT, PHILADELPHIA.

The many advantages in cloth over leather for carriage linings, where ladies are passengers, recommends its use in all cases. Silks and satins, if not ruined, are spoiled by coming in contact with morocco, and even admitting that cloth costs a little more, still in the end it is the cheapest, all things considered.

Our engraving is from a pattern of manufactured lace, numbered 627. The materials used are silk and worsted, but this pattern looks well in worsted alone. In the design, the darker shades represent worsted, which is black, and the lighter shades or tints the silk wool, which is dark blue. This, although much plainer in design than some of the samples we have selected, makes a very pretty lace, showing off to good advantage when made up.



## MACHINE THREAD.

SINCE we published our observations on this subject (see page 58 *ante*), we have been literally overrun with orders for it. These we have in all cases filled when the parties ordering were known to us. But our friends do not yet appear to consult their own interests as fully as they might. Instead of asking us to send the thread by express, C. O. D., they ought to send the money with the order, and thereby (if the order exceeds \$10) save the five per cent. deducted for cash, and the expressman's additional bill for collection, which in most cases is an important item. Some customers do not think of this—that in every instance express companies make one charge for delivery of goods, and where a bill is sent with them they make another for the collection and delivery to us of the money. For this last service the charges are quite as high as for the transportation of the goods originally. This, of course, our customers must pay. Will it not then be to your interest to forward the money? To the amount of \$30, this can be done with perfect safety in post-office orders. Try this hempen thread, instead of paying treble for silk, when you get an article no better for your purpose. To ascertain the price per pound, add to our last quotation the *premium* on gold as given in your paper on the day you forward your order. For instance, No. 532 (the most popular number) is quoted in this journal at \$2.30 *in gold*. To get the price *in currency*, add to each dollar and fractional part thereof the premium—say 39 cents on the dollar. This will show the price of a pound of thread to be at the time \$3.18 in currency. If you buy a package of three pounds—which is the better way—treble the amount—\$9.54—and you have the required sum.

## Editor's Work-bench.

## CONSIDERATIONS FOR CORRESPONDENTS.

SINCE the war has ended we find that our letter correspondence is gradually increasing, as well as in some instances becoming complex. This complexity, doubtless, has in some degree been owing to the necessity of a better understanding between our friends and us on several points. Some of these we will endeavor to review, and, if possible, provide a remedy for.

The public, under the mistaken idea that when an individual volunteers to cater for them, that they have a perfect right to his services, whenever business or fancy incites them to demand it, appear to forget, that like themselves, he is finite, and therefore limited in time and strength. They forget that there may be forty or fifty others requiring some favor at our hands at the same moment, each of which have equal claims upon our attention; and, that to attend to them all at once, is impossible. That we may set some of these right, we here produce some of the "items" found in the letters we have received during the month past, accompanied by such remarks as we hope will prove mutually instructive.

A gentleman in the West, who is not a subscriber,

writes to learn the present prices of almost the entire catalogue of materials found in our prices current. Were we to answer his queries in detail, he would still "jog on" as he has heretofore done, without subscribing for our Magazine, the result of which would be, we should receive only "labor for our pains." Of course, to answer will not pay. If he *was* our true friend and patronized our journal, his wishes would be anticipated every month, without taking trouble upon himself, or troubling us.

Another gentleman, in the most laconic terms, writes: "Please send me a specimen number of your Magazine," without even adding the tempting inducement that he wishes to become a subscriber. Instead of a number we send him our circular. This brings us fifty cents, with the gratuitous remark, "It appears to me as if you dealt with great suspicion, or else you might have sent me a specimen, stating the price, and I would have remitted the amount at once." Perhaps so, but having *experimented* in this way a thousand times, with untold loss, we doubt it. As he signed himself M. D., and called for the December number, we saw at once that his *sole* object was to get the drawing for a physician's phaeton, on plate xxv, without paying for it.

Another correspondent, who gets a copy through a bookseller, blows us up because we did not answer his letter, sent us without a stamp for return postage. As he wishes us to post him in the whole art of sham-caning, we are rather surprised that he did not think it worth three cents! We have further to say, that we consider no man a subscriber whose name is not on *our* mail-book.

Besides the above, we have received several orders for tools necessary in working the Guard Wheel Machine. Our answer is, we cannot supply them separate from a machine, for the best of reasons—they cannot be purchased of the inventor. Those who write us ought to know this as well as ourselves, after having tried it unsuccessfully.

Another writes us a *frothy* letter because we paid no attention to a note, with which he says he sent us \$1, when, in fact, he must have neglected putting it in, as his first letter bore no trace of its having been tampered with.

An old Canada subscriber, who knows that our terms are *cash in advance*, tells us to send him "a copy as soon as possible, and then, on receipt, he will send us the price of a year's subscription." Now, the question arises, had we better transgress our published rules, and comply with his request, or he send us five dollars with his order?

There are more matters we would like to see corrected, but which we have not space to consider here. It is evident to any reflecting mind that there is no use of establishing a rule without a purpose; and when these purposes are transgressed, who ought to suffer the consequences? If our rules are strictly followed no one will



ever have cause for complaint against us. We try our best to please, and think that we have been as successful in this respect as any of our contemporaries. We know that our position renders it convenient for the trade to correspond with us on different subjects, and this we are glad to have them do; but we wish it distinctly understood that for the trouble we take, we expect suitable remuneration. Those, then, who come under the head of "bores," expecting our services "free gratis for nothing," had better economize in the purchase of postage-stamps as the first step towards reform.

#### PROPOSED CHANGE IN THE INTERNAL REVENUE LAWS.

THE commission appointed by authority of an act of the last session of Congress "to inquire and report upon the best and most efficient means of raising and collecting the revenue" has made a preliminary one, in which among other things, several modifications are proposed, more favorable to carriage-manufacturers. This, the committee tell us, is the result of their consultation with "representative business men, each speaking about his profession, and often revealing facts which in daily life are screened from the public eye." Had this course been taken earlier, the craft would not have suffered so much as it now has from blundering legislation. But *light* is breaking in the right direction, and we are encouraged to hope for some relief. It has been discovered that "a nation of manufacturers can only subsist as they can sell their produce, and they can sell it only as they can sell it cheap. But the ability to sell their produce cheaply implies a cheap command of the raw material and of the workman's food. To tax these is to decree the nation's ruin, and involve all classes alike in bankruptcy and pauperism."

In distributing the taxes originally, our law-makers appear to have been greatly influenced by those levied in England. But the *status* of the two communities are widely different. The lines between the rich and the poor are more distinctly drawn in England than among us, and with more forethought than our law-givers have exhibited, they have there layed the taxes more in accordance with justice—on those who will suffer the least in paying them. The aristocracy, who revel in "servants, dogs, horses and carriages," are able to pay for these luxuries by a direct tax on the articles enumerated; but the English government, with commendable forethought, has always had a proper regard to the exemption of home industry from unnecessary burdens. The same may be said of France, where the appetites and indulgences of the people are more directly visited with the effects of taxation.

One great defect in the revenue law, which we have before complained of, is that of compound taxation. The committee tell us—we always knew this—that "the Gov-

ernment levies and collects from eight to fifteen per cent. (and even in some instances twenty per centum) on almost every finished industrial product." When, for instance, it is remembered that a finished carriage is always an aggregate of several distinct and separate manufacturing processes, having several times been already taxed, some idea of the injustice done us will appear. Such a system violates all the fundamental principles of taxation, inasmuch as the taxes are unequally distributed, and fall with crippling effect upon the industrial interests. To remedy this, the commission recommend "*such a revision of the present internal revenue system as will look to an entire exemption of the manufacturing industry of the United States from all direct taxation.*" What follows is of so much interest that we give it entire:

It is an error to assume that manufacturing establishments, large or small, are always profitable. It can, undoubtedly, be shown that in most departments they do not yield large profits in more than three years out of ten, and they scarcely ever escape two years of heavy losses in every ten years. These losses arise from a variety of causes, such as the fall of prices, disasters to machinery, the bankruptcy of customers, commercial revulsions attended with stoppage of business and cessation of demand. Fluctuation of prices is the bane of domestic industry, for though a great rise yields at times enormous profit, it carries fear and perilous change into every business, and causes men for years to stand on the very verge of insolvency. Not less than a third of those who engage in the production of any commodity subject to competition from abroad and the special fluctuations of foreign trade are utterly ruined before they can attain that capital and strength which will enable them to maintain themselves under all contingencies.

The commission recommend that the change be made slowly, and for the present, and to begin July 1, 1866, or sooner; they urge the following changes:

1. A repeal of section 100 of the amended act of March 3, 1865 (generally known as schedule A), such of its provisions as relate to and impose a tax on "billiard tables" excepted.

2. A repeal of all that part of section 94 of the amended act of March 3, 1865, which provides for the assessment and collection of taxes on repairs of engines, cars, carriages, ships, etc.

3. A repeal (subject to certain exceptions) of all that part of section 94 which provides for the assessment and collection of taxes upon wearing apparel.

4. A repeal of the excise duty of \$2.40 per ton levied upon pig iron; the repeal of the duty of six cents per ton levied upon mineral coal; and of the duty of one dollar per barrel on crude petroleum.

5. A repeal of all excise taxes on printed books, magazines, pamphlets, reviews, and all other similar printed publications.

In addition to the reductions above specifically referred to and recommended, the commission would further recommend that on and after the first day of July, 1866, the taxes levied and paid upon all goods, wares, and merchandise enumerated in section 94 of the amended act of March 3, 1865, be reduced fifty per centum, and that no allow-



ance or deductions whatever in the payment of the same for freight, commissions, and other expenses of sale, be authorized or permitted. The reduction of the revenue from these repeals, is estimated at about \$15,000,000.

#### VISIT TO A WHEEL MANUFACTORY.

SOME days ago business called us to Newark, N. J., where, as our readers will find from an inspection of our advertising columns, is located the extensive wheel factory of our friend George Neefus. Mr. Neefus, who believes in availing himself of every means calculated to improve his work, has secured the services of an experienced wheel-maker in the person of Mr. S. O. Crane, long and favorably known to the public as being one of the firm of Crane & Kilburn. Under his superintendence Mr. N. is building up an extensive business by taking great pains to supply the carriage-makers with wheels well made from the best of stock. Personal inspection has satisfied us that whoever patronizes this establishment will be fairly dealt with. We saw that special attention is given to driving the spokes in the hub, by carrying out the process before advocated in these pages so as to secure solidity—a process we have ever found reliable. To specify the plan pursued might be taken as a breach of confidence in us, and therefore we maintain a silence at this time. We have only space to add that we are convinced that those who have occasion to order their wheels from Mr. Neefus will not only find in him a gentleman whose study is to please, but prove his wheels all he represents them to be.

#### FRENCH EXHIBITION OF 1867.

WE are not advised in regard to the preparation making among American carriage manufacturers for the contemplated exhibition at Paris in April of the ensuing year. This will certainly present an opportunity to our countrymen for showing our Gaelic cotemporaries, as well as England, which will no doubt be well represented there, that we are in no respect second to them in either our models or workmanship. Our superiority of timber gives us a decided advantage over Europeans in making light carriages. Less heavy, our vehicles are much stronger and more graceful. Some of the French as well as the English carriage-builders have for some time been importing our timbers for their factories, although very little has been said about it. We have indeed furnished them with a great many sets of our neatly made wheels, which appear to have given great satisfaction and stirred up no little jealousy among European wheel-makers. These "world's fairs" have no doubt been the means of making our products known where previously much ignorance existed, and the award of premiums to American exhibitors in England during the last few years sufficiently prove that national prejudices are fast fading away before the

light of truth. The disgraceful barbarism practiced in the last English exhibition upon our carriages, in cutting them to pieces, is not likely to be imitated by the French operatives, for as a class Frenchmen entertain the kindest feelings for us.

As a matter of speculation then it will be well for our carriage-builders to exert themselves and send their manufactures forward. Although they may not carry off *all* the prizes, yet they will assuredly do what is much better, secure orders from France, which may furnish them with remunerative employment hereafter. We are in a position to know that those firms which have been represented in former exhibitions abroad have subsequently been amply repaid in orders for all the trouble and outlay they have been at. Mr. Charles B. Norton, we understand is the American agent to take charge of the property of our countrymen in Paris. Those who are interested will therefore communicate directly with him in the French capital.

#### THE WAY THEY DO THINGS IN CINCINNATI.

THE Trades' Union journeymen in Cincinnati having "sown the wind," by notifying the carriage-making employers that they intended to *demand* an advance of ten per cent. on the first of February, are, doubtless, now "reaping the whirlwind." Nineteen of the bosses, comprising all the best shops, having, as a matter of protection, signed the following agreement on the 19th of January last:

WHEREAS, We the undersigned, Carriage-makers and Employers of Cincinnati, have been notified by our employes, through the "Journeymen Coach-maker's Protective Union of Cincinnati," that they have passed rules, laws and regulations, by which they and we are to be governed; said laws to be enforced against others in our employ, and that they have voluntarily become bound and pledged to sustain, uphold, and enforce said rules, laws and regulations:

And believing, as we do, that the action of said Journeymen's Union is arbitrary and unwarranted, subversive of our personal and natural rights, that the demands are unreasonable and unjust:

We do hereby bind ourselves to each other, that we will resist the demands of said combination, and will in no way recognize its authority; and that no member of said Union shall be hereafter taken into our employ.

Also, *Resolved*, That we agree to notify the hands in our employ, that we will not accede to the demand made upon us for an advance of ten per cent. on the first day of February next.

And to this agreement we hereunto set our hands.

This action on the part of the employers seems to have had its intended effect, to overcome which the "Protective Union" contemplate reorganizing under a new name. This further intention has been met with the further action of the principal carriage-manufacturers of Cincinnati:

WHEREAS, The said Union, as we are informed, do now



propose to change their title, and reorganize, under the name of a so-called "Coach-maker's Union," for the purpose and object of dictating and controlling the management of our business.

We do hereby declare our firm determination to resist said combination, and believing as we do in the righteousness and justice of our cause, will firmly adhere to the same during the year.

H. NIEMEYER, and sixteen others.  
CINCINNATI, Feb. 8th, 1866.

We know nothing about the merits of this business, not having had a line from the "Union," but judging from the arbitrary measures taken elsewhere by those *who would make labor dictate to capital*, we are not surprised at the steps taken by the capitalists of Cincinnati. As we have before advocated, all measures taken for the advancement of wages should be done with the interests of both parties mutually in view.

#### EDITORIAL CHIPS AND SHAVINGS.

**LARGEST CARRIAGE MANUFACTORY IN MAINE.**—The extensive carriage manufactory of G. P. Kimball, in Portland, Maine, is said to be the largest of the kind in the State. The buildings are spread over half an acre of ground, and he gives employment to fifty hands, and pays to Government over \$4,000 per annum in the form of revenue tax.

**LARGEST MANUFACTORY IN THE WORLD.**—The extent of F. Krupp's steel manufactory at Essen, Prussia (well known to be the largest in the world), is three hundred acres, and the length of railways for interior communication about twelve and a half English miles, on which four locomotives and one hundred and fifty wagons are in constant use. The buildings cover an area of forty-six acres. There is a gas-work, and a bakery and cooking establishment for the unmarried men. In 1864, in the steel works, exclusive of the collieries and blast furnaces, which are situated in Nassau and Tain, there were 6,600 workmen. In the same year there were in operation 350 smelting, heating and puddling furnaces; 136 steam engines, from 4 to 100 horse-power; 34 steam hammers, from 1 to 150 tons; 110 smithies, and 508 turning and other machines. The production of 1864 was 27,000 tons of cast-steel, in guns, axles, tires, springs, rails, boiler-plates, rollers; etc. In May, 1865, the establishment employed 8,000 workmen.—*London Building News.*

**STAGE-COACHES AND CONCORD HACKS "OUT WEST."**—The old-fashioned stage-coach is used from the Missouri westward 600 miles; to Denver, Colorado, and from California eastward 400 miles, to Austin, Nevada. Over the intervening gap of the great central route, and upon all its branches, plies the Concord hack, covered with duck or canvas, the driver sitting in front at a slight elevation above the passengers. Bearing no weight upon the roof, it is less top-heavy for mud-holes and mountain-sides, where preserving the center of gravity becomes, with Falstaff's instinct, "a great matter." Like human travelers on life's highway, it goes best under a heavy load. Empty, it jolts and pitches like a ship in a raging sea; filled with passengers, and balanced by a proper distribution of baggage in the rack behind and under the driver's feet, its motion is easy and elastic. Excelling every other in durability and strength, this hack is used all over the conti-

nent, and throughout South America. In a dozen localities its manufacture is imitated with more or less success, but never equaled. The little capital of the Granite State alone knows the art of making a vehicle which, like the one-hoss shay, "don't break down, but only wears out."

**THE DROSKEY.**—A late traveler says: "The droskey is the popular mode of conveyance in Russia. They are numberless. Every corner is blocked up by the droskey and its noisy driver, who is always crying, *droschy, by jolst* (droskey, if you please). They generally ask about twenty or thirty copecks, but never get it. A bargain must always be made before you enter the vehicle, otherwise you will have trouble. The drivers wear a long coat tied around the waist with a sash, and have their number on a brass ticket suspended from their neck. They have no fixed prices like the *cochers* of Paris, but are more good-natured.

**REPLEVIN OF A CARRIAGE.**—A case of some interest to the craft has lately been tried in the Supreme Court held in this city, Justice Clark presiding, in which Wood Brothers were plaintiffs, and Thaddeus M. Talcott, defendant.

The plaintiffs in this action are carriage manufacturers in New York City; the defendant, in May last, was a resident of Buffalo. In that month he came to New York City, went to the plaintiffs' carriage warehouse, selected a \$450 carriage, and said he would call in a day or two with the money to pay for it. Pursuant to agreement, he did call, and then stated to one of the Messrs. Wood that he had not enough ready money with him to pay for the carriage, but said that his father was largely engaged in business in Buffalo, in company with Mr. Dean Richmond; at the same time referring the plaintiffs to several large houses in that city with whom they were acquainted. Defendant then said he would give plaintiffs a sight draft on his father, or if they preferred it, on Mr. Richmond, for the price of the carriage. Plaintiffs finally consented to take a sight draft on defendant's father, and shipped the carriage to Buffalo. The draft was sent on, and came back protested. It appeared in evidence that defendant's father was a poor laboring man in Buffalo, having no business connection whatever with Mr. Dean Richmond. It was also shown that the defendant was a young man of very bad reputation, and goes by the name of "Swindling Talcott" in the city of Buffalo. The history of the carriage is somewhat interesting. The plaintiffs have it now in their possession, much the worse for hard usage. Since it left them in May last, it has been three times replevined in Buffalo, in suits brought against the defendant by his creditors. Once it was stolen, and the thieves got as far as Cleveland with it, when it was brought back. The jury in this case rendered a verdict, by direction of the court, that the plaintiffs are entitled to the possession of the carriage, and assessed the value thereof at \$450.

#### LITERARY NOTICES.

WE are gratified to hear that Messrs. Ticknor & Fields, the popular Boston publishers, are obtaining for their serial works the generous patronage of the literary public. In *Every Saturday* we find some of the most attractive articles reprinted from the best English periodicals, which to us prove delightful reading, and of which we never weary. This weekly has reached its seventh number, and if we may take the editor's past as an earnest of his future labors, there can be no doubt of his ability to please the



most fastidious. Each number contains 32 pages, amounting to 1,664 pages in a year, for the trifling sum of \$5—cheap enough!

Our old visitor, the ever-welcome *Atlantic Monthly*, published by the same enterprising firm, comes to us as regularly as the months roll round, freighted with "word paintings" of the choicest kind, contributed by the best and most original writers of the age. No one who reads this work, although he may not like all its teachings, will fail to elevate his literary *status*, nor miss obtaining that knowledge which is power—is wealth—is honor. Try the experiment for one year; it only costs \$4. And *Our Young Folks*, too—he must not forget that. It is the most attractive juvenile we know of, containing some of the prettiest pictures and daintiest letter-press the most fastidious may desire. Although we have no *very* "young folks," still so great a favorite is this periodical in our family with "the older members," that they *appropriate* it as soon as it reaches our table, and devour its contents greedily. For this monthly feast only the small sum of \$2 is charged. For the above periodicals an agency has recently been established at 523 Broadway, for this city and Brooklyn. Subscribers availing themselves of this arrangement will have their magazines delivered at their domicils free of postage.

"*The Seven Deadly Sins of London*, drawn in Seven several Coaches through the Seven several Gates of the City, bringing the Plague with them," is the quaint title of a book written early in the seventeenth century, and recently republished by C. Paine Collier, as an addition to his series of old English literature. This work, *opus septem dierum*, was written by an author whose name was Dekker, and is a very remarkable one.

## The Coach-maker's Letter-box.

### LETTER FROM ALABAMA.

[The following letter is from an old subscriber and friend in the South, whose name we suppress from prudential reasons. It gives a vivid exhibition of the state of affairs in Dixie, especially among that class who were opposed to the late secession. The writer's address will be furnished to any Union man who may wish to accept the offer made by our correspondent, with good Northern references as to his character and integrity.]

T \* \* \* \* \*, Ala., Jan. 31, 1866.

MR. STRATTON: *Dear Sir*,—Your circular came to hand, and I am sorry to say that circumstances that I had no control of have left me in rather an unfavorable fix. My business is about stopped, having during the war used up pretty much all of my stock, or left it in such a fragmentary condition that I am unable to go on now, and until a crop of cotton is made and sold, money will be very scarce here. Besides, workmen cannot be had, and if they could be, there is no money to pay for what they might do.

I have about the best shop in the South—I mean for its convenience. It was burned out in 1854, and rebuilt up from the ground, and every one who has seen it has thought it the best arranged. It is now, with some material on hand, standing idle. My energies are a little sub-

dued by the circumstances—having been burned out once twelve years ago, and lost enough then for once, and this last four years have done me quite as much injury—not that the Yankees have done me any damage, but from the effects of stay-laws. When they foolishly determined to secede, the Southerners undertook to protect themselves from the legitimate consequences of the act by passing stay-laws, and then with Confederate money they undertook to pay their debts, relieving themselves in this way. Whether we like it or not, by this means most business men are left flat, and notwithstanding they may have been Union men, as many were, they were browbeaten, and had to take many of their claims in Confederate money, then worth only seventy-five cents in the dollar. The planters may have paid up their debts, but some could not pay all, as the money would not pass. The Union men of the South had a hard time of it, and are hurt much more than the rebels.

Excuse me for all this. I would like to take your Magazine, and pay for it, but cannot now. I also would like to get some good competent man, who is younger than myself, and has the world before him, to come out and take my shop. There will not be much done this year, but a good energetic man could come and grow up with the place, as it will grow. The place is situated in a healthy locality, in which I had done very well up to the commencement of the war, and which I could do again if I was *younger* and more active. I would like to have a competent man who would take hold of, and go on, and do a good business. By all means he should be a good workman and an *honest* man. I could aid such a man along until he could go alone, should he be the right man, as I have managed to get through the war by exchanging off work, and getting about forty-six bags of cotton, which if sold will bring me from \$4,500 to \$5,000 currency, which will enable me to keep up this year.

A WORN-OUT CARRIAGE-MAKER.

## Patent Journal.

### AMERICAN INVENTIONS.

(51,756) MACHINE FOR SETTING SPOKES IN WAGON-WHEELS.—Richard Walker, Batavia, N. Y. :

I claim making an adjustable guage for setting the spokes and regulating the size of wheels in the manner herein described and particularly set forth, and for the purpose described.

(51,773) CARRIAGE-WHEEL HUB.—McClintock Young Frederick, Md. :

I claim, *First*, The channel *c*, in or on the journal, and curved outward and upward through the collar, and furnished with a hinged stopper for the purpose of introducing, holding and retaining a supply of oil or similar fluid lubricator, substantially as and for the purpose described. *Second*, In combination with the close band *D*, and nut *E*, each furnished with a hole, I claim a pin or stud introduced from the outside, for the purpose of forming a lock or tie between said band or nut to run the nut off from or on to the journal of the axle, substantially as herein described and represented.

(51,781) TURNOUT WAGON SEAT.—George Gregory, New Haven, Conn., assignor to Lawrence, Bradley & Pardee, New York City :

I claim the above described construction and arrangement of a turnout seat for wagons or other vehicles, substantially as and for the purpose set forth.



January 2, 1866. (51,808) CARRIAGE WHEEL.—Andrew J. Curtis, Winterport, Maine:

I claim the combination and arrangement substantially as herein before explained, of one or more screw-bolts F, and the stud C, with a wheel-felly and tire, or with the same and one or more socket pieces E, arranged with respect to the felly substantially as herein before specified.

(51,872) MACHINE FOR UPSETTING WAGON TIRE.—Elias Shopbell, Ashland, O.:

I claim, *First*, The construction and arrangement of the herein-described serrated cam levers E', F', serrated, cogged and concave slide D, serrated stationary block B, and the cogged segmental lever H', when combined and susceptible of adjustment substantially as described. *Second*, In combination with the above, I claim the arrangement of the punching die L, and standard L', for the purpose set forth.

(51,884) VARNISH FOR PAINTING.—Andreas Eigner, Augsburg, Bavaria, assignor to Sampson R. Webino, Roxbury, Mass.:

I claim the composition made of the ingredients and in the manner and for the purpose substantially as herein before described.

9. (51,911) HOLLOW AUGER.—Fordyce Beals and Major Smith, New Haven, Conn.:

We claim, *First*, The combination of the slide I with the cutter D, constructed and arranged to operate substantially as and for the purposes specified. *Second*, The arrangement and construction of the cutter D, adjusting screw h, and set screw d, combined so as to operate for the purpose of increasing or diminishing the depth of cut of the auger.

(51,938) WAGON BOX.—Wm. B. Geer and Almond H. Palmer, Portland, Ill.:

We claim the arrangement of the various portions of our machine for the purposes set forth.

(51,941) MODE OF RELEASING HORSES FROM CARRIAGES.—James T. Guthrie, Leesburg, Ohio:

I claim the double whiffletrees b, retaining bolt E, arm D, spring c, and strap F, in combination with cross-bar B, substantially as described, and for the purpose set forth.

16. (52,029) AXLE BOX.—James Christy, Philadelphia, Pa.:

I claim, *First*, The stop or projection d, fitting into an opening in the top of the box, and arranged in respect to the key E substantially as and for the purpose herein set forth. *Second*, The combination of the lid F, fitted to the front of the box, and combined with the projection or stop d, substantially as described. *Third*, the combination of the lid F, spring-catch G, and projection e on the box.

(52,056) AUGER.—Ebenezer G. Lamson, Windsor, Vt.:

I claim constructing twisted augers having curved cutting edges, with the base of the tug-screw depressed into the twisted pod beyond the line of the cutting edges of the floor lips at their lowest line of cut, substantially as described.

(52,058) HARNESS BELL.—C. Theodore Liebold, New York City:

I claim the fixation of the bell-shells opposite each other so that the two form a globe to cut in two, leaving a small space free between themselves, securing thereby the richest tone and greatest beauty of form possible.

23. (52,126) CARRIAGE-TOP PROP BLOCK.—William N. Barnett, Urbana, O.:

I claim carriage-top prop blocks, made as described above, as an article of manufacture.

(52,130) SPOKE MACHINE.—R. H. Boynton, Oshkosh, Wis.:

I claim the rotating cutters n, n, bent levers 4, 4, lever m, and cam-shaped pattern S, arranged with reference to each other

and to the endless bed or chain y, substantially as and for the purpose herein set forth.

(52,170) COUPLING FOR CARRIAGE THILLS.—James Howarth, Monroeville, Ohio:

I claim, *First*, The plates A and B, and clutch G, in combination with the bolts E, h, when arranged as and for the purposes substantially as set forth. *Second*, In combination with the above described construction, I claim the heads A, B, concave d, and the points b, b, all arranged as shown, and for the purpose specified.

(52,229) THILL-HOLDING LOOP.—William Morley, Rolfe, Iowa:

I claim a metallic thill-holding loop A, A, constructed substantially as described, and the suspending the same between two parts of a suspending strap E, E, substantially in the manner and for the purpose set forth.

(52,229) CARRIAGE SEAT.—Richard Walker, Batavia, N. Y.:

I claim the changeable carriage seat a, hung upon the arms c, d, hinged near the bottom of the body of the carriage, and also hinged to the bottom of the seat, in combination with the guide-irons m, m, and the duplicate seat b, all arranged substantially as described and for the purpose set forth.

#### FOREIGN INVENTIONS.

April 20, 1865. LAMPS FOR CALLING CABS AND OTHER VEHICLES.—E. Wilson, Pall Mall, London:

This lamp is constructed as follows: The patentee forms a metal frame, of an oblong shape, the sides of which are composed of glass, talc, or other transparent material, while both ends are of metal, one of which is hinged to act as a door. The base of the lamp is made of metal, by preference perforated, and on its inner side it carries a tapering guide, on or in which a holder for the reception of oil or other liquids capable of burning and affording light, or supporting a candle, is free to slide. To the outer sides of the base plate, he attaches wires, which are bent into a circular form, and grasp each other, in order to afford a firm support for the lamp. When set on a stand or other resting-place, he prefers wires for the sake of lightness, but plates may be used. The upper part of the frame of the lamp carries a canopy, with a handle on the top, and hooks on each side, the latter being used for suspending the lamps. The glass or talc sides of the lamp are colored differently—say red on one side and green on the other. On the canopy, over the red color, he writes "Hansom Cab," and paints a large H on the red glass. On the other side of the canopy, and over the green color, he writes "Four-wheeled Cab," and paints a large C on the glass.

May 19, 1865. MAN-MOTIVE CARRIAGE.—G. Read, Slitsford, Sussex:

For the purpose of communicating motion to the wheels whereby the carriage is propelled, the inventor places a screw wheel on the driving axle of the carriage; gearing into the screw wheel (as a substitute for the endless screw usually working in endless screws) is a disc having a series of friction bowls arranged around its periphery. These bowls take into the teeth of the screw, and by the rotation of the bowl-disc cause the screw-wheel to rotate, and so propel the carriage. The inventor places this bowl-disc on a vertical or inclined shaft, and continues it upward to any convenient position for driving by means of a winch handle or other convenient means on the top. He places a universal joint on this driving shaft, whereby it may be inclined and adapted to any position desired for the convenience of driving. He steers the vehicle by means of the fore-wheel or wheels, mounting it or them on an axis, and in bearings in which the axis can be moved in the different directions required for steering the vehicle, such motion being communicated by means of a hand lever and connecting rod, or it may be operated by the feet of the operator. According to this arrangement the one hand is engaged in driving the winch handle, while the other may effect the steering. *Not proceeded with.*



## CURRENT PRICES FOR CARRIAGE MATERIALS.

CORRECTED MONTHLY, FOR THE NEW YORK COACH-MAKER'S MAGAZINE.

NEW YORK, Feb. 22, 1866.

Apron hooks and rings, per gross, \$2.50.  
 Axle-clips, according to length, per dozen, 75c. a \$1.25.  
 Axles, common (long stock), per lb, 10½c.  
 Axles, plain taper, 1 in. and under, \$6.50; 1½, \$7.50; 1¾, \$8.50; 1¾, \$9.50; 1¾, \$10.50.  
 Do. Swelled taper, 1 in. and under, \$7.00; 1½, \$8.25; 1¾, \$8.75; 1¾, \$10.75; 1¾, \$13.00.  
 Do. Half patent, 1 in. and under, \$10.50; 1½, \$12.50; 1¾, \$15.00; 1¾, \$17.50; 1¾, \$21.25.  
 Do. do. Homogeneous steel, ½ in., \$15.00; ¾, \$15; 1, \$16.50; long drafts, \$4 extra.  
 ☞ These are prices for first-class axles.  
 Bands, plated rim, under 3 in., \$2.50; over 3 in., \$3  
 Do. Mail patent, \$3.00 a \$5.00.  
 Do. galvanized, 3½ in. and under, \$1; larger, \$1 a \$2.  
 Basket wood imitations, per foot, \$1.25.  
 ☞ When sent by express, \$2 extra for a lining board to a panel of 12 ft.  
 Bent poles, each \$2.00.  
 Do. rims, under 1½ in., \$2.25 per set; extra hickory, \$3.25 a \$4.00.  
 Do. seat rails, 50c. each, or \$5.50 per doz.  
 Do. shafts, \$8.00 per bundle of 6 pairs.  
 Bolts, Philadelphia, list.  
 Do. T, per 100, \$3 a \$3.50.  
 Bows, per set, light, \$1.50; heavy, \$2.00.  
 Buckles, per grs. ½ in., \$1.50; ¾, \$1.50; 1, \$1.70; 1½, \$2.10; 1, \$2.80.  
 Buckram, per yard, 25 a 30c.  
 Burlap, per yard, 30c.  
 Buttons, japanned, per paper, 25c.; per large gross, \$2.75.  
 Carriage-parts, buggy, carved, \$4.50 a \$6.  
 Carpets, Brussels, per yard, \$2 a \$3; velvet, \$3.25 a \$4.50; oil-cloth 75c. a \$1.  
 Castings, malleable iron, per lb, 20c.  
 Clip-kingbolts, each, 50c., or \$5.50 per dozen.  
 Cloths, body, \$4 a \$6; lining, \$3 a \$3.50. (See *Enameled*.)  
 ☞ A Union cloth, made expressly for carriages, and warranted not to fade, can be furnished for \$2.40 per yard.  
 Cord, seaming, per lb, 45c.; netting, per yard, 8c.  
 Cotelines, per yard, \$4 a \$8.  
 Curtain frames, per dozen, \$1.25 a \$2.50.  
 Do. rollers, each, \$1.50.  
 Dashes, buggy, \$1.75.  
 Door-handles, stiff, \$1 a \$3; coach drop, per pair, \$3 a \$4.  
 Drugget, felt, \$2.  
 Enameled cloth, muslin, 5-4, 70c.; 6-4, \$1.10.  
 Do. Drills, 48 in., \$1.00; 5-4, \$1.00.  
 Do. Ducks, 50 in., \$1.45; 5-4, \$1.40; 6-4, \$1.55.  
 ☞ No quotations for other enameled goods.  
 Felloe plates, wrought, per lb, all sizes, 25c.  
 Fifth-wheels wrought, \$1.75 a \$2.50.  
 Fringes, festoon, per piece, \$2; narrow, per yard, 18c.  
 ☞ For a buggy top two pieces are required, and sometimes three.  
 Do. silk bullion, per yard, 50c. a \$1.  
 Do. worsted bullion, 4 in. deep, 50c.  
 Do. worsted carpet, per yard, 8c. a 15c.  
 Frogs, 75c. a \$1 per pair.  
 Glue, per lb, 25c. a 30c.  
 Hair, picked, per lb, 65c. a 90c.  
 Hubs, light, mortised, \$1.25; unmortised, \$1.00—coach, mortised \$2.00.  
 Japan, per gallon, \$3.  
 Knobs, English, \$1.50 a \$1.75 per gross.  
 Laces, broad, silk, per yard, \$1.00 a \$1.50; narrow, 15c. to 20c.  
 Do. broad, worsted, per yard, 50c. a 75c.  
 Lamps, coach, \$20 a \$30 per pair.  
 Lazy-backs, \$9 per doz.  
 Leather, collar, dash, 31c.; split do., 18c. a 22c.; enameled top, 32c.; enameled Trimming, 30c.; harness, per lb, 50c.; flap, per foot, 25c. a 28c.  
 Moquet, 1½ yards wide, per yard, \$9.00.  
 Moss, per bale, 12½c. a 18c.  
 Mouldings, plated, per foot, ¼ in., 14c.; ⅜, 16c.; 18c.; 1 ead, door, per piece, 40c.  
 Nails, lining, silver, per paper, 12c.; ivory, per gross, 50c.  
 Name-plates.  
 ☞ See advertisement under this head on 8d page of cover.

Oils, boiled, per gallon, \$1.80.

Paints. White lead, ext. \$17, pure \$17½ p. 100 lbs.; Eng. pat. bl'k, 35c.

Pole-crabs, silver, \$5 a \$12; tips, \$1.50.

Pole-eyes, (S) No. 1, \$2.70; No. 2, \$2.90; No. 3, \$3.10; No. 4, \$4.50 per pr.

Sand paper, per ream, under No. 2½, \$5.50; Nos. 2½ &amp; 3, \$6.25.

Screws, gimlet.

☞ Add to manufacturer's printed lists 20 per ct.

Do. ivory headed, per dozen, 50c. per gross, \$5.50.

Serims (for canvassing), 20c. a 30c.

Seats, buggy, pieced rails, \$1.75; solid rails, \$2.50.

Shaft-jacks (M. S. &amp; S.'s), No. 1, \$2.75; 2, \$3.25; 3, \$3.50.

Shaft-jacks, common, \$1.50 a \$1.65 per pair.

Do. tips, extra plated, per pair, 37½c. a 56c.

Silk, curtain, per yard, \$2 a \$3.50.

Slat-irons, wrought, 4 bow, \$1.12½; 5 bow, \$1.25 per set.

Slides, ivory, white and black, per doz, \$12; bone, per doz., \$1.50 a \$2.25; No. 18, \$2.75 per doz.

Speaking tubes, each, \$8.

Spindles, seat, per 100, \$1.50 a \$2.50.

Spring-bars, carved, per pair, \$1.75.

Springs, black, 24c.; bright, 25c.; English (tempered), 28c.; Swedes (tempered), 32c.; 1½ in., 1c. per lb. extra.

If under 36 in., 2c. per lb. additional.

☞ Two springs for a buggy weigh about 23 lbs. If both 4 plate, 34 to 40 lbs.

Spokes, buggy, ¾, 1 and 1½ in. 9½c. each; 1½ and 1¾ in. 10c. each; 1¾ in. 9c. each.

☞ For extra hickory the charges are 10c. a 12½c. each.

Steel, Farist Steel Co.'s Homogeneous Tire (net prices); 1 x 3-16 and 1 x 1-4, 20 cts.; 7-8 x 1-8 and 7-8 x 3-16, 23 cts.; 3-4 x 1-8, 25 cts.; 3-4 x 1-16, 28 cts.

Do. Littlejohn's compound tire, 3-16, 10c.; 1-4, 9½c.; heavier sizes, 9c. currency.

Stump-joints, per dozen, \$1.40 a \$2.

Tacks, 9c. and upwards per paper.

Tassels, holder, per pair, \$1 a \$2; inside, per dozen, \$5 a \$12; acorn trigger, per dozen, \$2.25.

Terry, per yard, worsted, \$4; silk, \$9.

Top-props, Thos. Pat, per set 70c.; capped complete, \$1.50.

Do. common, per set, 40c.

Do. close-plated nuts and rivets, \$1.

Thread, linen, No. 25, \$1.30; 30, \$1.45; 35, \$1.65, gold.

Do. stitching, No. 10, 95c.; 3, \$1.15; 12, \$1.28, gold.

Do. Marshall's Machine, 432, \$2; 532, \$2.30; 632, \$2.60, gold.

Tufts, common flat, worsted, per gross, 20c.

Do. heavy black corded, worsted, per gross, \$1.

Do. do. do. silk, per gross, \$2.

Do. ball, \$1.

Turpentine, per gallon, \$1.30.

Twine, tufting, per ball, 50c.; per lb, 85c. a \$1.

Varnishes (Amer.), crown coach-body, \$5.50; nonpareil, \$6.50.

Do. English, \$6.25 in gold, or equivalent in currency on the day of purchase.

Webbing, per piece, 65c.; per gross of 4 pieces, \$2.40.

Whiffle-trees, coach, turned, each, 50c.; per dozen, \$5.50.

Whiffle-tree spring hooks, \$4.50 per doz.

Whip-sockets, flexible rubber, \$4.50 a \$6 per dozen.

Do. hard rubber, \$10.50 per dozen.

Do. leather imitation English, \$5 per dozen.

Do. common American, \$3.50 a \$4 per dozen.

Window lifter plates, per dozen, \$1.50.

Yokes, pole, each, 50c.; per doz, \$5.50.

Yoke-tips, extra plated, \$1.50 per pair.

## TO READERS AND CORRESPONDENTS.

J. R. of Pa.—We take subscriptions to begin with the December No., that being at the middle of the volume.

H. K. of O.—We take orders for English varnish, but as we can get no commissions on the article, we are obliged to charge 50 cents expenses for our trouble. When sent by express cans must be boxed, except for short distances.

NOTE.—Some of our Canada friends send us only \$5 instead of \$5.25. Our Government demands the U. S. postage pre-paid, and until the reciprocity treaty is renewed, we must insist on being reimbursed. If not sent, we keep back one number. Many, regardless of our instructions elsewhere, correspond with us on business purely their own without inclosing a stamp. Such must not expect an answer.



Faint, illegible text or a title, possibly describing the diagrams.



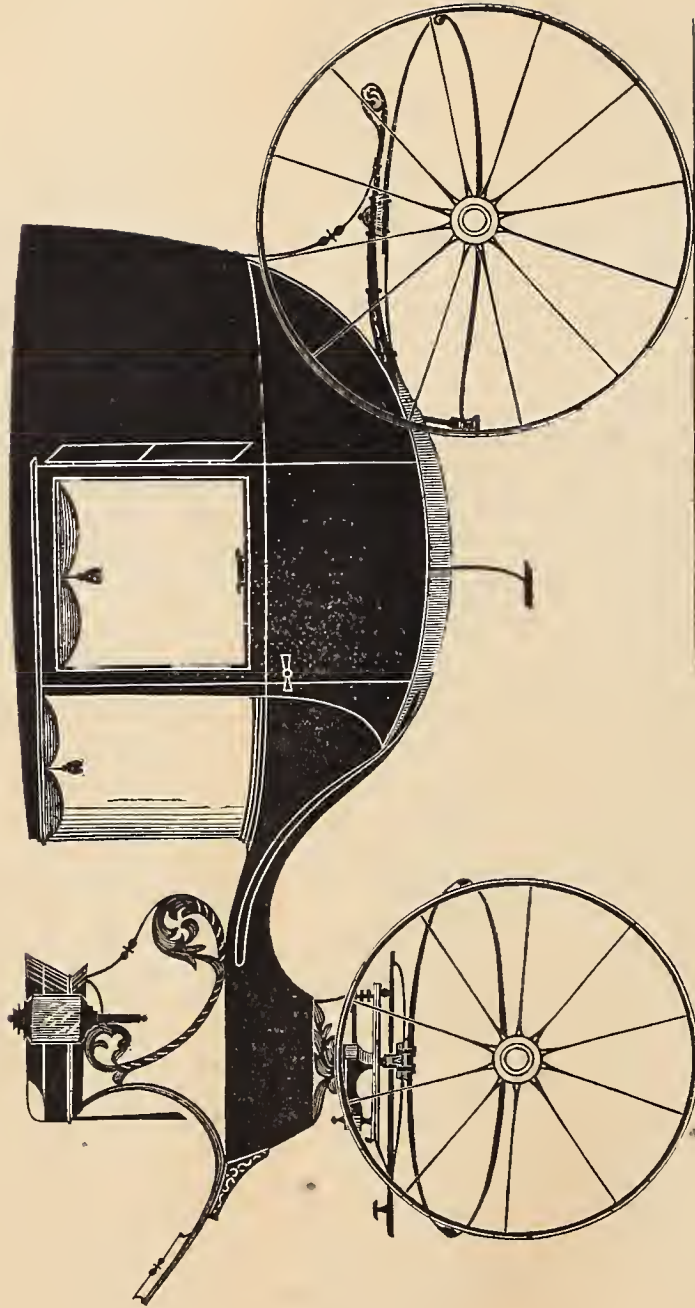

CLARENCE COACH.— $\frac{1}{2}$  IN. SCALE.  
*Engraved expressly for the New York Coach-maker's Magazine.*  
*Explained on page 167.*

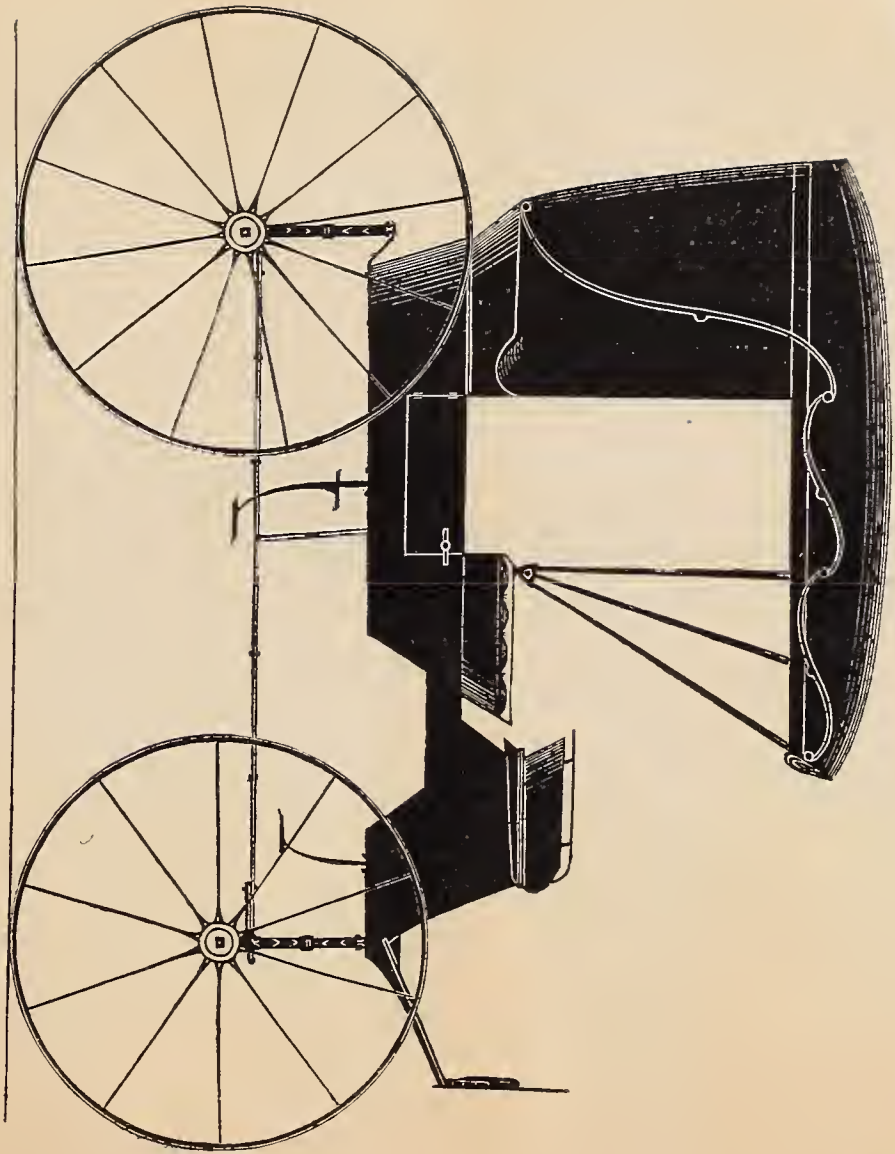

EXTENSION-TOP PHAETON.— $\frac{1}{4}$  IN. SCALE.

*Engraved expressly for the New York Coach-maker's Magazine.*

*Explained on page 167.*









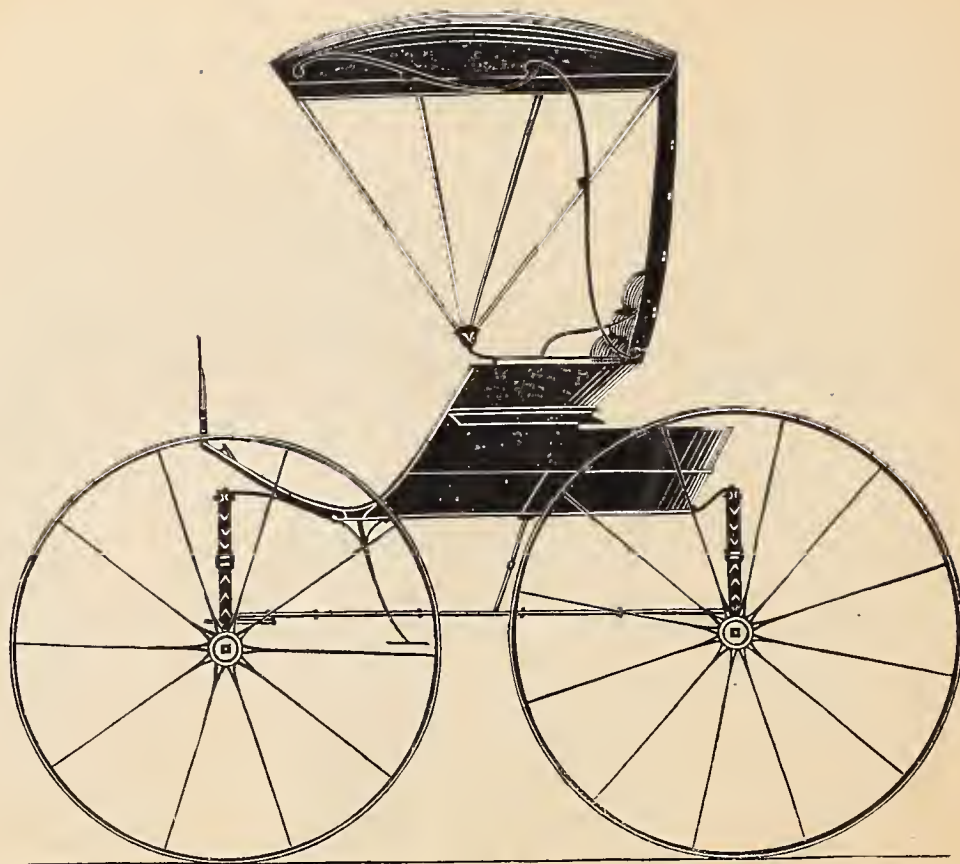

EXCELSIOR BUGGY.— $\frac{1}{2}$  IN. SCALE.

*Designed expressly for the New York Coach-maker's Magazine.*

*Explained on page 168.*



L. R.



F. S.

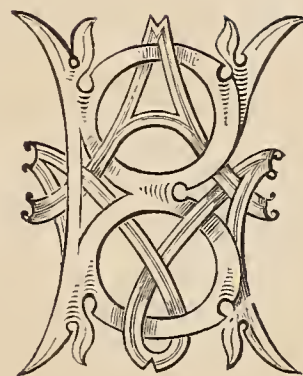

A. M. B.

ORIGINAL MONOGRAMS.

*See remarks on page 170.*







DEVOTED TO THE LITERARY, SOCIAL, AND MECHANICAL INTERESTS OF THE CRAFT.

Vol. VII.

NEW YORK, APRIL, 1866.

No. 11.

## Mechanical Literature.

### AMERICAN DICTIONARY FOR COACH-MAKERS.

(Concluded from page 133)

- SPRING CURTAINS.** Silk, or other curtains for carriage windows, which roll up on pulling the trigger tassel by means of a concealed spring.
- SPRING-BACK PLATE.** The main leaf of a spring.
- SPRING-BARS.** The bars to which the body is hung to the spring.
- SPRING-BARREL.** The tin tube in which is concealed a spring, and around which, by a simple pull, the window curtain is rolled up at will. See "Spring Curtains," *ante*.
- SPRING GUT PLATE.** The inside plate of a spring.—*Felton*.
- SPRING-HOOP.** The hoop confining the leaves of a spring together.
- SPRING-PERCH.** A modern substitute for rigid perches in carriages. Their use has convinced the public that they are destructive to carriage bodies, and the benefit derived is wholly to the advantage of the builder.
- SPRING STAY.** Iron braces for supporting the springs.
- STANDARD** (Fr. *etendard*). The upright posts or stanchions in the framings of carriage bodies; the principal supports.
- STANDING PILLARS.** Properly the two middle pillars of a body, to one of which the door is hung, and which shuts against the other.
- STAYS.** Iron supports to several portions of a carriage.
- STEP-PIECE BODY.** A peculiarly-formed body, of English origin, being little known in America. See Vol. iv, p. 106, fig. 25.
- STEP PLATES.** Thin iron plates to protect the body against wear in folding and unfolding the steps.
- STEP STOPS.** Small iron fixtures against which the folding steps rest, when let down.—*Felton*. Very seldom used in America now.
- STRAKE OR STRAIK TIRES.** The short pieces of iron which formerly constituted the shoeing of a wheel.
- STRAIK NAILS.** Nails made expressly for fastening the strakes of a wheel to the fellys.
- STRETCHERS.** The wooden supports to the inside of warped panels, to preserve a proper shape to them.

VOL. VII.—21.

**STUMP-JOINTS.** The joint section of carriage-top supports. The commercial name for an already-prepared joint for splicing out carriage joints.

**SUNKEN BOTTOM.** The American term for a drop-bottom, which see on page 52.

**SWA-BAR.** The swa-bar is a timber forming part of a circle made for a bearing against the perch, as far as the locking of the fore wheels makes it necessary. Its use is to preserve a steady action of the fore-carriage; it is bolted on the back ends of the futchels, usually plated on the top ends with iron; the middle is lined with hard leather to prevent a noise in use.—*Felton*, Vol. i, p. 51.

**SWA-BAR PLATE.** The iron plate employed in strengthening the wooden portion of the swa-bar.

**SQUABS.** A word improperly applied in this country to some portions of the inside body-lining. As originally used, it meant the "soft, thin cushions hung on the inside of the body, for the shoulder and head to lean against."

**SWORD CASE.** (Seldom used now.) An unsightly-looking projection stuck to the backs of carriage bodies—in Europe called a Boodge. See p. 22, *ante*.

**SULKY.** A very light two-wheel vehicle, carrying one male person. *Felton*, who wrote seventy years ago, says: "A sulky is a light carriage, built exactly in the form of a post-chaise, chariot, or demi-landau, but, like the vis-a-vis [sociable], is contracted on the seat, so that only one person can sit thereon, and is called sulky from the proprietor's desire of riding alone;" *i. e.*, none but sullen, sour, or morose persons are *desirous* of riding therein.

### T.

**TAIL-BOARD.** The back end of a wagon-body, which, being hinged thereto, is made to fall at will, for convenient loading.

**TANDEM.** (Horseman's Latin—*Webster*.) Driving one or more horses before another in a vehicle.

**TASSEL.** The pendant ornament to curtain strings, laceholders, &c.

**THOROUGH-BRACES.** Long leather straps extending from the front to the back end of such carriages as have the bodies thus hung upon braces.

**THIMBLES.** Small tubes acting as the rollers for bolts in the ends of thorough-braces, &c.



**THIMBLE-HOOKS AND EYES.** Two bolts having projections from their shoulders, one of which is wrought in a hook, the other in an eye to receive it; they are used to separate things which occasionally hang together.—*Felton.*

**THIMBLE-SKEINS.** A tubular iron casting much used on lumber-wagon axle-tree arms, to prevent the injurious effects of a revolving box to the wood.

**THUMB-NUT.** Nuts with lugs so formed as to be easily turned or screwed up, without a wrench, by the fingers.

**TILBURY.** A sort of gig, without a top, hung on two wheels, with the back of the body pendant from a cross-spring. See the construction as illustrated in Vol. iii., p. 31.

**TOP-PROPS.** The iron projections, on which the ends of the joints or supports of falling carriage-tops or heads are secured.

**TOP-RAIL.** The highest rail in the *framing* of a body.

**TRUNK FASTENERS.** Strong screws, with a collar and square heads, formerly used instead of baggage-straps to secure trunks, &c., to the rack or platform.

**TRANSOMS.** (Latin, *transenna.*) Timbers framed across the perch, on which the springs rest. Perches in some cases united to "the transom" by mortise and tenon.

**TREAD.** The flat portion of a step on which the foot rests in getting into a carriage.

**TRIMMING.** The upholstering or lining of carriage bodies with textile or leather fabrications, either inside or out.

**TRUNK OR BAGGAGE STRAPS.** Straps provided for securing baggage to the platform behind a carriage when traveling.

**TUB-BODY.** Round-bottomed gig bodies, as distinguished from the "fantail." See on page 53.

**TUFTS.** Knots or clusters of tread employed for both ornament and use in the cushions and side-linings of carriages.

**TUFT-NAILS.** Large-headed nails driven through and used in tufting where it cannot be done with twine.

**TUG-IRONS.** Iron fixtures for the underside of shafts, to prevent the swift descent of a wagon in going down a hill. These are, among us, frequently called "hold-backs," which see on page 68.

**TIRE.** The shoeing of the wheel, to prevent the wearing out of the fellys or rim.

#### U.

**UNDER CARRIAGE.** The *running* portion of a carriage, as distinguished from the body by the craft.

#### V.

**VALLENS.** The front strips of leather to the heads or tops of carriages, and occasionally improperly applied to designate other portions of trimming.

**VARNISH.** A resinous liquid substance laid on the paint to improve the color and preserve the paint.

**VENETIAN BLIND.** Blinds made of thin slats, set in a frame, moved up or down, to exclude the sun's rays, or to admit air.

**VENTILATORS.** (Fr. *ventilez.*) Apertures formed in the door, at the sides of close carriages, to admit air.

**VICTORIA.** A gig or chaise body of a peculiar descrip-

tion, hung on four wheels, originally built for the Queen of England; hence the name.

**VIS-A-VIS.** (Fr. *vis-a-vis.*) For the sociable. A carriage with two seats, in which the passengers sit fronting each other.

#### W.

**WEAR-IRONS.** See Wheel-dogs, *ante.*

**WEBBING, OR WEB LACE.** A strong hempen fabric, used chiefly for concealed stays in calash or falling-tops.

**WELL.** A strong box conveniently placed at the bottom of the carriage body, to carry luggage.—*Felton*, Vol. i, p. 220.

**WELTING.** Strips of leather enclosing a small cord, used often in place of seaming lace at the corners, in making cushions, &c.

**WHEEL-DOGS.** Wear-irons, turned at the ends and sharpened, to be driven into wood, to protect certain points against the wear or chafings of the wheel.

**WHEEL-IRONS.** Strong irons, which hook or bolt on the ends of the splinter-bar sockets, and go on to the end of the fore axle-tree arm, between the wheel-stock [hub] and nut, in order to stay and strengthen the splinter-bar, and assist the coachman in mounting.—*Felton*, Vol. i, p. 97.

**WHEEL-PLATE.** An iron washer to protect the small end of the hub against friction from the linch-pin.

**WHIFFLE-TREE, OR SWINGLE-TREE.** The playing bar to which the horse, in traces, is hitched, for the purpose of draft.

**WHIP-SOCKETS.** A tubular fixture for holding the whip when not in use.

**WINDOW-LIFTERS.** Made generally of broad lace, to lower and raise the windows from recesses by.

**WINGS.** Iron frames, covered with leather, and affixed to the sides of a carriage to protect the passengers from the dust raised by the revolution of the wheels. "The extended timbers of a carriage."—*Felton.*

### THE AXLE DISCUSSION.

MR. MILES' REPLY TO MR. HARPER.

VERY little good can result to your readers or the cause of truth by a continued attempt at defense against an opponent who meets us with error on one hand and misrepresentation on the other, under which he seeks to approach within striking distance of the truth we desire to inculcate. It is too much like the flag-of-truce dodge, which our late enemies practiced on the field, and, while my opponent professes to think himself the worst-abused of men, is, in reality, no less destitute of a grievance than they were.

I once had a nephew—I have several, but one in particular—who, when a little boy, got in a towering passion one morning at somebody or something, and rushing up to a basket partly filled with potatoes, and looking desperately into it, he vociferated, in his boyish rage: "Them ain't pertaters." Failing to see any one take his assertion as *causus belli*, as he expected, he proceeded to a projecting railing at the side of the room, and commenced bumping his own head, and screaming murder! How his bile got settled at last I have forgotten; nor should I have thought of the circumstance again but for



the very similar specimen of injured innocence furnished by the Wisconsin gauge-man. While I have embraced every opportunity to indorse his invention as a mathematical and mechanical triumph, I have seen fit to deny him the right to claim for it that which is foreign to its capabilities, for the purpose of tearing down another invention based upon equally sound principles. While he persists in this unfair and dishonorable course, we must continue to class him with the delectable tribe of patent-medicine men who would make us believe that their bottled humbug, though aimed particularly at spinal curvature, will also cure swelled head and running at the nose.

I will now notice one or two of Mr. H.'s most sensible positions, and I have done. It is true that a bar of iron bent while cold presents an apparent contradiction to my position, to wit: that cold iron will not stretch, for the outside of the bent bar will, as Mr. H. says, measure longer than before. Why? Here Mr. H., like the smart lawyer, knew right where to stop to produce an effect upon the unthinking reader. Let any one bend a cold bar of iron, and then examine it through a powerful microscope, and it will readily be seen how the stretching is done. On the outside of the bend the bar will show thousands of minute breaks. In fact, not a continuous fibre can be found near its outer surface, and the only reason why the bar does not fall asunder at once is because of the unequal strain upon its different fibres, having left those on the inside surface intact, though injured by forcible compression, and broken the rest in different parts of their length, so that their lateral cohesion still holds them together. We all know what effect one or two repetitions of this process has upon the bar.

Iron at common temperatures possesses malleability under the hammer to a very imperfect degree, but the only philosopher who ever gave it credit for ductility is the same one who says the axle-stock of his buggy possesses all the requisites and properties of a truss girder, and maintained that all the sound produced by the end-wise thrust of axles against the boxes could and should be prevented by the timely use of his inimitable gauge. The immaculate conception of modern time. Great man! Who can wonder that the labor which gave birth to a gauge of such marvelous functions, and trimmed it all over with brass, should have left him so weak that years of sickness followed.

Again, he pretends to understand my drawings, page 85, Volume vi, as showing the bolster as resting on the iron-work of the truss, which he says must bend before the spring can operate! I could go from one to another of these wretched shifts with no result but a feeling of having belittled myself in the eyes of those who live and study for honest purposes. When I have anything positive to report from a course of experiment I am engaged upon, you may hear from me again.

**FRENCH ODOMETER.**—Some of the hacks in Paris have attached to them a machine which indicates to the passenger engaging it, the time he is riding, the distance he has run, and the price he must pay, according to official regulations.

## PICTURES FROM POMPEII.

### THIRD ARTICLE.

LUCIAN, a learned and witty author, makes Cupid say, "I make myself familiar with lions themselves; I ride upon their backs; I hold their manes and use them for bridles; they wag their tails and lick my hands in flattery of me." This may explain in some manner the conduct of the boy-god as depicted in Fig. 1, on page 135.

In Figure 5 we find him engaged in driving his mothers *turn-out*—the chariot of Venus, which was some-

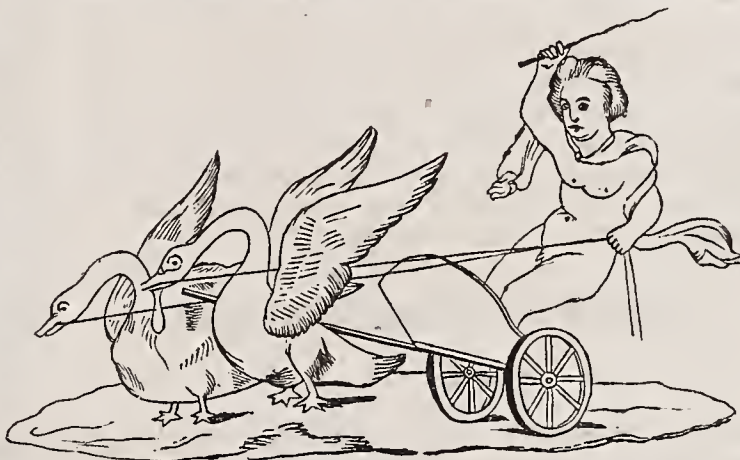

FIG 5.

times drawn by swans, and in other cases by doves or swallows. This chariot was formed of carved and gilded ivory. Taking the accompanying illustration as the model, we do not have very exalted ideas of the taste of Venus in selecting her chariot, or of the son's character in choosing his conveyance. Indeed it would seem that his pride had diminished since Lucian's time, and he become more dissipated. At all events, the artist has subjected him to a very ridiculous contrast. Perhaps, however, he is here shown "on a bender," although his ride had a better result—if history is faithful—than had the ancient Phaeton.

The design next introduced is one which has puzzled us not a little. We see above that Venus sometimes employed doves as draft-teams. May it not have been



• FIG 6.

on funeral occasions? But some may object, that in the present instance the bird looks more like a parrot. Perhaps the artist intended it for one. Indeed, it would



appear as though the pall-covered car, driven by the locust, emblematical of destruction, is intended as the representation of a funeral cortege, with the remains of Love. Among the ancients, in the parrot they embodied affection. Statius calls it the "*Humanæ sollers imitator linguæ*"—a clever imitator of the human voice.

In one of Ovid's Elegies, where he mourns the death of a parrot he had given to his Corinna, he says: "The parrot—the imitative bird, sent from the Indies of the East, is dead. Come in flocks to his obsequies, ye birds. Come in flocks, ye denizens of air, and beat your breasts with your wings, and with your hard claws disfigure your delicate features. \* \* \* Turn your attention to a bird so prized. It is a cause of sorrow, but, still, that is so old. All who poise yourselves in your career in the liquid air; but you, above the rest, affectionate turtle-dove, lament him. Throughout life there was a firm attachment between you, and your prolonged and lasting friendship endured to the end. What the Phocian youth was to the Argive Orestes, this same parrot was the turtle-dove to you as long as it was *by fate*."

### CRITIQUE ON CARRIAGE-WHEELS.

BY THE EDITOR.

PASSING by several other peculiarities in carriage-wheels, we come next to the circular Spring Wheel, invented by William B. Adams, in England, about thirty years ago. The inventor describes this wheel as follows: "A cylindrical iron ring, similar in appearance to an

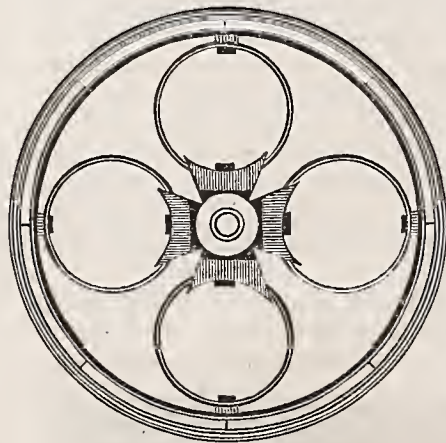

ADAMS' CIRCULAR SPRING WHEEL.

outer tire, but of considerably less weight, is first prepared.—Around this ring is fitted eight fellys of wood, forming true segments of a circle. The joints of these fellys are accurately cut in radial lines converging to a centre; and each pair of ends is connected by a dowel, as in ordinary wheels. Over these fellys an outer tire is shrunk on hot, and the whole three strata are riveted together. An outer circle is thus made, which, by its mode of construction, must necessarily have a tendency to preserve its circular form under all circumstances. It will be slightly resilient under concussion; but nothing less than a positive crushing of the parts could possibly make a permanent alteration of its arched form. To the interior tire of this ring are firmly bolted, at equal distances, four circular hoops of steel; a small block, or raiser of wood, being interposed between the hoops and the tire as a bedding or packing. The axle-box, which supplies the place of the ordinary nave (hub), is cast in the form of a Maltese cross; and to the projecting arms of it, the four hoop-springs are sufficiently secured on wooden blocks, similar to those at the periphery. One very important advantage arising from this mode of constructing the axle-box, is

its capacity for containing a circular oil-chamber round the center of the axle-arm, so that the oil is in actual contact with it, instead of feeding by a capillary action, and the due lubrication cannot by any possibility be impeded. In the naves of ordinary wheels this very desirable advantage cannot be attained.

"It must be evident that the four hoop-springs, being all firmly bolted to the same center and the same periphery, must all act together. No one of them can alter its form without the others doing the same; and these alterations of form must be from exact circles into ellipses. But if any alteration of form were to take place at those portions of the springs which are bedded on the blocks, they would soon work loose and probably break at the fastenings. Therefore, the springs must be so contrived, that at the bearing points the thickness and width of the metal may be so increased as to prevent all movement by their rigidity; while at the spaces between the bearings, the plates may be gradually diminished both in width and thickness, so as to afford the needful elastic action. In this mode each spring does in fact constitute a double bow; the bearings or blocks constituting the grips or hand-pieces. The elastic action, therefore, takes place at about an equal distance between the center and the periphery all round the wheel."

There are some contrivances that appear very fine drawn on paper. This circular Spring Wheel is one of them, although the inventor tells us that "their external appearances has been generally admired by those who have seen them, as they are lighter to the eye than ordinary wheels. If, therefore, their utility prove to be as great as the author has endeavored to show, two objects will have been gained—mechanical advantage united with graceful form."

Mr. Adams, who, it would seem, is not a practical coach-maker, but a mere theorist, anticipates difficulty in applying his invention to very small wheels, as in that case "the springs must necessarily be so much reduced in diameter that they would cease to be springs, and become rigid in the case of heavy carriages." To get over this disadvantage the inventor recommends that *all* carriage-wheels be made of equal size, and that a large one, a suggestion which thirty years of consideration has not yet brought John Bull to adopt. Nor has the old gentleman referred to, yet acknowledged with the author, "that wheels of unequal size in the same carriage are only proof of defective construction." A wheel built on this plan would doubtless contribute to render a carriage less noisy in running over paved streets, but even this advantage does not appear to have brought them into general use.

It has been observed "that where one mechanical advantage is attained, two of disadvantage are created." It is evident that a wheel of this kind could never be made generally useful. It might do for a light wheel to a buggy, but for a business wagon impracticable. A heavy load would throw the axle with the hub out of center, and at once present a resistance to locomotion the inventor seems never to have dreamed of. In addition to this a wheel of this kind could not well be made dishing, and therefore not suited for running in ruts, nor on inclined planes of which most roads are made up. There are other considerations which force themselves upon the attention of the practical carriage-maker, detrimental to the adoption of this kind of wheel, without our *running* on in this subject further at this time, to the exclusion of more important matter.



## EFFECTS WHICH DIFFERENT SHAPED RIMS (TIRES) HAVE ON ROADS.

BY ALEXANDER CUMMINGS, ESQ., F. R. S.

(Continued from page 136.)

WHEN the crown of the convex road is rendered impassable by the constant traffic of all carriages in the same track, if any are compelled to travel on the declivities on either side, the wheels force the hard materials down the sides (their own weight and the tremendous concussions on the roads, occasioned by the passing of heavy carriages, also promoting the descent), and the best materials of the convex road are insensibly shifted from the middle of the road to the sides—from the only part of the road constantly frequented, to the extremities, where they can be of no service.

*Flat roads, that are level from side to side*, are much more pleasant to travel on than the convex; every part of the whole breadth, being equally convenient, is equally frequented and equally worn; and, there being no such declivities as on the sides of convex roads, the materials have no tendency to shift from the spot on which they are laid. No deep ruts are formed, because the road is equally traversed and this traffic of carriages equally and voluntarily diffused over every part of its surface; and the track of every wheel, however shallow, becomes a small channel or drain to conduct the water along the road, in which direction it was intended to flow, provision being accordingly made to gain a proper current and to carry the water off the road by shallow channels across it at proper and convenient distances. And here it is to be observed that, as each carriage takes its own course, there being neither rut nor declivity to prevent it, every carriage making new channels to carry the water from the surface of the flat road lengthways, the more carriages that pass the sooner will the roads get dry. And thus the *frequency of carriages* passing on a *flat road* in rainy seasons has a tendency to keep it dry, and, in that respect, to improve it; whereas, on a convex road, the frequent passage of carriages tends to its immediate destruction. And whoever takes the trouble of observing how the water runs longitudinally in the ruts on a convex road, although the declivity down the sides be incomparably greater than in the direction which it is compelled to take in the ruts, will soon see the propriety of constructing roads so as to make the water run lengthways upon them, instead of attempting to gain a declivity by making it run from the middle to the sides.

It may here be inquired, since the water is found to take a longitudinal direction in the convex road as well as on the flat road, what additional advantage can be gained in this respect by abandoning the convex form in favor of any other? To this it may be answered that, where it is intended to make the water run longitudinally on the road, every advantage is taken for this purpose in the original conducting and formation of the road, which is often neglected when the theoretical advantages of convex roads are admitted; and by avoiding the convex form we avoid all the disadvantages inseparably connected with it, and may gain every advantage that belongs to any other form that may be preferred. But, taking for granted that the same declivity is longitudinally maintained on the convex as on the flat road, the advantages that must be gained by preferring the *flat* to the *barrelled form* may be

collected from what has been said under each of these heads, all of which gives a decided preference to the flat over the convex form.

*Concave roads.*—Let us suppose a strong trench or channel of wood or stone, having its whole length of equal breadth, and filled several inches in depth with any binding materials, such as are used in making roads, and moistened to such a degree as may promote their binding and coloring. If a heavy cylindrical roller, of the whole breadth of the channel, be made several times to pass on it, the materials not being able to escape sideways from the pressure of the roller, all its force is applied perpendicularly in compressing, consolidating, and bringing the parts into closer contact and within the sphere of mutual attraction; and, as the repeated rolling with the cylindrical wheel cannot in such case produce lateral motion after the materials have been once compressed, nor anyhow alter the relative situations of the parts, nor break the texture, nor retard the induration by any internal relative motion of the parts, the materials will at last become so compact and *incompressible*, so rigid, smooth, and close, that the wheel will roll on them with the same facility as on wood, stone, or iron, and, if always kept dry, might be almost equal to the best wagon-way. But, if the resistance of the *lateral action* be taken away, the materials retreating somewhat sideways every time the wheel passes, they can never become so compact and close as when the lateral motion is wholly prevented and the whole pressure is applied perpendicularly, and when the relative positions of the materials are never changed nor their connection broken.

This only serves to show the necessity of having all roads well bounded with walls, banks, or some other means of firmly resisting the tendency to spread by the lateral pressure of the wheels that pass upon them. For, if the parts of the road have a power of extension, the constant internal relative motion of the parts, however slow or imperceptible, will, by sometimes pressing the one way, sometimes the other, ever prevent induration and that complete degree of consolidation and *impenetrability* which might otherwise be obtained by the traffic of heavy carriages with broad cylindrical wheels. But, admitting that a road be consolidated to the greatest degree of perfection, if *wheels of the destructive shape described* (that is, *conical*) be used with a heavily-laden wagon, they would penetrate its surface and force the materials to each side; and, by the frequent passing of such wheels, the surface must be divided and the material broken and disunited to a considerable depth, so as to admit water, which introduces every other means of devastation. Every wheel that has but a partial construction in favor of this rim belongs to its destructive class.

*Roads that are level in the middle*, of a sufficient space for all carriages to drive on, that have an additional space on each side sloping toward the middle so as to join the level carriage road, serving to lay on materials from which the carriage-way is easily supplied, and at the same time serving as an abutment on each side against the extension and lateral pressure of the materials, and having ditches or drains on the field side of those sloping parts, to intercept springs and to keep those sloping parts or abutments always dry and rigidly immovable, may, from every consideration, be reckoned the best construction, having every advantage of the flat road, with the addition of better abutments against the lateral extension and other effects



of such internal relative motion of the materials as may take place by the pressure of a heavy carriage on this or on that side; for, however imperceptible such effects may be, it cannot be doubted that they retard, in a considerable degree, the consolidation, induration, and union of the whole mass.

Thus far have I been led, contrary to my intention, to consider the comparative advantages of the different forms of a road, *so far only* as they regard the effects which wheels of different shapes have upon them and the fitness of each form to resist the effects of such improper shape, and in the hope of showing the necessity of legislative authority in preventing the use of any other broad wheels than such as are truly cylindrical, with a smooth flat rim, and the heads of nails level with the tire.

It can scarcely be supposed that any carter or wagoner would prefer a road that was covered with small pebbles fixed to the surface, to a road that was quite level and smooth; yet we frequently see his cart-wheel of an immense size and weight, having its rim garnished all round with two or three rows of nails, the head of each projecting above the tire at least three-fourths of an inch. Surely, if the owner of such a cart and horses were aware that these projections on the rim of the wheel obstruct the progress of the horse on the best and hardest roads, and even upon the hardest pavement, as much as pebbles of the same size, fixed at the same distance, on the surface of the roads, would retard them, they would entirely discontinue this absurd and ruinous practice.

The damage that is done to the roads by locking the wheel of a heavily-laden wagon in going down hill deserves serious attention, for in dry seasons this rubbing of the locked wheel crushes the best materials to atoms, and in wet seasons it plows up the roads; for, whatever may be the steepness of the descent, the rubbing and resistance of the locked wheel will always be the same, and, when the declivity is gentle, there is sometimes as much or more exertion required to drag the carriage down hill as would draw it on level ground when the wheel was unlocked. It would, therefore, be very desirable if, to avoid these evils, any other means could be devised of checking the rapidity of heavy carriages in coming down hill by a *resistance proportioned to the declivity*.\*

Once, having occasion to wait on the Lord Chancellor, he showed me a drawing of a two-wheel cart in which this was effected in a manner that appeared to me equally new, simple, and judicious. On inquiry, I was told that *it was Lord Somerville's invention*; and, wishing to mention a matter that was so intimately connected with the subject on which my attention was then bent, and that had so long baffled all the attempts of ingenuity, I waited on his lordship, and he most politely assented to my mentioning it in any degree that I might judge most likely to render it useful to the public or to elucidate any part of the subject which I was then endeavoring to investigate.

The first thing that attracted my attention in this neat light cart, was a method, equally simple and expeditious, of adjusting the center of gravity of the load so as to have a proper bearing on the horse in going down hill, the advantage of which must be obvious to every man of science,

\* There can be no doubt that the whole of this paragraph is unpractical as will be seen by every man practically acquainted with wheeled vehicles. But we print it, simply because it has a place in a learned essay which is replete with a thousand practical truths; and we are unwilling, therefore, to maim the work in which they are found.

more especially with bulky loads, in which the center of gravity lies high.

The next thing, and what was more immediately interesting to me, was a method of applying friction to the side of the wheel to regulate the motion of the carriage in going down hill (instead of locking the wheels), the advantages of which method appear to be as follows:

Firstly, the pressure and degree of friction may with great expedition be adjusted to the steepness of the declivity, so that the carriage shall neither pass forward nor require much exertion to make it follow the cattle.

Secondly, the friction is with great propriety so applied to the wheel that a *given* pressure will have twice the effect in retarding the progress that it would have if immediately applied to the body of the carriage or to the axles; and, by applying the friction on both sides of the wheel, the risk of heating and destroying the friction-bar was applied in one place.

Thirdly, this apparatus is so conveniently placed that it can be instantly applied or adjusted without stopping the carriage or exposing the driver to the same danger as in locking a wheel.

And, fourthly, this useful contrivance, in which simplicity and ingenuity are so happily combined, will assume yet greater importance when applied to *both* the hind wheels of the wagons, by which means the resistance may always be proportioned to the steepness of the descent, the tearing-up of the road prevented, the necessary exertion of the cattle in drawing the *locked carriage* down hill avoided, the danger to which the driver is sometimes exposed in locking the wagon-wheel totally evaded, and the time now lost, in locking and unlocking the wheel, saved.

I have thought it best here to mention only the general principle and properties of this useful improvement, in hopes that the attempts of different men of genius to obtain the same end may be productive of different constructions, from some of which useful hints or immediate advantages may be gained that might be prevented by giving a more particular description in the first instance. I do not know whether this cart has yet been tried, but there cannot exist a doubt of the effect of the mechanical contrivance. The only doubt with me is whether the constant rubbing of the wheel in descending a long declivity may not generate a degree of heat that may occasion ignition. But, if ever this should happen, some means may be discovered hereafter to avoid it, and it may always be prevented by a careful driver.

Before turnpike roads were so generally established in this country, great obstacles were frequently met with in traveling, to be surmounted by carriages before they could pass. This induced men of science to compute the power necessary to draw a loaded carriage by the force required to draw it over such obstacles; and, as the force was less with high wheels than with lower ones, it appears to have been inferred generally that the resistance to the progress of a carriage on level roads also is diminished in the same proportion by enlarging the wheels; and this doctrine, in favor of high wheels, is maintained by some without limitation or regard to concomitant circumstances.

But we ought to examine whether, in practice, there may not be something to counterbalance the imaginary advantage when the wheel exceeds a certain size, and whether some disadvantage does not accompany the high wheel, that may *increase* the resistance to the progress with the height of the wheel.



On turnpike roads no such obstacles as these alluded to are now to be met with. They are all removed in making the roads; and the resistance to the progress of a carriage, although arising from a variety of mixed causes, is rendered much more uniform, and subject to laws very different from those by which the resistance of a fixed obstacle to a wheel passing over it is estimated. The advantages, therefore, which high wheels have in surmounting fixed obstacles, vanish when there are no such obstacles to be surmounted.

But yet another advantage attends high wheels, even in the improved state of the roads. A high wheel makes fewer revolutions in advancing the same space than a small wheel does. The friction, therefore, on its axis is less in proportion as its revolutions are fewer. But, although this friction has by some been considered as the greatest resistance to be overcome in drawing a carriage on a well-made level road, it does in fact bear no sensible proportion to the resistance at the circumference of the wheel, especially with conical rims.

The opposition of gravity in going up hill is by much the greatest resistance to be overcome on good roads. If, then, we compare the addition made to *this resistance* by the immense weight of the hind wheels of a large wagon, we shall find it to exceed the whole friction on the axis out of all proportion. And thus we see that, by using very large wheels, much more power may be lost by adding to the weight than is gained by the diminution of the friction. And, although it may be difficult to ascertain the very best height of wheels under all possible variety of circumstances, it may be best for all carriages of heavy burden, and that require much strength, to keep the height of the wheels within moderate limits, which limits may be much better ascertained by judicious experiments and local circumstances than by theoretic demonstration.

To show the impropriety of estimating the total resistance to the progress of a carriage by the force required to draw its wheel over fixed obstacles, it is only necessary to observe, that this mode of estimating is applicable only to such resistances as suddenly raise the center of gravity of the loaded carriage before it can pass. But all such resistances as are not sufficiently great to elevate the center of gravity of the load, or that have no tendency to resist, must be estimated by laws arising out of the nature and circumstances of each separate resistance.

The several resistances that conspire to retard the progress of a wheel carriage, so far as they occur to me at present, are:

1. The innate force or inertia of matter.
2. The opposition of gravity in gradual ascents.
3. The opposition of gravity in getting over fixed obstacles.
4. The friction of the axis.
5. The friction or partial dragging at the rim of all wheels that are not truly cylindrical.
6. The resistance to the rim in passing through sludge or any other substance that is partly fluid and non-elastic.
7. The resistance in compressing non-elastic substances that have no degree of fluidity.
8. The resistances of substances that have a degree of elasticity, by which they partly recover their position when the wheel has passed, but not sufficiently strong to raise the center of gravity of the carriage.
- 9, and last. The tenacity or cohesive attraction of substances that adhere to the wheels, such as clay.

From a due attention to the very different nature of each of these resistances from each other, the impropriety of estimating the whole by one general rule must be evident. All that art can accomplish in so complicated a case is, by attending to the nature of each resistance separately, its causes, and the laws by which it resists, is to *construct carriages that may be the least liable to each resistance, considered separately*, by which means we may be assured of meeting with the least possible resistance from the whole combined, in all the variety of changes and fluctuations that can happen among them, from the different circumstances of the roads and of the seasons, in the longest journey.

## New Illustrations of the Drafts.

CLARENCE COACH.

*Illustrated on Plate XL.*

CARRIAGES of this description are more popular in Europe than they have ever been in this country. They seem to be particularly adapted to aristocratic tastes, both in design and expense of building. This expensiveness confines its use to a select few—our *very* rich citizens. However, since fortunes are made much easier now than formerly, there remains very little doubt of their becoming more and more fashionable every day. To provide for a need in anticipation is now our intention.

Very little need be said in explanation of the design, except that it has been drawn expressly for this Journal, by one of our best artists. The lightness of the boot sets off this carriage to some advantage, although, as a general thing, we do not admire this mode of finish. Its application is *new* here, but *very* old elsewhere, it being merely an imitation of European architecture, and this probably is one reason why we dislike it.

EXTENSION-TOP PHAETON.

*Illustrated on Plate XLI.*

THIS design possesses some novel features, which the carriage-maker will likely discover as soon as it meets his notice. These, therefore, need not be pointed out here. For a family summer carriage this cannot be surpassed, we think, by any yet invented. The round corners we have applied to it, takes from it much of the clumsiness generally attached to the appearance of this species of vehicle. Hear what an old writer said of these vehicles one hundred years ago: "Phaetons, for some years, have deservedly been regarded as the most pleasant sort of carriage in use, as they contribute, more than any other, to health, amusement, and fashion, with superior advantage of lightness over every sort of four-wheeled carriage; and are much safer, and more easier to ride in, than those of two wheels." The Phaetons of that day



were sorry looking things in comparison with the more modern vehicles coming under that name.

EXCELSIOR BUGGY.

Illustrated on Plate XLII.

WE confess that we feel much gratified at our success in obtaining the original designs now presented to our subscribers, for buggies. Whether they are adopted as the fashions for this spring or not, rests with the public, but of the elegance in design, there can, we think, be no question. Should our patrons compare this with the drawing on Plate XXXIV. they will discover several points wherein this differs from that. The form of the front pillar and the moulding-off are extremely novel, imparting a very pleasing effect to the whole figure.

ESTIMATES FOR THE CONSIDERATION OF CARRIAGE-MAKERS.

SOME unknown correspondent sends us the following estimates for publication, with the request that we give our views on the subject. It will be seen that the circular is addressed to the public at large. What we have further to say on this subject will be found in the editorial columns of this number, under the head of "Costs of Carriages," to which the reader is referred :

GENTLEMEN: Your attention is respectfully called to the accompanying memoranda of the actual cost of a "Top Buggy," and a "Hack Coach."

These vehicles are selected on account of their simplicity, and because the prices of each of these two styles of carriages are more generally discussed than are the prices of the more expensive styles. We, in the trade, daily hear of sales of "Platform Coaches" being made at from one thousand to twelve hundred dollars—Top Buggies at four hundred dollars—and by no means unfrequently do we hear of fine *Landaus, Clarences, &c.*, being sacrificed at correspondingly ruinous rates—and this, too, by parties who are supposed to understand their business. Do they, can they, know the cost of their work? Presuming that they do understand themselves, do they foresee the inevitable consequences of this insane desire to sell? Your correspondent can see no good arising from this method of conducting business, but, on the other hand, failure and bankruptcy, and in the end, advanced prices of materials. For most assuredly, the merchants who supply these men with stock, will compel the solid and sensible manufacturers to make good the bad debts of these cheap men.

We do not find this system of underselling among the parties we deal with. We find in all mercantile houses a uniformity of prices and a unity of action. Why can it not be so with carriage-makers and dealers? Why not a wholesome competition among them as with others, based upon the merits of the work offered for sale? The first-class carriage-makers and dealers of this country are well enough known to the community not to require this selling at losing prices to secure custom.

COST OF A "HACK COACH."

*Hung on platform springs—full boot—trimmed in heavy English cloth—close back quarters—shifting front quarters, with glass quarters for summer use.*

Body, with rocker plates and extra quarters...	\$215 00
Carriage \$30, wheels, \$22, pole \$3, springs \$55.	110 00
Axles \$27, wrought-iron plated pole crab \$9..	36 00
Labor and materials for ironing \$140, painting \$135.....	275 00
Whip socket and fastening \$1.50, glass \$9....	10 50
Toe board handles \$4, door handles \$3,50....	7 50
Ivory inside furniture \$13, curtain barrels \$5	18 00
Lace plates \$1, hub caps \$2, lamps \$32.....	35 00
Dickey seat moulding \$2, mirror \$2,50, hair \$50.....	54 50
Braided dickey seat handles \$3, carpet \$12.50	15 50
Tube and whistle \$11, cushion bottoms and apron \$8.....	19 00
Cotton bats \$6, leather for dickey trimmings \$34.....	40 00
Whiffle-trees, braces, and evener straps \$9, tufts \$4.....	13 00
Muslin, buckram, burlaps, thread, cord, &c....	12 00
Carpet bindings, straps, apron straps, knobs, &c.....	5 00
Leathering and padding pole \$3, spiral springs \$1.....	4 00
Broad and narrow silk laces, at present prices.	61 80
Holder tassels, glass string and curtain tassels, and cord.....	9 50
Five yards curtain silk at \$4—\$20, slide wires 75c.....	20 75
17 yards broadcloth at \$4.75—\$80.75, trimmer \$62.....	142 75
Finisher's time, hanging up, &c., &c.....	10 00

\$1,114 80

Add the same per cent. as explained in the accompanying estimate of a Top Buggy— $33\frac{1}{3}$ .....

375 32

\$1,490 12

AVERAGE COST OF A TOP BUGGY.

Body \$42, carriage \$12, shafts \$4, wheels \$20	\$78 00
Springs \$16, axles \$16, shaft couplings \$3,50	35 50
Plating axle nuts \$2, slats irons, hub bands, check loops \$2.....	4 00
Time and materials for ironing \$52, painting \$52.....	104 00
Top bows \$1, top props, nuts and rivets \$1, back light 20c.....	2 20
Whip socket and fastenings \$1,25, carpet and oil carpet \$7.....	8 25
Curled hair \$7, cushion web \$1, apron and cushion bottom \$9.....	17 00
Seven yards cassimere at \$6.50—\$45.50, dash leather \$3,75.....	49 25
Top leather 60 feet at 32c.—\$19.20, harness and strap leather \$3.....	22 20
Shaft leather, railing and binding, split leather, &c., for front valance, cordings, bindings, &c., &c.....	12 00
Trimmers' and stitchers' wages \$21, finisher's wages \$4.....	25 00



Muslin, cord, thread, nails, &c. \$7, knobs, buckles, loops, &c. \$4.....	11 00
	\$368 40
Add working expenses of your factory, wastage, &c., Government revenue tax and profit —33½ per cent.....	124 03
	\$492 43

A full 20 per cent. is required to pay the *working expenses* of any ordinary factory, including the Government tax and incidental losses by *bad debts*; the profit on a Top Buggy is about \$60 on \$500, or 12 per cent. on any ordinary business—*little enough, I think.*

## Sparks from the Anvil.

### MISCELLANEOUS SCINTILLATIONS.

**PARALLEL AND TAPER VISE.**—An invention has recently been patented in England, having for its object the combination of a taper as well as a parallel adjustment of the jaws of a vise at the option of the workman. To effect this the inventor carries a cross-bar from the lower part of the fixed jaw, and forms a hole through the free end thereof. He inserts in this hole a spindle depending from a crutch formed with wings, and secures the spindle by a nut screwing on to a thread at the bottom, which passes through the cross-bar. The wings have pin-holes formed through them, and there are pin-holes to correspond in the cross-bar. The lower end of the movable jaw enters the crutch, and is free to move upon a pin. When the vise is used for parallel objects the crutch is prevented from turning by passing pins through the holes in the wings and into the cross-bar; on removing these pins the vise is ready for holding taper objects.

**AMERICAN ORDERS FOR ENGLISH IRON.**—A report comes to us that American orders for English iron are not as valuable now as formerly while our civil war was in progress; but there is still an encouraging demand for iron in Birmingham, for which reduced prices are readily accepted. Advices from New York are to the effect that iron cannot be sold there at the prices which are necessitated by the maintenance of the higher rates in England, for by the time iron is offered in that market it is not more than three dollars a ton under the prices of the American masters—and, at the present rate of exchange, three dollars is not 12s. Nevertheless, first-class firms have enough to do on old specifications from America to keep them tolerably well employed in that department of their foreign trade.

**TESTING SPRINGS.**—An English mode of testing springs has lately been invented in Europe. This is accomplished in part by the forcing of air into an accumulator by the aid of an air-pump worked by hand or steam power. The air, being the elastic body, is compressed by the action of water upon it, and when the required pressure is thus attained, it is released from the accumulator by a lever acting upon a valve into a horizontal cylinder, which forces a ram, and consequently compresses the spring into a straight line, or beyond, to any degree required, which returns to its original curvature by pressing a lever which opens a valve and releases a part of the accumulated water through a waste-pipe.

VOL. VII.—22.

**SCREW-BOLT SCREWERS.**—The Philadelphia bolt-makers, like the Ephesian shrine-makers, apprehensive that their craft is in danger, have got up a petition and presented it to Congress for an increase of duty on carriage screw-bolts, which has been referred to the Committee of Ways and Means—a *mean* business.

### HOMOGENEOUS STEEL FOR CARRIAGE TIRES.

WE have, in a previous article, very highly recommended homogeneous steel for light carriage tires. This was done when there was nothing of the kind known in this country except the English manufactured material. Experience has proved that this does not possess sufficient strength to resist the action of the frosts of our northern climate without breaking. Whether this is owing to the practically imperfect quality of the ore from which it is produced, or from the high temperature of the steel, we cannot tell; we only know that its use has caused us much trouble and great expense to keep our customers from leaving us in consequence of such occurrences. We are glad, however, to find this inferior steel driven out of the market by the American Homogeneous Steel advertised on the cover of this Magazine by the Farist Steel Company, at Windsor Locks, Connecticut. This, while it is properly hardened so as to protect the rims of carriage wheels against indentation when the wheel is passing over our rough roads, is also much tougher, more easily welded and seldom breaks. Indeed, the American is in many respects superior to the imported steel. So well is this fact established that the leading light carriage-makers of this country, some of whose names appear in the advertisement alluded to, will use no other. It is not only much better, but likewise much cheaper.

The practical advantages of homogeneous steel over the common iron tires are, they are a better protection to very light rims, and where—as among us—weight is an object, can be used much lighter and thinner. These thin tires should never be “bolted” on except where the two ends meet; all other fastenings should be the common wood-screw, since bolts through all light fellys weaken them very much. Disclaiming invidious comparisons with other substitutes, candor obliges us to say that, when taken all in all, we consider the American Homogeneous Steel the best article in the market for the purposes for which it is offered. When we say this, we give our own experience after long usage, uninfluenced by any person. We will add here, that this steel has been included among the materials we are furnishing to the trade at prices quoted monthly in our Prices Current.

## Paint Room.

### STRIPING PENCILS.

MUCH care is required in the selection of a striping pencil; more than the non-mechanical mind would suppose. Even with practical mechanics tastes differ. Some prefer a longer and others a shorter one; some a stiffer, and some one more soft and pliable. For these reasons it will be difficult to prescribe rules to meet the whims of all. The best way is for each to use his own judgment, where it can be done, and the privilege to do this is of much importance to the workman, inasmuch as the most



expert operator is often thwarted by an imperfect implement. In selecting his pencils, when purchasing at the store, the workman should take care to see that they are strongly as well as neatly made, and that they have not been cut at the end with the scissors, but are found to retain that soft and exquisitely fine part, which is scarcely visible, unless held before a light, but which is essential to the pencil's presenting a true point—that they are elastic, springing back to their form after being pressed a moment on the point; and finally that they do not swell at the insertion. Pencils, the hairs of which form several points or ends, may be condemned as worthless.

Some painters recommend the purchase of the larger sized pencils which, when divided, may be made into sizes to suit. In doing this, the tail feathers (quills) of various birds will be found useful. In this way economy may be practised, as well as fancy satisfied. To prepare striping pencils, after having cut the barrel of the quill to the proper length and cleaned it of its pith, you next draw the prepared hair into its place in the quill, by a string previously made fast around the end. The *brush* part is sometimes prepared by tying the hair in a circle around the end of a sharp pointed stick, but care in this case is necessary lest the thread slip over the point and thereby twist the hair out of shape.

Pencils are of three kinds, camel, sable, and fitch. The first, which is made of the camel's hair, is the cheapest and very little used now. The sable (*mustela zibellina*), a species of weasel, is that most used. These are of a reddish, or yellowish brown, more or less dark, and are the cheapest in the end, since one good sable pencil will outlast four made of camel hair. They are much stiffer than the camel hair, laying the color more evenly, while—unlike the camel, which carries more paint—they seem to lay on just what is required to make a good job. Probably the sable pencils do not as well preserve the proper shape in moist weather, but when they do get twisted, it only requires that they be laid on a flat piece of iron, not so hot but that you can bear your hand on it, when they may be rectified by the fingers. The fitch or fitchet (the "fitchew" of Shakespeare; the *polecat*, or *foumart*, *foul* or stinking *martin*; the *mustela putorius* of Linneus—another species of weasel), is black in color; firm, yet soft, and are usually called "fitches." Of these three kinds, as we have before said, the sable is the dearest, because the animal whose tail supplies the hair, is scarce. It is generally considered the best, because it is the most elastic.

More pencils are ruined from carelessness in putting them away than from use. Dipping them in oil, as is often done when they become stiff and *shiny*, ruins them. Pencils, when done with, should always be thoroughly cleaned. Objection is made to spirits of turpentine by some, although it does the work at once, because it crisps and turns up the ends of the hairs, making them assume the form of little hooks, and spoiling the shape. To avoid this, some recommend that pencils be cleaned in a preparation of one-third turpentine and two-thirds poppy, or sweet oil. After the pencil is freed from every vestige of paint, by pressure through a soft woolen rag, or between the fingers (which last is objectionable), they may be slightly greased with tallow, and laid straight on glass, until wanted again, without much danger of being injured. It will be found a good plan to keep a stock of pencils on hand at least six months, that they may become

seasoned, as they will be less likely to warp and twist when used. Having given our thoughts in this matter, we shall be glad to hear from any of our readers who are interested and may differ from us.

#### MORE ABOUT SHAM-CANING.

In the article given on page 152 of this volume, we recommended that the tubular end of the apparatus for sham-caning be made of zinc or stout tin. Some recommend that it be made of copper, as not only more durable, but a metal from which the paint will flow more freely. Probably, all things considered, this last is the best.

In preparing the paint for cane imitation, the usual plan in many shops is to grind white lead in turpentine and bind it with gold size. To get the mixture of a proper consistency for flowing from the tube, will require some experimenting. This cannot be taught on paper.

#### ORIGINAL MONOGRAMS.

*Illustrated on plate XLIII.*

WE have already published in this volume four plates of monograms—the usual number. This fifth, then, is an extra. We hope that it will be no less acceptable than those which have preceded it, and prove useful to our subscribers.

#### Trimming Room.

##### LINING CLOTHS.

ONE of the most, if not *the* most important item in carriage-building is that of cloths. This fact attaches to the subject much interest in either the rise or fall in price. In the early stage of our late civil war, many persons with forethought and some money at command, availed themselves of *that* opportunity and laid in a good supply, from which they have derived much pecuniary benefit; but such prospective advantages do not seem to present themselves now. Indeed, no one expects that prices will go higher, all seem to think they must be cheaper soon, but will they? So little is with certainty known in regard to this matter, that we cannot find any one who is able to give us a satisfactory reason why they command such high prices as are asked for them at present. It cannot be owing to the extravagant rates of exchange, as was once the cry from the merchant. Can it be *on account of high rents?* or do those who import know that gold is down to \$1.30?

Let us review this subject a little. When the premium on gold stood five times higher than now, body-cloths sold for \$6@8 per yard. The dealers still charge us from \$4@\$6 for the same article. Linings then stood at \$5, now the same brings from \$3.50 to \$4.00 per yard by the piece. Has the reduction in cloth been made proportionate to the fall in gold? This is a question of interest to us all. If not, why has it not?

When we come to enameled cloths, the case is quite as bad. A year ago, when these could be had 5-4 wide for \$1 per yard, they were thought too high. What can be thought of the same article now at 90c.?



### AFGHANS FOR CARRIAGES.

ONE of the most luxurious appendages to a modern carriage is the recently invented Afghan. It is designed to supersede the old carriage blanket, and is as much superior to it in elegance as broad-lace is to common webbing. As yet the article has but a local usage, and the manufacture appears to be confined to a few female hands in this city. At least there are but two or three women offering them for sale. These Afghans are worsted in textile, and would seem to be knit with the hand in close imitation of that useful thing called a "comforter." Some of these are decidedly beautiful, and of the gayest colors, such as reds, greens, browns, yellows, blacks, &c., and cost from \$60 to \$150, according to style and finish. We have examined some which rival the most splendid floor carpets in delicacy and softness. They certainly are a beautiful substitute for the old blanket, and no doubt will very soon drive it from the market altogether.

### Editor's Work-bench.

#### COSTS OF CARRIAGES.

UNDER the heading of "Estimates for the consideration of Carriage-makers," on page 168, will be found a memorandum of the costs involved in building two kinds of vehicles, which the anonymous author thinks "may have the effect of opening the eyes of some carriage-makers who *can think*, but apparently *do not*." We know not who the writer is, although in a private note he calls the editor *his* "friend." It would certainly have been more weighty, and looked more "like a square business" in the correspondent, to have appended his name, as the public have reason to suspect an individual who *fires* from an ambush of having sinister motives. As, however, in a matter of this character, every individual may form his own opinion of the correctness of the estimates there presented, we waive our usual claim of having the writer's name as a pledge of good faith in his premises.

Our unknown friend says "that many carriage-makers are in the habit of selling carriages, particularly buggies and the plainer styles of coaches, at bankrupt prices, and the writer's object is to 'wake-up' some of these *smart ones* to a sense of their true position, that they may *sell* to live, not sell for the pleasure of selling." Now, it is our candid opinion that many *unthinking* carriage-makers, in both city and country, are actually selling carriages below the first costs in total ignorance of the fact, because they have never yet taken the time to figure them out. Let us say to these *enterprising* individuals—who seem intent on putting the prices of carriages so very low as to be sure and undersell their neighbors, regardless of consequences—that they are taking a very unwise and dangerous course. This is the questionable ambition which produces so many irresponsible and

"poverty-stricken" members in this branch of trade—proverbially such. There ought to be some uniform system of prices adopted among us. This would promote the interest of all, without injury to the public, for whose pleasure we cater.

Some may think the estimates of our "friend" much too high; but when it is remembered that they are made in reference to first-class work, all doubt must vanish, and none but such as are engaged in throwing together cheap work, *at starvation prices*, find reason for cavil. It is an old maxim that "the laborer is worthy of his hire;" but an evident fact that many work without reward just because they are foolish enough to throw it away. They go on year after year, struggling with poverty and creditors, until final ruin overtakes them and their families. If they do not in time find themselves in the poor-house, it is simply because they have no friends out of it, not because they have not earned such a situation. These are our "views" of this matter.

#### PUBLIC CARRIAGES.

UNDER this heading a writer in the *American Artisan* tells us that "the New York Common Council has a design to require public vehicles to carry lamps, for what purpose we do not know; but something is said about the safety of persons in crossing streets before them." Now, we think *a little more light* than our cotemporary has shed on this subject may be given with advantage and profit.

The coach-maker indulges the idea that a lamp is applied to a carriage for two purposes; the first is to enable the driver, in the absence of natural, to supply himself with artificial light, so that he may drive his horses with safety to all interested; the second for ornamentation. Any one who examines the hack-coaches of our cities will find the lamps—some of them—of the most expensive kind and of the largest size. In this respect we see no cause for complaint. The fault-finding public see other points where reform is needed, but entertain little hope of aid from a Common Council quite as corrupt as the jarveys whose votes have put them in the position they occupy. They are, in the main, "birds of a feather," and consequently, "will flock together."

As before intimated, some reform in the entire hack system is very urgently called for. As now conducted it is disgraceful to any community professing civilization. Some of the vehicles, especially those driven at night, in vulgar parlance known as "night-hawks," are the vilest specimens of dilapidation imaginable, and in sober daylight would never receive the patronage of *sober* individuals, under any circumstances. Even the "greenies" from the rural districts, who are habitually and systematically fleeced by these *worthy* constituents of the corrupt Common



Council of the chief metropolis of this Western Hemisphere, would play shy of these "man-traps," did they know the amount of villainy attached to a New York city hack-establishment. As matters now stand, great improvement in the conduct of our hackmen might be effected had we *honest* officials to do their duty. Here the chief difficulty lays, and in this fact all hope of relief from a great evil finds a ready grave.

Our cotemporary says: "If a lamp had ground glass windows, of large size, the shape of the windows might distinguish the lines: square, round, hexagonal, diamond, and other shapes." This is a suggestion of some value when applied to the horse-cars. Something more is needed for our four-wheeled hack-coaches. Taking a hint from the invention recorded among the foreign improvements, on page 159, of this volume, entitled, "Lamps for Calling Cabs and other Vehicles," we suggest that every man taking out a license to run a hack, be compelled to have his name and number distinctly painted in black letters on the glass of his lamp, so as to be seen and read of all men. In addition to this, a law ought to be passed permitting an attachment to issue against his horses and carriage in all cases of overcharge, &c., to abide the result of all suits brought against offenders. This would have one good effect at least. In giving a security to obtain the use of his vehicle pending the suit, the prosecutor would have some reason for hope that when he obtained judgment there would be some expectation of getting repaid for his trouble and expense. Under our present system of license it would be hard to find "responsible owners," were a remedy at law attempted. As we find complaints similar to our own against the management of public conveyances in Europe, we arrive at the conclusion that the whole business urgently demands a thorough overhauling everywhere.

#### REVIEW OF TRADE.

Among business men the opinion prevails that we are about on the era of a financial revolution. Two reasons lead to such a prediction. One is the belief that high prices for merchandise cannot much longer be maintained, and another, that the cholera which will visit us the coming season must tend to such a result, by sending to the country the buyers and sellers of the principal cities. This, however, is a matter we need not speculate upon here. "Sufficient to the day is the evil thereof." Our business is with the present.

Business, at this present writing, among the sales-rooms of Broadway, is reported very dull—a not very unusual thing for this season of the year. There is one feature in trade this Spring which is somewhat amusing. "Our Southern friends," after the old custom, are "around," and, in the *old* habit, are, in some instances,

asking credit, just as though nothing had transpired to interrupt *peaceful* commerce during the last four years. A flat refusal, however, has in more than one instance to our knowledge, thrown a shadow over the spirit of their dreams. They find that the only pay popular since they passed stay-laws at the South to cheat Northern creditors, is "to plank down" the greenbacks. This is as it should be; just what they might expect after such folly as they have exhibited.

The city manufacturers, contrary to the repository men, are very busy getting ready work ordered by customers for the Spring. The leading builders tell us they have enough to keep them busy until July. The dealers in carriage materials, too, find trade lively. This, if nothing more, shows that preparation is being made for an extensive sale in the Spring by our country friends. We hope their fondest expectations will be met, but, if not too late, we would advise prudence in this respect. Although it is true, that in order to sell the builder must have his work ready in time, or he can do very little to advantage, still, there are times when prudence dictates caution, and we think the present are such.

#### CHARTS.

ONE of the most useful appendages to a coach-maker's office is a handsome chart, neatly framed, and hanging on the wall. It is not only useful but ornamental and attractive to customers, which often tempts them to order a carriage when otherwise they might go elsewhere. To supply the article needed, we have had printed two different charts, each being 20 by 26 inches, designated by us Nos. 3 and 4.

No. 3 has on it twenty-eight designs, on a half-inch scale, classed as follows: 5 no-top and 10 top buggies; 7 no-top Phaetons; 3 rockaways; 1 victoria; 1 coupé rockaway, and one landau. A space with a border is left blank for the insertion of your business card by pasting.

No. 4 contains twenty-five designs, drawn half-inch to the foot, assorted as follows: six no-top buggies; four phaetons; one physician's phaeton; one Boston chaise; three two-seat rockaways; one victoria; one break; one coupé; one park phaeton; four coaches, and two hearses, with a space for card, as in No. 3. Both charts have borders, making a very handsome set for the office. These we sell at one dollar each. Sent by mail, postage paid, on receipt of price. If only one is called for, specify the number wanted.

#### EDITORIAL CHIPS AND SHAVINGS.

CHARIOTS IN ANCIENT TIMES.—The reader of ancient history is surprised to find how numerous chariots were among some nations. The city of Thebes, from its hundred gates, could send out two thousand at a time. Terah, king of Ethiopia, had with his army three hundred war



chariots; Sesostris, king of Egypt, had twenty-seven scythe-armed, and Ninus, king of Assyria (nearly 2,300 years before Christ), sixteen thousand of the like description. Cyrus at one time possessed two thousand scythe-chariots, but these do not seem to have answered his purpose as well as he expected, and with this disappointment they were laid aside for a time.

**CARRIAGES MADE IN NEW ENGLAND.**—The number of carriages made in the Eastern States in 1860 were valued at \$7,383,104. At present there are nearly forty shops in New Haven, employing about 2,100 hands, and turning out 51,415 carriages of all kinds per year, of an aggregate value of \$134,314,759. Average value before the war, \$153; now, \$242. Orders for the Southern market are said to be very large.

**CARRIAGE FOR INVALIDS.**—A carriage has been patented in France which is air-tight, and so strong that the air may be compressed in it to a density suitable to the necessities of patients who have diseases that require them to be kept in compressed air, in order to breathe effectively. The air is constantly pumped in as the carriage runs, by a pump which is worked by an eccentric on the axle of the hind wheels.

**THE BLOOMINGDALE DRIVE.**—The public of New York city will be pleased to learn that the grand Bloomingdale Drive is being rapidly surveyed throughout its entire length from Fifty-ninth Street to the upper end of Manhattan Island. It is understood that the width of this splendid thoroughfare is to be 150 feet until it reaches the upper part of the Island, where, it is probable, its width will be reduced to about 80 or 90 feet. The macadamized drive from Fifty-ninth Street is to be 100 feet wide, with a row of trees on either side, but none in the middle, as has been supposed. Fifteen feet on each side of the drive will be devoted to sidewalks and ten feet to a grass or flower plot in front of each house. The railings and gateways to each will be of uniform character and in the purest taste. As the dwellings will be situated 10 feet from the walks, and ornamented with choice flowers and shrubbery in front, it cannot be doubted that they will be of an architectural character worthy of our great metropolis. Before long the plans will be completed nearly as we have mentioned.

**WIDE-TIRE WAGONS.**—The advantages of wide-tire wagons, is not sufficiently appreciated. Every farmer who has tried one upon sandy roads or fields, speaks highly in their favor, and they are equally valuable upon soft soil when it is wet, like much upon the great prairies, where their fellows cut through the sod and sink half a foot below the surface. Upon some meadows wheels with four-inch tire run freely, while those with the ordinary width of 18 inches cannot be used at all. Upon more than half the land and roads of the United States a wide-tire wagon will run easier, heavily loaded, with two horses, than a narrow tire will with three. It is then a saving of 50 per cent. Some turnpike companies allow wide-tire wagons to pass for half toll, and as a matter of public economy every road district could afford to pay a premium to have all burden wagons made with tires four inches wide.

**DESIGNS FOR MAY.**—A hearse for children, a physician's phaeton, the Hartford buggy, and a handsome title page, will be given in our next number, which closes the seventh volume.

## The Coach-maker's Letter-box.

COLUMBUS, OHIO, March 5th, 1866.

MR. E. M. STRATTON, *Dear Sir*: I notice in the last number of the Magazine a proclamation from the bosses in Cincinnati, in which they have pledged themselves against the Union, as they thought with a firm determination, but, as I understand it, has been broken badly, the journeymen having gone to work again without withdrawing from the Union, and in many cases have received their ten per cent. advance. So you see their year was of short duration.

Now, I suppose you differ in opinion from me, in regard to these Unions, as you stand in a different position from myself; you in the position of an employer, I, at this time, in that of an employé. [We claim to be neutral in this matter.] Now we do not think that labor ought to dictate to capital, nor do we think that capital should dictate and control labor, to its certain detriment, as it did slave labor in the sunny South. Labor has only become awakened to its own interests, hence comes our combination, for "self-preservation is the first law of nature," and enjoined upon us by the Holy Book. We expect persecution, and are receiving our full share of it, but it makes us that much stronger. Since the bosses signed that article there have been Unions organized in Indianapolis, Louisville, New Haven, and Bridgeport, large carriage-making towns, and they are extending into the New England States.

JOHN B. PEEK,  
Cor. Sec. of Union No. 8.

## Patent Journal.

### AMERICAN INVENTIONS.

Jan. 30. (52,255) METALLIC HUB FOR VEHICLES.—Joseph Abbot, Washington, Ind.:

I claim, *First*, The two-part body C, provided with lips *d d'*, to form mortices and employed in combination with the pipe A, shoulders B, and screw-cap D, as and for the purpose specified. *Second*, The oil-cup E, provided with a faucet F, and communicating with the interior of the pipe or box A, substantially as and for the purpose set forth. *Third*, The recess *h*, in the pipe or box A, when used in combination with the oil-cup E and faucet F, substantially as and for the purpose specified.

(52,260) REACH FOR LUMBER WAGONS.—George and William Bench, Auburn, N. Y.:

I claim the combination and arrangement of the short reach B, with subreach C, socket F, and loop C, constructed substantially as described and for the purpose set forth.

(52,307) SHAFT COUPLING.—Marvin Mead, Augusta, Mich.:

I claim the clip A, constructed as described, to hold the shank B, said clip being provided with a countersink beneath the end of the shank, in which countersink is placed a piece of india-rubber, or other elastic material, which is there held by means of a pin which passes through the clip, substantially as and for the purposes specified.

(52,341) WAGON WHEELS.—John Thresher, West Liberty, O.:

I claim the hub-band B, pivoted with sockets C, to fit the large part of the spokes, while the mortices in the hub receive the spoke tenons, all substantially as herein described.



Feb. 6. (52,422) WHEEL AXLE.—Thomas A. Lane, Cincinnati, O. :

I claim, *First*, A carriage-wheel provided with carved and elastic metallic spokes D, substantially as described, rigidly united to a spindle or shaft to be coupled to, but to revolve independently of the shaft of the corresponding wheel. *Second*, A wheel whose spokes consist of yielding metallic plates coinciding in form with a circular or simple arc.

(52,439) WHIP-SOCKET.—Charles B. Morehouse, New Castle, Ind. :

I claim the screw penetrating the ring from the outside, and the construction of the rings and their clamps, in combination with their metal bottom and elastic top, as herein described and for the purpose set forth.

(52,440) CARRIAGE CLIP.—Francis B. Morse, Milwaukee, Wis. :

I claim, *First*, A carriage clip, constructed substantially as described and for the purpose set forth. *Second*, The combination of the anti-rattler J, with the bolt H, and with the clip, substantially as described and for the purpose set forth.

(52,508) TUYERE.—Even Koons, Frinkstown, Md. :

I claim, *First*, The cup or dish formed of fire-iron or tuyere, constructed in the manner described, for the purpose of allowing the cinders to flow away from the air-discharge opening-arm, for the purpose of preventing the same from flowing out against the brick-work, substantially as described. *Second*, The use of the conical-weighted plug, constructed as and for the purposes herein described.

13. (52,561) AXLE FOR VEHICLES AND JOURNALS FOR MACHINERY.—R. P. Gillett, Sparta, Wis. :

I claim the collar B, on the axle A, constructed with a recess *a*, for the insertion of the butt end of the boxing *e*, substantially as and for the purpose described.

(52,586) THILL-COUPLING.—John McDermot, Washington, D. C. :

I claim, *First*, The use of the anti-friction faces or bushing-pieces *e e*, as described, in combination with the head of the thill-shank, and the jaws of the lug, to increase the extent and durability of the rubbing surface. *Second*, Coupling the head of the thill-shank in the jaws of the lug by the use of bushing-pieces *e e*, so made and arranged in respect to said jaws and said head that said head will act as a key to secure said bushing-pieces, while at the same time said bushing-pieces act as a coupling to unite the thills to the axle without the aid of a bolt. *Third*, The use of bushing-pieces *e e*, made with a flange on their inside surfaces to lap over and hold the ends of the thill-shank, and a tubular socket or projection on their outside surface to fasten in the jaws of the lugs and to receive the bolt, substantially as described.

(52,595) WAGON-BRAKE.—L. C. Percival, Philadelphia, Pa. :

I claim, *First*, The levers E E, pivoted to the braces F F, at the rear part of the reach or perch C, and provided with shoes G, at their outer ends, in line with the rear wheels B, in combination with the rods I J, and the levers K K, to which the breast straps of the team are attached, all arranged and applied substantially as and for the purpose set forth. *Second*, The spring-pins L, attached to the draft-pole D, in combination with the lips *i*, in the rod J, substantially as and for the purpose specified. *Third*, The strip M, applied to the thills N, and connected with rod I, substantially as and for the purpose set forth.

(52,600) VEHICLES.—T. W. Porter, Bangor, Me. :

I claim, *First*, The socket A (fig. 3), made of malleable iron, with the projections *d d*, and *b b*, as an article of manufacture and sale, for the uses and purposes set forth. *Second*, As an article of manufacture and sale, I claim the malleable iron-clip, or shaft-coupling, as shown in Fig. 10, with the lips I I, and tube *a*, cushion *n*, plate *r*, and wrought-iron clasp *e'*, substantially as shown and described. *Third*, As a new article of manufac-

ture and sale, I claim the malleable-iron tip or coupling *k*, (Fig. 10), substantially as shown and described and for the purpose specified. *Fourth*, As an article of manufacture and sale, I claim the pole-end H, of malleable iron with the straps *b b*, and double-tree pivot *a*, and projections *d d*, constructed and arranged as described and for the purposes specified. *Fifth*, As an article of manufacture and sale, I claim the malleable iron perch-coupling L (Fig. 8), with projection of straps *c*, and step *i*, constructed and arranged as described and shown, and for the purposes specified.

(52,619) ATTACHING SHAFTS TO VEHICLES.—J. L. Suesserott, Chambersburg, Pa. :

I claim, *First*, Constructing the shaft-box A with a stop D, for supporting an india-rubber block, and the recess *a*, for holding it in place, when used in combination with the block E, constructed substantially as and for the purpose set forth. *Second*, The box A, having a bar *b*, and step D, and india-rubber block E, arranged as set forth, when used in combination with the hooked termination of the shafts C, substantially as and for the purpose set forth.

(52,651) POLE AND THILL-COUPLING.—H. L. Taylor, Fredonia, N. Y. :

I claim, *First*, The combination of the hook E *e*, and drop bolt *g*, with the follower block K, india-rubber spring *j*, or its equivalent washer *i*, and self-locking key *o*, arranged and operating in the manner and for the purpose shown and described. *Second*, Constructing the block K, with the lips *l l*, and cheeks *m m*, in combination with the hook E *e*, and rubber *j*, substantially in the manner and for the purpose described. *Third*, The employment of the lever S, provided with the hook *t*, and spur *n*, in combination with the extension *g*, and hole *r*, for inserting and removing the key *o*, substantially as described.

20. (52,663) SLED.—Samuel R. Bowie, Portland, Maine :

I claim, *First*, the combination of the levers *b* and *c*, the plate *n*, the rope *e*, and pulleys *d*, substantially as and for the purposes specified. *Second*, The combination of the parts *a b* and *c*, with the device shown in fig. 3, substantially as described and for the purposes set forth.

(52,703) WAGON-BRAKE.—C. W. Gage, Homer, N. Y. :

I claim, *First*, Connecting the yoke-pins of the pole to and with the brakes by means of the connecting rod *r*, made in two or more sections, substantially as herein described and for the purpose specified. *Second*, In combination with the above, the weighted lever arm *m*, arranged and operating substantially as and for the purpose specified.

(25,731) WAGON-BRAKE.—Joseph McQueed, Mount Sterling, Ill. :

I claim the sliding brake or shoe-bar, connected to the shaft F by links E, or their equivalents, in combination with the eccentrics G G, on said shaft, and the lever J, connected with the shaft, and all arranged and applied to operate substantially as and for the purpose herein set forth.

27. (52,832) CARRIAGE-WHEEL.—H. C. & J. W. Drew, Waterloo, Mich. :

We claim, *First*, The use and application of the two bars K, in combination with the draft-pole J, and the bars L, and bars G, and the axles E E, the whole constructed and arranged as and for the purpose herein set forth. *Second*, The movable center-chain *h*, in combination with the link *l*, constructed in the manner and for the purpose herein specified. *Third*, the hinges S S, connecting the bars L, with the bars G, constructed and arranged substantially as herein described.

(52,889) DEVICE FOR HOLDING CARRIAGE-SPRINGS.—Rufus Rowell and Francis H. Briggs, Boston, Mass. :

We claim, *First*, The four flanges B B B B, on the spring-seat A A, substantially as and for the purpose herein described. *Second*, The four grooves *c c c c*, substantially as and for the purpose herein set forth. *Third*, The bolting of the seat and



spring together from E to E, and making a king-bolt of the same, substantially as and for the purpose herein described.

#### FOREIGN INVENTIONS.

JUNE 13, 1865. SELF-ACTING BRAKE FOR FOUR-WHEELED CARRIAGES.—J. Griffiths, Ludlow, Shropshire :

This invention is intended to cause the brake to be self-acting ; that is to say, that the brake shall be applied to the wheels whenever the carriage descends an incline, and whenever the horses are checked ; or in the case of a railway carriage, whenever the engine is slackened in speed or stopped. In constructing a four-wheeled carriage for common roads, according to this invention, the patentee constructs the turn-plate for the fore-carriage of two circular plates or rings, connected by a central bolt, the upper ring being attached by iron hoops to the body of the carriage and the lower ring, firmly connected to the under-carriage, and by means of the springs to the fore axle ; the pole or shafts is or are firmly connected to this lower ring. So far it resembles the ordinary arrangement, but, instead of the central bolt merely passing through circular holes in the turn-plates, so that they have merely a revolving or turning motion one over the other, he constructs the upper plate with a slot or mortice, so that it is capable of a sliding motion in the direction of the draft, as well as a turning motion round the central bolt. To the center of the lower plate is hinged to a connecting rod, attached to the other end by a cross-bar carrying two brake blocks a little in advance of the front part of the tires of the hind wheels. The result of this arrangement is, that as soon as the horses are checked the progress of the under-carriage is checked also, while the impetus of the body of the carriage carries it still forward, and the upper plate, sliding upon the lower (in consequence of the slot or mortice), the tires of the hind wheels of the carriage come in contact with the brake blocks, and thus the brake is self-acting.

14. ARRANGEMENT FOR OPENING AND SHUTTING CARRIAGE WINDOWS.—S. Cortland, Wadden, Surrey ; and C. W. Atkinson, St. Georges, Bloomsbury, London :

This invention consists in an eccentric motion, worked by a hand-lever or disc, describing either a whole revolution, or only the arc of a circle, so arranged as to be easily accessible, and to be capable of being turned, when it is desired, to raise or lower the window to any required distance. The before-named eccentric works a lever, to which is attached a chain, cord, or girt, passing round a pulley. Another pulley and cord or girt, derives its motion from the first-named pulley, and is constructed of such a diameter as to give the requisite distance of motion to the window. The cord or girt is passed round pulleys at or about the top and bottom of the bottom-sash, and is fixed to the bottom of the window-frame at or about the center thereof, by which means, when the eccentric is turned by the hand, the window is raised or lowered as required. The weight of the window is counteracted by a spring or weight, whereby the window can be raised with greater ease. The force of the spring or weight combined with the mechanical action of the eccentric, allows the window to remain at any required height.

23. DRAGS FOR CARRIAGES.—A. E. Dobbs, Lincoln's Inn, London :

In performing this invention a skid is fastened by means of a bar to a collar playing freely on the stock or nave (hub) of the wheel, intended to be retarded. When the drag is not in use, the skid is held up by a catch in front of the wheel, which is then free in revolving, and when the drag is to be used, the catch being moved, allows the skid to slip the wheel, and to be carried down by it until it is between the wheel and the ground. A projecting piece, attached to the skid, then comes in contact with the catch, and the dredge is thus fixed. When the skid is to be released, the catch is again moved, and the skid is carried by the wheel until arriving at its first position, where it is caught by the catch and held till again required, and at the same time is caused no longer to slip the wheel, which then can revolve freely as before.—*Not proceeded with.*

July 4. AXLES FOR CARRIAGES.—S. Wright, Smithwick, Stafford :

The patentee claims making the face of the flange on the arm of the axle, against which the back end or head of the axle-box bears, of a conical figure, and making the back end or head of the axle-box of a hollow conical figure, the said hollow conical end or head of the axle-box, engaging within a tubular or hollow cylindrical shoulder, at the base of the conical face of the flange, and fitting against the said conical face, as described.

CARRIAGES.—J. Harington, Acre-lane, Brixton, Surrey :

This invention has for its object improvement in carriages. In constructing the bodies of two-wheeled carriages of the description known as Hansom's carriages, when the entrance is from the front and the driver's seat at the back, the patentee makes the two doors of the full height between the floor and the roof of the carriages, or nearly so. The roof is divided into two parts, the hinder part being fixed and the front part hinged to such hinder part, so that it can, when desired, fold back thereon. When the front part of the roof is folded back out of the way, the carriage is an open one, very similar to an ordinary Hansom carriage ; but when the front part of the roof is closed down, and the doors shut, the carriage is a closed one, and more roomy and convenient than a Hansom carriage. The front of the carriage is formed in three parts ; the central part behind the horse is fixed, and it rises from the floor to where the front part of roof rests when shut down thereon. This central part may, when desired, be formed with a window. On either side of this central part is a door which may be hung in different ways. In one arrangement the doors are hung on radial arms, having their centers of motion at the roof and on the floor respectively, and they are arranged to move behind the central part of the front when opened. Or, in place of the doors being hung on radiating arms, they may be arranged to slide to and from the central parts of the front of the carriage by being suspended from above, or otherwise. Or, the doors may be hinged to the central part and fold back behind the same. The body is arranged to be hung on springs on an axle and wheels, and the shafts are applied similarly to an ordinary Hansom cab.

8. BRAKE FOR RETARDING THE PROGRESS OF WHEEL-CARRIAGES.—W. E. Newton, Chancery-lane, London :

In carrying out this invention a lever is adapted to the axle-tree of the hinder wheels, and is connected thereto by a block or bracket provided with a pin, which constitutes the center of motion of the lever. This lever is formed with an arm, which carries the brake or shoe which rests or bears on the periphery of the running wheel when the lever is forced down. At the outer end the lever is provided with a flat horizontal plate, on which the conductor or other person can stand, so that his whole weight, multiplied by the length of the lever, may be brought to bear on the friction-brake or shoe, which will thus produce a very powerful effect on the wheel, without overstraining any part of the carriage or apparatus, as is now the case in friction brakes. The lever may, if desired, be provided with a string-spring for the purpose of keeping the friction-brake or shoe up from the wheel when not in use ; or the lever may be lifted up by means of a chain or rod, and suspended by a block. When the brake is required, the conductor will allow it simply to descend on the ground, and will then place himself on the plate at the end of the lever so as to press the same down on the wheel.

27. OMNIBUSES.—A. Cheffins, Randolph Street, Camden-town, London :

This invention consists in constructing the omnibus with open iron sides and a central space between four vertical partitions, whereby the lower part of the vehicle may be divided on each side into a series of sittings for passengers, resembling a series of Hansom Cabs, capable of being entered separately through low doors or flaps, and the upper part may be fitted with seats on the top, with a strap or space for the feet of outside passengers.—*Not proceeded with.*



## CURRENT PRICES FOR CARRIAGE MATERIALS.

CORRECTED MONTHLY, FOR THE NEW YORK COACH-MAKER'S MAGAZINE.

NEW YORK, March 21, 1866.

Apron hooks and rings, per gross, \$2.50.  
 Axle-clips, according to length, per dozen, 75c. a \$1.25.  
 Axles, common (long stock), per lb, 10½c.  
 Axles, plain taper, 1 in. and under, \$6.50; 1½, \$7.50; 1¾, \$8.50;  
 1¾, \$9.50; 1¾, \$10.50.  
 Do. Swelled taper, 1 in. and under, \$7.00; 1½, \$8.25; 1¾, \$8.75;  
 1¾, \$10.75; 1¾, \$13.00.  
 Do. Half patent, 1 in. and under, \$10.50; 1½, \$12.50; 1¾, \$15.00;  
 1¾, \$17.50; 1¾, \$21.25.  
 Do. do. Homogeneous steel, ½ in., \$15.00; ¾, \$15; ¾, \$16.50;  
 long drafts, \$4 extra.  
 ☞ These are prices for first-class axles.  
 Bands, plated rim, under 3 in., \$2.50; over 3 in., \$3  
 Do. Mail patent, \$3.00 a \$5.00.  
 Do. galvanized, 3½ in. and under, \$1; larger, \$1 a \$2.  
 Basket wood imitations, per foot, \$1.25.  
 ☞ When sent by express, \$2 extra for a lining board to a panel of 12 ft.  
 Bent poles, each \$2.00.  
 Do. rims, under 1½ in., \$2.25 per set; extra hickory, \$3.25 a \$4.00.  
 Do. seat rails, 50c. each, or \$5.50 per doz.  
 Do. shafts, \$9.00 per bundle of 6 pairs.  
 Bolts, Philadelphia, list.  
 Do. T, per 100, \$3 a \$3.50.  
 Bows, per set, light, \$1.50; heavy, \$2.00.  
 Buckles, per grs. ½ in., \$1.50; ¾, \$1.50; ¾, \$1.70; ¾, \$2 10; 1, \$2.80.  
 Buckram, per yard, 25 a 30c.  
 Burlap, per yard, 30c.  
 Buttons, japanned, per paper, 25c.; per large gross, \$2.75.  
 Carriage-parts, buggy, carved, \$4.50 a \$6.  
 Carpets, Brussels, per yard, \$2 a \$3; velvet, \$3.25 a \$4.50; oil-cloth  
 75c. a \$1.  
 Castings, malleable iron, per lb, 20c.  
 Clip-kingbolts, each, 50c., or \$5.50 per dozen.  
 Cloths, body, \$4 a \$6; lining, \$3 a \$3.50. (See *Enameled*.)  
 ☞ A Union cloth, made expressly for carriages, and warranted not to fade,  
 can be furnished for \$2.25 per yard.  
 Cord, seaming, per lb, 45c.; netting, per yard, 8c.  
 Cotelines, per yard, \$4 a \$8.  
 Curtain frames, per dozen, \$1.25 a \$2.50.  
 Do. rollers, each, \$1.50.  
 Dashes, buggy, \$1.75.  
 Door-handles, stiff, \$1 a \$3; coach drop, per pair, \$3 a \$4.  
 Drugget, felt, \$2.  
 Enameled cloth, muslin, 5-4, 60c.; 6-4, \$1.05.  
 Do. Drills, 48 in., 95c.; 5-4, 90c.  
 Do. Ducks, 50 in., \$1.35; 5-4, \$1.40; 6-4, \$1.45.  
 ☞ No quotations for other enameled goods.  
 Felloe plates, wrought, per lb, all sizes, 25c.  
 Fifth-wheels wrought, \$1.75 a \$2.50.  
 Fringes, festoon, per piece, \$2; narrow, per yard, 18c.  
 ☞ For a buggy top two pieces are required, and sometimes three.  
 Do. silk bullion, per yard, 50c. a \$1.  
 Do. worsted bullion, 4 in. deep, 50c.  
 Do. worsted carpet, per yard, 8c. a 15c.  
 Frogs, 75c. a \$1 per pair.  
 Glue, per lb, 25c. a 30c.  
 Hair, picked, per lb, 55c. a 75c.  
 Hubs, light, mortised, \$1.25; unmortised, \$1.00—coach, mortised  
 \$2.00.  
 Japan, per gallon, \$3.  
 Knobs, English, \$1.50 a \$1.75 per gross.  
 Laces, broad, silk, per yard, \$1.00 a \$1.50; narrow, 15c. to 20c.  
 Do. broad, worsted, per yard, 50c. a 75c.  
 Lamps, coach, \$20 a \$30 per pair.  
 Lazy-backs, \$9 per doz.  
 Leather, collar, dash, 31c.; split do., 18c. a 22c.; enameled top,  
 32c.; enameled Trimming, 30c.; harness, per lb, 50c.; flap, per  
 foot, 25c. a 28c.  
 Moquet, 1½ yards wide, per yard, \$9.00.  
 Moss, per bale, 12½c. a 18c.  
 Mouldings, plated, per foot, ¼ in., 14c.; ¾, 16c.; 18c.; ½, 1 ead, door,  
 per piece, 40c.  
 Nails, lining, silver, per paper, 12c.; ivory, per gross, 50c.  
 Name-plates.

☞ See advertisement under this head on 3d page of cover.

Oils, boiled, per gallon, \$1.80.  
 Paints, White lead, ext. \$17, pure \$17½ p. 100 lbs.; Eng. pat. bl'k, 35c.  
 Pole-crabs, silver, \$5 a \$12; tips, \$1.50.  
 Pole-eyes, (S) No. 1, \$2.70; No. 2, \$2.90; No. 3, \$3.10; No. 4,  
 \$4.50 per pr.  
 Sand paper, per ream, under No. 2½, \$5.50; Nos. 2½ & 3, \$6.25.  
 Screws, gimlet.

☞ Add to manufacturer's printed lists 10 per ct.

Do. ivory headed, per dozen, 50c. per gross, \$5.50.  
 Scrims (for canvassing), 16c. a 25c.  
 Seats, buggy, pieced rails, \$1.75; solid rails, \$2.50.  
 Shaft-jacks (M. S. & S.'s), No. 1, \$2.75; 2, \$3.25; 3, \$3.50.  
 Shaft-jacks, common, \$1.50 a \$1.65 per pair.  
 Do. tips, extra plated, per pair, 37½c. a 56c.  
 Silk, curtain, per yard, \$2 a \$3.50.  
 Slat-irons, wrought, 4 bow, \$1.12½; 5 bow, \$1.25 per set.  
 Slides, ivory, white and black, per doz., \$12; bone, per doz., \$1.50  
 a \$2.25; No. 18, \$2.75 per doz.  
 Speaking tubes, each, \$10.  
 Spindles, seat, per 100, \$1.50 a \$2.50.  
 Spring-bars, carved, per pair, \$1.75.  
 Springs, black, 24c.; bright, 25c.; English (tempered), 28c.;  
 Swedes (tempered), 32c.; 1¼ in., 1c. per lb. extra.  
 If under 36 in., 2c. per lb. additional.

☞ Two springs for a buggy weigh about 23 lbs. If both 4 plate, 34 to 40 lbs.

Spokes, buggy, ¾, 1 and 1½ in. 9½c. each; 1½ and 1¾ in. 10c. each;  
 1¾ in. 9c. each.

☞ For extra hickory the charges are 10c. a 12½c. each.

Steel, Farist Steel Co.'s Homogeneous Tire (net prices); 1 x 3-16  
 and 1 x 1-4, 20 cts.; 7-8 x 1-8 and 7-8 x 3-16, 23 cts.; 3-4 x 1-8,  
 25 cts.; 3-4 x 1-16, 28 cts.

Do. Littlejohn's compound tire, 3-16, 9½c.; 1-4, 9c.; heavier  
 sizes, 8½c. currency.

Stump-joints, per dozen, \$1.40 a \$2.

Tacks, 9c. and upwards per paper.

Tassels, holder, per pair, \$1 a \$2; inside, per dozen, \$5 a \$12;  
 acorn trigger, per dozen, \$2.25.

Terry, per yard, worsted, \$3.50; silk, \$8.

Top props, Thos. Pat, per set 70c.; capped complete, \$1.50.

Do. common, per set, 40c.

Do. close plated nuts and rivets, \$1.

Thread, linen, No. 25, \$1.45; 30, \$1.55; 35, \$1.80, gold.

Do. stitching, No. 10, \$1.00; 3, \$1.20; 12, \$1.35, gold.

Do. Marshall's Machine, 432, \$2; 532, \$2.25; 632, \$2.60, gold.

Tufts, common flat, worsted, per gross, 20c.

Do. heavy black corded, worsted, per gross, \$1.

Do. do. silk, per gross, \$2.

Do. ball, \$1.

Turpentine, per gallon, \$1.30.

Twine, tufting, per ball, 50c.; per lb, 85c. a \$1.

Varnishes (Amer.), crown coach-body, \$5.50; nonpareil, \$6.50.

Do. English, \$6.25 in gold, or equivalent in currency on the  
 day of purchase.

Webbing, per piece, 65c.; per gross of 4 pieces, \$2.40.

Whiffle-trees, coach, turned, each, 50c.; per dozen, \$5.50.

Whiffle-tree spring hooks, \$4.50 per doz.

Whip-sockets, flexible rubber, \$4.50 a \$6 per dozen.

Do. hard rubber, \$10.50 per dozen.

Do. leather imitation English, \$5 per dozen.

Do. common American, \$3.50 a \$4 per dozen.

Window lifter plates, per dozen, \$1.50.

Yokes, pole, each, 50c.; per doz, \$5.50.

Yoke-tips, extra plated, \$1.50 per pair.

**SPECIAL NOTICE.**—With the next number will be given [an index and title-page for the seventh volume. On receiving it the larger proportion of our subscribers will have in their possession all they have paid for, consequently, unless they renew, we shall be compelled to stop sending the Magazine to many. We hope, however, that this will be prevented in time by the reception of \$5, which will be the price for the forthcoming volume. Hope was entertained that we would be able to reduce the price, but this is now abandoned, in view of the fact that paper and labor are as high as ever, with no signs of abatement.





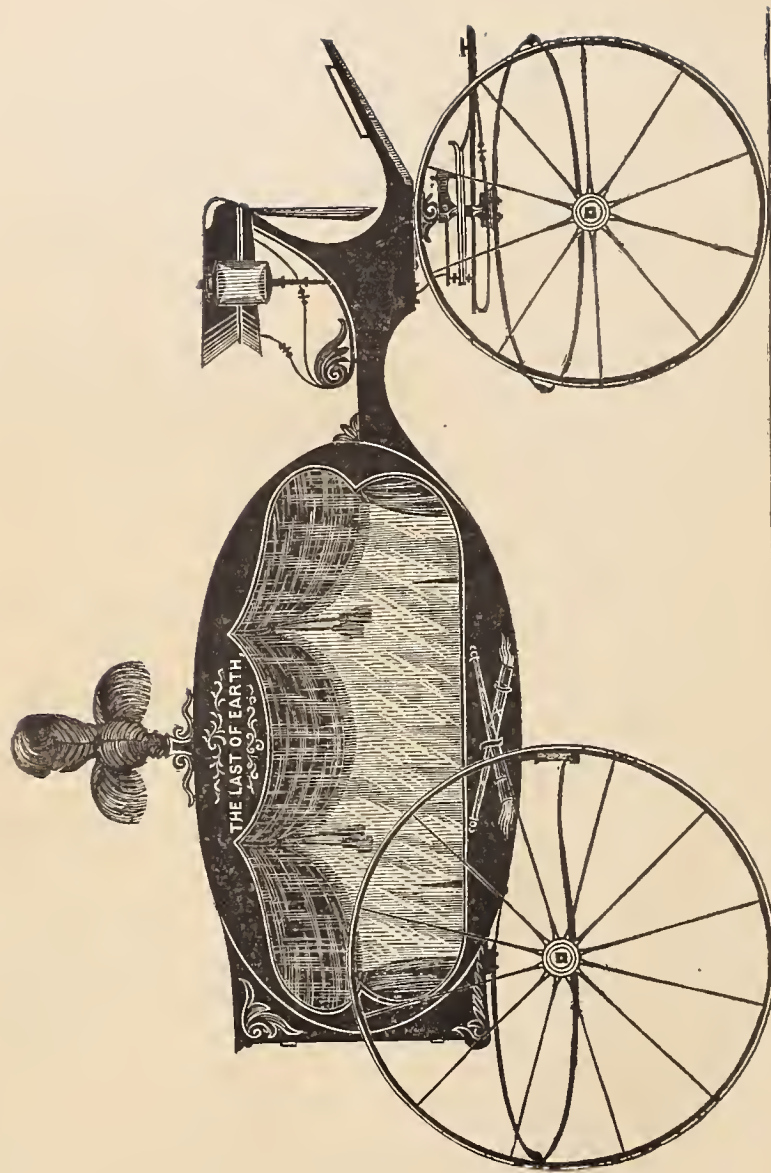

JUVENILE HEARSE.— $\frac{1}{2}$  IN. SCALE.  
*Designed expressly for the New York Coach-maker's Magazine.*  
*Explained on page 180.*

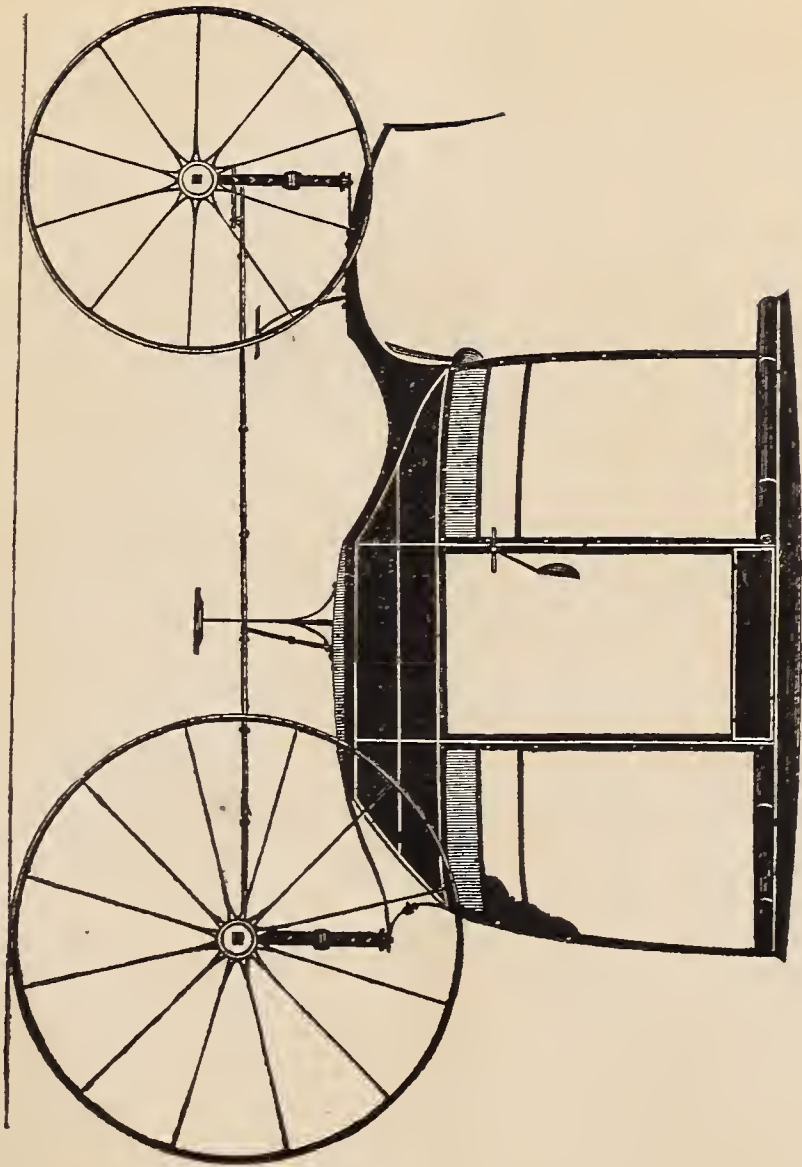

TRIANGULAR ROCKAWAY.— $\frac{1}{2}$  IN. SCALE.

*Designed expressly for the New York Coach-maker's Magazine.*

*Explained on page 181.*









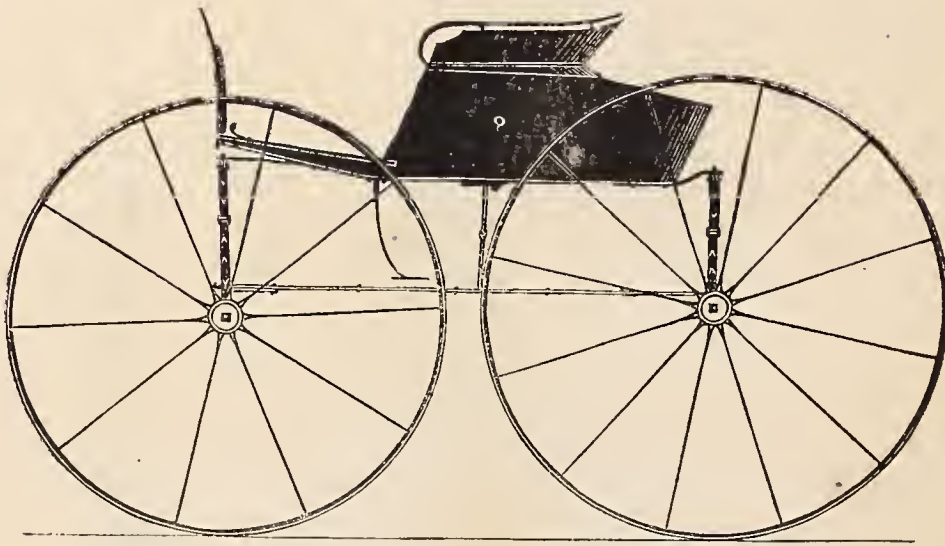

THE HARTFORD BUGGY.— $\frac{1}{2}$  IN. SCALE.

*Engraved expressly for the New York Coach-maker's Magazine.*

*Explained on page 181.*



DEVOTED TO THE LITERARY, SOCIAL, AND MECHANICAL INTERESTS OF THE CRAFT.

Vol. VII.

NEW YORK, MAY, 1866.

No 12.

## Mechanical Literature.

### PRACTICAL SUGGESTIONS FOR WOOD-WORKMEN.

BY J. B. PEEK.

IN choosing tools to be used in business, those most necessary are planes, saws, chisels, and draw-knives. We will consider these with respect to the wood they are manufactured from and the steel which forms the cutting part thereof. And, first, beech is generally and ought *always* to be used, except for chisel-handles, for which hickory, elm, or apple-tree is better, as they are of a tougher texture and not liable to split or warp.

Now, there are two kinds of beech, usually distinguished by the names of black or red beech, and the white beech. The former is by far the best in every respect, and always known by its color and texture, which is darker and more hard in substance. The white is also more apt to warp, and soon wears with use; it should therefore always be rejected as improper.

Again, if you examine a piece of beech endwise, you will find the grain running in streaks, which, among workmen, is called the beat of the wood, and in all planes this grain or beat (which is the hard fibrous particles) should run in a direction perpendicular to the face of the plane, which in that case appears full of little hard specks; whereas, if the beat runs parallel to the face, it will appear in irregular streaks, which situation of the grain should always be avoided, as the face will be apt to wear uneven, and is more subject to warping and twisting. In saw-handles and brace-stocks the beat should run in the same direction as the stock when laid on its side. In molding-planes it is very frequently the case that pieces of box are let into that part of the face that forms the quick of the molding; but that, when possible, should be avoided, as the texture of the two woods are very different, and different temperatures in the atmosphere will cause a difference in their contraction, and consequently the plane will be liable to cast. If it is at any time introduced, I would recommend only a small piece just at the mouth of the plane, firmly dovetailed in, which will not be so apt to derange the accuracy of the plane.

With respect to saws, chisels, and other edge-tools,

their value depends much upon the quality of the steel, which should be uniform throughout. It is always better to have these tempered rather too hard than too soft, for use will reduce the temperature. If at any time it is found necessary to perform the operation yourself, the best method I can recommend is to melt a sufficient quantity of lead in which to immerse the cutting part of the tool. Having previously brightened its surface, plunge it into the melted lead for a few minutes, till it gets sufficiently hot to melt a candle, with which rub its surface; then plunge it in again, and keep it there till the steel assumes a straw color, care being taken not to let it turn blue; when that is the case, take it out and rub it again with the tallow, and when it is sufficiently hot plunge it into cold spring water, or water and vinegar mixed. By a proper attention to these directions, and a little practice, every workman will have it in his power to give a proper temper to the tools he has occasion to use.

If a saw is too hard, it may be tempered by the same means; but as it would be not only expensive, but in many cases impossible to do it at home, a plumber's shop, near by, will afford the proper facilities when they are melting a pot of lead. But here observe, that as the temper necessary is different from other cutting tools, you must wait till the steel just begins to turn blue, which is a temper that will give it more elasticity, and at the same time sufficient hardness. By paying proper attention to these directions, and a little care, the workman will be enabled to keep his tools in order, and to select such as are proper for the purposes for which they are intended.

### LONDON OMNIBUS SYSTEM.

BY EDMUND YATES.

WITH the exception of some very few private proprietors, and one organized opposition company (the "Citizen"), the entire omnibus service of the metropolis and its suburbs, extending from Highgate in the north to Peckham in the south, and from Hampstead in the northwest to Greenwich in the southeast, embracing more than seventy routes, is worked by—as it is called familiarly—the "London General." In this traffic are engaged upwards of six hundred omnibuses and six thousand horses, the working of which is divided into ten separate districts, each with a head district establishment. Each of these



omnibuses travels on an average sixty miles a day, and to each is attached a stud of ten horses, under the care of a horse-keeper, who is responsible for them, and who knows the exact times when they will be wanted, and whose duty it is to devote himself to them. A horse is seldom changed from one stud to another, or removed, except in case of illness; each horse is numbered, and all the particulars relating to him are entered in a book kept by the foreman of the yard. The purchase cost of these horses averages twenty-six pounds apiece, and the majority of them come from Yorkshire, though agents of the company attend all the principal fairs in England. They are of all kinds: long stragglings bony hacks, short thick cobs; some looking like broken down hunters, some like "cast" dragon-chargers, some like Suffolk Punches who have come to grief; but the style most valued is, I am told, a short thick horse, low in the leg, round in the barrel, and with full strong quarters, whence all the propelling power comes. The average work of each horse is from three to four hours a day, and each horse consumes daily an allowance of sixteen pounds of bruised oats and ten pounds of mixture, formed of three parts hay and one part straw. Their general health is, considering their work, remarkably good; to attend to it there are eight veterinary surgeons, who are responsible for the health of the whole horse establishment, and who are paid by contract, receiving four guineas a year for each stud of ten horses. The shoeing is also contract work, twenty-five farriers being paid two pounds per month for each stud. At Highbury, where there is a large depot of six hundred horses, there are exceptions to both these rules; a veterinary surgeon and a farrier, each the servant of the company, being attached to the establishment. I went the round of the premises—a vast place, covering altogether some fifteen acres—with the veterinary surgeon, and saw much to praise and nothing to condemn. True, the stables are not such as you would see at Malton, Dewsbury, or any of the great racing establishments, being for the most part low long sheds, the horses being separated merely by swinging bars, and rough litter taking the place of dry beds and plaited straw; but the ventilation was by no means bad, and the condition of the animals certainly good. My companion told me that glanders, that frightful scourge, was almost unknown; that sprains, curbs, and sand-cracks were the commonest disorders; and that many of his cases resulted from the horses having become injured in the feet by picking up nails in the streets and yards. There are a few loose boxes for virulent contagious disorders and "suspicious" cases, but it appeared to me that more were wanted, and that as "overwork" is one of the most prevalent of omnibus-horse disorders, it would be a great boon if the company could possess itself of some large farm or series of field paddocks, where such members of their stud as are so debilitated could be turned out to grass to rest for a time. Some such arrangement is, I believe, in contemplation; but the company has only a short lease of their Highbury premises, and is doubtful as to its future arrangements there. While on this subject I may state that an omnibus-horse generally lasts from three to four years, though some are in full work for six or seven, while there are a few old stagers who have been on the road ten or twelve.

The coach-building department also has its head-quarters at Highbury, and employs one hundred and ninety men, whose average wages are two hundred and fifty

pounds a week. Here all the omnibuses (with the exception of some six-and-twenty provided by two contractors) are built and repaired, as also the vans used in conveying the forage to the outlying establishments from the central depot (of which more anon), and the chaise-carts and four-wheelers in which the superintendents visit their different districts. Every morning, at six A. M., three compact little vans leave Highbury for the various districts, each containing three men, and an assortment of wheels, axles, and tools, for any repairs that may be wanted. One of these men is always left behind at the head district depot, to meet any contingency that may arise during the day. When an accident occurs in the street, an omnibus is immediately dispatched to take the place of that which has broken down; the "plates" (*i. e.*, the legal authorization of the Inland Revenue) are shifted from one to the other; and if the smash has been serious, a large van arrives and brings off the disabled omnibus bodily up to Highbury. But such accidents are very rare, owing to the constant supervision given to the axles, tons of which are constantly thrown aside. These axles are all manufactured on the premises, and are composed of ten or twelve pieces of iron "fagoted" together. The trade or cost price of an ordinary omnibus is one hundred and thirty pounds; but the large three-horse vehicles, which are of tremendous weight (those from Manchester, in use in 1862 plying to the Exhibition, weighed thirty-six cwt.), cost two hundred pounds. The ordinary time of wear is ten years; after that they are of little use, though some last seventeen years. The wheels require entire renewal every three years, and during that time they are under frequent repairs, the tires lasting but a few months. So soon as an omnibus is condemned it is broken up; such portions of it as are still serviceable are used up in repairing other omnibuses, but in a new omnibus every bit is thoroughly new. The condemned omnibuses stand out in an open yard abutting on the line of the North London Railway; and the superintendent of the coach-builders told me he had often been amused at hearing the loudly-expressed indignation of the railway passengers at the shameful condition of the company's omnibuses—they imagining that the worn-out old vehicles awaiting destruction, which they saw from their railway carriage-windows, were the ordinary rolling-stock of the London General. The wood used in the composition of the omnibuses is English and American ash, elm, deal, and Honduras; but the poles are invariably formed of stout English ash. The superintendent told me that these poles last far less time than formerly, and this he attributes to the stoppages having become so much more frequent, owing to the introduction of short fares; the strain upon the pole, occasioned by constant pulling up, gradually frays the wood and causes an untimely smash.

The receipts of the company are very large, averaging between eleven and twelve thousand pounds a week (in one week of the Exhibition year they were above seventeen thousand pounds), and I asked one of the chief officers if he thought they were much pillaged. He told me he had not the least doubt that, by conductors alone, they were robbed to the extent of *twenty-five thousand pounds a year*; and a practical superintendent of large experience, on my repeating this to him, declared that he believed the sum did not represent the half of their losses from the same source. I asked whether no check could be devised, and was told none—at least, none so efficient as to be



worthy of the name. Indicators of all kinds have been suggested; but every indicator was at the mercy of the conductor, who could clog it with wood, and so allow three or more persons to enter or depart, while the indicator only recorded the entrance of one; and unless some such turn-table as the turn-table in use at Waterloo Bridge could be applied (for which there is obviously no space in an omnibus), check was impossible. The sole approach to such check lay in the service as rendered by a class of persons technically known as "bookers," who were, in fact, spies traveling in the omnibus, and yielding to the company an account of every passenger, the length of his ride, and the amount of his fare. But it was only in extreme cases, where the conductor was incautious beyond measure, that such evidence could be efficient against him. These "bookers" are of all classes—men, women, and children—all acting under one head, to whom they are responsible, and who alone is recognized by the company. The best of them is a woman, who, it is boasted, can travel from Islington to Chelsea, and give an exact account of every passenger, where he got in, where he got out, what he was like, and the fare he paid.

## PICTURES FROM POMPEII.

### FOURTH ARTICLE.

HAVING very little taste for the fabulous, we are not much inclined to speculate about the griffin so cleverly harnessed to the vehicle shown in Fig. 7. This symboli-



FIG. 7.

cal combination of two different natures exists only in fancy. Physiologists have shown that such could not live. Probably the ancients borrowed this combination from the Scriptural descriptions of the cherubims, connected with the religious rites of the Hebrews. The winged bulls of the Assyrians, which the researches of Layard and others have brought to light, have a similar origin; like as the cherubim guarded the gates of Paradise (Gen. iii, 24); so likewise were the winged bulls in stone, placed as silent guardians to royalty, beside the chief entrances to the abodes of their kings. Carrying out, then, this idea of protection, we see the intention the artist had in view, when he placed this incarnation of strength as a protection to neatness embodied in the butterfly which merely stands, but takes no part in directing the movement of the draft-animal. Read sentimentally, it teaches us that in the married state man is constituted the guardian of the weaker half against the storms and ills of life. Architecturally, the chariot is similar to the one shown on page 146, Fig. 4.

This series of articles would be incomplete were we to stop without giving our readers something in relation to the history of Pompeii. According to Salinus, it derived its name from the Greek word *ΠΟΜΠΗ*, in allusion to the pomp with which Hercules celebrated his victories while awaiting his fleet at the mouth of the Sarnus. Besides this, there are several explanations given for the name, all of which have become more or less mystified in the course of time.

Sixteen years previous to its destruction, in the ninth year of Nero's reign, Pompeii had been visited with a very severe earthquake, which had thrown down a large portion of the buildings, but which, at the time of its final overthrow, were being rapidly rebuilt. From this we learn that its ruin was the work of two distinct periods of calamity. As before mentioned, its complete overthrow took place in the year 79. It was suffered to remain in a buried state until 1748, when the excavating began. The excavations already made show that the ruin of Pompeii was not accomplished by uniform showers of cinders and pumice-stones, as many have supposed, but by a succession of eruptions. In some places the debris lies in five distinct tiers, twenty feet deep; the three first being composed of pumice-stone in small pieces resembling a light cinder, the next six parts beginning with a stratum of small black stones, not more than three inches deep; next to this a layer of mud or earth mixed with water; on this a thin series of light stones of a mixed hue, blue predominating. A stratum of mud, separated by a thin wavy line of mixed blue stones, completes the fourth. The fifth or highest division is earth which has accumulated during the past seventeen centuries.

The following extract, from the "Penny Magazine," will convey to the reader's mind some idea of the storm which broke in destruction over Pompeii:

"In the autumn of 1822," says an English traveler, "I saw Pompeii under very interesting circumstances. It was a few days after an eruption of Vesuvius, which I had witnessed, and which was considered by far the grandest eruption of recent times. From Portoci, our road was coated with lapilla or pumice-stone, and a fine impalpable powder, of a palish gray hue, that had been discharged from the mountain, round whose base we were winding. In many places this coating was more than a foot deep, but it was pretty equally spread, not accumulating in any particular spot. As we drove into Pompeii our carriage-wheels crushed this matter, which contained the principal components of what had buried the city; it was lodged in the edges of the houses' walls, and on their roofs (where the Neapolitan government had furnished them with any); it lay inches thick on the tops of the pillars and truncated columns of the ancient temples; it covered all the floors of the houses that had no roofs, and concealed the mosaics. In the amphitheatre, where we sat down to refresh ourselves, we were obliged to make the guides clear it away with shovels—it was everywhere. Looking from the upper walls of the amphitheatre, we saw the whole country covered with it—trees and all were coated with the pale-gray plaster, nor did it disappear for many months after."

The following, from a late English periodical, gives us some insight into the domestic habits of the people:

"The excavations at Pompeii are going on with an activity stimulated by the important discoveries made at almost every step, and the quantities of gold and silver



found, which more than suffice to cover the cost of the works. Near the Temple of Juno, of which an account was recently given, has just been brought to light a house belonging to some millionaire of the time, as the furniture is of ivory, bronze, and marble. The couches of the triclinium, or dining-room, are specially of extreme richness. The flooring consists of immense mosaic, well preserved in parts, of which the center represents a table laid out for a good dinner. In the middle, on a large dish, may be seen a splendid peacock with its tail spread out, and placed back to back with another bird also of elegant plumage. Around them are arranged lobsters, one of which holds a blue egg in its claws, a second an oyster, which appears to be fricasseed, as it is open and covered with herbs; a third, a rat *farci*, and a fourth, a small vase filled with fried grasshoppers. Next comes a circle of dishes of fish, interspersed with others of partridges, hares, and squirrels, which all have their heads placed between their fore feet. Then comes a row of sausages of all forms, supported by one of eggs, oysters, and olives, which in its turn is surrounded by a double circle of peaches, cherries, melons, and other fruits and vegetables. The walls of the triclinium are covered with fresco paintings of birds, fruits, flowers, game, and fish of all kinds—the whole interspersed with drawings which lend a charm to the whole not easy to describe. On a table of rare wood, carved and inlaid with gold, marble, agate, and lapis lazuli, were found amphoræ still containing wine, and some goblets of onyx."

### CRITIQUE ON CARRIAGE-WHEELS.

BY THE EDITOR.

WITHOUT having at all exhausted the subject, we come now to the consideration of a wheel which for defects in construction, goes beyond anything we have before described

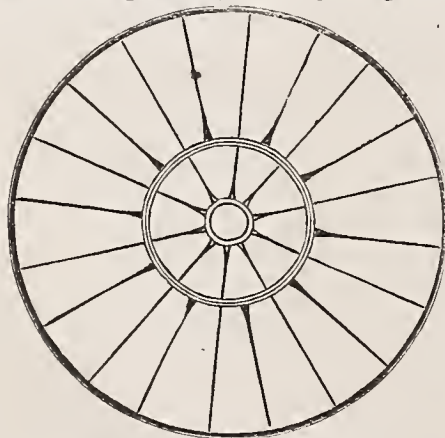

SHELLEY'S PATENT WHEEL.

or criticised in these pages. Probably very few of our readers have ever seen one, much less heard of it. Like some other inventions, it goes ahead of anything produced abroad—in absurdity. It is known, if known at all, as "Shelley's Patent Wheel," and was invented about eleven years ago. The *Scientific American* foolishly said of it at the time that "a more durable and stronger wheel [could be made on this plan] than are the ones now in common use. It is customary to use small hubs in the construction of carriage-wheels; they are considered ornamental, and add much to the light appearance of the wheel. Large hubs would render a wheel unsaleable. It will be seen that a small hub with mortises made in it to receive sixteen or eighteen spokes, will be much cut up or weakened, besides there cannot be much of a shoulder allowed for the spokes, as they are close together at the hub. By this

improvement the hub has only half the usual number of mortises cut in it, and the long spokes may have requisite shoulders at their ends adjoining the hub, so that they may be well supported in the hub, and prevented from working or becoming loose therein. At the same time the fellys composing the rim are well supported, as the usual number of spokes are inserted in them, the ring or band allowing the requisite support to be given to the fellys by means of the short spokes, and also diminishing the number of mortises usually made in the hub. Thus a strong and durable wheel is obtained, the spokes are well supported by a ring or band, and prevented from twisting or bending when the tire is shrunk on the rim; small hubs may be used, and the cost of manufacture will not exceed that of the ordinary wheels."

There are three deliberate falsehoods in the above extract. *First*, A wheel cannot be made as light on this as on the old plan. *Second*, It is not as strong; and *Thirdly*, They will cost a great deal more to make. This is evident to every *real* mechanic, and none but such as are made blind by interest would ever have the hardihood to deny it.

*First*, As to lightness. It is evident from an inspection of our drawing that the weight of spoke is equal if not beyond that of the common light wheel. This wheel is *extra* heavy to the extent of the inner circle. When it is known that this is plated on each side by two cast-iron rings, the reader will judge of the lightness of such wheels from analogy.

*Secondly*, As to its strength. There are but ten spokes entering the hub, and just at this point—instead of the greater strength—is found the greatest weakness. As these are forced to support the ten intermediate, ending at the inner circle without receiving any co-operative assistance from them, as when all end in the hub in the old way. This was so apparent in practical use that they were soon abandoned as worthless.

*Thirdly*, As to costs. This is increased to more than one-third, in the extra number of mortises required and the rings and circles for the inner wheel. When one looks at the thing with a practical eye, he is led to conclude that of all the worthless contrivances got up under the name of wheels, *this thing is the most worthless, and inefficient.*

### Pen Illustrations of the Drafts.

JUVENILE HEARSE.

Illustrated on Plate XLIV.

SEVERAL hearses have appeared in the pages of this Magazine, but this is the first we have published intended expressly for conveying the remains of children to "the house appointed for all living." Although as a people we profess plainness in the principal affairs of life, still when dead it seems as though we must go to the extremes of expense and show in order to properly honor the memory of our departed friends. We do not intend to censure the practice here, we only intend to notice a fact, without dwelling upon its inconsistency, if such it be, and as a sort of excuse for the elaboration shown in the original



design under consideration. The drawing will be found so faithfully its own interpreter that we are spared special details further in regard to it.

TRIANGULAR ROCKAWAY.

Illustrated on Plate XLV.

In this drawing our artist has evidently "let himself out," in an endeavor to produce something *original*—and we think he has succeeded—so far as to have drawn a sketch at variance with all the generally received notions of beauty as found in outlines. We cannot say that we approve of them, and yet there is something in the combination that may meet with favor from others. A carriage after this design would appear lighter than when made with a more round back pillar, but doubtless less graceful, judged by our present standard of taste.

THE HARTFORD BUGGY.

Illustrated on Plate XLVI.

For this drawing we are under obligations to Mr. E. Hallenbeck, of Hartford, Conn. In a letter he modestly remarks, that "the body has some new points about it, but more old ones, although the arrangement of them, I think, is a little novel. The dimensions are, 4 feet long, and 2 feet 1 inch wide at the bottom, and 2 feet 5 inches wide at the top of the body. The bracket in front is 17 inches long on the top side, and does not rise on as steep an angle as most long brackets, which in my eyes is a very great advantage. I do not like extremes in such matters, and always choose a medium. The bottom-boards are laid directly on the top of the sills, thereby admitting of very light ones. These are beaded on the lower side corners of the bracket only, as this is the place where it is seen to advantage, the body-loop covering the rest. A flat piece rests on and projects over the bracket 3 inches, serving as a "mud fender," by which unsophistical name they are known here. This fender is of the same thickness as the bottom-boards, to which it is matched, and with which it is made flush on the top. These sell here, open and without a pole, well finished, for \$185; with pole and a top for \$300."

Sparks from the Anvil.

STEEL PRODUCERS AND STEEL CONSUMERS.

WE take what follows from the N. Y. *Evening Post* :

My attention has just been called to a statement of Senator Sprague, just reported in the *Washington Globe* of 16th of January last, in which he says :

"I have received several communications from manufacturers in different parts of the country, growing out of the resolution I had the honor to propose before the recess. One of them relates to the manufacture of steel,

in which it is *proved* that the internal revenue tax upon the manufacture of steel is greater than the duties levied upon the imported article."

I am not sufficiently familiar with the manufacture of steel, and the precise amount of internal revenue tax levied thereon, in its various stages of manufacture, to enable me to say that the figures on which Senator Sprague bases his statement are absolutely incorrect, but I am familiar with one branch of the steel trade on which a large portion of our manufacturers are dependent on England for their supplies, and I will, with your leave, give you a few facts, which can be substantiated by any one to their own satisfaction by reference to our various tariffs which have been in operation during the past ten years.

Common German steel for springs of locomotives and railroad cars, and for wagon springs and tires of all kinds, is worth now in Liverpool (£15) fifteen pounds sterling per ton of 2,240 pounds, and the duty on importing it is 2½ cents per pound, or \$50.40 per ton in gold, or say 70 per cent. *ad valorem*.

To show the amount and rate of increase in the duty since 1856, I append the following table :

Tariff.	Rate of Duty.
July, 1846....	15 per cent., <i>ad valorem</i> , which, on £15 at \$4.84, equals \$10.89 per ton.
July, 1857....	12 per cent. <i>ad valorem</i> , which on £15 at \$4.84, equals \$8.71 per ton.
April, 1861....	\$33.60 per ton (specific).
August, 1862..	\$39.20 " " "
July, 1864....	\$50.40 " " "

If we compare the present duties with those formerly paid, we find the increase to be

28½ per cent.	upon tariff of 1862.
50	" " " " 1861.
578	" " " " 1857.
462	" " " " 1846.

The correctness of the above figures can be proved by the testimony of all the spring-makers in the country, or by reference to the tariffs quoted, and they, I have no doubt, would like to see Senator Sprague's proof that our domestic makers are subject to a more onerous tax. If you think well to do so, I should like if you could find a place for this statement in your columns, that our legislators may see both sides of a question of such great moment to all our railroads, and such a large and respectable body of our manufacturers.

Yours, IMPORTER.

FRICITION OF IRON AXLES.

A WRITER in *The Country Gentleman* says: "There is a great deal of teaming done here, and some discussion as to the relative value of iron or wooden axles as respects ease of draft. The advocates of wooden arms say the others pull harder up hill; but we would like to have reports of systematic experiments with dynamometer or otherwise, if any such have taken place, and in default of these, the opinions of experienced men."

To the above the editor of *The Country Gentleman* answers: "We know of no experiments made with the dynamometer to determine this point—it is not probable that this instrument is sufficiently accurate or delicate to show any difference. The famous experiments made by



Movin at Paris, on the amount of friction between two wooden surfaces, one of wood and one of metal, and between two metal surfaces when kept properly lubricated with appropriate surfaces, showed that there was comparatively little difference. Olive oil or lard mixed with black lead, reduced the friction to a little more than one-half of that when tallow alone was applied; and as a general rule he found there was least friction when lard was used for hard wood rubbing on hard wood; at least when oil was used for metal rubbing on wood, or metal on metal—the friction being about the same in all these instances. The smaller the axle the less will always be the friction, other things being equal; because the spokes have a greater purchase, the friction being the resisting force, and being nearer the end of the lever when the axle is small.

## Paint Room.

### PAINTERS' BRUSHES.

PROBABLY there is as much judgment required in selecting our brushes as in choosing a pencil of which we treated last month. In all these, tastes differ. Some prefer the stiffer and some the more limber one. For the more practicable purposes, such as priming and painting carriage parts, the coach-painter prefers the firm white hog's bristle-brushes of the oval form; but for varnishing they are not fine enough when used on bodies. For varnishing, one writer recommends those made of bear's hair. Another, the hair of the badger (the *ursus meles* of Linn, and *taxus m.* of Cuvier); these distributing the varnish more even and uniform in putting on *flowing* coats. These are matters which require personal use in order to get them right.

Brushes of badger's hair are made of several sizes, all of them spreading more or less. Those used for varnishing are flat like a whitewash brush, the hair being long, light, and pliant, a dirty white at either extremity, and a reddish black in the middle. There is likewise the "fitch brush;" firm, though soft, of various sizes, round and flat. Brushes ought always to be cleaned when done with and laid by, as this tends to make them wear longer. In this connection we give some extracts from the letter of a correspondent of the *London "Builder,"* which may interest the reader. It was written because another correspondent had expressed the hope that the English would shortly be gladdened by an importation of foreign brushes in lieu of the inferior class of goods made there, for which high prices are charged. He says:

"If you will allow a brush-manufacturer, with the personal experience of upward of a quarter of a century, and whose house has been known for eighty-eight years, to reply to your correspondent, I shall feel obliged. Foreign (French are meant) manufactured painting brushes have been introduced into this country under every advantage; they are subject to no import duty, and agents for the sale of foreign manufacturers abound in London and elsewhere; but they never have found, and never will find, purchasers among painters and decorators who require brushes to do work well, and to be durable, which is the true test of cheapness. Why? The best English painting brushes are made of Russian bristles; the painting brushes made in France are made of the soft bristles

of that country; very pretty and neat in appearance, like everything French, but far inferior in durability, as well as power of laying on colors.

"No doubt the greed of gain and yearning for cheapness, has brought into disrepute many English brushes, by inducing some manufacturers to adulterate them with fibers of horse-hair, &c.; and it is well known that no material but bristles should ever be used in a painting brush; but, whenever painters are contented to pay the printed list price of the trade, without abatement, they are enabled to get as cheap a brush as they can desire to use."

How the American-made brushes compare with the English, we have no opportunity of knowing, but a regular John Bull thinks that "the well-broken-in Bristol brushes," are far ahead of our "blenders," as soft hair brushes are called. We shall be pleased to hear from any one who will favor us with his observations on this subject of brushes for publication. We think that much might be said to profit.

### MIXED ENGLISH VARNISHES.

FRIEND STRATTON: I think I have a piece of valuable information, not very generally known among coach-painters, which was imparted to me by my old friend Beckhaus, of Philadelphia. It is in regard to English varnish. All coach-makers are troubled with having to wait from ten days to two weeks for the varnish to get dry and hard, so that the job can be handled without marring the varnish. I have tried this process, and can handle a job just as quick after it is laid on, as I can with American varnish, and it will wear from six to nine months longer, hold its brilliancy better, and will not spot with mud, or turn blue with rain or water. It is this: Take one-third of hard drying English, and mix with two-thirds Noble & Hoare's best English wearing varnish, and varnish on a clear day, and I will guarantee there will be a good job, and one that will stand, and save the poor carriage-maker and painter much perplexity.

Yours as ever, J. B. PEEK.

## Trimming Room.

### SILK MACHINE THREAD.

WE cannot imagine why some trimmers persist in using silk, when hempen thread, which is much cheaper and looks about as well, can be bought for less than half the price. Indeed all the advantage in using silk appears to revert to sewing-machine companies, which, in order that they may the more successfully extort by charging \$2.20 for a small spool of the article, tell the public that so important is it to have the right kind of thread that we must buy it where we buy our machine, for they have it made for these expressly. Nonsense! We don't believe a word of it.

A word further in regard to this thread. Many friends send us orders for this silk, which puts us to some trouble, for which we can get no remuneration from the merchant unless we buy four or five pounds at a time. This refusal to allow us a commission obligates our charging a small sum for such service hereafter. Those who are not willing to do so must not trouble us.



### CARRIAGE-TOP PROP-BLOCK.

ON page 159 will be found a notice of a patent secured for a carriage-top prop-block. Since that was published we have been favored with further particulars in regard to it. They are these. The inventor proposes to have made in the usual form, with a few modifications, a prop-block of india-rubber to slide on to the prop-rim, as a substitute for the wooden one trimmed with leather. If these rubber ones can be made cheap enough we see no reason why they may not better serve the purpose intended. They certainly can be made to look far nicer, and will doubtless out-wear them a long time. At any rate we trust the experiment will be made, and a step taken in the road to improvement where such has long been needed.

### Editor's Work-bench.

#### TO OUR PATRONS AND FRIENDS.

PROBABLY there is no greater pleasure permitted an editor than to find after years of toil, that he has rallied around him a host of patrons and sincere friends. This is our position to-day, while closing the labors of our eighth year of public life, devoted to the interests of the coach-maker's art. Although, as we anticipated, we have not succeeded in pleasing everybody, still we have the majority on our side. The greatest, we may say the arch, enemy we have had to war against has been that hideous monster, jealousy. We have seen him on our track from the journeyman because we have not taken their supposed interests in hand to the detriment of the capitalist, and because of fancied bias on our part, being one of the latter class ourself. Was there any truth in the charge we would not complain; but knowing as we do its falsity, the present appears to be the time for "speaking right out in meeting."

We have no reason for treating the laboring classes with other than the kindest feelings. A journeyman ourself for four years, we know how to fully sympathize with them in our toils. But our life-long experience has led us to think differently of the mode in which to accomplish certain ends. We are fully convinced that nothing is gained by threatenings. It is an old but trite saying that "you can catch more flies with molasses than vinegar." The moment one resorts to threatening he exhibits a weakness fatal to his interests. Believing this so earnestly we have refused to publish some documents sent us, and to-day we are fully satisfied that our course has been a judicious one. Should we err, we shall do so under the influence of good motives, with "the literary, social, and mechanical interests" of the entire craft at heart, believing that the *interests* of both journeymen and bosses are one and indivisible. But we are getting outside of the object with which we started.

Our intention here is to remind our friends, that with this number the larger proportion of our subscribers will receive the last for which they have paid us, and to ask that they immediately renew, and to do it safely wherever practicable, send us a post-office order for the amount required. When this cannot be done send national currency in a registered letter. Although other means of remitting may be safe, still if resorted to and lost we assume no risks, and you have no redress. During the war everything seemed to go on smoothly, but during the past year the mails have been tampered with to some extent. A loss by post-office order cannot in any possible way benefit a *thief* nor seriously injure you.

We have a large number of subscribers against whose names we have a standing order to continue. This class, who have always been ready to respond punctually on presentation of their bills, will find us indulgent of confidence, still; the reverse of this will be "left out in the cold" to freeze. We had some of these "confidence men" on our books the past year, which it would be our duty to show up, could we do it legally. Since the libel laws takes these *renegades* under its protection, honesty remains at a large discount, and must for the present. We intend however the next year to protect our honest subscribers against the bad effects of dishonest ones while protecting our own interests. Our terms then will be, as now, Five Dollars *in advance* for the Eighth Volume, the June number of which we intend to have ready on the fifteenth of May, if possible, in improved appearance. What is strange in view of the reduction in the premium on gold, is the fact that to-day paper and press-work are still as dear as ever—dearer than one year ago. The rise in this respect since August last, has seriously—although our sales have more than doubled—diminished our profits. When our price was \$3 we could buy paper for eleven cents per pound; now for the same we are charged thirty. We have not increased our rates double, as others have done, but kept them at the lowest remunerative point for the accomplishment of usefulness and the improvement and credibility of art. We trust, therefore, that our friends will remember us, and not only early renew their own subscriptions but induce others who may come under their influence to subscribe also. Every little helps, and anything done for us of this kind receives, as it justly deserves, our warmest thanks. In our late visit to the West we made many friends who have taken upon themselves no little trouble of this kind, but which their native modesty will not permit us to mention here. In another visit westward in June next, we hope to add to the number.

In conclusion permit us to say—that as in the past so in the future, we hope to show that not in words merely



but in deeds we are in earnest, and intend to exert our best efforts to promote the interests of those for whom we toil. We intend to be fully up with, and if possible a little ahead in the fashions, in mechanical information, and other matters we deem advantageous to the public. To carry this out in some measure, we intend to keep up a skirmish with those enemies of the craft—the *patent* “humbugs.” As a matter of course we do not include honest inventors in this category, but only such as *fraudulently* lay claim, under the cover of law, to improvements not *legitimately* their own. That we may the more effectually wage an uncompromising hostility to this class we solicit the continued correspondence of the trade from all points where they undertake to operate. We likewise solicit communications from our literary brethren in mechanical matters, so as to not only lighten our toils, but to give a still greater variety to our pages. These matters all properly attended to, we hope, at the end of another year, to have a flattering tale to unfold. Finally, we value our friends according to the promptness they show in renewing their subscriptions.

#### LABORING TO ADVANTAGE.

“NEVER do your work twice over.” Such was the instruction inculcated with our first lesson in mechanics, and which we have endeavored to carry out all through life. Untold has been the advantages of this practice. While some mechanics have exhausted days in performing certain pieces of work, this rule has saved us one-third the time spent by those unmindful of the injunction. The importance of economizing time is second only to that of judiciously spending one's income, for, as is generally admitted, “Time is Money.” Poor Richard's remark that, “many estates have been spent in the getting” is very significant—spent in the getting from waste of that which can never be recalled, time. This reflection is of special importance to all such as work by the piece, and ought not to be ignored by such as hire by the day.

To make our theory more clearly understood: we have seen a fellow-mechanic at our elbow shaping a stick of timber into a spoke, with a profuse outlay of time and labor, when, had he been properly educated, he might have accomplished his object in two-thirds of the time taken. Instead of properly shaping his timber, *seriatim*, with ax, draw-knife, jack and fore-planes, spoke-plane, spoke-shave, jarvis and file, closing with sand-paper, in a judicious manner, we have seen the tools mentioned only applied one-sidedly at first, next to the other side, finishing the back of the spoke last. This manner of procedure necessarily involves extra labor at the overlapping corners, before they can be made to assume the proper shape and finish. A judicious and properly instructed workman, would have carried each detail separately through the entire set, finish

ing with the file and sand-paper last. The modern practice adopted in finishing bodies, supplies an apposite illustration of our subject. Formerly in building “paneled work” it was customary to form “the beading” (moulding) on each part immediately after “ruttering” for the panel. When the framing was put together, much had to be done over, to produce a uniform trueness. This is now more economically and nicely done by beading, after all has been put together, and the panel in, and dry. These are but a part of the details to which labor may be advantageously applied, and of which our examples are intended to be illustrative. They will suggest themselves to our readers.

#### PROGRESS IN CARRIAGE-MAKING.

GREAT changes have been effected in the art of carriage-building during the last thirty years. No doubt much of this improvement has been stimulated by the circulation of designs throughout the land. Time was—we remember it well—when to find a carriage-drawing was a good treat, and if obtained at all, was to be had only at much expense. But those times have fortunately passed away. The most fashionable American designs are presented to our patrons in this Magazine for about ten cents each, sixteen pages of reading matter being monthly thrown in as a gratuity. For our part we ask no better evidence of the utility of THE NEW YORK COACH-MAKER'S MAGAZINE, than is found in the fact that certain houses now refuse to patronize us, because, as they say nothing new can be introduced in New York without our immediately spreading it all over the country. Well, let them go on, they lose more by their course than we do, without the most distant hope of ever stopping us. These enemies are few and powerless beside the great mass of the craft who, we are happy to find, are on our side, and taking special interest in the enterprise.

Thirty-five years ago, ten varieties comprehended all the carriages then in use in this country. Among these the buggy, gig, wagon, chariot and barouche were the best known. Coaches then were rarely seen outside of the large cities, and then were only possessed by a few aristocratic families. We have a MS. volume in our possession entitled “The Rudiments of Coach-making,” containing working drawings of the carriages of that period, which we intend hereafter to have engraved for the edification of the public. They will be certain to amuse if nothing more. To us, they look very antique, and yet are valuable as showing the status of art at an earlier period in the history of our country. Since that time gradual progress has been going on, so that to-day the coach-maker occupies a prominent place in the temple of science.

As before noticed thirty years ago pleasure carriages were confined to a few varieties and presented but a lim-



ited field for the exercise of art. Then the builder was his own draftsman, now he employs one whose special duty it is to shape his work. This step has led to the production of new varieties, until they have so multiplied, that it would sorely puzzle many carriage-makers themselves to assign a proper name to some of them. It is quite a study to get fully acquainted with the names alone of the different carriages in the coach-maker's vocabulary, as the dictionary published in this volume proves. We risk nothing in asserting that we have a far greater variety than all England, France, and Germany put together. It is true we have some models not very creditable to art, but aside from these we have enough good ones to redeem our character, if not to place the American coach-maker in the front rank as a skilled mechanic.

### CHARTS.

LAST month we called special notice to these indispensable additions to a coach-maker's office. That notice, besides bringing us numerous orders for single charts, which we sell at a dollar each, also increased the demand for them in quantities, beyond our expectations. That—anticipating further calls—our friends may have the costs before them, by which to regulate their remittances, we present the following tariff: When ten copies are ordered at one time, the charge will be \$9; fifteen copies, will be \$13.50; twenty copies \$18; twenty-five copies \$22; fifty copies \$37.50; The additional charges when a business card is printed in, will be for twenty-five copies \$2 extra; for fifty copies \$3.50 extra, or in that proportion for other quantities. Where the money is not sent with the order, the express company's charge for collection must be added to our bill. Should the money accompany the order we engage to deliver the charts free of charges for transportation. For details, we refer the reader to the article on page 172, before alluded to.

### RELICS OF OTHER DAYS.

HAPPENING into the manufactory of Messrs. J. C. Parker & Co., of this city, a few days since, we discovered, neatly framed and hanging in the office, "scraps for history," which will doubtless interest the reader. The name mentioned in the bills will be readily recognized as that of *the* John Hancock who so *boldly* and bravely put his name to *our* Declaration of Independence, which forever separated us, we trust, from monarchical rule. They were presented to the firm by Mr. Franklin Hancock, a lineal descendant of the hero of revolutionary times. The two bills are from different carriage-makers, and cover the space of nearly two years. Instead of being receipted as we are accustomed to do such things, both are receipted on the back of the bills, the indorsements being in Han-

cock's own hand. We give a literal transcript, both in orthography and punctuation.

Hon <sup>ble</sup> John Hancock to Nath. Frothingham & Son Dr.	
1785	
April	To 6 Peaces for Glass Frames for Chariot [£] 0 : 12 : 0
	To Box for Chariot & front Rale for Seet 0 : 12 : 0
	To Bathening Doer Pannil 0 : 1 : 6
	To Wooding Step for Chariot 0 : 0 : 9
	To Sharft and Bar for Sulke 0 : 16 : 0
Dec <sup>ber</sup>	To 2 Locks <sup>3</sup> / <sub>4</sub> and fixing to [two ?] Boxes <sup>1</sup> / <sub>8</sub> 0 <sup>0</sup> 4 : 6
1786	To 2 Wiffaltrees 0 : 4 : 0
Jan 7	To Pole for Slay 0 : 12 : 0
August	To 2 Springs 2 Bars for Sulke 1 : 0 : 0

Boston March 14 1787 £4 : 2 : 9  
Errors Excepted

Receipted on the back, and lengthwise the Bill, Nath. Frothingham & Son.

Hon <sup>ble</sup> John Hancock To Thomas Wheeler Dr	
1785	
to	To accompts given in of sundries 10 . 10 . 5
1786	
Dec 30	
1787	
Jan 4	To 3 staples, 1 ketch, 1 lock, fixing bolt &c. 0 . 1 . 6
13	To mend sleigh shoe, 1 key, 2 plates, nails &c. .. 4 . 0
27	To mending sleigh shoe 0 . 2 : 0
Boston March 14, 1787 £10 . 17 . 11	
Errors Excepted	
Receipted on the back, Thomas Wheeler.	

### ADVERTISING CUTS.

MANY correspondents have written to know our charges for small sized engravings of carriages, for advertising purposes in the country newspapers. To answer all would tax our time beyond measure. We will therefore try and answer here. It has been found that wood engravings soon wear out, and therefore we have resorted to taking electrotypes of the cuts. They will wear a long time in printing. Our charge for a reduced engraving of the designs we have published, will be from \$4.50 to \$6 each, for the cut and its duplicate, in electrotype.

### EDITORIAL CHIPS AND SHAVINGS.

ENGLISH AND RUSSIAN ARISTOCRACY.—In an address the other evening, at the Cooper Institute, concerning Russia and the Russians, Bayard Taylor told us that was the Prince of Wales to hire a carriage from the stand, when he had occasion to use one, the English aristocracy would never forgive him for the insult offered to the dignity of the nation. This was used for the purpose of illustrating the fact that Russian nobility had less pride than English. Whether true or not we will not dispute. We are inclined, however, to present a picture of the procession lately made by the Queen in state in her carriage to open the Parliament.

"Perhaps the respectability of the crowd rendered it much less demonstrative than usual; there was curiosity, decorum, respectful welcome everywhere, but no popular enthusiasm—the Prince and Princess of Wales obtaining a much warmer reception than Her Majesty. Probably



the spectators hardly discriminated the royal carriage from the others, missing the gorgeous, old gilt, gilt-gingerbread shandrydan commonly used on such occasions; and then the Queen sat so far back that she was hardly visible, except to those who happened to be close to the carriage windows. This I think provoked a little dissatisfaction. However, there were the orthodox six pair of cream-colored horses attached to the royal carriage—and the same number to six other vehicles. (The color, you know, is sacred to British and Hanoverian Majesty—when Bonaparte the 1st gobbled up the latter, he also annexed all the cream-colors he could find in the stables to use at his own coronation—a practical joke which induced old George III. thenceforth to sport only black horses.)

**MAN-ODOMETER WANTED.**—A lady who had read of the extensive manufacture of odometers, to tell how far a carriage had run, said she wished some Connecticut genius would invent an instrument to tell how far husbands had been in the evening when they just step down to the post-office.

**THE BUNGAY LOST PONY.**—In 1822 the following singular advertisement was published in England: "On February 21st, 1822, this devil bade me adieu. Lost, stolen, or astray, not the least doubt but run away, a mare pony that is all bay:—if I judge pretty nigh, it is about eleven hands high;—full tail and mane, a pretty head and frame;—cut on both shoulders by the collar, not being soft or hollow:—it is about five years old, which may be easily told; for spirit and for speed, the devil cannot her exceed. Whoever can give information or bring the said runaway to me, John Winter, Glass-stainer and Combustible-maker, Upper Olland Street, Bungay, shall be handsomely rewarded for their trouble."

**DRIVING A COACH WHEEL.**—The *Gentleman's Magazine* records that on the 23d of September, 1751, a man ran, driving a coach-wheel, from the Bishop's-head in the Old Bailey to the eleventh mile stone at Barnet and back again, in three hours and fifty-one minutes, having four hours to do it in, for a wager of fifty pounds.

**GINZROT'S WAGEN UND FAHRWERKE.**—We have recently discovered a large quarto German work, of two volumes, in the Astor Library, devoted to ancient carriages and harness, with one hundred engravings. Some of these we intend to reproduce in our pages, with descriptive translations. It was published at Munich, in 1817, at about \$60.

#### LITERARY NOTICES.

We are in the regular receipt, from Messrs. Ticknor and Fields, of Boston, of *The Atlantic* and *Our Young Folks*, both monthlies, devoted to choice original literature, the first for older heads and the last to the children; and also the *Every Saturday*, a weekly publication of choice reading, selected with rare ability from foreign current literature. Madame Waldeborough's carriage, in the *Atlantic* for April has amused us greatly; and, to any lover of a good story, is worth more than a year's subscription, which is \$4. There are many other articles of interest: Last Days of Walter Savage Lander; Passages from Hawthorne's Note Books; A Struggle for Shelter; Killed at the Ford; The late Insurrection in Jamaica; The Chimney Corner for 1866; The President and Congress; Griffith Gaunt, and Reviews and Literary Notices.

## Patent Journal.

### AMERICAN INVENTIONS.

March 13, 1866. (53,186) AXLE-BOX.—O. H. P. Robinson, Bellport, N. Y.:

I claim, *First*, surrounding an axle or shaft, having a rotary motion, with free spherical bodies inclosed within an annular space formed around the axle or shaft, so as to form the bearing of such axle or shaft, substantially as described. *Second*, The false axle H, combined with axle B, made and applied substantially as above set forth.

(53,209) PROPELLING WHEELED VEHICLES.—John G. Wilkinson, Quincy, O.:

I claim the shaft E, provided with the pulleys, F F, and the wheels *k k*, bands G H, pulleys C, for propelling the vehicle, in the manner and for the purpose herein specified.

(53,210) WAGON-BRAKE.—J. H. Wilkinson, Kickapoo, Ill.:

I claim, *First*, The rods *e e* and *f f*, in combination with the clip D, and brakes E E, substantially as shown and described. *Second*, The clip D, in combination with sliding reach B, and stationary reach C, and brakes E E, substantially as and for the purpose specified. *Third*, The combination of the sliding reach B, stationary reach C, clip D, brakes E E, rods *e e*, and *f f*, and hind and forward wheels of a vehicle, all operating together substantially as and for the purpose specified.

(53,214) PROPELLING CARRIAGES.—Charles K. Bradford, assignor to himself, C. B. Sanderson and Minot Ter- ril, Jr., Lynn, Mass.:

I claim, *First*, The combination of the connecting rods B, with the friction band K, and the clutch C, transmitting motion to the wheel G, as described, in one direction only, substantially as and for the purpose described. *Second*, The combination of pivot-pin L, with the lever A, having notches, E E, so that the leverage may be increased or diminished at will for the purpose described. *Third*, The combination of the notched levers A, with the combination set forth in the first claim, so as to allow greater power to be exerted without increasing the length of the stroke.

(53,216) MACHINE FOR BORING HUBS.—L. A. Dole, assignor to himself and A. R. Silver, Salem, O.:

I claim, *First*, The arrangement of the fixed chuck-plate D, adjusting plate C, hollow-supporting frame A, and the turning cap *c*, with its adjusting-bearing plate *c2*, substantially as described. *Second*, The arrangement of the scroll-adjusting plate C, chuck-plate D, oscillating plate *m*, augur shaft B, and adjustable bearing plate *c2*, substantially as described. *Third*, The radial arms E, provided with adjustable sliding blocks, *j j*, in combination with a centering chuck and augur shaft, substantially as described. *Fourth*, The stepped blocks *j*, when applied to the radial arms E, and used substantially as described.

(53,220) LINC-PIN—Louis B. Gusman, assignor to himself and Edwin Steer, Philadelphia, Pa.:

I claim the linc-pin C, with its slot *x*, in combination with the spring D, the latter being constructed and attached to the linc-pin, substantially as for the purpose described.

REISSUE, (2,504) HOLLOW AUGUR.—Arcalons Wykoff, Elmira, N. Y. [Patented July 12, 1859.]:

I claim, *First*, In an annular augur in combination with a prime cutter *a a*, transverse auxiliary cutter *b*, carried back to the extremity of the stock, either longitudinally with the augur or obliquely towards the heel of the next preceding cutter. *Second*, In combination with the spiral flange B, I claim leveling to a thin edge the cylinder at *d*, in front of the base of the prime cutter, for the purpose of giving an outward direction to and carrying away the cuttings, substantially as set forth.



(53,400) MACHINE FOR BORING HUBS.—D. C. Breed, Lyndonville, N. Y. :

I claim, *First*, The combination and arrangement of the annular-plate L, adjustable connecting-plates *n n*, supporting arms J J, and adjusting screws, M, N, in connection with the spiral grooved chuck-plate K, and cog-bars, *m m*, substantially as herein specified, whereby the centralizing longitudinal and angular adjustments of the hubs are effected together, as set forth. *Second*, The combination of the adjustment of the cross-bar H, by the longitudinal scale *x*, and the transfer adjustment of the mandrel bearing I, by the scale *l*, with the adjustment of the chuck-plates H L, to suit hubs of different lengths, for the purpose of directly determining the required taper of the holes to be bored in the hubs, substantially as herein described.

(53,419) CARRIAGE CURTAIN-FASTENER.—Elmer Crawford and James H. Birch, Burlington, N. J. :

We claim the binding of the eyelets of carriage window-curtains by means of metallic plates riveted together, held fast to the frame by hooking on revolving knob-screws, applied to and in combination with carriage window-curtains, in the manner and for the purpose above set forth, using, to obtain the said effect, any metal, as brass, silver, galvanized iron, or any suitable material substantially equivalent or which will produce the intended effect.

(53,436) WHIFFLE-TREE.—Arrington Gibeon, River Falls, Wis., and William M. Newcomb, Clifton, Wis. :

We claim the bands F, with the lips C, bent lever D, in combination with the pin H, spring *f*, or its equivalent rod K, and strap N, constructed substantially as for the purpose specified.

(53,535) TUYERE.—Robert D. Kincaird, assignor to himself and Hall & Speer, Pittsburg, Pa. :

I claim, *First*, In combination with a water-box or reservoir, and a blast or air-pipe passing through it, the sleeve-jacket, or pipe surrounding said air-pipe, and open to and communicating with the water in the water-box for the tripple purpose of surrounding said blast-pipe with water, and for allowing for a free circulation of the water, and to prevent any sediment from clogging or lodging therein, substantially as and for the purpose described. *Second*, In combination with an air-pipe passing through the water-box, horizontally, and capable of being attached or connected with a bellows, I claim a vertical branch pipe rising up within the box, for the purpose of being connected with a fan-blower, both or either to be used substantially as described.

April 3. (53,556) CARRIAGE-SPRING.—M. L. Ballard, Canton, O. :

I claim the uniting and holding the ends or plates of a spring, by means of an independent cap, and bolt or rivet, made and applied substantially in the manner and for the purpose described.

(53,568) CARRIAGE.—Clark T. Bush, Rensselaerville, N. Y. :

I claim the management and combination of the side springs, *e e*, yielding-perch *f*, diagonal braces *h h'*, slot or loop *i*, hinges *p p*, substantially as and for the purposes set forth.

(53,583) MANUFACTURE OF WHITE-LEAD.—Clarence Delafield, Factoryville, N. Y. :

I claim, *First*, Uniting or combining a solution of the nitrate of potash (or its equivalent for this purpose), made substantially as described, with a solution of the carbonate of potash (or its equivalent for this purpose), made substantially as described, for the purpose of producing the white-lead of commerce. *Second*, Uniting or combining a hot solution of the carbonate of potash (or its equivalent for this purpose) with a hot solution of the nitrate of lead (or its equivalent for this purpose), without regard to the proportions in which the two solutions are made, for the purpose of producing the white-lead of commerce. [Beware of such compounds.]

(53,588) AXLE-BOX.—D. H. Dotterer, Philadelphia, Pa. :

I claim, *First*, Fitting the sections of packing of a journal-box in such manner that they may be adjusted from the outside of the box, substantially as described. *Second*, Constructing a sectional packing C D, so that the section D may move within the section *c*, in combination with a bridge-support E, and springs which are so applied as to keep such packing in place, substantially as described.

(53,698) SPOKE-SHAVE.—John G. Steiger, Cleveland, Ohio :

I claim the special construction of the cast-handle and clamp with the shoulder *b*, formed between the clamp and handle-blade B, and set-screws *d*, and operating substantially as described.

(53,722) HOLLOW AUGER.—Arcabous Wyckoff, Elmira, N. Y. :

I claim the cutters A A, constructed with two or more alternately-projected cutting-points C and D, so arranged as to cut in parallel but concentric planes, substantially in the manner and for the purpose set forth.

10. (53,828) ATTACHING THILLS TO CARRIAGES, ETC.—Winford R. S. Hunter, Blackberry, Ill. :

I claim, *First*, The employment of a spring C, in combination with the slotted thill-head or iron, substantially described and for the purpose specified. *Second*, Providing the slot *a*, with the recess *c*, as and for the purposes set forth. *Third*, The combination of the spring C, the bolt or pin E, and thills A, provided with a slot *a*, arranged as and for the purposes specified.

#### CANADIAN INVENTIONS.

Sept. 23, 1865. LUMBER WAGONS.—Chester F. Hall, Toronto :

This invention refers to improvements in the construction of lumber wagons designed expressly for use in mill and lumber yards, the object of which is to facilitate the unloading.

Oct. 25. SELF-ACTING CARRIAGE BRAKE.—Ephraim D. Card, Haldimand, Northumberland [Description not furnished.] :

Nov. 23. JACK FOR COUPLING CARRIAGES.—Thomas Dewitt, Morpeth, Kent Co. :

The inventor, who is a blacksmith, intends his spring-jack for coupling together certain portions of wheel-carriages.

24. TIRE FOR CARRIAGE WHEELS.—Josiah James, Whitchurch, York Co. :

This invention is known as the Eureka wheel, when the tire is applied.

#### FOREIGN INVENTIONS.

August 4, 1865. CONSTRUCTION OF AXLE-BOXES AND BEARINGS.—H. A. Bonneville, Portchester-terrace, Bayswater :

The object of this invention is the transformation of the sliding friction into a rolling friction in axle-boxes, and bearings of railway and other carriages, and of the shafts of screws, and machinery in general. *Not proceeded with.*

CHECKING OR CONTROLLING the payment of fares in cabs and other vehicles.—By the same as above.

The object of this invention is an improved combination of apparatus already known, intended for checking the payment of fares of public vehicles by printing on a ticket or card the time or distance during which the passenger has occupied the vehicle, and registering on the indicator the number of tickets marked by said apparatus. The invention consists in combining the above-mentioned apparatus in suitable number for the different species of time for which the vehicle is occupied, in a case, frame, or box provided with an ordinary time-keeper as represented in the drawings.



## CURRENT PRICES FOR CARRIAGE MATERIALS.

CORRECTED MONTHLY, FOR THE NEW YORK COACH-MAKER'S MAGAZINE.

NEW YORK, April 20, 1866.

Apron hooks and rings, per gross, \$2.00.  
 Axle-clips, according to length, per dozen, 75c. a \$1.25.  
 Axles, common (long stock), per lb, 10½c.  
 Axles, plain taper, 1 in. and under, \$6.50; 1½, \$7.50; 1¾, \$8.50;  
 1¾, \$9.50; 1¾, \$10.50.  
 Do. Swelled taper, 1 in. and under, \$7.00; 1½, \$8.25; 1¾, \$8.75;  
 1¾, \$10.75; 1¾, \$13.00.  
 Do. Half patent, 1 in. and under, \$10.00; 1½, \$11.00; 1¾, \$13.00;  
 1¾, \$15.50; 1¾, \$18.50.  
 Do. do. Homogeneous steel, ½ in., \$14.00; ¾, \$14; ¾, \$15.00;  
 long drafts, \$4 extra.  
 These are prices for first-class axles.  
 Bands, plated rim, under 3 in., \$2.00; 3 in., \$2.25, and larger sizes  
 proportionate.  
 Do. Mail patent, \$3.00 a \$5.00.  
 Do. galvanized, 3½ in. and under, \$1; larger, \$1 a \$2.  
 Basket wood imitations, per foot, \$1.25.  
 When sent by express, \$2 extra for a lining board to a panel of 12 ft.  
 Bent poles, each \$2.00.  
 Do. rims, under 1½ in., \$2.25 per set; extra hickory, \$3.25 a \$4.00.  
 Do. seat rails, 50c. each, or \$5.50 per doz.  
 Do. shafts, \$7.50 per bundle of 6 pairs.  
 Bolts, Philadelphia, list.  
 Do. T, per 100, \$3 a \$3.50.  
 Bows, per set, light, \$1.50; heavy, \$2.00.  
 Buckles, per grs. ½ in., \$1.50; ¾, \$1.50; 1, \$1.70; ¾, \$2 10; 1, \$2.80.  
 Buckram, per yard, 25 a 30c.  
 Burlap, per yard, 20 a 25c.  
 Buttons, japanned, per paper, 25c.; per large gross, \$2.50.  
 Carriage-parts, buggy, carved, \$4.50 a \$6.  
 Carpets, Brussels, per yard, \$2 a \$3; velvet, \$3.25 a \$4.50; oil-cloth  
 75c. a \$1.  
 Castings, malleable iron, per lb, 20c.  
 Clip-kingbolts, each, 50c., or \$5.50 per dozen.  
 Cloths, body, \$4 a \$6; lining, \$3 a \$3.50. (See *Enameled*.)  
 A Union cloth, made expressly for carriages, and warranted not to fade,  
 can be furnished for \$2.25 per yard.  
 Cord, seaming, per lb, 45c.; netting, per yard, 8c.  
 Cotelines, per yard, \$4 a \$8.  
 Curtain frames, per dozen, \$1.25 a \$2.50.  
 Do. rollers, each, \$1.50.  
 Dashes, buggy, \$1.75.  
 Door-handles, stiff, \$1 a \$3; coach drop, per pair, \$3 a \$4.  
 Drugget, felt, \$2.  
 Enameled cloth, muslin, 5-4, 60c.; 6-4, 90c.  
 Do. Drills, 48 in., 90c.; 5-4, 85c.  
 Do. Dueks, 50 in., \$1.20; 5-4, \$1.00; 6-4, \$1.35.  
 No quotations for other enameled goods.  
 Felloe plates, wrought, per lb, all sizes, 25c.  
 Fifth-wheels wrought, \$1.75 a \$2.50.  
 Fringes, festoon, per piece, \$2; narrow, per yard, 18c.  
 For a buggy top two pieces are required, and sometimes three.  
 Do. silk bullion, per yard, 50c. a \$1.  
 Do. worsted bullion, 4 in. deep, 50c.  
 Do. worsted carpet, per yard, 8c. a 15c.  
 Frogs, 75c. a \$1 per pair.  
 Gluc, per lb, 25c. a 30c.  
 Hair, picked, per lb, 55c. a 75c.  
 Hubs, light, mortised, \$1.20; unmortised, \$1.00—coach, mortised  
 \$2.00.  
 Japan, per gallon, \$3.  
 Knobs, English, \$1.50 a \$1.65 per gross.  
 Laces, broad, silk, per yard, \$1.00 a \$1.50; narrow, 15c. to 20c.  
 Do. broad, worsted, per yard, 50c. a 75c.  
 Lamps, coach, \$18 a \$30 per pair.  
 Lazy-backs, \$9 per doz.  
 Leather, collar, dash, 31c.; split do., 18c. a 22c.; enameled top,  
 32c.; enameled Trimming, 30c.; harness, per lb, 50c.; flap, per  
 foot, 25c. a 28c.  
 Moquet, 1½ yards wide, per yard, \$9.00.  
 Moss, per bale, 12½c. a 18c.  
 Mouldings, plated, per foot, ¼ in., 14c.; ¾, 16c. a 20c.; ½, 1 ead, door,  
 per piece, 40c.  
 Nails, lining, silver, per paper, 7c.; ivory, per gross, 50c.  
 Name-plates.

See advertisement under this head on 3d page of cover.

Oils, boiled, per gallon, \$1.80.

Paints. White lead, ext. \$17, pure \$17½ p. 100 lbs.; Eng. pat. bl'k, 35c.

Pole-crabs, silver, \$5 a \$12; tips, \$1.50.

Pole-eyes, (S) No. 1, \$2.50; No. 2, \$2.65; No. 3, \$2.85; No. 4,  
 \$4.50 per pr.

Sand paper, per ream, under No. 2½, \$5.50; Nos. 2½ &amp; 3, \$6.25.

Screws, gimlet.

Add to manufacturer's printed lists 10 per ct.

Do. ivory headed, per dozen, 50c. per gross, \$5.50.

Scrims (for canvassing), 16c. a 25c.

Seats, buggy, pieced rails, \$1.75; solid rails, \$2.12.

Shaft-jacks (W. S. &amp; S.'s), No. 1, \$2.65; 2, \$3.10; 3, \$3.35.

Shaft-jacks, common, \$1.50 a \$1.65 per pair.

Do. tips, extra plated, per pair, 25c. a 50c.

Silk, curtain, per yard, \$2 a \$3.50.

Slat-irons, wrought, 4 bow, 85c.; 5 bow, \$1.00 per set.

Slides, ivory, white and black, per doz., \$12; bone, per doz., \$1.50  
 a \$2.25; No. 18, \$2.75 per doz.

Speaking tubes, each, \$10.

Spindles, seat, per 100, \$1.50 a \$2.50.

Spring-bars, carved, per pair, \$1.75.

Springs, black, 22c.; bright, 23c.; English (tempered), 26c.;

Swedes (tempered), 30c.; 1¼ in., 1c. per lb. extra.

If under 36 in., 2c. per lb. additional.

Two springs for a buggy weigh about 23 lbs. If both 4 plate, 34 to 40 lbs.

Spokes, buggy, 7/8, 1 and 1½ in. 9½c. each; 1½ and 1¼ in. 9c. each;  
 1½ in. 10c. each.

For extra hickory the charges are 10c. a 12½c. each.

Steel, Farist Steel Co.'s Homogeneous Tire (net prices); 1 x 3-16  
 and 1 x 1-4, 20 cts.; 7-8 x 1-8 and 7-8 x 3-16, 23 cts.; 3-4 x 1-8,  
 25 cts.; 3-4 x 1-16, 28 cts.Do. Littlejohn's compound tire, 3-16, 9½c.; 1-4, 9c.; heavier  
 sizes, 8½c. currency.Under no circumstances will bundles be broken to furnish a single set—  
 bundles weigh from 110 to 120 lbs. each.

Stump-joints, per dozen, \$1.40 a \$2.

Tacks, 9c. and upwards per paper.

Tassels, holder, per pair, \$1 a \$2; inside, per dozen, \$5 a \$12;  
 acorn trigger, per dozen, \$2.25.

Terry, per yard, worsted, \$3.50; silk, \$8.

Top-props, Thos. Pat, wrought, per set 80c.; capped complete, \$1.50.

Do. common, per set, 40c.

Do. close-plated nuts and rivets, \$1.

Thread, linen, No. 25, \$1.45; 30, \$1.55; 35, \$1.80, gold.

Do. stitching, No. 10, \$1.00; 3, \$1.20; 12, \$1.35, gold.

Do. Marshall's Machine, 432, \$2; 532, \$2.25; 632, \$2.60, gold.

Tufts, common flat, worsted, per gross, 20c.

Do. heavy black corded, worsted, per gross, \$1.

Do. do. do. silk, per gross, \$2.

Do. ball, \$1.

Turpentine, per gallon, \$1.30.

Twine, tufting, per ball, 50c.; per lb, 85c. a \$1.

Varnishes (Amer.), crown coach-body, \$5.50; noupareil, \$6.50.

Do. English, \$6.25 in gold, or equivalent in currency on the  
 day of purchase.

Webbing, per piece, 65c.; per gross of 4 pieces, \$2.40.

Whiffle-trees, coach, turned, each, 50c.; per dozen, \$5.50.

Whiffle-tree spring hooks, \$4.50 per doz.

Whip-sockets, flexible rubber, \$4.50 a \$6 per dozen.

Do. hard rubber, \$10.50 per dozen.

Do. leather imitation English, \$5 per dozen.

Do. common American, \$3.50 a \$4 per dozen.

Window lifter plates, per dozen, \$1.50.

Yokes, pole, each, 50c.; per doz, \$5.50.

Yoke-tips, extra plated, \$1.50 per pair.

**SPECIAL NOTICE.**—With this number will be given an index and title-page for the seventh volume. On receiving it the larger proportion of our subscribers have in their possession all they have paid for, consequently, unless they renew, we shall be compelled to stop sending the Magazine to many. We hope, however, that this will be prevented in time by the reception of \$5, which will be the price for the forthcoming volume. Hope was entertained that we would be able to reduce the price, but this is now abandoned, in view of the fact that paper and labor are as high as ever, with no signs of abatement.

















SMITHSONIAN INSTITUTION LIBRARIES



3 9088 01548 7739