

STACK
ANNEX

5
961
485

Learn by Doing."

— Theme of

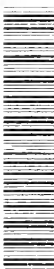

Simple Woodwork.

Joseph Henry Judd.

Illustrated ...

Clarkson & Griffiths Ltd.,
Bridge Street, Manchester.

5/-
NET

“Learn by Doing.”

A SCHEME OF

SIMPLE WOODWORK

DESIGNED ON FROEBELIAN PRINCIPLES.

*For Teachers in Special, Primary, and Secondary Schools, and for Students
in Training for the Certificates of the National Froebel Union.*

BY

Joseph Henry Judd,

*Superintendent of Handicraft Classes to the City of Manchester Education Committee, Member of the
Institution of Mechanical Engineers; Associate of the Institution of Civil Engineers; and
Examiner in Manual Training, etc., to the City and Guilds of London Institute,
and to the Examination Board of the National Union of Teachers.*

ALL RIGHTS RESERVED.

MANCHESTER
MESSRS. CLARKSON & GRIFFITHS LTD., 65, BRIDGE STREET.
1906.

CONTENTS.

	Page
PREFACE	5
INTRODUCTION	7
PLAN OF A GENERAL HANDCRAFT ROOM	13
ELEVATIONS AND SECTIONS OF A UNIVERSAL HANDCRAFT BENCH	14
LIST OF STANDARD AND ALTERNATIVE MODELS	15
SCHEME OF LESSONS AND MODELS FOR 1ST YEAR SCHOLARS	16
SCHEME OF LESSONS AND MODELS FOR 2ND YEAR SCHOLARS	17
SCHEME OF LESSONS AND MODELS FOR 3RD YEAR, 4TH YEAR, AND ADVANCED SCHOLARS	18
SUPPLEMENTAL AND SEQUENCE OR CONTINUATION LESSONS	19
PHOTO BLOCK OF TOOL EQUIPMENT	22
COST OF EQUIPMENT	24
DESCRIPTION OF, AND NOTES OF LESSONS ON :	
THE EQUIPMENT, APPARATUS, AND TOOLS	25
NOTES OF LESSONS	26, 28, 30, 33, 38, 41, 42, 46, 51, 55
TOOL POSITION DRILLS	31, 31, 39, 44, 48
NOTES ON THE WOODS AND OTHER MATERIAL USED	61
PHOTO BLOCK OF 1ST YEAR MODELS	72
DIAGRAM TO ILLUSTRATE STRIP PAPER DESIGNS	73
LINE DIAGRAMS OF MODELS, 1ST YEAR COURSE	73, 77, 80, 84, 89, 91, 91, 98, 102, 104, 109
PHOTO BLOCK OF 2ND YEAR MODELS	111
LINE DIAGRAMS OF MODELS, 2ND YEAR COURSE :	
113, 115, 118, 121, 125, 127, 131, 134, 137, 140, 143, 146	
PHOTO BLOCKS OF 3RD OR ADVANCED COURSE OF WORK, DRAWING AND CONSTRUCTION	
OF SIMPLE TOYS	149, 153, 158, 160, 166, 170, 174, 179, 181, 188, 194, 199, 200
LINE DIAGRAMS OF 3RD AND ADVANCED MODELS :	
151, 154, 156, 163, 168, 172, 177, 182, 186, 193, 197, 202, 204, 206, 208, AND 1 INSERT	
GLOSSARY OF TECHNICAL TERMS	213
INDEX	217

PREFACE.

In response to oft-repeated requests from many earnest students of child life, who are ever alert to the advantages to be derived from the systematizing of natural aptitude, I place this text-book of simple woodwork, based on Froebelian ideals, before my fellow teachers and the public generally.

Years of earnest thought have been devoted to the evolution of an occupation, untrammelled by convention, yet at once simple, natural, fascinating, and educationally effective, capable of being made the hub of co-ordination, and of being expounded by every thoughtful teacher, without undue study and preparation.

The scheme is designed to cultivate the active and creative instincts; to give practice in failure and success; to test the ability to concentrate the mind whilst doing a definite thing; to provide means of communication between the teacher and the child, whereby the latter can render observant information, from which the teacher can impart more exact knowledge; to open up an avenue of research for the student of child life, and to give to the teacher full scope for individualism in the attainment of educational ideals.

The "Suggestions for the consideration of Teachers" recently issued by the Board of Education—although distinctly stated to be of a tentative character—is a clear sign of impending changes. It is an official blast which sounds the clarion notes of a new era. The "bridging over" of the fatal gap which now exists, will be an accomplished fact in the near future. An "occupation craft-room" will be required in each school building, wherein each child on roll will receive—under the guidance of a specialist teacher—real co-ordinated instruction which

will infuse new life into ordinary school routine, and make the why and wherefore of education more apparent to the child.

“Many teachers may disagree with some of the suggestions in the following chapters; in that event, they should ask themselves whether their own procedure, however sanctioned by convention, may not be open to question.” The severe tests to which the scheme has been subjected, and the unqualified success which has invariably attended the trials, emboldens me to give assurances which would otherwise be impossible or egotistic.

In the introductory chapter, the general principles underlying the whole scheme are set forth, and the text and drawings following show, in the most simple and minute language, the necessary details of construction of each of the Standard Models, whilst the numerous diagrams of tools—kindly lent by Messrs. Marples & Sons, Limited, Sheffield—and photo. blocks illustrating the methods of handling and using the simple tools will be found of value for enlarging diagrams for demonstration purposes. A brief synopsis of the procedure for constructing each model is arranged at the end of each lesson to simplify and indicate method. The co-ordination lessons are suggested titles only, and these may be transposed, deleted, or modified to meet actual requirements.

I have to gratefully acknowledge my obligations to my old school-fellow, Mr. W. R. Todd, of Beenham, Reading, and Mr. R. Hodson, of Manchester, for revision of manuscript and proof reading; to Miss Amy Walmsley, of Bedford, and Miss J. B. Dickens, of Manchester, for warm appreciation, encouragement, and valuable suggestions; to my assistants, Messrs. Ogden, Fielding, and Deighton, the Lady Teachers of the Manchester Special Schools, and the Principals of Kindergarten Training Colleges and Schools, who have introduced the work, for their enthusiastic efforts to give correct renderings of the Ideals.

JOSEPH H. JUDD.

HEATON MOOR,

December 11th, 1905.

INTRODUCTION.

F the many and varied schemes of practical work devised with the object of training the Hand to deftness and the Eye to accuracy in observation, none has met with so widespread acceptance as Woodwork. The required material, being a direct and universal product of nature, is readily obtainable, cheap, and easily worked into forms of beauty, either in its natural or prepared state. Its ready adaptability to a course of handwork as a continuation of the Kindergarten gifts, makes it an equal, if not a superior, medium to any other known material.

In America, Germany, and other progressive countries, it is acknowledged, that when based on purely educational principles for the formation of habits of truthfulness, thoroughness, and self-reliance, and carried into effect with intelligence and enthusiasm by the teacher, a systematic preparatory scheme of woodwork will do much to bridge over the interval which unfortunately exists between the Kindergarten gifts and the more defined practical work in wood and metal, known as "Manual Instruction." As "the aim of technical instruction is to attain to skilled work by the right application of the right knowledge," so do these preparatory schemes of woodwork aim to help children to acquire true knowledge by the "right application of the right work."

To ensure success in any scheme of work designed to effect co-ordination, the Froebelian principles of connectedness and unbroken continuity of succession must permeate it, the manner of application being perfectly flexible, to vary with the altered condition—physical and mental—of the children, whilst allowing absolute freedom for individual effort.

Teachers may be guided on right lines, but they must employ their own methods of illustration, comparison, and language when imparting knowledge to each individual. Especially does this rule apply to the Handicraft work required in the higher classes of the special schools now being established for the direct and better education of backward children. The gradation of the scheme of work

from simple to complex aims to furnish the necessary repetition of exercises without causing weariness, and enables the teacher to select readily a model, or an element, suitable to the physical and mental capacity and progressive activity of each child.

Education by doing—imitation and mimicry—forms the essence of self-instruction; and “the knowledge begun in wonder grows into power, when applied to the doing of something which becomes the expression by the pupil of his own thought.” To a child, toys are the very essence of its existence; and every student of child-life can testify to the infinite delight shown in the most crude model made by the child himself, and his love for it, be it a copy, or the actualizing of a preconceived idea. Tools have a strange fascination upon all children, they love to hammer, to cut, to make, and under trained guidance simple woodwork undoubtedly stimulates latent inventive talents more quickly than any other known medium. Experiment has proved that even those children, whose mental powers are far below normal, most readily apply themselves with unique zeal and delight to study under its influence.

Drawing.

Following Froebelian principles the scheme presented embraces sketch-drawing and simple colour work as the most effective methods of giving quick expression to the thoughts and ideas of teacher and child, and of stimulating attentive observation.

In the very early stages absolute accuracy of measurement cannot be expected, but from the commencement every effort should be made to encourage the appreciation of truth for truth's sake.

A small portion of work accurately and neatly executed is far more educative than a completed exercise or model full of faults and inaccuracies.

To simplify the teaching of the measure of length, breadth, and thickness, the drawings of each standard model are dimensioned under a simple scheme of Unit numerals based on one-eighth of the standard inch: thus $3\frac{3}{8}$ " is expressed by the whole number 30•, the upper period point indicating the Unit, thus: 53• 6 $\frac{3}{8}$ ". It has been found from actual practice that by this method the children readily express

correctly the required dimensions; that by repetition they unconsciously realize the fractional parts of the standard of length, and more quickly appreciate the relative values of each division.

A further advantage of this method is, that by the simple substitution of any other numeral as the Unit, various sized (yet proportionate) exercises or models can be made from the same drawing. In the supplementary series, additional models as alternatives or substitutes are suggested in pictorial and proportional outline, and many others may be evolved from these, provided always that the elements of construction are correct. Great care must be taken to direct and guide any self-efforts of the children on correct lines, and, whilst granting full freedom and giving every encouragement to develop latent inventiveness, to avoid the fatal error of allowing ill-formed ideas and conceptions to gain credit, without giving adequate correcting criticism.

Experience has proved that the children of our Special and Kindergarten schools most readily apply themselves to the work, and that under a skilful and *sympathetic* teacher it reacts beneficially upon every subject of the school curriculum.

Following the most educational and intellectual method of procedure, the drawing of the model or exercises should be done by the scholars before the actual construction is attempted. It may be by means of paper strip, or by free-arm sketching on black board in coloured chalks, or on ordinary drawing paper, using the Tee and set squares.

In all cases the requisite dimensions in either the Unit system or standard method must be placed in the correct positions, the distance between the arrow points being the exact distance intended for measurement between any two lines, thus:

$$|\leftarrow \text{---} 30 \bullet \text{---} \rightarrow| \text{ not } |\leftarrow \text{---} 30 \bullet \text{---} \rightarrow|.$$

The use of the drawing board, Tee square, and set squares should be taught as early as possible in preparation for the more advanced work. A good hand and eye training may be effected by the aid of paper strip (cut by the children from either plain, coloured, or gummed paper, to the desired length and width), to be afterwards placed in correct position in their drawing books; the overlap of the

paper strip corresponding to the overlap of the wood strip in each case. The elevations and plans of all the strip models (see examples on page 73) can be produced in this way, the placing of each view in relative geometrical position being taught in the usual way by faint, full, or short dash line projectors. By adopting this simple method it will be easy to teach the simple essential elements of geometry and to inspire confidence in the children to execute the required line drawing direct from rough sketch measurement. When using paper they are dealing with two dimensions only, length and breadth, and they quickly realize that a line drawn round the paper figure produces a smaller but similar drawing to that made by the teacher on the black board. The usual method of cutting may be adopted, or, if the children can be trusted to use edge tools, the better way to quickly secure accuracy is to cut the strips required with a knife, using a piece of glass mounted on a millboard base as the cutting slab. (A zinc plate answers the same purpose for a time, but by constant cutting on, it acquires a serrated surface, and consequently tends to leave rough edges on the strips instead of the clean cut ones required for neat work.)

It is, however, essential that as soon as any secondary aids to secure neat copies can be dispensed with, they should be superseded by the orthodox geometrical drawings in orthographic, oblique, or isometric projection, or by the fully dimensioned free sketch method. The aim of each drawing lesson being definitely stated, it becomes a simple matter for the teachers to adopt, in each individual case, their own familiar methods to obtain the desired result in the most efficient manner.

Practical Work.

The simple exercises and models constituting the standard course are generally based on utilitarian objects, and, although only simple toys when completed, are designed on constructional lines with a view to establishing correct ideas, which may be readily adapted by the children, after school days, to an actual full-size object. The only alteration necessary is the substitution of one or other of the many forms of jointing taught in the higher Handicraft classes for the more simple method of direct butt joint nailing.

It is most essential that the instruction given be on sound lines and that nothing has to be unlearned by the pupil in after years. A definite course of procedure in working the standard models is given in each case to avoid confusion, a careful study of which will materially assist in producing satisfactory work.

Tool Position Drill.

Physical Methods to prevent undue Fatigue.

Another important feature of the scheme is the method adopted to secure discipline and the correct handling of the various tools used in the practical work class. It is intended that a few minutes of each lesson should be given to this part of the work: (*a*) to secure correct positions of the several members and muscles of the body to prevent fatigue, and (*b*) to minimise accidents to the children and to the tools they use.

These tool positions are not to be made mere mechanical drills in which the children are left to imitate as correctly as they can any demonstration given by the teacher. Each faulty handling or wrong position of the body assumed by any child in the class should immediately be taken advantage of by the teacher to demonstrate the correct method for the benefit of the whole. There is nothing more difficult to eradicate than a wrong method or a faulty construction once established as a first impression on a child's mind; therefore it is absolutely necessary for the teacher to be ever on the alert to immediately correct any insidious faults.

Little Talks on Common Things.—Observation Lessons.

The actual theory lesson section of the scheme is intended to be hidden treasure given under the guise of "Little Talks" identical with those admirable chatty lessons of the Kindergarten schools, and parallel to any scheme of Nature Study.

In most cases, only the merest suggestion or title of a lesson suitable for the practical work in hand is given to secure a correlation of the subject matter and lessons throughout, and to give that necessary individuality and independence of action so welcome to the intelligent and *enthusiastic* teacher.

The alternative and additional models provide a large and valuable range of exercises, any of which may be readily applied either as substitutes or extras. The aim of each can be seen from the equivalent model of the standard course.

The subject range of models is almost unlimited in extent, and therefore it is considered wise to keep the details of the standard course within the scope of one volume.

It is claimed that the correlation, connectedness, and continuity of the several sections outlined, materially adds to the educative value of this scheme of simple woodwork; for by its aid the necessity of absolute truthfulness and accuracy in definition is most strongly emphasized; it tends to creativeness; it stimulates latent inventive faculties, quickens perception, guides and directs on correct lines the natural impulses of child nature; and, whilst demanding close attention to and observation of detail, it trains the little fingers to deftness and skill in execution without detracting in any way from the established methods of the greatest thinkers and exponents of educational reform.

The equipment necessary for each child is of a very simple character, involving small outlay in first cost and upkeep, and the work can readily be done by either girls or boys on the ordinary school desks.

Should it, however, be considered advisable to set apart a special classroom for the effective teaching of other Handicrafts in addition to the woodwork, provision must be made for fixed benches suitable at once for all subjects. A plan of such a room (now in actual use at the new centres), together with details of the special bench which provides for the drawing lesson and for ample storage of all tools, work in progress, and finished work for exhibition, will be found on pages 13 and 14.

In well-organized institutions Froebelian woodwork may be taken up entirely without, in any way, lowering the standard of efficiency in other subjects; all that is necessary being a slight revision of time-tables, correlation, and an impartial trial, to secure a full appreciation of its value as a facile educative factor in the early training of the child.

— PLAN of a GENERAL HANDCRAFT ROOM —

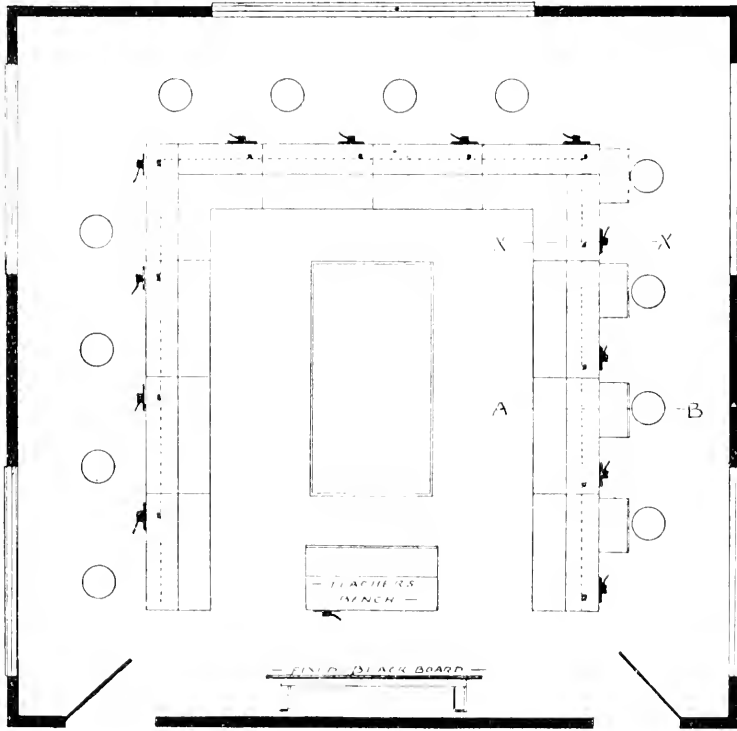

SECTION XX



SECTION XX



SECTION XX

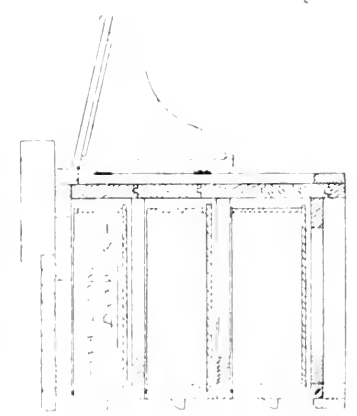

SECTION XX

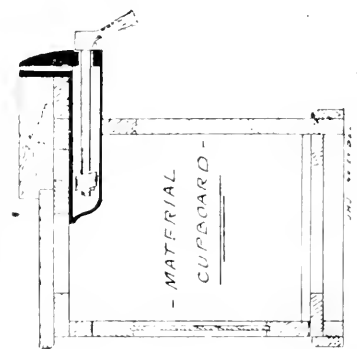

SECTION XX

1/2" = 1'-0"

MATERIAL CUPBOARD

List of Standard Models,

AND

Alternative or additional Models involving similar
constructional exercises.

STANDARD COURSE.	ALTERNATIVE OR ADDITIONAL COURSE.
1. Overlap cross	Windmill. Wheel arms. Base piece for posts.
2. Overlap frame	Picture frame. Wood mat. Lazy tongs.
3. Tee square	Letters E, T, H, L. Try square.
4. Base piece	Turnstile base. Draining grid. Bath mat.
5. Upright piece	Railway signal. Bevel square.
6. Spinning mill	Finger post. Turnstile. Giant stride.
7. Half lap cross... ..	Base piece. Letter X. Kettle stand.
8. Plant ladder	Letter rack. Book rest.
9. Plant carrier or bier ...	Canadian sleigh. Ship gangway.
10. Square frame	Geometrical forms and solids.
11. Garden railing	Simple overlap trellis. Bath mat.
12. Garden gate	Letters V, Z, A. Pantograph.
13. Garden steps or ladder	Plant stand.
14. Garden swing	Parallel bars. See-saw.
15. Garden seat	Camp chair. Letter rack. Easels.
16. Clothes-horse or maiden	Folding screen. Fire screen.
17. Bedstead	Key rack. Hat and coat rack. Swing gate.
18. Kitchen chair	High-back arm and rocking chairs. Foot stool.
19. Sofa	Kitchen table. Folding table.
20. Toilet table	Towel rail. Flower pot stand. Swing toilet glass.
21. Feeding trough	Salt cellar. Knife rest. Money box.
22. Wicket gate	Letters K, Y, W, M. Trellis panels. Hurdles.
23. Sack truck	Wheel ambulance bier. Railway float truck.
24. Wheelbarrow	Hobby horse. Parcel post cart.
25. Dog kennel	Rabbit hutch. Pencil box. Summer house.
26. Field roller	Garden roller. Hose reel.
27. Harvest cart	Baby's go-cart. Wagon. Cattle cart.
28. Merry-go-round	Market stall. Frame tent.
29. Advertising wheel	Sandmill.
30. Knife grinder	Windmill and vane. Hoisting crane.
31. 5-stamp crushing mill	Water wheel and mill.
32. Miner's hut	Winding cage and wheel.
33. Railway signals	Ball game board. Farmyard and sheds.
34. Signal cabin	Coal wagon (railway).
35. Motor car	Bicycle and trailer.
36. Locomotive and tender	Cattle truck (railway).

Scheme of Lessons and Models for 1st year Scholars.

LESSON GROUP No.	AIM OF DRAWING LESSON.	NAME OF MODEL.	AIM OF PRACTICAL LESSON.	TOOL POSITION DRILL AND DEMONSTRATIONS.
1	To teach reading of simple measurements at sight.	Overlap cross or string winder.	To familiarize the use of rule and try square.	Measurement with rule and try square.
2	Ditto.	Fishing line frame or Oxford picture frame.	To teach sawing to a line and to waste.	Sawing and angle testing.
3	To impress simple outline drawings and free sketches.	Tee square (drawing instrument).	To teach simple construction.	Planing, nailing, square and angle testing.
4	To teach the reason why more than one simple outline is necessary.	Base piece or column foot.	Ditto.	Planing and boring with awl.
5	Ditto.	Upright or column	Accuracy and neatness in finish.	Sawing to a line and planing.
6	To teach combination of drawings and to secure neatness in marking working dimensions.	Spinning mill.	To apply previous lesson to construction of working model.	Demonstration with wire cutters and pliers. <i>Eye making.</i>
7	To teach parallel projection.	Half lap cross, wheel arms.	To teach accuracy in measurement, sawing, fitting, and use of the file.	Gauging and sawing to waste and to line, and filing.
8	To familiarize the terms oblique lines and angles.	Plant ladder.	Setting out oblique work.	Use of chamfer knife, sight testing for balance.
9	To secure neatness in parallel line drawings.	Plant carrier or bier.	To teach accuracy in cutting to length and long end nailing.	Use of chamfer knife, testing for right angles and for winding
10	To impress simple elements of geometrical figures.	Square frame (halving joints).	Accuracy in simple construction and nailing end grain.	Boring and end nailing, square testing.
11	As in No. 9.	Garden railing.	To teach sight proportion and measurement in overlay and nailing.	Sight testing and planing.
12	To teach the use of rule and set square combined to replace Tee square.	Garden gate.	To teach oblique sawing to line, fitting, and nailing.	Wire working, square testing and nailing, use of glasspaper.

Scheme of Lessons and Models for 2nd year Scholars.

LESSON GROUP No.	AIM OF DRAWING LESSON.	NAME OF MODEL.	AIM OF PRACTICAL LESSON.	TOOL POSITION DRILL AND DEMONSTRATIONS
13	To familiarize the use of rule and set square in combination.	Step ladder.	Accuracy in sawing to length and nailing end grain.	Sawing and nailing.
14	To prove the necessity for <i>scale drawings</i> and the need of more than one outline.	Children's garden swing.	To teach the simple elements of triangular construction to secure strength.	Wire working, skew nailing, use of scratch beader.
15	To familiarize the use of set square for oblique line drawing.	Garden seat.	Ditto.	Sight testing and oblique nailing, demonstrate use of cutting gauge.
16	To teach simple combination of views.	Clothes-horse or maiden.	To give further training in accurate sawing and end nailing, and double strap jointing.	Square testing and demonstration of double jointing with tape bands.
17	Ditto (another method).	Bedstead.	Accurate sawing, fitting, and nailing.	Edge nailing and square testing.
18	To secure neatness in finished drawings and intelligent reading of the several views.	Kitchen chair.	Additional and more difficult end nailing with oblique surface jointing.	Demonstration on double nailing at right angles.
19	Ditto.	Sofa or settle.	Ditto.	Surface smoothing with plane.
20	Ditto.	Toilet table.	To give additional planing exercises in taper and surface work.	Use of cutting gauge.
21	To give additional training with rule and set squares in combination.	Wicket gate.	Additional and more difficult oblique sawing, fitting, and nailing.	Sight testing and wire eye making.
22	To demonstrate the need of more than one outline drawing.	Cattle feeding manger.	Oblique surface sawing and nailing thin slab-wood.	Oblique and skew nailing.
23	As in No. 18.	Sack truck.	To teach simple method of construction. Wheel making.	Demonstration on brace and bits, boring disc and cutters.
24	Ditto and No. 22.	Wheel barrow.	Ditto.	Ditto.

Scheme of Advanced Lessons and Models for 3rd and 4th year and older Scholars.

LESSON GROUP No.	AIM OF DRAWING LESSON.	NAME OF MODEL.	AIM OF PRACTICAL LESSON.	TOOL POSITION DRILL AND DEMONSTRATIONS.
25	To teach the geometrical terms used in parallel projection.	Dog kennel.	Simple nailing of flat surface work.	Use of rasp and file, surface sawing across and with grain.
26	To teach projection of views and reading of sections.	Field roller.	Simple construction in toy making.	Chamfering with knife, use of rasp and file in surface rounding.
27	To teach proportionate free sketching of details.	Harvest cart.	Combining previous exercises in model toy making.	Demonstration on wheel rim making and disc cutting.
28	To teach detail drawing.	Merry-go-round or high-flier.	Ditto, and to encourage <i>commune</i> working.	Ditto on curved work with file and rasp, oblique double nailing, wire-working.
29	Ditto.	Rotary advertising machine.	Ditto.	Ditto.
30	As for No. 27.	Treadle knife machine.	Ditto.	Ditto.
31	As for No. 26.	Five-stamp ore crushing mill.	More difficult constructional details and combinations.	As for Nos. 26, 27, and 28 models.
32	As for No. 25, and pictorial sketches of frame work.	Miner's hut.	To teach method of lap boarding, window frame making, and door hanging.	Demonstrate use of grooving plane and cutting gauge.
33	To teach detail drawing to scale.	Railway signals.	To stimulate <i>commune</i> work and to apply previous knowledge of simple constructional elements.	Demonstrate on the wire-work details.

LESSON GROUP No.	AIM OF DRAWING LESSON.	NAME OF MODEL.	AIM OF PRACTICAL LESSON.	TOOL POSITION DRILL AND DEMONSTRATIONS.
34	To teach pictorial sketching of models and detail drawings for commune work.	Signal cabin and approach stair-way.	To teach method of framing, panelling and window making, etc., and further stimulation of commune working.	Demonstrate use of grooving plane and triangular framing.
35	Ditto.	Motor car.	More difficult constructional details and accuracy for combination work.	Use of bow-saw, rasp, file, and bent wood forming.
36	Ditto.	Locomotive and tender.	Ditto.	Demonstrate the forming of the splasher plates, by hot water method, use of bow-saw, centre bits, and all extra tools.

Supplemental Lessons :

Little talks on—

1. Simple measurements by Units.
2. Definition of length, breadth, and thickness.
3. Use and value of drawing instruments, Tee square.
4. What a picture drawing shows. Plan designing with Gifts 3, 4, 7.
5. Angles and set square, and beauty forms made by squares and triangles.
6. Colour tints and combination by overlay. Making of coloured pictures.
7. Geometrical terms and models.

Sequence or Continuation Lessons :

Little talks on—

1. Wool-string, St. George's Cross.
2. Sea fishing lines, Gift 8. Stick laying. The tools used—saw and hammer.
3. Wood pulp and paper making.
4. Boring tools, mechanical and natural. The earth worm, rodents, wood-boring insects and timber destroyers.
5. Continued.
6. Windmills, watermills, and other power producers.
7. Continued. Colour effects on revolving disc or arms.

Supplemental Lessons—*continued*.**Little talks on—**

8. Oblique lines and cross measurements. Free sketching black board lesson.
9. Parallel lines and neat drawings.
10. Geometrical solids and skeleton figures.
11. Mental calculations and sub-divisions. The circle and its division into degrees.
12. Angles, set squares and scales.

Continuation Lessons—*continued*.**Little talks on—**

8. Plants that require supports when growing for effect, utility, and of necessity.
9. Work in our garden. Nature study. Ambulance Corps and their work.
10. Daily work in our greenhouses. Nature study.
11. Work in our garden enclosures and shrubbery. Colonial compounds.
12. Garden produce, flowers, fruit, and vegetables.

13. Neatness and accuracy.

14. Proportionate measurements.

15. Geometrical terms and figures. Value of instruments to secure accuracy.

16. Projection, parallel and oblique. Model drawing.

17. Combining views and transposing drawings.

18. What our drawing lesson teaches.

19. The value of coloured chalks, why used?

20. Mechanical *versus* freehand drawing, relative values.

13. Work in our garden in Autumn. Gathering fruit. Ladders in daily use. Fire escapes, etc.

14. Playtime. Recreation—what it is, and why necessary.

15. Parks and pleasure grounds—why provided, and how to be used.

16. Household duties, helping mother. Our clothes, raw material, manufacture, and after care.

17. Household duties, rest after work; how best obtained. Ventilation needed for good health.

18. Household duties in the kitchen. Preparation of food. Past and present designs of furniture for the home.

19. Home comforts, rich and poor. Western and Eastern customs compared.

20. Home comforts, ancient and modern. Toilet materials—soaps, combs, brushes, etc.

Supplemental Lessons—*continued*.**Little talks on—**

21. Mechanical aids to secure neatness and accuracy.
22. Sections, their use and value to the craftsman.
23. Circles and tangents.
24. Value of detail drawing and free sketches, full dimensioned.
25. Free sketching in chalk.
26. Scale drawing of details.
27. Circles and geometrical curves.
28. Ditto.
29. Speed of revolving circles.
30. Ditto.
31. The value of full-size drawings.
32. The ensemblement of details.
33. The value of commune work.
34. Ditto.
35. Ditto.
36. Ditto.

Continuation Lessons—*continued*.**Little talks on—**

21. Country life in Spring, Summer, Autumn, Winter. A ramble through the fields. Nature study.
 22. Cattle of the Homestead and Prairie. Nature study.
 23. Farm work after harvest time, or in the warehouse. Our imports and export trade.
 24. Work in Spring time on the farm, or in the garden. Canal and railway making.
 25. The dog and its work. "Tally Ho!"
 26. Nature study in Spring time.
 27. Nature study in Summer time.
 28. Holiday time.
 29. Ditto.
 30. Simple mechanical toys.
 31. Ore mining at home and abroad.
 32. Colonial life at the mines and on the veldt.
 33. Signals in use on land and sea.
 34. Our railway system.
 35. Motor cars, cycles, and other means of locomotion, past and present.
 36. Railway workers and their duties.
-

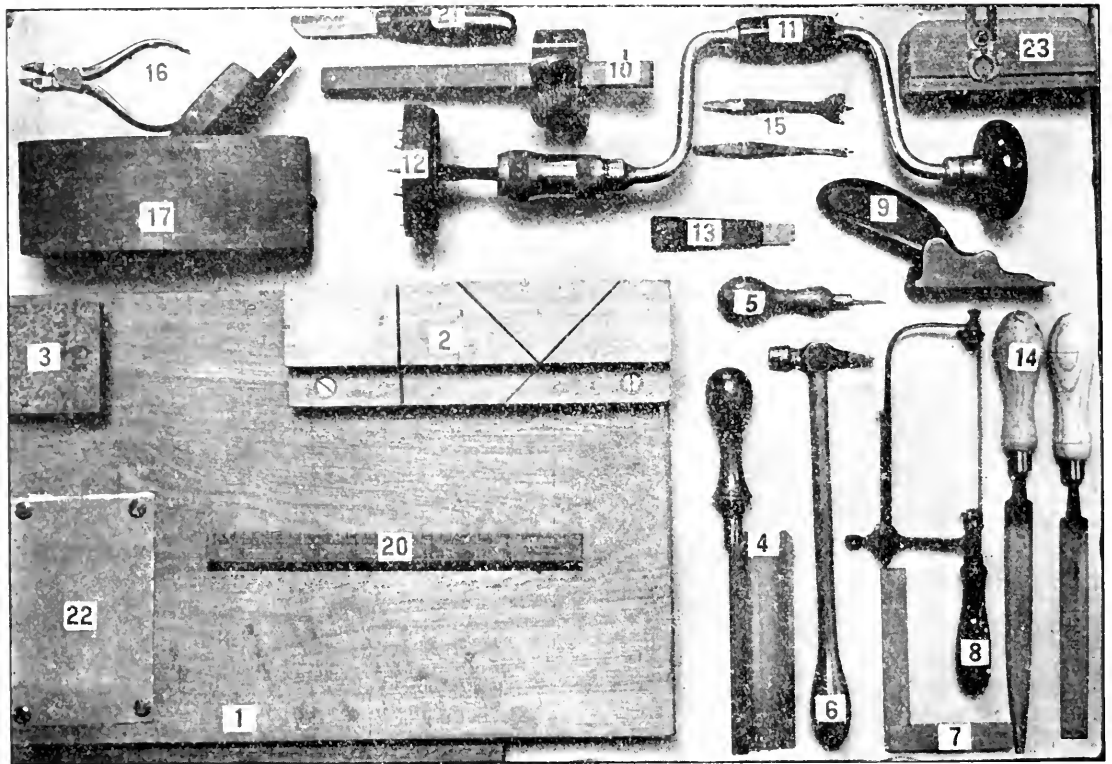

FIGS. 1 TO 23. TOOL EQUIPMENT.

The Equipment. —Tools and Materials.

The ordinary school desk or a table is suitable for the bench accommodation; although a specially fitted up room, to be used exclusively for the various forms of educational handicrafts in schools or institutions whereat the number of classes is sufficient to engage the whole time service of a special teacher, offers many advantages not possible otherwise.

In all cases the minimum equipment of apparatus and tools for each child should be as follows:

- 1 work board and sawing block, "patented" (Figs. 1 and 2).
- 1 small back saw (Fig. 4).
- 1 small bradawl or pricker (Fig. 5).

- 1 small hammer (*Fig. 6*).
- 1 4-inch try square (wood or steel) (*Fig. 7*).
- 1 Unit rule, registered (*Fig. 20*).
- 1 sheet of No. M2 glasspaper (*Fig. 22*).
- 1 clinching block (*Fig. 3*).

For every four or six children in class :

- 1 registered grooving plane (*Fig. 23*).
- 2 small single iron smoothing planes (*Fig. 9*).
- 1 marking-cutting gauge (*Fig. 10*).
- 1 registered chamfer knife (*Fig. 21*).
- 2 cutting and bending round-nose pliers (*Fig. 16*).
- 1 6-inch cabinet half-round rasp, handled (*Fig. 14*).
- 1 6-inch cabinet flat second cut file (*Fig. 14a*).
- 1 pair pencil compasses.

For every ten or fifteen children and teacher's use :

- 1 beech wood double iron smoothing plane (*Fig. 17*).
- 1 American pattern brace (*Fig. 11*).
- 2 centre bits, 1 inch and $\frac{1}{4}$ inch (*Fig. 15*).
- 1 No. 3 "Warrington" hammer.
- 1 3-inch jaw parallel vice (optional).
- 1 10-inch tenon saw.
- 1 Washita oil stone, in case.
- 2 scratch reeders or bead formers (*Fig. 13*).
- 1 wheel rim and disc cutter (*Fig. 12*).
- 1 small adjustable bow or fret saw (*Fig. 8*).
- 2 cork rubber pads.
- 1 glue kettle and heating stove.

The ordinary school drawing equipment should be augmented by the addition per child in class of

- 1 small drawing board, 12" \times 8".
- 1 small Tee square, 12" blade.
- 1 pair set squares, 60° \times 45°.
- 1 H pencil.

Cartridge paper, 11" by 7", or an Althorp Handicraft Drawing Book should be used for the drawing lesson, rough sketches, and notes.

The material suggested for use is clean sawn strips of best Canary whitewood, Swiss pine, Archangel spruce, Bay wood, Canadian maple, or English lime. These may be obtained from any timber merchant, at a very nominal cost, in suitable lengths of 2 feet, and cut to any fixed dimensions.

The nails used are technically known as *panel pins*, and are obtainable, in large or small quantities of the several lengths required, from any first-class ironmonger or hardware merchant.

The actual cost of equipment will vary considerably in districts. The following will serve as a guide :

For every child in class = Eight shillings and sixpence.

For every six children = Four shillings.

For every ten or more = Twenty-five to thirty shillings.

The additional apparatus for the drawing class work should not exceed two shillings and sixpence per child.

DESCRIPTION OF AND NOTES OF LESSONS ON:
THE EQUIPMENT, APPARATUS, AND TOOLS.

The Work Board and Sawing Block (*Figs. 1, 2, and 2A*).

The work board or bench top is made of beech or birch wood, 18"×12"×1", surfaced true. It is provided with a strip wood vice actuated with two thumb screws, on the front edge, which is increased in thickness by a square stop strip securely fitted to the underside of the board.

At the right hand top corner of the work board is fitted the sawing block or saw guide, secured from the underside with screws. The open space in the block gives facility to saw at any angle through 90°; the two sides of the opening being at right angles to each other, serve as guides for mitre and bevel cutting. To the left of the open guide is the square cut kerf or guide, which provides a ready means for teaching square line sawing. The surface of the step upon which the work in hand is placed should be protected with a waste strip of wood to prevent it being cut when the saw teeth have passed through the fibres. If nailed on with 3/4-inch panel pins at each end and near the centre, *but always clear of the track of the saw*, it can be readily removed or renewed when necessary. By its use the "life" of the sawing block is much prolonged. A strip of brass fitted on the vertical face of the block, provided with the necessary slit openings for the saw blade to pass freely through, adds to its value and efficiency. At the top left hand corner a hole is cut to receive the under tongue of the cast-iron clinching block. A square piece of leather or thick felt, fitted over the tongue, before the block is placed in the work board, serves to deaden the noise of the hammering. The underside of the work board itself may be covered—glued on—with rough felt or cloth to prevent any injury being done to the polished surface of the desk or table upon which the work is being executed. It also has the advantage of preventing the work board from slipping about during use. The tool box cover provides effective protection for the set of tools used, and a storage place for the elements of the models in progress.

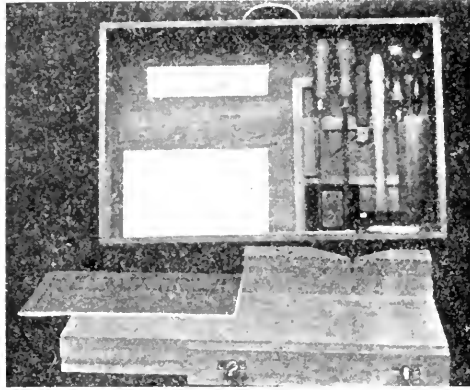

FIG. 24. THE WORK BOARD AND TOOL CASE.

Notes of Lesson on the Work Board.

Apparatus: All details of a Complete Board.

MATTER.

METHOD.

- | | |
|--|--|
| <p>1. Its name and parts:—</p> <p>(a) Trued surface.</p> <p>(b) Strip vice.</p> <p>(c) Sawing block: use of.</p> <p>(d) Clinching „ „ „ „</p> <p>2. Name of material used for each detail.</p> <p>3. Method of fixing sawing block to prevent injury to tools. Felt pads to prevent noise or damage and to give additional grip.</p> | <p>1. Teacher to show details and eluce names. Write the correct terms on black board. “What kind of surface is this?” Try to get the word <i>true</i> from the children. Value of truth. “What is the surface used for?”</p> <p>2. Ask for names of materials used in construction, reasons why, especially the cast iron. Compare all details.</p> <p>3. “Why is not all the woodwork made in one piece?” Explain difficulties. “Why are screws used to fix block on? Why put in from below? Why should a pad be necessary?”</p> |
|--|--|

Give full demonstration of the use of each saw cut, square, mitre, oblique to right and left, and also of the advantage of the wood shield to prevent saw teeth from cutting into the trued surface. Impress upon children the great amount of care required to produce good work.

The Unit Rule (*Fig. 20*).

The Unit of 8 forms the basis upon which the scheme of measurement introduced in this course of simple Handicraft is founded. It at once provides (a) an easy means of teaching the divisions of the English system of measurement, (b) a ready and effective method for the production of scale drawing, and (c) a very

Reduction of dimensions can be as readily performed. Suppose $8\frac{7}{8}$ " drawing is to be reduced, say, to half full size. Then the $71\bullet$ becomes $35\bullet$, or 71 half-units, or 35 units plus one half-unit, and so on. Thus the simple multiplication or division of the Unit measurement number at once places scale drawing on a level with the most simple full-size method, and enables the teacher to early apply the principles of arithmetic to constructional calculations.

By the Unit system, any diagram not dimensioned can be readily measured up and marked, with the assurance that the measurements made will bear a certain (but unknown) proportion to the original drawing from which the diagram was produced. This will prove of great value to those teachers who desire to introduce new models to their classes from photographs and text-book blocks.

To enable the teacher to rapidly reproduce any of the drawings in this scheme of work, it is suggested that the black board rule used should be marked on each edge identically the same as the rule used by the children, except that the "unit" should measure half-inch, or, in other words, the markings should be four times larger than the Unit standard. This will ensure the drawing being a true enlarged copy of the diagram supplied, or of the model used as a pattern or copy, and miscalculations will also be avoided.

Notes for Lesson on Measurement by Unit.

Apparatus: (1) Some 1" cubes (Gift 3).
 (2) Strips of paper and wood.
 (3) A rule for each child.

MATTER.

1. The standard measure of length, breadth, and thickness.
2. The divisions into inches and fractions of an inch. The Unit.
3. Various dimensions or numbers required to denote the extent of length, breadth, or thickness.

METHOD.

1. Teacher to sketch an oblong on the black board to represent a strip of wood like a rule.
2. "Does that look like your rule?" "No." "What is wanted?" "Some marks across." "Yes." "How many?" "Several."
3. "What do the long marks across the full width of your rule tell you?"

- | | |
|--|--|
| 4. Produce 1" rule. | 4. Teacher to place 8 one-inch cubes together to form one line, and show that the division lines formed by each cube are like those on the rule. |
| 5. The Unit numerical system of marking the extent of length, etc. | 5. "How are these long marks numbered? How many show in 6 inches—4 inches? Can the space between these long lines be divided? Into what?" "Halves." "Yes. Let us do so on the top edge. How many halves have we got now?" "8, 12, 16." "Yes." "What marks have you got on the other side of your rule?" "Several." On another oblong educe the further divisions of one-quarter and one-eighth, and let each scholar attempt to make a simple one-inch rule on the cardboard, paper, or wood strips. |

Class drill in measurements will be found of great service to teach quick perception of markings and to break the monotony of a theory lesson. Thus: "Attention. Rules up (right hand, with tip of thumb free to slide, on lower edge). Show $3'' = 24'$. Arms out. Rules away. Attention."

The Try Square (*Fig. 7*).

The name of this tool implies its use, *i.e.*, the trying or testing whether anything is *square*—the angle containing 90° —or accurate in construction; it is also useful for many other purposes.

Essentially it consists of two parts: (*a*) the *Stock*, (*b*) the *Blade*. The former is generally made of ebony or rosewood, faced on the upper edge with a strip of brass, into which is fitted accurately the thin parallel piece of steel plate called the *blade*. Two or more rivets are passed through stock and blade to securely hold the blade in position.

The object of the brass strip fitted on the upper edge of the stock is to retain an accurate angle of 90° between blade and stock, longer than would be possible if wood alone were used.

For some special purposes, however, both these elements are made of wood; this form is advised for Froebelian woodwork, as being efficient, effective, and cheap.

In whatever material this tool is made, the accuracy of the angle formed between the stock and the blade is *the* essential feature of construction, and periodical tests with readjustment when necessary must be made, if accuracy in the construction of a model is desired.

Test for accuracy: Hold the stock in the right hand (as for testing), place it close up to the front edge of the work board, the blade being flat on the trued surface; then with a very fine pencil point or scribe draw a line close up to and along the inner edge of the blade.

Now reverse the square, *i.e.*, turn the stock and blade over to the left, and bring the reversed blade up to the marked line; if the edge of the blade coincides exactly with the original line, the test declares the square accurate; if not, the inaccuracy is at once apparent by the non-parallelism of the blade edge and the line, the amount of error being equal to half of the greatest distance between the two lines which represent the edge of the blade in reversed positions.

The outer edge of the blade is tested in the same way; or if the inner edge is accurate the outer may be made exactly parallel with it.

Notes of Lesson on a Try Square.

Apparatus: (1) A 6-inch Try square for the teacher.

(2) A small wood ditto for each child.

MATTER.

1. Parts of squares.
 - (a) The stock.
 - (b) The blade.
 - (c) How united?
2. Value of brass strip as fitted on stock.
3. Uses of a try square.
4. Useless as a testing tool if inaccurate.

METHOD.

1. Educe the names of the materials used for both types of the square. Write down the technical names of the parts and commit to memory. Explain how the blade is secured in the stock.
2. Explain the use of the brass face strip, and why this metal is used instead of steel or iron.
3. Demonstrate fully the use of the tool for
 - (a) Testing.
 - (b) Setting out work.
4. Explain the technical term *square*.

Give testing drill at close of lesson.

Try Square. Position Drill.

“Attention:” Each child to stand in front of the work board, heels together, hands by side.

“Square testing drill. Ready.”

Place try square and work in progress in position on work board.

“Position by numbers:”

1. Take up the square in right hand; work in progress or model in left hand.
2. Place stock of square to the edge of any horizontal upper strip on model, and slide it along until the edge of blade and a cross strip or vertical piece are near together.
3. Hold up to the light and *sight* test for accuracy of angle formed by the cross strip or piece.
4. Reverse positions of both tool and work, and re-test.
5. Replace tool and work and spring sharp back to position of attention for

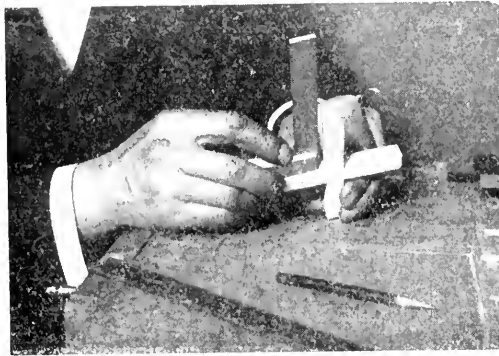

FIG. 25. TESTING ANGLE WITH TRY SQUARE.

“Marking out drill. Ready.”

Place try square and a length of spare strip wood on work board.

“Position by numbers:”

1. Place and hold stock of square against edge of strip wood.
2. Take up Unit rule, place end close up to edge of square blade.
3. Set off dimensions of length, 10", 16", 24", marking each by a pencil dot on the strip.

4. Re-test for accuracy and mark lines across face.
5. Replace try square and strip (as for "ready") and return smartly back to attention.



FIG. 26. MARKING OUT—MEASUREMENT OF LENGTH.

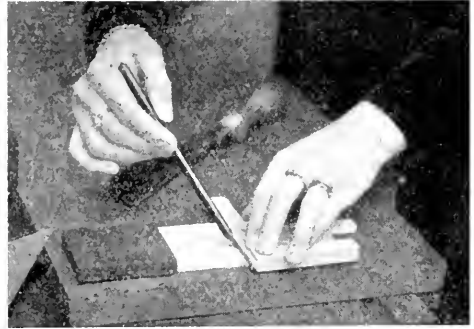

FIG. 26A. MARKING OUT SEVERAL STRIPS TO EQUAL LENGTH.

The Back Saw (*Fig. 4*).

This tool is sometimes called a tenon saw, and is designed and used for cutting with and across the grain any small details of wood-work construction. The blade is made of thin steel, which is stiffened, or held rigid, by means of a strip of brass, soft iron, or steel, folded over the top edge, thus forming the "Back"; the lower edge is provided with a number of triangular teeth from 10 to 20 per inch according to the type or size of blade. The handle in the larger sizes is secured to the blade by means of screw rivets which pass through the blade and handle. In the smaller sizes (*Fig. 4*) the handle is driven on to a tang, formed on the stiffening strip or back. To enable the saw to work with ease, the teeth are "set," *i.e.*, each tooth is slightly bent over to alternate sides, the effect being the production of a "kerf" or cut wider than the thickness of the saw blade.

When using the saw, it must be remembered that each little tooth is a tool doing its own share of work, and that as a number of these are in contact with the wood fibres at one time, it is imperative that only a very slight downward pressure be applied when moving the saw blade across the wood.

Heavy pressure will result in the teeth being forced into the wood to such an extent that excessive force would have to be applied to drive the saw forward, to remove the portions of wood—sawdust—in front of each tooth; such force would tend to buckle or distort the saw blade, rendering it useless for accurate work afterwards.

Some practice will be necessary to secure the correct handling and movement of this tool. Special care should be exercised in placing the saw in position when commencing the cut. The square sawing cut or guide of the sawing block, fitted on the work board, will aid the children to secure a fair amount of accuracy quickly, but independent sawing to a line should be attempted by all.

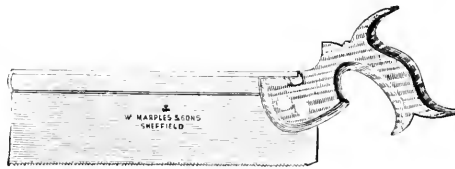

FIG. 4A. TENON OR BACK SAW.

Notes for a Lesson on the Saw.

- Apparatus:* (1) A pin.
 (2) A tenon saw and a small back saw.
 (3) A piece of strip tin with serrated edge.

MATTER.

- The component parts:
 - Forms of handles.
 - Material of ditto—wood.
 - Blade—steel.
 - Back strip—brass or iron.
 - Form of teeth—60° triangle.

METHOD.

- Show the two saws. “What are the names of these tools? What can they be used for? How many parts have each?” “Three.” “What are they? Are they exactly alike in each case?”
- Explain how the handles are fitted to the blades, and educe the reason why wood is used for the handle and steel for the blade, and why a back strip is necessary.

3. The abrasive cutting action of the teeth.
4. Freedom in use.
5. The material removed.
6. The space left—"kerf."
3. Demonstrate, on a piece of soap or other similar substance, the cutting action of the saw tooth
 - (a) With a pin.
 - (b) With a piece of serrated metal strip.
 "By what action is the work done?"
4. Show the bad effects of heavy downward pressure when sawing. Educe the correct method to produce good work.
5. "What is the material called which is removed by the cutting action of the saw?"
6. Show how the cut or kerf made is wider than the thickness of the saw blade. Sketch the end view of the tenon saw, with the teeth "set." "What is the proper name of the saw cut made?"

Give saw drill at end of lesson.



FIG. 4C. PAD-SAW BLADE.



FIG. 4B. PAD-SAW HANDLE.

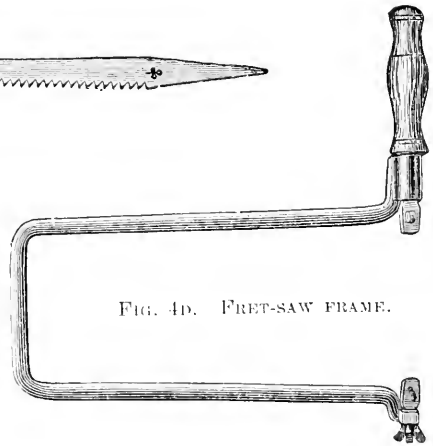

FIG. 4D. FRET-SAW FRAME.

Sawing Position Drill.

- "Attention:" Each child to stand in front of the work board, heels together, hands by side.
- "Saw drill. Ready."
- All await further command.
- "Position by numbers:"
1. Step back half pace with right foot, and stand firm and free.
 2. Outstretch left arm, bending forward from the hips until the left hand can easily grasp the sawing block fixed on work board.

- From its normal place in front of sawing block take up the saw in right hand (holding the handle firmly in palm of hand with the forefinger extended along the back edge), and make to and fro movements with right arm swinging from the shoulder in a direct line, keeping the saw blade level, upright, and parallel with the work board, and to the right of the sawing block. The thumb of the left hand should project slightly beyond the block, to act as a guide.

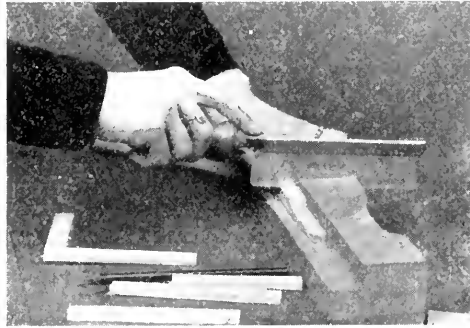

FIG. 27. SQUARE SAWING—ACROSS THE FIBRES.



FIG. 28. OBLIQUE SAWING—ACROSS THE FIBRES.



FIG. 28A. OBLIQUE SAWING ON SAWING OR BENCH HOOK.

- Make similar movements with the saw blade in the guide cut; also to the right and left, in or over the angular space, always standing so as to give the necessary free and parallel movement of the arm from the shoulder, and to use the thumb of the left hand as the guide.
- Return the saw to its normal position, and spring sharp back to attention.

For ambidexter training, the movements given above must be reversed, *i.e.*, for *right*, read *left* in each instance.

To be efficient, the drill movements must be correct in every detail.

Smoothing Planes (Figs. 9 and 17).

These tools, although dissimilar in outline, form, and material, are used for similar purposes, *viz.*, the smoothing up of the woolly fine-sawn surface of the prepared wood by the removal, with the fixed blades or cutting irons, of shavings of a certain thickness.

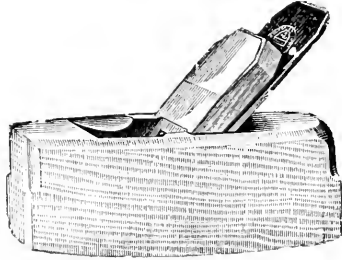

FIG. 17A. SMOOTHING PLANE.

The ordinary beech wood form has a double iron, *i.e.*, the *cutting* or *plane iron* is furnished with a cap or cover iron to assist in breaking the shaving as it leaves the surface of the wood. This cap iron is adjustable by means of a set screw, and adds materially to the efficient cutting action of the plane as *the* tool for the production of a uniform or plane surface.

The edge of the plane iron projects very slightly beyond the bottom or sole of the stock or body. As a general rule the plane iron is held in position by a wedge, the exceptions being in the higher class iron planes which are furnished with a screw adjustment. It must be noted that the double iron of the ordinary plane is placed with the straight steel face (upon which the cap iron rests) uppermost in the plane stock, whilst that of the single-iron pattern is placed downwards; also that the angle of the *pitch-bed*—that part of the stock upon which the cutter is placed in the two patterns—is altered.

The cutting action of each tool is the same, and each cutter is ground and sharpened in the same way, *i.e.*, ground to an angle of 25° , the honed facet angle adding 10° more.

To *set* the plane :—Hold the stock in left hand ; insert cutting iron in *throat* (sometimes called the socket) ; hold it firmly with left thumb ; then insert wedge, pressing it well in ; turn the sole or face upwards and “sight” down it ; notice if sharp edge of cutting iron projects through the *mouth* (the narrow opening across sole or face) ; if it does not, lightly tap its upper end until a dark line appears across the sole or face ; then by tapping the wedge, fix the iron securely in this, its correct cutting position. Should the edge project too far through the mouth, it can be readily withdrawn by striking a smart blow on the *heel* or back end of the stock, the effect being “to jar” back the wedge and thus release the holding power. *Never try to drive the plane iron back by hitting its cutting edge.*

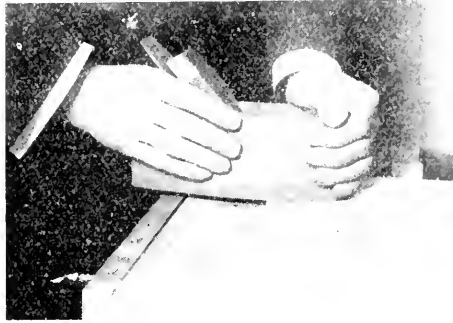

FIG. 29. USING THE SMOOTHING PLANE

For effective use the plane (either pattern) must be held firmly with both hands, the sole or face being flat on the surface of the work, along which it must be pushed gently but firmly forward, with an equal force throughout the stroke.

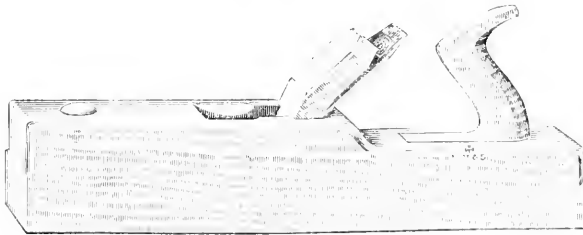

FIG. 18. SMALL JACK PLANE

Many other forms of planes are used by woodworkers, but all are

the same in principle, being adjusted for use by either the screw, lever, or wedge methods.

Notes of a Lesson on Planes.

*Apparatus: (1) Smoothing planes, two patterns, single and double irons.
(2) Chart-Section of a plane.*

MATTER.

METHOD.

- | | |
|--|---|
| <p>1. Names of parts, compare:</p> <p>(a) Stock or body.</p> <p>(b) Plane iron or cutter, cutting iron or blade, double iron with cap or cover iron—single iron.</p> <p>(c) Wedge.</p> <p>(d) Comparison of material, form, etc.</p> | <p>1. Exhibit either or both planes. Name this tool. "What is this part called? What this? And this? How many chief parts?" "Three." Compare patterns, asking for any special point of difference noticed by the children. Material, size, outline.</p> |
| <p>2. Names of sub-parts or elements of</p> <p>(a) Stock or body, mouth, throat and escapement, sole, heel, toat or handle.</p> <p>(b) Irons: Cutting iron, adjusting cap screw, cap iron.</p> | <p>2. "Have these parts any other names? Well, has the stock of this plane any part about it that ought to have a particular name? What would you call this narrow opening?" Educe the word <i>mouth</i>. Show how the shaving entering the mouth will pass into the stock or body. Educe the word <i>throat</i>. Give the word <i>escapement</i> as a technical term.</p> <p>"Where would you expect to find the <i>sole</i> of anything? Yes. Then where would the <i>heel</i> be? What do we call the handle?" Show the elements of the double iron, and write all terms on black board.</p> |
| <p>3. Materials used for:</p> <p>(a) Stock—beech wood.</p> <p>(b) Cutting iron—soft iron faced with cast steel.</p> <p>(c) Cap iron—soft steel.</p> <p>(d) Wedge—beech wood,</p> | <p>3. "Can anyone tell me the name of this wood?—and this metal? Why should steel be required to make the cutter? Would not lead do? Why? What is this curved iron for? How is it to be fixed to the cutter?" Explain the use of the cap iron and the wedge. Recapitulate by B.B. summary and questions.</p> |

4. Uses.

For producing uniform plane surfaces and also plain cylindrical surfaces — rollers — broom sticks—drill wands.

NOTE. — An enlarged cross-section diagram of both patterns, showing the irons in position, with the several elements and sub-names distinctly marked by reference letters, should be prepared for this lesson, and be always *en evidence* when demonstrating the correct method of holding and using the plane.

Planing position drill should be demonstrated at the close of this lesson.

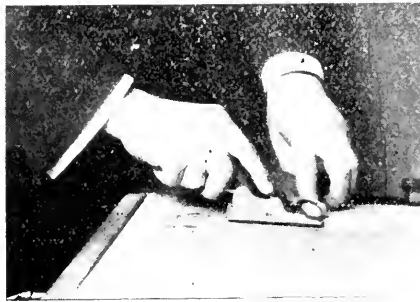

FIG. 30. USING SMALL IRON PLANE.

Smooth Planing. Position Drill for small Iron Plane.

“Attention:” Children to stand in front of the work board, heels together, hands by sides.

“ Planing drill. Ready.”

Place small plane on work board, then make half turn to the left and stand firm.

“ Position by numbers:”

1. Take hold of plane with right hand (the spherical head of the wedge to be in the hollow palm of the hand, thumb on left side, and fingers on right of stock).
2. Lift plane up and place the tip of left hand index finger in the hollow boss near front end of stock.
3. Step smartly forward with left foot, slightly bending the left knee, whilst bringing the plane lightly to rest on the work board or on a piece of wood strip.
4. Return plane to its normal place (the left of the sawing block), freeing the left hand only.
5. Release hold of plane and return smartly back to attention, making the movement distinct from half left turn to front.

Should the whole class not be provided with small planes, the drill movements should be made by the teacher, then by one or more of the children, the remainder copying the physical movements by mimicry. Some dummy forms of the plane stock will be found of great advantage in securing the correct handling and movements.

The photo-plate, or a large diagram made from it, showing the method of holding the beech-wood pattern, as distinct from the iron pattern, should be exhibited to the class.

The Bradawl or Pricker (*Fig. 5*).

This primitive boring tool is of value to a fixed extent only; in action it cuts and crushes the fibres of wood into which it is forced, but does not remove any material. It consists essentially of a tang-shouldered prong of steel fitted into a turned or rounded handle. It is useful for boring small holes to ensure the correct direction of a nail when being driven in, to prevent it bending, and to avoid possible splitting of the wood fibres.

The chisel-shaped cutting edge must always be inserted square across the fibres, *i.e.*, at right angles to the direction of the grain of the wood in which the hole is to be made. When joint nailing is being done, the diameter of the prong should be smaller than the nail to be used.

The *Pricker* differs from the Bradawl in having a fine needle point instead of the chisel edge; it is much smaller in diameter, and of no value for boring deep holes. It is useful for marking the outline of curves in the advanced *slab work*, and for making slight holes or indents to receive the points of the small panel pins used in the simple over-nailing exercises and models.



FIG. 5A. BRADAWL.

Notes of Lessons on Bradawl and Pricker.

Apparatus: Separate parts of each tool.

MATTER.

1. Parts of tools:
 - (a) Tang-shouldered prong.
 - (b) Turned handle—various shapes.
 - (c) Ferrule or ring to prevent handle splitting.
 - (d) Chisel shaped end to cut fibres.
 - (e) Needle point to pierce and crush fibres.
2. Tang of bradawl is parallel sided, but tapered on edge:
 - (a) To provide secure hold in handle.
 - (b) To aid removal when broken.

Shoulder — To prevent prong being driven into handle by the pressure used when making the hole.

METHOD.

1. Educe common names of each part. Write technical terms on black board and commit to memory. “How is the handle made?” Explain briefly the turning lathe, and how it is used.

“Why is it necessary to put a ring on the handle?” Explain.

Educe how the chisel cutting edge is made, its shape, and why the pricker is not capable of boring deep holes.

2. Educe why the tang is made parallel on sides and tapering on edge. Explain why a parallel tang holds better than a fully tapered one.

Educe why the shoulder is necessary; show its outline by an enlarged black board sketch.

Prong — Chisel edged, ground equal on each side to cut the fibres; note needle point of pricker.

Demonstrate the correct methods of holding, inserting, and using

(a) The bradawl.

(b) The pricker.

3. Uses of each tool.

3. Demonstrate why the diameter of the prong of the bradawl should be less than the nail-used.



FIG. 31. USING BRADAWL.

The Hammer (*Fig. 6*).

There are several forms of this tool designed for specific purposes, but all are alike in the chief essentials.

The head, usually made of cast steel, is furnished with an oval-shaped hole, called the *eye*, into which is securely fixed, by means of a wedge, the shaft or handle. One end of the head is cylindrical, having a slightly convex end *face*, the other terminating generally in a wedge-shaped *pane* or *pean*. Straight-grained wood of the ash tree is used for the *handle* or *shaft* because it gives the requisite strength and lightness, combined with the essential elasticity and durability.

As the simplest form of all percussion tools, the hammer provides a most efficient and effective means for training the hand to precision and delicacy of movement and touch, and upon the dexterous use of it will depend, almost exclusively, the excellence of the work done by the students of Froebelian woodwork.

The handle should be grasped lightly but firmly near the end of the shaft with the forefinger extended along the top, in order to ensure full command of the tool and effectiveness of the blow struck, heavy or delicate. Do not under any circumstances attempt to drive home with one blow, even the shortest nail used.



FIG. 6A. EXETER HAMMER HEAD

Notes of Lesson on Hammers.

- Apparatus :* (1) Large and small hammer heads.
 (2) A finished shaft.
 (3) Rough piece of ash wood.

MATTER.

1. Parts of hammer :
 - (a) *Head* of steel—ordinary and special forms.
 - (b) *Eye* of oval and double tapered form to prevent turning and sudden release.
 - (c) *Face*—slightly convex.
 - (d) *Pean*—generally of a long taper form, but also made spherical for special purposes.

METHOD.

1. Show specimens. Educe the names of the parts and write each on black board.

Sketch the section through *eye*, and educe how the enlarged space above the centre line can be filled up.

Explain that when filled up the section resembles a dovetail both on the long and short axis of the oval hole.

Explain why the *face* is made convex—to prevent damage to material.

Explain the use of the tapered *pean*, and also of the spherical form for rivetting and expanding metal.

2. Handle of ash wood:
 - (a) Durable, light, strong, elastic.
 - (b) Form of handle, reduced in diameter near head.
 3. Head secured by a wood wedge, dovetail formed, thus giving security readily and simply.
2. Show how the shaft should be held (a) for light work, (b) for heavy work.

Educe why the forefinger is extended in one case and not in the other.

Educe why ash wood is used for the shaft.

Explain *elasticity*.
 3. Explain briefly the mechanism of the wedge.

Give hammer drill at end of lesson.

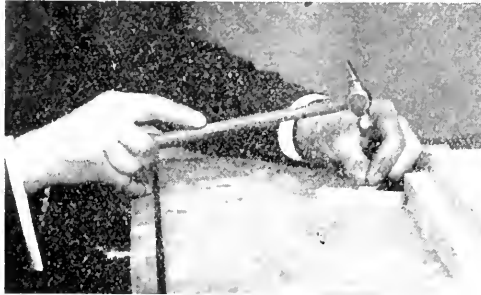

FIG. 32. USING HAMMER POSITION 1

Hammer Drill Positions.

“Attention:” Each child to stand in front of the work board, heels together, hands by side.

“Hammer drill. Ready.”

Place a waste piece of wood on work board near the centre, and return smartly to attention.

“Position by numbers:”

1. Pick up hammer with right hand, extend the index finger along shaft, bring wrist down to rest on the front edge of the work board, holding the hammer head elevated at about an angle of 15° with the work board surface.
2. Give several downward movements with wrist only, not allowing the hammer head to touch the surface (Elasticity of handle felt).
3. Place *face* of hammer on the waste piece of wood, raising forearm to form a straight line with the hammer shaft.

4. Give a series of light consecutive blows in class unison.
5. Return hammer to its normal place on work board and spring smartly to attention.

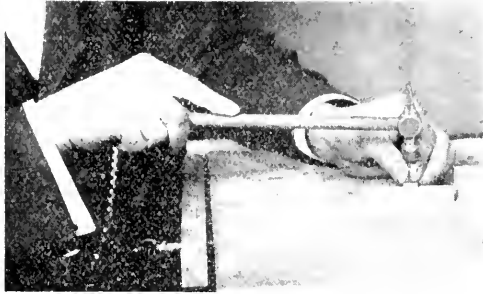

FIG. 33 USING HAMMER POSITION 3.

Beading Tool or Scratch (*Fig. 13*).

This is a simple form of tool admirably suited for our use, to break up the repetition of square angles and to add a slight ornament to several of the otherwise severely simple models.

It consists of a piece of fine cast steel blade, on the end and corners of which are formed hollow curves, of different diameters. The blade is encased in a handle, and securely fixed either by rivets which pass through both (as in the saw), or by a tang (as in a table knife).

When used it should be held vertical and with a downward and sideward (corner) pressure, firmly drawn or *scraped* along the angle, until the bead formed thereon by such action is fully developed. It is better to first remove the sharp corner or *arris* with a plane. The tool may be readily sharpened by rubbing (with heavy pressure) a piece of hardened steel wire inside and across the hollows, the object being to form a *wire edge*.

Demonstrate both construction and use before constructing Model 13.

The Cutting and Bending Pliers (*Fig. 16*).

Several forms of this tool are obtainable, the most useful is a combination pattern, which includes flat jaws, round nose, and cutter. The cutting edges will be useful for snipping off the ends of projecting

nails, the flat jaws for straightening bent ones, and the round-nose points for forming the small wire *eyes* which are used in many of the models as hinges and hooks. The inner surfaces of the flat (and sometimes the round) jaws are serrated like a file in order to obtain a more secure grip or hold on the wire during manipulation.

The little points formed by the cross serrations are called the teeth.

Notes for Lesson on Cutting and Bending Pliers.

Apparatus : Two or more pairs of pliers.

MATTER.	METHOD.
1. Names of parts : (a) Face. (b) Jaws. (c) Nose. (d) Teeth.	1. Sketch outline form on black board. Write the names against each part. "Do you know of any other thing that has these names? Are they exactly like these? Are your teeth made of steel?"
2. Uses of each part.	2. Explain fully the use of each part, and give demonstrations in nail-cutting, straightening, extracting, and in forming the eyelets and hooks.
3. Material made from.	3. Educe the name of material used in manufacture; explain why, and briefly give details of forging.

A definite position drill is not necessary for the use of this tool, because of the many different ways in which it may be required. Each child should, however, have individual instruction given as to how to manipulate the pliers most easily for each operation.

Cabinet Rasps and Files (*Figs. 14 and 14a*).

These common abrasive or rasping tools provide a ready means for reducing the edges of the wide surface material used in the more advanced models, especially those whose outline contains curved lines, convex or concave.

The cutting action is similar to the saw, the *teeth* of the rasp being triangular projections of solid steel, forced or raised up on the surface of the *blank* by means of a small triangular pointed chisel; those of the file by an ordinary flat chisel, which raises a number of ridges equidistant across and oblique to the length of the file; in

each case the cutting edges incline to the front end of the blank. When single ridges are cut, the file is called a *single-cut*, as distinct from *double-cut*, in which a second set of ridges are formed oblique to the first set, which break up the cutting edge of the first ridge into a number of triangular teeth, similar but much finer than those of the rasp.

The cross section form of the blank defines the proper name of each file, as triangular, half round, square, flat, fish back, round, etc.

The file blanks are made of cast steel, forged and thoroughly softened or annealed; they are then ground smooth, hand cut, according to grade of fineness required, and afterwards re-heated and finely tempered in oil or some other semi-liquid preparation to produce the necessary degree of hardness to each cutting edge. The *tang* or taper point upon which the handle is afterwards fitted is not hardened.

Medium cut files are most suitable for wood workers, and in length vary from 6 in. to 12 in., the blanks of all forms selected being tapered on all sides from tang end to point. When the teeth become clogged with the fibres of wood abraded, the cutting action is impaired; this may be readily re-established by scouring the file with strong and hot soda water and stiff brush, thoroughly drying before a fire, to remove all moisture.



FIG. 34. USING THE RASP FOR FORMING CURVES.

A very delicate hand training can be given by the use of the file, especially when hard wood is used on which to produce rounded or curved surfaces and outlines, and especially is this recognised when the work is not fixed.

Notes of Lesson on Files and Rasps.

Apparatus: (1) *Rasps*—Files of two or more forms.
 (2) *Saw*—Model of saw teeth.
 (3) *Enlarged sketch of file ridges.*

MATTER.

METHOD.

- | | |
|---|---|
| <ol style="list-style-type: none"> 1. Names of parts :
 <i>(a)</i> Blank.
 <i>(b)</i> Teeth.
 <i>(c)</i> Tang. 2. How formed on each tool, special shape of teeth to make cutting action certain. 3. Cutting action compared with abrasive action. 4. Pressure necessary to make all teeth do work. 5. Manipulation. | <ol style="list-style-type: none"> 1. Exhibit the Saw. "What tool is this? What is it used for? What kind of edge has it? Why is it made so?" Compare the teeth, tang, and blank of each, saw, file, rasp. 2. Educe how the teeth of a saw are made. Exhibit model of saw teeth. Compare model with elevation sketch of file teeth. Give details of manufacture of files. Explain the terms <i>tempering</i> and <i>hardening</i>. 3. Demonstrate the action of the saw, afterwards the file, and compare the waste dust produced by each tool. 4. Recapitulate the lesson on the saw, by questions about the effect of heavy downward pressure. Show by demonstration that a file resembles a number of saws placed side by side, and that much more pressure is necessary when the material is of a hard nature—to do the same amount of work in the same time. 5. Demonstrate method of use for
 <i>(a)</i> Fixed work.
 <i>(b)</i> Loose work. |
|---|---|

Give position drill at end of lesson.

Rasping and Filing. Position Drill.

Apparatus: (1) *Each child to have a 6-in. rasp or file, or a wooden substitute shaped to form.*
 (2) *Piece of slab wood about 6 in. × 2 in. fixed in vice.*

"Attention:" Children to stand in front of work board, facing strip vice and sawing block, heels together, hands by side.

"Filing drill. Ready."

"Position by numbers (for fixed work):"

1. Take up file, holding handle firmly in right palm, forefinger outstretched

along the handle, hold it level with the top of the work board, elbow by side, but free to move from the shoulder.

2. Bring left hand round (with a swing), take hold lightly of extreme end of file with finger and thumb (whole hand rests on for heavy work).
3. Take half pace backwards with right foot, slightly bend left knee, and make several to and fro unison movements with arms moving from the shoulder (*the body must not move*).
4. Make similar movements diagonally across the fixed piece of wood, taking or using the full length of the file in traversing from end to end.
5. Place file on work board, release vice screw, place piece of wood by the side of the file, and return to attention for

“Position by numbers (for loose work):”

1. Take hold of file with right hand, index finger outstretched along the handle.
2. Take up piece of work in left hand, place it on ledge of sawing block, and hold it firmly in place by grasping the two together.
3. Same movement as for fixed work.
4. Same movement as for fixed work.
5. Place file and work in position on work board, and return smartly to attention.

Cutting and Marking Gauge (*Fig. 10*).

This important measuring tool, although so simple in construction, is one of the most difficult to use with efficiency, therefore it is not called into use in this scheme of work to the same extent as in the Higher Handicraft classes.

It will, however, materially assist later work, if, on its first introduction in a demonstration lesson given by the teacher, some information and instruction is given to the children on the essential parts of it, and upon the methods of using it.

In its most simple form it consists of four details or elements :

- | | | |
|--|---|---------------------|
| (a) <i>The head</i> | } | made of beech wood. |
| (b) <i>The stem</i> | | |
| (c) <i>The thumb or adjusting screw</i> —made of box wood. | | |
| (d) <i>The spur or cutter</i> —made of tempered steel. | | |

The *head*, into which is fitted the adjusting screw, being made to freely slide along the full length of the *stem*, near the end of which

is inserted the *spur* or *cutter*; any definite measurement can be set off between it and the spur point. The head is then held in such position by tightening the adjusting screw on the stem.

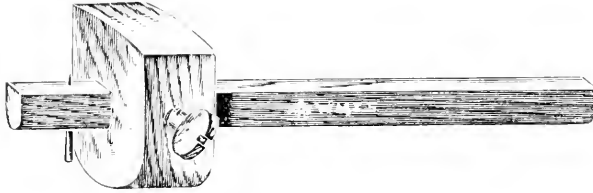

FIG. 10A. MARKING GAUGE.

Method of setting and adjusting the gauge :—

Take up the tool with left hand, holding the stem with spur *point upwards*, and with the *thumb screw outwards*.

Release the thumb screw by turning it towards the right—head of gauge should now be free to slide along the stem.

Take up Unit rule in right hand; place the first Unit end close to the face of block, with the Unit edge resting on the spur point; move the head along the stem until the required measurement appears between the face and the spur point; hold the head firmly in that position with pressure by the left thumb, then turn the thumb-screw to the left to tighten it to the stem. Bring the rule again to measuring position; retest the fixed distance, and adjust, if necessary. If the thumb-screw is not screwed up too tight, slight adjustments may be made by tapping the ends of the stem on the work board.

When the gauge is finally set it may be used in either hand, but the right hand, at least with young children, is advisable.

Method of holding and using the gauge (right hand) :

Take gauge up with right hand, spur point downwards, thumb screw outwards, thumb free on stem behind the spur, forefinger curved over head of gauge—finger tip should touch the thumb screw—remainder of fingers folded round the stem behind the head.

Hold the work to be gauged or cut in position (see *Fig. 35*); bring the face of gauge head close up to the right hand edge of the work, then, with a combined side and forward pressure, slide the tool along the work, taking care to prevent the head being forced away from the edge by reason of the spur

following the line of least resistance, *i.e.*, the soft portion of the annual ring or grain of the wood.

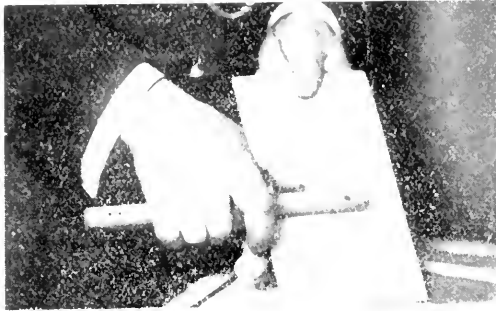

FIG. 35. USING MARKING-CUTTING GAUGE.

If a gauge is available for each child, a collective class drill in the several movements should be arranged, before individual attention is given to its use on the actual models.

Notes of a Lesson on the Cutting=Marking Gauge.

Apparatus : Two or more forms of Gauges.

MATTER.

METHOD.

- | | |
|---|---|
| <ol style="list-style-type: none"> 1. Names of parts : <ol style="list-style-type: none"> (a) Head or block. (b) Stem or spindle. (c) Spur or cutting point. (d) Thumb-screw. 2. Set of gauge. The measure of length between the face of the head and the exact point of the spur. | <ol style="list-style-type: none"> 1. Show cutting-marking gauge to class. Name, and write on black board the several parts, and also the names of the material used in construction. 2. "How shall we set the gauge? Why does this block move up and down the stem? Can we fix it to prevent it moving? How?" Educe the use of the thumb-screw. "How shall we be certain that the distance or measurement required will be correct?" "By testing again with rule." "Yes." "Why is it necessary to measure from the exact point of the spur?" "Because that is the part which will make the line or cut." "What do we call the fixing of the head to the stem in a certain position?" "Setting the gauge." "Yes." "Have you ever 'set' anything else?" Give instances or examples where the word is used correctly and incorrectly. |
|---|---|

3. Use of gauge. For making well-defined lines parallel to the edges of prepared material, and for cutting off parallel strips, by gauging lines on each side of thin material.

A combined side and forward pressure being necessary to keep the spur to its work.

3. "How shall this tool be held? What has to do the cutting or marking?" "Yes, the spur." "How shall we keep it from running away from a straight line?"—A good moral lesson on restraint and self-control may with advantage be included here.—"Yes, it must be carefully guided." Demonstrate the correct positions for effective use in marking and cutting respectively, and let several children individually repeat the movements.

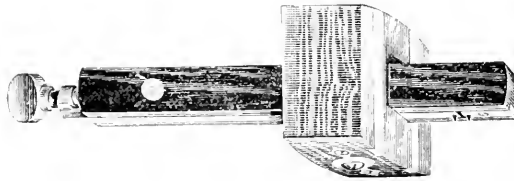

FIG. 36. DOUBLE POINT OR MORTISE GAUGE.

The Brace and Brace-bits (*Figs. 11 and 15*).

The purpose of the *brace* is to provide a support, and a lever power for actuating any one of the many forms of woodboring tools or *bits*. It consists of the *Head*, *Crank*, *Socket*, and *Jaws*. The head is a mushroom-shaped piece of rosewood attached to the neck of the crank spindle and made free to move upon a number of small steel balls, which form a roller-bearing to reduce friction and to give freedom of movement to the crank arms when in use.

The crank pin is provided with a *hand grip*—a piece of wood which encircles the pin—in which it also freely revolves. The bulb-like socket at the lower end of the spindle encloses and actuates the jaws, which in turn grip the square shank end of the brace-bit. The jaws are hinged at the top end and are usually provided with teeth, as seen in the diagram. A slot way is cut in the lower end of the spindle, forming a fork, into which the jaws fit easily to retain them in position. The socket is provided with a conical seat upon which

the tapered ends of the jaws rest; therefore when a turning movement is given to the brace, the resistance set up by the bit entering the wood tends to advance the socket on its thread, and thus cause the grip on the bit shank to be increased in proportion.

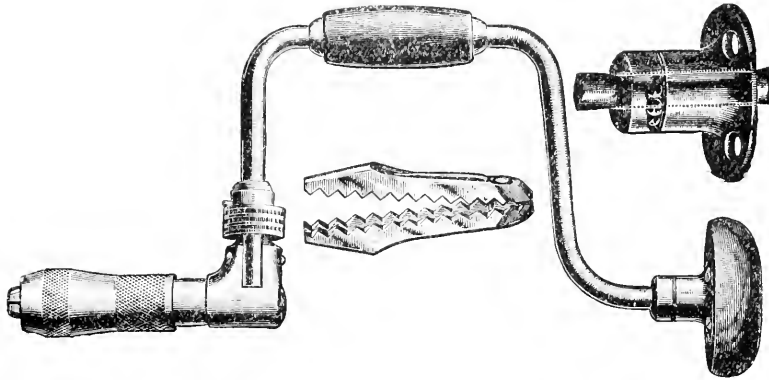

FIG. 11A DETAILS OF BRACE, SHOWING JAWS AND BALL BEARING HEAD.

When in use the brace must be held in a line coincident with the direction of the hole to be bored. The pressure required to keep the bit to its work is furnished, for vertical boring, by the forehead of



FIG. 37. USING BRACE AND DISC CUTTER.

the operator resting on the back of the hand in which the head of the brace is held, and for horizontal work, by the operator's body.

If the brace-bit is in good order, the pressure required will be very slight indeed. The right hand should be used only for turning the crank: it should not take any part in keeping the cutter or bit to its work.

Several forms of brace-bits are available for wood boring; the the most common being the centre-bit.

As its name implies, it acts with a centre pin as a guide or axis, about which the cutting action of the nicker and router-cutter takes place. One of the cutters takes the form of a vertical knife point, its duty being to incise or nick a circular groove at each revolution of the brace: the other is a chisel edge placed horizontal, its duty being to remove the material within the incised circle.

It therefore follows that these three elements of a brace-bit have each a definite function to perform in a particular sequence or order, *i.e.*, (1) the centre point fixes the exact position of the required hole; (2) the nicker fixes the exact diameter, and prepares a definite tract for (3) the cutter to come into action to remove the waste material enclosed within the circle, which—if the cutter is sharp and set in its correct position—should come away in a continuous spiral shaving.

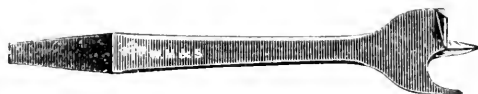

FIG. 15A. BRACE CENTRE-BIT.

To prevent the under surface of the wood being damaged by the sudden breaking through of the bit, it is wise to stop the boring action as soon as the centre pin emerges, then to reverse the wood; insert the bit in the small hole made by the pin; carefully revolve the brace to make the circular incision, which by cutting the fibres, effectually prevents any splitting when the cutter again comes into action. When the boring is done from both sides in this way, a small disc—thicker in the centre than at the edges—is left on the centre pin; this shows at once the *lead* of the cutter in forming the spiral shaving.

Notes of Lesson on the Brace and Brace-bits.

Apparatus : A brace in parts.

A gimlet.

Several forms of bits.

MATTER.

METHOD.

1. Names of parts :
 - (a) Head.
 - (b) Crank.
 - (c) Hand-grip.
 - (d) Socket.
 - (e) Jaws.
 2. Material used in construction. Wood, steel.
 3. Use of brace :
 - (a) Adaptability of jaws.
 - (b) Leverage of crank to give power and quick turning action to bits.
 - (c) Compare brace and bit with gimlet.
1. Educe the names of the several parts by comparison with other known tools. Write correct names on black board. "Why is this part called a crank? What is its use? Why is this part surrounded with wood?" Let children handle the brace, asking each to maintain silence. Select one or two to give reason, "What would most likely occur to your hand if the metal crank pin revolved in it for a long time?"

Educe the meaning of the word socket. "Of what value is it to this tool? Why is it formed like a pear or bulb?" "What are the jaws for?" "Yes, to bite." "Why are they joined together at the top end? Do they resemble any part of yourself?" Demonstrate the holding power, illustrating how it is effected.
 2. Educe the name of the material used in the manufacture, and give brief reasons why such are used.
 3. Show how the jaws are made to move freely, how formed to prevent turning in the socket, and give reason for the centre groove in each jaw, and the teeth. "What is a lever? What advantage can be gained by its use?" Illustrate see-saw. Show how and when a lever becomes a crank. Ask for examples. Cycle, sewing machine, and illustrate how a crank converts motion. Using the gimlet and brace to illustrate, show how difficult it would be to bore a large hole without lever power.

4. Centre bits :

- (a) Essential points of construction.
- (b) Spiral-cutting action.
- (c) How held and used.

Educe the common names of the parts of a bit. Compare other tools. Write down the terms, and make a large sketch of a centre bit on black board. Demonstrate the why and wherefore of the spiral cutting action of the chisel cutter and the use of the knife or nicker.

Educe how the bit could be held without a brace, and demonstrate the difficulty in keeping it vertical.

The Wheel Rim and Disc Cutter (*Fig. 12*).

The use of this tool is limited to cutting out from the solid, the wheel rims and discs required in the standard models of this course of work. It consists essentially of a disc of beech wood, into which is fitted a shank and centre pin, and any required number of spur points, which project from the under side of the disc to act as cutters.

These spurs may be made of $\frac{1}{8}$ " round steel wire driven tight through the disc, or from the shanks of No. 6 wood screws. The latter have an advantage over the steel wire spurs in that any one of them can be readily withdrawn to prevent it acting, and for re-adjustment or sharpening without damaging the disc. The cutting points of either form must be filed thin and tapering, and be placed directly circumferential with the centre pin, to allow of a free scraping-cutting action by each.

The shank is furnished with a tapered square end, by which the tool is held in position, and actuated by the brace (*Fig. 11*) when being used. *Fig. 37* shows how the operation is best performed, but a horizontal position of the brace may be adopted provided the wood to be cut is suitably held and supported.

If the cutter or spur points are kept in good order, the tool will be found fully efficient for the purpose for which it was designed.

The Grooving Plane (*Fig. 23*).

The stock or body of this tool is made of beech wood ; on one side is formed a rebate, and on the end a finger guide ; on the rebate side

is fitted an adjustable cutter or *router*, the two cutting edges of which are arranged to enable the plane to be drawn towards the operator when in use. Being designed specially to meet the requirements of Froebelian Woodwork Models where grooves of a fixed depth are wanted, its use is limited to the width of the cutters and depth of the rebate. It will cut equally well both with or across the grain; the *leading cutter*, consisting of two spurs formed by the V groove, acts in a similar way to a cutting gauge, making two lines or cuts, parallel with the edge of the wood upon which the groove is required, the material between these lines being simultaneously removed by the *follower cutter*. It is a tool which does not readily get out of order, but the cutters require sharpening, when dull, either by dead smooth filing or slip honing.

Piercing or Adjustable Frame Bow Saw (Figs. 8 and 38).

This form of bow saw has been selected as being the most suitable for children's use; because it admits of easy adjustment and provides ready facilities for using short pieces of broken saw blades; its construction is simple, and it cannot get out of order if used with ordinary care; it is light, and easy of manipulation. Its chief disadvantage is the short depth or distance between the saw blade and the sliding frame back, but the curves upon which it will be used in making the standard models can be easily cut by it. The saw blade

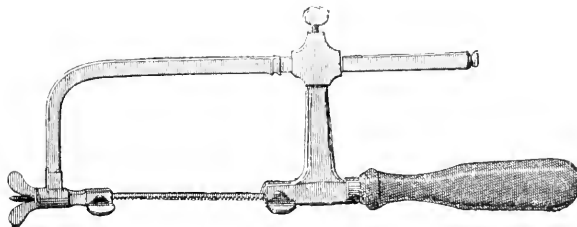

FIG. 38. PIERCING SAW.

used is a narrow ribbon of fine steel, having on one edge about 18 teeth per inch; it is tapered in width section, *i.e.*, the plain edge is thinner than that upon which the teeth are formed—to admit of free movement when cutting round curves of small radius. It is held in

position by thumb-screws at each end of the frame. When fixing the blade in the frame, first place one end of it—cutting faces of teeth being forward, like those of the small tenon saw—between the clamps near the handle; next adjust the sliding back, until the free end of the blade just enters the front clamp or head, and tighten the back set screw to fix it securely in position: then, with careful pressure, shorten the distance between the two clamps, allowing the free end of the blade to slide forward until at least one-half inch of it is within the clamp; then, still maintaining the pressure on the head, turn the thumb-screw, and tighten the clamp to the blade to firmly grip it in this, its working position.

If correctly fitted, the blade should feel rigid when the pressure is released. When the saw is to be used for removing pieces within any boundary lines, as in Model 36—Loco-tender frames—a small hole must be bored, through which to pass the blade, before it is finally fixed in its frame. A class demonstration lesson should be given to show how it is held and used, immediately on its introduction as a tool required to work any detail of a model.

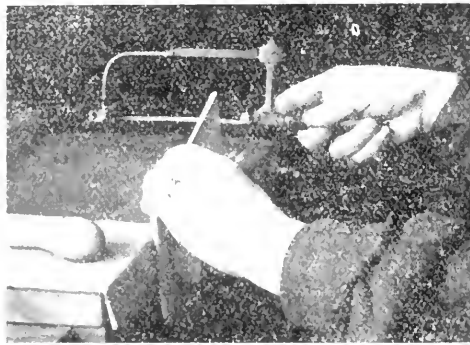

FIG. 33. USING PIERCING SAW FOR CUTTING CURVES.

Chisels (*Figs. 40, 41, 42*).

Cutting tools having unguarded or unsupported keen-sharpened edges are not suitable for use by young children, therefore chisels have been excluded from the primary set of tools, and admitted only

for the use of the teacher in the demonstration and comparison object lessons to illustrate the cutting action of the plane, and for showing the difference in the manufacture: the coincidence of the keen-cutting edges, the character of the material used, and many other obvious characteristics similar and dissimilar.



FIG. 40. BEVEL EDGE FIRMER CHISEL.



FIG. 41. FIRMER CHISEL.



FIG. 42. FIRMER CHISEL.—HANDLE REMOVED.

Chart drawings should be made from *Figs. 40* and *42*, and explanation given as to the form of the tang, shoulder, ferrule, and handle; reference being made, during the lesson, to the parts of the bradawl which bear the same names.

Sharpening Hones or Oilstones.

There are several kinds of stone suitable for giving a keen-cutting edge to tempered steel tools, some of which are quick cutting, others very slow or sluggish. Turkey stone and Charnley Forest are considered the best by many experts, but for general use—economic reasons being a feature—those sold as Washita answer all requirements.

The stone—rectangular in form—should be encased in a wood

box, the bottom and top of which is made removable, so that both sides of the stone are available.

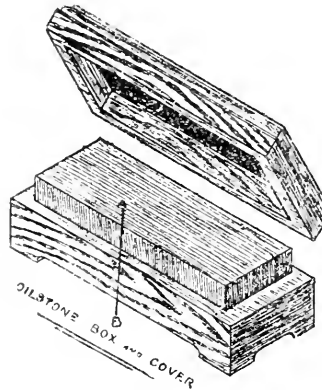

FIG. 43.

The keen edge of a cutting tool is obtained by rubbing the tip of the ground angle steadily and evenly—with an equal pressure throughout the stroke—along the surface of the oilstone (*animal or vegetable oil alone being used as a lubricant*) until a small facet of equal width appears across the edge; during this process a minute portion of the fine honed edge has been turned up on the flat or face side of the tool; this—technically termed a wire edge—must be removed by turning the face of the tool down on the stone—perfectly flat—rubbing it gently with a firm pressure downwards along the surface two or three times. Great care must be exercised in performing this operation in order to

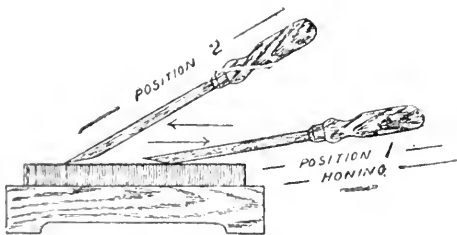

FIG. 44.

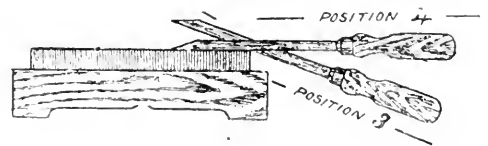

FIG. 45.

avoid the fatal error of forming a facet on the face side. *Figs. 44, 45* give the relative positions of a chisel during each operation, which also apply to all tools of similar construction. The honed facet

should never alter the ground angle—the angle formed by the grindstone—more than 10°.

To maintain an oilstone in good condition it must be kept thoroughly clean at all times; all the lubricant—which contains minute particles of steel—after use must be immediately removed with a piece of old rag or cotton waste, and the surface left as dry as possible. Under no circumstances should paraffin oil be used, either as a lubricant or for cleaning purposes, as it hardens the texture of the stone, and renders it useless as a hone. Should the surface of the stone become uneven through frequent use, it can be renewed by briskly rubbing it on a sheet of No. 3 emery cloth, fastened on to a piece of hard wood.

The several important points of tool sharpening should be fully explained to the children, before actually demonstrating the use of the oilstone, and recapitulated by eduction and black board summary from time to time as occasion requires.

Glass or “Sand” paper (*Fig. 22*).

The abrasive action of glass or “sand” paper is identical with that of the file or rasp; the fine particles of glass which are glued on to the background of stout paper take the place of the raised-up points of steel on the file blanks.

Glasspaper is manufactured in several grades or degrees of fineness, that classed as Middle 2 being the most useful for general work. It enters largely into this scheme of work, not on account of any educational value it may possess in delicate hand training, but chiefly because it offers the most simple and ready method of smoothing the woolly surfaces of the prepared—sawn—strip wood, and for removing the small bevelled corners and chamfers which so often occur in making the series of standard models.

The photo. block shows a half sheet of M 2 pinned on the surface of the work board. In this position the children can very readily smooth up the material—when sawn to length—on surfaces, edges, or

ends, as required, without fear of destroying the rectangular section, both hands being available for guidance, although sufficient pressure can be exerted by the forefinger, as shown in *Fig. 46*.



FIG. 46. ROUNDING ENDS ON GLASS PAPER.

For smoothing large surfaces, or built-up models, it will be advisable to neatly wrap a piece of glasspaper round a rectangular block of cork—termed a cork rubber—in order to give an equal pressure over a large area, and to avoid rubbing off the sharp angles or arrises of the details of the models which are being finished. For the inside finishing of curves, or other irregular surfaces or edges, a piece of cork filed to the required contour, similarly covered with glasspaper, can be used. A piece of cork measuring about $4'' \times 3'' \times 1\frac{1}{4}''$ length, breadth, and thickness respectively, will be found a very convenient size for the ordinary rubber.

A lesson on the abrading action of glasspaper, the method of using it to meet special cases, or on its manufacture should be given.

Demonstrations upon the efficient, and careless use upon finished work will do much to impress the necessity of care and judgment upon the children.

The Parallel Vice.

This tool is not an absolute necessity for a small equipment, but in schools or centres where a specialist teacher is engaged,

many little necessary tool repairs can be effected by its aid. There are many forms in the market, but the pattern shown is the most suitable.

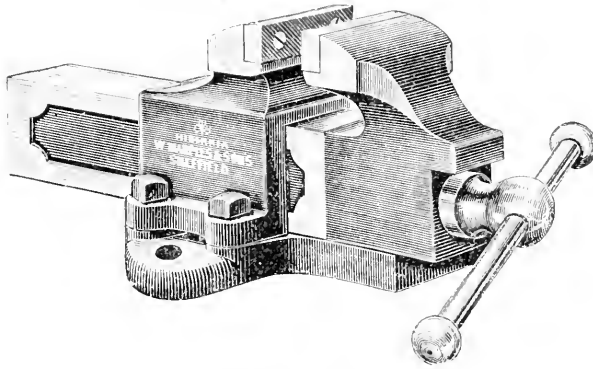

PARALLEL VICE

**Notes on the Woods and other materials suggested for
use in the construction of the Standard Series
of Models.**

CANARY WHITEWOOD. *Liriodendron tulipifera.*

Natural order: *Magnoliaceæ.*

The chief supplies of this are obtained from America and Canada in the form of waney logs and sawn boards of considerable size.

Its grain is very fine, but somewhat spongy; it finishes with a dull lustrous surface which readily soils, and changes in tone of colour, if unprotected. Its colour range varies considerably from white to canary, often with a greenish grey tinge, but sometimes it is met with of a distinct brownish black—very closely resembling common black walnut. It takes stains very readily, and for this reason it enters largely into the manufacture of cheap “walnut” furniture. It is cheap, easy to work, does not readily split when nailing, and has been found to be a most suitable material for Froebelian woodwork.

As a timber of commerce it probably holds the record for the number of alternative names under which it is obtainable. Amongst the number are: Whitewood, Canadian whitewood, Tulip tree, Canoe wood, Saddle tree, Poplar, Yellow poplar, Virginian poplar, Canary wood, Yellow wood.

BASS WOOD. *Tilia Americana.*

Natural order: *Tiliaceæ.*

This wood so very closely resembles the foregoing in texture and general appearance, being grown in the same districts, and received from the same source of supply, that it is very often delivered as Whitewood. It is obtainable in very wide boards sawn to standard thicknesses, and also in round logs of considerable dimensions. Its

grain is very fine; the surface finish of worked specimens being much more lustrous than Canary wood, whilst the range of colour is more uniform, from white to creamy white or ecru. It does not split when being nailed, is easily worked with simple tools—there being very little difference between the Autumn and Spring growths—and is, therefore, specially serviceable for model making.

Well-grown timber of this tree is rather heavier than similar grown wood of the tulip tree—relatively as 38 : 45 lbs. per cubic foot.

In its native forests—on the shores of Lakes Erie and Ontario—it is known as the Linden or Lin, also the Bee tree and Willow in the United States.

SWISS PINE. *Pinus picea* (Silver Fir).

Natural order: *Coniferæ*.

The wood of the silver fir is imported into London as “Swiss pine,” and used largely for musical instrument making; it is very suitable for toy making, being chiefly used for that purpose in the Tyrol. It is easily worked with simple tools, is usually very white and clean, takes glue and nails very well, and is fairly strong and durable. The tree, in its native forests of Southern Italy, grows to very large proportions, and is considered one of the most picturesque features of the landscape, its branches growing in almost geometrical precision from base to summit.

The Western white fir—*Abies grandis*—the American species of this tree, grows to a large size. The wood is not held in very high esteem, being perishable and brittle; it is chiefly used in box and packing case making, but the selected “stuff” is very suitable for Handicraft classes.

ARCHANGEL SPRUCE. *Picea excelsa*.

Natural order: *Coniferæ*.

The wood of the common spruce grown in the Russian forests, and received at the port of Archangel for shipment, is identical in general characteristics with the wood of the spruce of Norway. The best quality, obtained from the higher altitudes of Northern Europe, is very suitable for toy making, being light and elastic.

The wood when newly cut is of a yellowish-white, but sometimes of a brownish-red colour; the annual rings are very distinct. It usually contains, in the common qualities, many hard, glassy knots, which render it unfit for the best work. Almost every part of this tree is of commercial value, as the following will illustrate :

- (a) The bark is used in tanning.
- (b) The pith of the young trees is an article of diet in Lapland.
- (c) The spines and young shoots are used in the manufacture of the spruce or black beer of Norway and Sweden.
- (d) The resin, which exudes during growth, supplies the Burgundy pitch and Stockholm tar of commerce.
- (e) From the discarded branches and roots are obtained charcoal, potash, pearlash, etc.
- (f) From the waste of the saw mills, engaged in preparing this timber for the markets of the world, and from the rough grown wood—otherwise useless—is manufactured wood pulp for paper and cardboard making.

BAYWOOD (Mahogany). *Swietenia mahogani*

Natural order: ***Cedrelaceæ***.

Whether the timber sold as bay wood—especially the softer qualities—is the product of the Bay Forests of Honduras, is questionable. There is at present great confusion in nomenclature; many of the so-called cedars being the product of large forest trees belonging to the natural order Meliaceæ. The supplies received from India and Burmah, Queensland and New South Wales, under the names of Indian Mahogany, Moulmein Cedar, and Red Cedar, are the product of the Toon, "*Cedrela toona*," and so closely resemble the true mahogany in grain, colour, and physical characteristics, that correct classification is extremely difficult. Both species grow to considerable dimensions.

The colour ranges from light brick-red to deep reddish-brown, generally uniform throughout. The wood is easily worked, and finishes with a silky lustrous surface; it is very suitable for advanced Froebelian woodwork, being fairly straight in grain, and taking glue and nails well; it is largely used for cabinet making, cigar boxes, tea boxes, and, by the natives, for dug-out canoes.

CANADIAN MAPLE. *Acer macrophyllum*.Natural order: *Lapindaræ*.

The wood furnished by the broad-leaved maple of Canada is very suitable for toy making; although the grain is "fine, dense, even, and compact," it is easily worked and finished. The lustrous surface shows up well in the Froebelian slab wood models for which it is specially suitable. It can be obtained in large sizes; the trees on Vancouver Island are very fine specimens. The wood enters very largely into the domestic life of Canada and the United States of America. The colour range is from light reddish-brown in the heart wood to creamy white in the sap wood. The distinguishing features of the sugar maple (*A. saccharinum*), *i.e.*, the beautiful curled grain and yellowish-white spots—the bird's eye—are absent, although in some specimens appear spot markings of much smaller size.

LIME TREE (small leaved). *Tilia cordata*.Natural order: *Tiliaceæ*.

The wood of the European species is most suitable for the advanced models in which curved surfaces or edges are worked; it cuts well in all directions without splitting, being close grained and soft, and finishes with a fine silky surface. Supplies of this wood are often obtained which give out a "peculiar and rather unpleasant odour," a characteristic not found in the American species—bass wood. It has long been used for wood carving, many of the finest examples of the craft being wrought in this wood. Its colour is pale yellow or white, uniform throughout, which, if protected by a spirit varnish, gives a very effective appearance to the finished models.

It is very largely used by cabinet and pianoforte makers, and for the manufacture of domestic articles, turned boxes, and toys. The branches, which are not considered commercial timber, are used for charcoal making. The bark of the lime is an important article of commerce; the bast, or inner bark, after treatment by water, is manufactured into mats—commonly known as bass or Russian mats—which are largely used for packing purposes and for screening and protecting ends of timber when stacked, and by gardeners for a variety of purposes. As a tree it is used largely for public walks and

avenues, especially on the Continent; the shade afforded by its leafy branches and the perfume of its flowers makes it a special favourite.

SATIN WALNUT. *Liquidambar styraciflua.*

Natural order: *Hamamelidæ.*

The physical characteristics of this wood closely resemble those of the true walnut—*Juglandaceæ*—although in other essential points there is no resemblance. The grain is extremely fine and even; the surface finishes dull, but sometimes shows glistening points; it warps and twists badly if not steamed “immediately after sawing into planks”; it takes glue and nails readily; polishes well; and if thoroughly dry and well seasoned, is well adapted for the full range of Froebelian woodwork. The colour ranges from red to reddish-brown, the heart wood being clearly defined against the cream-coloured or whitish sap wood. The best quality wood is used largely for cheap classes of furniture; the more common, when fully creasoted, makes excellent silent and smooth street paving. It is imported as California Red Gum, the United States of America and Mexico being the chief sources of supply.

Nails, Screws, and Glue.

Nailing, or jointing by means of nails, is the most simple method of uniting two or more pieces of wood, and, consequently, is the principal means of building up the whole of the models included in this scheme of work.

Several forms of nails, designed for specific purposes, are in common use. Those known as French wire nails, and panel pins are the most suitable for simple woodwork. The *flat head* of the former, and the bullet or butt-rivet head of the latter, are the chief distinguishing features of these types.

When nailing, it is always advisable to prepare a way with a bradawl or pricker in the direction it is intended the nail should be driven; the diameter of the bored hole must always be smaller than that of the nail to be used, if its full holding power is desired. It is not always desirable to bore through, especially in thin material; a

depth sufficient to ensure the correct direction is all that is necessary. To prevent it bending or diverting from its path the nail should be held firmly between finger and thumb, and be hit smartly and square on the head.

When any constructional detail involves nailing into the end grain of the wood, always use the longest possible nail. Oblique nailing is the most difficult operation, and some preliminary practice exercises should be worked before attempting any models involving oblique construction.

Jointing by means of screws is necessary when some detail of a model is required to be removed, or taken apart for adjustment or other purposes. The general form of a wood screw is well known by most children, but reference should be made to the peculiar form of the thread or spiral which tapers to a point; so designed to cut its own way into the wood fibres when turned by means of a *screwdriver* or *turnscrew*.

To secure the full value of the grip or holding power of the thread, it is absolutely essential that the blank part of the screw shall pass freely (not loosely) through the first piece of material; the resistance offered by the head then brings the two pieces into close contact. When a conical-headed screw is used, the clear hole is hollowed out—countersunk—to allow the head to fit level with the surface of the work. Round-head screws are used when thin metal plates are introduced to add strength to the construction, or for ornamentation details.

Wood screws are made to standard sizes in brass and iron; the diameters being denoted by numerals, 0, 1, 2, . . . 16, etc., and lengths in ordinary measurements of inches and fractions.

Glue—How made and prepared for use.

This well-known cement for wood is manufactured from all kinds of animal offal, which is treated with a dilute alkali to remove the most offensive matter previous to being subjected to gentle ebullition in steam-heated boilers, whereby the gelatinous substance is gradually

reduced to a viscous liquid; it is afterwards purified and run into shallow metal trays or moulds to solidify. It is then cut into square pieces, termed cakes—placed on suitably supported wire netting, and exposed to the drying influences of the sun and air.

Special drying stoves are now substituted in many manufactories, as being more speedy and effective.

The best quality glue is of a rich golden brown colour, clear and translucent, hard and glossy; it is not readily affected by any atmospheric changes, and quickly dissolves in hot water; cold water, although causing it to swell considerably, has but little effect towards fluidity.

In preparing glue for use, it is necessary to use two utensils or pans, the inner one to contain the broken pieces of glue cake, the outer the hot water; the already water-soaked mass contained in the inner pan is then rendered fluid by the application of gentle heat to the outer pan. Care must be taken to prevent the bottom of the inner pan coming in direct contact with the outer; if the ordinary glue kettle is not used, the best plan is to stand the inner pan on an open pastry cutter, or the rim of a tin lid, so that a quantity of water is free to circulate below it.

Alternative methods of preparation :

1. By previous soaking: Cover a cake of glue with water for 24 hours, then place the softened mass in the inner vessel; half fill the outer pan or kettle with water, and bring the whole to a gentle boil; continue boiling, occasionally stirring; skim off any fat which may rise to the surface, until the glue becomes a clear golden-coloured liquid, then remove it from the fire or stove and proceed to use at once. Reheat when necessary.
2. By direct boiling: Fold a duster or other piece of dry cloth round a cake of glue; break into small pieces with a hammer; place these in the inner vessel, with sufficient water to cover, then proceed to gently boil as for the first method until the broken pieces are all thoroughly dissolved, when it is ready for immediate use.

Freshly made glue is a much more efficient cement than when it has been reheated several times.

To make an efficient glue joint, the following conditions are essential :

- (a) The surfaces of the pieces of wood must be in true contact with each other, and perfectly dry.
- (b) The glue must be well prepared—a liquid—and applied hot.
- (c) The joint must be *well rubbed* to expel the air and superfluous glue.
- (d) Some fixture or apparatus should be used to maintain a constant pressure on the joint until the glue is thoroughly dry.

If these conditions are carried out, then the strength of the glued joint is as strong—in some cases stronger—than the solid wood. For small work where rubbing the joint cannot be done, a little hot glue should be smeared evenly over the parts to be united; maintain an effective pressure until thoroughly dry; or, if the work will admit of it, at once use nails or screws.

Ordinary glue may be rendered liquid by the addition of dilute acetic acid without losing its adhesive qualities. A very strong *liquid glue*, especially suited for Froebelian woodwork, may be made as follows :

Soak a piece of best Scotch glue in dilute acetic acid, and render it liquid by gentle heat—do not boil it—then add one part of methylated spirit in which one-quarter part of unslaked lime and a small quantity of alum has been well mixed, thoroughly stir the whole to the consistency of thick cream, bottle, and store for use.

If kept in the collapsible tubes which have contained colours for use in the brushwork classes, this wood cement—which dries white—is always ready without further heating, is equally strong, to a certain extent damp resisting, and will be also found a suitable adhesive medium for cardboard modelling.

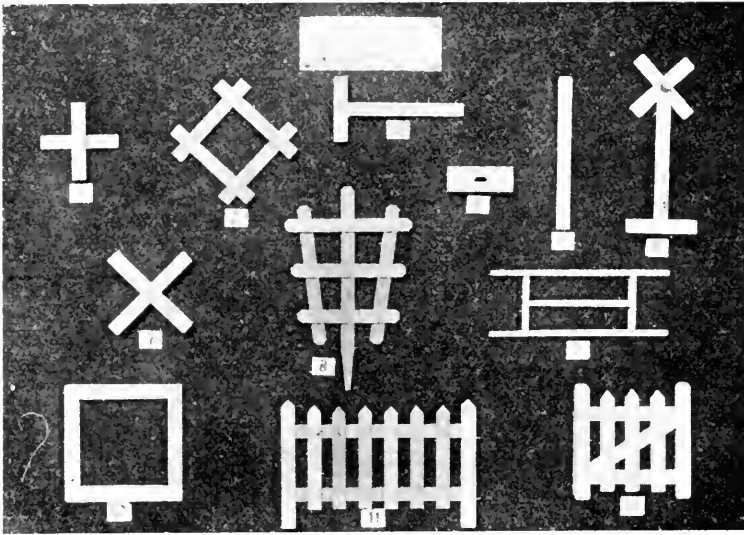

First Course of Work.

GROUP OF LESSONS No. 1.

MODEL 1 : Overlap Cross or String Winder.

Aim of Drawing Lesson: To teach the reading of simple measurements at sight.

Aim of Practical Lesson: To supplement drawing lesson by direct application of the simple measurements copied from the drawing, and to familiarize the use of the rule and try square.

The most simple method of teaching the divisions and subdivisions of the English standard rule is by the use of Gifts 3 and 4; and afterwards, by the aid of the Unit rule, clearly defining the inches, half, quarter, and eighth of an inch, with the relative values of each to the whole in fractional numbers.

1

OVERLAP CROSS OR STRING WINDER.

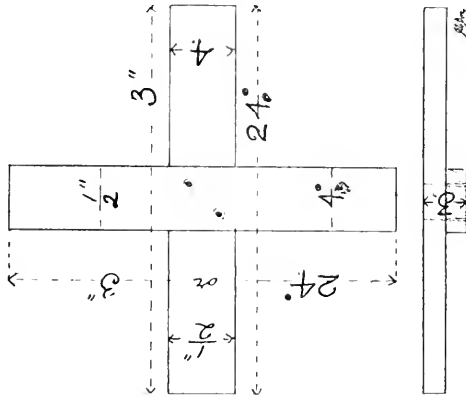
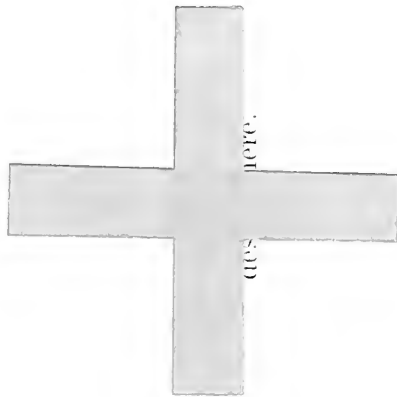

Name _____

As previously suggested, the measurement of strips of paper may be taken as a preliminary exercise to the actual drawing lesson: when a correct length is obtained, the piece may be held in a defined position on the sheet of drawing paper, and its outline traced with a sharp pointed lead pencil. From this copy similar outlines may now be measured and drawn with rule and set square.

Exhibit a model of the string winder; let the children draw its general outline (*a*) as seen from the front, (*b*) as seen from the side. Show how the front view of the model may be made by the overlap of two pieces of paper, and let the children state the difference between this and the side views. Explain the terms length, breadth, thickness. Give examples of articles of two dimensions only. Then make a correct drawing on the black board, giving all dimensions, which the children should copy, using drawing board, Tee square, set square, and rule.

Position drill: Measurement at sight.

Supplemental Lesson.

Little talk on simple measurements by Units.

Practical Lesson.

Materials required : Length of strip wood and a few panel pins for each scholar.

Tools required : Rule, try square, saw, pencil, hammer, and prickler for each scholar.

Exhibit small try square and demonstrate its use.

Take marking out drill (pages 31 and 32).

Refer to the dimensions of the finished model, and to those on the black board drawing and children's own work.

Mark off 24• (eighth units); test for accuracy. "Attention. How shall we cut this piece of wood off?" Exhibit a saw and a knife. "Which of these tools shall we use? Why?" Educe the reason, or explain briefly.

Let each child take up saw, teacher demonstrating its use and method of holding (pages 35 and 38); then follow on with sawing drill (pages 34 and 35).

Show work. "What length should each piece be? Can we make the model accurately if each piece is not correct? Then what have we learnt? If you make an error on your drawing what can you do?" "Correct it." "Yes; how?" "By using a piece of india-rubber." "Can we correct an error made in sawing by the same method?" "No." "What is the result?" "Waste." "Then what does careful working prevent?" Now find the centre or exact middle of each piece of wood; mark it with pricker; bore through each. Place one piece over the other at right angles; the four arms should be of equal length; insert pin in centre hole; mark with pencil the position of each piece across the face of the other, and also the positions of the nails (as shown on the drawing); pierce the latter with the pricker; touch the under surface of top piece with liquid glue; replace it in exact position, and insert the panel pins ready for nailing.

Demonstrate the method of holding and using a hammer for square nailing (pages 44 and 45).

Nail the pieces together as placed, reversing the model and clinching (or turning over) each nail point on the cast-iron clinching block.

Carefully clean up the surfaces with sandpaper and cork rubber and complete Model 1.

It will be noted that all the simple tools are required to construct this model, and that to produce it with any degree of accuracy all the correct positions in the handling and efficient use of them have been at once introduced; for the permanent value of the whole scheme depends largely upon the thoroughness of the foundation work. Method must not be relaxed in the slightest degree; the most elementary and apparently superfluous detail may not be passed over as being of little consequence, for as first impressions are lasting, so also are false or careless methods of working.

If the necessary tool positions have been taken as preliminary lessons (a system very strongly recommended to ensure success), and thoroughly grasped by each scholar, it will not be necessary to interrupt the procedure of the actual lesson, except to ask a few questions as to certain positions or uses of each tool brought into use, which

will serve to refresh the memories of all, and to impress the value of the previous lessons or exercises.

Procedure for the construction of Model 1 :

1. Prepare surface of wood strip with glasspaper.
2. Mark off length A 24" and length B 24" with try square and pencil.
3. Saw off each length to marked lines.
4. Find centre of each piece and bore with pricker.
5. Place piece A across piece B, and mark exact square position and prick for nails.
6. Insert nails, drive home and clinch.
7. Clean up with glasspaper and cork rubber.

Sequence or Continuation Lesson.

Little talks on wool, string, St. George's Cross, etc.

GROUP OF LESSONS No. 2.

MODEL 2: Overlap Oxford Frame or Fishing Line Winder.

Aim of Drawing Lesson: To teach quick reading of the simple measurements of length and width.

Recapitulate the points and methods deduced from Lesson 1, and repeat position drill, "Measurement at sight."

The drawing of the frame may be traced by the paper strip method, or made direct from a dimensioned sketch on the black board. Encourage the children to build up their drawing, as they would build up a similar design with the oblong and cube gifts, the idea being to co-ordinate and apply all previous instruction in concrete form.

Supplemental Lesson.

Little talks on definitions, with examples of Length, Breadth, and Thickness.

OVERLAP OXFORD FRAME OR FISHING LINE WINDER.

Place paper strip
design here.

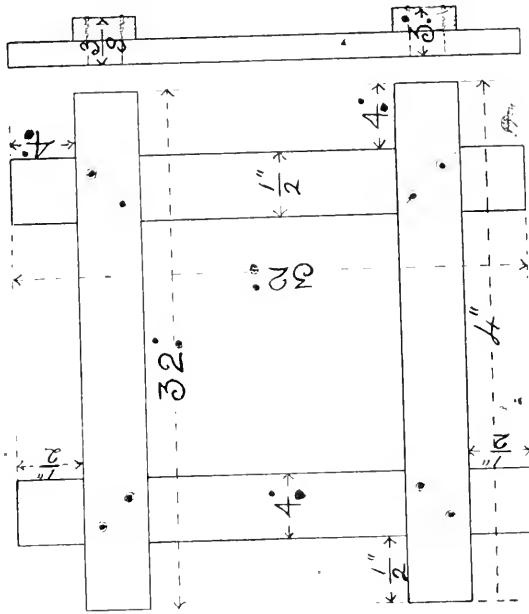

Name _____

Aim of Practical Lesson.

To teach accuracy in sawing to a line, to waste, and the use of the try square for testing right angle construction.

Materials required : Length of strip wood and a few panel pins for each scholar.

Tools required : Rule, try square, pencil, saw, hammer, and prick.

Procedure for the construction of Model 2 :

1. Mark off on strip a length = 32" (eighth units), and repeat this operation three times.
 - Be careful to show that it is necessary to make two lines across the wood to leave a space for the saw kerf. Ask what the total length of the wood should be to cut four pieces each 32" long. Show that it must be longer than a piece of paper which contains four lengths of 32" each.
 - Demonstrate the reason for the extra length on the black board, and also show that it is not always necessary to mark the whole number of lengths required at one time.
2. Saw off the four equal lengths.
3. Smooth off all surfaces with glasspaper.
4. Arrange them side by side to test accuracy of length.
5. Place try square across and set off 4" from each end.
6. Set off width of strip from this line and mark across.
7. Across two of the strips draw diagonal lines between the width lines, and thereon, mark or prick the positions for nails, as shown on drawing.
8. Touch the under side of these strips with liquid glue, and place all in position for nailing.
9. Insert and drive in one nail at each joint.
10. Test with try square for correctness of angles. Adjust if necessary. Then
11. Place, drive, and clinch all other nails required.
12. Clean up all edges and ends with glasspaper and pad, completing Model 2.

Sequence or Continuation Lessons.

Little talks on (1) Picture frames, sea fishing lures, application of Gift 8 — stick laying.

(2) Principal tools used, saw and hammer.

Position drills : Sawing to a line : testing for right angles.

GROUP OF LESSONS No. 3.

MODEL 3: Tee Square.

Aim of Drawing Lesson: To impress value of simple outline drawings and free sketches.

As a preliminary to this group of lessons, outline forms as constructed from Gift 4—oblongs, or Gift 8—stick laying, should be made and copied as free sketches by each child, to be followed afterwards by the outline paper method; or Gift 7—tablets, may be introduced with advantage to elucidate the value of the set squares of fixed angles, 45° , 60° , and 30° , when used in conjunction with the Tee square, in constructing various geometrical figures. Deal only with the two dimensions of length and breadth at present. Exhibit the model to be made, outline its form on the black board, mark the dimensions of each detail (as on the given drawing), and let the children reproduce a line drawing to full size. Now show that the model to be made has *thickness* which varies in the head and blade. “What shall we require to know before we can make the model?” “Yes, the exact size of the third dimension.” Exhibit the edge view of model. Make a side elevation of it projected from the previous drawing on black board, fully dimension it, and ask children to complete their own drawing accordingly. Recapitulate the little talk on three dimensions in previous group of lessons, and lead children to realize the necessity of accuracy in measurement. Give a few moments to measurement drill, aiming at quickness of addition, thus: “Attention.” Show 34° , add 6° , and 3° , and 9° . “What is the total length now? Yes, 52° eighths. How many full inches does 52° measure? Yes, 6. And what are left?” “ 4° .” “Yes. And how much of one inch are 4° ? Then what does 52° actually measure?” “ $6\frac{1}{2}$ inches.” Proceed thus to familiarize the rule measurements.

Supplemental Object Lesson.

Little talks on simple aids to line drawings, and the use and value of a Tee square.

3

A TEE SQUARE.

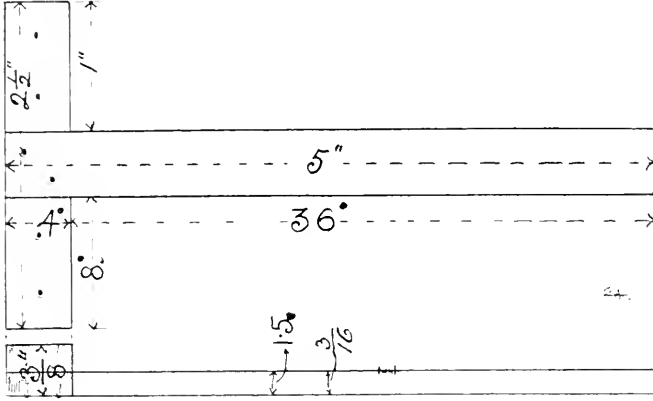

Place paper strip
design here.

Name

Aim of Practical Lesson.

To teach simple elements of construction requiring, accuracy in sawing to length, in fitting, and in nailing.

Materials required : A strip of wood and some panel pins.

Tools required : Rule, try square, pencil, saw, plane, pricker, and hammer.

Before commencing the practical work lesson, attention is called to a new tool, which will be used to smooth off the surface of the wood before the model is made from it. A demonstration of the method for correct holding and use, is to be given by the teacher, and similar demonstrations by selected children should form part of the preliminary lesson. If a small plane is supplied to each scholar, the drill positions for surface planing may be given (pages 37, 39).

Procedure for the construction of Model 3 :

1. Mark and saw off length for blade, 40" (5").
2. Mark and saw off length for head, 20" (2½").
3. Mark and saw off two lengths for head, 8" (1").
4. Plane up surface of each piece.
5. Place one short piece on the 20" piece and nail in position.
6. Place 40" length and other short piece in position, and nail the latter close up to the edge.
7. Test the angle of blade and head ; if correct, remove blade and touch under surface with liquid glue.
8. Replace and nail in position, testing for accuracy after each nail is driven home and clinched.
9. Finally test by side line method ; if correct, clean up and finish Model 3.

Sequence or Continuation Lesson.

Little talks on wood pulp, cardboard, and paper-making, using the shavings, sawdust, and waste pieces of wood made during practical lesson as the object material.

Position drills : Nailing : square and angle testing ; planing.

GROUP OF LESSONS No. 4.

MODEL 4: Base Piece or Column Foot.

Aim of Drawing Lesson : To teach and impress the reason why more than one outline drawing is necessary when a solid model has to be made.

Recapitulate the main points of last lesson, and refer to outline drawing of two dimensions only. Educe reason why three drawings are necessary for model building. Sketch plan of some design or form built up of Gift 4 ; ask children to free sketch the same on paper by proportionate or sight measurement method, holding pencil at arm's length to obtain relative proportions. Now construct this design with the oblongs, and show that only the upper surface or PLAN has been copied. Exhibit the standard model, and lead the children to elucidate the drawing required, and show that the model to be made is *built up* of a number of oblongs. Sketch the front view or ELEVATION (define) of it on the black board ; mark the required dimensions thereon, and ask if any one in the class can make the model from that sketch. "Why not?" "Something more is wanted." "Yes." Proceed to develop the other view in correct position below the elevation and write the word PLAN under it. Refer to the oblong hole in the model, and its form and position (which may now be marked in red, to better define it) on the black board drawing. "How deep would you make the hole?" Explain why it cannot be shown on both drawings, and educe the necessity for another view to give the actual depth of the hole. Exhibit an orange to the class, draw its outline on the black board, and ask what is hidden by the skin. "Can you tell me how thick the skin is? Can you tell me how far from the outside I shall find the pips?" "No." "Why not?" "Because we cannot see through a solid." Exhibit the model and show that the hole goes right through, and therefore is not exactly the same as a complete solid. Refer to the drawing to point out that only the upper edge of the hole appears on the plan, the lower edge being hidden. Lead the children to ask for a drawing which will show the inside, and to realize the necessity of more than *two* drawings when

some interior construction has to be shown. Cut the orange in two, and complete the outline sketch on the black board. Cut the model in two across the hole, and make a complete drawing of the SECTION (explain the term) in correct relative position to the other views, and direct the children to carefully reproduce the drawings of the model to full-size dimensions.

Supplemental Lessons.

- (a) What a picture drawing shows.
 (b) Plan designing with Gifts 3, 4, and 7.

Aim of Practical Lesson.

To teach simple construction.

Materials required : A length of strip wood and a few panel pins.

Tools required : Rule, try square, pencil, saw, plane, prick, bradawl, and hammer.

Procedure for the construction of Model 4 :

1. Mark and saw off 4 pieces, each 20" long ($2\frac{1}{2}$ ").
2. ,, 2 ,, 8" ,, (1").
3. Plane up one side of two 20" pieces only (for outsides).
4. Touch rough sides with glue and nail two long pieces together.
5. Repeat No. 4 with the other pair.
6. Glue and nail short piece on one pair ; insert spare piece 4" wide ; place other short piece close up, glue and nail in position.
7. Remove spare strip, and adjust cover pair in position.
8. Bore holes through cover pair with bradawl ; insert long nails and carefully nail all together.
9. Clinch nails if necessary ; smooth up all surfaces on glasscloth and complete Model 4.

The bradawl having been introduced for this model, a demonstration by the teacher of its correct use, its form and construction, should be given during the lesson. A short drill might with advantage be arranged to ensure correct use and to avoid accidents from careless handling.

4 & 5

BASE PIECE OR COLUMN FOOT
AND
SIMPLE COLUMN.

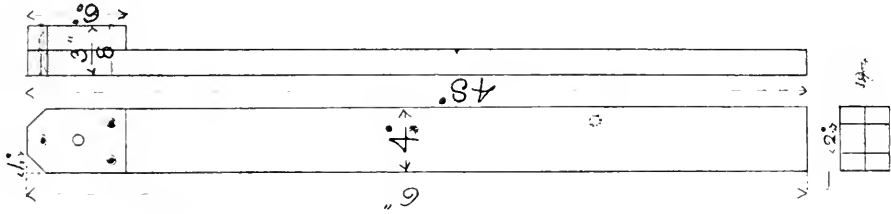
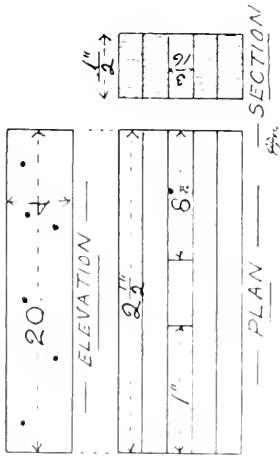

Name

Place paper strip
design here.

Place paper strip
design here.

Sequence or Continuation Lessons.

Little talks on mechanical and natural methods of boring, including nature study of the earth-worms, rodents. Lead up to wood-boring insects (land and marine) as timber destroyers.

Position drills : Planing ; squaring ; and boring.

GROUP OF LESSONS No. 5.

MODEL 5: Simple Column.

Aim of Drawing Lesson : To impress the essentials of Lessons 3 and 4.

Employ Gifts 4 and 5 (oblongs and cut cubes) to impress the terms PLAN, ELEVATION, SECTION, and for the free sketching of simple built-up forms on both black board and paper. Wherever possible, let the child assume the role of teacher. Let all examples lead up to the required drawing in simple outline. The introduction of the 45° set square to form the bevelled top lines on the elevation will open up a practical lesson on the component parts of a square (use the cut cubes of Gift 5 and also the tablets of Gift 7). Demonstrate the combined use of Tee square and set square in making the black board drawing. Fully dimension when completed, and get the children to make the three simple views in correct projection.

Supplemental Object Lesson.

Little talks on angles, set squares, and the “beauty forms” made possible by combination of squares and triangles.

Aim of Practical Lesson.

Accuracy and neatness in finish.

Materials required : A strip of wood and some panel pins.

Tools required : Rule, try square, pencil, saw, plane, bradawl, and hammer.

Procedure for the construction of Model 5 :

1. Mark and saw off one piece 48" long (6').
2. Plane up surfaces.

3. Mark off the bevelled corners at one end with set square.
4. Rub corners off to line on glasscloth.
5. Mark and saw off one piece 6" long ($\frac{3}{4}$ ").
6. Touch with glue and nail to upper end of long piece.
7. Rub projecting corners down to line.
8. Mark off and bore hole 3" from upper end and equidistant from each side.
9. Test for accuracy by drawing, and finish off Model 5.

Sequence or Continuation Lesson.

Continue previous nature study lesson.

Position drills : Sawing to a line, and planing.

GROUP OF LESSONS No. 6.

MODEL 6: Working Model of Mill.

Aim of Drawing Lesson : To teach combination of drawings and to secure neatness and accuracy in marking working dimensions.

To enable the children to more readily pick out the several details which they have previously made in a smaller size in Lessons 1, 4, 5, the model used to illustrate this drawing lesson should be somewhat larger than previous examples. The teacher should sketch large-size diagrams of every detail, naming each element in plain lettering, and under the direction of the children, who should be asked to indicate where the several details have to fit, build up complete drawings to serve as copies for the children. Each diagram should be fully marked in detail, duplicate and overall dimensions, to enable the children to compare identical and relative parts of the whole. Build up a model during the lesson, adding the detail or element *before* drawing the same on the black board. At the close of the lesson adjust the cord on the turning drum or barrel, and demonstrate the movement of the sail-arms, explaining the change of motion, rectilinear, reciprocal, to circular or rotary. Prepare a few coloured strips of paper; gum them to the sail arms at varying distances; revolve the sails, and ask the children to name

the resultant rings of colour produced. Very pretty colour effects can be produced by fixing to the sail-arms discs of cardboard upon which the children have worked coloured geometrical designs.

Supplemental Lesson.

Little talks on primary and secondary colours and combinations. Overlay of colours in the production of coloured pictures, wall diagrams, almanacs, etc.

Aim of Practical Lesson.

To apply previous lessons on simple construction to the ensemblement of details for building up working models.

Materials required: Strip wood, short and long panel pins, and about 1 foot of fine macrame string for each scholar.

Tools required: Rule, try square, pencil, saw, plane, bradawl, hammer, file, and cutting pliers.

Procedure for the construction of Model 6 :

1. The detailed procedure as given for Models 1, 4, and 5 may be followed, or the model may be built up of the several details or elements, made separately at each of the lessons named. If the latter course is considered better, then
2. Insert column piece (Model 5) in base piece (Model 4), and secure in position by nailing and clinching.
3. Round up with file a short square piece of wood to about the size of an ordinary lead pencil.
4. Saw from rounded piece a length of 6".
5. Drive a long panel pin through centre of sail-arms; pass through hole in column; and drive into the end centre of the rounded piece or turning barrel, so that the sail-arms may turn freely.
6. Bore a small hole in turning barrel, and fix the piece of macrame string in it; or, if preferred, the string may be glued on to the barrel.
7. From long panel pins, form two eyelets with the round-nose cutting pliers.
8. Insert these in their positions on the column, as shown by the drawing, and pass the string through each.
9. Attach a head or tassel to end of string, and adjust on barrel.
10. Smooth up neatly all edges, and finish off Model 6.

The introduction of the file and round-nose cutting pliers will

REVERSING SPINNING MILL.

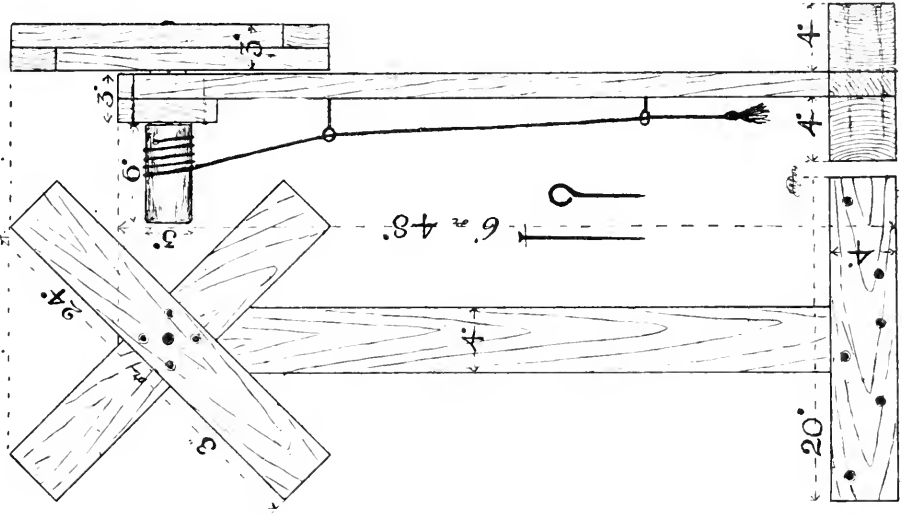

Place paper strip
design here.

Name

involve demonstrations in the use of these tools (pages 46 and 45). If considered advantageous to the class as a whole, full lessons on each should be given before the completion of the model.

Sequence or Continuation Lesson.

Little talks on windmills, watermills or turbines, and other power producers, explaining how the sails or arms are *set* to catch the wind or water, and how the speed is regulated. Illustrate the lesson by means of the ordinary toy paper sails windmill. (The pattern having the square pieces of paper glued on to thin wood arms is the best to illustrate alteration of *set* to regulate speed.)

GROUP OF LESSONS No. 7.

MODEL 7: Half-lap Cross, Wheel Arms.

Aim of Drawing Lesson : To teach the correct parallel or geometrical projection of simple outline solids.

Exhibit examples of Model 1 and Model 7. Educe points of difference (*a*) as seen from the front, (*b*) from above, (*c*) from either side. Write best replies on black board, and sketch the front elevation of each model. Instruct children how to produce the side views of each example. Now elucidate the construction of Model 7, and educe a correct drawing of the plan direct from the elevation, explaining, where necessary, any special feature of the work, or terms used, which are either new or uncommon.

Show that the model has no nails in it to hold the two arms together. "How are they secured?" Show that one piece passes over the other as in Model 1, but yet both faces are "flush" or quite flat. Build up a Model 1 by nailing pieces on each arm to have similar flush faces. Now ask if the two drawings made, give all the necessary information required to make a correct model. "What more is wanted? Another view? What kind?" Educe the term or name "section." Explain that a notch has to be cut to a certain

7

— HALF LAP CROSS OR WHEEL ARMS. —

Place paper strip
design here.

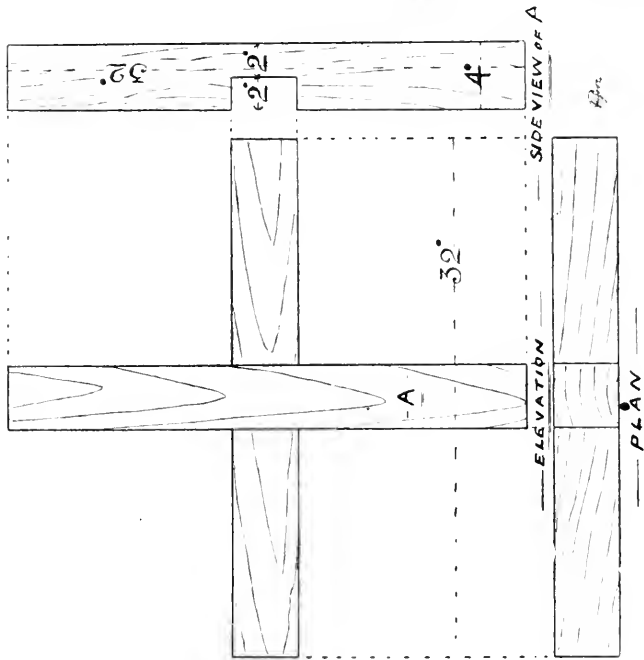

Name _____

depth in each piece, and that the new drawing must show how deep that notch is.

Proceed to project the new drawing from the elevation, and explain that the name of the joint defines the depth of the notch—Half-lap or half the depth or thickness. Show also that the drawing in this case need not be a section, but simply a side elevation of one of the arms. Clear up any doubts on this point by sawing one arm through, parallel with the side, and exhibiting the two parts.

Complete the black board drawing with neat dimensions—short dash (as on drawing) projector lines in red or other colour, and indicate, by radial lines, the end grain of each piece, to represent the annual rings or growth of wood.

Encourage the children to reproduce the drawing neatly to full-size dimensions, and to use for all vertical lines the Tee and set square, and for all horizontal lines the Tee square blade only.

Supplemental Object Lesson.

Little talks on geometrical models and terms used in drawing.

Aim of Practical Lesson.

To secure accuracy in simple measurement, sawing to line, fitting, and use of file.

Materials required: A length of 4" square whitewood.

Tools required: Rule, try square, pencil, saw, plane, gauge, and flat file.

Procedure for the construction of Model 7:

1. Mark and saw off two pieces, 32" long.
2. Plane or smooth up each side and mark pieces A and B respectively.
3. Find centre of each length and mark across with try square and pencil.
4. Carefully measure off width of piece A and set off, one-half of such width on each side of centre line on piece B.
5. Repeat similar measurement of B on piece A.
6. Set marking gauge to half thickness of either piece and gauge lines for depth of notch on each edge.
7. Continue lines over on A and B to join gauge lines by using try square and pencil.

8. Saw carefully down *inside* of the face lines to stop exactly at gauge lines.
9. Break out or cut away the small piece of wood left between these saw cuts, and file the surface of the notch level to gauge lines.
10. Fit A to B and note correctness of fit, of level or flush surface of each face, and of the length of each arm.
11. Test for accuracy of sawing, by trying the square of each angle formed by the cross arms. (See diagram, page 31.)
12. Correct if necessary, clean up and finish Model 7.

Providing there be any inaccuracy in sawing either too deep, out of square, or not to the exact line, repeat operations 3 to 10 at each end of the pieces before issuing new material. Before good results are obtained, some little time may have to be spent on this sawing to waste exercise, but such will be well spent, because upon accurate sawfitting depends the satisfactory completion of a large proportion of the working models; and further, it will reduce to a minimum the possibility of waste material.

Large chalk diagrams showing the results of good and bad sawing should be prepared as wall charts, and constantly used for reference during any demonstration of sawing.

The introduction of the marking-cutting gauge will involve a brief lesson on its construction and use.

Sequence or Continuation Lesson.

Little talks on windmills, wheel arms or spokes, and the part they play in power-producing machines.

Position drills: Sawing to a fit line; gauging.

GROUP OF LESSONS No. 8.

MODEL 8: Plant Ladder.

Aim of Drawing Lesson: To familiarize the terms of oblique parallel lines, and angles.

In classes where the Tee square and set square are not available, some difficulty may be experienced in producing the drawings

8

A PLANT LADDER.

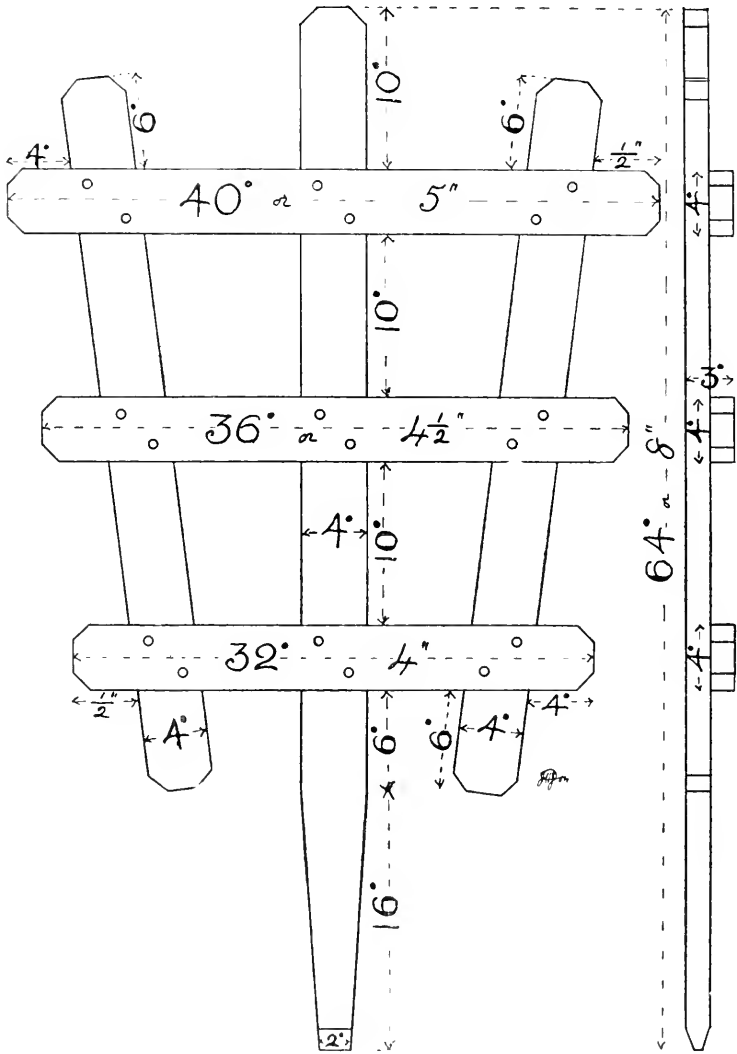

Name

Place paper strip
design here.

necessary for the making of this model. Much encouragement will have to be given to maintain interest through difficulties which very quickly dishearten the youthful worker. The most simple and effective way is to use the paper strip method to form the front elevation. Make a large-size sketch on the black board; fully dimension each part, then ask the children to produce a similar design with gummed paper strip cut accurately to the given widths and lengths. The side view need not be drawn, because the thickness of the strip wood from which the model will be constructed is the same throughout.

The enclosed area method is sometimes used as a variation, but the best results are obtained by the aid of the simple drawing aids named.

By whatever method the final results are obtained, no item should be considered too insignificant for explanation; the detail, duplicate, and overall dimensions should be neatly and clearly marked in correct order. The positions for the nailing should be marked on diagonal lines joining the opposite points of each overlap, and the continuity of the centre and side supports may be indicated by dotted lines.

Supplemental Lesson.

Little talks on, and black board free sketching of, parallel lines in three directions: vertical, oblique, and horizontal.

Aim of Practical Lesson.

To teach accuracy in setting out and fixing oblique work.

Materials required: Some odd lengths of strip wood and some $\frac{3}{4}$ -in. panel pins

Tools required: Rule, try square, pencil, saw, plane, prickler, hammer, knife, file.

Procedure for the construction of Model S:

1. Mark and saw off the following lengths:

1	piece	64" (8')	long.
2	"	44" ($5\frac{1}{2}$ "	"
1	"	40" (5'	"
1	"	36" ($4\frac{1}{2}$ "	"
1	"	32" (4'	"

2. Plane up all surfaces.
3. Square lines on 61" length across face as shown on the drawing.
4. Place all other pieces (face sides) together and level at one end; measure off 4" from the end and square a line across all with try square.
5. Reverse ends and repeat No. 4.
6. Find centre of each length and mark a line at 45° through centre point, and on this, prick out nail positions.
7. Bevel corners off on each length as shown, and form the long taper point on the middle support, as shown on drawing.
8. Touch under side of joints with glue, insert nails, place bars across the middle support, and nail in place.
9. Repeat similar details for outer supports.
10. Test for accuracy of position as per drawing; if correct,
11. Drive home and clinch all nails.
12. Clean up and neatly finish Model 8.

The introduction of the knife or file here, will involve a demonstration lesson in correct handling for effective and safe use.

Nature study chats on plants that require support during growth

- (a) For effect.
- (b) For utility.
- (c) Of necessity.

GROUP OF LESSONS No. 9.

MODEL 9: Plant Carrier or Bier.

Aim of Drawing Lesson: To secure neatness and accuracy in parallel line drawings.

The direct application of the black board free sketching of parallel lines, taught in the last supplemental lesson, is now possible. Let the children in turn build up, under guidance, a black board sketch of this model from a finished example; give assistance when absolutely necessary, but let the children feel that the work done is theirs, "not teacher's."

Finally correct, and add all working dimensions; then ask

— A PLANT CARRIER OR BIER. —

9

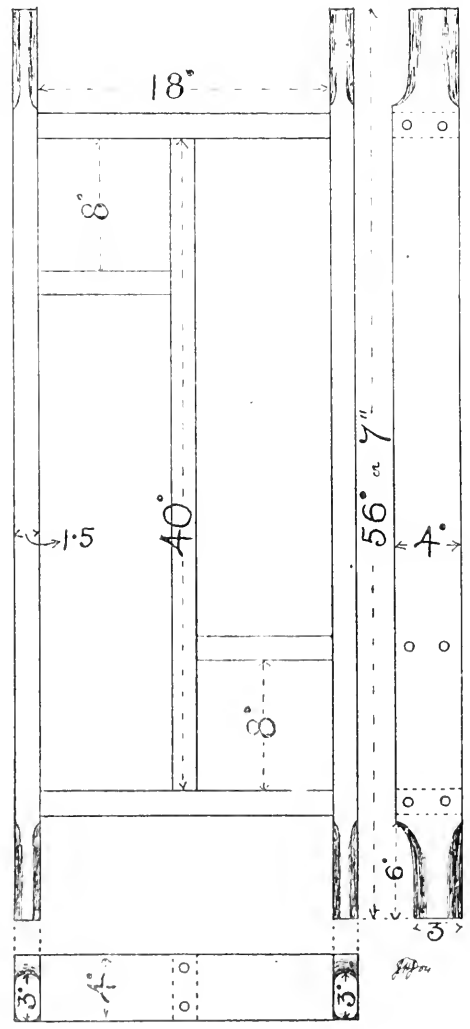

Name _____

Place paper strip
design here.

children to reproduce a finished drawing for their own use in making the model.

Show how the rounded portion of each handle is to be represented, and explain the value of the dotted lines on the side and end elevations.

Supplemental Lesson.

Little talks on parallel lines and neat drawings. Exhibit best work done in class.

Aim of Practical Lesson.

To teach accuracy in sawing to length, and square end nailing.

Materials required : A length of strip wood and some $\frac{3}{4}$ -in. panel pins.

Tools required : Rule, try square, pencil, saw, plane, pricker, knife, hammer, file.

Procedure for the construction of Model 9 :

1. Mark and saw off two strips 56" (7') long.
Mark and saw off two strips 18" ($2\frac{1}{4}$ ') long.
Mark and saw off one strip 32" (4') long.
2. Plane or smooth up all surfaces.
3. Form with file or knife, a handle at each end of the long pieces.
4. Find centre of each short piece, draw square line across, with try square and pencil; prick nail positions.
5. Glue and nail short lengths at each end of centre rib as shown on drawing.
6. Mark and saw off two pieces equal in length to the cross projecting pieces on each side of centre rib.
7. Test for accuracy of length: glue and nail these in position, one on each side of centre rib, 8" from the cross pieces, as on drawing.
8. Measure exact overall dimensions of the cross rib and ends, and set off half this distance on each side of the centre line of side pieces. Mark lines across with try square and pencil.
9. Prick positions for nailing on each side piece.
10. Touch each end of cross pieces with glue, carefully adjust one side, insert nails, and "square drive" home. *The nail must be held vertical whilst being driven in, to secure direct square nailing.*
11. Repeat No. 10 on the other side piece.
12. Test accuracy of work with drawing measurements, clean up and neatly finish off Model 9.

The introduction of end nailing into thin wood will involve a demonstration, and probably some practice on waste pieces, before attempting procedure 5.

Position drills: (a) Rounding with knife, (b) Sight testing for winding, and for right angles.

Sequence or Continuation Lesson.

Nature study chats on the transport work in our garden, re-potting and moving plants; or, little talks on ambulance corps and their work; first aid, etc.

NOTE.—If the latter sequence lesson is given, the model should be modified by fixing a piece of canvas cloth on each cross piece, omitting the centre rib and division bars.

GROUP OF LESSONS No. 10.

MODEL 10: Square Frame.

Aim of Drawing Lesson: To impress the simple elements of geometrical figures.

The overlap form of construction adopted for this model provides a simple method readily adaptable to the building up of any simple framing, where it is necessary that the faces of each component part shall be "flush," or in one plane. Reference may be made to the built-up comparison model used in drawing lesson No. 7, and also to the form of the Tee square head, as constructed for model No. 3, before making a pictorial view of one side of the model. A specimen or standard model should be shown to the children. (For clearer illustration, this model should be made to readily come apart; dowel pins (wood pegs) being used at the corner joints instead of nails). The children should be encouraged to make free sketches of the joint, and to place the several dimensions (as given by the black board drawing in correct projection) in each respective position; afterwards a finished line drawing, showing the elevation, plan, and constructional side view, should be made by each child to serve as a working drawing.

BUILT-UP SQUARE FRAME.

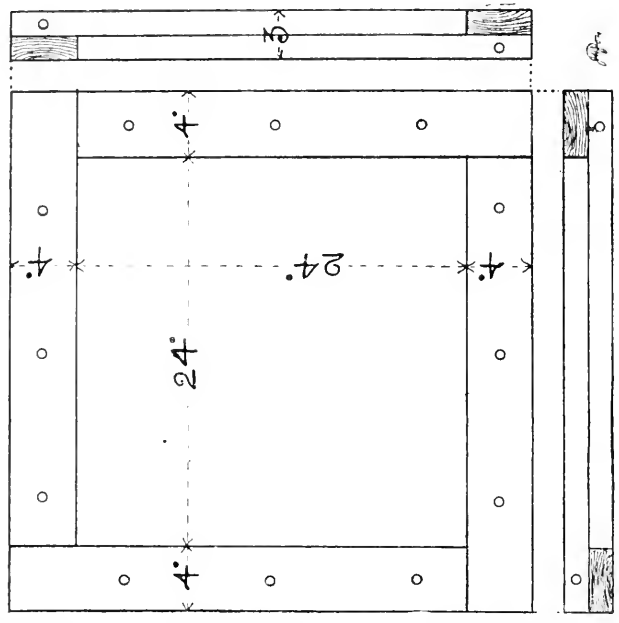

Place paper strip
design here.

Name.

Supplemental Lesson.

Little talks on geometrical solids and skeleton figures.

Aim of Practical Lesson.

Accuracy in simple construction, and long nailing in end grain.

Materials required : Two lengths of strip wood, some long and short panel pins.

Tools required : Rule, try square, pencil, saw, plane, pricker, hammer.

Procedure for the construction of Model 10 :

1. Mark and saw off eight pieces 32" (4') long.
2. Plane or smooth up *one surface and one edge only* of each piece.
3. Place all pieces together (rough side up) and test for exact length, and square ends.
4. Square lines across 4" away from each end. (*Fig. 26A.*)
5. Prick positions of face nails on four pieces, as shown on the drawing.
6. Touch rough surfaces with glue, place end of one piece to marked line on another, to build up sides.
7. Insert nails, drive home and clinch.
8. Test for accuracy of length (*all pieces must be equal*).
9. Form two right angles by edge nailing two built-up sides together at the joint corner, using two nails at each.
10. Test each angle, correct if necessary, then
11. Form the square by joining the free ends of the side pieces, and nailing as for No. 9, and test all angles.
12. Carefully smooth off both faces and edges on glasspaper and neatly finish Model 10.

Position drill: Square testing. Boring, and end nailing.

Sequence or Continuation Lesson.

Little talks on daily work in gardens and greenhouses.

GROUP OF LESSONS No. 11.

MODEL 11: Enclosure Rails.

Aim of Drawing Lesson: To secure neatness in drawing parallel lines, and inserting dimensions.

An elevation of the model to be made should be sketched on the

ENCLOSURE RAILS OR PALINGS.

11

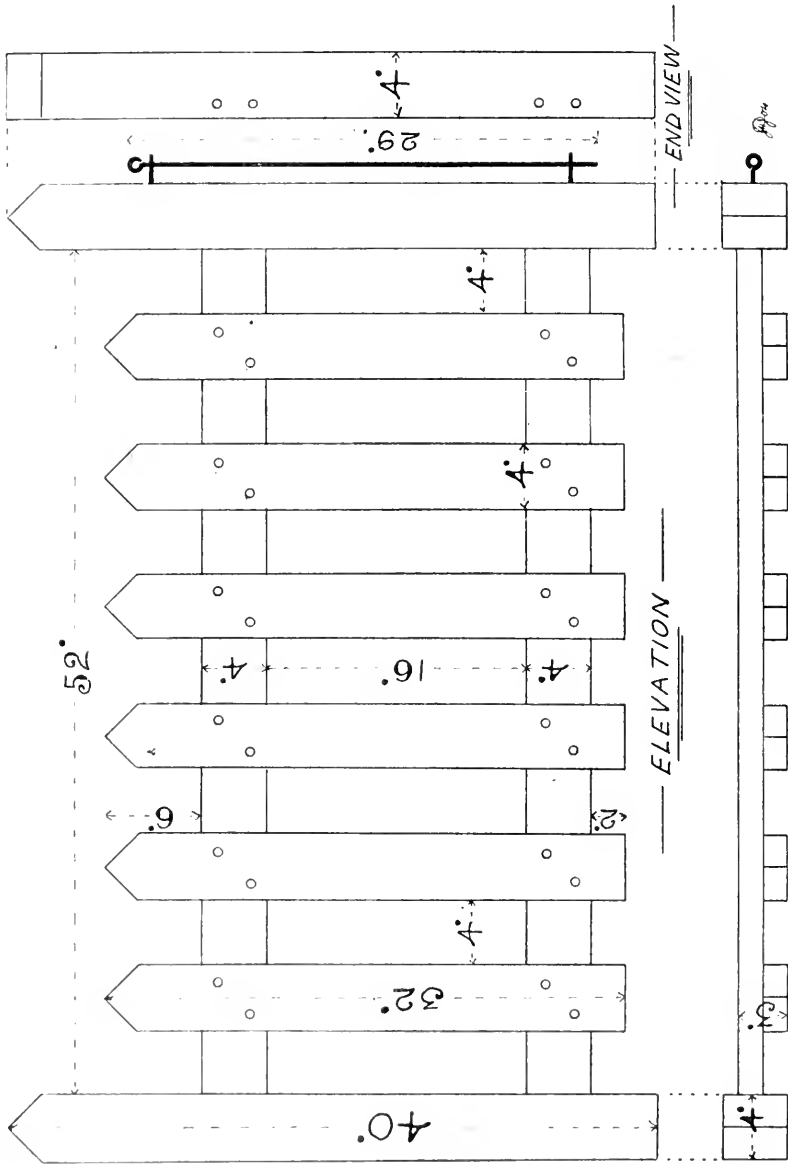

Name _____

Place paper strip
design here.

black board; encourage the children to produce a plan, and also a side view in correct relationship. Use a finished standard model to aid their efforts, and give the names of the several elements—rails, posts, etc.

Give the various overall dimensions, and ask for the distances between certain points; write down the answers, and encourage the children to correct, where necessary. A free use of the Unit rule will materially assist these calculations. Lead the children to apply their simple arithmetic lessons to mental calculations.

The completed full-size drawing made by each child, should show an ELEVATION and PLAN, and be neatly finished with all the detail, duplicate, and overall dimensions in correct style.

NOTE.—The pointed head of each rail may be drawn with the aid of set square and rule, or Tee square and 45° set square, as may also the diagonal spacing of the face nails on each rail.

Supplemental Lesson.

Little talks on mental calculations, sub-divisions and parts, using concrete examples, and finally leading up to the necessity of dimensions.

Aim of Practical Lesson.

To teach sight proportion and measurement, overlay construction and nailing.

Materials required: A piece of $\frac{1}{2}$ " square whitewood over 10' long, two lengths of strip wood, and long and short panel pins.

Tools required: Rule, try square, pencil, saw, plane, picket, file, broadawl, knife, hammer.

Procedure for the construction of Model II:

1. Mark and saw off 2 pieces $16'' \times 1''$ ($5'$) long for side posts.
 2 .. $52''$ strip wood ($6\frac{1}{2}'$) long for cross rails.
 6 .. $32''$.. ($4'$) long for palings.
2. Plane or smooth up all surfaces.
3. Bevel or shape top of rails with knife, file, and glasspaper.

4. From the square end of each rail, measure and square lines across at $2'' + 4'' + 16''$ as shown on drawing.
5. Prick positions for nails on each rail as shown on drawing.
6. Test length of cross rails and square lines across $4''$ from each end.
7. To these lines and to the square lines on each face, place in position a rail at each end.
8. Glue, nail, and clinch in position.
9. Place the remaining rails at proportionate distances apart and test, for equality of spacing; then mark to each position.
10. Insert nails, glue, nail, and clinch in position.
11. Set off $4''$ from bottom of each side post; mark position for nailing, and bore holes nearly through post.
12. Insert long nails; glue and adjust posts to cross rails; hold nails square and drive each home.
13. Test with try square, and sight test for "winding"; adjust where necessary.
14. Clean up with glasspaper and neatly finish Model 11.

A short piece ($12''$ long) of strip wood may be double nailed on the bottom of each side post to give more stability. Two wire eyelets made from long panel pins may also be fixed in one side post to provide a hinge upon which to hang a swing gate. A long wire pin is passed through these eyelets, as shown on the drawing.

Position drill: Test for "winding." Planing.

Sequence or Continuation Lesson.

Little talks on garden enclosures and shrubberies; colonial compounds, penal settlements, stockades, etc.

GROUP OF LESSONS No. 12.

MODEL 12: Garden Gate.

Aim of Drawing Lesson: To teach the use of set squares and rule in combination, in lieu of the Tee square.

Following on the method suggested in the previous lesson, a proportionate free black board sketch elevation of the gate, should be

made by the teacher. The children meanwhile should draw a series of parallel lines in three positions with set square and rule combined, as was done in the supplemental lesson in Group 8, in order to become familiar with these aids, and to gain full confidence for further application.

Ask for instructions, as to producing the plan and side view drawings. "Where should the plan be placed? How shall I begin? You show me. Is that correct, children?" and thus arouse direct interest. Exhibit a standard model and get the children to name the several elements, point out the close resemblance to previous model (exhibit the best example done in class). Ask children to note any point of difference. State the object of the diagonal strut or rib. Show how a square frame may be distorted — changed in form, by opposing forces applied at the corners. Now tie a piece of macrame string across, to form a diagonal of a similar square frame, and apply similar opposing forces; let children note the result, then explain that the strut is sometimes called a *tie bar* because it ties the square together by forming two triangles, and lead up to the statement that the alteration of the angles of any triangle, involves an alteration in the length of the sides which enclose such angles. Get the children to realize, that when the gate is fitted to the side post of the previous model, it is suspended, and that its own weight would be sufficient to alter the right angles if the strut were not fitted.

Further illustrate the statement, by reference to the black board easel, where the front and back legs form two sides of a triangle, the floor being the third. Firmly impress this important principle of construction, for upon it, depends very largely the efficiency of future work.

A complete elevation and plan of the gate, fully dimensioned as a working drawing, should be the final result of the lesson.

Supplemental Lesson.

Little talks on the circle, its division into degrees and angles. The set squares and other drawing instruments.

GARDEN GATE.

Place paper strip
design here.

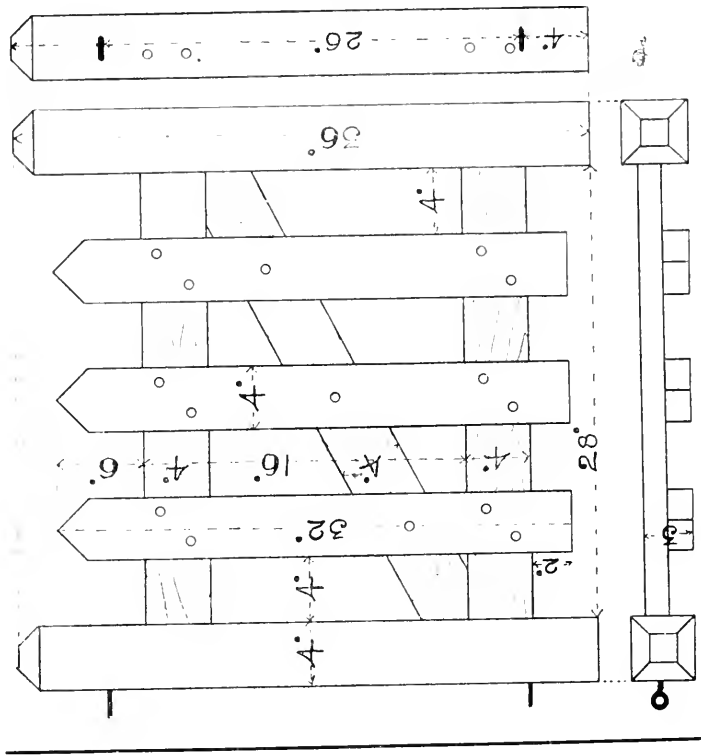

Name _____

Aim of Practical Lesson.

To teach oblique sawing to line, accurate measurement, fitting, and nailing.

Materials required : $\frac{1}{2}$ " square and strip whitewood, long and short panel pins.

Tools required : Rule, try square, pencil, saw, pricker, file, plane, knife, bradawl, hammer.

Procedure for the construction of Model 12 :

1. Mark and saw off to given lengths the posts, rails, and cross rails.
2. Plane or smooth up all surfaces.
3. Shape tops of rails and posts with knife, file, and glasspaper.
4. Place palings at proportionate spaces on cross rails; mark positions; glue, and nail complete.
5. Mark position of cross rails on side posts; bore for long nailing; glue rail ends, and nail each in place.
6. Test for square angles.
7. Measure accurately, length of diagonal between side posts and cross rails.
8. Mark and saw off length of strip wood for strut.
9. File and fit strut between posts.
10. Re-test for accuracy of square angles.
11. Remove strut; smooth all surfaces; glue, and nail to rails, as shown on drawing.
12. Clean up with glasspaper all outside surfaces.
13. Prepare two eyelets as in previous model.
14. Mark off positions; insert eyelets to form hinges, and attach to Model 11.

Position drills: Square and sight testing, end nailing, and use of glasspaper in finishing.

Sequence or Continuation Lesson.

Little talks on garden produce, fruit, flowers, vegetables.

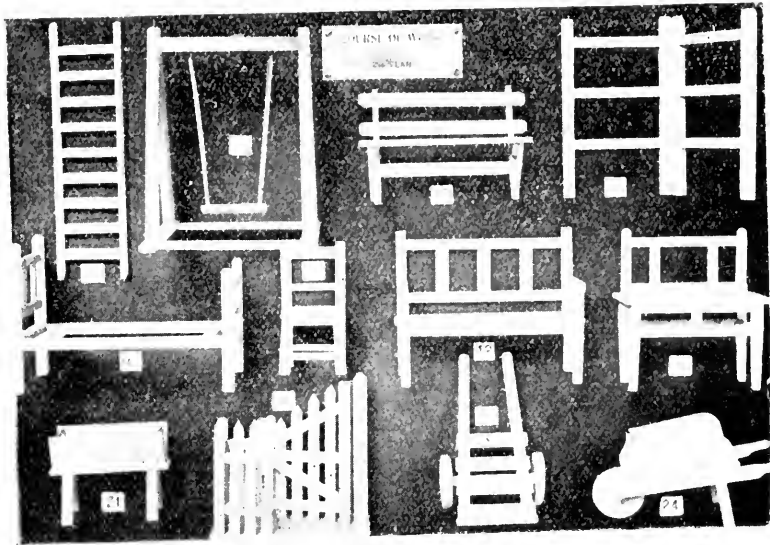

Second or Intermediate Group of Lessons.

GROUP OF LESSONS No. 13.

MODEL 13: Stepladder.

Aim of Drawing Lesson: To familiarize the combined use of rule, set square, and Tee square.

For ready reference, a full detail drawing of this model should be prepared previous to the lesson; make free use of a standard model to show how the *steps* are placed parallel with each other, and oblique to the front elevation. A sketch drawing may be built up as the lesson proceeds, to show how the oblique lines are obtained and produced parallel to each other, by the aid of rule and set square.

Encourage careful measurement and setting out on the sectional view, as upon the accuracy of such will depend the value of the other views. The final result should be neatly dimensioned in detail, duplicate, and overall measurements, and carefully grained to show

the longitudinal and end grain of the wood. Questions upon the plan of the model should be asked, but a finished drawing of it is unnecessary.

Supplemental Lesson.

Little talks on neatness and accuracy.

Aim of Practical Lesson.

To give additional training in accurate sawing to length, and end nailing.

Materials required : Two lengths of strip wood and some long panel pins.

Tools required : Rule, try square, pencil, saw, plane, pricker, scratch beader, knife, hammer, file.

Procedure for the construction of Model 13 :

1. Find centre of one length (2 ft.) strip wood, and on each side of it set off 1" ; square lines through the points, and join by a diagonal across the face.
2. Saw exactly *on* this diagonal line, cutting length in two.
3. Plane up all surfaces, and scratch-bead outer front edges.
4. Mark and saw off waste to leave each piece 80" long (10").
5. Shape ends with knife and file.
6. Set off positions of steps on each inside, *i.e.*, draw a line parallel with and 6" away from the oblique bottom of each side ; then a second line parallel to, and thickness of strip wood away from, the first ; and continue these distances and lines for eight other steps.
7. Bore holes 1" away from each edge, in each narrow space or step way (bradawl *point* to just show through).
8. Mark and saw off nine pieces 18" long (2 $\frac{1}{4}$ ").
9. Test for square ends, and accuracy of length.
10. Plane up all surfaces.
11. Glue ends, and nail in position, top and bottom steps.
12. Test for square angles, and winding of sides ; adjust if required.
13. Glue ends ; insert and nail centre step ; test.
14. Repeat 13 until all steps are fixed in position.
15. Re-scratch outer bead ; smooth up and neatly finish step edges, sides, and ends of Model 13.

NOTE. The introduction of the scratch-beading tool (*Fig. 13*) will involve a demonstration of its use during the lesson.

A STEP LADDER.

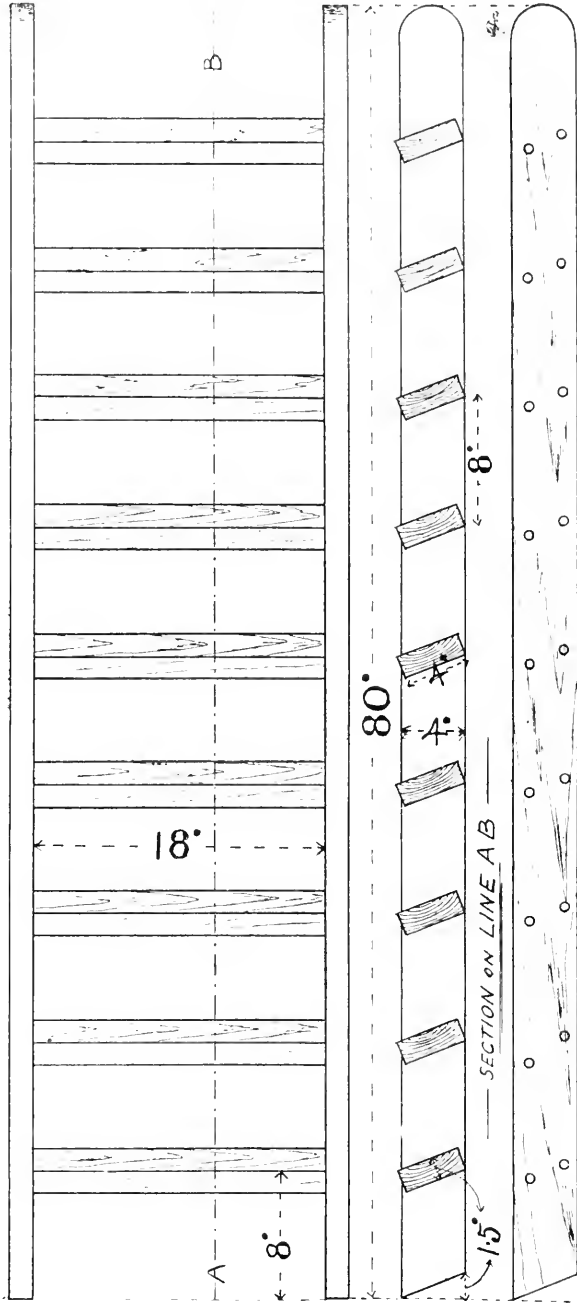

Sequence or Continuation Lesson.

Little talks on garden work in Autumn, gathering fruit, etc.; or use of ladders in every-day life for buildings, fire escapes, etc.

Position drill: Sawing, and nailing to a line.

GROUP OF LESSONS No. 14.

MODEL 14: Children's Garden Swing.

Aim of Drawing Lesson: To prove the necessity of scale drawings, and the need of more than one outline.

A full-size standard model should be exhibited to the class, to show that to make a complete drawing of it, as we have done for previous models, a much larger piece of paper would have to be used. Lead up to educating that a smaller drawing, if correctly marked with full-size measurements, will answer the same purpose. Explain how large buildings are made from small drawings, often from photographs, and that for any very difficult part, large-size detail drawings are made. Induce the children to suggest how a smaller drawing of the swing can be made by using the Unit rule. Show that by dividing each Unit into two parts, and using one-sixteenth as the scale Unit, a drawing half the original size of the model is readily made.

The black board or chart drawings should be at least three times full size; these may be drawn line by line during the lesson, or be previously prepared (the former plan is more satisfactory).

Front and end elevations only will give no indication of the actual form of the base framing. Point this out carefully, to enable the children to realize the difficulty they would have, in making a model with the two views only supplied. Let them sketch the base plan from the model, the aim being to obtain from each child in class neat half-size drawings, fully dimensioned for accurate working.

Supplemental Lesson.

Little talks on Unit rule proportion, proportionate and scale measurements.

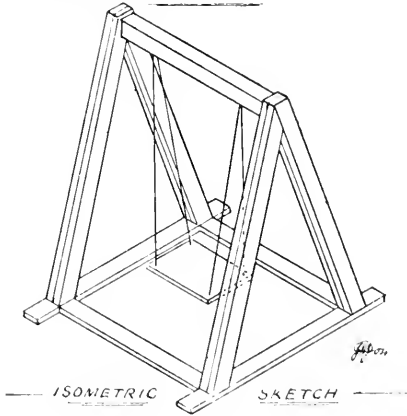
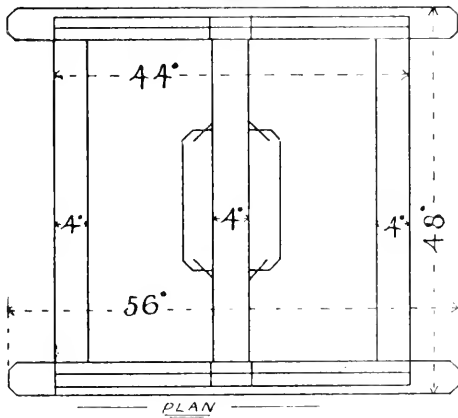
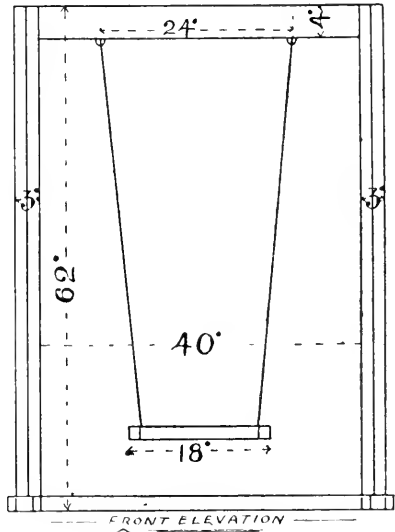
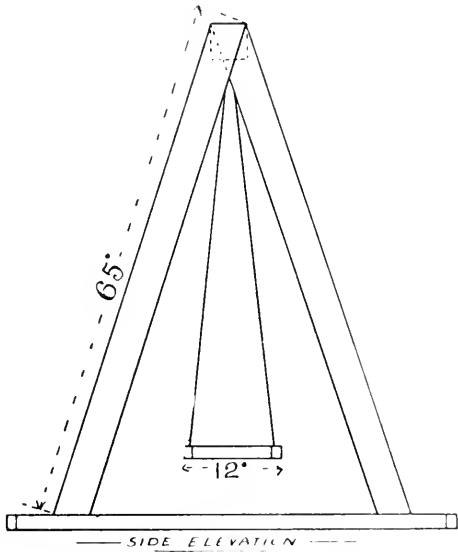

Aim of Practical Lesson.

To teach the simple elements of construction by triangles.

Materials required for each model :

- A 5" length of $\frac{1}{2}$ " square white wood.*
- Three lengths of strip wood 2" long.*
- Two lengths of fine wire 15" long.*
- Some $1\frac{1}{4}$ ", $\frac{3}{4}$ ", and $\frac{3}{8}$ " panel pins.*

Tools required : Rule, try square, pencil, saw, plane, pricker, scratch beader, file, hammer, and cutting pliers.

Procedure for the construction of Model 14 (side frames) :

1. Mark and saw off eight pieces 66" long ($8\frac{1}{4}$ ").
2. Plane or smooth up one side of each piece.
3. Cut a card template or "tablet" to fit the angle of the Λ framing as formed on the drawing.
4. Apply this template to four of the pieces : mark at one end across face, and saw off waste.
5. Glue rough surface of other pieces : place in pairs (square ends together), nail and clinch to form built-up sides.
6. Carefully plane up both edges, and scratch-bead outer edges only.
7. Glue, place, nail, and clinch the half jointing to form the frames.
8. Test for equality : place rule across bottom outside points, and draw a line across each side.
9. Saw off small waste piece, and finish with file, to form bottom butt joints.
10. Test for accuracy (each frame to stand vertical) : clean up beads, and finish frames.

For base framing and head piece :

1. Mark and saw off two pieces 56" long (7") :
two " 40" " (5").
2. Plane or smooth up all surfaces, and bevel off corners.
3. Mark lines across edges 6" from each end of 56" lengths.
4. Bore for double nailing.
5. Glue and nail framing together.
6. Saw off 4" square piece 18" long for head piece.
7. Plane up all surfaces.
8. Fix head piece in position, bore side frames, glue, and double nail.
9. Make two wire eyelets and fix in position shown, *i.e.*, 12" on each side of centre of head piece.
10. Fit, glue, and nail Λ frames to base frame.

For seat piece :

1. Mark and saw off three pieces strip wood 18• (2 $\frac{1}{4}$ " long.
2. Bore for edge-nailing on two pieces; glue, and nail all together to form seat slab.
3. Smooth surfaces and edges, and bevel off corners.
4. Bore at each corner for suspension rods.
5. Prepare two suspension rods (by turning a length of wire over nose of pliers to resemble long hairpins).
6. Cut off each length to 56•.
7. Pass ends through eyelets in head piece, and through holes in seat.
8. Bend over with square jaw of pliers 2• length of the projecting ends.
9. Test for seat level when suspended.
10. Form back rest, by placing the ends of a piece of wire (bent to a bow form) into the holes of the back seat, and adjust as required.
11. Test for accuracy, free movement, and stability.
12. If correct, smooth all edges and complete Model 14.

NOTE.—If the wire suspension rods present any great difficulties in construction, thin macrame string may be used for hanging the seat, the same back rest being available.

Sequence or Continuation Lesson.

Little talks on playtime in the garden, or recreation, what it is and why necessary.

Tool position drill, or demonstration of tool manipulation :

- (a) Wire working with pliers.
- (b) Skew nailing.
- (c) Scratch beading.

GROUP OF LESSONS No. 15.

MODEL 15: Garden Seat.

Aim of Drawing: To familiarize the use of set squares for oblique work, and to demonstrate the need of more than one drawing.

A single line or skeleton diagram of this model should be sketched on the black board in pictorial elevation, and the children encouraged

A GARDEN SEAT.

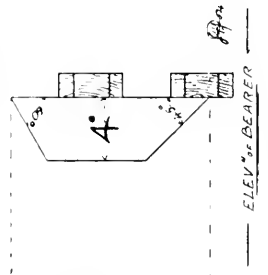
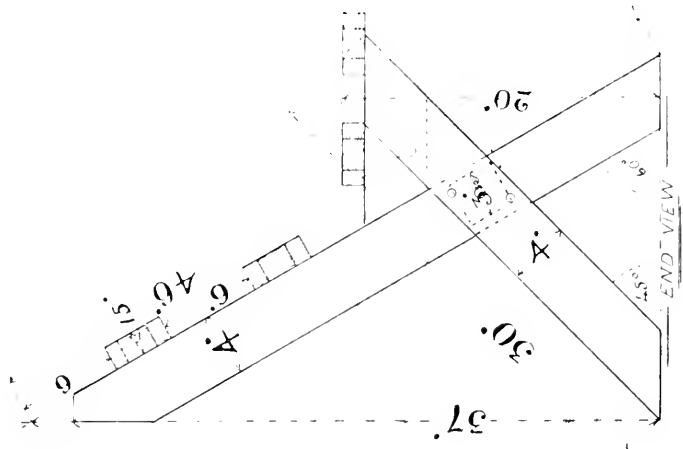
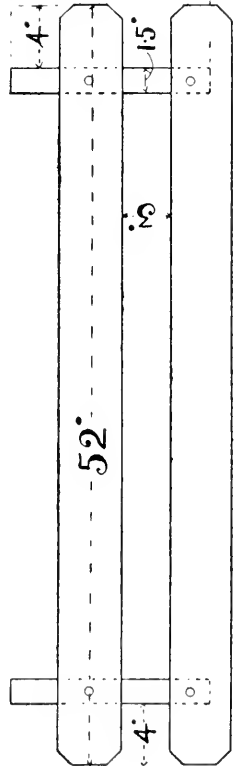
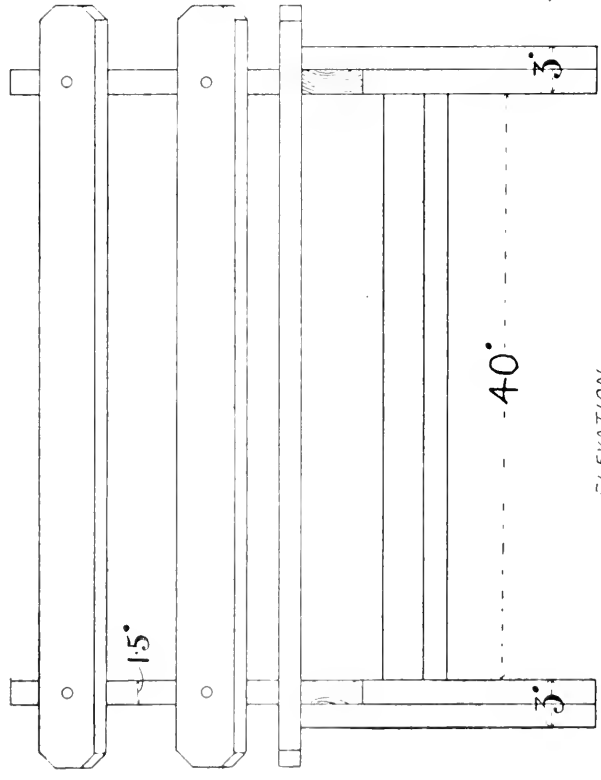

to put in the details. This should be followed by a "line by line built-up" end elevation, using the set squares to obtain the oblique lines, the children carefully following the teacher's copy. Encouragement should now be given to secure from each child a properly projected front elevation, a finished standard model being exhibited freely during this part of the lesson. Educe the necessary particulars as to the total height of the elevation, and why such differs from the actual length of wood required for the side pieces. "How long shall we make the seat? Does the side view tell us? What kind of a drawing would tell us?" "A pictorial view." "Yes." Mark the dimensions on the skeleton diagram, and ask the children to point out the relative positions of each on the finished drawing of the end view. From the children's answers, proceed to develop the front elevation, and aim at getting from each child a neat working drawing.

Supplemental Lesson.

Little talks on geometrical terms and figures, and on the value of the Tee and set squares as aids to accuracy.

Aim of Practical Lesson.

To teach the elements of triangular construction; to secure strength with simplicity, and to give more difficult nailing exercises.

Materials required: Lengths of strip wood, short and medium panel pins, and a piece of square whitewood.

Tools required: Rule, try square, pencil, saw, plane, prickler, bradawl, knife, hammer.

Procedure for the construction of Model 15:

1. Mark and saw off 4 pieces strip wood $52''$ ($6\frac{1}{2}''$), seat and back rails.
- " " 2 " " $16''$ ($5\frac{3}{4}''$), side frames.
- " " 2 " " $30''$ ($3\frac{3}{4}''$), "
- " " 2 " " $12''$ ($1\frac{1}{2}''$), seat bearers.
2. Plane or smooth up all surfaces.
3. Bevel off ends of seat and back rails.
4. Mark and saw off opposite ends of long side pieces to $60'$ and $30'$.
5. " " each end of short side pieces to $45'$.
6. " " opposite ends of seat bearer to $45'$ and $60'$.

7. Mark and saw off one piece 3" square, 40" (5') long, for stay, or stretcher piece; plane up all sides, and square each end.
8. Adjust each pair of side pieces (short lengths on the top) to the positions shown on the drawing, and bore a centre hole in each piece.
9. Adjust, glue, and nail each pair together.
10. " " " " bearer in position as shown.
11. ● " " " " nail stay in position as shown.
12. " " " " nail seat and back rails in position as shown.
(Front rail to be nailed from the under side.)
13. Test for accuracy and stability; adjust if necessary.
14. Finish off top end of side supports as on drawing; clean off all edges, and complete Model 15.

The use of the clinching block as a temporary nailing support must be demonstrated in this lesson.

Sequence or Continuation Lessons.

Little talks on parks and pleasure grounds, what they contain and why provided.

Position drill: Testing of oblique angles.

GROUP OF LESSONS No. 16.

MODEL 16: Clothes Aircr or Maiden.

Aim of Drawing Lesson: To teach simple transposition and combination of drawings.

The drawing of this model as given in parallel projection is a very simple exercise, when compared with some of the previous examples; but for the purpose of transposition, *i.e.*, the production of a pictorial delineation based on a geometrical basis, it is of sufficient difficulty to warrant progression.

A line diagram of the model should be made on the black board, and from this should be developed a free sketch, upon which may be placed all the necessary dimensions. A large-size drawing, in true parallel oblique projection, should be made as a chart, and freely used for observation purposes by the children, who should be encouraged

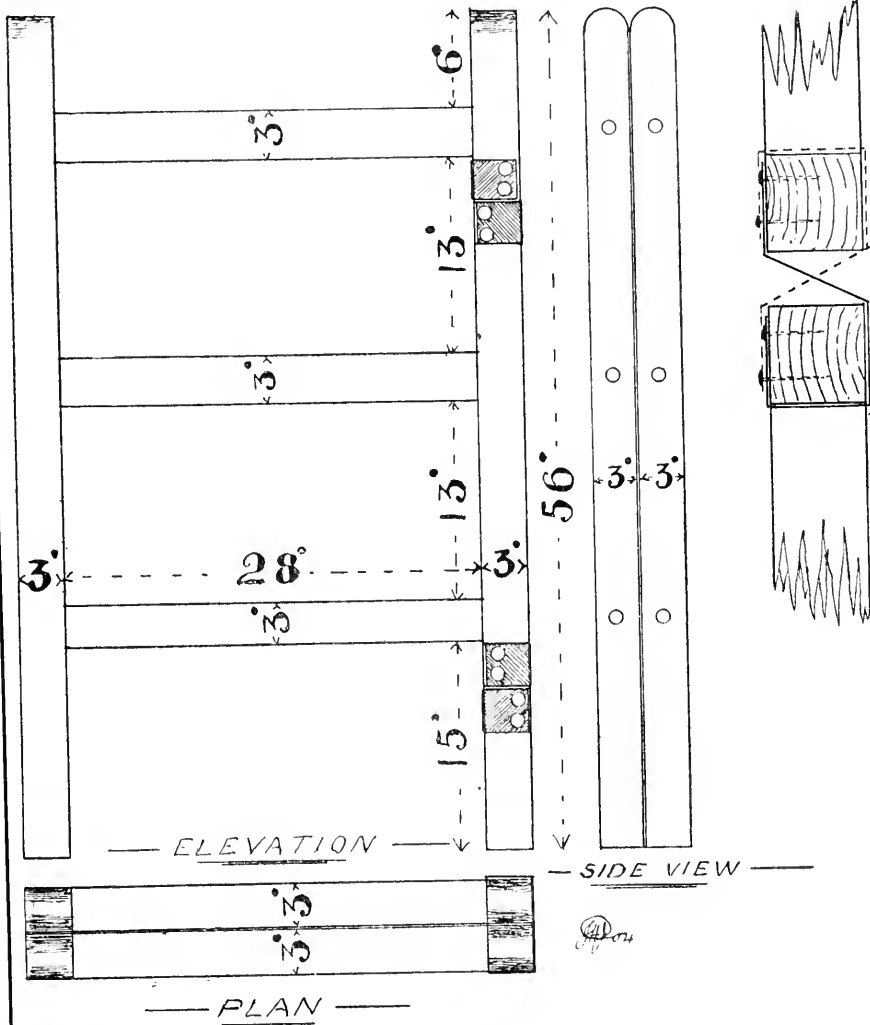

ENLARGED DETAIL OF STRAP HINGE

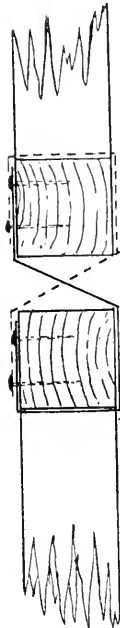

to direct the teacher how to produce a similar drawing on the black board by the line by line method, using the Tee and set square combined.

Should any difficulty be found in transposing the drawing, as a whole, demonstrate how one of the side pieces may be drawn to show solidity by the aid of a 30° set square (all measurements being set out full size on the respective lines drawn), adding the rails to the side, as would be done, if the practical lesson were being worked. Fully impress the general principle, that all lines, vertical, oblique, or horizontal, are parallel in each respective position, and that the measurements are always taken in the direction of each line.

As the principle may be readily applied to any of the models, it is suggested that some extra time be spent upon this lesson, in order to thoroughly elucidate all details of method, which may be necessary to produce the desired result, so that wherever and whenever a more intelligible rendering of any detail, or complete drawing, is required, recourse can be at once made to the method of oblique parallel projection.

Supplemental Lesson.

Little talks on parallel and oblique projections, model drawing, or sketches involving parallel lines.

Aim of Practical Lesson.

To give further training in accurate sawing to length, end nailing and double-strap hinging.

Materials required: Square whitewood, long panel pins, four short pieces of tape.

Tools required: Rule, try square, pencil, saw, plane, bradawl, file, hammer.

Procedure for the construction of Model 16:

1. Mark and saw off 4 pieces 56" (7') long for side posts.
 ,, ,, 6 ,, 28" (3½') ,, rails.
2. Plane or smooth up all sides, and accurately test lengths.
3. Round up with file one end of each side post.
4. Mark position of each rail on each side post.
5. Bore for end nailing.
6. Glue and nail rails in position.

7. Place frames together with tapes between and close below top and bottom rails.
8. Glue or nail end of tapes on left hand post; pass free ends under right hand post; draw tight; glue or nail on top side of right hand post.
9. Place other tapes just below those already fixed.
10. Glue or nail ends on right hand side post; pass free ends under left hand post; draw tight; glue or nail on top side of left hand post.
11. Test for accuracy of construction in every detail.
12. Carefully clean off all surfaces; smooth up, and complete Model 16.

NOTE.—If thought to be more simple, the tape hinges may be made to finish on opposite sides of the side posts, instead of in the manner shown on the drawing.

Sequence or Continuation Lesson.

Little talks on household duties:—Helping mother, washing, drying, and airing of flannels, cotton or silk fabrics; or on our clothes:—The raw material, production, make up, and after care.

Position drill: Square testing, and a demonstration lesson on strap double hinging.

GROUP OF LESSONS No. 17.

MODEL 17: Dolly's Bedstead.

Aim of Drawing Lesson: To teach a simple method of reducing repetition work on similar views, and to economize space.

The drawing of this model is to be obtained in a similar manner as the preceding, *i e.*, by transposition.

Exhibit a standard model, and deduce that each side of the centre of the head and foot pieces or frames respectively are identical. Lead the children to observe that a portion of the head piece is covered by the foot piece, and that they differ in the height of posts and panel rails only. Exhibit a large chart diagram of the model in pictorial, or oblique projection; educe that this drawing shows the

length, width, and thickness, or height of each piece of wood used in the model, and that it embodies the dimensions from which may be drawn the elevations and plan in parallel projection. Draw a large-size side elevation on the black board, and ask for directions to produce the elevations of the head piece, foot piece, and the plan.

Turn the chart diagram face to wall and remove the model.
 “How wide shall we make the next drawing? (Cannot you tell me? Does this elevation tell me anything about the width?” “No.”
 “What does it tell me?” “The height of the posts.” “Yes. Anything else?” “The height of the side rails.” “Yes. Anything else?” “No.” “Then we must determine the width ourselves. What width would you make it, Elsie? and you, Marion?” Thus lead the children to design or determine the other elements. Now exhibit the model, and ask the children to observe the proportion of width to length (training sight measurement), and finally give the required dimensions on a rough sketch end view. Next develop the plan on similar lines, and from it project the elevation of the foot piece. Name and fully dimension each view, and aim at producing neatly finished full-size drawings.

Supplemental Lesson.

Little talks on transposing drawings and on combination of views; or recapitulate lesson on parallel and oblique projections.

Aim of Practical Lesson.

To give additional training to get accurate sawing, fitting, and nailing.

Materials required: Square and strip whitewood, long and medium panel pins.

Tools required: Rule, try square, pencil, saw, plane, file, bead scratch, Bradawl, hammer.

Procedure for the construction of Model 17:

1. Mark and saw off square wood. 2 pieces 44^{\bullet} ($6\frac{1}{2}''$) long, head posts.
- " " " 2 " 36^{\bullet} ($4\frac{1}{2}''$) " foot posts.
- " " " 2 " 58^{\bullet} ($7\frac{3}{4}''$) " side pieces.
- " " " 1 " 28^{\bullet} ($3\frac{1}{2}''$) " stretcher pieces.

DOLLY'S BEDSTEAD.

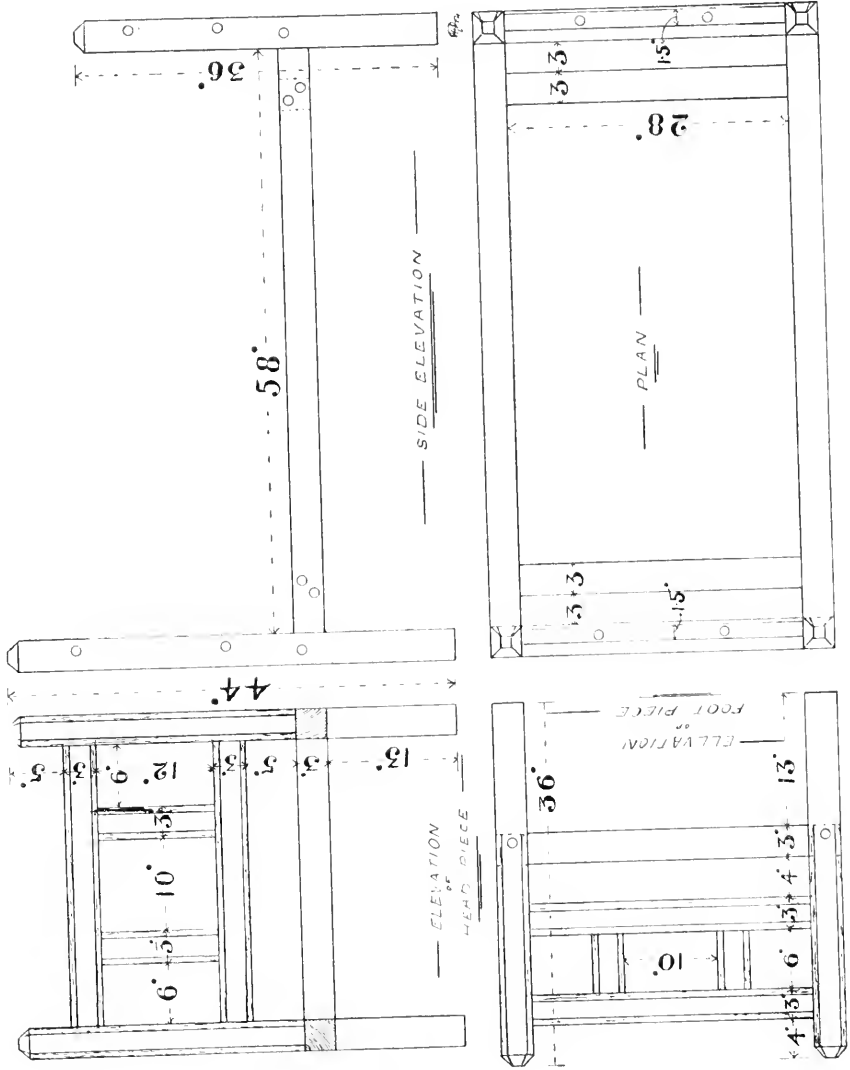

- | | | | |
|---------------------------------------|--------------------------------|---|---|
| Mark and saw off strip wood, 4 pieces | 28• ($3\frac{1}{2}$ " long) | } | Head and foot panel
pieces, rails, and ribs. |
| | 2 .. 12• ($1\frac{1}{2}$ " .. | | |
| | 2 .. 6• ($\frac{3}{4}$ " .. | | |
2. Plane or smooth up all surfaces, and test accuracy of equal lengths.
 3. Scratch-bead all strip wood pieces on two edges (face side), and likewise on head and foot posts, leaving 16• from one end of each piece square as planed
 4. File and finish top of each post as on drawing.
 5. Mark position of panel ribs on rails, and also rails on posts.
 6. Bore for edge nailing, glue, nail, and complete each panel.
 7. Glue, and nail panels to side posts: fit, glue, and nail square stretcher bars in position.
 8. Mark positions of bed stretcher bars on side pieces; bore, glue, and double-nail frame together.
 9. Test for accuracy; adjust; bore for nailing; glue, and double-nail head and foot pieces to bed frame.
 10. Re-scratch outer beads; test for winding; adjust, if necessary; clean up and carefully finish details of Model 17.

NOTE.—A piece of strong canvas (or pieces of broad tape may be interlaced), stretched, glued, and nailed to the stretcher bars, forms the bed support, or five intermediate cross rails may be nailed flush with the upper surface of the side pieces. If the latter method is adopted, the bars should be placed at equal distances apart (about 5•).

Position drill: Square testing, and edge nailing.

Sequence or Continuation Lessons.

Little talks on household duties: —Bed making, bedroom day; need of efficient ventilation when sleeping; rest after work, how best obtained.

GROUP OF LESSONS No. 18.

MODEL 18: Kitchen Chair.

Aim of Drawing Lesson: To secure neatness in finished drawings, and the intelligent reading of various views and projections.

The oblique character of the general outline of the model, constitutes an advance step in both the drawing and practical lessons.

A KITCHEN CHAIR.

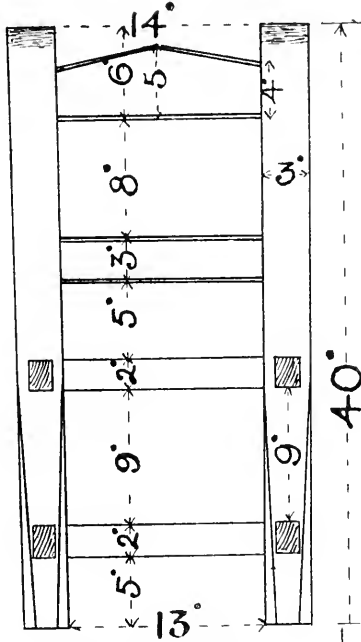

DETAIL OF BACK LEGS

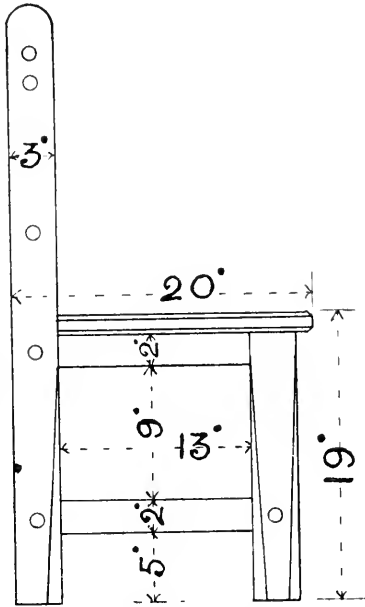

SIDE ELEVATION

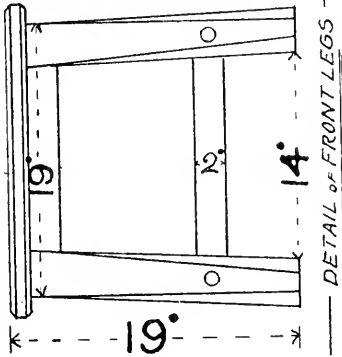

DETAIL OF FRONT LEGS

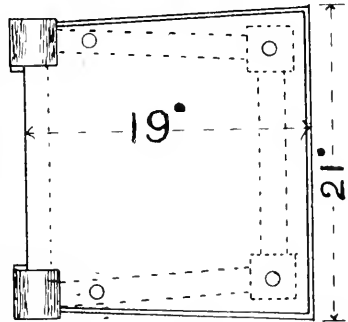

PLAN

J.P. 1924

The drawings in parallel projection require close attention to detail. Adopt the centre line method, so that equal obliquity of the lines forming the back and front legs may be secured. Having a standard model on view, build up, on the right of a centre line, a half elevation of the back and back legs, then encourage the children to add the details on the left of the line. Proceed thus, with the details of front legs and edge of seat, and also the plan.

A full pictorial view of the model in chart form may be used to enable the children to more readily see, how the details are grouped together. A skeleton line diagram quickly sketched on the black board will be of equal value, as upon this can be placed the respective dimensions of each detail. Some of the more advanced scholars should be encouraged to make similar skeleton drawings, either prior to, or after, the drawing lesson, but avoid any elaboration which will detract from the efficiency of the instruction given. To impress chief principles, and to consolidate the general scheme of instruction, a recapitulation of the elements of the lessons on combinations of views, especially that section descriptive of hidden parts, and the methods used to clearly illustrate their positions, should be included in this lesson. Let the explanations of constructional details be sound, simple, and above all, entertaining and educational. The net result of this lesson should be a neatly projected drawing of the model showing at least three views, dimensioned in detail to admit of a full-size model being built up therefrom.

Supplemental Lesson.

Little talks on the drawing lesson, its value, and what it teaches.

Aim of Practical Lesson.

To give additional and more difficult end nailing and oblique surface jointing.

Materials required : Square, strip, and slab whitewood, long and short panel pins.

Tools required : Rule, try square, pencil, saw, plane, file, knife, bead scratch, bradawl, hammer.

Procedure for the construction of Model 18 :

1. Mark and saw off square wood 2 pieces 40" (5") long, back legs.

Mark and saw off square wood, 2 pieces 18" (2 $\frac{1}{4}$ " long, front legs.
 strip wood, 1 .. 14" (1 $\frac{3}{4}$ " long, top back rail.
 3 .. 14" (1 $\frac{3}{4}$ " long, other rails as on
 6 .. 13" (1 $\frac{3}{4}$ " long, drawings.
 slab wood, 1 .. 21" x 19", bottom piece.

2. Plane and smooth up all surfaces.
3. Round off with file the top of each back leg.
4. Chamfer off front and back legs with knife, file, or plane.
5. Scratch-bead all details, as shown by double lines on the drawing.
6. Form top rail with knife, plane, or file.
7. Mark positions of the top and bottom rails on each back leg piece.
8. Bore, glue, and nail these in place, and test for winding.
9. Fit in, bore, glue, and nail intermediate rails in positions shown on the drawing.
10. Mark positions of front rails; bore, glue, and nail each in place.
11. Prepare seat piece to fit in between back legs, above third rail.
12. Mark positions for, and fit in side and front, seat rails.
13. Glue and nail these in place under seat.
14. Place front legs in position, glue, and nail through seat.
15. Fit in, glue, and nail lower rails between the front and back legs.
16. Smooth up all edges of the seat; test for accuracy of measurement, and stability.
17. Re-scratch outer edges of back and rails; smooth up all details, and complete Model 18.

Position Drill: Use of file for rounding and chamfering.

Sequence or Continuation Lesson.

Little talks on household duties:—Daily work in the kitchen, preparation of food, etc. Furniture making:—Processes of manufacture, and materials used in common and high-class chair making. General designs in common use.

GROUP OF LESSONS No. 19.

MODEL 19: Dolly's Couch.

Aim of Drawing Lesson: To secure neatness of finish, and an intelligent reading of projected views.

The methods adopted in the previous lessons on parallel projection can be readily applied to this model, as the front elevation, side view, and plan give all the essential particulars for the practical lesson.

Draw a large-size view of one end of the model on the black board, placing the several dimensions thereon; then sketch a skeleton outline of it in oblique projection, and ask for the other dimensions, the children to compare by observation only, the length with the height and width of the standard model exhibited. Write down several replies; finally measure the model, and place the correct dimensions *on* the skeleton line diagram.

Develop the front elevation from the end view and the given dimensions, and follow on with the plan in due order.

Point out the advantage of the pictorial sketch, and lead the children to reproduce it for their own guidance. In some cases, the skeleton outline will be more readily understood than the other views. The teacher should then devote more time to obtaining a correct representation to actual full-size dimensions, by making the orthographic drawings the secondary part of the lesson.

Sustained interest is obtained if the children are allowed to build up a black board pictorial view direct from the model, before attempting their own individual drawing. Coloured chalks, dark red for mahogany, light brown for oak, dark brown for walnut, may be used to give additional effect, and to familiarize the names of the timber trees, which supply wood for the purpose of furniture making.

Whatever means are adopted to secure the intelligent reading of the several details, the result should be a neat line drawing fully dimensioned, from which a replica of the model may be made.

Supplemental Lesson.

Little talks on the value of coloured chalks for black board sketching.

Aim of Practical Lesson.

To give additional training in the use of the plane and file, for taper and surface working.

Materials required: Square, strip, and slab whitewood, large and small panel pins.

Tools required: Rule, try square, pencil, saw, plane, file, pricker, bradawl, bead scratch, and hammer.

Procedure for the construction of Model 19:

- | | | | | | | |
|----|-------------------------------|---|-------------|------------------------|-------|--------------|
| 1. | Mark and saw off square wood, | 2 | pieces | 47" ($5\frac{7}{8}$ " | long, | back legs. |
| .. | .. | 2 | .. | 28" ($3\frac{1}{2}$ " | .. | front legs. |
| .. | .. | 2 | .. | 22" ($2\frac{3}{4}$ " | .. | arms. |
| .. | .. | 2 | .. | 50" ($6\frac{1}{4}$ " | .. | back rails. |
| .. | .. | 2 | strip wood, | 50" ($6\frac{1}{4}$ " | .. | under rails. |
| .. | .. | 2 | .. | 16" (2" | .. | .. |
| .. | .. | 3 | .. | 14" ($1\frac{3}{4}$ " | .. | back ribs. |
| .. | .. | 1 | slab wood, | 57" × 23" | .. | seat. |
2. Plane or smooth up all surfaces.
 3. Round up one end of each back leg and arm piece.
 4. Work taper on back and front legs (as shown on detail).
 5. Scratch-bead all rails, ribs, front and back legs above taper part.
 6. Construct framing to form back of couch, glue, and nail up.
 7. Fit in the back ribs, glue, bore, and nail in position.
 8. Fix arms, and under side rails to front legs in pairs.
 9. Mark positions, bore for, glue, and nail one end frame to back framing.
 10. Fit in, bore for, glue, and nail front under rail in position on the other end frame.
 11. Prepare seat, to fit between back legs and side arms.
 12. Re-scratch all outer beads.
 13. Fix seat in position, top nailing front as shown: glue and nail all elements together.
 14. Test for accuracy of measurement, squareness, and stability: adjust, if necessary.
 15. Smooth off all edges, and neatly finish Model 19.

Position drills: Surface planing, and testing.

Sequence or Continuation Lessons.

Little talks on home comforts and life in ancient and modern times, comparing Western and Eastern customs.

GROUP OF LESSONS No. 20.

MODEL 20: Toilet or Dressing Table.

Aim of Drawing Lesson: To secure neatness of finish and an intelligent reading of the several views:

The drawings of this model furnish a slightly more difficult lesson than the two previous ones; if the same methods of production are employed, the front elevation, with the double lines indicating the bead as worked on the several edges, gives good training in drawing neat parallel lines, whilst the various dimensions offer full facilities for transposition if desired. To give connectedness and continuity with previous lessons, full black board demonstrations, showing the several details apart, should be given, together with the building up of a completed outline drawing of the model, as seen from the usual points of view. Obtain the necessary data from the children whenever it is possible, and emphasize the necessity of accurate working to obtain best results. Point out the similar and dissimilar details in this, and previous models; and show, by reassemblment, how other models may be devised by similar means.

Supplemental Lesson.

Little talks on the comparison of mechanical with freehand drawing, and relative values of each for specific cases.

Aim of Practical Lesson.

To secure neatness in finished drawing, and intelligent reading of the several views.

Materials required: Square, strip, and slab whitewood, and some 1" panel pins.

Tools required: Rule, try square, pencil, saw, plane, scratch bead, Bradawl, hammer.

Procedure for the construction of Model 20:

1. Mark and saw off square wood, 4 pieces 28" ($3\frac{1}{2}$ ") long for legs.
- strip wood, 6 .. 35" ($1\frac{3}{4}$ ") long for frame bars.
- " 4 .. 14" ($1\frac{3}{4}$ ")
- " 2 .. 20" ($2\frac{1}{2}$ ") long for side pieces.

DOLLY'S
TOILET OR DRESSING TABLE.

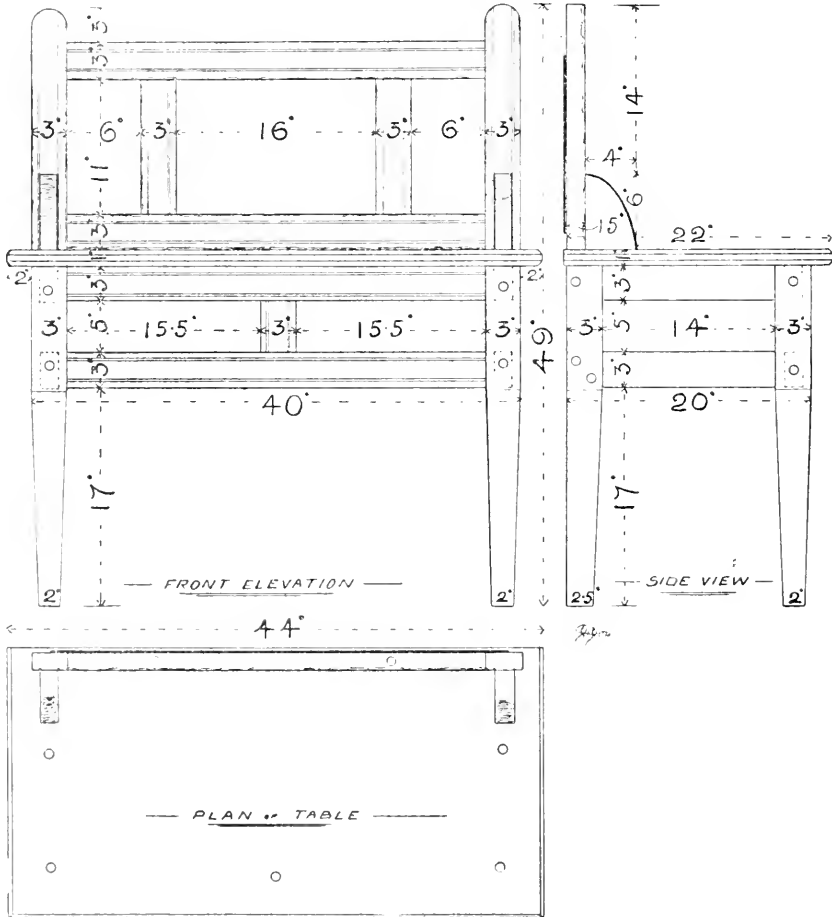

Mark and saw off strip wood, 2 pieces $11''$ ($1\frac{3}{4}''$) long for frame ribs.

„ „ „ 1 „ $5''$ ($\frac{3}{8}''$) „ „
 „ „ slab wood, 1 „ $44'' \times 22''$ for table top.
 „ „ „ 2 „ $6'' \times 4''$ for brackets.

2. Plane or smooth up all surfaces.
3. Scratch-bead all bars, side pieces, and ribs.
4. Set out, mark, bore for, glue, and nail together details of back frame.
5. Prepare chamfer on edges of table top; fit back frame in place; glue, and nail from under side of top.
6. Prepare the side brackets, glue, and fix in position.
7. Test for accuracy of angle between table top and the back panels.
8. Prepare the taper of each leg according to the drawing.
9. Adjust the end frame bars to each pair; bore, glue, and nail together.
10. Adjust, glue, and fix the front and back frame bars to each pair of legs.
11. Test for accuracy and stability of framing.
12. Adjust table top on framing, and glue and nail in place.
13. Smooth up all edges, and re-scratch all outside beads.
14. Test of accuracy of construction to complete Model 20.

NOTE.—If a more realistic effect is desired, a piece of silvered glass, or marble paper or cloth, may be glued on the outside of the back centre panel.

Position drill: Surface making with plane and glasspaper.

Sequence or Continuation Lesson.

Little talks on toilet materials,—the manufacture of brushes, combs, soap, mirror glass, pins, and trinkets; compare home comforts in the houses of the rich with those of the poor.

GROUP OF LESSONS No. 21.

MODEL 21: Field-Path Wicket Gate.

Aim of Drawing Lesson: To give additional training in the combined use of set squares and rule, in drawing oblique parallel lines.

It will be necessary to use a standard model in addition to a prepared (coloured chalk) chart drawing, to enable the children to understand the difficult points which may occur by the frequency of

the oblique lines. To somewhat reduce the complication of the posts and rails, a sectional elevation is suggested which portrays the actual bevels of the two cross struts at the contact points with posts and horizontal rails. The building up of the plan and sectional elevation should proceed simultaneously, the end elevation being left, until the children are able to read the details of the other views. If the material used is to be of a standard size, the drawing done by the children should be fully dimensioned, but not necessarily in duplicate. The setting out of the fixed wicket rails and posts, offers facilities for teaching the method of centre line work, whilst the varying heights of the swing-gate rails give additional training in the manipulation of the usual drawing tools. If it be possible, let the children *advise* the black board sketch, which should be built up with reference to the finished chart and model. Any intricate or difficult point or detail in construction, may be readily made easier of conception, by the aid of large detail diagrams worked in coloured chalks. The method of hanging the gate, the reason for the upper eye passing through the post, the simplicity of the centre pin for the lower fixing, should each be fully dealt with in this lesson, as a preparation for future models, which involve similar methods of swing-door fixing. No detail should be considered too simple for explanation, nor should the teacher be satisfied with any "near enough" results, as such engender false impressions on the scholars and foster deceit.

Supplemental Lesson.

Little talks on mechanical aids to secure accuracy in drawing.
Freehand and coloured chalk drawings.

Aim of Practical Lesson.

To furnish additional and more difficult oblique sawing, fitting, and nailing exercises, and to give additional training in sight testing and planning.

Materials required : Square, strip, and slab whitewood, long and medium panel pins and wire.

Tools required : Rule, try square, pencil, saw, plane, knife, file, bradawl, hammer, and cutting pliers.

A FIELD-PATH WICKET GATE.

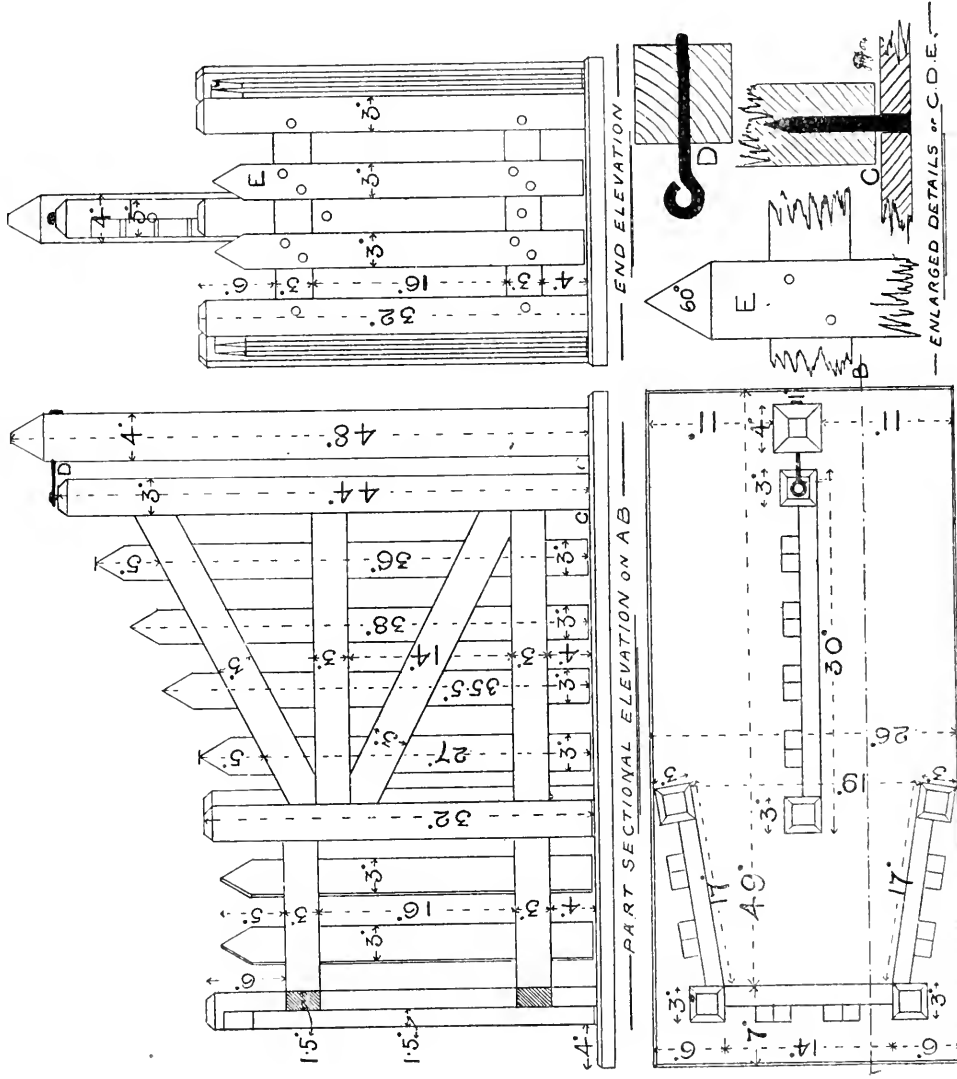

ENLARGED DETAILS OF C.D.E.

FULL PLAN OF WICKET-GATE

Procedure for the construction of Model 21 :

1. Mark and saw off square wood, 1 piece 48^\bullet ($6''$) long for standard post.
- " " " 1 .. 44^\bullet ($5\frac{1}{2}''$) .. for gate post.
- " " " 5 .. 32^\bullet ($4''$) .. for corner, gate, and striking posts.
- " " strip wood, 1 .. 41^\bullet ($5\frac{1}{4}''$) ..
- " " " 1 .. 38^\bullet ($4\frac{3}{4}''$) ..
- " " " 1 .. $35\cdot5^\bullet$ ($4\frac{7}{16}''$) ..
- " " " 1 .. 32^\bullet ($4''$) ..
- " " " 2 .. 24^\bullet ($3''$) .. for rails.
- " " " 2 .. 21^\bullet ($2\frac{5}{8}''$) .. for struts.
- " " " 6 .. 31^\bullet ($3\frac{7}{8}''$) .. for fixed palings.
- " " " 6 .. 14^\bullet ($1\frac{3}{4}''$) .. for fixed rails.
- " " slab wood, 1 .. $56^\bullet \times 26^\bullet$.. for base board.
2. Plane or smooth up all surfaces.
3. Prepare and chamfer off the tops of all posts and palings.
4. Mark off positions of all horizontal rails on corner gate and striking posts.
5. Bore, glue, and nail rails to posts in pairs.
6. Mark off positions for railings on each pair.
7. Glue, and nail in place.
8. Fit in bevel ends of struts between gate framing: glue, and nail in position.
9. Build up fixed wicket.
10. Prepare standard post and wire eyelet.
11. Prepare base board; chamfer upper edges.
12. Mark off positions of fixed wicket and standard post; and fix all to base board (long nailing from below).
13. Adjust swing gate to eyelet; and mark position of gate post on base board.
14. Bore through centre of marked square.
15. Clean up all edges and surface of rails on gate.
16. Clean up all details of fixed wicket and base board.
17. Adjust swing gate; and fix with panel pins through eyelet and base board.
18. Test for vertical position and swing of gate; adjust if necessary, and complete Model 21.

Position drills : Oblique sawing and filing; outside square testing.

Sequence or Continuation Lessons.

Little talks on country life; field walks in Spring, Summer, Autumn, and Winter. Nature study.

GROUP OF LESSONS No. 22.

MODEL 22: Cattle-feeding Manger.

Aim of Drawing Lesson: To demonstrate the need of more than one drawing for the construction of a model.

Educe, by the aid of a standard model, the points of difference, when it is viewed from several positions, and lead the children to realize the foreshortening of a line, when it is placed obliquely before the eye. Illustrate this point very clearly by black board sketches, and references to past models or drawings, which have involved the use of oblique lines.

A large-size drawing should be built up in full view of the children; taking the end view as being the most important, carefully project therefrom the front elevation and plan, and encourage the children to give the necessary details of procedure. Explain the use of parallel lines to give the rounded edge effect, and emphasize that great care is necessary to produce a satisfactory plan. For the drawing of the end view (which also may be a sectional view), the centre line method of construction should be adopted, as being the most likely to give quick and accurate results with true symmetry or balance. A pictorial chart drawing may be used with advantage, during the building up of the several views.

The children should produce their drawings, in correct projection, from the measurements given, and correctly place the important dimensions thereon, in order to facilitate the work of the practical lesson.

Supplemental Lesson.

Little talks on sections:

- (a) Their use and value to the craftsman.
- (b) Why and when such drawings are essential.

Aim of Practical Lesson.

To teach oblique surface sawing, and nailing in thin slab wood.

Materials required: Square and thin slab whitewood, and long panel pins.

Tools required: Rule, try square, pencil, saw, plane, file, pricker, bradawl, and hammer.

CATTLE-FEEDING MANGER.

22

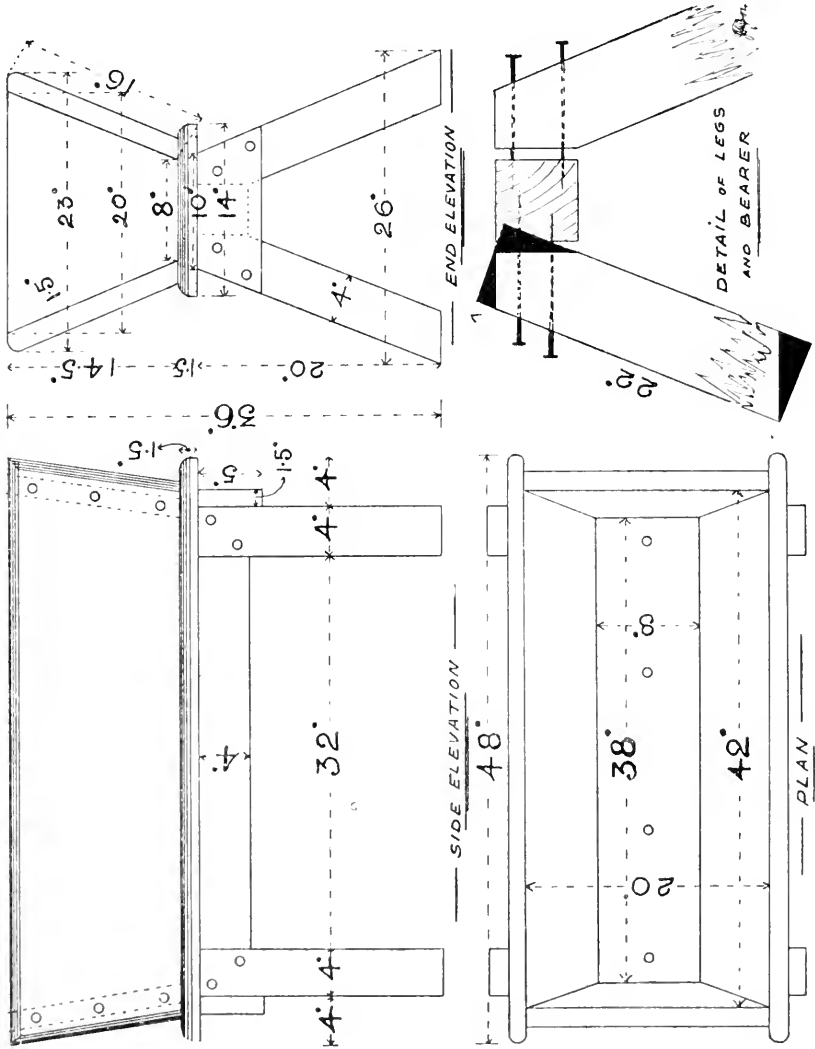

Procedure for construction of Model 22 :

1. Mark and saw off square wood, 4 pieces 22" long ($2\frac{3}{4}$ " for legs.

..	..	slab wood,	2	..	48×16 (6×2) for sides.
..	1	..	48×14 ($6 \times 1\frac{3}{4}$) for bottom.
..	2	..	20×15 ($2\frac{1}{2} \times 1\frac{7}{8}$) for ends.
..	2	..	14×5 ($1\frac{3}{4} \times \frac{5}{8}$) for clamps.
..	..	square wood,	1	..	40" long (5") for under bar.
2. Plane or smooth up all material cut.
3. Set out the taper or slope of each side and end piece from the dimensions on the drawing.
4. Saw off waste material, and neatly round off each side piece.
5. Prepare, by filing, each leg to the bevels as on drawing.
6. Test each pair for accuracy of bevel and length.
7. Bore for, glue, and fix to the under bar, each pair of legs in position.
8. Prepare bottom piece, by rounding off the upper side on all edges.
9. Adjust ends to sides : bore for, glue, and nail together.
10. Prepare lower edges, by planing off outer rim, to fit on bottom piece.
11. Mark position of box on the bottom ; bore through, glue, and nail *obliquely* together.
12. Test accuracy of all bevels, lengths, and widths.
13. Adjust box on stand ; bore through bottom ; glue, and nail all together. *Use the clinching block, as a solid support when nailing.*
14. Smooth up all edges ; adjust base of feet if necessary, and complete Model 22.

Position drill : Oblique nailing.

Sequence or Continuation Lesson.

Little talks on the cattle of the homestead, and prairie. Nature study.

GROUP OF LESSONS No. 23.

MODEL 23: Sack Truck or Barrow.

Aim of Drawing Lesson: To secure neatness in drawing, and an intelligent reading of co-ordinate views.

To secure accuracy and neatness, this drawing involves the use

of compasses; if, however, these are not available, cardboard or metal discs of the required diameters may be used as templates.

With a standard model as a copy, a side elevation should be drawn to a large scale on the black board, from which may be developed, in projection, an end view and plan outlines in length and height only. Educe why the latter drawings cannot be completed. "What other dimensions are required?" "Thickness of wheel." "Yes." "Width of barrow." "Yes. Look at the model. Are the shafts or handles parallel with each other?" "No, they come nearer together towards the handle end." "Now, can anyone tell, how we made the last drawing, which had oblique lines, symmetrical or balanced?" "By drawing a centre line." "Yes. Then we must build up this plan in the same way." Encourage the children to give the necessary dimensions, by actual measurement of the model passed round the class. Proceed to build up the end view in a similar way, leading the children to realize the relative positions of each detail, as you develop the sketch.

Fully dimension each essential detail, demonstrate the use of the Tee and set square thoroughly, and aim at obtaining from each child a neatly finished side elevation and plan.

Supplemental Lesson.

Little talks on a circle and its divisions and complementary lines—diameter, radii, chords, and tangents.

Aim of Practical Lesson.

To teach simple methods of construction, wheel disc making and fitting.

Materials required: Square, strip, and slab wood, medium and long panel pins, and 2 metal squins.

Tools required: Rule, try square, pencil, saw, plane, file, knife, pricker, bradawl, hammer, brace, and wheel disc cutter.

Procedure for the construction of Model 23:

1. Mark and saw off square wood, 2 pieces 52" long ($6\frac{1}{2}$ " for side pieces.
- " " " 2 .. 9" .. ($1\frac{1}{8}$ " for axle-bearers.
- " " " 1 .. 26" .. ($3\frac{1}{4}$ " for axle-tree.

A SACK TRUCK OR HAND BARROW.

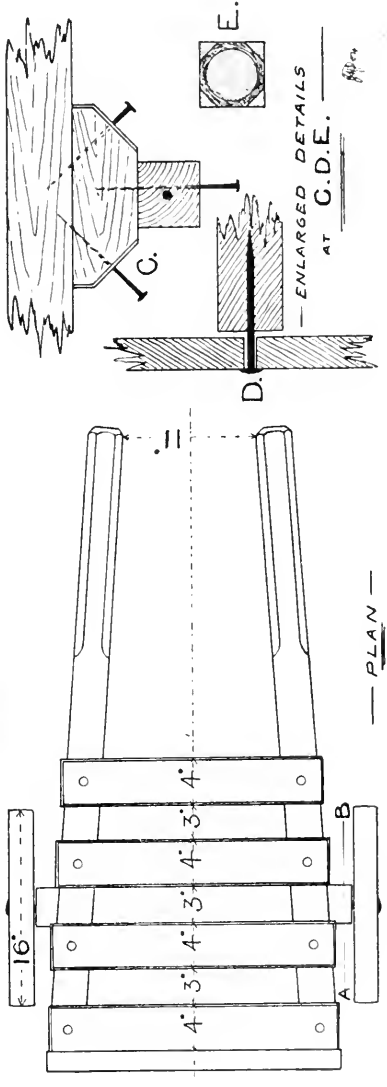
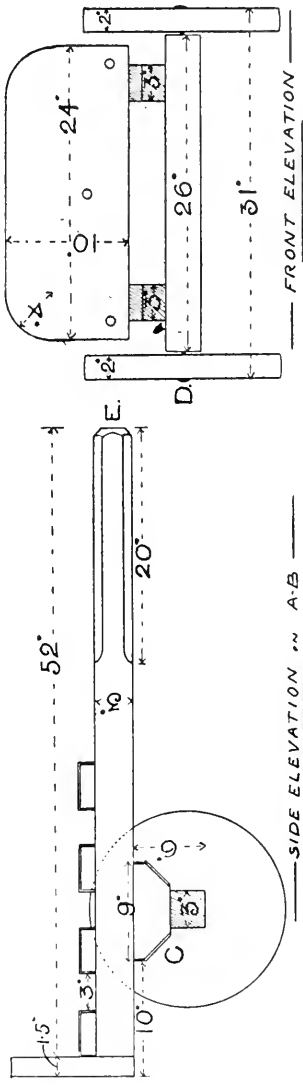

Mark and saw off strip wood, 2 pieces	24• long (3")	}	for cross bars.
.. 1 ..	23• .. (27/8")		
.. 1 ..	22• .. (23/4")		
.. .. slab wood, 1 ..	24• × 10• for front board.		

2. Bore out, with brace and disc cutter, 2 discs 16• × 2• for wheels.
3. Plane or smooth up all pieces.
4. Chamfer off, or round up side pieces at one end, to form handles as shown on the drawing.
5. Mark off and round off the corners of the front board.
6. Prepare the axle-bearers, as shown on the drawing.
7. Bore for, glue, and nail axle-bearers in position on side pieces.
8. Bevel off square ends of side pieces to fit front board, and to give the taper form of the body frame.
9. Glue and nail front board to side pieces.
10. Mark off positions of cross bars; bore, glue, and nail in place.
11. Adjust axle-tree on bearers to be parallel with front board, and nail in place.
12. Find centre point at each end of axle-tree, and prick hole for axle-pin.
13. Insert axle-pin through metal sequin (to form a washer), then through the wheel disc, and fix to axle-tree.
14. Repeat 13 for other disc; and, when driving axle-pin in, make provision to avoid the other axle-pin being driven tight home, or the disc will not revolve freely.
15. Neatly clean up all edges, and finish Model 23.

Position demonstration: Wheel disc and rim cutting with brace.

Sequence or Continuation Lesson.

Little talks on:—Work on the farm after harvest, or in the warehouse; conveying goods for sale and transport; imports and exports.

GROUP OF LESSONS No. 24.

MODEL 24: Wheelbarrow.

Aim of Drawing Lesson: To give additional training in neat working, intelligent reading of co-ordinate views, and to demonstrate more fully the necessity of such.

To make the drawings for the construction of this model easily understood by the scholars, previously prepared large-size

diagrams in full detail and complete ensemblement must be used, together with a standard model, from which the children should take direct measurements during the lesson. Commencing the black board drawing with the side elevation, as being the view most readily understood, and making constant reference to both diagram and model, lead the children to give the necessary details for the drawing of the framing or *undercarriage*, and encourage them to give these measurements from the standard model. The foreshortening of the depth of the sides, as shown on the plan, should be explained fully, as also the meaning of the dotted lines on the side elevation and plan, which are to show the position of details, inside or hidden from direct view by some other detail.

An enlarged detail of the leg and side stay should be drawn by each scholar, the portion shown in black, illustrating the piece to be removed, or "waste material," receiving special attention.

In some cases it has been found necessary, to adopt the detail method of drawing, *i.e.*, to make full-size drawings of each part in full elevation, and to use paper for cutting out the exact size of each piece previous to marking out the woodwork. Such method has its advantage, and may be freely used by the teacher, if the ordinary methods of projecting oblique lines are found to be above the capabilities of the scholars. Whichever method is adopted, the drawings must be fully dimensioned to ensure correct working to measurement. Care must, however, be taken to avoid any neglect of principles, and the making of a model without any drawing lesson being given. *The mere copying of a model is not educational training.*

Supplemental Lesson.

Little talks on the advantages derived from fully dimensioned detail drawings and free sketches.

Aim of Practical Lesson.

To teach simple methods of construction and wheel-axle making.

Materials required : Square and slab whitewood, short and medium panel pins.

Tools required : Rule, try square, pencil, saw, plane, file, wire cutters, prickler, bradawl, knife, wheel cutter, brace, and hammer.

A WHEELBARROW.

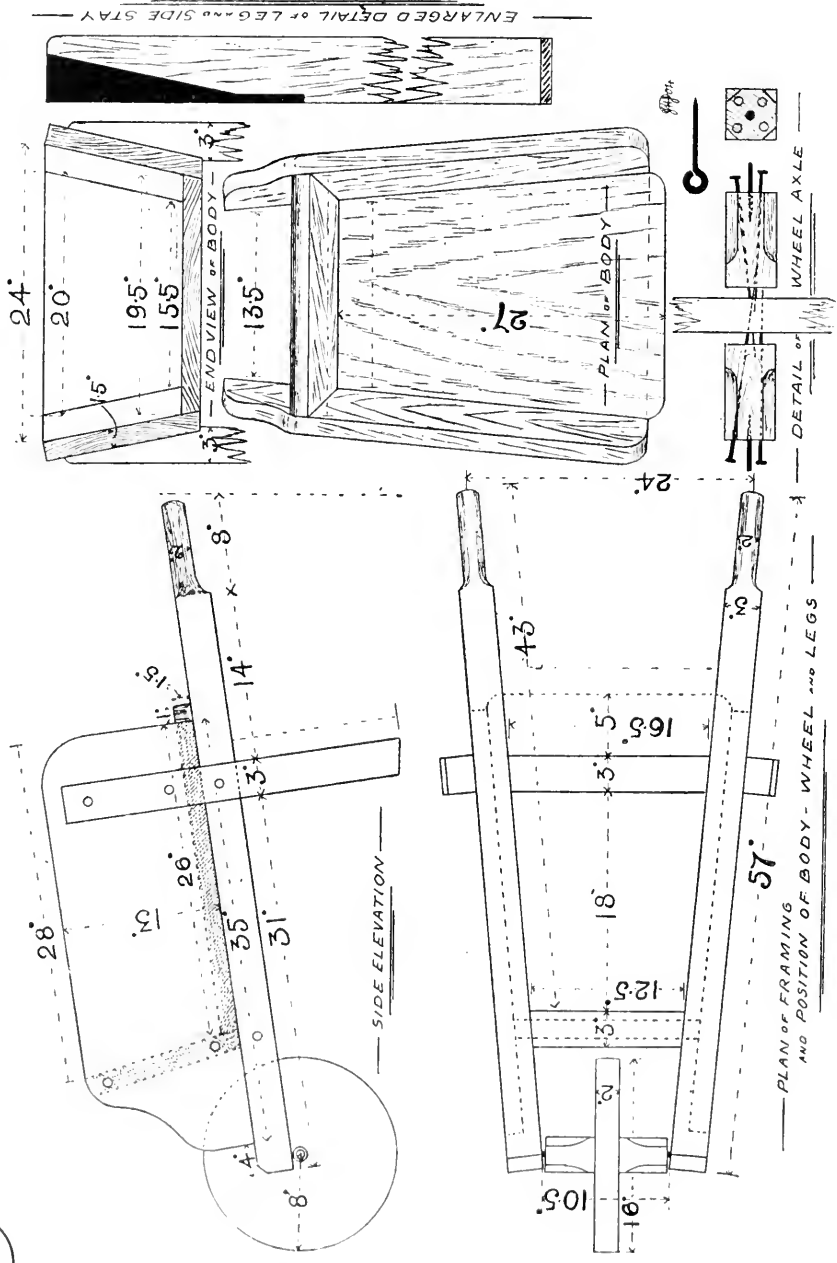

Procedure for the construction of Model 24 :

1. Mark and saw off square wood 2 pieces 56" long (7") for side frames.

..	..	1	..	17"	..	(2 $\frac{1}{2}$ ") for frame
..	..	1	..	13"	..	(1 $\frac{3}{4}$ ") stretcher bars.
..	..	2	..	28"	..	(3 $\frac{1}{2}$ ") for side stays & legs.
..	..	2	..	4"	..	($\frac{1}{2}$ ") for axle-trees.
..	slab wood	2	..	35" x 13" for sides.		
..	..	1	..	20" x 13" for front board.		
..	..	1	..	27" x 20" for bottom board.		
2. Bore out with disc cutter and brace, one disc 16" x 2" for wheel.
3. Plane or smooth up all surfaces, and form handles with knife and file on each side frame piece.
4. Mark out curves on side pieces, and reduce to the lines with file and glass-paper.
5. File ends of stretcher bars to taper, as on drawing, and adjust to side frame pieces.
6. Construct undercarriage : bore for, glue, and nail frame together.
7. Taper front board to given dimensions : fit to sides ; glue, and nail together.
8. Shape bottom board to the taper of undercarriage frame ; glue, and nail it *between* the side pieces, to form body of barrow.
9. Work taper on the side stays and legs ; adjust to side pieces, and undercarriage frame.
10. Construct two axle-pin eyelets from medium panel pins.
11. Build up wheel and axle-trees, as shown on detail drawing, and insert axle-pins.
12. Fit wheel and axle between side frame ; insert eyelets ; adjust, and test for true running of wheel in position.
13. Fit body to undercarriage ; mark position ; bore for, glue, and nail in position.
14. Fix side stays and legs in correct position ; glue, and nail.
15. Neatly clean up all edges with fine glasspaper, test for accuracy and stability of construction, and complete Model 24.

Position drill : Oblique nailing and filing.

Sequence or Continuation Lesson.

- Little talks on (a) Work on the homestead, and in the garden during Spring time.
- (b) Canal and railway making by hand labour, and by mechanical aids for excavating and removal of débris.
- (c) Ancient and modern methods of transportation of goods.
-

END OF SECOND GROUP OF LESSONS AND COURSE OF WORK.

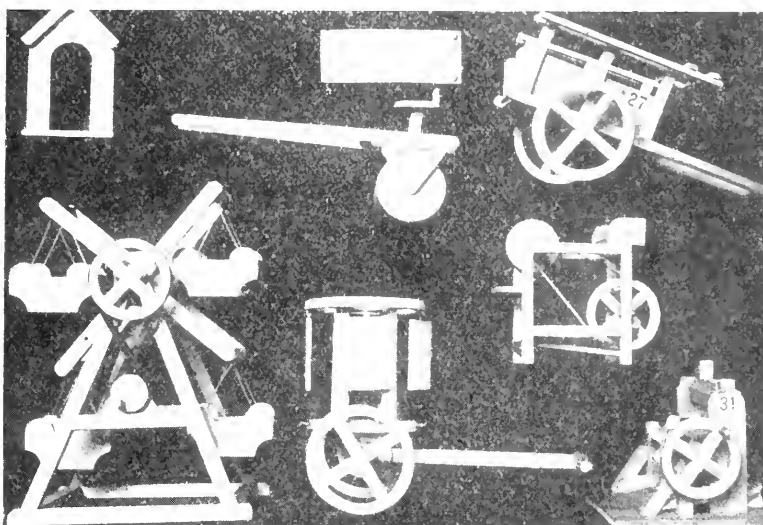

Third or Advanced Course of Work.
Drawing and Construction of Simple Toys.

GROUP OF LESSONS No. 25.

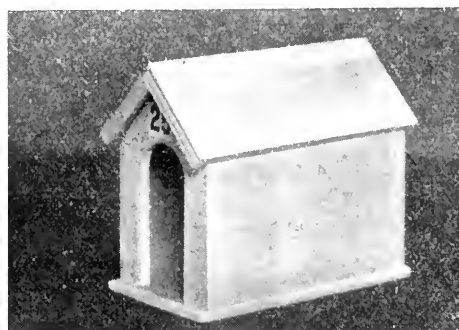

FIG. 47.

MODEL 25: Dog Kennel.

Aim of Drawing Lesson: To impress the simple elements of Geometrical projection, and to familiarize technical terms and nomenclature.

A black board freehand sketch, showing the general outlines of this model, should form the basis of the lesson.

Educe that either the side or end may be an elevation, although the outlines will differ in area and shape; that a plan will only show the roof, and projecting base board; and that a section will be necessary to show the thickness of the sides of the kennel. Encourage and lead the children to make sketches on both black board and paper, and to develop the projected views from the given dimensions. The graining of the wood may be attempted on this drawing, which is free from complicated joints and oblique lines. From the dimensions, as measured by the children from a standard model, build up the three views given, and clearly show how a section of the sides may be obtained. Aim to secure the production of at least the end and side elevations, neatly dimensioned and finished by each member of the class.

Supplemental Lesson.

Little talks on the value of free sketching in coloured chalks.

Aim of Practical Lesson.

To teach simple nailing, and construction involving careful sawing, squaring, and testing of angles.

Materials required: Strip and slab whitewood, and medium panel pins.

Tools required: Rule, try square, pencil, saw, plane, file, bead scratch, bradawl, knife, hammer.

Procedure for the construction of Model 25:

1. Mark and saw off 4 base piece $48'' \times 26''$ ($6'' \times 3\frac{1}{4}''$), slab wood.

..	..	2 side	..	$40'' \times 25''$	($5'' \times 3\frac{1}{4}''$)	..
..	..	4 end	..	$37'' \times 21''$	($4\frac{1}{2}'' \times 3''$)	..
..	..	4 roof	..	$46'' \times 20''$	($5\frac{3}{4}'' \times 2\frac{1}{2}''$)	..
..	..	4 roof	..	$46'' \times 19''$	($5\frac{3}{4}'' \times 2\frac{3}{8}''$)	..
..	..	2 half-front pieces	$37'' \times 12''$	($4\frac{1}{2}'' \times 1\frac{1}{2}''$)	slab wood.	
..	..	2 "verge" boards	$20''$ long	$\times 3''$ wide,	strip wood.	
2. Carefully plane and smooth up all surfaces, and finish to exact widths given.
3. Mark out opening on half-front pieces; nail together (flat); saw or knife out waste, and file curve and edges to the marked lines.

A DOG KENNEL.

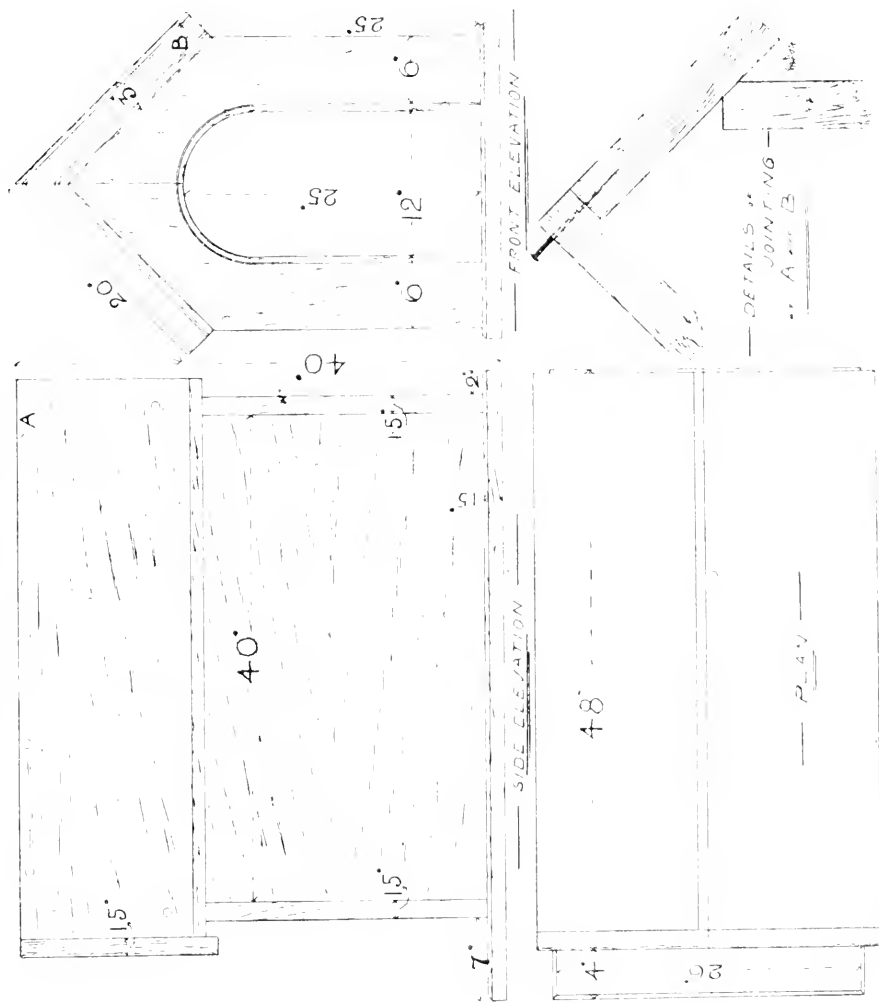

4. Scratch-bead the finished edges of entrance, and also the front face of the verge-board strips.
5. Mark out and saw off the triangular waste on the end and front pieces, and test the finished work with try square.
6. Glue one of the waste pieces flat across the two halves of the front opening, and close up to the apex of each; nail in position to keep vertical joint close.
7. Adjust, bore for, glue, and nail ends to sides.
8. Prepare the base piece; chamfer off top edges; adjust body of kennel; bore for, glue, and nail to *sides*, being careful to have the top edges of the sides resting on something solid, and not on the apexes of the front and back ends.
9. Glue and nail roof pieces together; make each side of equal depth when finished.
10. Adjust roof to body; if necessary, bevel off side pieces on outer edges.
11. Mark its position, bore for, glue, and nail it to each *end* piece.
12. Mitre joint verge-board strips; glue, and nail in position.
13. Test all angles, smooth off all corners and edges, and complete Model 25.

Position drills and demonstration: Oblique surface sawing, filing inside curves, and oblique nailing.

Sequence or Continuation Lesson.

- Little talks on (a) The shepherd dog and its work.
 (b) Fox hunting: "Tally Ho."
 (c) Types of dogs in other countries: St. Bernard, Esquimaux, etc.

GROUP OF LESSONS No. 26.

MODEL 26: Field Roller.

Aim of Drawing Lesson: To impress the previous lessons on projection, and the necessity and value of sectional drawings.

The ordinary parallel projection of the several views of this model will clearly indicate the general build of the whole framing; but a longitudinal section through the roller will also be necessary to explain the method employed in its construction. The procedure adopted for the drawing of Models 23 and 24 may be again employed

in setting out the taper form of the carriage framing, and also in dealing with the several details or elements. Rough sketches of

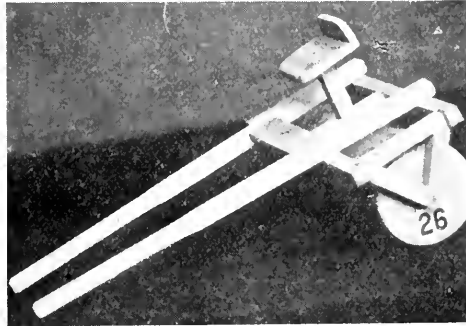
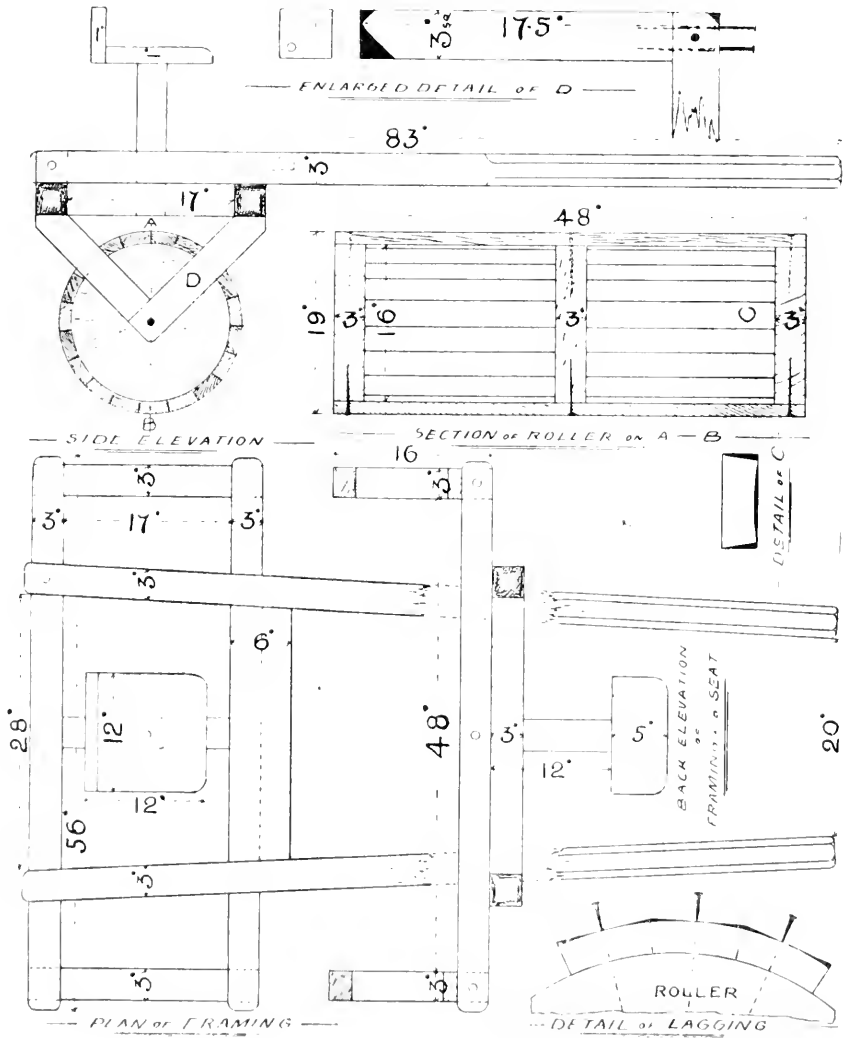

FIG. 18.

these (previously done as diagrams) will be found advantageous, when naming the several parts, *e.g.*:—Shafts, upper carriage framing, axle or journal frames, seat, seat pillar, roller, strengthening disc or ring, footboard, etc. A finished diagram in pictorial form is essential, in addition to a standard model.

During the lesson educe the reasons (1) Why the shafts are not placed parallel. (Ask if a heavy farm horse is the same width across the front as at the back.) (2) Why the end or axle-frames are made like a triangle. (Explain that a triangle cannot alter in form without breaking one of the joints, and that, therefore, it is the strongest form of construction.) (3) Why the shafts are placed across the top of the carriage framing, and not simply fixed to the front bar. (The pull of the horse is thereby distributed through the framing, and therefore readily causes the roller to move, without breaking any of the framing joints). (4) Why the roller has a *strengthening* disc or ring fixed inside. (The term defines its use.) “What material would be used for a real roller? Why? Would not wood do?” “Not heavy enough.” Tell the children that large blocks of stone were used in ancient times, and are also used to-day in some parts of the world. Maintain the interest by asking the children to sketch any part of the model on the black board, placing the requisite dimensions in correct positions, and explaining in their own language the why and the wherefore of the particular detail selected.

A FIELD ROLLER.



The result of the lesson should be a neatly dimensioned side elevation and plan of the model, drawn full size by each child in class.

Supplemental Lesson.

Little talks on the value of detail drawings to the craftsman.

Aim of Practical Lesson.

To teach simple methods of construction, involving circular work by segments and by bevel-edge jointing.

Materials required : Square, strip, and slab whitewood, medium and long panel pins.

Tools required : Rule, try square, pencil, saw, plane, cabinet rasp and file, knife, bradawl, hammer, disc-cutter and brace, with strip edge berelling cradle as an adjunct.

Procedure for the construction of Model 26 :

1. Mark and saw off 2 shaft pieces 83• long ($10\frac{3}{8}$ ") out of square wood.
- " " 2 frame " 56• " (7") " " "
- " " 3 " " 17• " ($2\frac{1}{8}$ ") " " "
- " " 2 end axle-frames 18• " ($2\frac{1}{4}$ ") " " "
- " " 2 " " 15• " ($1\frac{7}{8}$ ") " " "
- " " 1 seat pillar 12• " ($1\frac{1}{2}$ ") " " "
- " " slab wood for seat, back, and foot rest to the dimensions shown on the drawing.
- " " 15 segments 48• long (6") out of strip wood.
2. Plane up or smooth all surfaces.
3. Bore out 3 discs 16• diameter and 3• thick.
4. Trim up edges of each disc with file, square with the sides.
5. File or rasp each end of segments hollow, to fit outer edges of discs.
6. Note space left between two strips when fitted on discs; then carefully bevel off edges with plane until a close joint is made; fit each segment to the discs as finished; glue, and nail in position.
7. Round up the roller with file and glasspaper.
8. Form octagonal portion of each shaft piece, as shown on the drawing, and chamfer each end.
9. Round off ends of framing; insert cross pieces; bore for, glue, and nail all together.

10. Bevel off one end of each piece, to form axle-frames.
11. Construct the axle-frames, and adjust to framing.
12. Bore for, glue, and nail in position.
13. Bore the axle-pin hole in each frame, and try the roller in position.
14. Prepare seat pillar and seat according to the drawings; bore for, glue, and nail to centre cross piece in framing.
15. Prepare foot rest.
16. Fit shafts across framing, nail in position, and nail foot rest between.
17. Fix roller in position with axle-pins.
18. Test for freedom of movement, accuracy, and stability of construction; clean up and finish Model 26.

Position drills and demonstration: Filing segments, bevel planing, nailing curved work, and at an angle.

Sequence or Continuation Lesson.

Little talks on (a) Nature's work in Spring time—the roots of plants, etc.

(b) Man's work in Spring time—seed sowing, etc.

GROUP OF LESSONS No. 27.

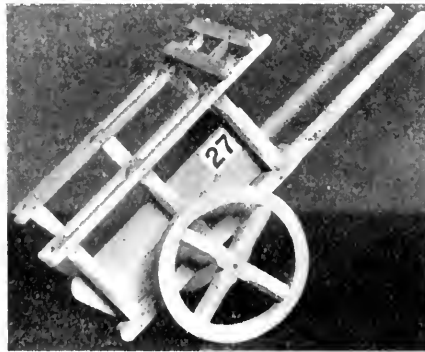

FIG. 49.

MODEL 27: The Harvest Cart.

Aim of Drawing Lesson: Proportionate free sketching of details.

To enable the children to fully realize the ensemblment of the

details, a large pictorial sketch of this model is essential. A clear explanation of each element should be given before commencing the actual class drawings. Encourage each child to produce a free sketch of any detail of the standard model exhibited. Educe the relative proportions of length and height, diameter of wheels to depth of body, the reason for and use of the upper frame work, for the tapering form of the space between the shafts, and the use of the axle-tree. Give, in the most simple language, the names of the several parts of the wheel, *e.g.*, rim, spokes, nave. Illustrate these and other technical terms, by examples, in order to impress the instruction. Should compasses not be available for the drawing of the wheel, the outer circle may be made with a loop of thread equal in length to the given radius, one end of which passes round a pin as centre and the other round a sharp pencil point as tracer. The inner circle may be described in a similar way.

The finished drawings should consist of a simple line side elevation, and a plan of the framings. Be fully conversant with all the detail dimensions of each element, but do not attempt with the children the somewhat complicated end elevation of the body. Let each finished drawing be fully dimensioned by the children, either from direct measurement of the standard model, or from the black board sketches.

Supplemental Lesson.

Little talks on curved lines and "nature forms."

Aim of Practical Lesson.

To combine previous lessons and elements of construction, and to give more difficult exercises in fitting and nailing.

Materials required : Square, strip, and slab whitewood, medium and long panel pins.

Tools required : Rule, try square, pencil, saw, plane, file, hammer, bradawl, wheel rim cutter and brace.

Procedure for the construction of Model 27 :

1. Mark and saw off 2 shaft pieces 86" long ($10\frac{3}{4}$ " square wood.

THE HARVEST CART.

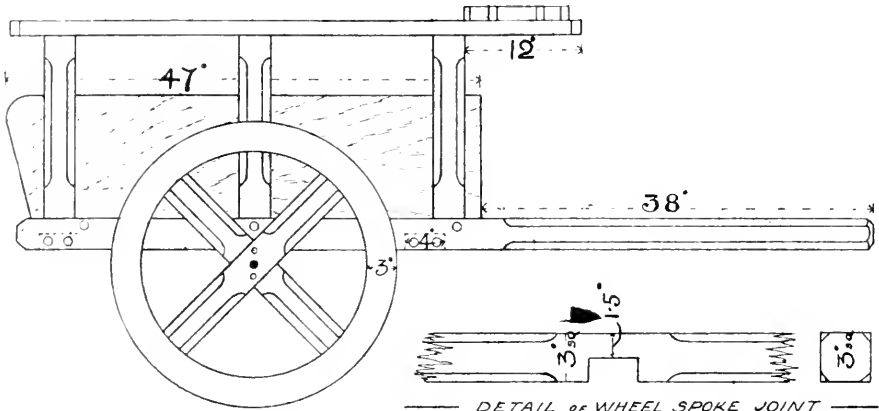

SIDE ELEVATION

DETAIL OF WHEEL SPOKE JOINT

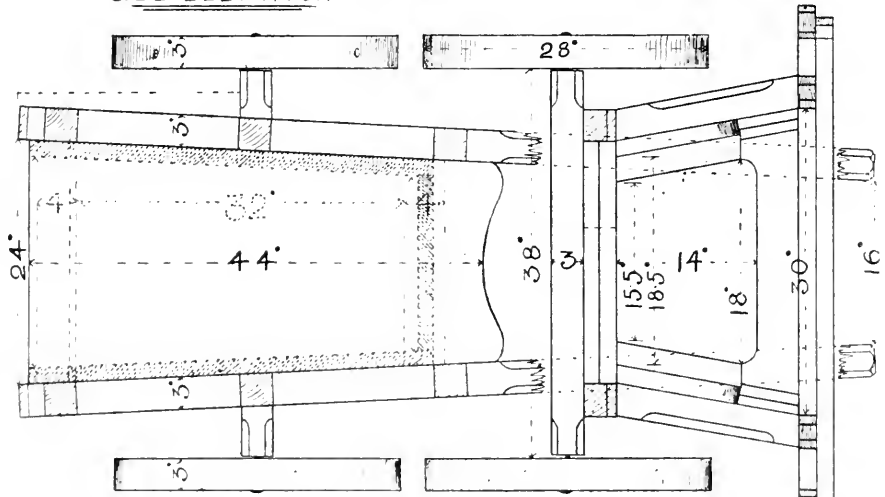

PLAN OF FRAMING WITH POSITION & END VIEW OF BODY

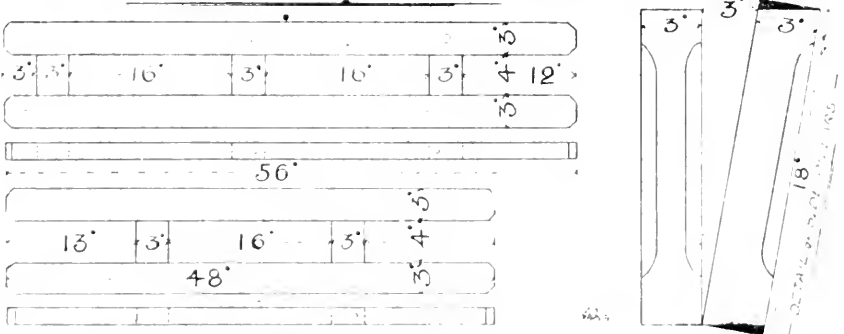

PLANS AND ELEVATIONS OF TOP FRAMES

- | | |
|---------------------------------|---|
| Mark and saw off 6 side pillars | 18" long (2 $\frac{1}{4}$ "), square wood. |
| „ „ 1 axle-tree | 38" „ (4 $\frac{1}{2}$ ") „ „ |
| „ „ 2 side boards | 47" \times 13", slab wood. |
| „ „ 1 front „ | 18" \times 13" „ „ |
| „ „ 1 bottom „ | 46" \times 24" „ „ |
| „ „ 1 stretcher bar | 24" \times 5" strip wood. |
| „ „ 1 „ „ | 20" \times 5" „ „ |
| „ „ 4 top framing | 56" \times 3" „ „ |
| „ „ 2 „ „ | 48" \times 3" „ „ |
| „ „ 8 „ „ | 4" \times 3" „ „ |
2. Bore out with wheel cutter and brace 2 wheel rims, 28" diameter.
 3. Mark and saw off 4 wheel cross spokes, 22" \times 3" square.
 4. Mark out, saw down, remove waste, and fit wheel arms. (See procedure for Model 7.)
 5. Chamfer each edge of spokes ; bore the wheel rim with bradawl to prevent splitting ; glue and nail in position. (*Do not insert a nail in the same direction of the fibres of the rim wood, but always across or diagonal with them.*)
 6. Construct or build up each element of the top frames ; double nail each stretcher bar or rib.
 7. Prepare side and front pieces with file and sandpaper.
 8. Prepare each side pillar ; chamfer front side only, and file each end to the bevel shown on the detail drawing.
 9. Prepare octagonal part of each shaft, and bevel off ends.
 10. Prepare stretcher bars to fit bevels, and build up to shafts to form under-carriage ; glue and nail in position.
 11. Fix axle-tree in position ; glue, nail, and clinch.
 12. Fix side pillars in position on under frame.
 13. Test for accuracy of slope ; if correct, glue and nail.
 14. Fix side pieces to pillars in position.
 15. Mark off dimensions of bottom board ; reduce to marked lines, and fit *between* the side pieces, nail to stretcher bars.
 16. Fit front board ; bore for, glue, and nail in position.
 17. Adjust upper frames to top of side pillars ; bore for, glue, and nail in position.
 18. Adjust upper front cross frame ; glue, and fix.
 19. Find the centre of each end of axle-tree ; chamfer ends as shown on drawing, and prick centres for axle-pins.
 20. Insert axle-pins through metal sequins and wheels, and drive home, to allow each wheel to revolve freely.

21. Test for accuracy of dimensions, balance, and stability; smooth off all edges, and neatly finish Model 27.

Position demonstrations: (a) Boring with rim cutter; (b) Filing bevel ends; (c) Edge nailing.

Sequence or Continuation Lessons.

Little talks on harvest time, harvest home, harvest festivals; nature, and the lessons to be learnt therefrom.

GROUP OF LESSONS No. 28.

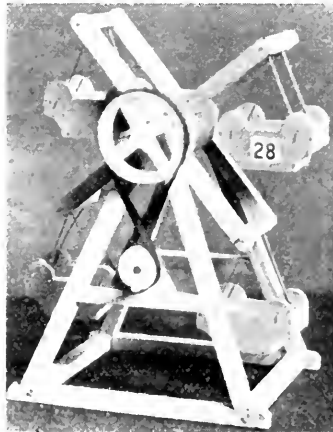

FIG. 50.

MODEL 28: High-flying Merry-go-round.

Aim of Drawing Lesson: To further emphasize the value of detail drawings for general ensemblément.

This model, outlined in the two elevations given, may appear to be far beyond the capabilities of any child; but the difficulty is only apparent, as the whole of the elements or details of which it is constructed, have been already introduced and worked by each scholar, who has completed satisfactorily the full series of lessons up to this point.

In order, however, to more fully develop common and mutual responsibility and fellowship among the children, and to further give effect to the principles of Froebel, it is suggested that with this, and the following models, the commune method of working be adopted, *i.e.*, the distribution amongst the members of the class of the several elements forming the whole. Each individual is responsible for the particular detail assigned, being made in accordance with the sketch or drawing made by himself, whilst the general ensembling of the details as represented by the standard model exhibited, forms a class demonstration by the teacher, or by the most capable of the children. The resultant models become then the joint work of each respective group of children. This method has also the advantage of providing easy exercises for the more backward children, whilst giving progressive employment to the sharp ones, and thus mutual encouragement and continued interest are maintained without any special effort.

For commune work, the detail drawings necessary should be clear line diagrams made to full-size dimensions, each dimension being neatly marked in its correct position to avoid any error in construction. The work now being individual, some slight alterations in the methods of class teaching will be essential; but avoid the common practice of providing each child with an exact copy for reproduction. Use correctly dimensioned free sketches, which will require the self-effort of the child to elucidate, in order to produce neatly finished drawings.

During the lesson, the reasons for the general outline of the framing should be educed, *e.g.*, (1) Why it is made wider at the base; (2) Why wire rods instead of string are used to suspend the cars; (3) Why the cars are made with two ends; (4) Why the suspension rods require to be of equal length; (5) Why the plate or gusset piece is required on the arms; (6) Why the cars always assume a horizontal or lying down position; (7) How it is made to revolve, and many other interesting and educative questions of a similar character. Encourage the children to give their own ideas, and observations of any similar apparatus or machine. Give the technical names of the several elements, such as side frames, base framing, motion bracket, main axle, swing axles, revolving arms, cleats, etc.

In addition to the model exhibited, a large-size pictorial sketch in coloured chalk should be prepared, to clearly illustrate the general ensemblement of the details, and, if considered of any advantage, a copy of the two elevations given, may be made for class demonstration in projection of drawings. In forming the curves of the car sides, recourse may be made to coins of suitable diameters; the sides being first drawn as rectangles, the coins (halfpenny for upper curve and one penny for the lower one) are placed close up to the lines forming the right angle, and the outline of the coin drawn as a semicircle and quadrant respectively. The circles of the driving or turning gear may be produced by the pin and loop of string method. All the other details are based on parallel lines and should not present any difficulty.

Supplemental Lesson.

Little talks on curved lines, circles, and tangents.

Aim of Practical Lesson.

To combine previous exercises involved in mechanical toy making, and to encourage collective or commune working.

Materials required: Square (two sizes), strip, and slab whitewood, some fine wire long and medium panel pins.

Tools required: Rule, try square, pencil, saw, plane, file, rasp, coins, bradawl, wire cutters, knife, brace, wheel rim and disc cutter.

Procedure for the construction of Model 28—Commune working:

- | | | |
|-----------|---|---|
| Scholar A | } | 1. Mark and saw off 4 side frame pieces 72" long (square wood). |
| | | 2. " " " 2 " " struts 33" " " " |
| | | 3. Plane or smooth up all surfaces. |
| | | 4. Mark and file off ends to bevels shown on drawings. |
| | | 5. Place details on drawing; test for accuracy, and fit in struts. |
| | | 6. Bore for, glue, and nail side frames together, in pairs. |
| Scholar B | } | 1. Mark and saw off 2 base pieces 64" long (square wood). |
| | | 2. " " " 2 " " 48" " " " |
| | | 3. Plane up or smooth all surfaces, and bevel off ends as shown. |
| | | 4. Test for accuracy of length of short pieces; carefully true the ends square. |
| | | 5. Place details on drawing, and mark positions of nailing. |
| | | 6. Bore for, glue, and nail base frame together. |

A MERRY-GO-ROUND HIGH-FLIER.

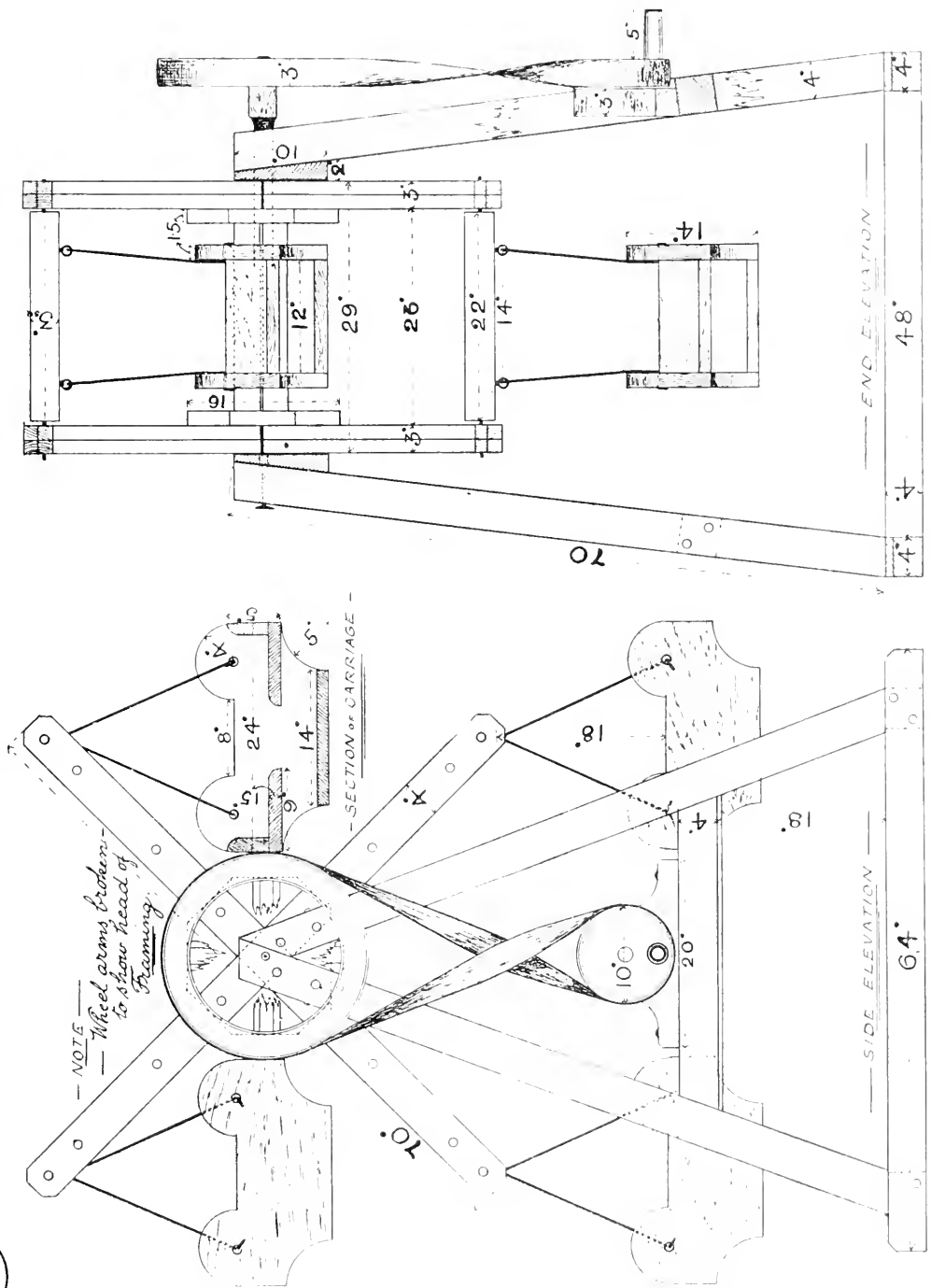

- Scholar C.
1. Mark and saw off 8 arm pieces 72" long (strip wood).
 2. Plane up edges, and one side of each piece only.
 3. Build up by cross lapping (Model 1) each side arm ; glue rough inner surface, and nail together.
 4. Finish off each end as shown on drawing.
 5. Find exact centre of each cross, and bore a fine hole through : also mark out the axle-pin holes on each arm and bore through.
- Scholar D.
1. Mark and saw off 1 hanger axle-bars 22" long (square wood).
 " " 1 main axle-tree 19" " "
 " " 2 gusset plates 16" square (slab wood).
 2. Plane up sides, smooth, and exactly square off each end of axles.
 3. Work gusset plates to octagon shape, as shown on drawing.
 4. Find exact centre of each octagon, and also each end of main axle.
 5. Bore hole through and into axle : glue, and nail plates in place.
 6. Find exact centre of each end of hanger axle-bars, and insert axle-pins to project 3".
- Scholar E, F, G, H.
1. Mark and saw off 2 car sides 24" x 14" (slab wood).
 " " 1 " base 14" x 12" " "
 " " 2 " seats 12" x 9" " "
 " " 2 " backs 12" x 4" " "
 2. Clean up all surfaces, and round front edge of seat piece, and top of back piece.
 3. Glue and nail seat and back together at right angles.
 4. Mark out, and work with rasp and sandpaper to curved lines, the two side pieces being nailed together.
 5. Prepare the base piece and test for equal length with seat.
 6. Mark positions of each on inside of car sides ; glue and nail in position, and bore the holes for each suspension rod.
- Scholar J.
1. Mark out, and work with rasp, file, and sandpaper, the first motion bracket (shown fitted to the cross strut of side frames), carefully noting the bevel form of the bottom.
 2. Bore out 1 wheel rim and 1 disc, and finish rims off with file and sandpaper.
 3. Construct 1 pair of wheel spokes as for Model 27, and fit into position.
 4. Fit handle to disc as shown, and disc to the motion bracket.
 5. Prepare the length of axle (part square and part rounded) for attachment to the main axle-tree made by Scholar D.
- Scholar K.
1. Construct 8 wire eyelets for suspension rods.
 2. " " 8 double suspension rods, each rod to be 22" long.

Procedure for ensembling of details :

1. Bore right hand side frame, cross arms, and main axle-tree to receive round axle-pin attached to driving wheel.
2. Fix first motion bracket and disc on cross strut.
3. Adjust side frames to base frame ; glue, and nail in position.
4. Adjust cross arms to gusset plates and main axle ; glue, and securely nail and clinch in place.
5. Fix eyelets in hanger axle-bars.
6. Adjust and attach suspension rods to cars and axles.
7. Adjust and attach revolving arms to side frames ; carefully glue in the round piece of axle into the main axle.
8. Attach each hanger axle and suspended car to the respective ends of revolving arms ; if necessary, adjust length of the suspension rods, to allow each car to swing clear when passing over the main axle.
9. Make a tape belt, and adjust to correct length by trial on the two driving wheels.
10. Test all parts of the model for proper adjustment, and neatly finish off all edges with sandpaper before completing Model 28.

NOTE.—Should the adjustment of the driving wheels give much difficulty, a groove may be filed round the rim of both wheel and disc to admit of a cord being used instead of a tape belt.

Position drills or demonstrations :

- (a) Filing interior and exterior curves.
- (b) Adjustment of bevel surfaces and oblique nailing.

Sequence or Continuation Lesson.

Little talks on holidays, and how to use them for education and pleasure.

GROUP OF LESSONS No. 29.

MODEL 29 : Mechanical Advertising Machine.

Aim of Drawing Lesson: To give additional exercises in detail drawing and ensembling of parts by free sketching.

The principal feature of this model is the method adopted to give a rotary motion to the body of the machine, upon which is

carried the advertising or sandwich boards. Upon the spokes or arms of one wheel is fixed a disc; from the face of this disc projects a number of panel pins, driven in at equal distances apart, on a circle



FIG. 51

coincident with the centre of the wheel. The upper or body structure is placed on a base wheel of larger diameter, which is provided on the under surface with a number of similar projecting pins (but much shorter), placed at equal distances apart and on a circle as before. The distance between the pins on this second wheel is so arranged as to allow two of the pins on the first wheel to pass easily between. When ensembled, these wheels and pins come into contact with each other, and as the machine is drawn along by the fixed handle, the upper part revolves. Letters, figures, or other illustrations being fixed on the sandwich boards, are in turn brought into full view; the number of boards may vary according to fancy and requirements, provision being made for fixing in position by the centre pin method. Each board may be a fixture or free to revolve at will. Beyond the careful setting out, and driving in of the wheel teeth pins, all the other details of construction are simple repetitions or combinations of past models and exercises. For the purpose of class teaching, a large-size diagram of the complete model together with an actual specimen should be prepared. The children's drawings should be in detail rather than ensemblément, their knowledge of the latter being obtained direct from the standard model. When building, all dimensions should be carefully noted and worked to. Encourage the children to make suggestions as to the number

of boards to be used, the matter to be placed on each, and further arouse interest, by showing that a number of transparencies can be used as readily as any other form. An ordinary night-light placed within the body of the machine gives a sufficient and effective illumination for this purpose. If desired, a small bell dome (part of an old bicycle bell will suit admirably) may be fixed to the free wheel end of the axle, and two or more tumbling hammers arranged to strike it when the machine is in motion. The length of the handle, as shown on the drawing, is proportionate to the general design of the model, but may be increased and jointed, if necessary, for effective use as a mechanical toy.

Supplemental Lesson.

Little talks on relative speeds of wheels of different diameters; general knowledge of mechanical movements.

Aim of Practical Lesson.

To give knowledge of simple mechanical movements suitable for toy mechanism and to apply previous exercises in toy making.

Materials required: Square and slab wood, long and short panel pins.

Tools required: Rule, try square, pencil, saw, plane, bradawl, knife, file, brace and wheel cutter, hammer, cutting pliers.

Procedure for the construction of Model 29:

- | | |
|------------------------------------|-------------------------------|
| 1. Mark and saw off for axle-tree, | 1 piece 32" × 4" square wood. |
| " " " handle bar, | 1 " 44" × 4" " " |
| " " " " " | 2 " 24" × 4" " " |
| " " " centre columns, | 2 " 32" × 3" " " |
| " " " front board carriers, | 2 " 15" × 3" |
2. Bore out and prepare 2 wheel rims 30" diameter.
 " " 2 " " 32" "
 3. Prepare a set of arms for each rim, and fix in place.
 4. Find exact centre of each wheel, and bore through for axle-pin.
 5. Prepare 1 disc 20" diameter, 3" thick, and describe a teeth-pitch circle of 17" diameter.
 6. On this circle set out positions for 16 teeth or pins; drive panel pins in at each point, each pin to project 3" from face of disc.

A MECHANICAL ADVERTISING MACHINE.
WORKING MODEL.

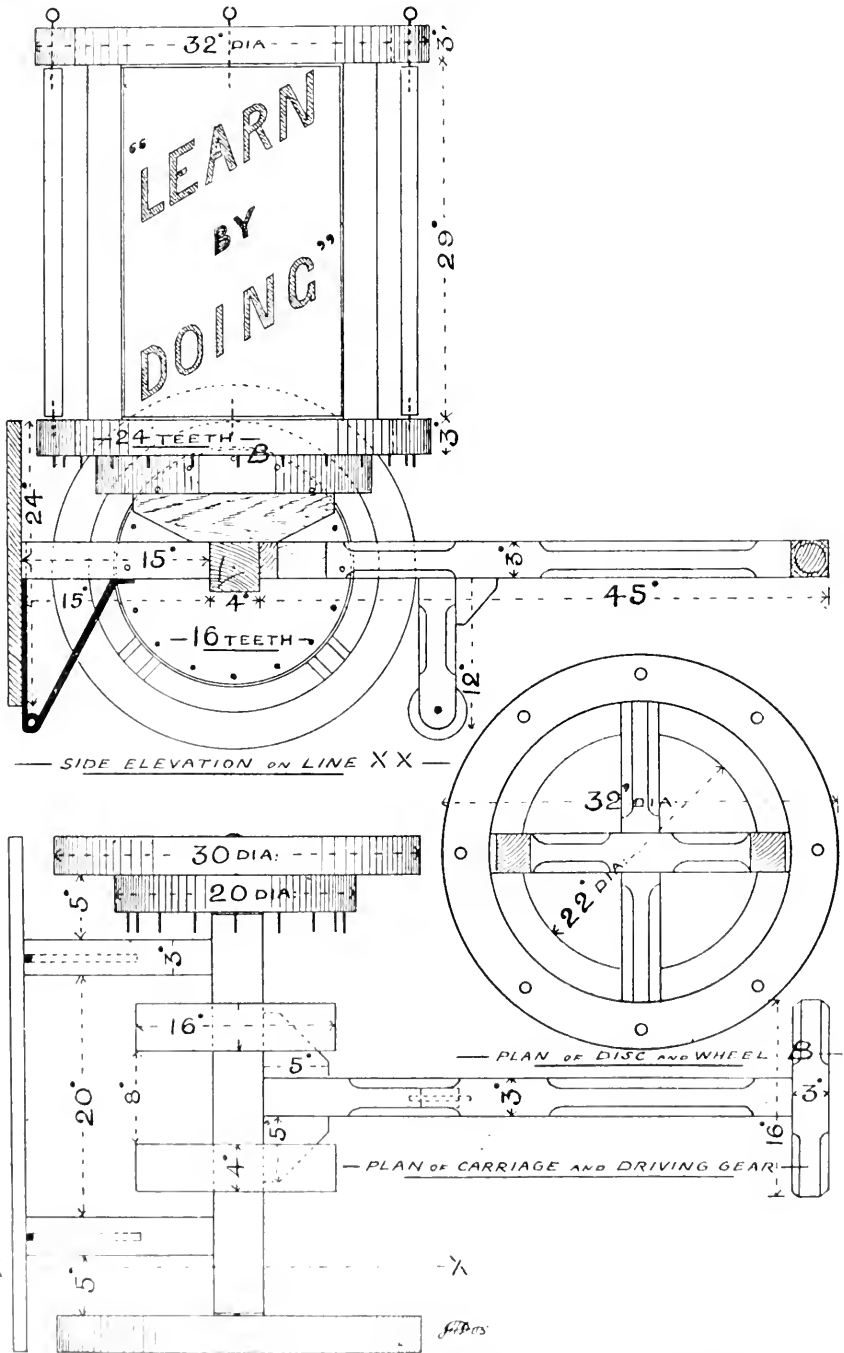

7. Fix this disc exactly in the centre of one of the 30" diameter wheels.
8. Describe a pitch circle of 30" diameter on one of the 32" diameter wheels.
9. On this circle set out positions for 24 teeth or pins; drive panel pins in at each point, each to project 1" from the face of wheel rim.
10. Prepare 1 bearing disc 22" diameter, and attach to axle-tree with cross bearing pieces, to allow all teeth pins on driving disc to revolve freely, without touching the under surface of the second toothed wheel.
11. Chamfer edges of, and attach handle bar to axle-tree draw bar; chamfer cross bar and fix it in position; also prepare leg to receive small wheel, and wire standards for front supports.
12. Prepare 3 angle bracket pieces; glue, and nail these in angles formed at junction of handle bar and axle-tree, and between draw bar and leg.
13. On upper surface of the second driving wheel, 2" from the outer edge of rim, bore eight holes, as on detail drawing, to receive the centre pins of the advertising boards; corresponding holes must also be made in the upper rim, through which will pass the wire eye pins, to hold the advertising boards vertical.
14. Connect these two wheels together by the two pillars placed 18" apart on the wheel arms.
15. Prepare 4 or more advertising boards 28" \times 16" of thin slab wood, fitting in each board one pin in the centre of one end, and bore a hole in the other end to receive top holding pin (wire eye pins).
16. Attach small wheel to supporting leg; adjust body to carriage, and test for easy running of mechanism.
17. Fix advertising boards in position; test for easy and free movement of each.
18. Test all details for accuracy of construction and stability.
19. Prepare front advertising board 40" \times 24" of thin slab wood, and fix it in position on the carriers.
20. Clean up neatly all edges; attach letters or figures on each board, and neatly finish Model 29.

Position drill: Wheel and disc cutting and forming.

Position demonstration: Setting out for pin teeth on pitch circle.

Sequence or Continuation Lesson.

Little talks on ways and means of obtaining publicity for trading; on the good and evil effects of pictorial advertisements, artistic posters, etc.

GROUP OF LESSONS No. 30.

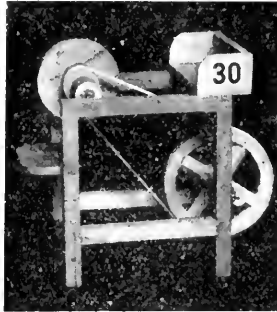

FIG. 52.

MODEL 30: Knife-grinding Machine.

Aim of Drawing Lesson: To give additional emphasis to statements made as to value of detail drawings, and free sketches in coloured chalks.

The several details of this well-known and popular toy will be found to give admirable exercises for both free sketch and full scale work on both black board and paper. A side elevation will show the general ensemblment, and will, in most cases, be all that is necessary to complete the general lesson on outline form.

A pictorial view should be exhibited, together with a standard model, and the children encouraged to compare the treadle movement with that of the sewing machine and foot lathe. Explanation (1) of the transforming of reciprocating (to and fro) motion into rotary (revolving or circular) motion should be given; (2) of the difference in speed between the large and small wheels and discs when revolving, educating, if possible, the fact that every fixture on the same shaft revolves at the same speed, but that the distance travelled by a point on the rim of each disc varies according to the diameters; (3) the reason why the piece of tape (used as a driving belt) does not run off the narrow rim of the large wheel; (4) why the wheel is weighted in the rim; (5) why the axle upon which the wheel is fixed is not made straight, as for the axle of a wheel-barrow (Model 24); and (6) why the crank has to be built up in this instance. Be careful to

reduce all technical terms, names, and phrases to simple language, and to awaken latent interest by smart and ready references to homely examples, encouraging the children to suggest some methods of procedure for both the drawing and practical lessons. If the commune method of production is again adopted, each child should prepare a full-size drawing of the respective detail, from which to build up the element; otherwise, a fully-dimensioned side elevation, from which an end view of the simple framing and shelf can be projected, should be the result of the drawing lesson. The drawing showing the method of building up the crank axle, should be made as a chart diagram, for reference during the practical lesson.

Supplemental Lesson.

Little talks on circular motion, introducing the planetary system, released gyrotory motion, David's sling, Maxim's flying machine, etc.

Aim of Practical Lesson.

To teach simple methods for the construction of mechanical movements in toy making.

Materials required: Square, strip, and slab whitewood, two sewing-cotton reels, long and medium panel pins, and some fine wire.

Tools required: Rule, try square, pencil, saw, plane, files, bradawl, hammer, brace and wheel cutter, pliers.

Procedure for the construction of Model 30:

1. Mark and saw off 4 pieces 32" long for side frames (square wood).
- " " 2 " 36" " " "
- " " 2 " 26" " " "
- " " 2 " 26" " stretcher bars "
- " " 2 " 18" " wheel arms "
- " " 1 " 7" " axle end "
- " " 1 " 5" " " "
- " " 1 " 26" × 10" for seat piece (slab wood).
- " " 1 " 26" × 10" " tool shelf "
- " " 1 " 43" × 6" " " front and ends (slab wood).
- " " 1 " 36" × 4" " treadle piece (strip wood).
- " " 1 " 26" × 2" × 2" for secondary shaft.

A KNIFE-GRINDING MACHINE.
WORKING MODEL.

30

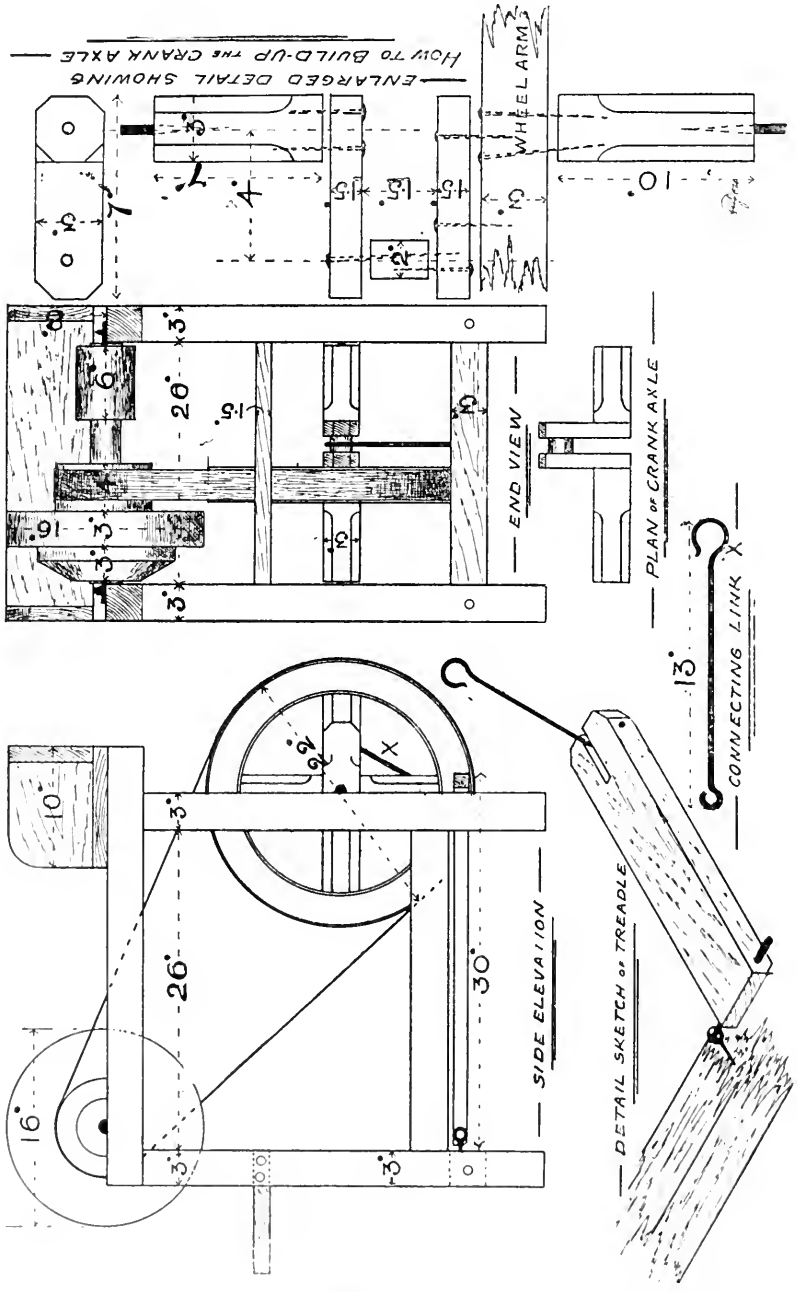

2. Smooth up all surfaces.
3. Build up side frames to dimensions; glue, and nail.
4. Bore out disc and rim of crank wheel.
5. Fit arms in rim and chamfer as shown.
6. Saw off and prepare crank webs 7" long.
7. Build up crank shaft on wheel arms.
8. Make a connecting link of wire to the form shown on detailed drawing.
9. Make 6 eyelets for axle-pins to revolve in.
10. Adjust the side frames: fit and fix in stretcher bars.
11. Work the curves on seat ends, and on end pieces of workshelf.
12. Prepare secondary shaft, rounding up to fit the holes in cotton reels.
13. Cut cotton reels in sections, to form "pulleys" as shown on drawing.
14. Bore hole in disc to receive shaft, and build up the secondary shaft with disc and pulleys complete.
15. Fix crank shaft in position.
16. Fix secondary shaft in position.
17. Prepare treadle piece, and insert connecting link.
18. Adjust treadle piece to front stretcher bar, and connect link to crank pin.
19. Make a tape belt to connect driving wheel and pulley.
20. Adjust shafts (if necessary) to secure direct driving.
21. Fix front and ends, to work shelf and secure in place.
22. Fix seat piece between back framing, as shown.
23. Test for easy running, and, if necessary, add a small piece of lead to affect balance of driving wheel.
24. Clean up all edges and neatly finish off Model 30.

NOTE.—Some difficulty may be experienced in building up the small crank; a little patience will, however, surmount it. The short journal, upon which the wire connecting link works, may be made from a piece of bamboo bead; the hole in which is then filled up with a small piece of wood, which, projecting at each end, is readily glued into the two crank webs, one of which is fixed to the wheel arm, the other to the length of axle. The mounting or building up of the axles, to admit of the attached wheels running true, is the most difficult part of the model, and may be beyond the capabilities of some children, who can make all the other details without assistance; it is therefore necessary to arrange the commune work accordingly.

The correct position of the treadle when fitted, is parallel to the crank webs, the arms of the wheel being vertical and horizontal respectively—it may be found necessary to slightly alter the length of the connecting link to meet this requirement. The hinging of the treadle bar to the back stretcher bar is by the eyelet and pin method, as shown on detail drawing. The dimensions of the

several pulleys on the secondary shaft are not given; ordinary sewing-cotton reels of various sizes may be used in the construction of Mechanical toys; it is most important that all elements of movement shall be perfectly free to move in detail, to ensure freedom of working when ensembled.

Position drills and demonstrations: Rounding-up small shafts with file and sandpaper; eyelet forming and crank building.

Sequence or Continuation Lesson.

Little talks on the manufacture of

- (a) Scissors, knives, and other common cutting tools.
- (b) The industries of Sheffield.
- (c) Horn, bone, ivory and its modern substitutes—celluloid, xylonite, etc.

GROUP OF LESSONS No. 31.

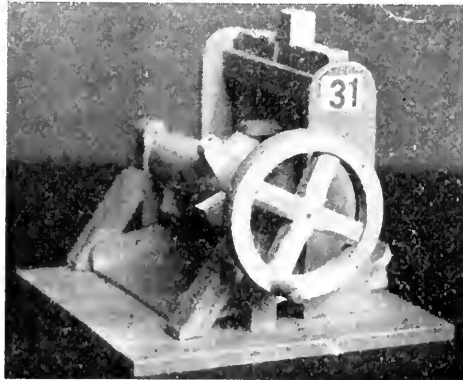

FIG. 53.

MODEL 31: Ore-crushing Mill.

Aim of Drawing Lesson: To give additional training in projecting and on the reading of views and sections.

This is at once a simple yet difficult model; simple in its several details or elements, none of which are beyond the capabilities of the average scholar; yet difficult in the complications of the ensemblement of such details. It is a most fascinating mechanical toy, and

as a medium around which to weave out stories of our latest colonial possessions it has no rival. The teacher should (before attempting to give any lesson upon it) have become thoroughly conversant with all the intricate details by actually constructing a standard model for class use. It offers a splendid opportunity for effective and deeply interesting commune work, and if the selection of details and scholars is carefully made, no difficulty whatever will ensue.

The sectional end elevation should form the basis of the class drawing of an ensemblment of the details, as this view shows all the features of the model except the driving wheel. The detail commune drawings should in all cases be fully dimensioned and, as with the practical work, be kept well within the capabilities of the scholar.

The pictorial drawings of the several details given will illustrate clearly the general form of each, and the relative positions are indicated by the index letters. Duplicate dimensions are used where necessary, and dotted lines showing hidden details serve to explain several points; therefore, taking the several elements which form the mill when erected or ensembled, the most difficult will be the "tappet" or "sprogett" barrel. This may be built up of four pieces of square whitewood, glued and nailed together, and afterwards rounded up with rasp, file, and glasspaper to the given dimensions, or it may be cut direct from a broomstick or broken drill wand. The projecting pieces or tappets (C) must be carefully hollowed out with the rasp to fit the round surface of the barrel, and then be accurately placed at equal distances apart circumferentially and on the axis, each being glued and double nailed in position. The side standards with cross-bars and division plates, (G) forming the drop stamp hammer slides, require careful fitting and adjustment, to admit of free movement, whilst the journal standards, fitted with the bearing caps (A), should present very little difficulty at this stage.

The base board upon which the mill details are fitted may be made in one piece, but should the material at hand not be wide enough, an effective base may be readily made by nailing edge to edge a number of square or strip wood pieces, or wider material laid edge to edge, and securely held together by under strips or "battens"

nailed and clinched thereto. Either of the latter methods provides a very good exercise for the backward scholars.

The hinged and tilted feed board (H), fitted in front of the drop stamps (F), is a detail which can be made an extra model, as can also the delivery slope (B), which fits in between the side standards at the back and below the tappet barrel. The stamp beam (K) must be fixed between the standards exactly below the drop stamps. The adjustment of the tappets on the barrel should lift each drop stamp in rotation, the rise of one immediately commencing at the fall of its neighbour. The exact fulfilment of this essential will depend upon the rounding off of the upper edge of each tappet; and each stamp must drop suddenly and squarely on to the stamp beam.

The fitting of the hand-wheel and axle (D) is a repetition of driving-wheel of Model 28; the detail diagram clearly shows how the connection is made with the tappet barrel.

Supplemental Lesson.

The value of full-size detail drawings to the craftsman.

Aim of Practical Lesson.

To teach simple methods of construction through more difficult exercises and mechanical movements.

Materials required: Square, strip, and slab whitewood, long and medium panel pins.

Tools required: Rule, try square, pencil, saw, plane, rasp, file, blemmer, cutting pliers, knife, brace, and wheel and disc cutter.

Procedure for the construction of Model 31 (commune working):

	1.	Mark and saw off for side standards,	2 pieces 36" × 10" (slab wood).
Sch. A stamp guides,	1 .. 32" × 4" (strip wood).
 division plates,	6 .. 24" × 4"
 stamps and stamp beam,	6 .. 32" × 4" (square wood).
 stamp lifters,	5 .. 6" × 4" (strip wood).
		Mark and saw off for tappet barrel,	1 piece 8" round (broomstick).
 tappets,	5 pieces 5" × 3" (square wood).
Sch. B		Bore out 22" diameter wheel rim.	
		Mark and saw off for wheel arms,	2 pieces 17" × 3" (square wood).
 wheel axle,	1 .. 12" × 3"
 wheel handle,	1 .. 6" × 2" round.

AN ORE-CRUSHING DROP-STAMP MACHINE.
WORKING MODEL.

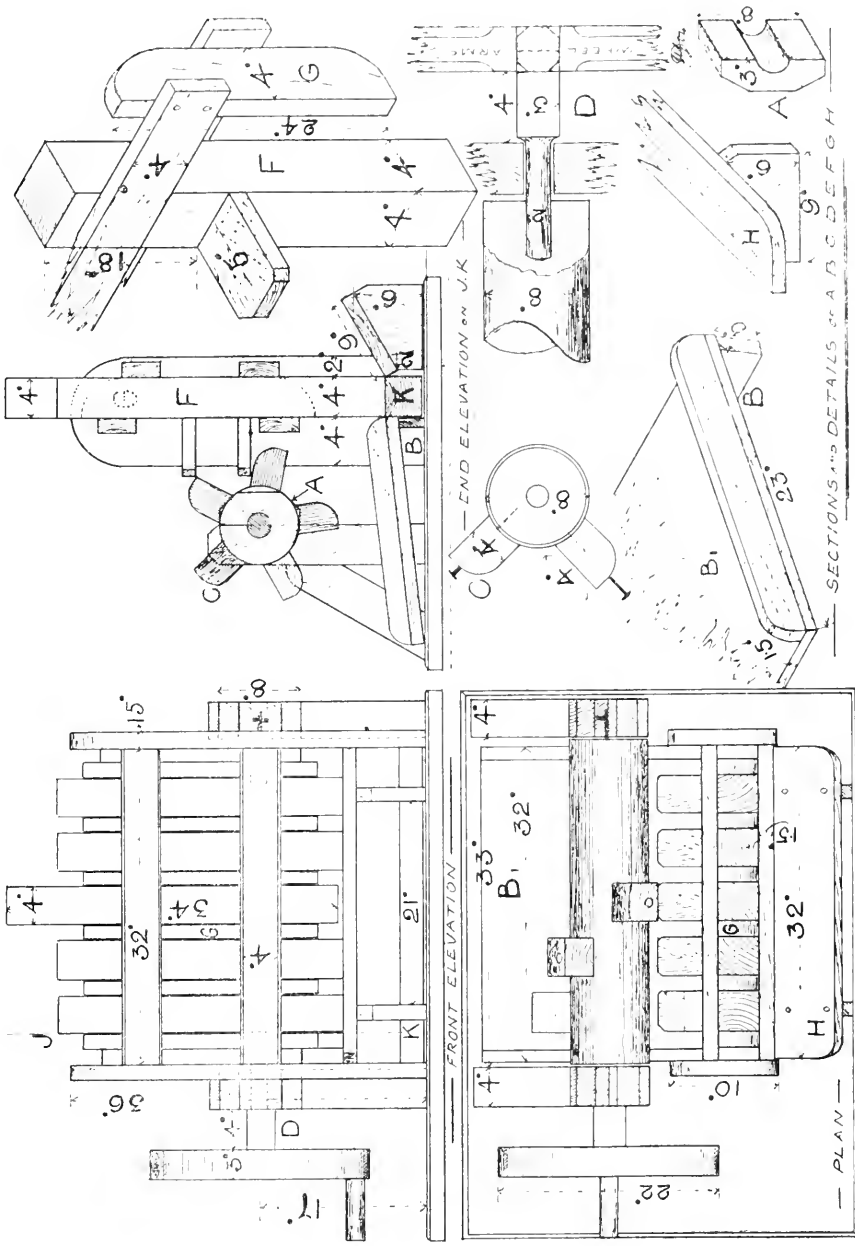

Sch. C.	(Mark and saw off for journal standards,	2 pieces $23^{\bullet} \times 4^{\bullet}$ (square wood).
		" " " "	2 " $18^{\bullet} \times 4^{\bullet}$ " "
Sch. D.	(" " " caps,	2 " $8^{\bullet} \times 4^{\bullet}$ " "
		Mark and saw off for delivery slope,	2 pieces $23^{\bullet} \times 4^{\bullet}$ (strip wood).
Sch. E.	(" " " "	1 " $31^{\bullet} \times 3^{\bullet}$ " "
		" " " "	1 " $31^{\bullet} \times 23^{\bullet}$ (slab wood).
Sch. F.	(Mark and saw off for feed board,	1 piece $32^{\bullet} \times 10^{\bullet}$ (slab wood).
		" " " "	2 " $6^{\bullet} \times 10^{\bullet}$ " "
Sch. G.	(Mark and saw off for base board,	1 piece $48^{\bullet} \times 48^{\bullet}$ (slab wood).
		(Or build up with 48^{\bullet} lengths of square, strip, or slab wood.)	

2. Smooth or plane up all surfaces.
3. Prepare stamp framing and guides : glue, and nail together.
4. Prepare division plates and stamps; adjust plates, and nail in position, to give free but not loose movement of stamps.
5. Prepare lifters, and mark in exact position on each stamp.
6. Insert stamps in framing, and fix lifters by double nailing, and also fix stamp beam.
7. Prepare tappet barrel, mark exact positions for each tappet.
8. Fit tappets to barrel, bore for, glue, and fix in place.
9. Prepare the journal standards and caps.
10. Prepare the driving wheel, axles, and handle.
11. Prepare tappet barrel for journals (axles).
12. Fix driving wheel and axle to tappet barrel, and test for true running of each.
13. Adjust journals and caps, to admit tappet barrel to revolve freely in standards.
14. Adjust drop stamps and tappet barrel standards on base board; bore for, glue, and nail in position.
15. Test for accuracy of movement and adjust, if necessary.
16. Prepare feed board and fix to framing.
17. Prepare delivery slope and adjust between standards.
18. Test for accuracy of measurement, detail, and collective movement; add a lead ball to top of each stamp, to give additional weight, and neatly finish off Model 31.

Position demonstration : Adjustment of tappet pieces.

Sequence or Continuation Lessons.

Ore crushing; gold and diamond mining; our colonial possessions in Australia, South Africa, America, and India.

GROUP OF LESSONS No. 32.

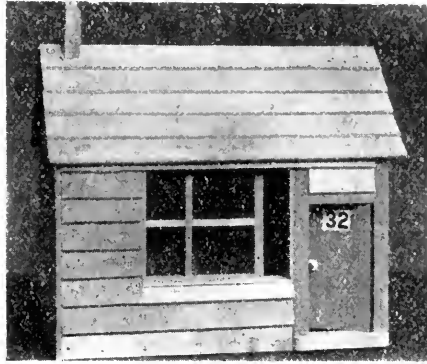

FIG. 51.

MODEL 32: Miner's Hut or Cabin.

Aim of Drawing Lesson: To give a direct application of pictorial delineation by means of parallel and oblique lines.

The large dimensions of this model will preclude the making of a full-size drawing of the whole ensemblément, but details may be readily made from the pictorial scale drawing given. It should be possible at this stage to make scale drawings on the Unit system of measurement, *i.e.*, dividing by 2 the given dimensions in units of $\frac{1}{8}$ " , to represent new units of $\frac{1}{16}$ " , thus produce a drawing of 6" = 1 foot, or to a scale of half full size.

The children should first be encouraged to make free sketches of the cabin, as seen from various points of view, and of the details of the window, door, etc., placing all the essential dimensions thereon, and afterwards to complete the required scale drawings therefrom.

Large diagrams of the cabin in skeleton framing, either in detail projection or in pictorial form, together with a standard model, should be available for reference and direct measurement.

To admit of further commune working, the several details are arranged as complete models of framing, and each may be covered with the "shingles" or "weather board" before or after ensemblément. The framings should present no difficulty, being merely repetition

work of past models. The new features are: (a) the grooved framing necessary to hold the glass which forms the window, and (b) the cutting and overlay of the boards or strips, which form the covering of sides, ends, and roof. The former is produced mechanically by means of the small grooving cutter (*Fig. 23*), which is worked as a plane on the edges of a length of strip wood. The depth of the groove is determined by the length of cutter which projects below the rebated side of the tool; this is readily adjusted by releasing the small screw, which fixes the cutter in the desired position. Some little assistance beyond a demonstration of its use may be necessary to produce a satisfactory window frame (built on the lines suggested), but do not discourage any attempt at self-effort.

The use of the cutting-marking gauge is now to be fully demonstrated by cutting the shingles from a thin slab of Canadian birch or whitewood; the cutter is held up close to the planed or trued edge of the slab, and made to cut into the wood first on one side and then on the other; one or two movements throughout the length will cause the cutter to sever the piece to the required set width. *The edge of the slab must be trued up after each strip is cut off.*

Another very effective method of covering the framing is to use the natural wood hoops of Canadian apple barrels. This style of covering more closely resembles the log huts of Canadian settlers, and if finished with a coating of green shellac varnish produces a most realistic effect.

The centre-pin method of hanging the door is simple and efficient; it is readily done by boring holes through the "transom" rail and step, near the right-hand ends; through each of these holes a panel pin is passed, and then driven into the end grain of the piece of slab wood which forms the door.

The sliding of the window is also a simple arrangement, the inside overlay strips forming a groove, into which fits the window frame.

Provision has not been made for a floor, but this can readily be added, if considered necessary, by building up a base board (as for Model 31) to the dimensions as measured between the sides and end frames when the details of the model are ensembled.

It will be necessary to give clear explanations of the several elements by reference to known details of house building, during the lesson, and to lead the children to compare methods of general construction and arrangement.

Apportion with due care the respective details to the scholars, and encourage the production of neat diagrams, fully dimensioned, for future use in the practical lesson.

Supplemental Lesson.

Little talks on mechanical toys, and the ensembling of constructional details.

Aim of Practical Lesson.

To teach simple methods of construction, lap-boarding or shingling, window-frame making and door hanging, as applied to toy making.

Materials required : Square and strip and slab whitewood, split willow bands or Canadian birch slab wood; long, medium, and short panel pins, and one piece of glass, $4\frac{1}{4}'' \times 3\frac{1}{4}''$.

Tools required : Rule, try square, pencil, saw, plane, bradawl, hammer, grooving tool, bead scratch, file.

Procedure for the construction of Model 32 (commune working) :

Scholar A.	{	1. Mark and saw off for front framing, 2 pieces $72'' \times 3''$ square wood.
		" " " " 2 " $52'' \times 3''$ " "
		" " " " 1 " $42'' \times 4''$ " "
		" " " " 1 " $52'' \times 4''$ " "
		" " " " 1 " $16'' \times 4''$ " "
		" " " " 1 " $29'' \times 4''$ strip wood.
Scholar B.	{	Mark and saw off for back framing, 2 pieces $72'' \times 3''$ square wood.
		" " " " 2 " $52'' \times 3''$ " "
		" " " " 1 " $42'' \times 3''$ " "
		" " " " 2 " $54'' \times 3''$ " "
Scholar C.	{	Mark and saw off for 2 end frames, 4 pieces $38'' \times 3''$ square wood.
		" " " " 4 " $48'' \times 3''$ strip wood.
		" " " " 2 " $54'' \times 3''$ square wood.

A MINER'S HUT OR CABIN.

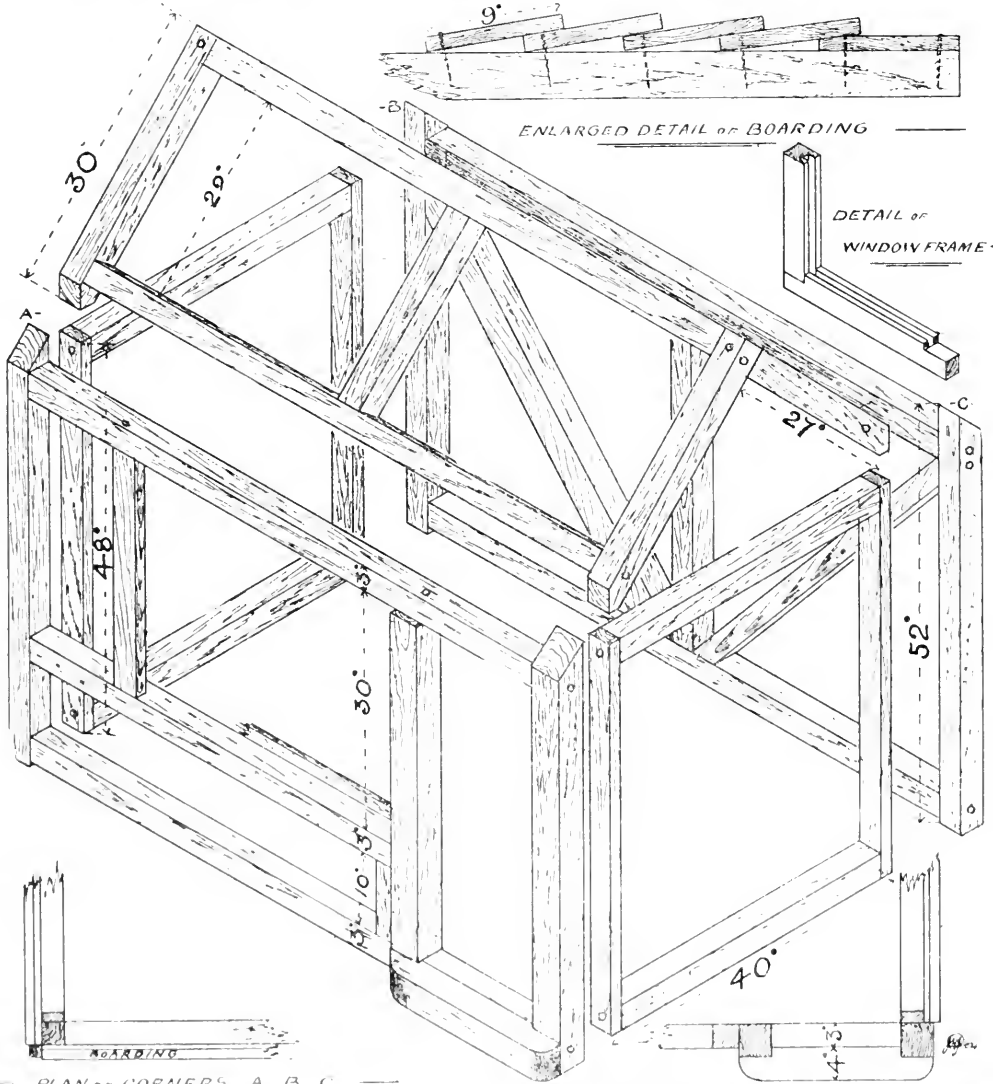
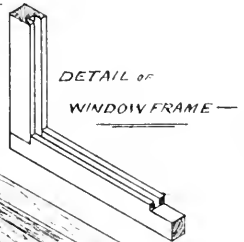
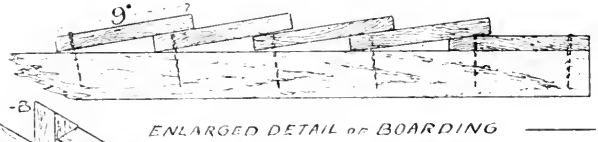
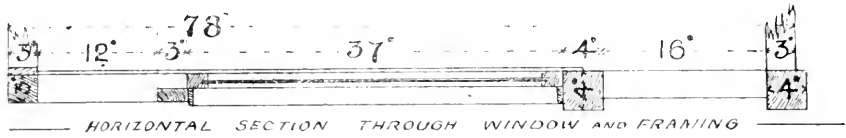

PLAN OF DOORWAY AND ANGLE

Scholar D.	Mark and saw off for roof frame,	3 pieces	$72^{\circ} \times 3^{\circ}$ square wood.
	" " "	4 "	$28^{\circ} \times 3^{\circ}$ " "
	" " "	2 "	$22^{\circ} \times 3^{\circ}$ " "
	" " chimney stack,	2 "	$12^{\circ} \times 3^{\circ}$ " "
" " "	1 "	$6^{\circ} \times 3^{\circ}$ " "	
Scholar E.	Mark and gauge off for roof	covering,	10 pieces $86^{\circ} \times 9^{\circ}$ thin slab wood.
	" " back	" 8 "	$78^{\circ} \times 9^{\circ}$ " "
	" " left-hand end	" 8 "	$48^{\circ} \times 9^{\circ}$ " "
	" " right-hand end	" 8 "	$44^{\circ} \times 9^{\circ}$ " "
	" " front	" 5 "	$20^{\circ} \times 9^{\circ}$ " "
	" " "	" 1 "	$76^{\circ} \times 6^{\circ}$ " "
" " "	" 2 "	$56^{\circ} \times 9^{\circ}$ " "	

Also narrow bead strips for window ledges and inside slips.

1 door $32^{\circ} \times 16^{\circ} \times 2^{\circ}$, and 1 door step $24^{\circ} \times 3^{\circ}$ square.

1 over door panel $16^{\circ} \times 7^{\circ} \times 2^{\circ}$, and cover boards for each gable end.

2. Smooth up all surfaces with glasspaper.
3. Build up all framings to drawings; glue, and double nail all joints, and fit cover boards to each.
4. Prepare window frame; adjust to piece of glass; glue, and end nail the frame together with glass fitted in.
5. Cut narrow strips to form pane divisions, and glue in place.
6. Prepare the door and fit into front framing, with panel pins through transom rail and step rail.
7. Fit overdoor panel in and fix.
8. Prepare slips to form window slide; adjust to inside of frame; nail, and fix in position to allow free movement of window.
9. Fit covering boards to front framing, and cut top ends of side posts to fit roof framing (see bevels on drawing).
10. Build up roof framing, and prepare cover boards.
11. Adjust all framings; try together; if correct, nail ends to back framing; then to front framing in position.
12. Try up, and adjust roof framing to structure.
13. Adjust and fix roof covering, and finish gable ends and chimney.
14. Prepare square corner pieces to cover ends of covering boards, as shown on the drawing.
15. Test for stability and squareness; fix door knob.
16. Smooth off all angles, and neatly complete Model 32.

Position demonstrations: (a) Grooving with special tool.

(b) Door hanging by centre-pin method.

(c) Cover boarding or shingling.

Sequence or Continuation Lesson.

Little talks on life in the colonies, Canadian backwoods and prairies; the Australian bush and South African veldt; or on Pioneers of the Empire.

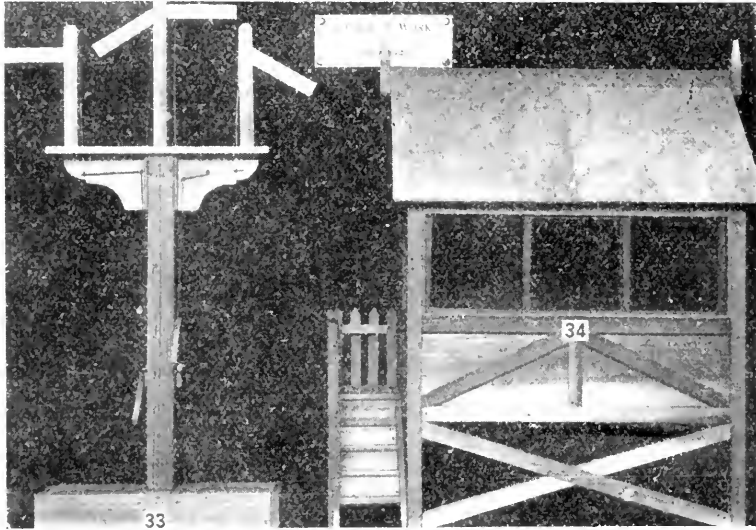

RAILWAY SIGNALS AND SIGNAL CABIN

GROUP OF LESSONS No. 33.

MODEL 33: Standard Railway Signals.

Aim of Drawing Lesson: To teach detail drawing to scale, free sketching, and ensemblément of elements.

This model provides an opening for the direct application of simple wirework exercises, in the mechanism for the working of the signal arms.

As all the several elements have been previously made and applied in various forms, no great difficulty should appear, provided due care and attention be paid to the exact position, and absolute freedom of movement of each detail, together with a frequent testing

of the whole combination during the progress of ensembling. A full lesson on the wire mechanism may be given, and a selection of the most accurate work, made for direct application on the models to be constructed; or the details may be given to those children most competent to produce good work.

The general ensembling of the woodwork details should be illustrated by free sketches on the black board, by a prepared chart in pictorial elevation, and by a standard model.

Each scholar should now be able to produce a detail drawing of the portion above the levers, *e.g.*, the upper platform and range of signal posts and arms; the curves of the supporting brackets may be freehand or geometric according to taste, provided always the outline of each is in balance. Fully-dimensioned details of the element apportioned to each scholar is essential to secure accuracy of construction.

The three signal posts, with respective arms, may form the work of three scholars, the main column of a fourth, the upper platform and supporting brackets of a fifth, the base box of a sixth, the movement levers and back bracket piece of a seventh, whilst the ensembling should be the work of the most expert scholars, under the direct guidance of the teacher, as in previous models.

To provide for the wire rods (which move the centre arms) to pass through the brackets to the working levers below, a saw-kerf is cut across the end of each bracket sufficiently deep, to give absolute freedom of movement to each wire.

The brackets, being then nailed to the platform, slide over the centre column between the guide pieces. The centre column or main standard may be built up or wrought from the solid, the corner in either case being scratch-beaded, as shown on the enlarged section.

The positions of the two pairs of levers are placed, to admit of them passing between the rails of the stairway platform of the signal cabin (Model 34), whilst giving the maximum of movement necessary to drop or raise the signal arms. The drawings given fully illustrate the general ensembling, and the details of construction.

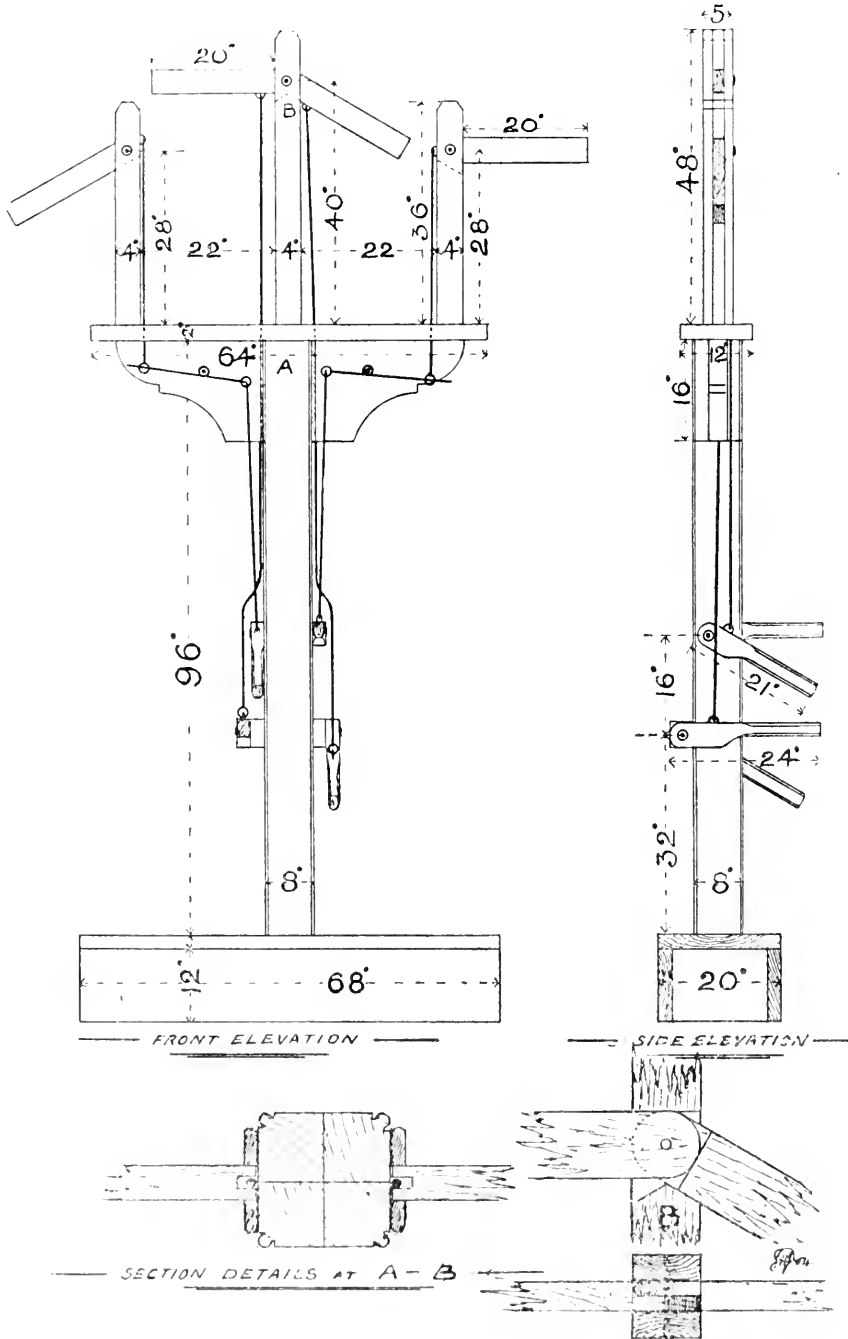

Supplemental Lesson.

Little talks on the value of commune work. Citizenship and co-operation.

Aim of Practical Lesson.

To stimulate co-operation and commune work, in the application of previous lessons to simple elements of construction.

Materials required : Square, strip, and slab wood, some lengths of wire, long, medium, and short panel pins.

Tools required : Rule, try square, pencil, saw, plane, file, bradawl, bead scratch, wire cutters.

Procedure for the construction of Model 33 :

- | | | | | |
|--|---|--------|--------------------------------|--------------|
| 1. Mark and saw off for main standard, | 4 | pieces | $96^{\circ} \times 4^{\circ}$ | square wood. |
| " " centre signal post, | 3 | " | $48^{\circ} \times 4^{\circ}$ | strip wood. |
| " " side " " | 6 | " | $36^{\circ} \times 4^{\circ}$ | " " |
| " " signal arms, | 4 | " | $24^{\circ} \times 4^{\circ}$ | " " |
| " " upper platform, | 1 | " | $64^{\circ} \times 16^{\circ}$ | slab wood. |
| " " support brackets, | 2 | " | $24^{\circ} \times 16^{\circ}$ | " " |
| " " base box, | 1 | " | $68^{\circ} \times 26^{\circ}$ | " " |
| " " " " | 2 | " | $68^{\circ} \times 12^{\circ}$ | " " |
| " " " " | 2 | " | $16^{\circ} \times 12^{\circ}$ | " " |
| " " back bracket, | 1 | " | $11^{\circ} \times 4^{\circ}$ | square wood. |
| " " levers, | 4 | " | $22^{\circ} \times 4^{\circ}$ | strip wood. |
2. Smooth or plane up all surfaces, except two sides of each piece forming main standard, and inside piece of each signal post.
 3. Build up main column, and finish each outer corner with scratch bead, working from each side to form full bead.
 4. Construct base box, and fix main standard in position.
 5. Prepare all signal arms, rounding one end to full semicircle, and one pair to form half-lap joint, as shown on enlarged detail for centre post arms.
 6. Prepare centre pieces of each signal post to receive ends of signal arms.
 7. Build up each signal post by over nailing.
 8. Insert signal arms in openings, bore through and fix in position with panel pin, cut off flush with post.
 9. Construct four wire staples, and fix in signal arms as shown on drawing.

10. Construct two wire levers to fix on support brackets.
11. Prepare support brackets and fix to upper platform.
12. Adjust brackets and platform on head of main column.
13. Bore holes in platform for connecting wires.
14. Fix the three signal posts in position on platform.
15. Construct the four levers to the designs shown.
16. Construct four wire staples and fix in levers.
17. Attach the levers to side of main standard and back bracket respectively.
18. Construct the connecting links; attach to levers and arms, and adjust to allow freedom of movement throughout.
19. Test for accuracy of detail and stability of construction ; clean up and neatly finish Model 33.

Position drill: Edge and end nailing; demonstration on wire work details.



FIG. 55.

Sequence or Continuation Lesson.

Little talks on the use of signals on land and sea. Methods in use : flags, flash light, explosives, musical sounds, electricity, wireless telegraphy.

GROUP OF LESSONS No. 34.

MODEL 34: Signal Cabin.

Aim of Drawing Lesson: To give additional practice in detail drawing, and ensembling of parts by free sketches.

The general ensembling of the details of this model should be shown by a large pictorial view of the general framing of the complete model; also by means of a standard model, built by the teacher from the given drawing.

The framework drawings may be drawn to full-size or to half-size scale, provided always that the full-size dimensions are clearly shown in the correct positions. The general construction is similar to Model 32, and under the commune system of working, no great difficulties should arise to prevent speedy and effective work. Apportion the several elements to those children most capable of producing the same, both in the drawing and construction. Encourage competition for excellence of workmanship, and stimulate true helpfulness and comradeship between each little band of workers.

The five windows—two of which are made to slide and two others to swing open—are framed in grooves as before; the size of glass being 26" square (old lantern slide negatives or cover-glasses will be very suitable, and are obtainable at any photographic stores at sixpence per dozen). The bead slips fitted into the opening in the framing retain the window frames in position, whilst the inside cover slips provide the necessary groove for sliding. The centre window is a fixture. The floor may be made in one piece and beaded in from below, or the more orthodox method of board flooring nailed to cross joists or bearers may be adopted. The covering of the roof may be full boarded with thin Canadian birch or whitewood slab, lined out on the surface to represent tiles or slates, or it may be lap-boarded as for Model 32. Insert-panels, nailed in, are adopted for the front, ends, and back, all of which are separate framed pieces, which readily constitute commune models. The door is hinged by the centre-pin method.

Unattached, but forming a constituent part of this model, is the entrance stairway and railed platform; this provides a progressive model for the more expert of the scholars, and should be worked simultaneously. The drawings furnished show clearly the general construction, the dotted lines on the stringer (a technical term for the sides of the stairway into which the treads and risers forming the steps are inserted) serve to indicate the position of the steps.

A complete drawing of this model should be made by the scholar to whom is apportioned the task of building, and should be fully dimensioned to admit of ready reference and correct workmanship. When built, the surface of the platform should be level with the door-step sill of the cabin.

Supplemental Lesson.

Little talks on further advantages of detail drawings when used for commune working.

Aim of Practical Lesson.

To teach simple methods of construction: to secure strength and rigidity of structures or frame work in toy making.

Materials required: Square, strip, and slab whitewood, fire lantern slide cover-glasses, wire, and panel pins of various lengths and sizes.

Tools required: Rule, try square, pencil, saw, planes, hammer, files, grooving tool, bead scratch, cutting pliers, pricker, and Bradawl.

Procedure for the construction of the Cabin Model 34 (commune working):

Scholar A.	1.	Mark and saw off for front framing, 2 pieces	96" × 4"	square wood.
	"	" " " 3 "	84" × 4"	" "
	"	" " " 2 "	88" × 4"	" "
	"	" " " 1 "	84" × 4"	strip wood.
	"	" " " 2 "	45" × 4"	" "
	"	" " " 1 "	20" × 4"	" "
	"	" " " 1 panel	84" × 20"	slab wood.



DETAILS OF SIGNAL CABIN

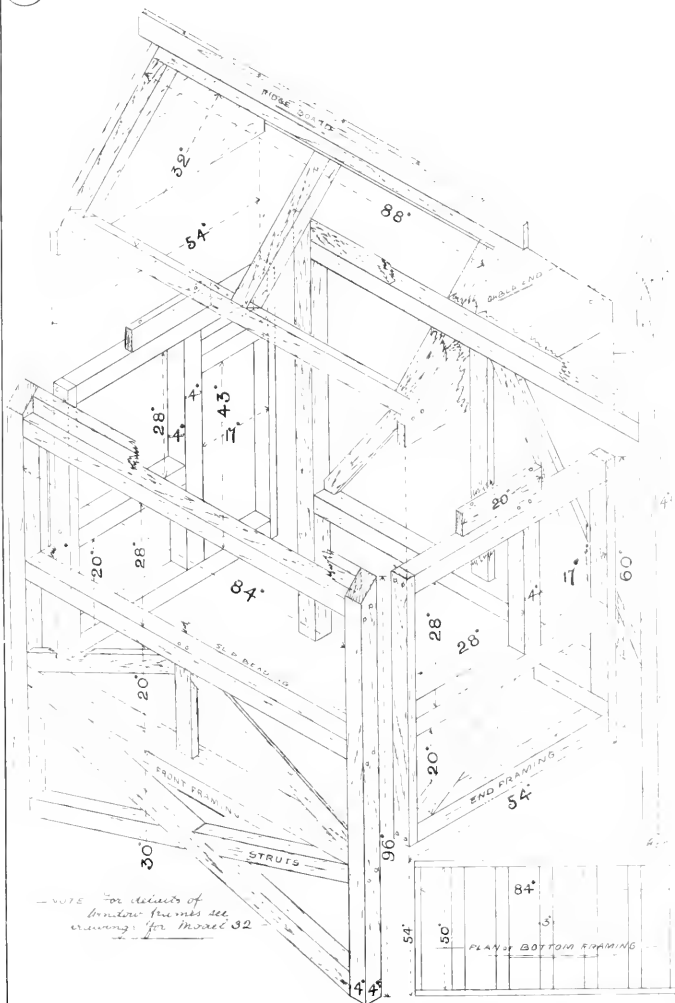

Scholar B.	Mark and saw off for back framing, 2 pieces	96" × 4"	square wood.
	" " " 2 "	84" × 4"	" "
	" " " 1 "	53" × 3"	strip wood.
	" " " 2 "	73" × 3"	" "
	" " " 1 "	84" × 4"	" "
" " " 1 panel	84" × 53"	slab wood.	
Scholar C.	Mark and saw off for entrance end, 2 pieces	50" × 4"	square wood.
	" " " 1 "	53" × 4"	" "
	" " " 1 "	28" × 4"	" "
	" " " 1 "	35" × 4"	strip wood.
	" " " 2 "	44" × 4"	" "
	" " " 1 panel	28" × 20"	slab wood.
	" " " 1 door	43" × 17"	" "
" " " 1 transom	17" × 4"	square wood.	
and one overdoor panel to fit.			
Scholar D.	Mark and saw off for end framing, 3 pieces	50" × 4"	square wood.
	" " " 1 "	28" × 4"	" "
	" " " 2 "	44" × 4"	strip wood.
	" " " 1 "	36" × 4"	" "
	" " " 1 "	28" × 4"	" "
	" " " 1 panel	50" × 20"	slab wood.
" " " 1 "	28" × 17"	" "	

2. Prepare grooved frames for 5 windows from strip wood.
3. Smooth up all surfaces for framing.
4. Build up front, back, and end frames; glue, and double nail all joints.
5. Fit and fix all panels in position, also door in entrance end.
6. Fit and fix all diagonal face struts on panels (nail from inside).
7. Prepare length of slip beading for window opening and slides.
8. Frame all windows, and adjust to respective openings; insert windows and beadings.
9. Plant on slips to form slides inside front framing.
10. Glue tape hinge on each end window, and make fixture to side of framing; adjust for free opening.
11. Test each framing for accuracy and stability of construction.
12. Ensemble all frames in position; bore for, glue, and nail ends to sides. Test for square angles and freedom of movement for door windows.

- Scholar E. {
13. Prepare material for bottom panel or floor, the approximate dimensions of which and method of construction are as follow :
- Mark and saw off 2 pieces $84^{\bullet} \times 3^{\bullet}$ strip wood,
 2 .. $50^{\bullet} \times 3^{\bullet}$
 5 .. $50^{\bullet} \times 3^{\bullet}$ square wood.
 And either 1 panel $84^{\bullet} \times 53^{\bullet}$ or 13 pieces of 4^{\bullet} strip wood 84^{\bullet} long,
 to be laid and nailed edge to edge.
- Scholar F. {
14. Prepare material for roof framing, and covering for roof and gables, approximately as follows :
- Mark and saw out 2 gable panels 48^{\bullet} right-angle sides (slab wood).
 3 pieces $88^{\bullet} \times 3^{\bullet}$ square wood.
 6 .. $32^{\bullet} \times 3^{\bullet}$
 1 .. $100^{\bullet} \times 5^{\bullet}$ strip wood, for ridge board.
 And either full boarding for covering, or 9^{\bullet} strips of Canadian birch or whitewood for overlap boarding, as for Model 32.
15. Build up roof framing : adjust gable panels to fit between corner post of cabin and fix to roof frame.
16. Full board or overlap board the roof frame.
17. Fix ridge board and finials (fleurons) on end of roof frame.
18. Test for accuracy : adjust to cabin framing ; and fix, if desired, by attachment to stop pieces fitted on the top of each end frame.
19. Clean up all details ; examine for any defects, and neatly finish the cabin of Model 34.

Procedure for the construction of the Stairway (individual work) :

- | | | | |
|----------------------------------|----------|------------------------------------|--------------|
| 1. Mark and saw off for strings, | 2 pieces | $54^{\bullet} \times 8^{\bullet}$ | slab wood. |
| treads, | 1 .. | $17^{\bullet} \times 10^{\bullet}$ | |
| risers, | 1 .. | $17^{\bullet} \times 5^{\bullet}$ | |
| landing, | 1 .. | $26^{\bullet} \times 18^{\bullet}$ | |
| handrail | 1 .. | $38^{\bullet} \times 3^{\bullet}$ | square wood. |
| handrail posts, | 2 .. | $31^{\bullet} \times 3^{\bullet}$ | |
| back posts, | 2 .. | $56^{\bullet} \times 3^{\bullet}$ | |
| stretchers, | 3 .. | $11^{\bullet} \times 3^{\bullet}$ | strip wood. |
| railings, | 5 .. | $28^{\bullet} \times 3^{\bullet}$ | |
| railing bars, | 2 .. | $25^{\bullet} \times 3^{\bullet}$ | |
| under ties, | 2 .. | $31^{\bullet} \times 4^{\bullet}$ | |
| struts, | 2 .. | $14^{\bullet} \times 4^{\bullet}$ | |
2. Clean or plane up all surfaces.
3. Mark out strings, and bore for fixing treads and risers.
4. Build up treads and risers, angle pieces.

5. Adjust, and fix by double nailing between strings.
6. Build up back and side rails, under ties and struts.
7. Adjust all to fit under sides of strings, and fix landing.
8. Prepare handrail, and fix posts to side of string.
9. Adjust and fix handrail in position.
10. Test for accuracy and stability of construction.
11. Adjust height of platform or landing to door sill of cabin.
12. Attach (if desired) to cabin front and back posts.
13. Examine all details, and complete Model 34.

Position drill : Square testing.

Position demonstration : Ensemblément of details ; oblique nailing.

Sequence or Continuation Lesson.

Little talks on (a) The history of our railway system.

(b) The influence of the steam engine on the civilization of the world.

(c) How accidents occur ; the responsibility of the man who works the signals.

GROUP OF LESSONS No. 35.

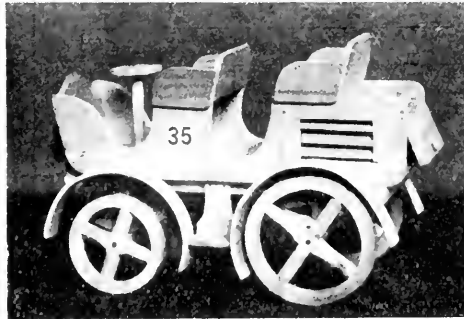

FIG. 56.

MODEL 35 : MOTOR CAR.

Aim of Drawing Lesson : To give further instruction in detail ensemblément and free sketching.

In order to convey an intelligent reading of the total ensemblément by the children, it will be necessary to prepare large-sized diagrams of the details and of the side sectional elevation of this model, in addition to making free use of a standard model. Designed to aid commune working, the details are generally self-contained and will form distinct exercises or repetitions of some item of previous work. A careful selection of the scholars for the apportionment, according to known ability, will secure and maintain efficiency and speed in working. The drawings executed by the children should be full size and dimensioned in every detail to avoid any error in construction. The curves of the side openings may be drawn freehand, or suitable metal or cardboard discs may be used as templates, whilst those of the wheels and splashers (mud guards) may be drawn as before, *i.e.*, by looped string, if compasses are not available. Rough freehand sketches (fully dimensioned) of each detail may be given to guide the respective workers. These should be prepared before the lesson, and for easy reference should each bear a distinguishing letter, which has its counterpart on the large-size diagram.

During the construction lessons, interest is readily maintained by occasional temporary ensemblément of partly finished elements, and by class demonstrations upon some difficult point of construction or tool manipulation. Endeavour to make each test a necessary part of the lesson on accuracy; encourage the children to recall failures in past work; and elicit how improvement has been made, suggesting further ways and means to always produce best work.

The introduction of the small bow or "piercing" saw will of necessity require a full demonstration of its use, together with a short object lesson on the points of difference between it and the tenon and pad saws (*Figs. A, A₁, B, C*).

Do not demonstrate on the children's work, but on some waste material, or upon the elements of a demonstration model.

In order to remove the deep curves of the side pieces, fix them together in the vice, and saw down inside of the curved marked line; break out the waste; then, if the saw bow is shallow and will not

admit of turning, carefully remove the material left, with half-round rasp (*Fig. 14*), and neatly finish off the edges with glasspaper.

The spaces for the ventilation panels on each side may be cut out with the bow saw—first boring a small hole at each corner, to thread blade of saw through, before fixing it in the bow frame—and finished off with the flat file. The panels should be built up and fitted into place by the worker responsible for the side pieces.

The elliptical form of the springs, upon which the “chassis” or undercarriage rests, provides also good exercises for the use of the bow saw and rasp. The wheel steering gear, with the wheels, axle, springs, and swivel bar may be completed, but cannot be fitted until the general ensembling is complete.

The lamp, body, and bracket fitted to the front is a simple yet effective detail; part of an ordinary cotton reel may be used for the front. The swing door at the back of the car is centre-pin hinged. For the mud guards or splashers, strips of wood, soaked in hot water and bent to shape, must be used.

Method for bending: Prepare thin strips of Canadian birch or American whitewood very straight in grain; place these in a pan of boiling water for about thirty minutes, occasionally removing to test for flexibility; when thoroughly soaked and pliable, bend round the inside of an ordinary 2-pound jam jar, as a mould, and hold in position by inserting a smaller jar or block of wood; or (if the length of the pieces will admit of it) bring both ends of strip together, overlap them, and press firmly to the jar sides. Allow the bent wood to remain in the mould until dry, when the required length for each mud guard may be cut off ready for fitting to the respective supports.

*Do not hurry the process of soaking and bending, or the strips will snap across the fibres, cause delay and “ * + : ”*

Supplemental Lesson.

Little talks on detail ensembling and free sketching.

STEAM MOTOR CAR.
SECTIONS AND ELEVATION DETAILS.

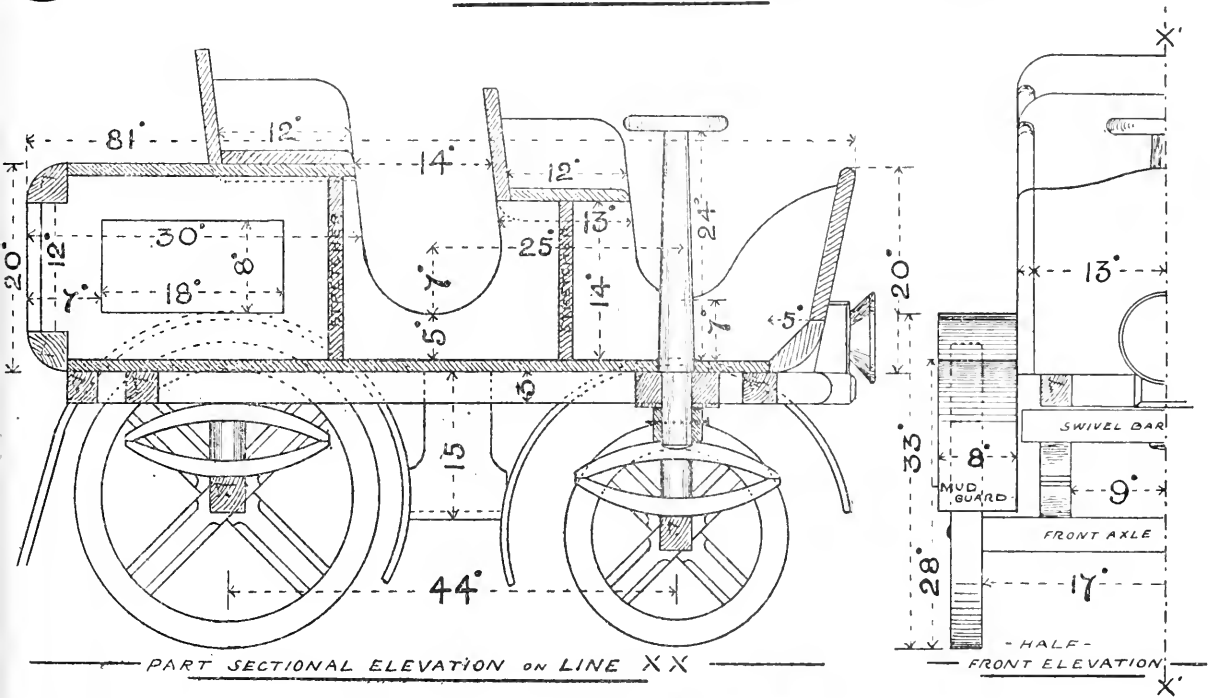

PART SECTIONAL ELEVATION ON LINE XX

HALF FRONT ELEVATION

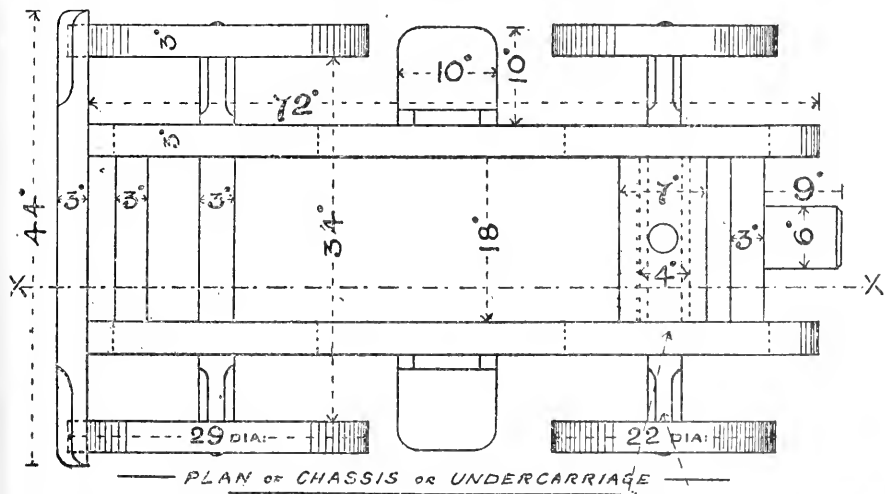

PLAN OF CHASSIS OR UNDERCARRIAGE

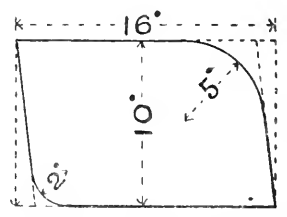

DETAIL OF SEAT-ENDS

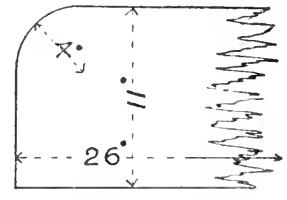

DETAIL OF SEAT-BACK

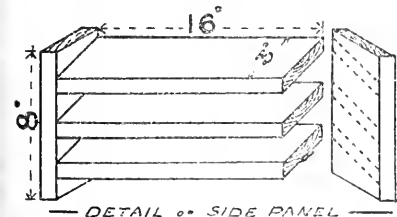

DETAIL OF SIDE PANEL

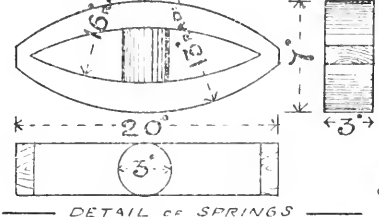

DETAIL OF SPRINGS

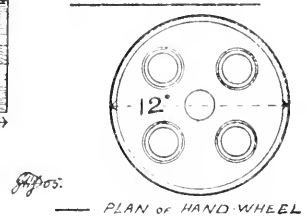

PLAN OF HAND WHEEL

Aim of Practical Lesson.

To give further methods of construction in corner forming, for securing strength and solidity in toy making.

Materials required : Square, strip, and slab wood; cotton reel end : long, short, and medium panel pins.

Tools required : Rule, try square, pencil, saw, plane, rasp, file, bradawl, brace and wheel cutter, bow saw, hammer, knife.

Procedure for the construction of Model 35 (commence working) :

Scholar A.	{	1. Mark and saw off for undercarriage, 1 piece $72^{\circ} \times 3^{\circ}$ square wood.
	 2 .. $48^{\circ} \times 3^{\circ}$
	 mud guard bar, 1 .. $44^{\circ} \times 3^{\circ}$
	 lamp bracket, 1 .. $9^{\circ} \times 6^{\circ} \times 4^{\circ}$ slab ..
Scholar B.	{ swivel bearer, 1 .. $48^{\circ} \times 7^{\circ} \times 4^{\circ}$
		Mark and saw off for axle-trees, 2 pieces $34^{\circ} \times 3^{\circ}$ square wood.
		Bore out and prepare 2 rims for wheels 29° diameter, slab wood.
	 2 22°
Scholar C.	{	Mark and saw off for wheel arms, 4 pieces $23^{\circ} \times 3^{\circ}$ square wood
	 4 .. $17^{\circ} \times 3^{\circ}$
		Mark and saw off for steering rod, 1 piece $32^{\circ} \times 3^{\circ}$ square wood.
	 swivel bar, 1 .. $28^{\circ} \times 4^{\circ} \times 3^{\circ}$ slab wood.
Scholar D.	{	Prepare hand wheel from slab wood $12^{\circ} \times 2^{\circ}$.
		Mark and saw off for springs, 4 pieces $20^{\circ} \times 7^{\circ} \times 3^{\circ}$ slab wood.
		Bow saw and rasp to shape as on drawing.
		Fit in centre bar of each
Scholar E.	{	Mark out and saw to line, for sides, 2 pieces $81^{\circ} \times 20^{\circ}$ slab wood.
		Prepare ventilator panels from 3° strip wood, and fit.
		Mark and saw off for seats, 2 pieces $29^{\circ} \times 12^{\circ}$ slab wood.
	 backs, 2 .. $29^{\circ} \times 11^{\circ}$
Scholar F.	{ ends, 1 .. $16^{\circ} \times 5^{\circ}$
	 steps, 2 .. $15^{\circ} \times 10^{\circ}$
	 steps, 2 .. $16^{\circ} \times 10^{\circ}$
		Mark and saw off for bottom, 1 piece $66^{\circ} \times 26^{\circ}$ slab wood.
	 front, 1 .. $26^{\circ} \times 26^{\circ}$
	 top, 1 .. $26^{\circ} \times 28^{\circ}$
	 stretcher plates, 1 .. $26^{\circ} \times 17^{\circ}$
	 stretcher plates, 1 .. $20^{\circ} \times 11^{\circ}$
Scholar G.	{ back corners, 2 .. $26^{\circ} \times 4^{\circ}$ square wood.
	 front corners, 1 .. $26^{\circ} \times 5^{\circ}$
	 swing door, 1 .. $26^{\circ} \times 12^{\circ}$ slab wood.

2. Prepare 4 mud guards (by method described) from thin Canadian birch or American whitewood slab, 7" wide.
3. Smooth up all detail pieces of elements.
4. Build up each element : securely glue, and nail all joints.
5. Test all elements for accuracy of construction.
6. Try up in respective positions all cross connections with side pieces.
7. Fix stretcher pieces in place ; and also each corner piece in the rough form.
8. Work curves of corners on corner pieces.
9. Fit in, adjust, and fix bottom, front, top, and door.
10. Attach axle-trees to springs.
11. Attach axle-trees to undercarriage frames.
12. Prepare steering post, as on drawing ; bore for, adjust through bottom and bearing plate.
13. Fix steering post to swivel bar, and adjust for free movement.
14. Fix seats across sides in correct positions.
15. Prepare front lamp and fix to bracket.
16. Prepare and cut off to length, and fix each mud guard.
17. Fix axle-pins through centre of each wheel, and attach each to axle-tree.
18. Test for freedom of movement of each wheel.
19. Adjust all details where necessary : round up all edges, and neatly finish off Model 35.

Position drill : Curve forming with file and plane.

Position demonstration : Bow sawing and bent wood forming.

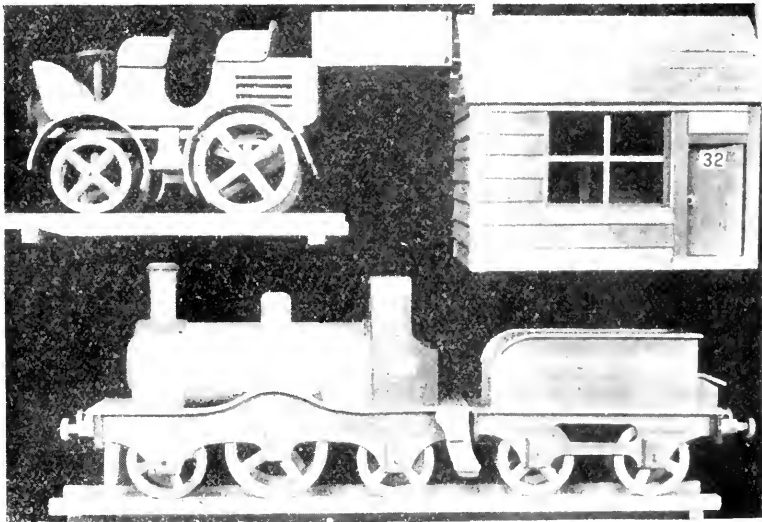

STEAM MOTOR CAR.

MINER'S HUT

EXPRESS LOCOMOTIVE.

Sequence or Continuation Lesson.

Little talks on modern means of locomotion:—How we see our country by cycle and automobile. Old-world travelling in England compared with modern methods. Present day methods of inter-communication in the interiors of our Colonial Possessions.

GROUP OF LESSONS No. 36.

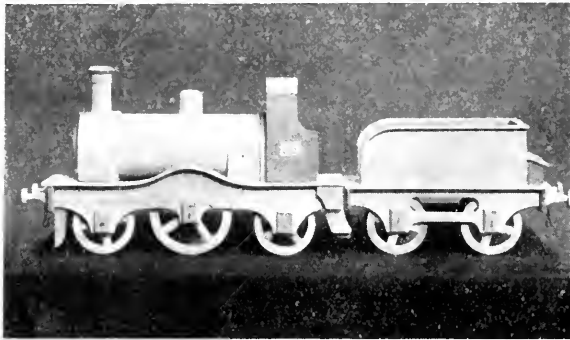

FIG. 57

MODEL 36: Locomotive Engine and Tender.

Aim of Drawing Lesson: To give direct effect to previous lessons on sectional details, and to the correct reading of co-ordinate views.

These models provide many elements and details which involve accurate working, and require concentration of thought in the production. They embody in some form or other, nearly the whole of the previous lessons on construction, without being merely repetitions (the wheels excepted). A careful selection of the workers according to capabilities will give ready effect to communc work.

In addition to the full-size detail drawing of the part to be worked, each child should be encouraged to produce a neat free sketch or measured drawing of the complete model in side elevation, and to round up the circular forms by cross shading or parallel lines.

Enlarged diagrams of the details, and a sectional elevation to show the internal structure, together with a standard model, should form the basis of the drawing lesson.

Similar methods being used for the curves of the engine and tender frames as for the previous models, the general outline becomes a simple exercise involving only careful measurement.

The practical lesson should present no great difficulty, provided attention is paid to accuracy of jointing and fitting. Unabated interest will be readily obtained, the greatest trouble being to repress enthusiasm in the desire "to see the wheels go round." The trial ensembling of several of the elements will be necessary during the progress of the work, to ensure alignment.

The introduction of the centre bit will involve a short demonstration, to ensure correct handling.

The side frames must be worked out together in pairs with bow saw, rasp, and file, the edges being finished off smooth with glass-paper.

The boiler is constructed on the segment method as for the field roller, Model 26, and the other details of construction, representing the fire-box, smoke-box, steam dome, and chimney, should present no difficulty.

The curved footplate, the smoke-box casing, and the bands round the fire-box, are made of thin Canadian birch or whitewood, bent to the respective forms by the method employed for the mud guards of Model 35.

The steam dome and chimney are made from parts of ordinary cotton or silk reels; a centre pin passing through each part serves to connect in the correct position.

To enable the three pairs of wheels to be in contact with any flat surface for running purposes, the centre axle-pin holes are elongated. To ensure easy running of the other wheels, and to admit of larger axle-pins being used, short lengths of bamboo beads may be glued in position in the sham axle-box covers and frames; or a wire tube—made by coiling a length of soft iron wire round each axle-pin—may be inserted.

SECTIONAL ELEVATION OF LOCOMOTIVE.
PLAN AND END VIEW.

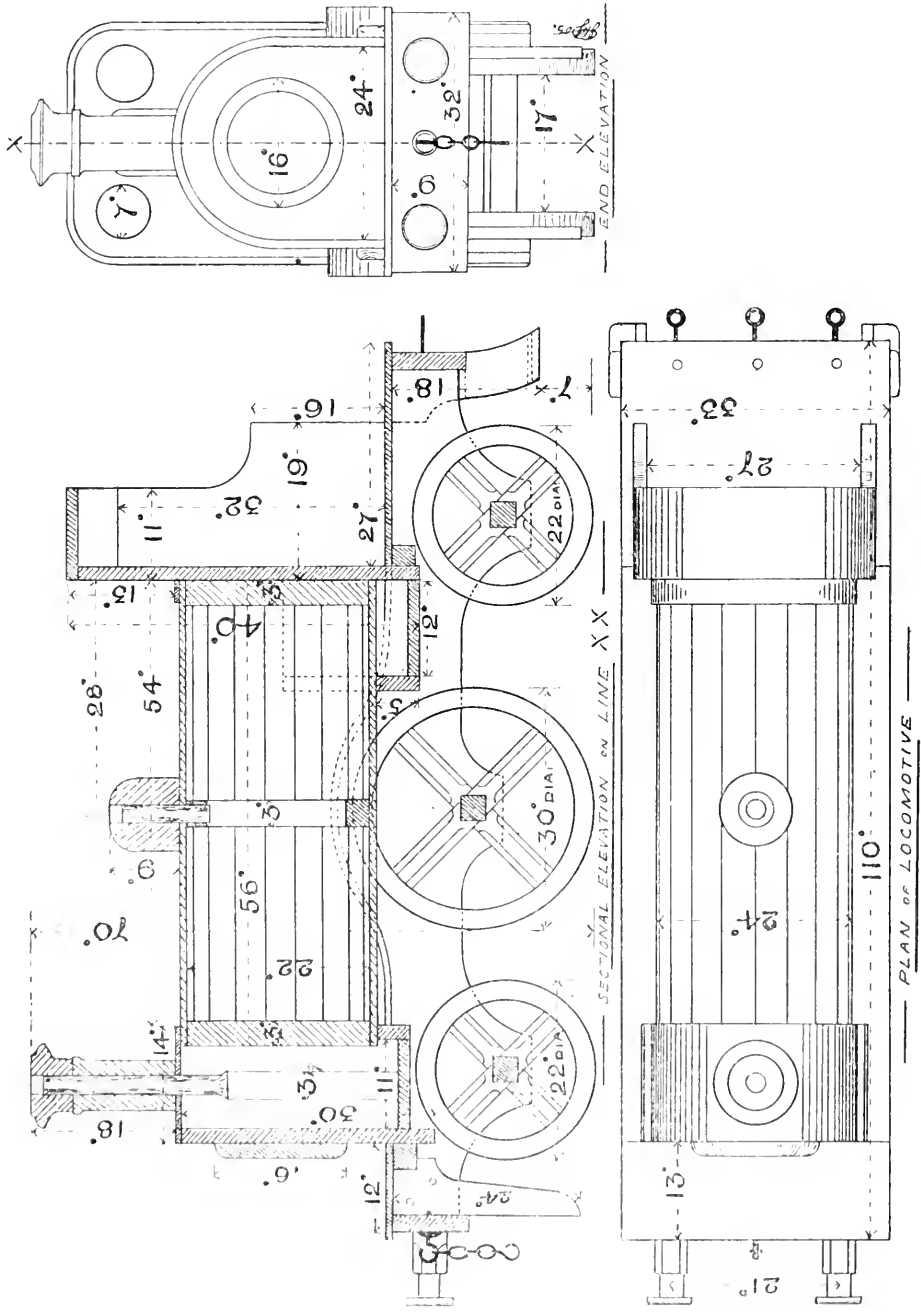

The buffer heads may be made from parts of cotton reels; the cases are short lengths of square wood with octagonal chamfers (see detail drawing).

The connection between engine and tender is effected by means of wire links which pass through the buffer beams, and are held in position by pins dropped in from the footplate.

The cab is built complete in itself, the top rounded corners being formed with rasp and file to the desired exterior and interior curves. It is attached by simple nailing direct to the boiler front.

The tool-box, with its tape-hinged lid, attached to the back of the tender, is also complete in itself and forms a neat little element or detail model for a careful worker.

The draw bar hooks and coupling chains may be made as a wire-work exercise, or a piece of manufactured chain may be used with small brass screw hooks attached.

Supplemental Lesson.

Little talks on sectional elevations and their value to the craftsman.

Aim of Practical Lesson.

To embody and combine known methods of simple construction, varied in form and application, in the manufacture of children's toys.

Materials required: Square, strip, and slab whitewood, wire, bamboo beads; short, long, and medium panel pins, wire nails, and cotton reels.

Tools required: Rule, try square, pencil, saw, plane, brace, centre bits, wheel cutter, knife, rasp, file, wire cutters, bow saw, hammer, bradawl, prickler.

Procedure for the construction of Model 36 (commune working).

For the engine:

Scholar A.	{	1. Mark and saw off for frames,	2 pieces	104" × 24" slab wood (thin).
	 buffer beams,	4 ..	29" × 10" (thick).
		1 ..	33" × 10"
	 stretchers,	2 ..	24" × 3" square wood.
	 buffers,	2 ..	5" × 4"
	 rail guards,	2 ..	24" × 6" slab wood.

DETAILS OF LOCOMOTIVE FRAMING.

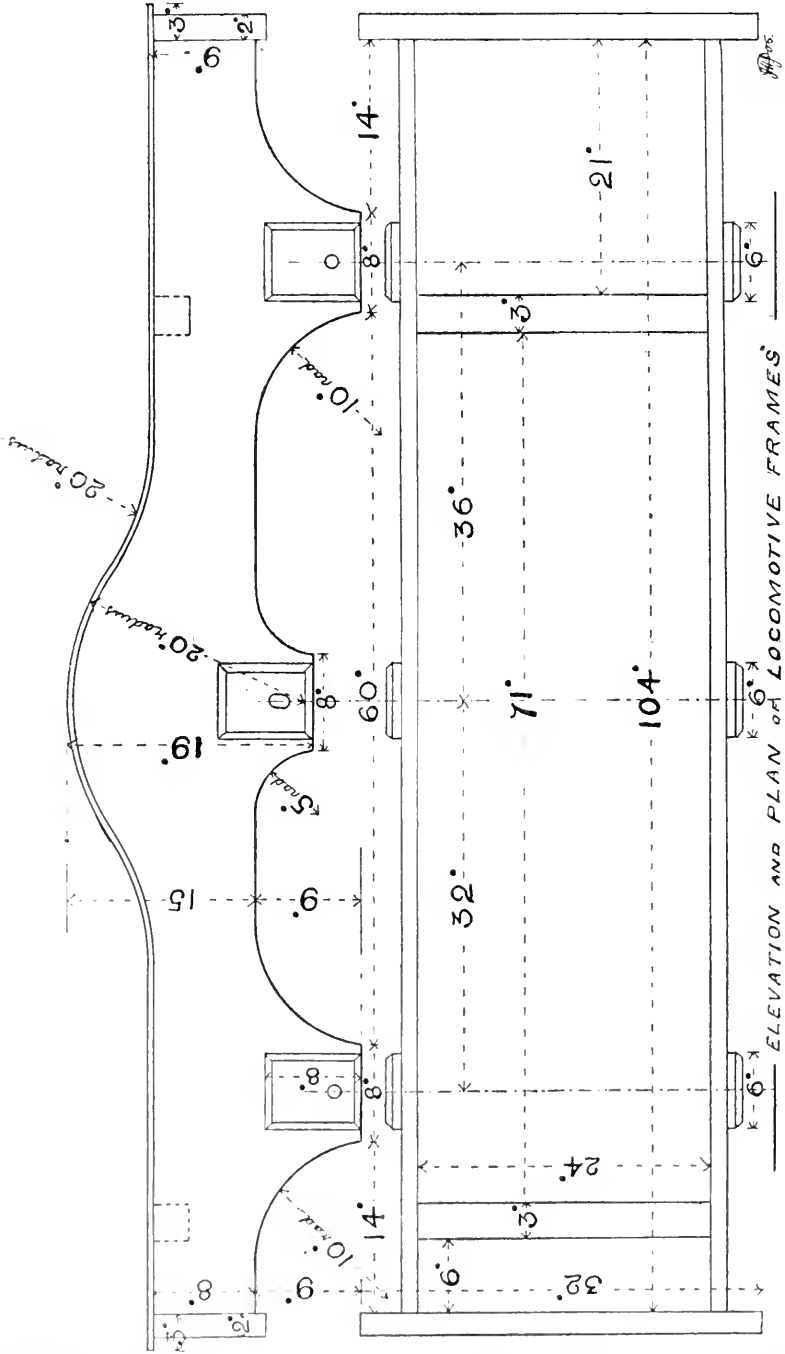

- Sch. A. { 1. Mark and saw off for axle-box fronts, 6 pieces $8^{\bullet} \times 6^{\bullet}$ slab wood.
 steps and plates, 2 .. $20^{\bullet} \times 10^{\bullet}$
 " .. 4 .. $7^{\bullet} \times 4^{\bullet}$ strip wood.
- Scholar B. { Mark and saw off for axles, 3 .. $17^{\bullet} \times 3^{\bullet}$ square wood.
 Bore out and prepare, 2 driving wheel rims, 30^{\bullet} diameter.
 2 trailing 22^{\bullet} ..
 2 leading 22^{\bullet} ..
 Mark and saw off 3^{\bullet} square wood for wheel spokes.
 Prepare wheel spokes and fit in each rim.
- Scholar C. { Prepare 2 discs 22^{\bullet} diameter for boiler ends.
 .. 1 rim 22^{\bullet} ring.
 Saw off for boiler barrel, 19 pieces $56^{\bullet} \times 4^{\bullet}$ strip wood.
 Prepare each end with rasp to fit end discs, and each edge to form tight joints when nailed to discs.
 Mark and saw off for fire-box sides, 2 pieces $16^{\bullet} \times 14^{\bullet}$ slab wood.
 " front, 1 .. $11^{\bullet} \times 21^{\bullet}$
 " bottom, 1 .. $20^{\bullet} \times 12^{\bullet}$
- Scholar D. { Mark and saw off for cab sides, 2 .. $32^{\bullet} \times 19^{\bullet}$ slab wood.
 " top, 1 .. $20^{\bullet} \times 11^{\bullet}$
 " corners, 2 .. $11^{\bullet} \times 7^{\bullet} \times 3^{\bullet}$
 " spectacle plate, 1 .. $40^{\bullet} \times 27^{\bullet}$
 " fire-hole door .. 1 .. $12^{\bullet} \times 9^{\bullet}$
- Scholar E. { Mark and saw off for smoke-box front, 1 .. $30^{\bullet} \times 24^{\bullet}$ slab wood.
 " bottom, 1 .. $24^{\bullet} \times 10^{\bullet}$
 " back, 1 .. $14^{\bullet} \times 24^{\bullet}$
 and one disc 16^{\bullet} diameter for smoke-box door.
 Prepare the front and back foot plating to dimensions as given on drawing.
 Prepare a thin piece of whitewood or Canadian birch $78^{\bullet} \times 14^{\bullet}$ and bend (by hot-water method) to form smoke-box side plating, and also the foot-plating strip on the top of side frames.
- Scholar F. { Obtain 3 cotton reels and prepare steam dome and chimney as shown on drawing, also the 4 buffer heads.
 Prepare from 3^{\bullet} square wood the round pieces to fit holes in reel sections; and prepare also the wire coupling hooks, chains, and links.

2. All scholars to smooth or plane surfaces of apportioned details.
3. Set out curves of side frames and work out with bow saw and rasp.
4. Build up framing with stretchers and buffer beams.
5. Work to outline curves given, the rail guards and stop plates.

ELEMENTS OF LOCOMOTIVE.

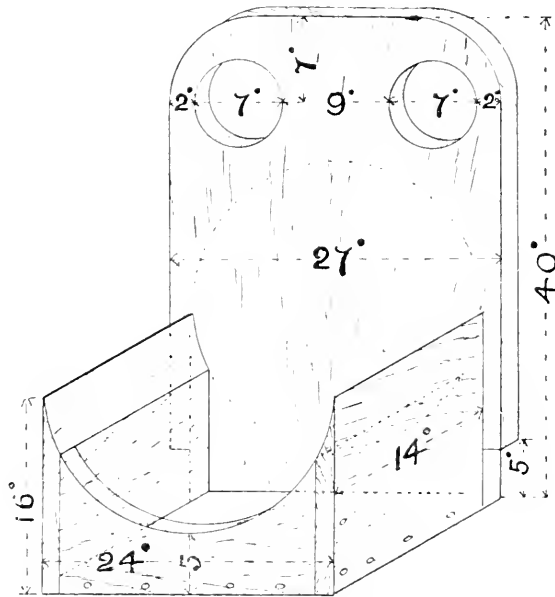

— VIEW OF FIRE-BOX, BUILT UP —
TO FIT BOILER BARREL AND
ATTACHED TO CAB FRONT —

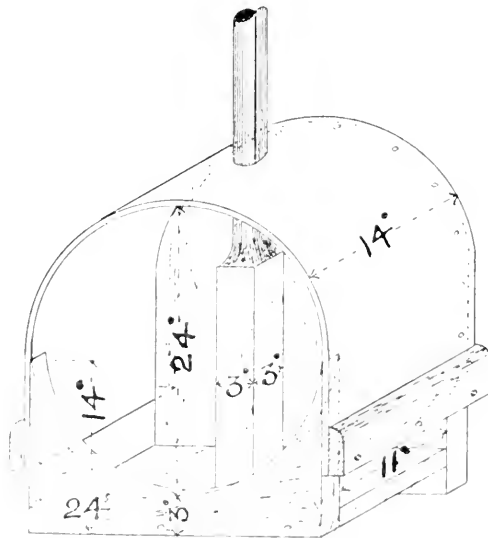

— VIEW OF SMOKE BOX - AS BUILT UP —
TO FIT BOILER BARREL —

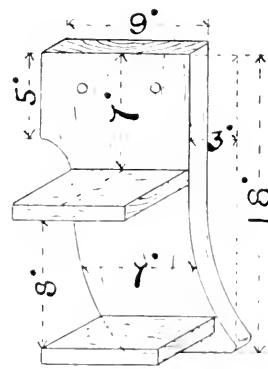

— DETAIL OF FOOT-STEP
AND BRACKET —

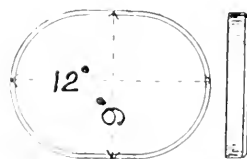

— FIRE-HOLE COVER —

J. P. Fos

6. Adjust and fix each in position on framing.
7. Prepare and fix axle-box covers; bore for and insert the bamboo beads for axle-pins to work in for trailing and leading wheels only.
8. Make vertical elongated hole through driving axle-box cover, to admit of free vertical movement of the driving wheel axle-pins.
9. Build up boiler barrel with segment strips; nail each to end discs and centre ring.
10. Work to a cylindrical form with file and sandpaper; bore for, and insert the centre pin on which to fit the steam dome.
11. Build up fire-box sides and bottom; mark out front piece to fit outer diameter of boiler barrel; work to marked lines with bow saw and rasp, and fit in position.
12. Bevel off top edges of fire-box sides to fit boiler barrel.
13. Adjust to fit loosely between engine framing.
14. Build up cab. Bore (with centre bit) the spectacle or look-out holes in front plate; shape with bow saw and file; fit each side to edges of front plate, and attach top piece.
15. Prepare the 2 top corner pieces to fit exactly between the edges of sides and top, and fix in position with glue and nails.
16. Shape to oval form and attach fire-hole door.
17. Reduce the projecting piece of front plate at each side, to fit in between engine frames.
18. Adjust fire-box to boiler barrel, and fix at the bottom of cab front plate; test for accuracy and adjustment.
19. Prepare top edge of smoke-box front plate with bow saw and file to 24° semicircle, and the back plate to fit barrel of boiler.
20. Nail back plate to bottom piece, and build up smoke-box, with bent wood piece for sides and top; fix smoke-box door to front plate.
21. Reduce the bottom projecting piece of front plate at each side, to fit in between engine frames.
22. Fit chimney bottom to curve of smoke-box top. bore for centre pin of chimney.
23. Insert centre pin through smoke-box casing, and securely nail square bottom end to bottom plate of smoke-box.
24. Attach smoke-box to boiler barrel by neat nailing.

36a

SECTION ELEVATION OF LOCO TENDER.
PLAN OF FRAMING AND END VIEW.

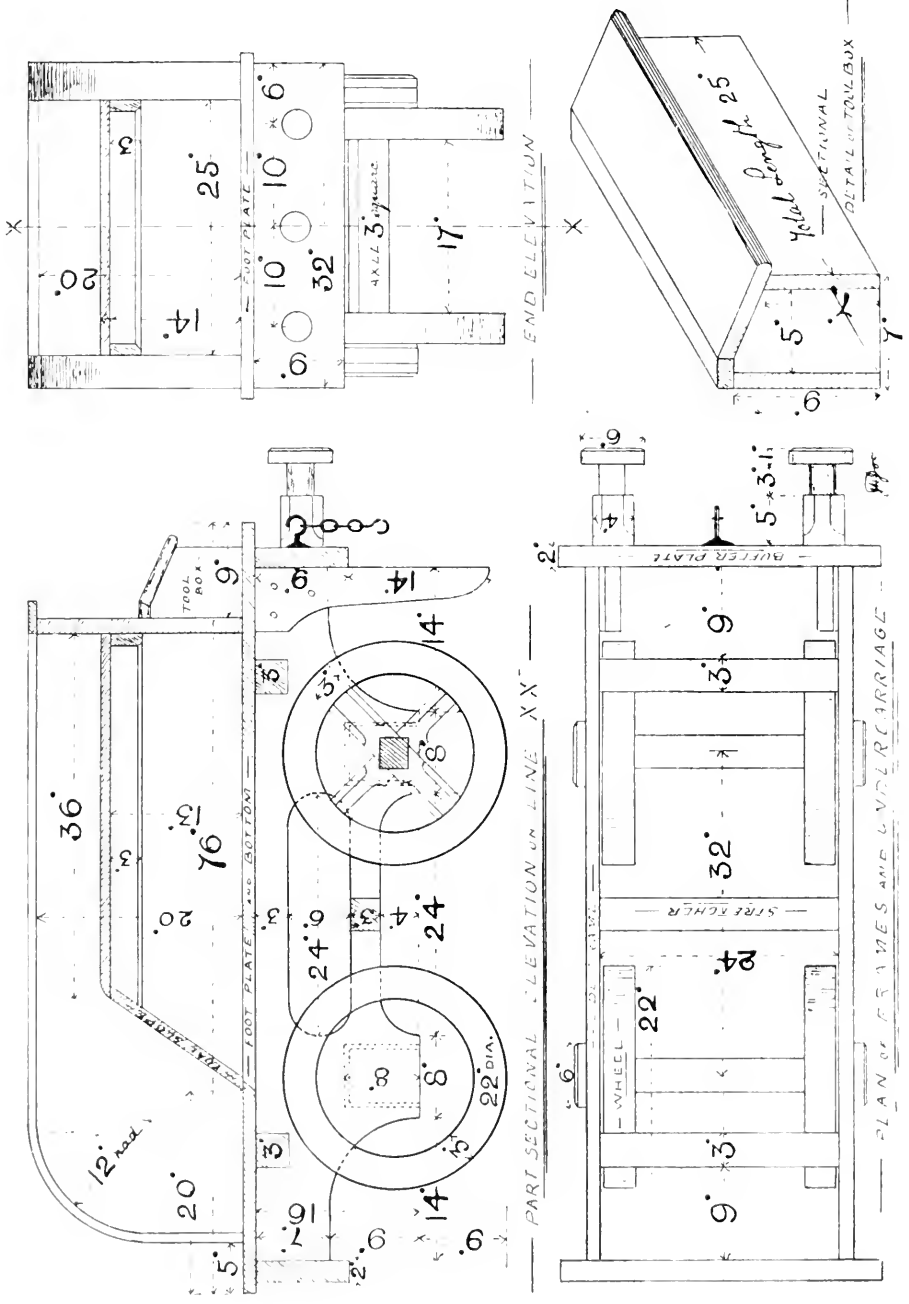

25. Attach cab and fire-box to other end of boiler barrel, carefully testing for true alignment.
26. Prepare bottom of steam dome to fit curve of barrel, and fix dome and chimney in position.
27. Adjust combined elements to fit between side frames.
28. Fix front, back, and side foot plates to and across side frames.
29. Connect all wheels to respective axles, and adjust to width between engine frames, and find exact centre of each pair of wheels.
30. Insert axle-pins through axle-box covers, and into centre of each wheel.
31. Test for perfect freedom of running (all the wheels must be in contact with a flat surface at the same time).
32. Prepare bearing strips on each side of the smoke-box, and also on the sides of the fire-box, as shown on drawings.
33. Fit the boiler, etc., between side frames, and mark the exact position for bearing strips, fix in position.
34. Fit buffer heads and spindles in buffer blocks, and attach coupling hook and chain.
35. Fit the 3 coupling links in back buffer beam : bore for and pass panel pins through from the top of footplate.
36. Test for accuracy and stability of construction, and complete the engine section of Model 36.

Procedure for the construction of the Tender (commence working) :

Scholar A.	{	1. Mark off and saw for frames,	2 pieces 68" × 16" slab wood
		" " buffer plates,	2 " 32" × 9" " "
		" " stretchers,	3 " 24" × 3" square wood.
		" " foot and bottom plate	1 " 76" × 33" thin slab wood.
		" " buffer blocks,	2 " 5" × 4" square wood.
" " axle-box fronts,	4 " 8" × 6" slab wood.		
Scholar B	{	Mark and saw off for tender sides,	2 " 60" × 20" slab wood.
		" " " end,	1 " 25" × 20" " "
		" " tank lid,	1 " 37" × 25" " "
		" " coal slope,	1 " 25" × 16" " "
		" " lid bearers,	2 " 36" × 4" strip wood.
and prepare curved and straight edge beading for top of sides.			

Scholar C

Bore out and prepare 4 wheel rims 22" diameter.
 Mark and saw off 8 wheel arms to fit, from 3" square wood.
 2 axles, 2 pieces 17" x 3"
 Build up each pair of wheels.

Scholar D

Prepare 2 buffer heads and spindles, as for engine.
 Build up back tool-box with hinged lid to given dimensions, and make wire
 coupling chains and hooks. Prepare 2 rail guards from waste slab wood
 as for engine.

2. Each scholar to smooth or plane up surfaces of apportioned details.
3. Set out curves of side frames; bore centre out with centre bit, and work others with box saw and file to marked lines.
4. Build up side frames to buffer plates and stretcher.
5. Attach buffer blocks to back buffer plate, and bore front buffer plate, to receive eyes of coupling links.
6. Prepare and build up sides and back of tender, and fit tank lid bearers in position.
7. Fix foot and base plate to lower edge of sides and back piece by nailing, also top beading as prepared.
8. Adjust the coal slope, piece and nail it in between the sides.
9. Fit the wheels between the side frames; bore for, and insert bamboo beads or wire tubes in axle-box fronts and frames.
10. Insert axle-pins through each axle-box cover, and into the centre of each wheel.
11. Test for perfect free running, as for engine.
12. Attach tender body to frames by nailing it to buffer plates and stretcher.
13. Fit back tool-box on foot plate to back end of tender.
14. Insert and fix buffer spindles into buffer blocks.
15. Fit coupling hook and chain in position.
16. Test for accuracy and stability of construction, and finish off neatly all other details of the tender.
17. Pass coupling links attached to the engine into the holes prepared in front buffer plate of the tender.
18. Insert the drop coupling pins through the footplate.

19. Test for freedom of slight vertical and lateral movement.
20. Test free movement of all wheels, alignment of engine and tender footplates, and complete Model 36.

Position drills : Bow sawing and curve filing.

Position demonstration : Nailing on circular work, rounding with file, use of centre bit.

Sequence or Continuation Lessons.

Little talks on railway workers and their duties.

END OF ADVANCED COURSE.

GLOSSARY OF TECHNICAL TERMS.

- Angle pieces or brackets*: Triangular pieces of material, which are fitted into the angle formed by two pieces or elements joining at any point; used as stays, supports, struts, and connections.
- Arris*: Extreme edge, or corner, of an angular solid.
- Axle-pins*: Round nails, or short lengths of wire, driven into the end grain of axle-trees to form the journal.
- Axle-box*: The complete bearing arrangement for an axle or journal.
- Back iron*: The front or cover iron of a plane, which breaks the shavings removed by the cutting-iron, as they pass through the "mouth."
- Base framing or plate*: The foundation upon which the main pieces of constructional work are built.
- Bearing strips*: The narrow strips which support on the frames the smoke box of the locomotive.
- Bearing caps*: Covers which serve to retain in position the axles or journals of machines.
- Boiler barrel*: The cylindrical portion of the locomotive in which is contained the water and steam, and through which are passed, to the smoke box, the heated gases from the furnace.
- Braces*: Tie bars, generally used to form the third side of triangular constructions.
- Buffer beam*: A piece of timber or iron upon which is bolted or fitted the buffers in locomotive rolling stock.
- „ *box or case*: The casing which contains the buffer spring and buffer rod.
- „ *heads*: The disc against which the contact of buffers takes place.
- Cab*: The hood or cover which arches over the foot-plate of a locomotive.
- Centre-line*: The line, from which symmetrical dimensions are set off.
- Centre-pin*: A vertical pin or rod upon which an element of construction can revolve.
- Chamfering*: Forming a bevel on the arris of rectangular solids.
- Chassis*: The under carriage of a motor car, upon which all the driving mechanism is built and fitted.
- Cinching*: The act of turning projecting points of nails into the wood, to form a cramp or grip hook.
- Cleat*: A block of wood which provides a steady point of attachment for a part of a structure; a strengthening block.
- Connecting rod or link*: The rod which converts the rectilinear motion of a treadle into the rotatory motion of a crank.
- Crank shaft*: The shaft or rod upon which the crank arm is fitted, to receive and transmit the circular motion.

- Commune working.* The co-operation of workers for the development of mutual responsibility and common fellowship by individual actions.
- Cross-bearer or girder.* Any transverse beam which unites longitudinal girders, side frames, and becomes a distance piece, strengthening piece, or stretcher.
- Cross rails.* The longitudinal timbers upon which are fastened upright or diagonal palings.
- Cross strut.* See cross-bearer.
- Division plates.* The pieces of material which form the slide spaces in which drop hammers work.
- Distance piece.* See cross-bearer.
- Dowel pins.* Projecting pieces of wood or metal used to retain a pair of elements in correct relationship during construction or use.
- Double strap hinging.* Forming a double joint or hinge with tapes.
- Draw-bar coupling.* The bar coupling which connects a locomotive to its tender.
- Driving wheels.* The wheels of a locomotive engine, which are fixed on the crank shaft to receive and transmit the motive power.
- Edge nailing.* Nailing through the narrow edge of the strip wood.
- Elevation.* The appearance of a model or element as seen, on a vertical plane, by an observer placed immediately in front of it.
- Expansion bracket.* The bracket fitted on the fire-box sides of a locomotive, to support the boiler on the engine frames, and to allow free movement for expansion due to the heat of the furnace.
- Eyelet.* The looped or ring end of a pin or nail when used as a hinge.
- Felloes.* Segments of the rim of a wheel.
- Flush.* Elements are said to be flush, when their surfaces are on the same level or plane.
- Fire box.* That part of a boiler in which the fuel is burnt.
- Fool plate.* The plating fitted on the upper edges of the side frames of a locomotive and its tender.
- Fool board.* The board or foot rest of a treadle; or the board fitted as a foot support where necessary.
- Grip piece.* The piece of hard wood which surrounds the crank pin of a brace, and is free to revolve thereon.
- Gusset piece.* A triangular piece of material, used to stiffen an angular portion of a structure.
- Hammer slides.* The guide spaces formed by the division plates in drop-hammer machines.
- Insert-panels.* Pieces of material fitted into any space after construction of the framing, and held in position by beaded strips nailed in the angles.
- Joists.* The timbers which span a room or structure from side to side, and upon which are placed the floor boards.
- Journals.* The turned ends of shafts, or those parts of a shaft which revolve in the bearings.
- Journal frames or standards.* Elements which, when in position, give support to the bearings.
- Lap boarding.* The wood covering of rough-built huts, or cabins, each board overlapping the edge of that preceding it.
- Loading wheels.* The front wheels of a locomotive.
- Main axle.* The principal shaft of a power machine.
- Motion bracket.* A bracket which supports some moving mechanism.
- Mud guards.* Splash guards which prevent the road grit, etc., being thrown by centrifugal force on the occupants of road vehicles.
- Nave.* The centre or boss of a wheel into which the spokes are fitted.
- Oblique nailing.* Jointing an angular construction at the junction of the elements by nailing across the fibres.

- Overall dimensions* : The aggregate measurement of a number of short lengths taken in one direction.
- Paw, pean, penc, peit* : The tail, or smaller end, of a hammer head.
- Panels* : The central thin portion of the filled-in framing of doors, etc.
- Plan* : The appearance of an element or model to an observer looking at it from above (disregarding perspective).
- Pictorial views* : Sketches, or line diagrams, of elements or models, which show three dimensions on one drawing. Oblique projection or isometric drawing.
- Pulley* : A disc or wheel upon which runs a belt to transmit motion.
- Rail guards* : The curved bars which extend below the side frames of a locomotive in front of the leading wheels, and nearly touch the rails, in order to throw off any obstructions.
- Rails* : The upright timbers of enclosure palings, etc.
- Risers* : The vertical elements of stairs, which fit between the treads.
- Saw-kerf* : The cut made by a saw blade when set.
- Saw-set* : A tool designed to bend over the teeth of saws to form the "set."
- Seat pillar* : A short, stout support upon which a seat is fitted.
- Section* : A term used in drawing to indicate those particular views by which the internal or central parts of an object are delineated. The direction of the section cut is indicated by the words used, as "oblique," "vertical," etc.
- Second-motion shaft* : An intermediate power-transmitting shaft.
- Set of a saw* : The difference between the width of the saw cut, or kerf, and the thickness of the saw blade, due to the bending over by the saw set of the teeth to right and left alternately.
- Shingles* : Split pieces of pine-wood trees, used for hut building in the Canadian forests.
- Side frames* : The main frames or supports of machines which carry the shaft-bearings and chief motor elements.
- Skeleton line diagrams* : Single line diagrams chiefly used to give intermediate dimensions only.
- Shew nailing* : See oblique nailing.
- Smoke box* : The front part of a locomotive into which the products of combustion discharge, after passing through the boiler tubes.
- Smoke box casing* : The curved plating which forms the smoke box.
- Socket* : The bulb end of a brace in which the "bit" is held.
- Spectacle plate* : The front plate of the cab (above the boiler top) through which the engine-driver may observe the signals.
- Sprocket barrel* : The cylinder, or casting, upon which is fitted the sprockets, tappets, or projecting lifters.
- Sprockets, or sprocket* : A projecting element which gives an intermittent movement to other elements in connection.
- Splashers* : The guard-plate or strap which covers the top of a revolving wheel.
- Stamp beam* : The transverse beam upon which the stamp or drop-hammer falls.
- Steam dome* : The element on the top of the locomotive boiler which forms the reservoir, from which dry steam is taken by pipes to the cylinders.
- Stretcher bars* : See cross-bearers.
- Strengthening ring* : A ring or disc fitted in the centre of the cylindrical tube or barrel to give support to the strips.
- Stringer* : The inclined side support of stairways, on or into which the risers and treads are fitted.
- Strut* : A supporting element of construction

Swivel bar: The cross-bar which carries the fore axle springs and wheels of the motor car model.

Swing axles: Axles from which other mechanism is suspended.

Tang: The unhardened tapered part of a tool upon which a handle is fitted.

Tappets or wipers: The projections on the barrel of a drop-stamp machine which give motion to the hammers.

Templates: A temporary pattern or guide by which elements are marked out, or tested.

Tie-bar: A bar, or brace, which, when in constructional position, completes an approximate triangle.

Toot: The shaped handle of a plane.

Transom rail: The bar or piece which fits between the side posts of a doorway, and between the top of the door and the head piece; the space left is occupied by the fan-light.

Trailing wheels: The pair of wheels on a locomotive below the cab foot-plate.

Treads: The horizontal pieces upon which a person ascends a stairway.

Treadle-bar: A bar which carries the treadle-board of foot-power machines.

Tumbling hammers: Small pieces of metal, free to fall on a bell when revolved.

Under carriage: The framing or structure upon which is carried the body of vehicles.

Upper carriage: A secondary frame upon which is carried the body of vehicles.

Waste material: The residue of worked material, parts of which may be of further service.

Wedge: The element of a plane which holds the cutting-iron in position when set. A mechanical power.

Winding: The variation of a surface from a true plane, when considered in its length and width.

INDEX.

NOTE.—References to line drawings of Models are shown in small capital letters.

A

- A PLANT CARRIER OF BIER, 98
- Abies grandis*, 65
- Accuracy, testing square for, 30
- Acer macrophyllum*, 67
- Acer saccharinum*, 67
- Advanced course of work, 149
- Aim of scheme of work, 5
 - „ drawing lessons, 16, 17, 18, 19
 - „ practical „ 16, 17, 18, 19
- Alteration of angles in a triangle, 108
- Alternative models, 12, 15
- Ambidexter training, 36
- American whitewood, notes on, 64
- Archangel spruce, notes on, 65
- Arithmetic, application of, 28, 106
- Arrises, 45

B

- Balanced drawings, method of obtaining, 96, 136
- BASE PIECE OF COLUMN FOOT, 81
- Bass wood, notes on, 64
- Bast fibres „ 67
- Bay wood, notes on, 66
- Beading tool or scratch, illus. of, 22
 - „ „ „ notes on, 45
- Beech wood smoothing plane, illus. of, 22, 36
- Bench hook, use of, 35
- Bending strip wood, method for, 196
- Bent wood mould, 196
- Bevel-edge chisel, illus. of, 59
- Bits, notes of a lesson on, 56
- Bradawl, notes of a lesson on and illus. of, 41
- Building crank axle, 173
- BUILT-UP SQUARE FRAME, 102

C

- CABIN STAIRWAY, 193
- Cabinet rasps, illus. of, 22, 47
 - „ „ notes on, 46
- Canadian maple, notes on, 67
- CATTLE-FEEDING MANGER, 110
- Cedrelaceae*, 66
- Centre bits, illus. of and notes on, 57
- Centre line drawings, 136, 142, 153
- Chamfer, 129
- Charnley Forest stone, 59
- Chart diagrams, reference to, 93, 114, 120, 124, 139
- Child as teacher, 86
- CHILDREN'S GARDEN SWING, 115
- Chisels, compared with planes, 59
- CLOTHES AIRER OF MAIDEN, 121
- Colour combinations and overlay, 88
- Colour effects, 87, 130
- Commune work, 161, 185, 189, 195, 200
- Coniferae*, 65
- Constructional exercises, 15
- Cost per child, equipment multiples of ten, 24
- Crank of brace, 52, 53
- Cutting pliers, illus. of, 22
 - „ „ notes on, 45

D

- Demonstration lessons, 16, 17, 18, 19
 - „ caution, 195
- Description of equipment, apparatus, and tools, 25 to 63
- Development of drawings, 130
- DOG KENNEL, 151

DOLLY'S REDSTAD, 125
 .. COUCH, 131
 Dotted lines, use of, 100
 Double point gauge, illus. of, 52
 Drawing, co-ordinate views, 141
 .. equipment, 23
 .. of circles without compasses, 157,
 162
 Drawings in pictorial form, 115
 DROP STAMP MACHINE, 177

E

Education by doing, 8
 Effective teaching of other handicrafts, 12
 ENCLOSURE RAILS OR PALINGS, 104
 End of first year group of lessons, 110
 .. second 148
 .. advanced 210
 Ensemblement of details, 162, 170, 175, 180,
 185, 190
 "Exeter" hammer head, illus. of, 43
 Express locomotive, 199

F

Familiarizing Unit rule measurement, 79
 FIELD ROLLER, 151
 Files, illus. of, 22
 .. notes on, 16
 Firmer chisels, illus. of, 58
 First course of work, 72
 Fixing work, 25
 Foreshortening of oblique lines, 146
 Fret saw frame, illus. of, 34
 Froebelian principles, 8
 Froebel's Gifts, 86

G

GARDEN GATE, 100
 .. STAFF, 118
 Gauge, description of, 49
 .. illus. of, 50
 .. notes of lesson on, 51

Gauging thin wood, photo. of position, 51
 Geometrical drawing, 10
 Gimlet, 55
 Glasspaper, notes on, 61
 .. rounding up ends, photo. of position
 for, 62
 Glasspaper, block or rubber, 62
 Glossary of technical terms, 211
 Glue, how made, 69
 .. prepared for use, 70
 .. alternative methods of preparation, 70
 .. liquid, 71
 .. efficient jointing with, 71
 Gradation of work, 9
 Graining of wood, 150
 Grinding angles of tools, 36
 Grooving plane, description of, 56
 Groups of lessons, 16, 17, 18, 19
 Guiding saw-kerf on work board, 25

H

HALF-LAP CROSS, 91
Hamamelidee, 68
 Hammer, notes of lesson on, 43
 .. photos of positions for using, 44, 45
 .. "Warrington" head, 22
 HANDBARROW OR SACK TRUCK, 113
 HARVEST CART, 158
 Hinge for clothes airer, how formed, 121
 Honing angle of cutting tools, 60
 How a gate should hang, 108
 How to "centre pin" hang a door, 180

I

Inaccurate sawing, remedy for, 93
 Index, 212
 Inner bark of lime tree, 67
 Interest, maintenance of, 153
 Intermediate group of lessons, 111
 Introduction, 9

J

Juglans, 68

- K**
- KITCHEN CHAIR, 127
- KNIFE-GRINDING MACHINE, 172
- L**
- Lapindara*, 67
- Little talks on common things, 11
- Line tree, 67
- Line diagrams, 128
- Liquidamber styraciflua*, 68
- Liriodendron tulipifera*, 64
- List of alternative models, 15
- ,, standard models, 15
- Locomotive and tender, photo. block of, 200
- LOCOMOTIVE, DETAILS OF FRAMING, 204
- ,, ELEMENTS OF, 206
- ,, SECTIONAL ELEVATION, 202
- ,, TENDER AND TOOL BOX DETAILS, 208
- M**
- Maquiuacca*, 61
- Mahogany, 64
- Manual instruction, 7
- Marking-out drill, 31
- ,, to length, 32
- ,, to several lengths, 32
- Marking gauge, illus. of, 50
- ,, description of, 49
- ,, setting and adjusting, 50
- Material requisites, 24, 64
- Measurement by units, lesson on, 28
- ,, at sight drill, 74
- MECHANICAL ADVERTISING MACHINE, 168
- Mechanical toys, 160, 165, 170, 174, 189, 191
- Mental calculations, 106
- MERRY-GO-ROUND, 163
- Metal sequins, 142
- Method of hinging, 106, 107, 123, 138
- MINER'S HUT OR CABIN, 182
- Model 1, procedure for constructing, 76
- ,, 2 ,, 78
- ,, 3 ,, 81
- ,, 4 ,, 83
- ,, 5 ,, 86
- Model 6, procedure for constructing, 88
- ,, 7 ,, 92
- ,, 8 ,, 96
- ,, 9 ,, 100
- ,, 10 ,, 103
- ,, 11 ,, 106
- ,, 12 ,, 110
- ,, 13 ,, 112
- ,, 14 ,, 116
- ,, 15 ,, 119
- ,, 16 ,, 122
- ,, 17 ,, 121
- ,, 18 ,, 128
- ,, 19 ,, 132
- ,, 20 ,, 133
- ,, 21 ,, 138
- ,, 22 ,, 141
- ,, 23 ,, 142
- ,, 24 ,, 147
- ,, 25 ,, 150
- ,, 26 ,, 155
- ,, 27 ,, 157
- ,, 28 ,, 162
- ,, 29 ,, 167
- ,, 30 ,, 171
- ,, 31 ,, 176
- ,, 32 ,, 181
- ,, 33 ,, 187
- ,, 34 ,, 190
- ,, 34A ,, 192
- ,, 35 ,, 198
- ,, 36 ,, 203
- ,, 36A ,, 209
- Mortise gauge, illus. of, 52
- MOTOR CAR, 197
- Mould for bending wood, particulars of, 196
- N**
- Nailing positions for, photo. blocks, 44, 45
- ,, caution, 159
- Nails, screws, and glue, 68, 69, 70, 71
- Names of models, 16, 17, 18, 19
- Necessity of accuracy, 133
- Notes of lessons, 26, 28, 30, 33, 38, 41, 43, 46, 48, 51, 55

Notes on woods, 64, 65, 66, 67, 68
 „ tools, 25, 27, 29, 32, 36, 40, 42, 45, 46,
 49, 52, 56, 57, 58

Notes on materials, 59, 61, 62, 68, 69
 Not “teacher’s work,” 97

O

Obligations, 6
 oblique parallel projections, 122
 „ nailing, 144
 Observation lesson, 11
 “Occupation” class-room, 5, 13
 Oilstones, notes on and use of, 59
 ONE-CRUSHING OR STAMP MILL, 177
 OVERLAP CROSS OF STRING WINDER, 72
 Overlap jointing, 10
 Overlap strip paper designing, 9, 73, 74
 OXFORD FRAME, 76

P

Pad saw, handle and blade, illus. of, 31
 Panel pins, 68
 Paper strip diagram, example of, 74
 Parallel vice, illus. of, 63
Picea excelsa, 65
 Piercing saw, photo. of, 57
Pinus picca, 65
 Pitch-bed, 36
 Plan of general handicraft room, 13
 Planes, description and uses of, 36
 „ illus. of, 36, 37
 „ iron or cutter, 36
 „ using smoothing plane, 37
 „ small iron plane, 39
 „ notes of lesson on, 38
 „ position drill for, 39
 PLANT LADDER, 94
 Positions for honing, 60
 Practical work, 10
 Preface, 5
 Pricker, 11
 Products of Coniferae, 66

R

RADWAY SIGNALS, 186
 Rasping and filing, positions for, 48
 Rasps and files, notes of lesson on, 18
 Reciprocating motion, 170
 REVERSING SPINNING MILL, 89
 Rotary motion, 170
 Round-nose cutting pliers, notes on, 15
 Russian mats, 67

S

SACK TRUCK, 143
 Sandpaper, notes on, 61
 Satin walnut, notes on, 68
 Sawing, photo. positions for square, 35
 „ „ „ „ oblique, 35
 „ on bench hook „ 35
 „ position drill, 33
 „ block, 25
 „ to waste, 212
 „ to line, 212
 Saws, construction of, 32
 „ illus. of, 22, 33, 34
 „ form of teeth, 33
 „ damage to, 33
 „ notes of a lesson on, 33
 Scale drawing by Unit system, 27, 111, 171
 Scheme of lessons, 16, 17, 18, 19
 Scratch or heading tool, illus. of, 22
 Screws, sizes of, 69
 Sections, how to teach about, 82
 „ how placed, and value of, 83, 86
 Setting a plane, 37
 Sharpening a chisel or other cutting tools,
 illus. of, 60
 SIGNAL CABIN, 190A insert page
 Silver fir, 65
 SIMPLE COLUMNS, 81
 Spruce, 65
 STEP LADDER, 113
 Sugar maple, 67
Swietenia mahogany, 66
 Swiss pine, 65

T

Tee square, use of, 79, 92
 TEE SQUARE, 80
 Templates, use of, 116, 145
 Tenon saw, illus. of, 33
 ,, description of, 32
 Testing accuracy of angles, 31
 ,, ,, of dimensions, 32
Tilia Americana, 64
Tilia cordata, 67
Tiliaceæ, 67
 TOILET OR DRESSING TABLE, 134
 Tool equipment and cost of, 22, 24
 Tool position drills, 11, 16, 17, 18, 19
 Training, sight measurement, 124
 Transposing drawings, 120
 Treadle and crank movement, 170
 Triangle, strength of, 116
 Try square, construction of, 29
 ,, accuracy test, 30
 ,, notes of a lesson on, 30
 ,, position drill, 31
 Turkey stone, 59

U

Unit rule, illus. of, 27.
 Universal handicraft bench, 14
 Use of Tee and set square, 92

Use of clinching block, 141
 Using smoothing plane, 37
 ,, iron smoothing plane, 39
 ,, bradawl, 42
 ,, hammer, 44 and 45
 ,, back saw, 35
 ,, rasp for forming curves, 17
 ,, marking cutting gauge, 51
 ,, brace and disc cutter, 53
 ,, piercing saw for cutting curves, 58

V

Value of dotted lines, 100

W

Washita stone, 59
 WHEEL ARMS, 91
 WHEELBARROW, 146
 WICKET GATE, 137
 Windmill, paper sails, 90
 Wire edge on sharpened tools, 45, 60
 Wire nails, 68
 Wire suspension rods, 117
 WORKING DRAWINGS OF SPINNING MULL, 89
 Working models, 89, 168, 172, 177, 186, 197, 202

WORKS BY THE SAME AUTHOR.

The “Althorp” Blank Drawing Book,
— FOR —
Manual Training Subjects.

Specially Ruled and Printed for Theory Notes.

Size: 11 in. by 8 $\frac{3}{4}$ in., 48 leaves. **GOOD CARTRIDGE PAPER.**

Price **4d.** net ; **36/=** per gross.

N.B.—The above may be had in Loose Sheets.

The “Althorp” Manual Training Series.

42 SPECIMEN WOODS,

With the Common and Botanical Names.

For use in **ELEMENTARY, SECONDARY, and TECHNICAL SCHOOLS.**

In Neat Sliding-lid Box. Price **3/6** net.

WORKS BY THE SAME AUTHOR.

1st SUPPLEMENTARY SERIES

— OF THE —

.. Alternative Models ..

50 Designs. 1/- net.

The Unit Scale Rule, 6d. per doz.

(REGISTERED)

SIMPLIFIES THE WORK FOR THE CHILDREN.

Manual Instruction in Wood.

1st Year Course, 1/- (9d. net).

2nd Year Course, 1/6 (1/1½ net).

Arranged for the use of Teachers and Pupils of Elementary,
Secondary, and Technical Schools.

THE "ALTHORP"

Manual Training Series

MEDIUM—WOODWORKING.

1st and 2nd Year Course suitable for Evening Schools.

Complete, 1/6 net.

PRINTED BY
MORRIS & YEAMAN, 44, LLOYD STREET, ALBERT SQUARE,
MANCHESTER.



A 000 039 917 0

