

TT
185
.W5

ELEMENTARY WOODWORKING PROJECTS

HAROLD R. WISE





Class _____

Book _____

Copyright N^o. _____

COPYRIGHT DEPOSIT.

ELEMENTARY WOODWORKING PROJECTS

HAROLD R. WISE

INSTRUCTOR MANUAL ARTS, BOSTON PUBLIC SCHOOLS

INSTRUCTOR IN CABINET MAKING, SOUTH BOSTON SCHOOL OF ARTS



THE MANUAL ARTS PRESS
PEORIA, ILLINOIS

Copyright 1922
HAROLD R. WISE
12 D 22

© Cl. A. G. 56650

Printed in the United States of America

NOV 1922

FOREWORD

THIS book is intended for use in the upper grammar grades where bench work in wood is first introduced to the pupils.

The aim has been to present a collection of working drawings of useful projects that are suitable for beginners of the age found in these grades. Not all of the projects can be called "new," but all have been successfully worked out at the bench by grammar grade pupils.

The writer wishes this to be recognized as a *collection* of drawings, not a *course* or *series*. No effort has been made to present a sequence of projects or exercises. That is the job of the individual teacher. He should be the best judge of what will lead his pupils to do their best work. He should be capable of selecting

the project that involves such exercises in wood-working as his pupils are prepared to do in a workmanlike manner.

It is not the intention that the notes that accompany each working drawing are to be substituted for the usual demonstration and instruction by the teacher. While in most cases the notes outline the steps to be taken, their purpose is to be helpful, to clinch the teacher's demonstration and instruction, and to stimulate the pupil to do a little planning and thinking for himself. Nearly every project—even those most simple in character offer possibilities for modification by the pupil without upsetting the teacher's plan of presentation of the technical part of the work.

CONTENTS

I PLANING TO DIMENSIONS.....	6	IV BORING.....	44
Steps in Planing		15 Broom Holder	
First Method		16 Pen and Pencil Holder	
Second Method		*17 Tooth Brush Rack	
Third Method		18 Clothes-line Reel	
Fourth Method		19 Towel Stand	
Fifth Method		20 Trousers Hanger	
Sixth Method			
II NARROW SURFACE PLANING.....	14	V OBLIQUE PLANING.....	56
* 1 Pencil Pointer		21 Door Stop	
2 Key Board		22 Laundry Stick	
* 3 Knife Strop		*23 Clock Shelf	
* 4 Fish-line Reel		24 Shoe-polishing Stand	
* 5 Trellis		25 Towel Rack	
* 6 Pail Stand			
* 7 Dish Drainer		VI CONSTRUCTION—BOXES, ETC.....	67
8 Back Rest		*26 Telephone Bracket	
9 Sewing Stand		27 Milk Bottle Holder	
III BROAD SURFACE PLANING.....	32	28 Tray for Table Silver	
*10 Cutting Board		29 Poultry Feeder	
*11 Writing Board		30 Letter Tray	
*12 Foot Stool		31 Bird Feeding Shelf	
13 Miter Bench Hook		*32 Sewing Stand	
*14 Boot Blacking Stand			

VII MODELLING.....	82
*33 Match Striker	
34 Suit Hanger	
*35 Rolling Blotter	
*36 Pen and Ink Stand	
*37 Letter Holder	
*38 Ink Stand	
*39 Necktie Rack	
*40 Whisk Broom Holder	
*41 Book Stall	
VIII GOUGING.....	102
42 Safety Match-Box Stand	

*43 Pen and Pencil Rest	
*44 Ink Stand and Stationery Holder	
IX JOINTS.....	108
*45 Waste Paper Basket, (Glue)	
*46 Book Supports, (Dado)	
*47 Hot Dish Rest, (Cross lap)	
48 Cord Winder, (Cross lap)	
49 Skirt Marker, (Mortise and Tenon)	
*50 Spool Reel, (Housed Dado)	

NOTE: The projects marked (*) are such as encourage the individual to plan or choose for himself suitable construction or contour.

I. PLANING TO DIMENSIONS

There are several ways of planing the pieces of wood contained in a project. When the project is a simple one, there are two common sets of steps that may be used. The first is used when the wood for the project is furnished mill-planed to the finished thickness. The second is used when the wood is furnished thicker than the finished dimension. The first set of steps is generally used in most elementary work, on simple objects. It is also followed by the workman who is making very large objects, such as bookcases, large cabinets, etc., when the large surfaces are planed very carefully by machinery to save labor. In such large projects the joints and intricate work are finished before the surfaces are dressed off by hand. In no case is it considered desirable from the viewpoint of a skilled workman to allow machine marks to show on the finished article, whether it is large or small. If one will examine furniture of various types, it will be found that only that which is very inferior shows any machine marks on the surfaces.

The second set of steps in planing is the one used most often in the manual training shop, or where very fine, close and accurate work is to be done. Seldom is a piece of wood procured that is perfectly flat or straight across, as it is "subject to change without notice" after it leaves the sawmill, due to changes in temperature, dampness, etc. To plane the broad surfaces flat and true would tend to make the board too thin. Therefore the stock should be procured thicker than the finished size is to be. The usual allowance for planing, as made by careful workmen, is: $\frac{1}{8}$ " in thickness, $\frac{1}{4}$ " in width, $\frac{1}{2}$ " in length.

The two common sets of steps in planing follow in "Steps in Planing," (First Method) and (Second Method).

When a number of pieces are to be made that have several dimensions in common, it is more economical to plane the pieces in such a way as to save time, labor, and material. There are several cases where this is done to advantage, and they are outlined in plates C, D, E, and F.

STEPS IN PLANING

A. (First Method)

Planing in two dimensions, or, steps in planing when the wood is of the required thickness.

1. Mark the hollow, or concave side of the board with one straight line, thus: / Call this the "working face."
2. Plane the better edge straight and smooth, and square to the working face (/). Mark with two lines, thus: // Call this the "working edge."
3. Gage the width from the working edge (//), and plane to the line.
4. Plane the better end square to the working face (/) and the working edge (//).
5. Mark off the length from the finished end, saw next to the line, and plane the second end square to the working face (/) and the working edge (//).

STEPS IN PLANING

B. (Second Method)

Planing in three dimensions, or steps to be taken when the wood is thicker than the required dimensions.

1. Plane the better broad face flat and smooth. Mark thus: /
Call this the "working face."
2. Plane the better edge straight and smooth, and square to the working face (/). Mark / .
Call this the "working edge."
3. Gage the width from the working edge (/) and plane to the line.
4. Gage the thickness from the working face (/) and plane to the line.
5. Plane the better end square to the working face (/) and to the working edge (/).
6. Mark off the length from the finished end, saw next to the lines to remove the waste wood, and plane the second end square to the working face (/) and the working edge (/).

NOTE: When the wood is narrow the end planing may be done with the aid of the bench hook, using the block plane.

When the wood is 4" wide, or wider, it is better to hold it end up in the vise.

When the board is very wide, 8" or more, the smoothing plane or the jack plane will be used to better advantage than the block plane for end planing.

In any case, plane only part way across the end from each edge. Planing all the way across the end of a piece of wood causes the corners to be split off.

STEPS IN PLANING

C. (Third Method)

When there are two long pieces of the same length, width, and thickness, or of the same length and thickness.

1. Procure a piece of stock wider than the combined width of the two pieces.
2. Plane the better broad face flat and smooth. Mark
Call this the "working face."
3. Plane both edges straight and smooth, and square to the working face (). Mark both
of these edges //. They are the working edges—one for each piece.
4. Gage the thickness from the working face (), and plane to the line.
5. Gage the width of each piece from the working edges () saw between the lines, and
plane the sawn edge of each piece to the gage lines.
6. Plane the better end of each piece square to the working face () and the working edge
(//).
7. Mark off the length of each piece, saw next to the line and plane the ends square to the
working faces () and the working edges (//).

STEPS IN PLANING

D. (Fourth Method)

When there are two or more short pieces of the same width and thickness to be made.

1. Procure a piece of stock longer than the combined length of the pieces.
2. Plane the better broad surface flat and smooth. Mark \perp .
Call this the "working face."
3. Plane the better edge straight and smooth, and square to the working face (\perp). Mark \parallel .
Call this the "working edge."
4. Gage the width from the working edge (\parallel), and plane to the line.
5. Gage the thickness from the working face (\perp), and plane to the line.
6. Plane both ends square to the working face (\perp) and the working edge (\parallel).
7. Mark the lengths of two pieces, measuring from the finished ends. Saw next to the lines
and plane the new ends square to the working face (\perp) and the working edge (\parallel).

NOTE: If there are three pieces to be made the wood sawed out of the middle will make the third piece. The ends should be squared to make it the proper length.

If there are four pieces to be made repeat steps 6 and 7 on the wood sawed out of the middle of the strip.

If there are five pieces to be made repeat steps 6 and 7 and the first part of this note.

STEPS IN PLANING

E. (Fifth Method)

When there are two, three, or more long and narrow pieces of the same thickness and similar lengths.

1. Procure a piece of stock wider than the combined width of all the pieces.
2. Plane the better broad face flat and smooth. Mark \perp .
Call this the "working face."
3. Plane both edges straight, smooth, and square to the working face (\perp). Mark each of these edges \parallel .
Call them the "working edges."
4. Gage the thickness from the working face (\perp), and plane to the line.
5. Gage the widths of two of the pieces from the working edges (\parallel), saw near the lines, and plane to the lines on the pieces sawn off.
 - a) If only three pieces are to be made, plane the edge of the piece sawed out of the middle of the board. This edge should be planed straight and smooth, and square to the working face (\perp). Mark it \perp . Gage the width from this edge and plane to the line.

(over)

- b) If there are four pieces to be made, the wood sawed out of the middle of the original piece will make the third and fourth piece. Plane each edge straight and smooth, and square to the working face (/) and mark //. Gage the widths of the third and fourth pieces from these edges, saw between the lines, and plane to the lines.
 - c) If there are five or more pieces to be made the above steps are repeated until all the pieces have been planed to the proper width and thickness.
6. Plane the better end of each piece square to the working face () and the working edge ().
 7. Mark off the length of each piece, saw to the lines, and plane the second end of each piece square to the working face (/) and the working edge (/).

STEPS IN PLANING

F. (Sixth Method)

When there are two pairs of pieces of medium length to be made.

1. Procure stock longer than the combined length of the two pairs when the pairs are placed end to end, and wider than the combined widths of the two pieces in each pair.
2. Plane the better broad face flat and smooth. Mark \cdot .
Call this the "working face."
3. Plane both edges straight and smooth, and square to the working face. Mark \cdot .
Call these the "working edges."
4. Gage the thickness from the working face (\cdot), and plane to the lines.
5. Gage the widths from the working edges (\cdot), saw near the lines and plane to the lines.
6. Plane both ends of each piece square to the working faces (\cdot) and the working edges ($//$).
7. Mark off the lengths of each piece from the ends of the strips. Saw near the lines, and plane the ends square to the working faces (\cdot), and the working edges ($//$).

II. NARROW SURFACE PLANING

PENCIL POINTER

This article is used to put the final point on a newly sharpened pencil.

First procure the wood, $\frac{3}{8}'' \times 1\frac{1}{2}'' \times 8''$ and plane it to the proper thickness, width and length, following the steps in Planing.—(First Method) or (Second Method), page 7 or 8.

The workman may use the outline for the handle shown on the drawing, or he may design a suitable outline for himself. The handle should be kept symmetrical in outline.

If the outline shown on the drawing is followed; first, draw the center line, upon which

the hole is located and bored. Next draw off the taper and plane carefully to the line. All surfaces should be cleaned with sandpaper. The No. O sandpaper shown on the drawing is cut from the larger sheets. Ordinarily sandpaper is torn to size, and not cut, as it may be plainly seen that it would ruin the cutting edge on any tool. In this case an old knife may be used to prepare the paper, as a smooth edge is desired. The paper is glued to the wood with a very thin coat of glue. The handle may be decorated with a stencil design or simple carving.

PENCIL POINTER

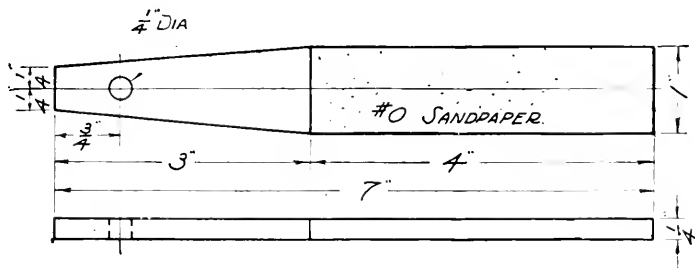

KEY BOARD

This project is intended for one of the first exercises in planing. The material is procured $\frac{3}{4}$ " \times 4 $\frac{1}{2}$ " \times 13" and planed to the finished dimensions in the method outlined in the "Steps in Planing," page 8. The position of the holes and hooks are carefully located. Bore the

holes with a drill bit. Mark for the hooks with a marking awl, pricking a small hole in the wood to give the screw on the hook a start. Sandpaper all the surfaces clean and smooth. Finish with wax or shellac. The board may also be stained. Use brass cup hooks to hang the keys on.

KEY BOARD

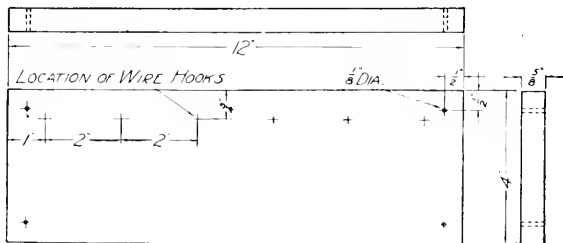

KNIFE STROP

The working drawing shows the knife strop in its simplest form. The better workmen may choose one of the other forms illustrated.

Procure material $\frac{1}{2}'' \times 1\frac{3}{4}'' \times 15''$ and plane to the finished dimensions shown on the working drawing. Locate the hole in the handle and bore the hole, boring only until the spur of the bit shows thru. Then the wood is turned around and the boring is finished from the opposite side.

If one of the optional outlines for the handle is chosen, this is drawn on the wood and cut out. Then the surfaces are sandpapered smooth and clean. A fine sandpaper should be used for this. The emery cloth should not be cut out with any of the bench tools. There is probably an old knife kept in the shop which may be used for this kind of work. If desired, one side of the strop may be covered with leather, instead of emery cloth.

KNIFE STROP

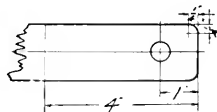
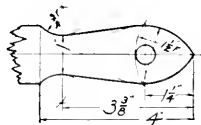
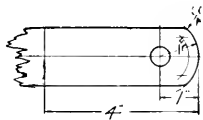
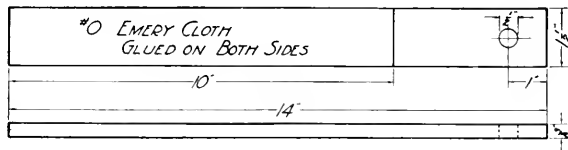

OPTIONAL TREATMENT FOR HANDLE.

FISH-LINE REEL

This may also be used for a kite string or for the odds and ends of twine saved at home. It is intended for one who is just beginning woodwork. Procure stock $\frac{1}{2}'' \times 3'' \times 11''$ and plane to the finished dimensions following the Steps for Planing (First or Second method, pages 7 and 8). Draw the center lines both ways and

draw the outlines of the notches. The heavy line shows the simplest kind of cut, as it may be made with the back saw. The dotted lines show two other ways to make the notch. These are cut out with the coping saw. See that all edges are smooth and all surfaces are clean before calling the object finished.

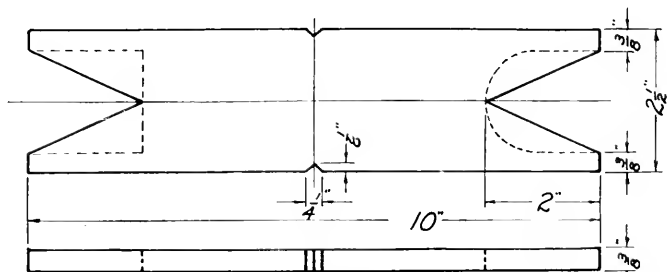
FISH LINE REEL.

DOTTED LINES SHOW OPTIONAL END OUTLINES.

TRELLIS

This project may easily be changed in construction or dimensions to suit some individual need. It may be made taller, with more cross pieces, or some other arrangement of parts may be used by the workman. If the drawing is followed: Procure stock in two pieces, one $5/8'' \times 2 1/2'' \times 25''$, to make the upright parts, the other $5/8'' \times 2 1/2'' \times 12''$, to make the cross pieces.

Plane these pieces to thickness, and on each edge. Then gage the widths of the parts from the edges, saw between the gage lines, and plane the sawn edges of each piece to the gage lines. Point the ends of the long pieces as indicated in the drawing, using either the knife or the chisel. Then measure for length and square ends on the pieces to make them the required length.

When assembling, tack the pieces in place with only one brad in each joint. Then make sure that the pieces are square to each other, and secure them with a second brad in each joint.

White or green paint is a good finish for this project.

PLANT LABEL AND GARDEN STAKE

The steps taken in making these objects are quite similar to those for making the trellis.

Procure material enough larger than the finished sizes to allow for planing. Plane to the finished width and thickness, draw the shape of the point carefully, and whittle or chisel to the lines. Then mark off the length and square the second end.

The plant label has a saw cut in the top to hold a card with the name of the plant written on it. This card is held in place with a small nail or wire thrust through the hole shown, and thru the card when it is in the saw cut.

The garden stake is trimmed as shown with the chisel or knife.

These two objects may be left unfinished or may be painted to suit one's taste.

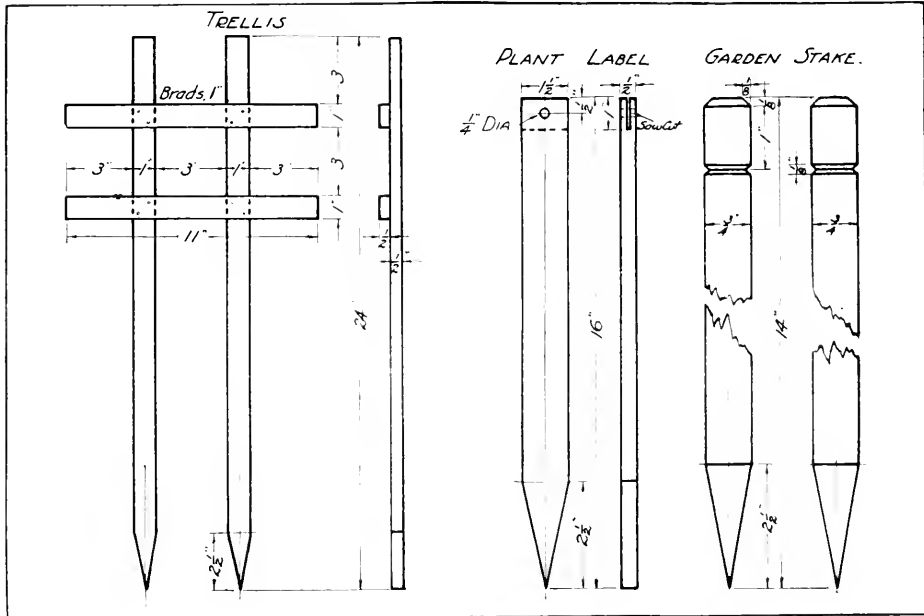

PAIL STAND

This project gives practice in planing long pieces and in making duplicate parts. Procure stock for the slats and square them up after the method described on page 11. The legs are planed square after the method on page 10.

The outline for the bottom of the legs shown in the drawing may be used, or one more pleasing may be designed by the workman. If the drawing is followed, locate the center of the hole as indicated. Then draw the slanting lines shown. After boring the hole, saw on these slanting lines, and smooth up the edges.

Sandpaper all the surfaces smooth and assemble, using either nails or screws. To be sure that the stand will go together squarely, first fasten the legs to one of the outside slats, making sure that the legs are at right angles to the outer edge of the slat. Then fasten the other outside piece so that it is flush with the other ends of the legs. The middle slat is then put in place and the job is done. Make sure that the ends of the slats overhang the legs the proper amount, and that they are in line, also that the stand rests level when stood on a flat surface.

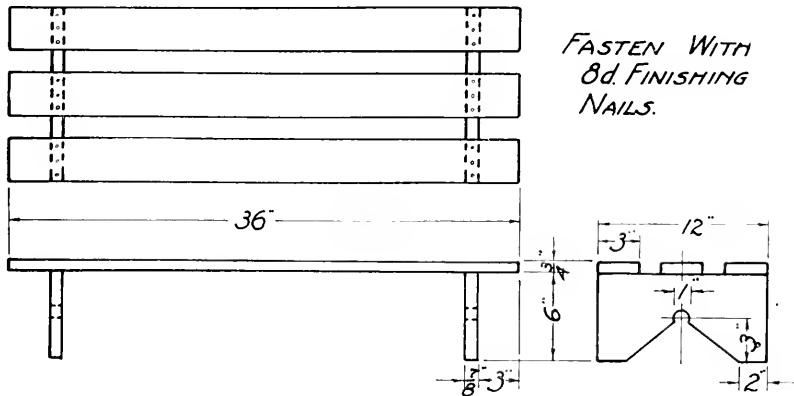
PAIL STAND.

DISH DRAINER

This article is intended to be used in the bottom of the kitchen sink to raise the dishes placed upon it to drain off.

The dimensions may be readily changed to fit any particular sink.

Considerable drill is obtained by the maker in the planing of narrow surfaces. He should read the matter on planing; pages 9, 10, 11, and 12, and should try to apply the rules in such a way that he will complete the work in the most efficient manner, as demanded by the stock he has to use. In the making of an article like this the workman often has an opportunity to make use of a good deal of material that has

been accumulated as waste. Care should be taken to keep the stock to dimensions so that all similar pieces will be alike.

When nailing the parts together, considerable care must be taken to insure a good job. Mark where each nail is to go. Nail the outside slats to the cross pieces with only one of the nails at each joining. The four-sided frame made in this way may then easily be squared, and held in shape by the second nail in each joint. The remaining slats may then be located and nailed in place. Keep the ends in line with each other. Sandpaper clean but do not apply any finish to this object.

DISH DRAINER.

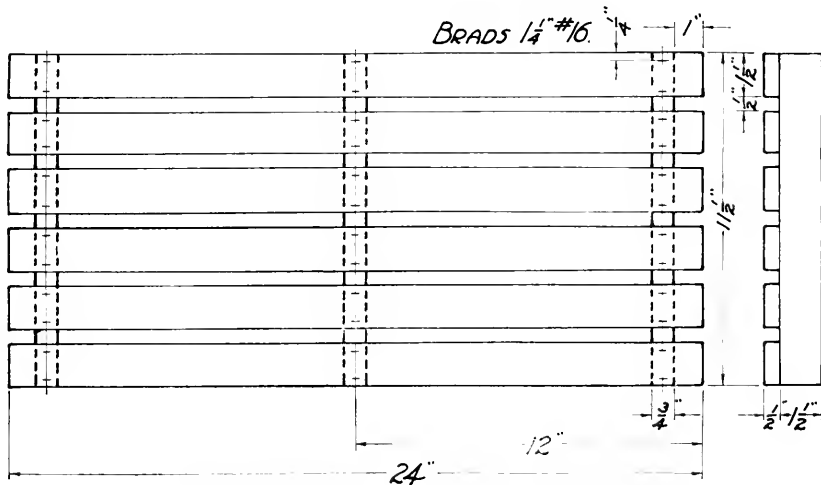
BRADS $1\frac{1}{4}$ " #16.

BACK REST

This project gives the workman lots of drill in planing narrow surfaces. Generally there is material in strips about the shop that will work into the making of a few of these objects to advantage.

Follow the rules for planing carefully. (Steps in Planing; Second Method, page 8, or Fourth Method, page 10.) When assembling, it is good to square a line across the outer edges of two of the slats to mark where the edges

of the cross pieces are to come. ~~Mark the~~ outer slats in place with only one nail in each cross piece. The four sided frame, thus produced may be squared, and held true by the second nail in each corner. The middle strip may then be located and tacked in place. Finally the remaining strips are placed carefully and fastened. If screws are used the same steps may be taken. If the nails should show thru they may be clinched on the under side.

BACK REST.

FASTEN WITH
3d. SHINGLE NAILS
OR 1#8 F.H. SCREWS.

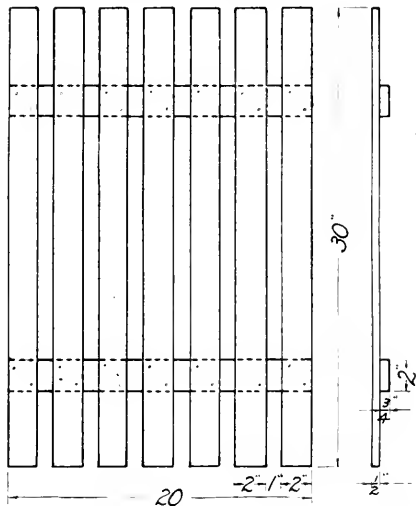

FOR USE IN CANOE,
COUCH HAMMOCK,
OR FOR INVALID.

SEWING STAND

This is a very popular little sewing stand because of its extreme lightness which makes it easy to carry about. When not in use it may be stowed away in a closet as it takes but little room when folded.

The maker of this stand gets experience in planing duplicate pieces and in boring. The material for the legs is procured in one piece, $5\frac{1}{2}'' \times 6'' \times 27''$, and is planed as described on page 11. All four legs should then be the same width and thickness. This method is useful in making boxes and any other object made with a number of long duplicate parts. The ends of the legs are next marked out with the compasses and trimmed to shape with the chisel. When marking for the holes for the dowels, place the legs on the bench edge to edge and square the lines across all four at one time. Bore very

carefully. If any hole is bored at an angle, the frame will be skewed and a poor job will result. The dowels should be carefully cut to length with the ends nicely trimmed. Sandpaper all the parts before assembling. The lower dowels are glued and nailed. The upper dowels are fastened in place with round head screws, so that they may be removed to receive the cretonne sewing bag as shown in the drawing. Before turning in the screws make a hole slightly smaller than the worm of the screw, otherwise the screw will surely split the dowels.

This stand should receive a good finish. Mahogany stain, shellaced and rubbed down, seems most suitable for an object of this kind. Under certain conditions paint may also be used. Do all the finishing before attaching the work bag.

SEWING STAND.

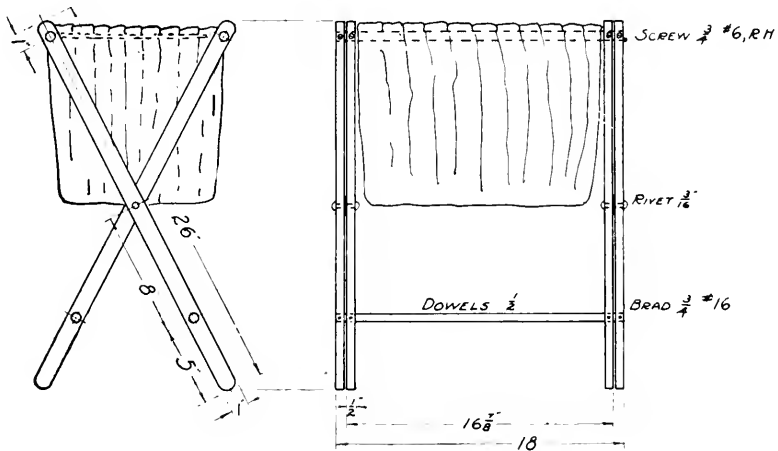

III. BROAD SURFACE PLANING CUTTING BOARD

This is a simple exercise in broad surface planing. Procure the material $7\frac{1}{8}'' \times 6'' \times 1\frac{1}{2}''$. Plane to the required size, following the rules for planing in three dimensions, page 8. A choice of four designs is offered on the drawing. The curve in the working drawing is made with compasses, sawed out with the turning saw and smoothed with the spoke shave. The other designs show simpler treatments. Locate the holes as shown. Remember to bore only until the spur shows thru. Then reverse the wood, finishing the boring from the opposite side. Be sure all surfaces are clean and smooth. No stain or shellac should be used on this project.

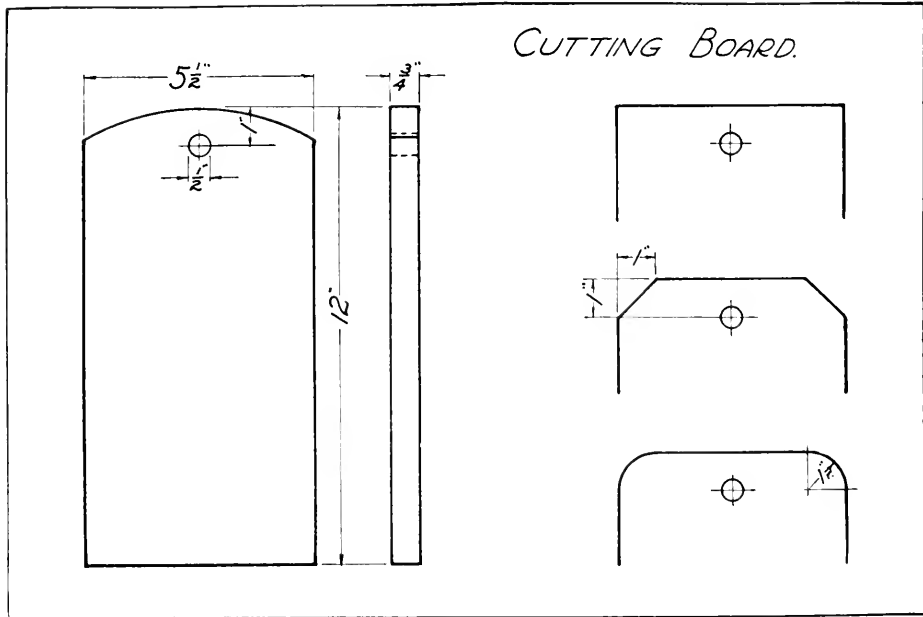

WRITING BOARD

This is a useful article that a boy beginning to use woodworking tools can make well. It gives him an opportunity to learn to plane a broad surface flat and smooth, and to square the end on a wide board. The rules for planing given on page 8 should be followed closely to ensure a good result.

The dotted lines suggest two modifications of the design. Line *A* represents half of a simple decorative curve for the top edge. Line *B* combines a pleasing curve with a feature for increasing the usefulness of the board, as a wide rubber band may be passed around the board at the notch marked *C*, to hold the paper in place, or to tuck the pencil under when not in use.

The drawing for the Tooth-Brush Rack and several other projects suggest other curves that may be applied to the top edge of this board. The boy may originate his own design very easily by folding a piece of paper the size of the board, and cutting a number of curves with the scissors. No deep incisions in the edge should be made, as they would tend to destroy the usefulness of the board. After making a number of patterns get the teacher's advice as to which one is the most suitable to use.

The board may be stained, or finished in natural color, according to the kind of wood used. Four thin coats of shellac should be applied and rubbed down with fine pumicestone and raw linseed oil.

WRITING BOARD.

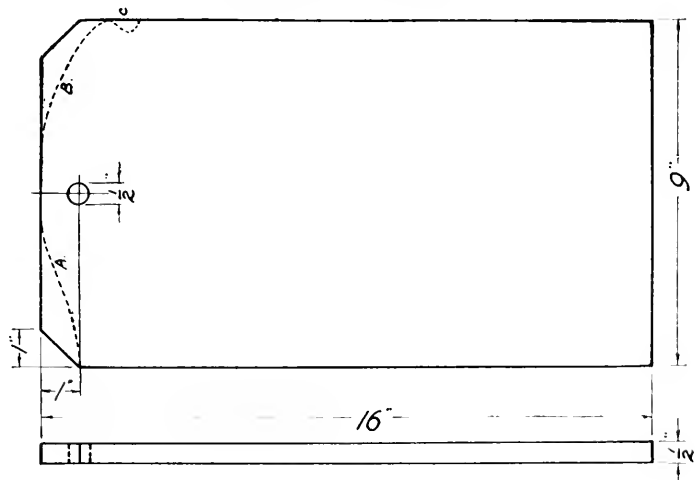

FOOT STOOL

This article finds its place of usefulness by the easy chair or in the sewing room.

The pieces are to be planed to size after the method outlined in the plates showing the steps in planing. In the case of the legs it would save labor to procure a piece of stock long enough to make both legs and plane it to width and thickness before sawing it in two, as indicated on page 10.

The drawing shows how the stool may be modified in design to satisfy the individual taste.

After assembling, the stool had better be stained and polished as this is difficult to do after the upholstering has been done.

The upholstering is very simple. First tack strips of burlap or heavy cloth, 4" wide, to the top of the stool so that two thirds the width

overlaps the edge of the top. Make a long roll of the material that is to be used for stuffing (curled hair, cotton, or tow) and lay it around the edge of the top. Carry the free edge of the strip of burlap over the filling and tack it down as shown on the drawing. This makes a soft, round edge, all along the outer edge of the top. The stuffing will fill the space inside this roll. It is covered with burlap or other rough, cheap material which is tacked down around the outer edge of the top. The top cover may then be smoothly stretched and tacked around the edge. Bind the edges with gimp, tacked with covered tacks that match the top material. The gimp should cover all the rough edges of the cover and the plain tacks. With reasonable care, after studying these directions, any boy ought to be able to do a very neat job.

FOOT STOOL.

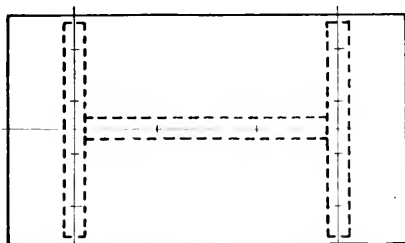

FASTEN WITH 6d. FINISH. NAILS.

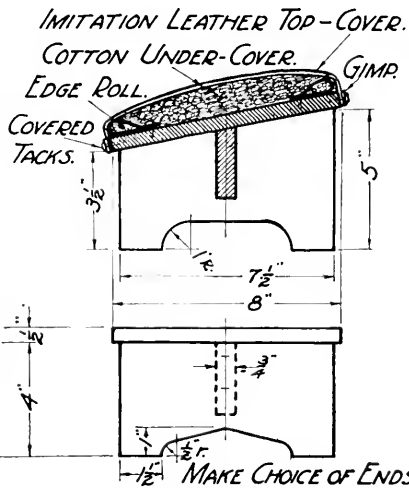
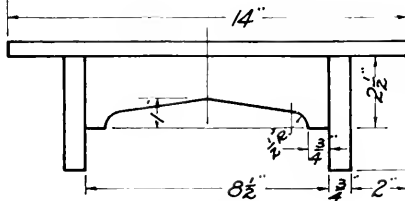

MITER BENCH-HOOK

This project lays strong emphasis on the squaring-up process.

The stock for the base should be carefully squared to size following the rules for planing on page 8. The center line may then be drawn and the holes located upon it and bored, as indicated in the drawing. Procure a piece of stock long enough to include the miter block and the two end blocks. Plane this to the width of the base and to the thickness indicated on the drawing. The angle of 45° for the miter blocks may then be marked off and the surplus wood cut away by carefully sawing near the line with the back saw. Care should be taken to plane this surface to the exact angle and at the same time keep the surface at right angles to the broad surface. When this has been done, the length of the miter block may be marked off and the piece trimmed to size.

The material remaining should make the two end blocks. Carefully square both ends before marking the length of these pieces and sawing them in two. In this case the "length" goes the short way of the board, as "length" in wood is generally understood to run with the grain. When these pieces have been trimmed to the finished size they are carefully glued in place, preferably with hot glue, and left in clamps until dry. The corners may then be trimmed as shown and the work cleaned up. The miter block is held in place with a piece of dowel, which is glued only to the block. The block may then be set aside, when it is desired to use the bench hook for square end stock.

Give this project two coats of shellac to keep it clean and to protect it from the atmosphere. Apply the shellac in thin coats, allowing each coat to dry over night before sanding smooth.

MITER BENCH HOOK

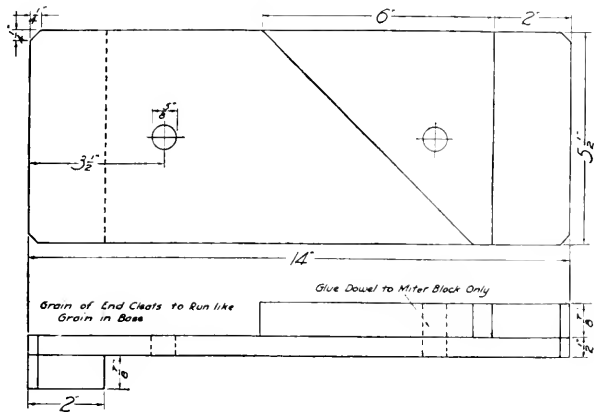

BOOT-BLACKING STAND

This project is an old favorite of the boys and gives excellent practice in broad surface planing and simple construction.

The ends and sides should be planed according to the rules for planing, B, page 8.

The construction lines for the pattern cut on the end have been left on the drawing to aid the workman to reproduce the curve on the wood. Draw the center line first and locate the center of the hole. Make a mark 2" from each edge on the bottom end. Adjust the compasses to half the distance from this mark to the center of the hole and describe the arcs shown in light lines. Where these arcs intersect is the center of the arcs that outline the pattern. The radius is the same for all arcs. Bore the hole and then saw the curves with the turning-saw. The pupil may design his own outline with the permission of his teacher. When these curves have been smoothed nicely, the joint may be marked out. First make a line across the edges as far

from the top end as the side boards are wide. Square this line with lead pencil on both sides of the board. Set the gage to the thickness of the side boards and gage lines parallel to the edges on both sides of the end piece, from the top to the pencil lines. Saw very carefully just to this line with the rip saw, so that the saw will leave a flat surface for the side board to fit against. If the sawing is well done, no trimming will be necessary. Saw across the grain with the back saw to complete the joint. The sides and ends should next be assembled. All inside surfaces should be made smooth and clean.

The location of the brads should be marked lightly and the brads started in the sides as shown on the drawing. Put glue on the edge of the end piece before placing the sides and driving the nails home. The corners of the box should be square when nailed together. The bottom board may be planed to thickness and with one edge and one end squared. The length is then

BOOT BLACKING STAND.

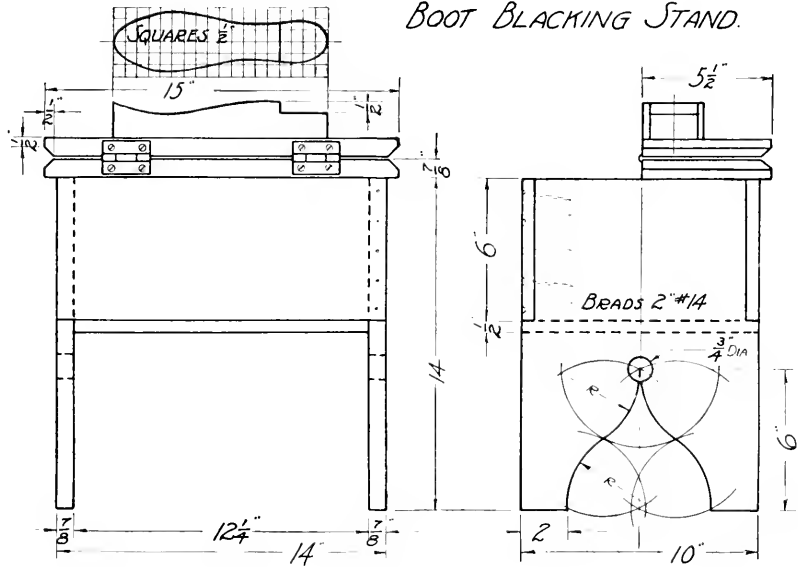

marked very carefully and the board fitted and nailed in place. The edges may be trimmed off flush to the sides of the box. The pieces for the top are planed to dimensions and chamfered as shown on the drawing. One side is fastened down and the other is hinged to it. If the box is to be painted the brads may be driven thru the top, but if it is to be stained and polished it would be best to fasten the top with "blind nails" and glue. To do this drive brads into edges of the box on the side the cover is to be fastened to and cut off the heads $\frac{3}{8}$ " above the surface of the wood. Press the top down on these brads until it touches the top edge of the box, then remove it and put glue on the edge of the box and clamp the top down with hand-screws. Wipe off any surplus glue and set

aside to harden. The foot rest may be started at this time. Make a cardboard pattern from the drawing and mark around it on the wood. Saw to the lines with the turning-saw and smooth the edges with the spokeshave. The heel rest is sawed out with the back-saw. The place for the sole of the shoe is cut out with the spoke shave. The foot rest is fastened to the inner side of the hinged half of the top with dowels and glue, or "blind nails" and glue. When fitting the hinges remember these things: Half the thickness of the hinge when folded is sunk into each piece and the center line of the hinge pin should be just in line with the corner of the board. To locate hinges it is safe as a rule to place them one sixth of the length from the end of the board.

IV. BORING

BROOM HOLDER

Procure a piece of stock $\frac{7}{8}'' \times 3'' \times 11''$, plane to the required thickness, width and length, as described under Steps in Planing, B, page 8. Mark out the corners square, without the curves, and saw to the lines with the back-saw. To locate the center of the arc for the round corners, draw a 1'' square in each of these corners and the inside corner of this square will be the center of the arc. Trim to the arc with the chisel or coping-saw and finish the surface

smooth with file and sandpaper. Locate the centers of the screw holes as shown on the drawing and bore the holes with a $\frac{3}{16}''$ bit. Draw the center lines and bore a hole with the expansive bit set at $1\frac{3}{4}''$ dia. Bore only until the spur shows thru, then reverse the wood and finish the boring from the other side. Draw lines $9\frac{1}{16}''$ each side of the center line and saw out the opening shown on the drawing.

Sandpaper all surfaces smooth and clean.

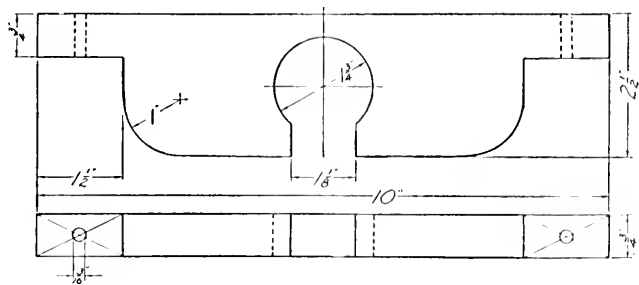
BROOM HOLDER.

PEN AND PENCIL HOLDER

To make a good job of this project the workman must use extreme care in boring the holes. Therefore he gains valuable experience in using the auger bit.

The two pieces are first planed carefully to the dimensions shown in the drawing. Then the holes are located on the thicker piece. First draw the center lines the long way on each edge. Then square pencil lines around the piece to locate the holes, as shown. When boring, the position of the bit should be carefully noted so that the holes will be straight. If the boring

is exact the spur on the bit will show thru at the intersection of the lines on the opposite side. The pieces should then be reversed and the boring completed from the opposite sides. If the holes are not bored straight the fact will be emphasized when the pencils are placed in them, as they will stand very much out of line. After boring, sandpaper all surfaces, and nail the two pieces together as shown on the drawing.

Finish this object well with wax, or with stain, shellaced and rubbed down with pumice stone and raw linseed oil.

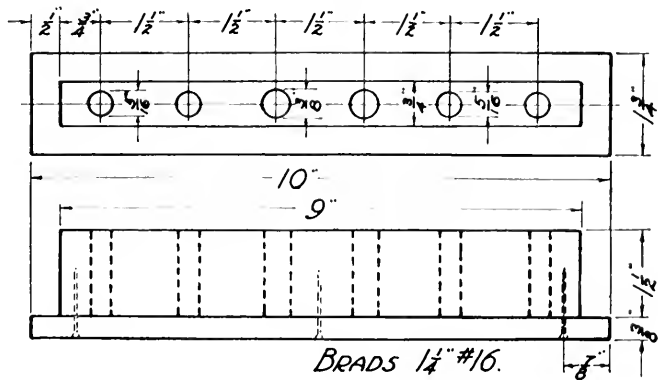
PEN AND PENCIL HOLDER.

THE TOOTH BRUSH RACK

This project gives the maker practice in planing duplicate parts, in boring, and fastening with brads.

It is a project offering a number of opportunities for the maker to exercise his ingenuity. The drawing shows five very simple designs for the outline of the back, and the workman may design many more by cutting paper patterns.

Often boys want to make the rack hold more brushes. This is easily done by adding $1\frac{1}{2}$ " in width for each extra hole.

The back is planed to dimensions according to the rules for planing given on page 8. The wood for the cross pieces is procured long enough to make the two pieces in one strip. This is planed to proper width and thickness and the ends squared before it is cut in two. (See page 10.) This is the best way to get out pieces of wood of similar dimensions, especially when they are short, as it is much more difficult to

plane short pieces of wood straight than it is to plane longer pieces that give better support for the plane.

When boring the holes, bore until the point of the bit shows thru, then turn the stock and complete the boring from the other side. This is to avoid the splintering of the edge of the hole, which happens when this precaution is not taken.

Locate the brads carefully and drive them thru the back so that the points just show thru. The cross pieces pressed down on these points will be held in place while the brads are being driven home. Take care to have the cross pieces square to the edge of the back.

The rack should be given a first class finish. White enamel over two coats of flat white paint well sandpapered makes a desirable kind of finish, as it may be cleaned without injury by washing with soap and water.

TOOTH BRUSH RACK

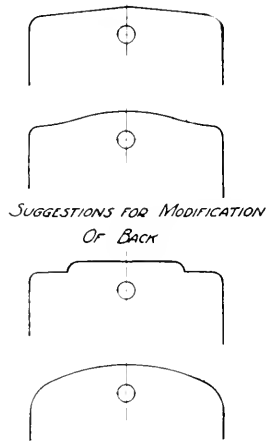
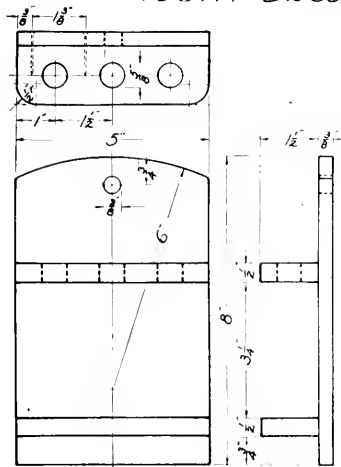

CLOTHES-LINE REEL.

This is a very useful article and a favorite with beginners in woodwork. The maker gets experience in planing duplicate pieces, in boring and in nailing.

Procure stock for the sides in one piece, $5\frac{3}{4}'' \times 5'' \times 17''$. Plane out the sides as described on page 9.

Draw the center lines on the side pieces. Then place the pieces side by side and draw the lines across both at once, 5'' from each end. This will make the holes sure to be in line. When boring the holes make sure that the bit is at right angles to the wood. If any one hole is bored at an angle the frame will be distorted, making a poor job. Bore until the point of the bit shows, then turn the wood over to finish from the other side. The corners of the side

pieces are easily trimmed with the chisel after they have been carefully marked out as shown on the drawing.

Procure two pieces of dowel 12'' long $\times 3\frac{1}{4}''$ in diameter. Smooth the ends and sandpaper them. Then sandpaper the pieces for the sides. Care must be taken in driving the nails, especially if the dowels are made of hard wood. In this case it is best to drill for the brad first. To do this one may cut off the head of one of the brads with the pliers. Place this in the chuck of the hand drill and use it as a drill to make the holes to start the brads.

This article does not call for a fine finish. It is enough to make it clean and smooth with sandpaper. Two coats of white paint may be applied if desired, to protect it from the weather.

CLOTHES LINE REEL.

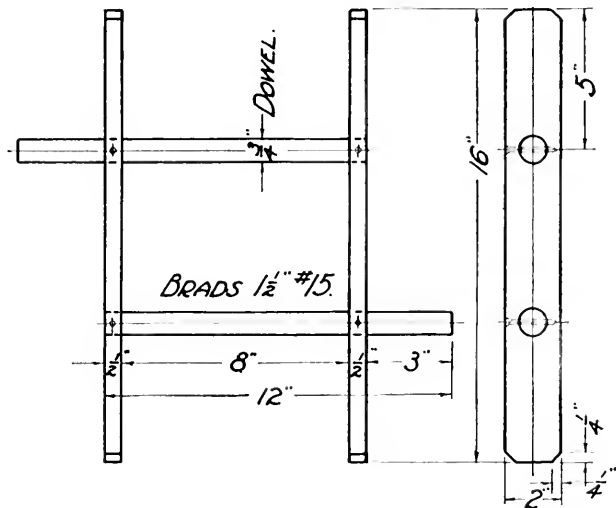

TOWEL STAND

This rack is intended to be used in the bath-room, or kitchen, where towels may be hung to dry. It is so easily moved about that it may be stood before the radiator or stove to take advantage of the heat in drying out towels. Another use of this rack is that of holding newly ironed linens, such as towels, pillow slips, sheets, etc., until the ironer is ready to put the things away.

To save lumber and labor, procure two pieces of stock, one $7\frac{3}{8}'' \times 5'' \times 22''$ and one $5\frac{3}{8}'' \times 5\frac{1}{2}'' \times 26''$. The first will furnish the top and bottom pieces for each end. The second will furnish the four upright pieces. Plane the first piece according to the rules on page 13. To cut the curve of the lower edges of each piece, hold a pair edge to edge in the vise and bore a hole $2\frac{1}{2}''$ from each end with a 1" auger-bit. Bore only until the spur of the bit shows thru and turn the wood around. Finish boring from the other side to avoid splitting off the edges of the

hole. When taken apart each piece will have half the hole in it. A line may be gaged tangent to these holes and the wood to be removed may be cut away with the knife, chisel or coping-saw.

The curve for the corners should be drawn with compasses and trimmed with the chisel. The second piece of stock may next be planed to make the four upright pieces after the rules on page 11. The uprights are fastened to the top and bottom pieces by $\frac{3}{8}''$ dowel pins. Holes $\frac{3}{8}''$ are bored 1" deep for the dowel, as indicated in the drawing. The end frame should be glued together before boring for the towel rods. Clean and smooth all surfaces before assembling, as this is easier to do at this time. When the glue has hardened the holes for the rods may be located and bored and the dowels glued.

Two coats of white paint and one coat of white or colored enamel will make the most serviceable finish for this article.

TOWEL STAND

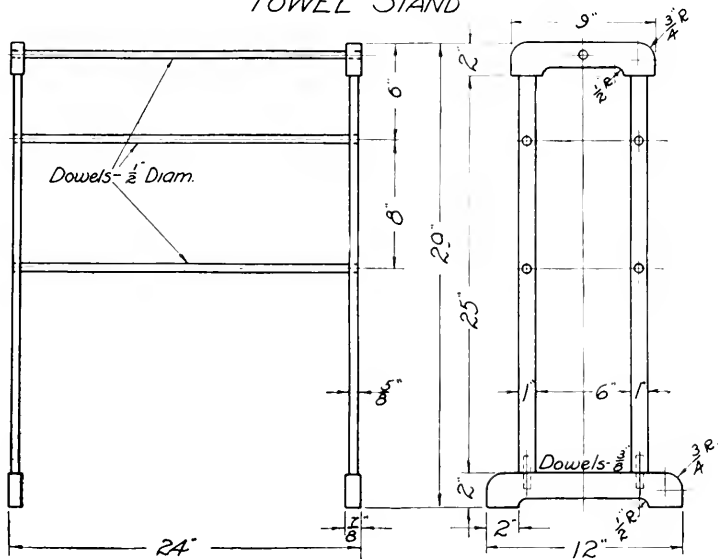

TROUSERS HANGER

This is another useful article for the home. It is designed to hold two pairs of trousers. Any kind of wood may be used.

First plane the material to the thickness, width and length called for in the drawing. See page 8 for method of planing. Then draw the center lines for the holes as indicated and bore the holes with the auger-bit.

Draw the lines for the slots with the marking gage on both sides of the board. Saw out the slots with the rip-saw, making the kerf on the inside of the lines. Mark out the "V" shape

openings at the ends of the slots and saw with the back-saw. Before driving the screws shown in the drawing, bore with drill bits, first with one the size of the shank of the screw, and then with one smaller than the worm of the screw, so that the wood will not split as the screw enters.

Use the countersink to ream the edge of the hole to fit the screw head. Sandpaper the surfaces smooth and clean, and turn the screw hook into a hole made with bradawl in the center of the board.

TROUSERS HANGER

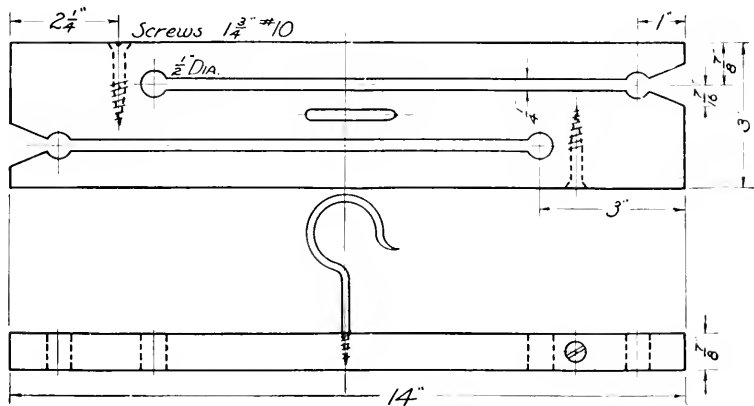

V. OBLIQUE PLANING

DOOR STOP

This project teaches the principle involved in oblique planing. Procure stock $3\frac{1}{4}'' \times 2\frac{1}{2}'' \times 13''$. This will make both pieces to size as described in Steps in Planing, page 10.

In marking for the oblique surfaces, square lines across the edges and ends of the pieces the required distance from the corners, as shown on the drawing. Connect the ends of these lines with oblique lines drawn on both sides of each

piece. Saw next to the lines with the back-saw, holding the pieces on the bench hook, broad side up. Smooth to the lines with the plane. To plane obliquely one must remember to plane from the edge of the board towards the end. The surface will be badly torn and roughed if the planing is done in the opposite direction. Sandpaper the surfaces smooth and clean and fasten the pieces together with brads.

DOOR STOP.

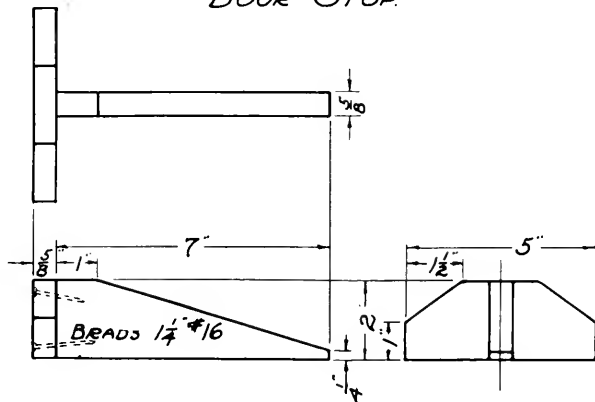

LAUNDRY STICK

This project should make the workman familiar with oblique planing.

The wood is procured $7\frac{1}{8}'' \times 2\frac{1}{2}'' \times 24\frac{1}{2}''$.

Plane the working face and working edge. Square the ends, making the piece the proper length. Then draw the center line parallel to the working edge and locate and bore the holes on it. When the holes have been bored, the tapering sides may be drawn by measuring $\frac{1}{2}''$ to each side of the center line on the end which is to be reduced, and $1''$ to each side of the center line on the larger end, drawing straight lines to connect the points found. The

waste wood outside the outlines may be trimmed off with the plane. If desired some of the waste wood may be removed with the rip-saw. The planing should be done from the big end to the small end to follow the grain.

The forked end may be drawn as shown in the working drawing, and the rip-saw should be used in such a manner that very little trimming will have to be done after the fork is sawed out.

Sandpaper all the surfaces smooth, and run the sandpaper over the sharp corners, so that they will feel better in the hand. It is not necessary to apply any finish to this project.

LAUNDRY STICK.

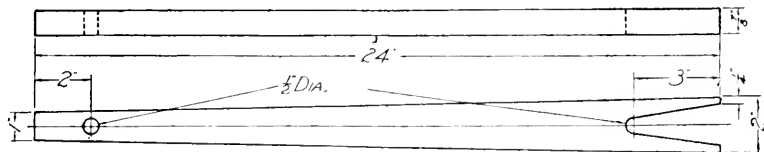

CLOCK SHELF

This drawing shows two extremely simple outlines for a clock shelf. One outline is shown on each side of the center line. The pupil is urged to try to originate his own outline by means of cutting paper patterns. Neither outline shown on the drawing is very beautiful, and the workman ought to find it very easy to improve them.

The pieces should first be planed to size after the rules on page 8. Then the pattern decided

on may be marked on the wood and the outlines cut with the coping-saw.

Thoroughly sandpaper all the pieces before nailing. The bracket should be nailed to the shelf first. Then it will be easy to nail the back to the shelf and bracket. Note that the size and position of the nails are shown clearly on the drawing.

Stain or paint the shelf to match the wood work of the room in which it is to be placed.

CLOCK SHELF.

TWO MODIFICATIONS.

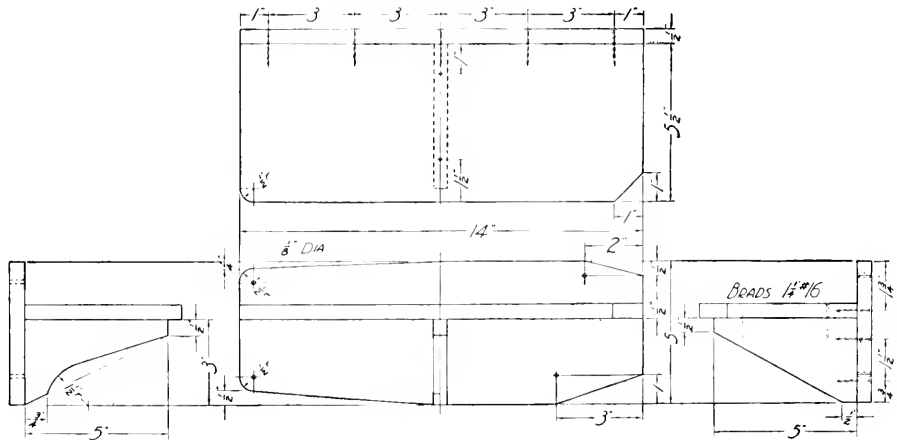

SHOE-POLISHING STAND

This project may be made of whitewood or pine.

The pieces selected should be enough larger than the finished dimensions to allow for planing. The top and two sides are simply squared up to size, following the rules for planing (See page 8). The bottom board is not planed to exact width until after it is nailed in place, when its edges are planed flush with the edges of the legs.

Plane the working face and edge on each of the pieces for the legs, or ends. Gage the thickness and plane to the line. The ends should be squared to the working edge and working face. Then the center lines may be drawn and the shape of the ends as shown on the drawing may be marked out by measuring to each side of the center. When the edges have been trimmed down to the lines with the saw and plane, the curve on the bottom may be drawn with com-

passes and cut out with the coping-saw, or the turning-saw. Smooth the edge after sawing. Before assembling, all the pieces should be sandpapered clean and smooth.

To assemble the stand, first nail the two 3" sides to the bottom, 2 $\frac{1}{2}$ " from each side of the center. Then the ends may be nailed on, to protrude 3 $\frac{1}{2}$ " below the bottom. Next nail on the top.

Paint seems to be the most practical finish for this kind of article. After setting the nails, shellac over any knots or rich places in the wood. Then put on a thin coat of paint for a priming coat. Next putty the nail holes and any other opening that blemishes the surface. The second coat of paint may be a little heavier than the first. It should not be applied until the first coat has thoroly dried, at least for forty-eight hours. The finishing coat may be a coat of black or gray enamel.

SHOE POLISHING STAND.

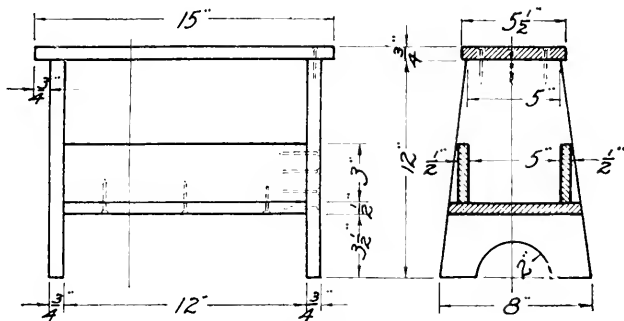

FASTEN WITH 6d. FINISH NAILS.

TOWEL RACK

This project gives practice in narrow-surface planing, oblique planing, and end planing. Two methods of planing pieces of duplicate dimensions may be followed, one for planing the back and brackets, the other for planing the rods.

For the back and brackets, one piece should be procured, long enough to make all three pieces. This may be planed to dimensions as has been described in the Steps in Planing, Fourth Method, page 10. The arms all have the same dimensions. If we planed them after the method used for the back and brackets, we would encounter considerable unnecessary difficulty because we would have a very long, slender stick to work on. If we saw out three separate sticks we increase our work somewhat thru dealing with so many pieces. The most efficient way of dealing with this kind of a job is to obtain one piece of stock wide enough to furnish material for the three pieces. Plane out the pieces after the rules under Fifth Method,

page 11. It will be noticed that the rods are tapered on the bottom edge. This taper should be carefully drawn on the sides of the rod. To do an accurate job it is best to square a pencil line across the bottom edge of the stock $2\frac{1}{2}$ " from the back end and another line $\frac{1}{4}$ " from the bottom edge on the outer or free end of each rod. The ends of these lines may then be connected with straight lines on both sides of each stick. If care is taken to follow these lines in planing off the bottom edge, all pieces will be the same shape and size. Great care must be taken in locating and boring the holes for the bolt. If one hole is only a tiny bit out of the way, the rods will not go together nicely. Square a pencil line all around each rod $1\frac{1}{4}$ " from the big end. Locate the middle of the line on the top and bottom edge of each piece and use the marking awl to prick a hole at that point. This will make a definite spot for the auger bit to start in, and there is very little

danger of getting the hole off center, as might happen if only pencil marks were used. This method of marking is good to use whenever very accurate boring is to be done. In this case, when boring, it will be best to bore only half way thru from each side to make sure the holes are exactly centered on the rods.

The front corners of the brackets, and all four corners of the back are to be rounded. The curve should be marked on both sides of the wood with compasses. The bulk of the waste wood is removed with the chisel. The wood may be held in the vise and the chisel used so as to cut from the side towards the end wood, so as to follow the grain. Another way of chiseling would be to hold the wood flat on a scrap piece and chisel vertically, beginning at the side and proceeding around the corner toward the end. The flat side of the chisel is held next to the wood. The corner is finished smooth in both cases by filing or sandpapering around the end. When finished, there should be no corner or

ridge where the curve began or ended, but the curve should blend into the straight side and end. The rods and brackets should next be sandpapered clean and smooth, and bolted together as shown on the drawing.

The center lines for the screw holes are next drawn on the back pieces. It will be noticed that the drawing shows how far from the top the upper screw holes are. A line is squared across the piece at the distance from the top shown on the drawing. Then the center line for the lower holes is located as far below the first line as the distance between the centers of the brackets. The screwholes may then be bored, the holes countersunk and the rack assembled. The holes for hanging the rack to the wall should not be overlooked when boring. To find a solid place for this rack, tap on the wall lightly with a hammer if it is plastered. Fasten the rack where the wall sounds solid so that the screws will enter the framework of the house instead of only plaster.

VI. CONSTRUCTION—BOXES, ETC.

TELEPHONE BRACKET

This bracket is designed to hang on the wall at a suitable height to support the telephone, either for a person sitting or standing while talking. If fastened so that the upper shelf is about 30" from the floor, the bracket takes the place of a telephone table. The upper shelf supports the telephone, the lower shelf forms a pocket for the telephone directory. Before getting out the material for the bracket make sure that the pocket is large enough for the directory used in your locality. If not, the dimensions should be changed to suit.

A board $1\frac{1}{2}'' \times 9\frac{1}{2}'' \times 40''$, is needed for the two shelves and the two ends. Plane one edge of this board straight, smooth, and square to the broad faces. Next mark off the width (9") and plane the second edge to the line. This procedure ensures your making all four pieces,

i.e., the two shelves, and two ends, of an equal width. This board may then be cut up to make the four pieces, care being taken to keep to the dimensions called for in the working drawing. The best method would be to square both ends of the board first, then mark off the length of one shelf from each end. These pieces may then be sawed off, and the ends trimmed to the lines. The pieces remaining should make the two ends. This may be left intact until after the pattern is drawn upon it, as it may be noted from the drawing that the ends are not squared, but modelled from an outline preferably designed by the individual workman.

The wood for the back should be 14" long, taken from a board slightly wider than 10". If it is difficult to obtain a board wider than 10",

one slightly under may be used, as the design may be made so as to compensate for a slight difference in size. One edge should be planed straight and square, and the ends should be squared to this edge, making the board the required length.

The workman should now proceed to develop his paper patterns for the outlines. He should cut a half dozen at least, bearing in mind that intricate curves and deep incisions are altogether out of place. Avoid true arcs, or parts of circles as much as possible, as they give the work a stiff, mechanical appearance, and are much less interesting than flowing curves that have the appearance of knowing where they are going. Wavering or wandering curves are also undesirable. When satisfactory patterns have been developed they may be used as templates to

mark around to apply the outline to the wood. The curves may be sawed out with the coping-saw and smoothed.

Before assembling the parts set the plane to take a thin, fine shaving, and smooth the broad surfaces of each piece. Then sandpaper the surfaces to a fine finish.

The bracket may be fastened together with either brads or screws. If brads are used, use $1\frac{1}{2}$ " No. 15, and drive four into each joint, one about $\frac{1}{2}$ " from each edge, and the others spaced evenly between. If screws are used, use $1\frac{1}{4}$ " No. 6 Rd Hd Blued screws for the sides, and the same size in flat head screws for the back. Three screws for each joint should be enough.

Apply a first class finish to harmonize with the bracket's future surroundings.

TELEPHONE BRACKET

*Contour of Back and Sides
may be from Individual Design*

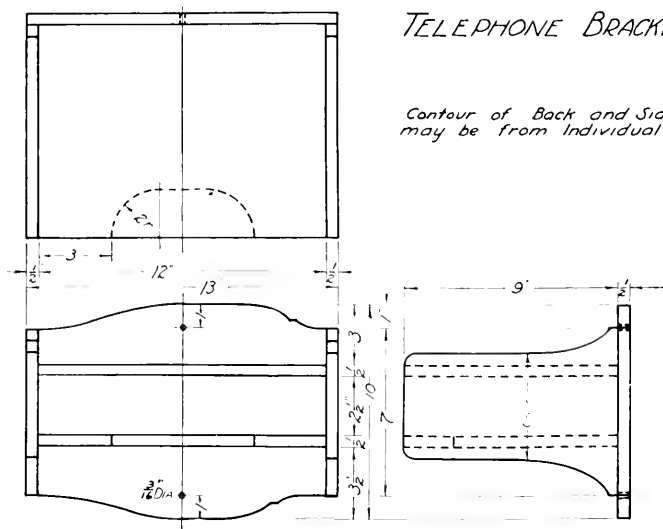

MILK BOTTLE HOLDER

This rack will hold the bottles that are placed outside where milk is delivered, keeping the milk and bottles out of reach of stray cats and dogs. It is designed for two bottles but may be easily changed to accommodate a larger number.

Procure two pieces of wood, one for the sides, $7\frac{7}{8}'' \times 4\frac{3}{4}'' \times 20''$, and one for the front and bottom $5\frac{5}{8}'' \times 4\frac{3}{4}'' \times 19''$. Plane the $7\frac{7}{8}''$ piece to proper width and thickness, after which the outline for the ends may be marked out with the compasses. The curved edges may be

sawed out with the turning-saw or the coping-saw. After sawing they should be smoothed carefully. When the holes have been bored the ends will be finished except for cleaning with sand paper. The second piece of stock is planed as described under Third Method of Planing, page 9. All pieces are then smoothed with sandpaper and nailed together.

Since this object is going out-doors where it will be exposed to the weather it should be given two coats of paint.

MILK BOTTLE HOLDER.

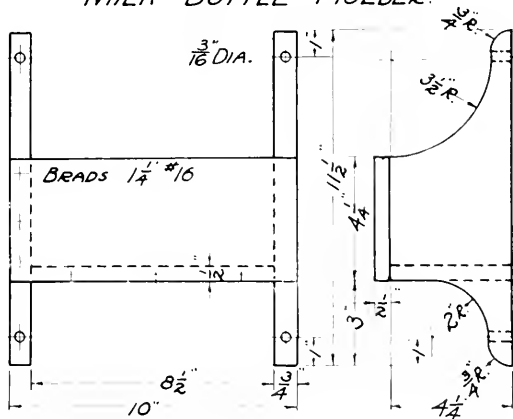

FOR EACH EXTRA BOTTLE ADD $4\frac{1}{4}$ " TO LENGTH.

TRAY FOR TABLE SILVER

This tray is used in the drawer of the serving table or sideboard to make a separate place for each kind of table silver—knives, forks, teaspoons and tablespoons. It gives the workman considerable practice in accurate planing and teaches him to make a “butt-joint.” The material for sides may be provided in one piece $\frac{3}{8}'' \times 6'' \times 15''$.

To plane out the two pieces, proceed as described in the Third Method under Steps in Planing, page 9.

The best way to make the end pieces and partitions (if no small pieces are available in the shop that will work in at this time) is to use two strips, one $\frac{5}{8}'' \times 3'' \times 29''$, and the other $\frac{5}{8}'' \times 3'' \times 19''$. These strips will make three and two pieces respectively when planed out as described under Fourth Method, page 10. Mark out the positions of the brads that fasten the sides and partitions together. When these are located, prick a hole into the wood with a brad point or marking awl and sandpaper the

surfaces clean—excepting the ends.

The ends are not sandpapered because they are apt to be rounded and thereby spoil the joints. Nail the pieces together very carefully, taking care to drive the nails straight, or slightly “toed,” that is, inclining towards one another to increase their holding power. Only a poor workman will allow the brads to come out thru the sides. Use the nail set to sink brads slightly below the surface of the wood.

The bottom board is made from a piece of stock $\frac{3}{8}'' \times 10'' \times 15''$. It is planed to thickness and one edge and one end only are planed square. It is then sandpapered clean on the inside surface and nailed to the box frame, with care taken to have the tray frame exactly flush with the finished end and edge. This ensures the squareness of the tray. The projecting side and end may then be trimmed carefully flush with the box. The inside of the tray may be lined with felt or similar material if desired.

TRAY FOR TABLE SILVER

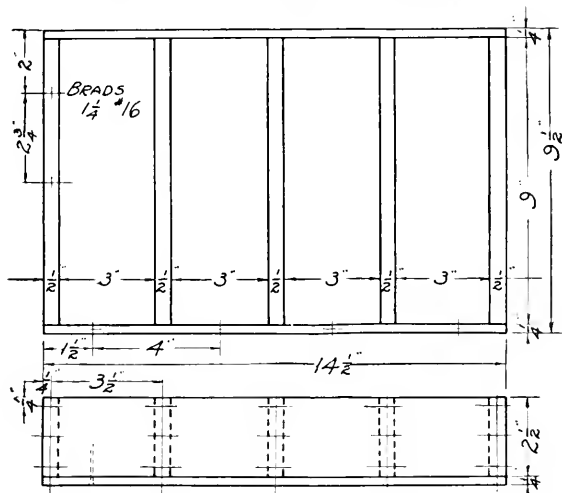

POULTRY FEEDER

For this project $\frac{1}{2}$ " stock planed on two sides may be used. The pieces may be squared up after the method outlined on page 7.

The drawing should be studied carefully to learn the sizes of the various parts. It would be well to write these sizes down in a "bill of material" arranged in tabular form showing first the length and width of each piece in its "rough dimensions" and then the length and width of each piece in its "finished dimensions." Such a bill of material tends to eliminate many chances of error, such as duplication of work, pieces cut out to wrong dimensions, etc. Square all the pieces to size except the upper front piece, and the bottom. All surfaces should be sandpapered clean and smooth.

Fasten the parts together with $1\frac{1}{2}$ " No. 15

brads. It would be best to nail the front and back to the sides first. Then the upper front piece, forming the "hopper" may be planed to fit exactly between the sides, after which it is nailed in place. One edge and one end of the bottom are planed square. The bottom is then nailed in place with the squared side and end flush to the side and front of the box. The overlapping rough edge and end may then be carefully trimmed flush with the box. The cover is reinforced by two cleats screwed to the under side. These are planed to the width and thickness shown on the drawing, and cut to a length that makes an easy fit between the front and back of the box. These cleats are screwed to the cover so as to hold it in position. The cover may also be hinged.

POULTRY FEEDER.

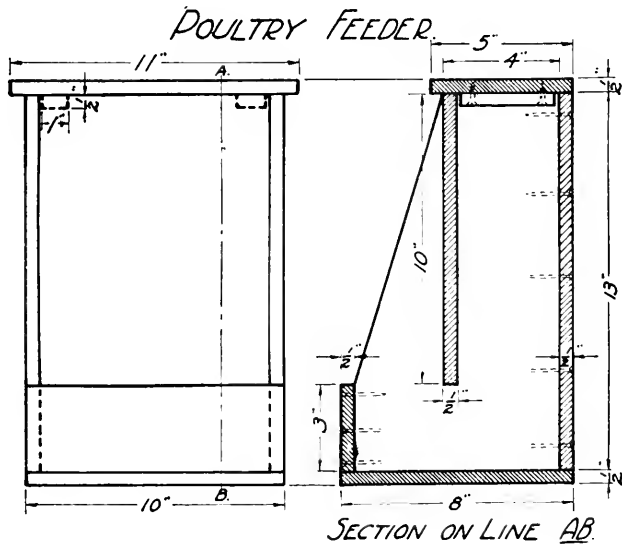

LETTER TRAY

If someone uses a typewriter at home or in office work, one of these trays will be found almost indispensable, as it takes care of the paper used on the machine, or keeps letters in place until they can be taken care of. Many business men are accustomed to have three trays like this on their desks, one marked "IN," containing the letters to be examined, one marked "OUT," containing work completed, and one marked "HOLD," containing letters or work that needs attention later.

To make this project use a piece of stock for the sides $\frac{1}{2}'' \times 8'' \times 15\frac{1}{2}''$, and another piece $\frac{5}{8}'' \times 8'' \times 11\frac{1}{2}''$, for the ends. These pieces are planed as described on page 9.

If either of the optional joints are used the lengths of the sides and ends will have to be changed.

One end only of the tray is cut down as shown on the end view. This is cut to lines drawn with the compass. Saw with the coping-saw and

smooth with the knife and sandpaper.

If the plain butt joint is used, locate the position of the brads, and prick a little hole in the wood with the brad point. Then sandpaper the pieces on the inner side and nail together.

The bottom should be planed to thickness, with one edge and one end squared. The inside surface is then sandpapered, and the piece is nailed with the finished edges flush with the side and end of the tray. The remaining edge and end are then trimmed flush with the tray. This is the most practical way to fit the bottom to a box.

The tray should be well finished. It may be stained to match the desk it is to be used on and polished with four coats of shellac rubbed down with pumice stone and raw linseed oil. An additional finishing touch may be given by gluing a piece of felt over the entire bottom of the tray to prevent the box from scratching the top of the desk.

LETTER TRAY

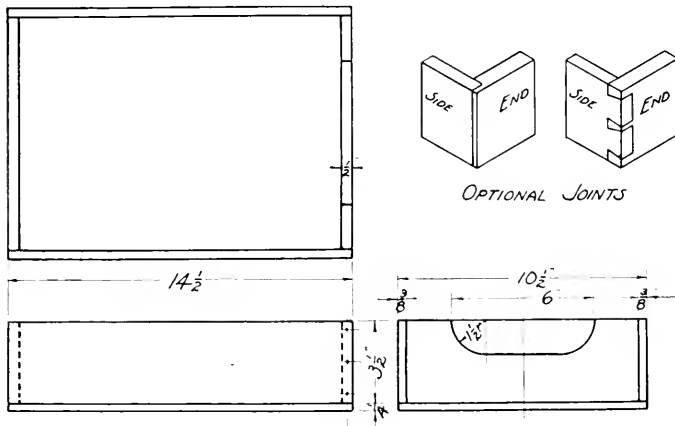

BIRD FEEDING SHELF

This little shelf is made very much like the grain feeders for poultry. The food is placed in the hopper and sifts thru as the birds eat away that which is at the bottom. The top is made overhanging to shelter the food and the floor is made with an incline to make sure that the rain will run off and away from the food. The floor is also wide to catch and save any food flicked about by the birds.

The drawing shows how the sides are marked out to prevent waste of wood. These sides are

made of $\frac{3}{4}$ " material so that there will be plenty of thickness to hold the nails. The rest of the feeder is made of $\frac{1}{2}$ " stock.

The top is hinged to make it simple to place the food in the hopper. Give the feeder at least two coats of paint before placing it outdoors to preserve it from the action of the weather.

A piece of spruce 2" x 3" x 6 feet in length will serve for a pole. The feeder may be fastened to the pole by means of two $\frac{1}{4}$ " x 2 $\frac{1}{2}$ " carriage bolts.

BIRD FEEDING SHELF.

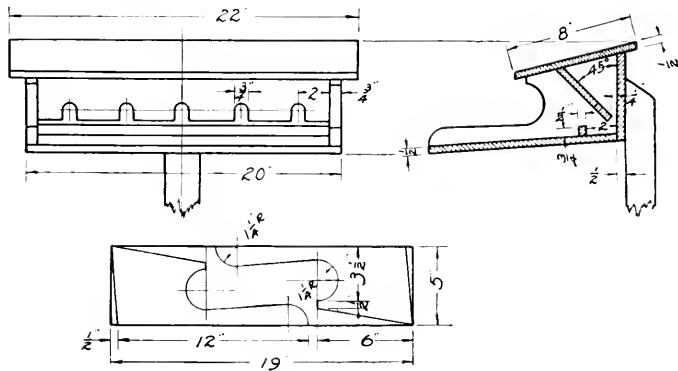

SEWING STAND

The boy who has learned to plane broad surfaces well should have no difficulty in making this sewing stand.

Make the ends, or legs first. The outline may be drawn directly on the wood, or a stiff paper pattern may first be cut out and used for marking on the wood. Care should be taken when cutting the wood to shape, to keep the sides symmetrical.

Next prepare the sides. These may be planed to dimensions as indicated in Steps in Planing, page 8. The side pieces are nailed to the legs, and the upper edge is planed to the same angle that is on the upper end of the legs. The workman should remember that it is good practice to sandpaper the inner surfaces of an object like this before it is nailed together.

The piece for the handle should next be prepared. The outline may be modified to suit the individual. To make the hand hole, bore holes with a 1-inch auger bit for the ends of the open-

ing. See page 48 for directions for boring. Gage lines on both sides of the wood connecting the holes and tangent to them. Saw next to these gage lines with the key-hole saw, and trim to the lines, making the surfaces smooth. Round the sharp corners slightly. Sandpaper the handle smooth and clean and nail and glue it in place as indicated.

Next work out the piece for the bottom. Notice that it has to be fitted carefully. Both edges are beveled.

The lids are easily squared up, and are to be hinged. A piece of light chain fastened between two screw-eyes will hold the lids in a horizontal position when open, so as to form a shelf for sewing equipment.

If desired a movable tray may be made, and supported just below the handle. It will hold buttons, pins, and other sundries.

Mahogany stain, or walnut stain, with a good shellac finish should be applied.

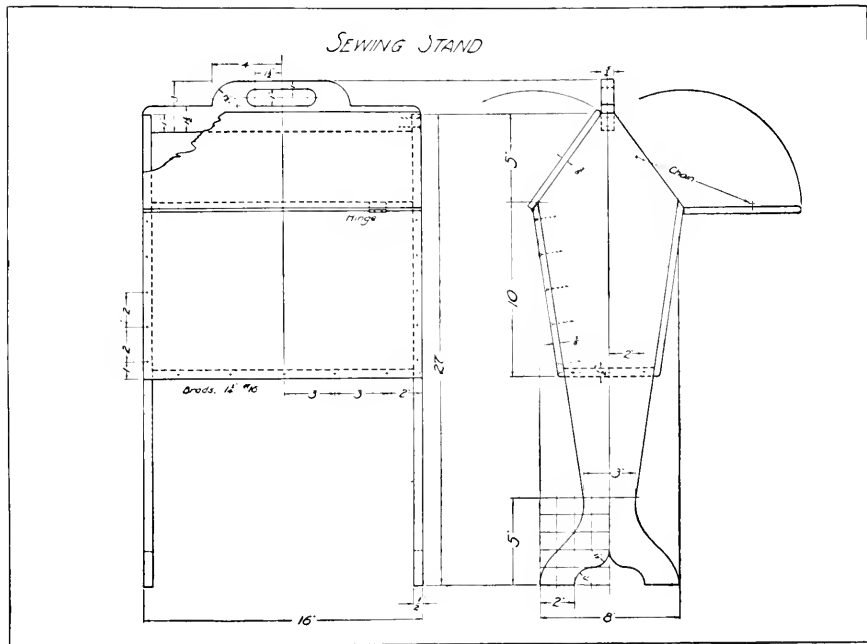

VII. MODELLING

MATCH STRIKER

This project is for the beginner, and therefore is very simple. Stock $\frac{3}{4}$ " thick may be used and planed in the method used when stock is furnished the proper thickness. This method is described on page 7. The center line is located and the holes are bored as shown. Several suggestions are shown for working out the outline. It is not necessary for the pupil to follow any of these patterns as he may easily design one of his own. Cut pieces of paper to the size of the pieces of wood and fold on the center line. Then cut out a number of patterns

for the top and bottom edges, remembering that deep cuts or "fancy" cuts are not appropriate. Keep the outline as simple as possible. Thruout this book are many samples of the right kinds of outlines of articles like this.

Do not cut the sandpaper with your bench tools but with an old knife or tool kept for this purpose. Finish the wood before the sandpaper is glued on. Stain may be used, or the wood finished in a natural shellac and wax finish to suit your own taste or demands made by the kind of wood used.

MATCH STRIKER

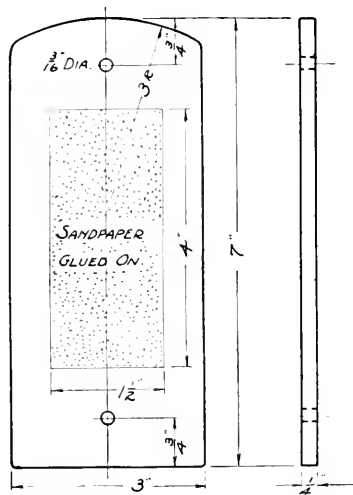
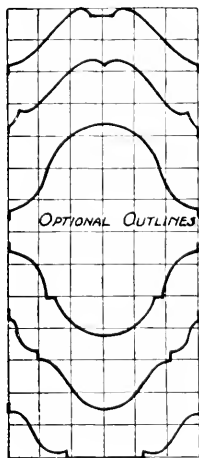

SUIT HANGER

This is an article that everyone has use for. The maker gains experience in using the turning-saw and compass-saw, and in smoothing curves with the spokeshave.

The material may be pine, whitewood or basswood. It is planed to dimensions in the usual way, except the planing to width, which is omitted on this project, as the width is determined when the curve is laid out.

After the board is planed to thickness and length, lines are drawn across the board at 3-inch intervals as shown on the drawing. The curve is plotted by marking on each of these lines the distance called for on the drawing, measuring from the working edge. The curve is drawn freehand, so that it passes thru each mark. Care should be taken to have the curve smooth and free from irregularities.

The opening for the trousers is made next. A 1-inch hole is bored thru on the two outer section lines, the centers of these holes being

$1\frac{1}{4}$ " from the straight edge. The edges of these holes are connected with lines made with the marking gage held against the straight edge. Start the compass-saw in one of the holes, sawing inside of the line, far enough to admit the end of the rip-saw, which will finish the cuts to the opposite hole. The edges of the opening made in this way are then smoothed with the knife or chisel, and file and sandpaper.

The turning-saw will cut off the waste wood beyond the curve. The workman should learn to cut close to the line, on the waste side so as to leave a small amount of wood for smoothing to the line with the spokeshave. The edge should be smooth and square to the working face after spokeshaving. There should be no lumps or humps in the curves.

To round the top edge as shown in the drawing, first chamfer the corners $\frac{1}{8}$ " \times $\frac{1}{8}$ " with the spokeshave. Then shave off the upper ridges, making the surface as round as possible

SUIT HANGER

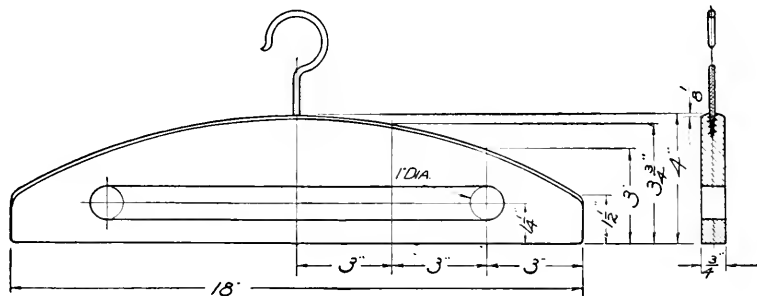

with the outer edges kept sharp as shown. When sandpapering, this sharpness is preserved by holding the sandpaper flat and doubled between the thumbs and forefingers, with the thumbs on top. Rub with the pressure

on the thumbs. A very smooth edge is obtained in this way. After the other surfaces are sandpapered turn the screw hook into a hole made with the brad awl. This article may be stained and finished or may be left unfinished.

ROLLING BLOTTER

This project gives the student an opportunity to learn some of the principles involved in modeling a broad surface with hand tools.

The piece of wood for the base is first planed to the dimensions called for on the drawing. Center lines are drawn around the short way of the piece. It is next held in the vise so that the edge is flush with the top surface of a waste piece of wood that lies flat on the bench. The center line is then extended square across the waste piece. The center of the arc outlining the base is located on this line, and the arc drawn with the compasses. When the arc has been drawn on both edges, saw cuts are made with the back-saw across the grain on the bottom side, nearly to the arc. These cuts should be about $\frac{1}{4}$ " apart. Their purpose is to make it easier to remove the waste wood with the chisel. It is best to do the chiseling part way across the board from each edge, rather than to cut all the way across the wood. In cutting clear across a board with a chisel, (or any cutting tool), one

is apt to chip off the further edge. When the waste wood is removed, the spokeshave may be used to model the surface true to the lines. When finished this surface should test straight across, and should be without lumps—a nice true curve from end to end.

The top piece is very simply prepared, as it needs only to be planed square and true to dimensions. If desired, the top edge may be chamfered, measuring $\frac{1}{4}$ " in on the top, and $\frac{3}{8}$ " down on the sides and ends. The holes for the screws should be located and bored carefully so that they will correspond with those in the handle.

It would be appropriate to apply some surface decoration to the top surface of the blotter. Either carving or simple stencilling in colors would be suitable. The top piece could be covered with ooze leather, which has been tooled, and the idea could be carried out in the making of a complete desk set.

The handle offers a boy an opportunity to

design his own pattern. Sometimes a drawer knob is used for a handle. The metal kind that has the screw threaded into it is the best.

If the drawing is followed in making the handle, a piece of wood $3\frac{1}{4}'' \times 2'' \times 4\frac{1}{2}''$ should be used. This is planed to size except for the width, which is not changed. Then the centers of the curves are located and the arcs drawn with the compasses as shown on the drawing. The coping-saw or turning-saw may be used to

cut to the curves and the edge is smoothed, care being taken to make the edge square to the broad surface.

The holes for the screws are located and bored from the bottom edge and all the pieces sandpapered clean and smooth, and assembled.

This model should be nicely finished, either with stain, or wax or shellac, according to the kind of wood used and the finish on the furniture with which it is to be used.

ROLLING BLOTTER.

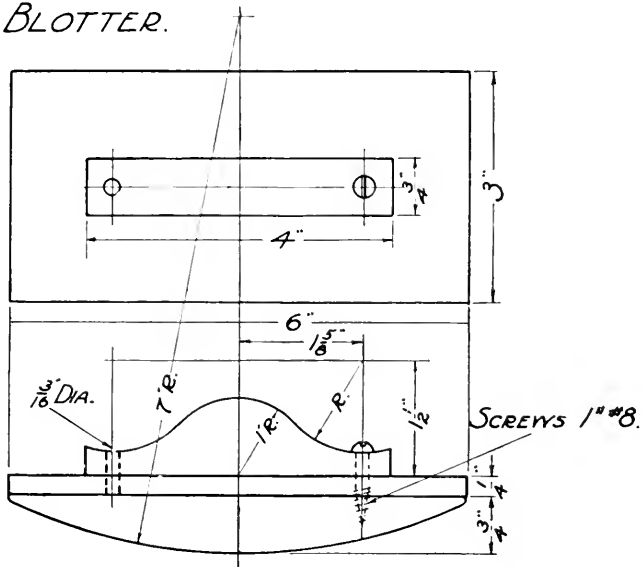

PEN AND INK STAND

For this project procure three pieces of wood, one for the back, $\frac{3}{8}'' \times 7\frac{1}{2}'' \times 7\frac{1}{2}''$, one for the brackets, $\frac{3}{8}'' \times 2\frac{1}{2}'' \times 12''$, and one for the base, $\frac{7}{8}'' \times 5'' \times 7\frac{1}{2}''$.

Plane the base and back after the rules for planing under Second Method, page 8.

Square up the wood for the brackets after the rules for planing under Fourth Method, page 10.

The workman may use the outlines shown in the drawing, or he may try to originate his own outline by means of cutting paper patterns

until he develops an outline that is satisfactory. Use the coping-saw to cut the curves.

Sandpaper all the parts thoroly before nailing.

Nine brads should be enough to hold this object together, three in each joining. Nail the back to the brackets first, then nail the back to the base.

Any kind of an ink bottle may be used with this stand.

Stain with a mahogany or walnut stain, and polish nicely.

PEN AND INK STAND

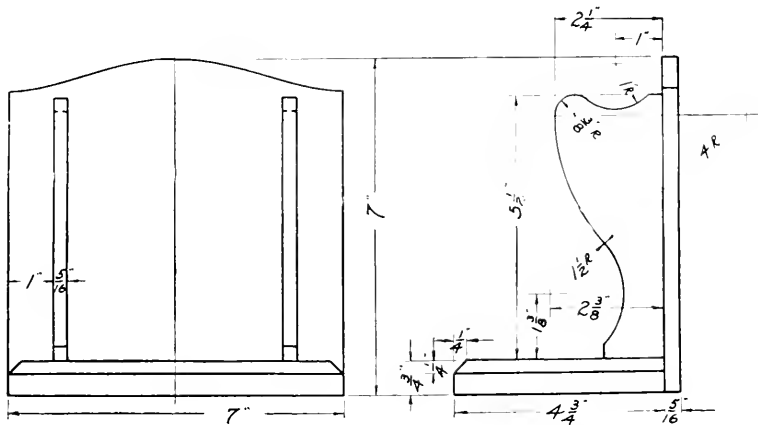

LETTER HOLDER

Generally the workman will find small pieces of stock in the shop to make this project.

All pieces are first planed to the finished dimensions, following the Steps in Planing, Second Method, page 8. The screw holes are then located and bored.

The pupil may choose one of the outlines

shown, or he may design one for himself, taking care to avoid any intricate or deeply cut outlines. The coping-saw will cut out the pattern and the edges should be sandpapered smooth. If desired, a stencil design may be applied to the front surface. Finish with stain and wax or shellac.

LETTER HOLDER.

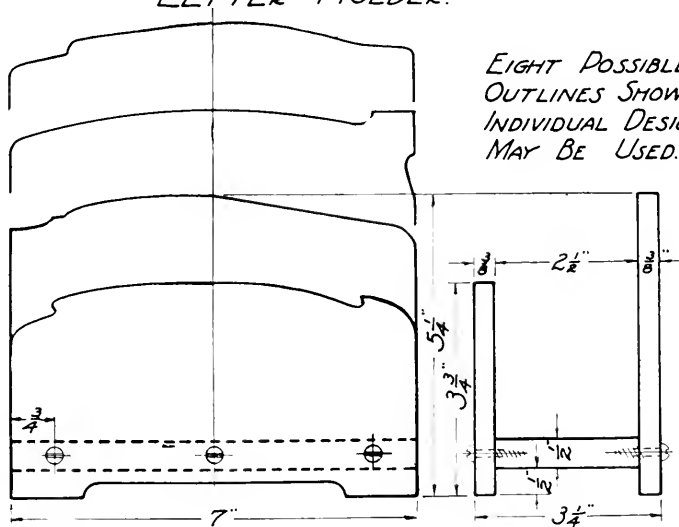

INK STAND

This inkstand is made of thin stock, and gives the workman an opportunity to practice planing duplicate pieces, to originate his own outline, and to use brads in nailing the parts together.

Procure three pieces, one $\frac{1}{2}'' \times 3'' \times 16''$, one $\frac{1}{2}'' \times 1\frac{1}{4}'' \times 11''$, and one $\frac{1}{2}'' \times 6\frac{1}{4}'' \times 9''$.

The first will make the back and top piece, the second will make the two cross pieces, and the third will make the bottom piece. Plane the first and second pieces after the rules in Fourth Method, page 10, and plane the third piece after the rules under Second

Method, page 8.

When the workman has developed satisfactory paper patterns for the outlines they may be applied to the wood. The coping-saw will cut out the shapes, after which the edges should be nicely smoothed.

The size of the opening for the ink bottle is easily changed to suit the individual.

Assemble the parts with 1'' No. 18 brads.

Stain and polish to suit taste and kind of wood used.

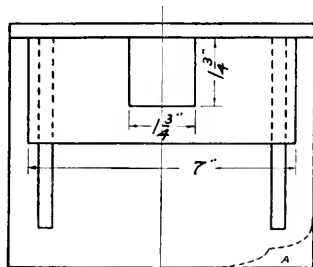

INK STAND
BLANK DESIGN

PUPIL TO ORIGINATE
DESIGN FOR OUTLINE
AS SUGGESTED BY
DOTTED LINES AT "ABC"

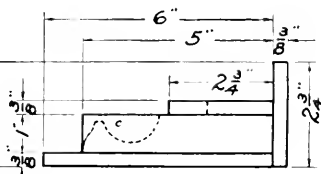
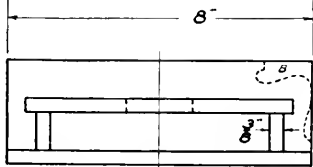

FASTEN WITH BRADS, 1" #18.

NECKTIE RACK

This model may be enriched in outline by the pupil. Several suggestions are offered in the drawing.

First procure material wide enough to include both the back and tie rod. Plane the two pieces by the method described on page 9.

The wood for the brackets is best procured in a piece long enough for the two end to end. Plane these pieces after the rules on page 10. It is best to assemble this model when all the pieces are squared up so that it will go together

well. It will then be taken apart so that the edges may be modelled to the workman's individual design.

Work out suitable designs by cutting out paper patterns. When a suitable one has been made, mark around the pattern on the wood and cut the outlines with the coping-saw.

Smooth all the edges carefully, sandpaper and reassemble. The article may be finished with stain and shellac, making it harmonize with the other furnishings in the room.

NECKTIE RACK.

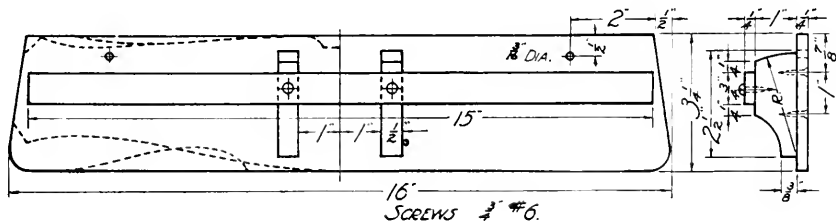

WHISK-BROOM HOLDER

An excellent opportunity is offered by this project for the pupil to design his own outlines. The drawing suggests five different patterns for each edge that are practical to model. The pupil may design many more by folding and cutting pieces of paper that are the same size as the piece of wood. After a number of simple patterns have been cut, the most pleasing may be applied to the wood and cut out with the coping-saw.

Procure material for the back enough longer,

wider and thicker than the finished sizes to allow for planing. The sides of the holder are made easiest from one piece $\frac{1}{2}'' \times 1\frac{3}{4}'' \times 6''$, which is planed to width and thickness before it is sawed in two (See page 10). The front is first squared to size, and then the edges are tapered as shown. The back is made the proper width and thickness, but it is necessary only to mark for length, as the ends are finished when the pattern is cut. Remember to bore the holes before assembling. Polish with wax or shellac.

WHISK BROOM HOLDER.
 PUPIL MAY ORIGINATE DESIGN OF OUTLINE.

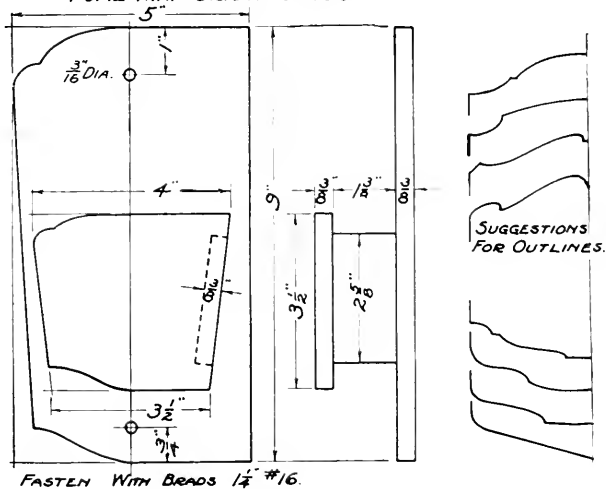

BOOK STALL

The workman may easily change the size of this project to suit his own needs.

If the size indicated in the working drawing is followed, procure material for the back and base, and plane the pieces to size after the method outline under Steps in Planing, Second Method, page 8.

The wood for the ends is best procured in one piece, $7/8'' \times 6\frac{1}{2}'' \times 15''$, and planed to size as indicated on page 10.

It will be noted that the back piece is set into a rabbet cut into the end pieces. This rabbet runs across the end wood and is, therefore, more easily sawed out with the back-saw than planed out with the rabbet plane.

The workman may design his own outline for the back and ends. Saw the outline with the coping-saw. The chamfer on the base is made on the front edge and the ends. If the bookstall

is to be used on a table or desk it is not necessary to bore the holes in the back, as they are intended for screw holes if the bookstall is to go on the wall. They are located 8'' each side of the center so that they will be 16'' apart, which is the distance the studding is spaced in modern houses. If the wall is tapped lightly with the knuckles or the hammer, the solid sound will indicate where the stud is. If one screw enters the other should.

The surfaces of all pieces are sandpapered smooth and clean before assembling. The back is nailed and glued to the sides, the brads, $1\frac{1}{2}''$, No. 15, passing thru the back, into the ends. The base is nailed to the back and ends after they are assembled. Take care to see that the ends are kept at right angles to the back when the base is nailed on.

Apply a good finish with stain and shellac.

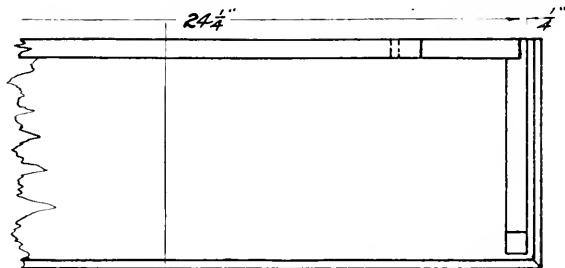

BOOK STALL

DESIGNED TO HANG
ON THE WALL OR
TO STAND ON THE
TABLE.

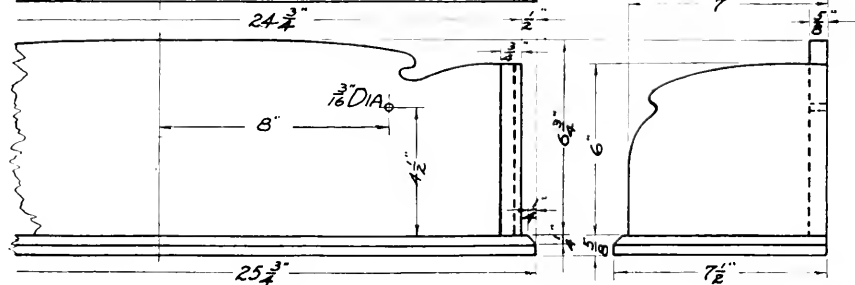

VIII. GOUGING

SAFETY MATCH-BOX STAND

This project offers the workman an opportunity to learn to use the gouge.

The design of the stand shown in the working drawing is extremely simple, and may be modified by the workman that is ambitious to have something more original. The stand for the match box may be placed in the middle of the base, for instance, and another groove cut in the opposite side of the base. The surface of the chamfer may be made concave with the gouge if desired. The size of the stand for the match box may be changed to suit the

size of the boxes common in any community.

The work is simple. The base is planed square after the rules found on page 8. The details are drawn on the piece next, and the edge is chamfered. The ends should be chamfered first. The gouge is then used to make the grooves. Smooth the surface of the grooves with sandpaper wrapped around a short piece of dowel, about 1" in diameter. Sandpaper all the flat surfaces with the sandpaper held flat on a block. Apply a good finish using stain and shellac to suit individual taste.

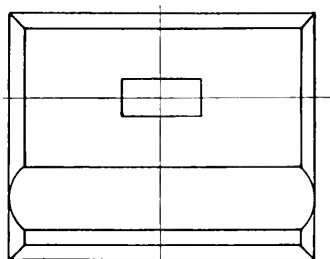

SAFETY MATCH-BOX STAND.

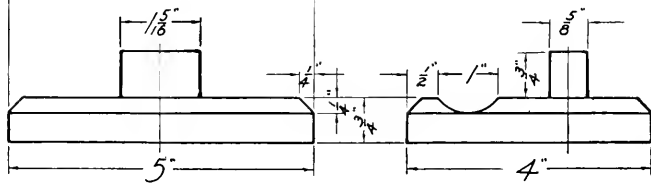

PEN AND PENCIL REST

This project is intended to give the workman practice in using the gouge, both with and across the grain. The design in the drawing is very simple. The ambitious workman may do much to beautify the object by using the gouge to model the ends and sides in some manner to make the surfaces more pleasing than the plain, flat surfaces shown in the drawing.

The stock is first planed square and to size in the manner described in Steps in Planing, Second Method, page 8. The lines locating the grooves are then placed as indicated in the working drawing. Suitable gouges are used to remove the waste wood. When cutting the crosswise groove the workman should remember

the rule that no cut should be made with any edge tool all the way across a piece of wood, going crosswise to the grain. These cuts should be made half way across from each side to insure a clean cut job. When the grooves are cut as smoothly as possible with the gouge they may be sandpapered, the sandpaper being held wrapped snugly around a suitable piece of dowel. The edges of the block may next be modelled to suit the workman. It will be found better to do the cutting on the ends before the sides are touched.

Sandpaper all the surfaces smooth, and apply a good finish. The stain should match the desk or table on which this will be used.

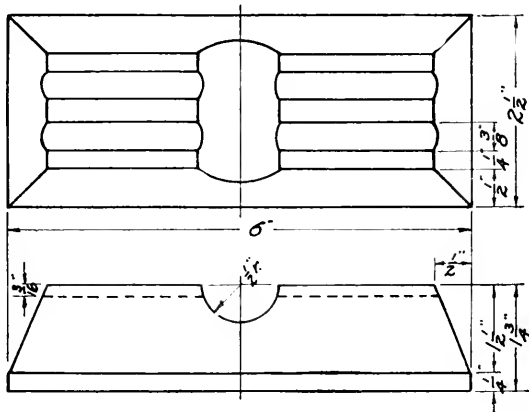
PEN AND PENCIL REST.

INK STAND AND STATIONERY HOLDER

This project gives practice in using the gouge and chisel and in modelling curves.

Procure stock for the base of this project first. Plane it to proper size, following the outline on page 8. Mark where the edge of the groove is to be, and use a gouge, about $\frac{3}{4}$ " wide to cut out the wood. The surface should be made as smooth as possible with the gouge. Then a piece of sandpaper may be wrapped around a piece of 1" dowel, and the surface dressed down smooth.

If the shop is equipped with a plow, the groove for the stationery holder should be planed out next. If no plow is to be had the groove may be chiselled out. Gage lines deeply to mark the sides of the groove, and chisel between them with a narrow chisel.

The recess for the ink bottle may be made to suit the bottle the boy wishes to use. Mark the outline with the knife point, and use the chisel to make the recess. The chisel is driven into the wood with the flat side against the edge of

the opening, and the bevelled side towards the waste wood. To cut out the waste wood the chisel is held bevel down, flat side up. When finished, the recess for the bottle should be flat on the bottom and the edges should be smooth, just fitting the bottle.

The chamfer may next be cut on the ends and front edge of the base.

The upright pieces for the stationery holder are squared to size, and the front piece planed carefully to fit the groove made for it. The pattern for the top edge outline may be designed by the individual and applied to the wood. The coping-saw will cut the shape. Sandpaper all the surfaces smooth and assemble. Glue will hold the front of the stationery holder in the groove. Glue and brad the back in place. Make sure that the front and back of the stationery holder stand at right angles to the base before the glue hardens.

Stain to suit the surroundings and finish. Use four coats of shellac, rubbed down.

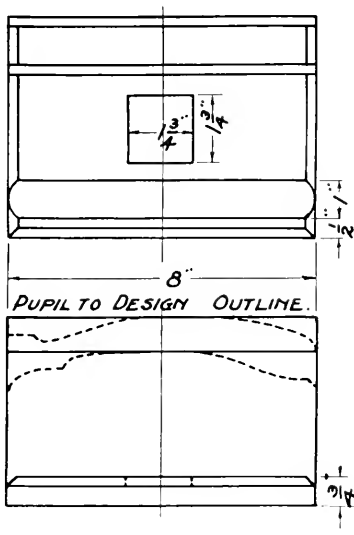

INK STAND AND
STATIONERY HOLDER.

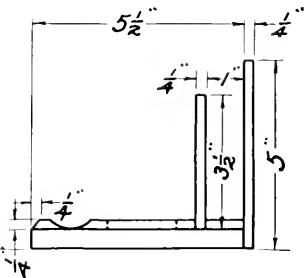

IX. JOINTS

WASTE PAPER BASKET

The workman making this waste paper basket gets practice in the making of the glue joint. The sides are each built up of three pieces of wood, the outer pieces being thicker than the middle pieces, giving the effect of panelling. Select a kind of stock for the sides that is not likely to warp or twist. Plane only one broad side of the middle piece, that side which is to be the low surface when the pieces are glued together. The other broad surfaces may be planed after the pieces have been glued together.

The first step in making the glue joints is to plane one edge of one outer piece as straight and flat as possible. One edge of the middle piece is then planed very carefully to match this edge, so that a perfectly tight joint is obtained, and the inner flush surface is flat. When this has been accomplished, the middle board is planed to width, and great care is taken to

make the new edge perfectly flat and smooth. The edge of the second outer piece is then carefully planed to match, and make a tight fitting joint with the middle board. Hot glue may then be spread on the surfaces of the joints, and the pieces are rubbed together quickly. The glued pieces are then laid flat on a piece of paper spread on a flat surface, and allowed to remain undisturbed until the glue has hardened. When this has happened, the center line is drawn down the middle board, and half the width is measured to each side of the center line, and lines are drawn to mark the width of the side. Plane the edges to these lines. Clean off the glue that may be on the surfaces, and plane them smooth. These steps are repeated to make each side. The outline for the top and bottom edges of the sides may be chosen or designed by the workman at this time, and may

WASTE PAPER BASKET.

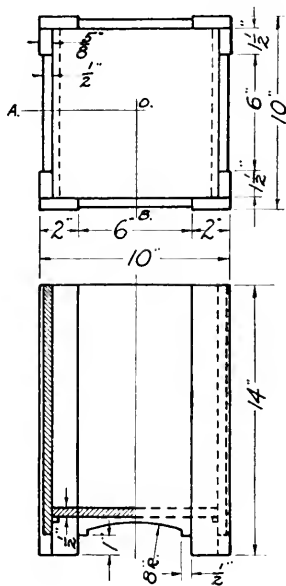

*THESE VIEWS ILLUSTRATE HOW THE
OUTLINES MAY BE MODIFIED BY INDIVIDUALS.*

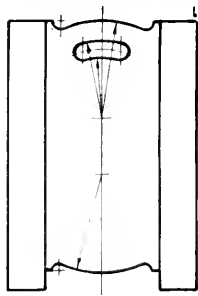
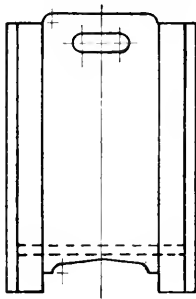

be applied to the wood, and cut out. The workman should see that the edges of the narrow sides fit snugly against the inner surfaces of the wide sides, so that a good joint will result when the sides are fastened together. Cold glue is spread on these edges, and the corners are

nailed together, each with five brads, $1\frac{1}{2}$ " No. 15, spaced evenly. The bottom is fitted into the frame, and its ends are supported on two cleats, braded to the sides of the frame. Smooth all surfaces, and apply a first class finish.

BOOK SUPPORTS

In making these book supports the workman practices the making of duplicate pieces, the modelling of edges, the making of the dado joint, and oblique planing on a broad surface. If time permits, he may also apply some form of surface enrichment to the ends, such as stencilling or simple carving. In the making of the supports, the following method of procedure has been found to work out best.

Procure two pieces of material, each $\frac{5}{8}$ " \times $6\frac{1}{4}$ " \times 14". Each piece will make one of the supports. Plane each piece square as described on page 10, except that the last step is to be omitted at this time, that is, the pieces will not

be cut in two. Next mark on the sides and edges of each piece the outlines of the oblique surfaces. The wood is then held in the vise at an angle that makes it easy to plane on the oblique surface. Most of the waste wood may be easily removed by first planing across the grain with the jack plane. If the plane is held at an angle with the edges of the board, with the knob or front end nearer the end of the wood, and is moved somewhat sideways, to cut squarely across the grain of the wood, the workman will be taking what is known as a "shearing cut." The wood will not tear up, nor break off on the far edge if the cut is made clear across the board.

BOOK SUPPORTS.
MAKE TWO.

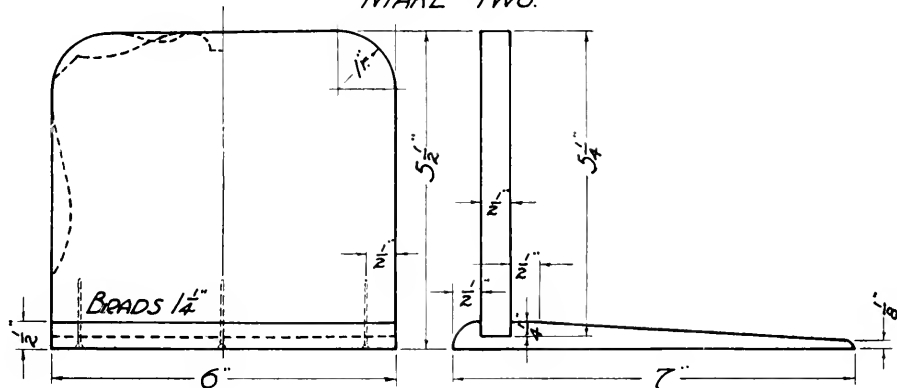

JOINT GLUED AND NAILED.

When the line is approached, the planing should be done with the grain, towards the end of the wood, to make the surface smooth and flat.

When the oblique surfaces are finished on each board, mark the length of the bases from the thin ends, and saw them off, squaring the ends. Trim the ends of the remaining pieces to make them the proper length.

The next job is to make the dado joints. Make a knife line $\frac{1}{2}$ " from the big end of each base. Place one edge of the lower end of the upright pieces against these lines, and mark with the point of the knife where the other edge of the upright meets the base. Make knife lines square across the base at the points located in this way. Saw with the back-saw so that the

saw-kerfs are just inside these lines. The outer sides of each saw kerf should fall on the line. The saw-kerfs should go only half way thru the base. Use a chisel to remove the waste wood. If a good job has been done the uprights will just fit the grooves.

Paper patterns will aid the workman to decide upon a suitable outline for the top edge of the uprights. When a decision has been made mark the line on the wood and saw with the coping-saw. Sandpaper all surfaces except the surfaces of the joints. It is very poor practice to use either file or sandpaper on the surfaces of joints.

Apply a first class finish with suitable stain and shellac.

HOT DISH REST

This project teaches the making of the cross-lap joint.

A piece of wood is procured $7\frac{1}{8}'' \times 1\frac{3}{4}'' \times 20''$ and planed to the size after the method described on page 10.

The making of the joints is the next step. Make sure that the top, or face side is marked on each piece. Then measure 2" from the ends of the longer piece and cut knife lines square across the bottom side, opposite the face side.

HOT DISH REST.

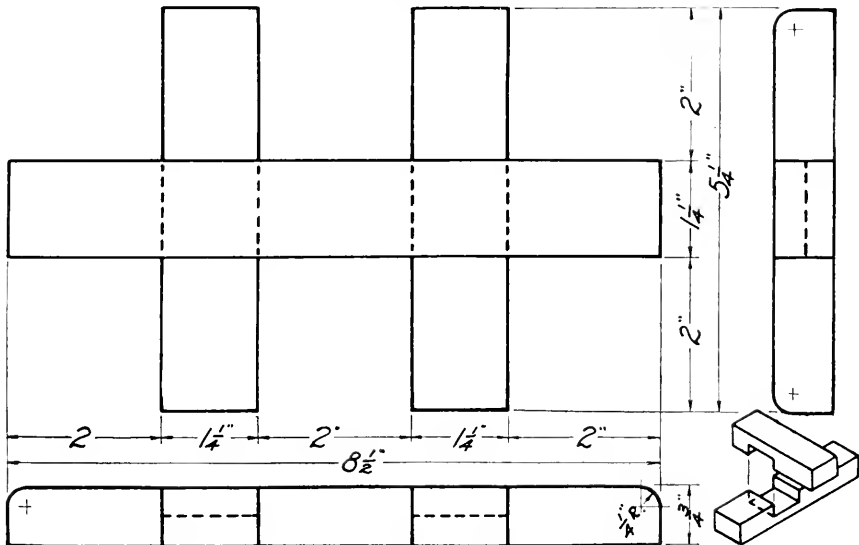

Then take one of the short pieces and hold it in the position it is to occupy with one edge against the knife line. With the knife point mark where the other edge comes on the board. Remove the short piece and square a knife line across the long piece at the point located. Do the same thing for the other joint, using the second short piece to mark by. These lines may next be squared half way across the narrow edges. The marking gage is set to half the thickness of the wood and a line is made on both edges of each piece parallel to the face side and between each pair of knife lines. Saw inside the knife lines the waste wood with the chisel. It will be found very carefully with the back-saw and pare out easier to pare out this wood if several saw cuts are made across it nearly down to the gage lines. Pare from each edge—not all the way across the wood.

CORD WINDER

The cord winder shown in the working drawing gives the workman a chance to learn to make the joint known as the cross-lap, the halved together, or the half-lap joint.

The joints should fit tightly, so that they stay together by themselves. Round off the top corners at the ends of each piece. When sand-papering, work very little on the edges, as one is very apt to make the pieces too narrow for the joints if not extremely careful.

Since this article is to be used on the dining table it should be nicely finished. The most practical finish would be obtained with raw linseed oil rubbed in with No. O sand paper and polished off with soft shavings. The finish will not be hurt by the heat as would varnish or shellac. The ends of the pieces could be beautified if cut to a more pleasing outline than the simple one shown on the drawing. The pupil should cut out paper patterns for such an outline and submit them to the teacher for approval before attempting to apply them to the wood.

The finished article may be used to wind a kite string or for the clothes-line, fish-line, or pieces of cord and twine saved at home.

First procure a strip of wood $\frac{7}{8}'' \times 2'' \times 25''$.

CORD WINDER.

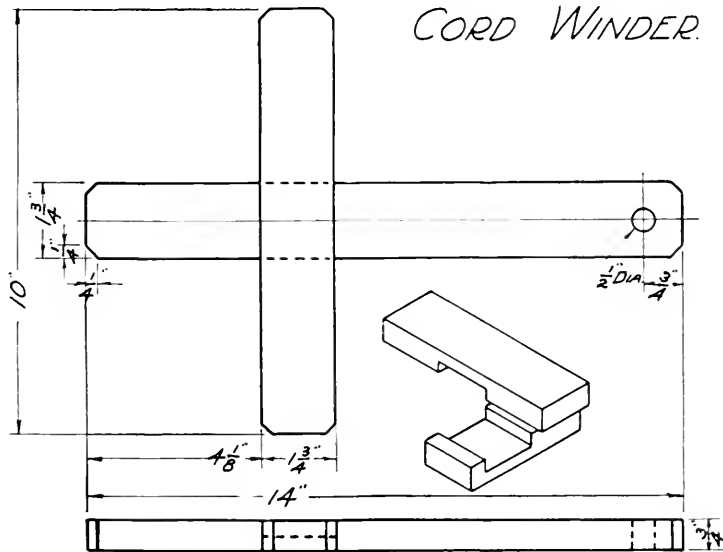

Plane this piece of wood after the method described on page 10.

Make sure that the face marks are on each of the pieces. Square a knife line across the longer piece $4\frac{1}{8}$ " from the end. Place the edge of the shorter piece against this line and mark with the point of the knife where the opposite edge comes on the long piece. A second knife line squared across the piece at this point marks off the exact width of the joint. In a similar way the width of the joint may be marked on the shorter piece. One must take care to locate the joint in the middle of this piece, and on the side opposite to the face side. These lines are then squared half way down on the edges of both pieces. Lines are made parallel to the

face sides with the marking gage set to half the thickness of the wood. With the knife cut a notch on the inner side of each knife line on the broad surfaces. This makes a place for the back-saw to start in and makes the saw-kerf come just within the knife lines. Several other cuts may be made between the knife lines to make it easier to chisel out the waste wood. Take care to cut only to the gage lines, and to chisel only half way across from each edge of the board. If each step is carefully taken a perfect fitting joint should be made.

The hole is easily located and bored, and the corners trimmed as shown with the chisel. The joint may then be glued and the surfaces sand-papered.

SKIRT MARKER

The making of the mortise and tenon joint may be learned thru this project. First prepare the base, planing it to size as indicated on page 8. Do not chamfer the edges until after the joint has been cut. Procure the wood for the

post long enough to include the piece that slides on it. This strip may be planed to width and thickness before it is cut in two to make the post and cross piece. (See page 10.) When all pieces have been planed to size the openings

SKIRT MARKER.

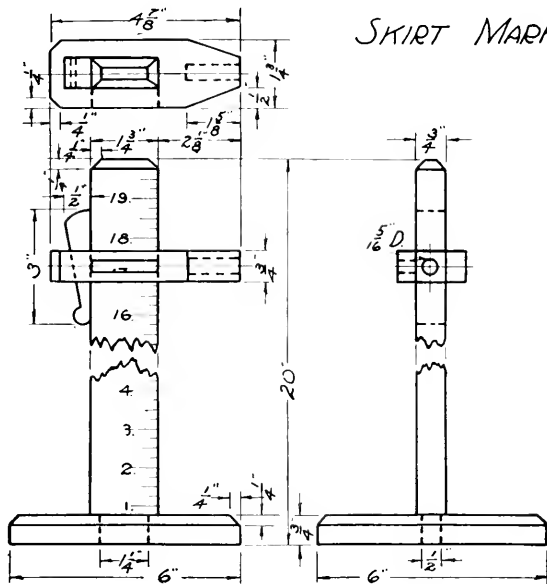

may be marked with the gage and knife. Bore out as much stock as possible before chiseling to the lines. Square a knife line around the post to mark for the shoulder of the joint. Gage on each side of the post for the sides of the tenon as dimensioned on the drawing. Saw across the sides of the post and chisel off the waste wood, making the tenon fit snugly into the mortise (the opening in the base). If care is taken in

cutting, the post will stand solidly, and square to the base. The opening in the sliding piece is made in a similar manner to that in the base. Note that one end of this opening is inclined to fit the wedge.

The remaining features are all shown clearly enough on the drawing for the workman to complete the project. The post is glued in the base. Finish with shellac.

SPOOL REEL.

This project was originated by a boy to hold the spools of thread or carpet warp used by his mother in crocheting.

The uprights are fastened to the base with housed dado joints. The rod for the spools is loose in the holes.

To make the project procure two pieces of wood, one for the base, $7\frac{7}{8}'' \times 4\frac{1}{4}'' \times 8\frac{1}{2}''$, and one for the uprights, $5\frac{5}{8}'' \times 3\frac{1}{4}'' \times 12''$. Plane the first piece after the rules in Steps in Planing, page 8, and the second piece after the rules on

page 10. Do not chamfer the edges of the base until after the joints have been made.

The joint is marked on the base first. Square a knife line across the top side of the base, $\frac{1}{2}''$ from each end. Stop these lines $3\frac{3}{4}''$ from each edge, so that they will not overrun the joint and show after the work is finished. Stand one of the uprights on end with one of its edges against one of the knife lines. With the point of the knife mark where the other edge falls on the base. At this point square another line across

SPOOL REEL.

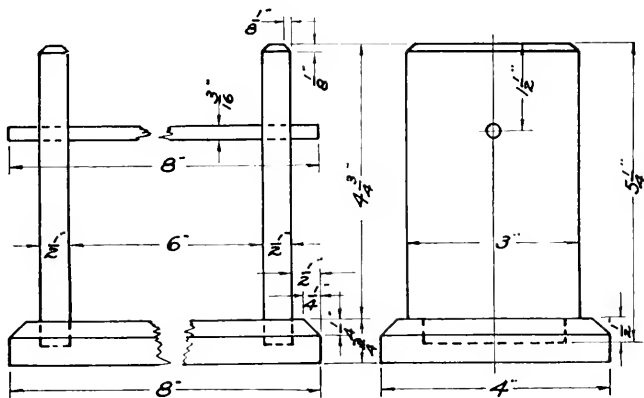

the base similar to the others. Then the width of the dado will be marked on the base and it will be exactly equal to the thickness of the upright that is to fit into it. Repeat the process for the second joint. It would be well to mark these *A* and *B*, or in some similar way, so that they will not be confused later. Set the gage at $\frac{3}{4}$ " and gage from each edge of the board so as to make a line between the two knife lines of each joint. This marks the length of each dado. To chisel out the waste wood use a $\frac{1}{4}$ " chisel to cut across the grain of the wood, just inside, and parallel to the knife lines. Use a mallet to drive the chisel. The second cuts may be made with the chisel edge directly in the knife lines, and with the flat side of the chisel next to the lines. The reason for doing this is that the chisel crowds the wood to each side when it is driven in. The first cut in the waste makes an opening into which the wood is crowded when the second cut is made on the line. This process

prevents the chisel from making the dado too wide. The wood between the chisel cuts is removed with a $\frac{3}{8}$ " chisel. Do not try to remove all the wood with the first cut of the chisel. About $\frac{1}{8}$ " is enough to expect to remove before cutting again with the wider chisel across the grain. Proceeding in this way the workman will soon remove the waste wood to the proper depth. The sides of the dado should be clean cut and square to the top side of the base. The uprights may then be marked out to fit the dados. Use the back-saw to remove the waste wood in the corners of the uprights. When gluing together make sure that the uprights are square to the base. The outline of the upright pieces could be made more beautiful if modelled to pleasing curves. The outline may be designed by the individual workman. All the minor details are shown clearly on the working drawing. Apply four coats of shellac, and rub down smooth with pumice and oil.

INDEX

A	
Assembling four-sided frame.....	22-28
Awl, marking with.....	16
B	
Back rest, Plate 8.....	28
Bill of material.....	74
Bird feeding stand, Plate 31.....	78
Blind nailing.....	42
Book stall, Plate 41.....	100
Book supports, Plate 46.....	110
Boot-blackening stand, Plate 14.....	40
Boring.....	44, 48, 50, 65
for screws.....	54
for bracket.....	50
with auger bit.....	18, 30, 32, 43, 44, 46
Box bottom, fitting.....	72-76
Broom holder, Plate 15.....	44
Butt joint.....	37, 39, 49, 57, 61, 63, 65, 69, 71, 73, 75, 77, 79, 81, 91, 93, 95, 97, 99, 109
C	
Chiseling across the grain.....	87
Chiseling around a corner.....	66
Clock shelf, Plate 23.....	60
Clothes-line reel, Plate 18.....	50
Contents.....	4
Cord Winder, Plate 48.....	114
Cross-lap joint, making.....	112-116
Cutting board, Plate 10.....	32
D	
Dado joint.....	107-112
Dado joint, housed.....	118
Designing outlines.....	34, 68, 82
Dish drainer, Plate 7.....	26
Door stop, Plate 21.....	56
Dovetail joint.....	77
Dowel joint.....	31, 51, 53
E	
Emery cloth, cutting to size.....	18
F	
Fastening an object on the wall.....	66, 100
Fish-line reel, Plate 4.....	20
Fitting bottom to box.....	72
Footstool, Plate 12.....	36
G	
Gain joint.....	41, 77, 101
Garden stake, Plate 5.....	22
Glue joint, rubbed.....	108
Gouging across grain.....	104

H		
Hinges, locating and fitting.....	42	
Hot dish Rest, Plate 47.....	112	
Housed dado joint.....	118	
I		
Ink stand, Plate 38.....	95	
Ink stand and stationery holder, Plate 44.....	107	
J		
Joints		
Butt joint.....	77	
Cross lap.....	112-116	
Dado.....	112	
Dowel.....	52	
Gain, or rabbet.....	41, 77, 101	
Housed dado.....	118	
Mortise and tenon.....	118	
Dovetail.....	77	
K		
Key board, Plate 2.....	16	
Knife strop, Plate 3.....	18	
L		
Laundry stick, Plate 22.....	58	
Letter holder, Plate 37.....	92	
Letter tray, Plate 30.....	76	
M		
Marking for holes in duplicate pieces.....	30, 50	
Match striker, Plate 33.....	82	
Milk bottle Holder, Plate 27.....	70	
Miter bench-hook, Plate 13.....	38	
Mortise-and-tenon joint.....	118	
N		
Nailing a box.....	72	
Nailing thru hard wood.....	50	
Necktie rack, Plate 39.....	96	
O		
Oblique planing.....	56-58	
Outlines, method of designing.....	34, 68, 82	
P		
Pail stand, Plate 6.....	24	
Paint, application of.....	62	
Pen and ink stand, Plate 36.....	90	
Pen and pencil holder, Plate 16.....	46	
Pen and Pencil Rest, Plate 43.....	104	
Pencil pointer, Plate 1.....	14	
Planing to dimensions.....	6	
Planing, steps in		
I. Two dimensions.....	7	
II. Three dimensions.....	8	
III. Two long pieces of the same thickness, width		

and length, or the same thickness and length	9	Skirt marker, Plate 49	116
IV. Two or more short pieces of the same thickness and width	10	Spool reel, Plate 50	118
V. Three or more long and narrow pieces of the same thickness and similar lengths	11	Studding, locating in wall	66, 100
VI. Two pairs of pieces of medium length	13	Suggestions for outlines. 19, 21, 25, 33, 35, 37, 41, 49, 61, 69, 71, 81, 83, 89, 91, 93, 95, 97, 99, 101, 107, 109, 111	
Planing, oblique	56-58	Suit hanger, Plate 34	84
Planing, shearing cut	110	T	
Plant label, Plate 5	22	Telephone bracket, Plate 26	97
Poultry feeder, Plate 29	74	Tooth brush rack, Plate 17	48
R		Towel stand, Plate 19	52
Rolling blotter, Plate 35	87	Towel rack, Plate 25	64
Rubbed glue joint	108	Tray for table silver, Plate 28	72
S		Trellis, Plate 5	22
Sandpaper, cutting to size	14, 82	Trousers hanger, Plate 20	54
Safety match-box stand, Plate 42	102	U	
Sewing stand, Plate 9	31	Upholstering stool top	36
Sewing stand, Plate 32	80	W	
Shearing cut with plane	110	Waste-paper basket, Plate 45	108
Shoe-polishing stand, Plate 24	62	Whisk-broom Holder, Plate 40	98
		Writing board, Plate 11	34

LIBRARY OF CONGRESS



0 013 973 850 0