

# WOOD

THE MAGAZINE FOR HOME WOODWORKERS

JAN./FEB. 1985 • ISSUE NO. 3

Display Until Feb. 19

- **BASIC CABINET CONSTRUCTION**  
how to build them like a pro

- **CLEAR FINISHES**  
tips on selecting the right one

- **WOOD TESTS**  
dado blades/sets

- **BUYING LUMBER**  
by mail

- **PROJECTS GALORE**  
wooden pulls  
stereo unit  
cheval mirror  
quick-clamp  
end vise  
kid's safe



**BUILD CABINETS**  
one easy step  
at a time



# SET YOUR OWN SPEED LIMIT.

## Introducing the New Delta 18" Variable Speed Electronic Scroll Saw.

At Delta, we don't believe anyone should impose their limits on you. That's why we've made the first infinitely variable speed scroll saw with an electronic "speedometer".

Take a curve *anywhere* from 100 to 2,000 CS/M. Watch the speed increase on the readout. Lock it in wherever it feels best.



Our electronics keep the blade speed constant. And a dry drive design makes for long, trouble-free performance.

The new Delta scroll saw makes intricate cutting a breeze—working in areas as tight as 1/64" diameter. For large jobs it has a big 2" thick capacity. And it makes cuts so fast and smooth, your sander will start feeling neglected.

Beyond simple cuts and curves, the 16" cast-iron table tilts to accommodate taper tenon and bevel cutting. It rotates 90°, and tilts 30° left, 45° right, 15° up, and 30° down.

Naturally, you'll want to put this versatility to work right away.

So we'll give you an assortment of 8 dozen blades with your new scroll saw.

With so many blades thrown in, you might expect to run through them like water.

But you won't. Our new solid "C" arm and constant blade

tension keep blade breakage remarkably low.

And when you have to change blades, or thread one into an intricate series of internal cuts, our pivoting blade chucks offer the fastest blade changing and tensioning in the industry.

If all this sounds remarkably well thought-out, well, it ought to.

After all, Delta introduced the original scroll saw back in the '20's.

Now, it's only fitting we introduce the ultimate one.

Call us toll-free to learn the name of the Delta distributor nearest you. Delta International Machinery Corp. (Formerly Rockwell Power Tool Division), 800/438-2486 (in PA, 800/438-2487).

 **DELTA**

Behind Our New Name Is Our Old Reputation.

 **DELTA**

**1875**  
STROKES/MIN.

**FASTER**  
**OFF**



115 VAC 1.3 AMP

**SAFETY**  
BEFORE

5. Hold workpiece firmly against table.
6. Keep hands and fingers away from blade.
7. Do not make any adjustments, remove pieces, until tool has been stopped.
8. Do not operate with worn stopped control or mechanism.



**A message to the readers of Wood Magazine from Las Vegas entrepreneurs, Richard Malott and Junior Sealy**

## WE HIT THE JACKPOT IN LAS VEGAS



### WHEN WE BOUGHT THE AUSTIN HARDWOODS FRANCHISE

#### Facts

- Started August, 1980 in the depths of the recession
- Began showing profit after four months
- Sales first year \$370,000
- Sales second year \$725,000
- Recovered entire initial \$90,000 investment in 20 months
- Doubled our warehouse capacity July, 1983 from 6,000 to 12,000 square feet
- Sales this year \$1,000,000 plus!

#### Opinions

We couldn't have done it without the flexibility and expertise provided by the Austin Hardwoods program. The parent company has worked hand-in-hand with us, keeping us abreast of changing market conditions, new products, and effective marketing techniques. Their program allows the franchise owners to tailor their operation towards any ratio of retail/wholesale and hobbyist/commercial sales, and to grow as fast as they are able. Sure there was a lot of hard work, but the record speaks for itself. Our Austin Hardwoods franchise turned out to be a sure bet.

Details are too numerous to list. This is a tremendous opportunity to make money either as an owner/operator or as an investor. If you happen to love dealing in fine woods, all the better. Current total investment is approximately \$90,000. Please let us hear from you.



**Franchise Marketing Department**

**Austin Hardwoods** P.O. Box 3096 • Austin, Tx. 78764

*Visit the Austin Hardwoods Dealer nearest you.*

<b>DALLAS, TX. 75229</b> 11353 Mathis Myles Lasner (214) 241-4777	<b>DENVER, COLO. 80223</b> 2625 S. Santa Fe Dr. Russ Brown (303) 733-1292	<b>AUSTIN, TX. 78764</b> 2119 Goodrich—P.O. Box 3096 Paul Fagan (512) 442-4001	<b>SAN ANTONIO, TX. 78217</b> 10841 Hillpoint Oren Dreeben (512) 657-9994
<b>EL PASO, TX. 79915</b> 904 Tony Lama Mike Loewenstein (915) 593-0126	<b>HOUSTON, TX. 77014</b> 1300 Stuebner-Airline #408 Bill Bryant (713) 440-0764	<b>LAS VEGAS, NEV. 89109</b> 2901 S. Highland #15A Richard Malott (702) 733-6677	<b>KIRKLAND, WASH. 98033</b> 11844 NE 112th St. Bill Thurmond (206) 823-2515
<b>LORTON, VA. 22079</b> 8930 Telegraph Rd. Hinds Wilson (703) 550-7076	<b>ANCHORAGE, AK.</b> Opening Soon Call Directory Assistance For Information	<b>SANTA ANA, CAL. 92703</b> 2330 Fifth St. Joe Brown (714) 667-0704	<b>PHILADELPHIA, PA. 19144</b> 923 Hunting Park Ave. Ted Missiras (215) 848-9663
<b>TACOMA, WASH. 98499</b> 3622 96th S.W. (206) 582-5484	<b>TUCSON, ARIZ. 85705</b> 2045 N. Forbes Blvd. #102A Ted Hill (602) 622-7383	<b>PHOENIX, ARIZ. 85040</b> 3821 E. Broadway (602) 243-7191	



## "SAVE \$75 ON OUR TOP-QUALITY 15-PIECE FORSTNER BIT SET AND GET A TRIPLE-BONUS FREE!"

For accuracy, versatility, speed — and always satisfying results, there's positively nothing better than our genuine Forstner bits made in Germany of high carbon steel.

Fact is, only Forstners let you bore through any wood like butter (even veneer, end grain & knots). You get clean round, arc, oval, pocket, angle, flat bottom or thru holes — all smooth as glass. Without dancing, splintering, gliding or burning.

And right now, you can get the entire set of 15 finest-quality Forstner Bits (1/4" to 2" shanked to fit a 3/8" or larger chuck) — a regular \$224 value, for only \$149.95. A price we guarantee to be unbeatable!

### YOUR FREE TRIPLE-BONUS IS WORTH OVER \$50.00!

Order before January 15, 1985 and you'll receive absolutely FREE...

1. Easy-Storage 15 Bit Carousel
2. Special 2 1/8" Forstner Bit
3. A 2-year subscription — Fine Tool Catalogs

Plus, automatic membership in the FTS Club where you'll get special discounts off our already-unbeatable prices!



**FREE 2 1/8" FORSTNER BIT**  
(Reg. \$29.95 value)



*Mortimer V. Schwartz*  
President, Fine Tool Shops, Inc.

### 30-DAY NO-RISK TRIAL

No other tool supplier or discounteer can match this special, limited-time value.

So order today. For fastest delivery, call toll-free 1-800-243-1037 (in Ct. call 797-0772 collect). Or mail the coupon below.

Either way, your satisfaction is *unconditionally guaranteed*. Try our Forstner Bit Set for 30 days. If it's not everything we say it is, return it for a full, prompt refund.



**FREE BIT CAROUSEL**  
(Reg. \$12.95 value)

### MAIL COUPON TODAY! Hurry! Offer Ends Jan. 15, 1985!

YES, please send me

- 15-pc. Forstner Bit Set plus all 3 Free Bonus Gifts for only \$149.95 200-2595
- 7-pc. Forstner Bit Set, sizes 1/4" - 1" for only \$49.95 200-2575
- Carousel with 7-pc set — \$54.90 200-2537
- Carousel only — \$12.95 200-2580
- FREE 68-page color catalog (please enclose \$1.00 for postage & handling)

- Check or money order enclosed. Charge my  VISA  MasterCard  Amex  Diner's Club

Card No. \_\_\_\_\_ Exp. Date \_\_\_\_\_  
Bit Orders: Add \$2.00 for postage & handling. Ct. Residents add 7 1/2% sales tax.

Name \_\_\_\_\_  
Address \_\_\_\_\_  
City \_\_\_\_\_  
State \_\_\_\_\_ Zip \_\_\_\_\_

The Fine Tool Shops, Dept. WMF5,  
20 Backus Ave., Danbury, Ct. 06810

# Better Homes and Gardens® WOOD

THE MAGAZINE FOR HOME WOODWORKERS

Jan./Feb. 1985 Issue No. 3

Editorial Director **DORIS M. EBY**  
Publisher **ADOLPH AUERBACHER**

#### Editorial/Art Staff

Editor **LARRY CLAYTON**  
Managing Editor **TIMOTHY LYNCH**  
Art Director **C.L. GATZKE**  
Design Editor **JAMES R. DOWNING**  
Features Editor **PETER J. STEPHANO**  
How-To Editor **MARLEN KEMMET**  
Project Builder **JAMES E. BOELLING**  
Administrative Assistant **DARLENE REYNOLDS**

Technical Consultants **GEORGE GRANSETH**, Product Testing **ALAN D. MILLS**, Finishing **VERNON U. WARD**, Collectible Tools

#### Editorial Services

Executive Director **DUANE L. GREGG**  
Director, Editorial Research **C. RAY DEATON**  
Administrative Editor **ROSE ANDERSON**

Associate Publisher **JERRY KAPLAN**  
National Advertising Manager **DAVE COHEN**  
Promotion/Research Director **TOM TROLAND**  
Circulation **JERRY WARD**  
Production **DALE SCHENKELBERG**

#### Publishing Group Officers

President **JACK D. REHM**  
Senior Vice-Presidents  
General Manager,  
Magazines **JAMES A. AUTRY**  
General Manager,  
Books and Newspapers **FRED STINES**  
Group Vice President,  
Editorial Director **DORIS M. EBY**

#### Corporate Officers

Chairman of the Board **E. T. MEREDITH III**  
President **ROBERT A. BURNETT**  
Group Presidents:  
Publishing **JACK D. REHM**  
Broadcasting **W. C. McREYNOLDS**  
Real Estate **ALLEN L. SABBAG**  
Senior Vice-President **JAMES CONLEY**  
Vice Presidents  
Corporate Relations **DONALD L. ARNOLD**  
General Council and  
Assistant Secretary **THOMAS G. FISHER**  
Product Development **NEIL KUEHN**  
Corporate Planning **HERB SCHULTE**  
Finance **WILLIAM H. STRAW**  
Administrative Services **GERALD D. THORNTON**  
Secretary **BETTY CAMPBELL MADDEN**  
Treasurer **MICHAEL A. SELL**

**Better Homes and Gardens® WOOD** — the magazine for home woodworkers (ISSN-0743-894X) is published bimonthly by Meredith Corporation, 1716 Locust Street, Des Moines, IA 50336. Application to mail at second-class postage rates is pending at Des Moines, IA. Trademark registered in Canada and Australia. Marca Registrada en Mexico. **SUBSCRIPTION PRICES:** One year \$15 in the United States and its possessions. Canada and other countries add \$6 per year. **POSTMASTER:** Send address changes to WOOD 1716 Locust Street, Des Moines, IA 50336. January/February 1985, No. 3. **CUSTOMER SERVICE:** For service on your magazine subscriptions, including change of address, write to Customer Service Manager **ROBERT AUSTIN**, P.O. Box 10628, Des Moines, IA 50336. Please enclose a recent address label. ©COPYRIGHT MEREDITH CORPORATION 1985. ALL RIGHTS RESERVED. PRINTED IN U.S.A.

# WHAT DO YOU SCORE ON THIS WOODWORKER'S QUIZ?

Special  
**FREE Magazine Subscription**  
Details Below

**Find out and get an information-packed booklet on power tools FREE!**

The quiz only takes a minute.

Just answer each question, total your score and enter it on the coupon. Then fill in your name and address and send to Shopsmith®.

For your effort, you'll receive a FREE copy of "How To Determine Your Best Power Tool Buy", a fact-filled booklet to help you get the power tools right for your needs and your budget.

And as a special bonus, we'll also send you a one-year subscription to "Hands On," The Home Workshop Magazine. So grab a pen or pencil and get started!

**Circle A, B or C for each question:**

**1** How much experience do you have in woodworking, home repair and/or home maintenance?

- A) Little or no experience.
- B) Some experience.
- C) A great deal of experience.

**2** Which phrase best describes your workshop?

- A) A selection of hand tools and portable power tools.
- B) A table saw or radial arm saw, along with hand tools and portable power tools.
- C) A good selection of stationary and portable power tools, along with hand tools.

**3** How involved do you want to become with woodworking, home repair and/or home maintenance?

- A) Not very involved.
- B) Moderately involved.
- C) Heavily involved.

**4** What's the likelihood that you'll buy some kind of woodworking tools within the next year?

- A) Not likely.
- B) Somewhat likely.
- C) Highly likely.

**5** Which describes you?

- A) I do home repairs and maintenance only when it can't be done any other way.
- B) I do some woodworking and a variety of home repairs and maintenance.
- C) I'm primarily interested in fine craftsmanship woodworking.



© Shopsmith, Inc., 1984



you circled, six for each (B) and three for each (C). Then enter your total on the coupon, fill in the special blank about Question #5 and enter your name and address. Mail the coupon to the Shopsmith address below.

Your copy of "How To Determine Your Best Power Tool Buy" will arrive soon. And because you're interested in woodworking, we'll also send you a complimentary Information Kit about the Shopsmith MARK V, the complete home woodworking system anyone can use and enjoy. You'll learn all about Shopsmith's exclusive Gold Medal Buyer Protection Plan and how you can try the MARK V in your shop for 30 days without risking a penny.

As a special gift, you'll receive "Hands On," The Home Workshop Magazine, chock full of useful plans, projects and articles on woodworking for a full year FREE of charge.

The MARK V combines the five power tools you need most — in one economical, space-saving unit. It's the tool to start with... the system you grow with!

Quality Woodworking Tools Built In The U.S.A.



**Shopsmith Inc.**

The Home Workshop Company  
6640 Poe Avenue  
Dayton, Ohio 45414-2591

**Send in this coupon today!**  
**For faster service, Call 1-800-228-2212**  
**(In Nebraska 1-800-642-8788)**

Shopsmith® is a registered trademark of Shopsmith, Inc.

**My Test Score Is \_\_\_.**

On Question #5, I circled the letter \_\_\_\_\_. Please send me a FREE copy of "How To Determine Your Best Power Tool Buy" and a FREE Shopsmith MARK V Information Kit. And be sure to sign me up for a one-year subscription to "Hands On". I understand I am under no obligation.

Name \_\_\_\_\_

Address \_\_\_\_\_

City \_\_\_\_\_

State \_\_\_\_\_ Zip \_\_\_\_\_

Send to: **Shopsmith, Inc.** Dept. 372M

The Home Workshop Company  
6640 Poe Avenue, Dayton, Ohio 45414-2591

**How to find your score:**

It's easy! Give yourself nine points for each (A)

# BOSCH Power Tools

## BLOW OUT SALE!



LIST  
\$159.00  
SALE  
\$87.45

### Orbital Finishing Sander, Model 1288 034

- With 10,000 orbits per minute the counter-balanced, vibration-free 1288 034 gives maximum performance with less operator fatigue — it weighs just 6 pounds.
  - The compact design allows close-quarter work — orbit diameter is 3/16".
  - The bearings and drive mechanism are completely sealed against dust contamination.
  - Lever action, positive-paper clamping system saves valuable production time — sheet capacity is 4 1/2" x 11"
  - Double Insulated. UL listed. 115V AC.
- SUPPLIED WITH: auxiliary handle and assorted sandpaper sheets.



LIST  
\$155.00  
SALE  
\$93.00

### 3/8" 2-Speed, Variable Speed, Reversing Cordless Drill, Model 1920VSRK

- Totally portable, no-cord required; plus amazing value and work power.
- Reversing switch for screwdriving, freeing bound-up bits
- 2 speeds to fit torque and speed to job
- Recharges in just 1 hour; charger has automatic cut-off
- Delivers 300/650 RPM under full charge
- Switch lock prevents accidental discharges/ tool switch-ons
- Drill weighs only 2.75 lbs.
- UL Listed, complies to OSHA.



LIST  
\$179.00  
SALE  
\$98.45

### Orbital Finishing Sander, Model 1288 934

- Powerful and efficient dust-removal system prevents sandpaper clogging — ensures smoother finish and longer sandpaper life.
  - The counter-balanced, vibration-free 1288 934 gives maximum performance with less operator fatigue.
  - The compact design allows close-quarter work — it's 12" long, 5 1/2" wide, and 7 1/2" high with dust bag, and weighs 6 pounds.
  - The bearings and drive mechanism are completely sealed against dust contamination.
  - Lever action, positive-paper clamping system saves valuable production time.
  - Double Insulated. UL listed. 115V AC.
- SUPPLIED WITH: auxiliary handle, assorted sandpaper sheets and dust bag.

### Orbital Action Jig Saws, Model 1581VS

- New 520 watt motor provides more power for the most demanding cutting applications.
  - Adjustable foot plate tilts left and right up to 45° with locks at 0° and 45° bevel for most cutting applications
  - Top handle design with trigger switch puts your hand over the work for extra control under heavy loads.
  - Model 1581 produces 3,100 strokes/minute for cutting wood and light gauge metal.
  - Model 1581VS has a variable speed switch: 500-3,100 strokes/minute. It produces full output at low speeds needed for cutting very hard materials.
  - 115V, Double Insulated, UL Listed, OSHA, 5.75 lbs.
- Supplied with: Three assorted blades, blade locking screwdriver, anti-splintering device, hex key.



LIST  
\$225.00  
SALE  
\$135.00

### Orbital Action Jig Saw, Model 1582VS

- 520 watt motor provides more power for the most demanding industrial cutting jobs.
  - Adjustable foot plate tilts left and right up to 45° with locks at 0° and 45° bevel cutting applications.
  - Model 1582 produces 3,100 strokes/minute for cutting wood and light gauge metal.
  - Model 1582VS has a variable speed switch: 500-3,100 strokes/minute. It produces full output at low speeds needed for cutting very hard materials.
  - Barrel grip and removable rotating handle allow precise pattern cutting.
  - 115V, Double Insulated, UL Listed, OSHA, 5.5 lbs.
- Supplied with: Three assorted blades, blade locking screwdriver, anti-splintering device, hex key.



LIST  
\$209.00  
SALE  
\$125.40



CALL FOR PRICES  
AND  
AVAILABILITY

### 1 HP Router, Model 1601

- Excellent power to weight ratio.
- Captive templet guide for quick, easy seating.
- Fully Insulated, 115V AC, UL Listed



CALL FOR PRICES  
AND  
AVAILABILITY

### 1 1/4 HP Router, Model 1604

- Excellent power to weight ratio.
- Captive templet guide for quick, easy seating.
- Double Insulated, 115VAC, UL Listed.



### 3" x 24" Belt Sander, w/Dust Collector, Model 1272D

- At 1500 SFPM, the 1272D is rated super-duty for production sanding applications. It sands flush to vertical surfaces for close-quarter work.
- Built-in vacuum minimizes airborne dust.
- Heavy-duty tracking system with twist knob allows easy belt adjustment.
- Lever-action release provides quick belt changing.
- Carbide wear-inserts protect housing from belt damage.

VISA AND MASTERCARD ACCEPTED

FREIGHT PRE-PAID  
ON ALL TOOLS

NO!! SALES TAX ON  
OUT OF STATE SHIPMENTS

5% DISCOUNT TO  
WALK-IN CUSTOMERS  
CASH OR CHECK

D & D SAW & SUPPLY  
6162 MISSION GORGE RD.  
SAN DIEGO, CA 92120  
(619) 280-9320

RODMAN CO., INC.  
1827 S. HOPE ST  
LOS ANGELES, CA 90015  
(213) 749-6441

A & W ELECTRIC INC.  
2337 S. BROADWAY  
SANTA ANA, CA 92707  
(714) 540-3060

AAA WHOLESALE  
TOOL & SUPPLY  
17309 ROSCOE BLVD.  
NORTHBRIDGE, CA 91325  
(818) 996-1800

# WOOD

## CONTENTS

THE MAGAZINE FOR HOME WOODWORKERS

January/February 1985

Issue No. 3



Quick-Clamp End Vise

Page **88**



Dado Blade Buymanship and Testing Page **77**



Cheval Mirror

Page **85**

CRAFTSMAN CLOSE-UP — Don Yarger and his split oak baskets . . . . .	45
MAPLE the wood that's hard, soft, and sweet . . . . .	49
BUILD YOUR OWN wooden pulls . . . . .	50
PROBLEM-SOLVING HARDWARE . . . . .	53
WOODEN SAFE for kids . . . . .	55
BASIC CABINET CONSTRUCTION how to build them like a pro . . . . .	59
NOW YOU CAN BUILD IT	
stereo component unit . . . . .	70
simple cabinet desk . . . . .	74
DADO SETS getting in the groove . . . . .	77
CHOOSING THE RIGHT CLEAR FINISH . . . . .	82
MORE PROJECTS	
cheval mirror . . . . .	85
quick-clamp end vise . . . . .	88
drill press stand . . . . .	90

Letters to the editor . . . 9, WOOD's basic, common-sense tool kit . . . 10, Products that perform . . . 21, Books worth reading . . . 27, Tips and techniques . . . 34, News and events . . . 57, Kit builder . . . 67, Where readers show their stuff . . . 68, Buying wood by mail . . . 92, Wood anecdote — pink ivory . . . 99, Old tools — the table saw scene . . . 100, Associations . . . 111, Taking care of woodworking materials . . . 123



### Factory Lumber Outlet

"Woods of the World"

200 SHREWSBURY STREET  
BOYLSTON, MASSACHUSETTS 01505

We stock over 100 species of domestic & exotic woods including:

- All Domestic Woods
- Apple
- Balsa
- Bengé
- Brazilian Rosewood
- Bubinga
- Ceylon and African Ebony
- Ceylon Satinwood
- Cocobolo
- Curly and Birds Eye Maple
- East Indian Rosewood
- English Brown Oak
- European Pearwood
- Goncalo Alves
- Holly
- Honduras Mahogany
- Honduras Rosewood
- Iroko
- Jelutong
- Macassar Ebony
- Mahogany
- Mexican Rosewood (Bocote)
- Padouk
- Philippine Mahogany
- Purple Heart
- Shedua
- Teak

During more than a half century as millwrights and cabinetmakers, we have become experts in acquiring and working with the finest hardwoods and softwoods. Our knowledge of the best domestic and worldwide sources of rare woods is without peer. The large volumes in which we buy fine woods affords us the best possible prices which, in turn, we pass along to you. Laccarino and Son is also your source for the finest lines of high quality woodworking hand tools.

### Call For Free Catalog

(617) 869-2791

TOLL FREE:

In Mass. 1-800-521-0039  
New England 1-800-222-1420

**AT LAST!  
A HIGH-PRECISION  
SCROLL<sup>®</sup>  
SAW  
AT AN  
AFFORDABLE  
PRICE!**

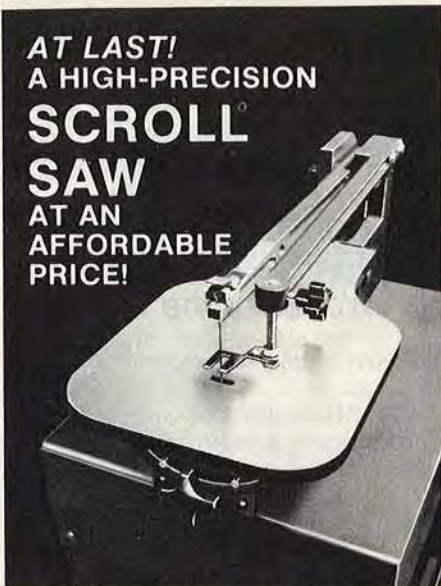

**THE SAW THAT TURNS  
BEGINNERS INTO EXPERTS!**

Use this high-precision saw to make hundreds of profitable, unusual items . . . toys, name-bars, filagree work, clocks, holders . . . the list is nearly endless! Because the Model 1600 cuts so smoothly, sanding is virtually unnecessary!

**BUILT TO LAST!**

The sturdy new Woodmaster Model 1600 gives you all the features found in more expensive machines including a big, 16-in. throat capacity, 2-in. cutting depth, a generous, oversize worktable, ball-bearing drive . . . and much more!

**FULL TILTING WORKTABLE!**

Unlike any other scroll saw, the Woodmaster's table tilts and locks in any position up to 45° right or left. This means you can produce work on the Model 1600 impossible to duplicate on any other parallel or C-arm scroll saw! Can be ordered complete with motor, stand and dust blower. Easy Terms.

**30-DAY FREE TRIAL!**

Send For Complete Facts! See how you can use the Woodmaster Model 1600 in your own shop for one full month completely without risk! MAIL COUPON TODAY or:

**Call Toll-Free**

**1(800) 824-7888 Oper. 642**

**Woodmaster Power Tools, Inc.  
Dept. CW4  
2908 Oak, Kansas City, MO 64108**



No Obligation . . .  
No Salesman Will Call

Woodmaster Power Tools  
Dept. CW4  
2908 Oak  
Kansas City, MO 64108

YES! Please rush me, free and without obligation, your Complete information Kit on the new MODEL 1600 SCROLL SAW plus facts on Woodmaster's 30-Day FREE TRIAL Money-Back Guarantee!

Name \_\_\_\_\_  
Address \_\_\_\_\_  
City \_\_\_\_\_  
State \_\_\_\_\_ Zip \_\_\_\_\_

**The Editor's Angle**



It wasn't easy, but I finally managed to round up the WOOD staff for a group mug shot the other afternoon. If some of these people look sleepy, you'll have to forgive them. They've been up late lots of nights making sure this magazine reaches you on time every two months. I'll go from left to right and front to back.

Marlen Kemmet, WOOD's How-To Editor, comes to us from Devil's Lake, North Dakota. Marlen's interest in woodworking knows no bounds; in fact, after hours, it's not unusual to find him turning a bowl or working on some other project in the shop.

I'm seated in the chair between Marlen and Jim Boelling, our Project Builder. Jim has been actively involved in woodworking since 1968, both as a practitioner and, since 1976, as a teacher of adult education classes.

Lee Gatzke, WOOD's Art Director, wears lots of hats around here, in addition to laying out the magazine. Lee's training in commercial art, his years of magazine design experience, and his knowledge of and skill in woodworking make him a valuable member of the staff.

In the back row, far left, is Pete Stephano, a veteran magazine man and our Features Editor. Pete does most of our Craftsman Close-Up features, travels around quite a bit gathering new material, and also coordinates the efforts of some of our free-lance writers.

To Pete's left sits Jim Downing, Design Editor. Jim's years of practical woodworking experience, his commonsense approach to figuring things out, and his well-developed design sense have found a home at WOOD.

Darlene Reynolds, WOOD's Administrative Assistant, makes order out of chaos everywhere she goes. Every operation in America should be blessed with someone with her considerable skills.

 **Print this article**

*Larry Clayton*



# Like Having A Lumberyard Right in Your Shop!



## PLANER MOLDER JOINTER 4-IN-1 POWER-FEED SANDER

**FREE  
30-DAY  
TRIAL!**  
Send Coupon  
Today For  
Complete Facts!

### Saves You Money!

Put this versatile power-feed tool to work in your own shop. See how fast it **pays for itself!** Quickly converts low-cost rough lumber into valuable finished stock. Turns out perfect quarter-round, casing, base mold, tongue & groove ... all popular patterns ... any custom design. Joints super-true edges, squared stock, bevels and chamfers.

### Makes You Money!

Now you can start your own high-profit business selling all types of millwork to lumberyards, carpenters, contractors, picture framers, do-it-yourselfers. Use it to make grandfather clocks, gun cabinets, furniture, toys, planters, porch swings, benches, paneling, flooring. In fact, this one power-feed tool opens up a truly astonishing range of products you can make and sell.

### Revolutionary Quick-Change Molding Head!

Exclusive patented design lets you mold up to six patterns in a single pass! Eliminates time consuming set-ups. Uses low-cost cutterbits. Makes it easy to produce patterns impossible to duplicate on any other planer.

### New Sanding Attachment

Quickly converts machine to one of the finest drum sanders available. Consistent power feed eliminates "low spots" and irregularities caused by hand sanding method.

### Factory-Direct Shipment Keeps Cost Low!

Woodmaster Tools is the exclusive national direct-by-mail source for these planers. Low price includes motor, switch, stand, knives, full instructions ... ready to use. Easy terms.

### Here's What Woodmaster Owners Say:

**Shop Test Results** — "It does an excellent job of planing, on a par with more expensive machines, and even better than some commercial models."

*Jay Hedden, Editor, Workbench Magazine*

**Gets More Done** — "I build grandfather clocks, music boxes, toys and picture frames. They say a craftsman is only as good as his tools, and let me tell you, my Woodmaster is tops. I get more done, and done right, than I ever did before."

*R.V. Delacourt, Cleveland, Ohio*

**Best Value** — "After checking them all, Woodmaster was obviously the best deal for the money. Also, I would like to acknowledge the polite and prompt service."

*E.D. Holtz, North Carolina*

**Likes Woodmaster Best** — "I have two other planers in my shop ... wouldn't trade my Woodmaster for either one. I am delighted with its versatility and precision."

*Ron's Custom Cabinets, Colorado*

**Paid Off Fast** — "Paid for itself in no time flat."

*E.L. Walters, North Dakota*



Jointer attaches in seconds ... designed to let you move directly to planing without changeover.

Produces tongue & groove with one set-up, two boards in same pass.

Turns out high-value, satin-smooth custom moldings plus all popular patterns.

New sanding attachment quickly converts machine to a power-feed drum sander!

**FREE  
INFORMATION  
KIT**

**MAIL COUPON TODAY  
OR CALL TOLL-FREE  
1(800) 824-7888 Oper. 642**

Woodmaster Tools, Dept. PW4, 2908 Oak, Kansas City, MO 64108



**YES!** Please rush me your FREE information kit which tells in words and pictures why this amazingly designed power-feed shop is so much better than other single-purpose or combination tools. Also send me details on your 30-DAY FREE TRIAL GUARANTEE.

Woodmaster Tools, Dept. PW4, 2908 Oak, Kansas City, MO 64108

NAME \_\_\_\_\_  
ADDRESS \_\_\_\_\_  
CITY \_\_\_\_\_  
STATE \_\_\_\_\_ ZIP \_\_\_\_\_

### FREE 30 DAY TRIAL!

Send for complete facts on how you can try this low-cost, 4-in 1 power tool in your own shop for 30 days completely without risk! We'll also send you complete details on how you are fully protected by Woodmaster's One Full Year Limited Warranty.

# SUPERSALE

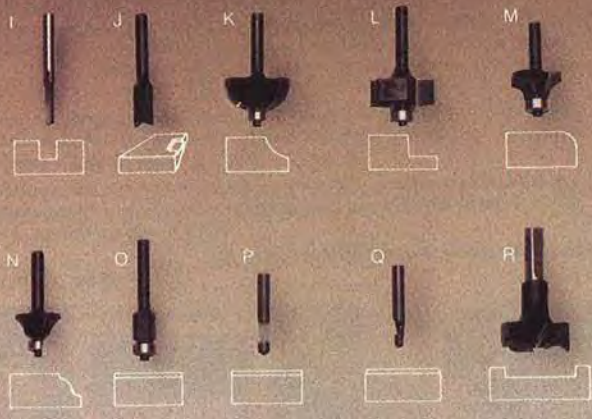
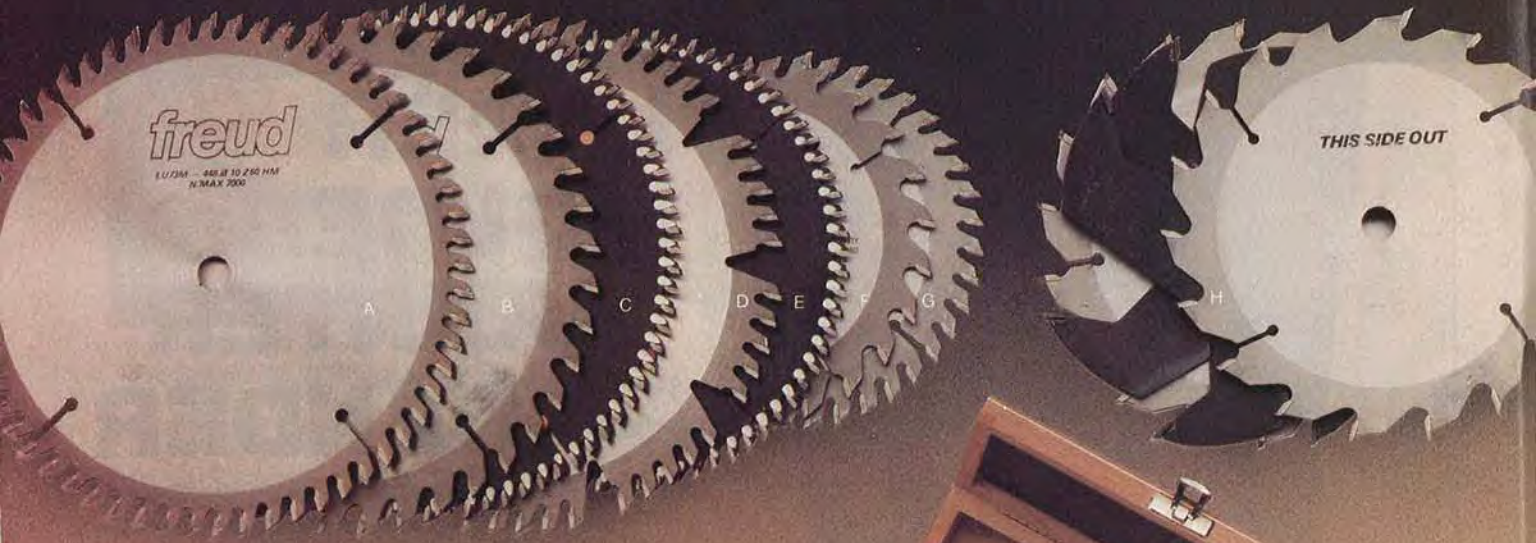

ITEM	DESCRIPTION	LIST	SALE
A	LU73M010 10" x 60 Teeth Gen. Purpose ATB	\$ 79.65	\$ 44.90
B	LU72M010 10" x 40 Teeth Gen. Purpose ATB	68.58	39.90
C	LU85M010 10" x 80 Teeth Super Saw ATB	110.88	73.90
D	LU84M011 10" x 50 Teeth Combination 4 & R	74.51	44.90
E	LU85M009 9" x 72 Teeth Super Saw ATB	101.98	64.90
F	PS203 7 1/4" x 24 Teeth Gen. Purpose ATB	27.45	18.90
G	PS303 7 1/4" x 40 Teeth Gen. Purpose ATB	32.97	24.90
H	DS308 #3 Dado 8" Max. Width of Cut <sup>13</sup> / <sub>16</sub> "	170.25	119.50
I	04-106 1/4" Diam. 3/4" Cut. Length Solid Carbide	11.05	8.80
J	16-100 1/2" Diam. Mortising Bit CT.	12.73	10.10
K	30-106 1/2" Radius Cove Bit CT.	33.64	25.90

ITEM	DESCRIPTION	LIST	SALE
L	32-100 1 1/4" Diam. Rabbeling Bit CT.	\$ 27.62	\$ 22.10
M	34-110 1/4" Radius Rounding Bit CT.	27.62	22.10
N	38-100 3/32" Radius Ogee Bit CT.	32.90	26.30
O	42-106 1/2" Diam. 1/2" Cut. Length Flush Trimming Bit	15.62	12.50
P	64-100 Solid Carbide Flush Trim Bit	7.64	6.10
Q	66-100 Solid Carbide 7° Bevel Bit	8.30	6.64
R	3557R 35MM Diam. 10MM Shank Boring Bit	31.90	25.50
S	06218 2 1/8" Diam. 1/2" Shank Boring Bit	89.00	69.80
T	C310 Set of 3 4" x 3/8" x 1/8" Jointer Knives	18.29	13.40
U	C350 Set of 3 6" x 3/8" x 1/8" Jointer Knives	27.45	19.90
V	C441 Set of 3 8" x 3/8" x 1/8" Jointer Knives	36.58	28.90

**Sales Ends April 30, 1985**

Note: All Saws & Dado have 5/8" Bore  
All Router Bits have 1/4" Shank  
ATB = Alternate Top Bevel

4 & R = 4 Teeth & 1 Raker Tooth  
CT. = Carbide Tipped

**freud usa**

218 Feld Ave., High Point, NC 27264 (919) 434-3171  
1570 Corporate Dr., Suite G  
Costa Mesa, Cal. 92626 (714) 751-8866

- In California  
Call Toll Free:  
1-800-824-0141
- If You Live  
In This Area:  
Call Toll Free:  
1-800-824-8045
- If You Live  
In This Area:  
Call Toll Free  
(Outside NC)  
1-800-334-4107



US Virgin Islands  
Puerto Rico

TALKING BACK

LETTERS

We welcome comments, criticisms, suggestions . . . even an occasional compliment from readers. While the volume of mail we receive makes it impossible to answer every letter, we intend to publish excerpts from a cross section of our correspondence in each issue of the magazine. Send letters to:

Letters Editor  
Better Homes and Gardens®  
WOOD Magazine  
1716 Locust Street  
Des Moines, IA 50336

I cannot locate the 10-24 brass knurled nuts for the Collector's Edition Marking Gauge (WOOD, Sept./Oct. 1984, page 62).

—Hugo Gregory,  
Yonkers, N.Y.

When we built the marking gauge, we walked into a local hardware store and bought brass knurled nuts manufactured by Midwest Fastener of Kalamazoo, Michigan. Apparently we had better luck than a number of readers, because we received several letters similar to Mr. Gregory's.

We haven't been able to locate a mail-order source for these nuts. Can any reader help?

Am well pleased with your advertising segments, as I just know there have to be cheaper places to buy tools and supplies than the local hardware stores.

—Jean Dresselhaus,  
Lewiston, Minn.

Your magazine already has too much advertising, and that is why I have quit subscribing.

—Harold Sweeney,  
Lancaster, Wis.

"It is a very hard undertaking to seek to please everybody," Publius wrote in the first century B.C. When it comes to the topic of advertising, nothing seems to have changed in 2,000 years.

Advertising revenues pay many of the bills around here, and

when we're looking to buy tools and supplies, we join reader Dresselhaus and read all the ads we can find. We're sorry that Mr. Sweeney feels differently, and we'll miss him as a subscriber.

I want to tell you how much we have enjoyed the first issue of your magazine, WOOD. I work for Kittinger's Furniture Company as a cabinetmaker. I also have a workshop at home and build for family and friends. I have

searched for many years for a magazine such as yours with fresh ideas and good instructions to expand my own ideas.

My wife loves the magazine. We both feel that it is going to be a welcome addition to our household.

Welcome to our home.

—Alfred and Diana Jacob,  
West Seneca, N.Y.

We're honored to be invited into your home, and we'll do our best not to wear out our welcome. ■

# The World's Most Expensive Scroll Saw?

**HEGNER** scroll saws let you make toys, names, puzzles and gifts like no other tool.

And now **HEGNER** gives you the widest choice of models, from the new Multimax-1® at a breakthrough low price, to the Polymax-3®, the world's most expensive scroll saw.

- Easy to use
- Precise
- Reliable
- Profitable

**NEW**

Write for your free brochure today!

AMI, Ltd.

P.O. Box 312, Dept. 10  
New Castle, Delaware, 19720

302-322-2226



Advanced Machinery Imports

# We Supply The Best...

## Superior 'Swiss Made' Carving Tools

For over 20 years, Woodcraft has been the exclusive U.S. agent for 'Swiss Made' carving tools. Three generations of experience and a commitment to quality combine to make these the finest woodworking tools available—unsurpassed in excellence.

Skilled Swiss craftsmen forge, finish, and sharpen the blades by hand. High quality steel alloy is hardened and tempered to Rc58-60, resulting in an edge which will stay extremely sharp during long periods of carving. The octagonal handles are select European ash and designed for optimum control. We believe our 'Swiss Made' carving tools shape all woods more precisely than any other tools made.

This set includes six of the most popular shapes, making it perfect as a starter set—or a replacement for those tools that fall short of your expectations. It's also the perfect set to build on. We offer over 200

additional styles, all of unequalled quality. Our 6-pc. set contains:

3mm veiner; 8mm chisel; 6mm "V" parting tool; 10mm #9 sweep gouge; 10mm #7 sweep gouge; 12mm #5 sweep gouge. Overall length 9½" to 11". All presharpended and ready to use. Money back guarantee. Reg. \$59.95.

**Now only \$49.<sup>95</sup>ppd.**

### Credit card orders call 800-225-1153

Yes, please send me your 6-pc. 'Swiss Made' Carving Tool Set 05W10-ZZ. I enclose \$49.95 (add 5% sales tax for delivery in Massachusetts) or charge my  VISA  MasterCard  AMEX

Acct. # \_\_\_\_\_

Exp. Date \_\_\_\_\_

Signature \_\_\_\_\_

#### Please print

Name \_\_\_\_\_

Address \_\_\_\_\_

City \_\_\_\_\_

State \_\_\_\_\_ Zip \_\_\_\_\_

Please send me your FREE tool catalog.



## WOODCRAFT®

Dept. WBH15, 41 Atlantic Avenue,  
Box 4000, Woburn, MA 01888

## TOOL BUYMANSHIP



## buying a basic, commonsense tool kit

Perhaps you've just completed a beginning woodworking course, or maybe you've recently assembled your first kit project. You thoroughly enjoyed these tastes of woodworking, and now you're ready for bigger challenges. But one obstacle blocks your way; you don't own the proper tools.

What tools does a beginning woodworker need, and how should he or she acquire them? In an unscientific poll of WOOD staff members, we assembled a basic tool kit for woodworkers—tools we think should be a part of any woodworking shop. With this equipment—and skill—you can perform most woodworking operations.

As you read the list, you'll notice we don't mention stationary power tools—the table saws, drill presses, band saws, and jointers that professional woodworkers and serious amateurs swear by. We left them out because this is a *basic* tool kit.

In at least one case, we did so with great reluctance. All of us would have liked to include a table saw in the package, but we omitted it for reasons of economy.

Even without the table saw, if you walk into your local tool shop

and ask for everything on our list, the clerk might ask you for a \$1,000 bill. How can you get a start in this hobby without robbing a bank? We believe the answer is to plan carefully and buy wisely.

### Plan Ahead

Equip your shop a few tools at a time. As your skills improve, so will your tool inventory. In this basic kit, we list the tools that we find indispensable in **bold-face type**. They're the items you're likely to find most useful and use most often, so think about purchasing them first.

Can you sidestep any processes for which you're not well equipped? Some retail wood outlets will joint, rip, thickness, and crosscut lumber to size, for example. You pay for this service, of course, but in the short run it's less expensive than buying the tools you'd need to do the work yourself.

As you budget each new project, try to figure in the purchase of one new and necessary tool. You'll spread out the cost of equipping your shop, and you'll be able to enjoy a new tool with each new project.

Finally, remember that there *are* woodworkers who make exceptional pieces with hand tools only. We are addicted to the power tools in our shop, but we know that life can go on without them.

*Continued*



# Your screwdriver just became obsolete.



Once you've used the Skil Cordless Screwdriver, you won't want to go back to your old screwdriver. The Skil Cordless Screwdriver weighs mere ounces and is so small it fits into your pocket. Yet its high torque motor has the power to drive up to 500 screws on a single charge.

The Skil Cordless Screwdriver recharges in 3 hours or less and even has a special built-in feature to help prevent stripping of screws. And since it's cordless, it's perfect for everything from everyday fixups in or out of the house, to serious do-it-yourself projects.

With everything it can do, you'd think the Skil Cordless Screwdriver would be expensive, but it's not. Not at all. And its surprisingly low price makes it a great gift.

So forget about all the stripped screws, tired arms and blisters that went with your ordinary screwdriver. The Skil Cordless Screwdriver just made them obsolete.

**SKIL**® We build tools  
that last and last and last.



SKIL CORPORATION  
SUBSIDIARY OF EMERSON ELECTRIC CO.  
4801 WEST PETERSON AVENUE  
CHICAGO, IL 60646

# ALL NEW LIGHTWEIGHT SAND-O-FLEX®

Power Sands Curves  
with Greater Ease!



The professional way to sand paint, moldings, furniture, carvings is now made easier. Designed for power drills it's perfectly balanced, easier to handle. Revolving brushes cushion slashed abrasive over curves and detail, without gouging. Wheel has hi-impact-resistant plastic body and yards of longer lasting, industrial cloth abrasive 1" wide. Turning cover feeds out new abrasive as needed.

**ORDER BY MAIL** 6 1/2" overall dia. brush tip to brush tip. 8-brush wheel and coil of abrasive only \$15.95. Extra 2.44 yard Abrasive Refills \$4.50 ea. **\$15.95** in Coarse, Medium or Fine. Add \$1.50 postage and handling.

**MERIT ABRASIVE PRODUCTS, INC.**  
201 W. Manville, Dept. BHGW,  
Compton, CA 90224

## RIPSTRATE® SAVES FINGERS

### AND GIVES STRAIGHTER CUTS

If you own a table or radial arm saw you know what that whirling blade could do to your hands. RIPSTRATE guides the work tight against the fence and table while you push it through with a stick, with both hands away from the blade. **ALSO PREVENTS KICKBACKS.**

Requires no adjustment. RIPSTRATE is not just a safety device. Professional shops use it because it gives straighter cuts and speeds the work. Money back guarantee. \$59.50. Add \$3.50 shipping. Check, Visa, M/C. Free brochure.



Write, or call our  
Toll free number:

800 421 0256

Fisher Hill Products  
4 Fisher Hill  
Fitzwilliam, NH 03447

## TOOL BUYMANSHIP

### Continued from page 10 **basic, commonsense tool kit**

#### Be a Smart Tool Buyer

When you're ready to buy tools, shop carefully. Check more than one store, read all the catalogs you can obtain (the information they contain will save you substantially more than the few dollars they may cost), and *always, always look for sales and specials.*

Mail-order advertisements in magazines such as WOOD regularly offer substantial price reductions on top-quality tools. And sales are such normal marketing techniques at several nationwide retail chains that it sometimes seems difficult to pay full retail price for their popular tools.

Many manufacturers offer several product lines: inexpensive tools for "hobbyists" and more elaborate heavy-duty models for commercial and professional use. How much tool do you need?

In general, it makes sense to buy the best equipment you can afford, particularly when you're purchasing hand tools. It's unlikely that a good saw or plane will become obsolete, and with basic maintenance there's no reason why these tools can't last for centuries. The thought that a great-great-grandchild might one day enjoy using your combination square could make spending extra dollars seem like a wise investment.

When it comes to power tools, however, it gets easier to fall into the "overkill" trap. If a 1-horsepower router will be entirely adequate for your needs, do you really need a 3-horsepower model?

Good tools don't go out of style. A 100-year-old hand plane or wood chisel looks pretty much the same as a brand-new one, and some woodworkers insist that, the older the tool, the higher the quality. As this issue's article about classic saws demonstrates, old tools can actually be more expensive than new models. But auctions and newspaper classifieds are often good sources for low-cost, high-quality items, so think about buying your

Continued on page 14

# Total Shop . . . the name for quality.

You've heard of the Shopsmith® woodworking machine — now take a look at Total Shop — the improved woodworking machine.

*For Example:*

1. 1½hp motor develops nearly 3hp while Shopsmith® motor is 1⅛hp developing 2hp.
2. Motor can be altered by owner to 220V. Shopsmith® does not have this option.
3. Though a larger and more powerful motor, Total Shop runs quieter than the Shopsmith® machine.

*Let us send you 11 more reasons  
Total Shop is a better buy.*

**Attention Shopsmith® Owners:  
Call today for our accessory brochure  
and save money.**

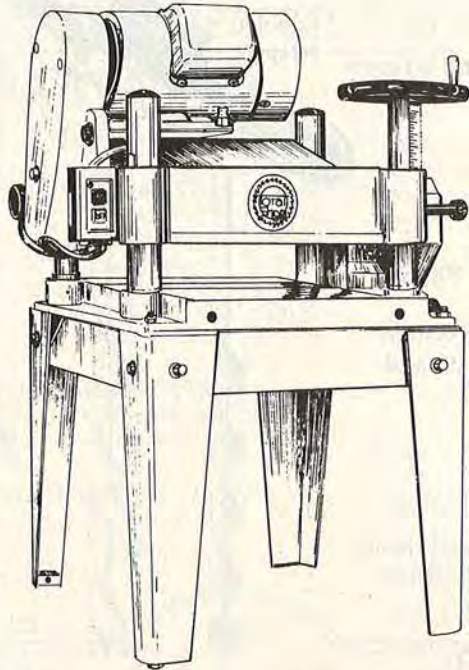

**TotalShop®**

P. O. Box 16297/Greenville, SC 29606



**CALL TODAY**  
toll free  
**1-800-845-9356**  
in S.C. call  
288-4174

*Introducing:*

## **Total Shop TS 15-6 Planer**

- 110 V or 220 V
- Stand & dust collector available
- 2 HP motor
- 15" width, 6" thickness

clip and mail coupon for: Free Informational Kit

**TotalShop®**

Dept. Q  
P.O. Box 16297  
Greenville, SC 29606

Your Name \_\_\_\_\_

Address \_\_\_\_\_

City \_\_\_\_\_ State \_\_\_\_\_ Zip \_\_\_\_\_

Phone \_\_\_\_\_

Multipurpose tool     TS 15-6 Planer

Training Schools available

©United Metal Services, Inc.

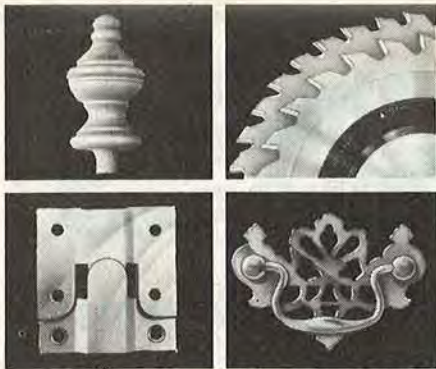

**NEW** 1984/85  
**CATALOG**  
 112 Pages of Woodworking  
 Supplies & Hardware

Enclosed  \$1.00 (3rd Class)  
 \$2.00 (1st Class)

Name \_\_\_\_\_

Address \_\_\_\_\_

City/State/Zip \_\_\_\_\_



**The Woodworkers' Store**  
 21801 Industrial Blvd. Dept. H909  
 Rogers, MN 55374

**FREE  
 PLAN**  
**\$3.95  
 VALUE**



Let us send you our three-in-one Hall Clock Plan FREE as a way of introducing ourselves. We will also send our Klockit catalog which features American-made quartz clock movements, clock kits, furniture kits, brass movements, dials, woodworking tools, and much, much more.

Send \$1 for postage and handling, and your FREE clock plan and catalog will be on their way.



Dept. WD15  
 P.O. Box 629  
 Lake Geneva, WI 53147  
 414/248-1150



**KLOCKIT**

**TOOL BUYMANSHIP**

Continued from page 12

**basic, commonsense tool kit**

tools used. You might even find a great deal on that table saw we'd so much like you to have.

**Basic, Commonsense Tool Kit**

Measuring tools:

- Combination square
- Sliding bevel
- Marking gauge
- Framing square
- Steel tape (10' or 12')
- Folding rule
- Compass
- Scratch awl

Cutting tools:

- Crosscut saw (12 pt.)
- Rip saw (6½ or 7½ pt.)
- Backsaw or dovetail saw (15 tpi)
- Coping saw
- Hacksaw
- Slip-joint pliers
- Needlenose pliers
- Diagonal cutters

Shaping tools:

- Smooth plane
- Low-angle block plane
- Wood chisels (¼", ½", ¾", 1")
- Single-cut mill bastard file
- Round rasp
- Flat rasp
- Cabinet scraper and hand scrapers
- Utility knife

Joining tools:

- Claw hammer (16 oz.)
- Finish hammer (8 oz.)
- Nail set
- Wooden mallet
- Screwdrivers (Straight, Phillips)
- Doweling jig
- Bench vise or clamping system
- Bar or pipe clamps (2-3' and 2-5' min.)
- Handscrews
- C-clamps

Portable power tools:

- Router (1 HP, ¼" collet)  
 (Purchase bits as needed: bead, chamfer, cove, dado, straight, round-over, rabbet)
- Circular saw (7¼")
- Drill (⅜" variable speed)
- Twist drills (⅜"-⅝")
- Spade shaped drill bits
- Brad point drills
- Saber saw

- Dual-action pad sander (straight-line and orbital)
- Belt sander (3" x 21" with dust collection)

Safety and maintenance:

- Face shield or safety glasses
- Hearing protector
- Dust mask or respirator
- Sharpening stone (dual-purpose, coarse/fine) ■

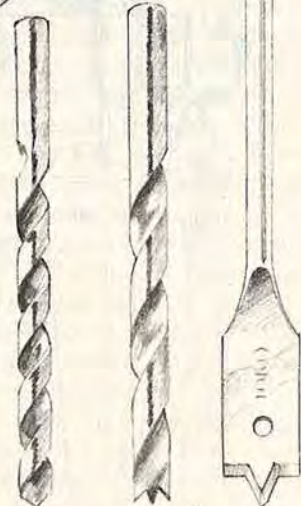
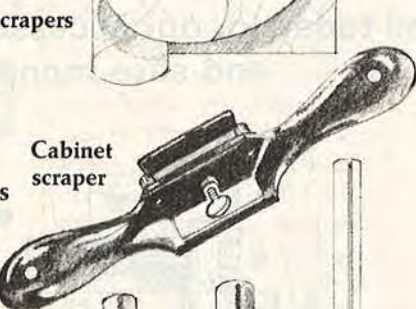
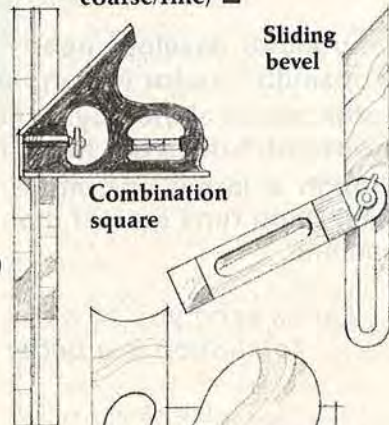

Twist bit      Brad point bit      Spade bit



# NEW FREUD HAND TOOLS!

Freud's high quality hand tools are an outstanding value! These items incorporate features that the most demanding professional will appreciate — at surprisingly low prices!

All blades are precision ground **chrome vanadium**, assuring very long tool life. The chisels and carving tools have handles of rare, close grained **Boxwood**, hooped at both top and bottom. The turning tools have long Ash handles. Each set comes complete with it's own wooden box for storage.

Discover the pleasure of using fine hand tools with these new products from Freud. They also make a great gift!

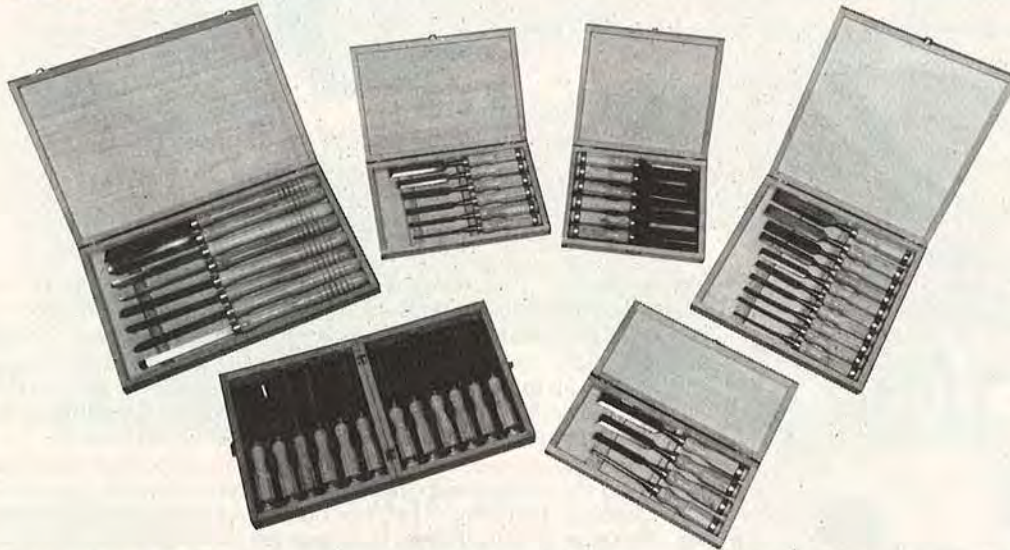

WC104	4 pc. Chisel Set .....	\$26.95	CS106	6 pc. Carving Set .....	\$ 64.95
WC106	6 pc. Chisel Set .....	\$33.95	CS112	12 pc. Carving Set .....	\$114.95
WC110	10 pc. Chisel Set .....	\$55.95	TT108	8 pc. Turning Set .....	\$56.95



## DON'T FORGET FREUD'S FAMOUS CARBIDE TOOLS

### SAWBLADES

LM72M	10", 24t, flat top rip	\$ 42.00
LU73M	10", 60t, ATB cutoff	\$ 42.00
LU84M	10", 50t, smooth comb.	\$ 42.00
SET	ALL THREE ABOVE	\$125.00
LU82M	10", 60t, triple chip	\$ 49.00
LU85M	10", 80t, super blade	\$ 72.00
DS306	6" dado 1/4" - 13/16"	\$ 99.00
DS308	8" dado 1/4" - 13/16"	\$120.00
TR100	3 blades and 8" dado	\$259.00

### OUR PERFECTIONIST'S SET

Includes the LU85M super blade, the LM72M rip blade and the DS308 dado set.  
ALL THREE .....

\$229.00

**ALL ROUTER BITS**                      **25% off**

### WOODWORKING BOX

This set of four carbide shaper cutters will make many mouldings and several complete raised panel door styles. Optional cutter is advised for door sets. Bore is 3/4", add \$15.00 for smaller spindle.

WB101	Woodworking Box .....	\$309.00
OPT101	Optional Cutter .....	\$ 62.50

### SHAPER SHOP

A universal shaper head with 20 pairs of profiled steel knives. Bore is 1-1/4", add \$7.00 for smaller spindle.

Shaper Shop .....

**ALL PRICES INCLUDE SHIPPING**

**ORDER TOLL FREE**  
**1-800-354-9083**

IN KENTUCKY CALL  
**(606) 254-9823**



WE  
ACCEPT



138

THE  
**Xylophile's**  
COMPANY

138 E. Loudon Avenue • Lexington, KY 40505

# Take this giant \$47.90 Capotosto WOODWORKING LIBRARY FOR JUST \$3.95

as your welcome to Popular Science Book Club

PLUS DELIVERY AND HANDLING

More than  
**3000 ORIGINAL  
ILLUSTRATIONS, PLANS,  
SEQUENCE PHOTOS**  
show you every detail of project construction  
with hand and power tools... plus every  
woodworking technique you must know!



## COMPLETE BOOK OF WOODWORKING WOODWORKING TECHNIQUES & PROJECTS

by Master Woodworker R. CAPOTOSTO

Whether you're a weekend woodworker or a pro in the business, your woodworking success and satisfaction for projects big and small are practically guaranteed with this superb how-to library! Super-handy and unique, these excellent Capotosto books demonstrate all the basics and fine points you need to know and they introduce scores of innovative woodworking tips and techniques that save you time, materials, and dollars!

You'll gain confidence and learn new skills with these important books. They're loaded with illustrated answers on wood identification, selection, handling... pro tips on wood joinery, sizing, measuring, cutting, matching, filling, finishing... valuable time and money-saving how-to on building, repairing, construction techniques—including dozens of original woodworking project plans you can build and finish yourself!

You get nearly 50 measured construction plans for tables, chairs, beds, cabinets, lamps, benches, a dry sink, mobile greenhouse, butcher block, tea cart, gateleg table, campaign desk, grandmother clock, rolltop desk, hutch, lounge, candlestand, full-function wall unit and much, much more!

Yes, this valuable \$47.90 woodworking package—custom-written exclusively for Popular Science Book Club—offers you an enormous range of do-it-yourself ideas, know-how, and challenge. More than 3000 illustrations, photos, diagrams (created specifically for these books), show you exactly how to do each technique and project step by step. More than 840 pages of easy-to-follow text instruct you carefully and exactly. Nothing is left out!

As a member of Popular Science Book Club, you get to choose the best from hundreds of brand new, hard-to-find do-it-yourself books on: Home Repair & Improvement, Home Workshops, Basic & Advanced Woodworking, House Building, Remodeling, Insulation, Wiring, Plumbing, Masonry, Electronics, Appliance Repair, Furniture Building, Energy Savers, Solar, and much more. It's always your choice and there are many bargains to choose from! To become eligible for these bargains, mail the card today. There's no risk!

**FREE** when you join



This handy Shop Guide measures in inches, centimeters. It's also a compass, protractor, drill and chisel grinding gauge, bolt and screw sizer, bolthead and penny nail measurer, and more!



Working an entire edge with a pattern. The collar and pattern are in the lower position. The work is held to the pattern with several brads driven through the bottom of the pattern.



One of the simplest methods of drawer-and-guide construction which can be made with power tools. The drawer slides in slots dadoed into the 3/4" plywood cabinet sides. (American Plywood Assn.)

## WORK WONDERS WITH WOOD!

It's easy with master woodworker Rosario CAPOTOSTO as your step-by-step, start-to-finish guide! Mr. Capotosto is a skilled woodworker/craftsman and a prolific how-to writer/photographer who has contributed hundreds of articles to leading handyman publications. His

superb step-by-step photos show you exactly how to create and build exciting new furniture projects *and* how to do basic and fine woodworking techniques with ease, accuracy, and an original professional touch, *even if you're a beginner!*

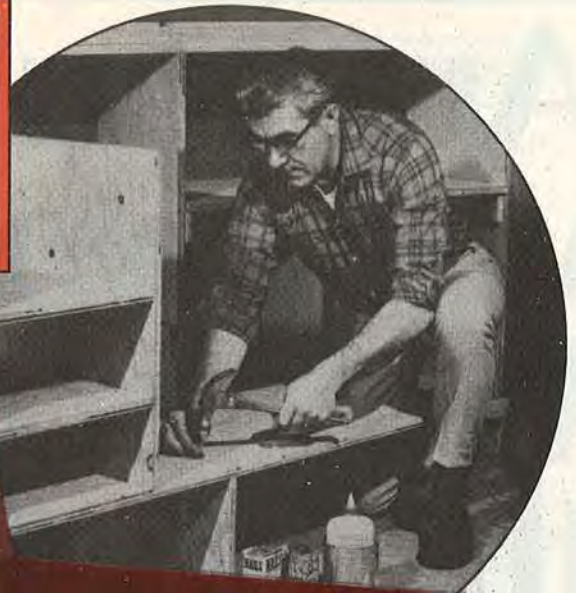

# COMPLETE BOOK OF Woodworking

A Popular Science Book

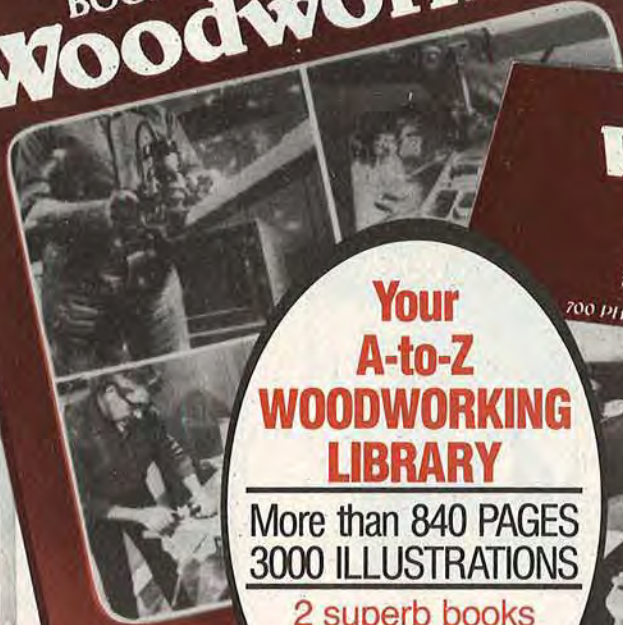

# CAPOTOSTO'S Woodworking Techniques AND Projects

A Popular Science Book

700 PHOTOS • 45 DETAILED PLANS • 100 DIAGRAMS



## Your A-to-Z WOODWORKING LIBRARY

More than 840 PAGES  
3000 ILLUSTRATIONS

2 superb books  
by a master  
woodworker

### HOW YOUR CLUB WORKS

First, you get your \$47.90 Capotosto WOODWORKING LIBRARY along with your FREE 20-IN-1 SHOP GUIDE for just \$3.95 plus delivery and handling. Send no money. We'll bill you after you receive your books. Then, about every four weeks (14 times a year) you'll receive a colorful Club Member's bulletin describing the coming main selection and a large selection of alternate books also available. In addition, up to 4 times a year, you may receive selected mailings on seasonal and annual products of special interest to the membership, many at giant bargains! If you want the main selection only, do nothing. It will be sent automatically. If you don't want it or want an alternate book, or no books at all, simply indicate your wishes on the handy form that comes with the bulletin and return it to us by the date shown. (No envelope needed.) Club mailings are carefully scheduled to assure you

of at least 10 days in which to do this, but in the unlikely event that you don't have 10 days, and you receive an unwanted selection, you may return it at our expense.

You take only the books you want and your only obligation, after accepting your joining books, is to buy just two more selections or alternates of your choice within a year. After that, membership may be cancelled by either you or the Club.

**GIANT DISCOUNTS!** Club books are comparable in every way to the original publishers' editions, yet you may save up to 50% and sometimes more on many special bargains offered throughout the year to the membership. To become eligible for these bargains, mail the attached postpaid card today! What a great way to build a valuable handyman's library of first-rate books that can really save you time, effort, and dollars in the months ahead!

*Mail attached card today!*

If card is missing, write to:

**Popular Science Book Club**

P.O. Box 2006, Latham, N.Y. 12111

# Are you working with wood? We wrote the book!

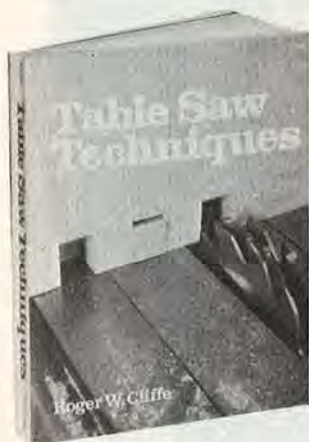

## TABLE SAW TECHNIQUES

**Roger W. Cliffe.** A veritable encyclopedia packed with the latest information on every model of table saw, blade, accessory, jig, technique! Includes closeup photos, easy-to-follow diagrams, superb draftsman-quality drawings, floor plans, and projects. Nothing is left out. The author includes tips, pointers, special set-ups. Nor is this book for master woodworkers only. Small details such as safety latch position, choosing the right table, cutting different types of wood and much more are included. If you want to solve problems and build projects like a pro while getting the absolute most out of the table saw you already own or intend to buy, act now. 352 pages, 8×10, 700 photos, drawings, plans, diagrams.

Paper \$14.95



## WOOD FINISHER'S HANDBOOK

**Sam Allen.** From the newest space age techniques to the traditional, this is a state-of-the-art book. Find out how to prepare new wood, repair old wood by hand and machine, make and apply stains, varnishes, lacquer and shellac. Full coverage on French polishing, gilding, stenciling & reproducing antique stains. Includes formulas for mixing your own. 160 pages, 8×10, 150 photos.

Paper \$9.95

## DECOY PATTERN BOOK

**Keith Bridenhagen.** Award-winning master carver gives 40 double-page duck patterns on graph paper for easy tracing—for mallard, gadwall, pintail, canvasback, redhead, bufflehead, ring-neck, dozens of others—each accurate in scale, coloring & feathering, etc. Includes several head & body patterns for maximum variation. Priceless! 128 pages, 8½×11, 94 patterns, photos.

Paper \$9.95

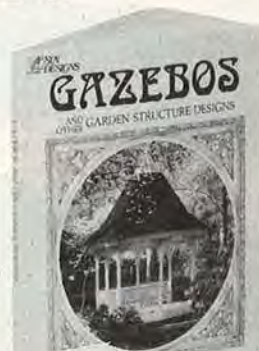

## COMPLETE GUIDE TO WOOD CARVING

**E.J. Tangerman.** A 50-year bonanza of projects by the world's most renowned carver. Hundreds of projects: animals, plants, boats, faces, heads, human figures, over 600 photos & drawings and countless hints. Covers everything from sizing drawings & capturing personality to complete finishing details. For carvers, it's a must! 384 pages, 7×10.

Paper \$12.95

## GAZEBOS AND OTHER GARDEN STRUCTURE DESIGNS

**Janet A. Strombeck and Richard H. Strombeck.** A nostalgic look at a variety of garden structures—55 different and exciting gazebos, birdhouses and feeders, arbors. Includes complete blueprints for some projects, all others available. All drawings have exact dimensions, plus alternate selections for accessories. 96 pages, 8½×11, 57 drawings, 23 diagrams, 8 pages of plans.

Paper \$7.95

## THE WOODTURNER'S COMPANION

**Ron Roszkiewicz.** An expert's step-by-step guide. 340 photos from the turner's actual point of view highlight every detail and technique. Roszkiewicz opens up his workshop, showing how the lathe, tool box, sharpening systems and workbench are set up. *Bonus:* secrets for sanding & finishing, adhesives & clamps, and the latest discoveries in tools & turning aids. 256 pages, 8×10.

Paper \$12.95

# STERLING: THE #1 BOOK SOURCE FOR WOODWORKERS

# S STERLING WOODWORKING BOOKS ARE AVAILABLE AT THESE FINE OUTLETS

## ARIZONA

**The Cutting Edge of Arizona**  
10844 N. 23rd Ave.  
Phoenix, AZ 85029  
602/997-8665

## CALIFORNIA

**WOODLINE**  
**The Japan Woodworker**  
1731 Clement Ave.  
Alameda, CA 94501  
415/521-1810

**R. Sorsky Bookseller**  
3845 N. Blackstone Ave.  
Fresno, CA 93726  
209/227-2901

**The Cutting Edge**  
3871 Grand View Blvd.  
Los Angeles, CA 90066  
213/390-9723

**The Cutting Edge of San Diego**  
7826 Miramar Rd., Ste. 3500  
San Diego, CA 92126  
619/695-3990

**Hardwoods Center**  
2611 South Harbor Blvd.  
Santa Ana, CA 92704  
714/540-7117

**Whispering Winds Hardwoods**  
565 - 7th Ave.  
(In the Boat Yard)  
Santa Cruz, CA 95063  
408/476-9030

## COLORADO

**Paxton Beautiful Woods**  
**Frank Paxton Lumber Co.**  
4837 Jackson  
Denver, CO 80216  
303/399-8810

**Lewis Tool and Supply**  
912 W. 8th St.  
Loveland, CO 80537  
Catalog \$1.00

## CONNECTICUT

**The Fine Tool Shops, Inc.**  
20 Backus Ave.  
Danbury, CT 06810  
203/797-0183

**Mystic River Hardwoods**  
2 Elm St., Route 215  
Noank, CT 06340  
203/536-4118

## FLORIDA

**Constantines Wood Center**  
**of Florida, Inc.**  
1040 E. Oakland Park Blvd.  
Ft. Lauderdale, FL 33334  
305/561-1716

## GEORGIA

**Highland Hardware**  
1045 N. Highland Ave. NE  
Atlanta, GA 30306  
404/872-4466

**Silverlake Woodcarving Supply**  
PO Box 930056  
Norcross, GA 30093  
\*\*\*Free Catalog\*\*\*

## ILLINOIS

**Owl Hardwoods Lumber Co.**  
1514 E. Algonquin Rd.  
Arlington Heights, IL 60005  
312/439-5580

**The Hardwood Connection**  
420 Oak St.  
DeKalb, IL 60115  
815/758-6009

## BERLAND'S

**House of Tools**  
1524 Centre Circle  
Downers Grove, IL 60515  
312/620-0026

## INDIANA

**The Wood-Craftsman's Store**  
2116 W. Coliseum Blvd.  
Fl. Wayne, IN 46808  
219/482-4822

**Northwest Lumber Co., Inc.**  
5035 Lafayette Rd.  
Indianapolis, IN 46254  
317/293-1100

**Johnson's Workbench**  
51315 U.S. 33 North  
South Bend, IN 46637  
219/277-8350

## IOWA

**The Woodcraft Shop**  
419 E. 59th St.  
Davenport, IA 52806  
319/386-5318

**Paxton Beautiful Woods**  
**Frank Paxton Lumber Co.**  
1400 Market St.  
Des Moines, IA 50309  
515/283-2131

## KENTUCKY

**Manny's Woodworker's Place**  
602 S. Broadway  
Lexington, KY 40508  
606/255-5444

**Bob Morgan**  
**Woodworking Supplies**  
1123 Bardstown Rd.  
Louisville, KY 40204  
502/458-2545

## LOUISIANA

**Kent Courtney's Woodshed**  
**The Carver's Journal**  
625 W. Main  
PO Box 626  
Broussard, LA 70518  
318/837-9470

## MARYLAND

**Craftwoods**  
10921 York Rd.  
Cockeysville, MD 21030  
301/667-9663

## MASSACHUSETTS

**Factory Lumber Outlet**  
200 Shrewsbury St.  
(Route 140)  
Boylston, MA 01505  
617/869-2791

**Trend-lines, Inc.**  
365 Beacham St.  
Chelsea, MA 02150  
617/884-8882

**Woodcraft Supply Corp.**  
41 Atlantic Ave.  
PO Box 4000  
Woburn, MA 01888  
617/935-5860

## MICHIGAN

**Johnson's Workbench**  
563 N. Cochran Ave.  
Charlotte, MI 48813  
517/543-2727

**Dalek Woodworks**  
**Bench Mark for Quality**  
2013 Austin St.  
Troy, MI 48064  
313/689-0230

## MINNESOTA

**Wood Carvers Supply, Inc.**  
**Complete Wood Working**  
**Outfitters**  
3056 Excelsior Blvd.  
Minneapolis, MN 55416  
612/927-7491

**Meisel Hardware Specialties**  
PO Box 258  
Mound, MN 55364  
612/472-5542

**The Woodworker's Store**  
21801 Industrial Blvd.  
Rogers, MN 55374  
612/428-4101

## MISSOURI

**Paxton Beautiful Woods**  
**Frank Paxton Lumber Co.**  
6311 St. John Ave.  
Kansas City, MO 64123  
816/483-7000

**Skates Belting & Supply Co.**  
321 Southwest Blvd.  
Kansas City, MO 64108  
800/821-5041 or 816/421-4158

**The Wood & Shop**  
5605 N. Lindbergh  
St. Louis, MO 63042  
314/731-2761

## NEBRASKA

**Midwest Woodworkers**  
**Supply, Inc.**  
**Fine Tools & Hardwoods**  
13209 I St.  
Omaha, NE 68137  
402/330-5444

## NEW JERSEY

**Tool Chest, Inc.**  
45 Emerson Plaza E.  
Emerson, NJ 07630  
201/261-8665

## NEW MEXICO

**Paxton Beautiful Woods**  
**Frank Paxton Lumber Co.**  
1909 Bellamah NW  
Albuquerque, NM 87104  
505/243-7891

**Woodworker's Supply, Inc.**  
5604 Alameda NE  
Albuquerque, NM 87113  
505/821-0500

**Woodpecker's Tool, Inc.**  
614 Agua Fria St.  
Santa Fe, NM 87501  
505/988-2288

## NEW YORK

**Albert Constantines & Sons, Inc.**  
2050 Eastchester Rd.  
Bronx, NY 10461  
212/792-1600 (Mail Order)

**Garrett Wade**  
161 Avenue of the Americas  
New York, NY 10013  
212/807-1155

**Pittsford Lumber and Woodshop**  
50 State St.  
Pittsford, NY 14534  
716/586-1877

**Cryder Creek Wood Shoppe, Inc.**  
**Complete selection of turning**  
**wood, tools and accessories**  
101 Commercial Ave. E.  
Whitesville, NY 14897  
607/356-3303

## OHIO

**Shopsmith, Inc.**  
6640 Poe Ave.  
Dayton, OH 45414  
513/898-6070

## OKLAHOMA

**Paxton Beautiful Woods**  
**Frank Paxton Lumber Co.**  
1815 S. Agnew Ave.  
Oklahoma City, OK 73148  
405/235-4411

**Paxton Beautiful Woods**  
**Frank Paxton Lumber Co.**  
5420 S. 99th East Ave.  
Tulsa, OK 74145  
918/665-2411

**Woodcrafters Lumber Sales, Inc.**  
212 NE 6th Ave.  
Portland, OR 97232  
503/231-0226

## PENNSYLVANIA

**Woodcrafters' Supply, Inc.**  
7703 Perry Hwy. (Rt. 19)  
Pittsburgh, PA 15237  
412/367-4330

**Exotic Woodshed**  
65 N. York Rd.  
Warminster, PA 18974  
215/672-2257

## TENNESSEE

**Hardwoods of Memphis, Inc.**  
PO Box 12449  
Memphis, TN 38182-0449  
901/452-9663 or 800/321-5239

**The Woodworker's Shoppe**  
**Specializing in fine tools**  
**and hardwoods**  
5513 Brainerd Rd.  
Chattanooga, TN 37411  
615/855-0400

## TEXAS

**Paxton Beautiful Woods**  
**Frank Paxton Lumber Co.**  
1105 Sixth Ave.  
Carrollton (Dallas), TX 75006  
214/245-1192

**Paxton Beautiful Woods**  
**Frank Paxton Lumber Co.**  
2625 Hemphill  
FL Worth, TX 76110  
817/927-0611

**Wood World**  
1351 S. Floyd Rd., Ste. 101  
Richardson, TX 75081  
214/669-9130

## VERMONT

**Sisco Supply, Inc.**  
4050 Williston Rd.  
PO Box 9499  
South Burlington, VT 05401  
802/863-9036

## WASHINGTON

**The Wooden Boat Shop**  
1007 NE Boat St.  
Seattle, WA 98105  
206/634-3600

## WISCONSIN

**Punkin Hollow**  
**Wood and Tool**  
N34 W24041 Captiol Dr.  
Pewaukee, WI 53072  
414/691-9411 or 800/558-8665

## PRODUCTS THAT PERFORM

### Light, strong, laminated mallets



Pressure-impregnate beech veneers with synthetic resins, laminate them, and the result is Lignostone, a rock-hard material that is perfect for mallet heads. These handsome tools are available in sizes and shapes for woodworkers and carvers, furniture restorers, and others who require a light but firm touch. *Lignostone Mallets. No. 445, Woodcarving Mallet, \$13.65; No. B2, Sculptor's Mallet, \$29.95; No. 855, Hobby Mallet, \$13.45; other sizes available. Order from Themans, Inc., 5721G Bayside Road, Virginia Beach, VA 23455.*

### Threaded inserts for wood



These inserts can be installed with a screwdriver, although we prefer to use a drill press (see page 51). Once in place they provide sturdy threads where you want them. Simply drill a hole the same size as the insert, then install a little below the surface. Available in 1/4" and 3/8" sizes. *Threaded Inserts. \$26 per 100 (\$.32 each) plus shipping and handling. We ordered ours from The Woodworkers' Store, Dept. W, 21801 Industrial Blvd., Rogers, MN 55374, but they're available at large retail outlets.*

Continued

# AT LAST... WOODWORKERS

The Package You  
Have Waited for:

## Handi-Pak by ESC



Specialized Screws for your Woodworking. In packages of 50 - 100. (Hinge Screws: 500)

### CASE-HARDENED STEEL

won't  
snap  
in half.

**RAZOR  
SHARP**  
Points  
penetrate  
easily.  
Phillips &  
Square  
Drive

**STOCKED**

for  
**IMMEDIATE SHIPMENT.**

*Satisfaction guaranteed or your money back.*  
(\$35.00 MINIMUM ORDER)



Please send

- SamplePak (3 screws for inspection)  
 Fastener Guide/Price List

Company \_\_\_\_\_

BHW 1-85

Address \_\_\_\_\_

City \_\_\_\_\_

State/Zip \_\_\_\_\_

Phone ( ) \_\_\_\_\_

Name \_\_\_\_\_

Title \_\_\_\_\_

**EQUALITY**

**SCREW CO. INC.**  
P.O. Box 1645  
El Cajon, CA 92022

(619) 562-6100  
Toll Free 800-854-2886  
In California 800-552-8844

## PRODUCTS THAT PERFORM

Continued from page 21

### Rotary part storage



Store screws, nails, and other hardware in a *Turnbox* container. Rugged plastic compartments are stacked five to a level on a steel spindle for rotary action. Though large enough for lag screws and carriage bolts, the pie-shaped bins won't sag when full. Screw holes in the base allow attachment to a workbench. The five-level *Turnbox* shown is 12" high and 8" in diameter with 25 compartments. *Turnbox*. Five-level, \$12; Three-level, \$8; Eight-level, \$16. Available by mail order from *Themans, Inc.* Dept. W, 5721G Bayside Road, Virginia Beach, VA 23455.

### Stainless steel caliper rule



This beauty of a caliper doesn't cost an arm and a leg. The vernier-style instrument is precise—measuring depth and inside and outside dimensions in both metric and standard scales. The slide moves effortlessly along the beam and locks securely

in place with a thumbscrew. Knife blade points grasp round and thin objects securely and help you focus on fine marks. Made of hardened stainless steel with satin-polished chrome finish, this instrument is manufactured to industrial quality and should last for years. *Central Forge Model 939 0-150 mm, 6" Caliper Rule*. \$11.50, direct from *Harbor Freight and Salvage Company*, Dept. W, P.O. Box 15833, North Hollywood, CA 91615-5833. Telephone 1-800-423-2561

### Rechargeable cordless screwdriver



After using this lightweight power screwdriver, you'll be tempted to toss out all your others.

The *Skil Cordless Screwdriver* weighs about a pound and drives up to 500 screws on a single charge. It has off/on plus forward and reverse switches. Speed is rated at 130 rpm, and the manufacturer says there's a built-in feature that helps prevent over-tightening. The unit requires three hours and a 110-volt outlet to recharge. The body of the tool is high-impact, shock-resistant plastic. A reversible bit—one end Phillips, the other straight—is included (regular drill bits won't work). *2000 Cordless Screwdriver*. Available at retail outlets, about \$30. *The Skil Corporation*, 4801 West Peterson Ave., Chicago, IL 60646.

Continued on page 24



Clock measures 7¼ inches tall, scaled 1 inch to 1 foot. Features a door that opens and closes to reveal the solid brass clock weights and pendulum! Kit has everything needed to assemble clock.

A \$9.95  
Retail Value

The House of Miniatures invites you to build...  
**A collection of authentic  
 true-to-scale antique furniture**

Experience the personal satisfaction of creating antique *miniature* reproductions with your very own hands. Imagine the thrill of displaying classic Chippendale in your home. Showing off a Hepplewhite dining set or a Queen Anne table. These are among the world's most treasured antiques. Now you can enjoy the timeless beauty and charm of these furniture masterpieces *in miniature*—with our extraordinary museum quality kits.

Each House of Miniatures kit is precision-scaled to 1/12 of the full-size original and cut to exact specifications. Only furniture-quality hardwood is used, and fittings and hardware are of solid brass—finished to fit perfectly.

Kits include detailed step-by-step instructions. No special tools or skills are required for assembly.

Begin your collecting adventure with our miniature reproduction of the William & Mary clock kit for only \$1 when you become a trial member of The House of Miniatures Collectors Society.

As a trial member, you will have the opportunity to purchase, *if you wish*, other museum quality miniature kits. However, you are not obligated to buy any additional kits—ever!

Remember, this William & Mary clock kit is available for \$1 by mail only. *With no further obligation on your part.* Mail coupon today!

Take this  
 museum quality  
**William & Mary  
 Clock Kit for only \$1\***  
*with no further obligation*

© 1984 Craftmark Inc.

Each kit has fine details

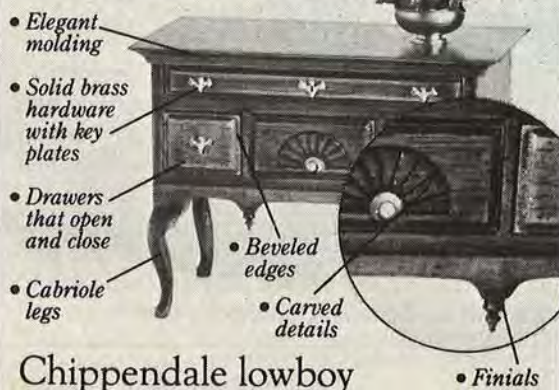

**THE HOUSE OF MINIATURES**

Division of Craftmark Inc., 80 Newbridge Road, Bergenfield, NJ 07621  
 Please enroll me as a trial member of the Society and send me the William & Mary clock kit. Bill me only \$1\*. If I am not completely satisfied, I may refuse delivery of the second shipment by writing "cancel me" on the shipping label. If I keep the second shipment, I will be a regular member and receive additional shipments every four weeks. Prices for each shipment, which will contain one or two kits, are \$9.95\* or less. I may return any shipment and I am not obligated to accept any minimum number. BR06

Mr.  Mrs.   
 Ms.  Miss  All enrollments are subject to acceptance.

Address \_\_\_\_\_

City \_\_\_\_\_ State \_\_\_\_\_ Zip \_\_\_\_\_

\*Plus shipping, handling and sales tax.

**FREE BONUS**

Professional Quality Finishing Samples  
 Include tinted glue, oil base stain (for authentic color), glaze stain for antiquing and highlighting and other materials to professionally finish your kit to museum quality.

**FREE** COLOR CATALOG

Build Your Own Grandfather Clock  
Prices Starting Under

**\$300**

(including movement and dial)

- Do-it-yourself case kit, parts pre-cut
- Finished clocks
- Solid 3/4" hardwoods: black walnut, cherry, oak
- Heirloom quality
- Factory direct prices
- Solid brass West German chiming movements
- Money back guarantee
- Prompt shipment

Write for **FREE** information



**EMPEROR**  
CLOCK COMPANY

WORLD'S LARGEST MANUFACTURER  
OF GRANDFATHER CLOCKS

Dept. 1336, Emperor Industrial Park  
Fairhope, Alabama 36532 • Phone 1-205-928-2316

I am interested in  Do-It-Yourself Kits  
(please print)  Finished Clocks

Name \_\_\_\_\_  
Street \_\_\_\_\_  
City \_\_\_\_\_  
State \_\_\_\_\_ Zip \_\_\_\_\_

**Get Into  
The Woods  
With Us**

**EDICO**

*School Shop Suppliers  
For 33 Years*

*Now Serving  
Craftsmen • Cabinet Makers*

**Top Grade  
Hardwoods**

*Appalachian & Imported  
Softwoods • Veneers  
Turnings*

*All Kiln Dried*

**Catalogue \$1.00  
Write Today**

**EDICO**

P.O. Box 5373 W  
Asheville, N.C. 28813



Call  
(704) 255-8765

**EDUCATIONAL LUMBER CO., INC.**

## PRODUCTS THAT PERFORM

Continued from page 22

### Clamps with bite



Stainless steel jaws with double rows of serrated teeth grab and hold wood, plastic, and soft metal at practically any angle. Clamps adjust to frames 1/2" to 3" wide, irregularly shaped moldings, compound miters, and joints larger or smaller than 45 degrees. Use a number of clamps to assemble longer miters. Pivoting jaws are 1 1/4" long; overall length, 9 1/2"; and maximum jaw opening, 3 1/2". Because of their teeth, these clamps are not recommended for use on finished wood. *Iraids Multi-Clamps. \$6.75 each plus shipping and handling. Available by mail order from The Woodworkers' Store, Dept. W, 21801 Industrial Blvd., Rogers, MN 55374, through selected catalog sources, and at some local hardware stores. Manufactured by Arvids Iraids, Cincinnati, Ohio.*

### No-bubble level and angle indicator



Using a new optical technology that eliminates the traditional bubble, the *Inogon Level and Angle Indicator* reads easily in any position. It

determines horizontals, verticals, and any angle in between with 0.2° precision. To check angles, place the tool on or against the work-piece (magnetic models cling to saw tables), then rotate the adjustment screw until parallel lines appear in the window. To set angles, dial the desired number of degrees, then tilt the tool until the parallel lines appear. Made of black anodized, brushed aluminum, the rule is calibrated in inches and centimeters. Indicator frame and window are high-impact plastic. This tool comes in 10", 24", and 48" lengths, and either magnetic or nonmagnetic models are available. *Inogon Level and Angle Indicator. Retail, from \$51.45 to \$73.95, depending on size and style. Or order direct from Sylvax Corporation, Dept. W, 342 Madison Ave., New York, NY 10016.*

### Snap-tie board hooks



Falling hook frustration ends with *PEG 'ems*, plastic hooks that won't come loose when you reach for a tool. Available as single hooks, double hooks, multi-tool holders, shelf brackets, and loop hooks, they're packaged in quantities varying by size. The hooks can be used with perforated hardboard or their own *Peg Strips*.

*PEG 'ems. In retail stores at \$1.09 per package. Peg Strips, 11" at \$1.99, 16" at \$2.99. Made by VSI Fasteners, Stanton, California. ■*



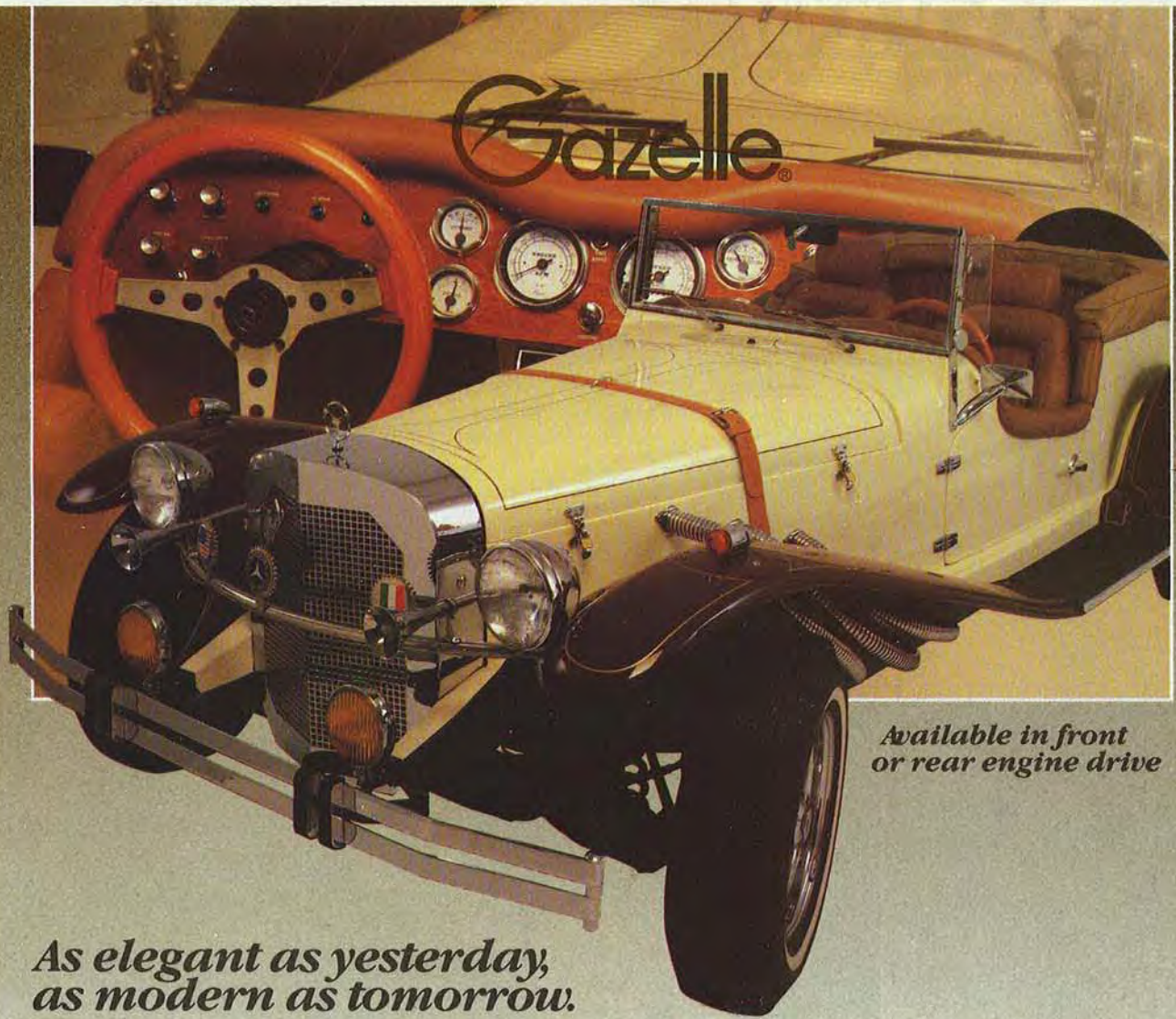

*Available in front  
or rear engine drive*

***As elegant as yesterday,  
as modern as tomorrow.***

*Classic Motor Carriages, the world's largest replicar assembly manufacturer, presents its classic line for the 80's. Millions of dollars have been spent in engineering research to enable Classic Motor Carriages to produce the finest replicar assemblies available. Gelcoat finish... no rusting ever! All replicar assemblies are fully warranted by a company that cares.*

*Classic owners report gas mileage of 30-34 MPG. Our replicar assemblies are designed for the person of average mechanical skills using ordinary tools.*



*Classic TD*



*Speedster*

*Fill out the coupon below and begin the most rewarding experience of your life.*

861-A-5

**CLASSIC MOTOR CARRIAGES**  
 16650 N.W. 27th Ave., P.O. Box 10  
 Miami, Florida 33054, (305) 625-9700  
 Mon. - Fri. 9AM-9PM Sat. 9AM-5PM Sun. 11AM-4PM

Enclosed is \$1 ea. for a full color brochure and consumer buying guide for Replicar Assembly: Gazelle \_\_\_\_\_ Classic Speedster \_\_\_\_\_ Classic TD \_\_\_\_\_ Classic Speedster C \_\_\_\_\_

Enclosed is \$5 ea. for a full color brochure on the handcrafted, factory-finished: Gazelle \_\_\_\_\_

Name \_\_\_\_\_  
 Address \_\_\_\_\_  
 City \_\_\_\_\_ State \_\_\_\_\_ Zip \_\_\_\_\_  
 Phone Home (Area Code) \_\_\_\_\_  
 Bus. (Area Code) \_\_\_\_\_

Please charge on my: MasterCard \_\_\_\_\_  
 VISA \_\_\_\_\_ Am. Express \_\_\_\_\_  
 Acct. No. \_\_\_\_\_ Exp. Date \_\_\_\_\_  
 Signature \_\_\_\_\_

*Look for our displays at airports in Amarillo, Baltimore/Washington International, Boston, Chicago, Cincinnati, Cleveland, Dallas/Love, Detroit, Grand Rapids, Gulf Port/Biloxi, Jacksonville, Kennedy, LaGuardia, Memphis, Miami, Minneapolis/St. Paul, Monterey, New Orleans, Palm Springs, Phoenix, Portland, Reno, San Jose, St. Louis, Tulsa.*

© 1984 Classic Motor Carriages, Inc. Some equipment depicted is optional.

# WHY GO ROUND AND ROUND WITH OLD-FASHIONED 'C' CLAMPS?

Position the old-fashioned 'C' clamp with one hand. Tighten it with the other hand. Then loosen it. Reposition it. Retighten it...

Why bother? New VISE-GRIP® locking 'C' clamps with swivel pads do dozens of wood crafting jobs faster and easier. And they won't mar your work because the self-leveling swivel pads grip even the softest woods smoothly and firmly.

New VISE-GRIP locking 'C' clamps with swivel pads are available in 6", 11" and 18" lengths. Pick one up today wherever quality tools are sold.



**VISE-GRIP®**

© 1984 Petersen Mfg. Co., Inc.  
DeWitt, Nebraska 68341

The natural beauty  
of wood . . .

# WATCO

*The Original and Still the Best*  
**DANISH OIL FINISH**



comes in this can!

You'll be amazed at how easy it is to finish wood beautifully with Watco Danish Oil. Watco gives wood that natural hand-rubbed look with long lasting durability. And because Watco is IN the wood . . . not on it like temporary surface coatings . . . there is no finish that will wear off. Watco Danish Oil is ideal for furniture, antiques, paneling, cabinets, doors, and trimwork. It's also safe for butcher blocks, cutting boards, and children's toys. Choose from 8 beautiful finishes . . . Natural, and Medium, Dark, and Black Walnut shades, and Cherry, Golden Oak, Fruitwood, and English Oak colors.

Send today for "FREE" color booklet "How to Beautifully Finish Wood" and the name of your nearest Watco distributor.

WATCO-DENNIS CORP. 1756-22nd St.  
Santa Monica, CA 90404, Dept. BH-W15

Name

Street

City

State  Zip

(213) 870-4781



## BOOKS WORTH READING

### **Adhesives and Glues: how to choose and use them.**

By Robert S. Miller  
Franklin Chemical Industries, Columbus, Ohio.  
1980. 186 pages. \$6.95

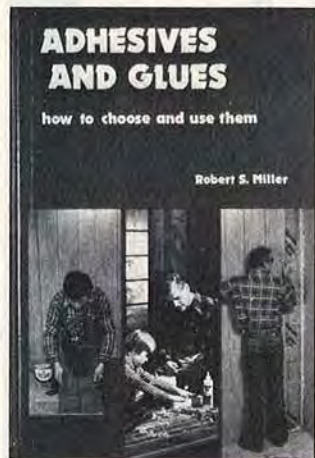

The goal of this book is to help people choose an appropriate adhesive for practically any "putting-it-together" task. In the process, author Robert Miller draws on more than 30 years of experience in the adhesives industry to share valuable ideas, useful tips, and practical information. Numerous photographs and drawings illustrate his points.

In a chapter on wood glues, Miller compares ready-to-use products, water-mixed adhesives, and two-part adhesives. Pointing out that the integrity of glue joints is important to both the durability and appearance of a woodworking project, he offers a detailed discussion of wood-grain direction, shrinkage, and major joint types.

A thorough examination of clamping includes plans for making a variety of clamps—a picture frame clamp and a simple spring clamp, for example—and discusses wedging and other homemade set-ups. The author covers joinery, veneering, and laminating as well.

Miller devotes a valuable chapter to basic repair techniques, and talks about mending split or broken parts, tightening loose joints, repairing drawers, and replacing broken veneer. He also discusses contact adhesives and their uses, and he addresses one question that has plagued woodworkers for generations, "Why didn't it stick?" ■

**"The adhesive or glue is only a minute part of the total cost of your project in terms of time, labor, and materials. Therefore, the little time it takes you to familiarize yourself with the label copy and directions is just some added insurance for you to achieve a better and more professional job."**

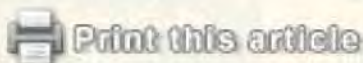

# rbi industries



PICTURED ARE VARIOUS PIECES CUT OUT OF HARDWOOD BY THE EAGLE SCROLL SAW



**MODEL 216**

The Eagle features the pat. pend. "C" arm for maintenance free use year after year. The pivot point in the arm, and the pitman drive have sealed ball bearings. A large cast table allows tilt adjustment up to 45 degrees to the right and 20 degrees to the left. Full 16 inch throat.

## the Eagle...

**ONE PIECE CAST ALUMINUM "C" ARM FOR SAFETY & BALANCE.**

**FULL 2 INCH CUTTING DEPTH. LARGE 16 INCH x 29 INCH ADJUSTABLE CAST TABLE 45° TO RIGHT/20° TO LEFT.**

**HAND SAW ACTION**

### FALCON MODEL 212

- Max. Cutting Depth 2"
- Stroke  $\frac{5}{8}$ "
- Strokes/Min. 1725
- Motor  $\frac{1}{8}$  H.P. TEFC
- Drive: Direct



**Made in the U.S.A. by Craftsmen**

**rbi industries, inc.**

201 FIRST STREET  
PLEASANT HILL, MO. 64080

Telephone: 816-987-2121

## MODEL 408 AND MODEL 612 POWER-FEED WOODPLANERS

**MAKES YOU MONEY BY SAVING YOU MONEY...** this versatile power tool pay for itself by converting low-cost rough lumber into valuable finished stock. Turns out perfect quarter-round, casing, base mold, tongue & groove... all popular patterns... plus any custom designs



**READY TO USE  
TWO MODELS AND FOUR  
POWER-FEED-FUNCTIONS**

**PLANER • MOLDER • JOINTER  
• DRUM SANDER •**

DEALER INQUIRIES INVITED

**Woodplaner sold only thru dealers!**

## Falcon...

**A QUALITY BUILT** affordable precision Scroll Saw that will give professional results that are associated with expensive imported models. Twin cast parallel-arms with a simple tension adjustment allows a highly tensioned blade to make accurate cuts while enabling quick blade replacement.

CLIP AND SEND FOR MORE INFORMATION

NAME \_\_\_\_\_

ADDRESS \_\_\_\_\_

CITY \_\_\_\_\_ STATE \_\_\_\_\_ ZIP \_\_\_\_\_

**• Woodplaners • Scroll Saws •**

## BOOKS WORTH READING

### ***Adventures in Wood Finishing:***

**88 Rue de Charonne.**  
By George Frank. The Taunton Press, Inc., Newtown, Conn. 1981. 120 pages. \$9.95



Although wood finishing may not sound like the stuff of which adventures are made, the title of George Frank's engaging book turns out to be entirely appropriate. With such clients as the Baron Rothschild, the Pasha of Marrakesh, and the "ex-khediye of a certain North African country," and such experiences as being locked in a bank with a gang of amateur robbers, Frank's career as a master of stains and wood coloring has been anything but dull.

Working out of a small shop at 88 Rue de Charonne in Paris, a few of his professional challenges have involved finding a way to duplicate the color of virgin hemp in wood, helping to make and finish a set of 34 Louis XIV chairs for the Royal Court of Egypt, and finishing all the woodwork in a bank lobby two days before its grand opening.

Frank blends personal anecdotes with practical information throughout the book. He talks about protecting wood, changing its color and tactile characteristics, accentuating wood markings with colored fillers, and also discusses charring and sandblasting wood surfaces.

Woodworkers who haven't ventured much beyond conventional staining and varnishing because most volumes on the subject remind them of high-school chemistry texts will find this book a pleasant way to broaden their wood-finishing skills and knowledge. ■

**"More wood is ruined by finishing under improper lighting than it is by any other single cause . . . You must have as much light as possible and it must be as close as possible to natural daylight."**

**"We began by ordering two truckloads of the best horse manure and by making sure we could obtain enough old wood, for using aged wood is the first requirement in copying antiques."**

## Build What You Need! Restore, Refinish What You Own! Do It Yourself and SAVE!

### **New Catalog Has Everything**

See page after page of hard-to-find products plus plans and instructions.

Cabinet and furniture woods. Mahogany, walnut, cherry, maple, oak, teak, rosewood, padauk, etc. Kiln-dried, 1/8" to several inches some kinds.

Veneers. Colorful, richly grained. 79 kinds. 3-ft. lengths. 19 flexible veneers to 36" wide, 8 ft. long (cover beatup surfaces and unpainted furniture) 11 fancy burls & crotches, 16 exotic veneers, 7-ft. long.

### **hardwoods veneers hardware shop equipment inlays wood finishes moldings how-to-books specialty hand tools cane and so much more.**

Carving blocks, 54 sizes & kinds. 118 carving tools & chisels. 32 upholstery tools & essentials. 39 clamps. 13 turning squares 1" to 4" sq.

76 assembled inlay designs. Birds, floral, scrolls, animals, chess & card pips, butterfly, Madonna, sunburst, Zodiac, eagle, professional, fraternal.

Wood finishes. Period & modern hardware. Latches, locks, hinges, pulls, escutcheons. Music instrument woods. Small box hardware. 72 lamp parts.

96 how-to books: cabinetmaking, furniture, crafts, carpentry, shop techniques.

Wood picture kits. 73 appealing subjects. Some pre-cut, ready to assemble. Others are marquetry kits for you to cut and assemble.

Picture molding. Prefinished. 33 beautiful styles. 500 plans: furniture, cabinets, shelves, toys, desks,

IF YOU are at all handy with tools—or willing to learn in easy steps—here's the modern-day way to SAVE considerable sums of money. Build what you need. Restore and refinish what you own. Save on every project.

Everything you need—fine woods, veneers, specialty tools, wood finishes and how-to guidance—can be ordered by mail from Constantine. Read this partial list

workbenches, period reproductions, cradle, clocks, home bars, Boston rocker, beds, etc.

Old-time icebox restoration pop up kitchen shelf hardware 18" hole cutter attachment maple plywood, 8 sizes. 1/4". Balsa wood, 19 sizes.

Cane, fiber rush, round re-

Hard-to find. Tea wagon wheels, platform rocker hdwe. Wood bowl seal, coffee mill & pepper mill mechanisms, sliding hdwe. Revolving hdwe. Clock parts. Serving tray molding needs no handles. Music movements.

Specialty tools. Framing clamps, wood-threading tools, doweling jig, miter boxes, dovetail saw, bench holdfast, deep-throat fret saw, wood-burning tool, angle-cutting jig, circle cutter, inshave, veneer saw, pantograph, bow saw, mat cutter, miter trimmer.

Pipe briar block for carving. Carvers hardwood mallet. Turned, carved & square-taper furniture legs.

33 designs plastic painting stencils. Wood tea wagon wheels plus all hardware to make cart.

11 furniture casters, glides, levelers. Power sander. 14 specialty cutting tools from Japan. Dovetail jig. Laminate edge trimmer. 8 special-purpose planes. Dozens of drill bits, router bits. Drill speed reducer. Solid brass numerals, 4".

Cabinet lumber 1/4 to 3/4 thick. Cherry, oak, mahogany, maple, poplar. Up to 6 ft. long.

wer tools. 4" table saw. saw, 15" throat.

per saw, heavy-duty router, 3/4 variable speed

# woodworker CATALOG

116 Pages



**CONSTANTINE Est. 1812**

2054 Eastchester Road, Bronx, N.Y. 10461

★ Send Woodworker Catalog. \$1 enclosed

Double Your Money Back!

\$2 Refunded on 1st Catalog Order

Get \$2 BACK

Name .....

Address .....

City..... State..... Zip.....

**Order \$1 Catalog NOW**

**\$2 Refunded**

Double Your Money Back!

\$2 Refunded on 1st Catalog order

**CONSTANTINE**

# TIMBERS COUNTRY STORE

## WOODWORKERS, GET ORGANIZED!

Introducing a NEW organizer unit especially for the woodworker. Nine large interlocking plastic bin boxes hold hundreds of the most needed wood parts.

This special woodworkers organizer unit comes complete with:

- 64 1" Toy Wheels
- 24 1 1/4" Toy Wheels
- 12 1 1/2" Toy Wheels
- 100 Axle pegs for wheels
- 100 1/4 x 1 1/2" Glue Pins
- 80 3/8 x 2" Glue Pins
- 150 1/4" Maple Screw Hole Buttons
- 150 3/8" Maple Screw Hole Buttons
- 100 1/2" Maple Screw Hole Buttons
- 100 3/8" Maple Round Head Plugs
- 100 1/2" Maple Round Head Plugs
- 10 3 1/2" Hardwood Shaker Pegs
- 9 Large Plastic Interlocking Bin Boxes in three colors.
- 3 Plastic Bin Box Dividers
- 9 Descriptive Labels for Bin Boxes
- \* Assembled unit measures 5 1/2" x 8 1/2" x 12"



For Bank Card Orders:  
Call TOLL FREE  
800-824-5897  
(in California or Canada,  
phone 916-581-4141)

FREE  
CATALOG  
WITH  
ORDER:



Catalog with hundreds of wood-working patterns and books, plus many hard to find specialty furniture and toy making parts and wood-working tools. The catalog is included free with your order, or is \$1 alone.

**TIMBERS COUNTRY STORE**  
Woodworkers Catalog, Dept. BH1  
Lake Forest Rd.  
Carnelian Bay, CA 95711-0850

### MORE THAN 1,000 PIECES IN ALL

Introductory offer: ALL FOR ONLY  
**\$29.95** PPD\*/Regular \$55 retail value.

\*California residents add 6% sales tax  
Canadian orders, add \$5 Shipping and Handling

ACT NOW, SAVE SHIPPING  
CHARGES, after 12/1/84, add  
\$2.00 for shipping and  
handling.

## BOOKS WORTH READING

### *The American Shakers and Their Furniture.*

By John G. Shea.  
Van Nostrand Reinhold Co.  
New York, 1971. 208 pages.  
\$10.95

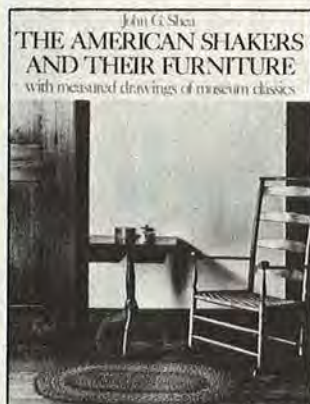

This is a "How-they-did-it"—not a "How-to-do-it"—book, author John Shea explains as he examines the American Shakers of more than a century ago and investigates their superlative craftsmanship in detail.

Shea believes that understanding this workmanship—and the underlying economy of detail that allowed furniture of great strength to be fashioned from remarkably delicate parts—depends on knowing how the Shakers lived, worshipped, and worked. In search of this knowledge, he traces the history of the movement, from its beginning in England to its gradual decline, a decline caused in part, no doubt, by the Shaker belief in celibacy.

But if celibacy was the best-publicized Shaker characteristic, Shea believes that inventiveness was the most important Shaker trait. He notes that it contributed to the design of original types of chairs, chests, and desks.

Shaker craftsmen were highly skilled in all phases of cabinetry and allied trades. They used the most advanced tools of the day and often invented implements—a tongue-and-groove machine and a circular saw among them.

What may be of greater interest to home woodworkers, however, are the 88 scale drawings—one-half of the book—that are based on measurements of Shaker museum pieces ranging from candle sconces to classic chairs, tables, and chests. ■

**"Shaker furniture is, above all, functional. It works and it serves. In strict adherence to practical principles, it discards all adornments of decorative embellishment which do not contribute to basic requirements."**

**"While they can't be credited with 'inventing' the rocking chair, the Shakers did more to develop its design and promote its use than any other chairmakers."**



# Get in on the PROFITS in SMALL ENGINE service and repair

## Start your own money



### BEAT INFLATION!

Cash in on the huge demand for small engine repair.

Work part time, full time right at home - we help you every step of the way.

## making business!

In just a short time, you can be ready to join one of the fastest growing industries in America...an industry where qualified men are making from \$10.00 to \$15.00 per hour...and that's just for labor. Parts, engines and accessories add even more to the profits.



Because the small engine industry has grown so quickly, an acute shortage of qualified Small Engine Professionals exists throughout the country. In fact, it's not unusual for a good small engine man to be three to four weeks behind in the summer and at least a week behind in the winter. When you see how many small engines are in use today, it's easy to understand why qualified men command such high prices—as much as \$17.50 for a simple tune-up that takes less than an hour!

### 65-million small engines are in service today!

That's right — there are over sixty-five million 2-cycle and 4-cycle small engines in service across the U.S.A. That's the official count from the Engine Service Assn., and new engines are being built at a rate of one-million per month! With fully accredited and approved Foley-Belsaw training, you can soon have the skill and knowledge to make top money servicing these engines. Home-owners and businessmen will seek you out and pay you well to service and repair their lawnmowers, tillers, edgers, power rakes, garden tractors, chain saws, mini-bikes, go-carts, snowmobiles, generators, snowblowers, paint sprayers... the list is almost endless.

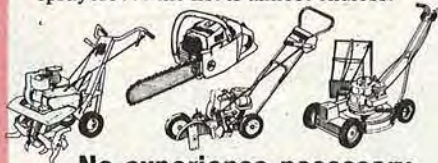

### No experience necessary.

You don't need to be a 'born mechanic' or have prior experience. If you can read, you can master this profitable trade right at home, in your sparetime, without missing a single paycheck. Lessons are fully illustrated—so clear you can't go wrong.

### You receive trade secrets and business plans.

We guide you every step of the way, including tested and proven instructions on how to get business, what to charge, how to get free advertising, where to get supplies wholesale... all the "tricks of the trade"... all the inside facts you need to assure success right from the start.

#### Increased Income

"I've had about 8 years experience repairing small engines... but repairs were only minor... until I started the Foley-Belsaw Course."



Walter H. Strick Campbell, California

With our famous 'learn-by-doing' training method, you get practical 'hands-on' experience with specialized tools and equipment that you'll receive with your training *plus* a brand-new 4HP engine—all yours to keep!

### SEND FOR FREE FACTS!

You risk nothing by accepting this offer to find out how Foley-Belsaw training can give you the skills you need to increase your income in a high-profit, recession-proof business of your own.

Just fill in and mail coupon below (or send postcard) to receive full information and details by return mail. **DO IT TODAY!**

You get all this Professional equipment with your course, PLUS 4 H.P. Engine... ALL YOURS TO KEEP... All at NO EXTRA COST.

Send TODAY for this fact-filled FREE BOOKLET!



**FOLEY-BELSAW INSTITUTE OF SMALL ENGINE REPAIR**  
50529 Field Bldg., Kansas City, MO 64111

There is **NO OBLIGATION** and **NO SALESMAN** Will Call—ever!



Tells how you quickly train to be your own boss in a profitable Sparetime or Fulltime business of your own PLUS complete details on our 10-Day NO RISK Trial Offer!

FOLEY-BELSAW INSTITUTE, 50529 FIELD BUILDING KANSAS CITY, MO 64111



YES, please send me the FREE booklet that gives full details about starting my own business in Small Engine Repair. I understand there is no obligation and that no salesman will call.

Name \_\_\_\_\_

Address \_\_\_\_\_

City \_\_\_\_\_

State \_\_\_\_\_ Zip \_\_\_\_\_

## TIPS FROM YOUR SHOP (AND OURS)

No one knows everything about woodworking, but, with experience, we all run into better, safer, faster, or easier ways to do things. When we come up with interesting tips or techniques, we'll show them to you in this column. And when you share your favorites, we'll pay you \$25 for each submission we publish. No shop tips will be returned. Send your tips to:

**Shop Tips**  
**Better Homes and Gardens®**  
**WOOD Magazine**  
**Locust at 17th**  
**Des Moines, IA 50336**

 **Print this article**

**Raising dents and scratches**  
*Even the smallest dents and scratches mar the appearance of otherwise successful woodworking projects.* To remove small dents or raise minor scratches in wood surfaces, wet and then cover the problem area with a damp cloth. Using a household iron on a dry setting, apply heat to the cloth for 15-second intervals. Take care to avoid scorching the wood.

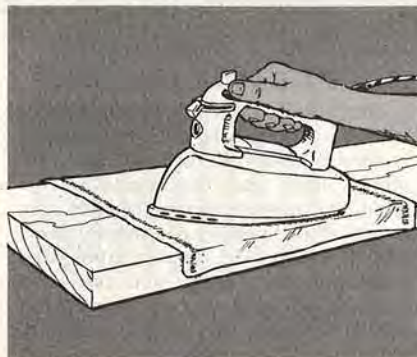

**Drill-bit straightener**  
*Small-diameter drill bits are easily bent during normal use.* To straighten a bent bit, chuck it into your drill and, while running the drill at full speed, insert the drill point into a piece of scrap wood. Apply slight sideways pressure to the drill to return the bit to its proper shape. When you release the pressure, the bit will continue to run true.

—Robert S. Tupper, Canton, S.Dak.

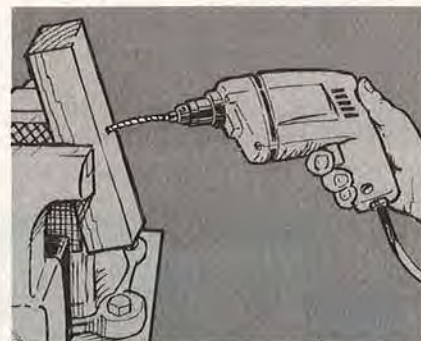

Continued on page 36

**We Dare You** — to find a better 8" Jointer than ours at even twice our price!



- 8" x 65" Heavy Duty Cast Iron Bed.
- Beds are stress relieved and precision ground for the ultimate in accuracy.
- Exclusive quick setting levers for raising and lowering the tables.
- Powerful 1 ½ H.P. Single Phase Motor.
- One piece stand has chip-chute for quick disposal.
- Large 3 blade cutter-head has lubricated-for-life ball bearings.
- Weighs close to 500 lbs. — certainly not a toy!

**Model G1018 Only \$575.00**

(F.O.B. BELLINGHAM)

*This is an old price and will be going up soon. Call for low freight rates!*



Call for  
 Low Freight  
 Rates on  
 these 2  
 machines.

## Dust Collection Systems

These powerful yet lightweight dust collectors are the answer to your messy shop. Chips get sucked in, whirl around the top bag and fall through a funnel into the bottom bag which can be removed for easy dumping. Bags are 19" in diameter and 35" high each.



3 super models and all are single phase power. All units come with casters making these very portable.

Model G1028 — 2 Bags/1 H.P. — \$295.00  
 Model G1029 — 2 Bags/2 H.P. — \$355.00  
 Model G1030 — 4 Bags/3 H.P. — \$455.00  
 (ALL ABOVE PRICES ARE F.O.B. BELLINGHAM)

Our merchandise is fully guaranteed with local parts and service back-up right in our warehouse. We also sell 15" planers, carbide-tipped saw blades, table-saws, lathe chisels, sanders and much more — All at super low prices. Send \$3.00 for our fully loaded 1985 color catalog! We import and sell direct to the users.



GRIZZLY IMPORTS INC.  
 P.O. BOX 2069, BELLINGHAM, WA 98227 • PHONE (206) 647-0801  
 PHONE YOUR ORDER IN USING YOUR VISA OR MASTERCARD OR SEND A MONEY-ORDER, CERTIFIED CHECK OR BANK DRAFT FOR INSTANT DELIVERY. PAYMENT BY REGULAR CHECK WILL DELAY SHIPMENT APPROXIMATELY 3 WEEKS.





You can buy  
a cheaper blade  
than DML...  
and that's just  
what you'll  
get



Cost counts when you buy blades — and DML is the last to deny that fact. A sharp buyer always looks for the best saw for his money. But wait a moment before you plunk down your dollar. Realistically, do you know your seller and his wares? Are his prices always the best? Is he always promoting some sort of discount? Don't you wonder . . . why?

DML, also, runs the occasional promotion. But we feel we should give you more than just dollar inducements. And we do.

DML offers you a saw for your every application: crosscutting; ripping; trimming; general purpose sawing; combination cutting. For your work in wood.

Hardboard. Plastics. And soft metals. Blades of heat-treated tool steel. Dressed to industrial standards, tipped with premium carbide, diamond honed, precision balanced and tensioned. Over 250 in all. In a whole slew of sizes and configurations, to fit your portable and stationary equipment. Industrial quality saw blades, matched to your exact cutting needs.

In sum, DML believes in giving you the right saw blade for your work. And for a fair price. You see, we're a bit suspicious of a saw that's always marked down by its manufacturer. Maybe you should be, too.



For more information or the distributor nearest you, write DML, Inc., 1350 S. 15th Street, Louisville, KY 40210

NAME \_\_\_\_\_

COMPANY NAME \_\_\_\_\_

ADDRESS \_\_\_\_\_

CITY \_\_\_\_\_

STATE \_\_\_\_\_

ZIP \_\_\_\_\_

**DML**  
Cutting everything but corners

A SUBSIDIARY OF VERMONT AMERICAN CORPORATION

# STROM TOYS

## CLASSIC TOYS IN WOOD



Truly an heirloom! Plans include patterns for bridle, stirrups, cushion, and rocker painting. 51" long, 38" high. **Plan - \$12.00**

### PRANCER



### STROM WAGON

All wood, full-sized wagon. You'll be pleased how well this handles. 38" long, 18" wide. **Plan - \$7.50**



### STEAM SHOVEL

PLAN - \$6.00

### DUMP TRUCK

PLAN - \$5.00

STROM TOYS is a book of extraordinary wood toys you can make. Contains 11 mini-plans, 40 designs for which plans can be ordered, and a richly illustrated children's story. **Only \$9.95 PPD.** (Wisconsin Res. add 5% Sales Tax.)

### OTHER BOOKS AVAILABLE

GAZEBOS & OTHER GARDEN STRUCTURES • BRIDGES & CUPOLAS • PRIVY-CLASSIC OUTHOUSE BOOK - 25 designs

All Three Books - **\$7.95 each PPD.**

### NEW BOOK

### BACKYARD STRUCTURES

Over 60 Designs in Full Color. 8 mini-plans in book. Contains: Storage, Cabanas, Dog Houses, Garbage Enclosures, Barns and More. **\$8.95 PPD.**



P.O. Box 206, Dept. 34  
Delafield, WI 53018  
(414) 567-4255

MC & VISA ACCEPTED  
(Wis. Res. Add.) 5% Sales Tax

## TIPS FROM YOUR SHOP (AND OURS)

Continued from page 34

### Avoiding nail splits

Even though you hammer carefully, your nail occasionally splits the wood. Blunt the tip of the nail by tapping it with your hammer to let the nail cut its way into the wood rather than part the material. Or chuck a proper-sized nail into a drill (you may need to cut off the nail head), pre-drill holes, and then hammer and set nails.

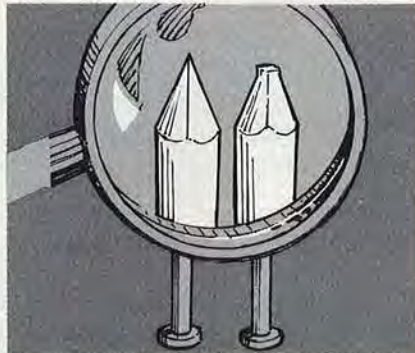

### First-aid for dull saber-saw blades

Halfway through a "must-do" project, you discover that the blade on your saber saw is dull, and you don't have a spare. Touch up the blade with a triangular file. Place the blade in a vise with teeth pointing up (don't pinch them). File away from you, giving each tooth two or three quick strokes. Rotate the blade 180°, and file the other side.

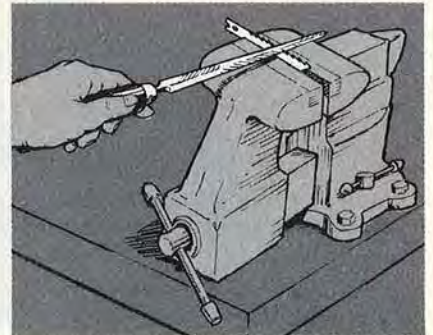

### Repairing torn grain

No matter how skillful you are with a plane, the grain patterns of some wood species make it almost impossible to avoid raising and tearing the grain. To fix tears, apply several drops of cyanoacrylate adhesive (the "super" variety made for wood and leather) to the affected area. Sand the spot immediately. Sanding presses the raised wood down, generates heat to set the glue, and produces fine sawdust that mixes with the glue to create an invisible and permanent repair.

—Dean Case, Nevada City, Calif.

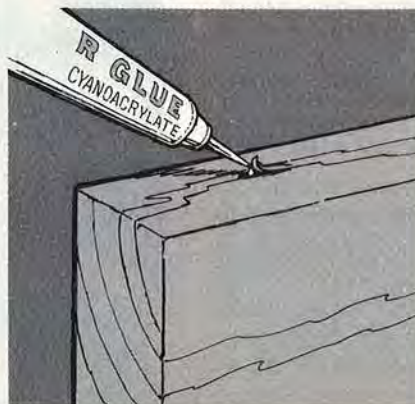

### World-champion finishing jig

Applying finish to more than one side of an object is an awkward, messy chore. A steel swivel made to support a boxer's punching bag makes an ideal shop aid for holding objects that need finishing. Attach the swivel to a secure overhead support, screw an eye-hook into the object to be finished, and hang the piece on the swivel. The workpiece—not the woodworker—does all the moving. (A plant hanger that swivels is an inexpensive alternative for working with light objects.)

—Tony Bofinger, Punxsy, Pa.

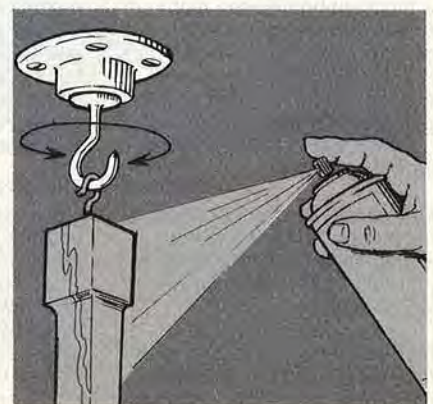

Continued on page 38

# Announcing **EXCALIBUR II**

Precision performance.  
Revolutionary design. \$495.\*



J. Philip Humfrey is proud to present the *next* generation of the renowned Excalibur Precision Saw - Excalibur II - featuring outstanding quality and craftsmanship, exclusive engineering features, with the same precision and control from a revolutionary cutting mechanism.

Excalibur II provides three cutting speeds with a single-speed motor. Optional variable-speed motor provides an infinite range.

Excalibur II's table and hold-down tilt 45° right and left. It easily accepts all 5" blades to cut material up to 2" thick. Throat depth is 18".

There is a host of construction and performance features unparalleled in a scroll saw of this price.

#### Features:

- Universal motor mount accepts any motor
- Precise, square cuts require virtually no sanding
- Worktable tilts 45° both ways
- New revolutionary design provides vibration-free operation
- Motor drive assembly completely enclosed for safety
- Cuts wood up to 2" thick, plus plastics, metal, etc.

\*As shown. Motor extra.

\*As shown. Motor extra.

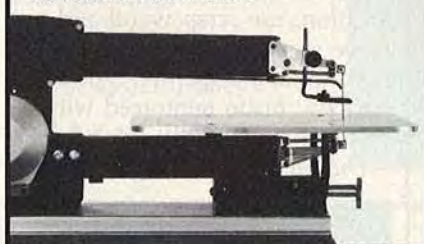
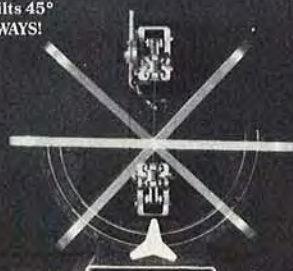

Table tilts 45°  
BOTH WAYS!



Precision-cast alloy components  
give best performance

For more information on the Excalibur II, the next generation in precision saws, call toll-free **1-800-387-9789**.

Or, mail this convenient coupon.

Excalibur II. Designed and manufactured for the woodworking craftsman who demands the best.

## J. Philip Humfrey International Inc.

3241 Kennedy Road, Unit 7 (Dept. WM 3), Scarborough, Ontario, Canada M1V 2J9 Telephone (416) 293-8624

- Please rush complete information on the exciting new Excalibur II.  
 Please rush complete information on the Original Excalibur 24 Scroll Saw

Name \_\_\_\_\_

Address \_\_\_\_\_

City \_\_\_\_\_ State \_\_\_\_\_ Zip \_\_\_\_\_

\*Introductory price. US funds





## Fine Brass Accents

... from The Renovator's Supply. For our full-color catalog of old-style and classic fixtures for the home, send \$2 to 3423 Renovator's Old Mill, Millers Falls, MA 01349.

Name \_\_\_\_\_  
 Address \_\_\_\_\_  
 City \_\_\_\_\_ State \_\_\_\_\_ Zip \_\_\_\_\_

**THE RENOVATOR'S SUPPLY**



### TIPS FROM YOUR SHOP (AND OURS)

Continued from page 36

#### Applying finishes smoothly

Uniform coats are the exception rather than the rule with some finishes. To apply lacquers and polyurethane finishes smoothly, fill a pan with hot tap water, and set the can of finish in it for a few minutes before use. Raising the material's temperature by only a few degrees—and choosing a polyurethane foam brush as an applicator—will help avoid an uneven look when the finish dries.

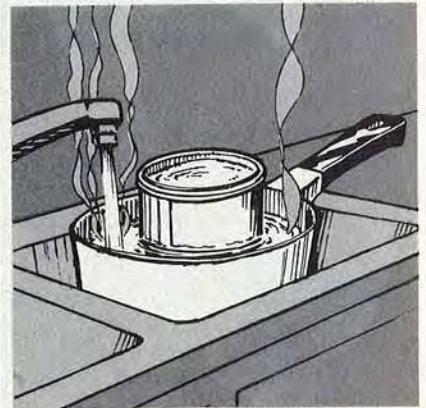

## Solid Butcher Block Tops

John Boos & Co. has been in the business of manufacturing Butcher Block since 1887. We know what it takes to build a fine product. All John Boos Butcher Block Tops are solid Hard Rock Maple or Appalachian Red Oak. They make great counter tops, work benches, cart tops, occasional tables and can be used anywhere in the home.

**To purchase the very best in Butcher Block Tops, write for the John Boos dealer nearest you.**

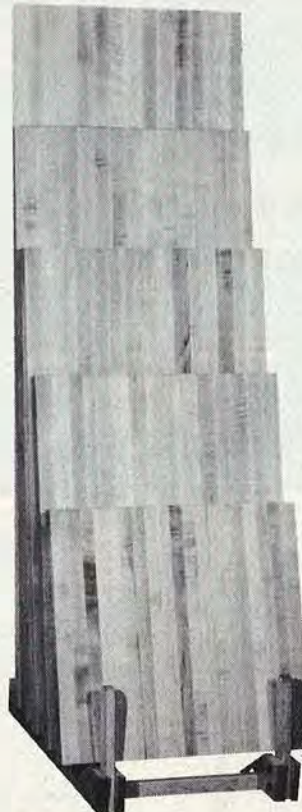

**John Boos & Co.**

315 South First Street • Effingham, Illinois 62401 • 217-347-7701

#### Handy tape dispenser

In many shops, finding the right tape at the right time can be a problem. Once located, it's often covered with sawdust and wood shavings. To keep various types and sizes of tape in one handy location, use scrap wood and a piece of dowel or broomstick to make a tape dispenser. An old hacksaw blade reinforced with a wooden strip makes a good cutter. —Dwight Blakeney, Seaford, Del.

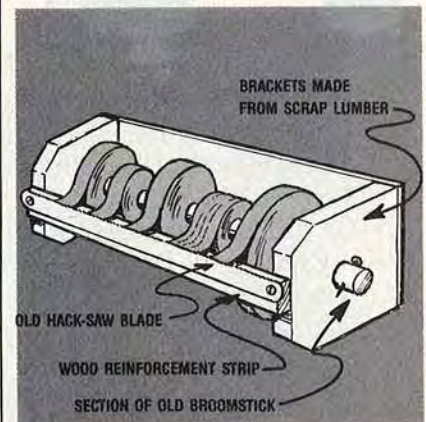

Continued on page 41

# BUILD YOUR OWN Router Table

Now you can get the most out of your router by mounting it to this shop-tested router table.

The first time you try this shop-tested router table, you'll agree it adds a whole new dimension to what a router can do for you.

The *Woodsmith* router table is designed to fit any router, and has features you'd expect only on professional models.

## Professional Features

The extra-large table provides a steady work surface for both large and small pieces. It also has a fully-adjustable fence that lets you make cuts exactly where you want them. And with the router mounted under the table, you can easily make molding cuts on narrow or curved boards, or make multiple cuts for special effects.

**Send for exclusive step-by-step plans.**

The plans for this router table are now available in a six-page plan booklet that shows how easy it is to build a full-size floor model with storage cabinet (shown in photo), or a portable bench-top model.

For a limited time, the Router Table plan booklet is only \$1.

Send to:

Woodsmith Dept. 60,  
Box 842, Des Moines,  
Iowa 50304.

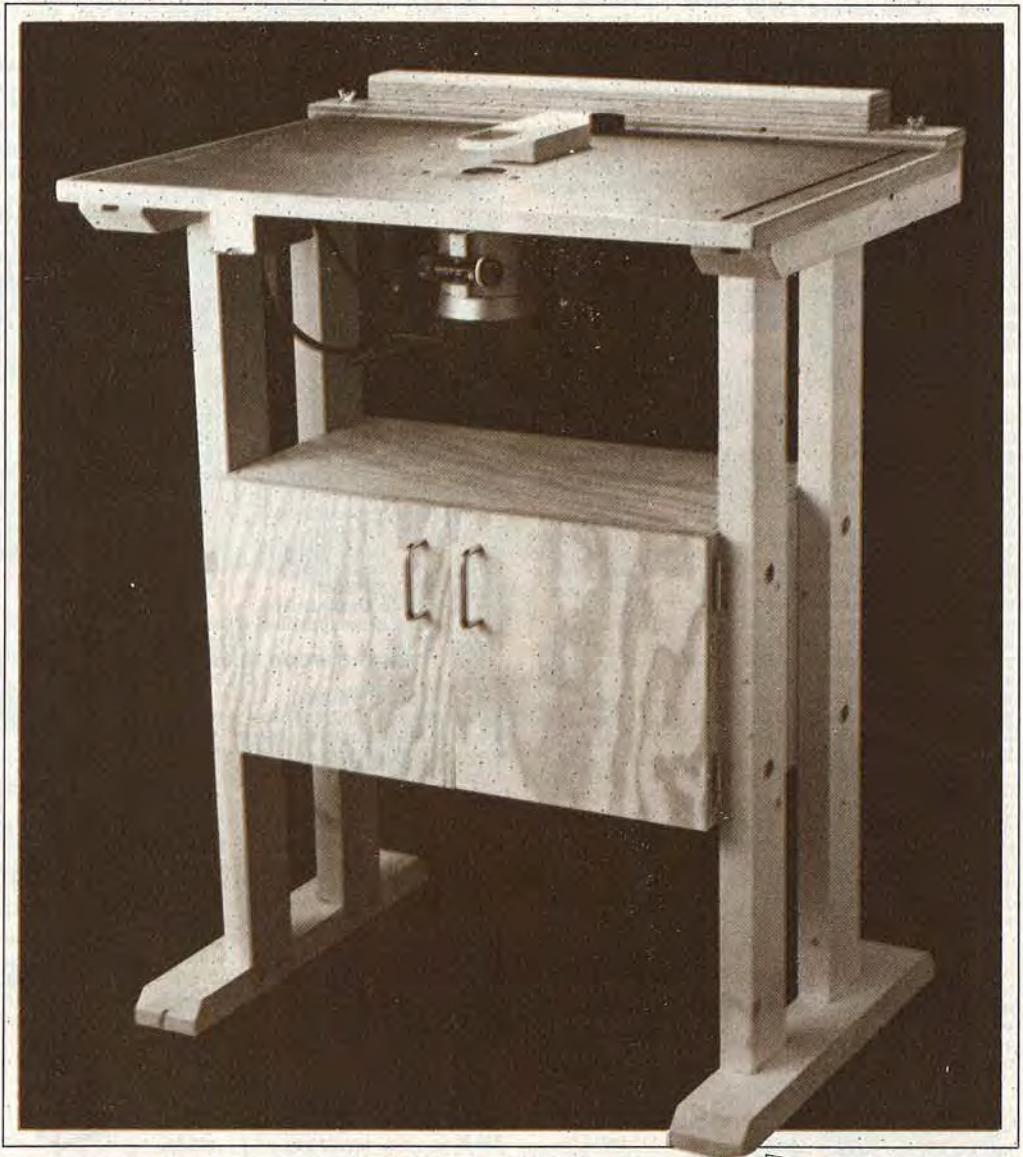

## Woodsmith® PLAN BOOKLET

Yes, send me the *Woodsmith Router Table* plan booklet — complete step-by-step directions for building a full-size and bench-top router table.



60

Name \_\_\_\_\_

Address \_\_\_\_\_

City \_\_\_\_\_

State \_\_\_\_\_

ZIP \_\_\_\_\_

# TREND-LINES BEATS ANY AD THIS ISSUE!

Free with any order:

- 1 Year (3-4 issues) catalog subscription
- Subscription to Woodworking Trends
- Membership in TLC with special offers
- Mention this ad and receive a free 6" flexible rule

All Freud router bits on sale

New! Freud tool sets	
4 Pc. Chisel Sets	\$ 26.75
6 Pc. Chisel Sets	33.95
10 Pc. Chisel Sets	55.75
8 Pc. Lathe Set	56.50
6 Pc. Carving Set	65.95
12 Pc. Carving Set	117.50

Free Wooden Case

If another prepaid price is lower, we match the price and give you a gift certificate worth \$5.00 when purchasing from our catalog. Few restrictions apply. **Minimum Order \$15.00**

**Freight prepaid in all U.S.A. on orders of \$35.00 or more.**

Note: Under \$35.00 add \$2.00 per order. Extra charge to Alaska & Hawaii on stationary machines. Misprints are subject to correction. This ad expires February 28, 1985. Watch for our next ad.

**FREE CATALOG WITH ORDER OR BY WRITING TO POST OFFICE BOX. SPECIAL SALE TO READERS OF THIS AD You Must Mention This Ad When Ordering**

800-343-3248 USA 800-322-6100 Mass. 617-884-8882 Non-Order Calls

**TREND-LINES, INC.**

375J Beacham St. P.O. Box 6447J Chelsea, Ma. 02150

Open Monday to Saturday 8:30 AM-5:00 PM plus Thursday until 9:00 PM

**30 DAY MONEY BACK GUARANTEE**  
Examine any item in your home or shop. If it's not what you expected, return it in original condition for a full refund.

## MAKITA TOOLS

1100	3/4" Planer Kit	\$164.75
1805B	6 1/4" Planer Kit	278.95
1900BW	3 1/4" Planer w/cs	97.95
2030	12" Planer/Jointer	1295.00
2040	15 1/2" Planer	1195.00
2400BW	10" Miter Saw w/blade	259.50
2401BW	10" Miter Saw w/blade	

2708	Table Saw	226.00
3601B	Router	249.95
3608BK	Router w/case	128.95
3612BR	3 H.P. Router	85.95
3700B	Laminate Trimmer	189.95
4200N	4 1/2" Circular Saw	84.25
4301BV	Vr Sp Orbital Jig Saw	94.50
5007NB	7 1/2" Circular Saw	129.95
5008NB	8 1/2" Circular Saw	103.95
5012B	12" Chain Saw	105.00
5081DW	3 3/4" Cord. Saw	119.95
5201NA	10 1/4" Circular Saw	110.40
5402A	16" Circular Saw	226.50
6000R	Uni-Drill	395.00
6010D	3/8" Cordless Drill	106.00
6010DL	Cordless Drill w/charger	79.95

6010DWK	Cordless Drill w/charger & case	99.50
6012HDW	Cord. Drill Kit 2-Sp.	88.75
6013BR	1/2" Reversible Drill	105.95
6300LR	1/2" Angle Drill	119.00
6510LR	3/4" Drill-Rev.	152.20

6710DW	Cord. Screwdriver	69.00
6800BV	Drywall Screwdriver	107.10
9030	1 1/4"x21" Belt Sndr	97.50
9035	Finishing Sander	123.50
9045B	Finishing Sander	49.95
9045N	Dustless Sander	99.50
9207SPB	7" Sander Polisher	112.50
9401	4"x24" Belt Sander	136.95
9501BKIT	4" Sander Grinder Kit	171.95
9900B	3"x21" Belt Sander	85.75
9924DB	3"x24" Belt Sander	125.50
BO4510	Finishing Sander	132.75
BO4530	6" Rnd Finish Sander	46.95
DA3000	3/4" Angle drill	52.95
DK1001	Drill (6010D), Charger & Vacuun Cleaner	116.50

DP3720	3/4" Reversible Drill	129.95
DP4700	Drill Reversible	56.90
GV5000	Disc Sander	96.95
HP1030	Hammer Drill	49.95
JG1600	Jig Saw Single Sp.	105.00
JR3000V	Recipro Saw	91.25
JR3000W	2 Sp. Reciprocaw Kit	134.75
124.75		

PONY CLAMP FIXTURES		
Each	Pkg 6	
No. 50	3/4" Pipe Clamp	\$7.70 6.95 ea
No. 52	1/2" Pipe Clamp	6.90 6.40 ea
No. 1215 (WEB)	15"	6.40 5.80 ea
No. 7456	Clamp Pads	2.50 2.25 ea

JORGENSEN BAR CLAMPS (Heavy Duty)		
Each	Pkg. 6	
No. 7224	24"	17.30 15.70 ea
No. 7230	30"	18.10 16.45 ea
No. 7236	36"	18.70 16.95 ea
No. 7248	48"	20.75 18.70 ea
No. 7260	60"	22.65 20.55 ea
No. 7272	72"	24.55 22.25 ea
No. 7284	84"	26.55 24.10 ea

JORGENSEN CLAMPS (Med Duty)		
No. 3712	12"	5.90 5.35 ea
No. 3724	24"	7.30 6.60 ea
No. 3736	36"	8.90 8.00 ea

JORGENSEN HAND SCREWS		
No. 3/0	3"	\$9.30 \$8.40 ea
No. 0	4 1/2"	9.90 8.95 ea
No. 1	6"	11.30 10.15 ea
No. 2	8 1/2"	13.45 12.15 ea

JORGENSEN BAR CLAMPS (5' reach)		
No. 4512	12" Open	17.05 15.35 ea
No. 4524	24" Open	19.05 17.15 ea
No. 4536	36" Open	21.20 19.20 ea

JORGENSEN & PONY CLAMPS		
No. 3325	3 Way Edging	\$5.40 4.90 ea
No. 1623	3" Hold down	7.20 6.40 ea
No. 3202HT	2" Spring	2.15 1.90 ea

9X11 Non-Loading Silicon Carbide	
Grit	A WEIGHT Pack of 100
400, 360, 320, 280, 240	
220, 180, 150, 120	\$19.60

## RYOBI TOOLS

B7075	3x21 Belt Sander	\$118.95
B7100	3x24 Belt Sander	148.50
B7200A	4x24 Belt Sander	167.90
D1010	3/4" Var. Sp. Drill	89.50
D1015A	3/4" Screwdriver/Drill	111.95

D1310	1/2" Drill	89.95
D1320R	2 Sp. 1/2" Rev. Drill	99.95
E3800A	Drywall Screwdriver	77.95
JS-60	Jig Saw	99.95
JSE-60	Electronic Jigsaw	125.90
L-120J	3 3/4" Planer	81.25
L1323ALS	3 3/4" Planer	129.95
LS-35	Finishing Sander	46.95
L-580	6 1/2" Planer	189.00
R-150	1 HP Plunge Router	88.00
R-330	2 H.P. Router	139.70
R-500	3 HP Plunge Router	165.00
RA-2500	10" Radial Saw	449.95
S500A	3x5 1/2" Finishing Sander	43.95
SU-6200	Finishing Sander	

TR-30	Laminate Trimmer	78.95
TS-251U	10" Miter Saw	189.95
TS-251U	w/ Accessories	199.95
W630	7 1/4" Circular Saw	99.50
W730	8 1/4" Circular Saw	109.75

MILWAUKEE TOOLS		
0228-1	3/4" VSR Drill	\$ 99.95
0234-1	1/2" VSR Drill	108.50
0375-1	3/4" Rev. Angle Drill	118.50
1107-1	1/2" VSR D Handle	147.50
1660-1	1/2" SSR Compact	174.65
5397	Hammer Drill Kit	177.50
5660	1 1/2 HP Router	162.00
5680	2 HP Router	208.50
5935	4"x24" Sander	219.95
6014	1/2 Sheet sander	105.00
6145	4 1/2" Angle Grinder	107.50
6255	VR.Sp.Jigsaw	149.95
6287	H.D. Jigsaw Kit	225.00
6367	7 1/4" Circular Saw	119.95
6460	10 1/4" Circular Saw	229.00
6507	Sawzall w/case	119.50
6543-1	1/4" Screwdriver	137.50
6749-1	Magnum Screwdriver	123.50
6750-1	H.D. Drywall screwdriver	96.50
6753-1	Drywall Screwdriver	79.95

ROCKWELL POWER TOOLS		
11-072	32" Radial Drill	\$379.95
22-651	13" Planer	1250.00
28-140	10" band Saw	349.75
28-243	14" Band Saw	518.50
31-205	8" Table Saw	149.50
33-150	Sawbuck	525.00
33-990	10" Radial Arm Saw	489.95
34-010	Miter Saw	158.95
34-410	10" Contractors Saw	725.00
34-895	10" Homecraft Saw	295.00
34-710	10" Tilling Arbor Saw	474.50
37-609	6" Jointer	370.00
43-122	Wood Shaper	539.95
46-140	11" Lathe	399.95

FREUD SAW BLADES 10" = 3/4" Bore		
Carbide Tipped	12" = 1" Bore	
No.	Size Teeth Use	Price
LU72M10	10" 40 General	\$35.00
LU73M10	10" 60 Cut-Off	38.00
LU73M12	12" 72 Cut-Off	76.90
LU78M10	10" 80 Plastic	83.50
LU82M10	10" 60 Cut-Off	44.00
LU82M12	12" 72 Cut-Off	85.95
LU84M10	10" 40 Comb.	36.00
LU84M11	10" 50 Comb.	38.00
LU85M10	10" 80 Cut-Off	67.00
LM72M10	10" 24 Ripping	37.50
TR100	3 blades & dado set	264.95
DS306	6" Dado	98.95
DS308	8" Dado	119.50

SUN GOLD SANDING SHEETS		
9x11 Aluminum Oxide C Weight		
Grit	Pk of 100	
150, 120, 100		\$21.95
80		23.70
60		28.90
40		32.05
20		38.30

## BLACK AND DECKER INDUSTRIAL TOOLS

1165	3/4" Angle Drill	\$119.50
1179	3/4" VAR. Sp. Drill	69.95
1180	3/4" VSR Holgun	99.95
1311	1/2" VSR Drill	119.75
1575	3/4" VSR ScruDrill	119.50
1940	3/4" Cordless Drill w/98060 Charger	118.50
1975	3/4" Cordless Screwdriver w/98060 charger	129.50
2034	Drywall Screwdriver	91.50
2054	VSR Screwdriver	155.00
2931	Cordless Screwdriver w/98060 Charger	159.95
3027-09	7" Circular Saw	79.95
3030	7 1/4" Circular Saw	119.95
3034	7 1/4" Circular Saw	118.65
3035	8 1/4" Circular Saw	129.50
3051	7 1/4" Wormdrive Saw	158.25
3091	10" Miter Saw	189.95
3103	2 Sp. Cut Sawkit	99.95
3105	Vr. Sp. Cut Sawkit	109.50
3107	Var. Sp. Orbital Cut Sawkit	119.50
3141	Cordless Jigsaw w/98060 Charger	149.95
3157-10	Var. Sp. Jigsaw	129.50
3265	Laminate Trimmer	145.65
3310	1 1/2 H.P. Router	139.50
3330	1 H.P. Router	99.95
3370-10	3 3/4" Planer	129.95
4010	Palm Sander	48.95
4018	1/2 Sheet Sander	99.50
4247	4 1/2" Disc Sander/Grinder	69.95
4260	Power File	189.50
6750	Heat Gun	69.75

WATCO DANISH OIL		
Natural, Medium, Dark, Black or Colors		
\$5.70 Qt.		\$17.65 Gal

TITEBOND WOOD GLUE		
\$5.75 Qt.		\$12.95 Gal

HITACHI TOOLS		
B600-A	14 1/2" Band Saw	\$1554.00
CJ65VA	Electronic Jigsaw	132.75
CR10V	Reciprocating Saw	124.75
C7SA	7 1/4" Circular Saw	69.95
C10FA	10" Miter Saw	279.00
C10FB	10" Miter Saw w/vice, extention	199.95
C12Y	12" Table Saw	1250.00
DRC-10	Cordless Screwdriver	98.50
DR-10	3/4" Drill/Screwdriver	108.00
D6V	1/4" Var Sp Rev Drill	71.00
D10V	3/4" Var Sp Rev Drill	74.95
D13V	1/2" Var. Sp. Rev. Drill	99.75
F-20A	3 3/4" Planer	99.75
F1000A	Planer/Jointer	1375.00
JH-60A	Jig Saw	103.50
P50	6 1/2" Planer	295.00
P100F	12" Planer	1095.00
PSM-7	7 1/4" Circular Saw	114.95
PSM8	8" Circular Saw	141.90
SB-110	4x24 Belt Sander w/dust bag	183.00
SO-110A	1/2 Sheet Sander w/dust bag	119.95
SB-75	3x21 Belt sander-2 Sp. w/dust bag	134.75
SB8T	3x24 Belt sander 2-Sp w/dust bag	149.95
TR-6	Laminate Trimmer	92.25
TR-8	1 H.P. Plunge Router	126.95
TR-12	3 H.P. Plunge Router	194.75
W6V	Screwdriver	94.50

SUNGOLD X-WEIGHT SANDING BELTS		
Sold in packs Outlasts regular of 10 only		
Size	Grit	10 Belts
3"x21"	120	100 \$ .98 ea \$ .84 ea
	80	1.00 ea .86 ea
	60	1.05 ea .92 ea
	50	1.07 ea .94 ea
	40	1.10 ea .96 ea
3"x24"	120	100 1.20 ea .93 ea
	80	1.22 ea .97 ea
	60	1.26 ea 1.12 ea
	50	1.31 ea 1.15 ea
	40	1.34 ea 1.18 ea
4"x24"	120	100 1.68 ea 1.46 ea
	80	1.73 ea 1.51 ea
	60	1.78 ea 1.64 ea

**TIPS FROM YOUR SHOP  
(AND OURS)**

Continued from page 38

**Rx for difficult gluing**

Getting the right amount of glue into hard-to-reach spots is a messy operation. To inject glue with "pin-point" accuracy, use a medical syringe with an 18- or 22-gauge needle. Keep the apparatus from seizing up after use by flushing the syringe and needle with warm water and storing them in a closed container of water.

—Styles Sass, Grafton, N.Dak.

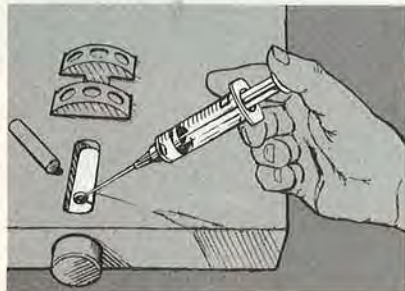

**Working with dowels**

A dowel's shape is both a blessing—it makes the material a remarkably versatile woodworking resource—and a curse: working a cylindrical object can be frustrating. This handy jig, a scrap 2×4 with a hole the diameter of the dowel bored through it, makes dadoing, trimming to length, or decreasing the diameter of a dowel a safe and simple procedure on your radial-arm or table saw. Drive a finish nail through the 2×4 and just far enough into the dowel to prevent it from turning. (This tip works well on the bench dogs for the quick-clamp vise featured in this issue of WOOD—see page 88.)

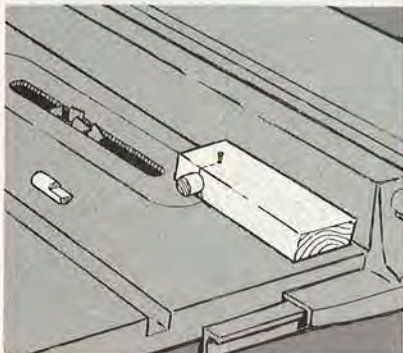

Continued on page 42

**Our catalog doesn't just sell you things. It teaches you things.**

The Garrett Wade Catalog is a new, 212-page collection of woodworking hand tools, machinery, finishing supplies and accessories that are simply the finest available. Anywhere.

And besides offering quality tools from around the world, we also give you a lot of quality advice. On woodworking techniques. On picking the proper tool for a particular job. On finishing, sharpening, clamping and more.

The catalog is filled with superb photography, honest specifications and reliable descriptions. It's neatly divided into seventeen sections, including a section on our Swiss INJECTA INCA power tools. And throughout the year, our catalog owners will receive several handy supplements—free of charge.

Just send in the coupon below with \$3.00, and we'll send out your copy of the 1985 Garrett Wade Catalog. It just may prove to be the most useful tool you own.



Garrett Wade Co., Dept. 233  
161 Avenue of the Americas  
New York, N.Y. 10013

Gentlemen:

Send your complete 212-page catalog of woodworking tools, machinery, and accessories. Enclosed is \$3.

I would like *only* the following sections of the catalog, for 50¢ each:

INJECTA INCA  Carving  Finishing

Enclosed is \$ \_\_\_\_\_

Name \_\_\_\_\_

Address \_\_\_\_\_

City \_\_\_\_\_

State \_\_\_\_\_ Zip \_\_\_\_\_



**Shop helper**  
**Safety Guides**

U.S. PAT. #3-738-403

**Anti-Kickback Stock Feeder**

**SAVE TIME! SAVE MATERIAL!**

**LIKE HAVING AN EXTRA PAIR OF HANDS!**

Keep your fingers away from cutters. Let Safety Guides hold your work. Use your hands to feed and control the operation. Push stock through Safety Guides with a follow board.

**WORK WITH CONTROL!**

Safety Guides provide control, stability, and smoothness in ripping and cutting operations. It helps eliminate uneven cuts binding and chatter of material when hand feeding power machinery.

**WORK WITH CONFIDENCE!**

The spring loaded SINGLE DIRECTION BALL BEARING WHEELS will not reverse, the hard composition wheels hold work down and against the fence without marring or marking.

**WORK SAFELY!**

SHOP HELPER Safety Guides hold work down firmly helping to assure safe handling of stock on: table saws, band saws, shapers, motorized mitre boxes, jointers, etc. SHOP HELPER Safety Guides meet CAL-OSHA requirements as an Anti-kickback device when properly mounted and adjusted.



**\$89.50**

Includes: One pair of Safety Guides with long mounting brackets and hardware, instructions for use and plans for auxiliary fences.

Extra Sets of Mounting Brackets  
Long Brackets: \$12; Short Brackets: \$8

Satisfaction Guaranteed  
or return within 30 days for a full refund.

**SAFETY IS A MATTER OF SELF-RESPECT!**

To Order: VISA/MC Call Toll Free: 800-344-7455; California: 800-828-8833

For Free Brochure Write: P.O. Box 1202, Tulare, CA 93275

# Why work for somebody else when you can be a contractor yourself?

**Learn to be a builder at home in your spare time with NRI's professional Building Construction Course.**

Whoever controls the job makes the money. And that can be you... as a successful building contractor. Now, you can get in on the 80's fast-growing building boom and also build yourself a big, new lifestyle. Over 18 million new homes will be needed in just the next ten years. And NRI can help you get in on the action.

## **Includes Energy-Efficient Home Plans**

Your training is built around actual plans for a modern energy-efficient home. Step-by-step, you learn to plan and supervise its construction. You learn to select energy-saving sites, estimate costs, actually build part of the home in miniature, then build framing sections full-size. You calculate heat loss, cooling costs, plan insulation, air-conditioning, and heating system. And when you finish, the plans are yours to go ahead and build your first house. Or, you can select low-cost plans from over 50 other homes specially selected by NRI.

## **Over 100 Hands-On Training Projects**

NRI training is practical training. You get special projects throughout your course that teach you the skills and secrets of carpentry, masonry work, roofing, painting, even dry wall, wiring, and plumbing. No, NRI



can't make you a plumber or an electrician, but we do give you the knowhow you need to deal with all the building trades.

## **Includes Regional Seminar**

As an exclusive service, graduates may participate in optional owner/builder seminar. You'll get expert advice on local building codes and conditions, meet builders, learn more about energy efficiency, receive tips on financing. There'll be demonstrations, insider info on remodeling, hands-on programs to take part in.

## **Send for Free Full-Color Catalog**

Build on what you already know to build yourself a bigger and better career. Send the coupon for the big free catalog that shows and tells all about your opportunities, the practical projects you'll do, and all 70 lessons. You'll see how you learn at home, at your convenience, without quitting your job... how you can be a success in the new building boom. If coupon has been removed, write to NRI Schools, 3939 Wisconsin Ave., Washington, DC 20016-9973.

## TIPS FOR YOUR SHOP (AND OURS)

*Continued from page 41*

### **Paint brush maintenance**

Your paint brush is clean but not dry. What's a good way to remove excess water or paint thinner? Hold the brush between your palms and spin it back and forth vigorously. Centrifugal force will spin away excess moisture and fluff out the bristles—which helps prevent the brush from drying into an unmanageable lump.



### **Sharpening with a drill press**

Putting the proper bevel on chisels and plane blades isn't an easy freehand skill. Use a drill press and drum-sander attachment with appropriate grit sleeves to grind blades. Clamp the blade or chisel in a drill-press vise with the blade perpendicular to the table and parallel to the quill. Position and secure the vise to the table with a C-clamp. With the sander turning slowly, raise and lower the quill to sharpen the blade. To move the blade closer to the drum, tap the vise with a mallet. Work slowly to prevent excessive heat buildup.

—J. J. Sawyer, Pensacola, Fla. ■

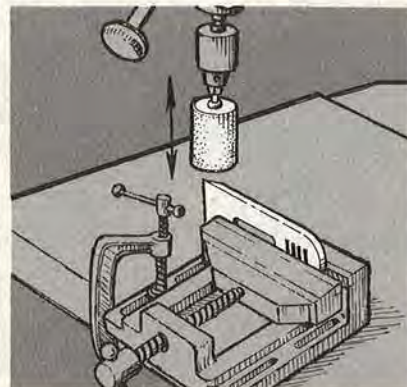

**NRI Schools**  
McGraw-Hill Continuing  
Education Center  
3939 Wisconsin Avenue  
Washington, D.C. 20016-9973



Please rush me the one free catalog I have checked. I understand there is no obligation.

- Building Construction
- Air Conditioning, Refrigeration & Heating Courses with Solar Technology
- Automotive Mechanics
- Small Engine Service & Repair
- Electrical Appliance Servicing
- CB/Communications
- Color TV/Audio/Video Servicing
- Computer Electronics Including Microcomputers
- Industrial Electronics
- Data Communications
- Industrial Control & Robotics

All career courses approved under GI Bill.  
 Check for details

Name \_\_\_\_\_ (Please print) \_\_\_\_\_ Age \_\_\_\_\_

Address \_\_\_\_\_

City/State/Zip \_\_\_\_\_

Accredited by the Accrediting Commission of the National Home Study Council

1335-015





Harder than sapphire!

4  
piece  
Carbide-  
Tipped Set  
No. 17545

NEW!



8 piece  
HSS  
Set  
No. 17858  
• 4 1/2" HSS  
triple-tempered  
tool steel blade  
• 10" hardwood  
handles



# TAKE PART... History in the making

You, too can go down in history. Experience the new **Carbide Tipped Woodturning Tools**; outstanding tool life and high quality performance under demanding work conditions!!

The traditional carbon steel turning tools have been around for years ...then along came HSS (which is more costly) but holds a useable sharp edge longer than plain carbon. Now, through latest technology, carbide tips have been added to the steel blade for the sharpest cutting edges that last longer between sharpenings and gives an even smoother finish.

**Buy your Woodturning Tools**...in kit form or individually to suit a particular project or add to your collection...

In addition to the 4 pc. carbide set and the 8 pc. HSS set you can add the **8 pc. Hobby set**...(not illustrated) same quality tempered and ground 3 1/2" HSS blades, with 5 1/2" hardwood handles. Use with large lathes for detailing or with small hobby lathes.

## re-EDGE-ucate your tools!!

To complete your workshop use the **NEW Universal Sharpener** to put a keen edge on all your turning tools.

Specially designed for low speed (200 rpm), low temperature dressing of your tool edges without having to use a grinder (which could possibly over-heat the tool thereby ruining its temper), or a cumbersome time consuming whetstone.

This sharpening system uses six inch diameter **removable disc pads** and replaceable, cloth-backed abrasive grit discs assuring a flat surface for keeping chisel and plane edges true.

- You have more flexibility and save time in sharpening.
- Comes with two disc pads and one each No. 150 and 240 cloth-backed abrasive grit discs.



**SHARPENS**  
Chisels  
Drill bits  
Knives  
Scissors  
Plane  
blades  
and  
more

**FREE!**

Chisel Storage  
Box Plans.  
Send name,  
address, zip,  
to Tools, Etc.



**Universal  
Sharpener  
No. 14630**

**ORDER TODAY!** No risk, money back guarantee. If you're not satisfied, just return in original carton for immediate credit or refund... we pay the shipping cost... both ways!

Item No.	Description	Qty.	Price	Extension	
<b>Carbide Tipped</b>					
17541	1" Skew Chisel		\$17.95	\$	
17542	1/2" Round Nose		17.95		
17543	3/4" Gouge		17.95		
17544	Right Skew; face plate		17.95		
17545	4 PC. SET — One each of the above (individually priced @ \$71.80) Plus FREE Silicone Carbide Stone <b>Save \$10.00</b>		61.80		
<b>High Speed Steel</b>					
17521	1/4" Gouge		7.45		
17522	1/2" Gouge		7.95		
17523*	3/4" Gouge		9.75		
17524	1/2" Spear Point		7.75		
17525*	1/2" Round Nose		7.45		
17526*	1/8" Parting Tool		7.45		
17527	1/2" Skew		7.45		
17528*	1" Skew		9.75		
17853	4 piece Beginning Set — includes items indicated by * (Individually priced @ \$34.40) <b>Save \$5.00</b>		29.40		
17859	8 piece Set — one each of all 8 Chisels No. 17521-28 (Individually priced @ \$65.00) <b>Save \$10.00</b> , plus FREE Detail tool for delicate work		55.00		
17984	8 piece Hobby Set		36.00		
14630	Universal Sharpener		59.95		
Shipping & Handling, add \$3.50 per order				3.50	3.50
KY residents, add 5% tax				—	
			<b>TOTAL (U.S. Dollars)</b>	<b>\$</b>	

### Method of Payment

Check Enclosed  VISA  MasterCard

Card \_\_\_\_\_ Good Thru \_\_\_\_\_

Name \_\_\_\_\_

Address \_\_\_\_\_

City \_\_\_\_\_

State \_\_\_\_\_ Zip \_\_\_\_\_

# TOOLS ETC.



Dept. 539501, 510 East Main St.  
Louisville, KY 40202

**Order by Phone 1-800-233-1133**  
(Except KY) 8:30 to 5:00 EST Mon.-Fri.

All items are U.S.A. manufactured

**First Time Ever! For Owners of DeWalt and Sears Radial-Saws!**

# MR. SAWDUST BRINGS PROFESSIONAL SHAPING TO THE SMALL SHOP!



"We're running this introductory ad a little early — to let you know we'll be demonstrating these new products in the fall shows. Make sure you **PHONE NOW** — for the **FREE Shop Poster** shown below!"



"I want the small shop to move up to professional cabinetry without a big investment. That's why we're introducing my New Twist cutter. (They also work on Tablesaws with 5/8" arbor.)"

## Your Choice of 73 PROFILES in My LOW-Cost "NEW TWIST"™ Cutters!

Your radial-saw is the most versatile tilt-arbor shaping/moulding machine you can own. You may not realize it — but cutters (specially-designed for radial-arms) have never been available before and there's never been a guard to *really* keep you safe.

Now, after 30 years of wishing and scheming, I've got what I always wanted — and it's all *YOURS*: The way to accomplish professional shaping — without the high cost of heavy machinery and expensive carbide heads.

No more shaper-heads. No more inserted knives. Just a fine piece of twisted-steel with a precision profile. Giving you a quality of cut that's equal to any in the business!

**ACTUAL SIZE of the Most Complete Line Ever Developed for the Serious Woodworker!**

HEAD, QUARTER-ROUND, ROUND-OVER											
1	2	3	4	5	6	7	8	9	10	11	12
1/8"	3/16"	1/4"	5/16"	3/8"	7/16"	1/2"	5/8"	3/4"	7/8"	1"	
FLUTE, COVE & CORE-BOX											
1A	2A	3A	4A	5A	6A	7A	8A	9A	10A	11A	12A
BEADING & BULL-NOSE											
1B	2B	3B	4B	5B	6B	7B	8B	9B	10B	11B	12B
FULL-PROFILE BEAD & COVE											
13	23	33	43	53	63	73	83	93	103	113	123
FULL-PROFILE COVE											
14	24	34	44	54	64	74	84	94	104	114	124
FOR MOULDINGS UP TO 4" DIAMETER											
15	16	17	18	19	20	21	22	23	24	25	26
FOR DOORS WITH GLASS											
27	28	29	30	31	32	33	34	35	36	37	38
FOR DOORS WITH PANELS											
39	40	41	42	43	44	45	46	47	48	49	50
FOR DOORS 1 3/8" TO 1 3/4" THICK											
51	52	53	54	55	56	57	58	59	60	61	62
GROOVES & TONGUE											
63	64	65	66	67	68	69	70	71	72	73	74
SPACERS 1/4" & 1/8"											
PANEL-RABBING, SURFACING											
STRAIGHT KNIFE											
GROOVERS FOR S-SERIES											
GROOVERS FOR D-SERIES											

Phone Forrest — TOLL FREE  
**1-800-526-7852**  
In N.J. — 201-473-5236

**New MR.SAWDUST SHAPER/DADO GUARD Does More Than Keep You Safe!**



**HORIZONTAL!**

Massive. Cast Aluminum. Rim is 3/8" thick! TOTAL protection with shaper-cutters or 8" dado-head!

**TILTED 45°!**

For face-moulding, hold-down shoes ride on material. Can be canted to hold material to fence.

**VERTICAL!**

Hold-downs also adjust to vertical! SAFETY when you need it most. Great for ploughing with dado-head!

Designed by America's Foremost Power Tool Pro for Use on DeWalt and Sears Radial-Arms for MR. SAWDUST "NEW TWIST" SHAPING

**GET YOUR 24" x 36" SHOP POSTER...NOW!**

Shows profiles FULL SIZE — and a lot of the amazing work they do! An education in itself!

(Includes prices & availability)

**PHONE TOLL FREE...1-800-526-7852**  
(In NJ: 201-473-5236)

**COMING!** My 180-page book, "Shaping with the Radial-Arm"! 160 drawings, 60 photos. The publisher has it. Should be ready by Christmas.

**FORREST**

FORREST MANUFACTURING COMPANY, INC.,  
250 DELAWANNA AVE., CLIFTON, N.J. 07014

**WE'LL BE DEMONSTRATING MY "NEW TWIST"™ CUTTERS AT ALL MAJOR WOODWORKING SHOWS!**



 Print this article

# split oak baskets

Don Yarger, student of an age-old craft

From finding a special tree nestled into a hillside to interweaving thin white oak splits, basket-making challenges the eye and hand, and rewards the craftsman with enduring creations that earn their keep.

Don Yarger, at 31, is still a few years away from becoming a "journeyman" basket maker, but he finds his apprenticeship a rewarding one. Don's work provides him, his wife, Annita; daughter, Jennifer; and son, Cody, with a comfortable home in Protom,



Continued

## CRAFTSMAN CLOSE-UP

a small Missouri Ozark town just a few miles from Silver Dollar City where Yarger makes his living weaving and selling split-oak baskets.

Early baskets were crafted from many common materials — cattail leaves, reed, willow, and tree bark. But the most easily made, most durable designs were made from thin, flexible strips of green sapwood from ash, hickory, and best of all, white oak trees. In fact, one species of white oak peels so easily into splits that it's referred to as "basket oak."

### Hunting the Basket Tree

Like wood-frame homes and table tops, baskets begin with trees, and Yarger knows that just any old tree won't do. He prefers white oak but has also used walnut and hickory for his baskets.

His search for the perfect white oak begins on the northeast slopes of Ozark hillsides. According to Yarger, there are three reasons to select a tree from a northeast slope. First, because the wind normally blows from southwest to northeast, the trees on a sheltered northeast slope tend not to be twisted. Also, the wood isn't dried out and brittle from too much sunshine. And third, since ground moisture remains longer on these slopes, the trees absorb and retain moisture so their wood tends to stay workable.

Finding the area is only the beginning. Next comes selecting the perfect tree—about 10 inches in diameter, free of branches for about the first 10 feet (to eliminate knots), and straight-grained.

How can Don tell if a standing tree is straight-grained? His trained eyes can spot a good tree a long way off: "I can tell how it's going to split by the way the bark looks. If it runs pretty much straight up and down the tree, it's going to be straight-grained and come apart pretty well," Yarger explains.

Ideally, Don looks for a tree that will yield a 5- to 6-foot log from the base to below the lowest limb—the moistest part of the tree.

### Laying Out, Halving, and Splitting the Log

After felling the tree with a cut as close to the ground as possible, and freeing the desired section from the rest of the trunk, Yarger studies the wood for halving and splitting.

"I look for knots when I lay it out on the ground," he says. "If there is a knot, I make the first split close to it, since that section will be lost anyway. I split down from the top of the log to the base. That way, if there's a knot in there somewhere, the split has a tendency to cut right through it. But I've found that if you run into a knot when splitting from bottom to top, the split usually runs around the knot and maybe even slabs off."

Using a maul and steel wedge, the basket maker splits the log in half. Then he moves one third of the way down each section, where he drives in the maul to quarter the log. This way, Don knows he's right in the run of the grain, since the true grain can't be seen from the ends of a section.

After the log has been quartered, he crosscuts it into about 3-foot sections, then slabs off the heartwood, which, if it is relatively knot-free, he uses later for handles, ribs, and accent strips. Then, Yarger splits the quartered sections into eighths, called *billets*.



**Making billets**

"In summer, the green, felled log must be split within ten days, or

the ends will dry out and check," Don says. "In winter, though, splitting can be done as long as four months after the tree has been dropped."

### From Billet to Split

Don begins the process of turning billets into splits by taking off the bark with a drawknife at the shaving horse.



**Removing the bark**

Next, the individual billets are shaped to desired form, also on the shaving horse. "The object," explains Don, "is to taper each end of the billet so that when strips come off, they'll be wide in the center for



**Splitting the billet with a drawknife**

the bottom of the basket, and they'll taper toward their ends to form the basket's ribs."

Don does this shaping with the drawknife, turning the billet to work it from both ends. He uses the same method to form *weavers*, the long, narrow, and straight pieces that tie the ribs together. He depends on a well-developed eye to maintain widths.

Traditionally, from the shaving horse, billets would move to the workbench to be split into weavers or ribs with a drawknife and a simple jackknife. Standing a billet on end, the basket maker would split it with the drawknife down its length parallel to the annual growth rings. He would keep splitting until the pieces could no longer be reduced by that method, then switch to the jackknife. Don knows the old way, too.

Placing the blade of the jackknife in the grain, Don begins the split. When the knife has separated enough of the wood to grasp by



#### **Pulling the split by hand**

hand, it's put aside, and the pulling begins.

Hand-pulling becomes increasingly delicate as the strips near their final thickness. "If the split runs off to one side, you pull toward the other side," he says while demonstrating.



#### **Final hand-pulling**

That's the traditional way, but in the high production basket shop, the traditional takes too long. Instead of hand-pulling, Don has fitted a cooper's spokeshave with a planer blade to shave weavers and ribs from the billets clamped on a shaving horse.



#### **Shaving a split with a spokeshave**

It's still hand work, and the results aren't always uniform. According to Don, "anything done by hand is going to have some variation on it."

With no gauge to rely on, the shaving technique requires a practiced eye. "The thickness of the split is solely a product of how hard the spokeshave is pushed down and the strength of the maker's pull," Don says.

He makes his splits "down the tree" with the spokeshave and then works the tool back and forth following the grain and keeping it to the center. "The strips must be constant in their thickness, with ribs thicker and weavers thinner. If they're thick on the ends and thin in the middle, the basket will have a weakness," Don explains.

The splits come off the shaving horse moist and pliable, ready for weaving. They'll stay that way for 3 to 4 days in normal weather, but hot days dry them out in an hour. That's when Don wets the splits down with a sprinkling can or gives them a good soaking.

#### **Two Types of Baskets in 50 Styles**

To this basket maker, the world of split-oak baskets is divided into two parts—designs woven over a form and those built completely free-hand. Yarger makes both, in 50 different styles. Starting below, we'll follow him through the steps in making a formed, rectangular basket that's a popular seller.

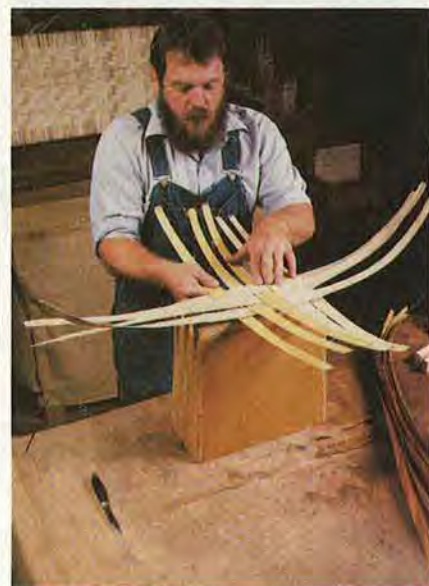

**1** Don begins by laying rib splits across the plywood box, then interweaves the side rib splits with the end rib splits. The interwoven ribs become the basket's bottom. They're tightened later in the process. So they'll bend over the form, Don wets the ribs.

*Continued*

## CRAFTSMAN CLOSE-UP



**2** Weavers gradually build up the sides. The "over-one, under-one" is the "checker" pattern. A band holds the weave.



**3** Don angle-clips the ribs so they'll tuck under the inside weavers. A thin-bladed knife helps to lift weavers slightly.

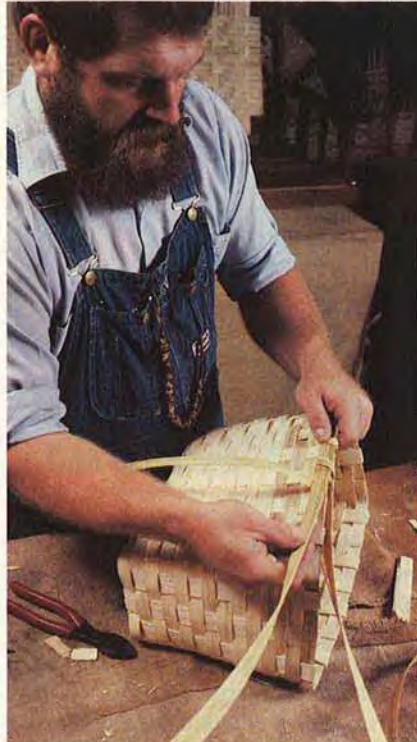

**4** To add strength, Don uses two weavers at once, and binds them to the top of the basket with a lashing of narrow splits (weavers cut lengthwise).



**5** Finishing the basket border, he uses a knife blade to tuck the lashing under a split after pulling it tight. Tucks are inside.

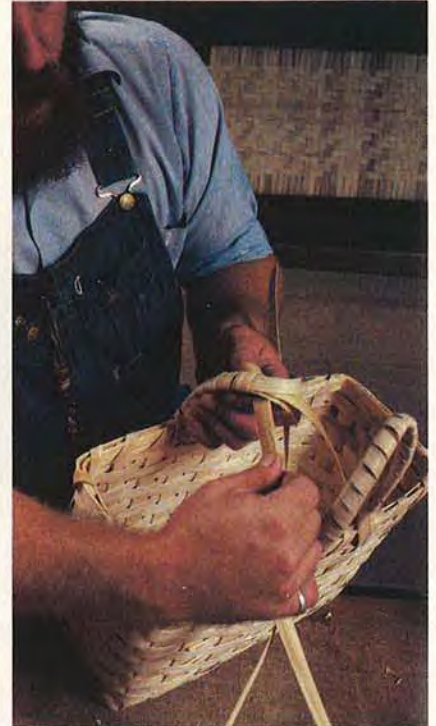

**6** Doubled splits bound twice with thinner weavers make strong handles. Don spaces them between the ribs of both basket sides and lashes them.

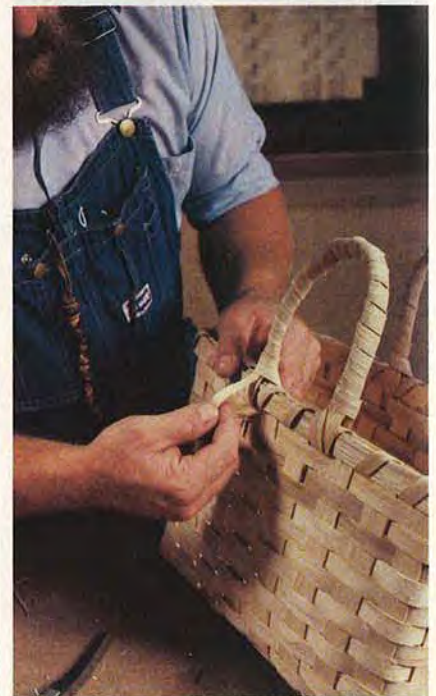

**7** The last tuck of the handle goes under the border splits. Don believes both basket and handle must be equally sturdy.



Paul L.  
McClure

Wood technologist; lecturer; owner of Wood World, a retail hardwood store in Tempe, Arizona; woodworking instructor, and former exotic hardwood buyer.

### Brief history

During the 1700s, a cabinetmaker named Rock manufactured "Rock's Hard Maple Furniture." The name stuck, and the terms "rock maple" and "rock-hard maple" remain popular today.

For generations, in fact, hard maple has been used for furniture and other items that take abuse: desks, workbenches and butcher blocks, for example.

### Wood identification

Twenty-three species of maple grow in Canada and the U.S. They form two broad commercial groups: soft maple and hard, or "sugar," maple—which is tapped each spring for its sap.

Hard maple flourishes west and south from southeastern Canada and Maine to Minnesota, Missouri, and Alabama. The largest quantities of hard maple are found around the Great Lakes, and Michigan and New York produce the most trees in this country. Soft maple follows the same range, but grows in damper ground—lowlands, swamps, and stream banks.

Maple sapwood has a clean, white appearance, is free from defects and is typically 3" to 5" thick.

# MAPLE

## hard, soft... and sweet



Straight  
grain



Fiddleback  
grain



Bird's-eye  
grain



Burl  
grain



Sugar maple

**Probably our most useful domestic hardwood, maple produces syrup for pancakes, school desks to scribble on . . . and much more in between.**

These qualities make it more valuable than heartwood, which is uniform in color and runs from light reddish brown to dark brown.

Generally straight-grained with a consistent texture, maple also can have a bird's-eye or curly (also called fiddleback) pattern. Many wood-

workers find the unique grain patterns of maple burl particularly appealing.

Soft maple, although similar in appearance to hard maple, produces lighter wood with more pronounced grain. Although not as tough, stiff, or heavy as hard maple, soft maple tends to resist warping and twisting

better. Its color ranges from pale brown to almost white with brown streaks.

### Working properties

Hard maple remains strong when bent, absorbs shock well, works nicely with both power and hand tools, and resists wear. It also turns well and requires no filling before finishing. Hard maple takes a high polish and has substantial screw-holding power.

Soft maple works even more easily than hard maple. It glues, stains, and finishes well but doesn't take as high a polish as hard maple.

### Uses in woodworking

Soft maple, used principally for lumber, paper pulp, and other industrial applications, continues to be suitable for cabinet frames, unseen parts of upholstered furniture, and jigs and forms used in woodworking shops.

Hard maple applications include bowling alley surfaces, chopping blocks, piano frames, turnings, furniture (particularly figured-wood pieces), ladder rungs, rulers, tool handles, even clothes pins.

### Cost and availability

Hard maple comes in average lengths of 6' to 12' and average widths of 6" to 10", while soft maple trees tend to produce somewhat wider boards. Both types are widely available and can be bought as lumber, veneer, and turning blocks. Maple is a relatively inexpensive hardwood, although bird's-eye, curly, and burl varieties can be expensive. ■

# BUILD YOUR OWN wooden pulls

Whether you're dressing up existing door and drawer fronts or starting a project from scratch, these easily made wooden pulls will help you get a good—and attractive—grip on the situation.

 Print this article

## Hardwood Wire Pulls

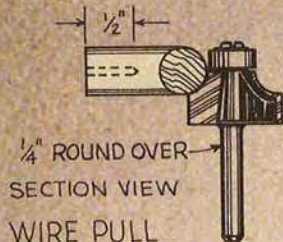
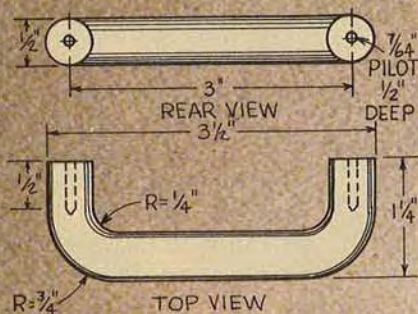

**1** Cut  $\frac{1}{2}$ " stock to  $2\frac{5}{8}$ " wide X  $3\frac{1}{2}$ " long. Each block will yield two pulls. (Cut extra blocks: you may lose a few to machining errors.)

**2** Cut the Wire Pull Template from  $\frac{1}{4}$ " hardboard (see the dimensions at

right). Then, clamp the template to one face of the block, and trace the rounded corners and drill-hole positions onto the block. Cut the rounded corners on a band saw or saber saw and sand the cuts smooth. Drill a  $\frac{1}{2}$ " hole in each

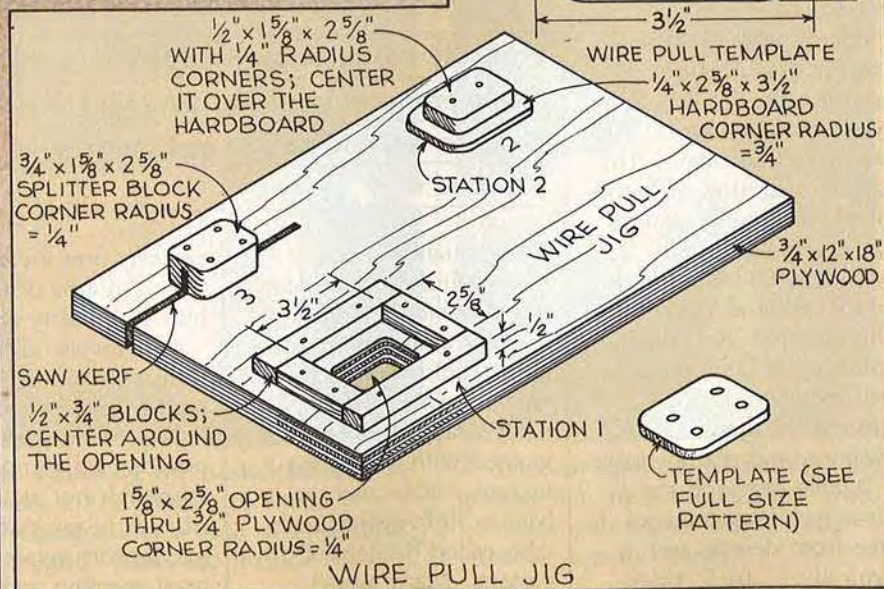
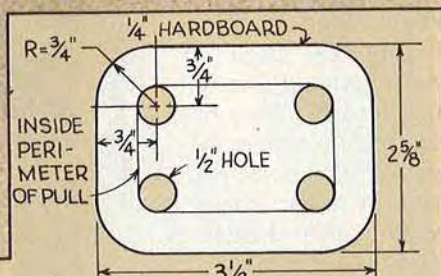



## SCRAP WOOD PROJECT

corner as marked. (We used a drill press and a Forstner bit for this step, since the grain can deflect a regular twist-drill bit.)

**3** Mark the inside perimeter of the pull on the block. Using a band saw or saber saw, cut to the inside of the marked line to rough-out the inside of each block.

**4** Construct the Wire Pull Jig as shown at left. The shape of the hole and the supports around it (Station 1), as well as the support blocks (Stations 2 and 3) must be cut and shaped accurately. Do not place any nails in the path of the saw kerf in Station 3.

**5** Place each block in the first station on the jig and use a router fitted with a flush-trimming bit to trim the inside. (The ball-bearing pilot rides against the sides of the hole in the jig, cutting the block interior to its proper size.)

**6** With the pull still in the first station, insert a  $\frac{1}{4}$ " round-over bit into the router. Rout the bottom and top inside edges of the pull as shown in the photo below. Move the pull to the second station and round-over the outside edges.



**7** Move the pull to the third station and place the jig on a table saw. With the blade set  $1\frac{1}{8}$ " above the table surface, cut the pull in two.

**8** Mark the centers of the ends of each pull, and drill a  $\frac{3}{16}$ " pilot hole  $\frac{1}{2}$ " deep for a #8 mounting screw.

**9** Sand by hand and apply finish.

### Whistle Pull

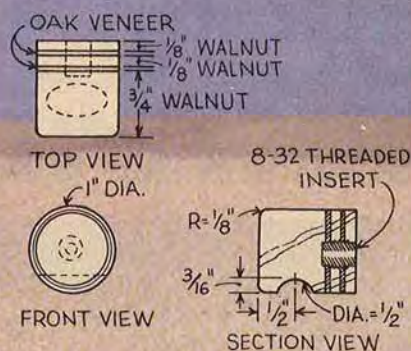

WHISTLE PULL

**1** Laminate the walnut and oak veneer in block form as shown in the top view in the Whistle Pull Drawing and the photo below.

**2** Using a 1" plug cutter, cut the pulls from the block.

**3** Mark the center of each pull on its back side. Clamp the pulls (one at a time) between the jaws of a



handscrew, then clamp the handscrew to a drill-press table and drill

a  $\frac{9}{32}$ " hole  $\frac{3}{8}$ " deep to accommodate an 8-32 threaded insert. (Threaded inserts in this size were ordered from Woodcraft, 41 Atlantic Ave., Box 4000, Woburn, MA 01888.

Catalog \$3, and are available from other mail-order sources. You may be able to locate them locally, too.) Install the insert as shown in the drawing below, turning the drill press by hand. (Unplug your drill press before performing this procedure. We used a drill press, as inserts are very difficult to install evenly using a screwdriver.)

**4** Use a round rasp to shape the grasp as shown in the photo below. (We clamped the pull in a vise to steady it for rasping.)



**5** Round the top by sanding; hand-sand the pull and apply finish.

### Hidden-Grasp Pull

**1** Cut a piece of  $\frac{3}{4}$ " oak to  $\frac{3}{4}$ "x16" for four pulls.

**2** Lay out the pulls by marking the oak at  $3\frac{3}{4}$ " intervals, leaving  $\frac{1}{8}$ "

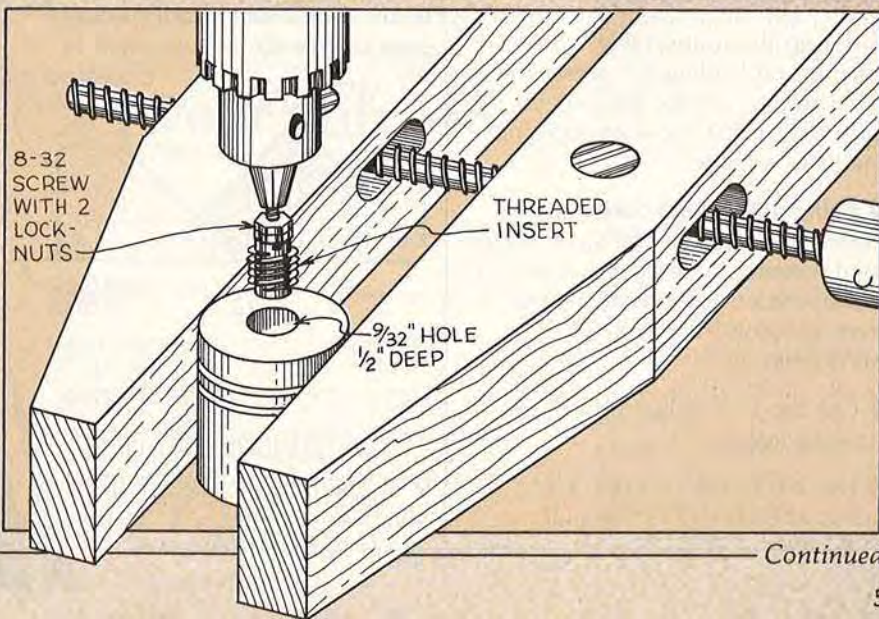

Continued

## SCRAP WOOD PROJECT

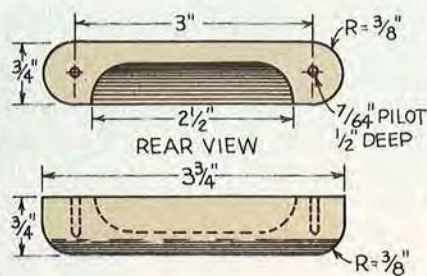

TOP VIEW

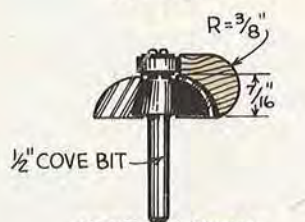

SECTION VIEW  
HIDDEN-GRASP PULL

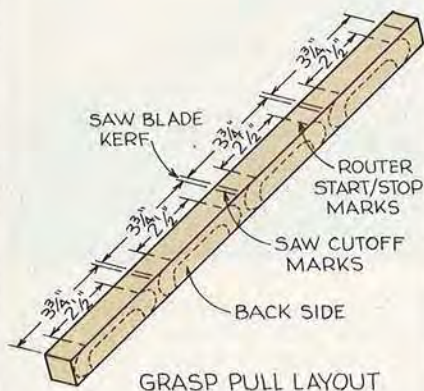

GRASP PULL LAYOUT

gaps for saw kerfs as illustrated in the Grasp Pull Layout above. Mark the router start and stop marks at 2 1/2" intervals for the hidden grasp as shown in the drawing.

**3** Set up the router table with a 1/2" cove bit protruding 1/16" above the table surface. Make the cuts for each pull, using the start and stop marks as a guide.

**4** Using a 3/8" round-over bit, rout both front edges of the piece. (We used a router table with a fence for this operation to prevent the bit from gouging the coves cut previously.)

**5** Cut the four pulls to their 3 3/4" finished length.

**6** Use a compass to mark a 3/8" radius at each end of the pull.

Round-over the end with a belt sander or stationary disk sander, or rasp and sand by hand.

**7** Locate and mark holes for mounting screws, and drill a 1/64" pilot hole 1/2" deep to accommodate #8 wood screws.

**8** Hand-sand each pull and apply finish. (We chose polyurethane.)

### Continuous Pulls

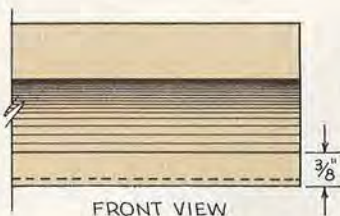

FRONT VIEW

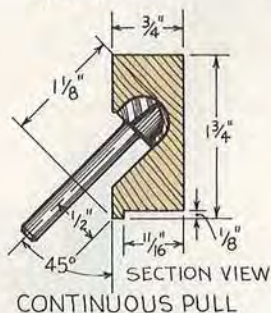

SECTION VIEW  
CONTINUOUS PULL

**1** To build the Continuous Pull Jig shown below, crosscut a 2x4 (1 1/2" x 3 1/2") to the length of your router table. Bevel-rip the 2x4 at a 45° angle as shown below, so that the shorter face of each piece is 7/8" wide. (You'll need both pieces of 2x4 for the jig.)

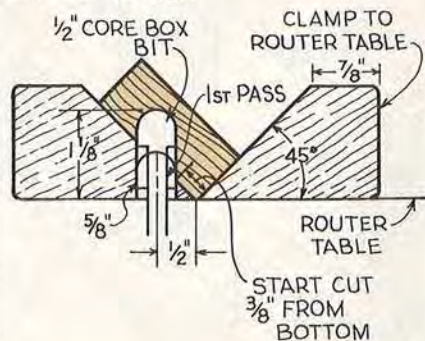

CONTINUOUS PULL JIG

**2** In one of the pieces, drill a 3/8" hole whose center is 1/2" in from the



angled edge and midway along the length of the block. Clamp the piece to the router table so the 3/8" hole centers over the 1/2" core box bit. Clamp the other half of the block to the table as shown above.

**3** Rip 3/4" lumber 1 1/4" wide and 1" longer than length of door or drawer it will be attached to.

**4** Pencil a mark 3/8" from one edge on one end of the 3/4" piece as shown. With the router off and the router bit set at about 1/2" above the table and protruding through the jig, push the marked end of the stock up next to the core box bit. The cut should start just above the penciled 3/8" mark. Start the router and push the stock over the bit to make the first pass. Raise the bit about 1/8" per pass until the full 1 1/8" depth is reached.

**5** "Break" the sharp edge on the pull with sandpaper. (We sanded the sharp edge by hand using 150 grit sandpaper followed by 220 grit paper attached to a sanding block.)

**6** Cut an 1/16" rabbet 1/8" deep along one edge of the pull to mount it to the door or drawer. (We used a dado blade on the table saw to cut the rabbet, using push sticks to safely position the pull next to the fence and push the piece over the rotating blade.)

**7** Cut the pull to the finished length. Finish-sand and varnish. Avoid varnishing the rabbeted edge that will be glued to the door edge.

**8** Glue and clamp the pull to the door edge, being careful when clamping not to mar its surface. ■

# PROBLEM-SOLVING hardware Print this article

**W**oodworkers who build cabinets or furniture always seem to be in need of just the right piece of hardware for one of their projects—hardware that meets a special need. Chances are good that the item you're looking for exists—but where? The products shown here represent but a few of the thousands of special-purpose hardware items available today.

It pays to know your hardware options, both at your local hardware store or home center and through mail order. For your convenience, on the next page, we list a group of mail-order firms (including The Woodworkers' Store, where we bought the items shown below) that offer selections of cabinet hardware. We think you'll find purchasing their inexpensive catalogs a good investment—and good reading, too.

## Quick-Insert Hidden Hinges

Completely invisible with the door shut, and unobtrusive when its open, these hinges install easily and quickly. Just drill matching holes in the door and frame, insert the hinge into those holes, drive a single screw through each side into the wood, and you're done!

**Plastic Drawer Dividers**  
Ideal for compartmentalizing

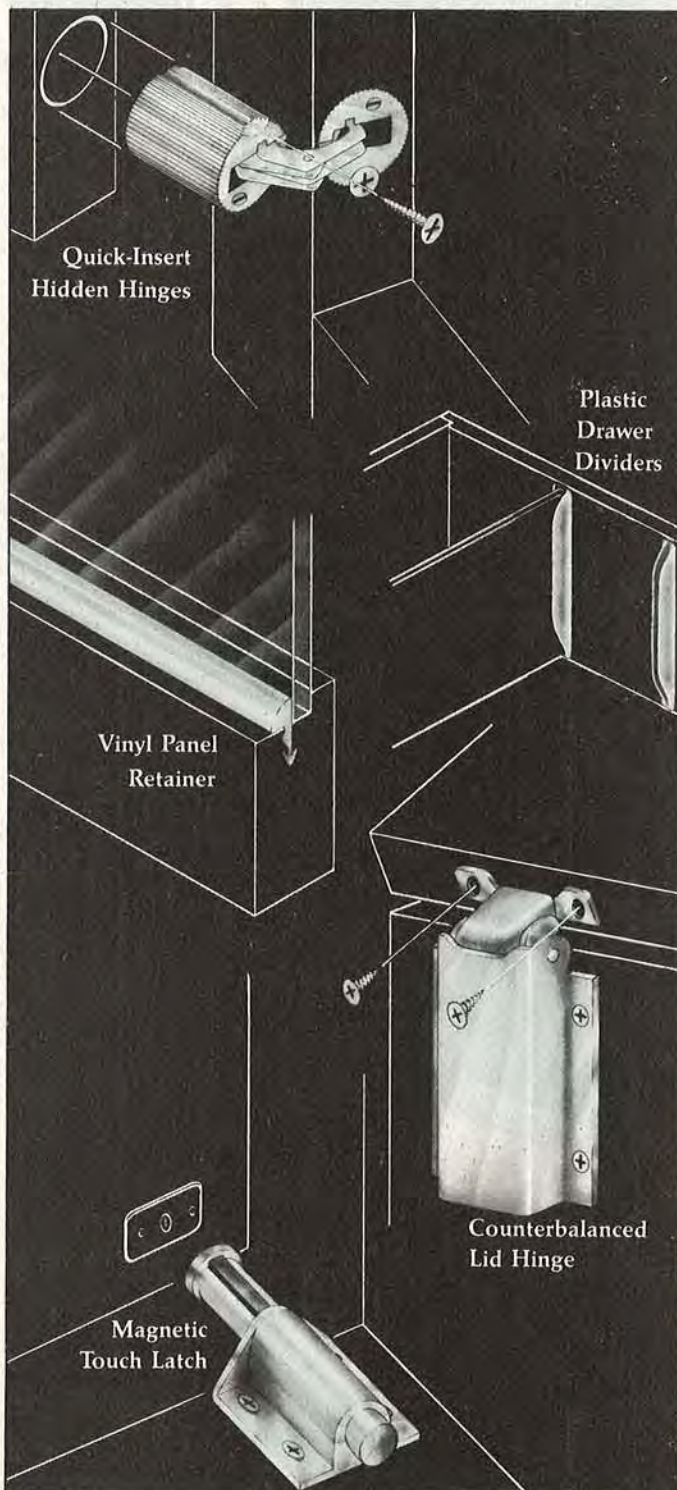

ing cabinet drawers, these nifty items fasten to the inside of the drawer sides with nails. The ones shown accept dividers from  $\frac{1}{8}$ " to  $\frac{5}{16}$ " thick, and come in two heights—2" and 3 $\frac{1}{2}$ ".

## Vinyl Panel Retainer

With frame-and-panel doors, you've got to secure the panel somehow. While you can cut thin strips of wood to do the job, this purposeful product sure makes the going a lot easier. You can cut it easily with a knife and miter it with standard tools. The type shown snaps into a groove cut into the frame.

## Counterbalanced Lid Hinge

This surface-mount, dual-purpose hardware item makes great sense for projects with lids, such as stereo cabinets and the like. Just position the lid and hinge, mark the location of the screw holes, drill starter holes, and mount the hinge. It's a snap!

## Magnetic Touch Latch

Looking for a sleek-looking set of cabinets without door pulls? This catch holds the door closed until you press on the face of the door. To close the door, push the door shut and the latch holds it. This spring-loaded latch can be

Continued

## BUYMANSHIP BASICS

mounted either horizontally or vertically.

### Plastic Magnetic Catch

Especially suited for small doors, this catch mounts in a hole bored into the frame; the metal strike attaches to the door. The catch shown is available in brown and white plastic.

### Ornamental Surface-Mount Hinge

Designed for  $\frac{3}{4}$ " flush inset doors, this hinge doesn't require mortising. The leaves of the hinge align to ensure just the right space between the door and frame.

### Out-of-Sight Shelf Supports

An interesting option to the more standard shelf support clips, these wire supports fit into small holes drilled in cabinet end and divider panels. Shelves with grooves cut into their edges slide onto the supports. To change shelf positions, just move the wire supports up or down.

### Easy-Does-It Glass Door Hinges

Hinging glass cabinet doors can be a hassle, but not with this temper-saving piece of hardware. To install a pair of these hinges, drill holes in the top and bottom of the cabinet, fit plastic inserts into the holes, slip the hinges into the inserts, slide the glass door into the hinges, and secure the door by tightening the screws in the hinge.

### Slip-On Glass Door Strike

This simple-to-install strike is the perfect match for the glass door hinges shown here. (You can also



Plastic Magnetic Catch

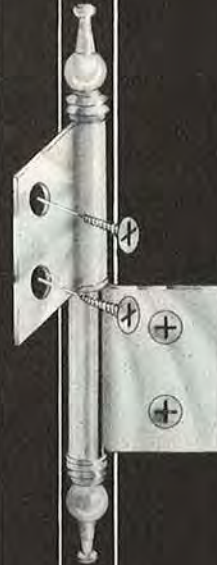

Ornamental Surface-Mount Hinge

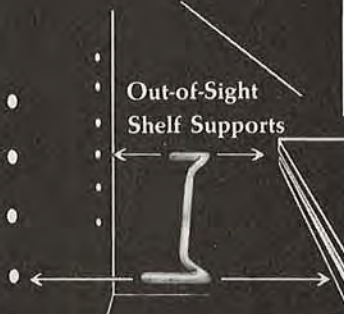

Out-of-Sight Shelf Supports



Easy-Does-It Glass Door Hinges



Slip-On Glass Door Strike

use it with the touch latch described above.) Foam rubber pads hold the strike securely in place.

### Mail Order Hardware Suppliers

The companies listed below represent a good cross section of the firms selling cabinet and furniture hardware (and in many cases other items) by mail. We'll tell you about others as we run onto them.

#### U.S. Suppliers:

##### Ball and Ball

436 West Lincoln Highway  
Exton, PA 19341  
215/363-7330  
Mini catalog: Free  
108-page catalog: \$5

##### The Brass Tree

309 North Riverside Drive  
St. Charles, MO 63301  
Catalog: \$2

##### Constantine's

2054 Eastchester Road  
Bronx, NY 10461  
Toll free: 800/223-8087  
108-page color catalog: \$1

##### Craftsman Wood Service Co.

1735 West Cortland Court  
Addison, IL 60101  
148-page catalog: \$1

##### Garrett Wade

161 Avenue of the Americas  
New York, NY 10013  
40-page brass hardware catalog: Free

##### Horton Brasses

Nooks Hill Road,  
P.O. Box 120J  
Cromwell, CT 06416  
203/635-4400  
Catalog: \$2

##### Imported European Hardware

4295 South Arville  
Las Vegas, NV 89103  
702/871-0722  
Catalog: \$1

Continued on page 115

# COLOR me safe

Children of all ages will love to keep little treasures safe and sound in this walnut safe.

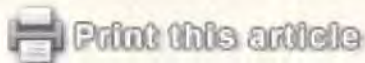

## How to Make the Box

- 1 Rip and crosscut the box's top, bottom, and sides (A) to size.
- 2 Build the Box Joint Jig shown below. Then, test the jig with  $\frac{3}{4}$ " scrap lumber to make sure the pieces will join together properly. Cut notches in the sides and top and bottom, using the Box Joint Jig as shown. (Notice that the side pieces have a finger at the front, while the top and bottom have a  $\frac{3}{4}$ " space and then the first finger.)

- 3 Refer to the cutaway drawing for the location of the hole in the side of the safe that will accept the lock bolt. Mark its center point, then drill a  $\frac{1}{16}$ " hole  $\frac{5}{8}$ " deep.

- 4 Glue and clamp the sides to the top and bottom. Check for square with a try square. Remove excess glue from the box after the glue forms a tough skin. Round-over the four outside corners, using a belt sander or a router with a  $\frac{3}{4}$ " round-over bit. Cut a  $\frac{3}{4}$ " rabbet  $\frac{3}{8}$ " deep

in the back of the box with a router; square the corners of the rabbet with a chisel.

- 5 Before cutting the back (B), measure the rabbeted opening to ensure a good fit. Cut B to size, then cut a  $\frac{1}{16}$ " rabbet  $\frac{1}{8}$ " deep around the outside edge of B. Glue and clamp the back to the box with the decorative rabbet facing out.

## Assembling the Front Door

- 1 Cut door parts C, D, and E to size, then notch C as shown in the exploded-view drawing. (We cut the notches with a table saw fitted with a dado blade.)
- 2 Trace the outline of the hinges on the outside edge of E and cut mortises to house them.
- 3 To ensure good alignment of the lock bolt holes, dry-clamp pieces D and E together edge to edge. Use a drill press to drill a  $\frac{1}{2}$ " hole through D and  $\frac{1}{8}$ " deep into E to accept the lock bolt (F). Next, mark the  $\frac{3}{4}$ "-long  $\times$   $\frac{1}{4}$ "-wide slot in the face side of part D for the sliding pin (G). (See the note on exploded-view drawing for position.) Using a  $\frac{1}{4}$ " bit, drill several holes side by side, then clean the slot with a chisel.
- 4 Glue and clamp door parts C, D, and E (we fit a  $\frac{1}{2}$ " dowel through the holes in D and E to keep the holes aligned while clamping).

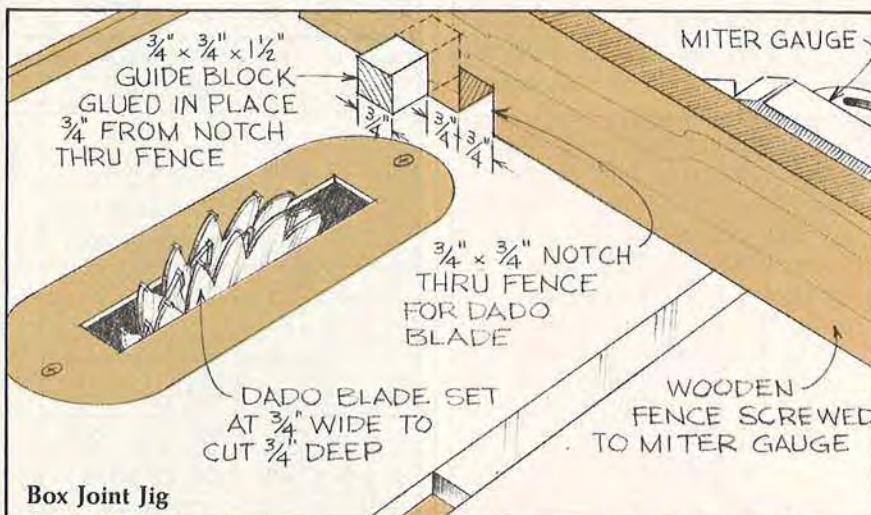

## Box Joint Jig

### How to Use It

1. A) For top and bottom: Clamp board to fence so front edge is  $\frac{1}{4}$ " from guide block; cut first notch
- B) For sides: Place front edge of board against guide block and cut first notch
2. Place notch over guide block and cut second notch
3. Repeat until all notches are cut

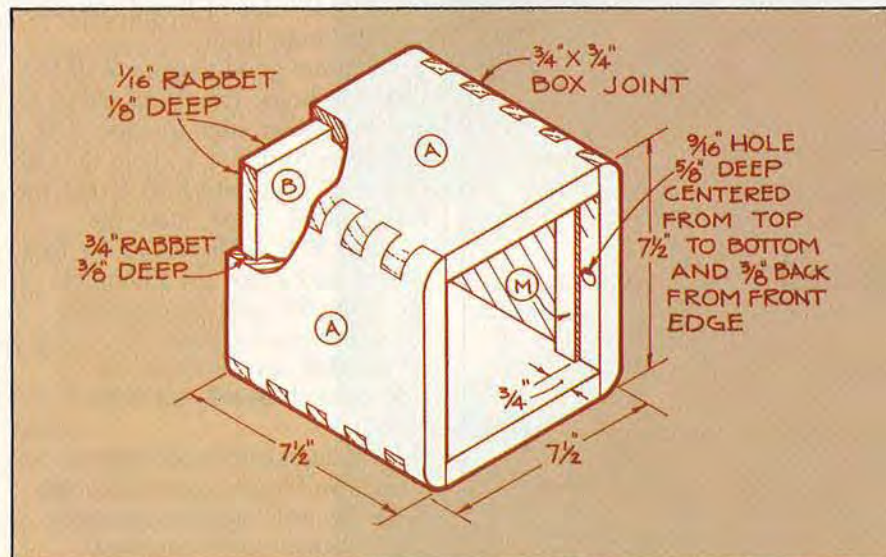
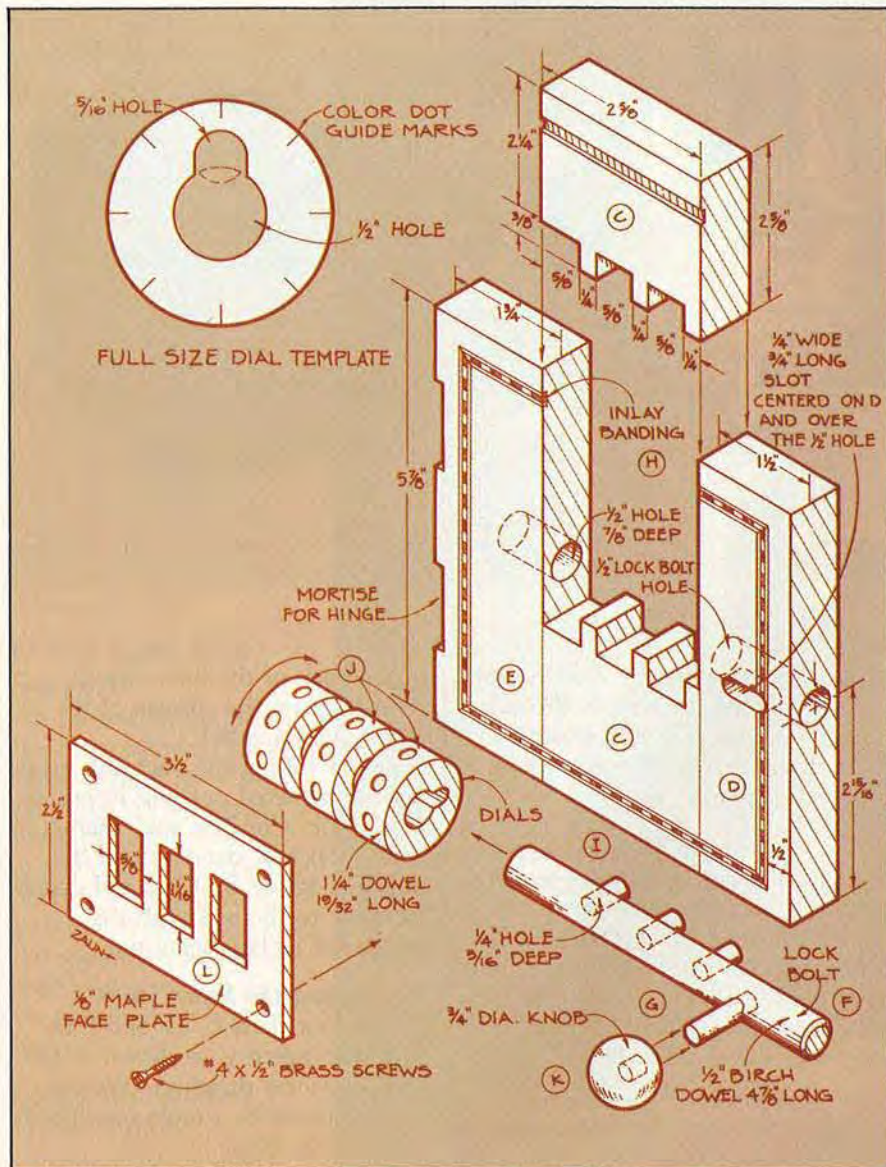

**5** To fit the inlay banding (H), rout a  $\frac{3}{16}$ " groove just a hair shallower than the thickness of the inlay, then glue the inlay in place. Let the glue dry, then sand the inlay flush with the surface of the door.

### Making the Lock Mechanism

**1** Cut the  $\frac{1}{2}$ " lock-bolt dowel (F), the  $\frac{1}{4}$ " dowels for the knob shaft (G), the lock pins (I) and the three  $1\frac{1}{4}$ " lock dial dowels (J) to length.  
**2** Using tracing paper, transfer the template markings to the dials (see the template at left.) Now, cut a  $\frac{1}{2}$ "

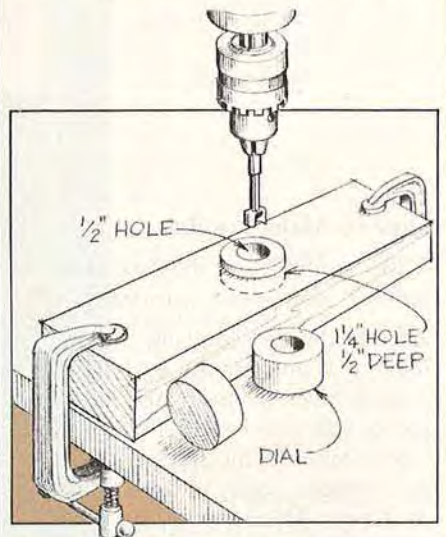

Bill of Materials					
Part	Finished Size			Material	Qty.
	T	W	L		
A	$\frac{3}{4}$ "	$7\frac{1}{2}$ "	$7\frac{1}{2}$ "	walnut	4
B	$\frac{3}{4}$ "	$6\frac{3}{4}$ "	$6\frac{3}{4}$ "	walnut	1
C	$\frac{3}{4}$ "	$2\frac{5}{8}$ "	$2\frac{5}{8}$ "	walnut	2
D	$\frac{3}{4}$ "	$1\frac{1}{2}$ "	$5\frac{7}{8}$ "	walnut	1
E	$\frac{3}{4}$ "	$1\frac{1}{4}$ "	$5\frac{7}{8}$ "	walnut	1
F	$\frac{1}{2}$ " diam.		$4\frac{7}{8}$ "	birch dowel	1
G	$\frac{1}{4}$ " diam.		$1\frac{1}{4}$ "	birch dowel	1
H	$\frac{1}{16}$ "	$\frac{3}{16}$ "	21"	inlay banding	1
I	$\frac{1}{4}$ " diam.		$\frac{9}{16}$ "	birch dowel	3
J	$1\frac{1}{4}$ " diam.		$1\frac{19}{32}$ "	birch dowel	3
K	$\frac{3}{4}$ " diam.		$\frac{3}{4}$ "	birch dowel	1
L	$\frac{1}{8}$ "	$2\frac{1}{2}$ "	$3\frac{1}{2}$ "	maple	1
M	$\frac{3}{4}$ "	$\frac{1}{4}$ "	6"	walnut	1

**Supplies:** car model paint (8 colors), 4-#4x $\frac{1}{2}$ " brass screws, 2-1" brass butt hinges and screws, paraffin wax, inlay banding, 4 rubber feet, finish (polyurethane, tung oil, shellac, or lacquer)

Continued on page 112

# news and events



**"The old pioneer familiarity with nearby forests is gone, dimmed by 20th-century urban influences. People have lost contact with real definitions of quality. The Newsletter's goal is to help reawaken wood awareness."**

—Wood Unlimited Newsletter

If you really like wood, you'll like the anecdotes and information in each issue of *The Wood Unlimited Newsletter*, a bimonthly publication edited by Larry Freye and other knowledgeable folks in Indianapolis. In four black-and-white pages, they present little-known facts about wood and in-depth pieces on such topics as veneers, plywood, and new technology.

Published as an industry service, the newsletter is circulated free to designers, architects, educators, and wood-products manufacturers. Your local lumberyard or hardwood retailer may have copies to give away,

but if not, subscriptions are available to the public for \$8 a year. Write: Wood Unlimited, Dept. W, P.O. Box 418044, Indianapolis, IN 46241. Back issues cost fifty cents each.

## **Southeast Asia's Best Teak Soon Available**

According to a friend of ours who is familiar with the international wood market, Thai teak will soon reach the U.S. in larger sizes and greater quantities. The Thai government has lifted its 1978 export restrictions, which limited shipments of teak lumber to small dimensions only. Many people think the Thai variety is the most desirable teak for woodworking, since it comes from 300- to 400-year-old trees (said to be the world's oldest). Noted for its fine color and texture, this stock works more easily than wood from younger trees.

Why? Because teak has the unusual ability to draw silica from the soil into its trunk as the sap flows. The silica breaks down and permeates the cellular structure as the tree grows old, acting much like a preservative. Young trees do have minute silica particles mingled in the grain, but the wood is rougher in texture and harder to work.

## **Woodworking Association of North America Launches Magazine**

In our November/December issue, we mentioned that this newly formed group was seeking members, and that a quarterly magazine would be included in the organization's annual dues. The first issue is out. *International Woodworking*, Vol. 1, No. 1, contains 22 black-and-white pages, and covers tips, craftsmen, books, and events. For membership information, write Woodworking Association of North America, Dept. W, 35 Main St., Suite 6, Plymouth, NH 03264.

## **January 11-13 Woodworking World—The Houston Show**

Location: Shamrock Hilton Hotel,

Main Street, Houston, Texas  
Admission: \$5

## **February 1-3 Woodworking World—The Toronto Show**

Location: Constellation Hotel & Convention Centre, Rexdale (Toronto), Ontario, Canada  
Admission: \$5

Tools, equipment, wood, and supplies for all levels of woodworking will be displayed and demonstrated by industry representatives. The schedule includes seminars on different aspects of woodworking. Hours for both shows: 5-9 p.m. Friday; 10 a.m. to 6 p.m. Saturday; 10 a.m. to 5 p.m. Sunday. For additional information about either show, contact Woodworking World, Plymouth, New Hampshire. Phone 603/536-3768.

## **February 16-17 Pacific Southwest Wildfowl Arts Festival**

Location: Holiday Inn at the Embarcadero, 1355 N. Harbor Drive, San Diego, California  
Admission: \$2 donation

Wildfowl carvings, carvers, supplies, and demonstrations, plus decorative decoy competition with entrants from throughout the U.S. and Canada will mark this event's 11th year. (Decoy carvers wishing to enter the competition have until February 14 to apply.) Hours: 9 a.m. to 5 p.m. Saturday; 9 a.m. to 4 p.m. Sunday. For details, entry blanks, and further information, contact Kent Thompson, 530 B Street, Suite 2333, San Diego, CA 92101. Phone 619/231-7922. ■

**News of interest to woodworkers and dates of national and regional woodworking events must be received at least three months before our publication date to be considered for the News and Events section. Send information to: News and Events, Better Homes and Gardens® WOOD Magazine, Locust at 17th, Des Moines, IA 50336.**

# the old hand ways

## THE CARPENTER

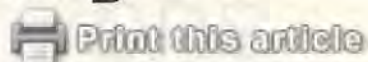

By Roy Underhill

Master housewright at Colonial Williamsburg, host of the highly successful P.B.S. series "The Woodwright's Shop," author, lecturer, and master craftsman.

**H**ow can one person make a building that will endure for centuries when another's work falls and turns to compost long before he does? Take some time to study the skeleton of a well-framed old barn. (It must have been well-framed. It's still standing, isn't it?) You will see the truth of what a 1745 book of trades said of the carpenter, that "Strength is the chief of his study."

Study the barn's frame, its vertical posts, horizontal beams, and diagonal braces. Older than Stonehenge, this "post-and-beam" construction is the essence of the English building tradition. Indeed, the first English settlers in the New World built houses and barns that were not much different from the ancient stone monuments they had left behind: simple frames consisting of posts set into the ground with beams spanning their tops. They were wooden houses, but hardly the work of carpenters. It's no wonder there aren't any of them left.

If you think of a building as a human body, then the old-time carpenter's job is to make the bones and the skeleton—the strong frame to which the joiners and roofers later apply the protective skin. Good carpentry makes strong

frames by exploiting the wood's strength in three dimensions: the size of the building's individual timbers, the connections between these pieces, and the design of the frame as a whole. When all these aspects of the building work together, the carpenter has earned his pay.

### Beams

Take a wooden pencil and push in from its ends to make it shorter. No go. Now bend it and it snaps in half. The point is that it is easy to make a strong post but harder to make a strong, yet lightweight beam. You need a way to size timbers so that they are as strong as they need to be, but no heavier than they must be. Fortunately you can turn to a simple guideline for help: *The strength of a rectangular beam varies directly with changes in width. With changes in depth, however, the difference in strength is squared.*

Imagine that you have to support a load with a beam measuring 2 inches wide and 4 inches deep. A 4 by 4 would be twice as heavy and twice as strong. A 2 by 8, however, twice as deep as the original timber, would also be twice as heavy, but would have four times the strength. A 2 by 12 would be nine times as strong, and only three times as heavy. The more a carpenter knows about the strength of his timbers, the more confidently he can approach the limits of the material.

### Joints

You often hear that old buildings are held together entirely by wooden pegs. True, the pegs are there, but the strength of the buildings is not in their pegs, but in their joints. These mortise-and-tenon joints interlock the timbers so that they sit solidly within one another. It is a rare building from which you couldn't remove every peg and have

it stand as strong as before. (Try this with the nails in a modern structure.)



Carpenters at Carter's Grove plantation work on a seventeenth-century style tobacco barn.

### Braced Frames

Although a post planted deeply in the ground won't fall over, it will invite destruction by termites and rot. Once you protect a building by placing it up on foundations, however, you must stiffen it by adding the strength of triangles to the rectangular frame.

Diagonal braces strengthen the building in several ways. Ideally, a post is a perfectly vertical column that is compressed but not bent. If the post does start to bow, it can snap relatively easily. Braces connected to the post prevent the bend from getting started. And, by blocking the closure of the right angles created between posts and beams, braces also prevent the collapse of a building under wind

Continued on page 119



# basic cabinet construction



Woodworkers everywhere appreciate the beauty of well-crafted cabinetry. But many of these same people labor under a false impression—that cabinets must be terribly difficult to make. Not so! And to prove it, we're going to walk you through the steps that will yield good-looking cabinets every time.

**W**  **Print this article**  
 We've selected a straightforward example—a base cabinet with a bar sink and a matching wall cabinet—to illustrate the basics you need to know as a novice cabinetmaker. (See the exploded-view drawings below for how they go together.) Once you've mastered the procedures that follow, you can handle many cabinetmaking situations. Though the dimensions, and maybe even the style of cabinet, may change, much of what you learn will still apply.

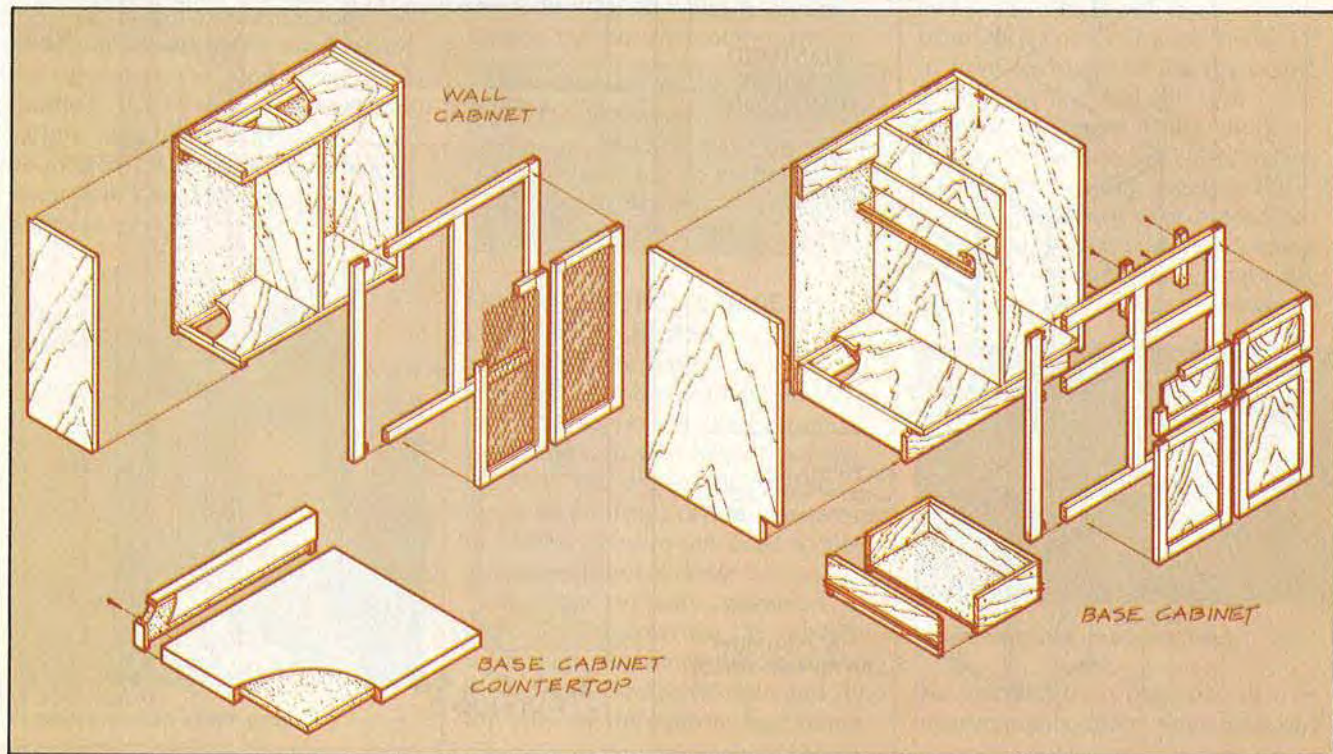

Continued

# SHOP-TESTED TECHNIQUES

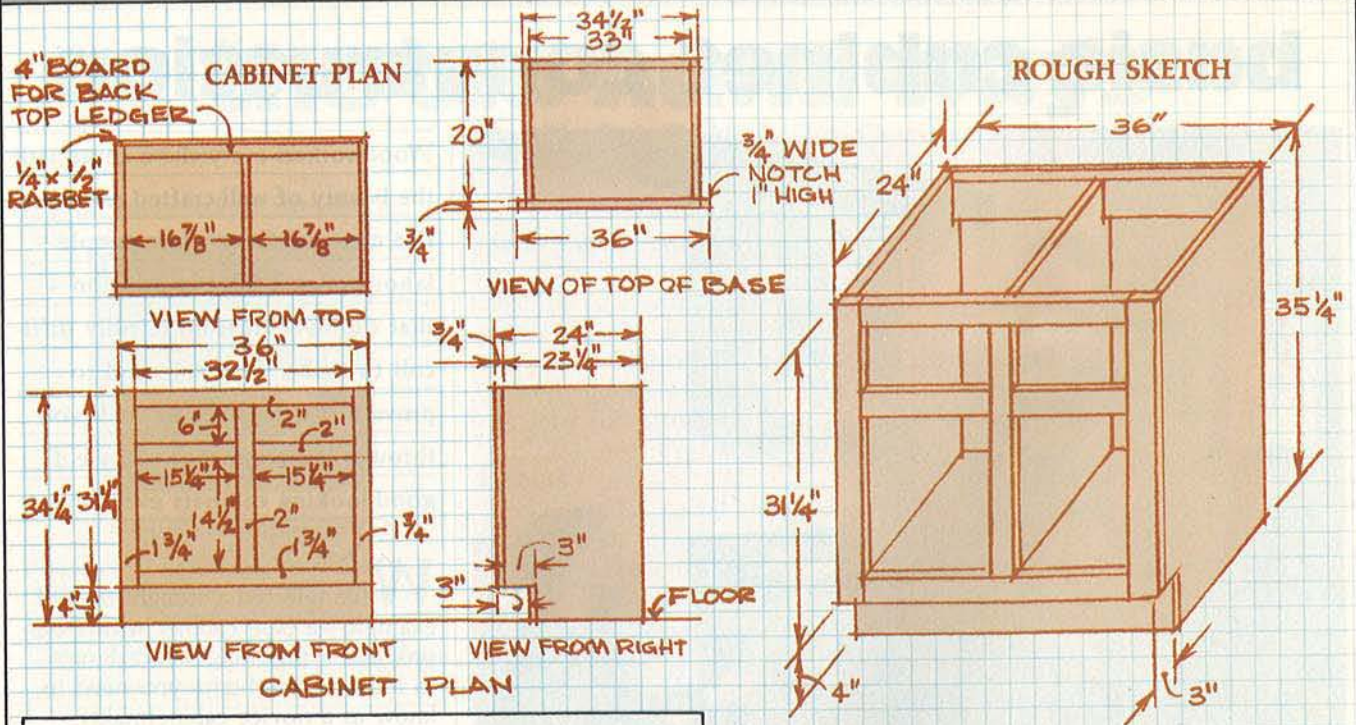

## TYPICAL CUTTING DIAGRAM

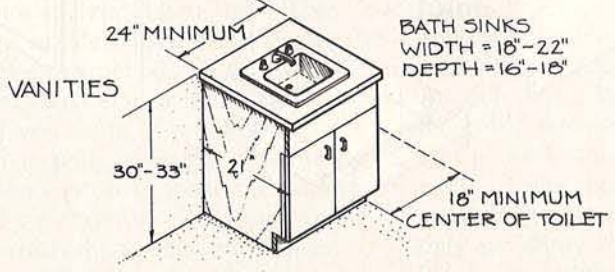
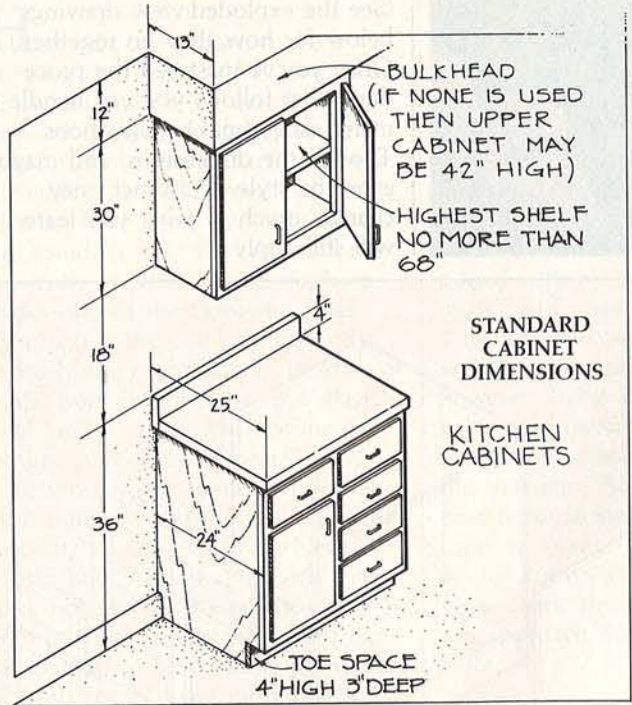
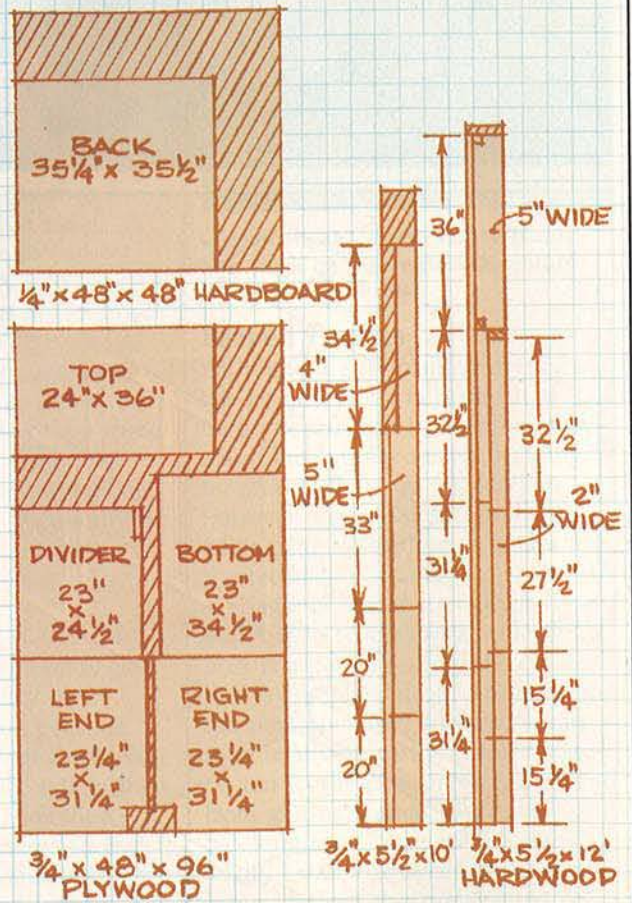

## START WITH A PLAN

Obviously, before you order a single sheet of plywood or a board for your project, you have to have a good idea of how you want the end product to look. You'll also want to settle on the cabinets' overall dimensions.

### The Rough Sketch

Though some visually oriented woodworkers can build as they go, most of us need a rough sketch to guide us along the way. This sketch needn't be sophisticated (see our example in the shaded area at left), but do try to be as detailed as possible. It's also helpful to draw front, end, and top views of the project as well as any other details that clarify construction. Since there are some cabinetmaking standards often used by professionals that you may not know about, we've included them in the box at left. Use them to flesh out your rough sketch.

### The Story Pole and How It Can Help You

Once you have established the width, depth, and height of a cabinet, make yourself a *story pole*. This device, which can be a scrap piece of lumber or sheet goods, will show you *exactly* how much room the cabinet will occupy when it's finished. It also shows you where various members of the cabinet will be located. And most important, a story pole allows you to measure distances exactly.



Visualizing with story pole

The photo at the bottom of the previous column shows what information we transfer to the front side of the story pole and how we use it to visualize the end result. (Essentially, what we have here is a section view of the cabinet near the front.) After studying the story pole and making any desired adjustments, we then turn our scrap



A view from the top

board over and plot what amounts to a top view of the cabinet (see the photo above). If you want, you can use the same technique to take a look at the cabinet's depth.

### Make a Cutting Diagram

When you make a cutting diagram, you're doing yourself a couple of big favors. Not only does the diagram help you figure the materials requirements for the cabinet, it also serves as a guide when it comes time to cut out the components.

**Note:** When laying out the cabinet's end panels on the plywood, make sure that you have the grain running from top to bottom. The same applies to doors if you plan to use plywood for them.

## HOW TO BUILD A BASE CABINET CARCASS

### Start With the Base

The base of a base cabinet adds structural support at the bottom of the cabinet. It also helps form the toe kick, the strategically placed recess at the front of the cabinet that allows you to get close to the cabinet without kicking it.

Toe kicks typically measure 4" high  $\times$  3" deep when the cabinet is finished. But since the bottom of the cabinet sits on the base and the top edge of the bottom face frame

rail rests flush with the bottom's top edge, you have to make the base somewhat taller to end up with a 4" high toe kick. (After referring to our story pole, we cut the *toe board* 5" high and as long as the cabinet is wide.)

Now, lay the toe board on a flat surface and mark the location of the notches that the end panels will pass through. Also lay out the posi-

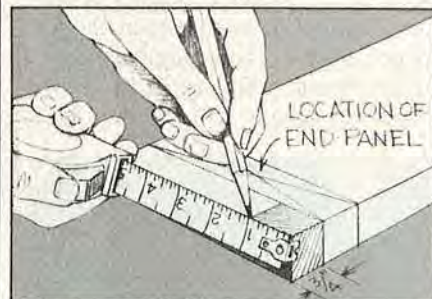

tion of the end panels as shown above. (The notch at both ends of the toe board in this instance measures  $\frac{3}{4}$ " wide and 1" deep.)

After notching the toe board, cut the sides and the back of the base to size. Since neither the sides nor back will show when you complete the cabinet, you may want to use scrap wood for these parts.

After dry-fitting the parts, nail and glue scrap wood cleats  $\frac{3}{4}$ " in from each end of the back and 1 $\frac{1}{2}$ " in from each end of the toe board. Then, glue and nail the base together as shown in the photo below. Note that the cleats make aligning and nailing together the base pieces a very easy procedure.

While the glue is still wet, check for square by measuring diagonally from corner to corner as shown in



Assembling the cabinet's base

the first photo on page 62. (If the measurements differ, your base isn't

*Continued*

## SHOP-TESTED TECHNIQUES



### Checking for square

square.) To square the base, you'll have to *rack* it as shown in the photo below. (You may have to make several adjustments to get the base into square, so be patient.)



### Racking the base

To hold the base in square, nail braces across the corners as shown in the photo above.

### Cut the End Panels

Typically, end panels measure  $\frac{3}{4}$ " shorter than the finished height of the cabinet and  $\frac{3}{4}$ " narrower than the depth of the cabinet. Start by cutting the side panels to size. Then, fasten the panels together (good faces out) with cleats tacked to two adjacent edges. The cleats keep the panels in alignment while you cut their notches.

Mark the location of the 4"-high  $\times$  3"-deep notch on both panels. If you'll be using a table saw, you have to make sure not to cut too far when making your cuts. To do this, raise the blade to its highest setting and mark the point on the auxiliary fence at which the blade enters the work.

Set the fence the correct distance from the blade, test the measurement on scrap, and then make your first cut (stop the blade when your cutoff mark aligns with the one on the fence). Now, turn the panels

over, reset the rip fence, and make the second cut.

You'll notice that the cuts fall somewhat short of the cutoff marks. Finish them with a hand-saw, as shown in the photo below. Before separating the panels, make a



### Notching the end panels

mark on the face of each (doing this will enable you to identify the outside of the panels later).

To complete the machining of the cabinet end panels, you need to cut a  $\frac{1}{2}$ " rabbet  $\frac{1}{4}$ " deep along the back edge of the panels. Unless you have a dado set or blade, making the rabbet requires two cuts. We show the setup for the first pass below. Note that a feather board and a brace (both clamped to the



### Rabbeting the end panels

saw table) provide the necessary control to make the cut accurately. To make the second cut, reset the rip fence, and the height of the saw blade, make a test cut, then complete the rabbet.

### Cut and Install the Bottom, Back, and Divider

Start by dry-fitting the end panels and the base. Pipe clamps will hold the assembly together well enough to take your measurements. Measure for the depth of the bottom as shown in the photo at the top of the next column (note that the bottom aligns with the front of the



### Measuring depth of bottom

end panels and the rabbet in back). Measure again for the width of the bottom, then cut the bottom to size. (Since the divider panel is the same depth as the bottom, cut both parts using the same saw setting.)

Set the bottom on the base, then measure the height of the divider panel as shown in the photo below. Cut the divider to size.

Measure and cut the  $\frac{1}{4}$ " hard-board cabinet back and the cleat



### Determining height of divider

that joins the end panels at the top back of the cabinet. (We used a 5"-wide cleat.) Then, glue and nail the end panels and bottom to the base. Secure the cleat between the end panels, either using hot-melt



### Securing cleat to end panels

glue as we did here, or with glue and clamps.

Predrill the hardboard back, then screw it to the end panels, base, and top cleat. Slip the divider into position and mark the bottom of the notch you need to cut in its top



**Marking notch in divider**

back edge (see the photo above). Notch and install the divider in its correct location. (Refer to your story pole for the exact location of the divider.)

## HOW TO BUILD A WALL CABINET CARCASS

Though base and wall cabinets do share many construction similarities, they differ in several respects, too. That's why we feel it's necessary to take you quickly through the following wall-cabinet carcass how-to.

Begin by cutting the end panels to size (refer to your story pole or drawing for the correct size). Then, cut a  $\frac{1}{2}$ " rabbet  $\frac{1}{4}$ " deep along the back edge of the panels.

Now, cut  $\frac{3}{4}$ " $\times$  $\frac{3}{4}$ " hardwood cleats, and glue and screw them to the top and bottom of the end panels as shown in the photo below. After doing this, rip the top



**Fastening cleats to end panels**

and bottom the correct width, then crosscut them to the correct length.

Glue and screw the top and bottom to the cleats on the end panels, check for square, and allow the glue to dry. Then, measure as shown in



**Measuring height of divider**

the photo above determine the correct height of the divider panel. (Note that we took the measurement near the end panel. By doing this, we avoided getting an inaccurate measurement if the top or bottom panel had been bowed.) Cut the divider panel to size.

To add further stability to the cabinet, cut and install hardwood ledgers below the top and bottom shelves. (We used a  $\frac{3}{4}$ " $\times$  $\frac{3}{4}$ " ledger under the bottom shelf and a  $\frac{3}{4}$ " $\times$  $1\frac{1}{2}$ " one under the top.)

Now, cut, notch, and install the plywood divider, and cut the back to size and screw it to the carcass.

## BUILD THE FACE FRAME

Face frames tie the front of the cabinet together structurally and at the same time finish it off visually. When determining how wide to cut the various face frame members, keep in mind that you want it to look balanced when you complete the cabinet.

In the base cabinet we're using as our example, the stiles and the bottom rail measure  $1\frac{1}{4}$ " wide; the top rail, mullion (or vertical member between the stiles), and muntins (the horizontal members between the rails), 2". Why the difference? All parts in the latter grouping have two doors or drawers overlapping them, whereas the stiles and the bottom rail have only one doing so. The net result: a visually balanced frame.

Keep in mind, too, that whenever you cut face frame parts, you do so from the outside in: stiles first, then the rails, then the mullion, and the muntins. But when you assemble the frame, you do so from the inside out: muntins first, and so on.

Start by measuring the distance between the top of the cabinet carcass and the top surface of the cabinet's bottom. We added  $1\frac{1}{4}$ " (the width of the bottom rail) to this measurement to determine the length of the stiles.) Cut the stiles to length.

To figure the length of the rails, measure from the outside of one of the end panels to the outside of the other. Add  $\frac{1}{4}$ " to that figure, then subtract the combined widths of the stiles. Cut the rails to size.

The photo below shows a quick, easy way to make sure the rails are



**Checking length of rails**

the right length. Set up a length stop, position the rail against it, and move the miter gauge forward just far enough to nick the rail. Pull the material back, check it for accuracy, and, if necessary, reset the length stop. Flip the rail over and make the cut from the opposite side. The nick will never show. This same procedure works well when cutting mullions and muntins, too.

Next, clamp the rails and the stiles together as shown in the photo below (note the placement of the clamps). Measure as shown to



**Measuring length of mullion**

find the length of the mullion, then cut it to length. Now, remove the

*Continued*

## SHOP-TESTED TECHNIQUES

clamps from the frame, line up the ends of the top and bottom rails, and mark the location of the mullion as shown below. Use the same procedure to find the length of the muntins, then cut them to length.



**Marking position of mullion**

Lay out the face frame parts. If any of the parts happen to be crowned (you can check this by sighting down the face of each board), the crown must face out (see the sketch below). Mark the

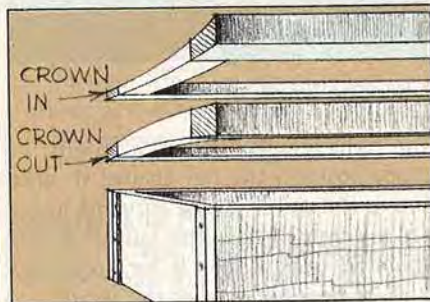

face of each part, then clamp all of them together. Once you have the parts aligned and in their proper spots, make two marks across each joint line where two members meet (see the photo below). Also mark



**Marking dowel pin locations**

each joint as A-A, B-B, and so on to avoid mixing up the parts.

Remove the clamps from the frame and then drill dowel holes, using your marks as a guide.

Remember that you want the combined depth of the mating holes  $\frac{1}{16}$ " or so deeper than the length of the dowel pins you're using.

Now, insert glued dowel pins into the holes you've bored, and assemble the frame—from the inside out. Use clamps to hold joints tight. While the glue is still wet, check for square, and rack the frame into square, if necessary. See the sketch below for how to do this.

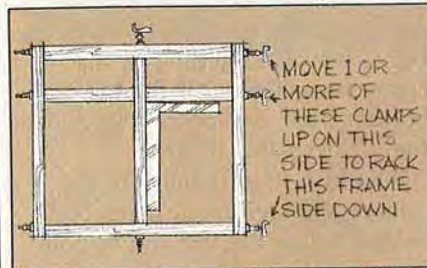

When the glue dries, remove the clamps and sand the face frame smooth.

### ATTACH THE FACE FRAME TO THE CARCASS

Glue and clamp the frame to the carcass, making sure that the top of the bottom rail aligns with the top of the carcass bottom, and that the frame overlaps both cabinet ends evenly. (See the photo below.)



**Attaching the face frame**

When everything aligns properly, drive finish nails through the frame and into the carcass sides and bottom.

Before nailing the mullion to the divider panel, be sure that you



**Centering divider behind mullion**

center the panel behind the mullion. Clamp the two members together as shown in the photograph above and then drive your nails.

### CUT AND INSTALL THE SHELVES

Usually, shelves measure  $\frac{1}{8}$ " narrower than the width of the cavity into which they fit and  $\frac{1}{8}$ " shorter than the distance from the cabinet's back to the back side of the face frame, so you shouldn't have any difficulty figuring their size.

Most cabinetmakers band the front edges of shelves with thin strips of a wood that's compatible with that being used on the cabinet. But you also can band them with wood veneer tape, if you wish. Either way, be sure to figure the thickness of the material used into your calculations.



**Positioning holes for shelf clips**

Cut the shelves to size, then test-fit them to make sure there's sufficient play to accommodate the shelf clips you'll be installing later.

The photo at the bottom of the previous column shows about the easiest way we know of to position the holes for shelf clips. The perforated hardboard serves as a template that ensures that the holes on either side of the shelves align exactly. Set the template on the cabinet bottom and against one of the end panels and drill a series of holes. Then, with the template in the same relative position, move it to the opposite panel and drill another series of holes using the same guide holes as before.

**Note:** If you drill holes into both sides of the divider, you'll need to offset one set from the other.

## BUILDING THE DOOR AND DRAWER FRONTS

With *slab-type* doors and drawers, you simply cut the panels to the appropriate size, band or veneer the edges, and perhaps decorate the panel. But the *frame-and-panel* option consists of a joined frame into which a variety of inserts can go. In our example, we've chosen to go with a frame that fits together with dowels, just as the face frame did. We've also opted for *overlay* doors and drawers rather than the *lipped* or *flush* type.

Typically, doors and drawer fronts overlap their openings by  $\frac{1}{4}$ " all around (the hinge configuration can alter this somewhat). In our example, to figure the size frames you need, add  $\frac{1}{2}$ " to both the height and width of each opening. Then, cut the frame parts to size (rails fit between the stiles here, too).

You machine and assemble these frames somewhat differently than you did the face frames. If you go with thin plywood panel inserts, you may want to cut a groove in the center of the inside edge of the frame members, and insert the panel as you assemble the frame. For glass or other inserts, you assemble the frame first, then rout out a rabbet on the back side of the



Routing back side of door

frame (see the photo at the top of the next column) to accept the material. (Since we decorated the fronts of the doors and drawer with a pattern along the inside edges, we used the latter technique.)

## HANG THE DOORS

Begin by screwing the hinges to the doors. (A general rule of thumb here calls for the hinges to be "a hinge-length in" from the top and bottom of the doors.) Then, position one of the doors over its opening as shown below (door must overlap opening evenly).



Positioning door over opening

Now, mark the position of the hinge mounting holes on the stiles, drill pilot holes, and hang the doors.

## BUILD AND INSTALL THE DRAWERS

Drawers certainly can be made in several different ways, but we've chosen to make ours with side-mount drawer slides and a drawer

front that screws onto the drawer assembly. (Door fronts that are independent of the drawer allow you to change the look of a cabinet at a later date if you want without totally rebuilding the door.)

First, cut and fasten drawer-mount blocks to one end panel and the divider panel. (The bottom of the block should align with the top of the muntin below the opening.) The idea is to provide a surface on which the drawer slide can bear: you'll want the block thick enough so that its face is flush with the inside edge of the stile and mullion.

How you size the drawers varies depending on the type of slide you use. With side-mount type drawer slides, you'll usually want the width of the drawer to be 1" narrower than the width of the opening (check the drawer slide package instructions to make sure). The height of the drawer parts should be  $\frac{1}{4}$ " shorter than the height of the drawer opening. And as for the drawer's depth, most cabinetmakers stop it just short of the depth of the cabinet. For example, if the distance from the front of the face frame to the cabinet back measures 23 inches, you'd want the drawer 22 $\frac{1}{2}$ " at most.

Now, cut the drawer parts to size and assemble them as shown in the photo below. Note that both ends of the drawer sides have rabbets that accept the front and back, and that all four sides of the box have

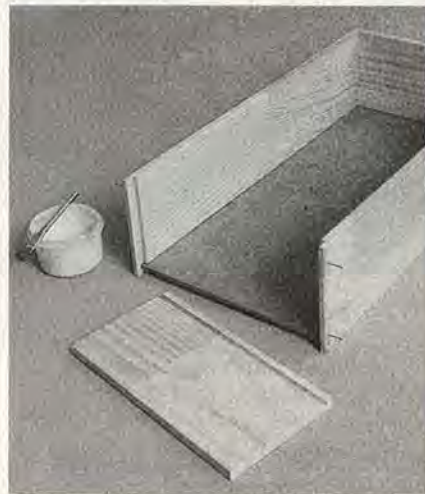

Assembling the drawer

Continued

## SHOP-TESTED TECHNIQUES

$\frac{3}{4}$ " grooves  $\frac{1}{2}$ " up from the bottom edge to accept the drawer bottom.

Install the drawer slides according to manufacturer's instructions. Then, put the drawer in the cavity, stick a couple of pieces of two-sided tape to its face, and position the drawer front as shown in the photo below. When you're satisfied with the front's position, squeeze the front and the drawer together, pull the



**Positioning the drawer front**

drawer partway out, and clamp the two together. Remove the drawer from the cavity and screw the drawer front to the drawer as shown here. (You'll undoubtedly have to shim and adjust the drawer slides to square the front with the face frame and to achieve a tight



**Screwing front to drawer**

fit, and that can require patience. We use cardboard for our shims.)

### ATTACHING A FALSE FRONT

In some cabinetmaking situations, such as in our example, plumbing

fixtures or other items make it impractical if not impossible to put a drawer where one would normally be. So what do you do? False fronts to the rescue!

You build false fronts exactly as you do the fronts of drawers. But instead of screwing the front to a drawer, you fasten false fronts to the face frame with cleats. The photo below shows you how. Align



**Attaching false front with cleats**

the front with the other doors and drawers on the cabinet before you tighten the cleats to the back side of the face frame.

### ADD A CABINET TOP

You can either purchase a commercially available top for your cabinet or build it yourself. We site-built ours, then covered it with plastic laminate. It's easy!

For tops without backsplashes, cut a piece of  $\frac{3}{4}$ " plywood  $\frac{1}{2}$ " wider and  $\frac{1}{4}$ " deeper than the cabinet. Now, face the front and sides of the cabinet with  $\frac{3}{4}$ "  $\times$   $1\frac{1}{2}$ "-strips on edge. Cover all exposed surfaces with plastic laminate, starting with the side edges, the front, and finally the top. Place the counter on the cabinet, scribe it to the wall if necessary, then fasten the top to the cabinet with metal angles.

If you want to add a backsplash, cut a  $\frac{3}{4}$ " plywood countertop that measures  $\frac{1}{2}$ " wider than the cabinet, and  $\frac{1}{4}$ " deeper than the cabinet less the thickness of the backsplash. Band the front and both sides with  $\frac{3}{4}$ "  $\times$   $1\frac{1}{2}$ " strips on edge.

Now, for the backsplash, cut a piece of  $\frac{3}{4}$ " plywood the width of the countertop, less the combined thickness of the scribe strip material that fastens to both ends of the backsplash. (The scribe strip allows you to custom-fit the cabinet to the wall.) Fasten the strips to the  $\frac{3}{4}$ " plywood as shown below.

Next, cover the counter with plastic laminate, starting with the side edges, the front, and the top. Do the same to the backsplash—ends first, the top, and the front.

Now, screw the backsplash to the counter, set the cabinet and countertop in place, scribe the backsplash to fit snugly against the wall (if necessary), and fasten the top to the cabinet with metal angles. ■

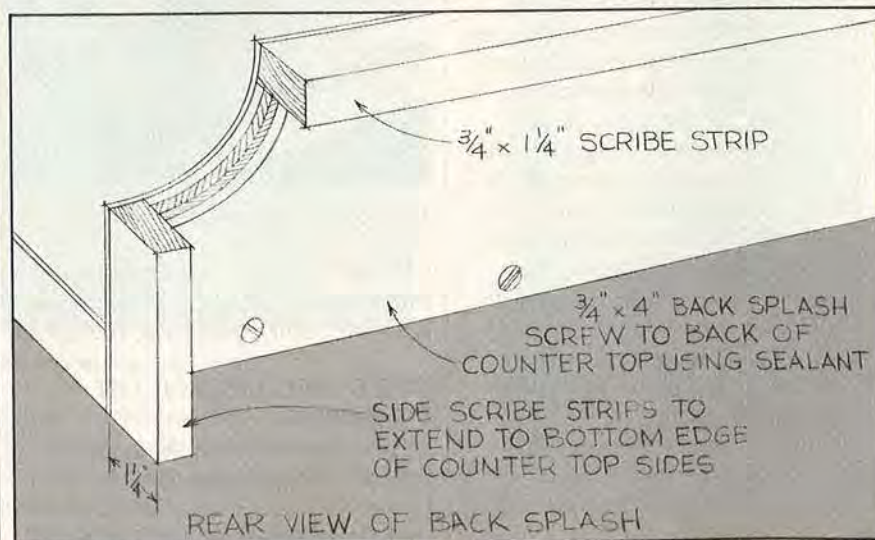



# the bow-back windsor chair

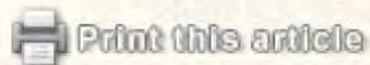

**We assemble every product featured in Kit Builder and give special attention to instructions, the quality of materials and parts, and the relative ease or difficulty with which the kit goes together.**

**I**n the 1770s, Joseph Henzey was a top chair maker in Philadelphia, the center of Windsor chair making in the American colonies. This bow-back armchair kit, a faithful reproduction of an original by Henzey, is a delight to build and an interesting lesson in nearly clamp-free joinery. The kit arrived with finely machined parts, glue, even a rope tourniquet for clamping the legs and stretchers. Sandpaper and stain were also included, but a finishing product was not. (Finishing is discussed in the instructions, but the choice—and purchase—of a varnish or oil finish is left to the individual.)

The clearly written step-by-step instructions were thorough and complete, although we felt that a bit more space could have been allotted to larger, clearer drawings. (The manufacturer told us that we had received preliminary plans and that final instructions were being prepared.) The chair is assembled in two general stages: from the seat down (for the leg assembly), and then from the seat up (for the back and arms). Construction took about four hours: less than two hours of actual working time (including 20 minutes for sanding spindle ends and finish sanding), plus two hours of waiting for glue to dry. ■



*The Henzey Bow Back Windsor Arm Chair Kit. Available from Cohasset Colonials, Dept. W., 494IX Ship Street, Cohasset Harbor, MA 02025. The kit sells for \$179 plus shipping. A color catalog of kits is available for \$1.*

# Project showcase

There's a lot of quality wood-working being done these days, and we like to show it off. In each issue of WOOD, we devote this space to a display of projects submitted by our readers. From boxes to bowls, and carvings to cabinets, we'd like to see them if they're made of wood. To submit projects, follow the instructions at the end of the article.

## A. Queen Anne Writing Table

Proving that he knows how to work the wood he's so knowledgeable about, our "Wood Profile" columnist, Paul McClure, of Tempe, Arizona, sent us this photo of the solid cherry writing table he made for his wife. To accentuate the "quilted" figure of the wood, Paul inlaid bird's-eye maple into book-matched pieces of re-sawn cherry. Being "in the business" helped, because all the cherry came from the same piece of wood which Paul had picked up during his wood buying years for a large lumber company.

He glued up the cabriole legs after turning the table's "doe" feet on a lathe. To finish the piece, McClure sprayed on and then buffed out Deft Clear Wood Finish thinned with acetone. Designed to fit his wife perfectly, the table measures 42"X20"X29" high.

## B. Touchdown Turning

An active member of the International Wood Collectors Society, Rex Vaught, of Rockville, Indiana, made this and several other full-sized footballs as gifts. Using a process he calls "post-blocking," Rex laid up pieces of walnut and maple for the



body, which he turned on a lathe. The laces are inlaid holly, ebony, and walnut. Rex doesn't throw passes with his creation, but he does win cheers for his woodworking talents wherever it's displayed.

## C. Catalpa Wood Carving

Fred Carrington of Nixa, Missouri, tells us that catalpa, a domestic softwood, can be worked green and will never crack. We hope so, because Fred used catalpa for this intricate carving, "Uninvited Guest," which depicts a scene from the Old West, Carrington's favorite subject area. Historically accurate down to the .50 caliber Smith & Hawkins rifle the figure reaches for, the carving stands 17" high.

Fred began the piece by fashioning a model in sculptor's clay. When he was satisfied with every detail, he began to carve. He spent six 50-hour weeks on the project,

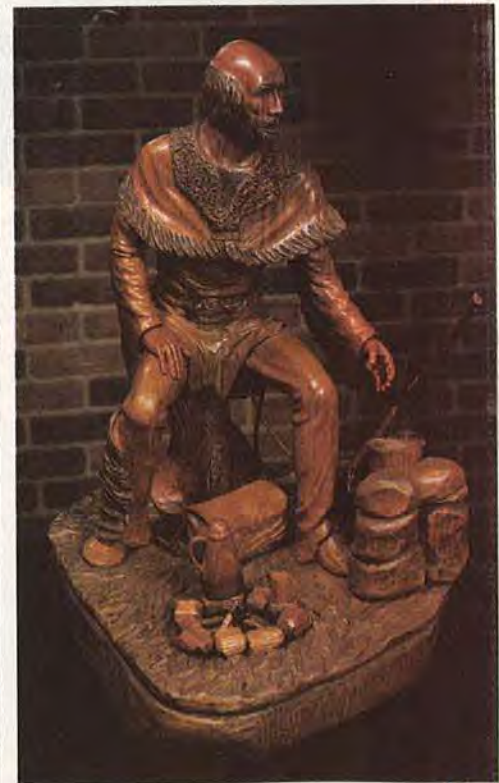

D.



which he finished with thinned artist's oils and Minwax. Occasional buffing with a soft cloth is all that's needed to keep the piece looking lustrous.

Incidentally, Fred belongs to a group called the Ozark Mountain Woodcarvers, headquartered in Branson, Missouri. If you ever have an opportunity to visit this group's retail outlets—in Branson, Silver Dollar City, and Gatlinburg, TN do so. You'll see some of the finest wood carvings anywhere.

### D. Band-Saw Bowl

Robert St. Pierre, of Hanover, Massachusetts, uses a band saw, not a lathe, to build pieces like this handsome mahogany vessel which measures 12" in diameter by 7" high. Robert has devised a mathematical formula that allows him to cut a series of consecutive rings at varying angles and then lay up the pieces to make objects in virtually any shape he wishes. After gluing up his designs, he fine-sands the piece and then coats it with oil-based urethane.

### E. Fine-Feathered Wall Clock

Plumage from a ringneck pheasant adds a warm, outdoors look to this oak-and-walnut wall clock made by

E.



Marlen Kemmet, who spends most of his time in the WOOD editorial offices and shop, where he works as the magazine's "How-To" editor.

Marlen glued up four pieces of 3/4" oak, alternating the grain to add visual interest, and routed a cavity in the back of the black walnut to accept a battery-powered clock movement. He applied satin-finish polyurethane to give his clock a low sheen. The feathers, attached with white glue, are untreated. If anything ruffles them, Marlen says, he holds them over steam to bring them back to shape.

### F. Chinese Motif Table

Traditional Chinese designs inspired David Lawrence, of Exeter, Rhode Island, to plan and build this distinctive table, which measures 25"×48"×29" high. A 5/4 walnut top with padauk trim sits atop gracefully curved legs, which are bent laminated, and joined with splined miters.

In the Chinese manner, David used frame-and-panel construction to fit the top into the table's edge molding. All the grid-work pieces on the table were made with mortise-and-tenon joints, a time-consuming method that ensures strength and stability in the piece.

To highlight the beauty of the wood, David rubbed on multiple coats of Watco Danish Oil. ■

F.



#### To submit your projects:

Send a 35-mm color slide, with the project as the focal point in a simple background. No people, please! Include a capsule description—materials used, special joinery techniques, finish, for example. WOOD will pay \$25 for published projects. Unless you enclose a self-addressed envelope with sufficient postage, we will keep all slides.

Send to:

Project Showcase  
Better Homes and Gardens®  
WOOD Magazine  
Locust at 17th  
Des Moines, IA 50336

# stereo component unit



Print this article



Cutting diagram

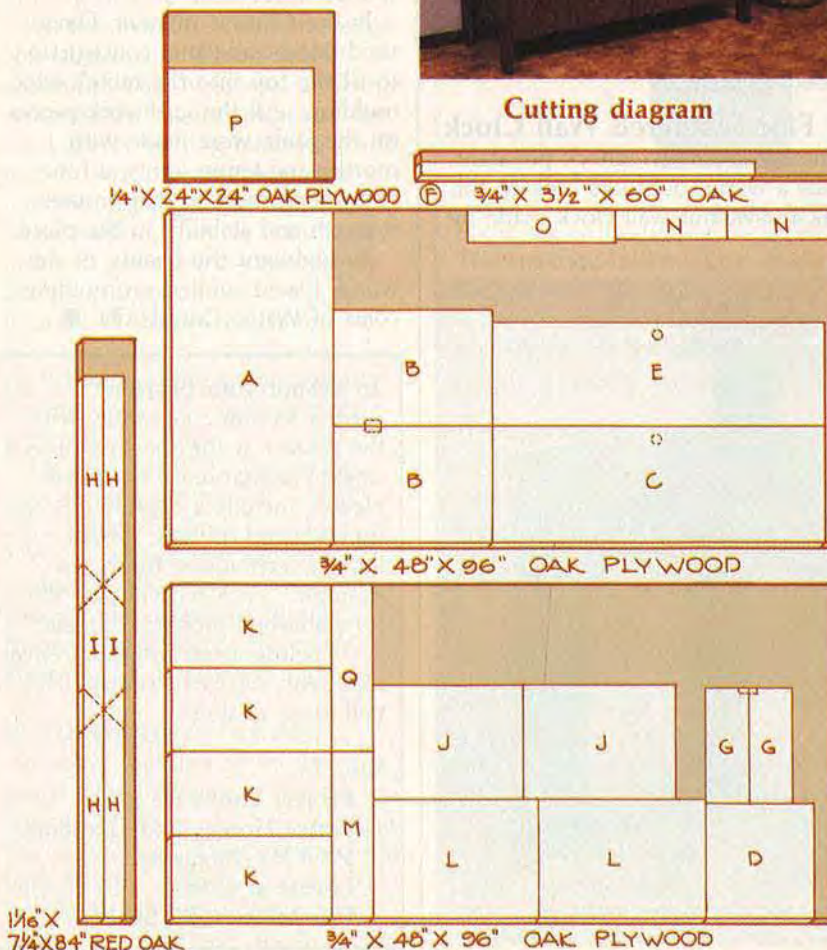

Clean design and basic cabinet-construction techniques converge in this handsome stereo cabinet. The cabinet we built measures  $50\frac{1}{8}$ " W  $\times$   $18\frac{1}{2}$ " D  $\times$   $30\frac{3}{4}$ " H. Please turn the page for step-by-step instructions.

## Bill of Materials

Part	Finished Size*			Material	Qty.
	T	W	L		
A	$\frac{3}{4}$ "	48"	$23\frac{3}{4}$ "	red oak plywood	1
B	$\frac{3}{4}$ "	$16\frac{7}{8}$ "	$23\frac{3}{4}$ "	red oak plywood	2
C	$\frac{3}{4}$ "	$16\frac{7}{8}$ "	$47\frac{1}{4}$ "	red oak plywood	1
D	$\frac{3}{4}$ "	$16\frac{1}{2}$ "	$15\frac{5}{8}$ "	red oak plywood	1
E	$\frac{3}{4}$ "	$16\frac{1}{8}$ "	$47\frac{1}{4}$ "	red oak plywood	1
F	$\frac{3}{4}$ "	2"	48"	red oak lumber	1
G	$\frac{3}{4}$ "	$16\frac{1}{2}$ "	$6\frac{1}{8}$ "	red oak plywood	2
H	$1\frac{1}{16}$ "	3"	$30\frac{1}{4}$ "	red oak lumber	4
I	$1\frac{1}{16}$ "	3"	$18\frac{1}{2}$ "	red oak lumber	2
J	$\frac{3}{4}$ "	16"	$22\frac{3}{4}$ "	red oak plywood	2
K	$\frac{3}{4}$ "	$11\frac{15}{16}$ "	$16\frac{7}{8}$ "	red oak plywood	4
L	$\frac{3}{4}$ "	18"	$23\frac{15}{16}$ "	red oak plywood	2
M	$\frac{3}{4}$ "	$23\frac{15}{16}$ "	$5\frac{1}{4}$ "	red oak plywood	1
N	$\frac{3}{4}$ "	$4\frac{3}{4}$ "	16"	red oak plywood	2
O	$\frac{3}{4}$ "	$4\frac{1}{4}$ "	$20\frac{3}{4}$ "	red oak plywood	1
P	$\frac{1}{4}$ "	16"	$20\frac{3}{4}$ "	red oak plywood	1
Q	$\frac{3}{4}$ "	$23\frac{15}{16}$ "	$5\frac{1}{4}$ "	red oak plywood	1

\*Dimensions of  $\frac{3}{4}$ " plywood include veneer tape on all exposed edges.

**Supplies:** woodworker's glue, 1 pair—side-mount door slides, 2 pairs—invisible hinges, 2 pairs— $\frac{3}{4}$ " concealed wraparound hinges, 12—#8  $\times$   $1\frac{1}{2}$ " flathead wood screws, magnetic door catch hardware,  $\frac{1}{4}$ " hardboard (for splines), red oak veneer tape, 8—shelf clips, 1 pair—counterbalance hinges, 25—#8  $\times$   $1\frac{1}{4}$ " flathead wood screws, stain, varnish.

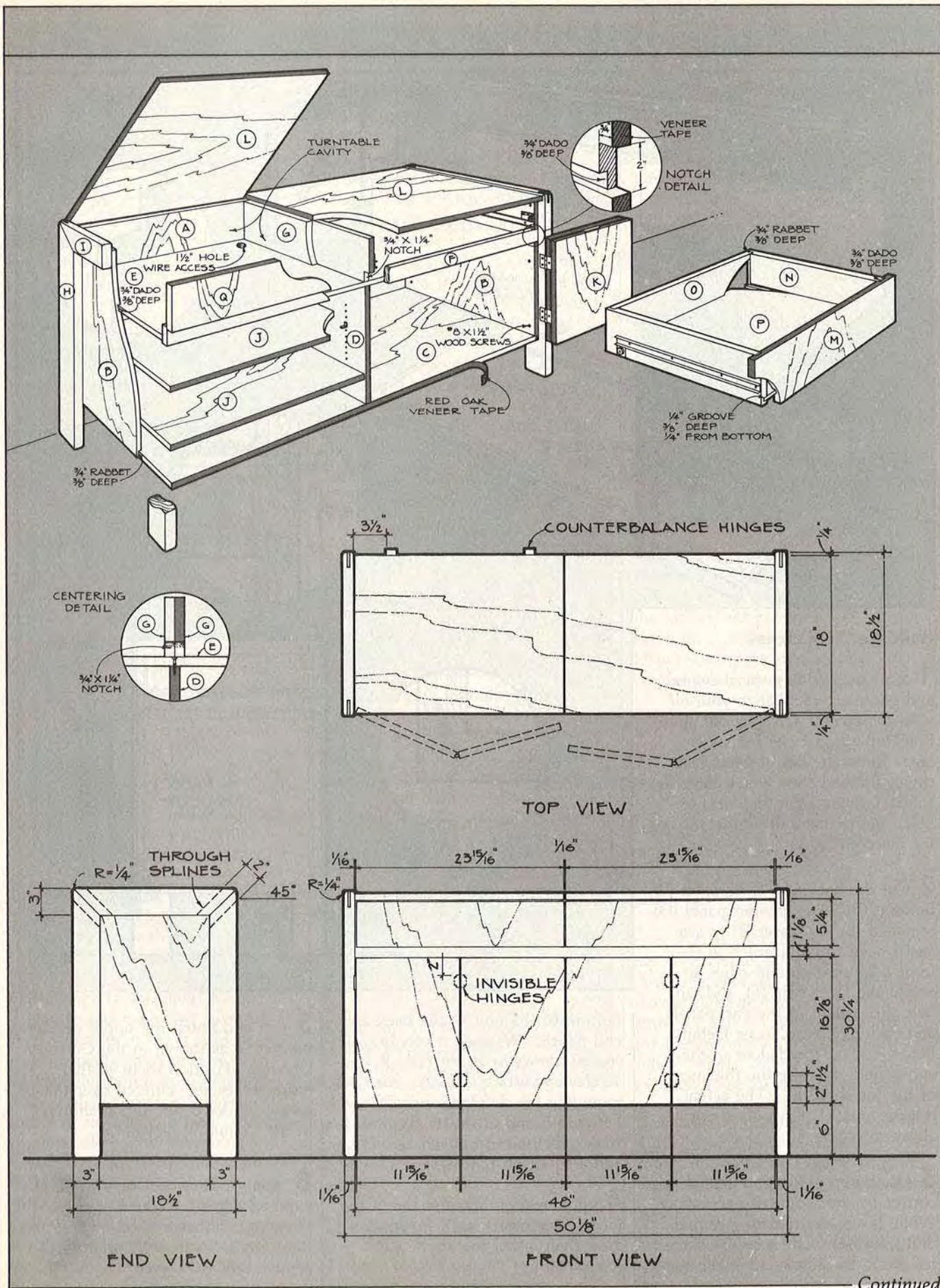

Continued

## NOW YOU CAN BUILD IT

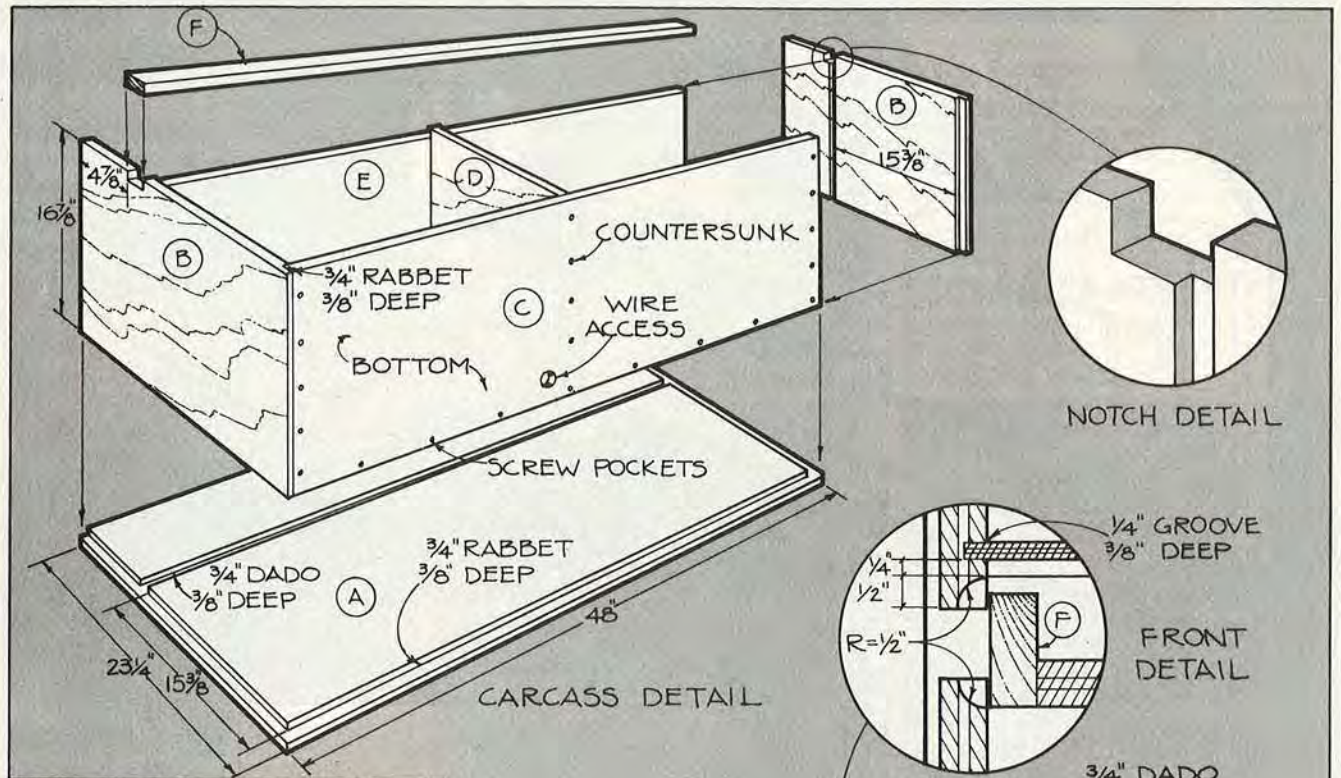

### Building the Carcass

**1** Start by studying the drawings and photos to familiarize yourself with the pieces. Give special attention to parts that call for veneer tape. Since the Bill of Materials shows finished sizes, you'll have to subtract veneer-tape thickness to determine actual cutting dimensions for these pieces.

**2** Cut the back (A), end panels (B), bottom (C), lower divider panel (D), top shelf (E), and facer (F) to size. You'll need to cut a notch in the front edge of each end panel to accept the facer strip (F), and rabbets and dados in the end panels and back (see the Carcass Detail). Before cutting the dados in the end panels, measure the thickness of the top shelf (E). (The actual thickness of 3/4" plywood is not always precisely 3/4".)

**3** Dry-clamp pieces A-F, check for correct fit, and adjust if necessary. While the pieces remain clamped, drill pilot holes and screw pockets for #8 x 1 1/4" screws to attach the

bottom of the unit to the back and lower divider panel. We used 5 evenly spaced screws to attach C to B, and 7 screws to attach C to A. For mounting the divider panel (D) between E and C, drill 4 countersunk pilot holes to attach E to D, and 4 to attach C to D.

**4** Glue, reassemble, and clamp the pieces together. Check for squareness, then install the #8 x 1 1/4" screws.

**5** Cut and notch the upper divider panels (G) as shown in the Cutaway Drawing. Position them so their inside edges are centered over the lower divider panel (D), as shown in the Centering Detail.

**6** Apply oak veneer tape to all exposed edges (see the Cutaway Drawing). Either iron-on edging or the type that adheres with contact cement will work well.

## The Leg Assembly

**1** Rip  $1\frac{1}{16}$ "-thick oak to 3" for leg parts (H, I). Miter both ends of each I and one end of each H to  $45^\circ$ , then crosscut all of them to length. Cut  $\frac{1}{4}$ "-wide grooves 1" deep in each mitered end of the six pieces and fit with  $\frac{1}{4}$ " spline material. Dry-clamp the legs together, checking for squareness and groove alignment. Glue, reassemble, and clamp the legs together, using clamp blocks as shown in the drawing below.

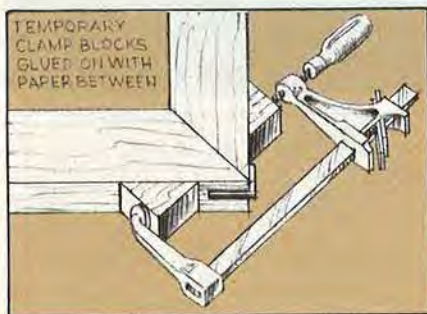

**2** After the glue has dried, remove the clamps and clamp blocks. Sand excess spline material, then rout a  $\frac{1}{4}$ " round-over on all edges of the legs, including their bottoms (to prevent legs from catching on flooring material). Sand the legs smooth and fasten them to the cabinet with #8  $\times$   $1\frac{1}{2}$ " screws driven from the inside of the cabinet into legs.

## Installing the Shelves and Doors

**1** Cut the adjustable shelves (J) to size, making sure that you allow clearance for shelf clips. Apply veneer tape to the shelf fronts.

Measure and mark the holes for shelf supports or use a strip of perforated hardboard (the type with  $\frac{1}{4}$ "-diameter holes) as a template. Then drill  $\frac{1}{4}$ " holes  $\frac{3}{8}$ " deep in the inside of the left end panel (B) and the left side of the lower divider panel (D). (We spaced the support holes 1" apart and 3" in from the front and back edges. To guard against drilling through the pieces, we wrapped a piece of electrical tape around the drill bit. Drill  $1\frac{1}{2}$ " holes through C and E for wire ac-

cess. The wires run behind the shelves (J).

**2** Cut the four doors (K) to size, allowing for veneer tape and the necessary  $\frac{1}{16}$ " clearance between the doors. Lay the doors in place to check for a good fit. (It's helpful here to put the cabinet on its back.) Mark location for magnetic door catch hardware and drill pilot holes if necessary. Apply veneer tape to all exposed edges. Using a router fitted with a cove bit, rout a hand pull in the top of the inner two doors. Make the pulls about 4" long and center them. Install invisible hinges between the inside and outside doors per manufacturer's in-

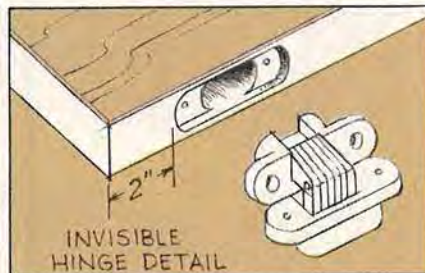

structions. (See Invisible Hinge Detail.)

To mount the door assemblies to the carcass, mortise the concealed wraparound hinges into the edges of the outer doors as shown in the

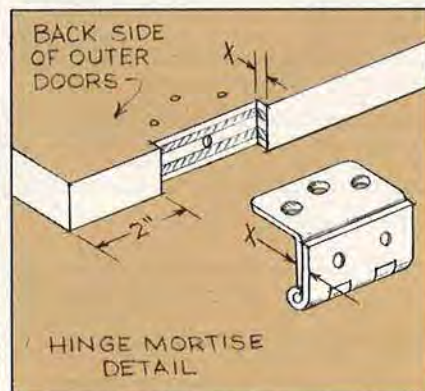

Hinge Mortise Detail above. Mark and drill pilot holes in the cabinet legs (H) for the wraparound hinges. Remove hardware and set all parts aside.

## The Cabinet Top and Drawer

**1** Cut the two cabinet top panels (L) to size, then test-fit them. Ap-

ply veneer tape to the front and side edges. Glue and clamp the right-hand panel in place. Use counterbalance hinges to install the turntable cavity top as shown in the photo below.



**2** Cut the drawer pieces (M, N, O, P) to size. Rout a hand pull in the bottom of the drawer front. Cut the rabbet and groove in the drawer sides (N) as shown in the Cutaway Drawing on page 67, and the dados and groove in the drawer

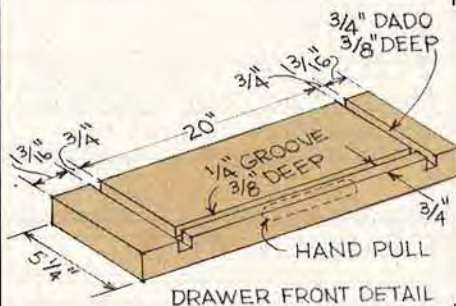

front (M) as shown here. Glue, nail, and clamp the drawer together. After the glue has dried, mount the drawer slides to the drawer sides and the cabinet carcass, following the instructions supplied with the slides. Apply veneer tape to all exposed edges of the drawer front.

**3** Cut the turntable cavity front (Q) to size. Apply tape to its edges, then glue and clamp it in place, in line with drawer front (M).

**4** Sand, then finish the unit as desired. (We used stain and polyurethane varnish.) Install all door hardware, then hang the doors. ■





G, H, and I on a flat surface in the arrangement in which they will be glued. Then, use pipe clamps to dry-fit the face frame parts. Mark the dowel locations. (We used a try square and pencil to mark reference lines on the end of each rail and adjoining stile. See the Doweling Diagram on page 72.)

**3** Drill two  $\frac{3}{8}$ " holes  $\frac{13}{16}$ " deep in each rail end, then drill like-sized

### Bill of Materials

Part	Finished Size*			Material	Qty.
	T	W	L		
A	$\frac{3}{4}$ "	$23\frac{1}{2}$ "	$29\frac{7}{8}$ "	red oak plywood	4
B	$\frac{1}{4}$ "	$20\frac{1}{4}$ "	$29\frac{7}{8}$ "	hardboard	2
C	$\frac{3}{4}$ "	$20\frac{1}{4}$ "	$23\frac{1}{4}$ "	red oak plywood	2
D	$\frac{3}{4}$ "	$\frac{1}{8}$ "	$23\frac{1}{2}$ "	red oak	4
E	$\frac{3}{4}$ "	2"	$19\frac{1}{2}$ "	pine	2
F	$\frac{3}{4}$ "	3"	$23\frac{1}{4}$ "	pine	8
G	$\frac{3}{4}$ "	$1\frac{7}{8}$ "	18"	red oak	2
H	$\frac{3}{4}$ "	$2\frac{5}{8}$ "	18"	red oak	5
I	$\frac{3}{4}$ "	$1\frac{1}{2}$ "	30"	red oak	4
J	$\frac{3}{4}$ "	$1\frac{7}{8}$ "	$7\frac{1}{2}$ "	red oak	8
K	$\frac{3}{4}$ "	$1\frac{7}{8}$ "	$16\frac{7}{8}$ "	red oak	2
L	$\frac{3}{4}$ "	$1\frac{7}{8}$ "	$15\frac{1}{2}$ "	red oak	25
M	$\frac{1}{2}$ "	$5\frac{3}{4}$ "	$16\frac{1}{2}$ "	drawer-side mat'l	8
N	$\frac{1}{2}$ "	$5\frac{3}{4}$ "	23"	drawer-side mat'l	8
O	$\frac{1}{4}$ "	$16\frac{1}{2}$ "	$22\frac{1}{2}$ "	hardboard	4
P	$1\frac{3}{16}$ "	25"	72"	particle-board	1
Q	$\frac{1}{16}$ "	25"	72"	plastic laminate	1
R	$\frac{3}{64}$ "	25"	72"	balance sheet	1
S	$\frac{7}{16}$ "	$1\frac{3}{8}$ "	$72\frac{7}{8}$ "	red oak molding	1
T	$\frac{7}{16}$ "	$1\frac{3}{8}$ "	$25\frac{7}{16}$ "	red oak molding	2
U	$\frac{3}{4}$ "	3"	3"	pine	8

\*Some parts are cut larger initially, then trimmed to finished size. Please read instructions before cutting.

Supplies:  $\frac{3}{8}$ " x  $1\frac{1}{2}$ " dowels, 6 drawer pulls, 4 pairs 22" drawer slides, 1 pair self-closing overlay door hinges, 56-#8 x 1" flathead wood screws, 4d and 6d finishing nails, contact cement, waxed paper, wood putty, finish of your choice.

### Cutting diagram

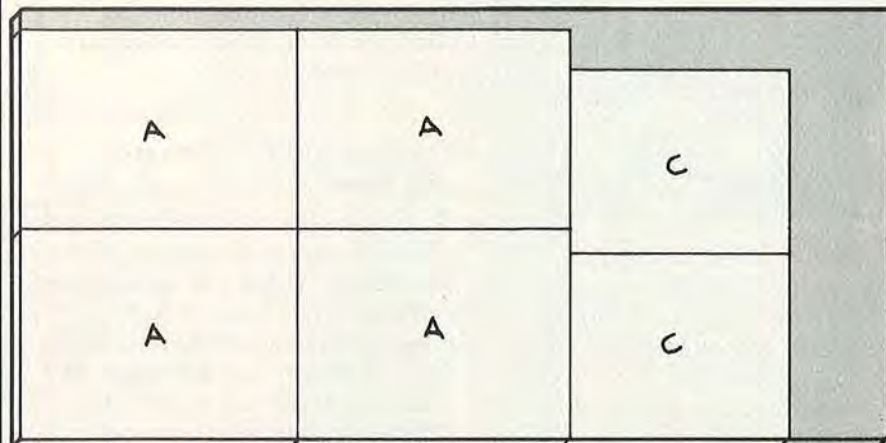

$\frac{3}{4}$ " X 48" X 96" RED OAK PLYWOOD

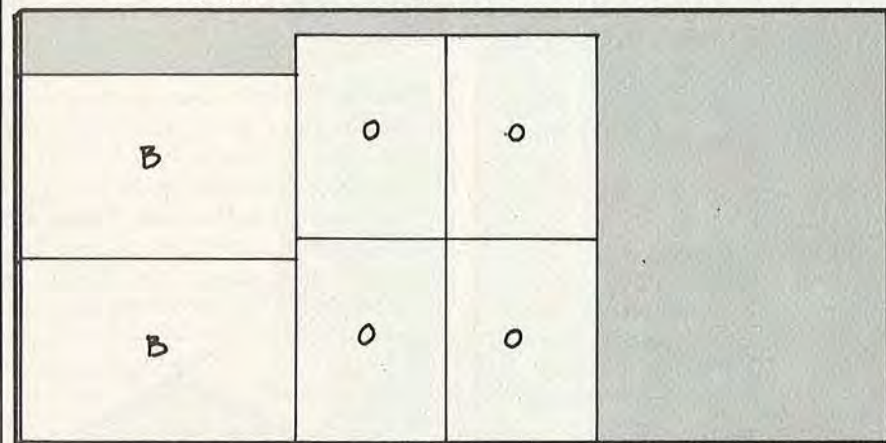

$\frac{1}{4}$ " X 48" X 96" HARDBOARD

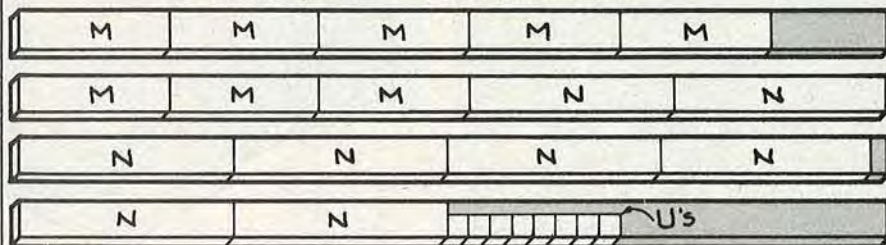

$\frac{1}{2}$ " X  $5\frac{3}{4}$ " X 96" PINE DRAWER SIDES



$\frac{3}{4}$ " X  $9\frac{1}{4}$ " X 96" PINE

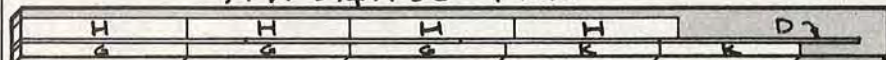

$\frac{3}{4}$ " X  $7\frac{1}{4}$ " X 96" RED OAK

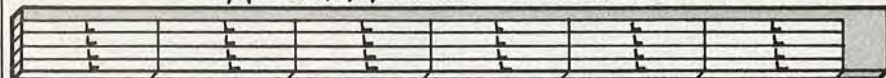

$\frac{3}{4}$ " X  $9\frac{1}{4}$ " X 96" RED OAK

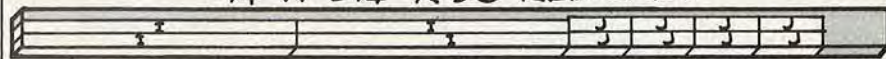

$\frac{3}{4}$ " X  $5\frac{1}{2}$ " X 96" RED OAK

Continued

## NOW YOU CAN BUILD IT

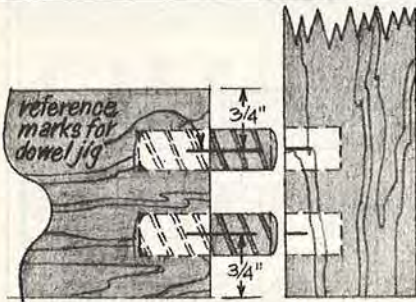

holes in the stiles. (We used a doweling jig to ensure that our dowels were in line with the reference marks and centered on the  $\frac{3}{4}$ " oak edges. Since it is risky to dry-fit doweled joints—they tend to break or stick—it is important to mark and drill the holes accurately.)

**4** Once you've drilled all the holes, use a small brush to apply glue to the dowels, dowel holes, and mating surfaces. Glue and clamp both face frames together on a flat surface, and check that the assemblies are square and flat.

**5** After the glue has dried, remove the clamps and scrape off the excess glue. Sand the front and back of each frame flush. (Even the best laid-out dowel joints seem to come out a little uneven.)

### Assembling the Cabinets

**1** Glue, clamp, and nail the cabinet face frames to the carcass. (We used 6d finishing nails to help position and attach the frame to the cabinet.) (See the tip on page 36 for how to avoid splitting the face frame as you nail.) The outside edges of each face frame will extend slightly beyond the carcass.

**2** Sand the face frames and base strips flush with the carcass. Don't sand through the veneer!

**3** Position the drawer-slide mounting blocks (F) on the cabinet sides. Make sure the bottom of the blocks align with the top edge of the face-frame rails (H). (See the cutaway portion of the Front View.) The blocks should also mount flush with the inside edge of each face-frame stile (I). If the blocks are too thick,

they can be sanded or jointed to proper size. We used glue and three—#8×1" wood screws to attach each mounting block to the cabinet sides.

### Constructing the Drawers and Door

**1** To make the 4 drawer fronts and 1 door front, rip the stiles (J, K) to width, then rabbet a  $\frac{1}{4}$ " groove  $\frac{1}{4}$ " deep along one edge of each stile to accept the rails. (You can cut the rabbet with a router, table saw, or radial arm saw.) Cut J and K to length. Cut the rails (L) to size, then rout a  $\frac{1}{4}$ " rabbet  $\frac{1}{4}$ " deep on each side of each end of L to form a  $\frac{1}{4}$ " tongue.

**2** Chamfer all face edges of the drawer and door front parts (J, K, L). (A table saw works well for cutting the ends and sides of the parts.) To chamfer the ends, clamp a stop to a fence mounted on the table saw's miter gauge, and tilt the saw blade to 45° as shown in the

photo below. (In both the photos below, we've removed the blade guard for photographic clarity.) To cut the rip-chamfers, position the saw's rip fence away from the blade

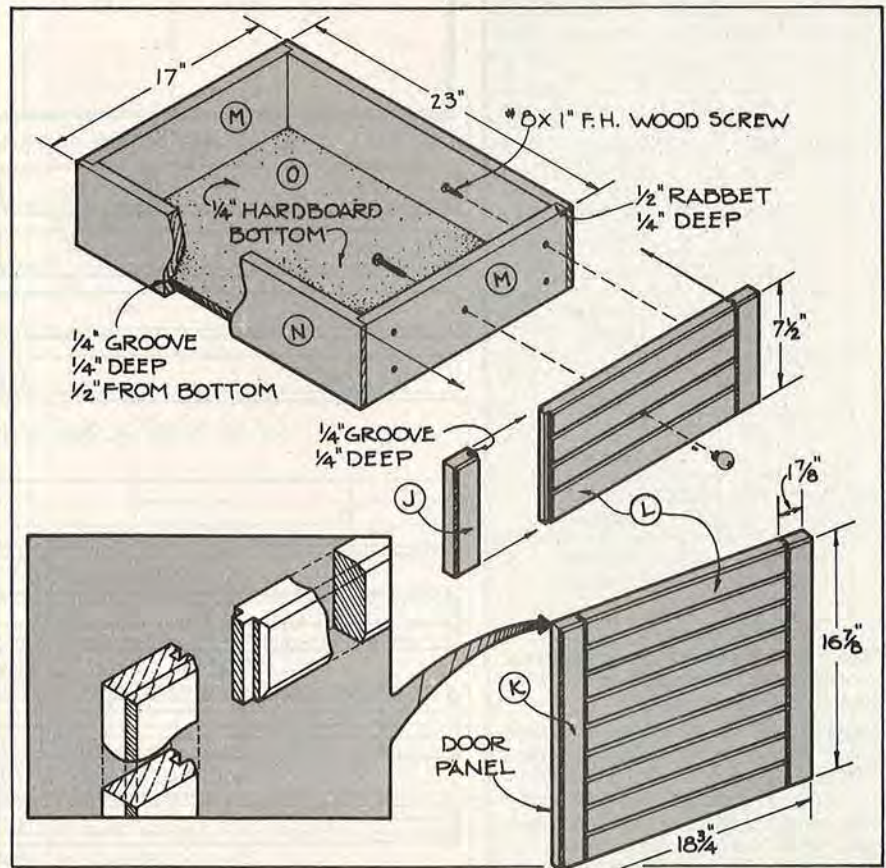

—Continued on page 104

# DADO

## BLADES & SETS

Getting in the Groove

You can spend \$25 or pay \$300 to equip your radial arm or table saw with a dado accessory.

What will you get for your money? What do you need?

Your plans call for a  $\frac{3}{4}$ " groove,  $\frac{3}{8}$ " deep. If you use your normal saw blade, its  $\frac{1}{8}$ " kerf will require you to make at least 6 passes to do the job. And if the groove must be 52" long . . . well, maybe you should turn on the basketball game and build the cabinet next weekend.

But what if you had a dado accessory, a device for cutting channels in wood that would make quick and safe work of dados, grooves, rabbets, and tenons?

Instead of positioning and repositioning your workpiece, you could set the dado head to the proper width, make one pass (or perhaps two if you were making an extra deep cut), finish the cabinet, and *still* watch the game.

### Do You Really Need One?

For a specialized shop accessory, a dado assembly isn't cheap, so ask yourself if you'd use the device often enough to justify buying it. If most of your projects don't involve cutting a lot of grooves, you probably *can* survive by making repeated passes with a standard saw blade, or by making a few passes and then chiseling out the waste. You can also achieve excellent results with a router.

But if you plan to do a substantial amount of work that calls for various types of grooves—a wall of bookshelves, say, or a set of kitchen cabinets—then you'll certainly appreciate the speed and precision that a good dado accessory offers, and purchasing one probably makes sense.

*Continued*



Print this article



## TOOL BUYMANSHIP

### The Bottom Line

You'll encounter many variables as you make your choice. There are various types of dado assemblies, composed of different materials. They are constructed with numerous blade grinding techniques and tooth configurations, and sold at a wide range of prices.

But all you're really interested in is how well the thing works and how much it's going to set you back. So those should be the key points to consider as you approach your buying decision.

### Stackable Sets Vs. Adjustables

Dado tools come in two general types. A *stackable dado assembly* consists of two outside *cutters* and from two to five inside *chippers*. The outside cutters slice the wood, scoring and perforating it to define the edges of the channel. The width of the groove is determined by adding or subtracting the inside chippers, which shear and remove material from the center of the cut, acting much like revolving wood chisels.

An *adjustable or "wobble" dado blade* is a single blade equipped with offset teeth. The blade revolves on a hub and spins eccentrically. Viewed head-on, its motion



Types of available dado tools. Clockwise from lower left: a flat-ground steel dado stack set with interchangeable outside cutters and 5 chippers; a thin-rimmed steel stack set; a carbide-tipped steel adjustable dado blade; a carbide-tipped steel stack set.

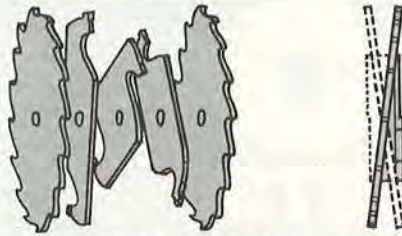

Stackable  
dado assembly

Adjustable  
dado blade

creates an hourglass pattern, as the single set of cutting teeth slants from side to side to cut the groove. Adjusting the hub alters the range of this lateral travel, and thus the width of the dado.

### Comparing the Two Types

Dado assemblies of either type will cut kerfs up to  $\frac{1}{16}$ " wide and  $\frac{3}{4}$ " deep in one or two passes (depending on the wood and the depth of the groove), but how well—and how quickly—they do the job varies all over the lot.

Because stack sets slice the wood, while adjustable dado blades more or less chop away at it, stackable assemblies tend to make the neatest cuts. The difference may not be too great in solid lumber, but does show up more often in plywood, where adjustable blades exhibit a greater tendency to chip or tear thin face veneers.

Since adjustable blades pivot from side to side, their cutters travel along an arc, and the bottom of the groove they cut isn't perfectly flat. This can cause problems when you try to square a cabinet as you assemble it. You could use a hand router to even things out, but you'd sacrifice speed in the process—one reason you considered buying a dado assembly in the first place.

In addition, since the adjustable blade not only has to move forward, but from one side to the other as well, the rate at which stock can be fed tends to be slower than with stack assemblies.

Before you dismiss adjustable dado blades entirely, however, consider two of their merits: they allow infinite kerf-width settings within their limits, and they're simpler to install and adjust than stack sets.

To set the width on an adjustable blade, you simply turn a dial on the hub. With a stack set, you must disassemble the dado head, add or remove chippers (and paper or cardboard washers for more precise adjustments), and then put the set back together.

### Considering Carbide Blades

Any dado assembly must be sharp to work effectively. If the chippers on a stackable set dull before the outside cutters, for example, they may "hammer" the wood rather than pare it away.

Blades with carbide teeth stay sharp substantially longer than regular steel blades, offering smoother cuts in the process. Their extra initial cost may be offset by subsequent savings, since they won't have to be resharpened as frequently.

You'll find both stackable dado sets and adjustable blades offered with carbide teeth. If the carbide tips are long enough, the blade can last a lifetime.

Some manufacturers market chromium-plated blades, which they say hold an edge better than regular carbon steel, won't scratch, and are less likely to become clogged with pitch. One manufacturer, U.S. Saw Corp./Oldham Saws, even guarantees that the blade body won't rust.

### Grinding Makes a Difference

To prevent binding and overheating, a saw blade must cut a kerf wider than its body. Brazed-on carbide teeth accomplish this by being wider than the rest of the blade,

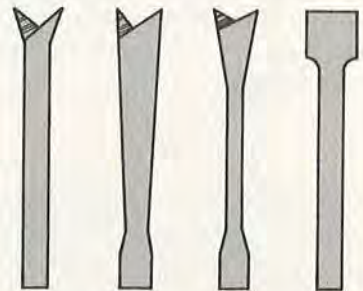

Styles of dado blade bodies. Left to right: flat ground; hollow ground; thin rim; carbide tip or swedge.

Continued on page 102

# WOOD tests 14 popular dado accessories

**W**e set out to test widely available dado accessories —both adjustable blades and stackable sets. Since dado blades should be at least 2" smaller than other saw blades, and since 10" table saws seem to be the most popular models among home woodworkers, we restricted our choices to dado assemblies with diameters of 8" or less and gathered 14 different models. (Some manufacturers chose not to participate.)

We used a 1.5 hp. Rockwell Model 10 table saw to test each dado tool. We ran stock through the saw at six to eight feet per minute, adjusting this feed rate when it was apparent that slower speeds would produce better cuts.

We selected test cuts to approximate the steps a woodworker might take in constructing a bookcase 8' long x 4' high x 1' deep with a middle divider and two end panels, all joined with dados.

The cutting sequence was:

Cuts 1 and 2: Dado and then groove 12" of 3/4" birch plywood.

Cuts 3 and 4: Dado and then groove 12" of 3/4" red oak plywood.

Cut 5: Groove 20' of poplar lumber.

Cut 6: Groove 18' of red oak lumber.

Cuts 7-10: Repeat cuts 1-4 for before and after comparisons.

We noted each product's performance in every sequence detailed above, a synopsis of which appears below each test photograph. The photos show the actual cuts each tool produced the second time across and with the grain in red oak plywood.



**Black & Decker / Model 73-560**  
Flat-ground steel, 6" stack set.  
Interchangeable cutters have 30 teeth, 5 rakers each; 5 chippers have two teeth each. Retail price: \$24.99. Micro burrs on teeth had to wear off before good cuts were achieved. On second pass, birch plywood was damaged. Good cuts in oak plywood. No chipped lumber edges. Very slow feed.



**Sears / Model 9-32475**  
Flat-ground steel, 8" stack set.  
Interchangeable cutters have 40 teeth, 8 rakers each; 5 chippers have 2 teeth each. Retail price: \$32.99. Veneers splintered across the grain in plywoods, but not with the grain. In all lumber cuts, this tool left saw marks on sides of kerf and ridges in the bottom. Small tear-outs when grooving lumber.



**Sears / Model 9-3263**  
Carbide adjustable, 7" with 16 teeth. Retail price: \$34.99. Even at a slow feed rate of 3-4 feet per minute, it chopped and splintered plywoods. To get a decent cut, we had to make gradually deeper passes. In grooving lumber, the blade left saw marks in the sides, chipped the edges, and hammered (a vibration that you can hear and feel) the grain.



**U.S. Saw Corporation / Oldham Saws / Model C-800 CPD**  
Steel flat-ground, 8" stack set.  
Interchangeable cutters with 48 teeth, 4 rakers each; 4 chippers have 2 teeth each. Retail price: \$41.04. Performed well in plywood and lumber, although dadoing had to be done very slowly (2-3 feet per minute). Saw marks on sides of grooves in lumber.

Continued

**Sears / Model 9-3253**

Steel thin-rim, 8" stack set. Interchangeable cutters with 128 teeth (no rakers) each; 5 chippers have 2 teeth each. Retail price: \$42.99. Plywood cuts had smooth sidewalls, but some veneer chips. Plywood cut better after assembly did the lumber cuts. Sides and bottoms in lumber were good, but tool started to burn stock during last few feet of feed cycle. Tiny ridges were noticeable in bottom of groove.

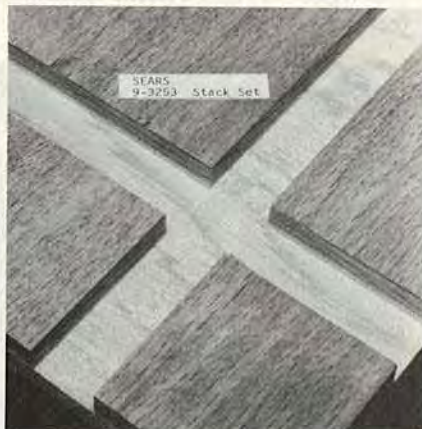
**Sears / Model 9-3261**

Carbide adjustable, 7" with 24 teeth. Retail price: \$44.99. Plywood was damaged during across the grain cuts even when fed at a rate slower than 2 to 3 feet per minute. Hammering was evident while cutting lumber, and grooves showed edge chipping, all at 2 to 3 feet per minute feed. More occurred at faster feed rate. Cuts improved with use of repeated pass technique.

**Sears / Model 9-3262**

Carbide adjustable, 7" with 32 teeth. Retail price: \$49.99. Satisfactory cuts in veneer plywood required feed rate of 3 to 4 feet per minute, either with the grain or across it. In the cuts with poplar and red oak lumber, we maintained the above rate and the blade vibrated somewhat, hammered, and left saw marks on sides of cut. Some chips on edges of kerf were produced, but not significant.

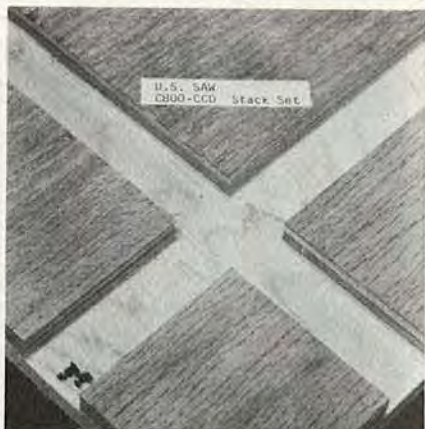
**U.S. Saw Corporation / Oldham Saws / Model C-800 CCD**

Carbide/steel, 8" stack set. Interchangeable cutters have 18 teeth each; 4 chippers have 2 teeth each. Retail price: \$96.41. This set produced a very nice cut on the first pass through birch plywood, but the second pass produced chips. It did not cut well in oak plywood either with or across the grain. Cuts in poplar and oak lumber were very good, with only minor grain tears.

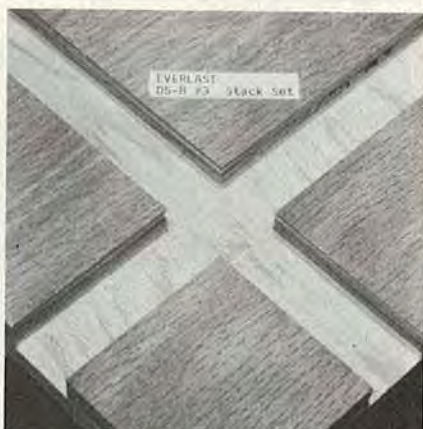
**Everlast Saw & Carbide, Inc. / Model DS-8 #3**

Carbide/steel, 8" stack set. Non-interchangeable cutters have 18 teeth each; 4 chippers have 2 teeth each. Retail price: \$162.25. Left tiny chips in birch plywood, very few across the grain in oak plywood. No chipping in cuts with grain of plywood. Nearly perfect cuts in lumber. Cutters run slightly deeper to leave "glue slots" in dadoes to lessen glue squeeze-out.

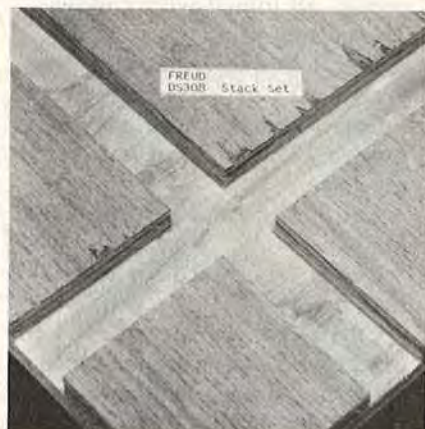
**Freud USA / Model DS-308**

Carbide/steel, 8" stack set. Non-interchangeable cutters have 18 teeth each; 4 chippers have 2 teeth each. Retail price: \$179.95. Left-side cutter chipped plywood across grain on both passes, left tiny nicks on second pass with grain. Lumber cuts very good, with nice sidewalls. Lots of carbide on tips for extended blade life. Unit cuts well at a faster speed rate than others (6 to 10 feet per minute).

**U.S. Saw Corporation / Oldham Saws / Model C-800 CHD**

Steel hollow-ground, 8" stack set. Interchangeable cutters have 48 teeth, 4 rakers each; 5 chippers have 2 teeth each. Retail price: \$60.48. Vibrated excessively and cut poorly so returned to manufacturer for tests. Replacement received too late to photograph, but cuts showed only slight chipping across grain, smooth cuts with grain in plywood.



**Freud USA / Model AD-800**

Carbide adjustable, 8" with 26 teeth. Retail price: \$62.90. Manufacturer says it's not recommended for plywood, and we agree, as it chipped badly on cross-grain cuts unless fed at 2 to 3 feet per minute. Lumber cuts in poplar and oak, if done slowly, were clean and neat, with only minor side-burning of groove. This blade has a very thick hub which only allowed us a few turns of the nut on the arbor.



**Sears / Model 9-3264**

Carbide/steel, 8" stack set. Interchangeable cutters have 22 teeth; 6 chippers have 2 teeth each. Retail price: \$89.99. Original chippers in set not bored out large enough to fit saw arbor. Replacement chippers cut shallower than outside blades so bottoms were uneven. Set produced very poor cuts in lumber and across grain in plywood even at a severely reduced feed rate of less than 2 feet per minute.



**Forrest Manufacturing Co., Inc. / "Mr. Sawdust" Dado King #3**

Carbide/steel, 8" stack set. Non-interchangeable cutters have 24 teeth each; three  $\frac{1}{8}$ " chippers have 4 teeth each, one  $\frac{1}{4}$ " chipper has 8 teeth. Retail price: \$299. Minor chipping in oak ply across grain. Glass-smooth dado sides. Excellent lumber cuts if feed rate reduced slightly. Multi-toothed chippers produced neat, clean, no-mar dados and grooves.

Looking at our test results, you may ask, "Why buy *any* of these accessories if even the best won't cut perfectly in every situation?" We share your concern. Chips, however small, were left in plywood by even the most expensive dado accessories.

Acting on the advice of Jim Boelling, our Project Builder, we contacted the experts—not dado blade experts but plywood experts—and discovered two good reasons for our test results: plywood veneers are getting thinner, and plywood adhesives are getting stronger. The combination makes it more difficult today than ever before to cut clean, chip-free dados. Thinner veneers chip more easily. Improved adhesives that are much more durable than the wood itself make it harder for a dado blade to shear material cleanly.

Here are some tips that may help

you combat these problems:

- Never force-feed your dado accessory. Feed stock only as quickly as the blade allows.
- Apply strips of masking tape to the plywood over the area of the dado, then cut through the tape. We've found that this procedure improves our cuts in many situations.
- Because of its rotary cutting action, a router may be less apt to tear thin veneers than a dado accessory under certain conditions. But you're more likely to require successive passes to achieve proper width and depth with a router, a process that increases your chances of making errors. Whenever possible, we think it's best to make cuts with a single pass.

Plywood veneers probably won't be getting any thicker in the future. Learn how to cope with thin-skinned materials now. ■



## FACTORS AFFECTING YOUR CHOICE

When it's time to finish your project, you can narrow your choices somewhat by asking yourself these questions:

1. **How and where will the project be used?** A dining room table, for example, requires a very durable finish to withstand the spills and constant wear it will encounter in use. A picture frame, on the other hand, won't need as much protection.
2. **Should it have a natural-looking, low-sheen finish that accents the texture and grain of the wood, or a finish with depth that can be polished to a very high luster?** Even though appearance is largely a matter of personal preference, the design itself and the type of wood used should help you make the decision.
3. **How much time and effort are you willing to expend applying the finish?** While some finishes are easy to work with, others require more skill and equipment to apply correctly.

Until you have some experience with a finish, it's not possible to know for sure if you'll like what it does to a certain wood species. For this reason, always test the finish you select first on scrap.

## THE TWO CLEAR-FINISH CATEGORIES

Clear finishes today fall into one of two categories: *penetrating* finishes and *surface* (or built-up) finishes. The penetrating ones — tung oil, linseed oil, Danish oil, mineral oil, and salad bowl finishes — soak down into the pores of the wood, forming a finish that resides in the wood itself. You wipe these on with a cloth or the palm of your hand, which makes the application practically mistake-proof.

Not surprisingly, surface finishes — natural varnish, polyurethane varnish, shellac, lacquer, and latex

**You've swept the shop clean, waited for the glue to dry, and now your masterpiece sits there in all its wooden nakedness. The grain is beautiful. The craftsmanship top rate. So what are you going to do to it now? What type of finish will you select? How much more time do you want to spend? Read on for answers that will help you decide.**

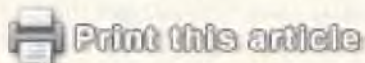

**M**ost woodworkers would rather spend their time making sawdust than thinking about which finish to use on their projects. That's understandable, but unfortunate because the finish you apply to your creation is vitally important. A clear finish enhances the appearance of the piece as well as protects the wood against moisture, dust, and wear.

Shopping for wood finishes these days isn't easy. A surprising array of products compete for your attention and your dollar. Therefore, the more you know about clear finishes, and what they'll do, the easier the selection process will become.

Continued



## FINISHING AND REFINISHING

finishes — lay on top of the wood surface, and build up with successive coats. These either brush or spray on and usually require the use of abrasives to rub out and polish the final surface.

### TYPES OF SURFACE FINISHES

**Natural Varnish.** This product, made from natural resins (secretions), has been used by woodworkers for years. In fact, much of the furniture you see in antique shops was probably originally finished with natural varnish because of its ability to render a durable finish capable of resisting water, alcohol, and wear. Varnish is also easily brushed on and rubbed out. Because of its amber color, it gives wood a deep, rich-looking tone.

Unfortunately, natural varnishes dry very slowly (24–48 hours.) Dust problems and the faster-drying synthetic varnishes have nearly eliminated natural varnishes. Except for marine and spar varnishes, which are for exterior use, you may even have a difficult time finding a supplier that carries one.

**Synthetic Varnish.** Most varnishes today contain the newer synthetic resins and are known as polyurethane varnishes. These finishes have become quite popular with professional woodworkers and home hobbyists because they're durable, moisture-resistant, and fast-drying. They also give wood the same warm tone and depth as natural varnishes. Keep in mind, though, that these extremely hard surfaces require more effort to rub out and to polish than some of the other finishes. Varathane (Flecto), Defthane (Deft), and Zar Polyurethane (Beverlee's) are three commonly available products in this category.

**Paste Varnishes.** Varnishes such as Velvit Poly Gel, Heritage Paste Varnish, and Bartley Paste Varnish offer another option when choosing a polyurethane finish. These finishes resemble petroleum jelly in consistency and are easy to apply

with a rag. They share all the advantages of polyurethane finishes, without the brush mark and settling dust problems normally associated with brushed or sprayed-on types. Because they form a thin finish with little surface buildup, poly paste varnishes create a natural-looking, low-sheen finish.

**Shellac.** This finish has been used for centuries, but since it produces a relatively brittle surface with low resistance to heat, moisture, alcohol, and abrasion, you should apply it only to items that will receive little wear and exposure.

At one time, it was a favorite finish for fine furniture because it was fast-drying, easy to apply, and polished to a high luster. Its numerous disadvantages make it a less popular choice today.

Even though shellac has been replaced largely as a wood finish, it's still used as a sealer over resinous knots to prevent stain and paste fillers from bleeding into certain finishes, such as lacquer. Parks Pure Shellac and Bull's Eye Shellac are two brands available.

**Lacquer.** The fast-drying champion of finishes, lacquer is used extensively in the furniture manufacturing industry. Many companies manufacture lacquer, but those most commonly available include Deft, Parks, and Behlen. Though not quite as durable as varnish, lacquer does produce a moisture and wear-resistant finish that polishes easily to a lustrous sheen. Because of the rapid drying times (approximately 30 minutes), you'll find spraying the most effective way to apply lacquer. Slower-drying, brushing lacquers such as Deft Clear Wood Finish and Pratt and Lambert's Wisk On make lacquer more practical for the home craftsman. Brushing lacquers still dry quickly, so restrict their use to small projects in which you can cover the entire surface in a short time.

Because lacquer is incompatible with most other finishing materials, you must use a sealer before applying lacquer to keep oil-based stains

and fillers from bleeding through the finish.

**Latex Finish.** Finishes such as Wood Armor (Deft) and Benjamin Moore's Vaqua Kleer represent a new development in wood finishing. Though water-based, latex finishes form a surprisingly durable and water-resistant finish when cured. The absence of noxious odors and the convenience of water clean-up make them a joy to use.

Straight from the can, these products have a milky-white appearance that transforms into a clear film when dry. Because of this clarity, they lack the rich-looking tone produced by varnish, but the finish is appropriate where minimal color change is desired. You can brush latex finishes on easily, but they don't respond well to polishing or hand rubbing, so removing imperfections will be more difficult. Despite these shortcomings, in situations where ventilation or the use of traditional solvent-based products present a problem, latex finishes provide you with a viable alternative.

### PENETRATING OIL FINISHES

**Tung Oil.** A centuries-old finish, that's enjoying great popularity today, tung oil comes in two forms — pure tung oil and polymerized tung oil. Of the two, polymerized dries much faster and has more luster. Both have a light golden color that imparts just the right amount of tone to accent the grain and texture of wood surfaces. And both form a moisture-resistant, durable coating that dries to a hard, solid film.





To apply tung oil, simply wipe it on with a cloth, let it set for several minutes, then remove the excess.

Several companies manufacture tung oil finishes — Southerland Welles, Formby, Parks, and the Hope Company.

**Linseed Oil.** Even though this old-time favorite yields a finish that looks "hand-rubbed," it has some shortcomings that limit its use. In addition to its tendency to deepen

*Continued*

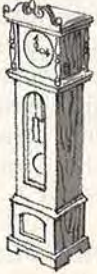
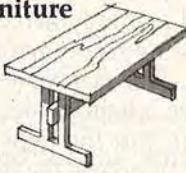
## WHEN TO USE WHICH CLEAR FINISH

Item type	Brand or Type Finish	Finish Category	Qualities
<b>Toys</b> 	Watco Danish Oil	Penetrating	Nontoxic (after 30 days), durable and easily repaired, natural-looking, low sheen
	Behlen's Salad Bowl Finish	Penetrating	Durable, natural-looking, satin sheen
	Numerous Latex Finishes	Surface	Hard, durable, good depth, dries very clear
<b>Food Contact Items</b> 	Behlen's Salad Bowl Finish	Penetrating	Highly resistant to moisture and food substances, natural-looking satin sheen, easily renewed
	Watco Danish Oil	Penetrating	Nontoxic (in 30 days), durable, easily renewed, natural-looking, low sheen
	Mineral Oil	Penetrating	Some moisture resistance, little wear protection, easily renewed, very low luster
<b>Low-Use Furniture</b> 	Lacquer	Surface	Moderately durable, rich-looking, easily polished to luster
	Latex	Surface	Good depth and durability, adds no tone
	Paste Varnish	Surface	Good durability, tones wood lightly, low build-up, hand-rubbed look, easily applied and repaired
	Tung Oil	Penetrating	Durable, moisture-resistant, non-darkening, low luster natural appearance, easily applied/renewed
	Danish Oil	Penetrating	Durable, easily repaired, warm tone, natural-looking, slightly more sheen than tung oil
	Oil/Varnish Mix	Penetrating	Extremely durable, natural appearance, easily, more protection and sheen than oil alone
<b>Hard-Use Furniture</b> 	Polyurethane Varnish	Surface	Excellent durability, high moisture and wear resistance, good depth, various lusters, lightly tones wood
	Paste Varnish	Surface	Comparable to above in durability, less surface build-up, natural-looking, easily applied/repared
	Oil/Varnish	Penetrating	Good durability, moisture resistance, satin luster, natural-looking, easily applied/repared
<b>Antiques</b> 	Oil/Varnish Mix	Penetrating	Good durability, hand-rubbed look, natural, satin luster, lightly tones wood, easily applied/repared
	Paste Varnish	Surface	Hand-rubbed look with slight surface build-up, good durability, adds warm tone, easily applied and repaired
	Tung Oil	Penetrating	Durable, adds light tone, low luster, hand-rubbed look
	Linseed Oil	Penetrating	Some durability, deepens wood tone, very low luster, hand-rubbed look
<b>Outdoor Projects</b> 	Spar or Marine Varnish	Surface	Exceptionally durable, highly moisture resistant, deepens wood tone, builds depth, high gloss
	Exterior Polyurethane	Surface	Durable and long-lasting, highly moisture-resistant, looks very similar to natural varnish
	Varathane Plastic Oil	Penetrating	Durable and long-lasting, easily renewed, satin sheen, natural-looking

—Continued on page 121



# cheval mirror

**Old-fashioned elegance with lots of appeal.**

## Building the Mirror Frame

**1** Rip the oak and walnut stock to width for parts A, B, C, and D. Cut the parts to length plus 1". Lay the pieces together on a flat surface in the arrangement that they will be glued and check for a good fit.

**2** Glue and clamp the A-B and the C-D assemblies together sandwich-fashion. Space the clamps evenly about 4" to 5" apart to ensure an even, invisible glue line. (We spread the glue with an old playing card. Then we used bar clamps, alternating the clamps on the top and bottom of the pieces to prevent warping.) After the glue has dried, remove excess and trim the assemblies to their finished length.

**3** Cut the corner blocks (E) to 3" square, with the grain running diagonally as shown in the Cutting Diagram. On a flat surface, fit all the frame parts together, then mark the location of the dowels that will join the corner blocks to the A-B and C-D assemblies. Drill  $\frac{3}{8}$ " holes  $\frac{1\frac{1}{2}}{16}$ " deep.

**4** Mark and cut the  $\frac{1}{2}$ " inside radius on the E parts (See Detail 1). Sand this arc smooth, then glue and clamp the mirror frame together. After the glue has dried, remove the excess.

**5** Mark and cut the outside radius on the E parts. Sand all surfaces and edges smooth.

**6** Rout a  $\frac{3}{8}$ " rabbet  $\frac{3}{8}$ " deep on the backside of the frame for the mirror and backing. Square the corners with a chisel. Rout a  $\frac{1}{4}$ " round-over on all outside edges, then rout a  $\frac{1}{2}$ " Roman ogee on the front inside edge. (See the Frame Corner Section.)



Design: Kent Welsh Photograph: George Ceolla

*Continued*

# FURNITURE PROJECT

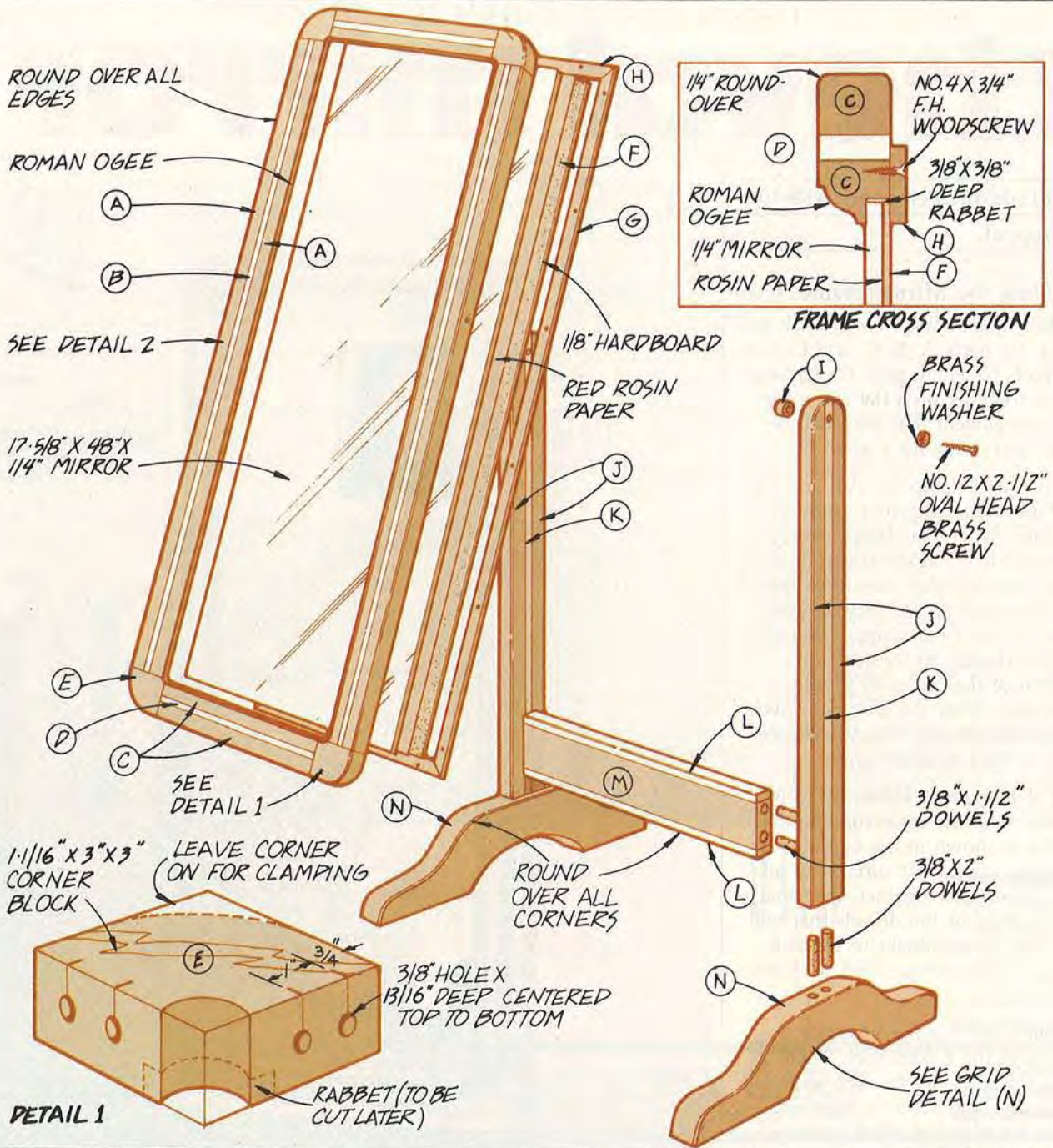

**7** Cut the hardboard backing (F) and the mirror stops (G, H) to size. Drill  $\frac{1}{8}$ " pilot holes through the walnut pieces (G, H) (see the drawing for positioning). Form I, using either a walnut dowel or a walnut plug, then drill a  $\frac{1}{4}$ " hole through the center.

## How to Make the Stand

**1** Rip parts J, K, L, and M to width. Laminate the vertical

supports (J, K) and the cross support (L, M) as you did the frame parts in step 2 earlier. After the glue has dried, trim to the finished length.

**2** Mark and cut a  $\frac{1}{4}$ " radius on one end of each vertical support (J, K), and drill two  $\frac{3}{8}$ " dowel holes  $\frac{1}{16}$ " deep in the opposite end of each. Drill a  $\frac{1}{4}$ " hole through each upright at the center point of the radius. Center and dry-clip the

cross support between the uprights. Mark the location of the dowel holes on the uprights and cross support. Drill two  $\frac{3}{8}$ " dowel holes  $\frac{1}{16}$ " deep in each end of the cross support and corresponding holes in one side each of the vertical supports.

**3** Cut the mirror's legs (N) to  $5" \times 23"$ . Then, while the pieces still have a flat bottom and top, center an upright on each leg and mark

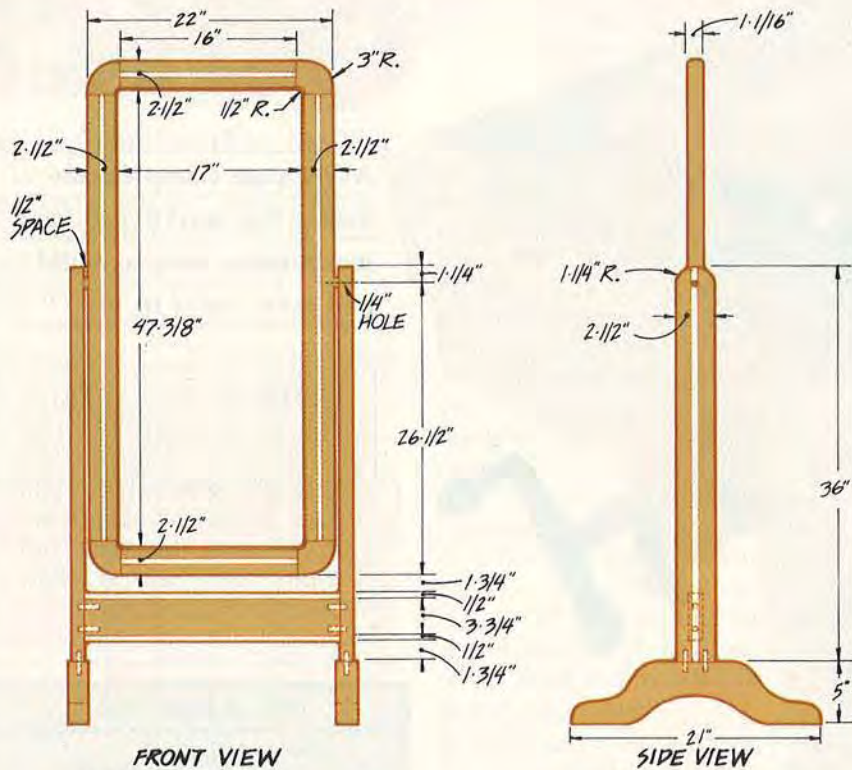

FRONT VIEW  
FRONT VIEW

SIDE VIEW

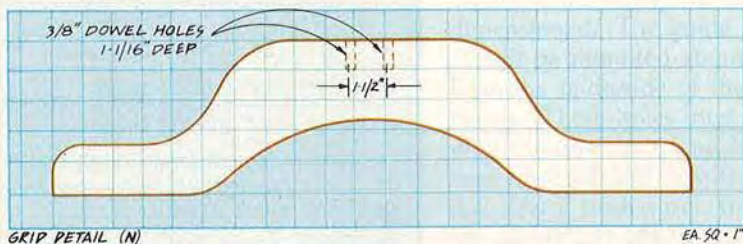

GRIP DETAIL (N)

EA. 5Q - 1'

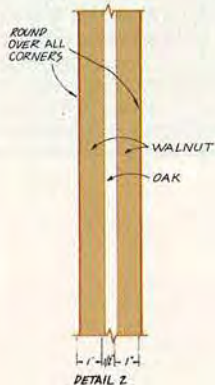

DETAIL 2

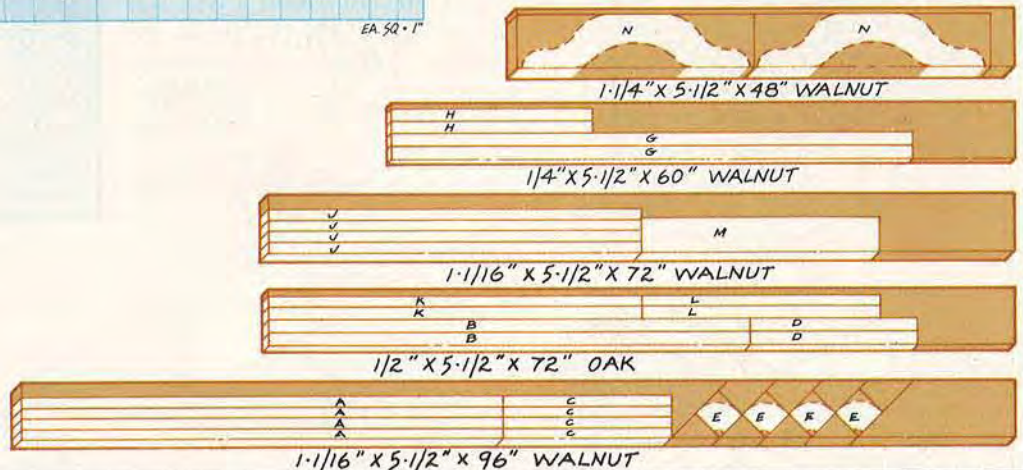

**Bill of Materials**

Part	Finished Size*			Material	Qty.
	T	W	L		
A	1 1/16"	1"	46 3/8"	walnut	4
B	1/2"	1 1/16"	46 3/8"	oak	2
C	1 1/16"	1"	16"	walnut	4
D	1/2"	1 1/16"	16"	oak	2
E	1 1/16"	3" x 3" diag. cut		walnut	4
F	1/8"	17 5/8"	48"	hardboard	1
G	1/4"	1 1/4"	50 1/4"	walnut	2
H	1/4"	1 1/4"	19 1/2"	walnut	2
I	3/4" dia. x 1/2" long			walnut	2
J	1 1/16"	1"	36"	walnut	4
K	1/2"	1 1/16"	36"	oak	2
L	1/2"	1 1/16"	23"	oak	2
M	1 1/16"	3 3/4"	23"	walnut	1
N	1 1/16"	5"	21"	walnut	2

\*Some parts are cut larger initially, then trimmed to finished size. Please read instructions before cutting.

**Supplies:** 2—#12 x 2 1/2" oval head brass screws, 2 brass finishing washers, 18—#4 x 3/4" flathead wood screws, 20—3/8" x 1 1/2" dowels, 4—3/8" x 2" dowels, 1/4" mirror 17 5/8" x 48", red rosin paper (available at your local lumberyard) or heavy brown wrapping paper.

and drill two 3/8" dowel holes 1 1/16" deep, corresponding to those in the vertical uprights. Cut N to shape.

**4** Sand the stand parts smooth and rout the legs, cross support, and vertical supports, using a 1/4" round-over bit.

**5** Glue and clamp the stand pieces together, being careful to maintain squareness. Finish-sand the frame and stand assemblies. Finish as desired.

**6** Install the mirror and the hardboard backing. (We placed red

rosin paper between the mirror and hardboard to prevent the mirror silver from scratching. Heavy brown wrapping paper will also work.) Mount the mirror frame to the stand, using the 2 1/2" brass screws, finishing washers, and the walnut pieces (I). ■

# QUICK-

A \$10 pipe clamp fixture makes this workbench vise inexpensive, easy to build, and even easier to use.

**NOTE:** We dimensioned this vise for a bench top that measures 2" thick X 30" wide (25" table with a 5" tool tray). If your workbench has a different thickness and width, you'll have to adjust the figures accordingly.

 Print this article

### Bill of Materials

Part	Finished Size*			Material	Qty.
	T	W	L		
A	2 1/8"	4"	25"	maple, laminated	1
B	1 1/16"	4"	30"	maple	1
C	1 1/16"	1 7/8"	11 1/2"	maple	1

\*Some parts are cut larger initially, then trimmed to finished size. Please read instructions before cutting.

**Supplies:** 2—3/4" x 24" steel bars, 1—#50 Jorgensen clamp fixture, 1—3/4" x 26" black pipe (threaded at both ends), 2—#8 x 1" flathead wood screws, 5—#12 x 3" flathead wood screws, 2—#8 x 2 1/2" flathead wood screws, 1/2" dowel 3 1/2" long, 1" dowel 14" long (enough for 6 bench dogs), 3/4" pipe cap.

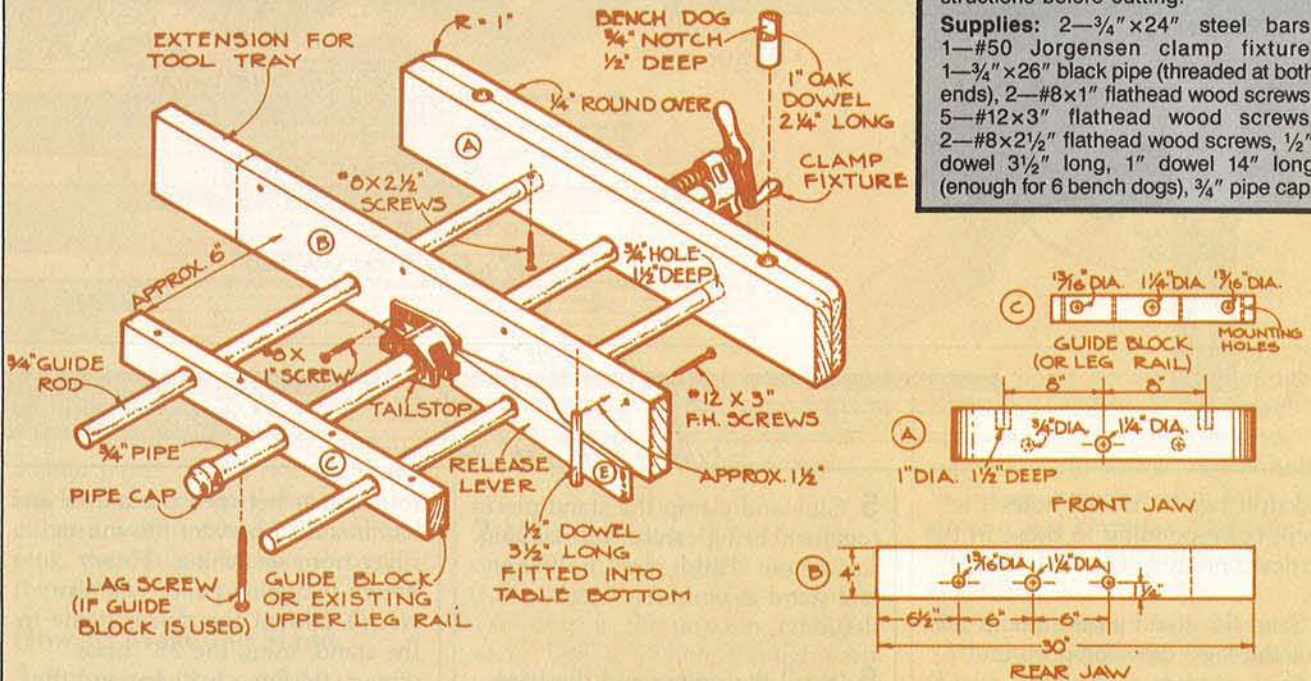

# CLAMP END VISE

## Building and Installing the Vise

**1** Rip the  $1\frac{1}{16}$ "-thick maple to 4" for parts A and B. Crosscut two 26" pieces for A and one 30" piece for B. Glue and clamp the two 26" lengths together to form A.

**2** Bore two  $\frac{1}{16}$ " holes for the guide rods and one  $1\frac{1}{4}$ " hole for the black pipe through B (see the dimensioned Rear Jaw in the drawing on the opposite page for positioning).

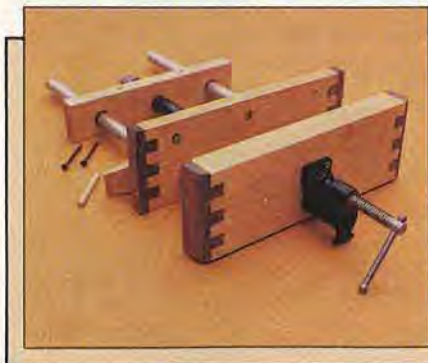
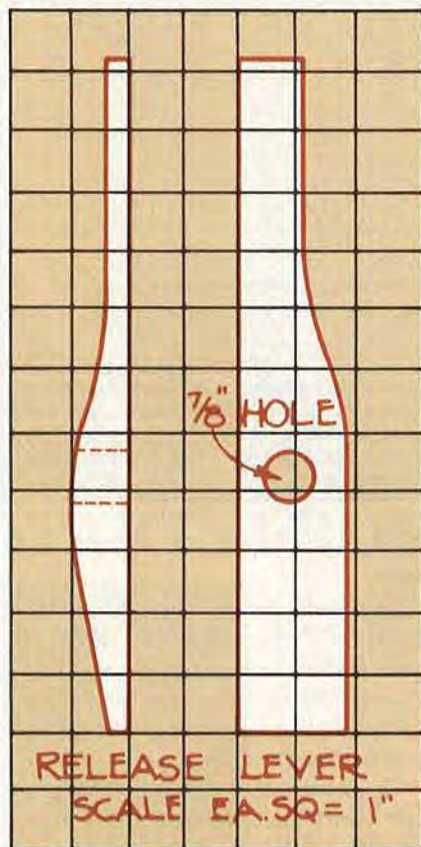

**3** After the glue has dried and you've removed any excess, trim A to 25". Scribe a 1" radius on the two front corners, and cut on the bandsaw. Clamp A to B and, using the previously drilled holes in B as a positioning template, mark the corresponding holes on A. Bore a  $1\frac{1}{4}$ " hole completely through A for the  $\frac{3}{4}$ " black pipe. Bore two  $\frac{3}{4}$ "-diameter holes  $1\frac{1}{2}$ " deep for the guide rods.

**4** Screw mount the pipe clamp hardware to parts A and B. (We used the pipe clamp itself to align and hold A and B together. Then, using a  $\frac{1}{2}$ " metal-cutting bit, we drilled one hole through each piece of hardware and installed the  $\#8 \times 1$ " wood screws.)

**5** Cut a guide block to size (see the Guide Block in the drawing on the opposite page) and drill holes as dimensioned. The guide block should be mounted about 6" from B on the underside of the workbench. These holes must line up with the ones in A and B to prevent the rods and pipe from binding. (As it turned out, the upper leg rail on our bench was positioned perfectly for this purpose, eliminating the need for constructing a guide block.)

**6** Glue and screw mount B to the bench. (We countersank 5 equally spaced  $\#12 \times 3$ " wood screws through B into the workbench end.)

**7** Using a router and a  $\frac{1}{2}$ " round-over bit, rout the outside edges of A. Sand A and B smooth.

## Woodworker's Vise

Actually a smaller version of the end vise, this one mounts on the front of workbenches. We followed the same construction process, but added box-jointed walnut ends to the maple. We cut the box joints on the table saw. This smaller version uses  $\frac{1}{2}$ " pipe rather than  $\frac{3}{4}$ ", and Jorgensen #52 rather than #50.

**8** Fit the guide rods into A, then use a  $\frac{1}{2}$ " metal-cutting bit to drill a hole into A and just through each guide rod (approximately  $1\frac{1}{4}$ " deep). Now, using a  $\frac{1}{2}$ " bit, drill a  $2\frac{1}{2}$ "-deep hole in A through the  $\frac{1}{2}$ " hole. Install  $\#8 \times 2\frac{1}{2}$ " screws to hold the guide rods in place.

## The Quick-Release Lever

**1** Cut part C to size. Transfer the pattern at left to 1" graph paper, then onto part C. Drill a  $\frac{7}{8}$ " hole through it and cut the lever to its finished shape.

**2** Screw the black pipe into the clamp fixture on A. Install the black pipe and guide rods through the holes in B, the release lever, and through the guide block.

**3** Position and bore a  $\frac{1}{2}$ " hole 1" deep in the table bottom and install a  $\frac{1}{2}$ " dowel  $3\frac{1}{2}$ " long to prevent the release lever from sliding along the guide rod. Screw the pipe cap to the black pipe. Choose and apply finish. (We finished all the parts with tung oil.)

**Note:** To use the vise, pull the release lever toward part B and pull out on the vise. Once you have reached the length needed for clamping, release the lever and give the clamp a quick jerk to set the tail-stop on the  $\frac{3}{4}$ " black pipe. Insert the project to be clamped and tighten the screw handle.

## Bench Dogs and Dogholes

**1** To clamp large projects easily, cut 1"-diameter dogholes  $1\frac{1}{2}$ " deep in part A as shown in the drawing, then drill corresponding holes at regular intervals along the bench top. (We placed our first bench-top doghole 4" in from B and cut the others at 10" intervals.)

**2** Cut the bench dogs  $2\frac{1}{4}$ " long and then cut a  $\frac{3}{4}$ "-long notch  $\frac{1}{2}$ " deep in one end of each. We clamped each dowel in a handscrew and cut notches on a band saw. ■

# DRILL PRESS STAND

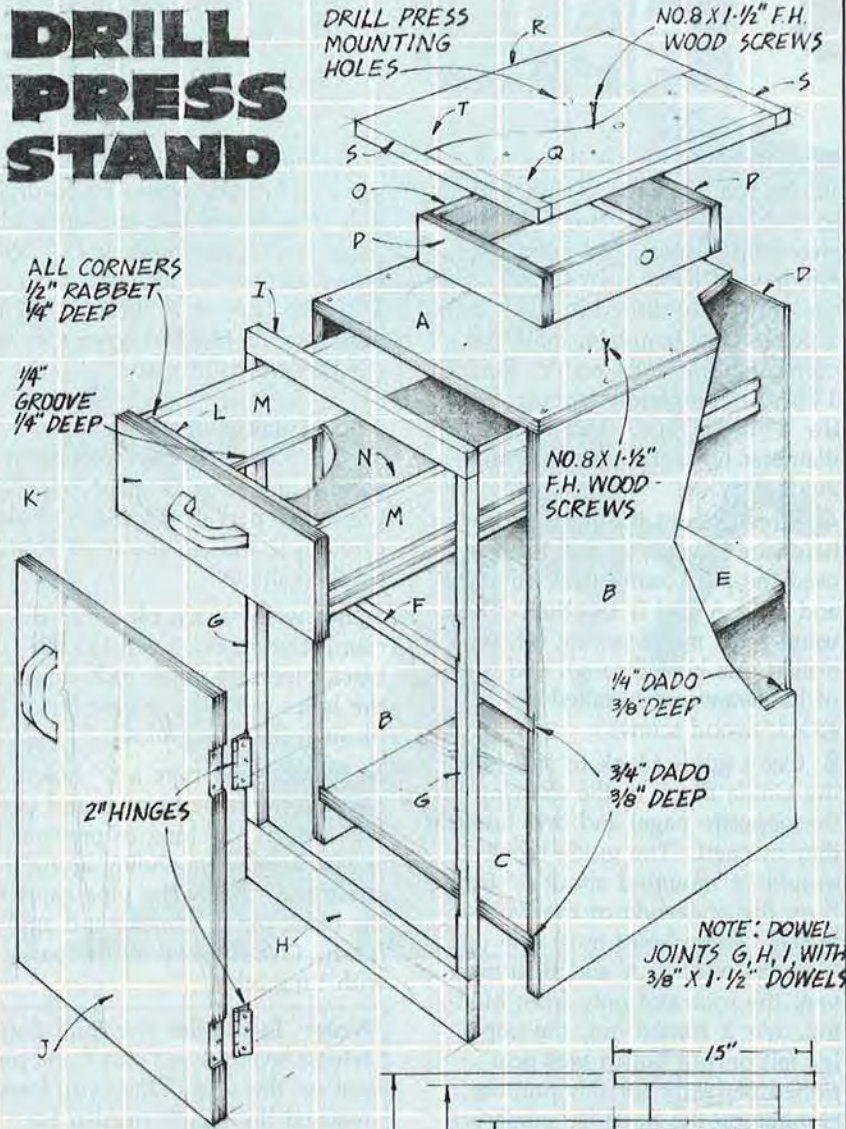

Bill of Materials					
Part	Finished Size			Material	Qty.
	T	W	L		
A	3/4"	15"	19"	plywood	1
B	3/4"	19"	32 1/2"	plywood	2
C	3/4"	18 3/4"	14 1/4"	plywood	1
D	1/4"	14 1/4"	32 7/8"	hardboard	1
E	3/4"	18"	14 1/4"	plywood	1
F	3/4"	3/4"	14 1/4"	pine	1
G	3/4"	3/4"	28 3/4"	pine	2
H	3/4"	3"	15"	pine	1
I	3/4"	1 1/2"	15"	pine	1
J	3/4"	13 3/8"	23"	plywood	1
K	3/4"	5 1/2"	13 3/8"	plywood	1
L	1/2"	5 1/2"	12"	pine	2
M	1/2"	5 1/2"	18"	pine	2
N	1/4"	12"	17 1/2"	hardboard	1
O	3/4"	4"	12 1/4"	plywood	2
P	3/4"	4"	9"	plywood	2
Q	3/4"	13 1/2"	18 1/4"	plywood	1
R	3/4"	3/4"	18 1/4"	pine	2
S	3/4"	3/4"	15"	pine	2

**Supplies:** 2—18" drawer slides, 2—2" butt hinges, 1 door catch, 2—hardwood pulls, #8x1 1/2" flathead wood screws, 6d finish nails, contact cement, polyurethane varnish, paint, 4—3/8" x 1 1/2" dowels, plastic laminate

NOTE: DOWEL JOINTS G, H, I, WITH 3/8" X 1-1/2" DOWELS

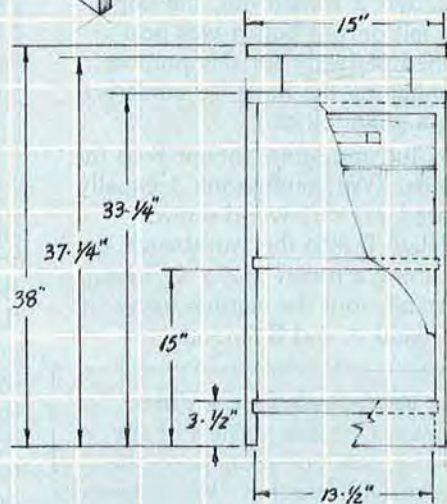

FRONT VIEW



[Print this article](#)

This drill-press stand measures 38" high, 19 3/4" deep, and 15" wide. If you prefer a different height, change the width of pedestal pieces O and P to raise or lower the pedestal top.

To construct the stand, assemble the cabinet carcass (A-F) as shown. Use dowel joints to build the face frame (G-I). Glue and nail the face frame to the cabinet. Build and fit the door (J) and drawer (K-N).

Construct the pedestal (O, P) and top (Q-S). Countersink and screw the top to the pedestal, and the pedestal to the cabinet. Cover the top with laminate. Use carriage colts to bolt your drill press through the top (Q) and through the cabinet top (A) for a sturdy support. Paint, let dry, and attach pulls and hardware. ■





Conover Woodcraft Specialties, Inc.  
18125 Madison Rd., Parkman, O. 44080  
(216) 548-3481

## Thread Box and Tap Sets in kit form An exclusive Conover money saver

A thread box is the craftsman's tool for cutting external threads on a wooden dowel. The corresponding size tap cuts the matching internal thread.

The beautiful Conover thread box combines contemporary technology and metallurgy with fine wood, polished brass and a time-tested design that is easy to use. And it really works. The original tool from which this design was adapted has been in regular use for more than a century.

Conover thread boxes and taps are available in the three most wanted sizes: 1/2", 3/4" and 1".

Here's a rare opportunity for any woodworker with a little patience and average skill. You can create your own thread box from a Conover kit and save more than 1/3 the cost.

The Conover Thread Box Kit comes with all parts fully machined. Holes are drilled, slots are milled and the thread aluminum insert, which extends the wear-life of the thread box indefinitely, is in place in the center hole. The kit includes the sharpened cutter blade, cutter holder and all other metal parts plus the tap, sharpened, and ready to use.

Your job in assembling this kit is to do the careful job of the master fitter in assembling the tool and adjusting the cutter to the correct position. And because the master fitter's time is very expensive you save that cost when you build the kit.

A final cost saving is realized when you sand and finish the wooden parts to your own taste.

Detailed drawings and simple assembly instructions are included with each kit.

- C030 1/2" x 8 \$39.00
- C035 3/4" x 6 \$43.25
- C040 1" x 6 \$47.25
- C025 extra cutter \$5.75 (fits any of the above boxes.)

C045 set of all 3 kits \$122.00

A Conover Special  
A \$129.50 Value **SAVE \$7.50**



Enclosed is \$1 for your 24p catalog of Conover tools and machinery (free with order)  
 charge to Visa       Master Charge       Payment enclosed — check or money order  
 card number \_\_\_\_\_  
 card expiration date \_\_\_\_\_

### Thread Box and Tap Sets

C030 1/2" x 8 \$39.00	C045 set of all 3 kits \$122.00
C035 3/4" x 6 \$43.25	SAVE \$7.50
C040 1" x 6 \$47.25	Ohio residents add 5% sales tax
C025 extra cutter \$5.75	Grand total

## at *Mason & Sullivan* BUILDING A GREAT CLOCK STARTS FROM THE INSIDE OUT



REGULATOR MOVEMENT

Any good clockbuilder knows that when you're building an heirloom you start with a great movement. Mason & Sullivan has been selling the finest movements available since 1947 and we back that statement up on our best brass movements with a 36 month guarantee against defects in workmanship.

After 38 years in the business, Mason & Sullivan has the know-how to assist you in every phase of your project, from initial planning, to movement installation. We want to make you a great clockbuilder too.

So whether your requirements are massive nine tube or mini-quartz, Mason & Sullivan has the movement to design your case around.

Send \$2 to receive a one year subscription to our 56-page color clockbuilding supply catalogue. Includes clock kits, dials, movements, weather instruments, hardware, tools, books and accessories.

*Mason & Sullivan*

"Fine Clockmakers Since 1947"

Dept. 2361, W. Yarmouth, Cape Cod, MA 02673



VIENNA REGULATOR

# RING MASTER

"The second new idea in power woodworking to come along in 100 years."

## Cut Perfect Rings In Any Wood...

any angle, any size up to 1" thick, 12" diameter.

1

Cut flat wood into angle or straight-edged rings, stack the rings and create ANY HOLLOW CYLINDRICAL SHAPE...Just glue, sand and finish...create matched sets of items.



**Ring Master is simple to operate.** Only 2 adjustments to set up, 3 operating steps to cut rings.

**In just two years Ring Master** is the center of attention in SCHOOLS, BUSINESS, and HOMES, AND is a welcome profit-maker for many -

**NOW Ring Master Model 2 works on your Shopsmith® Mark V. OR SIMILAR MACHINE** - attaches in 15 seconds.



Mr. B.W.H. of Santa Barbara, Cal. recently wrote about the Model 2; "Ring Master - is a new and fantastic machine - it fit(s) on the Shopsmith, it has simplicity and durability incorporated into it - I find it a tremendous addition to my woodworking shop."

3 To request a color brochure or to order - PHONE TOLL FREE 1-800-854-9815, in Florida 305 859-2664. We honor Visa, Master Card, personal check and COD.

Ring Master, Inc.  
P.O. Box 8527A, Orlando, FL 32856, 305/859-2664

Please send me complete facts about the ALL NEW Ring Master.

Name \_\_\_\_\_

Address \_\_\_\_\_

City \_\_\_\_\_ State \_\_\_\_\_ Zip \_\_\_\_\_

Ring Master DEALERS wanted in all areas.

## LUMBER BUYMANSHIP

 Print this article

# buying wood by mail

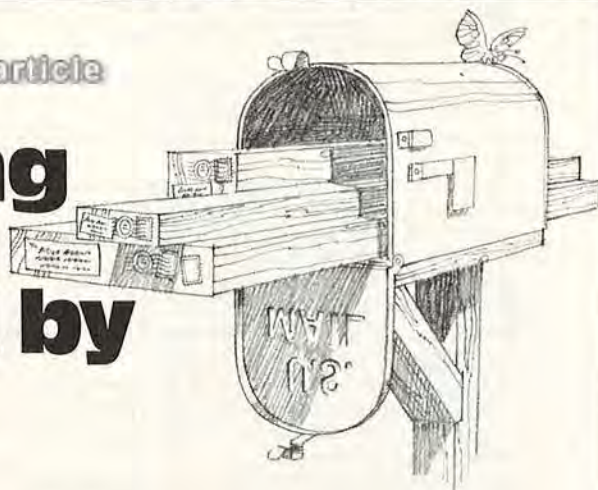

**F**inding the right materials is a predictable problem whenever you start an unusual woodworking project. The farther you live from big-city specialty stores, the bigger the problem, because most lumberyards can't afford to stock seldom-requested hardwoods or veneers.

You face a difficult choice: seek out and visit the nearest supplier, whose store may be hundreds of miles away, or send for catalogs published by mail-order wood merchants and let them come to you.

### Mail-Order Advantages

Because they sell to customers throughout the nation and even around the world, the dozen or so companies marketing wood products by mail in the United States can offer selections that far exceed local suppliers'. Constantine's in New York stocks the largest selection of veneers in the world, according to Glenn Docherty, vice president of the 172-year-old company. "We are very competitively priced because we buy our veneers from long-term sources all over the world," he adds.

Buying by mail is convenient. Drop your order in the mail (or place it by phone, if you're in a hurry) and your materials will usually arrive within a week or ten days. If you're willing to pay extra for air freight, your order will reach you in a day or two. Most dealers accept payment by charge card.

Because their success depends on repeat business, dealers in the field emphasize high-quality products,

reliable, prompt service, and satisfaction guaranteed.

Says Ann Rockler Jackson, president of The Woodworkers' Store in Rogers, Minnesota, "If a customer is unhappy with our merchandise, he returns it and we refund his money. We just take everything back."

### Disadvantages

When you're ready to buy, you probably want the product *right now*. So one drawback to buying by mail is having to wait to receive your purchases. And before you can even place an order, you need to locate a wood-by-mail source. To help you with this not-overly-easy chore, we've compiled a listing of over 20 such firms, beginning on page 95. You may also be able to uncover other outlets by looking in the various other woodworking publications.

Also, there's nothing quite like holding one piece of wood to compare it with other boards. Naturally this isn't possible by mail order. Instead, you're limited to thumbing through a catalog.

Moreover, you usually have to send for the catalog first, and include a dollar or two to cover postage and handling. But in most cases, the dealer will refund the charge with your first order.

Some mail-order merchants require their customers to meet minimums—50 board feet of each type of wood bought, perhaps, or a minimum dollar amount. (Others will sell wood by the linear inch.)

Continued on page 94

DO YOU USE OR COLLECT  
FINE HAND TOOLS?

ANTIQUE — OBSOLETE — MODERN

IF SO,

YOU SHOULD BE READING



**THE FINE  
TOOL JOURNAL**

PUBLISHED 10 TIMES ANNUALLY  
1 Year Subscription — \$10.00. Sample, \$1.50

REMIT TO:  
THE FINE TOOL JOURNAL  
RD #2 — Dept. W  
Poultney, VT 05764

**Make Clocks Easily!  
with Precision  
Quartz Movements**

**M88 Thinline**

2-3/16" square x 5/8" thick  
Step sweep hand. Uses AA cell.

**Made in Japan by  
the world's largest  
producer of quartz  
timepieces.**



**NEW LOWER PRICES!**

1-2	\$6.95	25	50	\$3.65
3-9	\$4.95	@		<b>FREE HANDS</b>
10-24	\$4.35	\$3.95		

PRICES INCLUDE HOUR AND MINUTE  
HAND. ADD 25¢ FOR SECOND HANDS.  
Add \$2.00 per order for postage & handling.

BOOK - How You Can Make Battery  
Operated Clocks...Easily. 64 Pages.  
Fully Illustrated. By Charlie Plumb  
\$6.95



**NEW CATALOG**  
50 pages of clock move-  
ments, dials, accessories,  
hands, tools, and more!  
Catalog #784 \$1.00  
(Free with order)

**Cas-Ker Co.**

BOX 2347-R CINTI, OH 45201  
PHONE (513) 241-7073

My Ebac  
**LUMBER DRYER**  
paid for itself  
in the first  
year.



An Ebac system  
is cost effective, even if you  
average as few as 100BF per month. To keep  
your total investment low, you construct the  
kiln and Ebac supplies the drying equipment.

Buy your lumber green, dry it yourself and  
pocket the kiln dried premium.

**QUIET · CLEAN · EFFICIENT · EASY · CONVENIENT**

Get the facts • Call Ebac  
800-433-9011 or 317-897-2100



**Ebac of America**  
8726 East 33rd Street, Dept X  
Indianapolis, Indiana 46226

**GIANT SCREEN TV**  
SAVE \$45. NOW ONLY \$59.95  
\$104.95 VALUE

Includes DUAL LENS - tube mounted  
and CABINET PLANS



**BUILD  
YOUR OWN...  
with our 8" tube  
mounted DUAL  
LENS SYSTEM!**

Quality lens - don't  
confuse with cheap  
single lens units.

**FREE!** Easy to follow  
design plans for cabinet  
(\$15.00 value) included  
FREE with order for 8"  
DUAL LENS SYSTEM.

Enjoy a larger-than-life  
quality picture using 12" to 15" TV

Easy to construct, build this 5-foot  
BIG SCREEN TV with less than \$100  
worth of particle board, screws, corner  
braces, etc. Finish as you like — laminate,  
paint, varnish or antique.

• Save \$2,000 or more! Equals \$2,000  
to \$3,000 systems.

• Satisfaction Guaranteed

**Send \$59.95** plus \$3.00 shipping & handling  
**R.E. MYERS, INC.** — TV Proj. Div., Dept. W-15  
4940-73rd Ave. No., Pinellas Park, FL 33565

**1(813)546-5129**

MC or VISA orders accepted

**10 FREE  
PLANS!**

If you own a lathe don't be  
without these plans.

**Dimensioned Plans**

for these 10 Projects:

- Bud Vase
- Goblet
- Gavel
- Wall Lamp
- Candle Stick
- Mortar & Pestle
- Covered Dish
- Potato Masher
- Honey Dipper
- Pagoda Bowl

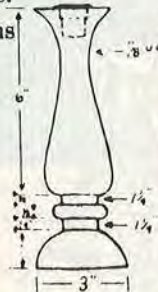

You'll also receive FREE the latest catalog from Cryder  
Creek. Featuring TURNING wood, tools, books, kits,  
plans, returned spindles, finishes and much much more!



Yes! Send me 10 Turning Project Plans. I have enclosed  
\$1.00 (cash only) for shipping and handling. Send to  
Cryder Creek Wood Shoppe, 101 Commercial Ave.,  
Whitesville, N.Y. 14897.

Name \_\_\_\_\_  
(Please Print)

Address \_\_\_\_\_

City \_\_\_\_\_ State \_\_\_\_\_ Zip \_\_\_\_\_

10333

**OLSON**

**Saw Blades**  
Economy • Quality • Value

You could pay 50 to 100% more and not get  
better blades. Made from the finest steels  
with sharp, filed or precision ground teeth  
for accurate sawing, smooth finishes, and  
long life. For cutting  
wood, plastic, or  
metals in indus-  
trial, school, and  
home workshops.



Send for FREE  
specification  
and price sheets.

**YES!** I am interested in more  
information on these Olson Saw  
Blades:  Band saw (wood and  
metal cutting),  Coping  Jig  
 Saber  Fret  Scroll.

Name \_\_\_\_\_

Company \_\_\_\_\_

Street \_\_\_\_\_

City \_\_\_\_\_

State \_\_\_\_\_ Zip \_\_\_\_\_



**THE OLSON SAW COMPANY**  
A DIVISION OF BLACKSTONE INDUSTRIES, INC.  
Bethel, CT 06801 • (203) 792-8622  
WM

**Now: Own a real Swiss shop bench for only \$395!**

F.O.B. La Mirada Calif.



CLASSIC: \$395.  
VERSATILE (NOT SHOWN): \$345.

Here's your dream workbench. It's a 60-inch version of the Lachappelle—the bench professional woodworkers use.

Made in Switzerland by Old World craftsmen, its top is of kiln-dried red beech (harder than most oaks). It has two vises with solid guide rods gliding on steel tubes. Has all your want-most features, like big rugged steel spindles and bench dogs.

Best of all is the price—an unbelievably low \$395! Send for literature and details now. Dealer inquiries invited.

**QUALITECH PRODUCTS**

14742 Beach Blvd., Suite 422, Dept AC4  
La Mirada, Calif. 90638

✓ Yes, please rush me details about the Lachappelle Swiss workbench.

Name \_\_\_\_\_

Address \_\_\_\_\_

City/State/Zip \_\_\_\_\_

**STOP DESTROYING YOUR VALUABLE CUTTING TOOLS.**

USE A



**SCANGRIND WET STONE**  
TO SAFELY SHARPEN EVERYTHING FROM SCISSORS AND KNIVES TO AXES AND MOWER BLADES.

Traditionally Wet Stones have been used to sharpen tools without removing their temper and their ability to hold an edge. This modern version is a heavy duty quality tool featuring a special fine grained 6" x 1 1/4" wheel—it's no toy, really can handle those bigger jobs. Runs forward and reverse with a flip of the switch. The sturdy tool rest adjusts to any angle.

Send this coupon together with your check or money order to:

**F & H MACHINERY CO.**

2433 HAMILTON RD.  
ARLINGTON HEIGHTS, IL 60005

**SCANGRIND 150 (6" wheel) \$125.00**  
(Price includes shipping & handling) Illinois residents add 7% sales tax  
**MONEY BACK GUARANTEE**

NAME \_\_\_\_\_

ADDRESS \_\_\_\_\_

CITY, STATE/ZIP \_\_\_\_\_

Please allow 2-4 weeks for delivery.

**LUMBER BUYMANSHIP**

Continued from page 92  
**buying wood by mail**

**Other things you should know**  
Even the most clearly written, best-illustrated catalog may not answer all your questions about a product. To avoid misunderstandings, it's important to be knowledgeable about the product.

"The worst thing we run into is the occasional novice who does not understand what a board foot is or that hardwoods come in random widths and lengths," comments Bob Carr, president of Educational Lumber Company, Inc., Asheville, North Carolina. "We kind of screen the customers. If they don't understand how things work, we suggest books they can buy and read to get started," he adds.

Plan your materials needs carefully so you will order enough but not too much. "When you contact the supplier, include a brief description of what you're going to build, including major dimensions," suggests Jay McBride, owner of World Timbers, in Los Angeles, which specializes in exotic woods.

"If you call in and say you want a piece of rosewood 2 inches thick by 12 inches wide by 8 feet long, I'll want to know how you will use it. Perhaps you'd end up cutting it down into pieces 12 inches long, 3 inches wide and so on. I may be able to suggest alternatives that better fit the use and save you money," McBride says.

When your order arrives, check it immediately to make sure you received everything you ordered and in good condition. If part of the order is missing or damaged, contact both the merchant and the post office or delivery service immediately so the supplier can make up the difference or retrieve the damaged goods and replace them with sound ones.

"Buying by mail order is fast, safe, and convenient," Ann Rockler Jackson points out. And for out-of-the-ordinary items, it's often practical, too.

Continued on page 95

**The complete woodworking machine... and you only pay for ONE motor.**



**Swing from bandsaw to table saw in seconds.**

**Table Sawing**



**Band Sawing**



Haul it to your cottage or cabin. Remodel your kitchen.



**Make Your Own Molding**

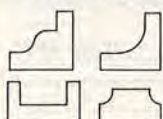

**Disc Sanding**



This versatile unit is 4-tools-in-one with a powerful 2.5 hp motor. It requires no disassembly or lengthy set-up to perform different operations. You can perform 8 other operations by adding optional accessories to the same base unit. It's portable and affordable...why buy a different tool for each function when you can do it all on the Multi-purpose Star 2000!

Add a lathe and much more... call or write today about this amazing machine.

**1-800-521-8289**

**emco\*USA** In Ohio Dial Direct 614/445-8382  
Dept. BW-155 P.O. Box 07795 Columbus OH 43207

## LUMBER BUYMANSHIP

Continued from page 94

### Mail-Order Lumber Outlets

Here are a number of direct-mail outlets for lumber supplies of all kinds. The letters at the end of each listing relate to the legend below and indicate the company's specialties.

#### LEGEND:

V = Veneers  
P = Plywood  
T = Turning stock  
H = Hardwoods  
S = Softwoods  
TS = Thin stock

#### American Woodcrafters

1025 South Roosevelt,  
Dept. W  
Piqua, OH 45356  
515/773-7414 X291  
Free Catalog  
V, T, H.

### buying wood by mail

#### Black Mountain Wood Co.

914/946-4111  
P.O. Box 3525, Dept. W  
Portland, ME 04104  
207/772-3332  
Price list: \$1  
P, T, H, S.

#### Boulter Plywood

24 Broadway, Dept. W  
Somerville, MA 02145  
617/666-1340  
V, P, H, S.

#### Certainly Wood

12613 Centerline Rd.,  
Dept. W  
South Wales, NY 14139  
716/655-0206  
Free Catalog  
V, P, H, TS.

#### Condon, Maurice L., Co., Inc.

248 Ferris Avenue, Dept. W  
White Plains, NY 10603

914/946-4111

P, T, H, S.

#### Constantine's

2065 Eastchester Rd.,  
Dept. W  
Bronx, NY 10461  
800/223-8087  
Catalog: \$1  
V, P, T, H, S, TS.

#### Craftsman Wood Service Co.

1735 W. Cortland Ct.,  
Dept. W  
Addison, IL 60101  
312/629-3100  
Catalog: \$1  
V, P, T, H, TS.

#### Craftwoods

10921 York Road, Dept. W  
Cockeysville, MD 21030  
301/667-9663  
Catalog: \$2

Free price list  
V, P, T, H, S, TS.

#### Cryder Creek Wood Shoppe Inc.

101 Commercial Avenue,  
Dept. W  
Whitesville, NY 14897  
607/356-3303  
Free catalog  
T, H

#### Educational Lumber Co., Inc.

P.O. Box 5373, Dept. W  
Asheville, NC 28813  
704/255-8765  
Catalog: \$1  
V, P, T, H, S.

#### General Woodcraft

100C Blinman Street,  
Dept. W  
New London, CT 06320  
203/442-5301  
V, P, H, S, TS.

Continued on page 97

# Once In A Lifetime Opportunity!

## Laminated Steel Chisels

### You Save \$20.00



#### Why the big discount?

We keypunched the wrong item number on the telex and received thousands of 10-piece laminated steel sets instead of the sets we wanted. Even for us, that's way too much.

#### What are laminated steel chisels?

During the forging of these chisels, a very hard (Rockwell 64-66C) high carbon, alloy steel (the blade) is fused to a very soft steel (the upper body).

#### What are the advantages of this production method?

What emerges is a tool capable of receiving and holding an extremely hard edge. Without the soft, upper body's ability to absorb the shock of mallet blows, the extraordinarily hard edge would be impractical.

These fine tools have additional, exceptional features:

1. A combination socket-tang construction for added strength.
2. A hollow ground back that minimizes the time spent in sharpening. To maintain a perfect edge, the back of the chisel blade must be absolutely flat. Thus, when the need arises, it is not enough to sharpen only the bevel; the back must also be worked on the stone.
3. Iron hoops, fitted to the handle ends, inhibit splitting.
4. Japanese red oak handles are long lasting and aesthetically pleasing.



#### Does your regular 90-day guarantee apply to the special offer?

Definitely! Everything we sell at The Fine Tool Shops is unequivocally covered by our 90-day guarantee of satisfaction. If you are anything less than delighted, return the product to us for a full and immediate refund, including the return postage.

#### What are the specs?

Overall length: 9" Blade length: 2 1/4" Sizes (converted from mm) 1/8", 1/4", 3/8", 1/2", 5/8", 3/4", 7/8", 1", 1 1/4", 1 1/2".

Our regular, low everyday price is \$94.95 per set. Now, you can benefit from our goof and own these magnificent tools for only \$74.95. This offer expires when present stock has been depleted or 31 Dec. 1984, whichever comes first.

OK, Fine Tool Shops, I'm sold. Ship the following chisel sets at the special price of \$74.95 — a \$20.00 saving.

— 104-0020 10-Pc. Laminated Steel Chisel Set @ \$74.95 ea.  
... **ADDITIONAL SAVING FOR CHISEL SET BUYERS ONLY** ...  
— 103-0140 Precision Honing Guide, Reg. \$11.95 only \$7.95

— FOR NOW. JUST SEND ME YOUR CURRENT 64 PAGE, FULL COLOR FREE CATALOG.

CARD HOLDERS CALL TOLL FREE 800-243-1037; in Ct. call 797-0772

or MAIL TO:  
THE FINE TOOL SHOPS, INC.  
P.O. Box 1282  
20 Backus Avenue  
Danbury, CT 06810

Payment by  
— Amer Exp — Visa  
— MasterCard — Diners  
Bank No. \_\_\_\_\_  
Card No. \_\_\_\_\_  
Exp. Date \_\_\_\_\_

NAME \_\_\_\_\_  
ADDRESS \_\_\_\_\_  
CITY \_\_\_\_\_ STATE \_\_\_\_\_ ZIP \_\_\_\_\_  
SIGNATURE \_\_\_\_\_

For your entire order, add Shipping & Handling only \$2.10  
Connecticut residents add 7 1/2% tax

FJ

# Free Tool Catalog!



New catalog contains hundreds of tools and tool kit values including many hard-to-find tools not readily available elsewhere. Write or call for your free copy.

HOME WORKSHOPPER - Dept. 380  
7815 S. 46th St. Phoenix, AZ 85040 (602) 968-6241

Name \_\_\_\_\_

Address \_\_\_\_\_

City \_\_\_\_\_ State \_\_\_\_\_ Zip \_\_\_\_\_

## SNOW ROOF It's AMAZING!

Save thousands \$\$\$ on commercial and residential tar roofs.

A cool white reflective rubber roof system that stays bonded to metal, tar roofs, roof decks, R.V.'S and mobile homes. STOP THOSE LEAKS with this truly MIRACLE PRODUCT. Just roll it on with a paint roller, brush it on or apply with an airless sprayer CLASS "A" fire rating. Lasts 10 to 20 years. REDUCES roof temperatures from 200°F to 80°F. Flexible and very elastic at -35°F, doesn't crack or peel off.

Distributors needed nationally  
A DO-IT-YOURSELF application product  
Available in 2 gal., 3½ gal. and 5 gal. containers

PRICE \$18.95 per gallon

Plus U.P.S. Shipping charges • F.O.B. Salem

For specifications write to:

OREGON RESEARCH AND DEVELOPMENT  
1920 McGilchrist St. SE, Salem, OR 97302  
(503) 588-7000, 58807300

We accept VISA, MASTERCARD and AMERICAN EXPRESS  
Credit cards. Check, money order or Bank draft also accepted.



OVER 250  
Craft Projects  
Plans  
Patterns  
& Things  
Catalog \$1.00 Refundable  
Craft Pack Dept. 66ND  
3838 N. 36th Ave.  
Phoenix, AZ 85019

## WOODTURNERS

TWO-DAY TURNERS' WORKSHOP [SINCE 1976]  
For beginners and experienced turners. Midweek or weekend throughout the year. Two students per class for personal attention. Sharpening and proper use of tools for faceplate and centers turning. Build confidence and experience, or just find out if you like to turn. Full accommodations available.

MYFORD ML8 WOODTURNING LATHE  
Finest quality and design, including outboard tool rest for bowl turning. 36" or 42" between centers.

THE ZIMMERMAN WOODTURNING LETTER  
Comprehensive; instructive; the "why" as well as the "how." Excellent preview or review for workshop.  
1983 EDITION: 76 PAGES \$7 ppd.  
1984 EDITION: 72 PAGES \$8 ppd.  
1985 EDITION: 72 PAGES \$9 ppd.

SEND 60¢ IN STAMPS FOR DETAILS  
Including SORBY turning tools, chucks, and DOUBLE-STICK TAPE. (Why use messy glue and paper to hold on bowls?)

RUSS ZIMMERMAN, RFD 3, BOX 242  
PUTNEY, VERMONT 05346



You can build this beautiful Bentwood Cradle in your shop with our easy to follow plan, including full size patterns. Order Plan 018. Send \$20.00 check or MO (US funds) to:

About Time Plans, Dept. WD15A  
7707 Aurora N. / Seattle, WA 98103  
Other plans brochure \$1.00 - refunded with order.

## THE MAGNIFICENT Mallet



- 14-oz ... \$6.60
- 18-oz ... \$6.60
- 24-oz ... \$6.90
- 32-oz ... \$6.90

+ \$2.25 Pstge.

Top Quality • Extra Durable • One-Piece  
Lignum Vitae Carver's Mallet

Liberal discount to Schools and Dealers.  
FREE 24-P. German steel tool catalog-write:

FRANK MITTERMEIER, INC.  
IMPORTERS OF FINE TOOLS SINCE 1936  
Dept. W-01, 3577 E. Tremont Avenue  
Bronx, New York 10465

## "MAKER'S MARK" BRANDING TOOL



SEND FOR  
FREE  
INFO PAGE

Put the heavy duty grip in most  
various ways with best  
choice of steel

NOW! Brand your own name permanently on wood and leather handcrafts! Simple to use. Long lasting U L approved electric handle. Brands full name. Guaranteed.

CRAFTMARK PRODUCTS, INC.  
P.O. Box 6308BH1 • Marietta, GA 30065

## The Toymaker Supply Company

We Feature  
Grampa's  
Workbench  
Wood Toy  
Patterns.

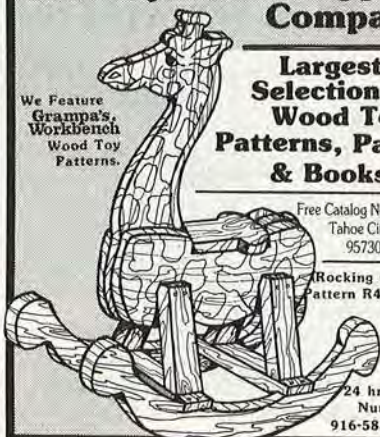

Largest  
Selection of  
Wood Toy  
Patterns, Parts,  
& Books.

Free Catalog No. G1,  
Tahoe City, CA  
95730-5459

Rocking Giraffe  
Pattern R4: \$3.98  
ppd

24 hr Phone  
Number:  
916-583-1555

## RECANE for fun and profit



Recane or re-rush heirloom chairs — for yourself or for others as a profitable hobby — with our full line of materials & instruction books.

Since 1934 America's largest selection of caning & basketry materials & supplies —

- Superior quality weaving cane & machine woven cane
- Flat, oval & round reeds
- Fibre & genuine rush
- Danish seat cord
- Raffia, rattan, seagrass

Illustrated catalog with complete how-to-do-it information, prices, order form: \$1 (refundable with 1st order)

## CANE & BASKET SUPPLY CO.

1283 S. Cochran, Dept. W, Los Angeles, CA 90019

## Wood Ship Models



Build a handsome model worthy of your time and care.

Our scale model wooden ship kits contain only the finest materials for plank-on-frame and solid hull construction. Send \$2 (refundable with purchase) for illustrated catalog of kits, fittings and supplies.

**BLUEJACKET**  
SHIP CRAFTERS

ESTABLISHED 1905

P.O. Box 533 - BH, Shelton, CT 06484

## High Profit in Wall Cabinets



Turn common inexpensive pine into beautiful colonial-style wall cabinets for use in every room of the home. Easy to make and very profitable.

Send for step-by-step plans of 3 best selling styles. \$6.95.

## BOX-ART

Dept. P, Box 8069  
Woodridge, Illinois 60517

PADOUK - BUBINGA - SHEDUA - WENGE - ADD THAT EXOTIC FLAIR TO YOUR NEXT PROJECT!

We offer the best wood, prices and service available — it's as simple as that. Call or write for our catalog:

**Wyndham Woods**

"The finest from around the world"

P.O. Box 506  
Ellettsville, Indiana 47429  
(812) 334-7735

PURPLEHEART - DOUSSIE - RED OAK - CHERRY  
GONCALO ALVES - PALDAO - WHITE OAK - ZEBRA

## LUMBER BUYMANSHIP

Continued from page 95

### wood by mail

**Hardwoods of Memphis**  
P.O. Box 12449, Dept. W  
Memphis, TN 38182-0449  
TN, call collect  
901/452-9663  
800/321-5239  
V, P, T, H, TS.

**Henegan's Wood Shed**  
7760 Southern Blvd.,  
Dept. W  
West Palm Beach, FL 33411  
305/793-1557  
Free price list — send SASE  
V, T, H, S, TS.

**Iaccarino & Son**  
200 Shrewsbury St.,  
Dept. W  
Boylston, MA 01505  
617/869-2791  
800/222-1420 (New  
England only)  
Free catalog  
V, P, T, H, S, TS.

**Kaymar Wood Products, Inc.**  
4603 35th S.W., Dept. W  
Seattle, WA 98126  
206/932-3584  
Free price list  
V, T, H, S, TS.

**Morgan Woodworking Supplies**  
1123 Bardstown Road,  
Dept. W  
Louisville, KY 40204  
502/456-2545  
Free catalog  
V, H.

**Native American Hardwoods Ltd.**  
R 1, Dept. W  
West Valley, NY 14171  
716/942-6631  
Price list: \$1 (refundable)  
T, H, TS.

**Real Woods**  
215 Forrest St.  
P.O. Box 908, Dept. W  
Metuchen, NJ 08840  
201/494-3730  
V.

**Talarico Hardwoods**  
Box 303, RD 3, Dept. W  
Mohnton, PA 19540  
215/775-0400  
V, T, H, TS.

**Tropical Timber Corp.**  
3125 Van Water, Dept. W  
Portland, OR 97222  
503/654-5349  
Free price list  
T, H.

**Weird Wood**  
Box 190WBH, Dept. W  
Chester, VT 05143  
802/875-3535  
Catalog: \$1  
T, H, S.

**Willard Brothers Woodcutters**  
300 Basin Road, Dept. W  
Trenton, NJ 08619  
609/890-1990  
Free price list  
V, P, T, H, S, TS.

**Woodcrafters' Supply**  
7703 Perry Hwy. (Rt 19),  
Dept. W  
Pittsburgh, PA 15237  
412/367-4330  
Catalog available 1st of year  
V, T, H, TS.











**Wood Shed**  
1807 Elmwood Avenue,  
Dept. W  
Buffalo, NY 14207  
716/876-4719/20  
Catalog: \$1  
V, P, H.

**(A) Woodworker's Dream**  
10 W. North St.  
P.O. Box 329, Dept. W  
Nazareth, PA 18064  
800/345-3103  
Free price list  
V, T, H, S, TS.

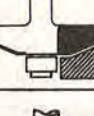
**Yukon Lumber Co.**  
520 W. 22nd Street,  
Dept. W  
Norfolk, VA 23517  
804/625-7131  
Free Catalog  
V, P, T, H, S, TS. ■

## CARBIDE TIPPED ROUTER BITS PROFESSIONAL PRODUCTION QUALITY SPECIAL OFFER — SAVE 50% - 75% BELOW COST

1000's SOLD TO READERS OF FINE WOODWORKING

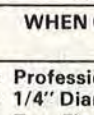
BEST CUT BEST PRICE	ITEM NO.	DESCRIPTION	RADIUS	LARGE DIAM.	CUTTING LENGTH	PRICE
	#01	1/4" R	1/4"	1"	1/2"	\$13.00
	#02	3/8" R	3/8"	1 1/4"	9/16"	14.00
	#03	1/2" R	1/2"	1 1/2"	5/8"	15.00
	#04	1/4" R	1/4"	1"	1/2"	15.00
	#05	3/8" R	3/8"	1 1/4"	5/8"	16.00
	#06	1/2" R	1/2"	1 1/2"	3/4"	19.00
	#07	5/32" R	5/32"	1 1/4"	15/32"	18.00
	#08	1/4" R	1/4"	1 1/2"	3/4"	20.00
	#11	3/8" RABBETING	Deep 3/8"	1 1/4"	1/2"	14.00
	#09	1/8" (KERF) SLOT CUTTER		1 1/4"	1/8"	14.00
	#10	1/4" (KERF) SLOT CUTTER		1 1/4"	1/4"	14.00
	#12	45° CHAMFER	45° Angle	1 1/2"	5/8"	15.00
	#15	RAISED PANEL	20° Angle	1-5/8"	1/2"	25.00
	#16	3/8" DOVETAIL 9°		3/8"	3/8"	7.50
	#17	1/2" DOVETAIL 14°		1/2"	1/2"	8.50
	#18	3/4" DOVETAIL 14°		3/4"	7/8"	10.50
	#19	3/8" CORE BOX	3/16"	3/8"	3/8"	11.00
	#20	1/2" CORE BOX	1/4"	1/2"	11/32"	14.00
	#21	3/4" CORE BOX	3/8"	3/4"	5/8"	18.00
	#22	1/2" GROOVING OGEE		1/2"	3/8"	16.50
	#23	3/4" GROOVING OGEE		3/4"	7/16"	21.00
	#24	1/4" Straight Bit		1/4"	1"	7.00
	#25	5/16" Straight Bit		5/16"	1"	7.00
	#26	3/8" Straight Bit		3/8"	1"	7.00
	#27	1/2" Straight Bit		1/2"	1"	7.00
	#28	3/4" Straight Bit		3/4"	1"	10.50
	#13	1/2" FLUSH TRIM		1/2"	1"	8.50
	#14	3/8" KEY HOLE (This Bit only HSS)	CUTS 3/8" KEY HOLE FOR FLUSH MOUNTING PICTURE FRAMES, ETC.			8.50

WHEN ORDERING ANY 3 OR MORE, DEDUCT \$1.00 EACH  
ALL PRICES POSTAGE PAID

- Professional Production Quality
- 1/2" Ball Bearing Pilot
- 1/4" Diameter Shanks x 1 1/4" Long
- One Piece Construction
- Two Flute Thick High Quality Tungsten Carbide Tips

To order by Master Charge or Visa Toll Free  
7 Day — 24 Hour Order Service Call  
1-800-523-2445 Ext. 56 (In PA 1-800-346-7511 Ext. 56)  
or send check to: **MLCS, P.O. Box 53, Rydal, PA 19046**

# INNOVATION!

NOW a miter fence system so versatile that you can design it to meet your own requirements. The SAWHELPER™ System 3. Three styles of fences with interchangeable components. Buy one system, later convert it to another. Or create your own design. Bolt on the parts, no drilling required. Universal mounts fit all power miter boxes. Many accessories available.

**ORDERING INFORMATION:** SAWHELPER™ Miter Fences and accessories are available at fine tool stores or by mail from: AMERICAN DESIGN AND ENGINEERING INC., 648 Turin Ave., South St. Paul, MN 55075, Phone 612-455-4243 (24 hrs. ans. service). Freight prepaid. Minn. and Wisc. residents add sales tax. Check, C.O.D., Master Charge or Visa

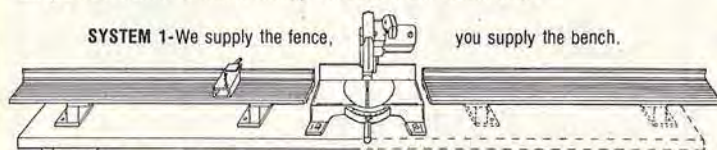

SYSTEM 1-We supply the fence, you supply the bench.

Quickstop Deluxe sliding stop Model QD \$24.95

**SYSTEM 1-STATIONARY MITER FENCE** that bolts to any bench. Easily converted later to System 2 or 3, with bolt on parts. No drilling required. Fence is tempered extruded aluminum, with built in sawdust groove and tape channel. Uses any 3/4" tape refill, tape not included.

- Model M85E Includes one 8 foot and one five foot fence \$89.95
- Model M55E Includes two five foot fences \$79.95
- Model M8E Includes one 8 foot fence \$44.95

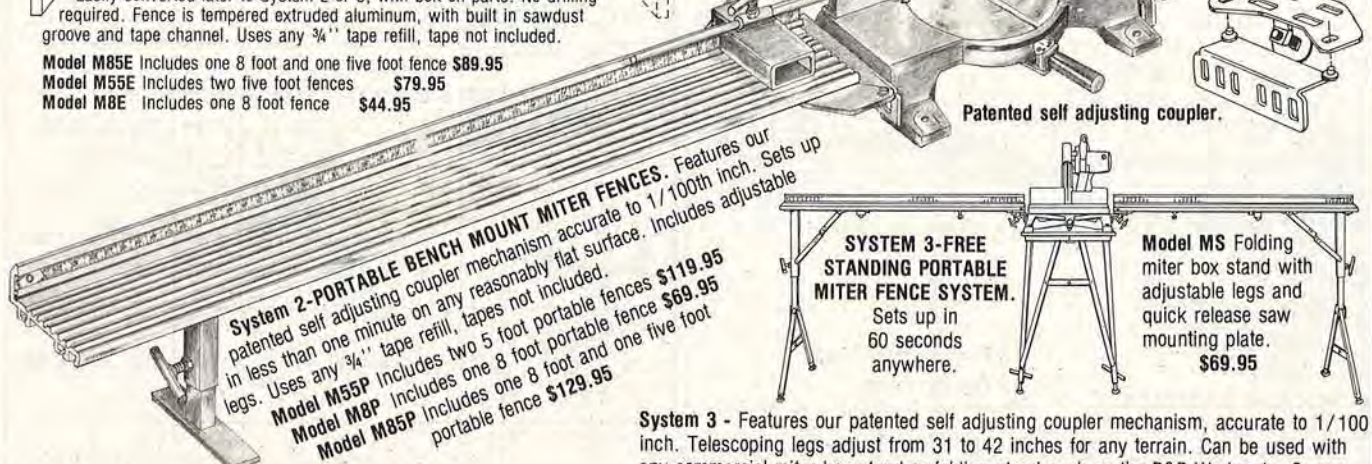

**System 2-PORTABLE BENCH MOUNT MITER FENCES.** Features our patented self adjusting coupler mechanism accurate to 1/100th inch. Sets up in less than one minute on any reasonably flat surface. Includes adjustable legs. Uses any 3/4" tape refill, tapes not included.

- Model M55P Includes two 5 foot portable fences \$119.95
- Model M8P Includes one 8 foot portable fence \$69.95
- Model M85P Includes one 8 foot and one five foot portable fence \$129.95

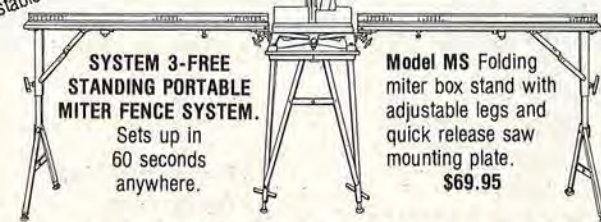

**SYSTEM 3-FREE STANDING PORTABLE MITER FENCE SYSTEM.** Sets up in 60 seconds anywhere.

Model MS Folding miter box stand with adjustable legs and quick release saw mounting plate. \$69.95

**System 3 -** Features our patented self adjusting coupler mechanism, accurate to 1/100 inch. Telescoping legs adjust from 31 to 42 inches for any terrain. Can be used with any commercial miter box stand or folding stand such as the B&D Workmate. Or purchase our folding stand with adjustable legs and quick release mounting plate.

- Model M85 Includes one 8 foot and one 5 foot fence \$175.95
- Model M55 Includes two 5 foot fences \$165.95

## Your most valuable tool. THE FROG CATALOG



When you open our big 100-page catalog you'll find the largest selection of quality woodworking tools and books in America.

We stock over 5000 different tools including the Myford lathe, and offer immediate service.

The FROG catalog belongs on your workbench. Send \$2.50 for two-year subscription, refundable.

FROG TOOL CO., LTD., DEPT. 85  
700 W. JACKSON, CHICAGO, IL 60606

## Wooden Memories T.M.



Featuring the Ole Gray Mare She's rugged, lovable and charming as a toy or accent piece.

with photos and step by step instructions

- Rocking Horse \$7.00
- Hi-Chairs (in 3 sizes) .. \$7.00
- Cradles (in 3 sizes) .. \$7.00
- Any 2 plans (save \$2.00) \$12.00
- All 3 plans (save \$5.00) \$16.00

Pa. residents add 6% sales tax. Postage FREE! Send check or money order to: Offer limited to continental U.S.A.

WOODEN MEMORIES  
Dept WO Box 490 Russell PA 16345

## Build Clocks for FUN and PROFIT!

INCREDIBLE VALUE!

A Solid Cherry Mantel Clock for ONLY \$19<sup>90</sup>!



Imagine, in just an hour, you can make a beautiful clock WORTH OVER \$60! Wood parts are completely pre-cut, ready to assemble and finish. Includes ultra-accurate quartz movement and pre-assembled ivory dial with convex crystal. 6"H x 4-1/2"W x 2"D.

#178011 Mantel Clock Kit ONLY \$19<sup>90</sup> (Plus \$1.50 Shipping and Handling: 1L Res. Add 6.25% Tax)



FREE!

NEW! 32-Page Clock Kit Catalog

Huge Selection! Clock kits from \$15 to \$1400. Over 80 quartz movements and a vast variety of dials and clock hardware. Music box and barometer kits too!

WE ACCEPT Write or Call (312) 584-9600

Craft Products Co.

Dept. BG5J, 2200 Dean Street, St. Charles, IL 60174  
Serving America's Craftsman Since 1940



In the 1920s, hardwood dealers treated their occasional pieces of exotic woods like negotiable bonds. Unique colors and grains, as well as the woods' origins in yet unfamiliar foreign lands, drove prices to as much as fifty cents a board foot. It was often standard procedure to keep these treasures under lock and key.

Today, through increased world trade and an international hardwood lumber industry, exotic woods are more commonly available to the home woodworker. One, however, is still so rare that when offered for sale its price is by the ounce. And that wood is pink ivory.

Noted for its color and pearl-like luster, pink ivory remains a real treasure among wood connoisseurs. Growing on rocky soil in the arid, remote areas of Transvaal and Natal, two provinces in South Africa, this tree for centuries has been sacred to the Zulu tribe. By tradition, only a

# pink ivory: a wood so rare it's sold by the ounce



Capped with ebony, this pink ivory humidior made by Jim Woodruff may be worth its weight in more customary valuables.

chief can fell a pink ivory tree, and then only when his son reaches manhood. To mark the occasion, the young Zulu fashions a spear from the wood. The pink ivory remaining decays or is burnt. Any one of lesser stature possessing the sacred wood may be killed.

According to the South African government, only about 50 pink ivory trees remain in native areas. This rarity, plus the conditions of its harvesting and the penalties attached to its possession, make pink ivory's high value easy to understand.

Some pink ivory does find its way into the outside world through clandestine means, but never in commercial quantities. A traveler to Johannesburg may be lucky enough to purchase a pair of small earrings, or a chunk of pink ivory from an international collector. But even in this trading center, it's easier to locate quality diamonds than this precious wood, which currently sells for about \$1.50 an ounce. ■

# NEW! POWER FEED DRUM SANDER

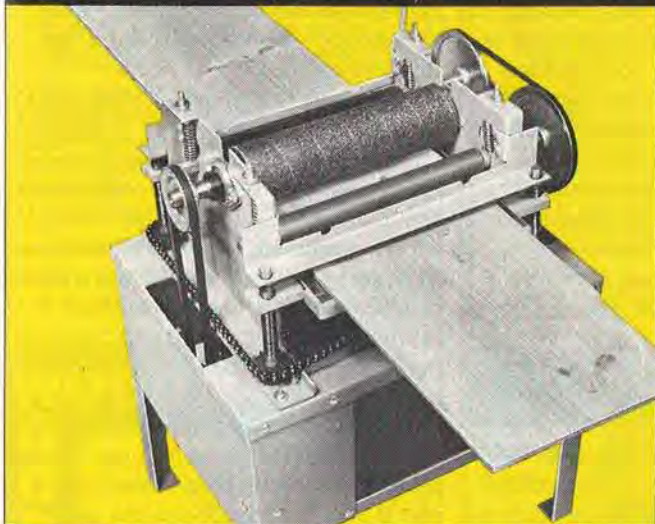

At last! A complete power-feed Drum Sander at an affordable price! Comes ready to use including hood, stand and motor!

### FINISH SANDING . . . THICKNESS SANDING

Use this high-tolerance machine for light dimensioning as well as the finest finish work. Now you can add new beauty to each woodworking project . . . save hours of tedious hand sanding! In a matter of seconds, the Model 1200 can produce a satin-smooth finish impossible to duplicate with hand methods or hand-held power sanders . . . no more low spots, waves or cross-grain marks!

### IMPROVES RESULTS!

Send for complete facts! See how the Model 1200 can dimension and finish-sand cabinet pieces, resawn stock, paneling, grandfather clocks, toys, tabletops, knees, burls, crotches, and much, much more! You'll soon find it's one of the most valuable tools in your shop!

Call Toll-Free 1(800) 824-7888 Oper. 642

### FREE 30 DAY TRIAL!

Send for complete facts on how you can try the Woodmaster Power-Feed Drum Sander in your own shop for 30 days completely without risk! We'll also send you complete details on how you are fully protected by Woodmaster's One Full Year Limited Warranty. Easy Terms.

SANDER  
FACTS



FREE  
DETAILS!

YES! Please rush my FREE Information Kit and details on your 30-Day Free Trial Guarantee.

Woodmaster Tools, 2908 Oak, Dept. RW4  
Kansas City, Missouri 64108

Name \_\_\_\_\_  
Address \_\_\_\_\_  
City \_\_\_\_\_  
State \_\_\_\_\_ Zip \_\_\_\_\_

# ROUTER SPECIALS



**New Makita 3612BR  
2HP Plunge Router  
\$199.95 Postpaid**

New model features 14 amp motor, improved 1/2" collet, & 3 adjustable depth stops. Handles 1/4", 3/8" & 1/2" bits. Optional guide holder, straight guide, and roller guide. \$24.50 Postpaid.

**Set of 4 Spiral End Mill  
Router Bits \$36.00 ppd.**

Excellent for mortising with a plunge router, these HSS bits can be plunged vertically like a drill bit and then moved laterally as a router bit. Clean-cutting. Set of 4 includes 1/4", 5/16", 3/8" & 1/2" 1/2" shanks.



**Ogee Fillet Raised Panel  
Router Bit \$99.95 ppd.**

This unique carbide router bit is excellent for all panel raising. Bit diameter is 2 1/2", 1/2" shank.

**Router Handbook**  
**\$9.95** plus \$2.50 shipping.

by Patrick Spielman.  
A comprehensive guide written to help you get the most out of your router. 224 pages, 510 photos.



1045 N. Highland Ave. Dept. B  
Atlanta, GA 30306 (404) 872-4466

MC/Visa users outside Georgia  
**ORDER TOLL FREE**  
**(800) 241-6748**  
(Orders Only)

Or send check, money order, or  
MC/Visa info to Highland Hardware.  
Prices are Postpaid in U.S. Send \$1.00  
for our tool catalog (free with order).

# NEW! ELEKTRA U.S.A.

The advanced technology woodworking system. One motor (2 1/2 h.p.) powers a complete range of woodworking machines.



**Jointer/  
Planer/  
Thicknesser  
\$1023.50**

**Spindle Shaper  
\$758.00**



**Unimex Motor  
\$226.50**



**Lathe \$326.50**



Also available: Bandsaws, Dust Extractors. See these machines demonstrated at the following shows: Houston, Jan. 11-13; Boston, Jan. 18-20; Wash. DC, March 1-3; Pasadena, CA, March 1-3; San Francisco, March 8-10; Dallas, March 29-31. Call 1-800-223-8600. Send \$1.00 for catalog. ELEKTRA BECKUM USA CORP. Dept. MJF, PO Box 24, Somerdale, NJ 08083

## TOOLS AND TOOL COLLECTING

### the saw scene



Testing the mettle of a Disston "London Spring" saw.

Print this article

Saws have cut their way through recorded history, even as far back as the Stone Age, when tool builders chipped crude saws from stone. As new technologies emerged, craftsmen gained greater control over their work, producing successive generations of improved saws from copper, bronze, and then iron. None of these saws was very efficient, however, and all required frequent sharpening.

Iron-working methods continued to improve, and saw plates were made thinner and stronger. But as the plates got thinner, the saws tended to kink on the push stroke. So, from the sixteenth to the mid-eighteenth century, the teeth on most saws were arranged to cut on the pull stroke only, a design still used by Oriental saw makers.

When steel was introduced to toolmakers, it finally became possible to manufacture extremely strong and resilient saws. Because the

English led the world in early steel technology, they manufactured the finest saws.

But when U.S. manufacturers set their sights on challenging Britain's industrial supremacy in the nineteenth century, several American saw makers set out to make superior products. Henry Disston, a member of this group, was so successful that his Disston "London Spring" saws continue to sell for premium prices (\$65-\$85) today—both in the U.S. and England!

As you can see in the photo, you can bend one of these beauties into a complete circle, then release it, and it will snap back straight as a die. Try that with any other saw, if you dare.

Several years ago, a carpenter in northern Vermont was asked to comment on his "London Spring" saw. "The best saw I've ever used," he said. "It doesn't even leave any sawdust." ■

## CLOCK COMPONENTS



### QUARTZ CLOCK MOVEMENTS

WE FEATURE BATTERY, PENDULUM, CHIME QUARTZ MOVEMENTS OF ALL TYPES. URGOS, HERMLE, GRANDMOTHER, GRANDFATHER CABLE DRIVE AND CHAIN DRIVE, KEY WIND MOVEMENTS OF ALL TYPES, 400 DAY CLOCKS, MUSIC BOX MOVEMENTS, FLAT AND BEZEL TYPE DIALS—PLUS A VAST ASSORTMENT OF WEATHER INSTRUMENTS. HUNDREDS OF CLOCK ITEMS. VERY COMPETITIVE PRICES. WRITE OR CALL FOR FREE 75 PAGE CATALOG. \$2 FOR AIR MAIL.

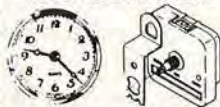

THE QUARTZ FITUP THE MINI QUARTZ  
Send To:  
**NEWPORT ENTERPRISES INC.**  
2313 W. Burbank Blvd.,  
Burbank, CA 91506  
(213) 845-0555



## Sandplate

### SANDPLATE, A BETTER "SANDPAPER"

...of hardened steel. Lasts up to 100 times longer than ordinary sandpaper. Includes special block for ease in handling. Coarse or fine texture. \$5.95 ea., 2 for \$8.95PP., Check or M.O. Allow 4 to 6 wks. delivery.

Order from:

**PANDY'S ENTERPRISES**  
Rt. #9, Box 161-A, Goldsboro, N.C. 27530

## TOYMAKERS FREE!



Largest toymaker's selection in US! Send for free price list of 210 toy parts, patterns, wheels, kits, books, dowels, supplies, plus toymaker's newsletter. Learn how to create 100's of unusual toys for fun or profit! *Hurry!* Get in on the action now! Special starter offers included. Send for free information now!



Morgan Toy Supplies, Dept. WO6B03  
1123 Bardstown Rd., Louisville, Ky. 40204

## FULL SIZE WOODWORKING PATTERNS

- 100 Assorted Patterns Packet ..... \$3.50
- 12 Action Windmills Packet ..... \$4.50
- 29 Birdhouses & Feeders Packet ..... \$4.50
- 12 Jigsaw Puzzles Packet ..... \$3.50
- 20 Toys Packet (Cars, Boats, etc.) ..... \$4.50
- 10 Weathervane Packet ..... \$3.50

### INQUIRE ABOUT OUR FURNITURE PLANS

Packets sent Prepaid 1st Class Mail. Catalog 25c Refundable.

## HAYES PATTERNS

6 Willow St., Dept. WD15  
Woburn, Mass. 01801



## ROLLTOP DESK PLAN



Build this classic desk measuring 43" high, 50" wide and 28" deep. Step-by-step plan includes directions and photos. Catalog pictures 700 other woodworking projects.

ROLLTOP DESK #571 . . . . \$3.95 (incl. postage)  
CATALOG . . . . . \$1.95 (incl. postage)  
U-BILD, Box 2383, Dept. 9813, Van Nuys, CA 91409

## Wood Moisture Meter

- Avoid Moisture Problems
- Protect your Masterpiece

### Pocket-Size MINI LIGNO

only \$110

Incl. Case, Batteries, and Pins for 3/16" and 7/16" Measuring Depth. Size: 1" x 2 1/4" x 5 1/2" Range: 6%, 7%, ... 20%



### also from Lignomat: MINI-LIGNO E

Range: 6%, 7%, ... 36%

Easy-to-use, sturdy instruments for the professional woodworker or serious hobbyist. Measures moisture in lumber, veneer, fiberboards. Ask for free catalog on the complete line of moisture meters and accessories. We can show you how to use a moisture meter efficiently.

**Lignomat USA Ltd.** Tel: 800-227-2105  
503-257-8957  
P.O. Box 30145 Dept. BH Portland, OR 97230

## NATIVE AMERICAN HARDWOODS

WALNUT, BUTTERNUT, CHERRY CURLY & BIRD'S-EYE MAPLE Most Other Domestic Woods

- EXTRA WIDE/EXTRA THICK STOCK
  - TURNING SQUARES/BLOCKS
  - QUARTERSAWN/BOOKMATCHED LUMBER
  - SPALTED LUMBER/BLOCKS
  - THIN STOCK
  - FLOORING/PANELING
- NO MINIMUM WHOLESALE & RETAIL

Comprehensive Listing—One Dollar (Refundable)

**NATIVE AMERICAN HARDWOODS LTD.**  
R1, W. VALLEY, N.Y. 14171 • (716) 942-6631

## BUILD THIS SATELLITE TV ANTENNA FOR UNDER \$200



Enjoy a new world of TV entertainment. Save \$. Easy-to-follow, fully illustrated plans.

- 8' square antenna made from plywood arcs and window screen.
- Steel pipe antenna base.
- Listing of electronic equipment suppliers.
- How to tune into the satellites in your area.

Send \$11.95 post. paid check or money order to

### PLAN CREATIONS

P.O. Box 983, Dept. W, Grass Valley, CA 95945  
We mail 1st class (California residents add \$7.2 tax)  
Visa & MasterCard—Please include Acc. # and Exp. Date.

• Satisfaction guaranteed

## WOOD PARTS

WOODWORKS

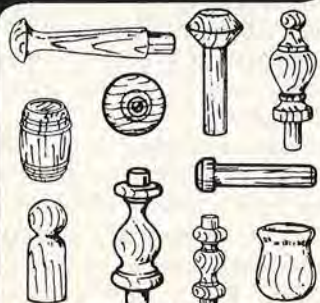

Catalog \$1.00 First Class  
Free Third Class  
**WOODWORKS**

4013-A Clay Ave. • Ft. Worth, TX 76117

## Go Pro

Rugged Quality at a Budget Price



Why pay \$7,000.00 for a Professional Planer?

SAVE OVER 50%!

24", 20", 16", 15"  
RETURNABLE WITHIN 30 DAYS FOR REFUND

**PRO SHOP**  
POWER TOOLS

Box 721, Dept. 4, Elmhurst, IL 60126  
(312) 832-3803

## LINCOLN CLAMP KIT

"Build Your Own Clamps At A Fraction Of The Cost"  
14" Jaw Length — Jaws Open to 10"

### DO IT YOURSELF KIT INCLUDES:

- 2 - 3/8 ACME Threaded Rods
- 2 Spring Pins
- 4 ACME Threaded Swivel Nuts
- Template and simple instructions for constructing jaws and handles from your own wood.

CUSTOM MADE CLAMPS ARE MOST ADAPTABLE TO YOUR JOBS

TO ORDER SEND \$850PPD to  
**LINCOLN TECHNOLOGIES**  
P.O. Box 3343-A / Farmington Hills, MI 48018  
Dealer Inquiries Satisfaction Welcome Guaranteed

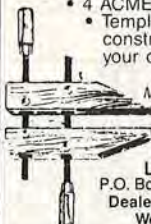

## BANDSAW MILL

The WOOD-MIZER is a one man portable sawmill with a huge 30" dia x 16' long cutting capacity. This safe, easy-to-operate mill cuts with an efficient traveling bandsaw carriage. Why waste lumber and money by cutting with an old fashioned circular mill when the WOOD-MIZER can give you 30% more usable lumber out of each log on less than half the fuel and horse power? This accurate cutting system is everything a sawmill should be and more.

For More Information Send \$1.00 to:  
**WOOD-MIZER, Dept. 20**  
4094 W. 10th St.  
Indianapolis, IN 46222  
(317) 243-7665





## BAND SAW BLADES

FINEST INDUSTRIAL QUALITY

Carefully Welded To Your  
Exact Specifications

WIDTHS	TEETH	PRICE/INCH
1/16"	24 and 32	\$.09
1/8" thru 5/8"	3 thru 32	\$.05

TO FIGURE PRICE:  
Inch Length x Price Per Inch + \$1.85 Weld Charge

**SANDING BELTS ALSO AVAILABLE**

MINIMUM ORDER: \$10.00

Add \$2.50 for Shipping and Handling  
PROMPT DELIVERY

SEND PAYMENT WITH ORDER OR WRITE  
FOR MORE INFORMATION TO:

**BUCKEYE SAW CO.**  
P.O. Box 14794, Cinti., OH 45214

## BRANDING IRONS

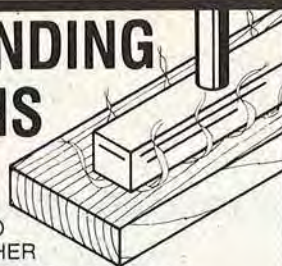

FOR WOOD  
AND LEATHER

- Brands Your Full Name With  
1/8" or 1/4" High Letters



**GUARANTEED**



SEND FOR FREE BROCHURE

**NOVA TOOL CO.**

4533 Colfax Circle, Dept. BH  
P.O. Box 29341, Lincoln, NE 68529

## DOVETAILS MADE EASY!

Router dovetail templates, supplied with carbide bits. A precision-milled tool for accurate, through-dovetail joints in 3/4" to 5/4" stock. This is the proven, time-saving template set with no fussy adjustments.



Write for details:  
**David A. Keller**  
Box 800, Bolinas, CA 94924



### WARREN TOOLS GIVE YOU THE EDGE

Send **\$28.25 Ppd.** for this complete set of carving tools and experience the pleasure of wood carving at its finest. Or send 60¢ for complete catalog.

Send Check or Money Order to:

**Warren Tool Co., Inc.**

Rt. 1 Box 14-A, Dept. BH&G-W,  
Rhinebeck, NY 12572

### KID'S CONVERTIBLE



IT'S A DESK, BENCH AND TOY CHEST ALL IN ONE!  
As a desk and bench, there's room enough to seat two children. Made from veneer plywood it becomes a fine piece of solid furniture for kids to enjoy for years.  
PLANS & INSTRUCTIONS: \$4.00. We'll ship immediately and include a catalog of our other unique and functional projects.

**BALLART DESIGN** 4606 S. 600 EAST  
SALT LAKE CITY, UTAH 84107

### BUILD YOUR OWN POWER TOOLS



METAL PARTS KITS AT LOW  
FACTORY DISCOUNT PRICES FOR:

- 12-IN. BAND SAW
- 18-IN. BAND SAW
- 10-IN. TILT/ARBOR SAW
- COMB. DRILL PRESS-LATHE
- 9-IN. TILT TABLE SAW
- 6-IN. BELT SANDER
- SPINDLE SHAPER

SAVE  
\$50  
TO  
\$500

Sold  
for  
38  
Years.

PLANS  
Full Size  
Patterns **\$5.00** per  
plan  
Deductible

KITS FROM  
**\$39.99 TO \$194.99**

Featured in Workbench, Popular Science, Mechanics Illustrated, Family Handyman. Step-by-step plans, photos, full-scale patterns show how. No machining, no welding. 5-Year Full-Service Guarantee.  
Send \$5 for plans plus \$1 for postage, stating tool plans wanted. Catalog included.  
Or, send \$1 for Catalog!

**GILLIOM MFG., INC., Dept. W-1**  
1700 Scherer Pkwy.  
St. Charles, MO 63303



### Porch Swing & Glider



Complete plan  
with full scale  
templates \$8  
Catalog \$1

(IL res. add sales tax)

Cornerstone Design Inc., Dept. A 2  
P.O. Box 300, Elmhurst, IL, 60126



Put it all together!

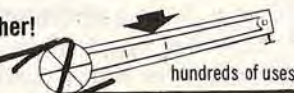

hundreds of uses

### New clamping idea

Simple MITY-TITE System provides a wide range of clamping and banding capabilities that lets you do-it-better, faster and cheaper. Kit contains Super Tough Nylon tensioner, 50' polyester and 100' polypropylene strapping (reusable) plus 10 metal and 10 plastic buckles. Kit is \$11.95 delivered. Satisfaction guaranteed or 100% money-back. Write for valuable data.

MITY-TITE Systems

3712B Lakeridge Drive W., Sumner, WA 98390

### SHAKER CHAIR KITS

An exciting collection of Shaker chair and furniture kits which exemplify the simplicity and versatile beauty of Shaker design. Also featured: Shaker needlework kits, baskets, rag rugs, pegs, pegboard, oval boxes and spirit drawings. Large selection of replacement chair tape.



Come to the source! New color  
catalog and 12 tape samples \$1.00

**SHAKER WORKSHOPS**  
Box 1028-WM15, Concord, MA 01742

### TIRED OF HUNTING FOR

22 1/2° ? **NEW**

### OCTAGON GAUGE

TO SET MITER TO SAW BLADE FOR 22 1/2° CUT. HARDENED ALUMINUM GAUGE HAS OCTAGON FORMULAS AND 14" RULER SCREENED ON. ALSO SCREW CHECKER AND INFORMATION.

**\$7.95**

Plus \$2.00 Handling  
and Shipping.

California residents add 6% sales tax. Send check or money order to:

**LYON**

ELECTRIC  
COMPANY, INC.

P.O. BOX 81303  
SAN DIEGO, CA 92138

### 101 GIFT & NOVELTY PATTERNS

This wonderful packet contains 101 FULL SIZE PATTERNS of Giltz, Novelties, Lawn Figures, Bird Houses, Shelves, Action Windmills, Alphabets, and many more things. Just trace and saw out. Plus "Make Money Jig Sawing". Only \$7.00 Prepaid 1st Class for this big packet.

MASTERCRAFT PLANS WEST, DEPT. 15H  
P.O. Box 625, Redmond, WA 98073



### Garden WINDMILLS FULL SIZE PATTERNS

Beauty your lawn with these picturesque old windmills, 4 to 6 ft. high. Easy to make with full size patterns and step by step instructions. Only \$7.00 Prepaid 1st Class for WINDMILL PACKET with patterns for both.

MASTERCRAFT PLANS WEST, DEPT. 119H  
P.O. BOX 625, Redmond, WA 98073



### WOODEN TOY PLANS



Sturdy designs - Complete dimensions & instructions.  
Logging truck 23" - Steam train 5 cars 46" - \$4 each.













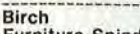
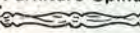



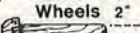
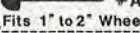
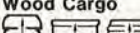

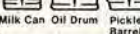



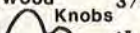

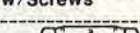
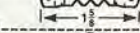
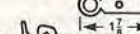



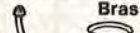

Send \$1 for catalog - modern trucks, pull toys, rocking horse and more.

**D & E CRAFTS**  
W 618 N. COAST HWY.  
NEWPORT, OREGON 97365

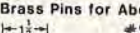
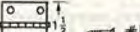

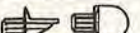
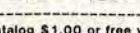
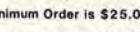
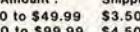
# Woodworkers' Hardware ORDER FORM

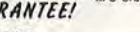
Qty. Total

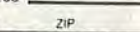
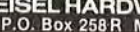
	Birch Mug Peg	\$ .37/ea. \$ .22/ea.
	Birch Shaker Peg	\$ .42/ea. \$ .25/ea.
	Birch Furniture Spindles	6 inch \$ .70/ea. \$ .42/ea.
	8 1/2 inch	\$ .65/ea. \$ .51/ea.
	#S4 Galley Spindle	\$2.50/10 \$1.50/10
	Wood	3/4" \$5.96/C \$3.57/C
	7/8"	\$7.95/C \$4.77/C
	1"	\$8.33/C \$5.00/C
	1 1/4"	\$13.35/C \$8.01/C
	1 1/2"	\$18.35/C \$11.01/C
	2"	\$30.90/C \$18.00/C
	#AP1 Axle Peg	\$6.95/C \$4.17/C
	Fits 1" to 2" Wheel	\$6.95/C \$4.17/C
	Wood Cargo	Oil Drum \$3.85/10 \$2.31/10
	Milk Can	\$3.90/10 \$1.80/10
	Pickle Barrel	\$3.85/10 \$2.31/10
	Screw Hole Buttons	3/8" \$2.90/C \$1.74/C
	1/2"	\$2.95/C \$1.77/C
	Dowel Pins 3/8"x2"	\$2.95/C \$1.77/C
	Wood Knobs	3/4" \$1.50/10 \$0.90/10
	1"	\$2.95/C \$1.77/C
	1 1/4"	\$2.40/10 \$1.40/10
	1 1/2"	\$2.40/C \$1.28/C
	1 3/4"	\$2.50/10 \$1.50/10
	2"	\$23.90/C \$13.80/C
	w/Screws	1 3/4" \$3.70/10 \$2.20/10
	2"	\$34.65/C \$20.79/C
	Saw Tooth Hangers	\$6.95/C \$4.17/C
	Picture Hanger	\$7.95/C \$4.77/C
	Clock Movements w/Hands	Q72 \$10.80/ea. \$6.48/ea.
		\$49.50/5 \$29.70/5
	Lazy Susan Bearing	3" \$1.15/ea. \$ .69/ea.
	4"	\$1.60/ea. \$ .96/ea.
	6"	\$2.89/ea. \$1.73/ea.
	Brass Plated Candle Cup	\$5.90/10 \$3.00/10
		\$49.00/C \$29.40/C
	Coat and Hat Hook	\$2.79/ea. \$1.67/ea.
	Brass Wreath	\$8.50/10 \$5.10/10
	Brass Anchor	\$5.50/10 \$3.30/10
	Brass Plt. Eagle	*878 \$3.60/10 \$2.16/10
	Escutcheon Pins	Brass Pins for Above \$ .95/C \$ .57/C
	#928 Butt Hinge	\$2.80/10 \$1.68/10
	#F124 Screw for Above	\$4.00/C \$2.40/C
	Clipboard Clips	3" \$ .59/ea. \$ .35/ea.
	6"	\$ .99/ea. \$ .59/ea.
	Plastic Shelf Pins	\$9.90/C \$5.40/C

Note: C = 100

Catalog \$1.00 or free with order Total Order

Minimum Order is \$25.00 MN Res. - 6% Tax

Order Amount: Shipping:

\$25.00 to \$49.99 \$3.50

\$50.00 to \$99.99 \$4.50

Over \$100.00 \$5.00

Visa  Master Card

**MONEY BACK GUARANTEE!** Alaska, Hawaii, Canada & APO Orders Add \$6.00

MEISEL HARDWARE SPECIALTIES P.O. Box 258R Mound, Minnesota 55364

## NOW YOU CAN BUILD IT

Continued from page 76

### simple cabinet desk

shown on page 76. Test all cuts on scrap lumber before cutting the oak fronts.

**3** After sanding all parts, glue and clamp the drawer fronts and the door front together. Work on a flat surface to keep the fronts flat and square when clamping.

**4** Cut the drawer ends (M) and sides (N) from the pine drawer-side material. Cut a 1/2" rabbet 1/4" deep in the sides (M) to receive the ends. Cut the drawer bottoms (O) and dry-clamp the drawers together to check for proper fit. Adjust if necessary, then glue and nail M, N and O together. (We used three 4d finishing nails at each corner.)

**5** Attach drawer-slide hardware to the drawer-slide mounting blocks and to the drawer sides, following the directions supplied with the slides. After installing the drawers, center the drawer fronts on the face-frame openings and attach to the drawers. (We drove four #8x1" wood screws into each drawer front.

**6** Mark and drill pilot holes for mounting the hinges on the door and face frame. (You'll attach the hinges after varnishing). Mark and drill holes for the drawer pulls on the front of each drawer. Drill holes for two door pulls to match those on the two lower drawers opposite. (Pulls should be mounted after finishing.)

#### Laminating the Top

**1** Cut the particleboard (P) to size. Cut both the plastic laminate top (Q) and the balance sheet bottom (R) to size plus 1" on all four sides to allow for edge trimming and positioning error. (Balance sheet, a plastic sheet goods, stabilizes laminated assemblies to prevent warping or bowing.)

**2** Following the manufacturer's instructions, apply two coats of con-

tact cement to the laminate and the particleboard.

**3** Position and apply laminate with extreme care: once the two surfaces touch, they can't easily be repositioned. (We called on two people for this operation. We placed waxed paper between the surfaces until they were properly aligned, and then, starting at one end and working toward the other, removed the waxed paper. To ensure good adhesion between the particleboard and laminate, we used a mallet and block of wood, and working from one end to the other, hammered the surfaces.)

**4** Follow the same procedure to apply the balance sheet to the bottom of the particleboard.

**5** Use a router equipped with a laminate trimmer to trim the laminate and balance sheet flush with the particleboard. Glue and nail decorative molding (Q, R) to the front and sides. (If you plan to position the desk away from a wall, you'll want to trim the back edge with molding, too.)

**6** With the desk top facedown on a flat surface, set the cabinets (without drawers), also upside down, on it. Position the cabinets so they are flush with the back of the top and abut the molding at each end. Cut positioning blocks (U) and set one block in place at the four inside corners of each cabinet. Glue and screw-mount the blocks to the underside of the desk top. Turn the cabinets and desk top right side up. The blocks act as guides so that the top sits in place on the cabinets.

**7** Set all nails and fill nail holes with wood putty. Sand the wood surfaces smooth and finish as desired. After the finish has dried, attach hinges and the door pulls. Hang the door. ■

# Your home workshop can PAY OFF ... ... BIG!

This One Low-Cost Power Tool—  
**SAWS** to desired Width...  
**PLANES** to desired Thickness...  
**MOLDS** all popular Patterns...

—All at once or separately... All By Power Feed!

The Only Complete Workshop Tool Of Its Kind In The World!

From the Day It Arrives... the Planer will make and save you money. With shortages and inflation driving lumber prices sky-high, this versatile power tool quickly pays for itself by easily converting low cost rough lumber into high value finished stock. In just one pass turn out your own quarter-round, door and window stop, casing, tongue-and-groove... all popular patterns. Other operators are making cases for grandfather clocks, furniture, picture frames, bee hives, bed slats, surveying stakes... all kinds of millwork.

Built For Pros... Priced For Home Craftsmen... it is engineered and built to industrial standards, but factory-direct selling keeps the price low. Handles tough oak and walnut as easily as pine, and so simple to operate even beginners with no experience can use it.

Start  
Your Own  
Business!  
Earn Extra  
Income  
Right At  
Home.

With just this one low cost power-feed machine in a corner of your garage or basement, you're set up to supply lumberyards, cabinetmakers, carpenters, remodelers, contractors and hobbyists in your area with custom-planned lumber, trim, molding... ALL of their millwork requirements. You can supply picture molding to art shops, hardware and department stores, or sell direct to framing shops. All standard patterns are available from stock, or we'll custom grind a knife to your own special design or sample.

## Does The Foley-Belsaw Pay? YOU BET!

### READ WHAT OWNERS SAY:

**A Good Investment** • Robert Sawyer, Roseburg, Oregon: "I believe that the Foley-Belsaw is the best investment I ever made. I've been a planer man for years and am now retired. The Foley-Belsaw has earned me \$60,000 extra income in the past eleven years."

**Pays For Itself** • R.S. Clark, Springfield, Ohio: "I bought a batch of walnut in the rough, and after planing it on the Foley-Belsaw I figured up the money I saved. It was enough to pay for two-thirds the cost of the Planer. It really does a good job."

**More Than Expected** • Stephen Schultz, Orangeville, Penna.: "This machine pays for itself by making money out of scrap boards. It is a very well built machine and I confess it is more than I really expected for the price. It does everything you say it will."

... And Foley-Belsaw Is The Choice Of Professionals:

"I recommend Foley-Belsaw Planer-Molder-Saw as the most useful shop tool any craftsman could own. We use one every day in the Workbench model shop, and couldn't get along without it."

JAY HEDDEN — Editor WORKBENCH Magazine



Try The  
Foley-Belsaw In Your  
Own Shop On Our  
**30-DAY FREE  
TRIAL OFFER**

Mail Coupon Below  
For Complete  
Details!

You Take NO RISK! The Planer/Molder/  
Saw Is Backed by Our Exclusive 100%  
Guarantee of Satisfaction:

• "Try the Foley-Belsaw in your shop for a full 30-Days and put it to work for you. Give it a thorough test and make it prove that it can do everything we say it will... use it just as much as you want. Then if you are not completely satisfied, just send it back and we'll return every penny you sent. And YOU are the sole judge! There are no questions asked... there are no fine print 'use' charges. Our flat guarantee is that YOU must be 100% satisfied or you get your money back."

**FREE  
BOOKLET!**

Get FREE  
Book with  
facts and  
full details  
... RUSH COUPON TODAY!



Just Mail Coupon...  
**NO OBLIGATION and  
NO SALESMAN Calls!**

**ACT NOW!**  
Coupon  
Brings  
Full Details!

If coupon has been  
removed, just send  
postcard with name  
and address to:

FOLEY-BELSAW CO.  
90535 FIELD BLDG.  
KANSAS CITY, MO 64111



FOLEY-BELSAW CO.  
90535 FIELD BLDG.  
KANSAS CITY, MO 64111

YES, please send me the FREE Booklet that gives me complete facts about your Planer-Molder-Saw and full details on how I can qualify for a 30-Day Free Trial right in my own shop. I understand there is No Obligation and that No Salesman will call.



NAME \_\_\_\_\_

ADDRESS \_\_\_\_\_

CITY \_\_\_\_\_ STATE \_\_\_\_\_ ZIP \_\_\_\_\_

# FREE PLANS!

How to get hundreds of FREE PLANS, Federal and State benefits, services, programs, grants, loans, cash, publications, much more—explained clearly in this NEW GUIDE. Your taxes help pay for all this—now it's YOUR turn to cash in! The author has written OVER 30 Government Benefits Guides and has 14 years of government service and research experience. ONLY \$1.95. Money-Back Guarantee.

"NATIONAL DIRECTORY OF FREE AND INEXPENSIVE PLANS, BENEFITS, AND LOANS FOR PEOPLE WHO ARE GOING TO BUILD, REMODEL, ADD ON OR DECORATE!"

**Mark Weiss, Author**  
Dept. WI, Box 402091 • Miami Beach, FL 33140

## MAKE TOYS & WOOD PROJECTS



7 CAR TRAIN  
\$6—Plan only  
\$26.50—Plan & turned parts (92 parts in all!)

62" long

100's of plans, kits, colored and unfinished hardwood parts for toys, crafts and furniture (Colonial, Shaker, primitive & modern). Bulk Prices available. Color catalog \$1. (614) 484-1746  
Cherry Tree Toys, Box 369-9, Belmont, OH 43718

### You can build this Stacking Bookcase in your shop.



You can build this beautiful bookcase with stacking shelves, each with its own glass door that lifts up and slides back.

No special hardware needed. Step-by-step plans with detailed illustrations.

You have the tools. (table saw and router) All you need is the plan!!

Order Plan 004 \$14.00

Send check or money order to:  
**About Time Plans, Dept. WD1-5**  
7707 Aurora N. / Seattle, WA 98103  
Brochure \$1.00 - refunded with order.

### New E-Z PNEUMATIC DRUM SANDER

...For woodworkers & carvers. Inflates to desired firmness, contours to the shape of your work. Eliminates hand-sanding. Freedom tools-Detail Master burning unit-Abrasives-Books and more, at great prices!

Catalog \$2.00 (refundable).  
North West Carving Supplies  
P.O. Box 5211  
Bozeman, MT 59715

### Shop In Your Shop!

SEND \$2 FOR

## WOOD TENDER'S New 42-Page Catalog

of in-stock woodworking tools, chair caning, reeding & rushing supplies, entry hardware, furniture brass, **WOOD TENDER®** finishing products and more!

All Orders Shipped Next Day  
\$2 Credit on First Order

## WOOD TENDER

8165 Big Bend, St. Louis, MO 63119  
314-962-7575

## SAVE \$100'S ON STORAGE BED!



### FULL-SIZE PLANS FOR 3 SIZES

Twin, full, or queen size bed with either 3 or 6 drawers: and with easy disassembly of headboard and footboard. Plans for all 3 sizes on Money-back Guarantee. Only \$11. Send for FREE illustrated catalog of furniture plans.

**FLEXIPLANS** Dept. GC  
48 Lowell St. Westwood, N.J. 07675

### ANTIQUE & USED TOOLS FOR SALE

Quality, older hand tools for collectors and woodworkers. Illustrated lists published 5 times a year.

SUBSCRIPTION > \$4.00  
CURRENT LIST > \$1.00

**BOB KAUNE** specializing in



buy and sell

511 W. 11th • Port Angeles, WA 98362

## WIPE-ON BEAUTIFUL WOOD FINISHING

Easy Wipe-On Techniques and Materials Explained in

### FREE BOOKLET GENERAL FINISHES

P.O. Box 14363 • Milwaukee, WI 53214



Develop a profitable second income in your spare time making small, unique bandsaw boxes. This unpublicized, little-known technique allows you to turn common inexpensive lumber and scraps into valuable utility boxes for the home and office. High demand in gift shops, stationery stores and craft fairs. Fully illustrated instruction booklet of 15 original and profitable designs. Satisfaction absolutely guaranteed. Send \$10.00 to **Box-Art, Dept. P, Box 8069, Woodridge, IL 60517.**



## Bolts - Nuts Screws

SAVE TIME — SHOP BY MAIL

All types available at discount prices.  
STEEL STAINLESS BRASS

Satisfaction or Money Back  
\$1.00 for catalogue—refundable with first order

**D.S. Houston**  
Box 18474, Houston, TX 77023

## HORTON BRASSES

Nooks Hill Road, P.O. Box 120J  
Cromwell, CT 06416 (203) 635-4400

HORTON BRASSES are authentic copies of 17th, 18th, 19th & early 20th century pulls



Mfrs. of Cabinet & Furniture Hardware for Homes & Antiques.  
Send \$2.00 for a Catalogue.



**FURNIMA**

Has router bits that make beautiful panel and frame doors.

1/4" shank set \$95.00  
1/2" shank set \$103.00

instruction manual & shipping inc.  
7% D.S.T. if applicable.

catalogue of router bits and shaper cutters FREE.

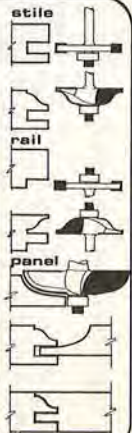

**Furnima Industrial Carbide,**  
Bierneackie road, P.O. Box 308,  
BARRY'S BAY, ONTARIO,  
K0J 1B0 ph(613) 756-3657



SCRAP WOOD PROJECTS

# TWO great ideas from our shop



## Drill Bit Holder

This nifty wall attachment stores drill bits within an arm's length of our drill press. We use it to keep a variety of bits and plug cutters neatly arranged. (The holder could easily be adapted for router bits, too.) The back of the holder measures  $\frac{3}{4}$ " $\times$ 7" $\times$ 18"; the angled front piece,  $1\frac{1}{2}$ " $\times$ 5 $\frac{1}{2}$ " $\times$ 18".

To construct the holder, cut the front and back pieces to length and width, ripping one edge of the front piece at a 25° angle.

Then, mark the hole locations. (We laid out four rows and spaced 14 holes 1" apart in each row. We chose  $\frac{1}{8}$ " holes  $\frac{1}{2}$ " deep for the first two rows;  $\frac{5}{16}$ " holes  $\frac{3}{4}$ " deep for the third row; and  $\frac{3}{8}$ " holes 1" deep for the last row. Check your inventory of drill bits to see if these dimensions will work for you.)

When you drill the holes, also drill a  $\frac{3}{16}$ " hole in each corner of



# Professional and Portable

- Heavy duty router/shaper offers affordable flexibility with most router bits.
- Equipped with a 1½ H.P. motor but will accommodate all Porter-Cable motors including the 3 H.P. production unit.
- Individually adjustable fences with micro adjustments for complete cutting accuracy.
- Dual starting pin holes for versatile free-hand routing.
- Safety lockable switch.

For more information consult the Yellow Pages under Tools (electric) for your local Porter-Cable Professional Tool Distributor or write for a free, full line product and accessory catalog.

Quality By Design  
**PORTER-CABLE**

PROFESSIONAL POWER TOOLS

P.O. Box 2468 • Advertising Dept. • Jackson, TN 38302-2468



the back piece for wall mounting. Glue the angled edge of the front piece to the back. (We beefed up our holder by gluing a block against the back, under the angled front piece.) Mount the drill bit holder using four #10 $\times$ 1½" wood screws with finishing washers.

## Clamp Rack

Small clamps were forever scattered around our shop until project builder Jim Boelling decided that enough was enough and created this handy wall rack. Now we know

where to look for C-clamps, hand-screws, and small bar clamps (and most of us know where to replace them).

The back piece of the holder measures  $\frac{3}{4}$ " $\times$ 3½" $\times$ 18"; the front, 1½" $\times$ 2½" $\times$ 18". After cutting these pieces to size, we rounded the front edge of the front piece with a router and  $\frac{1}{4}$ " round-over bit. After drilling a  $\frac{3}{16}$ " hole in each corner of the back piece, we glued the two parts together. We used four #10 $\times$ 1¼" wood screws and finishing washers to mount the rack. ■



# WOODWORKING ASSOCIATION OF NORTH AMERICA

THE FIRST INTERNATIONAL WOODWORKING ASSOCIATION  
"...dedicated to the advancement of woodworking as an industry, a hobby & as an art."  
YEARLY DUES \$15.00 / \$18 CANADIAN

WOODWORKERS DO IT WITH A FINE FINISH

T-SHIRTS (S, M, L, XL) \$7.00      SHOP APRONS \$9.00      BUMPER STICKERS \$2.00

Include \$1.00 Postage and Handling per Item

WOODWORKING ASSOCIATION OF NORTH AMERICA

35 Main Street, Suite 6      Plymouth, NH 03264      (603) 536-3876



Reproduce These  
CLASSIC ANTIQUES  
Simple, Easy To  
Follow Instructions



We Carry A Complete Line Of  
Furniture & Toy Plans and Those  
Hard To Find Accessory And Hard-  
ware Items, Lumber, Dowels, &  
Wooden Parts.

Send  
For Our Current Catalog \$2.00  
(Refundable) To:

**MASTER PLANS & SUPPLY CO.**  
P.O. Box 489W Macon, Georgia 31202  
MASTER CARD & VISA ACCEPTED

## TOOLS USA

TOOLS USA

Woodworkers  
Tooling Catalog  
Essential  
Operating  
Tool

THE  
ONLY  
TOOL  
CATALOG  
YOU  
NEED

An indispensable catalog and guide to tooling for the wood product  
manufacturer. (Includes prices and ordering info.)

SEND YOUR REQUEST AND \$2.00 OR  
CHARGE TO YOUR CREDIT CARD  
BY PHONE.



**TOOLS USA**  
8836 Brydon Way #WM  
Sacramento, CA 95826  
916-363-9428

## CUT PERFECT CIRCLES (without pivot hole)



with RADIAL ARM, TABLE or BAND SAW  
New, improved device locks in miter groove or clamps to wood table.  
Cut circles from 3 to 48 inches in diameter from any thickness wood or  
plastic without a center pivot hole. "Circ-L-Cut" is only \$15.20 PPD.  
Illustrated instructions included. Money back guarantee.

**HEPP INDUSTRIES, INC.**  
Box A154, BHW-9, Wantagh, N.Y. 11793

## BUILD THIS COUNTRY HUTCH



Order plans for this museum-like reproduction

Crafted in pine our authentic replica of a charming country  
hutch will draw raves from family and friends alike. Our  
20"D x 52"W x 77"H hutch features an open well below for  
large pot or vase display. Plans include instructions for  
getting the handsome antiqued painted finish.

To order plans, send check or money order for \$9.00 (Canadian  
residents remit postal money order in US funds) to: HAMMER-  
MARK ASSOCIATES, Box 201-W, Floral Park, New York 11002.  
Please allow four weeks.

Send for our catalog, \$2.00 (refundable). Catalog is  
included free with all plans orders.

DEALER  
ENQUIRIES  
INVITED

## SHOPSMITH OWNERS

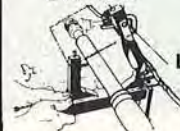

LATHE DUPLICATOR



DRUM  
SANDER

Clamps for all your  
woodworking needs

DOWELING  
ATTACHMENT



## UNIVERSAL CLAMP

CORPORATION

6905 Cedros Ave. • Van Nuys, Calif. 91405

# PARKS NEW MODEL

Compact, Ready-to-Run 12" X 4" Planer

98 MADE IN AMERICA



FREE  
LITERATURE



**PARKS** woodworking machine co.

1501 Knowlton Street/Cincinnati, Ohio 45223 Dept. BHG  
Manufacturing quality woodworking machinery since 1887

The best investment for your shop with these built  
in values:

- PARKS "Full Power" drive motor permits full 1/8" deep cut on the widest boards
- Cast Iron Construction
- Steel Feed Rollers and Bed Rollers
- Ball Bearing Cutterhead
- Microblade Adjustment
- And Much More...

Send for the latest catalog and price information.



## BUILD IT YOURSELF

TOYS • PUZZLES • PLAQUES • PLANTERS  
FURNITURE • LAWN ITEMS • BIRD HOUSES  
ROCKING & RIDING HORSES • PLAY SETS



SAME SIZE PATTERNS • WHEELS • HOW-TO BOOKS

40 PAGE ILLUSTRATED CATALOG \$1.00

Design Group, Box 514-Z, Miller Place, N.Y. 11764

## ASSOCIATIONS YOU SHOULD KNOW ABOUT



John Scheeler's "Goshawk and Crow" won the "Best In World, Decorative Life-Size" award at the 1981 Ward Foundation world competition. Photograph courtesy of the Ward Foundation

Some people consider wildfowl carving and painting a craft, but to the members and staff of The Ward Foundation, it's an art—the only art form, they say, that is native to North America.

Named in honor of Steve and Lem Ward, brothers considered to be pioneers of decorative bird carving, the nonprofit organization is dedicated to wildfowl carving and painting, and to the historical, educational, and environmental aspects of the art.

According to organization officials, decoy carving had reached a plateau by 1968. There were good carvers around, but they were widely scattered across the nation, and new carvers weren't being attracted to their ranks. To remedy the situation, a group of carvers started The Ward Foundation and set out to establish a museum and programs for wildfowl artists.

Today, through international competitions, exhibitions, seminars, workshops, and a museum program, the association has fostered a resurgence of interest in wildfowl carving and painting. New carvers—who design their work "to be a bird"—have picked up the skills of older masters, whose sole purpose was to create a decoy that would "catch a bird."

## THE WARD FOUNDATION

Woodworkers form a vast network of individuals who are eager to share knowledge, skills and experience with one another. This desire to trade information has spawned a variety of membership organizations devoted to woodworking specialties of all kinds.

The Ward Foundation supports the North American Waterfowl Art Museum, a Salisbury, Maryland, institution that tells the story of decoy and wildfowl carving through displays of classic hunting decoys and works by today's carvers. Dioramas, video presentations, and interpretive exhibits re-create the world of wildfowl at the museum.

The foundation's 16th Annual World Championship Wildfowl Carving Competition will be held in Ocean City, Maryland, April 25-28, 1985. Hundreds of carvers and painters will compete for cash prizes and international recognition in a number of categories. Techniques will be studied, works will be sold, and information will be traded at the annual event, which, in addition to carvers, attracts collectors and people who are simply interested in wildlife art.

Individual membership in The Ward Foundation is \$20 a year. Family memberships cost \$30. Members receive a free quarterly magazine, free museum admission, discounts on museum purchases, and window decal.

For information and membership application, contact:

The Ward Foundation, Inc.  
655 South Salisbury Blvd.  
Salisbury, MD 21801 ■

## "Jorgensen"® AND "Pony"® CLAMPS

Dependable extra hands for all types of clamping and work-holding jobs: woodworking projects, home maintenance, and furniture repair.

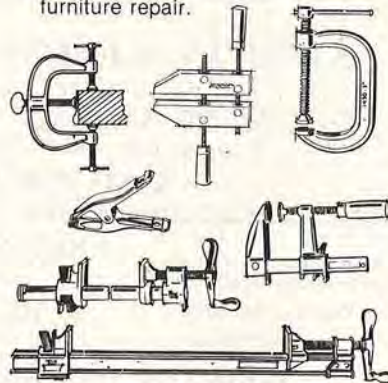

Write for FREE LITERATURE. For big 32-page "how-to-clamp-it" catalog, send 50¢.

ASK YOUR DEALER

**ADJUSTABLE CLAMP COMPANY**  
THE CLAMP FOLKS  
410 N. Ashland Ave./Chicago, IL 60622



## ROUTER HANDBOOK

If you own a router—or will ever buy one—this is a must!

\$9.95

Finally! The definitive guide to a revolutionary woodworking tool that belongs in every workshop. Patrick Spielman explains every step of its operation for beginners and experts alike, and includes an incredible variety of routers, bits and accessories. You'll learn how to make the router simplify and facilitate the creation of every project without any additional expensive equipment, what standard and unusual techniques you can do, how to build woodwork aids and devices, plus 600 photos and illustrations to make the entire process easy to follow.

You'll find it an incredible source of information! Discover:

- Scores of available routers, with an analysis of their advantages and disadvantages
- Safety and sharpening procedures
- Techniques for making and fitting carving designs on wood surfaces, and creating panels, cabinet doors, and wood signs
- Routing techniques for dovetails, plastic laminates, joints, and surfaces, as well as the use of templates and patterns
- Money-saving ways to make jigs and fixtures that will help in unusual routing techniques and production carving machines
- Overarm and pin-routing techniques
- And much, much more!

All this, plus patterns and instructions for dozens of projects that incorporate all this know-how.

Nothing is left out—no bit, jig or fixture escapes his notice; no shortcuts, no effects are ignored. From basic operating procedures for every woodworker to specialized skills every craftsman wants to know, this all-inclusive handbook will become the indispensable book on the essential tool for the home workshop.

Act now! Send your check for \$9.95, an incredible value, and we'll even ship postage free.

STERLING PUBLISHING CO., INC., Dept. WD-1,  
Two Park Avenue, New York, N.Y. 10016

# WOODWORKING WORLD

## HOUSTON SHOW

Shamrock Hilton Hotel  
Houston, Texas  
JANUARY 11  
5 pm - 9 pm  
JANUARY 12  
10 am - 6 pm  
JANUARY 13  
10 am - 5 pm



## TORONTO SHOW

Constellation Hotel  
Rexdale, Ontario  
FEBRUARY 1  
5 pm - 9 pm  
FEBRUARY 2  
10 am - 6 pm  
FEBRUARY 3  
10 am - 5 pm

## EXHIBITS, DEMONSTRATIONS & SALES

Machinery & Power Tools - Hand Tools - Hardwoods & Veneers  
Sawblades - Bits & Cutters - Hardware - Clockmaking Supplies  
Finishing Supplies - Magazines - Books & Plans  
& MUCH, MUCH MORE

### FREE SEMINARS

Featuring:

Wayne Barton  
Roger Cliffe

Hans Derke

Mark Duginske  
Allan Fitchett

LOOK FOR THE WOOD WORLD BALLOON

## EVERYTHING FOR THE WOODWORKER

ADMISSION \$5 / \$1 OFF WITH THIS AD

Sponsored by

WOODWORKING ASSOCIATION OF NORTH AMERICA

For More Information and Seminar Schedule Call or Write W.A.N.A.  
35 Main St., Suite 6, Plymouth, N.H. 03264 - (603) 536-3876

## Light to Heavy-Duty: one level of finish!



◇ 500 SERIES  
600 SERIES ◇

MODEL 100

Jenks is featuring special pricing on all Porter-Cable routers. All models feature micrometer depth of cut adjustment dial, replaceable bases and powerful motors protected against overload temperatures.

Send for the FREE W.S. Jenks & Son '84 Catalog for more values on hand tools, power tools, and machinery, including router bits and accessories for Porter-Cable routers.

Send the indicated items:

- |   |                           |
|---|---------------------------|
| <input type="checkbox"/> Model 100 router; ¾ HP; ½" collet chuck                              | \$134.00 ... Now \$ 97.50 |
| <input type="checkbox"/> Model 630 router; 1 HP; ½" collet chuck                              | \$145.00 ... Now \$105.00 |
| <input type="checkbox"/> Model 690 router; 1½ HP; ¼", ⅜", ½" collet chuck                     | \$189.00 ... Now \$135.00 |
| <input type="checkbox"/> Model 691 router; New 1½ HP w/ D-handle; ¼", ⅜", ½" collet chucks    | \$213.00 ... Now \$162.00 |
| <input type="checkbox"/> Model 536 router; 1½ HP Speedmatic ¼", ½" collet chucks              | \$295.00 ... Now \$221.00 |
| <input type="checkbox"/> Model 537 router; 1½ HP Speedmatic w/ D-handle; ¼", ½" collet chucks | \$310.00 ... Now \$232.00 |
| <input type="checkbox"/> Model 518 router; 3 HP; 5-speed; soft-start feature                  | \$475.00 ... Now \$355.00 |
| <input type="checkbox"/> Model 520 router; 3 HP; Large side handles                           | \$435.00 ... Now \$325.00 |
| <input type="checkbox"/> Jenks FREE '84 Woodworking Tool Catalog                              |                           |

- Money Order / Check enclosed in amount of \_\_\_\_\_
- Mastercard       Visa       American Express
- Card No. \_\_\_\_\_
- Signature \_\_\_\_\_
- Name \_\_\_\_\_
- Address \_\_\_\_\_
- City \_\_\_\_\_ State \_\_\_\_\_ Zip \_\_\_\_\_



W.S. Jenks & Son • 738 Seventh Street N.W., Washington, DC 20001 • TOLL-FREE order line: 1-800-638-6405

## JUST FOR KIDS

Continued from page 56

## color me safe

hole in the center of each dial, using the center point as a drilling guide. We made the jig shown below to hold the dials for drilling. First, we bored a ¼" hole ½" deep into a scrap of wood clamped to the drill press table. Without moving the clamped jig, we removed the ¼" bit and inserted a ½" bit in its place. (If the dials turn during drilling, line the ¼" hole with sandpaper and tap the dials into it.)

**3** Move the jig slightly and drill a ⅝" hole through the dials alongside the ½" hole. Chisel the edges between the ½" and the ⅝" holes to clean the notches.

**4** Using the color-dot guide marks for reference, drill ¼" holes around the perimeter of each dial. (We used the jig shown below and a depth stop to drill the holes ¼" deep.)

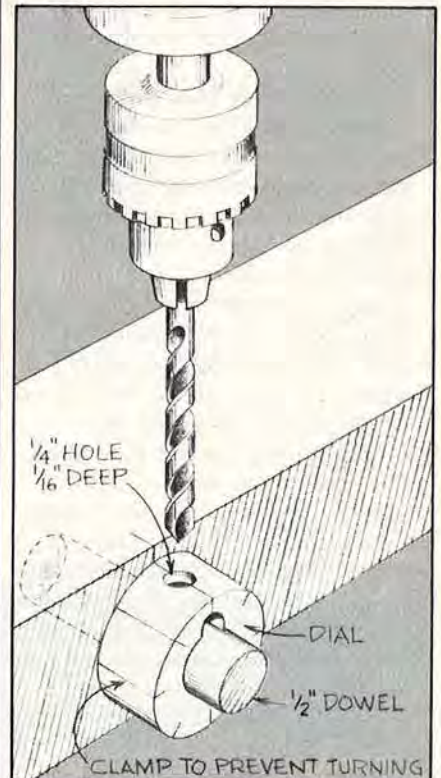

**5** Mark the location of the lock-bolt sliding pin (G). Do the same for the lock pins (I). To do this we slid the lock bolt through the holes in parts D and E, so that the bolt protruded ½" beyond the edge of

D. Then, working from the back side of the safe door, we marked the position of the lock pins on the dowel, centering the marks over the tongues separating the dial notches. Finally, working from the door's front side, we made a mark at the far right-hand side of the slot to position the knob shaft (G).

**6** Remove the lock bolt from the door and drill  $\frac{1}{4}$ " holes  $\frac{5}{16}$ " deep to accept all the lock pins. The pins must be in a straight line that is offset 180° from the knob shaft. (We clamped the lock-bolt dowel in a handscrew and drilled the holes on a drill press, again using the depth stop for consistent depths.)

**7** Paint the color codes on the dials (J), keeping in mind that the color that opens the lock is opposite the notch in the dial. (We used model car paints in eight distinct colors.)

**8** Dry-fit the lock mechanism, checking for smooth operation. You may have to sand or file the parts to achieve the proper movement.

**9** Spread a small amount of paraffin on the lock bolt, the holes and notches in the dials, and the holes in parts D and E to ensure a smooth sliding action. Then, reinstall all the lock parts, and carefully glue parts G and I into the lock bolt. Form the wooden knob (K) from a  $\frac{3}{4}$ " dowel. Drill a  $\frac{1}{4}$ " hole  $\frac{3}{8}$ " deep in the knob; glue onto G.

**10** Cut the faceplate (L) and check its fit over the tumblers. Make sure the dials turn freely before screwing the plate to the door.

**11** Install the door. Glue the door stop (M) in place so door closes flush with the front of the safe.

**12** Sand and varnish the safe. (Be careful to keep finish off the moving parts.) Attach rubber feet to the bottom of the safe.

#### How the Lock Mechanism Works

When the notches line up across the back of the lock mechanism, they align with the lock pins. This allows the lock bolt to slide back and forth through the door and the notches in the dials. Setting the combination to anything but the correct sequence puts the notches out of alignment. ■

# FREE SANDING BELTS

## DIRECT FROM THE MANUFACTURER

GET SIX FREE BELTS FOR EACH DOZEN ORDERED. All belts are aluminum oxide first quality. Our electronic presses make smooth bump-free splices.

Check your size and how many dozen. We will ship assorted grits unless otherwise specified.

<input type="checkbox"/> 1" x 30"	— \$12.70/doz.
<input type="checkbox"/> 1" x 42"	— 12.75/doz.
<input type="checkbox"/> 1" x 44"	— 12.80/doz.
<input type="checkbox"/> 3" x 18"	— 13.75/doz.
<input type="checkbox"/> 3" x 21"	— 14.25/doz.
<input type="checkbox"/> 3" x 23 $\frac{3}{4}$ "	— 14.70/doz.
<input type="checkbox"/> 3" x 24"	— 14.75/doz.
<input type="checkbox"/> 3" x 27"	— 15.25/doz.
<input type="checkbox"/> 4" x 21 $\frac{3}{4}$ "	— 16.75/doz.
<input type="checkbox"/> 4" x 24"	— 17.25/doz.
<input type="checkbox"/> 4" x 36"	— 20.95/doz.
<input type="checkbox"/> 6" x 48"	— 26.95/ $\frac{1}{2}$ doz. (3 FREE)

Other size belts on request.

### 9" x 11" Paper Sheets

A/O Cabinet Paper		No Load Finishing Paper	
	50/pk.	50/pk.	100/pk.
40-D <input type="checkbox"/>	\$17/pk.	<input type="checkbox"/>	\$31/pk.
50-D <input type="checkbox"/>	16/pk.	<input type="checkbox"/>	28/pk.
60-D <input type="checkbox"/>	15/pk.	<input type="checkbox"/>	26/pk.
80-D <input type="checkbox"/>	14/pk.	<input type="checkbox"/>	24/pk.
100-C <input type="checkbox"/>	13/pk.	<input type="checkbox"/>	22/pk.
120-C <input type="checkbox"/>	13/pk.	<input type="checkbox"/>	22/pk.
150-C <input type="checkbox"/>	13/pk.	<input type="checkbox"/>	22/pk.

### NEW ITEM!

BELT CLEANING STICK - \$6.95

### Wet or Dry S/C Paper

	50/pk.	100/pk.	
220-A <input type="checkbox"/>	\$15/pk.	<input type="checkbox"/>	\$25/pk.
320-A <input type="checkbox"/>	15/pk.	<input type="checkbox"/>	25/pk.
400-A <input type="checkbox"/>	15/pk.	<input type="checkbox"/>	25/pk.
600-A <input type="checkbox"/>	15/pk.	<input type="checkbox"/>	25/pk.

Prompt delivery from stock.  
MONEY-BACK GUARANTEE

Shipping Charges - Under \$35 add \$2.50; \$35 or more add \$4.00—PA residents add 6% sales tax.

Check or Money Order.  
 MasterCard  VISA Exp. Date \_\_\_\_\_

Acct. # \_\_\_\_\_

Name \_\_\_\_\_

Address \_\_\_\_\_

City, State & Zip \_\_\_\_\_

CALL TOLL FREE  
1-800-428-2222

PA Only - 1-800-222-2292

INDUSTRIAL ABRASIVES CO.  
643 North Eighth Street  
Reading, PA 19603

## Own this classic "Roll Top" OAK DESK from our pre-cut partially assembled Kit.



Here's the turn-of-the-century "Roll-Top" you've always wanted. A full size oak desk (oak and oak-veneers) now yours at extraordinary savings... because you put it together yourself from pre-cut Kit parts. No special tools needed. When finished, you'll possess a magnificent showpiece for your home or office — worth at least twice what you paid for the Kit! Send for details without obligation.

**FREE FULL COLOR CATALOG**  
gives you all the facts

Please send my free Craftsman's Corner color catalog featuring the Classic Roll Top Desk and many other quality hardwood kits. I understand I am under no obligation.

Print Name \_\_\_\_\_

Address \_\_\_\_\_ Apt. \_\_\_\_\_

City \_\_\_\_\_ State \_\_\_\_\_ Zip \_\_\_\_\_



Craftsman's Corner Dept. 1GS • 4012 N.E. 14th Street • Box AP • Des Moines, IA 50302



# Hardwoods of Memphis

NASHVILLE, TN  
MEMPHIS, TN  
LITTLE ROCK, ARK

- FREE DELIVERY in Continental U.S.A.
- FREE 15 BOARD FEET of exotic Emeri wood with each \$500 purchase.

"Fine Woods and Tools"

P.O. Box 12449 • Memphis, TN • 38182-0449  
TN., call collect (901) 452-9663 others (800) 321-5239



Makita



\$1,385.00



All complete with motors and stands except 9" miter saw which does not include stand.  
We accept VISA, MasterCard, Money Order, Cashier or Personal Check.

28-243	14" BANDSAW	.....	\$535
37-609	6" JOINTER	.....	\$299
34-410	10" CONTRACTORS SAW	..	\$759
34-010	9" MITER SAW	.....	\$159
34-580	9" HOMECRAFT SAW	.....	\$249

BEALL WOOD THREADER • PEN KITS • INSTANT GLUE • TILE

## WOODTURNERS

CHOOSE FROM THE FINEST AMERICAN AND ENGLISH TOOLS AVAILABLE.  
WE FEATURE:

- DALE NISH WORKSHOPS
- SORBY
- HENRY TAYLOR
- MYFORD LATHES
- TOP QUALITY WOOD

SEND \$2.00 FOR OUR NEW EXPANDED 1985 CATALOG REFUNDED WITH ORDER



EXCLUSIVE AGENTS FOR HARRISON WOODTURNING LATHES  
CRAFT SUPPLIES  
1644 SOUTH STATE ST. U  
PROVO, UT 84601 A  
801-373-0917

REVOLVING CENTERS  
CHUCKS  
RINGMASTER

WORKSHOPS  
RINGMASTER

MYFORD • FACEPLATES • BURL WOODS • CLOCKS

\$89.00



## DELMHORST MODEL J-88 Wood Moisture Tester— Pocket-Sized and Easy to Use!

LED display-type meter indicates ten ranges of wood moisture content between 6 and 25 percent. *One step operation* ideal for woodworking shop or hobbyist. Comes with limited three year warranty!

Shipped complete with carrying case, batteries, pins and easy-to-read instructions. *Order one today!*

CALL TOLL-FREE 1-800-222-0638. Ask us about our full range of wood moisture meters.



DELMHORST INSTRUMENT COMPANY  
51 Indian Lane East, Dept. 931 Towaco, NJ 07082  
NJ phone—201-334-2557

## Sleeveless DRUM SANDER

NO PRE-MADE SLEEVES TO BUY

ECONOMICAL - Simply cut sandpaper from standard size sheets  
UNIQUE way to holding sandpaper to drum. Twist of key tightens  
SPONGE RUBBER backing insures long wear of sandpaper



USE ON:

- Drill Press
- Small Motor
- Lathe
- Combo-Tools
- Radial Saw
- 1/4" Drill

1"x 3" long	.....	\$13.50
2"x 3" long	.....	\$15.50
2 1/2"x 3" long	.....	\$16.00
3"x 3" long	.....	\$17.50
1" and 2 1/2" ABOVE	\$26.75	
ABOVE 4 DRUMS	\$53.50	
3/4"x 3" long	.....	\$14.50
2 1/2"x 4 1/2" long	.....	\$21.00
3"x 4 1/2" long	.....	\$22.50
2 1/2"x 6" long	.....	\$25.50
3"x 6" long	.....	\$27.50

ADD \$2.50 PER ORDER FOR SHIPPING

AVAILABLE WITH:

- 1/2" Bore with 1/2" or 1/4" shaft
- 1/2-20 RH Thread except 3/4"x 3"
- 3/8" Bore except 3/4"x 3" and 2"x 3"

Send Check or Money Order  
MONEY BACK GUARANTEE

**SINGLEY SPECIALTY CO. INC.**

P.O. BOX 5087B  
GREENSBORO, N.C. 27403

## THE MOST INNOVATIVE PRODUCTS FOR TOYMAKERS - WOODWORKERS

TOY PLANS  
BOOKS  
VIDEO  
TOOLS  
POWER TOOL JIGS

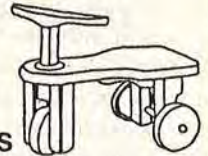

## DECRISTOFORO DESIGNS

27082 HORSESHOE LANE NO. 6  
LOS ALTOS HILLS, CA 94022-9990

1984 CATALOG \$1.00

## PATTERNS

for wood



Build an 1800 Trolley • Woodburning Locomotive • Horse Drawn Vehicle • Spinning Wheel • 1794 Clock • Early American Cradle • Weathervanes • Classic Toys • \$1 gets our catalog of FULL SIZE patterns, Kits, Mini-Lumber, Woodburning Equipment and patterns and Books. If you order, you get your dollar back!

Criss-Cross, Box 324BW, Wayne, NJ 07470



## NON TOXIC FINISHES

LIVOS is a new approach in beautiful finishing without the use of toxic chemicals. Your environment will be improved through the pleasant fragrance of plant oils, essential oils and natural tree resins. Breathing problems, dizziness and other after-effects are eliminated. No toxic fumes during application or from the dried product. No mineral spirits, no petroleum products, no chemical dryers.

Safe for children, animals and plants.

Send for FREE Mail Order Catalogue on:  
Oil Finishes, Waxes, Shellacs, Lacquers, Polishes, Stains & Wood Preservatives. (Product of West Germany)

WOODPECKER'S TOOLS, INC.  
614 AGUA FRIA STREET #10,  
SANTA FE, NM 87501  
(505) 988-2288



Please send me also your FREE Mail Order Catalogue of Quality Tools for Professionals and Craftsmen.

## SCROLL SAW OWNERS - Lettering Layout Guides!

- Use our specially designed guides to layout letters & numbers to be cut from wood or other materials.
  - Made from a durable plastic material.
  - Several styles & sizes.
- Send \$3.00 (Refundable with first order) for descriptive brochure & prices to:

**SEYCO SALES**

1238 Bardfield  
Box 472749  
Garland, Texas 75047



SOUND ADVICE

# Common cabinet mistakes

It's happened more than once. Just when things are going smoothly, we wonder, "Now what went wrong there?"

When we make mistakes in the shop, we often trace the trouble to four errors. They're all obvious, but perhaps we can spare you similar misery by sharing them.

**1. Math mistakes.** Reading rules and tapes incorrectly may be the most common mistake. To save wood and tempers, "Measure twice, cut once."

A related math problem concerns fractions. Some people become error-prone when they have to add  $1\frac{3}{8}$ " plus  $3\frac{3}{4}$ " plus  $6\frac{7}{16}$ ". If you're a member of that group, you might try using metric measurements when you design your own projects.

**2. Poor planning.** We like to "hit the ground running" when we begin a project, but sometimes we're not quite sure of our destination. When we really think a project through at the outset, and draw plans, measured drawings, or at least sketches before we turn on a saw or pick up a tool, we tend to avoid a lot of mistakes. We also develop our projects according to a set sequence: starting with outside dimensions, we work from the outside in.

**3. Mixed-up pieces.** It's about as easy to mistakenly interchange project parts as it is to mark them clearly. If you label all parts and mark their face surfaces, you'll avoid this common trap.

**4. Tool accuracy.** "It says 90°, so it must be 90°" is a dangerous thought. Drop a try square, and who knows if it will still measure a true right angle? If you automatically assume that your table saw will cut a true 45° today because it did last week, you run a considerable risk. Check all tool setups carefully before cutting. ■

## Build Your Own Whirligig!

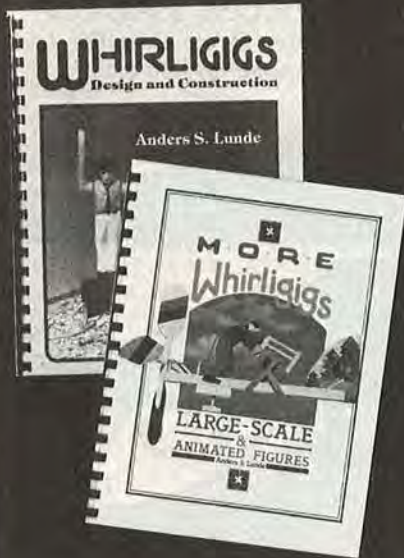

**WHIRLIGIGS: DESIGN AND CONSTRUCTION** by Anders S. Lunde (THE MOTHER EARTH NEWS, Inc.). Whirligigs are delightful toys that whirl and turn in the wind. This book traces their origins and provides a large selection of traditional designs with detailed instructions and working drawings for each. 80 pages. Paperback. **66189 \$6.95**

**MORE WHIRLIGIGS: LARGE-SCALE AND ANIMATED FIGURES** by Anders S. Lunde (THE MOTHER EARTH NEWS, Inc.). Lunde's second book on whirligigs provides scaled drawings and instructions for building such animated creations as Anne at the Pump, Pete Saving Wood, Feeding Chickens, and many more. 180 pages. Paperback. **66239 \$12.95**

**MOTHER'S BOOKSHELF** Dept. 240910  
105 Stoney Mountain Road  
Hendersonville, NC 28791

Use coupon or call Toll Free 800/438-0238 (in NC call 704/693-0238).

Please send me \_\_\_\_\_ copies of WHIRLIGIGS: DESIGN AND CONSTRUCTION (66189) at \$6.95 each.

Please send me \_\_\_\_\_ copies of MORE WHIRLIGIGS: LARGE-SCALE AND ANIMATED FIGURES (66239) at \$12.95 each.

Payment enclosed including shpg. & hdlg. (\$1.50 for 1 or 2 books). NC residents add 4-1/2% sales tax. Add 15% if remitting in Canadian funds except for charge card orders. Do not send cash in the mail.

Or charge my  VISA  MasterCard

Credit Card No. \_\_\_\_\_

Card Expiration Date \_\_\_\_\_

Signature \_\_\_\_\_

Name \_\_\_\_\_

Address \_\_\_\_\_

City \_\_\_\_\_

State \_\_\_\_\_ Zip \_\_\_\_\_

MOTHER'S BOOKSHELF®  
105 Stoney Mountain Road  
Hendersonville, NC 28791

Money refunded on books returned undamaged in 10 days. Books shipped within 72 hours after order arrives.

240910

## MUST LIQUIDATE HEAVY-DUTY DRILL PRESS

FACTORY NEW! FIRST QUALITY!

**16-speeds**  
From 260 rpm.  
to 3650 rpm.

- Ideal for metal, wood, plastic, etc.
- With 5/8" chuck and Morse Taper.
- Powerful 3/4 hp. motor.
- Quick-change belt pulleys for speed control.

### SPECIFICATIONS:

Swing	17"
Drilling capacity	5/8"
Spindle travel	4 3/4"
Spindle to base	49"
Spindle to table	29 1/2"
Table size	12" dia.
Spindle taper	MT No. 2
Column diameter	3 1/2"
Spindle rpm	260 to 3650
Overall height	66"
Base size	11.4" x 20.3"
Weight (approx.)	176 lbs.

Head and base of strong, fine-grained cast iron.

Fine Quality Floor Model



Liquidation due to factory surplus. For steel, cast iron, aluminum, brass, wood, plastic, etc. Base has longitudinal ribbing for added strength. Heavy-walled, machined column increases rigidity, provides smoother drilling operation. 12" production table swings 360° and tilts 0° to 45° in either direction. Precision movement of table, up and down. No. 2 Morse Taper lets you remove 5/8" chuck and insert big drill bits. Recessed light bulb socket.

Mfr. List: \$595.00

**\$158**

Liquidation Price . . . . . \$158  
Order No. 1023 Shipped freight collect.

Credit card members can order by telephone:



Toll-Free: 1-800-328-0609

In Minnesota, call: 1-800-742-5685

C.O.M.B. CO. Item F-687-1023

Send \_\_\_\_\_ Drill Press(es) at \$158 each. I will pay shipping and handling charge to the driver upon delivery. (Minnesota residents add 6% sales tax. Allow 4-5 weeks for delivery. Add 2-3 weeks extra if paid by check. No C.O.D. orders.)

My check or money order is enclosed.

Charge:  MasterCard®  VISA  Am. Ex.  Diners Club

Acct. No. \_\_\_\_\_ Exp. \_\_\_\_\_

PLEASE PRINT CLEARLY

Name \_\_\_\_\_

Address \_\_\_\_\_

City \_\_\_\_\_

State \_\_\_\_\_ Zip \_\_\_\_\_

Phone \_\_\_\_\_

Sign here \_\_\_\_\_

Rural Route Customer: If truck carriers do not normally deliver to your home, include a note with this order stating address of nearest store, friend or truck terminal where we can ship to.

**C.O.M.B. CO.**

Authorized Liquidator

14615 28TH AVENUE NORTH  
MINNEAPOLIS, MINNESOTA 55441-3357



# Make your own CABINETS



includes . . .

- step-by-step procedures
- errorless layout
- professional advice

No nonsense text and scores of detailed drawings make this manual an indispensable guide to the weekend craftsman as well as the professional.

Don't wait for this information, distilled from years of commercial small shop operations, it will save you time and money now.

To receive your postpaid copy send only \$10 (\$10.60 California, \$12 Canada) to Artisan Woodworkers, 21415 W Broadway, Sonoma, CA 95476

## Create A Classic



Full size patterns for Packard Le Baron and 1929 Chevy Truck, plus a catalog of over 100 wooden toy patterns, wooden wheels, axle pegs, people, and other hardwood turnings.

Send check or money order for \$10.00 for both patterns and catalog, or \$1.50 for catalog.

TOY DESIGNS - Dept. BW185, Box 441  
Newton, Iowa 50208

# FELDER

## Woodworking System

- 16" jointer/surfacar
- 16" planer/thicknesser
- 12" table saw
- heavy-duty shaper
- heavy-duty mortiser
- heavy-duty sliding table

Over 25,000 machines are already in use in Europe.

Write for your free brochure today!

**AMI**  
Advanced Machinery Imports

AMI, Ltd.  
P.O. Box 312-WZ  
New Castle, DE 19720

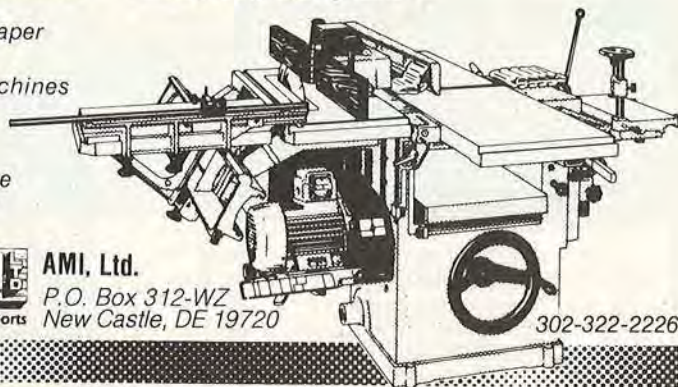

302-322-2226

## SIGNCARVING IS PROFITABLE!



And it's easy, if you use the Marlin Woodcarvers and accessories. You can carve signs quickly at home or at swap meets. The machines do the work, the operator has the fun and profits.

*No Special Training Is Required!*

SEND \$1.00 FOR OUR BROCHURE AND PRICE LIST, AND BEGIN TO PLAN YOUR FULL OR PART-TIME BUSINESS.

*Fine Carving Machines Since 1971*

### MARLIN INDUSTRIES

1911 OBISPO AVE., DEPT. D502  
LONG BEACH, CA 90804  
(213) 498-0767



## Furniture Hardware Chair Cane Lamp Parts

*Paxton  
Hardware*

7818 Bradshaw Rd., Dept. BH2, Upper Falls, MD 21156

Catalog \$2.50 3rd Class  
or \$3.50 1st Class

(301)592-8505



## A TOOL FOR THE MAN WHO HAS EVERY TOOL

A wooden plane bottle opener just for fun (\$8.88 ppd).

FOR A CATALOGUE OF OUR EXTENSIVE LINE OF FLEXIBLE VENEERS, TOOLS, LUMBER, BOOKS, ETC. ENCLOSE \$2.50.

1705 W. University  
Tempe, AZ 85281  
(602) 966-2444

1719 Chestnut Avenue  
Glenview, IL 60025  
(312) 729-9663

**WOOD WORLD**

## Sharpen your tools the Samurai way!

KING DELUXE WATER STONES from the original supplier of Japanese woodworking tools in the U.S.A. King water stones make it possible to obtain a razor edge with ease.  
1. #1000 grit coarse stone for fast initial sharpening: 8" x 2 1/2" x 1 3/8".  
2. #6000 grit polish stone for final honing and polishing: 7" x 2 7/8" x 1/2".  
Two stone set . . . \$18.50 postpaid. Full instructions and latest catalog included.

### THE JAPAN WOODWORKER

1731 Clement Ave., Alameda, CA 94501 / Phone (415) 521 1810

Enclosed is check, money order.  Catalog only . . . \$1.50

Credit card number:

NAME \_\_\_\_\_

ADDRESS \_\_\_\_\_

Phone No. \_\_\_\_\_

CITY \_\_\_\_\_

Calif. residents add sales tax.

STATE \_\_\_\_\_

ZIP \_\_\_\_\_



Stones are boxed for protection. Shipped postpaid.

## ICE BOX KIT

Designed and reproduced from an authentic ANTIQUE \*  
Hand crafted in solid OAK !!

Solid brass Hardware and name plate.  
Kit comes complete with detailed instructions and finishing materials!



\$359.00+freight+ 68 Pa. S. Tax (Pa. resident)  
Send your check or money order payable to "THE SHOP"

"THE SHOP"

VISA & MasterCard accepted.

Box 3711, R.D. #3, Dept. A9  
Reading, Pa. 19606

Phone 215-689-5885

Send \$1.00 for our catalog of hardwood kits !!

811 7-84



## Send For New 36 Page Woodworker's Catalog

100's patterns, veneers, toy supplies, hardwoods, shaker pegs, candle cups, dowels, spindles, cane, rush, splint, books, inlays, reproduction hardware, abrasives. Save to 25% on bonus starter offers! *Hurry!*

Morgan Woodworking Supplies, Dept. W06M03  
1123 Bardstown Rd., Louisville, KY 40204

Please rush my new 36 page woodcrafter's catalog.

Name \_\_\_\_\_

Address \_\_\_\_\_

City \_\_\_\_\_

State \_\_\_\_\_ Zip \_\_\_\_\_

## ULTIMATE DOVETAIL JIG

Ball bearing guides, cam clamps, machine & hand dovetails up to 16" wide

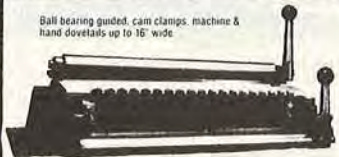

- DOVETAILS**
- Half inch machine
  - Quarter inch machine
  - Half inch hand type
  - Half inch box joint

### TAPERED SLIDING DOVETAIL

The ultimate method for joining shelves to carcass sides as in bookcases and stereo cabinets. Utilizes bit included with jig for producing a sliding dovetail with a slight taper so that shelf slides in easily, yet tightens up as it "hits home." Ideal for  $\frac{1}{8}$ " to  $\frac{1}{2}$ " lumber up to 16" wide.



FOR BROCHURE WRITE

**WOODMACHINE COMPANY**

• 2509 SHELLEY RD. • RALEIGH, N.C. 27612 • 919-782-0178

## WOOD TOY

★ Patterns

★ Parts

★ Wheels

★ Many New  
Patterns to  
Choose from.

★ Free Shipping  
in U.S.A.



SEND \$1.00 FOR NEW CATALOG  
AND RECEIVE COUPON FOR  
FREE WHEELS & AXLE PEGS.

### toys and joys

Box 628W Lynden, Wash. 98264

For families who enjoy and take pride in their homes, there is no more appropriate gift than a subscription to *WOOD*.

CALL US FOR QUOTATIONS  
ON MACHINES & ACCESSORIES  
BEFORE YOU BUY!



### POWERMATIC Model No. 26 Shaper— \$1,690.00 FOB McMinnville, TN

with either #1260050 solid spindle or #1260010 interchangeable  $\frac{1}{2}$ " or  $\frac{3}{4}$ " spindles, complete with motor and control.

Miss. residents add 6% tax.

Call toll free 800-821-2750.

In Miss. call 800-321-8107.

Ask for Max, Bobby or Van.

**Addison  
HARDWARE CO. INC.**

126 E. Amite St., P.O. Box 102  
Jackson, MS 39205

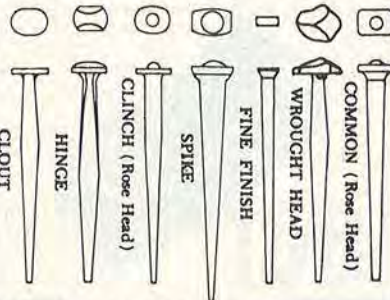

**Old-Fashioned Cut Nails.** The Tremont Nail Co. makes 20 varieties of cut nails using the old patterns, including rosehead, oval bung, and wrought-head. Sample kit containing one of each of the 20 patterns, a history of nails in America, and a price list is \$3.75 ppd. Tremont Nail Co., Dept. W51, Box 111, Wareham, Mass. 02571.



BUTTERNUT, WALNUT, ROSEWOOD, PINE, CHERRY, BUCKEYE and about a dozen other woods in boards, slabs and freeform cut ovals. Pieces up to 8" thick, 3' wide and 16' long in some species. We specialize in coffee tables, benches, bars, carving stock, clock ovals and movements, accurately cut for you to finish. We sell by mail and from our fantastic wood "museum," 9-5 Mon.-Sat., 11-4 Sun. Send 50¢ in coin or stamps for brochure. No checks, please.

**WEIRD WOOD, Box 190WBH  
Chester, Vt. 05143, 802-875-3535**

## Full-Size TRADITIONAL ROCKING HORSE PLAN



Bring back the magic of childhood using our full-size plan for

the Traditional Rocking Horse. Easy to build—body, legs and head are shaped using files. Rockers are curved for maximum action and shaped for desirable safety. Use pine or any available hardwood—paint to resemble live pony. Tomorrow's heirloom today!

Plan No. 121 \$10.75

### CATALOG

180 diff., full-size prof. furniture plans—\$2.00 (catalog free with order)

FURNITURE DESIGNS, Dept. BZ-15  
1425 Sherman Ave., Evanston, IL 60201

## Toolhauz CORPORATION™

14 Charles St., Needham, MA 02194

STANLEY 60 $\frac{1}{2}$  Block Plane Low Angle \$20.99  
KESON  $\frac{3}{4}$ " x 25' H.D. Tape \$6.99  
TSUMURA Japan Ultra Thin Carbide Blade \$13.44  
15 pc. Spade Bit Set  $\frac{3}{16}$ ,  $\frac{1}{2}$ " \$13.99  
FOOTPRINT England #4 Plane \$24.99



★SALE★ NOBEX 202 \$74.88

EXTRA BLADES  
24, 18, 12 TPI \$7.45

RYOBI SCREWDRIVER #2 BITS  
\$64.88 E-3800A 3.7A 0-4000 RPM 3/\$1.00

### Hand Screw Kits

8"—4.95 10"—5.25 14"—8.45 16"—10.95  
2 ea. handles, threaded rods, nuts & pins. Jaws not included

SHIPPING EXTRA (on all orders)

MAIL & PHONE ORDERS 617-449-4756 MC VISA AMEX

## CCW SUPPLY

CLOCK COMPONENTS  
WHOLESALE SUPPLIES

Highest Quality • Lowest Prices

quartz movements, hands numerals,  
wood clock faces and finishes  
• quantity discounts •

Write or call for free catalogue

CCW SUPPLY  
P.O. Box 566 Dept. W1  
Spring Green, WI 53588  
608 588-7613

If you would like more information about advertising in *Wood*, contact:

Jerry Kaplan  
750 Third Avenue  
New York, NY 10017

212-551-7099

Continued from page 58  
**old hand ways**

load. The timbers must shatter or the joints break open before the building can even begin to lean.

Braces are the most difficult part of a frame to cut and fit. I have seen men so frustrated with fitting braces that they swear never to touch a chisel again. Trimming one end makes the other end move in

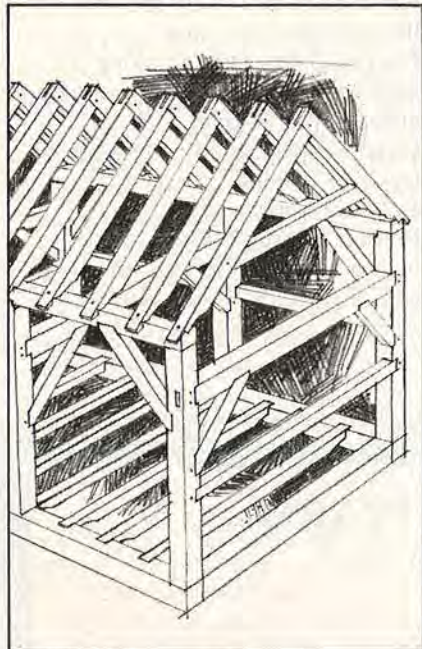

an arc. It must then be trimmed, which makes the first end move again. When my apprentices framed one building, they had almost half as many braces left over—spoiled by bad cuts—as were finally used in the whole building. Each man must cut his first bad brace, and then try again and make it right. Both the building and the builder are stronger for the experience.

It's not surprising that the timber frame tradition is undergoing a great revival these days. It is an ancient tradition with real strength behind it. But no matter how good the bones of a building are, without windows, doors, moulding and floors, it remains a skeleton. This more "curious" work comes from the hands of the joiners, and theirs will be the next of The Old Hand Ways. ■

Professional Model Builders... Architects...  
 Serious Hobbyists...  
 Introducing the

# Zéga model center



The new multi-purpose precision workcenter for the serious model craftsman. Lets you cut, carve, grind, shape, drill, sand or polish even the smallest pieces perfectly!

**T**he new multi-purpose precision workcenter for the serious model craftsman. Lets you cut, carve, grind, shape, drill, sand or polish even the smallest pieces perfectly!

If you've ever tried to use a full-sized saw or power tool for a model-sized, detailed job... you know what a nearly-impossible task it can be.

Now, Zega changes all that!

Thanks to the remarkable design and engineering skills of German craftsmen, you can get a new degree of precision and versatility never before available in a model or hobby craft saw—from one unique, multi-purpose tool. The Zega Model Center. Zega provides more professional features, more precision applications, and a more complete workshop capability than any potentially comparable saw or similar tool on the market.

And, Zega attachments add a remarkable degree of versatility. With its power take-off and flexible power shaft, you can virtually custom-create as comprehensive a model work center as you wish, simply by adding accessories.

**Try the Zega for 30 days —at absolutely no risk!**

Order any Zega Model Center and put it to the test for a full month. If, after 30 days, you don't agree that Zega is truly the rugged, versatile precision tool we say it is, just pack it up and ship it back to us. We'll promptly refund your full purchase price! So send for FREE information today.

**FREE BONUS ATTACHMENT (If you hurry!)**

## Zéga model center

A Division of Mantis Manufacturing Co.  
 1458 County Line Road, Dept. 102 Z  
 Huntingdon Valley, PA 19006

Name \_\_\_\_\_  
 Address \_\_\_\_\_  
 City \_\_\_\_\_  
 State \_\_\_\_\_ Zip \_\_\_\_\_

© 1985 MMC

# ROUTER AND SHAPER BITS

Zac Products has developed a selective line of quality carbide router and shaper bits. We feel that seeing is believing and want you to try our three most popular bits (all bits have a 1/4" shank, bit #2, straight cut 1/4" cut diam., & 1" cutting edge, #26, 3/8" radius round over, #36 flush trim 1/2" diam. & 1" cutting edge) at a special introductory price of \$26.50 delivered or both sets for \$105 delivered. If you are thinking of building or remodeling your kitchen or bathroom, our door shop will do the job. This clever set of router bits easily makes beautiful raised panel and frame doors with the use of your router and router table. The door shop set has three bits, two for style and rail and one for raised panel. These sets and your router are an economical alternative to the shaper. As a bonus, you will receive our 32 page illustrated catalog which contains 64 types of router bits, 58 types of shaper cutters, 4 types of router bit adaptors for the shaper, along with hundreds of moulding shapes, door style & rail sets, raised panel cutters, and much more. All at the best possible prices. C.O.D. orders accepted, add \$3.

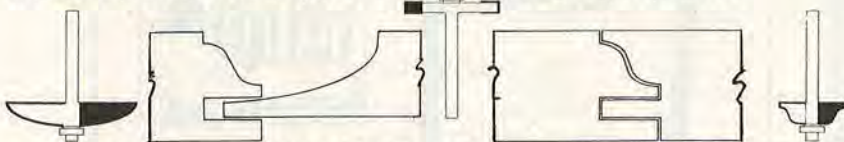

**CALL FREE**

INSIDE NY STATE  
 1-800-522-6622

# ZAC

OUTSIDE NY STATE  
 1-800-441-0101

TO ORDER FILL IN COUPON BELOW. TO RECEIVE CATALOG SEND \$1.50. N.Y. RESIDENTS ADD 8 1/4% TAX.

CK./MONEY ORDER ENCLOSED  CHARGE MY VISA/MASTERCARD  
 CATALOG & BITS 2, 26, 36, & DOOR SHOP \$105 PPD.  C.O.D. add \$3  
 CATALOG & DOOR SHOP \$89.50 PPD.  CATALOG & BITS 2, 26 & 36 \$26.50 PPD.  
 ACCOUNT NO. \_\_\_\_\_ EXP. DATE. \_\_\_\_\_  
 NAME \_\_\_\_\_  
 ADDRESS \_\_\_\_\_  
 CITY \_\_\_\_\_ STATE \_\_\_\_\_ ZIP \_\_\_\_\_

**PHILIPPS BROS. / PORTER-CABLE**

**SANDING SPECIALS**



**SPEED-BLOC, #330**

- Palm Grip, One Hand Use
- Flush Sanding All 4 Sides
- Direct Drive
- All Ball Bearing
- Double Insulated

LIST \$85.00

**SPECIAL**  
\$59.00  
ppd.

**H.D. FINISHING SANDER, #505**

LIST \$145.00

**\$109.00**  
ppd.

- Full Grip Top-side Handle
- Front Handle for Positive Control
- Fast, Less Fatigue



**BELT SANDER, #360 (Illus.)**

FEATURES OF ALL THREE BELT SANDERS

- Dustless • Ball & Needle Bearing Construction
- Perfect Balance

#360—3 x 24"  
LIST \$275.00

**SPECIAL**  
\$185.00

#362—4 x 24"  
LIST \$290.00

**SPECIAL**  
\$195.00

#337—3 x 21"  
LIST \$181.00

**SPECIAL**  
\$125.00

**SPECIAL ABRASIVE PRICES! BELTS, SHEETS, DISCS**

VISA MASTERCARD CHECK OR MONEY ORDER P.P.D. Cont. U.S.A.



**PHILIPPS BROS. SUPPLY, INC.**

Construction and Industrial Supplies

3159 BAILEY AVE. • BUFFALO, NY 14215 • 716/834-8353

Est. 1927

*the Affordable*

**SUPPORTABLE**  
**SUPPORTABLE**  
**SUPPORTABLE**

material support system.

**New!**



Patented

Height Adjustable



Folds for Space Saving Storage  
**STANDS INDEPENDENT OF ASSOCIATED EQUIPMENT**

Dealer inquiries welcome

For information write  
TURNING POINT, INC. • BOX 9303D • VILLAGE WEST • FARGO, ND 58109  
701-645-2319

**GLOSSARY**

**wood words**

**Adhesive:** A substance that bonds two other materials together.

**Arbor:** A rotating shaft on a woodworking machine to which another rotating part is secured.

**Bird's eye:** Small, circular areas on wood surfaces caused by indented wood fibers.

**Burl:** A swirling, twisted figure in wood grain caused by growths on the outside of the tree.

**Checks:** Splits running along the grain in wood that occur most frequently in end grain.

**Core:** In sheet goods, the layer or layers of material between the face and back veneers.

**Feather board:** A safety device, with a series of kerfs cut into one end, that holds wood securely against a table saw fence.

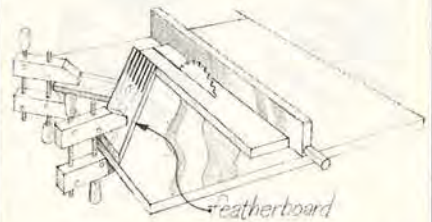

**Hardboard:** Sheet goods produced by applying heat and pressure to wood fibers. Lignin, the substance that bonds wood cells together in trees, acts as a natural adhesive to form the fibers into hardboard.

**Heartwood:** The mature wood at the center of a tree. (See *Sapwood*.)

**Kerf:** The slot made by a saw blade as it cuts through material.

**Mullion:** In frame-and-panel construction, an intermediate vertical divider. ■



## FINISHING AND REFINISHING

Continued from page 84

### choosing the right clear finish

the color of most woods, linseed oil never thoroughly cures, and therefore lacks durability, darkens and deteriorates with age. Some furniture craftsmen still stand by boiled linseed oil, but with few exceptions, other penetrating oils are superior.

**Danish Oil.** A blend of natural oils, such as tung and linseed, and small amounts of resins, Danish oils create a natural-looking finish superior to pure natural oils alone. Danish oils greatly enhance the grain pattern and texture of the wood and, at the same time, provide a durable finish that's easy to apply and maintain. Some blends, because they contain a few resins, give wood a very natural

look. Others, containing more resins, impart more sheen.

**Oil/Varnish Mixtures.** For people who prefer a natural-looking, wipe-on finish with more surface protection than pure or Danish oils, a mixture of oil and varnish can be the answer. Finishes such as Deftoil (Deft) and Varathane Plastic Oil (Flecto) are blends of tung oil and polyurethane, which make them extremely durable and moisture-resistant. Hope, Beverlee's, Formby, Parks, and Southerland Welles also manufacture oil/varnish mixtures. Apply these like penetrating oils.

**Nontoxic Finishes.** Many wooden items that contact food or the mouth — toys, cutting boards, salad bowls, and the like — require a nontoxic finish. With Behlen's Salad-Bowl Finish, a penetrating finish made specifically for these items, you simply wipe on the product and buff out the surface for

a protective satin sheen that increases luster with additional applications. You can easily renew the finish when necessary.

The manufacturers of Watco Danish Oil also market their product as nontoxic (after it has cured for 30 days).

Mineral oil, a common household item, also works as a nontoxic finish. This oil provides wood with some degree of protection, but it never really hardens. ■

**Note:** Before applying any finish, be sure to read the container's label directions carefully. Also keep in mind that these products are toxic, so you need to keep them out of reach of children. When applying finishes, work in a well-ventilated area that's well lit. Make sure, too, to work well away from any heat source because some of these finishes contain thinners, which can ignite easily.

U.S.A. CUTTING TOOLS • NORTON ABRASIVES • MAKITA • DEWALT • BIESEMAYER • AIR TOOLS

## BRATTON'S NEW YEAR SPECIALS

WE WILL BEAT ANYONE'S PRICES ANYWHERE

### Powermatic



#### Porter Cable

	List	SALE
695 Router Shaper 1½ hp	278.	209.
696 Shaper Table	149.	112.
330 Speed-Bloc Sander	87.	59.
505 Finish Sander	155.	109.
360 3 × 24 (Dustless) Sander	275.	205.
362 4 × 24 (Dustless) Sander	290.	218.
690 1½ hp Router	189.	142.

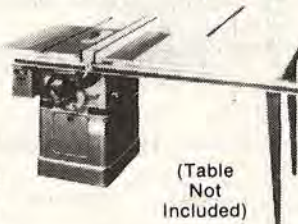

(Table Not Included)

Powermatic Model 66 with Biesemeyer Fence. 10" model 66 Table Saw complete with Biesemeyer Model 50, 50 inches rt. of blade, 1 ph., 3 h.p., 230 volt, magnetic controls.

List ..... \$2178.  
SALE ..... \$1839.

### Powermatic

	List	SALE
Model 66 10" Table Saw	2079.	1799.
Model 50 6" Jointer	1138.	949.
Model 60 8" Jointer	1572.	1365.
Model 100 12" Planer	2622.	2399.
Model 180 18" Planer 1 ph.	4817.	4582.
Model 26 Shaper	1973.	1775.
Model 45 Lathe 12"	2167.	1960.
Model 141 14" Bandsaw	1273.	1122.
Model 81 20" Bandsaw	2827.	2575.

(F.O.B. McMinnville, TN)

LEASE/PURCHASE plan now available—low down payment, tax credits

### Hitachi

	List	SALE
F1000A Planer/Jointer	2099.	1359.
P100F 12" Planer	1606.	1095.
B600A Bandsaw	2423.	1599.
TR-12 Plunge Router	314.	199.
C 12Y 12" Table Saw	2152.	1465.

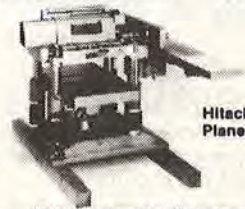

Hitachi F1000A Planer-Jointer

(F.O.B. Memphis, Tallahassee, Wilkes-Barre, PA)

### Delta/Rockwell

	List	SALE
10" Tilting Arbor Unisaw 3hp	2059.	1649.
10" Contractor Table Saw 1½ hp	1011.	720.
14" Bandsaw, encl. std. ¾ hp	897.	649.

### Biesemeyer

	List	SALE
Model 50"		284.
Home Shop Fence Systems		
Model 40"		209.
Model 52"		226.

### BRATTON MACHINERY & SUPPLY, INC.

ATTN: Dept. FWW  
1015 Commercial Street  
P.O. Box 20408  
Tallahassee, FL 32316

Call toll free: 1-800-874-8160  
In Florida: 1-800-342-2641  
Local: (904) 222-4842

Write for catalogs.

Enclose \$3 for postage & handling.

PORTER-CABLE • HITACHI • BLACK & DECKER • HITACHI

POWERMATIC • ROCKWELL • HEGNER • BLACK & DECKER

• JORGENSEN CLAMPS • AIR TOOLS • U.S.A. CUTTING TOOLS • NORTON ABRASIVES • GREENLEE

# JOINT-MATIC

Revolutionary  
Performance

Exceptional  
Capabilities

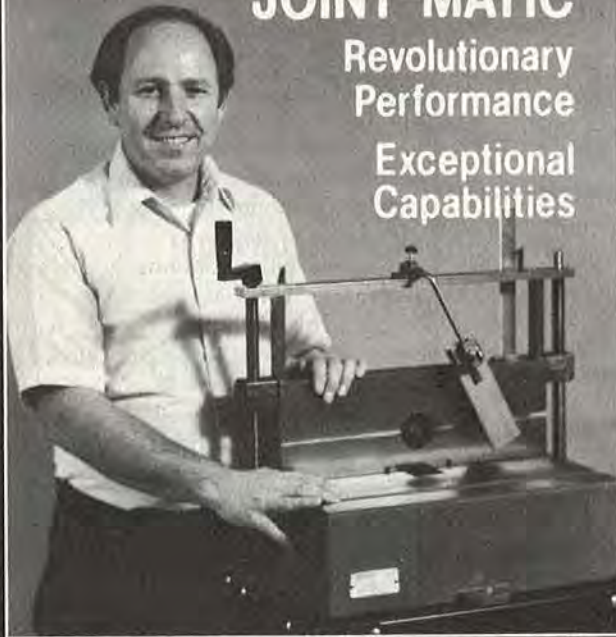

... The Joint-Matic 4200 is a new system in joinery that offers operating convenience, efficiency and accuracy that can not be compared to anything on the market. The Joint-Matic will help you produce woodworking pieces of elegance, precision and beauty more quickly and expertly than you ever thought possible. Now, in minutes make . . . Mortise, Tenon, Sliding and Through Dovetail, Box Finger Joint and much much more. Exclusive features of the Joint-Matic are so advanced in design and simplicity that set up time has been all but eliminated.

**Features:**

- Built for ruggedness and rigidity the table and slide unit have extra deep ribbing allowing a more accurate and chatter free cut.
- The base is heavy ribbed 1/2 inch thick casting, hardcoat anodized aluminum to a 52 Rockwell.
- The adjustment screws are rolled thread with a thread pitch of 3/4-16.
- Accuracy can be achieved to as close as .001th of an inch.
- Comes equipped with a 1-3/4 H.P. router.

For Your Brochure Please Send \$2.00 to:

**Strong** TOOL DESIGN

20425 Beatrice  
Dept. W  
Livonia, MI. 48152

Joint-Matic Machine Is Protected By U.S. Patent 4,163,465

# THE HEAVYWEIGHT

BUILT FOR THE PROFESSIONAL / PRICED FROM \$239

The Heavyweight is entirely American-made with top-quality materials and construction. It's priced for the hobbyist, but tough enough for the professional wood worker.

A 1/2HP motor with four-step pulley provides power to spare for turning, sanding, grinding, buffing and drilling. Accessories include a complete tool turning set and a face plate and sanding disk for outboard turning.



**12" Wood Lathe**

- Ground steel ways.
- 100% American-made.
- Cast iron head & tail stocks.
- 52" long; 38" between centers.
- Sealed ball bearing head stock.



Free brochure on request.

**WILLIAMS & HUSSEY MACHINE CO.**

Dept. 24, Milford, NH 03055

Toll-free: 1-800-258-1380 In NH: 1-673-3446

MAKITA • PORTER CABLE • ROCKWELL • BOSCH • LION  
**HILLER HARDWARE CO.**  
 ASSURES YOUR SATISFACTION ON ANY ITEM PURCHASED FROM US! WE CAN SHIP YOUR BANK CARD ORDER TODAY

*freud* INDUSTRIAL SAW BLADES

**10" CARBIDE TIPPED BLADES**

Blade	Description	Teeth	List Price	Hiller's Price
LU72	General Purpose	40	68.58	39.50
LU73	Cut-Off	60	79.65	40.95
LU81	General Purpose	40	69.30	40.95
LU82	General Purpose	60	86.50	42.75
LU84	Combination	40	70.99	39.50
LU84	Combination	50	74.51	42.75
LU85	Combination	80	110.88	73.90
LM72	RIP	24	64.85	43.95

5/8" BORE STANDARD, ADD \$8.00 FOR ANY OTHER BORE

- WE HONOR ALL FREUD NATIONALLY ADVERTISED SPECIALS
- CALL OR WRITE TODAY FOR CURRENT PRICES ON OTHER TOOLS/ACCESSORIES
- PRICES QUOTED, DELIVERED PREPAID
- VISA, MASTERCARD ACCEPTED

**HILLER HARDWARE CO.**  
 1411 ASSEMBLY STREET, P.O. BOX 1762  
 COLUMBIA, S.C. 29202-1762  
 803-779-3131 EXT. 12

YOUR WOODWORKING SPECIALIST IN THE SOUTHEAST

MARPLES • RECORD • WATCO • NU-LIFE • DOWEL-IT-CLESCO • GILLESPIE • FREUD  
 BLACK & DECKER • MILWAULKEE • FORSTNER • JORGENSEN • 3M • W.L. FULLER  
 HEGNER • STANLEY • GREENLEE • HENCKELS • MERIT

# lumbering home



**Today's wood prices make it worth your while to protect costly lumber purchases.**

**A**t a time when 8' hardwood boards can cost \$30 apiece, and when single sheets of veneer plywood retail for more than \$100, transporting lumber and sheet goods safely—and storing them wisely—has become a valuable woodworking skill. These tips will help you prevent expensive damage.

### Before you leave home

- Determine whether you can haul your load of lumber safely. An overloaded vehicle—whether it's a VW bug or a ¾-ton pickup—is an invitation to disaster. If you plan to buy more material than you can handle safely, consider some alternatives. Perhaps the store or yard will deliver to your home (you'll probably have to pay for the service). Maybe you should rent a trailer or van. Can you borrow a truck?
- If you'll be buying sheet goods or other heavy, bulky objects, bring a friend along to help you load, secure, unload, and store your purchases.
- Don't leave home without: rope, cord, twine, or elastic tie-downs if you'll need to lash material to the top of your car; a roof rack, cartop carrier, or even just a blanket to protect your car roof; cardboard or masking tape for the edges of sheet goods; and a red flag if you'll be hauling a long load. (The definition of a long load can vary from state to state; you'll be safe if you flag anything that extends past your bumper.) Don't automatically assume that your wood dealer will supply such materials.

### At the building materials outlet

- Protect your purchases. Use masking tape or cardboard to cover delicate edges of expensive plywood or other sheet goods. Take special care where tie-downs intersect the edges of your lumber, particularly if you've bought softwoods.
- Secure plywood panels front-to-back and side-to-side on the top of your car. If you're hauling thin sheets, sandwich them between thicker pieces (or between lengths of lumber) for the trip home.

### The road home

- Whenever possible, choose lightly traveled streets for the trip home. You'll be able to drive slowly, and if your load should shift or come loose, you can stop and fix things without dodging traffic.
- No matter how short the distance, don't even *think* about the "Of Human Bondage" transport method: one arm on the steering wheel and the other out the window clutching a board to the side or top of your car. You risk losing your wood *and* your arm.

### Storing your purchases

- Store all materials off the floor in a cool, dry place.
- Wherever possible, store lumber and sheet goods flat. (If you can't do this in your shop, store materials as close to vertical as possible to avoid warping or bowing.)
- If you have room for flat storage, "sticker" each board or sheet. As you stack your wood, place stickers—long, stick-like wood scraps—at both ends and at regular intervals along the length of the piece. Stickers allow air to circulate freely around your wood and provides adequate support for the material. Use stickers of the same species as the wood you are stacking to prevent leaching of unwanted color onto expensive lumber.
- If you are stacking irregular lengths of lumber, place the longest boards on the bottom of the pile and build succeeding layers with progressively shorter pieces to construct a stable structure and to provide the greatest possible support for each board. ■

## Mill-Route™ puts hundreds of new projects within your reach!

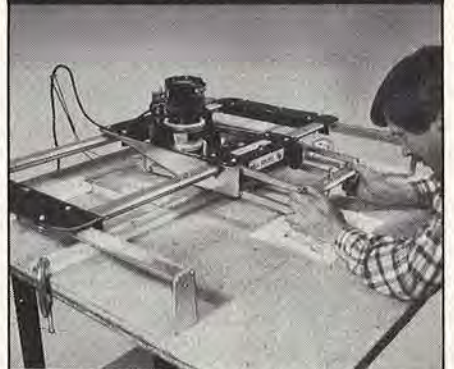

### TURN YOUR ROUTER INTO A PRECISION MANUFACTURING TOOL!

Create ovals, cutout letters and numbers, perfect circles, fancy frames, carved relief headboards—hundreds of projects you've only *wished* you could make! Mill-Route provides new precise control and versatility for your router:

- **Sets quickly** and accurately for straight line grooving and moulding.
- **Holds tight registration** for multiple-pass cuts.
- **Creates production templates** from pencil sketches.
- **Holds router perpendicular** to work at all times.
- **Travels smoothly** on 16 roller bearings.
- **Tracks effortlessly** in all 3 dimensions.
- **Covers 24"x20"** area with 3" vertical travel (extensions available).
- **Router retracts to "up" position** when hands are removed from guide.
- **Shields hands a safe 20"** from blade action.

ONLY **\$199<sup>00</sup>** Plus Shipping and Handling  
(router not included)

**90-DAY WARRANTY**

PLEASE SEND ME  
 FREE INFORMATION  
 MILL-ROUTE

PLEASE CHECK ONE:

CHECK  MONEY ORDER  
 VISA  MASTERCARD

VISA

M.C.

SIGNATURE \_\_\_\_\_

EXPIRATION DATE \_\_\_\_\_

I WISH TO ORDER:

Mill-Route Unit	\$199.00
plus shipping and handling	8.95
Texas residents add 5% sales tax (\$9.95)	
<b>TOTAL</b>	<b>\$</b>

NAME \_\_\_\_\_

ADDRESS \_\_\_\_\_

CITY \_\_\_\_\_

STATE \_\_\_\_\_

ZIP \_\_\_\_\_

Make Checks payable to Progressive Technology, Inc.

MAIL THIS FORM TO: Mill-Route  
P.O. Box 98  
Stafford, Texas 77477-0098

Mill-Route is a product of Progressive Technology, Inc., Houston, TX.

# Information

## WORTH WRITING FOR

You can get useful ideas and product information by mail. Use the coupon in this section to order your choice of literature listed below.

**SCROLL SAW AND LATHE INFORMATION** — More than 20 pages of information, including full-color photos, on HEGNER precision scroll saws, HEGNER lathes, and HEGNER duplicators. Find out why these machines are considered state of the art, and what to look for when shopping for scroll saws or lathes. AMI, Ltd. \$1.00. *Circle No. 1.*

**WOODWORKING PLANS FOR HOMESHOP** — Stacking bookcase, curio cabinet, grandfather clock, Bentwood cradle, and much more. Step-by-step detail procedural plans include material list, suggested tools, and fully illustrated steps. Price of brochure is refunded with first purchase. ABOUT TIME PLANS. \$1.00. *Circle No. 10.*

**FOR AMERICAN-MADE TOP QUALITY WOODWORKING EQUIPMENT** — Send for our catalogs on all the top American-made machinery like Powermatic and Delta. We also carry hard to find decorative hardware like Baldwin and Stage. ADDKISON HARDWARE. \$2.00. *Circle No. 15.*

**HOW-TO-CLAMP-IT CATALOG** — Illustrated catalog describes over 40 different styles of genuine "Jorgensen" and "Pony" hand clamps, including clamp selection guide, working advantages, and do-it-yourself project applications. ADJUSTABLE CLAMP CO. Free. *Circle No. 20.*

**POWER MITER SAW OWNERS** — Send for the free information kit describing the Sawhelter® Miter Fence System. Three styles of sawhelters are available. Choose from stationary fences or portable fences in bench top or free-standing models. Portable units set up in 60 seconds, then fold for compact storage or transport. Many accessories available. AMERICAN DESIGN AND ENGINEERING INC. Free. *Circle No. 40.*

**TOOL CATALOG** — Available from Anglo American Enterprises, the world famous Recod Marples Tool Catalog featuring the finest woodcrafting tools available. Send for catalog and price list. ANGLO AMERICAN ENTERPRISES CORP. \$2.00. *Circle No. 50.*

**WOODWORKERS' PLANS AND SUPPLIES** — Wood projects are simplified with the high quality plans, specialty hardware and other supplies offered by Armor Products. Over 100 plans are available for making toys, desks, clocks, pool tables, lamps, chests, and other furniture. Movements, dials, moldings, ornaments, and hardware also available. ARMOR PRODUCTS. \$1.00. *Circle No. 60.*

**VENEER CRAFTS AND MORE** — Artistry in Veneers presents its 1985 catalog of natural and dyed veneers, inlay borders, marquetry kits, carving sets, full-size furniture and toy plans, wood finishes, and tools. Our library of how-to books and professional services will broaden your knowledge of fascinating hobbies in wood. Send for our woodworker's catalog. Price of catalog is deducted from your first order. ARTISTRY IN VENEERS, INC. \$1.00. *Circle No. 65.*

**DISCOVER VENEER** — Artistry in Veneers' do-it-yourself guide to veneering shows you how simple this craft really is to master. Our color brochure identifies the most popular species of veneer and educates you on veneer matching, taping, and gluing. Send for your introductory brochure. ARTISTRY IN VENEERS, INC. 50¢. *Circle No. 66.*

**SHIP MODEL KITS** — Fully illustrated 32-page catalog of scale ship model kits from America's oldest model ship company. Build a beautiful museum quality model ship with the simplest tools and average skills. BLUEJACKET SHIP CRAFTERS. \$2.00. *Circle No. 130.*

**BOOS BUTCHER BLOCK FURNITURE** — Full-color literature featuring Butcher Block tables and chairs and gourmet items including tea carts, microwave oven tables, hostess carts, Butcher Block and cutting boards. JOHN BOOS & CO. \$1.00. *Circle No. 140.*

**WOODWORKING EQUIPMENT** — More than 75 pages filled with woodworking machinery, portable power tools, and supplies. Detailed information on all types of equipment for professional and home shop needs. Powermatic, Rockwell, Hitachi, Makita, and more. BRATTON MACHINERY AND SUPPLY, INC. \$3.00. *Circle No. 150.*

**CLOCK COMPONENTS AND SUPPLIES** — Best prices on quartz battery clock movements, hands, numerals, solid wood clock faces and finishes. We have a large supply with same day shipping. Send for catalog with ordering information. CCW SUPPLY. Free. *Circle No. 200.*

**CANE AND BASKET SUPPLIES** — Every item used in caning and basketry is pictured in this new catalog for hobbyists and others interested in caning, rushing, etc., for either fun or profit. CANE & BASKET SUPPLY CO. \$1.00. *Circle No. 230.*

**CLOCK MOVEMENTS CATALOG** — The 55-page catalog contains over fifteen different quartz clock movements, including pendulum, strike, and chime movements. Also shown are dials, hands, numerals, and accessories. It features movements made in Japan by the world's largest producer of quartz timepieces. CAS-KER CO. \$1.00. *Circle No. 250.*

**MAKE WOOD TOYS AND PROJECTS** — Hundreds of plans, kits, colored and unfinished hardwood parts for all types of toy, craft, and furniture projects (Colonial, Shaker, Primitive, and Modern.) For novice to experienced woodworkers. Send for beautifully illustrated color catalog. CHERRY TREE TOYS INC. \$1.00. *Circle No. 260.*

**WOODWORKERS TOOLS AND MATERIALS** — 116-page catalog offers fine hardwoods, veneers, inlays, picture molding, wood finishes, carving blocks, cabinet hardware, and cane. Specialty woodworking tools, shop equipment, plans, instruction books. ALBERT CONSTANTINE AND SON INC. \$1.00. *Circle No. 270.*

**BUILD HEIRLOOM CLOCKS** — Now create beautiful heirloom quality clocks right in your own home. Choose from magnificent chiming grandfather clocks to charming wall clocks. 32-page catalog also offers a selection of music boxes, music movements, traditional barometers, and a huge variety of quartz movements and dials for custom clock building. Satisfaction guaranteed. CRAFT PRODUCTS CO. Free. *Circle No. 273.*

**WOODWORKERS! HELP CELEBRATE OUR 55TH YEAR OF SERVICE** — Send for our new 148-page Craftsman 1985 catalog. 42 varieties of choice hardwoods 1/64-in. to 4-in. thickness. Fine hardwood veneers, tools, moldings, trim, marquetry inlays, upholstery and lamp supplies, finishes, clock kits, and hard-to-find hardware. 4,000-plus items for your projects. CRAFTSMAN WOOD SERVICE CO. \$1.00. *Circle No. 275.*

**WOOD TURNING** — Complete selection of round, square, and bowl stock for the wood turner — walnut, cherry, maple, and other domestic hardwoods. Large selection of traditional and contemporary turning tools. Each catalog contains complete details for various turning projects. New this year — kits and kit supplies. CRYDER CREEK WOOD SHOPPE. \$1.00. *Circle No. 290.*

**DECRISTOFORO DESIGNS SELLS HIGH-QUALITY PLAN SHEETS** — for wooden toys and power tool plans. We also carry woodworking books by R.J. DeCristoforo, the snap stop reference clamp, and video tapes. Send for catalog and information package. DECRISTOFORO DESIGNS. \$1.00. *Circle No. 310.*

**BUILD IT YOURSELF BETTER AND CHEAPER** — Why buy it when you can build it? Illustrated catalog of hundreds of interesting and fun items you can create yourself for personal use or profitable sale. Our 1985, 40-page catalog contains toys, games, plaques, puzzles, birdhouses, planters, accent furniture, and much more. All patterns are full-size blueprints — no enlarging is necessary. Simply trace and create. DESIGN GROUP. \$1.00. *Circle No. 320.*

**WOODWORKERS!** — Tremendous savings on finest quality tools, accessories, and supplies. Every item we sell is unconditionally guaranteed. Send for details. DUSTY SPLINTERS ENTERPRISES. Free. *Circle No. 350.*

**DO-IT-YOURSELF LUMBER DRYING** — This 22-page booklet *Kiln Chamber Construction Guide and Operation Manual* is designed for the individual wishing to dry his own lumber with a minimum investment of money, time, and space. Included are principles of dehumidification lumber drying, selection of which dryer is best for you, and kiln chamber plans and construction information. Also you will receive a questionnaire you can fill out and return. Once completed and returned you will receive free a computerized evaluation of your drying needs including investment considerations, operating costs, and payback. EBAC OF AMERICA, INC. \$3.00. *Circle No. 400.*

**GET INTO THE WOODS WITH US** — Educational Lumber Company, suppliers to school shops for 30 years, now offers you top grade Appalachian and imported hardwoods. We also handle softwoods, veneers, and turnings. All our products are kiln dried. Send for our catalog and receive your bonus: a set of 5 furniture plans. EDUCATIONAL LUMBER CO., INC. \$1.00. *Circle No. 420.*

**COMPLETE FASTENERS FOR THE HOME WOODWORKER** — Specialized fasteners for all types of wood — particleboard screws, hardwood and softwood screws. We have all lengths from 1/2 in. to 3 in. in various diameters. All types of packaging available including our Handipak designed for the home, small volume user. Send for complete color brochure. A must for the home woodworker. EQUALITY SCREW CO., INC. Free. *Circle No. 460.*

**SHARPEN TOOLS SAFELY** — Scangrind offers a modern version of the old-time knife grinder's whetstones. They sharpen everything from cutting tools and knives to axes and mower blades. Whetstone grinding gives an extremely sharp edge without heat build-up and temper loss, so tools hold their edge longer. Catalog gives complete details and specifications. F. & H. MACHINE CO. Free. *Circle No. 490.*

**FINE TOOL AND WOOD STORE** — where discriminating craftsmen obtain their tools. We offer an informative catalog, quality merchandise, toll-free number, and same day shipping. FINE TOOL & WOOD STORE. \$2.00. *Circle No. 500.*

**RIPSTRATE SAVES FINGERS** — for table saw and radial arm saw users. Brochure describes the RIPSTRATE and shows how it gives straighter cuts, speeds, the work, prevents kickbacks, and keeps hands away from the blade. FISHER HILL STUDIOS, INC. Free. *Circle No. 530.*

**FURNITURE PLANS, FULL-SIZE** — For the do-it-yourselfer with easy step-by-step directions. Illustrated list and description of 12 furniture designs, mostly Early American: desks, cabinets, tables, storage bed, etc. NEW! You can make each piece in 2 or 3 sizes. All dimensions shown in catalog. FLEXIPLANS. Free. *Circle No. 540.*

**EXCELLENCE IN SHARPENING EQUIPMENT** — This two-color, 56-page catalog from Foley-Belsaw Co. provides information on its complete line of equipment used for sharpening home, garden, and industrial shop saws and tools. Each machine is fully illustrated, complete specs and pricing infor-



mation are provided. FOLEY-BELSAW CO. Free. Circle No. 550.

**MR SAWDUST SAW BLADES** — Get your 16-page illustrated booklet on Mr. Sawdust I blades for radial arm saws. This also includes information on our special non-splintering dado sets. In addition we will send a folder on Mr. Sawdust II ultra-smooth planer blades for table saws. You deserve the finest cuts possible. FORREST MFG. CO., INC. \$1.00. Circle No. 555.

**CUTTING TOOLS** — Freud, USA provides the finest value in carbide cutting tools. From saw blades and boring bits to shaper heads and router bits. Our newest product — shaper heads for the half inch shaper spindle. Send for complete catalog. FREUD, USA. \$5.00. Circle No. 560.

**WOODWORKING TOOL CATALOG** — Complete 108-page catalog of hard-to-find hand woodworking tools. We have a stock of over 300 book titles and carry the Myford English wood-turning lathe. Also inventoried are wood finishes of all possible descriptions and carving tools unequaled anywhere in the United States. Send today for your ticket to woodworker's heaven (price refunded on first order). You too, can be turning out quality woodwork. FROG TOOL CO., LTD. \$2.50. Circle No. 570.

**CARBIDE ROUTER BITS AND SHAPER CUTTERS** — For all 1/4-in. and 1/2-in. shank router bit users, our catalog is a must. We carry the largest variety of stocked router bit designs available anywhere. We originated the *Furnima Cabinet System* for making panel and frame doors with a router, *Furnima Drawer Making System*, plus a multitude of other functional cutter designs. How do we do this? Simple, we listen to our customers' needs and turn good ideas into functional tools—see for yourself. Our catalog is sent free of charge to woodworkers in the United States and Canada. FURNIMA INDUSTRIAL CARBIDE. Free. Circle No. 580.

**FULL-SIZE FURNITURE PLANS CATALOG** — Illustrates and describes over 180 plans for making furniture of quality found in museums and fine furniture stores. Plans include rolltop desk, cradles, dining tables, chairs, buffets, chests, gun cabinets, poker table, children's furniture, rocking horse,

spinning wheels, and more. Bill of materials exploded drawings assist the woodworker. FURNITURE DESIGN, INC. \$2.00. Circle No. 585.

**PROJECT PLANS TO BUILD FOR CHILDREN** — Extensive use of color photos plus illustrations of over 130 projects that you and your children will love. Baby cribs, wooden toys, desks, bunk beds, doll houses, and lots more are included in this readily useable reference book. GARLINGHOUSE CO. \$4.65. Circle No. 590.

**PROJECT PLANS FOR OUTDOOR LIVING** — Year round fun and convenience is yours with over 125 outdoor projects. Barbeques, picnic tables, gliders, decks, dog houses, and lots of storage ideas are packed into this colorful 128-page book. Plan your outdoor projects today. GARLINGHOUSE CO. \$4.65. Circle No. 591.

**PROJECT PLANS FOR ALL AROUND THE HOUSE** — Make your home more comfortable, more efficient and more attractive by selecting from the more than 130 projects in this colorful, idea-packed book. Projects for every room in the house will complement any lifestyle or decor. GARLINGHOUSE CO. \$4.65. Circle No. 592.

**SET OF ALL THREE BOOKS OF PROJECT PLANS** — Get all three of these colorfully designed books including ideas for children, for outdoor living and every room in your house at a special price. Photos, diagrams, instructions, and nearly 400 pages with more than 300 projects will help you design the custom features you've always wanted in your home. GARLINGHOUSE CO. \$11.95. Circle No. 593.

**COMPLETE FURNITURE CATALOG** — Contains over 175 different furniture kits that can be purchased at a substantial savings through the mail from a number of manufacturers. Styles include Shaker, Colonial, Queen Anne, and many more. GARLINGHOUSE CO. \$4.25. Circle No. 594.

**1984-85 MASTER CATALOG** — contains 212 pages of the finest in woodworking hand tools, machinery, and finishing supplies plus over 125 books. Of particular note is the selection of Japanese tools. The format is all four-color. GARRETT WADE CO. \$3.00. Circle No. 600.

**BEAUTIFUL WIPE-ON WOOD FINISHING** — is explained in a booklet from a pioneer in wipe-on finishes since 1928. Wood finishes that produce a beautiful hand-rubbed finish without messy brushes or spraying. Specially formulated finishes that simply wipe-on with professional results every-time — guaranteed! Unlike conventional finishes these will never yellow, crack, or craze and they dry dustfree without runs. These finishes will bring out the natural beauty of the wood and never needs waxing. Send today for your wood finishing guide and products catalog. GENERAL FINISHES. 25¢. Circle No. 630.

**WOODWORKING MACHINERY CATALOG** — Just arrived — 1985 full-color catalog of quality imported machinery and tools at low prices. GRIZZLY IMPORTS, INC. \$3.00. Circle No. 670.

**PLANERS** — Heavy duty 15x6 in. planers with 2 hp. single-phase motors. Other woodworking equipment at low, low prices. Send for 1985 color catalog. GRIZZLY IMPORTS, INC. \$3.00. Circle No. 671.

**DUST COLLECTORS** — for the small/medium size shop. Capable of handling from 1 to 3 machines at the same time. Priced within the home shop budget, yet capable of handling cabinet shopwork. Other woodworking machinery and tools — low prices. Send for catalog. GRIZZLY IMPORTS, INC. \$3.00. Circle No. 672.

**INDUSTRIAL GRADE CARBIDE ROUTER BITS** — Delta-type three wing shaper cutter and two-wing boring bits at low prices. Send for complete brochure and price list. Price of brochure refundable with first order. H & S TOOL CO. \$1.00. Circle No. 700.

**CUT PERFECT CIRCLES** — from 3 inches to 4 feet in diameter with any radial arm, table, or band saw. Table tops, stool tops, wheels for toys and outdoor furniture, revolving storage bins — 101 uses. Send for information on CIRC-L cut, a most ingenious device. HEPP INDUSTRIES. 25¢. Circle No. 720.

**BRASS FURNITURE HARDWARE** — This 36-page catalog shows over 500 items of authentic reproduction hardware from the 1700's and on into this century. These superior drawer pulls, knobs,

TO ORDER THESE BOOKLETS, USE COUPON ON PAGE 134

Let's make this short  
... and very sweet!  
**MR. SAWDUST  
BLADE PRICES CAN  
NOW BE DROPPED 30%!**

I knew it could happen.

Everybody knows we've never quoted a price in our ads. If we had, we'd have scared the life out of you ... and the Mr. Sawdust Signature line would have died an early death.

You listened to our QUALITY story. You saw us prove our points in shows. You took us up on our *unlimited* guarantee. And you assured us that price was *not* the most important factor.

You moved our production from dozens to hundreds. And you made my blades the most desired among the serious woodworkers. You were good to us ... and for us ... and we can now be good to you.

For these good old American reasons, we are announcing permanent savings in our blade prices.\* (And we don't have to take a full-page ad to do it!)

America's Foremost  
Power Tool Professional

**FORREST**

FORREST MANUFACTURING COMPANY, INC., 250 DELAWANNA AVE., CLIFTON, N J 07014

For complete information and prices, write for our 2 brochures "The Cut is Everything." (also includes Dado sets) and "Mr. Sawdust II" (ULTRA SMOOTH PLANER SAWS).

Please enclose \$1.00 for Postage and Handling.

\*Dampeners and dado-heads not included in price-break.

**MR. SAWDUST I**

	WAS	NOW ONLY
10" 60T.	\$162.00	\$113.40
9" 60T.	156.00	109.20
8" 60T.	150.00	105.00

**MR. SAWDUST II**

	WAS	NOW ONLY
10" 40T.	\$156.00	\$109.20
30T.	135.00	94.50
9" 40T.	146.00	102.20
30T.	125.00	87.50
8" 40T.	136.00	95.20
30T.	115.00	80.50

6" Dampener \$23.00  
5" Dampener 22.00  
4" Dampener 20.00

TO ORDER ...  
PHONE TOLL FREE! 1-800-526-7852  
(In NJ: 201-473-5236)



## Have a problem with your subscription?

We want to solve it to your complete satisfaction, and we want to do it fast. Please write to:

Robert Austin, Better Homes and Gardens® WOOD, P.O. Box 10628, Des Moines, Iowa 50336

You can help us by attaching your magazine label here, or copy your name and address as it appears on your label. Send this along with your correspondence.

Name _____		
Address _____		Apt. # _____
City _____	State _____	Zip _____

**Moving?** Simply attach the mailing label from this magazine and write in your new address below. (Please allow 4-8 weeks.)

**Your New Address Goes Here**

Name _____		
Address _____		Apt. # _____
City _____	State _____	Zip _____

### Subscription Rate:

6 issues \$15.00. Add \$6.00 per year for Canadian or foreign postage.

Renewal     New Order

Better Homes and Gardens®  
**WOOD**

P.O. Box 10628 • Des Moines, Iowa 50336

### National Carvers Museum

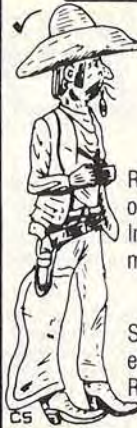

LEARN  
WOODCARVING  
AT HOME

Receive sample instructional pack on whittling and woodcarving. Includes copy of *Mallet* monthly magazine.

Send \$1.00 to The National Carvers Museum, 14960 Woodcarver Rd., Monument, CO 80132.

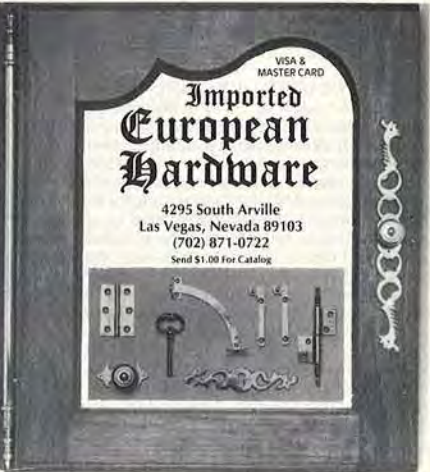

Imported  
**European  
Hardware**

4295 South Arville  
Las Vegas, Nevada 89103  
(702) 871-0722  
Send \$1.00 for Catalog



### SHOP SHAPE-UP

Bins, brackets, hooks, and shelves all fit into the grooved wall panels and cabinets of this German-designed modular storage system. You can buy one cabinet or panel (of foamed PVC) or outfit the whole shop.

For free literature write to:

Concept 2001, Inc.,  
1321 N.W. 65th Place  
Ft. Lauderdale, Fla. 33309



### BENCHES!

70"x30" Meyer Bench ..... \$169 *includes integral vise*  
70"x30" Euro Bench II.... \$199 *includes integral vise*  
50"x30" Solid Oak ..... \$ 97 *includes mallet*

Buy factory-direct from America's largest wood workbench manufacturer.

Free literature.

Tennessee Hardwood Company

800 West Main Street  
Woodbury, Tennessee 37190

615-563-2223

## PIN ROUTER

Speed and Precision at a Small Shop Price.

With the Award Winning Onsrud Inverted Router, templates are so simple it is economical to reproduce one part or hundreds.

Call or write for our free literature today.



MODEL 2003

(704) 528-4528

P.O. Box 416W, Troutman, N.C. 28166



Your own  
Personalized  
**BRANDING  
IRON**



Several styles  
and sizes available  
Send for brochure

TURNING POINT, INC.  
BOX 9303B • FARGO, ND 58109  
701-645-2319

hinges, finials, and other hardware items will greatly improve the appearance of your furnishings. HORTON BRASSES. \$2.00. Circle No. 750.

**IF YOU ARE INTERESTED IN FINE WOODWORKING** — you will not find better machinery than that sold by J.P. Humfrey Ltd. For example, we have 100, 10-in. general tablesaws (2 HP, magnetic switch, lever-lock fence) available at \$1,295 FOB New York. Send for brochure. J. PHILIP HUMFREY LTD. \$1.00. Circle No. 770.

**START SMALL BUSINESS WITH NEW SCROLL SAW** — The Excalibur precision scroll saw from Canada can turn your workshop into a profit center. Make toys and puzzles, do intricate marquetry work or detailed cabinet work with these "operator friendly" machines. Hundreds sold in the U.S. already. Save, buy direct, from \$495. up. Complete project patterns and plans available. Send for brochure. J. PHILIP HUMFREY LTD. \$1.00. Circle No. 771.

**BUY YOUR SANDING BELTS DIRECT FROM THE MANUFACTURER** — Industrial Abrasives is the company that gives you six free belts with every dozen ordered. But, sanding belts are not the only product we have to offer. In our catalog you will find many specialty items not readily available in your hardware store. Price of catalog refunded with first order. INDUSTRIAL ABRASIVES CO. \$1.00. Circle No. 780.

**THE CUSHION CONTOUR SANDER** — is a new concept in pneumatic drum sanding. Sanding sleeves are slid over an air bag (inflated with a hand tire pump) on an arbor to mount it between centers on a wood lathe. Drum effectively takes on profiles, curves, and bevels practically eliminating flat spots and chatter marks. INDUSTRIAL ABRASIVES CO. Free. Circle No. 781.

**THE FINE TOOL JOURNAL** — Published 10 times per year, this publication will keep you up to date with the many aspects of the world of antique and obsolete hand tools. Tools are offered for sale, books on tools are reviewed and sold, auctions are reviewed, articles on identification, values, and history. Send for sample copy. IRON HORSE ANTIQUES, INC. \$1.50. Circle No. 800.

**HOME CIDER PRESS KITS** — Solid maple kits of full-size, working cider and wine press. Complete kits includes all wood parts pre-cut, all hardware, and plans. Low cost basic kit has all the hardware, you supply the wood. Fully assembled model also available. Makes gallons of sweet cider with incredible ease. Send for literature. JAFFREY MFG. CO. \$1.00. Circle No. 900.

**FREE WOODWORKING TOOL CATALOG** — This 1984 catalog features hand tools, power tools, and shop machinery: professional quality tools — great selection and value priced. Great names, too: Marples, Sorby, Makita, Rockwell, Hegner, Freud, Primus, Porter-Cable, Milwaukee, Watco, and more. W.S. JENKS & SON. Free. Circle No. 930.

**HOME WORKSHOPPER** — New, fully illustrated, 48-page catalog of hard to find tools and accessories for home maintenance and do-it-yourself projects. Contains tips on wood grain, proper tools selection, time and money-saving ideas. Best resource for home craftsman, handyman, and hobbyist. JENSEN TOOLS INC. Free. Circle No. 950.

**TOOLS—ANTIQUE AND USED** — Quality, older hand tools for collectors and woodworkers. Many pre-1960 Stanley Tools. Hundreds of scarce planes, spoke-shaves, scrapers, drawknives, and other useable tools available. Illustrated tool lists published 5 times a year. Send for current list. BOB KAUNE. \$1.00 Circle No. 1020.

**QUALITY CLOCK KITS AND PLANS** — Handmade and semi-assembled of carefully selected ¾ in. cherry, oak, or walnut with beveled glass. Or build from "scratch" using our detailed plans and trim pieces. Choice of quality movements. Established in 1916. KUEMPEL CHIME CLOCK WORKS. Free. Circle No. 1070.

**FREE LITERATURE** — New brochure showing all moisture meters and accessories for moisture meters such as interchangeable electrodes and probes and cables for in-kiln moisture monitoring. Complete line of moisture meters include: Pocket-size Mini-Ligno with LED readout 6%-20%, Mini Ligno E 6%-36%, analog display meters 4%-30%, 60% and a digital moisture meter with built-in compensation for different wood temperatures. LIGNOMAT USA, LTD. Free. Circle No. 1130.

TO ORDER THESE BOOKLETS, USE COUPON ON PAGE 134

**PRODUCTION QUALITY CARBIDE TIPPED ROUTER BITS** — MLCS Ltd. offers a full line of professional production quality carbide tipped router bits at 50-70% lower than retail prices. We sell through the mail and only direct to craftsmen. Send today for information. MLCS LTD. Free. Circle No. 1210.

**FURNITURE AND TOY PLANS** — Hundreds of plans for everyone from the novice to the master craftsman along with the hardware, parts, and hard-to-find accessories and supplies to complete the project. MASTER PLANS & SUPPLY CO. \$2.00. Circle No. 1215.

**WHOLESALE WOODWORKERS HARDWARE** — Save 40% on shaker pegs, sawtooth hangers, wood wheels, dowel pins, candlecups, spice bottles, lazy susan bearings, coat hooks, and many more hard to find items. Send for 32-page catalog. MEISEL HARDWARE SPECIALTIES. \$1.00. Circle No. 1220.

**TIPS ON WOOD FINISHING** — A comprehensive, 22-page booklet includes numerous tips that save time and trouble for do-it-yourselfers. Information ranges from how to apply a preservative stain to a house exterior to restoring the finish of a priceless antique. Also included is a chart showing full range of both interior and exterior colors available. The name of your nearest dealer is provided. MINWAX CO., INC. Free. Circle No. 1240.

**GERMAN STEEL TOOL CATALOG** — 24 pages packed with finest quality tools manufactured in Germany. Included are thousands of unusual and hard-to-find chisels, gouges, parting tools, etc. — all hardened and tempered to hold a keen edge and give a lifetime of dependable service. FRANK MITTERMEIER, INC. Free. Circle No. 1250.

**MITY-TITE SYSTEMS** — No job is too tough for Mity-Tite. If you want to assemble furniture, fabricate most any item, frame a picture, work on your boat, do home improvements, do glueing, banding or any one of a thousand and one tasks, you need MITY-TITE SYSTEMS. Free. Circle No. 1255.

**GIANT SCREEN TV PROJECTOR PLAN** — Save \$2,000 by building this floor model cabinet. Also source of magnificent performing but low-cost

## SET OF FREUD 7¼" BLADES WITH THE SAME FEATURES AS THE 85 SERIES SUPER BLADES!



Saw Slick Material

Freud's 85 series blade has an extraordinary reputation with woodworkers. Woodsmith magazine said, "Freud's new teflon coated cut-off blade produced the finest finish of all the blades tested." Working with Freud, we've developed an exclusive 3 blade set that guarantees top performance with your circular saw. These blades cut faster, leave a smoother finish and cause **less wear and tear on your equipment!** The secret: anti-grip coating, precision grinding and sharp industrial carbide tips. The set consists of 3 blades (all 7¼"): 40 tooth fine cutting, 24 tooth general purpose and 12 tooth ripping. All have 5/8" arbor and diamond knockouts. Available only in 7¼" and only as a set of 3. **SPECIAL OFFER** with each set, we'll provide a **saw slick**, an extraordinary coated pad that adheres to the base of your saw to protect the wood finish and make your saw easier to handle.

**SET OF 3 FREUD 7¼" BLADES  
AND FREE SAW SLICK**

**\$59.95**

800-343-3248 (USA)  
800-322-6100 (MA)

**TREND-LINES, INC.**

375J Beacham St.  
P.O. Box 6447J  
Chelsea, Ma.  
02150



# PROJECT PLANS

Over 300 projects are contained in these three idea-packed books, representing the largest collection of Better Homes and Gardens project plans ever published. Nearly 400 pages of photos, diagrams and instructions plus order forms for blueprints of the more detailed projects. Each of these colorfully designed 128-page books focuses on a different area with plans for children, outdoors and home improvement projects.



from the pages of **Better Homes and Gardens**

- Project Plans to Build for Children ..... \$ 5.25
- Project Plans for Outdoor Living ..... \$ 5.25
- Project Plans for All Around the House ..... \$ 5.25
- ALL THREE BOOKS ONLY ..... \$12.95**

**FREE** Furniture Kit Catalog — a \$3.50 value — when you order all three books.  
All charges include shipping and handling. MasterCard and Visa accepted. No C.O.D.'s.

The Garlinghouse Company  
P.O. Box 299, Dept. WD  
Topeka, KS 66601  
(913) 267-2490

## NU-LIFE SANDING BELT CLEANER



**DON'T TOSS 'EM...CLEAN 'EM!**

**NU-LIFE MAKES CLOGGED SANDING BELTS AND DISCS LOOK AND PERFORM LIKE NEW. CLEANS IN SECONDS!**

For one introductory cleaner, send \$6.00 check or money order together with your name and shipping address to:

**ABRASIVE SERVICE CO., INC.**  
398 Broad Street  
Forestville, CT 06010

*Money back guarantee. We will send you the name of the nearest distributor for subsequent orders.*

## FURNITURE KITS



Unique Queen Anne and Chippendale furniture kits of solid walnut, cherry and Honduras mahogany. Handsomely carved cabriole legs for your woodworking projects. For a color brochure send \$1.00 to:



**W** Windsor Classics, Ltd.  
15937 Washington St. Dept. C3  
Gurnee, IL 60031

A Family Tradition Since 1916

## Kuempel Chime

**BUILD THE FINEST**  
We Know You Can Do It!



Easy to assemble quality Red-i-Kut Clock kits. A variety of designs hand made by our Grandfathers in solid 3/4" cherry, oak or walnut with beveled glass.

Tubular Bell or Rod movements. Handcrafted pendulums. Original bronze etched dials and hand painted moonwheels.

Or start from scratch. American Classic Plan - \$3.00

**Write for Free Literature or Call**

**1-800-328-6445**

Between 8 a.m. & 4 p.m.

## Kuempel Chime

Dept. 003, 21195 Minnetonka Blvd.  
Excelsior, MN 55331

## CARBIDE TIPPED 3/4" DOVETAIL 1/4" shank



Make beautiful drawers and decorative joints with this large bit.

**\$12** ppd.

## INDUSTRIAL CARBIDE TIPPED ROUTER BITS

Buy any three 1/4" shank bits and get the 3/4" dovetail FREE.

H205	1/2" Double-flute Straight	\$ 9.50
H208	3/4" Double-flute Straight	12.60
H304	1/2" Straight with Bearing Guide	11.50
H502	3/8" Panel Pilot with Drill Point	11.70
H702	1/2" "V" Grooving	18.00
H803	1/2" Cove Box	17.80
H1103	1/4" Slot Cutter	17.20
H1204	3/4" Corner Rounding	28.30
H1503	1/8" Round Nose	10.25
H1601	5/32" Radius Roman Ogee	28.00

For complete brochure/price list send \$1 (refundable with first order). All cutters guaranteed against defects. All prices include shipping. Calif. residents add 6-1/2% sales tax. Visa and M/C accepted.

**H&S TOOL CO.**

(415) 567-7276  
109 Minna St., Dept. 415  
San Francisco, CA 94105-3796

## BE CREATIVE!

**ARTISTRY IN VENEERS, INC.**  
Wants To Help.

Professional woodworkers have always used veneers to create beautiful pieces. Now these quality woods are available to you and are so simple to use.

You can resurface or repair furniture, create ceiling and wall designs, make beautiful chess or backgammon sets, or experiment with other woodcraft projects.

We stock 80 architectural veneers, matched edging, inlay borders, fancy butts, burls, crotches, swirls, and dyed wood veneers. To serve you, we have a complete line of quality tools and carving sets. There are over 25 marquetry kits, and our library of "how-to" books can broaden your knowledge of many fascinating hobbies in wood. Full size furniture and toy plans are an extra feature available for you. Professional services are also available.

Send \$1.00 for our woodworker's catalogue (deductible from your first order). The fine products we sell will add richness and character to your special wood projects.

**ARTISTRY IN VENEERS, INC.**  
450 Oak Tree Avenue  
South Plainfield, NJ 07080  
(201) 668-1430  
*(a subsidiary of Eagle Plywood & Door Manufacturers, Inc.)*

dual-element projector lens. Send for literature. R.E. MYERS, INC. 25¢. *Circle No. 1280.*

**WOOD CARVING** — You can obtain information on learning woodcarving by sending for our literature. The offer includes sample copy of *The Mallet Magazine* and two lesson sheets on carving. NATIONAL CARVERS MUSEUM. \$1.00. *Circle No. 1300.*

**CLOCK COMPONENTS** — We feature battery, pendulum, and chime quartz movements of all types: Urgos, Hermle, Grandmother, Grandfather cable drive and chain drive, keywind movements of all types. 400-day clocks, music box movements, flat and benzol type dials — plus a vast assortment of weather instruments. Hundreds of clock items. Very competitive. 75-page catalog. NEWPORT ENTERPRISES. Free. *Circle No. 1320.*

**OVER 300 CARBIDE ROUTER BITS** — plus 150 carbide-tipped saw blades from 7 in. to 16 in. Designed and manufactured for the professional woodworker, they are now available to the serious non-professional. Send for catalog. NIMROD TOOLS. \$2.00. *Circle No. 1340.*

**WOOD WORKERS—CARVERS SUPPLIES** — Catalog on hand to find items. E-Z pneumatic drum sander, Foredom tools and accessories, Detail Master woodburning unit, abrasive cartridge rolls, books, patterns, much more. NORTH WEST CARVING SUPPLIES. \$2.00. (Refundable). *Circle No. 1360.*

**PERSONAL BRANDING IRON** — Brochures describes line of branding irons that makes it easy to put your name on your work. Made especially for branding wood, they are available with 1, 2, or 3 lines of copy in either 1/8- or 1/4-in. letters. Makes a clean, sharp mark that shows pride in workmanship. Also included is information on handscrew clamp hardware that allows you to make your own clamps at approximately 50% savings. NOVA TOOL CO. Free. *Circle No. 1380.*

**OCCIDENTAL LEATHER OFFERS FOR HOME WOODWORKER** — A wide line of high quality and uniquely designed tools bags and holders for the woodworker and construction industry. Full color brochure. OCCIDENTAL LEATHER CO. \$1.00. *Circle No. 1410.*

**CABINETMAKER'S HARDWARE SUPPLY** — European hardware, Grass, Häfele, Elu plate joiners, Lamello plate joiners, Duo-Fast pneumatic tools, Sun Gold abrasives, Colonial Bronze. Send for catalog. ODA HARDWARE SUPPLY. \$1.00. *Circle No. 1420.*

**PIN ROUTER AND ROUTER BIT CATALOG** — Brochure showing the inverted pin router, the most versatile, easy-to-operate pin router in the world. Designed for operator safety and comfort. Included is a 22-page router bit catalog of all industrial grade bits in both highspeed steel and carbide. C.R. ONSRUD, INC. \$1.00. *Circle No. 1440.*

**"PUT YOUR ROOF ON A LIQUID DIET" BOOK-LET** — You can solve the roofing problems on your commercial building, house, mobile home, or RV with the white, reflective, elastomeric roofing system of the 80's. Snow Roof goes on like paint, but dries to form a rubber roofing membrane. Reduces your roof temperatures from 200°F to 80°F, and doesn't peel or crack. OREGON RESEARCH AND DEVELOPMENT INC. Free. *Circle No. 1450.*

**PETERSEN MFG. CO., INC.** — maker of VISE-GRIP® locking hand tools, manufactures a line of quick-locking C-clamps with self-leveling swivel pads available in 6 in., 11 in., and 28 in. sizes. The tools feature fast and easy locking and release action and enables the user to clamp most woods, plastics, and soft metals without marring the surface. PETERSEN MFG. CO., INC. Free. *Circle No. 1520.*

**PLANERS ARE OUR SPECIALTY** — Heavy duty 15, 16, 20, and 24 in. planers at the lowest prices in the U.S. We also carry quality jigsaws at realistic prices and a full-line of other shop tools. All tools are returnable within 30 days for full refund. Send for information. PRO SHOP. Free. *Circle No. 1560.*

**MAKE SIGNS, CARVINGS, PICTURE FRAMES** — Three dimensional wood carving system that is affordable and versatile. Carve by tracing template. Use existing template or create your own. Reduce from 75% to 25%. Start a part-time business for extra income. Made in the United States. PROGRESSIVE TECHNOLOGY. Free. *Circle No. 1570.*

**THE ALL NEW RING MASTER** — Get the free TO ORDER THESE BOOKLETS, USE COUPON ON PAGE 134

facts about Ring Master. Cuts perfect rings in any wood, any angle, any size, up to 12 in. diameter. Stack the rings and create any hollow cylindrical shape. Just glue... sand, and finish. Create matched sets of items. Choose from two models, one attaches to the Shopsmith Mark V. RING MASTER, INC. Free. *Circle No. 1625.*

**LETTER LAYOUT GUIDES** — Brochure containing complete information about a new product of special interest to scroll sawers, carvers, and wood sign makers. A lettering guide to layout large letters and numbers to be cut in wood or other materials. Made from a durable plastic material for years of use. Price of brochure is refundable with first order. SEYCO SALES CO. \$3.00. *Circle No. 1710.*

**PENNSYLVANIA DUTCH FURNITURE KITS AND PLANS** — All kits crafted in solid hardwoods in classic designs such as our original ice box, child's rocker, classic roll top desk, and more. Build from our easy-to-assemble kits or our blueprint plans. We include the hardware, fasteners, instructions, and you include the fun. THE SHOP. Free. *Circle No. 1720.*

**23 REDWOOD PROJECTS** — 36-page *Redwood Book of Wood/Book of Could II* features detailed plans for 23 redwood projects created by professionals in fine woodworking. Included are working-wood tips plus the fascinating story of redwood. SIMPSON TIMBER CO. \$3.95. *Circle No. 1730.*

**SLEEVELESS DRUM SANDERS** — Economical— simply cut sandpaper from standard size sheets. Unique way of holding sandpaper to drum—a twist of the key tightens. Sponge rubber backing insures long wear of sandpaper. Sanders can be used on drill press, small motor, lathe, combo-tools, radial saw, hand drill, and other revolving devices. Send for brochure. SINGLEY SPECIALTY CO., INC. Free. *Circle No. 1735.*

**SYSTEMS IN JOINERY** — New 25-page illustrated catalog featuring many uses of the joint-matic and introduction of other high quality machines, fixtures, and cutting tools that make many of the more difficult tasks in woodworking easier. STRONG TOOL DESIGN. \$2.00. *Circle No. 1745.*



## A CONSISTENT WINNER!

We have established ourselves as a supplier of quality, industrial grade equipment for probably the lowest prices in the U.S.A.! YOU CHECK!

### COMBINATION 1/8 SANDERS



- 1" x 42" Belt, 8" Disc.
- 1/2 H.P. 110v All Ball-bearing motor

**MODEL G1013**  
Only \$110.00 Prepaid  
to you via U.P.S.

### HEAVY DUTY 10 INCH TABLE SAWS WITH CAST-IRON WINGS



#### FEATURES:

- 1 1/2 H.P. factory-fitted all ball-bearing, induction motor which is also totally enclosed.
- Precision ground cast-iron table top with matching ground cast-iron wings.
- Table size with wings 41 x 27".
- Cuts 25" to-right of blade.
- Table has T-slots for miter gauge.
- Rip fence has fine adjustment and quick lock lever.
- 5/8" Arbor is 1 1/4" long and can easily handle dado sets.
- Machine comes standard with one dado insert and blade insert.
- Arbor is supported by sealed-for-life ball bearings.
- Machine weighs 220 lbs.

**SUPER INTRODUCTORY PRICE**  
**MODEL G1022 — ONLY \$325.00** (BELLINGHAM) F.O.B.

CALL FOR LOW FREIGHT RATES TO YOU!



**WINTER BREAK:**  
We will be closed from Dec. 24 through Jan. 1 — Happy Holidays!



QUALITY, GUARANTEED MERCHANDISE WITH LOCAL PARTS & SERVICE BACK-UP RIGHT HERE IN OUR WAREHOUSE.

### GRIZZLY IMPORTS INC.

P.O. BOX 2069, BELLINGHAM, WA 98227 • PHONE (206) 647-0801

WE SHIP REAL FAST IF YOU PAY BY VISA, MASTERCARD, MONEY ORDER, BANK DRAFT OR CERTIFIED CHECK. PAYMENT BY REGULAR CHECK WILL DELAY SHIPMENT 3 WEEKS.



## Full Size Plans



This Roll Top Desk is one of our finest furniture plans. It is similar to those of the 1800's and is made of oak lumber. Size: 55" x 21" x 49". Plans include base and roll-top unit. You do not have to purchase two separate plans.  
Desk - 311 \$14.50



Mr. Goodbank is a thrifty fellow who just loves to save coins. This cute guy is actually a bank and is 10 1/2" tall. Bank Plan - 329 \$3.00. Plan with eyes and nose \$4.50  
Our Rocking Horse features a soft saddle and flowing mane. Easily made of pine with basic tools. 36" x 25". Kit available containing foam, mane, eyes, rings, etc. Horse Plan - 245 \$7.00 Accessory Kit - HAK \$9.00

This collection of five toy vehicles will make any child happy. Made of pine they are easily built with hand or power tools. The trailer truck is 18" long and 7" tall. 5 Toy Vehicles - PLD \$8.50

This great Name Train spells out your child's name in 3" tall letters. Complete full-size alphabet included. Name Train Plan - 323 \$3.50

Catalog \$1.00 - Free with plans. Phone (516) 667-3328  
We accept Visa & Master Charge orders if over \$15.00

ARMOR Dept. L Box 290, Deer Park, NY 11729

## Wood Products from The Victorian Age

Whether you are building or remodeling, you can create Victorian elegance throughout your building. Over 350 mouldings, head-blocks, baseblocks, casings and wainscot of authentic Victorian designs are illustrated in our 32 page catalog. Custom milled mouldings are available in any wood as well as in a standard stock of pine and oak. Our catalog contains 40 detailed construction drawings to assist you in designing your own Victorian masterpiece. For catalog and price sheets send \$3.50 to:



Box 877-BHG  
Silverton, Colorado 81433  
303-387-5716

## WOODWORKING MACHINES 5 in 1 Combination

- 1 • 34" LATHE
- 2 • 10" TABLE SAW
- 3 • 11 3/4" DISC SANDER
- 4 • 16 1/2" VERTICAL DRILL PRESS
- 5 • HORIZONTAL DRILL PRESS

REG. \$1250  
NOW \$895



### VERY IMPORTANT

- The only machine built with
- A. ALL CAST IRON TABLES**
- B. HEAVY-DUTY DESIGN**
- C. 1 1/2 HP MOTOR DEVELOPS 3HP**
- D. BUILT AS AN INDUSTRIAL MACHINE**
- E. 5 YEARS LIMITED WARRANTY**

ONE PLACE FOR ALL YOUR NEEDS...

VISA  MASTERCARD  MONEY ORDER  
PLANT:

**MASTER WOODCRAFT CO.**  
800 SPRUCE LAKE DRIVE • P.O. BOX 669  
HARBOR CITY, CA 90710  
TOLL FREE 1-800 421-2467  
IN CALIFORNIA CALL COLLECT (213) 549-0761  
(A Republic-Lagun Group) • Dealership Available

## CRAFTSMAN'S 54th YEAR of SERVICE to WOODWORKERS

World's Largest Selection of  
fine dimensioned **HARDWOODS**  
and quality **VENEERS**

42 VARIETIES Amaranth to Zebra  
1/64" to 4" thick

### Save on Wood, Tools, Supplies

Fast service on all your needs in choice kiln dried Wood and Veneers, Complete choice of Mouldings, Trim, Hand and Power Tools, Lamp Parts, Upholstery Supplies, Clock Movements and Kits, Hard-to-Find Hardware, Finishing Materials, Books . . . over 4000 items in stock! Craftsman has been the Woodworker's best friend for 54 years . . . and we always save you money!



Send for **NEW**  
**CRAFTSMAN**  
148 page **CATALOG**

OVER  
**4000**  
ITEMS  
for your Wood  
Projects

Please enclose  
\$1.00 to help  
pay mailing  
and handling



**CRAFTSMAN** Wood Service Co.  
Dept. K-15  
1735 W. Cortland Ct., Addison, IL 60101

## PLATE JOINERY ALTERNATIVE FOR DOWELING



**\$335.00** POSTPAID

VALID THROUGH 2/28/85

MasterCard, Visa, M.O., Check

## THE VIRUTEX 0-81

FAST, ACCURATE JOINTS USING  
SLOTS AND WOOD SPLINES

Advantages Over Doweling:

- Stronger Joints
- Faster
- More Accurate Alignment

## Fine Tool & Wood Store

7923 N. May Avenue  
Oklahoma City, OK 73120  
In Oklahoma Call 405-842-6828 Collect

TOLL FREE 800-255-9800

Send \$2.00 for Catalog

## Professional Woodworker's Apron



Top grain leather

Protection  
of Leather  
for 69.95  
Shipping  
P.P.D.

Tool belts and accessories  
for the construction industry.  
Brochure Available on Request

Name \_\_\_\_\_

Address \_\_\_\_\_

City \_\_\_\_\_

State \_\_\_\_\_ Zip \_\_\_\_\_

Visa-M/C card # \_\_\_\_\_

Ex. Date \_\_\_\_\_

## OCCIDENTAL LEATHER



P.O. Box 364  
Valley Ford, CA 94972  
Call for fast service  
**707-874-3650**

TOLL FREE ORDERING  
(outside California only) **1-800-541-8144**

**CUPOLA AND BRIDGE STUDY PLAN BOOK** — Consists of designs for 22-ft. bridges, 8 covered bridges, 36 cupolas, and some history of each. Complete plans available for each design. SUN DESIGNS. \$7.95. Circle No. 1750.

**GAZEBOS AND OTHER GARDEN STRUCTURES** — The most comprehensive collection of gazebo designs found anywhere today. Includes 55 gazebo designs from 8 ft. to 30 ft., 13 strombrellas, 7 arbors, 14 bird feeders, and 4 birdhouse designs. Has mini-plans of 2 bird feeders and 1 of our most popular Tiffany gazebo. Complete construction plans can be ordered for all 93 designs. SUN DESIGNS. \$7.95. Circle No. 1751.

**BOOK OF OUTBUILDINGS** — 25 illustrated designs that can be used for unique storage sheds, playhouses, saunas, cabanas, guesthouses, or even privies. Send for *The Classic Outhouse* book. SUN DESIGNS. \$7.95. Circle No. 1752.

**"THE STROM TOYS"** — a full-color, 96-page paperback book of extraordinary wood toy designs, and a richly illustrated children's story. Contains 40 designs for which plans can be ordered, and 12 mini-plans. Makes an excellent gift. SUN DESIGNS. \$9.95. Circle No. 1753.

**BACKYARD STRUCTURES** — Contains designs for 21 really different storage sheds, 5 cabanas, 13 animal shelters, 3 barns, 13 garbage enclosures, 3 studios, and more, plus 8 plans in book. 66 designs in all, for which plans can be ordered. Full color. SUN DESIGNS. \$8.95. Circle No. 1754.

**TIMBERS COUNTRY STORE** — Catalog features hundreds of woodworking supplies, toy patterns, furniture patterns, tool use and instruction books, woodworking pattern books, hardwood toy and furniture parts plus many hard to find tools and shop supplies. TIMBERS COUNTRY STORE. \$1.00. Circle No. 1820.

**WOOD SCREWS, TOOLS, CARBIDE BLADES, BITS, AND SANDING BELTS** — Tools U.S.A., nationwide supplier to America's largest cabinet and furniture manufacturers, is now selling direct to the public at wholesale, mail order prices. Send for complete catalog. TOOLS U.S.A. \$2.00. Circle No. 1850.

**TOYMAKERS SUPPLIES** — Catalog of over 100 full-size wooden toy patterns — classic to contemporary designs from Packard Le Baron to Streamlined train and moon machine. Easy to follow, fully illustrated patterns which appeal to all ages. Hardwood wheels, shaker pegs, axles, etc., in stock. Accessory kits of pattern and turnings available. TOY DESIGNS. \$1.50. Circle No. 1860.

**WOOD TOY PATTERNS** — Patterns for all ages including children's patterns and executive toys. New catalog has many new patterns to choose from including parts and wheels. Send for new catalog and receive a coupon for free wheels and axle pegs. TOYS AND JOYS. \$1.00. Circle No. 1865.

**CLOCK MOVEMENTS/PLANS CATALOG** — Our 72-page clock catalog *A Time For All Seasons* features 35 clock plans, quality German and Japanese movements, dials, clock kits, hardware, and accessories. Everything for the clock building enthusiast. TURN CRAFT CLOCK IMPORTS CO. \$2.50. Circle No. 1880.

**PATTERNS FOR BETTER LIVING** — Picturing over 700 woodworking and handicraft projects including indoor and outdoor furniture, toys, garden and recreational items, soft sculptures, tole paintings, quilting, and much more. Patterns, plans, and guide books include step-by-step directions. U-BILD. \$1.95. Circle No. 1900.

**CLAMPS FOR ALL YOUR WOODWORKING NEEDS** — Information and prices on our new line of lightweight clamps especially designed for the small shop where work and storage areas are limited. Many replace those long, heavy lengths of pipe we've all wrestled for so long. Also have attachments for the Shopsmith Mark V and Multi Tool Imports. Prices include UPS delivery with shipment often the same day. UNIVERSAL CLAMP CO. Free. Circle No. 1930.

**WOODCARVING TOOLS** — Whittlers and carvers — Warren Tool Co. offers a catalog for you full of whittling and carving hand/power tools, books, stones, wood, and supplies. Since 1927, the finest in woodcarvers tools. WARREN TOOL CO., INC. 60¢. Circle No. 2020.

**BEAUTIFUL WOOD FINISHING** — with Watco

Danish Oil Wood Finish. Full-color *How to Beautifully Finish Wood* booklet enables anyone to create professional finishes the first time with all types of wood. One application of Watco Wood Finish seals, primes, finishes, hardens, protects, beautifies, penetrates deeply into the wood; outlasts surface coats three to one. Eight attractive Danish Oil colors now available. Eliminates pre-staining. WATCO-DENNIS CORP. Free. Circle No. 2025.

**FREE GIFTS FOR WOODWORKERS** — New *National Directory of Valuable Free Gifts and Things For Do-It-Yourselfers!* How and where to write for hundreds of free gifts, catalogs, samples, "how-to" instructions, manuals, courses, handbooks, magazines, books, plans, and hundreds of other free items for woodworkers. WEISS & DAUGHTERS. \$1.99. Circle No. 2030.

**FREE BUILDING AND REMODELING GIFTS** — New *National Directory of Valuable Free Gifts and Things—Plus Government Benefits—For People Who Are Going To Build, Remodel, Add On, Or Decorate.* How and where to write for hundreds of free gifts, plans, samples, layouts, building and remodeling plans, aids, books, government benefits, low-cost loans, and much more. WEISS & DAUGHTERS. \$1.99. Circle No. 2031.

**FREE PLANS** — New *National Directory of Valuable Free Plans for People Who Are Going to Build, Remodel, or Add On!* How and where to write for hundreds of free building plans, layouts, blueprints, planning and building aids, guides, magazines, handbooks, newsletters, how-to instructions, and much more. WEISS & DAUGHTERS. \$1.99. Circle No. 2032.

**FURNITURE KITS** — Queen Anne period antique reproduction furniture kits and cabriole legs carefully crafted in Black Walnut, Cherry, and Honduras Mahogany. Kits include illustrated instructions, hardware, and brass. Send for color brochure. WINDSOR CLASSICS. \$1.00. Circle No. 2050.

**THE WING M-100 ROUTER TEMPLATE — FAST AND EASY PRODUCTION FOR SMALL, MEDIUM, OR LARGE PANELS** — Both versatile and fast, the M-100 Router Template and its selection of interchangeable design units, allows competent production of a wide variety of ornamental borders by

TO ORDER THESE BOOKLETS, USE COUPON ON PAGE 134



**Woodworking BOOKS ON SALE**

(All prices post paid)

- Spielman — Router Handbook (list \$10) ..... \$9.00
- Dew — Make a Rocking Horse (list \$10) ..... \$9.00
- Bridenhagen — Realistic Decoys (list \$15) ..... \$13.00
- Sainsbury — Planecraft (list \$10) ..... \$9.00
- Feirer — Cabinetmaking & Millwork (list \$40) ..... \$35.00
- Frid — Joinery or Shaping (list \$18) ..... \$16.00
- both for \$31.00
- Hoadley — Understanding Wood (list \$20) ..... \$18.00
- Nakashima — Soul of a Tree (list \$50) ..... \$46.00
- Sam Maloof — Woodworker (list \$50) ..... \$44.00
- Dale Nish — Woodturning (2 book; list \$29) ..... \$26.00
- Techniques Vol. 1-6 \$15 ea. (list \$17) ..... All 6 — \$86.00
- Krenov — Set of 4 books in paperback (list \$54) ..... \$45
- Odate — Japanese Tools (list \$23) ..... \$20.00
- Watts — Houseful of Furniture (list \$19) ..... \$17.00

Call Toll Free for Other Titles

**Manny's Woodworker's Place**  
602 S. Broadway  
Lexington, Ky. 40508

Hours 10-5:30 Mon-Sat  
VISA, MC, Checks, COD (\$2)  
Ask for free sales brochure

ORDER TOLL FREE  
1-800-243-0713  
in KY call  
600-255-5444

SALE on



Industrial quality carbide tipped sawblades  
All prices include shipping.

- LM 72M — 10" Rip, 24t (list \$65) \$42
- LU 85M — 10" Crosscut 80t (list \$111) \$72
- LU 73M — 10" Crosscut 60t (list \$79) \$45
- LU 84M — 10" Combi 50t (list \$71) \$45

Shopsmith owners - Add \$8 ea. for 1 1/4" arbor

Carbide tipped Dado Heads

- AD 800 — 8" Adjustable Dado (list \$63) \$49
- AD 306 — 6" Dado Set (list \$140) \$98
- DS 308 — 8" Dado Set (list \$170) \$120

1/3 OFF

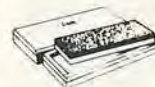

Arkansas Stones

- Bench Stones**
- Soft 6x2x1 \$12
- 8x2x1 \$17
- Hard 6x2x1 \$18
- 8x2x1 \$23
- Black 4x2x1 \$16
- 6x2x1 \$28

(All prices postpaid)

Combination Stones

- Soft - Hard
- 6x2x1/2 \$20
- 8x2x1/2 \$25

Block Mounted Stones

- Set 1 one ea. of soft, hard, & black, 6x1 1/2x1/2 — \$35
- Set 2 one ea. of soft, hard, & black, 8x1 1/2x1/2 — \$55

All stones individually packed in cedar boxes

# TURNCRAFT CLOCKS

•For the woodworker who enjoys a challenge we offer the "MINNESOTAN" Grandfather Plan as shown.

•TURNCRAFT is a leader in the clock plan industry with 35 clock plans. Ask for our FREE PLAN BROCHURE.

•72 page CLOCK CATALOG, hundreds of clock building items. \$2.50 refundable on your first \$25.00 order. Add \$2.00 for first class postage.

•Quartz Movements as low as \$2.75 in quantities. Ask for our FREE QUARTZ BATTERY BROCHURE.

THE "MINNESOTAN" Grandfather Plan #110 \$9.50 + \$1.50 Shipping 23½" Wide, 84" High, 14¼" Deep

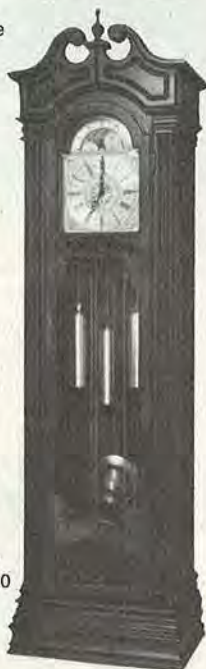

## TURNCRAFT CLOCK IMPORTS CO.

7912 Olson Hwy. 55 Golden Valley, MN 55427  
(612-544-1711) Dept. W85-14

Complete Detailed Plans For -  
**42" 4-Harness Folding Counterbalance Loom**  
\$15.00 Postpaid  
(Plans Only)

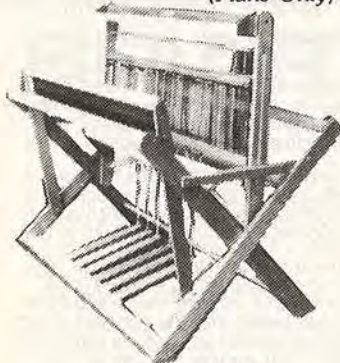

- Also Available -

Complete Kit For All Metal & Misc. Parts, Except Wood

Complete  
4-Harness Counterbalance Folding Looms, Floor Model, Ready To Weave -

Complete  
4-Harness Table Looms, Ready To Weave -

Send For Free Information To:

**TOMAR LOOMS**  
7711 N.W. 5th Ave.  
Vancouver, WA 98665

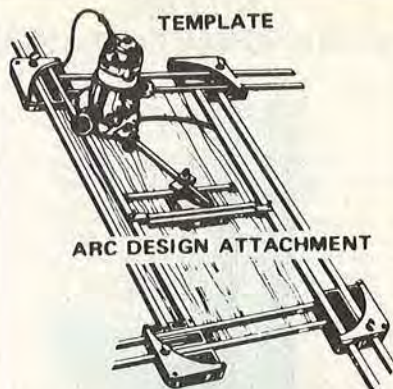

## COUNTLESS DESIGN COMBINATIONS

On panels, cabinet doors and drawers of all sizes  
...quick, professional results every time with the

**WING M-100 ROUTER TEMPLATE and the ARC DESIGN ATTACHMENT.**

BASIC TEMPLATE \$139.00  
ARC DESIGN ATTACHMENT \$78.00

**WING SALES & DISTRIBUTING CO. INC.**

918 E. Cedar Lane  
P.O. Box 1360  
Payson, Arizona 85547  
(602) 474-5836  
(602) 474-3036

## NEW! 24½ in. Variable Speed BAND SAW



At last, a pro-size, band saw priced for the home shop! Big 24½-in. throat easily handles large scrollwork, complex curves, 4 x 8 sheets. 9-in. vertical cut makes it easy to resaw valuable hardwoods. Ball bearing construction, all-steel welded frame to eliminate deflection. Can be ordered complete with motor, stand, dust collector, rip fence, scroll saw table. Full instructions.

### 30-DAY FREE TRIAL!

Send for complete facts on how you can try this versatile saw without risk! Easy Terms.

Call Toll-Free 1(800) 824-7888 Oper. 642

Woodmaster Power Tools, Dept. SW4  
2908 Oak, Kansas City, MO 64108

**YES!** Please rush me, free and without obligation, your Complete Information Kit on the new 24½" MODEL 500 BAND SAW plus facts on Woodmaster's 30-Day FREE TRIAL Money-Back Guarantee.

Name \_\_\_\_\_  
Address \_\_\_\_\_  
City \_\_\_\_\_  
State \_\_\_\_\_ Zip \_\_\_\_\_

## Pro-Edge®

**CONVERT YOUR 1 INCH Sander/Grinder into the IDEAL EDGE TOOL SHARPENER**



## SUPERB EDGES

ON CHISELS, GOUGES, PLANES AND MANY OTHER TOOLS

## Pro-Edge®

attaches with a single screw to Rockwell, Sears, Jet and other machines in minutes

WRITE FOR FREE BULLETIN

Send \$2.50 for Owner's Manual. Full refund with Pro-Edge order.



**Prakto, Inc.** 313/549-3833  
P.O. BOX 1023 Birmingham, Mich. 48012

## PERFECT MITERS GLASS-SMOOTH CUTS

Any wood:  
soft or hard!

Any angle:  
45°-90°



**CLEAN, PRECISE CUTS LIKE THESE ARE A SNAP**

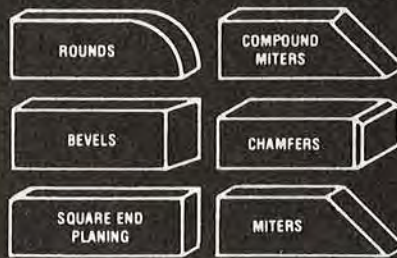

### LION MITER TRIMMER

POOTATUCK CORPORATION  
P. O. Box 24 • Dept. BHW1  
Windsor, VT 05089 (802) 674-5984

Name \_\_\_\_\_

Address \_\_\_\_\_

ZIP \_\_\_\_\_



either professionals or home craftsmen. It can be used with any make of portable router to decorate a door or drawer in just 30 seconds. Send for literature. WING SALES AND DIST. CO. Free. Circle No. 2055.

**WOOD FINISHING SUPPLIES** — A 36-page catalog of everything needed for finishing wood. From strippers, abrasives, stains, shellacs, varnish, lacquer, oil finishes, solvents, thinners, rubbing mediums, books, brushes, touch-up items, respirators, tack rags, to gold leaf and gilding supplies. The first 11 pages of this catalog are devoted to helpful information on how to use these materials. WOOD FINISHING SUPPLY CO., INC. \$2.50. Circle No. 2062.

**WOODWORKERS CATALOG** — More than a catalog — it's one of the best sources for quality wood-working tools. You'll find everything from bit braces to wood borers, from saws to sharpening stones. Every product is sold satisfaction guaranteed. WOODCRAFT SUPPLY CORP. Free Circle No. 2070.

**THE JAPAN WOODWORKER'S 1984 CATALOG** — is loaded with the best tools you can get your hands on. In our catalog you will find a complete selection of Japanese tools for the woodcarver, carpenter, and cabinet maker. Send for catalog plus supplements for next two years. WOODLINE-THE JAPAN WOODWORKER. \$1.50. Circle No. 2075.

**THE ULTIMATE DOVETAIL JIG** — Industrial quality Dovetail Jig utilizes ball bearing, guided router cutters for producing perfect machine, hand-typed, and sliding Dovetails using your router. WOODMACHINE CO. 25¢. Circle No. 2077.

**POWER-FEED DRUM SANDER** — Use the Woodmaster Model 1200 to dimension and finish-sand cabinet pieces, resawn stock, paneling, grandfather clocks, toys, table tops, knees, burls, crotches, and much more. This heavy-duty 12 in. sander comes complete with motor and stand. 30 day free trial...easy terms. Send for information kit. WOODMASTER TOOLS. Free. Circle No. 2080.

**HIGH PRECISION SCROLL SAW** — The sturdy, new Woodmaster Model 1600 gives you all the fea-

tures found in more expensive machines including big, 16-in. throat capacity, 2-in. cutting depth, a generous, oversized worktable, ball-bearing drive... and much more! Send for complete facts. See how you can use the Woodmaster Model 1600 in your own shop for one full month completely without risk. Send for information kit. WOODMASTER TOOLS, INC. Free. Circle No. 2081.

**GIANT 24½-IN., 3-SPEED BAND SAW** — Big 24½-in. throat easily handles large scrollwork, complex curves, 4x8 sheets. 9-in. vertical cut makes it easy to resaw valuable hardwoods. Ball bearing construction, all-steel welded frame to eliminate deflection. Can be ordered complete with motor, stand, dust collector, rip fence, scroll saw table. Full instructions. Send for complete facts on how you can try this versatile saw without risk. Easy terms. WOODMASTER TOOLS, INC. Free. Circle No. 2082.

**PLANNER/MOLDER/JOINTER** — This variable power feed tool converts low-cost lumber into valuable finished stock. Turns out perfect quarter-round casing, base mold, tongue and groove... all popular patterns including picture frames. Joints super-true edges, squared stock, levels and chamfers. Optional sanding attachment quickly converts unit to one of the finest drum sanders available. 30-day free trial... easy terms. Send for information kit. WOODMASTER TOOLS, INC. Free. Circle No. 2083.

**LIVOS NON-TOXIC FINISHES** — Safe for children, animals, and plants. Send for mail order catalog on: oil finishes, waxes, shellacs, lacquers, polishes, stain and wood preservatives. Send also for your mail order catalog of quality tools for professionals and craftsmen. WOODPECKER'S TOOLS, INC. Free. Circle No. 2110.

**WOODWORKERS SUPPLY** — Offers high quality tools and supplies for skilled, amateur, and professional woodworkers. Our complete catalog includes machinery, hand tools, plans, router bits, shaper cutters, wood specialties, and more. For your two year subscription send to WOODWORKERS SUPPLY OF NEW MEXICO. \$2.00. Circle No. 2125.

**QUALITY AMERICAN-MADE WOOD TURNINGS** TO ORDER THESE BOOKLETS, USE COUPON ON PAGE 134

— such as shaker pegs, spindles, toy wheels, toy parts, craft items, and dowel rods in birch, oak, walnut, and cherry. Send for complete 32-page catalog. WOODWORKS. \$1.00. Circle No. 2130.

**WOOD WORLD CATALOG** — Send for your catalog on lumber, veneer, hand and power tools, with helpful hints on how to use your tools and materials to their best advantage. Send for complete color catalog. WOOD WORLD. \$2.50. Circle No. 2140.

**EXOTIC HARDWOODS** — Wyndham Woods offers the finest exotic hardwoods, precision cut and dried to our specifications at a modern European mill. As a direct importer we can offer substantial savings on such fine woods as padouk, mahogany, shedua, doussie, zebra wood, and many others, as well as domestic species and veneers. For the best wood at the best prices, send for our catalog. WYNDHAM WOODS, INC. 50¢. Circle No. 2160.

**WOODWORKING POWER TOOLS AND MACHINERY** — A selection of full-line catalogs from leading manufacturers featuring complete specifications and accessory listings; discount price lists included. THE XYLOPHILE'S CO. \$2.50. Circle No. 2170.

**CARBIDE ROUTER AND SHAPER BITS** — Our industrial carbide router bits will make you and your work achieve your goals, make things happen, and avoid problems. Zac router bits will expand your possibilities and options while giving the precise details you need. With your router and our tooling your shop becomes a system that you and your family will be proud of. Feel the satisfaction of improving your shops while you and others will know you bought the best. We consistently deliver high-quality router bits shaper cutters. Our 32-page catalog will improve your knowledge and skills. Send for it today. ZAC PRODUCTS, INC. \$1.50. Circle No. 2195.

**WOODTURNING INSTRUCTION AND SUPPLIES** — Brochure describes program of personal instruction at our studio, with full accommodations. Also Myford lathes, Sorby tools, doublefaced tape, chucks, and our newsletter for turners. RUSS ZIMMERMAN. 60¢. Circle No. 2200.

**NEW!  
EXCLUSIVE**

# WORLD'S FIRST CALCULATING TAPE MEASURE!

**\$49.95**  
Special  
Introductory  
Price

## SMART/TAPE Jr

You just measure—enter—touch a button  
To make 33 different conversions—AUTOMATICALLY!

- Finds Hypotenuse of a Triangle fast, accurately
  - Diameter ↔ Circumference • Meters ↔ Inches
  - Miles ↔ Kilometers • Ounces ↔ Liters ↔ Grams
  - Fahrenheit ↔ Centigrade • Areas, Volumes
  - Plus...
  - Simple or Compound Interest • Squares and Powers
  - Reciprocals and Memory Calculations
- ...and it's a 16 foot/5 meter retracting steel tape!

All the formulas you learned in high school—programmed into a palm-size calculator that's not much bigger than an ordinary steel tape! 33 conversions at the touch of a button or two make this an amazing time-saver for anyone who works with measurements and numbers.

**Computerized SMART/TAPE**  
displays as you measure—in inches or meters

For even more sophisticated calculations. Measure up to 6 different dimensions, store them, then recall in any order to calculate diagonal length, area, volume, board feet required, etc. Measure from point to point, then adjust for sag, tension and temperature. Convert inches to meters and back; even convert currency or recall phone numbers. Instantly!



Introductory Special  
**\$149.95**



**IF YOU DO CARPENTRY**, cabinet-making or general construction, you'll find the automatic Pythagorean calculator alone is more than worth the price of the instrument in time and materials saved, errors eliminated!

**Order TOLL FREE 800-243-1037**  
In Connecticut call 797-0772

*the Fine Tool Shops* P.O. Box 1262, 20 Backus Avenue, Danbury, CT 06810

Qty. \_\_\_\_\_ SMART/TAPE Jr. @ \$49.95 (#108-0050) \$ \_\_\_\_\_

Qty. \_\_\_\_\_ Computerized SMART/TAPE @ \$149.95 (#108-0001) \$ \_\_\_\_\_

Shipping/Handling \$ 3.95

Charge my  MasterCard  VISA  AmEx  Diners' Club

TOTAL enclosed \$ \_\_\_\_\_

Card No. \_\_\_\_\_ Name \_\_\_\_\_

Exp. Date \_\_\_\_\_ Address \_\_\_\_\_

Signature \_\_\_\_\_ City \_\_\_\_\_ State \_\_\_\_\_ Zip \_\_\_\_\_

**UNCONDITIONAL GUARANTEE**

Use Smart/Tape for 30 days. If it doesn't save you time, prevent errors, and give you the right answers faster and easier than any other calculator you've ever used—return it for a prompt, cheerful refund!

Better Homes and Gardens®

# WOOD

THE MAGAZINE FOR HOME WOODWORKERS

## COMING NEXT ISSUE

### YOU'LL LEARN ABOUT

Veneering techniques...  
Table saw buymanship...  
Making an old finish look like  
new... Temper-saving turning  
tips... Dust masks and  
respirators... Checking and  
correcting the accuracy of  
your measuring tools



### YOU'LL WANT TO BUILD

Our low-cost, last-for-a-life-  
time router table... A modular  
workbench grouping for  
your shop... A Shaker-style  
cupboard... A traditional  
hall table... Extensions for  
your table saw



### YOU'LL READ ABOUT

New, old-fangled woodwork-  
ing machines... The joiner's  
Old Hand Ways... Basic  
woodcarving tools... Keep-  
ing your shop clean (and safe)  
... Mail-order tool sources  
... The cactus that's a tree...  
Norwegian-style wood carving

**ALL THIS AND MORE  
IN MARCH/APRIL  
WOOD**

# Information

WORTH WRITING FOR

Better Homes and Gardens®  
WOOD, Jan./Feb. 1985  
P.O. BOX 2051  
CLINTON, IA 52732

TO ENSURE PROMPT HANDLING OF YOUR ORDER FOLLOW THESE INSTRUCTIONS:

- Circle your choice
- Enclose cash, check, money order for cost of booklets plus \$1.00 service charge (no stamps/foreign)
- Send coupon and remittance to address above
- ALLOW 4-6 WEEKS FOR DELIVERY
- Coupon expires February 18, 1986

### FREE LITERATURE

Circle numbers below corresponding to items in this issue.  
Please include \$1.00 for handling charge

20	530	930	1240	1450	1735	2080
40	540	950	1250	1520	1930	2081
273	550	1070	1255	1570	2025	2082
350	580	1130	1320	1625	2055	2083
460	781	1210	1380	1720	2070	2110

### PRICED LITERATURE

Numbers below refer to items on which there is a charge.  
Please include proper remittance.

1.....\$1.00	260.....\$1.00	585....\$2.00	720.....25c	1340....\$2.00	1754....\$8.95	2062.....\$2.50
10.....\$1.00	270.....\$1.00	590....\$4.65	750....\$2.00	1360....\$2.00	1820....\$1.00	2075.....\$1.50
15.....\$2.00	275.....\$1.00	591....\$4.65	770....\$1.00	1410....\$1.00	1850....\$2.00	2077.....25c
50.....\$2.00	290.....\$1.00	592....\$4.65	771....\$1.00	1420....\$1.00	1860....\$1.50	2125.....\$2.00
60.....\$1.00	310.....\$1.00	593...\$11.95	780....\$1.00	1440....\$1.00	1865....\$1.00	2130.....\$1.00
65.....\$1.00	320.....\$1.00	594....\$4.25	800....\$1.50	1710....\$3.00	1880....\$2.50	2140.....\$2.50
66.....50c	400.....\$3.00	600....\$3.00	900....\$1.00	1730....\$3.95	1900....\$1.95	2160.....50c
130.....\$2.00	420.....\$1.00	630.....25c	1020....\$1.00	1745....\$2.00	2020....60c	2170.....\$2.50
140.....\$1.00	500.....\$2.00	670....\$3.00	1215....\$2.00	1750....\$8.50	2030....\$1.99	2195.....\$1.50
150.....\$3.00	555....\$1.00	671....\$3.00	1220....\$1.00	1751....\$7.95	2031....\$1.99	2200.....60c
230.....\$1.00	560.....\$5.00	672....\$3.00	1280.....25c	1752....\$7.95	2032....\$1.99	
250.....\$1.00	570.....\$2.50	700....\$1.00	1300....\$1.00	1753....\$9.95	2050....\$1.00	

Name (please print) \_\_\_\_\_  
Address \_\_\_\_\_  
City \_\_\_\_\_  
State \_\_\_\_\_ Zip Code \_\_\_\_\_

### I AM ENCLOSING:

\$ \_\_\_\_\_ for priced items  
\$ 1.00 for handling  
\$ \_\_\_\_\_ total remittance

### OUR EDITORS INVITE YOU TO HELP THEM BY ANSWERING THESE QUESTIONS:

- Did you or any member of your household purchase any of the following vehicles in the past 12 months? (Check all that apply)
  - Cars
  - A.  1
  - B.  2
  - C.  3 or more
  - Trucks
  - D.  1
  - E.  2
  - F.  3 or more
  - Pickups
  - G.  1
  - H.  2
  - I.  3 or more
  - Vans
  - J.  1
  - K.  2
  - L.  3 or more
  - Sport/utility
  - M.  1
  - N.  2
  - O.  3 or more
  - P.  Did not purchase any vehicles in the past 12 months
- Did you or any member of your household purchase any of the following building products in the past 12 months? (Check all that apply)
  1.  Windows
  2.  Doors
  3.  Kitchen/bathroom fixtures or cabinets
  4.  Flooring



## ***RACK AND PINION PRECISION, INDEPENDENT SUSPENSION, AND IT CORNERS LIKE A DREAM.***

Get behind a Black & Decker Plunge Cut Router. Take hold of those big comfortable handles with the built-in trigger switch for better maneuverability.

Feel the horsepower, as it makes fast, smooth corners as well as professional edges, joints and trim.

Then, take in the view as you work behind the wide shatterproof chip shield.

Notice how the rack and pinion controls make cuts as precise as 1/64th of an inch. The cutting is easy and accurate, because the plunge-cut feature gives the motor independent suspension. So the router base hugs the wood when you lower the bit.

And to change bits, just flip the router onto its flat top, for easy access to both the fingertip bit lock and the built-in wrench holder.

Get this or another Black & Decker router (except 7600) before June 30, 1985, and you can save on a whole package of optional equipment. Including a \$7 rebate on our 11-piece set of router bits, and more.

So see the whole line of high-performance routers from Black & Decker. You'll want to drive one home today.



***BUILT LIKE A BLACK & DECKER.***

MINWAX® PRESENTS:

# THREE EASY STEPS TO FINE WOOD FINISHING



There is no simpler way to get a truly fine wood finish.

First, sand with successively finer grades of sandpaper to produce a smooth, bare wood surface.

Then, in one easy step, stain *and* seal, using Wood Finish by Minwax. It penetrates deep into fibers to become an integral, breathing

part of the wood, not just a surface film.

Lastly, choose the type of extra protection you want by applying a protective finish by Minwax... Finishing Wax for a rich lustre, Antique Oil

for a soft lustre and hard finish, or Polyurethane Finishes by Minwax for extra durability. From first step to last, you'll discover the difference Minwax quality makes.

## Free 22-page Booklet

Send for "Tips on Wood Finishing" today. You'll see that Minwax products help you do fine wood finishing as easy as 1, 2, 3.

Minwax Company, Inc., Dept. WM-15  
Box 995, Clifton, NJ 07014

Please send free booklet.

Name \_\_\_\_\_

Street \_\_\_\_\_

City \_\_\_\_\_

State \_\_\_\_\_

Zip \_\_\_\_\_



AMERICA'S FAVORITE  
WOOD FINISH FOR 80 YEARS.