

Better Homes and Gardens®

WOOD

THE MAGAZINE FOR HOME WOODWORKERS

\$2.95

APRIL 1985 • ISSUE NO. 4
Display Until April 18

- **SHOP-TESTED**

how to apply
flexible wood
veneer

- **TABLE SAWS**
choosing the
right one for
your shop

- **WOOD CARVING**
a simple horse
for first-timers

- **LOTS OF
PROJECTS**
Shaker cupboard
waterfall table
modular
workbenches
hall table

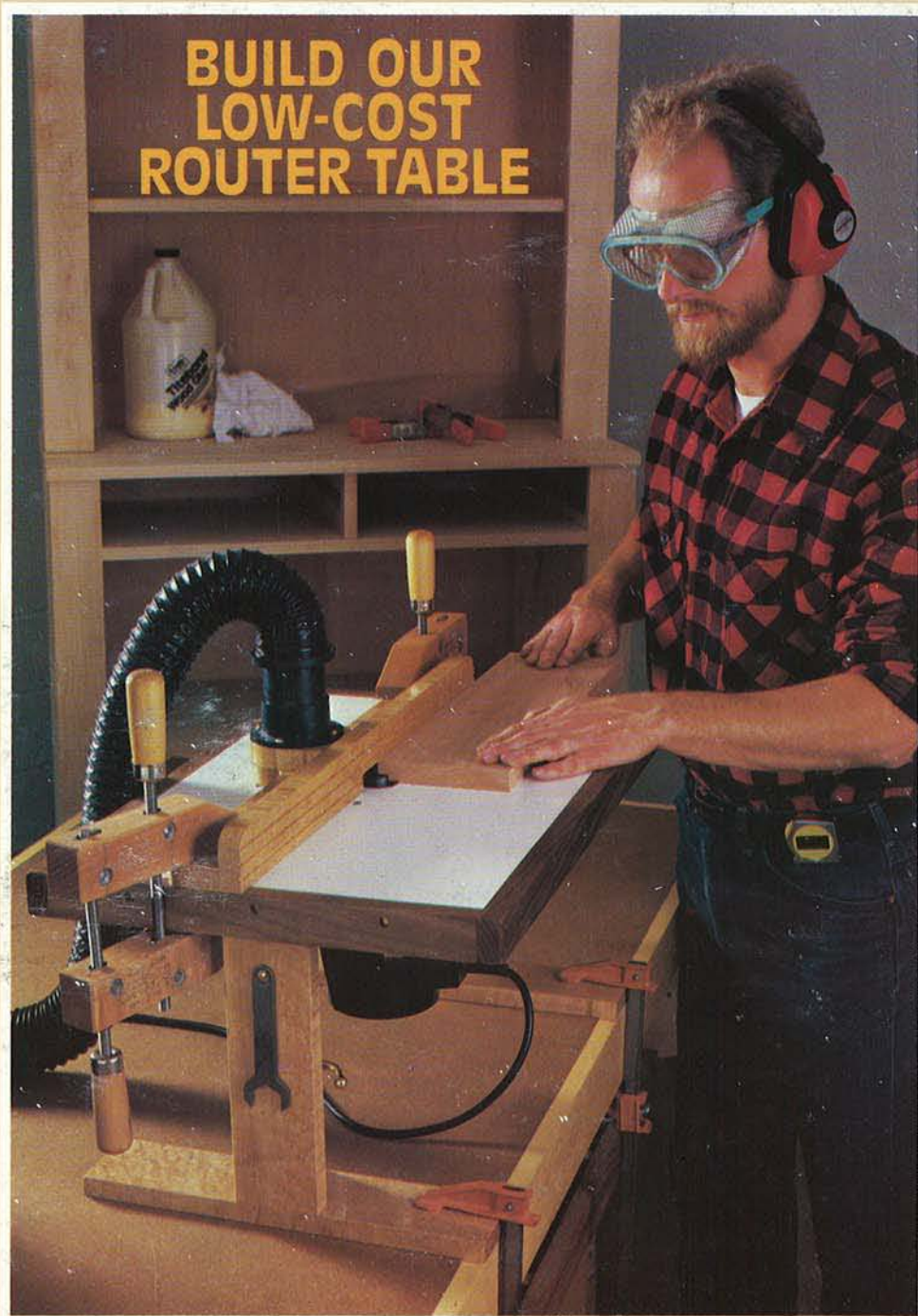

SET YOUR OWN SPEED LIMIT.

Introducing the New Delta 18" Variable Speed Electronic Scroll Saw.

At Delta, we don't believe anyone should impose their limits on you. That's why we've made the first infinitely variable speed scroll saw with an electronic "speedometer".

Take a curve *anywhere* from 100 to 2,000 CS/M. Watch the speed increase on the readout. Lock it in wherever it feels best.



Our electronics keep the blade speed constant. And a dry drive design makes for long, trouble-free performance.

The new Delta scroll saw makes intricate cutting a breeze—working in areas as tight as 1/64" diameter. For large jobs it has a big 2" thick capacity. And it makes cuts so fast and smooth, your sander will start feeling neglected.

Beyond simple cuts and curves, the 16" cast-iron table tilts to accommodate taper tenon and bevel cutting. It rotates 90°, and tilts 30° left, 45° right, 15° up, and 30° down.

Naturally, you'll want to put this versatility to work right away.

So we'll give you an assortment of 8 dozen blades with your new scroll saw.

With so many blades thrown in, you might expect to run through them like water.

But you won't. Our new solid "C" arm and constant blade

tension keep blade breakage remarkably low.

And when you have to change blades, or thread one into an intricate series of internal cuts, our pivoting blade chucks offer the fastest blade changing and tensioning in the industry.

If all this sounds remarkably well thought-out, well, it ought to.

After all, Delta introduced the original scroll saw back in the '20's.

Now, it's only fitting we introduce the ultimate one.

Call us toll-free to learn the name of the Delta distributor nearest you. Delta International Machinery Corp. (Formerly Rockwell Power Tool Division), 800/438-2486 (in PA, 800/438-2487).

 **DELTA**
Behind Our New Name Is Our Old Reputation.

 **DELTA**

1806
STROKES/MIN.

FASTER
OFF



115 VAC 1.3 AMP

SAFETY
BEFORE

5. Hold workpiece firmly against table.
6. Keep hands and fingers away from blade.
7. Do not make any adjustments, remove pieces, until tool has been stopped.

Do not operate while under the influence of alcohol or medication.

HOW-TO BOOK CLUB

The Best Source for Quality, Service and Value!

Practical Projects . . . Exciting Ideas . . . and Time- and Money-Saving Tools for Homeowners, Hobbyists, and Do-It Yourselfers!

Select 5 Books for Only \$2⁹⁵

Values to \$110.75

Join Now, Get a Shop Apron FREE!



1528
List \$18.95



1547
List \$11.50 (paper)



1574
List \$19.95



1381
List \$14.50 (paper)



1297
List \$17.95



1238
List \$8.25 (paper)



1762
List \$21.95



1046
List \$7.25 (paper)



1361
List \$18.95



1463
List \$13.95 (paper)



1639
List \$16.95



1597
List \$10.25 (paper)



1484
List \$14.95 (paper)

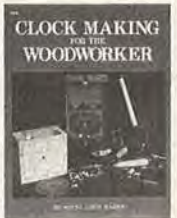

1648
List \$16.95



1458
List \$12.95 (paper)



1638
List \$26.95



1409
List \$15.95



1664
List \$14.50 (paper)



1554
List \$17.95



1348
List \$16.95



1784
List \$17.95



1440
List \$9.95 (paper)



1655
List \$21.95



1530
List \$15.50 (paper)



1508
List \$19.95



1321
List \$13.95



1658
List \$18.95



1504
List \$17.50 (paper)



7 very good reasons to join the How-To Book Club

- **Big Savings.** Save 20% to 75% on books sure to increase your how-to know-how
- **No-Risk Guarantee.** All books returnable within 10 days without obligation
- **Club News Bulletins.** All about current selections—mains, alternates, extras—plus bonus offers. Comes 13 times a year with hundreds of up-to-the-minute titles you can pick from
- **"Automatic Order."** Do nothing, and the Main selection will be shipped automatically! But . . . if you want an Alternate selection—or no books at all—we'll follow the instructions you give on the reply form provided with every News Bulletin
- **Bonus Books.** Immediately get a Dividend Certificate with every book purchased and qualify for big discounts of 60% to 80%
- **Extra Bonuses.** Take advantage of added-value promotions, plus special discounts.
- **Exceptional Quality.** All books are first-rate publisher's editions selected by our Editorial Board and filled with useful, up-to-the-minute information



HOW-TO BOOK CLUB

P.O. Box 8, Blue Ridge Summit, PA 17214

Please accept my membership in the How-To Book Club and send the 5 volumes circled below, plus, my FREE shop apron, billing me \$2.95 plus shipping and handling charges. If not satisfied, I may return the books within ten days without obligation and have my membership cancelled. I agree to purchase 4 or more books at reduced Club prices (plus shipping/handling) during the next 12 months, and may resign any time thereafter.

1046 1238 1297 1321 1348 1361 1381 1409 1440
1458 1463 1484 1504 1508 1528 1530 1547 1554 1574
1597 1638 1639 1648 1655 1658 1664 1762 1784

Name _____ Phone _____

Address _____

City _____

State _____ Zip _____

Valid for new members only. Foreign applicants will receive special ordering instructions. Canada must remit in U.S. currency. This order subject to acceptance by the How-To Book Club.

BHGW-385

FREE SANDING BELTS

DIRECT FROM THE MANUFACTURER

GET SIX FREE BELTS FOR EACH DOZEN ORDERED. All belts are aluminum oxide first quality. Our electronic presses make smooth bump-free splices.

Check your size and how many dozen. We will ship assorted grits unless otherwise specified.

- 1" x 30" — \$12.70/doz.
- 1" x 42" — 12.75/doz.
- 1" x 44" — 12.80/doz.
- 3" x 18" — 13.75/doz.
- 3" x 21" — 14.25/doz.
- 3" x 23 3/4" — 14.70/doz.
- 3" x 24" — 14.75/doz.
- 3" x 27" — 15.25/doz.
- 4" x 21 3/4" — 16.75/doz.
- 4" x 24" — 17.25/doz.
- 4" x 36" — 20.95/doz.
- 6" x 48" — 26.95/1/2 doz. (3 FREE)

Other size belts on request.

9" x 11" Paper Sheets

A/O Cabinet Paper

- 50/pk. 100/pk.
- 40-D \$17/pk. \$31/pk.
- 50-D 16/pk. 28/pk.
- 60-D 15/pk. 26/pk.
- 80-D 14/pk. 24/pk.
- 100-C 13/pk. 22/pk.
- 120-C 13/pk. 22/pk.
- 150-C 13/pk. 22/pk.

No Load Finishing Paper

- 50/pk. 100/pk.
- 180-A \$11/pk. \$19/pk.
- 220-A 11/pk. 19/pk.
- 280-A 11/pk. 19/pk.
- 320-A 11/pk. 19/pk.
- 400-A 11/pk. 19/pk.

Wet or Dry S/C Paper

- 50/pk. 100/pk.
- 220-A \$15/pk. \$25/pk.
- 320-A 15/pk. 25/pk.
- 400-A 15/pk. 25/pk.
- 600-A 15/pk. 25/pk.

NEW ITEM!

- BELT CLEANING STICK - \$6.95

Prompt delivery from stock.
MONEY-BACK GUARANTEE

Shipping Charges - Under \$35 add \$2.50; \$35 or more add \$4.00—PA residents add 6% sales tax.

- Check or Money Order.
- MasterCard VISA Exp. Date _____
- Acct. # _____
- Name _____
- Address _____
- City, State & Zip _____

CALL TOLL FREE

1-800-428-2222

PA Only - 1-800-222-2292

INDUSTRIAL ABRASIVES CO.

643 North Eighth Street
Reading, PA 19603

Shop Helper

Safety Guides

U.S. PAT. #3-738-403

Anti-Kickback Stock Feeder

SAVE TIME! SAVE MATERIAL!

LIKE HAVING AN EXTRA PAIR OF HANDS!

Keep your fingers away from cutters. Let Safety Guides hold your work. Use your hands to feed and control the operation. Push stock through Safety Guides with a follow board.

WORK WITH CONTROL!

Safety Guides provide control, stability, and smoothness in ripping and cutting operations. It helps eliminate uneven cuts binding and chatter of material when hand feeding power machinery.

WORK WITH CONFIDENCE!

The spring loaded SINGLE DIRECTION BALL BEARING WHEELS will not reverse, the hard composition wheels hold work down and against the fence without marring or marking.

WORK SAFELY!

SHOP HELPER Safety Guides hold work down firmly helping to assure safe handling of stock on: table saws, band saws, shapers, motorized mitre boxes, jointers, etc. SHOP HELPER Safety Guides meet CAL-OSHA requirements as an Anti-kickback device when properly mounted and adjusted.



\$79.50

Includes: One pair of Safety Guides with long mounting brackets and hardware, instructions for use and plans for auxiliary fences.

Extra Sets of Mounting Brackets
Long Brackets: \$12; Short Brackets: \$8
Satisfaction Guaranteed
or return within 30 days for a full refund.

SAFETY IS A MATTER OF SELF-RESPECT!

To Order: VISA/MC Call Toll Free: 800-344-7455; California: 800-828-8833

For Free Brochure Write: P.O. Box 1202, Tulare, CA 93275

Better Homes and Gardens

WOOD

THE MAGAZINE FOR HOME WOODWORKERS

April 1985 Issue No. 4

Editorial/Art Staff

Editor **LARRY CLAYTON**
Art Director **C.L. GATZKE**
Design Editor **JAMES R. DOWNING**
Features Editor **PETER J. STEPHANO**
How-To Editor **MARLEN KEMMET**
Project Builder **JAMES E. BOELLING**
Administrative Assistant **DARLENE REYNOLDS**

Technical Consultants **GEORGE GRANSETH**, Product Testing **ALAN D. MILLS**, Finishing **VERNON U. WARD**, Collectible Tools

Editorial Director **DORIS M. EBY**
Publisher **ADOLPH AUERBACHER**

Editorial Services

Executive Director **DUANE L. GREGG**
Director, Editorial Research **C. RAY DEATON**
Administrative Editor **ROSE ANDERSON**

Associate Publisher **JERRY KAPLAN**
National Advertising Manager **DAVE COHEN**
Promotion/Research Director **TOM TROLAND**
Circulation **JERRY WARD**
Production **DALE SCHENKELBERG**

Publishing Group Officers

President **JACK D. REHM**
Senior Vice-Presidents
General Manager,
Magazines **JAMES A. AUTRY**
General Manager,
Books and Newspapers **FRED STINES**
Group Vice President,
Editorial Director **DORIS M. EBY**

Corporate Officers

Chairman of the Board **E. T. MEREDITH III**
President **ROBERT A. BURNETT**
Group Presidents: Publishing **JACK D. REHM** Broadcasting **W. C. McREYNOLDS** Real Estate **ALLEN L. SABBAG**
Senior Vice-President **JAMES CONLEY**
Vice Presidents
Corporate Relations **DONALD L. ARNOLD** General Counsel and Assistant Secretary **THOMAS G. FISHER**
Product Development **NEIL KUEHN** Corporate Planning **HERB SCHULTE** Finance **WILLIAM H. STRAW**
Administrative Services **GERALD D. THORNTON**
Secretary **BETTY CAMPBELL MADDEN**
Treasurer **MICHAEL A. SELL**
Corporate Controller **LARRY D. HARTSOOK**

Better Homes and Gardens, WOOD — the magazine for home woodworkers (ISSN-0743-894X) is published bimonthly in February, April, June, August, October, and December by Meredith Corporation, 1716 Locust Street, Des Moines, IA 50336. Application to mail at second-class postage rates is pending at Des Moines, IA. Trademark registered in Canada and Australia. Marca Registrada en Mexico. **SUBSCRIPTION PRICES:** One year \$15 in the United States and its possessions. Canada and other countries add \$6 per year. **POSTMASTER:** Send address changes to WOOD 1716 Locust Street, Des Moines, IA 50336. April 1985, No. 4. **CUSTOMER SERVICE:** For service on your magazine subscriptions, including change of address, write to Customer Service Manager ROBERT AUSTIN, P.O. Box 10628, Des Moines, IA 50336. Please enclose a recent address label.

©COPYRIGHT MEREDITH CORPORATION 1985. ALL RIGHTS RESERVED. PRINTED IN U.S.A.

Total Shop . . . the name for quality.

You've heard of the Shopsmith® woodworking machine — now take a look at Total Shop — the improved woodworking machine.

For Example:

1. 1½hp motor develops nearly 3hp while Shopsmith® motor is 1⅓hp developing 2hp.
2. Motor can be altered by owner to 220V. Shopsmith® does not have this option.
3. Though a larger and more powerful motor, Total Shop runs quieter than the Shopsmith® machine.

*Let us send you 11 more reasons
Total Shop is a better buy.*

**Attention Shopsmith® Owners:
Call today for our accessory brochure
and save money.**

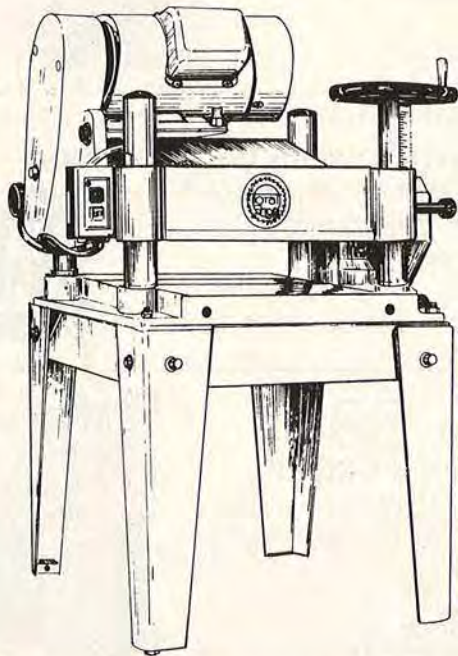

TotalShop®

P. O. Box 16297/Greenville, SC 29606



CALL TODAY
toll free
1-800-845-9356
in S.C. call
288-4174

Introducing:

Total Shop TS 15-6 Planer

- 110 V or 220 V
- Stand & dust collector available
- 2 HP motor
- 15" width, 6" thickness

clip and mail coupon for: Free Informational Kit

TotalShop®

Dept. Q
P.O. Box 16297
Greenville, SC 29606

Your Name _____

Address _____

City _____ State _____ Zip _____

Phone _____

Multipurpose tool TS 15-6 Planer

Training Schools available

©United Metal Services, Inc.

**NOW!
REDUCE THE
RISK AT YOUR
TABLE SAW**



folds down neatly

WITH THE **MOBILE™
NEW SAWING CENTER**

OUTFEED ROLLERS

- safe, accurate sawing
- available in 15" and 37" widths
- handle panels with ease
- dual-position table

AND INCREASE FLOOR SPACE

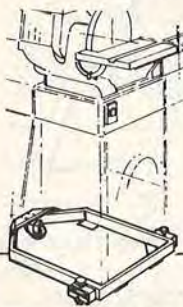

MOBILE MACHINE BASES

- increase shop working area
- maximize usable floor space
- 3 point base will not rock
- locking wheels
- makes machine so easy to use and store
- over 80 standard models

PLANER STAND WITH ROLLERS

- raises planer to proper working height
- provides machine mobility
- five-fold increase in workpiece support
- storage is a snap



A NEW ADDITION
portable, adjustable
rollertable -
for use with any
machine or operation

EASY DOES IT!

Discover HTC's many unique products designed only with you, the dedicated woodworker in mind. Find out how you can make your machining safer, increase working area of your shop and accomplish nearly impossible tasks easily, quickly and accurately - **all by yourself!**

CALL TODAY!

HTC PRODUCTS, INC.
120 E. HUDSON S-8
ROYAL OAK, MI 48067
(313) 399-6185



1-800-624-2027 ext. 108

Better Homes and Gardens®
WOOD

THE MAGAZINE FOR HOME WOODWORKERS

APRIL 1985

ISSUE NO. 4

WOOD PROFILE
CHERRY 27

Learn why this native American hardwood has found such favor among furniture makers for so many years

FURNITURE PROJECT
TRADITIONAL-STYLE HALL TABLE 28

Simple, straightforward design and the charm of genuine cherry wood combine to create a furniture piece of extraordinary beauty



HOMEMADE TOOLS
OUR LOW-COST, LAST-FOR-A-LIFETIME ROUTER TABLE 32

If you think your router does a lot for you already, just wait until you team it up with this easy-to-build accessory



TOOLS AND TOOL COLLECTING
OLD NEWFANGLED WOODWORKING MACHINES 35

In the 1880s and '90s lots of professional woodworkers looked to these ingenious tools to maintain that competitive edge



GREAT IDEAS FROM OUR SHOP
ANY-WAY-YOU-WANT-IT MODULAR WORKBENCH GROUP 38

Mix-and-match these 24"×24" modules for a truly efficient workshop work center with storage space galore



SHOP-TESTED TECHNIQUES
WORKING WITH FLEXIBLE WOOD VENEERS 45

If you haven't yet worked with this paper-thin wood product, you're missing out on some exciting new options in woodworking

NOW YOU CAN BUILD IT

"GIFT-WRAPPED" TISSUE BOX COVER 50

OVER-EASY WATERFALL TABLE 51

Two fun-to-build, useful projects that not only look great when they're finished but also help sharpen your veneer-application skills



TOOL BUYMANSHIP

TABLE SAWS: HOW TO CHOOSE THE RIGHT MACHINE FOR YOUR SHOP 55

Stationary saw or bench-top model, domestic or import, materials and machining, power-drive mechanisms, rip fence options, the matter of motors, and more helpful buymanship information

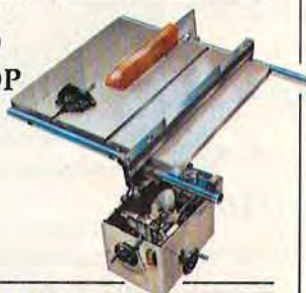

FURNITURE PROJECT

SHAKER-STYLE CUPBOARD 59

This back-to-basics rendition of a Shaker classic features the frame-and-panel construction these excellent woodworkers loved



FINISHING AND REFINISHING

EASY WAYS TO MAKE THAT OLD FINISH LOOK LIKE NEW AGAIN 66

Before you get out the rubber gloves, respirator, and finish stripper, consider some options that may save you lots of toil

CRAFTSMAN CLOSE-UP

HARLEY REFSAL AND HIS SCANDINAVIAN-STYLE CARVINGS 70

Read about how (and why) this accomplished wood carver depicts the hard realities of life of early Scandinavian immigrants



SHORT-SUBJECT FEATURES

Letters to the Editor	8	Old Hand Ways	54
Tips From Your Shop		The WOOD Magazine	
(And Ours)	10	3-ring binder jig	67
News and Events	18	Project Showcase	68
Books Worth Reading	22	Products That Perform	79
Associations You Should		Saguaro—The World's Slowest-	
Know About	24	Growing Tree	83



**Factory Lumber Outlet
"Woods of the World"**

200 SHREWSBURY STREET
BOYLSTON, MASSACHUSETTS 01505

We stock over 100 species of domestic & exotic woods including:

- All Domestic Woods
- Apple
- Balsa
- Bengé
- Brazilian Rosewood
- Bubinga
- Ceylon and African Ebony
- Ceylon Satinwood
- Cocobolo
- Curly and Birds Eye Maple
- East Indian Rosewood
- English Brown Oak
- European Pearwood
- Goncalo Alves
- Holly
- Honduras Mahogany
- Honduras Rosewood
- Iroko
- Jelutong
- Macassar Ebony
- Mahogany
- Mexican Rosewood (Bocote)
- Padouk
- Philippine Mahogany
- Purple Heart
- Shedua
- Teak

During more than a half century as millwrights and cabinetmakers, we have become experts in acquiring and working with the finest hardwoods and softwoods. Our knowledge of the best domestic and worldwide sources of rare woods is without peer. The large volumes in which we buy fine woods affords us the best possible prices which, in turn, we pass along to you. Iaccarino and Son is also your source for the finest lines of high quality woodworking hand tools.

Call For Free Catalog

(617) 869-2791

TOLL FREE:

In Mass. 1-800-521-0039

New England 1-800-222-1420

**AT LAST!
A HIGH-PRECISION
SCROLL
SAW
AT AN
AFFORDABLE
PRICE!**

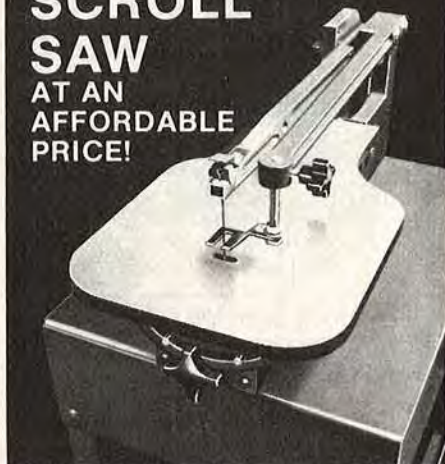

**THE SAW THAT TURNS
BEGINNERS INTO EXPERTS!**

Use this high-precision saw to make hundreds of profitable, unusual items . . . toys, name-bars, filagree work, clocks, holders . . . the list is nearly endless! Because the Model 1600 cuts so smoothly, sanding is virtually unnecessary!

BUILT TO LAST!

The sturdy new Woodmaster Model 1600 gives you all the features found in more expensive machines including a big, 16-in. throat capacity, 2-in. cutting depth, a generous, oversize worktable, ball-bearing drive . . . and much more!

FULL TILTING WORKTABLE!

Unlike any other scroll saw, the Woodmaster's table tilts and locks in any position up to 45° right or left. This means you can produce work on the Model 1600 impossible to duplicate on any other parallel or C-arm scroll saw! Can be ordered complete with motor, stand and dust blower. Easy Terms.

30-DAY FREE TRIAL!

Send For Complete Facts! See how you can use the Woodmaster Model 1600 in your own shop for one full month completely without risk! MAIL COUPON TODAY or:

Call Toll-Free

1(800) 824-7888 Oper. 642

**Woodmaster Power Tools, Inc.
Dept. CW4
2908 Oak, Kansas City, MO 64108**



No Obligation . . .
No Salesman Will Call

Woodmaster Power Tools
Dept. CW5
2908 Oak
Kansas City, MO 64108

YES! Please rush me, free and without obligation, your Complete information Kit on the new MODEL 1600 SCROLL SAW plus facts on Woodmaster's 30-Day FREE TRIAL Money-Back Guarantee!

Name _____
Address _____
City _____
State _____ Zip _____

The Editor's Angle



The bind-your-own ring binder jig

A big thanks to all of you who took the time to respond to our questionnaire in Issue 1. I appreciate your input as well as that from other readers who have been sharing their thoughts as to what they want to see more of in future issues of WOOD.

I had hoped all along that many of you would want to save past issues of WOOD as reference. So it was reassuring to hear that many of you intend to do just that. One subscriber, Raymond Dobelstein, from Flemington, New Jersey, even developed a jig (shown above) that allows you to drill binder holes in each issue. I liked the idea so much I purchased it from Ray. If you're interested in building a ring-binder jig—it's easy to do—see page 67. In Issue 5, we'll show you how to make a nifty wooden binder to hold your back issues.

Speaking of great ideas, remember that we're always on the lookout for well-designed projects to present in the magazine. If you've designed and built a project you want WOOD to consider for publication, I'd like to hear from you. Obviously, if you can send along a snapshot of the project, that will allow me to more clearly see what you have in mind.

One thing about the questionnaire results that did surprise me, though, is how few women responded. I know you're out there, ladies; let me hear from you. This magazine is for you, too, you know.

And speaking of ladies, my wife thinks that just because I'm Editor of WOOD, I can spend all my time building all those things she's been after me to build during our 14 years of marriage. (I'd love to, dear, but I'm just too busy putting out this magazine. Maybe later!) Sometimes I'm afraid to show her the latest issue; she's always finding something she likes. Here's hoping you do, too.



Print this article

Larry Clayton

Like Having A Lumberyard Right in Your Shop!

PLANER MOLDER JOINTER 4-IN-1 POWER-FEED SANDER



**FREE
30-DAY
TRIAL!**
Send Coupon
Today For
Complete Facts!
Made in U.S.A.

Here's What Woodmaster Owners Say:

Shop Test Results — "It does an excellent job of planing on a par with more expensive machines, and even better than some commercial models."

Jay Hedden, Editor, Workbench Magazine

Gets More Done — "I build grandfather clocks, music boxes, toys and picture frames. They say a craftsman is only as good as his tools, and let me tell you, my Woodmaster is tops. I get more done, and done right, than I ever did before."

R.V. Delacourt, Cleveland, Ohio

Best Value — "After checking them all, Woodmaster was obviously the best deal for the money. Also, I would like to acknowledge the polite and prompt service."

E.D. Holtz, North Carolina

Likes Woodmaster Best — "I have two other planers in my shop... wouldn't trade my Woodmaster for either one. I am delighted with its versatility and precision."

Ron's Custom Cabinets, Colorado

Paid Off Fast — "Paid for itself in no time flat."

E.L. Walters, North Dakota

Saves You Money!

Put this versatile power-feed tool to work in your own shop. See how fast it **pays for itself!** Quickly converts low-cost rough lumber into valuable finished stock. Turns out perfect quarter-round, casing, base mold, tongue & groove... all popular patterns... any custom design. Joints super-true edges, squared stock, bevels and chamfers.

Makes You Money!

Now you can start your own high-profit business selling all types of millwork to lumberyards, carpenters, contractors, picture framers, do-it-yourselfers. Use it to make grandfather clocks, gun cabinets, furniture, toys, planters, porch swings, benches, paneling, flooring. In fact, this one power-feed tool opens up a truly astonishing range of products you can make and sell.

Revolutionary Quick-Change Molding Head!

Exclusive patented design lets you mold up to six patterns in a single pass! Eliminates time consuming set-ups. Uses low-cost cutterbits. Makes it easy to produce patterns impossible to duplicate on any other planer.

New Drum Sanding Attachment!

Quickly converts machine to one of the finest drum sanders available. Consistent power feed eliminates "low spots" and irregularities caused by hand sanding method.

Factory-Direct Shipment Keeps Cost Low!

Woodmaster Tools is the exclusive national direct-by-mail source for these planers. Low price includes motor, switch, stand, knives, full instructions... ready to use. Easy terms.



Jointer attaches in seconds... designed to let you move directly to planing without changeover.

Produces tongue & groove with one set-up. Two boards in same pass.

Turns out high-value, satin-smooth custom moldings plus all popular patterns.

New sanding attachment quickly converts machine to a power-feed drum sander!

**MAIL COUPON TODAY
OR CALL TOLL-FREE
1(800) 824-7888 Oper. 642**

Woodmaster Tools, Dept. PW5, 2908 Oak, Kansas City, MO 64108

**FREE
INFORMATION
KIT**



YES! Please rush me your FREE information kit which tells in words and pictures why this amazingly designed power-feed shop is so much better than other single-purpose or combination tools. Also send me details on your 30-DAY FREE TRIAL GUARANTEE.

Woodmaster Tools, Dept. PW5, 2908 Oak, Kansas City, MO 64108

NAME _____
ADDRESS _____
CITY _____
STATE _____ ZIP _____

FREE 30 DAY TRIAL!

Send for complete facts on how you can try this low-cost, 4-in 1 power tool in your own shop for 30 days completely without risk! We'll also send you complete details on how you are fully protected by Woodmaster's One Full Year Limited Warranty.



LETTERS



We welcome comments, criticisms, suggestions . . . even an occasional compliment from readers. While the volume of mail we receive makes it impossible to answer every letter,

we intend to publish excerpts from a cross section of our correspondence in each issue of the magazine. Send letters to:

Letters Editor
Better Homes and Gardens®
WOOD Magazine
1716 Locust Street
Des Moines, IA 50336

(Regarding submitting material for consideration for Project Showcase) I have several projects and ideas to submit, but I do have one problem. I do not own a 35-mm camera. All I use is a regular camera, which provides good colored pictures. Would this be acceptable for publication?

—James D. Ebentier, Glenshaw, Pa.

In rare instances, when we receive a color print of exceptional quality, we do accept it for publication. But because of the detail and quality-loss normally associated with making a printed image from a color print, we much prefer using slides.

On the other hand, if you just want to share an idea with us and want to include a snapshot, that's fine. We've bought several project ideas from readers already, and are anxious to buy more.

Why can't more of the advertisements include the price of the tool (or other item for sale)? It seems a waste of time to have to write a letter to determine if the price is out of my range.

—John L. Reiningger, San Antonio, Tex.

We really don't have a good answer for you on this one. We do know, though, that mail-order advertisers depend greatly on having a current list of names of potential customers. We agree with you that it is a hassle to have to write to manufacturers, but consider this. Once an advertiser has your name on file, chances are good that the firm will keep you abreast of product introductions, special offers, and so forth. And we think that's worthwhile to you as a reader.

In the diagram showing how to make the bracelet mandrel ("Designer Bracelets," WOOD, Sept./Oct. 1984, page 75), the expansion plug is to be tapered, but you have the same diameter dimension on both ends.

—Donald Brinton, Carlisle, Pa.

The plug should taper from 2 1/4" to 1 1/2" in diameter.



Professional and Portable

- Heavy duty router/shaper offers affordable flexibility with most router bits.
- Equipped with a 1 1/2 H.P. motor but will accommodate all Porter-Cable motors including the 3 H.P. production unit.
- Individually adjustable fences with micro adjustments for complete cutting accuracy.
- Dual starting pin holes for versatile free-hand routing.
- Safety lockable switch.

For more information consult the Yellow Pages under Tools (electric) for your local Porter-Cable Professional Tool Distributor or write for a free, full line product and accessory catalog.

Quality By Design
PORTER-CABLE

PROFESSIONAL POWER TOOLS
P.O. Box 2468 • Advertising Dept. • Jackson, TN 38302-2468



TALKING BACK

I have never written a letter of complaint or praise to any company. Add that to the fact that I have never done any woodworking, and it becomes amazing that I have been reading a copy of WOOD for *three days!* Reading has always been one of my real pleasures, and your staff has done a wonderful job with this publication.

—Bruce P. Hawkins, LaSalle, Ill.

We're thrilled to hear that you enjoyed your first encounter with WOOD. Watch out, Bruce, you may be on your way to becoming a woodworker. It's habit-forming, you know!

I found the first issue of WOOD to be overly basic and redundant. Basic- and intermediate-level articles should be balanced with advanced projects and techniques.

—F. A. Rudolph, Falls Church, Va.

I think I would like to see more for the beginner.

—John J. Nicholson, Schenectady, N.Y.

The ultimate test for any publication is whether or not it serves its audience well over a long period of time. We know that each reader expects a little something different from us. And that's why we have so many subject categories in the magazine. We will continue to strive to serve up a balanced ration of articles that will please the more advanced as well as those who are just starting out in this wonderful hobby.

Don't split up the articles over several pages because of advertising. This irritates me and I am sure it does others, too.

—David W. Black, Portsmouth, Va.

Whenever possible, we try to present our articles in their entirety on consecutive pages, especially the woodworking projects. But sometimes, to tell the whole story, which we feel strongly we should do, an article may have to be continued toward the back of the magazine. We do share your concern. ■



Our catalog doesn't just sell you things. It teaches you things.

The Garrett Wade Catalog is a new, 212-page collection of woodworking hand tools, machinery, finishing supplies and accessories that are simply the finest available. Anywhere.

And besides offering quality tools from around the world, we also give you a lot of quality advice. On woodworking techniques. On picking the proper tool for a particular job. On finishing, sharpening, clamping and more.

The catalog is filled with superb photography, honest specifications and reliable descriptions. It's neatly divided into seventeen sections, including a section on our Swiss INJECTA INCA power tools. And throughout the year, our catalog owners will receive several handy supplements—*free of charge*.

Just send in the coupon below with \$3.00, and we'll send out your copy of the 1985 Garrett Wade Catalog. It just may prove to be the most useful tool you own.

Garrett Wade Co., Dept. 239
161 Avenue of the Americas
New York, N.Y. 10013
Gentlemen:

Send your complete 212-page catalog of woodworking tools, machinery, and accessories. Enclosed is \$3.

I would like *only* the following sections of the catalog, for 50¢ each:

INJECTA INCA Carving Finishing

Enclosed is \$_____

Name _____

Address _____

City _____

State _____ Zip _____



Woodcraft Specialties, Inc.
18121 Madison Road, Parkman, OH 44080
216/548-3481

Tradition is Back with

THE CONOVER LATHE SET

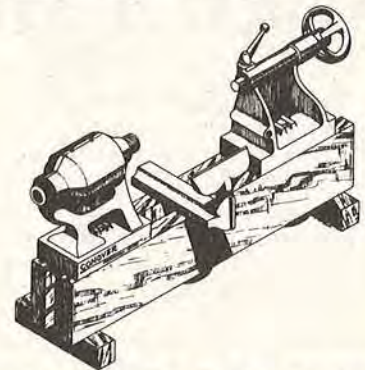

We manufacture the Conover lathe set in our Parkman, Ohio factory to insure its super high quality. It has heavy cast iron construction, precision Timken roller bearings, a 16" swing, and unlimited center distance. You can set it up as a bowl lathe or turn porch posts—your option!

The Conover Lathe Set is mounted on a bed of 8 quarter timbers, which you can make yourself—to any length. A wood bed absorbs shock better than metal and facilitates an affordable price. Our lathe indexes to 12 positions and is suitable for heavy face plate turning (inboard and outboard), metal spinning, and spindle turning. It has a full range of exciting accessories.

OK Conover,

_____ Enclosed is \$1 for your 16-page catalogue detailing the Conover Lathe Set and your entire line of handmade tools.

_____ Send me _____ Conover Lathe Set(s) @ \$895 each.

Enclosed is _____ Cheque _____ M.O. _____ MasterCard/Visa

Card # _____ Exp. Date _____

Name _____

Address _____

City _____ State _____ Zip _____

Phone _____

TIPS FROM YOUR SHOP (AND OURS)

In woodworking, no one knows it all. But through experience, we all run onto better, safer, faster, or easier ways to do things. When we come up with interesting tips or techniques, we'll show them to you in this column. And when you share your favorites, we'll pay you \$25 for each submission we publish. **No shop tips will be returned.** Send your tips to:

Shop Tips
Better Homes and Gardens®
WOOD Magazine
Locust at 17th
Des Moines, IA 50336

 Print this article

Blot up squeezed-out glue

Some glue squeeze-out is normal when clamping joints, but letting it dry makes it tough to remove later.

TIP: Sprinkle coarse sawdust along the joint to blot up the freshly squeezed-out, wet glue, then scrape or wipe it up immediately. Follow with a handful of fine sawdust rubbed into and over the area to pick up remaining glue particles you missed the first time.

—Paul Branton, Mt. Olive, Miss.

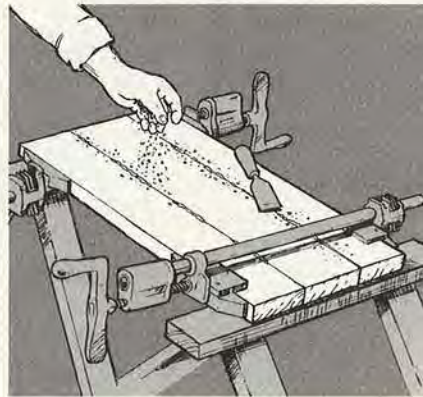

Keeping plugged in

How many times have you been left powerless when using a portable sander or saber saw because the tool cord and the extension cord pulled apart? Now you can stop this frustration with this simple trick.

TIP: Tie a loose overhand knot with the two cords and plug them together. Tension on the knot tightens the union and the power connection stays together.

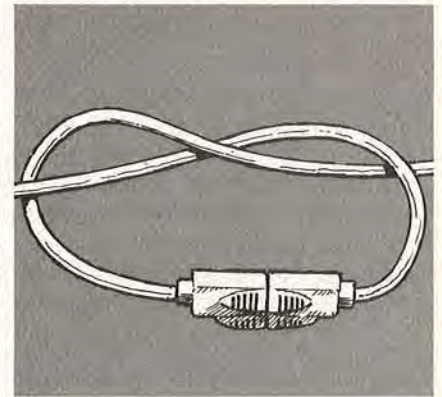

\$1000 A Month With Just A Hack Saw!

© Philip E. Brancato Sr. 1982

Yes, you can make \$1000 a month and more with just a hack saw in your spare time.

Will I Get Rich?

No, you will not get rich, but you can make over \$1000 a month in your spare time and have a ball doing it.

I tried all those "Get Rich" gimmicks that are advertised, that never tell you anything until you've sent them your \$25, and then you find out their gimmicks were not for you. Well, I've tried them all and I'm still not rich.

All I ever wanted was something I could do in my spare time with my hands, make a little money and enjoy myself and not have to buy \$3000 worth of tools or merchandise to do it.

Believe It Or Not

I found the most enjoyable and profitable business working with my hands and the only tools I use are a hack saw and measuring tape. The really nice thing about it is any man, woman or ten-year-old can do it.

What Do I Do?

I make beautiful indoor/outdoor P.V.C. pipe furniture. Such as chairs, lounges, tables, swings, and all kinds of baby furniture out of P.V.C. pipe; even birdhouses and feeders. P.V.C. pipe furniture is the hottest selling furniture on the market today, because it is unique and beautiful and will not rot or rust and it will virtually last a life time.

Profit Unbelievable!

The fantastic part of this business is the profit.



Just go look at some of this furniture in the stores and see some of the unbelievable prices it is selling for.

A chaise lounge that costs \$62.25 in material and three

hours of work is selling for over \$189 in the stores. I can sell my chaise lounge for anything I think my labor is worth.

Where can you buy the P.V.C. Pipe?

You can buy the P.V.C. pipe from any local hardware store to start. Plus I will supply you with the name and address of one of the largest manufacturers of pipe, fitting, cushions, and table tops who will sell to you at wholesale prices and you do not have to buy a minimum amount. You can buy one cushion or 50 plus I will supply you with my shop manual and six detailed shop drawings with pictures and measurements of six different designs.

Do you need my shop drawings?

No, you don't need my shop drawings unless you want to save hundreds of hours of trial and error work and thousands of dollars that I had to spend before I finally

found the right design and measurements and tricks to the manufacturing of P.V.C. pipe furniture. I only wish that when I started, I could have bought these shop drawings and I would have gladly paid \$100 for just one of them.

I will pay you!

Yes, I will pay you \$25 for any unique design shop drawing that I can use in my collection and workshop manual.

How do you start?

1) Decide if you like to work with your hands to create things and want to make money.

2) Can you afford \$12.00 for my shop manual and six drawings.

3) Send me your name and address along with your check for \$12.00 to:

Philip E. Brancato Sr.
P. O. Box 237WO-1
Riverview, Florida 33569
(813) 677-6948

Please allow about two weeks for delivery.

TIPS FROM YOUR SHOP (AND OURS)

Recycling paint thinner

It seems a waste to discard paint thinner after using it only once for cleaning brushes.

TIP: Recycle that thinner for additional cleanup jobs by storing it in a coffee can with a sealable lid. In a few days, the solids settle out, so you can pour most of the reusable thinner off the top and discard the remaining goo.

—Jack Mitchell, Concordia, Kans.



Pliable sanding blocks

It's darn-near impossible to evenly sand the surface of millwork, such as quarter round or cove moldings, with conventional flat-faced sanding blocks.

TIP: Custom-make sanding blocks for specific jobs, using scraps of polystyrene foam (used for packing material or insulation). Carve or press the foam to the desired shape and fasten sandpaper with double-sided carpet tape. The blocks then fit anything you wish to sand and they're easy to make as you go along.

—Norm Pedersen, Salt Lake City, Utah

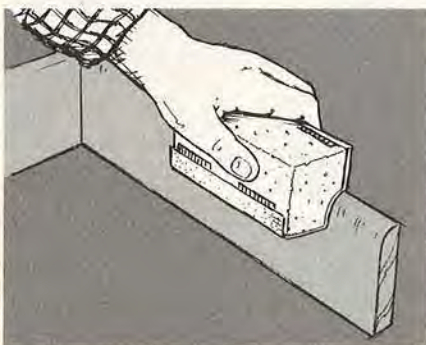

Round stock drill guide

Drilling a lot of holes in line with one another and perpendicular to the same plane can be a real challenge in round stock.

TIP: Cut a scrap wood block large enough to level with the bottom of the V-shaped notches on your drill guide base. Then place one end of the round stock into the guide and place the block under it. Drill through the stock and into the block. Now move the pieces out from under the drill guide and pin them together with a short dowel. As shown in the drawing, you'll now be able to drill as many holes as you need, where you want them, by simply positioning the block the appropriate distance away from the drill each time.

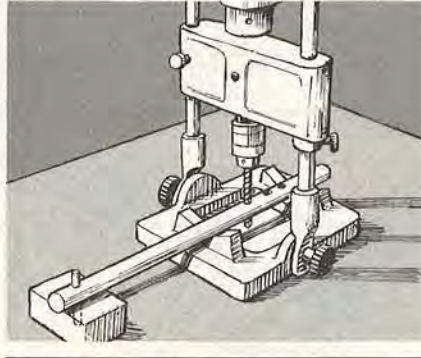

Avoid sanding gouges

Catching the power cord of a belt sander on the edge of a workpiece while you're sanding almost guarantees an ugly gouge.

TIP: Drape the cord over your shoulder to keep it up and out of the way and to prevent sudden halts.



Woodworkers' Hardware ORDER FORM

Qty.		Total
2	Birch Mug Peg \$.37/ea. \$.22/ea.	
2	Birch Shaker Peg \$.42/ea. \$.25/ea.	
6	Birch Furniture Spindles 6 inch \$.70/ea. \$.42/ea.	
8	1/2 inch \$.85/ea. \$.51/ea.	
2	#S4 Galley Spindle Birch \$.28/ea. \$.17/ea. Oak \$.34/ea. \$.20/ea.	
2	#S5 Galley Spindle Birch \$.41/ea. \$.25/ea.	
3/4"	Wood \$5.96/C \$3.57/C	
7/8"	\$7.95/C \$4.77/C	
1"	\$8.93/C \$5.00/C	
1 1/4"	\$13.95/C \$8.01/C	
1 1/2"	\$18.35/C \$11.01/C	
2"	\$30.90/C \$18.00/C	
1	#AP1 Axle Peg Fits 1" to 2" Wheel \$6.95/C \$4.17/C	
10	Wood Cargo \$3.85/10 \$2.31/10	
10	Milk Can \$3.90/10 \$1.80/10	
10	Pickle Barrel \$3.85/10 \$2.31/10	
3/8"	Screw Hole Buttons \$2.90/C \$1.74/C	
1/2"	\$2.95/C \$1.77/C	
2	Dowel Pins 3/8"x2" \$2.95/C \$1.77/C	
3/4"	Wood Knobs \$1.50/10 \$0.90/10	
1"	\$2.95/C \$1.77/C	
1 1/4"	\$2.40/10 \$1.40/10	
1 1/2"	\$2.40/C \$1.28/C	
1 3/4"	\$2.50/10 \$1.50/10	
1 1/2"	\$2.90/C \$1.80/C	
1 3/4"	\$3.70/10 \$2.20/10	
1 1/2"	\$34.65/C \$20.79/C	
10	Saw Tooth Hangers \$6.95/C \$4.17/C	
1	Brass Plt. Picture Hanger \$7.95/C \$4.77/C	
1	Clock Movements w/Hands Q72 \$10.80/ea. \$6.48/ea. \$49.50/5 \$29.70/5	
3"	Lazy Susan Bearing \$1.15/ea. \$.69/ea.	
4"	\$1.60/ea. \$.96/ea.	
6"	\$2.80/ea. \$1.73/ea.	
12"	\$8.95/ea. \$5.37/ea.	
10	Brass Plated Candle Cup \$5.90/10 \$3.00/10 \$49.00/C \$29.40/C	
1	Brass & Porcelain Hook \$4.95/ea. \$2.97/ea.	
10	Brass Plated Hinges #910 Butt Hinge \$1.65/ea. \$.99/ea.	
10	#928 Butt Hinge Brass \$2.80/10 \$1.68/10	
1	#F124 Screw for Above \$4.00/C \$2.40/C	
3"	Clipboard Clips \$.59/ea. \$.35/ea.	
6"	\$.99/ea. \$.59/ea.	
10	Plastic Shelf Pins \$9.90/C \$5.40/C	

Catalog \$1.00 or free with order Total Order

Minimum Order is \$25.00 MN Res. - 6% Tax

Order Amount: Shipping: Shipping:

\$25.00 to \$49.99 \$3.50 Total Enclosed

\$50.00 to \$99.99 \$4.50 Visa Master Card

Over \$100.00 \$5.00 Discover

MONEY BACK GUARANTEE! Alaska, Hawaii, Canada & APO Orders Add \$6.00

SIGNATURE _____

CARD NO _____ EXP DATE _____

NAME _____

ADDRESS _____ CITY _____

STATE _____ ZIP _____ PHONE () _____

MEISEL HARDWARE SPECIALTIES
P.O. Box 258 R Mound, Minnesota 55364 • (612) 472-5544

Continued on page 12



FORSTNER BITS MADE IN AUSTRIA!

We will not be undersold by anyone even though our Forstner bits are of the highest quality available.



Partial Arcs And End Grain Holes



Through Any Grain Pattern — Even Knots

Bore clean, effortless holes in any wood (even thin stock, veneer, end grain and knots!). These bits will make all other wood bits in your shop obsolete.

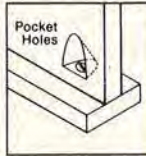

Pocket Holes

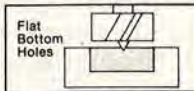

Flat Bottom Holes

MODEL	SIZE	PRICE EACH	
G1260	3/8"	\$ 5.50	Prepaid to you
G1261	1/2"	\$ 6.25	Prepaid to you
G1262	5/8"	\$ 7.00	Prepaid to you
G1263	3/4"	\$ 7.75	Prepaid to you
G1264	7/8"	\$ 8.50	Prepaid to you
G1265	1"	\$ 9.25	Prepaid to you
G1266	1 1/8"	\$10.00	Prepaid to you
G1267	1 1/4"	\$10.75	Prepaid to you
G1268	1 3/8"	\$11.50	Prepaid to you
G1269	1 1/2"	\$12.50	Prepaid to you
G1270	1 5/8"	\$14.00	Prepaid to you
G1271	1 3/4"	\$15.00	Prepaid to you
G1272	1 7/8"	\$17.00	Prepaid to you
G1273	2"	\$18.50	Prepaid to you
G1274	2 1/8"	\$19.95	Prepaid to you

Buy the complete set and save \$38.45!

15 pc. set from 3/8" to 2 1/8" inclusive.

ONLY \$135.00
Prepaid to you!

We ship real fast . . .
TRY US.

PHONE OR CALL YOUR ORDERS IN USING YOUR CREDIT CARD. PAYMENT BY REGULAR CHECK WILL DELAY SHIPMENT 3 WEEKS. MINIMUM ORDER REMAINS AT \$20.00 PLEASE.



GRIZZLY IMPORTS, INC.

P.O. BOX 2069, BELLINGHAM, WA 98227 • PHONE (206) 647-0801



TIPS FROM YOUR SHOP (AND OURS)

Continued from page 11

No-skin varnish storage

If you allow a skin to form over varnish, paint, or other finish stored in partially used cans, you're throwing money and material down the drain.

TIP: Put a layer of kitchen-type plastic wrap on the surface of the liquid, pressing its edges against the sides of the can. You want to make sure that little or no air is trapped between the finish surface and the plastic wrap.

—Lloyd Murphy, Oak Ridge, Tenn.



Safe way to sharpen a scraper

Skinned knuckles and sharp hand scrapers go together when you use a vise to hold the scraper for filing. One slip is all it takes.

TIP: Clamp a fine, single-cut bastard file horizontally in the vise as shown. While holding the scraper perpendicular to the file, draw it back with firm, even pressure. It only takes two or three strokes.

—Edwin C. Trefz, Norwood, Pa.

(You can also turn over the edges of a newly sharpened scraper by securing a burnisher in the vise.)



Continued on page 16



Plane Craft: A Woodworker's Handbook

If you are **\$9.95**
a woodworker,
you must own
this incredible book!

The definitive guide to one of woodworking's essential tools—the amazingly versatile plane. Step-by-step, plane after plane, master craftsman John Sainsbury provides meticulous instructions for beginner and seasoned pro alike to use an incredible variety of these marvelously efficient hand and power tools. With almost 300 easy-to-understand photos, diagrams and drawings and an information-packed 192 pages, learn how to assemble, adjust, sharpen, handle, set up and care for dozens of different planes—some ancient, others brand new—and best of all learn to use each to complete a wide variety of tasks. Discover how to:

- cut a groove or wide rebate
- make a raised panel
- fit drawers
- make mitred boxes
- create decorations
- square a piece of wood
- make several moulding styles
- make a butt, tongue & groove, dowel, corner, joints and more
- start mortises for haunched tenons
- make multiple reeds
- make return beads or toros
- make doors
- frame panels of doors
- lipping and facing
- many decorative applications
- the history of planes and technical advances

Whether you own or are buying any plane—block, rebate, plow, combination or multi, circular router, power or even a scraper—this book has all the information, even down to comparisons between manufacturers and models. Nothing is omitted, no basic operating procedure or specialized technique—making this a shop reference you can't afford to be without.

He covers every difficulty in planing, from simple problems like ridges on the planed surface (a result of poor sharpening techniques) to shooting an edge at various angles, with complete solutions. Plus—every contemporary plane maker, with technical analysis of each, and including a complete glossary.

Bonus! Projects galore. Each described with maximum clarity, step-by-step, with incomparable sequential drawings. This book is invaluable. If you are a woodworker, you must have this in your library. **Act now! Send your check for only \$9.95 (an incredible value) and we'll ship your book postage free.**

STERLING PUBLISHING CO., INC. DEPT. WD2
Two Park Ave., New York, NY 10016

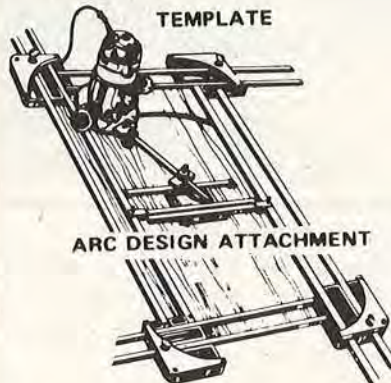

TEMPLATE

ARC DESIGN ATTACHMENT

COUNTLESS DESIGN COMBINATIONS

On panels, cabinet doors and drawers of all sizes
...quick, professional results
every time with the
WING M-100 ROUTER TEMPLATE
and the **ARC DESIGN ATTACHMENT.**

BASIC TEMPLATE \$139.00
ARC DESIGN ATTACHMENT \$78.00

WING SALES & DISTRIBUTING CO. INC.

918 E. Cedar Lane
P.O. Box 1360
Payson, Arizona 85547
(602) 474-5836
(602) 474-3036

Are you getting squeezed out of your workshop?



Discover the space-saving advantages of the Shopsmith® MARK V. It "expands" the floor space of every shop it enters.

The MARK V combines the five major power tools — table saw, vertical drill press, horizontal boring machine, lathe and disc sander — in one economical, freestanding unit.

And the MARK V is the tool to start with... the system you grow with. Whether you're ready to tackle simple repairs or Chippendale classics, you'll find a full range of MARK V Accessories that can make any job easier.

The Shopsmith Difference

With Shopsmith you get a dedication to woodworking, education, expandability of your future needs, and buyer protection. Our philosophy is represented in the old-fashioned virtues of quality, value, pride and craftsmanship; virtues present in our educational training and products.

Your Special "Bonus"

Learn how the MARK V can help you do

more projects more professionally. Send for your FREE MARK V Information Kit today! You'll see just how easy it is to make all those projects you've been dreaming about. Included in this kit is "How To Determine Your Best Power Tool Buy."

You'll also receive a FREE one-year subscription (\$6.00 value) to HANDS ON, our Home Workshop Magazine packed with project ideas and helpful tips. You are under no obligation. So mail your card today!

Phone Toll Free: 1-800-228-2112
In Nebraska: 1-800-642-8788



Shopsmith Inc.

The Home Workshop Company
6640 Poe Avenue
Dayton, Ohio 45414-2591

Quality woodworking tools made in the U.S.A.

©Shopsmith, Inc., 1984
Shopsmith® is a registered trademark of Shopsmith, Inc.

Mail this valuable coupon today!



YES! Please send me a Free MARK V Information Kit including the informative booklet "How To Determine Your Best Power Tool Buy". And enter my name for a FREE one-year subscription to HANDS ON magazine. I understand I am under no obligation.

Name _____

Address _____

City _____

State _____ Zip _____

I currently own a Shopsmith woodworking power tool.

Dept. 3684

SAWHELPER™ SYSTEM 3—NOW YOU CAN HAVE YOUR CAKE AND EAT IT TOO! Knock down miter fences that set up with super accuracy in 60 seconds anywhere, then fold up for compact storage or transport. Also available in stationary models (System 1) and a larger version for radial arm saws or the Rockwell "Sawbuck".

SYSTEM 2 PORTABLE BENCH MOUNT MITER FENCES. Fence is tempered extruded aluminum with built-in sawdust groove and tape channel. Uses any 3/4" tape refill, tape not included.

QUICKSTOP DELUXE SLIDING STOP \$25.95

PATENTED SELF ADJUSTING COUPLER MECHANISM

Model M55P includes two 5 foot portable fences \$119.95
Model M85P includes one 8 foot and one 5 foot fence \$129.95

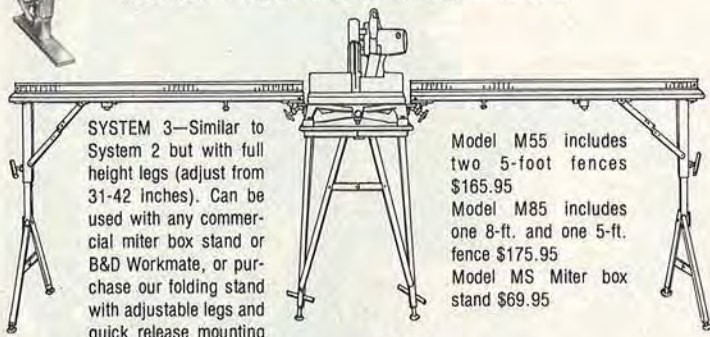

SYSTEM 3—Similar to System 2 but with full height legs (adjust from 31-42 inches). Can be used with any commercial miter box stand or B&D Workmate, or purchase our folding stand with adjustable legs and quick release mounting plate.

Model M55 includes two 5-foot fences \$165.95
Model M85 includes one 8-ft. and one 5-ft. fence \$175.95
Model MS Miter box stand \$69.95

ORDERING INFORMATION

Sawhelper™ Miter fences and accessories are available at fine tool stores or by mail from: AMERICAN DESIGN & ENGINEERING INC., 648 Turin Ave., South St. Paul, MN 55075, Phone 612-455-4243 (24-hrs. answering service). Freight prepaid. MN and WI residents add sales tax. Check C.O.D., Master Charge or Visa. Order today!

TIPS FROM YOUR SHOP (AND OURS)

Continued from page 12

Putting contact cement and brushes "on hold"

Laminating large projects with contact cement often requires doing some work now and some later, with lots of mess and the loss of a dried-out brush in between.

TIP: Use a coffee can with a plastic lid to hold and store both cement and brush. Pour the amount of cement you think you'll be using into the can to save on mess. Cut enough off your brush handle so it fits into the can. To quit for a while, put the brush in the can. Add lacquer thinner to cover bristles, then seal the container. Thinner keeps the brush and cement workable, but pour it off before laminating.

—Allan Kruger, New Port Richey, Fla.



Stripping irregular shapes

How do you get the old finish out of ornate carvings and details on furniture that you're stripping?

TIP: Wear rubber gloves and use a handful of sawdust or coarse wood chips as a scrubber to remove the stripper and old finish from difficult spots. The chips' scouring action take off the softened finish without damaging the wood. ■



RIPSTRATE® SAVES FINGERS

AND GIVES STRAIGHTER CUTS

If you own a table or radial arm saw you know what that whirling blade could do to your hands. RIPSTRATE guides the work tight against the fence and table while you push it through with a stick, with both hands away from the blade. **ALSO PREVENTS KICKBACKS.**

Requires no adjustment. RIPSTRATE is not just a safety device. Professional shops use it because it gives straighter cuts and speeds the work. Money back guarantee. \$59.50. Add \$3.50 shipping. Check, Visa, M/C. Free brochure.



Write, or call our Toll free number:

800 421 0256

Fisher Hill Products
4 Fisher Hill
Fitzwilliam, NH 03447

Precision Hand Tools

by **freud**[®]



TT-108



WC-110



CM-100



CS-112

Freud is pleased to introduce an exciting new line of precision hand tools. Utilizing the finest materials available from choice boxwood to chrome vanadium steel, Freud hand tools will exceed all your expectations for precision woodworking instruments.

Our comprehensive selection of tools meets the needs of even the most demanding jobs with ease and durability. All tools provided with box jointed wood case as shown.

Ask your local dealer about these and many other fine products by Freud.

Chisel Sets

WC-110 (shown above), Set Includes: 1/4", 5/16", 3/8", 1/2", 5/8", 3/4", 7/8", 1", 1 1/4", 1 1/2". **\$66.90.**

WC-106, Set Includes: 1/4", 3/8", 1/2", 5/8", 3/4", 1". **\$39.90.**

WC-104, Set Includes: 1/4", 1/2", 3/4", 1". **\$29.90.**

Carving Tools

CS-112 (shown above), Set Includes: 3/8" Straight Chisel — , 3/8" Skew Chisel — ,
1/4" Flat Gouge — , 5/16" Gouge — , 3/16" Spoon Gouge — , 1/2" Gouge — ,
1/4" Gouge — , 3/16" Gouge — , 3/8" Gouge — , 3/8" Gouge — , 1/8" Gouge — ,
1/4" Parting Tool — . **\$139.90.**

CS-106, Set Includes: 3/8" Straight Chisel — , 1/2" Gouge — , 1/4" Gouge — , 3/8"
Gouge — , 1/8" Gouge — , 1/4" Parting Tool — . **\$74.90.**

CM-100, (shown above) Carver's Mallet: Oak Handle, Beechwood Head, Wt. 15 oz. **\$9.90.**

Turning Tools

TT-108 (shown above), Set Includes: 1/2" Diamond Point, 1/2" Round Nose, 1/2" Parting Tool, 1/2" Skew,
1" Skew, 1/4" Gouge, 5/8" Gouge, 7/8" Gouge. **\$67.90.**

Call Us Toll Free!

FOR THE NAME OF YOUR LOCAL DISTRIBUTOR:

- | | | |
|--|--|---|
| <input type="checkbox"/> In California | <input type="checkbox"/> If You Live In This Area: | <input type="checkbox"/> If You Live In This Area |
| Call Toll Free: | 1-800-824-0141 | 1-800-824-8045 |
| | | Call Toll Free (Outside NC) |
| | | 1-800-334-4107 |

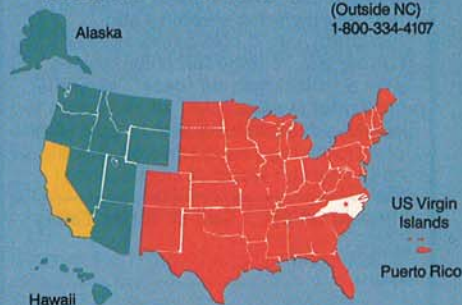

freud[®]

218 Feld Ave., High Point, NC 27264
(919) 434-3171

1570 Corporate Dr., Suite G
Costa Mesa, Cal. 92626
(714) 751-8866

\$ Save \$ with :



Dusty
Splinters
Enterprises

Quality Tools & Supplies

Stop paying too much!
Now in stock:

RYOBI PowerTools

HERE ARE SOME OF OUR LOW PRICES

	List	Our Price
R 150 1hp Plunge Router	\$120	\$ 84
R 330 2hp Router	220	137
R 500 3hp Plunge Router	265	163
S 500A Palm Sander	70	42
LS 35 Orbital Sander	74	48
B 7075 3x21 Sander	160	115
B 7100 3x24 Sander	198	144
TR 30 Trimmer	115	76

To make this offer even better, we will ship your order POST PAID during Mar. & Apr. '85. We will be demonstrating these great tools at the WoodWorld show in Springfield MA, Apr 12-14. Visit us there in booth 92.

TO ORDER

Send check or money order to the address below, or call: 1-718-386-2098, for COD orders add: \$2.50. NY res add sales tax.

MEMBER



JOIN US

P.O. Box 3204 W, Flushing, New York 11386

QUARTZ CLOCK MOVEMENT



Our way of saying
Welcome to Clockmaking!

Made in America, this Q80 quartz movement is our most popular series. It regularly sells for \$6.50...but now is just \$1.00! That's much below our cost and includes shipping and handling. You'll also get two brass hands, our 72-page full color catalog plus a "Clockmaking Ideas" pamphlet. This offer is so special, we request one-to-a-customer please. It's our way of introducing you to the wonderful do-it-yourself world of clockmaking!

Limited Offer... Call or Write Today!

Name _____

Address _____

City, State, Zip _____

Credit Card No. _____ Exp. Date _____

KLOCKIT

DEPT. WD25
P.O. BOX 629

LAKE GENEVA, WI 53147



1-800-KLOCKIT



In Wisconsin Call... 414-248-1150

**news
and
events**



Photograph: Courtesy of Formica Corp.

Contemporary material, unique design talent, and skilled hands combine in an exciting furniture exhibit to tour the U.S.

Print this article

Highgirl (photo above)

was created by Wendy Maruyama as a colorful takeoff on the traditional "highboy" chest of drawers. She and 18 other top woodworkers, including Wendell Castle, Edward Zucca, and Judy Kensley McKie, produced 23 innovative furniture pieces for "Material Evidence: New Color Techniques in Handmade Furniture," an exhibition that opens at the Renwick Gallery of the Smithsonian Institution, in Washington, D.C., on April 26. Cosponsored by the Formica Corporation and The

Gallery at Workbench, a New York-based contemporary furniture retailer, contributing artisans were challenged to design and build furniture using Formica's new COLORCORE surfacing material. The bright, graphic furniture that evolved is on display at the Renwick until September 22, then it goes on a two-year tour to 12 major cities.

**March 1-3
10th Annual Mid-Atlantic Wildfowl Festival**

Location: Pavilion Convention Center, 1000 19th Street, Virginia Beach, Virginia. A carving event featuring decoys and other wildfowl, with demonstrations, seminars, equipment, and sales. *Hours:* 1-10 p.m. Friday; 10 a.m. to 10 p.m. Saturday; 10 a.m. to 5 p.m. Sunday. For information, write William M. Walsh, Jr., P.O. Box 805, Virginia Beach, VA 23451.

Woodworking World—The Washington, D.C. Show

Location: Hyatt Regency Crystal City, Arlington, Virginia
Admission: \$5

Equipment, supplies, tools, and wood for all woodworking levels will be displayed and demonstrated. Seminars on technique are scheduled. *Hours:* 5-10 p.m. Friday; 10-6 p.m. Saturday; 10 a.m. to 5 p.m. Sunday. Contact Woodworking World, 35 Main St., Suite 6, Plymouth, NH 03264 for more information.

The Woodworking Show For Craftsmen & Hobbyists

Location: Pasadena Center, Pasadena, California

Admission: \$5
Workshops from 45 minutes to 2½ hours in length, tool demonstrations, supplies, and equipment mark this well-attended show where the atmosphere is California casual. *Hours:* 12-9 p.m. Friday; 10 a.m. to 6 p.m. Saturday; 10 a.m. to 6 p.m. Sunday. For details, contact The Woodworking Show, 1516 South Pontius Ave., Los Angeles, CA 90025.

Continued on page 20



In 1984 I sold 624 workbenches like this for \$449.95. Then the dollar got stronger.

NOW! only \$249⁹⁵!

Mortimer V. Schwartz, President, The Fine Tool Shops, Inc.

It's made in Sweden. It's over 4 feet long. And you won't find a finer medium-size bench anywhere – not even at twice the price!

At \$449.95 this was my best selling workbench. And no wonder. The 3-layer laminated wood top won't warp or shrink, and it's topped with fine red beech. There are 5 roomy drawers and a 2 cubic foot lockable storage compartment. The joints are dovetailed, it's finished with 5 coats of lacquer, and the pivoting nylon pad on the shoulder vise holds irregularly shaped pieces.

Running the length of the top is a series of holes which house bench "dogs" that you can push below the top for an unobstructed work surface, or raise as little as 1/4" to grip workpieces up to 50 1/4" long for full-length planing or sanding. For gripping extra large pieces, the slotted deadman leg next to the tail vise accommodates an optional clamp, which also fits in the hold down hole for benchtop gripping. A 5 3/4" wide tool trough runs the length of the bench. Overall width is 17 1/8", with a 10 3/8" wide working surface.



SAVE 44%!

33 1/4" high
50 1/4" long
Tail vise capacity between dogs: 50 1/4".

Holdfast Clamp \$14.95
With pivoting nylon pad, grips regular or irregularly shaped pieces. Use as holddown on bench top, or with deadman leg.

Save 27% on my 6' workbench.



My six foot Swedish workbench has a giant bottom storage compartment and laminated birch top with full length tool trough and a steel lined hole to accommodate a holdfast clamp. The joints are carefully fitted, there's a smooth lacquer finish, the shoulder vise rides on acme threaded steel rods and, like the four foot bench, it features the Swedish system of adjustable tail vise and dogs for gripping long workpieces. I've sold hundreds at \$549.95. Maximum capacity with tail vise extended, 68 1/2".

Now! only \$399⁹⁵!

The Fine Tool Shops, Inc. Dept. WMM5
20 Backus Avenue, Box 1262, Danbury, CT 06810

YOU'RE ON! Send me _____ (qty.)
400-0110 4' Swedish Workbench(es) for just \$249.95 plus \$25.00 shipping and handling (total \$274.95).

BETTER YET, send me _____ (qty.)
400-0140 6' Swedish Workbench(es) at only \$399.95 plus \$25.00 shipping and handling (total \$424.95).

INCLUDE _____ (qty.) Holdfast Clamp(s)
400-0320 at \$14.95 plus \$1.50 shipping and handling (total \$16.45).

My check is enclosed Charge my
 VISA AmEx MasterCard _____

Account # _____ Exp. Date _____

Name _____

Address _____











City/State/Zip _____

ORDER TOLL FREE 1-800-243-1037
(In Connecticut, 797-0772)

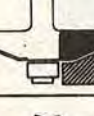
Send me a copy of your full color catalog of woodworking tools, workbenches and accessories – **FREE.**

**CARBIDE TIPPED ROUTER BITS
PROFESSIONAL PRODUCTION QUALITY
SPECIAL OFFER — SAVE 50% - 75% BELOW COST**

1000's SOLD TO READERS OF FINE WOODWORKING

BEST CUT BEST PRICE	ITEM NO.	DESCRIPTION	RADIUS	LARGE DIAM.	CUTTING LENGTH	PRICE
	COVE					
	#01	1/4" R	1/4"	1"	1/2"	\$13.00
	#02	3/8" R	3/8"	1 1/4"	9/16"	14.00
	#03	1/2" R	1/2"	1 1/2"	5/8"	15.00
	ROUND OVER					
	#04	1/4" R	1/4"	1"	1/2"	15.00
	#05	3/8" R	3/8"	1 1/4"	5/8"	16.00
	#06	1/2" R	1/2"	1 1/2"	3/4"	19.00
	ROMAN OGEE					
	#07	5/32" R	5/32"	1 1/4"	15/32"	18.00
	#08	1/4" R	1/4"	1 1/2"	3/4"	20.00
	3/8" RABBETING					
	#11	Deep	3/8"	1 1/4"	1/2"	14.00
	#09	1/8" (KERF) SLOT CUTTER		1 1/4"	1/8"	14.00
	#10	1/4" (KERF) SLOT CUTTER		1 1/4"	1/4"	14.00
	#12	45° CHAMFER	45° Angle	1 1/2"	5/8"	15.00
	#15	RAISED PANEL	20° Angle	1-5/8"	1/2"	25.00
	DOVETAILED BITS					
	#16	3/8" DOVETAIL 9°		3/8"	3/8"	7.50
	#17	1/2" DOVETAIL 14°		1/2"	1/2"	8.50
	#18	3/4" DOVETAIL 14°		3/4"	7/8"	10.50
	CORE BOX (ROUND NOSE)					
	#19	3/8" CORE BOX	3/16"	3/8"	3/8"	11.00
	#20	1/2" CORE BOX	1/4"	1/2"	11/32"	14.00
	#21	3/4" CORE BOX	3/8"	3/4"	5/8"	18.00
	GROOVE FORMING OGEE					
	#22	1/2" GROOVING OGEE		1/2"	3/8"	16.50
	#23	3/4" GROOVING OGEE		3/4"	7/16"	21.00
	#24	1/4" Straight Bit		1/4"	1"	7.00
	#25	5/16" Straight Bit		5/16"	1"	7.00
	#26	3/8" Straight Bit		3/8"	1"	7.00
	#27	1/2" Straight Bit		1/2"	1"	7.00
	#28	3/4" Straight Bit		3/4"	1"	10.50
	#13	1/2" FLUSH TRIM		1/2"	1"	8.50
	#14	3/8" KEY HOLE (This Bit only HSS)	CUTS 3/8" KEY HOLE FOR FLUSH MOUNTING PICTURE FRAMES, ETC.			8.50

**WHEN ORDERING ANY 3 OR MORE, DEDUCT \$1.00 EACH
ALL PRICES POSTAGE PAID**

- Professional Production Quality
- 1/2" Ball Bearing Pilot
- 1/4" Diameter Shanks x 1 1/4" Long
- One Piece Construction
- Two Flute Thick High Quality Tungsten Carbide Tips

**To order by Master Charge or Visa Toll Free
7 Day — 24 Hour Order Service Call
1-800-523-2445 Ext. 56 (In PA 1-800-346-7511 Ext. 56)
or send check to: MLCS, P.O. Box 53, Rydal, PA 19046**

Continued from page 18

news and events

March 29-31

The Woodworking Show For Craftsmen & Hobbyists

Location: Dallas Market Hall, Dallas, Texas

Admission: \$5

Same features as Pasadena show, previous. Use same address for information. *Hours:* 12-9 p.m. Friday; 10 a.m. to 6 p.m. Saturday; 10 a.m. to 6 p.m. Sunday.

April 12-14

Woodworking World—The New England Show

Location: Springfield Civic Center, Springfield, Massachusetts

Admission: \$5

Identical in most ways to the Washington, D.C. show in early March, but with special emphasis on wooden boat building. *Hours:* 5-9 p.m. Friday; 10 a.m. to 6 p.m. Saturday; 10 a.m. to 5 p.m. Sunday. Write to address listed under Washington, D.C. show.

Mid-Atlantic Woodcarving Show and Competition

Location: Penn State Abington Campus Gym, Abington, Pennsylvania

Admission: \$3

Sponsored by Pennsylvania/Delaware Valley Wood Carvers, this Saturday and Sunday show includes top carvers competing for awards, as well as exhibits, supplies, demonstrations, and tools. *Hours:* 10 a.m. to 5 p.m. Saturday and Sunday. Write Elmer Jumper, 142 DiMarco Dr., Philadelphia, PA 19154.

April 26-28

15th Annual World Championship Wildfowl Carving Competition

Location: Convention Hall, Ocean City, Maryland

Admission: \$5; students, \$2; children under 12, free
This largest of wildfowl carving events highlights works of top decorative carvers in many categories.

Competition is stiff for nearly \$50,000 in awards. *Hours:* 10 a.m. to 9 p.m. Friday and Saturday; 10 a.m. to 4 p.m. Sunday. For details, write Knute Bartrug, Chairman, 707 Eastern Shore Drive, Salisbury, MD 21801, or phone 301/749-5174.

Of Incidental Interest: March 16, Tage Frid demonstrates dovetail joinery at Woodcraft Supply's store, 313 Montvale Ave., Woburn, Massachusetts.

News of interest to woodworkers and dates of national and regional events must be received at least three months before our publication date to be considered for the News and Events section. Send information to: News and Events, Better Homes and Gardens® WOOD Magazine, Locust at 17th, Des Moines, IA 50336. ■

THE ULTIMATE WOODWORKING POWER TOOL IMPROVED!

FOR YOUR HOME WORKSHOP

URNS LOW-COST ROUGH LUMBER INTO HIGH-VALUE MOLDING, TRIM, FLOORING and PICTURE FRAMES

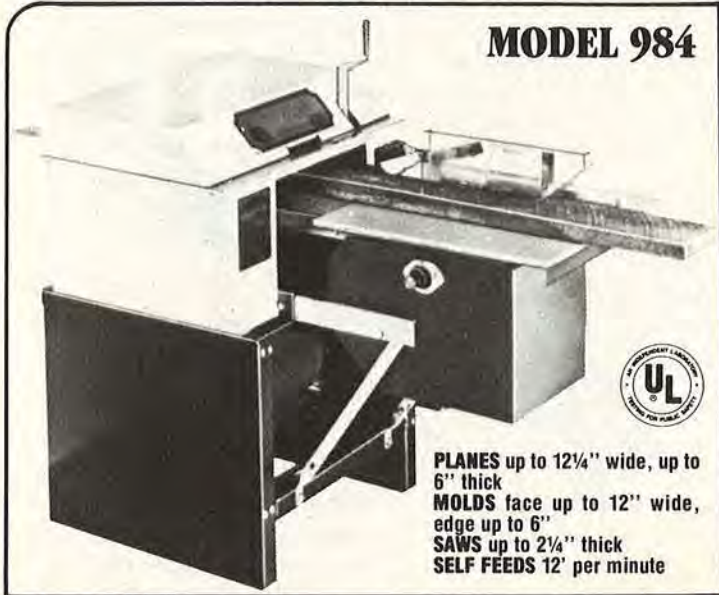

PLANES up to 12¼" wide, up to 6" thick
MOLDS face up to 12" wide, edge up to 6"
SAWS up to 2¼" thick
SELF FEEDS 12' per minute



PLANES up to 12¼" wide, up to 6" thick
MOLDS face up to 12" wide, edge up to 6"
SELF FEEDS 12' per minute

Well over 50 years of manufacturing and engineering experience have resulted in the New Improved Model 984 and 985 Planers. The same integrity and quality that have made Foley-Belsaw the most sought after planer on the market are still built into every machine and combined with new improved features to put the 984 and 985 Planers a step ahead — **THE ULTIMATE WOODWORKING POWER TOOL — IMPROVED.**

This versatile power tool will make your home workshop pay off big plus save you both time and money. Never again do you have to depend on lumberyards for stock finished to proper dimensions for your project. The Foley-Belsaw Planer delivers true, smooth wood at the standard power feed rate of twelve feet per minute or at the optional twenty foot rate.

Foley-Belsaw planer operators are making and selling picture frames, fencing, furniture, bed slats and all kinds of millwork for contractors, lumberyards, paint shops, department stores . . . and direct to end-users.

Inexpensive rough sawn lumber converts to the required thickness high value finish stock right in your shop, where you need it, when you need it. The big capacity of the Foley-Belsaw Planer easily handles stock up to 12-3/8" wide and up to 6-1/4" thick. The built-in versatility of this machine also gives you the capability of ripping boards up to 2-1/8" thick and planing and molding them to finished dimension and pattern on the same pass. Unique design allows the saw blade to be placed at any point from side to side on the arbor shaft. Inexpensive molding bits can be used in the center of the planer cutterhead or on either end — while the planer knives still remain precisely installed in the cutterhead!

Crowns, casings, bases, tongue-and-groove, over two hundred custom knife patterns are available from stock. This vast choice of molding knives gives you the freedom and flexibility to produce the exact molding you need from any species of wood. Custom knives are ground from 1/4" high speed tool steel which allows molding to be cut with one knife, speeding installation and eliminating tedious alignments.

Special pattern knives can also be ground to allow you to match any existing patterns or make special moldings of your own design. Just send us a wood sample or drawing for a prompt quotation.

The Foley-Belsaw operates on either 3 HP or 5 HP Electric Motors. 3 HP is normally all that is required for the average home workshop while Foley-Belsaw recommends 5 HP for commercial or heavier duty, continuous applications.



The Only 12" Planer good enough to meet the rigorous standards of the Underwriters Laboratory.

**TRY THE MODEL 984 OR MODEL 985
 IN YOUR OWN SHOP ON OUR
 30 DAY FREE TRIAL OFFER
 MAIL COUPON BELOW FOR COMPLETE DETAILS**

JUST MAIL COUPON

NO OBLIGATION ACT NOW! COUPON BRINGS FULL DETAILS NO SALESMEN



FOLEY-BELSAW CO.
 90619 FIELD BLDG.
 KANSAS CITY, MO 64111

YES, please send me the FREE INFORMATION that gives me complete facts about your Planer-Molder-Saw and full details on how I can qualify for a 30-Day Free Trial right in my own shop. I understand there is No Obligation and that No Salesman will call.

NAME _____

ADDRESS _____

CITY _____ STATE _____ ZIP _____

Build It Together

By Katie and Gene Hamilton. Charles Scribner's Sons, 597 Fifth Avenue, New York, New York 10017. © 1983, 1984.



197 pages
\$14.95
paperback

"A piece of wood, a hammer, and thou, my child" (with apologies to Omar Khayyám) might make an appropriate synopsis of this book, which shows that adults and children can have fun and gain satisfaction by making things together from wood. "All 27 projects in this book are designed for beginners, people with little or no experience in woodworking," the authors point out. "You don't need a fancy workshop and expensive power tools. Our projects can be built on a kitchen or Ping-Pong table. The materials are easy-to-find dimensional lumber available at home centers and lumberyards."

The projects include a hanging plant holder, tool boxes, a bat-and-ball rack, a bulletin board, a footstool, a model-building board, a bird feeder, a workbench, and an elevated play fort. Although these projects are simple, easy-to-build designs, they are functional, useful things that mostly require only a half-day to complete.

The authors provide a page or two of clearly written instructions for each project and include photographs and drawings showing crucial steps to keep readers on track. Noting that they tested each of these plans on parents and kids, they comment, "We hope kids and their parents or grandparents, teachers, or scout leaders find projects they want to build and then get right to it and enjoy the wonderful fun of building together."

"Not too long ago, the first project most apprentices completed was a box to hold their tools. Here are two easy-to-construct traditional tool boxes, one scaled for a master craftsman, the other just right for his apprentice. These matching tool boxes are constructed out of inexpensive but hardworking pine with hardboard bottoms."

"There is nothing more adorable than an almost-lifelike cuddly doll, but we noticed there's not much furniture built for them. Here is an easy-to-make slide just right for a doll 12"-20" tall. A dowel hinge makes the slide collapsible..."

Let's make this short ... and very sweet!

MR. SAWDUST BLADE PRICES CAN NOW BE DROPPED 30%!

I knew it could happen.

Everybody knows we've never quoted a price in our ads. If we had, we'd have scared the life out of you... and the Mr. Sawdust Signature line would have died an early death.

You listened to our QUALITY story. You saw us prove our points in shows. You took us up on our *unlimited* guarantee. And you assured us that price was *not* the most important factor.

You moved our production from dozens to hundreds. And you made my blades the most desired among the serious woodworkers. You were good to us... and for us... and we can now be *good* to you.

For these good old American reasons, we are announcing permanent savings in our blade prices.* (And we don't have to take a full-page ad to do it!)

America's Foremost
Power Tool Professional

FORREST

FORREST MANUFACTURING COMPANY, INC., 250 DELAWANNA AVE., CLIFTON, N.J. 07014

For complete information and prices, write for our 2 brochures "The Cut is Everything..." (also includes Dado sets) and "Mr. Sawdust II" (ULTRA SMOOTH PLANER SAWS).

Please enclose \$1.00 for Postage and Handling.

*Dampeners and dado-heads not included in price-break.

MR. SAWDUST I

	WAS	NOW ONLY
10" 60T.	\$162.00	\$113.40
9" 60T.	156.00	109.20
8" 60T.	150.00	105.00

MR. SAWDUST II

	WAS	NOW ONLY
10" 40T.	\$156.00	\$109.20
30T.	135.00	94.50
9" 40T.	146.00	102.20
30T.	125.00	87.50
8" 40T.	136.00	95.20
30T.	115.00	80.50

6" Dampener \$23.00

5" Dampener 22.00

4" Dampener 20.00

TO ORDER...

PHONE TOLL FREE! 1-800-526-7852

(In NJ: 201-473-5236)



THE HEAVYWEIGHT

BUILT FOR THE PROFESSIONAL / PRICED FROM \$239

The Heavyweight is entirely American-made with top-quality materials and construction. It's priced for the hobbyist, but tough enough for the professional wood worker.

A 1/2HP motor with four-step pulley provides power to spare for turning, sanding, grinding, buffing and drilling. Accessories include a complete tool turning set and a face plate and sanding disk for outboard turning.

12" Wood Lathe

Ground steel ways.

100% American-made.

Cast iron head & tail stocks.

52" long; 38" between centers.

Sealed ball bearing head stock.

Free brochure on request.

WILLIAMS & HUSSEY MACHINE CO.

Dept. 24, Milford, NH 03055

Toll-free: 1-800-258-1380 In NH: 1-673-3446



the Affordable
SUPPORTABLE
SUPPORTABLE
SUPPORTABLE

material support system.



Dealer inquiries welcome

For information write

TURNING POINT, INC. • BOX 9303D • VILLAGE WEST • FARGO, ND 58109
701-645-2319

BOOKS WORTH READING

Make a Windsor Chair with Michael Dunbar

By Michael Dunbar. The Taunton Press, Inc., 52 Church Hill Road, Box 355, Newtown, Connecticut 06470. © 1984.



165 pages
\$13.95
paperback

The delicate elegance of the Windsor chairs pictured on the cover of this book at first glance seems achievable only by a master craftsman. But Michael Dunbar confesses in his introduction that 14 years ago he had "no experience working wood and, furthermore, had no interest in it whatsoever." His unexpected fascination with a small black chair encountered at a yard sale launched his career as a chair maker.

Acknowledging that he takes an unorthodox approach to working with wood, Dunbar seems to believe that anyone with enough interest can build one of these chairs. So he shows the reader how.

Chapters cover such topics as sculpting the seat, making Windsor-chair joints, turning the legs, socketing the seat, turning the stretchers, assembling the under-carriage, bending the backs, whittling the spindles, assembling the backs, finishing, and even sharpening chair-making tools. The book also boasts plans for the sack-back and continuous-arm-style chairs featured in the text, plus a gallery of Windsor chair designs. Except for a lathe needed for turnings, Dunbar employs hand tools for most tasks.

The book is illustrated with 349 photographs and 27 drawings. **Caution:** Dunbar's clear, enthusiastic writing style is persuasive enough to tempt most woodworkers to build a Windsor chair.

"Green wood is a joy to turn. Once you have tried it, you will regret any time you have spent in combat with dry, hardwood turning squares. After the greenwood blank is completely round, the chips come off in unbroken lengths like ticker tape..."

"The comment is often made that Windsor chairs were only painted to cover the fact that so many different woods were used in the chair. On the contrary, I think the craftsman who developed the Windsor forms had a painted surface in mind from the beginning—to a great extent, paint dictated what Windsor chairs would look like."

JOINT-MATIC

Revolutionary
Performance

Exceptional
Capabilities

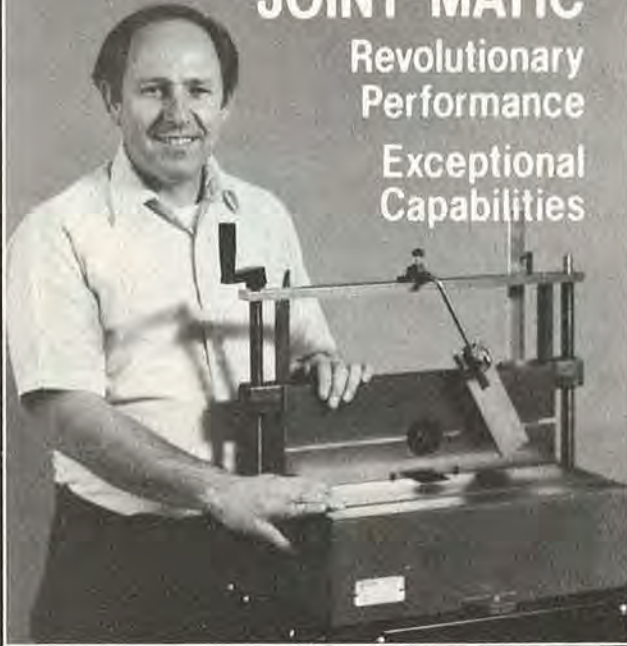

... The Joint-Matic 4200 is a new system in joinery that offers operating convenience, efficiency and accuracy that can not be compared to anything on the market. The Joint-Matic will help you produce woodworking pieces of elegance, precision and beauty more quickly and expertly than you ever thought possible. Now, in minutes make . . . Mortise, Tenon, Sliding and Through Dovetail, Box Finger Joint and much much more. Exclusive features of the Joint-Matic are so advanced in design and simplicity that set up time has been all but eliminated.

Features:

- Built for ruggedness and rigidity the table and slide unit have extra deep ribbing allowing a more accurate and chatter free cut.
- The base is heavy ribbed 1/2 inch thick casting, hardcoat anodized aluminum to a 52 Rockwell.
- The adjustment screws are rolled thread with a thread pitch of 3/4-16.
- Accuracy can be achieved to as close as .001th of an inch.
- Comes equipped with a 1-3/4 H.P. router.

For Your Brochure Please Send \$2.00 to:

Strong TOOL DESIGN

20425 Beatrice
Dept. W
Livonia, MI. 48152

Joint-Matic Machine Is Protected By U.S. Patent 4,163,465

 Print this article

ASSOCIATIONS YOU SHOULD KNOW ABOUT

Photograph: Jim Elder



Antique woodworking tools, like these planes from the collection of member Vern Ward, reflect only one aspect of the Early American Industries Association's broad interests.

THE EARLY AMERICAN INDUSTRIES ASSOCIATION

Woodworkers are a vast fraternity, willing to share knowledge, skills, and experience. And many of the craft's specialties are channeled into associations where members focus their common interests.

Old tools generally fascinate woodworkers as much as new ones.

"Who owned it?"

"What does it, or did it, do?"

"When and where was it made?"

Questions like these form the mystique shrouding the tools, obsolete trades, and industries of long ago that have been the focus of the Early American Industries Association (EAIA) for over 50 years.

More than 24,000 members from 53 states and 12 countries join together under the EAIA charter "to encourage the study and better understanding of early American industries in the home, in the shop, on the farm, and on the sea; also, to discover, identify, classify, preserve, and exhibit obsolete tools, implements, and mechanical devices which were used in early America."

Membership in EAIA is open to any individual or institution sharing this interest and purpose, and includes collectors, curators, conservators, researchers, writers, teachers, and institutions such as libraries, museums, and restoration groups.

You'd expect a diverse group to have varied interests. Try picking an area to explore from these identifiable EAIA specialties: farm implements and dairy equipment; woodworking, metalworking, and leather-

ASSOCIATIONS

working tools; textile machines; lighting devices; domestic utensils; hunting, fishing, trapping, or nautical equipment; medical and dental equipment; scientific instruments; weighing and measuring devices; industrial equipment; and vehicles.

At EAIA semiannual meetings, held each spring and fall, members have the chance to exhibit and view collections, add to them at tool sales and exchanges, and learn of bygone techniques and domestic industries through demonstrations, exhibits, and seminars. Bath, Maine, will host the 1985 spring meeting, scheduled for May 30 to June 2.

Researching the old ways, and sharing that research through publications, has been a primary activity of the EAIA. In *The Chronicle*, the association's quarterly magazine, members describe past technology, current collecting, preservation techniques, and other related subjects. *Shavings*, the periodic newsletter, reports on meetings and activities.

Films and books for research and study are available through the EAIA library located in the Spruance Library of the Mercer Museum in Doylestown, Pennsylvania. Discounts on books published by the association, affiliated organizations, and trade and university presses, are available.

Organizations with ties to the EAIA include EAIA West, Mid-West Tool Collectors Association, South West Tool Collectors Association, and the Three Rivers Tool Collectors Association.

Individual membership is \$15 per calendar year, and includes the publications plus an annual membership directory.

For more information and membership application, write:
John S. Watson, Early American Industries Association, P.O. Box 2128, Empire State Plaza Station, Albany, NY 12220. ■

**START YOUR OWN
PROFITABLE CASH BUSINESS
EVEN WHILE LEARNING!**



BE YOUR OWN BOSS... BE A LOCKSMITH

**There is a difference
in locksmithing
training and
the difference
is NRI**

Only NRI gives you such complete training, so much real bench experience, and the confidence and all the tools you will need to earn cash money fast.

A well-trained locksmith earns money in many different ways—installing locks in apartments, homes, businesses, and automobiles, fixing broken locks, cutting new keys, and more. And this huge market is just begging for new qualified locksmiths. Today there is only one locksmith for every 18,000 people!

The Newest, Most Advanced Course of Its Kind

Thorough step-by-step lessons and professional locksmithing equipment such as the Taylor KD5 Key Machine give you hands-on experience in this exciting growth field. You'll start earning huge cash profits of 800% to 900% duplicating keys. And only NRI offers you an Electronic Security Alarm training system.

Compare! NRI offers the only course that is nationally approved by the accrediting commission of the National Home Study Council.

Compare! NRI's course training has been broken down into 10 learning modules, each with the right number of lessons to keep your

training at an easy-to-follow pace. All the lessons, hands-on training, and experiments have been developed to ensure that you begin practicing from the very first day... and can begin making cash as soon as you like. All the money-making secrets of a locksmithing trade will become yours with your NRI training.

Plus, only NRI gives you training in both locksmithing and electronics security systems in one complete course.

Start Your Own Business, Full or Part-Time, Even From Your Home

Add to your income with part-time work with established locksmiths... start your own part-time or retirement business in your own home... make locksmithing and security a full-time career as a skilled technician in your own growing business. There is opportunity everywhere!

NRI's free 4-color booklet will show you how quickly you can train to be your own boss in a profitable locksmithing business and gain the respect you deserve as a trained technician like other professionals in your community.

**SEND FOR FULL INFORMATION BOOKLET TODAY! COMPARE.
THERE'S NO OBLIGATION AND NO SALESMAN WILL CALL!**

NRI SCHOOLS
McGraw-Hill Continuing Education Center
3939 Wisconsin Avenue, Washington, DC 20016

We'll give you tomorrow.

- CHECK ONE FREE CATALOG ONLY
- Locksmithing & Electronic Security
- Data Communications
- Robotics & Industrial Controls
- Color TV, Audio, and Video System Servicing
- Electronics Design Technology

- Digital Electronics
- Communications Electronics
- Industrial Electronics
- Basic Electronics
- Telephone Servicing
- Small Engine Servicing

- Appliance Servicing
- Automotive Servicing
- Air Conditioning, Heating, Refrigeration, & Solar Technology
- Building Construction
- Computer Electronics with Microcomputers

For Career courses
approved under GI bill
 check for details.

Name (Please Print) _____

Age _____

Street _____

City/State/Zip _____

Accredited by the National Home Study Council

1726-035

TREND-LINES BEATS ANY AD THIS ISSUE!

Free with any order:

- 1 Year (3-4 Issues) catalog subscription
- Subscription to Woodworking Trends
- Membership in TLC with special offers
- For special prices, ask for code WDMA5

New! Freud tool sets

- 4 Pc. Chisel Sets \$ 26.75
- 6 Pc. Chisel Sets 33.95
- 10 Pc. Chisel Sets 55.75
- 8 Pc. Lathe Set 56.50
- 6 Pc. Carving Set 65.95
- 12 Pc. Carving Set 117.50

Free Wooden Case

If another prepaid price is lower, we match the price and give you a gift certificate worth \$5.00 when purchasing from our catalog. Few restrictions apply. **Minimum Order \$15.00**
Freight prepaid in all U.S.A. on orders of \$35.00 or more.

Note: Under \$35.00 add \$2.00 per order. Extra charge to Alaska & Hawaii on stationary machines. Misprints are subject to correction. This ad expires April 30, 1985. Watch for our next ad.

FREE CATALOG WITH ORDER OR BY WRITING TO POST OFFICE BOX.

SPECIAL SALE TO READERS OF THIS AD
 You Must Mention This Ad When Ordering

800-343-3248 USA 800-322-6100 Mass.
 617-884-8882 Non-Order Calls

TREND-LINES, INC.

375J Beacham St.
 P.O. Box 6447J
 Chelsea, Ma. 02150



or personal check

Open Monday to Saturday 8:00 AM-5:00 PM
 plus Thursday until 9:00

30 DAY MONEY BACK GUARANTEE

Examine any item in your home or shop. If it's not what you expected, return it in original condition for a full refund.

MAKITA TOOLS

- 1100 3 3/4" Planer Kit \$168.75
- 1805B 6 1/2" Planer Kit 278.95
- 1900BW 3 1/4" Planer w/cs 97.95
- 2030 12" Planer/Joiner 1175.00
- 2040 15 1/2" Planer 1295.00
- 2400BW 10" Miter Saw w/blade 259.50
- 2401BW 10" Miter Saw w/ blade w/electric brake 226.50
- 2708 Table Saw 249.00
- 3601B Router 128.95
- 3608BK Router w/case 85.95
- 3612BR 3 H.P. Router 189.95
- 3700B Laminate Trimmer 84.25
- 4200N 4 3/8" Circular Saw 94.50
- 4301BV Vr Sp Orbital Jig Saw 129.95
- 5007NB 7 1/4" Circular Saw 103.95
- 5008NB 8 1/4" Circular Saw 105.00
- 5012B 12" Chain Saw 119.95
- 5081DW 3 3/8" Cord. Saw 110.40
- 5201NA 10 1/4" Radial Saw 226.50
- 5402A 16" Circular Saw 395.00
- 6000R Uni-Drill 106.00
- 6010D 3/8" Cordless Drill 79.95
- 6010DL Cordless Drill w/recharger light & case 99.50
- 6010DWK Cordless Drill w/recharger & case 88.75
- 6012HDW Cord. Drill Kit 2-Sp. 105.95
- 6013BR 1/2" Reversible Drill 119.00
- 6300LR 1/2" Angle Drill 152.20
- 6510LVR 3/4" Drill-Rev. 69.00
- 6710DW Cord. Screwdriver 107.10
- 6800DBV Drywall Screwdriver 97.50
- 9030 1 1/2"x21" Belt Sndr 123.50
- 9035 Finishing Sander 49.95
- 9045B Finishing Sander 99.50
- 9045N Dustless Sander 112.50
- 9207SPB 7" Sander Polisher 136.95
- 9401 4"x24" Belt Sander 171.95
- 9501BKIT 4" Sander Grinder Kit 85.75
- 9900B 3"x21" Belt Sander 125.50
- 9924DB 3"x24" Belt Sander 132.75
- BO4510 Finishing Sander 46.95
- BO4530 6" Rnd Finish Sander 52.95
- DA3000 3/8" Angle drill 116.50
- DK1001 Drill (6010D), Charger & Vacuum Cleaner 129.95
- DP3700 3/4" Reversible Drill 56.90
- DP4700 Drill Reversible 96.95
- GV5000 Disc Sander 49.95
- HP1030 Hammer Drill 105.00
- JG1600 Jig Saw Single Sp. 91.25
- JR3000V Recipro Saw 134.75
- JR3000W 2 Sp. Recipro Saw Kit 124.75

RYOBI TOOLS

- B7075 3x21 Belt Sander \$118.95
- B7100 3x24 Belt Sander 148.50
- B7200A 4x24 Belt Sander 167.90
- D1010 3/8" Var. Sp. Drill 89.50
- D1015A 3/8" Screwdriver/Drill 111.95
- D1310 1/2" Drill 89.95
- D1320R 2 Sp. 1/2" Rev. Drill 99.95
- E3700A Drywall Screwdriver 77.95
- JS-60 Jig Saw 99.95
- JSE-60 Electronic Jigsaw 129.90
- L-120U 3 3/8" Planer 81.25
- L1323ALS 3 1/4" Planer 129.95
- LS-35 Finishing Sander 46.95
- L-580 6 1/4" Planer 189.00
- R-150 1 HP Plunge Router 88.00
- R-330 2 H.P. Router 139.70
- R-500 3 HP Plunge Router 165.00
- RA-2500 10" Radial Saw 449.95
- S500A 3x5 1/2" Finishing Sander 43.95
- SU-6200 Finishing Sander 1/2 Sheet 89.50
- TR-30 Laminate Trimmer 78.95
- TS-251U 10" Miter Saw 189.95
- TS-251U w/ Accessories 199.95
- W630 7 1/4" Circular Saw 99.50
- W730 8 1/4" Circular Saw 109.75

BLACK AND DECKER INDUSTRIAL TOOLS

- 1165 3/8" Angle Drill \$119.50
- 1179 3/8" VAR. Sp. Drill 69.95
- 1180 3/8" VSR Holgun 99.95
- 1311 1/2 VSR Drill 119.75
- 1575 3/8" VSR Scruddrill 119.50
- 1940 3/8" Cordless Drill w/98060 Charger 118.50
- 1975 3/8" Cordless Screwdriver w/98060 charger 129.50
- 2034 Drywall Screwdriver 91.50
- 2054 VSR Screwdriver 155.00
- 2931 Cordless Screwdriver w/98060 Charger 159.95
- 3027-09 7" Circular Saw 79.95
- 3030 7 1/4" Circular Saw 119.95
- 3034 7 1/4" Circular Saw 118.65
- 3035 8 1/4" Circular Saw 129.50
- 3051 7 1/4" Wormdrive Saw 158.25
- 3091 10" Miter Saw 189.95
- 3103 2 Sp. Cut Sawkit 99.95
- 3105 Var. Sp. Cut Sawkit 109.50
- 3107 Var. Sp. Orbital Cut Sawkit 119.50
- 3123 Port. Band Sawkit 305.00
- 3141 Cordless Jigsaw w/98060 Charger 149.95
- 3157-10 Var. Sp. Jigsaw 129.50
- 3265 Laminate Trimmer 145.65
- 3310 1 1/2 H.P. Router 139.50
- 3370-10 3 1/4" Planer 129.95
- 4010 Palm Sander 48.95
- 4018 1/2 Sheet Sander 99.50
- 4247 4 1/2" Disc Sander/Grinder 69.95
- 4260 Power File 189.50
- 6750 Heat Gun 69.75

Watco Danish Oil

Natural, Medium, Dark, Black or Colors \$17.65 Gal

TITEBOND WOOD GLUE

\$5.75 Qt. \$12.95 Gal

HITACHI TOOLS

- B600-A 14 1/2" Band Saw \$1554.00
- CJ65VA Electronic Jigsaw 132.75
- CR10V Reciprocating Saw 124.75
- C7SA 7 1/2" Circular Saw 69.95
- C10FA 10" Miter Saw 279.00
- C10FB 10" Miter Saw w/ vise extension 199.95
- C12Y 12" Table Saw 1250.00
- DRC-10 Cordless Screwdriver 98.50
- DR-10 3/8" Drill/Screwdriver 108.00
- DGV 1/4" Var Sp Rev Drill 71.00
- D10V 3/8" Var Sp Rev Drill 74.95
- D13V 1/2" Var. Sp. Rev. Drill 99.75
- F-20A 3 1/4" Planer 99.75
- F1000A Planer/Joiner 1375.00
- JH-60A Jig Saw 103.50
- P50 6 3/4" Planer 295.00
- P100F 12" Planer 1095.00
- PSM-7 7 1/4" Circular Saw 114.95
- PSM8 8" Circular Saw 141.90
- SB-110 4x24 Belt Sander w/dust bag 183.00
- SO-110A 1/2 Sheet Sander w/dust bag 119.95
- SB-75 3x21 Belt sander-2 Sp. w/dust bag 134.75
- SB8T 3x24 Belt sander 2-Sp w/dust bag 149.95
- TR-6 Laminate Trimmer 92.25
- TR-8 1 H.P. Plunge Router 126.95
- TR-12 3 H.P. Plunge Router 194.75
- W6V Screwdriver 94.50

MILWAUKEE TOOLS

- 0228-1 3/8" VSR Drill \$ 99.95
- 0234-1 1/2" VSR Drill 129.50
- 0375-1 3/4" Rev. Angle Drill 139.75
- 1107-1 1/2" VSR D Handle 147.50
- 1660-1 1/2" SSR Compact Hammer Drill Kit 174.65
- 5397 1 1/2 HP Router 179.00
- 5660 2 HP Router 224.95
- 5935 4"x24" Sander 219.95
- 6014 1/2 Sheet sander 125.50
- 6145 4 1/2" Angle Grinder 107.50
- 6255 VR.Sp.Jigsaw 149.95
- 6287 H.D. Jigsaw Kit 225.00
- 6367 7 1/4" Circular Saw 119.95
- 6460 10 1/4" Circular Saw 249.75
- 6507 Sawzall w/case 137.50
- 6543-1 1/4" Screwdriver 137.50
- 6749-1 Magnum Screwdriver 123.50
- 6750-1 H.D. Drywall screwdriver 119.50
- 6753-1 Drywall Screwdriver 79.95

ROCKWELL POWER TOOLS

- 11-072 32" Radial Drill \$399.95
- 22-651 13" Planer 1450.00
- 28-140 10" band Saw 359.95
- 28-243 14" Band Saw 595.95
- 31-205 8" Table Saw 159.50
- 33-150 Sawbuck 595.00
- 33-990 10" Radial Arm Saw 499.95
- 34-010 Miter Saw 169.95
- 34-410 10" Contractors Saw 799.95
- 34-695 10" Homecraft Saw 339.75
- 34-710 10" Tilting Arbor Saw 495.75
- 37-609 6" Jointer 395.00
- 43-122 Wood Shaper 559.95
- 46-140 11" Lathe 419.95

FREUD SAW BLADES

- 10" = 3/8" Bore Carbide Tipped 12" = 1" Bore
- No. Size Teeth Use Price
- LU72M10 10" 40 General \$38.50
- LU73M10 10" 60 Cut-Off 42.95
- LU73M12 12" 72 Cut-Off 76.90
- LU78M10 10" 80 Plastic 83.50
- LU82M10 10" 60 Cut-Off 48.50
- LU82M12 12" 72 Cut-Off 85.95
- LU84M10 10" 40 Comb. 42.50
- LU84M11 10" 50 Comb. 44.40
- LU85M10 10" 80 Cut-Off 72.00
- LM72M10 10" 24 Ripping 41.90
- DS306 6" Dado 98.95
- DS308 8" Dado 119.50

SUN GOLD SANDING SHEETS

- 9x11 Aluminum Oxide C Weight Grit Pk of 100
- 150, 120, 100 \$21.95
- 80 23.70
- 60 28.90
- 50 32.05
- 40 38.30

PONY CLAMP FIXTURES Each Pkg 6

- No. 50 3/4" Pipe Clamp \$7.70 6.95 ea
- No. 52 1/2" Pipe Clamp 6.90 6.40 ea
- No. 1215 (WEB) 15" 6.40 5.80 ea
- No. 7456 Clamp Pads 2.50 2.25 ea

JORGENSEN BAR CLAMPS (Heavy Duty) Each Pkg. 6

- No. 7224 24" 17.30 15.70 ea
- No. 7230 30" 18.10 16.45 ea
- No. 7236 36" 18.70 16.95 ea
- No. 7248 48" 20.75 18.70 ea
- No. 7260 60" 22.65 20.55 ea
- No. 7272 72" 24.55 22.25 ea
- No. 7284 84" 26.55 24.10 ea

JORGENSEN CLAMPS (Med Duty)

- No. 3712 12" 6.15 5.60 ea
- No. 3724 24" 7.55 6.80 ea
- No. 3736 36" 9.20 8.35 ea

JORGENSEN HAND SCREWS

- No. 3/0 3" \$9.30 \$8.40 ea
- No. 0 4 1/2" 10.90 9.85 ea
- No. 1 6" 12.40 11.15 ea
- No. 2 8 1/2" 14.80 13.35 ea

JORGENSEN BAR CLAMPS (5" reach)

- No. 4512 12" Open 17.05 15.35 ea
- No. 4524 24" Open 19.05 17.15 ea
- No. 4536 36" Open 21.20 19.20 ea

JORGENSEN & PONY CLAMPS

- No. 3325 3 Way Edging \$5.40 4.90 ea
- No. 1623 3" Hold down 7.20 6.40 ea
- No 3202HT 2" Spring 2.15 1.90 ea

9X11 Non-Loading Silicon Carbide Grit A WEIGHT Pack of 100

- 400, 360, 320, 280, 240
- 220, 180, 150, 120 \$19.60

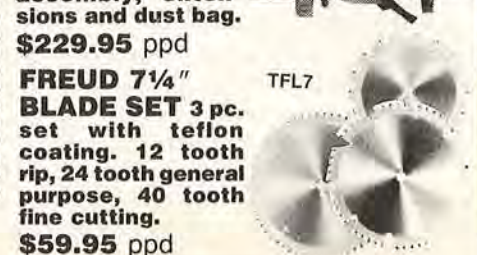
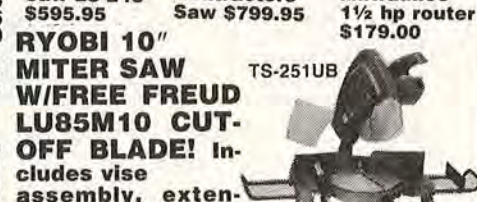



Paul L. McClure

Wood technologist; lecturer; owner of Wood World, a retail hardwood store in Tempe, Arizona; woodworking instructor, and former exotic hardwood buyer.

Brief History

Black cherry (*Prunus serotina*) was abundant when the first settlers came ashore in the New World. And, fortunately, the wide distribution of the seeds of its fruit by birds have always assured us of a supply.

Colonial furniture makers called cherry "New England Mahogany" because of its tendency to turn dark red-brown after exposure to sunlight, and used it side by side with the real thing.

Black cherry has a variety of nicknames—choke cherry, rum cherry, whiskey cherry, and wild cherry—all due to the use of its small, bitter, dark purple fruit as a flavoring in jellies and drinks such as the potent "cherry bounce." Extractions from its bark have long been an ingredient in medicines for bronchitis and coughs.

Wood Identification

Of the many cherry species found in Europe, Asia, and the United States, only black cherry is commercially important.

Cherry wood has a straight, satiny grain, often with a ripple figure. Heavy and hard, stiff and strong, the wood resists

CHERRY

the popular choice for bronchitis, bounce, and breakfronts

Once only an imitator, cherry has earned its place among woodworkers' fine hardwoods. And who hasn't tried a wild cherry coughdrop?



Straight grain



Resin-spot grain



Ripple grain



Black Cherry

knocks, and other abuse.

When first cut, cherry looks a pale, pinkish brown, but it gradually darkens to a mahogany-like red. Often, the very light-colored sapwood, as well as resin or gum pockets, will be present in boards. FAS (firsts and

seconds) grading standards accept their presence, but woodworkers shouldn't.

Cherry veneers, normally plain-sliced, feature straight-grain, though you'll occasionally find gummy (with resin pockets) and a mild ripple figure available.

Working Properties

While cherry shrinks considerably in the drying process, contraction and expansion are moderate after seasoning.

Cherry works well with all hand and machine tools, although it will burn if cutting edges aren't extremely sharp. Carvers and wood turners find that cherry adapts well to the knife and lathe, too. It takes a radiant finish, and its rich, natural color most often goes unstained.

Uses in Woodworking

Since cherry withstands shock, compaction, and abuse, furniture-makers as a general rule love working with it. Choice cherry logs find their way into veneers for architectural paneling and into hardwood plywood for cabinets. And solid stock becomes fine furniture, musical instruments, carvings, and turnings.

Cost and Availability

Cherry-veneered hardwood plywood remains expensive, but the cost of cherry lumber approximates that of oak, depending on how far you live from the supply.

Boards normally run to about 10" wide, since cherry is a comparatively small tree. And lengths usually don't exceed 12'.

Sources of Supply

Black cherry grows from the Dakotas south to Texas, east to northern Florida, and north to Nova Scotia. The Appalachian mountain region of Pennsylvania and West Virginia have the largest stands. ■

TRADITIONAL- STYLE HALL TABLE



Photograph: Al Elder Design: Dave Ashe

Simply stated lines and quality cherry lumber combine to make this furniture piece a pleasure to build and to own.



Print this article

Constructing the Table's Base

1 Rip, then crosscut the $\frac{1}{4}$ "-thick cherry stock to size for the table legs (A). (If you can't find stock this thick, laminate thinner cherry pieces, then rip and crosscut to size.)

2 Rip the side aprons (B) and the back apron (C) to width and crosscut them to length. Now, cut the rails (D) and stiles (E, F) to size for the front frame.

Clamp the frame members (D, E, F) together and mark a pair of dowel holes at each joint. (Mark the joints A-A, B-B, and so on, as shown in the Leg/Rail Doweling Diagram, so you won't have a problem getting the mating members back together again.) Remove the clamps, then drill $\frac{3}{8}$ " dowel holes $\frac{13}{16}$ " deep in pieces D, E, and F. Glue and clamp the front frame (D, E, F) together. Remove glue squeeze-out when the glue forms a tough skin. After the glue dries, sand the assembly smooth.

3 Now, clamp the front frame and the side and back aprons (B, C) to the legs. Make marks for dowel holes at each joint. (See the Leg/Rail Doweling Diagram for correct positioning.) Drill the dowel

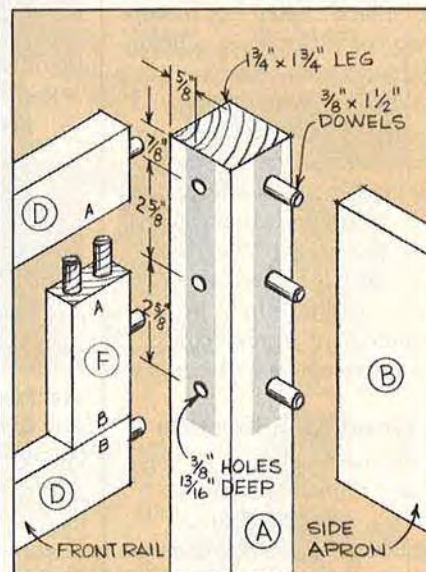

holes, then glue and clamp the pieces together. Check for square with a framing square. Set the frame upright and check to see that the table stands flat. If it doesn't,

Continued

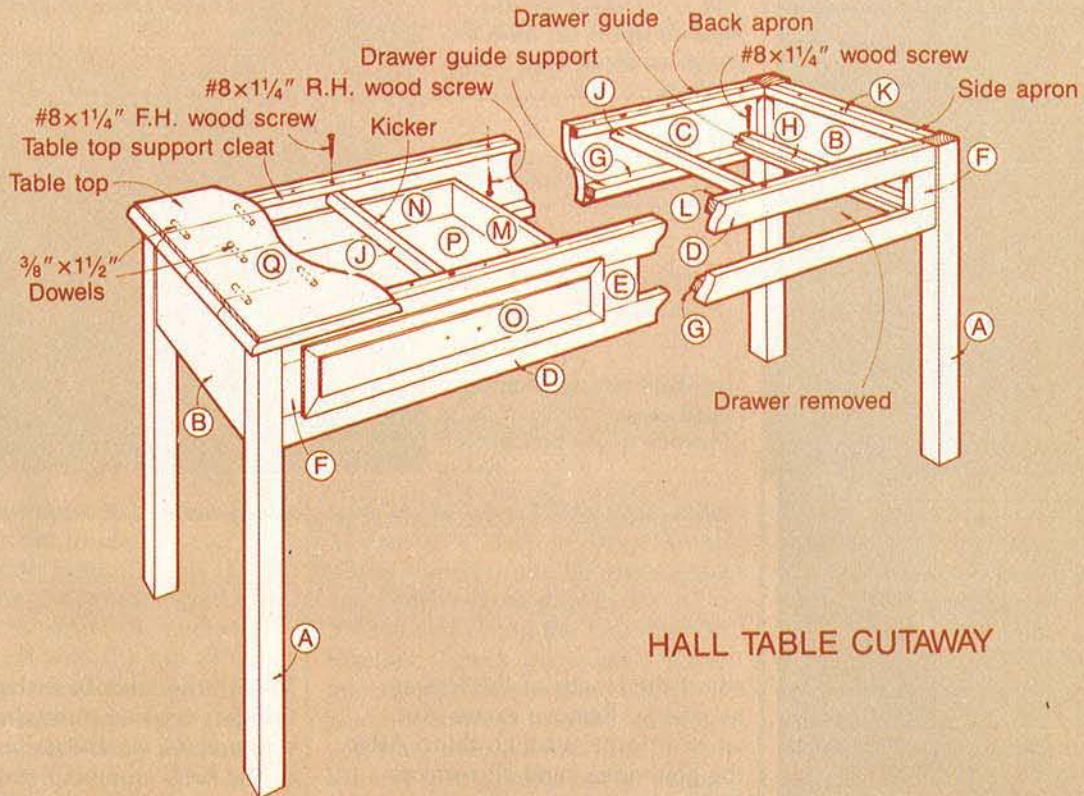

HALL TABLE CUTAWAY

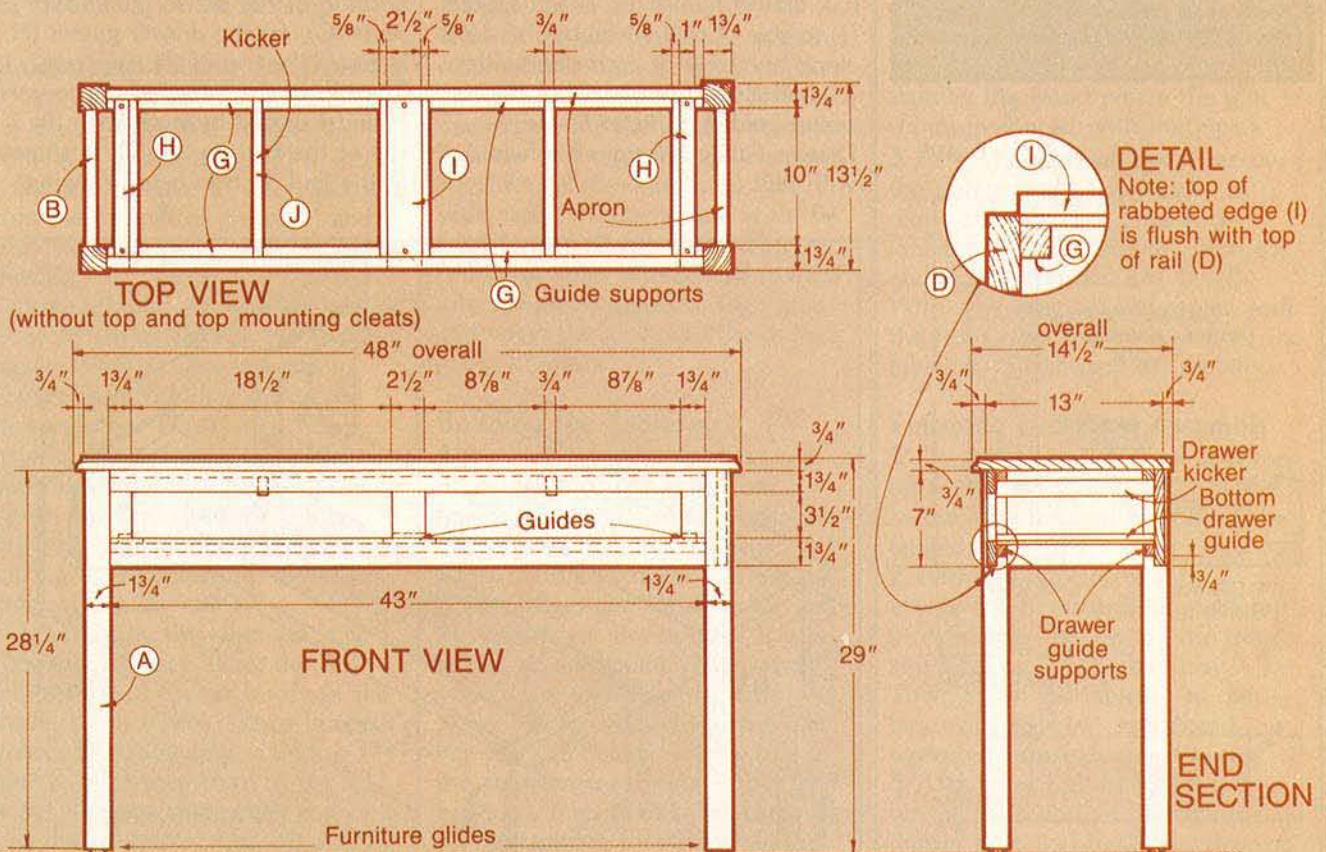

Continued

FURNITURE PROJECT

Bill of Materials

Part	Finished Size*			Material	Qty.
	T	W	L		
A	1 3/4"	1 3/4"	28 1/4"	cherry	4
B	3/4"	7"	10"	cherry	2
C	3/4"	7"	43"	cherry	1
D	3/4"	1 3/4"	43"	cherry	2
E	3/4"	2 1/2"	3 1/2"	cherry	1
F	3/4"	1 3/4"	3 1/2"	cherry	2
G	3/4"	3/4"	43"	cherry	2
H	3/4"	1 5/8"	11 1/2"	cherry	2
I	3/4"	3 3/4"	11 1/2"	cherry	1
J	3/4"	1 3/16"	11 1/2"	cherry	2
K	3/4"	3/4"	10"	cherry	2
L	3/4"	3/4"	43"	cherry	2
M	1/2"	3 1/4"	12"	cherry	4
N	1/2"	3 1/4"	17 7/8"	cherry	2
O	3/4"	4 1/4"	19 3/8"	cherry	2
P	1/4"	11 1/2"	17 7/8"	cherry ply.	2
Q*	3/4"	3 5/8"	48"	cherry	4

*Some parts are cut larger initially, then trimmed to finished size. Please read instructions before cutting.

Supplies: 2—drawer pulls, #8x1 1/4" round-head wood screws, 3/8"x1 1/2" dowels, #8x1 1/4" flathead wood screws, 4—furniture glides

Cutting diagram

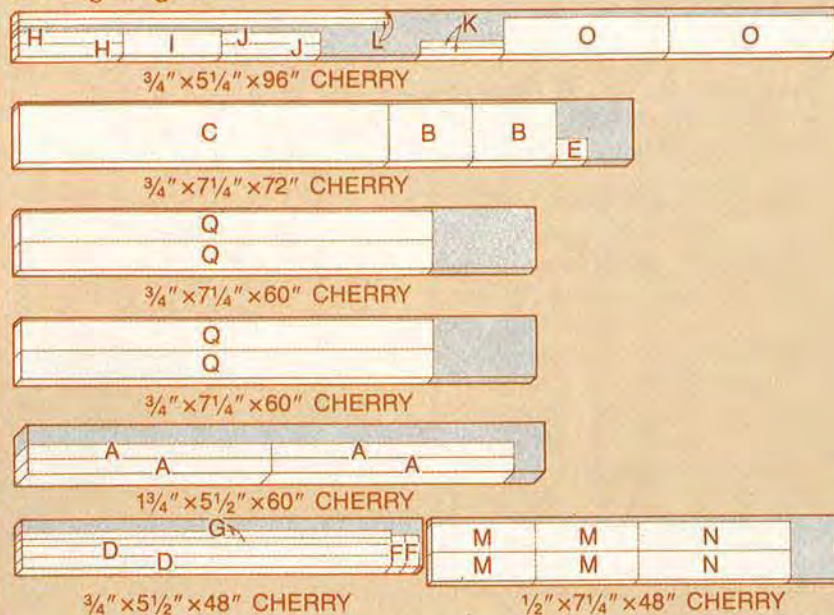

adjust the length of the legs as necessary. Remove excess glue when it forms a tough skin. After the glue dries, sand all surfaces.

4 Cut the drawer guide supports (G), drawer guides (H, I) and kickers (J) to size. Cut a 5/8" rabbet 1/2" deep along one edge of each side guide (H) and along both edges of the center guide (I). Refer to the Drawer Guide drawings for help with this.

5 With the table base standing upright, dry-clamp the drawer guide supports (G) 3/4" above the bottom of the back apron (C) and the front lower rail (D). To check for correct position of the drawer guide supports (G), set the drawer guides (H, I) across the top of the supports. The top of the rabbeted portions of H and I should be flush with the top of the bottom rail (D) as shown in the End Section detail drawing.

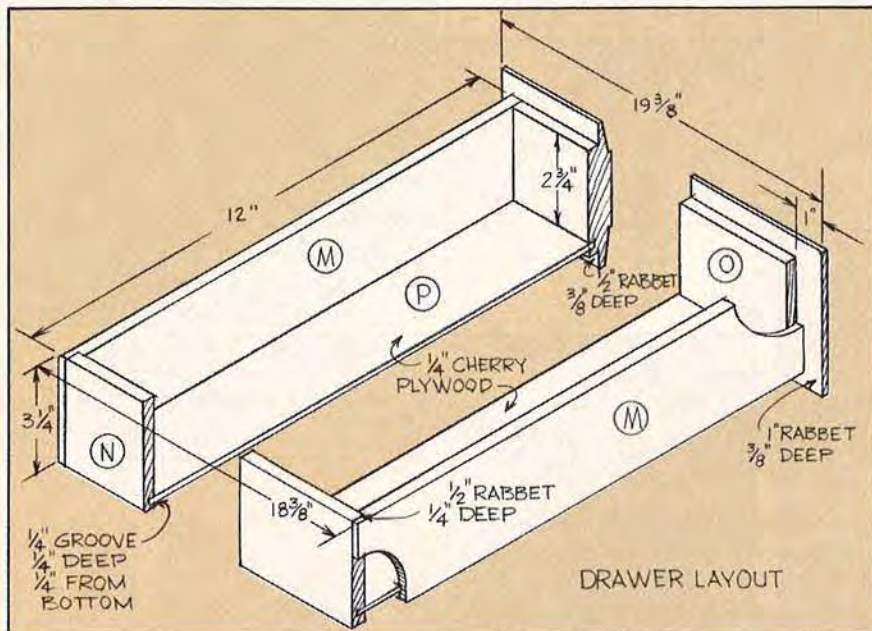
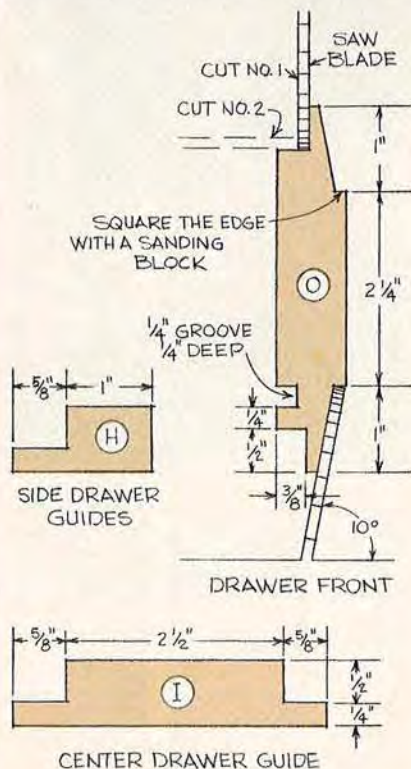



Cut the drawer front ends with the blade set at 10°, and push the fronts through with a push block as shown at right.

With the tablesaw blade set at 10°, cut the drawer front bottom and top as shown at left.



Mark the positions of G, then glue and clamp them in place.

6 Cut tabletop support cleats (K, L) to size. Glue and screw them to the base as shown in the cutaway drawing, flush with the top of the base. Center the kickers (J) in the drawer openings, then screw them to the top-support cleats as shown in the cutaway drawing. Drill $\frac{1}{2}$ " pilot holes through K and L for later mounting of the tabletop.

Making and Fitting the Drawers

1 Start by ripping, then crosscutting the drawer sides (M), backs (N), fronts (O), and bottoms (P) to size.
2 Cut a $\frac{1}{4}$ " groove $\frac{1}{4}$ " deep and $\frac{1}{4}$ " from the bottom of pieces M and N as shown in the Drawer Layout drawing.

3 Using a table saw with the blade set at 10° from vertical, cut the drawer fronts as shown in the Drawer Front drawing and in the photos above. (We test-cut scrap material first to check the bevel angle and the depth of the cut. Use a push block to push the fronts through when cutting the ends. You'll want to square up the edges after making the cuts.)

4 Again, using the table saw, cut a $\frac{1}{2}$ " rabbit $\frac{3}{8}$ " deep along the top and bottom of the back side of the drawer fronts (O) as shown in the Drawer Front drawing. Use the same two-cut procedure to cut a 1" rabbit $\frac{3}{8}$ " deep along each end of each drawer front. Also cut a $\frac{1}{2}$ " rabbit $\frac{1}{4}$ " deep along one end of

each of the drawer sides (M), and a $\frac{1}{4}$ " groove $\frac{1}{4}$ " deep in drawer fronts (O) as shown in the Drawer Layout and Drawer Front drawings.

5 Glue and clamp the two drawers together. Check for square. "Rack" into square, if necessary. (Don't glue the bottoms into the grooves; you want them to float free.) Remove glue squeeze-out as before and sand the drawers smooth after the glue dries.

6 To fit the drawers to the opening, set the drawer guides (H, I) on the drawer guide supports (G). Set the drawers on the guides and mark the location of the guides. (The guides should hold the drawers so they slide easily and are square with the front frame.) Remove the drawers, drill pilot holes through the guides into the guide supports, then glue and screw the guides to the drawer-guide supports.

Building the Tabletop

1 Rip and crosscut the pieces for the tabletop (Q). (We cut our boards 1" longer and $\frac{1}{4}$ " wider than the finished dimensions. This allows a little extra for jointing the boards' edges and for squaring up the ends later. If you don't have a jointer or don't joint your boards, you'll want to cut the tabletop pieces (Q) to finished width initially.) Lay the boards side by side in the arrangement in which they will be glued, then draw a large triangle on the tabletop for ease in realignment during clamping.

2 Mark the location of the dowels along the joint lines (we staggered them as shown in the cutaway drawing, and spaced them from 8" to 12" apart). Now, drill $\frac{3}{8}$ " holes $\frac{1}{16}$ " deep in the tabletop pieces (Q). Glue, dowel, and clamp the tabletop together. Alternate the clamps on the top and bottom of the boards, and space the clamps about 6" apart across the length of the top. (We placed waxed paper between the pipe clamps and cherry boards to prevent the clamps from staining the wood where the glue comes in contact with the pipe.)

3 After the glue has dried, remove the clamps and use a scraper to remove the excess. Sand both tabletop surfaces smooth. Trim the ends to the finished 48" length. With a beading bit and router, rout the front edge and both ends of the tabletop. Finish-sand the tabletop.

Finishing and Final Assembly

1 Finish the base, drawers, and top separately (be sure to apply finish to both the top and bottom of the tabletop).

2 With the tabletop and base upside down, position the tabletop (it overhangs the legs on the front and sides by $\frac{3}{4}$ "; the back, by $\frac{1}{4}$ "). Then, fasten the tabletop to the base with #8 x 1 $\frac{1}{4}$ " roundhead screws (see the cutaway drawing).

3 Attach the furniture glides, then set the table upright. Attach the drawer pulls and install the drawers in the base. ■

Our low-cost, last-for-a-lifetime ROUTER TABLE

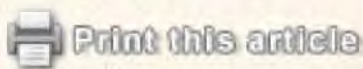

The perfect companion to your shop's most versatile tool, this go-anywhere, bench-top router table helps make even tough routing jobs easy. And its built-in vacuum attachment keeps dust and chips to a minimum.

Constructing the Base

- 1 Rip the feet (A), legs (B, C), and support frame pieces (D, E) to width, then crosscut them to length.
- 2 Glue and clamp the legs (B, C) in a T-shape, with C centered on and flush with the ends of B.
- 3 Cut half-lap joints at each end of the support frame pieces (D, E) as shown in the photo at right. (We did the work with a radial arm saw fitted with a dado set. We set the depth at one-half the thickness of the material, clamped a length stop 3" from the blade, made test-cuts with scrap, then made the cuts. It took several passes.)
- 4 Sand the support frame pieces smooth, then glue and clamp them together, checking for square.
- 5 Clamp the legs between the feet and the support frame (refer to the Router Table drawing for the correct position). Drill $\frac{1}{2}$ " pilot holes through A and E and on into the



legs. Enlarge the top $\frac{1}{2}$ " of the pilot holes by drilling with a $\frac{3}{16}$ " bit to house the shank of the screw. Remove the clamps, glue the mating surfaces, then countersink and install #10x2" wood screws.

Building the Top

- 1 Cut the tabletop (F) to size. Now, apply plastic laminate to the top surface and balance sheet to the bottom side (the latter stabilizes the



Photograph: William Hopkins Associates

tabletop and reduces the chances of warpage).

Note: We used a sink cutout for our tabletop. Often, you can purchase these very inexpensively at home centers and lumberyards.

- 2 Find and mark the center point of the tabletop as shown in the Router Table drawing. Drill a $\frac{1}{8}$ " pilot hole from the top side through the center point.
- 3 Place the tabletop facedown, then remove the plastic subbase from your router and install a V-grooving bit. To center the router over the $\frac{1}{8}$ " pilot hole, set the bit into the hole and trace the outside perimeter of the router's base.
- 4 Replace the V-grooving bit with a straight bit and, using the outline of the router base as a guide, rout out a recess $\frac{3}{32}$ " deep into the bottom side of the tabletop.

Bill of Materials

Part	Finished Size*			Material	Qty.
	T	W	L		
A	3/4"	3"	14 1/2"	maple	2
B	3/4"	3"	9 3/4"	maple	2
C	3/4"	2 1/4"	9 3/4"	maple	2
D	3/4"	3"	22 3/8"	maple	2
E	3/4"	3"	14 3/8"	maple	2
F	3/4"	14 1/2"	22 1/2"	plywood	1
G	3/4"	1 1/2"	24"	walnut	2
H	3/4"	1 1/2"	14 1/2"	walnut	2
I	3/4"	2"	24"	maple	1
J	3/4"	3 3/4"	24"	maple	1
K	3/4"	3 1/2"	3 3/4"	maple	1
L*	1 1/4"	3 1/2"	5"	maple (lam.)	1

*Some parts are cut larger initially, then trimmed to finished size. Please read instructions before cutting.

Supplies: 12—#10x2" flathead wood screws, 28—#8x1 1/4" brass flathead wood screws, 6—#8x3/4" brass roundhead wood screws, 1—8-24x1/2" brass roundhead machine screw, 1—#8x1" brass roundhead wood screw, 2—8-32x2 1/4" brass roundhead machine screws, 2—8-32 threaded inserts, screws to mount router to router tabletop, 2—brass coat hooks and mounting screws, 1/4" acrylic sheeting, plastic laminate, balance sheet, contact cement, 2—vacuum hose adapters, polyurethane.

5 Now, working from the top side, drill a 1 1/2" hole through the top, using the 1/8" pilot hole as the center point. (We used a 1 1/2" paddle bit to drill the hole and placed a piece of wood on the bottom side to prevent breakout.)

6 To mount the router to the bottom side of the tabletop, place the router into the router recess, then locate, mark, and drill the router mounting holes (the ones used to attach the plastic subbase). Counter-sink the mounting holes from the top side so that the machine screw heads will be slightly below the top surface. (The location and size of the machine screws will vary depending on your particular router.)

7 Rip and crosscut the walnut banding pieces (G, H) to size. Screw them to the tabletop, using #8x1 1/4" screws. Attach the tabletop to the maple base.

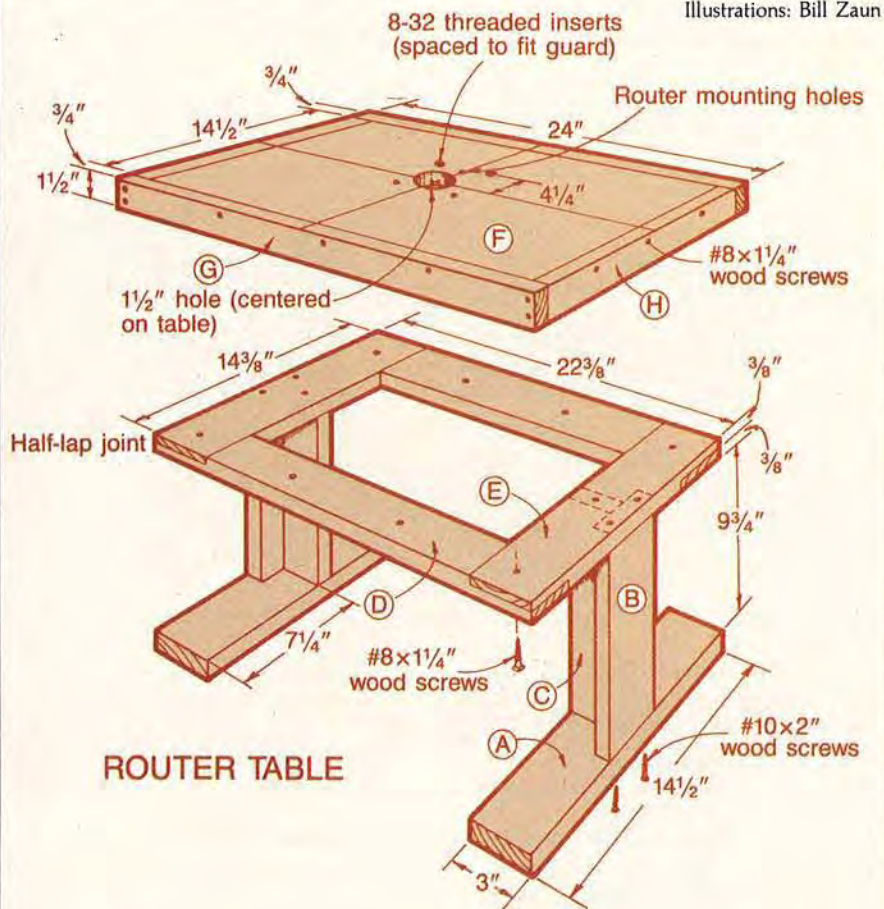

Illustrations: Bill Zaun

ROUTER TABLE

Cutting diagram

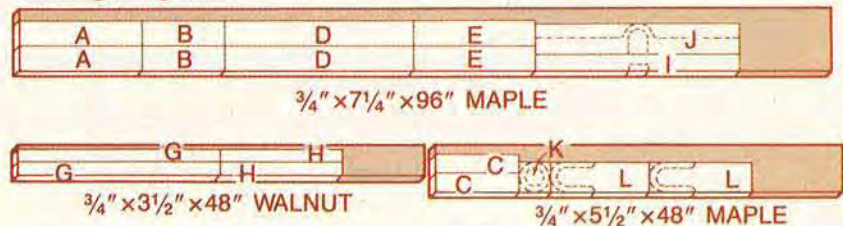

Building the Fence

Note: Both the fence and the guard were designed to accommodate a 2 1/4" vacuum-hose adapter. Dimensions may have to be adjusted to fit your vacuum. The fence works well when routing straight pieces such as decorative molding. The guard, designed for use with router bits that have pilots, performs best when routing the edge of an irregularly shaped object.

1 Rip and crosscut the upright (I), base (J), and filler block (K) to the

size indicated in the Bill of Materials.

2 Set the vacuum-hose adapter against the back edge of the filler block, trace both the inside and outside circumferences, and mark the screw hole locations. Cut the filler block to its finished shape, and either drill or cut out the 2 1/4" hole you just marked.

3 To shape the base and upright, measure over 12" from one end of both to find their center. Then, lower the filler block down onto the base (see the shaded area in the

Continued

OLD - NEW FANGLERS woodworking machinery

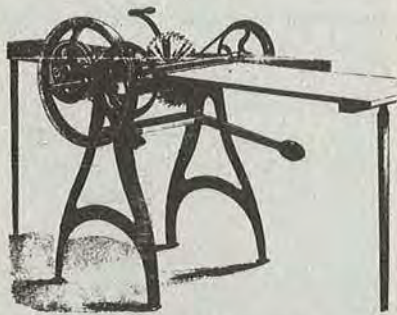

HAND CIRCULAR RIP SAW



COMBINED MACHINE

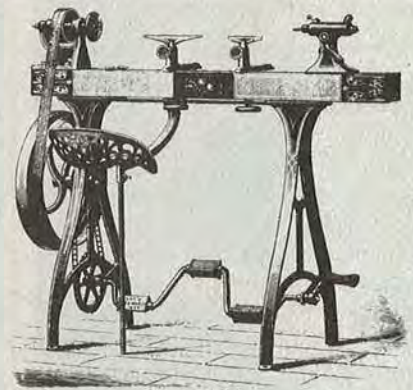

NO. 3 LATHE

The W.F. & John Barnes full line of professional woodworking machines as depicted in an 1882 advertising poster.

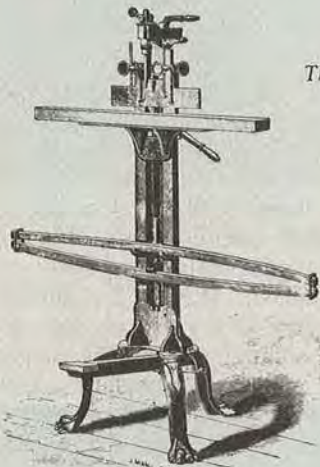

IMPROVED FOOT-POWERED MORTISING MACHINE

Fluting Attachment for Former.



FORMER



“Do not mistake these machines for the foot-power machines used by amateurs and boys for pastime and amusement. These machines are for profitable use in the workshop.”

—W.F. & John Barnes Company, 1882

Imagine yourself for a moment as the owner of a small cabinet shop in the late 1800s. You're in the middle of the Industrial Revolution. America has discovered steam. It powers boats, ships, carriages, and machines—even woodworking machines. You still rely upon muscle and hand tools, though, and you can't afford steam power. As a result, you're losing bids and money. What do you do?

Like thousands of others who made their livelihood from wood—contractors, builders, cabinetmakers, and craftsmen—you would probably read the advertisements of the W.F. & John Barnes Company of Rockford, Illinois, and find a way to compete. Their full line of newfangled foot- and hand-powered woodworking machinery, designed to offset steam's competitive edge, were



NO. 7 SCROLL SAW

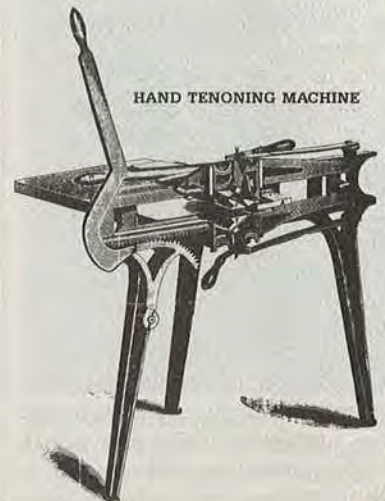

HAND TENONING MACHINE

Poster reprint courtesy of Roger K. Smith

Continued

TOOLS AND TOOL COLLECTING

the answer. And the machines were "affordable."

From the 1870s to the early 1920s the Barnes Company designed, manufactured, promoted, and sold their equipment to woodworkers across the nation.

Woodworkers such as A.R. Young, from Green Springs, Ohio, testified their satisfaction with the equipment in Barnes' advertisements: "Your machine does just as good work as can be done on any steam power machine. The machine is strong, the adjustments simple and the best I ever saw on any machine. No man can afford to do without it. The advantage of your machine is, it is always ready without raising steam."

Saving time and money through foot power

Patented from 1874 to 1878, the Barnes line did away with problems of direct power transfer encountered by previous manufacturers by "entirely overcoming dead centers, reducing friction to a minimum, and in other ways getting rid of the shortcomings of the old powers."

To support this claim, an 1882 advertising poster carries a comment by F.G. Mills, New Grenada, Pennsylvania, Furniture Rooms: "Your machines are turning out to my entire satisfaction. I would say that your machines are perfection."

As part of their marketing program, the Barnes Company offered their machines "on trial." A \$5 deposit with an order sent any machine out. Yet the cost to completely outfit a shop with their seven professional machines—the No. 7 Scroll Saw, the Former, the Mortising Machine, the Tenoning Machine, the Rip Saw, the Combined Machine and the Lathe—cost less than \$250.

For those who could not "spare ready money for the purchase complete of our machines at one order" Barnes suggested, "there are very few who cannot purchase one or more at a time, until he has obtained the complete outfit."



Some Barnes' machines, like this lathe, used a perforated leather belt to transfer power from the foot pedals.

Yesterday's machines for today's craftsmen

While the W.F. & John Barnes Company abandoned the manufacture of woodworking machines sometime in the 1920s and turned to oil well pumps, their machines can sometimes be found in the shops of collector/craftsmen still doing the work they were designed to do 100 years ago. One such collector/craftsman is Galena, Missouri's Bob Barnes.

Although the names are the same, Bob shares no relationship to



Decorative feet in the furniture style of the period could be screwed to the floor if necessary.

the original company partners. He collects and restores the Barnes machines because they're unique and quite usable.

"The Barnes Company was advanced. They were ahead of their time in the 1870s. Their machinery proves it," Bob told us as he walked from machine to machine, occasionally stopping to demonstrate. He has a complete collection of the machines, and believes he's the only one with them all. And all of his machines work.

At the lathe, Bob pointed out its features and explained its operation: "With the different pedals, people see it and say 'Where do you get a three-legged man to run it?' Well, the reason for the several pedals is to line up with the adjustable seat so you can always sit in front of your work."

Bob likes one machine, the Velocipede Scroll Saw No. 2 from the Barnes 1907 catalog, enough to market a reproduction. "It's really a pedal-powered jigsaw," Bob explained. "It has a 24" throat, but the base of my reproduction is of cast aluminum to reduce weight. The reproduction weighs just over 40 pounds, where the original weighed 90." Like the original scroll saw, it cuts delicate fretwork and silhouettes. Unlike the original, the Barnes Velocipede Scroll Saw No. 2 reproduction sells for \$600.

Barnes noted that the patented foot-power people from Rockford weren't the only manufacturers of such equipment. There was Star, Union, Crickett, Miller's Falls, New Rogers, and Champion, but W.F. & John Barnes was the largest manufacturer of hand- and foot-powered woodworking machinery during the 1800s. And he admires their ability to have kept moving forward.

Today, the W.F. & John Barnes Company has disappeared in the conglomerate McDermott Company, with traceable ties to a subsidiary division known as Babcock and Wilcox, a recognized leader in the development of nuclear power reactors.

Photographs: David Jordan

The Foot Power Former, Improved, made articles look costly and elegant with its "rapid and perfect work." Actually a router, it sold for \$20 in 1907.

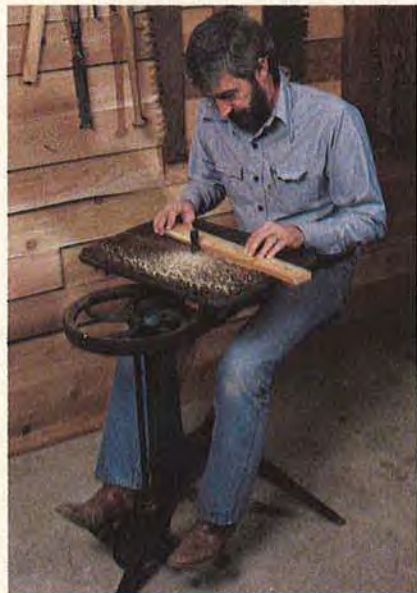

Billed as "the strongest, most powerful and eminently practical foot- and hand-power circular saw ever built," the No. 4 Circular Saw with self-feed cost \$60.



"Almost impossible to get out of order," the Foot Power Mortising Machine used the driving force of coiled spring steel to cut mortises and do light tenoning. The price: \$20.



"In order to meet the competition, it is an absolute necessity that a carpenter shall be equipped so that he stands on even terms with all comers"

—W.F. & John Barnes Company, 1882

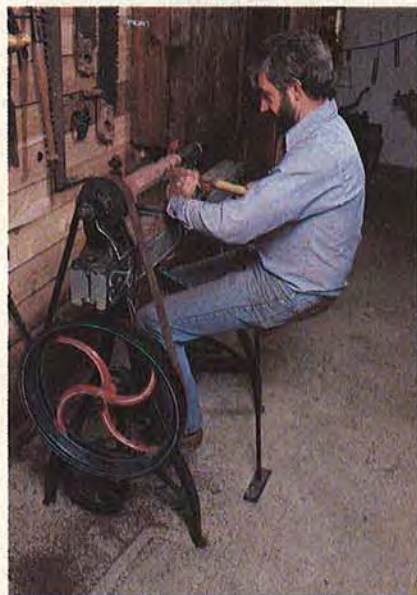

Operators of the No. 3 Lathe could "work steadily without fatigue" and develop speeds to 2,000 rpm. Work could be instantly reversed, started, or stopped—a bargain at \$40.

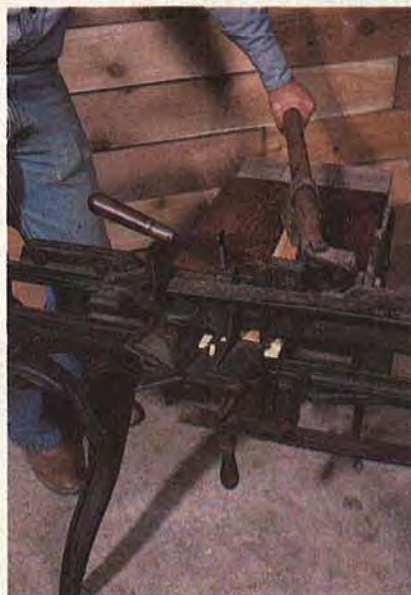

The Hand Tenoning Machine was "a hand machine with which as perfect tenons can be made as with steam power machinery." It cut "true, smooth, square shoulders" for \$20.

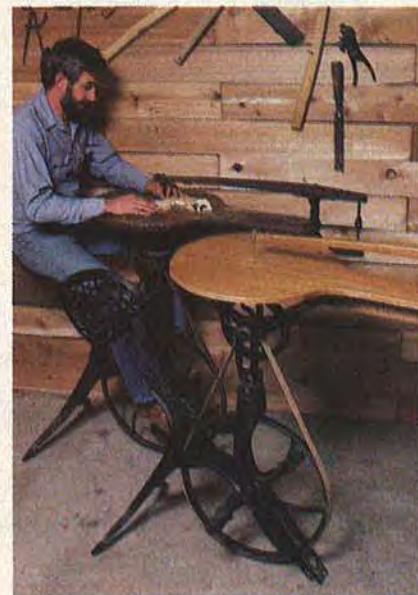

Bob Barnes' reproduction scroll saw, foreground, duplicates the original, which was "preferred by many on account of the velocipede foot power." It's 1907 price was \$20. ■



Any-way-you-want-it modular workbench group

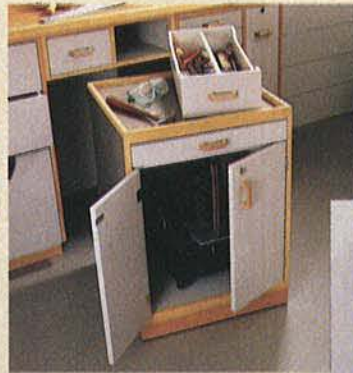

Drawer bridge and roll-around cabinet
See page 44



Scrap bin/
storage drawer unit
See page 43



Organize your tools and your work space with our interchangeable workbench group.

Photographs: Bob Calmer; William Hopkins Associates

Design: Dave Ashe

Illustrations: Bill Zaun

Multi-tool storage unit
See page 42



Bill of Materials

Part	Finished Size*			Material	Qty.
	T	W	L		
The Basic Cabinet Carcass					
A	3/4"	23 1/4"	41"	plywood	2
B	3/4"	22 1/2"	41"	plywood	1
C	3/4"	22 1/2"	23"	plywood	1
D	3/4"	4 3/4"	22 1/2"	pine	2
E	3/4"	4"	24"	pine	1
F	3/4"	3/4"	37"	pine	2
G	3/4"	1 1/2"	22 1/2"	pine	1
H	3/4"	3/4"	22 1/2"	pine	1
For a 3 1/8"-High Drawer					
I	3/4"	3 1/8"	22 3/8"	pine	1
J	1/2"	3"	22 1/2"	pine	2
K	1/2"	2 3/8"	21"	pine	1
L	1/4"	21"	22 3/8"	hardboard	1
The Drawer Organizer					
M	1/8"	1 3/4"	4"	hardboard	2
N	1/2"	1 3/4"	3"	pine	2
O	1/8"	4"	4"	hardboard	1
The Shelf					
P	3/4"	22 1/4"	22 1/8"	plywood	1
Q	3/4"	3/4"	22 1/8"	pine	1
The Bench Top					
R	3/4"	24 1/2"	72 1/2"	plywood	1
S	1/4"	24 1/2"	72 1/2"	hardboard	1
T*	1 1/2"	1 1/2"	75 1/2"	pine	1
U*	1 1/2"	1 1/2"	26"	pine	2
The Tool Rack					
V	3/4"	3 1/2"	73 1/2"	pine	2
W	3/4"	3 1/2"	36"	pine	2
X	3/4"	3 1/2"	34 1/2"	pine	1
Y	3/4"	3"	18 5/8"	pine	2
Z	1/4"	18 3/4"	35 1/4"	hardboard	1
AA	1/4"	34 1/2"	54 3/4"	perforated hardboard	1
BB	3/4"	2 1/2"	54 3/4"	pine	2
CC	3/4"	2 1/2"	33"	pine	3
DD	3/4"	3/4"	34 1/2"	quarter round	2
EE	3/4"	3/4"	54 3/4"	quarter round	2

*Some parts are cut larger initially, then trimmed to finished size. Please read instructions carefully before cutting.

Supplies: drawer pulls, 22" drawer slides, 18—#6x3/4" flathead wood screws, shelf support clips, paint, varnish or oil finish

Note: Obviously, all workshop situations vary considerably. And the component system shown opposite takes this fact into account. You can select a grouping from the options shown, or even adapt some of the ideas we present and come up with a system of your own. We've designed lots of "goodies" into these units; here's hoping you like what you see.

CONSTRUCTING THE CABINET CARCASS

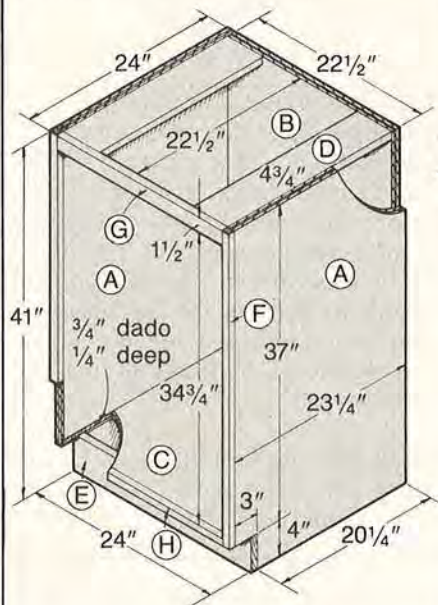

- 1 Rip, then crosscut the cabinet sides (A), back (B), bottom (C), cleats (D), and toe kick (E) to size. (We laid out pieces A, B, and C on a sheet of plywood, then two of us cut them on a table saw. When cutting large pieces, try to enlist a helper. You can guide the piece through the saw while the other person supports the panel.)
- 2 Cut a 3/4" dado 1/4" deep 4" from the bottom edge of the sides to receive the bottom (C). Cut a notch in the front lower corner of the sides. (This notched-out area creates the cabinet's toe kick.)
- 3 Glue, clamp, and nail the cabinet carcass together as shown in the Cabinet Carcass drawing. While the glue is still wet, check for square with a framing square. (You may

have to rack it into square with pipe clamps.)

4 Cut the face frame pieces (F, G, H) to size. Then glue, clamp, and nail them to the front of the cabinet carcass.

5 Sand all surfaces smooth. Mask the face frame and toe kick, then paint the carcass. Later, finish the pine parts with oil.

ASSEMBLING THE DRAWERS

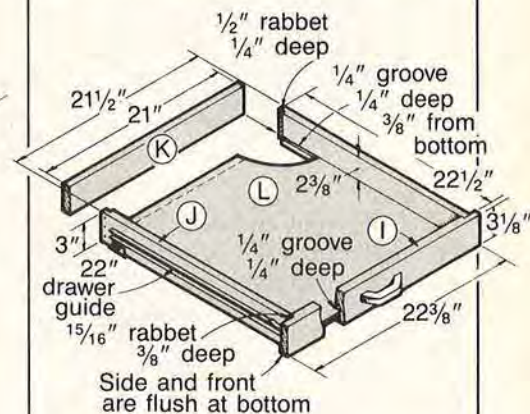

Note: In the Bill of Materials, we specify dimensions for a 3 1/8"-high drawer. See the Assembled Cabinet drawing for the heights of the other drawers.

- 1 To make the drawers, rip, then crosscut the drawer fronts (I), sides (J), back (K), and bottom (L) to size.
- 2 Cut a 1/4" groove 1/4" deep and 3/8" up from the bottom of the fronts and sides as shown in the Drawer drawing. Cut 1/16" rabbets 3/8" deep on the ends of the drawer front.
- 3 Glue, clamp, and nail the drawers together. (Nail the bottom (L) to the bottom edge of the back (K), but do not glue the drawer bottom into the groove; it should float in the joint.) Remove glue squeeze-out before it dries. Later, after the glue has dried, sand the drawers smooth.
- 4 Install drawer-slide hardware to the sides of the carcass and to the drawer sides. Paint the drawer fronts, then attach pulls to them.

Continued

1 To make the basic framework, cut the top and bottom rails (V), stiles (W), center divider (X) and tool holders (Y) to size. Drill holes in the holders to fit your tools. Cut $\frac{3}{4}$ " dados $\frac{3}{8}$ " deep in the left-hand stile (W) and center divider (X) to accept the racks.

2 Glue, clamp, and nail the framework (V, W, X) together (see the Tool Board drawing for how they join), using a framing square to check for square. (We did not glue or nail the racks (Y) into place, just in case we ever want to change the

arrangement or size of the holes.)

3 Cut the hardboard backing (Z) and the perforated hardboard (AA) to size. Rout a $\frac{3}{8}$ " rabbet $\frac{1}{4}$ " deep around the portion of the frame the hardboard fits into, then chisel the corners square. Check the fit of both the perforated hardboard and the hardboard in their respective openings. Trim, if necessary, then paint both backing pieces. Later, after the paint has dried, glue and nail the hardboard (Z) in place.

4 Cut parts BB and CC to size

(these fit behind and support the perforated hardboard). Glue and nail them in place flush with the back edge of the main frame (V, W, X).

5 Lay a bead of glue on the front edge of BB and CC, then set the perforated hardboard in from the front side.

6 Miter-cut the quarter-round pieces (DD, EE) to length and nail around the perimeter of the perforated hardboard. Finish the pine pieces with oil.

Continued

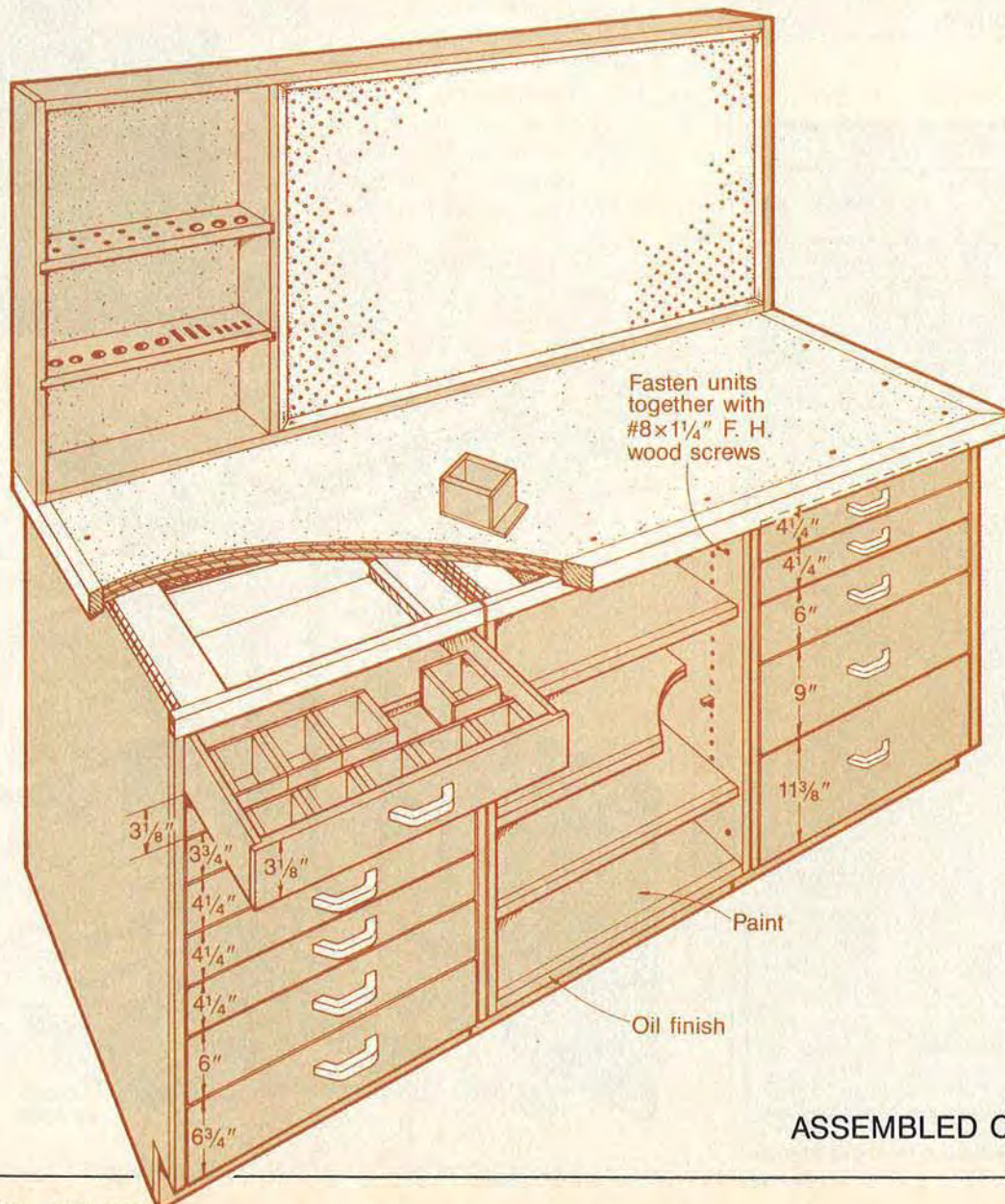

PROJECT SKETCHBOOK

multi-tool storage unit

Of all the modules we built, this one ranks #1 in variety. It boasts built-in blade storage and a slide-out tool caddy that houses several often-used tools. Two drawers and adjustable shelves round out this hard-working module.

Bill of Materials

Part	Finished Size			Material	Qty.
	T	W	L		
A	3/4"	22 1/2"	36 1/4"	plywood	1
B	3/4"	2"	13 3/4"	pine	1
C	1/2"	13 1/2"	20 1/2"	plywood	2
D	3/4"	7 7/8"	34 3/4"	plywood	1
E	1/2"	22"	33 3/4"	plywood	1
F	1/2"	7"	33 3/4"	plywood	1
G	1/2"	4 1/4"	22"	plywood	1
H	3/4"	6 1/2"	22 1/8"	plywood	2
I	1/4"	6 1/2"	22 1/8"	hardboard	1
J	1/2"	3"	22"	plywood	1
K	3/4"	3 5/8"	13 5/8"	plywood	2
L	1/2"	21 3/16"	12 1/8"	plywood	2
M	1/2"	3 5/16"	22 5/8"	plywood	4
N	1/4"	12 1/8"	22 1/2"	hardboard	2
O	3/4"	13 9/16"	28"	plywood	1
P	3/4"	1 3/8"	8 1/2"	pine	1
Q	3/4"	1 3/8"	7"	pine	2
R	1/8"	4"	10"	hardboard	1
S	1/8"	6 1/2"	12 3/4"	hardboard	1
T	3/4"	1 3/4"	11 1/4"	pine	1
U	3/4"	1 3/4"	9 5/8"	pine	2

Supplies: Paint, 2 pairs—22" drawer slides, 4—wood pulls, 2—2" flathead wood screws, oil or polyurethane finish, 2—cabinet locks, 2 pairs—22" full-extension drawer slides, 4—#8x1 3/4" flathead wood screws, 8—shelf support clips

Build the cabinet carcass as described on page 39, except set back the bottom piece of the face frame 3/4" to act as a stop. Cut to size and install the center divider (A), the horizontal support (B), and the shelves (C).

Cut the pieces for the pull-out caddy (D, E, F, G, H, I, J). Then, cut the grooves, rabbets, and dadoes, and assemble. Attach the caddy to the carcass with the 22" full-extension drawer slides. Rip and crosscut the drawer parts (K, L,

M, N) to size. Assemble the two drawers as described on page 40 using the dimensions listed below in the Bill of Materials. Cut the door (O) and blade holders (P, Q, R, S, T, U) to size and assemble.

Mask the pine and paint the rest, remove the tape and oil the pine. Let dry and attach the hardware. ■

Design: Dave Ashe
Photograph: William Hopkins Assoc
Illustration: Ron Chamberlain

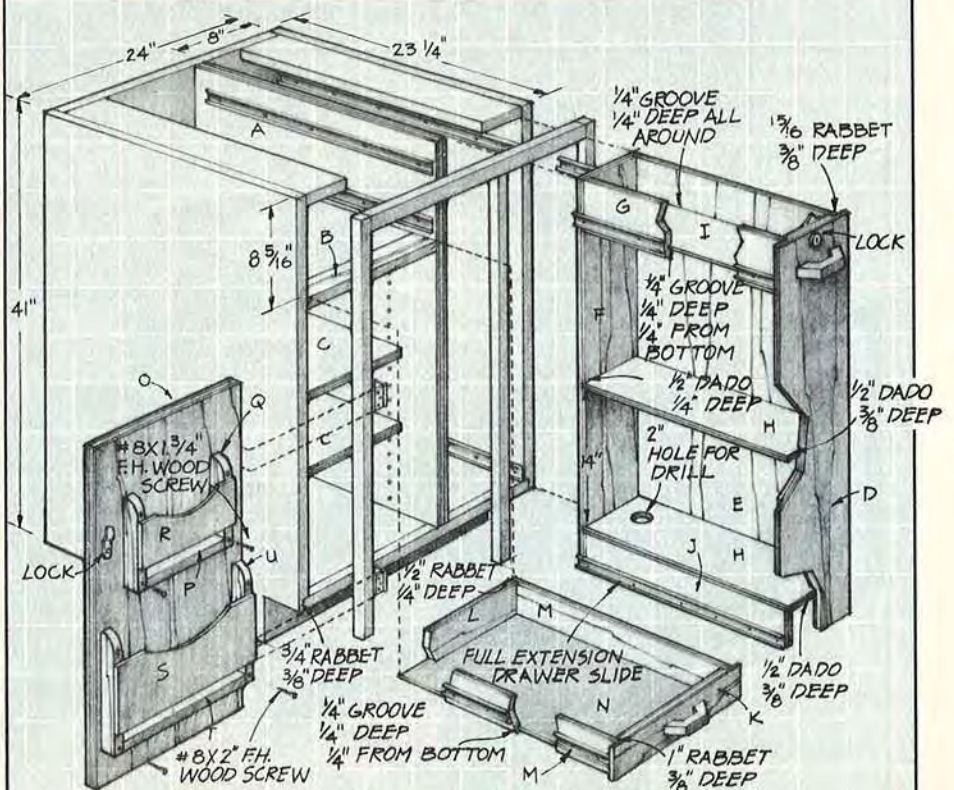

drawer bridge & roll-around cabinet

Go to where the action is with this winning combo. The tool totes pull out, and the roll-around unit slides out of its cubbyhole for help where you need it.

Bill of Materials

Part	Finished Size			Material	Qty.
	T	W	L		
Drawer Unit					
A	3/4"	22 1/2"	22 1/2"	plywood	2
B	3/4"	8 1/4"	23 1/4"	plywood	2
C	3/4"	6 3/4"	22 1/2"	plywood	1
D	3/4"	8 1/4"	22 1/2"	plywood	1
E	3/4"	3/4"	22 1/2"	pine	1
F	3/4"	3/4"	8 1/4"	pine	2
G	3/4"	3/4"	6"	pine	1
H	3/4"	1 1/2"	22 1/2"	pine	1
I	1/2"	5 7/8"	22 7/8"	plywood	4
J	3/4"	5 7/8"	10 1/4"	plywood	2
K	1/4"	10 1/4"	22 1/4"	hardboard	2
L	3/4"	5 7/8"	10 3/4"	plywood	2
Roll-Around Cabinet					
M	3/4"	22"	22 1/2"	plywood	1
N	3/4"	23 1/4"	31 1/4"	plywood	2
O	3/4"	22 7/8"	22 3/4"	plywood	1
P	3/4"	22"	31 1/4"	plywood	1
Q	3/4"	2"	22"	plywood	1
R	3/4"	4 1/4"	23 1/2"	pine	1
S	3/4"	3/4"	22"	pine	1
T	3/4"	3/4"	27"	pine	2
U	3/4"	1"	23 1/2"	pine	2
V	3/4"	1"	24"	pine	2
W	3/4"	10 7/8"	23"	plywood	2
X	3/4"	3"	21 7/8"	plywood	1
Y	1/2"	2 1/2"	20 5/8"	plywood	1
Z	1/2"	3"	22 5/8"	plywood	2
AA	1/4"	20 5/8"	22 1/4"	hardboard	1

Supplies: Paint, 1 pair—22" drawer slides, 5—wood pulls, 4—2" wraparound hinges, oil or polyurethane finish, 2—3/4" x 21 3/8" dowels, lock and catch, 2—4" swivel casters, 2—4" fixed casters

Construct the bridge-unit carcass (A, B, C, D) by ripping, then crosscutting the pieces to size and assembling. Cut the face-frame pieces (E, F, G, H) to size, then glue and nail them to the bridge unit. Cut and assemble the tool-tray drawers (I, J, K, L). (Use the drawer construction procedure described on page 40 and the dimensions given in the Bill of Materials.)

To build the roll-around, cut the carcass pieces (M, N, O, P, Q) and

frame pieces (R, S, T) to size and assemble. Now, add the lip (U, V) to the top of the unit. Cut the doors (W) to size and attach. Finally, cut the drawer parts (X, Y, Z, AA) to size and assemble.

Mask the pine pieces with tape and paint the rest. Remove the tape and after the paint dries, finish the pine with oil or polyurethane. Attach the casters to the rollout and screw the bridge unit between two adjacent cabinets. ■

Design: Dave Ashe
Photograph: Scott Little
Illustration: Ron Chamberlain

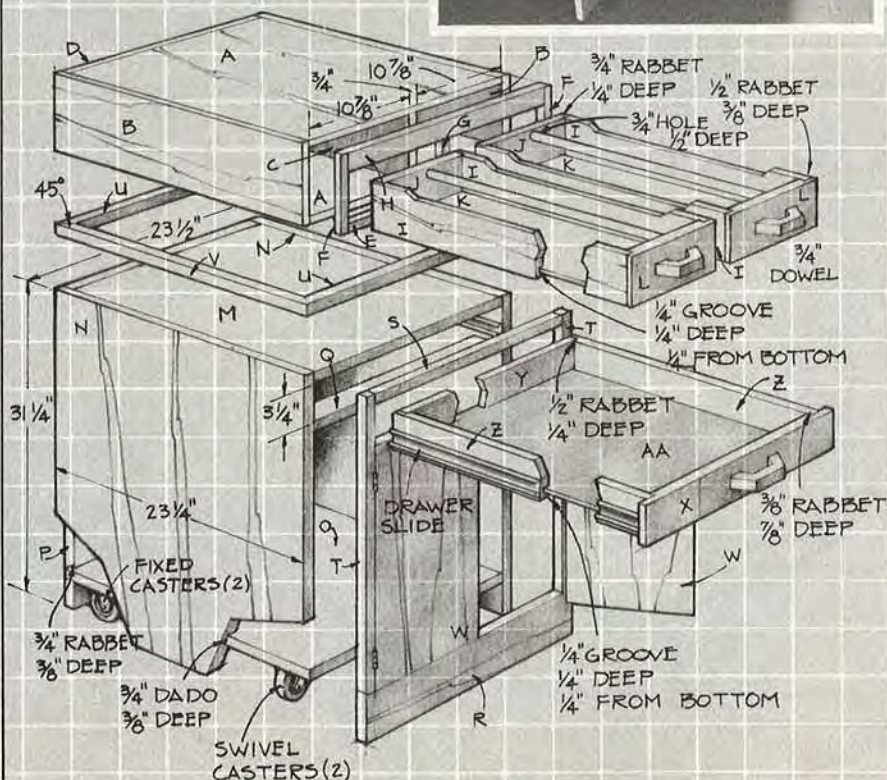

VENEERING BASICS

**working with
flexible wood
veneers**

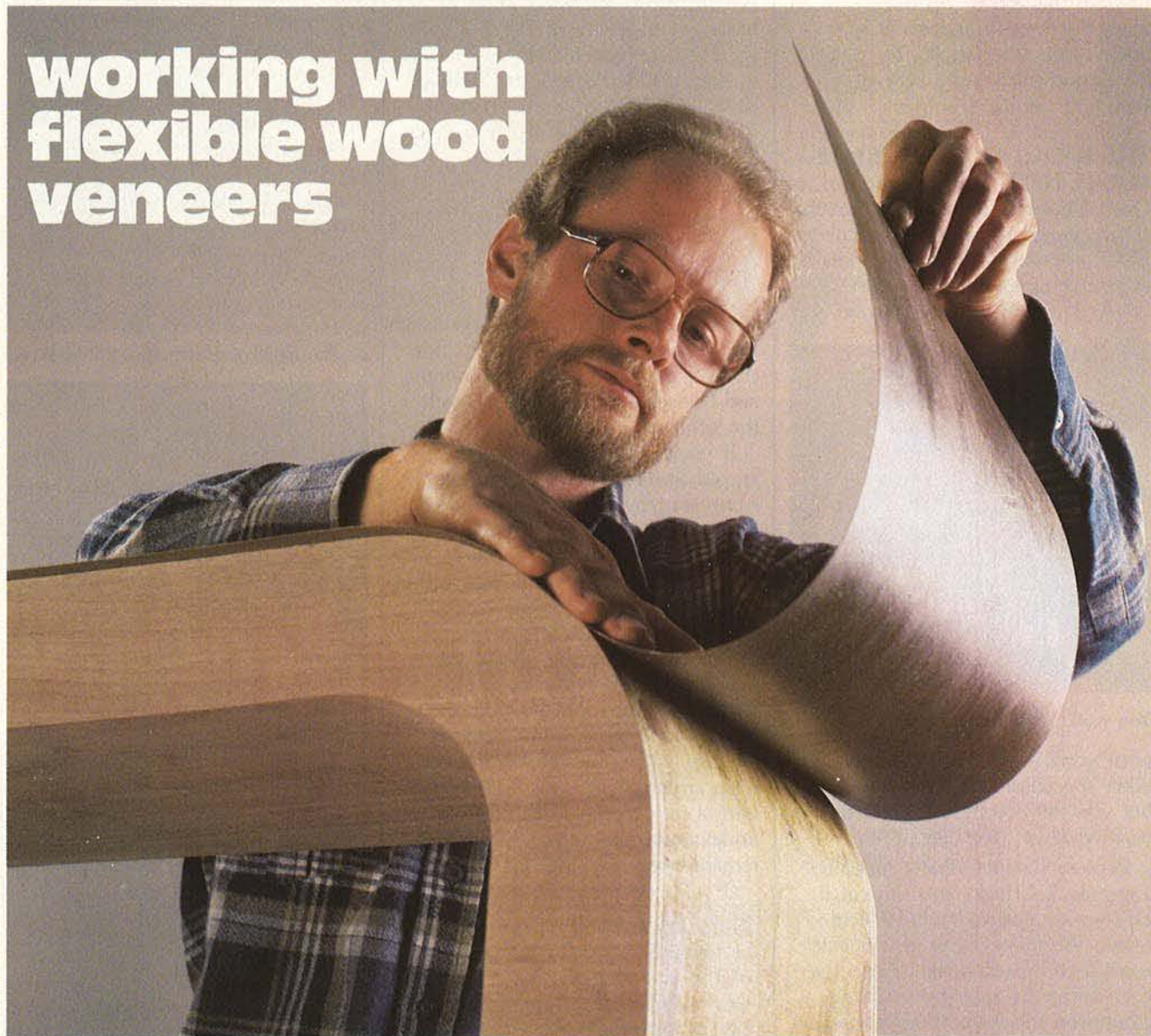

Goodbye, veneer presses, long glue-drying times, and random-width strips that require straight-line ripping before application.

Hello, paper-thin backed real wood veneer.



[Print this article](#)

Photographs: Bill Hopkins Associates
Illustrations: Herb Dixon

You can apply this factory-matched and machined product over existing furniture pieces, cabinets, and other such items to make them look brand-new. Or, on new projects, lay it down over an inexpensive substrate when you want the look of a beautiful domestic or imported wood—easily and more quickly than you might have thought possible.

Continued

SHOP-TESTED TECHNIQUES

We think that inexperienced and veteran woodworkers alike will appreciate the many merits of this thin-skinned, flexible material. And as you'll realize after you read through this article, learning to apply it correctly and expertly doesn't take long at all. You should have good success the very first time you use it.

THE TOOLS AND MATERIALS YOU'LL NEED

One of the things we like so much about backed flexible wood veneers is that we don't have to have lots of expensive equipment to get the job done. The photo below shows



You won't need many tools

what you'll need. You can buy other specialized tools, if you want, but you can accomplish good results with what you see here.

Because flexible veneer measures a minute $\frac{1}{4}$ " thick, you can cut it easily with a sharp-bladed X-acto knife. We make many of our cuts using a cork-backed steel ruler (the cork keeps the ruler from sliding around on the veneer). The masking tape keeps mating pieces of veneer stabilized while cutting and while butting the edges of two adjoining pieces together.

You'll need some solvent-base contact cement (the nonflammable type), a supply of waxed paper, and an inexpensive brush or roller for applying the cement (we like a roller best for large projects). And to make sure that the veneer bonds well to the substrate, you'll need a scrap wood tap block and a mallet

and/or a commercially available veneer roller.

And finally, just in case you position the veneer incorrectly when you lay it down (accidents do happen occasionally), you'll want to have a syringe and needle and some Formby's or Hope's refinisher handy to help lift off the veneer. Both of these products contain a chemical that breaks the bond of the contact cement quickly and easily.

PREPARING THE SURFACE FOR THE VENEER

No matter what material you put veneer onto—solid wood, plywood, particleboard, or hardboard—the surface must be smooth. If it's not, chances are good that those bumps and bruises will telegraph through the veneer.

If you're putting a new face on an old furniture piece or cabinet front, start by filling in any indentations in the surface and regluing any splintered wood or loose veneer. We've had good luck with Durham's Rock Hard Putty for filling holes and other blemishes. (If the piece is in terrible shape, you may be best off removing loose veneer.) Then, sand the surface smooth, and remove the resulting sawdust with a few blasts of air from an air compressor hose or with a tack cloth. With projects under construction, the procedures remain essentially the same.

Note: If you plan to shape the edges of a project in which you've used one of the composition materials (or a solid wood other than the veneer species) as a substrate, you'll want to add an edging to those surfaces that will be shaped. (We use a solid wood edging of the same species as the veneer.) Be sure to figure in the width of the edging when determining the size of the various substrate parts.

MAKING UP FOR WIDTH

Though you can mail-order flexible veneer in sheets up to 4'x12' long, you'll find yourself in situations from time to time in which

you'll need to edge-join two narrow pieces of veneer together.

Joining Manufactured Edges

From the factory, flexible veneers come with straight edges that make joining two pieces quite manageable. Of course, before doing anything, you should check to make sure that they haven't been banged up in any way.

Start by butting the two pieces together and settling on a grain match that appeals to you. Then, turn over one of the mating pieces and lay down a piece of masking tape so that about half of it overlaps the seam line. Now, turn that same piece over and butt the edge of the mating piece up against it as



Joining factory-edged veneer

shown in the photo above. To make sure you have a good bond between the tape and the veneer, run your fingernail along the seam line. (If you don't like the way the joint turned out, just pull the pieces apart and have at it again.)

If everything looks good, lay a strip of masking tape along the front side of the joint line (this stays put until you apply the veneer), and remove the tape from the back side. That's all there is to it; you're ready to apply the veneer as a single piece.

Joining Pieces with Irregular Edges
Especially when you're working



Overlapping veneer with irregular edges

with small, leftover pieces of veneer, you won't usually have straight edges to work with. But with flexible veneers, that's not a handicap in the least. Simply lay out the mating pieces, face up, and overlap them by $\frac{1}{2}$ " or so (make sure that you're satisfied with the grain match).

Now, tape the two pieces together with masking tape as shown in the photo above. Turn the veneer over, then once you're certain you know where the two pieces overlap, cut through both thicknesses of veneer with a sharp-



Double-cutting from the back side

bladed X-acto knife, as shown here. (You can do this freehand, if you want; actually, it's harder for the eye to see a crooked line than a straight one.)

Carefully remove the scrap pieces and fit the mating pieces together to check for a good fit. When you're satisfied, join the pieces with masking tape.

APPLYING THE VENEER

Note: When veneering a tabletop, cabinet door, shelf, or any other "floating" element, you must veneer both sides to keep it in balance. Veneering only one side may result in warping. You can save money by using a less-expensive veneer on the back side or underside.

Before you actually apply contact cement to the veneer or the substrate, you must first determine the

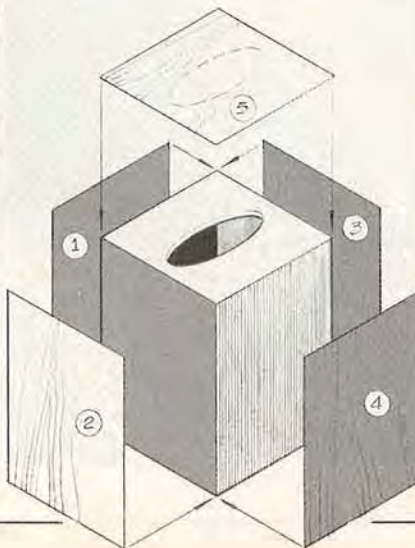

sequence of application. Let's take a simple example to illustrate. Say you want to veneer a tissue box cover like the one shown below. You would start by veneering the back, then move to the sides, then the front, and finally the top. By progressing in this order, you minimize the effect of the seams.

And to minimize waste, lay the veneer face down on a flat surface, and lay the object to be veneered on top of the veneer. Trace the outline of the object as shown here,

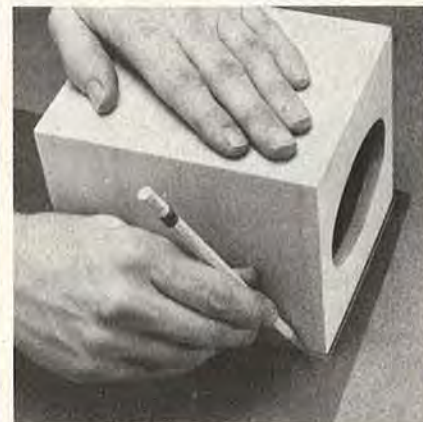

Tracing shape of item

then cut the veneer a bit oversize (we allow at least $\frac{1}{2}$ " all around).

Apply two coats of contact cement to the veneer and the substrate, allowing time to dry between coats. (Some brands of contact cement lose their gloss when they dry; others dry clear.)

Note: For obvious reasons, we recommend that you use a nonflammable contact cement and that you work in a well-ventilated area. We've had quite good luck with 3Ms Fast Bond 30, a nonflammable, nonodorous product, as well as Constantine's Veneer Glue.

Now (especially if you're veneering a surface of any size), gently lay a sheet of kraft paper, waxed paper, or freezer paper onto the substrate as shown at the top of the next page. (Doing this prevents the veneer from grabbing the substrate before you want it to.) Remember, it's difficult to separate them.

Continued

SHOP-TESTED TECHNIQUES



Easing veneer into place

Carefully align the veneer over the substrate, then press the veneer into place. Withdraw the paper an inch or two at a time and continue pressing the veneer from side to side as shown below until the entire surface has been covered. Continue to smooth the veneer with your hands, checking for any trapped air

bubbles while doing so. If you spot any of them, slit the veneer along the grain with your X-acto knife as shown in the photo below. Then,



Deflating air bubbles

press toward the slit with your fingers to remove the trapped air.

To make sure that there's a good bond between the substrate and the veneer, tap the surface with a block and mallet as shown at the top of the next column, or roll it with a commercially available veneer roller.

(Work from one end to the other, or from the center out, again watching for bubbles.)



Ensuring good contact

Now, trim the excess veneer that overhangs the edges. We usually lay the veneered surface face down on a backing block and trim the excess. But you can also cut the excess away as shown in the photo below. (Some WOOD staffers prefer a veneer saw to do the trimming; others like an X-acto knife



Pressing the veneer from side to side



Trimming panel edge

because they insist it does as good a job, and does it much more quickly. We haven't had any problems with the knife veering off and following the grain.)

Once you have finished trimming the veneer, sand it with a sanding block fitted with 80-grit sandpaper. Make sure you don't round-over the edges as you're sanding. And don't sand too long in any one spot. Remember, you're dealing with a $\frac{1}{64}$ "-thick layer of wood.

WHAT TO DO IF THINGS GO WRONG DURING APPLICATION

Nothing is perfect, right! It could happen that when applying the veneer, you misjudge its position, and before you realize it, the contact cement on both surfaces has made contact. Don't panic!

If you realize you've made a mistake before the veneer is completely down, lay hold of your refinisher-filled syringe. Spread some of the refinisher along the point of contact as shown in the photo below, then carefully lift off the veneer.

Sometimes you won't notice that



Patching a mistake

the veneer didn't cover the substrate entirely until it is completely down. In this case, you simply patch the uncovered area with a scrap piece of veneer as shown at left. Of course, you'll want to be sure to carefully match the grain before butting the patch piece against the other veneer.

APPLYING SOLID WOOD EDGINGS

Start by cutting the material the same thickness as the material you're attaching it to, and just a bit wider than necessary to accommodate the shaped edge. Then, glue and clamp the edging material, but only after making sure its thickness matches the mating material. After the glue has dried, sand all surfaces flush and smooth.

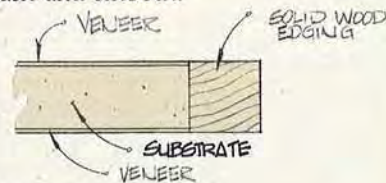

HOW TO FINISH YOUR VENEERED PROJECT

As with any other woodworking project, the smoother the surface when you apply the finish, the better the finished product will look. Fortunately, flexible veneers are sanded smooth at the factory, so a light finish-sanding will do. If you have routed the edges of the work, careful hand-sanding is in order.

You can stain, fill, and finish flexible veneers, but keep in mind that oil and contact cement don't get along too well. If oil penetrates the veneer and makes contact with the adhesive, you can be certain delamination will occur. We've found that several thin coats of polyurethane varnish make a good topcoat for veneered projects. (Some veneer experts insist that you can apply oil finishes sparingly with good results, but we haven't had much luck with oil-base products.)

Note: As always, test the finishing products on scrap to see what finish they will produce before applying them to your project. ■



Using refinisher to release the bond

“Gift-Wrapped” tissue box cover

A great first veneering project, this one-evening wonder will make you look like a veneering pro—and feel like one, too.

Building the Box

1 Rip, then crosscut the hardboard sides (A), top (B), and the pine ends (C) to size.

2 Glue and clamp the pieces together to form the box as shown in the cutaway drawing. To increase the strength of the joints, apply a fillet of glue between A and B as shown. After the glue has formed a tough skin, remove any excess except for the glue fillet.

3 Sand the outside of the box, being careful not to round the edges. (We recommend that you hand-sand the surfaces with a sanding block and medium-grit sandpaper.)

4 Mark the opening on B using a square. While doing this, extend the lines defining the opening's length across the top and down the sides of the box as shown in the cutaway drawing (these lines will be used later for veneer placement). Cut the opening to size with a saber saw.



Photograph: Bob Calmer

Illustration: Bill Zaun

Part	Finished Size			Material	Qty.
	T	W	L		
A	1/8"	2 3/4"	10 3/4"	hardboard	2
B	1/8"	5 1/8"	10 3/4"	hardboard	1
C	1/2"	2 3/4"	4 7/8"	pine	2

Supplies: contact cement, veneer, stain, polyurethane

7 1/4" x 36" CHERRY VENEER

Cutting diagram

1/2" overlap

Continued on page 77

Sleek, smooth, and very contemporary, this oak veneer end table speaks clearly yet with warmth about your good taste and your skill as a woodworker. A larger version of this same design will work equally well as a sofa table or buffet table.

 Print this article

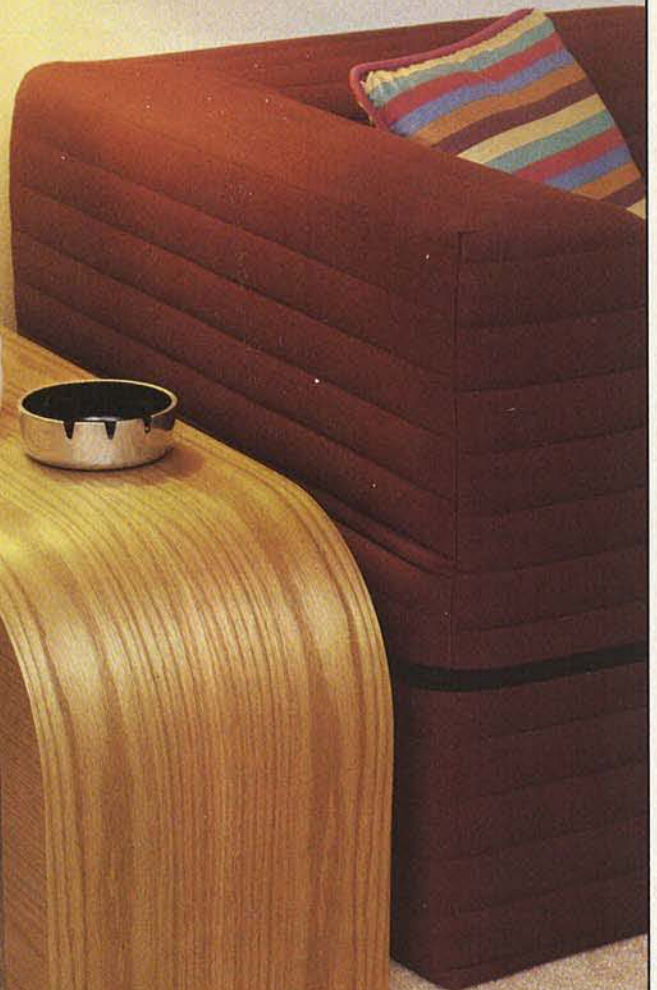
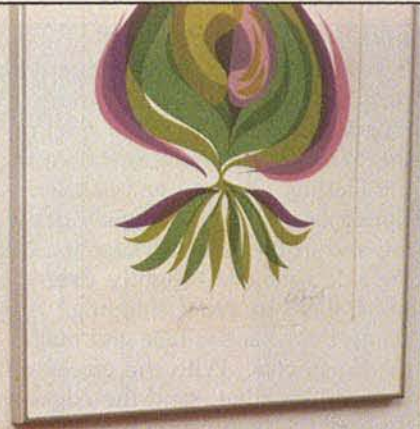

Over-
Easy
**waterfall
table**

Photographs: Bob Calmer; Bill Hopkins Associates
Illustrations: Bill Zaun

Continued

NOW YOU CAN BUILD IT

Building the Framework

1 Lay out and mark the framework parts (A, B, C) on the back side (opposite the face or good side) of the $\frac{3}{4}$ " plywood sheet as shown in the Cutting Diagram and as dimensioned on the exploded-view drawing and in the Bill of Materials. Cut the side panels (A) slightly oversized, then, to avoid chipping, clamp them face-to-face and make the finish cuts. With the pieces still clamped together, sand the edges flush to the layout line to obtain two identical pieces.

2 With the side panels laying face-down, rout a $\frac{1}{4}$ " rabbet $\frac{3}{8}$ " deep on the inside and outside edges to house the plywood skin you'll apply later.

3 Cut the spreaders (B, C), cleats (D), and center support (E) to size. (The top spreader (B) sits flush with the bottom of the rabbet, and the cleats hold it there. See the section view.) Measure to find the center of the cleats and the side panels, then glue, nail, and clamp the cleats to the panels. (We drove finish nails from the inside to prevent the cleats from slipping out of position during clamping.) After the glue has dried, remove the clamps, then glue, nail, and clamp the spreaders (B, C) in place.

4 Glue, nail, and clamp the support (E) to the bottom side of the cleats in the center of the table as shown in the exploded-view drawing. (The support serves as a joining location and a nailing surface for the first layer of $\frac{1}{8}$ " plywood on the underside of the table.)

5 Cut the $\frac{1}{8}$ " mahogany veneer plywood panels (F, G) to width, then cut each panel to the length given in the Bill of Materials. This length allows for overlap on the ends, which you can trim off later. (We used two layers of $\frac{1}{8}$ " plywood for the base to which the veneer is applied because of the flexibility needed to wrap the material around the curved ends of the frame.)

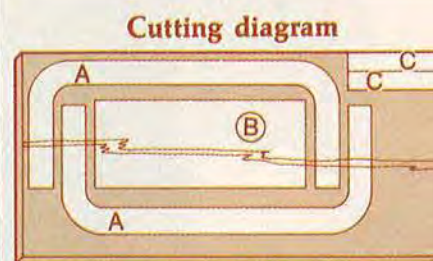
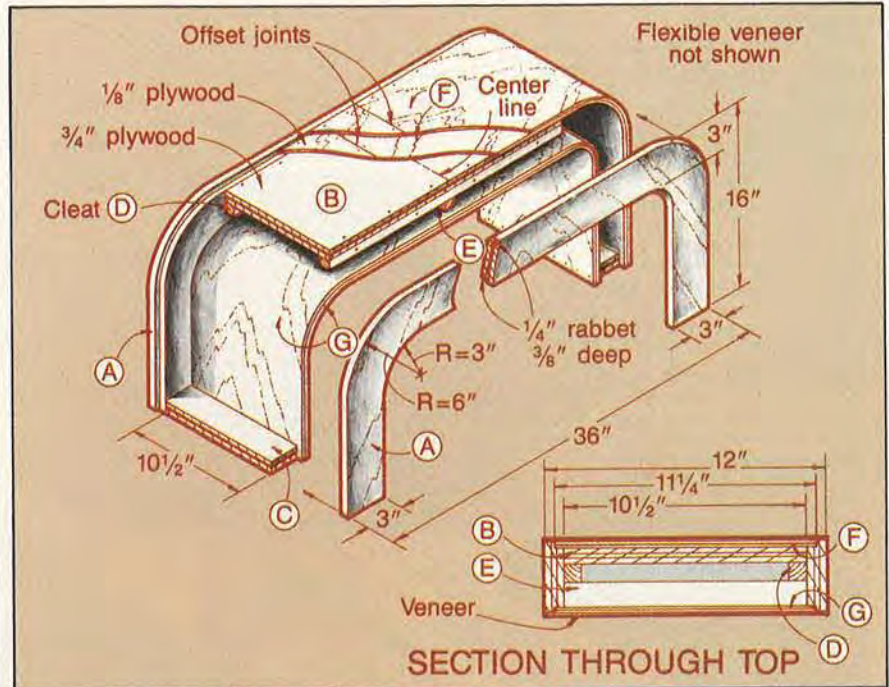

$\frac{3}{4}$ " x 24" x 48" PLYWOOD

Bill of Materials

Part	Finished Size			Material	Qty.
	T	W	L		
A	$\frac{3}{4}$ "	16"	36"	oak plywood	2
B	$\frac{3}{4}$ "	10 $\frac{1}{2}$ "	24"	oak plywood	1
C	$\frac{3}{4}$ "	2 $\frac{1}{2}$ "	10 $\frac{1}{2}$ "	oak plywood	2
D	$\frac{3}{4}$ "	$\frac{3}{4}$ "	24"	pine	2
E	$\frac{3}{4}$ "	1"	10 $\frac{1}{2}$ "	pine	1
F*	$\frac{1}{8}$ "	11 $\frac{1}{4}$ "	32 $\frac{1}{2}$ "	mahogany veneer plywood	4
G*	$\frac{1}{8}$ "	11 $\frac{1}{4}$ "	28 $\frac{1}{2}$ "	mahogany veneer plywood	4

*Plywood panels are cut to the dimensions given above to ensure an overlap.

Supplies: flexible oak veneer—exact size of top = 12" x 62 $\frac{5}{8}$ " and bottom = 12" x 53 $\frac{1}{4}$ " (remember to cut the pieces oversize for an overlap), brads, contact cement, wood putty, water-base stain, polyurethane

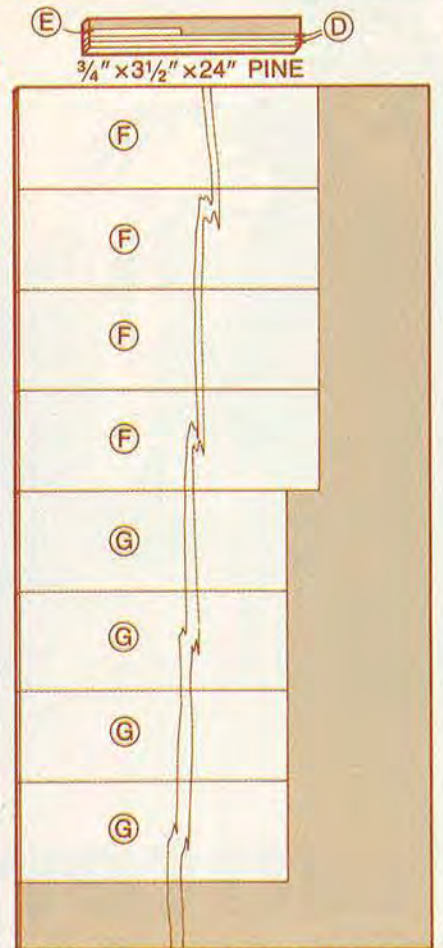

$\frac{1}{8}$ " x 48" x 96" PLYWOOD

6 Find and mark the center of the table. Then, tack both of the top panels (F) at that point with brads, lay a bead of glue along the length of the rabbets, and working out from there, glue and nail the top panels into the rabbet. Run a zig-zag bead of glue over the first layer for adhesion to the second. Then, apply the second layer of plywood over the first, offsetting the joint.

7 Using the same procedure as described in step 6, glue and nail the bottom panels (G) in place. (We had some trouble bending the panels around the curved ends on the bottom side of the table. We solved this problem by applying hot water to both sides of the panels at the point of curvature as shown in the photo below.) Clamp curved blocks, as shown in the photo, to pull the plywood into position on the inside curves. Then,



continue to glue and nail the rest of the plywood to the frame.

8 Trim the overlap of the plywood panels at the foot of each end. Fill all joints and nail holes with putty. Sand all surfaces smooth and flush, being careful not to round over the edges.

Applying the Flexible Veneer

1 Cut the veneer to size plus 1" extra (finished size is stated in the Supplies) in all directions for an overlap on the ends and sides. Mark the center of each piece of

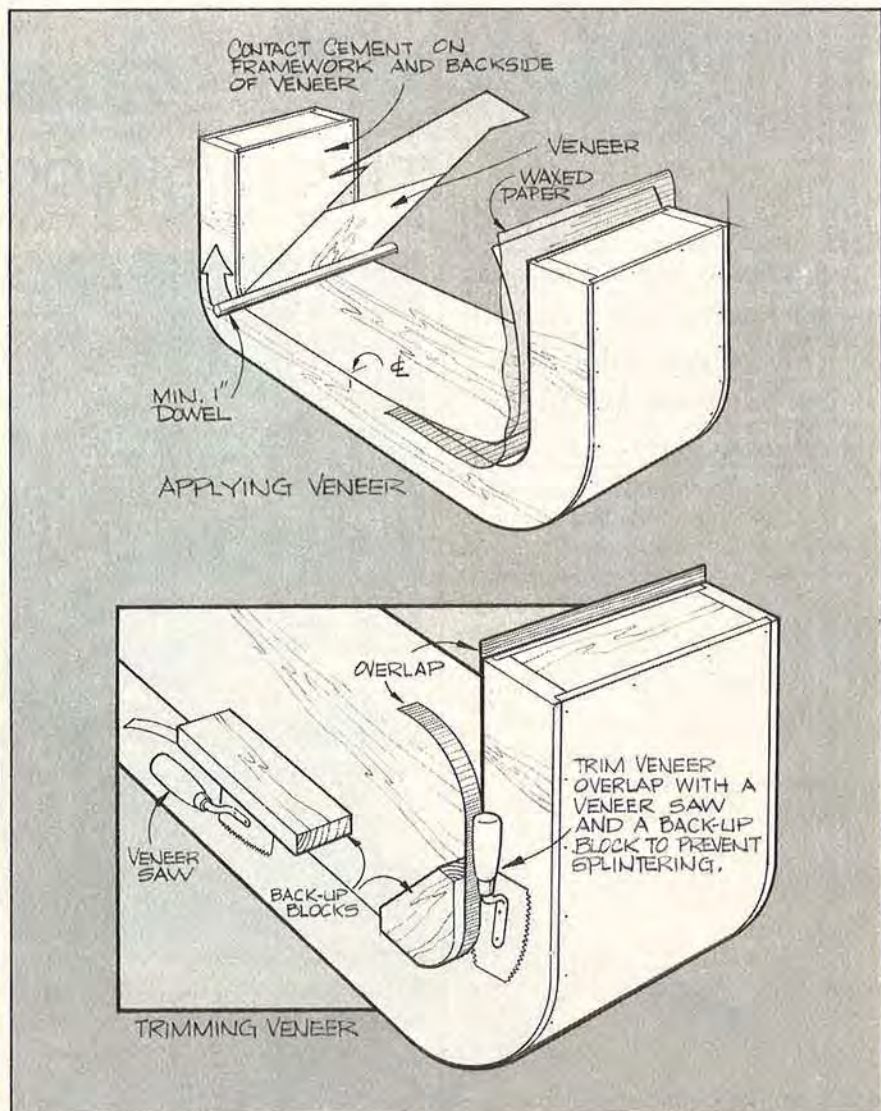

veneer for later positioning onto the frame.

2 Apply two coats of contact cement to the underside of the table and to the back side of the veneer.

3 Place waxed paper between the veneer and the frame (once the two mating surfaces come in contact with each other, there is no easy way to realign them). Starting at the center and working out from there, press the veneer into position, using a dowel as shown in the drawing below. (We discovered that this is one of those two-person tasks. Things seemed to work better when one person held the

veneer safely away from the plywood while the other rolled the veneer into position with the dowel.)

4 Trim the excess veneer, using a veneer saw and backup block as shown in the drawing (or an X-acto knife). Then, lightly sand the veneer flush.

5 Apply and trim the top veneer using the same method you used on the bottom side.

6 Finish-sand, being extremely careful not to sand through the veneer or round off the edges. Stain, if desired, and finish with several coats of polyurethane. (We advise using a water-base stain.) ■

The Old Hand Ways

THE JOINER

... this fellow will but join you together as they join wainscote; then one of you shall prove a shrunk panel and, like green timber, warp, warp.

William Shakespeare's
As You Like It



The adjustable plow plane is an essential tool of the joiner.

Shakespeare wrote these lines comparing a sham wedding to shoddy joinery in 1598, exactly one year after he bought his new house in Stratford on Avon from my ancestor, William Underhill. It's comforting to know that your work can serve as an inspiration to others.

A century later, Joseph Moxon, in his book *Mechanic Exercises*, offered a definition of joinery as it should be: "Joinery, is an art manual, whereby several Pieces of Wood are so fitted and joind together that they shall seem one intire Piece."

This is much the same as carpenter's work but for the fact that "... Joiners work more curiously, and observe the Rules more exactly than Carpenters need do."

Planes and Benches— The Joiner's Realm

Long before carpenters completed framing Shakespeare's house, the joiners would have been at work making his doors and windows, staircases, and trim. Quite likely, their work would not even be undertaken at the construction site but rather at their joiner's shop in the village. Here, they kept their glue pots and wood, their saws, mallets, and chisels, and, most significantly, their planes and benches.

The joiner's territory is marked by planes and benches. The two go together like carpenters and beer. One is not much good without the other. When woodworking planes were first developed during the Roman era, they created the need for a long level surface to support the work at convenient height. For the joiner of average stature, this height is about 30".

Even if he doesn't indulge in fancy moldings, the joiner needs lots of planes. Just as the ten speeds on a bicycle match the rider's strength to varying terrain, the joiner's key to efficiency is to use a tool that is precisely suited to each stage of the work. The joiner's planes make progressively finer and broader cuts as the work progresses. Trying to bring rough stock to precision dimensions with a single plane is like riding a one-speed bike in a hilly town.

The Work of the Plane

Starting off with a relatively short *scrub* or *jack plane* that has its iron (as the blade is called) ground to a convex profile, the joiner can quickly level the surface. The parallel hollows left by this initial step can then be smoothed by the finer-cutting *trying plane* and the final, dead level surface rendered by the *joiner*.



By Roy Underhill

Master housewright at Colonial Williamsburg, host of the highly successful P.B.S. series *The Woodwright's Shop*, author, lecturer, and master craftsman.

Continued on page 75

TABLE SAWS

how to choose the right machine for your shop

Whether you're a first-time buyer or a veteran woodworker looking to upgrade your equipment, it's going to take some study to make sure you make the best possible table saw purchase. New products continue to come to market, giving you more options than ever before. This article answers many of the questions you'll be asking yourself as you arrive at your decision.

Illustration: Taylor Associates

 Print this article

Do You Need a Stationary Saw Or Will a Bench-Top Model Do?

To answer this question, you have to analyze your particular woodworking situation. If you're just getting started in the hobby, on a limited tool budget, don't have room to devote to a full-size table saw, or do only small-scale projects, the bench-top option *may* make sense for you. Typically, bench-top saws cost only about half as much as the least-expensive floor models, but keep in mind the trade-offs associated with this lower cost. You won't get a tool that's as heavy-duty, precisely engineered, or accurately machined as the bigger machines, nor will the table surface be nearly as large. This latter characteristic

can make it difficult to work with large boards and sheet goods.

Some manufacturers offer tool stands and leg sets that attach beneath their bench-top models to make them freestanding (one even offers plans to make a cabinet in which to set the saw). But don't expect these options to transform a light-duty saw into a machine comparable to heavy, large ones. It won't!

Can you do quality woodworking with a bench-top saw? We know of some woodworkers who have done some very nice work using one, but as a general rule, it's easier to get good results with a heavier, larger saw.

Buymanship Note: Remember, you can do small work on a big saw, but it's difficult to do large work on a small one.

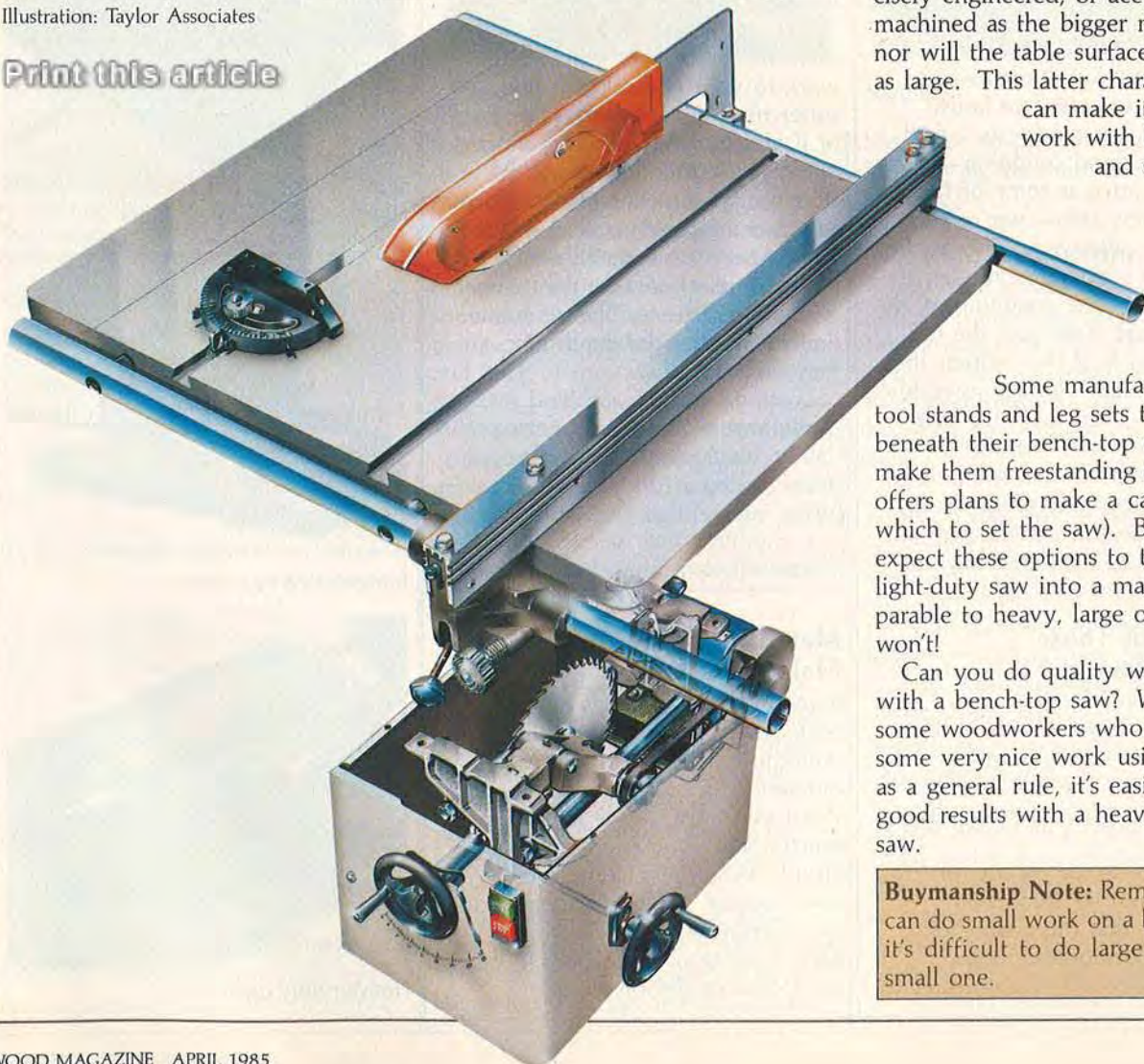

Continued

TOOL BUYMANSHIP

A stationary table saw, if you have the room for one, has several advantages over its bench-top counterpart. First, it has a heavy-duty blade carriage assembly, which increases cutting accuracy. Second, the large tabletop makes for more control when cutting larger goods. Third, because this tool is stationary, you don't have to get it out and put it away every time you use it. And if you've done any amount of woodworking, you know how time consuming this can be. And lastly, if you ever decide to trade up, a stationary saw has better resale value.

Should You Buy a New Or a Used Saw?

It's not uncommon to see used stationary table saws for sale in the classified advertising section of local newspapers. If the price of a new saw seems a bit too rich for your blood, these "experienced" saws may appeal to you. Some woodworking professionals we know insist that if you can locate a well-made saw in good condition—even at the same price as some of the low-priced new saws—you're better off with the older one. This applies especially to contractors' models.

To check out the condition of an older saw, first make sure the top hasn't warped, and that neither the top nor the blade carriage assembly has cracked. Then, with the belt off, check for worn bearings by wobbling the blade and spinning it. If you don't spot any problems in the process, and the motor runs smoothly under load, you have found a good machine.

What About Those Taiwanese Imports?

You've all seen advertisements promoting table saws with "unusually low" price tags—often less than half the price of the machines they're imitating. Pretty tempting, aren't they?

Before you decide on one of these machines, we think you should know that the quality of product being imported varies drastically from one manufacturer to

another. Some of the saws represent a good value; others don't.

If possible, you should inspect what you're buying before signing on the dotted line. You'll want to judge the quality of the castings and the trueness of the tabletop, and you should take a close look at the warranty offered with the product. There have been many reports of customers and retailers receiving damaged merchandise, so it's important to know in advance that the firm you're dealing with will stand behind the product.

How Much Table Saw Do You Need?

Manufacturers market four different sizes of table saws to the home woodworker—8", 9", 10", and 12". (These sizes refer to the largest-diameter blade the saw will accommodate.) The 8" and 9" saws take up less space and are lighter weight than the larger saws, which can work to your advantage if you suffer from limited workshop space or if you move the saw around frequently. On the minus side, 8" and 9" saws have smaller work surfaces, so balancing large materials while cutting becomes somewhat of a problem. And because they come with small-diameter blades, you're limited more in the depth of cut they will make.

Buymanship Note: Though we certainly wouldn't discourage anyone from buying a 12" table saw if they want, we feel that a 10" model will do anything that needs doing in home woodworking situations.

Materials and Machining Make a Difference

Some table saws cost as little as \$60; others, more than \$2,000. So, you know there must be great differences in quality and options. What you must decide is how much quality you need—and can afford. When purchasing a table saw, you can tell a great deal about the machine simply by giving it a good looking over, keeping in mind the following information:

BLADE-CARRIAGE ASSEMBLIES



Inexpensive stamped steel

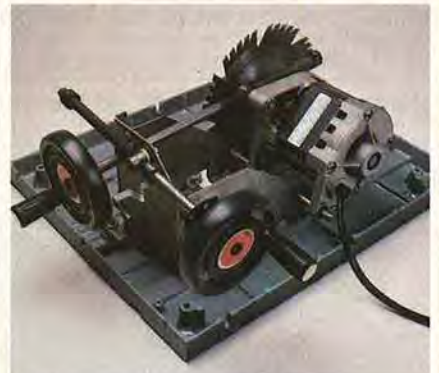

Heavier-duty stamped steel



Inexpensive cast iron



Heavier-duty cast iron

Table Construction. Of the five materials used—cast iron, cast aluminum, anodized cast aluminum, formed steel, and plastic—we think dollar for dollar, you're best off with a cast-iron saw table. This material has the advantage of being less prone to damage and warpage than the others, and generally is more accurately machined. Cast iron does rust easily, though.

Anodized (hardened) cast aluminum ranks as our second choice behind cast iron. A lightweight material, anodized cast aluminum won't rust and holds its shape much better than formed steel or plastic tops. Anodizing does wear off after a period of time, though, and when it does, the surface will oxidize and may become pitted.

Buymanship Note: When inspecting a cast-metal saw table, you can check for distortion by laying a level diagonally across the table. Good-quality products will have been machined true. Also, look at the table's surface for any evidence of pitting or hairline cracks—two telltale signs of an inferior casting. The smoother the surface, the better.

Saw Body Parts. Manufacturers use any of three materials for the housing beneath the saw table—formed (stamped) steel, aluminum, and plastic. All things considered, we think a heavy-gauge formed steel housing probably makes the best economic sense.

Blade Carriage Assemblies. More than any other part of a table saw, the blade carriage assembly separates the quality machines from their less-expensive competition (we show four different types at left). This mechanism largely determines how accurately the saw will cut. Because of the rigidity it imparts, cast iron gets our vote for the best material for this assembly. Following it would be cast aluminum and stamped steel.

The All-Important Rip Fence

Looking at the rip fence guide system on a table saw tells a lot about

RIP-FENCE GUIDES



Formed into tabletop



Flat iron



Angle-iron



Tubular

the saw's quality. Unfortunately, most rip fences don't measure up to most woodworkers' exacting requirements. In general, the more expensive the saw, the more accurate the fence will be. (See the examples shown above.) Those that slide along tubular guides at the front and back of the saw table usually perform best. Your second-best choice would be an angle-iron guide arrangement. Better saws will generally have a rip fence that locks onto the front and back guide rails.

Choosing Between Two Power-Drive Mechanisms

Table saw motors deliver power to the saw blade in one of two ways. With all bench-top table saws and some stationary saws, the saw blade mounts directly to the motor arbor. These so-called "motorized" saws tend to be the least-expensive product in a manufacturer's line because they're less expensive to build.

The more-expensive belt-drive saws transfer the motor's power by means of a belt-and-pulley system. We prefer this type because it puts

less stress on the motor, results in less play in the shaft, and is more accurate.

The Matter of Motors

If you have trouble understanding all the terminology used to describe the various table saw motor options, join the crowd. It confuses most everyone. To clarify things a bit, we'll discuss your options below.

Motor Type—Series or Induction

Series motors, the type that have replaceable carbon brushes, work well with portable power tools. But for tools designed to operate for longer periods of time under load, such as table saws, you're better off with an induction motor. Most stationary saws have them; only a few bench-top models do.

Motor Speed and Horsepower

You'll find that most of the available models operate at 3,450 rpm or higher. But horsepower varies significantly, as you can see in the chart on the following page.

(Text continued on page 82)

(See chart on next page)

TOOL BUYMANSHIP

TABLE SAW COMPARISON/SPECIFICATION CHART

Brand	Model	Blade Size	Arbor Size	Bench Top	Stationary	Table Type	Table Size (WxD)	Weight	Rip Capacity	Fence Guide	Cut Depth	Drive Mech.	Suggested Retail	Motor				
														Style	Type	AMPS	Continuous HP	Bearings
AMT	21645B	8"	1/2"	X		CI	10x13	23	5 1/2"	FI	2 1/4"	B	76.00	H	Recommends 1 HP		B	
AMT	21645	8"	1/2"	X		CI	10x13	23	5 1/2"	FI	2 1/4"	B	63.50	H	Recommends 1 HP		S	
AMT	21655B	8"	1/2"	X		CI	10x13	22	5 1/2"	FI	2 1/4"	B	65.00	H	Recommends 1 HP		B	
AMT	21655	8"	1/2"	X		CI	10x13	22	5 1/2"	FI	2 1/4"	B	62.50	H	Recommends 1 HP		S	
Black & Decker	9419	8"	1/2"	X		P	26 1/2 x 15 5/16	32	10"	FI	1 3/4"	D	109.99	B	I	7.5	1	B
Black & Decker	9429	8"	1/2"	X		P	26 1/2 x 15 5/16	32	10"	FI	1 3/4"	D	159.99	B	I	9	1 1/2	B
Delta Contractor	34-410	10"	5/8"		X	CI	40x27	223	25"	T	3 1/8"	B	803.00	H	Recommends 1 1/2 HP		B	
Delta Contractor	34-621	9"	5/8"		X	CI	22x30	120	24"	T	2 3/4"	B	530.00	H	Recommends 1 HP		B	
Delta Super 10	34-710	10"	5/8"		X	CI	27x37	Not Listed	24"	T	2 9/16"	D	597.00	B	I	Not Listed	1	B/S
Delta Homecraft	34-695	10"	5/8"		X	CA	22x42	119	24"	T	3 1/4"	D	349.00	B	I	13	Not Listed	B/S
Delta Homecraft	34-580	9"	5/8"		X	CA	22x32	101	15"	FI	2"	D	314.00	B	I	13	Not Listed	B/S
Delta Motorized	31-205	8"	1/2"	X		CA	16x26	40	10 1/4"	B	2 1/16"	D	206.00	B	I	9.5	Not Listed	B/S
Dremel	580	4"	1/2"	X		CF		15		B	1"	D	132.95	B	S	2.2	Not Listed	S
INCA	250	10"	3/4"		X	CAA	20 5/8 x 28 3/4	66	23"	AI	3 5/32"	B	798.00	H	Recommends 1 HP		B	
Makita	2708	8 1/4"	5/8"	X		CA	18 1/2 x 26	37 1/8	12"	B	2 1/2"	D	336.00	B	S	12	2	B
Sears Electronic	29065N	10"	5/8"		X	CI	40x27	218	24"	AI	3 3/8"	B	699.99	H	CI	13.2	1	S/B
Sears	29802N	10"	5/8"		X	CI	40x27	257	24"	AI	3 3/8"	B	449.99	H	CI	13.2	1	S/B
Sears Motorized	29805N	10"	5/8"		X	CA	40x27	130	24"	AI	2 1/2"	D	389.99	B	CI	Not Listed	1	SB
Sears Motorized	24272N	9"	5/8"		X	CA	37x20	110	24"	AI	2"	D	289.99	B	CI	Not Listed	3/4	S/B
Sears Motorized	22161C	8"	1/2"	X		CA	30x17	47	12 3/4"	FI	1 3/4"	D	144.99	B	I	Not Listed	1/2	S/B
Sears	2412C	8"	1/2"	X		CI	10 1/2 x 13	26	5"	FI	2 1/4"	B	84.99	H	Recommends 1 HP		B	
Shopcraft	T6780	10"	5/8"	X		CA	17x26	40	12"	B	3"	D	159.99	B	S	10	1 3/4	B
Skil	3102C	8 1/4"	1/2"	X		CA	16x27	37	12"	B	2 1/16"	D	189.99	B	S	10	2	S/B
Toolkraft	4100	10"	5/8"		X	F	42x20	75	24	AI	3 1/8"	B	359.95	B	S	11	2	B
Toolkraft	4107	10"	5/8"		X	F	47x20	80	24	AI	3 1/8"	B	399.95	B	S	11.5	2 1/4	B
Toolkraft	4116	10"	5/8"		X	CI	50x20	102	24	AI	3 1/4"	B	499.95	B	S	11.5	2 1/8	B
Toolkraft	4101	10"	5/8"		X	CI	45x27	130	24	AI	3 1/4"	B	579.95	B	S	11.5	2 1/4	B
Toolkraft	4122	10"	5/8"		X	CI	50x27	140	24	AI	3 5/8"	B	629.95	B	S	12.5	2 1/2	B
Toolkraft Tradesman	4125	10"	5/8"		X	CI	35x20	120	24	AI	2 1/4"	D	599.95	B	CI	10.5	1 1/8	B
Valuecraft	8000	10"	5/8"		X	CI	40 1/2 x 27 1/16	230	24	T	3 1/8"	B	599.99	H	CI	12	1	B
Valuecraft	8010	10"	5/8"	X		CA	26 x 17 1/4	40	12	B	3	D	169.99	B	S	10	1 1/2	B

Tabletop: CI — Cast Iron
 CA — Cast Aluminum
 CAA — Cast Anodized Aluminum
 F — Ferrolon® Plastic
 FS — Formed Steel
 P — Plastic
 CF — Cast Fiberglass

Motor Type: CI — Capacitor-Start Induction
 S — Series
 I — Induction

Motor Style: B — Built-In
 H — Hang-Behind

Drive Mechanism: D — Direct
 B — Belt

Fence Guides: B — Built-In
 T — Tubular
 AI — Angle Iron
 FI — Flat Iron

Bearings: S — Sleeve
 B — Ball

SHAKER-STYLE CUPBOARD



The Shakers viewed veneers as "deceitful", and declared that "whatever is fashioned, let it be plain and simple." They used solid maple extensively and particularly admired bird's-eye maple. These resourceful folks also developed the first tongue-and-groove and splining machines to facilitate joining solid woods. The design shown at left follows the Shaker philosophy quite closely.

 [Print this article](#)

Photographs: Bob Calmer;
William Hopkins Associates
Illustrations: Bill Zaun, Herb Dixon

This cupboard consists of two basic assemblies—the base cabinet and the upper case. And though we tell you how to build each separately, you may want to glue up the panels for both units at the same time. By doing it this way, you'll have less downtime—the panels will be

ready for machining when you are. Note also that the ends, shelves, and top of both the base cabinet and upper case are made up for width in the same way, which simplifies construction greatly. Read the instructions and study the drawings before beginning construction.

Continued

FURNITURE PROJECT

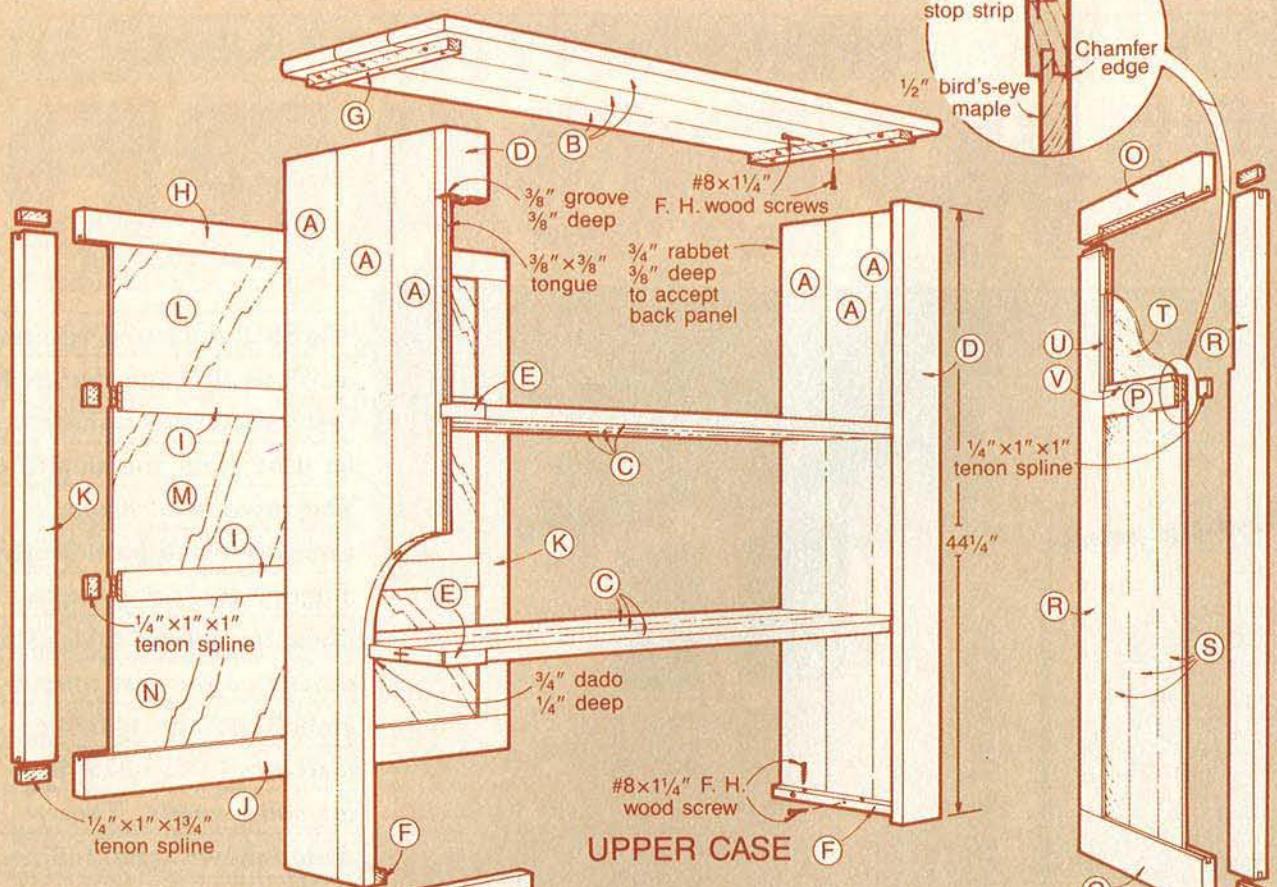
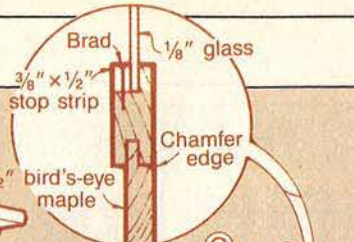

UPPER CASE

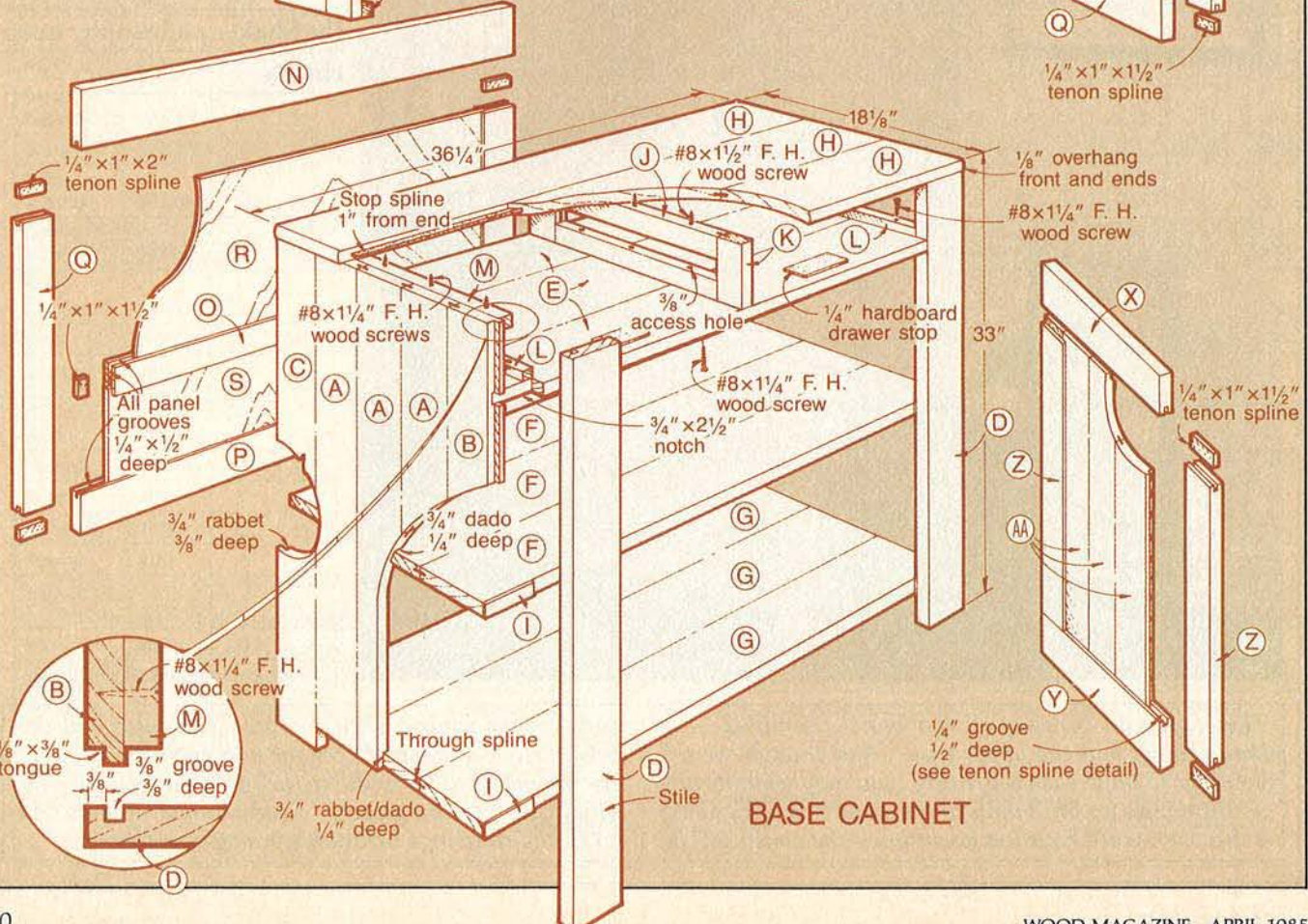

BASE CABINET

Bill of Materials

Part	Finished Size*			Material	Qty.
	T	W	L		
BASE CABINET — The Carcass					
A*	3/4"	4"	30 3/4"	maple	6
B*	3/4"	2 5/8"	32 1/4"	maple	2
C*	3/4"	3"	32 1/4"	maple	2
D*	3/4"	3"	32 1/4"	maple	2
E*	3/4"	5 3/4"	35"	maple	3
F*	3/4"	5 3/8"	35"	maple	3
G*	3/4"	5 3/8"	35"	maple	3
H*	3/4"	6 1/32"	36 1/4"	maple	3
I	1/8"	3/4"	2 1/4"	maple	4
J	3/4"	1 1/2"	14 1/4"	maple	2
K*	3/4"	1 1/2"	4 1/16"	maple	2
L	3/4"	3/4"	16 1/2"	maple	2
M	3/4"	3/4"	16 1/2"	maple	2
The Cabinet Back					
N	3/4"	4 3/4"	35 1/4"	maple	1
O	3/4"	2"	30 3/4"	maple	1
P	3/4"	3"	35 1/4"	maple	1
Q	3/4"	2 1/4"	23"	maple	2
R	1/4"	31 3/4"	12"	maple plywood	1
S	1/4"	31 3/4"	11"	maple plywood	1
The Drawers					
T	3/4"	4"	14 1/2"	maple	2
U	1/2"	4"	16 1/4"	maple	4
V	1/2"	3 1/4"	14"	maple	2
W	1/4"	14"	14"	maple plywood	2
The Doors					
X	3/4"	2"	14 15/16"	maple	2
Y	3/4"	3"	14 15/16"	maple	2
Z	3/4"	2"	20 7/8"	maple	4
AA	1/2"	3 15/16"	21 7/8"	bird's-eye maple	6

*Some parts are cut larger initially, then trimmed to finished size. Please read instructions before cutting.

Supplies: #8x1 1/2" flathead wood screws, #8x1 1/4" flathead wood screws, 1/4" hard-board for splines, 4—brass door pulls, 4—2" long (3/16" knuckle) brass butt hinges, 2 door catches, polyurethane

Cutting diagram

14 pieces—3/4" x 9 1/4" x 96" MAPLE

2 pieces—1/2" x 9 1/4" x 72" MAPLE

2 pieces—1/4" x 48" x 48" MAPLE PLYWOOD

Bill of Materials

Part	Finished Size*			Material	Qty.
	T	W	L		
UPPER CASE — The Carcass					
A*	3/4"	3 7/8"	44 1/4"	maple	6
B*	3/4"	4 1/32"	36 1/4"	maple	3
C*	3/4"	3 7/16"	35"	maple	6
D	3/4"	3"	44 1/4"	maple	2
E	1/8"	3/4"	2 1/4"	maple	4
F	3/4"	3/4"	10 1/2"	maple	2
G	3/4"	3/4"	10 1/2"	maple	2
The Cabinet Back					
H	3/4"	2"	35 1/4"	maple	1
I	3/4"	2"	30 3/4"	maple	2
J	3/4"	3"	35 1/4"	maple	1
K	3/4"	2 1/4"	39 1/4"	maple	2
L	1/4"	31 3/4"	11 7/8"	maple plywood	1
M	1/4"	31 3/4"	14 1/16"	maple plywood	1
N	1/4"	31 3/4"	12 5/16"	maple plywood	1
The Doors					
O	3/4"	2"	14 15/16"	maple	2
P	3/4"	2"	10 15/16"	maple	2
Q	3/4"	3"	14 15/16"	maple	2
R	3/4"	2"	39 1/8"	maple	4
S	1/2"	3 15/16"	26 1/8"	bird's-eye maple	6
T	1/8"	11 7/8"	12 7/8"	double-strength glass	2
U	3/8"	1 1/2"	13"	maple	2
V	3/8"	1 1/2"	10 15/16"	maple	2

*Some parts are cut larger initially, then trimmed to finished size. Please read instructions before cutting.

Supplies: #8x1 1/4" flathead wood screws, 2—brass door pulls, 6—2" long (3/16" knuckle) brass butt hinges, 2 door catches, brads, polyurethane

THE BASE CABINET Making Up Panels for Width

1 Rip end-panel parts A, B, C, and D to width, then crosscut them to length plus 1". Rip and crosscut the parts for the drawer shelf (E), the middle shelf (F), the bottom (G), and the top (H) at this time, too.

Note: Before cutting the grooves for the splines, lay out the panel pieces on a flat surface, alternate the end grain configuration, and match the pieces together for a smooth transition of the grain from one piece to the next. Once you have laid out a panel so it looks the best, draw a large triangle on the face of the panel. You will use this marking later for positioning the pieces when clamping up the panels.

2 Using a router fitted with a splining bit (we did our splining with the aid of our router table—see page 32 for how to build the table), cut 1/4" grooves 1/2" deep the full length to A and to within 2" of the bottom end of parts B and C. (Remember to run all the boards through the router facedown. If you do this, you won't have to worry if the grooves aren't exactly

Continued

FURNITURE PROJECT

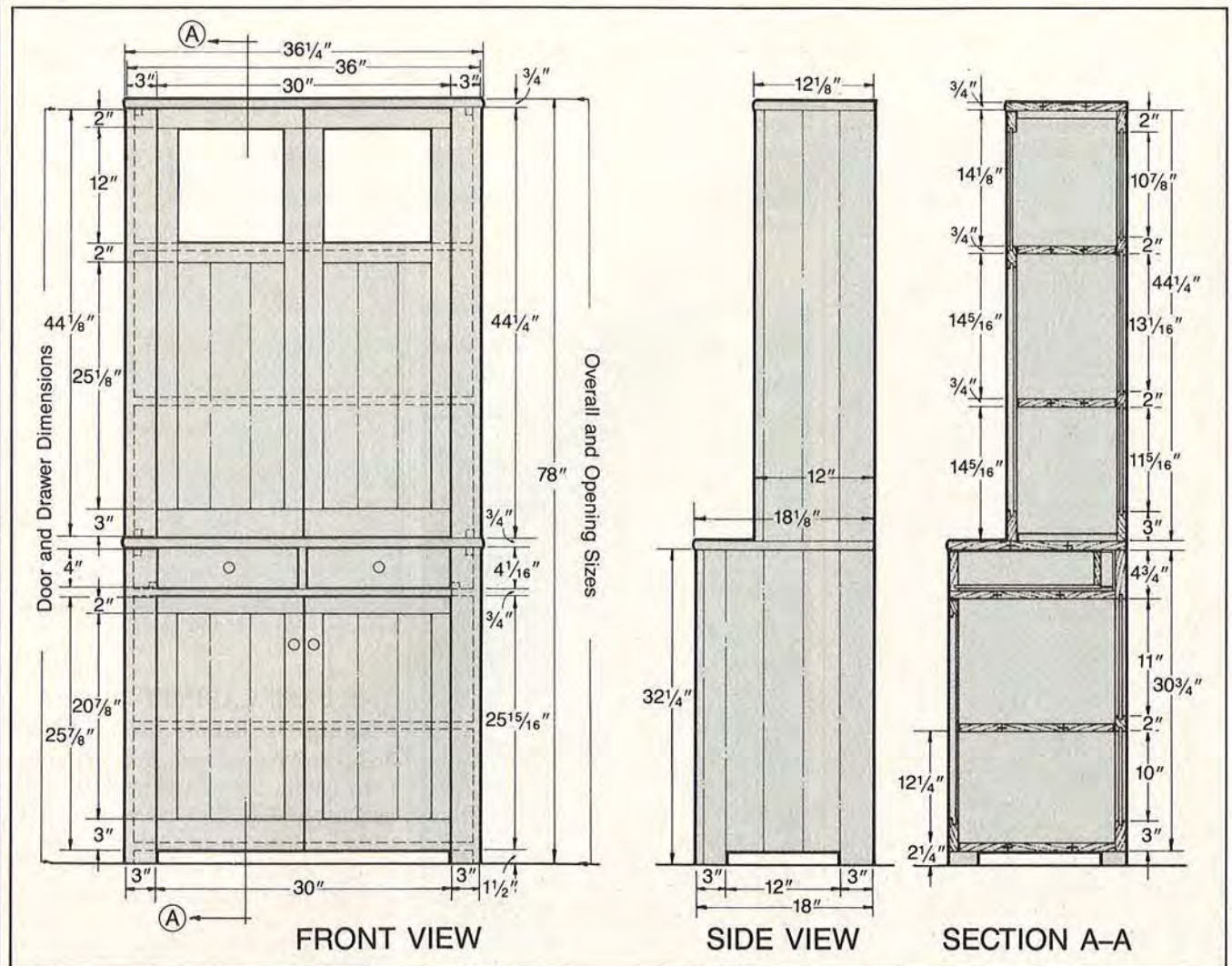

centered along the boards' edge.) Also, cut the grooves the full length of parts E, F, and G. And, cut the

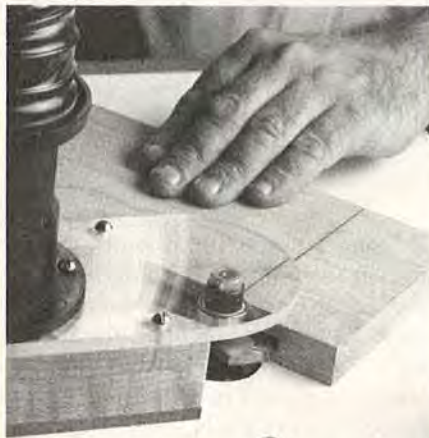

Cutting Stopped Groove for Spline

same-size grooves in the boards that will make up the top (H), but be sure to stop 1" from each end as shown in the photo at left.

3 Cut 7/8"-wide splines from 1/4" hardboard for all the joints. You will need to contour sand the stopped-spline ends to fit in the stopped grooves. Cut the filler blocks (I) to size. When installed, the filler blocks prevent the doors from slamming against the shelf.

4 Spread glue in the grooves of the A parts, on the splines, and on all mating surfaces, clamp the parts together to form the center portion of the cabinet ends. (You'll want to make sure your reference marks align.) Later, trim the bottom end square, and sand both panels smooth.

5 Join parts B and C in the same manner to complete the end panels. (The bottom end of B and C should extend 1 1/2" beyond the bottom of A.) After the glue has had a chance to dry, remove the clamps and excess glue, then cut the panels to their finished length.

6 Cut 3/4" dados 1/4" deep in the cabinet ends to house the shelves (E, F) and the cabinet bottom (G). Also cut a 3/4" rabbet 3/8" deep along the back inside edge of the end panels.

7 Measuring over 3/8" from the outside edge of each stile (D), cut a 3/8" groove 3/8" deep the length of both (we used a table saw fitted with a rip fence and a dado blade to make our grooves—see the photo at the top of the next page).

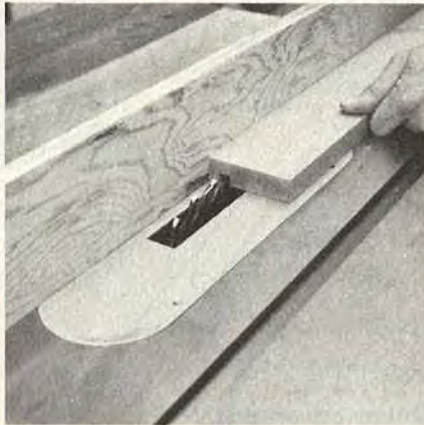

Cutting the Groove in the Stile

Safety note: Whenever possible, use safety guards. For photographic clarity, we have removed the guards for this operation.

Now, cut a $\frac{3}{8}$ " rabbet $\frac{3}{8}$ " deep along the outside edge of B as shown in the Rabbet Cutting photo below. (See the Base Cabinet detail drawing for how B and D fit together.)

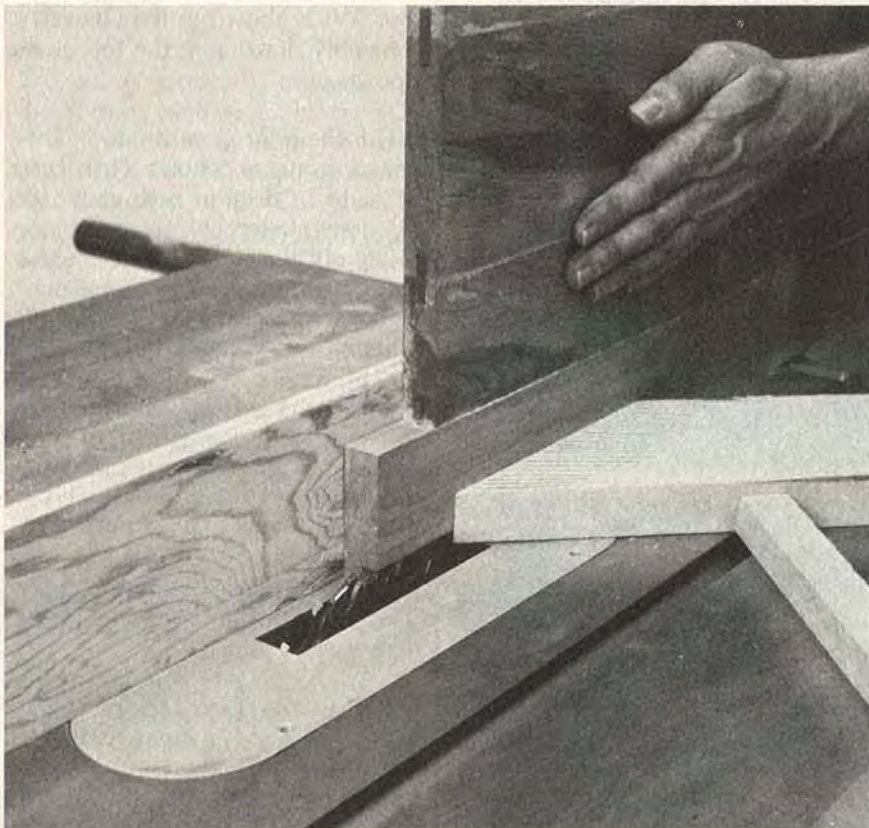

Cutting the Rabbet in Panel Edge

8 Trim the stiles (D) to their finished length, then glue and clamp them to the front edge of each end panel, being sure to keep them at a 90° angle to each other.

9 Glue and clamp together the shelves (E, F) and the cabinet bottom (G). After the glue has dried, remove the clamps and excess glue. Trim the panels to finished length, and sand all the panels smooth. Cut a $\frac{3}{4}$ " \times " $2\frac{1}{2}$ " notch in the front of E to accept the stiles (D).

Making the Drawer Divider and Guides

1 Cut the drawer divider rails (J) to size. To fashion the drawer divider stiles (K), rip a 12" maple board to $4\frac{1}{16}$ ". Then, cut a $\frac{1}{4}$ " groove $\frac{1}{2}$ " deep along both ends of the board as shown in the photo at right. Now, rip the two stiles to $1\frac{1}{2}$ ". Cut a like-sized groove along each end of both rails. When cutting an end-grain groove, it is important to first

rest the workpiece against a stationary point. (We used the corner of the guard—see the photo below.) Then, swing the board toward the center of the pilot bearing to start the cut. This method holds the

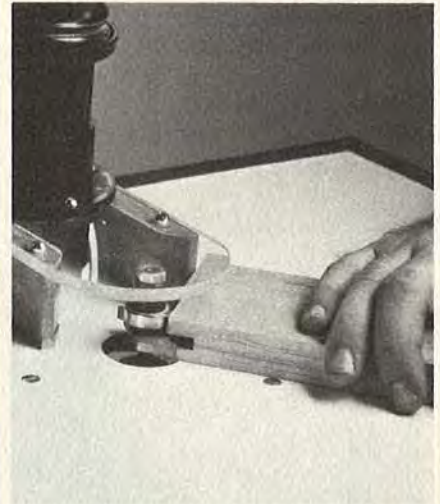

Cutting the End-Spline Groove

workpiece steady and helps to prevent kickback.

2 Clamp the rails (J) together edge to edge with the ends flush. Drill three equidistant $\frac{5}{32}$ " pilot holes through both pieces, then drill a $\frac{3}{8}$ " hole through the bottom rail and $\frac{1}{2}$ " into the top K. The $\frac{3}{8}$ " hole will be used later to allow access for your screwdriver.

3 Remove the clamps, then glue the splined divider together.

Assembling the Base Cabinet

1 Dry-clamp the end panels, shelves, and bottom to check for a good fit. (The front of the top shelf (E) should be flush with the front of D; there should be a $\frac{1}{8}$ " gap between both the lower shelf (F) and the bottom (G) and the back side of D. The back edge of E, F, and G should fall $\frac{1}{4}$ " short of the back edge of the end panels.)

2 After making any necessary adjustments, glue and clamp the cabinet together. Also, glue the filler blocks (I) between the front of the shelves (F, G) and stiles (D).

Continued

FURNITURE PROJECT

3 Cut the drawer guides (L) and the cleats (M) to size. Then, glue and screw the drawer guides flush with the inside edges of the stiles (D).

4 Screw the cleats to the bottom side of the top to fit between the end panels.

5 Screw the divider to the center of the top, as shown in the photo below. (Make sure the divider's back edge is $\frac{1}{4}$ " in from the back edge of the top.)



Attach the Drawer Divider to the Top

Position the top and divider onto the base and secure it there by driving screws through the cleats and on into the end panels. Screw the top shelf to the divider as shown in

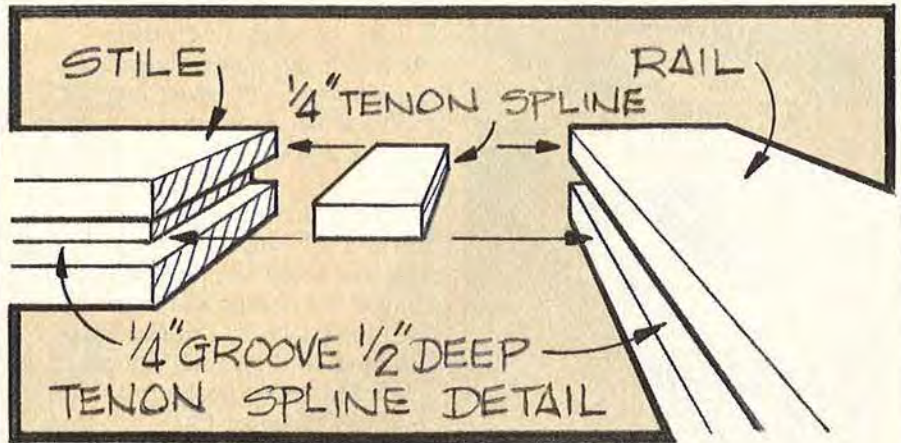

the photo below. (You'll want to drill pilot holes before driving the screws.)

Building the Base Cabinet Back

1 Cut the rails (N, O, P), stiles (Q), and panels (R, S) to size.

2 Cut $\frac{1}{4}$ " grooves $\frac{1}{2}$ " deep along the bottom edge of N, both edges and ends of O, top edge of P, and inside edge and both ends of Q. Cut $\frac{1}{4}$ " maple tenon splines to fit between the stiles and rails as shown in the Tenon Spline Detail above. Dry-clamp the parts together to check the fit.

3 Glue and clamp the panel together checking for square. Remove the glue after it has formed a tough skin.

4 Check the fit of the panel in the back of the cabinet and trim if necessary. Glue and clamp the back to the cabinet.

Building the Drawers

1 Rip and crosscut the drawer parts (T, U, V, W) to size. Cut a $\frac{1}{2}$ " dado in the drawer sides (U) that is $\frac{1}{4}$ " deep and 2" from the end of the back edge of each. Now, cut a $\frac{1}{4}$ " groove $\frac{1}{4}$ " deep and $\frac{1}{2}$ " from the bottom along the bottom edge of the sides to house the drawer bottom (W) as shown in the Drawer Assembly drawing at the top of the next page.

2 Cut the joint at each end of the drawer fronts as follows: First, cut a $\frac{1}{4}$ " dado $\frac{1}{2}$ " deep in both ends. (See the drawer assembly detail for how to lay out the joint.) Next, make a cut $\frac{1}{4}$ " in from the end to cut one of the tongues shorter than the other.

3 Dry-clamp the drawers together to check for proper fit; adjust, if necessary. Sand all parts smooth, then glue and clamp the drawers together.

4 Cut and install $\frac{1}{8}$ " drawer stops $\frac{3}{4}$ " back from the front edge of the drawer shelf (E).

Building the Two Doors

1 Rip and crosscut the rails (X, Y) and stiles (Z) to size. Rip the parts for the bird's-eye maple panels (AA) to width and to length plus 1". Glue and clamp the panels (AA)

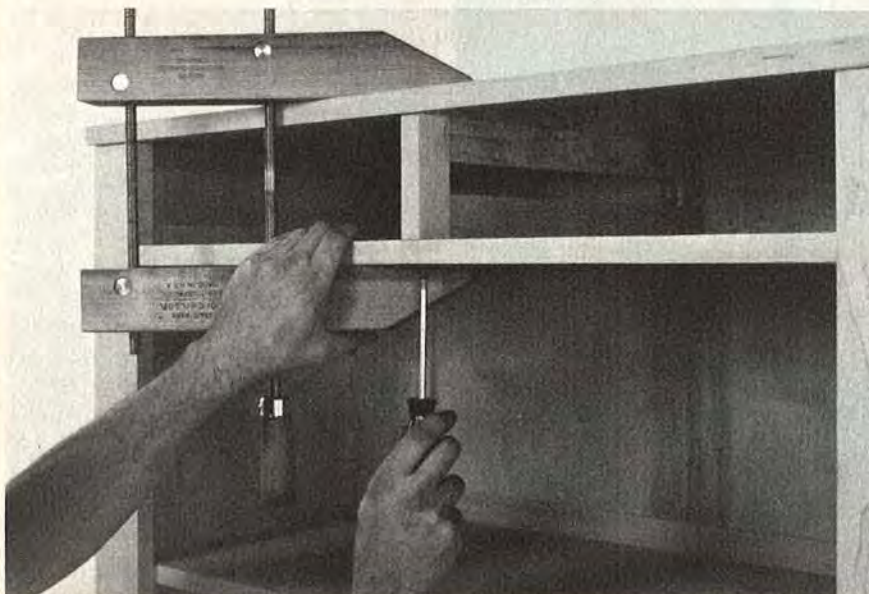

Screwing the Top Shelf to the Drawer Divider

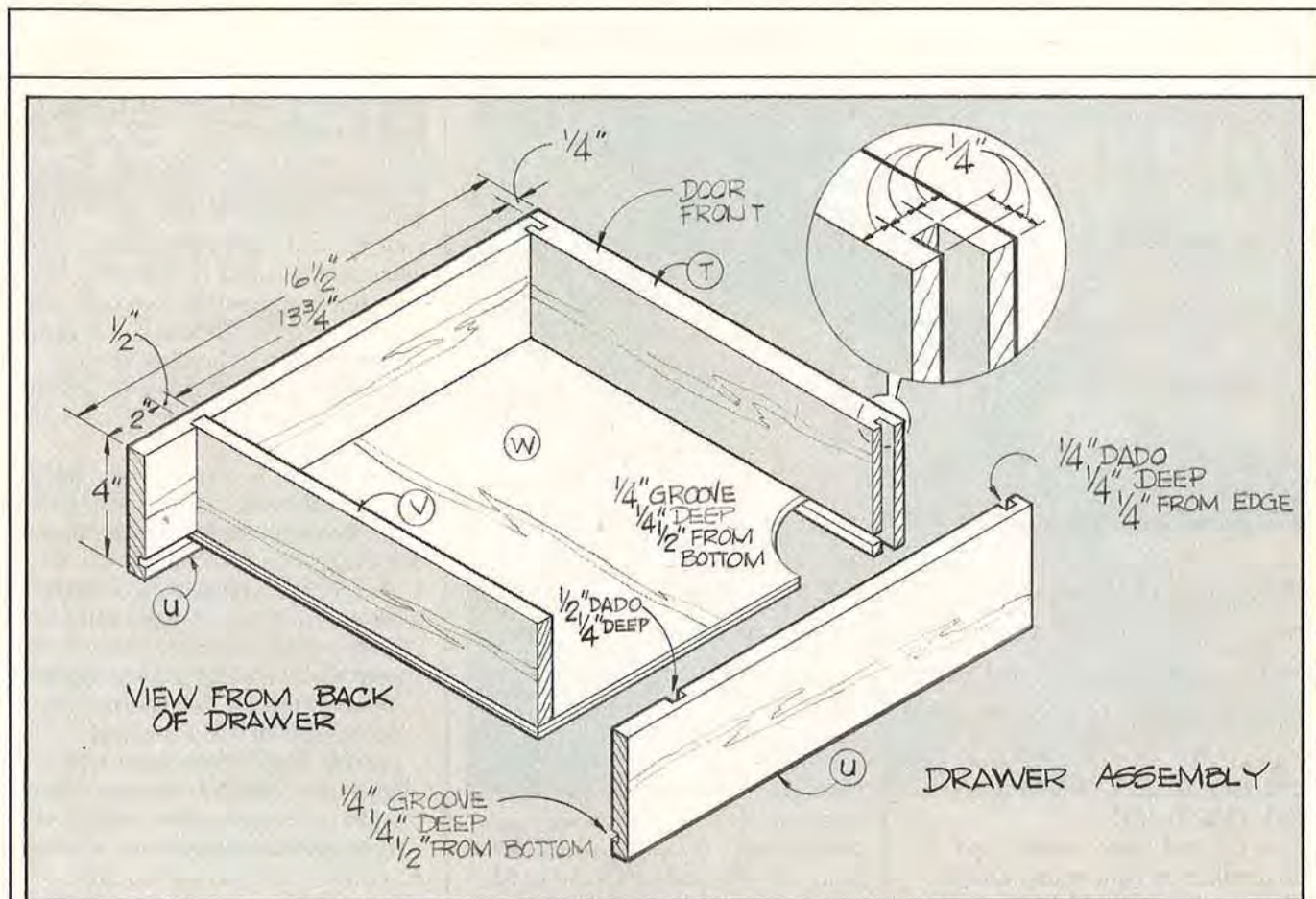

together, being sure to keep the pieces flat.

2 Cut a $\frac{1}{4}$ " groove $\frac{1}{8}$ " deep along the bottom edge of X, the top edge of Y, and the inside edges and both ends of Z. Cut $\frac{1}{4}$ " maple spline tenons for the joints. Cut the panels AA to their finished length and sand smooth. Cut a $\frac{1}{16}$ " rabbet $\frac{1}{4}$ " deep on all four face edges of the panel AA to fit into the grooved stiles and rails as shown in the door detail. Dry-clamp the doors together to check the fit. Glue, spline, and clamp the door parts together.

THE UPPER CASE

Making Up the Panels for Width

1 Rip and crosscut the pieces for the upper-case cabinet ends (A), top (B), and two shelves (C). Construct the panels, using the same procedures as used in constructing the panels for the base cabinet.

2 Cut stiles (D), filler blocks (E), and cleats (F, G) to size. Cut a groove in the stiles, a rabbet along

the front edge of each side panel, a rabbet along the back inside edge of each panel, and dados to accept the shelves. Then, glue and clamp the pieces together.

3 Drill pilot holes through F and G, then attach the bottom cleats (F) to the side panels and the upper cleats (G) to the top.

Building the Back

1 Rip then crosscut the rails (H, I, J), the stiles (K), and the panels (L, M, N) to size.

2 Cut the grooves in the stiles and rails. Dry-clamp the parts together to check the fit. Glue and clamp the panel assembly together. Remove the glue after it has formed a tough skin.

3 Glue and clamp the cabinet back into the rabbet.

Building the Doors

1 Rip then crosscut the door rails (O, P, Q) and stiles (R) to size, and the panels (S) to width and to length, plus 1".

2 Glue and clamp the panels together. Cut the grooves in the stiles and rails. Dry-clamp the door together to check the fit.

3 Glue and clamp the door assembly together. Set up the fence on your router table with a straight bit, and rabbet the back side of the door to house the glass. Check the measurement of the glass insert (T) and have it cut to size. Cut pieces U and V to hold the glass in place.

FINISHING THE CUPBOARD

1 Chisel a $\frac{1}{16}$ " deep notch in the doors to house the butt hinges. Drill pilot holes for the hinge screws.

2 Finish-sand all the cupboard parts and varnish them (we like the natural appearance of the maple and so we did not stain it).

3 Attach the door and drawer pulls, the hinges, the door catches, and install the glass.

4 Screw the upper case to the base. ■



Stripping an old finish isn't a pleasant task, so why do it if you can avoid it? Fortunately, the right materials, some know-how, and a little ingenuity will often save that "doomed" piece you've been meaning to work on.

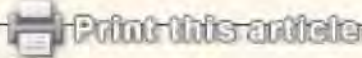

A GOOD CLEANING MAY DO THE TRICK

Dirt, oil, and wax combine and accumulate to darken and dull finishes on wood furniture. Even the rejuvenation of a lack-luster, near-antique might be as simple as cleaning with an appropriate cleanser. Murphy's Oil Soap—one commonly available, old-time favorite—cleans and conditions at the same time.

Varnish, recognizable by its tiny surface cracks, cleans well with a 50:50 mix of turpentine and tung oil (or boiled linseed oil.) Rub the dirty surface with a cloth saturated in the mixture.

Some finishes will be so heavily coated with dirt and grime that you'll have to use #0000 steel wool with the cleanser. Scrub lightly with the grain to avoid scratches.

HOW TO REMOVE SURFACE BLEMISHES

All furniture picks up minor surface scratches during normal use. Moisture, too, shows up as surface cloudiness or rings left by drinking glasses. The following tips will help you cope with these problems.

Abrasions on surface-finished items. Combat tiny scratches with the help of finely ground abrasive powders. Pumice, a powdered vol-

canic ash, has a medium grit. Mixed to a paste with lemon oil, it polishes well. Working with the grain, rub the paste into the finish with a felt pad until the scratches disappear. Wipe off the pumice paste with a clean cloth. For a higher gloss, follow the same procedure using rottenstone, a much finer abrasive powder of ground slate.

Abrasions on oil-finished wood.

On pieces finished with penetrating oil (Danish, tung, or linseed), bad spots are easy to repair. Just rub the marred area with #0000 steel wool, then apply a new coat of the appropriate oil to the entire surface.

Stubborn small scratches. Resistance to the pumice and rottenstone treatment calls for a heavy remedy. Step up to silicon-carbide (wet/dry) sandpaper. To use it, pour a small amount of lemon oil on the surface, then sand lightly with the grain until the blemish disappears. Start with finer grit 600 and progress down to heavier grit 320 as the blemish's stubbornness dictates.

Moisture-caused blemishes. Wet glass rings and surface cloudiness usually surrender to the pumice-and-oil paste treatment mentioned above if the moisture hasn't penetrated too deeply. If spots resist, the only solution is sanding and refinishing.

HOW TO CAMOUFLAGE DEEP SCRATCHES

When a scratch digs through the finish and damages the wood itself, abrasive remedies won't work. With patience and considerable practice, you could learn to fill scratches with hot lacquer sticks or cover them by spot refinishing, both permanent repairs. There are some less-permanent (and easier to accomplish) techniques, however, that will hide the damage.

- Shoe polish in a matching shade is a quick trick. Use a Q-tip or a toothpick to apply, then bring to a shine with a soft cloth.
- Defects that actually need filling are easy to conceal with putty sticks. They contain a waxy putty and come in a wide range of wood tones. Rub the tip of the stick (much like a crayon) back and forth over the scratch. Since they remain soft, don't use them on surfaces such as table-tops and chair arms.
- Scratches on hard-use surfaces should be stained to match, then filled with spot-finishing lacquer on an artist's brush. Polish the filled scratch with pumice and rottenstone.

CARING FOR FINE WOOD FURNITURE

Once the finish is refurbished, light maintenance keeps it in shape.

Avoid wax buildup. Dust furniture weekly with lemon oil sprinkled on a soft cloth.

Polish only when necessary. Spray-on and liquid polishes should be applied only when furniture actually needs polishing, not for weekly dusting.

Use paste wax only twice a year. Paste wax provides long-lasting sheen and a thicker protective barrier than spray-on and liquid polishes, but builds up fast. Therefore, apply it only every six months. When you note a paste wax-polished wood finish getting tacky to the touch, dull, and attracting fingerprints, don't put on more; there's too much already. Clean off the buildup with the oil soap or 50:50 mix of tung oil and turpentine mentioned earlier. ■

the WOOD magazine 3-ring binder drilling jig

 Print this article

WOOD readers constantly amaze us with their ingenuity! This simple idea for drilling holes through your issues of WOOD magazine, enabling you to catalog them in a three-ring binder, came from Ray Dobelstein, of Flemington, New Jersey. It came just in time, too, with the heavy reader interest in a way to keep their back issues of WOOD organized. Next issue we'll show you how to build a wooden three-ring binder.

1 Rip then crosscut the drill guide (A), base (B), and cleats (C) to size.

2 Clamp one cleat to each end of the base. Then, glue and screw the cleats to the base. (We used a drill/countersink bit to pre-bore the screw holes.)

3 Mark the location of the drill guide holes and those for the dowel pins (D) on part A. (See the drawing at right for correct positioning.) Now, clamp parts A to the B-C assembly and drill the holes through both part A and the base. (You'll want to place a piece of scrap wood beneath the base when drilling to prevent it from chipping.)

4 Cut the walnut pins (D) to length and chamfer one end of each. Glue the pins into the 1/4" holes in the base. Using a 3/32" bit, enlarge the 1/4" holes in A for an easier fit of the pins through the guide.

5 Test the fit by sliding the guide onto the dowels; sand if necessary.

6 Finish-sand all the parts and apply polyurethane or lacquer finish. (When applying the finish, try to keep it out of the drilled holes.) Apply wax to the pins for a smoother fit into the guide. ■

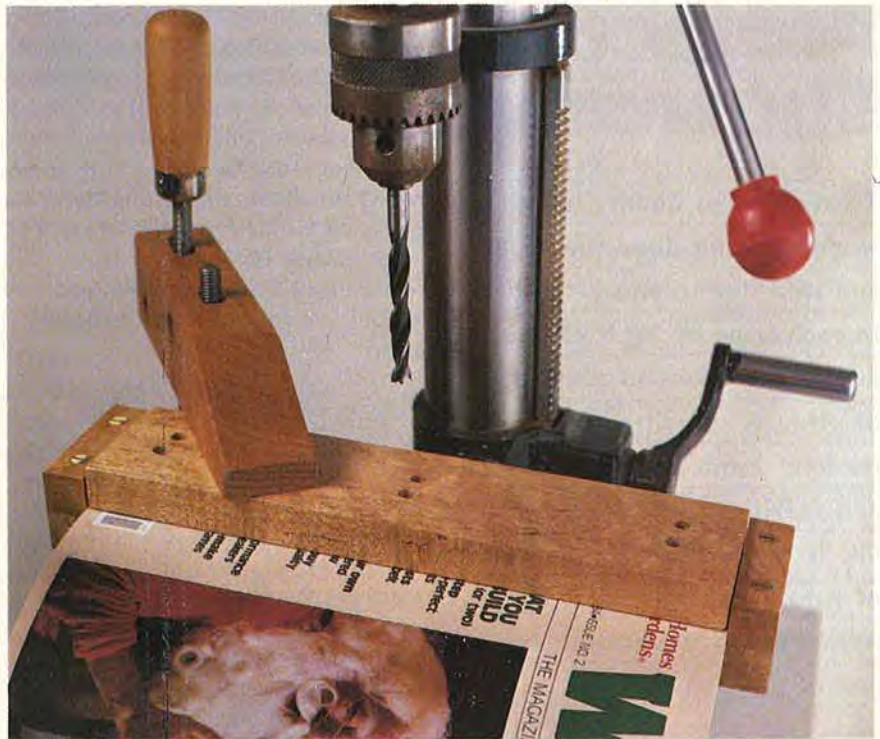

Design: Raymond A. Dobelstein
Photograph: Scott Little

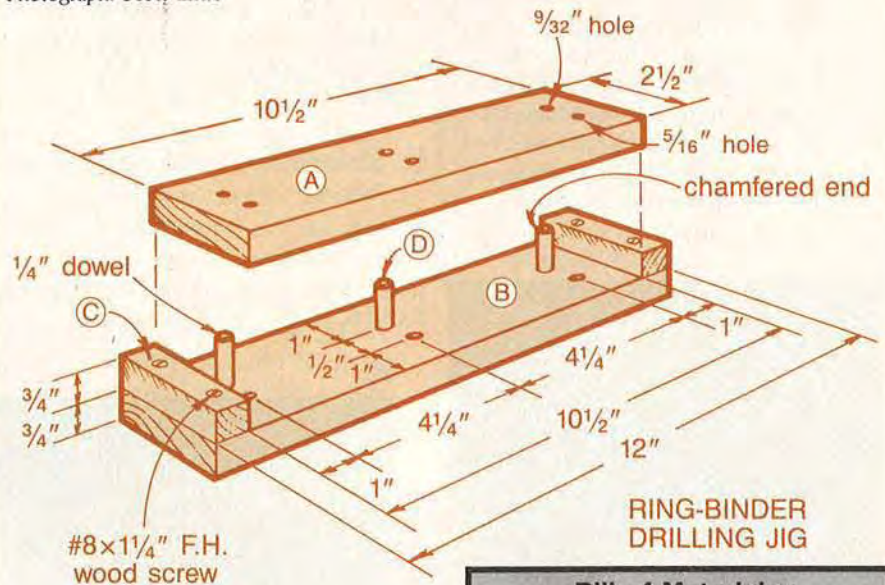

Bill of Materials					
Part	Finished Size			Material	Qty.
	T	W	L		
A	3/4"	2 1/2"	10 1/2"	maple	1
B	3/4"	2 1/2"	12"	maple	1
C	3/4"	3/4"	2 1/2"	maple	2
D	1/4" dia.		1 1/2"	walnut dowel	3

Supplies: 4—#8x1 1/4" flathead wood screws, polyurethane or lacquer finish, wax

Cutting diagram

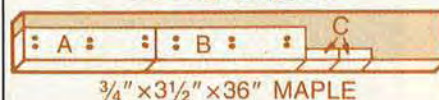



Project Showcase

There's lots of quality wood-working being done these days, and we'd like to show it off. In each issue of WOOD, we devote this space to a display of projects submitted by our readers. From boxes to bowls, and carvings to cabinets, we'd like to see them if they're made of wood. To submit projects, follow the instructions at the end of this article.

A. Grandfather's Clock Works

For a high school 4-H project, Darrel Schwilling, of Casper, Wyoming, gave new life to some old clock works his grandfather had bought at auction. He fashioned a handsome walnut clock case that features ornate half-turnings flanking the face as well as other turned or-

A.

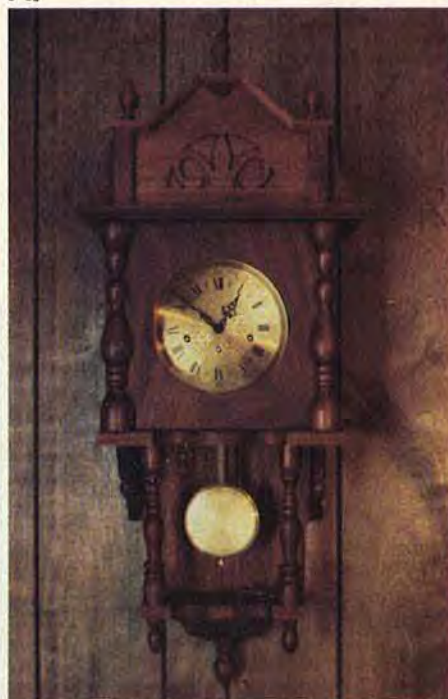

namentation. With an eye to the past, his case design blends perfectly with the clock face of yesteryear.

To make the half-turnings, Darrel glued newspaper between two pieces of stock before turning them, which made separating the twins fairly easy. He finished the clock with Danish oil.

We'll bet Darrel's grandfather would like his clock works back now!

B. Curved Stretcher Table

A beautifully curved stretcher sets this red oak writing table apart from the crowd, as shown by this photo William Hart sent to us from Allentown, Pennsylvania. He steam-bent a six-layer lamination and splinted it to the straight stretchers to create an unusually interesting effect.

In order to display continuous grain, Bill used a single piece of red oak for the front apron and drawer fronts. Keeping elegance simple, he finished his 56"×26"×29"-high table with three coats of Mohawk Natural Danish Oil. ■

C. Blue-Printed and Segmented Vessel

Laying out this bubinga-striped, yellow poplar vessel to actual size on graph paper gave Steve Levine, from Kendall Park, New Jersey, the

opportunity to plan each segment's size and wood grain appearance, as well as its angle, before construction began.

Each of the vessel's four rings have ten segments and were added one at a time to the base, then individually turned in a step-by-step building process. Steve deliberately offset the segment seams for strength and design interest. Sanding with progressions of 60- to 280-grit paper, then 15 coats of Deft and a final rub with #0000 steel wool gave his 16"-high×10"-diameter vessel its mirrorlike finish.

Steve, we think the result was

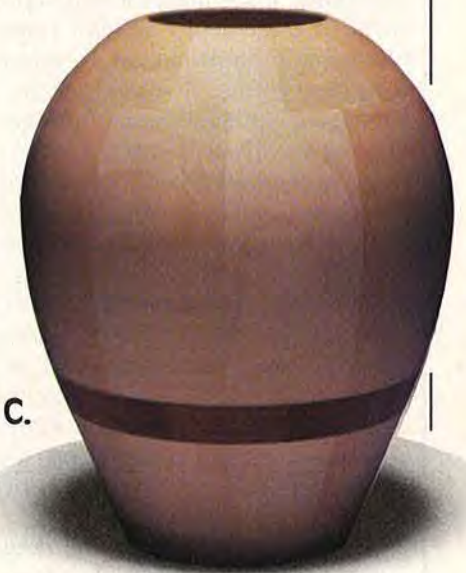

C.

B.



worth all the effort. Keep up the good work.

D. Euro-Style Inlay Jewelry

In his native Czechoslovakia, Josef Dolejs spent 18 years crafting hardwood veneers into fashionable inlaid jewelry. Josef now lives in Albuquerque, New Mexico, but he hasn't lost his interest or his touch, as his matched earrings, pendant, and bracelet prove.

Made of walnut, maple, and mahogany, the jewelry reflects both his European heritage and the influ-



E.



ence of the American Southwest. To make it, Josef cuts small pieces of contrasting woods, then glues them into place on the incised background wood. For the bracelet, he laid up four veneer layers around a wrist form, using the glue to make the wood flexible. For a finish, Josef sprays on one coat of lacquer, then a coat of clear epoxy for a durable, high-gloss look.

E. Magazine Rack Vanity

Framing, plumbing, electrical work, trim—Bob Hadzor, of Syracuse, New York, did them all as part of his bathroom re-do. His pride, though, is the red oak vanity he designed and built. Capped with a 1 1/8" red oak top and backsplash, the oak plywood base features a built-in "library" for books and magazines—easy to reach on the fixture side.

Bob edge-joined the top stock as well as the 3/4" oak door panels, and joined the frame using open mortise-and-tenons. Two coats of filler and five more of polyurethane finished the top. Bob says he spent \$300 for the entire vanity, including sink and faucet, which proves that woodworking can be satisfying as well as economical.

F. Trammel-Routed Chest

With a router and trammel attachment, woodworker Rudy Kouhoup of Bridgewater, New Jersey, added the front panel floral carving to this

traditional pine chest which measures 45"×20 1/2"×17 1/2" high. For the top and ends of the chest, and for the front panels, he rabbeted the edges of 1×12s, then edge-joined them shiplap fashion. The front panels fit into rabbets routed in the frame.

For the carving pattern, Rudy first drew his design on quadrille-lined paper, then marked the center points on the wood. The router and trammel made the carving nearly an effortless task, and with great results. He stained the project with Tungseal "fruitwood," then finished it with polyurethane for long-lasting durability and ease of maintenance. ■

Submit Your Projects:

Send a 35mm color slide, with the project as the focal point in a simple background. No people, please! Include a capsule description—materials used, special joinery techniques, finish, for example. WOOD will pay \$25 for published projects. Unless you enclose a self-addressed envelope with sufficient postage, your slides will not be returned.

Send to:

Project Showcase
Better Homes and Gardens®
WOOD Magazine
Locust at 17th
Des Moines, IA 50336



F.

SCANDINAVIAN-STYLE figure carving

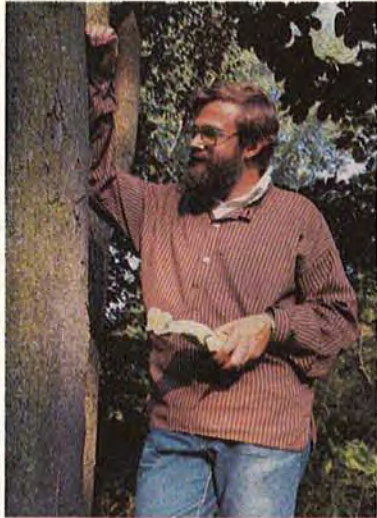

Born of Norwegian-American parents near Hoffman, Minnesota, Harley Refsal, 40, shown leaning against a basswood tree, above, has been carving since childhood. After majoring in language at Augsburg College in Minneapolis, then studying in Norway and Sweden, he began carving seriously.

When he's not enjoying his favorite hobby, Harley teaches Norwegian and advises foreign students at Luther College, Decorah, Iowa, where he, his wife Norma, and sons Carl and Martin make their home. Each summer, Harley teaches woodcarving through the Norwegian Craft Workshops of Vesterheim, the Norwegian-American Museum in Decorah.

Drawing on memories of rural Minnesota, Harley Refsal carves rough-hewn figures depicting the hardships of Norwegian immigrant life in the Upper Midwest.

A big basswood tree grows beside the stream that swirls past Harley Refsal's home on the outskirts of Decorah, Iowa. The tree may have been there in 1865 when the town was a gathering place for newly arrived Norwegian immigrants seeking land to clear and farm.

Harley doesn't know the tree's age for sure, only that ones like it provide him the wood to carve figures of the rugged, hardworking Norwegians that passed that way. His Scandinavian-inspired carving style portrays those early homesteaders as well as individuals he remembers from childhood.

"I draw on the immigrant and rural life of the Upper Midwest for my work," the carver says. "I don't carve sea captains or fishermen. I carve ice fishermen, inland folks, a farmer who incidentally happens to

Photographs: Bob Calmer; Jim Elder

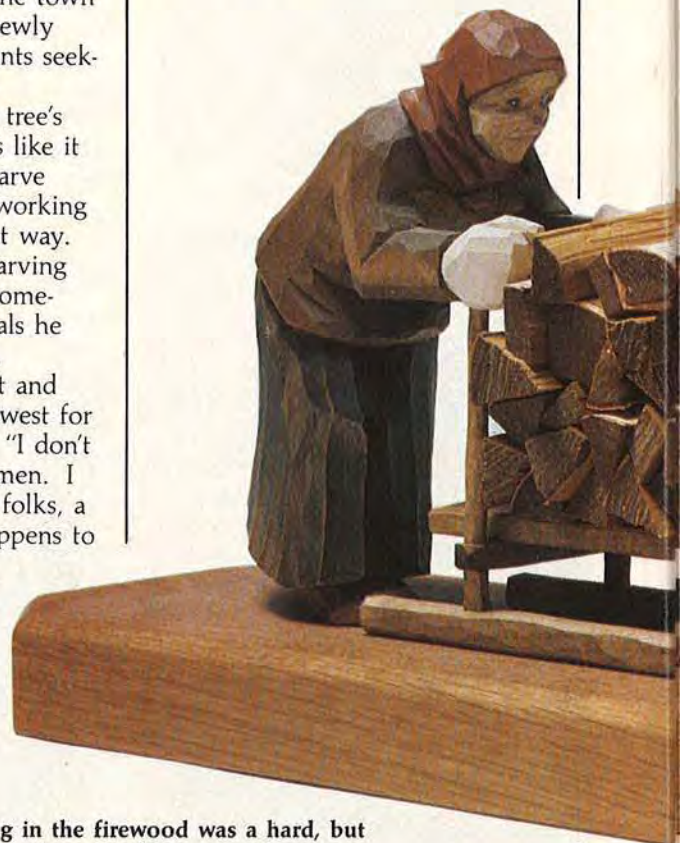

Bringing in the firewood was a hard, but necessary chore for Norwegian farmers. Harley captures the effects of their toil with a minimum of knife cuts.

be fishing. My carving style lends itself to the rough-hewn individuals who settled this part of the country. I feel that a non-refined kind of carving lends itself to non-refined sorts of people—chiseled faces of farmers at an auction, a fire-and-brimstone preacher—older people with rich lines. I believe just a few lines can say a great deal.”

Blending the Old World and the New

Refsal’s type of flat-plane carving, so-called because it leaves the small, flat plane of each cut exposed, comes from the rustic and rugged peasant carving found in Scandinavia and the areas of this country where immigrants settled. According to Harley, it’s a style only about 150–200 years old, which to the whole of Scandinavian carving is relatively new, “because it represents enough leisure time to be able to carve something just for fun, something that wasn’t functional.”

From study in Norway and Sweden, Harley gained a knowledge of and an appreciation for all types

of Scandinavian carving. And when it was time to focus on a style he felt comfortable with, he chose a blend.

“I guess I wedded a Scandinavian style to Scandinavian-American material,” he explains. “I’ve combined style from there with subject matter from here. I’ve not been interested in duplicating the kind of Norwegian folk carvings I’ve seen in Europe because I’m not as familiar with those subjects as I am with rural life around here.

“Having been born and raised on a farm in a Norwegian-American community,” Harley continues, “the people I know best are farmers and laborers, immigrant figures. I’m very much a product of the immigration. Norwegian was spoken in my home. My grandfather lived in Minnesota for 56 years and died never having learned English.”

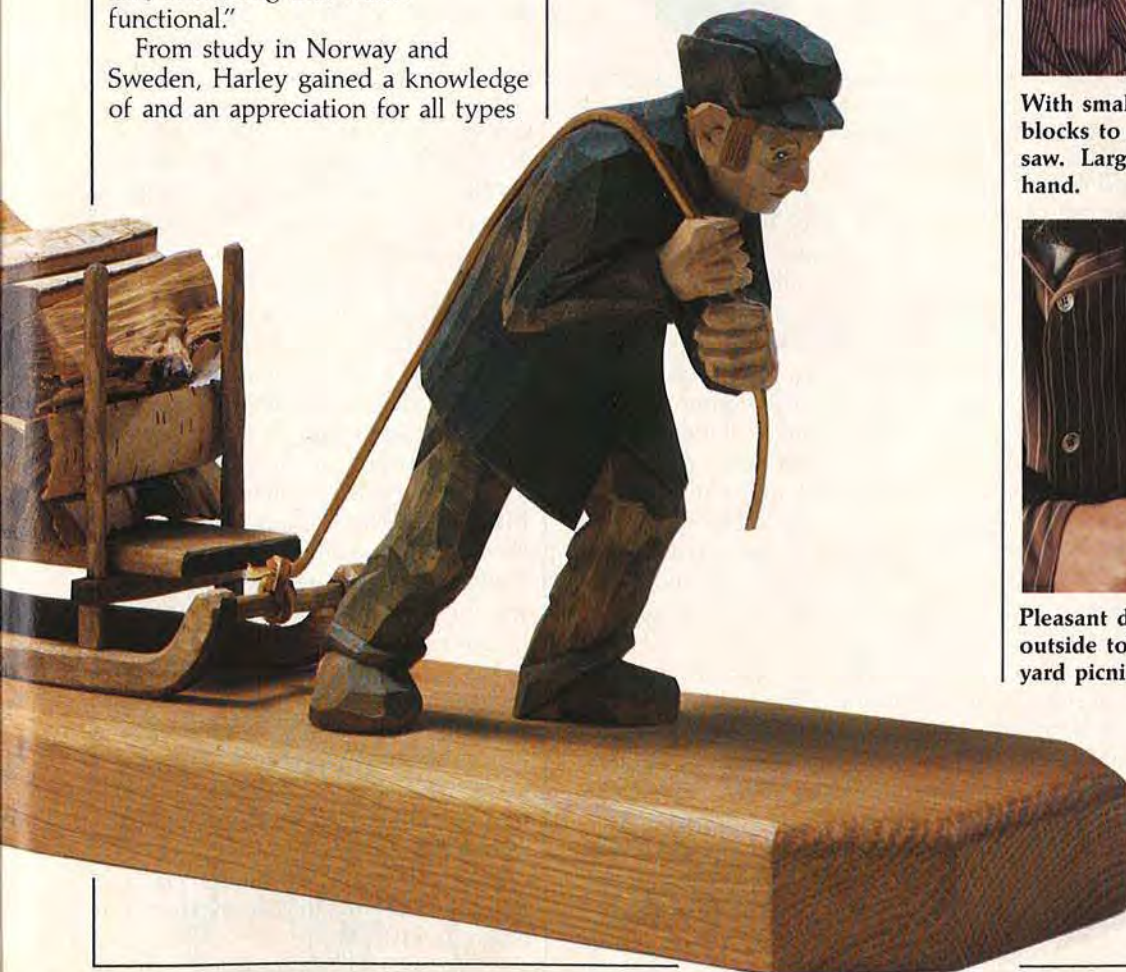

With a carving pattern tacked to the wall, Harley chooses an appropriate-size block from his stockpile.



With smaller figures, he can saw the blocks to rough shape on his band-saw. Larger ones require doing it by hand.



Pleasant days bring the woodcarver outside to work the figure. A front-yard picnic table is his favorite spot.

Refining a Carving Style

To the uninitiated, flat-plane carving may appear to be unsophisticated, but it takes a developed skill and a disciplined hand. And, Harley continually seeks to further refine it.

According to Harley, "In carving there's a stage where you strive to make a person look like a person every time—an old woman look like an old woman every time you do it, for instance. I can do that, but now I'm trying to conserve, to do it with fewer and fewer cuts."

As Harley refines his technique, he finds himself gradually using fewer tools. His workshop wall displays three dozen or more carving tools, yet more than half of them go unused. He rarely uses more than five tools on a carving, and ordinarily just a gouge, a carving knife, and a small V-tool. After more than 10 years of carving, this represents "coming full circle" for Harley, since he began with nothing but a pocketknife, a wood chisel his father had made from an old file, and an X-acto knife with a few blades.

Basswood by the Block

Just as a stone sculptor wouldn't do a Norwegian bachelor farmer out of white marble, neither would the Decorah woodcarver make him out of black walnut or cherry. He prefers basswood.

"Basswood lends itself very, very well to detail," Harley explains, "because of its uniform grain. Some pines have a light/dark, light/dark coloration when you look at the end grain. That light/dark translates to hard/soft when it's carved. Basswood doesn't have hard/soft, it's more like carving hard soap."

Harley has put up and dried a lot of local basswood, and with good results. He's convinced that northern basswood, air-dried, is the best carving wood. Now, though, he buys it from an Iowa supplier, paying two cents a cubic inch for 4"×4", 5"×5", and 6"×6" blocks. Buying wood gives him more time for carving, and the money is well spent.



This Norwegian farmer with milking stool might have been his neighbor in the immigrant community where he grew up.

Hands-On Carving

When he begins a carving, Harley first sketches a silhouette of the character on paper, makes a pattern, and transfers the shape to a basswood block. He then uses a bandsaw to rough out the approximate shape if the figure is under 6" in all dimensions. With larger figures too big for his bandsaw he removes the excess wood with a coping saw. Sometimes, on complicated figures he'll simply hand-hold it and use a short palm gouge to cut away wood.

After roughing, Harley starts the knife carving, hand-holding the piece and occasionally using his knees as a vise. He carves away from himself for safety. And the way he holds the knife makes a difference. Harley grasps the knife handle in his right hand (his power hand) and pushes and guides the blade with the thumb of his left.

That way, he always has control of the blade.

Harley's style of flat-plane carving requires him to carefully decide what each cut produces: "The marks that shape the piece always remain. They stay in there as part of it. When I make a cut to get away wood, I also may be putting a fold in the character's pants, for instance. I don't shape and then go around and put in knife marks. My knife marks do double-duty."

A small, gouge-like V-tool incises definitions on his carvings, but the lines are not overworked.

Turning the figure in his hands, he looks it over, announces it completed, then turns to finishing.

Understating for Effect

"If you see carving geared for a tourist market, they have bright, bright colors," Harley notes. "But I think that the life of the people I carve just wasn't that colorful."

Harley and his wife Norma thin acrylic paints with water to the consistency of a wash. After painting, a process Norma now does regularly, and drying, she dips the carving in a mixture of boiled linseed oil and an amber antiquing colorant. The oil mixture not only penetrates and preserves, it produces a shadow effect.

Some of Harley's pieces stand alone, while others rest on a base he selects to fit the carving: "An immigrant, a homesteader, that type of figure calls for something rustic, like a chunk of log. A subject more controlled, such as the schoolmaster or the nurse, demands a base that reflects their indoor environment. Occasionally an exception is made when the buyer requests a specific base material, or if I want to accent the rough-hewn look."

His carvings have brought him recognition, earning blue ribbons at fairs and woodcarving exhibitions. Harley sells his work at Scandinavian festivals and by commission, and that has brought some economic satisfaction. Based on an hourly rate of \$10 he set for himself, his individual immigrant carvings now begin at \$100. ■

carving the Refsal horse

Since the time of the Vikings, Scandinavian carvings have featured creatures of power. The plundering seafarers adorned their ships with fierce dragon heads. Inland, carvers chose more domestic symbols of strength—the goat, the rooster, and the horse. Harley Refsal's horse evidences power and strength in the thick, arched neck and squat, muscular body. His horse resembles one you could have found in 18th-century Norway or Sweden.

Design: Harley J. Refsal Photographs: Jim Elder; Scott Little

 Print this article



Finish the horse traditionally with a color wash, or use Danish oil.

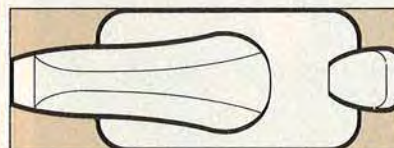

TOP VIEW

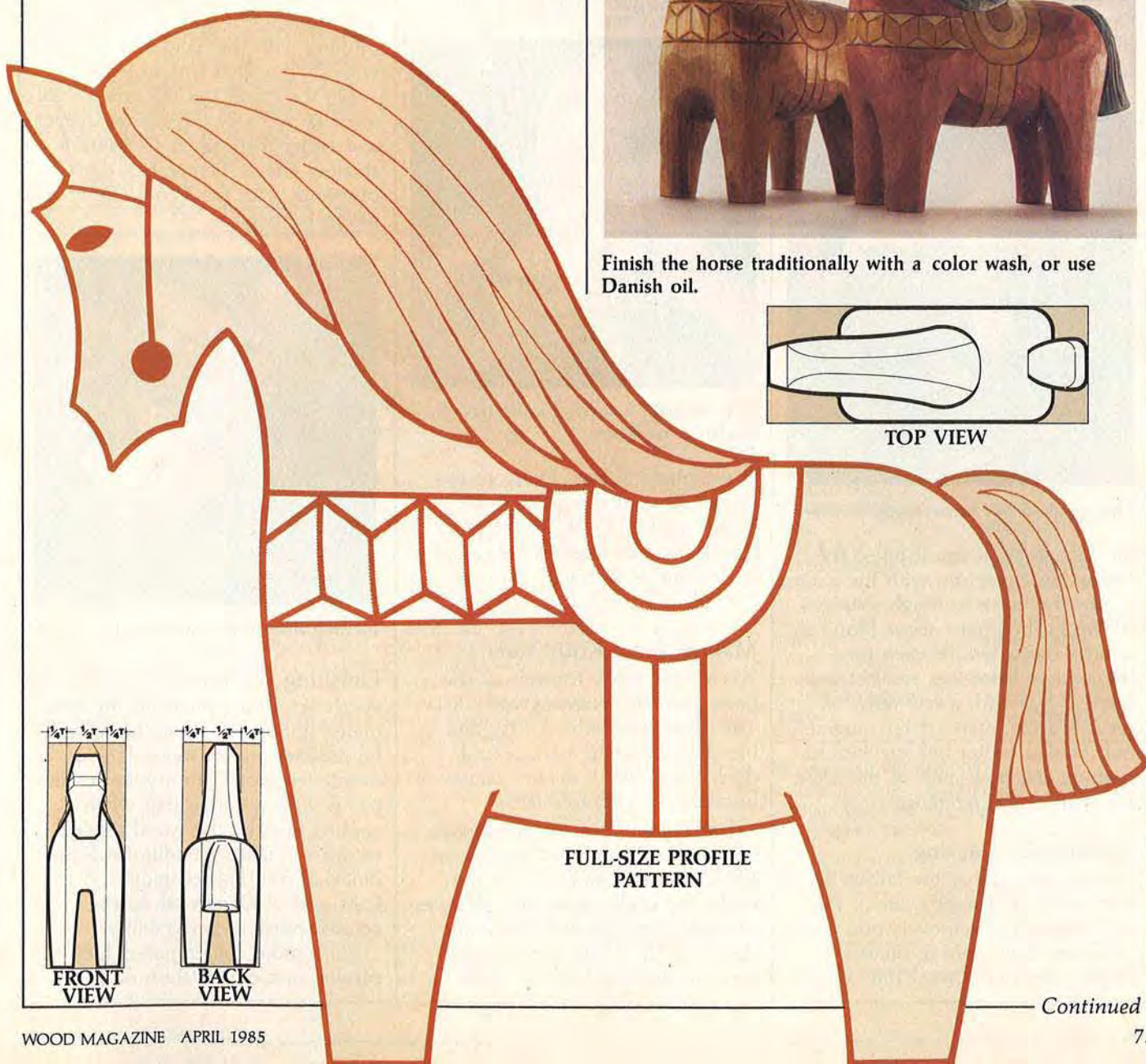

FULL-SIZE PROFILE
PATTERN

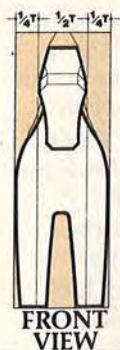

FRONT
VIEW



BACK
VIEW

CRAFTSMAN CLOSE-UP

The Materials You'll Need

To complete the horse, you'll need the following tools and supplies:

- a coping saw, saber saw, or band saw to rough out the shape;
- a carving knife or an X-acto knife;
- a small V-tool, or a V-tool blade for an X-acto knife;
- acrylic paints and Danish oil;
- a 2¼"×6¾"×6½" basswood block, or three ¾" clear-pine boards glued up to thickness with white or yellow glue (be sure the grain of all pieces runs in the 6½" dimension).

Getting Started

First trace our full-size horse pattern to heavy paper. Cut out the pattern, then trace the outline directly



The roughed out horse ready to carve

on your stock, lining it up so the legs of the horse run with the grain.

Saw the horse to rough shape as shown in the photo above (you can remove the wood between the figure's two front legs and between the rear legs with a saw now, or carve it away later). After roughing out, mark a center line on the top, bottom, and both ends of the horse for symmetrical reference.

Shaping the Carving

Starting from either the tail or the feet, use long, smooth cuts of the carving knife to remove wood and work the figure into a rounded shape. Working toward the horse's

head allows you to gain confidence and control, and to develop a sensitivity for the feel of the grain under the knife. Remember, that while Harley places the work between his knees during carving, until you've gained experience, it's wise to clamp your figure in a vise.

Try carving as he does: hold the knife in your power hand (right hand if right-handed, left if left-handed) and push and guide the blade into the wood with the thumb of your opposite hand. Carve away from yourself and let your thumb do the work.

Focus on removing wood from the areas of the horse's head, neck, mane, and tail as shown



Shaping with a carving knife has rounded the figure

in the photo above. Don't go too far, you'll want the smaller, flat knife marks to finish up the piece. Check for roundness of the figure by looking at it straight on from the tail.

Making Final Knife Cuts

You're now ready to even up the horse with flat, shaving-type cuts. The secret here is to *not* try and blend in the knife marks. And don't worry about details such as hooves—it's a stylized horse.

Use the knife to cut in features such as the saddle, the lines where the legs, mane, and tail join the body, the bridle, eyes, etc. A series of small chips cut with the knife, shown in the photo above, right, serve to define a line.



Evening up with flat knife cuts

Accentuating with the V-Tool

Hold the V-tool like you did the knife, guiding it with a thumb, but pushing with the hand it is in. Start with shorter lines first to learn.

On the mane and tail you'll want to make some of the gouges deeper and wider than others to create a shadow effect. Remember, don't overwork with the V-tool. Refer to photo for details.



Incising lines using the V-tool

Finishing the Horse

As shown in the photo of the completed horses, the Refsal horse can be finished in two ways. If you decide to color it, thin your acrylic paints with water so that when applied they let the wood show through. This is a traditional Scandinavian coloring technique. A light coat of Danish oil on the colored horse adds durability.

For a more contemporary-looking carving, use only Danish oil. ■

Continued from page 54

The Old Hand Ways

The long jointer plane uses its great length (around 30") to keep the iron from cutting wood in the valleys until the hills are all brought down. When the shavings emerge from the plane unbroken for the entire length of the stock being worked, the surface must be level and true (or close to it). It is tradition in many shops to tack the longest unbroken shaving on the wall over the bench. Our current ribbon runs 27 feet, 3 inches.

One other specialized plane that the joiner needs is the *plow*. The adjustable plow cuts a groove into the wood a given distance from one of the edges. By making a rectangular framework of this grooved stock, he can slip broad panels into the spaces and cover as large an area as necessary. This is panel frame construction.

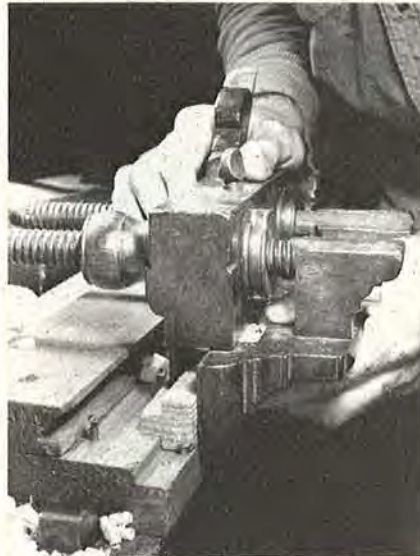

The joiner needs his planes and bench to make the doors, windows, and casings for the house.

The Joiner's Work Allows for Shrink

The shrinking and warping of Shakespeare's wainscot stem from

both the nature of wood and human nature as well. The purpose of panel frame construction is to allow the inevitable shrinking and swelling of the broad panels to take place harmlessly within the grooves cut for them in the frame. Only when the work is done hastily with unseasoned stock will the shrinkage be so great that it will pull free of the grooves and "warp, warp."

Shakespeare may not have been entirely displeased with the work of his local joiners. In *A Midsummer Night's Dream*, one of the "rude mechanicks" is a joiner named "Snug."

The tools of the joiner may be specialized and sophisticated compared to those of the carpenter. They remain, however, tools and not machines. Not machines like the lathe, the heart of another ancient woodworking trade, which we'll turn to in our next installment of the Old Hand Ways. ■

the American Woodworker

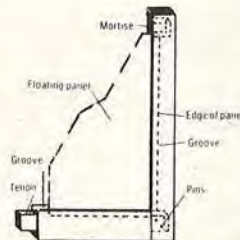

- We would like to take this opportunity to announce the publication of a new magazine for woodworkers. As you can see by the logo, our name is THE AMERICAN WOODWORKER. We are a very diversified publication printing a variety of articles including both projects and subjects of general interest to woodworkers. Our project sections are produced on three levels: beginning, intermediate and advanced. They include everything from a shaker candle holder to a Chippendale lowboy. Styles are both traditional and contemporary.
- The size of the magazine is a large 9" X 12" printed on a heavy glossy stock. It contains both photographs and easy to read drawings of all different styles of furniture and projects.
- In addition to other nationally known writers, there will be two regular columns: one written by Ernie Conover of The Dunbar-Conover Woodworking School. He will answer your questions about any woodworking subject. The other is a column about finishing written by George Frank, one of the world's leading authorities. He will answer your questions about finishing.
- There will be visits to interesting people and interesting places to discover what others are doing in woodworking. Also included are instructional articles including everything from quartersawing to inlaying, articles about tools, both hand and power, and much more.
- There is a section about manufacturing techniques including how to make and use jigs and fixtures. We also have historical articles about both people and furniture.
- There are show dates and locations, supply sources, and book reviews. THE AMERICAN WOODWORKER is dedicated to pure woodworking. There are no articles on home repair, etc.
- From time to time there will be informative articles that are unusually helpful to the woodworker. In our first issue there is an article explaining how to transfer a photograph or drawing to a piece of metal. This interesting technique can be used to make plaques, canister sets, inlays for various woodworking projects, etc.
- THE AMERICAN WOODWORKER will be published quarterly the first year. The subscription price is \$10.00, with the first issue out in March 1985. We have been woodworkers all our lives and hope that you will join us for an entertaining experience. Check us out if you like. We are old members of the Hendersonville business community, belonging to the Chamber of Commerce. If you are not 100% satisfied with your subscription, your money will be refunded. Use the coupon or just send your name and address along with your check or money order for your subscription. We guarantee you'll love it.

- BEGINNING, INTERMEDIATE, ADVANCED PROJECTS INCLUDING PHOTOS AND PLANS
- LARGE 9" X 12" SIZE ON HIGH QUALITY GLOSSY PAPER
- ALL STYLES OF FURNITURE AND PROJECTS
- TWO OF THE BEST COLUMNISTS, ERNIE CONOVER AND GEORGE FRANK
- INSTRUCTIONAL ARTICLES ON ALL PHASES OF WOODWORKING
- VISITS TO OTHER WOODWORKERS
- SECTION ON JIGS AND FIXTURES
- SHOW DATES, SUPPLY SOURCES, BOOK REVIEWS
- UNUSUAL ARTICLES OF SUBJECTS RELATED TO WOODWORKING

The American Woodworker

JM Publications, Inc. - Dept. W-1
13 Walton Mall, P. O. Box 1408
Hendersonville, TN 37075

Yes! Start my subscription immediately.
 \$10.00 check or money order enclosed

PLEASE PRINT

Name _____
Address _____
City _____ ST _____ ZIP _____

DO-IT-YOURSELF KITS

BUILD YOUR OWN GRANDFATHER CLOCK



Prices Starting Under **\$280**

(including movement and dial)

- Do-it-yourself case kit, parts pre-cut
- Finished clocks
- Solid 3/4" hardwoods: black walnut, cherry, oak
- Heirloom quality
- Factory direct prices
- Solid brass West German chiming movements
- Money back guarantee
- Prompt shipment
- No woodworking experience necessary

WRITE FOR FREE COLOR CATALOG



EMPEROR CLOCK COMPANY

WORLD'S LARGEST MANUFACTURER OF GRANDFATHER CLOCKS

Dept. 1446, Emperor Industrial Park
Fairhope, Alabama 36532 • Phone 1-205-928-2316

I am interested in Do-It-Yourself Kits
 Finished Clocks

Name _____

Street _____

City _____

State _____ Zip _____

(please print)

WOODWORKING MACHINES 5 in 1 Combination

- 1 • 34" LATHE
- 2 • 10" TABLE SAW
- 3 • 11 1/4" DISC SANDER
- 4 • 16 1/2" VERTICAL DRILL PRESS
- 5 • HORIZONTAL DRILL PRESS

REG. \$1250
NOW \$895



VERY IMPORTANT

- The only machine built with
- A. ALL CAST IRON TABLES**
- B. HEAVY-DUTY DESIGN**
- C. 1 1/2 HP MOTOR DEVELOPS 3HP**
- D. BUILT AS AN INDUSTRIAL MACHINE**
- E. 5 YEARS LIMITED WARRANTY**

ONE PLACE FOR ALL YOUR NEEDS...

VISA MASTERCARD MONEY ORDER
PLANT:

MASTER WOODCRAFT CO.

800 SPRUCE LAKE DRIVE • P.O. BOX 669
HARBOR CITY, CA 90710

TOLL FREE 1-800 421-2467

IN CALIFORNIA CALL COLLECT (213) 549-0761

(A Republic-Lagun Group) • Dealership Available

WOOD PARTS

WOODWORKS

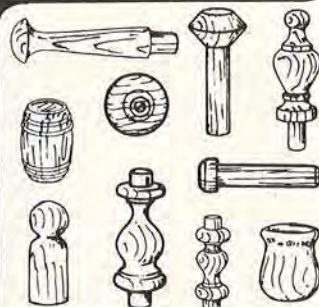

Catalog \$1.00 First Class
Free Third Class
WOODWORKS

4013-A Clay Ave. • Ft. Worth, TX 76117

CHECK.....OR USE

SEND MONEY ORDER, MASTER CARD / VISA

The original "Kik-Step" helps you reach those hard to get at storage areas... safely.

14" tall • heavy duty construction • easy rolling wheels lock when you step down on it... won't tip or scoot • 12 baked-on enamel colors



Order now for **\$32.95** DLVD

get 3 for 89.85 or write for more information to:

STEP-UP P.O. Box 3401
Kansas City, KS 66103

10 YEAR WARRANTY

SATISFACTION GUARANTEED

The Toymaker Supply Company

We Feature **Grampa's Workbench** Wood Toy Patterns.

Largest Selection of Wood Toy Patterns, Parts & Books



FREE Catalog
No. 69
Tahoe City, CA
95730-5459

Rocking Donkey Pattern
R2: \$5.98 ppd

24 hr. Phone No.
916-583-1555

RECANE for fun and profit



Recane or re-rush heirloom chairs — for yourself or for others as a profitable hobby — with our full line of materials & instruction books.

Since 1934 America's largest selection of caning & basketry materials & supplies —

- Superior quality weaving cane & machine woven cane
- Flat, oval & round reeds
- Fibre & genuine rush
- Danish seat cord
- Raffia, rattan, seagrass

Illustrated catalog with complete how-to-do-it information, prices, order form: \$1 (refundable with 1st order)

CANE & BASKET SUPPLY CO.

1283 S. Cochran, Dept. W, Los Angeles, CA 90019

KILN DRY YOUR OWN LUMBER

nyle corporation

the nation's largest manufacturer of dehumidification dry kilns is now offering small 500 to 10,000 board feet drying systems.

- ★ Made completely in the USA
- ★ The leader of the industry
- ★ Offering excellent warranties
- ★ Expert consultation and service

nyle DRY KILN SYSTEMS

Box 1107-A, Bangor, Maine 04401
Telephone 1-800-648-9200
or 207-989-4335

Complete Detailed Plans For -
42" 4-Harness Folding Counterbalance Loom
\$15.00 Postpaid
(Plans Only)

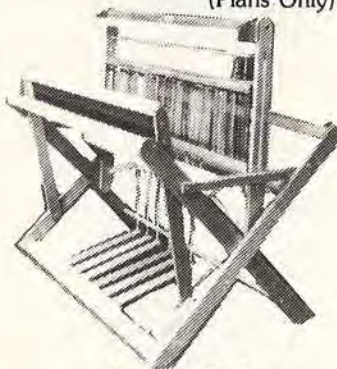

- Also Available -

Complete Kit For All Metal & Misc. Parts, Except Wood

Complete
4-Harness Counterbalance
Folding Looms, Floor Model,
Ready To Weave -

Complete
4-Harness Table Looms,
Ready To Weave -

Send For Free Information To:
TOMAR LOOMS
7711 N.W. 5th Ave.
Vancouver, WA 98665

NOW YOU CAN BUILD IT

Continued from page 50
tissue box cover

Cutting and Applying the Veneer

Note: If you haven't done any veneering work before, read the veneering article beginning on page 45 before going any farther. It contains information you need to know about. Also, refer to the cutting diagram to help lay out your cuts and to get the overlap where needed.

- 1 To mark the box ends for veneer placement, find and mark the center of the bottom of each end. Then, run layout lines from the center point to each upper corner to form a "V" as shown.
- 2 Set the box on end on a piece of veneer and trace its outline. Use the same procedure described in step 1 to mark the "V" on the veneer.
- 3 Using a straightedge and an X-acto knife, cut out the two V-shaped end pieces (1). Now, mark and cut the other end pieces (2, 3) to shape as laid out in the cutting diagram. Cut the pieces slightly oversized for trimming later.
- 4 Arrange the end pieces face up in the arrangement they will be in when glued to the box ends. Then, using masking tape, tape the pieces together. Apply contact cement to the back of the veneer pieces and to the box ends. Carefully place the veneer in position and trim the excess.
- 5 Mark and cut side pieces (4) to exact length, and to width plus $\frac{1}{8}$ ". Glue and apply the pieces. Mark and cut the outer side pieces (5) and apply them. Trim the excess.
- 6 Mark and cut the top inner pieces (6), then glue and apply them. Do the same for the top outer pieces (7). Trim the excess.
- 7 Finish-sand all surfaces with 220-grit sandpaper, then stain and apply finish. ■



This VET Did It - and YOU Can Do It Too!

"War injuries left me badly handicapped, but now I'm a financial success as a Locksmith, thanks to your training. Besides, the work is fascinating, if I can do it anybody can." — Glen Johnson, Larned, Kan.

Make Up to \$26.00 an Hour — even while learning!

Train FAST at Home! Be a LOCKSMITH!

If you enjoy fixing things, you're a "natural" to make hundreds of EXTRA DOLLARS a year in the fascinating business of Locksmithing. Rising crime has increased demand for service a thousandfold. **Yet there's only one Locksmith for every 17,000 people!**

COLLECT CASH PROFITS ALMOST AT ONCE!

You're "in business" ready to make \$10 to \$26.00 an hour a few days after you begin Foley-Belsaw's shortcut training. Easy illustrated lessons complete with ALL practice equipment **PLUS**

- ALL TOOLS YOURS TO KEEP
- KEY MACHINE YOURS TO KEEP
- EXPERT PERSONAL ASSISTANCE
- BUSINESS-BUILDING HELP

enable you to get your share of this always-profitable business. Hundreds we've trained are doing it. So can YOU.

MAIL COUPON to discover how Locksmithing can keep the extra money coming in during spare time — or in your own full-time business. Ideal for retirement—good jobs, too.

FOLEY-BELSAW INSTITUTE, 10632 Field Bldg. Kansas City, Mo. 64111

N. Hunt, Wilmington, Del.—"I make \$50 a week extra."

R. Davis, St. Louis, Mo.—"I cleared \$110 last Saturday."

Ed Boyle, Pittsburgh, Pa.—"My business going at top speed. I'm moving to bigger quarters."



MAIL THIS COUPON • NO SALESMAN WILL CALL

FOLEY-BELSAW INSTITUTE, 10632 Field Bldg. Kansas City, Mo. 64111



Rush **FREE** book, "Keys to your Future."

Name _____

Address _____

City _____ State _____ Zip _____

THIS DO-ALL PRO KEY MACHINE YOURS TO KEEP!

Can add \$50 to \$100 a week to your income... and doesn't cost you a penny extra!

FREE

INTRODUCING Zéga

The First COMPLETE WORK CENTER

for the Hobby Craftsman and Serious Model Builder.

The new Zéga multi-purpose precision work center is for the serious model builder or hobby craftsman. With Zéga, you'll be able to cut, carve, grind, shape, drill, sand or polish even the smallest pieces — perfectly!

If you've ever tried to use a full-sized saw or power tool for your detailed model projects, you know what a poor job they do.

Now, thanks to the remarkable design and engineering skills of German craftsmen, Zéga changes all that!

You'll get a new degree of precision and versatility never before available in a model or hobby craft saw — all from the unique, multi-purpose Zéga Model Center.

Zéga provides more professional features, more precision applications and a more complete workshop capability than anything else on the market.

Best of all, Zéga's attachments add a remarkable degree of versatility. With the power take-off and flexible power shaft, you'll have as comprehensive and varied

a model work center as you need — simply by adding accessories!

Try Zéga for 30 Days — At Our Expense!

Try the Zéga Model Center in your own home for a full month. If you don't agree that it is all we say it is (and much more!) simply return it and we'll promptly refund your money!

SPECIAL INTRODUCTORY PRICE AND FREE BONUS (If You Hurry!)

Zéga model center

A Division of Mantis Manufacturing Co. 1458 County Line Road, Dept. Z115 Huntingdon Valley, PA 19006

Rush me **FREE** information on the remarkable Zéga Model Center **PLUS** special prices and **FREE** bonus!

Name _____

Address _____

City _____

State _____ Zip _____

©MMC 1985

THE WOODWORKING SHOW

for craftsmen & hobbyists



2 SPECIAL SHOWS!

- 100 EXHIBITS
- FREE SEMINARS
- DOOR PRIZES

for the professional and aspiring fine woodworker

PASADENA, CA
March 1-2-3, 1985
 Pasadena Center
 300 E. Green St.

DALLAS, TX
March 29-30-31, 1985
 Dallas Market Hall
 2100 Stemmons Fwy.

Call (213) 477-8521 for further information.

With this ad \$1.00 off general admission price of \$5.00

National Carvers Museum

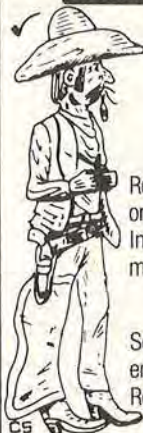

LEARN
WOODCARVING
 AT HOME

Receive sample instructional pack on whittling and woodcarving. Includes copy of *Mallet* monthly magazine.

Send \$1.00 to The National Carvers Museum, 14960 Woodcarver Rd., Monument, CO 80132.

ICE BOX KIT

Designed and reproduced from an authentic **ANTIQUE** * Hand crafted in solid OAK !! Solid brass Hardware



and name plate.

Kit comes complete with detailed instructions and finishing materials!

\$359.00+freight +

A handsome storage unit or bar! 6 1/2 Pa. S. Tax (Pa. resident)
 Send your check or money order payable to "THE SHOP"

"THE SHOP"

VISA & Master Card accepted.

Box 3711, R.D.#3, Dept. A9
 Reading, Pa. 19606

Phone 215-889-5885

Send \$1.00 for our catalog of hardwood kits !!



Develop a profitable second income in your spare time making small, unique bandsaw boxes. This unpublicized, little-known technique allows you to turn common inexpensive lumber and scraps into valuable utility boxes for the home and office. High demand in gift shops, stationery stores and craft fairs. Fully illustrated instruction booklet of 15 original and profitable designs. Satisfaction absolutely guaranteed. Send \$10.00 to **Box-Art, Dept. P, Box 8069, Woodridge, IL 60517.**

BAND SAW BLADES

WELDED TO YOUR EXACT LENGTH

WIDTHS	TEETH	PRICE/INCH
1/16"	24 & 32	\$.09
1/8" thru 5/8"	3 thru 32	\$.05

OTHER SIZES AVAILABLE — INQUIRE

To Figure Price:

Inch Length x Price/Inch + \$1.85 Weld Charge.

MINIMUM ORDER: \$10.00

Add \$2.50 for Shipping-Prompt Delivery

PHONE ORDERS —

1 (800) 543-8664 (Outside Ohio)

1 (513) 621-2159 (In Ohio)

VISA or MasterCard Accepted or

Send Payment with Order or

Write for More Information to:

BUCKEYE SAW COMPANY

P.O. Box 14794

Cincinnati, Ohio 45214

Make Clocks Easily! with Precision Quartz Movements

M88 Thinline

2-3/16" square x 5/8" thick
 Step sweep hand. Uses AA cell.



Made in Japan by the world's largest producer of quartz timepieces.

NEW LOWER PRICES!

1-2	\$6.95	25	50	\$3.65
3-9	\$4.95	@		FREE HANDS
10-24	\$4.35	\$3.95		

PRICES INCLUDE HOUR AND MINUTE HAND. ADD 25¢ FOR SECOND HANDS. Add \$2.00 per order for postage & handling.

BOOK - How You Can Make Battery Operated Clocks...Easily. 64 Pages. Fully Illustrated. By Charlie Plumb \$6.95



NEW CATALOG
 50 pages of clock movements, dials, accessories, hands, tools, and more!
 Catalog #784 \$1.00 (Free with order)

Cas-Ker Co.

BOX 2347-F CINTI, OH 45201
 PHONE (513) 241-7073

"Jorgensen" AND "Pony" CLAMPS

Dependable extra hands for all types of clamping and work-holding jobs: woodworking projects, home maintenance, and furniture repair.

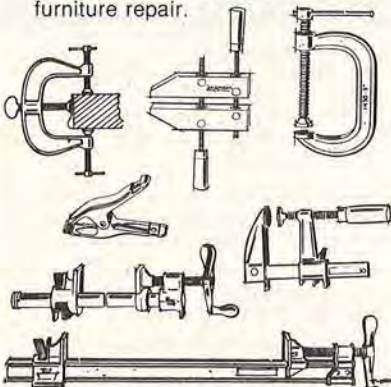

Write for FREE LITERATURE. For big 32-page "how-to-clamp-it" catalog, send 50¢.

ASK YOUR DEALER

ADJUSTABLE CLAMP COMPANY

THE CLAMP FOLKS

410 N. Ashland Ave./Chicago, IL 60622

WOOD REPAIR

Durham's Rock Hard Water Putty makes lasting repairs in wood. Won't shrink or fall out. Sets quickly, holds tight and can easily be painted. Economical, easy to use. Available at lumber, paint and hardware stores.

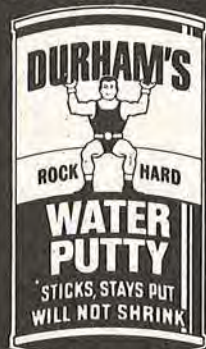

DONALD DURHAM COMPANY

Box 804-W Des Moines, IA 50304



Reproduce These
CLASSIC ANTIQUES
 Simple, Easy To
 Follow Instructions

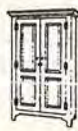

We Carry A Complete Line Of Furniture & Toy Plans and Those Hard To Find Accessory And Hardware Items, Lumber, Dowels, & Wooden Parts.

Send

For Our Current Catalog \$2.00

(Refundable) To:

MASTER PLANS & SUPPLY CO.

P.O. Box 489W Macon, Georgia 31202

MASTER CARD & VISA ACCEPTED

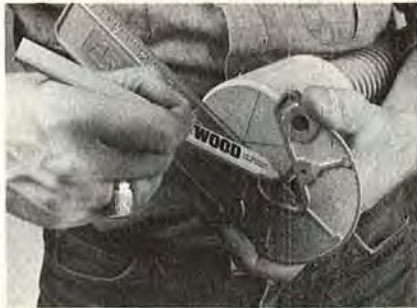

Easy-does-it center finder

No need to guess centers or calculate when you have the *Stanley Center Square*. Two different sets of locating pins, one for circles between $\frac{7}{8}$ " and $2\frac{1}{2}$ " in diameter and another for larger diameters, guide the rule for a two-location cross reference. A small recess allows you to find the center of circles less than $\frac{7}{8}$ ". *Center Square*. Available retail or through catalog sources, about \$5. Made by Stanley Tools, Division of The Stanley Works, New Britain, CT 06050.



Soap-away brush cleaner

Say good-bye to flammable solvents for brush cleanup! Here's a lathering soap that even removes dried-up oil-based paint. With Brookstone's *Brush Soap* and water, you can restore natural and synthetic bristles without fumes or mess. It also enables you to remove many stains from fabric, upholstery, and carpeting, says the manufacturer. *Brush Soap*. A 14-ounce tub, \$5.75, from the Brookstone Company, Dept. W, 127 Vose Farm Rd., Petersborough, NH 03458.



Dowel-making cutter set

You can make dowels or cut tenons for furniture and cabinetmaking easily with these hardened and ground tool steel cutters. Their $\frac{3}{8}$ " shank fits drill presses and portable electric drills. Set of four in a wooden case includes $\frac{1}{4}$ " \times $1\frac{1}{4}$ ", $\frac{3}{16}$ " \times $1\frac{1}{8}$ ", $\frac{3}{8}$ " \times $1\frac{1}{2}$ ", and $\frac{1}{2}$ " \times 2 " sizes. *Dowel and Tenon Cutter Sets*. About \$36 at retail stores. Made by General Hardware Manufacturing, New York, NY 10013.

Continued on page 80

NEW! POWER FEED DRUM SANDER

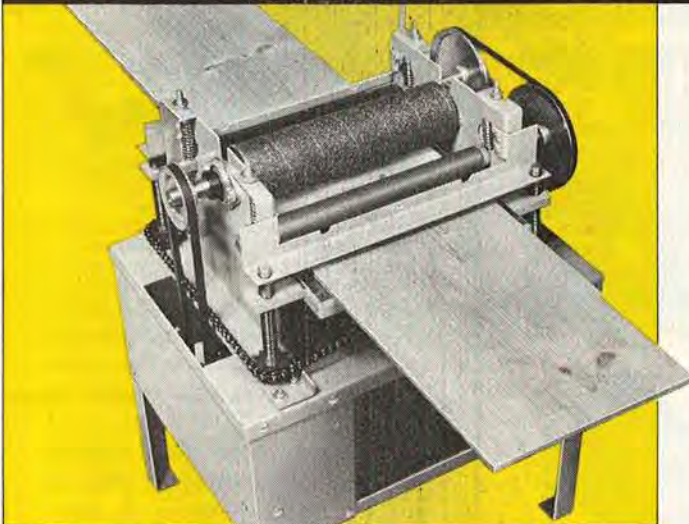

At last! A complete power-feed Drum Sander at an affordable price! Comes ready to use including hood, stand and motor!

FINISH SANDING . . . THICKNESS SANDING
Use this high-tolerance machine for light dimensioning as well as the finest finish work. Now you can add new beauty to each woodworking project . . . save hours of tedious hand sanding! In a matter of seconds, the Model 1200 can produce a satin-smooth finish impossible to duplicate with hand methods or hand-held power sanders . . . no more low spots, waves or cross-grain marks!

IMPROVES RESULTS!
Send for complete facts! See how the Model 1200 can dimension and finish-sand cabinet pieces, resawn stock, paneling, grandfather clocks, toys, tabletops, knees, burls, crotches, and much, much more! You'll soon find it's one of the most valuable tools in your shop!

Call Toll-Free 1(800) 824-7888 Oper. 642

FREE 30 DAY TRIAL!
Send for complete facts on how you can try the Woodmaster Power-Feed Drum Sander in your own shop for 30 days completely without risk! We'll also send you complete details on how you are fully protected by Woodmaster's One Full Year Limited Warranty. Easy Terms.

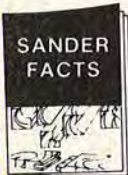

YES! Please rush my FREE Information Kit and details on your 30-Day Free Trial Guarantee.

**Woodmaster Tools, 2908 Oak, Dept. RW5
Kansas City, Missouri 64108**

Name _____
Address _____
City _____
State _____ Zip _____

BUY DIRECT AND SAVE!

● BOSCH ● HITACHI ● MAKITA

BOSCH

Air and Electric Power Tools

YOUR CHOICE! Variable Speed JIG SAWS ONLY \$135⁰⁰

Models 1581VS
1582VS



NO.	TOOL	SALE
93940	Bosch Overarm Router	\$900.00
3270D	3x21 Dustless Belt Sander	122.50
1920RK	3/8" Cordless Reversing Drill	85.00
1920VSRK3/8"	Cordless Var. Spd. Rev. Drill	99.00
1921VSRK3/8"	Cordless Var. Spd. Screwdriver	\$129.00
90900	Heat Gun, 650-900	62.00
1158VSR	3/8" Var. Spd. Rev. Drill	55.00
1160VSR	3/8" Var. Spd. Rev. Drill	86.00
90085	3/4" HP Router	87.00
93910	Cabinet Door System	500.00
1272	3"x24" Belt Sander	181.30
1272D	3"x24" Belt Sander w/Dust Collector	191.80
1273	4"x24" Belt Sander	191.80
1273D	4"x24" Belt Sander w/Dust Collector	202.30

SPECIAL! SPECIAL! BOSCH 3/4 HP ROUTER \$119.00 Bosch 1604



HITACHI Power Tools

C12Y	10" Table Saw	1250.00
P100F	12" Planer	1094.00
TR12	Plunge Router, 3 hp	190.00
S875	Belt Sander, 3"x24"	133.00
C10FB	10" Miter Box	195.00
DTC-10	Cordless Drill	80.00
DRC-10	Cordless Drill/Screwdriver	90.00
CR-10V	Reciprocating Saw	120.00
D-10V	3/4" Variable Speed Reversing Drill	73.00
C7SA	7" Circular Saw	55.00
B-600A	Band Saw, 1" Blade, Rubber Tires	1554.00

PLANER JOINTER



Model F-1000A
Lightweight, Portable

ONLY \$1290.00

FREE

\$19.95 value

5 pc. Magnetic Super
Screwdriver Set
with \$145.00 purchase

CALL TOLL FREE 1-800-525-0750
In Colorado Call 1-355-2391

AVIATION INDUSTRIAL SUPPLY
P.O. Box 38159 ● Denver, CO 80238

Clearance on all MAKITA TOOLS

MOST TOOLS PREPAID

WOOD CARVING



Carved legs, appliques, brackets, turnings and posts plus lots of Victorian gingerbread; ideal for the home carpenter. All solid oak or poplar.

Send \$3.75 for full color, 36-page product and design idea catalog

**Camberland
& Woodcraft Co.
INC.**

P.O. DRAWER 609, CARLISLE, PA 17013
Tel: (717) 243-0063 DEPT. 137WC

The Techniques of Oriental Lacquer

by Professor J. Llorca-Pons



- The secrets and techniques of Oriental Raised Lacquer to be offered for the first time in U.S.
- Course in video tape, V.H.S. or Beta, in full color. Each tape is a complete project.
- Each lesson offers different techniques and is accompanied by full-size drawings.
- The unpainted furniture may be acquired through the school.

Send for free color brochure
ORIENTAL LACQUER
P.O. BOX 0159
Hialeah, Fla. 33011-0159

PRODUCTS THAT PERFORM

Continued from page 79



Jointer knife-setting jig

Magna-Set allows you to replace jointer knives with precision in 10 minutes. Using permanent Alnico magnets that suspend 30 ounces of dead weight each, the jig holds the knife in proper alignment for resetting. Made of rugged 1/2" steel and hardened 1/4" steel drill rod, it will work on jointers up to 10" wide (you can order extension rods for larger machines). Magna-Set. \$39.95 plus \$2.50 shipping, direct from Quest Industries, Dept. W, P.O. Box 7768, Murray, UT 84107.



Magnetic angle finder

Here's a fast, simple way to double-check angle settings on your stationary power tool tables. The Pro Level and Angle Finder magnetically grabs any flat metal surface and gives an accurate reading from 0° to 90°. A groove allows you to check round stock, too. The plastic housing can't be affected by temperature. It also works as a protractor and plumb indicator. Pro Level and Angle Finder. At retail stores and through mail order companies, \$8.95. The Pro Products Company, Inc., 7440 Forest Hills Rd., Rockford, IL 61111. ■

DO YOU USE OR COLLECT
FINE HAND TOOLS?

ANTIQUE — OBSOLETE — MODERN

IF SO,

YOU SHOULD BE READING



**THE FINE
TOOL JOURNAL**

PUBLISHED 10 TIMES ANNUALLY
1 Year Subscription — \$10.00. Sample, \$1.50

REMIT TO:
THE FINE TOOL JOURNAL
RD #2 — Dept. W85
Poultney, VT 05764

WOOD MEDIC™
America's Only Complete
Repair / Touch-Up Kit For:

- ✓ Scratches & Nicks
- ✓ Gouges & Scuffs
- ✓ Cigarette Burns

Repairs Finishes on:

- Furniture
- Woodwork
- Cabinets & Trim
- Counter Tops

\$ 14.95

FREE DELIVERY in
Continental U.S.A.

CRAFTMAN'S KIT contains
these wood tones: Pine,
Oak, Walnut, Mahogany & Teak.

- Easy to use. Immediate results.

All you need to make permanent, professional
repairs and touch-ups complete in one handy kit.

"Master Craftsman Kit" \$24.95

AVAILABLE AT:



**HM Hardwoods
of Memphis**

P.O. Box 12449 • Memphis, TN • 38182-0449
TN., call collect (901) 452-9663 others (800) 321-5239

OLSON

Saw Blades
Economy • Quality • Value

You could pay 50 to 100% more and not get
better blades. Made from the finest steels
with sharp, filed or precision ground teeth
for accurate sawing, smooth finishes, and
long life. For cutting
wood, plastic, or
metals in indus-
trial, school, and
home workshops.



Send for **FREE**
specification
and price sheets.

YES! I am interested in more
information on these Olson Saw
Blades: Band saw (wood and
metal cutting), Coping Jig
 Saber Fret Scroll.

Name _____
Company _____
Street _____
City _____
State _____ Zip _____

THE OLSON SAW COMPANY
A DIVISION OF BLACKSTONE INDUSTRIES, INC.
Bethel, CT 06801 • (203) 792-8622



MAKE TOYS
& WOOD PROJECTS

7 CAR TRAIN
\$6—Plan only
\$26.50—Plan &
turned parts
(92 parts
in all!)



62" long

100's of plans, kits, colored and unfinished hard-
wood parts for toys, crafts and furniture (Colonial,
Shaker, primitive & modern). Bulk Prices available.
Color catalog \$1. (614) 484-1746

Cherry Tree Toys, Box 369-9, Belmont, OH 43718

**THE MAGNIFICENT
MALLET**



- 14-oz... \$7.50
- 18-oz... \$7.50
- 24-oz... \$7.95
- 32-oz... \$7.95

+ \$2.25 Pstge.

Top Quality • Extra Durable • One-Piece
Lignum Vitae Carver's Mallet
Liberal discount to Schools and Dealers.
FREE 24-P. German steel tool catalog—write:
FRANK MITTERMEIER, INC.

IMPORTERS OF FINE TOOLS SINCE 1936
Dept. W03, 3577 E. Tremont Avenue
Bronx, New York 10465

BUILDERS' EYE PROTECTION

\$9.95
delivered
N.Y.S. residents
add sales tax



- Constructed to stay on
- Scratch-resistant lenses
- Chemical/solvent resistant
- Tinted lenses available
- Certain eye lenses possible
- Guaranteed satisfaction
- Made in U.S.A.
- Designed for craftspeople
- Goggle-like protection
- Comfortable & stylish
- Ratchet hinge ensures fit
- Meets Z87.1 safety standards
- Send check or money order. Mastercard or Visa accepted. We ship promptly and guarantee satisfaction.

KENCO SAFETY PRODUCTS
P.O. Box 385, 78 Glasco Tpke., Woodstock, NY 12498
In N.Y.S. (914) 679-5246 Out of State 1-(800) 341-4103
Write For Free Catalog

**Learn Decoy
Carving**

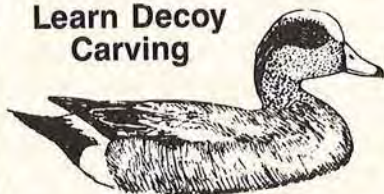

Send \$1.00 for tool and book
catalogues and sample of
THE CARVERS JOURNAL
625 West Main Street
Broussard, Louisiana 70518



**A TOOL FOR THE MAN
WHO HAS EVERY TOOL**

A wooden plane bottle opener
just for fun (\$8.88 ppd).

FOR A CATALOGUE OF OUR
EXTENSIVE LINE OF FLEXIBLE
VENEERS, TOOLS, LUMBER,
BOOKS, ETC. ENCLOSE \$2.50.

1705 W. University
Tempe, AZ 85281
(602) 966-2444

1719 Chestnut Avenue
Glenview, IL 60025
(312) 729-9663

WOOD WORLD



NOW! Get in on the PROFITS in

SMALL ENGINE REPAIR!



Start your own money making business!

Work part time, full time—right at home—we help you every step of the way.

No doubt about it... as a small engine pro, you can cash in on the huge demand for qualified men in one of America's fastest growing industries. You'll be able to command top hourly rates of from \$25.00 to \$30.00 per hour—and that's just for labor. A simple tune-up earns as much as \$49.95 for less than an hours work, and parts, engines and accessories will add even more to the profits.

Plenty of business waiting for qualified men.

65,000,000 Small Engines Are in Use Today!

That's the official count from the Engine Service Assn., and one-million new engines are being built each month. With fully accredited Foley-Belsaw training, you can soon have the skills and knowledge to make top money servicing these engines. People will seek you out and pay you well to service their lawnmowers, tillers, edgers, power rakes, garden tractors, chain saws, minibikes, snowmobiles, generators, go-carts, paint sprayers, snowblowers... the list is almost endless.



Professional Tools and Equipment, PLUS 4 H.P. Engine ALL YOURS TO KEEP... All at No Extra Cost. NO EXPERIENCE NECESSARY!

You don't need to be a 'born mechanic' or have any prior experience. You can master this profitable trade right at home in your sparetime. Lessons are fully illustrated...so clear you can't go wrong, and with our famous 'learn-by-doing' method you get practical 'hands-on' experience. We also show you how to get business, what to charge, where to get supplies wholesale...all the inside tricks of the trade you need to assure success right from the start.

Send for FREE Facts—Do It TODAY!

NO Obligation—NO Salesman Calls!

You risk nothing by accepting this offer to see how easily you can learn the skills you need to increase your income in a high-profit business of your own. Just fill in and mail coupon below (or send postcard with name and address) to receive full information by return mail.

RUSH COUPON TODAY

Foley-Belsaw Institute
50640 Field Building
Kansas City, Mo. 64111



FREE BOOKLET!

Send for your copy today!

FOLEY-BELSAW INSTITUTE
50640 FIELD BUILDING
KANSAS CITY, MO 64111



YES, please send me the FREE booklet that gives full details about starting my own business in Small Engine Repair. I understand there is No Obligation and that No Salesman will call on me.

NAME _____

ADDRESS _____

CITY _____

STATE _____

ZIP _____

Do-it-Yourself

WOODWORKERS

You can build it cheaper than buy it...

You can restore & refinish it cheaper than hire it!

Here's everything you need



Mail Coupon for—

116 Pages

CONSTANTINE'S Woodworker Catalog

IF YOU are at all handy with tools—or willing to learn in easy steps—here's the modern-day way to SAVE considerable sums of money. Build what you need. Restore and refinish what you own. Save on every project.

Everything you need—fine woods, veneers, specialty tools, wood finishes and how-to guidance—can be ordered by mail from Constantine. Read this partial list of CATALOG OFFERS: 14 kinds of cabinet & furniture woods. 90 veneers plus 19 flexible veneers to cover beatup or unpainted furniture. 76 inlays, 59 borders, 54 carving blocks, 118 carving tools & chisels, 32 upholstery tools & essentials, 39 clamps, 33 finished picture moldings, 72 lamp parts, 500 plans, 96 how-to books. Kitchen cabinet space-savers, carved molding, drill attachments, carbide saw blades.

ALSO: cane, fiber rush, reed. Period & modern hardware: latches, locks, hinges, pulls, escutcheons. Small-box hdwe. Framing clamps, wood-threading tools, angle-cutting jig, circle cutter, veneer saw, bow saw, mat cutter, miter trimmer, deep-throat fret saw. Turned, carved, square-taper furniture legs, wood bowl seal. Kits: gameboards, guitar, lazy Susan, furniture, clocks, coffee mill & pepper mill. Sliding & revolving hdwe. Plus page after page of useful products for shop, home and crafts.

Get \$2 BACK

Mail coupon now for dollar Catalog. We include \$2 refund Certificate good on 1st catalog order!

CONSTANTINE Est. 1812
2054 Eastchester Rd., Bronx, N.Y. 10461

Send new Woodworker Catalog. \$1 enclosed.

\$2 Refunded

Double Your Money Back!
\$2 Refunded on 1st Catalog order

Name _____

Address _____

CityStateZip _____

TOOL BUYMANSHIP

Continued from page 57

TABLE SAWS

Buymanship Note: If you're considering a stationary saw, we recommend at least a 1-hp motor, and preferably a 1½-hp motor, to power it.

When studying the horsepower ratings of the various models, don't pay too much attention to the developed horsepower figures touted by some manufacturers. This rating refers to the maximum amount of horsepower a motor can develop under a full load. If you were to run one of these motors at that horsepower for a prolonged period of time, you would quickly burn it out. The continuous horsepower rating tells you that the manufacturer has built the motor to run under load at that horsepower for prolonged periods.

Open Drip-Proof or Totally Enclosed. Of the two types of motors, the open drip-proof is much more common but not as good as the more-expensive totally enclosed type, which is sealed against workshop dust. Make sure either type has a reset button, which signifies that the motor has an overload-protected switch.

The Electronic Option



Sears has recently introduced an electronically controlled model that may set an industry trend. With this product, after educating yourself for a few minutes, you can raise and lower the blade and set it to the desired angle by pushing several buttons. Small motors inside the saw housing do the work the elevation and tilt wheels used to do. We've tried one of these saws, and it performed well for us. ■



A CONSISTENT WINNER!

We have established ourselves as a supplier of quality, industrial grade equipment for probably the lowest prices in the U.S.A.! YOU CHECK!

COMBINATION 1/8 SANDERS



- 1" x 42" Belt, 8" Disc.
- 1/2 H.P. 110v All Ball-bearing motor

MODEL G1013
Only \$110.00 Prepaid
to you via U.P.S.

HEAVY DUTY 10 INCH TABLE SAWS WITH CAST-IRON WINGS



FEATURES:

- 1 1/2 H.P. factory-fitted all ball-bearing, induction motor which is also totally enclosed.
- Precision ground cast-iron table top with matching ground cast-iron wings.
- Table size with wings 41 x 27".
- Cuts 25" to right of blade.
- Table has T-slots for miter gauge.
- Rip fence has fine adjustment and quick lock lever.
- 5/8" Arbor is 1 1/4" long and can easily handle dado sets.
- Machine comes standard with one dado insert and blade insert.
- Arbor is supported by sealed-for-life ball bearings.
- Machine weighs 220 lbs.

SUPER INTRODUCTORY PRICE
MODEL G1022 — ONLY \$325.00 (BELLINGHAM)
F.O.B.

CALL FOR LOW FREIGHT RATES TO YOU!

We also sell planers, shapers, dust collector systems, and much, much more
—all at super low prices. Send \$3.00 for our fully loaded 1985 catalog!

QUALITY, GUARANTEED MERCHANDISE WITH LOCAL PARTS & SERVICE BACK-UP RIGHT HERE IN OUR WAREHOUSE.

GRIZZLY IMPORTS INC.

P.O. BOX 2069, BELLINGHAM, WA 98227 • PHONE (206) 647-0801

WE SHIP REAL FAST IF YOU PAY BY VISA, MASTERCARD, MONEY ORDER, BANK DRAFT OR CERTIFIED CHECK. PAYMENT BY REGULAR CHECK WILL DELAY SHIPMENT 3 WEEKS.



WOOD ANECDOTE

Yes, the saguaro (pronounced sa-WAR-o) cactus, found in the southwest deserts of the United States, is a tree. In fact, the saguaro (*Cereus giganteus*) is a hardwood. But it grows so slowly and has such weird wood that the lumber industry didn't even bother to snub it officially.

How slow is slow? Saguaros, at 8 to 10 years of age, are barely 4" tall. By age 30 they reach about 3 1/4 feet! After that, growth accelerates, and a saguaro can add 4" per year. The largest of these cacti may be 50' tall and well over 200 years old.

The wood, once it's discovered under the soft, fleshy green skin-like bark, is a composite of vertical rods about 1" in diameter, much like bamboo poles. There aren't many of them—the saguaro is roughly 98 percent water by weight, although the content varies by season. Like a

SAGUARO the world's slowest- growing tree



Desert Indians make jelly from the saguaro's fruits, drink its juices, and build fences from its wood.

Print this article

sponge, the saguaro expands and contracts in proportion to the amount of water it is holding.

Gold seekers, on their way to California in the rush of 1849, appreciated the much-needed water they found inside the saguaro. To the Papago and Pima Indians, who gather its fruits for sweet jelly, its water for drink, its seeds for chicken feed, and its wood for fence poles, the saguaro has long been a staple. Arizona has adopted the saguaro blossom as its state flower.

One of nature's most unique plants, the towering saguaro is a desert landmark signaling sustenance to those who know its secrets. Offering food, water, and wood, it is famed in Southwestern folklore and noted in the annals of the Frontier. Rarely has one plant played such a dominant role in the cycle of life in such an easygoing style. ■

Information



Print this article

WORTH WRITING FOR

You can get useful ideas and product information by mail. Use the coupon in this section to order your choice of literature listed below.

SCROLL SAW AND LATHE INFORMATION — More than 20 pages of information, including full-color photos, on HEGNER precision scroll saws, HEGNER lathes, and HEGNER duplicators. Find out why these machines are considered state of the art, and what to look for when shopping for scroll saws or lathes. AMI, Ltd. \$1.00. *Circle No. 1.*

WOODWORKING PROFESSIONALS ONLY — Now save 50% on machinery, 70% on operating costs! How? By using the world's finest production quality universal machine. Commercial durability, utmost precision, set-up in seconds. No other tool combines usable capabilities like PELDER. Thousands sold all over the world. Now available in America through AMI. Send for brochure. AMI LTD. \$1.00. *Circle No. 2.*

FOR AMERICAN-MADE TOP QUALITY WOODWORKING EQUIPMENT — Send for our catalogs on all the top American-made machinery like Powermatic and Delta. We also carry hard to find decorative hardware like Baldwin and Slage. ADDIKISON HARDWARE. \$2.00. *Circle No. 15.*

HOW-TO-CLAMP-IT CATALOG — Illustrated catalog describes over 40 different styles of genuine "Jorgensen" and "Pony" hand clamps, including clamp selection guide, working advantages, and do-it-yourself, project applications. ADJUSTABLE CLAMP CO. Free. *Circle No. 20.*

POWER MITER SAW OWNERS — Send for the free information kit describing the Sawhelter™ Miter Fence System. Three styles of sawhelpers are available. Choose from stationary fences or portable fences in bench top or free-standing models. Portable units set up in 60 seconds, then fold for compact storage or transport. Many accessories available. AMERICAN DESIGN AND ENGINEERING INC. Free. *Circle No. 40.*

TOOL CATALOG — Available from Anglo American Enterprises, the world famous Record Marples Tool Catalog featuring the finest woodcrafting tools available. Send for catalog and price list. ANGLO AMERICAN ENTERPRISES CORP. \$2.00. *Circle No. 50.*

WOODWORKERS' PLANS AND SUPPLIES — Wood projects are simplified with the high quality plans, specialty hardware and other supplies offered by Armor Products. Over 100 plans are available for making toys, desks, clocks, pool tables, lamps, chests, and other furniture. Movements, dials, moldings, ornaments, and hardware also available. ARMOR PRODUCTS. \$1.00. *Circle No. 60.*

VENEER CRAFTS AND MORE — Artistry in Veneers presents its 1985 catalog of natural and dyed veneers, inlay borders, marquetry kits, carving sets, full-size furniture and toy plans, wood finishes, and tools. Our library of how-to books and professional services will broaden your knowledge of fascinating hobbies in wood. Send for our woodworker's catalog. Price of catalog is deducted from your first order. ARTISTRY IN VENEERS, INC. \$1.00. *Circle No. 65.*

DISCOVER VENEER — Artistry in Veneers' do-it-yourself guide to veneering shows you how simple this craft really is to master. Our color brochure identifies the most popular species of veneer and educates you on veneer matching, taping, and gluing. Send for your introductory brochure. ARTISTRY IN VENEERS, INC. 50¢. *Circle No. 66.*

77 SUPER BARN PLANS — large and small, many types and styles for all purposes. Workshops, homes, horses, storage, offices, etc. Designed with

great care for beauty, efficiency, economy, and easier construction. Comprehensive catalog. Catalog price refunded with plan order. Plans are very reasonably priced. ASHLANDBARN. \$4.00. *Circle No. 75.*

INDUSTRIAL DUTY & PORTABLE AIR COMPRESSORS — Complete listings for Ingersoll Rand air compressors. Industrial duty, 2 stage ASME approved Energair models for under \$900. Sizes from 60 to 120 gallons available with one year warranty. Also complete details on portables with 20 and 30 gallon capacities. ASME approved tanks. Priced under \$400. Send for literature. AVIATION/INDUSTRIAL SUPPLY COMPANY. Free. *Circle No. 78.*

CATALOG OF PLANS AND KITS — A selection of functional projects, unique gifts, and decorative pieces for home or office. Included are a sandpile scooper, super bunk beds, miniature two-story out-house, birthday calendar, and many more. See our ad elsewhere in this issue. BALLART DESIGN. \$1.00. (Refundable) *Circle No. 100.*

SHIP MODEL KITS — Fully illustrated 32-page catalog of scale ship model kits from America's oldest model ship company. Build a beautiful museum quality model ship with the simplest tools and average skills. BLUEJACKET SHIP CRAFTERS. \$2.00. *Circle No. 130.*

BOOS BUTCHER BLOCK FURNITURE — Full-color literature featuring Butcher Block tables and chairs and gourmet items including tea carts, microwave oven tables, hostess carts, Butcher Block and cutting boards. JOHN BOOS & CO. \$1.00. *Circle No. 140.*

BURNHAM'S NEW HUNTING CATALOG — Call game up close — varmints, crows, deer, and elk. Hand and electronic calls, tapes, records. Guaranteed to work or money back. 52 pages, hundreds of items. BURNHAM BROTHERS. Free. *Circle No. 175.*

CLOCK COMPONENTS AND SUPPLIES — Best prices on quartz battery clock movements, hands, numerals, solid wood clock faces and finishes. We have a large supply with same day shipping. Send for catalog with ordering information. CCW SUPPLY. Free. *Circle No. 200.*

CANE AND BASKET SUPPLIES — Every item used in caning and basketry is pictured in this new catalog for hobbyists and others interested in caning, rushing, etc., for either fun or profit. CANE & BASKET SUPPLY CO. \$1.00. *Circle No. 230.*

THE CARVERS JOURNAL — Provides you a list of the carving clubs in your area; reviews books on turning, sculpture, and carving; reports major decoy and carving shows with prizes up to \$10,000; interviews winning carvers; tests the new power woodcarving machines. Send for kit which includes catalogs on woodburners, Tupelo carving wood, power carving machines, and a sample copy of The Carvers Journal. Price of kit is refundable. THE CARVERS JOURNAL. \$1.00. *Circle No. 240.*

CLOCK MOVEMENTS CATALOG — The 55-page catalog contains over fifteen different quartz clock movements, including pendulum, strike, and chime movements. Also shown are dials, hands, numerals, and accessories. It features movements made in Japan by the world's largest producer of quartz timepieces. CAS-KER CO. \$1.00. *Circle No. 250.*

MAKE WOOD TOYS AND PROJECTS — Hundreds of plans, kits, colored and unfinished hardwood parts for all types of toy, craft, and furniture projects (Colonial, Shaker, Primitive, and Modern.) For novice to experienced woodworkers. Send for beautifully illustrated color catalog. CHERRY TREE TOYS INC. \$1.00. *Circle No. 260.*

UNIQUE, VERSATILE TOOL AND PARTS STORAGE SYSTEM — features tool panels, cabinets, and workbench attachments to safely store and

organize your valuable hand and power tools and small parts. This very functional system offers interchangeable tool hooks, bins, and shelves to let you custom-tailor your work area. Ideal for wood-working and hobby applications. CONCEPT 2001, INC. Free. *Circle No. 262.*

CONOVER'S UNIQUE HANDMADE TOOLS — 16-page catalog of unique reproduction and hard-to-find tools, such as miniature brass palm planes, wood threading tools, and spokeshaves. These high quality tools are made by the Conover family in Parkman, Ohio, and by dealing direct with the manufacturer you save. CONOVER WOODCRAFT SPECIALTIES, INC. \$1.00. *Circle No. 265.*

TURN BED/PORCH POSTS — Conover Woodcraft's unique, super high quality lathe has unlimited center length. It can turn porch posts or set up as a bowl lathe — your choice. Manufactured in Conover's Parkman, Ohio factory, this lathe has heavy cast-iron construction with Timken roller bearings and 16 in. swing. Suitable for heavy face-plate work, metal spinning, or spindle turning. 16-page catalog. CONOVER WOODCRAFT SPECIALTIES, INC. \$1.00. *Circle No. 266.*

TAKE A WOODWORKING VACATION — at the Conover Workshops summer program at Hiram College in Hiram, Ohio. Intensive one-week courses include room, board, tools, materials, and instructions in \$575. tuition. Conover worries about the details so you can worry about woodworking. 1985 session from June 16-28. Courses offered: Windsor Chairmaking, Handtool Techniques and Joinery, Woodturning. Send for brochure. THE CONOVER WORKSHOPS. Free. *Circle No. 267.*

WOODWORKERS TOOLS AND MATERIALS — 116-page catalog offers fine hardwoods, veneers, inlays, picture molding, wood finishes, carving blocks, cabinet hardware, and cane. Specialty woodworking tools, shop equipment, plans, instruction books. ALBERT CONSTANTINE AND SON INC. \$1.00. *Circle No. 270.*

BUILD HEIRLOOM CLOCKS — Now create beautiful heirloom quality clocks right in your own home. Choose from magnificent chiming grandfather clocks to charming wall clocks. 32-page catalog also offers a selection of music boxes, music movements, traditional barometers, and a huge variety of quartz movements and dials for custom clock building. Satisfaction guaranteed. CRAFT PRODUCTS CO. Free. *Circle No. 273.*

WOODTURNERS — Craft Supplies offers the finest selection of both English and American tools available. We feature Sarkey, Henry Taylor, and Precision Machine tools and accessories. Choose from a complete line of figured woods, chucks, Harrison lathes, kits, and one-of-a-kind items. Send for our 48-page catalog and Dale Nish workshop information. Price of catalog refunded with order. CRAFT SUPPLIES USA. \$2.00. *Circle No. 274.*

WOODWORKERS! HELP CELEBRATE OUR 55TH YEAR OF SERVICE — Send for our new 148-page Craftsman 1985 catalog. 42 varieties of choice hardwoods 1/64-in. to 4-in. thickness. Fine hardwood veneers, tools, moldings, trim, marquetry inlays, upholstery and lamp supplies, finishes, clock kits, and hard-to-find hardware. 4,000-plus items for your projects. CRAFTSMAN WOOD SERVICE CO. \$1.00. *Circle No. 275.*

WOOD CATALOGS — Full-color catalogs picture and describe a complete line of solid wood (oak or poplar) Victorian millwork, bars, and accessory carvings. Line includes fretwork, corbels, brackets, spandrel, medallions, Victorian ceilings, moldings, carvings, appliques, gazebos, bars, backbars, and bar treatments. 36 pages. Many typical installations illustrated. CUMBERLAND WOODCRAFT CO. \$3.75. *Circle No. 295.*

WOODEN TOYS FOR FUN AND PROFIT — Build quality toys from plans that reflect close attention



Mahogany Masterpieces
Masterpiece Tools

New Photo Catalogue Masterpiece Tools

The world's finest and most beautiful tools can be found clearly photographed in our spectacular new photo catalogue of MASTERPIECE TOOLS. Each tool has been photographed by a renowned New England silver and pewter photographer using large format 4" x 5" cameras for maximum detail. Striking colour and high-tech black and white photographs have been designed in an informative way that makes sense to woodworkers. All of our masterpiece chisels are photographed next to each other, in colour, for comparison. All of our masterpiece planes have their blades and subblades closely photographed for detail, separate from their wood bodies. Our select and aged tool woods are elegantly photographed in colour. We've included rare photographs of the master Japanese toolmakers we alone have personally met, interviewed, and photographed for history. Even the thick glossy paper is exceptional, and the pages are far wider than all other tool catalogues. Our catalogue had to be the best, we sell historic tools, we sell tools with souls.

Send \$5 today for our new MASTERPIECE TOOLS PHOTO CATALOGUE, and Volume 1, Editions 1 to 5 of our Masterpiece Tools Newsletter will be included at no extra charge.

3 Master Craftsmen have just visited from Japan and all agreed that our selection of MASTERPIECE TOOLS is the finest selection of tools in the world, including Japan. You're welcomed to visit us too!



SUNCOOK,
N.H. 03275 USA
(603) 736-8227

日本
工具
の
名
工
匠

"I was convinced that no other machine could match its quality or versatility."

The HEGNER Universal Precision Saw has, as the editor of WOODWORKER'S JOURNAL wrote, "propelled (its owners) into a new world of scroll sawing."

HEGNER Scroll Saws will let you saw the most intricate patterns accurately, quickly, without any relief cuts and without major sanding.

A customer wrote:
"After seeing you saw in action I was convinced

that no other machine could match its quality or versatility."

The Sport Auto shown at right was made from wood scraps and is just one example of how HEGNER saws can be put to use for pleasure or for profit, or for both. HEGNER offers no gimmicks. Just pure and simple quality, unsurpassed performance, ease of use, reliability and the best warranty. HEGNER - there's only one!



And now, the excellence of HEGNER design and manufacture surfaces again. We are proud to introduce the new

49" HEGNER Woodturning Lathe.

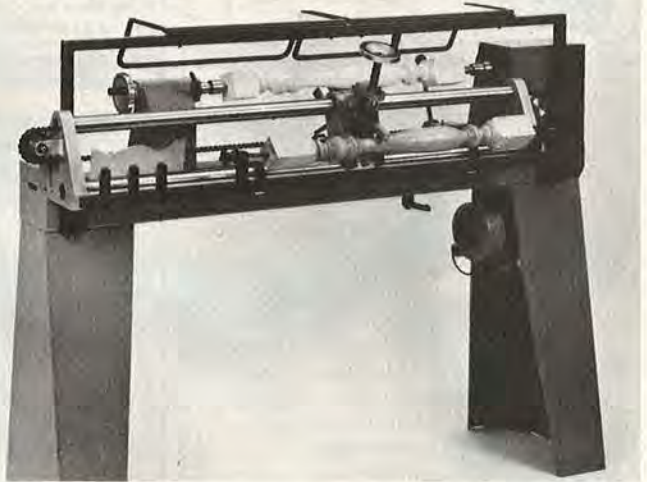

Simplicity, quality and precision are combined in this woodturning lathe to give you the results you expect from HEGNER tools.

The 47" Duplicating Attachment shown with the HEGNER Lathe is without match in terms of precision, quality, and ease of operation. It is mounted on the back of the lathe and allows you to duplicate from an original turning or from a template.

Send for complete information today.

AMI, Ltd.

P.O. Box 312, Dept. 25
New Castle, Delaware 19720
Phone: 302-322-2226



Advanced Machinery Imports

- Please send me your free brochure on HEGNER saws.
- Please send me your free brochure on HEGNER lathes.
- I enclose \$5.00. Send me the 10" Sport Auto pattern.

Name: _____

Address: _____

City: _____ State _____ Zip _____

Phone No.: _____

MARPLES • RECORD • WATCO • NU-LIFE • DOWEL-IT-CLESCO • GILLESPIE • FREUD
 BLACK & DECKER • MILWAULKEE • FORSTNER • JORGENSEN • 3M • W.L. FULLER

MAKITA • PORTER CABLE • ROCKWELL • BOSCH • LION
HILLER HARDWARE CO.
 ASSURES YOUR SATISFACTION ON ANY ITEM PURCHASED FROM US! WE CAN SHIP YOUR BANK CARD ORDER TODAY

DELTA SPECIALS

	Model	Price
10 in Tilting Arbor Saw	34-429	899.00
10 in Unisaw 3 H.P.	34-763	1599.00
H.D. Wood Shaper	43-371	1879.00
8 in Joiner Long Bed	37-315	1399.00
New 18 in Scroll Saw	40-601	949.00
Sawbuck	33-150	525.00
Unifeeder	34-150	449.00
13 in Planer RC-33	22-651	1299.00
14 in Band Saw Complete	28-283	699.00
6 in x 48 in Sander Complete	31-730	1239.00
1 H.P. Dust Collector	50-180	365.00
15 in Drill Press	15-091	369.00

25% OFF DELTA CARBIDE SHAPER CUTTERS

- WE HONOR ALL FREUD NATIONALLY ADVERTISED SPECIALS
- CALL OR WRITE TODAY FOR CURRENT PRICES ON OTHER TOOLS/ACCESSORIES
- VISA, MASTERCARD ACCEPTED

HILLER HARDWARE CO.
 1411 ASSEMBLY STREET, P.O. BOX 1762
 COLUMBIA, S.C 29202-1762
 803-779-3131 EXT. 12

YOUR WOODWORKING SPECIALIST IN THE SOUTHEAST

HEGNER • STANLEY • GREENLEE • HENCKELS • MERIT

HUMFREY'S FOR GENERAL

15" WOOD CUTTING BANDSAW #490-1



- One-piece cast iron construction
- c/w Arbor Pulley
- 1/4" Blade
- enclosed Steel Stand
- Belt Guard
- Motor Pulley & V-belt

SHIPPED FREIGHT COLLECT

\$750. U.S.*

NO OTHER CHARGES
*Electrics extra.

HUMFREY'S ORDER PHONE
IN THE U.S. CALL TOLL FREE

1-800-387-9789

VISA MasterCard

J. Philip Humfrey Ltd.

3241 Kennedy Road, Unit 7 Department WM 3/4c
Scarborough, Ontario M1V 2J9 (416) 293-8624

Please rush me a copy of your latest catalog. I enclose \$1.00 for postage and handling.

Name _____

Address _____

City _____ State _____ Zip _____

A Family Tradition Since 1916

Kuempel Chime

BUILD THE FINEST
We Know You Can Do It!

Easy to assemble quality Red-i-Kut Clock kits. A variety of designs hand made by our Grandfathers in solid 3/4" cherry, oak or walnut with beveled glass.

Tubular Bell or Rod movements. Handcrafted pendulums. Original bronze etched dials and hand painted moonwheels.

Or start from scratch. American Classic Plan - \$3.00

Write for Free Literature or Call

1-800-328-6445
Between 8 a.m. & 4 p.m.

Kuempel Chime
Dept. 004, 21195 Minnetonka Blvd.
Excelsior, MN 55331

Full Size Plans

This Roll Top Desk is one of our finest furniture plans. It is similar to those of the 1800's and is made of oak lumber. Size: 55" x 21" x 49"H. Plans include base and roll-top unit. You do not have to purchase two separate plans.
Desk - 311 \$14.50







Mr. Goodbank is a thrifty fellow who just loves to save coins. This cute guy is actually a bank and is 10 1/2" tall.
Bank Plan - 329 \$3.00. Plan with eyes and nose \$4.50

Our Rocking Horse features a soft saddle and flowing mane. Easily made of pine with basic tools. 36" x 25".
Kit available containing foam, mane, eyes, rings, etc.
Horse Plan - 245 \$7.00 Accessory Kit - HAK \$9.00

This collection of five toy vehicles will make any child happy. Made of pine they are easily built with hand or power tools. The trailer truck is 18" long and 7" tall.
5 Toy Vehicles - PLD \$8.50

This great Name Train spells out your child's name in 3" tall letters. Complete full-size alphabet included.
Name Train Plan - 323 \$3.50

Catalog \$1.00—Free with plans. Phone (516) 462-6228
We accept Visa & MasterCard orders if over \$15.00

ARMOR, Dept. L, Box 445, E. Northport, NY 11731

CALL US FOR QUOTATIONS ON MACHINES & ACCESSORIES BEFORE YOU BUY!



POWERMATIC Model No. 26 Shaper—
\$1,690.00 FOB McMinnville, TN
with either #1260050 solid spindle or #1260010 interchangeable 1/2" or 3/4" spindles, complete with motor and control.
Miss. residents add 6% tax.

Special net prices Thru April 30, 1985
FREUD carbide raised panel cutters.

#EC-202	#EC-209
#EC-210	#EC-211
#EC-212	#EC-213

Prepaid in U.S.A.
\$79.00 each

Call toll free 800-821-2750.
In Miss. call 800-321-8107.
Ask for Max, Bobby or Van.

Addkison
HARDWARE CO. INC.
126 E. Amite St., P.O. Box 102
Jackson, MS 39205

to all dimensions and instructions needed for you to make the complete toy. A 12-page illustrated catalog shows plans for modern-style trucks, pull toys, trains, rocking horse, and more. D & E CRAFTS. \$1.00. Circle No. 300.

DECRISTOFORO DESIGNS SELLS HIGH-QUALITY PLAN SHEETS — for wooden toys and power tool jigs. We also carry woodworking books by R.J. DeCristoforo, the snap stop reference clamp, and video tapes. Send for catalog and information package. DECRISTOFORO DESIGNS. \$1.00. Circle No. 310.

BUILD IT YOURSELF BETTER AND CHEAPER — Why buy it when you can build it? Illustrated catalog of hundreds of interesting and fun items you can create yourself for personal use or profitable sale. Our 1985, 40-page catalog contains toys, games, plaques, puzzles, birdhouses, planters, accent furniture, and much more. All patterns are full-size blueprints — no enlarging is necessary. Simply trace and create. DESIGN GROUP. \$1.00. Circle No. 320.

TREMENDOUS SAVINGS — on finest quality tools, supplies, and accessories. Ryobi power tools, Everlast saw blades, Velepec router bits, Stanley hand tools, and more. Every item we sell is unconditionally guaranteed. DUSTY SPLINTERS ENT. Free. Circle No. 350.

DO-IT-YOURSELF LUMBER DRYING — This 22-page booklet *Kiln Chamber Construction Guide and Operation Manual* is designed for the individual wishing to dry his own lumber with a minimum investment of money, time, and space. Included are principles of dehumidification lumber drying, selection of which dryer is best for you, and kiln chamber plans and construction information. Also you will receive a questionnaire you can fill out and return. Once completed and returned you will receive free a computerized evaluation of your drying needs including investment considerations, operating costs, and payback. EBAC OF AMERICA, INC. \$5.00. Circle No. 400.

MULTI-PURPOSE HOME WOODWORKING SYSTEM - The Emco Start-2000 is a table saw, band saw, moulding machine and disc sander and you can change operations in less than 30 seconds. One big 2 hp. motor does it all. With optional accessories you can do wood turning, mortising, horizontal drilling, and more. Send for four-color information. EMCO* USA. Free. Circle No. 402.

DO-IT-YOURSELF GRANDFATHER CLOCK KITS — Direct from world's largest manufacturer of grandfather clock kits. Prices starting at under \$280 including West German Westminster chiming movement. Choose from black walnut, cherry, and oak. Other quality heirloom kits also available. Send for brochure. EMPORER CLOCK CO. 50c. Circle No. 450.

FINE TOOL SHOPS' CATALOGS — Presently, the Fine Tool Shops publishes a new full-color catalog every three months. It illustrates the world's finest woodworking tools at prices guaranteed to be the lowest in the mail order industry. In addition, there are special discounts for continuing customers, incentive bonuses, and name brand U.S. made tools at spectacular savings. THE FINE TOOL SHOPS. \$1.00. Circle No. 495.

RIPSTRATE SAVES FINGERS — for table saw and radial arm saw users. Brochure describes the RIPSTRATE and shows how it gives straighter cuts, speeds, the work, prevents kickbacks, and keeps hands away from the blade. FISHER HILL PRODUCTS. Free. Circle No. 530.

FURNITURE PLANS, FULL-SIZE — For the do-it-yourselfer with easy step-by-step directions. Illustrated list and description of 12 furniture designs, mostly Early American: desks, cabinets, tables, storage bed, etc. NEW! You can make each piece in 2 or 3 sizes. All dimensions shown in catalog. FLEXIPLANS. Free. Circle No. 540.

EXCELLENCE IN SHARPENING EQUIPMENT — This two-color, 56-page catalog from Foley-Belsaw Co. provides information on its complete line of equipment used for sharpening home, garden, and industrial shop saws and tools. Each machine is fully illustrated, complete specs and pricing information are provided. FOLEY-BELSAW CO. Free. Circle No. 550.

BEAT INFLATION AND HIGH LUMBERYARD PRICES — Turn trees into valuable lumber with the world-famous ONE-MAN PORTABLE SAWMILL. Goes right to the trees — turns out smooth, truecut

TO ORDER THESE BOOKLETS, USE COUPON ON PAGE 98

lumber every time. No crew needed . . . no experience necessary. Send for booklet. FOLEY-BELSAW CO. Free. Circle No. 551.

FREE SUBSCRIPTION TO FOLEY-BELSAW NEWS BULLETION — For a limited time Foley-Belsaw will be giving away a 1-year subscription to their 64-page color publication. This publication includes stories and shop tips on all types of wood-working, tool sharpening, upholstery, engine repair, and locksmithing. The magazine, which is published six times a year, includes many special offers on Foley-Belsaw equipment. FOLEY-BELSAW CO. Free. Circle No. 552.

MR SAWDUST SAW BLADES — Get your 16-page illustrated booklet on Mr. Sawdust I blades for radial arm saws. This also includes information on our special non-splintering dado sets. In addition we will send a folder on Mr. Sawdust II ultra-smooth planer blades for table saws. You deserve the finest cuts possible. FORREST MFG. CO., INC. \$1.00. Circle No. 555.

CUTTING TOOLS — Freud, USA provides the finest value in carbide cutting tools. From saw blades and boring bits to shaper heads and router bits. Our newest product — shaper heads for the half inch shaper spindle. Send for complete catalog. FREUD, USA. \$5.00. Circle No. 560.

FULL-SIZE FURNITURE PLANS CATALOG — Illustrates and describes over 180 plans for making furniture of quality found in museums and fine furniture stores. Plans include rollout desk, cradles, dining tables, chairs, buffets, chests, gun cabinets, poker table, children's furniture, rocking horse, spinning wheels, and more. Bill of materials exploded drawings assist the woodworker. FURNITURE DESIGN, INC. \$2.00. Circle No. 585.

1984-85 MASTER CATALOG — contains 212 pages of the finest in woodworking hand tools, machinery, and finishing supplies plus over 125 books. Of particular note is the selection of Japanese tools. The format is all four-color. GARRETT WADE CO. \$3.00. Circle No. 600.

BEAUTIFUL WIPE-ON WOOD FINISHING — is explained in a booklet from a pioneer in wipe-on finishes since 1928. Wood finishes that produce a beautiful hand-rubbed finish without messy brushes or spraying. Specially formulated finishes that simply wipe-on with professional results every time — guaranteed! Unlike conventional finishes these will never yellow, crack, or craze and they dry dustfree without runs. These finishes will bring out the natural beauty of the wood and never needs waxing. Send today for your wood finishing guide and products catalog. GENERAL FINISHES. 25¢. Circle No. 630.

WOODWORKING MACHINERY CATALOG — Just arrived — 1985 full-color catalog of quality imported machinery and tools at low prices. GRIZZLY IMPORTS, INC. \$3.00. Circle No. 670.

PLANERS — Heavy duty 15x6 in. planers with 2 hp. single-phase motors. Other woodworking equipment at low, low prices. Send for 1985 color catalog. GRIZZLY IMPORTS, INC. \$3.00. Circle No. 671.

DUST COLLECTORS — for the small/medium size shop. Capable of handling from 1 to 3 machines at the same time. Priced within the home shop budget, yet capable of handling cabinet shopwork. Other woodworking machinery and tools — low prices. Send for catalog. GRIZZLY IMPORTS, INC. \$3.00. Circle No. 672.

BRASS FURNITURE HARDWARE — This 36-page catalog shows over 500 items of authentic reproduction hardware from the 1700's and on into this century. These superior drawer pulls, knobs, hinges, finials, and other hardware items will greatly improve the appearance of your furnishings. HORTON BRASSES. \$2.00. Circle No. 750.

BOLTS, NUTS, AND SCREWS — Catalog shows many types of zinc plated steel, stainless steel, and brass fasteners available from stock. Non-standards also can be special ordered. D.S. HOUSTON CO. \$1.00. Circle No. 760.

IF YOU ARE INTERESTED IN FINE WOODWORKING — you will not find better machinery than that sold by J.P. Humfrey Ltd. For example, we have 100, 10-in. general tablesaws (2 HP, magnetic switch, lever-lock fence) available at \$1,295 FOB New York. Send for brochure. J. PHILIP HUMFREY LTD. \$1.00. Circle No. 770.

TO ORDER THESE BOOKLETS, USE COUPON ON PAGE 98

\$12 AN HOUR
YOU CAN EARN UP TO THAT AMOUNT

Start Your Own Business!
Earn Extra Income Right At Home.



Sharpen Saws...
... ALL Garden and shop tools for home and industry

Get In On The Profits!

Yes there's plenty of business waiting for the man who can professionally sharpen saws and all types of edge-cutting tools. SHARP-All does them all, and at big profit for you. No inventory is involved . . . no selling. You earn a year-round Cash income and make 90¢ profit out of every dollar you take in. Work sparetime hours or fulltime right at home, and no experience is needed.

Send TODAY for details of our 30-Day FREE Trial Offer!

With SHARP-ALL It's Easy To Get Started!
You don't need to invest thousands of dollars to get started in business for yourself. Low cost Sharp-All and our 50 years of experience in helping sincere men to earn extra income, plus the desire to get ahead is all you need. Complete Operators Manual gives clear, step-by-step instructions, shows exactly how to sharpen each tool, where to get the "tricks of the trade". And Sharp-All does the kind of precision job that brings customers back time after time.
There are NO franchise fees of any kind. With Sharp-All YOU are the boss . . . YOU set the hours you want to work . . . you put the profits in YOUR pocket.

FREE BOOKLET! Send for your copy today. No obligation.

LIFETIME SECURITY with YOUR OWN BUSINESS

If coupon has been removed, just send us a postcard with your name and address to—

FOLEY-BELSAW CO.
60431 FIELD BLDG.
KANSAS CITY, MO. 64111

There is NO OBLIGATION and NO SALESMAN Will Call!

FOLEY-BELSAW CO.
60431 FIELD BLDG.
KANSAS CITY, MO. 64111

RUSH COUPON TODAY!

YES, please send me the FREE booklet "Lifetime Security" and full details on your 30-Day Free Trial Offer. I understand there is No Obligation and that No Salesman will call on me.

NAME _____
ADDRESS _____
CITY/STATE _____ ZIP _____

FREE BOOK

STATE-OF-THE-ART
Resin Over Resin Bonded
SANDING BELTS
FREE BONUS



These belts were manufactured for durability and performance. Their economy shows up in their productivity. There are no better belts made!
We guarantee your complete satisfaction. If these belts are not the best, by far, of any you have ever had, return them within 90 days — used and unused — for a full and complete refund, including return postage.
As a free bonus, just for giving us a chance at your business, you will receive, with your order, a belt and disc restorer. It unclogs your abrasives like magic just by holding it against the moving belt or disc, and, whether you keep the belts or return them, you get to keep the free bonus.

CALL TOLL FREE 1-800-243-1037 (In Connecticut, 797-0772)
Or write: **The Fine Tool Shops, Inc.** Dept. WMA5
20 Backus Avenue, Box 1262, Danbury, CT 06810

No. of Packs	Belt Size	Grit	Price Per Pack	Total
1	Belt Restorer			FREE
1	Full Color Tool-Abrasive Catalog			FREE
			Subtotal	
			Shpg. & Hndlg.	\$1.50
			CT Sales Tax	
			TOTAL	

GRIT SIZES AVAILABLE FOR EVERY BELT: 50; 60; 80; 100; 120; 150; 180; 240.

Prices are for 1 pack of 10 belts in 1 grit. Sizes 4x36 and 6x48 are packed 5.

3x18 ... 10 for..... \$ 9.95
3x21 ... 10 for..... \$10.95
3x24 ... 10 for..... \$11.95
4x21 1/4 ... 10 for..... \$13.95
4x24 ... 10 for..... \$14.95
4x36 5 for..... \$ 9.95
6x48 5 for..... \$21.95

\$ _____ enclosed Charge my: _____
 VISA AmEx MasterCard

Account # _____
Exp. Date _____
Name _____
Address _____
City/State/Zip _____
Telephone (_____) _____

The only thing small about this bandsaw is the price!



The New BS-3 Benchtop Bandsaw is BIG... BIG in capacity, performance, convenience and quality...yet it takes up just 1½' x 3' of bench space. Its built-in disc sander adds the BIG advantage of sanding right on the saw. BIG 15" throat. BIG 6¼" cutting depth. BIG quiet-running 3-speed motor has plenty of power for Wood, Metal or Plastic. BIG 16" x 18" worktable tilts up to 45°. This BIG 86 lb. Benchtop Bandsaw comes with a built-in vacuum hook-up, a BIG list of accessories (drum and belt sanding, and more)...and BIG Buyer Protection. Call or write today. If you think that high quality has to mean high price...you're in for a BIG surprise.



(In Ohio: 614/445-8382)

Call **1-800-521-8289**

emco★USA™

Dept. HM35B • 2080 Fairwood Avenue
P.O. Box 07795 • Columbus, Ohio 43207

ROUTER BITS

CASCADE PRECISION TOOL CO., INC. HAS HIGH QUALITY, LONG LASTING, SHARP CUTTING, TUNGSTEN CARBIDE TIPPED ROUTER BITS AND SHAPER CUTTERS FOR YOU AT REASONABLE PRICES. TO PROVE IT, WE ARE OFFERING A SET OF SIX STURDY, ONE-PIECE, ¼" SHANK ROUTER BITS FOR \$59.95—THE LOWEST PRICE OFFERED ANYWHERE FOR A SET OF ROMAN OGEE, CORNER ROUND, COVE, RABBET, DOVETAIL AND STRAIGHT BIT—ALL SHAPES NEEDED BY THE SERIOUS WOODWORKER. CHECK OUR NEW CATALOG FOR SIMILAR SAVINGS ON OTHER ROUTER BITS AND SHAPER CUTTERS IN 100'S OF SIZES AND PROFILES. DON'T DELAY. SEND \$64.95 PPD. (MO, CHECK, OR MC/VISA # EXP. DATE, TELE #) or \$1 FOR CATALOG (REFUNDABLE WITH 1st ORDER).



CASCADE PRECISION TOOL CO., INC.
P.O. BOX 848, MERCER ISLAND, WA 98040.

WOOD TOY

- ★ Patterns
- ★ Parts
- ★ Wheels
- ★ Many New Patterns to Choose from.
- ★ Free Shipping in U.S.A.

SEND \$1.00 FOR NEW CATALOG AND RECEIVE COUPON FOR FREE WHEELS & AXLE PEGS.



toys and joys

Box 628W Lynden, Wash. 98264

Send For New 36 Page Woodworker's Catalog

100's patterns, veneers, toy supplies, hardwoods, shaker pegs, candle cups, dowels, spindles, cane, rush, splint, books, inlays, reproduction hardware, abrasives. Save to 25% on bonus starter offers! **Hurry!**

Morgan Woodworking Supplies, Dept. W06M04
1123 Bardstown Rd., Louisville, KY 40204

Please rush my new 36 page woodcrafter's catalog.

Name _____
Address _____
City _____
State _____ Zip _____

If you would like more information about advertising in *Wood*, contact:

Jerry Kaplan
750 Third Avenue
New York, NY 10017
(212-551-7099)

Wood Moisture Meter

- Avoid Moisture Problems
- Protect your Masterpiece

Pocket-Size **MINI LIGNO**

only \$110

Incl. Case, Batteries, and Pins for 7/16" and 7/8" Measuring Depth. Size: 1" x 2¼" x 5½"
Range: 6%, 7%,20%

also from Lignomat: **MINI-LIGNO E**
Range: 6%, 7%,36%

Easy-to-use, sturdy instruments for the professional woodworker or serious hobbyist. Measures moisture in lumber, veneer, fiberboards. Ask for free catalog on the complete line of moisture meters and accessories. we can show you how to use a moisture meter efficiently.



Lignomat USA Ltd. Tel: 800-227-2105
503-257-8957
P.O. Box 30145 Dept. BH Portland, OR 97230

For families who enjoy and take pride in their homes, there is no more appropriate gift than a subscription to **WOOD**.

SIGNCARVING IS PROFITABLE!



And it's easy, if you use the Marlin Woodcarvers and accessories. You can carve signs quickly at home or at swap meets. The machines do the work, the operator has the fun and profits.

No Special Training Is Required!

SEND \$1.00 FOR OUR BROCHURE AND PRICE LIST, AND BEGIN TO PLAN YOUR FULL OR PART-TIME BUSINESS.

Fine Carving Machines Since 1971

MARLIN INDUSTRIES

1911 OBISPO AVE., DEPT. D504
LONG BEACH, CA 90804

(213) 498-0767



PLANS:



All plans ©1984 by Demurge

WOODEN POWER TOOLS®

A child's work is his play. Equip him with his own play tools. Most tools can be made in an evening using only a drill, sabre saw, wood rasp and sandpaper. Create a toy of today for a keepsake tomorrow.
CHAIN SAW \$6.95/ROUTER \$4.95/DRILL \$4.95/
SABRE SAW \$4.95/CIRCULAR SAW \$4.95/
BELT SANDER \$4.95/
PAD SANDER \$4.95. Send check or money order to: **STEP-UP/P.O. Box 3401 Kansas City, KS 66103**

START SMALL BUSINESS WITH NEW SCROLL SAW — The Excalibur precision scroll saw from Canada can turn your workshop into a profit center. Make toys and puzzles, do intricate marquetry work or detailed cabinet work with these "operator friendly" machines. Hundreds sold in the U.S. already. Save, buy direct, from \$495. up. Complete project patterns and plans available. Send for brochure. J. PHILIP HUMFREY LTD. \$1.00. *Circle No. 771.*

BUY YOUR SANDING BELTS DIRECT FROM THE MANUFACTURER — Industrial Abrasives is the company that gives you six free belts with every dozen ordered. But, sanding belts are not the only product we have to offer. In our catalog you will find many specialty items not readily available in your hardware store. Price of catalog refunded with first order. INDUSTRIAL ABRASIVES CO. \$1.00. *Circle No. 780.*

THE CUSHION CONTOUR SANDER — is a new concept in pneumatic drum sanding. Sanding sleeves are slid over an air bag (inflated with a hand tire pump) on an arbor to mount it between centers on a wood lathe. Drum effectively takes on profiles, curves, and bevels practically eliminating flat spots and chatter marks. INDUSTRIAL ABRASIVES CO. Free. *Circle No. 781.*

THE FINE TOOL JOURNAL — Published 10 times per year, this publication will keep you up to date with the many aspects of the world of antique and obsolete hand tools. Tools are offered for sale, books on tools are reviewed and sold, auctions are reviewed, articles on identification, values, and history. Send for sample copy. IRON HORSE ANTIQUES, INC. \$1.50. *Circle No. 800.*

FREE WOODWORKING TOOL CATALOG — This 1984 catalog features hand tools, power tools, and shop machinery: professional quality tools — great selection and value priced. Great names, too: Marples, Sorby, Makita, Rockwell, Hegner, Freud, Primus, Porter-Cable, Milwaukee, Watco, and more. W.S. JENKS & SON. Free. *Circle No. 930.*

TOOLS—ANTIQUE AND USED — Quality, older hand tools for collectors and woodworkers. Many pre-1960 Stanley Tools. Hundreds of scarce planes, spoke-shaves, scrapers, drawknives, and

other useable tools available. Illustrated photo lists published 5 times a year. Send for current list. BOB KAUNE. \$1.00 *Circle No. 1020.*

KLOCKIT — 68-page color catalog full of precision American-made quartz clock movements, dials, hands, and accessories. Also, top quality clock and furniture kits. Toy and lamp parts. Electronic and mechanical music box movements. Unique and hard-to-find tools. There's something for every woodworker, hobbyist, and home handyman. KLOCKIT. Free. *Circle No. 1050.*

QUALITY CLOCK KITS AND PLANS — Handmade and semi-assembled of carefully selected ¾ in. cherry, oak, or walnut with beveled glass. Or build from "scratch" using our detailed plans and trim pieces. Choice of quality movements. Established in 1916. KUEMPEL CHIME CLOCK WORKS. \$1.50. *Circle No. 1070.*

FREE LITERATURE — New brochure showing all moisture meters and accessories for moisture meters such as interchangeable electrodes and probes and cables for in-kiln moisture monitoring. Complete line of moisture meters include: Pocket-size Mini-Ligno with LED readout 6%-20%, Mini Ligno E 6%-36%, analog display meters 4%-30%, 60% and a digital moisture meter with built-in compensation for different wood temperatures. LIGNOMAT USA, LTD. Free. *Circle No. 1130.*

PRODUCTION QUALITY CARBIDE TIPPED ROUTER BITS — MLCS Ltd. offers a full line of professional production quality carbide tipped router bits at 50-70% lower than retail prices. We sell through the mail and only direct to craftsmen. Send today for information. MLCS LTD. Free. *Circle No. 1210.*

MAGNETIC JOINTER KNIFE SETTING JIG — Change jointer knives accurately and economically in less than 10 minutes in any size jointer. MAGNA SET firmly holds jointer knives in precise alignment for resetting. Perfect cutting results guaranteed or your money back. Send for brochure. MAGNA-SET/QUEST IND. Free. *Circle No. 1213.*

MASTERPIECE TOOLS — World's finest wood-working tools are available from Mahogany Masterpieces. The world's finest selection of Japanese TO ORDER THESE BOOKLETS, USE COUPON ON PAGE 98

hand tools can be seen in a beautiful photo catalog. We are the No. 1 Inca dealer in the United States. Exclusive importers east of the Rocky Mountains for Ulmia woodworking machines, the "Mercedes" of table saws. MAHOGANY MASTERPIECES. \$5.00. *Circle No. 1214.*

FURNITURE AND TOY PLANS — Hundreds of plans for everyone from the novice to the master craftsman along with the hardware, parts, and hard-to-find accessories and supplies to complete the project. MASTER PLANS & SUPPLY CO. \$2.00. *Circle No. 1215.*

WOODWORKING PLANS — Catalog of full-size plans printed on heavy paper for toys, gifts, novelties, action windmills, shelves, birdhouses, garden furniture, Dutch windmill, lawn ornaments, old-fashioned lawn swing, jigsaw projects for children, and more. MASTERCRAFT PLANS WEST. \$1.00. *Circle No. 1216.*

WHOLESALE WOODWORKERS HARDWARE — Save 40% on shaker pegs, sawtooth hangers, wood wheels, dowel pins, candlecups, spice bottles, lazy susan bearings, coat hooks, and many more hard to find items. Send for 32-page catalog. MEISEL HARDWARE SPECIALTIES. \$1.00. *Circle No. 1220.*

THE SMALL TOOL SPECIALISTS — This new 48-page catalog features over 1,000 hard-to-find and unusual tools you probably won't find in your local hardware store or any other mail order catalog. Tools for woodworking, model building, bird carving, clock making, gunsmithing, marquetry, jewelry making, metal casting, and industrial prototype work. MICRO-MARK. \$1.00. *Circle No. 1230.*

TIPS ON WOOD FINISHING — A comprehensive, 22-page booklet includes numerous tips that save time and trouble for do-it-yourselfers. Information ranges from how to apply a preservative stain to a house exterior to restoring the finish of a priceless antique. Also included is a chart showing full range of both interior and exterior colors available. The name of your nearest dealer is provided. MINWAX CO., INC. Free. *Circle No. 1240.*

GERMAN STEEL TOOL CATALOG — 24 pages packed with finest quality tools manufactured in



ELEKTRA BECKUM

LOOKING FOR THE MOST MACHINE
FOR YOUR MONEY ??

Who has an exceptional Dust Extractor?



SPA1000

Your partner in woodworking,
ELEKTRA BECKUM, has it:
The SPA1000 Dust Extractor.

- ¾ HP motor
- Suction capacity 765 cfm
- Suction hose 4" x 98"
- Cleaner working conditions
- Suitable for all ELEKTRA machines or any machines with 4" hose connection.
- Accepts any standard trash bag

All these features for only \$450
FOB Somerdale, NJ

ELEKTRA BECKUM AT THE HEART OF A GOOD JOB

See the ELEKTRA BECKUM machines demonstrated at these shows:

Washington, DC Mar. 1-3
Pasadena, CA Mar. 1-3
Seattle, WA Mar. 22-24
Dallas, TX Mar. 29-31
Springfield, MA Apr. 12-14

Call today for your closest dealer
1-800-223-8600

Send \$1.00 for full color catalog to:

ELEKTRA BECKUM USA CORP.

P.O. Box 24, Dept. WMA

Somerdale, NJ 08083

My hands-free bookstand keeps your plans
in plain sight while you work. And it never
loses your place.

Mortimer V. Schwartz, President
The Fine Tool Shops, Inc.

HOLD IT!

For
WOODWORKERS
MODELMAKERS
HOBBYISTS
STUDENTS
COMPUTER USERS
COOKS



... those who need two hands free while they
follow directions, copy, take notes or just plain read.

- Holds any size book — even 1000 page paperbacks
- Holds plans, workbooks, magazines, newspapers
- 45° angle for strain-free reading
- Spring arm holds page flat, flicks open for turning

ONLY
\$14.95!

ORDER TOLL FREE 1-800-243-1037

In Connecticut, 1-797-0772

The Fine Tool Shops, Inc. Dept. WMB5
20 Backus Ave, PO Box 1262, Danbury CT 06810

Send me _____ (qty.) HOLD-IT bookstand(s) for just \$14.95 plus
\$2.00 shipping and handling (total \$16.95).

I enclose \$_____.

Charge my: VISA MasterCard AmEx

Account # _____ Exp. Date _____

Name _____

Address _____

City _____

State _____

Zip _____

HUMFREY'S FOR
GENERAL



10" TILTING ARBOR TABLE SAW #350-05
Including 3Hp Motor, Magnetic Control, Guard, Guide Rails & Fence. 425 lbs. Ready to use.

SHIPPED FREIGHT COLLECT
\$1400. U.S.
NO OTHER CHARGES

HUMFREY'S ORDER PHONE IN THE U.S. CALL TOLL FREE
1-800-387-9789



J. Philip Humfrey Ltd.

3241 Kennedy Road, Unit 7 Department WM 3/4a
Scarborough, Ontario M1V 2J9 (416) 293-8624

Please rush me details of the General 10" Table Saw.

Name _____

Address _____

City _____ State _____ Zip _____

WOODTURNERS

T.S. HARRISON LATHES:



Shortbed Model
Capacity: 19" diameter
Weight: 375 lbs.
Price: \$2165.00

- Features:**
- Quick release tool support
 - Rigid iron casting
 - Safety Features
 - Precision Machining
 - Competitive Price



Graduate Model
Capacity: 12" inboard
19" outboard
Sizes: 30", 42", 54", Models
Weight: 450-550 lbs.
Price:
30" ... \$2430.00
42" ... \$2545.00
54" ... \$2725.00
Same features as Shortbed Model

Harrison lathes will perform with the best American lathes, and are priced competitively with any lathe on the market, when workmanship and quality are a consideration. When compared to the higher priced American lathes, at today's prices, the Harrison line of lathes are super values. As used by Lindquist Studios and Rude Osolnik.

Send \$2.00 for our new 46 page catalog featuring the finest selection of woodturning tools and supplies available. Also, Dale Nish workshop information. \$2.00 refunded with order.



CRAFT SUPPLIES USA
specialists in woodturning tools
1644 S. State St. Provo, UT 84601
Tel (801) 373-0917

Full-Size TRADITIONAL ROCKING HORSE PLAN



Bring back the magic of childhood using our full-size plan for the Traditional Rocking Horse. Easy to build—body, legs and head are shaped using files. Rockers are curved for maximum action and shaped for desirable safety. Use pine or any available hardwood—paint to resemble live pony. Tomorrow's heirloom today!

Plan No. 121 \$10.75

CATALOG
180 diff., full-size prof. furniture plans—\$2.00 (catalog free with order)

FURNITURE DESIGNS, Dept. 8Z-35
1425 Sherman Ave., Evanston, IL 60201

NEW! BACKYARD STRUCTURES SOMETHING DIFFERENT IN STORAGE



BOOK HAS DESIGNS FOR STORAGE SHEDS, CABANAS, STUDIOS, ANIMAL SHELTERS, BARN AND MORE. IN FULL COLOR.

8 MINI PLANS INCLUDED IN BOOK
BACKYARD STRUCTURES - \$8.95
GAZEBOS AND OTHER GARDEN STRUCTURES - \$7.95



SUN DESIGNS

P.O. BOX 206 - Dept. 34
DELAFIELD, WI 53018
(414) 567-4255

MC & VISA ACCEPTED

VIDEO TAPES

FROM

R. J. DE CRISTOFORO

TABLE SAW EXPERTISE
RADIAL ARM SAW
DRILL PRESS METHODS

PLUS:
TOY PLANS
BOOKS
POWER TOOL
JIG PLANS

CATALOG — \$1.00

DECRISTOFORO DESIGNS
27082 HORSESHOE LANE #1
LOS ALTOS HILLS, CA 94022

Problem Resolution Program

If you have a tax problem that has not been solved after going through normal IRS channels, call the IRS and ask for the Problem Resolution Officer.



A PUBLIC SERVICE MESSAGE FROM THE INTERNAL REVENUE SERVICE

QUARTZ CLOCK MOVEMENTS & ACCESSORIES

- Deal Direct with Nation's Largest Independent Distributor
- Most Orders Shipped Within 48 Hours

FREE CATALOG

Send for your new Spring '85 Edition



PRECISION MOVEMENTS
2024 Chestnut St., P.O. Box 689
Emmaus, PA 18049
(215) 967-3156

Dept. G

BUILD THIS SATELLITE TV ANTENNA FOR UNDER \$200



Enjoy a new world of TV entertainment. Save \$. Easy-to-follow, fully illustrated plans.

- 8' square antenna made from plywood arcs and window screen.
- Steel pipe antenna base.
- Listing of electronic equipment suppliers.
- How to tune into the satellites in your area.

Send \$11.95 post. paid check or money order to

PLAN CREATIONS

P.O. Box 983, Dept. W3, Grass Valley, CA 95945

We mail 1st class (California residents add 8.72 tax)

Visa & MasterCard—Please include Acc. # and Exp. Date.

Satisfaction guaranteed

Germany. Included are thousands of unusual and hard-to-find chisels, gouges, parting tools, etc. — all hardened and tempered to hold a keen edge and give a lifetime of dependable service. FRANK MITTERMEIER, INC. Free. Circle No. 1250.

MITY-TITE SYSTEMS — No job is too tough for Mity-Tite. If you want to clamp furniture, assemble fabricated items of any shape or form, frame a picture, do home improvements, do glueing, banding or any one of a thousand tasks, you need Mity-Tite. MITY-TITE SYSTEMS. \$1.00. Circle No. 1255.

WOOD CARVING — You can obtain information on learning woodcarving by sending for our literature. The offer includes sample copy of *The Mallet Magazine* and two lesson sheets on carving. NATIONAL CARVERS MUSEUM. \$1.00. Circle No. 1300.

CLOCK COMPONENTS — We feature battery, pendulum, and chime quartz movements of all types: Urgos, Hermler, Grandmother, Grandfather cable drive and chain drive, keywind movements of all types. 400-day clocks, music box movements, flat and benzol type dials — plus a vast assortment of weather instruments. Hundreds of clock items. Very competitive. 75-page catalog. NEWPORT ENTERPRISES. Free. Circle No. 1320.

WOOD WORKERS—CARVERS SUPPLIES — Catalog on hard to find items. E-Z pneumatic drum sander, Foredom tools and accessories, Detail Master woodburning unit, abrasive cartridge rolls, books, patterns, much more. NORTH WEST CARVING SUPPLIES. \$2.00. (Refundable). Circle No. 1360.

PERSONAL BRANDING IRON — Brochures describes line of branding irons that makes it easy to put your name on your work. Made especially for branding wood, they are available with 1, 2, or 3 lines of copy in either 1/8- or 1/4-in. letters. Makes a clean, sharp mark that shows pride in workmanship. Also included is information on handscrew clamp hardware that allows you to make your own clamps at approximately 50% savings. NOVA TOOL CO. Free. Circle No. 1380.

PIN ROUTER AND ROUTER BIT CATALOG — Brochure showing the inverted pin router, the most versatile, easy-to-operate pin router in the world.

Designed for operator safety and comfort. Included is a 22-page router bit catalog of all industrial grade bits in both highspeed steel and carbide. C.R. ONSRUD, INC. \$1.00. Circle No. 1440.

HIGHEST QUALITY FURNITURE HARDWARE, CHAIR CANE, AND LAMP PARTS — 62-page catalog features large selection and detailed information on all products. Reasonable prices. Fast shipment. PAXTON HARDWARE, LTD. \$2.50. Circle No. 1480.

HOW TO BUILD A SATELLITE TV ANTENNA FOR UNDER \$200. — A 42-page booklet of complete information with step-by-step fully illustrated instructions. Tells how to install, how to find the satellites from your area, lists electronic equipment suppliers, and much more. Enjoy a new dimension of TV entertainment in your home. PLAN CREATIONS. \$11.95. Circle No. 1535.

QUARTZ CLOCK MOVEMENTS — Deal directly with the nation's largest independent distributor of quartz clock movements. Thousands of ultra-thin, pendulum, and chime movements in stock at all times. Our 36-page catalog features a large selection of hands, dials, numerals, weather instruments, as well as many other clock making supplies. Most orders shipped within 48 hours. PRECISION MOVEMENTS. Free. Circle No. 1555.

PLANERS ARE OUR SPECIALTY — Heavy duty 15, 16, 20, and 24 in. planers at the lowest prices in the U.S. We also carry quality jigsaws at realistic prices and a full-line of other shop tools. All tools are returnable within 30 days for full refund. Send for information. PRO SHOP. Free. Circle No. 1560.

SWISS WOODWORKING BENCHES — Woodworkers, Qualitech Workbenches offers you a free brochure and price list for high quality woodworking benches imported from Switzerland. Affordable prices and a 30-day money-back guarantee. QUALITECH WORKBENCHES. Free. Circle No. 1580.

WOODWORKING "KLAMP-KIT" — Save 50% or more on the cost of readymade parallel wood screw clamps. We supply Acme threaded steel components and instructions, you supply the wood for jaws and handles. Send for Klamp-Kit instruction brochure and information. THE ROCKLEDGE CO., INC. \$1.00. Circle No. 1650.

LETTER LAYOUT GUIDES — Brochure containing complete information about a new product of special interest to scroll sawers, carvers, and wood sign makers. A lettering guide to layout large letters and numbers to be cut in wood or other materials. Made from a durable plastic material for years of use. Price of brochure is refundable with first order. SEYCO SALES CO. \$3.00. Circle No. 1710.

PENNSYLVANIA DUTCH FURNITURE KITS AND PLANS — All kits crafted in solid hardwoods in classic designs such as our original ice box, child's rocker, classic roll top desk, and more. Build from our easy-to-assemble kits or our blueprint plans. We include the hardware, fasteners, instructions, and you include the fun. THE SHOP. Free. Circle No. 1720.

SLEEVELESS DRUM SANDERS — Economical— simply cut sandpaper from standard size sheets. Unique way of holding sandpaper to drum—a twist of the key tightens. Sponge rubber backing insures long wear of sandpaper. Sanders can be used on drill press, small motor, lathe, combo-tools, radial saw, hand drill, and other revolving devices. Send for brochure. SINGLEY SPECIALTY CO., INC. Free. Circle No. 1735.

HOME CRAFTSMAN BOOK CATALOG — over 125 titles in every area of woodworking and for every level of expertise. From detailed instructions on routers and table saws to exquisite patterns for decoys and wooden toys to the best in wood turning. Discounts available on every order, and the catalog charge is refundable on your first order. STERLING PUBLISHING CO., INC. \$1.00. Circle No. 1740.

SYSTEMS IN JOINERY — New 25-page illustrated catalog featuring many uses of the joint-matic and introduction of other high quality machines, fixtures, and cutting tools that make many of the more difficult tasks in woodworking easier. STRONG TOOL DESIGN. \$2.00. Circle No. 1745.

CUPOLA AND BRIDGE STUDY PLAN BOOK — Consists of designs for 22-ft. bridges, 8 covered bridges, 36 cupolas, and some history of each. Complete plans available for each design. SUN DESIGNS. \$7.95. Circle No. 1750.

TO ORDER THESE BOOKLETS, USE COUPON ON PAGE 98

FREUD PROFESSIONAL 15 PIECE ROUTER BIT SET.

Freud carbide tipped router bits are used by professional woodworkers and serious craftsmen throughout the United States. We asked Freud to select the 15 most needed router bits and install them in a sturdy wooden case. The result was everything we expected and less - a lot of tools for a lot less money than we dreamed possible. Freud's total list price with the case is over \$300.00. Our price is little more than 1/2 of list! Here's what you get.

04-106	Straight	32-100	Rabbeting
04-160	Straight	34-114	Rounding Over
16-100	Mortise	38-100	Roman Ogee
18-104	Round Nose	40-106	Chamfer
20-104	V-Groove	42-106	Trimming
22-104	Dovetail	64-100	Trimming
26-100	Panel Pilot	66-100	Trimming
30-106	Cove		

Router bits are all 1/4" shank.

CODE WDMA5H

\$167.50 ppd



800-343-3248 (USA)
800-322-6100 (MA)

TREND-LINES, INC.

375J Beacham St.
P.O. Box 6447J
Chelsea, Ma.
02150

HUMFREY'S FOR EXCALIBUR II

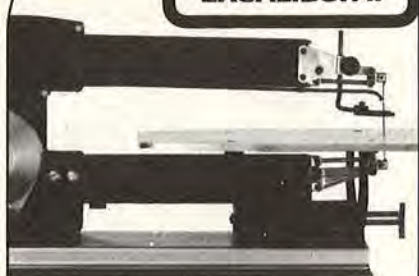

PRECISION SCROLL SAW EX-II

SHIPPED FREIGHT COLLECT

\$495. U.S.

NO OTHER CHARGES

- 1400, 800 & 400 Strokes/PM
- 19" throat, up to 2" thick
- Accepts all 5" blades
- Table tilts 45° left & right
- Cuts wood, plastics, metals etc.

HUMFREY'S ORDER PHONE IN THE U.S. CALL TOLL FREE 1-800-387-9789



J. Philip Humfrey International

3241 Kennedy Road, Unit 7 Department WM 3/46 Scarborough, Ontario M1V 2J9 (416) 293-8624

Please rush me details of the Precision Scroll Saw EX-II.

Name _____
Address _____
City _____ State _____ Zip _____

NEW AFFORDABLE BANDSAW MILL

The WOOD-MIZER is a one man portable sawmill with a huge 30" dia X 16' long cutting capacity. This safe, easy-to-operate mill cuts with an efficient traveling bandsaw carriage. Why waste lumber and money by cutting with an old fashioned circular mill when the WOOD-MIZER can give you 30% more usable lumber out of each log on less than half the fuel and horse power? This accurate cutting system is everything a sawmill should be and more.

For More Information Send \$1.00 to:
WOOD-MIZER, Dept. WZ
4004 W. 10th St.
Indianapolis, IN 46222
(317) 243-7585

BURNHAM BROTHERS

Write for our FREE catalog. Loaded with the best wildlife calls, calling equipment, and sporting accessories and much more. For Booklet "Thrills of Game Calling" enclose \$1.00.

Name _____
Address _____
City/State _____ Zip _____

Burnham Bros.

P.O. Box 669 Dept. W5 1-512-693-3112 Marble Falls, TX 78654

CLOCK COMPONENTS



QUARTZ CLOCK MOVEMENTS

WE FEATURE BATTERY, PENDULUM, CHIME QUARTZ MOVEMENTS OF ALL TYPES. URGOS, HERMLE, GRANDMOTHER, GRANDFATHER CABLE DRIVE AND CHAIN DRIVE, KEY WIND MOVEMENTS OF ALL TYPES. 400 DAY CLOCKS, MUSIC BOX MOVEMENTS, FLAT AND BEZEL TYPE DIALS—PLUS A VAST ASSORTMENT OF WEATHER INSTRUMENTS. HUNDREDS OF CLOCK ITEMS. VERY COMPETITIVE PRICES. WRITE OR CALL FOR FREE 75 PAGE CATALOG. \$2 FOR AIR MAIL.



THE QUARTZ FITUP THE MINI QUARTZ
Send To:
NEWPORT ENTERPRISES INC.
2313 W. Burbank Blvd.,
Burbank, CA 91506
(213) 845-0555

BUILD IT YOURSELF

TOYS • PUZZLES • PLAQUES • PLANTERS
FURNITURE • LAWN ITEMS • BIRD HOUSES
ROCKING & RIDING HORSES • PLAY SETS



SAME SIZE PATTERNS • WHEELS • HOW-TO BOOKS
40 PAGE ILLUSTRATED CATALOG \$1.00
Design Group, Box 514-Z, Miller Place, N.Y. 11764

GIVE YOUR WOOD A PRECISION CUT

WITH THE FINEST PRECISION CARBIDE SAW BLADES FOR TABLE SAWS

Rips—Bevels—Cross Cuts—Miter Cuts A Smooth Finish Ready For Gluing, Without Jointing

Telephone your order Toll Free: 800-336-7305
In Virginia call Collect: 703-667-1151

Winchester
CARBIDE SAW, INC.

2631 Papermill Rd., Winchester, Va. 22601

"MAKER'S MARK" BRANDING TOOL



Oh! how my namey gets to last
worse waspy ink best
chew not acid!

NOW! Brand your own name permanently on wood and leather handcrafts! Simple to use. Long lasting U L approved electric handle. Brands full name. Guaranteed.

CRAFTMARK PRODUCTS, INC.

P.O. Box 6308BH3 • Marietta, GA 30065

PADOUK - BUBINGA - SHEDUA - WENGE - ADD THAT EXOTIC FLAIR TO YOUR NEXT PROJECT!

We offer the best wood, prices and service available— it's as simple as that. Call or write for our catalog:

Wyndham Woods

"The finest from around the world"
P.O. Box 506
Ellettsville, Indiana 47429
(812) 334-7735

PURPLEHEART - DOUSSIE - RED OAK - CHERRY
GONGCALOALVES - PALDAO - WHITE OAK - ZEBRA

101 GIFT & NOVELTY PATTERNS

This wonderful packet contains 101 FULL SIZE PATTERNS of Gifts, Novelties, Lawn Figures, Bird Houses, Shelves, Action Windmills, Alphabets, and many more things. Just trace and saw out. Plus "Make Money Jig Sawing". Only \$7.00 Prepaid 1st Class for this big packet.

MASTERCRAFT PLANS WEST, DEPT. 25H
P.O. Box 625, Redmond, WA 98073

30 BIRDHOUSES FULL SIZE PATTERNS

Attractive new bird houses and feeders. Expertly designed to attract Wrens, Martins, Robins, etc. Easily made. Full size patterns and directions. Only \$7.00. Prepaid 1st Class.

MASTERCRAFT PLANS WEST, DEPT. 216H
P.O. Box 625, Redmond, WA 98073

SAVE \$100'S ON STORAGE BED!

FULL-SIZE PLANS FOR 3 SIZES

Twin, full, or queen size bed with either 3 or 6 drawers; and with easy disassembly of headboard and footboard. Plans for all 3 sizes on Money-back Guarantee: Only \$11. Send for FREE illustrated catalog of furniture plans.

FLEXIPLANS, Dept. GD
48 Lowell St., Westwood, N.J. 07675

WOODTURNERS

TWO-DAY TURNERS' WORKSHOP (SINCE 1976)
For beginners and experienced turners. Midweek or weekend throughout the year. Two students per class for personal attention. Sharpening and proper use of tools for faceplate and centers turning. Build confidence and experience, or just find out if you like to turn. Full accommodations available.

MYFORD M8 WOODTURNING LATHE
Finest quality and design, including outboard tool rest for bowl turning. 36" or 42" between centers.

THE ZIMMERMAN WOODTURNING LETTER
Comprehensive; instructive; the "why" as well as the "how." Excellent preview or review for workshop.
1983 EDITION: 76 PAGES \$7 ppd
1984 EDITION: 72 PAGES \$8 ppd
1985 EDITION: 72 PAGES \$9 ppd

SEND 60¢ IN STAMPS FOR DETAILS
Including SORBY turning tools, chucks, and DOUBLE-STICK TAPE. (Why use messy glue and paper to hold on bowls?)

RUSS ZIMMERMAN, RFD 3, BOX 242
PUTNEY, VERMONT 05346

GAZEBOS AND OTHER GARDEN STRUCTURES

— The most comprehensive collection of gazebo designs found anywhere today. Includes 55 gazebo designs from 8 ft. to 30 ft., 13 strombrellas, 7 arbors, 14 bird feeders, and 4 birdhouse designs. Has mini-plans of 2 bird feeders and 1 of our most popular Tiffany gazebo. Complete construction plans can be ordered for all 93 designs. SUN DESIGNS. \$7.95. Circle No. 1751.

BOOK OF OUTBUILDINGS — 25 illustrated designs that can be used for unique storage sheds, playhouses, saunas, cabanas, guesthouses, or even privies. Send for *The Classic Outhouse* book. SUN DESIGNS. \$7.95. Circle No. 1752.

"THE STROM TOYS" — a full-color, 96-page paperback book of extraordinary wood toy designs, and a richly illustrated children's story. Contains 40 designs for which plans can be ordered, and 12 mini-plans. Makes an excellent gift. SUN DESIGNS. \$9.95. Circle No. 1753.

BACKYARD STRUCTURES — Contains designs for 21 really different storage sheds, 5 cabanas, 13 animal shelters, 3 barns, 13 garbage enclosures, 3 studios, and more, plus 8 plans in book. 66 designs in all, for which plans can be ordered. Full color. SUN DESIGNS. \$8.95. Circle No. 1754.

TIMBERS COUNTRY STORE — Catalog features hundreds of woodworking supplies, toy patterns, furniture patterns, tool use and instruction books, woodworking pattern books, hardwood toy and furniture parts plus many hard to find tools and shop supplies. TIMBERS COUNTRY STORE. \$1.00. Circle No. 1820.

BUTLER SERVING TRAY TABLE PLANS — 16-page instruction booklet with full-size leg and detail templates for easy construction of this table and 7 others: curio table, lamptable, nightstand, or nightstand with shelf, 2 Queen Anne tables, and a Pembroke dropleaf. TOOLS, ETC. \$4.95. Circle No. 1845.

TOYMAKERS SUPPLIES — Catalog of over 100 full-size wooden toy patterns — classic to contemporary designs from Packard Le Baron to Streamlined train and moon machine. Easy to follow, fully illustrated patterns which appeal to all ages. Hard-

wood wheels, shaker pegs, axles, etc., in stock. Accessory kits of pattern and turnings available. TOY DESIGNS. \$1.50. Circle No. 1860.

WOOD TOY PATTERNS — Patterns for all ages including children's patterns and executive toys. New catalog has many new patterns to choose from including parts and wheels. Send for new catalog and receive a coupon for free wheels and axle pegs. TOYS AND JOYS. \$1.00. Circle No. 1865.

WOODWORKERS CATALOG — of discount power tools, hand tools, books, plans, saw blades, router bits, sanding belts and sheets, cane, adhesives, screws, and much more. One year catalog subscription (3 to 4 issues) also includes a subscription to "Woodworking Trends", a house publication debuting this spring. TREND-LINES, INC. \$2.00. Circle No. 1870.

BRANDING IRON — Let the world know who made it! Personalize and sign your work with one of our flame or electrically heated custom made branding irons. Send for complete details. TURNING POINT INC. \$1.00. Circle No. 1885.

SUPPORTABLE — The material support system that works equally well with your complete line of woodworking equipment; table and radial saws, planers, jointers, etc. Supportable allows you to handle the big pieces alone — safely. Send for complete brochure. TURNING POINT INC. \$1.00. Circle No. 1886.

WOODCARVING TOOLS — Whittlers and carvers — Warren Tool Co. offers a catalog for you full of whittling and carving hand/power tools, books, stones, wood, and supplies. Since 1927, the finest in woodcarvers tools. WARREN TOOL CO., INC. 60¢. Circle No. 2020.

BEAUTIFUL WOOD FINISHING — with Watco Danish Oil Wood Finish. Full-color *How to Beautifully Finish Wood* booklet enables anyone to create professional finishes the first time with all types of wood. One application of Watco Wood Finish seals, primes, finishes, hardens, protects, beautifies, penetrates deeply into the wood; outlasts surface coats three to one. Eight attractive Danish Oil colors now available. Eliminates pre-staining. WATCO-DENNIS CORP. Free. Circle No. 2025.

TO ORDER THESE BOOKLETS, USE COUPON ON PAGE 98

WOODWORKING-CARBIDE SAW BLADES — We at Winchester Carbide Saw take a lot of pride in making the best quality blades on the market today. We are not a factory that mass produces thousands of blades — we are a small shop that custom makes a few blades at a time in as perfect a manner as possible. The guarantee that goes with each blade we sell says "You like it, or we buy it back!" If you are not satisfied, then we aren't either. We would enjoy the opportunity to help you select the best blade, proper tooling, bits, and cutters for your operation. We will work hard to satisfy your needs. Send for our catalog. WINCHESTER CARBIDE SAW, INC. \$1.00. Circle No. 2045.

THE WING M-100 ROUTER TEMPLATE — FAST AND EASY PRODUCTION FOR SMALL, MEDIUM, OR LARGE PANELS — Both versatile and fast, the M-100 Router Template and its selection of interchangeable design units, allows competent production of a wide variety of ornamental borders by either professionals or home craftsmen. It can be used with any make of portable router to decorate a door or drawer in just 30 seconds. Send for literature. WING SALES AND DIST. CO. Free. Circle No. 2055.

WOODWORKERS CATALOG — More than a catalog — it's one of the best sources for quality woodworking tools. You'll find everything from bit braces to wood borers, from saws to sharpening stones. Every product is sold satisfaction guaranteed. WOODCRAFT SUPPLY CORP. Free Circle No. 2070.

THE JAPAN WOODWORKER'S 1984 CATALOG — is loaded with the best tools you can get your hands on. In our catalog you will find a complete selection of Japanese tools for the woodcarver, carpenter, and cabinet maker. Send for catalog plus supplements for next two years. WOODLINE-THE JAPAN WOODWORKER. \$1.50. Circle No. 2075.

THE ULTIMATE DOVETAIL JIG — Industrial quality Dovetail Jig utilizes ball bearing, guided router cutters for producing perfect machine, hand-typed, and sliding Dovetails using your router. WOODMACHINE CO. 25¢. Circle No. 2077.

SPECIAL Pricing on DELTA® 10" UNISAW & ACCESSORIES



- 34-781 10" UNISAW w/1/2 HP Motor, SEE-THRU Guard & UNIFENCE **\$1499.00**
- 34-782 10" UNISAW w/3 HP, Single Phase Motor, SEE-THRU Guard & UNIFENCE **\$1775.00**
- 34-783 10" UNISAW w/3 HP, Triple Phase, 230 V Motor, SEE-THRU Guard & UNIFENCE **\$1775.00**
- 34-150 UNIFEEDER **\$ 485.00**
- 34-155 Adapter Kit For UNIFENCE **\$ 37.80**
- 43-150 Adapter Kit For Shapers **\$ 151.20**
- 34-172 Tenoning Attachment **\$ 154.60**

Ask for details on our free saw blade promotion with purchase of Delta Unisaw.
GET A COPY OF YOUR FREE W.S. JENKS WOODWORKING CATALOG TODAY

W.S. JENKS & Son

Toll-Free Order Line
1-800-638-6405
738 7th Street NW
Washington DC 20001
(202) 737-7490

BOOKS ON SALE

All prices post paid. Call for other prices.

- Holdley — Understanding Wood (list \$20) **\$18.00**
- Cary — Kitchen cabinets (list \$12) **\$10.50**
- Spielman — Router Handbook (list \$10) **\$9.00**
- Nakashima — Soul of a Tree (list \$52) **\$46.00**
- Sam Maloof — Woodworker (list \$50) **\$44.00**
- Dale Nish — Woodturning (2 books) (list \$29) **\$26.00**
- Krenov — Set of 4 books in paper back (list \$54) **\$45.00**

3 Wing Carbide RAISED PANEL Cutters

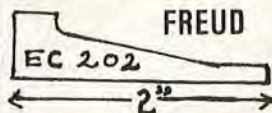

for your 1/2" or 3/4" spindle shaper
6 shapes — EC202, EC 209 thru EC 213

List \$122 SALE \$98 ea.

All prices including shipping

SALE on **freud**



- LM 72M — 10" Rip 24t \$42
- LU 85M — 10" Crosscut 80t \$72
- LU 73M — 10" Crosscut 60t \$45
- LU 84M — 10" Combi 50t \$45
- Shopsmith Owners — Add \$8 ea. for 1/4 arbor
- AD 800 — 8" Adjustable dado \$49 (Reg. \$63)
- DS 306 — 6" Dado set \$98 (Reg. \$140)
- DS 308 — 8" Dado set \$120 (Reg. \$170)

MANNY'S WOODWORKER'S PLACE
602 S. Broadway, Lexington, Ky. 40508
Hours: 10 - 5:30 Mon-Sat
VISA, MasterCard, Checks, COD (\$2)
Ask for free sales brochure.

ORDER TOLL FREE
1-800-243-0713
in KY call
606-255-5444

**NEW! 24 1/2 in. Variable Speed
BAND SAW**



**30-DAY
FREE
TRIAL!**

At last, a pro-size, band saw priced for the home shop! Big 24 1/2-in. throat easily handles large scrollwork, complex curves, 4 x 8 sheets. 9-in. vertical cut makes it easy to resaw valuable hardwoods. Ball bearing construction, all-steel welded frame to eliminate deflection. Can be ordered complete with motor, stand, dust collector, rip fence, scroll saw table. Full instructions.

30-DAY FREE TRIAL!

Send for complete facts on how you can try this versatile saw without risk! Easy Terms.

Call Toll-Free 1(800)824-7888 Oper. 642

**Woodmaster Power Tools, Dept. SW5
2908 Oak, Kansas City, MO 64108**

YES! Please rush me, free and without obligation, your Complete Information Kit on the new 24 1/2" MODEL 500 BAND SAW plus facts on Woodmaster's 30-Day FREE TRIAL Money-Back Guarantee.

Name _____
Address _____
City _____
State _____ Zip _____

**BE CREATIVE!
ARTISTRY IN VENEERS, INC.
Wants To Help.**



Professional woodworkers have always used veneers to create beautiful pieces. Now these quality woods are available to you and are so simple to use.

You can resurface or repair furniture, create ceiling and wall designs, make beautiful chess or backgammon sets, or experiment with other woodcraft projects.

We stock 80 architectural veneers, matched edging, inlay borders, fancy butts, buris, crotchets, swirls, and dyed wood veneers. To serve you, we have a complete line of quality tools and carving sets. There are over 25 marquetry kits, and our library of "how-to" books can broaden your knowledge of many fascinating hobbies in wood. Full size furniture and toy plans are an extra feature available for you. Professional services are also available.

Send \$1.00 for our woodworker's catalogue (deductible from your first order). The fine products we sell will add richness and character to your special wood projects. Tear out ad and mail today.

ARTISTRY IN VENEERS, INC.
450 Oak Tree Avenue
South Plainfield, NJ 07080
(201) 668-1430

(a subsidiary of Eagle Plywood & Door Manufacturers, Inc.)

NAME _____
ADDRESS _____
CITY _____ STATE _____ ZIP _____

**Have a problem
with your
subscription?**

We want to solve it to your complete satisfaction, and we want to do it fast. Please write to:

Robert Austin, Better Homes and Gardens® WOOD, P.O. Box 10628, Des Moines, Iowa 50336

You can help us by attaching your magazine label here, or copy your name and address as it appears on your label. Send this along with your correspondence.

Name _____ Apt. # _____
Address _____ State _____ Zip _____
City _____

Moving?

Simply attach the mailing label from this magazine and write in your new address below. (Please allow 4 - 8 weeks.)

Your New Address Goes Here

Name _____
Address _____ Apt. # _____
City _____
State _____ Zip _____

Subscription Rate:

6 issues \$15.00. Add \$6.00 per year for Canadian or foreign postage.

- Renewal
 New Order

Better Homes and Gardens®

WOOD

P.O. Box 10628 • Des Moines, Iowa 50336

**WARREN TOOL CO., INC. ANNOUNCES:
A New Combination Kit For Whittling And Carving
ALL AMERICAN AND PROUD OF IT.**



#COMBI-TCE \$75.00

OUR FINEST COMBINATION WHITTLERS AND CARVERS KIT
Contents: 1 Redwood Box, 1-#CWH-R Rosewood handle, 1-#L-Palm Walnut handle, (one each) #PTV-1, #LBG, #SBG, #PTV-2, #STC, #STG, #SFTG, #SKU, Gouges, 1-#LD2 (Large Blade), #6SBL (6-Small Blades), 1-Leather Strop Block, 1-Abrasive Paper Block, 1-Instruction Sheet. All blades and gouges sold in their own plastic storage tubes to avoid damage to these honed ready-to-use tools. Catalog FREE with order or send 60¢ for catalog only to:

WARREN TOOL CO., INC.

Rt. 1, Box 14A, Dept. Wood, Rhinebeck, NY 12572

**BRANDING
IRONS**

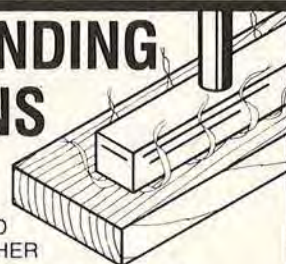

FOR WOOD
AND LEATHER

- Brands Your Full Name With
1/8" or 1/4" High Letters



GUARANTEED



SEND FOR FREE BROCHURE

NOVA TOOL CO.

4533 Colfax Circle, Dept. BH
P.O. Box 29341, Lincoln, NE 68529

Porch Swing & Glider



Complete plan
with full scale
templates \$8
Catalog \$1

(IL res add sales tax)

Cornerstone Design Inc., Dept. A5
P.O. Box 300, Elmhurst, IL, 60126



WOODWORKERS

Save on Wood - Tools - Supplies!

42 VARIETIES
1/64" to 4"
Thickness

Send for New 1985
**CRAFTSMAN
CATALOG**

148 Pages!
Over 4000 Items!



**Finest Dimensioned
HARDWOODS and
Quality VENEERS**

Fast service on choice kiln dried Wood and Veneers, Moldings, Trim, Hand and Power Tools, Lamp Parts, Upholstery Supplies, Clock Movements and Kits, Hard-to-Find Hardware, Finishing Materials, Books... over 4000 items in stock! Craftsman—Woodworker's best friend for 55 years — we save you money!

CRAFTSMAN WOOD SERVICE

Dept. K-45

1735 W. Cortland Ct., Addison, IL 60101

Please enclose \$1.00 to help pay postage and handling.

POWER-FEED DRUM SANDER — Use the Woodmaster Model 1200 to dimension and finish-sand cabinet pieces, resawn stock, paneling, grandfather clocks, toys, table tops, knees, burls, crotches, and much more. This heavy-duty 12 in. sander comes complete with motor and stand. 30 day free trial...easy terms. Send for information kit. WOODMASTER TOOLS. Free. Circle No. 2080.

HIGH PRECISION SCROLL SAW — The sturdy, new Woodmaster Model 1600 gives you all the features found in more expensive machines including big, 16-in. throat capacity, 2-in. cutting depth, a generous, oversized worktable, ball-bearing drive... and much more! Send for complete facts. See how you can use the Woodmaster Model 1600 in your own shop for one full month completely without risk. Send for information kit. WOODMASTER TOOLS, INC. Free. Circle No. 2081.

sdGIANT 24½-IN., 3-SPEED BAND SAW — Big 24½-in. throat easily handles large scrollwork, complex curves, 4x8 sheets. 9-in. vertical cut makes it easy to resaw valuable hardwoods. Ball bearing construction, all-steel welded frame to eliminate deflection. Can be ordered complete with motor, stand, dust collector, rip fence, scroll saw table. Full instructions. Send for complete facts on how you can try this versatile saw without risk. Easy terms. WOODMASTER TOOLS, INC. Free. Circle No. 2082.

PLANER/MOLDER/JOINTER — This variable power feed tool converts low-cost lumber into valuable finished stock. Turns out perfect quarter-round, casing, base mold, tongue and groove... all popular patterns including picture frames. Joints super-true edges, squared stock, bevels and chamfers. Optional sanding attachment quickly converts unit to one of the finest drum sanders available. 30-day free trial... easy terms. Send for information kit. WOODMASTER TOOLS, INC. Free. Circle No. 2083.

WOODWORKING ASSOCIATION OF NORTH AMERICA — First International Association for Woodworkers. Sample benefits include our quarterly magazine "International Woodworking", specials from selected manufacturers, group health, homeowner and auto insurance, access to the woodworking network. WOODWORKING ASSOCIATION OF NORTH AMERICA. Free. Circle No. 2127.

QUALITY AMERICAN-MADE WOOD TURNINGS — such as shaker pegs, spindles, toy wheels, toy parts, craft items, and dowel rods in birch, oak, walnut, and cherry. Send for complete 32-page catalog. WOODWORKS. \$1.00. Circle No. 2130.

WOOD WORLD CATALOG — Send for your catalog on lumber, veneer, hand and power tools, with helpful hints on how to use your tools and materials to their best advantage. Send for complete color catalog. WOOD WORLD. \$2.50. Circle No. 2140.

EXOTIC HARDWOODS — Wyndham Woods offers the finest exotic hardwoods, precision cut and dried to our specifications at a modern European mill. As a direct importer we can offer substantial savings on such fine woods as padouk, mahogany, shedua, doussie, zebrawood, and many others, as well as domestic species and veneers. For the best wood at the best prices, send for our catalog. WYNDHAM WOODS, INC. 50¢. Circle No. 2160.

WOODWORKING POWER TOOLS AND MACHINERY — A selection of full-line catalogs from leading manufacturers featuring complete specifications and accessory listings; discount price lists included. THE XYLOPHILE'S CO. \$2.50. Circle No. 2170.

CARBIDE ROUTER AND SHAPER BITS — Our industrial carbide router bits will make you and your work achieve your goals, make things happen, and avoid problems. Zac router bits will expand your possibilities and options while giving the precise details you need. With your router and our tooling your shop becomes a system that you and your family will be proud of. Feel the satisfaction of improving your shops while you and others will know you bought the best. We consistently deliver high-quality router bits shaper cutters. Our 32-page catalog will improve your knowledge and skills. Send for it today. ZAC PRODUCTS, INC. \$1.50. Circle No. 2195.

WOODTURNING INSTRUCTION AND SUPPLIES — Brochure describes program of personal instruction at our studio, with full accommodations. Also Myford lathes, Sorby tools, doublefaced tape, chucks, and our newsletter for turners. RUSS ZIMMERMAN. 60¢. Circle No. 2200.
TO ORDER THESE BOOKLETS, USE COUPON ON PAGE 98

ROUTER AND SHAPER BITS

4 BIT SPECIAL: ZAC offers you 4 of its most popular carbide tipped 1/4" shank router bits. #5, straight cut 1/2" diam. by 1" cutting edge, #6, straight cut 3/4" diam. by 3/4" cutting edge, #36, flush trim 1/2" diam. by 1" cutting edge, #25, 1/4" radius round over bit, and our 32 page catalog all for \$35 delivered (previous customers call for options). **THE DOOR SHOP:** Use your router to make perfect 3/4"-1-1/8" thick doors for cabinets, kitchens & bathrooms. This 3 piece set makes complete stile & rail raised panel doors with ease. All bits are 1/4" shank, ball bearing & carbide tipped. The complete Door Shop set & cat. \$89.50 PPD. All 4 specials & the Door Shop & cat. \$110 ppd. **THE CATALOG:** Our fully illustrated catalog of carbide tipped

bits & saws will solve your routing, shaping & sawing problems. You can achieve your goals and expand your options with our detailed cutters. We consistently deliver high quality carbide tipped router bit, shaper cutters & saw blades. **MORE SHAPER CUTTERS:** ZAC announces the addition of over 50 new 1/2" bore shaper cutters, including 14 door sets, 31 molding cutters, 5 raised panel cutters & more, plus a host of new router bits. We now have the most comprehensive carbide tipped router & shaper cutter catalog in the U.S.A. Our cutters are designed for safety and performance. All cutters have a minimum 1/8" thick carbide tip. Send for our catalog today \$1.50.



CALL FREE

INSIDE
NY STATE
1-800-
522-6622

OUTSIDE
NY STATE
1-800-
441-0101

ZAC

PRODUCTS, INC.
533 West 34th Street, NYC, NY 10001

TO ORDER FILL IN COUPON BELOW TO RECEIVE CATALOG SEND \$1.50. N.Y. RESIDENTS ADD 8.14% TAX

CK / MONEY ORDER ENCLOSED CHARGE MY VISA / MASTERCARD
 CATALOG & BITS 5, 6, 25, 36 & DOOR SHOP \$110 PPD C.O.D. add \$3
 CATALOG & DOOR SHOP \$89.50 PPD CATALOG & BITS 5, 6, 25 & 36 \$35 PPD

ACCOUNT # _____ EXP. DATE _____
 NAME _____
 ADDRESS _____
 CITY _____ STATE _____ ZIP _____

Ken's NEW full scale plans with photos and easy step-by-step instructions

Wooden Memories T.M.

EDITION NO. 4

An exclusive True-To-Life version of a Clydesdale team

Clyde'n Dale

Rocking Team with Toy Box Wagon

■ Horses & Harness with team & single rocker plans... \$12.50

■ Toy Box Wagon plan (no lathe work required) ... \$8.00

■ All Plans... \$16.50 (save \$4.00)

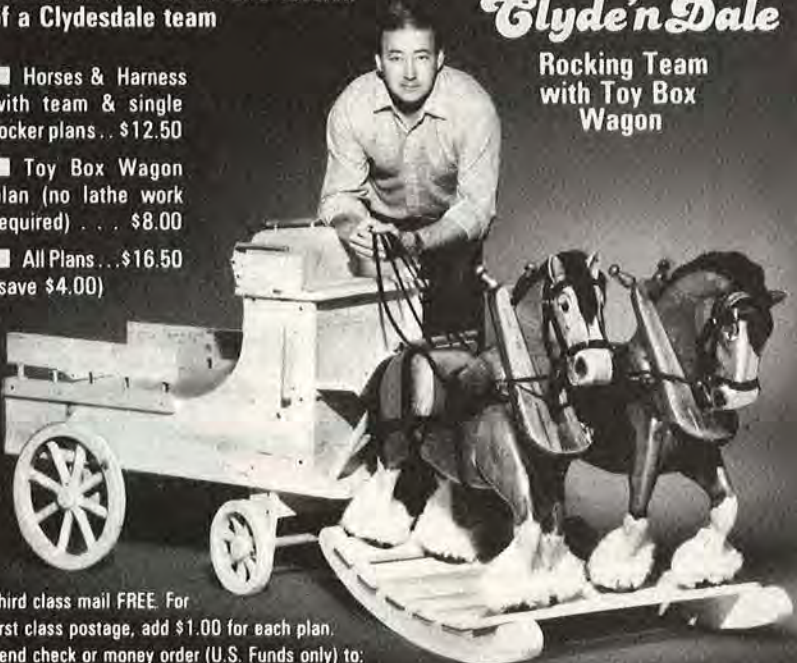

Third class mail FREE. For first class postage, add \$1.00 for each plan. Send check or money order (U.S. Funds only) to:

WOODEN MEMORIES Dept. WO Box 490 Russell, Pa. 16345

Pa. residents add 6% sales tax.

PIN ROUTER

Speed and Precision at a Small Shop Price.

With the Award Winning Onsrud Inverted Router, templates are so simple it is economical to reproduce one part or hundreds.

Call or write for our free literature today.

See us at the show in Springfield, Massachusetts, April 12-14, Booth 39.



MODEL 2003

(704) 528-4528

P.O. Box 416W, Troutman, N.C. 28166



Bolts - Nuts Screws

SAVE TIME — SHOP BY MAIL

All types available at discount prices.

STEEL STAINLESS BRASS

Satisfaction or Money Back

\$1.00 for catalogue—
refundable with first order

D.S. Houston

Box 18474, Houston, TX 77023

FINALLY.

STATE-OF-THE-ART BENTWOOD IN A FURNITURE KIT

FROM:

Cohasset Colonials
by HAGERTY



Original at
Independence Hall
Philadelphia.
Bowback Arm Chair Kit
\$179. plus \$7 shipping

We have worked for three decades to perfect ash and maple bends for our museum reproduction furniture kits. In our harbor-side factory, we are the first to stabilize one piece arm bows and continuously tapered top bows for kits. See why thousands of customers consider us to be the best. Send for our catalog.

Please send your color catalog of authentic museum reproduction furniture kits, fabric, pewter, paint, stain. I'm enclosing \$1.

Name _____
Address _____
City _____ State _____ Zip _____

Cohasset Colonials
495CA Ship St., Cohasset, MA 02025
Tel. (617) 383-0110, MasterCard & Visa

ANTIQUE & USED TOOLS FOR SALE

Quality, older hand tools for collectors and woodworkers. Illustrated lists published 5 times a year.

SUBSCRIPTION > \$4.00

CURRENT LIST > \$1.00

BOB KAUNE

specializing in



buy and sell

511 W. 11th • Port Angeles, WA 98362

HORTON BRASSES

Nooks Hill Road, P.O. Box 120J
Cromwell, CT 06416 (203) 635-4400

HORTON BRASSES are authentic copies of 17th, 18th, 19th & early 20th century pulls



Mfrs. of Cabinet & Furniture
Hardware for Homes & Antiques.

Send \$2.00 for a Catalogue.

SCROLL SAW OWNERS - Lettering Layout Guides!

- Use our specially designed guides to layout letters & numbers to be cut from wood or other materials.
- Made from a durable plastic material.
- Several styles & sizes.

Send \$3.00 (Refundable with first order) for descriptive brochure & prices to:

SEYCO SALES

1238 Bardfield
Box 472749
Garland, Texas 75047

Create A Classic



Full size patterns for Packard Le Baron and 1929 Chevy Truck, plus a catalog of over 100 wooden toy patterns, wooden wheels, axle pegs, people, and other hardwood turnings.

Send check or money order for \$10.00 for both patterns and catalog, or \$1.50 for catalog.

TOY DESIGNS - Dept. BW385, Box 441
Newton, Iowa 50208

Woodworkers

ORGANIZER UNIT



* More than a 1,000 pieces! *
\$29.95 plus \$2.00 for shipping & handling

FREE Catalog Hundreds of woodworking patterns, books, tools & wood parts!
TIMBERS COUNTRY STORE
No. G9
Carnelian Bay, CA
95711-0850
24 hr Phone No.
916-581-4141

Wood Ship Models



Build a handsome model worthy of your time and care.

Our scale model wooden ship kits contain only the finest materials for plank-on-frame and solid hull construction. Send \$2 (refundable with purchase) for illustrated catalog of kits, fittings and supplies.

BLUEJACKET SHIP CRAFTERS

ESTABLISHED 1905

P.O. Box 533 - BH, Shelton, CT 06484

Put it all together!



hundreds of uses

New clamping idea

Simple MITY-TITE System provides a wide range of clamping and banding capabilities that lets you do-it-better, faster and cheaper. Kit contains Super Tough Nylon tensioner, 50' polyester and 100' polypropylene strapping (reusable) plus 10 metal and 10 plastic buckles. Kit is \$12.95 delivered. Satisfaction guaranteed or 100% money-back. Write for valuable data.

MITY-TITE Systems

3712B Lakeridge Drive W., Sumner, WA 98390

Your own Personalized BRANDING IRON



Several styles and sizes available
Send for brochure

TURNING POINT, INC.
BOX 9303B • FARGO, ND 58109
701-645-2318

KID'S CONVERTIBLE



IT'S A DESK, BENCH AND TOY CHEST ALL IN ONE! As a desk and bench, there's room enough to seat two children. Made from veneer plywood it becomes a fine piece of solid furniture for kids to enjoy for years. PLANS & INSTRUCTIONS: \$4.00. We'll ship immediately and include a catalog of our other unique and functional projects.

BALLART DESIGN 4606 S. 600 EAST
SALT LAKE CITY, UTAH 84107

22 1/2° OCTAGON GAUGE



TO SET MITER TO SAW BLADE FOR 22 1/2° CUT. HARDENED ALUMINUM GAUGE HAS OCTAGON FORMULAS AND 14" RULER SCREENED ON. ALSO SCREW CHECKER AND INFORMATION.

\$7.95

Plus \$2.00 Handling and Shipping

California residents add 6% sales tax. Send check or money order to:

LYON ELECTRIC COMPANY, INC.
P.O. BOX 81303 SAN DIEGO, CA 92138

Sharpen your tools the Samurai way!

KING DELUXE WATER STONES from the original supplier of Japanese woodworking tools in the U.S.A. King water stones make it possible to obtain a razor edge with ease.
1. #1000 grit coarse stone for fast initial sharpening: 8" x 2 1/2" x 1 3/8".
2. #6000 grit polish stone for final honing and polishing: 7" x 2 1/8" x 1/2".
Two stone set . . . \$18.50 postpaid. Full instructions and latest catalog included.

THE JAPAN WOODWORKER

1731 Clement Ave., Alameda, CA 94501 / Phone (415) 521 1810

Enclosed is check, money order. Catalog only . . . \$1.50

Credit card number:

NAME _____

ADDRESS _____

Phone No. _____

CITY _____

Calif. residents add sales tax.

STATE _____

ZIP _____

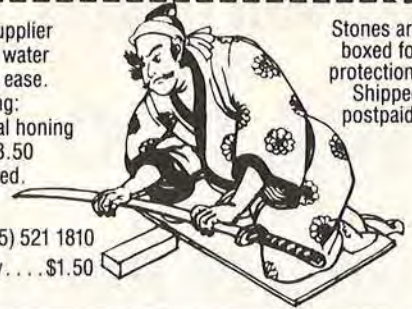

Stones are boxed for protection. Shipped postpaid.

WOODWORKING WORLD 3 BIG SHOWS

WASHINGTON, D.C. SHOW

Hyatt Regency Crystal City, Arlington, Virginia

MARCH 1 - 5 pm - 10 pm; MARCH 2 - 10 am - 6 pm; MARCH 3 - 10 am - 5 pm

NEW ENGLAND SHOW

Springfield Civic Center, Springfield, Massachusetts

APRIL 12 - 5 pm - 9 pm; APRIL 13 - 10 am - 6 pm; APRIL 13 - 10 am - 5 pm

KANSAS CITY SHOW

Kansas City Market Center At Executive Park, Kansas City, Missouri

MAY 3 - 2 pm - 9 pm; MAY 4 - 10 am - 6 pm; MAY 5 - 10 am - 5 pm

ADMISSION \$5 / \$1 OFF WITH THIS AD

FOR MORE INFORMATION

WOODWORKING ASSOCIATION OF NORTH AMERICA
35 Main St., Suite 6, Plymouth, N.H. • (603) 536-3876



MORE THAN A CATALOG...

Woodcraft is more than a catalog—it's one of the best sources for quality woodworking tools you'll ever discover. We're your source for everything from bit braces to wood borers, from saws to sharpening stones. Every item is crafted to meet precise standards of excellence, and backed by our guarantee of satisfaction. Some people may call this a catalog, but if you're a woodworker we think you'll call it indispensable. Send for your FREE Woodcraft Tool catalog today.



Please send me your FREE tool catalog.

Name _____

Address _____

City _____

State _____

Zip _____



WOODCRAFT

Dept. WBH35, 41 Atlantic Avenue,
Box 4000, Woburn, MA 01888

Sleeveless DRUM SANDER

NO PRE-MADE SLEEVES TO BUY

ECONOMICAL - Simply cut sandpaper from standard size sheets
UNIQUE way to holding sandpaper to drum. Twist of key tightens
SPONGE RUBBER backing insures long wear of sandpaper



USE ON:
Drill Press
Smal Motor
Lathe
Combo-Tools
Radial Saw
1/4" Drill

1" x 3" long \$13.50
2" x 3" long \$15.50
2 1/2" x 3" long \$16.00
3" x 3" long \$17.50
1" and 2 1/2" ABOVE \$26.75
ABOVE 4 DRUMS \$53.50
3/4" x 3" long \$14.50
2 1/2" x 4 1/2" long \$21.00
3" x 4 1/2" long \$22.50
2 1/2" x 6" long \$25.50
3" x 6" long \$27.50
ADD \$2.50 PER ORDER FOR SHIPPING

AVAILABLE WITH:
1/2" Bore with 1/2" or 1/4" shaft
1/2-20 RH Thread except 3/4" x 3"
5/8" Bore except 3/4" x 3" and 2" x 3"

Send Check or Money Order
MONEY BACK GUARANTEE

SINGLEY SPECIALTY CO. INC.

P.O. BOX 5087B
GREENSBORO, N.C. 27403

EASY WOOD FINISHING
with

WATCO[®]

The Original

DANISH OIL FINISH

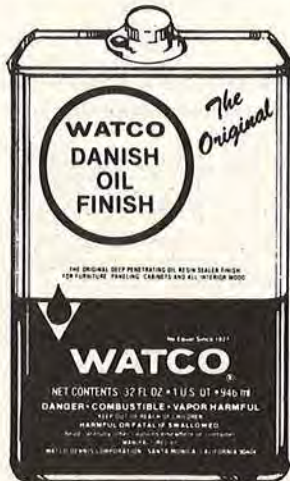

You'll be amazed at how easy it is to finish wood beautifully with Watco Danish Oil. Watco gives wood that natural hand-rubbed look with long-lasting durability. And because Watco is **IN** the wood... not on it like temporary surface coatings... there is no finish that will wear off. Watco Danish Oil is ideal for furniture, antiques, paneling, cabinets, doors, and trim-work. It's also safe for butcher blocks, cutting boards, and children's toys. Choose from 8 beautiful finishes... Natural, and Medium, Dark, and Black Walnut shades, and Cherry, Golden Oak, Fruitwood, and English Oak colors.

Send today for "FREE" color booklet "HOW to Beautifully Finish Wood" and the name of your nearest Watco distributor.

WATCO-DENNIS CORP., 1756 22nd St.
Santa Monica, CA 90404, Dept. BH-W35

Name _____
Street _____
City _____
State _____ Zip _____

213/870-4781

Information

WORTH WRITING FOR

Better Homes and Gardens[®]
WOOD, March/April, 1985
P.O. BOX 2051
CLINTON, IA 52732

TO ENSURE PROMPT HANDLING OF YOUR ORDER FOLLOW THESE INSTRUCTIONS:

- Circle your choice
- Enclose cash, check, money order for cost of booklets plus \$1.00 service charge (no stamps/foreign)
- Send coupon and remittance to address above
- ALLOW 4-6 WEEKS FOR DELIVERY
- Coupon expires April 19, 1986

FREE LITERATURE

Circle numbers below corresponding to items in this issue.
Please include \$1.00 for handling charge

20.	267.	550.	1130.	1380.	2025.	2083.
40.	273.	551.	1210.	1555.	2055.	2127.
78.	350.	552.	1213.	1560.	2070.	
175.	402.	781.	1240.	1580.	2080.	
200.	530.	930.	1250.	1720.	2081.	
262.	540.	1050.	1320.	1735.	2082.	

PRICED LITERATURE

Numbers below refer to items on which there is a charge.
Please include proper remittance.

1.....\$1.00	240.....\$1.00	400.....\$5.00	760.....\$1.00	1255.....\$1.00	1752.....\$7.95	2075.....\$1.50
2.....\$1.00	250.....\$1.00	450.....50c	770.....\$1.00	1300.....\$1.00	1753.....\$9.95	2077.....25c
15.....\$2.00	260.....\$1.00	495.....\$1.00	771.....\$1.00	1360.....\$2.00	1754.....\$8.95	2130.....\$1.00
50.....\$2.00	265.....\$1.00	555.....\$1.00	780.....\$1.00	1440.....\$1.00	1820.....\$1.00	2140.....\$2.50
60.....\$1.00	266.....\$1.00	560.....\$5.00	800.....\$1.50	1480.....\$2.50	1845.....\$4.95	2160.....50c
65.....\$1.00	270.....\$1.00	585.....\$2.00	1020.....\$1.00	1535.....\$11.95	1860.....\$1.50	2170.....\$2.50
66.....50c	274.....\$2.00	600.....\$3.00	1070.....\$1.50	1650.....\$1.00	1865.....\$1.00	2195.....\$1.50
75.....\$4.00	275.....\$1.00	630.....25c	1214.....\$5.00	1710.....\$3.00	1870.....\$2.00	2200.....60c
100.....\$1.00	285.....\$3.75	670.....\$3.00	1215.....\$2.00	1740.....\$1.00	1885.....\$1.00	
130.....\$2.00	300.....\$1.00	671.....\$3.00	1216.....\$1.00	1745.....\$2.00	1886.....\$1.00	
140.....\$1.00	310.....\$1.00	672.....\$3.00	1220.....\$1.00	1750.....\$7.95	2020.....60c	
230.....\$1.00	320.....\$1.00	750.....\$2.00	1230.....\$1.00	1751.....\$7.95	2045.....\$1.00	

Name (please print) _____
Address _____
City _____
State _____ Zip Code _____

I AM ENCLOSING:

\$_____ for priced items
\$ 2.00 for handling
\$_____ total remittance

OUR EDITORS INVITE YOU TO HELP THEM BY ANSWERING THESE QUESTIONS:

1. What is the age of the head of your household?
 - A. 18-24
 - B. 25-34
 - C. 35-49
 - D. 50-64
 - E. 65 or older
2. What is the highest level of education reached by the head of your household?
 1. Graduated college
 2. Attended college
 3. Graduated high school
 4. Attended high school
 5. Did not attend high school
3. Do you live in:
 - F. A large city
 - G. A suburban area of a large city
 - H. A small city or town (not a suburb)
 - I. A rural area
4. Approximately how long do you expect to keep this issue of *Better Homes and Gardens Wood*?
 6. Less than a month
 7. 1 to 3 months
 8. 3 to 6 months
 9. 6 months to a year
 0. More than a year
5. In which of the following categories is your annual household income before taxes?
 - J. Under \$15,000
 - K. \$15,000 to \$19,999
 - L. \$20,000 to \$24,999
 - M. \$25,000 to \$34,999
 - N. \$35,000 to \$49,999
 - O. \$50,000 to \$74,999
 - P. \$75,000 to \$99,999
 - Q. \$100,000 or more
6. Within the past 12 months, have you bought or ordered merchandise from mail order companies?
 1. Yes
 2. No
7. Within the past 12 months, how much do you think you spent on ordering merchandise from mail order advertisers?
 - R. Less than \$50.00
 - S. \$50.00 to \$99.99
 - T. \$100.00 to \$149.99
 - U. \$150.00 to \$199.99
 - V. \$200.00 to \$300.00
 - W. Over \$300.00
 - X. Nothing

EXPERIENCE THE SATISFACTION OF BUILDING IT YOURSELF WITH...

Better Homes and Gardens®

WOOD

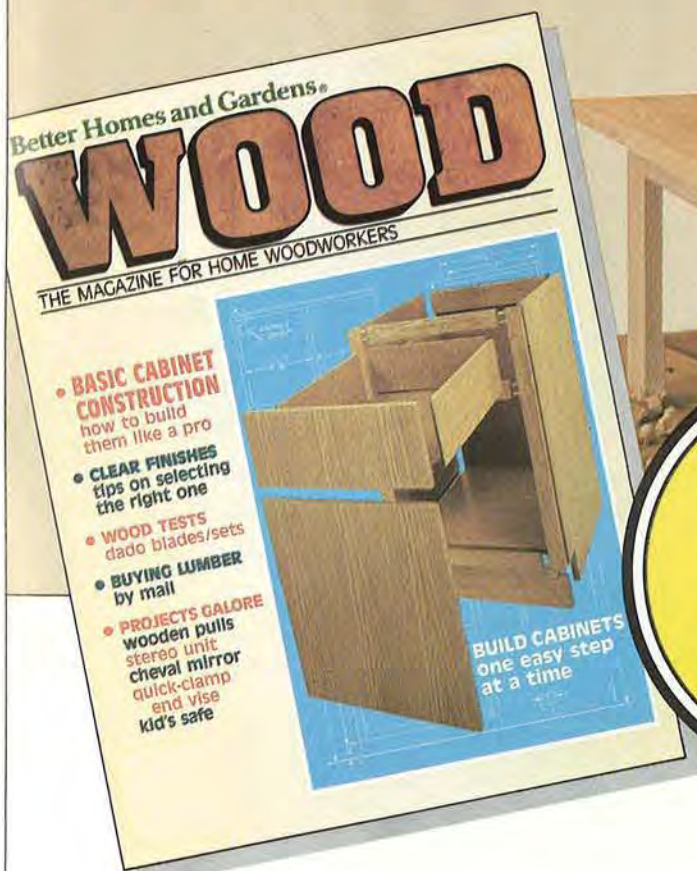

Whether you're an experienced craftsman or just beginning, Better Homes and Gardens® WOOD magazine helps you get the most satisfaction out of your home woodworking!

Just imagine building projects like living room furniture... hand-crafted toys... even tackling major home improvements like adding a deck. Now it's easy to do it yourself with the shop-tested plans in WOOD!

Every issue brings you such a wide variety of projects—for all tastes and skill levels. And

CHARTER OFFER

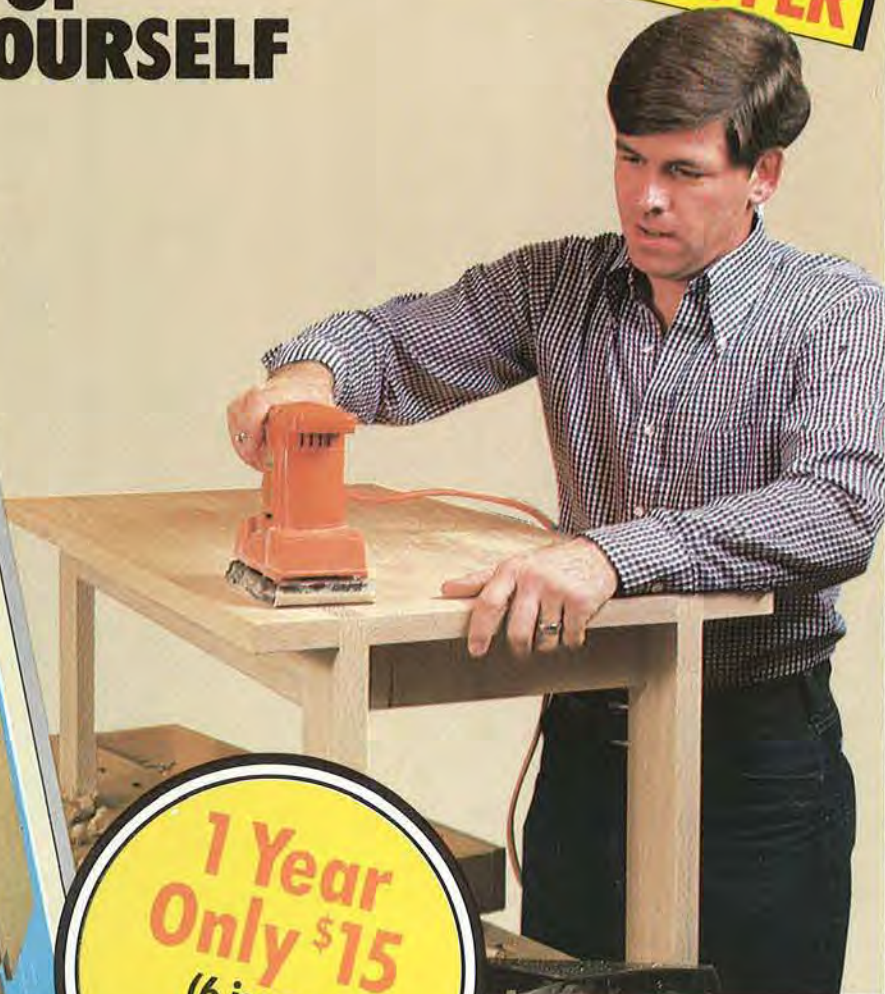

**1 Year
Only \$15
(6 issues)
SAVE \$2.70 OFF
single-issue rate**

each comes complete with cutting lists, cutting diagrams and assembly instructions. PLUS advice on how-to techniques, shortcuts and problems to watch out for.

But that's not all! Our editors—all of them woodworking experts—comb the countryside to bring you great shop tips... workshop setups... and the best new tools on the market.

So start experiencing the satisfaction of making it yourself! Become a Charter Subscriber to WOOD now and SAVE \$2.70 off the single-issue rate.

Return card enclosed in this issue or write to: Better Homes and Gardens® WOOD, Locust at 17th, Des Moines, Iowa 50336

MAIL TODAY!

Plumb® explains its built-in knack for driving nails straight.

A nail is driven properly when the center of your hammer's striking face meets the center of the nailhead.

But for that to happen on every blow, the hammerhead must be balanced to release its force in a near-perfect 90-degree arc.

In a sense the hammer must "want" to fall plumb.

And now you know what the pros have known since 1856:

The Plumb hammer didn't get its name by accident.

Lick for lick, a properly-balanced Plumb will give you more accuracy and striking power than hammers that are apt to fall off-square or "turn" in your hand.

It's also why a Plumb will probably feel more responsive than another hammer of equal



weight. And why it won't use you as a shock absorber.

The model below, for example, is our premium 16 oz. claw.

The head is secured to its fiberglass handle at the proper angle by means of a chemical wedging process we call Permabond.

The striking face is beveled to prevent chipping, and gently rounded, or crowned, so you can nail flush without denting your work.

And because faces and claws are subject to different stresses, the areas are tempered to different levels of hardness and toughness.

Compare it to any of the slick imports or heavily-advertised names. It'll make you wonder what they're charging you for.

CooperTools

BOKER® CRESCENT® LUFKIN® NICHOLSON® PLUMB® WELLER® WISS® XCELITE®

The difference between work and workmanship.



© 1983 The Cooper Group

