

Better Homes and Gardens®

WOOD®

THE MAGAZINE FOR HOME WOODWORKERS

\$3.95

APRIL 1988 • ISSUE NO. 22
Display until April 12

TRY YOUR HAND AT ONLAY

The parquet-like
treatment for furniture
and accessories

BRUSHED LACQUER

A terrific finish
for small projects

HORSE LOGGING IN THE ADIRONDACKS

Learn how lumber was
harvested in the ol' days

PROJECTS GALORE

Herringbone dining table

All-occasion vase

Blade-height gauge

Teddy bear clock

Scroll-saw necklace

Carved serving board

Kids' clothes rack

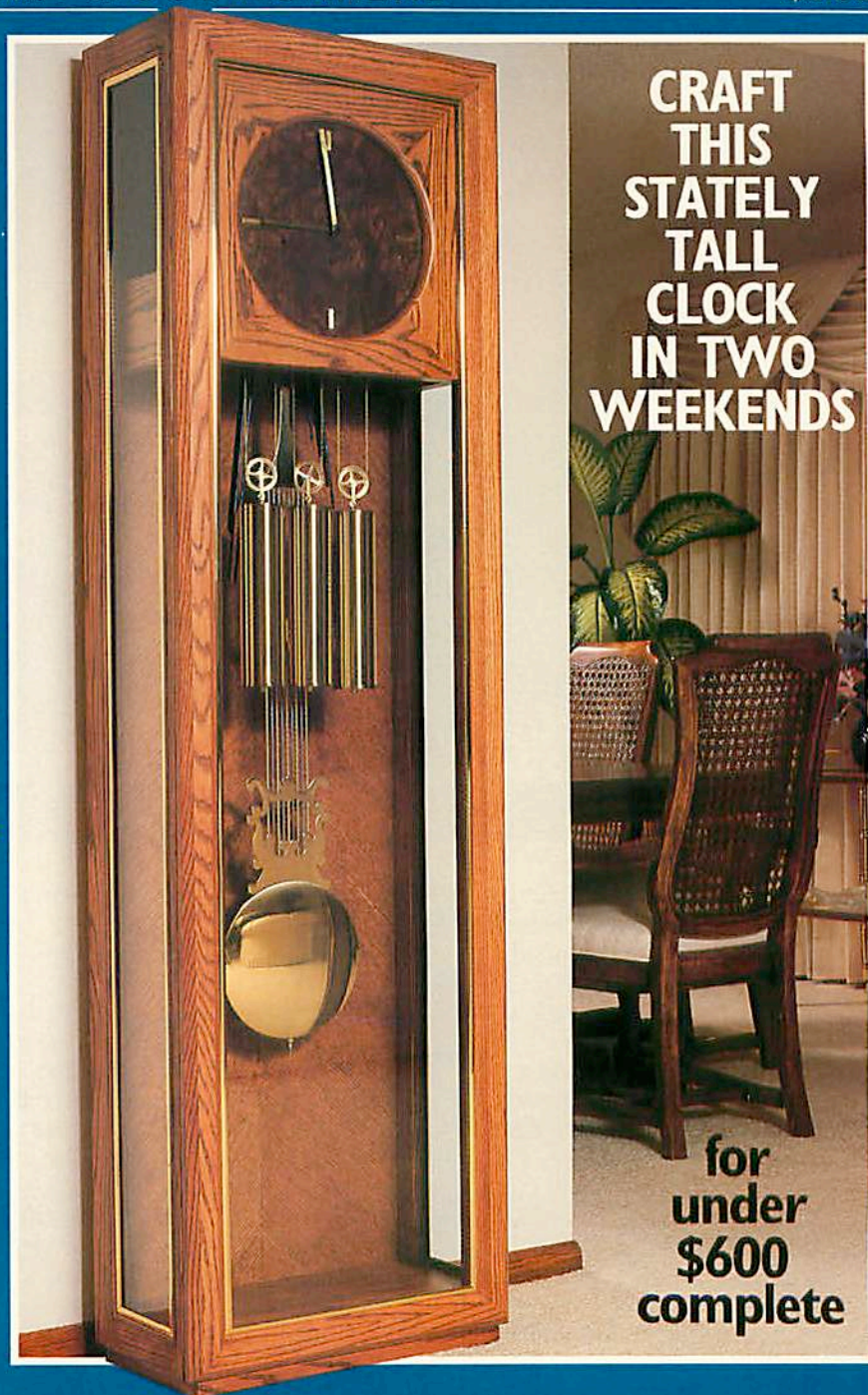

**CRAFT
THIS
STATELY
TALL
CLOCK
IN TWO
WEEKENDS**

**for
under
\$600
complete**

**NOW!
REDUCE THE
RISK AT YOUR
TABLE SAW**



folds down neatly

WITH THE **MOBILE™
SAWING CENTER**

OUTFEED ROLLERS

- safe, accurate sawing
- available in 15" and 37" widths
- handle panels with ease
- dual-position table

AND INCREASE FLOOR SPACE

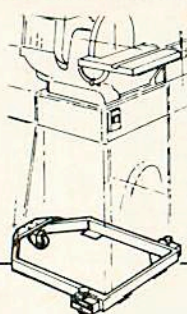

MOBILE MACHINE BASES

- increase shop working area
- maximize usable floor space
- 3 point base will not rock
- locking wheels
- makes machine so easy to use and store
- over 80 standard models

PLANER STAND WITH ROLLERS

- raises planer to proper working height
- provides machine mobility
- five-fold increase in workpiece support
- storage is a snap



NEW



**ROLLERTABLE
Rock Solid Support**

- adjustable
- portable
- use at any machine

PEDESTAL
ROLLER

Discover HTC's many unique products designed only with you, the dedicated woodworker in mind. Find out how you can make your machining safer, increase working area of your shop and accomplish nearly impossible tasks easily, quickly and accurately - **all by yourself!**

CALL TODAY!

HTC PRODUCTS, INC.
120 E. HUDSON S-8
ROYAL OAK, MI 48067
(313) 399-6185



1-800-624-2027 ext. 108

Better Homes and Gardens®

WOOD®

This issue's cover wood grain: White (slippery) elm

APRIL 1988

ISSUE NO. 22

WOOD PROFILE

TEAK—SEAWORTHY STOCK WITH TRUE GRIT 27

Teak, the world's most popular seafaring wood, takes a long journey of up to five years before arriving at Asian sawmills for processing.



SHOP-TESTED TECHNIQUES

TRY YOUR HAND AT ONLAY 28

Because of new hot-melt glue technology, you now can assemble furniture with the same handsome designs that long have graced parquet floors and fine furnishings.



NOW YOU CAN BUILD IT

PURE SOUTHWEST ONLAY VASE 33

Put the onlay techniques you've learned to good use and build our stylish vase. Expensive? Not on a bet! Thin strips of maple, padouk, and walnut create the pattern.



**DINE IN STYLE AT THIS
OAK HERRINGBONE TABLE** 34

You'll search a long time before you find a dinner table for six as sturdy and handsome as this one. And you can't beat the price either. We built ours for less than \$150.



CRAFTSMAN CLOSE-UP

TIMBER-FRAME JOINERY 36

Timber framing, once a dying craft, comes alive under the skillful joinery hands of Samule Aaron. With a razor-sharp chisel and a powerful mallet, this ambitious craftsman frames homes the dependable way of old.



CONTEMPORARY TALL CLOCK 40

Who says beautiful projects have to be expensive and time-consuming to build? We built this stately oak tall clock in two weekends for less than \$600 including the dependable clock movement. You can, too!

IN SEARCH OF THE PERFECT FINISH

FERN WEBER'S SATINY-SMOOTH BRUSHED LACQUER FINISH 48

This Kansas City carver encourages customers to touch her carving. "If they do, I usually make a sale," Fern says.



TOOL BUYMANSHIP

COMBINATION WOODWORKING MACHINES 52

Crowds gather three and four deep at wood-working shows to learn more about these powerful European combination machines.



BLADE-HEIGHT GAUGE 58

Adjusting your table-saw blade to just the right height can be a pain. Get relief with this handy, easy-to-make shop helper.



HIGH-TECH SAW-BLADE MANUFACTURING 60

With the motto "Sharpen the tool better than it was built," the Chandler family has built a thriving business in Arizona. Join us for a closer look.

TEDDY BEAR WALL CLOCK 64

Hibernating from the workshop? Beat the winter blahs with this honey of a project featuring a chubby oak-and-walnut teddy bear.



COUNTRY-STYLE SWAN NECKLACE 66

Can't get enough of that country look! Cut this swan from our full-size pattern.



RABBIT CLOTHES RACK 67

This terrific scroll-saw project may just convince your child that being tidy can be fun.



HORSE LOGGING IN THE ADIRONDACKS 68

Meet Paul Dicob, a logger who believes draft horses have a place in today's environmentally conscious timber operations.



CARVE A SERVING BOARD 74

Else Bigton imparts a Norwegian influence to her Old-World patterns.

SHORT-SUBJECT FEATURES

Editor's Angle	6	Products That Perform	22
Talking Back	10	Cutting-Board Tips	83
Tips From Your Shop (And Ours)	12	Magazine Customer Service .	98
		Bulletin Board	100

NOW! Get in on the PROFITS in SMALL ENGINE REPAIR!



Start your own money making business!

Work part time, full time—right at home—we help you every step of the way.

No doubt about it... as a small engine pro, you can cash in on the huge demand for qualified men in one of America's fastest growing industries. You'll be able to command top hourly rates of from \$25.00 to \$30.00 per hour—and that's just for labor. A simple tune-up earns as much as \$49.95 for less than an hours work, and parts, engines and accessories will add even more to the profits.

Plenty of business waiting for qualified men.

65,000,000 Small Engines Are In Use Today!

That's the official count from the Engine Service Assn., and one-million new engines are being built each month. With fully accredited Foley-Belsaw training, you can soon have the skills and knowledge to make top money servicing these engines. People will seek you out and pay you well to service their lawnmowers, tillers, edgers, power rakes, garden tractors, chain saws, minibikes, snowmobiles, generators, go-carts, paint sprayers, snowblowers—the list is almost endless.



Professional Tools and Equipment, PLUS 4 H.P. Engine ALL YOURS TO KEEP... All at No Extra Cost. NO EXPERIENCE NECESSARY!

You don't need to be a 'born mechanic' or have any prior experience. You can master this profitable trade right at home in your sparetime. Lessons are fully illustrated...so clear you can't go wrong, and with our famous 'learn-by-doing' method you get practical 'hands-on' experience. We also show you how to get business, what to charge, where to get supplies wholesale...all the inside tricks of the trade you need to assure success right from the start.

Send for FREE Facts—Do It TODAY! NO Obligation—NO Salesman Calls!

You risk nothing by accepting this offer to see how easily you can learn the skills you need to increase your income in a high-profit business of your own.

Just fill in and mail coupon below (or send postcard with name and address) to receive full information by return mail.

RUSH COUPON TODAY
Foley-Belsaw Institute
6301 Equitable Rd.
Dept. 51380
Kansas City, MO 64120



FREE BOOKLET!
Send for your copy today!

FOLEY-BELSAW INSTITUTE
6301 Equitable Rd., Dept. 51380
Kansas City, Mo. 64120



YES, please send me the FREE booklet that gives full details about starting my own business in Small Engine Repair. I understand there is No Obligation and that No Salesman will call on me.

NAME _____

ADDRESS _____

CITY _____

STATE _____ ZIP _____

HOMES YOU CAN BUILD YOURSELF AND SAVE



\$33,350*

Tyler I



\$58,800*

Huntington

- No Down Payment.
- Below Market Construction Financing.
- Low Monthly Payments.
- Step-by-Step Instructions.
- Framing Assistance Available for Qualified Buyers.
- FREE Home Building Seminars.
- Large Selection of Models.

Miles Homes® Insilco

4700 Nathan Lane, P.O. Box 9495
Minneapolis, MN 55440

Call 24 Hrs. 1-800-642-9606

*Basic Home Package as described in the Miles Homes Catalog includes electrical, plumbing and heating packages. Prices may vary by state.

SEND TODAY FOR MORE INFO

- Please send me: (check one)
- FREE COLOR INTRODUCTORY BROCHURE.
 - Yes, I want to attend a FREE Miles Home Building Seminar in my area.
 - I am not able to attend a FREE Miles Home Building Seminar, but would like a Full-color Catalog. Enclosed is my check for \$10.00.

NAME _____

ADDRESS _____

CITY _____

STATE _____ ZIP _____

PHONE () _____

LAND Own (1) Making Payments (2) Looking (3)

Combined income †

Under \$18,000 (1) \$35,000 - \$45,000 (4)

\$18,000 - \$26,000 (2) \$45,000 - \$50,000 (5)

\$26,000 - \$35,000 (3) Over \$50,000 (6)

†Husband and wife MWOH0388

B. DALTON IS YOUR WORKSHOP FOR BOOKS

We have the woodworking books you need!



ROUTER HANDBOOK

Patricia Spielman

The definitive guide! Complete instructions & over 600 photos show you how to: carve, drill, cut wood and metal, and hundreds of other essential tasks. This thorough, expert evaluation of the strengths and weaknesses of every major brand and type includes tips on how to use accessories and make jigs and fixtures economically, plus special help on unusual routing operations, overarm and pin-routing techniques, much more! 224 pages, \$10.95



HOUSEBUILDING:

A Do-It-Yourself Guide
R. J. DeCristoforo

This lifetime reference from *Popular Science* has 656 pages of expert tips & 1000 plus draftsman-quality illustrations for building from the foundation up. Start with buying land, developing plans; then pour the foundation, build the frame. Make floors, doors, windows, walls & cabinets; install cooling, heating, electrical systems. Whether building a house, a toolshed or addition—every step, every carpenter's trick is covered. 656 pages, \$16.95



CARPENTRY

Gasper Lewis

3 pounds of carpentry know-how. With 1000 plus illustrations, this complete source book is the best accessory you'll ever own. Whether you're building, renovating or just fixing up, step-by-step instructions & tips of the trade cover virtually every tool, material, building technique you'll ever need. It's a nail-by-nail guide to the ins-and-outs of joinery, making/replacing windows & doors, fixing creaky stairs, insulating, roofing, foundations, installing ceilings, floors & kitchen cabinets, much more! Save time, money & aggravation with this oversized, 2-color complete course. 576 pages, \$18.95



SCROLL SAW PATTERN BOOK

Patricia & Patricia Spielman

450 patterns—the most ever in one book—and less than 5 cents each! Most are full-size, ranging from simple wall plaques and puzzles to fine frames and marquetry design. Make thousands of adaptations with complete instructions for changing sizes, flipping, cropping, woodburning, finishing, stenciling. 256 pages, \$12.95

B Dalton
BOOKSELLER

See the Yellow Pages for the B. Dalton location nearest you or call 1-800-367-9692.

Better Homes and Gardens®

WOOD

THE MAGAZINE FOR HOME WOODWORKERS

April 1988 • Vol. 5, No. 2 • Issue No. 22

Editorial/Art Staff

Editor **LARRY CLAYTON**
Managing Editor **CARL VOSS**
Art Director **C. L. GATZKE**
Design Editor **JAMES R. DOWNING**
Features Editor **PETER J. STEPHANO**
How-To Editor **MARLEN KEMMET**
Project Builder **JAMES E. BOELLING**
Graphic Designer **PERRY A. MCFARLIN**
Administrative Assistant **DARLENE REYNOLDS**
Business Office Clerk **JODI DOWNING**

Technical Consultants: **GEORGE GRANSETH** Product Testing; **PAUL L. McCLURE** Wood Technology

Publisher **JERRY KAPLAN**

National Advertising Manager **MARK S. HART**
Advertising Representatives **JOHN BELLUARDO,**
ANTHONY IMPERATO

Marketing Services Manager **NANCY DALY**
Promotion/Research Director **THOMAS R. TROLAND**
Circulation Director **WILLIAM HUMMEL**
Circulation Manager **BILL REED**
Production Director **DALE SCHENKELBERG**
Editorial Research Director **C. RAY DEATON**

Weekend Woodworking Projects

Managing Editor **JIM HARROLD**

Magazine Group Officers

Group President **JAMES A. AUTRY**
Group Vice Presidents: Publishing Directors **ADOLPH AUERBACHER, BURTON H. BOERSMA**; Editorial Director **DORIS M. EBY**; Operations **CHRISTOPHER M. LEHMAN**

Corporate Officers

Chairman of the Board **E. T. MEREDITH III**
President **ROBERT A. BURNETT**
Executive Vice President—Corporate Services
JACK D. REHM
Group Presidents: Magazine **JAMES A. AUTRY**; Broadcasting **W. C. McREYNOLDS**; Real Estate **ALLEN L. SABBAG**; Book **JERAMY LANIGAN**
Vice Presidents: Corporate Relations **DONALD L. ARNOLD**; General Counsel and Assistant Secretary **THOMAS G. FISHER**; Product Development **NEIL KUEHNL**; Special Projects **FRED STINES**; Finance **JAMES F. STACK**; Administrative Services **GERALD D. THORNTON**
Secretary **BETTY CAMPBELL MADDEN**
Treasurer **MICHAEL A. SELL**
Controller **LARRY D. HARTSOOK**









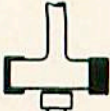

Better Homes and Gardens WOOD — the magazine for home woodworkers (ISSN 0743-894X) is published bimonthly in February, April, June, August, October, and December by Meredith Corporation, Locust at 17th, Des Moines, IA 50336. Second-class postage paid at Des Moines, Iowa. Trademark registered in Canada and Australia. Marca Registrada en Mexico. SUBSCRIPTION PRICES: One year \$18 in the United States and its possessions. Canada and other countries add \$6 per year. POSTMASTER: Send address changes to WOOD, 1716 Locust Street, Des Moines, IA 50336. April 1988, Vol. 5, No. 2, Issue No. 22. CUSTOMER SERVICE: For service on your magazine subscriptions, including change of address, write to Customer Service Manager ROBERT AUSTIN, P.O. Box 10628, Des Moines, IA 50336. Please enclose your address label from a recent issue. If you wish to phone, call toll free 1-800-678-2666.

© COPYRIGHT MEREDITH CORPORATION 1988. ALL RIGHTS RESERVED. PRINTED IN U.S.A.

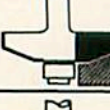
CARBIDE TIPPED ROUTER BITS

PROFESSIONAL PRODUCTION QUALITY

1000's SOLD TO READERS OF FINE WOODWORKING

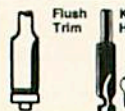
BEST CUT BEST PRICE	ITEM NO.	DESCRIPTION	RADIUS	LARGE DIAM.	CUTTING LENGTH	PRICE
	COVE					
	#01	1/4" R	1/4"	1"	1/2"	\$13.00
	#02	3/8" R	3/8"	1 1/4"	9/16"	14.00
	#03	1/2" R	1/2"	1 1/2"	5/8"	15.00
	ROUND OVER					
	#04	1/4" R	1/4"	1"	1/2"	15.00
	#05	3/8" R	3/8"	1 1/4"	5/8"	16.00
	#06	1/2" R	1/2"	1 1/2"	3/4"	19.00
	ROMAN OGEE					
	#07	5/32" R	5/32"	1 1/4"	15/32"	18.00
	#08	1/4" R	1/4"	1 1/2"	3/4"	20.00
	#11	3/8" RABBETING	Deep 3/8"	1 1/4"	1/2"	14.00
	#09	1/8" (KERF) SLOT CUTTER		1 1/4"	1/8"	14.00
	#10	1/4" (KERF) SLOT CUTTER		1 1/4"	1/4"	14.00
	#12	45° CHAMFER	45° Angle	1 1/2"	5/8"	15.00
	#15	RAISED PANEL	20° Angle	1-5/8"	1/2"	25.00
	#35	1/4" V Groove 90°		1/4"	1/4"	8.00
	#36	3/8" V Groove 90°		3/8"	3/8"	9.00
	#37	1/2" V Groove 90°		1/2"	1/2"	11.00
	#16	3/8" Dovetail 9°		3/8"	3/8"	7.50
	#17	1/2" Dovetail 14°		1/2"	1/2"	8.50
	#18	3/4" Dovetail 14°		3/4"	7/8"	10.50
	CORE BOX (ROUND NOSE)					
	#19	3/8" Core Box	3/16"	3/8"	3/8"	11.00
	#20	1/2" Core Box	1/4"	1/2"	11/32"	14.00
	#21	3/4" Core Box	3/8"	3/4"	5/8"	18.00
	GROOVE FORMING OGEE					
	#22	1/2" Grooving Ogee		1/2"	3/8"	16.50
	#23	3/4" Grooving Ogee		3/4"	7/16"	21.00
	#24	1/4" Straight Bit		1/4"	3/4"	7.00
	#25	5/16" Straight Bit		5/16"	1"	7.00
	#26	3/8" Straight Bit		3/8"	1"	7.00
	#27	1/2" Straight Bit		1/2"	1"	7.00
	#28	3/4" Straight Bit		3/4"	1"	10.50
	#13	1/2" FLUSH TRIM		1/2"	1"	8.50
	#14	3/8" KEY HOLE (This Bit only HSS)	CUTS 3/8" KEY HOLE FOR FLUSH MOUNTING PICTURE FRAMES, ETC.			

WHEN ORDERING ANY THREE OR MORE DEDUCT \$1.00 EACH
ALL PRICES POSTAGE PAID

- Professional Production Quality • 1/2" Ball Bearing Pilot
- 1/4" Diameter Shanks x 1 1/4" Long • One Piece Construction
- Two Flute Thick High Quality Tungsten Carbide Tips

To order by MasterCard or Visa Toll Free
7 Day—24 Hour Order Service Call
1-800-533-9298
or send check to:

MLCS, P.O. Box 4053D, Rydal, PA 19046

THE EDITOR'S ANGLE

NOT EXACTLY NOAH'S ARK... BUT ONE BIG WOODWORKING PROJECT



Design Editor Jim Downing plotting his next nautical move.

Ever since I've known Design Editor Jim Downing, I've been impressed by his ability to get things done. So I wasn't surprised when our resident sailor announced a few months back that he was going to build a 30' sailboat.

It's been interesting watching him set about accomplishing his goal. First, there were scale drawings of various hull styles on his walls, then section views, then drawings of the interior space, and even a scale model.

After the design phase, Jim decided he wanted to focus his efforts on building the deck, cabin, and interior rather than the hull. A quick call to a fiberglass hull manufacturer in Florida set that part of the project into motion. While the hull was being manufactured, Jim purchased all the makings for a 6-ton, 25' trailer and built it from scratch.

And since a guy has to have a place to work — especially when he's undertaking a 2,000-hour project — Jim called on his carpentry skills to "add on" to his single-car garage. To keep the roofline at a standard height and to make it easier to climb in and out of the hull, Jim and his brother, Hal, rented a backhoe and dug a 4x5x24' pit. Then, they picked up the hull, with a little help from a crane, and lowered it into a cradle Jim had built. He's now got an 11x56' all-weather workshop.

It's been about 6 months since Jim came up with his boat-building idea, and he hasn't cut one board for the boat yet. But, boy, is he ever ready. I am betting the results will be spectacular. Is all this effort and ingenuity going to pay off? Jim figures he'll have \$30,000 invested in a boat that should be worth \$75,000 when it's finished. That \$20 per hour! Gee, I hope he doesn't take up boat building full time. ♣

Larry Clayton

ABBEY TOOLS

WE OFFER DISCOUNTS UP TO 50% AND MORE

Prepaid Freight to 48 States Any Item This Page

PORTER+CABLE

MOD#	DESCRIPTION	Sell
100	7/8 H.P. Router	91
126	Door Planer	165
310	Laminate Trimmer	123
312	Laminate Tr. Offset Base	132
314	Panel Saw 4 1/2"	124
319	Tri Base Lam. Trmr	154
330	Block Sander	99
345	NEW! Saw Boss	99
361	3x24 Belt Sander	169
363	4x24 Belt Sander	182
504	H.D. 3x24 Belt Sander	332
505	H.D. 1/2 Sht Pad Sander/109	
513	Lock Mortiser w Router	679
518	3 HP 5 Speedronic Router	319
520	3 HP Router	299
555	NEW! Plate Jtr w/case	168
627	2 speed Tiger Saw	135
630	1 HP Router	107
690	1 1/2 HP Router	125
727	Chipper Cleaner	499
5069	NEW! Stair Template	135
7520	3" Taper	279
9100	7/8 HP Classic Router	125
9118	Porta Plane Kit w/case	183
95381	Hinge Template w/case	145
95829	Hinge Temp. Acc. Kit	99
43263	Carb. Cutter for 125 Plane	49

NEW! FROM PORTER CABLE

555 Biscuit Joiner \$169



Model 555

SAW BOSS \$99

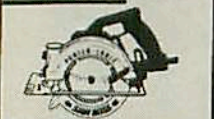

BIESEMEYER FENCES

52"	Commercial System	282
52"	Homeshop System	245
40"	Homeshop System	199
28"	Homeshop System	170

TR12 3HP Router \$169

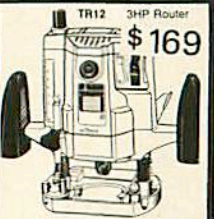

Hitachi Power Tools

C6DA	6 1/2" Cordless Circ Saw	129
DR10	3/8" Cordless Screw-Drill	89
D10DC	Same as DR10 w/Var Spd	99
TR6	Laminate Trimmer	83
TR12	3HP Router	169
PDL160	7" Disc Grinder	99
C10FA	10" Miter Saw	265
CR10V	Var Spd Recip. Saw	109
W5VA	0-2600 RPM Screwdr	69
D10V	3/8" VSR Drill	79
DH55YA	1 1/2" Roto Hammer Spine Shnk	365

Milwaukee Tools

HEAVY DUTY SAWZALL CASE \$117



6511 2 Spd

0228-1	3/8" VSR Drill	79
0222-1	3/8" VSR Drill	98
0224-1	1/2" VSR Drill	105
0587-1	Drain Cleaner Kit	229
1007-1	1/2" Drill Sc	148
1250-1	1/2" Drill	148
1610-1	1/2" Spade Hndl Drill	139
1630-1	1/2" Compact Drill	148
1670-1	1/2" Hole Hwng	195
3002-1	Rt angl Electricians Drill	178
3107-1	Rt angl Drill Kit	199
3300-1	Rt angl Magnum Drill	195
5347	1 1/2" Rotary Hmr	399
5399	1 1/2" Hammer Drill	179
5455	7 1/2" Polisher	136
6012	Orbital Sander	116
6096	7-9" Disc Grinder	116
6215	Chain Saw	135
6377	7 1/4" worm Drive Saw	168
6511	2 Spd Sawzall, case	117
6539	Cordless Screwdriver	89
6543-1	0-4000 rpm Screwdriver	149
8975	Heat Gun	59

freud

Carbide Blades and Cutters

LM7M2010	10x24T RIP	33
LU7M3010	10x60T ATB	29
LU82M010	10x60T Tr Chip	38
LU84M012	10x60T Combo	69
DS308	8" Dado Set	109
FB100	16 Pc Forstner Bit Set	138
DI050	50 Piece Drill Bit Set	59
90-100	16Pc Router Bit Set	139

\$145



94-100	5PC Router Bit Set	145
99-210	13ru Raised panel	
99-213	Router bit each	58
J5050	Blade Stabilizer 5/8" bore	17
TT108	8Pc Lathe Turning Set	55
EC210 to 213	Raised Panel	89
9924B	3/4 Stile-Rail Stp Bit	165

\$265



EC090	Complete Cabinet Set	166
EC091	Cove and Bead Set	166
EC900	Shaper Door System Set	255
99 034	Lock Miter Router Bit	59
99 032	Wedge tongue rtr bit	48
99 033	Wedge groove rtr bit	48
99 260	Ogee stile & rail rtr bit	79
99 263	cove-bead stile rail bit	79
99 PK1	Multiform Router Bit	75
WB101	Woodworking Box	269

NEW! From Freud

Biscuit Joining Machine comes with carbide blade, assortment of biscuits instructions & case

J.S.100	Our Price	\$169
0-10-20	BISCUITS 1000	29.50

RYOBI POWER TOOLS

10" \$169

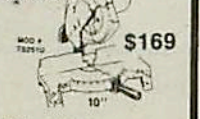

AP10	10" Surface Planer	349
E3800	0-4000 Drywall Dr.	74
E3810	0-2500 Drywall Dr.	74
J5280	Jig Saw Var Spd	119
RJ100V	VSR Reciproc Saw	99
S500A	Block Sander	88
SP1800A	7" Sander Polisher	109
TR30U	Laminate Trimmer	77
TS251U	10" Miter Saw	179
TS250S	16 1/4" Beum Saw	339
RA200	8" Portable Rad Arm Saw	227
BD101R	3/8" Cordl Drill	47
R501	1/2" VSR Drill	169
B7100	3x24 Belt Sander	129
AP10	Planer Blades	29

RYOBI \$343

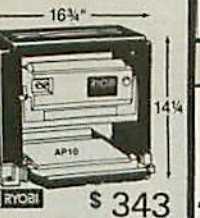

Skil Tools

77	7 1/4" Worm Dr Saw	134
471-2	1/2" Impact Wrench	
492	VS Jig Saw	159
542	Spade Handle Drill	109
551	5 1/2" Circular Saw	79
597	3/8" VSR Drill	59
598	1/2" VSR Drill	69
7565	Palm Sander	39
2016-2	3/8" cordl vsr Drill	95

ABBEY TOOLS

A DIVISION OF ABBEY MACHINERY
616 NORTH BROOKHURST STREET • ANAHEIM, CALIFORNIA 92801
ORDER BY PHONE - WE ACCEPT VISA, MASTER CARD, CHECK, MONEY ORDER
Toll Free 1-800-225-6321 Calif. 1-800-252-2221
Orange County (714) 772-7222
PRICES SUBJECT TO CHANGE WITHOUT NOTICE
Calif. Residents Add 6% Sales Tax

Makita Power Tools

#612HDW \$109

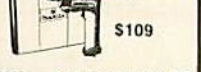

1100	3 1/4" Planer w/case	179
1900BW	3 1/4" Planer Kit	119
2708	6 1/4" Table Saw	119
3601B	1 3/8" HP Router	129
3612BR	3HP Plunge Router	189
420N	4 3/8" Trim Saw	109
5077B	Hypod Dr Saw	149
5081DW	3 3/8" Cordless Saw	119
5402A	16 3/4" Beum Saw	329
5600DW	Cordl. Circ Saw 6 1/4"	169
6012HDW3/8"	Cordl. Scndrill	109
6301LR	1/2" D Handle Drill	109
6510VLR	3/8" VSR Drill	69
6801DBV	0-4000 Drywall Scraper	89
6905B	1/2" Impact Wrench	159
6906	3/4" Impact Wrench	319
8419B2W	3/4" Hammer Drill	159
9030	1" Belt Sander	139
9207SPB	7" Polisher 2 Spd	139
9501BK	4" Mini Grinder	69
9820-2	Blade Sharpener	169
9924B	3x24" Belt Sander	129
B04550	Block Sander w/Bag	49
DP4700	1/2" VSR Drill	107
HP1020	3/8" Hammer Drill	59
DP3720	3/8" Var Spd Recip Saw	119
JR3000V	Var Spd Recip Saw	119
MAKITA 1100 & 1900	Carbide Planer Blade for	29
Makita Battery Pack Special		29
9.6 VOLT		28
7.2 VOLT		28

Engle Compressors

3/4 H.P.	115 Volt	125 PSI
AM39-HC2	1.5 Gal. Single Tank	255
AM39-HC4	3 Gal. Twin Tank	279
AM39-HC4V	3 Gal. Twin Tank	279

1.5 H.P. 115 Volt 125 PSI



All Models come with Pr. switch, on/off sw. pressure gauge, tank drain and regulator/shutoff valve.

BLACK & DECKER

\$119



3310	1 1/2 HP Router	119
1179	3/8" Drill D-1200	79
99	1980 3/8" Cordl drill w/Clutch	99
3051	7 1/4 Worm Dr Saw	119
3103	2 Spd Outsw	89
4010-10	Palm Sander	39
3310	1 1/2" HP Router	119
6513-09	1/2" Dr. Impact Wrench	119
98003	Cordl Drill Battery Pack	38

Delta Compressors

35-560	8" Carb. Dado Set	109
35-642	12" carb. Bl. 36 T ATB	49
35-613	10" carb. Bl. 40 T ATB	29
35-623	10" carb. Bl. 80 T ATB	59

Nail Guns

CALL FOR PRICES \$124



Bosch Power Tools

1581VS	Orbital Acton Jig Saw	124
11202B	1 1/2" Roto Hammer	349
1601	1 HP Router	89
1604	1 3/4 HP Router	115
91064	3/8" VSR Drill	89
11305	30lb Demo Hammer	645
1608T	Tri Base Lam. Trmr	89
1609	Offset Laminate Trmr	115
1609K	Lam Trmr Inst. Kit	165
1651	7 1/4" Circ Saw	89

TALKING BACK

We welcome comments, criticism, suggestions . . . even an occasional compliment. The volume of mail we receive makes it impossible to answer every letter, but we promise to do our level best. Send your correspondence to: Letters Editor, Better Homes and Gardens® WOOD® Magazine, Locust at 17th, Des Moines, IA 50336.

RUBBER-BAND DRAGSTER A HIT AT FAMILY CAMP

The Rubber-Band Dragster on page 84 of the April 1987 issue made a very acceptable part of my craft program for a camp group we be-

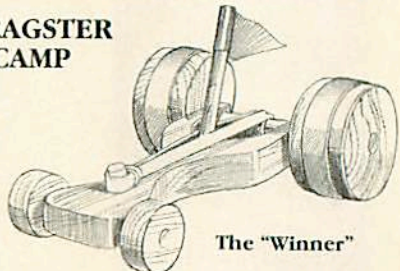

The "Winner"

long to. I made up several of them for my grandchildren prior to our annual weekend camp and found the rear axle with a nail unacceptable for young children. I substituted a 5/16x4 1/4" dowel for the rear axle. I carefully drilled a 1/8" hole in the rear axle and glued in a 1/8x3/4" dowel for the pin.

At any rate, I made up 43 kits, put all the parts in plastic bags, and the "kids" from ages 4 to 75 in our family group had a ball painting them all combinations of colors and racing them all afternoon. Thanks for making approximately 65 kids happy.

—Roger D. Bowers, Cayaboga Falls, Ohio

Roger, sounds like you belong to a fun group! Doweling is an alternative method. We recommended the brad because we felt a 1/8" dowel would weaken the axle too much. In addition, we felt some of our readers would have difficulty accurately drilling the 1/8" hole. On the same project, we also heard from a couple of readers who suggested an additional source of rubber bands for the rear wheels. The rubber bands some grocers use to bundle broccoli may be just what you're looking for.

ABRASIVE MANUFACTURERS, NICE PEOPLE

From the "Know Your Woodworking Abrasives" article beginning on page 50 of the December 1987 issue, we have some additional names to add the source list:

Belts and disks

- Econ-Abrasives, P.O. Box 86501, Plano, TX 75086; 214/377-9779.
- Oxo Abrasives Inc., P.O. Box 690653, Houston, TX 77069; 713/537-2728.

Inflatable and flapper sanding devices

- Northwest Carving Supplies, P.O. Box 407, Manbatan, MT 59741; 406/284-6009.
- Sand-Rite Manufacturing Co., 321 N. Justine St., Chicago, IL 60607; 800-521-2318.

BRIGHT LIGHT AT THE END OF THE TRAIN TUNNEL

The train-tunnel bookends project on page 80 of the April 1987 issue calls for 14 pieces of 1/8" brass rod cut 1/2" long. The thought of sore fingers and inaccurate lengths was somewhat dismaying. My solution is a 1 1/2 x 1 1/8" piece of scrap pine with a table-saw kerf 3/4" deep as shown in the drawing at right. At a right angle to the kerf, I drilled a 1/8" hole. When secured in a vise, the jig held the rod snugly while I cut the 1/2" pieces easily and accurately. You can apply this idea to cutting small-diameter rods of various lengths.

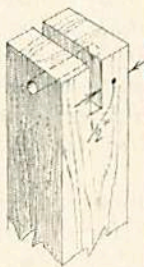

—Duane C. Hawk, Rush, N.Y.

PLAUDITS TO A TURNER

After reading your article "Secrets of a Production Turner," February 1986, I got a hold of Bert Thompson and went to Toronto, Ontario to study with him that same month. He is an extraordinary fellow. Bert has his own way of doing things, but he certainly changed my career path. I left knowing that I was going to be a woodturner, and be a good one.



Bert Thompson

Bert spent a week with me at my home last fall, helping me set up a 14' lathe bed. He did it just to see that I got started right. You might remind readers again that Bert wants to pass on his skills. Someday, that wise old teacher isn't going to be around.

—Bob Neal, Quality Woodworking, Peoria, Ill.

Bob, thanks for those comments about our old friend, Canadian woodturner Bert Thompson. We saw him awhile back, too, and at a perky 72 years of age, he still seems to have one aim in life—to teach people to turn "the proper way." Bert's address is Canadian School of Woodturning, 1069 Southdown Road, Mississauga, Ontario L5J 2Y1, Canada.

A CLOSER LOOK AT FILE CABINET DIMENSION

The Bill of Materials for the stackable file cabinet on page 73 of the February 1988 issue incorrectly lists the width of the bottom frame front and back pieces (F) as 2". The pieces should be 1 3/8" wide. If you've already cut the parts and assembled the bottom panel, just rip 3/8" off the front and back pieces. The finished length of the bottom frame and panel should be 23 1/4". The change does not affect the drawer size. We apologize for any inconvenience this may have caused.

WOODWORKERS HARDWARE

WHOLESALE ORDER FORM

Part No.	Price	Part No.	Price	Part No.	Price
Hardwood Toy Wheels		Oak or Birch Galley Spindles		Picture Hangers	
#W075100 . 3/4" . \$3.50/100		#S1 Birch . 1-1/8" . \$1.30/10		#S23 . 1-7/8" . \$4.70/100	
#W087100 . 7/8" . \$4.70/100		\$9.00/100		Mini Hanger	
#W100100 . 1" . \$6.00/100		#S4 Birch . 1 1/2" . \$1.70/10		#7247 . 5/8" . \$2.60/100	
#W125100 . 1 1/4" . \$8.00/100		\$15.60/100		Saw Tooth Hangers	
#W150100 . 1 1/2" . \$11.00/100		#S10AK . 1-1/8" . \$1.50/10		#S59 . 1-5/8" . \$4.17/100	
#W175100 . 1 3/4" . \$15.60/100		\$12.00/100		#S60 . 2 3/4" . \$4.50/100	
#W200100 . 2" . \$19.50/100		#S40AK . 1 1/2" . \$2.40/10		#406 . Self-Fastening Hangers	\$4.77/100
#W22520 . 2 1/4" . \$7.30/20		\$22.00/100		Prong Hanger	
#W25020 . 2 1/2" . \$8.80/20		Birch Screw Hole Buttons		#7248 . \$2.90/100	
#W27520 . 2 3/4" . \$10.20/20		#1432 . 3/8" . \$1.76/100		Solid Brass Cup Hooks	
Axle Pegs		\$7.50/500		#812 . 1/2" . \$5.55/100	
#AP1 . fits 1"-2" . \$4.10/100		#1434 . 1/2" . \$1.76/100		#858 . 5/8" . \$6.30/100	
#AP4 . fits 2 1/4"-2 3/4" . \$1.60/20		\$8.00/500		#834 . 3/4" . \$7.45/100	
2" Wood Wheels With Tread Grooves		Oak Screw Hole Buttons		6" Brass & Porcelain Hooks	
#705020 . Front . \$6.30/20		#1452 . 3/8" . \$3.70/100		#6417 . 3 Prong . \$5.85/ea.	
#7050100 . \$25.50/100		\$15.50/500		#6416 . 2 Prong . \$2.97/ea.	
(Order AP4 Peg for above)		#1454 . 1/2" . \$3.80/100		Black Hammer Hinge w/Screws	
#705120 . Dual Rear . \$10.50/20		\$16.00/500		#1730 . \$1.62/2	
#7051100 . \$42.90/100		Birch Candle Cups		\$7.17/10	
#APS . Axle Pegs for Dual Rear Wheel . \$1.98/20		#7290 . 1" . \$2.00/10		Brass Plated Hinges	
\$9.00/100		\$13.00/100		#910 . 1" . \$1.49/10	
Birch Shaker Pegs		#CC1 . 1 1/2" . \$2.90/10		\$928 . 1 1/2" . \$2.39/10	
#7226 . 3 1/2" . \$15.00/100		\$19.00/100		Screws for Above	
#7280 . 2 1/2" . \$1.90/10		2" Brass Eagles		#F124 . \$2.40/100	
\$13.90/100		#878 . \$2.49/10		Production Screws	
#7227 . 1 1/4" . \$1.10/10		Quartz Clock Movement W/Hands		#6277 . 1 1/4" x #6 . \$1.70/100	
\$7.60/100		#082 . 1-4 . \$6.48/ea.		#6278 . 1-5/8" x #6 . \$1.90/100	
Oak Shaker Pegs		# . 5-9 . \$5.10/ea.		#6279 . 2" x #6 . \$2.50/100	
#SKP2 . 3 1/2" . \$3.35/10		# . 10-24 . \$4.55/ea.		#6282 . 3" x #8 . \$4.75/100	
\$28.00/100		# . 25+ . \$3.95/ea.		Sand Paper Sheets 9" x 11"	
#7261 . 1 3/4" . \$2.00/10		Push-Thru Lamp Socket		#81220 . 220gr . \$16.75/100	
\$15.00/100		#940 . \$1.59/ea.		#81150 . 150gr . \$16.80/100	
Birch Mug Pegs		Lazy Susan Bearings		#81120 . 120gr . \$16.90/100	
#7237 . 3 1/4" . \$2.27/10		#LC3 . 3" . \$5.95/ea.		#81100 . 100gr . \$17.20/100	
\$19.90/100		#LC4 . 4" . \$1.25/ea.		#81080 . 80gr . \$11.50/50	
Birch Country Pegs		#LC6 . 6" . \$2.25/ea.		#81060 . 60gr . \$11.60/50	
#1770 . 3 1/2" . \$1.80/10		#12C . 12" . \$5.99/ea.		#81050 . 50gr . \$11.70/50	
\$13.00/100		Clipboard Clips		#81234 . Assort . \$16.50/70	
Birch Spindles		#L5 . 3" . \$5.55/ea.		Sanding Belts 3" x 21"	
#S6 . 5 1/4" . \$4.99/ea.		#S16 . 6" . \$7.75/ea.		#1700 . 120 gr . \$12.20/10	
#S85 . 9" . \$8.55/ea.		Magnetic Strip		#1701 . 80 gr . \$13.00/10	
#S110 . 11" . \$1.35/ea.		#120A . 120" x 1/2" . \$4.40/roll		#1702 . 50 gr . \$13.50/10	
Birch Dowel Pins		Paper Towel Roller (spring loaded) #7238		#1703 . 36 gr . \$14.65/10	
#1142 . 1/4" x 2" . \$1.90/100		\$1.19/ea.		#1704 . 120 gr . \$13.10/10	
\$8.50/500		Toy Train Plans		#1705 . 80 gr . \$13.50/10	
#1382 . 3/8" x 2" . \$2.00/100		30" #T55 . \$6.99/set		#1706 . 50 gr . \$14.60/10	
\$9.25/500				#1707 . 36 gr . \$15.85/10	

ORDER TOLL FREE 1-800-441-9870

MN 1-612-472-5544
8 AM - 5 PM Central

Send \$1.00 for Catalog or \$5.00 for Catalog plus Best Selling plan package (\$10.00 value) or order directly from this ad by phone or mail.

HOW TO ORDER: State quantity, part number, item, price, and total of order. Send check, money order, or Visa or M.C. number and Exp. date. Shipping: \$25.00 to \$49.99 add \$3.50, \$50.00 to \$99.99 add \$4.50, Over \$100.00 add \$5.00. MN Res. add 8% tax. Minimum order \$25.00.

Please send me: Catalog \$1.00 Catalog and Plan Package \$5.00

Print Name _____

Address _____

City _____

State _____

Zip _____

Phone # (_____) _____

MEISEL HARDWARE SPECIALTIES

P.O. BOX 70 WD-4
Mound, MN 55364

SOFT TOUCH WITH STAIN

Using a paintbrush to apply oil-based stains works well enough, but cleaning the brushes afterward takes time and wastes paint thinner.

TIP: Use scraps of foam rubber as stain applicators. You can buy leftovers at crafts stores for pennies and cut pieces to just the size and shape to fit the staining job. The foam rubber reaches into corners and cracks while your hands stay clean. When finished staining, simply discard the applicator.

—Thornton H. Waite, Idaho Falls, Idaho

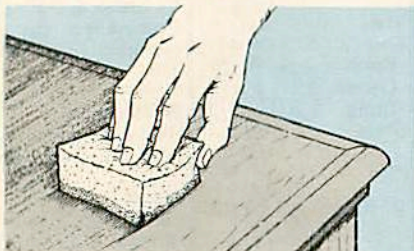

ALIGNED RIGHT THE FIRST TIME

When crosscutting with a table saw, it's not always easy to line up the stock with the blade so the saw kerf occurs precisely on your cutting mark. Positioning the material against the miter gauge may take two or three tries before you get it right.

TIP: Mark the location and thickness of the saw-blade cut or kerf on a piece of masking tape placed a few inches in front of the blade. To do this, lay a straightedge along one side of the blade to mark the tape. Or, clamp a piece of stock to the miter gauge, cut the stock, and use the cut end as a guide for marking the tape. Repeat these steps on the opposite side of the blade to mark the other side of the kerf. Use the marks on the tape to line up stock for first-time accurate cuts.

—Dennis Bennett, Kirtland AFB, N.M.

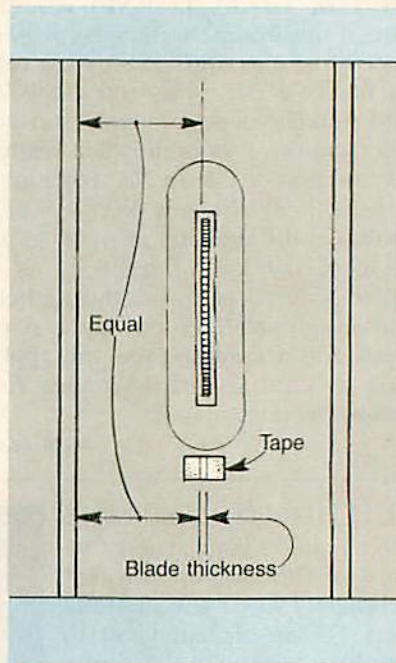

WHEN DUST GETS IN YOUR EYES

You can get lost in a cloud of dust when working with an orbital or belt sander. The dust obscures your work, to say nothing of restricting comfortable breathing.

TIP: Blow those troubles away with a small, nonoscillating household fan placed 3 or 4 feet away from the sander you're using. The trick is to turn the fan to a low speed and place it at a right angle to your work and to remove the dust without raising a dust storm. In small shops, however, this may cause an airborne dust problem.

—From the WOOD magazine shop

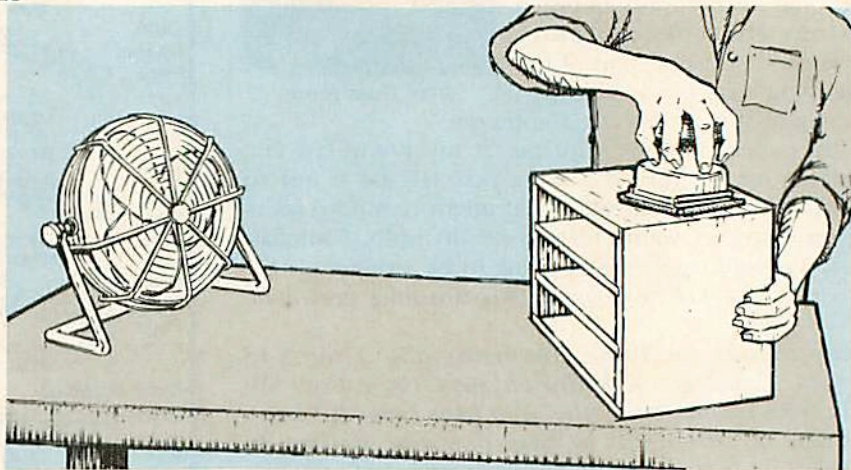

QUICK FIX FOR LOOSE MITER-GAUGE BARS

It's unnerving when the miter-gauge bar on your table saw or band saw rattles loosely in the slot. A loose bar also affects the accuracy of the cut. You should replace the bar. Here's a temporary fix.

TIP: Use a center punch, as shown at right, to put well-spaced dimples in each side of the rail. This removes extra play until the metal raised by the punch wears away.

—Larry Bedaw, North Swazey, N.H.

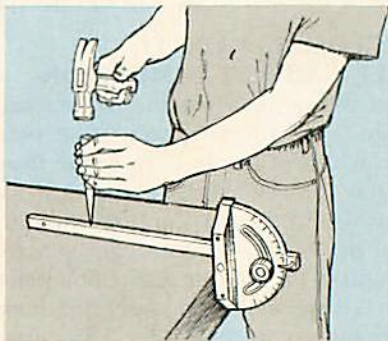

Do you have any good tips you'd like to share with our readers? We'll pay you \$25 for each submission we publish. No shop tips can be returned. Mail your tips to:

Shop Tips
Better Homes and GardensSM
WOODSM Magazine
Locust at 17th
Des Moines, IA 50336

Continued on page 14

Sometimes,
the difference between a project
and a masterpiece
is having the proper guidance.



The Delta Unifence® Saw Guide gives you accuracy, versatility, and performance no other fence can match.

Its exclusive dual English/metric scale makes set-ups to $\frac{1}{64}$ " (.5 mm) quick and easy.

Its unique fence body slides back and forth across the cutting area and locks in place. So you can easily make fast repetitive cut-offs, do precision ripping, or cut large panels.

Fast, accurate cuts on laminated stock up to 4' x 8' are easy, too. Lay the two-position fence body on its side and veneer surfaces can extend over its lip. Or raise it $\frac{1}{8}$ " and run the laminate underneath.

The Unifence Saw Guide works with your Delta Unisaw® or just about any other table saw. It even comes with a sturdy steel table frame and legs. (You can order our table board or make your own for it.) And last but not least, you can get a Unifence for a really great price.

No tool is a substitute for craftsmanship. But a Delta Unifence can provide the guidance to help you do your very best. Call toll-free for the name of your Delta Distributor. Delta International Machinery Corp., 800/438-2486 (in PA, 800/438-2487).

 **DELTA**
Building On Tradition

TIPS FROM YOUR SHOP (AND OURS)

Continued from page 12

SLICK SOLUTION FOR RIBBED BAND-SAW TABLES

The grooves tooled into the table surface of some band saws can interfere with the movement of small wood pieces while you're sawing them. This lack of control not only poses a hazard to your fingers, but can botch the cutting job, too.

TIP: Attaching an overlay sheet of $\frac{1}{4}$ " clear acrylic plastic to the top of the table provides a slick work surface for cutting small pieces. Saw a kerf halfway into the acrylic sheet so it's aligned with all four table edges, as shown. Cut or notch an opening for the table-leveling screw, if necessary. Tape the sheet to the tabletop with small strips of double-faced tape.

—Bob Ward, Lakewood, Ohio

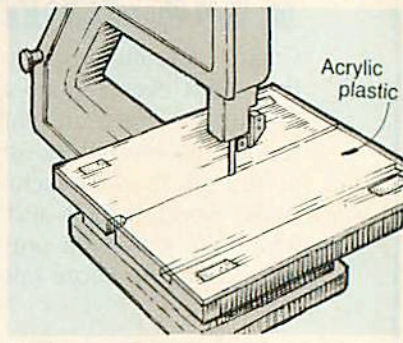

JAWS III

There's a good reason three-jawed Jacobs chucks used on portable electric drills, drill presses, and most lathes have three evenly spaced holes for inserting the chuck key.

TIP: When tightening the chuck, use the key in all three holes—not just one. This applies equally distributed pressure on the jaws, so bit and accessory shanks won't have as great a tendency to slip.

—John Seminev, Crete, Ill.

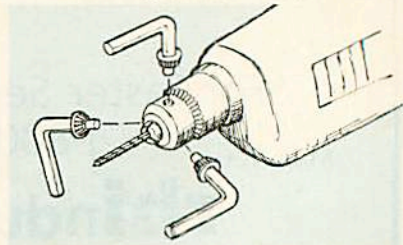

Continued on page 16

Continued from page 14

SUPER TRACING MATERIAL

Paper and cardboard patterns take a real beating when you trace them repeatedly onto the workpiece.

TIP: Use the original pattern as a master for making a working pattern out of matte acetate. This material looks frosty on its matte side, which has a texture that readily takes pencil marks. Use a slightly dull soft-lead pencil to trace the pattern onto the acetate. Now, tape one edge of the acetate sheet to the workpiece, and slip a piece of carbon paper under the pattern, as shown in the drawing below: Use a pencil or length of sharpened dowel to trace the image onto the workpiece.

—James R. Gates, Hermitage, Tenn.

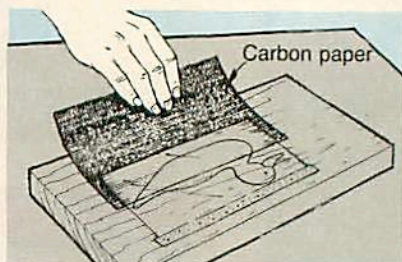

HOW TO KEEP STOP BLOCKS IN THE CLEAR

Many woodworkers clamp a square block of wood to their saw or router table to serve as a stop for making repeated cuts. But the accumulation of sawdust and chips against the block results in inconsistent lengths.

TIP: Turn the block so that only a corner of it stops the movement of your workpieces. Waste particles will now blow to the side and back of block, leaving the front clear to precisely stop the cut.

—Richard Kandus, Arcata, Calif.

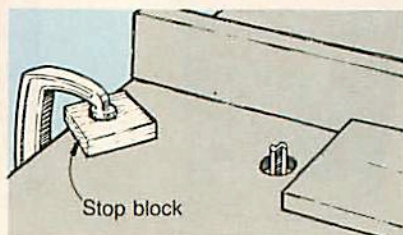

Continued on page 18

THINK ALL C-CLAMPS ARE THE SAME? THINK AGAIN.

Not all C-Clamps are created equal. For a tradition of quality and performance, choose VISE-GRIP® Locking C-Clamps.

Old fashioned screw-type C-Clamps just don't compare with VISE-GRIP clamps. Unique self-leveling swivel pads protect work. They're easy to use, lock on quickly and provide a sure grip on any surface.

With nine sizes—ranging from 4" to 24"—there's a VISE-GRIP Locking C-Clamp for every job.

Don't go round and round with screw-type C-Clamps when you can have the quality and efficiency of VISE-GRIP Locking C-Clamps.

VISE-GRIP. THE ONLY NAME YOU NEED TO KNOW IN LOCKING HAND TOOLS.

© 1987 1988 Peterson Manufacturing Co., Inc. Lincoln, Nebraska 68508



Backyard Camelback

Build our rendition of the classic Camelback sofa for your deck or patio. Coordinating coffee table plans are also available. Both include full size patterns.

Plan # 782-w	\$8.95
Table # 783-w	\$5.95
Postage and handling	
U.S. and Canada	\$1.50
Foreign countries	\$3.50
Plan Catalog	\$1.95
Total	\$

Iowa residents add sales tax.

WORKSHOP BLUEPRINT

P.O. BOX 65725, WEST DES MOINES, IA 50265

Furniture Restoration

Big Money in Small Business

Stripping * Repairing * Refinishing
Mirror Resilvering * Veneering

Earn \$200-\$1000 a day!

At home or in shop * Spare time, full time * Men or women * Complete training, no experience necessary * Simple, fast, safe, fun.

FREE CATALOG

Send \$1.00 for postage & handling to:
MINUTEMAN, INC., Dept. 17,
115 N. Monroe St., Waterloo, WI 53594

Just 3 of the 36 Reasons Hitachi Woodworking Tools Are the Choice of Master Craftsmen

Your work is good and getting better. You know the value of a superior, go-the-distance tool; the tool that gives you exactly what you want, time after time. You're ready for Hitachi.



C15FB

Consider just 3 of Hitachi's superb line of 36 woodworking tools:

Hitachi 15" Heavy-Duty Power Miter: Cuts wood, plastic and aluminum. All ball bearing construction with the largest cutting capacity of any power miter. Consistent power, a workhorse that will stay with you for years of steady service.

Hitachi Heavy-Duty 3" Belt Sander: No sander will take you farther. Two speeds to select for the job and clean sanding with efficient dust collector.

Pick it up. The grip and weight and design all say: "The best 3" belt built."

Hitachi 3HP Super-Duty Plunge Router: Fast clean cuts by an unmatched horsepower motor. Quick changes in cutting depth. Again, when you pick it up and use it, you know. Here's



TR12

the tough, exacting tool to match your standards. Invest in one Hitachi tool and you're going to want more of the supreme woodworking power tool line. Some may say it's more tool than necessary, but try one and you'll quickly disagree. You'll see why master craftsmen the world over are turning to Hitachi and staying there. Hitachi works. Hitachi stays.

Send to address below for complete catalog listing of all Hitachi Power Tools. Be sure to include complete return address.



SB75

HITACHI
The Boss

East: 4487 E Park Drive, Norcross, GA 30093 Tel: 404-925-1774-5 West: 7490 Lampson Avenue, Garden Grove, CA 92641 Tel: 714-891-5330

TIPS FROM YOUR SHOP (AND OURS)

Continued from page 16

OUT ON THE CUTTING EDGE

While at your workbench, have you ever needed to cut a piece of string, cord, or tape—and didn't have a knife or pair of scissors?

TIP: Add an integral string and tape cutter to your bench: To one edge of the benchtop, glue or tack the serrated metal strip cut from an empty box of aluminum foil or plastic wrap. Position it with the serrated edge level with the bench surface, as shown, in a location where you won't accidentally bump into it. A used hacksaw blade will also work, but isn't quite as sharp.

—Wally King, Oakland, Calif.

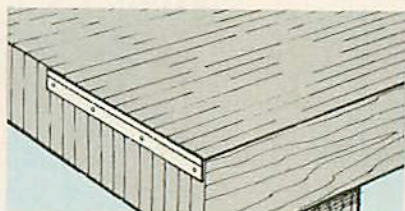

ZAP INSECT INVADERS

"Surprise" insects in carving blocks and other small pieces of wood can be unpleasant discoveries, particularly when a finished piece turns out to be infested. There must be a chemical-free way to get rid of the bugs.

TIP: A quick shot in a kitchen microwave oven will put all intruders out of business. Set the oven on its lowest setting and turn it on for 1 minute. The resulting molecular vibration, not the heat, kills the bugs. To avoid splits and checks, be careful that you don't overheat the wood.

—John C. Monaghan, Goleta, Calif.

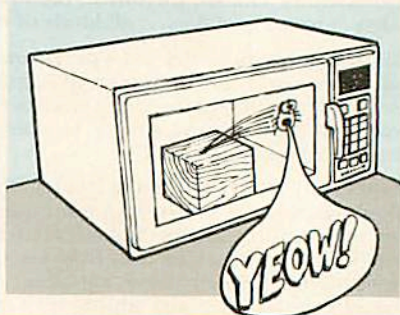

SHOWS COLUMBUS, OH

Veterans Memorial Hall
Columbus, OH
Mar. 11 - Noon - 6 pm
Mar. 12 - 10 am - 6 pm
Mar. 13 - 10 am - 5 pm

BOSTON

Bayside Expo Center
Boston, MA
Apr. 29 - 5 pm - 9 pm
Apr. 30 - 10 am - 6 pm
May 1 - 10 am - 5 pm

INFO: W.A.N.A., P.O. Box 706, Plymouth, NH 03264
Call Toll Free 1-800-521-7623, 10am - 4pm, M-F

FREE PLANS!

How to get hundreds of FREE PLANS, Federal and State benefits, services, programs, grants, loans, cash, publications, much more—explained clearly in this NEW GUIDE. Your taxes help pay for all this—now it's YOUR turn to cash in! The author has written OVER 30 Government Benefits Guides and has 14 years of government service and research experience. ONLY \$1.95. Money-Back Guarantee.

Mark Weiss, Author
Dept. WI, Box 402091 • Miami Beach, FL 33140

"NATIONAL DIRECTORY OF FREE AND INEXPENSIVE PLANS, BENEFITS, AND LOANS FOR PEOPLE WHO ARE GOING TO BUILD, REMODEL, ADD ON OR DECORATE!"

A "MITER FINE" CUTOFF FIXTURE

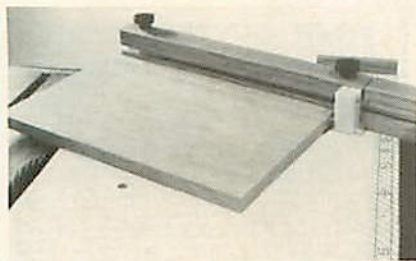

Most table-saw miter gauges have difficult-to-read scales. And more often than not, the setting is just an estimation of the true angle. Not so with the Dubby cutoff fixture. It has a large, easy-to-read Mylar angle scale and a long, sturdy backstop (fence) attached to a sliding platform, providing plenty of support for large workpieces. And, we've never seen a more accurate miter fixture than this one.

What makes the Dubby so accurate? The large, precise scale helps. But here's the secret: When you set

up the Dubby, you reference the sliding table, fence, and angle guide to the saw blade, not to the miter slot in the table. We fitted the Dubby to an old Sears table saw with a reputation for inaccurate crosscuts and miters. The fixture enabled the saw to make exact cuts every time, even in wide boards.

The sliding table attaches to a guide bar, which rides in the miter slot on your saw table. When you order the fixture, specify your saw brand and model so the manufacturer can provide the right-sized guide bar and table.

We'd recommend the Dubby to anyone who is interested in doing careful, precision work. We did find that it takes some time for initial setup, which must be done carefully to ensure complete accuracy.

Dubby Cutoff Fixture; \$130 ppd. from In-line Industries, 661 S. Main St., Webster, MA 01570.

LASER-CUT FILIGREE: FANCY!

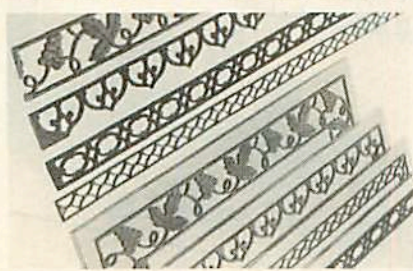

Dress up furniture, frames, bookshelves, and other projects with these fancy filigree strips from Constantine's. The wood-cutting laser used to make this filigree cuts a precise, intricate pattern out of 1/8" two-faced maple plywood. Each of the 12 samples we ordered were of excellent quality, ready to be stained or painted.

Laser-Cut Filigree; 12 different styles in 36" lengths, \$5.75 to \$11.75 each ppd. from Albert Constantine & Son, Inc., 2050 Eastchester Rd., Bronx, NY 10461.

Continued on page 22

NEW
From
Penn State
Industries... a
supplier of quality products
for over 40 years

Professional quality, precision . . . Super 15" Scroll Saw

Comparable value over \$500
Only ~~\$139.95~~ **\$129.95** shipped complete
ready to run

New Lower Price
\$129.95

This versatile machine makes cutting intricate wood patterns easy — **great for making toys, jewelry, puzzles, fretwork, etc.** The blade is driven on both up and down stroke with a smooth cutting parallel rocker arm system. This system avoids blade breakage and **creates a smooth finish that virtually eliminates sanding.** Our saw is easy to use and is made with a cast construction that insures durability. **We fully support our product with replacement parts and repairs if needed. Thousands of satisfied customers use our saw world-wide.**

SPECIFICATIONS:

- Cast iron construction
- Throat depth — 15"
- Max. depth of cut — 2"
- Cuts per minute — 1725
- Weight — 43 lbs
- Motor — Heavy duty totally enclosed fan cooled 110V - 120V UL listed, ball bearing — induction motor
- **Dust Blower (Optional - Add \$15.00)**
- Use standard 5" blades
- Stroke length — 3/4"
- Table Tilt — 0 - 45°
- Table Size — 8" x 17"

NEW!



Dear Penn State:

"My SUPER Scroll Saw was delivered two days ago and it performs like the neighbor's \$700 one. I'm delighted."

Mrs. S.A. Swartz
White Cloud, KS

"I recently received one of your 15" Scroll Saws as a gift and was impressed with its construction and other features. I'd say it can be compared favorably with such saws as Excaliber and the Hegner line."

Mr. E. L. Brendza
San Bernardino, CA

"I am thrilled with the performance as is my wife who has operated it more than I have. As a special automatic machine designer for the last 40 years, I feel that I am qualified to compliment you on a well-designed machine."

C.M. Smeigh
Ft. Worth, TX

The Editor The Woodworker's Journal

"Kudos for the folks at Penn State Industries for value and customer service! When I contacted them concerning a minor problem, replacements were rushed out to me the same day."

As an amateur woodworker, I was pleased to find that lower priced, well made equipment is available from people who are willing to stand behind their products.

A. Mortenson
New Milford, CT

30 Day Money Back
Guarantee—1 year
warranty parts/labor

FREE: 12 Blades &
Blade Holder Set
with purchase

PENN STATE INDUSTRIES -W

2850 Comly Road • Philadelphia, PA 19154
1-215-676-7609 (Ext. 15)

* Add \$15.00 for Blower Option • Visa, MasterCard, Check or Money Order Accepted
Add \$10.00 for shipping in Continental U.S. • Pennsylvania residents add 6% sales tax

"EVER-LAST" Belts from...

**INDUSTRIAL
BRASIVES CO.**



Check your size and how many dozen. We will ship assorted grits unless otherwise specified.

- 1" x 30" \$13.70/doz.
- 1" x 42" \$13.75/doz.
- 1" x 44" \$13.80/doz.
- 3" x 18" \$14.75/doz.
- 3" x 21" \$15.25/doz.
- 3" x 23 3/4" \$15.70/doz.
- 3" x 24" \$15.75/doz.
- 3" x 27" \$16.25/doz.
- 4" x 21 3/4" \$17.75/doz.
- 4" x 24" \$18.25/doz.
- 4" x 36" \$21.95/doz.
- 6" x 48" \$27.95/1/2 doz.

Other size belts on request.

STIKY DISC, Rugged cloth with PSA backing.

- 6" diameter ... \$1.00 each
- 8" diameter ... 1.25 each
- 9" diameter ... 1.50 each
- 12" diameter ... 2.00 each

9" x 11" PAPER SHEETS

A/O Cabinet Paper
50/pk. 100/pk.

- 40-D ... \$17/pk. \$31/pk.
- 50-D ... 16/pk. 28/pk.
- 60-D ... 15/pk. 26/pk.
- 80-D ... 14/pk. 24/pk.
- 100-C ... 13/pk. 22/pk.
- 120-C ... 13/pk. 22/pk.
- 150-C ... 13/pk. 22/pk.

No Load Finishing Paper
50/pk. 100/pk.

- 180-A ... \$11/pk. \$19/pk.
- 220-A ... 11/pk. 19/pk.
- 280-A ... 11/pk. 19/pk.
- 320-A ... 11/pk. 19/pk.
- 400-A ... 11/pk. 19/pk.

- BELT CLEANING STICK
2" x 2" x 6" ... \$6.95

For Fast Delivery Call Toll Free
1-800-428-2222 (U.S.A.)
1-800-222-2292 (PA only)

**INDUSTRIAL
BRASIVES CO.**
643 N. 8th STREET
READING, PA 19612

SHIPPING CHARGES - Under \$35 add \$2.50. \$35 or more add \$4.00. Over \$100, shipping free. PA residents add 6% sales tax.

- MONEY ORDER CHECK
- MASTER CARD VISA Exp. Date _____

Acct. # _____
NAME _____
STREET _____
CITY _____ STATE _____
ZIP _____ DAYTIME PHONE () _____

FREE Sanding Belts
... get 6 FREE Belts for each dozen ordered. All belts, aluminum oxide, first quality, with bump-free splices.

MONEY-BACK GUARANTEE

Prompt delivery from stock.

PRODUCTS THAT PERFORM

Continued from page 21

CARVERS: A NEW WAY TO FIGURE IT OUT

Have you ever tried to carve an anatomically correct human figure, only to have it turn out like the Hunchback of Notre Dame? You could take a course in human figure drawing, but here's an easier way to put your carvings into proportion.

With this human-figure proportion wheel, you simply dial in the overall height of your carving and it automatically gives you the correct proportional dimensions for arms, legs, hands, feet, head, torso, and other body parts for males and females. Includes 2-page instruction pamphlet.

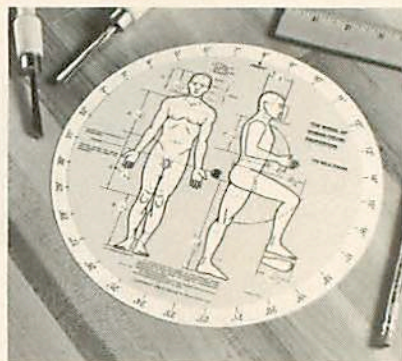

The Human Figure Proportion Wheel; \$9.50 ppd. from Woodcraft Supply Corp., 41 Atlantic Ave., P.O. Box 4000, Woburn, MA 01888.

RIG YOUR ROUTER FOR MORTISES

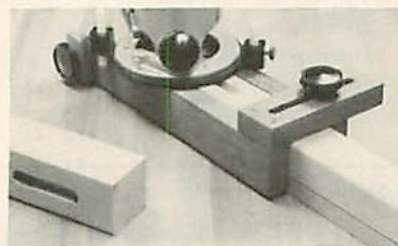

Rig-A-Mortise, a simple, inexpensive router attachment, makes blind mortising a cinch. Here's how it works: The attachment consists of a plastic router base with two adjustable guide pins. You install a straight bit of the desired size, set the router for depth

of cut, and then mark the length of the mortise you want on the stock. To center the bit on the stock, rotate the router base until the guide pins contact the sides of the workpiece. Then, turn on the router, lower it into the stock, and cut a perfectly centered mortise.

The set includes instructions for a simple jig that solves this problem shown in the photo at left; also for a jig that enables Rig-A-Mortise to cut tenons.

Rig-A-Mortise; \$14.95 ppd; hardware for mortise-and-tenon jigs \$9 ppd. from Tool-Aid, 6950 Eric Lane, Wheatland, CA 95692.

PUT YOUR WORK WHERE YOU WANT IT

Carvers rely on multiposition workstands to position their work for carving, gluing, burning, sanding, and painting. Here's one at an affordable price. Made of die-cast, machined aluminum, the stand clamps to work surfaces up to 2" thick. With a base that swivels 360° and arm that pivots 180°, the workstand positions your workpiece at any angle with single-knob operation.

Multi-Position Work Stand; \$24.95 ppd., extra mounting plate \$3.95 ppd. from Woodcraft Supply Corp., 41 Atlantic Ave., P.O. Box 4000, Woburn, MA 01888.

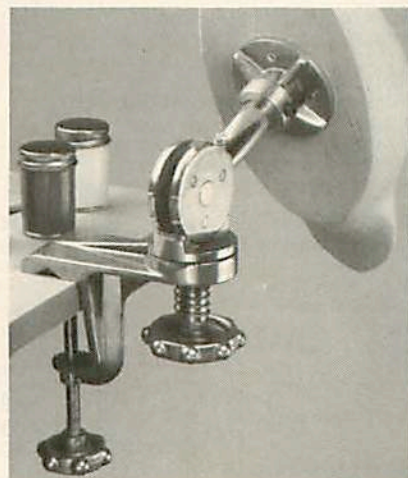

Continued on page 24

NEW
"Quad-Drive"

DRUM SANDER

with Infinitely Variable Power Feed!



At last! A complete power-feed Drum Sander at an affordable price! Choose from 12" and 26" models SAVES TIME...IMPROVES RESULTS. Use this high-tolerance machine for light dimensioning as well as the finest finish work.

Now you can add new beauty to each woodworking project, save hours of tedious hand sanding! In a matter of seconds you can produce a satin-smooth finish impossible to duplicate with hand methods or hand-held power sanders...no more low spots, waves or cross-grain marks! Check these advantages...

FREE FACTS!

Send for complete facts on how you can try this low-cost tool in your own shop for one full month without risk. See how the sander can dimension and finish-sand cabinet pieces, resawn stock, paneling, toys, tabletops, knees, burls, crotches and much, much more! You'll soon find it's one of the most valuable tools in your shop! Made in U.S.A. Easy Terms.

Call Toll-Free 1(800)538-4200, Ext. 2423

30-DAY FREE TRIAL!

NEW INFINITELY VARIABLE FEED RATE gives you total control in any sanding situation!

EXCLUSIVE QUAD-DRIVE FEED SYSTEM...four, power-feed rollers for maximum traction. Eliminates oversanding at first and last few inches of a board!

NEW FELT-BACKED ABRASIVE mounts in just seconds to Velcro covered drum. The harder you sand, the tighter it stays! Eliminates stretching...allows fast removal and re-use!



YES! Please rush my **FREE INFORMATION KIT** and details on your 30-Day Free Trial Guarantee.

Woodmaster Tools, Dept. RW23, 2908 Oak, Kansas City, MO 65108

NAME _____
ADDRESS _____
CITY _____ STATE _____ ZIP _____

PRODUCTS THAT PERFORM

Continued from page 22

A NEW ANGLE ON BOWL GOUGES



Unsatisfied with the factory-ground edge on his Sorby bowl gouges, professional woodturner Liam O'Neill of County Clare, Ireland, reground the gouges to a steeper, more acute angle. By doing this, Liam found the tools easier to use. His special grind angle increases the cutting area of the gouges, which does two things: The tools stay sharp longer, and are easier to control. (The steeper grind allows you to hold the tool at a more horizontal position.)

The acute-angled blade has another advantage: With it, you can finish-cut with the grain on the outside of a bowl where it narrows at the base near the faceplate; a conventional gouge would cut against the grain.

So we don't lead you astray, these tools aren't for the beginning woodturner. But they do make an excellent addition to a dedicated turner's arsenal. You can buy the gouges, autographed by O'Neill, with or without his custom-turned handles.

Sorby Bowl Gouges by Liam O'Neill: 1/4" gouge \$38 (without handle), \$52 with handle; 3/8" gouge \$44, \$62 with handle; 1/2" gouge \$49, \$72 with handle. Order ppd. from Harold Imber, 1005 Meadow Lane, Middletown, PA 17057.

POWERMATIC



Call For Our Low Prices! We carry the entire Powermatic line at very attractive prices. Please call for our prices on the Model 66 and other Powermatic machines. You'll be glad you did!

Model 66 Table Saw with 50" Biesemeyer Rip Fence, 3HP, 1PH or 5HP, 3PH motor. FOB our Warehouse.

Mini-Max

World's Best Jointer-Planer

FS35 Jointer-Planer \$2195

Length 63" Width 13 1/4" Weight 719 lbs. 3HP, 1PH or 3HP, 3PH Motor

Please call or write for more information on the FS35 jointer-planer. We stock the entire Mini-Max line. Please call for our prices. FOB our Warehouse. Call for discounted freight rates.



MAKITA

- 804510 4" finishing sander \$59
- 1100 3 1/4" planer kit \$179
- 1805 6 1/4" planer kit \$277
- 2708 8 1/4" table saw \$229
- 3612BR plunge router \$169
- GUIDES for 3612BR \$ 28
- 3601B 1/2" router \$118
- 3700B 1/2" trimmer \$ 95
- 4301BV orbital jig saw \$139
- 5007NB 7 1/4" circular saw \$109
- 6000LR 1/2" clutch drill \$119
- 6012HDW 1/2" cordless clutch drill \$109
- 9900B 3x21 belt sander \$129
- 99824DB 3x24 belt sander \$139
- 8401 4x24 belt sander \$159
- 98202 blade sharpener \$169

RYOBI SPECIALS

- S500A 3 x 4 1/4 Pad Sander \$ 39
- SU6200 1/2 Sheet Pad Sander \$ 99
- B7075 3 x 21 Dustless Belt Sander \$105
- B7100 3 x 24 Dustless Belt Sander \$121
- B7200A 4 x 24 Dustless Belt Sander \$148
- R151 1HP Plunge Router \$ 95
- RS01 2 1/2HP Plunge Router \$159
- TR30U Trimmer \$ 77
- TS380 14" Miter Saw \$369

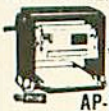

AP-10 Thickness Planer

FREUD SPECIALS

- TT-108 8 Pc. Turning Tool Set \$54
- 90-100 15 Pc. Router Bit Set \$138
- 92-100 26 Pc. Router Bit Set \$284
- 94-100 5 Pc. Router Cabinet \$159
- FB-100 16 Pc. Forstner Bit Set \$159
- EC-900 5 Pc. Shaper Cabinet Set \$264
- EC-209-213 Raised Panel Cutters \$85
- EC-260 1/4" Cabinet Door Set \$157

Sawblades

- LM72M 10", 24T, Rip Blade \$38
- LU73M 10", 60T, ATB Cutoff \$38
- LU84M 10", 50T, Combination \$38
- Set of Three Above \$107
- LU82M 10", 60T, Triple Chip \$42
- LU85M 10", 80T, Super Blade \$59
- DS306 6" Dado \$99
- DS308 8" Dado \$109
- JS100 Plate Joiner \$169
- JS020 1000 Biscuits \$29
- F1100 Spare Cutter \$ 34

MAKITA STATIONARIES

- 2030N 12" Planer - 6" Jointer \$1275
- 2040 15" Planer \$1275
- 2020 8" Jointer \$775

HITACHI

- F-1000A Jointer-Planer \$1395
- CB75F Resaw Bandsaw \$1645
- C15FBP 15" Miter Saw \$409
- C101FB 10" Miter Saw \$279
- TR12 Plunge Router \$173

PORTER CABLE

- 518 3HP Speedtronic Router \$323
- 630 1HP Router \$ 93
- 690 1 1/2HP Router \$124
- 310 Laminate Trimmer \$124
- 312 Off-Set Laminate Trimmer \$133
- 319 Tilt-Base Laminate Trimmer \$138
- 330 Speed-Block Sander \$ 54
- 352 3 x 21 Dustless Belt Sander \$130
- 360 3 x 24 Dustless Belt Sander \$185
- 362 4 x 24 Dustless Belt Sander \$198
- 555 Plate Joiner \$169

JET POWER TOOLS

- JBS-14MW Metal/Wood Bandsaw \$349
- JJ-6 6" Jointer \$339
- JTS-10 10" Contractors Saw \$439
- CTAS-10 10" T/A Table Saw \$1275
- with 50" Biesemeyer Fence \$899
- JJ-8 8" Long-Bed Jointer \$999
- JWP-15H 15" Thickness Planer \$309
- DC-610 1 HP Dust Collector \$309
- DC-1182 2 HP Dust Collector \$449

JET Prices include delivery.

LEIGH

- TD514L 24" dovetail jig with 1/2" bits for 1/2" dovetails \$239
 - D125-12 New 12" jig for through and half blind dovetails \$245
 - D125-24 New 24" jig for through and half blind dovetails \$269
- Optional Bits in Stock

The Xylophile's Company

138 E. Loudon Ave. • Lexington, KY 40505

1-800-354-9083 —M/C VISA— (606) 254-9823

Orders over \$35.00 include delivery unless otherwise noted. Prices subject to change without notice.

Since the days of clipper ships and the spice trade, shipbuilders have cherished teak as seafaring wood for decks and trim. Yet, any sea story featuring teak pales before the remarkable tale of how this hardwood arrives in the hands of craftsmen.

For much of the world's finest teak, the journey to market begins deep in a Southeast Asian rain forest. Workers girdle selected trees with a cut through the sapwood. Then, so that the dense and heavy green wood becomes dry enough to float, the trees die and season on the stump for up to three years.

When it's time to log the trees, elephants play a major role. These great beasts, each able to move a four-ton teak log miles through the jungle to the river, still prove more practical than machinery in remote terrain.

At the river, too low to float logs except during the monsoons, the teak lies for months. When pouring rains finally fill the river banks, the logs become loosely knit rafts and begin their float to a major port or city. Because of the seasonal river levels, the logs' trip from the interior may take five years.

Wood identification

A native of the rain forest in Burma, Cambodia, India, Laos, Thailand, and Vietnam, teak (*Tectona grandis*) was transplanted to other countries by Dutch traders in the 18th and 19th centuries. Now teak grows throughout

TEAK

Seaworthy stock with true grit



Teak heartwood

Indonesia and in Latin America.

After 200-300 years, teak trees growing in the wild reach heights of 100' and diameters up to 12'. Teak grown on plantations (the Dutch started the practice) becomes taller, though smaller in diameter, but can be cut in as little as 60 years.

If teak's size were not enough to distinguish it, teak's leaves surely would. The largest and perhaps the roughest of any tree, teak leaves grow as large as 24 x 36" and natives use them as sandpaper.

Little of teak's thin-layered, yellow sapwood reaches woodworkers.

Instead, traders and importers prefer the coarse-textured, golden-brown heartwood, often darkly streaked. Silica, which the growing tree extracts from the soil, makes the wood feel oily.

Working properties

Teak has all the properties a woodworker dreams of: rich color, strength of oak, resistance to water, chemicals, and insects, easy workability with all tools, and screw-holding power. However, silica in wood from younger trees dulls saw blades and makes gluing difficult. To assure adhesion, wash the wood with lacquer thinner.

Although teak sands well, it tends to clog abrasives. In finishing, avoid plastic-based products, such as polyurethane, that react adversely with silica. You'll have best results with oil finishes and lacquer.

Uses in woodworking

Teak found fame in ships, boats, and Scandinavian-style furniture. However, you'll like it in any project requiring a premier hardwood.

When used in outdoor furniture, teak takes abuse. It will not check or corrode fasteners, but it eventually will weather to a gray color. Sanding renews the color.

Cost and availability

Teak grading and pricing follow standards set by the Burmese a century ago. Unlike American hardwoods, teak's price per board foot escalates with the width and length of the board. For example, 1" stock 8" wide may cost \$7 per board foot while boards narrower than 5" sell for \$1 or more less.

Expect to pay top dollar for teak-faced hardwood plywood. Veneers, however, remain moderately priced.

Even though most exotic hardwood dealers stock teak, watch the quality. The best teak to work (and the most expensive) comes from old-growth trees harvested in Burma or Thailand. Much of the silica will have decomposed in these old trees. 🌳

Illustration: Steve Schindler
Photograph: Bob Calmer



TRY YOUR HAND AT ONLAY

Use this exciting, wood-stingy technique to create original designs for tabletops, cabinet doors, cutting boards, artistic wall hangings, and more.

Have you ever admired the geometric beauty of a parquet floor—and wondered how you could apply the same idea to furniture or other woodworking projects? We've got the answer! Using our onlay technique, you can lay up panels of any size—in traditional parquet floor patterns or bold geometric designs of your own creation.

HERE'S HOW ONLAY WORKS

You start with boards from one or more species of wood, all the same thickness. (We've found that $\frac{3}{4}$ "-thick stock works best for most projects.) Then, you rip them into $\frac{1}{4}$ "-thick strips and crosscut them into the lengths needed to form your pattern. Next, you glue the pieces to a particleboard or plywood substrate with hot-melt glue.

To complete the onlaid panel, you trim it to finished size and add an edge band to cover the exposed edges. Then, fill the cracks with wood filler, sand, and apply the finish.

And what have you got when you're done? A smooth, continuous panel for a tabletop, cabinet, cutting board, bed headboard, or even a decorative wall hanging.

To illustrate this technique, we made a tabletop with a herringbone design. We also designed a base to support it. You'll find the dimensions for the top and instructions for building the base on page 34. Or, you may want to try the onlay vase project on page 33.

CUTTING THE ONLAY PIECES

Note: No matter what size onlay pieces you've chosen, the boards from which you cut them must all be exactly the same thickness. Otherwise, you'll end up with pieces of slightly different widths. This will result in irregular gaps between the pieces when you glue them to the substrate. Plane the boards, if necessary, to ensure uniformity in thickness.

Ripping the Onlay Strips

If you're starting with long boards, it's easier to rip your onlay strips from them if you first crosscut the boards into manageable lengths for ripping. To make best use of material, cut the boards into multiples of the lengths of your onlay pieces, plus 1" for waste. (For the herringbone tabletop, we cut two 8' oak boards into 26" lengths).

Now, joint one edge of each board, and rip the boards into $\frac{1}{4}$ " strips as shown in the photo below.

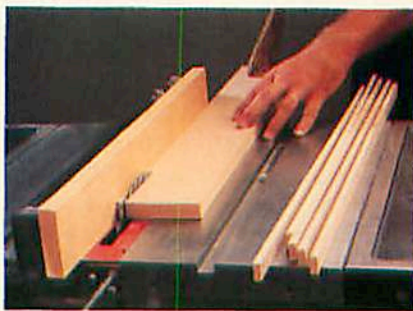

On the table saw, position the fence $\frac{1}{4}$ " from the blade, and rip stock into $\frac{1}{4}$ "-thick strips, using a push stick for safety.

To cut the strips, we used our table saw, equipped with a sharp, carbide-tipped blade. If you're using scrap pieces too short to rip safely on a table saw, we recommend doing it on a band saw. To get the straightest cut possible, use the widest band-saw blade you have and plane the edge every 4 or 5 cuts.

For uniformity in thickness, rip all the strips you need (plus about 5% extra for waste) at the same time. If you have to come back later and reset the fence to rip additional strips, they may not come out at exactly the same thickness.

Crosscutting the Pieces

Now, crosscut the pieces to finished length. To ensure pieces of uniform length, clamp a stop block to the fence on your radial arm saw or table-saw miter gauge, as shown in the photo below. Check each piece for defects that may not have been apparent before ripping the board. Discard any defective pieces.



To cut pieces to identical lengths, clamp a stop to the fence of your radial arm saw or power miter saw.

HOW TO LAY OUT YOUR DESIGN

The design you choose determines not only the size of the onlay pieces you'll need but also the sequence in which you glue the pieces to the substrate. For most designs, you'll

start laying the pieces at the intersection of centerlines marked on the substrate, and then work outward to the edges.

These drawings show the starting

layout sequence for four designs, including the herringbone pattern for our tabletop on page 34 and the southwestern Indian design in the photo on the opposite page.

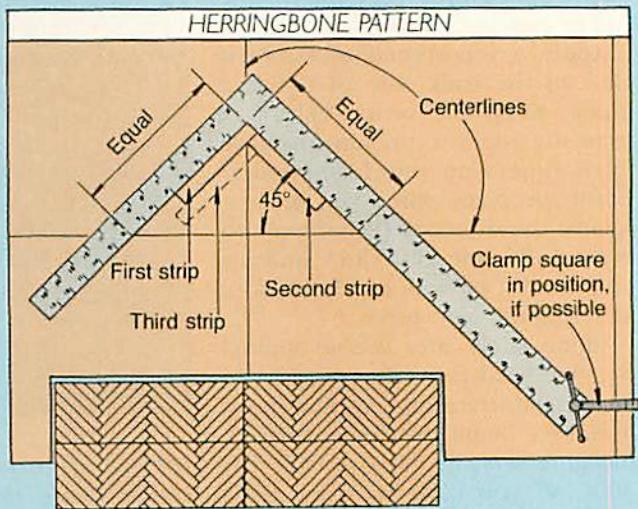
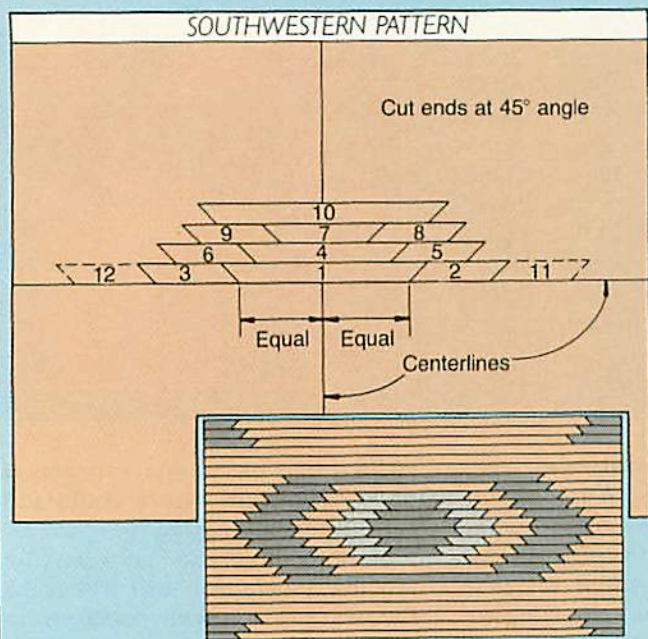

Note: See page 34 for complete layout details on this design.

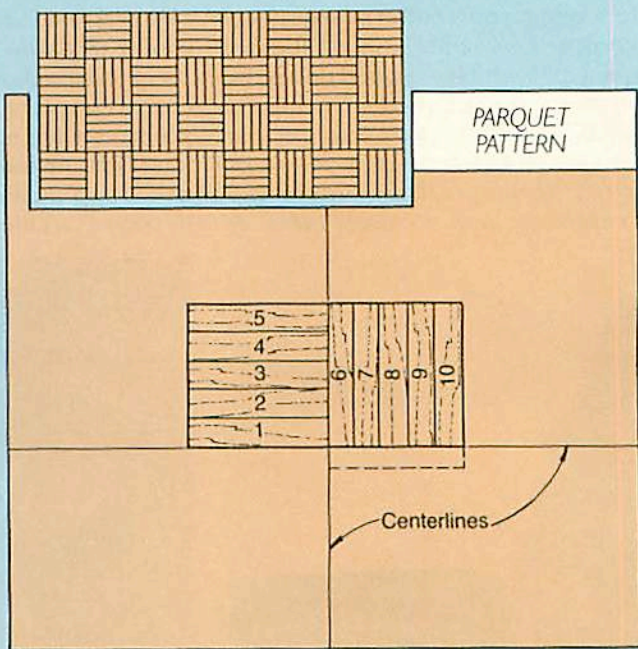
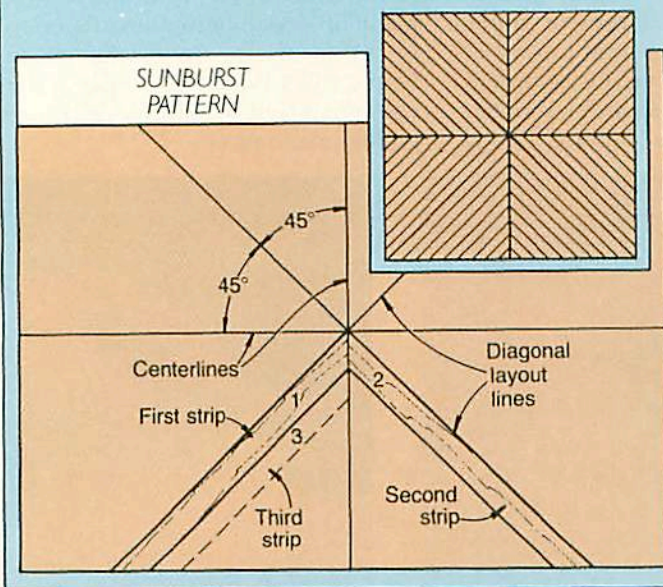

CUTTING THE SUBSTRATE

Mark and cut a piece of particle-board or plywood 1" to 3" larger in each dimension than the finished size of your panel. The larger the panel, the bigger the margin you need to leave. (For the herringbone

tabletop, we cut a piece 36x74".) Now, use a chalkline to bisect the substrate in both directions, forming the centerlines for your pattern layout. (Note that the sunburst design *above* also requires diagonal layout lines.)

GLUING DOWN THE PIECES: YOU HAVE TO WORK FAST!

If it weren't for hot-melt glue sticks and glue guns, the onlay process would be impractical, if not impossible to do. Hot-melt glue sets up quickly so you don't need to

Continued

TRY YOUR HAND AT ONLYAY

clamp the pieces. And, it's much faster and easier to use than messy contact cements or epoxies.

After a lot of testing, we decided to use a Black & Decker yellow hot-melt glue because the glue has a long working time. (See the Buying Guide on page 32.)

Apply a wavy bead of hot-melt glue to the back side of the first piece. Keep the bead slightly in from the edges to prevent the glue from squeezing out from underneath the piece when you press it against the substrate (see the photo below). If some glue does squeeze out, clean it off with a chisel before adhering the next piece.

Immediately after you've applied the glue bead, press the piece down on the substrate into its final position. (We found that, once applied, the glue sets up in 10 to 15 seconds, so you have to work fast!) Hold it firmly in place for about 4 seconds. Then, glue down the remaining pieces in the same manner, following your pattern sequence. Photos 1, 2, and 3 show the sequence in which we glued down the strips for the herringbone tabletop. **Note:** When you glue down the first two or three onlay pieces, you must align them precisely—with the centerlines and to each other. If

ONLYAY SEQUENCE FOR OUR HERRINGBONE

The following sequence works for all herringbone patterns. Our herringbone tabletop uses $\frac{1}{4} \times \frac{3}{4} \times 5''$ pieces. Be sure you've read the preceding sections on cutting and gluing the onlay pieces before following these instructions.

First, clamp a framing square 45° to your centerline, where shown on the herringbone pattern layout drawing on page 29. Glue the first two pieces on the substrate where shown in photo 1, at right.

Now, using the first two pieces as guides, lay an initial path two strips wide. Work back from the center until you reach the end of the substrate facing you. Then, go back and

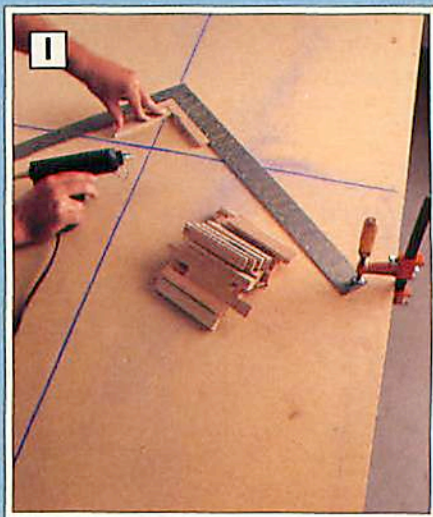

they're slightly crooked or off-center; they'll throw off the rest of the pattern. For the herringbone design, we clamped a framing square to the substrate to align the first two pieces 45° to the centerline, as shown in photo 1, above right.

No matter how carefully you've cut your pieces, a few of them probably will end up a bit too wide, too short, or too long. Or, you may glue down a piece slightly crooked. If you've accidentally glued down

an ill-fitting piece, you can pop it off the substrate with a chisel and substitute another one.

Sometimes, cracks between the last few pieces you laid will make the next one too wide, as shown in the photo below center. If you can't remove the problem-causing pieces, plane one edge of the next piece to be fitted, as shown in the photo below right. Check its fit against the rest of the glued-up pieces before gluing it into place.



Apply a wavy line of hot-melt glue to the back of the onlay piece.

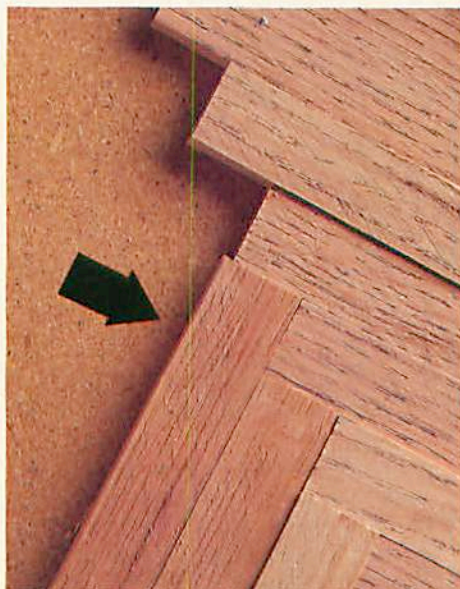

If you've glued down a too-wide strip as shown at left, pop it off with a chisel. Then, plane a new strip to fit (right).

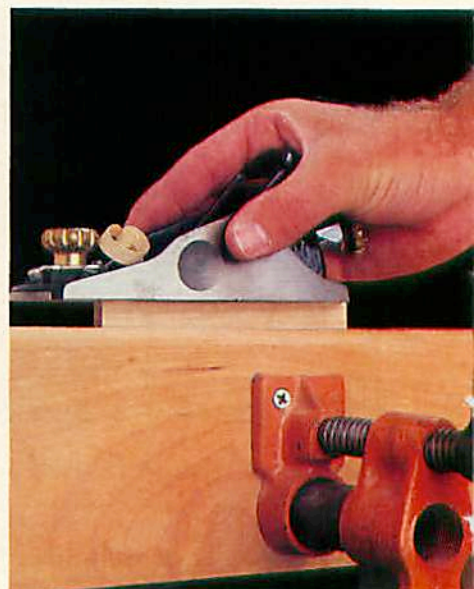

TABLETOP

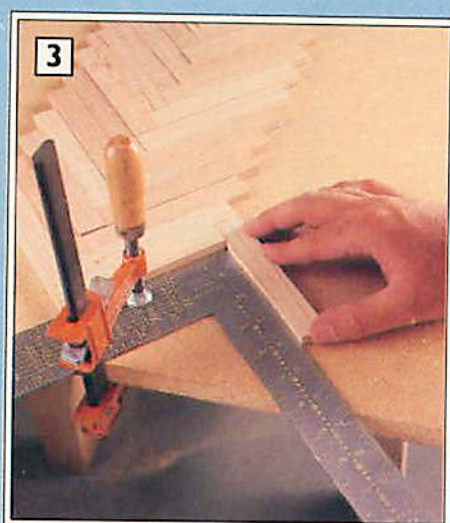
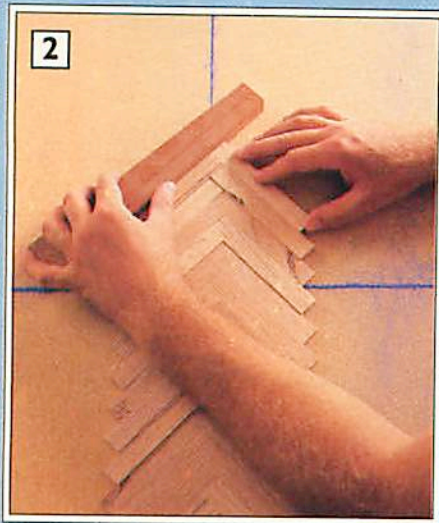

work in the other direction, as shown in photo 2.

Note: When laying the pieces in the direction of the arrow formed by the herringbone pattern, you'll need a straightedge to keep them aligned. We used a wood block slightly thicker than the pieces, as shown in photo 2.

After you've glued down the center path, clamp a square to one side, where shown in photo 3. Now, lay a *single* row of pieces on one side of the center path until you reach the other end. Continue laying single rows on both sides of the center path until you've covered the entire surface of the panel.

CUT THE PANEL TO FINISHED SIZE

After you've glued down all the pieces, belt-sand the entire surface with 80-grit sandpaper. Then, on the top surface, mark the finished size of your panel, minus the width of the edge band or trim. With a square, transfer the marks to the edges of the panel, as shown in the photo *below*. Then, flip the panel upside down, and transfer the lines to the bottom side.

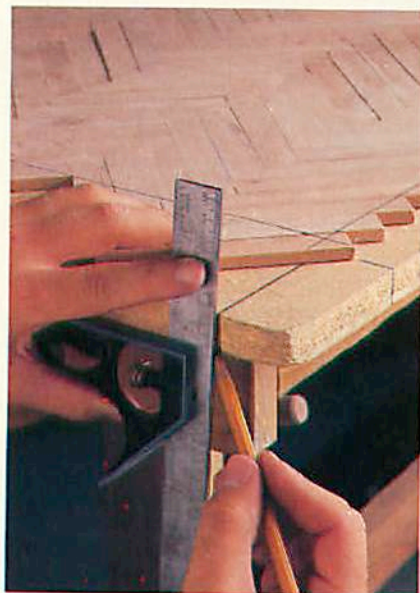

Mark the panel's finished size, then transfer the marks to the back side.

Now, cut the panel to finished size, using a portable circular saw equipped with a sharp carbide-tipped blade. For each cut, align the saw blade with the marked line, and clamp a straightedge to the workpiece to serve as a guide. See the photo *below*.

ATTACH THE EDGE BAND

Most onlay projects will need an edge band or trim piece to cover the exposed edges of the particleboard

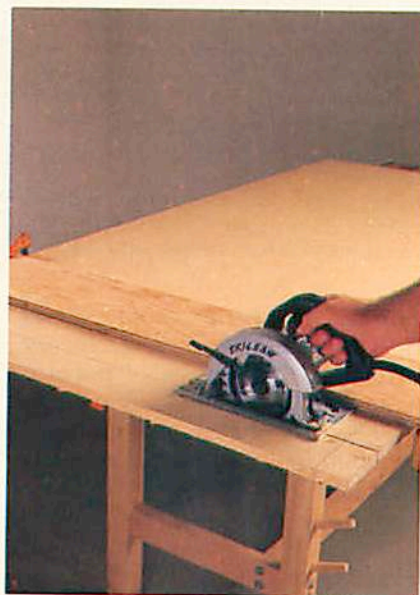

Clamp a straightedge to the workpiece, and cut the top to finished size.

or plywood substrate and the onlay pieces. If you're building the herringbone tabletop, see page 35 for edge-band and spline dimensions.

With a router and slot-cutting bit, rout matching spline grooves in the band and panel edges as shown on the drawing *below*. Cut the splines to size. Use woodworker's glue and pipe or bar clamps to spline-join the band to the panel. Later, remove the clamps and belt-sand the panel with 100-grit sandpaper.

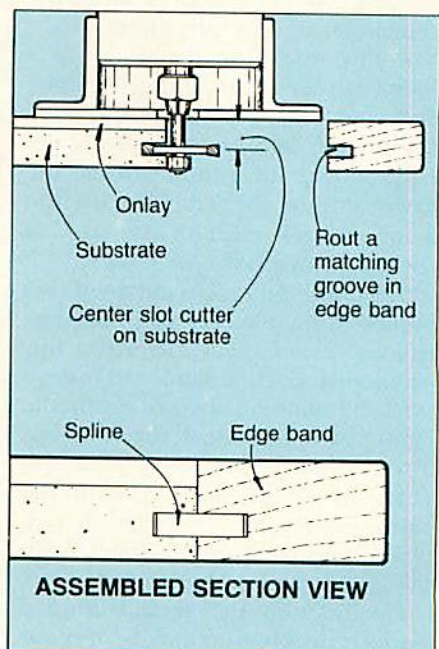

Continued

TRY YOUR HAND AT ONLAY

SAND, FILL, AND FINISH

If you've used all one species of wood, we suggest filling the cracks between the onlay strips with FIX pigmented wood filler after the initial belt-sanding. Force the wood filler into the cracks with a putty knife, as shown in the photo at *right*, and let it dry. Belt-sand the entire surface with 100-grit paper, followed by 150-grit paper. Finally, finish-sand with a palm sander and 220-grit paper.

When filling cracks between two different wood species, such as the padauk and maple panel shown in the photos *below right*, we found that a mixture of woodworker's glue and sawdust makes a better wood filler than commercially available ones. Here's how to use the "glue and sawdust" method for filling cracks:

Start by belt-sanding the entire surface with 80-grit, then 100-grit sandpaper. Now, fill the cracks with woodworker's glue. A needle-nosed glue dispenser works well for this. Force the glue into the cracks with a plastic putty knife, as shown in the photo at *right*. (Don't use a steel putty knife. We found that woodworker's glue reacts with the steel in the knife, causing the glue to discolor.) Use a damp rag to remove excess glue and to force the remainder farther into the cracks.

Before the glue dries, equip a palm sander with 100-grit paper, and sand the pieces to raise a small amount of fine sawdust. With the palm sander still running, force the sawdust into the cracks with the front or back edge of the pad, as shown in the photo *far right*.

Try not to fill cracks between two pieces of light wood with sawdust from a darker piece. To avoid this problem, use a belt sander to make a small amount of sawdust from the lighter wood. Collect the sawdust, force it into the cracks by hand, and sand the cracks smooth with the palm sander and 100-grit paper. Finish-sand the entire surface with 150-, 220-, and 320-grit paper.

Finally, with the surface sanded smooth, apply the finish of your



We used FIX oak-colored wood patch to fill the cracks between the oak strips on our tabletop. Force the wood filler into the cracks with a putty knife.

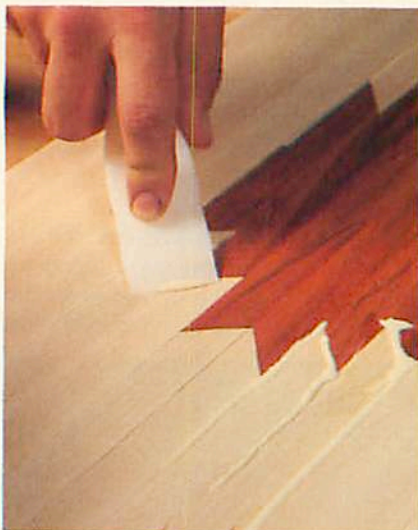

If your project consists of two or more wood species, use this method: Force glue into the cracks with a plastic putty knife (*left*). Then, run a palm sander over the glue lines to force sawdust into them (*right*).

choice. For tabletops, cabinet doors, and other high-wear surfaces, we recommend two coats of polyurethane sanding sealer, followed by several coats of clear polyurethane. Use 0000 steel wool between initial coats and 600-grit wet/dry sandpaper between finish coats.

For cutting boards, finish with vegetable or mineral oil, or a commercially available salad-bowl finish, such as Behlen's.

BUYING GUIDE

• **Black & Decker yellow hot-melt glue for wood.** Available at Black & Decker dealers nationwide. Our source: Craft Woods, 10921 York Rd., Hunt Valley, MD 21030. Package of 24 4" sticks (cat. no. 112-0020) \$6.95 ppd. ♣

Produced by Jim Barrett and Marlen Kemmet
Photographs: Bob Calmer, Bill Hopkins
Illustrations: Bill Zaun



PURE SOUTHWEST

ALL-OCCASION ONLAY VASE

Its design is southwestern, but, sleek lines and good looks allow this vase to fit in with most any setting.

Note: Read the *Onlay Technique* article starting on page 28 for details on laying up a decorative surface like the one we used on the front and back of the vase.

CUT THE VASE SIDES AND THE ONLAY STRIPS

1 Cut the sides (A, B) to the size listed in the Bill of Materials from $\frac{3}{4}$ "-thick maple stock.

2 Rip $\frac{1}{4}$ "-thick onlay strips (C, D, E, F) to size plus 1" in length. Miter-cut strips C and E to length. Miter-cut one end of strips D and F.

APPLY THE ONLAY STRIPS AND FORM THE VASE

1 Mark centerlines on one face of the front and back (B). Mark the lengthwise center on the walnut strips. Apply a wavy bead of hot-melt adhesive to one walnut strip, and glue it to the front piece, aligning the centerlines where shown on the drawing at left.

2 Adhere the other walnut strip (C), the maple strips (D), padauk strips (E), and finally the maple strips (F) to obtain the design shown in the Front View Drawing. Repeat for the back panel.

3 Trim the protruding ends of parts D and F flush with the ends of the substrate. If the onlay strips don't end up even with the edges of the substrate, joint or rip them flush. Remember, if you decrease the width of one onlay panel, you must do the same with the other panel.

Continued on page 77

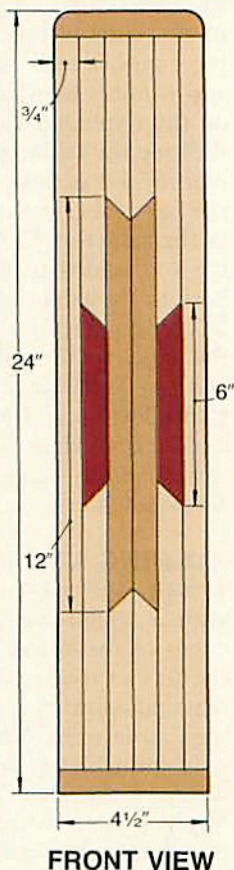
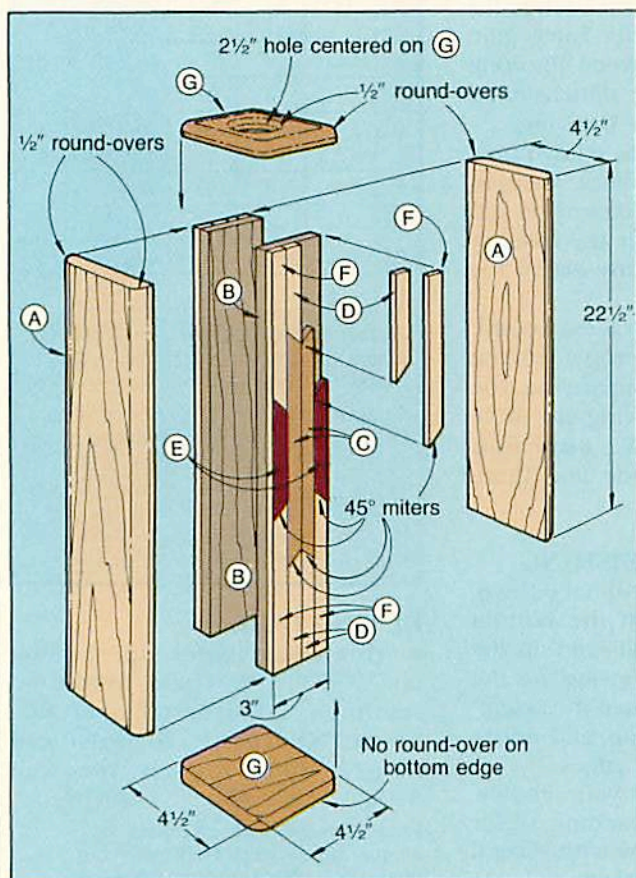
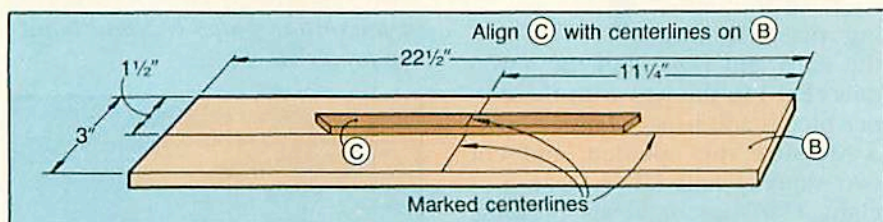

FRONT VIEW

Bill of Materials

Part	Finished Size*			Material	Qty.
	T	W	L		
A	$\frac{3}{4}$ "	$4\frac{1}{2}$ "	$22\frac{1}{2}$ "	maple	2
B	$\frac{3}{4}$ "	3"	$22\frac{1}{2}$ "	maple	2
C*	$\frac{1}{4}$ "	$\frac{3}{4}$ "	12"	walnut	4
D*	$\frac{1}{4}$ "	$\frac{3}{4}$ "	6"	maple	8
E*	$\frac{1}{4}$ "	$\frac{3}{4}$ "	6"	padauk	4
F*	$\frac{1}{4}$ "	$\frac{3}{4}$ "	9"	maple	8
G	$\frac{3}{4}$ "	$4\frac{1}{2}$ "	$4\frac{1}{2}$ "	walnut	2

*Parts marked with an * are cut larger initially, and then miter-cut to finished length. Please read the instructions before cutting.

Supplies: hot-melt adhesive, 0000 steel wool, polyurethane.

DINE IN STYLE AT THIS OAK HERRINGBONE DINING TABLE



WE BUILT THIS BEAUTY FOR UNDER \$150

FORMING THE FOUR LEGS

1 Rip and crosscut 12 pieces of $1\frac{1}{16}$ "-thick oak stock to $3\frac{5}{16} \times 29$ " for the legs (D). With the edges and ends flush, glue and clamp three pieces together face-to-face for each of the four table legs.

2 After the glue dries, scrape off the squeeze-out, plane one laminated edge smooth, and rip the opposite edge for a $3\frac{3}{16}$ " finished width. Now, crosscut $\frac{1}{4}$ " off one end of each leg for a square end. Set a stop, and cut the opposite end so each leg measures 28" long.

3 Using a rule and straightedge, measure and mark the saw-cut layout lines on all four faces of one leg where dimensioned on the Leg Drawing on the opposite page.

4 Follow the instructions on Cutting the Leg Tapers Drawing to cut each leg. If you don't have a taper jig, refer to our shop-built jig on page 45 of the August 1987 issue of *WOOD*, or see the Buying Guide.

5 Sand the saw marks off each tapered surface. Sand a round-over on the bottom edges of each leg.

MAKING THE APRON RAILS AND ASSEMBLING THE BASE

1 Cut the side rails (E) and end rails (F) to the sizes stated in the Bill of Materials. Cut four corner blocks (G) to size. (We cut a piece of $1\frac{1}{16}$ "-thick oak to 3" wide by 30" long. Then, we bevel-cut each corner block to 7" length from the long strip on the table saw.)

2 Following the steps on the drawing titled Joining the Rails and Legs, join the apron rails (E, F) to the legs with the corner blocks and hanger bolts.

3 Measure the opening, and cut two support rails (H) to size. Cut eight $1\frac{1}{16}$ "-square cleats 3" long. Glue the cleats (one on each side) to the ends of the rails. Later, glue the support rails between the long apron rails (E) where dimensioned on the Exploded-View Drawing.

4 Place the tabletop facedown on a workbench or saw horses. Position the base (also upside down) on top of the tabletop. Center the base on the top, and then lightly clamp the base to the tabletop.

5 Using chair-leg braces, secure the base to the tabletop (see the Section Detail accompanying the Exploded-View Drawing for hole and screw sizes). We used four braces along each side and three across each end.

SANDING AND FINISHING

1 With the table still facedown, sand a round-over on the bottom edges of the apron rails and on the corners of the legs. Finish-sand the legs and apron rails. Turn the assembled table right side up, and finish-sand the tabletop and edges.

2 Apply the stain of your choice. Apply polyurethane sanding sealer to the assembly. Follow with several coats of clear polyurethane.

Price a high-quality oak table in any furniture showroom. You could probably buy a good table saw for less money. But, using our lumber-saving onlay technique for the top and the plans for the base shown here, you can be the proud owner of this classic for under \$150.

Note: Refer to the onlay technique article starting on page 28 to construct the herringbone tabletop. To size and band the top, see the Bill of Materials and the Exploded-View Drawing at right for the size of the onlaid panel (A) and banding pieces (B, C).

Bill of Materials

Part	Finished Size*			Material	Qty.
	T	W	L		
A	$\frac{3}{4}$ "	33"	$70\frac{3}{4}$ "	particle-board	1
B	$1\frac{1}{16}$ "	3"	$76\frac{3}{4}$ "	oak	2
C	$1\frac{1}{16}$ "	3"	39"	oak	2
D*	$3\frac{3}{16}$ "	$3\frac{3}{16}$ "	28"	oak (laminated)	4
E	$1\frac{1}{16}$ "	3"	69"	oak	2
F	$1\frac{1}{16}$ "	3"	$31\frac{1}{4}$ "	oak	2
G*	$1\frac{1}{16}$ "	3"	7"	oak	4
H	$1\frac{1}{16}$ "	3"	$34\frac{3}{4}$ "	oak	2

*Parts marked with an * are cut larger initially, and then trimmed to finished size. Please read the instructions before cutting.

Supplies: 14— 1×1 " chair-leg braces (Stanley part no. 996 $\frac{1}{2}$) and two #8 $\times\frac{3}{4}$ " flathead wood screws per brace, #10 $\times 1\frac{1}{2}$ " flathead wood screws, 4— $\frac{3}{8} \times 4$ " hanger bolts with nuts and flat washers, stain, polyurethane sanding sealer, clear polyurethane, 0000 steel wool.

BUYING GUIDE

• **Aluminum taper jig.** Catalog no. VA377, \$19.95 ppd. from Constantine's, 2050 Eastchester Rd., Bronx, NY 10461. To order call 800-223-8087, in New York call 800-822-1202. 🌲

Project Design: Marlen Kemmet
Photographs: William Hopkins
Illustrations: Kim Downing, Bill Zaun

CUTTING THE LEG TAPERS

Step 1 Adjust the angle of the taper jig so the saw-cut layout line on the leg runs parallel to the fence.

Step 2 Adjust the fence position so the blade lines up with the layout line. Cut two adjacent sides on all four legs.

Step 3 Adjust the angle of the taper jig so the remaining saw-cut layout line on the leg runs parallel to the fence.

Step 4 Adjust the fence position so the blade lines up with the remaining layout line. Cut the other two adjacent sides on each leg.

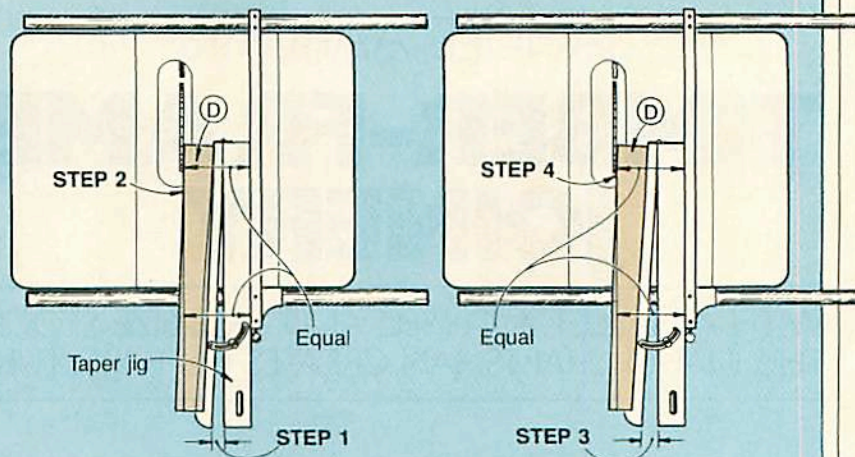

JOINING THE RAILS AND LEGS

Step 1 Locate center points. Drill a $\frac{3}{8}$ " hole for hanger bolt and use a #10 screw pilot for the screw holes.

Step 2 Mark a corner-block reference line on both ends of E and F.

Step 3 Position corner block on F, and drill pilot holes. Glue and screw blocks to both ends of both F's.

Step 4 Drill pilot holes, and screw top corner blocks to both ends of E.

Step 5 Chamfer the top of each leg.

Step 6 Position the top of the leg flush with the top of the apron rails. Through the $\frac{3}{8}$ " hole in the corner block, drill a pilot hole into the leg. Fasten each leg to the apron assembly.

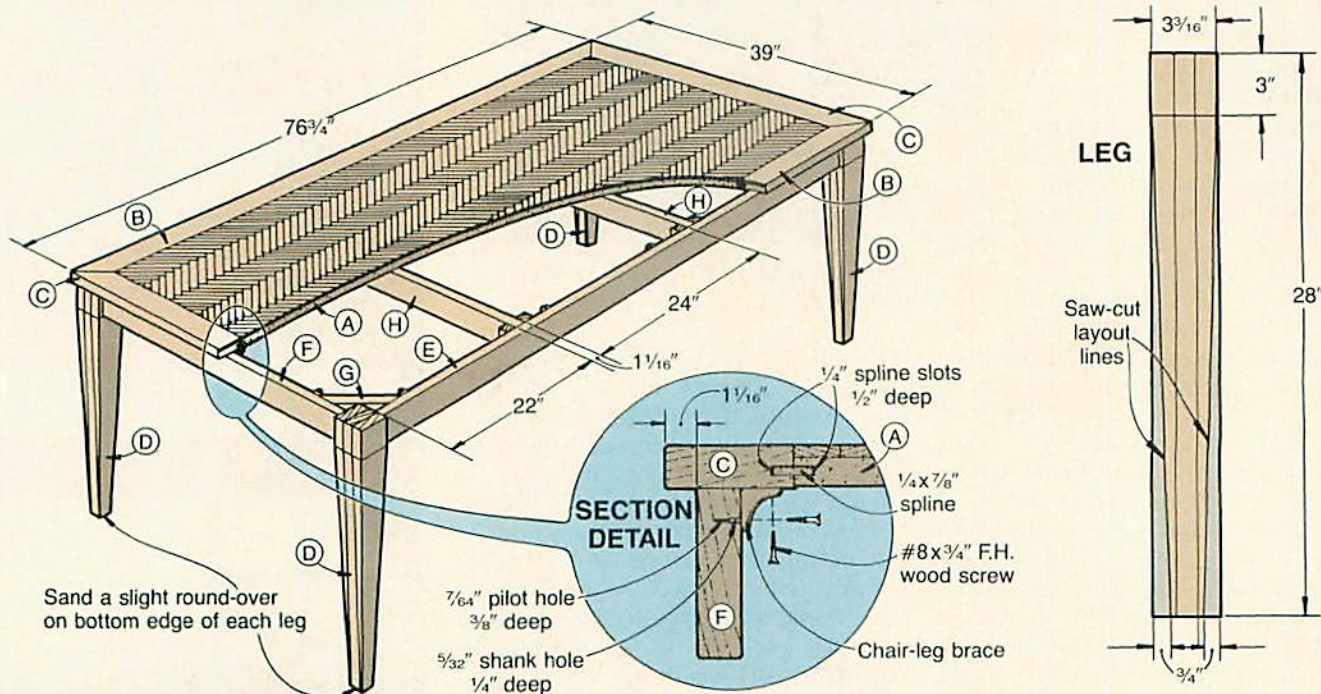
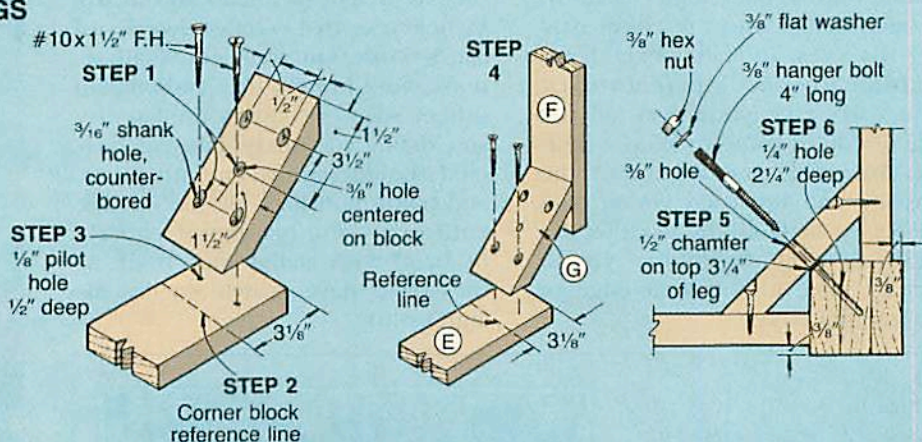

SAMULE AARON'S TIMBER-FRAME JOINERY

WITH A MALLET, A CHISEL, AND TREE-SIZE STOCK, THIS IDAHO CRAFTSMAN CREATES BIG FURNITURE

WHACK! WHACK! WHACK! With controlled power, Samule Aarons unerringly slams his wooden mallet into the chisel handle. His eyes, though, never leave the blade to glance where it strikes. "You can't take your eyes off the edge if you're going to keep a mortise line crisp and accurate," the muscled and browned young man advises. As he talks, the wood of the 8x10" Douglas fir timber yields, curl by curl, to the knife-edge of the framing chisel.

Nearby, stacked in regimental file, expertly cut timbers—some double the height of a man and nearly as heavy as two—reflect weeks of Sam's work. On some, dovetail tenons stand in rank like soldiers. On others, shadows cast by the late-day sun define the sharp lines of beveled shoulders, bird's-mouth joints, and tenon housings. He has cut the entire rank and file almost entirely by hand with mallet and chisel. As the stacks have grown, so has his anticipation.

Samule Aarons was at least 125 years tardy in following journalist Horace Greeley's advice to "Go West, young man." In 1980, after a summer spent helping build a timber-frame home, Sam was convinced that working wood was more to his liking than studying books. That fall, he exchanged ivy-covered halls and traditional academics in New Hampshire for on-the-job learning in Idaho.

A call from a friend brought Sam to Idaho City, an old mining town ringed by the pine-plated mountains of the Boise Basin. There, the neglected and sagging gold-rush era buildings offered him a unique opportunity. Restoring them, Sam could learn more of the centuries-old skill of timber framing and still make a living. With two antique



Sam assembles a king-post strut on the end section of the timber frame.

chisels, a mallet hewn from a 4x4", a book on timber framing, and a heap of self-confidence, Sam launched a joinery career. Now, at age 27 an experienced timber-frame joiner and log builder, Sam keeps his chisels busy on new construction in western Idaho. We journeyed to Idaho City and a timber-frame job site to see this modern-day joiner ply his skills on what he calls "BIG furniture."

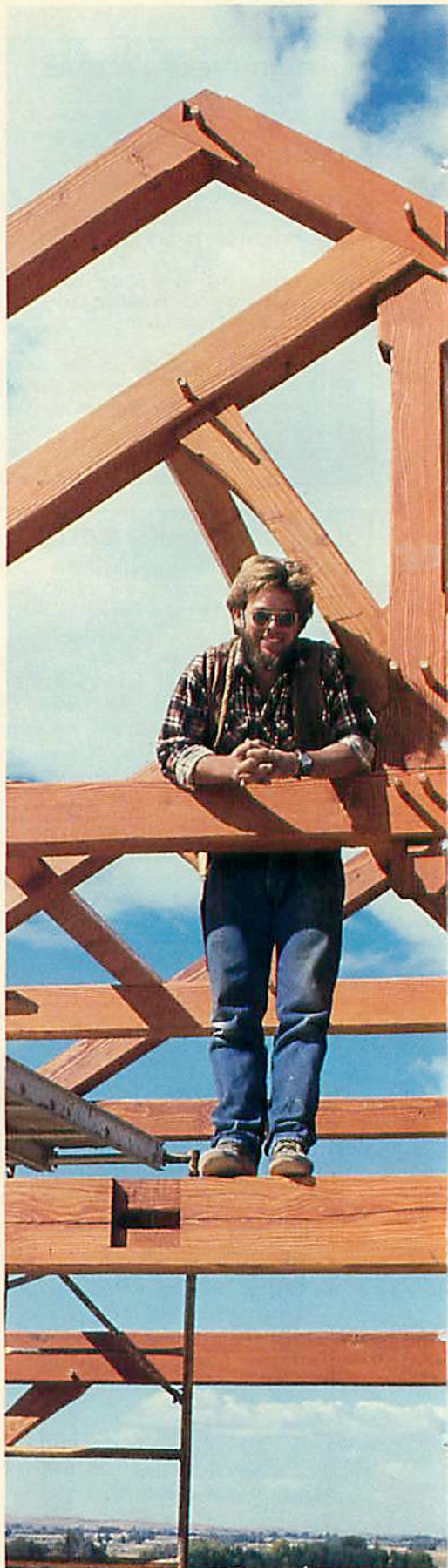

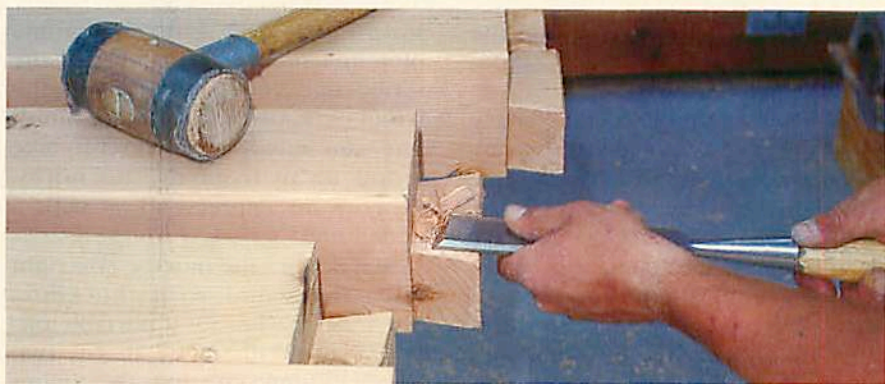
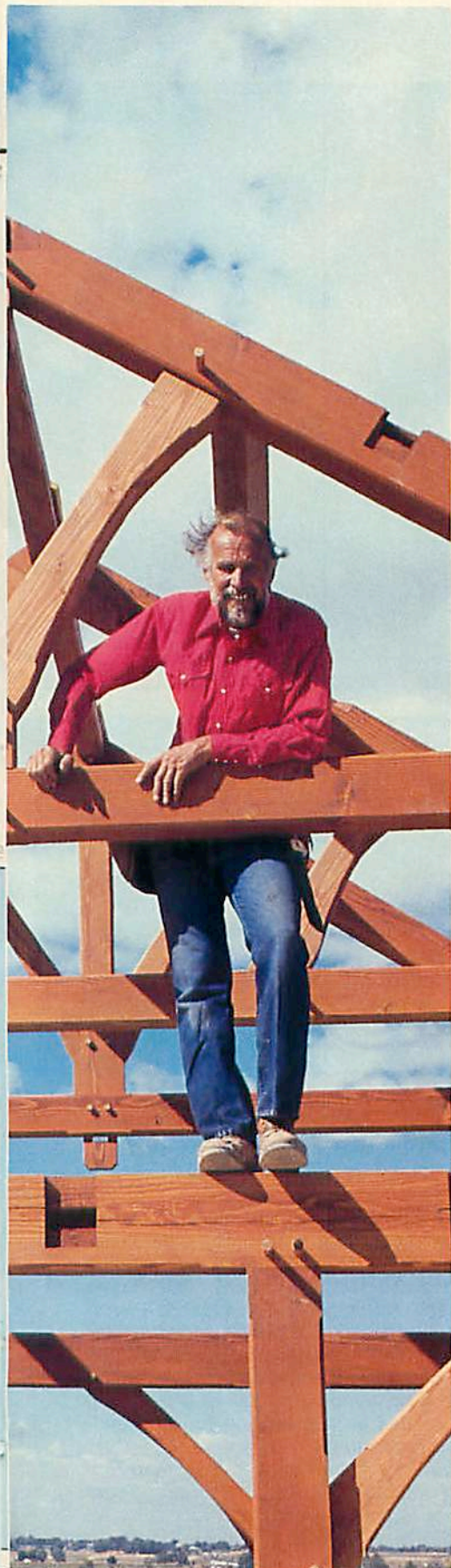

Left: At the raising of the timber frame, Sam Aarons, the joiner, at left, and Spike Baker, the homeowner, pause to take in the view of the Payette River.

Above: To make sure that his hand-cut dovetail tenons lock tightly into the mortise, Sam trims them with his chisel. "You can't slip in a dollar bill," Sam says.

In a few days, without first trying them for fit, Sam, a party of friends, and a rented crane will raise the massive fir timbers and interlock the mortise-and-tenons into a post-and-beam framework. Only driven oak pegs will stay the hand-cut joints for the home overlooking Idaho's Payette River. Sam's work will be over. Someone else will sheath the roof and walls. Sam will head home, pleased in knowing that the same hand-tool skills and techniques practiced during the Middle Ages have crafted another piece of BIG furniture.

FURNITURE-CLASS JOINTS IN BIG-TIMBER SIZES

Sam was introduced to timber framing in New Hampshire. While in college, he had worked part-time as a carpenter's helper. When the carpenter decided he wanted a timber-frame home, he called on Sam to assist him. "I was the lift-truck," says Sam jokingly about his first experience with big timbers. "But I did learn how to use a chisel and a mallet, and found out that it's possible to build without nails."

After his move to Idaho, Sam, on his own, began refining his new skills. Working for practically no pay, he reframed the falling-down building that once housed "The Idaho World," the 1800s territorial newspaper in Idaho City. Another nearly caved-in, 100-year-old structure followed. Locals noticed Sam's method and quality workmanship, and he

was hired to design and build an entire timber-frame building to serve as a mechanic's garage.

Word of the joiner spread, eventually leading Sam to a job with a timber-frame builder in Montana. There, he was schooled in the fine points of timber-frame craftsmanship. "I chopped a lot of joints," he recalls, "and I learned to sharpen my tools, to scribe, and to calculate framing. I gained a lot of finesse.

"A timber frame," Sam continues, "is an interesting concept incorporating the help of gravity in strengthening the joints, but also defying it in long spans. It has vertical support at given points as well as its own structural integrity to rely on for lateral strength. In a timber frame, the joinery is so strong because it allows movement without breaking apart." (See illustration on page 38.)

Head back, he draws in the aroma of the fir. "Timber frames have a beauty and honesty, too," Sam adds.

QUALITY IS EQUITY

His business card introduces him as a "joiner." The word means someone who connects wood. Sam chose it because it doesn't limit him to one technique. And joinery is all the construction he does.

Sam also chose the symbol of the swan-necked mortising chisel to accompany his name, for the seldom-seen hand tool signifies the handcrafting he relies on for his big-timber joinery. The imprinted

Continued

TIMBER-FRAME JOINERY

motto "Quality is Equity" strikes the heart and investment sense of potential customers.

Sam bids a timber-frame joinery job. Few people would pay him by the hour, knowing that hand craftsmanship goes slowly.

"Doing it by hand, I get a better fit, a better-quality joint, and I have absolute control of the size and shape of the cut. Besides, wood breathes and moves," he says, sliding his hand over the severed outline of a mortise. "You can't work it without feeling. I lose that feeling when I use a power tool. But I *do* live in the eighties!"

Sam's working knowledge of trigonometry allows him to calculate and project timber lengths, dimensions, and configurations into stable structures. "Until you start chopping the joints," he says, "all the calculations seem pretty abstract. But I live by the fact that it's easier to raise a pencil than lift a timber." That's half the reason why Sam never feels the need to trial-fit joints before timbers join in silhouette against the sky. The other half is the outlining of the joints.

THE SECRET OF TIGHT JOINTS LIES IN THEIR ACCURATE SCRIBING

The contents of Sam's aged and well-traveled leather tool bag reflect his appreciation of fine old hand tools. However, the tools most important to his craft may be the simple utility knife and small metal square he uses to scribe the outline

square he uses to scribe the outline of joints on timber. "Because the scribe line you cut deep into the wood is actually the joint's finish line, you only use the chisel to take wood away from it," he notes. "There's no imprecision as with a pencil line."

Sam scribes the mortise size right onto the wood with the knife. Then, he reaches for a portable circular saw. With it, he makes two parallel plunge-cuts into the timber about $\frac{1}{4}$ " inside the scribed mortise sides. Next, with a $\frac{1}{2}$ " electric drill equipped with an auger bit (his "hole hawg"), Sam bores out wood from a series of holes in the center of the mortise. After the boring, he uses a corner chisel to take out wood to within $\frac{1}{8}$ " of the line. And finally, Sam cleans up the mortise edge with a $1\frac{1}{2}$ " framing chisel, occasionally checking depth and plumb with a small square. "The fit is so tight," he says proudly, "that when the timbers are raised, you can't slip a dollar bill into the joints!"

What about mistakes? A mismeasurement? "If you miscut some timbers, they're just gone," the joiner informs us, "because all wood for a frame is mapped."

Mapped, in the language of timber framing, means accounting for all timbers and incorporating them into the design by length as well as outside dimension. It's exactly the reverse of drawing up a bill of materials—Sam begins planning his joints based on the size of the mate-

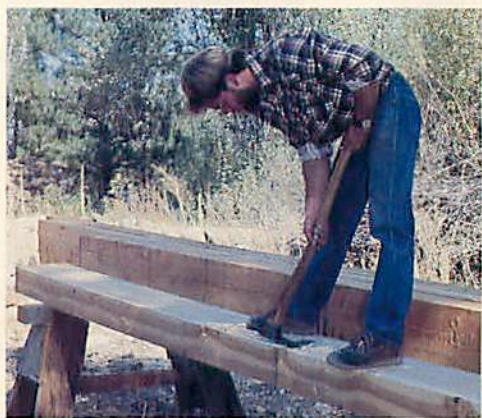
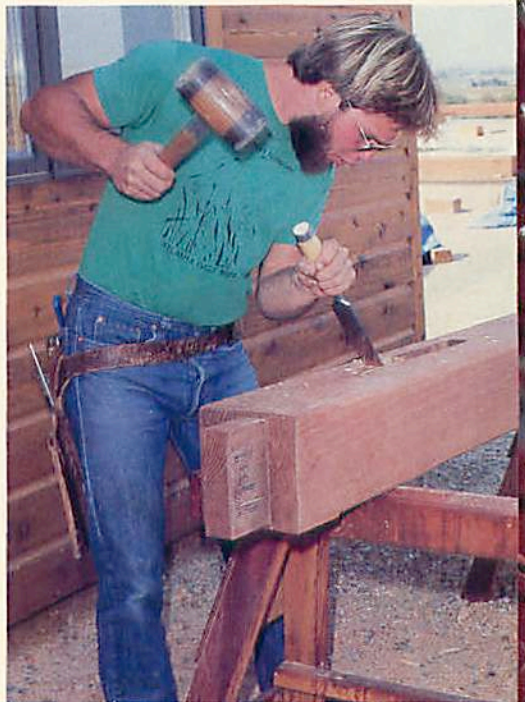

Above: With an adze, Sam smooths one of the pine timbers for his picnic-table gazebo. He pulls the adze toward him.

ANATOMY OF A TIMBER FRAME

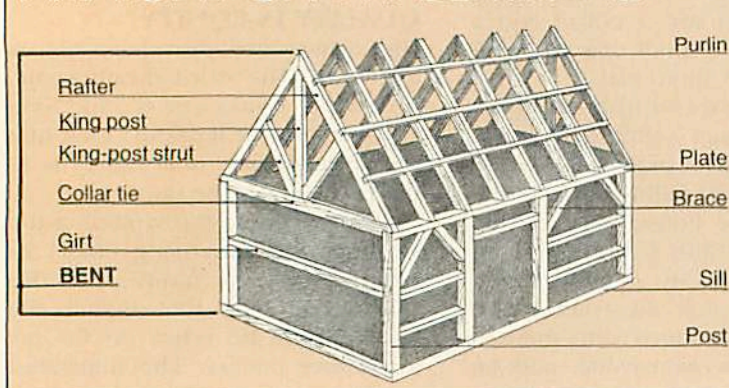

Prior to the mid-1800s, a great percentage of homes and barns were framed with huge timbers (*left*). Because the joinery (*right*) stayed firm while the immense timbers expanded and contracted, many timber-frame buildings still stand. As the new nation expanded westward, timber frames declined. Sawmills ripped lumber by the wagonload, and even novice carpenters could build a stud-frame structure faster than a housewright could assemble a post-and-beam frame. Only during the last 20 years has an appreciation for the hand-made revived the timber frame.

For more information about timber frames, read *Timber Frame Construction, All About Post-and-Beam Building*, by Jack Sobon and Roger Schroeder, 1984, Garden Way Publishing, Pownal, VT 05261, \$12.95.

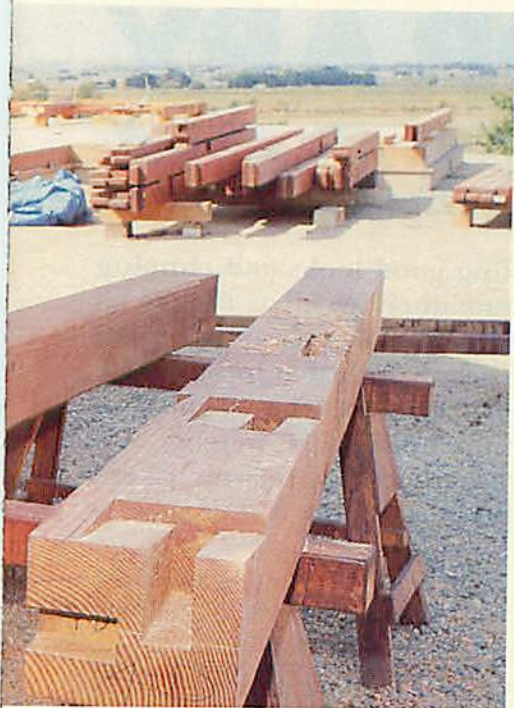

because their size determines girt lengths, and all your posts may not be exactly the same dimension.

"You have to take a good look at your timbers, measure them, take notes, and calculate all outside dimensions. Then, you figure all lengths from there—so far from shoulder to shoulder of each mortise, each joint," that's mapping, he says.

TOOLS THAT HOLD AN EDGE ALL DAY

It wasn't many years ago that Sam depended on a flat bastard file to sharpen his chisels. Today, each of his edged tools will shave hairs off your arm.

Sam doesn't have any sharpening secrets. His technique simply requires a lot of time. "I use a grinding, sharpening, honing, finishing sequence," he says. "I begin with a slow grind, and use a grinding wheel (about 200 grit) that runs in a water bath at 200 rpm. That's to shape the edge.

"To sharpen it, I move to a 1,000-grit Japanese water stone to remove all the grinding marks and smooth out the surface. Next, I hone with another Japanese stone of 8,000 grit to further cut down the finish that the 1,000 grit left. That turns the steel into a mirror. If you can see a mirrorlike surface on the steel, the wood you cut will be glass-smooth. For the finest finish, I pass the blade over a leather strop impregnated with green jewelers' rouge. My old Greenlee, the flagship of my chisels,

can chop mortises through knots and dry wood all day and still be sharp."

MORE THAN A LIVING TO CHISEL OUT

Using hand tools ranging from framing chisels to broad axes and adzes, jack planes to a Stanley 55 combination plow and fillister plane, Sam has made his joinery all-encompassing. For example, he built 14x7' frame-and-panel doors for the timber-frame mechanic's garage in Idaho City. For a special order, he constructed a large pine entry door, and smoothed it with an adze. And, combining elements of Japanese architecture with his hand-tool skills, Sam and a friend, stone mason Bob Wyllie, built a Ponderosa pine log gazebo and picnic table tuned to the Idaho landscape. "The timber in it has all the different surface textures of the tools," Sam explains.

The timber gazebo and table show Sam's interest in and respect for Japanese architecture, but from most folks it elicits comments such as, "But how would I ever move it?" Yet, the young joiner remains confident and undaunted for future pursuits.

"Expressing what I believe in through my work—that's my only goal," says Sam. "I would like to be comfortable, I would like to make a living, but I don't have any desire to do less than my best." 🌲

Written and produced by Peter J. Stephano
Photographs: David Donnelly
Illustrations: Jim Stevenson



Top: Sam's hard hits with his mallet on the framing chisel handle quickly cut a mortise out of the 8x10" fir timber.

Above: Ponderosa pine logs—first peeled with a drawknife, then smoothed with a chisel—nestle as a picnic table.

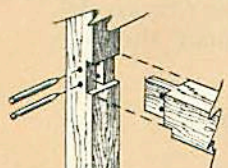

Pegged mortise and tenon

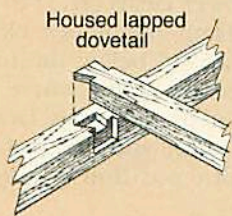

Housed lapped dovetail

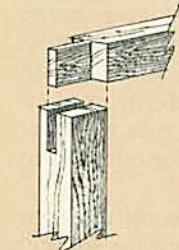

Open mortise and tenon

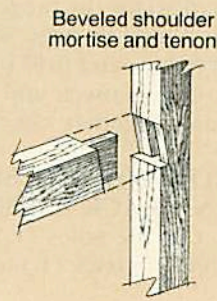

Beveled shoulder mortise and tenon

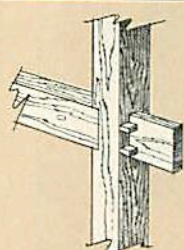

Through mortise and tenon

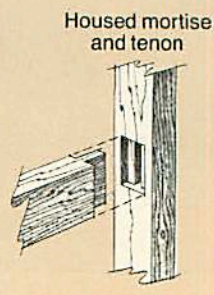

Housed mortise and tenon

TIME MARCHES ON STYLISHLY WITH OUR CONTEMPORARY TALL CLOCK

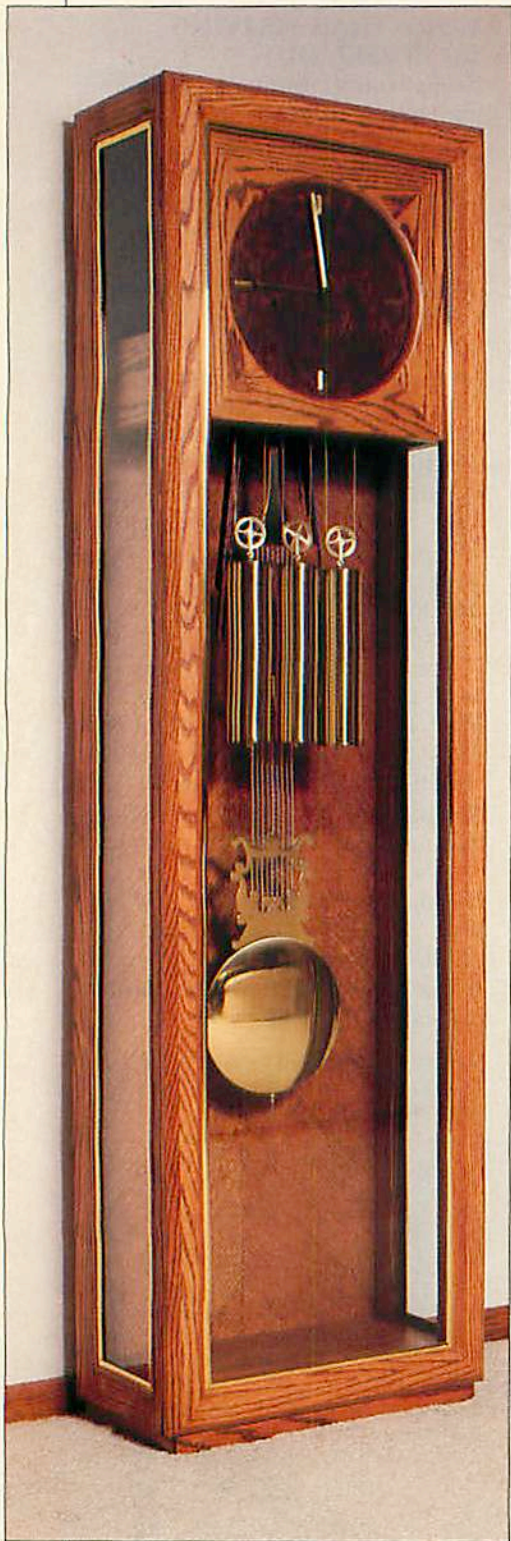

Almost everyone loves the striking good looks and chiming melodies of a tall clock, or "grandfather" clock as they're so nicknamed. Unfortunately, the traditional style of most tall clocks doesn't blend with every decor. With that in mind, we designed our own contemporary version. The large glass panels draw you inside to watch the brass gears, weights, and pendulum mark time with fine-tuned accuracy. As with the tall clocks of old, this one will no doubt stand the test of time.

LET'S BEGIN WITH THE FACE FRAME

1 Cut the face-frame stiles (A) and rails (B) to the sizes listed in the Bill of Materials on page 43.

2 Mark the location of, and cut a notch in each stile where dimensioned on the Face Frame Drawing.

3 Drill a pair of $\frac{3}{8}$ " dowel holes $1\frac{1}{16}$ " in both ends of each rail (see the Dowel Hole Detail accompanying the Face Frame Drawing for location). Insert dowel centers in the holes, and dry-clamp the frame together to transfer the hole locations to the stiles. Depending on the number of dowel centers you have, you may need to transfer the locations one joint at a time. Remove the clamps, and drill the mating dowel holes.

4 Mark three hinge-hole centerlines where dimensioned on the Face-Frame Drawing. (For ease in locating the hinge leaves later, mark horizontal lines across the entire width of the stile.) Bore three 35 mm holes $\frac{1}{2}$ " deep where marked for the hinges. (See the Buying Guide on page 78 for our source of hinges and drill bit.)

5 Glue, dowel, and clamp the face frame together, checking for square.

NOW FOR THE SIDE AND BACK ASSEMBLY

1 Cut the stiles (C), rails (D), and plywood back (E) to size. Cut a $\frac{3}{4}$ "

rabbet $\frac{1}{2}$ " deep along the back edge of each stile (see the Side and Back Assembly Drawing).

2 Mark the dowel-hole center points on both ends of each rail (see the Dowel Hole Detail accompanying the Face Frame Drawing). Drill the holes, and use dowel centers to transfer the hole center points to the stiles (A, C). Drill mating dowel holes in the stiles.

3 Glue, dowel, and clamp both side frames (C, D) to the face frame. Lay the back panel in the rabbet to help square-up the assembly.

4 Glue and screw the back panel to the framework, using the hole sizes and locations on the Screw Hole Detail accompanying the Side and Back Assembly Drawing.

5 So that you can install the glass later, rout a $\frac{3}{8}$ " rabbet $\frac{3}{8}$ " deep around the entire inside edge of the *outside* face of each side frame where shown on the Carcass Assembly Drawing. Square the corners with a chisel.

FITTING THE TOP AND BOTTOM

1 Cut the upper cleats (F, G) and lower cleats (H, I) to size. Glue and clamp the upper cleats into position $\frac{3}{4}$ " below the top edge of the cabinet frame where shown on the Carcass Assembly Drawing.

2 Glue and clamp the lower cleats into position $\frac{3}{4}$ " below the top

CONTEMPORARY TALL CLOCK

4 Drill a $\frac{3}{8}$ " hole, push a $\frac{5}{16}$ " T-nut into the bottom of each corner block, and add the floor glides.

5 Lay the clock cabinet on its back. Glue and screw the base assembly to the bottom of the cabinet flush with the back of the cabinet and centered from side to side. (Refer to the Screw Hole Detail for the screw sizes and location.)

THE DOOR COMES NEXT

Note: We constructed our first door from solid stock and it warped. To keep the door from warping, we found it best to laminate the door parts.

1 From $\frac{3}{4}$ "-thick oak stock, cut four pieces to $2\frac{3}{8} \times 72$ " for the door stiles (N) and four pieces $2\frac{3}{8} \times 22$ " for the rails (O).

2 Place waxed paper on top of the cabinet face frame. Glue and clamp the door stiles together, using the front of the cabinet as a form (see the drawing above right). This ensures a tighter fit later between the door and cabinet. Mark one stile "left" and one "right" for repositioning on the same sides later.

3 Later, remove the clamps, and scrape the excess glue from each laminated stile. Repeat the same process for the door rails (O).

4 Plane one edge of each stile and rail. Rip the opposite edge of each part for a $2\frac{1}{8}$ " finished width.

5 Set your table saw blade 45° from center, and bevel-rip the front face of each stile and rail to produce a double-chamfered face (see the Section View accompanying the Door Drawing for reference). Sand the chamfered edges smooth.

6 Dado or rout a $\frac{3}{8}$ " rabbet $\frac{3}{8}$ " deep along the bottom inside edge of each door stile and rail.

7 Measure the length and width of the front face of the cabinet frame, and miter-cut the stiles and rails to length. (We test-cut scrap stock first to ensure an accurate 45° angle.)

8 With the cabinet frame still on its back, lay waxed paper on each corner of the cabinet frame. Glue and clamp the door frame members together and to the cabinet.

LAMINATING THE PARTS

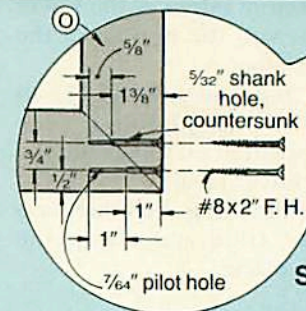
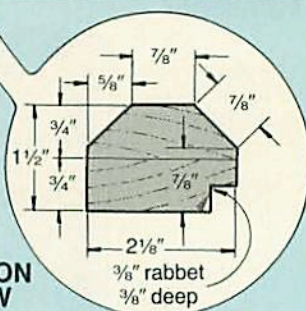
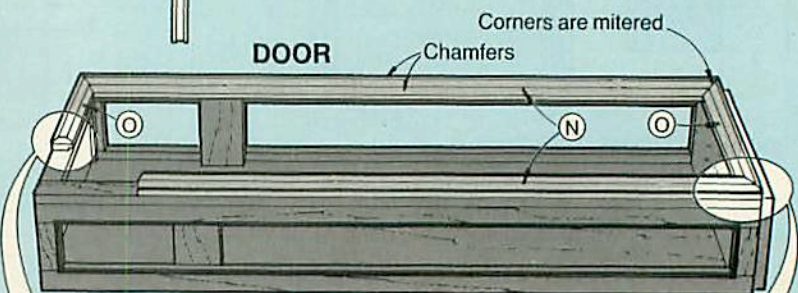
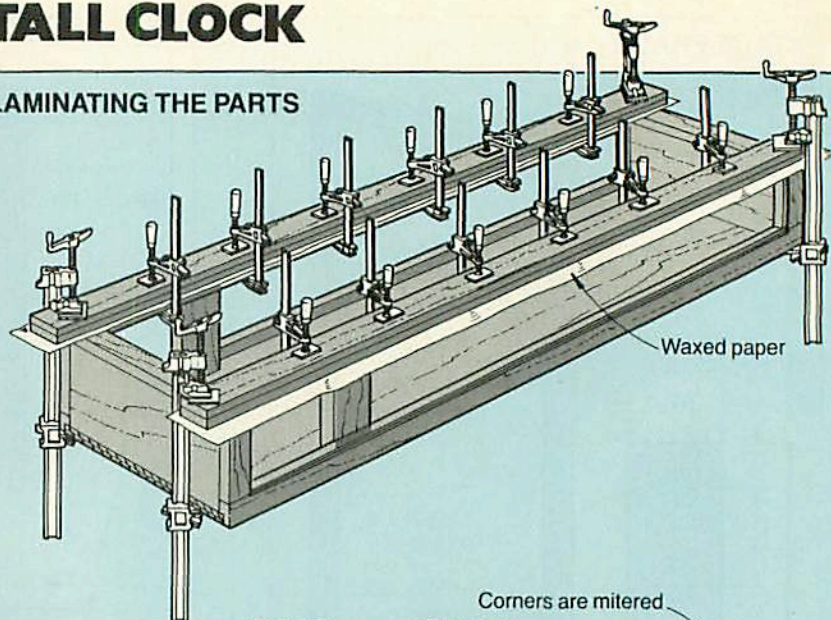

9 Drill a pair of holes at each corner of the door frame, using the hole sizes and locations given on the Screw Hole Detail accompanying the Door Drawing. Drive the screws.

NOW, HANG THE DOOR

1 Clamp the door frame flush with the right-hand door-frame stile where shown on the Hinge Installation Drawing far right.

2 Transfer the hinge centerlines from the face-frame stile (A) to the door stile (N). Measure over $\frac{3}{4}$ ", as shown, and make a leaf reference line. Locate a hinge leaf on the door where shown on the drawing. Mark

and drill a pair of leaf pilot holes for each of the three leaves.

3 Screw the leaves to the door frame. Drill pilot holes, and screw the hinges to the face frame. Remove the clamps. Connect the leaves to the hinges, and tighten the mounting screws. Close the door to check the alignment of the door to the face frame. To correct any misalignment, loosen the leaf mounting screws, and adjust the door alignment screws.

4 Once the leaves are positioned correctly, loosen the mounting screws, and remove the door from the cabinet. Now, score the outline

Bill of Materials

Part	Finished Size*			Material	Qty.	Part	Finished Size*			Material	Qty.	Part	Finished Size*			Material	Qty.
	T	W	L				T	W	L				T	W	L		
THE FACE FRAME						I	3/4"	1 3/8"	17 7/8"	oak	1	MOUNTING BOARD ASSEMBLY					
A	1 1/16"	2 1/8"	70"	oak	2	J	3/4"	7 9/16"	17 7/8"	oak plywood	1	P	3/4"	6 13/16"	15 5/8"	oak	1
B	1 1/16"	2 1/8"	15 3/4"	oak	2	K	1 1/16"	4 1/2"	8 5/8"	oak	2	Q	3/4"	4 1/2"	15 5/8"	oak	1
THE SIDE AND BACK ASSEMBLY						THE BASE						CLOCK FRAME AND FACE					
C	1 1/16"	2 1/8"	70"	oak	2	L*	1 1/16"	1 1/4"	19"	oak	2	S	1 1/16"	7 7/8"	15 3/4"	oak	4
D	1 1/16"	2 1/8"	6 3/16"	oak	4	M*	1 1/16"	1 1/4"	9 7/8"	oak	2	T*	1/4"	11 3/4" diam.	oak plywood	1	
E	3/4"	18 7/8"	70"	oak plywood	1	THE DOOR						GLASS STOPS					
THE CARCASS PARTS						N*	1 1/2"	2 1/8"	70"	oak (laminated)	2	U*	1/4"	3/8"	66 1/2"	oak	6
F	3/4"	3/4"	6 13/16"	oak	2	O*	1 1/2"	2 1/8"	20"	oak (laminated)	2	V*	1/4"	3/8"	6 15/16"	oak	4
G	3/4"	3/4"	17 7/8"	oak	1							W*	1/4"	3/8"	16 1/2"	oak	2
H	3/4"	1 3/8"	6 3/16"	oak	2												

*Parts marked with an * are cut larger initially, and then trimmed to finished size. Please read the instructions before cutting.

Supplies: 3/8" dowel pins 2" long, #8x3/4" flathead wood screw, #8x1 1/4" flathead wood screws, #8x1 1/2" flathead wood screws, #8x2" flathead wood screws, #10x1 1/2" flathead wood screws, #10x1 3/4" flathead wood screws, #10x2" flathead wood screws, 3/8" dowel stock for trammel pivot pin, waxed paper, 1/4" hardboard for trammel base, 1/4x1 3/8" thumbscrew with a 1/4" threaded insert, 1/8x16 3/8x66 3/8" double-strength glass, 2—1/8x6 13/16x66 3/8" double-

strength glass, #10x3/4" flathead wood screw, 4—1/4" flat washers, 3/16x5 1/2" turnbuckle with eyes at both ends, 3/16x2 1/2" eyebolt hook, 3/16" short hollow wall anchor, 3/4"x17 brads, 1/16"-diameter brass 7 1/2" long for pull rod, masking tape, epoxy, stain, finish.

strength glass, #10x3/4" flathead wood screw, 4—1/4" flat washers, 3/16x5 1/2" turnbuckle with eyes at both ends, 3/16x2 1/2" eyebolt hook, 3/16" short hollow wall anchor, 3/4"x17 brads, 1/16"-diameter brass 7 1/2" long for pull rod, masking tape, epoxy, stain, finish.

Cutting Diagram

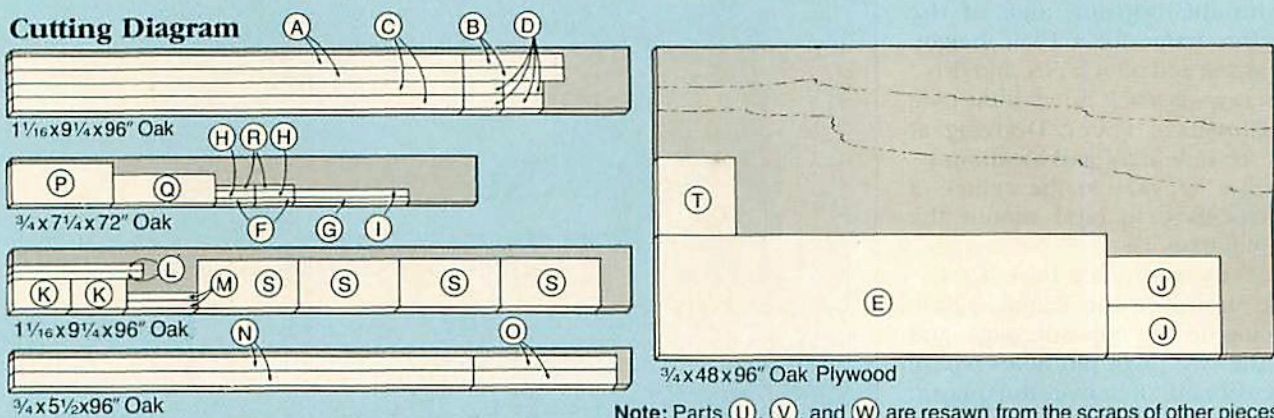

of each leaf onto the door stile with a hobby knife, and then remove the leaves. Using a chisel, form a 1/16"-deep mortise for each leaf. Check the fit of each leaf in its respective mortise. Remove the hardware, and finish-sand the door.

FORMING AND INSTALLING THE MOUNTING BOARD

- 1 Cut the mounting board (P) and apron (Q) to size.
- 2 Using the Mounting Board Drawing as a guide, mark the notch, slot, and push-rod hole locations on the mounting board. Cut the notch and slot to shape, and drill the hole.

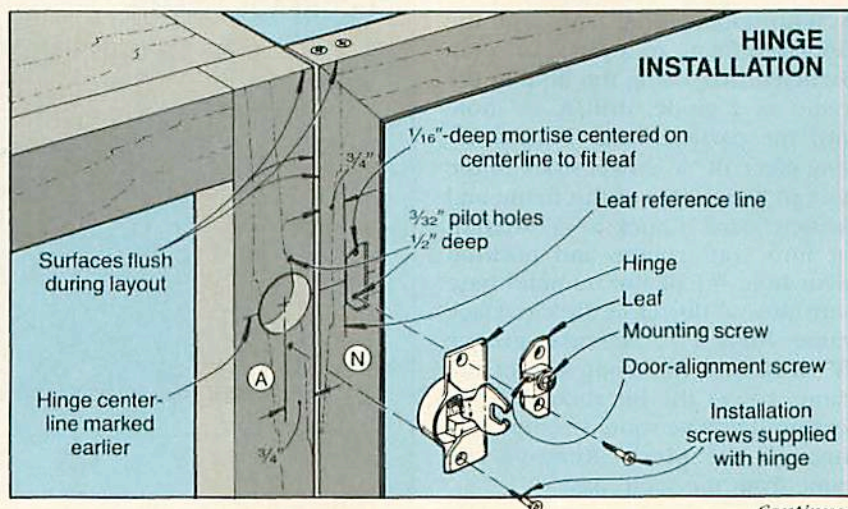

Continued

CONTEMPORARY TALL CLOCK

3 Drill a $\frac{1}{4}$ " hole in the apron $\frac{3}{4}$ " from the bottom edge and centered from end to end for the thumbscrew that holds the clockface in position.

4 Glue and clamp the apron to the front of the mounting board, with the ends flush.

5 Cut the mounting-board supports (R) to size. Glue and screw them to the cabinet sides where shown on the Mounting Board Assembly Drawing. Install the mounting-board assembly in position on the supports. Drill shank and pilot holes, and screw the mounting board to the cleats.

NOW FOR THE CLOCKFACE FRAME

1 Miter-cut the clockface frame parts (S) to size. Glue and clamp the parts together, keeping the surfaces flush.

2 Trim the bottom edge of the clockface frame for a $15\frac{3}{8}$ " height. Drill shank and pilot holes, and drive the screws at each miter joint (see the Clockface Frame Drawing at right for hole sizes and locations).

3 Drill a $\frac{3}{8}$ " hole at the center of the clockface to later mount the trammel base.

4 Cut the trammel base to the shape shown on the Trammel Base Drawing on the opposite page, and drill the two pivot pin holes where dimensioned. Remove the plastic subbase from your router, and mount the trammel base in its place.

5 With double-faced tape, tape the clockface frame to a piece of scrap particleboard. Using the hole in the frame as a guide, drill a $\frac{3}{8}$ " hole into the particleboard. Stick a 2"-long piece of $\frac{3}{8}$ " dowel stock in the hole in the center of the frame and particleboard. Chuck a $\frac{1}{2}$ " straight bit into your router, and position pivot hole #1 of the trammel base onto the $\frac{3}{8}$ " dowel in the clockface frame. Rout a $\frac{1}{2}$ " circular groove $\frac{1}{4}$ " deep into the front face of the frame. Lower the bit about $\frac{1}{4}$ " per pass until you've routed completely through the piece. Remove the frame from the scrap base.

MOUNTING-BOARD ASSEMBLY

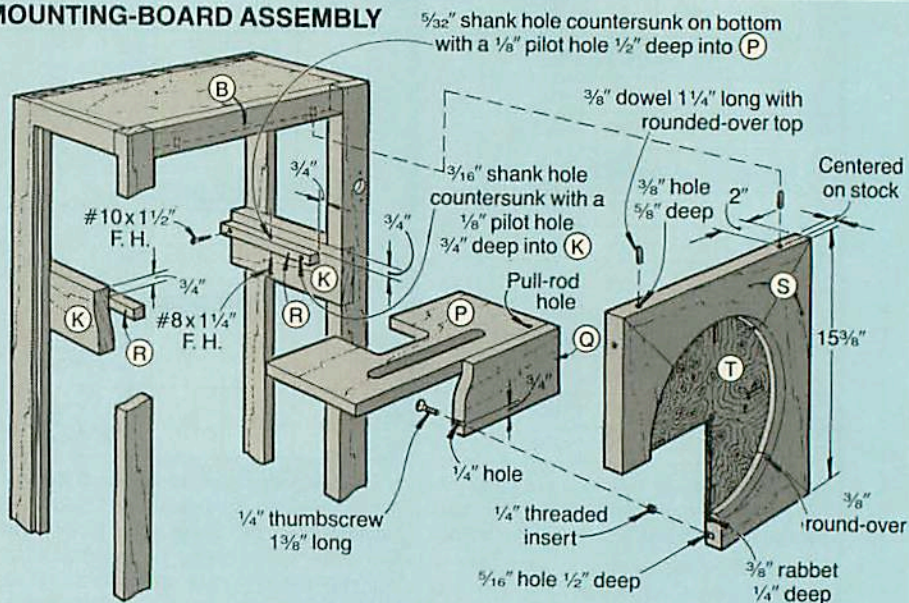

MOUNTING BOARD

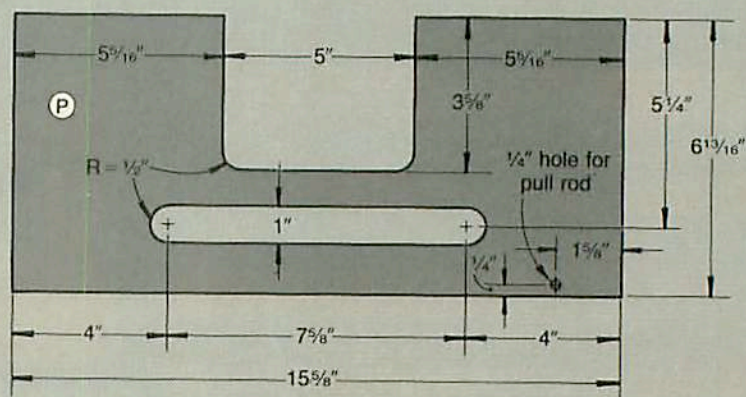

CLOCKFACE FRAME

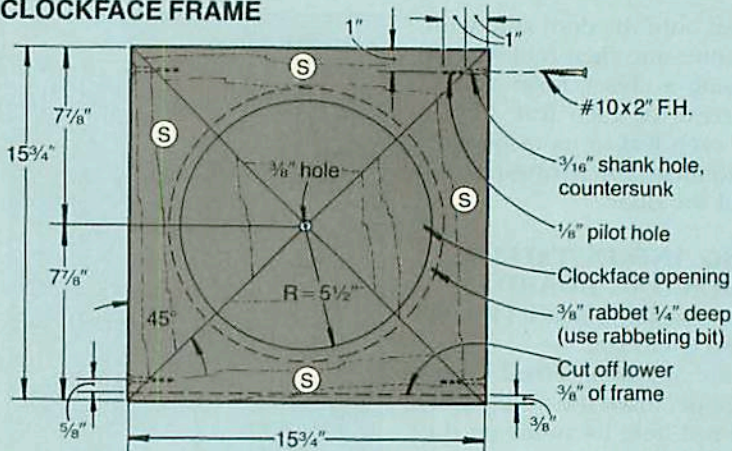

TRAMMEL BASE

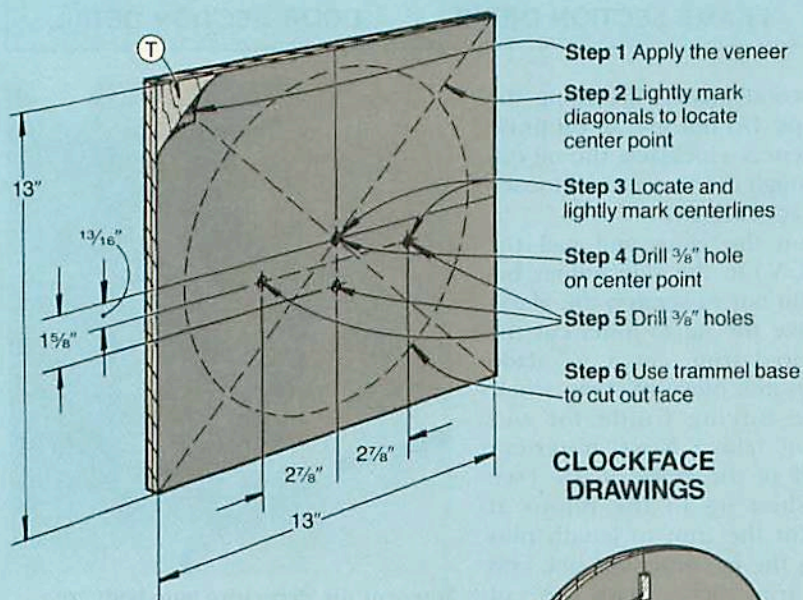
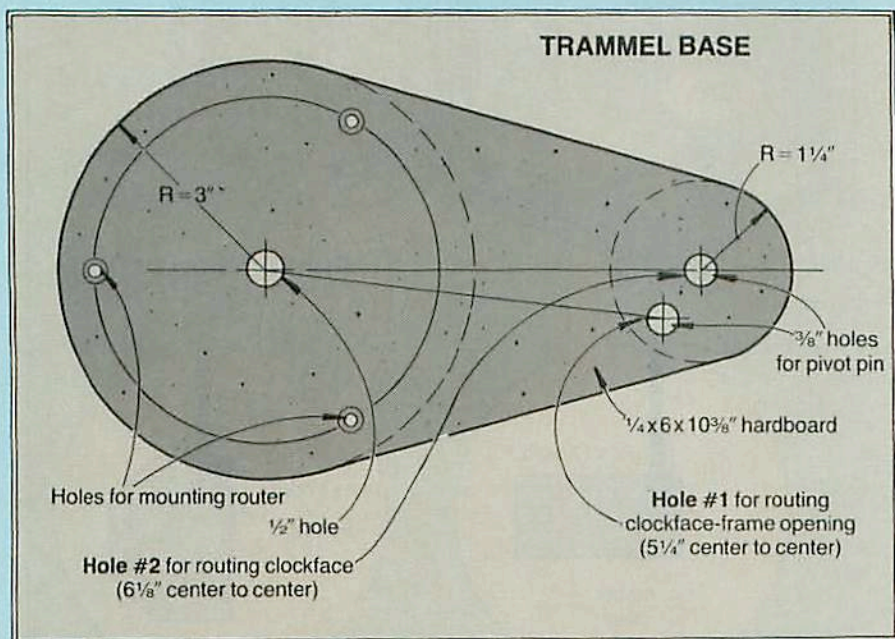

CLOCKFACE DRAWINGS

.016 x 1/4 x 1" brass epoxied to face

Redrill center hole to 7/16"

Centerlines

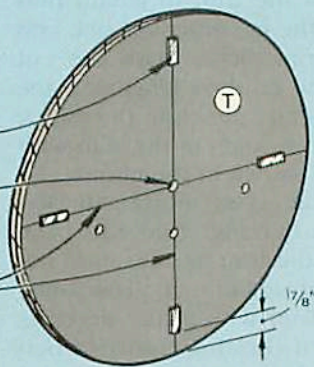

6 Use a rabbet bit chucked to your router to rout a $\frac{3}{8}$ " rabbet $\frac{1}{4}$ " deep on the back inside edge of the frame. Use a $\frac{3}{8}$ " round-over bit, and rout a round-over on the front inside edge of the frame opening.

HERE'S HOW TO MAKE THE VENEERED CLOCKFACE

1 Cut the clockface substrate (T) to size from $\frac{1}{4}$ " plywood. Apply veneer to one surface of the substrate (we used flexible walnut burl veneer—see the Buying Guide for our source of veneer and adhesive).
2 Follow steps 2 and 3 on the Clockface Drawing to locate and mark diagonals and centerlines. Now, follow steps 4 and 5 for drilling the holes. *Take your time when locating and drilling the holes; it is important that they are located where dimensioned.*

3 Using double-faced tape, tape the clockface to a piece of scrap stock. Drill a $\frac{3}{8}$ " hole through the center of the clockface into the scrap substrate. Stick a 2"-long piece of $\frac{3}{8}$ " dowel in the hole in the center of the face and scrap. Cut the clockface to shape, using a router fitted with a $\frac{1}{2}$ " straight bit, pivot hole #2 on the trammel base, and the $\frac{3}{8}$ " dowel fitted in the clockface center. *Note: The clock movement isn't available with the brass timing marks and hands as shown in the opening photo. Please see the Buying Guide on page 78 for our source of these custom-made parts.*

4 Locate and epoxy the 3-, 6-, 9-, and 12-o'clock timing marks to the veneered face, referring to the Clockface Drawings.

5 Redrill the $\frac{3}{8}$ " shaft hole to $\frac{7}{16}$ ". Glue the clockface into the rabbet in the clockface frame. To align the clockface in the frame, line up the pencil-marked diagonals on the face with the miters on the surround. Once aligned, glue and clamp in position. Immediately remove any excess glue from the veneer. Later, remove the clamps, and sand away the pencil lines on the clockface, being careful not to sand through the thin veneer.

Continued

CONTEMPORARY TALL CLOCK

6 Drill the $\frac{3}{8}$ " holes in the top edge of the clockface frame—see the Mounting Board Assembly Drawing for dimensions. Insert $\frac{3}{8}$ " dowel centers in the two holes. Position the front face of the clockface frame flush with the front of the face frame, and transfer the hole locations from the clockface frame to the bottom edge of the frame rail (B). Drill a pair of $\frac{3}{8}$ " holes $\frac{3}{4}$ " deep into the bottom edge of the frame rail. Cut two $1\frac{1}{4}$ "-long dowels from $\frac{3}{8}$ " dowel stock. Chuck one of the dowels in the drill press, and sand a bulletlike shape on one end. Repeat for the other dowel. Glue the dowels in the holes in the top edge of the clockface frame.

7 Dry-clip the clockface frame in place. Working from the back side of the apron, mark through the hole in the apron to mark the threaded-insert location on the back face of the clockface frame. Drill the hole and install the insert.

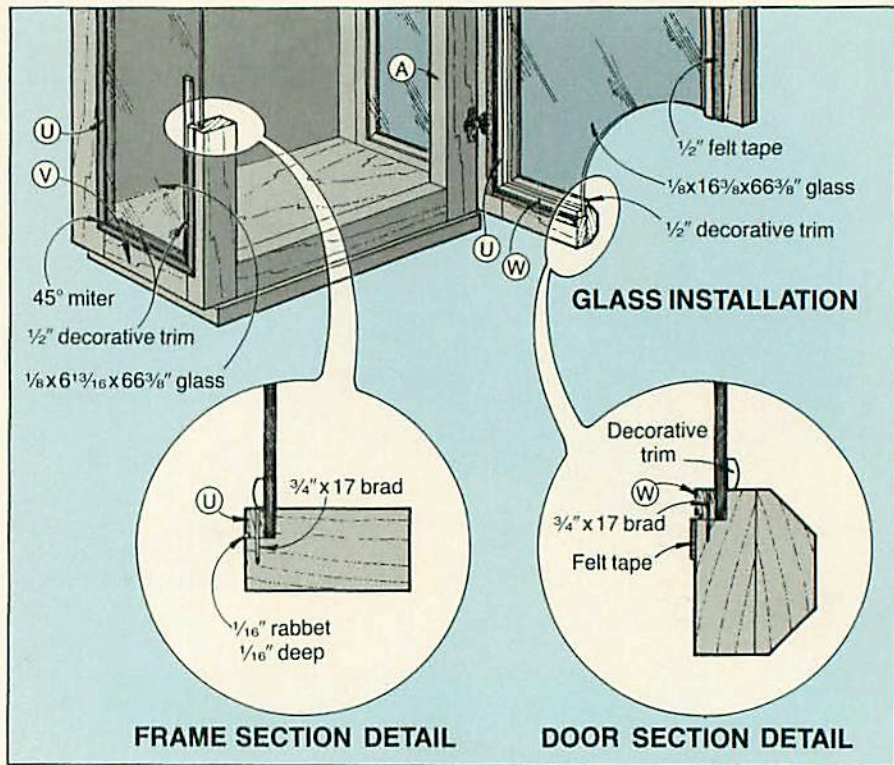

CUTTING THE GLASS STOPS AND INSTALLING THE GLASS

1 Resaw the glass stops (U, V, W) to size plus 2" in length.

2 Rout a $\frac{1}{16} \times \frac{1}{16}$ " decorative rabbet along one edge of each stop (see the Frame Section Detail above right for the location). Miter-cut the glass stops to length.

3 Measure the openings, and order $\frac{1}{8}$ " double-strength glass for the sides and door. (We had ours cut $\frac{1}{8}$ " less in width and length than the openings to allow for movement of the wood. We had ours cut to the sizes listed in the Supplies.)

4 Using one of the brads as a bit, drill pilot holes in the stops. Position the glass panel in the door frame. Using a brad set, nail the door stops into position. Sand the stops flush with the surface of the door frame. Do not install the glass in the side frames yet.

APPLY THE FINISH AND ADD THE TRIM

1 Finish-sand all the parts.

2 Mask off both faces of the glass panel in the door. Stain and finish

all the wood pieces, including the glass stops. Do not use an oil finish on the veneer clockface; the oil can seep through the veneer and loosen the contact cement.

3 Position the glass, and nail the stops (U, V) in the side frames being careful not to scratch the glass.

4 To make the jig to miter-cut the gold-colored trim, cut a $\frac{1}{2}$ " dado $\frac{3}{16}$ " deep in a piece of scrap stock. (See the Buying Guide for our source of trim.) Next, miter-cut each end of the stock at 45° (see the finished jig in the photo at right). Cut the trim to length plus 1". Using the jig, miter-cut one end of each trim piece. Mark the cut line for the finished length on the opposite end, position the block over the trim, and cut the trim with a chisel as shown in the photo.

5 Clean the glass thoroughly. Remove the backing from the trim, and press the trim into position onto the front side of each glass panel. Heat the trim with a hair dryer as you apply it (heating ensures a better bond between the trim and glass).

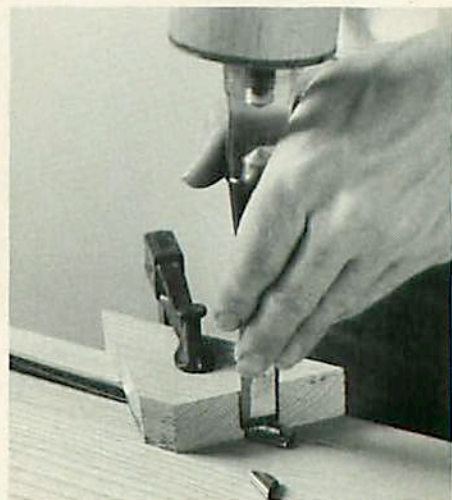

Miter-cut the decorative auto-body trim to length with a chisel and held in place with a scrap-wood jig.

6 Apply $\frac{1}{2}$ "-wide felt tape to the back of the door where shown on the Glass Installation Drawing above. Attach the hinge hardware to the door and frame.

7 Using the Turnbuckle Attachment Drawing as a guide, attach a turnbuckle to the top of the cabinet. The turnbuckle prevents the clock from accidentally tipping for-

CLOCK WORKS ASSEMBLY

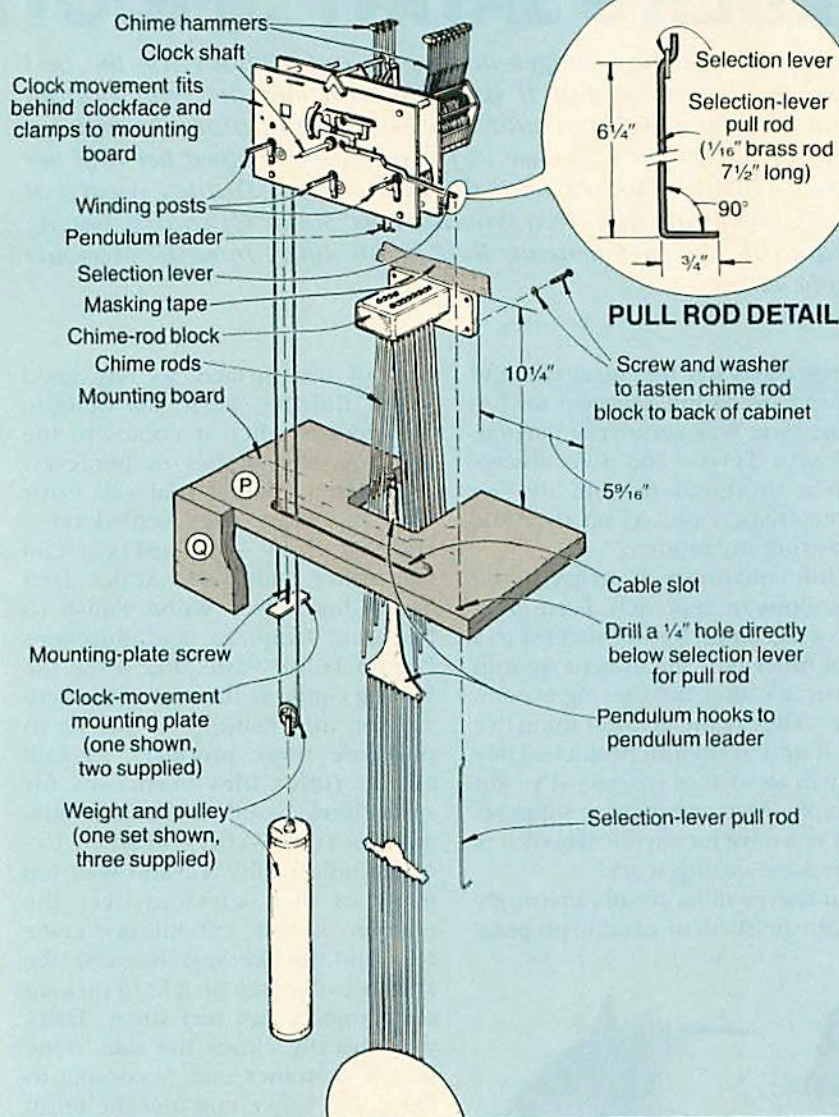

PULL ROD DETAIL

Screw and washer to fasten chime rod block to back of cabinet

Cable slot

Drill a 1/4" hole directly below selection lever for pull rod

Pendulum hooks to pendulum leader

Selection-lever pull rod

TURNBUCKLE ATTACHMENT

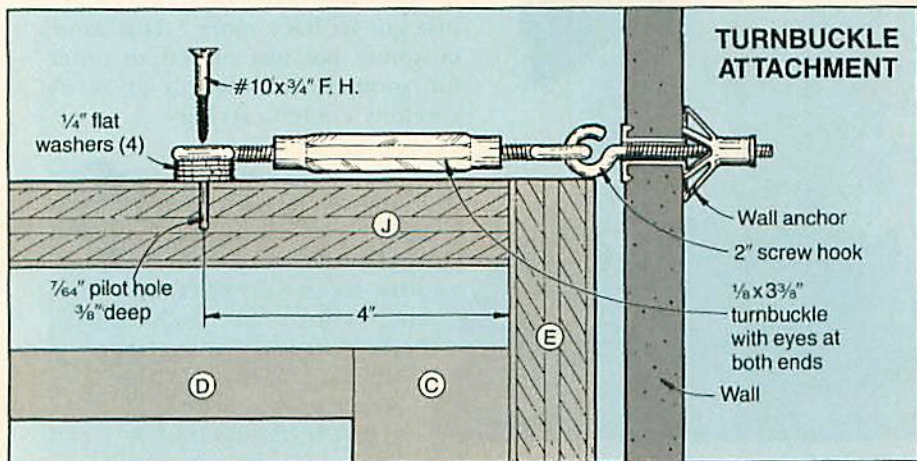

ward later. Position and level the clock against the wall where it will stand, and attach the hardware.

INSTALLING THE MOVEMENT

Note: Refer to the directions accompanying the clock movement and the Clock Works Drawing for details on the following steps.

1 Remove the clockface and frame assembly. Measure up 10 1/4" from the top edge of the mounting board, and place a piece of masking tape on the plywood back panel (E) to act as a reference line. Remove the mounting board assembly.

2 Position the top of the chime-rod block flush with the masking tape, and center the block from side to side. Now, mark the location of and drill four 1/4" holes through the back panel. Screw the chime rod block to the back panel.

3 Reposition the mounting-board assembly on the cleats, and screw it into place.

4 Hold the clock movement above the cable slot, and drop the pulleys through the slot. Finger-tighten the mounting plate screws to hold the movement over the slot.

5 Position the clockface-frame assembly against the front of the clock movement. Move the clock movement until the winding posts and shaft align with the holes in the clockface. Firmly tighten the mounting-plate screws, and remove the clockface assembly.

6 Loosen the chime-rod block, and center the chime rods between the hammers. Retighten the block to the back panel. Bend the hammer arms slightly if necessary to align the hammers with the chime rods.

7 Form the selection-lever pull rod from a 7 1/2" length of 1/16"-diameter brass rod (see the Pull Rod Detail above left for shape).

8 Hang the weights, pendulum, and selection lever. Insert the thumb-screw, and tighten it to hold the clockface firmly against the mounting-board assembly.

9 Attach the hands to the clock shaft (see the Buying Guide for our source of custom-made hands).

Continued on page 78



The One People Love To Touch

FERN WEBER'S SATINY-SMOOTH

We asked this Kansas City carver how on earth she gives her projects such a heavenly look. Now that she's told us, we're passing along the good finishing news to you.

Carving competition judges don't give out ribbons for the best finish on a carving, but if they did, you can bet your bottom dollar that Fern Weber would win her share of blues. In fact, we think it's partly her expertise at finishing that helped her and her husband, Walt, walk off with the Best Overall Display Award at last year's Kansas City-Area Woodcarvers' Show. Of course, having top-quality carvings beneath that finish didn't hurt the Missouri couple, either.

When Fern enrolled in a tole painting class a decade ago, she never dreamed of getting involved in carving, or finishing for that matter. About the same time, Fern convinced her soon-to-be retired husband to sign up for a wood-carving class to keep him busy. To her surprise and delight, Walt really took to carving—and became very good.

The only thing is, it seems Walt liked to carve a lot more than he liked applying the finish to his projects. That's when Fern offered her help, and ever since then she's been "tidying up" and finishing Walt's—and now her own—carvings.

Fern says that it was her tole painting instructor who

impressed on her the importance of properly preparing a project for finishing. "She was very, very particular," says Fern, "and I've always been a thorough person, too—a characteristic I picked up over the years from my mother."

While obviously it helps to be meticulous in approach, Fern gives part of the credit for her success to a set of riffler files she uses to smooth the surface after the carving is complete. "They're the greatest thing I've ever found to smooth projects. They come in all sorts of shapes—I've got a couple dozen of them, I suppose. They're a must for anyone who wants to do good-quality work."

But there's more to this amazingly smooth finish than careful prepara-

tion of the surface. As any good wood finisher, Fern has definite preferences when it comes to the products she applies to her carvings. After a lot of trial and error over the years, she's settled on—and swears by—McCloskey's Stain Controller and Wood Sealer, Deft Semi-Gloss Clear Wood Finish (a brushing lacquer), and Butcher's Boston Polish Paste Wax. (See the Buying Guide at the end of the article for information on where to purchase these products, as well as the riffler files Fern uses for smoothing wood surfaces.) How good is Fern Weber's brushed lacquer finish, really? She and Walt sell many of their carvings over the counter at mall exhibitions, crafts fairs, and the like, and she says, "We always encourage people to pick up our projects and feel them. That's what usually closes the sale." One recent customer said, according to Fern, that "once you feel the finish on one of Fern's carvings, you've just got to have more." That same customer has just placed an order for another \$450 worth of Fern's carefully crafted carvings.

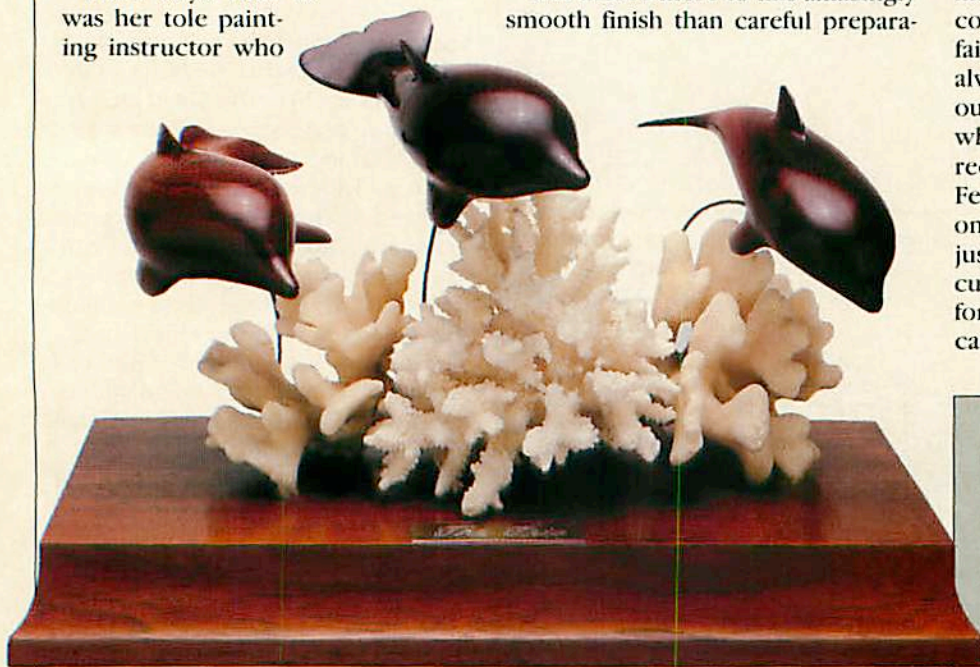

Padauk dolphins carved by Walt Weber and finished by Fern

If you or one of your friends uses a finishing system you'd like to crow about, why not drop us a line. Write to: "In Search of the Perfect Finish," 1716 Locust Street, Des Moines, IA 50336. Who knows, maybe we'll do an article about you.



BRUSHED LACQUER FINISH



Here's How Fern Finishes Her Projects—Step-By-Step

I Because Fern executes sleek and stylized carvings, they just have to be smooth. She removes any evidence of knife cuts and gets into all those grooves and hard-to-get-at places with her set of riffler files. "They're a must," Fern says, "if you want to do good-quality work. They make very fine cuts, so smooth in fact that I almost never need to use coated abrasives coarser than 220-grit."

2 When she deems the piece ready for sanding, Fern exchanges the riffler files for sandpaper. "I try to sand with the grain whenever possible, and I gauge the final readiness by feeling the project rather than looking at it. You can feel when it's ready; don't hurry," she says. Note the "remodeled" Rubbermaid Spice Carousel that Fern uses to store her carving tools. Walt bored holes in the carousel so the tools stand upright.



Continued

FERN WEBER'S LACQUER FINISH

3 With her carefully prepared project in hand, Fern applies one coat of McCloskey's sealer with an inexpensive nylon brush. "I wipe off the excess sealer with a clean, lint-free rag and let the sealer dry for 24 hours," Fern notes. "That drying time is important; the following coat of Deft will bubble if you put it on before the sealer has dried completely," she adds. "In fact, the label on the sealer says not to use McCloskey's under a lacquer finish, but it works well for me." Fern buys this product in quart containers, then divides the contents into several small jars with tight-fitting lids. Doing this, she says, prevents the sealer in the unused jars from congealing.



Cypress-knee carving titled "Meditation"

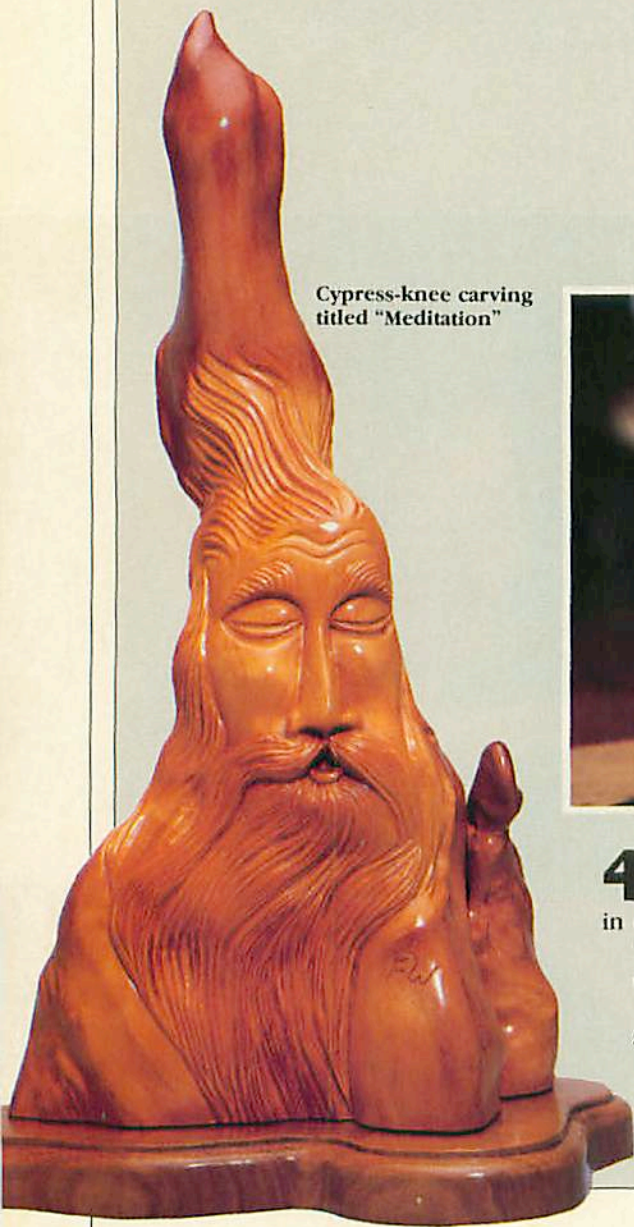

4 When applying the Deft Semi-Gloss Clear Wood Finish—sometimes up to ten coats—Fern takes great pains to brush the lacquer in one direction only. And she insists on a camel's hair lacquer brush. "Less-expensive brushes just don't lay down the finish as smoothly as the camel's hair," Fern advises.

"I like to wait at least an hour between coats, and don't forget to steel-wool and tack-cloth your project between coats," she says.

5 After each coat of Deft, Fern sands all surfaces, including the cracks and grooves with 0000 (the finest) steel wool. "Doing this," she says, "removes the hairlike grain the Deft finish raises. The softer the wood the more severe the grain-raising." A careful wiping of the surface with a tack cloth removes all metal shards left as the result of sanding.

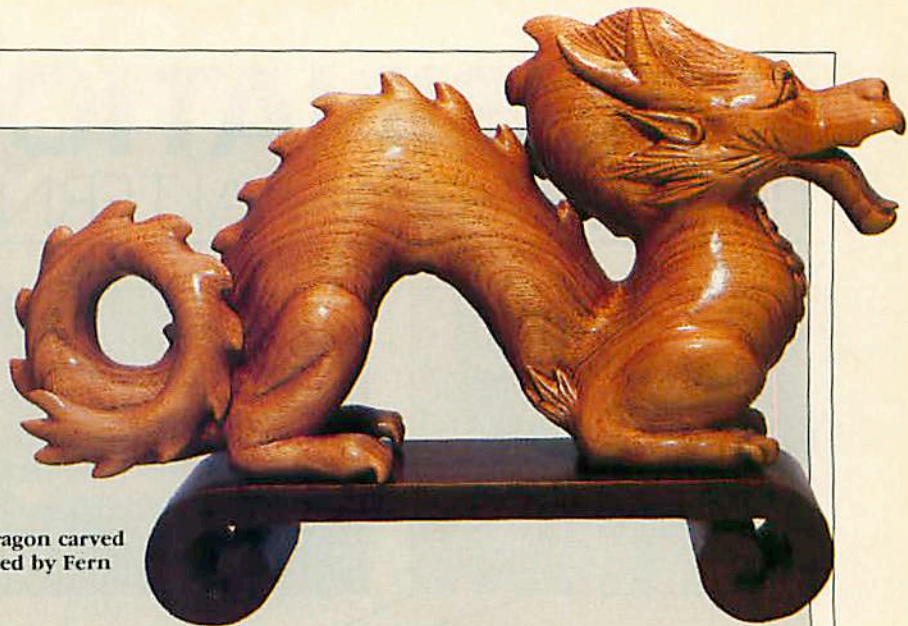

Medieval dragon carved and finished by Fern



6 "After the final coat and a light rubbing with steel wool, I apply three coats of the Butcher's Wax," Fern counsels. "I leave each coat of wax on for about 20 minutes before buffing it with a clean cloth. Old diapers work well here."

BUYING GUIDE

- **Rifflers (files).** Several sets available from Woodcraft, 41 Atlantic Avenue, P.O. Box 4000, Woburn, MA 01888.
- **McCloskey Stain Controller and Wood Sealer, (Clear).** The McCloskey Corp., Philadelphia, PA. Call 800-345-4530 for the name of the nearest distributor.
- **Deft Semi-Gloss Clear Wood Finish.** Available nationwide at many hardware and home center stores.
- **Butcher's Boston Polish Paste Wax (Amber).** Call 800-225-9475 for the name of the nearest distributor. ♣

Produced by Larry Clayton with Marlen Kemmet Photographs: Tom Gann

COMBINATION WOOD

THE EUROPEAN ALTERNATIVE TO SINGLE

MORTISE!

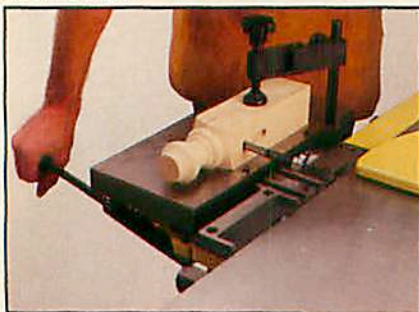

JOINT!



SAW!

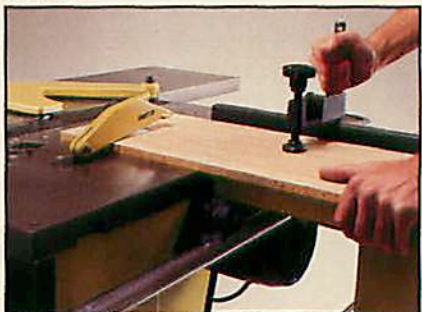

PLANE!

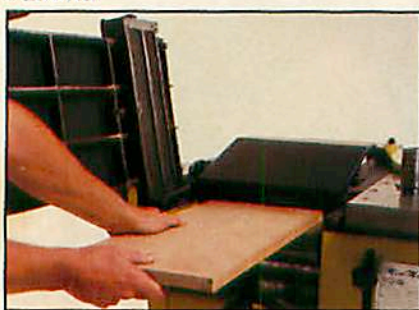

SHAPE!

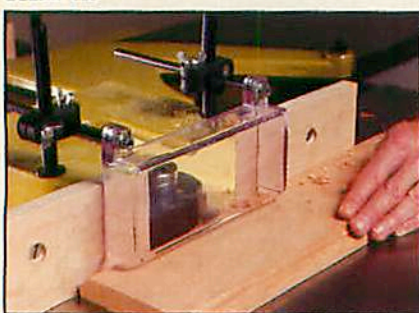

Mini Max C30

If you're like most American woodworkers, you probably think in terms of single-purpose stationary tools: a table saw for straight-line sawing, a band saw for curved cuts, a drill press for drilling, a jointer for surfacing stock, and so on. But it's a different story in Europe. There, woodworkers have learned how to make small shops work big. For decades, European tool manufacturers have made woodworking machines that combine two or more functions.

The most popular of these—the combination woodworking machine—combines the five tools most often used in small cabinet shops: a table saw, jointer, thickness planer, shaper, and slot mortiser. And, the entire unit fits into the space ordinarily occupied by a table saw. So, if you're tight on shop space, a European combination tool may be the answer.

Although these imports are still relatively new in this country, the multitool concept isn't. Back in 1947, Shopsmith introduced their lathe-based 5-in-1 combination machine, which converts to a table saw, drill press, horizontal boring machine, and disk sander. Since then,

the Shopsmith has gained a strong, loyal following among home woodworkers. Total Shop and Master Woodcraft later introduced similar machines.

And now, importers of the European combination machines bet that they, too, can capture a share of the multimachine market. That's why at any given woodworking show, you'll see one or more importers demonstrating their units. After watching several of these demonstrations, we decided it was high time to take a closer look at these tools, and get a bit of hands-on experience with them. For this report, we tested models from six of the importers. Here's what we found:

WORKING MACHINES

-PURPOSE STATIONARY TOOLS

HOW DO THEY WORK? EASIER THAN WE IMAGINED!

Never having worked with this type of machine before, we anticipated a lot of complex procedures to switch from one tool to another. But we were pleasantly surprised. Typically, you select the tool or function you want by operating a dial, button, or lever. (Each of the combination machines works a bit differently in this respect.) In some instances, you also must attach or detach fences and guards when switching from one tool to another. Here's how they work:

TABLE SAW: COMPLETE WITH A SLIDING TABLE

On all machines except the two Kity models, the table saw and shaper share the same table. So you have to lower the shaper spindle and remove the shaper fence and guard to use the saw. While this may seem like a hassle, we found the switchover takes less than a minute on the machines we tried.

All of these units—except the Kity models—include a sliding table as standard equipment.

JOINTER/THICKNESSER: A COMBO THAT MAKES SENSE

All of the European-built combination machines include a jointer/thicknesser that share the same cutter block. This combination makes the overall machine more compact, and gives you the same capacity for both the jointer and the thicknesser—a plus for truing wide boards.

SHAPER: IT SHARES THE SAW'S TABLE

To use the shaper on combination machines, you have to lower the saw blade below the table surface, remove the saw fence, and attach the shaper fence/guard (see remarks on Kity models, *left*). Again, it's not really much trouble to make the switchover. And, there's an advantage to both tools sharing the same main table: You can use the saw's sliding table for the shaper, too. Among other tasks, the sliding table and hold-downs provide a safe, quick means of tenoning the ends of boards on the shaper.

MORTISER: MORTISING AND MUCH MORE

Although you might think of a mortiser as an extravagance for your shop, it can do more than cut mortises and bore holes. You also can fit the mortiser with disk- and drum-sanding attachments and grinding wheels for tool sharpening. Except on the Toolmax and Kity K5, the mortise chucks have either a right-hand chuck rotation (counterclockwise as you face the chuck) or reversible (left- or right-hand) rotation. Several of the tools come with metric chucks (usually 16 mm), but most of the manufacturers also offer 1/2" or 5/8" chucks, so you can fit the mortiser with ordinary drill bits and attachments (see chart on page 56).

To use the mortiser, you clamp the workpiece to the mortise table, adjust the table height, and set the stops on the table carriage for mortise depth and length. Two levers control table movement: One moves it front-to-back for mortise depth; the other moves it side-to-side for mortise length.

ROUGH STOCK TO FINISHED MOLDING—IN 4 EASY STEPS

While testing the European combination machines for this report, we invited several of the tool importers to our WOOD® magazine shop

to demonstrate their machines. In these photos, Ray Owen from Toolmax transforms rough stock into a finished molding, using four of the

five tools on his machine. With few variations, the other combination machines operate in much the same way as this one.

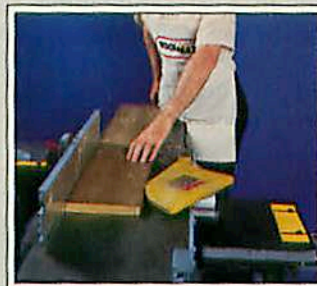

1 With the tool in the jointer mode, Ray Owen joints one side and one edge of the oak stock.



2 After swinging the jointer tables out of the way, he surfaces the stock to exact thickness on the thicknesser.



3 With the jointed edge against the saw fence, Ray rips the stock to the desired width on the table saw.



4 Ray forms his oak molding on the shaper. For clarity, we've removed the front guard on the shaper.

WE PUT SIX MACHINES TO THE TEST

FELDER BF5/41: THE MERCEDES OF THE MULTIS

Tools: 12" tilting-arbor saw; 16" jointer/thicknesser; 1 1/4" tilting-arbor shaper; mortiser with 16-mm (5/8" optional) shank capacity.

Without a doubt, this high-priced Austrian machine outclasses all the rest in size and quality. With three 3-hp motors (4-hp optional), this ton-and-a-half behemoth delivers more than enough power to drive its industrial-size components. Also,

the precision, double-milled cast-iron tables and extensions for the saw, shaper, and jointer/thicknesser have plenty of capacity for the size and power of these tools.

We especially liked the sturdy rip fence, which slides unobstructedly from the saw blade to the far side of the jointer table, providing a full 39" rip capacity to the right of the blade. Also, the shaper has a remov-

able quill, so you don't have to lower it below the table to use the saw. This way, you can keep the cutters on the quill and maintain the exact height setting, should you later want to duplicate a molding. The tilting arbor increases the versatility of your shaper cutters.

The chart on page 56 lists the many other superlative features the BF5/41 offers. But as much as we

KITY DD: THE MODULAR APPROACH

Tools: 9" saw (tilting table); 10" jointer/thicknesser; 3/4" shaper; mortiser with 1/2" shank capacity.

Unlike the other machines, the French-made Kity DD consists of individual components mounted on a common stand. The jointer/thicknesser, saw, and shaper share a common motor; a separate motor powers the mortiser.

Although not as compact as the machines with equal or greater capacity, the Kity DD "system" *far right*, has several advantages. For one, you can start with the basic drive unit and one or two machines, and later add more as you can afford them.

As shown in the photo at *center right*, a direct-drive control panel

operates an electric clutch that transfers the drive from one tool to the other. We found the DD by far the easiest of the machines to operate. The smaller Kity K5, shown at *near right*, employs the same modular principle, but you must manually change the drive belt to switch functions. Unlike the Kity DD, you can't buy the K5 components separately.

MINI MAX C30: PRECISION PLUS

Tools: 8" fixed-arbor saw; 8 1/2" jointer/thicknesser; 3/4" shaper; mortiser with 16-mm (5/8" optional) shank capacity.

The exceptionally smooth, positive operation of the controls, and accurate machining of all parts makes the Mini Max C30 a joy to

work with. We like the extra-large sliding table, which comes as standard equipment on this model.

To switch functions on this one-motor machine, you slide a lever to the appropriate setting, then twist it to engage the drive belt. A second lever locks the belt in position.

We found all the Mini Max components easy to adjust and use, and the motor has plenty of power to drive them. We do consider the fixed-arbor saw a limitation. Mini Max also offers a larger, two-part machine, the FSB35/MC90. You can buy the two units separately.

TOOLMAX T310: MORE CAPACITY FOR YOUR MONEY

Tools: 10" tilting-arbor saw; 12" jointer/thicknesser; 1" shaper; mortiser with 9/16" shank capacity.

Powered by three 3-hp motors (with a separate 1/4-hp motor to drive the thicknesser feed rollers), the Toolmax delivers as much capacity and power as machines costing al-

most twice as much. Features on this Belgian-made tool include large, rugged cast-iron tables and positive, easy-to-use controls—change the planer to thicknesser in about 20 seconds! You can split the Toolmax into two separate machines (jointer/thicknesser/mortiser and saw/

shaper), making it easier to transport through small doorways.

We found the combination rip fence for the saw/jointer somewhat flimsy and awkward to move from one tool to the other. But Jerry Spangler at Toolmax tells us they're introducing a Vega rip fence, com-

ZINKEN MIA 6: FOR THOSE WHO THINK SMALL

Tools: 6" saw; 6" jointer/thicknesser; 3/8" shaper; mortiser with 13-mm (1/2" optional) shank capacity.

Five stationary tools in 22x32" of bench space? You bet! And this

scaled-down Italian machine has all the basic features of the bigger machines, including sliding tables. The tiny collet chucks for the shaper accept 1/4" and 3/8" router bits, plus two metric sizes. Zinken offers a

large selection of cutters for the shaper. Cast-aluminum tables, fences, and guards contribute to its light weight (106 pounds).

The Zinken had a surprising amount of power for its size, and

drooled over this precision powerhouse, its \$14,900 price tag puts it beyond the reach of most home woodworkers we know. Although we wanted to show you the top of the line, we consider one of the smaller, lower-priced Felder machines more practical for the home woodworker (see the chart on page 56). The smaller machines offer the same rugged construction.



Above: Tilting-arbor shaper is a Felder exclusive; rip fence for table saw slides to far side of jointer table, providing a 39" rip capacity. **Right:** Felder BF5/41: Largest and most expensive machines.

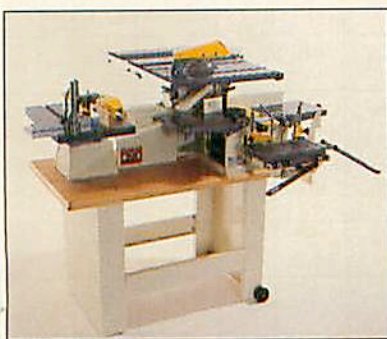
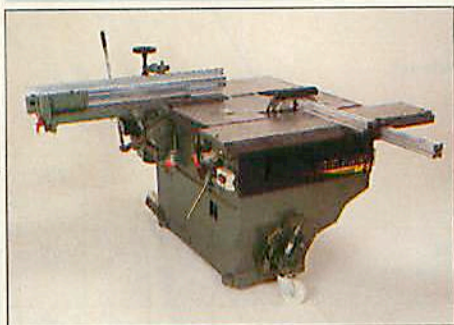

Left: Kity K5: To switch functions on this inexpensive, one-motor machine, you change the drive belt from one component to another. **Right:** Kity DD: You can begin with the basic drive unit and one or two machines, then add the rest as need and budget allows. **Center:** Central control panel on the Kity DD operates electric clutch (at bottom of photo) to switch functions.

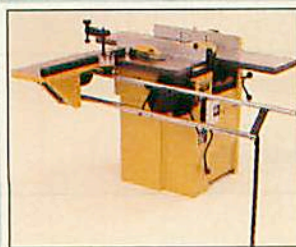
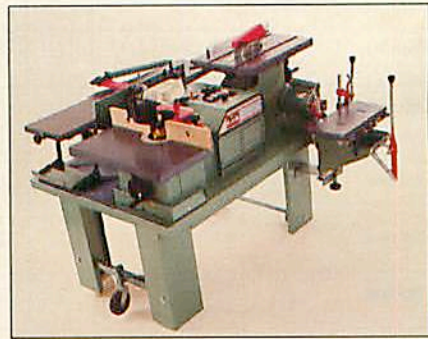

Left: Mini Max C30: We like the Italian precision quality and the large sliding table with a long bed of travel.

Right: Lever-operated clutch on the Mini Max C30 (see arrow) enables you to switch functions without shutting off the motor. A second lever locks the belt.

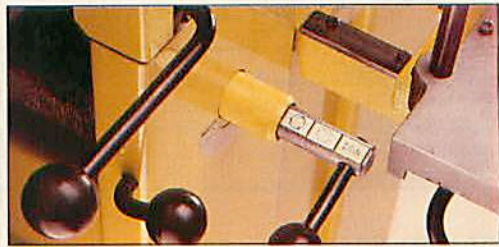

patable with the Toolmax table, which should be a tremendous improvement. Toolmax also has plans for a lathe attachment for the mortiser chuck.

The mortiser chuck has a left-hand rotation, which means you must buy special left-hand mortise

bits (available from Toolmax). Also, you can't use standard drill bits or router bits with the mortiser. Despite this drawback, we consider the Toolmax an exceptional bargain.

Right: Toolmax: At \$3,895, this sturdy machine gives you plenty of power and capacity for the money.

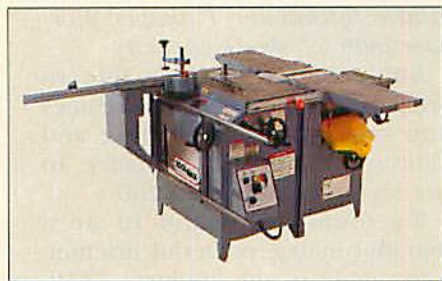

the components worked as accurately as some of the better single-function bench-top tools.

We think the MIA 6 would be a great apartment-size tool for small projects, but it's somewhat pricey for

what you're getting (\$2,095 retail, usually discounted to about \$1,500).

Right: Zinken MIA 6: This workshop on a bench top has the same five components as the big boys.

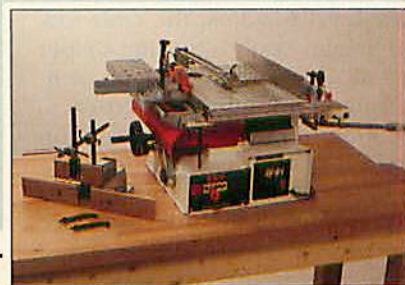

COMBINATION WOODWORKING MACHINES

COMBINATION WOODWORKING MACHINES																	
Manufacturer	Model	POWER TRAIN					TABLE SAW						JOINTER/THICKNESSER				
		No. of motors ¹	Horsepower (each motor)	Volts	Phase ²	Blade size (inches)	Maximum cutting depth (in.)	Blade speed (RPM)	Arbor ³	Blade-height ⁴ adjustment	Rip capacity (width, in.)	Maximum-cutting ⁵ width (in.)	Maximum-cutting depth (in.)	Thickness capacity (inches)	No. of knives	Cutter blade speed (RPM)	Maximum feed rate (ft. min.)
Felder	BF5 26	3	3	220	3	12	3¾	4,800	T	L	46½	10¼	¾	7½	3	5,000	24.5
Felder ¹⁴	BF5 41	3	4	220	3	12	3¾	4,800	T	L	60	16½	¾	7½	2	5,000	24.6
Kity	K 5	1	1½	110	1	8	2½	4,750	F	L	24½	6	¾	4	2	5,700	24
Kity	K DD	2	2	220	1,3	9	2¾	4,760	F	H	23	10	½	6	2	7,000	21.3
Mini Max	C30	1	2	220	1	8	2½	3,800	F	L	21½	12	¾	4½	3	5,000	22
Mini Max ¹⁵	FSB 35/ MC 90	3	3	220	1,3	10	3¾	3,500	T	L	12½	13½	¾	9.4	3	4,500	23
Robland	K260	3	3	220	1,3	10	3.3	3,200	T	L	20	10	¼	7	3	4,500	19.6
Robland	K310	3	3	220	1,3	12	3.9	4,000	T	H	25	12	¼	9	3	4,500	23
Toolmax	T310	3	3	220	1	10	2¾	4,500	T	H	24	12	½	8	3	5,700	15
Zinken	MIA 6	1	1½	110	1	6	2	5,000	F	L	13½	6	¼	2½	2	5,500	16.4
Zinken	ZC 21	1	2½	220	1	8½	3	3,500	F	L	27	8¼	¾	4¼	3	4,600	22¼

1. Does not include motor for power feed on thicknesser.
 2. Most homes are wired for 1-phase power only. Specify phase when ordering: Felder tools require a phase converter for 1-phase operation.

3. (T)ilting (F)ixed: Kity machines & Zinken ZC 21 have a tilting table.
 4. (L)ever (H)andwheel (crank)
 5. Both tools.

6. (LH) Left-hand (RH) Right-hand (REV) Reversible rotation
 7. Front-to-back table travel.
 8. Side-to-side table travel.

ROBLAND K260

Tools: 10" tilting-arbor saw; 10" jointer/thicknesser; 1" shaper; mortiser with 5/8" shank capacity.

Although we weren't able to bring one of the Robland machines into our offices for testing and photos, we did get a chance to work with the Robland K260.

We found the K260 to be a smooth-running, powerful machine comparable to the Toolmax T310. Features we liked include a quick-release level to adjust the table saw blade height, easily adjusting shaper guard fence and a 4-clamp self-centering chuck on the mortiser.

An emergency stop button on two sides of the machine immediately switches off the motors—a safety bonus. Robland literature

also highlights a special tenon cutter accessory that mounts on the shaper spindle.

Unlike the Toolmax, the jointer feeds from the same direction as the table saw. The Robland machines include some standard accessories (saw blades, shaper cutters, and mortise bits) that other distributors sell as options. Don't overlook Robland's prepaid freight bill when comparing prices. The freight ticket on many combination machines can be more than \$225.

However, you probably won't be able to purchase the K260 in 1988. An upgrade model, the X310 (not to be confused with the K310 on the chart), is essentially the same machine as the K260 but with one

significant difference: The 10¼" jointer/thicknesser upgrades to 12¼". The X310 suggested list price is \$4,950 including freight.

The Robland K260

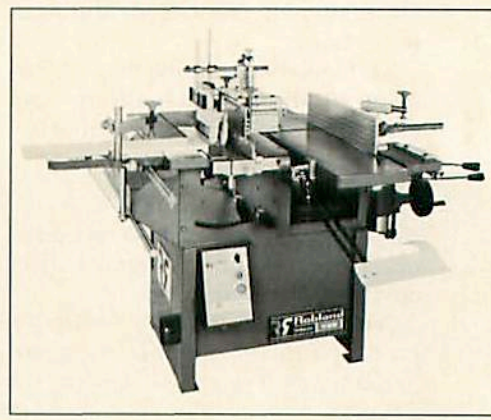

- VITAL STATISTICS

SHAPER						MORTISER						WORK TABLES				ACCESSORIES ¹²		
Cutterhead speed (RPM)	Spindle diameter (max. inches)	Maximum spindle height (inches)	Maximum cutter diameter (profile, in.)	Bit-shank capacity (inches)	Speed (RPM)	Chuck rotation ^s	Maximum boring depth (inches) ^r	Maximum boring length (inches) ^r	Table height travel (inches) ^r	Material ¹⁰	Saw table ¹¹ (W x L, inches)	Jointer tables (overall length, in.)	Sliding table (W x L, inches)	Overall dimensions (W x L x H, inches)	Weight (lbs.)	Standard	Optional	Suggested ¹³ retail price
3,800 6,100 7,800	1 1/4	5 1/4	10 3/4	3/8	5,000	Rev	5 1/8	8 3/8	4 3/4	CI	18 1/2 x 37	51	18.1 x 37.4	65 1/4 x 53 x 31 3/4	590	A, F	B, C, D, E	7,524
4,000 5,600 8,300	1 1/4	5 1/4	10 3/4	3/8	5,000	Rev	5 1/8	8 1 1/16	4 3/4	CI	18 1/2 x 37	59 1/2	33 x 41	71 1/4 x 59 1/4 x 33	1,433	A, F	B, C, D, E	14,134
6,200	3/4	3 3/8	4	3/8	5,700	LH	3 1/2	4 1/4	2	CA	13 x 19 1/2	28	N/A	22 x 40 x 24	1,984	C, E, F	A, B, D	1,695
6,200	3/4	3 3/4	7	3/8	7,000	RH	4 1/4	5 3/4	2 3/4	CA	15 3/4 x 21 1/2	42	8 x 14	42 x 60 x 38	475	C, E, F	A, B, D	3,995
6,000	3/4	3 3/8	5	3/8	5,000	RH	3 1/2	5.1	3.9	CI	16 x 27	53	16 x 27	51 x 53 x 42	585	A, C, F		3,145
2,000 3,500 7,000	1 1/4	4.7	6.7	3/8	4,500	RH	3 1/2	5.2	3.9	CI	17.7 x 35.4	63	17.7 x 35.4	63 x 69 x 43	1,463	A, C, F		5,190
3,000 6,000	1 1/4	5 1/2	12	3/8	6,000	Rev	5.9	5.1	3.1	CI	16 1/2 x 32 1/8	49	9 1/2 x 14 3/4	37 1/2 x 49 x 38 1/2	772	A, B, C, D, E, F		4,450*
3,000 6,000	1 1/4	4.3	12	3/8	4,500	Rev	5.9	8 1/2	5.9	CI	13.8 x 37.4	59	17.7 x 21.6	63 x 45 x 43	1,213	A, B, C, D, E, F		7,900*
3,000 6,000	1	5 1/2	4 3/4	3/16	5,700	LH	4 1/4	5 1/4	4	CI	36 x 32	60 1/2	16 x 12	48 x 61 x 34	970	A, B, F	C, D, E	3,795
8,000	1/2	2 1/2	2	1/2	5,500	RH	2	3.3	2.3	CA	20 x 19 1/2	19	5 1/2 x 21 1/2	21 1/2 x 31 1/2 x 17 7/8	106	A, C, E, F	D	2,095
8,000	1 1/4	3 1/2	3 3/4	1/2	4,600	RH	4	5	5	SS	13 1/2 x 27 1/2	29 1/2	6 x 19	34 x 37 x 33	350	A, C, E, F	D	2,995

9. Measured from axis of bit.

10. (CI) Cast Iron (CA) Cast Aluminum (FS) Formed Steel (SS) Stainless Steel

11. Shaper shares same table.

12. A. Sliding table B. Table extensions C. Saw blades

D. Shaper cutters E. Mortise bits F. Jointer knives
For additional accessories, consult manufacturer.

13. Importers sometimes run special discounts at wood-

working shows; (*) indicates freight paid.

14. Also available with 12" jointer thicknesser (BF531).

15. Also sold as two separate machines (jointer/thicknesser/mortiser and saw/shaper).

WHAT ABOUT COST?

Most of us buy our woodworking machinery piecemeal, either as we need it or as we can afford it. So the price tags on combination machines may, at first, take your breath away.

But you can look at it this way: you're buying five large stationary tools at once. Generally, the combination units cost less than the stationary machines they replace, given the same quality and capacity.

Presently, most of the importers sell these machines by mail order. (Robland picks up the freight charges, others don't—see the chart above.) So if you're serious about buying a combination woodworking machine, we suggest you first watch a demonstration. 🌱

FOR MORE INFORMATION

FELDER

Advanced Machinery Imports, Ltd.
P.O. Box 312
New Castle, DE 19720
302/322-2226

KITY

Farris Machinery
2315 Keystone Drive
Blue Springs, MO 64015
816/229-3055

MINI MAX

SCMI
5933-A Peachtree Industrial Blvd.
Norcross, GA 30092
404/448-1120

ROBLAND

LAGUNA TOOLS
2081 Laguna Canyon Road
Laguna Beach, CA 92651
800-345-5952
(In California, call 800-522-5952)

TOOLMAX

Atlantic Wood Products, Inc.
2441 Front St.
West Sacramento, CA 95691
800-535-4788
(In California, call 800-325-8330)

ZINKEN

Zinken International Corporation
P.O. Box 459
Marengo, IL 60152
815/568-8988

Lathe-based Multimachines

MASTER WOODCRAFT MACHINE CO.
P.O. Box 669
Harbor City, CA 90710
800-421-2467
(In California, call collect 213/549-0761)

SHOPSMITH
3931 Image Drive
Dayton, OH 45414
800-526-3900

TOTAL SHOP
P.O. Box 17859
Greenville, SC 29606
800-845-9356
(In South Carolina, call 288-4174)

Written by Jim Barrett; Technical Consultant: George Granseth; Photographs: Jim Kascoutas

GET IT RIGHT EVERY TIME WITH OUR BLADE-HEIGHT GAUGE

Not long ago, a woodworking friend of ours claimed that "a shop aid that really works is worth its weight in ebony." We couldn't agree more! That's why we're so anxious to share this blade-height gauge with you. With it, you can easily set your table-saw blade to exactly the right height.

Note: When cutting the parts, we cut everything extra long for machining safety. By cutting to the lengths stated, you'll have enough material for an extra gauge—perhaps for a woodworking friend.

CONSTRUCT THE SUPPORT AND SLIDING BAR

1 Cut a piece of $\frac{3}{4}$ "-thick oak to $\frac{5}{8}$ " wide by 14" long for the support (A). Cut a $\frac{1}{2}$ " groove $\frac{1}{8}$ " deep centered along one edge where shown on the Step 1 Drawing below.

2 Rip a $\frac{1}{8}$ "-thick strip from the edge of a piece of $\frac{3}{4}$ " oak stock, and crosscut it to 14" for part B.

3 Rub paraffin wax on the inside edges of the $\frac{1}{8}$ " groove you cut in part A (this will help to keep the glue from sticking to them). With the edges of parts A and B flush, apply glue sparingly, and clamp them together (see the Step 2 Drawing). Immediately after clamping, remove any glue from the groove with a thin piece of wood.

4 Using a $\frac{1}{4}$ " dado blade, cut a $\frac{1}{4}$ " kerf centered from side to side the length of the support where shown on the Step 3 Drawing.

5 Cut a $6\frac{3}{4}$ " piece from the lamination (don't forget, you'll have enough material for two supports).

6 Drill a $\frac{3}{8}$ " hole through the support (A) where shown on the Exploded-View Drawing. Don't drill through the two strips (B).

7 Cut a piece of $\frac{3}{4}$ "-thick oak to $1\frac{3}{16} \times 14$ ". Follow Step 4, 5, and 6 drawings to form the sliding bar (C). (Note that the kerfs in the sliding bar are offset to align one edge of the bar flush with the surface of the metal rule.) Check the sliding bar's fit in the support, and sand the mating edges if necessary. Cut the sliding bar to length.

NOW, LAMINATE AND CUT THE BASE

1 Cut a piece of $\frac{3}{4}$ "-thick oak stock to $\frac{3}{4}$ " wide by 19" long for the base (D). Cut three 3" strips from this piece (if you're building two gauges, cut 6 strips).

2 Position three strips around the support where shown on the drawing at right. Mark a reference line across the top of the two outer strips. Spread a thin film of glue on the mating edges, realign the pieces (without the support this time), and clamp the base pieces together.

3 Using the dimensions on the Exploded-View Drawing, mark the shape of the base on the lamination, and cut it on the band saw.

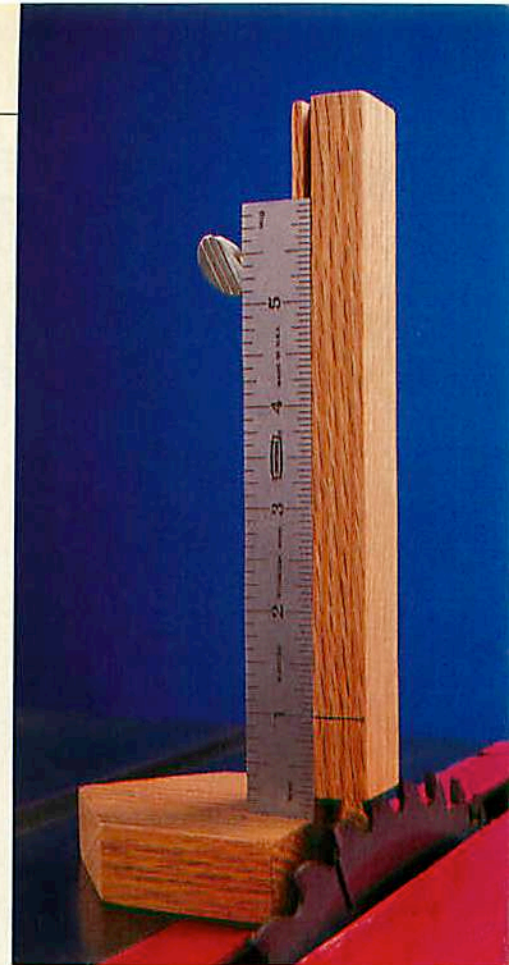

4 Using a flat-bottomed bit (we used a Forstner bit), bore a pair of $\frac{3}{4}$ " holes $\frac{1}{4}$ " deep on the bottom of the base for the magnets.

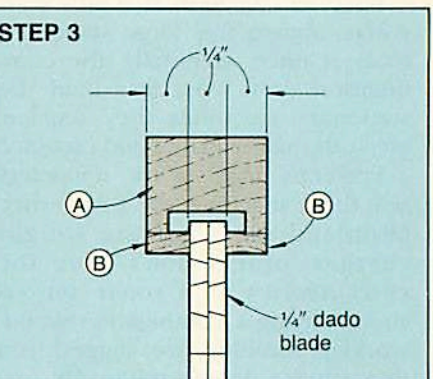
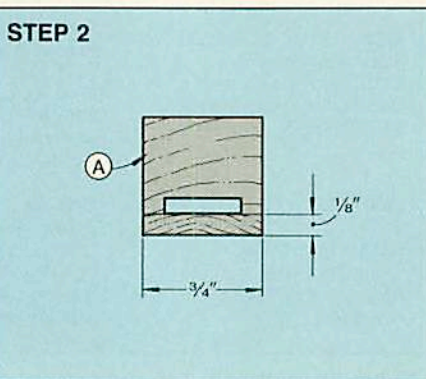
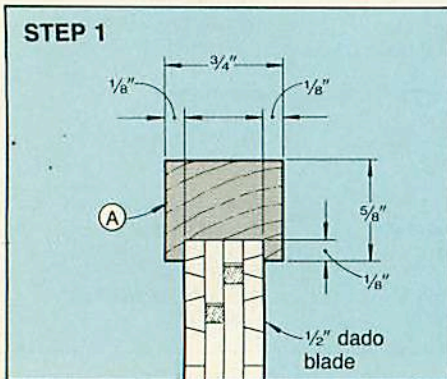
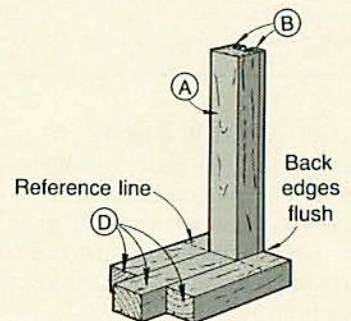

Bill of Materials

Part	Finished Size*			Material	Qty.
	T	W	L		
A*	3/4"	5/8"	6 3/4"	oak	1
B*	1/8"	1/4"	6 3/4"	oak	2
C*	3/4"	1 3/16"	6 3/4"	oak	1
D*	3/4"	2 1/4"	3"	oak (laminated)	1

*All the parts are cut larger initially, and then trimmed to finished size. Please read the instructions before cutting.

Supplies: 2—3/4"-diameter round magnets, epoxy, 1/4" thumbscrew 1/2" long, 6" metal rule (Sears catalog no. 9GT40136, \$4.50), paraffin wax, 1/4" threaded insert, 3/16" dowel stock, finish

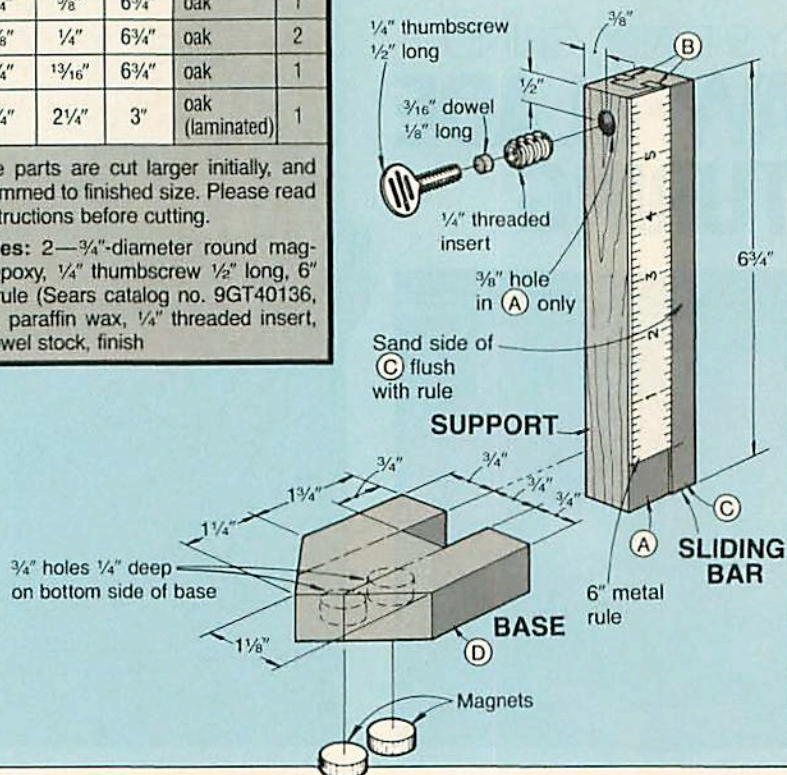

5 Epoxy the magnets in place in the 3/4"-diameter holes in the base (see the Buying Guide for our source). When dry, sand the bottom of the base flush with the magnets.

FINAL ASSEMBLY

1 Glue the support into the notch of the base, checking for square.

2 Sand the back of the rule for better adhesion. Epoxy the metal rule to the support where shown on the Exploded-View Drawing (the bottom edge of the rule should be flush with the top of the base).

3 Finish-sand all the pieces.

4 Screw a 1/4" threaded insert into the 3/8" hole in the support. Don't screw the threaded insert into the grooved area. Cut a 1/8" length from a 3/16"-diameter dowel (the dowel prevents the thumbscrew from marring the sliding bar).

5 Position the bottom edge of the support flush with that of the sliding bar. Use a square and a hobby knife to scribe a line across the sliding bar even with the bottom edge of the metal rule as shown in the photo at the top of the next column. Darken the scribed line with pencil lead. Mask off the rule, magnets, and

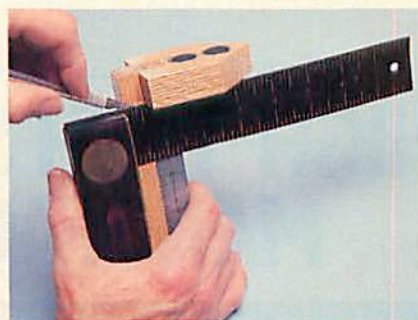

scribe a line across the sliding bar even with the bottom of the rule.

threaded insert, and apply a clear finish to all the pieces.

6 To allow the bar to slide freely in the support, wax the mating edges, and fit the sliding bar into the groove in the support. Place the 3/16" dowel in the hole in the threaded insert. Thread the thumbscrew into the threaded insert.

Putting the gauge to use

Position the height gauge on the table saw with the sliding bar above the highest point of the blade (directly above the arbor). Raise the blade, which raises the sliding bar, until the scribed line matches the desired height.

BUYING GUIDE

• **Height-gauge hardware kit.** 6" metal rule, 2 disk magnets, 1/4" thumbscrew, 1/4" threaded insert. Catalog no. 7451, \$10.75 ppd. for one kit, \$18.75 ppd. for two kits. Meisel Hardware Specialties, P.O. Box 70, Mound, MN 55364. ♣

Project Design: Paul L. McClure
Photographs: Bob Calmer
Illustrations: Kim Downing; Bill Zaun

STEP 4

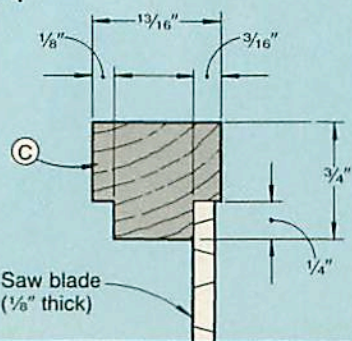

STEP 5

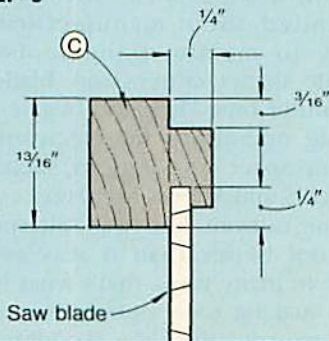

STEP 6

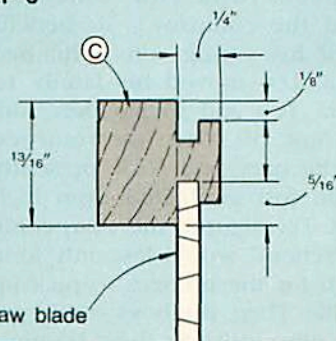

ONE ARIZONA FAMILY'S DAILY GRIND HIGH-TECH SAW-BLADE MANUFACTURING



In Chandler, Arizona, the Woodburys keep their noses to the family grindstone in their tool-manufacturing business, Cherokee Tool Company. Leo and Joy (at center, above) and sons (from left) Nick, Neil, Nathan, and Nolan showed us what goes into making a leading-edge, carbide-tipped, circular saw blade. They threw in some advice on what makes a great blade, and gave us pointers on how to care for one.

“Cherokee Tool wasn’t started strictly as a moneymaking business. I simply wanted my sons to have a trade. I thought I owed that much to them, and to society,” recalls Leo Woodbury about the company’s 1969 startup.

Five years earlier, Leo had sold his tool-sharpening business in Cherokee, Iowa (for which he named the company). To benefit one of his young sons who had asthma, Leo moved his family to Arizona. Leo and Joy’s oldest son, Neil, now 39, had just returned from the navy, and Nick, presently 35, had just graduated from high school. Leo figured the sharpening “shop/school” would last only long enough for the trainees to pick up his skills. Then, the boys would get “real” jobs utilizing their training.

He was in for a surprise: Their work volume grew to a point the Woodburys never imagined possible.

As the three Woodburys continued to sharpen and repair tools, Cherokee Tool evolved into a custom saw-blade manufacturer, first filling the needs of woodworkers who wanted a blade they couldn’t find on a store shelf. Then, they expanded their manufacturing scope to metalworking tools—carbide shaper cutters, saw blades, and router bits. They also began retooling operations for electronics and aerospace corporations, such as Motorola and Martin Marietta.

“Our bottom line was ‘Sharpen the tool better than it was ever built.’ In many ways, that’s what led us to making tools ourselves—our way,” explains the elder Woodbury.

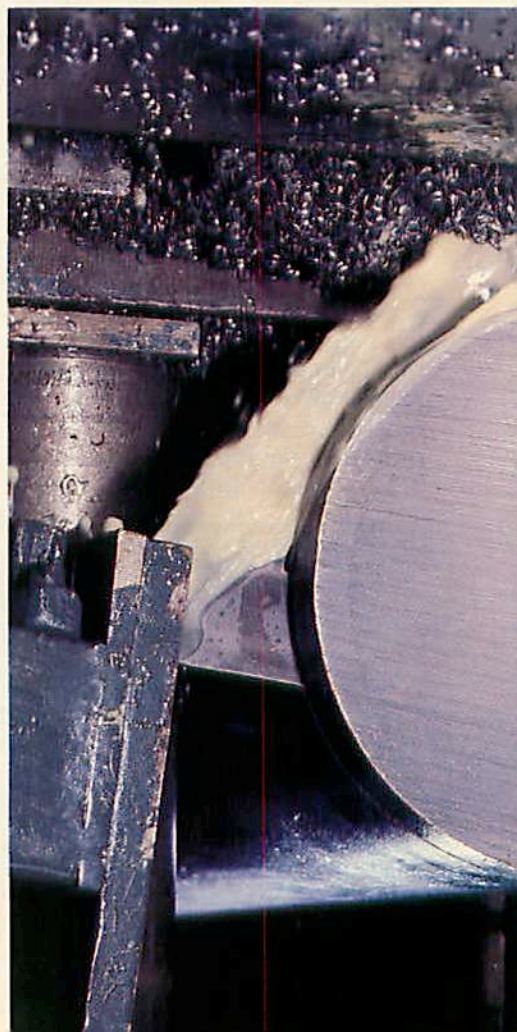
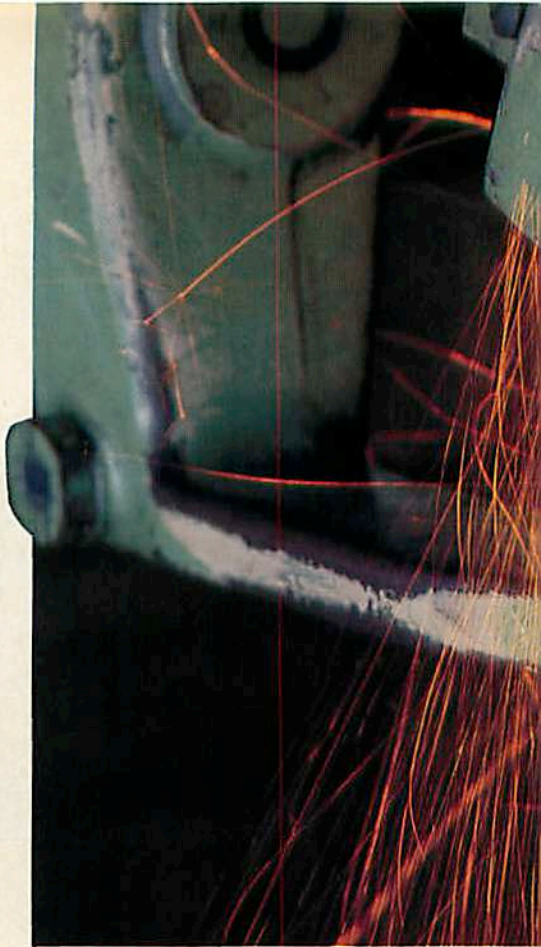



Left: A saw blade begins as part of a rolled steel bar that weighs 1,200 pounds. A liquid-cooled band-saw blade slices the blanks.

Above: Cherokee Tool began as a sharpening service, and that's still part of the operation. Here, a steel blade's old tips meet the grinder.

Cherokee Tool now counts 20 employees, including the oldest sons Neil and Nick, and younger sons Nathan, 30, and Nolan, 27, who have been "schooled" in the company, too. Joy manages the finances in the office.

The Woodburys don't always make tools the fastest way. They also don't make inexpensive ones. Their carbide-tipped circular saw blades cost more than a few bucks — \$119 for the combination planer, \$72 for the rip saw.

Says Nolan, as family pride surfaces in a smile, "We're delivering a tool that will do the job it's supposed to do... and our customers keep coming back."

GEOMETRY STARTS SAW BLADES SPINNING

A circular saw blade seems like a simple-enough tool: a body with a center hole and teeth with cutting edges. But a blade's simplicity proves deceptive when you learn more

about how it's made. "First, you have to engineer the blade for the specific job," says Nick, who oversees saw-blade engineering and manufacturing. "We have lots of what I call 'tooth geometry'—figuring out what one saw tooth is going to look like from all the options.

"Just the top geometry for the tips includes alternate bevel, flat tops, triple chips, and primary clearance angle. After that, the object is to make all the teeth just like that one tooth. But, we have lots of machinery to help us," he adds.

Although the Woodburys work with steel instead of wood, woodworkers would feel at home with much of the equipment in the first stage of saw-blade manufacturing. When a large order for a particular blade comes in, manufacturing starts by slicing *blank saw plates* with a band saw from 10'-long cylinders of steel, *left*. Called *hot rolled billets*, each cylinder weighs in at about 1,200 pounds. For

Continued



SAW-BLADE MANUFACTURING

smaller orders, Cherokee Tool buys top-quality blanks and then brazes on their own engineered carbide tips. No matter whether blades begin as billets or blanks, Nick, who directs machine-tool manufacturing, happens to be pretty selective about the steel.

"Before carbide tips, woodworkers demanded high-carbon steel blades because they stay sharp longer," Neil comments. "Now, even with carbide tips, some folks think the blade still should be that hard." He continues, "Ours is a special alloy tool steel that won't become brittle when the tips are brazed on. In tooling vernacular, it's called *roll-tensioned, heat-treated, high-carbon steel*. Tensioning," Nick explains, "means adding stress to the steel by stretching it mechanically so that the blade won't warp, or even worse, crack."

The band saw cuts each steel blank saw plate to within $\frac{1}{32}$ " of its final thickness. Automated metalworking lathes then turn the plates down to within .003-plus inch, and fine-tune the diameter.

Another lathe turns out the center hole. "The center hole of a blade should be given respect," says Nick. "It is the basis of the saw because the teeth revolve around it. If the hole isn't exactly at center, all the teeth won't cut as it revolves on the arbor." For that reason, the tolerance on blades with a $\frac{5}{8}$ " arbor hole is within .0005".

SHAPING UP A SAW BLADE

With the next step, blanks begin to look like saw blades. On a milling machine, cutter heads whirl to shape the edges of the blank into teeth and gullets, photo, *below*.

Gullets, the deep cutouts between teeth or series of teeth, gather and hold sawdust chips until the blade exits the wood. In general, the less space taken by the gullets, the slower the sawing. For instance, on a rip saw, which produces large chips, you need a larger gullet than on a crosscut blade.

Cherokee stands behind a rounded, rather than a V-shaped, gullet. They believe the rounded shape produces more efficient chip release and less chance of the chips packing together in the gullet.

Cherokee cuts expansion slots in crosscut and other types of blades that don't have deep gullets. The long slits prevent the blade from warping or buckling in use by allowing the metal to expand and contract. Cherokee Tool mills an expansion hole into the end so that the slots themselves don't crack. Then, to keep the blades from "singing" while cutting, each hole receives a plug.

In the next manufacturing step, a surface grinder grinds the evolving blades perfectly flat, a process

Below: Each pass of the milling machine creates a tooth and a gullet on the steel billet. Here, the machine mills thick, industrial cutters.



Top: To braze on the carbide tips, Nick heats the silver brazing alloy to the melting point for a bond between the steel blade and the carbide tip.

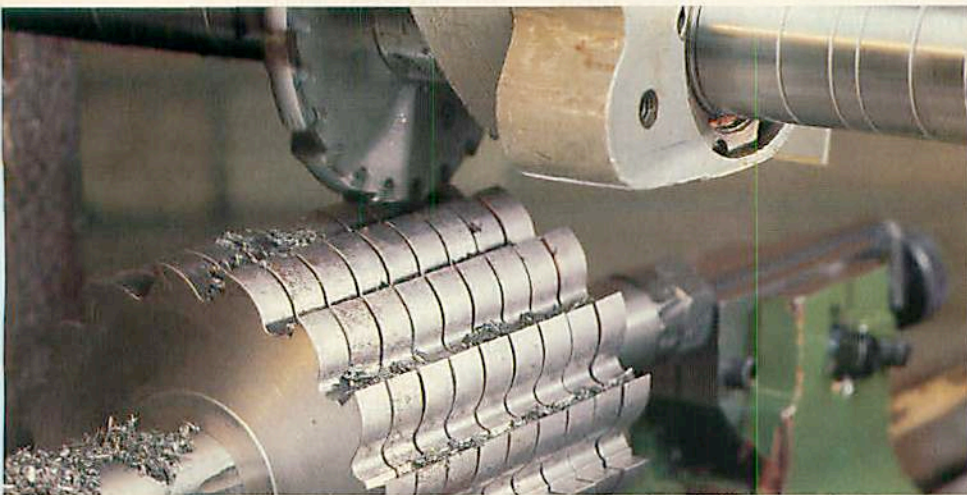



Above: Peering into a 100-power microscope, Leo makes the final inspection. He checks for microscopic cracks in the brazed joints.

called *leveling*. To the woodworker, this step means that a blade will cut true to the line and not “walk” in the kerf. Leveling also unifies tooth thickness around the blade.

“Every cutter head and saw blade goes through this grinding process to make sure both surfaces are absolutely parallel,” says Nick. “They’re surface-ground to within .0005.” According to Nick, some manufacturers sandblast blades to level them, rather than grind.

THE HARDEST OF THE HARD WON’T WORK

Tungsten-carbide-tipped teeth stay sharp longer than teeth of high-carbon tool steel. That’s a well-known fact, but a misleading one. According to Nick, who hand-brazes carbide tips onto teeth, photo, *left*, all tungsten carbides aren’t the same. The harder the carbide, the longer it retains an edge. Yet, the harder the carbide, the greater its brittleness, and thus, the less its shock resistance (the pressure it will stand per square inch). For woodworking purposes, C-4-grade carbide happens to be the hardest used; C-1 the softest.

“The softest grade of carbide will cut the hardest wood, that’s no problem,” Nick explains. “The appropriate grade of carbide, however, has more to do with how the blade will be used than with the type of wood being cut.”

For instance, Nick chooses a C-2, or medium grade of hardness for Cherokee’s ripsaw. Because of the angle at which ripsaw blades cut, more pressure is exerted on their teeth than on the teeth of other blades. He brazes C-3-plus tips onto their combination planer blades.

DIAMONDS ARE A BLADE’S BEST FRIEND

To obtain the smoothest cut possible, the folks at Cherokee Tool shape and sharpen their carbide-tipped saws with precision grinding machines that use specially designed and formulated diamond wheels. Human eyes and hands still control much of this work, although computerized programming has been installed.

Nick explains the difference Cherokee’s precision grinding makes: “If you just go out and pick up a blade retail, you’ll find that most have teeth ground straight and flat. The thing that makes a saw like our combination blade special is alternate-face beveling. It cuts down on the pressure exerted from the saw blade to the wood,” Nick explains. “That means that on a delicate piece of material like plywood, it results in less damage to the wood. It’s a severing cut that won’t tear and chip the wood.

“As far as I know, we’re the only saw manufacturer that puts an alternate-face bevel on a stock combination planer saw blade,” Nick adds. “Even when comparing blades you must look hard to see it, but you’ll feel the difference, hear the difference, and you’ll see the difference in the work.”

NO TOLERANCE FOR INTOLERANCE

After the extensive grinding process, each blade undergoes a close-up inspection by one of the company’s tool experts, photo *left*. An *optical comparator and measuring machine* projects the magnified image of the blade against a grid, comparing the blade to its blueprint to make sure that everything that was supposed to happen in manufacturing did happen. To point out how carefully they treat quality control at Cherokee Tool, Nick explains that a sheet of paper measures .003” thick, while many stages of their final inspection measure to tolerances within .0002”.

“One of our strong points, we believe,” says brother Neil, “is that we use the same tolerances for our woodworking tools—whenever feasible—as we do for the aerospace and electronics industries. And to think that some folks believe all we do is stamp out saw blades!”

See page 80 for related article on saw-blade care.

Written by Emily Freeman Pinkston
Photographs: Jeff Welcker

A HONEY OF A PROJECT— TEDDY BEAR



DON'T, we repeat DON'T show the photograph of this clock to your spouse, or children unless you're ready to build a few. This oak and walnut clock has proven to be simply irresistible, and for some reason, it's not just the children who seem to want one.

The chubby little bear has its parts cut to shape on a scroll saw and shaped with a drum sander. All-in-all, it shouldn't take but a few hours to build and a lifetime to enjoy.

Note: When making the sculpted bear, you'll end up with enough pieces for two of these little critters. So you may want to go ahead and build two clocks while you're at it.

BUILDING THE CLOCK FRAME

Note: You'll need some thin stock for this project. You can resaw or plane thicker stock to the correct thickness.

- 1 Cut a strip of $\frac{1}{2}$ "-thick oak stock to $1\frac{3}{4}$ " wide by 30" long for the outer-frame parts (A). Miter-cut the parts to length (7").
- 2 Glue and clamp the oak frame parts together. Be sure to check the frame for square.
- 3 Cut a piece of $\frac{3}{4}$ " walnut to 2×30 ". Resaw a $\frac{1}{4}$ "-thick piece from it. Cut a $\frac{1}{4}$ "-wide piece from the 2" width for the inner-frame parts (B). Miter-cut the inner-frame parts to fit inside the oak frame.

Glue in position, flush with the front edge of the oak frame.

4 Cut the clock face (C) to the size of the opening less $\frac{1}{16}$ " in width and length to allow for movement of the wood.

5 Draw diagonals on the clock face to find its center. Drill a $\frac{3}{8}$ " hole for the clock movement shaft at the marked center point. (The shaft size of your particular movement may require a different-sized hole.)

6 Referring to the dimensions on the Exploded-View Drawing below, mark the center point for the 3-, 6-, 9-, and 12-o'clock dowel locations. Drill a $\frac{3}{8}$ " hole $\frac{1}{4}$ " deep at each center point. Cut four $\frac{3}{8}$ " walnut plugs $\frac{5}{16}$ " long (or cut the pieces from $\frac{3}{8}$ " dowel stock), and plug the holes. Sand the plugs flush with the oak and walnut frame.

7 Sand the clock frame smooth, sanding a slight round-over on all sharp edges.

Bill of Materials (The Bear Essentials)					
Part	Finished Size*			Material	Qty.
	T	W	L		
A*	$\frac{1}{2}$ "	$1\frac{3}{4}$ "	7"	oak	4
B*	$\frac{1}{4}$ "	$\frac{1}{4}$ "	6"	walnut	4
C	$\frac{1}{2}$ "	$5\frac{5}{16}$ "	$5\frac{1}{16}$ "	oak	1
D*	$\frac{1}{2}$ "	5"	5"	walnut	1
E*	$\frac{1}{2}$ "	5"	5"	oak	1
F	$\frac{1}{4}$ "	$\frac{1}{2}$ "	$1\frac{1}{2}$ "	oak	1

*Parts marked with an * are cut larger initially, and then trimmed to finished size. Please read the instructions before cutting.

Supplies: carbon paper, $\frac{1}{8}$ " plywood or hardboard for backing board, double-faced tape, sawtoothed hanger with 2— $\#3 \times \frac{3}{8}$ " roundhead wood screws, silicone sealant, finish

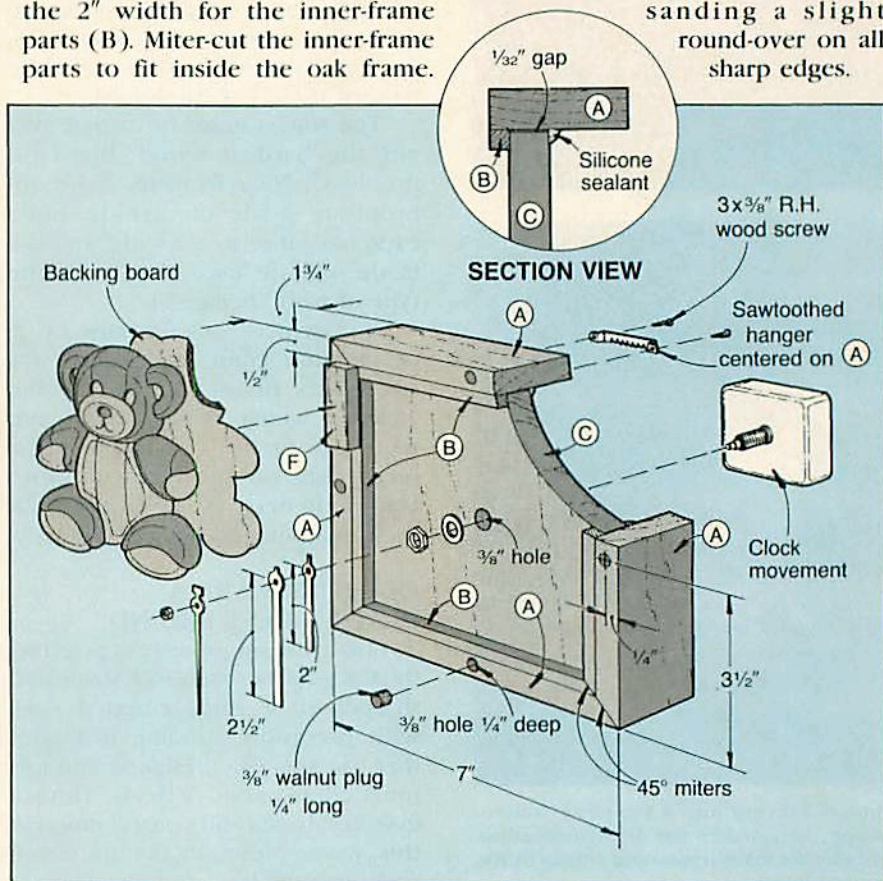

WALL CLOCK

FORMING THE BEAR PARTS

1 From $\frac{1}{2}$ "-thick walnut and oak, cut two 5"-square pieces (D, E).

2 Cover one face of the oak with double-faced tape, and stick the walnut to it. Using carbon paper, transfer the full-size bear pattern *below* to a piece of 5x5" paper. Using spray-on adhesive, adhere the pattern to the top piece.

3 Drill $\frac{1}{16}$ " holes through the walnut and oak where shown on the drawing *below*. Cut the parts to



Cut the parts to shape from the taped-together pieces of walnut and oak.

shape. For the nose and eyes, insert the scroll-saw blade through the start holes, and make the cuts. Make accent cuts to form the mouth. Separate the pieces, and remove the tape.

ASSEMBLING THE BEAR PARTS

1 Round-over the front edges of the parts with a drum sander. Finish-sand the parts by hand.

2 Cut two pieces of $\frac{1}{8}$ " plywood to 4 $\frac{1}{2}$ x5". Mix the walnut and oak parts, and position them on the $\frac{1}{8}$ " backing. Trace each bear's outline on the backing, and remove the parts. Cut the backing *slightly smaller* than the marked outline.

3 Apply woodworker's glue on the backing, and position all the parts except for the muzzle and nose. To elevate the muzzle, cut and glue a $\frac{1}{4}$ x $\frac{3}{4}$ "-diameter filler block in the opening. Glue the muzzle to the top of the filler block. Put glue in the muzzle hole, and position the

nose so it sticks up about $\frac{1}{8}$ " above. **4** Sand the $\frac{1}{8}$ " backing at the edges to make it less noticeable.

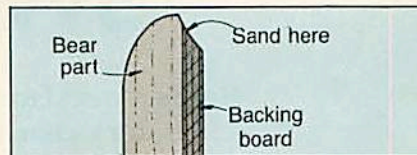

FINAL ASSEMBLY AND FINISHING

1 Cut the mounting block (F) to size, and glue it to the frame. Finish-sand the clock frame and face.

2 Apply finish to the frame, face, and bear. Sand the front of the mounting block, and glue the bear to it. Lay the frame, face side down, and center the face in the opening. Hold the face in place with a small bead of silicone.

3 Fasten a sawtoothed hanger, and install the movement. If you use the movement listed *below*, trim the hands to length, and attach.

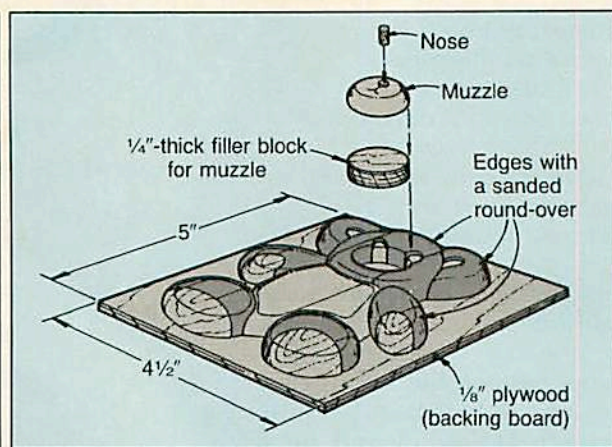
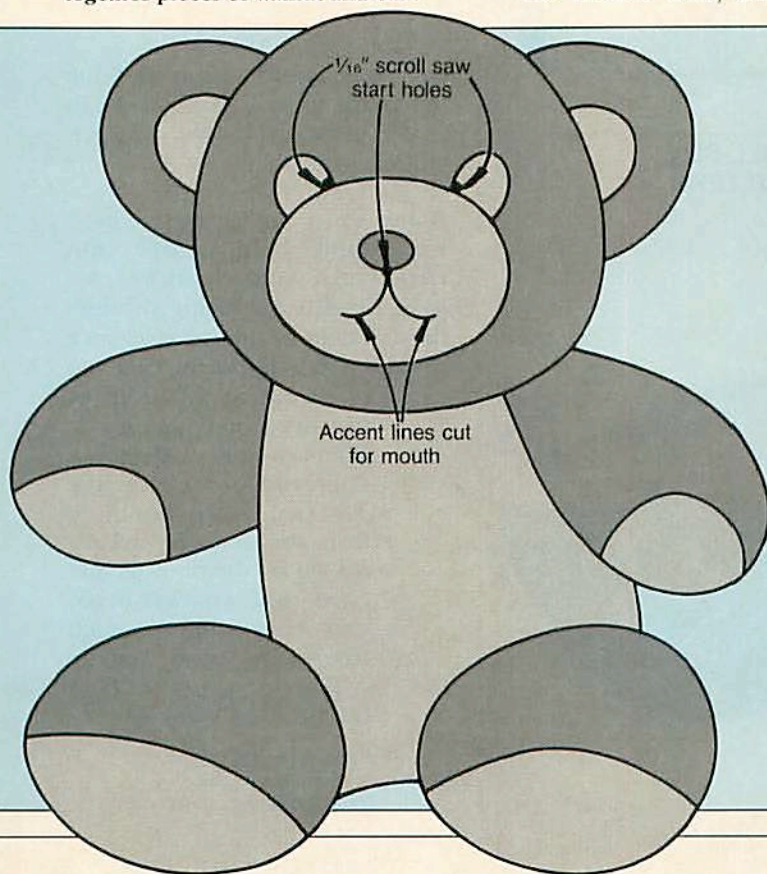

BUYING GUIDE

• **Clock movement.** QC18 movement with #17 black hour and minute hands and SH4 brass, second hand. \$9 ppd from Precision Movements, 2024 Chestnut St., P.O. Box 689, Emmaus, PA 18049, or call 215/967-3156 to order. 🌱

Project Design: Karen and August Caryl
Photographs: Bob Calmer
Illustrations: Kim Downing; Bill Zaun

TRUMPET SPRING'S ARRIVAL WITH OUR **COUNTRY-STYLE SWAN NECKLACE**

Here's a necklace project you'll want to dive into. It has that certain country charm not often found in jewelry. Using the full-size photograph as a pattern and your scroll saw or band saw, you're on your way to a sure-to-be appreciated gift.

1 Using carbon paper, transfer the full-size swan outline (as photographed on this page) to $\frac{3}{8}$ "-thick stock (we planed down $\frac{1}{2}$ " birch).

2 With a scroll saw or a band saw fitted with a $\frac{1}{8}$ " blade, cut the swan to shape.

3 Chuck a $\frac{1}{8}$ " brad-point bit in your drill press. Then, clamp the swan piece in a handscrew clamp, position the swan below the bit, and drill a $\frac{1}{8}$ " hole through the head and neck where shown in the drawing above right.

4 Hand-sand the swan smooth, sanding a slight round-over along the front face.

Note: Most hobby shops and craft stores stock the lacing and wooden beads (used for macrame) noted in the following steps and shown in the photo.

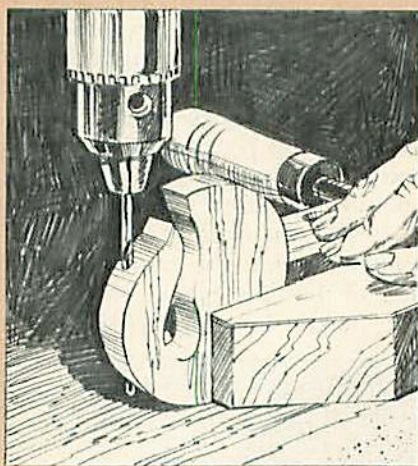

**FULL-SIZE
PATTERN**

5 Paint the swan and the beads to the colors shown in the photograph (we used artist's acrylic paint).

6 Cut a piece of lacing (we used white rattail cord; narrow satin ribbon also would work) to 30" long. Thread the lacing through the $\frac{1}{8}$ " hole in the swan. Center the swan on the lacing, and tie one knot at the front of the head and another at the neck to keep the swan centered on the lacing. Tie two more knots 2" from the first ones where shown on the photograph. Next, add wooden beads onto the lacing on each side of the swan, and tie two more knots to hold the beads in place. ♣

Project Design:
Marie Fredrickson
Photograph: Jim Kascoutas

WHIMSICAL WABBIT CLOTHES RACK



Just watch how your child's room changes after you hang this rambunctious bunny on the wall. Who knows, pretty soon you may not even be able to complain how messy the room is. Wouldn't that be nice!

1 Draw a 1" grid measuring 7x14" on paper, or see the note at the end of this article for a full-size pattern. Using the Front View Grid for reference, lay out separate patterns for the head and upper body (A), nose (B), teeth (C), and one eyebrow (D). Mark the center points for the two hanger dowels, eyes, and nostrils. Cut the patterns to shape.

2 Spray the back side of the paper patterns with spray adhesive. Adhere the head, nose, and eyebrow patterns to 3/4"-thick stock (we used cedar) and the teeth to 3/4" pine. Cut the pieces to shape. Use the nose piece (B) as a template to mark the second nose piece. Then, cut it to shape.

3 Band-saw the 3/4"-thick eyebrow piece in half to form two thinner pieces (D). Glue and clamp the two nose pieces together.

4 Tilt your drill press table 30° from center, and drill two 3/8" holes 1/2" deep for the hanging dowels in the head piece. Drill holes for the

eyes and nose. Remove the paper patterns from the wood pieces. Drill two angled holes in the back of the head for hanging.

5 Drum-sand or cut the back surface of the teeth (C) to the shape shown on the Side View Drawing. Sand all the pieces smooth.

6 Glue the teeth to the bottom of and flush with the front of the nose piece. Later, clamp the nose-teeth assembly in a handscrew clamp, and band-saw a 1/8"-deep kerf in the front edge. Glue and clamp the nose and eyebrows to the head.

7 Cut to length, and glue two 3/8" dowels in the holes in the head and upper body. Apply the finish.

Note: For a free full-size pattern, send a self-addressed, stamped No. 10 business envelope to: Whimsical Wabbit, WOOD Magazine, Locust at 17th, Des Moines, IA 50336.

Project Design: Janet Betts
Photograph: William Hopkins
Illustrations: Kim Downing, Bill Zaun

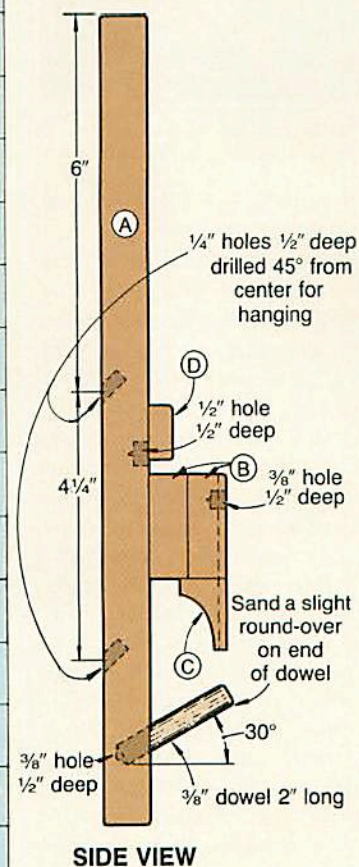
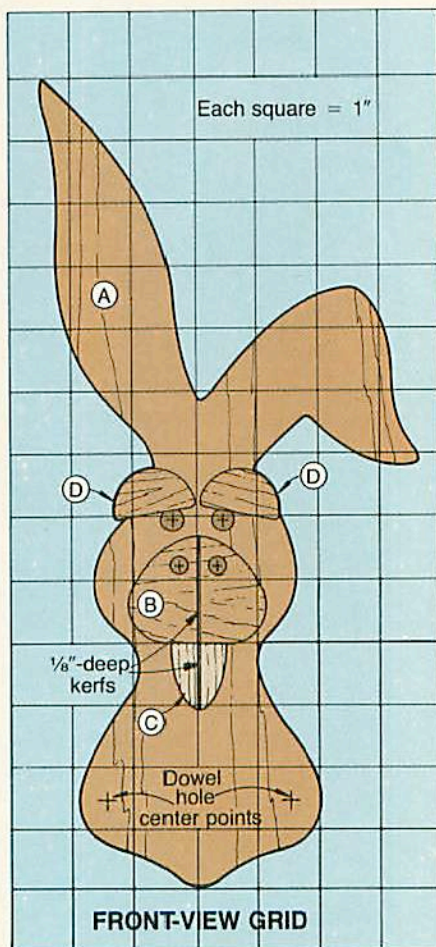

HITCH 'EM UP AND HAUL 'EM OUT HORSE LOGGING IN

"I walk a lotta miles in a day, you know. Following these horses, you get a lot of miles on. Never go fast. It's better that you go just steady and easy so they don't play themselves out. Just like a man... he pushes himself half a day, then he's played out. You gotta use judgment with horses."

—Paul Dicob, logger, in the Adirondack foothills near Lowville, New York

WOOD® OFF THE ROAD



My "Giddap!" moves two tons of Belgians and a hemlock log.

With horses, the jingle of logging chains and the squeak of harness substitute for engine roar. "Gee" and "Haw," the universal shouts for directing draft animals, fail to silence forest sounds. And natural smells replace diesel smoke.

For a guy like me, who spent lots of time in large, commercial logging operations, horse logging was a refreshing experience. From the moment I spotted a man and his team coming from the stand of hemlock, I thought I'd gone back in time. What a great feeling! Combine it with the thrill of directing a team down a logging trail, and that visit last spring ranks right up there with the best times of my life.

—Peter J. Stepbano, Features Editor



THE ADIRONDACKS



Left: Chains jingling, Hilary Widrick's team emerges from the woods with a log in tow. A team can skid about twice their weight. That's about 8,000 pounds of logs.

Above: With tongs in hand, Paul Dicob maneuvers his Belgian draft horses Charlie and Prince in position to skid out a log. Backing up, the horses move gingerly. Starting a pull, they lunge.

Paul Dicob, of Lowville, New York, has been working horses in harness for nearly 50 years. He uses his Belgian draft horses to log the surrounding Adirondack Mountains year-round, except "when the snow's up to their brisket" or spring melt turns the turf to greasy muck. He sees the growing demand where he lives for skidding logs with horses, and believes in its possibilities.

"If you like to work alone, one man could make a real healthy livin', financially," he says. "A man and a team...it costs you 30 quarts of grain per horse a day, a bale of hay per horse per day, and about 30 gallons of water each a day. Now, if you rent a skidder [a specialized

tractor], you got fuel expense at over \$1 a gallon on top. And when you rent them and bust them, you got to fix them. You break one down, it ain't like breaking a strap on a harness."

SKIDDERS OUTPULL BELGIANS, BUT THE WORK ISN'T NEARLY AS PEACEFUL

Horse logging faded into memories after World War II in the face of machinery for high-volume logging. Now, logging with horses seems to be making a comeback. Paul Dicob says it's happening in the East. And there's indication of a Midwestern revival.

Why the turnabout? According to Lee Ekstrom, a consulting forester

in Michigan, horse logging sometimes happens to be the most practical way to get logs out, such as in steeply hilled country. Also, environmentally minded landowners, those with small timber stands, and folks selling only prime hardwood for selective cutting, tend to prefer loggers with draft animals. There's no way to measure the renewed interest, but Lee says he knows five loggers within a 50-mile radius of him who now use horses.

Yet, mechanized loggers bring out four times the wood in a day that horses can. Working two teams of huge Belgians, the best daily haul Paul figures on runs about 6,000 board feet of saw logs (20-30), or enough logs to equal the 15 cords

Continued

HORSE LOGGING

of pulpwood (a pulp cord measures 4x4x17') it takes to fill a flat-bed trailer.

"Belgians will pull double their weight," he notes. "My team weighs about 40-hundred [4,000 lbs.]. They'll slide 80-hundred pretty good. A team can't do too much at a time, compared to a skidder." Pausing, he adds: "But, I like it in the woods with horses. It's kinda peaceful, and I like their smell. You gotta like horses to work with them, and have patience."

As a boy on the farm, Paul worked his dad's field horses in the woods during the winter. He hasn't been far from horses since. And he favors Belgians. "I think a Belgian is chunkier than a Percheron...more short-legged and blocky for pulling. If you're a horse lover, though, you like all horses," he says.

Of all the horses he has owned, Paul doesn't designate one a favorite. He does prefer to work behind

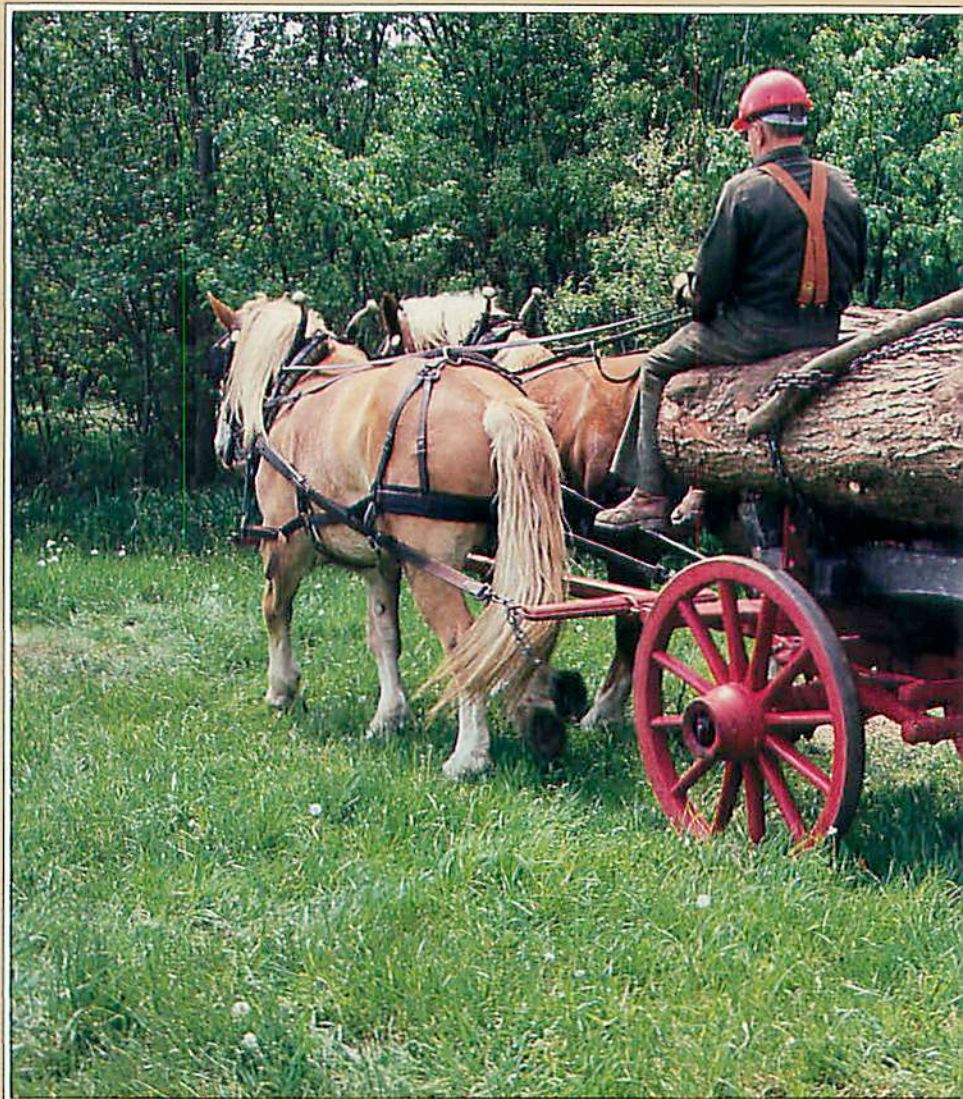

Left: For the camera, Paul, Elmer, and Hilary demonstrate how logs were loaded onto wagons in the old days. Each log has a chain run around it that goes to the team. Peavies at the ready, Paul and Elmer stand by.

Prince and Charlie, though, rather than another team he could pair from his other Belgians—Dan, Dick, and Banner. He's had Prince for several years. Charlie is a relatively recent addition, and he didn't come cheap.

"A good horse is high priced," Paul states. "You have to give at least \$2,500. That's what I gave for Charlie at a sale. He was a hitch horse, for pulling wagons, and lots of people wanted him for show. Charlie was mistreated some, but he got over it."

Paul runs his hand over his horses' haunches, just as a father

would pat his children's heads, and continues. "These two got a lotta ambition, anyway. My other ones are bigger, but easier going."

IN THE WOODS, HORSES GET FREE REIN

Paul bids on all kinds of timber, from cherry and yellow birch down in the river valley that he sells to a factory for furniture stock, to pine and aspen for paper pulp. When he buys a job, he hires Hilary Widrick, 66, and his team of Belgians, and Elmer Zehr, 45, who cuts fast enough with his chain saw to keep two teams hauling.

Explaining his purchase of the standing hemlock he, Hilary, and Elmer were working when he visited, Paul says, "A fella can pay more for stumpage in an area like this, where you can get to the logs pretty fast. With horses, you only want to go about 1,000' [about three football fields] into the woods from the landing where the logs are stacked for hauling. Over 1,000', that's quite a distance for pulling. A skidder can go deeper, pull a cord per hitch, and make money."

Paul shakes his head, and adds: "You take around here, though, some people don't want skidders in



Above: Chains and a levered hickory sapling hold the huge hemlock logs in place on the wagon. A fully loaded wagon would have six or more logs and could weigh upwards of 10 tons. Hilary's wagon dates to about 1900.

the woods 'cause it tears them up. But it all depends on the operator. A rough operator, he don't care."

Some of the hemlock in the stand, the smaller ones, will become paper pulp. The big trees, a local sawmill will buy for lumber. Paul knows roughly how much wood they'll get. "We'll pretty well clean 'er," says the woosy veteran. "Maybe 100 cord of pulp, 75,000-100,000 board feet of saw logs."

At 7:30 a.m. Paul, Hilary, and Elmer are at the logging site, already at work. The pile of logs in the clearing at the edge of the woods tips passersby as to what's going on be-

hind the screen of trees. The horse trailers parked nearby name the loggers and proclaim the method.

The buzzing of the chain saw back in the woods changes locations every hour or so. Every few minutes, the jingle and clink of chains announce either Paul or Hilary's emergence from the trees, a log in tow behind their team.

Methodically, the drivers direct the flexing horses to cross in front of the pile of tree trunks. "Whoa" stops them. The log is released, the team swung around, and back into the woods they go. And so they work, hour after hour.



Handmade by an Amish craftsman, a working harness for a Belgian costs about \$300.

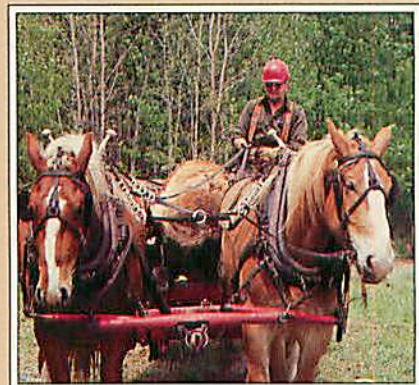

If Paul and Hilary were logging close to a sawmill, they even today might use a wagon to haul logs.

"We break about eleven for lunch in the clearing," Paul announces. "Have to feed the horses and water them. Take about half an hour out, then we're going again. Gotta grain 'em pretty heavy. They gotta have something, too, just like a man when he's working hard."

Back among the hemlock after the noon break, Elmer decides which tree to drop next, and where to lay it down. Paul explains the planning: "He drops most trees so we can go straight out with them. Sometimes, though, there's trees in the way. Then, he better line up and drop the logs so we can swing 'em.

Continued

HORSE LOGGING

You can't swing these or you'll get bound in between." He points to a 20' length of log lying between two trees. "It ain't like a skidder. They keep on a-going. Smash everything."

To skid a log out of the woods, Paul first backs his team up, just like a truck. "Back Charlie, Prince!" he barks. The Belgians reverse hesitatingly, feeling their way across the roots and stubble. Once in place, Paul drops the reins and grabs the tongs fastened to the end of the log chain and opens them. Whunk! He buries their points into the end of the log—below center so the pull will raise it slightly from the ground.

Standing behind and to the side of the team, the reins still on the ground, Paul bellows "Giddap Charlie, Prince!" The horses launch themselves forward in a straight pull. The log breaks from the brush. "Whoa!" Paul shouts. The team stops. But not every log comes out as easily.

When there's a standing tree in the way, blocking a direct pull to the trail, the team must pull the log at a 90-degree angle. The log then has the standing tree for a pivot. And when the team pulls, the log swings around like a boomerang, clearing limbs from its path.

"You can get pinned in a hurry if you're not watchin'. That's one of the most dangerous things there is," Paul advises. "I never been hurt by horses. Usually, when you holler 'Whoa' they stop. With horses, you get in a tight place, you just let the reins go. Holler 'Whoa' they'll stop, yep."

DANCING DOWN THE SKIDDING TRAIL, LOGGERS SOMETIMES MISS A STEP

Following two draft horses hitched to a log down the skidding trail isn't much different from a walk in the park. Paul could let go of the reins if he wanted to. The horses know which way to head.

Yet, with reins in hand, he can stop Charlie and Prince about every 20 yards for a break. "You don't have to rest them long, just enough to catch their wind. It's better if you don't





Left: Skidding two hemlock logs at once on his travois, Hilary heads his team down the trail. Maximum pulling distance is about three football fields.

Above: The horses will first pull the log away from its stump. From the harness, the log chains pass through the whiffle-tree and join at the tongs.

stand them long, 'cause just like a person, they'd get stiff," he says.

Gently holding the reins also keeps your mind from wandering, something you don't want to do when you're walking next to a moving log, according to Paul. He describes his backwoods ballet: "Horses go to the left, you got to jump over onto the right side of the log. Otherwise, you get your feet taken out from under you, and maybe the log on top. You yell 'Whoa,' but it might be too late."

One log at a time, trip after trip, Paul and Hilary guide their animals to the landing where the logs are piled. The skidding trail, despite becoming scraped of cover, displays no ruts. The trees bordering it show no bruises from passing logs. Odors of sweat, leather, manure, and hemlock boughs mix pleasantly.

For awhile toward the end of the day, Hilary switches from one-log hauling to the *travois*, which can carry two. Sometimes called a "log boat," the sled-like travois allows him to bring a few more logs out to complete a truckload. It also means that loading takes twice as long as

hitching up to a single log. From years of experience, Hilary believes a travois has its time and place.

About 4:30 p.m., when the sinking sun warms open spots in the woods with orange light, Paul, Hilary, and Elmer follow the skidding trail for the last time. After the teams drop their logs at the pile, and fail to head back down the trail, they edge closer to the trailers. The four Belgians know the day has come to an end.

The men will head home to clean up for supper. But Paul and Hilary first care for their horses. "After I get the horses home," Paul declares, "it ain't a good idea to wash them down. They'll catch cold. I go over 'em with a curry-comb. They like they're backs itched. But what a horse likes best is to turn right out to pasture. They roll—itch their own backs, you know. They'll lay down and dig away with their back, get up and shake, then lay down on the other side and roll some more. After that, they'll go to eating. They're satisfied." 🌲

Produced and written by Peter J. Stephano
Photographs: Fred Schneider

CARVE A SERVING BOARD

A MEDIEVAL DRAGON MOTIF BY ELSE BIGTON



Else Bigton

Else Bigton and her husband, Phil Odden, live amidst the timber surrounding Barronett, Wisconsin. In their Norsk Woodworks, they build and carve Scandinavian-style furniture.

Else trained to become a professional woodcarver in her native Norway. There, decoratively carved wooden serving pieces and utensils continue to be widely used. According to Else, the stylized dragon symbolized power and was a commonly featured motif during the Middle Ages.

True to Scandinavian tradition, Else selected birch for her project. "Scandinavian carvers prefer lighter-colored woods. Birch is also food safe and hard enough to stand up as a cutting board on the noncarved side," she explains.

Tips on carving the dragon board

Enlarge the half-size pattern, then trace it onto a $\frac{3}{4} \times 8\frac{1}{2} \times 17$ " birch board. Saw the board to shape and drill the $\frac{1}{2}$ " hole.

Else uses a V-tool to carve low-relief designs such as this. A chip carving knife will work, too.

To maintain the light, natural wood color, Else doesn't use a stain. Instead, she prefers a clear, nontoxic oil, such as Behlen's Salad Bowl Finish. Hang the finished board as a usable accent in your kitchen, den, or family room. ♣

One in a collection of regional carving patterns from the nation's top carvers

Design: Else Bigton
Photographs: Chip Peterson,
Darrell D. Henning

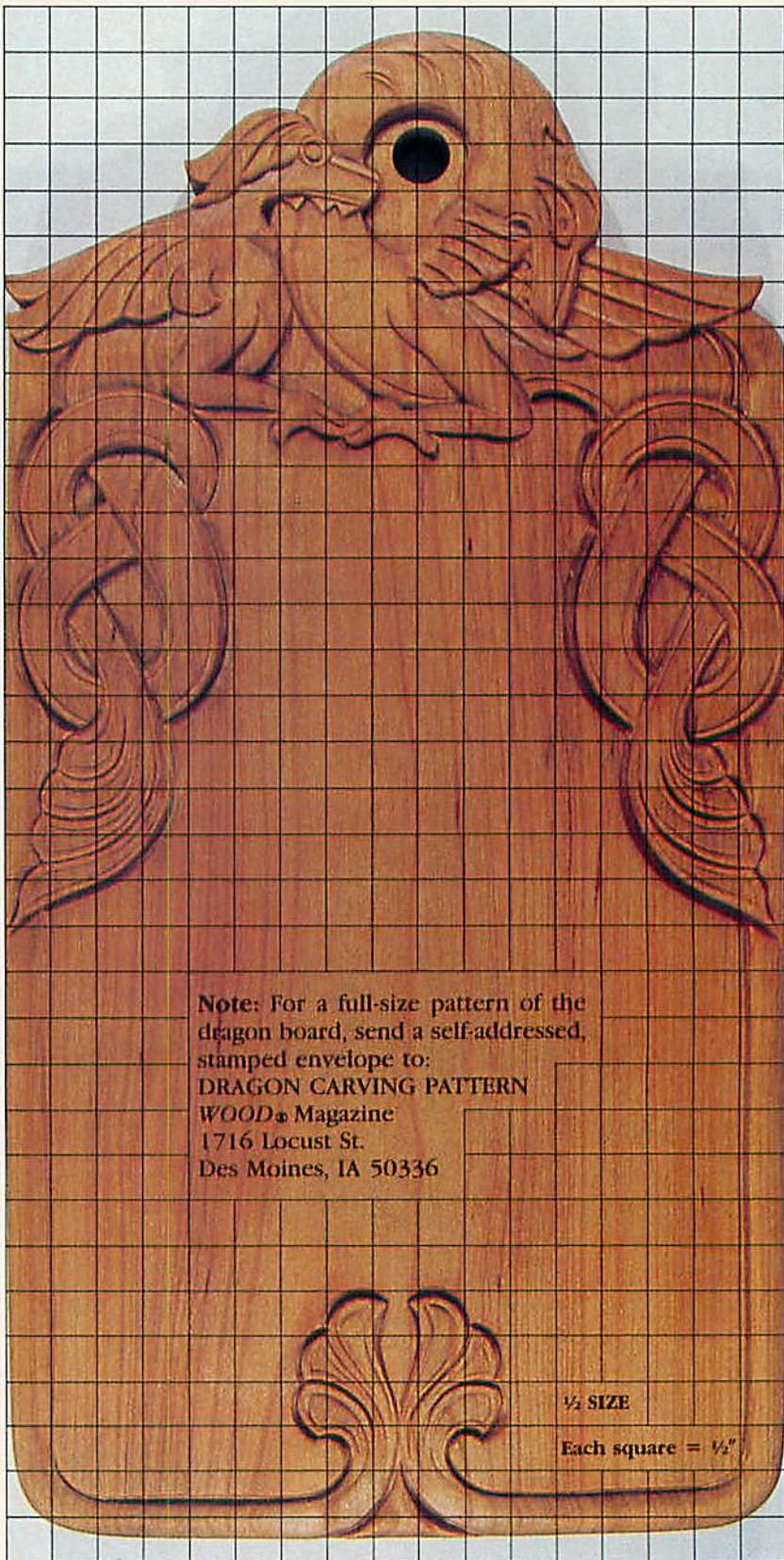

Note: For a full-size pattern of the dragon board, send a self-addressed, stamped envelope to:

DRAGON CARVING PATTERN

WOOD Magazine

1716 Locust St.

Des Moines, IA 50336

$\frac{1}{2}$ SIZE

Each square = $\frac{1}{2}$ "

ONLAY VASE

Continued from page 33

Belt-sand the panels. If any small cracks exist, see the photos on page 32 for our crack-filling remedy.

4 With the ends and edges flush, glue and clamp the sides (A) to the onlay panels.

5 Cut the top and bottom (G) to size. Chuck a circle cutter to your drill press, and cut a 2½"-diameter hole through the top piece as shown in the photo below.

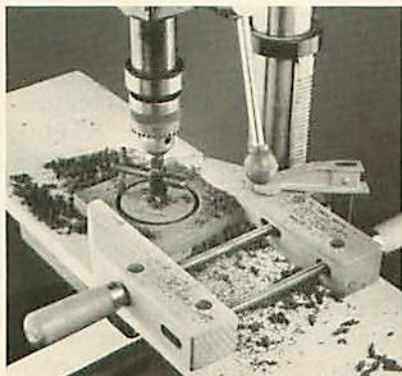

Clamp the vase top firmly to the drill press table, and use a circle cutter to cut the opening.

6 Fit your table-mounted router with a ½" round-over bit. Now, as shown in the photo below, firmly grip the walnut square, and rout a round-over around the 2½"-diameter opening.

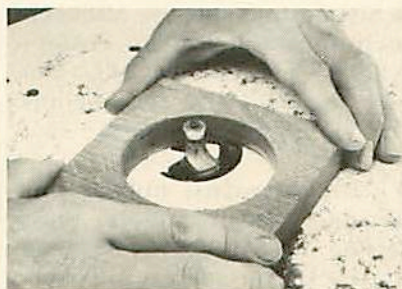

Rout the ½" round-over along the edge of the opening in two passes, raising the bit the second path.

7 Glue and clamp the top and bottom to the vase. Later, sand the edges of the top and bottom flush with the vase sides. Rout a ½" round-over along all but the bottom edges of the vase. Sand the vase, and apply the finish. 🌿

Project Design: James R. Downing
Photographs: William Hopkins, Bob Calmer
Illustrations: Kim Downing, Bill Zaun



This VET Did It – and YOU Can Do It Too!

"War injuries left me badly handicapped, but now I'm a financial success as a Locksmith, thanks to your training. Besides, the work is fascinating. If I can do it anybody can." — Glen Johnson, Larned, Kan.

Make Up to \$26.00 an Hour — even while learning!

Train FAST at Home!

Be a LOCKSMITH!

If you enjoy fixing things, you're a "natural" to make hundreds of EXTRA DOLLARS a year in the fascinating business of Locksmithing. Rising crime has increased demand for service a thousandfold. Yet there's only one Locksmith for every 17,000 people!

COLLECT CASH PROFITS ALMOST AT ONCE!

You're "in business" ready to make \$10 to \$26.00 an hour a few days after you begin Foley-Belsaw's shortcut training. Easy illustrated lessons complete with ALL practice equipment PLUS

- ALL TOOLS YOURS TO KEEP
- KEY MACHINE YOURS TO KEEP
- EXPERT PERSONAL ASSISTANCE
- BUSINESS-BUILDING HELP

enable you to get your share of this always-profitable business. Hundreds we've trained are doing it. So can YOU.

MAIL COUPON to discover how Locksmithing can keep the extra money coming in during spare time — or in your own full-time business. Ideal for retirement — good jobs, too.

FOLEY-BELSAW INSTITUTE

6301 Equitable Rd., Dept. 11361
Kansas City, MO. 64120

N. Hunt, Wilmington, Del. — "I make \$50 a week extra."

R. Davis, St. Louis, Mo. — "I cleared \$110 last Saturday."

Ed Boyle, Pittsburgh, Pa. — "My business going at top speed. I'm moving to bigger quarters."



MAIL THIS COUPON • NO SALESMAN WILL CALL

FOLEY-BELSAW INSTITUTE
6301 EQUITABLE RD., DEPT. 11361
KANSAS CITY, MO 64120



Rush FREE book, "Keys to your Future."

Name _____

Address _____

City _____

State _____

Zip _____

THIS DO-ALL PRO KEY MACHINE YOURS TO KEEP!



Can add \$50 to \$100 a week to your income... and doesn't cost you a penny extra!

FREE

ANYTIME ANYWHERE ANYWOOD

mold plane and edge

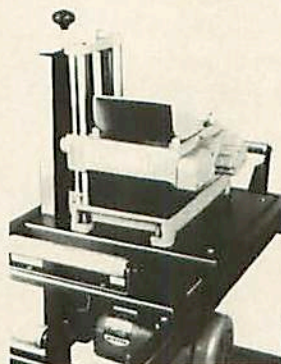

Professionals and hobbyists alike know the strengths of the W&H molder-planer. Superior US-made construction and quick two-minute cutter changes make it a snap to cut moldings and plane hardwoods. It's fast, easy, and super-smooth.

Picture frames. Crown moldings. Raised panels. And more. Our three models offer the best value in your shop or on the job site!

Our five-year warranty and free 30-day trial are your assurance that W&H goes the distance.

Mail this ad or call us toll-free today.

1-800-258-1380 In NH 603-673-3446

Williams & Hussey Elm Street Dept. 238DM

Milford, NH 03055

YES! Send your free information kit today.

Name _____

Address _____

City _____

State _____

Zip _____

I am a professional I am a hobbyist

I am also interested in your 12" lathe



**Sometimes,
the difference between
a project and a masterpiece
is guaranteed.**



DELTA
Industrial Quality

DELTA
Industrial Quality

DELTA
Industrial Quality

When it comes to making those clean, smooth cuts that separate the best work from everything else, nothing beats Delta carbide-tipped saw blades.

In fact, we guarantee it.

Try one of our premium carbide-tipped blades on your Delta saw (or just about any other saw). If you don't agree it's as good as any blade you've ever used, simply return it to your Delta distributor. He'll replace it or refund your money. No questions asked.

We design our carbide-tipped blades for optimum performance and service life. With fine-grain carbide tips silver-brazed to polished chrome alloy steel bodies. And runout tolerances of an incredible .00019" for precision cutting accuracy and quiet running.

Right now, Delta distributors are offering special prices on our blades. So if you demand the highest level of craftsmanship in your work, demand it in your saw blades, too. Delta carbide-tipped saw blades won't disappoint you. We guarantee it.

For the name of your Delta distributor call toll free: Delta International Machinery Corp., 800/438-2486 (in PA, 800/438-2487).

DELTA
Building On Tradition

TALL CLOCK

Continued from page 47

BUYING GUIDE

• **Hinges and bit.** Frame-mounted hinges, catalog no. TEC82, \$7.80 for three. High-speed steel bit for drilling a 35 mm hole for TEC82 hinge, catalog no. DB35, \$11.95. \$22.75 ppd. for hinges and bit from Constantine, 2050 Bronx, NY 10461, or call 800-223-8087 (800-822-1202 in New York) to order.

• **Walnut-burl veneer and adhesive.** Flexible veneer (much easier to apply than regular veneer), 24x24", catalog no. A5057, \$27.25. Contact cement, one pint, catalog no. N2900, \$6.75. The Woodworkers' Store, 21801 Industrial Blvd., Rogers, MN 55374, or call 612/428-2199. Minimum order \$7.50, plus \$2.50 handling charge per order.

• **Felt tape.** 1/2" wide x 17" long, catalog no. D1717, \$7. The Woodworkers' Store, address and ordering requirements above.

• **Floor glides.** Catalog no. C1405, four needed, 75 cents each. T-nuts, 5/16"-18, catalog no. D1306, \$1.65 for a package of 10. The Woodworkers' Store, address and ordering requirements above.

• **Clock movement.** Eight-day movement featuring 12 tuned chime rods that play Westminster, Whittington, and St. Michael's melodies. Catalog no. 13904, \$399.95 ppd. Klockit, P.O. Box 629, Dept. WD381, Lake Geneva, WI 53147, or call 800-556-2548 to order.

• **Clock timing marks and hands.** Made from solid brass, catalog no. 67925, \$14.95. From Klockit, see the address and phone number above.

• **Decorative gold trim.** Flexible, durable vinyl, 3/8" wide by 20' long. Stock no. 15-9868U (page 132), \$8.49 per kit (2 kits needed). \$21 ppd. for two kits from J.C. Whitney & Co., 1917-19 Archer Ave., P.O. Box 8410, Chicago, IL 60680, or call 312/431-6102 to order. ♣

Produced by Marlen Kemmet
Project Design: James R. Downing
Photographs: William Hopkins
Illustrations: Kim Downing, Bill Zaun



A Cut Above
Lesser Saw Fences...

The Excalibur T-Slot Saw Fence

When choosing
investments,
cheaper isn't better...
better
is
better!

...and there's a
good reason why

Like any other precision tool, a saw fence is an investment. And when it comes to choosing investments, cheaper isn't better. Better is better. So T-Slot owners rightfully count themselves among the ranks of perfectionists who have high standards and are willing to pay a bit more to maintain them. A better saw fence...and a more accurate one. The Excalibur T-Slot saw fence will convert your table saw into a precision wood-cutting machine.

EXCALIBUR
MACHINE & TOOL
COMPANY

U. S. A.
210 Eighth St. South
Lewiston, NY 14092
Toll Free: 1-800-387-9789

CANADA
3241 Kennedy Rd., #7
Scarborough, Ont. M1V 2J9
(416) 291-8190

- ✓ Quick installation on General, Rockwell/Delta, Powermatic, Craftsman and most other saws
- ✓ Ripping of large stock is quickly accomplished
- ✓ Positive front and rear rail locking
- ✓ Built-in scale and adjustable half-inch cursor for precise cuts every time
- ✓ Easy parallelism adjustment
- ✓ The necessity of always having to measure from the saw blade to the fence has been eliminated
- ✓ Manufactured from high-quality materials
- ✓ Efficient reassembly for ripping to right or left of saw blade — plus many more exciting features, including the Ultimate Guarantee.

For the name of your nearest Dealer, please Phone 1-800-387-9789

This isn't what you think !

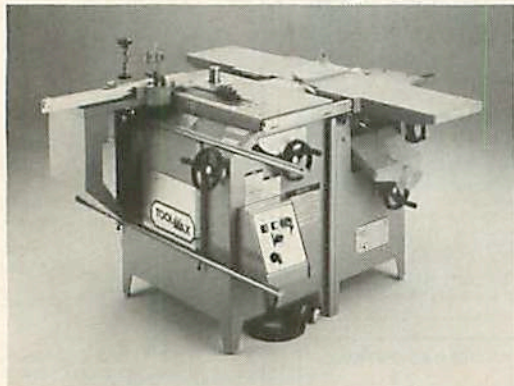

You're probably looking at this machine thinking to yourself, "Oh, it's one of those all in one tools that takes forever to set-up and really isn't practical." Think again. This is the Toolmax T310. The T310 is a quality woodworking tool that requires almost no set-up and meets almost any commercial quality specification for individual equipment. The T310 has 4 Separate motors which power the 10" Table Saw, 1" Spindle Shaper, 12" Jointer, 12" Planer, and Mortise.

If you want to save over 90% of the space in your shop and up to 60% of the cost of buying individual equipment, call Toolmax for more information or send \$19.95 (VISA, MC, AMEX customers call toll free 1-800-535-4788 to order by phone) for an informative video demonstration tape.



TOOLMAX
2439 FRONT ST.
WEST SACRAMENTO CA 95691

1-800-535-4788 USA 1-800-325-8330 CA

HOW TO KEEP YOUR CARBIDE BLADES ON THE SAW—NOT OUT FOR SHARPENING

See related article on page 60

Make your carbide blades work better and last longer by following this advice from the folks at Cherokee Tool:

- Use a blade only for the cutting it was designed to do. For instance, don't rip with a crosscut blade because excess heat will build up and warp the blade.
- Use a carbide blade only for the job it was made to do. Cutting anything but wood may break off the tips — a real safety hazard.
- To lessen the chance of dropping it, hold the blade just as you would a record album, with thumb in center hole and middle finger at the edge.
- Clean blades after use, especially when working oak (because its tannic acid erodes carbide), plywood, or particleboard. Soak the blade in laundry detergent and water for an hour, then scrub it with a toothbrush, and let dry thoroughly. Other cleaners include fingernail polish remover, oven cleaner, carburetor cleaner, and lacquer thinner.
- To prevent rust, oil a blade before storing, but wipe it off before using. Oily blades slip.
- Never lay a blade down on metal, and never stack blades.
- Clean the saw's arbor and stabilizing collar when you change a blade. Built-up sawdust and wood slivers can shim out a blade and cause it to wobble, as well as damage the arbor hole.
- Be sure to tighten the arbor nut securely when installing it on the arbor. Otherwise, it will run off center and the center hole will wear unevenly. Overtightening won't bother blade operation, but could result in accidental damage during removal.
- When a blade binds, always stop feeding stock and turn off the saw, then back the blade out. Never force the cut. ♣

"I CAN DO THAT!"

ORTHO Books represent the most comprehensive body of do-it-yourself know-how you can buy. Generous illustrations, clear instructions, give you the confidence that comes with competence. ORTHO has an encouraging message for you: "YOU CAN!"

Look for the newly revised **Wood Projects for the Garden!**



cause allergic reactions in some individuals.

Since you can use shorter pieces for cutting boards, your scrap bin and the discounted "shorts" at many lumber yards are excellent sources for wood.

2 Make 'em thick! Unfortunately, many cutting boards are made by edge-joining $\frac{3}{4}$ "-thick stock. This results in a lamination thinner than $\frac{3}{4}$ " after scraping and sanding. A cutting board this thin is much more likely to warp than a thicker lamination. To make thicker boards, rip pieces at least $1\frac{1}{4}$ " wide, and then glue and clamp them together face to face (not edge to edge). This way, even after scraping and sanding, you'll end up with a cutting board more than $1\frac{1}{8}$ " thick. Plus, I've found that thicker boards sell better than thin boards.

3 Don't worry about the glue you use. Many sources recommend against water-soluble glue; I've always used regular woodworker's glue (Titebond) without a joint failing. The key is not the glue, but sealing the board later so water can't get to the wood and glue joints.

Apply glue to both mating surfaces. Then, hold the pieces together, and rub them back and forth to form a thin, even film of glue on both pieces. After a bit of practice, you learn to put just the right amount onto the wood so the squeeze-out after clamping is minimal.

Continued on page 84

TRIED-AND-TRUE TIPS FROM OUR CUTTING-BOARD WHIZ



Constructing and selling stacks of cutting boards put spending money in my pocket during college. And, when you only clear a few dollars on each board, you can't afford mistakes. Here are a few tips you won't have to learn the hard way, as I did.

Mark Kemmet

How-To Editor

1 Select the right stock. Closed-grain wood such as maple, beech, cherry, and ash are especially good. Padauk, purpleheart, and other exotics work well for accent color. Avoid open-grain woods—they are hard to seal. Softwoods dent too easily, and oily woods such as teak can cause joints to split apart later. Also, beware of woods from the rosewood family. The dust encountered when sanding rosewoods such as cocobolo can

"I CAN SAVE ON THAT!"

Now ORTHO Books saves you money on the books themselves. Buy any of the following six best-selling ORTHO titles and get a \$2 rebate: *Decks & Patios*, *Deck Plans*, *Plumbing, Wiring, Kitchens*, and *Bathrooms*. ORTHO now makes it even easier to say, "I CAN!"

Good through Sept. 1, 1988.
© 1987 Chevron Chemical Co.
All rights reserved.



ORTHO INFORMATION SERVICES

\$2.00 REBATE



"Jorgensen"[®] AND "Pony"[®]

CLAMPS

Dependable extra hands for all types of clamping and work-holding jobs:
Woodworking Projects, Home Maintenance, and Furniture Repair.

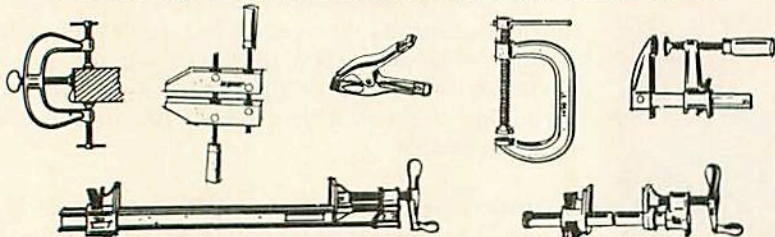

Write for FREE LITERATURE.

For big 32-page "how-to-clamp-it" catalog, send \$1.00.

ASK YOUR DEALER

ADJUSTABLE CLAMP COMPANY

THE CLAMP FOLKS

410 N. Ashland Avenue • Chicago, IL 60622

**Call 1-800-233-SAWS for a copy
of DML's quarterly promotions and
your closest DML distributor.**



DML, Inc., 1350 S. 15th St., Louisville, KY 40210

CUTTING-BOARD WHIZ

Continued from page 83

4 Clamp the pieces together flat. When clamping the pieces together, keep the top and bottom edges of all the pieces flush. Careless clamping creates lots of needless scraping and sanding to achieve a flat surface.

5 Rout a round-over on the edges. A routed round-over along all edges not only makes the cutting board smoother to handle, it also gives the lamination a cleaner, more attractive look.

6 Add feet for convenience. Not all cutting boards need be destined to lie flat on a counter. Raising a cutting board even 1/2" or so with wood or rubber feet makes it easier to pick up the board and food, and enhances many distinctive designs.

7 Use the right finish. Due to the numerous recommended finishes, you can get confused easily as to which one to apply. I've tried mineral, peanut, cottonseed, and corn oil, all with good initial results. But each requires frequent reapplications to keep the board properly sealed. Then, I applied a product that seemed too good to be true, Behlen's Salad Bowl Finish. Even with heavy daily use, a cutting board finished with Behlen's should last at least a year before it requires touch-up sanding and another coat of finish.

8 Keep your cutting boards dry and clean. Improper cleaning and neglect ruin more cutting boards than any other cause. To clean a board, scrub it with a damp (not soaking wet) cloth, and then dry the board with a clean, dry towel. Never submerge a cutting board in water or wash it in a dishwasher.

You must keep the wood sealed against moisture. If your board was originally sealed with an oil, frequent reapplications (every two to three weeks) are a necessity. ♣

Photograph: Bob Calmer

The Bulletin Board

WOODWORKING FACTS, FACES & FABLES

FLEET-FOOTED FURNITURE

During the turbulent Middle Ages, battles and hasty retreats dictated that craftsmen design furniture for quick escapes.

Glueless joints assured disassembly in a jiffy.

The ultimate piece of fleet-footed furniture was a simple board attached to a wall. Called a *sideboard*, it was the forerunner to the ornate cabinet of later centuries.



CONCRETE FACT: A SOLID LATHE

"When you need a tool to do something specific, you make it," believes Denver Ulery, a physics and woodshop teacher at Overlake School in Redmond, Washington. So, when Denver's bowl-turning hobby demanded a vibration-free lathe, he built one. Made with a concrete base, his face-plate lathe weighs in at 1,500 lbs.!

He says he has turned a 28"-diameter burl bowl (it will handle 32" with the tool rest at an angle) without a shake or shimmy. Friends in Denver's woodturner's club have borrowed his plywood forms to pour bases for their own lathes, and he helps them round up the parts. No doubt, Redmond boasts the steadiest turners anywhere!

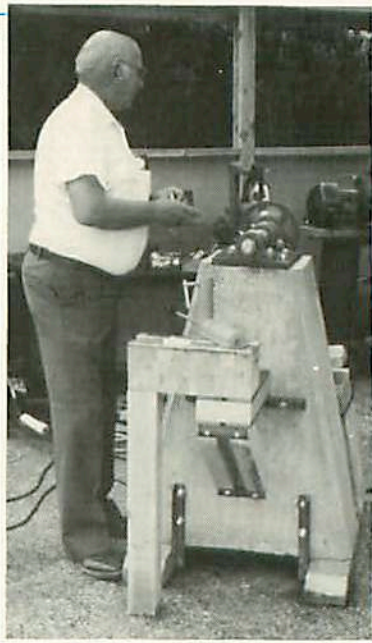

Denver Ulery and his vibration-free, 1,500-pound, concrete-based lathe.

TAKE A LOOK AT YOUR TIMBER

At least in theory, as a U.S. citizen you own a few trees in America's 191 million acres of federally owned national forests and grasslands. And you won't have to travel far to see them. The system includes areas in 43 states.

For a map of all the national forests and grasslands, as well as a listing of regional headquarters, write: *Director of Recreational Management, U.S. Dept. of Agriculture, Forest Service, P.O. Box 2417, Washington, D.C. 20013.*

AT WEST POINT, FORESTRY INCLUDES THE ROCKETS' RED GLARE

Thriving under a management plan dating to 1889, the 12,736-acre forest at the U.S. Military Academy in West Point, New York has become the only parcel of fed-

eral land to certify as an official Tree Farm. Among the nation's nearly 60,000 privately owned forests that make up the American Tree Farm System, the academy's

stands alone as the only one where sound forestry includes combat training!

Each year the acreage yields a selective harvest of mixed hardwoods for saw logs and veneer. A thinning program promotes growth. Yet, a forestry plan allows for ambushes, artillery barrages, small-arm's fire, and foxholes.

Says Joe Deschenes, West Point's forester, "Most people don't think of the Department of Defense as a manager of natural resources. But, the department does take care to see that their land is productive for wood, wildlife, and clean water."

The American Tree Farm System, an organization sponsored by the American Forest Council, encourages and recognizes good forestry practices on more than 88 million acres of private land. 🌲



West Point cadets parade against a backdrop of marketable hardwood. U.S. Army photo