

Better Homes and Gardens®

# WOOD®

THE MAGAZINE FOR HOME WOODWORKERS

\$3.95

JUNE 1988 • ISSUE NO. 23  
Display until June 14

## BASIC STAVE CONSTRUCTION

You can make  
beautifully patterned  
bowls with this  
time-tested technique

HOW TO RECANE  
A CHAIR  
in under 60 minutes!

6 EASY WAYS TO  
DUPLICATE PROJECT  
PATTERNS  
(See page 54)

## OUTSTANDING PROJECTS

Gallery-quality bowls  
Kids' play tower  
Pantograph board  
Turned earrings

## DECK YOUR OUTDOORS WITH THIS STURDY TEAK PATIO SET

See page 65

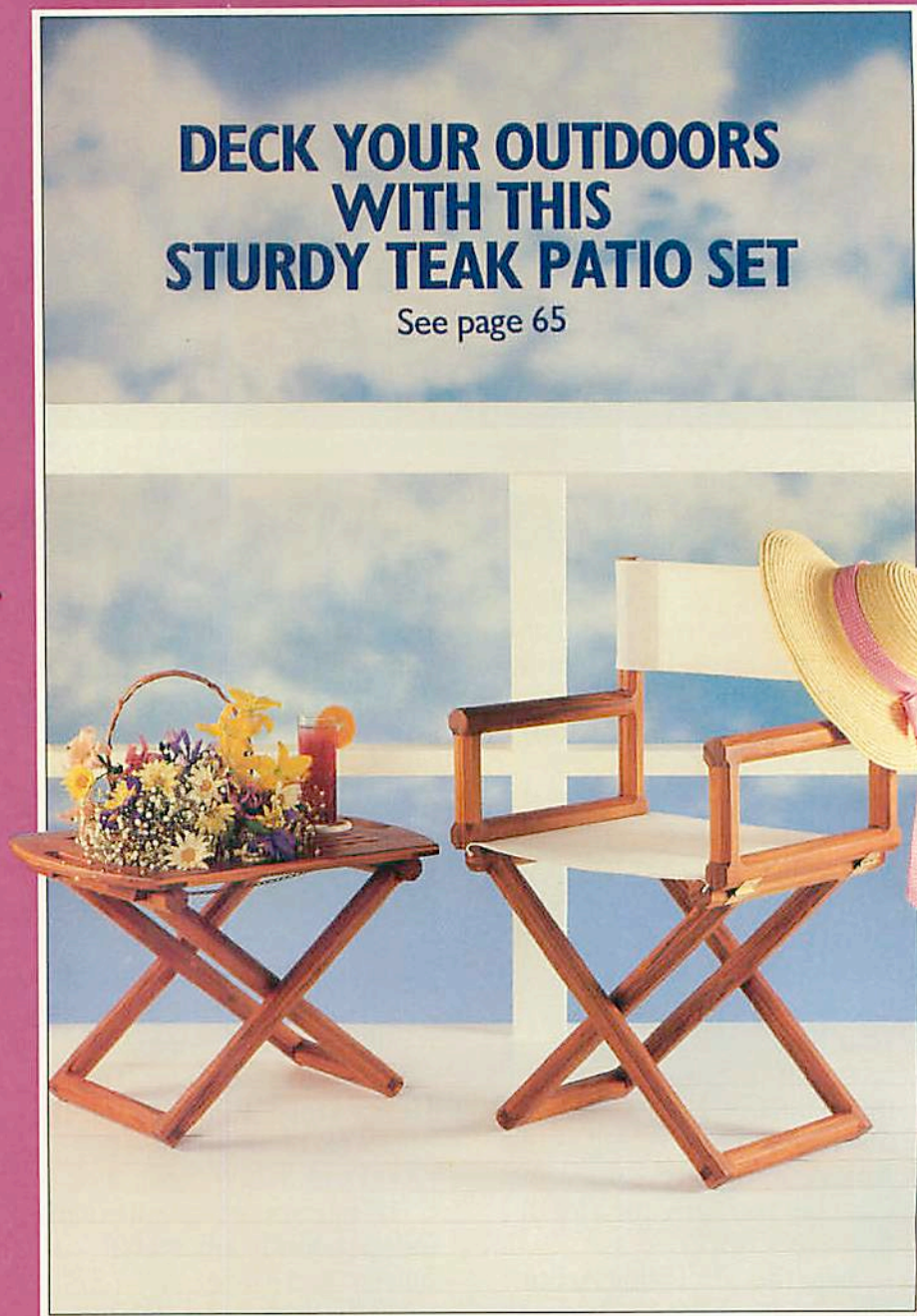

**NOW!  
REDUCE THE  
RISK AT YOUR  
TABLE SAW**



folds down neatly

WITH THE **MOBILE™  
SAWING CENTER**

**OUTFEED ROLLERS**

- safe, accurate sawing
- available in 15" and 37" widths
- handle panels with ease
- dual-position table

**AND INCREASE FLOOR SPACE**

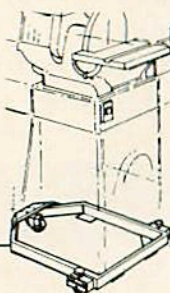

**MOBILE MACHINE BASES**

- increase shop working area
- maximize usable floor space
- 3 point base will not rock
- locking wheels
- makes machine so easy to use and store
- over 80 standard models

**PLANER STAND WITH ROLLERS**

- raises planer to proper working height
- provides machine mobility
- five-fold increase in workpiece support
- storage is a snap



**NEW**



**ROLLERTABLE  
Rock Solid Support**

- adjustable
- portable
- use at any machine

PEDESTAL  
ROLLER

Discover HTC's many unique products designed only with you, the dedicated woodworker in mind. Find out how you can make your machining safer, increase working area of your shop and accomplish nearly impossible tasks easily, quickly and accurately - **all by yourself!**

**CALL TODAY!**

HTC PRODUCTS, INC.  
120 E. HUDSON S-8  
ROYAL OAK, MI 48067  
(313) 399-6185



1-800-624-2027 ext. 108

Better Homes and Gardens®

**WOOD**

This issue's cover wood grain: Teak

JUNE 1988

ISSUE NO. 23

WOOD PROFILE

**SWEET GUM—THE WOOD THAT STEPPED  
IN WHEN WALNUT WENT TO WAR** 29

When walnut became gun stocks for World War II soldiers, Americans turned to sweet gum for furniture and millwork.



SHOP-TESTED TECHNIQUES

**BASIC STAVE-BOWL CONSTRUCTION** 30

The thriftiness of transforming dimensional lumber into bowls makes economic sense. Our project team uncovered ideas to guarantee attractive projects, too.



NOW YOU CAN BUILD IT

**A GALLERY-QUALITY  
QUILTED MAPLE BOWL** 36

With just \$4 in materials and our stave-bowl techniques, this stylish bowl—accented with walnut—can be yours.



**A DANDY SASSAFRAS  
FRUIT BOWL** 38

Staved walls are just part of this bowl's story: We show you how to assemble a segmented bottom that should turn some heads, too.

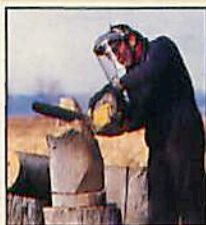

CRAFTSMAN CLOSE-UP

**COLORADO'S COTTONWOOD CARVER** 40

When Pat Fushimi isn't teaching school, leading a fishing expedition, or instructing cross-country skiers, you'll find him creatively carving—with a chain saw!



TOOL BUYMANSHIP

**MAKE STRONG, ACCURATE JOINTS  
IN SECONDS WITH A PLATE JOINER** 44

Plate joiners, recognized in Europe for delivering fast, accurate, and strong joints, have won converts on this side of the Atlantic, too.



**CANE A CHAIR...IN A JIFFY** 48

A treasured family chair becomes as good as new in less than an hour with prewoven caning materials. Save money and do it yourself!

## DIAMONDS ARE FOREVER 50

WOOD magazine takes a closer look at the increasing popularity in diamond sharpening stones. Find out if they cut faster and last longer than conventional stones.



## WOODWORKING STANDARDS

## REPRODUCING PROJECT PATTERNS 54

Mention the idea of enlarging patterns, and many woodworkers shake with fear. We show you six ways to put confidence into your pattern work.



## HOMEMADE TOOLS

## BE YOUR OWN PATTERNAKER WITH OUR PANTOGRAPH DRAWING BOARD 58

Enlarging patterns just got easier! Take advantage of the best patterns ideas you uncover by building an inexpensive pantograph board in an afternoon.



## MUSIC TO YOUR EARS 60

Tonal quality plays a huge role in the woods selected for musical instruments. Learn why instrument makers rely on snakewood, pernambuco, grenadilla, and others.

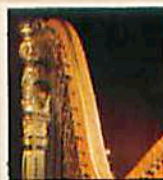

## DESIGNER EARRINGS RIGHT OFF THE LATHE 64

A woodturner shows you how to fashion miniature bowls into earrings.



## TEAK TABLE AND DIRECTOR'S CHAIRS 65

Designed by our own Jim Downing, this classy combo features sturdy mortise-and-tenon joints that stand up to rough treatment.



## A KID'S RETREAT 72

Stretch a child's imagination—but not your pocketbook—with this all-in-one play tower/swing set/sandbox. Our how-to editor's daughters could hardly wait for their dad to finish this nifty project.

## SHORT-SUBJECT FEATURES

Talking Back .....	6	Ask WOOD .....	78
Tips From Your Shop (And Ours) .....	14	Wood Anecdote .....	83
Products That Perform .....	23	Magazine Customer Service .....	85
Project Showcase .....	52	Bulletin Board .....	104

# WOODWORKS

## American Made Woodturnings

	SHAKER PEG		
	MUG PEG		
		Qty.	Total
3-1/2" Maple Shaker Pegs		\$20.00/100	_____
2-1/2" Stubby Peg		16.00/100	_____
Medium Shaker Peg		15.00/100	_____
1-3/4" Mini Shaker Pegs		7.00/100	_____
3-3/8" Kitchen Mug Pegs		20.00/100	_____
2-7/16" Tie Rack Pegs		7.00/100	_____
Bean Pot Candle Cup		17.00/100	_____
Medium Bean Pot		15.00/100	_____
Small Bean Pot		12.00/100	_____
Mini Bean Pot		10.00/100	_____

## LOW PRICES

	(24 Sizes)		
Dia. x Thick			
3/4" x 1/8" Hearts		\$3.00/100	_____
3/4" x 1/4"		4.00/100	_____
3/4" x 1/2"		5.00/100	_____
1-1/4" x 1/8"		8.00/100	_____
1-1/4" x 1/4"		9.00/100	_____
1-1/4" x 1/2"		11.00/100	_____
1-3/4" x 1/8"		3.50/25	_____
1-3/4" x 1/4"		3.75/25	_____
1-3/4" x 1/2"		5.00/25	_____

## HIGH QUALITY

3/4" Full Round Balls		\$8.00/100	_____
1" Full Round Balls		10.00/100	_____
Apples		1.50/Each	_____
Large Egg 1-7/8" x 2-1/2"		35.00/100	_____
Small Eggs 1-3/8" x 2"		25.00/100	_____
5/8" Mini Eggs		10.00/100	_____
1" Toy Wheel		6.50/100	_____
1-1/2" Toy Wheel		10.00/100	_____
Axle Peg		4.50/100	_____

## FAST SERVICE

3/8" Maple Buttons		\$2.15/100	_____
1/2" Maple Buttons		2.25/100	_____
3/8" x 2" Dowel Pins		2.20/100	_____
1-1/2" Maple Spindles		9.00/100	_____
1-1/2" Oak Spindles		12.00/100	_____
2-1/8" Maple Spindle		14.00/100	_____
2-1/8" Oak Spindle		18.00/100	_____
Picture Hanger		1.50/100	_____
1-5/8" Sawtooth Hanger		4.50/100	_____
Nailess Sawtooth Hanger		8.00/100	_____

## MONEY BACK GUARANTEE

**BONUS** CHECK THIS BOX, AND AS A BONUS WITH ANY ORDER FOR WOOD PARTS, WE WILL SEND YOU A COMPLIMENTARY 8 OZ. BOTTLE OF FRANKLIN TITE-BOND WOOD GLUE.  
 CHECK HERE  
**\$2.25 VALUE #B3**

	<b>ORDER NOW</b>	
	TOTAL FOR GOODS	
32 PAGE 1987 CATALOG \$1.00 (Free With Order)	TEXANS ONLY ADD 6% SALES TAX HANDLING AND INSURANCE	<b>\$3.00</b>
	FINAL TOTAL	

MC OR VISA  CHECK ENCLOSED

ACCOUNT # \_\_\_\_\_

EXPIRES \_\_\_\_\_ PHONE \_\_\_\_\_

NAME \_\_\_\_\_

SHIP TO \_\_\_\_\_

CITY/STATE/ZIP \_\_\_\_\_

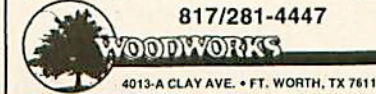

# SystiMatic saws cut smoother and run quieter. (And they're made in America!)

For a catalog or the name of your nearest dealer, call 800-426-0000\*, ext. 80.

SystiMatic Company  
12530 135th Avenue Northeast  
Kirkland, Washington 98034

\*Except Canada



### POWERMATIC



**Call For Our Low Prices!** We carry the entire Powermatic line at very attractive prices. Please call for our prices on the Model 66 and other Powermatic machines. You'll be glad you did!

**Model 66 Table Saw with 50" Biesemeyer Rip Fence.**  
3HP, 1PH or 5HP, 3PH motor    FOB our Warehouse.

### Mini-Max

**World's Best Jointer-Planer**

**FS35 Jointer-Planer \$2195**  
Length 63" Width 13 1/2" Weight 719 lbs.  
3HP, 1PH or 3HP, 3PH Motor

Please call or write for more information on the FS35 jointer-planer. We stock the entire Mini-Max line. Please call for our prices. FOB our Warehouse. Call for discounted freight rates.



---

### MAKITA

B04510	4" finishing sander	\$ 59
1100	3 1/2" planer kit	\$179
1805	6 1/2" planer kit	\$277
2708	8 1/2" table saw	\$229
3612BR	plunge router	\$189
GUIDES	for 3612BR	\$ 28
3601B	1/2" router	\$118
3700B	3/4" Trimmer	\$ 95
4301BV	orbital jig saw	\$139
5007NB	7 1/4" circular saw	\$109
6000LR	1/2" clutch drill	\$119
6012HDW	1/2" cordless clutch drill	\$109
9900B	3x21 belt sander	\$129
99824DB	3x24 belt sander	\$139
8401	4x24 belt sander	\$159
98202	blade sharpener	\$169

### FREUD SPECIALS

TT-108	8 Pc. Turning Tool Set	\$54
90-100	15 Pc. Router Bit Set	\$138
92-100	26 Pc. Router Bit Set	\$284
94-100	5 Pc. Router Cabinet	\$159
FB-100	16 Pc. Forstner Bit Set	\$159
EC-900	5 Pc. Shaper Cabinet Set	\$264
EC-209-213	Raised Panel Cutters	\$85
EC-260	3/4" Cabinet Door Set	\$157

### Sawblades

LM72M	10", 24T, Rip Blade	\$38
LUT73M	10", 60T, ATB Cutoff	\$38
LU84M	10", 50T, Combination	\$38
LU82M	Set of Three Above	\$107
LU85M	10", 60T, Triple Chip	\$42
LU85M	10", 60T, Super Blade	\$59
DS306	6" Dado	\$99
DS308	8" Dado	\$109
JS100	Plate Joiner	\$169
JS020	1000 Biscuits	\$29
F1100	Spare Cutter	\$ 34

### PORTER CABLE

518	3HP Speedtronic Router	\$323
630	1 1/2HP Router	\$ 93
690	1 1/2HP Router	\$124
310	Laminate Trimmer	\$124
312	Offset Laminate Trimmer	\$133
319	Tilt-Base Laminate Trimmer	\$138
330	Speed-Block Sander	\$ 54
352	3 x 21 Dustless Belt Sander	\$130
360	3 x 24 Dustless Belt Sander	\$185
362	4 x 24 Dustless Belt Sander	\$198
555	Plate Joiner	\$169
345	Saw Boss	Call

### JET POWER TOOLS

JBS-14MW	Metal/wood Bandsaw	\$349
JJ-6	6" Jointer	\$339
JTS-10	10" Contractors Saw	\$439
CTAS-10	10" T/A Table Saw	\$1275
JJ-8	with 50" Biesemeyer Fence	\$899
JWP-15H	15" Thickness Planer	\$999
DC-610	1 HP Dust Collector	\$329
DC-1182	2 HP Dust Collector	\$449

---

### RYOBI SPECIALS

S500A	3 x 4 1/4" Pad Sander	\$ 39
SUE200	1/2" Sheet Pad Sander	\$ 99
B7075	3 x 21 Dustless Belt Sander	\$105
B7100	3 x 24 Dustless Belt Sander	\$121
B7200A	4 x 24 Dustless Belt Sander	\$148
R151	1HP Plunge Router	\$ 95
R501	2 1/4HP Plunge Router	\$159
TR30U	Trimmer	\$ 77
TS360	14" Miter Saw	\$369

10" width of cut  
13 Amp, 110v  
Motor  
Powerfeed  
**CALL FOR OUR PRICE!**

**AP-10 Thickness Planer**

### MAKITA STATIONARIES

2040	15" Planer	\$1275
2020	8" Jointer	\$775

### HITACHI

F-1000A	Jointer-Planer	\$1395
CB75F	Resaw Bandsaw	\$1645
C15FBP	15" Miter Saw	\$409
C101FB	10" Miter Saw	\$279
TR12	Plunge Router	\$173

---

### LEIGH

T0514L	24" dovetail jig with 1/2" bits for 1/2" dovetails	\$239
D1258-12	New 12" jig for through and half blind dovetails	\$245
D1258-24	New 24" jig for through and half blind dovetails	\$279

Optional Bits in Stock

Better Homes and Gardens®

# WOOD®

THE MAGAZINE FOR HOME WOODWORKERS

June 1988 • Vol. 5, No. 3 • Issue No. 23

Editorial/Art Staff

Editor **LARRY CLAYTON**  
Managing Editor **CARL VOSS**  
Art Director **C. L. GATZKE**  
Design Editor **JAMES R. DOWNING**  
Features Editor **PETER J. STEPHANO**  
How-To Editor **MARLEN KEMMET**  
Products/Techniques Editor **BILL KRIER**  
Project Builder **JAMES E. BOELLING**  
Graphic Designer **PERRY A. McFARLIN**  
Administrative Assistant **DARLENE REYNOLDS**  
Business Office Clerk **JODI DOWNING**

Technical Consultants: **GEORGE GRANSETH** Product Testing; **PAUL L. McCURE** Wood Technology; **PHILIP WHITBY**, Collectible Tools

Publisher **JERRY KAPLAN**

National Advertising Manager **MARK S. HART**  
Advertising Representatives **JOHN BELLUARDO**,  
**ANTHONY IMPERATO**, **JASON B. WEINGER**  
Promotion/Research Director **THOMAS R. TROLAND**  
Marketing Services Manager **NANCY DALY**  
Circulation Director **WILLIAM HUMMEL**  
Circulation Manager **BILL REED**  
Production Director **DALE SCHENKELBERG**  
Editorial Research Director **C. RAY DEATON**

Weekend Woodworking Projects™

Managing Editor **JIM HARROLD**

Magazine Group Officers

Group President **JAMES A. AUTRY**  
Group Vice Presidents: Publishing Directors **ADOLPH AUERBACHER**, **BURTON H. BOERSMA**; **CHRISTOPHER M. LEHMAN**; Editorial Director **DORIS M. EBY**; Operations **DEAN PIETERS**

Chairman of Executive Committee **E. T. MEREDITH III**

Corporate Officers

Chairman of the Board **ROBERT A. BURNETT**  
President **JACK D. REHM**  
Group Presidents: Book **JERAMY LANIGAN**; Broadcasting **W. C. McREYNOLDS**; Magazine **JAMES A. AUTRY**; Real Estate **ALLEN L. SABBAG**;  
Vice Presidents: Administrative Services **GERALD D. THORNTON**; Corporate Relations **DONALD L. ARNOLD**; Finance **JAMES F. STACK**; General Counsel and Assistant Secretary **THOMAS G. FISHER**; Product Development **NEIL KUEHNL**; Special Projects **FRED STINES**  
Corporate Secretary **BETTY CAMPBELL MADDEN**  
Treasurer **MICHAEL A. SELL**  
Corporate Controller **LARRY D. HARTSOOK**

Better Homes and Gardens® WOOD® - the magazine for home woodworkers (ISSN 0743-894X) is published bimonthly in February, April, June, August, October, and December by Meredith Corporation, Locust at 17th, Des Moines, IA 50336. Second-class postage paid at Des Moines, Iowa. Trademark registered in Canada and Australia. Marca Registrada en Mexico. **SUBSCRIPTION PRICES:** One year \$18 in the United States and its possessions. Canada and other countries add \$6 per year. **POSTMASTER:** Send address changes to WOOD, 1716 Locust Street, Des Moines, IA 50336, June 1988, Vol. 5, No. 3, Issue No. 23. **CUSTOMER SERVICE:** For service on your magazine subscriptions, including change of address, write to Customer Service Manager **ROBERT AUSTIN**, P.O. Box 10628, Des Moines, IA 50336. Please enclose your address label from a recent issue. If you wish to phone, call toll-free 1-800-678-2666.

© COPYRIGHT MEREDITH CORPORATION 1988. ALL RIGHTS RESERVED. PRINTED IN U.S.A.

The Xylophile's Company

138 E. Loudon Ave. • Lexington, KY 40505

1-800-354-9083 —M/C VISA— (606) 254-9823

Orders over \$35.00 include delivery unless otherwise noted. Prices subject to change without notice

# TOOLS-TO-GO INC.

15935 N.W. 57TH AVENUE • HIALEAH, FLORIDA 33014

TO PLACE AN ORDER:  
WE ACCEPT MC/VISA/CHECK/MONEY ORDER

CALL TOLL FREE: 1-800-4451419 (USA) 1-800-330-5057 (FL)



Call for quotes on other products. Orders over \$50.00 shipped FREE. Over 70 lbs. shipped F.O.B. Hialeah, Florida. Call our toll free # for freight quote. Florida residents add 6% sales tax. Prices good while supplies last.

TTG 125 \$401 Limited Time

## 12.5" SURFACE PLANER

Limited  
Time  
Now Only

\$401



TTG 125! THE ULTIMATE POWER PLANER!  
IT'S THE ONE YOU'VE WAITED FOR!

\*Actual model may vary slightly from picture shown.  
F.O.B. Hialeah

## HITACHI

*TR12	3 HP Plunge Router, \$60.00 Free Accessories.....	\$160.00
C10FA	10" Deluxe Miter saw.....	\$625.00
*C15FB	15" Deluxe Miter saw.....	\$370.00
CJ65V	D handle, orbital jigsaw, variable speed.....	\$130.00
CJ65VA	Orbital jigsaw, variable speed.....	\$130.00
F20A	3 1/4" Planer.....	\$90.00
D10D	3/8" Screwdriver Cordless Drill 9.6V.....	\$120.00
D10VC	3/8" Var speed Rev. Drill.....	\$74.00
DRC1D	3/8" cordless screwdriver drill 7.2V.....	\$80.00
D10DC	Var. Cordless 3/8" screwdriver drill 7.2V.....	\$118.00
GP2	1/4" Long nose die grinder.....	\$107.00
SV12SA	1/4" shear orbital block sander.....	\$36.00
SB75	3x21 belt sander.....	\$150.00
CEDA	6 1/4" cordless circular saw.....	\$108.00

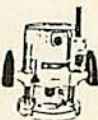

## AES ALL PRO™

A LOT TOUGHER THAN THE JOB

*HBSE755	Var. Speed 3x21 sander with bag & stand.....	\$149.95
EZ502	Cordless screwdriver, adj. 2 position handle.....	\$59.95
EZ506	Cordless var. speed drill/driver 7.2V.....	\$118.00
EZ560	2 speed cordless drill/driver 7.2V.....	\$113.00
PC70-1	7 1/4" parallel shoe circular saw - the most power/f.....	\$129.00
SSPEB00	Sabretooth Reciprocating saw.....	\$130.00
BSPE60	Electronic top handle jigsaw orbital in steel case.....	\$130.00
EH025	3 1/4" finish planer - includes carbide blades and 800 w power.....	\$189.00
VS130	2000rpm- 1/3 sheet.....	\$67.00



## Makita

6010D	3/8" cordless drill rev. screwdriver.....	\$85.00
6093DW	Cordless driver drill kit - 2 speed var. speed reversible.....	\$135.00



## SAFETY EQUIPMENT

NP303 / RC101		
NP305	NP102.....	\$1.56
NP304	NP22.....	\$1.49
RC201	F2.....	.77
RC203		

Freight Collect

## Portalign

Pocket Hole Guide.....	\$33.00
Pocket Hole System.....	\$48.00
100 Screws.....	\$5.50
500 Screws.....	\$15.00

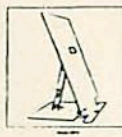

## HAND TOOLS

Vice 11" opening.....	\$58.95
25 pc. Brad PT wood bit set - Austrian.....	\$49.95
Rabona Mortise Marking Gauge - Rosewood.....	\$24.95
Router bit depth gauge.....	\$8.95
Stationary saw step gauge.....	\$8.95

We are not responsible for typographical errors - Limited quantities

# TALKING BACK

We welcome comments, criticism, suggestions ... even an occasional compliment. The volume of mail we receive makes it impossible to answer every letter, but we promise to do our level best. Send your correspondence to: Letters Editor, Better Homes and Gardens® WOOD® Magazine, Locust at 17th, Des Moines, IA 50336.

## GOOD READING FOR SCROLL-SAW USERS

Since printing the scroll saw article in the December 1987 issue, readers have flooded us with requests for additional patterns and more information on scroll saws.



Patrick Spielman, featured previously in WOOD magazine, has written two good books on the subject. The books, Scroll Saw Handbook and Scroll Saw Pattern Book, are \$14.95 ppd. each or \$28.20 ppd. together from R. Sorsky Bookseller; 3845 N. Blackstone, Fresno, CA 93726; 800-345-4447 (in California, 209/227-2901). The pattern book alone has 450 projects.

## GIVING CREDIT WHERE DUE

I'm writing about the miter-gauge square technique described in the "Talking Back" department in the February 1988 issue. I, too, responded to the shop tip that first appeared in the October 1988 issue. I was always told to give credit where credit is due, so wouldn't you agree it would only be fair to name everyone who wrote in instead of just one person? In my October letter responding to the "Talking Back" item, I submitted a shop tip similar to one that appeared in the December issue. I was a little discouraged, to say the least.

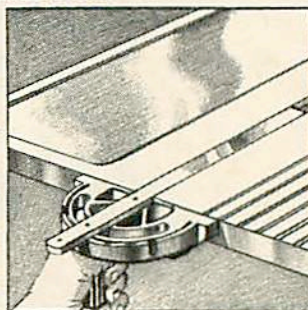

—Joseph Hannon, Miami, Fla.

We're sorry to disappoint you, Joseph. In most cases, when more than one reader submits a similar "Talking Back" response, we publish the response with the earliest postmark.

We apply the same rule to "Tips From Your Shop (And Ours)," and we bear the same fairness complaint. Please understand that we work at least six months ahead of schedule on our tips; by the time this issue hits your mailbox, our February tips will be selected! With more than 450,000 readers, it's common to receive a dozen similar tips. The early bird gets the credit, but if it's any consolation, great minds run on the same track!

Continued on page 10

## CONTROL THE SPEED OF YOUR ROUTER

ROUTE AT THE SPEED THAT GIVES THE BEST RESULTS WITH THE WOOD AND BIT YOU ARE USING!

- LESS TEAR OUT
- STOPS BURNING
- FEED AT COMFORTABLE RATE
- BETTER, SAFER RESULTS WITH LARGE DIAMETER PANEL-RAISING BITS
- LESS WEAR ON BITS
- LESS NOISE AND SOFTER STARTS AT LOWER SPEEDS

INTRODUCTORY PRICE  
**\$39.95**  
POSTAGE PAID  
 VALUE OVER \$100.00

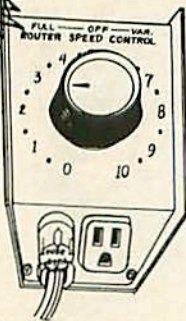

### FEATURES:

- SPEED ADJUSTABLE FROM FULL SPEED TO 0 RPM
- FULL HORSEPOWER AND TORQUE AT ALL SPEEDS
- GO BACK AND FORTH FROM ANY PRE-SET SPEED TO FULL SPEED AT THE FLIP OF A SWITCH
- WORKS WITH ALL ROUTERS 3 HP OR LESS
- 120V 15 AMP
- GIVES YOUR ROUTER A FEATURE ONLY AVAILABLE ON ROUTERS THAT COST OVER \$500.00

**EASY TO USE** — SIMPLY PLUG IN SPEED CONTROL AND PLUG YOUR ROUTER INTO THE SPEED CONTROL — TURN DIAL FOR BEST RESULTS. (SPEED CONTROL HAS A CLIP THAT CAN BE WORN ON YOUR BELT OR HUNG ON WALL OR LEFT LOOSE.)

- REDUCES SPEED ELECTRONICALLY WITHOUT REDUCING TORQUE; ELECTRONIC FEED-BACK MAINTAINS SPEED BY INCREASING VOLTAGE TO MOTOR AS LOAD INCREASES.

To order by Master Charge or Visa Toll Free  
 7 Day — 24 Hour Order Service, Call

**1-800-533-9298**

or send check to MLCS, Ltd., P.O. Box 4053DS, Rydal, PA 19046

## MULTI-FORM MOLDING MAKER #159

MAKES BEAUTIFUL LARGE AND SMALL MOLDINGS

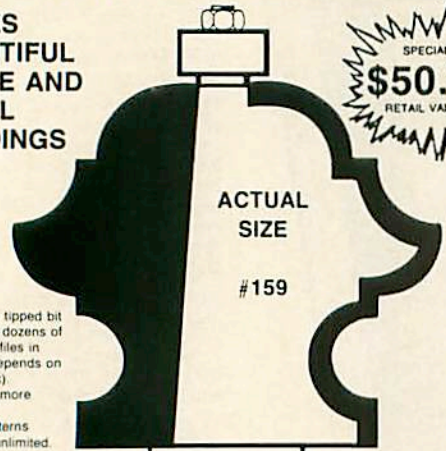

SPECIAL OFFER  
**\$50.** POSTAGE PAID  
 RETAIL VALUE \$108.00

This carbide tipped bit will produce dozens of different profiles in one pass (depends on size of stock). With two or more passes, the possible patterns are almost unlimited.

Simply adjust the depth of cut and position of the fence and create beautiful large or small moldings. Any portion of the bit can be used to achieve the desired effect.

- For use in router table
- 1/2" Shank
  - Two flute
  - Tungsten Carbide Tips
  - Production quality
  - Supplied with ball bearings
  - We pay shipping

1/2" Shank

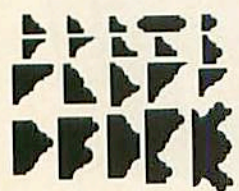

The profiles shown are just a few of the almost unlimited possibilities.

To order by Mastercard or Visa Toll Free  
 7 Day—24 Hour Order Service, Call

**1-800-533-9298**

or send check to: MLCS, Ltd., P.O. Box 4053D, Rydal, PA 19046

## TALKING BACK

Continued from page 6

### THE CASE OF THE MISPLACED GROOVE

We build every project that appears in WOOD magazine, but somehow we goofed on the router-template illustration and photo at the top of page 68 of the Barrister's Bookcase project in the February 1988 issue. Build the template shown on the drawing below, and locate it on the end frame where shown for a properly placed pin groove.

Although we built our frame correctly, we erred in showing you how to do it. We apologize for any inconvenience this may have caused.

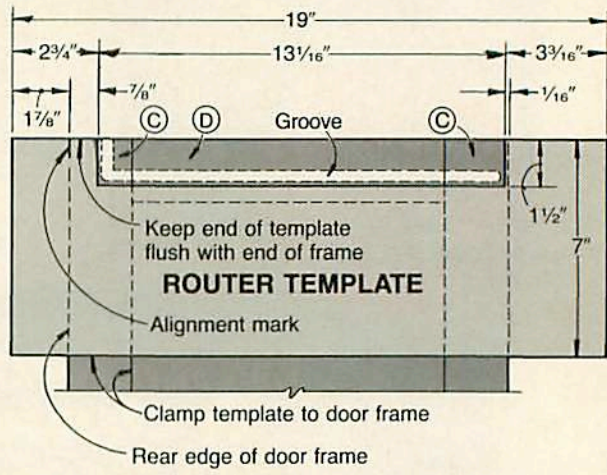

### PLANE FACTS ON BUILDING TOOLS

I have a home workshop full of the modern electrical power tools, but would like to add some of the hand tools as shown on Roy Underhill's public television series, *The Woodwright Shop*. My problem is purchasing these tools or even finding the plans to build such tools. I would much rather construct these tools if plans are available. Can you help?

—Carlton Measels, Batesville, Ark.

An admirable thought, Carlton. It seems hand tools still have a fascination for the modern craftsman. Occasionally, a reader submits a hand tool he has made for inclusion in "Project Showcase," usually a form of hand plane. However, these submissions prove rare. And, a search through our library shows no books with hand-tool plans.

Once in awhile, we feature a hand tool plan in WOOD magazine. Before building a hand tool, try contacting one of the tool collectors' groups. Frequently, these collectors of old hand tools are also woodworkers, and may know of available plans. See page 50 of our August 1987 issue for more about collecting tools. One national tool-collecting association is the Early American Industries Association, Harvey E. Jaecock, President, 29 Creamery Lane, Ridgefield, CT 06877. The organization has a \$15 annual membership that includes a quarterly magazine.

Continued on page 12



## CUSTOMIZED DRUM SANDERS AT A FRACTION OF THE COST

*Drum sanders are super for smoothing concave curves, but sometimes the drums and sleeves you have just don't match the job.*

**TIP:** Making your own drums can save you both a trip to the hardware store and a fistful of change while suiting the job to a tee. Here's what you need: A replacement core, such as a length of mailing tube or the center of a roll of paper toweling; two circular pieces of wood with a slight taper, a threaded rod, nuts, washers, and sawdust. Assemble as shown in the drawing, packing the tube with sawdust. Tightening the ends compresses the sawdust, adding firmness to the spindle. Finally, cover the drum with sandpaper, securing it with glue or double-faced tape.

—Greg Lehman, Rochester, New York

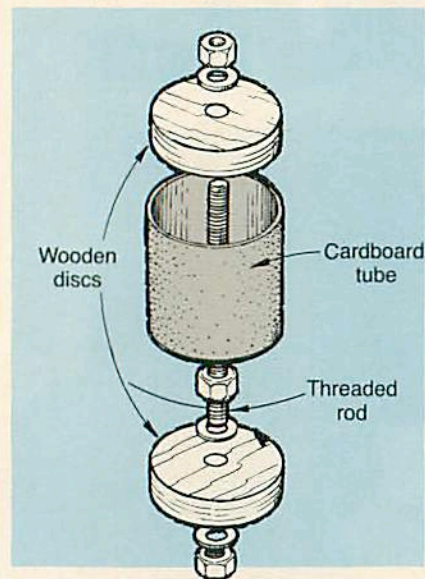

Do you have any good tips you'd like to share with our readers? We'll pay you \$25 for each submission we publish. No shop tips can be returned. Mail your tips to:

**Shop Tips**  
**Better Homes and Gardens®**  
**WOOD® Magazine**  
**Locust at 17th**  
**Des Moines, IA 50336**

## CAN'T HOLD IT ALL UP? LOOK, MA, MORE HANDS!

*Make a clamping error and you'll pay in time and sweat. Sometimes it seems as if a person needs three or four hands to tighten pipe or bar clamps without allowing the boards to slip. This is especially true when you try to hold insert wood scraps to prevent the clamps from marring the project material.*

**TIP:** Cut clamping blocks out of scrap wood or plywood the appropriate size in a suitable shape to fit the clamp (see illustration below) and drive tacks or small nails into the edges. Loop rubber bands over the clamp jaws to hold the blocks in place before tightening.

—Dave Tobey, Fort Worth, Texas

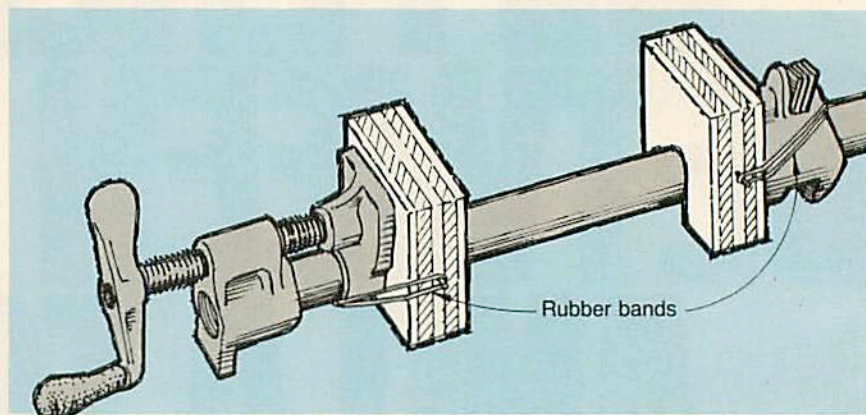

## SACKING A MESS BEFORE IT BECOMES ONE

*Drilling holes in wall paneling, especially drywall, leaves unsightly particles on the wall and the floor, fine dusty material that's tough to clean up.*

**TIP:** Tape an open paper bag to the wall a few inches below where you plan to drill. Once that bit starts chewing and spitting out nasty particles, they fall right into the sack. When finished drilling, simply pull loose the masking tape, close the sack, and toss out the mess that never even happened.

—Earl Hagen, Livonia, Mich.

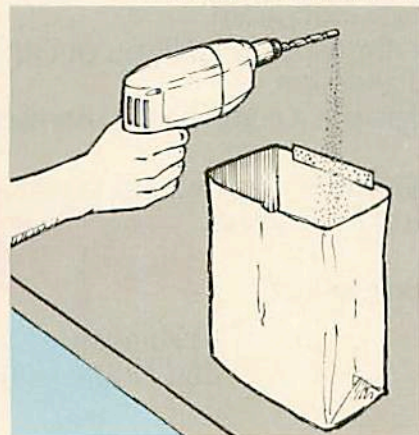

## GIVE THROWAWAY PAINT BRUSHES A SECOND LIFE

*No one enjoys wasting material, but it seems a shame to throw out any part of those disposable foam brushes, even though they are relatively inexpensive to buy.*

**TIP:** Get more than your money's worth from these brushes by recycling the plastic handles for such uses as paddles for spreading glue and stirring such materials as putty and epoxy glue. Strip off the foam and reshape the handles on a belt sander if necessary for the task you decide to give it.

—Ken Thompson, Sheridan, Ill.

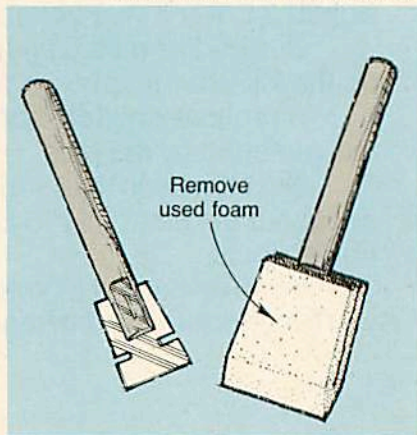

Continued on page 16



New VISE-GRIP® Locking Bar Clamps



## THINK ALL BAR CLAMPS ARE THE SAME? THINK AGAIN.

Not all bar clamps are created equal. There's only one VISE-GRIP® Locking Bar Clamp. Conventional bar clamps just don't compare. For ease of use, speed, versatility, and most important, long lasting quality. VISE-GRIP Locking Bar Clamps adjust in seconds. Lock tight and release in a snap. Unique self-leveling swivel pads protect work. VISE-GRIP Locking Bar Clamps bring even big jobs down to size.

Choose from two sizes - 10" bar or the even larger 18" bar for extra-long reach and versatility. Available with regular tips or swivel pads.

Extend your clamping capabilities with VISE-GRIP Locking Bar Clamps. Because not all bar clamps are created equal.

**VISE-GRIP THE ONLY NAME YOU NEED TO KNOW IN LOCKING HAND TOOLS.**

© 1988 Peterson Manufacturing Company, Inc. Lincoln, Nebraska 68508 - U.S. and Foreign Patents Applied For

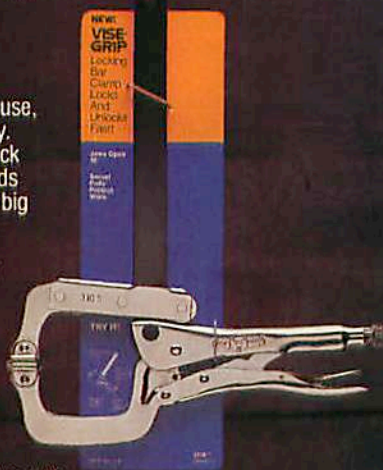

## TIPS FROM YOUR SHOP (AND OURS)

Continued from page 14

### A TWO-FACED HELPER YOU'LL APPRECIATE

It's an excellent idea to do a trial fitting of the parts of a project before tackling the permanent assembly and applying finish. A major problem with this practice is holding everything in place so later you can easily take the pieces apart.

**TIP:** Double-faced cellophane tape provides adequate gripping for this job and generally is easy to remove. If some of the stickiness remains after the trial assembly, wipe it away with a cloth dampened with a solvent such as acetone or lighter fluid. **CAUTION:** First wipe a piece of scrap wood to make sure the cleanup material doesn't stain the wood.

—Russell Grinolds, Owatonna, Minn.

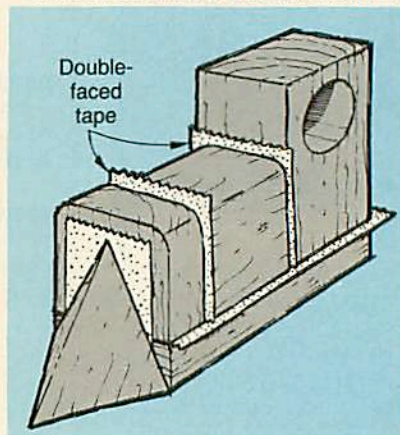

### IN-THE-GROOVE SANDING

Sanding often wears away fine grooves in wood instead of making them look more attractive.

**TIP:** When you want to retain or define a sharp line or edge while sanding V-grooves in a project, wrap your sandpaper over the edge of a cabinet scraper. Sand one side first, as shown, and then the opposite side.

—From the WOOD® magazine shop



Continued on page 18

## Quality EXOTIC WOOD TURNERS

Burls / Thick Planks / for Bowls / Squares

### CABINET MAKERS

Individually Selected Lumber for Furniture / Boxes / Inlays  
OVER 70 SPECIES

All Inquiries Welcome - Call or Write

**The Berea Hard Woods Co.**

125 JACQUELINE DRIVE, DEPT. 10  
BEREA, OHIO 44017  
216-243-4452

"It's a Matter of Pride for Both of Us"

## CREATE A FAMILY TREASURE WITH KUEMPEL CHIME Red-i-Kut Kits



Each case is carefully handcrafted by grandfathers in 3/4" walnut cherry or oak. Precision West German movements, handcrafted pendulums, and individually handpainted moonwheels.

Write or Call for Catalog \$2  
1-800-328-6445  
Kuempel Chime

Dept. 018  
21195 Minnetonka Blvd.  
Excelsior, MN 55331  
Serving clockmakers for 65 years.

# "Jorgensen"<sup>®</sup> AND "Pony"<sup>®</sup>

## CLAMPS

Dependable extra hands for all types of clamping and work-holding jobs:  
Woodworking Projects, Home Maintenance, and Furniture Repair.

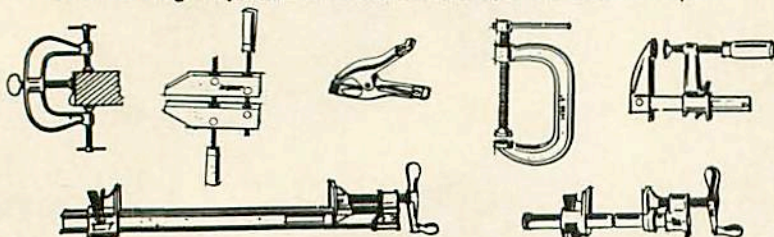

Write for FREE LITERATURE.

For big 32-page "how-to-clamp-it" catalog, send \$1.00.

ASK YOUR DEALER

**ADJUSTABLE CLAMP COMPANY**

THE CLAMP FOLKS

410 N. Ashland Avenue • Chicago, IL 60622

## TIPS FROM YOUR SHOP (AND OURS)

Continued from page 16

### HERE'S JUST THE THING FOR TIDY TRACINGS

Using conventional tracing paper to transfer markings for wood burning, carving, or outlining often creates a mess, leaving ugly lines and smears you don't want on the stock.

**TIP:** Graphite paper makes great stuff for these kinds of tracings. Graphite paper is neat and its marks erase easily, but it's not usually stocked by hardware or office-supply stores. Check hobby shops and stores selling drafting supplies. Seral is one brand name of graphite paper you may ask for.

—Sara Jane Treinen,  
Des Moines, Iowa

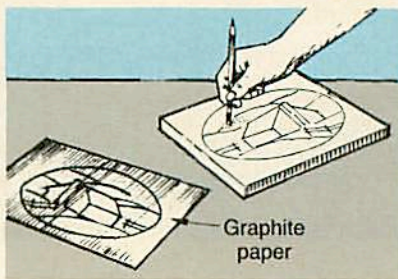

Graphite paper

### CLEVER STORAGE BINS FROM ORDINARY TINS

You could buy all sorts of storage units to bring order to fasteners and repair parts, but you don't get around to it.

**TIP:** Make handy bins from rectangular metal cans used for packaging liquid products such as paint thinner and camp-stove fuel. Lay an empty can on its side. At each corner, drill holes 1/2" from the sides, making the holes large enough to accept tin-snip blades. Cut out the rectangle formed by the holes and fold over the resulting sharp edges by hammering.

—Dave Wilson, Aberdeen, Wash.

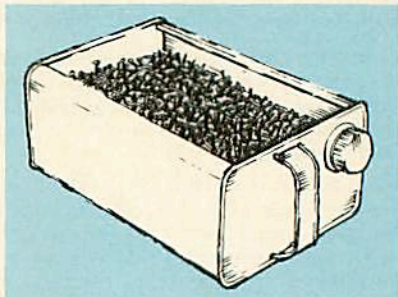

Continued on page 20



**A Cut Above  
Lesser Saw Fences...**

**The  
Excalibur  
T-Slot  
Saw Fence**

When choosing investments, cheaper isn't better... better is better!

**RATED #1 BY FINE WOODWORKING<sup>®</sup> JAN. 1988**

**...and there's a good reason why**

Like any other precision tool, a saw fence is an investment. And when it comes to choosing investments, cheaper isn't better. Better is better. So T-Slot owners rightfully count themselves among the ranks of perfectionists who have high standards and are willing to pay a bit more to maintain them. A better saw fence...and a more accurate one. The Excalibur T-Slot saw fence will convert your table saw into a precision wood-cutting machine.

- ✓ Quick installation on General, Rockwell/Delta, Powermatic, Craftsman and most other saws
- ✓ The necessity of always having to measure from the saw blade to the fence has been eliminated

- ✓ Ripping of large stock is quickly accomplished
- ✓ Built-in scale and adjustable half-headline cursor for precise cuts every time
- ✓ Manufactured from high-quality materials

- ✓ Positive front and rear rail locking
- ✓ Easy parallelism adjustment
- ✓ Efficient reassembly for ripping to right or left of saw blade — plus many more exciting features, including the Ultimate Guarantee.

**EXCALIBUR MACHINE & TOOL COMPANY**

U.S.A.  
210 Eighth St. South  
Lewiston, NY 14092  
Toll Free: 1-800-387-9789

CANADA  
3241 Kennedy Rd., #7  
Scarborough, Ont. M1V 2J9  
(416) 291-8190

For the name of your nearest Dealer, please Phone 1-800-387-9789

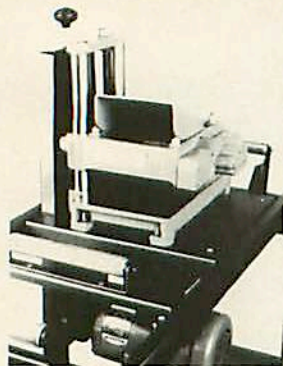

# ANYTIME ANYWHERE ANYWOOD

## mold plane and edge

Professionals and hobbyists alike know the strengths of the W&H molder-planer. Superior US-made construction and quick two-minute cutter changes make it a snap to cut moldings and plane hardwoods. It's fast, easy, and super-smooth.

Picture frames. Crown moldings. Raised panels. And more. Our three models offer the best value in your shop or on the job site!

Our five-year warranty and free 30-day trial are your assurance that W&H goes the distance.

Mail this ad or call us toll-free today.

1-800-258-1380 In NH 603-654-6828

Williams & Hussey Elm Street Dept. 238EM  
P.O. Box 1149, Wilton, NH 03086



YES! Send your free information kit today.

Name \_\_\_\_\_

Address \_\_\_\_\_

City \_\_\_\_\_ State \_\_\_\_\_ Zip \_\_\_\_\_

- I am a professional  I am a hobbyist  
 I am also interested in your 12" lathe

## TIPS FROM YOUR SHOP (AND OURS)

Continued from page 18

### HELP FOR SANDING MIDGET PARTS

Attempting to use a vertical belt sander on miniature parts is difficult—and even dangerous—because of the comparatively wide gap between the edge of the sander's table and the abrasive surface of the belt.

**TIP:** Clamp an auxiliary top of 1" wood stock or plywood onto the existing table, leaving zero clearance between the sanding belt and the new working surface. This will provide a safe, stable support for those little wooden parts as you sand them.

—From the WOOD® magazine shop

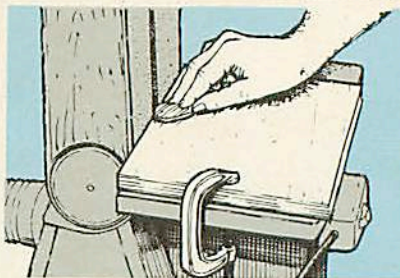

NEW  
"Quad-Drive"

# DRUM SANDER

with Infinitely Variable Power Feed!



At last! A complete power-feed Drum Sander at an affordable price! Choose from 12" and 26" models SAVES TIME...IMPROVES RESULTS. Use this high-tolerance machine for light dimensioning as well as the finest finish work.

Now you can add new beauty to each woodworking project, save hours of tedious hand sanding! In a matter of seconds you can produce a satin-smooth finish impossible to duplicate with hand methods or hand-held power sanders...no more low spots, waves or cross-grain marks! Check these advantages...

#### FREE FACTS!

Send for complete facts on how you can try this low-cost tool in your own shop for one full month without risk. See how the sander can dimension and finish-sand cabinet pieces, resawn stock, paneling, toys, tabletops, knees, burls, crotches and much, much more! You'll soon find it's one of the most valuable tools in your shop! Made in U.S.A. Easy Terms.

Call Toll-Free 1(800) 538-4200, Ext. 2424



**YES!** Please rush my FREE INFORMATION KIT and details on your 30-Day Free Trial Guarantee.

Woodmaster Tools, Dept. RW24,  
2908 Oak, Kansas City, MO 64108

NAME \_\_\_\_\_

ADDRESS \_\_\_\_\_

CITY \_\_\_\_\_ STATE \_\_\_\_\_ ZIP \_\_\_\_\_

**NEW INFINITELY VARIABLE FEED RATE** gives you total control in any sanding situation!

**EXCLUSIVE QUAD-DRIVE FEED SYSTEM** ...four, power-feed rollers for maximum traction. Eliminates oversanding at first and last few inches of a board!

**NEW FELT-BACKED ABRASIVE** mounts in just seconds to Velcro covered drum. The harder you sand, the tighter it stays! Eliminates stretching...allows fast removal and re-use!

### COOLING EAGER EPOXY

Sometimes epoxy cement begins to set up before you're through using a batch. This is most likely to be a problem when you're working in a warm place or during hot weather.

**TIP:** Extend the set-up time of epoxy by keeping it cool. One successful way to do this is to mix the ingredients in the recess in the bottom of a chilled can of soft drink. When finished gluing, return the pop to the refrigerator or open it and have a cool one.

—Rich Webb, Grand Island, Neb.



**ALL-ENCOMPASSING YARDSTICK**

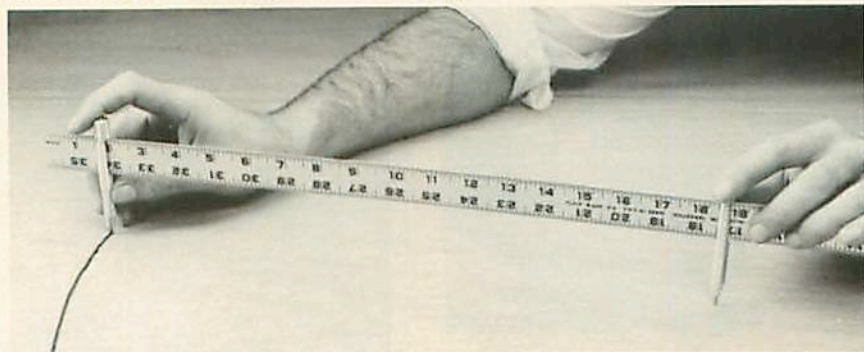

Sometimes, laying out a project involves drawing large circles or arches. When it does, the job dwarfs compasses. And who trusts a string-and-pencil rig?

The Griffhold Yardstick Compass saves you the trouble. Its trammel points attach to a yardstick, turning it into an inflexible radial arm. Just slip the two trammel points onto any yardstick, read off the distance between them, and that is your

radius. For circles or arches with a radius of more than 36 inches, cut a piece of wood the same width and depth of a yardstick.

A word of caution: the aluminum trammels are relatively fragile.

*Griffhold Yardstick Compass by Griffin Manufacturing Co., (catalog no. 06A51) \$4.95 ppd. from Woodcraft Supply Corp., 41 Atlantic Ave. Box 4000, Woburn, MA 01888.*

**FAST-CUTTING SAND BLOCK**

Here is a sanding block that won't clog even while cutting through end grain because of a Swedish-made hardened steel surface that resists buildup. Our test crew agreed with the manufacturer's claim that the Sandplate works five times faster than regular sandpaper. The manufacturer claims the Sandplate lasts 100 times longer than sandpaper.



*Sandvik's Sandplate abradar with fine sheet (cat. no. M4510), \$6.45 ppd. from The Woodworkers' Store, 21801 Industrial Boulevard, Rogers, MN 55374. Fine or coarse sheets available for \$2.50.*

*Continued on page 24*

# ONLY THE PIRANHA<sup>®</sup> BLADE DESERVES THESE CUTTING REMARKS.

THE PIRANHA<sup>®</sup> BLADE'S UNIQUE CURVED CARBIDE TEETH SLICE THROUGH WOOD FOR SMOOTHER, FASTER CUTS THAN CONVENTIONAL CARBIDE BLADES.

CONVENTIONAL BLOCK SHAPED CARBIDE TOOTH

The Black & Decker Piranha<sup>®</sup> Carbide Tooth Saw Blade outperforms both conventional carbide and steel blades. The Piranha<sup>®</sup> Blade lasts up to fifty times longer than steel blades and it's resharpenable. It's also available in sizes from 5½"–10" to fit all brands of saws. And that adds up to one very remarkable saw blade.

The Piranha<sup>®</sup> Blade. Only from Black & Decker.

THE PIRANHA<sup>®</sup> BLADE'S "FISH HOOK" GULLET REMOVES CHIPS FAST, REDUCES DRAG, AND MAKES CUTTING EASIER.



**Piranha**  
Carbide Tooth Saw Blade





## It can do so much, it's almost unfair to call it a sander.

The new Delta 1" Belt Sander is so handy that there's almost no end to what you can do with it. And at only \$69.95, just think what a great addition it'd make to your shop.

You can use it to sand, grind, deburr, contour, sharpen, buff, or polish just about any material. It uses standard 1" x 30" abrasive belts. And there's a power take-off for mounting an accessory flexible shaft with attachments that can do dozens of extra jobs.

In fact, our new 1" Belt Sander does so many things so well, you may wonder how you ever got along without it. Call toll-free for the name of your Delta Dealer. Delta International Machinery Corp., 800/438-2486 (in PA, 800/438-2487).

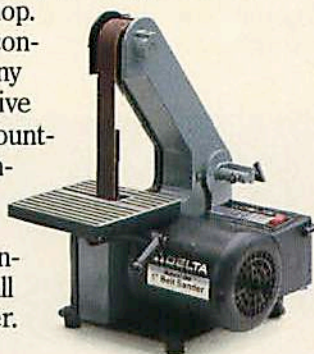

**DELTA**  
Building On Tradition

## PRODUCTS THAT PERFORM

Continued from page 23

### A GRIPPING IDEA

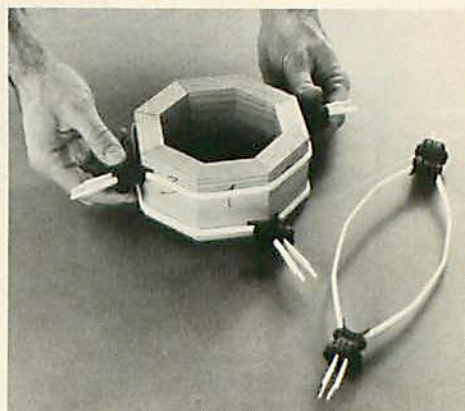

Having the right clamp—or combination of clamps—for a specific job can tie up a small fortune in the workshop. And building a multi-sided project, as the bowl project shown on page 36, particularly frustrates a lot of woodworkers.

One high-tech solution for this low-tech problem is Multi-Clamp, a 14" nylon strap that developed as an odd-job helper. Suggested uses range from loosening jar lids to clamping car hoses to tying up tree saplings. But we like it best as a woodworking clamp.

The 200 pounds of pressure derived by hand sufficiently tightens the acetal nut for most home projects. We feel most projects require two or more of the inexpensive straps. Additionally, the more straps you add, the more points there are from which you can apply pressure. Our woodworkers found two straps ideal for clamping octagons and hexagons with 6" diameters. The clamp's design makes it easy to lengthen any straps.

We found other shop uses for these clamps. Try ganging several together to assemble picture frames. Or before sanding an irregular piece of wood, use the clamps to secure the piece to a saw horse.

*MosSmith Industries Multi-Clamp; about \$1.70 at hardware stores nationwide; also available from some mail-order catalogs. Order 12 direct for \$24 ppd. from MosSmith Industries, 6065 Mission Gorge Road, Suite No. 46, San Diego, CA 92120.*

**HORTON BRASSES**  
Nooks Hill Road, P.O. Box 120J  
Cromwell, CT 06416 (203) 635-4400

**HORTON BRASSES** are authentic  
copies of 17th, 18th, 19th & early  
20th century pulls

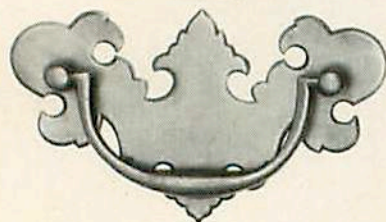

Mfrs. of Cabinet & Furniture  
Hardware for Homes & Antiques.  
Send \$3.00 for a Catalogue.

## MAKE TOYS AND WHIRLIGIGS

100's of plans, parts, kits, books, finishes & supplies for toys, whirligigs, classic autos, swing sets, doll houses, crafts & furniture. Also toy, craft, game & furniture parts in maple, oak, walnut & cherry. Bulk prices available. 54 page color catalog subscription \$1. (614) 484-4363  
Cherry Tree Toys, Box 369-409, Belmont, Ohio 43718

**WOOD CHOPPER**  
21" long  
Uncut Kit: \$24.95  
Just cut, sand and assemble



Pre-cut Kit: \$29.95  
Just sand and assemble

## BRUSHES THAT DON'T BADGER



Three types of animal hair combine to make Dunnet's Badger X Double brush, *above left*, an excellent tool for applying stain, shellac, and varnish. The combination of badger hair (not quite as fine as premium-quality hog bristles), skunk, and hog creates a good "cutter" that paints a clean line. Though of moderate thickness, the 1" brush we tried held an adequate amount of varnish. You may use this brush with latex finishes.

Lorient's Chisel White Bristle varnish brush, *above right*, offers an equally handsome and somewhat less-expensive alternative. White hog bristles provide excellent flow and minimum brush marks. The 2" model we tried also had excellent cutting ability and produced a sharp chisel. Because it's designed primarily for applying varnish and lacquer to top-quality cabinets and furniture, the Lorient shouldn't be used with water-based paints.

Both brushes have black lacquered wood handles with capped ferrules. Both lack a hole in the handle for hanging—something easily remedied. The Lorient model in particular should be wrapped in paper after cleaning to prevent bristles from breaking in storage.

*The 1" Dunnet Badger X Double brush, No. B901-40021, \$11.40; the 2" Lorient Chisel White Bristle brush, No. B901-20163, \$11.62 from Wood Finishing Supply Co. Inc., 1267 Mary Drive, Macedon, NY 14502. Add \$2 for shipping with each order.*

Continued on page 26

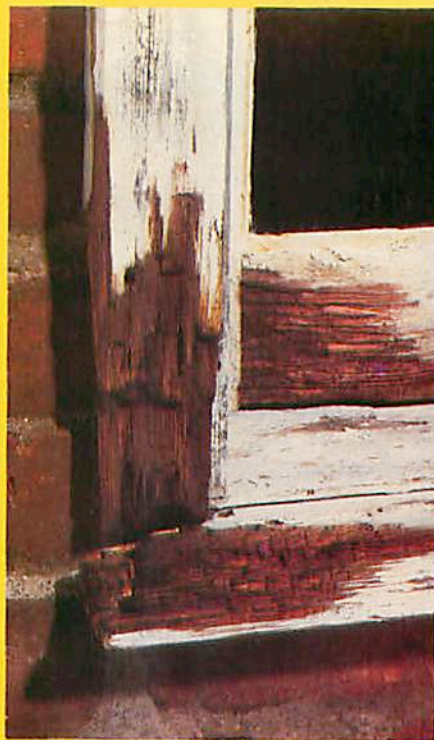

## \$300 to replace. \$10 to repair.

Now there's a wood filler for the big jobs, indoors or out. High Performance Wood Filler by Minwax. It won't shrink, crack or fall out. It hardens in 15 minutes and can be sanded, planed, drilled, painted or stained.

If the wood is soft because of rot, prepare a rock-solid base with High Performance Wood Hardener.

Send today for our free 30-page booklet, *Tips on Wood Finishing*. Minwax Company, Inc., Dept. WO-058 P.O. Box 426, Little Falls, NJ 07424.



### High Performance Wood Filler



## FULL SIZE WOODCRAFT PATTERNS

**SIMPLE TO MAKE • FUN • PROFITABLE**

- 200 pattern packet for scroll, band & jigsaws
- "Country Critters"-100 patterns, unique projects
- 6 enjoyable "Wind-Action" whirligigs
- "Country Classics" - best selling country projects
- 100 yard ornaments, animals, birds and more
- 17 "Show Stoppers" - craft show best sellers

Send \$7.00 per blueprint packet or choose any 3 FOR ONLY \$14.00.

Fast Service • Satisfaction Guaranteed!

**ACCENTS** Dept. MA58, Box 7387, Gonic, NH 03867

Catalog of 1000 patterns - \$1.00 (Free with order)

## EDLCO

Appalachian Hardwood Specialists

21 species

Domestic Hardwoods  
Softwoods

Kiln Dried Delivered Prices  
Catalogue \$2.00

Write Today EDLCO  
Box 5373 W  
Asheville, N.C. 28813  
Phone (704) 255-8765

**We Know Our Lumber**

**EDUCATIONAL LUMBER CO., INC.**

# HOBBY WORKHORSE



Whether your hobby is building planes, trains, automobiles or hobbyhorses, you need the right tool for the job.

The Dremel Moto-Tool® is a hobby workhorse that works wonders. It shapes cherry wood into lifelike wildlife. Cuts off model railroad tracks at the end of the line. Sands balsa wood smooth enough to really take wing. And buffs an old iron horse to a showcase shine.

The Moto-Tool lets you get more satisfaction and enjoyment out of your hobby by putting more precision and control into it.

With speeds up to 30,000 RPM, the Moto-Tool gives you the "horsepower" to cut, grind, sand, drill and polish with pinpoint accuracy. And its lightweight housing makes hours of work seem effortless.

See the Moto-Tool at your hobby, craft or hardware dealer. And put a little more horsepower into your hobby.



## PRODUCTS THAT PERFORM

Continued from page 25

### A BOLD BIT

A specially designed point on Black & Decker's new Bullet Pilot Point drill bit keeps it from "walking" on wood and reduces splintering.

The point eliminates the need for center-punch starts, and the flute produces a cleaner hole.

Black & Decker touts the bit boring through metal four times faster and lasting 14 times longer than standard twist bits. In our tests, the



bit lived up to its aggressive billing. When drilling at low RPM, it compares favorably with brad-point bits. In a power hand drill, the weight of the drill provided enough pressure to push a  $\frac{3}{8}$ " bit through oak. If anything, the bit may be a tad too bold because it grabbed slightly.

*Black & Decker Bullet Pilot Point drill bits; \$3.49 suggested retail for a  $\frac{1}{4}$ " bit at hardware stores nationwide.*

### THE CUTTING EDGES

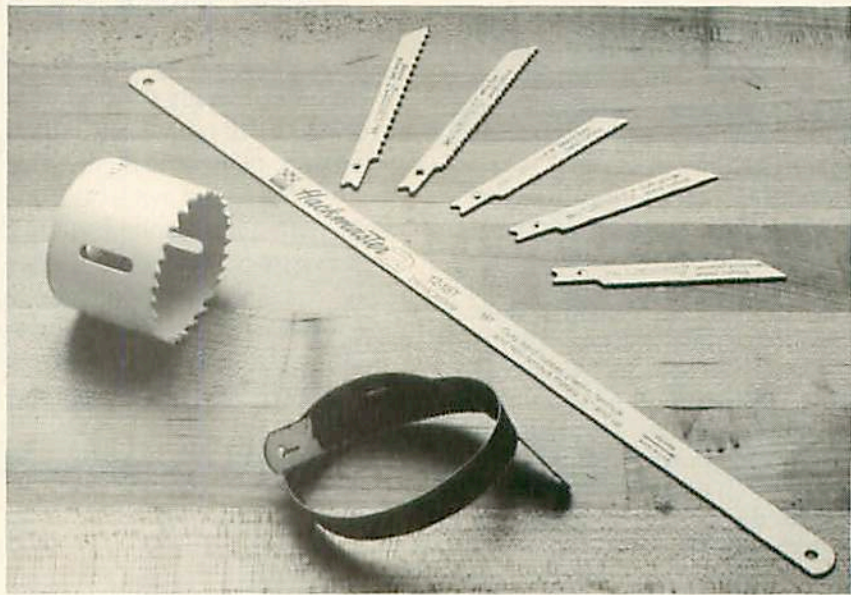

Tying a hacksaw blade in a knot serves no useful purpose, except to demonstrate the flexibility of Lenox's Hackmaster 2 blade. The bi-metal construction—a spring steel back joined by an electron-beam weld to a steel edge—accounts for the unusual flexibility, but it's the hard, long-lasting edge that makes the blade worth paying extra money at the cash register.

Because of this rugged manufacturing technique, tradesmen rely on Lenox's bimetal construction to

cut through tough building materials. And, the saber-tooth saw blades are less likely to break because of spring-steel backing. The hole saw incorporates the same manufacturing methods.

*Lenox saw blades; available at hardware stores nationwide; suggested retail prices: Hackmaster 2 hacksaw blade, \$1.30; five-pack assortment of saber-saw blades, \$8.60; 2" hole saw, \$9.60. Also available at some plumbing- and electrical-supply houses.*

Until the 1920s, few woodworkers had ever even seen a sweet gum board. Although sweet gum trees grew from Texas to Connecticut, little of the wood became lumber because of uncontrollable warping problems during seasoning.

When lumbermen finally discovered that sweet gum boards had to be either heartwood or sapwood—never containing both—for satisfactory drying, production boomed. By the 1930s, sweet gum climbed from commercial obscurity to a rank of seventh in hardwood usage.

Then, with the advent of World War II, most of the commercial walnut supply went to war as gunstocks. Only the wealthy could afford furniture made from the scant walnut remaining. So sweet gum stepped in as “poor man’s walnut.” Stained, the figured wood made a superb walnut imitation in economically priced furniture and radio cabinets. Sweet gum was even introduced to Europe as “satin walnut,” and many board feet still sail in annual export.

In contrast to the come-from-behind popularity of sweet gum wood, sweet gum sap has always boasted a reputation. It has a delicate fragrance that at one time was extracted for scenting ladies’ gloves. The sap also acts as an antiseptic for surface wounds, and a modern extraction, liquid storax, becomes an ingredient of styrene plastic.

## SWEET GUM

### The stock that stepped in when walnut went to war



Sweet gum heartwood

Sweet gum sapwood

#### Wood identification

Frequently called red gum because of its brightly colored fall foliage, sweet gum (*Liquidambar styraciflua*) tints autumn from southern Connecticut to Florida and as far west as Texas, Oklahoma, and southeast Missouri. In rich, moist soil, the tree grows to heights of 120' and diameters of 36".

The dark-gray, deeply furrowed bark on the main trunk of sweet gum trees often measures 1" thick. Limbs tend to have broken-patterned, wart-like bark resembling alligator skin.

Often heavily figured by streaks of darker shades, sweet gum's

reddish-brown heartwood has a satiny appearance. Sapwood, marketed separately, ranges from a light pink to a pearl white, and seldom contains figure.

#### Working properties

Weighing slightly less than walnut, sweet gum heartwood has an interlocking, close grain. And, it rates nearly as hard, stiff, and strong as walnut. Sapwood, however, doesn't come comparably close on these points.

The wood's grain demands that you use sharp hand or power tools to reduce tearing the fibers. Keeping that in mind, you'll find sweet gum—especially the sap-

wood—excellent for turning. And all sweet gum holds nails and screws well without splitting. However, before gluing heartwood, you should always wipe surfaces with alcohol.

Sweet gum takes stain evenly, and you can bring any finish to a beautiful luster with little effort. In fact, sweet gum heartwood's naturally attractive grain makes it look like an expensive cabinet wood.

#### Uses in woodworking

Use sweet gum sapwood for turned objects, treenware, and the hidden parts of furniture. You can work heartwood into furniture, cabinets, and interior trim. The wood's fragrance makes it a pleasant choice for the sides and bottoms of lingerie and linen drawers.

#### Cost and availability

Except for 3x3" turning stock, you'll rarely find sweet gum sapwood sold in the western states. Shipping costs prove prohibitive for this inexpensive wood. Heartwood, in both lumber and veneer, sells at retail throughout the U.S.

Board-foot prices for heartwood range between \$2 and \$3, compared to walnut at about \$4. Veneer costs about \$1 per foot. Sapwood, available only in lumber, costs less.

The highly figured heartwood of sweet gum becomes plywood and architectural panels. These products command top-dollar prices. ●

Photographs: Bob Calmer  
Illustration: Steve Schindler



# BASIC STAVE-BOWL

CREATE BEAUTIFULLY FIGURED BOWLS WITH THIS



**A**long the eastern seaboard during the early years of American colonization, stave construction played an important role in commerce. In order to transport goods safely (and dryly) from the colonies to their trading partners across the ocean, merchants hired thousands of craftsmen to fashion wood containers and vessels of all kinds.

Back then, if you had the skills necessary to make watertight vessels, containers, or barrels to hold expensive dry goods, spices, or even spirits such as rum and whiskey, work was always available.

With the passage of time, though, along came the introduction of other packaging materials and labor-saving machinery to manufacture them. And with these improvements came the demise of *coopering*, the trade devoted to shaping wooden staves into barrels, buckets, churns, and other such utilitarian items.

The tradition lives on, though, in some of the living history museums around the country and through the skills of some home woodworkers. Read on and we'll tell you what we have learned about stave construction—a truly fascinating woodworking technique—here in the *WOOD* magazine shop.

And if you get as excited about what you learn as we did, you'll want to take a look at pages 36 and 38. There you'll find a couple of great-looking bowls Design Editor Jim Downing dreamed up for you. Bet you can't resist building one or both of them!



## ANATOMY OF A STAVE BOWL

Anyone who has ever sectioned an orange can appreciate the theory behind stave construction. Each *stave*, or section, when cut to the correct *bevel*, fits neatly next to adjacent pieces. And once you join them together, they form a multi-sided ring that, when turned, becomes the bowl's wall.

As you can see from the anatomy sketch at *right*, a stave's grain direction can run either horizontally or vertically. The latter makes slightly stronger bowls because the staves come together edge grain to edge grain. And you can use either  $\frac{3}{4}$ " or  $1\frac{1}{16}$ " stock for your bowl. The more sides the project has, the thinner the stock can be.

The bottom of the bowl, typically  $\frac{3}{8}$ "- to  $\frac{1}{2}$ "-thick solid stock, fits into a  $\frac{1}{8}$ "- to  $\frac{1}{4}$ "-wide rabbet you cut

# CONSTRUCTION



CENTURIES-OLD TECHNIQUE—WE SHOW YOU HOW!

## THE STAVE ADVANTAGE

Let's face it! If you wanted, you could find several easier, less time-consuming ways to make a bowl. So why do serious craftsmen and home hobbyist woodworkers go to such lengths to cut, join, and turn these multisided creations?

Several reasons, actually. First and foremost, stave construction allows you to create relatively large-diameter bowls using a minimum amount of material. Second, because you arrange and join the staves (short sections of wood) end grain to end grain or edge grain to edge grain, the finished project displays only beautiful face grain.

Stave bowls also turn smoothly on the lathe and tend not to suffer from grain tearout during turning. Add to these advantages the design flexibility you have with stave construction, and it's easy to see why this technique fascinates woodworkers who take the time to learn it.

## PROJECT PLANNING TIPS

Start by giving some thought to what function you want the bowl to serve as well as to its diameter and height. Next, decide the number of segments you want your bowl to have. Then, simply refer to the chart below as a guideline:

Diameter of Bowl	Min. No. of Staves
6" or less	8
7"	10
8-12"	12

Once you've determined the number of staves needed, simply refer to the chart at *right*. It tells you how long to cut each stave.

And to find out the maximum wall thickness you have to work with on your particular bowl, see the other chart at *right*. Keep in mind that with  $\frac{3}{4}$ "-thick staves, you have less design flexibility than if you select  $1\frac{1}{16}$ " material.

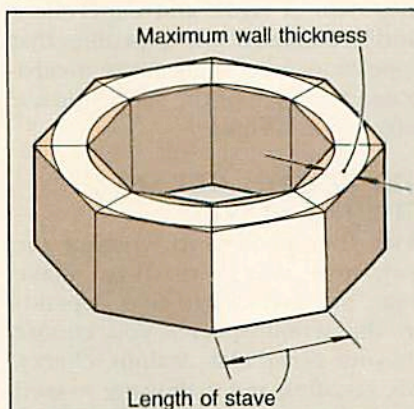

## LENGTH OF STAVE

Dia.	Number of Sides		
	8	10	12
4"	$1\frac{2}{32}$ "	$1\frac{5}{16}$ "	$1\frac{1}{16}$ "
5"	$2\frac{1}{16}$ "	$1\frac{5}{8}$ "	$1\frac{1}{32}$ "
6"	$2\frac{1}{2}$ "	$1\frac{15}{16}$ "	$1\frac{5}{8}$ "
7"	$2\frac{29}{32}$ "	$2\frac{1}{4}$ "	$1\frac{7}{8}$ "
8"	$3\frac{3}{16}$ "	$2\frac{17}{32}$ "	$2\frac{1}{8}$ "
9"	$3\frac{3}{4}$ "	$2\frac{15}{16}$ "	$2\frac{7}{16}$ "
10"	$4\frac{5}{32}$ "	$3\frac{1}{4}$ "	$2\frac{1}{16}$ "
11"	$4\frac{9}{16}$ "	$3\frac{9}{16}$ "	$2\frac{15}{16}$ "
12"	5"	$3\frac{29}{32}$ "	$3\frac{7}{32}$ "

## MAX. WALL THICKNESS\*

Dia.	Number of Sides		
	8	10	12
4"	$\frac{5}{8}$ "	$1\frac{1}{16}$ "	$\frac{45}{64}$ "
5"	$\frac{19}{32}$ "	$2\frac{1}{32}$ "	$1\frac{1}{16}$ "
6"	$\frac{9}{16}$ "	$\frac{5}{8}$ "	$\frac{43}{64}$ "
7"	$\frac{17}{32}$ "	$\frac{19}{32}$ "	$2\frac{1}{32}$ "
8"	$\frac{31}{64}$ "	$\frac{9}{16}$ "	$\frac{41}{64}$ "
9"	$2\frac{1}{64}$ "	$\frac{17}{32}$ "	$\frac{5}{8}$ "
10"	$\frac{3}{8}$ "	$\frac{1}{2}$ "	$\frac{39}{64}$ "
11"	$2\frac{1}{64}$ "	$\frac{31}{64}$ "	$1\frac{9}{32}$ "
12"	$\frac{5}{16}$ "	$1\frac{5}{32}$ "	$\frac{37}{64}$ "

\* $\frac{3}{4}$ " stock shown; add  $\frac{5}{16}$ " if you use  $1\frac{1}{16}$ " stock.

into the wall. How deep you cut the rabbet depends on the bowl design. If you want to conceal the base, cut the rabbet the full thickness of the bowl bottom. To accent the base, cut it  $\frac{1}{8}$ " or so shallower.

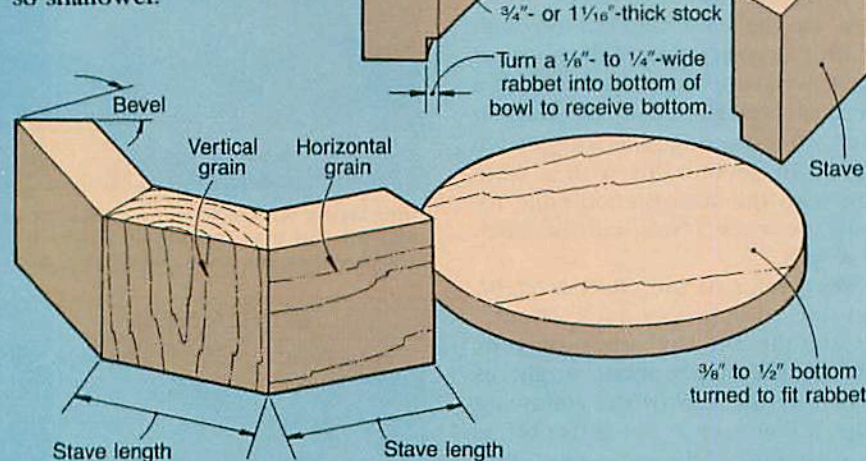

Continued

# STAVE-BOWL CONSTRUCTION

Now that you know the maximum wall thickness, draw a full-size section view of the wall and bottom as shown at *right*, and experiment until you settle on a profile that appeals to you. Then, make a cardboard template of the shape for use later while turning.

## GET READY...GET SET... CUT THE STAVES

With the "book work" out of the way, now you're ready to make some sawdust. What kind depends on the wood species you choose for your bowl. Oak, walnut, cherry, ash, sassafras, and mahogany, as well as the exotic hardwoods, make beautiful staved bowls, but give your favorite wood a try as well.

No matter which wood you select, though, make sure that it has been kiln-dried or thoroughly air-dried. Otherwise, the bowl's joint lines almost certainly will pull apart and ruin your project. Also take care to choose flat and defect-free boards. And since you have to be precise when cutting staves, reject warped or cupped stock. As Project Builder Jim Boelling would say, "You want the eye of the steak."

### Prepare the Stock for Cutting

Start by selecting a grain direction for your bowl walls. If you're new to stave construction, you may want to go with vertically grained walls because they're stronger and easier to turn than horizontally grained ones. In addition, with the former, you won't have to worry as much about matching the grain from section to section.

If the grain will run vertically, use the following formulas to determine the length and width of board needed for your staves:

**Length** = Height of bowl × no. of sides + 30% for waste

**Width** = Length of one stave + 1/4"

If you elect to go with a horizontally grained bowl, figure the length and width this way:

**Length** = No. of staves × length of each + 30% for waste

**Width** = Height of bowl + 1/4"

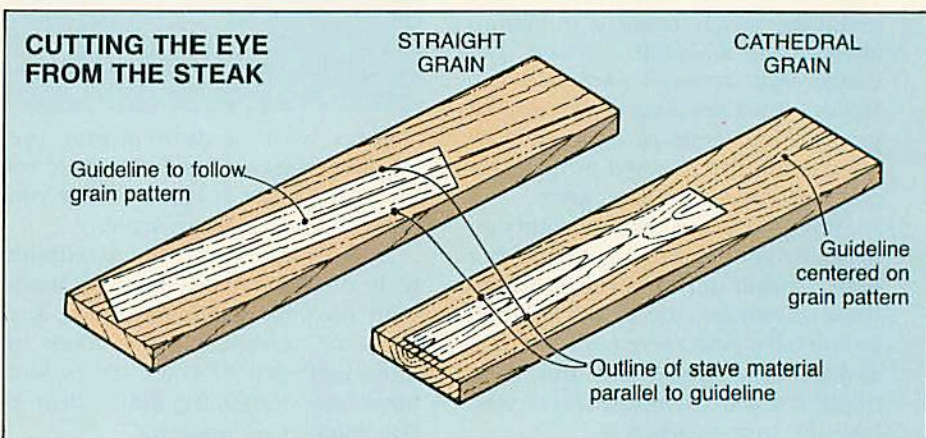
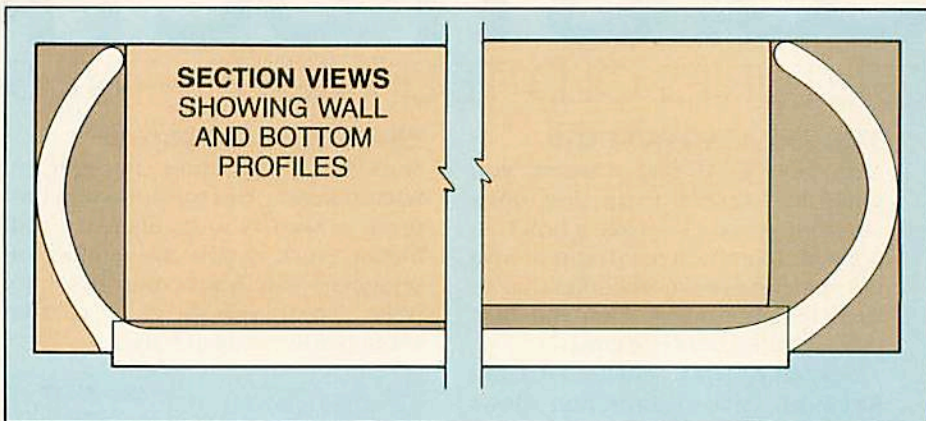

Now, draw the outline of the stave material onto a board as shown *above*. To ensure uniformity of grain pattern in the finished bowl, mark a guideline following the grain of the board. Then, complete the outline.

### Cutting the Staves to Size

First, rip the stave material to rough width. (As you can see in the photo at *right*, we made our first cut with a circular saw guided by a straight-edge. After one edge was straight, we made our second cut with a table saw, with the straightened edge toward the fence.) Now, cut the stock to length.

Next, refer to the chart at *right*, and select the proper angle of cut.

Carefully tilt the arbor of your saw to the appropriate angle as shown at the top of the following page. If you have as much trouble as we do being precise in your settings, you'll appreciate knowing about an

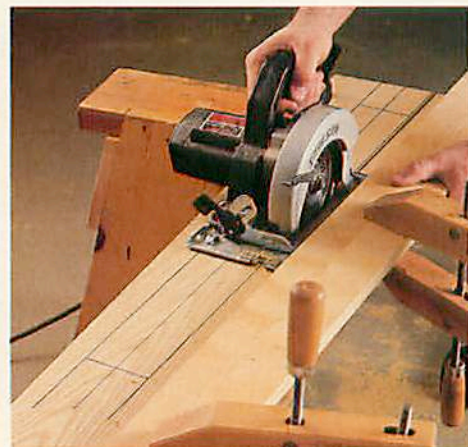

After laying out the location of the stave material, cut it to length and width. We straightened one edge with a circular saw.

STAVE ANGLES	
No. of Sides	Cut Angle
8	22.5°
10	18°
12	15°



With an adjustable triangle, set the blade angle carefully.

adjustable triangle, a drafting tool we ran across at our local art supply store. You can't beat it for quickly setting accurate angles. See our Buying Guide for our source.

Even a small error in the blade angle can cause untold problems later when you glue up the staves. So always cut test staves and dry-clamp them as shown *below*. If the toes of the staves touch each other, decrease the angle of your blade a bit and cut new test staves. And if the heels touch, you need to increase the blade angle slightly.



Dry-clip the test staves to check for angle accuracy.

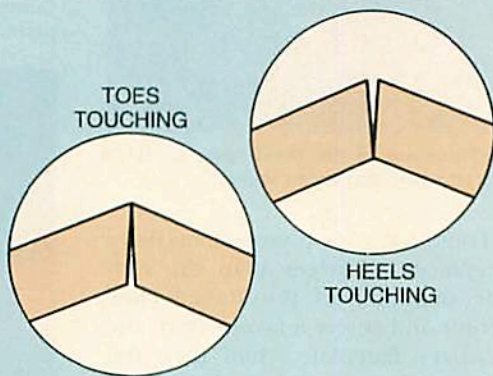

**Note:** Use a sharp saw blade when cutting staves. Otherwise, the joints won't fit together well.

Now, cut the staves to size. Here again, how you do this depends on the grain direction of the staves when glued up. If it will run vertically, rip the stave material to its final width as shown *below*; then reset the saw blade to cut at 90°, and crosscut the staves to length.

However, if the grain will run horizontally, follow this sequence: First, add an auxiliary fence to your saw's miter gauge. Then, raise the angled blade to cutting height, and pass the fence through the blade.

Now, mark a cutoff line on the auxiliary fence the correct distance from the inside edge of the saw blade (see sketch *below, left*). Make the first bevel cut at the end of the stock, then turn the board over, align it with the cutoff line, and make your second cut as shown *below*. Turn the board back over, trim off the end as shown in the bottom photo, and repeat this process for all the staves. Number each stave in the order it comes out of the stock.



For bowls with horizontal grain, make your first bevel-cut, mark a cutoff line on the auxiliary fence, flip the board over, and make the second cut.



Now, flip the board over again and make another cut to reestablish the bevel angle. Repeat this process.

For bowls whose sidewall grain will run vertically, bevel-rip the stave material to width. Then, crosscut each stave (at 90°) to length.

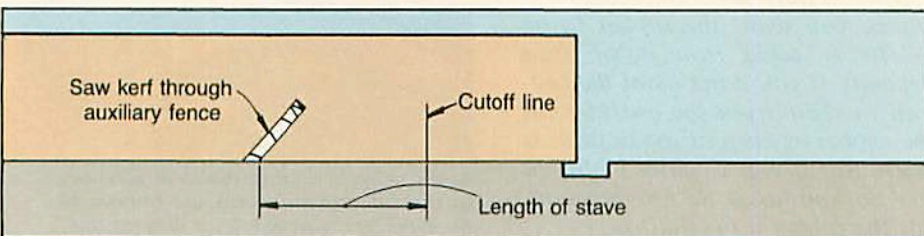

*Continued*

# STAVE-BOWL CONSTRUCTION

## GLUING UP THE STAVES

Even if you've worked carefully and made your cuts accurately, you may have to make some minor adjustments prior to glue-up to make the staves fit perfectly. To check your staves for a good fit, dry-clamp them together. If you detect any openness in the joints, note whether you've got a toe-to-toe problem or a heel-to-heel problem.

Then, remove one or more of the staves, and sand both ends slightly to correct the problem. We've had good luck making these microadjustments with a table saw fitted with a disc sanding attachment as shown *below*.



To make minor fitting adjustments, sand each end of one or two staves. Work carefully; it won't take much stock removal to make things right.

After you're satisfied with the fit of the staves, apply glue to both ends of each as shown *below*. Use band clamps to apply even pressure all around. Allow the glue to dry.



Apply glue to both end surfaces of each stave. Then, band-clamp, making sure the tops remain flush.

**Note:** Woodworker's glue works well in most situations, but we like 5-minute epoxy glue when we're in a hurry or when working exotic woods. Also, for maximum adhesion with exotics, wipe mating edges with alcohol before gluing.

## ROUGH-TURNING THE BOWL

To prepare the staved ring for turning, begin by truing up the top of it. We do ours by chucking a disc sander into our drill press, locking the height, and rotating the blank as shown *below*.

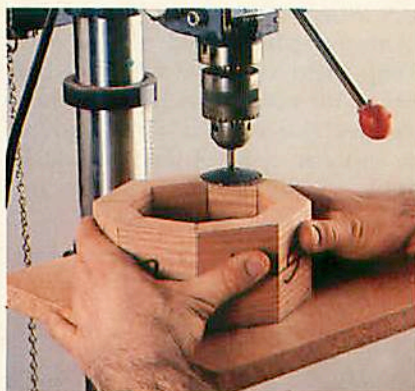

Sand the top of the bowl smooth. It's a breeze using the setup shown.

Then, cut a  $\frac{3}{4}$ " plywood auxiliary faceplate  $\frac{1}{2}$ " larger than the outside diameter of the staved ring. Center and screw a faceplate to the auxiliary faceplate, then turn the auxiliary faceplate to the outside diameter of the ring. Carefully center the bowl on the auxiliary faceplate, and glue and clamp the two together as shown in the photograph at the top of the next column.

Now comes the creative part! Turn the bowl round with a spindle gouge, using the slowest speed on your lathe. (We like to remove material slowly to reduce the chances of tearout.) Then, with a parting tool, true up the bottom of the bowl as shown at *right*.

Now, reposition your tool rest, and cut a rabbet into the bottom of the bowl with a parting tool (see photo at *right*).

**Note:** At the joint lines between staves, you want the rabbet to be  $\frac{1}{8}$ " to  $\frac{1}{4}$ " wide. How deep? That depends. If you don't want the bottom to show from the outside, cut the rabbet as deep as the bottom is thick. But if you'd rather highlight the bottom as a design element, cut the rabbet a bit shallower.

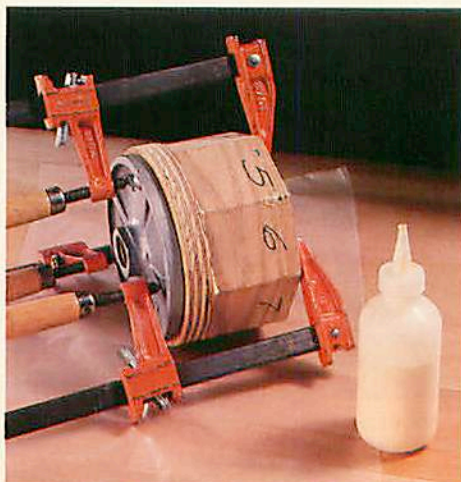

Center the bowl on the auxiliary faceplate, and clamp as shown.



After turning the bowl round with a spindle gouge, true up the bottom using a parting tool.



Again using a parting tool, cut a rabbet in the sidewall to accept the bottom of the bowl. See note at left for dimensions.



Periodically check for a snug-fitting bottom while turning.

## FITTING THE BOTTOM TO THE BOWL

After cutting the rabbet for the bottom, remove the faceplate from the auxiliary faceplate. Then, cut another auxiliary faceplate slightly larger than the inside diameter of the bowl. Attach it to the faceplate as you did before, and turn it round.

Cut a solid-wood bottom over-size (we usually use  $\frac{3}{4}$ "-thick material), and glue the centered auxiliary faceplate over the bowl bottom. Turn the bottom down to the thickness you want it (we like  $\frac{3}{8}$ "- to  $\frac{1}{2}$ "-thick bottoms).

Now, turn the bottom until it fits snugly into the rabbet you cut into the bowl. Inspect the bottom often during turning to check it for size as shown *above left*. Once you've got it right, glue the bottom into the rabbet, and let the glue dry.

### **Caution: Wood does move!**

*As you know, wood expands or contracts as dictated by existing conditions. We've talked to several woodworkers who specialize in stave bowls, and though they acknowledge this fact, they claim good results with solid-bottomed bowls. That's been our experience, too. Keep these things in mind, though. The thicker the bottom and the larger the bowl diameter; the greater pressure there will be on the bowl wall. Also, when applying finish to your project, be sure to cover all surfaces evenly, including the bottom, to minimize uneven stress.*

## FINAL TURNING AND FINISHING

Begin by parting off the auxiliary faceplate from the top of the bowl. Then, true up the top of the bowl, and turn the outside of the bowl to shape. Be sure to check the shape frequently with your template as shown at *left*.

When you finish turning the outside of the bowl, reposition your tool rest, and shape the bowl's interior. We found that the bowl



For turning the sidewall, we had good results using a bowl scraper, and we smoothed the bottom with a skew.

scraper shown *above* yielded good results on the wall and at the intersection of the bottom and the sidewall. For the bottom, we called on a skew.

From here on out, you finish stave bowls as you would any other turning project. We sand all surfaces with a succession of abrasive grits up to about 220, then chase away all the dust with a few blasts of air from our air compressor. After this, you can apply the finish of your choice on the lathe.

Now, separate the bowl from the auxiliary faceplate with a mallet and chisel. We made the split at the joint line of the ply closest to the bottom. (Be careful you don't let the bowl drop and break.)

Then, sand the plywood from the bottom on a stationary belt sander, and remove the resulting scratches with an electric sander.

Inscribe your name and the date on the bottom of the bowl, apply a little finish, and you have a one-of-a-kind bowl that you or the lucky recipient will treasure forever. Happy turning!

## BUYING GUIDE

- **6" adjustable triangle.** Available at art and drafting supply stores or for \$11 ppd. from Standardblue Artworld, 924 Grand Ave., Des Moines, IA 50309; 515/288-1927. ♣

Produced with James R. Downing and James E. Boelling  
Written by Larry Clayton  
Photographs: Bob Calmer  
Illustrations: Kim Downing, Bill Zaun

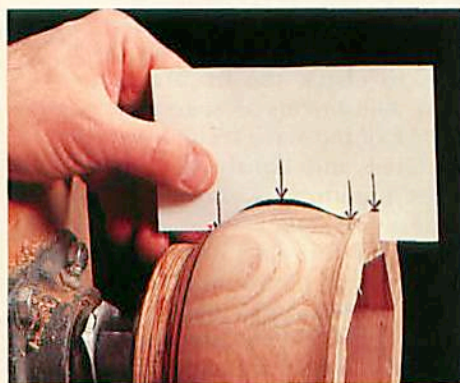

Work the outside of the bowl until it matches the shape of the template. Check the shape often with your template.

# A GALLERY-QUALITY QUILTED MAPLE BOWL

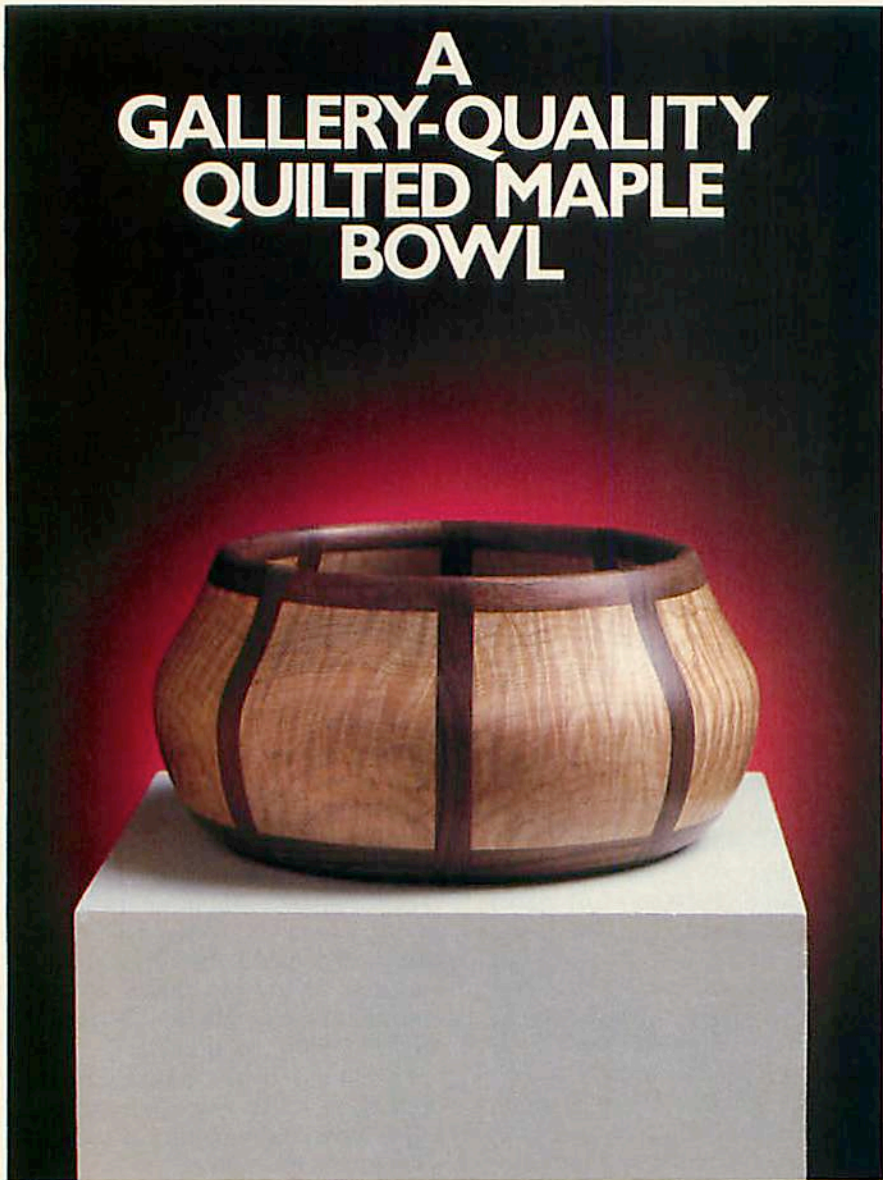

You'd expect to see a bowl of this quality in a gallery or similar showy setting. Truth is, you can proudly display this artistic creation in your home after just a few hours in the shop. And talk about a big return on your investment! We used less than \$4 worth of wood for a bowl that looks like a million bucks.

*Note: If you're new to wood-turning and/or stave construction, you'll want to refer to the Basic Stave-Bowl Construction technique article starting on page 30. It will provide you with the necessary background information needed to successfully complete this project.*

## CUTTING THE BOWL WALL PARTS TO SIZE

**1** Cut a piece of  $1\frac{1}{16}$ "-thick stock (we chose maple) to  $2 \times 24$ " long for the center section (A). Cut another couple of strips the same length from scrap stock. (You'll use them later to test-cut staves.)

**2** Now, cut the top and bottom walnut highlight strips (B) to  $\frac{1}{4} \times 1\frac{1}{16} \times 24$ " long. Glue and clamp the maple piece between the two walnut strips where shown on the drawing at *right*.

**3** For the inset strips (C), cut a piece of  $\frac{3}{4}$ " stock to  $1\frac{1}{8} \times 24$ " wide. Resaw it to  $\frac{1}{4}$ " thick, and cut eight  $2\frac{1}{2}$ "-long pieces from the  $\frac{1}{4}$ " strip.

**4** Tilt your saw blade  $22\frac{1}{2}^\circ$  from vertical center. Cut and dry-clamp eight test staves to check the fit of the joints. If they're not flush, adjust the blade angle, and repeat the process. Now, cut eight staves for the bowl ring (see the Bowl Ring Lamination Drawing for how these come out of the stave stock).

## GLUING THE STAVES

**1** Cut two pieces of plywood  $6$ " square each.

**2** Dry-clamp the staves and inset strips to check the fit. Make any minor adjustments as suggested on page 34 of the stave technique article. Glue and lightly clamp the pieces together as shown in the photo *above right*.

**3** Position the ring between the two pieces of plywood, being sure to put waxed paper between the ring and plywood pieces. Clamp the assembly together as shown at *right* to ensure flush tops and bottoms of the stave pieces. Tighten the clamp around the ring to pull the pieces firmly together. (See the review on

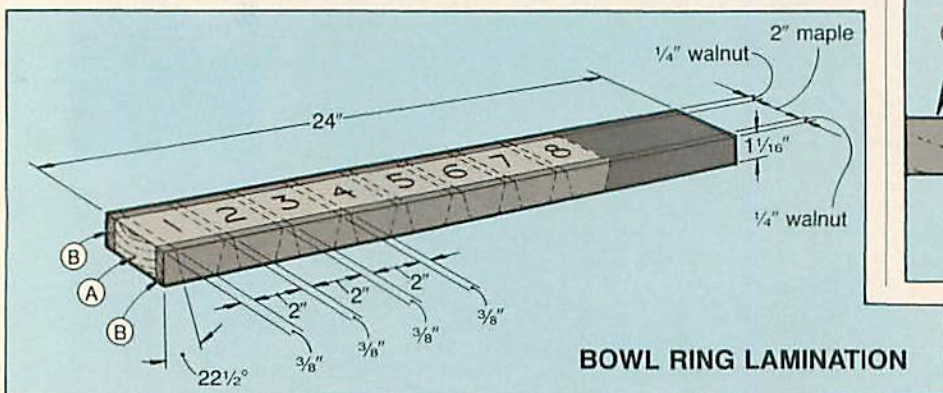
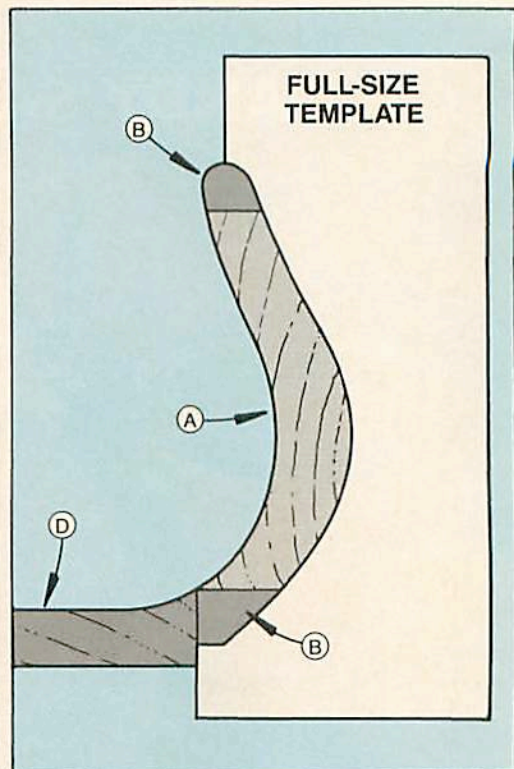
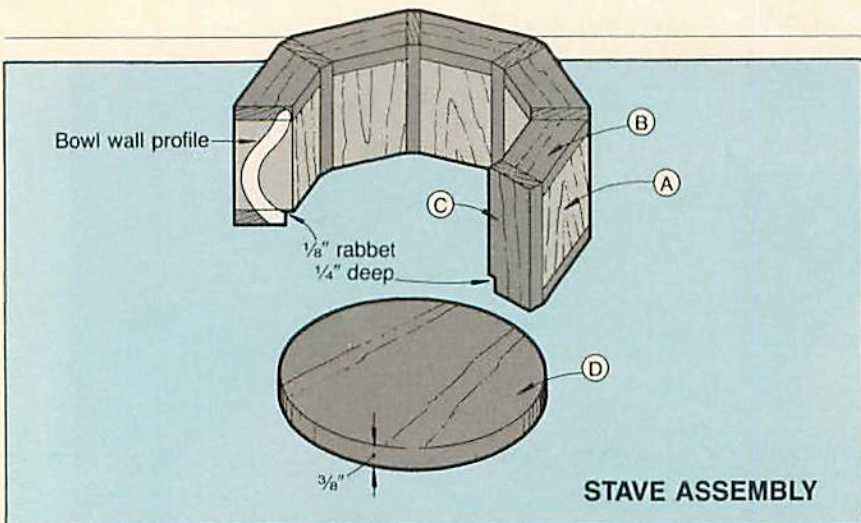

page 24 in the Products That Perform column for our source of the clamp shown.)

**4** Later, remove the clamp, and sand the top of the ring smooth. See page 34 for how we do this.

### SHAPING THE BOWL

**1** Center the staved ring over and glue it to a 3/4" plywood auxiliary faceplate. Turn the outside round, and true up the bottom of the ring. Next, turn a 1/8" rabbet 1/4" deep for later housing the bottom. Remove the project from the lathe.

**2** Lay out and band-saw a 3/4" walnut disk (D) 1/2" larger in diameter than the rabbeted opening. Center and mount the disk to an auxiliary faceplate. Turn the disk round; then, using a parting tool, turn it to 3/8" thick. Now, turn the disk to fit snugly into the rabbeted opening. Glue the disk into the rabbet.

**3** Turn the bowl to shape. Refer to the template above to reproduce the shape shown in the photo on the opposite page. Apply the finish. 🌲

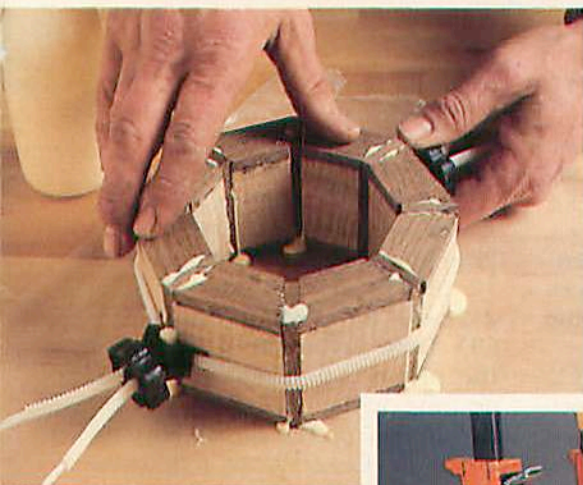

◀ Apply an even coat of glue to the mating edges, place the assembly flat on waxed paper, and lightly clamp the bowl-wall segments together.

Lightly clamp the ► staved ring between two pieces of plywood to hold the top and bottom edges flush. Then, firmly tighten the band clamps.

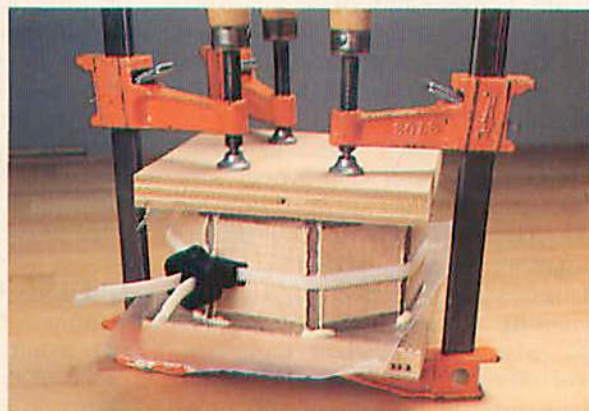

Project Design: James R. Downing  
Photographs: Hopkins Associates,  
Jim Kascoutas  
Illustrations: Kim Downing, Bill Zaun



## A DANDY SASSAFRAS FRUIT BOWL

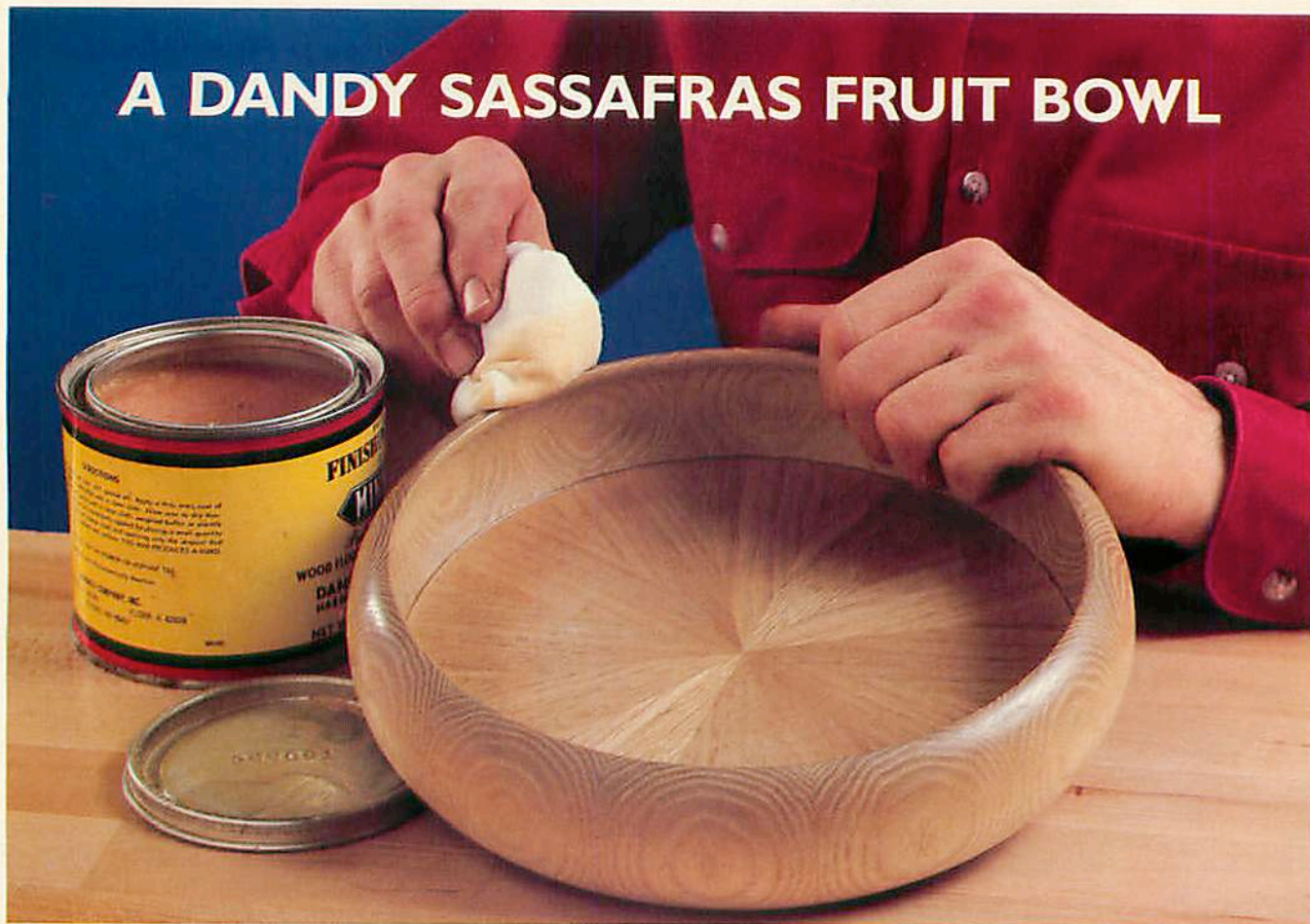

Distinctively patterned sides put stave bowls in a class all their own. Not being satisfied with just a stunning bowl wall, we decided to go one step further and create an equally attractive bottom for our 9"-diameter fruit bowl.

**Note:** For more detailed information about how to plan, cut, assemble, and turn stave bowls, please read the *Basic Stave-Bowl Construction* article starting on page 30. In this article we focus primarily on creating the sunburst bowl bottom.

Also, you'll need at least a 6" swing to turn this project on your lathe.

### CUT, LAMINATE, AND FORM THE STAVED BOWL WALL

**1** Cut a piece of 1½"-thick stock (we used sassafras) to 3x30" long for the stave stock. See page 32 for how to lay out and cut this piece. Also note in the Stave Stock Drawing how the identical grain pattern of each stave segment relates to the grain direction of the stave stock.

**2** Tilt your table-saw blade 15° from center, and bevel-rip both edges of the strip for a 2⅝" finished width. Straighten the blade.

**3** Crosscut 12 staves 2" long for the bowl wall segments (A).

**4** Dry-clamp the staves together to check the fit, and sand if necessary for tight joints as explained on page 34. Glue and clamp the pieces together to form the staved ring. Later, sand one end of the ring smooth, and glue it, centered, on a ¾" plywood auxiliary faceplate. Turn the outside of the bowl round, true up the bottom of the bowl

wall, and turn a ⅛" rabbet ¼" deep into the inside edge of the wall.

### HERE'S HOW TO CUT THE BOWL BOTTOM PIECES

**1** Cut a piece of stock to 5½x32". Plane the stock to ½" thick, and cut 12 pieces of ¾"-thick stock to 2⅝x4⅞" for the bottom segments (B). Draw layout lines on one of the pieces where shown on the drawing on the opposite page.

**2** Cut two pieces of ¾" particle-board to 4x12". Now, follow the three-step drawing on the opposite page to form jig 1 and to cut one edge of each bottom segment. Follow steps 4 and 5 on the drawing to form jig 2 and to cut the opposite edge of each segment to shape.

### GLUING UP THE BOTTOM

**1** After forming a right angle with two wood strips, nail the strips to a piece of flat stock to form a jig as shown in the photo *above right*.

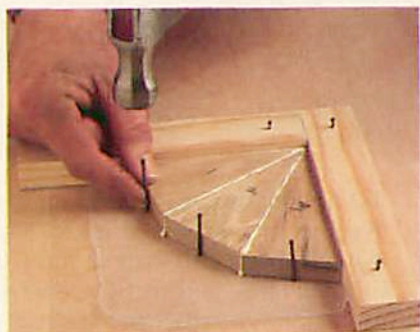
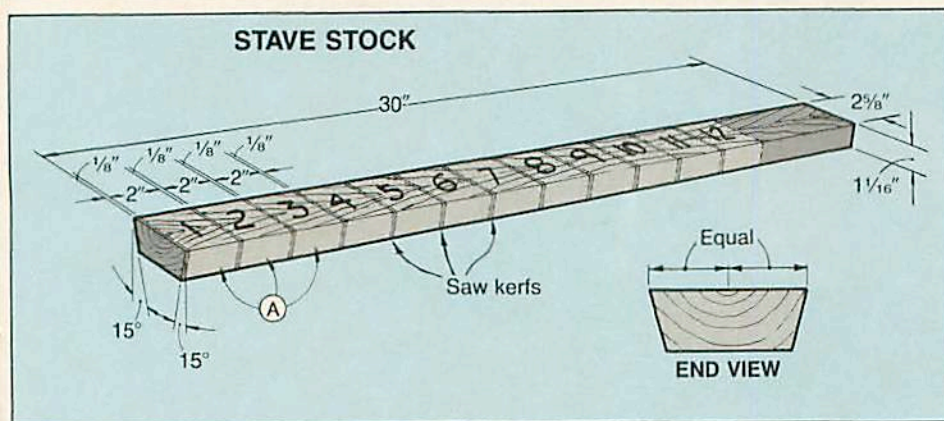
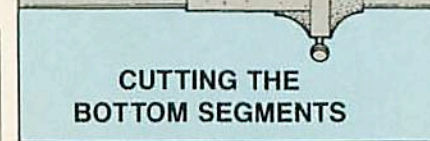
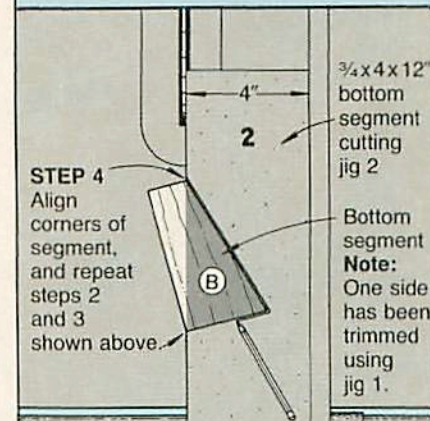
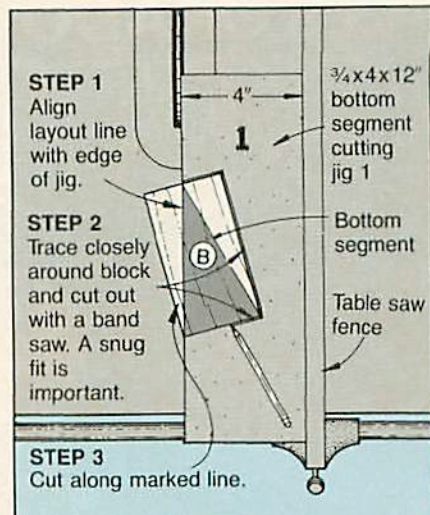
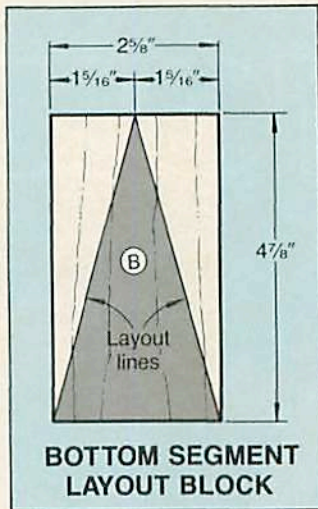
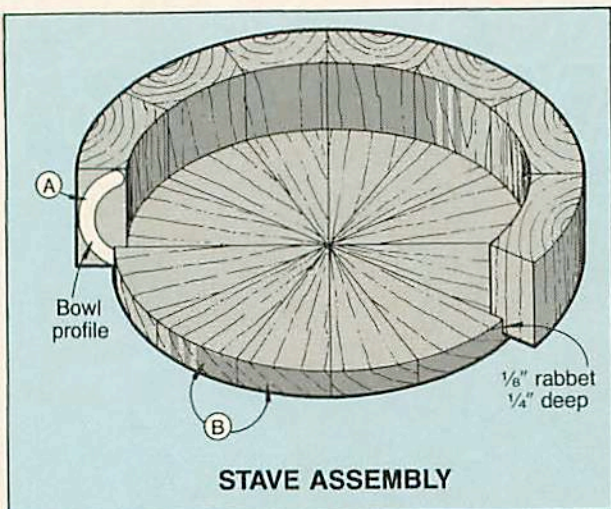

"Clamp" three bottom segments together by nailing them into a square corner.

**2** Apply glue (we used regular woodworker's glue) to the mating edges of three of the bottom pieces, and "clamp" them as shown in the photo above. (We placed waxed paper between the bottom pieces and plywood to prevent them from sticking to each other.) Repeat for each of the remaining quarter sections. After the glue dries, check each quarter section for square, and sand square if necessary.

**3** Glue and "clamp" two of the quarter sections together to form a half section. Repeat to form the other half section.

**4** Now, glue and band-clip the two half sections together, keeping the points in the center aligned.

**TURNING THE BOWL**

**1** Carefully center and mount the laminated bottom to an auxiliary faceplate, and turn it to a  $\frac{5}{8}$ " thickness. Now, reduce the base diameter until the base fits snugly into the rabbet in the bottom of the bowl wall. Glue the bottom into the rabbet, aligning its joint lines with those of the bowl wall. Later, finish turning the bowl to shape using the full-size template shown at right as a guide. Sand smooth, apply the finish, and part from the auxiliary faceplate.

Project Design: James R. Downing  
Photographs: Hopkins Associates  
Illustrations: Bill Zaun

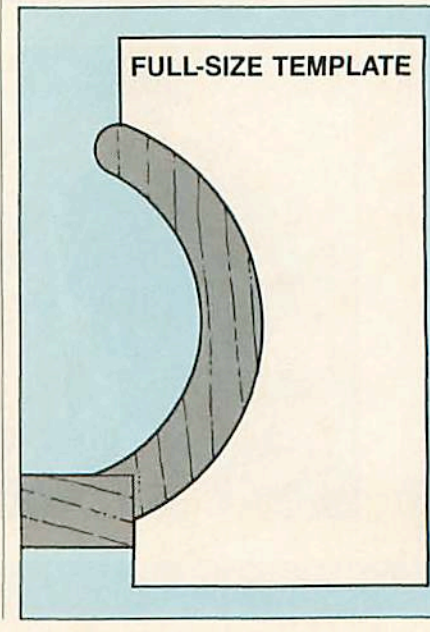

# COLORADO'S COTTONWOOD

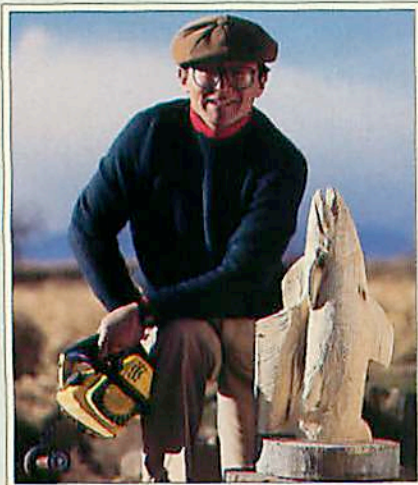

Pat Fushimi, *left and above*, never seems to slow down. When his high school industrial arts classes dismiss for the summer, Pat takes off for the mountains and his favorite trout streams. When he's not fishing, he's guiding someone who is. When snow hits Colorado's slopes, so does Pat. Nearly every weekend and every break during ski season, Pat is in the mountains teaching the fine points of high-country, cross-country skiing. Yet, in between all his activities, he somehow still finds time to grab his chain saw and do some carving.

Pat, 42, began his chain-saw carv-

ing hobby about 15 years ago. He became so skilled that a chain-saw manufacturer sent him around the United States, and to New Zealand, to pack in crowds with demonstrations. He sells his work, too, to visitors who spot his carvings in resort-area galleries.

We've seen the work of a number of wood carvers, but never anything like this. On a Colorado visit, we sought Pat out for a personal demonstration.

*Right:* Usually no taller than 24", Pat's chain-saw carvings can be displayed on tabletops or as mantelpieces. A polyester resin coating prevents cracking.

# CARVER

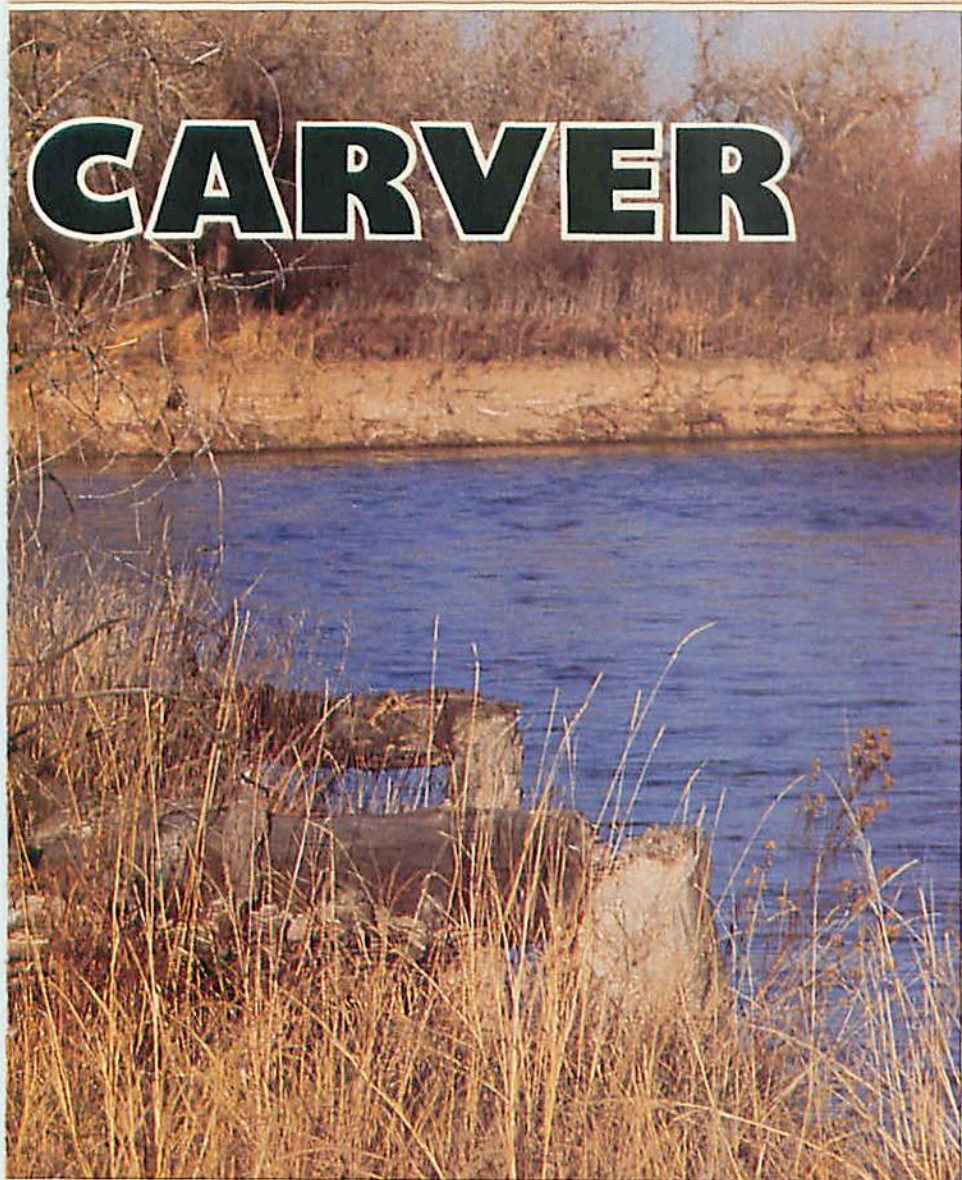

Pat Fushimi visualizes forms in the wood he gathers along the South Platte River, then calls on a chain saw to release them.

**T**he few trees around Fort Lupton, Colorado, can't stop the wind racing down from the Rockies. It pummels the flat farm fields and helpless homesteads. Dust, sand, and sound get carried a great distance.

Occasionally on Saturday mornings, Hank Kiyota's neighbors awake to the growl of a chain saw drifting with the tumbleweed across acres of grain. Over coffee, they'll speculate on what's taking shape at the Kiyota place. But, they know that by passing that way today, they'll witness a new form emerging from another chunk of cottonwood off the pile behind the house. Hank's nephew is at his carving again.

Pat Fushimi looks forward to the time he can spend wielding his chain saws at Uncle Hank and Aunt May's farm north of Denver. Unlike in the city, chain sawing doesn't annoy anyone there. Pat lived out that way himself once, and drove back and forth to teach at south-suburban Denver's Chatfield High School. Now, he misses the open countryside, clean earth smells, and the sight of the distant, blue-hued mountains. The atmosphere inspires him.

"Carving is a discipline for me," says Pat, his always-twinkling eyes taking a serious set. With the attention of a samurai warrior to his swords, the carver checks his tools as he unloads them from his 4x4 station wagon. "I always sharpen the saws and get them ready the day before. I want to be able to start carving immediately."

## ANIMALS THAT HIDE IN THE COTTONWOOD

Sometimes, Pat discovers a piece of cottonwood begging to be carved to a specific animal or fish shape. But most often, he dictates the shape to the wood. "I'll pick up a piece of wood and say 'This is going

*Continued*

## COLORADO'S COTTONWOOD CARVER

to be a brown trout coming out of the water.' Then, I visualize it and start carving."

At work with one of his chain saws, Pat makes chips and sawdust fly as he maneuvers the chain bar around, down, and into the wood standing before him. Every once in awhile, the carver stops, drops the tool to his side, and steps back. His hand reaches to the wood and runs over it. Then, he raises the chain saw to the wood again.

In lighter moments, Pat claims his artistry as a heritage from his Japanese ancestors. But he doesn't kid around with a chain saw in hand. His creativity comes from inside, forced out by concentration. "I have to feel my carving—feel the animal, feel the motion in it," he says, trying to explain the inspiration. "At first, when I start to carve, I'm separate of the wood. It's just plain cottonwood.

"Then, I can see the figure in my mind. I can see the flow of the body in the wood as it should be. After that, I'm concentrating so much on what I'm doing that everything except the carving becomes oblivious." Pat adds, a chuckle in his voice as he remembers, "I've carved in the rain and not even noticed it until I got soaking wet!"

Seeing Pat in action, his attention riveted to a chain moving through wood, it's hard to believe he once laughed at such endeavors.

"I was on vacation in San Diego, and watched a TV news program. This guy was carving a totem pole. When I saw what he was doing, I laughed so hard I was rolling on the bed," Pat recalls. "It was so bad. Yet, he got \$1,500 apiece for them!"

Back in Colorado after the California trip, Pat decided to try chain-saw carving for a relative's wedding gift. "I wanted to make a totem with a turtle and a cat on it for his pets, and a bear sitting on a stump eating a fish to represent his fishing hobby," he says.

"It turned out to be harder than it looked. With the log lying on the ground, I started into it. It kept rolling between my legs! It took me a

whole afternoon to do the top of the bear's head and his ears," he recalls with much amusement.

Even though frustrated, the technique fascinated Pat. "When I started carving the head and the ears, it began to look like the animal was hiding in the wood!"

Following this humbling beginning, Pat went on to carve more figures during the ensuing months. Drawing on his knowledge of the outdoors, he created from cottonwood with his chain saw all types of animals, birds, and fish he'd seen in the wild, and resort area galleries sold them for up to \$500.

### CRUDENESS THAT REQUIRES A SURGEON'S SKILL

"Carving with a traditionally coarse tool, such as a chain saw," Pat points out, "requires that you handle it like a surgical instrument. It has the same challenge as sculpting from marble with nothing but dynamite."

Chain-saw dealers don't equate themselves with carving tool suppliers. Although, when Pat replaces his tools, that's where he buys them. His saws sell over the counter; except for a simple modification, they're not unusual.

Pat uses a large saw—with a 14" or 16" bar—to rough-out his carving from the log. For smoothing and finish work, he switches to his "detail" saw. It has a 10" bar that Pat fitted with a turned, wooden handle to give him more control and leverage during difficult cuts.

To start a carving, Pat relies on his saw with an automatic-oiling feature to lubricate the chain and bar. When he switches to the smaller, detail saw, however, he turns the oiler off. "Otherwise," Pat explains, "the surface would become saturated with oil and it wouldn't take a finish. Every once in awhile, I'll spray the blade with oil to lubricate it, then run it on nonimportant cuts to work the oil out."

To do things chain saws weren't meant to do, such as saw end grain, rip, and plunge, Pat relies on chains he sharpens himself. "Sometimes," says Pat, "I have to touch up my saws

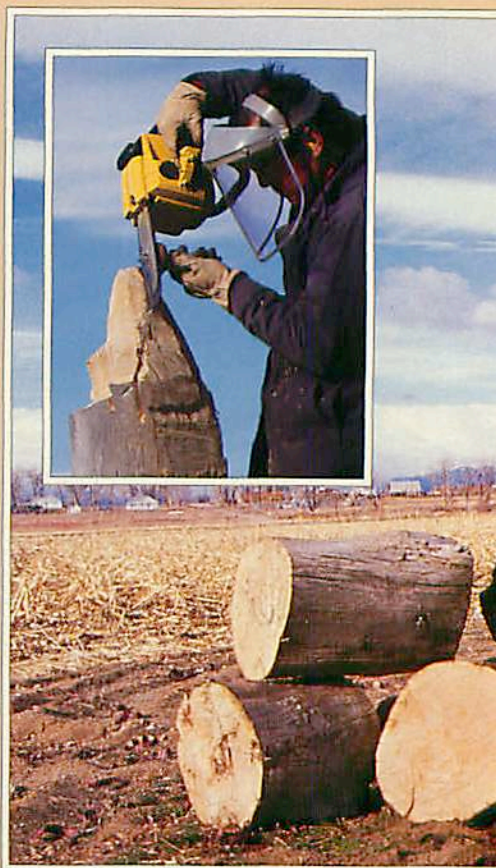

twice a day because the downed cottonwood out here is very abrasive. Sand gets blown into it."

### DANGER WITH EVERY BITE

Chain saws strike fear in the unfamiliar and uninitiated. And well they should. Even long-time users view them with the respect due their sharp and dangerous revolving cutters. Pat uses chain saws in ways that invite trouble. He's always on guard.

In his role as teacher in a high school woodshop, and even on the ski slopes, Pat has always followed his three-rule philosophy for success. And it applies to his chain-saw carving:

"The first rule—'Safety First,' for you and other people. Second—'Enjoy being there,' enjoy doing what you're doing. Third—if you follow the first two, 'You'll learn in spite of the teacher, or anyone else.'"

Pat wears ear plugs while carving—the high pitch of a chain saw engine can damage hearing. For eye protection, he dons a face shield. To guard against nicks, cuts, and hot moving parts, he pulls on leather



**Above:** For roughing the chunk of cottonwood to shape, Pat uses a saw with a 14" or 16" blade.

**Above left:** After roughing out his carving with a large chain saw, Pat switches to the detail saw with its controllable, 10" blade.

**Right:** Nose-boring with a chain saw, even a small one, rates as risky business. Pat keeps his head to the side to avoid impact from a kickback.

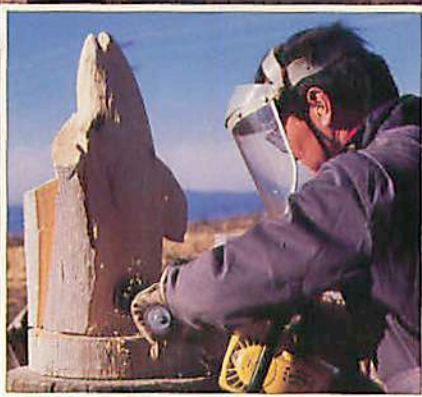

work gloves. Heavy-duty safety boots keep the accidental roll of a log from crushing his toes.

"I've never had a chain-saw accident, yet I learned early on to be mindful of where the saw's chain bar is at all times." While carving, Pat always knows where the chain is and plans accident avoidance. "The chain saw was designed to only crosscut wood. I use it to nose-bore," he points out. "Imagine the saw teeth going over the bar's rounded nose and you're trying to stick it into the wood! What happens? It jumps straight up into the air! That's scary," Pat admits.

With a reassuring tap on his face shield to reinforce his point, he

continues, "Even with this shield, I try to be aware and stand to the side out of the bar's possible path. It also helps to find just the right throttle feed—you can't push it."

#### A FINISH MEANT FOR THE TOUCH OF FINGERTIPS

Pat labels his chain-saw carvings "representative" artwork, and he doesn't smooth them over by sanding or do details with knives or gouges. Yet, no one has ever asked what the subject was. "At schools where I've demonstrated, I've had blind children come up and run their hands over my carvings and recognize exactly what they were."

With the sharp cutters of his

saws, Pat captures the essence of his subjects, much as a cartoonist does with a caricature. "Bears, for example, have massive heads and slender snouts, but rounded, 'teddy bear' ears," he notes. "I overaccentuate these characteristics."

On wood-hunting trips, Pat pokes through the fallen cottonwood along the South Platte River near his uncle's farm. Sometimes, a cottonwood chunk dictates what he'll carve. "I found a log one time that had a pronounced knot," he recalls. "I could see it as a whale spout, so I carved a whale around it. In New Zealand, I carved a whale out of some pine with very twisted grain. I followed it and made the whale twisting and jumping."

When Pat puts away his chain saws, he brings out the propane torch. To avoid a contrived, unnatural look, Pat scorches the wood in stripes, dots, patches, and other markings germane to the animal or fish. "I use a narrow, pencil-flame head that gives me lots of control. I wouldn't want to watch two days labor go up in smoke," he jokes.

Two coats of brushed-on polyester resin, the thick type of coating used to take punishment on bar tops, prepare Pat's carvings for travel to anywhere. "I actually started using it to strengthen the wood, though," notes Pat. "It would stiffen thin parts on my carvings. But it also seals the moisture in so they won't crack when the air gets real dry. The resin also contains an ultraviolet filtering agent, so that it won't deteriorate in sunlight. And," he adds, the prankster in him evident in his voice, "if there's any termites in the wood, there they'll stay—entombed!"

**CAUTION:** The photos and description of Pat Fushimi's chain-saw carving techniques in this article do not in any way imply acceptable, safe techniques. Using a chain saw for any purpose other than cross-cutting is dangerous! — The Editors. 🐻

Produced and written by Peter J. Stephano  
Photographs: Ron Coppock

MAKE STRONG,  
ACCURATE JOINTS  
IN SECONDS WITH

# PLATE JOINERS

**W**e wouldn't put these machines in our "top-10" list of must-have power tools for the home woodshop. But if you do a lot of joinery, you won't find another machine to match a plate joiner's speed, accuracy, and ease of use.

## HERE'S HOW THEY WORK

An odd-looking machine, yes. But plate joiners are really nothing more than simple slot-cutting machines. Equipped with a motor-driven 4" circular saw blade, the joiner cuts matching dish-shaped slots into the pieces to be joined. You then glue wood biscuits into the slots to join pieces. The biscuits cost about \$30 per 1,000.

To center the slots, you align an index mark on the joiner's faceplate to corresponding marks on the pieces to be joined. A stop sets the depth of cut to fit one of three biscuit sizes (#0 cuts  $\frac{3}{8}$ " deep; #10,  $\frac{1}{2}$ "; #20,  $\frac{5}{8}$ ").

To make the cut, you hold the tool by its body and push the blade through a slot in the faceplate and into the wood. The blade cuts slightly oversize slots for the biscuits, so you can make alignment adjustments to the pieces before clamping them together.

Many woodworkers switching to plate joiners do so because they don't want to take the extra care and time for precision dowel joinery. With a plate joiner, you enjoy about  $\frac{3}{16}$ " tolerance to the left and right of each slot and can still clamp a perfect joint. Here's why:

## THE BISCUIT ADVANTAGE

After you glue the compressed beechwood biscuits into the slight-



ly oversize slots (with water-based woodworker's glue) and join the pieces, the moisture in the glue causes the biscuits to swell inside the slots. This creates a tight, strong mechanical joint; that is, the swollen biscuits hold the pieces tightly together all by themselves, even before the glue dries. This reduces clamping time to 10 minutes or less, depending on the application.

But here's what we wanted to find out: Do biscuits make stronger joint reinforcements than ordinary screws or dowels? We decided to put them all to the test. Using each of these reinforcements, we glued 3-foot lengths of 1x4 oak end-grain to face-grain. We then applied increasing amounts of weight to each of the joints (by means of a porta-

ble scale hooked to screw eyes in the ends of the boards). Our doweled joint failed first (at 18 pounds pressure)—then the screws (19 pounds), and finally the biscuits (22 pounds). We repeated our test several times to affirm that the biscuits do, indeed, make stronger joint reinforcements than dowels or screws. Thus, plate joiners have unbeatable advantages—speed, strength, and accuracy.

## HOW VERSATILE ARE THESE TOOLS?

Although limited to reinforcing flush (butt and miter) joints, plate joinery has more applications than you might think. That's because most woodworkers use butt and miter joints—in one form or

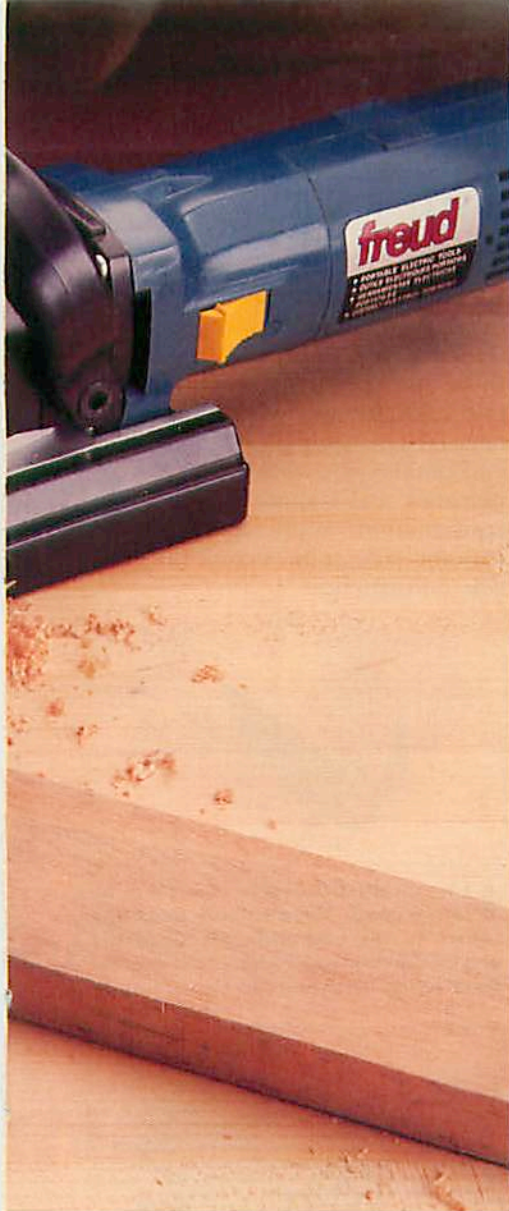

another—more often than any other type. On page 46 we show you how they're used to make a basic butt joint.

### THE TOOLS: OUR FINDINGS

As with any tool, much of a plate joiner's speed and reliability depends upon the operator. You'll have to develop a feel for the way these machines work. You'll also have to adjust to the individual quirks of the various machines. But despite their differences, all these tools have the same basic components.

(At the present time, major Japanese manufacturers—Hitachi, Makita, and Ryobi—do not have plans to introduce a plate joiner.)

Here's what we learned about each of the tools:

### ELU

This tool manufactured by Black & Decker operates differently than the others: The blade pivots rather than plunging into the work. Because you must lift the machine with one hand and still keep it in contact with the stock with the other, we judged the Elu more difficult to operate than the others.

The Swiss-made Elu doesn't have small spurs on the faceplate to grip the wood. So, you may find yourself cutting the slots longer than necessary until you get used to the machine. But the lack of spurs, combined with a special fence, enable you to cut continuous grooves for splines, as shown in the photo at *right*.



To cut with the Elu, you must simultaneously raise the handle and hold the Elu against the stock.

### FREUD

Although one of the least expensive tools, the Freud has a lot going for it. We like the positive, easy-to-adjust fence, and easy-to-read height-adjustment scale, shown in the photo at *right*.

Although the Freud doesn't have the heavy-duty feel of more expensive tools, (Lamello, Elu), we consider the Freud a well-built machine, and perfectly suited to the serious home woodworker and light-production shops.



The Freud JS100 fence features quick-action adjusting knobs.

### KAISER MINI 3D VARIO

Commercial shops purchase about 80 percent of the Kaisers sold in the United States and for good reason: It's a sturdy machine with a no-slip fence surface. Unlike other joiners that depend on two tiny spurs to grip the wood, Kaiser's wide rubber surface firmly grips even narrow rails.

Additional features include a convenient switch location, sensible handles for left-handed and right-handed operators, and a speedy blade-changing system.



Cutting narrow rails is no problem with the ribbed Kaiser fence.

*Continued*



# PLATE JOINERS

## LAMELLO

Swiss cabinetmaker Herman Steiner patented the first plate joiner in 1956. The company he founded, Steiner-Lamello, continues to be an industry leader in expanding the use of plate joiners.

The Lamello Top, the most expensive machine we tested, is the only joiner with a tilting faceplate for joining miters at angles other than 45° without a jig or other support. See photo at *right*.

The Lamello Junior lacks some of the Top's sophistication, but retails for almost half as much. The Junior has a sturdy plastic 45°/90° fence attachment that we judged easier to accurately adjust than the Top fence. Unlike the conveniently located Top switch position, the Junior's toggle switch is recessed in the back of the motor housing.

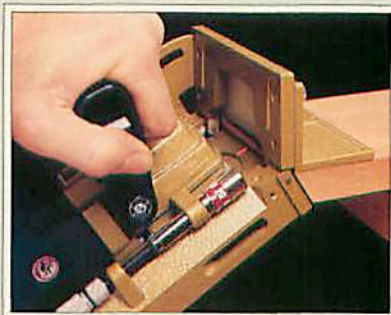

Only the Lamello Top can cut angles other than 45° or 90°.

Lamello offers the wide range of accessories, many of which you can use with the other joiners, too. Among the more useful are two types of biscuit-shaped knock-down fittings (for quick joint disassembly), translucent biscuits for joining plastics, and a cabinet hinge system.

## PORTER-CABLE

This tool represents a departure from the "modified right-angle die grinder" design of the European models. And with two good results:

First, with the motor mounted vertically on the base, the attached handle correctly positions your hand and arm to the plunging action of the tool. We found that the basket-type handle on the Freud, Virutex, and Lamellos were next to useless, except for toting the tool around the shop. Our nat-

ural tendency was to hold these tools by the motor body to operate them.

Second, the Porter-Cable uses a belt, instead of a gear system, to drive the blade. As a result, the tool runs quieter than the others. According to Dennis Huntsman, manager of product development, the 555 models on the market now have a newly designed fence that tracks parallel to the blade, and larger, triangular locking knobs.

## VIRUTEX

We liked the solid, rugged construction of this Spanish-made tool shown at *right* in the butt-joint pictures. We detected no slop in the fence attachment when setting the fence height. And, the scale on the faceplate (in metric and fractions) parallels the Freud for accuracy and earns a superior rating. The fence locking levers and

guides operate efficiently and faster than any machine we tested.

We found the switch position somewhat awkward, and the protective dust boot leaves you guessing whether the switch is ON or OFF when you plug in the tool. In addition, some repair shops have reported a higher-than-usual incidence of Virutex switch failures.

## PLATE JOINERS IN ACTION

To give you a better idea of how these slick, quick joining machines operate, we show you the basic three-step sequence for a simple butt joint. Biscuits really show their muscle when joining edge grain to end grain, such as this simple corner joint, and T-joints used in frame construction. Applications include cabinet face frames and rail-and-stile construction.



**1** Lay out the two pieces of stock to be butt joined. Measure and mark the center of the end-grain piece, fit the pieces together, and then transfer the mark to the adjoining piece.



**2** Align the index mark on the tool's faceplate with the mark on the stock, then make your cuts. Use the largest biscuit possible for the size piece you're joining; we inserted the #20 biscuit here.



**3** Apply woodworker's glue to both surfaces and inside the slots. Then, insert the biscuit, assemble, and clamp. (Glue causes the biscuit to swell in the slot.)

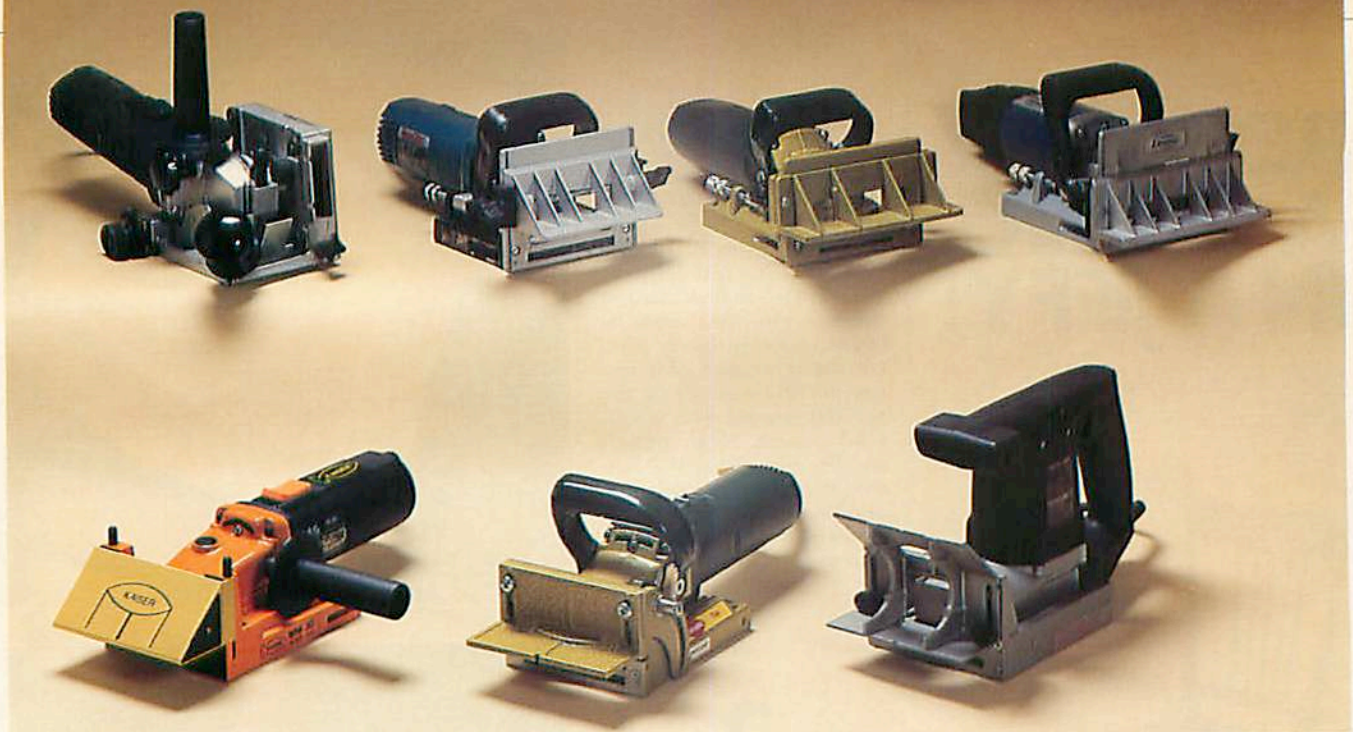

Front row, left to right: Kaiser Mini 3D, Lamello Top, Porter-Cable 555. Back row: Elu 3380, Freud JS100, Lamello Junior, Virutex 0-81.

## FACTS AND FIGURES ON PLATE JOINERS

Manufacturer	Model	POWER TRAIN				Fence-height scale <sup>3</sup>	Dust extractor <sup>4</sup>	Cord length (feet)	Weight (net) (lbs.)	Suggested list <sup>5</sup> price
		Amps	No-load speed (RPM)	Drive <sup>1</sup>	Switch <sup>2</sup>					
Elu	3380	5	7,500	G	S	I	Y	10'	7	\$485.00
Freud	JS100	5	10,000	G	S	M,I	N	7½'	6.2	\$271.95
Kaiser	Mini 3D Vario	5.7	10,000	G	S	M	Y	10'	6.2	\$529.00
Lamello	Junior	4.6	10,000	G	T	M	Y	8½'	6.5	\$375.00
Lamello	Top	5.2	8,000	S	S	N	Y	8½'	7	\$675.00
Porter-Cable	555	5	8,000	B	TR	I	N	10'	5	\$269.95
Virutex	0-81	5	10,000	G	S	M,I	Y	7½'	7	\$300.00

1. (G)earred (B)elt (S)lip clutch

2. (T)oggle (S)lide (T)rigger

3. (M)etric (I)nches/fractions (N)one

4. Available as accessory

5. Tools often discounted 10-30% below list

### MANUFACTURERS LISTING:

**Elu**  
(Manufactured by Black & Decker)  
Call 800-235-0870 for nearest dealer

**Freud**  
218 Feld Ave.  
High Point, NC 27264  
800-334-4107

**Kaiser**  
(Imported by W.S. Jenks & Sons)  
1933 Montana Ave. NE  
Washington, DC 20002  
800-638-6405

**Lamello**  
(Imported by Colonial Saw Co. Inc.)  
P.O. Box A  
Kingston, MA 02364  
617/585-4364

**Porter-Cable Corp.**  
P.O. Box 2468  
Jackson, TN 38302  
901/664-0332

**Virutex**  
(Imported by Holz Machinery)  
45 Holiday St.  
Jersey City, NJ 07304  
201/433-3800

# RECANE A CHAIR... IN A JIFFY!

JUST FOLLOW  
THESE 5 EASY STEPS



With ready-made, woven, natural cane, a few hand tools, glue, and about 60 minutes or less, you can recane a chair with professional results. And you'll save money to boot. We had a great time, and spent less than \$10! Here's how:

Select your prewoven, natural cane from available widths of 12" to 24" and in patterns that range from the traditional open-weave to a modern closed-weave. Measure the width and depth of your chair's splining groove, and buy the reed spline accordingly (see Buying Guide at end of article for supplies). Cut eight or so  $\frac{3}{4}$ x3" hardwood wedges, round up a mallet, tape measure, scissors, pattern paper, pencil, felt-tip marker, yellow glue, and a utility knife, and set aside time for recaning.

## 1

**TRACE A PATTERN**—Start by removing any dried glue or dirt from the splining groove. This is important so the new glue you apply later will bond properly. Now, lay paper on the seat and transfer the contour of the splining groove with a soft-lead pencil. Next, pencil another line about  $1\frac{1}{2}$ " outside the first line. This second line allows for the extra material you'll drive down into the groove.



## 2

**CUT THE WOVEN CANE**—After cutting out your paper pattern along the outside line, lay it on the woven cane and draw the outline with a felt-tip pen. Cut the material to the shape of the pattern. Then, soak the cane for the seat and the reed spline in warm water for at least 20 minutes. (Leave the reed spline soaking until you need it.)

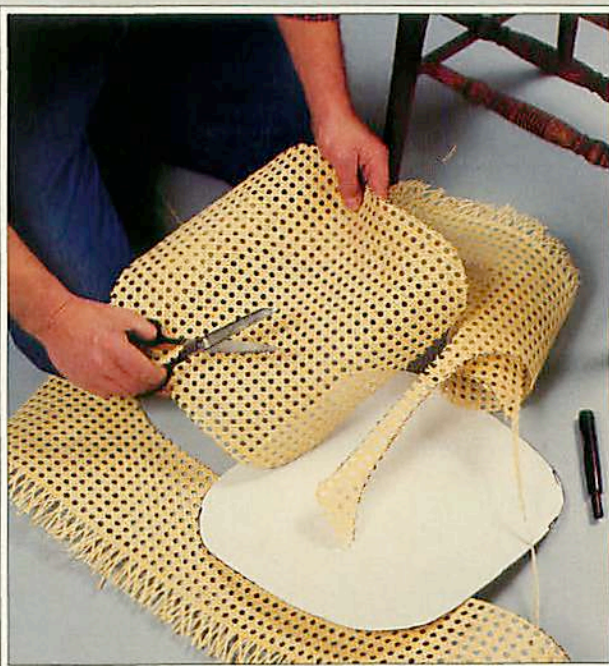

## 3

**WEDGE-IN THE CANE**—Lay the cane over the chair seat opening, aligning the weave with the front and back of the chair. Now, starting at the center of the back, force the damp cane deeply into the groove by tapping the  $\frac{3}{4}$ x3" wedges with a mallet. Work to the outside as you straighten and pull the cane tight. Move to the front (and then to the sides) and repeat the procedure.

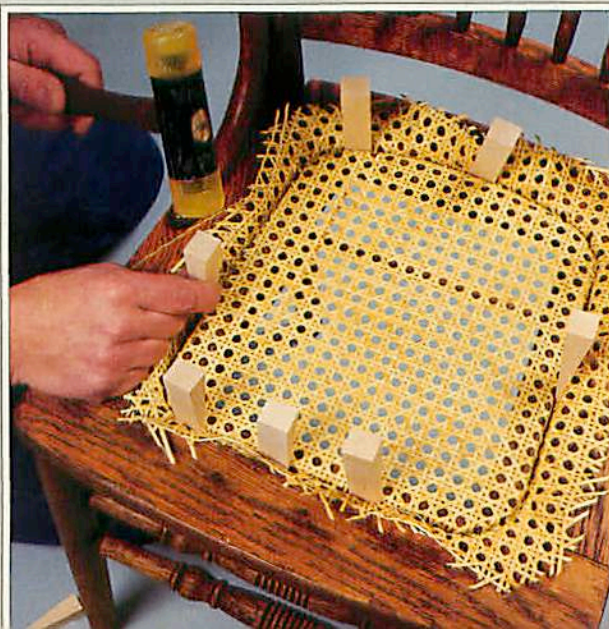

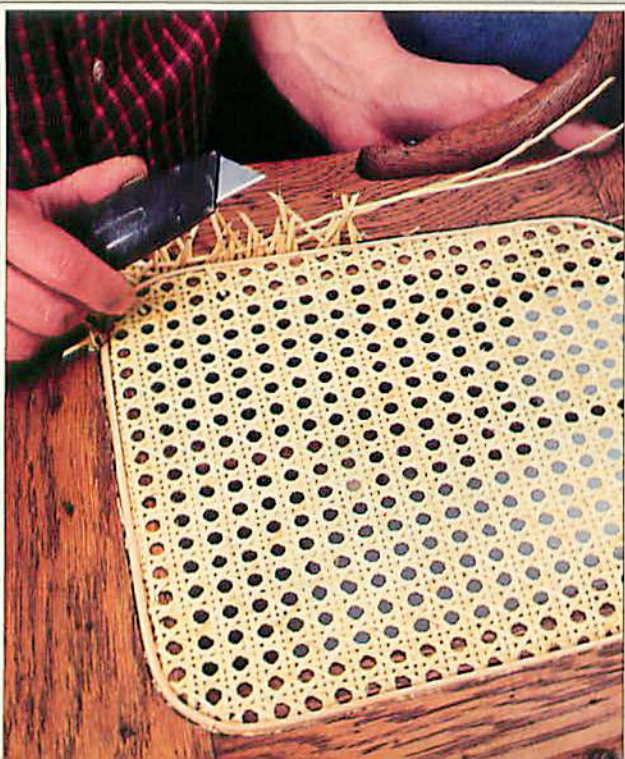
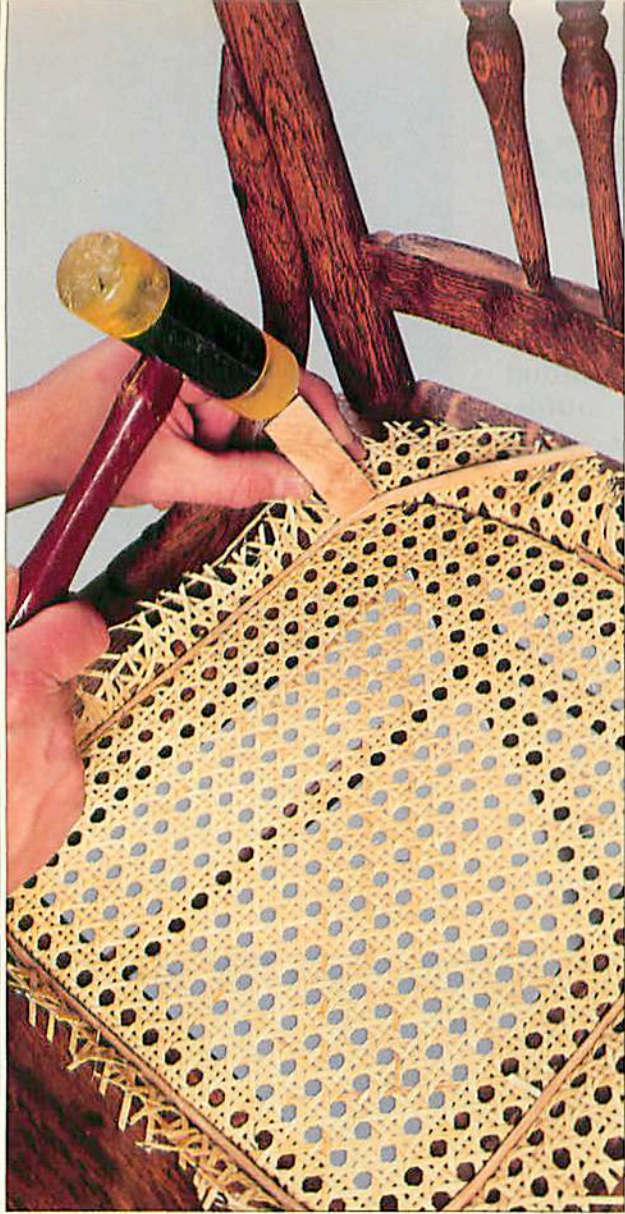

## 4

**DRIVE THE SPLINE**—For a seat with rounded corners, first measure the groove's length with a tape measure, then add about 1". Cut the amount of spline needed from the length soaking in the water. Be sure to cut the reed at an angle so you'll later be able to join the two ends with a miter joint.

Now, lay a bead of yellow woodworker's glue into the groove on top of the cane. Then, pick your starting point somewhere along the back edge, and with your fingers, press the spline partially into the groove. Where the reed spline meets itself at the back edge of the seat, cut reed at an angle to exact length.

With a mallet and one of the wedges as a drive block, work your way around the chair seat, gently tapping the spline partway into the groove. Be sure the spline fits evenly in the groove.

A square groove in your chair means that you must cut four pieces of spline. Then, miter the corners as you would a picture frame.

## 5

**TRIM THE EXCESS**—With a sharp utility knife, trim away the excess cane outside the spline by cutting it as deep as you can in the groove. Finally, tap the spline all the way down into the groove around the seat with your mallet and a wedging block. Let your newly caned seat air-dry overnight to drumhead tightness before using.

### BUYING GUIDE

● **Woven natural cane.** The Woodworkers' Store, 21801 Industrial Blvd., Rogers, MN 55374. In four patterns and widths from 12" to 24". Prices from 38 cents to 72 cents per lineal inch (cost increases with width and pattern complexity). Conventional weave, as shown: Catalog no. H1122, 24" width, 72 cents per lineal inch.



Fine conventional weave



Modern closed weave



Modern basket weave

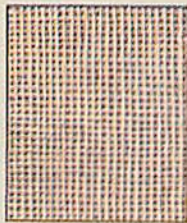

Modern open weave

● **Reed spline.** Same as above. Catalog no. H1141, 1/4" x 1/4", \$1 for 10'. Other spline dimensions available.

*Shipping for all materials, at extra cost.* ♣

Photographs: Jim Kascoutas  
Illustrations: Jim Stevenson

# DIAMOND STONES

## LIGHTNING-FAST CUTTERS THAT LAST AND LAST

Just the thought of putting a truly sharp edge on a dull cutting tool makes many woodworkers shudder. In their minds, sharpening is a mysterious art reserved for the masters gifted with skill, patience, and time. But help is on the way.

**R**eally, the problem is that people haven't had the tools to make sharpening simple," says Bob McGee of Eze-Lap Diamond Products. "Thinking they can't do it successfully, they throw up their hands hopelessly. But there is an answer."

Not surprisingly, he's talking about diamond sharpening tools, which have enjoyed growing popularity among woodworkers in the past few years. Eze-Lap and Diamond Machining Technology (DMT), two American companies, dominate the diamond-coated sharpener market.

### GAINING ACCEPTANCE AMONG WOODWORKERS

"We sell an absolute ton of the small-sized diamond stones," says David Draves of Woodcraft Supply Co. Their popularity, he believes, results from customers wanting to experiment with diamond stones—and their affordable price (usually under \$15)—before purchasing larger stones. Diamond stones quickly cut tool steel and some customers, according to Draves, also purchase larger diamond stones to flatten conventional oilstones or water stones that show uneven wear.

For decades, heavy industries have relied on diamond-tipped tools for their most-difficult cutting chores. But now, recently developed methods of bonding the diamond particles to suitable substrates have led to a product the general public also can afford.

DMT uses an electroplating process to embed the diamond grit into a layer of nickel that's bonded to

a sheet of perforated steel. You can recognize these stones by their distinctive polka-dot pattern. Eze-Lap, the other major domestic manufacturer, adheres a layer of diamond particles on a steel plate and uses a multistep plating process to achieve a durable, self-sharpening surface.

### HOW THEY WORK DIFFERS FROM OTHER STONES

We asked Leonard Lee, an engineer who owns Lee Valley Tools, a mail

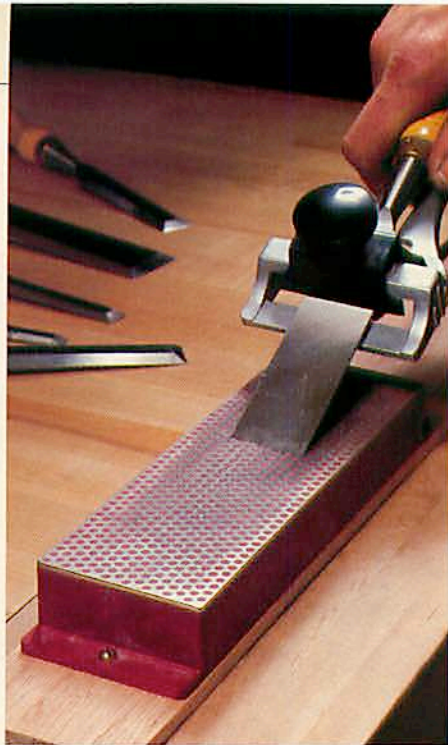

A sharpening guide, shown partially above, firmly holds a chisel at a 30° angle for accurate sharpening on an 8" Diamond Machining Technology stone.

From left: Eze-Lap, Diamond Machining Technology, and Robert Sorby, Ltd. diamond stones



order supply house in Ottawa, Canada, to summarize the difference among the major cutting-stones categories. According to Lee, if you want an Arkansas stone to continue cutting well, you must periodically lap it on a piece of silicon carbide abrasive to reveal sharp, new particles. He likens this process to breaking up a paved road.

"Japanese waterstones," Lee says, "have a controlled rate of wear that always reveals fresh particles."

With the exception of the Eze-Lap polycrystalline diamond surface that's designed to fracture with use, Lee confirms that diamond stones don't wear over time. This means that the cutting action doesn't diminish and the stone remains flat.

Robert Sorby, Ltd., of Sheffield, England, produces a sharpening kit that consists of an aerosol can containing diamond particles and a ceramic tile sharpening stone.

"The diamond coating builds up with repeated sprayings," says

Sorby's Tony Walker, "so you don't need to charge the stone every time you use it." Walker cautions against applying excessive spray and wiping Sorby stones before storing.

### NOT QUITE PERFECT, BUT GETTING BETTER

A recurring defect in diamond sharpening stones has been their failure to be less than dead flat, which is essential for shaping the backs of beveled cutting edges. To deal with this problem, DMT improved the design of its plastic base and sells an optional lapped version that is flat to within .003 of an inch.

Four rubber pads on the wooden base support the tile in the Sorby kit. Under hand pressure, the tile may bow slightly, resulting in a less than truly flat stone, the manufacturer admits.

According to Leonard Lee, when shaping small blades on the polka-dot DMT stone, you may notice a "shock effect" that occurs when the

edge meets the back part of each perforation, which he finds objectionable. DMT engineers say the perforations improve the cutting action and clear the fines (metal particles) from the cutting surface.

Also, Lee has heard complaints from customers about the abrasive coating stripping off some of Eze-Lap's bench stones. Bob McGee of Eze-Lap termed these problems occasional, and went on to recommend his fine-grit stones as adequate for virtually all sharpening.

"Most woodworkers like our diamond stones for sharpening, for flattening a blade and maybe even for the final sharpening," observes George Pettee of DMT, "but the real connoisseurs go on to a polishing stone, such as a hard Arkansas or a Japanese waterstone."

"As for use on tools, I'd say it excels for major stock removal and shaping," Lee says, "but it isn't really that good for fine honing—it's too aggressive for a fine edge."

### OUR ASSESSMENT

We worked with an assortment of DMT and Eze-Lap products to sharpen plane irons, chisels, and knives. The fast reshaping was impressive, but we agree that you're better off doing the final honing with an Arkansas oilstone or a Japanese waterstone. We tested the fine-grit Sorby kit, which we judged disappointing, especially considering the price tag.

Although DMT and Eze-Lap produce stones in different types of industrial diamonds, we simply couldn't detect any difference in the way either product performed on our bench test.

We're not suggesting you use diamond sharpeners to replace all of your sharpening stones, but one of them would make a splendid addition to round out your sharpening arsenal and whisk away the worry of renewing dull edges.

*You can purchase the products at retail or through most mail-order houses, some of which advertise in WOOD magazine.*

Written by George Brandsberg  
Photographs: Hopkins Associates

### DIAMOND SHARPENING DEVICES AT A GLANCE

Item	Dimensions (Inches)	Grit*	Use	Price
Pocket stones	3x1, 4x1	F, M, C, X	General use	\$6-18
Paddles	8x1¼ (4" stone)	F, M, C, X	Tools and general use	\$5-18
Countertop stones	6x2	F, M, C, X	Tools and general use	\$24-57
Bench stones	8x2½ 12x2½	F, M, C, X	Tools and general use	\$31-76 \$55-134
Aerosol-charged bench stones	8x2 tile on a 9x2 wood base	2600, 1220, 325 grit	Tools and general use	\$54
<b>Miscellaneous sharpening products for the home</b>				
Vee knife sharpener	7x2x5	C	Kitchen knives	\$16
Butcher steels	10, 12, 14	C	Kitchen knives	\$24-38
Sanding disks	⅞, 2, 5, 6, 7	120, 220 mesh	Deburring, carving, shaping, grinding most non-ferrous hard materials	\$7-22
Chain saw file	8x⅞, ⅝, ⅜	X	Chain saw chains	\$5-22
*DMT stones come in Fine (600 grit), Coarse (325), X, extra coarse (220); Eze-Lap stones come in Superfine (1,200), Fine (600), Medium (230/270), and Coarse (140/170).				

READERS,  
IT'S YOUR  
TURN!

# PROJECT

As four fellow craftsmen ably demonstrate, woodworkers don't have to "make do" with the commonplace.

## CONFORMING TO A CORNER

Ronald H. DiPalma, 47  
Meridian, Mississippi  
Bank officer

Ready-made cabinets large enough to store the DiPalmas' three sets of china weren't available anywhere in or near their community. Phone calls elsewhere proved futile. And before Ron would commission someone else to build exactly what they needed, he decided to try it himself. The challenge required some fine honing of his woodworking skills!

The result? A 34"-high, one-piece lower cabinet that angles out 46" in each direction from the corner. In the middle, adjustable shelving is deep enough for plates; at the ends, there's 9"-deep storage. Extras built in the top cabinet include beveled-glass door panels and shelves, dovetail joints on rails and stiles, a felt-lined interior, and a hand-carved cornice.

The many types of wood Ron used complicated the finishing and became quite a task. How do you match birch, fir, oak, and pine with one finish?

Ron began by sealing all the wood with thinned polyurethane. After sanding the wood lightly, he wiped on a fruitwood stain, then used a dry paintbrush to grain and mark it. To distress it, he spattered stain about. Next came another sealer coat. Then, more sanding before a coat of ebony stain. Two more coats of polyurethane finished his masterpiece. Whew!



## A DOUBLING OF EFFORTS

Frank C. Bozarth, 58  
Trenton, New Jersey  
Boatwright, Princeton rowing team

Necessity has mothered many inventions. For Frank, his daughter-in-law's motherhood created necessity. She had twins, and he had promised a cradle. "Now, what will you do?" inquired his son. "Build two?"

Before building the 31½x35½x39" pine double cradle, Frank constructed a mock-up. "I wanted to be sure that when it was swung, the cradles wouldn't collide," he notes.

The double cradle, joined by doweled mortise and tenons, rocks one baby as easily as two. To ensure smooth, one-handed rocking, Frank lubricated the maple dowels pinning the cradles with candle wax.

Grandsons Jason and Bryan won't wear out their double-cradle's finish. After Frank applied an oil stain, he put on five coats of satin varnish. A final rub with rottenstone and lemon oil produced a baby-smooth finish.

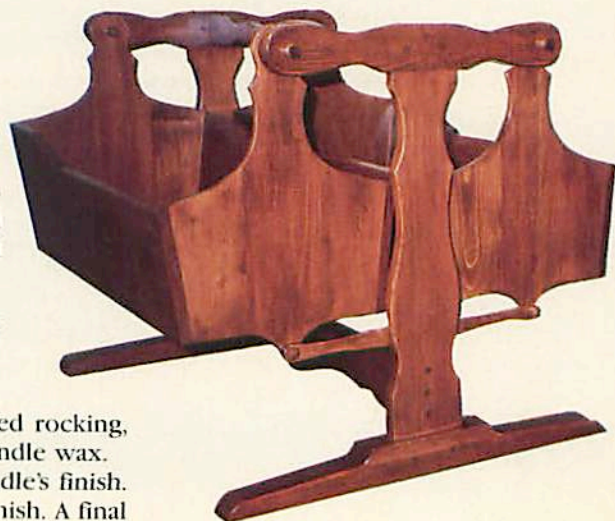

# SHOWCASE



## PUTTING HIS HEART IN HIS WORK

*Michael S. Hardy, 29  
Seneca, Pennsylvania  
Industrial arts instructor*

Mike doesn't stop woodworking when the class bell rings. Unlike his high school students, he enjoys homework.

From an 8x8x4" piece of black walnut—once part of a barn beam—Mike bandsawed his heart-shaped jewelry box. For the intricate cuts, he used a 1/8" blade. "The thin blade makes virtually invisible cuts for glue lines," Mike says. "But, you have to overtension the blade, although not too much."

The drawer, cut at an angle so the grain would match, extends through the box. It opens with a push from the rear. "The drawer can be closed flush, but cannot be completely removed," explains Mike, "because I placed a register pin in the guide dadoed in the drawer bottom." He finished his project by spraying on three coats of lacquer, rubbing between each of them.

Mike, thanks for the lesson!

## NO REINING IN ON QUALITY

*Melody A. Mullis, 33  
Atascadero, California  
Woodworker/sign maker*



Apparently, when Melody decides on something, she goes full gallop. Her 4'7"-tall by 3'-long colt descended from a line of carousel horses she has refined with each new generation.

The horses began a few years back when her sister requested one. With little more than a college woodworking course behind her, Melody harnessed up for the task. She learned the technique of carcass construction and used it to build boxes of jelutong (an imported wood similar to basswood) in the basic shape of the body, legs, tail, head, and neck.

Trial and error taught her to use 2-3"-thick boards (rather than 3/4") to reduce the number of laminations. She also builds the head and neck from one box instead of two. Melody glues all joints with marine resin glue, and reinforces tail and leg joints with dowels.

After some controlled roughing out of the colt's shape with a chisel, Melody admits she reined in her activity a bit. "I spent some time looking at the wood, trying to figure out exactly what cuts to make next. But, after awhile, I just decided to go for it!"

Melody stained her colt walnut. For a topcoat, she rubbed in tung oil. ♣

### To submit your projects . . .

Send a 35-mm color slide (no prints, please), with the project as the focal point and a simple background—no people. Include a capsule description—materials, special joinery, finish, and dimensions, for example. *WOOD* will pay \$25 for published projects. Slides cannot be returned unless you enclose a self-addressed, stamped envelope.

**Project Showcase**  
**Better Homes & Gardens®**  
**WOOD® Magazine**  
Locust at 17th, Des Moines, IA 50336



# WOODWORKERS' STANDARDS

## REPRODUCING PROJECT PATTERNS

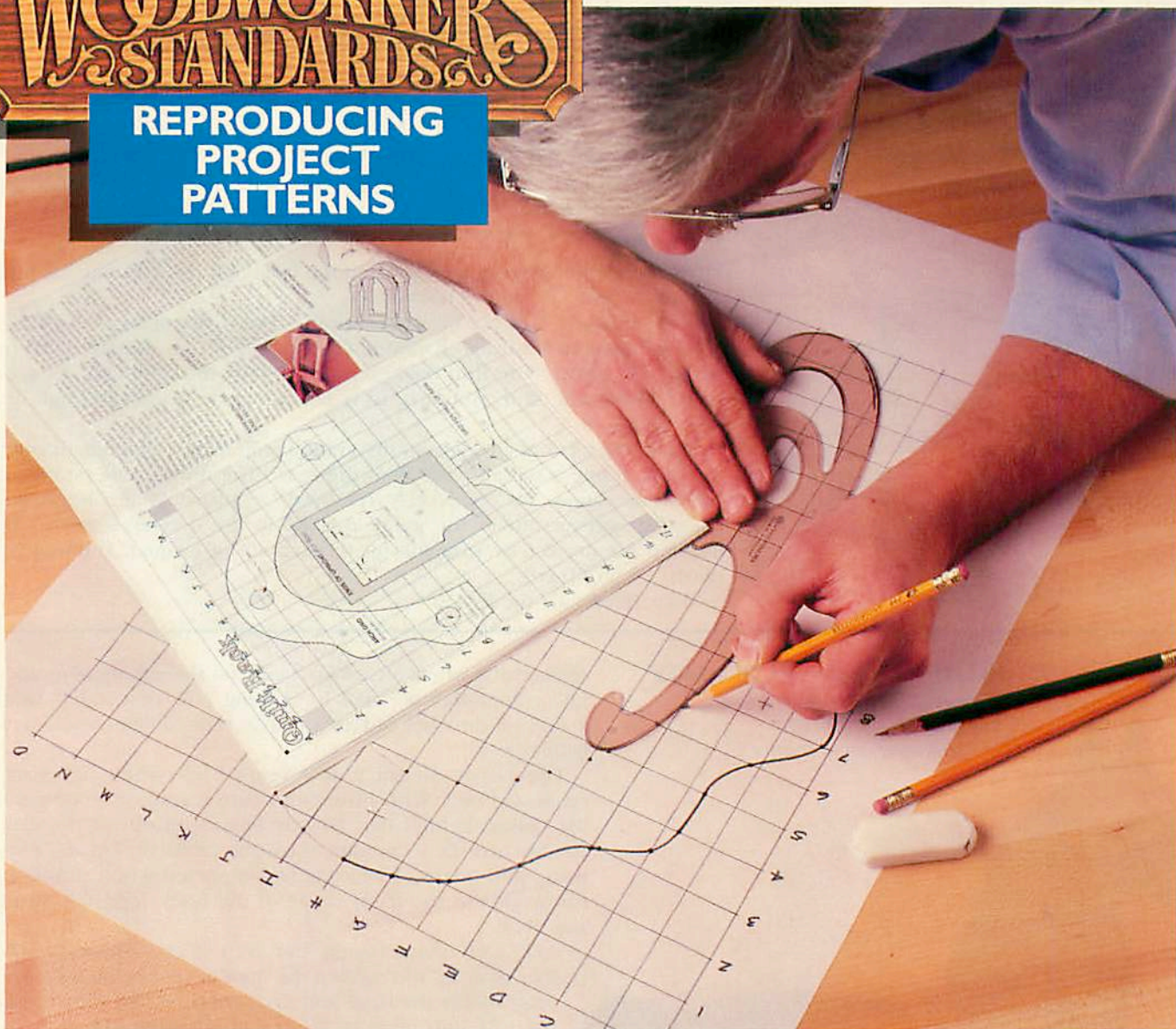

You won't find "gridphobia" listed in Webster's. Medical encyclopedias completely ignore it. But woodworkers feel gridphobia's grip when faced with enlarging a pattern. Their minds freeze at the thought of transposition. Yet, know-how immediately cures the ailment. With photographic technology, it happens in a flash. Even by hand, pattern enlargement becomes child's play.

**D**ue to space limitations, most carving patterns or designs published in magazines, books, and project plans *must* be printed at a reduced size—for you to enlarge. Many woodworkers cringe at the idea—finding pattern line intersections, placing dots on squares, penciling and erasing—and pass such projects by.

Enlarging isn't difficult, however, and special machines and tools make it even easier. Besides, learning the techniques of pattern enlargement and duplication unlocks unlimited sources of designs—ones gridphobiacs will never see.

### PLAY "FOLLOW THE DOTS" WITH HAND ENLARGEMENT

In publishing, graphic designers reproduce *grids* to illustrate patterns. Those requiring enlargement include the statement "Each square equals 1" (or  $\frac{1}{2}$ " and so forth). This notation means that no matter what size grid squares you see in the drawing, you *must* enlarge squares for your full-size pattern to the size indicated.

To use the hand-enlargement method called *transposing*, you'll need *cross-section graph paper* (the kind with heavier lines marking off each square inch and sub-

## HOW TO TRANSPOSE A PATTERN

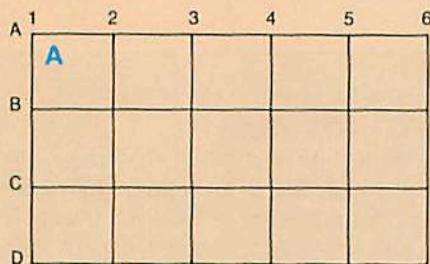

First, number each line in the vertical row. Then, place a letter on each horizontal line.

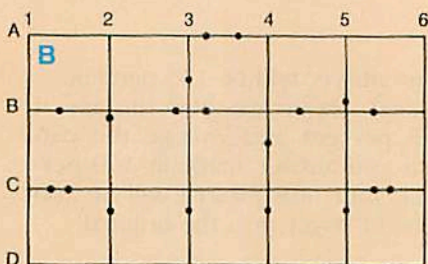

From the original pattern, plot every point where line intersects a square with a dot on your pattern.

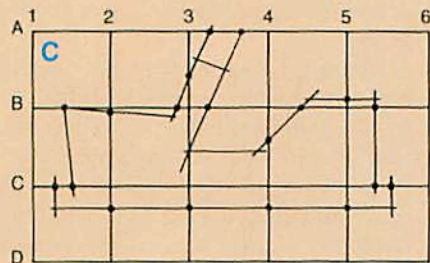
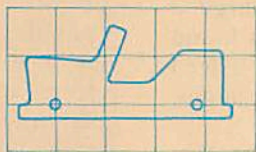

For a more accurate pattern, connect all the straight lines first.

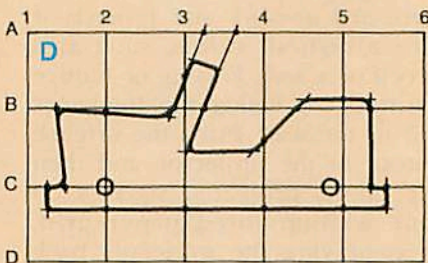

To complete the pattern, connect the dots that represent curves.

## TRACING AND TRANSFERRING A HALF-PATTERN

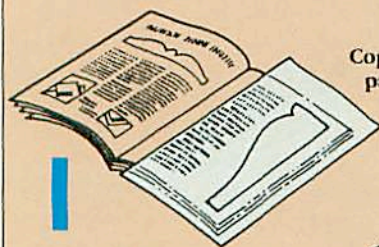

Copy the original published pattern onto tracing paper with a soft-lead pencil. Make heavy lines.

2

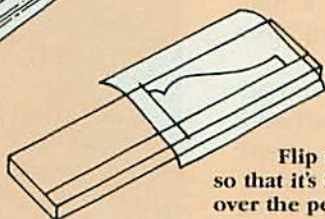

Flip the pattern over on the board so that it's face down, then again trace over the pencil lines.

3

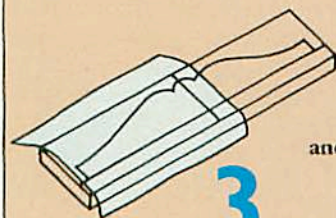

Lay the pattern down on the other half of the board and again trace over the design to impart pencil lines.

divisions of four or more inner squares), a ruler, an eraser, and a soft-lead pencil. If graph paper isn't available at art, mechanical-drawing, school-supply stores or variety retailers, make your own by dividing plain paper into the specified-size squares.

Begin by marking off on your grid paper the same number of squares as indicated on the pattern grid. Next, number each vertical line in the pattern from left to right and letter each horizontal line from the top down, as in drawing A, *left*. Then, mark the corresponding squares on your graph paper the same way.

Start your pattern enlargement by finding a square on your graph paper that matches the same square on the original. Mark the graph paper grid square with a pencil dot in the same comparative place where a design line intersects a grid line on the original, as shown at *left*. Work only one square at a time. Continue to neighboring squares, marking each in the same way where a design line intersects a grid line.

To avoid discovering any mistakes too late, mark only part of the design, then stop and join the dots with a pencil line. Try to reproduce the original contours as accurately as possible, as in drawing C, *left*. For more precision, draw all straight lines first; then add the curved and angled lines, shown in drawing D, *left*. Once you have transposed part of the design, finish marking the rest of the squares and join those dots in the same way.

Sometimes, as when a pattern repeats itself on the other side of a center line, you'll only have a *half-pattern* to use. To duplicate a full-size half-pattern, copy the original with a soft-lead pencil on tracing paper. Next, flip your traced pattern over and place it pencil-lines-down onto one half of the board. After aligning the pattern for position, go over the pattern lines with your

*Continued*

pencil to imprint it on the board. Then, flop the pattern onto the second half of the board and again retrace the pattern to imprint it, as shown in Step 3 in the tracing drawings on the previous page. This method proves faster than copying with carbon paper and doesn't mark up the original pattern.

### PUSH THE BUTTON AND LET A MACHINE DO THE WORK

In this technological age, a photocopier with enlargement capability enlarges a pattern faster and more accurately than transposing. (Not all copiers enlarge, and even some of those that do may be a little inaccurate, so always check your results with a ruler.)

To find out the enlargement percentage you'll need, measure the grid size of the pattern you want to copy. For example, if the magazine's pattern grid measures  $\frac{1}{2}$ " and the scale calls for 1", you'll need an enlargement twice the size, or 200 percent. A pocket calculator simplifies the mathematics—just divide the number representing the full-size scale by the grid size of the original magazine pattern, then hit the percent (%) key.

Photocopiers have limitations. The ideal photocopier for enlarging patterns—sometimes owned by architectural firms—has the ability to enlarge by 1-percent increments. Some may have only a few sizes of enlargement (or reduction) from which to choose, or have a limit on how large the enlargement can be. With the latter, you can still make a full-size pattern by enlarging it in two steps.

For instance, the photocopier's enlargement limit might be 150 percent and you need a 200-percent enlargement. So, first make an enlargement of the original to the 150-percent limit. Then, using a calculator, divide your desired size of 200 by your enlargement limit of 150 percent (200 divided by 150).

Your answer will be 133 percent.

Next, set the machine to copy at 133 percent and enlarge the pattern you already made at 150 percent. Your final pattern will be 200 percent larger than the original.

### PATTERNS BY PROJECTION —JUST LIKE SCHOOL

A few machines enable you to quickly and accurately enlarge a pattern. Typically, they're not found at home, but available (for a fee) from libraries, schools, and audiovisual rental companies.

An *opaque projector* accepts flat, horizontal artwork and projects it onto a vertical surface, such as a screen or a wall. Enlarge or reduce a pattern by taping a graph-paper grid to the wall. Place the original pattern in the projector, and then line up its projected squares on your wall-mounted paper grid. Keep moving the projector back and forth to the wall until the grids line up. When they do, pencil in the projected lines.

An *overhead projector* receives transparent material in the form of a clear acetate sheet, and projects the image onto a screen or wall. An overhead projector operates in the same way as an opaque projector, except that you must trace the lines of the original pattern onto the clear acetate with a non-smearing, felt-tip marking pen before projection.

The printing, publishing, and advertising industries enlarge artwork with huge cameras. The same method works perfectly for enlarging patterns. For a few dollars you can purchase a correctly sized *reproduction stat* ("stat"), a black-and-white photo print of the original that provides accurate detail. You simply request that the print be made to the exact size you want. Check the Yellow Pages under "Photostatic Copy Service" or "Photo Copying." Sometimes, fast-service print shops offer reproduction stats, too.

### A MECHANICAL TOOL TO TOY WITH

With a device called a *pantograph*, you can enlarge (or reduce) patterns at your desktop or workbench. Looking very much like the expandable, protective gate used to keep toddlers from tumbling down a stairwell, a pantograph consists of an arrangement of hinged arms. After you adjust the device for the enlargement needed, you outline the original pattern with the stylus, or tracing end. While you trace the lines with the stylus, the pantograph's pencil end draws the enlargement. It's as simple as that.

Although pantographs usually have an enlargement capability up to 8:1, you'll get sharper reproduction if you stick to a limit of 4:1 (400 percent). If you don't, you'll find yourself working in a tiny area with the stylus while the panto-

### FINDING PROPORTIONS WITH DIVIDERS

*Proportioning dividers*, available at drafting-supply stores for about \$10, enable you to accurately enlarge even a tiny section of a pattern, such as a fractional line or other detail. However, this tool won't draw the segment for you.

Dividers perform solely as a measuring device. First, you measure the length of a line on the original pattern with the points on one end of the dividers. By setting the enlargement size, the points on the opposite end will automatically extend themselves to the enlarged size. To transfer the measurement to the enlargement, simply flip ends of the dividers (see photos, *right*). With proportioning dividers, you can transfer minute details. 🍀

Written by Peter J. Stephano with James R. Downing  
Photographs: Jim Kascoutas  
Illustrations: William Zaun

graph's fully extended pencil arm flaps about. To enlarge greater than 4:1, do it in two steps. That is, for an 8:1 enlargement, use the pantograph to first make a 4:1 enlargement. Then, again enlarge the pattern 2:1. (See a related article about a pantograph board you can build on page 58.)

In setting up the pantograph on your worktable or drawing board, be sure to affix the original pattern and the copy sheet close enough to each other so that the arms won't spread excessively (see photo, right). Be sure, also, to tighten all the pantograph fittings. Any looseness creates wobbly, floppy arms and inaccurate tracing.

You can buy a pantograph at art supply stores. Made in wood or metal, they cost from \$9 to \$20.

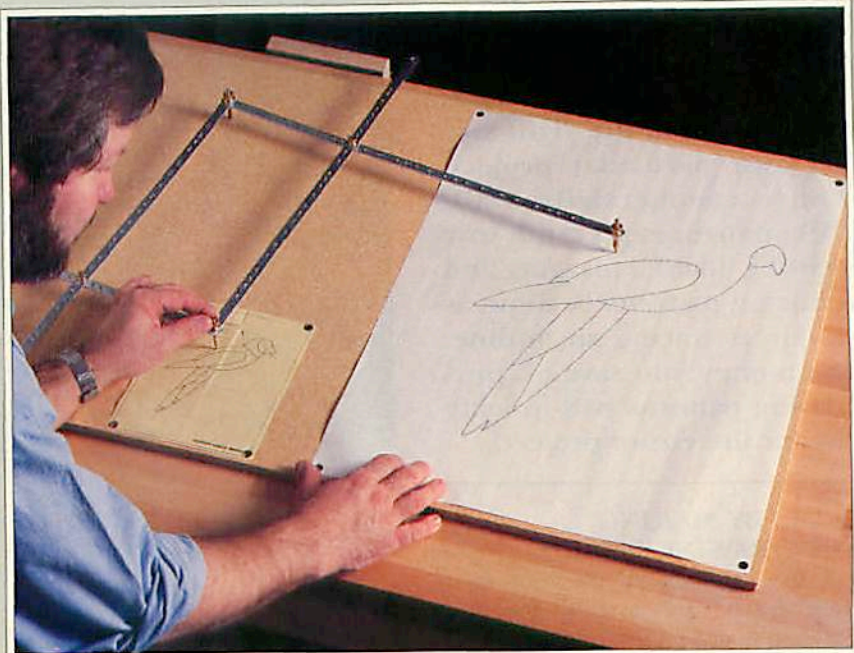

To avoid wobble which results in inaccurate reproduction, don't spread the pantograph's arms too wide. Tighten all fittings, too.

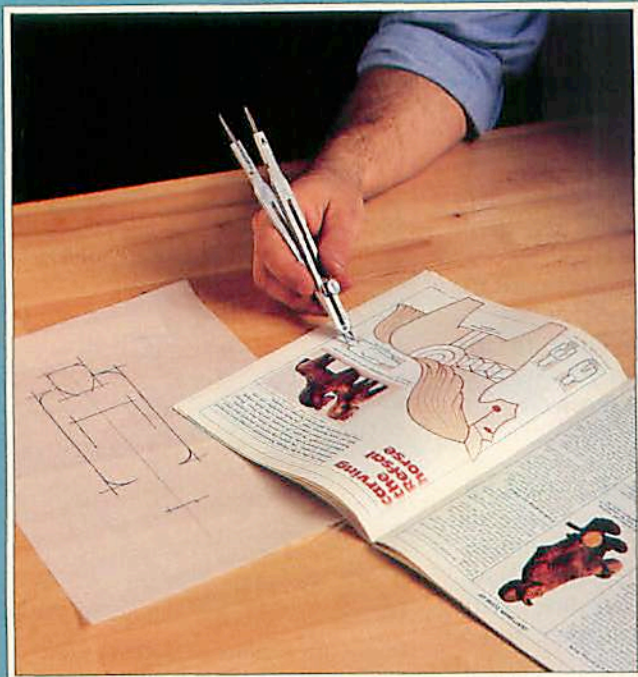

One end of proportioning dividers measures the dimension of a detail on the original.

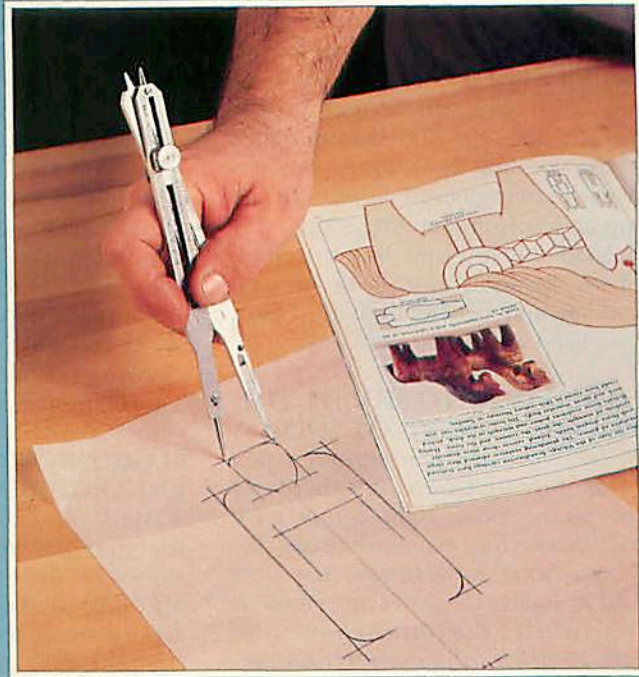

The other end translates the original dimension to the exact scale you choose for the reproduction.

# BE YOUR OWN PATTERNMAKER WITH OUR PANTOGRAPH DRAWING BOARD

Books, magazines, photos, and even coloring and comic books offer endless pattern sources for woodworkers. Unfortunately, though, they're seldom the right size for your particular project. With a commercially available pantograph and our drawing board, enlarging and reducing patterns become as simple as tracing an outline. The money you save on purchasing patterns will quickly pay for the entire project.

## START BY MAKING THE DRAWING BOARD

**1** Cut a piece of  $\frac{3}{4}$ " plywood (we used birch) to 24x40" for the drawing board (A).

**2** To band the plywood drawing board, rip two  $\frac{1}{4}$ x25"-long walnut strips from the edge of a  $\frac{3}{4}$ "-thick board for the ends (B). Rip two  $\frac{1}{4}$ x41"-long walnut strips for the top and bottom (C). Glue and clamp the end strips to the drawing board, checking that the surfaces are flush. After the glue dries, remove the clamps, and trim and sand the ends of the banding flush with the edges of the drawing board. Repeat for the top and bottom banding strips.

**3** Sand the top and bottom edges of the banding flush with the top and bottom of the drawing board (we used a palm sander).

## HERE'S HOW TO MOUNT THE PANTOGRAPH PIVOT SHOE

*Note: The Lutz pantograph listed in the Buying Guide and shown in the photo above right comes with an instruction brochure. Read the instructions to assemble the unit and to locate the parts described in this article. The instructions also give detailed information on operating the pantograph when enlarging or reducing patterns.*

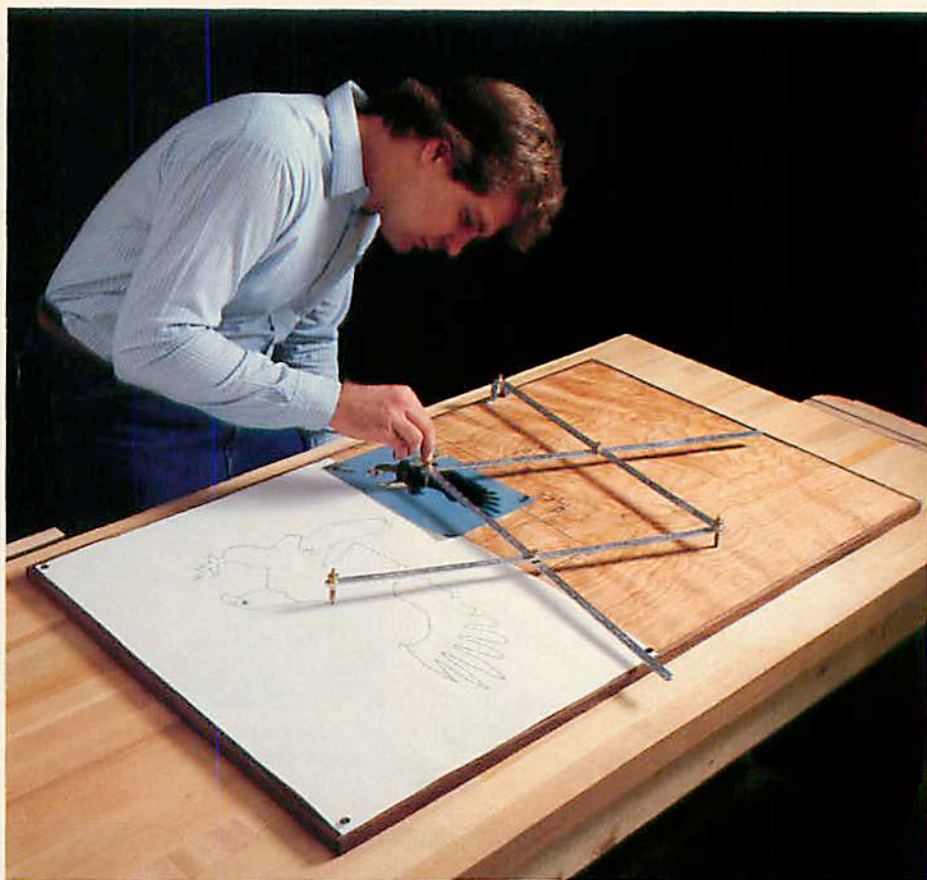

With the eagle pattern centered in the 2:1 ratio rectangle and the blank paper in the copy area, we're doubling the size of the pattern onto the blank paper.

**1** Using the dimensions on the Exploded-View Drawing, mark the location of the center of the pivot shoe. Using the holes in the pivot shoe as guides, drill a pair of  $\frac{3}{32}$ " pilot holes in the drawing board for mounting the pivot shoe.

**2** Fasten the pivot shoe to the drawing board with a pair of #6x  $\frac{1}{2}$ " roundhead wood screws.

## MARKING THE ENLARGEMENT RECTANGLES

**1** Mark the copy-area rectangle on the drawing board where dimensioned on the Exploded-View Drawing. (We darkened our lines with a permanent felt-tip marker and a straightedge.)

**2** To mark the 4:1-ratio rectangle ( $\frac{1}{4}$  the size of the copy-area rectan-

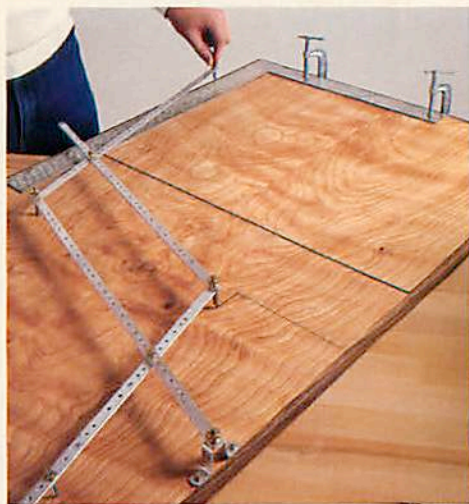

Follow the outline of the copy-area rectangle with the tracing point to mark the 4:1 ratio rectangle on the drawing board. Darken lines with a felt-tip marker.

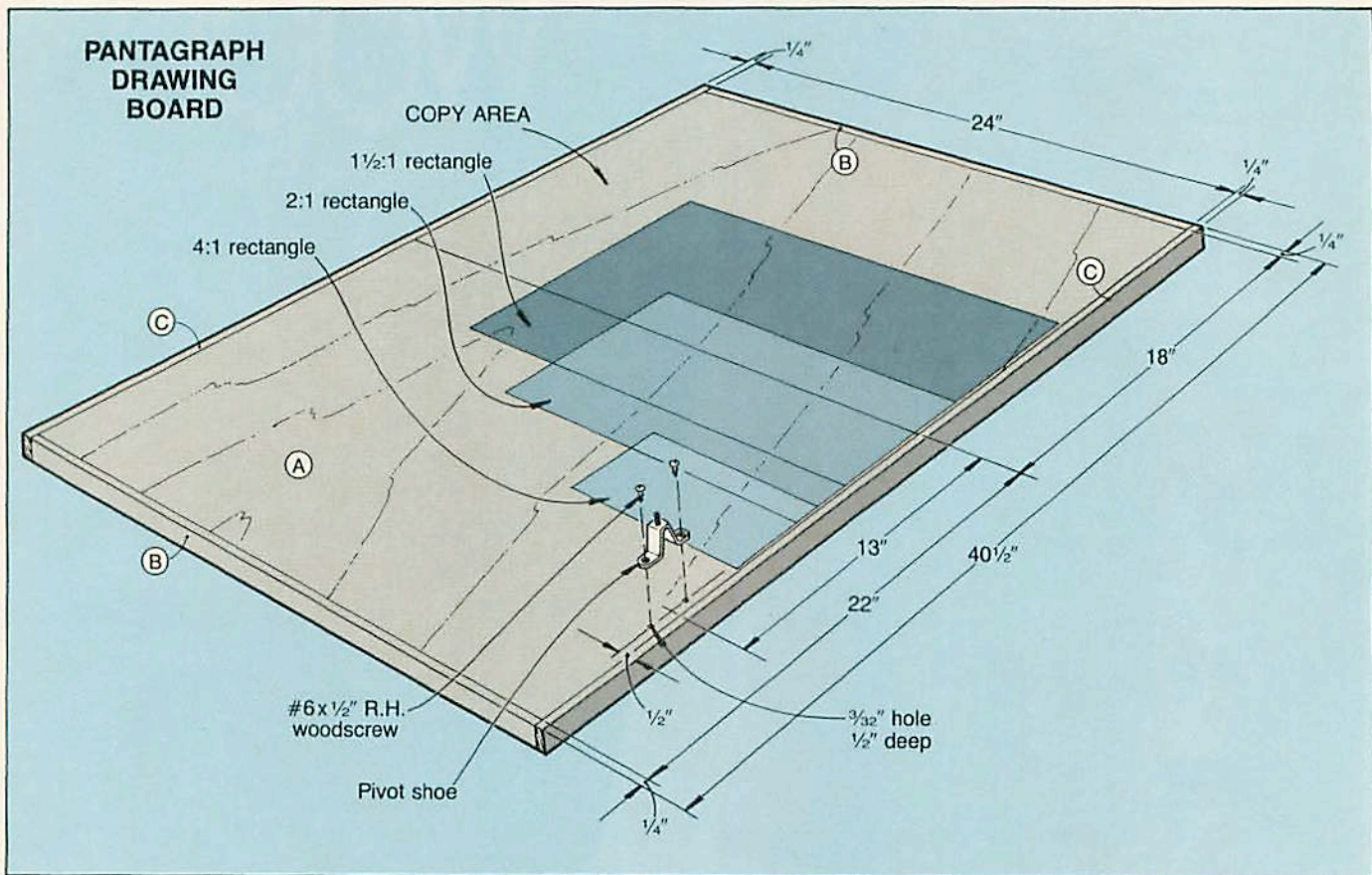

gle), set the ratio screws in holes number 4 in the pantograph bars. Then, exchange the position of the tracing point and lead holder as they come from the supplier. Now, trace the outline of the copy-area rectangle with the tracing point. As you do this, the lead will draw the small rectangle on the drawing board as shown on the photo at left. (Note that we clamped a framing square flush with the edges of the copy-area rectangle to ensure straight perimeter lines on the 4:1 ratio rectangle.)

**3** Repeat this same process with the ratio screws in holes number 2 for the 2:1 ratio rectangle, and in holes number 1 1/2 to mark the 1 1/2:1 ratio rectangle. (We selected the ratios most commonly used, although you may want to draw in other ratios as well. Also, when en-

larging, we have found the 4:1 setting about as large as we can go before the drawn enlargement starts getting sloppy.)

**4** Apply several coats of finish (we used polyurethane for a hard, durable finish).

#### HOW TO USE THE PANTAGRAPH

Begin by exchanging the position of the tracing point and lead holder. Now, to enlarge a pattern 4 times the original size, for example, tape the original pattern, centered, in the 4:1 ratio rectangle and tape the blank paper, centered, in the copy-area rectangle. Fasten the ratio screws in holes number 4 in the pantograph bars. Now, trace the original pattern with the tracing point and the lead will draw the enlarged pattern on the paper.

To reduce patterns, place the original pattern, centered, in the copy-area rectangle. Tape blank paper in the desired ratio rectangle. Reverse the positions of the tracing point and lead holder. Following the outline and detail lines with the tracing point, trace the original pattern.

#### BUYING GUIDE

● **Pantograph.** Constructed from aluminum, this device offers 25 enlarging ratios of 1/8 to 8 times and reducing ratios of 8/9 to 1/8. Includes instructions and replaceable lead points. Catalog no. 78147, \$24.95 ppd. Leichtung Workshops, 4944 Commerce Parkway, Cleveland, OH 44128; 800-321-6840 (in Ohio call 216/831-2555). 📍

Project Design: James R. Downing  
Photographs: Hopkins Associates  
Illustration: Bill Zaun



# WOOD

IT'S MUSIC TO YOUR EARS!

Most home woodworkers select their favorite wood because of color, grain, workability, or ease of finishing. Instrument makers, though, add other criteria—strength, elasticity, and tonal quality—to satisfy the demands of their finely tuned craft. Here are the species they choose, and why, for a symphony of wood.

**W**hen there's music to be made, count on wood. For thousands of years, wood has played a prominent role as man has added to his musical repertoire.

Primitive man produced a re-sounding beat with slit drums. These canoe-like, hollowed-out tree trunks, when placed cavity-side down over a pit and beat upon, were real rhythm makers. It took an inventive musician to stretch an animal skin over the end of a hollow log and create the prototype for today's drum.

The Stone-Age forerunner to a contemporary violin, cello, or harp was the hunter's bow. Held closely to the mouth for resonance, a plucked string twanged a somewhat raw chord. Early man also rolled up tree bark for trumpets and bored out twigs as flutes. Two pieces of wood clacked together became castanets. You can still frequently hear these primitive instruments played in ceremonies by remote tribes around the world.

### ORCHESTRATED WOOD

As man and civilizations developed, so did musical instruments. Yet it wasn't until the 18th century that Austrian composer Franz Joseph Haydn, "The Father of the Modern Orchestra," assembled musicians with their different instruments to achieve harmonious results.

Musical instruments had to keep pace with the improvements in orchestration. A musician whose instrument could not produce the tonal qualities and range composers demanded might well find himself out of work. Therefore, luthiers (craftsmen who make stringed instruments) and other instrument makers were under pressure to experiment with control mechanisms—and different woods.

The illustration of a typical orchestra arrangement, *next page*, depicts its instruments. Those made

*Opposite:* A harp's maple neck must resist 1,800 lbs. of tension, yet match strength with beauty. This model costs more than \$20,000.

primarily of wood represent nearly 75 percent, and can include more than two dozen wood species!

### WOODWIND'S STABLE STOCK

A musician plays a woodwind instrument by making the air inside it vibrate from the action of a mouth-piece containing a reed. All woodwinds have air inside them, but only some woodwinds are made of wood. Instrument makers fashion the finest clarinets, bass clarinets, oboes, English horns, and some pic-

---

## So heavy that ship captains once stowed it as ballast, African blackwood now becomes clarinets and oboes.

---

colos, from a rosewood. That, however, was not always the case.

In Europe, clarinet makers once relied on readily available, easily worked boxwood for their instruments. But the lightweight wood's tendency to warp from the moisture in an instrument always posed a problem. "Some instrument makers insisted they could predict the weather by the way the instrument pointed," quips Chip Owen of Fox Musical Products, an Indiana-based bassoon and oboe manufacturer. "Boxwood wouldn't crack, but you couldn't call it stable when used for an instrument."

By the mid-19th century, clarinet makers sought a stronger, denser wood to withstand the boring and attachment of complex, tone-controlling mechanisms. The solution was found cast aside on the docks of a European seaport. A to-this-day unnamed clarinet maker, frustrated by boxwood, discovered a discarded piece of dark, dense, and hard wood. Used as ballast by seagoing ships, it had been wetted, dried, and weathered, yet remained solid and stable. The wood was African blackwood, the rosewood now

called granadilla by instrument makers and musicians.

Bassoons require a hardwood body, too. However, granadilla is so hard that it produces notes too high for a bassoon. Therefore maple has become the traditional wood for bassoons. And, unique to a bassoon, each of its sections must be fashioned from maple of different grain. This type of construction gives each section a specific tonal quality.

### A SERENDIPITY OF SPECIES FOR STRINGS

Violins, violas, cellos, basses, and harps compose an orchestra's string section. For strength, tone quality, and beauty, luthiers make the backs and sides of violins, violas, cellos, and basses from specially selected, fiddleback-figured European sycamore or maple.

The sounding-board top must be flexible enough to transmit the vibrations of the strings, yet strong enough not to split. Quarter-sawn spruce or white pine fills the prescription perfectly. Because of their reputation for being unmatched in appearance, durability, and stability, ebony or rosewood becomes fingerboards and chin rests. And fine, handcrafted bows of Brazilian pernambuco, famed for its resiliency, bring forth the best notes.

The piano, one of the most versatile stringed instruments of all, boasts an abundance of wood species. Despite frequent reference to "the ivories," a piano's keys often prove to be made from ebony and holly. The complex linkage, platforms, and hammers of the action must be of only the hardest, most shock-resistant woods—beech, hornbeam, maple, and African mahogany. The soundboard, the heart of the piano, relays the messages of the strings, and only laminates of white pine, basswood, or spruce fill the bill. A casework of laminated mahogany and decorative veneer of walnut often cover the piano's iron frame. (In the past, pianos could even boast of solid mahogany cases.) Built-up or solid legs of

*Continued*



# WOOD IT'S MUSIC TO YOUR EARS

mahogany, beech, or African sapele support weight of a ton or more.

According to Bob Storm of Lyon & Healy, Chicago harp makers since 1889, a concert harp's body must be rigid and strong enough to withstand a constant tension of 1,800 pounds from 47 wire, gut, or nylon strings. However, the frame must be flexible enough to vibrate with the strings to make sound. "To accomplish this," Storm notes, "we use a 15-ply lamination of hard maple for the neck. To add even more strength, each ply must be laid up at a 45-degree angle to the one before it.

Then, so it's pleasing to the eye, we cover the plies with a veneer of bird's-eye or curly maple. We've also used rosewood on custom order." A soundboard of quarter-sawn spruce allows this oldest of all stringed instruments, when fitted with pedals, to duplicate all the notes of a piano.

## STICKS AND TONES

From the first primitive drum, percussion has been synonymous with wood. Not only drumsticks—turned from hickory or exquisitely figured snakewood from Guyana and Suriname—but the drums themselves.



*Bassoons*  
Maple, pallsander

*Clarinets and bass clarinets*  
African blackwood

*Bass*  
Ebony, maple, rosewood, spruce, sycamore

*Violins*  
Ebony, maple, rosewood, spruce, sycamore

*Piano*  
Basswood, beech, ebony, holly, mahogany, pine, sapele

The circular bodies of an orchestra's bass and side drums are formed of laminated birch, maple, beech, or mahogany. Jay Wanamaker of Yamaha Music Corporation's percussion division, says that the plies used by drum makers range from 1/16" to 1/8" thick. "The stronger a drum needs to

be, the more plies it will have," notes Wanamaker. "Tightening the head of a drum makes it sound a higher note. So, the higher you want a drum to sound, the stronger it must be. A very strong drum will have as many as 10 plies, laid up one at a time, then shaped under vacuum pressure."

When a musician taps the tone bars of a xylophone with small wooden hammers, wood chosen especially for its tonal quality elicits bell-like sounds. Tulipwood from Brazil, or a heavy, coarse-textured rosewood from Honduras, has long been used for the tone bars.

And what of the conductor, the master blender of symphonic sound? What wood takes the shape of the baton that directs, emphasizes, and harmonizes the performance of each musician? Holly, white as ivory and polished to perfection. 🌿

Written by Peter J. Stephano  
 Illustration: Jim Stevenson  
 Photograph: Lyon & Healy Harp  
 photo courtesy of Lyon & Healy



*Xylophone*  
 Rosewood, tulipwood



*Bass and side drums*  
 Birch, hickory, mahogany



*English horns and oboes*  
 African blackwood



*Cellos and Violas*  
 Ebony, maple, rosewood, spruce, sycamore



*Harp*  
 Maple, spruce



# A TURN FOR THE BETTER DESIGNER EARRINGS

ANOTHER IN A COLLECTION OF PATTERNS  
FROM THE NATION'S TOP WOODTURNERS



Bonnie Klein

**B**onnie Klein of Renton, Washington, excels in turning small items. Her idea for turned jewelry evolved from a desire to turn earrings that didn't look like miniature

spindles. We think you'll agree that her method of turning tiny bowls, and then cutting and sanding them to shape, creates earrings that are anything but ordinary.

## FIRST, SHE MAKES A SCRAP FACEPLATE

Bonnie starts by marking a 3"-diameter circle on a piece of 1½"-thick pine, and then cuts it to shape on the band saw. To mount the scrap faceplate to the lathe, Bonnie drills a ¾"-deep hole at the center point. The hole measures ⅛" smaller in diameter than the outside diameter of the headstock spindle on her lathe. Rotating the headstock spindle by hand, the industrious turner threads the pine faceplate onto the spindle. Next, she starts the lathe, turns the pine to a 1¾" diameter, and squares the face. With the lathe

running, she marks concentric circles about ⅛" apart on the face of the faceplate. The circles aid when centering the turning stock later.

## NOW, BONNIE TURNS AND FINISHES THE SMALL BOWL

For the earring blanks, Bonnie marks and band-saws pieces 1½" in diameter from ¾" or thicker stock. Using the concentric circles on the scrap faceplate, she centers and glues the earring blank to the faceplate. Bonnie turns the earring blank round and trues up the face.

Turning a shallow depression—⅜" deep—in the face of the earring blank with a ¼" spindle gouge comes next. Bonnie then turns the back of the piece with a ¼" skew chisel to form a small bowl as shown in the drawing *below*. "I leave a ⅛"-diameter stub to hold the bowl on the lathe for sanding and finishing," notes Bonnie. "After sanding, I use a mixture of shellac, alcohol, and linseed oil on some of the pieces. Some woods, such as cocobolo and kingwood, look best with just an application of wax." Then, as shown *below right*, she parts the miniature bowl from the lathe, hand-sands, and applies a finish to the unfinished area left by the stub.



## THE FINAL TASK—CUTTING AND SHAPING THE EARRINGS

Bonnie cuts the bowl in half on a scroll saw, and disk-sands the cut edge to shape the earring. By holding the earring against the disk at different angles, she can vary the final shape. Hand-sanding the shaped edges comes next, followed by drilling a ⅛" hole, and attaching the ear wire. "Pay close attention to how you want the earrings to hang," Bonnie says. "There's a definite left and right earring. Adjust the direction the earrings hang by twisting the lower rings."

## BUYING GUIDE

● **Fishhook earrings.** Gold finish, catalog no. 455-78, six pairs for \$5 ppd. Hobby Haven, 7672 Hickman Road, Des Moines, IA 50322. 🌳

Photographs: Jim Kascoutas, Richard Reynolds  
Illustrations: Bill Zaun

### SECTION VIEW

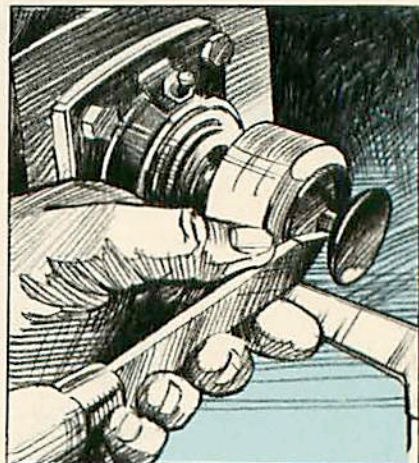
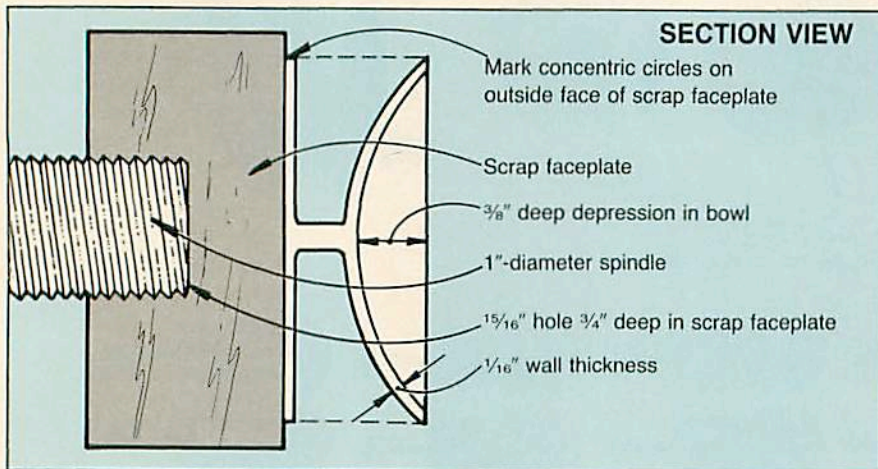



Build this fashionable outdoor furniture set

# TEAK TABLE AND DIRECTOR'S CHAIRS

**Note:** *The instructions and Bill of Materials on page 67 give the directions and number of pieces needed to build a single chair. To make additional chairs, we suggest you cut and laminate all identical pieces at the same time to ensure uniformity. When cutting the numerous pieces to length, we used a stop to ensure consistent lengths.*

#### DESIGN NOTES

For this design, I chose teak, one of my personal favorites and a wood with the reputation for being able to stand up well to the weather. It's been used for centuries in the boat-building business with great success. And because deck furniture typically gets lots of use, I specified mortise and tenon joinery and slow-set epoxy. You don't have to worry about these joints coming apart!

Also note that the table and chairs have identical bases to simplify construction. I think you'll enjoy building these projects.

*James Downing*  
Design Editor

# TEAK DIRECTOR'S CHAIRS

## CUT THE PIECES TO LENGTH AND WIDTH FOR THE SIDE AND LEG ASSEMBLIES

*Note: For perfectly centered mortise and tenons, it's important to start with stock exactly 3/4" thick. Buy stock this thick, or plane thicker stock to size.*

**1** From 3/4"-thick teak, rip and crosscut eight pieces 1 3/4 x 16 1/2" long (we used a stop clamped to the radial-arm-saw fence for consistent lengths). You'll use four of the pieces for laminating the two backrest supports (A) and four for the armrests (B). For ease in mating the teak parts later, label the parts A and B. Cut and label four pieces 1 3/4 x 16" long for the lower supports (C), and four pieces 1 3/4 x 9" long for the two front supports (D).  
**2** From 3/4" teak, rip and crosscut four pieces 1 3/4 x 16" long. You'll use two of these for the top inner leg (E) and two for the top outer leg (F). Then, cut eight pieces 1 3/4 x 24 1/2" long for the inner and outer leg supports (G). Next, cut two pieces 1 3/4 x 12 3/8" long for the lower inner-leg spacer (H), and two pieces 1 3/4 x 15 1/2" long for the outer-leg spacer (I). Label the teak pieces (E, F, G, H, I) for ease in mating when epoxying later.

### CHAMFER DETAIL

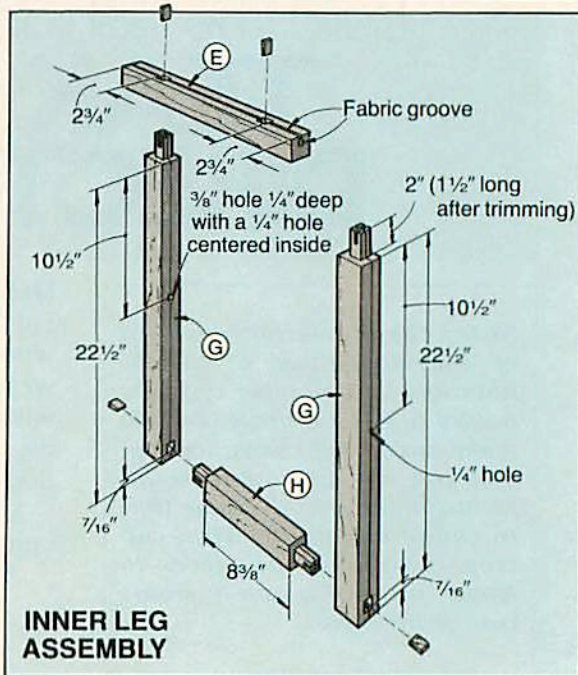
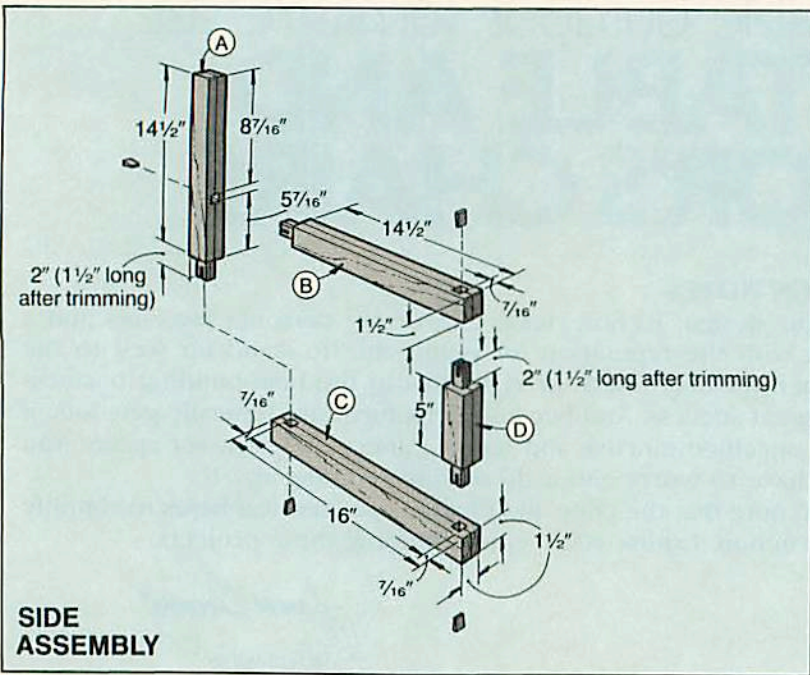
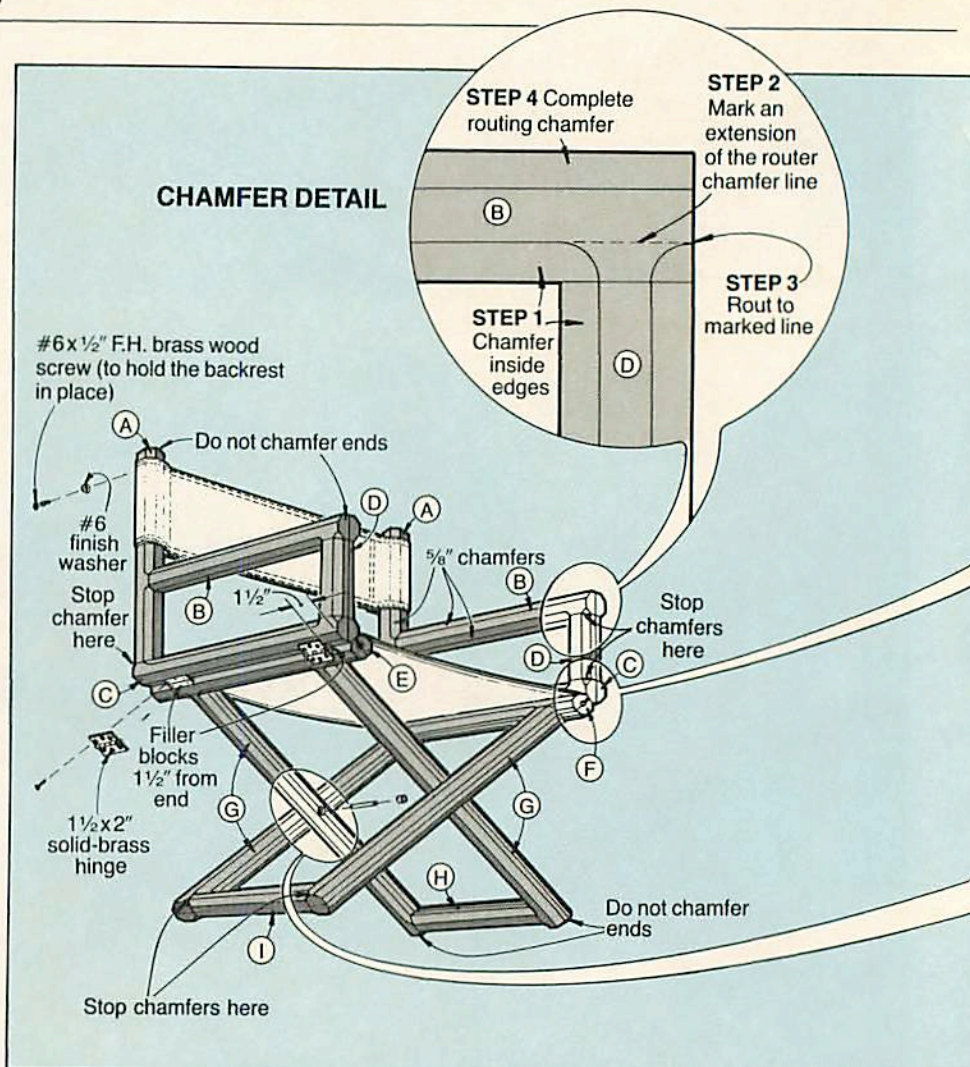

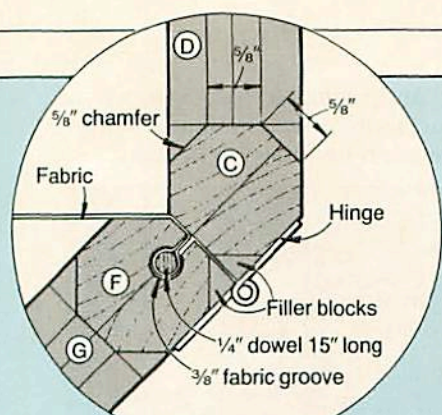

**FABRIC GROOVE DETAIL**

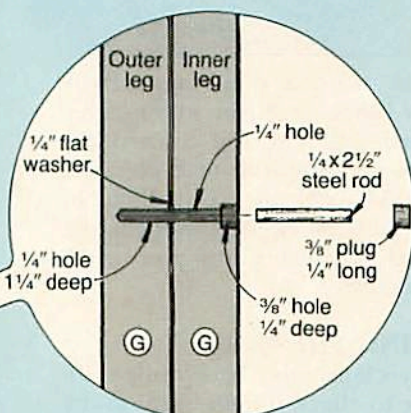

**SECTION VIEW PIVOT PIN DETAIL**

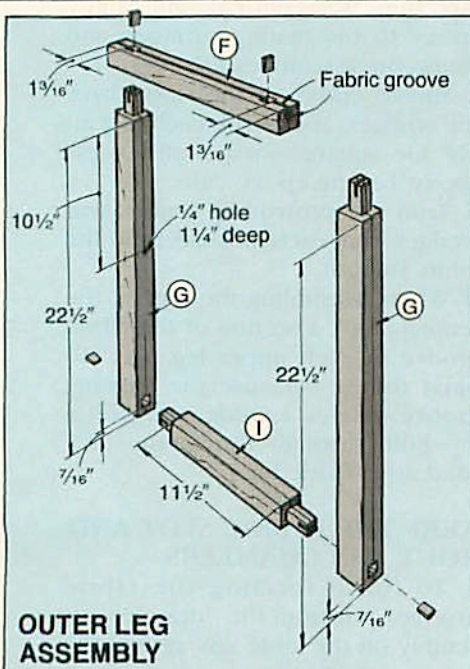

**OUTER LEG ASSEMBLY**

**Cutting Diagram**

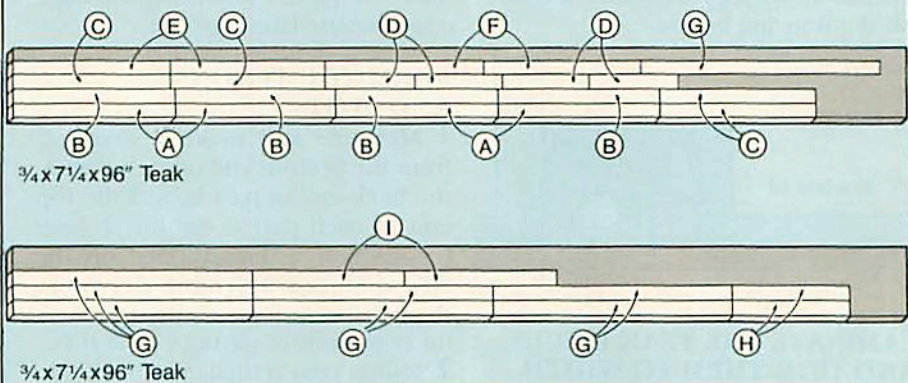

**Bill of Materials For One Chair**

Part	Initial Sizes*			Material	Qty.
	T	W	L		
<b>Side Assemblies</b>					
A*	1 3/4"	1 1/2"	16 1/2"	teak (lamin.)	2
B*	1 3/4"	1 1/2"	16 1/2"	teak (lamin.)	2
C*	1 3/4"	1 1/2"	16"	teak (lamin.)	2
D*	1 3/4"	1 1/2"	9"	teak (lamin.)	2
<b>Inner and Outer Leg Assemblies</b>					
E*	1 3/4"	1 1/2"	16"	teak (lamin.)	1
F*	1 3/4"	1 1/2"	16"	teak (lamin.)	1
G*	1 3/4"	1 1/2"	24 1/2"	teak (lamin.)	4
H*	1 3/4"	1 1/2"	12 3/8"	teak (lamin.)	1
I*	1 3/4"	1 1/2"	15 1/2"	teak (lamin.)	1

\*The sizes listed above are the sizes of the laminations before they are trimmed to 1 1/2" wide and the wedged tenons are trimmed.

**Supplies:** latex gloves, 2—1/4"-diameter by 2 1/2"-long steel pins (cut from 1/4"-diameter steel rod), 2—1/4" flat washers, 4—1 1/2 x 2" solid brass hinges (Stanley part no. CD5304), 1/4"-thick clear acrylic for router base (optional), fabric recommended for outdoor use (see the drawings for size), 2—#6 x 1 1/2" flathead brass wood screws and brass finishing washers, 2—1/4 x 15"-long oak dowel stock, alcohol, paraffin, finish.

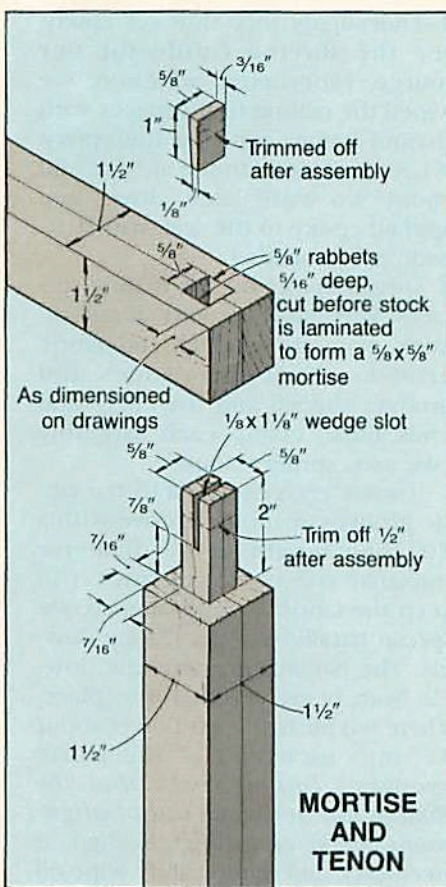

**MORTISE AND TENON**

**NOW, CUT THE DADOES AND ROUT THE COVES TO FORM THE FABRIC GROOVE**

**Note:** For perfectly square mortises, we cut dados in the individual teak pieces. Then, we laminated the pieces together, and aligned the dados. This method worked better than drilling and chiseling the mortises to shape after laminating the pieces.

**1** Mark the location, and cut a 5/8" dado 5/16" deep in all the parts (except D, H, and I) where dimensioned on the Side and Inner- and Outer-Leg Assembly drawings at left. (We cut ours on the radial arm saw fitted with a dado blade, and clamped a stop to the fence for accurately placed dados.)

**2** To form the fabric groove in the top inner- and outer-leg parts (E, F),

*Continued*

## TEAK DIRECTOR'S CHAIRS

route a  $\frac{3}{8}$ " cove  $\frac{3}{16}$ " deep the length of each upper-leg part where shown on the drawing below:

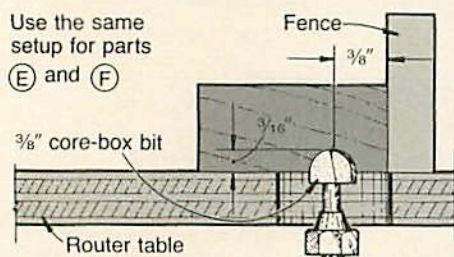

### LAMINATE THE TEAK PIECES, AND TRIM THEM TO WIDTH AND LENGTH

**1** Thoroughly mix slow-set epoxy, see the Buying Guide for our source. (For better adhesion, we wiped the mating teak surfaces with alcohol before applying the epoxy. When working with the alcohol and epoxy we wore latex gloves and applied epoxy to the teak with a 1" wide nylon brush.)

**2** Spread epoxy on the mating surfaces, keeping the epoxy about  $\frac{1}{4}$ " away from the dadoes and fabric grooves. With the dadoes and grooves aligned and the edges and ends flush, clamp each assembly (we used spring clamps).

If some epoxy seeps into the fabric grooves, ream the groove with a 20"-long length of  $\frac{1}{4}$ "-diameter threaded rod or dowel stock. (To keep the fabric grooves aligned, we spread paraffin on  $\frac{3}{8}$ x1"-long dowels. The paraffin prevents the dowels from being epoxied into place. Then, we pushed each dowel about  $\frac{1}{4}$ " into each end of the fabric grooves.) *Double-check that the dadoes did not come out of alignment when clamping.* Realign, if necessary, and immediately wipe off any excess epoxy.

**3** After the epoxy cures for 24 hours, remove the clamps, and scrape any excess epoxy from one edge and both ends of each lamination. Use a sharp  $\frac{1}{2}$ " chisel to remove all epoxy in the mortises.

**4** Plane the *scraped* edge of each chair part. Set the table-saw fence  $1\frac{1}{2}$ " from the inside edge of the saw blade. With the *planed* edge against the the fence, rip the oppo-

site edge of each chair part to  $1\frac{1}{2}$ " wide. On parts E and F, cut the edge *opposite* the fabric groove.

### FORM THE TENONS AND SLOTS

**1** Measure and make a mark 2" from the bottom end of each part A, the back end of part B, and the top end of each part G for the 2"-long tenons where dimensioned on the Side and Leg Assembly drawings. Repeat the process to mark tenons on *both* ends of parts D, H, and I.

**2** Using your radial arm or table saw and a stop clamped to the fence, cut the tenons to shape. (We first test-cut a tenon in  $1\frac{1}{2}$ x $1\frac{1}{2}$ " scrap stock to check the fit of the tenon into the previously cut mortises.) See the Mortise and Tenon Drawing for dimensions.

**3** Band-saw a  $\frac{1}{8}$ "-wide slot  $1\frac{1}{8}$ " long in each tenon where shown on the Mortise and Tenon Drawing. Notice that the slot is perpendicular to the glue line. You'll need to make a couple of passes to form the slot. (To ensure a straight slot, we positioned the chair part against the fence when cutting the slots. We also clamped a stop to the fence to ensure  $1\frac{1}{8}$ "-long cuts.)

### FINAL MACHINING BEFORE JOINING THE PARTS

**1** So that you'll be able to join the inner- and outer-leg assemblies later, drill a  $\frac{3}{8}$ " hole  $\frac{1}{4}$ " deep where marked on the inside edge of both inner-leg supports (G). See the Inner Leg Assembly Drawing for dimensions and the Pivot Pin Detail Drawing for hole sizes. Now, drill a  $\frac{1}{4}$ " hole through the center of each  $\frac{3}{8}$ " hole.

**2** Using the Outer Leg Assembly Drawing as a guide, drill a  $\frac{1}{4}$ " hole  $1\frac{1}{4}$ " deep, centered from side to side, on the inside edge of each outer-leg support (G).

**3** To form the wedges for the tenon slots, start by cutting a piece of teak to  $\frac{5}{8}$ x $1$ x $10$ " long. Fit your table with a zero-clearance insert (we used hardboard). Next, set your table saw miter gauge  $2^\circ$  from cen-

ter, and clamp a spacer block to your table saw rip fence where shown on the drawing below:

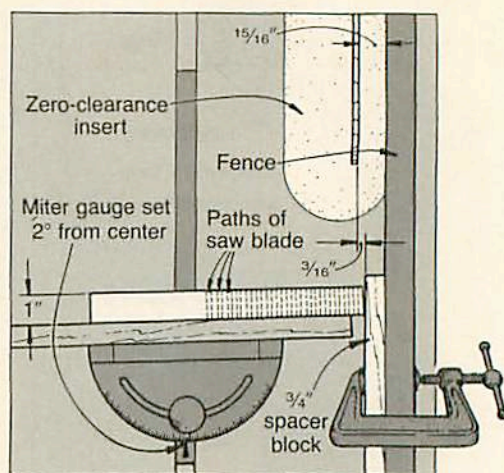

**4** Slide the teak piece against the spacer block, push the miter gauge forward, and cut and discard the first piece. Turn the teak piece  $\frac{1}{2}$  turn, and make the second cut to form the first wedge. Repeat the turning and cutting until you cut 16 teak wedges.

### JOINING THE PARTS

**1** Dry-clamp the assemblies together to check the fit. Position the leg supports (G) correctly to keep the pivot pin holes facing the right direction. Wipe with alcohol, apply epoxy to the mating surfaces, and clamp the assemblies together.

**2** Spread epoxy in the slots, drive the wedges, and check each assembly for square. Scrape off excess epoxy. Let the epoxy cure.

**3** Trim the protruding tenons and wedges from each mortise. Sand the joints smooth.

**4** When assembling the pieces, the tenons block a section of the fabric groove in each upper leg part. To open the groove, use the existing groove hole as a guide, and drill a  $\frac{3}{8}$ " hole through the tenon. (We used a  $\frac{3}{8}$ " spade bit.)

### KERF THE FABRIC SLOT AND ROUT THE CHAMFERS

**1** To finish forming the fabric groove, position the inner-leg assembly on the table saw against the fence and directly over the saw

blade where shown on the drawing *below*: Cut a  $\frac{1}{8}$ " kerf the length of the top inner-leg part (E) and the top outer-leg part (F).

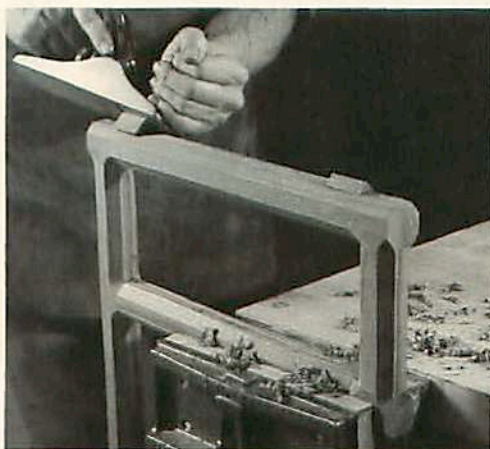
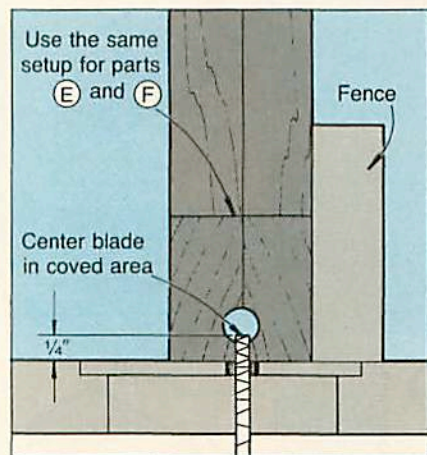

Plane the hinge-support blocks flush with the chamfered edges.

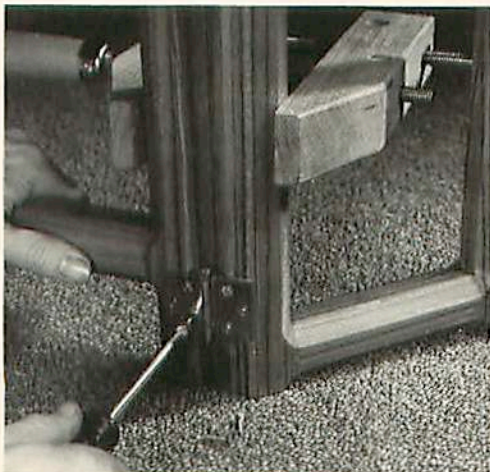

Screw the brass hinges to the hinge-support blocks.

**2** Rout a chamfer along the edges of the side and leg assemblies, lowering the bit each pass to reduce chip-out. Don't rout the ends where shown and described on the four-step Chamfer Detail accompanying the Exploded-View Drawing. (We stopped routing just short of the ends, and sanded the teak parts to finish forming the chamfers.)

*Note: For greater support and a better view when routing, we cut a 12"-diameter disk from  $\frac{1}{4}$ " acrylic. We removed the subbase from our router and mounted the acrylic base in its place.*

### CUTTING THE PIVOT PINS AND FILLER BLOCKS

**1** To make the pivot pins that join the legs, cut two pieces of  $\frac{1}{4}$ "-diameter steel rod to  $2\frac{1}{2}$ " long.

**2** To make the filler blocks that support the hinges, bevel-rip the edge of a 20" length of  $\frac{3}{4}$ " teak to a  $\frac{1}{2} \times \frac{1}{2}$ " wedge. Set a stop, and crosscut eight filler blocks  $1\frac{1}{2}$ " long each from the 20" length.

**3** Mark the positions for the filler blocks where shown on the Exploded-View Drawing, and epoxy them to leg pieces E and F and the lower support (C).

**4** Later, plane the filler blocks flush with surfaces of the chair parts as shown in the photo at *left*.

**5** Insert the  $\frac{1}{4}$ " steel pins into the pivot-pin holes, and place a  $\frac{1}{4}$ " washer between the leg assemblies (see the Pivot Pin Detail). Cut two  $\frac{3}{8}$ "-diameter plugs  $\frac{5}{16}$ " long, and plug the holes. Sand the chair assemblies smooth.

### APPLY THE FINISH AND SEW THE SEAT AND BACK

**1** Apply the finish (see the Buying Guide at *right* for our source).

**2** Clamp the chair parts together as shown in the photo at *left*, drill pilot holes, and screw the hinges to the filler blocks and chair parts.

**3** Cut a piece of fabric to  $18 \times 20\frac{1}{2}$ " for the seat and one piece  $8 \times 31\frac{1}{8}$ " for the backrest (we used Sunbrella—an awning material—canvas, or another material suited for outdoor use, would work also). Fold and

hem all four edges of the backrest and the front and back edges of the seat, using the drawings *below* as guides. To finish forming the tube-shaped ends on the seat, fold the nonhemmed ends over and sew the edges to the fabric. Repeat the sewing procedure to form the backrest.

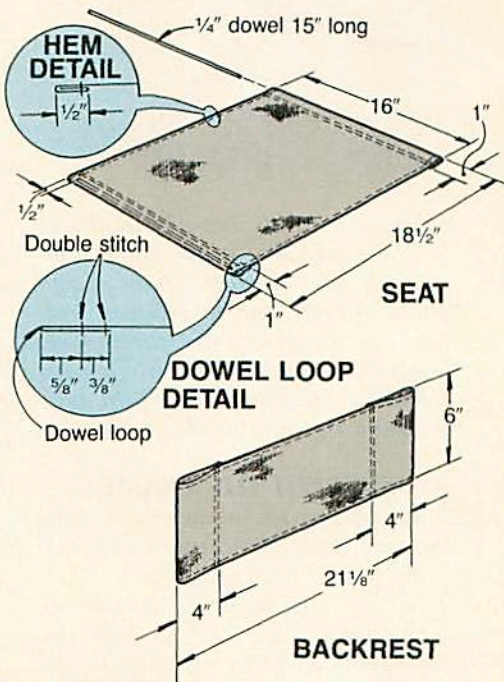

**4** Cut two pieces of  $\frac{1}{4}$ " oak dowel to 15" long. Insert one dowel in each looped end of the seat. Slide the dowel and fabric into the fabric groove in the top pieces of the leg assemblies. Slip the backrest on and screw it into place where shown on the Exploded-View Drawing.

### BUYING GUIDE

● **Slow-set epoxy kit.** Kit includes 750 ml. (26 oz.) of resin and hardener, gloves, mixing cups, and instructions. Catalog no. 11P33, \$20.95 ppd. from Woodcraft, 41 Atlantic Ave., P.O. Box 4000 WBH, Woburn, MA 01888; 800-225-1153 (in Massachusetts 617/935-9278).

● **Finish.** Decks Olje, a two-part, penetrating oil finish. Call 800-321-3444 for location of the nearest distributor. To order by mail, send \$21.41 ppd. for the two-quart package to: E & B Discount Marine, P.O. Box 3138, 201 Meadow Rd., Edison, NJ 08818; 800-533-5007.



# TEAK TABLE



**Note:** The table base is identical to the inner and outer leg assemblies of the director's chair, except you omit the fabric grooves. Follow the instructions starting on page 66 to build the chair leg assemblies. Here, we'll explain how to make the tabletop/tray.

## BEGIN WITH THE FRAME

**1** Rip and crosscut the frame ends (A) and sides (B) to the sizes listed in the Bill of Materials.

**2** To cut the frame half laps, set your dado blade to cut half the thickness of your teak material. Test-cut scrap stock first. Now, set a stop, and cut a 2½"-long half lap on each end of the frame ends (A), and a 3⅞"-long half lap on each end of the frame sides (B) where shown on the Half Lap Detail.

**3** Mix the epoxy, clean the mating surfaces of the half laps with alcohol, and apply the epoxy. Lightly clamp the frame pieces together, checking for square. Wipe off any excess epoxy immediately. Let the epoxy cure for 24 hours, and sand the entire frame smooth.

**4** Measure 9¼" from one edge of each A frame member, and mark radii center points. Using the drawing on the *opposite* page, mark the radii lines for the frame and handles (we used trammel points).

**5** Drill a 1" hole at each handle center point where shown on the Frame Top View Drawing. (Backing the stock with scrap prevents chip-out.) Use a jigsaw to cut the handles to shape.

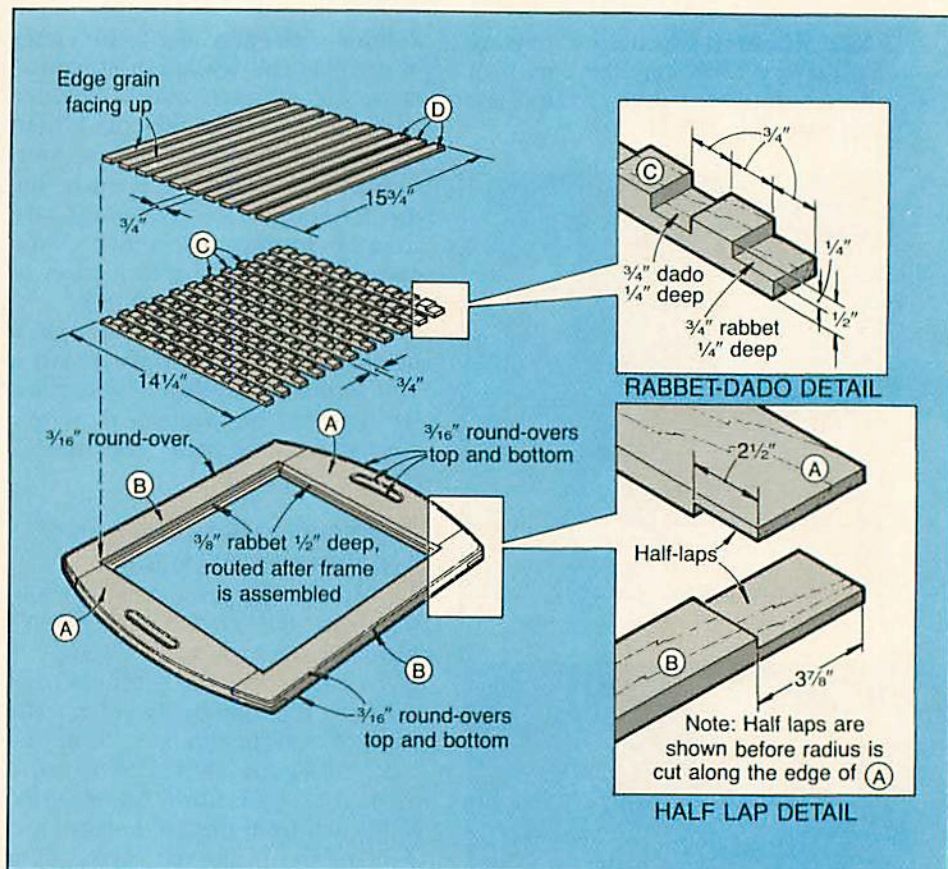

**6** Using a band saw, cut the frame ends to shape. Sand the ends and handle openings smooth. (We used a palm sander on the ends and a drum sander in the handles.)

**7** Rout a round-over on the outside top and bottom edges of the frame where shown on the Exploded-View Drawing. Rout the same size round-over on the top and bottom edges of the handle openings.

**9** Switch to a ⅜" rabbet bit, and rout a ⅜" rabbet ½" deep along the inside top edge of the tray frame. Chisel the corners square.

## NEXT COMES THE GRATE

**1** To cut the grate parts (C) to size, start by setting the table-saw fence ½" from the inside edge of the saw blade. Rip 11 pieces from the edge of a teak board that measures at least 15" long. Measure the distance between the rabbets in the frame side pieces (it should measure 14¼"), and crosscut the grate parts (C) to length.

**2** Position the table-saw fence ¼" away from the inside edge of the blade, and, using a push stick, cut 10 upper grate parts (D) to width from a board at least 16" long. Measure the rabbeted opening between the end pieces (it should measure 15¾"), and crosscut the upper grate parts to length.

**3** Mark the rabbet and dado locations on one of the ½"-wide pieces. Attach a dado blade set to your saw (we used our radial-arm saw), and clamp a stop to the saw fence. Now, cut a ¾" rabbet ¼" deep where marked on both ends of each grate part C. (The stop ensures that all the rabbets and dados align.) Move the stop, align the blade with the marked layout lines, and cut a dado as shown in the photo at *right*. Repeat the process to cut all the dados in each part.

**4** Dry-fit the grate pieces together, and check the fit of the grate inside the rabbet in the frame. Trim if necessary. Wipe the mating surfaces

## FINAL ASSEMBLY

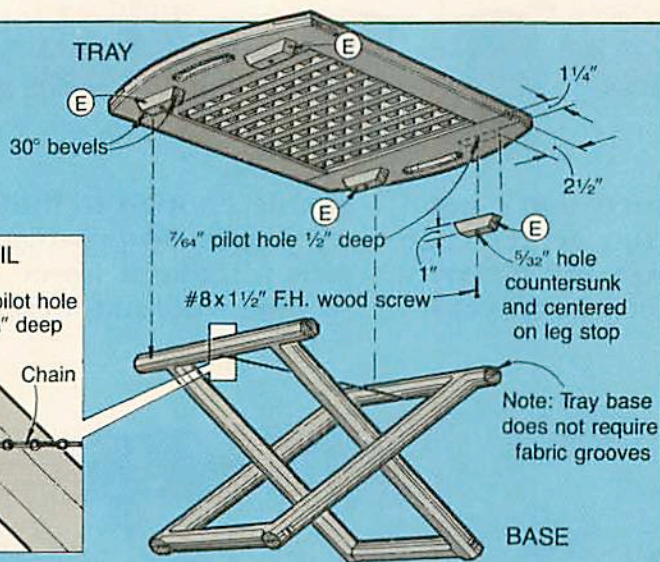

### SCREW HOLE DETAIL

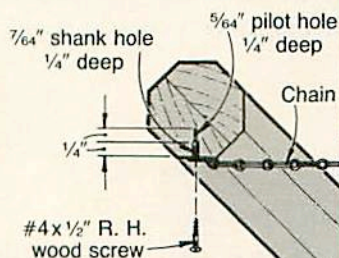

Bill of Materials Initial Size*					
Part	Finished Size*			Material	Qty.
	T	W	L		
A	3/4"	3/8"	18 1/2"	teak	2
B	3/4"	2 1/2"	22 3/4"	teak	2
C*	1/2"	3/4"	14 1/4"	teak	11
D*	1/4"	3/4"	15 1/4"	teak	10
E	3/4"	1"	3 3/4"	teak	4

\*Parts marked with an \* are cut larger initially, and then trimmed to finished size. Please read the instructions before cutting.

**Supplies:** latex gloves, #4 x 1/2" round-head brass wood screws, #8 x 1/2" flathead brass wood screws, alcohol, 16 1/2" of 1/0 bright-brass safety chain. See the Buying Guide at the end of the teak chair article for our source of epoxy and finish.

## FRAME TOP VIEW

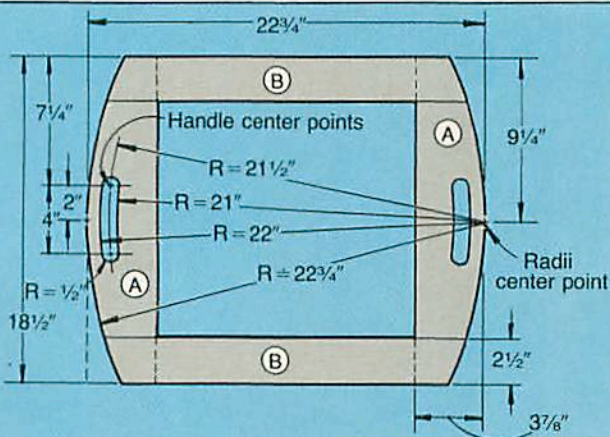

## Cutting Diagram

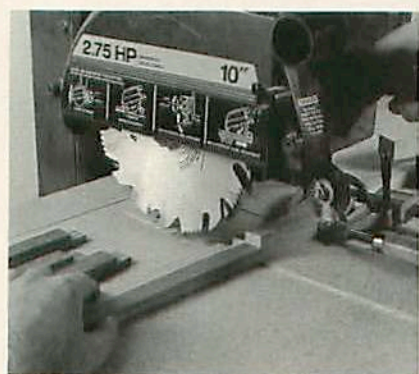
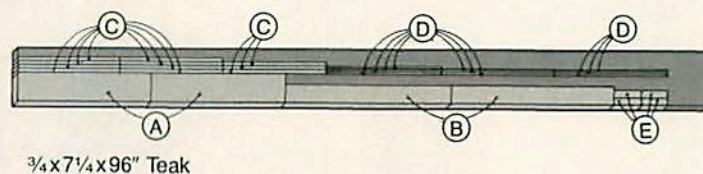

Cut the dados in all of the lower grate parts. Use a stop to ensure consistent placement from part to part.

with alcohol. Epoxy the grate pieces together, and then epoxy the grate into the rabbet in the frame. Wipe off any excess epoxy before it hardens. Later, sand the tray assembly smooth.

## FINAL ASSEMBLY

**1** Cut four leg stops (E) to size. Drill mounting holes through each leg stop (see the hole sizes on the drawing at the top of the page).

**2** Using the dimensions on the drawing, position the leg stops on the bottom of the tray, and drill pilot holes into the tray bottom. Screw and epoxy the leg stops to the bottom of the tray.

**3** Finish-sand the tray and the base. Apply the finish (see the Buying Guide on page 69 for our source).

**4** With the tray upside down, position the base on it and against the leg stops as shown in the photo at right. Drill mounting holes (see the Screw Hole Detail accompanying the Final Assembly Drawing for hole sizes), and screw a brass safety chain (2 links per inch) to the base.



Turn the tray upside down, and position the base between the leg stops. Screw the brass chain to the base.

The chain keeps the base from collapsing when the tray is removed from the base. ♣

Produced by Marlen Kemmet  
Project Design: James R. Downing  
Photographs: Hopkins Associates  
Illustrations: Kim Downing, Bill Zaun

# A KID'S RETREAT

THAT'S NOT FAR FROM HOME

Finally, a play structure that's good looking enough to occupy center stage in your backyard. Its size and diversity allow several kids to keep busy, yet it's

simple enough to build in a couple of weekends. Two swings, plus a sandbox, plus a lookout tower add up to many summers of fun for creative youngsters.



## FORMING THE FRAMEWORK

**1** From 2x4 pressure-treated stock, cut the end support post parts (A, B) to the lengths listed in the Bill of Materials.

**2** Mark centerlines—6" from center to center—for the decorative notches on one face of the shorter board (B) where shown on the Joint Detail accompanying the Framework Drawing. Now, mark a pair of notches at each centerline (we used the corner of a square to outline the notches). Cut the V-shaped notches with a jigsaw.

**3** Sandwich the three boards together, with the notched face in the middle where shown on the Joint Detail. Drill  $\frac{1}{8}$ " pilot holes, and screw the three pieces together.

**4** From 4x4 treated stock, miter-cut the lookout-tower posts (C) and rafters (D) to the lengths listed in the Bill of Materials and shown

on the Side View Drawing. Attach a dado blade to your radial arm saw, and cut angled half laps where shown on the drawing. Screw the

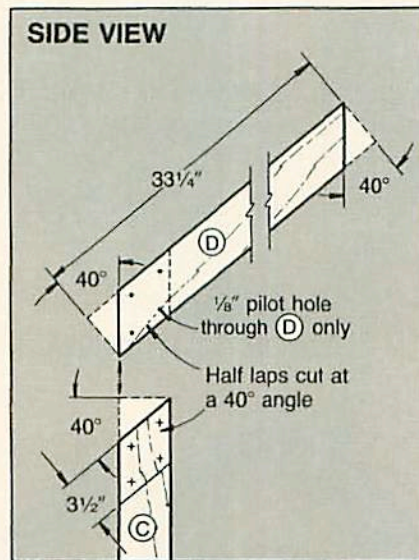

parts together to form each of the four frame components (C, D).

**5** Cut the ridgeboard (E) to length. Using the dimensions on the Framework Drawing and Swing Support Detail, cut and bend four pieces of  $\frac{1}{4}$ " steel strap around the ridgeboard where shown. Now, drill  $\frac{1}{4}$ " holes through the steel strap and ridgeboard where shown in the detail. Paint the steel strap, add a  $1\frac{1}{2}$ " ring to each support, and bolt each swing support in place.

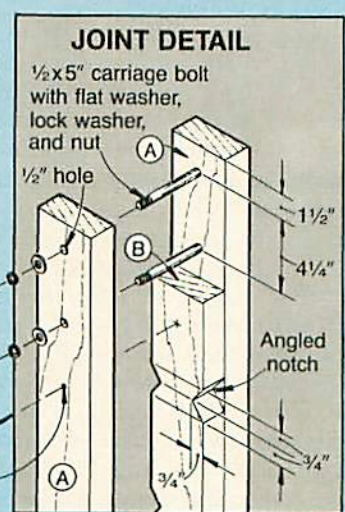
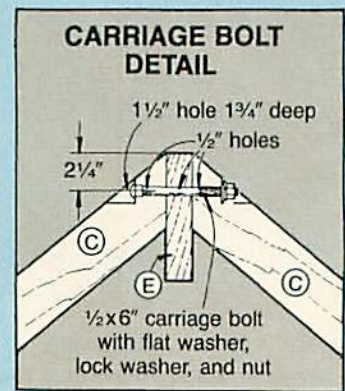
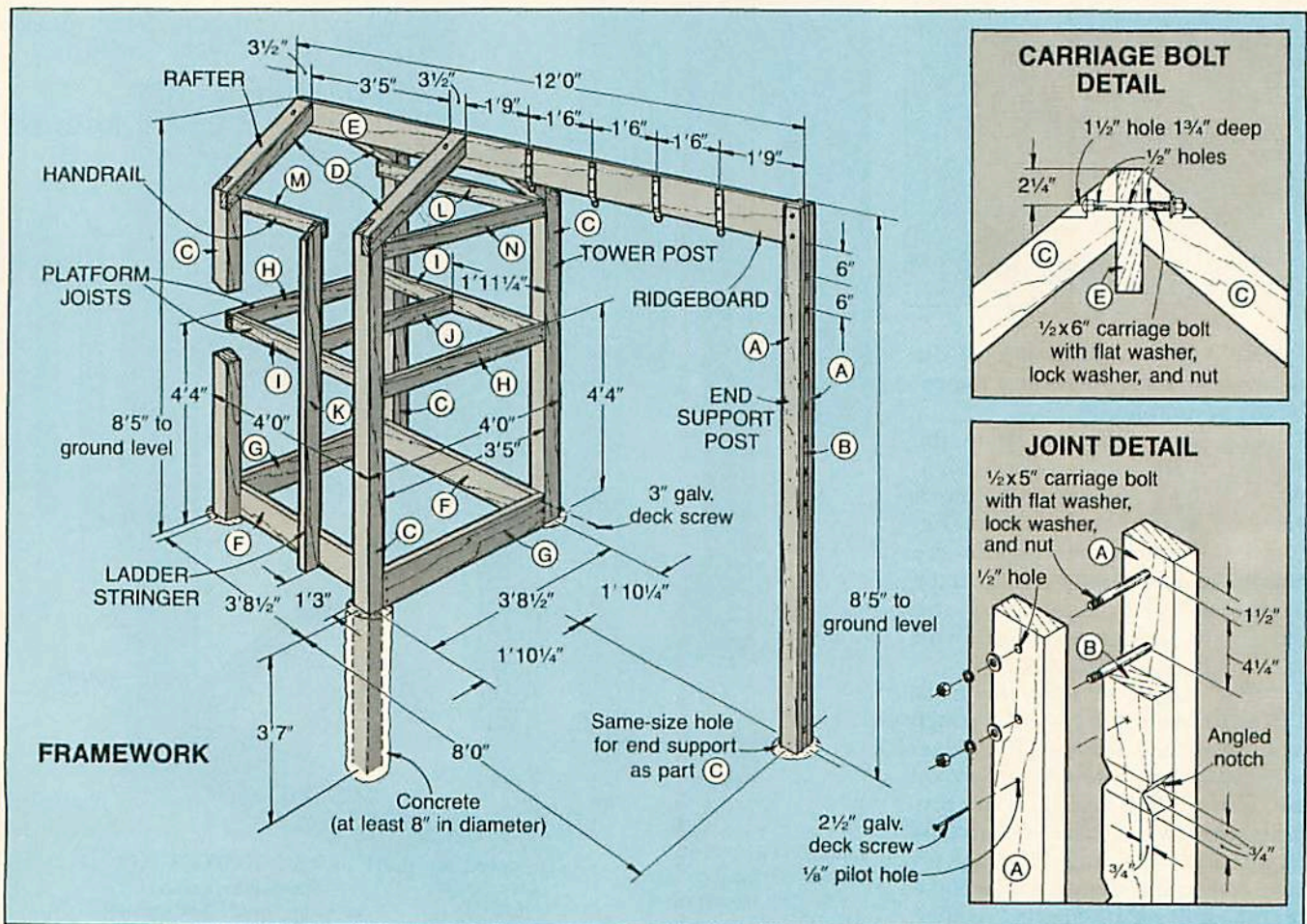
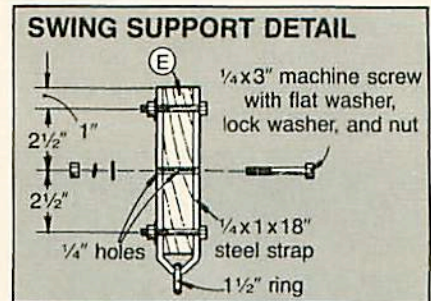

Continued

# A KID'S RETREAT

**6** Fit the ridgeboard into the notch in the top of the support post (A, B). Drill  $\frac{1}{2}$ " holes where shown on the Joint Detail, and bolt the ridgeboard to the end support post, checking for square.

## DIG THE HOLES AND ASSEMBLE THE FRAMEWORK

**1** Using the dimensions on the Framework Drawing, dig five holes  $4\frac{3}{4}$ " deep. (We used a post-hole digger, and put the dirt on tarps for easy cleanup later.)

**2** Temporarily nail the posts together where shown below. Repeat for the second frame.

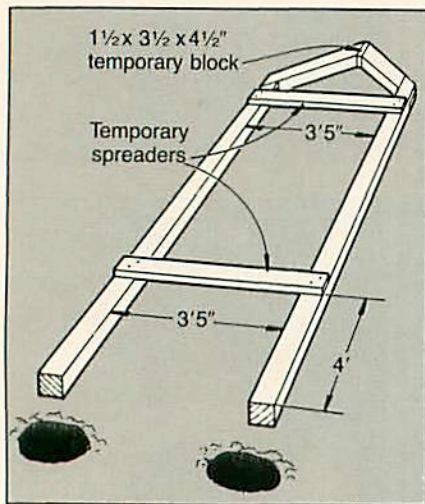

**3** With a helper, stand one of the frames upright in the holes. Repeat for the second frame.

**4** Again with a helper, stand the ridgeboard and end support assembly (A, B, E) in the last hole. Knock the  $2 \times 4$  scrap spacers from between the rafters (D), and fit the ridgeboard into place (you'll need a stepladder for this). Nail the ridgeboard in position flush with the top edges of the rafters.

**5** Being careful to miss the nails, drill and counterbore holes through each rafter and through the ridgeboard using the hole sizes shown on the Carriage Bolt Detail on the previous page. (We used an electrician's bit to drill the long  $\frac{1}{2}$ "-diameter hole, and counterbored with a Forstner bit.) Bolt the roof parts together.

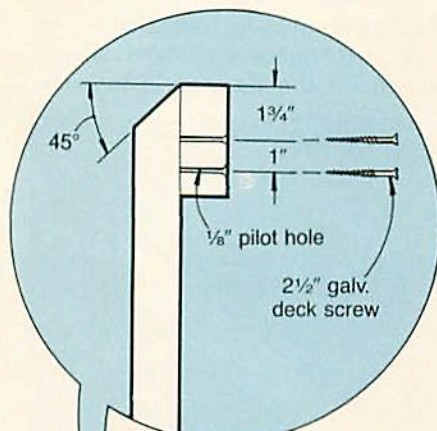

SCREW HOLE DETAIL

**6** Check that the tower posts are plumb in both directions and the ridgeboard is level. Mix and pour concrete into the holes.

## ADDING THE HORIZONTAL FRAMING

**1** Cut the sandbox surround boards (F, G) to size, and screw them to the posts where shown on the Framework Drawing.

**2** Cut the platform joists (H, I) to size, and screw them to the tower posts, checking for level. Measure the distance, and cut the middle joist (J) to length. Screw the middle joist into position.

**3** Miter-cut the ladder stringer (K) to length. Screw it to the sandbox surround (F) and platform joist (I), checking for plumb.

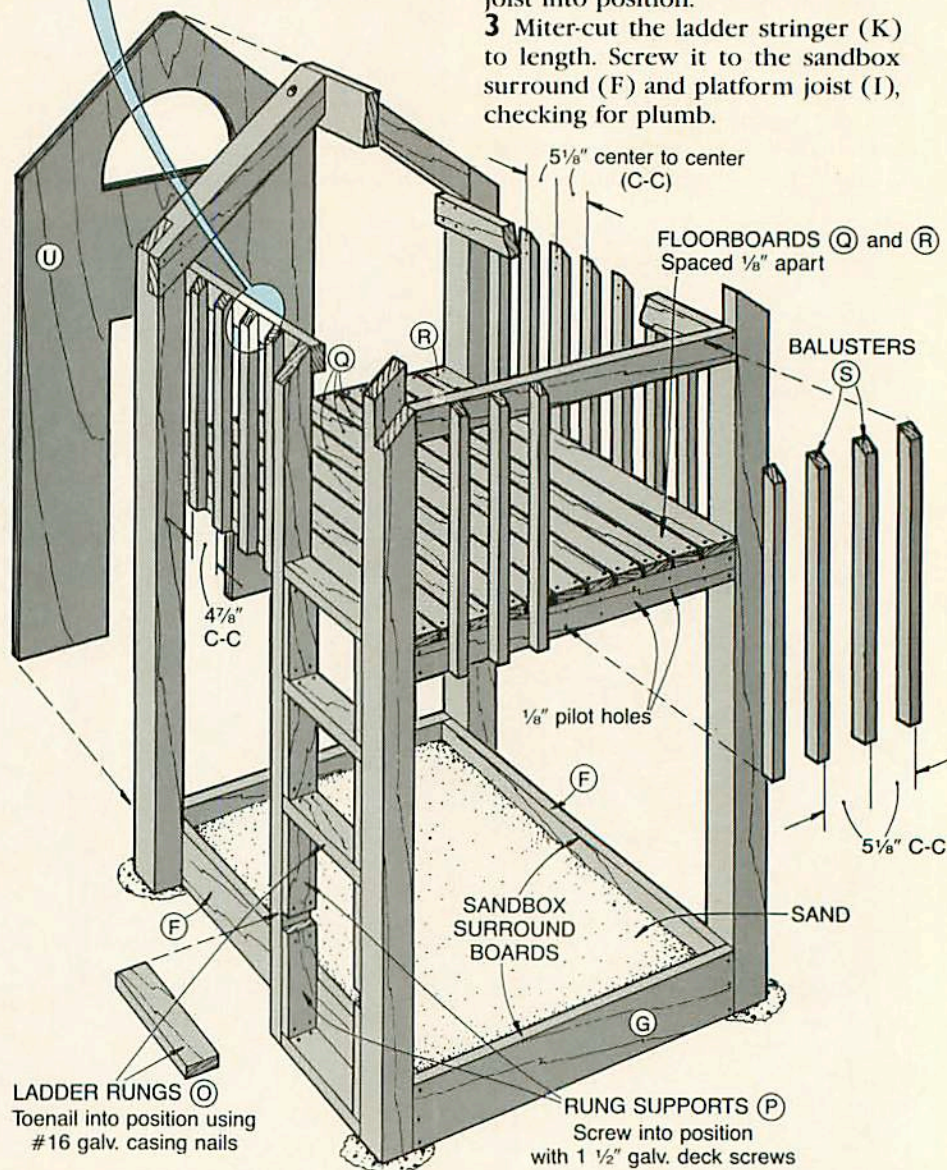

4 Finally, cut the handrails (L, M, N) to length. Cut a 2x2 cleat to fasten part N to the ladder post (C). Screw the handrails into position.

### CONSTRUCT THE LADDER, ADD DECKING, BALUSTERS

1 Cut the ladder rungs (O) and rung supports (P) to the sizes listed in the Bill of Materials.

2 Position the bottom face of the lowest rung flush with the bottom edge of the sandbox surround board (F). Toenail it to the post (C) and ladder stringer (K). Working your way up the ladder, screw the rung supports in place, and toenail the rungs on top of them.

3 Cut the platform decking (Q, R) to size. (We ripped part R to width from a 2x6.) Drill  $\frac{1}{8}$ " pilot holes and screw the pieces in place, spacing them  $\frac{1}{8}$ " apart. (We cut spacers  $\frac{1}{8}$ " thick to position the decking pieces correctly before fastening them to the joists.)

4 Miter-cut 18 balusters (S) to length from 2x2 stock. Using the center-to-center (c-c) dimensions on the Final Assembly Drawing, position the balusters, drill the pilot holes, and screw the balusters to the joists and handrails.

### ADDING THE THRESHOLD AND FACADE

1 Cut the threshold (T) to size. Mark and cut a notch in each end where shown on the Threshold Drawing. Screw the threshold to the sandbox surround.

2 Using the Facade End View as reference, mark the window and door openings on a 4x8 sheet of exterior plywood for the facade (U). Cut the openings to shape with a jigsaw.

3 Position the facade on the threshold and against the end framework, and temporarily nail it into position against the framework. Now, get up on the platform, trace the roof outline onto the back side of the plywood facade. Remove the facade from the framework, support it on sawhorses, and cut the marked roof outline to shape.

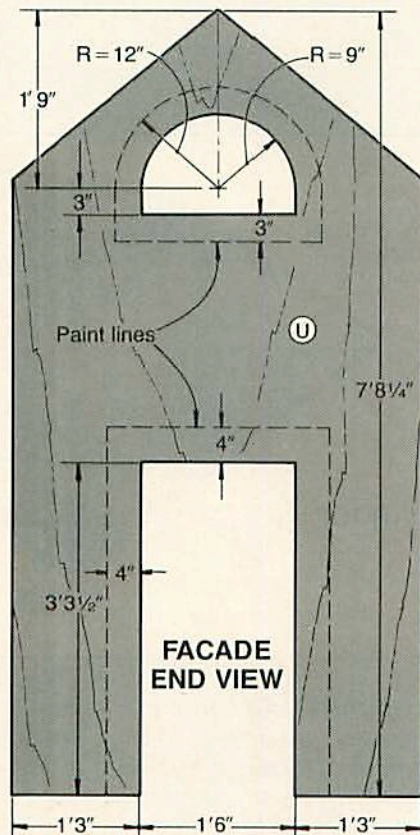
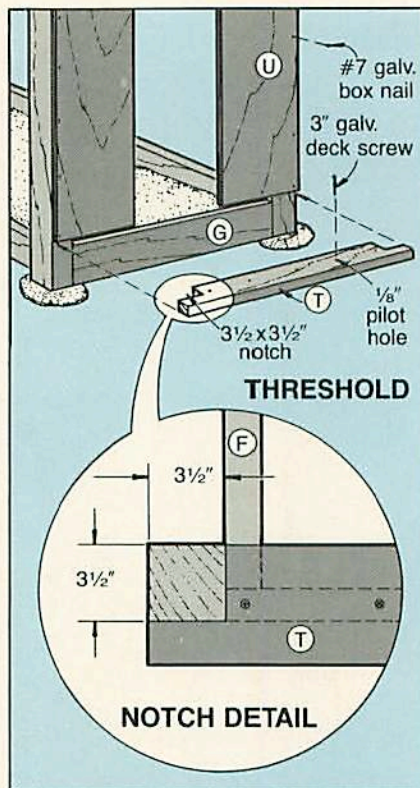

Bill of Materials					
Part	Finished Size			Material	Qty.
	T	W	L		
<b>BASIC FRAMEWORK</b>					
A	1 1/2"	3 1/2"	12'	2x4 (treated)	2
B	1 1/2"	3 1/2"	11'4 3/4"	2x4 (treated)	1
C	3 1/2"	3 1/2"	10'7 1/2"	4x4 (treated)	4
D	3 1/2"	3 1/2"	2'9 1/4"	4x4 (treated)	4
E	1 1/2"	7 1/4"	12'	2x8 (treated)	1
<b>TOWER FRAMING</b>					
F	1 1/2"	7 1/4"	3'9"	2x8 (treated)	2
G	1 1/2"	7 1/4"	3'5"	2x8 (treated)	2
H	1 1/2"	3 1/2"	3'5"	2x4 (treated)	2
I	1 1/2"	3 1/2"	3'9"	2x4 (treated)	2
J	1 1/2"	3 1/2"	3'2"	2x4 (treated)	1
K	1 1/2"	3 1/2"	6'8"	2x4 (treated)	1
L	1 1/2"	3 1/2"	3'10 1/2"	2x4 (treated)	1
M	1 1/2"	3 1/2"	2'5 1/2"	2x4 (treated)	1
N	1 1/2"	3 1/2"	3'5"	2x4 (treated)	1
<b>FINAL ASSEMBLY</b>					
O	1 1/2"	3 1/2"	1'3"	2x4 (treated)	5
P	3/4"	3 1/2"	11 7/8"	1x4 (treated)	8
Q	1 1/2"	3 1/2"	4'	2x4 (treated)	10
R	1 1/2"	4 3/4"	4'	2x6 (treated)	1
S	1 1/2"	1 1/2"	2'7 1/2"	2x2 (treated)	18
T	1 1/2"	5 1/2"	4'	2x6 (treated)	1
U	3/4"	4'	7'8 1/4"	ext. plywood	1
V	1 1/2"	5 1/2"	1'7 1/2"	2x6 (treated)	2

**Supplies:** 1 1/2", 2 1/2", and 3" galvanized deck screws, #7 galvanized box nails, #16 galvanized casing nails, 2—1/2x6" carriage bolts with nuts and washers, 2—1/2x5" carriage bolts with nuts and washers, 12—1/4x3" machine screws with nuts and washers, 4 pieces of 1/4x1x18" steel strap, 4—1 1/2" rings, 8—1/4x2 1/2" eyebolts with 16—1/4" nuts and washers, 34' of #2 straight-link coil chain, 16—chain-link connectors, 12—60-lb. bags of concrete, exterior primer and paint, 49 3/4x63" material for roof (dimensions are before hemming), 6—1/4" grommets, 6-mm plastic, sand.

Continued

## A KID'S RETREAT

**4** Prime and paint the bottom edge of the facade. After the paint dries, nail the facade to the framework.

**5** Using a belt sander, sand the edges of the facade flush with the outside edges of the 4x4 framework. Sand the plywood edges at the door and window openings.

**6** Prime and paint the facade as desired, being careful to paint all exposed plywood edges several times to prevent moisture damage later. Now, paint the door and window outlines as dimensioned on the Facade Drawing.

### NOW FOR THE SWINGS

**1** Cut the two swing seats (V) to size from 2x6 stock. Rout a  $\frac{3}{8}$ " round-over on all edges, and then sand the seats smooth.

**2** Using the dimensions and hole sizes on the Swing Drawing, drill the holes, and attach the  $\frac{1}{4}$ x $2\frac{1}{2}$ " eyebolts to each seat.

**3** Using chain connectors, attach four lengths of chain to the rings strapped to the ridgeboard. Cut the lengths of chain to achieve the best seat height for your youngsters.

**4** To ensure that the swing seats will sit level, start by cutting two 16" lengths of chain, making sure you have an odd number of links. With chain connectors, attach the chain to the pair of eyebolts at each end of the swing seat.

**5** Connect a chain connector to the middle link of each 16" length of chain. Attach the 16" lengths to the ends of the long lengths with chain connectors where shown on the Swing Drawing.

### FILL THE SANDBOX AND CALL THE KIDS

**1** Belt-sand all sharp edges, especially those around the ladder.

**2** Cover the floor and interior surfaces of the sandbox surround boards with 6-mm plastic. Cut small slits in the plastic to let any water drain out. Fill the box with sand. 🌳

Produced by Marlen Kemmet  
Project Design: Dave Ashe  
Photographs: Bob Calmer  
Illustrations: Kim Downing, Bill Zaun

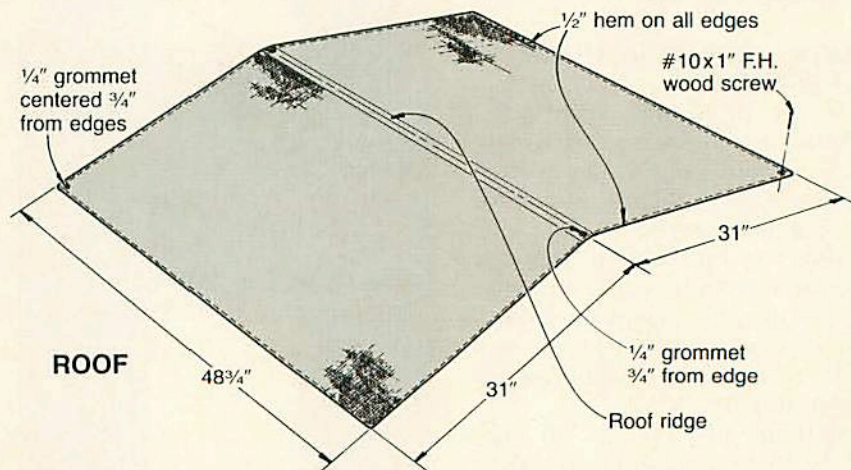
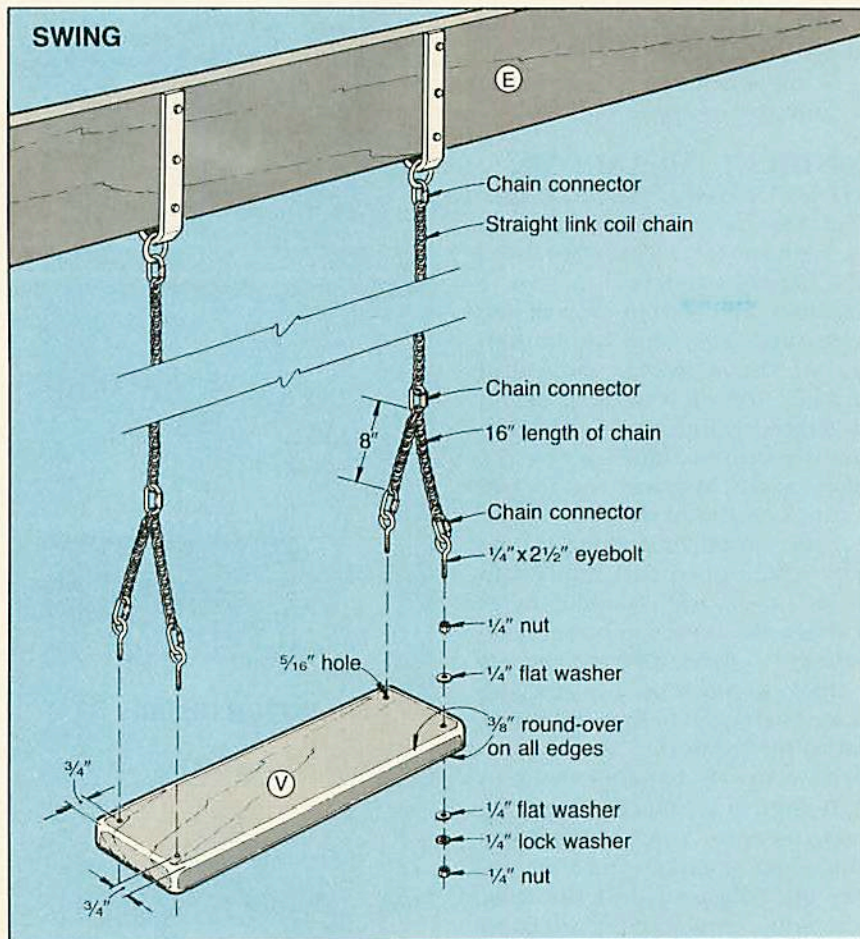

**Options:** Add house numbers, a gravel sidewalk, a roof, and plants, if desired. If you plan to add the roof, see the drawing above for details. (We used Sun-

rella—a fade-resistant awning material; canvas also would work. Check the hemming and grommeting prices at a nearby awning shop.)

# WOODWORKERS HARDWARE

## WHOLESALE ORDER FORM

# ASK WOOD

Part No. Price Part No. Price Part No. Price

### Hardwood Toy Wheels

- #W075100... 3/4" ... \$3.50/100
- #W087100... 7/8" ... \$4.70/100
- #W100100... 1" ... \$6.00/100
- #W125100... 1 1/4" ... \$8.00/100
- #W150100... 1 1/2" ... \$11.00/100
- #W175100... 1 3/4" ... \$15.60/100
- #W200100... 2" ... \$19.50/100
- #W22520... 2 1/4" ... \$7.30/20
- #W25020... 2 1/2" ... \$8.80/20
- #W27520... 2 3/4" ... \$10.20/20

### Axle Pegs

- #AP1... fits 1"-2" ... \$4.10/100
- #AP4... fits 2 1/4"-2 3/4" ... \$1.60/20

### 2" Wood Wheels With Tread Grooves

- #705020... Front... \$6.30/20
- #7050100... \$25.50/100
- (Order AP4 Peg for above)
- #705120... Dual Rear... \$10.50/20
- #7051100... \$42.90/100
- #AP5... Axle Pegs for Dual Rear Wheel... \$1.98/20
- ... \$9.00/100

### Birch Shaker Pegs

- #7226... 3 1/2" ... \$15.00/100
- #7280... 2 1/2" ... \$1.90/10
- ... \$13.90/100
- #7227... 1 1/4" ... \$1.10/10
- ... \$7.60/100

### Oak Shaker Pegs

- #SKP2... 3 1/2" ... \$3.35/10
- ... \$28.00/100
- #7261... 1 1/4" ... \$2.00/10
- ... \$15.00/100

### Birch Mug Pegs

- #7237... 3 1/4" ... \$2.27/10
- ... \$19.90/100

### Birch Country Pegs

- #1770... 3 1/2" ... \$1.80/10
- ... \$13.00/100

### Birch Spindles

- #S6... 5 1/4" ... \$4.49/ea.
- #S85... 9" ... \$8.50/ea.
- #S110... 11" ... \$1.35/ea.

### Birch Dowel Pins

- #1142... 1/4" x 2" ... \$1.90/100
- ... \$8.50/500
- #1382... 3/8" x 2" ... \$2.00/100
- ... \$9.25/500

### Oak or Birch Galley Spindles

- #S1 Birch... 1-1/8" ... \$1.30/10
- ... \$9.00/100
- #S4 Birch... 1 1/2" ... \$1.70/10
- ... \$15.60/100
- #S10AK... 1-1/8" ... \$1.50/10
- ... \$12.00/100
- #S40AK... 1 1/4" ... \$2.40/10
- ... \$22.00/100

### Birch Screw Hole Buttons

- #1432... 3/8" ... \$1.76/100
- ... \$7.50/500
- #1434... 1/2" ... \$1.76/100
- ... \$8.00/500

### Oak Screw Hole Buttons

- #1452... 3/8" ... \$3.70/100
- ... \$15.50/500
- #1454... 1/2" ... \$3.80/100
- ... \$16.00/500

### Birch Candle Cups

- #7290... 1" ... \$2.00/10
- ... \$13.00/100
- #CC1... 1 1/2" ... \$2.90/10
- ... \$19.00/100

### 2" Brass Eagles

- #878... \$2.49/10

### Quartz Clock Movement W/Hands

- #882... 1-4 ... \$6.48/ea.
- ... 5-9 ... \$5.10/ea.
- ... 10-24 ... \$4.55/ea.
- ... 25+ ... \$3.95/ea.

### Push-Thru Lamp Socket

- #940... \$1.59/ea.

### Lazy Susan Bearings

- #LC3... 3" ... \$1.95/ea.
- #LC4... 4" ... \$1.25/ea.
- #LC6... 6" ... \$2.25/ea.
- #12C... 12" ... \$5.99/ea.

### Clipboard Clips

- #L5... 3" ... \$5.55/ea.
- #ST6... 6" ... \$7.75/ea.

### Magnetic Strip

- #120A... 120" x 1/2" ... \$4.40/roll

### Paper Towel Roller

- (spring loaded) #7238... \$1.19/ea.

### Toy Train Plans

- 30" #T55... \$6.99/set

### Picture Hangers

- #S23... 1-7/8" ... \$4.70/100

### Mini Hanger

- #7247... 5/8" ... \$2.60/100

### Saw Tooth Hangers

- #S59... 1-5/8" ... \$4.17/100
- #S60... 2 1/4" ... \$4.50/100
- #A06... Self-Fastening Hangers... \$4.77/100

### Prong Hanger

- #7248... \$2.90/100

### Solid Brass Cup Hooks

- #B12... 1/2" ... \$5.55/100
- #B58... 5/8" ... \$6.30/100
- #B34... 3/4" ... \$7.45/100

### 6" Brass & Porcelain Hooks

- #6417... 3 Prong... \$5.85/ea.
- #6416... 2 Prong... \$2.97/ea.

### Black Hammer Hinge w/Screws

- #1730... \$1.62/2
- ... \$7.17/10

### Brass Plated Hinges

- #910... 1" ... \$1.49/10
- #928... 1 1/2" ... \$2.39/10

### Screws for Above

- #F124... \$2.40/100

### Production Screws

- #6277... 1 1/4" x #6... \$1.70/100
- #6278... 1-5/8" x #6... \$1.90/100
- #6279... 2" x #6... \$2.50/100
- #6282... 3" x #8... \$4.75/100

### Sand Paper Sheets

- 9" x 11"
- #81220... 220gr... \$16.75/100
- #81150... 150gr... \$16.80/100
- #81120... 120gr... \$16.90/100
- #81100... 100gr... \$17.20/100
- #81080... 80gr... \$11.50/50
- #81060... 60gr... \$11.60/50
- #81050... 50gr... \$11.70/50
- #81234... Assort... \$16.50/70

### Sanding Belts

- 3" x 21"
- #1700... 120 gr... \$12.20/10
- #1701... 80 gr... \$13.00/10
- #1702... 50 gr... \$13.50/10
- #1703... 36 gr... \$14.65/10
- 3" x 24"
- #1704... 120 gr... \$13.10/10
- #1705... 80 gr... \$13.50/10
- #1706... 50 gr... \$14.60/10
- #1707... 36 gr... \$15.85/10

### Sanding Belt Cleaner

- 8" #1710... \$5.37/ea.

Whether your woodworker's license reads "Beginner," "Intermediate," or "Advanced," you're bound to have a few questions about your favorite hobby. We can help. We'll consult our experts for answers to your most-asked questions. Send your questions to:

Ask WOOD  
Better Homes and Gardens®  
WOOD® Magazine  
Locust at 17th  
Des Moines, IA 50312

Due to the volume of mail, we can't promise to answer all questions, but we'll try. We may edit letters selected for publication.

### BUGGED BY POWDER POST BEETLES

**Q.** I have a problem I wish you could help me solve. Some small creature is living in my ash stock and eating it full of small tunnels. I have never seen the creature, so I don't know if it is an ant or a worm. The tunnels are very tiny, but there are enough to honeycomb the wood.

What can be done to get rid of them? I put a couple of pieces in the microwave oven, but doing that dried and curled the wood. The wood is piled in an outdoor shed and has gone through freezing. Will it have to be sprayed, dipped, fogged, flogged? Or should I call a medicine man?

—Victor O. Schwarz, Smith Center, Kan.

**A.** Vic, we've got some bad news for you. Your ash appears to be riddled by powder post beetles. Calls to the U.S. Forest Products Laboratory in Madison, Wisconsin as well as Iowa State University Extension Service in Ames disclosed some possible remedies. Kiln-drying your wood at 150 degrees for three hours should kill all the beetles, no matter their stage of development. In the summer when the beetles are active, stashing your infested stock in a deep freeze for a day or two works. However, the stock could be subject to reinfestation.

Another solution: Since powder post beetles only attack and live in ring-porous sapwood, you could dispose of all the ash sapwood you have to end the cycle. You also can spray your wood with a pesticide containing Dursban TC, available at your garden center under the brand name Ortho-Klor. Follow directions on the container. However, you'll have to spray all your ash stock to kill the beetles.

By the way, natural freezing and thawing won't kill cold-blooded powder post beetles. They survive winter by hibernating. When you bring wood inside, once the wood reaches about 50 degrees, they wake up and go to work! So, whichever way you choose to get rid of them, do it in their active season.

If you microwave wood, use a defrost or low-power cycle to prevent curling.

Continued on page 80

ORDER TOLL FREE 1-800-441-9870 MN 1-612-471-8550  
8 AM - 5 PM Central

Send \$1.00 for Catalog or \$5.00 for Catalog plus Best Selling plan package (\$10.00 value) or order directly from this ad by phone or mail.

HOW TO ORDER: State quantity, part number, item, price, and total of order. Send check, money order, or Visa or M.C. number and Exp. date. Shipping: \$25.00 to \$49.99 add \$3.50, \$50.00 to \$99.99 add \$4.50, Over \$100.00 add \$5.00. MN Res. add 6% tax. Minimum order \$25.00.

Please send me:  Catalog \$1.00  Catalog and Plan Package \$5.00

Print Name \_\_\_\_\_  
Address \_\_\_\_\_  
City \_\_\_\_\_ State \_\_\_\_\_ Zip \_\_\_\_\_  
Phone # ( \_\_\_\_\_ ) \_\_\_\_\_

MEISEL HARDWARE SPECIALTIES P.O. BOX 70 WD-6 Mound, MN 55364



**NOW! Get in on the PROFITS in**

**SMALL ENGINE REPAIR!**



**Start your own money making business!**

**Work part time, full time—right at home—we help you every step of the way.**

No doubt about it... as a small engine pro, you can cash in on the huge demand for qualified men in one of America's fastest growing industries. You'll be able to command top hourly rates of from \$25.00 to \$30.00 per hour—and that's just for labor. A simple tune-up earns as much as \$49.95 for less than an hours work, and parts, engines and accessories will add even more to the profits.

**Plenty of business waiting for qualified men.**

**65,000,000 Small Engines Are In Use Today!**

That's the official count from the Engine Service Assn., and one-million new engines are being built each month. With fully accredited Foley-Belsaw training, you can soon have the skills and knowledge to make top money servicing these engines. People will seek you out and pay you well to service their lawnmowers, tillers, edgers, power rakes, garden tractors, chain saws, minibikes, snowmobiles, generators, go-carts, paint sprayers, snowblowers... the list is almost endless.



**Professional Tools and Equipment, PLUS 4 H.P. Engine ALL YOURS TO KEEP... All at No Extra Cost. NO EXPERIENCE NECESSARY!**

You don't need to be a 'born mechanic' or have any prior experience. You can master this profitable trade right at home in your sparetime. Lessons are fully illustrated... so clear you can't go wrong, and with our famous 'learn-by-doing' method you get practical 'hands-on' experience. We also show you how to get business, what to charge, where to get supplies wholesale... all the inside tricks of the trade you need to assure success right from the start.

**Send for FREE Facts—Do It TODAY!**

**NO Obligation—NO Salesman Calls!**

You risk nothing by accepting this offer to see how easily you can learn the skills you need to increase your income in a high-profit business of your own. Just fill in and mail coupon below (or send postcard with name and address) to receive full information by return mail.

**RUSH COUPON TODAY**  
Foley-Belsaw Institute  
6301 Equitable Rd.  
Dept. 51424  
Kansas City, MO 64120



**FREE BOOKLET!**  
Send for your copy today!

**FOLEY-BELSAW INSTITUTE**  
6301 Equitable Rd., Dept. 51424  
Kansas City, Mo. 64120



YES, please send me the FREE booklet that gives full details about starting my own business in Small Engine Repair. I understand there is No Obligation and that No Salesman will call on me.

NAME \_\_\_\_\_

ADDRESS \_\_\_\_\_

CITY \_\_\_\_\_

STATE \_\_\_\_\_

ZIP \_\_\_\_\_

# ASK WOOD®

Continued from page 78

## HOLES IN THE ROUND

**Q.** Can you tell me how to accurately drill three holes through a wooden ball so that the holes are perpendicular to each other and pass through the exact center of the ball? Also, sometimes I want to make the third hole a different size than the others.

—James W. Ward, Hammond, La.

**A.** You bet, Jim. Here's one way: Prepare a block of wood the same thickness as the diameter of the ball you want to drill. Make it at least 1" wider and longer than the ball's diameter.

Draw diagonals on the top and two sides of the block to find the centers as shown in Step 1.

Using a drill press, bore the two side holes, drilling all the way through the block. Make them the same diameter as the holes you want in the ball.

Next, center the block under the drill press and bore a hole the same diameter as the ball through it. Screw the block to a piece of scrap, center the block under the drill, and clamp the entire assembly to the drill press table. Leave it clamped to the table for the rest of the operations.

Place the ball in the hole of the block. Insert two short dowels in opposite holes in the block, and clamp as shown in Step 2. They will keep the ball from spinning when drilling the holes.

Drill the first hole, then loosen the clamp. Rotate the ball forward 90° so the hole in the ball aligns with the open holes in the block. When you've aligned the holes, push a dowel (same diameter as the holes) through the block and ball to register, and hold the ball in place. Tighten the clamp again to keep the ball from turning. Drill the second hole.

Remove the clamp and short dowels used while clamping (leave the other dowel in place). Rotate the ball 90° toward the open hole. When holes align,

push a dowel through the hole in the block and the ball to register and hold the ball, as shown in Step 3. Now, drill the third hole, then remove all dowels and the ball from the block.

If you want a hole to be of different diameter, drill it last.

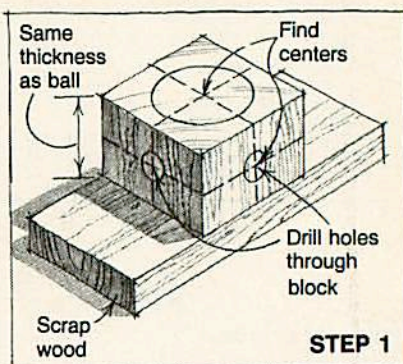

**STEP 1**

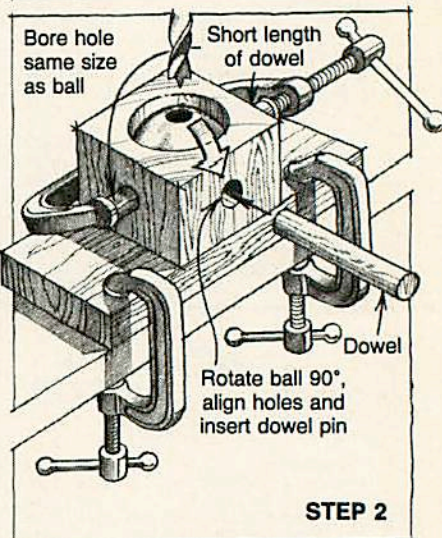

**STEP 2**

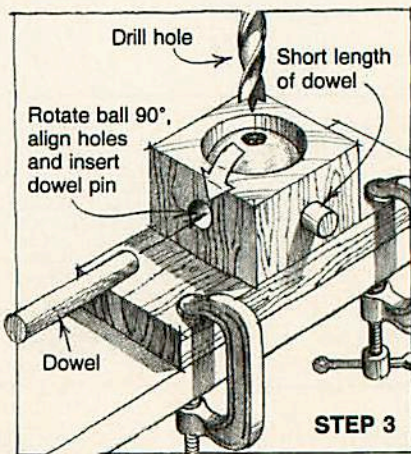

**STEP 3**

Illustrations: Jim Stevenson

## MILK AND BLOOD—TWO OLD-FASHIONED FINISHES

**Q.** In recent months, I have come across material that refers to a "milk finish." In one instance it was applied to a mahogany chair and ottoman. I am not familiar with this type of finishing and have been unable to locate any information on what it is, how it is applied, and what are its characteristics.

Second, in early American times, some of the furniture of the period was made of poplar and other native woods and finished with what became known as a "blood" finish. The result was a light red or pink color that resembles cherry or light mahogany. I have an old poplar bed that has this finish on it. So far I have been unable to locate any information on this procedure. Would you be so kind as to furnish any information on it or refer me to a source from which I might obtain data?

—William H. Mason, Lafayette, Ind.

**A.** The "milk finish" you refer to is actually called "milk paint" or "casein paint" and was used extensively in days gone by. The milk, blended with a coloring pigment, acts as a carrier that bonds as it dries. The interest in the country look has revived this mixture, and powdered milk paint is now sold by Constantine's, 2050 Eastchester Road, Bronx, NY 10461; 800-223-8087 (800-822-1202 in New York). Many refinishers curse milk finishes because they are nearly impossible to remove.

Concerning your second question, William, we believe the "blood finish" you mention to be the "Venetian Red" of colonial times. This was made with ferrous (iron) sulfate crystals and water. Rather than staining the wood, this once popular solution causes a chemical reaction and colors it. An excellent source for more information is George Frank's *Adventures in Wood Finishing*, from the Taunton Press. 🌱

## Organize and Protect your copies of **WOOD®**

Now there's an easy way to keep copies of **WOOD®** protected, organized, and close at hand when you want to reread an article.

Designed exclusively for **WOOD®**, these custom-made titled slipcases and binders are sized to hold two years' issues (12 copies). Each binder and slipcase is manufactured from reinforced board covered with durable leather-like material in spice brown. **WOOD®** is hot-stamped in gold on the spine of each. We include free personalization foil if you care to add indexing by year. Slipcases are V-notched for easy access; binders have special spring mechanism to hold individual rods which easily snap in.

### SLIPCASE

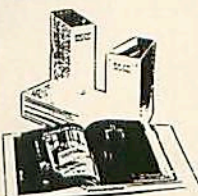

### BINDER

PRICES		
Quantity	Slipcases	Binders
One	\$ 7.95	\$ 9.95
Three	\$21.95	\$27.95
Six	\$39.95	\$52.95

Add \$1 per case/binder postage and handling. Outside USA add \$2.50 per case/binder (U.S. funds only). Personalization optional, add \$8. sales tax.

### CREDIT CARD ORDERS

CALL TOLL FREE

1-800-972-5858

**Order Form**  
Please send me \_\_\_\_\_ slipcases; \_\_\_\_\_ binders for **WOOD®** Magazine.

Enclosed is my check for \$ \_\_\_\_\_  
 Charge my purchase (Minimum \$15) to:  
 American Express  MasterCard  VISA

Account No. \_\_\_\_\_

Signature \_\_\_\_\_

Exp. Date \_\_\_\_\_

Send my order to: (Please Print)

Name \_\_\_\_\_

Address \_\_\_\_\_

(No P.O. Box Numbers Please)

City \_\_\_\_\_ State \_\_\_\_\_ Zip \_\_\_\_\_

Send your order to: **WOOD®** Magazine,  
Jesse Jones Industries,  
Department WD,  
499 East Erie Avenue,  
Philadelphia, PA 19134

--- SATISFACTION GUARANTEED ---

introducing . . .

# rbindustries family of fine quality tools . . .



## The rbi Hawk™

### Precision Scroll Saw

America's best selling scroll saw can give you the capabilities you need at a price you can afford. With five models to choose from, the Hawk is the scroll saw for you! Unlock your creativity and enjoy precision woodworking you never dreamed possible. Send for a free fact kit today!



## rbi Joint Machine™

Create beautiful wood joints so precise they don't even require gluing. Make beautiful finger joints, dovetails, mortise and tenons, and more! By using the optional inverted pin router attachment you can make wooden signs and any precision router work all with one simple machine. Send today for more information!



## rbi WOODPLANER®

Planer • Sander • Molder • Gang Saw

Four heavy duty precision operations in one rugged, dependable workhorse of a tool. Plane tough stock into finished lumber, put a satin smooth finish on your projects with the sanding head attachment, create beautiful custom moldings with the molding head assembly, or gang saw lumber to exact dimensions with the power fed gang saw. Send today for your free fact kit on all RBI products.

For Faster Service Call Toll Free

1-800-535-8665

MAIL TO:

## rbindustries

1801 Vine Street, P.O. Box 369  
Harrisonville, MO 64701

Yes! Please Rush Me A FREE Information Kit  
(Check One)  RBI WOODPLANER  RBI JOINT MACHINE  
 RBI HAWK PRECISION SCROLL SAW

Name \_\_\_\_\_  
Address \_\_\_\_\_  
City \_\_\_\_\_ State \_\_\_\_\_ Zip \_\_\_\_\_

## WOOD ANECDOTE

### BALSA CARRY A CORD HOME



Balsa, a swift-growing hardwood, contains mostly air.

In Ecuador's Andes Mountains grows a towering hardwood tree that matures in less than a decade. A man can carry a 30"-diameter log from this tree on his shoulder. A board foot sawed from that log, afloat in water, will support more than four times its 8-ounce weight.

Spanish colonists settling Ecuador in the 16th century named the remarkably light and buoyant wood *balsa*, meaning raft. And for generations before it was sold commercially throughout the world, Ecuadorians lashed balsa logs into rafts to transport goods to market.

Growing wild or on plantations, a balsa tree begins as a pinhead-size seed. Spurred by the equatorial climate, it shoots up to an 80' height and a 30" diameter in five to seven

years. Strangely, balsa accomplishes this rapid growth without sapwood, relying instead on the pith to carry nourishment.

Loggers must fell mature balsa trees at once. If left to compete with surrounding vegetation, they form a tap root similar to a cactus. In a bizarre twist of nature, the world's most buoyant wood becomes saturated with water, making it commercially worthless!

Before inflatable gear became available, balsa was used extensively for lifesaving flotation devices on ships, since the wood contains about 92 percent dead-air space. Now, it's sold for making model airplanes, for insulating freight cars, and for shock-absorbing packing. 🌲

Illustration: Jim Stevenson  
Photograph: Bob Calmer

## GRIZZLY'S WINNERS!

### 20" PLANER



- Large 20" x 8" capacity
- 4 Blade ball bearing cutterhead
- 2 Automatic feeds - 16 & 20 FPM
- 3 H.P. single phase 220V motor
- Table size is 26" x 20" and is precision ground cast iron.
- Dust hood and extension rollers are standard equipment.
- Weighs a hefty 950 lbs.

**MODEL G1033**  
**ONLY \$1295.00!**

FOB WILLIAMSPORT, PA  
or BELLINGHAM, WA



### DUST COLLECTORS

These three models have sold extremely well and are an absolute necessity for any shop where sawdust & chips are a problem.

MODEL G1028 — 2 Bags, 1 H.P.  
**ONLY \$295.00**

MODEL G1029 — 2 Bags, 2 H.P.  
**ONLY \$355.00**

MODEL G1030 — 4 Bags, 3 H.P.  
**ONLY \$525.00**

PRICES ARE FOB BELLINGHAM, WA  
or WILLIAMSPORT, PA



### 15" PLANER

THE  
BEST 15"  
PLANER  
ON THE  
MARKET!

(STAND IS  
OPTIONAL)

- 15" x 6" capacity
- 3 blade, ball-bearing cutterhead
- 2 H.P. single phase 220V motor
- Heavy duty cast-iron construction
- Dust hood & extension rollers are standard equipment
- Weighs a solid 500 lbs.

**MODEL G1021**  
**ONLY \$695.00!**

FOB WILLIAMSPORT, PA  
or BELLINGHAM, WA

OUR 1988 FULL COLOR, FULLY-LOADED CATALOG IS AVAILABLE FREE - CALL US!

WEST OF THE MISSISSIPPI:  
P.O. BOX 2069  
BELLINGHAM, WA 98227  
(206) 647-0801 Several Lines



EAST OF THE MISSISSIPPI:  
2406 REACH ROAD  
WILLIAMSPORT, PA 17701  
(717) 326-3806 Several Lines

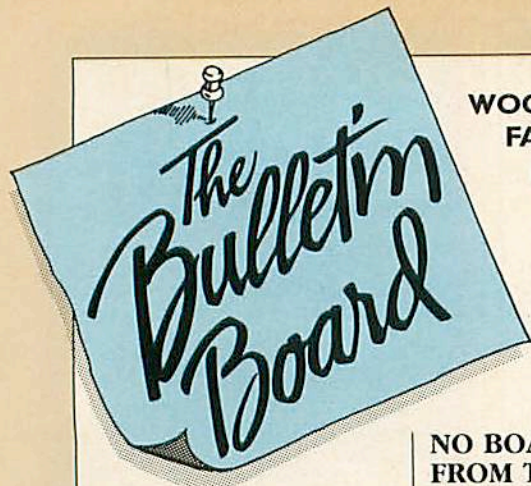

## WOODWORKING FACTS, FACES, AND FABLES

### BEAM 'EM INTO BOARDS, SCOTTY

Sawing logs with laser beams sounds like Star Trek technology, but it may happen. Henry Huber, a forestry professor at Michigan State University, believes that the use of high-energy lasers will increase efficiency of hardwood production.

According to Huber, the laser's narrow kerf results in a yield increase of five percent. Couple that with a fully automated lumber processing system and production jumps 22 percent. He admits, though, that there's more research to do. Lasers still cut too slow, and tend to scorch the wood.

### NO BOARDS FROM THIS OAK

In Portugal, Spain, southern Italy, and the countries in North Africa that hug the Mediterranean Sea, the bark from the stubby cork oak (*Quercus suber*) has more value than the wood beneath it! That's because manufacturers purchase the bark as cork for making bottle stoppers, floor coverings, and other products. Workers harvest the raw cork by completely peeling the short tree trunks of their thick outer bark.

The cork oaks in no way suffer from the harvest, which occurs about every 10 years. In fact, the trees live on to produce higher quality cork following each stripping in their 150-year life span.

### WAITER, IS THAT REALLY ROSEWOOD?

Built in the late twenties and opened in 1931, Cincinnati's opulent Omni Netherland Plaza hotel at 35 West 5th St. boasts lavish Brazilian rosewood paneling in its lobby, restaurant, and other public rooms. In fact, hotel management claims the no-longer-available rosewood represents a half acre of trees.

Fred Jahnke of Wisconsin-based Conrad Schmidt Studios, restoration specialists who restored the Omni Netherland about seven years ago, recalls the remarkable paneling. "It's not veneer. In rooms such as the 20x60' Palm Court, panels are made up of edge-joined, book-matched boards  $\frac{5}{8}$ " thick, about 3' wide, and maybe 7 $\frac{1}{2}$ ' tall. It takes three such panels to reach floor to ceiling!"

Jahnke no longer has details on the amount of rosewood in the hotel, but he won't dispute the half-acre claim. What he remembers most is that when restoration crews started work, the rosewood was hidden by six layers of wallcovering! "We stripped them off, cleaned, repaired, and stained, then finished the wood with two coats of Pratt & Lambert's No. 38 varnish."



Cincinnati's Omni Netherland Plaza hotel surrounds visitors with  $\frac{5}{8}$ "-thick panels of Brazilian rosewood.

## DOWN THE STRETCH, IT'S OAK IN THE LEAD, MAPLE SECOND, AND CHERRY COMING UP FAST

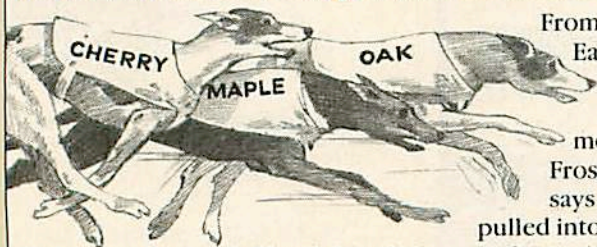

For a decade and half, oak has dominated the woodworkers' shop as the perennial favorite for furniture and cabinets. Now, that may be changing. Domestic popularity, as well as sales to Europe and Asia, have driven oak prices up and supplies down. As one result, more and more woodworkers are returning to another classic—cherry.

From the West Coast to the East, however, oak remains at the top of woodworker's lists, but cherry is moving up fast. G. G. Frost of Frost Hardwoods in San Diego says that cherry has recently pulled into a solid third place behind walnut. At Frank Paxton Lumber Company's Beautiful Wood store in Denver, Dave Tudor says that cherry, despite a price increase to \$3.50 a board foot, climbed during 1987 to second place behind oak. Paxton outlets in Chicago and New Orleans indicate cherry now running in third, behind poplar and maple respectively. Mar-Wood Hardwoods of

Philadelphia reports oak, cherry, and maple running 1-2-3.

From the southern hardwood belt, Bob Carr, owner of Educational Lumber Company, Inc., in Asheville, North Carolina, tells us cherry sales show a surprising increase. "In board-foot volume, it's red oak first, poplar second, and cherry third. In dollar volume, it's oak, walnut, cherry. That's a lot of cherry, since it sells for less."

What does it all mean? If furniture makers start to buy more cherry there will be less quality boards around. Until supply catches up with demand, cherry's price will climb. 🌲

Photograph: Courtesy Omni Netherland Plaza

Illustration: Jim Stevenson