

Better Homes and Gardens®

WOOD®

THE #1 MAGAZINE FOR HOME WOODWORKERS

\$3.95

JUNE 1989 • ISSUE NO. 29

Display until June 13

**UPGRADE YOUR
TABLESAW WITH A
REPLACEMENT FENCE**

**LEARN TO MAKE
YOUR BENCH PLANES
WORK WONDERS**

**MEET DESIREE HAJNY:
WILDLIFE CARVER
EXTRAORDINAIRE**

**JOIN THE SEARCH
FOR AMERICA'S
BIGGEST TREES**

TERRIFIC DESIGNS

Low-voltage lighting

Kids' train whistle

Laminated bud vase

Raccoon carving

Nifty napkin holder

Parrot mobile

Tip-top tops

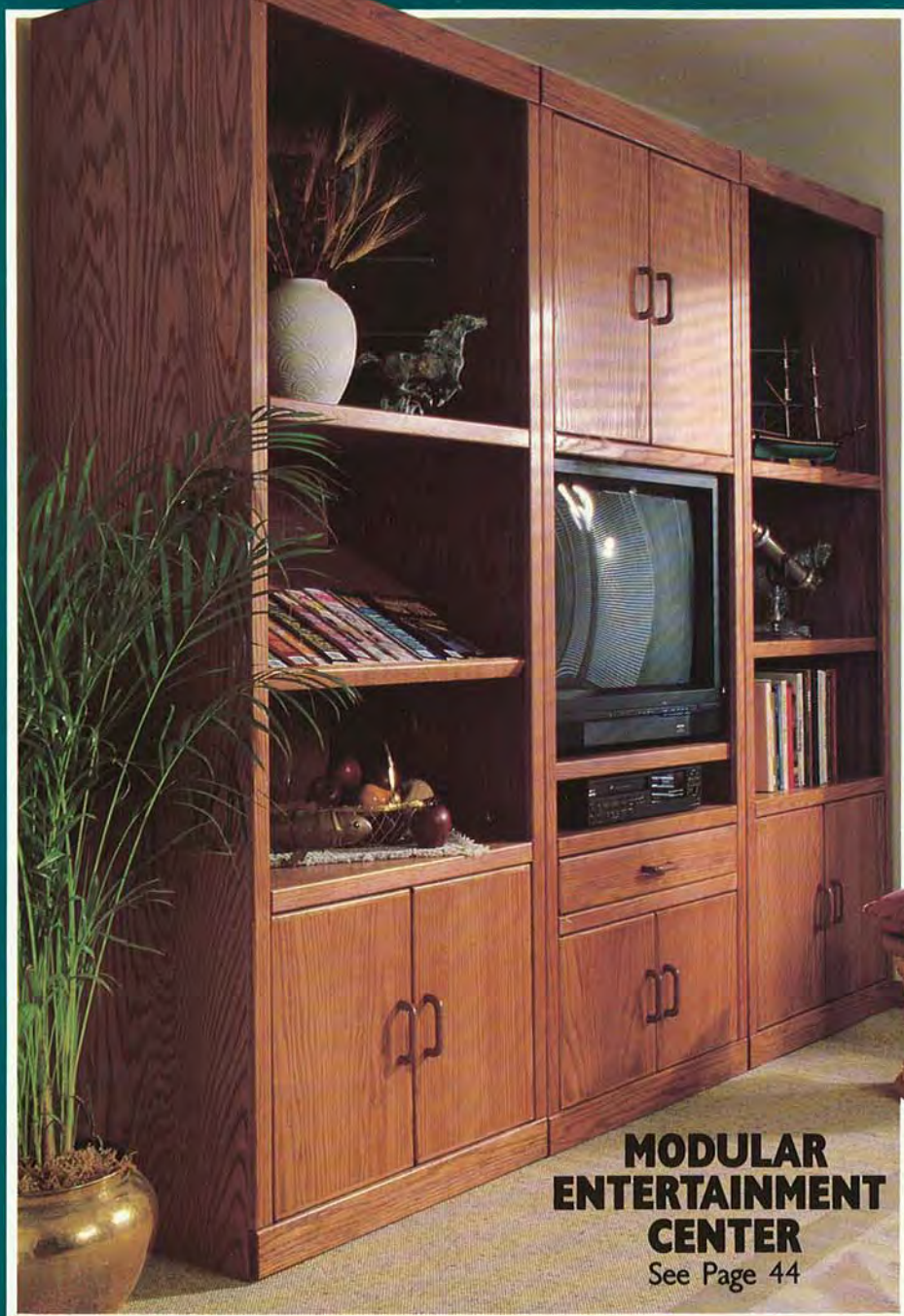

**MODULAR
ENTERTAINMENT
CENTER**

See Page 44



Next to Fire and Termites, Moisture is Wood's Biggest Enemy.

That's right. Moisture can be as damaging to the wood around your home as fire and termites. And most premium paints can't stop it. You need Rust-Oleum Wood Saver™ paint. It's specially formulated to fight the damaging effects of moisture on wood.



WHAT'S A SPONGE GOT TO DO WITH IT?

Wood is naturally porous, like a sponge. So it needs a special coating to protect it from moisture. And don't be fooled by a painted surface that looks good, because damage to your wood could already be taking place. Now is the time to protect your wood from moisture with Rust-Oleum Wood Saver paint.



THE LOWDOWN ON PREMIUM PAINTS

All paints aren't created equal. Most premium paints, for example, aren't formulated to prevent moisture from getting through to wood. So to protect wood where moisture is a problem, don't just pick any paint. Pick Rust-Oleum Wood Saver paint.

STROKE OF GENIUS

The scientists at Rust-Oleum have made an incredible discovery. They found that **TEFLON***, the same ingredient used on frying pans, makes a coat of Rust-Oleum Wood Saver a superior moisture-resistant barrier.

PROOF POSITIVE

Don't just take our word for it. Try pouring a little water onto your window sill or other painted flat wood surface. In a few minutes, you'll see it disappear *into* your wood. On the other hand, water poured on wood painted with Rust-Oleum Wood Saver paint beads and evaporates.

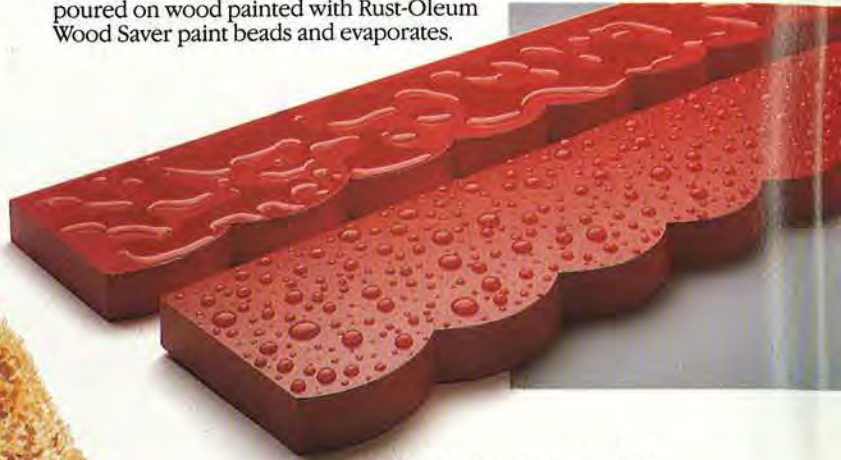

GOING...GOING...GONE



Don't wait. Protect your wood with Rust-Oleum Wood Saver paint. After all, you can replace your paint now...or you could replace your wood later.

Rust-Oleum Wood Saver™
If it's going to get wet, get Rust-Oleum.™

RUST-OLEUM
CORPORATION

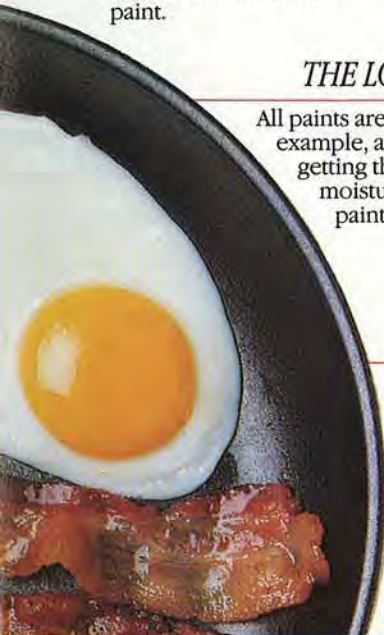

© 1989, Rust-Oleum Corporation, U.S.A.
*TEFLON® Resin is DuPont's registered trademark.

ED 7162 (Semi-gloss)

Twice the Moisture Resistance of Ordinary Paint

More New Items for '89

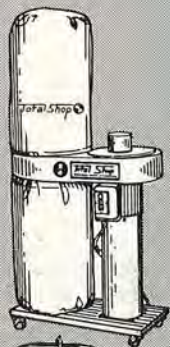

Dust Collector

- 1 hp, 110v
- 4" inlet
- Commercial quality
- Compact size

Reg. \$348.00
\$209.00
 (Shp. & Hdgl. \$30.00)

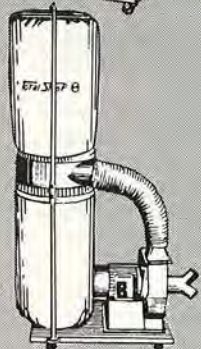

Industrial Dust Collector

- 2 hp, 110v
- Two 4" inlets
- 1185 CFM
- 125 lbs.

\$499.00 Value
\$339.00
 (ships freight collect)

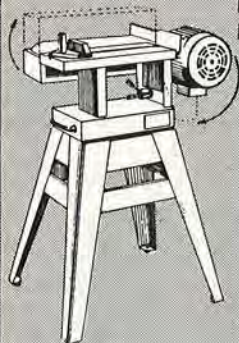

MS-648 Sanding Machine

- Table tilts 2 ways for horizontal or vertical sanding
- ¾ hp
- 6" x 48" Band
- 17¾" Table

Reg. \$369.00
\$269.00
 (ships freight collect)

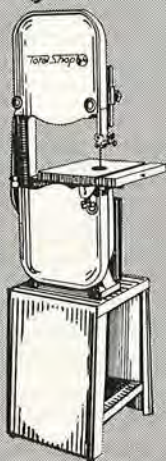

TS 14-56 14" Bandsaw

- Blade size up to ¾" wide
- Cast iron construction
- 180 lbs.
- ¾-hp

\$259.00
 (ships freight collect)



List \$1315

\$915

In less than a minute The Total Shop Multipurpose machine can be converted into any of five basic power tools necessary for any building project. yet it takes up less space in your shop than a couple of old trunks. The Total Shop multipurpose machine is strong, precise and versatile, not to mention priced so that owning your own woodworking shop is a real possibility and not a problem.

Call Toll Free



1-800-845-9356

or in S.C. 288-4174

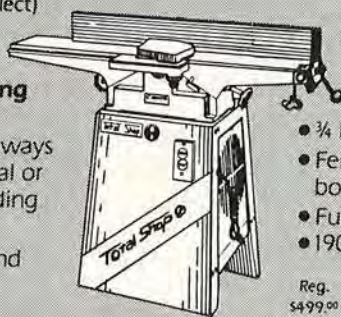

6" Long Bed Jointer

- ¾ hp, 110v
- Fence tilts 45° both ways.
- Fully adjustable
- 190 lbs.

Reg. \$499.00
\$299.00
 (ships freight collect)

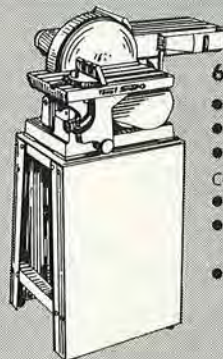

6" Belt Sander

- ¾ hp
- 6" x 48" belt
- Cast iron construction
- 152 lbs.
- 9" Sanding Disc Included
- Ball Bearings

\$199.00
 (ships freight collect)

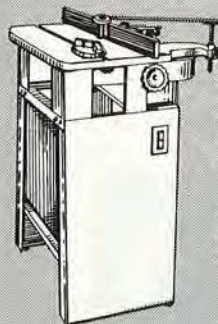

Wood Shaper

- ½" Spindle
- 1 hp
- Cast iron construction
- Precision fence
- 160 lbs.
- Ball bearings

Reg. \$499.00
\$239.00
 (ships freight collect)

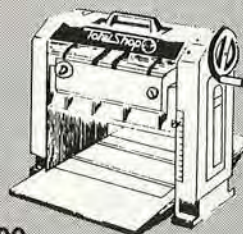

12" Thickness Planer

- Depth of cut ⅛"
- Feed rate 26 fpm
- 69 lbs.
- Safety Switch
- All ball bearing

\$395.00
 (Shp. & Hdgl. \$20.00)

15" and 20" Planers also available

1 Hour Video Brochure



- YES! Please send me your free 24 page catalog.
- YES! Please send me your 1 hour video brochure. (Enclose \$10.00 refundable deposit - specify VHS or Beta)

Total Shop®

Dept. 3
 P. O. Box 25429, Greenville, SC 29616

Name _____
 Address _____
 City _____
 State/Zip _____
 Phone _____

FREE 24 PAGE CATALOG

Call Toll Free or Write for our newest catalog today **1-800-845-9356**

100,000 REASONS WHY YOU SHOULD OWN A T-SQUARE® SAW FENCE.

Over 100,000 in fact. Bob in Buffalo. Jim in Phoenix. Richard in Sydney. Heinz in Stuttgart. The list of Biesemeyer T-Square saw fence owners spans the globe.

Why so many? Because Biesemeyer sets the industry standard. The T-Square saw fence system cuts precision parts for all your home shop projects. Safely. Affordably.



Biesemeyer's famous T-Square saw fence system fits any table saw. Shown here with our new BladeGuard™ system.

Biesemeyer's new sliding table system makes cross-cutting a breeze.



And now Biesemeyer introduces the new sliding table. Perfect for cross-cutting. By using the T-Square sliding table on your table saw, you get the benefits of a radial arm saw—for a fraction of the cost. Cap off your saw fence and sliding table with the added safety of Biesemeyer's new BladeGuard system. Safety was never this convenient before. BladeGuard easily lifts out of the way for dado cuts and sliding table use.

For more information, call 1-800-782-1831. In Arizona, 835-9300. And for useful hints on the many uses of our products, just ask for Bill Biesemeyer, fellow woodworker.

1-800-782-1831

Try them for two weeks. If you're not completely satisfied, you'll receive a full refund plus shipping costs.



BIESEMEYER
It still costs less to own the best.

Better Homes and Gardens® **WOOD**

THE #1 MAGAZINE FOR HOME WOODWORKERS

June 1989 • Vol. 6, No. 3 • Issue No. 29

Editorial/Art Staff

Editor **LARRY CLAYTON**
Managing Editor **CARL VOSS**
Art Director **C. L. GATZKE**
Design Editor **JAMES R. DOWNING**
Features Editor **PETER J. STEPHANO**
How-To Editor **MARLEN KEMMET**
Products/Techniques Editor **BILL KRIER**
Project Builder **JAMES E. BOELLING**
Senior Graphic Designer **PERRY A. MCFARLIN**
Administrative Assistant **DARLENE REYNOLDS**
Business Office Clerk **JODI DOWNING**

Technical Consultants: Product Testing **GEORGE GRANSETH**;
Wood Technology **PAUL L. McCLURE**; Collectible Tools
PHILIP WHITBY

Publisher **JERRY KAPLAN**

National Advertising Manager **TERRY MCINTYRE**
Advertising Representatives **ROBERT NEWKIRCHEN**,
NEIL A. ORNE, **ERIC VERCH**
Promotion/Research Director **THOMAS R. TROLAND**
Marketing Research Manager **EILEEN SULLIVAN**
Marketing Services Manager **NANCY DALY**
Circulation Director **CLEM SEVDE**; Circulation Manager **ALAN BRUSH**;
Newsstand Circulation Director **MICHAEL SENIOR**
Production Director **ROBERT C. FURSTENAU**
Editorial Research Director **C. RAY DEATON**

Weekend Woodworking Projects™

Managing Editor **JIM HARROLD**

Magazine Group Officers

Group President **JAMES A. AUTRY**
Senior Vice President, Publishing Director **ADOLPH AUERBACHER**
Group Vice Presidents: Publishing Directors **MYRNA BLYTH**,
BURTON H. BOERSMA, **CHRISTOPHER M. LEHMAN**;
Controller **MAX RUNCIMAN**; Editorial Director **DORIS EBY**;
Operations **DEAN PIETERS**

Chairman of Executive Committee **E. T. MEREDITH III**

Corporate Officers

Chairman of the Board **ROBERT A. BURNETT**
President and Chief Executive Officer **JACK D. REHM**
Group Presidents: Book **JERAMY LANIGAN**; Broadcasting **WILLIAM McREYNOLDS**; Magazine **JAMES A. AUTRY**; Real Estate **ALLEN SABBAG**. Vice Presidents: Administrative Services **GERALD D. THORNTON**; Corporate Relations **LEO R. ARMATIS**; Finance **JAMES F. STACK**; General Counsel and Secretary **THOMAS G. FISHER**; Product Development **NEIL KUEHN**; Special Projects **FRED STINES**; Treasurer **MICHAEL A. SELL**; Controller and Assistant Secretary **LARRY D. HARTSOOK**

Better Homes and Gardens® WOOD® — the magazine for home woodworkers (ISSN-0743-894X) is published bimonthly in February, April, June, August, October, and December by Meredith Corporation, Locust at 17th, Des Moines, IA 50336. Second-class postage paid at Des Moines, Iowa. Better Homes and Gardens trademark registered in Canada and Australia. Marca Registrada en Mexico. ONE-YEAR SUBSCRIPTION PRICES: United States and its possessions, \$18; Canada, \$24; other countries, \$30. POSTMASTER: Send address changes to WOOD, Locust at 17th, Des Moines, IA 50336. June 1989, Vol. 6 No. 3, Issue No. 29. CUSTOMER SERVICE: For service on your magazine subscriptions, including change of address, write to Customer Service Manager **ROBERT AUSTIN**, P.O. Box 10628, Des Moines, IA 50336. Please enclose your address label from a recent issue. If you wish to phone, call toll-free 800-678-2666.

©COPYRIGHT MEREDITH CORPORATION 1989. ALL RIGHTS RESERVED. PRINTED IN U.S.A.

6" JOINTER



**Exclusive
47" Bed!**

Heavy duty cast iron construction, 3 blade all ball-bearing cutter-head, precision ground cast iron beds with gib adjustment on dovetail ways. 1 H.P. single phase motor, weighs 260 lbs.

MODEL G1182

\$310⁰⁰

15" PLANER



**NOW WITH
2 SPEEDS!**



STAND IS
OPTIONAL

This is the most popular planer on the market. 15"x6" capacity, 3 blade cutterhead, all ball-bearing construction, 2 H.P. motor, weighs 500 lbs.

MODEL G1021

\$695⁰⁰

10" TABLESAW



Thousands sold! this is an excellent heavy duty saw that features precision ground table with cast-iron wings, 1 1/2 H.P. motor and much more! Weighs 235 lbs.

MODEL G1022

\$325⁰⁰

ABOVE PRICES ARE F.O.B. WILLIAMSPORT, PA OR BELLINGHAM, WA

**THE INCREDIBLE "SHOPHELPER"
ANTI-KICKBACK DEVICE**

Sold elsewhere for \$89.95

MODEL G1630

ONLY \$49⁹⁵ Prepaid to you

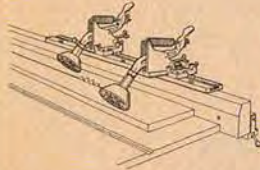

ALSO AVAILABLE: Model G1578 Green shophelpers for shapers! Used as hold downs, these green shop helpers are very popular with shaper owners.

Only \$49.95 Prepaid to you

**PRICE
BREAKTHROUGH!**

INCRA JIG



Make intricate dovetails, finger joints, etc . . . with this amazing jig.

Introductory Price!
MODEL G1768

\$29⁹⁵ Prepaid to you

15" SCROLL SAW



**MODEL
G1572**

**ONLY
\$99⁵⁰**

Prepaid to you!

- Table tilts 45°
- Max. thickness of cut -2"
- Table size 7 3/8" x 17"
- 1/2 HP totally enclosed motor
- Uses standard 5" blades

DUST COLLECTOR STAMPEDE

G1031



G1028/29



G1030



We are waging a war on our competitors and in the process, making you the ultimate winner.

**We will not be
undersold!**

MODEL G1031 - Mini dust collection system. 2 bags, 1/2 H.P. motor, weighs 75 lbs. Stands 58" high and has a 4" intake hole.

Only \$175⁰⁰ Prepaid to you! (BEWARE - A lot of importers are selling this as a 1 H.P.)

MODEL G1028 - 2 bags, 1 H.P./12 amp motor, 610³ ft. min. Weighs 185 lbs.

Only \$265⁰⁰ F.O.B. Williamsport, PA or Bellingham, WA

MODEL G1029 - 2 bags, 2 H.P. motor, 1182³ ft. min. Weighs 210 lbs.

Only \$295⁰⁰ F.O.B. Williamsport, PA or Bellingham, WA

MODEL G1030 - 4 bags, 3 H.P. single phase motor, 1883³ ft. min. Three 4" intake holes. Base measures 21" x 46". Weighs 270 lbs.

Only \$410⁰⁰ F.O.B. Williamsport, PA or Bellingham, WA

MULTI STOP



Precisely and quickly position work on radial arm saws & table saws for repeat cuts.

MADE IN U.S.A.

MODEL G1821

Only \$27⁵⁰

Prepaid to you!

**DUST COLLECTOR
ACCESSORIES**



G1553 3" Gate \$12.95

G1571 4" Gate \$15.95

(Both prepaid to you)

We also have a complete range of hoses, clamps and fittings all at excellent prices. Call for a free catalog.

Large parts inventory to back up our machines, highly qualified service departments with an in-house motor rewinding shop, courteous phone operators and fast shipping are just some of the things that make dealing with us a pleasant experience. We buy direct from the factories and sell direct to the user at low prices. 2 large warehouses on the East and West coasts enable us to serve you better. Try us once and you'll be our customer for life!

CALL TOLL FREE (FOR ORDERS AND CATALOG REQUESTS ONLY)

EAST OF THE MISSISSIPPI: 1-800-523-GRRR
(717) 326-3806

← (For Orders & Catalogs Only) →
← (For Inquiries & Customer Service) →

WEST OF THE MISSISSIPPI 1-800-541-5537
(206) 647-0801

NOW! Get in on the PROFITS in

SMALL ENGINE REPAIR!



Start your own money making business!

Work part time, full time—right at home—we help you every step of the way.

No doubt about it... as a small engine pro, you can cash in on the huge demand for qualified men in one of America's fastest growing industries. You'll be able to command top hourly rates of from \$25.00 to \$30.00 per hour—and that's just for labor. A simple tune-up earns as much as \$49.95 for less than an hours work, and parts, engines and accessories will add even more to the profits.

Plenty of business waiting for qualified men.

65,000,000 Small Engines Are In Use Today!

That's the official count from the Engine Service Assn., and one-million new engines are being built each month. With fully accredited Foley-Belsaw training, you can soon have the skills and knowledge to make top money servicing these engines. People will seek you out and pay you well to service their lawnmowers, tillers, edgers, power rakes, garden tractors, chain saws, minibikes, snowmobiles, generators, go-carts, paint sprayers, snowblowers... the list is almost endless.



Professional Tools and Equipment, PLUS 4 H.P. Engine ALL YOURS TO KEEP... All at No Extra Cost. NO EXPERIENCE NECESSARY!

You don't need to be a 'born mechanic' or have any prior experience. You can master this profitable trade right at home in your sparetime. Lessons are fully illustrated... so clear you can't go wrong, and with our famous 'learn-by-doing' method you get practical 'hands-on' experience. We also show you how to get business, what to charge, where to get supplies wholesale... all the inside tricks of the trade you need to assure success right from the start.

Send for FREE Facts—Do It TODAY!

NO Obligation—NO Salesman Calls!

You risk nothing by accepting this offer to see how easily you can learn the skills you need to increase your income in a high-profit business of your own. Just fill in and mail coupon below (or send postcard with name and address) to receive full information by return mail.

RUSH COUPON TODAY
Foley-Belsaw Institute
6301 Equitable Rd.
Dept. 51665
Kansas City, Mo 64120



FREE BOOKLET!

Send for your copy today!

FOLEY-BELSAW INSTITUTE
6301 Equitable Rd., Dept. 51665
Kansas City, MO 64120



YES, please send me the FREE booklet that gives full details about starting my own business in Small Engine Repair. I understand there is No Obligation and that No Salesman will call on me.

NAME _____

ADDRESS _____

CITY _____

STATE _____

ZIP _____

Better Homes and Gardens®

WOOD

THE #1 MAGAZINE FOR HOME WOODWORKERS

This issue's cover wood grain: knotty pine

JUNE 1989

ISSUE NO. 29

WOOD PROFILE

CHESTNUT: THE PIONEERS' DO-EVERYTHING WOOD

37

Although a devastating blight humbled America's chestnut trees, some loyal woodworkers still rely on this sturdy tree for their finest cabinetry.



SHOP-TESTED TECHNIQUES

BENCH-PLANE BASICS

38

Old-world craftsmen mastered the bench plane out of necessity, but in today's world, many woodworkers overlook this useful tool.



MODULAR

44

ENTERTAINMENT CENTER

What luck! An Oregon reader has agreed to share his handsome design for units to house stereo equipment, television, VCR, and lots more. You'll want to build this one.



LOW-VOLTAGE LIGHTING: TALK OF THE TOWN AT SUNDOWN

50

Sure, you can buy plastic outdoor lights if you want. But we think you'll agree that store-bought versions pale compared to these sturdy, first-class redwood fixtures.

WAX—THE PERFECT PROTECTION FOR FURNITURE?

54

Don't neglect caring for the finish you worked so hard to attain. Most experts agree that wax affords wood the best protection.



CRAFTSMAN CLOSE-UP

DESIREE CAME OUT OF THE WEST

56

Wildlife carver Desiree Hajny has piled up a stack of blue ribbons in just four years of carving competition. Find out how she brings her subjects to life.



CARVING PATTERN

ROSCOE THE RACCOON

60

Our featured carver offers an exclusive pattern with detailed notes and drawings, and a roughed-out blank.

DEVELOP YOUR SHOP SKILLS

EDGE-JOINING: THE CAN'T-MISS WAY 64

Here's a nifty way to glue up panels that have perfectly matched joints—even if your power tools won't cut an exact 90° angle.



TOOL BUYMANSHIP

REPLACEMENT RIP FENCES 65

Many woodworkers swear by the accuracy of these retrofit tablesaw fences. Our article provides you with a detailed look at what's available today and how each tool performs.



STEAM LOCOMOTIVE WHISTLE 70

All aboard for a jiffy project with an authentic toot from yesteryear. Can you hear the train a-comin'?



LAMINATED BUD VASE 72

Could a maple-and-walnut scrapwood project rival a rose for beauty? We think so! Build this vase in a few hours and see if you agree.



CHAMPION TREES 74

If you enjoy wood more than a board foot at a time, you might have the right stuff to become a Big Tree hunter.



WE'RE TALKIN' HARDWOOD 78

All of us can learn more about buying lumber. We surveyed hardwood dealers to find out what questions fellow woodworkers keep asking.

SPICED-UP NAPKIN HOLDER 80

Pack three mealtime essentials into one tidy package.

PARROT MOBILE 82

Catch a flight of fancy with this tropical bird.



TIP-TOP TOPS 84

The woodturner who tipped us off to these toys says he can't satisfy the demand for them.



SHORT FEATURES

Editor's Angle	6	Products that Perform	27
Talking Back	8	Wood Anecdote	33
Tips from Your Shop (And Ours)	14	Yesterday's Tools	34
Ask WOOD	22	Tool Industry Insider	94
		Old Hand Ways	96
		Finishing Touches	112

NOW! REDUCE THE RISK AT YOUR TABLE SAW

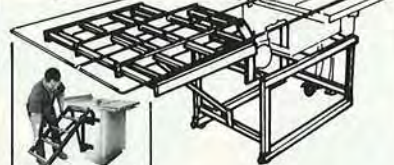

folds down neatly

WITH THE NEW MOBILE™ SAWING CENTER

OFFFEED ROLLERS

- safe, accurate sawing
- handle panels with ease
- available in 15" and 37" widths
- dual-position table

AND INCREASE FLOOR SPACE



MOBILE MACHINE BASES

- increase shop working area
- maximize usable floor space
- 3 point base will not rock
- locking wheels
- makes machine so easy to use and store
- over 80 standard models

PLANER STAND WITH ROLLERS

- raises planer to proper working height
- provides machine mobility
- five-fold increase in workpiece support
- storage is a snap



NEW



ROLLERTABLE Rock Solid Support

- adjustable
- portable
- use at any machine

Discover HTC's many unique products designed only with you, the dedicated woodworker in mind. Find out how you can make your machining safer, increase working area of your shop and accomplish nearly impossible tasks easily, quickly and accurately - **all by yourself!**

CALL TODAY!

HTC PRODUCTS, INC.
120 E. HUDSON S-8
ROYAL OAK, MI 48067
(313) 399-6185



1-800-624-2027 ext. 108

WHICH TOOL SHOULD YOU BUY? THAT DEPENDS!



Three scroll saw woodworkers, each with dramatically different tool needs.

Back in the early 1900s when the Ford Motor Company began mass-producing cars, deciding which one to buy was easy. When you ordered a 1916 Model T, for example, for the outrageous price of \$345, you knew it would have 4 cylinders and 20 horsepower. And you'd probably opt for the color black, the most popular hue available. Boy, how times have changed since then!

Purchasing decisions have gotten much more complex in the woodworking tool business lately, too. Why? Because American and foreign manufacturers alike realize how wonderfully diverse a group woodworkers are. They know that to maximize their sales, they have to offer products for every woodworking skill level and pocketbook.

That's why when we take a look at a particular category of tools in *WOOD*® magazine, we rarely tell you exactly which tool to purchase. Not because you wouldn't like that; we know you would. In fact, we get letters and calls all the time chiding us for allegedly shirking our editorial responsibilities and for being afraid of offending our advertisers.

We don't look at it that way. Here's what we do and why. After deciding which category of tools to review, we order in representative products from various manufacturers and assemble the machines. Then, working with one or more freelance tool consultants who have hands-on knowledge of the tools, we sit down and decide what information a prospective buyer needs to know before plunking down his or her money.

We also take a good, close look at the tools we get in, field-test them, and form *our opinion* of what features seem important from a consumer's standpoint. Then, we gather all this information and present it to you. After you read the article and examine the information in the chart, you should be in an excellent position to make a wise purchasing decision.

Believe me, if we thought that there was one "perfect" tool in each category, we'd tell you in black and white. Fact is, what's right for one woodworker may be totally inadequate for another.

Larry Clayton

BOSCH



Woodworking



Shape Solid Surfacing Beautifully.

5 bits in 16 sizes handle solid surface undermount bowl and decorative edge routing with micro-grain carbide-tipped efficiency. Line includes 15° bevel, rounding over, ogee, no drip and edge inlay bits.



Trimming Laminates or Veneers?

Bosch 1608 Laminate Trimming System includes 5.6 amp motor and complete set of accessories for virtually all shop, installation tasks. Includes standard, tilting and offset bases.



Sander Features Exclusive Belt Tracking/Tensioning.

Model 1273 and companion models have unique belt centering system. Rated super duty for high production, the unit also has pinch point guards for safety and lever action for easier belt changes.



and bit size — and get far better cutting results.

1611EVS electronics give you two more big advantages, too. "Soft start" when you press the trigger — no jarring "torque twist" means better control. And by monitoring RPM and feeding power as needed, it keeps you from bogging down, even in the toughest cuts.

Master Of Ergonomics.

From the first moment you get your hands on the variable speed model 1611EVS or the single speed model 1611, you'll know what separates it from other plunge routers. The handle grips feel like they were molded especially to fit your hands. The trigger switch, built into the right handle, and the plunge lock mechanism by your left thumb, let you reach these controls without taking your hands off the router.

Then press the trigger and take the plunge. Feel the housing glide down, and the ample power at your command as the bit slices effortlessly into your workpiece. Release the spring-loaded plunge lever and the housing locks firmly into position. And you can use the multiple-step depth-stop to make progressively deeper cuts with precision.

Both models accept the full array of $\frac{1}{2}$ ", $\frac{3}{8}$ " or $\frac{1}{4}$ " shank bits. And with their built-in, spring-loaded shaft lock, changing bits is fast and simple.

The Bosch models 1611EVS and 1611 are available in cooler running, higher horsepower 220V models, too. Ask about them and the complete line of fine Bosch power tools for woodworkers, at your nearest Bosch power tool distributor. He's listed in the Yellow Pages under "Tools — Electric."

The Speed Varies So The Results Won't.

The new 3.25 H.P. Bosch electronic variable speed plunge router lets you make perfect plunge cuts time after time, no matter what the material or bit size. That's because it puts you in total control of speed, cutting depth, and the router itself, due to an

excellent ergonomic design.

The Advantages Of Variable Speed.

Select any speed, from 12,000 to 18,000 RPM, to match your material



BOSCH













"Quality You Can Hold On To.™"

©1989 Robert Bosch Power Tool Corporation

CARBIDE TIPPED ROUTER BITS

PROFESSIONAL PRODUCTION QUALITY

1000's SOLD TO READERS OF FINE WOODWORKING

BEST CUT BEST PRICE	ITEM NO.	DESCRIPTION	RADIUS	LARGE DIAM.	CUTTING LENGTH	PRICE
	#01	COVE 1/4" R	1/4"	1"	1/2"	\$13.00
	#02	3/8" R	3/8"	1-1/4"	9/16"	14.00
	#03	1/2" R	1/2"	1-1/2"	5/8"	15.00
	#04	ROUND OVER 1/4" R	1/4"	1"	1/2"	\$15.00
	#05	3/8" R	3/8"	1-1/4"	5/8"	16.00
	#06	1/2" R	1/2"	1-1/2"	3/4"	19.00
	#07	ROMAN OGEE 5/32" R	5/32"	1-1/4"	15/32"	\$18.00
	#08	1/4" R	1/4"	1-1/2"	3/4"	20.00
	#11	3/8" RABBETING	Deep 3/8"	1-1/4"	1/2"	\$14.00
	#09	1/8" (KERF) SLOT CUTTER		1-1/4"	1/8"	14.00
#10	1/4" (KERF) SLOT CUTTER			1-1/4"	1/4"	14.00
	#12	45° Chamfer	45° Angle	1-1/2"	5/8"	\$15.00
	#15	Raised Panel	20° Angle	1-5/8"	1/2"	\$25.00
	#35	1/4" V Groove 90°		1/4"	1/4"	\$ 8.00
	#36	3/8" V Groove 90°		3/8"	3/8"	9.00
	#37	1/2" V Groove 90°		1/2"	1/2"	11.00
	#16	3/8" Dovetail 9°		3/8"	3/8"	\$ 7.50
	#80	1/2" Dovetail 8° (For Leigh Jigs)		1/2"	13/16"	12.00
	#17	1/2" Dovetail 14°		1/2"	1/2"	8.50
	#18	3/4" Dovetail 14°		3/4"	7/8"	10.50
	#19	CORE BOX (ROUND NOSE) 3/8" Core Box	3/16"	3/8"	3/8"	\$11.00
	#20	1/2" Core Box	1/4"	1/2"	11/32"	14.00
	#21	3/4" Core Box	3/8"	3/4"	5/8"	18.00
	#056	Tongue & Groove (FOR WOOD THICKNESS FROM 1/2" to 1")		1-5/8"	1"	\$30.00
	#24	1/4" Straight Bit		1/4"	3/4"	\$ 7.00
	#25	5/16" Straight Bit		5/16"	1"	7.00
	#26	3/8" Straight Bit		3/8"	1"	7.00
	#27	1/2" Straight Bit		1/2"	1"	7.00
	#28	3/4" Straight Bit		3/4"	1"	10.50
	#13	1/2" FLUSH TRIM		1/2"	1"	\$ 8.50
	#14	3/8" KEY HOLE (This Bit Only HSS)	CUTS 3/8" KEY HOLE FOR FLUSH MOUNTING PICTURE FRAMES, ETC.			\$ 8.50

WHEN ORDERING ANY THREE OR MORE DEDUCT \$1.00 EACH
ALL PRICES POSTAGE PAID

Professional Production Quality • 1/2" Ball Bearing Pilot
• 1/4" Diameter Shanks x 1-1/4" Long • One Piece Construction
• Two Flute Thick High Quality Tungsten Carbide Tips

To order by MasterCard or Visa Toll Free
7 Day—24 Hour Order Service Call
1-800-533-9298
or send check to:

MLCS Ltd., P.O. Box 4053D-1, Rydal, PA 19046

TALKING BACK

We welcome comments, criticisms, suggestions, and even an occasional compliment. The volume of mail we receive makes it impossible to answer every letter, but we promise to do our best. Send your correspondence to: Letters Editor, Better Homes and Gardens® WOOD® Magazine, Locust at 17th, Des Moines, IA 50336.

WHY WE DON'T PUBLISH EVENT CALENDARS

We drove 100 miles to Indianapolis for a wood show that was supposed to open at 10 a.m.—according to some newspapers. When we got there, we found out it didn't open until 4 p.m. We just turned around and went home because we didn't feel like waiting all day. In the future, could you print show times?

—Ed Wilkens, Pimento, Indiana



We've often thought about publishing a calendar of events, but situations such as the one you describe tell us it's not a good idea. Although an events calendar would help some people, Ed, too many shows change locations, dates, and hours after we go on press—but before you receive your magazine. Two major show organizers frequently advertise in WOOD magazine. We suggest you call the toll-free numbers listed in their ad for up-to-date information. And, watch your local newspaper for announcements of upcoming woodworking shows in your area.

MICHIGANDER'S BETTER BOX-JOINT JIG

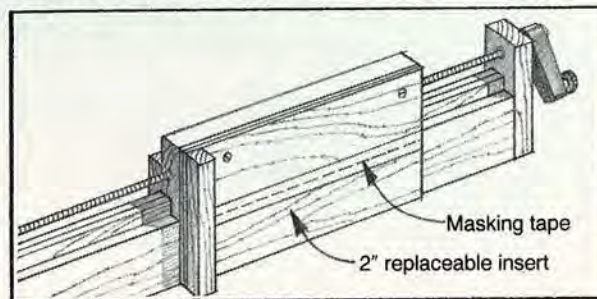

I am a new member of the WOOD magazine family and already I like your magazine better than the other four woodworking magazines I get.

I made the box-joint jig in issue 27 (February 1989) and it works great. However, I made two changes: I used two T nuts instead of plain hex nuts in the sliding block. Second, I made the 1/4" plywood support 4" wide and added a 2" replaceable insert below it. I slid the insert under the stop and secured it with masking tape. Maybe this will help others.

—Walter Prpich, Livonia, Mich.

Thanks for taking the time to write, Walter. Both of your suggestions improve the design and utility of this jig. Most hardware stores stock T nuts.

Continued on page 10

Build along with Norm Abram!

Discover fine woodworking skills as you create beautiful projects for your home!

Rodale Press and *American Woodworker* are proud to offer you the exclusive hardcover edition of THE NEW YANKEE WORKSHOP—at a special subscriber price!

This is a high-quality, colorful book you'll use as much to learn new woodworking skills as you will to create traditional American furnishings for your home.

You'll get *detailed plans* for a traditional drop leaf table . . . workbench . . . blanket chest . . . bedside table . . . bathroom vanity . . . trestle table . . . book shelf . . . chest of drawers . . . hutch . . . writing desk . . . and more.

Each project combines for you the benefit of traditional-style furnishings—with the ease of using modern tools, materials and techniques!

The companion volume to this spring's 12-part PBS-TV series

This spring, THE NEW YANKEE WORKSHOP will be featured on PBS-TV stations all over the country. With this comprehensive guide, you'll be able to follow along as Norm Abram builds each project.

Better still, this hardcover edition will give you a *lasting reference* to the skills and techniques he employs to achieve such remarkable results.

You'll get tips on joint-making . . . finishing . . . measuring and marking . . . safety . . . and expertly using a lathe, router, table saw, drill press, band saw and other pieces of power equipment.

Here's your chance to give your woodworking skills a boost from master woodworker Norm Abram. Don't miss out. Send for your copy today!

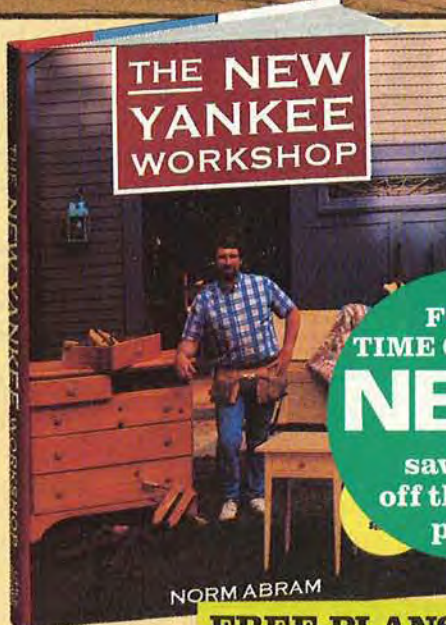

- Step-by-step directions
- 28 full-color photos
- 128 detailed black-and-white photos
- 70 illustrations
- Easy-to-use 9×12-inch size
- Unique “planning box” streamlines every project

FIRST TIME OFFERED
NEW!
save \$5
off the retail price!

FREE PLANS to build this CORNER CUPBOARD



TRY IT FREE FOR 21 DAYS!

YES! Please send me my free Corner Cupboard Plans and a copy of Norm Abram's THE NEW YANKEE WORKSHOP to examine free for 21 days. If I decide to keep the book, I'll pay for it in **three easy monthly installments of \$8.32 (\$9.98 Canadian) each** plus postage and handling. (There is no interest or finance charge.) If I do not want the book, I'll return it with the invoice within 21 days and owe nothing. The plans are mine to keep regardless.

SAVE CASH by sending \$24.95 (\$29.95 CDN Funds) now and we'll pay postage and handling. Same return privileges as above. 42351

Name _____
 Address _____
 City _____ Apt. # _____
 State _____ Zip _____

(NY, PA, CA, and IL residents please add state sales tax.)
Clip and mail to: RODALE BOOKS, Emmaus, PA 18098

WOODWORKER'S PLANS & PARTS

HEIRLOOM ROCKER

Build our classic rocking horse and create a family heirloom which will delight the children in your family for generations to come.

Size:
35" x 58"

Order Plan 400
Only \$10.25



This great rocker retails for over \$300.00

Accessories available
See our catalog

Low, low prices on wood parts

Smooth Maple	
Wood Wheels	
Eight Sizes	
WT-3/4"	\$4.50/100
WT-1"	\$5.00/100
WT-1-1/4"	\$7.00/100
WT-1-1/2"	\$10.00/100
WT-1-3/4"	\$15.00/100
WT-2"	\$18.00/100
WT-2-1/4"	\$5.00/20
WT-2-1/2"	\$7.00/20

DOOR HARP PLANS AND PARTS



Same Day Service

Harp Plans \$4.00 each or buy all four \$12.50

Plans include stencil design

New design No fret bar

Hardware Kit (no plywood)
One harp 3.50
Four harps 12.50

Axle Pegs 
AP-1 fits 1" to 2"
\$4.00/100

Full Round Wood Balls 
Four Sizes

BA-3/4"	\$8.00/100
BA-1"	\$10.00/100
BA-1-1/2"	25each
BA-2"	60each

Shaker Peg Candle Cup 
Reg Peg \$16.00/100
Mini-Peg \$6.00/100
Candle Cup \$16.00/100
Mini-Cup \$7.00/100

Tie Peg  \$6.00/100

Harp Wire
10¢ per ft.
25' for 2.50
1/2 lb. for 12.00
1 lb. 34.00

Tuning Pins
30¢ each
50 for 11.00
100 for 18.00
500 for 75.00

Tuning Pin Wrench
3.50 or FREE if
harp order totals
35.00

Door Harp Plywood
11 1/2" x 11 1/2" 1.00 ea.
10 for 9.00
30 for 24.00

Shipping \$2.50. NY Res. add tax. Catalog \$1.00 FREE with order.
We accept VISA & MASTERCARD. Phone (516) 462-6228

Armor Products Box 445-L East Northport, NY 11731

TALKING BACK

Continued from page 8

MORE THOUGHTS ON RATING MOTORS

I have just finished reading the February 1989 issue of *WOOD* magazine, and I felt compelled to write you concerning the item "Peak HP" in the Tool Industry Insider on page 92. This article caught my attention because I have a pet peeve about the game of "peak" horsepower that tool companies play.

The article contains good information; however, I would like to take exception with a statement from Dean Ruffner of Jet Equipment and Tools. "The consumer needs to look for a UL (Underwriters Laboratories) listing on the motor. If it has a UL mark, the rating should be correct." This is somewhat misleading in that UL and CSA (Canadian Standards Association) test the unit to see that it meets certain criteria for fire hazards and electrical shock. Neither laboratory checks to see if it meets any kind of manufacturing standard pertaining to motor performance.

I would suggest to readers that a better alternative is to look at the data plate on the side of the motor. If the motor is built to National Electrical Manufacturers Association (NEMA) standards, the data plate will tell you the operating voltage, full-load rpm (3450 or 1725 in most cases), full-load horsepower rating, duty rating (continuous or intermittent) and the full-load current the motor draws. If the motor plate doesn't list all this, it probably isn't built to NEMA specs.

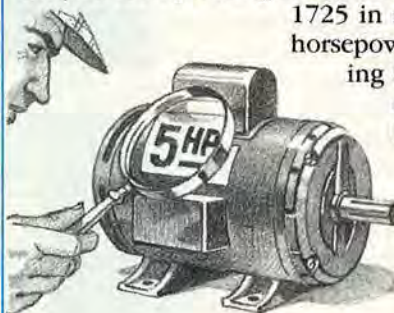

A 115-volt induction motor requires about 10 amps at full load to produce one continuous horsepower, and a 230-volt induction motor requires about 5 amps at full load to produce one continuous horsepower—without overheating. You aren't getting your money's worth if the motor doesn't meet or exceed these guidelines.

Manufacturers also mistreat ratings of series-wound AC motors or universal motors found on electric drills, routers, and belt sanders. It seems some companies calculate the horsepower when the motor "stalls." If a motor stalls, it is NOT producing horsepower. (Stall the engine in your car and try to drive it somewhere!) Reputable manufacturers will put the voltage rating, full-load rpm and full-load amperage draw of this type motor on the motor data plate.

Thank you for letting me sound off a little.

—Donald F. Austin, electrical maintenance trainer,
Arkansas Power and Light Co. Redfield, Ark.

In this price-is-king society, manufacturers sometimes sacrifice dependability and durability to market the cheapest tool. And unfortunately, horsepower fascinates too many of today's buyers.

Continued on page 12

PLATE JOINER SALE!!!

Choose from two of the best names in plate joiner technology.

freud.

PORTER-CABLE
PROFESSIONAL POWER TOOLS



JS100 JOINER SYSTEM

- Double Insulated
- High Density Plastic Storage Case
- Cast Aluminum and High Impact Plastic Housing
- Easy on-off switch
- Allows joining edge-to-edge or at 45° & 90°
- Fits all 3 sizes of standard splines

List Price \$259.00

SALE \$169.95

MODEL 555 PLATE JOINER

- Super Torque PD™ belt drive
- Unique verticle handle
- Trigger switch
- Rotating depth adjustment with preset stops
- Exclusive miter fence
- Steel carrying case

List Price \$269.95

SALE \$179.95

- WE HONOR ALL FREUD NATIONALLY ADVERTISED SPECIALS
- CALL OR WRITE TODAY FOR CURRENT PRICES ON OTHER TOOLS/ACCESSORIES
- PRICES QUOTED, DELIVERED PREPAID ON \$75 MINIMUM ORDER
- VISA, MASTERCARD ACCEPTED

CALL TODAY FOR NEXT DAY SHIPPING

1-800-476--HILR(4457)



1411 Assembly Street
P. O. Box 1762
Columbia, S.C. 29202-1762
803-779-3131 Ext. 19

YOUR WOODWORKING SPECIALIST IN THE SOUTHEAST

BRIDGEWOOD®

WOODWORKING MACHINERY

ACT NOW — SPECIAL PRICES VALID WHILE QUANTITIES LAST

← DUST COLLECTORS AND ACCESSORIES



1 H.P. MOTOR WITH CASTERS **BW-015A**
\$199

- BW-015A — 1 HP, 2 BAG . . . \$199
- SF-015 — 1 HP, 2 BAG . . . 319
- BW-002A — 2 HP, 2 BAG . . . 379
- BW-003A — 3 HP, 4 BAG . . . 595
- SF-003 — 3 HP, 4 BAG . . . 795

REDUCERS (STEEL)

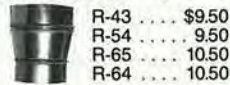

- R-43 . . . \$9.50
- R-54 . . . 9.50
- R-65 . . . 10.50
- R-64 . . . 10.50

ELBOWS (STEEL)



- EL-3 . . . \$4.00
- EL-4 . . . 4.50
- EL-5 . . . 5.00
- EL-6 . . . 5.50

STRAIGHT METAL DUCT



- IN 2 FOOT SECTIONS
- MD-3 . . . \$3.60
 - MD-4 . . . 4.00
 - MD-5 . . . 4.60
 - MD-6 . . . 5.60

SMOOTH FLOW TEE (STEEL)



- T-443 . . . \$15.50
- T-544 . . . 16.00
- T-555 . . . 16.00
- T-654 . . . 17.50

CAST ALUM. GATES



- | | | |
|------|-----------|------------------------|
| | PRICE EA. | PRICE EA.
4 OR MORE |
| GA-3 | \$14.00 | \$11.50 |
| GA-4 | 15.00 | 12.50 |
| GA-5 | 19.50 | 15.50 |
| GA-6 | 24.00 | 19.50 |

HOSE CLAMPS



- HC-3 . . . \$1.90
- HC-4 . . . 2.40
- HC-5 . . . 3.00
- HC-6 . . . 3.15

Y-FITTINGS (STEEL)



- Y-433 . . . \$16.00
- Y-444 . . . 16.00
- Y-555 . . . 16.50
- Y-544 . . . 16.00

H.D. FLEX HOSE - PVC



- PRICE PER FOOT
10 FT. MIN.
- BW-FH-3 . . . \$1.90
 - BW-FH-4 . . . 2.50
 - BW-FH-5 . . . 3.55
 - BW-FH-6 . . . 4.45

PLANERS



BW-15P
\$795

3 H.P.
2 SPEED
15" PLANER
WITH STAND
AND
DUST HOOD
AND MOTOR

- BW-12P — 12" x 6" portable . . . \$ 349
 - BW-15P — 15" x 6" econ. 795
 - BW-20P — 20" x 8" econ. 1295
 - ★ BW-16PV — 16" x 7" H.D. 2495
 - ★ BW-20PV — 20" x 7" H.D. 2995
 - ★ BW-508 — 20" x 9" INDUST. 3695
 - ★ BW-612PV — 24" x 9" INDUST. 5995
- ★ — WITH USA MOTORS

15" SCROLL SAW



- 2" Thick cutting capacity
- 15" Throat depth

\$119



BW-6J
\$299

6" x 42"
table
1 H.P. MOTOR
WITH STAND

← JOINTERS

- BW-6J - 6" x 42" 1 HP, w/STD . . . \$ 299
- BW-8J - 8" x 66" less motor 699
- BWJ-872 - 8" x 72" H.D., 2 HP,
U.S. motor 1695
- BW-12J - 12" x 80" H.D., 3 HP,
U.S. motor 2495
- CE-40N - 16" x 100" INDUST., 7 1/2 HP
U.S. MOTOR 4395

← BANDSAWS



BW-14BS
\$299

BW-14BS
14" x 6" cap., 3/4 HP
\$299

BW-18BS
18" x 12" cap., 2 HP
\$795

PBS-500
20" x 12" cap., 2 HP
w/Carter guides
\$1495

SHAPERS

- BW-1S**
1/2" spindle . . . \$269
- BW-2S**
1/2", 3/4" spindle
2 HP \$795
- BW-3S**
1/2", 3/4", 1" spindle
3 HP \$1295

- BW-511TS**
sliding table, tilt spindle
3 HP \$2495
- BW-512TS**
sliding table, tilt spindle
5 HP \$3395
- TC-50**
sliding table, industrial
7 1/2 HP \$4695

EXTRA LARGE
20" x 24"
TABLE SIZE
2 H.P.
MOTOR



BW-2S
\$795



ALL PRICES
QUOTED F.O.B.
YORK, PA

IF YOU VALUE YOUR FINGERS..... YOU NEED A **RIPSTRATE®**

The RIPSTRATE holds the work tight against the fence with no hands near the blade. Makes perfect, straight cuts. Wheels lock to prevent kickbacks. *Requires no adjustment for stock width or thickness.*

Over 30,000 now in use in amateur, professional, school, government, military, and corporate maintenance shops.

One year guarantee, 30 day money back trial. \$69 plus \$3.50 for shipping. Check, M.O., Visa or M.C. Free Brochure.

Write or call our toll free number: 800-421-0256.

Fisher Hill Products 4 Fisher Hill Fitzwilliam, NH 03447

Dealer inquiries invited.



WHY PROFESSIONALS USE BRAD POINT DRILLS

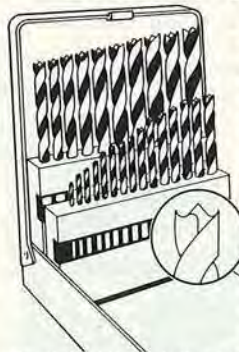

Brad Points are engineered especially for wood - soft wood or hard.

The center point (brad point) of the drill is pushed into the marked location for the hole. It locks into position and will not slide out. When the motor is turned on. The hole is drilled *exactly* where it is wanted. This is the most important part of doweling, after proper measuring.

The two outside spurs cut clean entry holes. There is no tear out (splintering) - not even in Oak or Curly Maple - so that if the hole is to be later plugged to cover a screw, the periphery of the hole will be almost invisible.

These spurs provide smooth hole walls and almost flat bottoms. A

dowel should touch bottom to glue properly. Metal working drills leave a tapered bottom.

It is best to own a complete 25-pc set and have every size from 1/8" to 1/2" in increments of 1/64ths (.0156") because commercial doweling is seldom sized exactly. Dowels that are too loose don't cut it; those that are too tight don't fit.

WHY DOLLAR'S BRAD POINTS ARE BEST: Our drills are milled from the solid; others are only roll forged. Our brad points and spurs are first milled then ground for accuracy. We use high carbon, alloy steel. Many others are made from plain carbon steel. Our drills are heat treated and hardened to Rockwell C48-52. They are tough, sharp and long lasting. Most companies that sell drills do not know what they are made of, or what the hardness is.

AS FOR PRICE, YOU BE THE JUDGE.

These drills will fit any 3/8" or larger chuck.
FREE metal index included.

ORDER #10-0100 25-pc Brad Point Drill Set **only \$29.95 ea.**
2 or more sets to one address **only \$26.95 ea.**

Ship/Handling \$3.00 for 1, \$5.00 for 2 or more to one address.

CALL TOLL FREE: 800-447-7770 • VISA/MC/AMEX
Dollar Trading Corp. (Est. 1953); P.O. Box 8433, Grand Rapids MI 49518
Dept. WM05 • Sales Tax MI 4%; CT 7-1/2%
NO HASSLE, 30-DAY MONEY BACK GUARANTEE

TALKING BACK

Continued from page 10

THE FRUGAL LATHE OPERATOR

I rate your article on segmented bottoms for stave bowls in the June 1988 issue as excellent. One paragraph might have been added, however. When I finished cutting the 12 pieces, I found I could glue together the 24 wedged-shaped waste pieces to make a segmented bottom for another bowl.

It was more attractive to first glue together the long sides of the waste pieces. This produced 12 pieces to be assembled in the same way as you described. The only waste from the project was kerfs from the initial cutting on the bandsaw.

I like *WOOD* magazine!
—Jerry L. Griffith, Hoisington, Ka.

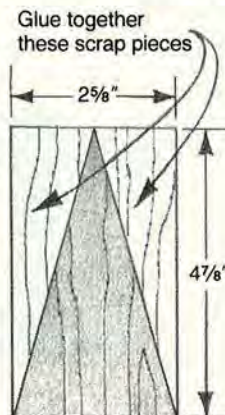

Sounds like you found another bowl bottom in your waste bin, Jerry.

HOW THICK WAS THAT?

Tom Rose from Los Angeles bets that we meant .003 mm—not 3 mm—in a February 1989 "Talking Back" reference to Du Pont double-matte Mylar. Tom, you're correct. We apologize if this caused confusion.

THE BASICS OF HIGH STICKING

Occasionally, readers ask about the double-faced tape we refer to in cutting out and building our projects. Actually, we rely on two varieties that we buy from a local hardware store.

When we need superior sticking quality to fasten together pieces of wood, we call on 1 1/2" Manco cloth professional carpet tape (item DFC-1). This works great to bandsaw identical parts, for example. A 12' roll sells for about \$2.25. When we stick patterns to wood, a lightweight plastic double-faced tape has sufficient strength. We buy 1 1/2"-wide Manco plastic carpet tape (S-42) in 42' rolls for about \$2.85. Lacquer thinner releases the adhesive from both products.

HONING COMPOUNDS: SOLID, NOT EXACTLY PASTY

Apparently we confused a few readers when we referred to honing compounds as "pastes" in the shop skills article on sharpening carving tools in our February 1989 issue. Some readers expected a product of a somewhat-liquid consistency when they ordered the emery and tripoli compounds from Woodcraft, the source listed in the article's Buying Guide.

To use the solid bars of compound, cut a hand-size portion of compound from the bar and rub it into the strop's leather surface. Recharge the strop with compound as necessary. Woodcraft now includes instructions with the compounds. 🌲

Thin Kerf. Advanced Design.

The Freud Difference

Superior Carbide. Some of the physical properties of carbide, elasticity, hardness and resistance to chemicals, can be changed to meet cutting requirements.

To ensure the blade you buy has the best carbide qualities for its purpose, Freud produces special blends at its own factory. Through a combination of robotic and computer monitoring, each batch is checked to assure purity and quality.

Advanced CAD System. The Computer-Aided Design System simulates actual cutting conditions in three dimensions and records the blade performance. This allows Freud engineers to electronically vary the material being cut and the blade's physical characteristics to develop saw blades that provide optimum cutting performance.

Laser Technology. A computer-controlled, 500-watt laser is used in the production of Freud cutting tools. The concentrated beam of light creates a perfectly round blade, produces shoulders identical in shape and size and precisely centers the arbor hole. In addition, expansion slots are strategically placed to allow for heat dissipation during brazing and blade body expansion during actual use.



Thin kerf blade compared to standard kerf blade



Freud thin kerf blades
Rip (left), Crosscut (right)

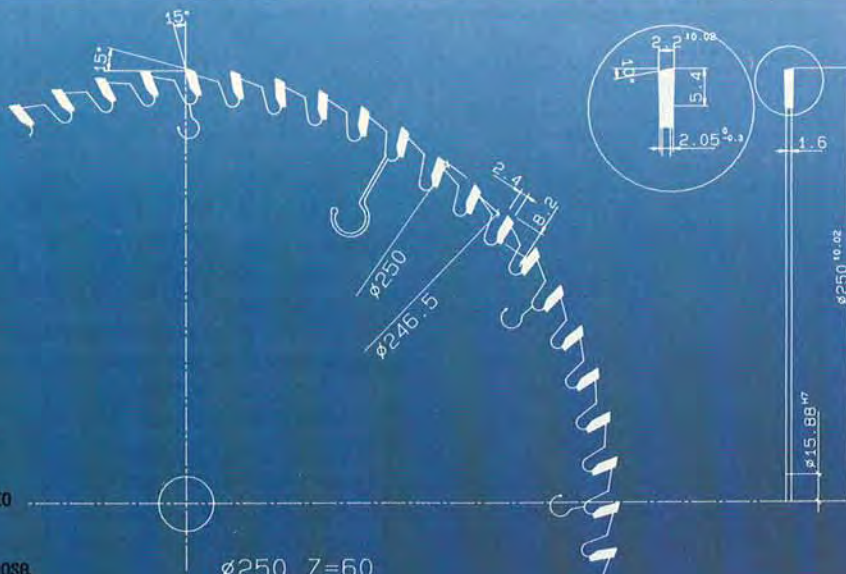

Freud Perfects the Thin Kerf Blade.

Using advanced technology, Freud's international team of European and North American engineers have perfected the thin kerf saw blade. They have eliminated misaligned teeth, poor blade body tensioning, carbide chipping and a variety of other problems common with some thin kerf blades.

The kerf on the Freud 10-inch crosscut blade, 28% thinner than the standard .126 inch kerf blade, reduces material loss when working with rare or expensive wood.

Freud's thin kerf blade also requires less energy to feed the material into the saw blade, eases the strain on your power tool and makes your work easier and safer.

Turn your under-powered saw into a real board cutting champion with Freud's thin kerf blade. Each thin tooth takes out less wood than the standard carbide blade, thus requiring less horsepower to produce equally good results. Also, the radial arm saw's aggressive self-feeding characteristics are virtually eliminated.

For the best value in advanced thin kerf blade technology, demand Freud.

Stock Number	Thin Kerf Rip	Kerf	Suggested Retail
LJ87M008	8" x 22 x 5/8"	.086 inch	\$49.00
LJ87M009	9" x 22 x 5/8"	.094 inch	\$54.00
LJ87M010	10" x 24 x 5/8"	.094 inch	\$56.90
Stock Number	Thin Kerf Crosscut	Kerf	Suggested Retail
LJ88M008	8" x 48 x 5/8"	.082 inch	\$59.90
LJ88M009	9" x 54 x 5/8"	.090 inch	\$63.90
LJ88M010	10" x 60 x 5/8"	.090 inch	\$69.90

Call for the name of your local distributor:

freud

Freud Inc.
218 Feld Ave.
High Point, NC 27264
(919) 434-3171

EARN CASH, PRIZES FOR YOUR TOP SHOP TIP

Do you have a great shop tip (or two) you'd like to share with other WOOD® magazine readers? For each published submission, you get:

- \$25 from WOOD magazine;
- A matching \$25 gift certificate from one of our mail-order advertisers—this time from Leichtung Workshops; and:
- A chance to be selected as the Top Shop Tip winner for the issue. This issue's winner will receive a Skil portable circular saw as shown below right.

We try not to use shop tips that have run in other publications, so please send your tip to only one magazine. We cannot return shop tips. Mail your tips, address, and daytime phone number to:

TOP SHOP TIPS
Better Homes and Gardens®
WOOD Magazine
 Locust at 17th
 Des Moines, IA 50336

THESE CONNECTORS KEEP SAWDUST OUT OF MOTORS

Fine sawdust can turn up in surprising places—such as inside totally enclosed motors and capacitor boxes on table and radialsaws, drill presses, and the like. This invasion, which can shorten motor life and pose a fire hazard, may result from power cords being held with Romex connectors that permit the dust to infiltrate the connection box.

TIP: Replace Romex connectors with flexible cord and power-cable connectors. Their liquid-tight connectors successfully block the dust invasion. You'll find them in all knockout sizes and a wide range of cable sizes. If your hardware store doesn't have them, an electrical-supply dealer should.

—C. Clay Milner, Atlanta

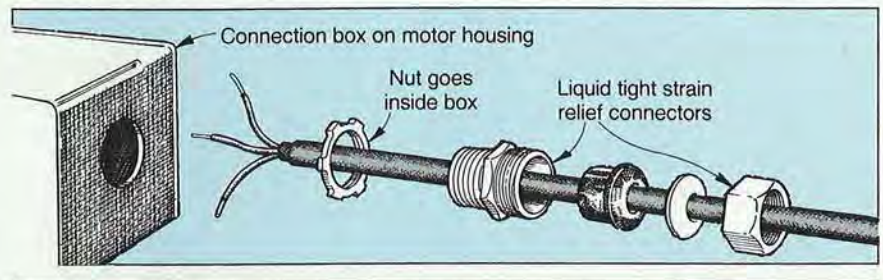

LET TRAPPED AIR AND GLUE ESCAPE DOWEL HOLES

Driving long dowels into snug holes may be impossible because of the air and glue trapped inside.

TIP: Place the dowel in your woodworking vise and with a thinner kerf blade, saw a 1/16"-deep groove to provide an air/glue escape route. Rest the saw against the vise jaw to control the cut as shown at right.

—From the WOOD magazine shop

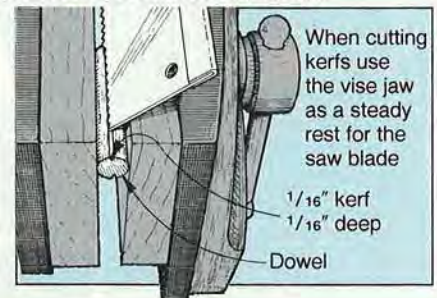

PROTECTION PLAN EARNS READER A SKIL CIRCULAR SAW

Even when you try to be careful, the woodworking plans in WOOD magazine can take a real beating from liquid spills in your shop. And, how many times have you employed an awkward weight to hold the magazine open to a certain place, only to tear a page when you reposition the magazine? Before you know it, you've accidentally soiled or torn your only copy of WOOD magazine.

TIP: Preserve the entire magazine with a protective holder like the one shown at left. Start with a base of 1/2" plywood large enough to hold WOOD magazine (18x13"), glue a 1/2 x 1/2" lip along one of the longer edges, fit an 18x12 1/2" sheet of 1/8" acrylic, and install 3/16" stove bolts with wing nuts to hold it all together. Bolts should protrude about 3/4" through the base.

—Julie Manuel, Oklahoma City

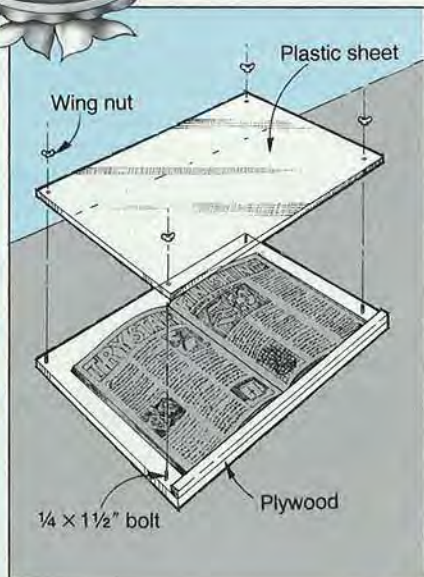

For her winning tip Julie receives a Skil model 5825 6 1/2" portable circular saw shown at left.

Continued on page 16



Our 10th ANNIVERSARY Gift To You!

ACT NOW! Buy 1-Dozen Belts

12
Get 6 Belts FREE!

We are celebrating our 10th Year supplying Belts and Sanding Accessories direct to the Woodworker.



SANDING BELTS

Available in 36, 40, 50, 60, 80, 100, 120, 150, 180, 220, 240, 320 grit sizes. Please specify when ordering. We will ship an assortment of 24 Fine, Medium and Coarse unless otherwise specified.

BELTS - x weight, a/o, cloth.

- 1 1/2" x 21"\$13.50/doz.
- 1" x 30" 15.50/doz.
- 1" x 42" 15.70/doz.
- 1" x 44" 15.75/doz.
- 2" x 48" 19.50/doz.
- 2 1/2" x 16" 16.50/doz.
- 3" x 18" 16.75/doz.
- 3" x 21" 17.75/doz.
- 3" x 23 3/4" 17.90/doz.
- 3" x 24" 18.00/doz.
- 3" x 27" 18.50/doz.
- 4" x 21" 19.95/doz.
- 4" x 21 3/4" 20.00/doz.
- 4" x 24" 20.50/doz.
- 4 1/2" x 26" 20.95/doz.
- 4" x 36" 23.95/doz.
- 4 1/8" x 52 1/2" 34.95/1/2 doz.*
- 6" x 48" 32.95/1/2 doz.*
- 6" x 89" 57.95/1/2 doz.*
- 4" x 132" 59.95/1/2 doz.*

*(6 FREE)

STIKY DISC

Stiky Disc, Rugged Cloth. Buy5, get 1 FREE. Available in 50,80,120,180,240 grit size.

- 6" diameter\$5.00/pk.
- 8" diameter 6.25/pk.
- 9" diameter 7.50/pk.
- 12" diameter 10.00/pk.

PRO'S BEST

- 0000 Steel Wool \$3.95/pk.
 - 000 Steel Wool 3.95/pk.
- 1 Pack contains 16 pads.

"Wooden Memories" PLANS

- Bessie the Cow \$9.00
 - Bill E. Goat 9.00
 - Beezer the Burro 9.00
 - Ole Grey Mare 7.00
- Build an heirloom today!
Life like, full size rockers.

- MONEY BACK GUARANTEE!
- SHOP OUR OUTLET STORE IN READING, PA. "The Outlet Capital of the World"
- PROMPT DELIVERY FROM STOCK!

Singley "Sleeveless" DRUM SANDERS

No pre-made sleeves to buy. Cut your 9 x 11 sandpaper, lock into drum and begin sanding.



- 3/4" x 3" \$13.95
- 1" x 3" 13.95
- 2" x 3" 15.95
- 2 1/2" x 3" 16.95
- 3" x 3" 17.95



- 12 Piece Extra Length **SANDING DRUM KIT** \$9.95
Included are 1 Fine and 1 Coarse abrasive band for each size drum. 1/2", 3/4", 1", 1 1/2" dia. x 2" long.

- RE-FILL PACK.**
16 pc. asst., 1 Fine, 2 Medium, 1 Coarse per drum \$5.95

9" x 11" PAPER SHEETS

A/O Cabinet Paper (Brown)

- | | |
|-------------------|-----------------------------------|
| 40-D.....\$17/pk. | <input type="checkbox"/> 100/pk. |
| 50-D.....16/pk. | <input type="checkbox"/> \$31/pk. |
| 60-D.....15/pk. | <input type="checkbox"/> 28/pk. |
| 80-D.....14/pk. | <input type="checkbox"/> 26/pk. |
| 100-D.....13/pk. | <input type="checkbox"/> 24/pk. |
| 120-D.....13/pk. | <input type="checkbox"/> 22/pk. |
| 150-D.....13/pk. | <input type="checkbox"/> 22/pk. |

Garnet Paper (Red)

- | | |
|-------------------|-----------------------------------|
| 40-D.....\$17/pk. | <input type="checkbox"/> 100/pk. |
| 50-D.....16/pk. | <input type="checkbox"/> \$31/pk. |
| 60-D.....15/pk. | <input type="checkbox"/> 28/pk. |
| 80-D.....14/pk. | <input type="checkbox"/> 26/pk. |
| 100-C.....13/pk. | <input type="checkbox"/> 24/pk. |
| 120-C.....13/pk. | <input type="checkbox"/> 22/pk. |
| 150-C.....13/pk. | <input type="checkbox"/> 22/pk. |
| 180-A.....12/pk. | <input type="checkbox"/> 20/pk. |
| 220-A.....12/pk. | <input type="checkbox"/> 20/pk. |

No-Loading Finishing Paper (White)

- | | |
|-------------------|-----------------------------------|
| 80-C.....\$16/pk. | <input type="checkbox"/> 100/pk. |
| 100-C.....14/pk. | <input type="checkbox"/> \$28/pk. |
| 120-C.....14/pk. | <input type="checkbox"/> 24/pk. |
| 150-C.....14/pk. | <input type="checkbox"/> 24/pk. |
| 180-A.....11/pk. | <input type="checkbox"/> 19/pk. |
| 220-A.....11/pk. | <input type="checkbox"/> 19/pk. |
| 280-A.....11/pk. | <input type="checkbox"/> 19/pk. |
| 320-A.....11/pk. | <input type="checkbox"/> 19/pk. |
| 400-A.....11/pk. | <input type="checkbox"/> 19/pk. |

Wet or Dry S/C Paper (Black)

- | | |
|--------------------|-----------------------------------|
| 220-A.....\$15/pk. | <input type="checkbox"/> 100/pk. |
| 320-A.....15/pk. | <input type="checkbox"/> \$25/pk. |
| 400-A.....15/pk. | <input type="checkbox"/> 25/pk. |
| 600-A.....15/pk. | <input type="checkbox"/> 25/pk. |

"SANDVIK"

- HAND SCRAPER** \$5.95
6" x 2 1/2" x .030 high quality steel cabinet scraper.

- BELT CLEANING STICK** \$6.95
2" x 2" x 6" - Makes your Belts, Discs, Sleeves last 3 x as long.

Bench Top CUSHION CONTOUR SANDERS

Simply ... chuck into your drill press or hand drill, inflate to desired hardness and you're ready to go. You receive 4 FREE asst. sleeves with purchase of sander!

- 2" x 4 1/2" Sander w/3/8" shaft \$34.95
 - 1 1/2" x 4 1/2" Sander w/3/8" shaft 33.95
 - Pk. of 5 Replace. Sleeves* 2" x 4 1/2" 4.75
 - Pk. of 5 Replace. Sleeves* 1 1/2" x 4 1/2" 4.25
- *Choose from 80, 100, 120, 150 grit.



SAND-O-FLEX UNIT

- Metal SAND-O-FLEX \$18.00
 - Plastic SAND-O-FLEX 14.95
 - 3/8" Shank Adapter for Metal Sand-O-Flex . . . 2.00
 - Sand-O-Flex Abrasive Re-fills* 4.35
- *Available in 80, 120, 180 grits.



BOWL SANDING KITS

Kit includes 1 each, 2" dia. and 3" dia. sanders with 1/4" shaft. Sander conforms to the contour of the bowl.

- Kit comes with 3 flexible discs/sander. 1 each, Fine, Medium and Coarse \$9.95
 - 25 2" PSA FLEX DISCS 7.00
 - 25 3" PSA FLEX DISCS 9.95
- Choose from 80, 120, 180 & 220 grits. All 25 pcs. same grit.



MITCHELL'S ABRASIVE CORDS/TAPE

- Abr. Cord (.055 dia. x 25 yds., 150 grit) . . . \$9.95
 - Abr. Tape (3/32" x 25 yds., 150 grit) . . . 10.95
- Reaches those "near to impossible places" with ease!



SEND FOR FREE CATALOG

FREE! WITH ANY ORDER OVER \$50.00, CHOOSE A BELT CLEANING STICK OR A "Wooden Memories" PLAN.



- Belt Cleaning Stick
- Bill E. Goat
- Ole Grey Mare
- Bessie the Cow
- Beezer the Burro

INDUSTRIAL
BRASIVES CO.
643 N. 8th STREET
READING, PA 19612

For Fast Delivery Call Toll Free
1-800-428-2222 (U.S.A.)
1-800-222-2292 (PA only)

SHIPPING CHARGES - MIN. ORDER \$25.00
Under \$35 add \$2.50. \$35 or more add \$4.00. PA residents add 6% sales tax.

- MONEY ORDER
- MASTERCARD
- VISA
- CHECK

Acct. # _____ Exp. Date _____

Name _____ DAYTIME PHONE () _____
PLEASE PRINT

Street _____

City _____ State _____ Zip _____

USE THIS AD TO ORDER

USE THIS AD TO ORDER

Cascade Precision Tool Co.
 Box 848, Mercer Island, WA 98040
 Call Toll-Free: 1-800-235-0272

Write or call for our
NEW 1989 Catalog!!
 Great **SALE** prices!!

Dear Woodworker:

Learn what our customers know so well! These SY Brand tools are the best quality **carbide** tipped router bits and shaper cutters you'll ever use! And, our prices are the lowest around.

Check our catalog for a huge selection of tools and related products.

Write or call for our New 1989 catalog with **Great Sale Prices!** And, thanks for your business!

Phil Granquist
 Cascade Precision Tool Co.

FOR THE SHAPER
 3 mm thick C-2 carbide, 3/4" Bore w/1/2" Bushing
Straight



SY-1212-1 1/4" \$24.95	SY-1212-4 3/4" \$32.95
SY-1212-2 3/8" \$26.95	SY-1212-5 1" \$35.95
SY-1212-3 1/2" \$28.95	SY-1212-6 1-1/2" \$36.95
	SY-1212-8 2" \$59.95

Flute



SY-1223-1 1/4" \$24.95	SY-1223-4 3/4" \$32.95
SY-1223-2 3/8" \$26.95	SY-1223-5 1" \$35.95
SY-1223-3 1/2" \$28.95	

Bead



SY-1224-1 1/4" \$24.95	SY-1224-4 3/4" \$32.95
SY-1224-2 3/8" \$26.95	SY-1224-5 1" \$35.95
SY-1224-3 1/2" \$28.95	

NOW A Choice of Edge Beading Bits

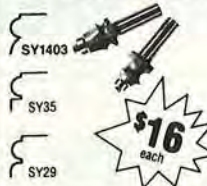

FOR THE ROUTER!

Cove Bits

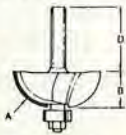

PART NO.	A	PRICE
S702Y	1/16	\$12
S704Y	1/8	\$12
S706Y	3/16	\$12
S708Y	1/4	\$13
S710Y	5/16	\$14
S712Y	3/8	\$15
S716Y	1/2	\$16
S716Y-1/2	1/2	\$16
S724Y-1/2	3/4	\$28

Roundover

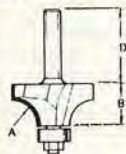

PART NO.	A	PRICE
S502Y	1/16R	\$11
S504Y	1/8R	\$11
S506Y	3/16R	\$11
S508Y	1/4R	\$12
S510Y	5/16R	\$13
S512Y	3/8R	\$15
S516Y	1/2R	\$16
S516Y-1/2	1/2R	\$16
S520Y-1/2	5/8R	\$20
S524Y-1/2	3/4R	\$20
S528Y-1/2	7/8R	\$34
S532Y-1/2	1R	\$34
S536Y-1/2	1-1/4R	\$40

Bull Nose

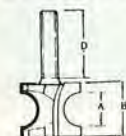

PART NO.	A	PRICE
SY9-1	1/4	\$14
SY9-1 1/2	1/4	\$14
SY9-3	3/8	\$15
SY9-3 1/2	3/8	\$15
SY9-4	1/2	\$15
SY9-4 1/2	1/2	\$15
SY9-5	5/8	\$16
SY9-5 1/2	5/8	\$16
SY9-6	3/4	\$16
SY9-6 1/2	3/4	\$16
SY9-8 1/2	1	\$18
SY9-9 1/2	1-1/8	\$30
SY9-10 1/2	1-1/4	\$35
SY9-11 1/2	1-3/8	\$38
SY9-12 1/2	1-1/2	\$40

TIPS FROM YOUR SHOP (AND OURS)

Continued from page 14

TOOL UP FOR STRAIGHT EDGE GLUING

Using 2x4s as flush clamp bars when gluing up boards edge-to-edge can easily result in misaligned boards toward the middle of the panel. The problem occurs because nontapered boards exert more pressure at the ends of the assembly than in the middle. The means to a solution: your jointer.

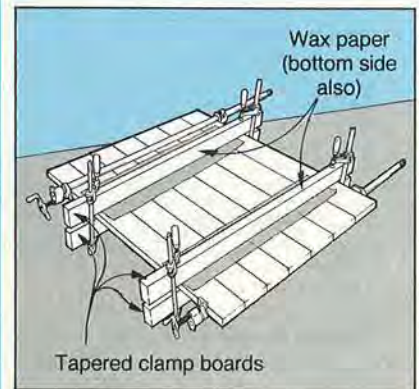
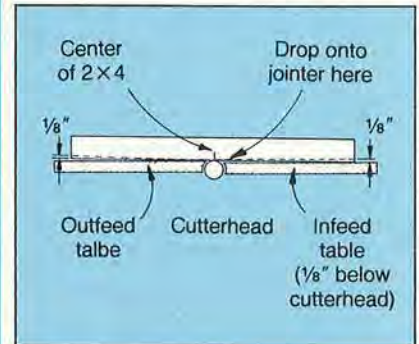

TIP: Mark the center of the length of a 2x4 on its face side and set the infeed table of your jointer 1/8" below the cutterhead as shown in the illustration above top. Lower the workpiece over the cutter at the center mark and feed it off the table so it makes a tapered cut from the middle to one end. Keep downward pressure on the infeed side of the table throughout the cut. Turn the piece end for end to make an identical cut from the center to the opposite end. This will create a clamping bar that gently bows with a central crown 1/8" higher than its ends.

—From the WOOD magazine shop

Continued on page 18

1/2" SHANK CARBIDE TIPPED CABINET DOOR SET



Big 3-1/2" O.D. PANEL RAISER 3 pc. set **\$179.95** Now **\$149**
 RAIL/STILE CUTTER RAIL END CUTTER PANEL RAISER ALONE **\$69.95** Now **\$50**

NEW Concept in Router Bit Cabinet Door Construction!!

The SY brand 3" Panel Raiser with undercutter in 5 profiles automatically provides a 1/4" tongue, and your panels and rail & stile are at the same height. Complete with bearing for template and freehand cutting.



\$59.95



CARBIDE TIPPED SHAPER CUTTER PANEL RAISER — 3 WING, 5 PROFILES, 3MM THICK CARBIDE
 • 4-5/8" O.D. with 3/4" BORE (1/2" BUSHING)
 • 5-1/2" O.D. with 1-1/4" BORE (1" BUSHING)

\$69.95 each



6 PC CARBIDE TIPPED CABINET SETS

• 3 mm CARBIDE
 • 3/4" BORE W/ 1/2" BUSHING
ONLY \$179.95 each
 13 Great Cabinet Sets including these popular Profiles:

SY 1280		SY 1283	
(1-1/4" Bore with 1" Bushing— ONLY \$249.95)			
SY 1281		SY 1284	



Only **\$495** Frt. Incl.
CAS-15 WOODSHAPER

- 1 1/2" HP, 2 speed, Reversible
- 3/4" and 1/2" spindles
- 1.2" vertical spindle travel • Holddown clamps
- Individual fence assembly adjustment
- 1/2" and 1/4" router collets
- Mitre dovetailed into table

MC/VISA/COD USERS ORDER TOLL FREE
 1-800-235-0272
 IN WASHINGTON STATE CALL 1-236-0272
 7AM - 7 PM Monday through Friday (P.T.)



*Indicates 1/2" shank.

Escape to the pleasures of woodworking



What do you expect to get from your leisure time? A little fun. A chance to unwind. Maybe even a way to do something nice for your family or friends.

Then consider woodworking. It can give you *all* these things—more easily and more economically than you might think.

Look what woodworking has to offer!

First, it's enjoyable. You start with an idea and some wood. Then you combine them to create something uniquely your own.

It's also a great way to get rid of stress because when you're working on a project, the pressures of your job seem to fade away and you end up feeling more relaxed and refreshed than you did when you started.

And it's rewarding. You can take pride in projects like end tables or bookcases or kitchen cabinets—they add warmth to your home—and they cost a lot less than you'd pay in a store.

Shopsmith® helps you enjoy it all.

At Shopsmith we have everything you need to get the most out of woodworking.

Start with the Shopsmith MARK V. It gives you a table saw, vertical drill press, horizontal boring machine, lathe and disc sander—all in one compact, high-precision unit. That means you can enjoy all these big shop capabilities with a minimum of space and expense.

You can add accessories to handle almost any woodworking operation. And since they're powered by the MARK V, you won't strain your budget or outgrow your shop when you add new capabilities.

Plus all the know-how you need.

As a MARK V owner, you get a complete set of operating literature—plus you can learn more about woodworking through our classes, seminars, educational video tapes, catalogs and our magazine for owner's, "Hands On."

You can also call us Toll-Free for the answers to your woodworking questions. And you'll have the confidence of dealing directly with Shopsmith either by mail, Toll-Free phone or at one of our growing network of Shopsmith Stores.



Dept. 3774

Ask for a FREE Information Kit.

To find out more about woodworking with the MARK V, call Toll-Free or mail the coupon below. We'll rush you a FREE Information Kit in your choice of Full Color Brochure or VHS Videocassette.

No Obligation!

Remember, there's no obligation, so act NOW. *Even the call is Free!*

For your FREE Information Kit Call

1-800-445-4040

or mail the coupon below to:



Shopsmith Inc.

3931 Image Drive
Dayton, Ohio 45414-2591

© 1989, Shopsmith, Inc.
Shopsmith™ is a registered trademark of Shopsmith, Inc.

Yes! I'd like to know more about the pleasures of woodworking with the Shopsmith MARK V. Please send me:

- FREE Color Brochure on the Shopsmith MARK V, or
 FREE VHS Videocassette and Color Brochure. (3775)

Name _____

Address _____

City _____ State _____ Zip _____

I currently own Shopsmith Power Equipment.

Send to: Shopsmith, Inc., 3931 Image Drive, Dayton, Ohio 45414-2591

FACTORY DIRECT CLOCKS AND FURNITURE



Do-It-Yourself Kits or Assembled and Finished

- Grandfather Clocks, Mantel and Wall Clocks
- Cabinets, Chests, Tables, Chairs, Desks...and more!
- Solid 3/4" Black Walnut, Cherry, or Oak
- Heirloom Quality
- Solid Brass West German Movements and Dials
- Money Back Guarantee



SEND \$1 FOR COLOR CATALOG

EMPEROR CLOCK COMPANY

World's Largest Manufacturer of Grandfather Clock Kits
Dept. 3109, Emperor Industrial Park
Fairhope, Alabama 36532 • Phone 1-205-928-2316

I am interested in

Do-It-Yourself Kits Finished Clocks Finished Furniture

Name _____

Street _____

City _____

State _____ Zip _____

(Please Print)

RING MASTER

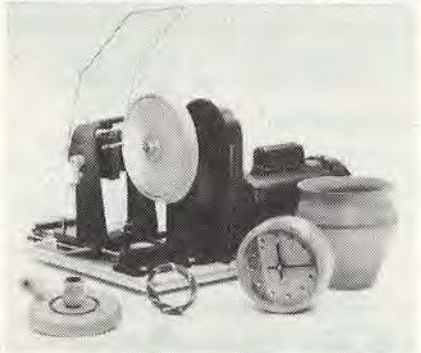

TEST YOUR IMAGINATION

Create Any Hollow Cylindrical Shape up to 12" dia. Cut flat wood into straight or angle rings, stack rings, glue, sand, & finish. All on your Ring Master.

Now Ring Master Attaches To Your

- SHOPSMITH MARK V
- CRAFTSMAN 12" LATHE

ORDER YOUR **FREE BROCHURE** TODAY

We accept Master Card, Visa, & C.O.D.

Call 1-800-634-9281 in NC 919 762-6334

TIPS FROM YOUR SHOP (AND OURS)

Continued from page 16

GREAT WAY TO PUT BRUSHES "ON HOLD" BETWEEN COATS

Between finishing coats, it would be nice if you didn't have to thoroughly clean the brush. You could place the brush in a jar filled with thinner, but that often damages the bristles.

TIP: Recycle a container of wet wiping cloths such as Handiwipes for use as a temporary brush container. The slits in the cover form a snug opening and suspend the brush in a bath of solvent without bending the bristles. Some solvents will dissolve plastics, so check by placing a small amount of the solvent in the container ahead of time.

—Daniel Borken, Bloomington, Minn.

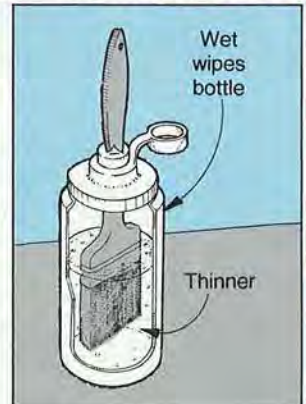

PUT THAT CHUCK KEY WHERE YOU'LL ALWAYS FIND IT

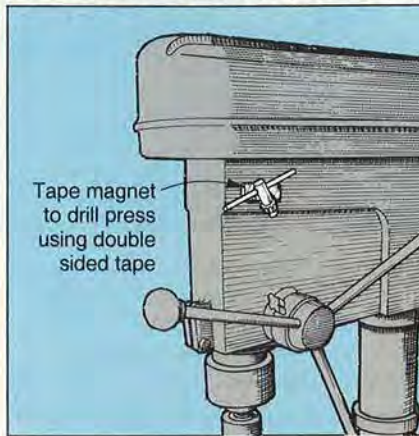

Tape magnet to drill press using double sided tape

A drill press chuck key has a nasty way of disappearing when you want it. For example, it may be in the pocket of another pair of pants or out of sight in some corner of your shop. You can waste a lot of time looking for it.

TIP: Use cloth-backed, double-sided carpet tape to attach a small magnet in a convenient location on the head of your drill press. The magnet will hold that elusive chuck and keep it from wandering.

—Lyle Kruger, Effingham, Ill.

HARNESS A SAWHORSE TO HOLD YOUR WORKPIECES

Every once in a while, it's necessary to rip, crosscut, drill, or shape workpieces that are just too long to rest securely on the table of a stationary power tool. If someone is available, you could enlist them to hold up the far end of a long piece, but that may actually be dangerous in terms of binding or kickback and the like, depending on the machine and situation.

TIP: Use some clamps, a piece of 3/4" plywood, and a sawhorse to put together a reliable support for that stretched-out job. The configuration shown *below left* works nicely to support long pieces. The second setup shown *below right* proves handy for holding sheet stock as you plane an edge or for securing a door while you install hinges.

—From the WOOD magazine shop

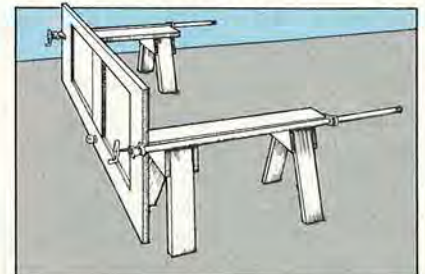
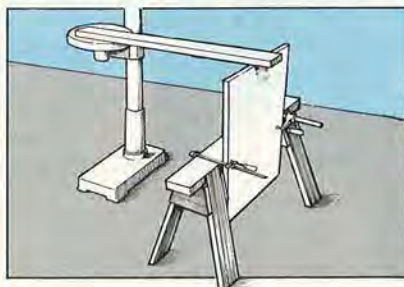

Continued on page 20



Porta-Nails, Inc., P.O. Box 1257, Wilmington, NC 28402

Like Having A Lumberyard Right In Your Shop!



**FREE
30-DAY
TRIAL!**

MADE IN U.S.A.

NOW! Choose From **Only Woodmaster®**
Two Sizes—Popular
12-in. Planer or
NEW 18-in. Model!

lets you

PLANE MOLD & SAND

with the Precision Control of
Infinitely Variable Power-Feed!
MAKES YOU MONEY... SAVES YOU MONEY!

Put this versatile power-feed tool to work in your own shop . . . see how fast it pays for itself! Quickly converts low-cost rough lumber into valuable finished stock. Turns out perfect picture frame moldings, quarter-round, casing, tongue & groove . . . all popular patterns . . . any custom design!

✓ **Just a twist of the dial** puts twice as many cuts-per-inch at your fingertips as any comparable planer—from 70 to over 1,000 CPI! This heavy-duty machine will sail through even the toughest oak at higher speeds, or you can slow it down to handle those “hard-to-work” pieces like curly maple, knotty cedar, burls, knees and much more! A valuable feature for molding work, where profiles make sanding impossible.

✓ **Now choose from two powerful models!** Woodmaster introduces the first 18” Planer/Molder . . . the “Big 18” . . . with all of the features that have made the 12-inch model the most versatile Planer/Molder on the market.

✓ **Change to Molding or Sanding in just minutes!** Unique “Morse-Taper” Quick Change Cutterhead guarantees fast change-over . . . bearings remain factory set . . . precisely aligned at all times.

Here's What Woodmaster Owners Say:

Shop Test Results—“It does an excellent job of planing, on a par with more expensive machines, and even better than some commercial models.”

Editor, Workbench Magazine

Gets More Done—“I build grandfather clocks, music boxes, toys and picture frames. They say a craftsman is only as good as his tools, and let me tell you, my Woodmaster is tops. I get more done, and done right, than I ever did before.”

R.V. Delacourt, Cleveland, Ohio

Best Value—“After checking them all, Woodmaster was obviously the best deal for the money. Also, I would like to acknowledge the polite and prompt service.”

E. D. Holtz, North Carolina

Likes Woodmaster Best—“I have two other planers in my shop . . . wouldn't trade my Woodmaster for either one. I am delighted with its versatility and precision.”

Ron's Custom Cabinets, Colorado

Paid Off Fast—“Paid for itself in no time flat.”

E. L. Walters, North Dakota



Woodmaster's Quick-Change Molding Head lets you create custom moldings from any stock. Choose from over 250 standard trim and picture frame patterns . . . or design your own!



Power-fed sanding speeds production and improves the quality of your work. No more waves or cross-grain scratches. Separate sanding head installs in just minutes.

MAIL COUPON TODAY OR CALL TOLL FREE 1-800-538-4200 Ext. 2331



YES! Please rush me your FREE Information Kit which tells in words and pictures why this amazingly designed powerfeed shop is so much better than other single-purpose or combination tools. Also send me details on your 30-DAY FREE TRIAL GUARANTEE.

Woodmaster Tools, Dept. PW31, 2908 Oak, Kansas City, MO 64108

NAME _____

ADDRESS _____

CITY _____

STATE _____ ZIP _____

FREE 30 DAY TRIAL!

Send for complete information on how you can try this versatile power tool in your own shop for 30 days. You must be satisfied! We'll also send you details on Woodmaster's One Full Year Warranty and our convenient Easy-Payment Plan.

WOODCARVING IS FUN & PROFITABLE!



Want to carve decoys, statues or gun stocks?

It's easy when you use the Dupli-Carver Series wood carving machines. A patented five axis carving action allows these machines to complete difficult undercuts and contours as no other machine can. Complete machines are available starting as low as \$359.00

SEND \$1.00 FOR OUR FULL LINE BROCHURE AND PRICE LIST AND START PLANNING YOUR FULL OR PART-TIME BUSINESS.



MARLIN INDUSTRIES, INC.

Rt. 70, Box 191, Dept. D96
Cashiers, NC 28717
(704) 743-5551

BRANDING IRON

FATHERS DAY SALE
\$24.00

CALL TOLL FREE TO ORDER YOUR BRANDMARK
1-800-323-2570
(ORDERS ONLY)
8:00 - 5:00 EASTERN TIME

Your Satisfaction Guaranteed

- Convenient torch heating
- Solid Brass—lasts years
- 1st line as shown
- 2nd line—19 letters/spaces max.
- 1/4" letters
- distinctive border
- Add \$2.50 shipping & handling
- OH res. add \$1.44 tx



• Electric Model available (\$41.95)



Order by mail from

BrandMark



462 Carthage Dr • Dept. W-3 • Beavercreek, OH 45385
513-426-6843

WE OFFER A WIDE VARIETY OF STOCK LEGS AVAILABLE IN MAPLE, CHERRY, OAK, MAHOGANY, WALNUT NO MINIMUM ORDER



FREE BROCHURE DEPT. M6

Adams Wood Products, Inc.
974 Forest Drive • Morristown, TN 37814
Phone (615) 587-2942



CALL TOLL FREE!!



Learn all about combination machine woodworking. Free color catalog and other material available. Tremendous Savings. Expands your workshop area by 90 percent.



Dealer Inquiries Welcome!
1-800-535-4788 USA
1-800-325-8330 CA

Send for your Fine Woodworking videolog.

- 50-minute sampling of the world's best woodworking videos (VHS or Beta). Includes valuable tips and techniques.
- Only \$5.00 (good toward your first order).

Just write to The Taunton Press
Att: Video Dept.
63 S. Main St., Box 355W
Newtown, CT 06470
Or call toll-free 1-800-888-8286

TIPS FROM YOUR SHOP (AND OURS)

Continued from page 18

A DUST BLASTER TO USE ON YOUR LATHE

Many power tools, including the lathe, produce mountains of irritating, fine wood dust. A dust-collection system provides the ideal solution, but an expensive one.

TIP: To keep dust out of your eyes and nose while turning wood, build this slingshot-style fan that you can install in the outboard tool rest of your lathe. Cut the 3/4"-thick yoke to fit a

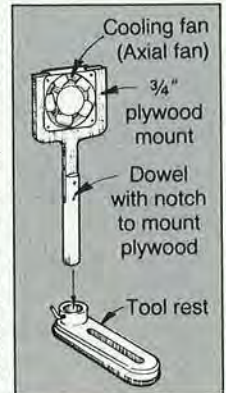

4-5" axial fan typically used for cooling a computer or audio equipment. You can purchase the fans from electronic-supply stores for about \$15. Screw together the yoke and a notched dowel of the appropriate size to fit the tool rest. Wire the fan with standard 14-gauge power cord, including a switch near the fan.

—Rus Hurt, Port Wing, Wis.

MORE TIPS FROM OUR WOODWORKING PROS

You'll find other useful shop tips scattered throughout this issue of *WOOD* magazine:

- Make your your plane glide effortlessly over workpieces using our tip on page 41.
- Ensure level shelves by dading a large panel, and then cutting the individual sides from the panel. See page 44.
- When building a cabinet, use a penny as a spacer for an even overhang on face frames. See the entertainment-center project on page 47.
- Need holes longer or larger than your largest drill bit? Try routing them on a router table fitted with a cove bit. We show you how on page 60.

MAKE MONEY

WITH FURNITURE RESTORATION

SAFE, DEPENDABLE, EASY stripping and refinishing systems and products, featuring HYDROCOTE™ water-base finishes.

AMITY

Quality Restoration Systems

Wisconsin: 608-837-8484
Nationwide: 800-334-4259



STOP PERFBORARD HOOK FALLOUT!

M-CLIPS™ are THE guaranteed perfect solution to this annoying problem! Fit both 1/8" and 1/4" perfborard. Send SASE for free sample or \$5.99 + \$1 p&h for pkg of 50 to:

AETECH, P.O. Box 6298, Dept. W,
Lawrenceville, NJ 08648



We help you repair your

Get a handle on household repairs with **The Home Solution®** you fix, glue, caulk...do just about anything that needs doing in



Seals Drafty Windows
A long-lasting flexible seal that insulates and waterproofs.

Glues Wood
Penetrates wood deeply for a strong, long-lasting bond. Available in original and darker wood formulas.

Patches Cracked Walls
Super fast and easy. Requires little or no sanding. Dries in minutes.

Fills Nail Holes, Gouges
Easy to apply. Shrink resistant. Accepts dark and light stains.

For Replacing Broken Windows
Goes on easily. Paintable in only 30 minutes.

ASK WOOD

 Print this article

Whether your woodworker's license reads "Beginner," "Intermediate," or "Advanced," you're bound to have a few questions about your favorite hobby. We can help. We'll consult our staff and outside experts for answers. Send your questions to:

Ask WOOD
Better Homes and Gardens®
WOOD® Magazine
Locust at 17th
Des Moines, IA 50336

Due to the volume of mail, we can't promise to answer all questions, but we'll try. We may edit letters selected for publication.

AN OLD SCHOOL DESK MAKES THE GRADE

A relative has asked me to refinish an old oak school bench and desk. The wood is well preserved and dry. It will require some sanding and possibly filling—especially on the bench.

My relative doesn't want a dark stain or shiny finish and certainly wants to preserve the carved initials on the desk. What might I use to preserve this antique?

—M.L. Metz, Bella Vista, Ark.

We telephoned Homer Formby, a well-known furniture refinisher, about your desk. "I think you'll be able to restore this desk to its natural appearance with less work than you may expect," Homer said.



"First, I suggest that you go over the wood with 0000 steel wool soaked with my Furniture Refinisher to remove any remaining finish. Even if the desk appears to be bare of finish, there may be some finish left in the grain of the wood, so don't neglect this step. This process shouldn't remove color from the wood or raise the grain. You mentioned that the wood is dry—a common problem in antiques. Recently, we added conditioners to our Furniture Refinisher to replace moisture in wood while you refinish.

"I don't think you'll need to sand the wood unless there are some jagged, rough edges. Instead, after you've completely removed the old finish, lightly buff the wood with 0000 steel wool. I also don't think you'll need to use wood filler. The carved initials and other gouges put there by students are part of its charm, and it sounds like you want to preserve them.

home from top to bottom.



© Borden Inc 1989

products from Elmer's® High-quality, dependable products that let your home. So next time you need help, stick with a name you can trust.



Finishes Fine Woodwork
Perfect for delicate work. Requires little or no sanding. Accepts all kinds of stains.

Cements Laminate to Counters
Dries in 15 minutes for a strong, long-lasting bond.

Glues Almost Anything
A strong, high-tech adhesive that resists heat, water and cold.

Protects Your Hands
Apply before a dirty job. Then come clean with just soap and water.

Seals Tub Tiles
Gives you a strong, flexible seal that resists water and mildew.

"If the desk is not going to be used for writing or drawing, I would finish it with Tung Oil Finish. If it is going to be used, I would apply Formby's Poly Finish for extra protection for the surface. You can hand-rub both of these finishes for a natural look, and both are available in high or low gloss."

For other answers to your finishing questions, call 800-FORMBY'S from noon to 8 p.m. Mondays through Fridays and from 10 a.m. to 6 p.m. Saturdays and Sundays (all Eastern times).

WOODY VEGETABLES

Since there must be many woodworkers who have vegetable and flower gardens, does anybody have knowledge of a process for converting sawdust to a garden additive?

—Norman Paterson,
Morganton, N.C.

There are some people right up the road from our offices who know about this subject. According to our sources at Iowa State University Extension Service, you can add the sawdust of most woods to a compost pile or till directly into the garden. Fresh sawdust does, however, remove nitrogen from the soil. To balance things out, replenish the soil with a nitrogen-rich fertilizer. A word of caution: Do not add walnut sawdust, which has toxic properties, to the soil.

BLACK LACQUER—IT'S BASIC

I am an avid reader of your publication and I'm sure you can help me. I would like to finish a wood clock in jet-black lacquer.

—Louie Betbke, Madison, Wis.

We can help you, Louie. A quick call to John Moser, owner of Wood Finishing Supply Co., provided an answer. With open-grain woods, John suggests you first fill the pores with Behlen's Pore-O-Pac deep-black paste wood filler. Then, our New York friend recommends applying two coats of black Behlen's Undercoat, a sanding sealer. Between coats, John dry-sands with a #400 wet/dry paper. Finally, spray a minimum of two coats of black lacquer enamel.

John recommends gloss-black lacquer for most furniture and accessories, but if your project has a lot of carvings, try a satin finish for a uniform appearance. He rates poplar as a good, economical choice for black-lacquer projects.

If you'd like a complete catalog of John's product line, send \$2.50 to: Wood Finishing Supply Co. Inc., 100 Throop St., Palmyra, NY 14522; 315/597-3743.

Continued on page 24



It's Childs Play

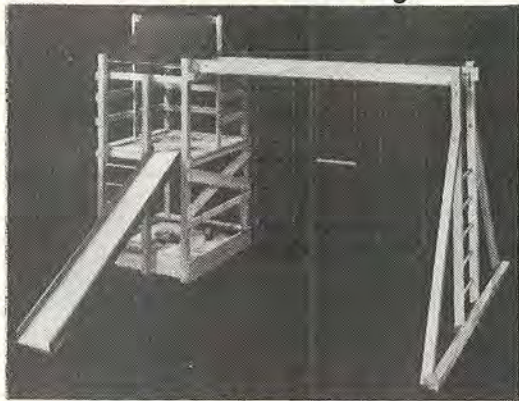

Free Standing Backyard Gyms . . .

. . . and a whole lot more! With a CWI free standing backyard gym you're giving your child a stimulating play environment. An environment that helps develop better motor skills and coordination, strong muscles and increasing cardiovascular strength. With each new game your childrens imagination grows along with their confidence.

Each free standing backyard gym is designed with skill and built with experience and care. Our safety measures exceed the industry and government standards.

- no weight limit
- 4x6 and 4x4 construction
- guaranteed to last 40 years
- easy above ground installation
- complete kit includes lumber and playground tested hardware

CWI[®]
 Countryside Woodworking
 1410 River Place
 Two Rivers, WI 54241
 1-800-445-2486

SAVE EVEN MORE
 do-it-yourself hardware kits also available

For more information write or call CWI toll free.

THE SANDER WITH WIDE APPEAL

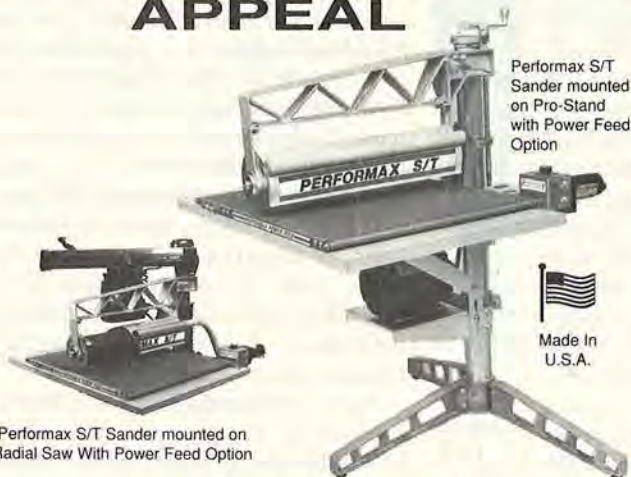

Performax S/T Sander mounted on Pro-Stand with Power Feed Option

Performax S/T Sander mounted on Radial Saw With Power Feed Option

44" TO BE PRECISE

Uniform thickness accuracy to within .010 of an inch—precision that you almost have to see to believe. Or take the word of thousands of woodworkers who are achieving flawless sanding results in their cabinet shops, craft shops, home workshops, custom furniture shops and in musical instrument making.

The Performax Component Sander appeals to such a wide variety of woodworkers because it allows you to select the components to fit your needs now with retrofitting options for potential heavier use later.

Plus, your sanding width won't ever be limited with the 44" wide sanding capacity, due to the open-end design of the Performax S/T Sander, which is just one of the many innovative features that makes the Performax Component Sander a wise investment and an excellent choice for all types of woodworking.

For More Information or the Dealer Nearest You
 Call 1-800-334-4910 or Write to:

Performax Products, Inc., 11975 Portland Ave. S., Suite 142, Burnsville, MN 55337

ASK WOOD

Continued from page 23

BATTLING ULTRAVIOLET LIGHT

What finishing material can I apply to red juniper—known locally as red cedar or aromatic cedar—to retain the beautiful red hues? I want to avoid the brown tones that develop when cedar is exposed to air and light.

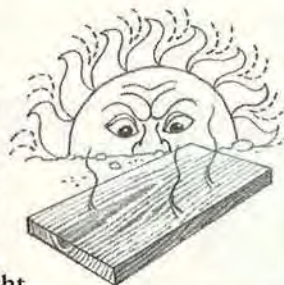

—G.C. Fonall, Plainfield, Ontario

We turned to our friend Ron Asbby at Liberion Supplies for an answer. "Ultraviolet (UV) light and air cause all woods to oxidize," Ron says. "You have to expect cedar and other woods to darken some. But you can do a few things to slow the process.

"Avoid oil finishes—oils can make the wood look even darker. First, apply a water-white lacquer sanding sealer. Follow with several coats of water-white gloss lacquer (avoid amber lacquers) to maintain clarity. If you want a semigloss finish, apply it only as the top coat. Don't forget to undercoat the inside or underside with sealer and two or more coats of lacquer. Finally, protect the project with a couple coats of cabinetmaker's wax.

"If you prefer varnish, stay with traditional high gloss products with UV inhibitors. Another method is to bleach out all the wood tone with a two-part bleach and then try to duplicate the cedar wood tone with an aniline dye. The dye creates a more-or-less permanent color."

You can contact Ron at Liberion Supplies, P.O. Box 86, Mendocino, CA 95460; 707/937-0375.

CLEANEST SHOP IN TULSA?

I am planning to build a workshop for my woodworking projects, and would like information about exhaust fans. The dimensions of the workshop will be about 18x24'. My plan is to have a fan that would keep fine dust from settling on everything and a dust-collection system to take out chips and most of the sawdust. It also is important that the exhaust system work effectively when I spray materials.

—Donald G. Ray, Tulsa, Okla.

From the seriousness of your letter, Don, we can tell you place a premium on the air you breathe. We reviewed several dust collection systems in the April 1987 issue of WOOD magazine. The size of fan you need depends on the amount of spray and the size of your projects. For additional help, contact the Center for Safety in the Arts, 5 Beekman St., New York, NY 10038; 212/227-6220. If you do a lot of spraying, you should have a spray booth, or at the minimum, an explosionproof fan. Wear a respirator with an organic-vapor cartridge and a paint spray prefilter whenever you spray finishes. 🌱

MEISEL HARDWARE SPECIALTIES



Woodworking Plans and Parts



Grocery List Project

You can make these 16" high Grocery List Projects from standard 3/4" thick lumber. We supply the Full size blueprint together with enough Grocery Lists (500 sheets) and Brass Plated Bolt Sets (10 sets) to make 10 projects. Grocery Lists are 11" long and are printed on peach colored paper with a rich brown ink.

#7453 Country Grocery List Package\$14.55/EA

NON-TOXIC FINISHES

Hydrocote Clear Sanding Sealer

Sanding Sealer is used to seal the wood and provide a rapid build-up. It sands easily without gumming to provide a very smooth surface ready for a final finish of polyurethane or other clear finish.

#8406 Hydrocote Sanding Sealer.....\$6.99/QT
#8407 Hydrocote Sanding Sealer.....\$19.99/GAL

Hydrocote Clear Finish - Satin/Gloss

Heavy solids content assures fast build-up. Gloss - 85% Sheen, Satin - 35% Sheen. Easy water clean-up.

#8411 Hydrocote Satin Finish.....\$6.99/QT
#8412 Hydrocote Satin Finish.....\$19.99/GAL
#8416 Hydrocote Gloss Finish.....\$6.99/QT
#8417 Hydrocote Gloss Finish.....\$19.99/GAL

Hydrocote Polyurethane Clear Satin/Gloss

Polyurethane produces a surface with the highest resistance to marring, heat, water, and household chemicals. Can be brushed or wiped on over any Hydrocote face coat.

#8421 Hydrocote Polyurethane Satin.....\$8.99/QT
#8422 Hydrocote Polyurethane Satin.....\$29.99/GAL
#8546 Hydrocote Polyurethane Gloss.....\$8.99/QT
#8547 Hydrocote Polyurethane Gloss.....\$29.99/GAL

Hydrocote Penetrating Stain

Dye based liquid stains for application on new wood. Can be coated in 30 minutes or less. Non-fading. Penetrates deeply.

#8426 Hydrocote Golden Oak Penetrating Stain.....\$5.99/QT
#8430 Hydrocote Dark Walnut Penetrating Stain.....\$5.99/QT
#8434 Hydrocote Extra Dark Walnut Penetrating Stain.....\$5.99/QT
#8438 Hydrocote Fruitwood Penetrating Stain.....\$5.99/QT
#8442 Hydrocote Maple Penetrating Stain.....\$5.99/QT

Rubber Band Cars Plan

Probably the neatest looking rubber band cars ever designed! You get full sized blueprints for all 4 different cars including a '32 Ford and *T* bucket.

#W227 Rubber Band Cars Plan.....\$3.50/EA

Rubber Band Car Hardware Kit

58 piece Hdw. Kit includes wheels, axles, drive bands, traction bands and misc. parts to build all four cars in plan #W227. You supply the remaining wood.

#7469 Rubber Band Car Hardware Kit..\$11.99/EA

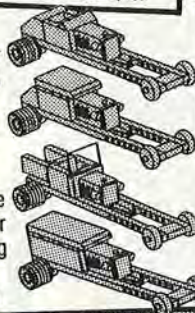

Musical Animals

Push the button and enjoy a musical tune! Full size plans available. Very easy to make from 3/4" pine! Hardware kit contains the music box, ribbon bow, and eyes. You supply the remaining wood. Plan and kit sold separately.

PLANS ONLY

#W287 Musical Rudolph Plan.....\$2.00/EA
#W320 Musical Rabbit Plan.....\$2.00/EA
#W327 Musical Dinosaur Plan.....\$2.00/EA
#W328 Musical Teddy Plan.....\$2.00/EA
#W330 Musical Clown Plan.....\$2.00/EA

HARDWARE KIT ONLY

#7906 Rudolph HDW Kit.....\$4.79/EA
#8390 Rabbit HDW Kit.....\$3.79/EA
#8494 Dinosaur HDW Kit.....\$3.19/EA
#8495 Teddy HDW Kit.....\$4.19/EA
#8525 Clown HDW Kit.....\$3.19/EA



CANDLE CUPS



#CC1 1-1/2" CANDLE CUP
7/8" Hole
.....\$19.00/100
#7290 1" CANDLE CUP 1/2" Hole
.....\$13.00/100

SHAKER PEGS



#7226 3-1/2" long, 1/2" tennon dia.
.....\$15.00/100
#7227 1-3/4" long, 1/4" tennon dia.
.....\$7.60/100

DOOR HARP PLANS

You'll find our jumbo 22" X 34" blueprints very clear and easy to follow. Full step-by-step instructions explain every step. All drawings are FULL SIZE.

#W263 Raccoon Plan.....\$3.50/EA
#W306 Federalist Eagle Plan.....\$3.50/EA
#W310 Hen Door Harp Plan.....\$3.50/EA
#W312 Big Apple Plan.....\$3.50/EA
#W316 Barn "Kicker" Plan.....\$3.50/EA

HARDWARE PARTS KITS

These kits contain the hard-to-get parts - special high resonance plywood, tuning pins, clapper balls, music wire and plastic eyes. You need to supply some 3/4" stock, and the paint. Plan is not included with kit, order separately above.

#8227 Federalist Eagle HDW Kit.....\$7.00/EA
#7765 Raccoon HDW Kit.....\$6.50/EA
#7769 Hen HDW Kit.....\$6.25/EA
#8252 Big Apple HDW Kit.....\$7.25/EA
#8255 Barn HDW Kit.....\$8.39/EA

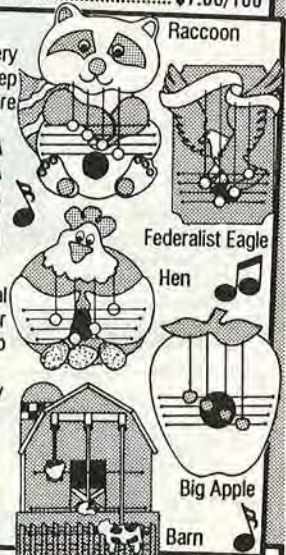

ORDER TOLL FREE 1-800-441-9870
LOCAL MN 612-471-8550

Send \$1.00 for Catalog or \$5.00 for Catalog plus Best Selling plan package (\$10.00 value) or order directly from this ad by phone or mail.

Please send me: Catalog \$1.00 Catalog and Plan Package \$5.00

HOW TO ORDER: State quantity, part number, item, price, and total of order. Send check, money order, or Visa or M.C. number and Exp. date. Shipping: \$25.00 to \$49.99 add \$3.50, \$50.00 to \$99.99 add \$4.50, Over \$100.00 add \$5.00. Minimum order of \$25.00.

Print Name _____
Address _____
City _____ **State** _____ **Zip** _____
Phone # (_____) _____



DUST COLLECTOR
 UFO-90.....1HP Motor
 UFO-101.....2HP Motor
 UFO-102B....3HP Motor



DRUM SANDER
 SK-15DS....\$1545.00
 15" sanding width, 3 HP
 SK-20DS....\$1875.00
 20" sanding width, 3 HP
 SK-25DS....\$2355.00
 25" sanding width, 5 HP
 Two different grit precision contact drums.
 Dust chute. 1/4 HP feeding motor.



STROKE BELT SANDER
 SK-1500BS.....\$1095.00
 60"x21-1/4" sliding table
 6" sanding belt width 2 HP
 SK-2100BS.....\$1599.00
 80" x 21-1/4 sliding table
 6" sanding belt width 3 HP



JOINTER
 JT-0012.....\$1595.00
 12" planing width
 13-3/4" x72" precision ground cast iron table
 3 HP motor

**TRUE VALUE &
 TRUE QUALITY**

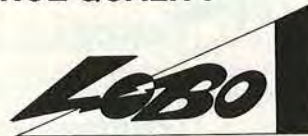

LOBO POWER TOOLS

10922 Klingerman St #3, So.El Monte,
 CA 91733, USA (818) 350-1096

Unit 3, 2375 Alpha Ave, Burnaby, B.C.
 Canada V5C 5L2 (604) 299-0911
 All F.O.B. So. El Monte, CA

Write or call now

FREE BROCHURE

One year free parts warranty

We specialize in customer satisfaction



12" PORTABLE PLANER
 WP-3012.....\$379.00
 Stand (Optional)
 WP-12ST.....\$ 39.00
 FREE SHIPPING



BAND SAW
 SK-20BS...\$1195.00
 20" cutting width
 2 HP motor
 cast aluminum wheel



12" TILTING ARBOR TABLE SAW
 HTS-0012A\$825.00
 With cast aluminum guide rail.
 3 HP motor 2 Belt drive



10" TILTING ARBOR TABLE SAW
 TS-1010.....\$1155.00
 With cast aluminum guide rail.
 3 HP 3 belt drive



POWER FEEDER
 SK-303FD....\$659.00
 1 HP, 3 phrases
 SK-301FD...\$699.00
 1 HP, 1 phrases
 SK-321FD...\$390.00
 1/4 HP, 1 phrases



WIDE BELT SANDER
 A-2548....\$5535.00
 24" working width
 A-3760....\$8685.00
 36" working width
 3 precision balanced contact drum. Rugged heavy duty metal construction. Full power motors drive sanding and auto infeed smoothly. Computer control adjust table.



SPINDLE SHAPER
 SK-30SPA.....\$799.00
 1" and 3/4" Spindle
 28" x 30" table
 forward and reverse
 Springhold down, 3 HP
 SK-35ST.....\$199.00
 Sliding Table



WHOA! SLOW DOWN THAT ROUTER

MLCS's variable speed control for routers and other AC/DC universal and DC-only induction motors adds a whole new dimension to fixed-speed power tools. I found it especially useful for slowing down large router bits with overall cutter diameters of 1½" or more. By slowing down those big cutters, you'll work safer and enjoy better cuts.

The unit performed well overall, although slower speeds were some-

what choppy. The control handles motors up to 15 amps and will not work with AC-only motors such as the ones found on stationary wood-working equipment.

—Tested by Steve Oswalt, a Des Moines woodworker and frequent contributor to *WOOD*® magazine

MLCS variable speed control, \$39.95 ppd. from *MLCS Ltd.*, P.O. Box 4053, Rydal, PA 19046, or call 800-533-9298.

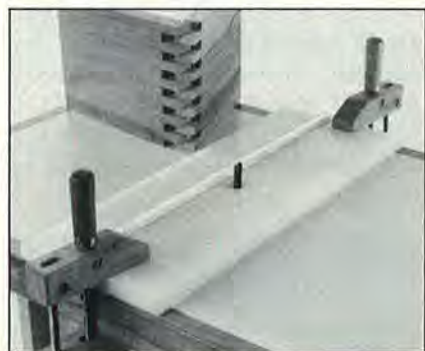

FAST FINGER JOINTS

What McDonald's is to hamburgers, this spacer fence is to finger joints—quick, easy, and steady quality at a reasonable price. The high-density polyethylene plastic should last a long time, and wood slides over it smoothly. I had to trim a hair off the width of the jig's tongue to get it to match the size of my ⅜" router bit, but once I did, my stock slid easily along the

tongue for some of the quickest, hassle-free finger joints I have cut. These fences were designed by router expert Bob Rosendahl.

—Tested by Steve Oswalt

Finger-joint spacer fence, in ¼", ⅜", and ½" patterns, \$19.50 each plus postage from Garrett Wade, 161 Avenue of the Americas, New York, NY 10013, or phone 800-221-2942.

Continued on page 28

The Shaker Desk Kit

Precision-cut, pre-sanded pine parts; all hardware; furniture glue; and illustrated, step-by-step instructions. Finished price: \$299.



Only \$159

“I saved \$140 by building this desk myself. Don't tell my wife how easy it was!

A Shaker Desk under \$200 and solid wood? Couldn't be done, my wife said. So, I pointed out the Yield House kit: over 45% off the finished price and the same high quality, solid pine parts. Directions were easy to follow, and the desk went together with simple household tools. I got to finish it just the way I wanted, and now I get to boast about it to all my friends.”

Yield House™

America's leader in furniture kits since 1947.

Call toll-free:
1-800-258-4720

Check Visa MC AMEX
Card # _____ Expires _____
Name _____
Address _____
City _____
State _____ Zip _____

— Please ship Shaker Desk Kit at \$159 + \$15 ship./hand. *Satisfaction guaranteed.*
— Send free 1989 Yield House Catalog.

Mail to: Yield House, Dept. DW95 North Conway, NH 03860

WOODWORKER'S CATALOG

There are over 4,000 money-saving reasons why woodworkers rely on Constantine.



Unique products. Hard-to-find products. 4,000 woodwork items! Everything important for people who like to Build-Restore-Repair-Refinish—and like to save money doing it. Cabinet or furniture wood? Choose from over 200 sizes and kinds. Beat up surface to cover? Choose from 150 richly-grained veneers. Plus 500 plans . . . cabinet hardware . . . 96 How-To Books . . . 118 carving tools and chisels . . . 76 inlay designs . . . and lots more for One-Stop, Right-Price Shopping without leaving home!

CONSTANTINE Est. 1812
2051N Eastchester Road, Bronx, NY 10461

CONSTANTINE Est. 1812 Send 116 page
2054M Eastchester Road catalog
Bronx, New York 10461 \$1.00 enclosed

Name _____
Address _____
City _____ State _____ Zip _____

ENERGY-SAVING SUN-PORCH™ CONVERTIBLE SUNSPACE More value for less money!

**INSULATED
WINTER SUN SPACE CONVERTS
TO A SUMMER SCREEN ROOM!**



MOUNTS
READILY ON
DECKS, PATIOS,
OR LANDSCAPE
TIES

- Bronze aluminum Shatter-resistant 1" thick double-wall glazing Do-it-yourself assembly
- Ideal greenhouse, spa/hot tub room, entry way.

Send \$2 for Color Catalogues, Prices,
SENT FIRST CLASS MAIL.
Dealer Inquiries Welcome



VEGETABLE FACTORY, INC.
P.O. Box 2235, Dept. WOO
New York, NY 10163

PRODUCTS THAT PERFORM

Continued from page 27

DAD'S PASSES THE TEST



You can't ask a paint remover to do a tougher job than our bowling-pin test: A couple of spray coatings of Dad's Easy Spray and a little steel

wool lifted the plastic-coated epoxy right off our pin.

Dad's comes complete with a convenient pump-spray applicator. The solution quickly adheres to the surface and begins to gel, preventing running. This system, more cost-conscious than aerosols, beats drippy brush-on solvents by a mile. Dad's paint remover washes off with water. Please carefully follow instructions and package warnings.

—Tested by Steve Oswalt

Dad's Easy Spray paint, stain, and varnish remover; available nationwide at hardware stores for \$23.99 a gallon (suggested retail price).

RABBIT PLANE KIT VISITS THE PAST

For woodworkers who enjoy building things the old-fashioned way, this bronze and rosewood rabbit plane kit should be as much fun to make as it will be to use. Based on a 19th-century wedged-rabbit pattern, the tool has a ½"-wide blade and 5¼"-long body.

Accurate assembly of the attractive plane may require a little more skill than suggested by the instructions. We had to plane at least ⅜" off the width of the blank before it would fit the casing, but the retailer says this problem has been corrected. Filing a slot in the sole also challenged us.

—Tested by Steve Oswalt



The bronze shoulder plane kit, catalog No. 13H10; \$39 ppd. from Woodcraft Supply Corp., 41 Atlantic Ave., Box 4000, Woburn, MA 01888. Call 800-225-1153.

THE WONDERS OF TUNGSTEN CARBIDE



These tungsten-carbide sanding sleeves cut quickly and clean easily. The 2"-long sleeves come in four diameters from ½" to 1½" and in two grits—a coarse silver grit and a

medium gold grit. We found little difference between the grits.

Before use, it's a good idea to carefully examine the sleeves. We knocked off several high points, preventing some unwanted gouging. The sleeves quickly load up, but a stiff wire brush or propane torch works well for cleaning.

—Tested by Steve Oswalt

We ordered ours from Woodcraft Supply Corp. (see product above for address and phone No.) The ½" coarse grit, No. 04M65, lists for \$14.75 ppd.; the 1" coarse grit, No. 04N10, lists for \$16.95 ppd.

Continued on page 30

Compare this offer with any other book club for Price • Quality • Benefits • Selection!

An absolutely no-risk guarantee.



1648P \$14.95 2909P \$12.95



2629 \$24.95 2971 \$17.95



3058 \$24.95 Counts as 2 1465P \$10.95



2774P \$14.95 2829 \$29.95



3001 \$23.95 Counts as 2 1675P \$9.95



1554P \$14.95 3011 \$23.95 Counts as 2



2944 \$24.95 1871 \$16.95

Select 5 Books for only \$395

(values to \$137.70) and get a FREE Gift!



1122P \$11.95 3053 \$19.95



2964P \$6.95 2979 \$22.95



1530P \$15.95 3073 \$23.95



1763P \$11.95 2984 \$21.95



2878P \$14.95 2863 \$24.95



3005P \$21.95 2871P \$10.95



3064 \$21.95 2778P \$14.95

Membership Benefits • Big Savings. In addition to this introductory offer, you keep saving substantially with members' prices of up to 50% off the publishers' prices. • **Bonus Books.** Starting immediately, you will be eligible for our Bonus Book Plan, with savings of up to 80% off publishers' prices. • **Club News Bulletins.** 14 times per year you will receive the Book Club News, describing all the current selections—mains, alternates, extras—plus bonus offers and special sales, with scores of titles to choose from. • **Automatic Order.** If you want the Main Selection, do nothing and it will be sent to you automatically. If you prefer another selection, or no book at all, simply indicate your choice on the reply form provided. As a member, you agree to purchase at least 3 books within the next 2 years and may resign at any time thereafter. • **Ironclad No-Risk Guarantee.** If not satisfied with your books, return them within 10 days without obligation! • **Exceptional Quality.** All books are quality publishers' editions especially selected by our Editorial Board.

FREE when you join!

15 Practical Woodworking Projects From Percy Blandford

Fascinating projects from master craftsman Percy Blandford include toys, furniture, a go-cart, and more!

a \$6.95 value!

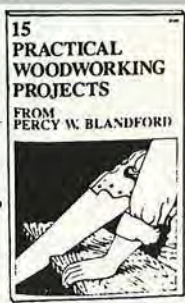

HOW-TO BOOK CLUB®

Blue Ridge Summit, PA 17294-0800

Please accept my membership in the How-To Book Club® and send the 5 volumes listed below, plus my FREE copy of 15 Practical Woodworking Projects From Percy Blandford (3124P), billing me \$3.95 plus shipping and handling charges. If not satisfied, I may return the books within ten days without obligation and have my membership cancelled. I agree to purchase at least 3 books at regular Club prices (plus shipping/handling) during the next 2 years and may resign any time thereafter.

Name _____
 Address _____
 City _____
 State _____ Zip _____ Phone _____
 Signature _____

Valid for new members only. Foreign applicants will receive special ordering instructions. Canada must remit in U.S. currency. This order subject to acceptance by the How-To Book Club®. BHGW589

(Publishers' Prices Shown)
 All books are hardcover unless number is followed by a "P" for paperback.

**The Convenience of Individuals...
The Sense of a Combination...**



Turn your "dream" projects into finished projects with the power and precision of a professional cabinet shop!

You can saw, plane, mold, and mortise with ease and accuracy -- yet the K-5 is a compact combination that takes up less than 12 square feet and runs on 110 Volt AC power.

Find out how you can use this tool for 30 days -- without risk!

Call or Write for Complete Information ...

1-800-USA-KITY

Mail Coupon To:

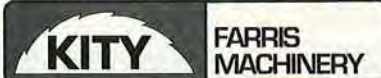

309 N. 10th • Blue Springs, MO 64015

Free Information Pack

VHS Video Pack - \$14.95

Name _____

Address _____

City _____

State _____ ZIP _____ Phone _____

D389

BUILD SOME RESPECT



V1. Glider Pony

Also Available:
V2. Rocking Horse
C1. Carousel Mare
C2. Carousel Rabbit

Precut Kits: \$49.95 each.

1/6 Scale Plans: \$14.95 each.

Ans. 3 for: \$29.95.

All 5 only: \$44.95.

Brochure S1 (free with order)

He said I'd created a masterpiece. He called me an artist! I saw a new respect in his eyes. All I could say was,

"Thanks Dad."



C3. Carousel Lion

The MASTER'S WORKBENCH
P.O. Box 15284 Dept. BW-39 Portland, OR. 97215

KELLER DOVETAIL SYSTEM

"In a class by itself . . .

. . . made exceptionally clean cuts. It has several advantages over the other jigs. Cleverly simple!" — WOOD Magazine

NOW with a 20 Year Limited Warranty!

Cut through dovetails with your router and get it right the first time.

See your Dealer or contact:

KELLER & CO., Dept. G59
1327 I Street, Petaluma, CA 94952
(707) 763-9336



Nothing compares to the texture and grain of Appalachian hardwoods. ■ We carry 21 species of the finest hardwoods, softwoods and hard-to-find imports. All wood is hand selected and kiln-dried to meet optimum cabinetmaking and furniture requirements. Finishing at no charge. All prices include delivery. ■ Order your Appalachian Hardwood Catalogue today. Send \$2.00 (refunded with order) to: **EDLCO**

P.O. Box 5373-D, Asheville, N.C. 28813 • 1-704-255-8765

Hardwood specialists since 1952.

DMT® Diamond Whetstone™

The answer to your sharpening needs
A few light strokes will sharpen knives and achieve perfect edges on all tools.

- Durable
- Fast
- Versatile
- Clean

Available at quality woodworking stores or
DIAMOND MACHINING TECHNOLOGY, INC.
85-WD Hayes Memorial Drive
Marlborough, MA 01752

BE IN CONTROL OF YOUR LIFE!

"Will you have a job tomorrow?"

ONE WEEK INTENSIVE COURSES
Third Generation Master Craftsmen



- Fine Finishing
- Impossible Repairs
- Hand Joinery

You Don't Have to Spend a Fortune To Start Your Own Business
Send \$5.00 for complete information including testimonials and tool catalog.

The Hymiller School
912 Lakeshire Drive
Fairfield Glade, TN 38555
615-484-9309

PRODUCTS THAT PERFORM

Continued from page 28

AN EASY-TO-DRIVE SCREW



Square-drive screws rank as one of the neatest products I've ever tested. With the square driver and light downward pressure from one hand, it's easy to drive screws that would slip out of a Phillips driver under strong downward pressure from two hands.

With a power driver, I one-handed a variety of square-drive screws through 3/4" oak with ease and without pilot holes (although I don't suggest trying this on your projects). Two configurations of screwheads work with these square-drivers: the original square recess, and a "Recex" version. Slotted corners in this new type let you use a traditional Phillips-head driver when a square-head tool isn't handy.

Square-drive screws were developed in Canada in the early 1900s, but outside of industrial applications, they haven't caught on in this country. I'd never tried them because I didn't want to bother with the initial cost of new drivers and screws. But, the cost is not out of line for comparable-quality Phillips or slotted screws and drivers, and the drivers are increasingly available. Although I've used slotted and Phillips-head screws all my life, I'm sold on their square-drive cousins.

—Steve Oswalt

Square-drive and Recex screws, drivers, and power hex drivers, available from McFeely Hardwoods and Lumber, P.O. Box 3, 712 12th St., Lynchburg, VA 24505, or call 800-443-7937 (800-542-2023 in Virginia).

Your workshop can PAY OFF ... BIG!

SAVE... convert low cost rough lumber for use in your home projects

OR

EARN EXTRA INCOME by supplying custom Planed Lumber, trim, and molding to lumberyards... contractors... cabinetmakers... home hobbyists and others...



**SAVE!!
FACTORY
PRICES
DIRECT TO
YOU**

Try The
Foley-Belsaw In Your
Own Shop On Our
**30-DAY FREE
TRIAL OFFER**
Mail Coupon Below
For Complete
Details!

FOUR BIG ADVANTAGES ● ● ●

PLANE



MOLD



SAW



SAND



You can rip, plane, mold & sand All with Automatic Power Feed!

From the Day It Arrives... the Planer will make and save you money. With shortages and inflation driving lumber prices sky-high, this versatile power tool quickly pays for itself by easily converting low cost rough lumber into high value finished stock. In just one pass turn out your own quarter-round, door and window stop, casing, tongue-and-groove... all popular patterns. Other operators are making cases for grandfather clocks, furniture, picture frames, bee hives, bed slats, surveying stakes... all kinds of millwork.

Built For Pros... Priced For Home Craftsmen... it is engineered and built to industrial standards, but factory-direct selling keeps the price low. Handles tough oak and walnut as easily as pine, and so simple to operate even beginners with no experience can use it.

Start Your Own Business... with just this one low cost power-feed machine in a corner of your garage or basement, you're set up to supply lumberyards, cabinetmakers, carpenters, remodelers, contractors and hobbyists in your area with custom-planed lumber, trim, molding... ALL of their millwork requirements. You can supply picture molding to art shops, hardware and department stores, or sell direct to framing shops. All standard patterns are available from stock, or we'll custom grind a knife to your own special design or sample.

FREE BOOKLET!
Get FREE Book with facts and full details... **RUSH COUPON TODAY!**

NOW YOU CAN Turn Extra Time Into Extra Income!
FOLEY-BELSAW POWER TOOLS

If coupon has been removed, just send postcard with name and address to:
Foley-Belsaw Co.
6301 Equitable Rd., Dept. 91456
Kansas City, Mo. 64120

**Just Mail Coupon . . .
NO OBLIGATION and
NO SALESMAN Calls!**

ACT NOW!
Coupon Brings Full Details!

FOLEY BELSAW *Foley Belsaw Co.*
6301 Equitable Rd., Dept. 91456
Kansas City, Mo. 64120

YES, please send me the FREE Booklet that gives me complete facts about your Planer-Molder-Sander-Saw and full details on how I can qualify for a 30-Day FREE Trial right in my own shop. I understand there is No Obligation and that No Salesman will call.

NAME _____
ADDRESS _____
CITY _____ STATE _____ ZIP _____

NOW YOU CAN Turn Extra Time Into Extra Income!
FOLEY-BELSAW POWER TOOLS
Send for your copy Today!

**1/2" SHANK CARBIDE-TIPPED ROUTER BITS
MOULDING PLANE PROFILES**

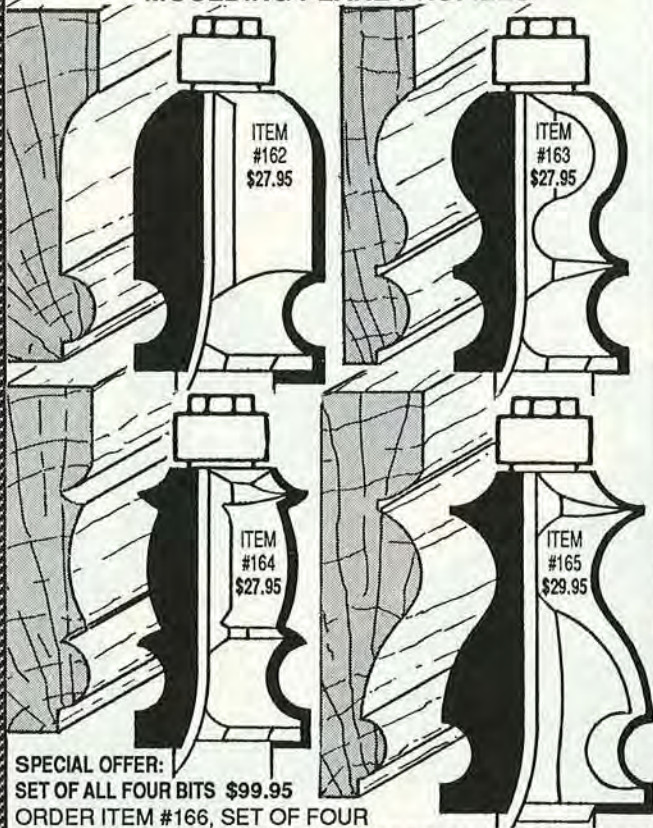

ITEM #162
\$27.95

ITEM #163
\$27.95

ITEM #164
\$27.95

ITEM #165
\$29.95

SPECIAL OFFER:

SET OF ALL FOUR BITS \$99.95

ORDER ITEM #166, SET OF FOUR

QUICKLY PRODUCE CLASSIC TRADITIONAL MOULDINGS
BITS ARE SHOWN FULL SIZE - 2 FLUTE CARBIDE TIPPED.

MULTI FORM*



ITEM #159
\$50.00
2 1/4" d.

2" high

FINGER JOINT*

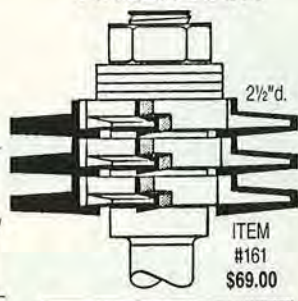

2 1/2" d.

ITEM #161
\$69.00

7/8"

Unlimited Moulding
Patterns

RAISED PANEL*

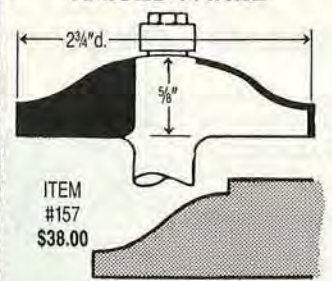

2 3/4" d.

ITEM #157
\$38.00

LOCK MITRE*

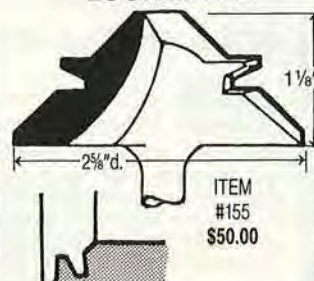

1 1/8"

ITEM #155
\$50.00

2 3/4" d.

*shown smaller than actual size.

To order by MasterCharge or Visa Toll Free
7 Day - 24 Hour Order Service. Call

1-800-533-9298 or send check to:

MLCS, Ltd., P.O. Box 4053D-A, Rydall, PA 19046

CONTROL THE SPEED OF YOUR ROUTER

**ROUT AT THE SPEED
THAT GIVES THE BEST
RESULTS WITH THE
WOOD AND BIT YOU
ARE USING!**



- LESS TEAR OUT
- STOPS BURNING
- FEED AT COMFORTABLE RATE
- BETTER, SAFER RESULTS WITH LARGE DIAMETER PANEL-RAISING BITS
- LESS WEAR ON BITS
- LESS NOISE AND SOFTER STARTS AT LOWER SPEEDS

INTRODUCTORY PRICE \$39.95
Order Item #200 POSTAGE PAID
VALUE OVER \$100.00

FEATURES:

- SPEED ADJUSTABLE FROM FULL SPEED TO 0 RPM
- 3 POSITION TOGGLE SWITCH: VARIABLE - OFF - FULL SPEED
- FULL HORSEPOWER AND TORQUE AT ALL SPEEDS
- GO BACK AND FORTH FROM ANY PRE-SET SPEED TO FULL SPEED AT THE FLIP OF A SWITCH
- WORKS WITH ALL ROUTERS 3 HP OR LESS
- 120V 15 AMP
- GIVES YOUR ROUTER A FEATURE ONLY AVAILABLE ON ROUTERS THAT COST OVER \$500.00

EASY TO USE — SIMPLY PLUG IN SPEED CONTROL AND PLUG YOUR ROUTER INTO THE SPEED CONTROL — TURN DIAL FOR BEST RESULTS. (SPEED CONTROL HAS A CLIP THAT CAN BE WORN ON YOUR BELT OR HUNG ON WALL OR LEFT LOOSE.)

- REDUCES SPEED ELECTRONICALLY WITHOUT REDUCING TORQUE; ELECTRONIC FEED-BACK MAINTAINS SPEED BY INCREASING VOLTAGE TO MOTOR AS LOAD INCREASES.

**MAKE BEAUTIFUL RAISED PANEL DOORS . . .
WITH YOUR 1/4" ROUTER!**

SET ALSO AVAILABLE IN 1/2" SHANK — \$79.95 — Item #154
Professional production quality bit makes it quick and easy to produce matching rails and stiles — the panel raising bit with ball bearing guide makes the raised panel perfect every time.

Regular value Over \$150.00

ORDER ITEM #054 for 1/4" Shank Set
(Includes all bits shown)



SALE PRICE **\$69.95** FOR COMPLETE SET

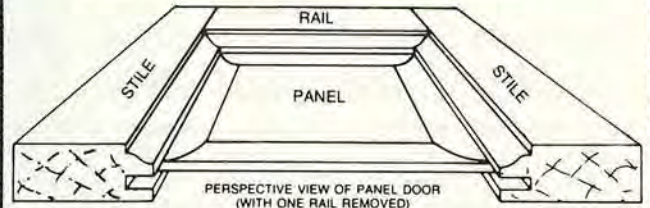

PERSPECTIVE VIEW OF PANEL DOOR
(WITH ONE RAIL REMOVED)

**RAISED PANEL BIT
SUPPLIED WITH
BALL BEARING**

2" Large Diameter

CARBIDE TIPPED
1/4" Shank



**REVERSIBLE
COMBINATION
RAIL and STILE BIT**

(For making matching rails and stiles in raised panel doors, etc.)
Works with stock from 1 1/16" to 7/8" thick

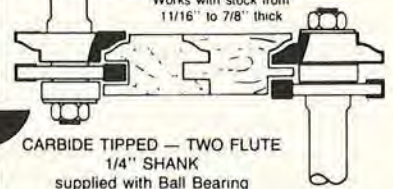

CARBIDE TIPPED — TWO FLUTE
1/4" SHANK
supplied with Ball Bearing

To order by MasterCharge or Visa Toll Free
7 Day - 24 Hour Order Service. Call

1-800-533-9298 or send check to:

MLCS, Ltd., P.O. Box 4053D-C, Rydall, PA 19046

PEROBA

ONE-STOP STOCK

In Brazil, this tree family furnishes lumber for everything from canoe paddles to homes.



Around Sao Paulo, in southern Brazil, grows a tree that's a veritable homecenter of stock. In a South American version of one-stop shopping, local craftsmen use its wood for everything. From the strong, straight-grained stock that resembles oak, they build entire houses—the framing, paneling, millwork, moldings, flooring, and furniture.

A home and its contents built of *peroba* doesn't have to be monochromatic, though. The species is a family of rainbow hues. For variety, Brazilian woodworkers choose from *peroba rosa* (brownish red and best known), *peroba preta* (rose-red with black veins), *peroba muida* (red with dark patches), *peroba poca* (off-white), *peroba rajada* (pink and black), *peroba tremida* (yellow and gold), and even *peroba reversa* (bird's-eye figured).

Although the *perobas* form quite a clan, the family tree branches out still further to encompass some

pretty strange but no less utilitarian cousins. There's *yaruru*, for instance. Color doesn't make this cousin from northern Brazil notable, shape does. Unlike *peroba*, which can grow 125' tall and big enough around to yield lots of long, straight lumber, the deeply fluted trunk of *yaruru* looks like thick boards standing randomly on end with only their edges touching. In fact, to make a canoe paddle, natives simply saw off one of the board-like flutes from the trunk and shave the end for a handle.

Then, there's cousin *quebracho blanco*. From western Brazil, this tall and paunchy tree dwarfs even the majestic *peroba*. One tree can yield about 15,000 board feet of lumber—almost what you'd get from 15 oak trees with trunks 30" in diameter and clear of branches for 40'. Now, that's a tree! 🌳

Photograph: Bob Calmer
Illustration: Jim Stevenson

NEW!
"QUAD-DRIVE"

DRUM SANDER

with Infinitely Variable Power Feed!



At last! A complete power-feed Drum Sander at an affordable price! Choose from 26" and 38" models

SAVES TIME...IMPROVES RESULTS. Use this high-tolerance machine for light dimensioning as well as the finest finish work. Now you can add new beauty to each woodworking project, save hours of tedious hand sanding! In a matter of seconds you can produce a satin-smooth finish impossible to duplicate with hand methods or hand-held power sanders...no more low spots, waves or cross-grain marks! Check these advantages...

FREE FACTS! Send for complete facts on how you can try this low-cost tool in your own shop for one full month without risk. See how the sander can dimension and finish-sand cabinet pieces, resawn stock, paneling, toys, tabletops, knees, burls, crotches and much, much more! You'll soon find it's one of the most valuable tools in your shop! Made in U.S.A. Easy Terms.

NEW INFINITELY VARIABLE FEED RATE gives you total control in any sanding situation! **EXCLUSIVE QUAD-DRIVE FEED SYSTEM**...four, power-feed rollers for maximum traction. Eliminates oversanding at first and last few inches of a board! **NEW FELT-BACKED ABRASIVE** mounts in just seconds to Velcro covered drum. The harder you sand, the tighter it stays! Eliminates stretching...allows fast removal and re-use!

Call Toll-Free 1(800)538-4200, Ext. 2431

YES! Please rush my **FREE INFORMATION KIT** and details on your 30-Day Free Trial Guarantee.

Woodmaster Tools, Dept. RW31, 2908 Oak, Kansas City, MO 64108

NAME _____

ADDRESS _____

CITY _____ STATE _____ ZIP _____



30-DAY FREE TRIAL!

MOLDING PLANES

PLENTIFUL PROFILES FROM THE PAST



Usually made of birch and beech, the planes featured narrower chamfering around the handhold (or none at all) and, to better fit the woodworker's toolbox, a length rarely exceeding 9½".

Notable exceptions were planes made in southeastern Massachusetts and Rhode Island. These have a slightly thinner and longer body with a lyrical-shaped wedge (see the half-round Lindenberger plane at left).

In the 150 years before the demise of the wooden molding plane, America claimed more than 31,000 planemakers who imprinted their mark on tools they sold. Some one-man shops faltered after limited production; larger companies such as Ohio Tool, Chapin Co., and Auburn Tool Co., made thousands of planes.

Today, simple molding planes for cutting rabbets, rounds, half- and quarter-rounds, and other uncomplicated shapes, remain fairly common. Their abundance results in a reasonable price, too. Only rare examples, or matched sets, command prices above \$20. Complex-profile planes, on the other hand, with their greater thickness and overall length, bring higher prices (\$100 and up). Inlays of ebony or rosewood that provide a hard-wearing surface add value.

A maker's mark and an owner identification mark increase a plane's value as a collectible. The maker's mark on a molding plane usually appears as a stamp in the upper front of its body. You'll find the owner's mark or initials there, too, or on the side of the body. Sometimes, you'll see fractional numbers stamped on the plane's heel. These indicate the minimum size stock to make the cut, not the blade width.

Fight the temptation to "re-store" a molding plane. Just clean it and preserve it with wax. 

Written with Philip Whitby
Photograph: Hopkins Assoc.

Clockwise, from lower left: Ovolo plane by Sandusky Tool Co., Sandusky, Ohio, about 1890, beech, \$25; rabbit plane by J. Denison, Saybrook, Conn., 1850, beech, \$45; tongue and groove plane by

Wilson, of Manchester, England, 1880, beech, \$40; half-round plane by I. Lindenberger, Providence, R.I., early 1800s, with lyrical wedge profile, chamfers, unusual 10" length, birch, \$250.

Just about every antique store has a few molding planes. And, at flea markets and auctions, you'll frequently find dozens of them selling for anywhere from \$7 to \$20. With so many available, can any of them be really collectible? You bet!

CULL THE COMPLEX FROM THE COMMONPLACE

These forerunners to the router and shaper typically have only three parts: a body, a metal blade, and a wooden wedge that secures the blade. There, all similarity ends.

Basically, molding planes fall into two categories: simple profiles and complex profiles. Simple ones generally have bodies less than 2" thick. With one or two blades, they cut uncomplicated profiles, such as rabbets and quarter-rounds, in nar-

row wooden trim. Complex molding planes have thicker and longer bodies to accommodate irregularly shaped cutters for making more intricate moldings.

Having one plane for one purpose meant lots of planes. That's why, prior to Stanley's mass-marketing of the metal combination plane in the late 1800s, craftsmen had large tool chests.

PLANES MADE BY A THOUSAND NAMES

Early American planemakers from England and Europe brought plane designs with them—planes with thick, heavily chamfered bodies up to 11" long. But, by around 1820, a distinctive American molding plane style began to develop (some say influenced by the design simplicity of the Shakers).

rbindustries family of precision, quality tools, American - made and affordably priced



The RBI HAWK Scroll Saw

Family of Precision Scroll Saws

America's largest line of Precision Scroll Saws can unlock your creativity. With **6 models to choose from**, there is one suited for **your needs**. It takes a real woodworker to build a first class tool and that's what RBI is all about. We're American Woodworkers building quality, affordable tools with pride for you - the American Woodworker. Send today for your free information kit to see why rbi is the best value for your woodworking dollars.

The RBI JOINT MACHINE

Precision Joint Making • Spindle Shaper • Router Table • Inverted Pin Router

Create beautiful wood joints so precise, you may be tempted not to glue them! **Making finger joints, mortise and tenons, all types of dovetail joints, mitered joints, and raised panel doors has never been easier.** Your rbi Joint Machine can also convert into a spindle shaper or an inverted pin router with accessory attachments. Send for your free fact kit today!



Call Toll Free 1-800-535-8665
(In MO 816-884-3534) for information
Dealer Inquiries Invited

rbindustries
1801 Vine St.
PO Box 369
Harrisonville, MO
64701



The RBI WOODPLANER™

Planer • Sander • Molder • Gang Rip Saw

Four essential woodworking functions designed into one precision, dependable machine. **Plane** your rough stock into dimensioned lumber to the size you want, **save yourself hours of hand sanding** using the sanding attachment, you can **edge cut and width dimension** your stock with the **power-fed gang rip saw** attachment, or create beautiful **standard or custom moldings** out of any wood you want with the molding head assembly. All these functions without having to remove the knives from the cutterhead and the time and trouble needed to reset the planer knives again like other machines on the market. Send today for your free fact kit on this extraordinary tool!

Yes, Please rush me a free fact kit on:

Hawk Scroll Saws Woodplaners

Joint Machine (Mark Interest)

Name _____

Address _____

City _____

State _____ Zip _____ W 30

EXPERT TECHNIQUE.



EXPERT TECHNOLOGY.



Powerful plunge routers have always been beyond the grasp of budget-conscious woodworkers.

That is, until Skil handed them the new Model 1835.

This versatile tool combines smooth plunging action with a powerful 1¾ H.P. motor.

It has an adjustable depth stop for fine tuning. Big, easy-to-grip handles. Convenient wrench storage slot. A compartment that holds 3 bits.

And a price tag that's under \$100.

Give your technique the technology it deserves. Grab the Skil 1835 Plunge Router. And grab a real bargain.

SKIL®



Skil Corporation,
Subsidiary of Emerson Electric Co.,
4300 W. Peterson Avenue,
Chicago, IL 60646. © 1989 Skil Corp.



Chestnut has a long association with appetites. From the staple made of ground nuts called *polenta* that fed Caesar's legions, to chestnuts roasting by a yuletide fire, the tree's fame has spread by story and song.

Introduced to northern Europe and Great Britain by the invading Romans, the European variety of the chestnut tree has been cultivated not only for its nuts but for its durable, decay-resistant wood. In the United States, the native American chestnut once dominated the eastern hardwood forests. Growing to a girth greater than most oaks, the chestnut provided the country's pioneers with wood for every imaginable use.

Then, in the early part of this century, a severe blight swept the chestnut, reducing it to a nearly extinct species. Today, the available chestnut lumber and veneer comes from blight victims or from European trees.

Wood identification

Sighting full-grown chestnut trees in Europe is commonplace. *Castanea sativa*, the European species, remains hearty. In the U.S., the experience could be historic.

However, there's a ray of hope for the American chestnut (*Castanea dentata*). Researchers at the American Chestnut Foundation have found a thriving stand of chestnut trees at an undisclosed site. And, according to a spokesman for the Na-

CHESTNUT

The pioneers' do-everything wood

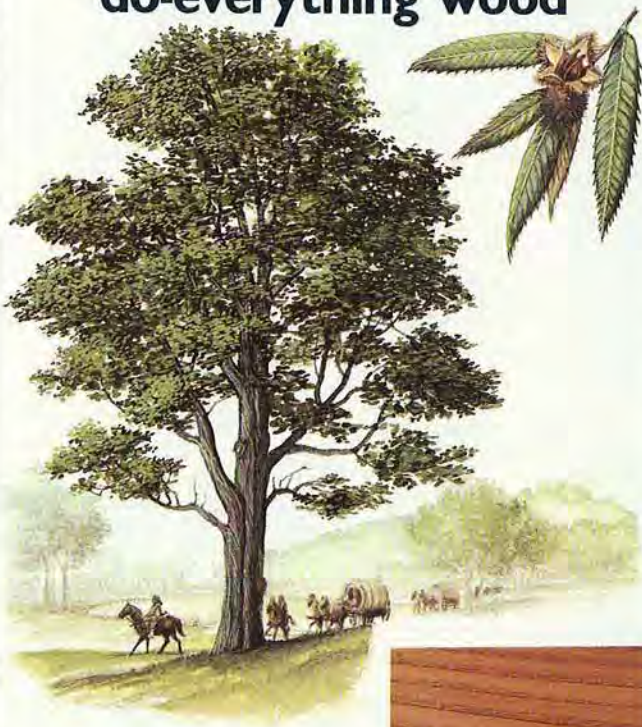

tional Arboretum, foresters have discovered a new, harmless strain of the original chestnut blight fungus.

When it reproduced unhampered, American chestnut grew best on the lighter soils in a range from southern Maine to North Carolina, Tennessee and west to Indiana and Michigan. At maturity, these burly trees stood 60-80' tall and measured 5-6' around the trunk. Deeply furrowed bark formed broad, flat ridges spiraling up the tree.

Early July brought blooms among chestnut's long, thin, toothed leaves,

the heartwood results in highly-valued "wormy" chestnut with tiny holes.

Working properties

Due to its coarseness, chestnut does not turn as well as oak. However, it works easily with other hand and power tools. Lumber from downed wood tends to be brittle, so, use fasteners *and* glue.

You can sand chestnut glass-smooth without difficulty, and the wood responds well to any finish. And, in service, you'll find chestnut one of the most stable woods.

Uses in woodworking

From colonial times, chestnut has been made into anything destined to last: shingles, siding, fence rails and posts, railroad ties, and furniture. It was prized casket stock.

Today, woodworkers select chestnut veneer for custom cabinets, and solid stock for clocks, chests, and furniture. And, antique furniture restorers demand chestnut for replacement parts.

Cost and availability

You can purchase solid (from American and European trees) and wormy chestnut (from American trees) as lumber in up to 3" thickness. However, you'll find it primarily on the East Coast, and in limited quantities. At about \$10 per board foot, you'll also pay dearly. More readily available than chestnut lumber, veneer sells for about \$4 per square foot. 🌱

Illustration: Steve Schindler
Photographs: Jim Kascoutas



American chestnut



Wormy chestnut

followed by small, prickly burrs. By the end of August, the hard-shelled burrs yielded nuts.

Chestnut has a tiny band of light-colored sapwood. The biscuit-colored heartwood, slightly lighter in weight than maple, resists decay. In color and grain, chestnut strongly resembles oak. Pinworm infestation of

BENCH-PLANE

With jointers, portable power planers, routers, and the like so readily available today, you might wonder why anyone would need a bench plane in this power-everything woodworking world of ours. Fact is, though, that the trusty bench plane will perform many jobs including cabinet cleanup, window and door trimming, and surface planing better than a power tool. And it will do these tasks—and more—without using a watt of electricity or breaking down.

As *WOOD* magazine's project builder Jim Boelling puts it: "Even if you rely on power tools, you should learn how to crawl with a bench plane before you walk with a power jointer. A plane gives you an understanding of the surfacing process that a jointer can't."

In this article, we're going to restrict our comments to the smoothing plane, which can accomplish most all your planing chores. You can apply the same techniques to using the other types of bench planes—jack, fore, and jointer—all similar to the smoothing plane, just longer and wider.

“Just as musical instruments have a sound, the plane is the violin in the orchestra of woodworking. As you work with a plane, you'll hear the sound of the wood rather than the whining of a motor. When you hear the wood, you become closer to the workpiece—you become a part of the project.”

—Roy Underhill, host of the popular PBS series *The Woodwright's Shop*, and frequent contributor to *WOOD* magazine

A TOOL AS OLD AS WOODWORKING ITSELF



In modern times, the bench plane has evolved from versions made completely of wood except for the cutter (*left*), to planes made of metal with wood bodies, to models made almost completely of metal except for wooden or plastic handles. Today, the Primus plane from Germany combines old and new technology in a wooden body with metal and plastic parts.

Nobody knows when the first plane was made, but historians do know that ancient Romans used wooden planes surrounded by metal sheaths. By medieval times, every carpenter and cabinetmaker had wooden planes in his tool kit. During the 17th century, English immigrants brought planes to America and by 1790 many individuals found steady employment in

plane-making. As the Industrial Age swung into full gear around 1900, metal planes became the tool of choice for most craftsmen. Why? Because they proved more durable and adjustable than their wooden counterparts. By 1925, the wooden plane-making business in the U.S. had ceased to exist. Today, although metal planes dominate the market, some European companies still manufacture high-quality wood planes as shown *above*.



Few sensations compare to the feel of long, paper-thin shavings flowing from a bench plane.

 Print this article

BASICS

EVERYTHING YOU NEED TO KNOW ABOUT USING THIS CLASSIC TOOL

THE NUTS AND BOLTS OF A BENCH PLANE

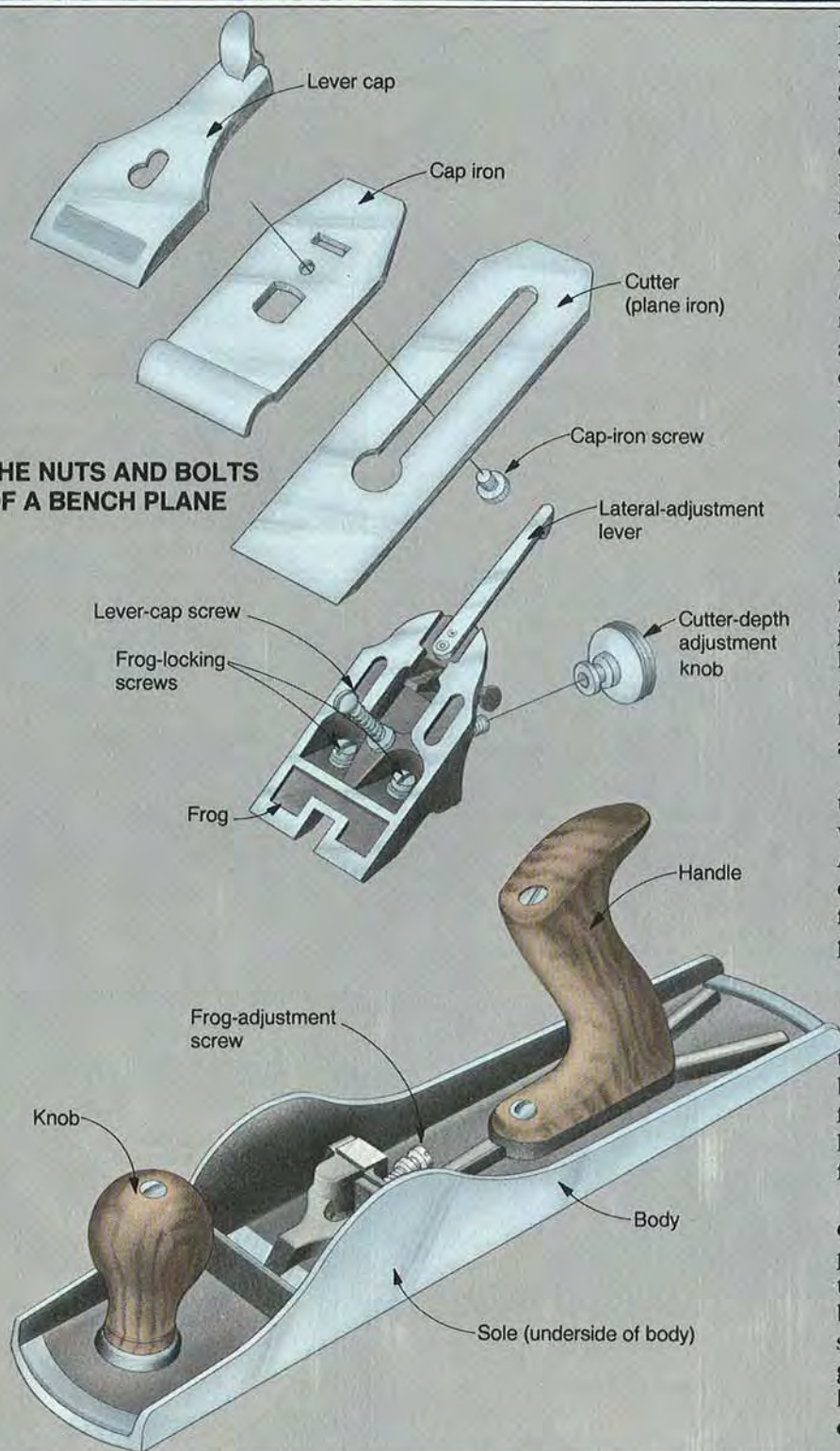

PLANE ADVICE: KNOW THESE PARTS

Stripped to its barest bones, a plane consists of two essential elements: A sharply honed **cutter** that projects through a perfectly flat **sole**. So what's the purpose of all those other parts depicted in our anatomy illustration at *left*? Adjusting them changes the relationship between the cutter and sole—and that relationship determines whether your plane will glide over the work and peel out smooth shavings or come to a screeching, splintering halt. Here's a quick rundown of what each of these parts does:

To lower or raise the cutter for a deeper or shallower cut, you need to turn a **cutter-depth adjustment knob**. Just above this knob, a **lateral-adjustment lever** *tilts* the cutter, something you might want to do in squaring up an edge.

Screwed tightly to the top of the cutter, a **cap iron** curls wood shavings out of the plane. A **lever cap** locks the cutter and cap iron in place on top of a **frog**. This peculiarly named piece moves the cutter back and forth to adjust the size of the opening in the sole. To accommodate deeper cuts and thicker shavings, you'll need a bigger opening. To move the frog, first loosen the two **frog-locking screws**. Then, turn the **frog-adjustment screw**.

The plane's **body** carries the entire assembly along the workpiece in a motion that allows it to shave off high areas while bridging low spots in the wood surface. You guide the body by gripping the **knob** with your lead hand and pushing the **handle** with your dominant hand.

Continued

BENCH-PLANE BASICS

GETTING DOWN TO THE BUSINESS OF PLANING

Before diving into any project, always put a sharp edge on the cutter for smooth, effortless planing. If your cutter is dull or nicked, start by using a fine stone to grind the cutting edge square to its sides. Then, grind a straight, sharp edge on the cutter as shown at *right*. Periodically use a square to check the edge. For more information on hollow-grind sharpening, refer to pages 67-73 in the June 1986 issue of *WOOD* magazine. We've improved plans for a sharpening jig that appeared in that article and would be glad to send you a free copy (see the offer at *right*).

To restore the cutter's edge after normal use and following any grinding, use the two-step whetting process shown at *right*. First, lay the cutter flat on the stone and make 8-10 figure-8 motions as shown in Step 1. Then, turn the cutter over and place the edge on the stone as shown in Step 2. Stroke the cutter 8-10 times. To help you with Step 2, many commercially available honing guides will hold the blade at the proper angle while you roll the guide along the length of the stone. Repeat both steps as necessary until the cutter will easily slice through a sheet of paper.

EFFECTIVE PLANING: IT'S ALL IN THE ADJUSTMENTS

Even with a razor-sharp cutter, more than one woodworker has tried to plane a board, met with little success, and assumed his plane doesn't work. The real cause: improper adjustment.

Before you turn any adjustment mechanisms, however, stop to think about the hardness of the wood you're working and the kind of cut you want. For example, to make a cut that rapidly removes stock and leaves a relatively coarse surface, adjust the plane as shown in the green box at *right*.

To put a finished surface on any material, set the cap iron and cutter for a dime setback and move the

HOW TO HOLLOW-GRIND THE CUTTER

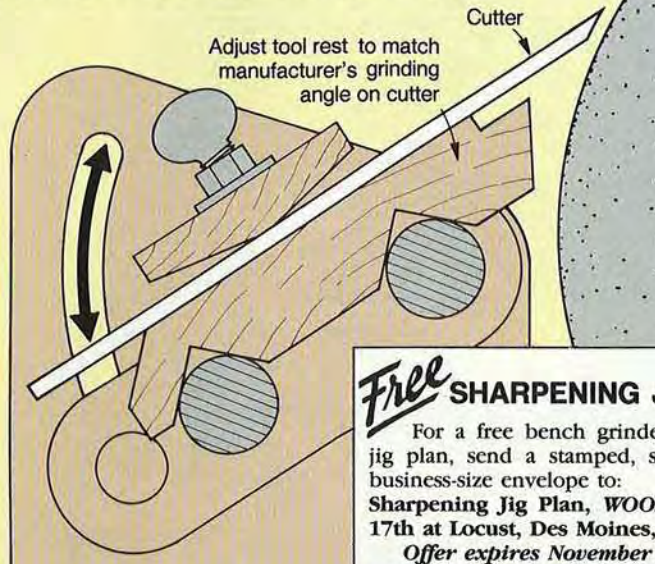

Free SHARPENING JIG PLAN
 For a free bench grinder sharpening jig plan, send a stamped, self-addressed, business-size envelope to:
Sharpening Jig Plan, WOOD magazine,
 17th at Locust, Des Moines, IA 50336.
Offer expires November 30, 1989.

WHETTING: AS EASY AS 1-2

STEP 1

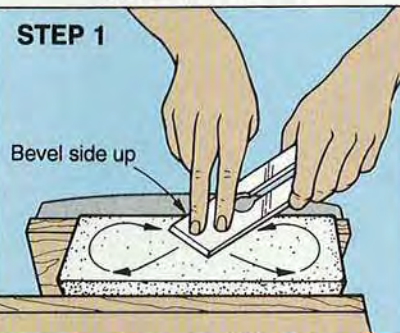

STEP 2

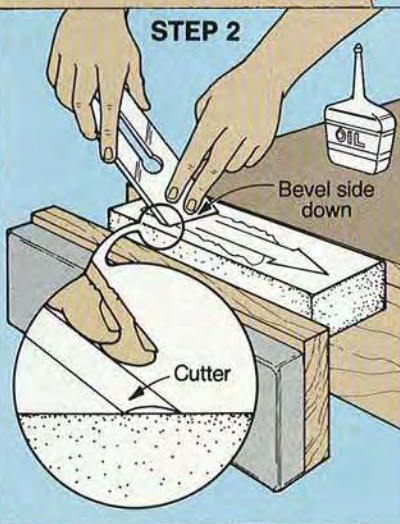

COARSE PLANING

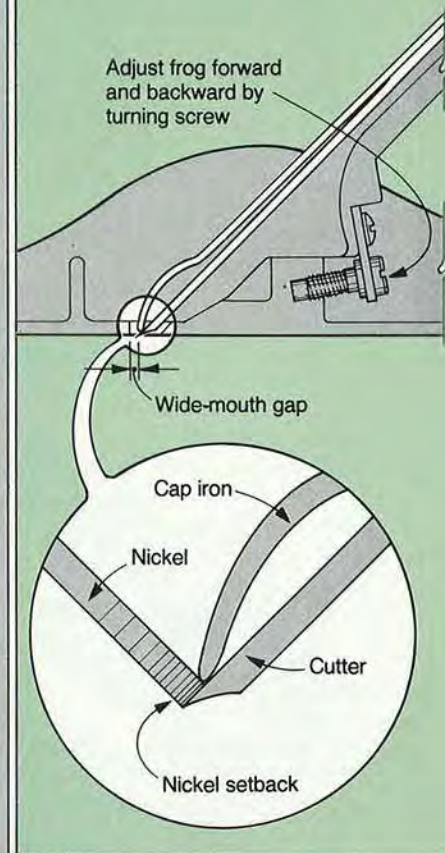



Apply paraffin to the sole of the plane to reduce surface drag.

FINISH PLANING

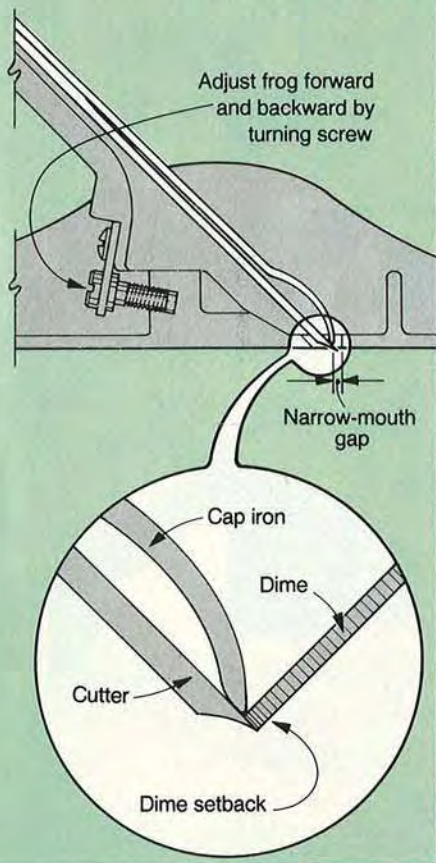

frog forward as shown *below left*. Both of these adjustments serve as a starting point—you'll need to practice these techniques and make adjustments as you work. For example, if the opening (known as the mouth) of your plane clogs with chips, then adjust the frog backward to enlarge the mouth. For a smoother surface, adjust the cutter for a shallower cut.

Next, adjust the cutter's edge so it's parallel to the sole of the plane. To accomplish this, turn the cutter-depth adjustment knob until the cutter extends about $\frac{1}{16}$ " out the bottom of the plane. Hold the plane as shown *below*, sight down the length of the sole, and move the lateral adjustment lever side to side to pivot the cutter edge.

With that accomplished, readjust the cutter for a shallow cut (the blade should just peek out of the sole) before you do any planing. If the plane removes little or no stock, slightly increase the depth of the cutter until thin ribbons of wood flow from the plane. After making the necessary adjustments, spend some time practicing your strokes on scrap stock. Oh, and don't be surprised if you become mesmerized by the sensation of smooth, slender curls of wood eagerly dancing from the plane.

Sight down the underside of the plane to adjust the cutter parallel to the sole.

SOME TIPS BEFORE YOUR PLANE TAKES FLIGHT

- Jim Boelling suggests holding the plane with the index finger of your dominant hand along the side of the cutter as shown on page 42. "Hold the plane with a firm grip that puts you in control, but don't use a 'death grip' that fatigues your hand," Jim says.

- Make sure you work with the grain of a board when planing it. If the grain changes directions, plane in the direction that results in the least amount of grain tearing, close up the mouth opening, and take shallow cuts.

- When planing long edges, keep your weight behind the plane by pushing the plane ahead of you, then walking up to it and repeating this motion. If your weight goes on or ahead of the plane, you'll feel uncomfortable and have less control over the planing stroke.

- Your plane will glide effortlessly over the workpiece when you apply paraffin to the sole of the plane as shown *above left*.

Continued



BENCH-PLANE BASICS

HOW TO JOINT ANY EDGE WITH A BENCH PLANE

Once you become proficient at the following method, you'll never need a power jointer for edge work—just your trusty smoothing (or larger) plane. First, use a straightedge to mark a line on one face of the board that shows you how much stock to remove from the edge as shown at *right*. Remember, you want to create a straight, clean edge while removing a minimum of stock.

Now, clamp the board in a vise and plane down any high spots. With the edge roughly straightened so far as your eye can tell, plane the entire length of the edge, making a shallow, full-length cut. Hold the plane at a slight angle to the edge to reduce drag. When you have planed almost to the line you drew on the board, use a straightedge as shown at *right* for a final check.

Then, test the edge for square as shown at *bottom right*. If the edge slopes to one side, slightly turn the lateral-adjustment lever to tilt the cutter and bring the edge square.

Make several more shallow cuts, again checking for a square edge.

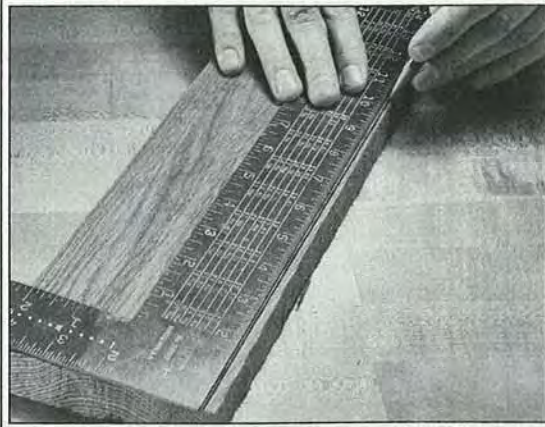

Left: Mark a straight line to help you know when to stop planing an edge.

Below: A straightedge such as a framing square tells you when you've properly straightened the board's edge. To protect the cutter's edge, always lay the plane on its side.

Bottom: With your try square, check the edge for square at several points along its length.

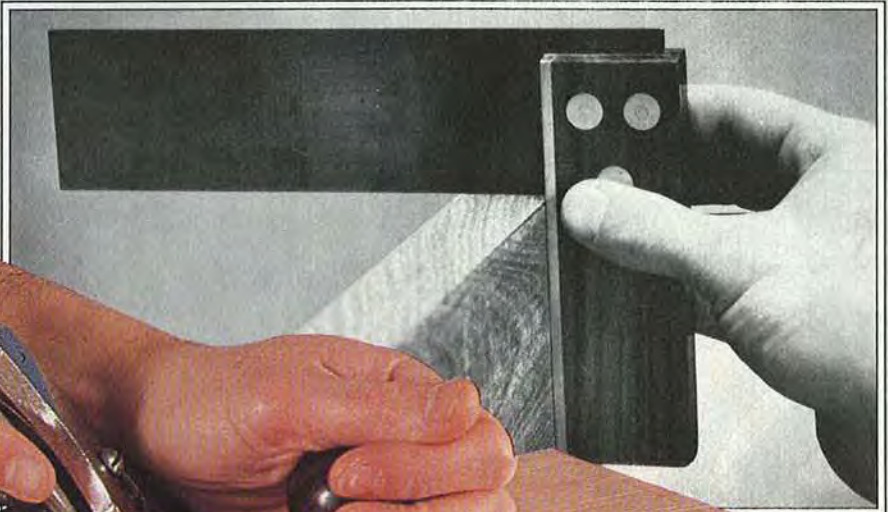
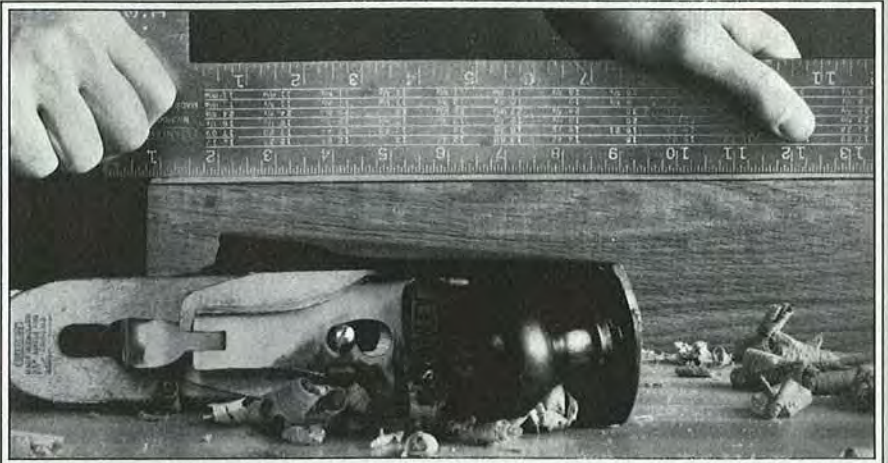

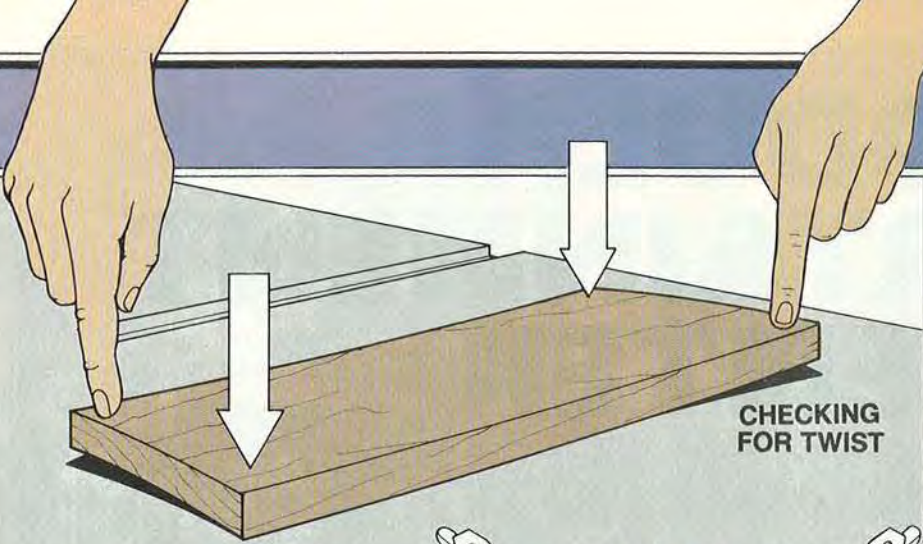

A SUREFIRE WAY TO PLANE SURFACES

For simplicity and affordability, it's tough to beat a bench plane as a means of removing warp from a board—once you know how. First, identify the type of warp and select the face side of the board based on grain, color, and absence of defects. If you suspect a twisted board, place it facedown on a flat surface such as a tablesaw top and press with your fingers on the board's opposite corners. As shown at *left*, pressing down on the low corners of the face side will make the board wobble. Arrows indicate the high corners on the face side.

Now, turn the board over and draw two parallel pencil lines on the face side from one high corner to the other. With your plane held at an angle to the edge of the board as shown at the *bottom* of page 42, start at one corner and make short strokes as you move down the marked alley. Remove just enough stock to make the pencil marks disappear and don't plane across the entire width of the board.

To remove bow from a board, start at one end on the hollow side of the board and scrub the plane diagonally as shown by the Step 1 arrows in the illustration at *left*. Then, change positions and scrub in the opposite direction (Step 2). Repeat this procedure on the other end of the board and for both ends until the warp disappears. Finish-plane the board by holding the plane parallel to the long edge of the board and planing the entire surface as the Step 3 arrows show. Check the flatness of this surface using a straightedge just as you checked an edge for straightness on page 42. The side view at *left* shows the effect of this procedure.

This technique also works on the crown side of a bowed board if you first work its center as shown in the illustration at *bottom left*. After truing one face of any warped board, you're ready to resaw or thickness plane the board to remove bow from the other side. ♣

Illustrations: Kim Downing, Mike Henry

REMOVING BOW FROM THE HOLLOW SIDE

- Step 1 →
- Step 2 →
- Step 3 →

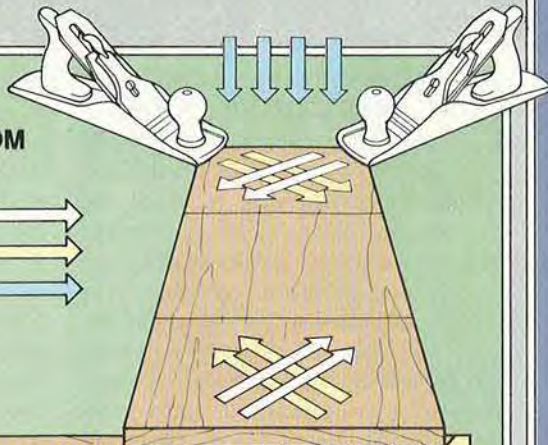

Material removed

Material removed



REMOVING BOW FROM THE CROWN SIDE

Material removed

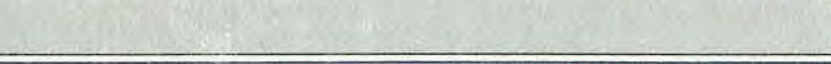
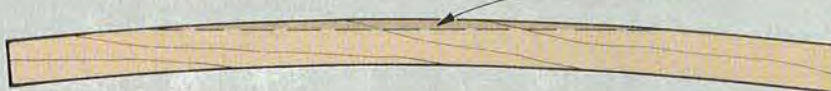

MODULAR ENTERTAINMENT CENTER

 Print this article

A PROJECT DESIGNED WITH FLEXIBILITY IN MIND

With just a radialsaw, router, and palm sander, Gary Schuknecht, of Troutdale, Oregon, set out to build an entertainment center in his garage workshop. When he finished, Gary knew he had a top-notch design.

"We needed an entertainment center for our stereo, TV, records, videotapes, and magazines," Gary told us. "I designed the units plenty deep so the TV and turntable wouldn't stick out the front. My wife, Linda, claims this is the nicest woodworking project I've ever made."

We liked Gary's design so well that we decided to build three sections ourselves and then share his design with you. Start modest and build just one unit, or if you have the materials, build all three.

Note: The three-unit entertainment center shown consists of a center electronics cabinet flanked by matching display units. Here, we explain how to build the electronics cabinet. Refer to the directions on page 92 to construct the display units.

OK, LET'S GET STARTED!

FIRST, THE CABINET SIDES

1 To form the cabinet's two sides (A), use the dimensions on the Exploded-View Drawing to mark the dado locations across the full width of a 4×8 sheet of oak plywood. See the Cutting Diagram on page 47 for layout reference. (The top dado becomes a rabbet later when you trim the plywood panel to length.) Double-check your marked dado locations—4×8 sheets of oak plywood aren't cheap.

2 Chuck a 3/4" straight bit into your router. Using a board as a straight-edge, rout 3/4" dados 1/4" deep across the plywood panel as shown in the photo below. (Routing the dados in the large panel and then cutting the sides from the panel ensures perfectly aligned dados in the assembled cabinet.)



Mark all dado locations first. Then, position and clamp a straightedge in place, and rout the 3/4"-wide dados.

3 Fit your portable circular saw with a plywood-cutting blade. Cut along the top shoulder of the top dado to trim the 8' plywood sheet to 83" long (see the drawing below for cut location).

4 Rip two 21 1/4"-wide sides (A) from each plywood panel.

5 Cut a 1/4" rabbet 1/2" deep along the back inside edge of each cabinet side. Mark the location first; it's easy to rout along the wrong edge.

6 Rip two 1/4"-thick by 22"-long strips (B) from the edge of a 3/4"-thick oak board. With the edges flush, glue and tape (most clamps aren't long enough so we used masking tape) a strip to the bottom end of each side panel. Later, remove the tape, and trim the strip ends flush with the cabinet sides. Sand the strip edges flush with the face of the cabinet sides. Sand a slight round-over along the bottom edges of each strip.

CUT THE TOP, BOTTOM, AND FIXED SHELVES

1 Rip two 21"-wide panels from a 4×8 sheet of oak-veneer plywood.

2 Cut the top, bottom, and three fixed shelves (C) to length (29") from the two strips.

3 Mark the location of the wiring and cooling notch along the back

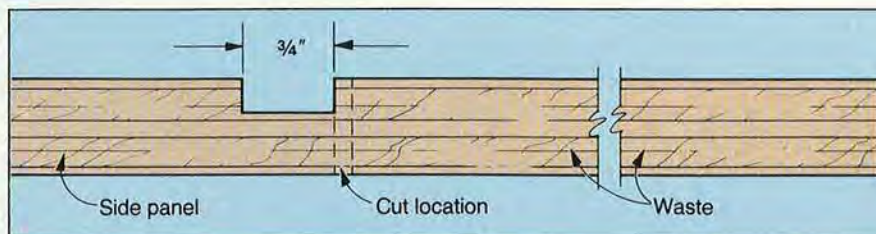

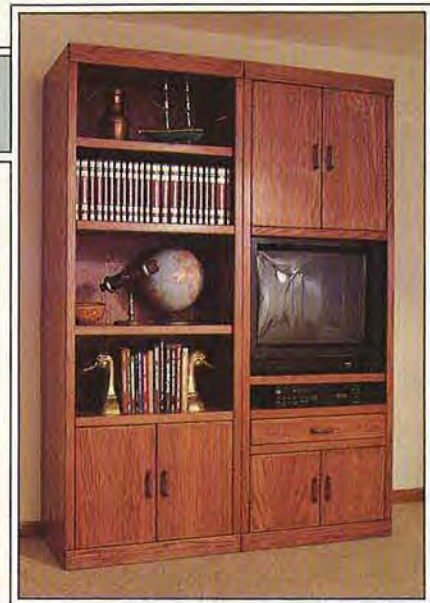

edge of the top shelf (see the Exploded-View Drawing for reference). Cut the notch to size.

ASSEMBLE THE CABINET

1 Cut 10 braces to the size shown below and as laid out on the Cutting Diagram on page 47.

2 Now, glue and clamp the bottom (C) in the lowest dado as shown in photo below right. Use two braces for stability and to ensure squareness. Repeat the operation to glue

the top in the rabbet at the opposite

end of the panel. Be sure that the *back edge* of the top and bottom is flush with the *inside edge* of the rabbet. Wipe off any glue squeeze-out with a damp cloth. After the glue dries, remove the braces. With a helper, turn the assembly over, and repeat the process to glue and clamp the second panel (A) to the assembly; check for square.

3 Measure the opening, and cut the cabinet back (D) to size from $\frac{1}{4}$ " oak plywood. Hold the back in place with masking tape, and mark the location of the two cooling

slots shown on the Exploded-View Drawing. Remove the back from the cabinet. Drill a blade start hole and cut the slots to size. Set the back aside for now—to avoid stain marks across the grain, we'll stain it later, and then nail it in place.

NOW, PUT ON YOUR BEST FACE (FRAME)

1 Rip and crosscut the oak face-frame top and bottom rails (E) to size—the width of the cabinet plus $\frac{1}{8}$ " to allow for a $\frac{1}{16}$ " overhang beyond each side panel.

2 Rout $\frac{1}{4}$ " round-overs along the front face of each rail where shown on the Exploded-View Drawing. Sand the routed rails smooth (we used a palm sander). Glue and clamp the rails to the cabinet with a $\frac{1}{16}$ " overhang on each end.

3 Measure the distance between the top and bottom rails (E), and cut the face-frame stiles (F) to size. Rout $\frac{1}{4}$ " round-overs along the front face of each stile. Sand the routed ends.

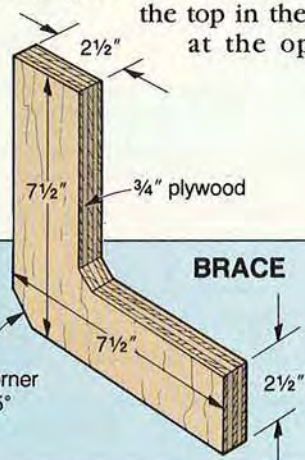

Clamp the bottom, shelves, and top into the dados, using scrap braces to keep them square until the glue dries.

Continued

ENTERTAINMENT CENTER

4 As shown in the photo below, glue and clamp the oak stiles to the cabinet front, using a penny as a spacer. (We applied masking tape to the adjoining areas to protect the plywood from excess glue.) Allow the glue to dry, and then remove the clamps and tape.

5 Turn the cabinet over so it's resting on its face. Apply masking tape to the areas next to the dados. Brush glue in the dados in the cabinet sides. Then, slide the three shelves (C) into place, and use the braces to keep the shelves square while the glue dries.



Using a penny as a spacer for an even overhang, glue and clamp the stiles to the cabinet front.

6 Measure the distance between the stiles (F), and cut the shelf facing (G) to length. Rout $\frac{1}{4}$ " round-overs along the front of each. Glue and clamp a facing strip to the front of each of the three shelves.

THE DOORS: HERE'S HOW TO BUILD AND HANG THEM

1 Cut the lower door panels (H) to size. To match the grain from door to door, note and mark the approximate location of the oak wire pulls on each door where shown on the Cutting Diagram.

2 Rip four $\frac{3}{8}$ "-wide by 12"-long banding strips (I) from the edge of $\frac{3}{4}$ " stock. Glue and clamp them to the sides of both door panels. Later, trim the ends of the strips flush with the top and bottom of the door panels. Repeat this process to cut and adhere the banding strips (J) to the top and bottom of each door. Sand the doors smooth.

3 Repeat steps 1 and 2 above to build the upper doors (J, K, L).

Continued

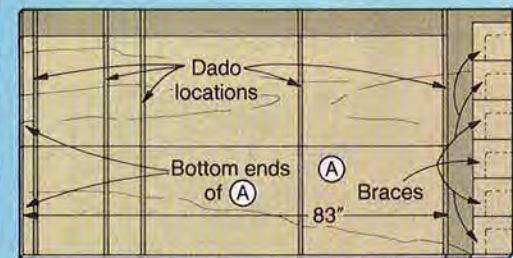
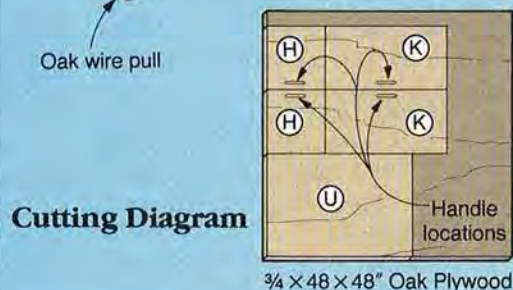
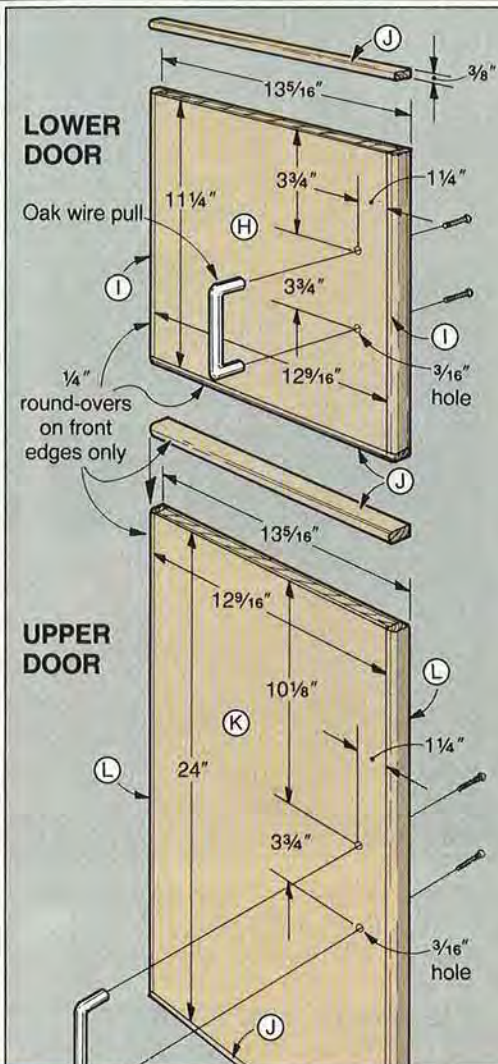

Bill of Materials											
Part	Finished Size*			Mati.	Qty.	Part	Finished Size*			Mati.	Qty.
	T	W	L				T	W	L		
THE BASIC CABINET						THE DRAWER (Continued)					
A* sides	3/4"	21 1/4"	83"	OP	2	P bottom	1/4"	15 3/4"	25 1/2"	OP	1
B* strips	3/4"	1/4"	21 1/4"	O	2	Q face	3/4"	5"	26"	OP	1
C shelves	3/4"	21"	29"	OP	5	R* banding	3/4"	3/8"	5"	O	2
D back	1/4"	29 1/2"	80 3/4"	OP	1	S* banding	3/4"	3/8"	26 3/4"	O	2
THE FACE FRAME						T filler blocks	3/4"	6 3/4"	21"	OP	2
E rails	3/4"	3"	30 1/8"	O	2	THE ADJUSTABLE SHELF					
F stiles	3/4"	1 9/16"	77"	O	2	U shelf	3/4"	20"	28 1/4"	OP	1
G shelf facing	3/4"	1 1/2"	27"	O	3	V facing	3/4"	1 1/2"	28 1/4"	O	1
THE UPPER AND LOWER DOORS						THE DISPLAY CABINET DOORS					
H panels	3/4"	12 9/16"	11 1/4"	OP	2	W panels	3/4"	12 9/16"	18 3/4"	OP	2
I* banding	3/4"	3/8"	11 1/4"	O	4	X banding	3/4"	3/8"	18 3/4"	O	4
J* banding	3/4"	3/8"	13 5/16"	O	8	Y banding	3/4"	3/8"	13 5/16"	O	4
K panels	3/4"	12 9/16"	24"	OP	2	Key: O=oak OP=oak plywood *Cut parts marked with an * larger initially, and trim them to finished size as directed in the how-to instructions.					
L* banding	3/4"	3/8"	24"	O	4						
THE DRAWER						Supplies: #17x1" brads, #8x1 1/4" flathead wood screws, #8x1" flathead wood screws, #17x3/4" brads, stain finish.					
M front	1/2"	5 3/8"	25 1/2"	O	1						
N sides	1/2"	5 3/8"	20"	O	2						
O back	1/2"	4 7/8"	25 1/2"	O	1						

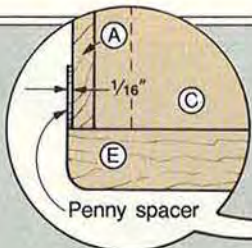

TOP VIEW DETAIL

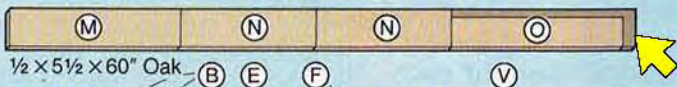
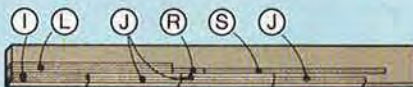
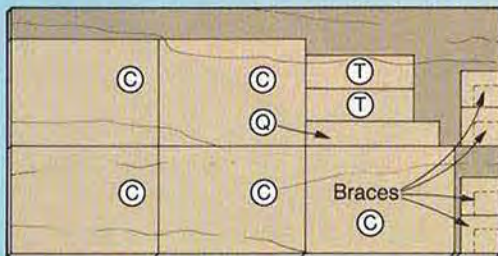
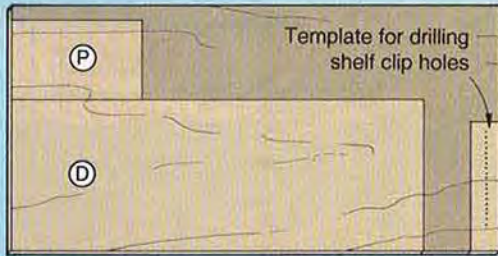
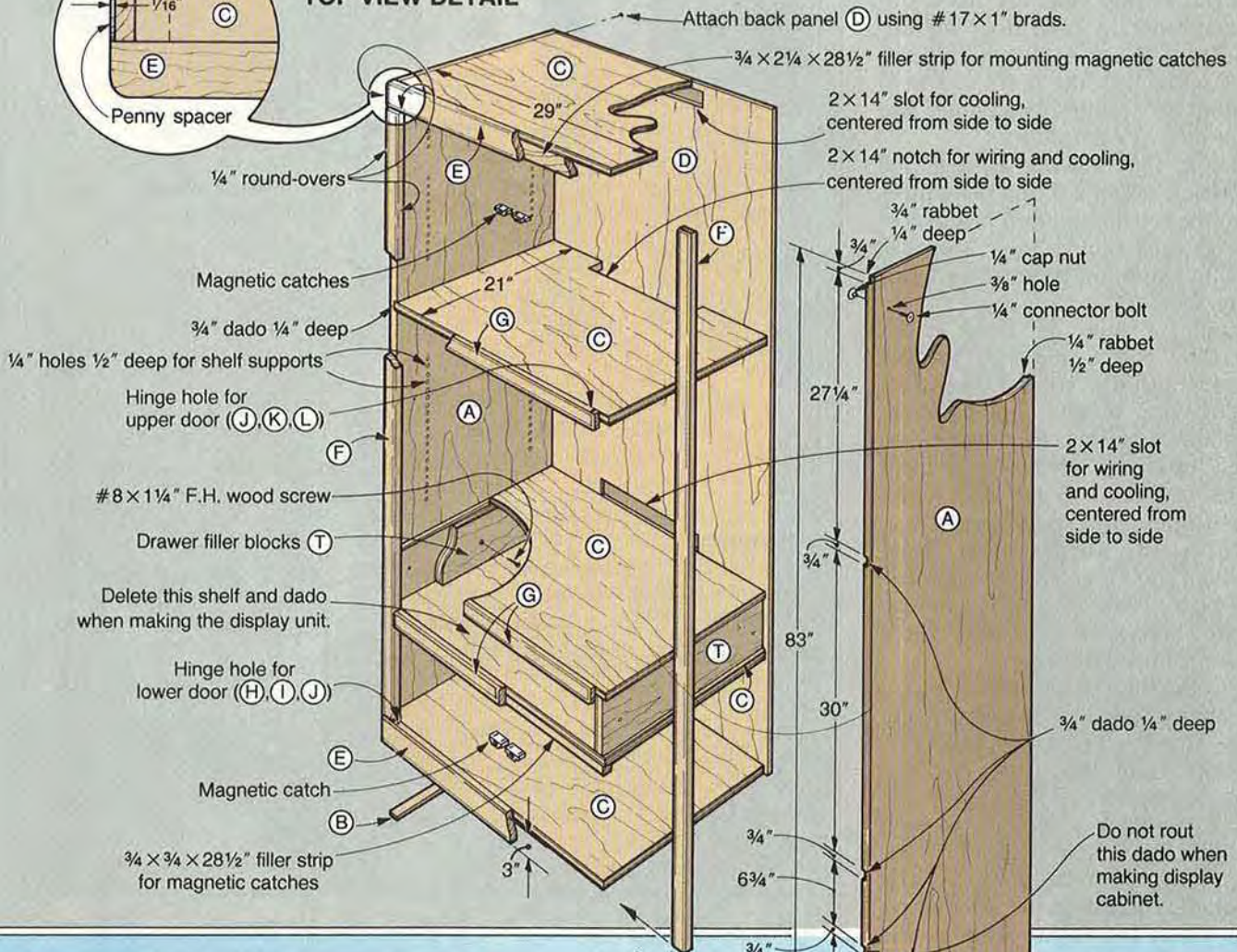

Sand a slight round-over on bottom edges.

ENTERTAINMENT CENTER

4 Using the dimensions on the Door Drawing, carefully mark the centerpoints on each door for the holes you'll use to fasten the oak wire pulls. Drill the holes to size.

5 Rout $\frac{1}{4}$ " round-overs along the front face of each door.

6 Using the drawing at *right* for reference, fasten a fixing plate flush with the top and bottom inside corners of each cabinet door. (See the Buying Guide on page 92 for hardware source.)

7 Drill $\frac{5}{16}$ " holes $\frac{3}{8}$ " deep in the rails (E) and facing (G) for the plastic bushings where shown on the drawing at *right*. Insert a bushing into each hole. Fit a hinge into each bushing, slide the fixing plates (attached to the door) into the hinges, and then thread the side-to-side adjustment screw through the hinge and into the fixing plate. Position the two adjustment screws as necessary for a good fit of the doors.

8 Cut the filler strips (dimensioned on the Exploded-View Drawing) to size—these support the magnetic catches. Glue and clamp the oak strips to the back of the top rail (E) and to the back of the bottom shelf facing (G) where shown on the Exploded-View Drawing. Attach magnetic catches to the filler strips, and fasten the strike plates to the back of the doors. Remove the doors from the cabinet. Now, remove the fixing plates, strikes, and hinges (you'll reattach them after applying the finish).

NEXT COMPONENT: THE VIDEOTAPE DRAWER

1 Rip and crosscut the drawer front (M), sides (N), back (O), and bottom (P) to the sizes listed in the Bill of Materials.

2 Cut or rout a $\frac{1}{2}$ " rabbet $\frac{1}{4}$ " deep across the front of each drawer side. (See the Drawer Drawing for reference.) Now, cut a $\frac{1}{2}$ " dado $\frac{1}{4}$ " deep 4" from the back of each drawer side. Finally, cut a $\frac{1}{4}$ " groove $\frac{1}{4}$ " deep $\frac{1}{4}$ " from the bottom edge into the drawer sides (N) and drawer front (M). Dry-clamp the pieces to check the fit.

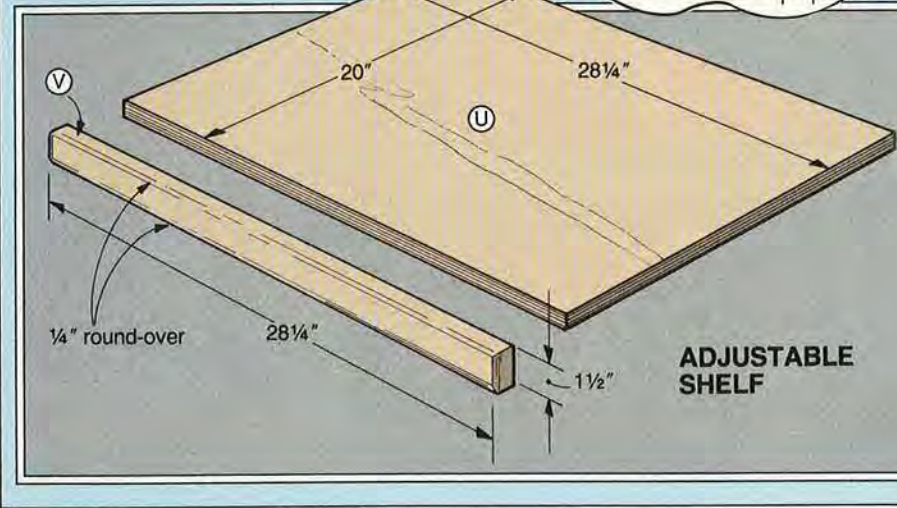
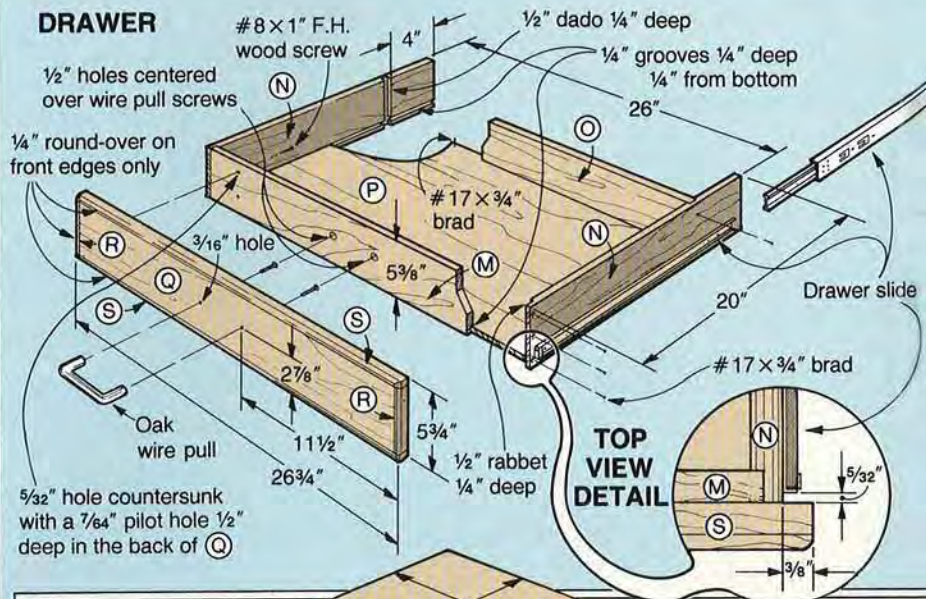
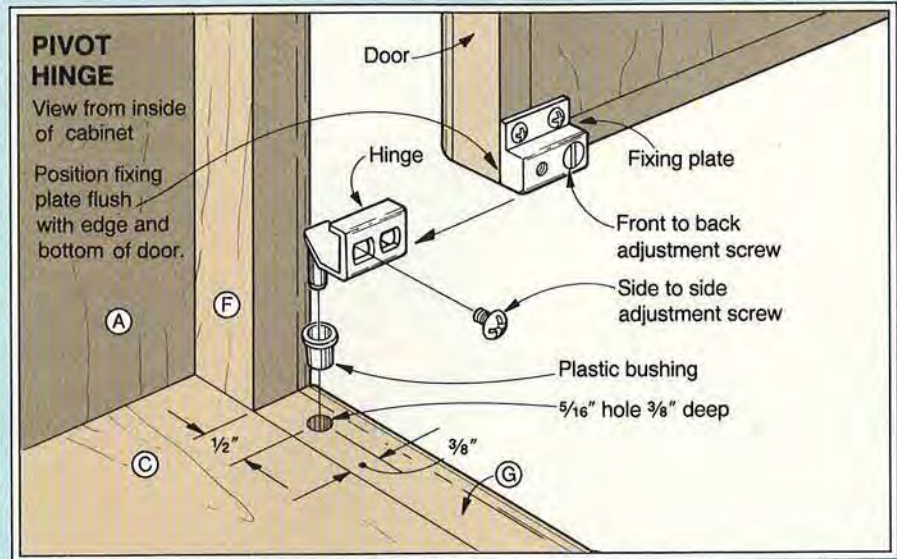

SHELF SUPPORT HOLE GUIDE

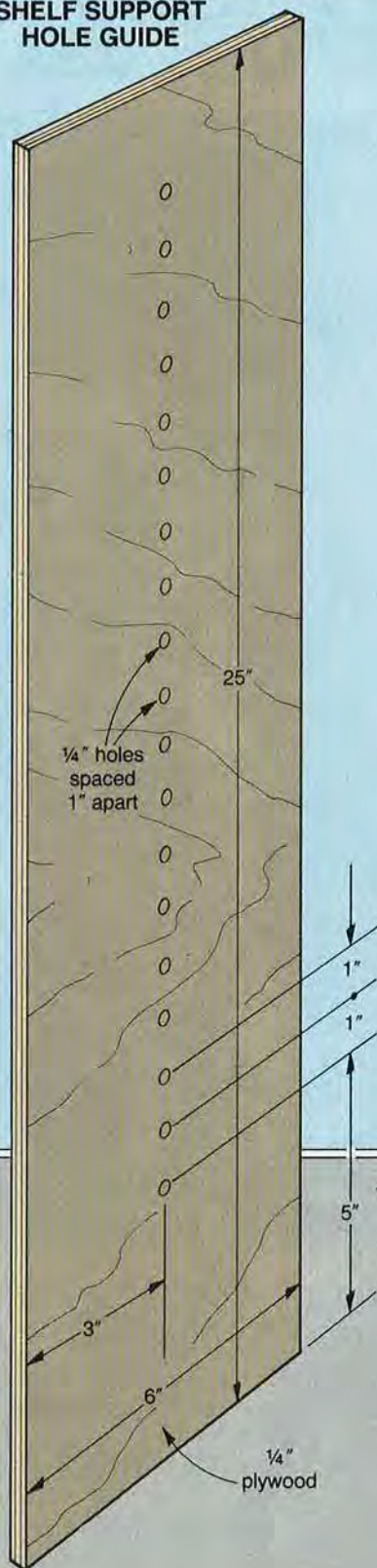

3 Glue and clamp the drawer together, checking for square. Do not glue the bottom (P) in the $\frac{1}{4}$ " groove; instead, secure it to the back (O) with $\frac{3}{4}$ " brads.

4 Cut the drawer face (Q) to size. Now, cut the banding strips (R, S) to size plus 1" in length. Glue and clamp the banding strips (R) to the ends of the drawer face. When dry, trim off the excess. Repeat the process to add the top and bottom banding strips (S). Rout $\frac{1}{4}$ " round-overs along the front face of the banded drawer face.

INSTALL THE DRAWER, THEN TAKE A BREAK

1 Cut the filler blocks (T) to size. Drill and countersink a pair of shank holes in each block, and screw them to the inside of the drawer opening where shown on the Exploded-View Drawing.

2 Following the directions supplied with the drawer slides, attach the slides to the drawer sides and the filler blocks. Install the drawer.

3 Place a piece of double-faced tape on the front face of the drawer front (M). Then, position the banded drawer face (Q, R, S), centered from side to side and top to bottom. (We taped a nickel to each end and two nickels on the bottom edge to help center the drawer face in the opening and against the drawer front.) When correctly positioned, press firmly against the taped drawer face.

4 Remove the drawer and taped-on face, and clamp the drawer face to the drawer. Drill two holes through the drawer face and drawer front for the wire pull screws (see the Drawer Drawing for reference). From inside the drawer, drill and countersink four holes through the drawer front and just into the back of the drawer face. Drill a $\frac{7}{64}$ " pilot hole $\frac{1}{2}$ " deep into the back side of the drawer face. Later, you'll fasten the drawer face to the drawer front with wood screws.

5 Pry the drawer face from the drawer front and remove the tape. Enlarge the two $\frac{3}{32}$ " holes for the wire pull in the drawer front (M) to $\frac{1}{2}$ ". Screw the drawer face to the drawer front.

START THE MUSIC— YOU'RE NEARLY FINISHED

1 Cut the adjustable shelf (U) and the front facing strip (V) to size. Rout a $\frac{1}{4}$ " round-over along the front face of the strip.

2 Glue and clamp the facing strip to the front of the shelf. The top edge of the strip sits flush with the top face of the shelf.

3 To drill the shelf-clip holes for the adjustable shelf, start by making a hole guide like the one shown at left. Position the guide flush with the back edge of the rabbet in the cabinet side, and drill $\frac{1}{4}$ " holes. (We used a stop on our drill bit to keep from drilling through the cabinet side.) Keeping the same end down, move the guide from the back to the front along each side and drill the holes.

4 If you plan to build more than one cabinet, we recommend using joint connector bolts and cap nuts to hold a set of cabinets together. (See the Buying Guide on page 92 for our source and the Exploded-View Drawing for reference.)

5 Sand smooth the cabinet, cabinet back, doors, adjustable shelf, and drawer. Apply the stain and finish. Finally, glue and nail the back into the rabbet in the back of the cabinet. Attach the hardware, install the drawer, and hang the doors.

Continued on page 92

SHELF INSTALLATION SECTION VIEW

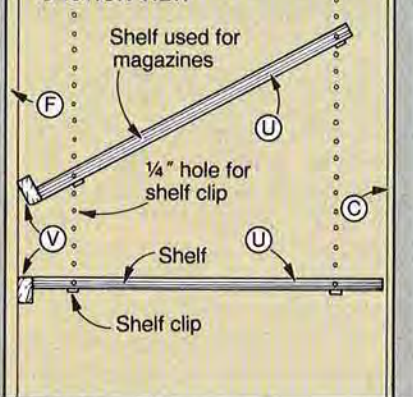

LOW-VOLTAGE LIGHTING

TALK OF THE TOWN AT

You'll be able to enjoy your beautiful yard and walkways 'round the clock once you build a set of these landscape lighting fixtures. We've kept the construction simple, and because the lights operate at 12 volts, you can wire the system yourself—safely and inexpensively. Best of all, operating these handsome fixtures costs only about 5 cents an evening.

NOTE: The instructions, Bill of Materials, and Cutting Diagram give the directions and number of pieces needed to build a single light box. To make additional boxes, be sure to cut all identical pieces at the same time to ensure uniformity.

The kit described in the Buying Guide on page 53 includes the prices for kits with both four and eight lights (eight is the maximum number you can use with one power pack). Build as many light boxes as you'll need.

CONSTRUCT THE LIGHT BOXES TO GET ROLLIN'

1 Cut the center panel strips (A) to the size listed in the Bill of Materials plus 2" in length. Now, crosscut a 1¼"-long spacer (B) from one end of each center strip. Then, trim each center strip (A) to a 16¾" finished length. And finally, cut the side strips (C, D) to size.

2 With the ends and surfaces flush, glue and clamp each of the two narrow redwood panels (A, B, C) and the two wide panels (A, B, D) together as shown in the photo on the opposite page. (Note that we protected the relatively soft redwood from the metal clamp jaws with scrap blocks. We also used resorcinol, a waterproof adhesive, for our light boxes.) Immediately wipe or scrape off excess glue.



3 Rip and crosscut the redwood shelf cleats (E) to size.

4 Mark a hole centerpoint ¾" from both ends of both cleats (see the drawing titled Constructing the Light Box for reference). Drill and countersink ⅝" shank holes at each mark. Now, mark the cleat location on each narrow panel (A, B, C); see the above-mentioned drawing for positioning particulars. Lightly clamp or tape the cleats in place. Using the previously drilled

shank holes as guides, drill a pair of ⅞" pilot holes ½" deep into each side panel. Secure cleats into position with #8×1¼" wood screws.

5 With the ends and surfaces of the four side panels flush, glue and clamp together. Check for square. Immediately remove excess glue.

6 Sand the light box smooth. Fit your router with a chamfer bit, and rout a ½" chamfer along the inside edges of each window opening.

Continued

SUNDOWN

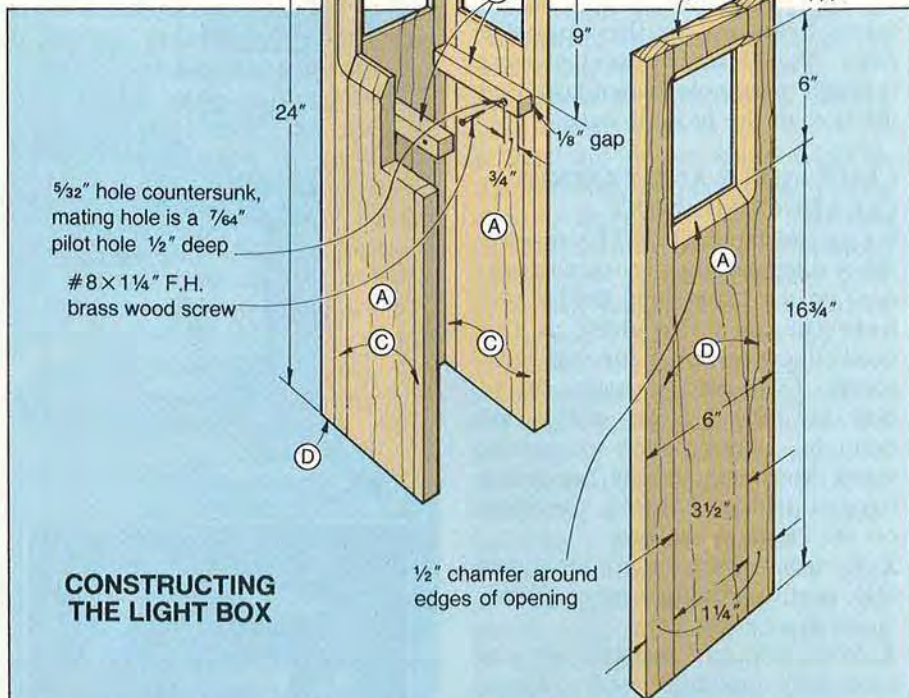

CONSTRUCTING THE LIGHT BOX

Bill of Materials

Part	Finished Size*			Mater.	Qty.	Part	Finished Size*			Mater.	Qty.
	T	W	L				T	W	L		
A* center panel	3/4"	3 1/2"	16 3/4"	R	4	F lamp shelf	3/4"	4 3/8"	4 3/8"	R	1
B* spacer	3/4"	3 1/2"	1 1/4"	R	4	G* corner cleat	1/2"	1/2"	7 3/8"	R	4
C side strip	3/4"	1/2"	24"	R	4	H lid top	1 1/2"	6"	6"	LR	1
D side strip	3/4"	1 1/4"	24"	R	4	I lid bottom	3/4"	4 1/2"	4 1/2"	R	1
E shelf cleats	3/4"	3/4"	4 1/4"	R	2	J stake	1 1/2"	3 1/2"	32"	R	1

Key: R-redwood, LR-laminated redwood

*Cut parts marked with an * larger initially, and trim them to finished size as directed in the how-to instructions.

Supplies: resorcinol, #8 x 1 1/4" flathead brass wood screws, 2" galvanized deck screws, stain, finish, 1/8" white acrylic.

Cutting Diagram

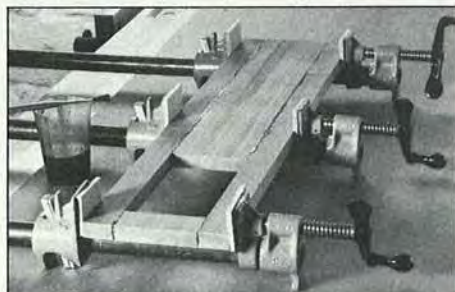
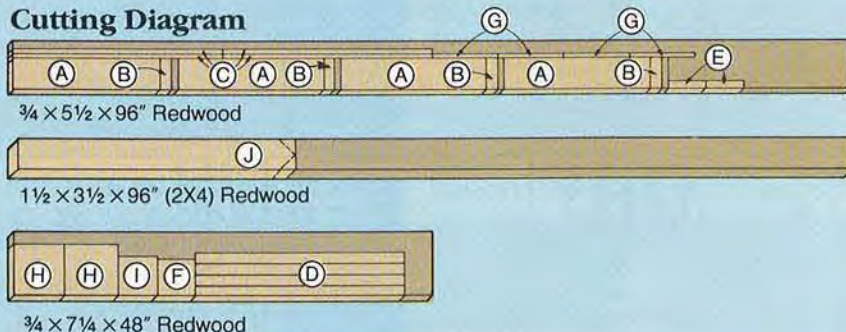

Using wood clamp blocks to prevent denting the soft redwood, glue and clamp each lightbox side panel together.

LOW-VOLTAGE LIGHTING

To prevent chip-out, rout the chamfer in two passes.

7 Mark the centerpoints, and drill two $\frac{1}{8}$ " holes in the back panel where dimensioned on the Ground Stake Drawing on the opposite page. You'll later insert screws through these holes when fastening the box to the ground stake.

LAMP SHELF AND CORNER CLEATS COME NEXT

1 Cut the lamp shelf (F) to size. Draw diagonal lines (corner to corner) on the lamp shelf. Drill a $1\frac{3}{8}$ " hole through the shelf at the marked centerpoint for the bulb socket. (We used a spade bit to drill the hole.) Now, drill a $\frac{3}{4}$ " drain hole in the shelf to prevent water from accidentally becoming trapped inside. Position the shelf on the cleats in the box.

2 To make the four corner cleats (G), start by cutting a piece of redwood to $\frac{1}{2} \times \frac{1}{2} \times 32$ ".

3 Now, chuck a straight bit into your table-mounted router. Using the two-step drawing *below* for reference, rout a pair of $\frac{1}{8}$ " rabbets $\frac{1}{4}$ " deep the length of the redwood strip. (You also could use a dado blade mounted to your tablesaw to form the rabbets.)

4 Crosscut four corner cleats (G) to length from the 32" rabbeted redwood strip.

5 Glue a redwood cleat in each corner of each light box as shown in the photo at *right*. (We applied glue to the mating edges. Then,

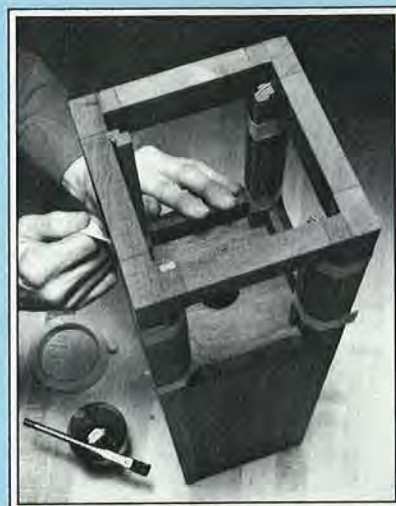
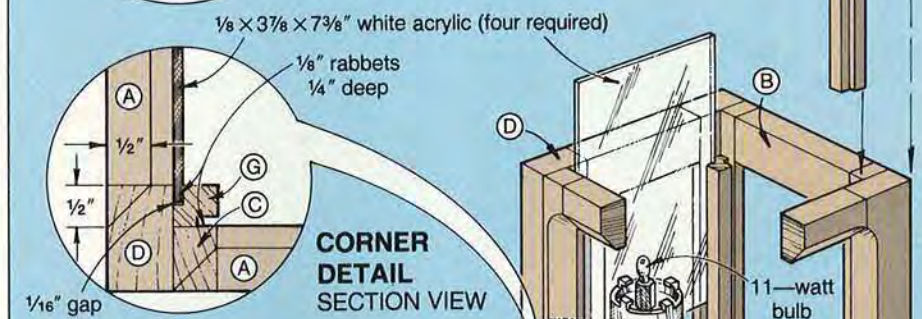
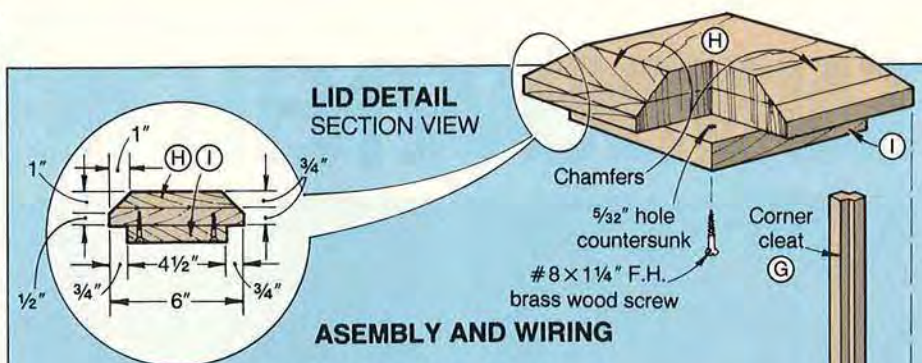

With the shelf in place, glue and tape each corner cleat in position.

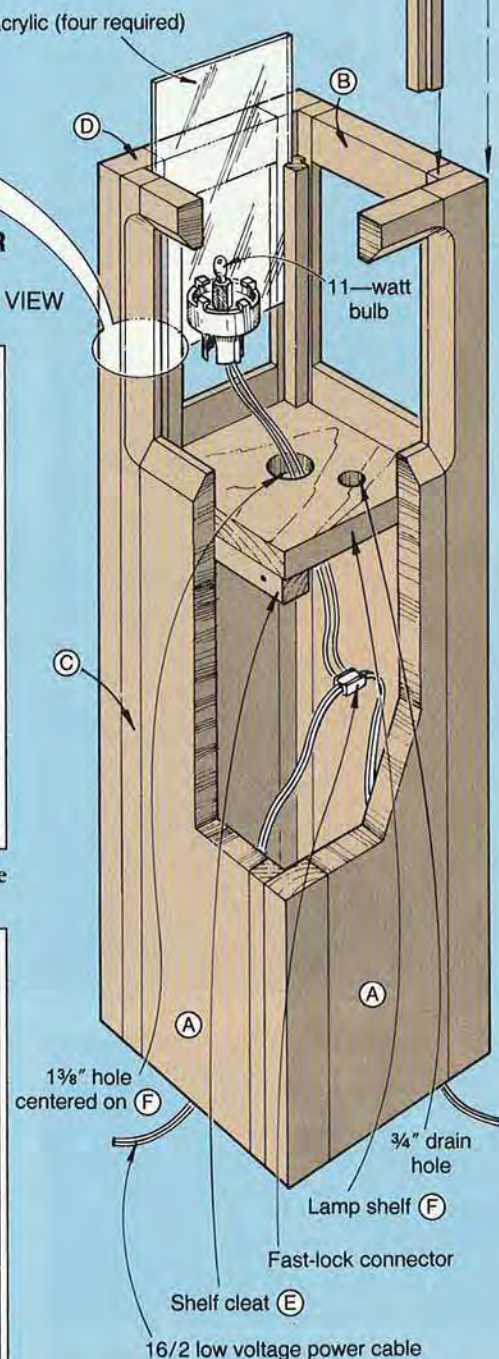
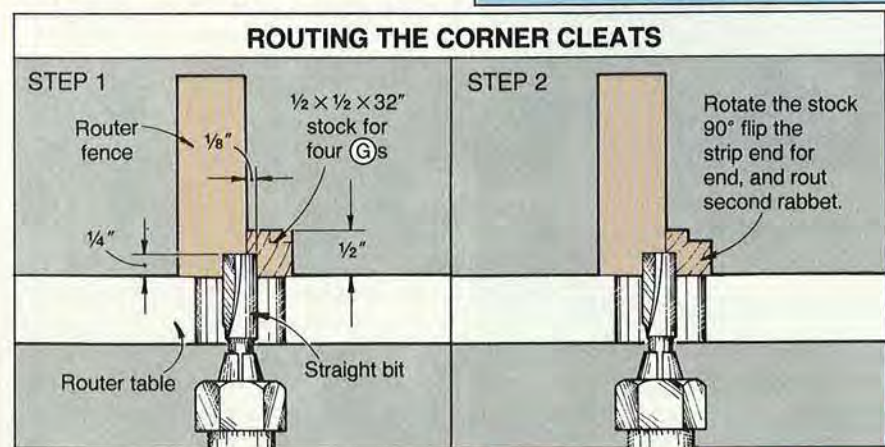

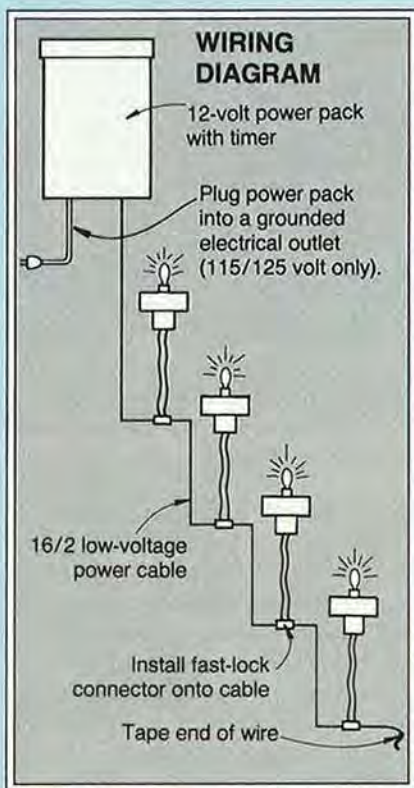
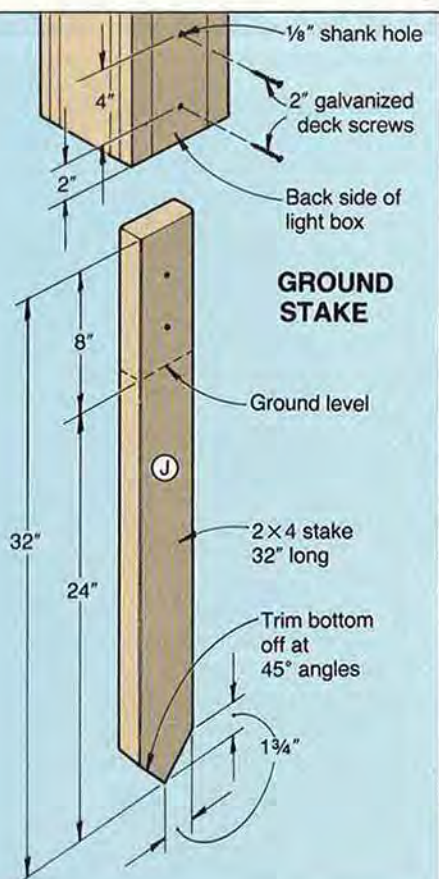

with the shelf in place, we held the cleats in position with masking tape.) Immediately remove glue squeeze-out from the rabbets (we used a thin strip of wood to remove the excess glue). After the glue has dried, remove the tape.

6 Using the tablesaw fitted with a carbide-tipped blade, cut the $\frac{1}{8}$ " white acrylic panels to $3\frac{7}{8} \times 7\frac{3}{8}$ ". Home centers sell this material for ceiling lights. Check each acrylic panel for proper fit. You want a $\frac{1}{16}$ " gap between the acrylic and the corner cleats to allow for expansion and contraction of the light box. (We forgot to do this the first time around, and later we had to replace a cracked panel.)

TO TOP IT ALL OFF, CONSTRUCT THE LID

1 From $\frac{3}{4}$ "-thick redwood stock, cut two 6" squares and one $4\frac{1}{2}$ " square for the lid pieces (H, I). Glue and clamp the two 6" squares together with the edges flush. Allow the glue to dry.

2 Tilt your tablesaw blade 45° from vertical. Using a push block for safety, cut a 1" chamfer along each edge of the 6"-square lamination.

3 Center and clamp (no glue) the $4\frac{1}{2}$ " square (I) to the bottom face of the chamfered square. Temporarily fasten the squares together with a 1" brad. Remove the clamp and check the fit of the lid. If the edges of the lid aren't flush with the outside surfaces of the light box, reposition the $4\frac{1}{2}$ " square lid. Drill a pair of pilot holes and screw the $4\frac{1}{2}$ " square in place.

4 Sand the light box and lid. Finish as desired. (We finished our light boxes and lids with Flood Company's CWF Clear Wood Finish. Call 800-321-3444 for the dealer nearest you. In Canada, call 216/650-4074 for this information.)

HERE'S HOW TO LOCATE AND WIRE THE LIGHTS

Note: The lighting kit described in the Buying Guide comes complete with installation instructions. We'll cover the basics here; see the supplied information for details.

1 Cut one stake per light box to the size shown on the Ground Stake Drawing at left. (We cut ours from a redwood 2×4 ; a CCA-treated 2×4 would also work.) Trim the bottom of the stake to a point where shown on the drawing.

2 Position the light boxes in your yard where desired.

3 Bare the power cable wires at one end, and connect the bare-wire ends to the power cable terminals on the bottom of the unplugged power pack. Fasten the power pack to a wall within 1' of a standard grounded electrical outlet (115/125 volt only). Run the power cable from the power pack to the light boxes where shown on the Wiring Diagram Drawing. It is not necessary to bury the cable. If you wish to hide the cable from view, bury it a few inches.

4 Push a socket into the $1\frac{3}{8}$ " hole in each light box shelf. Run the power cable from the power pack to each light box. Slide each fast-lock connector onto the power cable where a light will be located. (The fast-lock connector pierces the power cable to make the connection; no soldering or wire stripping needed.)

5 Drive a stake into the ground and screw the back of the light box to the stake. Check the box for plumb and tilt accordingly.

6 Slide the acrylic panels into place, add the bulb, and fit a lid onto each light box. Finally, set the timer, settle into a lawn chair, and wait for sundown to enjoy.

BUYING GUIDE

• **Lighting kit.** Intermatic 12-volt power pack (transformer) with timer, 50' of low-voltage 16/2 cable, four socket assemblies, four 11-watt bulbs. \$68.50 ppd. (\$75 Canadian). Add four additional sockets and bulbs for \$10.00. Albright Lighting, 3029 Ingersoll Ave., Des Moines, IA 50312. 🌳

Produced by Marlen Kemmet
Project Design: James R. Downing
Photographs: Hopkins Associates
Illustrations: Kim Downing; Bill Zaun
Graphic Design: Perry McFarlin

WAX

THE PERFECT

From a refinishing pro, a preservation expert, and furniture manufacturers, the answer seems to be “yes.”

Wax is the wear and tear, abrasion layer of fine wood furniture,” says Ron Ashby, a professional woodworker, refinisher, lecturer, and owner of Liberon Supplies in Mendocino, California. “Superficial scratches, dings, and dents should happen to the wax layer—not the finish you slaved over.”

DON'T DABBLE IN DUST

Despite the multitude of furniture care products that promise to “feed” or “polish” your fine furniture, Ashby believes high-quality furniture wax is the best choice. “All the other care products available attract dust with the residue they leave behind,” he says.

At Virginia's Colonial Williamsburg, Wallace Gusler, director of conservation, oversees the preservation of authentic colonial furniture. “Our primary concern with pieces that have an intact, original finish is conservation,” he says. “For that, we use wax.” And, Gusler believes, all wood furniture, not just historic pieces, deserves wax protection. “Everyone collects furniture to some extent,” he notes, “but their collection happens to be their household furniture.”

What about lemon oil, another popular wood-care product? Gusler says, “The value of oil to wood is folklore. Of course, oil gives a wood finish a superficial shine, but it isn't beneficial. In fact,” he elaborates, “commercial lemon oil has nothing to do with lemons. It's essentially kerosene, and can be harmful to a finish.”

Then, there are aerosol spray cleaners and polishes that contain

silicone. They may not harm the present finish, say Ashby and Gusler, but they will cause problems down the road if you contemplate refinishing. “Products with silicones are cheap, quick, and easy, but they don't protect,” comments Ashby. “Besides, silicones make refinishing difficult because, even after stripping, a new finish won't adhere.”

TOO MUCH WAX?

What about the infamous “wax buildup” that advertising people say their products avoid? Roy Frizzell, Supervisor of Quality Control, Ethan Allen, Inc., Danbury, Connecticut, recommends wax only in small doses. “We tell customers to dust with a damp cloth, then maybe every six months use wax. Otherwise,” he comments, “they'll put wax on every time they dust.”

Ed Finnety, customer service manager at Harden Furniture, McConnellsville, New York, acknowledges that most people over-polish. “They're zealous,” he says.

Ashby finds amusement in some companies' product claims denying wax buildup. “If you avoid wax buildup, you don't have any protection for your furniture,” he muses. “It does build up, but it builds up clear.”

According to Colonial Williamsburg's Gusler, wax should never create a buildup problem when used in moderation. That's because all the wax you put on doesn't remain there. “It gets buffed, worn off, and even oxidizes,” he says.

Old wax can be removed with special products developed just for the purpose, according to Ashby. “But, if the furniture is heavily soiled, too, you should use a wood cleaning and wax-removing product, such as Liberon Wood Cleaner and Wax Remover.”

POLISH-ON PROTECTION

You can apply wax over any finish—penetrating oils, varnish, lacquer, or polyurethane—Ashby advises. But, only buy a high-quality, cabinetmaker's wax, one designed specifically for wood furniture, at woodworking stores or through mail order catalogs. Some notable brands include: Liberon's Black Bison, Goddard's, Butcher's Wax, Antiquax, and Renaissance Wax.

Products such as these are traditionally formulated from a number of waxes—carnauba, beeswax, synthetics, and vegetable. Expect to pay from \$8 to \$10 for a one-pound tin of good quality cabinetmaker's paste wax. And, notes Ashby, don't confuse floor wax with furniture wax. Floor wax won't hold up on furniture because it's actually softer. He notes, too, that furniture wax comes as paste or liquid. “Generally,” says Ashby, “less solid forms apply easier but have less wax.”

Liquid wax does have a place in the home, though. Advises Ashby, “For highly carved wood surfaces and the legs and stretchers of chairs, you can use liquid. Also, it works as the initial wax coat on cabinets, much like a sealer.”

Applying paste wax isn't complicated, and the method doesn't differ for newly finished furniture or older furniture. All furniture to be waxed, though, must be clean and free of oil and grease.

MAINTAINING FINISHES

Following the initial three coats, Ashby suggests you reapply wax according to the rate of “wear and tear” your furniture receives. “You might wax the arms of a dining chair weekly, but the legs and stretchers only every 18 months.”

To maintain a wax coat on your furniture, follow Ashby's tips:

PROTECTION FOR FURNITURE?



At Colonial Williamsburg, conservator Leroy Graves waxes a mahogany chest of drawers dating to 1790. Experts say your household collection deserves the same treatment.

- Dust weekly with a soft, dry, all-cotton cloth.
- Don't use polishes or oils over your coat of protective wax.
- Wipe up spills as soon as possible to prevent spotting.
- Use coasters under glasses and vases, and pads or trivets under hot dishes.
- Reapply a coat of wax when

you can no longer buff the coating to a shine.

"On the West Coast today, it costs between \$650 and \$1,000 to have a dining tabletop custom refinished. If you have just finished one yourself, that's how much it's worth," comments the waxing expert. "Wax can preserve that expensive finish."

"You can make only two mistakes applying wax," Ashby notes. "You can put too much on, and you can try to buff it out too soon." Too thick of a coat won't dry evenly, resulting in a spotty sheen. And, if you buff wax before it has dried, you just redistribute the wax.

Here are the most frequently asked questions and answers regarding the application of wax:

● *Do you have to apply wax with steel wool?* Ashby recommends an oil-free, wood finisher's 0000 steel wool (see where to buy at end of article) to avoid streaks and blurs. A cloth will do, although it takes more effort.

● *Does it matter how you spread the wax?* "No," says Ashby, "but, on large surfaces, such as a tabletop, I use a circular motion, then even it out with the grain."

● *How can you tell if you have applied the right amount of wax?* "If you see ridges across the surface, there's too much," he says.

● *Will one coat do?* "On a new piece or one not previously waxed, put down three light, successive coats at four- to eight-hour intervals."

● *What do you need for buffing?* Buff the dry wax with terry cloth, a cotton diaper, or an old T-shirt. "The higher the gloss you want, the softer the material for buffing you use," he says. "And, buffing with the grain or cross-grain doesn't matter."

BUYING GUIDE

● **Oil-free steel wool, Black Bison wax, wax remover.** Liberon Supplies, P.O. Box 86, Mendocino, CA 95460. Call 707/937-0375. Other waxes available from woodworking supply stores. ♣

Written with Amy Elbert
Photograph courtesy of the
Colonial Williamsburg Foundation,
Williamsburg, Virginia

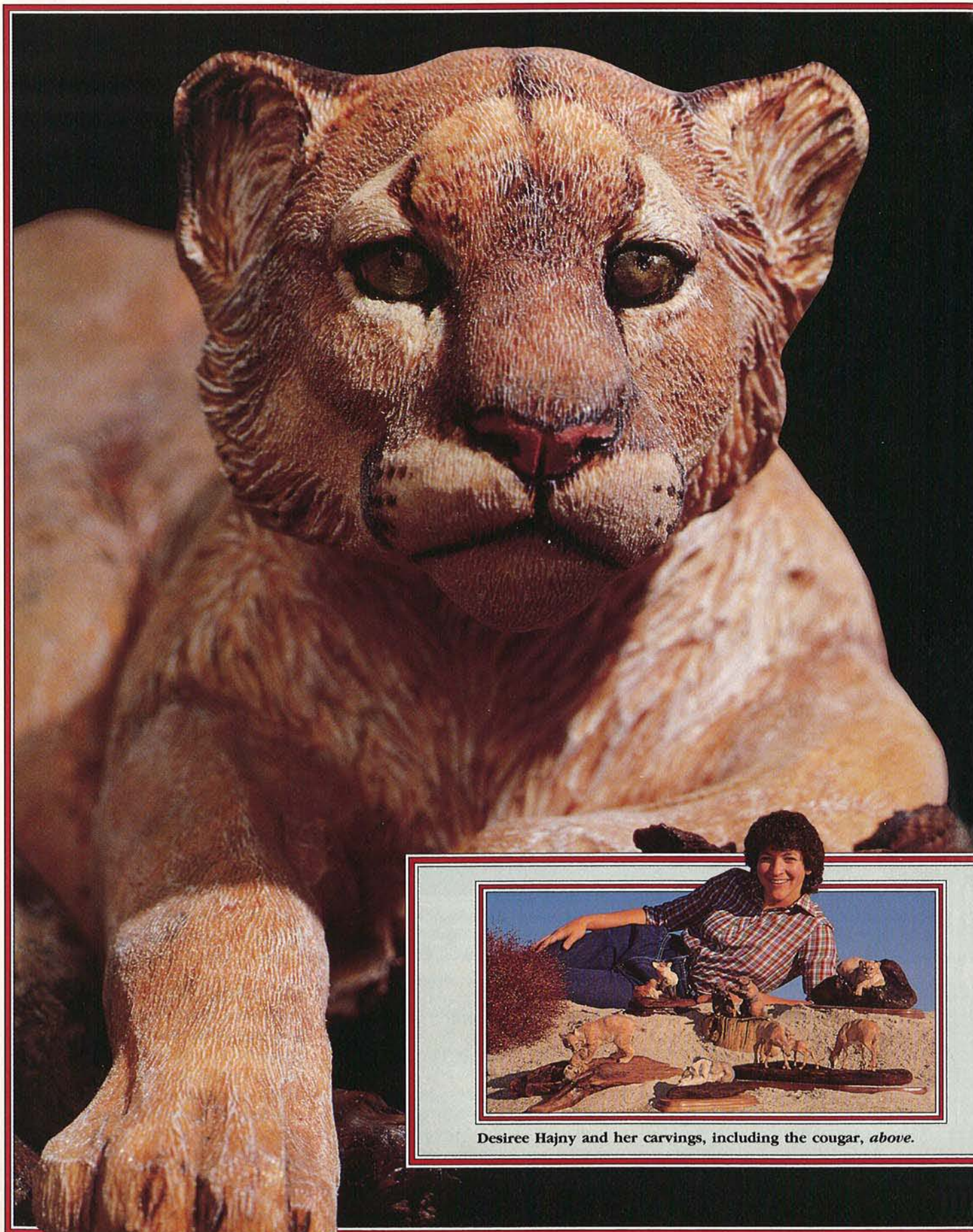

Desiree Hajny and her carvings, including the cougar, *above*.

Desiree

CAME OUT OF THE

WEST

Packing a dream
and a talent
for carving

How Colorado-raised Desiree Hajny became a woodcarver might have been lifted from a paperback western: *"What ya' aim to teach, ma'am?" inquired the dusty cowpoke. "Art," replied the new school marm. "Not much call for that in these parts," he guffawed, then ambled on down the street. In cattle country, the young teacher had her work cut out. Rawboned cowboys, toughened ranchers, and others of sturdy stock had little regard for what they considered impractical.*

"But, it's true," Desiree laughs. Planting her hands in the back pockets of her denim jeans, she tells about her first year as a high school art teacher in Nebraska's sandhills cattle country. "They were ranch kids in Bassett [pop. 1,000], and boys and girls alike could dig a fence-post hole to beat the band."

Raising one hand to shake a finger, she continues. "Lots of the parents told their children, 'You'll never get anything useful from art.' As an art teacher, it

was tough. I had a heck of a time, until I hit on carving to get them involved. Crimine, they all had pocketknives!"

Until that time, Desiree had never carved. Yet, as the students took to it, so did the teacher. And, drawing on images from

"You always return to what you love and remember best."

her beloved Rocky Mountains, a champion eventually came out of the West.

ROCKY MOUNTAIN REMEMBRANCES

In college, Desiree studied all aspects of art. It was cartooning,

however, that really caught her interest. "I drew cartoon figures all the time," she remembers, "and when I began carving, cartooning surfaced."

Why the switch to wildlife?

Desiree explains, "Because I grew up in the Colorado Rockies, surrounded by nature's animals. My brothers and I even raised a mule deer fawn we called 'Baby Doe.' It seems you always return to what you love and remember best."

Many of Desiree's pieces reflect a strong feeling of family and togetherness, part of her mountain remembrances. "We had such a close family. My father always said, 'We got to stick together like a covey of quail.' And, my brothers and I would say, 'What's a covey?' Then, he'd describe how quail watch out for each other and tell us to do the same."

Images from those fondly remembered family years consistently show up in her carvings. A bobcat mother carefully mouths her kitten for transport. A doe, ears and eyes alert, cuddles her fawn. *Continued*

Desiree Hajny, *left*, shows some of her detailed wildlife carvings that have captured the hearts of the public and the eyes of judges from Anchorage to Kansas City and Toronto. Note the reclining cougar resting by Desiree's left elbow. That's the same carving we've blown up to five times actual size in the photograph on the opposite page.

In the nine years since she tackled her first carving, Desiree, 32, has turned a dream shared by many carvers into reality. She piles up blue ribbons, galleries demand her work, and commissions from collectors take her a year to fulfill. She's so busy, she couldn't possibly be happier.

Husband Bernie, 30, a special education teacher, inspires and encourages her. Son Jeff, 4, the driving reason Desiree began carving full-time at home, benefits from her companionship. And, Desiree thrives. "I love doing things that people enjoy, and it's fun to see how much better I can get year to year, and competition to competition."

What makes Desiree's work so popular? It's not only realistic, but candid. In her home workshop in Columbus, Nebraska, we discovered why—and how—Desiree imagines, then records in wood what most people expect only from the most expert wildlife photographers.



Ears and eyes alert, a doe guards her resting fawn against forest predators, man and beast.



"I always carve the head first, because that's how I look at an animal," says Desiree. Note her backhand style.

Sleeping instead of howling under a full moon, Desiree's lone wolf hardly appears as dangerous or menacing as its reputation.



Desiree
CAME OUT OF THE
WEST

True to life in their carefully painted pelts, her animals halt in unexpected poses, more like house pets than beasts of the wild. Desiree enjoys watching people react to her carvings. "At a show, a man and woman will stop, look, then look again. Pretty soon, the woman will giggle or laugh. 'Hey, George, look at this!' she'll say. I like doing poses that catch your eye."

Her penchant for cartooning hasn't been neglected. "With the lion and bobcat kittens, I make the feet a little bit bigger, exaggerate them," she says. "Then, people get the impression of playful little fur balls."

BLUE RIBBONS BY MAIL

"When we moved to Columbus in 1986, Bernie and I decided to enter my animals in carving competitions," says Desiree. "At the worst, I thought I could always learn something from losing."

That year, Desiree's work only went to competitions where attendance wasn't required. And the ribbons started coming in. The initial one, a third place in a wildlife art show, arrived from Dubois, Wyoming. "We sent two other pieces, but they broke in shipping. We learned how to pack better after that," she laughs. Encouraged, Desiree entered the Alaskan Fur Rendezvous, and earned a division championship. From the 10th Canadian International Woodcarving Exhibition in Toronto came a first and second place. Since, Desiree has won top honors in Iowa, Kansas, Missouri, Oklahoma, Minnesota, and again in Alaska and Canada.

"Things just started clicking. The more shows we entered, the more success we had, the more contacts we made, and the greater the sales," she bubbles. "Now, people are asking us to be at their shows—something you dream about, but never believe will happen."

PRETEND YOU'RE A MOOSE IN THE WILD

According to Desiree, it takes research to carve lifelike animals. Besides drawing from her own memories, she subscribes to a nature book club and *Ranger Rick* magazine, and spends a lot of time watching productions on cable television's Discovery channel. "I also pose in the positions I carve my animals in. Really!" she grins, kicking a foot to the top of an imaginary rock.

"I took a physiology class to study animal bones and muscles. I wanted to see what does what and why it does it." An infectious smile breaks her lips. "I'll bet you didn't know that a moose's knee is here," she says, indicating her hip.

Desiree's three-dimensional carving requires a lot more attention to detail than relief carving, or even painting. "You have to pay more attention to such things as the back leg and the feet," she says. "Animal artists, particularly painters, are famous for covering the feet. They hide them in the grass, or rocks, or snow. I can't do that. Besides," she notes, "for some reason, a woman gets critiqued more than a man. So, I'm more careful with details."

Prolific as well as talented, Desiree produces more than 50 carvings a year. She never tires of it.

"That's because I go through phases. I'll do cats for awhile, and do as many as I can. Once I'm out of the phase, no matter how hard I try, cats won't look right." Cocking her head and wrinkling her nose, she explains, "Cats have so many expressions. When a cat looks directly at you, it can be love at first sight. Or, you don't like them."

CARVING FACE TO FACE

Most figure carvers delay detailing the face until they carve the body. Desiree reverses that technique. First, she draws the face on the blank, in detail. Next, she draws the lines where the backbone, chest, feet, and other body parts

will be. Then, instead of completely roughing out the animal, she focuses on the head. "That's how I look at a person or an animal—the face first, then the body," she comments. "So, I start with the head and face. If I like it, I finish the body. If I don't, I put it away to redo later."

Because Desiree starts with the face, there's always a lot of wood left to remove before she can even begin to see a body in the rough-out. Yet, as with most things she does, she has a reason. "I do use an awfully big chunk for a rough, but that allows for the body to curve and contour. If I want to curl the tail, I've got the wood to do it. I use the whole piece."

Desiree chips away with an Auto-Mach power carver to get the wood to the point where she can work with a knife and gouges—work that she does, strange enough, backhand (see photo at left). After the detailing with those tools, she prepares the carvings for woodburning by sanding. "I sand, because I want them real smooth to emphasize the burns," she notes.

DECORATING THE PETTING ZOO

Desiree says that she often uses jelutong wood for some of her pieces, and for quite an unexpected reason. "People actually pet many of my carvings. When they do, their fingers can rub off any burned-in texture on basswood. Jelutong holds up better to the touch."

In the evenings, when Bernie needs to unwind from his teaching job, he helps Desiree burn in the hair texture on her animals. "I do all the burning on the faces and mark the areas on the body for him to follow. Then, we sit around together in the living room or at the dining table, talking and working on the carvings," she says.

Unlike the array of paint tubes that decoy and bird carvers rely on, Desiree reaches for a shoe box filled with tiny bottles. "Those little

bottles are acrylics, but for tole painters. They're already dull, and they're less expensive than name-brand tube colors." Desiree uses *Apple Barrel*, *Cream Cote*, and *Folk Art* brands, priced at 88 cents to \$1.75 per 6 oz. bottle.

To let the wood show, Desiree brushes on thinned acrylics, building up color with a wet-on-wet technique. "When the paint dries, I apply highlights of color by dry-brushing [dabbing with unthinned paint on a dry brush]," she explains. "Then, I put on a coat of tung oil."

TAKING AIM ON THE FUTURE

Hundreds of pushpins decorate a U.S. map on Desiree and Bernie's den wall. They represent sales from the Rockies to New York.

For instance, singer Barbara Mandrel bought two carvings. An arrow points to China—a Chinese official has one. Several arrows indicate owners of Desiree's carvings in England, West Germany, and other European countries.

Will Desiree keep up the pace? Seriously, she says, "Carving never gets old. One reason is all the things I still want to carve; another, I challenge myself."

Back in 1986 when Desiree took her last look at a classroom and became a full-time carver, her younger brothers presented her with a poster. It now prominently decorates the door of a workshop cabinet: "Happy are those who dream dreams and are ready to pay the price to make them come true." For Desiree, the words become ones to live by. 🍄

Written by:
Peter Stephano
Photographs:
Hopkins Associates
Graphic design:
Perry McFarlin

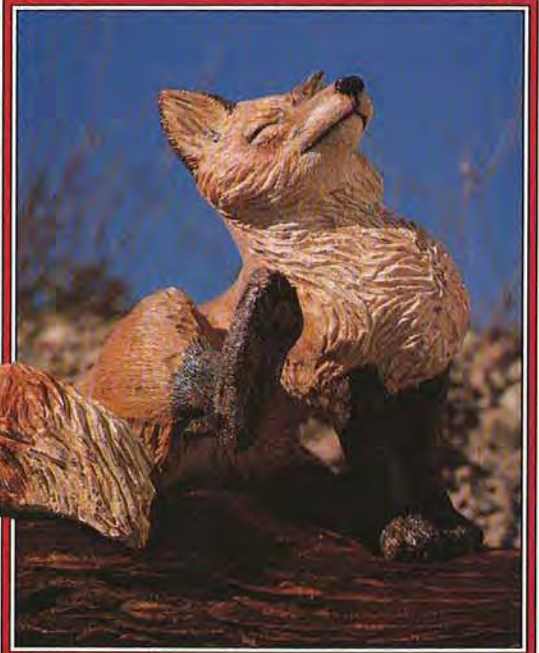

Hardly cunning when caught up in a scratch, this red fox may remind you of a favorite pet.

Wildlife photographers rarely capture the feeling of family shown in this carving of a bobcat and her two playful kittens.

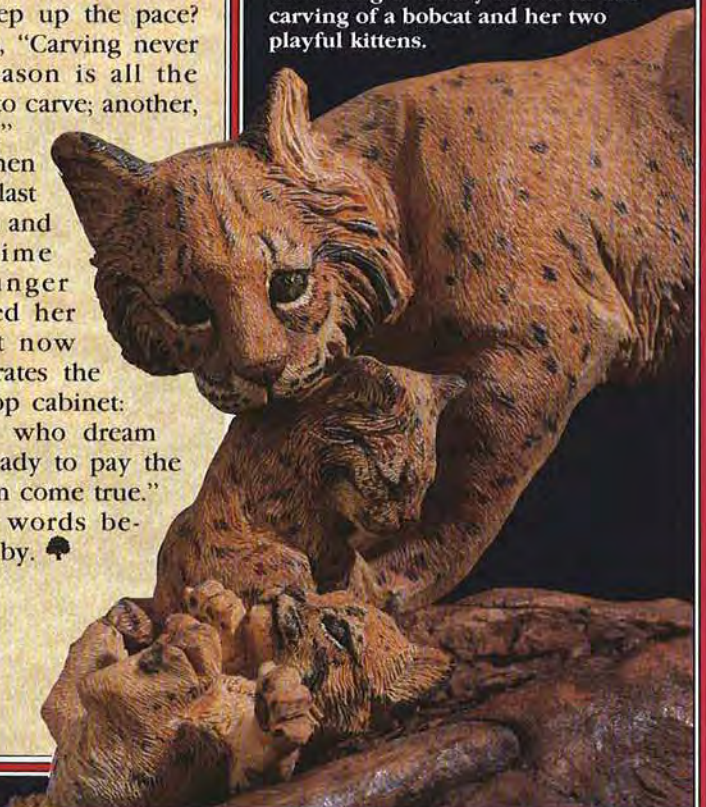

CARVE A
DESIREE HAJNY
WILDLIFE ORIGINAL
**ROSCOE
THE
RACCOON**

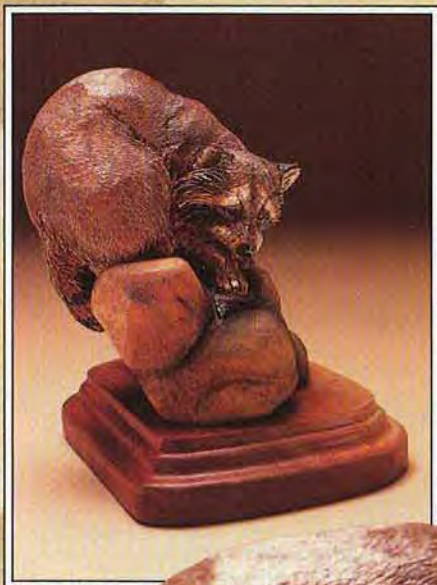

Start from scratch, or send for our 70-percent complete, crafting this cautious little creature. And, with every order,

To make it as easy as possible for you to carve your own Roscoe the Raccoon, Desiree helped us develop this special, four-page article of step-by-step instructions. The drawings, photos, and painting guide lead you through the detailing process as if you were enrolled in one of Desiree's carving classes. And, with our 70-percent complete, precarved rough-out (see box on page 63), even novices will be successful.

STEP 1: ROSCOE THE RACCOON SHAPES UP

If you ordered the roughed-out carving, jump ahead to "Carving a face for Roscoe," below. Otherwise, trace the full-sized pattern onto a 2½ x 3¾ x 5" piece of basswood or jelutong. Then, bandsaw the block to shape.

Begin carving by removing the excess wood until your rough has the curves and contours shown in the full-body views, *right*. "Be sure to leave about ½" of excess wood around the face," Desiree advises, "so you'll have plenty of area to work in all the angles and planes with small gouges and a knife."

STEP 2: CARVING A FACE FOR ROSCOE

"The face is critical," Desiree says. "From the side, the muzzle is a triangle; the nose, an upside-down heart with the point removed."

From the nose to a stop cut between the eyes, carve a flat, narrow bridge. Then, widen it up to the forehead. For an eye, cut a V-shape

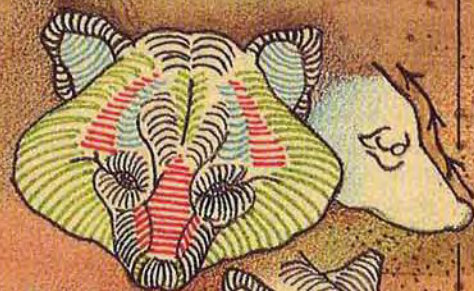

COLOR CODE

-  Flat
-  Rounded, curved
-  V-cuts
-  Hollowed out with veiner, gouges



Roscoe's unpainted face shows carved-in detail to imitate.

at the bridge for the upper lid and tear duct. Under it, make an inverted V-cut to start the lower lid. Outline the eye with curving stop cuts, then round the eyeballs. Fan the mask out for the ruffs of fur that extend behind and below the ears. For contour, see drawings *above*.

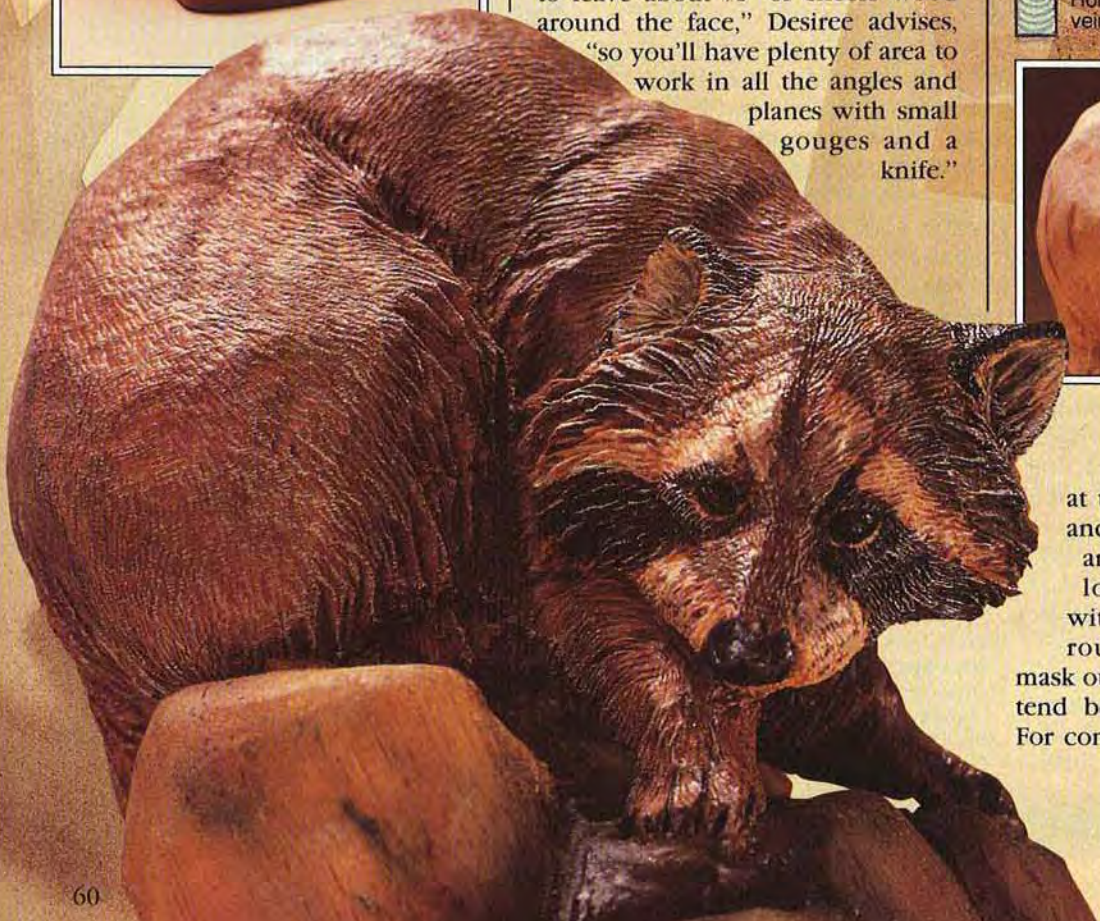

precarved rough-out so you can concentrate on detail. Either way, we know you'll enjoy you'll support the National Wildlife Federation's Backyard Wildlife Habitat Program.

STEP 3: GIVE YOUR RACCOON A FUR COAT

For the deep, narrow cuts that represent the heavier fur on the raccoon's rump, tail, legs, and ruffs, Desiree uses a 1/8"-wide parting tool (V-tool), as shown in the photo, below left. For the finer body hair that completely covers the back, thighs, head, face, and feet, she re-

lies on an electric woodburning tool with interchangeable tips. You can simulate hair by stippling paint—short strokes applied with a No. 1 or smaller fine-tipped brush—(see photo, page 62). Or, order the woodburning kit offered in our Buying Guide. Then, sand your carving smooth before

burning-in the fur. If you paint the fur on, first seal the wood with tung oil or spray lacquer so the paint won't soak in.

Regarding woodburning, Desiree says, "Make small marks in layers,

Continued



A V-tool carves the lines that represent heavy fur.

Sear the nose and eyes with the side of a hot woodburning tip.

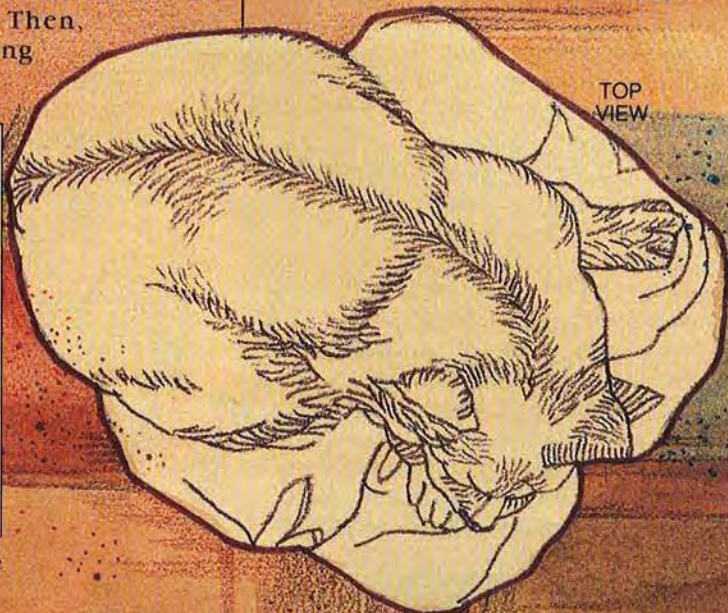

TOP VIEW

FULL-SIZED PATTERNS

Raccoons are kind of like cats, their faces telegraph lots of moods. Raccoons also get into lots of mischief. This little fella, I nicknamed Roscoe, could be contemplating your garbage can!
Desiree Hajny



BACK VIEW



SIDE VIEW

ROSCOE THE RACCOON

(as shown in the drawing, *next page*). Use a fluid motion, and avoid putting in too many straight lines. Remember, gravity bends hair into a slight arc."

Hair flows around an animal's body in tracts, following its contours. To see the direction of these tracts on a raccoon, study the detailed drawings, *right*. Use them as reference for your burned-in or painted-on hair marks.

To obtain shiny eyes and a nose on your carving, here's a tip from Desiree's workshop. "Sear the wood of the eyes and nose with the side of a hot woodburning tip," she says. "This seals the wood as it darkens it. When you put on the coat of tung oil after painting, the seared areas won't absorb it, and they'll glisten." (Varnish over flat paint works, too.) Her technique, shown on page 61, works so



You can paint hair on with short brush strokes.

well that at carving competitions, other carvers have accused Desiree of putting glass eyes in her animals!

STEP 4: PAINT BRINGS ROSCOE TO LIFE

After completing all burning, you're ready to begin Roscoe's paint job. Desiree paints only with acrylics, but oil will work just as well. "Whatever type of paint you choose, though," advises Desiree, "keep it thinned so the pigment doesn't clog up burn marks or carv-

ing details. To build color, use several thin coats rather than one thick one. You want to let some of the natural wood color show through."

Desiree suggests that you follow this painting procedure: Apply light colors, then dark ones. That means that you'll want to paint all white areas first. Next, paint the brown-gray areas. Then, add black. Refer to the color keys, *next page*, to guide you as you paint.

After the paint has completely dried, you can begin the dry-brush-

ing of the brown-gray areas with white mixed with tan. This adds realism to the fur. And, if you have never tried dry-brushing before, think of it as "painting with the bristles." That is, keep the paint and your brush *dry* enough that it doesn't flow onto your carving in a coat. Instead, the bristles of your brush leave behind only hints of color. Practice on paper first.

For the rock base Roscoe perches on, mix the colors you have used already. Create various shades by applying the paint in thin coats and adding darker colors in the crevices. After your painted carving dries, add a coat of tung oil.

Basic hair (fur) tracts of a raccoon



FRONT FACE



GENERAL BODY AREA

RIGHT BACK LEG

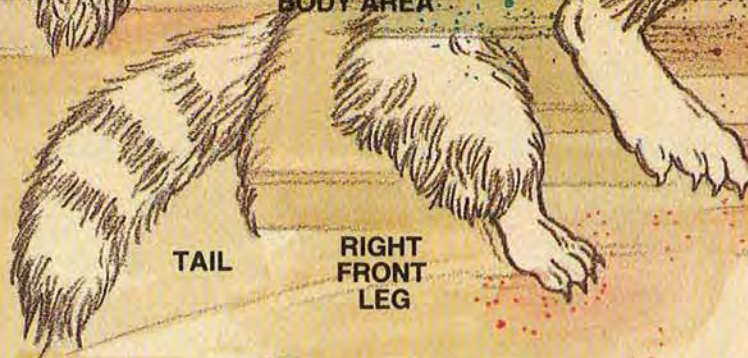

TAIL

RIGHT FRONT LEG

COLORS FOR ROSCOE THE RACCOON

Eyes and nose—black, white underlining eyeballs.

Mask and outside of ears—black mixed with a touch of brown.

Bridge of muzzle upward to forehead—brown to black to tan.

Spots on muzzle—black or brown.

Muzzle, area above eyes, and inside of ears—white mixed with just a touch of tan or brown.

Body—brown mixed with gray.

dry-brushed on top with an off-white for accent.

Front paws—dark brown/gray with black claws.

Back paws—light gray to dark gray with black claws.

Tail—brown/gray with three black stripes and black tip.

Boulders and rocks—gray/black to light gray, darker accents in crevices (mix up leftover raccoon body colors). Suggest moss or vegetation with dabs of green.

TOOLS AND MATERIALS

For carving Roscoe, Desiree used the gouge and V-tool sizes and shapes shown below. Similar ones are available from the Warren Tool Co. (address below) or other carving-tool suppliers.

Gouges (general wood removal, shaping): 1/2" No. 3, 1/2" No. 5, 1/8" No. 7, 1/8", 1/4" No. 9

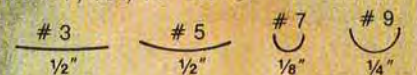

Parting, or V-tools (deep grooves and heavy fur): 45° in 1/4", 1/8"

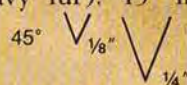

Bench-style carving knife

(general wood removal, stop cuts, fine lines, hair)

Wood: 2 1/2 x 3 3/4 x 5" basswood or jelutong (or precarved rough-out)

Paint (acrylic or oil): white, black, brown, tan, gray

Clear finish: Tung oil

Sable or camel hair brushes: sizes 00, 0, 1, 3. Paint and brushes available from art or hobby supply stores

Woodburner (for fur)

Woodburning tips: spade, needle

Want to try woodburning Roscoe without investing a bundle? Send a check or money order for \$27.50 (includes postage) to Warren Tool Co., Inc., Rte. 1, Box 14A, Dept. WD, Rhinebeck, NY 12572 and you'll receive a special Hot Tool Woodburning Kit that includes an electric burner with wooden handle, a standard tip, and a needle tip for fur. About this tool, Desiree says that many of her carving students have used it successfully. "For darker fur areas, burn lines close together. For lighter areas, spread lines farther apart," she advises. You'll also receive a carving tool catalog (regular price, \$1). The burning tool carries a full guarantee. ♣

Photographs: Jim Kascoutas
Illustrations: Jim Stevenson
Design, how-to notes: Desiree Hajny
Graphic design: C. I. Gatzke



BACKBONE & FUR TRACT DIRECTION

Fur marks are layered

ORDER A ROSCOE THE RACCOON ROUGH-OUT

Our 2 1/2 x 3 3/4 x 5" precarved, basswood rough-out already looks like a raccoon. For every rough-out you buy, WOOD® magazine will earmark \$1 for the National Wildlife Federation's Backyard Wildlife Habitat Program (not applicable with orders from Calif., Conn., Fla., N.H., and N.Y.).

To order: Send a check or money order for \$8 for one, \$15 for two (all include postage), payable to:

WOOD® Magazine
ROSCOE THE RACCOON
Locust at 17th St.
Des Moines, IA 50336

Please allow 4-6 weeks for delivery.
Offer expires November 1, 1989.



EDGE-JOINING

THE CAN'T-MISS WAY

If the world were perfect, you could set your jointer or tablesaw for precisely 90° and end up with flawless butt joints every time as shown in drawing A. Because nothing's perfect, here's a way to set your equipment for about 90° and still cut edges that match exactly as shown in B.

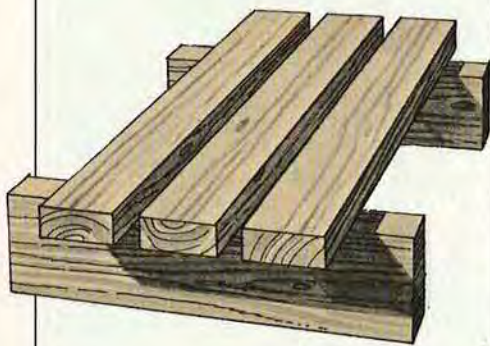
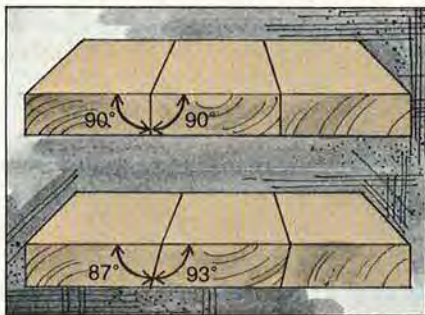

Working with nonwarped boards of uniform thickness, place them across a pair of 2x4s so they lie flat and elevated. Then, arrange the boards so that the curvature of their growth rings alternates as shown above. This procedure increases the dimensional stability of the glue-up, making it less prone to warping. Now, shuffle the boards around to achieve the best color and grain match, but be careful to maintain the alternating growth-ring pattern for at least 80 percent of the boards.

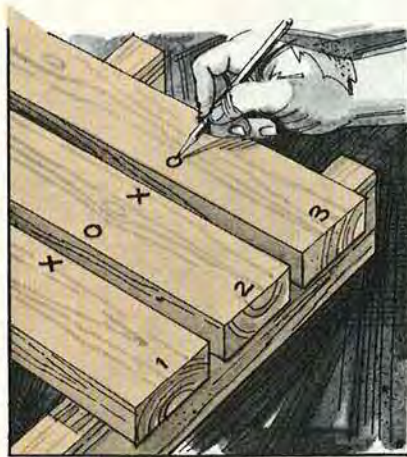

2 Next, number the boards with a pencil so they stay in proper sequence, and mark alternating Xs and Os along the joint lines on the face sides of the boards as shown above. Whether you're using a tablesaw or a jointer to cut the mating edges, these Xs and Os will tell you how to position the boards for ripping and gluing later.

3 If you're cutting the edges with a tablesaw, always place the boards faceup when you trim the O edge as shown below. Then, rip the X edge by flipping the board over (face side down with the same end of the board toward you) and ripping it again.

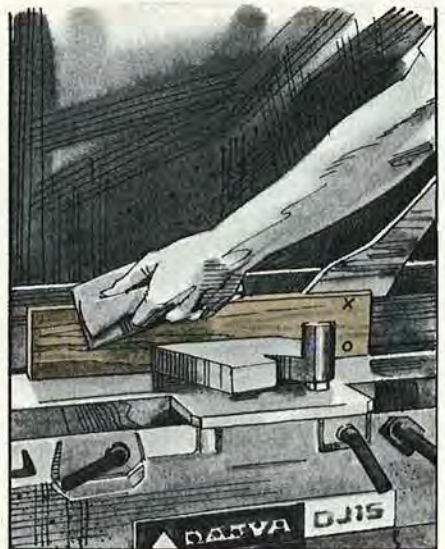

4 This procedure works equally well with a jointer. First, position the board face side up against the fence and pass the O edge through the jointer as shown above. Now, place the X edge on the jointer table with the face side (X and O) against the fence and joint that edge. Repeat for the other boards. ♣

Illustrations: Jim Stevenson

 Print this article

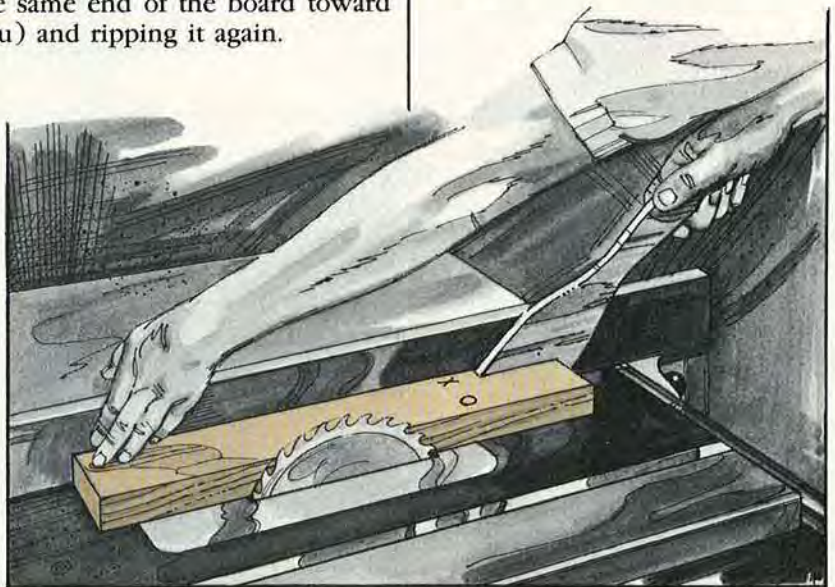

PACK NEW PRECISION INTO YOUR TABLESAW

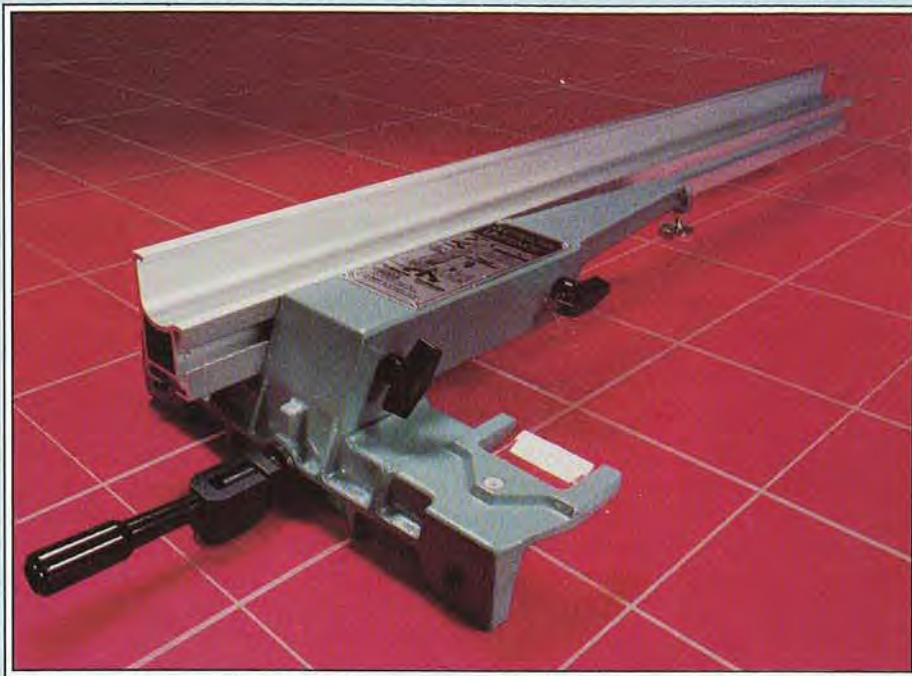

REPLACEMENT RIP FENCES

 [Print this article](#)

Put away that tape measure! Why? Because in the second or so it takes to extend the tape, you can accurately set an aftermarket rip fence. The catch? You'll spend from \$219 to more than \$400 for this upgrade that many of your fellow woodworkers swear by.

Before you buy an accessory that may cost more than your table saw, you deserve to know how these fences can help you. Besides being fast and accurate, an aftermarket fence stays parallel to the blade through heavy use and locks securely when you make a cut. The payoff: You work safer and save money in stock not wasted from bad cuts.

Here's another big advantage, especially if you cut large panels: more cutting capacity to the left or right of the saw blade. Because each of the fences we tried extends at least 50" to one side of the blade, you'll need to add an extension table off the side of your saw (some models extend only 28"). Remember this fact if you're operating in a small shop.

FIRST WITH A FENCE: BILL BIESEMEYER

After working in cabinet shops for 35 years, Bill Biesemeyer of Phoenix "became so disgusted with available table saw fences that I finally built my own," as he puts it. The year was 1962, and Biesemeyer improved his fence until he patented the first commercially available replacement table saw fence in 1977. In the following two years, "I went

on selling trips and sold, built, and installed 250 fences," Biesemeyer said. During 1984 and 1985, his firm made *Inc.* magazine's list of the 500 fastest-growing private companies in the U.S.

Biesemeyer's success didn't go unnoticed by other manufacturers—today four competing firms offer models similar in function but different in design.



Continued

REPLACEMENT RIP FENCES

THE INSIDE STORY: HOW THEY WORK

Like standard fences, all of the replacement fences ride along a front rail. Some, such as the Biesemeyer commercial model shown at *right*, include a rear rail to add rigidity to an extension table or support the fence on that end. As shown in these illustrations, the real differences among these fences lie in the locking mechanisms, rail construction, and configuration of the contact points where they lock to the rails. Here's a quick rundown:

Color code:

- Orange: locking mechanism
- Gray: fence
- Blue: fencehead
- Red: rails
- Green: saw table
- Yellow arrows: direction of pull when fence secured

HERE'S HOW THEY WORK
(All fences are shown in the locked position.
Unlock by flipping lever up).

BIESEMEYER (COMMERCIAL MODEL)



As shown *above*, the Biesemeyer commercial model rides along a front-end rail of square, tubular steel, with Teflon glide pads on the front and rear of the fence. The simple locking mechanism consists of a cam-action lever that you push down to bring two contact points against the front rail. A 16"-spread between the ends of the contact points (widest of all the fences) minimizes the chances of alignment error in the fence. Biesemeyer's home-shop version duplicates the commercial fence, but in a scaled-down model (see chart on page 69 for specifics).

DELTA UNIFENCE

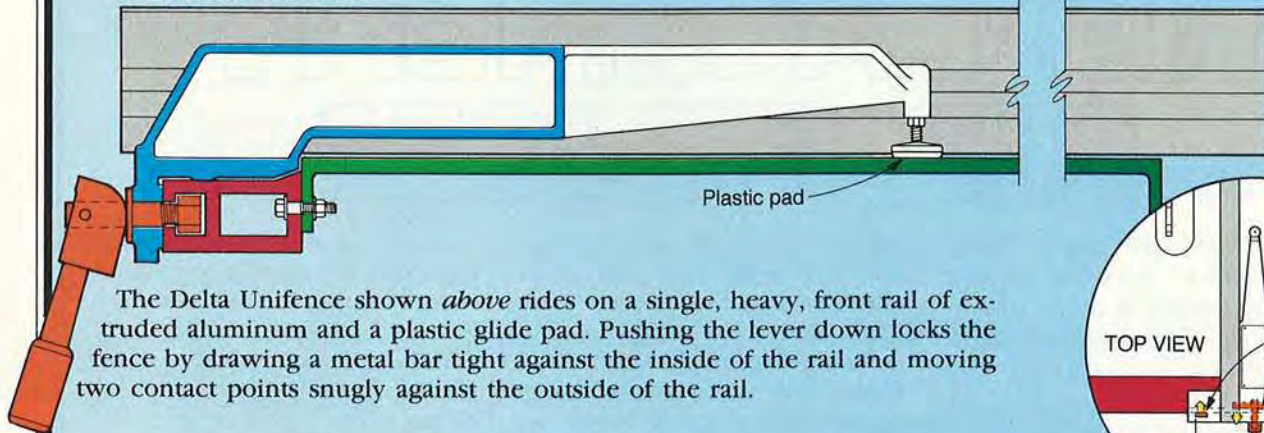

The Delta Unifence shown *above* rides on a single, heavy, front rail of extruded aluminum and a plastic glide pad. Pushing the lever down locks the fence by drawing a metal bar tight against the inside of the rail and moving two contact points snugly against the outside of the rail.

EXCALIBUR

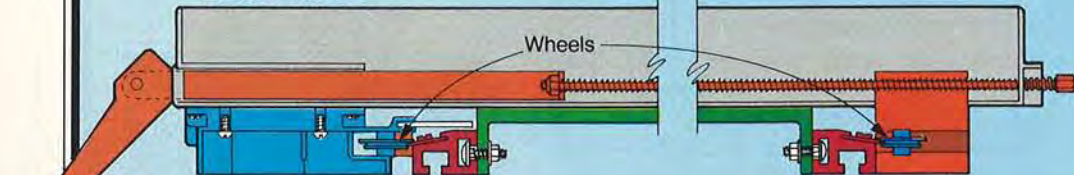

Unlike the Biesemeyer and Delta, the Excalibur fence shown *above* rides on wheels that roll along a steel strip mounted to the extruded aluminum front and rear rails. Pushing down the lever draws the rear wheel in and causes the spring-loaded front wheels to retract, bringing two solid contact points and a rear contact point firmly against the rails.

PARALOK CABLE SYSTEM
(Arrows show cable movement direction)

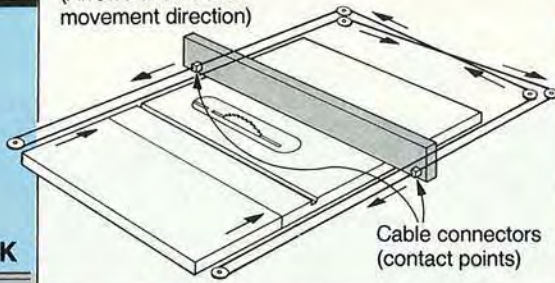

The Paralok fence quickly releases from its cable system with a tug on its cable connectors.

PARALOK

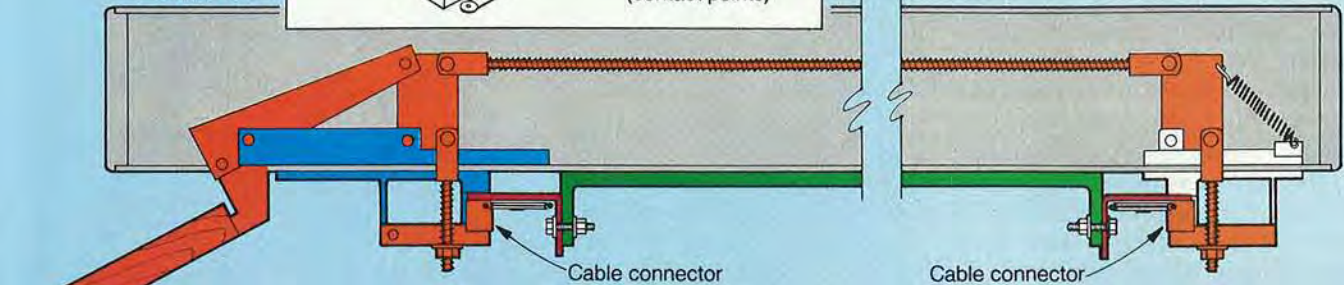

On a totally different track than the other fences, the Paralok works like a cable-rigged drafting table as shown above. The fence attaches to a continuous cable, slides along front and rear rails and locks in place when you de-

press the lever to bring two cable connectors up against the front and rear rails. With the unit unlocked, you can disconnect the fence from the cable by pulling the cable connectors away from the fence as shown above. You remove the Paralok by sliding the fence off the rails.

VEGA

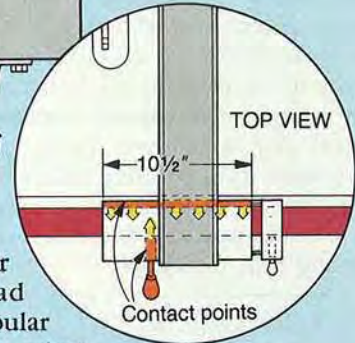
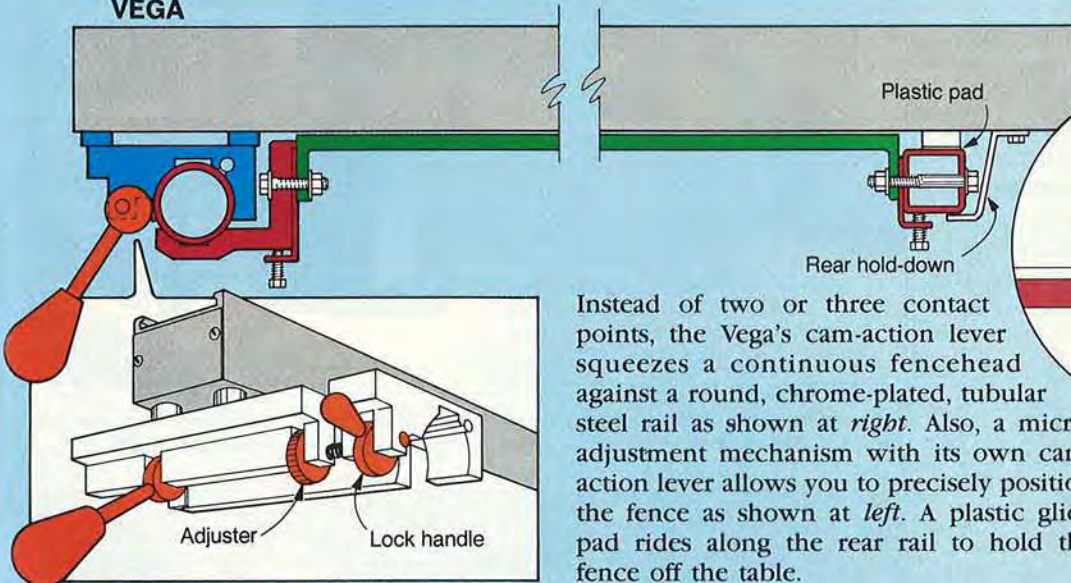

Instead of two or three contact points, the Vega's cam-action lever squeezes a continuous fencehead against a round, chrome-plated, tubular steel rail as shown at right. Also, a micro-adjustment mechanism with its own cam-action lever allows you to precisely position the fence as shown at left. A plastic glide pad rides along the rear rail to hold the fence off the table.

VEGA MICRO-ADJUSTMENT MECHANISM

INSTALLATION: SOME EASIER THAN OTHERS

We found the Vega the easiest to install because it arrives with bolts that fit the existing holes in your tablesaw (if you own a Delta Unisaw or contractors saw, Powermatic model 66, or most Sears 10" saws). Otherwise, you'll have to drill two or four holes. Even if you're not mechanically inclined, you'll find the Vega, Biesemeyer, and Delta fences a snap to install on nearly any tablesaw.

You shouldn't have any problem installing the Excalibur if you follow its instructions closely, but this fence does require a perfectly flush and flat mounting surface for the front rail. Why? The aluminum Excalibur rail will bend when you lock the fence in place if there's distortion along that surface. Common distortions: burrs on the saw table or misalignment between the saw table and extension table.

Installing the Paralok challenged us a great deal. The cable system assembles relatively easily, but we were stumped by its poorly written and illustrated instruction book. Darryl Waters of Quintec Mfg. (makers of Paralok) said his firm recognizes the problem, and he sent us a preliminary copy of a new instruction booklet to back up his point. We found the new book considerably easier to understand.

Continued

REPLACEMENT RIP FENCES

DESIGN AND MATERIALS: WHAT TO LOOK FOR

Since all of the fence systems do basically the same thing, it pays to consider their design and materials. With the exception of the Biesemeyer, all the manufacturers use light, high-quality, extruded aluminum for the fences. We found Biesemeyer's 28-pound steel fence to be sturdy, but cumbersome.

However, Biesemeyer continues its all-steel construction where it really helps—the rails. The steel adds strength, rigidity, and durability to this component. The Vega and Paralok also have steel rails. Only one system—the Delta Unifence—has no rear rail. If you purchase the Delta system, you might want to consider adding an angle iron to the rear of the tablesaw to sturdily hold the extension table.

Delta does all the manufacturers one better by making a two-part fence system that allows the fence to slide forward and backward along the fencehead. By pulling the fence back, you can use it as a safe cutoff stop as shown *above right*. You also can remove the fence from the fencehead and reinsert it so it works as a low fence for safely cutting thin materials.

WE LIKE QUICK, ACCURATE ADJUSTMENTS

You can align both the Delta and Biesemeyer parallel to the miter-gauge slot by simply turning two setscrews as shown on the Biesemeyer *middle right*. You can do this on the Delta without even removing it from the saw. However, the Vega requires you to first remove the laminate cover over the top of the fence, loosen four cap screws as shown *below right*, move the fence to parallel, and then reverse these steps. Whew!

Although you'll only occasionally check and adjust the fence parallel to the blade, you'll be adjusting the fence for different rip widths all the time. Thanks to its wheels, the Excalibur gets a top grade for its effortless glide up and down the rails.

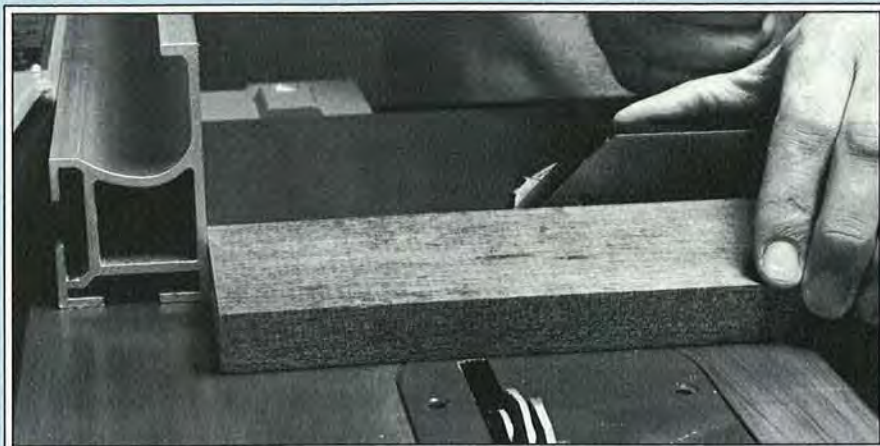

The Delta Unifence slides backward and forward along the fencehead, allowing

you to use the fence as a stop block for fast, accurate, and safe crosscuts.

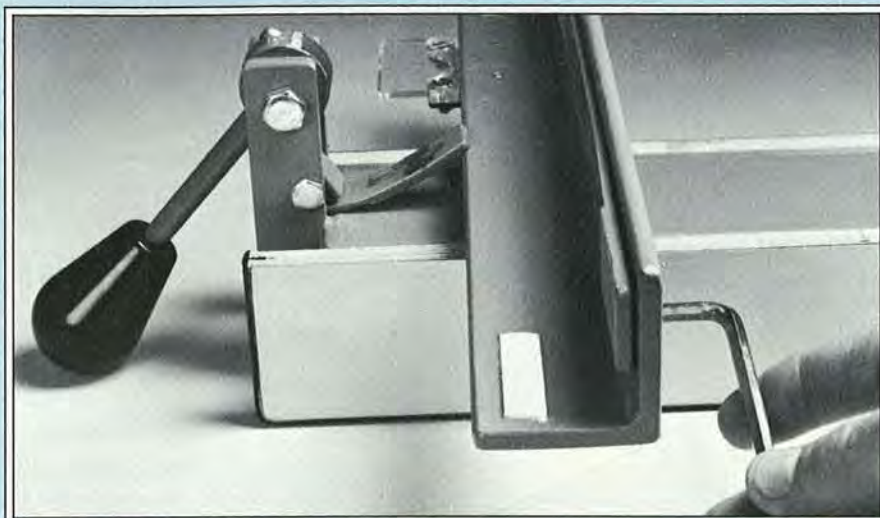

Two setscrews on either side of a sturdy angle iron allow you to speedily adjust

the Biesemeyer so it's parallel to the miter gauge slot and the saw blade.

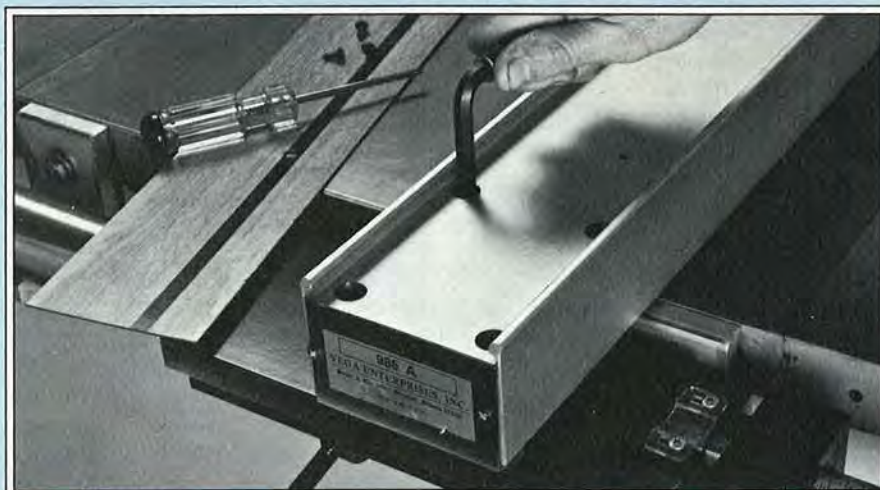

To adjust the Vega, you need to remove three screws, then slide away its lami-

nate cover, and turn four cap screws with a special tool.

STILL RIDING THE FENCE? CHECK THESE STATS

MANUFACTURER	MODEL	Capacity		Materials		FENCE LENGTH (INCHES)	FENCE HEIGHT (INCHES)	CUSTOM SIZES AVAILABLE (Y,N)	MICRO-ADJUSTMENT (Y,N)	AVAILABLE ACCESSORIES*	COUNTRY OF ORIGIN	WEIGHT OF SYSTEM (POUNDS)	WEIGHT OF FENCE ONLY (POUNDS)	PRICE†
		LEFT (INCHES)	RIGHT (INCHES)	RAILS‡	FENCE‡									
Biesemeyer (Commercial)	26-122*	0-48	26-122	S	S, C	42, 48	2½	Y	N	BT, XT	USA	66-145	28	\$279-583
Biesemeyer (Home shop)	28, 40, 52	0-24	28, 40, 52	S	S, C	36	2	Y	N	XT	USA	45-65	20	219-284
Delta	Unifence	8¾	51, 96	A	A	43	½-3½	N	N	CO, XT	USA	70	6¾	465-719
Excalibur	T-Slot	**	**	A, S	A	45	2½	Y	N	AK, RF, RK, SP, XT	Canada	50	20	369
Quintec Mfg.	Paralok	***	***	S	A	47¾	4	Y	N	C	USA	34-60	15	330-390
Vega	40, 50	7	40, 50	S	A	42, 50	2½	N	Y	AK, CO, LH, SP	USA	60, 67	9, 11	232-252

*Biesemeyer model nos. refer to cutting capacity to right of sawblade. Nine capacities from 26" to 122" available in 12" increments.

**Fence travels a maximum of 78". You can position as much or as little of this travel on either side of blade.

***Fence travels a minimum of 28" or maximum of 96", depending on length of rail. You can position as much or as little of this travel on either side of blade.

1. (A) Aluminum; (S) Steel; (C) Coated particleboard (facing on side of fence)

2. (AK) Anti-kickback device; (BT) Back table; (C) Various cursors; (CO) Cutoff fence; (LH) Laminate hold-down; (RF) Router fence; (RK) Router-mounting kit; (SP) Stock pusher; (XT) Extension table
3. Actual selling prices except for Delta. Delta list prices may be discounted 10-30 percent

MANUFACTURERS LISTING

Biesemeyer
216 S. Alma Road, Suite 3
Mesa, AZ 85202
Outside AZ: 800-782-1831
AZ residents: 602/835-9300

Delta International Machinery Corp.
246 Alpha Drive
Pittsburgh, PA 15238
Outside PA: 800-438-2486
PA residents: 800-438-2487

Excalibur Machine & Tool Co.
3241 Kennedy Rd., #7
Scarborough, Ont. M1V2J9, Canada
Calls from U.S.: 800-387-9789
Canadian residents: 416/291-8190

Quintec Mfg. (Paralok)
5128 N.E. 42nd Ave.
Portland, OR 97218
Outside OR: 800-423-9611
OR residents: 503/281-6096

Vega Enterprises Inc.
Route 3, P.O. Box 193
Decatur, IL 62526
Outside IL: 800-222-8342
IL residents: 217/963-2232

WHICH ONE SHOULD YOU BUY?

Among the less-expensive models (under \$300), we think the Biesemeyer offers a good value because of its rugged simplicity, proven track record, and customer service. For example, Biesemeyer will refund the total cost of the fence plus shipping if you're dissatisfied. If you want to take up the matter with Bill Biesemeyer, he's readily available at the company's toll-free number. Unless you use your table-saw for several hours each day, the home-shop version should be durable enough for your needs.

For a few dollars more, you can buy the smoother-gliding and incredibly precise Paralok system (\$330-\$390) if the installation

doesn't scare you—and it really shouldn't if you can allot a couple hours to the task. The susceptibility of the pulleys to sawdust and wear over time concerned us, but Waters said his firm "has shipped no more than 30 replacement pulleys and six cables" to the owners of the 4,000-plus units in service.

If you're a routing enthusiast and plan to mount a router in your extension table, the Excalibur (\$369) offers you a lot of extras. First, an accessory list includes a router-mounting kit and router fence. Second, since you have to stand on the rear side of a table-saw when routing, the Excalibur has the advantage of allowing you to turn the

fence around and lock the lever end on the rear rail. When it's time to move the fence, none of them slide as smoothly up and down the rails as the Excalibur.

At \$465 list, the Delta ranks as the most expensive of the five systems, but if you do a lot of cutoff or thin-stock work, you'll appreciate its high-low fence that slides back for crosscuts. The Delta system, like the others, will mount to other manufacturers' table-saws, not just the Delta Unisaw. 📌

Written By Bill Krier
Technical consultant: George Granseth
Illustrations: Kim Downing; Mike Henry
Graphic Design: Perry A. McFarlin
Photographs: Jim Kascoutas



STEAM



Note: You'll need some $\frac{3}{8}$ "-thick maple stock for this project. You can either plane or resaw thicker stock to size.

LET'S GET ROLLIN' WITH THE WHISTLE BLANK

1 Cut a $\frac{3}{8}$ "-thick piece of maple to $1\frac{1}{2}$ " wide by $16\frac{1}{2}$ " long. (We cut a piece of $\frac{3}{4}$ " stock to $1\frac{1}{2} \times 16\frac{1}{2}$ " and then resawed it to $\frac{3}{8}$ " thick.)

2 Chuck a $\frac{1}{2}$ " core-box bit into a table-mounted router. Clamp a 40"-long straight board to the router table to act as a fence. Elevate the bit to cut a $\frac{1}{4}$ "-deep groove. Position the fence $\frac{3}{8}$ " from the center of the bit where shown on the Section View below. Measure $14\frac{7}{8}$ " from the center of the bit in both directions along the fence and make two equidistant marks on the fence where shown on the drawing below. Repeat by marking a pair of lines $15\frac{7}{8}$ " from center.

3 Set stops at each $15\frac{7}{8}$ " mark and rout a $\frac{1}{2}$ " stopped groove $\frac{1}{4}$ " deep along one face of the

In the early 1800s, when steam locomotives provided one of the main means of transportation and freight hauling, the whistle communicated many messages (see our box at right for examples). Now, we've designed our own whistle, reminiscent of days (and trains) gone by. Kids love 'em and many adults can't resist them.

WHAT DO THOSE WHISTLE BLASTS MEAN?

- 2 long, 1 short, 1 long: Warning when approaching a crossing
- 3 shorts: Train backing up
- 1 long: Train stopping
- 2 long: Acknowledgement of a conductor's signal, and also that the train is about to move ahead



Apply glue to the mating surfaces. Then, glue and clamp the pieces with the edges and end flush.

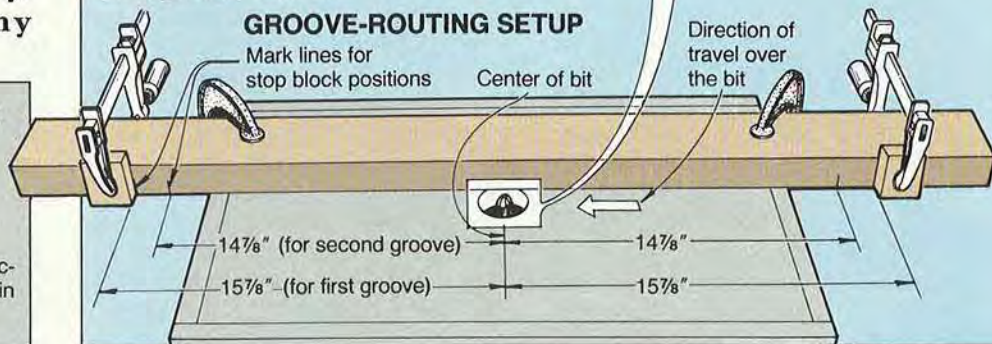
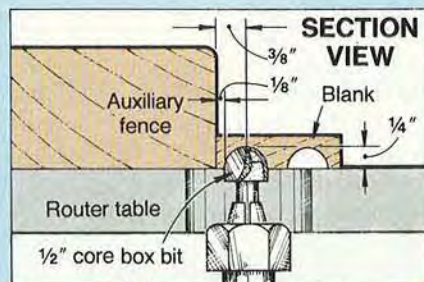

Written by: Marlen Kemmet



LOCOMOTIVE WHISTLE

whistle blank. Reset the stop blocks to the 14 7/8" pair of lines (don't move the fence), turn the block around, and rout the second stopped groove.

4 Using the Routed Blank Drawing below for reference, crosscut a 7 3/4"-long piece for the whistle bottom (A) and a 7/8"-long piece for part B from the maple blank. Now, tilt your saw blade 45° from vertical, and miter-cut the top piece (C) to a 6 7/8" finished length from the remaining maple blank.

5 For reference later when cutting the angled end of the assembled whistle, mark an X on the edge nearest the longest routed groove on both pieces.

HOW TO MAKE THE TOOT FOR THE TOOTER

1 Crosscut a 12" length of 1/2" dowel stock. Sand a taper on each end of the dowel identical to that shown on the Dowel Detail on the Exploded-View Drawing. (We sanded the taper on a stationary sander; if your belt sander has a flat top, set the sander upside down, and then sand the dowel.)

2 Cut two 7/8"-long pieces from the ends of 12" section of 1/2" dowel. If either piece doesn't match the Dowel Detail, repeat the process on the remaining piece of dowel.

THE END OF THE LINE—FINAL ASSEMBLY

1 Spread glue on the mating edges of the whistle pieces as shown in the photo far left. Next, glue and clamp the pieces (A, B, C) together with the edges and ends flush. If you get a small bit of glue in the grooves, remove it with a cotton swab or pipe cleaner.

2 Glue the 7/8"-long dowel pieces into the 1/2" holes in the end of the whistle. (For the best sound, keep the dowel tapers parallel with the bottom of part A.)

3 Trim about 1/32" off the mouthpiece end of the whistle.

4 Using a penny, trace around its outline to mark a radius, and then mark an angled cutoff line on the end of the whistle where shown on the Radius Detail accompanying the Exploded-View Drawing. Be careful to mark the radius on the corner nearest the marked X, or you'll cut into a stopped groove when angle-cutting the end to shape. Band-saw the whistle end to shape and sand smooth.

6 Rout a 3/8" round-over on all but the mouthpiece end. Sand smooth and apply the finish. (We used Behlen's Salad Bowl Finish; a vegetable oil also would work fine.) Finally, give the whistle a blast and watch kids come running. 🚂

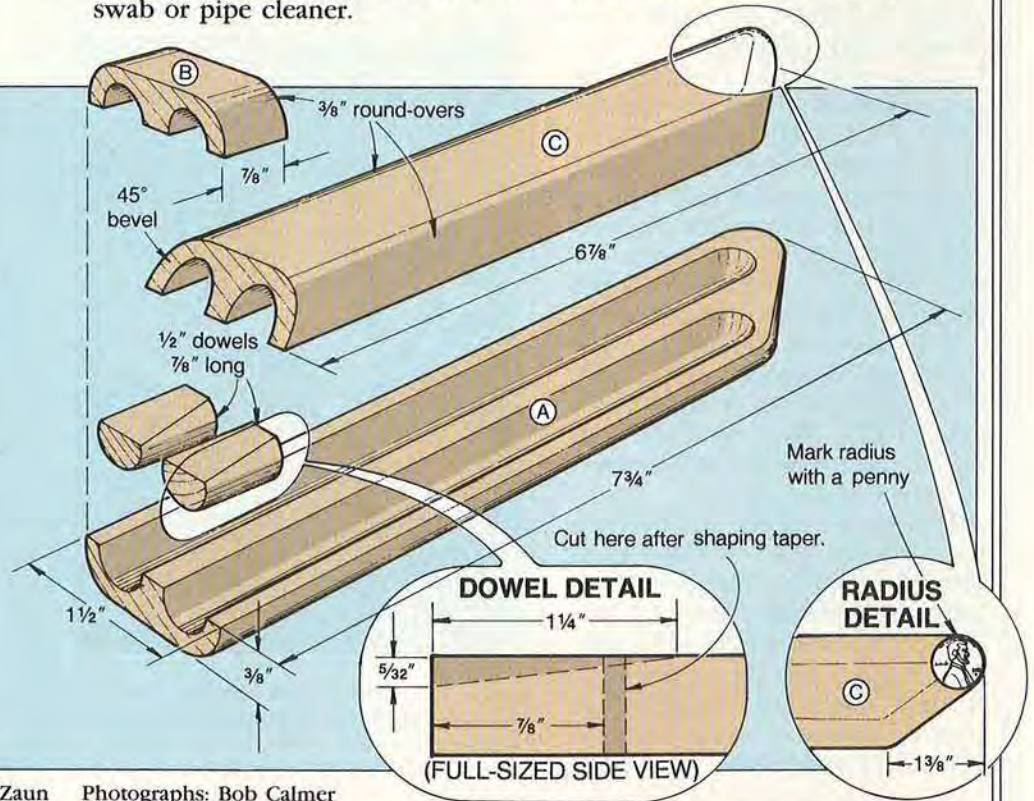
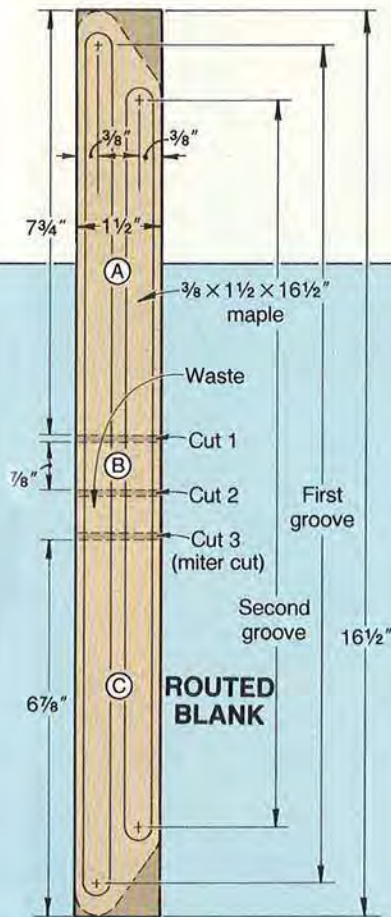

Illustrations: Kim Downing; Bill Zaun Photographs: Bob Calmer

SIMPLY SPECTACULAR

LAMINATED BUD VASE

It's time to make arrangements—flower arrangements, that is—for this see-through vase. The wood for this shamefully simple project should be as close as your scrapbox. And, we've found a convenient supplier for the test tubes you'll need to keep the flowers looking fresh day after day.

CUT AND ROUT THE MAPLE FOR THE VASE BODY

1 Rip and crosscut a piece of $\frac{3}{4}$ "-thick maple to $1\frac{1}{2}$ " wide by 18" long. You'll crosscut this later for the vase body (A).

2 Fit your table-mounted router with a $\frac{3}{4}$ " core-box bit (we used a carbide-tipped bit). Then, position the fence where shown on the drawing at right. Raise the bit $\frac{1}{4}$ " above the surface of the router table. Start the router, and rout down the center of the maple strip. Raise the bit $\frac{3}{8}$ " above the surface of the table and make the second cut.

3 Cut the 18" maple strip in half.

MAKE A TEMPLATE AND SHAPE THE OPENING

1 Using carbon paper, transfer the pattern shown at right to a piece of scrap stock (we used $\frac{1}{4}$ " hardboard). Cut the template to shape.

2 Dry-clamp the two maple pieces together (no glue) with the ends and edges flush. Next, measure $1\frac{3}{4}$ " from the top end and mark a perpendicular line across the joint line where shown on the photo at right. Center the template on the joint line with one point against the marked line. Then, trace the template outline onto the maple pieces as shown in the photo.

3 Remove the clamp, and bandsaw the marked curve on each maple piece. Sand each curve smooth (we used a drum sander chucked in a drill press). Hold the pieces together and check that the curves align.

4 Hold the pieces together (we used a handscrew clamp) with the edges and ends flush, and check

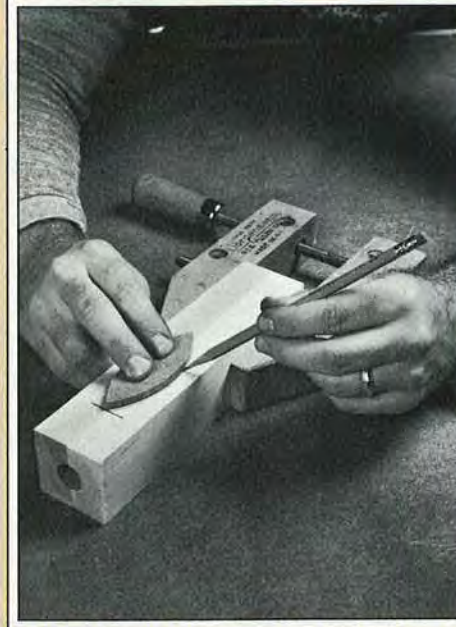
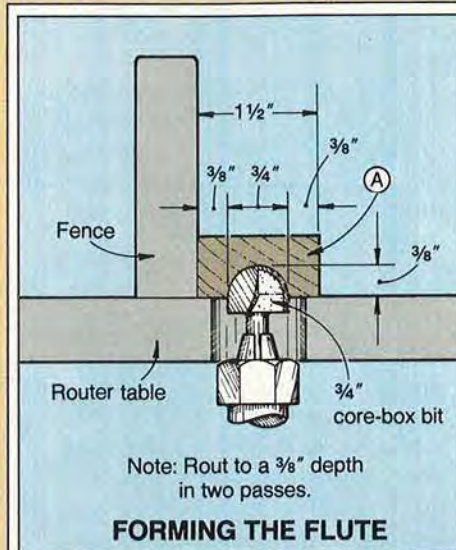

Center the template over the joint line and against the marked line. Trace the template outline onto the clamped-together maple pieces.

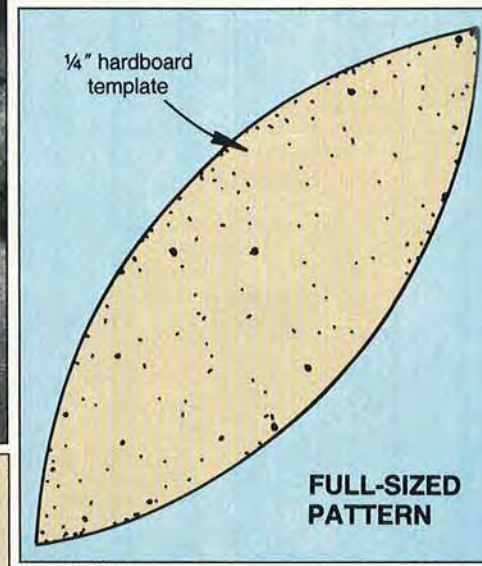
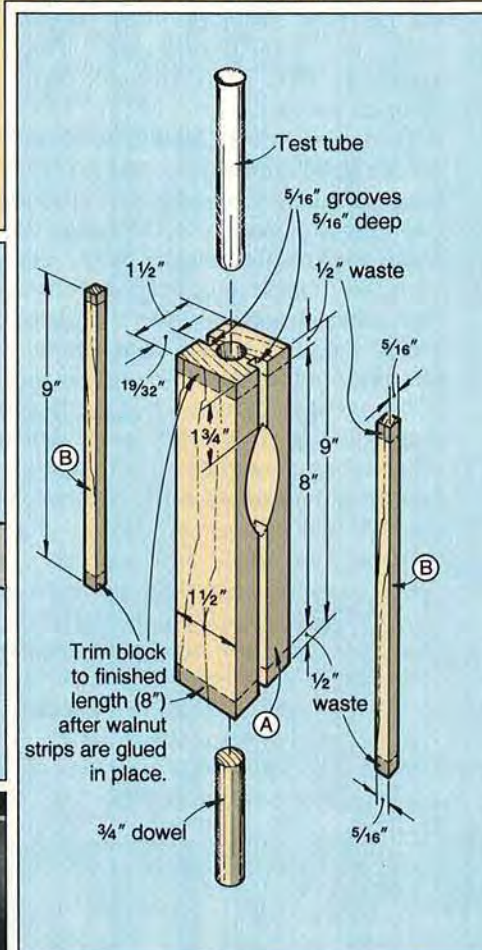



the fit of the test tube in the hole. (See the Buying Guide for our source of test tubes.) As shown on the drawing, sand the top 7" of each flute. Clamp the pieces and check the fit. The test tube should slide easily from the hole when you tip the vase upside down.

5 With the edges and ends flush, glue and clamp the two maple parts. Immediately remove any excess glue from the routed hole and opening. (We used a 1/2" dowel to remove glue from the hole.)

NOW, ACCENT THE VASE WITH WALNUT

1 Cut or rout a 5/16" groove 5/16" deep centered over the joint line on the front and back surfaces in the vase body (A). The Exploded-View Drawing shows the location.

2 Cut a piece of 3/4"-thick walnut to 1" wide by 9" long. Follow the three-step drawing *below left* to cut two walnut strips (B) from the 9"-long piece. Check the fit of the strips (B) in the grooves. Glue the strips into the grooves.

3 For a 8" length and flush ends, trim 1/2" off each end of the vase.

FIT THE TEST TUBE AND ADD THE FINISH

1 Insert the test tube into the top end of the vase, allowing 1/8" to protrude above the top of the vase.

2 Insert a 3/4" dowel into the opposite end of the vase until it makes contact with the bottom end of the test tube. Mark a cutoff line across the dowel flush with the bottom edge of the vase. Remove the dowel and cut it to length. Glue the dowel into the vase. Sand the vase smooth and finish as desired.

BUYING GUIDE

• **Test tubes.** 20 x 150mm (approximately 13/16 x 5 7/8") \$4.50 ppd. for a package of six. Sharay, P.O. Box 3093, Des Moines, IA 50316. 🌱

Project Design: Brian De Muth, Pinnacle Woodworks, Baltimore, MD
Photographs: Jim Kascoutas
Illustrations: Kim Downing, Bill Zaun

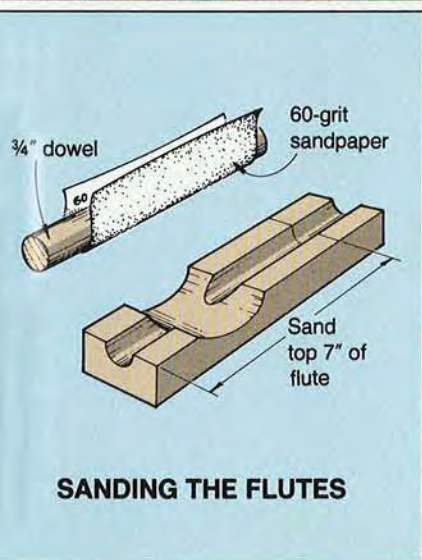

SANDING THE FLUTES

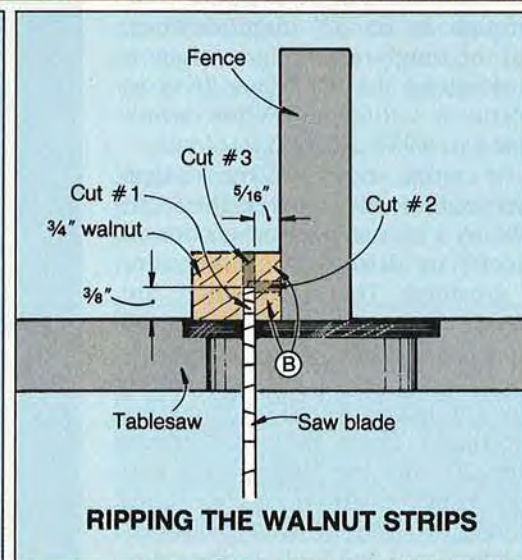

RIPPING THE WALNUT STRIPS

CHAMPION

Oregon Big Tree backers once offered \$300 to anyone finding a Douglas fir that could whip Washington's biggest Douglas fir. And Ohioans would love to have a specimen of their state tree crowned national champ—if it grows in the Buckeye State. Kansas was thrilled enough with their champion elm to protect it with a state park. If you enjoy looking at trees more than a board foot at a time, you just might have the right stuff to become a Big Tree hunter.

It's kind of a 'Ripley's Believe It or Not' of trees," says Deborah Gangloff, director of communications for the American Forestry Association (AFA) and coordinator of their National Register of Big Trees. "But, the whole point of the program is to get people interested in trees by identifying, then preserving them."

Gangloff receives more than 100 nominations a year from just such interested people across the nation who have found a tree they believe large enough to be a national champ. In fact, Big Tree hunters (see page 77) have been nominating trees for greatness since the program began in 1940.

The current Big Tree list came out in May 1988 (it's published in entirety every four years, and updated with listings of new winners every two). On it are 650 champions out of a possible 850 species of native and naturalized trees, as listed in the U.S. Forest Service's Agriculture Handbook No. 541, *Checklist of United States Trees (Native and Naturalized)*, 1979, by Elbert L. Little Jr.

AMONG THE GOLIATHS, SOME DAVIDS DWELL

On the latest Big Tree list, you'll find some dandies. For instance, the champion Giant Sequoia, in California's Sequoia National Park stands 275' tall and has a circumference of 83'2"! This country's

largest white oak happens to reside in Wye Mills, Maryland—it towers to 107' and measures nearly 35' around. Maryland officialdom was so delighted with their champion oak that they designated the ground it grows on as a state park.

That's what happened in Kansas, too, when the 95'-tall, 26'-circumference American elm growing near Louisville, on the banks of the Vermillion River, was crowned a national champ. The state acquired the 1½-acre plot where it grows for a one-tree state forest.

Then, there's the Goliath of a white ash that grows, of all places, next to a steakhouse in Palisades, New York. It comes in at a height of 95' with a girth of 25'. And who could help but cheer on the nation's biggest sugar pine? A fire burned a hole large enough to walk through in its 32' circumference, but the tough tree still grows vigorously along the Stanislaus River in northern California. When nominated in 1967, it stood 216' tall.

Of course, most Big Tree hunters seek out the largest tree they can find in a species. However, not all species are destined for dimensional greatness. That's why there are some comparative midgets on the Big Tree list, too.

The Alleghany plum, for example: The largest found to date (two specimens claim the title) plows only 20' into the Virginia sky and you could easily ring your arms around it. And in Fredericksburg, Virginia, you can look up the clammy locusts that share the species'



TREES

Across the nation, the search is on for colossal contenders. Why not join in the hunt, and the fun?



crown, that is, if someone hasn't borrowed them for clothesline poles. They each measure but 5" around and stand just 12' tall!

WAR BETWEEN THE STATES—TREE BY TREE

According to the Big Tree program coordinator, "There's a little good-natured competition between many of the states, especially Oregon and Washington." In one story she tells about the friendly conflict, Oregon had dibs on the largest Sitka spruce, a 206'-high giant. But in Washington, a new, eager-beaver state Big Tree coordinator set his sights on capturing the crown. And, sure enough, he found one suitable for nomination. It was shy of champion height by 15', but boasted 2' more girth than Oregon's defender. After tape measures were drawn, extended, and the results duly recorded, the matchup was a draw—Oregon's and Washington's Sitkas now reign as co-champions. Miffed, Oregon Big Tree backers promptly set out searching for a Sitka spruce that could win it all. After all, Oregonians are still willing to pay \$300 for a Douglas fir bigger than the one Washington has on the national register. Especially since the Doug fir happens to be the Oregon state tree!

As you might suspect, having the largest tree of a species in any particular state represents quite an honor. Yet, it doesn't hold a candle to the swell of pride that could sur-

face if that largest tree also turned out to be the official state tree. Says Gangloff, "The people in Ohio are obviously concerned because the largest Ohio buckeye tree happens to be in Kentucky."

Cross-checking the Big Tree register with a list of official state trees, only nine states so far claim "native" champions: California, Colorado, Florida, Maryland, Mississippi, New Mexico, Oregon, Virginia, and Washington. By the time you have read this though, the records could have changed. And, if your state isn't represented on the Big Tree list by a native son, you better think about looking for a champ!

HOW TO SIZE UP A CHAMPION

Big Tree hunters first must accurately identify their challenger. You'll find that easy enough with some species, such as white birch. Others—the oak, for instance, with more than 40 family members—might require an expert's opinion. Then, after you're absolutely certain of the tree's true identity, you must carefully measure it.

Follow the guidelines set by The National Register of Big Trees (see where to write for details at end of this article). It crowns a champion based on the number of points derived from the combination of three measurements: trunk circumference, or girth (in inches, measured 4½' above the ground) vertical height (in feet) *plus* ¼ of

continued

GUESS WHERE THE TREES ARE!

At press time, The American Forestry Association listed 47 states with state foresters or volunteers serving as Big Tree program coordinators, although not all those states can brag about a champ on

the national list. *Can you guess which states aren't represented by record-setting timber? And, what states have the most Big Trees?*

For the surprising answers to these questions, turn the page.

◀ "The Dyerville Giant," the national champion coast redwood, in California's Humbolt Redwoods State Park, measures more than 52' in girth! On the Big Tree list since 1966, the redwood stands 362' tall.

its average crown spread (in feet) equals number of points.

Let's say it was you who spotted the reigning black walnut tree up in Humboldt County, California, way back in 1975. Here's how your measurements would have added up: girth, 271" plus height, 122' plus spread, 34' ($134' \div 4$) equals 427 points. And, remember, according to the rules in force at this time, it takes a challenger with at least five more points to dethrone a Big Tree.

In the free pamphlet, *The National Register of Big Trees*, that describes the program, the AFA details exactly how to take the required measurements and submit a nomination. For \$5, you can get a spiral-bound copy of the latest Big Tree list. It includes the description and location of the champions in each species. For either publication, and the name of your state Big Tree coordinator,

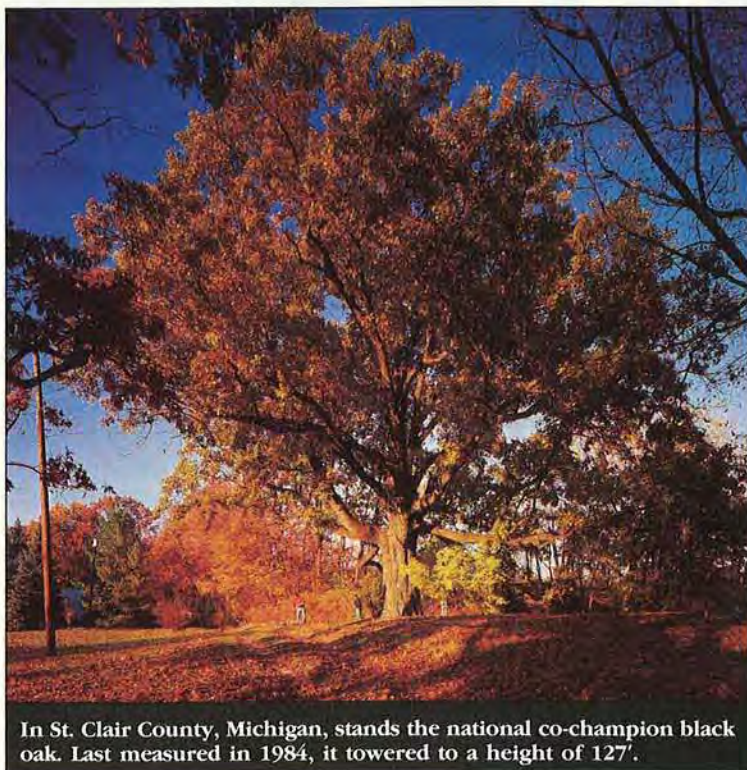

In St. Clair County, Michigan, stands the national co-champion black oak. Last measured in 1984, it towered to a height of 127'.



TRIUMPHANT TREE HUNTERS

"There's probably very few championship-caliber trees in the Northwest I don't know about," proudly states avid Big Tree hunter Maynard Drawson of Salem, Oregon. And, that's not bragging.

Maynard—who describes him-



Oregon's Maynard Drawson

self as a "young 63"—has found and nominated about 50 national champion trees since he became fascinated with the program 25 years ago. "But that's counting dethroned champions, too," he adds. "Currently, I have a dozen."

A semiretired barber, Maynard caught the Big Tree bug on his days off, with the help of an expert. "In 1964, I met the late Oliver Mathews, founder of the National Register of Big Trees. He was up there in age, going blind, and couldn't drive. So, I'd take him around to see trees, and learned about them. I found out that you don't just go out and get a sack lunch and start looking. You look all the time, wherever opportunity takes you."

As advice to would-be tree hunters, the giant-seeker says that 90 percent of his champions were found along the highway, in a park, or in someone's yard. "You

just learn to pay attention. For instance, I found a champion tree while visiting a champion tree. I took my five boys up to Duvall, Washington, to see this big spruce [since dethroned]. We were walking down the trail, when suddenly I told them to stop," he remembers. "Right there was the biggest vine maple that has ever been recorded! It was 4'3" in circumference, when vine maples are usually only about as big around as your forearm. Hundreds of foresters and other people had come through the years to see that record spruce and walked right past the vine maple!"

HUNTING UP STATE PRIDE

Paul Thompson, 79, of Bloomfield Hills, Michigan, has been hunting big trees since the early '50s. He claims about 50 present champions, and says it all began because of state pride.



At 35½' tall, a David compared to some Big Tree Goliaths, this southern crab apple tree in North Carolina still ranks as a champion.

write: *National Big Tree Program, The American Forestry Association, Dept. WD, P.O. Box 2000, Washington, DC 20013.*

Keep in mind, you don't have to be a tree expert to find champion trees. In the words of Maynard Dawson, Oregon's barber-turned-Big Tree hunter, "If you have an interest in trees, then the Big Tree program is open to you." Happy tree hunting!

**ANSWERS:
WHERE THE TREES ARE**

Although these findings could change, presently Nebraska, North Dakota, and South Dakota aren't represented on the national Big Tree list by any species. Florida leads with 106. Texas ranks second with 77, then comes California with 73. "These states have so many trees on the list because, in the first place, they have many more species than other states, and secondly, they have active state Big Tree coordinators," notes the American Forestry Association's Deborah Gangloff.



Michigan's Paul Thompson

"When I first saw the AFA's national Big Tree list in 1945, there were only three national champions in Michigan, out of 228," says Paul. "I figured there were a lot more Big Trees around in this state than that."

At the time, Paul was looking for a project for the Michigan Botanical Club. "We put together a committee, got some publicity, and found out right away that we could get some new champions fast," he recalls. "As you might expect, there are quite a few trees in this state. All we had to do was find the big ones. Eventually, we became the leading state in the country for a number of years—until Florida got active."

A professional ecologist, Paul traveled the state in his role as a field representative for Michigan's Nature Conservancy. "Quite often I'd spot champion trees from the road when I was traveling

around," notes Paul. "On a recent trip for a research study, I picked up 12 new trees for state and national records."

To novice Big Tree hunters, Paul offers this counsel: "Once you get some idea of what size to look for, finding big trees becomes easier. Measure some trees, compare them with the records. Get an idea of what a large tree looks like. And, don't forget, there also are small trees that most people don't pay attention to that could still be national records," he notes. "A number of years ago, we had a national champion redbud tree that was about 115" in circumference. But it was pretty old, and in a few years it died. The new champion was about half that size!"

Written by Peter J. Stephano
Photographs: Coast redwood, Harald Sund; black oak, southern crab apple, Henry Groskinsky

WE'RE TALKIN'

9 QUESTIONS WOODWORKERS KEEP ASKING

If you think you're the only one who has questions about buying hardwoods, think again! We surveyed eight hardwood dealers from around the country—perhaps one of these guys sold you a piece of wood last week—and here's what they hear from customers day after day.

1 What do flat-, rift-, and quarter-sawed mean? Mill operators today try to squeeze as much usable lumber as possible out of a log, so they run the raw stock through a blade that slices off one board after another.

This through-and-through cutting method creates about 80 percent flat-sawed lumber. A log can be cut to yield a lower percentage of flat-sawed lumber, but with considerably greater time, effort, and wastage. Here's a brief guide to the three types of sawed lumber:

Flat-sawed: As shown below, end-grain runs in long, sweeping lines almost parallel to the face of the board, creating the familiar cathedral face grain. According to Dick Boak of the Martin Guitar Company in Nazareth, Pa., these boards have a greater tendency to cup, twist, or crack (especially near the middle of the board) than lumber in the next two categories.

Rift-sawed: Grain lines run at about 45° to the face of the board. These boards show a beautiful figure in the form of long, sweeping stripes resulting from the rays that run from the center of the tree toward the bark. You'll often see this figure in oak.

Quarter-sawed: With grain lines running at 90° to the face, these cuts produce strong, stable boards with straight-grain face figure. Manufacturers of products that require strong woods, such as cue-stick makers, purchase large quantities of quarter-sawed lumber. For example, Howard Hughes built his infamous *Spruce Goose* almost entirely of "aircraft-quality" or quarter-sawed spruce. You can specify quarter-sawed boards from some manufacturers, but expect to pay a premium price.

2 I'm making a gift for a woman. What woods should I use? What woods appeal more to men?

"Women prefer light-colored woods and woods with more 'flash,' such as Brazilian tulipwood, bird's-eye maple, purpleheart, and Brazilian satinwood," according to Jim Heusinger of Berea Hardwoods of Berea, Ohio. How does Heusinger know this? "When a man and woman shop for wood together, I often hear the woman say 'Look at this beautiful wood!' And that's usually the wood they buy.

"On the other hand, men seem to prefer dark, rich woods with straighter grain, such as walnut, wenge, bubinga, ebony, cocobolo, and mahogany.

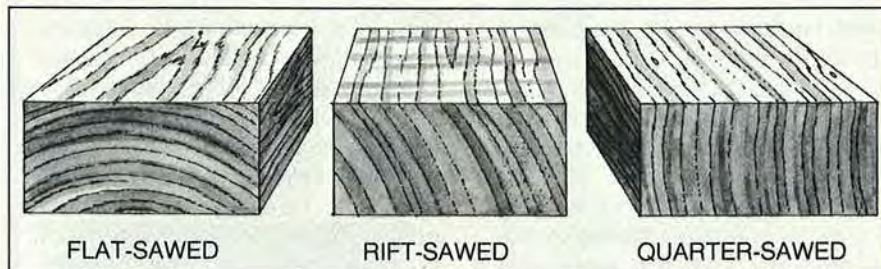

HARDWOOD

3 What does "random width and length" mean, and why can't I buy hardwoods in dimensional sizes (1×6, 2×4, 2×8, etc.)?

"Because hardwood trees take longer to grow—making them more valuable than softwoods—they're cut in random widths and lengths to yield as much wood as possible from each log," says Dave Forness of Northeastern Hardwoods in Salamanca, N.Y. "Loggers die bringing these hardwoods out of the forest, so I hate to see anything wasted. On the other hand, relatively inexpensive softwood logs are cut to the standard sizes necessary in the building trades, leaving a lot of waste on the floor of the mill."

But consumer demand changes the market. Some hardwood outlets, including Frank Paxton Beautiful Wood stores in the central part

of the country, now sell some hardwoods in dimensional sizes.

"Five years ago, you couldn't have sold hardwoods that way, but people don't seem to mind paying the extra price for it," says Bob Byers of Paxton's Denver store. For example, red oak finished on three sides (both faces and straightline ripped on one edge) sells for \$3.69 per board foot in random widths and lengths at Paxtons. The same species finished on four sides, in 1×12 dimension, sells for \$5.05 per lineal foot—a cost difference of about 36 percent.

Officials at Weyerhaeuser Corporation in Titusville, Pa., seem to agree with Byers' assessment, because the firm now markets dimensioned hardwoods in 3,600 home centers and hardware stores nationwide. Through its Choice-woods program, the company surfaces hardwood on four sides and sells it in 2"-8" widths, in 3'-8' lengths, and in red oak, poplar, maple, cherry, walnut, western red alder, and ash. For this highly finished product, you'll pay a premium price. For example, a 1"×6"×6' red oak board costs \$16.99, or \$5.66 per board foot. Why? "We guarantee every board to be free of defects, so we only get a 42 percent yield from each log," says Doug Bolton of Weyerhaeuser.

4 What woods are toxic?

"I wouldn't sell any wood if it was poisonous—that would be insane," Jim Heusinger says about so-called toxic woods. "Some woods, such as cocobolo or aromatic red cedar, cause more allergic reactions than other woods, but sensitivity to all woods varies greatly from individual to individual. My advice: If you notice a reaction such as a rash when you're working around a specific wood, just stop using that wood. And since wood dust of any type can harm you, it only makes sense to wear a dust mask no matter what wood you're working."



5 What does 4/4 (pronounced "4 quarter"), 5/4, etc. mean?

Dick D'Abate of Woodworkers Supply in Phoenix hears this question often, and here's how he answers it: "A board that's 7/4 started as a 1¾"-thick board and was surfaced on both sides and is now 1½"-thick. An 8/4 board was 2" thick in

Continued on page 88

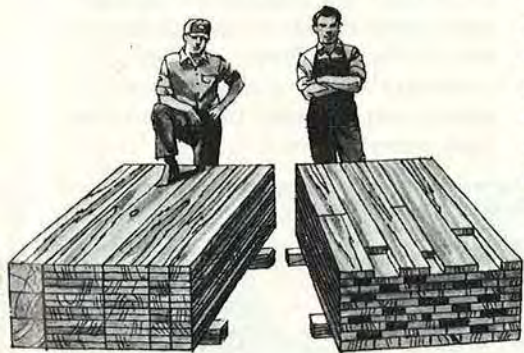

How many of these hardwoods can you identify?

You can find the true identities on page 90.

SPICED-UP NAPKIN

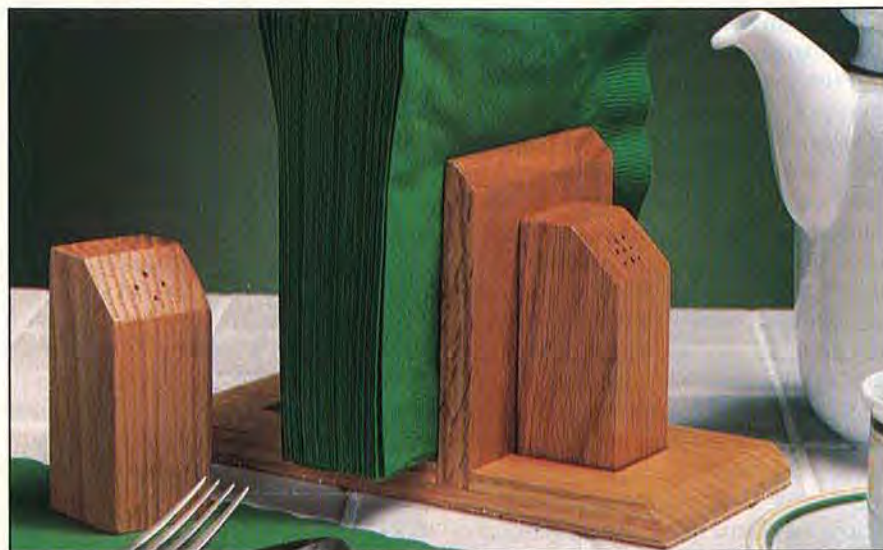

Great projects deserve attention. This helpful dining accessory will get rave reviews because it organizes three mealtime essentials into an attractive angular package. So, tie on a shop apron and follow our how-to recipe.

BUILD THE BASE FIRST

1 From $\frac{1}{2}$ " oak, cut the base parts (A, B) and uprights (C) to the sizes listed in the Bill of Materials.

2 With a square, mark the locations and then cut a pair of $1\frac{1}{16}$ " dados $\frac{1}{4}$ " deep for the shaker recesses in part A where dimensioned on the drawing *below right*. Then, sand the dado bottoms smooth.

3 Glue and clamp the base pieces (A, B) with the edges and ends flush. Immediately remove any glue squeeze-out in the dadoed recesses. Later, remove the clamps, scrape off the excess glue, and trim about $\frac{1}{32}$ " off each end for flush ends.

4 Mark the location of the dados for the uprights (C) where dimensioned on the drawing *below right*. As shown on the drawing, cut the dados to the same depth as the previously dadoed recesses.

5 Chamfer both ends of the base (A, B) and one end of each upright as dimensioned on the Chamfer Detail *below*. (We formed the chamfers using a table-mounted router and chamfer bit.) Sand the base smooth.

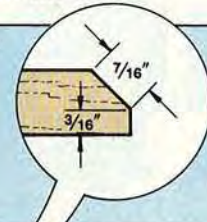
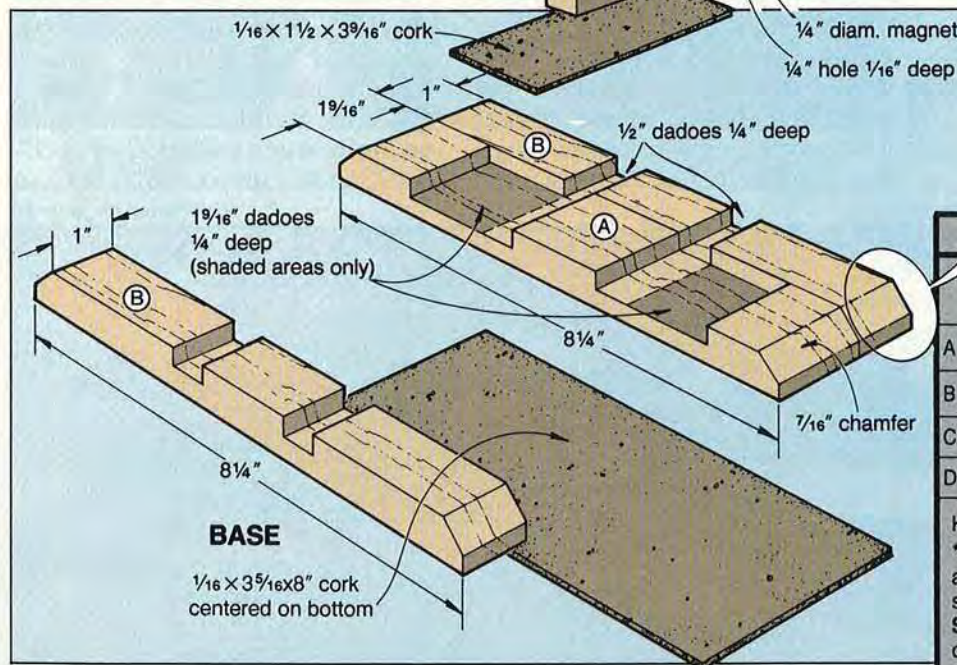
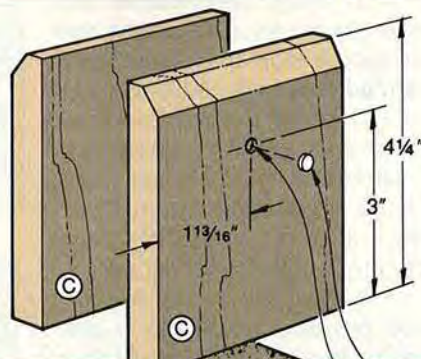

CHAMFER DETAIL

Bill of Materials						
Part	Finished Size*			Mati.	Qty.	
	T	W	L			
A	base center	$\frac{1}{2}$ "	$1\frac{1}{16}$ "	$8\frac{1}{4}$ "	O	1
B	base edges	$\frac{1}{2}$ "	1"	$8\frac{1}{4}$ "	O	2
C	uprights	$\frac{1}{2}$ "	$3\frac{9}{16}$ "	4" $\frac{1}{4}$ "	O	2
D*	shakers	$1\frac{1}{2}$ "	$1\frac{1}{2}$ "	$3\frac{3}{8}$ "	LO	2

Key: O=Oak LO=Laminated Oak
 *Part marked with an * is laminated oversize and then trimmed to size. Please read the instructions before cutting.
Supplies: two #7 corks, spray-on adhesive or double-faced tape, finish, $\frac{1}{16}$ "-thick cork, four $\frac{1}{4}$ "-diameter magnets.

HOLDER

6 Glue and clamp the uprights into the dadoes, checking that they are square with the base. Remove excess glue with a damp cloth.

7 Cut a piece of $\frac{1}{16}$ " cork to $3\frac{3}{8} \times 8$ ". Glue the cork to the bottom of the base (we used woodworker's glue). The cork sits in $\frac{1}{8}$ " from each edge. Cut and glue a piece of cork between the uprights.

THE SHAKERS COME NEXT

1 From $\frac{1}{2}$ " stock, rip and crosscut one strip $1\frac{3}{4}$ " wide by $30\frac{1}{2}$ " long. Cut three 10"-long pieces from the strip. Now, glue and clamp the pieces together face to face with the edges and ends flush. (You'll need a lamination this long for safe machining in the next step.)

2 Remove the clamps and scrape off the excess glue. Rip or joint the edges (not the faces) for a $1\frac{1}{2}$ "-square lamination.

3 Crosscut both ends of the 10"-long lamination square. Now, measure $3\frac{3}{8}$ " in from each end and mark cutoff lines across the lamination. Repeat for the other end. Then, using a combination square

and the dimensions on the shaker drawing, mark an angled cutline on each end of the lamination.

4 Cut each of the two shakers to $3\frac{3}{8}$ " length; *do not* angle-cut the pieces yet.

5 Mark diagonals on the bottom end of each shaker to find center. With a Forstner bit, bore a $\frac{1}{4}$ " hole $\frac{3}{8}$ " deep centered into the bottom of each shaker. Switch to a $\frac{3}{4}$ " Forstner bit, and bore a $2\frac{5}{8}$ "-deep hole centered inside the $\frac{1}{4}$ " hole. See the Section View for reference.

6 Angle-cut the top end of each shaker (we used our radialsaw to make the angled cut).

7 Push a #7 cork into the $\frac{7}{8}$ " hole in each shaker. If the bottom of the cork protrudes, belt-sand the cork flush with the shaker bottom.

DRILL THE HOLES AND ADD THE MAGNETS AND FINISH

1 Trace or photocopy the full-sized hole and outline patterns onto white paper. Cut the outlines to shape and adhere one to the angled surface of each shaker with spray-on adhesive or double-faced tape.

2 Clamp a shaker into a vise with the angled surface level. Make an indentation at each hole mark with an awl. This keeps the drill bit from wandering when drilling the holes. Then, drill $\frac{1}{16}$ " holes where indented. Remove the pattern and repeat with the second shaker.

3 Sand the base and shakers smooth. Stain if desired (we left ours natural) and apply the finish.

4 To remove any finish that may have seeped into the $\frac{1}{16}$ " condiment holes, hold a $\frac{1}{16}$ " drill bit with your fingers. Then, insert the bit into each hole, and twist the bit with your fingers.

5 Drill a $\frac{1}{4}$ " hole $\frac{1}{16}$ " deep in each upright where located on the Base Drawing. Place a $\frac{1}{4}$ " dowel center in each hole. Position a shaker in each dadoed recess and press each against the dowel center to transfer the mating magnet hole location to the shaker. Drill a $\frac{1}{4}$ " hole $\frac{1}{16}$ " deep into each shaker where indented.

6 With instant glue or epoxy, glue a magnet in each hole. Check that each magnet faces the right way to attract the mating magnet. 🍌

TOP VIEW

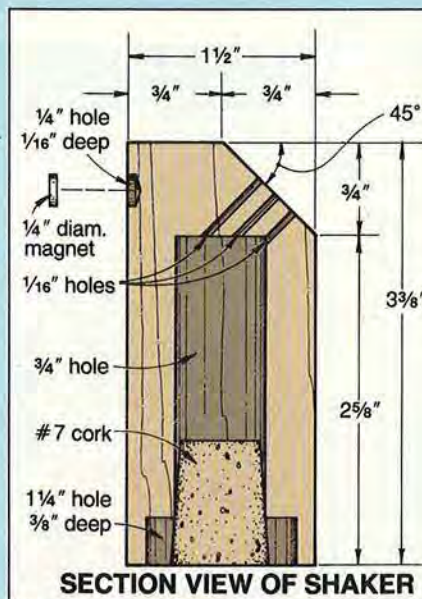
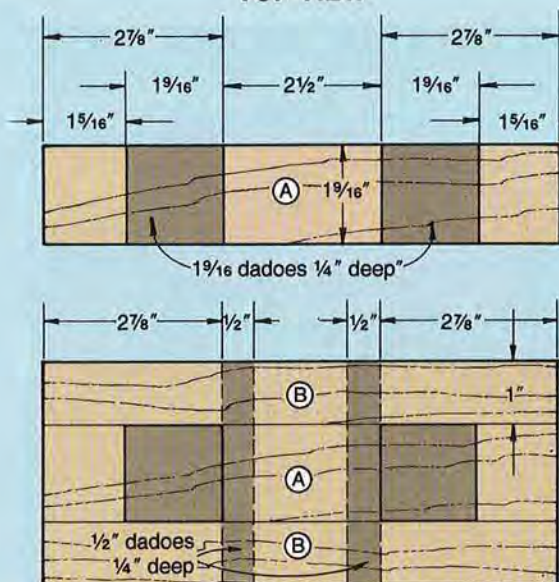

PEPPER

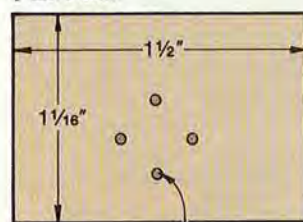

SALT

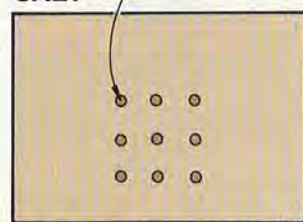

SECTION VIEW OF SHAKER

FULL-SIZED PATTERNS



FLIGHT OF FANCY PARROT MOBILE

Note: For your convenience, we have created full-sized patterns of the body and wings, which you can order from us FREE. (See the end of the article for ordering instructions. You also get full-sized patterns with the parrot kit listed in the Buying Guide.) Or, if you just can't wait to get started, enlarge the patterns shown here.

2 Using a square, a straightedge, and a pencil, draw a 1" grid (1×1" squares) on each piece of paper. Using the Body and Wing Grid Patterns shown below as guides, lay out the shape, the paint lines, and the hole centerpoints of the parrot body on the 9×15" grid. Do the same for the wing on the 8×14" grid. To do this, mark the points where the pattern outline crosses each grid line. Draw lines to connect the points.

3 Carefully cut each paper pattern to shape with a scissor.

FIRST THINGS FIRST: ENLARGE THE PATTERNS

1 Cut one piece of paper to 9×15" and another to 8×14".



Using the templates, trace the outlines onto the plywood.

KNOT DETAIL

Section View

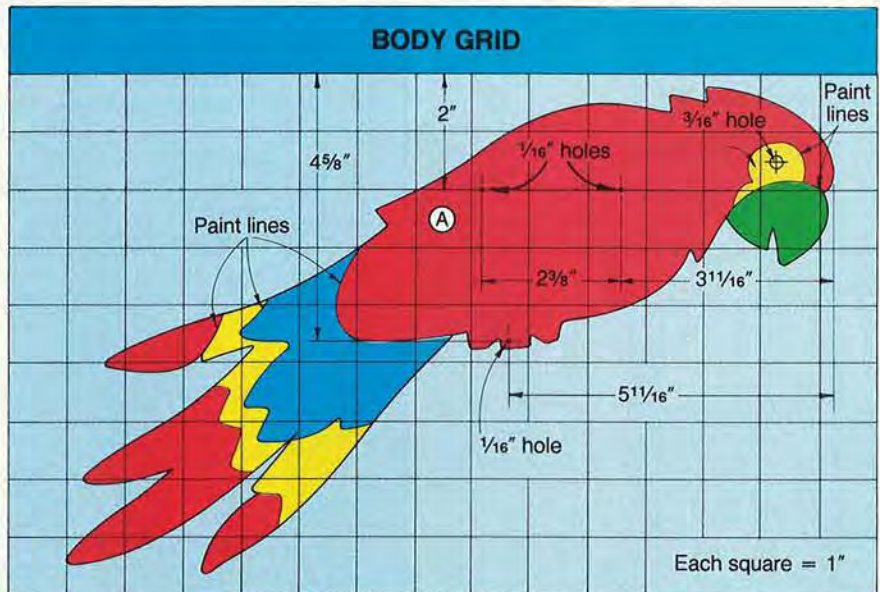
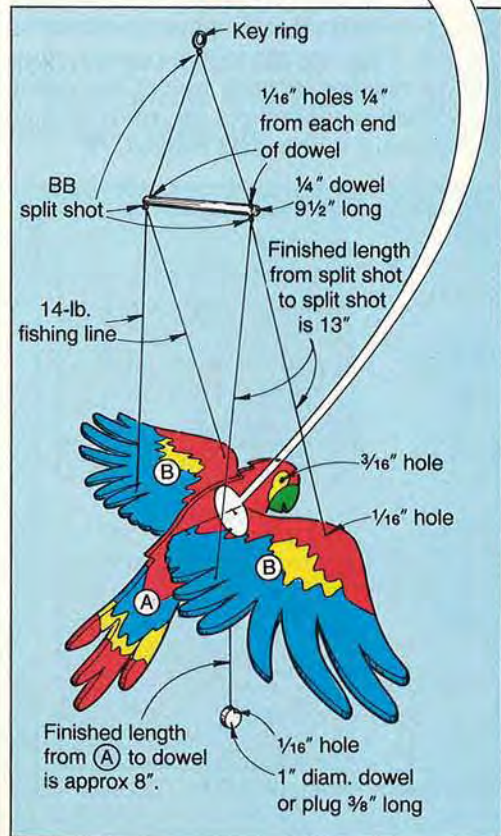
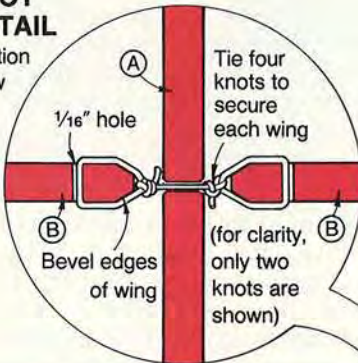

This whimsical design comes to us from Don Zacharias, one of our Canadian readers from Vancouver. Don has made an astonishing 5,000 of these feathered friends, and tells us that "people can't resist pulling the line to set these brightly colored birds in motion. You never grow tired of it."

4 Cut a piece of 1/4" plywood to 12x24" (we used lauan for our indoor model and exterior plywood for the outdoor version). Position and trace the patterns on the plywood as shown in the photo at left. With an awl, poke through the marked centerpoints on the patterns and into the plywood.

5 Cut the body and wings to shape on a scrollsaw or bandsaw. Sand a bevel on the wing edges that will butt against the parrot body (see the Knot Detail for reference). Next, sand a slight round-over on all edges of each piece. Drill the 1/16" string holes and a 3/16" eye hole where indented.

PAINT THE PIECES TO MAKE POLLY PRETTY

1 Paint the three pieces with two coats of primer (use an exterior primer if you intend to display the parrot outdoors, or see the Buying Guide for our source of supplies). Allow the paint to dry.

2 Using carbon paper and the grid patterns as guides, lightly trace the paint lines on both sides of each wing and the parrot body.

3 With a small brush, paint all the blue areas. Clean the brush and wait for the blue paint to dry. Then, paint the yellow and later the red areas. Finally, paint the beak green.

STEADYING THE WINGS FOR A SMOOTH FLIGHT

1 Connect the wings to the body as shown on the Knot Detail. Snip off the excess fishing line with a fingernail clipper.



Hold the parrot upright, thread the lines through the wings, and crimp the split shot in place. Secure each split shot with instant glue.

2 Cut a 1/4" dowel to 9 1/2" long. Drill 1/16" holes through the dowel 1/4" from each end.

3 Follow steps 1 through 5 on the drawing on page 86 to form the line-support assembly. (After positioning and crimping each split shot with a needle-nosed pliers, we put a drop of instant glue on the split shot. The instant glue prevents the fishing line from slipping through the split shot.)

4 Now, as shown in the photo at left, hold the parrot body upright in a handscrew clamp, and follow Step 6 on the drawing on page 86 to connect the line-support assembly to the parrot wings.

5 Cut a 1"-diameter plug from thin stock, or cut 3/8" off the end of a 1"-diameter dowel. Drill a 1/16" hole through it, and suspend it on fishing line 8" below the parrot body.

Supplies: 14-lb. monofilament line, instant glue, PSS-BB split shot (available at fishing supply stores), key ring, primer, paint.

BUYING GUIDE

● **Parrot kit.** Full-sized patterns and supplies for three parrots. 20 yards of line, 21 split-shot sinkers, 3—1/4"-diam. by 9 1/2" birch dowels, 3—1/2" key rings, 2 ounces each of red, green, blue, and yellow acrylic paints. \$14 ppd. for kit no. 8358 from Meisel Hardware Specialties, P.O. Box 70, Mound, MN 55364. ♣

FREE PATTERN OFFER

Full-sized parrot body and wing pattern. Just send a self-addressed, stamped, No. 10 business envelope to: Parrot Patterns, WOOD® Magazine, Locust at 17th, Des Moines, IA 50336. Offer expires October 15, 1989.

Project Design: Don Zacharias, Paradise Design Studio, Vancouver, B.C., Canada
Photographs: Jim Kascoutas
Illustrations: Kim Downing; Bill Zaun

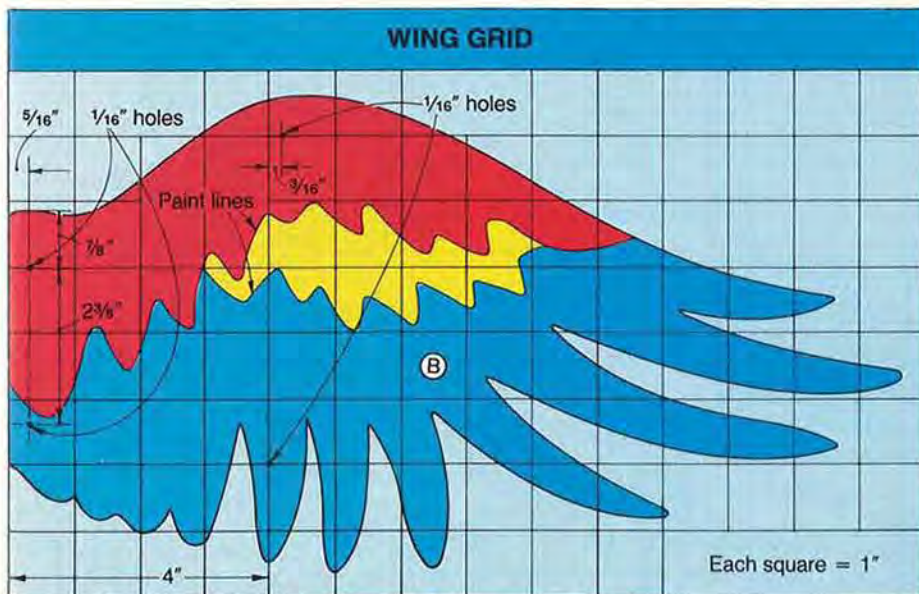



Craig Lossing

TIP-TOP TOPS

GIVE THIS PATTERN A SPIN

Craig Lossing markets at crafts fairs from his lake-dotted home state of Minnesota to sunny Arizona. Although he specializes in bowls, this Minneapolis native quickly notes that few people leave his booth without giving one of his tops a spin. Priced at less than \$5 apiece, his top sales often pay more than a third of his exhibit fee.

Although the shapes of his two most popular sellers resemble each other somewhat (see the full-sized patterns at *right*), Craig creates distinctiveness by experimenting with several types of woods. "Domestic woods such as ash, walnut, and maple are lighter and easier for younger hands to spin," Craig notes. "Exotic woods such as cocobolo, bocote, and ebony tend to be heavier, spin longer, and have more dramatic grain."

HOW CRAIG MOUNTS AND TURNS THE TOPS

This creative woodturner starts by cutting a piece of stock to 2" square by 5" long. (If you don't have stock this thick, laminate thinner stock to size.) Next, he marks diagonals on one end to find

center, drills a pilot hole at the centerpoint, and threads the turning square onto a screw center.

With a 1/2" gouge—the only tool he needs to fashion the tops—Craig turns the square round. As shown in Step 1 on the three-step drawing at *right*, Craig turns and sands the bottom. Then, as shown in Step 2, he shapes and sands the disc. "It's important to sand after shaping each portion," Craig states. "If you wait until the very end to sand, it's easy to snap the thin handles."

Finally, Craig turns the handle. "Rather than apply tool pressure directly against the handle, I angle the tool and direct some pressure toward the headstock to lessen the chance of breaking the handle," Craig says. Then, he carefully sands the handle and parts the top from the faceplate. Craig finishes his tops with mineral oil.

TAKING IT OUT FOR A SPIN: IT'S ALL IN THE FINGERS

"You'll get a longer spin time using your thumb and middle finger rather than your weaker index finger," Craig claims. "Also, with a bit of practice, you can spin these tops on their handles." 🌳

 Print this article

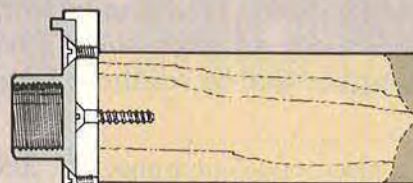

Step 1

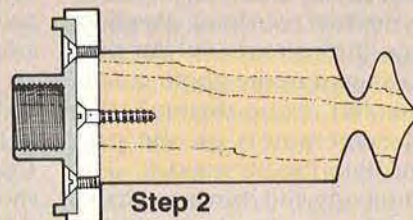

Step 2

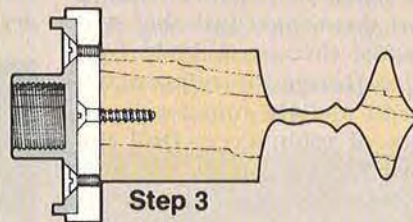

Step 3

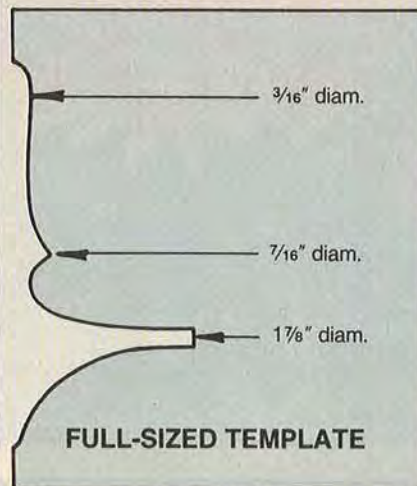
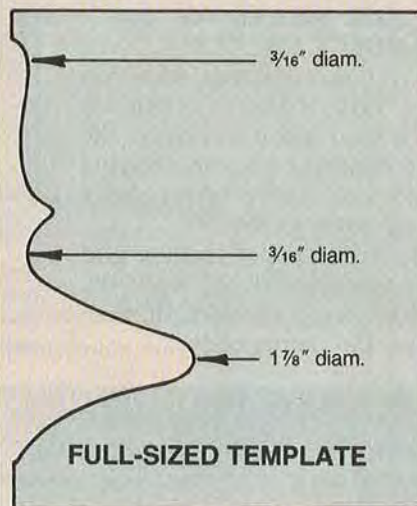

Another in a collection
of patterns from the
nation's top woodturners

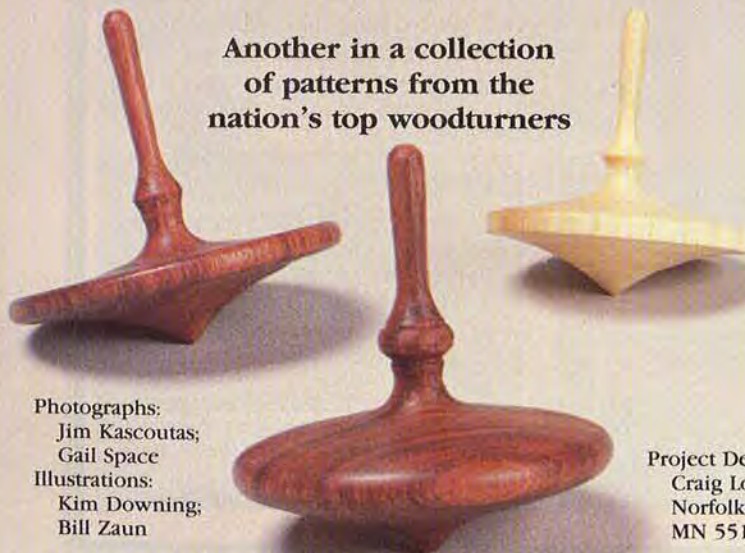

Photographs:
Jim Kascoutas;
Gail Space
Illustrations:
Kim Downing;
Bill Zaun

Project Design:
Craig Lossing, 1768
Norfolk Ave., St. Paul,
MN 55116

From Penn State Industries... Professional Quality Woodworking Machines At Affordable Prices

Super 15" Scroll Saw
Comparable value over \$500 • Shipped complete & ready to run • Includes \$37 Free accessory package !!!
On Sale..... \$129.95

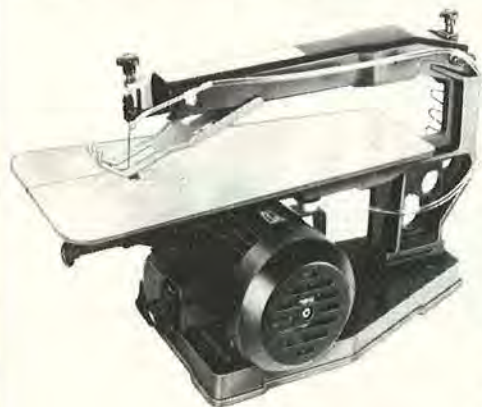

This versatile machine makes cutting intricate wood patterns easy - Its great for making toys, jewelry, puzzles, fretwork, etc. The blade is driven on both up and down stroke with a smooth cutting parallel rocker arm system that avoids blade breakage and creates a smooth finish that eliminates sanding. The Super 15" Scroll Saw is easy to set-up and use and is made with a cast construction that insures durability.

SPECIFICATIONS:

- Construction Cast Iron
- Throat depth 15"
- Max depth of cut 2"
- Machine weight 43 lbs
- Motor - Heavy duty totally enclosed fan cooled 110-120V, UL listed, ball bearing induction motor
- Blades - uses 5" standard & pinend
- Stroke length 3/4"
- Table tilt 0 - 45° to left

OPTIONS:

- Dust Blower • 37" Saw Stand

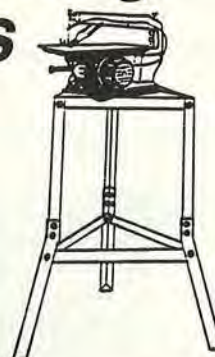

Free with Purchase of Saw
12 Blade Assortment \$ 3.50 value
Extra Blade Holder set 8.50 value
Plastic Lettering guide set & patterns..... 25.00 value
FREE ... \$37.00 VALUE

Saw & Accessories Price List

	PRICE (UPS)
Super 15" Scroll Saw	\$129.95 (10.00)
Dust Blower	15.00 (*)
Saw Stand - 37" high	39.00 (4.00)
4 dz blades (2dz pin, 2dz #9)	14.00 (*)
2 dz Spiral blades (size #2)..	10.00 (*)

(*) No freight charge if ordered with Saw; \$3 for any combination of these accessories ordered separately

Super 125 Planer
Portable with "Power Feed" • Shipped assembled • Retail value over \$600.00
On Sale \$349.95



This machine will pay for itself time and again by planing your own lumber. At 65 lbs, you can carry this Planer to a job site or mount it permanently in your workshop like any stationary machine. You'll spend hundreds of dollars less for this 12-1/2" power feed Planer than for a traditional stationary model of a similar capacity - with comparable results.

SPECIFICATIONS:

- Knives.... 2ea, 12-1/2" wide, HSS
- Motor-16 Amp, 115V, 8000 RPM
- Auto Feed rate 26.2 FPM
- Cutting speed 16000 Cuts/min
- Thickness of stock 3/16" to 6"
- Size 15-1/2"HX22"WX21" Bed
- Max Depth of cut 3/16"
- Machine Weight 65 Lbs.



Planer & Accessories Price List

	PRICE (UPS)
Super 125 Planer.....	\$349.95 (15.00)
Extra Set of 2 Knives	25.00 (*)
Dust Chute for vacuum	24.00 (4.00)
Planer Stand	44.00 (6.00)
Heavy Duty, 27-1/2"high	
Roller Stand - variable ht.....	35.00 (5.00)
Hvy duty, ball bearing, ht 25-45"	

(*) No frt chg if ordered w/Planer, otherwise add \$3.00

Dust Collector

Keep your shop clean and safe from sawdust with our large capacity, commercial style system. This collector has up to 10 times more air flow than most Industrial Vacuums. We include over \$15.00 of free hose and adapters with your purchase.

SPECIFICATIONS:

- 4" inlet • 1hp, 110/220V (pre wired 110V)
- 610 CFM air flow • 2 Bags 15" dia X 22"
- Casters on base for maneuverability
- Weight 75lbs • Size - 26"X15"x57"H

On Sale ... \$189.95

Add \$17.00 UPS Freight

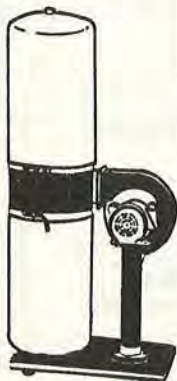

Penn State's Commitment

Our company has been in business for over 50 years. We unconditionally guarantee your satisfaction with our fine machines. All of our machines carry a Thirty day Money Back Guarantee and One year Warranty for Parts and Labor.

Penn State Industries-W
2850 Comly Road • Phila, Pa 19154
Order Toll Free 1-800-288-7297 (Ext 28)

For information 1-215-676-7609 (Ext 15) • Visa/Mc accepted Pa residents add 6% Sales Tax • Add UPS Shipping Charges as noted (Continental U.S. only)

PARROT MOBILE

Continued from page 83

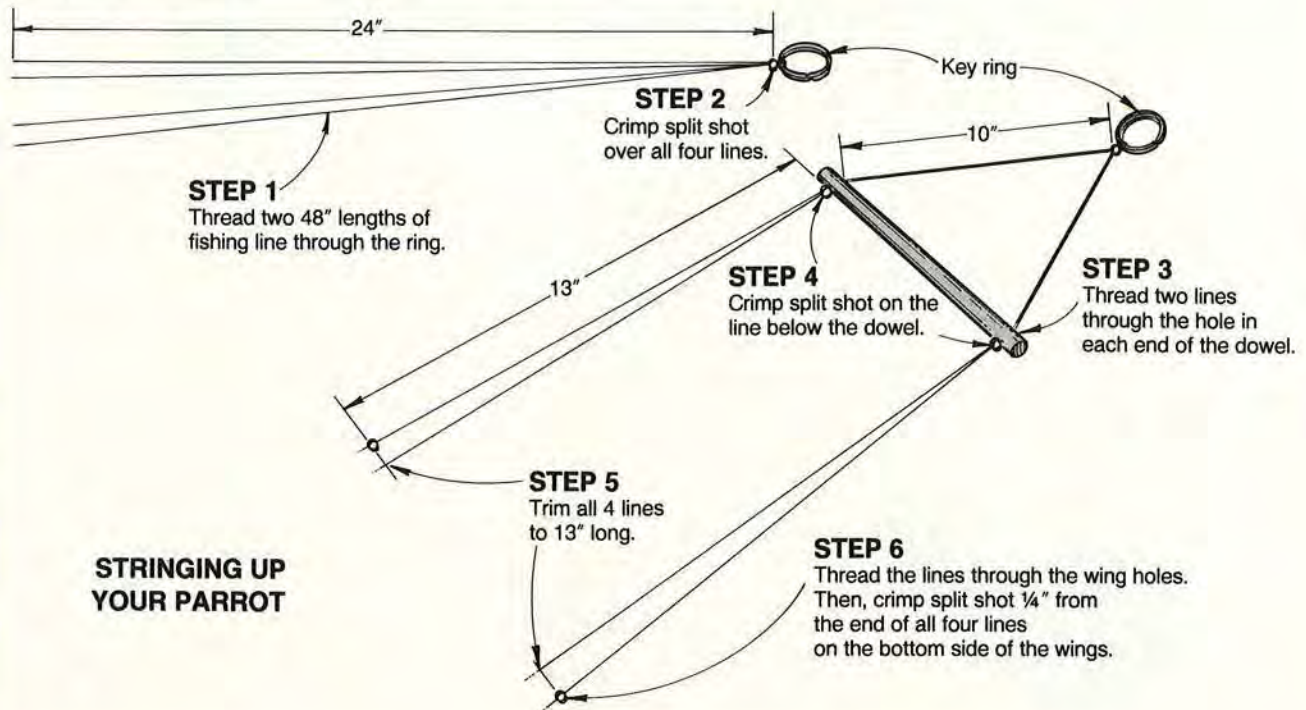

STRINGING UP YOUR PARROT

TRANSPOWER

12" AUTO PLANER
Sale \$328



2HP, 12.5"x6" capacity, 2 feeders, 8000 RPM/16000 cuts, 1/8" cut, 65 lbs.

20" AUTO PLANER
Sale \$1175

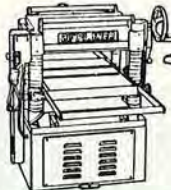

5HP, 20"x8" capacity, 1/4" max. cut, 4 blades, 2 feed speeds, 2 feeders, 1/8"-8" planing range, 20000 cuts/min., 980 lbs.

We are NOT NO. 1 in catalogue and advertising.
We are NO. 1 in QUALITY, PRICE & WARRANTY.

CALL 1-800-654-7702



3HP SHAPER
Sale \$645 2HP \$295



1", 3/4" & 1/2" spindles, 1/4" & 1/2" router chucks, 25"x22" table, 3HP, 2 revers. speeds, 2.5" travel, 390 lbs.

8" JOINTER
Sale \$625 6" \$285

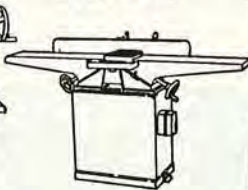

2HP, 9"x68" long bed, 3 blades, 2 V-belt drive, 1/2"x8" cut, 36" fence, 4500 RPM, precision lead screw, 500 lbs.

18" BAND SAW
Sale \$595 14" \$239

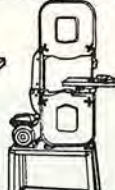

2HP, 18"x10" cutting capacity, 18" tilting table, adj. fence, 680 RPM, 1 1/2" blade capacity, 380 lbs.

15" AUTO PLANER
Sale \$645 2 spds. \$685



2HP, 15"x6" capacity, 2 feeders, 3 blades, 1/4" max. cut, 1/8"-6" range, 15300 cuts, 16/20 feed rate, 500 lbs. Free stand.

10" TABLE SAW
Sale \$795

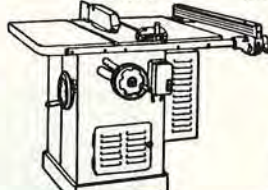

3HP, 3" max. cut, 36"x27" mirror table, top precision 21"x37" base w/casters, 10 lbs. fence, T-slot, 3 V-belt, cast iron construction, 500 lbs.

6"x12" SANDER
Sale \$365



1HP, 6"x48" vert./horizontal belt, 12" disc, 2 tilting tables, 3600 RPM, quick release belt, 180 lbs.

DUST COLLECTOR
Sale \$285 1HP \$185



2HP, three 4" holes, 1500 CFM, 28"x10" cast iron table, adj. fence, quick release design, free sturdy stand, 260 lbs.

90" EDGE SANDER
Sale \$445

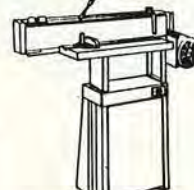

2HP, 6"x90" belt tilts 90°, 28"x10" cast iron table, adj. fence, quick release design, free sturdy stand, 260 lbs.

AIR DRUM SANDER
Sale \$245



1HP, 6"x9" brush, 4"x9" air drum, 1" spindle, optional stand, 85 lbs.

DRILL PRESS
Floor \$195 Bench \$165



3/4 HP, 16 speeds, 5/8" chuck, MT 2 spindle, 13" swing, 12" tilting round table, 66" height, 200 lbs.

INDUSTRIAL CARBIDE MULTI-CUTTER SET



\$169 Your Choice

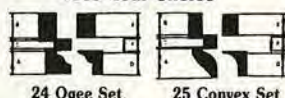

PANEL RAISING \$49 Your Choice

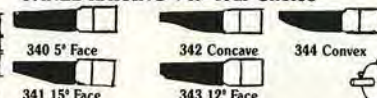

- Band Saw Motor ... \$ 48
- Table Saw Motor ... \$ 78
- Jointer Motor ... \$ 65
- Belt Sander Motor ... \$ 58
- Shaper Motor ... \$ 85
- Auto Planer Motor ... \$125
- Dust Collector Motor \$ 95
- Drill Press Motor ... \$ 48

TCM Industries, Inc. 322 Paseo Sonrisa, Walnut, CA 91789 IN CA. (714) 594-0780

FREE!
\$60.00 Value

Router Table Kit

...when you invest in an
Excalibur T—Slot Fence system.

The Excalibur T-Slot Fence System turns table saws into precision woodworking machines. Easily fitted to General Rockwell/Delta, Powermatic, Craftsman, etc., for a lifetime of precision performance!

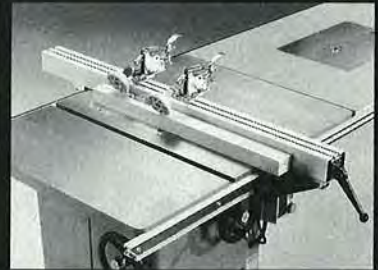

EXCALIBUR

MACHINE & TOOL CO.

EXCALIBUR MACHINE & TOOL COMPANY

U.S.A.

210 Eighth St. South,
Lewiston, NY 14092

TOLL FREE: 1-800-387-9789

CANADA

3241 Kennedy Rd., #7
Scarborough, Ont. M1V 2J9

(416) 291-8190

PLEASE PHONE FOR THE NAME OF YOUR NEAREST DEALER

Precision cuts will be easier and always accurate when you equip your table saw with an Excalibur T — Slot Fence System.

Dealer inquiries are welcome.

MAKE CLOCKS

TOYS & WHIRLIGIGS

Make wooden clocks, toys, whirligigs, dollhouses, classic cars, music boxes, weather instruments, desk sets, games, crafts & furniture with our plans, parts (hardwood & metal), kits (for all skill levels), books, tools, finishes and supplies. Bulk prices available.

(614)484-4363. Sixty-page color catalog subscription \$1.

Peter Rabbit Clock

•Uncut Kit: \$14.95

Just cut, sand,

assemble & paint

•Precut Kit: \$19.95

Just sand, assemble & paint

•Visa/MasterCard accepted

CHERRY TREE TOYS, Bx 369-9, Belmont, OH 43718

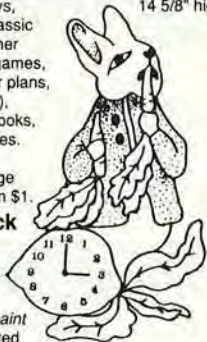

14 5/8" high

Full-Size Professional Plan ADIRONDACK CHAIR



Make this classic American design. Our special version may be folded for storage by using ordinary hardware available at your local store. Be ready for Summer and get your plan now!

CATALOG 200 full-size professional furniture plans — \$2.00

Plan #700 \$12.00
(Catalog free with order)

FURNITURE DESIGNS, INC. Dept. BA-69

1827 Elmdale Ave., Glenview, IL 60025
(312) 657-7526

Van Dyke's

Presents a Catalog

with supplies for upholstery, antique restoration, wood working, caning, brass hardware, carvings and many related trades!

36 Years in Creative Arts & Trades

Many Hard-To-Find Items!

SEND \$1.00 FOR CATALOG TO:

Van Dyke's Restorers
Dept. D55 - Woonsocket, SD 57385



WOOD TOY

- ★ Patterns
- ★ Parts
- ★ Wheels
- ★ Many New Patterns to Choose from.
- ★ Executive toys

SEND \$1.00 FOR NEW CATALOG & RECEIVE COUPON FOR FREE WHEELS & AXLE PEGS.



toys and joys

Box 628W Lynden, Wash. 98264

BAND SAW OWNERS!

A NEW TOOL is now available so you can make or repair any length Band Saw Blade in minutes!

This patented tool was developed for use in our own shop and has proven itself with thousands of high quality, true running splices.

Our splicer enables any craftsman to make up any length blade from economical coil blade stock QUICKLY and EASILY. The resulting silver brazed joint normally outlasts the service life of the blade.

Three models are currently available:

- 1C-001 1/4" to 3/4" Blades \$ 49.95 ppd
- 1C-002 1/2" to 3/4" Blades 49.95 ppd
- 1C-003 3/4" to 1 1/2" Blades 150.00 ppd

The tool comes complete with detailed instructions and supplies for approximately 100 splices.

We also carry additional supplies and OLSON band saw stock at reasonable prices.

Send L.S.A.S.E. for FREE information to:

NEW MILFORD SPECIALTIES CO.

Dept. BH, P.O. Box 241

Botsford, CT 06404-0241

(203) 426-4276

DEALER INQUIRIES INVITED

LEARN TO CARVE FOR LESS THAN \$20.00 FOR A LIFETIME OF ENJOYMENT

WARREN TOOL CO. INC. invites you to learn basic woodcarving our professional tools, are honed sharp for a safe, pleasurable carving experience.

SPECIAL INCLUDES:
#KB3 Packaged in Plastic Box (not shown)

—WITH—
WARREN INTERCHANGEABLE HANDLE

#KB3
KIT OF TOOLS

BOOK #23 "BASIC CARVING IN TEN LESSONS" WRITTEN BY NATIONAL CARVERS MUSEUM. SPECIFICALLY FOR WARREN TOOL USERS (not shown).

Complete catalog of carving tools, and supplies (FREE with order) or send \$1.00 for catalog only.
REQUEST: BASIC CARVING SPECIAL #1 — \$19.95 PPD.



ALL TOOLS MADE IN U.S.A.

(C.O.D. AVAILABLE)

Offer expires 7-9-89

Send check or money order to:

WARREN TOOL CO. INC.

RT. 1 BOX 14-A

RHINEBECK, NY 12572

TEL (914) 876-7817

101 GIFT & NOVELTY PATTERNS

This wonderful packet contains 101 FULL SIZE PATTERNS of Gifts, Novelties, Lawn Figures, Bird Houses, Shelves, Action Windmills, Alphabets, and many more things. Just trace and saw out. Plus "Make Money Jig Sawing". Only \$7.00 Prepaid 1st Class for this big packet.



MASTERCRAFT PLANS WEST, DEPT. 55H
P.O. Box 625, Redmond, WA 98073

Garden WINDMILLS FULL SIZE PATTERNS

Beautifully your lawn with these picturesque old windmills, 4 to 6 ft. high. Easy to make with full size patterns and step by step instructions. Only \$7.00 Prepaid 1st Class for WINDMILL PACKET with patterns for both.



MASTERCRAFT PLANS WEST, Dept. 519H
PO Box 625, Redmond, WA 98073

SQUARE DRIVE SCREWS

- "Cam-Out" is a Thing of the Past
- Heat Treated for Strength
- Deep Thread for Holding Power

SPECIAL: 100 each of the following sizes, plus a power driver bit and hand driver.

Size	Length	Price
#6x 1/2, 3/4, 1, 1 1/4, 1 1/2		13.35
#8x 3/4, 1, 1 1/4, 1 1/2, 2, 2 1/2		16.65
#10x 1 1/4, 1 1/2, 2, 2 1/4, 2 1/2, 3		23.65

Order Total	S & H
Shipping & Handling \$0.01 to \$20.00	\$3.00
U.P.S. Ground Service \$20.01 to \$50.00	\$4.50
Va. Res. add 4.5% Tax \$50.01 to \$80.00	\$6.00
Over \$80.00	\$7.50



McFEELY P.O. Box 3, 712 12th St.
HARDWOODS Lynchburg, VA 24505
1-800-443-7937 • In VA 1-800-542-2023

WE'RE TALKIN'

Continued from page 79

its rough state and 1/8" was surfaced off both sides to make it a 1 3/4"-thick board, and so on. We carry up to 16/4 boards (4" boards surfaced to a thickness of 3 3/4").

According to National Hardwood Lumber Association (NHLA) specifications, the idea that dressed boards are always 1/4" less thick than their unsurfaced thickness works only for 7/4 and thicker boards. For instance, a 6/4 board can be surfaced to a minimum of 1 1/16" thickness, a 5/4 board must be at least 1 1/16" thick after dressing, and a 4/4 board cannot be surfaced to less than 1 3/16".

Because few mills cut hardwood lumber less than 4/4 thick, you will pay the price of 4/4 stock, plus surfacing charges, for any board 1 3/16" thick and less. As Bob Garst, assistant manager of the NHLA puts it: "When you buy wood, you're buying two things: the wood and the modification to that wood."

6 I'm just getting started in woodworking; what are some good but inexpensive woods to work with?

"When I feel a woodworker doesn't have the necessary equipment or expertise for a given project, I steer him toward poplar at about \$1.25 per board foot, or knotty white pine at about \$1 per board foot," says Bob Carr of Educational Lumber Co. in Asheville, N.C. "Both of these woods work well and have good strength, and poplar is fairly stable. Neither will break most pocketbooks if a project doesn't work out the first time."

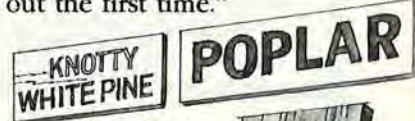

HARDWOOD

7 How do I calculate board footage?

Some woodworkers order their wood by the board foot and others simply take a cutting diagram to their supplier. In any case, the hardwood outlet will charge you by board footage, so it helps to know how to figure it out.

"I get this question fairly often," said Dick D'Abate, "and the answer

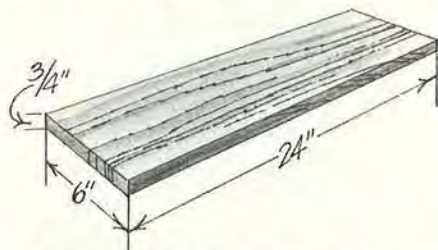

is pretty simple. First, you take the thickness of the board before the board was surfaced (1" for a 4/4 board), multiply that figure times length in inches, then multiply that figure times width in inches, and divide by 144. For instance, a 3/4" board that's 6" wide and 2' long started as a 1"-thick board so the equation goes: 1" x 6" x 24" equals 144; divide 144 by 144 and you have one board foot."

8 What woods are waterproof?

For outdoor projects, Dick Boak recommends these woods: western red cedar, true mahoganies, redwoods, and teak. Avoid luan—it lacks the water-repelling tight grain of true mahoganies.



Continued on page 90

ADDING TO THE TRADITION

The Delta 8 1/4" Bench Saw.

Tough as the day is long.

We set out to build a saw that would be as comfortable in the back of a pickup as in a warm, dry shop.

Tough enough to hold it's own on the nastiest of job sites. And take all the abuse a work crew can dish out. Yet precise enough to spend an evening at home on the bench making all sorts of perfect cuts. Or go from the basement, to the deck, to the attic on a Saturday afternoon.

The new 8 1/4" Bench Saw from Delta. Its 20" x 26" table is made of space-age SMC. A new, reinforced polyester resin compound that won't rust, spring or warp.

Its powerful 13 AMP motor turns a carbide-tipped blade that'll cut 2 1/4" stock at 90°, or 1 3/4" at 45°. You can rip 12" right of the blade, or add an accessory extension wing, and rip to the center of a 4-foot panel. All day long.

Call toll-free for the name of your Delta dealer; Delta International Machinery Corp., 800/438-2486. (In PA, 800/438-2487).

Building On Tradition

DELTA
A Pentair Company

The Japan Woodworker's Catalog is . . .

loaded with the best tools you can get your hands on. In our catalog you will find a complete selection of Japanese tools for the woodcarver, carpenter and cabinetmaker. Send \$1.50 for our catalog and supplements during the next two years.

THE JAPAN WOODWORKER
1731 Clement Ave., Alameda, CA 94501
Phone (415) 521-1810

Furniture Restoration

Big Money in Small Business

Stripping ★ Repairing ★ Refinishing
Mirror Resilvering ★ Veneering

Earn \$200-\$1000 a day!

At home or in shop ★ Spare time, full time ★ Men or women ★ Complete training, no experience necessary
★ Simple, fast, safe, fun.

FREE CATALOG

Send \$2.00 for postage & handling to
MINUTEMAN, INC., Dept. 17,
115 N. Monroe St., Waterloo, WI 53594

STEVE WALL LUMBER CO.

Quality Hardwoods and Woodworking Machinery For
The Craftsmen and Educational Institutions

Call for best prices on
RBI Scroll Saws &
Planes.

Special Hawk

H-14 \$499
H-16 \$599
H-20 \$699



CEDAR: (Aromatic Red)	4/4 1C & Btr.	\$ 1.10
CHERRY:	4/4 FAS	2.25
OAK: (Red or White)	4/4 FAS	1.80
MAPLE: (Hard)	4/4 FAS	1.45
MAHOGANY (Genuine)	4/4 Select	2.50
WALNUT	4/4 FAS	2.35

Above Prices are for Kiln Dried Rough Lumber Sold by Bd. Ft. FOB
Mayodan, NC - Quantity discounts available. For other sizes
and species send \$1.00 for Lumber & Machinery Catalog.

Route 1
BOX 287
MAYODAN
N.C. 27027
919-427-0637
1-800-633-4062

WE'RE TALKIN' HARDWOOD

Continued from page 89

9 How is lumber graded? Most hardwood outlets that cater to the home woodworker sell only firsts and seconds (usually combined as one grade called FAS)—the highest grade for hardwood lumber. In



the FAS grade, boards will yield a minimum of 83 1/3 percent clear cuttings at least 3" x 7' or 4" x 5'. Common uses for these boards include: quality furniture, interior trim, and solid wood moldings.

In the next grade down, Selects, one face is FAS, the other is No. 1 common (see below).

No. 1 common boards will yield from 66 2/3 to 83 1/3 percent clear wood cuttings at least 3" x 3' or 4" x 2'. They're best suited for furniture and cabinets.

No. 2 common boards find use as unexposed furniture components, and picture and cabinet frames. The boards will yield 50 to 66 2/3 percent clear wood cuttings at least 3" x 2' in size.

For more information, send \$1.50 ppd. for *An Introduction to Grading Hardwood Lumber*, from the National Hardwood Lumber Association, P.O. Box 34518, Memphis, TN 38184. 🌲

ANSWERS TO HARDWOOD QUIZ:

Top layer (from left): Honduras mahogany, red gum, red oak, walnut.

Middle layer: teak, wenge, birdseye maple, cocobolo, zebrawood.

Bottom layer: alder, ash, butternut, padauk, cherry, white oak, pau cetim (also known as Brazilian satinwood).

Illustrations: Jim Stevenson

Photograph: Hopkins Associates

MAKE THESE!



**WAGNER
SAFE-T-PLANER**
Fits Drill Press or Radial Arm Saw
ABSOLUTELY SAFE!
Impossible to Grab or Kick Back

PICTURE FRAMES, RAISED PANELS, ROSETTES,
PLANES, RABBETS, TENONS, MOULDINGS

KIT INCLUDES: 3 lifetime hi-speed steel cutters, grinding
wheel, arbor, wrench, 8 pg. photo instructions.

MONEY BACK GUARANTEE!

DRILL PRESS KIT \$35.00

RADIAL SAW KIT \$40.00

\$2.50 S&H OK ADD TX.

(State Make, Model,
Shaft Dia)

Order Direct—

Write For Free Literature

G & W TOOL CO.

P. O. Box 691464

Tulsa, OK 74169

(918) 486-2761



"Quality Planers Since 1956"

GAZEBOS

Included in this delightful book are designs for 55 Gazebos, plus many Bird Feeders, Bird Houses, Arbors and Strobrellas. Construction plans available for all designs. Gazebos and Other Garden Structures \$8.95



Also Available
Backyard Structures
65 Designs \$8.95
Bridges and Cupolas
55 Designs \$8.95

Please include \$1.90 postage and handling for 1st book,
.50 for each additional book.



173 E. Wisconsin Ave.
P.O. Box 6, Dept. 34
Oconomowoc, WI 53066
(414) 567-4255

MONEY BACK GUARANTEE - MC & VISA ACCEPTED

Door Harp Parts



	QTY.	TOTAL
Pre-Drilled Balls (3/4")	100/8.00	_____
Tuning Pins (1-3/4")	100/17.00	_____
Music Wire (550 Ft)	550 Ft/12.00	_____
Tuning Pin Wrench	8.00	_____
Plywood (2 Ft X 2 Ft)	4.00	_____
Door Harp Bridge (8")	2/1.00	_____
Set of 5 Door Harp Plans	Set/5.00	_____
Shaker Pegs (3-1/2")	100/16.00	_____
Bean Pot Candle Cup	100/16.00	_____
Full Round Balls (1")	100/12.00	_____
Door Harp Kit (Builds 2) You Supply 3/4" Stock	16.00	_____

Kit Includes:

5-Complete Plans	Total for Goods	_____
10-3/4" Balls	Texas Only - Add	_____
16-Tuning Pins	7% Sales Tax	_____
2-8" Bridges	Handling and	_____
30 Ft of Music Wire	Insurance	\$3.00
4 Sq Ft of Plywood		_____

WOOD PARTS CATALOG \$1.00

(Free With Order)

B39

MC OR VISA

CHECK ENCLOSED

ACCOUNT # _____

EXPIRES _____

PHONE _____

NAME _____

SHIP TO _____

CITY/STATE/ZIP _____

4500 Anderson Blvd.
Fort Worth, Texas 76117
(817) 281-4447



Woodworks

FREE CATALOG

Woodworker's
Supply



Write today to start your FREE two-year subscription. Complete selection of all kinds of woodworking tools, competitive prices and fast, friendly service have made Woodworker's

Supply of New Mexico the preferred source for professional woodworking tools and supplies.

Please start my two-year subscription.

Name _____

Address _____

City _____ State _____ Zip _____

**Woodworker's
Supply**
OF NEW MEXICO

5604 Alameda Place, NE • Dept. WO6
Albuquerque, NM 87113 • 505-821-0500

1-800-645-9292

Have a problem with your subscription?

We want to solve it to your complete satisfaction, and we want to do it fast. Please write to: Robert Austin, *Better Homes and Gardens*® WOOD®, P.O. Box 10628, Des Moines, Iowa 50336.

You can help us by attaching your magazine label here, or copy your name and address as it appears on your label. Send this along with your correspondence.

Name _____
 Address _____ Apt. # _____
 City _____ State _____ Zip _____

Moving?

Simply attach the mailing label from this magazine and write in your new address below. (Please allow 4-8 weeks.)

Name _____
 Address _____ Apt. # _____
 City _____ State _____ Zip _____

For Fast Service...

... it is better to write us concerning your problem and include the magazine label. Also, address changes are handled more efficiently by mail. However, should you need to reach us quickly the following toll-free number is available:

Subscription Rate:

6 issues — 1 year — \$18. Add \$6 for Canadian, or \$12 for other foreign subscriptions.

Renewal New Order

1-800-678-2666

WOOD®
 magazine

P.O. Box 10628 • Des Moines, Iowa 50336

WILLIAMS
Tool
 SALES COMPANY, INC.
 EST. 1946

Call for FREE Router Bit Chart
 2"x3" Color Chart Showing our Entire Selection!

1-800-338-6668

Satisfaction Guaranteed. Merch. shipped complete w/ factory standard accessories

DELTA

10' Contractor's Saw

\$598⁰⁰

#34-444

34-429	10' Tilt Arbor Bench Saw	\$995
34-782	Unisaw	Call
34-740	Super 10' Table Saw	349
34-670	10' Table Saw	314
33-050	Sawbuck Trim Saw	529
34-985	Prod. Stock Feeder	554
34-995	Prod. Stock Feeder 3ph.	739
34-994	Prod. Stock Feeder	829
28-283	14' Band Saw 3/4 hp	588
28-243	14' Band Saw 1/2 hp	480
33-890	12' Radial Saw	1148
33-990	10' Radial Saw	568
37-350	8' Precision Jointer	1388
37-154	8' Jointer DJ-15	908
37-280	6' Motorized Jointer	295
43-122	Wood Shaper	599
34-080	10' Motor. Miter Box	195
17-900	16-1/2" Drill Press	298
34-330	8-1/4" Bench Saw	225
40-601	18" Elec. Scroll Saw	699
31-340	1x42" Belt/Disc Sander	159

ELU

\$266

#3338

2-1/4 hp Elec. Plunge Router

3337	2-1/4 hp Plunge	247
3304	1 hp Electronic Plunge	180
3303	1 hp Plunge	145
4024	3x21 Electric Belt Sndr.	206
4023	3x21 Belt Sander	192
3375	Universal Planer	195
3380	Jointer/Splinter	325
4029	4"x24" Belt Sander	325
40900	Router Access. Kit	135

2017 White Settlement Rd.
 Ft. Worth, TX 76107

Limited Quantities-Errors Subject to Correction

BOSCH

1-3/4 hp Router

\$118 — #1604

1581VS	VS Orb. Jig Saw	\$128
1611	3 hp Plunge Router	198
1198VSR	1/2" VSR Ham. Drill	124
1196VSR	3/8" VSR Ham. Drill	107
1609K	Laminate Kit	155
1582VS	VS Orb. Jig Saw	118

HITACHI

1/2" Super Duty Router

\$159

TR12

CB75F	Band Saw	\$1575
C15FB	15" Hvy Duty Miter Saw	359
C8FB	8" Compnd Miter Saw	479
TR8	1/4" Hvy Duty Router	118
#F1000A	12" Planer Jointer	1389

RYOBI

10" Surface Planer

\$347

#AP10

RE600	3 HP Router	\$195
BE321	3x21" VS Belt Sander	119
R500	2-1/4 HP Plunge Router	154

PORTER CABLE

\$54

#330

Speed Bloc® Sander

690	Router, 1-1/2 hp	\$114
100	Router, 7/8 hp	90
691	D Hndl Router 1-1/2 hp	129
7548	VS Top Hndl Jig Saw	124
555	Plate Joiner	157
	Biscuits pkg.	25

INTRODUCING MERLE® THE ADJUSTABLE CORNER CLAMP

PAT. PEND.

BY **MLCS** LTD.

• **MERLE** is a one piece clamp that has almost no capacity limitation (from as small as 2-5/8" x 2-5/8" to 69" x 69", or 22 feet around, but can be extended to any length by using standard 3/8" steel banding or strapping)

• **MERLE** forces a frame into perfect square

• **MERLE** holds frame (picture frame or any frame) in square for jointing

• **MERLE** creates even jointing force at all corners, while holding frame in square

• **MERLE** is excellent for wide cabinet type frames (can be used in the center or edges)

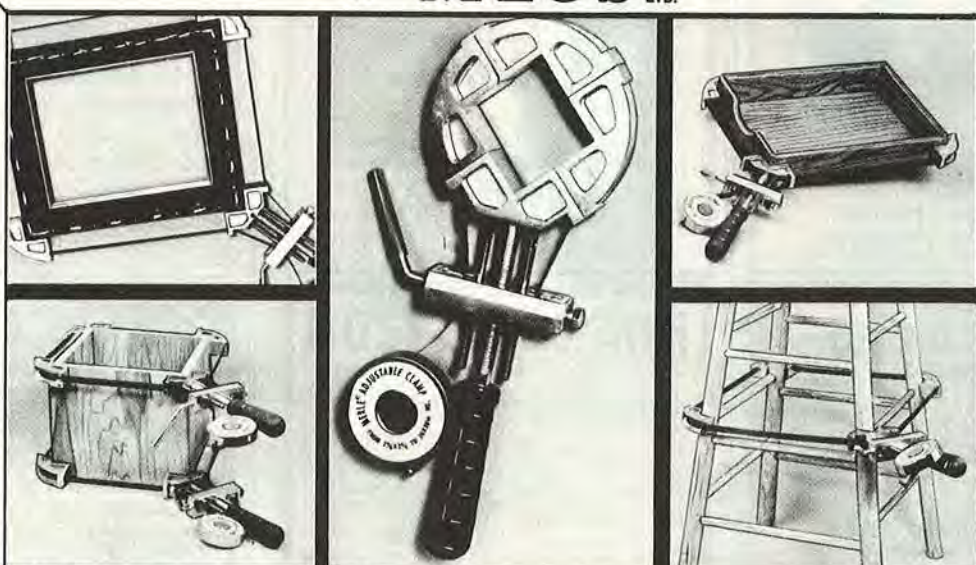

• **MERLE** is the quickest way to clamp mitres

• **MERLE** is perfect for holding work for gluing, nailing or screwing

• **MERLE** is quick and easy to use

• **MERLE** will allow you to use as much or as little clamping pressure as needed

• **MERLE** is cast aluminum and steel construction — a true industrial quality tool

• **MERLE** is quick action

• **MERLE** is a valuable tool in any shop

• **MERLE** is excellent for narrow picture frames

TO ORDER

Price **\$22.95**
 POSTPAID

Toll Free — 7 Day — 24 Hour Order Service,
 Call 1-800-533-9298

or send check to MLCS, P.O.Box 4053D-9, Rydal, PA 19046

MAKE TOYS

CLOCKS & WHIRLIGIGS

Make wooden toys, whirligigs, clocks, dollhouses, autos, music boxes, weather instruments, games, crafts & furniture with our plans, parts (hardwood & metal), kits (for all skill levels), books, tools and supplies. Bulk prices. Catalog \$1. (614)484-4363
Cherry Tree Toys, Bx 369-409, Belmont, OH 43718

GARDENER
Precut Kit: \$29.95
Just sand & assemble



22" long
Visa/MC
Uncut Kit: \$24.95
Just cut, sand & assemble

SCROLL SAW LETTERS EASILY...



...with Seyco's Layout Guides!

SPECIAL! (Style #RST-001) 1 1/2" (pictured above)
\$25⁰⁰ includes brochure and shipping cost.
Make Name Plates, Signs, Gifts and more.
Our unique Lettering Guides are available in many styles and sizes to suit your needs. Upper and Lower Case, Script and Block Styles...and numbers too. Send \$1.00 for brochure and prices to:

SEYCO *The Scroll Saw Specialists*

1414 Cranford Dr. • Box 472749 • Garland, TX 75047

HORTON BRASSES

Nooks Hill Road, P.O. Box 120J
Cromwell, CT 06416 (203) 635-4400

HORTON BRASSES are authentic copies of 17th, 18th, 19th & early 20th century pulls



Mfrs. of Cabinet & Furniture
Hardware for Homes & Antiques.
Send \$3.00 for a Catalogue.

Quality EXOTIC WOOD TURNERS

Burls / Thick Planks / for Bowls / Squares

CABINET MAKERS

Individually Selected Lumber for Furniture / Boxes / Inlays
OVER 70 SPECIES

All Inquiries Welcome - Call or Write

The Berea Hard Woods Co.

125 JACQUELINE DRIVE, DEPT. 10
BEREA, OHIO 44017
216-243-4452

"It's a Matter of Pride for Both of Us"

BAND SAW BLADES

WELDED TO YOUR EXACT LENGTH

Complete Band Saw Blade Line
Including Saw Mill Blades

We also carry:

Scroll Saw Blades • Hand Saws
Circular Saw Blades • Hole Saws
Hack Saws • Sanding Belts
Sanding Disks • Router Bits
Files • Rasps • Scrapers

SEND \$1.00 FOR CATALOG or
TO ORDER PHONE OR WRITE TO:

BUCKEYE SAW COMPANY
P.O. BOX 14794
CINCINNATI, OHIO 45250-0794
1-800-543-8664 (Except Ohio)
1-513-621-2159 (In Ohio)



SCRATCHBUILDERS PLANS

Build a miniature Concord Stage Coach or Conestoga Covered wagon in 1" scale. Plans include full size cutting patterns, exploded assembly views, photos and construction hints on two 2 foot x 3 foot sheets. \$15.95 each set + \$2.50 h/d/ins. We also offer a plan for the first gas auto, an 1893 Duryea also in 1" scale, a modelers delight...\$15.95. Buy all 3 plans and get a free S5 plan for making miniature wheels. Wagons measure approx. 14" long. For some background on the subject, "Making Model Horse Drawn Vehicles" by English author John Thompson, 94 pgs pbk, \$18.95. Please include \$2.50 h/d/ins on all orders. Catalog brochure \$1, free w/order. Credit card orders \$20 min. Tel. orders (201) 835-9339. N.J. res. add 6% sales tax.

Criss-Cross • Box 324BF • Wayne, N.J. • 07470

WE AREN'T FINISHED... UNTIL YOU'RE SATISFIED!

Since 1928, WOODCRAFT has been an industry leader in supplying quality products to woodworkers. Our services and guarantee are the best, our quality control program, second to none. Buying from WOODCRAFT gives you that kind of commitment... plus a whole lot more.

Why not give us a try, you won't be disappointed!

To receive a free copy of WOODCRAFT's tool catalog, please call toll free 1-800-225-1153 or write:



WOODCRAFT
Dept. WBH59
41 Atlantic Avenue, Box 4000
Woburn, MA 01888

SPECIAL OFFER

BRANDING IRON

For hard and soft wood

HAND CRAFTED BY
YOUR NAME HERE

\$24⁰⁰

Plus \$2.00 for shipping and handling

Nebr. residents add correct sales tax

SATISFACTION GUARANTEED or your money back

- Shipped in 1 week
- Solid brass head — deep cut letters
- First Line: HAND CRAFTED BY — as above
- 2nd line: Your choice — 20 characters/spaces max.
- Compact size
- As above but with 3rd line — \$37.00 + \$2.00

ORDER TOLL FREE 1-800-826-7606 (except Nebraska)
In Nebraska 1-402-464-0511

For free brochure, write or call (402) 464-0511

Order by mail from: **NOVA TOOL CO.**

12500 Finigan Rd., Dept. BH
P.O. Box 29341, Lincoln, NE 68529



ENTERTAINMENT CENTER

Continued from page 49

LET'S BUILD A DISPLAY CABINET OR TWO

The display cabinet varies from the electronics cabinet on a few details. First, don't cut the dados or add the fixed shelf shown second from the bottom on the Exploded-View Drawing. Also, delete the drawer and lower doors. Instead, build the display cabinet doors shown *below*. To display magazines, just turn an adjustable shelf upside down and angle it as shown on the Shelf Installation Drawing on page 49.

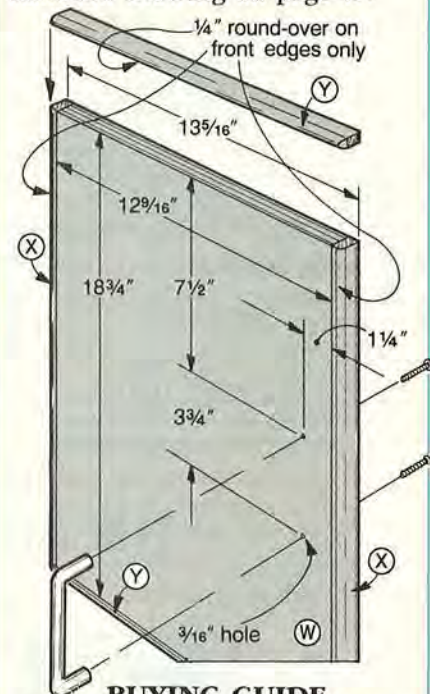

BUYING GUIDE

• **Hardware.** Brass-plated shelf clips, catalog no. D9156, 16¢ each. Full-extension 18" drawer slide, catalog no. D7513, \$16.95 per pair. Magnetic catch, catalog no. D2107, 95¢ each. Pivot hinge, catalog no. D5600, \$2.75 per pair. Oak wire pull, catalog no. D5620, \$2.25 each. Joint-connector bolt, catalog no. D6620, 35¢ each. Cap nut, catalog no. D6615, 45¢ each. Add \$3.50 per order for shipping. The Woodworkers' Store, 21801 Industrial Blvd., Rogers, MN 55374. Or, call 612/428-2199.

Produced by Marlen Kemmet
Project Design: Gary Schuknecht
Photographs: Hopkins Associates;
Jim Kascoutas
Illustrations: Kim Downing; Mike Henry



Carousels

4 HORSES: 14" TALL X 11" 8 HORSES: 15 1/2" TALL X 18"

Childhood memories of warm summer nights come alive with our exclusive **CAROUSELS**. A perfect scroll saw project. **FULL SIZE PLAN PLUS** solid brass rods, lazy susan bearing, screws and flag. Small: \$7.00, Large: \$10.00, **ONLY \$15.00 for BOTH**. Fast **FREE** shipping. Plan, Tool, and Book Catalog **FREE** with order; \$1.00 separately. Send order **TODAY** to:

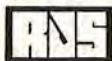

RJS Custom Woodworking
P.O. Box 12354, Dept AA
Kansas City, KS 66112

Table Saw Owners

Now you can make precision cuts every time with the Paralok fence system. Simple, proven principles guide both ends of the fence eliminating binding and creep.

Never again will you have to turn off the saw to measure fence alignment. The fence can be removed and reinstalled in seconds — with no tools and no loss of alignment.

Call or write us. We'll talk with you about your sawing needs.



1-800-423-9611 (In Oregon 281-6096)
Quintec Manufacturing, Inc.
5128 N.E. 42nd Ave., Portland, OR 97218

If you would like more information about advertising in **WOOD**, contact:

Terry McIntyre
WOOD Magazine
750 Third Avenue
New York, NY 10017
212-551-7130

WOODWORKERS

Save on Wood - Tools - Supplies!

OVER
4000
ITEMS

Finest Dimensioned
HARDWOODS and
Quality **VENEERS**
42 VARIETIES
1/64" to 4" Thickness

Fast service on choice kiln dried Wood and Veneers, Moldings, Trim, Hand and Power Tools, Lamp Parts, Upholstery Supplies, Clock Movements and Kits, Hard-to-Find Hardware, Finishing Materials, Books... over 4000 items in stock! Craftsman — Woodworker's best friend.

Send for
New 1989
148 Page
Money Saving
CATALOG



CRAFTSMAN WOOD SERVICE

Dept. WM-49, 1735 W. Cortland Ct., Addison, IL 60101
Please enclose \$1.00 to help pay postage and handling.



(17"D x 18"H x 36"W)

BUILD THIS BLANKET CHEST

Order plans for this charming reproduction

This beauty will be admired by family and friends alike—especially when they see the great storage space that you've gained for your prized quilts and blankets.

The chest lid is hinged, and a pair of shallow drawers below add an authentic touch.

For complete building plans, including the know-how for duplicating the beautiful antiqued, painted finish, send \$12 p.p. (Canadian residents please remit postal money order in US funds) to:

HAMMERMARK ASSOCIATES

Box 201—ABW4, Floral Park, NY 11002.
Catalog available for \$1.00 (refundable).
Prices effective through 12/31/89.

National Carvers Museum

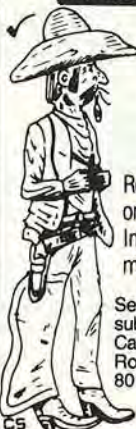

LEARN WOODCARVING AT HOME

Receive sample instructional pack on whittling and woodcarving. Includes copy of *Mallet* monthly magazine.

Send \$2.00—deductible upon subscription payment to The National Carvers Museum, 14960 Woodcarver Road, P.O. Box 389, Monument, CO 80132.

(719) 481-4737

MARBLE TOWER

Marbles release automatically to cascade down ramps, thru tunnels, over a xylophone staircase, around a spiral and down a switch-back to chime a bell, separate and spin dual paddle wheels. Captivates children, delights adults. Smart styling for home or office. 41" high.

Full-size plans, catalog, and unique shop tips... \$9.95
Postage & Handling... \$2.00
Catalog and shop tips only... \$2.00

Forest Street Wood Designs
538 Holiday Dr.
Brigham City, UT 84302



COMPUTER SOFTWARE

for Cabinet Shops
featuring...

- kitchen and bath floorplan generator
- complete cutting list and material list
- detailed cost analysis and bid
- 32mm and faceframe construction
- modular and non-modular cabinets
- 2 and 3 dimensional drawings
- on screen manual

Professional Version: \$650 and up
Homeowner Version: \$65
Demonstration Disk: \$10
Hardware: IBM or compatible with graphics capability.

Contact: **Siskiyou Products**
1012 E. Jackson
Medford, OR 97504

MAKE UP TO
\$26.00 an HOUR

START YOUR OWN
MONEY MAKING BUSINESS

Hundreds of FOLEY-BELSAW trained men have succeeded in this fascinating and highly profitable field...

You Can Do It Too! ... BE A

BE YOUR OWN BOSS

LOCKSMITH

FREE BOOKLET



Never before have money-making opportunities been so great for qualified Locksmiths. Now lucrative regular lock and key business has multiplied a thousandfold as millions seek more protection against zooming crime. Yet there's only one Locksmith for every 17,000 people! Train **FAST** at Home — Collect **CASH PROFITS** Right Away. You're in business ready to earn up to \$26.00 an hour a few days after you begin Foley-Belsaw's shortcut training. Take advantage of today's unprecedented opportunities in Locksmithing for year-round **EXTRA INCOME** in spare time — or full time in a high-profit business of your own. Hundreds we've trained have done it. So can YOU! All tools plus professional Key Machine given you with course. These plus practice materials and equipment, plus simple, illustrated lessons, plus expert supervision, plus business building guidance will enable you to **KEEP THE MONEY COMING IN!** Ideal for retirement — good jobs, too.

SEND FOR EXCITING FACTS — NO OBLIGATION!
PRO KEY MACHINE YOURS TO KEEP **FREE**

This machine can add up to \$200 a month to your income... it won't cost you a penny extra with your training.



FIND OUT ABOUT IT
RUSH COUPON TODAY

FOLEY-BELSAW INSTITUTE
6301 Equitable Rd., DEPT. 11622
Kansas City, MO 64120

There is NO OBLIGATION * NO SALESMAN Will Call - ever!



FREE FOLEY-BELSAW INSTITUTE
6301 Equitable Rd., DEPT. 11622
Kansas City, MO 64120

PLEASE RUSH FREE BOOK "Keys To Your Future"

TELLS HOW TO MAKE MONEY IN LOCKSMITHING ALMOST FROM THE START!

NAME _____
ADDRESS _____
CITY-STATE-ZIP _____

WINDOWSILL CAT PATTERNS

12 DIFFERENT PATTERNS FOR WOOD CUTOUTS ALL FOR \$6

DAKOTA WIND
DEPT. W59
BOX 866
JAMESTOWN, ND 58402

Shop helper®

\$69.95

SHOPHELPER. Holds it down for a cut above. Shophelper's unique double wheel configuration gives it the stability required to virtually eliminate kickback and enhance safety. The offset wheel holds the material down to stabilize the cut. The offset wheel controls ripping as narrow as 1/2" x 1/2". Shophelper is the perfect safeguard for professionals and hobbyists alike.

Those Multi-Purpose Multi-Colored Wheels

- Yellow Wheels turn clockwise for table saw and radial arm saws.
- Orange Wheels turn counter-clockwise for radial arm saws.
- Green Wheels turn both directions for shapers, routers and jointers. (No anti-kickback).

• All Wheels can be Sold Individually and are Interchangeable on Arms

• Three different dual wheel designs, including single and multi-directional

• Wide range of shop uses

• Provides a virtually accident-free environment

• Straighter, cleaner cuts

• Saves time and materials

• Options include adjustable slotted track, auxiliary fence, saw guard

Call For Nearest Dealer
Call Toll Free: 800-344-7455 • In California Call: 800-828-8833
WESTERN COMMERCIAL PRODUCTS • P.O. Box 2338, Tulare, CA 93275

EASY TO BUILD



Lyres
Harps
Banjos
Violins
Psalteries
Dulcimers
Many other
Musical
Instrument
Plans, Kits
& Supplies

Send \$1.00
for catalog

ST. CROIX KITS
Dept. B3
423 S. Main St.
Stillwater, MN 55082
(612) 439-9120

ORDER TODAY

WOODWORKERS

SYSTI MATIC PLANER COMBINATION



50 TOOTH SPECIAL!
10" BUDKE BLADE \$39.95 ppd

FREE CATALOG SUBSCRIPTION
WITH PURCHASE.

CATALOG ONLY.

2 year subscription (8 issues) \$4.00.
Free \$5.00 gift certificate with catalog
order.

R. A. NESS & CO.
**THE WOODWORKERS
EMPORIUM**

8888 N. MILWAUKEE AVE.
NILES, IL 60648

(312) 824-0565



TOOL INDUSTRY INSIDER



POWERMATIC COURTS THE HOME WOODWORKER



If you've excluded Powermatic equipment from your tool-purchasing decisions because you thought the equipment was too expensive, the McMinnville, Tenn., company would like to change your mind. A name synonymous with heavy, high-quality, top-dollar equipment, Powermatic wants to make its mark on the home stationary power tool business with its new Artisan's Line of lighter, lower-cost machinery.

Powermatic's new Artisan's Line saw weighs and costs less than its model 66 tablesaw.

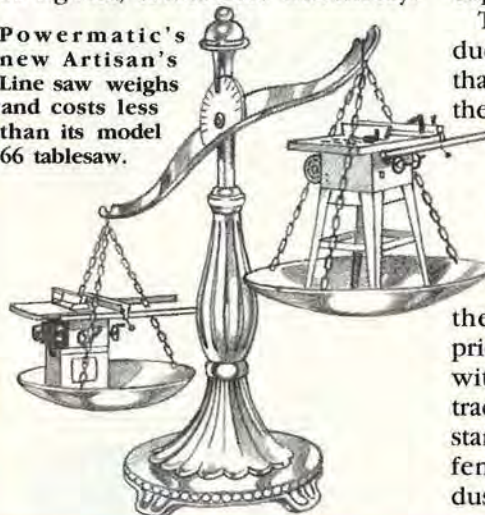

The equipment will cater to the home woodworker, especially the younger craftsman with limited funds and space.

"We see a lot of growth in the home end of the woodworking business," said Bob Aslup, a Powermatic product manager. "So we found out what things woodworkers expect in a line of smaller, less-expensive machines."

The result: Powermatic introduced a Taiwanese-made tool line that includes a scrollsaw similar to the 15"-models already imported by Delta, Grizzly, Jet, and others. Powermatic plans to market a drill press, shaper, and contractor's-type saw and two more as-yet-unannounced machines.

Powermatic has positioned the 10" tablesaw, with a selling price of about \$640, to compete with Delta's contractor's saw. To attract buyers, Powermatic includes standard features such as a Vega rip fence, retractable casters, and a dust-collection shroud.

SEARS SHAKEUP—WILL IT AFFECT THEIR TOOLS?

In late-1988, executives at Sears, Roebuck and Co., looking to make their company grow, increase profits, and fend off takeover attempts, announced sweeping changes aimed at making Sears competitive with discount chains. In order to keep up with the likes of K mart, Target, Toys R Us, and other discounters, Sears will revamp its entire system of merchandising, distribution, and inventory control.

"Twenty years ago, Sears didn't have that much competition, but now we have so much competition from specialty retailers that we have to do something about it," said Mike Mangan, power-tool product manager for Sears.

To test its new approach, Sears opened Brand Central departments at 13 stores in Indiana and four in

Louisville, where customers can choose from the same name-brand electronics and appliances available at other stores. Will the Brand Central concept spread to Sears' tool departments as well?

"The Brand Central idea is being explored in the tools and home improvement departments," Mangan told *WOOD* magazine, "but nothing definite has been set. We'll probably go with some national brands in small products such as fasteners, for example, so we don't have to make a big investment in our own packaging and inventory." Will the Craftsman brand survive this upheaval? "We won't throw out the Craftsman name—it's an institution—one that woodworkers know they can turn to for quality and service," Mangan said.

Illustration: Jim Stevenson

FINALLY A SCROLL SAW THAT DOESN'T CUT CORNERS.



The new Dremel two-speed Scroll Saw gives you all the features of the most expensive saws, except one. The price.

How'd we do it? Using the same Dremel engineering that's been bringing you intelligently-crafted,

DREMEL®

affordable power tools for over 80 years.

So if you're looking for a quality scroll saw that'll make your most intricate work a breeze, ask about the new 16" Scroll Saw from Dremel. And cut those expensive saws down to size.

© 1989 Dremel

EARN \$18.00 AN HOUR!



Turn Your Spare Time into EXTRA INCOME

Operate your own Profitable Saw & Tool Sharpening Business!

Now Use Your Spare Time To Generate Low Risk, High Profit Income!

Yours is a service business ... there's no selling involved, no inventory required. You spread the word about your business and people just start bringing their saws and tools for you to sharpen ... it's that easy ... and you pocket year 'round profits for the things you want to do.

Manage Your Own Time And Reap The Rewards Of Success And Satisfaction!

You're your own boss, so you set the hours. Work in your spare time or build into a full time operation right at home in your garage, basement or tool shed. Work as much as you want, as long as you like.

Plenty Of Business Just Waiting For You To Start Your Own Sharpening Business!

Every home and business has saws and tools of all kinds that need sharpening periodically and with your Sharp-All you can service the needs of your community ... no matter whether you live in a big city, small town or rural farm area ... you'll be the sharpening headquarters for carpenters, builders, manufacturers, craftsmen, hobbyists and homeowners.

Easy To Get Started, No Experience Necessary, Factory-Direct Low Prices!

You don't have to invest thousands of dollars to get started in business for yourself. In fact for less than \$2.00 a day, the low cost Sharp-All and your desire to get ahead, our Operators Manual and Guide to Profits will provide all the necessary information and step-by-step illustrated instructions you'll need to get started. With Foley-Belsaw you deal direct with a dependable company with a history of providing for independent businessmen and women.

To get started ... just fill in the coupon TODAY and MAIL IT!
30-DAY FREE HOME TRIAL OFFER!

You'll receive full details on how to start your own profitable Saw & Tool Sharpening Business with no risk on our 30-Day FREE Home Trial Offer! There's No Obligation to Buy ... and No Salesman will Call.



**ACT NOW!
 SEND FOR
 FREE FACTS
 TODAY!**



Foley-Belsaw Company Since 1926
 6301 Equitable Rd., Dept. 20830 • Kansas City, MO 64120

Yes, please rush my FREE "Lifetime Security" Fact Kit on starting my own profitable Saw & Tool Sharpening Business!

NAME _____
 ADDRESS _____
 CITY _____ STATE _____ ZIP _____
 PHONE () _____

NEW

FREE - The most complete selection of scroll saw blades, accessories, and improvements for almost any scroll saw, plus much, much more!



Catalog from the exclusive distributors of **HEGNER & FELDER** Woodworking Machinery.

Includes HEGNER Precision Scroll Saws, Lathes & Lathe Duplicators, JET Clamps, Workbenches, FELDER Systems, and more!

A \$2.00 value, now offered **FREE** during this special promotion.

CALL TODAY 1-800-962-2589
TOLL-FREE FOR YOUR COPY

Name _____
Address _____
City, State, Zip _____
Phone () _____

ADVANCED MACHINERY IMPORTS LTD. P.O. Box 312
Dept. 330
New Castle, DE
19720

SAVE MONEY!

KILN DRY LUMBER



MAKE MONEY!

Kiln Dry for others. As the nation's largest manufacturer of dehumidification Dry Kilns, we can supply you with the same type equipment used by many of the major firms.

Call or write today for free facts that will help you make and save money.

nyle DRY KILN SYSTEMS

1-800-648-9200

207-989-4335 Nyle Corporation
P. O. Box 1107, Bangor, Maine 04401

OLD HAND WAYS



Print this article

THE CARVER'S SON

A STORY OF WHAT COULD HAVE BEEN AND WHAT MIGHT BE

"One father is more than a hundred schoolmasters."

George Herbert, 1651



Anthony Merano's son took little interest in his father's work, which was just the way the old man wanted it. The elder Merano had immigrated to America from northern Italy in 1926 as a penniless apprentice woodcarver. He had worked hard, and eventually supplied fine architectural carving to builders across the nation.

Although Merano represented the fourth generation of woodcarving in his family, he thought there would be little demand for this old-fashioned craft in the space-age United States. That's why he sent his only son to nothing but the best schools, and eventually guided him to aerospace engineering.

As the years passed, the old, widowed woodcarver developed heart trouble and his son brought him to live with his family. When the elder Merano's health declined, he finally put away his carving tools. However, people continued calling for his work. Since father and son shared the same name, it soon became a family joke to answer calls for "Anthony Merano" by asking, "Do you want the woodcarver or the rocket scientist?"

The family joke went on until a slump hit the aerospace industry. Management employees suffered, too, and Anthony Merano, Jr., now at middle-age, lost his job. He tried to find work, but he simply could not compete with the younger people trained in the latest technology. His feelings of worthlessness increased. When his father died, the son's spirit was all but broken.

Sitting at the bottom of the basement steps one afternoon, pondering items to unload at yet another yard sale, Anthony Merano's gaze fixed on his late father's tool chest. The key was fastened to the lid with masking tape. Suddenly curious, he pulled the key free and unlocked the lid. Opening the chest revealed a sight no more comprehensible to him than the inner workings of a typewriter. There must have been 100 handles poking up from their racks.

He pulled out a gouge, then a surprisingly heavy mallet of chocolate- and butterscotch-colored wood. The tools felt good in his hands. Striking them together in the air, he heard the sound that filled so much of his cherished childhood.

Glancing back in the chest, he noticed bundles of wooden blocks, in various stages of carving, bound together with torn cloth strips. He set the tools aside, untied one of the sets, and spread the blocks out on his thighs. There were six blocks in this set, each measuring 6" square and 1" thick. He studied the two rows, then began to laugh.

The son had wondered what his father was doing in the cellar those

last few weeks. The answer lay before him. Here, in six precise steps, was the technique for carving a floral rosette. The other bundles held the steps for moldings, panels, and the full range of his father's work. That night he just looked, but things would change in the weeks and months that followed.

The following day, Anthony cleared off his father's carving bench, laid out the series of rosette blocks, and tried to match the tools to the work. The first block had the flower penciled on it with flawless sweeps of the compass. On the second block, his father had outlined the penciled design with knife cuts and a narrow groove. He searched in the chest to find a tool that matched the groove.

With the first block clamped in the vise, he set the V-shaped veiner (Anthony had looked up its name in a tool catalog) on the basswood block. He guided the tool around the curve of a petal, daring only to take the shallowest cut. The tool took off on its own, tracking into the grain and through the outline of an adjoining petal. He backed off and took a deeper, more forceful cut. This time, the edge caught under the grain and quickly tore off a splinter.

He stopped again and analyzed the problem. Parts of the sharp, V-edge led the tool with the grain, and other portions led the tool against the grain. But, whichever way he went, one edge or the other of the tool was always cutting against the wood's grain.

Then he remembered how his father had worked. He removed the block from the vise and held it pressed against a peg in the bench top. Now, he could quickly turn the block to let him approach the cut from the best angle to the grain. He finished outlining within the hour, anxious to copy the next block, where his father had struck the grooves with deep incisions.

Here, his father deepened each portion of each curve by striking down with the gouge that closely matched the curvature at that point. This part of the work went fast, and the son wondered if he could skip the first step. He tried tapping in without the initial valley cut, but the surface chipped to the side. No, his father had a purpose for each step.

The fourth block varied radically from the first three. Here, his father had swept away the background with long strokes of the gouge. He copied the gouge-work.

By that evening, the rocket scientist had copied the roughly shaped hollows of the wooden petals on the fifth block. But, he thought he had carved long enough, and that he could finish it with sandpaper.

Wrapping the sandpaper around his fingers to get in the hollows, he rubbed and rubbed all over, working by feel and scarcely looking at his carving. Finally, he held it up to the light. All the detail that gave interest to the piece had melted away. He knew he had made a mistake, but he felt great.

Within the year Anthony Merano was carving reasonably well. He still had a long way to go in judging proportion and working with any speed. But, he *was* working, he was good, getting better, and growing confident.

The phone rang. "Anthony Merano," he answered. "Oh, bello" came the voice on the other end. "I'm sorry, is this the rocket scientist or the wood carver?" Anthony Merano, now a fifth-generation woodcarver, didn't hesitate.

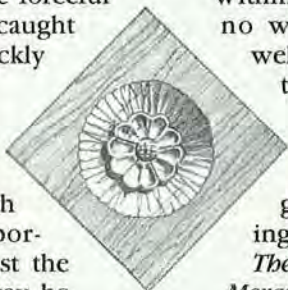

By Roy Underhill

Master housewright at Colonial Williamsburg and host of the popular PBS series The Woodwright's Shop, Underhill is also an author and lecturer.

Illustrations: Jim Stevenson

Announcing Price Breakthroughs from Penn State Industries

PLASTIC LETTERING GUIDES

ONLY \$12 / set (ppd)

Scroll Saw users, trace and cut perfect lettering patterns with these Neptune 1-1/2" style guides. Includes full upper/lower case alphabet+numbers • Made from durable .030" plastic, beveled edges, precision cut for accurate alignment • Package includes FREE pattern set. Shipped postage paid • Similar guides are sold by others for over \$40 !!



Dealers inquiries welcome

Two Heavy Duty 12" X 2" BALL BEARING ROLLERS

(Plus Plans for Stand)

ONLY \$15/set of 2 Rollers (ppd)

Build Your Own Roller Stands With This Versatile Package

Quality Roller stands are a must for every shop. Why spend over \$80 for two roller stands when you can build them yourself from wood for only \$12. These rollers are great for building infeed/ outfeed tables. Freight pre paid. Price includes 2 Rollers & Plans.

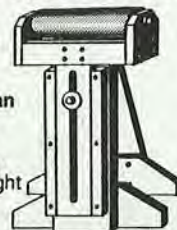

Penn State Industries • Dept L3

2850 Comly Rd • Phila Pa 19154

Check, Visa/Mc accepted, Order Toll Free

1-800-288-7297 (ext 28)

ANYTIME ANYWHERE ANYWOOD

mold plane and edge



Professionals and hobbyists alike know the strengths of the W&H molder-planer. Superior US-made construction and quick two-minute cutter changes make it a snap to cut moldings and plane hardwoods. It's fast, easy, and super-smooth.

Our five-year warranty and free 30-day trial are your assurance that W&H goes the distance.

Mail this ad or call us toll-free today. 1-800-258-1380 In NH 603-673-3446

Williams & Hussey
Elm Street, Dept. 239EM
Milford, NH 03055



YES! Send your free information kit today.

Name _____
Address _____
City _____ State _____ Zip _____

THE ULTIMATE CONTRACTOR'S SAW.



\$650

Strikingly different. A new standard for the industry.

As "the" producer of top end industrial woodworking machines since 1921, Powermatic now focuses their engineering expertise and resources for the craftsman, contractor and home hobbyist.

- Industrial Quality Vega Fence System provides unsurpassed rigidity for accuracy & speed
- T-Slot Miter Guage for increased accuracy and flexibility in stock width capabilities
- Built-In Dust Shroud for shop cleanliness

- Cast Iron Grate Extensions provide ruggedness for increased accuracy and longevity

- Unitized Wiring System readily removed for portability

- The Powermatic Name for value and service

You'll find no better quality or value . . . anywhere. For just a little more than you'd spend on a run-of-the-mill machine.

Talk to your Powermatic distributor today. For those who want the

best — the Powermatic 10" Contractor's Saw. Truly the **Ultimate Choice**.

The Ultimate Choice
POWERMATIC *IMI*

A Division of Stanwich Industries, Inc.
McMinnville, Tennessee 37110
800/248-0144 □ 615/473-5551
TELEX - 554455
FAX # 615/473-7819

The Discerning Craftsman



Father's Day Gift List

Father's Day is June 18. Check the items you want, tear out this section and casually leave it where your family can find it. They'll get the hint!

NEW SCROLL SAW UPGRADE KIT

Easier blade mounting & longer blade life with this kit. Contains 1 pr. 0.7 MM HEGNER Blade Clamps, Tuffrench (eliminates Allen screws) & a Blade Mounting Device. Replacing factory clamps on AMT, Delta Model 40-150, Jet, Penn State & other 15" Taiwanese saws. Sale Price \$34.95, plus \$3.95 S/H. AMI, LTD., P.O. Box 312, Dept. 337, New Castle, DE 19720 or call toll-free 1-800-648-4264.

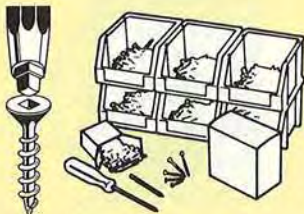

Special square drive assortments include 100 screws in each of six popular lengths, a hand driver, hex driver for use in a standard drill chuck and a set of six heavy-duty storage bins. #6 assortment \$13.35; #8 assortment \$16.65; #10 assortment \$23.65. See our display ad for s&h. MCFEELY HARDWOODS, 712 Twelfth St., Lynchburg, VA 24505. Call 1-800-846-2729 (in VA, 1-800-542-2023).



Hexagon Picnic Table - Plans, \$16.95. This 3 legged table automatically levels itself. Walk through seating for 6 people. Designed to accept an umbrella. SPECIALTY FURNITURE DESIGNS, 797 West Remus, Mt. Pleasant, MI 48858. VISA/MC accepted. MI residents add 4%.



Handsomely styled and ruggedly designed, Emperor's new solid oak Gun cabinet will make the perfect gift for the family sportsman. Our do-it-yourself kit features glass side panels and padded racks behind locking doors. Send \$1.00 for color catalog to EMPEROR CLOCK COMPANY, Emperor Industrial Park, Fairhope, Alabama 36532.



Build miniature horse-drawn vehicles. The Concord Stage Coach and the Conestoga Covered Wagon are some of the vehicles you can build using our plans in 1/12 and 1/8 scale. Concord Coach and Conestoga are available in full size 1" scale cutting patterns. Plans sets are \$15.95 each + \$2.50 handling/insur. Catalog/Brochure \$1. CRISS-CROSS CREATIONS, Box 324, Wayne, N.J. 07470.



Put Dad in the Groove with Woodmaster from DML! There is no limit to the projects you can finish with Woodmaster router bit kits from DML. Complete with a fine wood storage case, the Woodmaster is available with 8 or 12 bits tipped in premium carbide. Call 1-800-233-7297 for more information.



The new Freud Table Edge-Bander is ideal for pre-glued veneer and polyester materials. This machine is suitable for straight or curved edges. Father's Day Special Price \$299.95. Call today 1-800-476-4457 or write to: HILLER HARDWARE, 1411 Assembly Street, P.O. Box 1762, Columbia, S.C. 29202-1762.



Our wood parts make it easy to make professional looking furniture. We feature leg, arms & turned columns for tables, chairs, etc., in styles including Chippendale and Queen Anne plus chairs & occasional tables to assemble & finish. Our woods include walnut, mahogany, cherry & oak. ADAMS WOOD PRODUCTS, 974 Forest Drive, Morristown, TN 37814 or call 1-615-587-2942.



Vega Model 1200. Unbeatable product at the price. We've recently taken on the Vega line and can offer this 8-speed American made lathe at \$450.00! It's got a 12" swing with 36" between center. (Stand not included.) For more information and a complete line of woodworking tools and machinery call or write: WOODCRAFTERS SUPPLY COMPANY, 5331 Sinclair Road, Columbus, OH 43229. 614-436-6900.



The Paralok Table Saw Fence stays in precise alignment with your table saw. Never again will you have to turn off the saw to reset the fence. Its rugged, lightweight, anodized aluminum construction enables you to adjust and lock down with only one hand. The fence can be removed & reinstalled without tools in seconds. Fits virtually any saw. QUINTEC MFG., INC., Portland, OR. 1-800-423-9611.



"Supergrit" quality sandpaper belts, discs, and sheets by mail order at warehouse prices. Small and medium-sized buyers can purchase small quantities of abrasives at industry prices (\$25 minimum). Prompt, free UPS shipment to most USA areas. RED HILL CORPORATION, P.O. Box 4234, Gettysburg, PA 17325; Call 1-800-822-4003 for free catalog.



Choose from six speed ranges: the Bosch 1273 DVS variable speed belt sander lets you use it for everything from fine finishing to coarse stock removal. Dust collection bag, unique belt tensioning system and easy belt changing make it a professional and woodworking hobbyist's delight. For your BOSCH distributor, see your Yellow Pages: "Tools - Electric."



Lawn & Garden Ornaments! Create decorative and profitable yard "critters," birds, butterflies, whirligigs, signs and much more. This blueprint packet offers over 100 full-size patterns for our most popular lawn and garden designs, decorative alphabet and woodcraft catalog. Only \$7.00. ACCENTS IN PINE, Dept. GA 59, Box 7387, Gonic, NH 03867.



Buy this superb wooden block plane for about the same price that you pay for a high quality steel plane. Lightweight hornbeam body and super-tough lignum vitae soleplate. Was \$40; Holiday Special \$35 ppd. Catalog \$1.00 (refunded with first order). HAMMERMARK ASSOCIATES, Box 201-ABW12, Floral Park, N.Y. 11002.



Total shop 12" planer has been an instant success! Big 12" x 6" capacity is great for hobbyist or professional. Runs at feed rate of 26" per minute. Comes complete with everything you need to get started planing. No assembly or hassle with setup. Costs only \$395. Many other items available. For free 24 pg. cat. write TOTAL SHOP, P.O. Box #25429, Greenville, SC 29616 or call 1-800-845-9356.



Dial-in the motor speed you need to match any routing job with the Bosch 1611EVS variable speed plunge router. And enjoy the combination of plunge routing advantages, plus excellent ergonomic design and over 3 H.P. for heavy going. For your BOSCH distributor, see the Yellow Pages: "Tools - Electric."



Father's Day Special! Because Dad deserves the best, order Warren Tool Woodcarving Kit (shown) plus "Basic Woodcarving" book (not shown). #KBL3 Special only \$22.95 ppd. Offer expires 8-1-89. Send check or money order to: WARREN TOOL CO., INC., Rt. 1 Box 14-A Dept. FDW, Rhinebeck, N.Y. 12572. UPS-C.O.D. Extra charge. 1-914-876-7817.



Powermatic has recently introduced the new Model 63 Artisan's Saw. The 10" Tilting Arbor Saw features a 1 1/2 horse rear-mounted induction motor with modular wiring system, a deluxe T-slot miter gauge, a spacious cast iron top with cast iron open grade extensions, and a built-in dust collector shroud. For more information call or write POWERMATIC, Morrison Road, McMinnville, TN 37110, 1-615-473-5551.



Everybody loves TEDDY BEARS, especially if they have been hand-crafted by you! Create new, three-dimensional wooden EGG CRITTERS™ - ten unique designs - from our collection of full size patterns and instructions. Enjoy this new woodcraft technique plus our country woodcraft pattern catalog for only \$6.00. THE WINFIELD COLLECTION, 12044 Parkin Lane, Fenton, MI 48430.



Frame Clamp with 8 jaws holds rectangular, oval, round, hex, octagonal shapes. Capacity: 12" to 144." Fiberglass housing and jaws, nylon strapping. Use to clamp anything that needs to be glued. Father's Day Special. Order #01-0358, \$24.99 pre-paid. DOLLAR TRADING CORP., P.O. Box 8433, Grand Rapids, MI 49518. CT and MI residents please include sales tax. No Hassle. 30 Day Money Back Guarantee 1-800-447-7770. VISA/MC/AMEX orders.



Now you can keep work area, furniture and draperies dust free and eliminate the harmful effects of breathing wood dust. English's quiet, heavy-duty Dust Collector features 2 large chambers to collect chips, shavings and dust and filter the air you breathe. 21"H x 23"W x 26"L. \$379.50 (Prepaid). To order or to get a free catalog, write or call: P.C. ENGLISH, INC., P.O. Box 380, Dept. WM69, Thornburg, VA 22565. 1-800-221-9474.



Wood Identification Kit. What better gift for the serious woodworker than a collection of 50-4" x 9" veneer samples of the world's choicest woods. We have also INCLUDED the illustrated book "FINE HARDWOODS SELECTION" showing 174 species of woods. This combination set of samples and book is only \$20.45 ppd. CONSTANTINE'S, 20504WD Eastchester Road, Bronx, N.Y. 10461.



Wooden Whirligigs: A Gardener's Fancy! Summer gardens aren't complete without one of these early American whirligigs to amuse your fancy and to intimidate the local gopher. All the whirligigs come in three varieties of kits for varying skill levels in addition to kits for toys, doll houses, classic cars and swing sets. Bulk prices are available. Catalog subscription \$1. CHERRY TREE TOYS, P.O. Box 369-309, Belmont, OH 43718... or phone 1-614-484-4363.



Master Screwdriving Set. Quick-change magnetic insert bit set - perfect gift for professional or do-it-yourselfer. Includes hand driver, bit holder for power driving and 1/4" square drive socket adapter. 26 Phillips, slotted, Torx, square recess, clutch and Allen bits included. Retail approximately \$37.50. VERMONT AMERICAN TOOL CO., P.O. BOX 340, Lincolnton, NC 28093-0340. 1-704-735-7464.



The RBI Hawk Precision Scroll Saw. America's best selling scroll saw can give you the capabilities you need at a price you can afford. RBI Hawk 220 (20" Throat) available at special price of \$699.00. Call or write: STEVE H. WALL LUMBER CO., Route 1, Box 287, Mayodan, NC 27027. 1-919-427-0637



Personalize your finished projects with BrandMark's solid brass, torch-heated branding iron. Easy to use, lasts for years, satisfaction guaranteed. Makes an ideal gift. Custom irons available. Standard "Handcrafted By" and your name (20 letters), \$24 plus \$2.50 s/h. Check and all major credit cards accepted. Order from BRANDMARK by F&K, Dept. W3, 462 Carthage Dr., Beavercreek, OH 45385. 1-800-323-2570 or 513-426-6843.



Raised Panels, Moldings & More! This extremely versatile set allows you to produce fine cabinet doors and exciting moldings. With the 99-PK1 multi-profile bit, you can produce over 39 different profiles for molding or edge decorating. Designed to be used with a 1/2" table mounted router, this set is ideal for both professional and personal use. Freud #95-100. FREUD, P.O. Box 7187, 218 Feld Ave., High Point, NC 27264.



What a great gift idea! A 50 year calendar as small as a pocket watch. Made of solid brass and highly polished it will give the month and day at a glance until the year 2035. It is ideal as a paper weight too. They're inexpensive so why not order a few. \$6.50 each postpaid, two for \$12.00 or six for \$30.00. ARMOR PRODUCTS, Box 445, East Northport, NY 11731. New York residents add tax.



Stop perlboard hook fall-out forever! M-Clips are the guaranteed perfect solution to this annoying problem. M-Clips lock into adjacent holes and hold hooks tightly. Fits both 1/8" and 1/4" perlboard. Send SASE for free sample or \$5.99 plus \$1 P&H for package of 50 to: AETECH, Dept. W, Box 6298, Lawrenceville, N.J. 08648.



Build tomorrow's heirloom today! "Merrilegs" is designed to capture the spirit and beauty of a child's loyal steed as well as provide pleasure and satisfaction for the woodworker. Build this Rocking Horse using our full-size, easy-to-make plan. Plan #121, \$12 ppd. Catalog of 200 professionally designed plans for building furniture - \$2. FURNITURE DESIGNS, INC., 1827 Elmdale Ave., Glenview, IL 60025; UPS COD 312-657-7526.

Exotic & Domestic Hardwoods

BereaHardWoods.co

Quality exotic lumber and turning wood. Most exotic species available such as rosewoods, ebony, etc. Specializing in highly decorative lumber and turning wood from Australia / Tasmania. THE BEREA HARDWOODS CO., 125 Jacqueline Dr., Berea, OH 44017. 1-216-243-4452.



Ring Master - A unique woodwork machine that father will be delighted to receive on "His Special Day". The works of art that he will create on his Ring Master will be enjoyed by family and friends for years to come. The Ring Master is designed to cut exotic wood boards into concentric rings from which he can make any hollow cylindrical shape. For more information contact RING MASTER 1-800-634-9281.



Sand on a cushion of air! We supply 5 free "flexible" sanding sleeves to go along with the 1 1/2" diameter x 4" long heavy-duty sander. Chuck into your drill press or drill (3/8" shaft incl. in drum) & quickly polish out scratches, burns & cutting marks. \$33.95 + \$2.75 s&h. Cat. #01605. INDUSTRIAL ABRASIVES CO., 642 N. 8th St., Reading, PA 19603. 1-800-428-2222, 1-800-222-2292 (PA only).



Edico is offering a bundle of lumber. 10 board feet of 3/8" shorts, 3" and wider, 18" - 36" long in cherry, oak or walnut. Includes a "How To" project book and top-grade lumber catalog! Only \$39.95 delivered. Specify species and send check or money order to EDUCATIONAL LUMBER COMPANY, Box 5373 W, Asheville, NC 28813.



1", 3/4" & 1/2" spindle, 3 HP reversible speed, 9000/12000 RPM. Router bit chuck. Side & top hold-down. Steel fence & dovetailed miter gauge. Dead collar for irregular surface. 25" x 22" milled table. 2 1/2" spindle travel. Weight 395 lbs. TCM INDUSTRIES, INC., 322 Paseo Sonrisa, Walnut, CA 91789. Call toll-free 1-800-654-7702. In CA, call (714) 594-0780.



Musicmaker's Keep Book - a 36 page resource catalog for building and learning to play handmade musical instruments. This source book contains plans, blueprints, kits, books, hardware, strings and accessories for building such instruments as guitars, banjos, dulcimers, harps, violins, pipes and more. Catalog \$1.00. ST. CROIX KITS, 423 South Main, Stillwater, MN 55082. 1-800-432-KITS.



Upgrade your table saw to precision standards with the Vega Retrofit Saw Fence System that readily attaches to most table saws, featuring Micro Adjustment, incredible accuracy and optional "Finger Saver." Vega also manufactures a wide variety of Precision Woodworking Machinery and accessories. Call or write for details. VEGA ENTERPRISES INC., R.R. #3, Box 193, Attn: Dept 689, Decatur, Illinois 62526. (217) 963-2232.



The new RBI 720 Woodplaner-Molder-Sander-Power Fed Gang Rip Saw is built to handle any of these 4 basic woodworking functions with speed, precision, and set up is easy with RBI's patented quick change cutterhead system. Available in 8", 12" and 20" models. Proudly Made in America. RBI, 1801 Vine St., Harrisonville, MO 64701. 1-800-535-8665.



WILDLIFE CARVING patterns and instructions for creating unique wildlife sculptures from scrap wood. Developed with the beginner in mind. A great starter booklet for those wanting to try wildlife carving. Send \$6.50 to Wildlife Carving, DAKOTA WIND, Box 866, Jamestown ND 58402.



Curved molding, raised panels, dowels, crowns, and many others. Quick changeover, Five-year Warranty, and Free Thirty Day Trial. Whether you're a do-it-yourselfer or professional, you can rely on the W&H Molder/Planer to perform a range of woodworking jobs quickly, smoothly, and with warranted dependability. WILLIAMS & HUSSEY MACHINE CO., INC., Riverview Mill, P.O. Box 1149, Wilton, NH 03086.



"Merle," the adjustable corner clamp, forces your project into square. Fully adjustable from 25/8" x 25/8" to 69" x 69". Perfect for anything that requires 90 degree corner clamping. Cast aluminum and steel construction; quick and easy to use. \$22.95. MLC'S LTD., P.O. Box 4053D, Rydal, PA 19046 or call toll-free 1-800-533-9298. Visa/MC.



Now you can lay out precise letters and numbers for your wood craft projects. Scrollsawers and sign carvers use these specially designed lettering layout guide sets. Quick and easy-to-use - simply trace around the letters - guides are very durable. Several styles and different sizes are available. Brochure \$1. SEYCO SALES, 1414 Cranford Drive, P.O. Box 472749, Garland, TX 75047.



DRUM SANDER: 15" capacity endless belt feed. Machine will reduce hours of sanding time to minutes! Sands wild grain, frames, veneers and boards perfectly flat and uniform in thickness. Sells for less than \$1,000.00. American made! Call ROSS INDUSTRIES INC. (417) 223-4031.



The new compact Delta 8 1/4" Bench Saw comes with carbide-tipped 8 1/4" diameter x 20 ATB saw blade. 20" x 26" table expands to 44" x 26" with accessory extension wings; made of "space-age" corrosion-proof materials. Cuts dimensional 2 x 4 lumber. Self-aligning rip fence with single control and miter gauge. 2-yr. limited warranty. DELTA INTERNATIONAL MACHINERY CORP. Call toll-free 1-800-438-2486. In PA, call 1-800-438-2487.



NEW solid Walnut Radi-Plane lets you quickly and easily make perfect 45 degree chamfers adjustable from 1/16" to 1/4" wide on any board. When you feel the warmth of solid American Black Walnut in your hand, it will instantly become one of your favorite tools. Micro-adjusting twin cutters shape and finish a chamfer in a single pass. Chamfer Radi-Plane with extra cutter set and FREE hex key, \$25.45; plane and key, \$21.50. Free shipping. RJS CUSTOM WOODWORKING, P.O. Box 12354, Kansas City, KS 66112.



Classic through-dovetail joints, cut accurately, quickly and easily. Fast, simple set-up - no test cuts - with beautiful results. Variable spacing, too! Three models - for drawers, furniture, boxes and giftware. Warranted 20 years! Free information from KELLER & CO., 1327 "I" St., Petaluma, CA 94952. (707) 763-9336.



If you enjoy woodworking, a versatile Marlin Wood Carving Machine may be just what you need. Three-dimensional carving of sculptures, plaques, panels and mouldings is easy. Wood sign carving is simple. Available in three sizes. \$1 for complete catalog and price lists. MARLIN INDUSTRIES, INC., Route 70, Box 191, Cashiers, NC 28717. (704) 743-5551.



Yield House

Yield House: the best source available for solid pine furniture kits in fine American traditional designs. Kits include precision-cut, pre-sanded parts, hardware, furniture glue and easy-to-follow directions. Shown: the Bradford Desk. Call for your free catalog: 1-800-258-4720, Dept. DW95A.

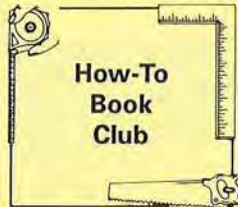

How-To Book Club is offering YOU (or your Father) the opportunity to receive 5 books, of YOUR choice, plus a FREE gift for ONLY \$3.95! Values to \$137.75! For details, write or phone: HOW-TO BOOK CLUB, Attn. L. Nunemaker, Blue Ridge Summit, PA 17294-0800. 1-800-822-8138.



There always seems to be one certain hanger which works best for each different item you need to hang. This 370-piece assortment includes 14 different hangers - 140 in all plus 230 fasteners and organizer box. Order #8403 Assortment at \$14.99 plus \$3.50 per order for P&H to MEISEL HARDWARE SPECIALTIES, P.O. Box 70 FD, Mound, MN 55364.



Wagner Safe-T-Planer. Absolutely Safe! Impossible to grab or kick back. Planes, tenons, rabbets make raised panels, rosettes, frames and more. Use on your drill press, \$35.00; on your radial arm saw, \$40.00. State make, model, shaft diameter. \$2.50 S&H. Guaranteed. Free literature. Order direct. G&W TOOL CO., P.O. Box 691464, Tulsa, OK 74169. (918) 486-2761.



Dremel's Freewheeler cordless Moto-Tool frees do-it-yourselfers to do even more home, auto and outdoor projects. The Model 850 Freewheeler uses advances in battery technology to cut the Moto-Tool's cord without sacrificing its high speed and usefulness. Suggested retail price for Model 850 two-speed cordless rechargeable Freewheeler is \$71.50. Available in new, attractive clamshell package throughout the U.S. at hardware, homecenter and hobby stores. (414) 554-1390.



New Skil Plunge Routers are the most powerful, fully featured do-it-yourself Plunge Routers available. They operate at 25,000 RPM, have all ball bearing motors, unique wrench storage, a flat top and collet lock. Suggested retail prices: Model 1835 (1 3/4 H.P. with bit storage in handle), \$110.99; Model 1823 (1 1/2 H.P.), \$93.99. Write or call SKIL CORPORATION, 4300 West Peterson Avenue, Chicago, IL 60646. (312) 794-7495.



Deluxe Cabinetmaker's Screwdrivers will fast become your favorite. Features special London pattern forged blades, precision ground tips, oval beech handles and brass ferrules. Set includes 3", 4", 5" and 6" drivers. A \$39.95 value, Wood readers can order this deluxe set for only \$29.95. Order #15W61 from WOODCRAFT SUPPLY, 41 Atlantic Ave., Woburn, MA 01888; credit card orders can call toll-free 1-800-225-1153.

Heavy Duty Woodworking Bench



"Father's Day Special" - List \$1,200.00, Now \$805.00. Your most important investment, and the foundation of all fine woodwork, is a proper bench. This German Master Joine Bench is 78 3/4" x 25 3/8". Don't miss this opportunity! JOHN HYMILLER - WOODWORKER. For Visa/MC, call (615) 484-9309.



Moisture-related problems such as shrinking, warping and cracking can ruin the most beautiful wood-pieces built. Avoid wood moisture problems by checking the wood with a moisture meter! The pocket-size Mini Ligno moisture meter is for the serious hobbyist and professional woodworker. LIGNOMAT, P.O. Box 30145, Portland, OR 97230. (503) 257-8957 or (800) 227-2105.



All-in-One Combination Machine is the best machine buy in the United States. 10 1/2" table saw, 1" spindle shaper (reduces 1/2 & 3/4), 12" jointer, 12" x 8" planer, 9/16" chuck mortiser. American Express now accepted. ATLANTIC MACHINE TOOLS, 8301 Monroe, Houston, TX 77061. (713) 947-7030.



Everything you need to repair cracks, loose joints and fill splits. Superior bonding, material will not crack, tear loose or break out. Fix your own projects or make money repairing furniture as a hobby/business. Complete instruction manual shows how to handle big structural repairs as well as quick-fix problems, \$249.95. Complete furniture restoration catalog, \$2. FREE professional workshops offered. MINUTEMAN, INC., Dept. 17C, 115 N. Monroe, Waterloo, WI 53594.



Unlock your creativity with our new Model 435 Scroll Saw. Features an extra large 20" throat and 2" depth of cut, a chuck that allows the blade to rotate a full 360° a 12" x 12" cast-iron worktable that tilts from 0° to 45° left or right, a variable speed control for the motor that adjusts cutting speed control for the motor that adjusts cutting speed from 600 to 2,000 strokes per minute. FOLEY-BELSAW COMPANY, 6301 Equitable Rd., Dept. 42021, Kansas City, MO 64120.



Band saw owners! A new tool is now available that enables craftsmen to make or repair any length band saw blade! Our splicer is available in two models: 1C-001 for 1/4" to 3/4" blades and 1C-002 for 1/8" to 3/8" blades each \$49.95 ppd. Comes complete with instructions and supplies for approximately 100 splices. NEW MILFORD SPECIALTIES CO., DEPT. BHG, P.O. Box 241, Botsford, CT 06404-0241. 203-426-4276.



Like a third hand. Provides that extra support so often needed. Its rugged, heavy-duty, all-steel construction makes it a tool you'll depend on for years. Roller is 13" long, galvanized and ball bearing. Adjusts in height from 25 3/4" to 45". When you're done, it folds flat. #HPR-13, \$39.95 + UPS. HTC PRODUCTS, INC. Toll free 1-800-624-2027. In MI, 313-399-6185.



UNIQUE CONVERTIBLE SUN-SPACE IDEA – Insulated winter sun room converts to a breezy summer screen room for year-round enjoyment. The 2-in-1 Sun-Porch features do-it-yourself assembly, shatter-resistant glazing, and mounts readily on decks, patios, or landscape ties. Colorful catalogue, prices, sent first-class mail. Send \$2 to VEGETABLE FACTORY, Dept. Woo, Box 2235, NYC 10163.



Obtain the sharpest edge possible with the Veritas Precision Honing Guide. Takes chisels & plane irons up to 2 1/2" wide and 5/8" thick. Only \$19.95, we pay shipping. With optional Angle Setting Jig, only \$29.95. WOOD-LINE the JAPAN WOODWORKER, 1731 Clement, Alameda, CA 94501.



ELU Woodworking Tools 2 1/4 HP Electronic Plunge Router #3338, \$266.00. This precision-crafted tool for the professional woodworker or serious hobbyist features precision-depth-setting for speed and accuracy when plunging and variable speed. Call for catalog and FREE router bit chart. WILLIAMS TOOL SALES, INC. 1-800-338-6668.



The Makita 6093 DW drill comes complete with a one hour fast charger, 9.6 volt battery, steel carrying case, and double-ended Phillips bit. The 6093 DW drill kit is variable speed (0-400 and 0-1100 RPM) with six position clutch for a variety of fastening applications. List price \$248, yours for \$119. TOOLS ON SALE, 216 W. 7th St., St. Paul, MN 55102. Call toll free 1-800-328-0457. In MN, call 612-224-4859.



Foredom Craft Kit gift special only \$204.90 (includes shipping). A \$253.00 value! This complete package includes our most popular machine and a variety of the most useful accessories. Powerful 1/8 HP motor. Order catalog number X0510B, CRAFTSMAN WOOD SERVICE CO., 1735 West Cortland Court, Addison, IL 60101. 1-800-543-9367.



Multi-Form Molding Maker – Makes beautiful large and small moldings. At last a carbide-tipped bit that will produce dozens of different profiles in one pass. With two or more passes the possible patterns are almost unlimited. This production quality bit has a 1/2" shank, two flutes, tungsten carbide tips, and is supplied with ball bearings. Order item #159, \$50.00 (postage paid). MLCS LTD., P.O. Box 4053D, Rydal, PA 19046. Visa or MC or COD. Call toll free 1-800-533-9298.



Precise wide surface sanding at an affordable price is now available. You select the components to fit your budget and your needs. The Performax S/T Sander attaches to radial saw, to Stand Hardware Kit or the new Pro Stand. Manual Feed or optional Power Feed Conveyor unit can be added. Free brochure: PERFORMAX PRODUCTS, INC., 11975 Portland Avenue South, Suite 142, Burnsville, MN 55337.



Heavy cotton canvas tool bags with hinged steel frame, leather handles and straps. Large and medium bags have leather reinforced bottom. Prices include shipping. Model #20J12.01/Large (20"L x 8"W x 14"H), \$65.20; Model 69J02.02/Medium (18"L x 5 1/2"W x 13"H), \$54.90; Model 69J02.03/Small (16"L x 5 1/2"W x 13"H), \$44.80. Available from GARRETT WADE Company, 161 6th Avenue, New York, NY 10013. (800) 221-2942.



FREE
30-DAY
TRIAL!

Complete power-feed Drum Sander with stand and motor. 12" x 38" models. In seconds produces satin-smooth finish impossible to duplicate by hand methods. Send for Free information kit. WOODMASTER TOOLS INC., P.O. Box 412551, Kansas City, MO 64141.



Easy to build...beautiful to display. Choose from these 1/6 scale woodworking masterpieces: V1. Victorian Glider Pony; V2. Old English Rocking Horse; C1. Early American Carousel Mare; C2. French Carousel Rabbit; C3. 19th Century Carousel Lion. Plans \$14.95 ea., 3 for \$29.95, or all 5 only \$44.95. Precut kits \$49.95 ea. Brochure \$1 (free with order). THE MASTER'S WORKBENCH, 6325 S.E. Stephens St., Dept. BW-9FA, Portland, OR 97215.



Best value gift. This 3HP shaper comes with 1" & 3/4" spindle, spring hold down; 28" x 30" cast iron table, magnetic switch, forward/reverse control, 8000/10000 RPM, 110/220V, 1 PH, table insert, mitre gauge. Sale price only \$799. Free catalog. LOBO POWER TOOLS, 10922 Klingerman #3, S. El Monte, CA 91733. 818-350-1096.



Cut a precise 1/4" thick tongue and have raised panel at same height as rail and stile. Cascade Tool's new S Brand 3" O.D. panel raisers come complete with undercutter, spacer, and top-mounted template bearing for cutting cathedral panels or free-hand use. 1/2" Shank Cutters avail. in 5 different panel raiser profiles, \$59.95 ea. 2 5/8" O.D. panel raisers, avail. in 5 profiles, \$29.95 ea. Available from CASCADE TOOLCO., Box 848, Mercer Island WA 98040. 1-800-235-0272 or 1-206-236-0272.



\$101,750...Carousel animals are expensive! Invest your talents instead of \$'s. The 1/6 scale masterpieces go beautifully anywhere. Your choice: Carousel Mare, Rabbit or Lion. Plans \$14.95 ea. All 3 only \$29.95. Precut kits \$49.95 ea. Brochure \$1.00 (free with order). THE MASTER'S WORKBENCH, 6325 S.E. Stephens St., Dept. BW-9FB, Portland, OR 97215.



Send for the new SHOPSMITH catalog. It's for all woodworkers! 92 pages filled with a complete line of woodworking items for your shop. Layout, sawing, finishing and more. Plus, a complete education section and all Shopsmith store locations nationwide. \$1.00. SHOPSMITH, 3931 Image Drive, Dayton, OH 45414.



Personalize your wood items quickly and easily with this brass branding iron. First line: HAND CRAFTED BY; second line: Your choice of up to 20 characters including spaces. Compact size. \$26 ppd. Guaranteed. Order toll-free 1-800-826-7606 (NE residents call 402-464-0511) or by mail from NOVA TOOL CO., P.O. Box 29341, Dept. BGL, Lincoln, NE 68529. Shipped within 1 week.



If you value your fingers you need RIPSTRATE®. Holds the work tight against the fence with no hands near the blade; makes perfect cuts; wheels lock to prevent kickbacks. No adjustment needed for stock width or thickness. One year guarantee. \$69 ppd. + \$3.50 s&h. Check, M.O., Visa or MC. Free brochure. FISHER HILL PRODUCTS, 4 Fisher Hill, Fitzwilliam, NH 03447. 1-800-421-0256.



Executive wood toys! Now you can create this 1929 Ford showpiece and many others like it from our detailed and easy to read patterns. We offer you a complete line of patterns, parts and wheels. Make this day a time to remember with one of our executive wood toys! Send \$1 for catalog to: TOYS AND JOYS, Box 628 GL, Lynden, WA 98264.



Multi-Stop. Precisely and repeatedly position work on tablesaws, radial arm saws, miter saws, and many more machines. Quick-cam action allows you to move this jig very quickly. This is a very high quality tool that is extremely useful. Model G1821 - \$27.50. GRIZZLY IMPORTS, INC., P.O. Box 2069, Bellingham, WA 98227. 1-800-541-5537.



Join the fastest growing woodcarving organization in the world! Get a one year subscription to "The Mallet" magazine, a woodcarver's publication reaching woodcarvers across the U.S. and 19 foreign countries each month. Send check or money order for \$20, or \$2 for an introductory packet to THE NATIONAL CARVERS MUSEUM, P.O. Box 389, Dept. W, Monument, CO 80132. For Visa or MC, call (719) 481-4737. Please allow 3-4 weeks for delivery.



1250 HOME DESIGNS ONE OF THEM IS YOURS.

You and your family will enjoy browsing through the hundreds of traditional and contemporary home designs, each featuring detailed exterior illustrations and innovative floor plans.



(1) 315 ONE STORY HOMES UNDER 2,000 Sq. Ft.
Create a fantastic home on a modest budget. Gathering rooms, formal and informal dining, two to four bedrooms, great indoor/outdoor livability. 192 pages. \$4.95



(2) 210 ONE STORY HOMES OVER 2,000 Sq. Ft.
Enjoy gracious living in one-story, Spanish, Western, Tudor, French, Contemporary and other styles. Sunken living rooms, master bedroom suites, atrioms and courtyards. 192 pages. \$4.95



(3) 150 1-1/2 STORY HOMES
Explore Cape Cod, Georgian, Tudor and Contemporary homes in low-budget and country-estate sizes. Formal dining rooms, sloped ceilings, country kitchens, covered porches and terraces. 128 pages. \$3.95



(4) 360 TWO STORY HOMES
Experience two-story living at its finest. English and American Tudors, Farmhouses, Georgians, Southern Colonials, French Mansards and more! Fabulous entryways, gathering rooms, libraries and dining rooms. 288 pages. \$6.95



(5) 215 MULTI-LEVEL HOMES
Discover new dimensions in family living! Exciting designs for flat and sloping sites. Bi-levels, tri-levels, hillside homes with sloped ceilings, balconies, decks and terraces. 192 pages. \$4.95



(6) 223 VACATION HOMES
Recreation or year-round homes. A-Frames, Chalets, Hexagons, Ski Lodges, and Cluster Homes. Dual-purpose spaces, decks, balconies, terraces, lofts and fireplaces. 176 pages. (120 in full color). \$4.95



SAVE! Order our complete collection, all 6 books, a \$30.70 value, for only \$19.95!

**Credit Card Orders Call
Toll-Free 1-800-322-6797**

HOME PLANNERS, INC.

Satisfaction Guaranteed!

Dept. BK, 23761 Research Drive, Farmington Hills, MI 48024

Please RUSH by return mail (check choice):

- | | |
|---|--|
| <input type="checkbox"/> (1) 315 ONE STORY HOMES (under 2,000 sq. ft.) \$4.95 | <input type="checkbox"/> (4) 360 TWO STORY HOMES \$6.95 |
| <input type="checkbox"/> (2) 210 ONE STORY HOMES (over 2,000 sq. ft.) \$4.95 | <input type="checkbox"/> (5) 215 MULTI-LEVEL HOMES \$4.95 |
| <input type="checkbox"/> (3) 150 1-1/2 STORY HOMES \$3.95 | <input type="checkbox"/> (6) 223 VACATION HOMES \$4.95 |
| | <input type="checkbox"/> SEND ALL 6 BOOKS AT \$19.95 (A \$30.70 VALUE!) |

Name _____ BHS95WW

Address _____

City _____ State _____ Zip _____

In Canada, add 20% to above prices and mail in Canadian funds to:
HOME PLANNERS, INC.
20 Cedar St. N., Kitchener, Ontario N2H2W8

Amount Enclosed: \$ _____
Add \$1.50 for Postage.
Mich. residents add 4% sales tax.

FULL SIZE Woodcraft PATTERNS



SIMPLE TO MAKE ★ FUN ★ PROFITABLE

- 125 pattern packet PLUS "Shop Secrets"
- Over 50 "Folk Art" patterns PLUS projects
- 6 enjoyable "Wind-Action" whirligigs
- 100 yard ornaments, animals, birds and more
- 27 toy cars, trucks, train, ferry and more!
- 17 "Show Stoppers" - craft show best sellers

Send \$7.00 per blueprint packet or
choose any 3 FOR ONLY \$14.00.

Fast Service • Satisfaction Guaranteed!

ACCENTS Dept. MA59, Box 7387, Gonic, NH 03867

Catalog of 1000 patterns \$2.00 (Free with order)

INDUSTRIAL QUALITY BAND SAW BLADES

72" 1/8 - \$7.57 3/16, 1/4 - \$7.11 5/16, 1/2 - \$7.31

93 1/2" 1/8 - \$9.04 3/16, 1/4 - \$8.43 5/16, 1/2 - \$8.69

- 1/8 - 9S SCROLL-WOOD
- 1/8 - 14R SCROLL-WOOD/PLASTIC
- 3/16 - 4S WOOD
- 3/16 - 10R FINE CUT-WOOD/PLASTIC
- 1/4 - 4PRX RESAWING
- 1/4 - 10R FINE CUT-WOOD/PLASTIC
- 1/4 - 110R, 14R, 16R, 24W WOOD/PLASTIC/METAL
- 1/4 - 10R FINE CUT-WOOD/PLASTIC
- 1/4 - 14R WOOD/PLASTIC/METAL
- 1/4 - 10R WOOD/PLASTIC/METAL
- 1/4 - 4PRX RESAWING

ALSO FOR 93 1/2" 3/4 - \$10.76

- 3/4 - 2PRX RESAWING
- 3/4 - 6R WOOD/METAL

BAND SAW BLADES WELDED TO ANY LENGTH. FULL LINE IN STOCK -
Other widths - teeth and Bi-metal available



CHANDLER BAND SAW, INC.
3498 N. San Marcos Pl. - #3, Chandler, AZ 85224
1-800-THE-BLADE
AZ 602-892-0120 (No collect calls)

S & H \$2.75. AZ res. add 6 1/2% sales tax. For prompt shipment send money order, cashiers check. Personal checks allow 2-3 weeks. C.O.D. \$2.75 additional (cash, money order, cashiers check).

* FREE BAND SAW BLADE OF EQUAL OR LESSER VALUE.

FREE WOODCARVER'S WISHBOOK



You'll find everything you need for decoy, bird and woodcarving in our new 48 page Wishbook including a complete line of special tools, cutouts, patterns, paints and supplies—all backed by our unconditional guarantee.

Send for your FREE catalogue today or
Call Toll Free 1-800-221-9474.

P.C. English, Inc.

P.O. Box 380, Dept. W59, Thornburg, VA 22565

NEW AND UNUSUAL TOOL CATALOG

Over 100 pages of latest books and quality woodworking hand tools at NEW LOW PRICES. Send for FREE FROG CATALOG today.

FROG TOOL CO. Ltd.
P.O. Box 8325 Dept. WM14
CHICAGO, IL 60680
Store: 700 W. Jackson

A BETTER FENCE? PRECISELY!

- Exclusive Micro Adjust
- Extreme Accuracy
- Faster Installation
- More Safety Features
- Satisfaction Guaranteed

Call or Write For Details

"American Manufacturers of Fine Woodworking Equipment"



H.R. S. DEPT. 099
DECATUR, N. G2526 • 217-963-2232

SHAKER PEGS CANDLE CUPS MUG PEGS

\$17.95 per 100, prepaid.
Wide selection of other wood products.

Catalog \$2.00 or free with order.

Benny's Woodworks

P.O. Box 840, Dept. WD15
Shelbyville, TN 37160
1-615-437-2295

Shaker Peg



Mug Peg



Wood-Mizer®

World's Largest Manufacturer Of Portable Sawmills



OWN YOUR OWN SAWMILL

Four Models To Choose From
BUY DIRECT

1(800)553-0219

In Indiana call: (317) 271-1542
44-page catalog or use your MasterCard or VISA to order our 50-minute demonstration video—\$10.00

Wood-Mizer Products, Inc. • Dept. QQ32
8180 W. 10th St., Indianapolis, IN 46214-2430

Where Do Ohio's Serious Woodworkers Shop?

**WOODCRAFTERS
SUPPLY®**

5331 Sinclair Road
Columbus, Ohio 43229
(Off I-71)
(614) 436-6900

Wood Moisture Meter

- Avoid Moisture Problems
- Protect your Masterpiece

MINI LIGNO

Incl. Case, Batteries and Pins for 3/4" and 1/2" Measuring Depth.

only \$110

also from Lignomat:
MINI-LIGNO E
Range: 6%

Easy-to-use, sturdy instruments for the professional woodworker or serious hobbyist. Great for lumber, veneer, fiberboards. Ask for free catalog on the complete line of moisture meters and accessories for kiln drying.



Lignomat USA Ltd.

P.O. Box 30145bh
Portland, OR 97230

OCTAGON PICNIC TABLES

Plans \$16.75

Easy to follow plans, instruction sheet and step by step pictorial.

Features include, walk through seating, ability to seat eight people in a sociable circle, the strength of a bolted construction.



Specialty Furniture Designs of Michigan

797 West Remus Road, Mt. Pleasant, MI 48858
VISA/MC Accepted MI. Res. Add 4%

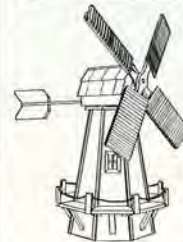

BUILD THIS AUTHENTIC DUTCH WINDMILL

Windmill swivels into the wind while the blades turn on low-cost and readily available bearings.

Surprisingly easy to build.

Plans take you through every step of construction. 40 illustrations.

Size: 53" high, 19" wide at base.

For complete plans, including "Mass Production Aids & Techniques" handbook, send \$9 to:

R.L. Zirbel, Box 338-B
Maplewood, WI 54226

FUN-PROFITABLE-EASY TO MAKE PROJECTS

WOODCRAFT

-full size patterns-

A. 10 Exciting Patriotic Projects
B. 17 Country Felina Projects
C. 9 Exclusive Folk Art Horses
D. 45 Country Folkart Figures
E. 10 Old Fashioned St. Nicks
F. 20 Craft Show Best Sellers
G. 24 New Shelf Critter Designs
H. 12 Country Shelf Designs
J. 14 Folk Art Shell Sitters
K. 10 Country "DAWG" Projects

\$5.00 EACH
3 FOR ONLY \$13.00

The Winfield Collection, Dept W4
12044 Parkin Lane, Fenton, MI 48430
CATALOG \$1.00—FREE WITH ORDER

Information



WORTH WRITING FOR

You can get useful ideas and product information by mail. Use the coupon in this section to order your choice of literature listed below.

POWER TOOLS

SCROLL SAW AND LATHE INFORMATION — More than 20 pages of information, including full-color photos, on HEGNER precision scroll saws, HEGNER lathes, and HEGNER duplicators. Find out why these machines are considered state of the art, and what to look for when shopping for scroll saws or lathes. AMI, LTD. \$1.00. *Circle No. 3.*

WOODWORKING PROFESSIONALS ONLY — Now save 50% on machinery, 70% on operating costs! How? By using the world's finest production quality universal machine. Commercial durability, utmost precision, set-up in seconds. No other tool combines usable capabilities like FELDER. Thousands sold all over the world. Now available in America through AMI. Send for brochure. AMI LTD. \$1.00. *Circle No. 4.*

THIS IS IT! THE CATALOG YOU'VE BEEN WAITING FOR!—ACME's catalog contains everything you need whether you're a professional woodworker, hobbyist, or contractor. All 120 pages are fully illustrated, and contain some of the lowest prices on name brand manufacturers that you will find anywhere. A must for anyone serious about saving money. ACME ELECTRIC. \$2.00. *Circle No. 6.*

BOSCH BELT SANDER, MODEL 1273DVS—10.5 amp 4"x24" Belt Sander with 6 speeds, speed selector guide. Use higher speeds with coarse grits; slower, with finer ones. Faster belt changes, automatic belt tensioning; uses dust collection bag or vacuum-boosted Bosch Air Sweep™ system. BOSCH POWER TOOL CORP. Free. *Circle No. 17.*

BOSCH LAMINATE TRIMMER KIT, MODEL 1608—Trim laminates, veneers; 5.6 amp motor. Complete with all bases; accessories for shop, installation tasks. One base handles routine cuts; tilting base trims odd angles or up to vertical surface; offset base for corners, angles. BOSCH POWER TOOL CORP. Free. *Circle No. 18.*

BOSCH 3 HP PLUNGE ROUTER—Ergonomics, superior safety and operator control, plus wanted features mark the Bosch 1611, 3 hp, 22,000 no load rpm Plunge Base Router. Controls are located so operator's hands stay on over-sized handles. Collet capacity to 1/2-inch. BOSCH POWER TOOL CORP. Free. *Circle No. 19.*

BOSCH JIG SAW, MODEL 1581VS—Virtually vibration-free top handle model has 6 speeds; 4 blade orbits. Controls; blade lock and guide; tilting footplate; blade options; and 4.8 amp motor let you meet sawing requirements with precision. BOSCH POWER TOOL CORP. Free. *Circle No. 20.*

FREE FULL COLOR POWER TOOLS APPLICATION GUIDE/CATALOG—from Dremel describes company's complete line of compact power tools, attachments, and accessories. It features newly designed Moto-Tools, Flex-Shaft attachment, and drill press. Literature also includes descriptions of 170 different bits for cutting, carving, polishing, clearing, routing, grinding, engraving, and more. DREMEL. Free. *Circle No. 33.*

FREE WOODWORKING POWER TOOL CATALOG—Buy planers, jointers, shapers, table saws, scroll saws, band-saws, drill presses, wood lathes, sanders, dust collection systems, and more...direct from the factory and save. Foley-Belsaw sells direct to you...so you save on every purchase. You'll find quality power tools, plus hand tools and accessories to meet all of your woodworking requirements. Complete money-back guarantee. Send for details. FOLEY-BELSAW. Free. *Circle No. 41.*

MANUFACTURED SINCE 1926—the Foley-Belsaw Model M-14 Circular Sawmill lets you go right to the trees to turn out smooth, true-cut lumber. Available with heavy-duty steel base or with plans and track provided for owner built wood base. Will accurately saw logs up to 14 ft. in length and up to 24 in. in diameter. Complete money-back guarantee. Send for details. FOLEY-BELSAW CO. Free. *Circle No. 42.*

INCA MACHINERY INFORMATION—Complete information on the famous line of Inca Swiss woodworking machines. Designed for precision work by the small to medium sized cabinet shop. Used by thousands of hobbyists and professionals. Table saws, bandsaws, joiner/planners, dust collector, radial arm saw. GARRETT WADE CO. Free. *Circle No. 44.*

KELLER DOVETAIL SYSTEM—"In a class by itself" — Wood Magazine. Beautiful through-dovetail joints made accurately, quickly and very easily with your router. For novice and pro. Warranted 20 years! Send for full descriptions. KELLER & CO. \$1.00. *Circle No. 56.*

LOBO POWER TOOLS—Our lower prices make our fine woodworking machines more affordable for you, "our customers." We sell a complete line of band saw jointers, planers, drum sanders, shapers, and much much more. All of our machines come with a 1-year warranty. Order today for a free catalog. LOBO POWER TOOLS. Free. *Circle No. 57.*

VERTICAL PANEL SAW/PANEL ROUTER PLANS—Now even working alone you can make deadly accurate rip and cross cuts up to 5 ft. wide in plywood, particle board, plastic laminates and most sheet goods. Instant set ups on V-Grooves, Dadoes and more. This extremely versatile tool is perfect for cabinet shops, sign shops and home workshops. Send for more info. BRAD O'CONNOR. Free. *Circle No. 70.*

SCROLL SAW—Information package available from Penn State Industries describing the specifications and applications of its super 15-inch scroll saw. Special discount pricing available on current promotion. PENN STATE INDUSTRIES. Free. *Circle No. 76.*

SURFACE PLANER—Information package available from Penn State Industries describing the specifications and applications of its super 12 1/2-inch surface planer. Special discount pricing available on current promotion. PENN STATE INDUSTRIES. Free. *Circle No. 77.*

QUINTEC PARALOCK TABLESAW FENCE—will help transform your ordinary table saw into the accurate woodworking instrument you need. Whether you're working with large panels or precision furniture joinery, the effortless accuracy of the Paralock Fence will make you a better and faster woodworker. QUINTEC MFG. Free. *Circle No. 80.*

QUALITY AMERICAN-MADE SCROLL SAWS—The RBI Hawk family of Precision Scroll Saws with 6 models. One to fit your needs. Patent pending Camover Quick Blade Change system, 2 way tilting tabletop, 2 speed or variable speed motor, all add up to make the Hawk the best value on the market today. Virtually end sanding forever! Send for the facts. RB INDUSTRIES, INC. Free. *Circle No. 84.*

AMERICAN WOODWORKING EQUIPMENT—Over 60 years of experience manufacturing first quality woodworking machinery. The RBI Woodplaner a leader in versatility and durability featuring planing, moulding, sanding and gang ripping capabilities all in one space saving machine. The RBI Joint Machine makes most precision joints simple to make in just seconds. Send for fact filled brochure. RB INDUSTRIES, INC. Free. *Circle No. 85.*

SAKURA SCROLL SAW INFORMATION—You owe it to yourself to compare the value-priced 14-inch 3-speed ScrollMate with other units before you make your buying decision. It offers a built-in air bellows; stand; quick, safe speed changes; and a full 2-year limited warranty—all at a price that's tough to beat. SAKURA USA. \$1.00. *Circle No. 87.*

SKIL CORPORATION—Full color, complete line, power tool catalog. Features cordless screwdrivers, drills and the cordless Skilwrench™. Corded products include circular saws, drills, drywall drivers, sanders, hammer drills, jigsaws, planes, roto hammers, sander/grinders, shears, routers, extra tools, bench top tools and reciprocating saw. All product accessories are also shown. SKIL CORPORATION. \$1.00. *Circle No. 88.*

THE VERSATILE TOOLMAX T310—woodworking machine solves the common "too small a shop" problem by combining a 10" table saw, 1" spindle shaper, 12" jointer, 12" planer and fully adjustable mortising table. Saves 90% on space and 60% on investment. Send for complete color information pack. TOOLMAX. \$1.00. *Circle No. 90.*

MOLDER-PLANERS FROM WILLIAMS & HUSSEY—Mold, plane, and edge, convert from moulder to planer in less than 2 minutes. The W-7 series is available in 3 models for manual, power in feed, or power in feed/out feed. The units plane to a satin, almost sanded finish, produce doll house to crown sized mouldings, raised panels, and virtually any shape profile. Custom knives available up to 7" wide and 3/4" depth of profile. Rugged, well-made, dependable, and transportable. Complete with sturdy movable stand. Send for catalog. WILLIAMS & HUSSEY. \$1.00. *Circle No. 93.*

PORTABLE SAWMILLS—Convert logs into valuable lumber—Wood-Mizer® Products manufactures a line of portable bandsaw mills that allows the novice as well as the experienced sawyer to safely convert standing logs into lumber. Then, with the use of our SolaryDry™ Kiln or Vacu-Kiln™ to dry your lumber, you could increase the value of every board you produce. We manufacture some of the most progressive woodworking equipment on the market

today. Product videos available. Send for our 44-page catalog. WOOD-MIZER PRODUCTS. \$1.00. *Circle No. 94.*

12", 18" and 25" PLANER/MOLDER/SANDER FROM WOODMASTER TOOLS—a size to meet any shop requirement...all with exclusive variable feed rate. Free information kit includes details on 30-day trial period and easy terms. WOODMASTER TOOLS, INC. Free. *Circle No. 99.*

COMPACT STROKE SANDER FEATURES BIG CAPACITY—The low-cost, Model 800 features three built-in speeds, a large, 24" x 48" sliding table with automatic elevation, and a traveling, lever-action, pressure platen. Open-ended design accommodates any length material. Long-lasting belts are 6" x 156". 30-day free trial! WOODMASTER TOOLS, INC. Free. *Circle No. 100.*

HAND TOOLS

WISE-GRIP™ LOCKING C-CLAMPS—and new, VIXE-GRIP locking bar clamps. All clamps available with self-leveling swivel pads to protect soft surfaces, and famous, time-saving, locking action. Sizes from 4-24 in. AMERICAN TOOL CO., INC. 25¢. *Circle No. 105.*

DIAMOND WHETSTONES BY DMT—Discover the ease and speed of sharpening on the finest Diamond Whetstones. Five sizes from 3" to 12" in fine, course, and extra course. Finest monocrystalline industrial diamonds permanently bonded in nickel. Lubricated with water rather than messy oil. Stays flat, unbreakable. Twelve years of serving sharpening needs. Satisfaction guaranteed. Send for full color catalog. DIAMOND MACHINING TECHNOLOGY, INC. \$2.00. *Circle No. 112.*

FINEST QUALITY WOODWORKING & CARVING TOOLS—Featuring Hirsch, Sorby, Footprint, and many other fine European and domestically made tools, books and plans. Carvers, turners and weekend woodworkers will appreciate these quality tools. Price of catalog is refundable with first purchase. NORTHLAND WOODWORKING SUPPLY. \$2.00. *Circle No. 115.*

PERSONAL BRANDING IRONS — Brochure describes branding irons that enable you to put your name on you work quickly and easily. Made especially for branding wood, they are available with 1, 2, or 3 lines of copy or with your logo. Changeable date also available. NOVA TOOL CO. \$1.00. *Circle No. 160.*

STAINS/FINISHES

DEFT SOUTHWEST COLLECTION PAMPHLET—Bring the colors of a desert sunrise into your home with Deft's new Desert Oak White Wood Stain and tint base. Pamphlet shows a wide variety of pastel colors available. DEFT, INC. Free. *Circle No. 215.*

FINISHING SUPPLIES—A complete selection of finishing products for furniture makers, woodworkers or hobbyists. Included are hundreds of name brand products—3M, Deft, Titebond, Watco, clamps, dyes, stains, sealers, and lacquers. Best prices in USA. FURNITURE CARE SUPPLIES. \$1.50. *Circle No. 221.*

BEAUTIFUL WIPE-ON WOOD FINISHING — is explained in a booklet from a pioneer in wipe-on finishes since 1928. Wood finishes that produce a beautiful hand-rubbed finish without messy brushes or spraying. Specially formulated finishes that simply wipe-on with professional results every time — guaranteed! Unlike conventional finishes these will never yellow, crack, or craze and they dry dustfree without runs. These finishes will bring out the natural beauty of the wood and never needs waxing. Send today for your wood finishing guide and products catalog. GENERAL FINISHES. 25¢. *Circle No. 225.*

ARTI ANILINE DYES—Color chart features 28 aniline colors and 8 toyemaker's colors. Price list and ordering instructions included. HIGHLAND HARDWARE. \$1.00. *Circle No. 232.*

PLANS

OVER 1000 WOODCRAFT PATTERNS!—Create gifts, toys, whirligigs, lawn ornaments, folk art, bird houses and feeders, magazine racks, household accessories, plus much more! Simple enough for the beginner, fun and profitable for the pro. Catalog plus sample pattern. ACCENTS IN PINE. \$2.00. *Circle No. 310.*

WOODWORKERS' PLANS AND SUPPLIES—Wood projects are simplified with the high quality plans, specialty hardware and other supplies offered by Armor Products. Over 100 plans are available for making toys, desks, clocks, pool tables, lamps, chests, and other furniture. Movements, dials, moldings, ornaments, dollhouse kits, door hardware and tuning pins are also available. ARMOR PRODUCTS. \$1.00. *Circle No. 315.*

BUILD MINIATURE HORSE-DRAWN VEHICLES—The Concord Stagecoach symbol of the Old West, the Conestoga Covered Wagon, and the Prairie Schooner are some of the vehicles you can build using our plans in 1/12 and 1/8 scale. Concord Coach and Conestoga are available in full size 1" scale cutting patterns. Also English vehicles, some in 1/20 scale cutting patterns excellent for beginners. Ready-made plastic wheels available for 1/20 scale vehicles. Also books featuring from England, "Making Horse-Drawn Vehicles" by John Thompson, who has done extensive work in this area. CRISS-CROSS CREATIONS. \$1.00. *Circle No. 332.*

PATTERNS BY DESIGN GROUP—Hundreds of interesting, useful and fun items to create for personal use or profitable sale. Our newest catalog contains plans for toys, games, plaques, puzzles, birdhouses, planters, furniture, and much more! All Design Group patterns are professional, "same size" blueprints. No enlarging or reducing is necessary. Simply trace outline of item onto wood and create! Started in 1977, Design Group has sold thousands of patterns to thousands of satisfied customers. Prices start at \$1.00, all patterns come with a full money-back guarantee. Wholesale and bulk prices are available on request. Fully illustrated catalog. DESIGN GROUP. \$1.00. *Circle No. 340.*

UNIQUE PROJECTS IN WOOD—including our whimsical Marble Tower. Marbles release automatically to cascade down ramps, over a xylophone, around a spiral funnel to ring bells and spin paddle wheels. Handsome styling for home or office. Also plans for clocks, dollhouses and furniture, tote projects, wooden guns, and our award-winning cavalry fort with men, horses and covered wagons. Send for illustrated brochure including free motorcycle and helicopter plans, plus 8 new and practical shop tips. FOREST STREET WOOD DESIGNS. \$2.00. *Circle No. 344.*

FULL-SIZE FURNITURE PLANS CATALOG—Illustrates and describes over 200 plans for making furniture of quality found in museums and fine furniture stores. Plans include rolltop desk, cradles, dining tables, chairs, buffets, chests, gun cabinets, poker table, children's furniture, rocking horse, spinning wheels, and more. Bill of materials exploded drawings assist the woodworker. FURNITURE DESIGNS, INC. \$2.00. *Circle No. 345.*

STICKLER FOR DETAIL?—At last an exciting new line of realistic wood block models that you can build with your own scrap wood and dowels and my easy-to-follow instructions. Highly detailed plans for a 20x83/4-in. dump truck. GATTO PLAN SUPPLY. \$8.00. *Circle No. 355.*

COUNTRY FURNITURE PLANS—Our catalog features more than 30 designs—from a washstand to a roll top desk. Our new book on finishing and refinishing will show you how to finish projects like the pros. Also included are various products for the home workshopper. Send for our latest catalog (price of catalog deductible from first order). HAM-MERMARK ASSOCIATES. \$1.00. *Circle No. 370.*

WOODWORKING PLANS—Catalog of full-size plans printed on heavy paper for toys, gifts, novelties, action windmills, shelves, birdhouses, garden furniture, Dutch windmill, lawn ornaments, old-fashioned lawn swing, jigsaw projects for children, and more. MASTERCRAFT PLANS WEST. \$1.00 (refunded with first order). *Circle No. 390.*

HEIRLOOM WOODEN HORSE—A decorative piece for your home or for your children's delight. Build this horse yourself, and they will ride it for years. Made of solid wood and beautiful brass. This horse will be the pride of your family for generations. Plan includes specific step-by-step instructions with full-size blueprint and material list. Free blueprint with your order. THE MASTERS PLAN. \$10.95. *Circle No. 395.*

WOODWORKING TREASURES—Create your own beautiful woodworking masterpieces. All you need is simple tools, and our easy to follow patterns and directions. You will be proud to display these 126 scale beauties. Choose from Victorian Riding Toys and Carousel Animals. Send for our latest brochure. THE MASTER'S WORKBENCH. \$1.00. *Circle No. 398.*

FULL SIZE PLANS—for fine furniture, home accessories, and toys featuring *Plan Plus*—the plan complete with hardware and hard-to-find components. "All American Tool Collection" spotlights shop-tested tools made in USA. 16-page catalog; price refunded with first order. RJS CUSTOM WOODWORKING. \$1.00. *Circle No. 424.*

BACKYARD STRUCTURES—Contains designs for 21 really different storage sheds, 5 cabanas, 13 animal shelters, 3 barns, 13 garbage enclosures, 3 studios, and more, plus 8 plans in book. 66 designs in all, for which plans can be ordered. Full color. SUN DESIGNS. \$10.45. *Circle No. 454.*

MAKING TIMELESS TOYS IN WOOD—contains 40 heirloom-quality designs, with 20 mini-plans in book. Full color, 96 pages. SUN DESIGNS. \$11.45. *Circle No. 455.*

CREATE FUN & PROFITABLE WOODCRAFTS—Popular folk-art, toys, decorative country items, old fashioned St. Nicks. 20-page catalog is overflowing with over 400 original projects for all skill levels. Full size blueprint patterns eliminate tedious enlarging—giving you more time to enjoy actual woodworking. THE WINFIELD COLLECTION. \$1.00. *Circle No. 480.*

LUMBER

QUALITY EXOTIC LUMBER/TURNING WOODS—We offer a comprehensive selection of fine quality exotic woods: Ebony, Kingwood, Tulipwood, Snakewood, African Blackwood, Cocobolo, Bloodwood, Figured Maple, Spalted Maple, Padauk, etc. Unique and unusual turning woods and burls are also available. Send for catalog. BEREA HARDWOODS. \$1.00. *Circle No. 510.*

WOODWORKERS! HELP CELEBRATE OUR 59TH YEAR OF SERVICE—Send for our new 148-page Craftsman 1988-89 Catalog #55. 42 varieties of choice hardwoods 1/64 in. to 4-in. thickness. Fine hardwood veneers, tools, moldings, trim, marquetry inlays, upholstery and lamp supplies, finishes, clock kits, and hard-to-find hardware. 4,000-plus items for your projects. CRAFTSMAN WOOD SERVICE CO. \$1.00. *Circle No. 520.*

DO-IT-YOURSELF LUMBER DRYING—This 22-page booklet *Kiln Chamber Construction Guide and Operation Manual* is designed for the individual wishing to dry his own lumber with a minimum investment of money, time, and space. Included are principles of dehumidification lumber drying, selection of which dryer is best for you, and kiln chamber plans and construction information. Also you will receive a questionnaire you can fill out and return. Once completed and returned you will receive a free evaluation of your drying needs including investment considerations, operating costs, and payback. EBAC LUMBER DRYERS. \$10.00. *Circle No. 525.*

EdLco — WE KNOW OUR LUMBER—Educational Lumber Company is pleased to offer you our new catalog, stacked with excellent buys at delivered prices. Available to you are over 21 species of imported as well as domestic hardwoods, softwoods, turnings, shorts, veneers. All our lumber is kiln dried. As school shop suppliers for 35 years, we know our lumber. It is top-grade. Send today and receive your BONUS GIFT: 4 new furniture designs. EDUCATIONAL LUMBER CO., Inc. \$2.00. *Circle No. 530.*

THIN LUMBER—Approximately 20 species—1/8" to 3/4" thickness. Thinner material sanded, all KD & surfaced—UPS delivery in continental US included in price. Packages of micro-lumber 1/8" - 1/2" thick. HARDWOODS OF ILLINOIS. 50¢. *Circle No. 545.*

THE BEST LUMBER AT THE RIGHT PRICE—Located in close proximity to some of the most ideal growing ranges for Red Oak, Pennsylvania grade Cherry, Hard Maple, Ash, Poplar, and other hardwoods, we can supply your needs with the highest quality hardwoods. Our experience in hardwood purchasing and our dedication to keeping our overhead low is your guarantee of low prices. No minimum order. Retail and wholesale. Send for 20-page catalog. NORTH EASTERN HARDWOODS. \$2.00. *Circle No. 563.*

LUMBER DRYING—Nyle Corp., the largest manufacturer in the United States of dehumidification Dry Kiln Systems, offers *Introduction to Dehumidification Lumber Drying*. NYLE CORP. Free. *Circle No. 565.*

RARE IMPORTED EXOTIC AND DOMESTIC HARDWOODS—The world renowned Martin Guitar Co. sells wholesale and retail exotic wood (4/4, 6/4, 8/4) and sawn veneers (1/4" & 1/2" Sanded Stock), plus guitar parts, kits, accessories and second quality guitars. Send for catalog. SAWMILL/WOODWORKER'S DREAM. \$2.00. *Circle No. 578.*

STEVE H. WALL LUMBER CO.—Quality hardwoods and woodworking machinery for the craftsman and educational institutions. 22-page catalog lists 15 species of popular hardwoods at wholesale prices. Also dealers for Delta, RBl, MiniMax, Freud and ProCut woodworking machines. STEVE H. WALL LUMBER CO. \$1.00. *Circle No. 592.*

VIDEOS

FINE WOODWORKING VIDEOLOG—Send for your 50 minute sampling of the world's most in-depth woodworking videos. Includes tips on finishing, turning, furniture repair, workshop techniques and other related subjects. Price is redeemable toward purchase. Order today. TAUNTON PRESS. \$5.00. *Circle No. 670.*

GENERAL WOODWORKING CATALOGS

ADVANCED WOODWORKING—Specialty products catalog from the exclusive distributors of Hegner & Felder woodworking machinery. Includes complete selection of scroll saw blades, accessories, and improvements for almost any scroll saw. Also the Hegner precision scroll saws, lathes & duplicators, Jet clamps, workbenches, Felder systems & more. AMI, LTD. \$2.00. *Circle No. 801.*

EVERYTHING FOR THE WOODWORKER—Wide selection of woodworking supplies, including candle cups and shaker pegs. Price of catalog is refundable with order. BENNY'S WOODWORKS. \$1.00. *Circle No. 810.*

CONSTANTINES' CATALOG FOR WOODWORKERS—116 pages packed with over 4,000 products for fine woodworking. Included are 250 kinds and sizes of domestic and

imported hardwoods; 150 varieties of exotic veneers, top quality woodworking tools, hard-to-find specialty hardware and accessories; wood finishes, books, plans, and more. 60-day money back guarantee if not fully satisfied. Serving the woodworker since 1812. ALBERT CONSTANTINE AND SON, INC. \$1.00. *Circle No. 820.*

UNBEATABLE PRICES—on the world's most respected tools. Great selection of woodworking aids, some quite hard to find. Send for full color catalog. FINE TOOLS INC. \$1.00. *Circle No. 850.*

WOODWORKING TOOL CATALOG—Complete 92-page catalog of hard-to-find hand woodworking tools. We have a stock of over 300 book titles and carry the Myford English wood-turning lathe. Also inventoried are wood finishes of all possible descriptions and carving tools unequalled anywhere in the United States. Send today for your ticket to woodworker's heaven. You too, can be turning out quality woodwork. FROG TOOL CO, LTD. \$2.50. *Circle No. 853.*

MASTER TOOLS CATALOG—1988-89 212-page master woodworking tools catalog. Full line of the best hand tools, power tools & accessories, machinery, glues, finishing supplies, and much more. Hundreds of books included. 212 pages. All four-color. Lots of technical information. GARRETT WADE CO. \$4.00. *Circle No. 855.*

WOODWORKING MACHINERY CATALOG—Planers, jointers, table saws, shapers, drill presses, sanders and much, much more. Buy direct from importer at super low prices. Full color catalog. GRIZZLY IMPORTS, INC. Free. *Circle No. 860.*

THE 1988 HILLER HARDWARE CATALOG—is a comprehensive collection of tools & accessories for you. Select from the best quality tools in the business at a price only a volume supplier can provide. Power tools, hand tools, cutters, blades, & accessories. 24 pages, over 240 tools! HILLER HARDWARE. \$1.00. *Circle No. 875.*

WOODWORKING TOOLS, MACHINERY, & SUPPLIES—W. S. Jenks & Son's new 128 page source book is packed with a full range of tools for the serious woodworker, from hand tools, to portable power tools, to woodworking machinery. Includes many imported and hard to find tools, from the best manufacturers at the most competitive prices. Send for catalog. W. S. JENKS & SON. \$2.00 (refundable with first order). *Circle No. 877.*

LEICHTUNG WORKSHOPS—Discover fine woodworking hand tools and hardware in our 102-page color catalog. For example: Our exclusively-designed 4-way Equi-Pressure Clamp, Double Doweling Jig, plus Brad-Point and Forstner Bits. LEICHTUNG WORKSHOPS. \$1.00. *Circle No. 878.*

FINE WOODWORKING TOOLS CATALOG—Lee Valley Tools catalog of fine woodworking tools and accessories has become a standard reference for woodworkers. It is a superb production containing over 400 professional photographs complemented by objective, straight-forward product designs and technical information on woodworking tools of all kinds. 250 pages, 8 1/2 x 11 size. LEE VALLEY TOOLS LTD. \$5.00. *Circle No. 879.*

WOODWORKING BOOKS AND VIDEOS AT DISCOUNT PRICES—Most complete listing of over 500 books and over 50 videos for woodworkers. Each book and video is discounted from 10% - 25% off the list price. There is absolutely no shipping charge to any address in the U.S.A. Woodworking, carving, turning, project books and videos by authors such as Roger Cliffe, Dale Nish, Spielman, Tangerman and Tage Frid are listed along with many hard-to-find titles. MANNY'S WOODWORKER'S PLACE. \$2.00. *Circle No. 880.*

WOODWORKING SUPPLIES CATALOG—1200 tools, patterns, veneers, thick and thin hardwoods, plywood, carving and turning stock, hardwood bundles shipped UPS, books, doweling jigs, hinges, hardware, drawer slides, dowels, spindles, 2 ply, flexibles, cane, finishes, stain, inlays, edging, burls, faces, more! Send for your catalog today! BOB MORGAN WOODWORKING SUPPLIES. \$1.00. *Circle No. 890.*

WOODWORKING TOOL CATALOGS—R.A. Ness & Co., the Woodworkers Emporium, offers a 2-year subscription, a total of eight huge sale catalogs. Thousands of industrial quality items — machinery, hand tools, portable electric tools, and supplies — are featured at super sale prices. The fee is refundable with purchase. R. A. NESS & CO., the Woodworkers Emporium. \$4.00. *Circle No. 900.*

RENOVATOR'S SUPPLY—America's Number One source for elegant, old-style reproductions at factory-direct prices! 48 colorful pages of door, window and cabinet hardware; lighting and bathroom fixtures; and gifts for the home in brass, oak, porcelain and wrought iron. RENOVATOR'S SUPPLY. \$3.00. *Circle No. 915.*

TOOLS ON SALE—A division of Seven Corners Ace Hardware Inc. offers a comprehensive catalog featuring over 430 pages of the most competitive prices in the industry. If you're looking for savings and fast delivery on over 4000 items, request our catalog. This catalog offers one of the most complete selections of power tools available anywhere from the most respected manufacturers in the industry: Milwaukee, Makita, Porter-Cable, Black & Decker, Freud, Bosch, Delta, and many more. SEVEN CORNERS ACE HARDWARE. \$1.00. *Circle No. 920.*

A WOODWORKER'S DREAM BOOK!—Power tools...hand tools...machinery...router bits...pneumatic tools...cutting tools...clamps...hardware...wood parts...books...and more! For our new catalog, we've selected the tools woodworkers want most from around the world...at prices that won't hurt your wallet. This is a must reference for every woodworking shop. So give us a try. Price of catalog is refundable with your first purchase. THE SOURCE. \$2.00. *Circle No. 935.*

TOOL CITY CATALOG HAS THE TOOL OR ACCESSORY FOR YOU—The 500-page 1987-88 Tool City Catalog is the most complete mail order catalog. It features a comprehensive selection of stationary & portable power tools; hand tools, tool accessories, hardware parts, woodworking books, and shop equipment. Priced to save you money in all categories. TOOL CITY. \$5.00. *Circle No. 945.*

WOODWORKING TOOLS OF EXCEPTIONAL QUALITY—Since 1928, we have searched the world for tools you don't just buy, but adopt: tools made by craftsmen for craftsmen, classics of lifetime quality for people who love to work with their hands...carvers, cabinetmakers, finishers, hobbyists, builders, teachers. Our catalog details over 4,000 tools, each backed by Woodcraft's unconditional guarantee of satisfaction. WOODCRAFT SUPPLY CORP. Free. *Circle No. 955.*

KITS

FREE STANDING BACKYARD GYMS—Countryside Woodworking Inc. (CWI) offers 6 models and 11 options for a wide variety of family fun gyms. The only Backyard Gym you'll ever buy. 4x6 and 4x4 construction, playground rated hardware. Complete kits include all lumber. Hardware only kits also available. Send for complete color catalog. CWI. \$1.00. *Circle No. 1005.*

CANOPY BEDS, WINDSOR CHAIRS, PLUS SHAKER AND QUEEN ANNE—museum reproductions lavishly presented with coordinated paints, lighting, pewter, and brass accessories. Furniture available assembled finished or ready-to-assemble kits. Since 1949 Cohasset Colonials has been the oldest and largest manufacturer of reproduction furniture kits. State-of-the-art joinery insures easy assembly. Custom bed hangings, quilts, fishnet canopies. Color catalog subscription. COHASSET COLONIALS. \$3.00. *Circle No. 1015.*

OAK FURNITURE AND ACCESSORY KIT CATALOG—features a full range of top quality oak furniture kits and accessory items plus unfinished assembled furniture. Featured items include roll top desks in several styles, stacking barrister's bookshelves, tables, chairs, trunks, file cabinets, bedroom furniture, Mariner's globe, plus many more. Send for full color catalog and enjoy true woodcrafting pleasure. CRAFTSMAN'S CORNER. Free. *Circle No. 1017.*

FACTORY DIRECT GRANDFATHER CLOCKS—Build a magnificent grandfather clock kit from world's largest manufacturer. Clocks are made of solid 3/4" hardwoods, primarily walnut, oak and cherry. West German-made solid brass movements. Send for color catalog showing our selection of grandfather clocks, furniture and home accent pieces. Buy direct from factory and save. EMPEROR CLOCK CO. \$1.00. *Circle No. 1030.*

WOODEN SHIP MODELS—Discover the world's hobby—building fine-quality, historic wooden ship models. Described are true-to-life scale replicas, lifelike in every detail. A 64-page color catalog introduces you to this fascinating hobby. MODEL EXPO, INC. \$2.00. *Circle No. 1060.*

MUSIC MAKER'S KEEP BOOK—A 36-page resource catalog for building and learning to play handmade musical instruments. This source book contains plans, blueprints, kits, books, hardware, strings and accessories for building such instruments as guitars, banjos, dulcimers, harps, violins, pipes, and more. ST. CROIX KITS. \$1.00. *Circle No. 1080.*

PUBLICATIONS

WOOD CARVING—You can obtain information on learning woodcarving by sending for our literature. The offer includes sample copy of *The Mallet Magazine* and two lesson sheets on carving. NATIONAL CARVERS MUSEUM. \$2.00. *Circle No. 1140.*

SHOP ACCESSORIES

RIPSTRATE SAVES FINGERS—for table saw and radial arm saw users. Brochure describes the RIPSTRATE and shows how it gives straighter cuts, speeds, the work, prevents kickbacks, and keeps hands away from the blade. FISHER HILL PRODUCTS. 25¢. *Circle No. 1235.*

CLASSIC WORKBENCH—This is a space saver's dream. Assembled & knocked down in minutes. Beautifully designed workbench is made of Danish Red Beech with a linseed oil finish. Other features include built-in precision steel spindle rises & dogs. Send for literature. LAGUNA TOOLS. \$1.00. *Circle No. 1240.*

EASY DOES IT—with HTC'S power tool accessories. Discover many unique items, designed only with you, the dedicated woodworker, in mind. Make your machinery safer, increase the working area of your shop and accomplish nearly impossible tasks easily, quickly, accurately. Full-line catalog and price list. HTC PRODUCTS, INC. \$1.00. *Circle No. 1245.*

CIRC-L-CUT FOR RADIAL ARM—table or band saw. Cut perfect circles from 3" to 48" in diameter from any thickness wood or plastic. DRIL-LATHE converts your drill press

into a vertical lathe in minutes! Get professional quality wood turnings up to 1 1/2" diameter x 12" long. HEPP INDUSTRIES. \$1.00. *Circle No. 1246.*

BUY YOUR SANDING BELTS DIRECT FROM THE MANUFACTURER—Industrial Abrasives is the company that gives you six free belts with every dozen ordered. But, sanding belts are not the only product we have to offer. In our catalog you will find many specialty items not readily available in your hardware store. Price of catalog refunded with first order. INDUSTRIAL ABRASIVES CO. \$1.00. *Circle No. 1248.*

WOOD MOISTURE METER—Avoid moisture problems such as cracking, warping, spilling, delamination etc. by using a moisture meter, as described in the latest brochure. Moisture Meter Mini-Ligno is designed for serious hobbyists and woodworkers. Attachments for depth measurements and remote reading during air and kiln drying are available. Available Moisture Range 6-20%, 6-36% or 4-30%, 4-60%. Catalog describes complete line of moisture meters. LIGNOMAT USA, LTD. Free. *Circle No. 1250.*

ROUTER SPEED CONTROL—Reduces speed electronically without reducing torque. Route at the speed that gives best results with the wood and bit you are using. Speed adjustable from full speed to 0 RPM. Less tear out—stops burning—less wear on bits—easy to use. Send today for information. MLCS LTD. Free. *Circle No. 1251.*

DUST COLLECTION SYSTEMS—Our 28 page catalog is filled with all the parts needed to design and install a dust collection system. Flex-hose, spiral hose, blast gates, reducers, y-branches, laterals, elbows, and more. The catalog includes tips on how to go about designing and installing your own dust collection system. As an added bonus we are including a duct calculator. Free. Send now for full catalog, duct calculator, and design information. MANUFACTURERS SERVICE CO. INC. \$2.50. *Circle No. 1252.*

AFFORDABLE PRECISION SURFACE SANDER—Tired of high and low spots and countless hours of sanding? Now you can buy the components to fit your budget and your needs: The Performax S/T Sander attaches to radial saw or stand, optional power feed conveyor unit, stand hardware kit for a build-your-own stand or all the metal, ready-to-assemble pro stand. Send for informative brochure. PERFORMAX PRODUCTS. \$1.00. *Circle No. 1253.*

CREATE ANY HOLLOW CYLINDRICAL SHAPE—with 3/4 in. wall thickness, 12 in. diameter. Ring Master cuts perfect rings in any wood, any angle, any size—stack the rings and create any cylindrical shape. Just glue—sand, & finish, all on the Ring Master. Create matched sets of items. Choose from 3 models, 1 attaches to Shopsmith Mark V, another attaches to Sears Craftsman 12" lathe, the original Ring Master is self-powered. RING MASTER, INC. Free. *Circle No. 1265.*

BITS, BLADES CUTTING TOOLS

BANDSAW BLADES FOR ALMOST ANY TYPE BANDSAW—both wood and metal cutting. Also circular saw blades, router bits, sanding belts and discs. Send for catalog. BUCKEYE SAW CO. \$1.00. *Circle No. 1307.*

OVER 700 ROUTER BITS—are now available. The all-new 1989 Byrom catalog features 1/4" to 3/4" shank in high speed steel, carbide and carbide tip. Over 20 pages, 80 new items, and over 80 technical drawings. "Industrial Information Kit" includes catalog, price list, promotional items and the name of the dealer nearest you. Dealer inquiries invited. BYROM INTERNATIONAL. \$3.00 (refundable). *Circle No. 1308.*

CARBIDE TIPPED ROUTER BITS AND SHAPER CUTTERS—Over 400 router bits and shaper cutters displayed in catalog featuring 6 piece cabinet sets, 3 piece 1/2-in. shank router bit panel raising system, and 3 wing industrial shaper cutters. An outstanding selection of top quality shaper cutters available in 1/2-in. - 1 1/4-in. bore, and router bits offered in 1/4-in. and 1/2-in. shank at the industry's best factory direct prices. CASCADE PRECISION TOOL CO. \$1.00. *Circle No. 1315.*

INDUSTRIAL QUALITY BAND SAW BLADES—Precision welded to any length for most applications: All woods, steels, stainless steels, non-ferrous metals, cardboard, plastics and more. Widths from 1/8" - 1 1/4", flexback, hardback, bimetal, special orders. Send for troubleshooting guide to help solve common problems (blade breakage, tooth stripage, etc.). Also included is a blade width selection chart for profile (scroll) sawing. CHANDLER BAND SAW, INC. \$1.00. *Circle No. 1316.*

THE 16-PAGE COLOR—Choice Precision Tool Catalog offers 350 carbide router bits available in 1/4" or 1/2" shanks. Also included are 48 carbide shaper cutters. Router table and router accessories are available as well. Send today for your catalog. CHOICE PRECISION TOOL. 50¢. *Circle No. 1317.*

CUTTING TOOLS MADE TO PERFORM—A set of three colorful posters from DML will decorate your woodworking shop and give you fast reference to a complete line of carbide-tipped, industrial-quality cutting tools. Saw blades, router bits and shaper heads (with a diagram of each cut) are all featured with a graphic display of each tool, along with tool capabilities and sizes. DML, INC. \$1.50. *Circle No. 1319.*

WOODWORKING TOOLS—Freud provides the finest in hand tools, carbide cutting tools, and hand held power

tools. From drills and sanders to carbide saw blades and router bits. Send for catalog. FREUD. \$1.00. *Circle No. 1321.*

PRODUCTION QUALITY CARBIDE TIPPED ROUTER BITS—MLCS Ltd. offers a full line of professional production quality carbide tipped router bits at 50-70% lower than retail prices. We sell through the mail and only direct to craftsmen. Send today for information. MLCS LTD. Free. *Circle No. 1350.*

SAW BLADE VALUES—Olson Saw's unique "furniture band" is specifically designed to provide fast, smooth cuts in all types of wood. Included in Olson's free literature package are a huge list of resin on resin abrasives and carbide tipped circular saw blades in addition to a growing selection of band scroll (incl. pinned), jewelers and spiral saw blades. OLSON CATALOG SALES. Free. *Circle No. 1365.*

BANDSAW BLADES—from quality American made stock. Carbon and bi-metal stock are available for wood and metal cutting. Blades will not break when flexed back and forth a couple times. Send for literature. STEVE'S SHARPENING. \$1.00. *Circle No. 1376.*

HARDWARE/WOOD PARTS

OUR READY TO ASSEMBLE KITS—for Queen Anne chairs and occasional tables make it easy for you to make professional looking furniture. We also stock individual Queen Anne legs for every project. Complete information in our brochure packet. ADAMS WOOD PRODUCTS. 50¢. *Circle No. 1401.*

SPECIALTY WOODEN PARTS—Hundreds of turned wooden parts in maple, birch, oak, cherry, walnut, and colors for toys, furniture, games, and crafts. Included are Shaker pegs, mug pegs, gallery spindles, wheels, axles, balls, finials, smokestacks, plugs, buttons, people, pegs, cargo, game pieces, knobs, handles, candle cups, stool legs. Bulk prices available. Send for color catalog subscription. CHERRY TREE TOYS, INC. \$1.00. *Circle No. 1415.*

HARDWARE CATALOG—A unique 64-page catalog of the very finest in classic, traditional solid brass cabinet hardware. All of British or No. American manufacture. Double & single post handles, knobs, escutcheons, standard & specially hinges, box hardware, brass screws, castors, latches, catches, locks, and more. GARRETT WADE CO. \$2.00. *Circle No. 1427.*

BRASS FURNITURE HARDWARE—This 36-page catalog shows over 500 items of authentic reproduction hardware from the 1700's and on into this century. This fine quality hardware is a must for the furniture craftsman working on a new project, or the refinisher who needs replacement hardware. HORTON BRASSES. \$3.00. *Circle No. 1430.*

SQUARE DRIVE SCREWS—Once you try them, you will never want to use anything else! The square drive recess virtually eliminates work-damaging driver bit "cam-out," the "lo-root" thread design results in superior holding power; and they are heat treated for strength. Sizes from #6 x 1/2" to #12 x 3", with stainless steel, brass plated, solid brass, and zinc plated available. Quantity discounts. Send for literature. McFEELY HARDWOODS. 75¢. *Circle No. 1450.*

WOODWORKER'S SPECIALTIES—64-page catalog of plans and hard-to-find hardware for woodworkers. Dozens of door harp plans, wood toy plans & accessories, including wood wheels. Also wood turnings, brass hardware, canister liners, stencil supplies, & wood cutouts. MEISEL HARDWARE SPECIALTIES. \$1.00. *Circle No. 1455.*

DESIGNER MOULDING—America's most beautiful, hard-to-find genuine wood mouldings add depth and beauty to every room of your house. Hundreds of styles available. Thousands of decorating uses. Prices start at only \$3.50/ft. for 8 ft. lengths. In stock for immediate delivery. Full color catalog. R&R WOOD PRODUCTS CORP. \$1.00. *Circle No. 1468.*

WOOD TOY PATTERNS—Patterns for all ages including children's patterns and executive toys. New catalog has many new patterns to choose from including parts and wheels. Send for new catalog and receive a coupon for free wheels and axle pegs. TOYS AND JOYS. \$1.00. *Circle No. 1480.*

QUALITY AMERICAN-MADE WOOD TURNINGS—such as shaker pegs, spindles, toy wheels, toy parts, craft items, and dowel rods in birch, oak, walnut, and cherry. Send for complete 32-page catalog. WOODWORKS. \$1.00. *Circle No. 1490.*

INCOME OPPORTUNITIES

AMITY, NATION'S #1 QUALITY FURNITURE RESTORATION CO. SINCE 1971—New product catalog featuring: Complete restoration systems, Hydrocote non-flammable water based stains and finishes, Permatuse repair products, stripping solvents, chemicals and supplies. Amity 1-2-3 wipe-on finishes and much more. Regional workshops in your area. AMITY. \$1.00. *Circle No. 1605.*

START SMALL BUSINESS WITH NEW SCROLL SAW—the Excalibur precision scroll saw can turn your workshop into a nice profit center. Make toys and puzzles, do intricate marquetry work or detailed cabinet work with these "opera-

tor friendly" machines. Hundreds of satisfied users. Dealer opportunities available. EXCALIBUR MACHINE & TOOL CO. \$1.00. Circle No. 1655.

WOODCARVER MACHINES—Make signs in wood, pictures in wood, arts and crafts. Make money the very first day. Use as a small business, hobby money, week-end craft shows. Our machines are template guided, easy to use, table top size. Return \$50 per hour to you. Dust collector, self centering. Visitors welcome. Send for info pack. KIMBALL WOODCARVER CO. \$1.00. Circle No. 1656.

\$20 PER HOUR/PART TIME!—Sell Mason Shoes in your spare time. We'll help you turn Saturday mornings into big money. No risk! No investment! It's easy! Send for free catalog and sales kit. MASON SHOE MFG. CO. Free. Circle No. 1658.

WOOD CARVING MACHINES AND ACCESSORIES—make all types of wood carving easy, fun and profitable. The machines do the work. Whether for sign carving, flat 3-D, decoys, panels, gun stocks or furniture, we have the proper machine for the job. Professional woodcarving for the hobbyist and superior quality for the professional. Begin your hobby or full or part-time business by ordering our catalog and price list. MARLIN INDUSTRIES. \$1.00. Circle No. 1659.

MASS PRODUCTION FURNITURE REFINISHING—a revolutionary new concept from Master Finishers System™. Totally new, tremendously profitable! The old hand process is now done automatically with Master Finishers Furniture Refinishing Factory. Send for brochure. MASTER FINISHERS. \$5.00. Circle No. 1660.

MAKE MONEY IN FURNITURE RESTORATION THE MINUTEMAN WAY—Earn \$200-\$1000 per day stripping, repairing, refinishing, mirror resilvering, and/or veneering, at home or in shop, spare time or full time. We provide complete free training; no experience necessary. Free workshop teaches you latest in furniture restoration. You have to see it to believe it! Send for catalog. MINUTEMAN. \$2.00. Circle No. 1661.

BUILDING CONSTRUCTION—Learn how to profit as an independent contractor or save thousands building your own home...with NRI at-home training in Building Construction. 70 lessons, plus over 100 practical hands-on projects cover the full spectrum of construction—from site selection to exterior finishing & landscaping. Send for catalog. NRI SCHOOL OF BLDG. CONSTRUCTION. 25¢. Circle No. 1665.

MISCELLANEOUS

MAKE WOODEN TOYS—Whirligigs, doll houses, classic autos, clocks, music boxes, weather instruments, desk sets, games, crafts & furniture with our plans, parts (hardwood and metal), kits (for all skill levels), books, tools, finishes and supplies. Bulk prices available. Send for 60-page color catalog subscription. CHERRY TREE TOYS, INC. \$1.00. Circle No. 1918.

MAKE WOODEN CLAMPS—Save 60%. Kits and plans for 8, 10, and 12 in. wooden handscrew clamps. Acme threaded steel rods, components, handles and full-sized plans provided. Kits also available with uncut and pre-cut maple jaws. You decide how much you want to save. Also available are hundreds of plans, kits, parts, and supplies for wooden toys and whirligigs in our beautiful color catalog. CHERRY TREE TOYS, INC. \$1.00. Circle No. 1919.

FOLEY-BELSAW INSTITUTES' NEW WOODWORKING CORRESPONDENCE COURSE—for people with the desire to learn how to work with wood and the proper use of tools. Create over 20 projects using professional plans and tools like a table saw, router with stand, and more...all included with the course. Complete money-back guarantee. Send for details. FOLEY-BELSAW INSTITUTE. Free. Circle No. 1930.

LEARN ALL THE SKILLS—of professional upholstery and refinishing techniques in the comfort of your own home. The Foley-Belsaw Institute system of "hands on" training provides clear, step-by-step instructions in the use of tools and materials on actual furniture "kits"...all included with the course. Complete money-back guarantee. Send for details. FOLEY-BELSAW INSTITUTE. Free. Circle No. 1931.

JOHN HYMILLER WOODWORKER—is a third generation master finisher and woodworker offering one week courses, as well as mail order, European tool and machinery sales. Customers are given expert advice on their purchases. School info, testimonial and tool catalog. JOHN HYMILLER. \$5.00. Circle No. 1960.

THE CUSHION CONTOUR SANDER—is a new concept in pneumatic drum sanding. Sanding sleeves are slid over an air bag (inflated with a hand tire pump) on an arbor to mount it between centers on a wood lathe. Drum effectively takes on profiles, curves, and bevels practically eliminating flat spots and chatter marks. INDUSTRIAL ABRASIVES CO. \$1.00 (refunded with first order). Circle No. 1976.

BANDSAW OWNERS—A new tool is now available so you can make or repair any length bandsaw blade in minutes. Our splicer enables craftsmen to make up any length blade from economical coil blade stock quickly and easily. Three models are currently available to accommodate blade widths from 1/8 to 1 1/2 in. The tool comes complete with detailed instructions and supplies. We also carry OLSON bandsaw stock at reasonable prices. Send for literature. NEW MILFORD SPECIALTIES CO. 50¢. Circle No. 2025.

COMPUTER SOFTWARE—to generate complete floor plans, cut lists, bids, and 3-D drawings of kitchen cabinets, file cabinets, bookcases, etc. Handles 32mm and face-frame construction. Professional and homeowner's versions available (IBM). Send for demo disk. SISKIYOU PRODUCTS. \$10.00. Circle No. 2065.

ATTENTION! ANTIQUE RESTORERS! WOODWORKERS! COLLECTORS! AND HOBBYISTS!—This 192-page wholesale catalog is loaded with unique, hard to find items! Includes hundreds of essential antique restoration parts, brass reproduction hardware, oil lamps and accessories, wood parts, caning, basketry, upholstery, and art supplies, wood refinishing products, tools, books, etc. VAN DYKE'S RESTORERS. \$1.00. Circle No. 2077.

UNIQUE GREENHOUSE/SCREENHOUSE IDEA—A gardener's paradise during the winter months, a bug-free screen room during the summer months. That's the concept behind the versatile new Sun-Porch. This two-in-one sunspace features sturdy aluminum framing, 1" shatter-resistant glazing, do-it-yourself assembly, and mounts readily on decks, patios, landscape ties. Color catalog includes models, prices; send first class mail. VEGETABLE FACTORY, INC. \$2.00. Circle No. 2078.

SERIOUS WOODWORKERS—In our shop we offer the finest: INCA, Jet, König, RBL, Ryobi, Virutex, Apollo—Keller, Leigh, Excalibur, Portalign—Freud, Byrom, Onsrud—3M, Walco, Behlen's—Imported and U.S. made hand tools—Hardwoods, domestic & exotic—Veneers—Craft plywoods—Books & magazines—Quality, Service and competitive prices. WOODCRAFTERS SUPPLY CO. \$2.00. Circle No. 2080.

CARVING SUPPLIES

DECOY AND WOOD CARVERS WISHBOOK—48-page catalog features wide selection of tools and supplies for decoy carvers, wood carvers, wood turners. Chisels, gouges, sharpening stones, precision grinding tools, Fordom tools, Fire Brush burners, pneumatic sanders, glass eyes, pewter feet, patterns, paints, reference books. P. C. ENGLISH, INC. Free. Circle No. 2115.

CARVERS' & ARTISTS' SUPPLIES!—Now you have a sourcebook for the most sought-after supplies for your pursuits! Thousands of decoy carving patterns; kolinsky sable artist brushes; acrylic, alkyd, and oil paint; carving knives and gouges; Fordom & Dremel moto tools; hundreds of moto tool cutters and accessories. New 1989 catalog; 80 pages, over 4500 items! C. J. HUMMUL CO. Free. Circle No. 2130.

WOODCARVING TOOLS—Whittlers and carvers—Warren Tool Co. offers a catalog for you full of whittling and carving hand/power tools, books, stones, wood, and supplies. Since 1927, the finest in woodcarvers tools. WARREN TOOL CO., INC. \$1.00. Circle No. 2185.

CLAMPS

MERLE ADJUSTABLE CORNER CLAMP—Quick & easy to use. Fully adjustable from 2 1/2" to 69x69 in. Perfect for clamping picture frames, cabinets, or anything that requires 90° corner clamping. The Merle Clamp is cast aluminum & steel construction, a true industrial quality tool. Send today for information. MLCS LTD. Free. Circle No. 2250.

CEILING

TOF OFF—your remodeling project with a good-looking, functional Armstrong tile ceiling or suspended ceiling. You can choose from a wide variety of patterns, from plain white to decorative to warm "wood" grain. Want peace and quiet? Select an acoustical ceiling. It absorbs a minimum of 45% of the noise striking its surface. Send for color brochure that tells you all you need to know. ARMSTRONG. Free. Circle No. 2710.

FLOORS

SURPRISED—That's what you'll be by the sheer variety of Armstrong no-wax floors—hundreds of patterns and colors to choose from, a wide range of prices, even many you can install yourself. To help you pick the no-wax floor that's right for you, Armstrong has prepared an information packet that explains what you need to know to shop intelligently. Contains planning guides, brochures on most Armstrong lines, and color photographs of beautifully decorated rooms. ARMSTRONG. Free. Circle No. 2810.

Information

WORTH WRITING FOR

TO ENSURE PROMPT HANDLING OF YOUR ORDER FOLLOW THESE INSTRUCTIONS:

- Circle your choice
- Enclose check or money order for cost of booklets plus \$2.00 service charge (no stamps/foreign)
- Send coupon and remittance to address above
- ALLOW 4-6 WEEKS FOR DELIVERY
- Coupon expires June 11, 1990

WOOD SUBSCRIPTION

1. A 1 year WOOD subscription (6 issues) for \$18.00 (U.S. price) — a \$3.00 savings off newsstand rate. Allow 6-8 weeks for first issue. Canadian price \$24.00. Be sure to include payment with total below. NO FOREIGN ORDERS ACCEPTED ON THIS COUPON; please contact Subscription Dept. directly.

FREE LITERATURE

Circle numbers below corresponding to items in this issue. Please include \$2.00 for handling charge

17.	41.	76.	99.	955.	1350.	2115.
18.	42.	77.	100.	1017.	1365.	2130.
19.	44.	80.	215.	1250.	1658.	2250.
20.	57.	84.	565.	1251.	1930.	2710.
33.	70.	85.	860.	1265.	1931.	2810.

PRICED LITERATURE

Numbers below refer to items on which there is a charge. Please include proper remittance.

3....\$1.00	232....\$1.00	480....\$1.00	855....\$4.00	1060....\$2.00	1319....\$1.50	1659....\$1.00
4....\$1.00	310....\$2.00	510....\$1.00	875....\$1.00	1080....\$1.00	1321....\$1.00	1660....\$5.00
6....\$2.00	315....\$1.00	520....\$1.00	877....\$2.00	1140....\$2.00	1376....\$1.00	1661....\$2.00
56....\$1.00	332....\$1.00	525....\$10.00	878....\$1.00	1235....25¢	1401....50¢	1665....25¢
87....\$1.00	340....\$1.00	530....\$2.00	879....\$5.00	1240....\$1.00	1415....\$1.00	1918....\$1.00
88....\$1.00	344....\$2.00	545....50¢	880....\$2.00	1245....\$1.00	1427....\$2.00	1919....\$1.00
90....\$1.00	345....\$2.00	563....\$2.00	890....\$1.00	1246....\$1.00	1430....\$3.00	1960....\$5.00
93....\$1.00	355....\$8.00	578....\$2.00	900....\$4.00	1248....\$1.00	1450....75¢	1976....\$1.00
94....\$1.00	370....\$1.00	592....\$1.00	915....\$3.00	1252....\$2.50	1455....\$1.00	2025....50¢
105....25¢	390....\$1.00	670....\$5.00	920....\$1.00	1253....\$1.00	1468....\$1.00	2065....\$10.00
112....\$2.00	395....\$10.95	801....\$2.00	935....\$2.00	1307....\$1.00	1480....\$1.00	2077....\$1.00
155....\$2.00	398....\$1.00	810....\$1.00	945....\$5.00	1308....\$3.00	1490....\$1.00	2078....\$2.00
160....\$1.00	424....\$1.00	820....\$1.00	1005....\$1.00	1315....\$1.00	1605....\$1.00	2080....\$2.00
221....\$1.50	454....\$10.45	850....\$1.00	1015....\$3.00	1316....\$1.00	1655....\$1.00	2185....\$1.00
225....25¢	455....\$11.45	853....\$2.50	1030....\$1.00	1317....50¢	1656....\$1.00	

Name (please print) _____
 Address _____
 City _____
 State _____ Zip Code _____

I AM ENCLOSING:

\$_____ for priced items
 \$ 2.00 for handling
 \$_____ total remittance

ORDER TOLL FREE 1-800-328-0457 - MAIL ORDER HOURS 7:00-5:30 C.S.T. MONDAY-FRIDAY

DELTA BENCH TOP TOOLS			
Model	List	Sale	
23-700	Wetdry grinder	201	139
23-680	6" bench grinder 1/2 H.P.	81	62
23-880	8" bench grinder 1/2 H.P.	136	99
23-980	10" bench grinder 1 H.P.	246	215
11-950	8" drill press	164	125
14-040	14" drill press	313	259
40-150	15" hobby scroll saw	178	125
28-150	10" hobby band saw	185	135
31-050	1" belt sander 2.0 amp	93	69
31-460	4" belt/6" disc sander	178	125
31-340	"NEW" 1" belt/8" disc sander	228	159

DELTA STATIONARY			
Model	List	Sale	
34-761	10" unisaw 1 1/2 H.P.	1579	1199
34-740	Super 10" motorized table saw	600	399
34-429	10" tilting arbor bench saw		
28-243F	14" band saw w/stand, no motor	621	419
33-990	32" radial arm saw	727	555
11-072	32" radial drill press	487	375
37-260	6" motorized jointer	440	335
50-179	3/4 H.P. 2 stage dust collector	435	339
50-181	1 H.P. dust collector	535	425
50-180	2 H.P. dust collector	760	615
31-154	Deluxe D.J-15 6" jointer		
	w/3 H.P. motor	1268	979
33-950	"NEW" 8 1/4" Sawbuck	742	559
34-330	"NEW" 8 1/4" Table Saw 13A	321	245
34-670	10" motorized table saw	437	325
34-985	1/2 H.P. stock feeder	698	545
28-160	16" x 3 wheel band saw	546	355

MILWAUKEE TOOLS			
Model	List	Sale	
0395-1	"NEW" 9V cordless drill		
	comp. w/case	264	159
0224-1	3/8" drill 4.5A magnum	179	110
0234-1	1/2" drill 4.5A mag 0-850 rpm	189	105
0244-1	1/2" drill 4.5A mag 0-600 rpm	189	105
0222-1	3/8" drill 3.5A 0-1000 rpm	154	90
0228-1	3/8" drill 3.5A 0-1000 rpm	154	90
0375-1	3/8" close quarter drill	208	119
0379-1	1/2" close quarter drill	243	139
0212-1	3/8" cordless drill w/spd.	263	149
6539-1	Cordless screwdriver 190 rpm	108	64
6540-1	Cdss. screwdriver w/bat & cse.	137	89
6546-1	Cdss. screwdriver 200 & 400 rpm	120	72
3102-1	Pilmbit rt angle drill kit	235	175
3002-1	Electricians rt angle drill	290	175
5399	1/2" D-hole hand drill kit	299	179
1676-1	H.D. Hole Hawg w/cls	395	229
6511	2 sp SawZall w/cls	209	119
6405	8 1/4" circle saw	209	120
6750-1	Drywall gun 0-4000 4.5A	149	89
6798-1	Tek screwdriver	173	105
6507	TSC SawZall w/case	219	129
6170	14" chop saw	430	275
6012	Orbital sander 3 1/2"x7 1/2"	179	105
6014	Orbital sander 4 1/2"x9 1/2"	189	110
6305	6 1/4" cordless circle saw	284	165
6753-1	Drywall gun 0-4000 3.5A	129	83
8977	Var. temp heat gun	109	70
0214-1	3/8" v. spd. cordless drill	220	125
5397-1	3/8" v. spd. hammer drill kit	227	135
5371-1	3/8" v. spd. hammer drill kit	313	179
3107-1	1/2" v. spd. rt angle drill kit	305	179
6754-1	Drywall gun 0-4000 4.5A	179	110
6747-1	Drywall driver 0-2500	149	87
0230-1	3/8" drill 0-1700 rpm	169	99
3300-1	1/2" v. spd. magnum rt angle kit	289	179
5620	Router 1 H.P.-8 amp	289	169
5660	Router 1 1/2 H.P.-10 amp	299	179
5680	Router 2 H.P.-12 amp	350	205
5455	7/8" polisher 1750 rpm	199	125
5535	7" polisher 2800 rpm	209	129
6215	6" chain saw	280	189
8975	Heat gun	85	55
6366	7 1/4" circular saw	198	112
6368	7 1/4" circular saw w/cse	226	129
0216-1	2 spd cordless drill Hi-Torque	222	145
0235-1	1/2" drill keyless chuck mag	199	115
6016	3/4 sheet pad sander	75	44
6145	4 1/2" grinder 10,000 rpm	149	95
6950	8 gal wetdry vac	205	145
8955	10 gal wetdry vac	279	189
0239-1	1/2" drill keyless chuck	189	114
6749-1	Drywall gun 0-2500 4.5A	189	115
6377	7 1/4" worm drive saw	275	155

FREUD SAW BLADES				
3/8" Bore - Industrial Grade				
CARBIDE TIPPED SAW BLADES				
Item No.	Description	Diam.	Teeth	
LUM7M010	Gen Purp ATB 10"	40	77.49	34
LUM8M010	Gen Purp T-Ch 10"	40	79.32	39
LUM9M010	Cut-off 10"	60	98.89	42
LUM0M010	Combination 10"	50	85.25	35
LUM5M010	Super Cut-off 10"	60	126.90	50
LUM7M010	Ripping 10"	24	74.22	30
LUM3M010	Cut off 10"	60	91.16	37
LUM7M010	Thin kerf 10"	24	56.90	36
LUM8M010	Thin kerf 10"	60	69.90	43
PS203	Gen Purp 7 1/4"	24	31.42	16
PS303	Pinewood 7 1/4"	40	37.74	22
DS306	8" Dado - Carbide		158.13	95
DS308	8" Dado - Carbide		205.89	108
F0	1 1/2"x1 1/2" Biscuits 1000-Qty		25	25
F10	2 1/2"x1 1/2" Biscuits 1000-Qty		25	25
F20	2 1/2"x1 1/2" Biscuits 1000-Qty		25	25
FA	Assorts Biscuits 1000-Qty		28	28
WC104	4 pc chisel set w/cse 1/4"x1"		39	29
WC106	6 pc chisel set w/cse 1/4"x1"		52	38
WC110	10 pc chisel set w/cse 1/4"x1 1/2"		88	59
FB100	16 pc forstner bit set 1/4"x1 1/2"		262	149
FA100	5 pc router bit door system		260	159
JS100	Biscuit Joiner w/case		235	154
EB100	"NEW" edge banding machine		350	209

MAKITA CORDLESS			
Model	List	Sale	
6070WD	3/8" var. spd. rev. 7.2v	123	69
6071DWK	1/2" var. spd. rev.		
	w/removable batt, 7.2v	190	105
9000DW	3/8" saw kit, 9.6v	243	125
6500DDW	6 1/8" circular saw, 10.8v	317	167
6010DDW	3/4" cordless drill kit, 7.2v	155	89
6010SDW	3/4" cordless drill, 7.2v	103	59
DA3000DW	3/4" angle drill, 7.2v	238	130
6010DD	9.6v c/dts. recip saw kit	218	124
6010DL	3/4" drill w/flshlight, 7.2v	198	113
6012HDW	2 spd. driver drill		
	w/clutch & case, 9.6v	224	110
6710DW	Cordless screwdr kit, 7.2v	186	103
6092DW	W/spd. drill kit, complete	237	115
6093DW	W/spd. drill w/clutch-complete	248	119
6891DW	Drywall gun 0-1400, 9.6v	225	119
632007-4	9.6 volt battery	49	29
632002-4	7.2 volt battery	42	27
2012	BRAND NEW 12" portable planer	855.00	519
5007NBA	7 1/4" saw w/elec. brake	228	119
5008NBA	7 1/4" saw w/elec. brake	278	139
B04510	1/4 sheet pad sander	80	45
9900B	3"x21" belt sander w/bag	254	139
9924DB	3"x24" belt sander w/bag	268	139
9035	1/2 sheet finish sander	106	60
9045B	1/2 sheet finish sander	216	115
9045N	1/2 sht. fin. sand. w/bag	219	116
4200N	4 1/4" circ. saw 7.5 amp	213	114
5201NA	10 1/2" circ. saw 12 amp	560	285
4301BV	Orb. vsp. jg saw 3.5 amp	274	145
JR3000VL	2 sp. recip saw w/cse	220	122
JR3000V	5/8" recip saw w/case	224	125
LS1000V	New 10" mitre saw	440	229
9820-2	Blade sharpener	354	205
410	Dust collection unit	480	259
3705	Offset trimmer	255	129
1900BW	3/4" planer w/case	198	115
9100	3/4" planer w/case	381	225
9202SPC	7" sander-polisher	262	145
3601B	1 1/2 H.P. router	242	125
3700B	1 1/2 H.P. trimmer	180	92
6501B	4" grinder, 3.5 amp	137	65
B04530	8" round sander	95	57
B04550	1/4" sheet pad sander w/bag	85	46
DA3000R	3/4" angle drill	256	138
DP4700	1/2" vsp. w/rev. 4.8 amp	198	109
6001BL	1/2" angle drill w/rev	325	169
2788W	8 1/4" table saw	474	239
2711	10" table saw w/brake	890	450
605000	Disc sander 5"	109	65
6800DB	0-2500 rpm 3.5 amp	154	89
6800DD	0-2500 rpm 3.5 amp	154	89
6801DB	4000 rpm 3.5 amp	154	89
6801DD	0-4000 rpm 3.5 amp	154	89
2030N	12" planer/jointer	2970	1599
2040	15 1/2" planer	2470	1375
1805B	5 1/4" planer kit w/case	646	345
JV1600-1	var. speed jg saw	220	119
JV2000	var. speed orb. jg saw	242	127
5005BA	5 1/2" circular saw	211	115
9305BH	4 1/2" sander-grinder	153	79
6404	3/4" drill 0-2100 rpm, 2 amp	102	60
6510LR	3/4" drill rev. 0-1050 rpm	137	72
6013BR	1/2" drill rev. 6 amp	240	125
5402A	1 1/8" circular saw - 12 amp	805	325
3512BR	3 H.P. plunge router	376	185
9401	4"x24" belt sander w/bag	382	168
3520	1 1/2 H.P. plunge router w/cse	382	168
4302C	W/spd. orb. jg saw	387	145
5077B	7 1/4" Hypoid saw	248	139
LS1440	14" Mire saw	624	409
2414	14" cut-off saw AC/DC	350	195
5007NB	7 1/4" circ saw 13 amp	209	110
3612B	3 HP plunge router s/br	376	185

DELTA TOOLS			
Model	List	Sale	
34-444	Table Saw Complete w/1 1/2 H.P. motor & stand	589.00	
33-150	8 1/4" Saw Buck	499.00	
33-890	12" Radial Arm Saw 1 1/2 H.P. complete w/legs	1139.00	
28-283F	14" Band Saw w/encloused stand & 3/4 H.P. motor	599.00	
22-651	NEW 13" Planer	1095.00	
17-900	16 1/2" Floor Drill Press	315.00	
40-601	18" Scroll Saw w/stand and blades	679.00	

SKIL SIZZLERS			
Model	List	Sale	
5510	(551) 5 1/8" circ saw	112	92
5625	(552) 6 1/2" circ saw	175	115
5656	(553) 7 1/4" circ saw	132	105
5665	(554) 8 1/4" circ saw	204	125
5750	(807) 7 1/4" circ - drop foot	198	122
3765	(808) 8 1/4" circ - drop foot	216	135
5780	(810) 10 1/4" circ - drop foot	400	245
5825	(367) 8 1/4" worm saw	229	139
5865	(825) 8 1/4" worm saw	250	149
4580	Var. orbit jg saw w/cse.	144	98
3810	10" Mitre saw	263	195
585	3"x21" sander w/bag 5.5A	197	125
7565	1 1/4" palm sander	52	34
7913	3x18 belt sander 4.5A	72	58
77	7 1/4" worm drive	230	137
5350	2 1/2 HP circ saw	80.99	69
5250	2 1/4 HP circ saw	68.99	55
XTRA SPECIAL BY SKIL			
2735-04	12v W/spd. Cordless Drill comp. w/cse & 2 Batt.	210	128
LEIGH DOVETAIL JIGS			
D1258-12	List 314.00 - Sale 255.00		
D1258-24	List 375.00 - Sale 290.00		

HITACHI TOOLS			
Model	List	Sale	
TR6	Trimmer	177	99
TR8	Plunge router, 1 1/2 H.P.	219	119
TR12	Plunge router, 3 H.P.	354	169
CI09A	10" dixe. mitre saw	490	265
CR9	8 1/2" dixe. compound saw	659	475
CI5F	15" mitre saw	745	399
FREUD LU85M015	15" Carb. Bld. 108 Tooth	181	115

1989 TOOL CATALOG AVAILABLE
 Call Toll-Free 1-800-328-0457 - In Minnesota Call (612) 224-4859
 CHECK • MONEY ORDER • VISA • MASTERCARD • DISCOVER
SEVEN CORNERS ACE HDW., INC.
 216 West 7th St. • St. Paul, MN 55102 • Est. 1933

DELTA TOOLS
 34-444 Table Saw Complete w/1 1/2 H.P. motor & stand 589.00
 33-150 8 1/4" Saw Buck 499.00
 33-890 12" Radial Arm Saw 1 1/2 H.P. complete w/legs 1139.00
 28-283F 14" Band Saw w/encloused stand & 3/4 H.P. motor 599.00
 22-651 NEW 13" Planer 1095.00
 17-900 16 1/2" Floor Drill Press 315.00
 40-601 18" Scroll Saw w/stand and blades 679.00

TOOLS ON SALE™
 AMERICA'S LOWEST PRICED TOOLS
 FREE FREIGHT TO THE 48 CONTINENTAL STATES ON EVERY ITEM.
 PRICES SUBJECT TO CHANGE WITHOUT NOTICE

PIRANHA By Black & Decker				
CARBIDE TOOTH SAW BLADE				
Model#	Diameter	#Teeth	List	Sale
73-716	6-1/2	18	13.10	7.10
73-756	6-1/2	36	28.96	16.30
73-717	7-1/4	18	13.14	7.10
73-737	7-1/4	24	16.36	9.00
73-757	7-1/4	40	29.72	16.35
73-758	8	40	42.04	24.15
73-759	8-1/4	40	42.86	24.60
73-719	8-1/4	22	18.96	10.60
73-739	9	30	31.48	17.85
73-769	9	60	65.56	38.95
73-740	10	32	32.98	18.95
73-770	10	60	67.02	36.90
73-715	5-1/2	16	13.00	7.30

STYLE 32 PONY SPRING CLAMPS				
with coated tips and handles				
Model	Size</			

ONE SMALL STEP FOR LUMBER...

Let's see: You could use that prime oak slab for a coffee table or a carved door. Or, you could sell it to the Chinese for blasting into space as a heat shield!

While the United States took its typically high-tech approach to their spacecrafts' exterior heat shields, China took the low-tech route. It's reported that they swathed 10 vehicles in shields of native oak.

The heat shield protects the spacecraft during reentry



through the earth's friction-causing atmosphere. Oak chars, but apparently insulates sufficiently to serve the purpose.

ROUTERMANIA

Don't feel guilty about craving that second or third router. Take Bob Rosendahl as your inspiration. At last count—and the number has probably increased by now—this Canadian manufacturer of router jigs and fixtures owned 43 routers!

"We've got every make you can name," said Rosendahl, 56. He and his three sons operate Oak Park Enterprises, Ltd., in Winnipeg, Manitoba, and employ just three or four others. So, it seems that they always have plenty of routers to go around.

"There's always something new in routers," said Rosendahl, who goes by the name "Mr. Router" when he gives weekend seminars at woodworking shows. "Besides, we don't change bits much."

His oldest model is a 1951, ¼-hp Stanley. His favorite among newer ones—a 3-hp Hitachi. Buying advice? "I wouldn't buy anything but a plunge router now."

THE UNLUCKIEST TREE

"Beware the oak, it draws the stroke." The lightning stroke, that is, according to English folklore. A recently published book, *The Weather Companion* (John Wiley & Sons, N.Y., 1988, \$12.95, paperback), recounts old studies that found oaks were hit by lightning more often than elm, ash, pine, poplar, or beech. In fact, 60 times more often than beech.

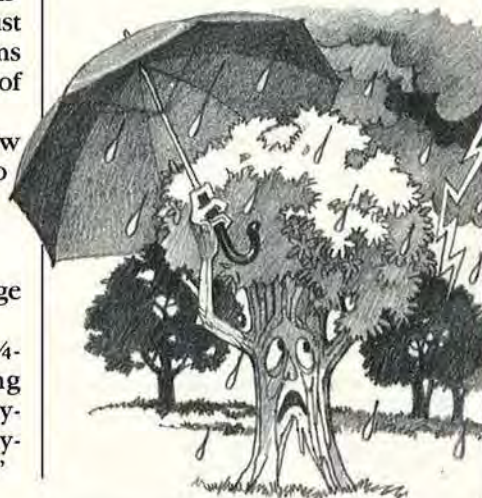

WORLD'S FASTEST PLYWOOD

Not enough space for a full-blown workshop and an arsenal of equipment? No whining.

Alan "Bo" Schide, a supervisor of new auto product testing at Delco, and Ron Brunner, a semi-retired auto mechanic, built a world-champion, inboard hydroplane out of wood. And, the woodworking hobbyists from

Dayton, Ohio, did it in Brunner's garage with one stationary power tool—a Shopsmith Mark V.

The 1988 U.S. and world champion 5-liter boat, sponsored by Shopsmith, was constructed in 1985, has a framework of Sitka spruce, and a shell of lightweight, yet impact-resistant, aircraft plywood imported from

Holland. The *Shopsmith E-31* measures 17'9" x 9' and weighs 550 pounds (less its Chevrolet engine that powers it to speeds over 100 mph). "Most racing boats have bodies of fiberglass, composite materials, or aluminum," Schide says, "but, wood is easier to work, repair, and it's less expensive." ♣

Right. Ron Brunner, on the left, and "Bo" Schide, built their all-wood hydroplane with a Shopsmith Mark V. The boat, *below*, goes 118 mph.



Photographs: Courtesy of Shopsmith, Inc. Illustrations: Jim Stevenson



DYANITE™ BREAKS THE PERFORMANCE BARRIER.

New Golden Eagle™ saw blades with Dyante™ outperform ordinary carbide-tipped blades.

This is the revolutionary new Golden Eagle saw blade. It performs like no other blade you have ever seen.

The secret is cutting teeth made of Dyante premium carbide, a breakthrough compound far tougher than any grade of carbide ever developed. Dyante means incredible performance and durability.

In numerous field tests under identical cutting conditions, Dyante premium carbide blades outperformed standard C-4 carbide-tipped blades in cutting a variety of materials... hardwood, particle-board, green lumber, plastic laminates, and more.

Dyante carbide can be given a sharper edge than standard carbide, yet requires no special tooling to be resharpened. It's more corrosion-resistant than other grades of carbide and more resistant to high temperatures generated during cutting.

The Golden Eagle line of saw blades featuring Dyante premium carbide teeth totals 37 blades in sizes ranging from 8" to 16" in diameter, in 24 to 100-tooth configurations.

Golden Eagle saw blades from DML. They're available only where quality industrial tools are sold. Call for the name of your nearest distributor.

**800-233-7297 (SAWS)
800-626-1802**

Dyante has patents pending.

DML
Cutting everything but corners.

BLACK & DECKER® PRESENTS: "BUILD IT WITH PRIDE," THE MOVIE.



NOW PLAYING AT STORES EVERYWHERE.

If you want to add star quality to your home improvement projects, Black & Decker's got the ticket. Just go to your local retailer and look for our Build It With Pride promotion.

Then purchase a high-quality Black & Decker tool. You'll be able to choose from among 19 circular saws, sanders, jigsaws, routers and drills. So you'll be sure to find exactly the tools you

need to add improved power and versatility to your workshop.

After you've made your purchase you'll be able to send in and get a home project video tape for only \$1.98. The tapes available are: Decks, Three Season Porches, Storage Projects, and Basement Remodeling.

When you receive the tape just settle back and enjoy the movie. Then get to work. And be a star in your own home. Thanks to Black & Decker.