

Better Homes and Gardens

WOOD®

THE #1 MAGAZINE FOR HOME WOODWORKERS

\$3.95

OCTOBER 1989 • ISSUE NO. 31
Display until October 10

**BOY! DID WE HAVE
A TOY CONTEST!**

Winners: page 38

**TIPS GALORE FOR
SMALL-SCALE PROJECTS**

WOOD® UPDATE
**WHAT'S HAPPENING TO
THE WORLD'S WOODS?**

**JOINTER BASICS
AND BUYMANSHIP**

IRRESISTIBLE!

Waddling duck
Woven basket
Candle holder
Tabletop frame

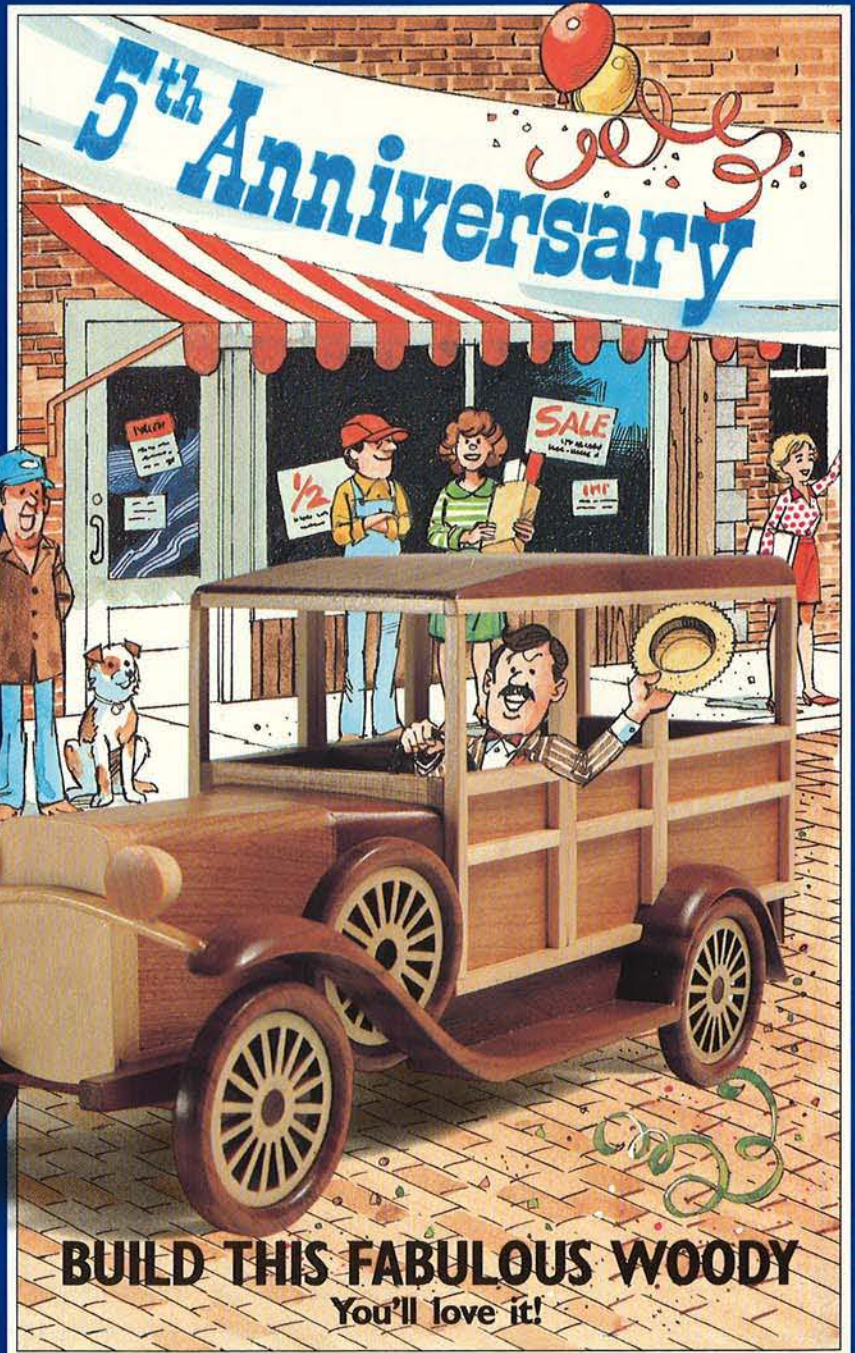

Our New Cordless Drills Are Turning Some Heads.



load breaker protects the motor from damage and can be easily reset when tripped. The chuck key is conveniently stored in a locked position on top of each drill.

Two Great Reasons To Turn To Freud.

The variable two speed, reversible 9.6 volt drill with 6 position clutch and brake – AND – the two speed, reversible 7.2 volt drill with belt clip. Lightweight, extremely comfortable and engineered for the job at hand. Whether your needs are around the home, shop or on a remote site, these drills

Model #	9638VRC	7238RC
Voltage	9.6	7.2
Reversible	Yes	Yes
Chuck Size	3/8"	3/8"
Torque Settings	6	1
Speed	2 (Variable)	2
Speed Range	0-400 RPM and 0-1100 RPM	250 RPM or 600 RPM

deliver the performance you need and expect from Freud tools.

Both drills have a 3/8 inch chuck for maximum versatility. The fast charge battery can be ready to go with an hour or less charging time. The reversing switch is conveniently located above the trigger for quick access. The over-



Each drill comes in a blow mold carrying case with a 1 Hour Fast Charge Battery and Charger.

With all of these built-in features, Freud gives you what you need and expect from a cordless drill. Put one of these professional cordless drills in your hand today. The 9.6 (9638VRC) list price: \$189.90 and the 7.2 (7238RC) list price: \$129.90. Call us for the name of your local distributor.



freud®

Precisely what you need.

High Point, NC • (919) 434-3171



FREE 24 pg. Color Catalog



List \$1315
\$915

In less than a minute
The Total Shop
Multipurpose machine
can be converted into

- Disc Sander
- 34" Lathe
- Overhead Pin Router
- 16½" Drill Press
- 10" Table Saw

The Total Shop multi purpose machine is strong, precise and versatile, not to mention priced so that owning your own woodworking shop is a real possibility and not a problem.

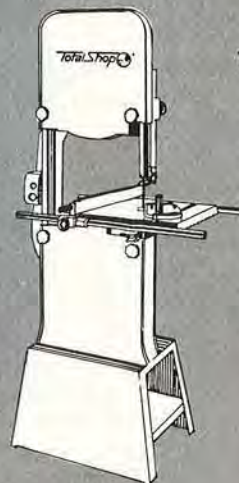

18" Band Saw

- 1½ hp
- 18" x 18" table size
- ½"-1½" blade size
- 400 lbs.

\$674.00
(ships freight collect)

16"
\$510.00
(ship freight collect)

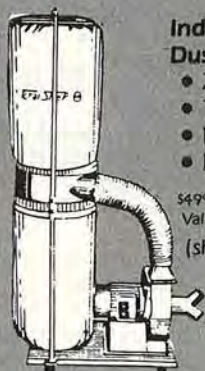

Industrial Dust Collector

- 2 hp, 110v
- Two 4" inlets
- 1185 CFM
- 125 lbs.

\$499.00
Value **\$339.00**
(ships freight collect)

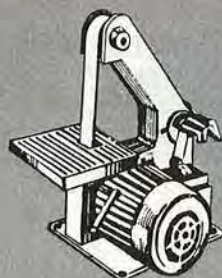

1" Belt Sander

- ⅓ hp
- 16 lbs.
- Table tilts 0° - 45°
- Die-cast aluminum

\$59.95
(UPS shipping)

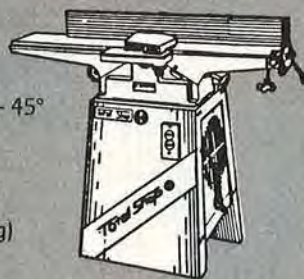

6" Long Bed Jointer

- ¾ hp, 110v
- Fence tilts 45° both ways.
- Fully adjustable
- 190 lbs.

Reg. \$499.00
\$299.00
(ships freight collect)

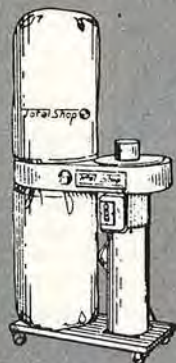

Dust Collector

- 1 hp, 110v
- 4" inlet
- Commercial quality
- Compact size

Reg. \$348.00
\$209.00
(Shp. & Hdg. \$30.00)

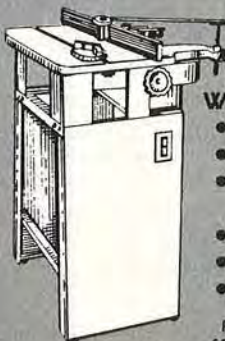

Wood Shaper

- ½" Spindle
- 1 hp
- Cast iron construction
- Precision fence
- 160 lbs.
- Ball bearings

Reg. \$499.00
\$259.00
(ships freight collect)



6" Belt & 9" Discs Sander

- ¾ hp
- 6" x 48" belt
- Cast iron construction
- 152 lbs.
- 9" Sanding Disc Included
- Ball Bearings

\$199.00
(ships freight collect)

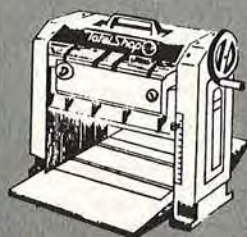

12" Thickness Planer

- Depth of cut ⅛"
- Feed rate 26 fpm
- 69 lbs.
- Safety Switch
- All ball bearing

\$359.00
(Shp. & Hdg. \$20.00)
15" and 20" Planers also available.

Call Toll Free  **1-800-845-9356** or in S.C. 288-4174

1 Hour Video Brochure

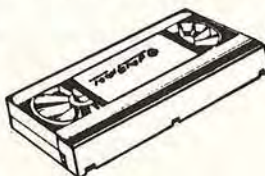

- YES! Please send me your free 24 page catalog.
- YES! Please send me your 1 hour video brochure. (Enclose \$10.00 refundable deposit - specify VHS or Beta)

Total Shop

Dept. #3
P.O. Box 25429, Greenville, SC 29616

Name _____
Address _____
City _____
State/Zip _____
Phone _____

K5

WOOD MACHINING CENTER

VIDEO DEMONSTRATION
\$14.95

The Basics of Cabinetry

- Table Saw • Thickness Planer
- Jointer • Shaper • Mortiser

Teachers, Authors, and Professionals agree -- these machines are the basics for furniture and cabinet construction.

Now, you can see in your own home how the K-5 combines these functions into one compact economical unit. Plus, you'll get a \$25 gift certificate and a free set of woodworking plans (12.95 value!) along with your video.

Call or Write to Order Your Video Pack or Free Info Kit!

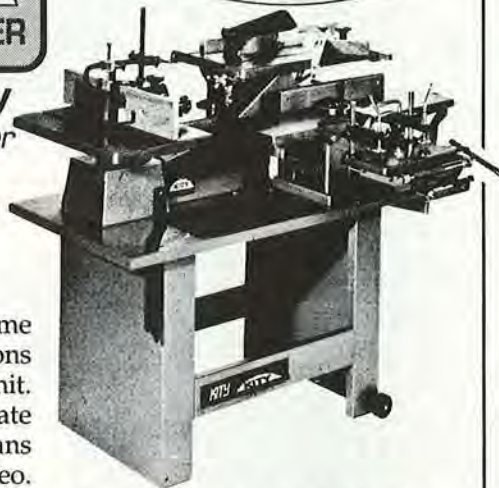

1-800-USA-KITY

Mail Coupon To:
Farris Machinery
320 North 11th Street
Blue Springs, MO 64015

Yes. Please rush me the K-5 Video along with my FREE Woodworking Plans, savings certificate, and complete ordering details. I've enclosed a check or money order for \$14.95. Free Information Kit

Name _____

Address _____

City _____ State _____ ZIP _____



Free Catalog Subscriptions!

Hot off the press! 2 exciting, new full-color catalogs, packed full of new tools and accessories—Woodcraft's Fall '89 Woodworking Catalog and Carving Catalog—ask for one or both.

Starrett Combination Squares

Versatility plus!

06I21 6" **\$49.95**

06R19 4" **\$42.95**

Postage paid
Fully guaranteed

For catalogs & credit card orders

Call Toll Free
1-800-225-1153

or write to:

WOODCRAFT
Dept. WBH99
Wood County Park #210, P.O. Box 1686
Parkersburg, WV 26101



Build Power Tools You Can Be Proud Of... And SAVE!!!

Remember when "quality craftsmanship" meant something? With GIL-BILT tools it still does.

- Construct your own:
- 12-in BAND SAW
 - 18-in BAND SAW
 - 10-in. TILT/ARBOR SAW
 - LATHE/DRILL PRESS COMB.
 - 9-in TILT TABLE SAW
 - 6-in BELT SANDER
 - SPINDLE SHAPER
 - CIRCULAR SAW TABLE

GIL-BILT kits include step-by-step plans, full scale patterns and all necessary metal parts and components except wood and motor. Made in America with pride by Gilliom Manufacturing, Inc. since 1946.

Send \$6 per plan or \$24.50 for plans for all eight tools listed above or send \$1 for descriptive brochure only. Satisfaction Guaranteed.

GILLIOM MANUFACTURING, INC.,

Dept. WD-S09
P.O. Box 1018,
St. Charles, MO 63302
Phone (314) 724-1812



Featured here: 18-in. Band Saw

Specs: Throat capacity 18 in.
Thickness capacity 12 in.
Table size 26 in. x 28 in.

Table tilt 0° to 45°
Blade furnished 124 in. x 1/4 in. x 6T
Table height 39 1/2 in.

Overall dimensions 33 1/2 in. wide
29 in. deep
71 1/2 in. high

Speed (w/1,725 rpm motor)
425 rpm 2000 blpm

Order No. 451-K only \$219.50 (less cost of plan, if previously purchased) plus shipping

Speed reduction kit available for cutting steel.

Better Homes and Gardens® WOOD®

THE #1 MAGAZINE FOR HOME WOODWORKERS

October 1989 • Vol. 6, No. 5 • Issue No. 31

Editorial/Art Staff

Editor **LARRY CLAYTON**
Managing Editor **CARL VOSS**
Art Director **C. L. GATZKE**
Design Editor **JAMES R. DOWNING**
Features Editor **PETER J. STEPHANO**
How-To Editor **MARLEN KEMMET**
Products/Techniques Editor **BILL KRIER**
Project Builder **JAMES E. BOELLING**
Senior Graphic Designer **PERRY A. MCFARLIN**
Administrative Assistant **DARLENE REYNOLDS**
Business Office Clerk **JODI DOWNING**

Technical Consultants: Product Testing **GEORGE GRANSETH**;
Wood Technology **PAUL L. McCLURE**; Collectible Tools
PHILIP WHITBY

Publisher **JERRY KAPLAN**
Advertising Director **TERRY McINTYRE**
Advertising Representatives **MARK S. JOSEPHSON, NEIL A. ORNE, ERIC VERCH**
Promotion/Research Director **THOMAS R. TROLAND**
Marketing Research Manager **EILEEN SULLIVAN**
Marketing Services Manager **NANCY DALY**
Marketing/Sales Assistant **GRETA FRANKLIN**
Sales Secretary **LORIANN DeCICOPPO**
Circulation Director **CLEM SEVDE**; Circulation Manager **ALAN BRUSH**;
Newsstand Circulation Director **MICHAEL SENIOR**
Production Director **ROBERT C. FURSTENAU**
Editorial Research Director **C. RAY DEATON**

Magazine Group Officers

Group President **JAMES A. AUTRY**
Senior Vice President, Publishing Director **ADOLPH AUERBACHER**
Group Vice Presidents: Publishing Directors **MYRNA BLYTH, BURTON H. BOERSMA, CHRISTOPHER M. LEHMAN**;
Controller **MAX RUNCIMAN**; Editorial Director **DORIS EBY**;
Operations **DEAN PIETERS**

Chairman of Executive Committee **E. T. MEREDITH III**

Corporate Officers

Chairman of the Board **ROBERT A. BURNETT**
President and Chief Executive Officer **JACK D. REHM**
Group Presidents: Book **JERAMY LANIGAN**; Broadcasting **PHILIP A. JONES**; Magazine **JAMES A. AUTRY**; Real Estate **ALLEN SABBAG**
Vice Presidents: Administrative Services **GERALD D. THORNTON**; Corporate Relations **LEO R. ARMATIS**; Finance **JAMES F. STACK**; General Counsel and Secretary **THOMAS G. FISHER**; Special Projects **FRED STINES**; Treasurer **MICHAEL A. SELL**; Controller and Assistant Secretary **LARRY D. HARTSOOK**

Better Homes and Gardens® WOOD® — the magazine for home woodworkers (ISSN-0743-894X) is published bimonthly in February, April, June, August, October, and December by Meredith Corporation, Locust at 17th, Des Moines, IA 50336. Second-class postage paid at Des Moines, Iowa. Better Homes and Gardens trademark registered in Canada and Australia. Marca Registrada en Mexico. **ONE-YEAR SUBSCRIPTION PRICES:** United States and its possessions, \$18; Canada, \$24; other countries, \$30. **POSTMASTER:** Send address changes to WOOD, Locust at 17th, Des Moines, IA 50336. October 1989, Vol. 6 No. 5, Issue No. 31. **CUSTOMER SERVICE:** For service on your magazine subscriptions, including change of address, write to Customer Service Manager **ROBERT AUSTIN**, P.O. Box 10628, Des Moines, IA 50336. Please enclose your address label from a recent issue. If you wish to phone, call toll-free 800-678-2666.

©COPYRIGHT MEREDITH CORPORATION 1989. ALL RIGHTS RESERVED. PRINTED IN U.S.A.



Introducing SmartLevel™ The First Level That Makes You Look Like a Pro.

Does it seem like your projects always come out looking almost – but not quite – professional?

There's a reason. Pros know that nothing is perfectly straight. Walls are never exactly plumb. Ceilings aren't truly level. It's due to the settling of foundations and common wear and tear.

But ordinary levels can't measure these differing angles and slopes. So pros learn how to estimate them.

The result is work that looks truly professional. Cabinets that really fit. Blinds that hang straight.

Pros take years to acquire this skill. But now it can be yours in a matter of seconds. With SmartLevel from Wedge Innovations.

180 times more powerful than the bubble.

Bubble levels only measure level and plumb. SmartLevel measures 180 times more angles. And it's three times more accurate than the bubble, capable of measuring precisely to 1/10th of a degree.

Actually, most levels are even more inaccurate due to rough usage. Professionals know this. That's why many replace their levels 2 to 3 times a year.

But with SmartLevel, a push of a button automatically recalibrates its internal sensor to rebalance the system. That's why SmartLevel never needs replacing.

The professional results you've always wanted are now quick and easy.

You'll achieve professional results on the toughest projects. On walls that are no longer plumb. Floors that are no longer level.

Plumbing that needs a 5% slope for drainage. Roofs that are set to different pitches. In fact, everywhere you look in your house, you'll see new uses for SmartLevel.

SmartLevel's LCD display gives you four modes of measuring to

eliminate tedious conversions: in degrees for most projects, percent slope for plumbing or masonry, inches per foot of run for roofs and stairways, and a simulated bubble for simple level and plumb measurements.

And SmartLevel lets you adjust sensitivity to match your project. So you can use it for everything from rough framing, to critical jobs like leveling your stereo turntable.

Brainchild of a team of Silicon Valley engineers.

SmartLevel was created in California's Silicon Valley by a top electronic engineer (and former carpenter). Through two years of development, he and his hand-picked team created a solid-state

instrument strong enough to withstand the rugged professional construction environment.

The SmartLevel module has a large, clear LCD that can read from up to ten feet away. You can use it alone as a torpedo-style level. Or snap it into any of the glove-sized handholds on the sleek SmartLevel rail. SmartLevel offers rails in 2, 4 and 6-foot lengths for more accurate readings. Rails are fashioned from polished aircraft-grade aluminum and solid nautical teak — the strongest and most durable wood available. A single 9-volt battery (not included) provides power for up to 2 years.

Proof we're on the level. Call for a risk-free 30-day trial.

SmartLevel is available exclusively from its manufacturer — Wedge Innovations. Use it in your shop, around your house, or on a yard project. After a full 30 days, if you're not satisfied, simply return it for a prompt refund — no questions asked. Wedge also provides a full one-year warranty.

Call our toll-free line now to order: 1-800-SMARTLEVEL. We accept Visa or Mastercard. Or send a check. Act now, and take advantage of our special introductory price while supplies last.

Remember, you won't find a level anywhere that's this accurate and versatile. For straighter, cleaner, more professional results on all your projects, order your SmartLevel now.



Order Now By Phone or Mail CALL 1-800-SMARTLEVEL (1-800-762-7853)

7:30 AM – 5:00 PM (PST) Monday – Friday
Please mention number I9WD



The SmartLevel electronic module locks into any handhold in the SmartLevel rail—or can be used alone as a torpedo level.

The sensor module is interchangeable between all rails.

Description	Item #	Quantity	Special Introductory Price	Amount
SmartLevel System				
Sensor module w/2' teak rail	SMTR2		\$104.95	\$
Sensor module w/4' teak rail	SMTR4		\$129.95	\$
Sensor module w/6' teak rail	SMTR6		\$154.95	\$
Additional Components				
Sensor module only	SM		\$79.95	\$
2' teak rail only	TR2		\$25.00	\$
4' teak rail only	TR4		\$50.00	\$
6' teak rail only	TR6		\$75.00	\$

CA residents: Add 6.5% sales tax
Shipping: add \$5.00 per rail ordered

Check
 VISA MC

Card No. _____ Exp. Date _____
 Authorizing Signature _____
 Name _____
 Address _____
 City/State/Zip _____
 Daytime Phone _____

I9WD

Wedge Innovations • 532 Mercury Drive • Sunnyvale, California 94086

**NOW!
REDUCE THE
RISK AT YOUR
TABLE SAW**



folds down neatly

WITH THE **MOBILE™
NEW SAWING CENTER**

OUTFEED ROLLERS

- safe, accurate sawing
- handle panels with ease
- available in 15" and 37" widths
- dual-position table

AND INCREASE FLOOR SPACE



MOBILE MACHINE BASES

- increase shop working area
- maximize usable floor space
- 3 point base will not rock
- locking wheels
- makes machine so easy to use and store
- over 80 standard models

PLANER STAND WITH ROLLERS

- raises planer to proper working height
- provides machine mobility
- five-fold increase in workpiece support
- storage is a snap



NEW



**ROLLERTABLE
Rock Solid Support**

- adjustable
- portable
- use at any machine

PEDESTAL
ROLLER

Discover HTC's many unique products designed only with you, the dedicated woodworker in mind. Find out how you can make your machining safer, increase working area of your shop and accomplish nearly impossible tasks easily, quickly and accurately - **all by yourself!**

CALL TODAY!

HTC PRODUCTS, INC.
120 E. HUDSON S-8
ROYAL OAK, MI 48067
(313) 399-6185



1-800-624-2027 ext. 108

Better Homes and Gardens®

WOOD

THE #1 MAGAZINE FOR HOME WOODWORKERS

This issue's cover wood grain: slippery elm

OCTOBER 1989

ISSUE NO. 31

WOOD PROFILE

MESQUITE: PRIME FOR STEAK, BETTER FOR STOCK 37

Not all mesquite goes up in smoke inside the barbecue grill. Craftsmen have discovered that this Southwest tree makes excellent furniture, too.



BOY! DID WE HAVE A TOY CONTEST! 38

We tip our hats to all the generous readers who entered WOOD® magazine's first design competition. See the complete list of winners on pages 40-41.



DUCK WADDLES OFF WITH A GRAND PRIZE 42

Here's the irresistible duck that stole the hearts of our Design-A-Toy™ judges. We think you'll want to build this pull toy for holiday giving.

WHAT'S HAPPENING TO THE WORLD'S WOOD? 46

Mankind and Mother Nature have combined to slice up our planet's forests, causing alarm around the world. After capsulizing the situation, features editor Pete Stephano asks forestry experts to look to the future.



SHOP-TESTED TECHNIQUES WORKING SMALL 50

Jim Boelling, our project builder, has gone absolutely buggy over detailing tiny masterpieces in his spare time. Now, Jim shares techniques he's developed for working in a small world.

CRAFTSMAN CLOSE-UP FOWL LANGUAGE 56

Butch Richenbach, who grew up in Stuttgart, Arkansas—site of the World Championship Duck Calling Contest—has carted home his share of awards. Today, top-flight competitors rely on Butch's duck calls.

HOMEMADE TOOL RIGHT-ON RIP FENCE 60

If you don't have the money in your budget for a commercially made replacement rip fence, we want to show you how to make your own fence to upgrade your tablesaw's accuracy.

DEVELOP YOUR SHOP SKILLS

HOW TO SAFELY FEED STOCK THROUGH A JOINTER 65

Whether you're a novice woodworker or you've jointed boards for decades, you'll find it worth your time to review these jointer procedures.



TOOL BUYMANSHIP

JOINTERS: MACHINES THAT GIVE YOU THE EDGE QUICKLY AND ACCURATELY 66

Shopping for a new jointer? Today, you'll find (as we did) that 6" models dominate the market. Before you buy, read about the models we tested and how they vary in quality, features, and price.

FIFTH-ANNIVERSARY SPECIAL THE CLASSIC WOODY 72

For this occasion, our design editor created a model reminiscent of a 1930 Ford Woody. Photograph your Woody car and we'll mail you a free brass license plate.



HANDWOVEN WHATNOT BASKET 78

When Marlen Kemmet, our how-to editor, spotted this basket at a Minneapolis craft fair, he couldn't wait to build one in our shop. Amazingly, you find that you can cut all the woven pieces in your shop from solid stock.

PINT-SIZED PICTURE FRAMES 82

After you build our handy jig, you can make a batch of these tabletop frames for those school pictures kids bring home each year. Talk about a great gift idea! This is it!



TURNING PATTERN

TULIP TIME AT YOUR LATHE 84

With the help of a belt sander and files, discover how Mark Burhans, a talented Ohio woodturner, puts flare in his candle holders.



SHORT-SUBJECT FEATURES

Editor's Angle	6	Products That Perform	29
Talking Back	8	Wood Action Groups	93
Tips from Your Shop (And Ours)	14	Tool Industry Insider	94
Old Hand Ways	25	Ask WOOD	98
		Finishing Touches	112



	QTY.	TOTAL
3-1/2" Economy Shaker Peg	\$16.00 / 100	_____
2-1/2" Medium Shaker Peg	\$14.00 / 100	_____
1-3/4" Mini Shaker Peg	\$ 8.00 / 100	_____
Large Bean Pot	\$20.00 / 100	_____
Mini Bean Pot	\$ 8.00 / 100	_____



3/4" x 1/8" Hearts	\$ 3.50 / 100	_____
1" x 1/8" Hearts	\$ 4.00 / 100	_____
1-1/4" x 1/8" Hearts	\$ 5.00 / 100	_____
1-1/2" x 1/8" Hearts	\$ 5.90 / 100	_____
1-3/4" x 1/8" Hearts	\$ 9.50 / 100	_____
2" x 1/4" Hearts	\$12.90 / 100	_____



1" Maple Toy Wheels	\$ 6.00 / 100	_____
1-1/4" Maple Toy Wheels	\$ 7.00 / 100	_____
1-1/2" Maple Toy Wheels	\$ 8.00 / 100	_____
Axle pegs for above wheels	\$ 4.00 / 100	_____
1-1/2" Maple Spindles	\$10.00 / 100	_____
2" Maple Spindles	\$14.00 / 100	_____
3/8" Maple Buttons	\$ 2.00 / 100	_____
1/2" Maple Buttons	\$ 2.00 / 100	_____

Door Harp Parts!



3/4" prebored Door Harp Balls	\$ 9.00 / 100	_____
Tuning pins	\$17.00 / 100	_____
Wire-550 Ft. (.013 diameter)	\$12.00 / roll	_____
Poplar Plywood		_____
11-3/4" x 11-3/4"	\$ 1.00 / each	_____
Set of 5 Door Harp Plans	\$ 5.00 / set	_____
Door Harp Kit (Builds 2)*	\$16.00 / each	_____
*Balls, Pins, Wire, Wrench, Plywood, Plans		_____
1" Full Round Balls	\$12.00 / 100	_____
2" Full Round Balls	\$10.00 / 10	_____
3" Full Round Balls	\$ 3.00 each	_____



1-5/8" Sawtooth Hanger	\$ 4.00 / 100	_____
Small picture Hanger	\$ 2.00 / 100	_____
#17 Screw Eye 1/2" long	\$ 2.00 / 100	_____
#14 Screw Eye 13/16" long	\$ 3.00 / 100	_____
Small Eggs 1-3/8" x 2"	\$ 8.75 / 25	_____
Large Eggs 1-3/4" x 2-1/2"	\$12.50 / 25	_____
Apples	\$ 1.50 each	_____



Total for Goods	_____
Texans Only - Add 7% Sales Tax	_____
Handling and Insurance	\$3.00
Total	_____

ALL NEW WOOD PARTS CATALOG \$1.00
(Free With Order)

Total B59

MC OR VISA CHECK ENCLOSED

ACCOUNT # _____

EXPIRES _____ PHONE _____

NAME _____

SHIP TO _____

CITY/STATE/ZIP _____

Woodworks

4500 Anderson Blvd.
Fort Worth, Texas 76117
(817) 281-4447

THE EDITOR'S ANGLE

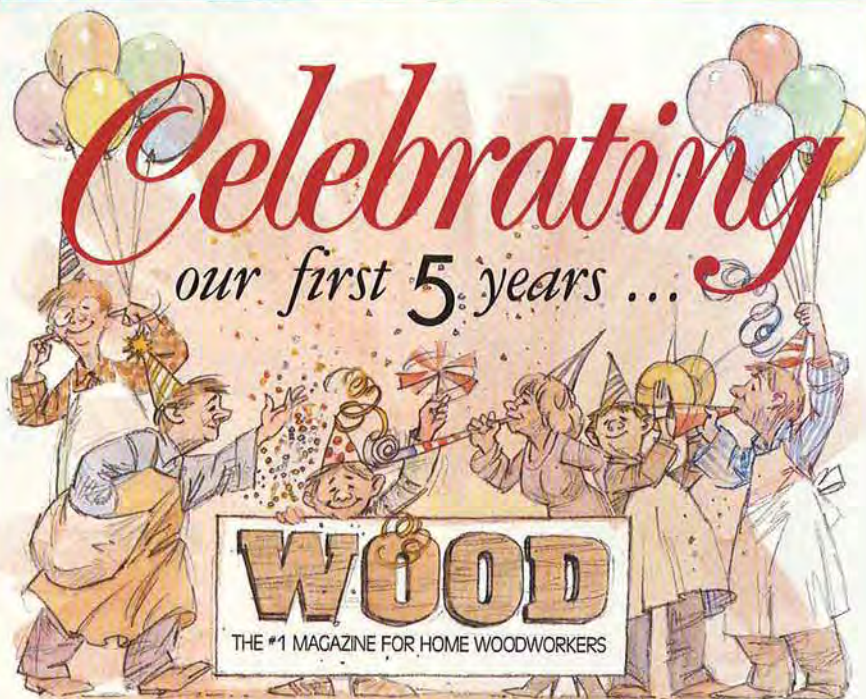

*... and looking forward
to serving you for many more!*

Ever since it dawned on the staff and me a few months back that *WOOD*® magazine would turn five years old with this issue, we've been plotting our strategy for a blockbuster issue to mark the occasion. And now that the moment has finally arrived, we hope you enjoy the final product.

As promised, we're showcasing the winning entries in our Design-A-Toy™ competition along with instructions on how to build one of the grand-prize winners. And, be sure to take a look at Pete Stephano's fact-filled piece titled "What's Happening to the World's Wood." This timely article not only summarizes the situation as it exists around the world today, but also offers a glimpse into the future of one of man's most important renewable resources.

I'd also like to call your attention to a couple of dandy projects—

both designed by our own Jim Downing—that we think you're really going to like. The first, a homemade version of the commercially available replacement rip fences, will add unbelievable accuracy to your tablesaw—for under \$50. And the second, a model car reminiscent of the 1930 Ford Woody (pictured on the cover), should tickle the fancy of lots of readers.

We've also included several other great project designs, as well as our regular menu of articles covering techniques, product buymanship, and feature articles for your reading pleasure.

Oh, I almost forgot! If you're interested in seeing and learning a little more about the crew that brings you *WOOD*® magazine every two months, take a look at page 112. The gang's all there.

Enjoy!

Larry Clayton



Print this article

BOSCH



Woodworking



Shape Solid Surfacing Beautifully.

5 bits in 16 sizes handle solid surface undermount bowl and decorative edge routing with micro-grain carbide-tipped efficiency. Line includes 15° bevel, rounding over, ogee, no drip and edge inlay bits.



Trimming Laminates or Veneers?

Bosch 1608 Laminate Trimming System includes 5.6 amp motor and complete set of accessories for virtually all shop, installation tasks. Includes standard, tilting and offset bases.



Sander Features Exclusive Belt Tracking/Tensioning.

Model 1273 and companion models have unique belt centering system. Rated super duty for high production, the unit also has pinch point guards for safety and lever action for easier belt changes.



and bit size — and get far better cutting results.

1611EVS electronics give you two more big advantages, too. "Soft start" when you press the trigger — no jarring "torque twist" means better control. And by monitoring RPM and feeding power as needed, it keeps you from bogging down, even in the toughest cuts.

Master Of Ergonomics.

From the first moment you get your hands on the variable speed model 1611EVS or the single speed model 1611, you'll know what separates it from other plunge routers. The handle grips feel like they were molded especially to fit your hands. The trigger switch, built into the right handle, and the plunge lock mechanism by your left thumb, let you reach these controls without taking your hands off the router.

Then press the trigger and take the plunge. Feel the housing glide down, and the ample power at your command as the bit slices effortlessly into your workpiece. Release the spring-loaded plunge lever and the housing locks firmly into position. And you can use the multiple-step depth-stop to make progressively deeper cuts with precision.

Both models accept the full array of $\frac{1}{2}$ ", $\frac{3}{8}$ " or $\frac{1}{4}$ " shank bits. And with their built-in, spring-loaded shaft lock, changing bits is fast and simple.

The Bosch models 1611EVS and 1611 are available in cooler running, higher horsepower 220V models, too. Ask about them and the complete line of fine Bosch power tools for woodworkers, at your nearest Bosch power tool distributor. He's listed in the Yellow Pages under "Tools — Electric."

The Speed Varies So The Results Won't.

The new 3.25 H.P. Bosch electronic variable speed plunge router lets you make perfect plunge cuts time after time, no matter what the material or bit size. That's because it puts *you* in total control of speed, cutting depth, and the router itself, due to an

excellent ergonomic design.

The Advantages Of Variable Speed.

Select any speed, from 12,000 to 18,000 RPM, to match your material



BOSCH

"Quality You Can Hold On To.™"

©1989 Robert Bosch Power Tool Corporation

BRAD POINT DRILL SETS



7 Pc. set in pouch or 25 Pc. set in metal case.

7 Pc. set contains 1/8" to 1/2" by 1/16" increments. MODEL G1834 **ONLY \$6⁹⁵**
 25 Pc. set contains 1/8" to 1/2" by 1/64" increments. MODEL G1835 **ONLY \$27⁵⁰**
 Both Sets Prepaid To You!

INCR A JIG



Make intricate dovetails, finger-joints, etc. . . with this amazing jig.

Introductory Price!
MODEL G1768

\$29⁹⁵ Prepaid To You

TEMPLATES FOR INCR A-JIGS

MODEL G1832

ONLY \$14⁹⁵ Prepaid To You

TALKING BACK

We welcome comments, criticisms, suggestions, and even an occasional compliment. Send your correspondence to: Letters Editor, Better Homes and Gardens® WOOD® Magazine, 1716 Locust St., Des Moines, IA 50336.



U.S., CANADIAN DOOR OPENS WIDER

Our growing Canadian readership occasionally asks questions about purchasing woodworking tools and supplies in the U.S. Until this year, Canada collected a 9 to 10 percent tariff on U.S.-made goods crossing the border. U.S. Customs, on the other hand, collected a 4 to 5 percent tariff on Canadian-made goods headed south. The recently enacted Canada-U.S. Free Trade Agreement will phase out tariffs, including most woodworking-equipment duties, by Jan. 1, 1993; the first 20 percent reduction occurred Jan. 1 of this year. The agreement affects only goods made in Canada and the U.S.; a set of German-made chisels, for example, would still be subject to tariffs.



This new trade agreement should be good news for woodworkers on both sides of the border. But, Canadians should keep in mind that the fluctuating exchange rate could add about 18 percent to their purchase. And, they may be subject to federal and provincial taxes on their U.S. purchases.

WOOD magazine readers Sherry Sanne of Winnipeg and D. L. Myhre of Lethbridge, Alberta, asked if Canadians can take advantage of free pattern offers in the magazine. You bet! If Canadians—or any foreign residents—include an international reply coupon with your self-addressed envelope, WOOD magazine will send you any free pattern that strikes your fancy.

Many firms advertising in WOOD magazine do ship to Canada and foreign countries. They must declare the contents and value of the order on a customs declaration form affixed to the outside of the shipping box. "We get thousands of orders each year from Canada," says Glenn Docherty at Albert Constantine & Son. "But before we ship, we let them know what the additional postage will be. Canadians then pay duty at their post office. United Parcel Service also will collect duties on orders they deliver in Canada."

"We charge \$4 extra for each Canadian order," says David Draves of Woodcraft, "to cover the additional postage and paperwork. Recently, we've noticed an increase in catalog interest from Canada—perhaps because of attention to the new trade agreement."

47-YEAR-OLD MYSTERY SOLVED

A feature article in the February issue of WOOD magazine—"Paldao, A Truckful of Horrors"—caught

Continued on page 10

THE INCREDIBLE SHOPHELPER

PRICE BREAKTHROUGH!

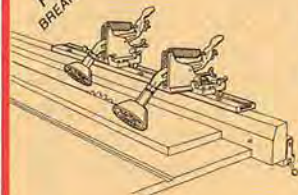

A MODEL FOR EVERY APPLICATION!

- MODEL G1630 - YELLOW SHOPHELPERS FOR TABLE-SAWS
- MODEL G1578 - GREEN SHOPHELPERS FOR SHAPERS
- MODEL G1766 - ORANGE SHOPHELPERS FOR RADIAL-ARM SAWS

YOUR CHOICE - ONLY \$49⁹⁵
 Prepaid To You!

Thousands sold at up to \$89.95!

MADE IN USA!

EAST OF THE MISSISSIPPI:



WEST OF THE MISSISSIPPI:

IMPORTS, INC.

1-800-523-GRRR CALL TOLL FREE 1-800-541-5537

(FOR ORDERS AND CATALOG REQUESTS ONLY) 89-109



Send for **FREE Catalog!**
 (Include area code & phone no. to be used as cust. no.)

1-800-338-6668

Satisfaction Guaranteed. Merch. shipped complete w/ factory standard accessories

BOSCH

1-3/4 hp Router
\$122 — #1604

1581VS	VS Orb. Jig Saw.....	\$131
1611	3 hp Plunge Router.....	201
1198VSR	1/2" VSR Ham. Drill....	118
1196VSR	3/8" VSR Ham. Drill....	120
1609K	Laminate Kit.....	159
1582VS	VS Orb. Jig Saw.....	121

HITACHI

1/2" Super Duty Router
\$169
 TR12

CB75F	Band Saw.....	\$1795
C15FB	15" Hvy Duty Miter Saw	374
C8FB	8" Compnd Miter Saw....	489
TR8	1/4" Hvy Duty Router....	124
#F1000A	12" Planer Jointer.....	1650

RYOBI

10" Surface Planer
\$359
 #AP10

RE600	3 HP Router.....	\$199
BE321	3x21" VS Belt Sander.....	123
R500	2-1/4 HP Plunge Router....	157

PORTER CABLE

\$55
#330
 Speed Bloc® Sander

690	Router, 1-1/2 hp.....	\$118
100	Router, 7/8 hp.....	90
691	D Hndl Router 1-1/2 hp....	132
7548	VS Top Hndl Jig Saw.....	124
655	Plate Joiner.....	160
	Biscuits pkg.....	27

DELTA

10" Contractor's Saw
\$639⁰⁰
 #34-444

34-429	10" Tilt Arbor Bench Saw	1080
34-782	Unisaw.....	1725
34-740	Super 10" Table Saw.....	395
34-670	10" Table Saw.....	330
33-050	Sawbuck Trim Saw.....	550
34-985	Prod. Stock Feeder.....	599
34-995	Prod. Stock Feeder 3ph.	839
34-994	Prod. Stock Feeder.....	899
28-283	14" Band Saw 3/4 hp.....	699
28-243	14" Band Saw 1/2 hp.....	519
33-890	12" Radial Saw.....	1200
33-990	10" Radial Saw.....	568
37-350	8" Precision Jointer.....	1480
37-154	6" Jointer DJ-15.....	1028
37-280	6" Motorized Jointer.....	350
43-122	Wood Shaper.....	615
34-080	10" Motor, Miter Box.....	214
17-900	16-1/2" Drill Press.....	349
34-330	8-1/4" Bench Saw.....	239
40-601	18" Elec. Scroll Saw.....	699
31-340	1x42" Belt/Disc Sander....	179

ELU **\$266**
#3338

2-1/4 hp Elec. Plunge Router

3337	2-1/4 hp Plunge.....	247
3304	1 hp Electronic Plunge..	180
3303	1 hp Plunge.....	145
4024	3x21 Electronic Belt Sndr	206
4023	3x21 Belt Sander.....	192
3375	Universal Planer.....	195
3380	Jointer/Splinter.....	325
4029	4"x24" Belt Sander.....	325
40900	Router Access. Kit.....	135

Freight paid on most items

2017 WHITE SETTLEMENT ROAD
 FORT WORTH, TX 76107

Limited Quantities-Errors Subject to Correction

Build along with Norm Abram!

Learn Norm Abram's Woodworking Secrets

Get the hardcover edition of **THE NEW YANKEE WORKSHOP** at a special discount price, and create traditional American furnishings for your home with the expert help of Norm Abram!

You'll get detailed plans for a traditional drop-leaf table . . . workbench . . . blanket chest . . . bedside table . . . bathroom vanity . . . trestle table . . . bookshelf . . . chest of drawers . . . hutch . . . writing desk . . . and more.

Learn how to create beautiful, traditional pieces easily, using modern tools, materials and techniques!

Follow along with the companion volume to the 12-part PBS-TV series.

THE NEW YANKEE WORKSHOP is being featured on PBS-TV across the country.

With this book you can follow along as Norm Abram builds each handsome project. You'll have a hardcover reference to use over and over—a guide to Norm Abram's remarkable skills and techniques.

Learn Norm Abram's tips for using a lathe, router, table saw, drill press, band saw and other equipment; benefit from his advice on joint-making, finishing, measuring and more!

Improve your fine-woodworking skills with the guidance of master woodworker Norm Abram. Send for your copy of **THE NEW YANKEE WORKSHOP** today!

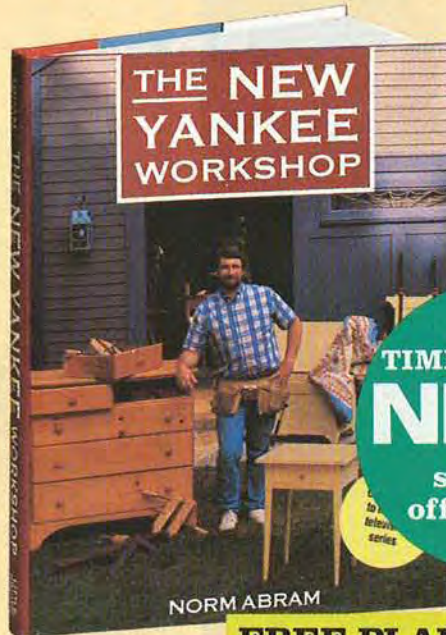

- Step-by-step directions
- 28 full-color photos
- 128 detailed black-and-white photos
- 70 illustrations
- Easy-to-use 9×12-inch size
- Unique "planning box" streamlines every project

FIRST TIME OFFERED
NEW!
save \$5
off the retail price!

FREE PLANS
to build this
CORNER CUPBOARD



TRY IT FREE FOR 21 DAYS!

YES! Please send me my free Corner Cupboard Plans and a copy of Norm Abram's **THE NEW YANKEE WORKSHOP** to examine free for 21 days. If I decide to keep the book, I'll pay for it in **three easy monthly installments of \$8.32 each** plus postage and handling. (There is no interest or finance charge.) If I do not want the book, I'll return it with the invoice within 21 days and owe nothing. The plans are mine to keep regardless.

SAVE CASH by sending \$24.95 now and we'll pay postage and handling. Same return privileges as above. 42353

Name _____

Address _____

Apt. # _____

City _____

State _____ Zip _____

(NY, PA, CA, and IL residents please add state sales tax.)

Clip and mail to: **RODALE BOOKS, Emmaus, PA 18098**

The most versatile chuck available.

30 applications including screw chucks, 3 jaw chucks, spigot collets etc. Basic chuck offers 7 different uses with free 14 page instructional handbook.



Combination chuck available from:
 Albert Constantine & Sons Inc., 2050 E. Chester Rd., Bronx, NY 10461.
 Garrett Wade Co. Inc., 161 Ave of the Americas, New York, NY 10013
 Shopsmith, 3931 Image Drive, Dayton, OH 45414
 Woodcraft Supply Corp., 41 Atlantic Ave. PO Box 4000, Woburn, Mass 01888.
 Russ Zimmermans, House of Woodturning RFD3, Box 242, Putney, VT 05346.
 Also available from Craft Supplies LTD., The Mill, Millers Dale, Buxton, Derbyshire, England SK17 8SN.

Continued from page 8

my attention. This may be the wood that I've wondered about and inquired about since 1942. Where did I see this tree? On Guadalcanal in the Solomon Islands with the First Marine Division. The trees I saw were of great height and diameter. I never saw one in open ground, but always in dark, heavy swamps. The article said the things I believe to be buttresses started outward from the tree from a height of about 30 feet. This 3" or 4" wall would twist and wind away from the tree. I don't know how many of these walls there were on each tree, but I do know that you could walk all around the trunk of the tree and be completely concealed.

—Maj. Harry Campbell, Springhill, Fla.

Major, we inadvertently solved your 47-year old mystery that originated on Guadalcanal. The tree you remember, and the supports called buttresses, was no doubt paldao (*Dracontomelum dao*), or one of its close family members. The tree's great natural range includes the Philippines and New Guinea, as well as most of the Southwest Pacific. Besides its common name of paldao, the wood trades under the names sengkuang, New Guinea walnut, lamio, dao, damoni, dorea, loup, and New Guinea wood, according to the U.S. Forest Service's Forest Products Laboratory in Madison, Wisconsin. Paldao grows to about 120', and often has a straight trunk of 80' above the buttresses. Woodworkers prize the walnut-like wood, as our story told you, for paneling and furniture.

WOODWORKER'S PLANS & PARTS

HEIRLOOM ROCKER

Build our classic rocking horse and create a family heirloom which will delight the children in your family for generations to come.

Size:
35" x 58"

Order Plan 400
Only \$10.25



This great rocker retails for over \$300.00

Accessories available
See our catalog

Low, low prices on wood parts

Smooth Maple Wood Wheels
Eight Sizes

WT-3/4"	\$4.50/100
WT-1"	\$5.00/100
WT-1-1/4"	\$7.00/100
WT-1-1/2"	\$10.00/100
WT-1-3/4"	\$15.00/100
WT-2"	\$18.00/100
WT-2-1/4"	\$5.00/20
WT-2-1/2"	\$7.00/20

Axle Pegs 
AP-1 lts 1 to 2
\$4.00/100

Full Round Wood Balls 
Four Sizes

BA-3/4"	\$8.00/100
BA-1"	\$10.00/100
BA-1-1/2"	25 each
BA-2"	60 each

Shaker Peg  Candle Cup 
Reg Peg \$16.00/100
Mini-Peg \$6.00/100
Candle Cup \$16.00/100
Mini-Cup \$7.00/100

Tie Peg  \$6.00/100

DOOR HARP PLANS AND PARTS



Harp Plans \$4.00 each
or buy all four \$12.50

Plans include stencil design

New design
No fret bar



Hardware Kit (no plywood)
One harp 3.50
Four harps 12.50

Harp Wire
10¢ per ft.
25' for 2.50
¼ lb. for 12.00
1 lb. 34.00

Tuning Pins
30¢ each
50 for 11.00
100 for 18.00
500 for 75.00

Tuning Pin Wrench
3.50 or FREE if
harp order totals
35.00

Door Harp Plywood
11 1/2" x 11 1/2" 1.00 ea.
10 for 9.00
30 for 24.00

Shipping \$2.50. NY Res. add tax. Catalog \$1.00 FREE with order.
We accept VISA & MASTERCARD. Phone (516) 462-6228

Armor Products Box 445-L East Northport, NY 11731

OF MILLIMETERS, MILS, AND INCHES

How thick was that Mylar? In February, you said the DuPont double-matte Mylar was 3 mm thick. Now in the June issue, you say its .003 mm. I believe you really mean 3 M, which stands for *mils*. Circular mils is a term used by the electrical and plastics industries, and normally shortened to just mils. A sheet of 3 mil plastic equals .003 of an inch in thickness. Many people get their m's and mm's confused, as a result of our metric conversion.

—E.W. Bingham, Portland, Ore.

Bing, you were the first of a half dozen sharp-eyed readers to straighten us out on mils. Thomas Nelson Jr. of DuPont confirmed the facts as you state. Case closed—we hope.

THE CASTERS ARE EXTRA

Powermatic product manager Robert Alsop informs us that retractable casters listed as standard equipment on the new model 63 Artisan 10" table saw are a \$32 optional accessory. The saw, mentioned in the June 1989 "Tool Industry Insider," lists for \$650.

GLAD YOU THOUGHT OF THAT

I have a suggestion on how to improve the trestle table featured in your April 1989 issue. Fasteners like the one shown at right allow for the different wood movement of the tabletop and the table supports.

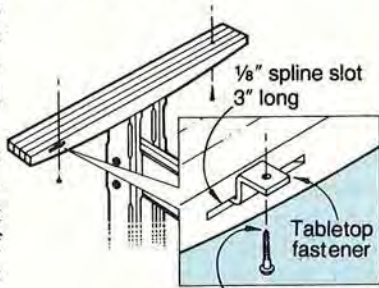

#8 x 3/4" R.H. screw

—David G. Schwenker, Portsmouth, Va.

You have a good idea, David. One bracket at each end of the table allows the natural expansion and contraction of wood to continue. Inquire at your local hardware store for a 3/4" Stanley tabletop fastener (part number 1910).

SCRAPING AWAY FOR A BETTER TOOL

I am delighted with the scraper presented in the April 1989 issue, and wasted no time in getting one made. In the process, I made a few changes that I believe made a good tool even better.

First, I rabbeted a shoulder in the blade-mounting surface. This stop positions the blade and prevents it from slipping when applying pressure.

Since I didn't happen to have a solid-brass strike plate, I substituted a brass-coated steel plate. The results please me, since the steel plate is stiffer, doesn't spring away when releasing the blade, and doesn't distort when tightening the clamp nut. Please note that I changed the bend angle to apply clamping pressure where it's most effective.

Instead of a 1/2" round-over on the top, I intentionally cut it flat to provide a surface perpendicular to the desired rake angle on the edge of the blade. By resting the scraper on this surface, I can quickly produce a straight cutting edge on a disc sander.

—Tom Rose, Los Angeles

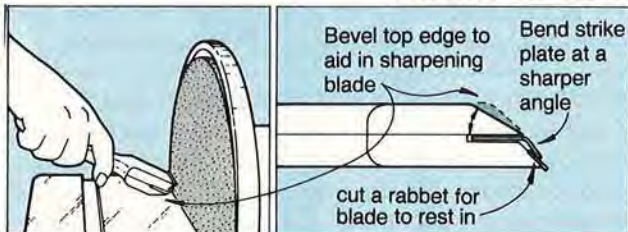

Once again, Tom, you have insightful comments. Since publishing the project, Jim Downing, our design editor, has discovered that solid carbide blades for hand-held power planers work even better than the backsaw blades we originally suggested. Jim snapped off about 1" from blades he picked up at a local Black & Decker store.

Continued on page 12

NEW

TOP QUALITY DRUM SANDER



- Rubber surface drum uses STANDARD abrasive!
- Alloy steel lift screws
- Steel slider feed bed
- Direct gear motor feed drive
- Dust collector
- Quadruple steel rollers prevent ALL SNIPE!
- Endless conveyor belt feed

PLEASE SEND ME FREE BROCHURE
Telephone orders (417) 223-4031
Ross Industries Dept. WN1
100 North Highway W, Box 637, Pineville, MO 64858

ROSS
INDUSTRIES INC.

Name _____
Address _____ Phone _____
City _____ State _____ Zip _____

IF YOU VALUE YOUR FINGERS..... YOU NEED A **RIPSTRATE®**

The RIPSTRATE holds the work tight against the fence with no hands near the blade. Makes perfect, straight cuts. Wheels lock to prevent kickbacks. Requires no adjustment for stock width or thickness.

Over 30,000 now in use in amateur, professional, school, government, military, and corporate maintenance shops.

One year guarantee, 30 day money back trial. Only \$69 delivered. Check, M.O., Visa or M.C. Free Brochure.

Write or call our toll free number: 800-421-0256.

Fisher Hill Products 4 Fisher Hill Fitzwilliam, NH 03447
Dealer inquiries invited.



Free * SANDPAPER * Free

*FREE: All items in this ad shipped within 72 hours or freight is free

BELTS: Grits assorted unless otherwise specified

Material: Aluminum Oxide Resin over Resin Cloth

1x30.....\$0.69ea	3x21.....\$0.77ea	4x24.....\$0.94ea
1x42.....0.69	3x23¾.....0.80	4x36.....1.14
1x44.....0.69	3x24.....0.80	6x48.....2.98
2½x16.....0.73	3x27.....0.83	2½x80.....2.74
3x18.....0.74	4x21¾.....0.91	Other sizes on request

SHEETS (9x11)

Both cabinet & finishing paper available in Garnet or Aluminum Oxide

CABINET PAPER

40D.....\$16/pk	50/pk 100/pk	80-A.....\$9/pk	50/pk 100/pk
50D.....15/pk	\$30/pk 27/pk	100 thru 280A	8/pk 14/pk
60D.....14/pk	25/pk	WET/DRY PAPER	
80D.....13/pk	23/pk	220 thru 600A	50/pk 100/pk
100 thru 150C	12/pk 21/pk		\$13/pk \$23/pk

NO LOAD PAPER

180A thru 400A	50/pk 100/pk
	\$10/pk \$18/pk

Coarser GRITS available on request

FINISHING PAPER

WET/DRY PAPER

220 thru 600A	50/pk 100/pk
	\$13/pk \$23/pk

Coarser GRITS available on request

JUMBO CLEANING

STICK

Size: 2x2x12
\$8.80

ABRASIVE ROLLS FOR ABRASIVE PLANERS

Material: Aluminum Oxide Resin over Resin Cloth

SIZE 4x25 yds	SIZE 4x50 yds
GRIT 100 & Finer	GRIT 100 & Finer
80	80
60	60
50	50
40	40
36	36
24	24

Other sizes on request

WIDE BELTS • ROLLS • FLAP WHEELS • PUMP SLEEVES • ROUTER BITS • DISCS & MORE

ECON-ABRASIVES

P.O. Box 865021 Plano, TX 75086
Telephone (214) 377-9779
Outside Texas 1-800-367-4101

SATISFACTION GUARANTEED

MASTERCARD, VISA OR CHECK
MINIMUM ORDER \$25

TEXAS RESIDENTS ADD 7% SALES TAX
SHIPPING CHARGE ADD \$4.25

TALKING BACK

Continued from page 11

STRAPPING DOWN THOSE FILE-CABINET DRAWERS

I built the two-drawer file cabinet in the February 1988 issue and found the instructions and illustrations easy to follow.

However, I'd like to point out a hazard connected with all filing cabinets and particularly with this one. When the top file drawer is loaded and fully extended, the file may tip forward. (Most commercial cabinets have a device that allows only one drawer to open at a time.) Since the individual components are not tied together, this could be even more dangerous if three or four drawers are stacked. I solved the problem by bolting the sections together with metal angle brackets.

—Bob Vanderbeyden, Green Bay, Wis.

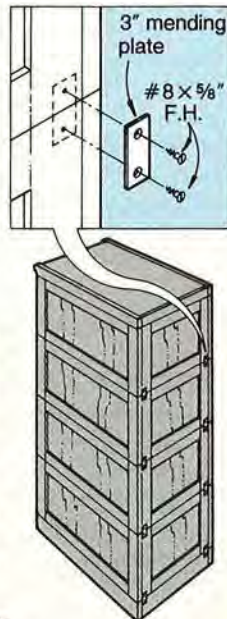

Bob, you're right—we should have foreseen this as a potential problem. Here's another solution: We recommend ½x3" brass mending plates (Stanley part number CD5350) to secure the pieces as shown in the illustration above.

BIGGER CHESTNUT TREES

Your Wood Profile article on page 37 of the June 1989 issue indicates that chestnut trees "measured 5–6' around the trunk." As you no doubt know, 5–6' was the diameter.

—Ty Baldwin, Richmond, Ky.

Ty, you certainly know an American chestnut tree when you see one. Of course, we meant a 5–6' diameter, not circumference as stated. After all, these trees were BIG, and plenty of them grew in Kentucky.

BOWLED OVER, POLYCHROMATICALLY

I was impressed by your fine article on stack-laminated bowls in the April 1989 issue. Your readers may want to know that the correct name for this kind of turning is polychromatic assembly. Two books have been published on this subject. I recommend *Polychromatic Assembly for Woodturning*, by Emmett and Cyril Brown (Linden Publishing Co, 1982). The book includes plans for a beautiful bowl with a 12-point star. I've searched unsuccessfully for years for another book on the subject, *The Art of Polychromatic and Decorative Turning*, written by George and Berthod Audsley in 1916. ♣

—Robert Walter, Baltimore

Give Your Imagination Permission, And Start Your Own Family Traditions!

**Whether You Do Scroll Sawing As A Hobby, For Making Money, Or As A Craftsman,
The Hawk Is The Tool For You!**

**The Hawk can make you feel good
about your woodworking...
and make others envy your skill!**

There isn't any other kind of woodwork that looks more complex and professional than scroll sawing. And that's what scares most beginner woodworkers. But the pros know the tool's the secret. With the right saw, some instruction and practice, a few patterns and lots of imagination, **anyone** can turn out beautiful scroll-work.

The Hawk is the "right" scroll saw for you. It will open up new woodworking frontiers for you **even if you've never done scroll sawing before!** That's why we designed it for beginners. Yet we wanted it to last for years and handle the work as the user's skills grew. So, we built it for the fine woodworkers to get maximum use from, too.

**Make Money or Just Scroll For
The Fun Of It.**

You'd be surprised how easy it is to make money with scroll woodworking. Hundreds of folks start doing it the minute they set The Hawk up in their workshops. Many use this to pay for their machines, supplement incomes and even start full time businesses.

Experienced craftsmen find they can do intricate scrollwork for their fine woodworking projects in half the time it takes on a bandsaw or jigsaw.



**Hawk 20"
Model**

The Hawk

"America's favorite Precision Scroll Saw"

If coupon is missing write your name and address
on a postcard and mail to: RBIndustries,
P.O. Box 369, Harrisonville, MO 64701



**We Designed Our Precision Scroll Saws
For Beginners and Built Them
For Fine Woodworkers.**

- Make simple crafts like toys and puzzles to give as presents
- Paper towel holders, wall sconces, name cutouts and hundreds of others you can sell for profit
- Fancy scallops and precision scrollwork for clocks, heirlooms, intricate inlays and dovetails.

How creative do you have to be to scroll saw? If you can draw a line, you can follow it with a Hawk...and, like that, you're scroll sawing, with the kind of results you've always dreamed of. Trace any kind of pattern onto your wood and follow the lines. It's that simple.

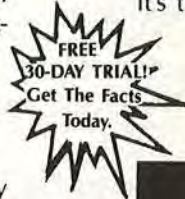

MAKE THESE PROJECTS AND MORE!



**CALL US TOLL FREE TO FIND OUT ALL
THE FACTS ABOUT SCROLLING TODAY!**

800-535-8665

YES! Put me on your mailing list
to receive my Free Fact Kit.

Name _____

Address _____

City _____

State _____ Zip _____

Phone _____

**Mail To: RBI Inc., P.O. Box 369, 1801 Vine St.
Harrisonville, MO 64080**

© RBI INC 1989

EO189

EARN CASH, PRIZES FOR YOUR TOP SHOP TIP

Do you have a great shop tip (or two) you'd like to share with other WOOD® magazine readers? For each published submission, you get:

- \$25 from WOOD magazine;
- A matching \$25 gift certificate from one of our mail-order advertisers—this time from Leichtung Workshops, Inc.; and
- A chance to be selected as the Top Shop Tip winner for the issue. This issue's winner will receive a Makita model 3601B D-handle router as shown at right.

We try not to use shop tips that have run in other magazines, so please send your tip to only one magazine. We cannot return shop tips. Mail your tips, address, and daytime phone number to:

SHOP TIPS

Better Homes and Gardens®
WOOD Magazine
1716 Locust St.
Des Moines, IA 50336

BRACKET SUPPORTS LONG STOCK AT WORKBENCH

Many workbenches—home-made and commercial models alike—don't incorporate features to support long pieces protruding from the vise. As a result, it's necessary to scrounge around for an acceptable temporary support or go look for someone to serve as a willing assistant. There has to be an easier way!

TIP: Here's an inexpensive solution: modify and install a readily available shelf bracket on your workbench. First, screw a 1½–2'-length of vertical shelf bracket on one leg of your workbench as shown above. Then, grab a metal shelf bracket and for the protection of your workpieces face it with a grooved piece of wood, glued in place with epoxy. You may wish to make several brackets of different sizes and configurations to handle special situations. Adjust the bracket up and down for various stock widths. This setup gives you a sturdy and economical support system.

—Tom E. Moore, Madison, Va.

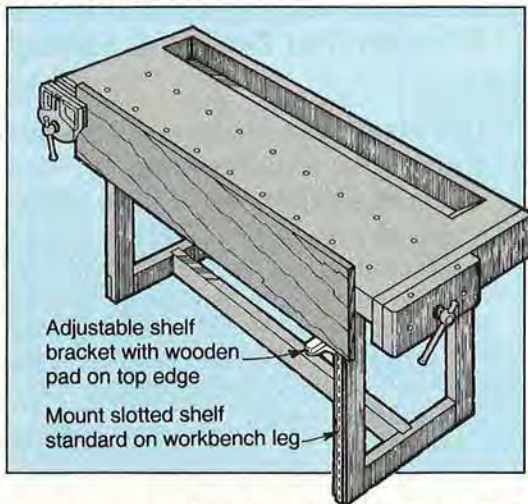

For his winning tip, Tom receives the Makita model 3601B 1¾-hp, fixed-base router shown at left.

ROLL ALONG EASILY WITH TEMPLATE ENLARGEMENTS

Enlarging templates by small increments—like ¼ or ½"—can be a real pain, especially when you're trying to increase the dimensions of a curved or irregularly shaped object. Sometimes, you need to draw template offset lines that match a router guide bushing. Here's a solution utilizing parts on hand.

TIP: Use a flat metal washer as a spacer between the edge of the template and the point of your pencil as illustrated at right. Washers come in many different sizes, giving you a wide choice in enlarging capabilities. Maintain even pressure on the pencil as you draw.

—From the WOOD magazine shop

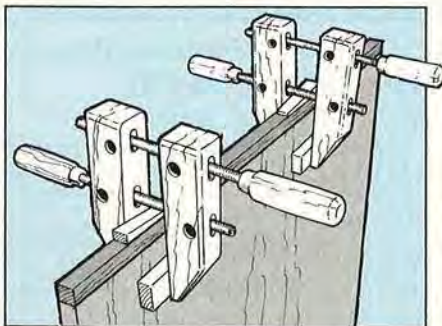

WOODWORKER'S CLAMPS GLUE EDGES, TOO

You can't top edge clamps for edge-gluing projects, but like all quality tools, a fistful of them represents a tidy investment. Without denting your wallet, wouldn't it be nice if clamps you already own would work for this task?

TIP: Call your woodworker's clamps into action for those occa-

sional edge-gluing jobs by using them in combination with homemade wooden wedges. After fitting together the glued workpieces, tighten the clamps in place as shown at left and tap wedges in place for the desired lateral pressure. Suitably sized C-clamps work quite well in this arrangement, too.

—From the WOOD magazine shop

Continued on page 16



JOINTER

JT-0012.....\$1795.00
 12" planing width
 13-3/4 x 72" precision ground cast iron table
 3HP motor.



INDUSTRIAL PLANER

3 HP, 20" max width, 7 5/8" max thickness, 1/4" max cut, 3 knives, return roller, mag. switch.
 WP-1120.....\$1855.00
 5 HP, 24" max width
 WP-1124.....\$2655.00



DUST COLLECTOR

1HP Motor - UFO-90\$199.00
 2HP Motor - UFO-101\$339.00
 3HP Motor - UFO-102B\$465.00



TILTING ARBOR TABLE SAW

Cast aluminum guide rail. Quick lock fence.
 3HP Motor 2Belt drive HTS0012A. \$825.00
 3HP Motor 3Belt drive TS-1010...\$1195.00

**Best Quality
 Now Improved!**

POWER FEEDER

1HP, 8 Speed,
 Forward & Reverse
 Safety features and more!

Two Year Warranty!

30 Days FREE TRIAL!

CHIU TING



CT-280F.....\$1200.00

1/4 HP
 SK-321FD.....\$390.00

Offering a complete line of fine quality tools including...

- ✓JOINTERS
- ✓LATHES
- ✓MORTISERS
- ✓PLANERS
- ✓SANDERS
- ✓SAWS
- ✓and more!

Featuring:

SPINDLE SHAPER

SK-30SPA. \$799.00
 1" and 3/4" Spindle 3HP
 28"x30" table F/R Switch

SLIDING TABLE SK-35ST.....\$199.00



WIDE BELT SANDER

A-2548....\$6150.00
 24" working width
 A-3760....\$8995.00
 36" working width

3 precision balanced contact drum. Rugged heavy duty metal construction. Full power motors drive sanding and auto infeed smoothly. Computer control adjust table.



STROKE BELT SANDER

SK-1500BS.....\$1295.00
 60"x21-1/4" sliding table
 6" sanding belt width 2 HP
 SK-2100BS.....\$1599.00
 80" x 21-1/4" sliding table
 6" sanding belt width 3 HP



DRUM SANDER

Double drums. Dust chute. 1/4 HP feeding
 15" 3 HP - SK-15DS.....\$1795.00
 20" 3 HP - SK-20DS.....\$1975.00
 25" 5 HP - SK-25DS.....\$2355.00

TRUE VALUE & TRUE QUALITY



LOBO POWER TOOLS

9034 Bermudez Street, Box 456
 Pico Rivera CA. 90660
 (213)949-3747

In Canada:
 Unit 3, 2375 Alpha Ave, Burnaby, B.C
 Canada V5C 5L2 (604) 299-0911
 All F.O.B. Pico Rivera, CA

Write or call now

FREE BROCHURE

Or \$3 Catalog (\$5 refunded with order)
 One year free parts warranty
 We specialize in customer satisfaction



16" WOOD BAND SAW

2HP, 3speed, BS-8163. \$465.00
 18" BAND SAW
 2 HP, MBS-0181.....\$895.00

12 SHOWS IN FALL 1989!

• Free Workshops

• 100 Exhibits • Win a Jeep 4x4

★ *The*
Woodworking Shows ★
machinery
tools • supplies



See the Widest Variety of Woodworking
Products All Under One Roof
HUNDREDS OF ITEMS

Machinery • Power & Hand Tools • Supplies

September 8-9-10	Greater Cincinnati
September 15-16-17	Twin Cities
September 22-23-24	* Metro-Detroit
Sept. 29 - Oct. 1	Western Washington
October 6-7-8	* No. California
October 13-14-15	Baltimore/Washington
October 20-21-22	Pittsburgh Tri-State
October 27-28-29	Central Florida
November 3-4-5	Oregon
November 10-11-12	So. California
November 17-18-19	San Diego
December 1-2-3	Delaware Valley

*Special Woodworking/Home Improvement Show

Seminars by Ian Kirby - Roger Cliffe -
Bob Rosendahl - Rude Osolnik - Nick Cook
- and other Master Craftsmen

1-800-826-8257 or 213-477-8521

Call for free brochure 8:30 - 5 Pacific Time

**Save \$1 off reg. \$6
admission with this ad**

BRANDING IRON

Your Satisfaction Guaranteed

- Convenient torch heating
- Solid Brass—lasts years
- Special wording available
- Electric Models Start at \$41.95
- 2nd line—
20 letters/spaces max.
- 1/4" letters
- Distinctive Border
- Add \$2.50 shipping
and handling
- OH res. add 6% sales tax



\$25⁰⁰

Order by mail from:

BrandMark

462 Carthage Dr., Dept W5
Beavercreek, OH 45385
(513) 426-6843

TO ORDER CALL TOLL FREE

1-800-323-2570

(ORDERS ONLY)

8:00-5:00 EASTERN TIME



GRANDMA'S HALL CLOCK

Our Hall Clock is designed so
beginning woodworkers are
able to build it. Finish it in
either stain or antiqued
country paint. Order Plan
Number 8839 WEEKEND
WORKSHOP for \$7.00 ppd.
To use VISA or MasterCard,
call 516-352-5198.

HAMMERMARK ASSOCIATES
P.O. Box ABW9
Floral Park, NY 11001-0201
Price guaranteed through 3/90.



COUNTRY CRAFTS
FULL-SIZE-CRAFT-PATTERNS

28 FULL SIZE Projects; Peg Racks, Lamp, Clock, Basket,
Mirror, Clipboard, Towel Rack & More PLUS Dozens of Full
Size Country Geese, Pigs, Lambs, Cats, Bear, Chicks &
More. Just Trace, Cut, & Paint. Only \$8 Prepaid, 1st Class.

MASTERCRAFT PLANS, Dept. 93H
P.O. Box 625 • Redmond, WA 98073



more COUNTRY CRAFTS
FULL-SIZE-CRAFT-PATTERNS

27 MORE FULL SIZE Projects; Apple Book Rack, Paper
Towel Holder, Shelf, Lamp, Note Holder, Heart Wreath,
PLUS Dozens More Country Animals; Carousel Horse,
Ducks, Cats, Goat, Mice & More. Only \$8 Prepaid 1st Class.

MASTERCRAFT PLANS, Dept. 96H
P.O. Box 625 • Redmond, WA 98073



WOODWORKER'S CATALOG

There are over
4,000 money-saving
reasons why
woodworkers rely
on Constantine.

4,000 woodwork items—
to help you Build-Restore-Repair-Refinish! Over 200
different woods . . . 150 veneers . . . 500 plans . . . cabin-
et hardware . . . 96 How-To Books . . . 118 carving tools
and chisels . . . 76 inlay designs . . . and lots more for
One-Stop, Right-Price Shopping without leaving home!

116 Page Catalog-Only \$1.00

CONSTANTINE Est. 1812
2054S Eastchester Road, Bronx, New York 10461



TIPS FROM YOUR SHOP (AND OURS)

Continued from page 14

CLOTHESPINS BECOME MIGHTY MICRO-CLAMPS

Putting together tiny projects such
as dollhouse furniture, wooden
models, or jewelry, can get awfully
frustrating, especially when you're
gluing intricate parts.

TIP: Reshape spring-activated
wooden clothespins into miniature
clamps as shown below. You can
tailor their tips to fit different situa-
tions. The softwood pins won't
damage delicate surfaces.

—John Monaghan, Goleta, Calif.

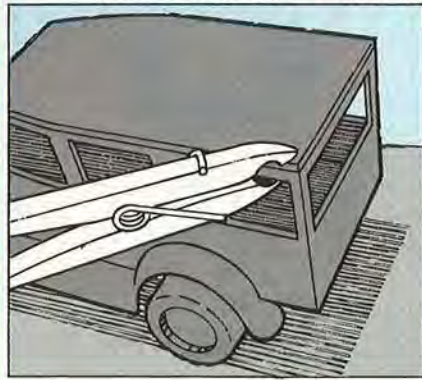

**A DRILL BIT FINDS
DEAD CENTER OF A DOWEL.**
Locating the center of a wooden
dowel can be a hit-or-miss proposi-
tion if you try to do it with a
straightedge and a pencil. Typically,
the smaller the dowel, the greater
the chance for missing the middle.

TIP: Hit the center by using a
Forstner bit of the same diameter as
the dowel to bore a hole through a
block of scrap-
wood. Then, in-
sert the dowel
into the hole on
one side of the
block and the bit
on the other side.
Press in slightly
as you twist the
bit a few times to
mark the center
of the dowel.

—From the **WOOD**
magazine shop

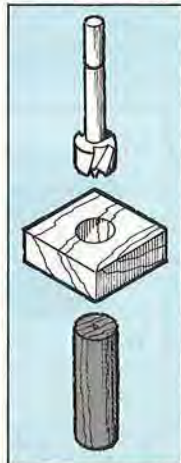

Continued on page 18

Wood-Mizer®

World's Largest
Manufacturer
Of Portable
Sawmills



OWN YOUR OWN SAWMILL

Four Models To Choose From
SAVE MONEY—
CUT YOUR OWN LUMBER

- Remote hydraulic log handling
- Capacities up to 32" in dia.
by 33' long
- Portable—precise—rugged
- Efficient—more lumber per log

CALL FOR FREE CATALOG

1(800)553-0219

In Indiana call: (317) 271-1542

44-page catalog or use
your MasterCard or VISA
to order our 50-minute
demonstration video—\$10.00

FREE



Wood-Mizer Products, Inc. • Dept. QQ39
8180 W. 10th St., Indianapolis, IN 46214-2430

Your workshop can PAY OFF ...BIG!

SAVE ... convert low
cost rough lumber
for use in your
home projects

OR

EARN EXTRA
INCOME by supplying
custom Planed Lumber,
trim, and molding to
lumberyards ...
contractors ...
cabinetmakers ... home
hobbyists and others ...



FOUR BIG ADVANTAGES ...



PLANE



MOLD



SAW



SAND

You can plane, mold, saw & sand All with Automatic Power Feed!

From the Day It Arrives ... the Planer will make and save you money. With shortages and inflation driving lumber prices sky-high, this versatile power feed tool quickly pays for itself by easily converting low cost rough lumber into high value finished stock. In just one pass turn out your own quarter round, door and window stop, casing, tongue-and-groove ... all popular patterns. Other operators are making cases for grandfather clocks, furniture, picture frames, bee hives, bed slats, surveying stakes ... all kinds of millwork.

Built For Pros ... Priced For Home Craftsmen ... it is engineered and built to industrial standards, but factory-direct selling keeps the price low. Handles tough oak and walnut as easily as pine, and so simple to operate even beginners with no experience can use it. **Start Your Own Business ...** with just this one low cost power feed machine in a corner of your garage or basement, you're set up to supply lumberyards, cabinetmakers, carpenters, remodelers, contractors and hobbyists in your area with custom-planed lumber, trim, molding ... All of their millwork requirements. You can supply picture frame moldings to art shops, hardware and department stores, or sell direct to framing shops. All standard patterns are available from stock, or we'll custom grind a knife to your own special design or sample.

**FREE
BOOKLET!**

Get **FREE
BOOK** with
facts and
full details
... **RUSH COUPON TODAY!**



Just Mail Coupon ...
**30-DAY FREE
TRIAL OFFER!!!**
ACT NOW!
Coupon
Brings
Full Details!

SAVE!!! FACTORY PRICES DIRECT TO YOU!



FOLEY-BELSAW CO.
6301 EQUITABLE RD., DEPT. 91474
KANSAS CITY, MO. 64120
Established in 1926

YES, please send me the FREE Booklet that gives me complete facts about your Planer-Molder-Sander-Saw and full details on how I can qualify for a 30-Day FREE Trial right in my own shop. I understand there is No Obligation and that No Salesman will call.

Name _____
Address _____
City _____ State _____ Zip _____

TIPS FROM YOUR SHOP (AND OURS)

Continued from page 16

HIDE EDGES IN PLYWOOD AND OTHER MATERIALS

Panels constructed of hardwood-faced plywood have pretty faces, but the laminated edges simply are not presentable on cabinetry or other projects. Veneering is a possible solution—providing you have the materials and tools to do the job.

TIP: To disguise the plywood layers, cut beveled strips from the material with your tablesaw or radial-arm saw set at 45° as shown in drawing A. Make a second cut perpendicular to the first one as shown and discard the resulting scrap. Finally, glue the first strip in place as shown in drawing B. This procedure also extends the face-grain pattern onto the edge. Use this technique to disguise freshly sawed edges on weathered barn boards used for picture frames.

—Howard Pieplow, West Allis, Wis.

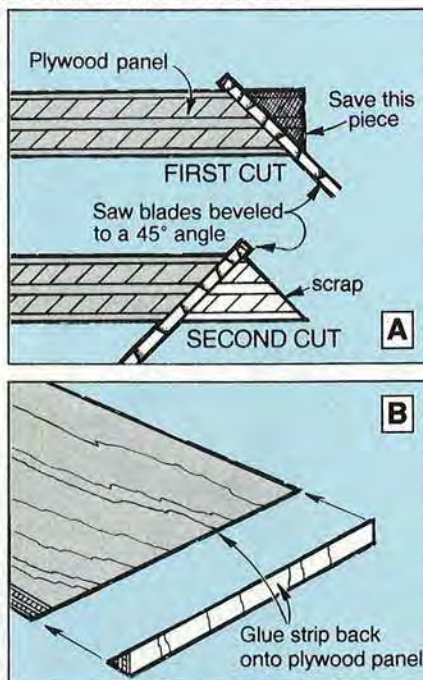

GIVE TOUGH STRIPPING PROBLEMS THE BRUSH-OFF

When refinishing furniture, working the stripper into tight corners and finely detailed work can prove hard work. Brass brushes help, but cost money, too.

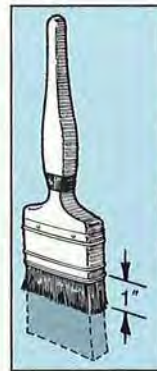

TIP: Scrub away the loosened finish from intricate carvings, deep grain, and other hard-to-get areas with an old paintbrush. First, cut off the bristles to a length of 1" to make them stiff enough to work nicely. For best results, generously

dab on the stripper without over-brushing it during application.

—Mark Ceola, Fayetteville, Ark.

Continued on page 21

FINALLY A SCROLL SAW THAT DOESN'T CUT CORNERS.



The new Dremel two-speed Scroll Saw gives you all the features of the most expensive saws, except one. The price.

How'd we do it? Using the same Dremel engineering that's been bringing you intelligently-crafted,

affordable power tools for over 50 years.

So if you're looking for a quality scroll saw that'll make your most intricate work a breeze, ask about the new 16" Scroll Saw from Dremel. And cut those expensive saws down to size.

DREMEL®

Here's another "buy 1 tool get our 212 page tool free" offer.

Just a few of the unique woodworking tools of the 3,500 others available from our most versatile tool, the 1990 Garrett Wade Catalog.

The 212 page Catalog, regularly \$4.00, is Free with any order from this ad. Or if you would just like the Catalog, send us \$4.00 with your name and address. It's the one woodworking source book you shouldn't be without.

A / Our 202GF Gap Filling Glue Has Remarkable Properties

It has a very high solids content so that small gaps in our joinery are actually filled - with strength. And the "squeeze-out" beads right up and chips off when dry. No soaking in to ruin finishes. Dries to a light tan. Water clean-up.

- 62J01.01 1 pt. 202GF \$ 6.50
- 62J01.03 1 qt. 202GF \$11.50

B / Saw Setting Gauge Can Be Read From Any Position

Most saw setting gauges have at least one or two main weaknesses. They either rest partially on the insert plate which is usually not the same height as the main table, or they are so thin that it is difficult to ensure that teeth are being gauged at the top of the arc. This Gauge is made from machined Aluminum a full 3/4" thick and 9" long. With 1/4" graduations on one end and 1/8" on the other, it will indicate any height from 1/8" to 2". Most useful for Table Saws but also handy for Router depth setting. The markings are vertical on one face and horizontal on the other, so you can read them easily and accurately.

- 71K26.02 Saw Setting Gauge \$16.95

C / Deluxe Cabinet Scraper

With an extra-heavy main iron casting and Solid Brass thumb screws, this is clearly the best of the cabinet scrapers available. The Sole is a full 1/4" thick, very flat, and polished. It has good heft and feels very satisfying to use. One of our most highly recommended tools.

- 19K06.05 Deluxe Cabinet Scraper \$26.50

D / Super-Hard, Pre-Sharpened Scrapers Keep Their Edge Longer

Most scraper blades are sheared from steel hardened to Rc 38-42. This makes them fairly easy to file, stone and burnish. The hook, however, wears quickly in hard use. These are sheared from spring steel hardened to a Rc 48-51. Both edges are surface ground to a sharp, square 90°.

The prepared edge saves you filing and stoning initially and the extra hardness lets you use the scrapers longer between burnishings. Supplied with edge guards, which you should always replace after use. Comes in a set of 4: .015", .025", .035" and .042." thick.

- 51K07.04 Set 4 Super-Hard \$15.95
- 19K03.01 Triangular Burnisher \$9.10



E / The "Blind Nailer" Used To Be A Staple In Every Tool Box

This unique tool functions like a positioning jig. Simply slip the Special Chisel in and tighten. Then place the flat Sole on the wood. You will be able to operate it in a one-handed fashion, using no mallet, as the chisel, which has a "finger-nail" shaped cutting edge, is mushroom shaped to fit comfortably in your palm.

The chisel edge, controlled by the Blind Nailer, will lift a perfect small chip. Hammer your nail in and then glue the chip back in place. Result: No nail head hole. You can work very quickly.

- 44K01.03 Nailer Plus Chisel \$14.95



F / VIX Bits Save Hours When Drilling Screw Holes For Hardware

Includes hinges, door butts, window pulls and latches, door latch bolts, striker plates and many others. The hardened Retractable Guide (includes depth stop) recesses as you drill, ensuring that the hole is accurately centered - every time. Fits any drill. 2 sizes: 3/64" for #5 and #6 screws, 1/64" for #8, #9 and #10 screws.

- 66K07.03 Both Sizes \$13.95

Garrett Wade Co., Inc.

161 Avenue of the Americas
New York, NY 10013 Dept. 635
Call Toll Free 800-221-2942
(NY 212-807-1757 No Collect Calls Please)



Please send me these Garrett Wade tools and include a FREE 1990 Catalog with my order. (Prices good until August 31, 1990)

Name: _____

Address: _____

City: _____ State: _____ Zip: _____

Check or Money Order Card Number

Visa MasterCard

American Express

Expiration Date: _____

STOCK #	QTY.	DESCRIPTION	PRICE	TOTAL
GW	1	1990 Catalog (free with order)	\$4 00	

New York Residents add applicable Sales Tax
Shipping & Handling: \$2.90 for order total up to \$10
\$4.10 for \$10.01 to \$20
\$4.95 for \$20.01 to \$50
\$6.25 for over \$50

Sub Total	
Sales Tax	
Shipping	
Grand Total	

CONTROL THE SPEED OF YOUR ROUTER - ROUT AT THE SPEED THAT GIVES THE BEST RESULTS WITH THE WOOD AND BIT YOU ARE USING!

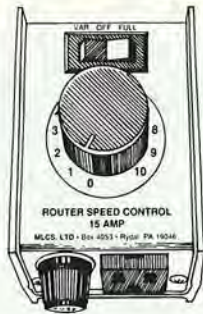

FEATURES:

- Speed Adjustable from Full Speed to 0 RPM
- Full Horsepower and Torque at All Speeds
- Go Back and Forth from Any Pre-Set Speed to Full Speed at the Flip of a Switch
- Works with All Routers 3 HP or Less
- 120V 15 Amp
- Gives Your Router a Feature Only Available on Routers Costing Hundreds of Dollars!

- Less Tear Out
- Feed at Comfortable Rate
- Better, Safer Results with Large Diameter Bits
- Less Wear on Bits
- Less Noise and Softer Starts at Lower Speeds
- Stops Burning

EASY TO USE - Simply plug in Speed Control and plug your router into the Speed Control - turn dial for best results. (Speed Control has a clip that can be worn on your belt or hung on wall or left loose.)

• Reduces speed electronically without reducing torque; electronic feed-back maintains speed by increasing voltage to motor as load increases.

NOW ONLY \$39.95 Order Item #200

CARBIDE TIPPED ROUTER BITS PROFESSIONAL PRODUCTION QUALITY GUARANTEED WHEN ORDERING ANY THREE OR MORE DEDUCT \$1.00 EACH. ALL PRICES ARE POSTAGE PAID

ITEM NO.	BEST CUT BEST PRICE	DESCRIPTION	ANGLE/DEPTH/RADIUS CIRCLE DIAMETER	LARGE DIA.	CUTTING LENGTH	SHANK SIZE	PRICE
#490		1/4" Classical		1/4"	5/8"	1/4"	\$25.00
#491		1 1/2" Classical		1 1/2"	3/4"	1/4"	\$25.00
#792		1 1/2" Classical		1 1/2"	7/8"	1/2"	\$25.00
#231		5/32" Roman Ogee	5/32" R	1/4"	1 5/8"	1/4"	\$17.00
#232		1/4" Roman Ogee	1/4" R	1 1/2"	3/4"	1/4"	\$18.00
#661		1/4" Roman Ogee	1/4" R	1 1/2"	3/4"	1/2"	\$21.00
#340		1/8" Cove	1/8" R	5/8"	1/2"	1/4"	\$12.00
#341		1/4" Cove	1/4" R	1"	1/2"	1/4"	\$13.00
#342		3/8" Cove	3/8" R	1 1/4"	3/4"	1/4"	\$14.00
#343		1/2" Cove	1/2" R	1 1/2"	5/8"	1/4"	\$15.00
#644		3/4" Cove	3/4" R	1 7/8"	3/4"	1/2"	\$28.00
#350		1/8" Round Over	1/8" R	3/4"	1/2"	1/4"	\$11.00
#351		3/16" Round Over	3/16" R	7/8"	1/2"	1/4"	\$11.00
#230		1/4" Round Over	1/4" R	1"	1/2"	1/4"	\$12.00
#354		3/8" Round Over	3/8" R	1 1/4"	5/8"	1/4"	\$15.50
#355		1/2" Round Over	1/2" R	1 1/2"	3/4"	1/4"	\$17.00
#656		3/4" Round Over	3/4" R	2"	7/8"	1/2"	\$21.00
#657		1" Round Over	1" R	2 1/2"	1"	1/2"	\$33.00
#370		3/8" Rabbeting	3/8" Deep	1 1/4"	1/2"	1/4"	\$14.00
#670		3/8" Rabbeting	3/8" Deep	1 1/4"	1/2"	1/2"	\$14.00
#366		1/8" Slot Cutter	3/8" Deep	1 1/4"	1/8"	1/4"	\$14.00
#368		1/4" Slot Cutter	3/8" Deep	1 1/4"	1/4"	1/4"	\$14.00
#403		3/8" Dovetail	9 degree	3/8"	3/8"	1/4"	\$ 7.50
#405		1/2" Dovetail	14 degree	1/2"	1/2"	1/4"	\$ 8.50
#409		3/4" Dovetail	14 degree	3/4"	7/8"	1/4"	\$10.50
#709		3/4" Dovetail	14 degree	3/4"	7/8"	1/2"	\$10.50
#402		3/8" Dovetail	8 degree For	3/8"	1/2"	1/4"	\$12.00
#404		1/2" Dovetail	8 degree Leigh	1/2"	1 3/16"	1/4"	\$12.00
#708		1 1/16" Dovetail	8 degree Jigs	1 1/16"	1"	1/2"	\$17.50

ITEM NO.	BEST CUT BEST PRICE	DESCRIPTION	ANGLE/DEPTH/RADIUS CIRCLE DIAMETER	LARGE DIA.	CUTTING LENGTH	SHANK SIZE	PRICE
#415		1/4" Core Box	round nose	1/4"	1/4"	1/4"	\$10.00
#416		3/8" Core Box	round nose	3/8"	3/8"	1/4"	\$11.00
#417		1/2" Core Box	round nose	1/2"	1 1/2"	1/4"	\$14.00
#418		3/4" Core Box	round nose	3/4"	5/8"	1/4"	\$15.00
#719		1" Core Box	round nose	1"	3/4"	1/2"	\$18.00
#470		1/4" Straight	plunge cutting	1/4"	3/4"	1/4"	\$ 7.00
#471		5/16" Straight	plunge cutting	5/16"	1"	1/4"	\$ 7.00
#472		3/8" Straight	plunge cutting	3/8"	1"	1/4"	\$ 7.00
#474		1/2" Straight	plunge cutting	1/2"	1"	1/4"	\$ 7.00
#775		1/2" Straight	plunge cutting	1/2"	2"	1/2"	\$14.00
#476		9/16" Straight	plunge cutting	9/16"	1"	1/4"	\$ 7.00
#478		5/8" Straight	plunge cutting	5/8"	1"	1/4"	\$ 8.00
#479		3/4" Straight	plunge cutting	3/4"	1"	1/4"	\$10.00
#781		1" Straight	plunge cutting	1"	1 1/2"	1/2"	\$12.00
#500		3/8" Flush	Trimming	3/8"	1/2"	1/4"	\$ 7.00
#502		1/2" Flush	Trimming	1/2"	1/2"	1/4"	\$ 7.50
#503		1/2" Flush	Trimming	1/2"	1"	1/4"	\$ 8.50
#804		1/2" Flush	Trimming	1/2"	1 3/16"	1/2"	\$ 9.00
#545		Tongue & Groove	Straight	1 5/8"	1"	1/4"	\$30.00
#845		Tongue & Groove	Straight	1 5/8"	1"	1/2"	\$30.00
#546		Tongue & Groove	Wedge	1 3/16"	1"	1/4"	\$30.00
#846		Tongue & Groove	Wedge	1 5/8"	1"	1/2"	\$30.00
#450		1/8" Beading	1/8" R	3/4"	1/2"	1/4"	\$11.00
#451		3/16" Beading	3/16" R	7/8"	1/2"	1/4"	\$11.00
#233		1/4" Beading	1/4" R	1"	1/2"	1/4"	\$13.00
#453		5/16" Beading	5/16" R	1 1/8"	1/2"	1/4"	\$14.00
#454		3/8" Beading	3/8" R	1 1/4"	5/8"	1/4"	\$15.50
#455		1/2" Beading	1/2" R	1 1/2"	3/4"	1/4"	\$17.00
#375		45 degree Chamfer	45 degree	5/8"	1 1/2"	1/4"	\$15.00
#676		45 degree Chamfer	45 degree	7/8"	1 7/8"	1/2"	\$23.00

New 24-page catalogue now available, featuring hundreds of bits.

MAKE BEAUTIFUL RAISED PANEL DOORS . . . WITH YOUR 1/4" ROUTER!

SET ALSO AVAILABLE IN 1/2" SHANK - \$79.95 - Item #852

Professional production quality bit makes it quick and easy to produce matching rails and stiles — the panel raising bit with ball bearing guide makes the raised panel perfect every time.

SAVE 55%

SALE PRICE **\$69.95** Regular value Over \$150.00 FOR COMPLETE SET

ORDER ITEM # 554 for 1/4" Shank Set (Includes all bits shown)

REVERSIBLE COMBINATION RAIL and STILE BIT

(For making matching rails and stiles in raised panel doors, etc.) Works with stock from 11/16" to 7/8" thick

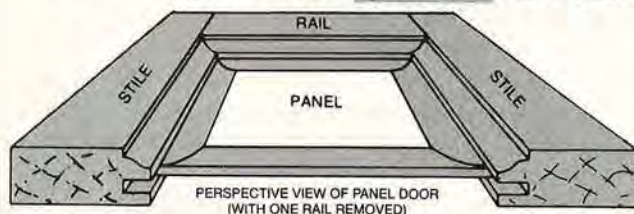

PERSPECTIVE VIEW OF PANEL DOOR (WITH ONE RAIL REMOVED)

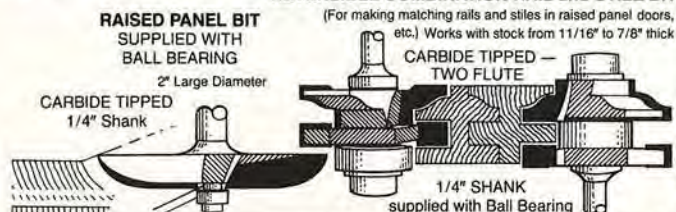

To order by Master Charge or Visa Call Toll Free, 7 Day - 24 Hour Order Service

1-800-533-9298 or send check to: **MLCS Ltd., P.O. Box 4053DF, Rydal, PA 19046**

TIPS FROM YOUR SHOP (AND OURS)

Continued from page 18

CHECK YOUR MITER GAUGE POINTER FOR ACCURACY

Most tablesaw miter gauges have an adjustable pointer for setting the gauge. Accidentally dropping the miter gauge may knock the pointer out of alignment, or vibration can loosen the setscrew so you no longer get a correct reading at the tip of the pointer.

TIP: To check the trueness of your miter gauge, set it for a square cut and crosscut a short length of 6"-wide board, holding it snugly against the miter gauge as shown in drawing 1. We exaggerated an out-of-square cut for clarity.

Now, flip the board end for end and make a similar cut. If the gauge is set correctly, both edges of the board will be the same length ("A" and "B" shown in drawing 2 would be equal). A difference of 1/16" between "A" and "B" on a 6" wide board indicates the angle is 0.3 degrees out of square. The wider the board you use, the more accurate the measurement becomes. Correct misalignment by resetting the gauge, adjusting the pointer, and making new crosscuts to check the adjustment.

—F.V. Chmielowiec, Boulder, Colo.

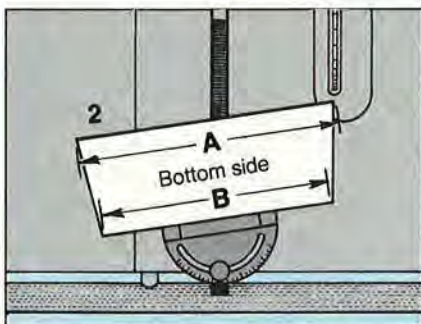
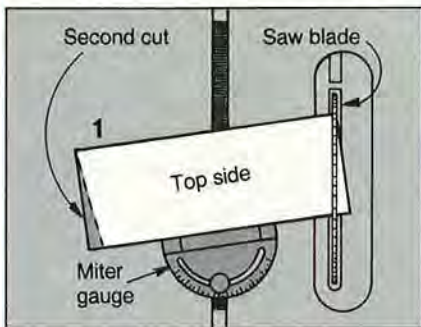

Continued on page 22

FREE STORAGE BINS WITH EVERY ORDER!
Please request with your order. Our staff will include heavy cardboard boxes based on the items you order. Offer expires 10/31/89.

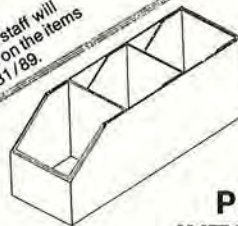

WOOD PEGS AND CANDLE CUPS

ITEM#	SIZE/DESCRIPTION	/100
16001	Shaker Pegs 3.5"	15.00
16006	Oak Shakers 3.5"	22.00
16101	Mug Pegs 3.375"	24.00
18031	Lg. Candle Cup	17.00
18036	Lg. Oak Candle Cup 7.00/20	
18091	Brass Inserts	9.00



WOOD BALLS AND BALL KNOBS

ITEM#	SIZE/DESCRIPTION	/100
13104	1/2" Wood Ball	5.90
13106	3/4" Wood Ball	7.90
13108	1.0" Wood Ball	10.90
13112	1.5" Wood Ball	29.00
13204	1.0" Wood Knob	18.90
13206	1.5" Wood Knob	25.90
13208	2.0" Wood Knob	31.90
S1300	Screws for Knobs	3.00

ITEM#	SIZE	/100
10812	1.5" dia. 1/4" hole	10.50
10914	1.75" dia. 1/4" hole	15.00
11216	2.0" dia. 3/8" hole	19.00
11218	2.25" dia. 3/8" hole	22.00
11220	2.5" dia. 3/8" hole	25.00/20
11222	2.75" dia. 3/8" hole	29.00/20

AXLE PEGS

ITEM#	SIZE	/100
12001	7/32" x 1-3/8"	4.10
12004	11/32" x 1-5/8"	7.40
12005	11/32" x 2-3/8"	9.00

CRAFTERS MART
P.O. BOX 2342W • GREELEY, CO 80632
CATALOG: \$2.00 with credit against first order, Free with any order. MIN. ORDER: \$20 - Check, MasterCard or Visa (Include card no., exp. date, signature, and daytime phone.) Colo. res. add 6% tax No CODs. Foreign orders pay US funds plus 20%. PROCESSING CHARGE: \$4.00 - provide UPS street address. PHONE ORDERS: 1 - 800 - 999-3445 - 8am-5pm - M-F, 9am-5pm Sat/Sun. Mountain time.

HARDWOOD BUTTONS

ITEM#	SIZE	/100	/500
14013	3/8"	1.75	7.50
14014	1/2"	1.75	8.00
14016	3/4"	4.50	20.70
14017	7/8"	4.65	21.90
14018	1.0"	6.30	29.70

OAK BUTTONS

14043	3/8"	3.70	15.50
14044	1/2"	3.80	16.00

WALNUT BUTTONS

14073	3/8"	4.70	22.50
14074	1/2"	4.80	23.50

HARDWOOD FLAT HEADS

14213	3/8"	1.90	8.00
14214	1/2"	1.90	8.00

HARDWOOD OVAL HEADS

14413	3/8"	1.90	8.00
14414	1/2"	1.90	8.00

X-MAS CAT.

Watch for our X-citing X-mas Catalog packed full of X-cellent projects to boost your boutique sales! An order will reserve your copy.

SPIRAL DOWEL PINS - 2"

14614	1/4"	2.00	9.00
14615	5/16"	2.10	9.50
14616	3/8"	2.20	9.50
14617	7/16"	2.60	11.70
14618	1/2"	3.10	14.40

MULTI-GROOVED PINS - 2"

14814	1/4"	1.90	8.50
14815	5/16"	2.00	9.00
14816	3/8"	2.00	9.25

HARDENED STEEL SCREWS

ITEM#	SIZE	/100	/1000
S6260	#6 1.0"	1.25	10.25
S6261	#6 1.25"	1.40	11.50
S6262	#6 1.625"	1.80	15.00
S6263	#6 2.0"	2.40	19.75
S6264	#7 2.25"	2.75	22.75
S6265	#8 2.5"	4.30	35.50
S6266	#8 3.0"	4.55	37.25

FREE

...Win a HEGNER Variable Speed Scroll Saw

Today more than ever, HEGNER Scroll Saws are the most desired in America. Combining German engineering, reliable performance, long blade life, and sand-free workpiece finish, they offer you unmatched value!

By popular demand, once again we are giving a free HEGNER Multimax Variable Speed Scroll Saw to a lucky woodworker somewhere in America! To enter the drawing, just complete the coupon or call right now - no purchase is necessary.

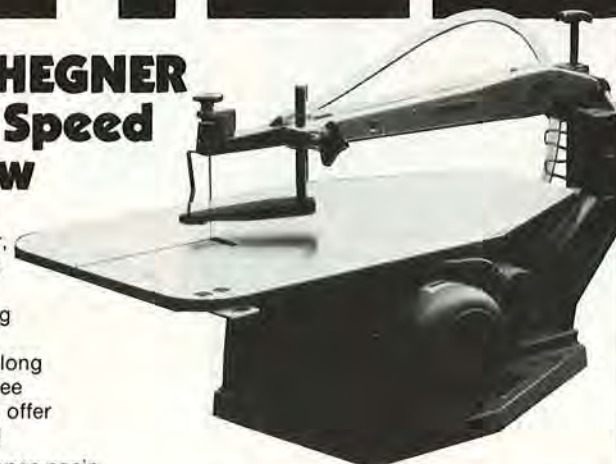

Yes, enter me in your drawing for a FREE Hegner Multimax Variable Speed Saw.

Also, send me FREE information on ordering a Hegner Scroll Saw...no obligation

Name _____

Address _____

City, State, Zip _____

Phone (_____) _____

1-302-322-2226

ADVANCED MACHINERY IMPORTS LTD.
P.O. Box 312, Dept. 356
New Castle, DE 19720



We thought you'd like to see the nice round numbers you'll get with these Delta saws.

Here's a chance to cut yourself a \$100 rebate check from Delta when you buy either our 18" Electronic Variable Speed Scroll Saw or 14" Wood Cutting Band Saw.

The 18" Scroll Saw allows you to lock in any speed from 40 to 2,000 CS/M. Work in areas as tight as $\frac{1}{64}$ " diameter, on stock up to 2" thick.

The 14" Band Saw, with its $6\frac{1}{4}$ " capacity and micrometer adjustable blade

guides, is perfect for contours, straight cuts and resawing.

If you're ready to cut it with the best of them, call toll free for the name of your nearest Delta dealer. Delta International Machinery Corp., 800/438-2486 (in PA, 800/438-2487).

Offer good on 18" Scroll Saw/ Model 40-601 and 14" Band Saw/ Model 28-283 only from participating dealers in continental U.S., Alaska and Hawaii from July 1 to December 31, 1989.



Building
On Tradition
DELTA
A Pentair Company

TIPS FROM YOUR SHOP (AND OURS)

Continued from page 21

A GADGET FOR SANDING CONCAVE SURFACES

Sanding wooden moldings on furniture and other concave surfaces with hand-held sandpaper often results in skinned fingers and a bit-and-miss smoothing job.

TIP: Gather up an old door hinge, a short length of the appropriate-diameter dowel, a piece of sandpaper for the desired grit, and a couple of round-head machine screws with wing nuts. Cut the dowel to the correct length and the sandpaper to the appropriate dimensions and assemble as shown *below*. Cutting additional dowel pieces of varying diameters gives your handy little sander extra flexibility.

—Fred A. Race, Euclid, Ohio

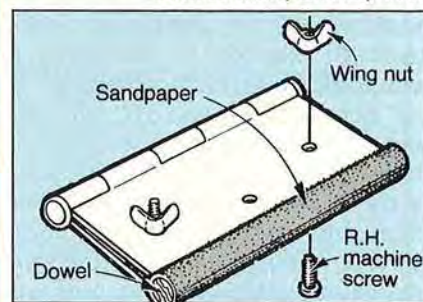

MORE SUPER TIPS FROM TOP WOODWORKERS

You'll find more shop tips in this issue of *WOOD* magazine:

- How do you bandsaw the head of a bird or animal to a rough form prior to rounding and smoothing it? Try our procedure on page 45.
- You can try your hand at several methods to make usable stock from scrap. See the article on working small beginning on page 50.
- We've found a way to darken grooves in wood turnings for contrasting accents. See page 58.
- If you would like to fashion your own turning tools, see page 58 for a source of good steel.
- See the basket project on page 78 for a way to safely cut thin strips on the side of a tablesaw blade opposite the fence.

PATTERNS \$100

SAME SIZE OUTLINE DRAWINGS
NO ENLARGING NECESSARY
TRACE & CREATE

FREE CATALOG WITH ORDER

SEND THIS AD & \$1.00 FOR EACH PATTERN
(Plus 50c postage per order)

DESIGN GROUP, Box 514-JJ, Miller Place, NY 11764

BAND SAW BLADES

WELDED TO YOUR EXACT LENGTH

Complete Band Saw Blade Line
Including Saw Mill Blades

We also carry:

Scroll Saw Blades • Hand Saws
Circular Saw Blades • Hole Saws
Hack Saws • Sanding Belts
Sanding Disks • Router Bits
Files • Rasps • Scrapers

SEND \$1.00 FOR CATALOG or
TO ORDER PHONE OR WRITE TO:

BUCKEYE SAW COMPANY
P.O. BOX 14794
CINCINNATI, OHIO 45250-0794
1-800-543-8664 (Except Ohio)
1-513-621-2159 (In Ohio)

Experience the joys of woodworking the Shopsmith way!

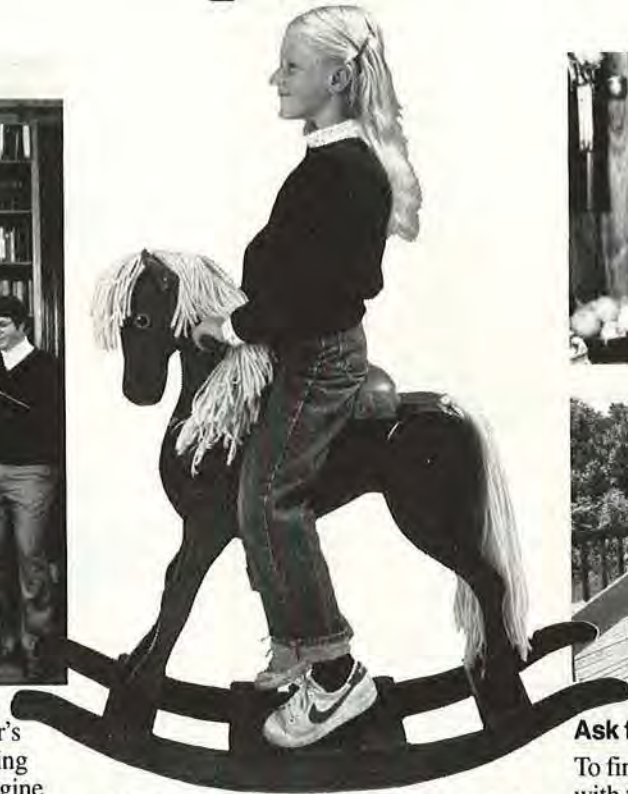

Imagine the gleam in your daughter's eyes the first time she sees the rocking horse you made just for her. Or imagine how much pleasure your family would get from a beautiful backyard deck, a more efficient kitchen or custom-built shelves and bookcases.

That's what the joy of woodworking is all about! It's a hobby of the imagination as well as the hands. Starting with nothing more than an idea, you can create projects that express your individuality. You solve problems, learn new skills and save money in the process. And it's *fun!*

Shopsmith® helps you get the most out of your woodworking.

Whether you're a beginner or a seasoned craftsman, Shopsmith can help you experience those joys with the MARK V home shop system. It gives you a table saw, drill press, horizontal boring machine, disc sander and lathe—all in a single, affordable unit that requires no more storage space than a bicycle.

In fact, with the MARK V at your fingertips you can turn any spare corner of your basement or garage into a really complete home shop. And because Shopsmith is the *original* multi-purpose woodworking system, we offer you the most complete line of accessories in the industry and all the support you need to be a success.

Discover the Shopsmith difference!

As a MARK V owner, you receive complete operating instructions—plus you can learn more about woodworking through our classes, seminars, educational video tapes and catalogs as well as our special magazine for MARK V owners, "Hands On".

You can also call us Toll-Free for the answers to all your woodworking questions. And you'll have the confidence of dealing directly with Shopsmith, either by mail, Toll-Free phone or at one of our growing network of Shopsmith Stores.



Dept. 3782

Ask for a FREE Information Kit!

To find out more about woodworking with the Shopsmith MARK V, call Toll-Free or mail the coupon below. We'll rush you a FREE Information Kit in your choice of Full Color Brochure or VHS Videocassette and Color Brochure. There's no obligation, so act NOW.

For your FREE Information Kit Call

1-800-526-1700

or mail the coupon below to:



Shopsmith Inc.

3931 Image Drive
Dayton, Ohio 45414-2591

© 1988, Shopsmith, Inc.
Shopsmith® is a registered trademark of Shopsmith, Inc.

Yes! I'd like to know more about the "joys of woodworking" with the Shopsmith MARK V. Please send me:

- FREE Color Brochure on the Shopsmith MARK V, or
 FREE VHS Videocassette and Color Brochure. (3783)

Name _____

Address _____

City _____ State _____ Zip _____

I currently own Shopsmith Power Equipment.

Send to: Shopsmith, Inc., 3931 Image Drive, Dayton, OH 45414-2591

BUY ANY 10
ITEMS AND
DEDUCT 10%

CASCADE TOOL CO.

BUY ANY 10
ITEMS AND
DEDUCT 10%

Box 3110, Bellingham, WA 98227

QUALITY CARBIDE-TIPPED  ROUTER BITS AND SHAPER CUTTERS!

FOR THE ROUTER!

Double-Fluted

Straight	PART NO.	D	PRICE
	SY4-6	1/4	\$6
	SY4-8	5/16	\$6
	SY4-10	3/8	\$6
	SY4-12	1/2	\$8
	SY4-1 6	5/8	\$10
	SY4-19	3/4	\$10
	SY4-25	1	\$12
SY4 = 1/4" SHANK			
SY8 = 1/8" SHANK			
	SY8-6	1/4	\$6
	SY8-8	5/16	\$6
	SY8-10	3/8	\$6
	SY8-12	1/2	\$8
	*SY8-12 (2")	1/2	\$15
	SY8-16	5/8	\$10
	*SY8-16 (2-1/2")	5/8	\$15
	SY8-19	3/4	\$10
	*SY8-19 (2")	3/4	\$15
	SY8-25	1	\$12
	SY8-30	1-1/4	\$12
	SY8-35	1-3/8	\$15
	SY9-40	1-5/8	\$18

* LONGER CUTTING EDGE

Roundover

PART NO.	A	PRICE
S502Y	1/16R	\$11
S504Y	1/8R	\$11
S506Y	3/16R	\$11
S508Y	1/4R	\$12
S510Y	5/16R	\$13
S512Y	3/8R	\$15
S516Y	1/2R	\$16
*S516Y-1/2	1/2R	\$16
*S520Y-1/2	5/8R	\$16
*S524Y-1/2	3/4R	\$20
*S528Y-1/2	7/8R	\$34
*S523Y-1/2	1R	\$34
*S536Y-1/2	1-1/4R	\$40

Core Box

PART NO.	A	PRICE
S408	1/4	\$10
S412	3/8	\$10
S416	1/2	\$12
S420	5/8	\$14
S424	3/4	\$15
*S424-1/2	3/4	\$15
*S423-1/2	1	\$18
*S450-1/2	1-1/2	\$30

Dovetail

PART NO.	D	PRICE
802	3/8	\$7
804	1/2	\$7
*804-1/2	1/2	\$7
806	9/16	\$8
810	3/4	\$9
*810-1/2	3/4	\$9
*812-1/2	1	\$12

Beading

PART NO.	A	PRICE
S602Y	1/16R	\$11
S604Y	1/8R	\$11
S606Y	3/16R	\$11
S608Y	1/4R	\$12
S610Y	5/16	\$13
S612Y	3/8R	\$15
S616Y	1/2R	\$16
*S616Y-1/2	1/2R	\$16
*S624Y-1/2	3/4R	\$20

Flush Trimming

PART NO.	A	PRICE
S8012Y	3/8	\$7
S8016Y	1/2	\$8
*S8016Y-1/2	1/2	\$8
S8020	5/8	\$10
*S8020-1/2	5/8	\$10

Roman Ogee

PART NO.	A	PRICE
S5705Y	5/23	\$16
*S5705Y-1/2	5/32	\$16
S5708Y	1/4	\$18
*S5708Y-1/2	1/4	\$18

Cove Bits

PART NO.	A	PRICE
S702Y	1/16	\$12
S704Y	1/8	\$12
S706Y	3/16	\$12
S708Y	1/4	\$13
S710Y	5/16	\$14
S712Y	3/8	\$15
S716Y	1/2	\$16
*S716Y-1/2	1/2	\$16
*S724Y-1/2	3/4	\$28

Slot Cutter - 4 Flutes

PART NO.	A	PRICE
SY7002	1/8	\$20
*SY7002-1/2	1/8	\$20
SY7004	5/32 (4mm)	\$22
*SY7004-1/2	5/32 (4mm)	\$22
SY7006	3/16	\$22
*SY7006-1/2	3/16	\$22
SY7008	1/4	\$24
*SY7008-1/2	1/4	\$24

A Choice of Edge Beading Bits

\$16 each



SY35 SY1403 SY29

NEW Concept in Router Bit Cabinet Door Construction!! \$59.95



SY brand. Complete with bearing. Now time spent adjusting the bit to achieve a perfect 1/4" tongue has been eliminated - and your rail & stiles and center panels can all be the same height with this incredible cutter - and it's only \$59.95 in any of our five raised panel profiles.

FOR THE SHAPER!

3mm thick C-2 carbide, 3/4" bore with 1/2" bushing

Straight

SY-1212-1	SY-1212-4
1/4" \$24.95	3/4" \$32.95
SY-1212-2	SY-1212-5
3/8" \$26.95	1" \$35.95
SY-1212-3	SY1212-6
1/2" \$28.95	1-1/2" \$36.95
	SY-1212-8
	2" \$59.95

Bead

SY-1224-1	SY-1224-4
1/4" \$24.95	3/4" \$32.95
SY-1224-2	SY-1224-5
3/8" \$26.95	1" \$35.95
SY-1224-3	SY-1224-6
1/2" \$28.95	1-1/2" \$36.95
	SY-1224-8
	2" \$59.95

Flute

SY-1223-1	SY-1223-4
1/4" \$24.95	3/4" \$32.95
SY-1223-2	SY-1223-5
3/8" \$26.95	1" \$35.95
SY-1223-3	SY-1223-6
1/2" \$28.95	1-1/2" \$36.95

Corner Round

SY-1225-1	SY-1225-4
1/4" R \$24.95	3/4" R \$32.95
SY-1225-2	SY-1225-5
3/8" R \$26.95	1" R \$35.95
SY-1225-3	SY-1225-6
1/2" R \$28.95	1-1/4" R \$49.95

CARBIDE TIPPED SHAPER CUTTER PANEL RAISER -
3 WING, 5 PROFILES, 3MM THICK CARBIDE
• 4-5/8" O.D. with 3/4" BORE (1/2" BUSHING)
\$69.95 • 5-1/2" O.D. with 1-1/4" BORE (1" BUSHING)



6 PC CARBIDE TIPPED CABINET SETS

• 3 mm CARBIDE
• 3/4" BORE W/ 1/2" BUSHING
ONLY \$179.95

13 Great Cabinet Sets including these popular Profiles:



THE ROUTER HANDBOOK

A definitive guide demonstrating how your router can be used to carve, drill, cut, as well as perform an array of other tasks more quickly and accurately than any other tool in the workshop.

\$7.95



CALL TOLL FREE: 1-800-235-0272

7 am - 5 pm Pacific Time/Monday-Friday



ON THE ANNIVERSARY OF THREE CENTURIES OF WOODWORKING WRITING

"Began Jan. 1, 1677. And intended to be Monthly continued."

Joseph Moxon

And so began the revelation of the woodworker's secrets that, in part, became Englishman Joseph Moxon's *Mechanick Exercises or The Doctrine of Handy-Works*. The volume not only was the first real how-to book, it was also the first book published in installments. It was the predecessor to today's how-to magazines.

All who enjoy reading, and writing, about woodworking owe Joseph Moxon. His influence lies like DNA at the heart of all how-to writing. Publishers have adapted his 300-page book for centuries, but, like Shakespeare and homecooking, nothing beats the original. Moxon is the wood-writer's insightful an-

cestor, and his long out-of-print work rates acquaintance.

FROM TOOL BUYMANSHIP TO SHOP TIPS

Keeping the horse ahead of the cart, Moxon began his book with a discourse on blacksmithing, figuring that woodworkers depended on the smith for their tools. He then began the woodworking section by examining the tools, telling how to "use them with more ease and delight, and make both quicker and nearer Work with them."

The woodworker of Moxon's day could purchase a variety of sophisticated hand and foot-powered tools. But, as ever, the buyer had to be careful. Many of the handsaws of his time were made from hammer-hardened iron rather than of fine steel. The hammering and grinding of the iron produced saws



of uneven quality, and Moxon—in true buymanship fashion—told his readers how to avoid getting stuck with a bad one. This was three centuries ago, but watch anyone shopping for saws at the hardware store today, and sooner or later, you will see them perform Moxon's final test. They will flex the saw in their hands, as have millions before them, knowing that "if it bend into a regular bow all the way, and be stiff, the Blade is good."

No woodworking book or magazine would be complete without its share of shop tips. When he gets around to hammers, editor Moxon

Continued on page 26

Like Having a Lumberyard Right In Your Shop!



FREE 30-DAY TRIAL

NOW! Plane, Mold and Sand with Infinitely Variable Power-Feed! (Choose from 12", 18" and 25" Models)

Just a twist of the dial gives you from 70 to over 1000 cuts per inch . . . you can sail through even the toughest oak at higher speeds, or slow down to surface stock that is virtually impossible on any other machine. Slower speeds turn out glass smooth molding . . . no sanding needed!

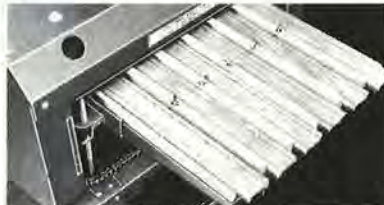

Woodmaster's Quick-Change Molding Head lets you create custom moldings from any stock. Choose from over 250 standard trim and picture frame patterns . . . or design your own!



Power-fed sanding speeds production and improves the quality of your work. No more waves or crossgrain scratches. Separate Sanding head installs in just minutes.

Now choose from three powerful models! Woodmaster introduces the first 18" and 25" Planer/Molders . . . with all the features that have made the 12" model the most versatile Planer/Molder on the market! Send for Free Facts today!



WOODMASTER TOOLS, INC., DEPT PW33 • 2908 Oak Street KANSAS CITY, MO 64108 • Or Phone 1-800-538-4200 Ext. PW33

YES! Please rush me your FREE Information Kit plus details on your 30-DAY FREE TRIAL GUARANTEE!

NAME _____
ADDRESS _____
CITY _____
STATE _____ ZIP _____

WOODWORKING WRITING Continued from page 25

digresses from shop tip to shop trick: "A little trick that is sometimes used among some (that would be thought cunning Carpenters) is to privately touch the Head of the Nail with a little Ear-wax, and then lay a Wager with a stranger to the Trick that he shall not drive that Nail up to the Head with so many blows. The stranger thinks that he shall assuredly win, but does assuredly lose; for the Hammer no sooner touches the Head of the Nail, but instead of entering the Wood it flies away, notwithstanding his utmost care in striking it down-right."

Most of *Mechanick Exercises*, though, bestows solid instruction on basic technique. Moxon told his readers how to accurately dimension stock and cut a mortise-and-tenon joint. The pioneer editor and publisher covered basic woodturning, beginning with building a lathe and ending with a finish of

beeswax pressed against the spinning work. Then, setting "a gloss on it with a very dry Wollen rag, lightly smear'd with Sallad Oyl."

KNOWING YOUR CRAFT, AND YOUR READERS

Moxon knew what still makes home craftsmen tick. He wrote shamelessly about building things that have no purpose except to "make others that know not the way how it is done to Admire their skill." One such feat was turning a free-moving ivory cube within an ivory sphere. He mentioned that the reader must make the cube large and the hole in the sphere small "to make this Thing more Admirable to the ignorant Spectator."

Projects aside, the first how-to writer knew the limits of book-learning. "This Craft of the Hand must be acquired with some continued Use and Practice, which will better inform your Judgement

what Errors you may be subject to commit, than many words."

Moxon's words continue, however, to this day and beyond. On this, the occasion of the fifth anniversary of *WOOD*® magazine, we'd like to tip our hats to Joseph Moxon. After all, he knew 300 years ago what we're attempting to do: To show you, our woodworking reader, "How pleasant and healthy this their Diversion is."

For information on the availability of a reprint of Joseph Moxon's book, write: The Early American Industries Assoc., c/o John S. Kebabian, 2 Winding Lane, Scarsdale, NY 10583. 🍀

By Roy Underhill

Master housewright at Colonial Williamsburg and host of the popular PBS series *The Woodwright's Shop*, Underhill is also an author and lecturer.

Illustration: Jim Stevenson

NOW!! BUY BRIDGEWOOD IN CANADA . . . BRETTWOOD MACHINERY WORKS LTD. MADOC, ONTARIO, CANADA K0K 2K0 613-473-4920

BRIDGEWOOD®

ALL PRICES QUOTED
F.O.B. YORK, PA

WOODWORKING MACHINERY
ACT NOW — SPECIAL PRICES VALID WHILE QUANTITIES LAST

WE ARE A FULL LINE MACHINERY CO. — NOT JUST A POST OFFICE BOX, 500 NUMBER OR WAREHOUSE. YOU CAN TRUST WILKE, A FAMILY OWNED & OPERATED COMPANY — WE KNOW MACHINERY.



JOINTERS

CE-40N - 16"x100" \$4395
BW-12J - 12"x80" 2495
BWJ-872 - 8"x72" 1695
BW-8J - 8"x66" less motor . 699
BW-6J - 6"x42" 329



PLANERS

BW-612PV - 24"x9" \$6195
BW-508 - 20"x9" 3895
BW-20PV - 20"x7" 3195
BW-16PV - 16"x7" 2495
BW-20P - 20"x8" econ . 1295
BW-15P - 15"x6" econ . 795
BW-12P - 12" portable . . . 349



SHAPERS

BW-513TS - 10 HP, tilt, slid. tab. \$5995
TC-50 - 7½ HP, slid. tab. . . . 4695
BW-512TS - 5 HP, tilt, slid. tab. . 3695
BW-511TS - 3 HP, tilt, slid. tab. . 2995
BW-3S - 3 HP, 3 spindles 1295
BW-SP30 - 3 HP, 2 spindles 995
BW-2S - 2 HP, 2 spindles 795
BW-1S - ¾ HP, 1 spindle 299



DUST COLLECTORS

SF-003 - 3 HP, 4 bag \$795
BW-003A - 3 HP, 4 bag 595
BW-002A - 2 HP, 2 bag 389
SF-015 - 1 HP, 2 bag 319
BW-015A - 1 HP 2 bag 229

WILKE MACHINERY CO.
ONE OF AMERICA'S MOST
RESPECTED MACHINERY DEALERS



GROWING BIGGER . . . TO SERVE YOU BETTER . . . AT THE LOWEST PRICES

NEW 6,000 SQUARE FOOT MACHINERY TEST AREA! . . . NEW 10,000 SQUARE FOOT SHOWROOM . . . OVER 35,000 SQUARE FEET OF WAREHOUSE SPACE!

3230 SUSQUEHANNA TRAIL • YORK, PENNSYLVANIA 17402 • TELEPHONE 717-764-5000 • FAX 7177643778

CALL OR SEND \$1.00 FOR COMPLETE 52-PAGE CATALOG

New Feet-Inch Calculator Solves Woodworking and Home Building Problems—In Seconds!

Amazing Pocket Handyman™ Lets You Work Like a Pro for Only \$39.95!

Now you can solve all your wood working and do-it-yourself problems right in feet, inches and fractions—with the new Pocket Handyman feet-inch calculator.

This new amazing calculator will save you hours upon hours of time on any project dealing with dimensions.

And best of all, it puts an end to costly errors caused by inaccurate conversions using charts, tables or regular calculators.

Adds, Subtracts, Multiplies and Divides in Feet, Inches and ANY Fraction

You never need to convert to 10ths or 100ths because the Pocket Handyman works with all dimensions just like you do.

Plus, it lets you work with any fraction— $1/2$'s, $1/4$'s, $1/8$'s, $1/16$'s, $1/32$'s, even down to $1/64$'s, or no fraction at all.

You enter a feet-inch-fraction number just as you'd say it—7 [Feet], 6 [Inches], 1 [$\frac{1}{2}$]. What's more, you can mix all fractions ($3/8 + 11/32 = 23/32$) and all formats (Feet + Inches + Yards + Meters) in your problems.

In addition, you can easily figure square and cubic measurements instantly. Simply multiply your dimensions together and the Pocket Handyman does the rest.

Converts Between All Dimension Formats

You can also convert any displayed measurement directly to or from any of the following formats: Feet-Inch Fraction, Decimal Feet (10ths, 100ths), Inches, Yards and Meters.

It also converts square and cubic.

Plus the Pocket Handyman actually displays the format of your answer right on the large LCD read-out—“Square Feet,” “Cubic Yards,” etc.

Comes Complete

The Pocket Handyman also works as a standard math calculator with Memory (which also handles dimensions) and battery-saving Auto Shut-Off.

And the Pocket Handyman is com-



New Pocket Handyman™ feet-inch calculator solves home improvement problems with the touch of a button.

compact ($2\text{-}3/4 \times 5\text{-}1/8 \times 1\text{-}1/4$ ") and lightweight (3.5 oz.), so it fits easily in your pocket.

What's more, it comes with easy-to-follow User's Guide, full 1-Year Warranty, replaceable 2-Year batteries and vinyl carrying case.

FREE Gift - Order Now!

Plus, if you order within the next 10 days, we'll include — FREE — a custom fitted leather case, personalized with your initials hot-stamped in rich gold. A \$14.50 value — Free!

Use the new Pocket Handyman™ to solve all these problems:

- Dimension Checks
- Furniture Making
- Roofing Projects
- Cement & Concrete (Volume)
- Cabinets & Woodworking
- Estimating All Materials
- Spacing Problems
- Carpeting (Sq. Yards)
- Stairs & Decks
- Wall Paper/Paint (Area)
- Brickwork
- Foundations
- Tile Flooring
- Skylight Installation
- Windows & Other Glass
- And much, much more

To order your Pocket Handyman at the discounted price of just \$39.95, or 2 for \$74.95, complete and return the coupon below to: *Calculated Industries, 22720 Savi Ranch Pkwy., Yorba Linda, CA 92686.* Or **Call Toll-Free 24 hours every day:**

1-800-854-8075

And if for any reason you're not completely satisfied with your new Pocket Handyman, simply send it back within 30 days for a full refund.

So you can't go wrong!

Start saving time and put an end to costly errors, order your Pocket Handyman feet-inch calculator now!

ONLY \$39.95
100% 30-Day Money-Back Guarantee

If for any reason you are not 100% delighted, return your calculator within 30 days for a full, no-questions-asked refund. Your satisfaction is our #1 concern.

© Calculated Industries, 1989. All rights reserved.

Clip & Mail Today!

Calculated Industries, Inc.
22720 Savi Ranch Parkway
Yorba Linda, CA 92686

Toll-Free 24 Hrs. 7 Days
1-800-854-8075

Qty.	Price	Shipping*	Total
1 Pocket Handyman	\$39.95	\$3.95 each calc.	\$
2 Pkt. Handymn. <small>Save \$7.40</small>	\$74.95	\$5.45 each pair	\$
Black Leather Case <small>Case Reg. \$10.00, Initials \$1.50 ea</small>		BOTH FREE with calculator purchase	\$
Gold Initials [] [] [] []			\$
* Add \$1.50 shpg. for ea. additional unit ordered.		In CA add 6% tax	\$
TOTAL			\$

Name _____
Address _____
City/ST/Zip _____
 Check VISA MasterCard Am/Exp
Account # _____ Exp Date ____/____/____
Sign Here _____

Qty. Discounts
5+ \$37.50 ea.

BHWM-989

1989 WOOD® DESIGN-A-TOY™ AWARD WINNERS

HOME HOBBYIST: NO MOVABLE PARTS

Grand Prize:

Alvin J. Curtis, Oshkosh, WI

First Prize:

David Cartwright, Arlington Heights, IL

Special Citations:

Ronald Busdiecker, Euclid, OH
Sam Roberts, Roseburg, OR
Merle Halter, North Platte, NE
Donald Flanagan, Shell Knob, MO
Robert E. Sweet, Toledo, OH

HOME HOBBYIST: MOVABLE PARTS

Grand Prize:

Robert W. Sanders, St. Marys, GA

First Prize:

Harold E. Geiselman, Canton, OH

Special Citations:

Bill Kaiser, Huntingburg, IN
Mike Gradeless, Columbia City, IN
Brian W. Anderson, Waseca, MN
Larry Groninger, Reevesville, PA
Rene Knetsch, Oklahoma City, OK

SCHOOL AGE: MOVABLE PARTS

Grand Prize:

Ed Park and Walter Green, Newark, OH

First Prize:

Dustin Ehrman, Middle Amana, IA

Special Citations:

Bob Pils, White Bear Lake, MN
Flay Terres, Gastonia, NC
Warren J. Kaeb, Buckley, IL
Steve Smith and Brian Beaver, Newark, OH
Steve Lukes, Middle Amana, IA

SCHOOL AGE: NO MOVABLE PARTS

Grand Prize:

George Powers, Chad Cooperrider
and Jim Watson, Newark, OH

First Prize:

Shon Lowery, Corby Franks and Joe Browett,
Newark, OH

Special Citations:

John Duncan Jr., Des Moines, IA
Gregg Klatt, Menominee, MI
Matt Mohler, Keenan McKee and
Todd Journey, Newark, OH
Peter Barrette, Des Moines, IA

PROFESSIONAL: MOVABLE PARTS

Grand Prize:

Neil Seely, Rochester, NY

First Prize:

Richard Grunwald, North Java, NY

Special Citations:

Kurt Jobke, Pewaukee, WI
Steven A. Bruni, Fort Madison, IA
Mike Jagielo, Almond, WI
Peter P. Belski, Jr., Pittsburgh, PA
Richard Milam, Metairie, LA

PROFESSIONAL: NO MOVABLE PARTS

Grand Prize:

Michael Watters, Saginaw, MI

First Prize:

Mike George, Slidell, LA

Special Citations:

Roger D. Coddington, Traverse City, MI
Jerry R. Syfer, Laurel MD
James N. Moen, East Grand Forks, MN
Clyde R. Moore, Cocur d'Alene, ID
Stuart L. Woldman, Shaker Heights, OH

NONWINNERS DRAWING:

James Craine, North Bloomfield, OH
Jim Sweet, Coulterville, IL
Ronald Myer, Kokomo, I
Ron Hale, Joshua Tree, CA
Alan Boyer, Cypress, CA
Ed Schott, Sacramento, CA
Heath Smith, Newark, OH

Announcing the winners of the 1989 WOOD® Magazine Design-a-Toy™ Competition.



Oak Tool Box with Tools
Bill Kaiser, Huntingburg, IN

Sometimes, even the people who don't win are left feeling very good. That's the way we look at the results of the 1989 Design-a-Toy™ competition. You're all winners.

Every WOOD® magazine reader who submitted a toy should know that some kid somewhere is happier for your having cared. And, for your having applied your terrific skill in woodworking to create that much-loved toy.

At WOOD magazine, we're grateful to all the generous people who joined together to make Design-a-Toy™ a great success: The Toys for Tots program of the U.S. Marine Corps Reserve, the many manufacturers who provided prizes, our judges, Homer Formby; Major Bruce Butler of the U.S. Marine Corps Reserve; Jim Downing, Design Editor, WOOD; Roy Underhill of *The Woodwright's Shop* on PBS-TV; and Phil Vanderploeg, President, Toys and Joys.

It's been great.

DESIGN-A-TOY PARTICIPATING SPONSORS

Total Shop • Black & Decker • Foley Belsaw Company • Delta International Machinery
Advanced Machinery Imports, Ltd. • Hitachi Power Tools USA, Ltd. • Makita USA, Inc.
Garrett Wade Company, Inc. • Thompson & Formby, Inc. • Grolier Book Clubs, Inc.
Woodmaster Tools, Inc. • Freud, Inc. • Grizzly Imports, Inc. • Skil Corporation
Bosch Power Tools Corporation • DML, Inc. • Dremel • Minwax Company, Inc.
Shopsmith, Inc. • Porter-Cable Corporation • Ryobi America Corporation
AEG Power Tool Corporation • Fisher Hill Products

RIPPING GOOD NEWS

From the cutting edge of technology comes Freud's new thin-kerf blades for crosscutting and ripping. Computer-designed, laser-manufactured, Teflon-coated, carbide-tipped, 25 percent thinner than normal blades; these wood-gobblers have it all. Crosscuts leave end grain so smooth it has a sheen, and the rip blade requires less energy than full-bodied carbide-tipped blades, so it's less likely to bind and burn on thick stock. I easily ripped through 2"-oak, leaving only a light scoring. Also, you won't suffer the high-pitch noise so common with crosscut blades. The body thinness limits stock thickness to about 2"—beyond that the blade will wobble some. The rip blade is 25 percent thinner than normal; crosscut, 28 percent thinner.

—Tested by C.L. Gatzke, WOOD® magazine's art director

Freud thin-kerf crosscut and ripping blades, available in 8", 9", and 10" sizes from hardware stores and mail-order outlets nationwide at

suggested retail prices of \$51.90–\$59.90 for the three sizes of ripping blades. Crosscut blades range from \$62.90 to \$73.90.



Continued on page 31

WHY PROFESSIONALS USE BRAD POINT DRILLS

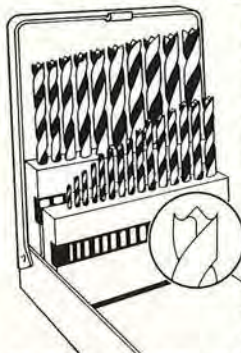

Brad Points are engineered especially for wood - soft wood or hard. The center point (brad point) of the drill is pushed into the marked location for the hole. It locks into position and will not slide out. Then the motor is turned on. The hole is drilled exactly where it is wanted. This is the most important part of doweling, after proper measuring.

The two outside spurs cut clean entry holes. There is no tear out (splintering) - not even in Oak or Curly Maple - so that if the hole is to be later plugged to cover a screw, the periphery of the hole will be almost invisible.

These spurs provide smooth hole walls and almost flat bottoms. A

dowel should touch bottom to glue properly. Metal working drills leave a tapered bottom.

It is best to own a complete 25-pc set and have every size from 1/8" to 1/2" in increments of 1/64ths (.0156") because commercial doweling is seldom sized exactly. Dowels that are too loose don't cut it; those that are too tight don't fit.

WHY DOLLAR'S BRAD POINTS ARE BEST: Our drills are milled from the solid; others are only roll forged. Our brad points and spurs are first milled then ground for accuracy. We use high carbon, alloy steel. Many others are made from plain carbon steel. Our drills are heat treated and hardened to Rockwell C48-52. They are tough, sharp and long lasting. Most companies that sell drills do not know what they are made of, or what the hardness is.

AS FOR PRICE, YOU BE THE JUDGE.

These drills will fit any 3/8" or larger chuck. FREE metal index included.

ORDER #10-0100 25-pc Brad Point Drill Set **only \$29.95 ea.**
2 or more sets to one address **only \$26.95 ea.**
Ship/Handling \$3.00 for 1, \$5.00 for 2 or more to one address.

CALL TOLL FREE: 800-447-7770 - VISA/MC/AMEX
Dollar Trading Corp. (Est. 1953), P.O. Box 8433, Grand Rapids MI 49518
Dept. WM09 - Sales Tax MI 4%; CT 7-1/2%
NO HASSLE, 30-DAY MONEY BACK GUARANTEE

WOOD PARTS FROM MIDWEST DOWEL WORKS

Compare Our Low Prices!

	Qty.	Cost
3-1/2" Poplar Shaker Peg	\$15/100	—
1-3/4" Mini Shaker Peg	\$7/100	—
3-1/2" Country Wall/Mug Peg	\$15/100	—
2-1/2" Country Shorty Peg	\$12/100	—
Large Bean Pot Candle Cup	\$17/100	—
Brass Inserts	\$9/100	—
1/2" Mini Candle Cup	\$10/100	—
1-1/2" Toy Wheel	\$10/100	—
2" Toy Wheel	\$17/100	—
Axel Pegs	\$4/100	—

Great Buys!

	Qty.	Cost
3/8" x 36" Standard Dowels	\$21/100	—
3/4" x 36" Oak Dowels	\$15/10	—
3/8" Maple Buttons	\$2.15/100	—
1/2" Maple Buttons	\$2.25/100	—
1-1/2" Maple Spindles	\$9/100	—
2-1/8" Maple Spindles	\$18/100	—

ORDER NOW

MC/Visa Check Enclosed

Total Cost _____

Handling **\$3.00**

Ohio residents add 5 1/2% sales tax _____

Final Cost _____

MC/Visa Number _____
Expires _____ Phone _____
Name _____
Address _____
City/State/Zip _____

FREE 16-PAGE CATALOGUE

Circle this section for FREE Dowels — mixed pack, Maple, Oak, Walnut Cherry, from 1/4" up to 1" Approximately 10 LFT. 14" long. \$5.00 value with any order.

MIDWEST DOWEL WORKS

4631 Hutchinson Road
Cincinnati, Ohio 45248
(513) 574-8488

Same Day Service | Order before Noon
Factory Direct | Satisfaction Guaranteed

TRANSPOWER

We are NOT NO. 1 in catalogue and advertising.

We are NO. 1 in QUALITY, PRICE & WARRANTY - You check! CALL 1-800-654-7702

**SHAPER/ROUTER MACHINE**

Extra Large Table

Only \$698

1/4", 1", 3/4" & 1/2" spindles, 1/4" & 1/2" router chucks, 3HP motor, 25"x22" mirror table, dovetailed miter gauge, 8000/11000 reversible 2 speeds, 3" spindle travel, precision steel fence, 6" insert opening, side & top spring hold-down, dead collar for irregular surface, 34" height, 425 lbs.
Optional roller extension.

12" AUTO PLANNER

Sale \$328



2HP, 115V, 12"x6" capacity, 1/4" max cut, 0.2"6" range, 26.2 FPM rate, 8000 RPM, 16000 cuts, 2 feeders & extensions, all ball bearings, 65 lbs.

10" TABLE SAW

w/Standard Fence \$795



w/Biesemeyer Fence \$995
3HP, double lock top precision fence with micro adjustment, cast iron construction, 3 v-belt drive, 3" max cut, 40"x27" mirror table with T-slot, 5/8" arbor 4200 RPM, 33.5" rip capacity, 500 lbs.

15" AUTO PLANNER

8" Opening, 2 spds 1685



15"x8" capacity, 2 feeders, 3HP 18 AM, motor, 3 blades, 1/4" FMP rates, 1/4" max. cut, 0.2"6" range, 5100 RPM/15300 cuts, 20"x16" table, 2 extensions, 520 lbs.

8" JOINTERJT860A \$625 Econ.
JT 860 \$685 H.D.

2HP, 9"x68" extra long bed, 3 blades, 2 v-belt drive, 1/2"x8" cut, 36" fence, 4500 RPM, precision lead screw, built-in chip chute, 500 lbs.

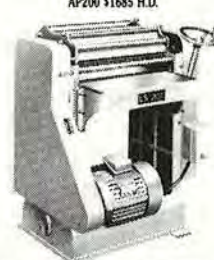
20" AUTO PLANNERAP200A \$1175 Econ.
AP200 \$1685 H.D.

5HP, 20 AMP motor, 20"x8" capacity, 4 blades, 1/4" FMP rates, 1/4" max. cut, 0.25"8" range, 20000 cuts/min, 26"x20" table, 2 feeders & extensions, 980 lbs.

DRUM BRUSH SANDER

Sale \$248



2HP, induction motor, sealed ball bearing, universal drum/brush design, 1"x40" spindle, 1725 RPM, optional stand, 85 lbs.

DUST COLLECTOR

Sale \$284



2HP, 3 intake holes (4"), 1250 CFM, 21"x37" base w/casters, 19"x36" bags, 78" height, 6.04 static pressure at 6", 210 lbs.

90" EDGE SANDER

Sale \$394



1 1/2HP, 6"x90" belt tilts 90°, 28"x10" cast iron table, T-slot miter gauge, quick belt release design, heavy duty stand, adjustable fence, 260 lbs.

TRANSPOWER

TCM Industries, Inc. 322 Paseo Sonrisa, Walnut, CA 91789

Inquiries (714) 594-0780
Send \$1.00 for 54-page catalogue

Make Your Router More Versatile!

Table Mount Your Router like Rick and Bob Rosendahl, The Router Experts.



Convenient bit tray and accessories.

Table Mount System includes:

- 1 - Half Fold Bench/bit storage tray. (HF060)
- 1 - 11x11 Router Base Plate (BP1101 or BP1192)*
- 1 - Safety Pin (SGP010) 1 - Table Fence (F016)
- 1 - Brass Insert (IS026) 1 - Brass Ring Nut (GN02)
- FREE BONUS Storage Bench Plan (P021)

* Our standard BP1101 will be sent unless you state the make and model of your Router.

RETAIL PRICE \$230.00 U.S.

Special \$199.95 U.S.
ADD \$10.00 for U.P.S. Shipping
WHILE QUANTITIES LAST!!



Router adjustments and bit changes made easy.



Snap together assembly.

To order by Mastercard or Visa call toll free 1-800-665-0252
or mail to:

Oak Park Enterprises Ltd., P.O. Box 13, Stn. A, Winnipeg, Manitoba, Can. R3K 1Z9

PRODUCTS THAT PERFORM

Continued from page 29

A HANDY JIG FOR FAST, ACCURATE KNIFE-SETTING

Accurately replacing jointer knives can be a real chore, but this jig helped me get the job done with precision in 10 minutes. Using permanent Alnico magnets, the jig holds the knife in alignment with the outfeed table for resetting. It will even work on nonferrous metal tables on jointers up to 10" wide, except for the Inca jointer/planer.

—Tested by Marlen Kemmet, *WOOD* magazine's how-to editor



Magnetic jointer knife-setting jig, item no. 20J04.01, \$54.90 ppd., from Garrett Wade, Dept. WD, 161 Avenue of the Americas, New York, NY 10013. Call 800-221-2942.

POWER LIFTING

I've had my share of sore backs from lifting sheet goods, so I jumped at the chance of testing a product that might help with this chore. With the Panel Toter you can easily handle 4x8' sheet goods. This tool lets two arms do the work of four by giving you added leverage and balance. I found the Panel Toter durable, and its handle was comfortable to use—two big pluses if you move around a lot of sheet goods.

—Tested by Steve Oswalt



Panel Toter (cat. no. 72975), \$14.99 ppd. from Leichtung Workshops, 4944 Commerce Parkway, Cleveland, OH 44128.

INSTANT GRIP WITHOUT GLUE

Mr. Grip, a thin, corrugated metal fastener, provides a simple solution to the age-old problem of loose joints and screws. Just slip one of these inexpensive 1/4" or 3/4" strips into a screw hole or over a loose tenon and apply pressure. I found that the fastener's rough surface supplied an amazingly firm bond.

—Tested by Steve Oswalt



Mr. Grip, available in 4x1/4" strips for furniture repair or 2x3/4" pieces for stripped screw holes. \$5.99 ppd. for each kit from Leichtung Work-

shops, 4944 Commerce Parkway, Cleveland, OH 44128. Call 800-321-6840 to place orders. Ohio residents call 261/831-2555.

Continued on page 32

Fun To Make!

DOOR HARPS

Easy to make! Our Door Harps make great gifts that will provide years of enjoyment. Your choice of two pattern books—Musical Zoo or Traditional. Each pattern booklet includes 15 full-size patterns with easy, detailed instructions.

"Musical Zoo" Door Harps T720 \$6.98

These friendly faces will be right at home in your house! Designs include a Reindeer, Moose, Cat, 2 Cows, 2 Bears, Duck, Fish, Dinosaur, Puppy, Bunny, Pig, Tiger, & a Rooster!

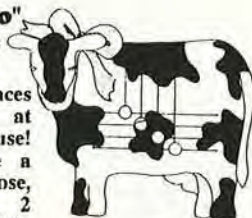

Traditional Door Harps T718 \$6.98

These Traditional Patterns include the Tulip, Pear, Colonial, Corkboard, Heart, Bulb, Leaf, Hexagon, Harp, Frying Pan, Oak Leaf, Egg, Star, Note & Bell.

Timbers Woodworking - (916) 581-4141

ORDER FORM Patterns & Supplies

- T720 Musical Zoo Patterns \$6.98
 T718 Traditional Patterns \$6.98

Note: Each door harp needs 4 Clapper Balls, 8 Tuning Pins and 3' Tuning Wire.

- 3/4" Clapper Balls
QTY Single .15 ea./100 pkg \$9.90
- Nickel Steel Tuning Pins
QTY Single .35 ea./100 pkg \$25.00
- Tinned Steel Tuning Wire
QTY 3' .50 / 30' \$3.00
- "T" Handle Tuning Pin Wrench
QTY \$9.95

Amount for patterns/supplies _____

If you live in Calif, 6% Sales Tax _____

Shipping/Handling Charge \$ 2.50

Total Enclosed _____

Ship to:

Name _____

Address _____

City _____

State _____ Zip _____

Woodworker pattern catalog included
FREE with order. \$1 alone.

Timbers Woodworking
A76 Lake Forest Road
Carnelian Bay CA 95711

Visa or Mastercard Orders
Phone 24 hours:
916-581-4141

CUT & MAIL ORDER FORM

NO COUPON NEEDED

Buy America's #1 selling wood glue and get 25% more, free.



Light wood, dark wood, all wood, it's the right glue for super-strength performance. It grabs fast, sets fast and dries to a heat- and water-resistant bond that's perfect for finishing. And right now, it's a great deal. Quantities are limited.

© Borden, Inc., 1989.

PRODUCTS THAT PERFORM

Continued from page 31

A COLORFUL STAIN FOR COUNTRY PROJECTS

Many country projects call for pastel colors, and with Plantation Woodstains, you can add that color accent without resorting to paint. Although developed for industrial uses, Plantation Woodstains have broken into retail markets. Part of their appeal lies in the six colors available—kristy blue, peach, green, dark blue, red, and mauve. Plantation also offers four natural wood shades—walnut, rosewood, dark pine, and honey pine.

The stain applies easily, dries in 5 to 15 minutes, and requires no wiping. It gives off a powerful odor, so be sure to apply it in a well-ventilated area. The lightly toned kristy blue stain I tried performed best on open-grain woods such as pine and oak. It didn't do as well highlighting texture in harder, nonfigured woods.

—Steve Oswalt

Plantation Woodstains, available in many crafts stores at a \$4.59 suggested price for a 4-oz. can. For a list of dealers in your area, write Plantation Woodstains, P.O. Box 1028, Albertville, AL 35950.



"EARLY BIRD SPECIAL" GIVE YOUR LOVED ONE A LIFETIME OF PLEASURE

Warren Tool Co. Inc. Offers:
Basic Woodcarving Kit
#KB3-W ONLY \$19.95 PPD.

Carving Instructions Included

Kit Incl: Custom Made American Walnut with interchangeable solid brass jaw, six styles of blades, Plastic Box included, but (not shown) Blades honed razor sharp for carvers immediate carving pleasure.

Carvings NOT included in this special offer.

Made in U.S.A.

Complete catalog \$1.00, (FREE with order) Send Check or money order to:

WARREN TOOL CO. INC.

RT. 1 Box 14-A Dept. W Rhinebeck, NY 12572
TEL (914) 876-7817



#KB3-W \$19.95 ppd. U.S. ONLY* COD UPS Also Available *Canada and Foreign customers add additional \$1.75



MEISEL HARDWARE SPECIALTIES

CHRISTMAS & HALLOWEEN PROJECT PLANS



LIGHT-UP NOSE YARD STAKES PLANS

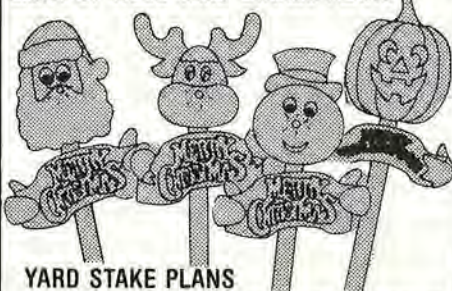

YARD STAKE PLANS

Large 22" x 34" blueprints are very clear and easy to follow. All drawings are FULL SIZE.

- #W420 Santa Plan \$3.99/EA.
- #W421 Rudolph Plan \$3.99/EA.
- #W422 Snowman Plan \$3.99/EA.
- #W423 Pumpkin Plan \$3.99/EA.

HARDWARE PARTS KITS

These kits contain the lighting kit, bulb, eyes, screws and pre-cut wood banner only. (Wood, plan and paint are not included.)

- #8766 Light-Up Santa Hdw. Kit \$5.50/EA.
- #8767 Light-Up Rudolph Hdw. Kit \$5.50/EA.
- #8768 Light-Up Snowman Hdw. Kit \$5.50/EA.
- #8769 Light-Up Pumpkin Hdw. Kit \$5.50/EA.

PLYWOOD YARD ORNAMENTS PLANS

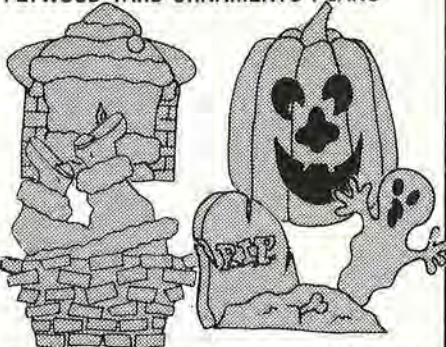

Designed to be easy to cut from 1/2" exterior plywood and easy to paint. Our FULL SIZE blueprints are available in a small, medium or large size. Large and medium ornaments mount with 2" x 2" stakes. Small ornaments use kit below.

- #W444 Santa Rear View Plan 20" \$3.99/EA.
- #W445 Santa Rear View Plan 30" \$5.99/EA.
- #W446 Santa Rear View Plan 40" \$7.99/EA.
- #W451 Santa Wedged Plan 24" \$3.99/EA.
- #W452 Santa Wedged Plan 36" \$5.99/EA.
- #W453 Santa Wedged Plan 48" \$7.99/EA.
- #W457 Jack-O-Lantern Plan 27" \$3.99/EA.
- #W458 Jack-O-Lantern Plan 40" \$5.99/EA.
- #W459 Jack-O-Lantern Plan 54" \$7.99/EA.
- #W463 Ghost & Grave Plan 20" \$3.99/EA.
- #W464 Ghost & Grave Plan 30" \$5.99/EA.
- #W465 Ghost & Grave Plan 40" \$7.99/EA.

MOUNTING ROD KIT (for small yard ornaments)

- #8675 Mounting Rod Kit
- 1-9 \$4.29/KIT
- 10-19 \$3.99/KIT

DOOR HARP PLANS & KITS

WHAT'S A DOOR HARP?

Mounted on the inside of your door, a door harp will welcome your guests with a beautiful musical tune each time the door is opened. You'll find it easy to build these door harps in your shop using only standard 3/4" stock and our special Hardware Parts Kits.

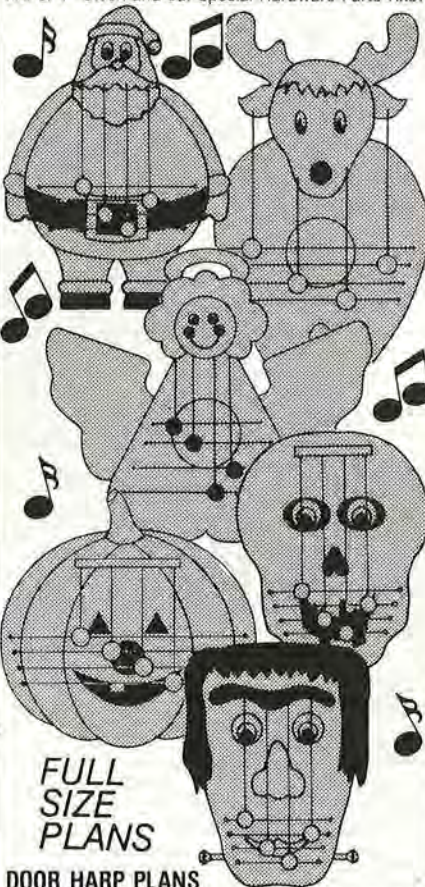

FULL
SIZE
PLANS

DOOR HARP PLANS

- #W426 Santa Plan \$3.99/EA.
- #W427 Rudy Plan \$3.99/EA.
- #W428 Angel Plan \$3.99/EA.
- #W314 Jack-O-Lantern Plan \$3.99/EA.
- #W430 Skull Plan \$3.99/EA.
- #W432 Frankenstein Plan \$3.99/EA.

HARDWARE PARTS KITS

These kits contain the hard to get parts—special high resonance plywood, tuning pins, clapper balls, music wire and plastic eyes. You need to supply some 3/4" stock, and the paint. Plan is not included with kit, order separately above.

- #8780 Santa Hdw. Kit \$6.95/EA.
- #8781 Rudy Hdw. Kit \$7.50/EA.
- #8782 Angel Hdw. Kit \$7.95/EA.
- #8254 Jack-O-Lantern Hdw. Kit \$7.25/EA.
- #8784 Skull Hdw. Kit \$7.50/EA.
- #8786 Frankenstein Hdw. Kit \$7.95/EA.

MUSICAL CHARACTERS

Push the button and the music box plays a tune. Order FULL SIZE plans and Hardware Parts Kit below.

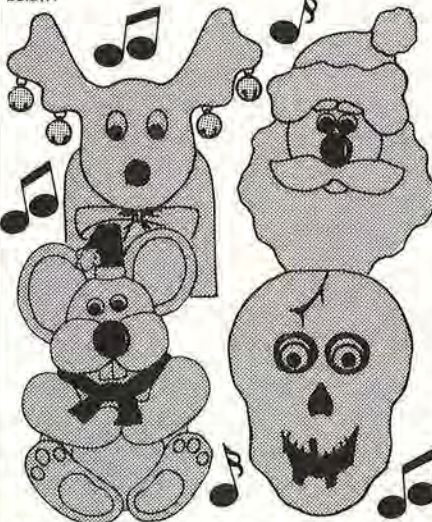

MUSICAL CHARACTERS PLANS

- #W287 Musical Rudy Plan \$2.75/EA.
- #W438 Musical Santa Plan \$2.75/EA.
- #W439 Musical Mouse Plan \$2.75/EA.
- #W441 Musical Skull Plan \$2.75/EA.

HARDWARE PARTS KIT

- Wood not included with kit.
- #7906 Music Rudy Hdw. Kit \$4.79/EA.
- #8840 Music Santa Hdw. Kit \$2.99/EA.
- #8841 Music Mouse Hdw. Kit \$4.79/EA.
- #8843 Music Skull Hdw. Kit \$3.79/EA.

TISSUE BOX HOLDER PLANS

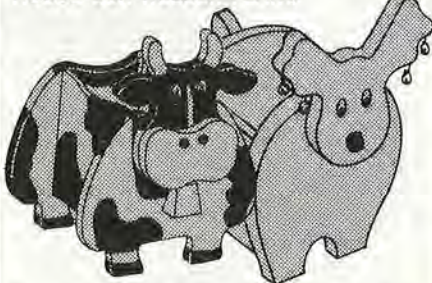

These cute animals hold a standard square tissue box. Easy to make from 1/2" plywood. Available in Bessy the Cow or Rudolph the Reindeer.

- #W411 Tissue Box Bessy Plan \$3.99/EA.
- #W443 Tissue Box Rudy Plan \$3.99/EA.

TISSUE BOX HARDWARE KITS

Includes the eyes, nose and bells only. (Wood, paint and project plan are not included.)

- #8621 Small Bessy Hdw. Kit \$1.39/EA.
- 10 or more \$1.29/EA.
- #8845 Tissue Box Rudy Hdw. Kit \$.99/EA.
- 10 or more \$.89/EA.



ORDERS ONLY 1-800-441-9870
CALL TOLL FREE Minimum Credit Card Order \$25.00

2 Catalogs available:
MHS Christmas Catalog \$1.00
Regular MHS Catalog \$1.00
or Both Catalogs sent FREE WITH ORDER

MAIL
\$2.00
TODAY
TO

HOW TO ORDER: State quantity, part number, item, price, and total of order. Send check, money order, or Visa or M.C. number and Exp. date. Shipping: \$25.00 to \$49.99 add \$4.95, \$50.00 to \$74.99 add \$5.95, \$75.00 to \$99.99 add \$6.95, over \$100.00 add \$7.95. Minimum order of \$25.00.

Print Name _____
Address _____
City _____ State _____ Zip _____
Phone # () _____

Participating Jet Dealers

ALABAMA

Birmingham Saw Works
910 No. 28th St.
Birmingham, AL 35203
(800) 289-SAWS

Branch: **Coastal Saw & Machinery**
1668 So. Belline
Mobile, AL 36609
(800) 333-SAWS

Branch:
Kentec Tool & Equipment #30
3133 Lorna Rd., Suite 107
Birmingham, AL 35206
(205) 822-6451

Branch: **Mobile Retail Sales Center**
3500 Government St.
Mobile, AL 36609
(205) 666-6351

ARIZONA

Glendale Industrial Supply
2224 No. 23rd Ave.
Phoenix, AZ 85009
(602) 254-4666

Branch: **Unicoa**
3232 E. 36th St.
Tucson, AZ 85713
(602) 620-1000

CALIFORNIA

California Woodworking Machinery
1566 W. Lincoln Ave.
Anaheim, CA 92801
(714) 772-2501

Mel's Industrial Supply
1210-H.E. 6th St.
Corona, CA 91720
(714) 737-8143

Branch: **Orange Tool Mart**
211 W. Katella Ave. #E
Orange, CA 92667
(714) 833-4211

Sacramento Machinery Co.
3412-A Auburn Blvd.
Sacramento, CA 95821
(916) 483-8513

Santa Rosa Tool & Supply, Inc.
1651 Piner Rd.
Santa Rosa, CA 94503
(800) 346-0387
(800) 345-8665 in California

COLORADO

Mountain & Plains, Inc.
2540-19th St.
Denver, CO 80211
(303) 480-9665

DELAWARE

The Tool Shed
18 Marrows Rd.
Newark, DE 19713
(302) 731-2025

FLORIDA

Southern Tool
4300 N.W. 72nd Ave.
Miami, FL 33166
(305) 591-8444
(800) 432-3523

Branch: **Florida Tool**
3538 Hardee St.
Fl. Myers, FL 33916
(813) 332-4033

GEORGIA

Kentec, Inc.
2660 Easterly Pl.
Decatur, GA 30035
(800) 282-7056
(800) 241-0148 in Georgia

Branch: **Liburn Retail Sales Center**
5005 Lawrenceville Hwy.
Liburn, GA 30274
(404) 925-3674

Branch: **Lithonia Retail Sales Center**
6641 Hillandale Rd.
Lithonia, GA 30058
(404) 482-1031

Branch: **Marietta Retail Sales Center**
1033 Franklin Rd., Space #20
Marietta, GA 30067
(404) 955-4249

Branch: **Roswell Retail Sales Center**
1219 Alpharetta St.
Roswell, GA 30075
(404) 998-0178

B. L. Roberson
2459 Brooks Dr. S.W.
Austell, GA 30001
(404) 949-8281

Stone Mountain Power Tool Corp.
6290 Jimmy Carter Blvd.
Norcross, GA 30071
(404) 446-8390

IDAHO

Coeur d'Alene Power Tool & Hardware
451 Cherry Lane at Hwy. 95
Coeur d'Alene, ID 83814
(208) 667-1158

ILLINOIS

Fox Valley Hardwoods
21 No. River St.
Batavia, IL 60510
(312) 679-9535

IOWA

C. W. Crossen Co.
706 E. River Dr.
Davenport, IA 52803
(800) 722-9342
(319) 324-9351

Hazen Supply Corp.
Rural Rt. One
Mt. Union, IA 52644
(319) 865-7641

Puckett Tools & Fasteners
841-11th St.
Des Moines, IA 50309
(800) 532-1267 in Iowa

MARYLAND

L. A. Benson Co., Inc.
3707 E. Monument St.
Baltimore, MD 21203
(800) 638-7212
(800) 492-0277 in Maryland

Thompson & Cooke, Inc.
4200 Kanilworth Ave.
Bladensburg, MD 20710
(301) 864-6380

MICHIGAN

Engelswood Power Tools
25402 Harper St.
St. Clair Shores, MI 48081
(313) 772-4488

Monitor Machinery Co.
315 Commerce Ave. S.W.
Grand Rapids, MI 49503
(616) 458-1890
(800) 782-8964 in Michigan
(800) 431-7457 Outside Michigan

The Tool Haus
630 No. Silverleaf
Gladwin, MI 48624
(800) 878-6657

Branch: **The Tool Haus**
Mid America Plaza
3600 So. Dort Hwy.
Flint, MI 48807
(313) 743-9300

MINNESOTA

Seven Corners Hardware
216 West Seventh St.
St. Paul, MN 55102
(612) 224-4859
(800) 328-0457

MISSOURI

McDonald Machinery Co.
1535 No. Broadway
St. Louis, MO 63102
(314) 231-9390

Pyramid Products, Inc.
7440 E. 12th St.
Kansas City, MO 64126
(800) 747-3600

The Wood & Shop, Inc.
5605 No. Lindbergh
Hazelwood, MO 63042
(314) 731-2761

Branch: **The Wood & Shop, Inc.**
13202 Tesson Ferry Rd.
St. Louis, MO 63128
(314) 843-5080

NEBRASKA

Pyramid North
4544 So. 133rd St.
Omaha, NE 68144
(800) 652-8872

NEVADA

Glendale Industrial Supply
2828 So. Highland
Las Vegas, NV 89109
(702) 454-0773

NEW HAMPSHIRE

Brentwood Machine Sales
Rt. 125
Brentwood, NH 03042
(800) 582-7229 (New England Wats)
(603) 679-8452

NEW JERSEY

Hunterdon Mill & Machine Supply
291 Rt. 22 E.
Lebanon, NJ 08833
(201) 534-2221

A. W. Meyer Co.
509 Broad Ave.
Ridgefield, NJ 07857
(201) 945-5500

Monmouth Cabinet & Tool Supply Co.
907 Bangs Ave.
Asbury Park, NJ 07712
(201) 775-2283

Toolathon
75 Rt. 17 So.
Hasbrouck Heights, NJ 07604
(201) 288-8819

NEW YORK

Culver-Atlantic Corp.
70 Greenleaf St.
Rochester, NY 14609
(716) 288-1430

Fowler & Keith
104 Smith Ave.
Kingston, NY 12401
(914) 331-0004

Jackson Saw & Knife Co.
517 State St.
Rochester, NY 14608
(716) 546-7485

Shields Sales Corp.
Port of Albany
Albany, NY 12202
(518) 436-8402

T. R. Smith, Inc.
5266 Seneca St.
Buffalo, NY 14224
(716) 674-4127

Tri-City Saw & Tool Co.
318 Broadway
Schenectady, NY 12305
(518) 372-7112

NORTH CAROLINA

Diversified Equipment & Supply
11223 Blair Rd.
Charlotte, NC 28227
(704) 545-5198

Woodworking Machinery & Supplies
290 Beaty Dr.
Belmont, NC 28012
(704) 827-3797 Locally
(800) 682-0947

NORTH DAKOTA

Acme Electric
1705-13th Ave. No.
Grand Forks, ND 58201
(800) 732-4287 in North Dakota
(800) 358-3096 Nationally

Branch: **Acme Electric**
1009 Basin Ave.
Bismarck, North Dakota
(701) 256-1267

Branch: **Acme Electric**
3401 Interstate Blvd.
Fargo, North Dakota
(701) 235-8060

Branch: **Acme Electric**
525-20th Ave. S.E.
Minot, North Dakota
(701) 839-2293

OHIO

Associated Suppliers, Inc.
715 W. Washington St.
Sandusky, OH 44870
(800) 225-2742
(419) 626-2721

Cleveland Tool & Cutter, Inc.
13100 Prospect Rd.
Strongsville, OH 44136
(216) 238-5770

Kohlmyer Supply, Inc.
5000 Grove Ave. (Rt. #57)
Lorain, OH 44055
(800) 358-9879

Power Tool Sales & Service
2934 Douglas Rd.
Toledo, OH 43606
(419) 473-0962

Quality Saw & Tool, Inc.
328 So. Main St.
Mansfield, OH 44903
(419) 526-4221

Spartan Tool Supply
1505 Alum Creek Dr.
Columbus, OH 43209
(800) 848-1368 Toll Free Out of Ohio
(614) 253-0942 in Ohio

T-Saw Tool
1777 Pennsylvania Ave.
Salem, OH 44460
(216) 332-4547

Tim Stone Power Tool
142 Union St.
Newark, OH 43055
(800) 345-4172 in Ohio
(614) 344-9404 Outside Ohio

True Value Hardware, Inc.
940 West Maple St.
Hartsville, OH 44632
(800) 345-2396
(216) 877-3831

Woodcrafters' Supply Co.
533 Sinclair Rd.
Columbus, OH 43202
(614) 438-6900

OREGON

Allen Industrial Tool
1415 Liberty St. N.E.
Salem, OR 97303
(800) 274-5220
(503) 363-3106

Branch: **Allen Industrial Tool**
1800 N.W. 167th, Space 115
Beaverton, OR 97006
(503) 629-5667

Barbo Machinery Co., Inc.
4617 S.E. Milwaukie Ave.
Portland, OR 97202
(800) 452-8503 in Oregon
Or (503) 232-8158

Cal-Ore Carbide
2917 No. Pacific Hwy.
Medford, OR 97501
(503) 772-2293

Woodcrafters
212 N.E. 6th Ave.
Portland, OR 97232
(800) 777-3709
(503) 231-0226

PENNSYLVANIA

Blue Ball Machine Co., Inc.
Rte. 322 East
Blue Ball, PA 17506
(717) 354-4478

Marwood Woodworkers Supply
406-A Huntingdon Pike
Philadelphia, PA 19111
(215) 683-4446 in Pennsylvania
(800) 255-8363 Outside Pennsylvania

Woodworkers World
1509 Litzl Pike
Lancaster, PA 17601
(717) 299-5264

Branch: **Woodworkers World**
Valley Forge Shopping Center
King of Prussia, PA 19406
(215) 265-3310

Branch: **Woodworkers World**
Capitol City Plaza
Camp Hill, PA 17011
(717) 731-1008

SOUTH DAKOTA

Campbell Supply
3101 E. 10th St.
Sioux Falls, SD 57103
(605) 336-2494

Branch: **Campbell Supply**
2425 Lazelle
Sturgis, SD 57785
(605) 347-6352

Branch: **Campbell Supply**
1401 No. Main
Mitchell, SD 57301
(605) 996-6305

Branch: **Campbell's Home and Auto**
3835 So. Western
Sioux Falls, SD 57105

TENNESSEE

Jackson Bearing Co.
603 So. Royal
Jackson, TN 38301
(800) 234-0606

Call for branch nearest you—
TN, AR, MS, MO, KY
Kentec Branch: New Nashville RSD
2177 Nolensville, Suite 101
Nashville, TN 37211
(615) 255-8771

Tennessee Machinery Co.
1133 Polk Ave.
Nashville, TN 37202
(615) 244-8150

Walter A. Wood Supply Co., Inc.
4509 Rossville Blvd.
Chattanooga, TN 37407
(800) 476-1415

TEXAS

Bluebonnet Tool Co.
10490 Shady Trail #104
Dallas, TX 75220
(800) 492-5174

Branch: **Dallas Saw & Supply**
2833 Irving Blvd.
Dallas, TX 75207
(800) 543-9334

Texas Tool Traders
Rt. 3, Box 351
Weimar, TX 78962
(409) 263-5015

Branch: **Texas Tool Traders**
2215 E. Division
Arlington, TX 76011
(817) 640-9846

Branch: **Texas Tool Traders**
10435 Burnet Rd., Ste. 110
Austin, TX 78758
(512) 339-4345

Branch: **Texas Tool Traders**
2414 So. Jupiter
Garland, TX 75041
(214) 278-0049

Branch: **Texas Tool Traders**
5900 No. Freeway
Houston, TX 77076
(713) 697-9909

Branch: **Texas Tool Traders**
440 Highway 6 So.
Houston, TX 77079
(713) 496-0811

Branch: **Texas Tool Traders**
2192 Jackson Keller
San Antonio, TX 78213
(512) 525-1418

VIRGINIA

Rocking R Hardware
1030 So. High St.
Harrisonburg, VA 22801
(800) 726-7625

G. G. Wilkins Co.
550 Oyster Point Rd.
Newport News, VA 23602
(804) 249-3500

The Source
7305 Boudinot Dr.
Springfield, VA 22150
(800) 468-1778 in Virginia
(800) 452-9999 in the U.S.A.
(703) 644-5460

Branch: **The Source**
9205 Venture Ct.
Manassas Park, VA 22111
(703) 330-9446

WASHINGTON

Eastdale Saw
12880 Bel-Fred Rd.
Bellevue, WA 98003
(206) 454-7627
(800) 962-0279

Spokane Power Tool & Hardware
E. 801 Trent
Spokane, WA 99202
(509) 489-4202 Locally
(800) 426-0013 in Washington
(800) 521-1770 Out of Washington

Tacoma Screw Products
2001 Center St.
Tacoma, WA 98409
(206) 572-3444
(800) 562-8192

Branch: **Tacoma Screw Products**
5241 Auto Center Way
Bremerton, WA 98312
(206) 479-0230

Branch: **Tacoma Screw Products**
20440-84th Ave. So.
Kent, WA 98032
(206) 395-9770

Branch: **Tacoma Screw Products**
11200-120th Ave. N.E.
Kirkland, WA 98033
(206) 822-2585

Branch: **Tacoma Screw Products**
3930 Leary Way N.W.
Seattle, WA 98107
(206) 632-7565

Branch: **Tacoma Screw Products**
607 So. Fidalgo St.
Seattle, WA 98108
(206) 767-3750

Branch: **Tacoma Screw Products**
2222 Port of Tacoma Rd.
Tacoma, WA 98421
(206) 383-4435

WEST VIRGINIA

Blue Ridge Machinery & Tools, Inc.
2806 Putnam Ave.
Hurricane, WV 25526
(800) 872-6500
(304) 562-3538

WISCONSIN

Lakeshore Machinery, Inc.
3620 No. 126th St.
Brookfield, WI 53005
(414) 781-7560

JET

EQUIPMENT & TOOLS

JET
EQUIPMENT & TOOLS

P.O. Box 1477
Tacoma, WA 98401
(206) 572-5000

J E T

A World Of Value.

Take A Close Look...



“at a real deal”

At these special prices you can complete your workshop. When you buy a JET machine from your local distributor you get a quality machine at a reasonable price, a full one-year warranty, parts availability and local technical assistance by your distributor!

The 10" table saw features a 27" x 40" table, 10" blade capacity, and a 1½ HP motor. The 14" bandsaw has a full 1 HP motor with three speeds for wood or non-ferrous metal cutting, and a 45° tilting 14" square table. The shaper has an 18" long table and ½" spindle capacity. The 6" jointer has a long 28" fence and 42½" table and a three-knife cutter. The powerful 15" planer has a 3 HP, 1 Ph motor which allows a maximum ⅛" full width cut. The portable dust collector may attach to a variety of machines and has a 2.12 C.F. capacity collector bag and a very quiet 55 D.B. noise level.

For full details, see your local JET Distributor today.

Prices are effective while supplies last.

	User Special		User Special
JTS-10 Table Saw	\$ 482.00	JJ-6 Jointer	\$ 405.00
JBS-14MW Bandsaw	\$ 419.00	JWP-15H Planer	\$1,150.00
JWS-18 Shaper	\$ 417.00	DC-610 Dust Collector	\$ 310.00

WOODWORKING

Four decades following the fall of the Alamo, the people of San Antonio paved the streets leading to this Texas shrine with mesquite slabs. Today, street maintenance crews occasionally uncover remnants of the wood, still sound.

In the eyes of southwestern Indians, mesquite was shade and sustenance. They ate the tree's bean pods, turned its sap into gum, dye, and medicine, and sewed with its thorns. The Indians relied on the wood for fuel and arrows. Learning from the native Americans, pioneer hands worked mesquite into construction timbers, railroad ties, fence posts, wagon wheels, and sturdy tables and chairs.

Because most craftsmen only equate mesquite with the barbecue grill, a group called *Los Amigos del Mesquite* (Friends of Mesquite) promotes the wood as furniture-class stock. Due to their efforts, mesquite's reputation as quality cabinet wood seems to be spreading.

Wood identification

It's estimated that the three varieties of mesquite (*Prosopis glandulosa*, *juliflora*, and *pubescens*) cover some 75 million acres of Texas alone. These hardy trees also extend into Arizona, Oklahoma, and Mexico.

In desert areas, mesquite develops more as a shrub than a tree. More favorable conditions allow it to

MESQUITE

Prime for steak,
better for stock



Dark mesquite



Light mesquite

grow to about 50' tall with a single, though somewhat crooked, trunk up to 3' in diameter.

Mesquite, with its chocolate-colored, furrowed bark isn't difficult to identify. Its wide, spreading canopy of frequently twisted branches sports long, thin leaves composed of evenly spaced leaflets. Bean pods up to 8" long follow the tree's bright, yellowish-white spring flowers. And, the short, sharp thorns amidst the leaves painfully pierce passing flesh.

Mesquite wood has fine, tightly interlocked grain. A narrow band of tan sapwood borders the deep brown heartwood.

Working properties

Mesquite remains quite stable during seasoning. Since the shrinkage occurs evenly, the wood sustains few drying defects. That's why carvers and turners work the wood green—it dries without checking.

Mesquite requires power tools because it's heavier than both oak and maple, but much

harder. And, since it's rather brittle and contains a high percentage of silica, the wood demands sharp cutting edges.

Due to the wood's brittleness and silica content, you must join it with both adhesives and screws. And, adhesives work best when you wipe the surfaces with lacquer thinner.

Mesquite sands silky smooth with little effort. Like a true cabinet wood, it accepts oils and topcoats equally well.

Uses in woodworking

Craftsmen draw upon mesquite for furniture, carvings, and turnings. In the home, it serves as attractive, hard-wearing flooring and decorative items such as fireplace mantels. It also makes premium gunstocks and knife handles.

Cost and availability

Although mesquite has not attained commercial importance, many small enterprises throughout the Southwest sell the wood. You'll find it most frequently as turning squares and blocks, and as lumber in 1×8 and 2×8 sizes up to 5' long.

Prices range from \$1.50 per board foot for non-select wood to \$10 or more for premium stock. Veneer isn't available.

For a list of mesquite suppliers and information concerning *Los Amigos del Mesquite*, write: *Ken E. Rogers, P.O. Box 310, Lufkin, TX 75901.* 🌳

Photographs: Bob Calmer
Illustration: Steve Schindler



BOY! DID WE HAVE

What an incredible outpouring of generosity! We wish all of you could have feasted your eyes on the row upon row of wooden toys lovingly made by WOOD® magazine readers for our first Design-A-Toy competition.

 [Print this article](#)

The 425 generous souls who built a toy for a needy child have every reason to be proud. And, some of you have an extra reason to cheer: The judges selected 41 contest winners. Later, we drew seven more names from the hat to receive prizes in our nonwinners drawing.





on our panel by surprise. "When I first looked in that room," Homer said, "I didn't expect to see as many toys or that quality of toys. It tells me a lot about the craftsmanship going on out there. Look at all those wooden toys and you can see people are getting tired of the plastic world we live in."

"It was like sneaking into Santa's workshop," Roy said when he peeked in our toy room for the first time. "Everyone's been surrounded by toys in a huge toy store. But this was different. There was so much individuality and creativity in these toys. You just don't see a lot of homemade stuff in one room. All you had to add was the kids."

The Marine Corps Reserve will supply that missing ingredient—kids. Reserve units around the country now have a mountain of toys to distribute this Christmas through their successful Toys For Tots program. We're certain that your generosity *and* creativity will light the faces of 425 needy kids.

So, we applaud all of you who participated in the contest: woodworkers, sponsors, judges, and, of course, the Marines. In upcoming issues of *WOOD* magazine and *Weekend Woodworking Projects*, we'll share some of the top designs.

And, if you're wondering about another contest, the answer is yes! Look for next year's contest rules in our December issue.

**PROFESSIONAL:
MOVABLE PARTS**

Grand Prize (\$1,500 in AMI/Hegner merchandise): Neil Seely, Rochester, N.Y., waddle duck.

First Prize (\$250 in Garrett Wade merchandise): Richard Grunwald, North Java, N.Y., fork lift.

Special Citations (\$100 in Woodmaster merchandise): Kurt Jobke, Pewaukee, Wis., pickup truck; Steven A. Bruni, Fort Madison, Iowa, biplane; Mike Jagielo, Almond, Wis., apple with pop-up worms; Peter P. Belski, Jr., Pittsburgh, tank; Richard Milam, Metairie, La., caterpillar.

**PROFESSIONAL:
NO MOVABLE PARTS**

Grand Prize (\$1,500 in Freud merchandise): Michael Watters, Saginaw, Mich., tugboat.

First Prize (\$250 in Bosch merchandise): Mike George, Slidell, La., cow puzzle.

Special Citations (\$100 in Minwax merchandise): Roger D. Coddington,

Traverse City, Mich., quilt puzzle; Jerry R. Syfert, Laurel, Md., three-layer puzzle; James N. Moen, East Grand Forks, Minn., teddy bear bank; Clyde R. Moore, Coeur d'Alene, Idaho, baby rattle; Stuart L. Woldman, Shaker Heights, Ohio, bank.

**HOME HOBBYIST:
MOVABLE PARTS**

Grand Prize (\$1,500 in Foley Belsaw merchandise): Robert W. Sanders, St. Marys, Ga., 1926 Mack truck.

First Prize (\$250 in Makita merchandise): Harold E. Geiselman, Canton, Ohio, bumpy road pickup truck.

Special Citations (\$100 in Popular Science Book Club merchandise): Bill Kaiser, Huntingburg, Ind., wooden tools; Mike Gradeless, Columbia City, Ind.,



Michael Watters of Saginaw, Michigan, hadn't built a toy before this contest, except to occasionally help neighborhood Cub Scouts with Pine-wood Derby entries. He's a signmaker by trade.



Neil Seely of Rochester, N.Y., a retired Eastman Kodak camera designer, started designing his waddle duck as a project for an adult education computer-design class. He estimates spending 30 hours developing the prototype. Neil shares the design for this pull toy on pages 42-45.



Alvin Curtis of Oshkosh, Wis., a retired college band director, made his first rocking whale for his grandson. He's already working on next year's contest.

dune buggy; Rene Knetsch, Oklahoma City, moving van; Brian W. Anderson, Waseca, Minn., crane; Larry Groninger, Reedsville, Pa., cat-and-mouse pull toy.

**HOME HOBBYIST:
NO MOVABLE PARTS**

Grand Prize (\$1,500 in Delta merchandise): Alvin J. Curtis, Oshkosh, Wis., rocking whale.

First Prize (\$250 in merchandise from Skil): David Cartwright, Arlington Heights, Ill., stack toy.

Special Citations (\$100 in Dremel merchandise): Ronald Busdiecker, Eu-

clid, Ohio, kaleidoscope; Sam Roberts, Roseburg, Ore., gum-ball machine; Merle Halter, North Platte, Neb., fishing game; Donald Flanagan, Shell Knob, Mo., highway bridge; Robert E. Sweet, Toledo, Ohio, doll playpen.

SCHOOL AGE: MOVABLE PARTS

Grand Prize (\$1,500 in Total Shop merchandise): Ed Park and Walter Green, Newark, Ohio, truck and sailboat.

First Prize (\$250 in Hitachi merchandise): Dustin Ehrman, Middle Amana, Iowa, 4-wheeler.

Special Citations (\$100 in Formby's merchandise): Bob Pilz, White Bear Lake, Minn., garbage truck; Flay Terres, Gastonia, N.C., train engine; Warren J. Kaeb, Buckley, Ill., space shuttle; Steve Smith and Brian Beaver,

Newark, Ohio, helicopter; Steve Lukes, Middle Amana, Iowa, wagon.

**SCHOOL AGE:
NO MOVABLE PARTS**

Grand Prize (\$1,500 in Black & Decker merchandise): George Powers, Chad Cooperrider, and Jim Watson, Newark, Ohio, telephone.

First Prize (\$250 in Grizzly merchandise): Shon Lowery, Corby Franks, and Joe Browett, Newark, Ohio, puzzle.

Special Citations (\$100 in DML merchandise): John Duncan Jr., Des Moines, Iowa, bank; Gregg Klatt, Menominee, Mich., snowmobile; Matt Mohler, Keenan McKee, and Todd Journey, Newark, Ohio, country buildings; Peter Barrette, Des Moines, puzzle.

NONWINNERS DRAWING

\$1,400 in Shopsmith merchandise:

James Craine, North Bloomfield, Ohio.

\$1,000 in Porter Cable merchandise:

Jim Sweet, Coulterville, Ill.

\$500 in Ryobi merchandise:

Ronald Myer, Kokomo, Ind.

\$250 in AEG merchandise:

Ron Hale, Joshua Tree, Calif.

Ripstrates from Fisher-Hill

Products: Alan Boyer, Cy-

press, Calif.; Ed Schott, Sacra-

mento, Calif.; Heath Smith,

Newark, Ohio. 🍀



Bob Sanders of St. Marys, Ga., spoiled the side dump truck he built a week before the contest deadline. He quickly changed bed designs and then rushed his 1926 Mack truck to Des Moines. Bob works as an electrical engineer for General Dynamics.

Walter Green and Ed Park spent six weeks building the tractor, semitrailer, and sailboat in their industrial arts class at Licking Valley High School in Newark, Ohio. Their teacher, Barry Healey, gave both boys an "A" on the project—and so did our panel of judges.



Jim Watson, Chad Cooperrider, and George Powers, also Licking Valley students, were—according to Jim—"pretty surprised and happy we won."

Photographs: Jim Kascoutas



READ ALL ABOUT IT! DUCK WADDLES OFF

After 30 years at Eastman Kodak, Neil Seely took early retirement from his job in the camera design department. Eager to expand his design knowledge, Neil took in a CAD (computer-aided design) course at a community college. For his final class project, Neil redesigned a wooden toy duck he had built years earlier as a gift for a neighbor's child. His new-and-improved duck had such an irresistible waddle and swinging head that it walked off with a grand prize in a professional division in our Design-A-Toy contest.

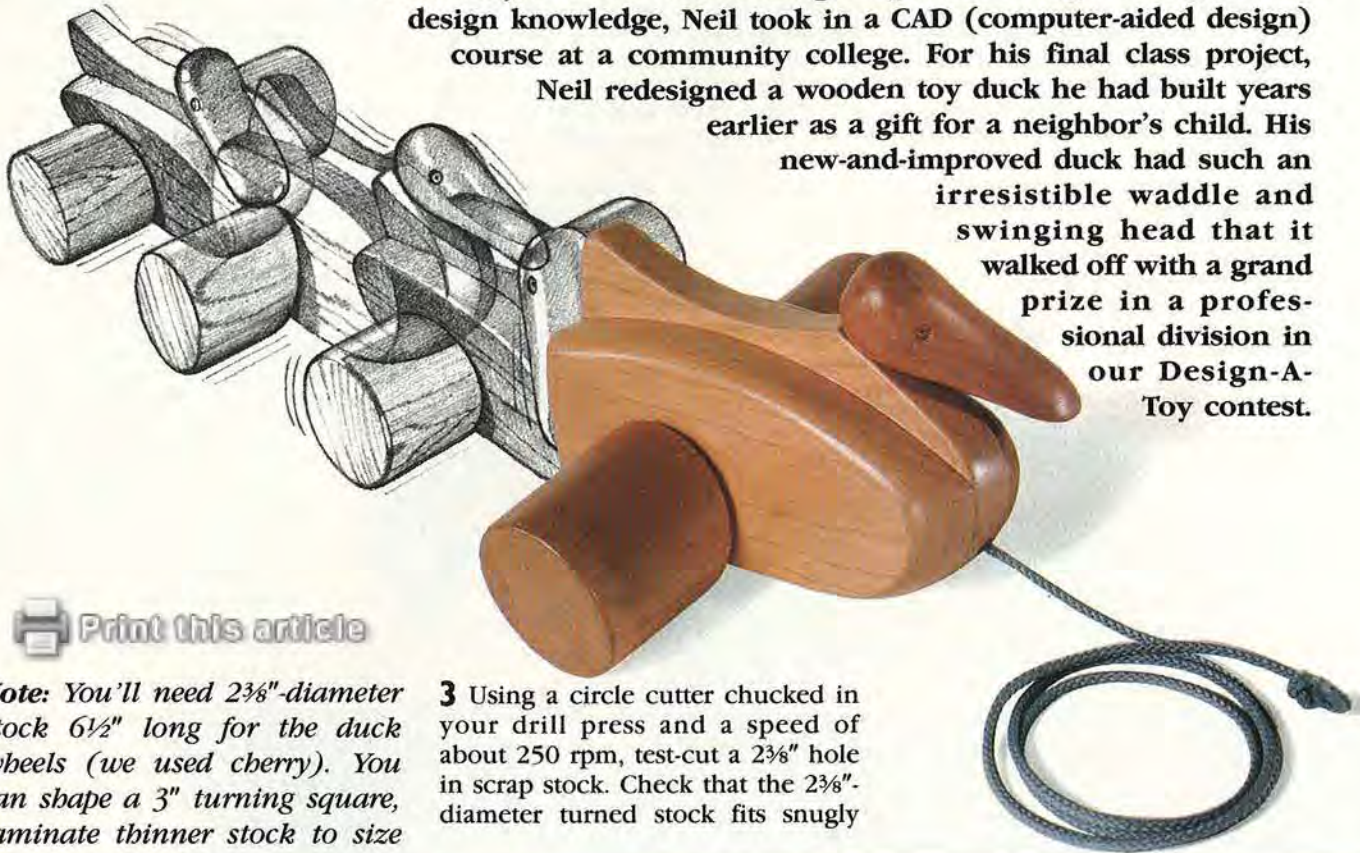

 Print this article

Note: You'll need $2\frac{3}{8}$ "-diameter stock $6\frac{1}{2}$ " long for the duck wheels (we used cherry). You can shape a 3" turning square, laminate thinner stock to size and turn it round, or see the Buying Guide at the end of this article for our source of either a 3" turning square or stock already turned to $2\frac{3}{8}$ ". If you turn your own stock, mount a turning square between centers, and turn it to a $2\frac{3}{8}$ " outside diameter. Check the diameter as you go with an outside calipers.

PRO"DUCK"TION BEGINS WITH THE WHEEL JIG

1 From $\frac{3}{4}$ "-thick particleboard or plywood, cut seven pieces $3\frac{1}{2}$ " wide by 11" long.

2 Measure and mark a centerpoint on the top face of each piece (see the Jig Lamination Drawing, right).

3 Using a circle cutter chucked in your drill press and a speed of about 250 rpm, test-cut a $2\frac{3}{8}$ " hole in scrap stock. Check that the $2\frac{3}{8}$ "-diameter turned stock fits snugly

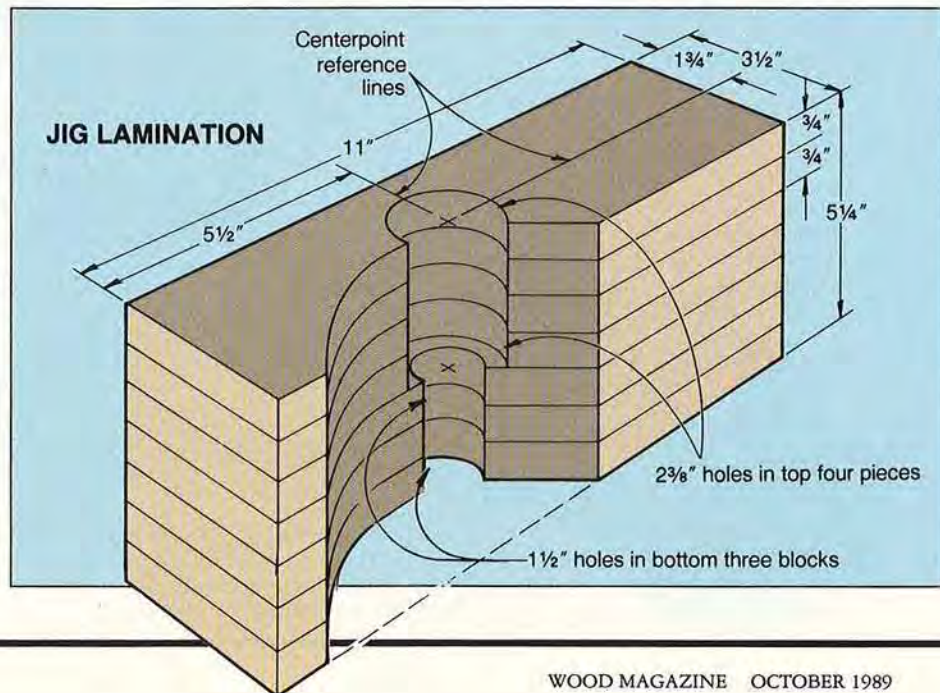

WITH A GRAND PRIZE

Bill of Materials						
Part		Finished Size				
		T	W	L		
A	wheels	2 3/8" diameter	6"		C	2
B	body center	3/4"	4"	7"	C	1
C	body sides	3/4"	4"	7"	C	2
D	head	1 1/4"	1 1/2"	4"	LC	1

Material Key: C-cherry, LC-laminated cherry
Supplies: particleboard for jig, 1/4" dowel stock for neck, 1/4" nut, 1/2" dowel stock for wheel axle, thumbtacks, 1/8"-braided nylon or venetian-blind cord 30" long, satin polyurethane.

inside the hole in the scrap stock. If the turned stock fits loosely, you will have problems later drilling an accurate axle hole. Adjust the circle cutter if necessary. Center the circle cutter pilot bit directly over the marked centerpoint. Slowly lower the cutter into the stock to cut a 2 3/8" hole in four of the jig pieces. Cut or bore a 1 1/2"-diameter hole in the other three pieces.

4 Carefully align the holes where shown on the Jig Lamination Drawing, and glue and clamp together the pieces with the 2 3/8" holes. (We inserted the 2 3/8" turned stock to align the four holes. Once aligned, we clamped together the pieces, removed the turned stock, and wiped off all glue squeeze-out with a damp cloth.) Now, glue and clamp together the three pieces with the 1 1/2" holes, making sure to align the holes. Finally, glue and clamp together the two laminations, with the ends and edges flush.

5 Now, follow the four-step drawing below left to mark and cut the jig lamination to shape.

ANGLE-CUT THE WHEELS WITH THE JIG

1 If you've turned your own cherry stock for the 2 3/8" wheels, crosscut about 1/8" off each end to remove the spur-center and tailstock marks.



Insert the turned cherry stock into the hole in the jig, and trim each 2 3/8"-diameter duck wheel to length.

Continued

CUTTING THE JIG TO SHAPE

STEP 1. Mark cutlines where dimensioned

STEP 2. Make first cut with bandsaw.

STEP 3. Trim both ends square with edge cut in Step 2.

STEP 4. Make final cut using the bandsaw.

LOCATING THE AXLE AND TACK CENTERPOINTS

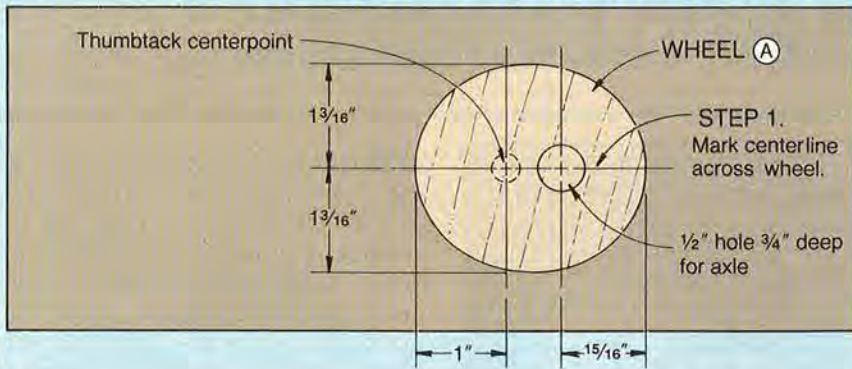

STEP 3. Measure 1" from left edge of wheel and mark a third reference line to locate thumbtack centerpoint.

STEP 2. Measure $\frac{15}{16}$ " from right edge of wheel and mark a second reference line across wheel to locate axle centerpoint.

2 Stick the $\frac{23}{8}$ " stock all the way into the $\frac{23}{8}$ " hole in the jig. To ensure your wheels will end up the right length, the turned stock must bottom out in the $\frac{23}{8}$ " hole in the jig. Position the jig between the tablesaw blade and fence where shown in the photo at the bottom of the previous page.

3 Start the saw and cut the turned stock flush with the face of the jig as shown in the above-mentioned photo to form one wheel (A).

4 With the wheel still in the jig, carefully locate and mark centerpoints for the $\frac{1}{2}$ " axle hole and the thumbtack on the cut end of the wheel where shown on the drawing above.

5 Chuck a $\frac{1}{2}$ " brad-point bit into your drill press and bore $\frac{3}{4}$ " deep into the turned stock as shown in the photo at right. (We had our drill press running at 250 rpm.) To prevent the wheel from turning in the jig, feed the bit slowly into the turned stock and back out several times to remove the waste stock. Push a dowel through the $1\frac{1}{2}$ " hole in the jig to pop out the wheel.

6 Repeat steps 1, 2, 3, 4, and 5 above to form the second cherry wheel (A).

7 Sand a slight round-over along the outside edge of each wheel where shown on the Exploded-View Drawing.

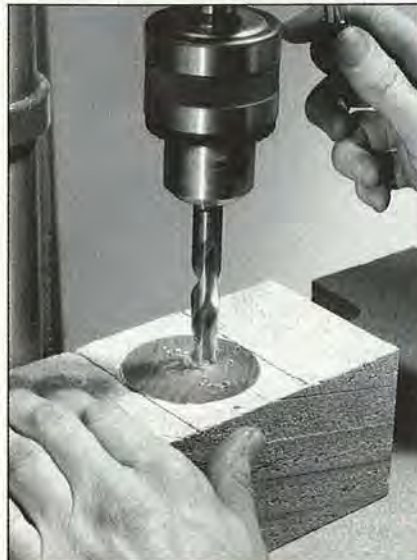

Center the bit over the mark, and drill a $\frac{1}{2}$ " hole $\frac{3}{4}$ " deep in the wheel; then remove the wheel from the jig.

NOW, MOVE ON TO THE DUCK'S BODY

1 From $\frac{3}{4}$ " cherry, cut three pieces 4×7 " for the duck body.

2 With carbon paper or by adhering a photocopy of the full-sized Side-View Body Pattern on the opposite page, transfer the outline, notch, and head-dowel centerline of the body center (B) to one of the 4×7 " pieces of cherry. Cut the outline and notch to shape.

3 Transfer the outline for the body side (C) to one of the remaining

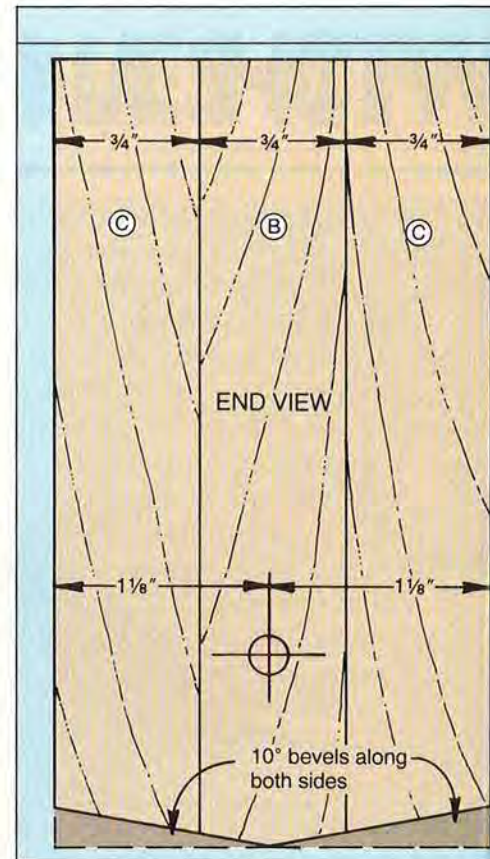

pieces. Bandsaw and sand it to shape, and use it as a template to mark the outline onto the other body side. Then, cut the outlined piece to shape.

4 Drill a $\frac{5}{16}$ " hole through the body center (B) for the head dowel (we used a dowel jig to help align the bit). Now, drill a $\frac{3}{16}$ " hole through the front of the body center for the pull rope where shown on the Body Pattern Drawing.

5 Rout a $\frac{3}{8}$ " round-over on both body sides (C) where shown on the Exploded-View Drawing. With the bottom and back edges flush, glue and clamp together the three body pieces.

6 Mark a 10° bevel line on the front and back ends of the body lamination where shown on the drawing above. Now, connect the ends of the bevel lines by drawing a line along each side of the lamination. Clamp the duck body upside down in a woodworker's vise and hand-plane or belt-sand the edges to the marked lines.

FULL-SIZED BODY PATTERN

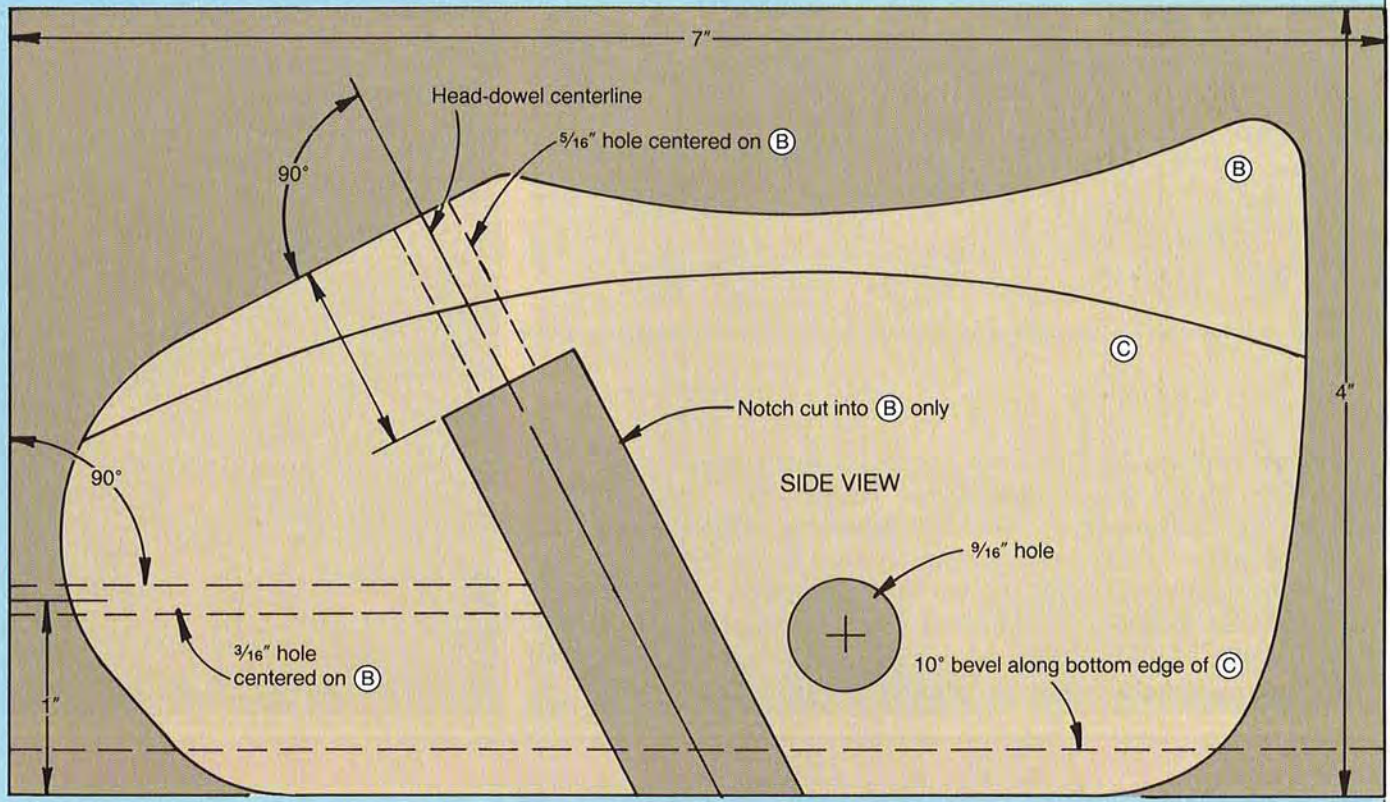

FULL-SIZED HEAD PATTERN

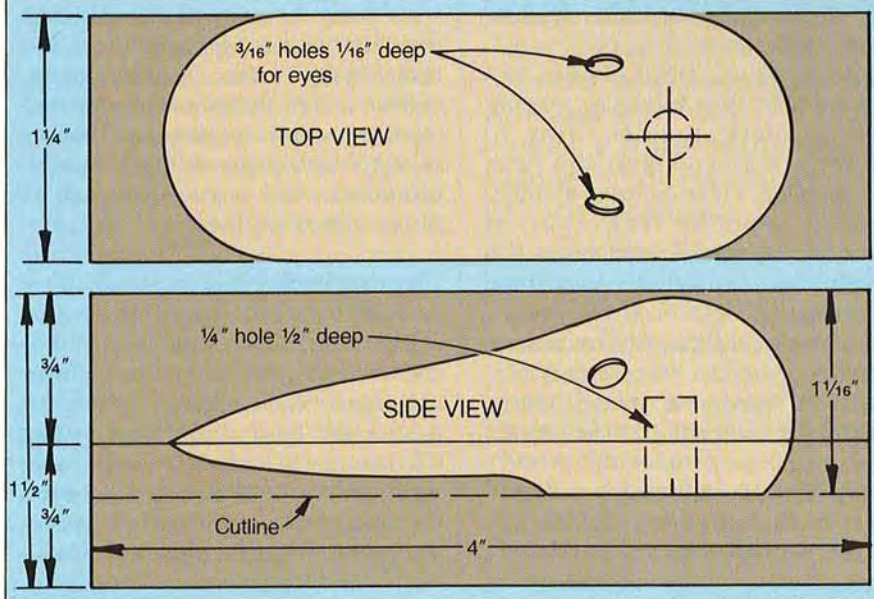

- 7** Mark the centerpoint location, and bore a $\frac{9}{16}$ " axle hole through the body where shown on the Body Pattern Drawing at top.
- 8** Sand the duck body smooth.

NEXT, CUT AND SHAPE THE DUCK'S HEAD

1 To form the head (D), cut a block to $1\frac{1}{4} \times 1\frac{1}{2} \times 4$ ". If you don't have stock this size, laminate $\frac{3}{4}$ "-

thick stock and trim it to size, noting the lamination line shown on the Side View of the Head Pattern.

2 Transfer the full-sized top and side head patterns to the cherry block. Mark the $\frac{1}{4}$ " dowel hole centerpoint, and drill the hole where marked. Bandsaw the head side view to shape. Tape together the pieces and cut the top-view pattern to shape as shown below.

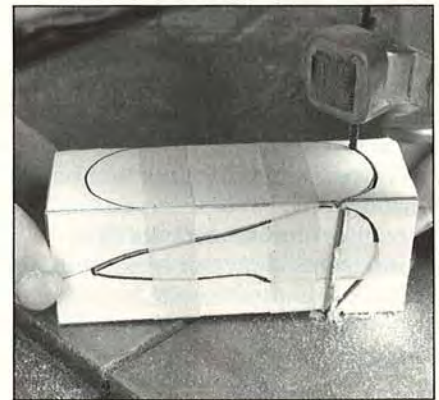

Cut the side-view head pattern to shape. Tape the pieces back together, and cut the top-view pattern.

Continued on page 88

WHAT'S HAPPENING TO THE WORLD'S WOOD?

 Print this article

Fueled by reports of millions upon millions of tropical and temperate forest acres threatened, then lost each year, it seems as if everyone—from schoolchildren to politicians, and a fair number of woodworkers—wants answers to what the future holds for the world's timber. In this four-page section, Pete Stephano, WOOD® magazine's features editor, capsulizes the situation around the world today and presents the outlook as related to him by some of the most informed people in the field.



CONCERN NO. 1: CAN WE SAVE THE TROPICAL FORESTS?

From the Congo to the Amazon to Java, 27 million acres of tropical forest are consumed each year—a rate of about one square mile every 12 minutes—for lumber, agriculture, grazing, roads, mining, and other purposes.

What's happening—and why

● The earth's tropical forests—once twice the size of the U.S.—have been cut in half. Remaining tropical forests in South America's Amazon, Southeast Asia, and the African Congo region, number about 3 billion acres. At present, the Congo forests remain relatively untouched.

● Commercial timber harvesting in the tropical forests accounts for 11 million acres per year—two-thirds of that in Southeast Asia.

● Conversion to agricultural land and pasture destroys the most forest. “Generally, the tropics are not a major source of commercial wood,” notes Roger Sedjo, of Resources for the Future.

● The most intensively logged tropical forests are in the South Pacific, from Malaysia and Indonesia to the Philippines.

● In the tropics, especially the Amazon, people clear forests by cutting down growth, then burning it. Known as slash-and-burn, this practice parallels clear-cutting, a sometimes acceptable technique of forest management. The forest has the ability to rejuvenate, given time to reestablish itself. However, in less-developed countries where food has priority, trees aren't permitted to regrow on cleared land.

● Burning tropical forests creates close to 20 percent of the world's carbon dioxide released into the atmosphere, contributing to the “greenhouse effect.” Total U.S. emissions from burning fossil fuels adds about 25 percent.

To the nations in the tropics, timber easily converts to needed financial capital. Historically, there's plenty of precedent for such action. “England cut her forests, built a navy, and as a result, dominated

the seas for 150 years. The Chinese traded forests for agriculture. Countries have always overexploited their timber resource to achieve national goals,” says Dr. Ben Jayne, author and professor of forestry and environmental resources at Pennsylvania State University. “It is very difficult to tell a country such as Brazil not to do that.”

The outlook

Lacking international guidance and regulation, there's little to restrain the lesser developed countries from cashing in their tropical forests for timber and agricultural land to pay off international debt and raise their standard of living. However, the horizon has some bright spots:

● *Brazil rethinks forest destruction.* Pressure from the World Bank and Inter-American Development Bank brakes the freewheeling destruction of Brazil's Amazon forests by urging land-use studies. In the U.S., legislation requires American investors to encourage nations to swap debt for forest conservation.



◀ Forests, such as this one in Madagascar, fall to roads, agriculture, and logging.
 ▼ Even clear-cut forests will rejuvenate all by themselves. This was taken on Washington's Olympic Peninsula.



● *Tropical countries add acres.*

Venezuela recently added 2.5 million acres to its national parks. Bolivia now manages a 1.2 million-acre forest for sustained yield. And, Costa Rica re-creates a 203,000-acre forest by planting and regeneration.

● *Trees combat greenhouse effect.* Through photosynthesis, trees transform carbon dioxide (CO₂) into carbon, and thus become a major factor in keeping CO₂ in balance. On average, a forest tree absorbs about 13 lbs. of CO₂ a year.

As a possible prototype of private sector effort, a Virginia-based company, Applied Energy Services, plans to offset the CO₂ emissions from its new coal-fired power plant in Connecticut by planting trees in Guatemala. The company donated \$2 million for seedlings.

Global Releaf, a program of the American Forestry Association, promotes tree plantings. Focusing first on urban America, Global Releaf will attempt to fill 100 million tree spaces to displace 18 million tons of U.S. CO₂ from the air annually.

CONCERN NO. 2

HOW MUCH TIMBER DO WE HAVE LEFT?

Since settled agriculture began about 10,000 years ago, forests and woodlands have dwindled by nearly 5 billion acres, a third of the original total, reports the World-watch Institute.

What's happening—and why

● The American Forest Council estimates that U.S. forests today number 737 million acres, about 70 percent of what were encountered by the first New World settlers. In 1920, forests covered only 615 million acres.

● Today, forest cover remains fairly stable in most industrial countries. In fact, it's even increasing.

France, once 80 percent trees, had only 14 percent by the late 1800s. Today, about 25 percent of France has trees. The United Kingdom's forests have expanded 86,000 acres a year since the '60s. China has a goal of greening one fifth of its land by the year 2000.

In the U.S., reforestation reaches new heights. During 1987, tree plantings amounted to 2.3 billion seedlings on 3 million acres. That's, about 10 new trees for every American, cites the USDA Forest Service.

● Rivalled only by South America in acres of forest, the Soviet Union has 2.3 billion acres, spread primarily across Siberia.

The outlook

On this front, things look promising, for several reasons. First, forests increase in land area when nations undergo transition from a farming society to an industrial one. With the economic diversity, more land becomes available to revert to forest. Too, as young nations mature, management policies emerge to protect the forest resource. Modern agricultural methods also require less land. And, forests have a natural resiliency. Without a constant effort to

Continued

WHAT'S HAPPENING TO THE WORLD'S WOODS?

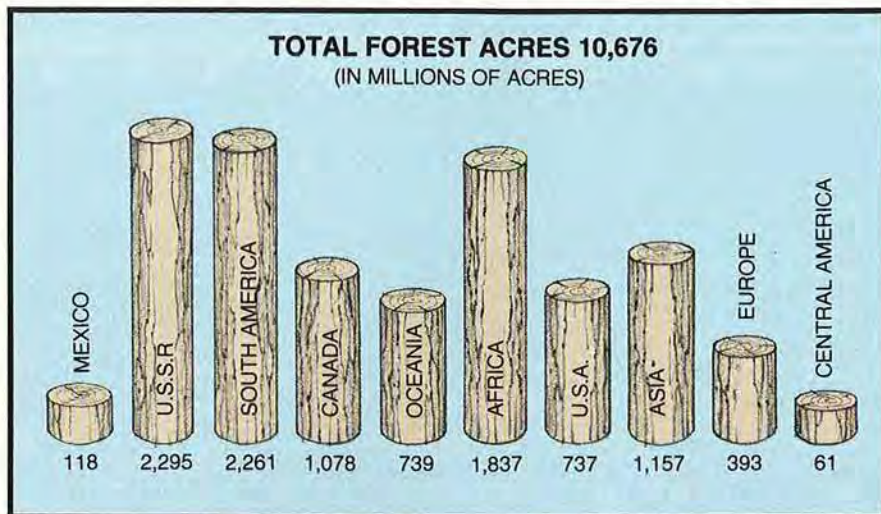

keep forests off the land, they move in to reclaim it.

Second, in some areas of the world, such as the vast Siberian forests of the Soviet Union, enormous hauling distances hamper timber harvesting. The African Congo region remains pristine because of its sparse population.

And third, through manipulative genetics, fertilization, commercial thinning, and other means, today's trees can reach maturity quicker. In fact, the Weyerhaeuser Company has developed trees that reach merchantable size in half the time it takes Mother Nature.

CONCERN NO. 3: CAN THE U.S. AFFORD TO EXPORT WOOD?

Japan, China, and other countries bought \$10 billion in forest products from the U.S. in 1987. Exported saw logs, veneer logs, and logs for other purposes amount to over 3 billion cubic feet annually.

What's happening—and why

- U.S. forest industries cut 17 billion cubic feet of wood in 1987. From that, 751 million cubic feet of forest products were exported.
- On an annual basis, U.S. forests grow 22 billion cubic feet of new timber, and we remove 17 billion.
- Tropical hardwood supplies, particularly in the Amazon basin and Southeast Asia, are being drawn down. "The drawdown of tropical hardwoods is beginning to create a shortage of quality hardwoods for furniture manufacture," notes Penn State's Ben Jayne. "Those who use that source for material—the Japanese and Taiwanese, for instance—have to seek other sources, such as the Appalachian hardwoods."
- Recent USDA Forest Service statistics indicate that the U.S. wood inventory appears solid, at least in the overview. "We have an accumulation of wood in most parts of the nation," Jayne explains. "But, it's mostly softwood. In the hard-

woods, there's probably a lower quality available now than there was in the past. Nevertheless, there is a larger number of small hardwood trees growing rapidly."

The Hardwood Manufacturers Association says the import of wood furniture rises every year. Crazy as it sounds, firms profit by shipping American logs and lumber to foreign countries manufacturing products with cheap labor, then shipping the goods back to the U.S. This raises U.S. wood prices.

The outlook

Expect new sources of wood. New Zealand, Chile, and South Africa

have extensive plantations of pine nearing the age for harvest.

Despite new wood sources, you can expect temporary shortages in the long-term. It may become difficult to get particular hardwood species, and board sizes will be smaller. Woodworkers will have to use more veneers and rely on boards made up for width. Substituting stock will also become commonplace as present low-value, under-appreciated wood replaces supplies of now-favored species. To alleviate long-term problems, hardwoods must now be managed as productively as softwoods, cautions international expert Jayne.



▲ Freighters leave North American ports loaded with exported logs. New spruce trees follow burned ones in this Canadian forest. ►

CONCERN NO. 4: FIRE, INSECTS, AND DISEASE: HOW HEAVY A TOLL?

Last year's Yellowstone fire burned, scorched, or somehow affected about one-third of the national park's 2.2 million acres. Other fires in U.S. forests during 1988 brought the total to 6 million acres, notching the year as one of the greatest for fire in recent times. And, insect infestations and blight continue attacking our forests every year.

What's happening—and why

- Compared to the past, 1988 wasn't a record year for fire. In the 1930s, a 40-million-acre loss to wildfire was common.

Natural fires, caused by lightning, often are permitted to burn themselves out in the publicly owned forests. Most such fires remain relatively small. Few fires happen on privately owned, industrial forestland, where there's little fuel build-up from dying trees. Increased forest use by campers, hikers, natu-

ralists, hunters, and fishermen, contribute accidental fires.

- Annual forest statistics do not provide a separate category for timber loss due to disease and insects. In 1986, mortality, defined as sound wood in trees that died from natural causes, including fire, was about 4.5 million cubic feet. This amount equals one-half of 1 percent of the total growing stock in the nation. Many of those trees, though, aren't lost. In infestations, as well as fires, it's common to salvage sawable timber. Tragic blights, such as the one that bowled the American chestnut over, prove rare.

- Acid rain, the combining of sulfuric oxide with precipitation, impacts U.S., Canadian, and European forests, but how and how much has yet to be determined.

The outlook

The ability to control fire has been a major factor in the expansion of our commercial forest land. Yet, in some cases, fire enables desirable new trees to sprout.

Reintroduction of natural controls, the recognition of insect threats, and technological advances in forestry genetics should reduce future damage from infestation.

For sources of more information, as well as organizations to join, please turn to page 93. 🌲

Written by Peter J. Stephano

Photographs: Madagascar, Frans Lanting; clear-cut, ©1989 T.W.

Ransom/Biological Photo Service;

freighter, ©1989 J.N.A. Lott/Biological

Photo Service; fire damage, ©1989 B.J.

O'Donnell/Biological Photo Service

Illustrations: Jim Stevenson

Compiled with aid from the American Forestry Association; American Forest Foundation; Environmental Defense Fund; John Heissenbuttel, American Forest Council; Dr. Ben Jayne, Pennsylvania State University; Rain Forest Action Network; Roger Sedjo, Resources for the Future; Profs. Buck Sanford and Dan Binkley, Colorado State University; The Smithsonian Institution; Timber Holdings, Ltd., Milwaukee, Wis.; USDA Forest Service; and the Worldwatch Institute.

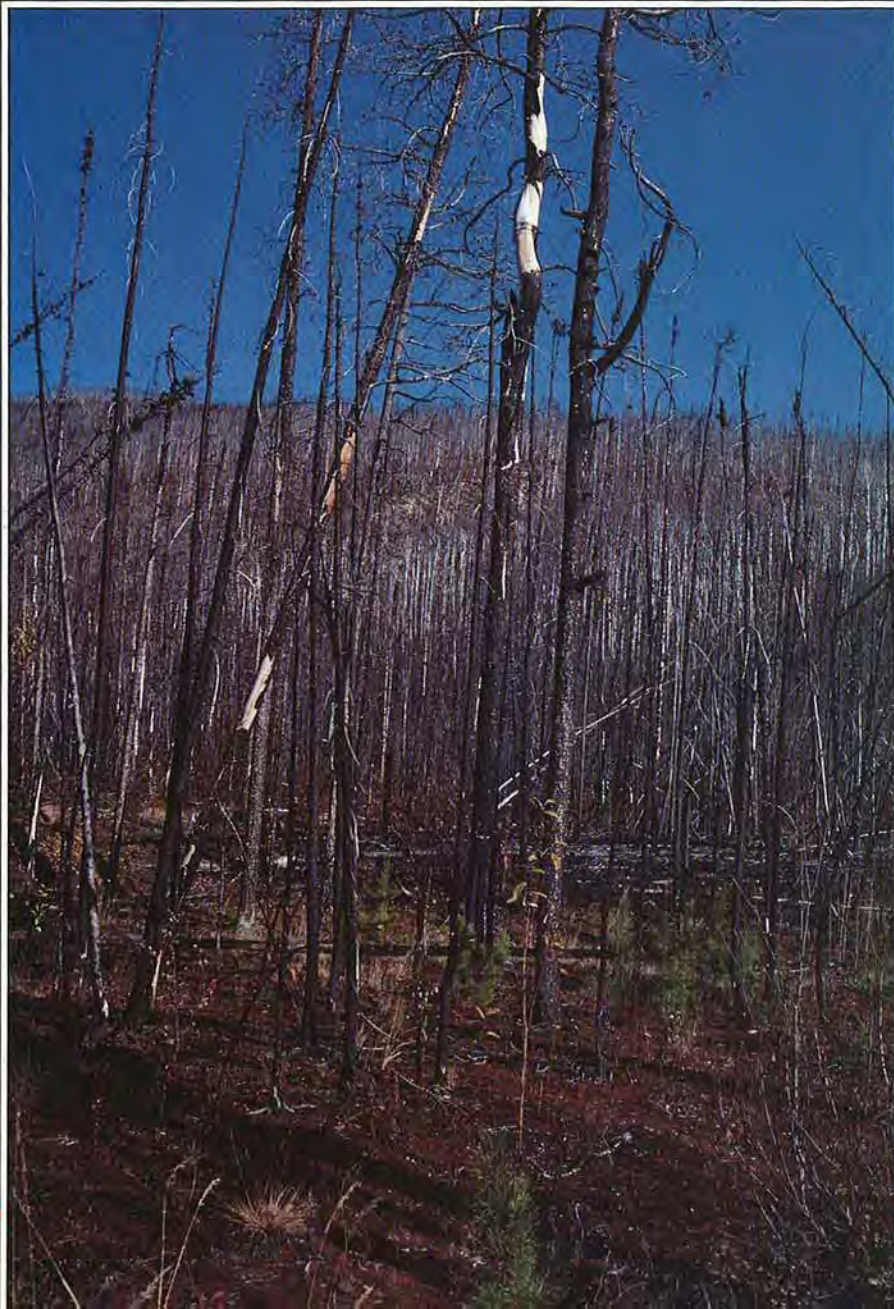

WORKING

SMALL

TIPS AND STRATEGIES THAT LET YOU
EXPLORE THE WORLD OF SMALL-SCALE WOODWORKING

In woodworking, *bigger* is not always *better*. In fact, you'll find that working tiny pieces of wood into projects smaller than your fist can be just as gratifying as building cabinet-size projects. And, put away your wallet because woodworking in this Lilliputian land doesn't cost a plug nickel to try. You need only look to your scrapwood pile for a lumberyard of materials.

When *WOOD*® magazine's project builder Jim Boelling began experimenting with small pieces of wood a couple years ago, little did he know that he was embarking on something that would soon consume him. "After 20 years of checking for straight and square, it was a refreshing and creative change of pace to work on small, free-form objects," says Jim.

Nowadays, Jim constantly comes up with miniature creations like those shown on these pages. What's

his secret? "The key to working small is maintaining control of the workpiece while keeping your hands a safe distance from the cutting or shaping action."

In the course of working small, Jim goes through the same processes that you would with any project. But, he does them in some ways you may never have thought of.

We'll also look at a couple of tips that *WOOD* magazine reader Bill Wright shared with us on how to shape small objects with flexible sanding discs. Thanks, Bill!

SAWING

 Print this article

Slice your scrap into usable thin stock with your tablesaw and this handy technique. First, use cloth-type, double-faced tape to attach the scrap stock to a carrier board at least 6" high and a couple of inches longer than the scrap piece as shown at *right*. Ensure a good bond by squeezing the two pieces together in a bench vise.

Now, stick a 6" piece of duct tape to the other side of the scrap and double it over to form a handle. Then, adjust your tablesaw's fence so that the saw cuts a piece of wood of the desired thickness from the carrier-board side of the scrap. Remove 1/8" or thinner stock from the carpet tape by saturating the tape with lacquer thinner.



Here's an efficient way of cutting identical pieces that's about the neatest thing since sliced bread. You'll find this technique especially handy for making jewelry such as earrings or necklace pieces.

First, cut the desired shape with your scrollsaw. With that done, attach the stock to a

jobber stick (3/8" dowel) with cyanoacrylate (instant) glue (see page 55 for a buying source). Epoxy or hotmelt adhesive also works, but we like the convenience of the instant glue. Next, press the stock against a carrier board covered with double-faced tape and slice off a succession of blanks as shown at *right*. If the pieces resist being pryed off, apply lacquer thinner to the tape to dissolve the adhesive.

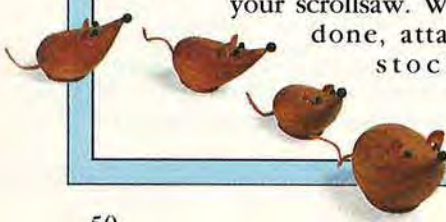
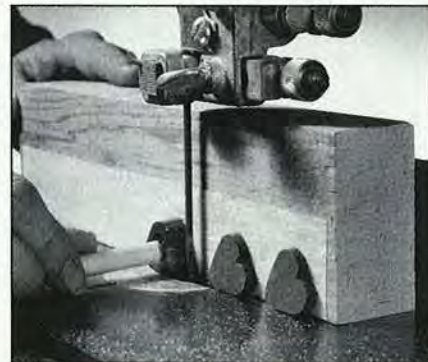



Jim Boelling works small in a big way. You can apply his tactics for handling tiny stock to your own projects.

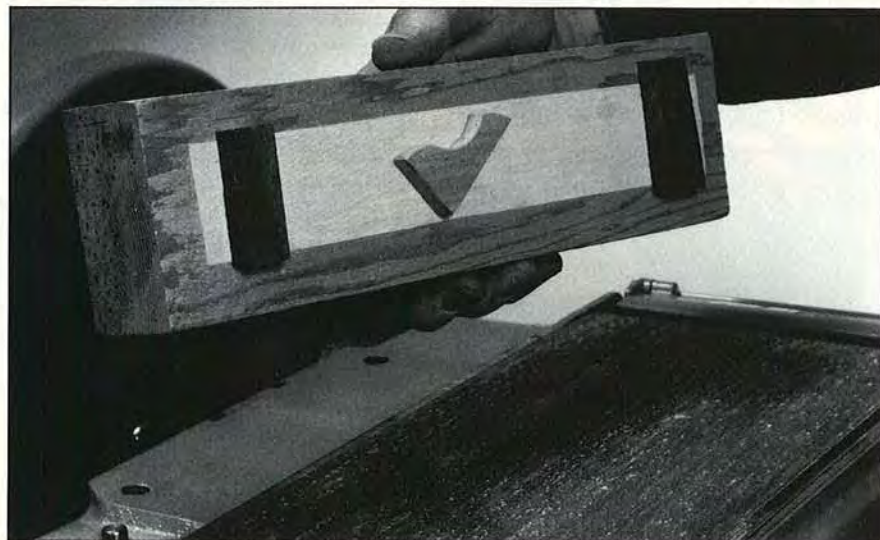

SANDING

You can avoid nasty sanding burns on your fingertips by sanding

small pieces as shown at *left* with a carrier board, double-faced tape, and two scrap blocks of the same thickness as your workpiece. By placing the project piece between the scrap blocks, you'll also eliminate the chance of rolling the workpiece and rounding its edges. Be sure to attach the workpiece so that you sand the grain in the same direction as the sanding belt.

Continued

ROUTING

Play it safe by keeping your hands clear of whirling router bits. We've found a couple of ways to do this. Which one you use depends on the size of the piece you're working. If the workpiece is large enough to attach a 1"-diameter jobber stick to it, use this method. If not, the method at *far right* may work for you.

First, attach the jobber stick (dowel stock, hand railing or closet pole works well) to the workpiece with carpet tape, epoxy or hotmelt adhesive. Then, build a "zero-clearance" auxiliary surface for your router table. To do this, start by boring a hole into a piece of tempered hardboard that's just large

enough for the router bit to stick through. This auxiliary surface fully supports the workpiece around the router bit.

To prevent the bit from grabbing your project, hold the workpiece tightly against the fence before you ease it into the cutting edges. As shown at *right* we're routing a cove along the edge of a miniature shelf.

If the bit's pilot sits so high on the shank that it doesn't contact the workpiece, you'll have to cut an auxiliary form for the pilot to ride on. The form should be the same shape as the workpiece and high enough to contact the pilot as shown at *right*. Attach the form to the workpiece with carpet tape.

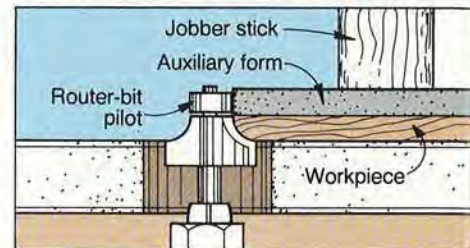

SHAPING

To shape small parts free-hand, we're sold on flexible sanding discs. (See the Buying Guide on page 55 for our source.) First, attach the workpiece to a jobber stick with instant glue. Then, sand it to shape as shown *below left* with 60-grit sandpaper and smooth it through a succession of 100-, 150-, 220-, and 320-grits. Remember to keep the workpiece moving, and use a light touch so you don't remove too much stock from one area. When you're satisfied with the results, cut off the jobber stick. (We used the bandsaw procedure

shown *below* to control the workpiece throughout the cut.)

You could mount the sanding disc in a drill press, but we found it more comfortable to chuck it into a portable drill. As shown at *right*, you can make a simple clamp from a 2x4 to hold the drill horizontally in a bench vise.

If your budget allows it, you may want to buy a separate disc for each grit to save you the trouble of constantly changing grits. In our shop, we have a storage rack like the one shown on the opposite page to hold the discs and the buff-

ing wheels we'll show you later in this article.

One note of caution: This method creates loads of fine sawdust, so for health's sake wear a dust mask and position a fan to blow the debris away from you.

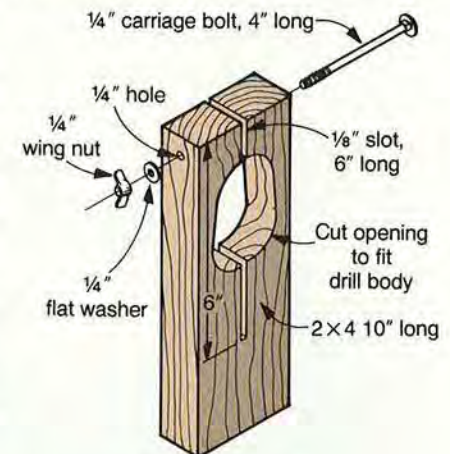
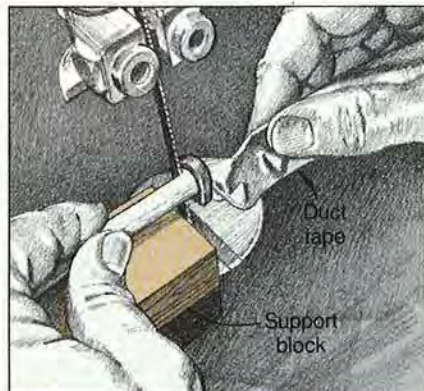

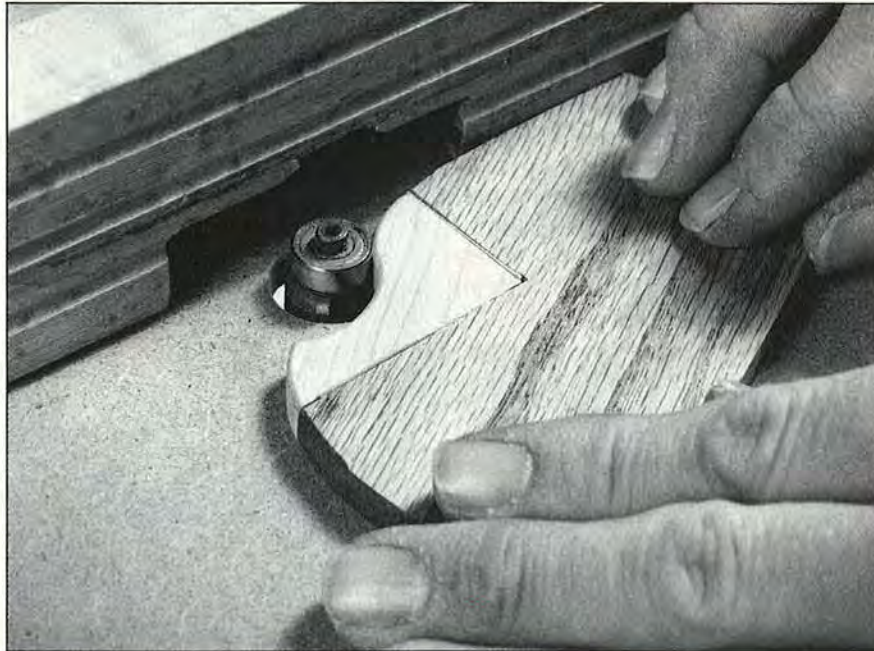

When the stock's too small for a jobber stick, make a carrier board of the same thickness as the stock and outline the shape of the workpiece onto it. Then, saw the carrier board to the correct shape and double-face tape it to the stock you're working. As you would do with a jobber stick, hold the workpiece or carrier board against the fence before routing. We're putting a round-over on the bracket shown at *left*, for the shelf top routed in the tip on the opposite page.

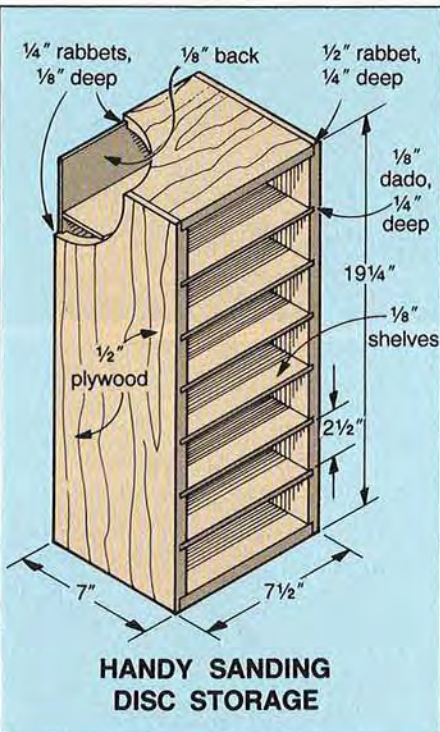

How do you clean up the back side of your shaped piece? That's simple. First, stick the workpiece to a 2-3" piece of duct tape as shown *right*. Then, form a handle with the rest of the tape and sand off the glue and stub end of the dowel with a 60-grit sandpaper disc.



With micro-sanding discs, you can even sand in tight areas as shown at *right*. You also can purchase micro-sanding drums. See the Buying Guide on page 55 for the address of Micro-Mark.



Continued

DETAILING

Power carvers make detailing a snap, but when you work on small objects such as the seahorse shown *below*, you'll appreciate a means of supporting the workpiece. Otherwise, you could power-carve your creation into smithereens. Or, worse yet, you

could carve your fingers if you hold the workpiece in your hand. Here's a cheap solution: Clamp an abrasive-cleaning stick into your bench vise and use it as a work support. The stick has a soft, non-mar, nonslip surface that gives you control over your project.

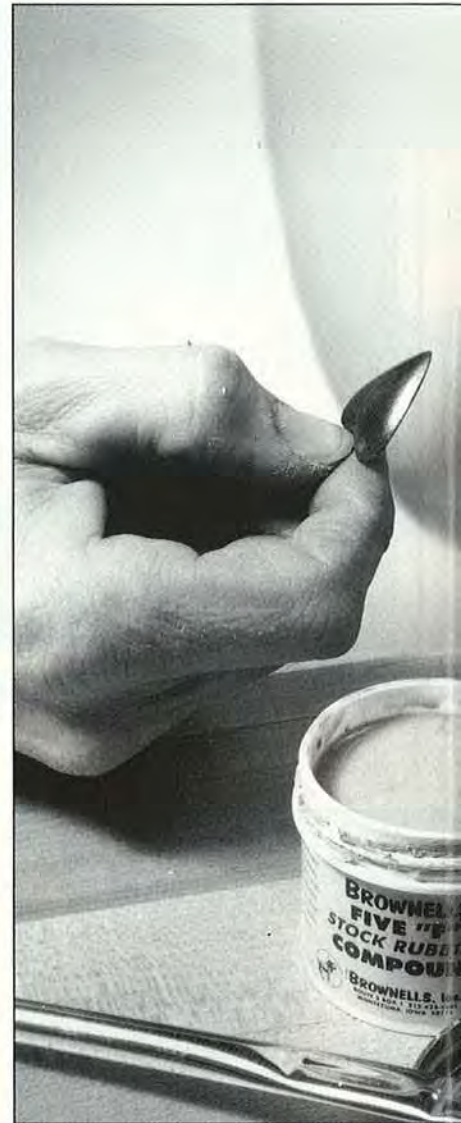

GLUING

A little dab will do it when you glue together small parts, but how do you control minuscule amounts of adhesive? Paper clips and toothpicks, that's how. As shown at *right* we first placed a few drops of instant glue on a cardboard work surface, then used a paper clip to transfer the adhesive to the bracket for the shelf we made earlier. You can work a dime-sized puddle of instant glue for about 5 to 10 minutes before it sets up.



FINISHING

For a super-glossy finish, we suggest gunstock rubbing compounds in conjunction with a buffing wheel. First, you'll have to build up four to five hard coats of finish on the workpiece because this process will remove a coat or two. Then, brush some of the gritty compound onto the workpiece and gently buff it as shown at *left*. We're holding this heart by a necklace ring that we mounted to it, but you also could hold the object with double-faced tape.

We start the process by using Brownell's Triple "F" compound (see the Buying Guide *below*), then switch to Five "F" for the final polishing. Be careful not to overdo it or you'll remove all the finish. Your buffing wheels will retain some of the compound, so be careful to mark the wheels and keep them separate. Finally, rub in two coats of paste wax to enrich the lustrous finish even more.



When it comes time to finish your project, try one of the two techniques shown at *left*. If your project has a hole in it, such as the eyehole in our whale, simply run a paperclip or other wire through it and suspend the piece from above. For projects such as the shelf, attach a thin dowel to an unexposed surface with hotmelt adhesive. Then, secure the dowel in a vise until the finish dries. (We prefer spray finishes for ease of application and even coverage.) Saw off the dowel and sand the glue mark.

BUYING GUIDE

- **Miniature woodworking tools.** Call Micro-Mark for a free catalog at 800-225-1066 (NJ residents call 201/464-6764).
- **6" flexible spindle sanding and polishing kit.** Available from Sears stores nationwide. We paid \$10.49 for ours.
- **Brownell's stock rubbing compounds,** triple "F" \$3.99 ppd. for 2 oz., \$6.38 ppd. for 10 oz.; five "F" \$4.23 ppd. for 2 oz., \$7.04 for 10 oz.; from Brownell's, Inc., 140 S. Front St., Montezuma, IA 50171. Call 515/623-5401. ♣

Written by Bill Krier with Jim Boelling
Photographs: Hopkins Associates
Illustrations: Jim Stevenson; Mike Henry





FOWL

World champion caller Johnny Mahfouz calls ducks within range of his pit blind in an Arkansas rice field. His technique, combined with a Butch Richenbach call, makes it a matter of fact.

LANGUAGE

Duck calls from a champion of champions

 [Print this article](#)

Arkansas' Quapaw Indians had no use for a duck call. According to local lore, they hollowed out huge gourds, stuck their heads in them, and then, immersed chin-deep in water, waded out to a resting flock. To bag a duck, a brave just grabbed its feet and pulled it under!

Today's duck hunter, although outfitted with a finely tuned duck call, the best of equipment, and a carefully trained retriever, often has difficulty luring birds within shotgun range. Butch Richenbach, call maker and former world duck-calling champion, has some advice.

CALLING OUT TO WINGS OVER THE PRAIRIE

Butch doesn't mind helping his friends and others become expert at what he now knows almost instinctively. After all, that's how he learned the vocabulary.

His tutor and friend was a home-grown legend: Chick Major, Stuttgart's dean of duck hunters, caller *extraordinaire*, and producer of the Dixie Mallard Call, a revered instrument known to fill hunters' daily bag limits. "I used to practically live over there," Butch recalls fond-

ly of the Major home. "Chick was like a daddy to me, and taught me all I know about duck calls."

Butch learned well. In 1972, he called his way to the top at Stuttgart's 37th annual World Championship Duck Calling Contest, the Super Bowl of such events. Three years later, he outcalled a gathering of former champions and became a champion of champions. Since

“He’s not going to produce one that doesn’t sound like he wants it. If he can’t get the call like he wants, he’ll bust it, and won’t nobody get it.”

then, he's coached a string of winners. Butch ticks off the records: "I've taught the current world champion, eight junior world champions, five intermediate world champions, ten women's world champions, and two or three Arkansas state champions. They won a bunch," he says proudly, and adds, "Last year, my students won

14 out of 17 places at the world championships."

As a duck-call maker, Butch also has reached the top. His calls consistently beat out all others as the favored call of world champions.

Why? "That's easy," says current champ, former student of Butch's, and Stuttgart duck-hunting guide, 30-year-old Johnny Mahfouz. "It's the craftsmanship Butch puts into every call. He's not going to produce one that doesn't sound like he wants it to sound. If he can't get the call like he wants it, he'll bust it with a hammer. If a call don't satisfy him, won't nobody get it."

THE SWEET SOUND OF WOOD

"I never intended duck-call makin' to be what it is," explains Butch about his business. "I was just doin' it for somethin' to do. Now, and I'm just guessin', I make close to 4,000 wooden calls a year."

Butch crafts calls of cedar, cherry, cocobolo, ebony, maple, Osage orange, several rosewoods, teak, and walnut. He also fashions acrylic, an ivory look-alike called Micarta, a plasticized-and-laminated

Continued



In Arkansas, they call it the Grand Prairie. The water-covered rice fields, acre upon acre of soybeans, and flooded stands of nut-producing pin oaks extend west 60 miles from the Mississippi River. Ducks on their way south consider the area an all-you-can-eat buffet. Hunters call it paradise.

Harry M. "Butch" Richenbach, left, grew up there. Like most of the boys in Stuttgart—the hub of Grand Prairie agriculture as well as hunt-

ing—he valued his shotgun and duck call as much as his bike and ball glove. To him, duck talk became a second language. In fact, Butch became so fluent that he eventually turned his skill into a highly specialized business.

Now, Butch, 42, makes duck calls for avid hunters wanting the best available. And, his handmade Rich-n-Tone brand calls help champion callers quack their way into the world-record books.

FOWL LANGUAGE



1. With a turning tool made from a used commercial planer blade, Butch shapes a call barrel. To make his calls, Butch relies on three Rockwell lathes.



2. After scoring the barrel with a parting tool, the turner darkens the decorative lines by scorching them with a fine wire held tightly to the wood.



3. To allow air to flow against the reed, Butch drills a hole in the throat of the endpiece with a portable electric drill and a 1/4" brad-point bit.

wood named Dymondwood (similar product to Pakkawood, often used for knife handles), and Corian, a kitchen-countertop material, into duck calls.

He does out-of-the-ordinary special orders, too. "Like real ivory. I can make a call anyway they want it made. After all, they wear my call with a little pride. They don't jam it in their pocket."

Rich-n-Tone duck calls retail at \$30 each in native woods, \$40 in imported as

well as laminated wood, and \$100 each in the synthetic materials. "The higher cost is partly the materials, but acrylic calls, for instance, take a long time because I have to shine 'em back up to take out the scratches," explains Butch.

A stickler for correct sound, Butch prefers some woods over others for his calls. "A few woods can lose their tone, you know, dependin' upon how much you use the call. It could take 10 years, could be five. It's hard to say. Probably due to density. It seems, usually, that the harder the wood the better the tone. I like cocobolo, because like teak, it tends to be oily," he continues. "That makes it resist collectin' moisture from your mouth, which deadens the tone."

Yet, despite his theories and calculated choices, wood still pulls strange tricks on the call maker. "You know, you can make two calls from the same block of wood—wood that was side by side—and one will go like heck and the other won't," Butch says, pushing a finger under his cap to scratch in wonderment. "You never have any say over it."

DUCKS DON'T NOTE SHAPE

Lots of people assume that a duck call's shape has much to do with its sound. Well, forget that notion. "Shape? Naw, it's just like a lot of things—depends on who's making it," Butch practically guffaws. "I come up with that design of mine

by thinkin' about a Coke bottle. I put that lip on, and made it shorter than most, about 5" long."

In the duck-call trade, where former champions and top guides all produce calls and vie for part of a specialized market, hunters scrutinize new calls. "When I first made it, everybody laughed at me 'cause it was smaller," Butch remembers. "But I told them 'What makes you think a duck call has to be big?' A duck don't fly by and say 'He's blowing a big duck call, I'll go in there!' Calls used to be at least an inch longer than mine."

Hunters should appreciate his call's size reduction. As Butch says, "Take going huntin'. You got a 12-pound gun, a pair of waders, a huntin' coat, two boxes of shells—all you need is a two-pound call hangin' around your neck."

MOONLIGHTING THE CALLER'S CALL

By day, Butch runs the Stuttgart Youth Center Inc., a job he loves nearly as much as duck calling. By night, though, you'll find him in his 24x48' metal building behind Mac's Sport Shop, turning out calls.

"A call doesn't have to be smooth, you could whittle one out," advises Butch as he sets up to turn at the first of three lathes. His calls, however, don't look rough at all. In fact, they're not only finely finished but of such uniform dimension one to another that it's hard to believe they're handcrafted.

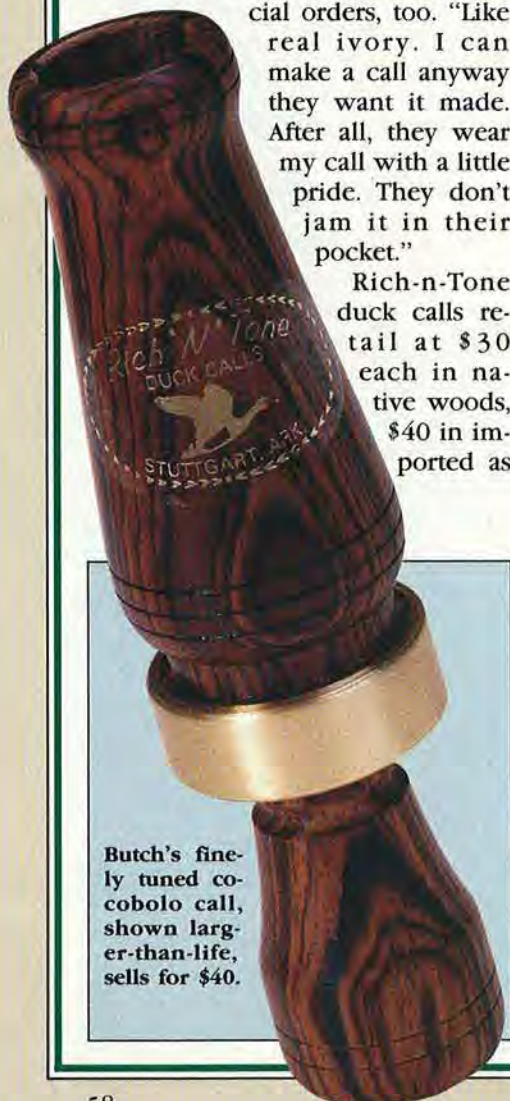

Butch's finely tuned cocobolo call, shown larger-than-life, sells for \$40.



4. Butch's work-worn hands perform the delicate work of tuning a call. For proper sound, the cork, shaved to fit, must hold the Mylar reed exactly right.

"I do make 'em one at a time, though," he advises. "But, I make maybe 10 or 12 mouthpieces, or barrels [see drawing, *right*, illustrating parts of a duck call], then I go make 10 or 12 ends."

And, Butch, with the sharp eye of a marksman, never relies on measuring devices or templates. "I got something to measure with, but I don't use it. As far as the shape, I don't need a pattern. I just look at it. And, they'll all be exactly alike."

To make a barrel, Butch starts with a piece of 1½"-square stock about 3" long. He chucks it on the lathe, then rounds it, trimming one end down to accept a brass ferrule. Then, he removes the barrel from the lathe, presses on the ferrule, and pins it in place. At the next lathe, see photo 1, *opposite page*, he completes the shaping, sands the wood, cuts in the trim, and seals it with orange shellac, which, Butch says, helps the finish adhere.

To darken the trim lines, Butch burnishes the cuts with a piece of fine wire, holding it in the grooves until the spinning wood smokes, as shown in photo 2, *opposite*. At the drill press, he bores out the center with a ¾" bit.

The shorter endpiece begins as 1½"-square stock. At his third lathe, Butch quickly turns it to shape, sands, and wipes it with shellac.

Then, he clamps the endpiece in a jig, and at his bandsaw, cuts away the section where he installs the reed and block. Next, he positions



Dymondwood

Osage orange

Walnut

Ivory with scrimshaw

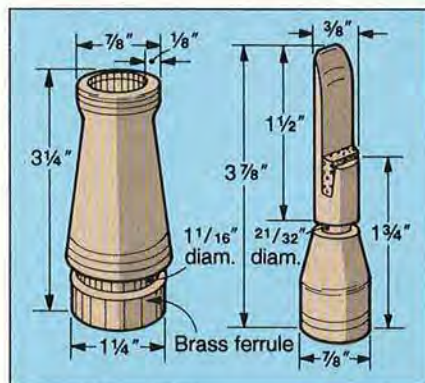

the wood in a vise and drills it with a ¼" bit for the air passage, as shown in photo 3, *opposite*.

With his stepped-up, production-like technique, Butch can craft a wooden call in less than 10 minutes. Even tuning, the most important step of all, takes little time in the expert's hands.

TO TALK LIKE A DUCK

Tuning a call to the perfect pitch begins with a minutely thin Mylar 1000A (about .01") reed placed in the notch of the endpiece. To hold the reed in place, Butch wedges in a tiny cork stopper. With a bench knife, he trims the cork and the edges of the reed, as in photo 4, *above*. Now, the critical moment. "After that it'll blow—or it's supposed to," he laughs.

Actually, tuning a duck call isn't difficult. It follows simple guidelines: The longer the reed, the deeper the sound and the harder the call is to blow. To make a louder, easier blowing call, just shorten the reed by a hair. But, shorten it too much and you'll get a squeaky call. Yet, every call Butch makes

must satisfy his ears first—the main reason for Butch's reputation.

Butch's duck calls won't do the job all by themselves, though. "The call's got a heck of a lot to do with it," notes Johnny, "but you have to know the right way to put the calls in to get them out."

So, what goes in? "Words, that's all," says Butch. "If you want to sound like a duck, you got to talk like a duck. If you think a duck says 'quack,' then you say 'quack.'

"You gotta find the right word, cause the same word don't fit everybody," the master caller advises. "Like 'hoot' for instance. It ain't 'hoot' when you blow in a duck call, it's 'oot.' You have to drop the first letter off."

To be a successful duck hunter, then, you combine the correct language with the right call. Ask Butch for the words. He'll tell you. But he won't insist you buy one of his calls. "I don't tell anybody that my duck call is better than anyone else's, because I don't know for sure that it will call a duck better. I just leave that judgment up to other people. I'm prejudiced, anyway." ♣

Want to learn how to blow a duck call by listening to a pro?

Butch has recorded a short instructional cassette tape packed with sounds you need to know. For a copy, send \$12 ppd. to:

Duck Tape, Rich-N-Tone Duck Calls, Dept. WD, 1010 North Grand, Stuttgart, AR 72160.

Written by Peter J. Stephano
Photographs: Bob Hawks
Illustration: Mike Henry

BUILD THIS TERRIFIC TABLESAW HELPER FOR UNDER \$50



RIGHT-ON RIP FENCE

If you're looking for an inexpensive way to upgrade your table saw, you've turned to the right pages. After using accurate aftermarket fences, we challenged our own Jim Downing to design a wooden replacement fence for the readers who like to build their own workshop tools *and* save a bundle of money in the process. Less than 12 hours later, Jim emerged from his workshop, proudly hugging his prototype.

We think Jim's design will please you, too. For less than \$50, you can have the smooth-sliding, easily adjustable fence that you've always dreamed of.

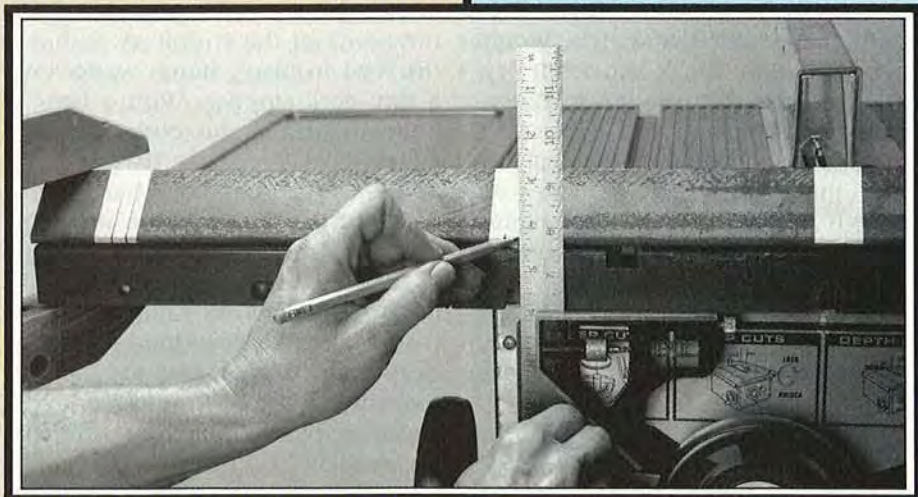

Print this article

Note: We designed our replacement rip fence to fit a Sears 10" motorized table saw. Some dimensions may vary for different table saws.

ACCURACY BEGINS WITH THE FRONT RAIL

1 From $\frac{3}{4}$ " birch, rip and crosscut three pieces $1\frac{3}{4}$ " wide by 53" long for the replacement guide rail (A).

With the edges and ends flush, glue and clamp the pieces face to face.

2 Later, remove the clamps and scrape off the excess glue.

3 Remove the existing front rail from your table saw.

4 Using a hacksaw, cut a piece of 2×2 " angle iron to 53" long.

5 With the left end of the angle iron flush with the left end of the table saw extension, clamp the angle iron to the saw table as shown in the photo *below*.

6 Apply masking tape to the angle iron directly above each bolt hole and slot. Using a square, transfer the table saw hole and slot locations onto the tape as shown in the photo *below*. Remove the angle iron.

7 Drill and countersink $\frac{1}{4}$ " holes through the angle iron, centering each hole between the lines and $\frac{5}{8}$ " from the top edge of the angle iron. See the Angle Iron Detail on the opposite page for reference.

▼ Clamp the angle iron to the saw table, and transfer the hole and slot locations from the saw table to the angle iron.

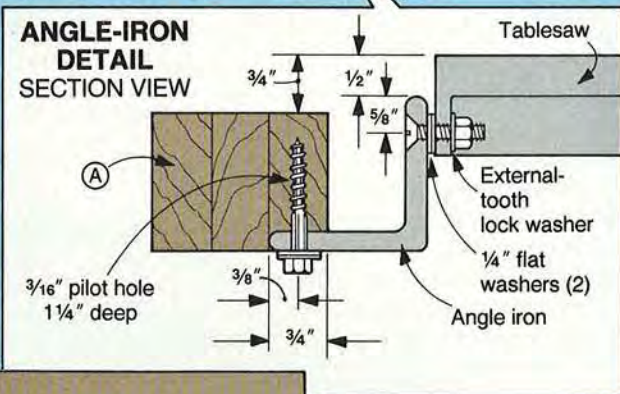
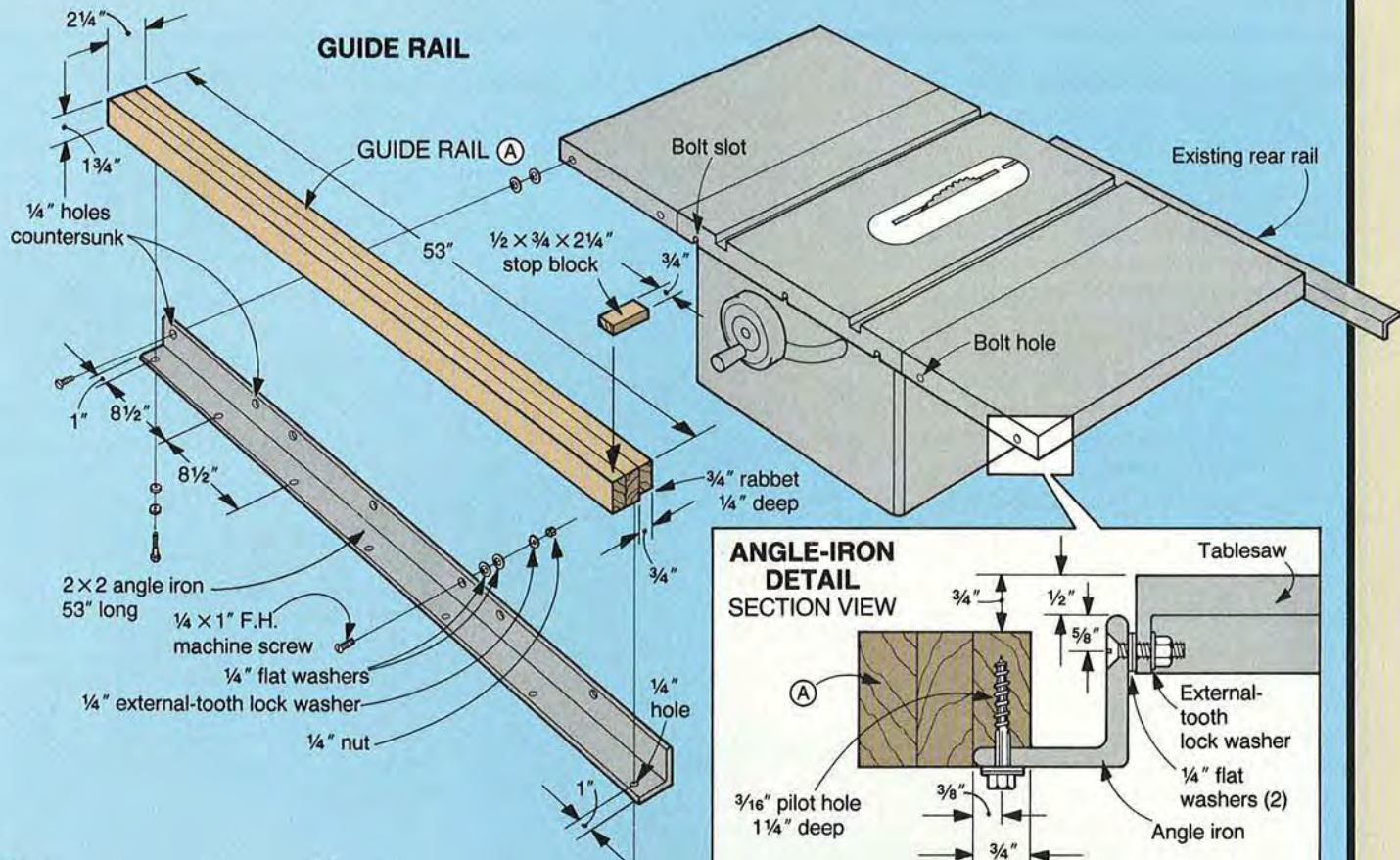

8 Clean the angle iron with paint thinner, sand it smooth, and spray it with rust-resistant black paint.

9 For your fence system to perform correctly when completed, position the top edge of the guide rail (A) 3/4" below the top surface of the saw table. To achieve this with our guide rail, we cut a 3/4" rabet 1/4" deep along one edge of the rail where shown on the Guide Rail Drawing and accompanying Angle Iron Detail. Your rabet depth may vary to achieve the 3/4" spacing.

10 Clamp the angle iron to the rabbeted recess where shown on the Angle Iron Detail. Now, drill seven additional 1/4" holes through the angle iron where shown on the Guide Rail Drawing above. Switch bits and drill 3/16" pilot holes 1 1/4" deep into the guide rail.

11 Using 1/4 x 1 1/2" lag screws, fasten the angle iron to the guide rail.

12 With 1/4 x 1" flathead machine screws, fasten the angle iron to the saw table, using two 1/4" washers as spacers (see the Angle Iron Detail). Check that the guide rail is parallel with the saw table.

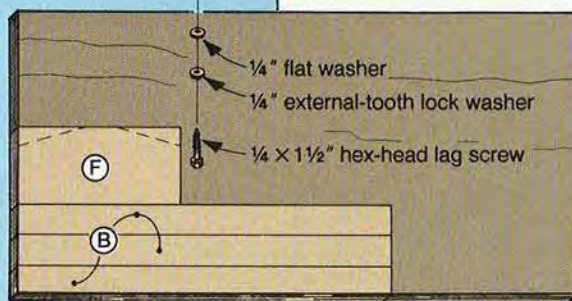

Cutting Diagram

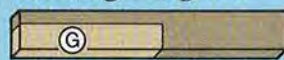

1 1/16" x 3 1/2" x 24" Birch

3/4" x 24" x 48" Birch Plywood

3/4" x 7 1/4" x 72" Birch

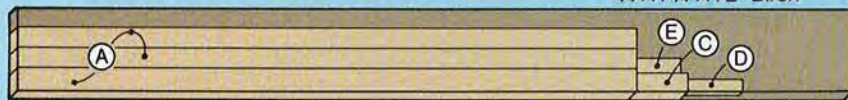

Bill of Materials

Part	Finished Size	Mater.	Qty.	Material Key: LB-laminated birch, P-plywood, B-birch			
					T	W	L
A	guide rail	1 3/4"	2 1/4"	53"	LB	1	Supplies: 1/4 x 2 x 2" angle iron 53" long, masking tape, paint thinner, rust-resistant black spray paint, 1/4 x 1" flathead machine screws (7), 1/4" flat washers (23), external-tooth lock washers (14), 1/4" nuts (9), 1/4 x 1 1/2" hex-head lag screws (7), 1/4 x 1 1/2" hex-head machine screws (2), 1/4 x 2" hex-head machine screw and lock nut, 1/4" threaded inserts (2), 3/8" dowel stock, 1 1/2" and 2 1/2" drywall (case-hardened) screws (4 each), finish.
B	fence	3/4"	2 1/2"	32"	P	3	
C	locking lever	3/4"	1 1/2"	4 1/4"	B	1	
D	connect block	3/4"	1/2"	5 1/8"	B	1	
E	finger clamp	3/4"	1 1/16"	3 3/4"	B	1	
F	head block	3/4"	6 1/4"	13 3/4"	P	1	
G	aligning block	1 1/16"	2 1/4"	13 3/4"	B	1	

RIP FENCE

CUT AND LAMINATE THE FENCE PIECES

1 Cut three pieces of $\frac{3}{4}$ " plywood (we used birch plywood) to $2\frac{1}{2} \times 32$ " for the fence parts (B).

2 With carbon paper or a photocopy, transfer the cutlines from the Mechanism Opening Drawing to the left end of one plywood strip.

3 Saw along both cutlines to cut the pieces (we used a bandsaw).

4 Position the support block on one of the remaining fence pieces where dimensioned on the Mechanism Opening Drawing. With the bottom edges flush, glue and clamp the support block to the outer fence part where shown on the drawing. Glue and clamp the remaining inner fence part to the same outer fence part where shown on the drawing. Remove any excess glue from the opening.

5 With the edges and ends flush, glue and clamp the remaining fence part to the assembly. Be careful not to get any glue in the cutout area. Later, sand a $\frac{1}{4}$ " round-over along the top front edge where shown on the Fence Drawing.

6 Drill a $\frac{1}{4}$ " hole through the fence assembly where dimensioned on the Fence Drawing. Now, bore a $\frac{3}{4}$ " hole $\frac{1}{4}$ " deep and centered over the $\frac{1}{4}$ " hole on both faces of the fence rail (we used a Forstner bit).

THE LOCKING MECHANISM HOLDS IT IN PLACE

1 Transfer the full-sized patterns and hole centerpoint of the locking lever (C), connecting block (D), and finger clamp (E) to $\frac{3}{4}$ " solid birch with carbon paper or by adhering a photocopy to the stock. Bandsaw the pieces to shape. Mark an X on the lever where shown.

2 Drill a $\frac{1}{4}$ " hole through the locking lever where marked. Slide the connecting block in place and bolt the lever in position. Locate the edge with the X next to the connecting block where shown on the Fence Drawing. To keep the lever moving freely, don't overtighten the nut on the machine screw. Slide the finger clamp in place.

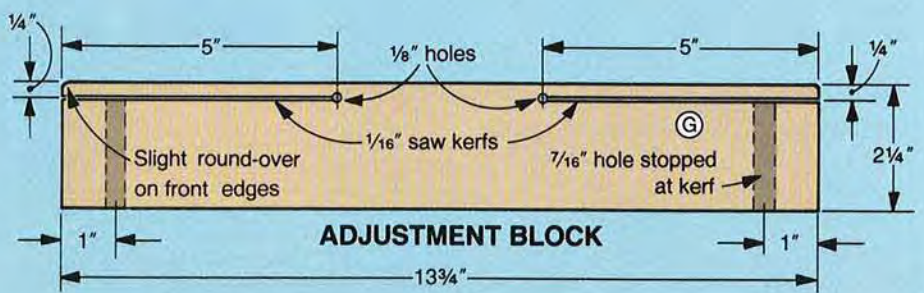
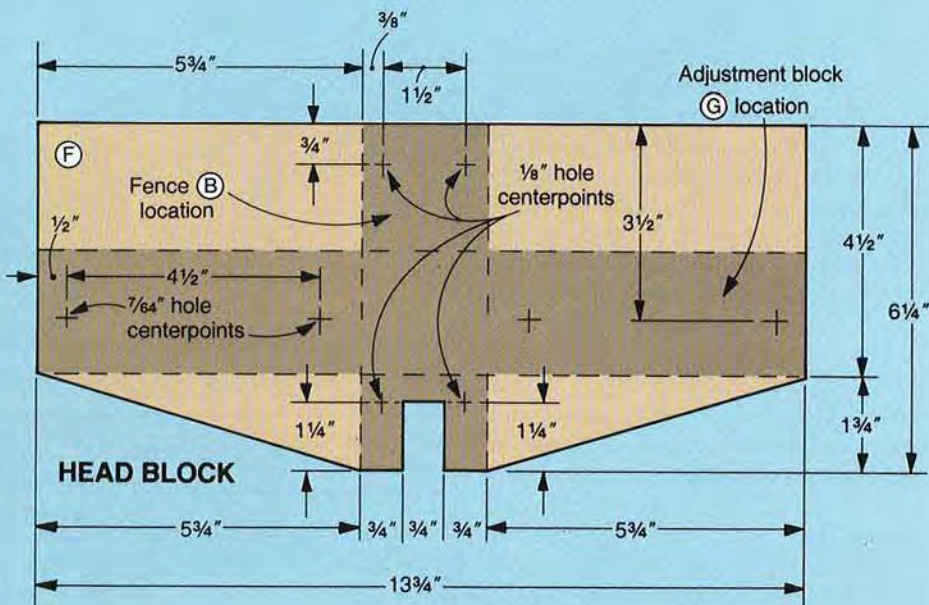
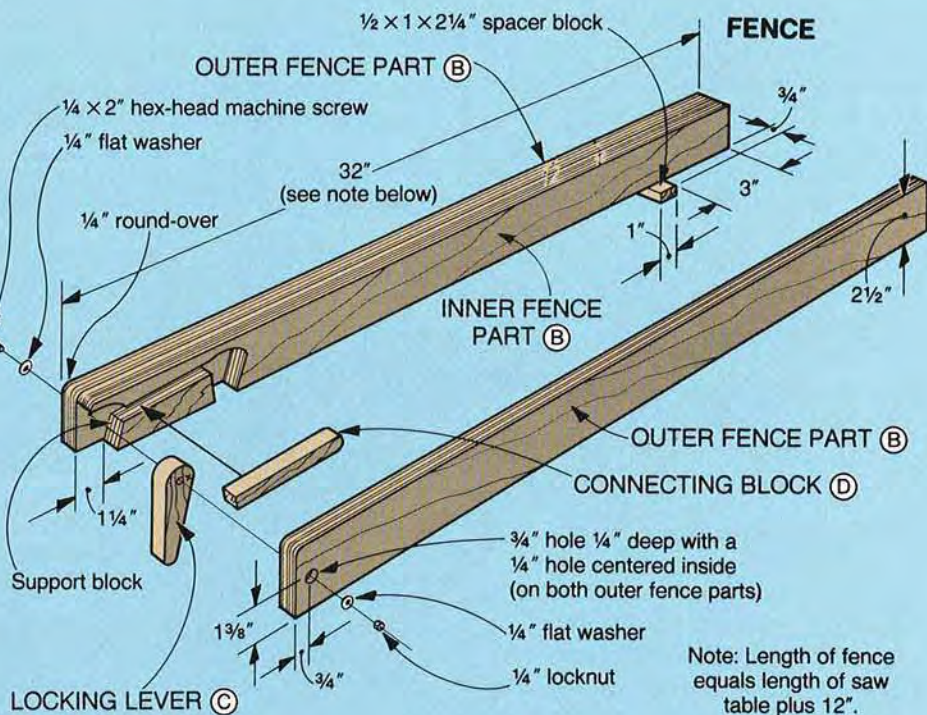

CONSTRUCT THE FENCE-HEAD ASSEMBLY

1 Using the Head Block Drawing for reference, mark the outline, notch, and the eight centerpoints for the head block (F) on $\frac{3}{4}$ " plywood. Bandsaw the head block to shape and sand smooth.

2 For mounting the fence to the head block later, drill four $\frac{1}{8}$ " holes where shown on the Head Block Drawing. Now, drill four $\frac{7}{64}$ " holes through the head block at the remaining marked centerpoints.

3 Cut the alignment block (G) to size. Using the Alignment Block Drawing for reference, transfer the $\frac{1}{8}$ " hole centerpoints and kerf locations to the block. Drill the two $\frac{1}{8}$ " holes where marked. Now, position

your bandsaw fence 2" from the blade. Start at one end and cut to the $\frac{1}{8}$ " hole. Stop the saw, and back the piece away from the blade. Switch ends, and cut to the other $\frac{1}{8}$ " hole as shown in the photo below left. Sand a slight round-over on the front edges of the block where shown on the drawing.

4 Position the alignment block on edge with the kerfed edge on your workbench. On the opposite edge, mark the $\frac{7}{16}$ " hole locations for the threaded inserts where shown on the Alignment Block Drawing. Drill $\frac{7}{16}$ " holes 2" deep, centered from edge to edge (stop drilling when you reach the bandsawed kerf).

Continued

Smooth ripping cuts require that the fence be parallel with the saw blade. The fences that come with many saws are hard to adjust and keep aligned with the blade. Our homemade-fence adjusts easily and locks down firmly.

A. R. Downing
Design Editor

FULL-SIZED PATTERNS



Position the fence and align the blade with the center of the $\frac{1}{8}$ " holes. Bandsaw to the holes to form a pair of kerfs in the alignment block.

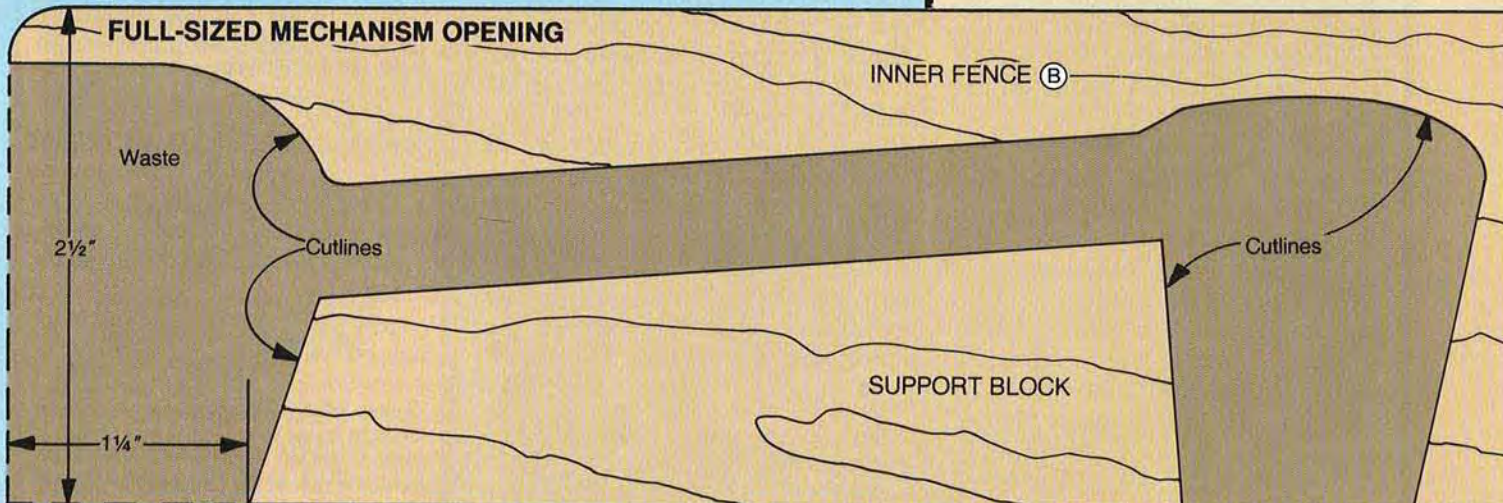
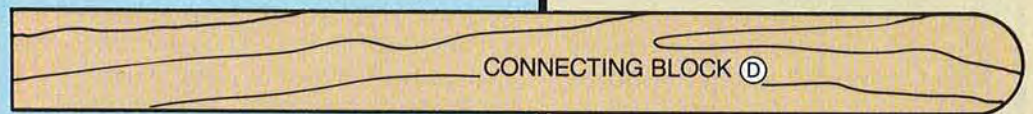
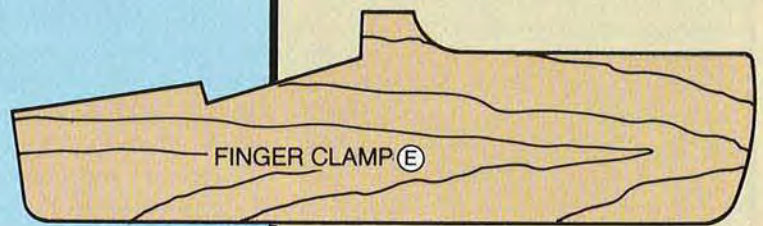
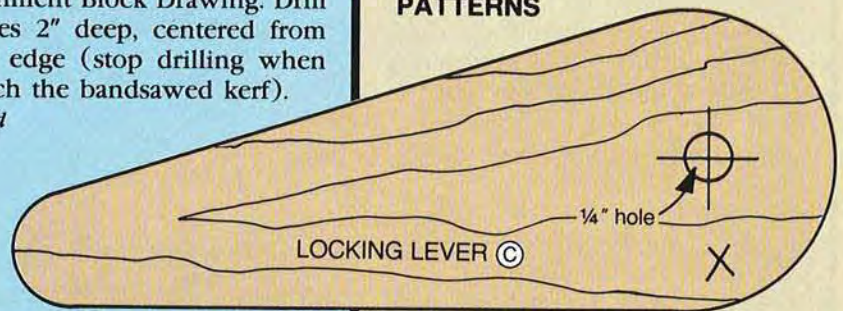

RIP FENCE

5 Cut two pieces of $\frac{3}{8}$ " dowel $1\frac{1}{4}$ " long and slide one into each $\frac{7}{16}$ " hole in the alignment block. Wax the threads of two $\frac{1}{4}$ " threaded inserts, and screw the inserts into the $\frac{7}{16}$ " holes in the adjustment block. Thread a $\frac{1}{4}$ " nut on each of the two $\frac{1}{4} \times 1\frac{1}{2}$ " hex-head screws. Thread a screw into each insert.

6 Position and clamp the alignment block to the bottom side of the head block. (See the Head Block Drawing for location.) Using the previously drilled $\frac{7}{64}$ " holes as guides, drill $\frac{7}{64}$ " holes $\frac{3}{4}$ " deep into the alignment block. Screw (no glue yet) the alignment block to the bottom side of the head block.

7 Position and clamp the fence head (F, G) to the bottom side of the locking end of the fence (B), *carefully* checking for square. Using the previously drilled $\frac{1}{8}$ " holes in the head block as guides, drill $\frac{1}{8}$ " holes $1\frac{3}{4}$ " deep into the bottom of the fence. Screw the assemblies together as shown on the photo at *right*.

8 Position the fence assembly on the guide rail and check that the locking mechanism secures the fence to the guide rail. If not, you may need to take the head assembly apart and shorten or lengthen the connecting block accordingly. Now, glue and screw the assembly back together, checking for square.

9 Cut a $\frac{1}{2} \times \frac{3}{4} \times 2\frac{3}{4}$ " stop block to size, and glue and clamp it to the guide rail where shown on the Guide-Rail Drawing. The block keeps the fence from sliding off the end of the rail.

ADD THE FINISH AND ADJUST THE FENCE

1 Mask the angle iron, and apply polyurethane to the fence assembly and guide rail. Later, after the finish has dried, remove the tape.

2 Move the existing rear rail so the left end of the rail aligns with the saw blade where shown on the Guide-Rail Drawing.

3 Position the fence assembly on the saw table and guide rail. Cut a

FENCE HEAD

HEAD BLOCK

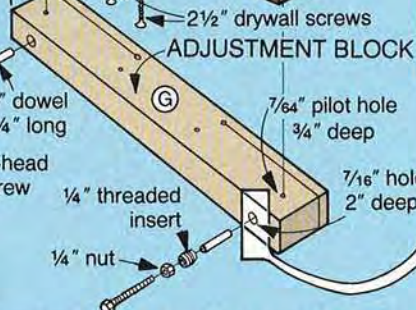
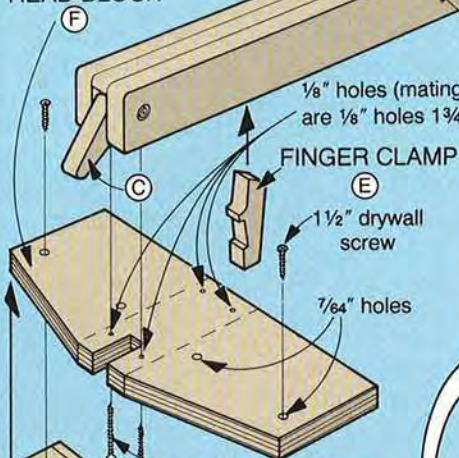

Assembled fence

Spacer block

$\frac{1}{8}$ " holes (mating holes are $\frac{1}{8}$ " holes $1\frac{3}{4}$ " deep)

FINGER CLAMP

$1\frac{1}{2}$ " drywall screw
 $\frac{7}{64}$ " holes

THREADED INSERT DETAIL

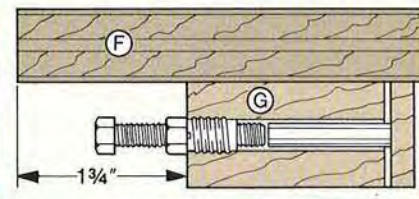

With the head/alignment block assembly square with the fence, glue and screw the parts together.

$\frac{1}{2} \times 1 \times 2\frac{1}{4}$ " spacer. Glue the spacer to the bottom of the fence so the spacer rides on the rear rail. See the Fence Drawing for reference.

4 Elevate your tablesaw blade as high as it will go. Slide the fence next to the blade. Using the drawing *below right* for reference, adjust the hex-head screws to align the fence parallel with the blade. Push the lever down, check the fence alignment to the blade, pull the lever up, adjust the screws, and recheck the alignment. Snug the $\frac{1}{4}$ " nut on each screw against the $\frac{1}{4}$ " threaded insert.

5 Refer to the drawing at *right* to secure the fence to the guide rail. When cutting plywood and other large pieces, position the fence, lock it in place, and clamp the end opposite the lock mechanism to the existing rear rail. This prevents the fence from flexing out of square.

LOCKING MECHANISM

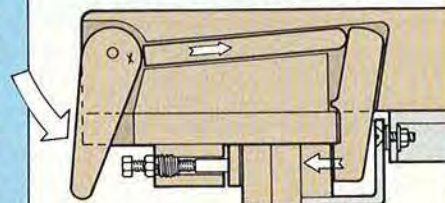

Push locking lever down to lock fence on guide rail. Raise the lever to release.

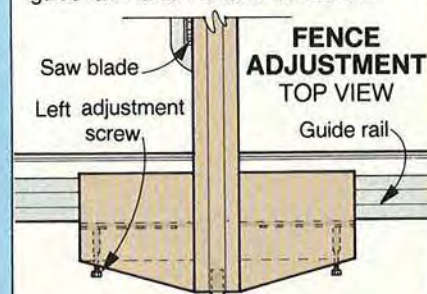

Tighten left adjustment screw and loosen the right screw to move the end of the fence to the left. Reverse this process to move the rear of the fence to the right.

Produced by Marlen Kemmet
Project Design: James R. Downing
Photographs: Hopkins Associates;
Jim Kascoutas
Illustrations: Kim Downing; Mike Henry

HOW TO SAFELY FEED STOCK THROUGH A

JOINTER

 Print this article

In knowledgeable hands, a jointer can make quick work of planing the edges and surfaces of boards. Here's how to get the job done correctly.



For most jointer operations, you'll set the fence at 90°. To check this angle, place a try square on the outfeed table as shown *above*, then adjust the fence until daylight disappears between the square's blade and the fence.

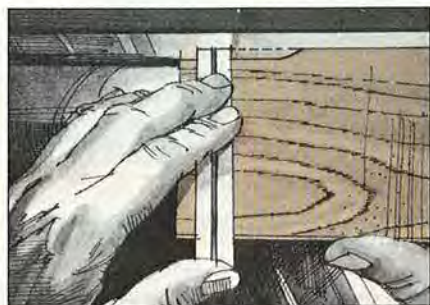

Next, make a 1"-long, 1/8"-deep test cut on a piece of scrap stock. Lay the cut edge of the scrap piece against the fence as shown *above*, and check the depth of cut with a rule. Set your depth-of-cut scale according to this test cut.

For a smooth cut, position the workpiece so its grain runs downhill from the outfeed table as shown *above*. If the grain runs every which way, position the board so the majority of the grain flows in the correct direction, take a shallow cut (about 1/32"), and be sure to feed the stock slowly.

When jointing edges, hold the surface of the board flat against the fence with your left hand and feed the board with your right hand. Keep your left hand behind the cutterhead as shown in drawing *A*.

With the board halfway across the cutterhead, swing your left hand around the blade guard as shown in drawing *B*. Now, place lefthand pressure down onto the outfeed table and toward the fence.

To remove stock from surfaces, move your hands in the same motion as described in step 4. To control the workpiece, use the fingertips of your left hand rather than your palm to guide the stock as shown *below*. For stock that's less than 4"

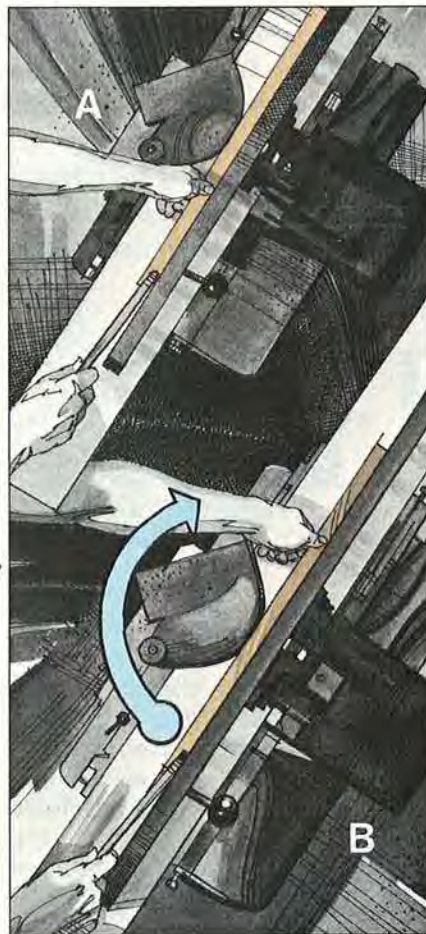

wide, use a push block to control the stock with your left hand. Be sure to clear any dust from the bottom of the block for a good grip. ♣

Illustrations: Jim Stevenson

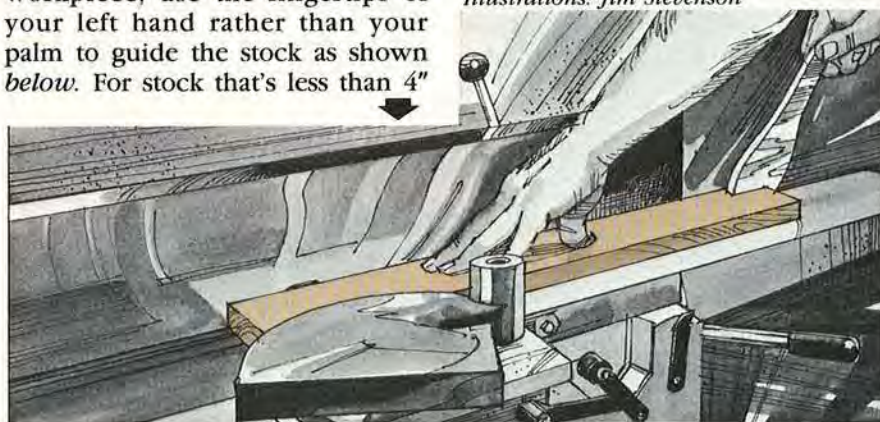

JOINTERS

Although some woodworkers consider a jointer to be a luxury item, a slew of us would feel lost without this machine in our workshop. Why? No other tool matches a jointer's ability to quickly cut a true, baby-skin-smooth edge at a precise angle.

Just as the tablesaw has replaced the handsaw for many woodworking tasks, so has the jointer sidelined the hand plane for many edge- and surface-preparation jobs. But, this versatile tool's usefulness doesn't stop there. You can even use it to cut tapered legs, chamfers, rabbets, and tenons.

Today, most of the jointers produced for the home-workshop market have 6½"-long knives, meaning that they will cut a 6½"-wide swath. Although you could purchase a 4" or 8" model (see the box on page 68), we will concentrate on the price-competitive 6" market. In this range you will find plenty of models under \$400, including the nine we tested in our *WOOD*® magazine shop.

STRAIGHT FACTS ABOUT HOW A JOINTER WORKS

To understand how a jointer works, think of it as a motorized hand plane turned upside down. In place of the plane's sole, jointers have two *tables*: one for *infeed* of the workpiece, and one for *outfeed* as

shown at *right*. Between the tables sits a rapidly rotating *cutterhead* containing two or three knives.

To pass a workpiece over the cutterhead, you normally set the infeed table from ½" to ⅛" below the top of the cutterhead, depending on how much stock you want to remove with each cut. The outfeed table sits flush with the top of the cutterhead. Combined, the infeed and outfeed tables make up the *bed* of the jointer. As you pass a workpiece across the bed, the knives remove the desired amount of material. During the cut, you hold the stock firmly against a *fence* that adjusts from 90° to 45°, producing a square or beveled edge.

Although some manufacturers tout depth of cut as an important asset, we feel it's an oversold fea-

ture. Why? Unless you use your jointer for making rabbets—a procedure we feel is better suited to a tablesaw or router table—you'll never need to remove more than ⅛" of stock in one pass.

ADJUSTMENTS: WE PREFER KNOBS AND CRANKS

Of the few controls on a jointer, you'll adjust the infeed elevation control more than any other. For this frequent change, we preferred the smooth and accurate crank-type controls found on most of the machines. Many manufacturers place this crank directly underneath the infeed table, but Jet wisely positions both the infeed and outfeed controls on the front of its model JJ6, making them easier to reach.

Continued



 Print this article



MACHINES THAT GIVE YOU THE EDGE QUICKLY AND ACCURATELY

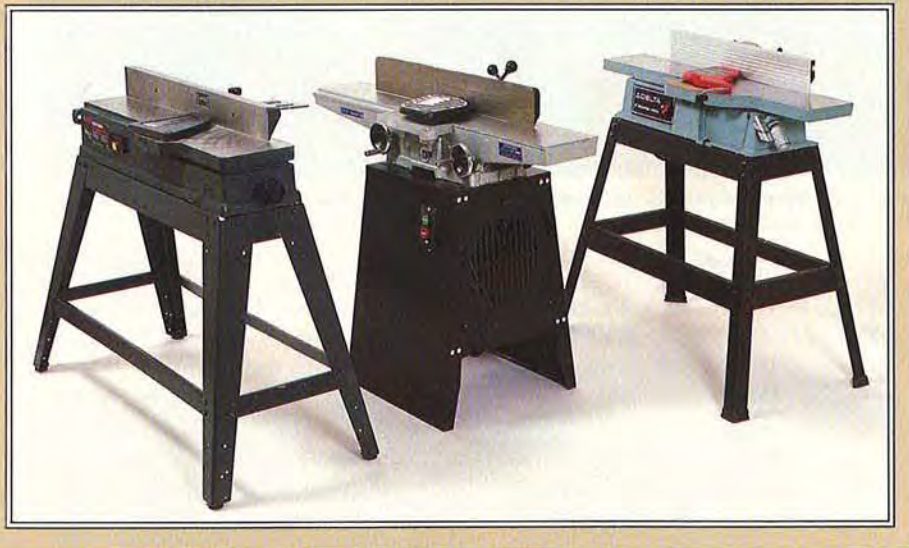
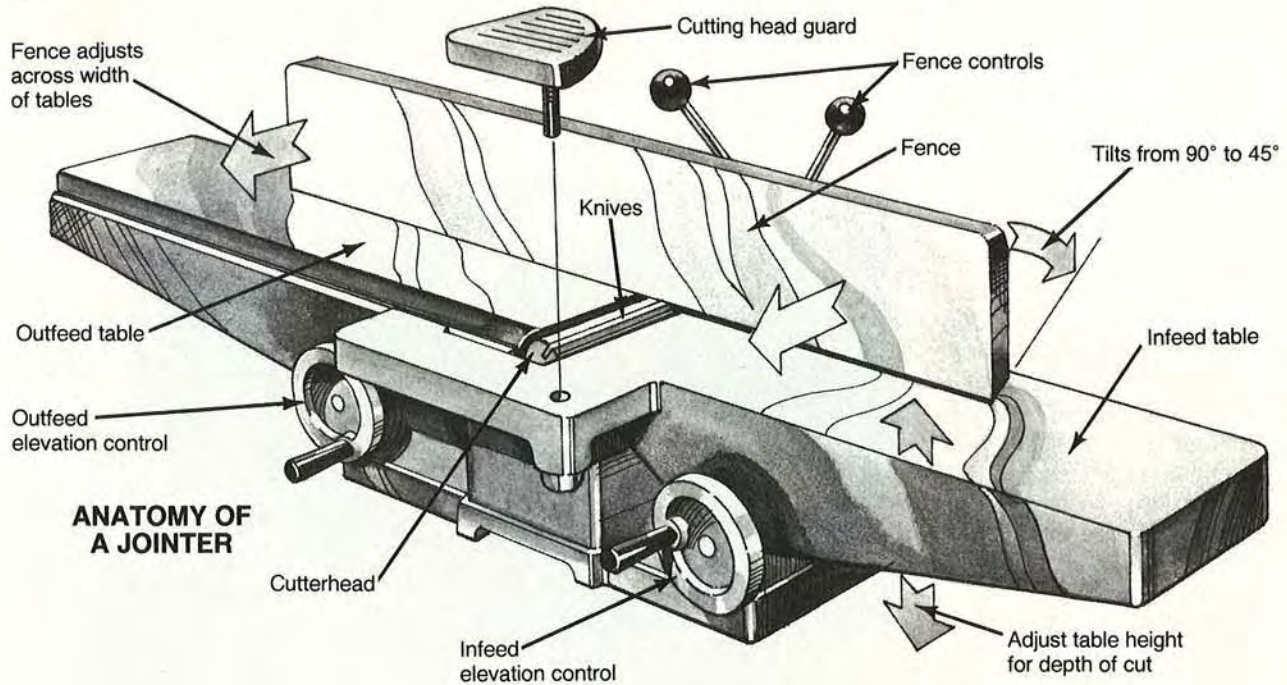

Opposite left: Foley-Belsaw model 445, Grizzly G1182, and Total Shop 915.

Near left: Sears model 23220, Jet JJ6, and Delta 37-280.



JOINTERS

The knob controls on the Delta 37-280 and Sears 23220 work much like the cranks. Similar in purpose, but different in design, the lever-operated controls on the Grizzly G1182 allow you to quickly adjust the tables up and down. However, our tests showed these levers make fine-tuning for a precise depth of cut difficult, and actually prolong the adjustment time.

With the exception of the Sears 23220, Delta 37-280, and the Ryobi JP-155, all the machines we tested had adjustments for the elevation and leveling of the outfeed tables. However, since all of the tables were true and level on the models called in for our tests, a lack of outfeed table adjustments does not appear to be a liability. In fact, we've never had to adjust the outfeed table on a Delta 37-150 during two years of service in our shop.

The infeed table, on the other hand, will take a pounding over time from dropped boards that could force it out of level. With the exception of the Ryobi JP-155, all the machines have infeed-table leveling controls. Al Nielsen of Ryobi says his company doesn't see a need for such adjustments because "our high-tech die-casting process enables us to maintain very tight tolerances and plenty of strength in the infeed table." We agree with Nielsen's assessment of the machine's high-quality castings, but we still would advise you to avoid dropping any heavy boards on this machine's infeed table.

Besides infeed-table adjustments, you'll also find yourself frequently adjusting the fence in two ways: across the width of the cutterhead to wear the knives evenly, and tilted for bevel cuts. We prefer fence controls located at the center of the fence to those mounted at the end of the fence such as on the Sears

23220 shown at *bottom* and the Total Shop 915. We found that the center-mounted controls adjust faster and lock the fence more securely. Among the centered controls, we appreciated the simplicity of the positive 90° and 45° stops common to the Jet JJ6 and Foley-Belsaw 445 as shown *below*.

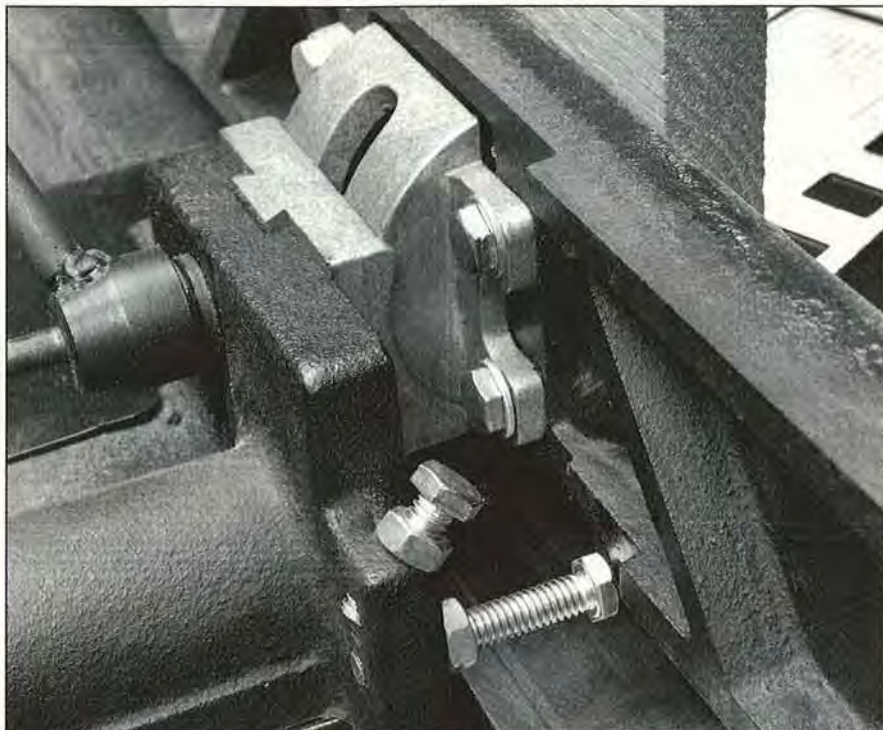

Two bolts serve as quickly adjustable 45° and 90° stops on the Foley-Belsaw model 445, *above*, and the Jet model JJ6: a simple and efficient system.

CAPACITY: HOW MUCH JOINTER DO YOU NEED?

Since you'll use a jointer mostly for edge work, you might think that a 4" machine such as the Sears model 236221 shown at *right* has all the capacity you need. But as the photo shows,

the differences between 4" and larger jointers goes well beyond the length of their knives. Most importantly, the majority of 6" jointers have 40" or longer beds and 28" or longer fences that allow you to comfortably joint stock up to 6' long. With a bed length of only 21½" on the Sears model, you'd have a hard time jointing boards longer than 4'.

Here's some good news if you joint stock over 6' long: You can now buy Taiwanese-made 8" jointers for under \$1,000. For example, the Grizzly model G1018 shown at *right* sells for \$665 plus shipping and has a 65½" bed.

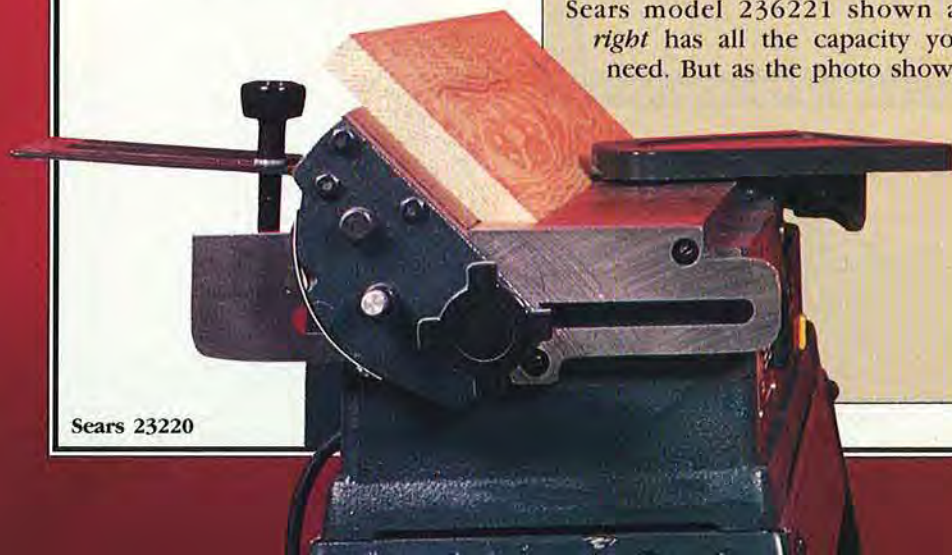

Sears 23220

CHANGING KNIVES: SHEAR DELIGHT ON SOME MODELS

Nothing will hurt the performance of your jointer more than dull knives. And, when it's time to re-sharpen them, you'll think highly of a machine that makes removal and resetting as simple as possible. Of the nine jointers we tested for

this article, only two—the Ryobi JP-155 and Sears 23220—have blade-adjustment screws that allow you to set the knives at the height of the outfeed table by means of two screws alongside the knives as shown in photo A. With cutterheads that don't have adjustment screws, such as those on the Grizzly

G1182 shown in photo B, adjusting the blades requires you to use a screwdriver or other instrument. No matter what machine you purchase, the knife-setting jig on page 31 will prove a big help.

SAFETY FEATURES: AN ABSOLUTE MUST

All of the machines we tested—with the exception of the Total Shop 915—had guards covering the cutterhead on both sides of the fence as shown on the Delta 37-280 on the following page. The Total Shop model we tested had no guard over the end of the cutterhead behind the fence, exposing up to 4 inches of spinning knives with the fence pulled toward the operator (see photo *below*). Wayne Preston of Total Shop says his firm now includes a guard that attaches to the backside of the fence. If you already own a Total Shop jointer that lacks this safety feature, you can purchase a guard from the company for \$10.95 plus a minimum \$3 shipping charge. You'll have to drill and tap three holes into the fence in order to mount the hinged plate.

We applaud the safety-conscious attitude of manufacturers that include push blocks with these machines: Delta 37-280, Ryobi JP-155, and Sears 23220.

Continued

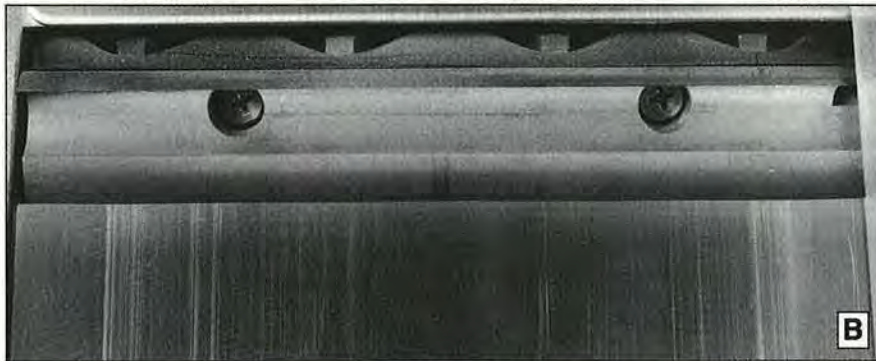
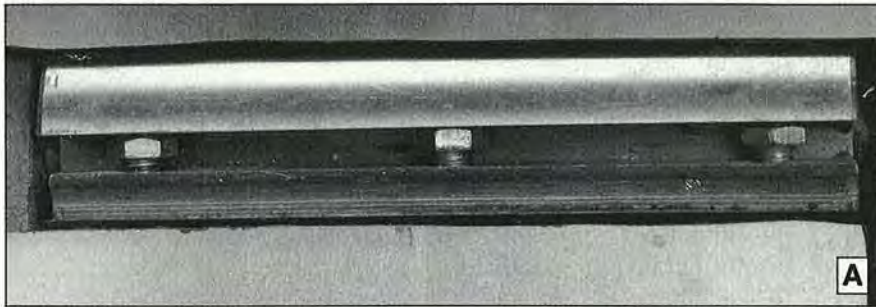

In addition to four blade locking bolts for a secure hold, the Ryobi JP-155 cutterhead shown at *bottom* has two blade height-adjustment screws to ease blade changes. The Grizzly G1182, as shown at *top*, has only three blade-locking bolts and no height-adjustment screws.

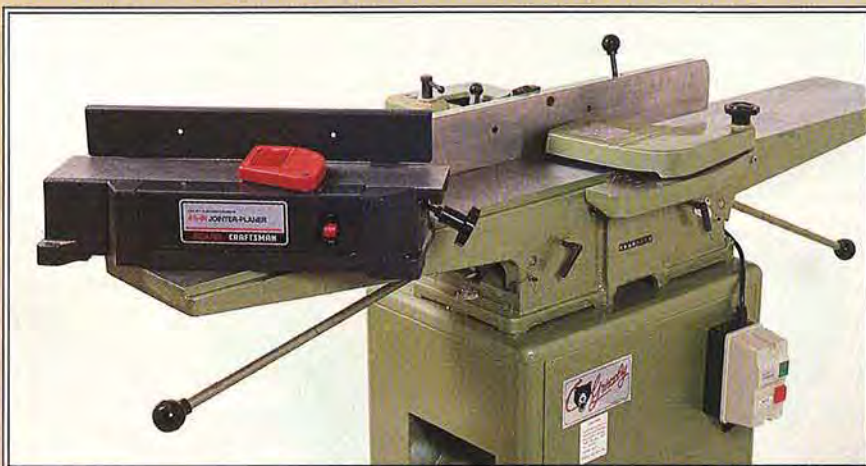

The big and small of it: Sears 4" model 236221 and the Grizzly 8" model G1018. A 4" difference in blade length makes for a big difference in overall capacity.



The Total Shop 915's lack of a guard behind the fence scared us. Total Shop says they've recently added a guard.

JOINTERS

MOTORS: SPEED AND POWER COUNT

We jointed a variety of woods with ease on all of the test machines, and happily, none of them lacks power. But, the Ryobi JP-155 produced a far-smoother finish than any of the other machines. Why?

With jointers, the higher the number of cuts per minute (cpm) the smoother the surface of your workpiece should be. Thanks to its rapidly turning universal motor, this mighty tike of a jointer (it weighs only 27 pounds) produces up to 32,000 cpm. Of the induction-motor jointers, none produce more than 24,600 cpm.

To confirm our theory that more cuts equals a smoother surface, we surfaced a 5"-wide piece of highly quilted maple on all of the jointers we tested. All of the machines except the Ryobi produced considerable grain tear-out.

The trade-off? Universal motors don't last as long on average as induction motors and have brushes that need occasional replacement. For the home workshop, a universal motor-powered jointer shouldn't require excessive maintenance. However, universal motors are noisier.

OTHER POINTS TO CONSIDER

● **Stands:** With the exception of the Ryobi JP-155 shown *below*, and the 4" Sears jointer, each machine we tested came with a stand. All the stands were stable except for the Total Shop 915. Rubber pads on its base contributed to a 2-3" sway with just a slight push on the machine. Total Shop plans to introduce a new base at a future date. Among the other machines, we liked the Grizzly stands that have chip chutes to direct cutting debris away from the motor and motor pulley, and conveniently into a trash container.

● **Construction materials:** Nearly all the jointers on the market have plenty of cast iron in their construction, making for stable, but heavy machines as shown in the chart *opposite*. And remember, if you buy one of these machines through the mail you'll pay freight on every extra pound.

The Delta 37-280, shown at *left*, makes a slight departure from the cast-iron trend by using extruded aluminum, a light but stable material, in its fence. But once again, the Ryobi JP-155 separates itself from the crowd by setting cast-aluminum tables and a fence on a plastic base for lightness. Ryobi engineers thoughtfully covered the outfeed table with a smudge-free stainless-steel sheet for long wear.



▲ Only one jointer—the Ryobi JP-155—has a variable-speed control: a plus as far as we're concerned.

◀ Delta 37-280

6" JOINTERS: WHO HAS THE EDGE?

MANUFACTURER/IMPORTER	MODEL	BED LENGTH (in.)	CUTS PER MINUTE	MAX. CUTTING DEPTH (in.)	MOTOR		FENCE					ADJUSTMENTS				STANDARD EQUIPMENT ⁵	JOINTER WARRANTY	MOTOR WARRANTY	U.S. SERVICE CENTERS	COUNTRY OF ORIGIN ⁶	WEIGHT (lbs)	SUGGESTED PRICE	SELLING PRICE	
					TYPE ¹	AMPS	VOLTS	KNIFE HEIGHT ADJUSTMENT SCREWS (Y/N) ²	FENCE MATERIAL ³	TABLE MATERIAL ³	HEIGHT (in.)	LENGTH (in.)	DEPTH (Y/N)	OUTFEED TABLE										TABLE ADJUST. CONTROL ⁴
														LEVELING (Y/N)	INFEED TABLE LEVELING (Y/N)									
AMT	4121	42	N/A	1/8	MOTOR NOT INCLUDED		Y	CI	CI	3 1/16	35 1/2	Y	Y	Y	C	S	10 yrs	-	1	T	202	\$459	\$349	
Delta	37-150	55 1/2	16,500	1/2	I	14/7	115/230	Y	CI	CI	5	36	Y	Y	Y	L	S	2 yrs	2 yrs	152	B/U ***	265	1173	1000-1100
Delta	37-280	35 1/2	12,900	3/8	I	14	115	N	EA	CI	3 3/4	24	N	Y	N	K	S, PB	2 yrs	2 yrs	152	T	143	440	370
Foley-Belsaw	445	45	14,490	1/2	I	12/6	110/220	N	CI	CI	4	28	Y	Y	Y	C	S	1 yr	90 days	1	T	197	650	425
General	1180-1	42 1/2	12,600	1/2	I	12/6	115/230	N	CI	CI	4	35	Y	Y	Y	C	S	1 yr	2 yrs	6	C	226	800	750
Grizzly	G1182	47	15,000	1/2	I	13/6.5	110/220	N	CI	CI	4	29 1/4	Y	Y	Y	L	S	90 days	1 yr	2	T	260	335	335
Jet	JJ6	42 1/2	13,500	1/2	I	12/6	115/230	N	CI	CI	4	28	Y	Y	Y	C	S	1 yr	90 days	530	T	194	456	360-410
Lobo	JT-0006	42 1/2	13,500	1/2	I	18/9	115/230	N	CI	CI	4	28	Y	Y	Y	K	S	1 yr	1 yr	1	T	194	379	295
Powermatic	1500040	48	15,000	1/2	I	14	115	Y	CI	CI	4	34 1/2	Y	Y	Y	L	S	1 yr	1 yr	425	U	290	1288	1100-1150
Ryobi	JP-155	28 1/2-54 1/2*	16,000-32,000**	3/32	U	10.5	120	Y	CA	CA/SS	2 5/8	28	N	N	N	K	PB	1 yr	1 yr	165	J	27	618	330
Sears	23220	36	12,900	1/8	I	8	120	Y	CI	CI	3 1/4	33	N	N	Y	K	S, PB	1 yr	1 yr	900	U	173	370	370
Total Shop	915	45	24,600	1/2	I	8/4	110/220	N	CI	CI	4 1/2	28	Y	Y	Y	C	S	1 yr	1 yr	1	T	170	499	299

* Bed length increases from 28 1/2" to 54 1/2" with the addition of two bed extensions. A set of extensions cost \$49.50 list.
** Variable speed.

*** Jointer made in Brazil. Stand, motor and electricals assembled in USA.
1. (I) Induction; (U) Universal.
2. All models have 3 knives except the Ryobi JP-155 which has 2.

3. (CA) Cast aluminum; (CI) Cast iron; (EA) Extruded aluminum; (SS) Stainless steel.
4. (C) Crank; (K) Knob; (L) Lever.
5. (PB) Push blocks; (S) Stand.

6. (T) Taiwan; (B) Brazil; (U) USA; (J) Japan; (C) Canada.
7. Approximate selling price based on advertisements, catalogs, and dealer inquiries at time of article's writing.

MANUFACTURERS LISTING:

American Machine & Tool Co. (AMT)
215/948-0400

Delta International Machinery Corp.
Outside Pa.: 800-438-2486
Pa. residents: 800-438-2487

Foley-Belsaw
Outside Mo.: 800-468-4449
Mo. residents: 800-892-8789

General Mfg. Co. Ltd.
819/472-1161

Grizzly Imports
206/647-0801

Jet Equipment & Tools
Outside Wash.: 800-426-8402
Wash. residents: 206/572-5000

Lobo Power Tools
818/350-1096

Powermatic
Outside Tenn.: 800-248-0144
Tenn. residents: 615/473-5551

Ryobi America Corp.
312/250-7999

Sears
Call or visit your local Sears store

Total Shop
Outside S.C.: 800-845-9356
S.C. residents: 803/288-4174

OUR RECOMMENDATION

With its JP-155 jointer, Ryobi has basically taken its 6 1/8" model L-580A hand-held planer, turned it upside down, and added variable speed. The formula works. Although we initially wondered about the wisdom of such a departure from typical jointer construction, this machine's ability to produce a smooth finish on dense and highly figured woods changed

our minds. And, the machine's smooth cut produced an extra benefit: increased safety. As Jim Downing, WOOD magazine's design editor puts it: "I like the Ryobi's manners—it doesn't hammer the wood or want to throw the wood back at you."

About the only things we can fault in this machine are the short height of its fence (2 5/8") and the length of its bed (only 28 1/2").

Ryobi markets bed extensions that increase the bed length to 54 1/2" but we weren't able to obtain a set to test for trueness. Because of its lightweight construction and universal motor, this unit wouldn't fare well in a heavy-use or user-abusive environment. 🌲

Written by Bill Krier
Technical consultant: Dennis Puckett
Illustration: Jim Downing; Jim Stevenson
Photographs: Jim Kascoutas



 [Print this article](#)

FIFTH-ANNIVERSARY SPECIAL THE CLASSIC WOODY

Help us celebrate **WOOD**® magazine's fifth anniversary in grand fashion by building our classic Woody. Once you've crafted this collector's item—reminiscent of a 1930 Ford Woody—send us a photo of the completed model, and we'll send you, free of charge, a ½ × 1" engraved brass license plate, like the one offered on page 76. We've numbered them sequentially, so get started right away and receive a low number.

Note: You'll need thin stock for this project. You can either plane or resaw stock to the thickness stated in the Bill of Materials. Or, see the Buying Guide on page 77 for our source. You'll find helpful suggestions in our "Working Small" article, starting on page 50, when working with the small car parts.

THE WHEELS START THE ASSEMBLY LINE ROLLING

Note: We found it best to build the wheels and add them to the chassis now for ease in positioning the fenders on the chassis in the next section. See the Buying Guide for our source of laser-cut spoked rims.

1 Cut a piece of ¼"-thick walnut to 2½" wide by 15" long (enough material for six tires—an extra tire in case one breaks during machining). Now, cut a piece of ½" or ¾" scrap stock to the same length and width as the walnut.

2 Cover the bottom side of the walnut with double-faced tape, and stick the walnut to the scrap block with the edges and ends flush. Mark reference lines on the walnut for locating the wheel centerpoints where dimensioned on Step 1 of the drawing titled Cutting The Tires on the opposite page.

3 Mount a circle cutter in your drill press, and follow the two-step

5th Anniversary Celebration

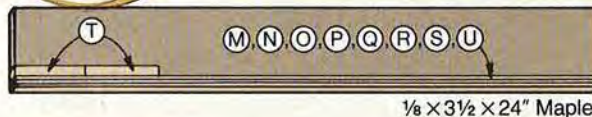
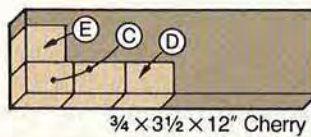

Cutting Diagram

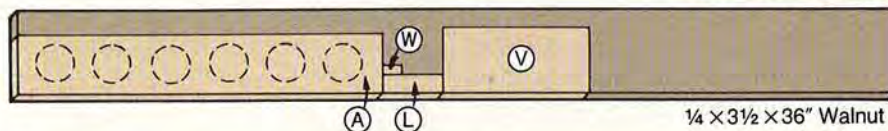
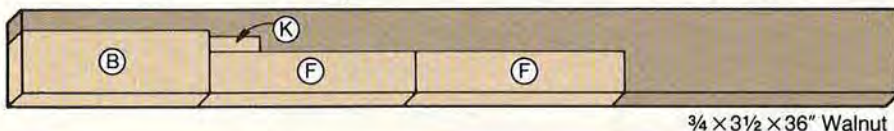
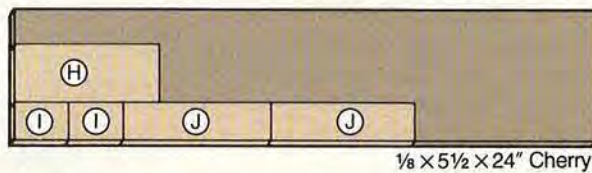
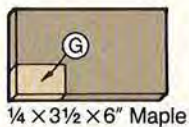

CUTTING THE TIRES

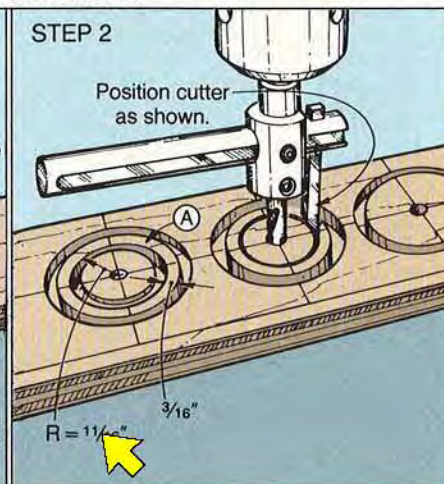
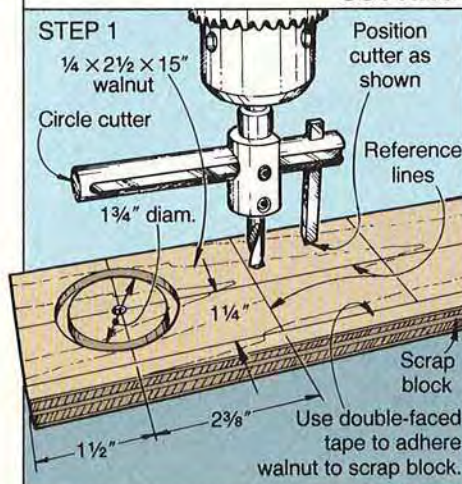

Bill of Materials

Part	Finished Size*			Mater.	Qty.
	T	W	L		
A tires	1/4"	1 3/4" diameter		W	5
B chassis	1/2"	2 1/2"	7 3/4"	W	1
C* side panels	1 1/2"	1 1/4"	2"	LC	1
D* hood	1/4"	1 1/2"	2"	C	1
E cowl	3/4"	1 1/2"	2 1/2"	C	1
F* fenders	3/4"	1 3/4"	8 1/2"	W	2
G radiator	1/4"	1 1/8"	1 3/4"	M	1
H floor	1/8"	2 1/2"	6"	C	1
I firewall, tailgate	1/8"	1 1/2"	2 1/4"	C	2
J side panels	1/8"	1 1/2"	6"	C	2
K seat	1/2"	3/4"	2 1/4"	W	1
L seat back	1/4"	1 1/2"	2 1/4"	W	1
M trim	1/8"	1/8"	7 7/8"	M	2
N trim	1/8"	1/8"	1 1/4"	M	2
O window posts	1/8"	1/8"	2 3/4"	M	12
P trim	1/8"	1/8"	6"	M	2
Q trim	1/8"	1/8"	2 1/2"	M	4
R trim	1/8"	1/8"	1 1/8"	M	8
S trim	1/8"	1/8"	2 1/2"	M	1
T trim	1/8"	1/4"	3"	M	2
U trim	1/8"	1/8"	2 1/4"	M	4
V roof	1/4"	2 3/4"	6 1/8"	W	1
W license block	1/4"	1/4"	3/4"	W	1

*Initially cut * parts oversized. Trim them to finished size according to the how-to instructions.
Material Key: W-walnut, LC-laminated cherry, C-cherry, M-maple
Supplies: double-faced tape, 1/4" walnut dowel stock for axles, 1/8" birch dowel stock for light bar, 1/2" birch dowel stock for headlights, masking tape, finish.

Continued

THE CLASSIC WOODY

drawing to cut the walnut tires to shape. Note the position of the cutter in each step.

4 To avoid breaking the tires when removing them from the scrap block, splash a little lacquer thinner over each tire to weaken the tape adhesive. Then, carefully pry the tires from the tape. Hand-sand a slight round-over on the inside and outside edges of each tire.

5 To smooth the outside edges of the rims—they're a little rough from the laser cutting—fasten them to a 6" length of 1/4" all-thread rod. Chuck the assembly into your drill press as shown in the drawing below. Using a sanding block, *lightly* sand the outside edges smooth; be careful not to sand too much. Remove the rims from the rod.

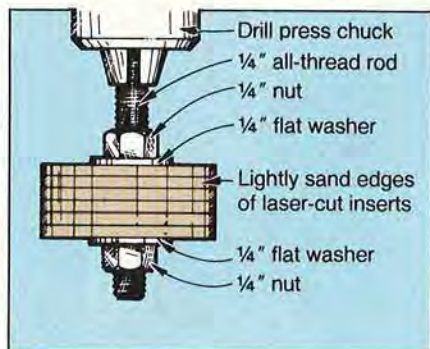

6 To adhere the rims to the tires, position one of the tires on a flat surface. Place a 1/4" washer inside the tire, and lay a rim on the washer. Apply a few drops of instant glue to adhere the tire to the rim as shown in the photo at top of the next column. (We used a pencil to center the rim inside the wheel when gluing.) Repeat for each wheel. (We found instant glue helpful to avoid problems adhering the small parts.) See the Buying Guide for our source of glue.

7 Cut the front and rear axles to 3 1/8" long from 1/4" walnut dowel stock. Glue the axles to the rims, with the ends of the axles flush with the *outside face* of each rim.

CONSTRUCT THE CHASSIS

1 Cut a piece of 1/2"-thick walnut (we planed 3/4" stock) to 2 1/2 x 7 3/4" long for the chassis (B).



Dab instant glue onto the joint between the tire and the laser-cut insert.

2 Mark the location, and dado on the bottom of the chassis, using the dimensions on the Chassis Side-View Drawing for reference.

3 Using the Side View for reference, mark the cutline for the taper along one edge at the front of the chassis blank. Bandsaw the taper.

4 Now, referring to the Top View Drawing, mark the shape of the chassis on the top surface of the walnut and cut the chassis to shape. Sand the chassis smooth.

5 Turn the chassis upside down. Center the axle assemblies from side to side on the chassis, and glue them into the dados.

NEXT, THE HOOD ASSEMBLY

1 To form the engine side-panel lamination (C), cut two pieces of 3/4" cherry stock to 1 1/4 x 4". With the edges and ends flush, glue and clamp together the two pieces.

2 Cut the hood (D) to the size listed in the Bill of Materials plus 2" in length. Glue and clamp the hood to

the engine side-panel lamination, with the edges and ends flush where shown on the drawing below. After the glue dries, trim both ends for a 2" finished length.

3 Cut the cowl (E) to size and glue it to the lamination where shown on the drawing below.

4 Mark the cutlines where shown on the drawing below, and bandsaw the sides of the assembly where marked. Sand smooth.

5 Rout or sand a 1/4" round-over along the top edges of the hood assembly where shown on the drawing on page 77.

6 With the front of the hood assembly flush with the notch in the chassis, glue the hood assembly to the chassis. Center the assembly from side to side on the chassis.

MAKING THE SIDE PANELS, HOOD, AND COWL ASSEMBLY

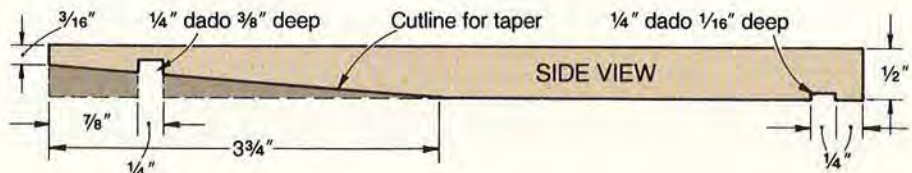
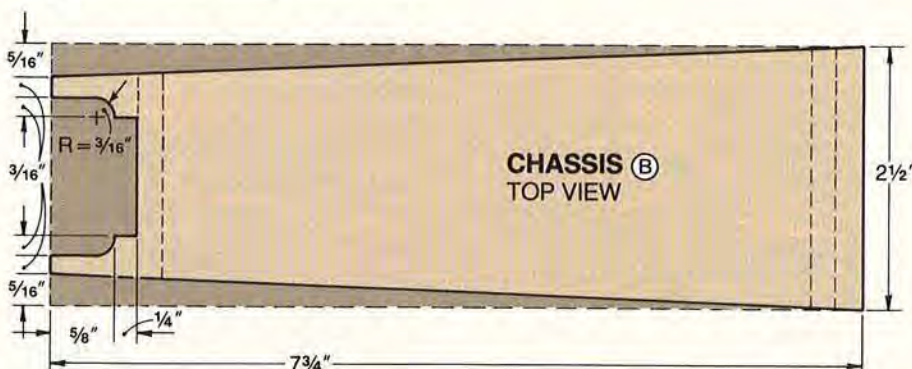
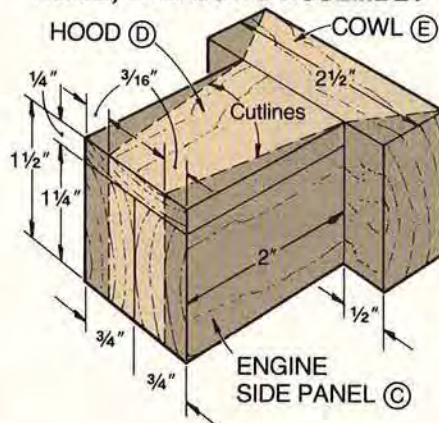

ON DOWN THE LINE, FORM THE FENDERS

1 Cut two pieces of $\frac{3}{4}$ " walnut to $1\frac{3}{4} \times 8\frac{1}{2}$ " long for the fenders (F).

2 Transfer a full-sized side-view fender pattern to the *outside face* of each fender blank with carbon paper or by adhering a photocopy of the pattern to the stock. Transfer the right fender top view to one blank and the left fender top view to the other.

3 Bandsaw (we used a $\frac{1}{8}$ " blade) along the cutlines on the outside face of each fender. Then, tape the pieces together and cut along the marked top-view cutlines to finish cutting the fender to shape as shown in the photo *below*.

4 Carefully sand round-overs on each fender where shown on the Fenders Drawing at *right* and in the opening photo. (We used the drill-and-disc-sanding technique shown on page 53 to sand the fenders; you also could hand-sand them to shape.)

5 Position and tape the fenders to the chassis. Taping the fenders in place frees your hands to apply the glue. When locating the fenders, keep an even gap between the rear wheel and fender, and hold the bottom of the front fender $\frac{3}{16}$ " above the top of the tire. When properly taped in position, glue in place. Later, remove the tape.

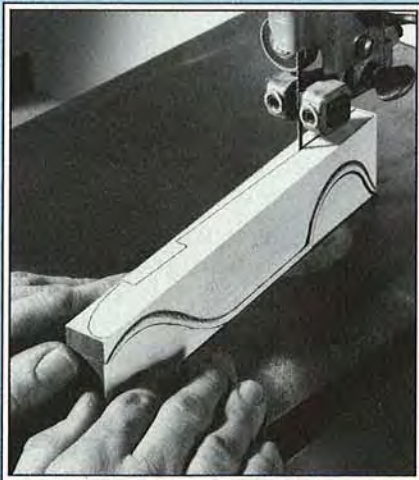

We adhered a photocopy of the pattern to the fender blank with spray-on adhesive, and then cut the fender to shape.

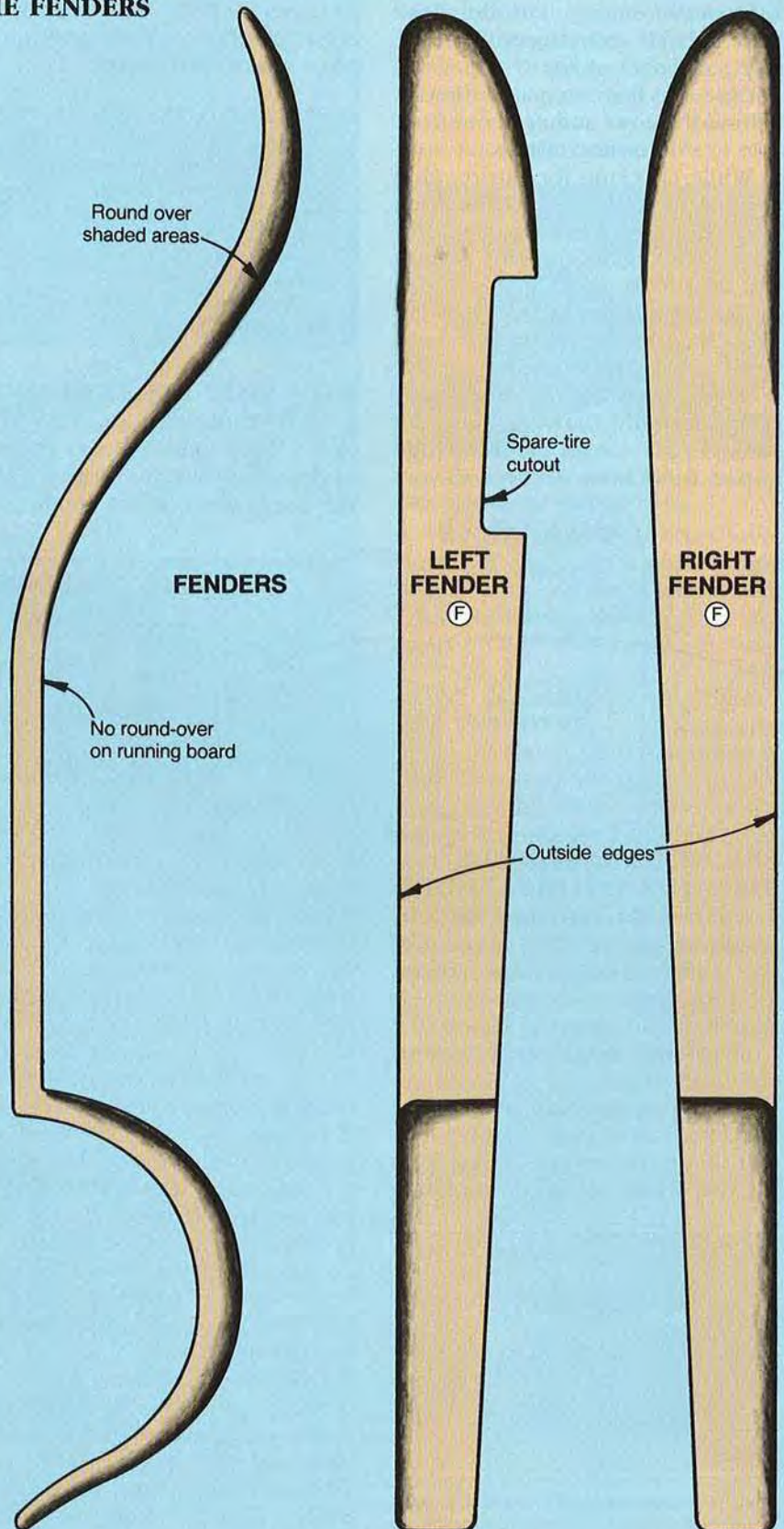

Continued



THE CLASSIC WOODY

BODY BY YOU

1 From 1/8" cherry, cut the floor (H), firewall and tailgate (I), and side panels (J) to size.

2 Glue the floor in place directly behind the cowl and centered from side to side on the chassis.

3 While checking for square, glue the firewall to the back of the hood assembly and to the top of the floor. Now, glue the side panels and tailgate in place.

4 Cut the seat pieces (L, K) to the sizes listed in the Bill of Materials. Sand a 1/8" round-over on each where shown on the Hood and Body Assembly Drawing. Glue the pieces in place with the front edge of part K 5/8" from the firewall.

5 With the back edge of the spare tire even with the back edge of the cowl, glue the spare tire and rim in place against the chassis.

FREE LICENSE PLATE

To order, just send us a photograph of your Woody and a self-addressed, stamped, No. 10 business envelope to:

I Built a Woody
WOOD Magazine
 Locust at 17th
 Des Moines, IA 50336

Offer expires Oct. 15, 1990.

LET'S VISIT THE TRIM SHOP

1 From 1/8" maple stock, rip 3 strips 1/8" x 1/8" x 24" long. See our method of ripping thin strips on page 79 of the handwoven basket article.

2 Cut bottom trim pieces (M, N) to length plus 1/4" from the 24"-long pieces. Sand one end of trim pieces M and N to conform to the fender. Glue trim pieces M and N in place.

3 Cut the maple window posts (O) to length. Mark centerlines on the outside face of the cherry side panels (J) where dimensioned on the Hood and Body Assembly Drawing at *right*. Glue the posts in position as shown in the photo on the opposite page. Sand the ends of four window posts to conform to the fender. Carefully align the top ends of the posts.

4 Cut the remaining trim pieces (P, Q, R, S, T, U) to the lengths listed in the Bill of Materials. Glue the remaining trim pieces in place.

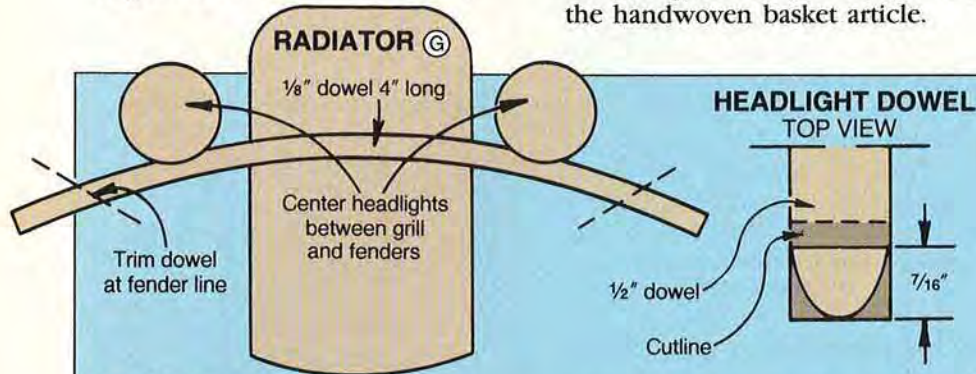

BRIGHT IDEAS FOR THE RADIATOR AND HEADLIGHTS

1 Transfer the full-sized radiator pattern to a piece of 1/4" maple. Cut the radiator (G) to shape. Hand-sand the radiator smooth.

2 Center the radiator against the front of the hood assembly and glue it in place.

3 Using a straightedge, mark a line the length of a piece of plywood. Mark four centerpoints 1" apart on the line where shown in the photo



Soak 1/2" dowel stock in water, and then bend the dowels around the nails to shape the headlight bars.

below left. Drive a 6d nail at each of the four centerpoints.

4 Cut three pieces of 1/8" dowel stock to 4" long for the headlight bar. Soak the three pieces of dowel in hot water for one hour. Remove the dowels from the water and weave them in position as shown in the photo. Let the dowels dry overnight in the form.

5 Remove the dowels from the form. Save the dowel that retains the most curve. Position that dowel on the full-sized Radiator and Headlight Drawing and mark the cutlines. Trim the headlight bar where marked. Check the fit of the bar between the front fenders and sand for a flush fit.

6 From 1/2" dowel stock, cut a piece 6" long. Chuck the dowel in your drill press. With the drill press running at about 500 rpm, hold a pencil against the spinning dowel and mark a line 7/16" from the bottom end of the dowel. As shown in the

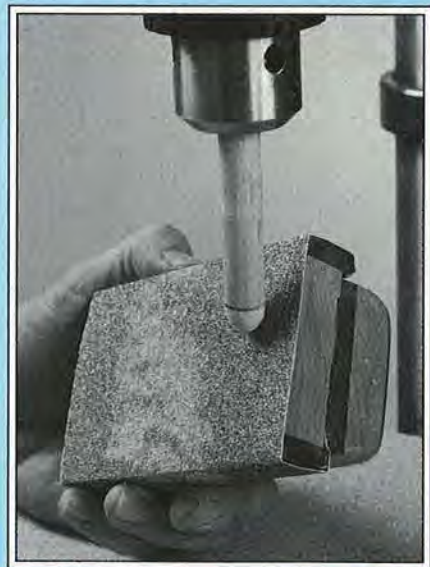

Chuck a 1/2" dowel into your drill press and sand the bottom end to form a headlight.

photo *above*, shape a headlight at the end of the dowel with a sanding block. See the Radiator and Headlight Drawing *above left* for reference. Remove the dowel from the drill press and trim the headlight where marked. Repeat the process to form a second headlight.

7 Glue the headlight bar in place between the fenders and against the radiator. Glue the headlights to the bar where shown on the Radiator and Headlight Drawing.

HOOD AND BODY ASSEMBLY

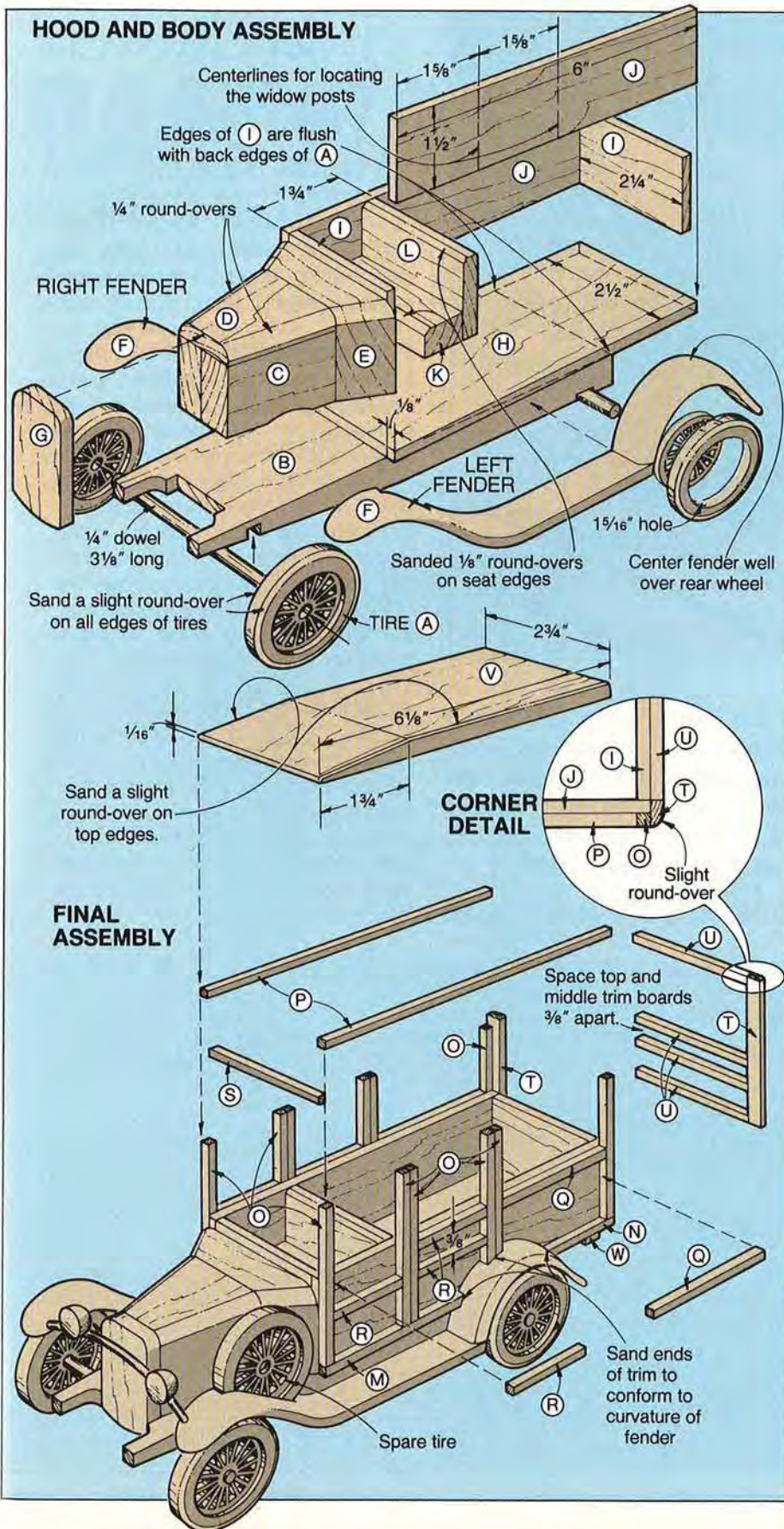

5 Cut the roof (V) to size and belt-sand a taper on the front top edge where dimensioned on the Final Assembly Drawing. Sand a slight round-over on the top edges of the roof where shown on the drawing. Glue the roof in place.



Position and glue one window post on each side of the marked lines.

6 Hand-sand a slight round-over along the back edges of the body where shown on the Corner Detail. **7** Cut the license block (W) to size and glue it to the floor.

PAINT IT, LICENSE IT, AND HIT THE ROAD

Apply the finish. Send us a photo of your Woody for a free, brass license plate (see the offer on the opposite page for details). Glue the license plate to the license block.

BUYING GUIDE

- **Instant glue kit (cyanoacrylate).** Hot Shot Special "T", bonds in 50 seconds, 2-oz. bottle. Solvent, 2-oz. bottle separates objects mistakenly bonded. One bottle of each for \$16.65 ppd. Garrett Wade, 161 Ave. of the Americas, New York, NY 10013 or call 800-221-2942.

- **Spoked inserts.** Six laser-cut baltic birch inserts, 1 5/16" diameter, \$5.45 ppd. Custom Awards, 1427 NW. 81 St., Des Moines, IA 50311.

- **Hardwood.** Same-sized pieces and types of wood shown in the Cutting Diagram. \$19.75 ppd. (\$24.75 in Canada). EDLCO, P.O. Box 5373, Asheville, NC 28813, or call 704/255-8765 to order. 🌲

Produced by Marlen Kemmet
 Project Design: James R. Downing
 Photographs: Hopkins Associates
 Illustrations: Kim Downing; Bill Zaun
 Opening illustration by Jim Stevenson



Handwoven WHAT A TOP DESIGN

NOTE: You'll need thin stock for this project. You can either resaw or plane thicker stock to size.

PREPARING THE STOCK;

1 For the base (A), uprights (B, C), bottom oak band (D), narrow walnut weavers (E), wide walnut weavers (F), center oak weaver (G), top oak bands (H, I), and lid pieces (J, K), rip and crosscut $\frac{3}{4}$ "-thick, straight-grained boards to the size shown on the Cutting Diagram. The pieces are cut large initially for safety when machining them later.
2 Plane the pieces to the thickness listed on the Cutting Diagram.

My travels around the country to the nation's top crafts fairs bring me in contact with many beautiful woodworking projects. But on a recent trek to Minnesota, I did a double-take when I happened onto this hardwood basket from designer/woodworker Keith Raivo. It's easy to make, thanks to Keith's method of cutting the weavers with a tablesaw.



Print this article

Marden Kemmet How-To Editor

START WITH THE BASE

1 Using carbon paper or a photocopy and spray-on adhesive, transfer the full-sized Base Pattern and the 10 upright locations to the bottom side of the base blank (A).
2 Bandsaw the blank to shape and sand the cut edge smooth. Set the base aside for now.

Cutting Diagram

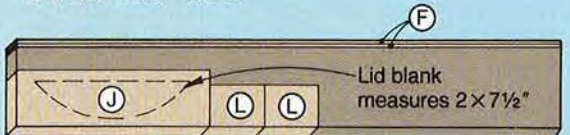
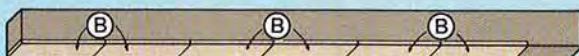
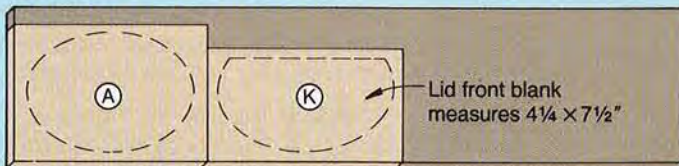

NOT BASKET

FROM THE UPTOWN ARTS FAIR IN MINNEAPOLIS

RIP THE THIN STRIPS WITH EASE AND SAFETY

Note: We cut twice as many bands and weavers (D,E,F,G,H,I) as needed; it's easy to break the thin strips during construction.

Stick a piece of masking tape to the tablesaw top where shown on the Strip Rip-

ping Drawing. Position a straight-edge against both sides of the saw blade and mark blade-reference lines on the masking tape. Now, mark a line parallel to the outside reference line $\frac{1}{16}$ " away from the blade where shown on the drawing.

(To prevent the thin strips from falling into the saw, we cut a piece of hardboard to the

same shape and thickness as the tablesaw insert. With the hardboard insert taped in place, we slowly raised the rotating blade through the hardboard to make a zero-clearance insert.)

2 Position the outside edge of the 20"-long walnut upright blank (B) along the $\frac{1}{16}$ " reference line. Using a push stick, rip a strip from the edge of the walnut. Measure the width of the strip and re-mark the line if the strip doesn't measure $\frac{1}{16}$ " (it took us a couple of tries).

3 Crosscut six uprights (B) to 3" long from the $\frac{1}{16} \times \frac{3}{4} \times 20$ " strip.

4 Repeat the procedure to cut the oak uprights (C), the bottom oak band (D), and the top bands (H, I) to size. Trim the top inside band (I) to length (it's slightly shorter than the top outside band (H)).

5 Remove the masking tape, mark a second line $\frac{1}{32}$ " from the outside blade-reference line, follow the procedure just described to cut $\frac{1}{32}$ "-thick weavers (E, F, G).

Continued

Bill of Materials					
Part	Finished Size			Matl.	Qty.
	T	W	L		
A base	$\frac{3}{8}$ "	$4\frac{1}{4}$ "	6"	O	1
B uprights	$\frac{1}{16}$ "	$\frac{3}{4}$ "	3"	W	6
C uprights	$\frac{1}{16}$ "	$\frac{3}{4}$ "	3"	O	4
D bottom band	$\frac{1}{16}$ "	$\frac{3}{8}$ "	$20\frac{3}{8}$ "	O	1
E narrow weavers	$\frac{1}{32}$ "	$\frac{1}{4}$ "	$19\frac{1}{2}$ "	W	4
F wide weavers	$\frac{1}{32}$ "	$\frac{3}{8}$ "	$19\frac{1}{2}$ "	W	2
G center weaver	$\frac{1}{32}$ "	$\frac{1}{4}$ "	$19\frac{1}{2}$ "	O	1
H top (in) band	$\frac{1}{16}$ "	$\frac{1}{2}$ "	$18\frac{7}{8}$ "	O	1
I top (out) band	$\frac{1}{16}$ "	$\frac{1}{2}$ "	$20\frac{3}{8}$ "	O	1
J lid back	$\frac{3}{8}$ "	$1\frac{1}{2}$ "	6"	W	1
K lid front	$\frac{3}{8}$ "	$3\frac{1}{4}$ "	$6\frac{1}{2}$ "	O	1
L hinges	$\frac{3}{8}$ "	$\frac{7}{8}$ "	$19\frac{1}{16}$ "	W	2

Material key: O-oak, W-walnut
Supplies: instant glue, double-faced tape, masking tape, $\frac{1}{8} \times \frac{1}{2} \times 6$ " leather strip, finish.

FULL-SIZED BASE

(A)

Mark upright reference lines on bottom of base

Upright locations

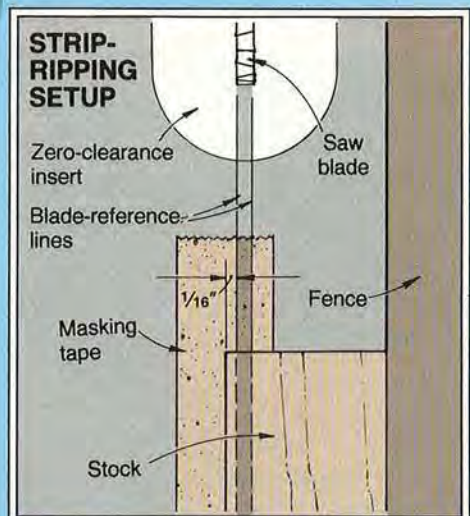

WHATNOT BASKET

ATTACH THE UPRIGHTS AND START WEAVING

1 Using instant glue or epoxy, secure the oak and walnut uprights (B, C) to the oak base where previously marked. (See our source for instant glue in the Buying Guide on page 81.) After you have glued all the uprights in place, sand the bottom of the base to remove the upright-location pencil marks.

2 Belt-sand a taper on both ends of the bottom band (D) and the top bands (H, I). See the Bottom-Band Detail *below* for reference.

3 To make the strips (D,E,F,G,H,I) easier to bend, soak them overnight in water. (We had to weight ours down to keep them from floating to the surface of the cake pan.)

4 Drill pilot holes, and glue and nail the bottom oak band (D) to the basket base. (See the Buying Guide on the opposite page for our source of copper clench nails.)

5 As shown in photo A, weave the bottom walnut weaver (E) through the uprights. (We wove the weaver at the top of the uprights. Once we completed the loop, we slid the weaver down next to the base.) Repeat the process until all but the top two bands (H, I) have been woven into place.

6 Loop the inside oak band (H) into position. Center the outside top band (I) over the *front* walnut upright (B). Clamp the band in place as shown in photo B. Drill a

$\frac{1}{16}$ " hole through the top bands and upright as shown in the photo.

7 Fit a nail through the hole. Snip the pointed end of the nail with wire cutters so only $\frac{1}{16}$ " protrudes on the inside of the basket. Using a ball-peen hammer, rivet (flatten) the nails as shown in photo C. Repeat the drilling and nailing at each upright, overlapping the bands as shown on the Fastening Detail *below*. Let the box dry overnight.

TO TOP THINGS OFF, ADD THE LID

1 Tape the lid back blank (J) to the lid front blank (K) with the surfaces and ends flush. (We used double-faced tape.)

2 Turn the basket upside down, and place it on the taped-together lid pieces so the basket covers $1\frac{1}{2}$ " of the walnut lid back.

3 Tape the woven basket to the lid pieces as shown in photo D. With the lead of a sharp pencil in the hole of a $\frac{3}{16}$ " washer, trace around the basket to lay out the shape of the lid as shown in the photo. Cut the lid to shape, and sand the cut edges smooth.

4 Chuck a $\frac{3}{8}$ " round-over bit in your table-mounted router. Rout a partial round-over on the top edge of the taped-together lid pieces where shown on the Hinge/Round-Over Detail. Sand smooth, and remove the tape holding the lid pieces together.



Weave the weaver into position at the top of the uprights. Then, slide the weaver against the base.

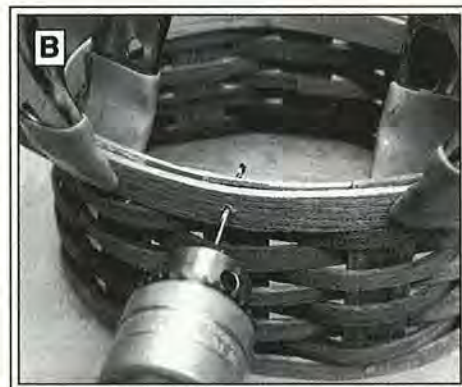

Drill a $\frac{1}{16}$ " hole through the top outside band, center walnut upright, and top inside oak band.

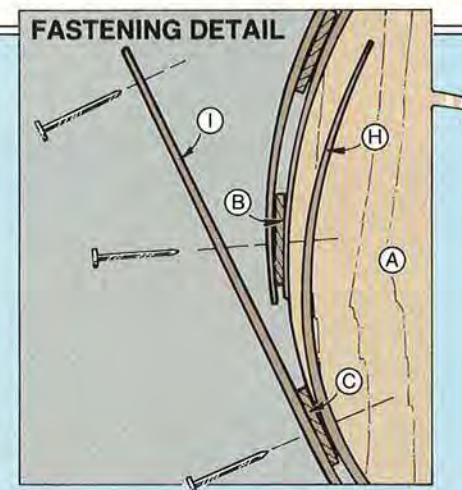
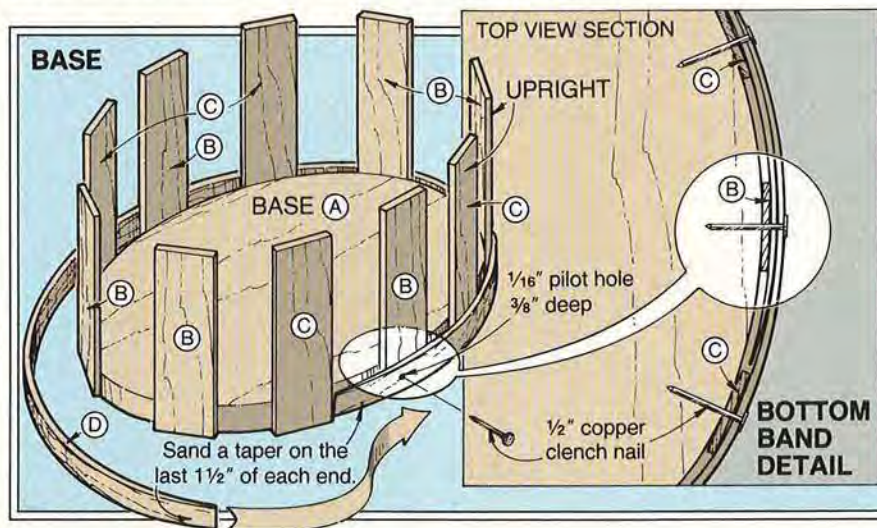

Produced by Marlen Kemmet



C Use a ball-peen hammer and the top of your vise or an anvil to rivet the nail on the inside of the basket.

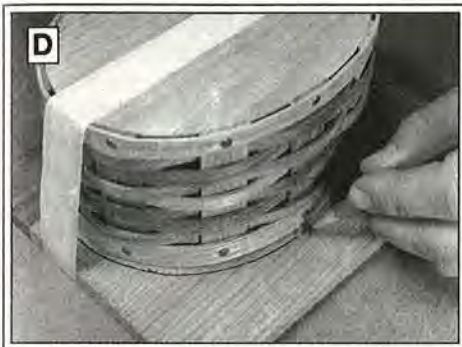

D Using a washer to ensure an even overhang, transfer the lid outline onto the taped-together lid pieces.

FORMING THE HINGES AND ATTACHING THE LID

1 Using the full-sized Hinge Pattern *below right*, lay out two hinges, including the opening and the nail hole centerpoint, on $\frac{3}{8}$ " walnut stock. Cut the hinges to size. Drill a blade start hole and use a scrollsaw or a coping saw to cut the opening in each hinge to shape.

2 Sand a slight round-over on all top edges of each hinge.

3 Mark the hinge slot locations on the lid back (J) where dimensioned on the Lid Back Drawing *below*. Drill start holes and cut the openings to shape. Sand a slight chamfer on the front and back edges of each opening for a better fit later of the hinge straps. (For reference, see the Hinge/Round-Over Detail accompanying the drawing titled Attaching the Lid.)

4 From $\frac{1}{8}$ "-thick by $\frac{1}{2}$ "-wide leather, cut two strips 3" long each. Loop the leather through the hole in each hinge. (We bought our leather at Tandy—you also could get it at a shoe repair store.) With the ends flush, glue together the ends of the leather strips. (We used instant glue and left just enough free play for the hinge to rotate snugly in the leather loop.

5 Wrap a leather strap around a hinge, slip a strap through each slot in the lid back. Drill a $\frac{1}{16}$ " hole through each leather strap where shown on the Hinge/Round-Over

Detail. Push a nail through each hole in the leather, and then bend it over as shown on the detail.

6 Hold the lid front (K) $\frac{1}{16}$ " away from the lid back, and mark the hinge locations on the lid front. Glue and clamp the hinges to the lid front where marked. Later, remove the clamps, and drill a $\frac{1}{16}$ " hole through each hinge and lid. Drive a copper clench nail through each hole—these two nails are for appearance only.

FINAL ASSEMBLY AND PRESTO, IT'S DONE!

1 Carefully belt-sand the top of the uprights flush with the top oak bands. Then, hand-sand the entire basket with 220-grit sandpaper. (Soaking the wood causes lots of raised grain.)

2 Glue and clamp the lid back (J) to the basket with an even overhang around the back edge. Immediately wipe off excess glue with a damp cloth.

3 Apply a clear finish. (We used an oil finish; an aerosol also would work well to help cover all those hard-to-get-at places.

BUYING GUIDE

• **Copper nails.** 100% hard-drawn $\frac{1}{2}$ "-long copper clench nails, made in England. Packet of 50 nails for \$5 ppd., 100 nails for \$9 ppd. Faering Design, Inc., Rt. 1, Box 223, Suttons Bay, MI 49682. ♣

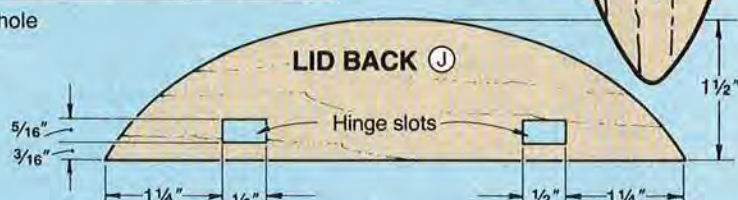
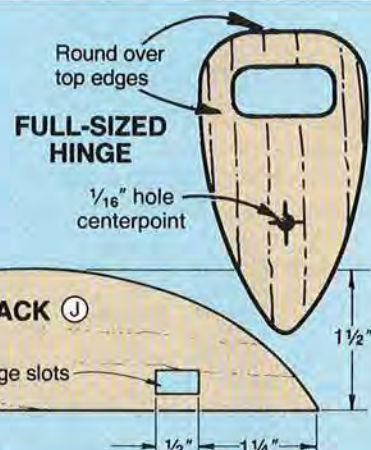
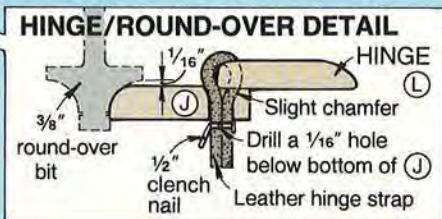
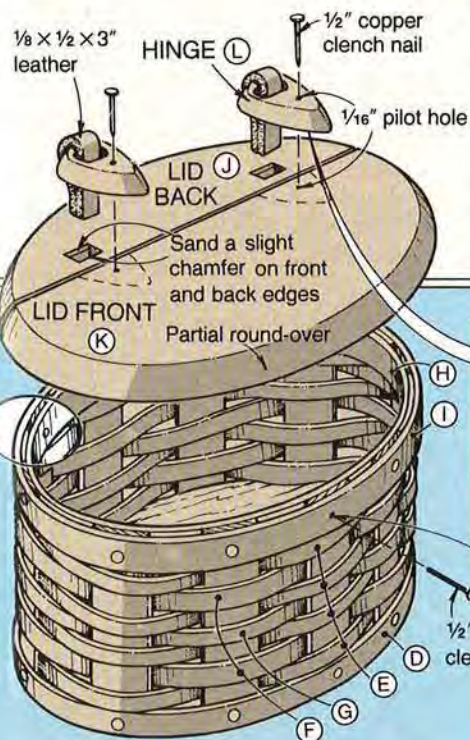

PINT-SIZED A TERRIFIC WAY

Note: You'll need 7/16" and 3/16" stock for this project. You can either plane or resaw thicker lumber to this thickness. You might also want to read the "Working Small" article on page 50. It provides helpful suggestions for machining small-parts projects such as this.

START WITH THE ROUTING JIG

Note: The jig allows you to mass-produce these frames easily.

I Cut a piece of 1/2"- or 3/4"-thick stock (we used walnut) to 4 1/4 x 5 1/4". With carbon paper or by adhering a photocopy, transfer the full-sized oval pattern shown *below left* to the center of the stock.



Aug. 13, 1989

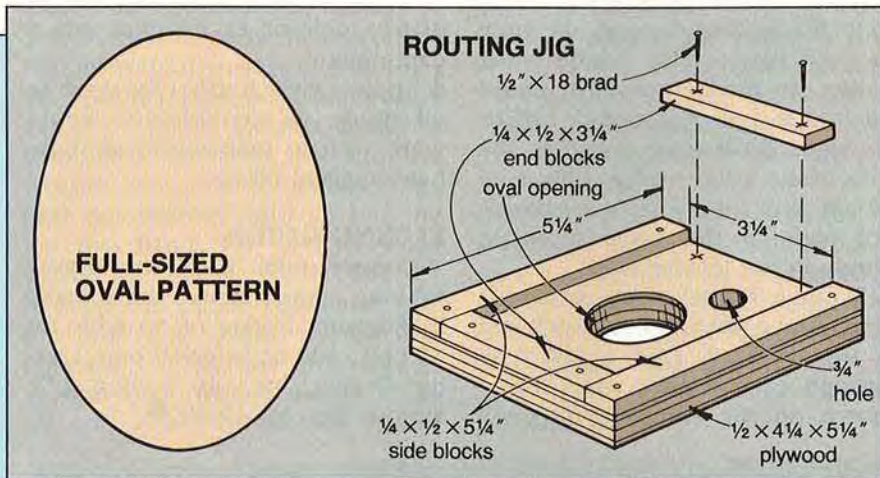

Supplies: 18 x 1/2" brads, silicone sealant, double-faced tape, clear plastic (DuPont Mylar) page protector, finish.

BUYING GUIDE

• **Carbide-tipped router bits.** 1/2" flush-trimming bit with 1/2" bearing, catalog no. S8016Y, \$8; add \$3.25 for 3/8" replacement bearing (used to cut the rabbet). 3/32" Roman ogee, catalog no. S5705Y, \$16. 3/16" round-over bit, catalog no. S506Y, \$11. Add \$2.50 for shipping. Cascade Tool Co., Box 848WD, Mercer Island, WA 98040. Or, call 800-235-0272.

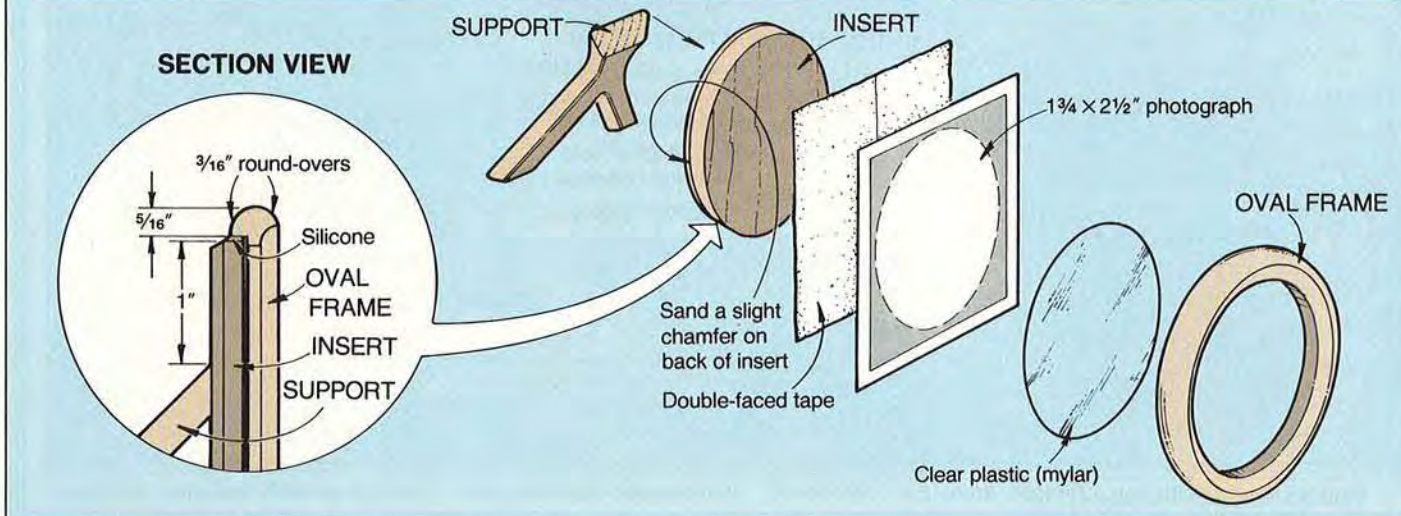

PICTURE FRAMES

TO SHOWCASE THOSE SPECIAL PHOTOS

2 Drill a blade-start hole, and carefully cut and sand the opening to shape. (We cut the oval with a scrollsaw and sanded the opening smooth with a 1" drum sander.)

3 Construct the jig shown on the Routing Jig Drawing on the opposite page. Drill a $\frac{3}{4}$ " hole through a corner of the jig.

CUT AND ROUT THE OVALS TO SHAPE

1 Cut a piece of $\frac{7}{16}$ " stock to $3\frac{1}{4} \times 4\frac{1}{4}$ " for each frame desired. (We planed a $3\frac{1}{4}$ "-wide by 18"-long piece of $\frac{1}{2}$ " walnut to $\frac{7}{16}$ " thick. Then, we crosscut four $4\frac{1}{4}$ "-long blanks from the length.) Check for a snug fit of the frame blank in the routing jig opening.

2 Fit a frame blank into the jig. Bore a $\frac{5}{8}$ " hole through its center.

3 Mount a $\frac{1}{2}$ " flush-trimming bit with a $\frac{1}{2}$ " pilot bearing to your table-mounted router. Position the jig and bit where shown on Step 1 on drawing below. See the Buying Guide for our source of bits.

4 Start the router and run the bearing along the inside edge of the jig to rout the oval interior.

5 Switch to a $\frac{3}{8}$ " pilot bearing on the router bit, lower the bit to the level shown on Step 2 of the drawing, and rout a $\frac{1}{8}$ "-deep rabbet along the bottom of the blank.

6 Stick a dowel through the $\frac{3}{4}$ " hole in the jig to push the blank free. Follow Step 3 on the drawing to finish routing the interior.

7 Set the pencil in a compass $\frac{5}{16}$ " from the point. As shown in the photo below, stick the compass point in the rabbet, and mark the oval exterior onto the blank. Cut the frame exterior to shape.



With a $\frac{5}{16}$ " gap between the lead and point of the compass, mark the oval perimeter on the frame.

8 Using a $\frac{3}{16}$ " round-over bit and Step 4 on the 4-step drawing at left for reference, rout round-overs on the outside edges of the oval frame.

ROUTING THE OVAL FRAMES TO SHAPE

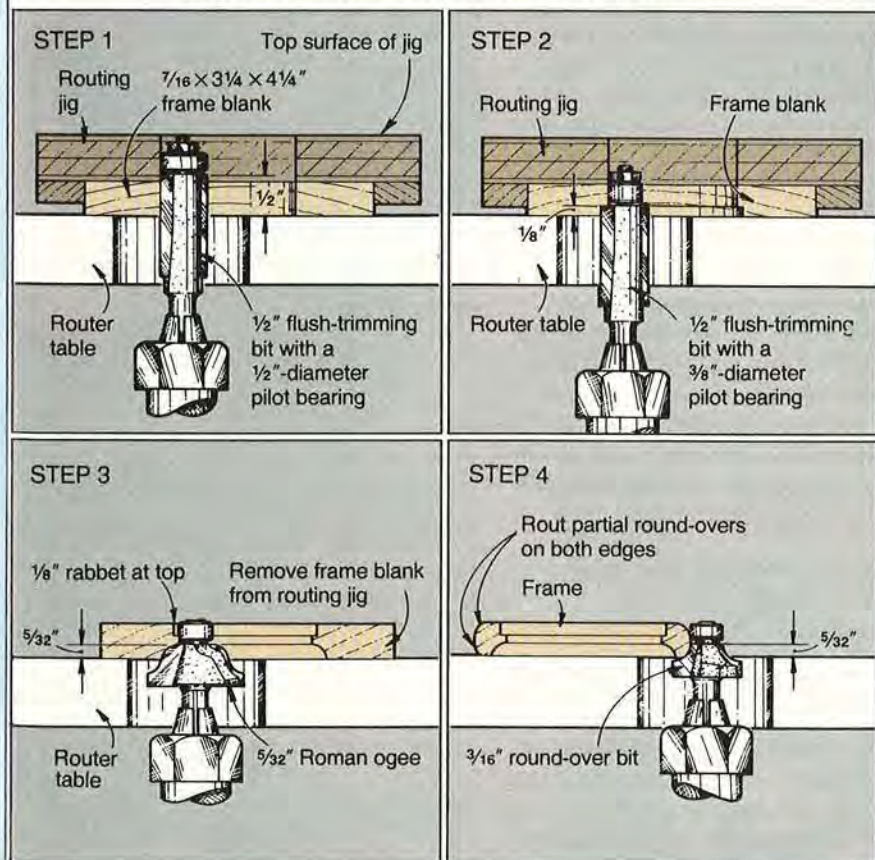

THE INSERTS COME NEXT

1 Lay the frame, rabbet side down, on a piece of $\frac{3}{16}$ "-thick stock. Hold a sharpened pencil at an angle, and trace the rabbeted opening's shape onto the $\frac{3}{16}$ " stock for the insert. Cut the insert to rough shape, cutting slightly outside the marked line. Sand to the marked line, and check the fit of the insert in the rabbeted opening in the oval frame. (We left about $\frac{1}{32}$ " gap between the frame and insert.)

2 Sand a chamfer along the back edge of the insert where shown on the Exploded-View Drawing.

3 Using the insert as a template, cut a piece of clear plastic (we used a Mylar page protector available at office-supply stores). Now, utilize the oval plastic insert as a template to cut the photo to shape.

Continued on page 90



TULIP TIME AT YOUR LATHE

CANDLE HOLDERS WITH A FLARE

Armed with a degree in woodworking and furniture design from Indiana University of Pennsylvania, Mark Burhans headed for the lathe to put his knowledge and skills to work. Six years later, this full-time



Mark Burhans

turner/furnituremaker markets a line of turned candle holders and weed vases. Mark, who lives in Athens, Ohio, prefers the local Appalachian hardwoods, such as cherry and walnut, for his creations.

bow grease, you also could file the opening to shape.

"I smooth the the sanded edges and finish-shape the flared top with a coarse and then a fine half-round file," says Mark (see the photo below). "Next, I wipe on a coat of Danish oil and let it

dry. Finally, I buff the candle holder with a muslin buffing wheel loaded with tripoli (a jeweler's polishing compound)." 🌿

Project Design: Mark Burhans,
95 Morris Ave., Athens, OH 45701
Photographs: Jim Kascoutas; Brian Blausser
Illustrations: Kim Downing; Bill Zaun

Another in a collection of designs from the nation's top woodturners

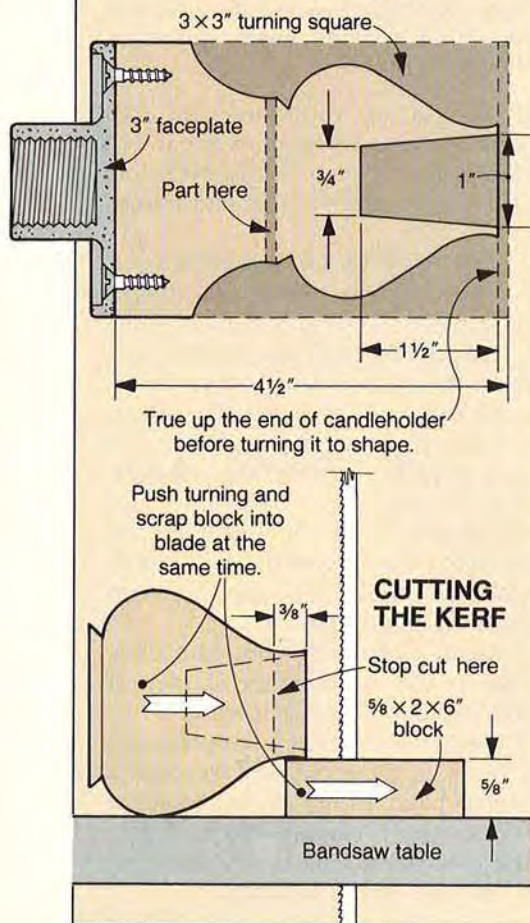

MOUNT THE STOCK AND TURN IT TO SHAPE

Mark starts by fastening a 3×3×4 1/2" block to his 3" faceplate. "I use a 1" spindle gouge ground to a 50° angle for roughing the block to a cylinder," Mark says. "All that's required is a sharp edge, a light touch, and good eye protection." With a parting tool and a lathe speed of 1,230 rpm, Mark trues up the top (the end opposite the faceplate) of the holder. Then, he switches to a 1/2" spindle gouge to turn the exterior to shape. A skew is used to form the V-cut for the base. (Make a full-sized template for help if necessary.)

Mark then moves the tailstock around to the end of the candle holder and calls on a parting tool to form the tapered opening. Smooth cuts leave the Ohio turner with little sanding before parting the holder from the waste stock.

FLARING THE TULIP TOP COMES NEXT

Mark supports the neck of the candle holder with a 5/8"-thick piece of stock, and cuts a kerf 3/8" into the center of the holder where shown in the drawing at left. Moving to a 1×42" strip sander, he slips the belt into the kerf and sands at an angle to flare the opening. Although it would take a bit more el-



Mark employs half-round files to smooth the belt-sanded edges of each candle holder.

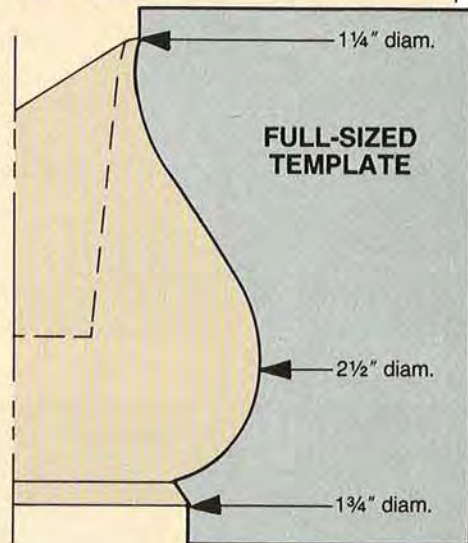

ORDER
TOLL FREE
1-800-288-7297
Extension 90

Professional Quality Woodworking Machines At Affordable Prices

SAW
STAND
On Sale!
reg. \$39.00
Now Only
\$26.00



New Low Price...

Super 15" Scroll Saw On Sale... \$119.95

Cut intricate wood patterns easily with this versatile machine. **Many extras, including:**
• Accessory package now worth \$52.00
• New "E-Z Set" Blade change system

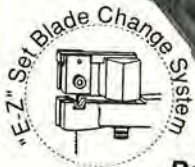

Add \$10 UPS Freight

FEATURES:

- **Parallel Rocker Arm Cutting System:** Drives the blade up and down, avoids blade breakage, polishes as it cuts, eliminates sanding.
- **"E-Z Set" Blade change system:** Clamps any thickness blade (down to "000" size) easily into the "E-Z Set" pivoting blade holders mounted permanently on the saw arms. Simplifies reattaching blades especially when making internal cuts.

SPECIFICATIONS:

- **Construction** Cast Iron
- **Throat depth** 15"
- **Max depth of cut** 2"
- **Machine weight** 43 lbs
- **Motor** - Heavy duty totally enclosed fan cooled 110-120V, UL listed, ball bearing induction motor
- **Blades** - uses 5" standard & pinend
- **Stroke length** 3/4"
- **Cut Speed** 1650/min
- **Table tilt** 0 - 45° to left

Options: Dust Blower & Saw Stand

Free with Purchase of Saw

- 12 Blade Assortment \$ 3.50 value
- Extra Std. Blade Holder set.... 8.50 value
- E-Z Set blade change system...15.00 value
- Neptune 1-1/2" plastic Lettering guide set & patterns..... 25.00 value

FREE ... \$52.00 VALUE

Scroll Saw and Accessories Price List

(Compatible with Penn State Super 15" Saw and Scroll Saws of similar design)

Super 15" Scroll Saw - complete & assembled
#SAW \$119.95 (\$10 UPS)

Dust Blower
Keeps your pattern line visible at all times, Our most popular accessory. Installation instructions included.
#BKT \$ 15.00/kit (*)

Scroll Saw Stand
37" high, drilled to align with saw, great convenience.
#STD ...reg \$39.00, **On Sale.... \$ 26.00** (\$4 UPS)

Scroll Saw Blades
#BPK - 4 dz asst (2dz Pinend, 2dz #9) ..\$ 14.00 (*)
#BPS - 2 dz Spiral blades (size #2)\$ 10.00 (*)

"E-Z Set" Blade Change System
(Free with purchase of saw). Includes top & bottom holders, all hardware and instructions.
#RET \$ 15.00/set (*)

Neptune 1-1/2" plastic Lettering Guide Set
(Free with purchase of saw). Includes upper & lower case alphabet + numbers + FREE patterns.
#LN1... reg \$25.00, **On Sale....\$ 12.00/set (*)**

Foot Switch
7 amp, 6 ft cord. For hands free operation.
#FSW.....\$ 20.00/ea. (*)

(*) No freight chg if ordered with Saw, \$3.00 for any combination of these accessories ordered separately

Don't settle for less from importers selling stripped down versions of our Saw

Super 125 Planer

Portable with "Power Feed" • Shipped assembled • Retail value over \$600.00

On Sale ... \$349.95



Add \$15
UPS
Freight

This machine will pay for itself time and again by planing your own lumber. At 65 lbs, you can carry this Planer to a job site or mount it permanently in your workshop like any stationary machine. **You'll spend hundreds of dollars less for this 12-1/2" power feed Planer than for a traditional stationary model of a similar capacity - with comparable results.**

SPECIFICATIONS:

- **Knives**.... 2ea, 12-1/2" wide, HSS
- **Motor** - 16 Amp, 115V, 8000 RPM
- **Auto Feed rate** 26.2 FPM
- **Cutting speed** 16000 Cuts/min
- **Thickness of stock** 3/16" to 6"
- **Size** ... 15-1/2"H X 22"W X 21" Bed
- **Max Depth of cut** 1/8"

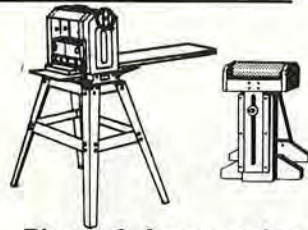

Free
plans for
roller stand
with
purchase
of rollers

Planer & Accessories Price List

Super 125 Planer - complete and assembled
#PLA \$ 349.95 (\$15 UPS)

Extra Set of 2 Knives - High speed steel, 12-12"
#PKN \$ 25.00/set (*)

Dust chute - for vacuum takeoff of wood chips
#PDS \$ 24.00 (\$3 UPS)

Planer stand - Heavy duty, 27-1/2" high
#PST ...reg \$44.00, **On Sale..... \$ 39.00** (\$6 UPS)

Ball Bearing Rollers - (Minimum purchase 2 rollers)
Build a roller stand, infeed/outfeed table etc. with these 13" X 2" Heavy Duty rollers. Purchase includes FREE plans for building the roller stand shown above.
#BBR \$ 6.50/ea (\$3 UPS/per order)

(*) No frt chg if ordered w/Planer, otherwise add \$3 UPS

DC-1 Dust Collector On Sale ... \$189.95

Keep your shop clean and safe from sawdust with our large capacity, commercial style system. This collector has up to 10 times more air flow than a Shop Vac and runs much quieter.

SPECIFICATIONS:

- 1hp, 110/220V (pre wired 110V)
- 610 CFM air flow • 6990 FPM air speed
- 2 Bags 15"dia X 22" • 20 gallon bag
- 4" inlet • Casters on base
- Weight 75 lbs • Size - 26"x15"x57"H

Free with Purchase of DC-1

20 Feet Of Duct Hose

4" To 3" Rigid Adaptor • 4" To 2" Flex Adaptor
Plans For 2 Stage Setup • Sources For Piping & Fittings

FREE ... \$15.00 VALUE



Add \$20
UPS
Freight

Penn State's Commitment

Our company has been in business for over 50 years. We unconditionally guarantee your satisfaction with our fine machines. All of our machines carry a Thirty day Money Back Guarantee and One year Warranty for Parts and Labor.

PENN STATE INDUSTRIES-W

2850 Comly Road • Phila, Pa 19154

Order Toll Free 1-800-288-7297 (Ext 90)

For information 1-215-676-7609 (Ext 15)

Visa, Master, & Discover Card accepted
Pennsylvania residents add 6% Sales Tax

Add UPS Shipping Charges as noted

Continental U.S. only (Call for shipping charges to other locations)

Plans & Kits

Mail Order Kits and Plans offer a wide variety of projects and many one-of-a-kind items. Start your rewarding and satisfying projects now! To order catalogs, circle the appropriate number on the Order Form.



Meisel Hardware

Plans for Holstein cow projects: Planters, doorstops, mug racks, electronic music boxes, tissue box holders and plywood yard ornaments. Order our Summer '89 catalog showing these and dozens of other project plans and specialty hardware kits for woodworkers.

Circle No 1 for \$1.00 Catalog



The Master's Workbench

Carousel Mare (13"x4"x12") - Mantel-sized woodworking treasures come in precut kits or plans. Also available:

Carousel Collection

- Armored Horse (13"x4"x12")
- Rabbit (14"x4"x13")
- Lion (14"x4"x8")

Victorian Collection

- Glider Pony (15"x5"x13")
- Rocking Horse (18"x4"x10")
- Pull-Along Horse (13"x5"x12")

Circle No 2 for \$1.00 Catalog



Adams Wood Products, Inc.

Build your own Queen Anne furniture! Just assemble our complete kits. Dining table and chairs shown above in unstained solid cherry. Other pieces available:

- 42" Round Dinette Table with cabriole base
- Hall & Sofa Tables
- Oval & Rectangular Coffee Tables
- Commode
- Lamp End Table

Available in solid cherry, oak, mahogany & walnut. No minimum order.

Circle No 3 for \$1.00 Catalog



Leichtung Workshops

Kits, Plans & More!

Full-Size Plans for:

- Roll-Top Desk
- Ultimate Rocking Horse
- Children's Rockers
- Toy Wagons
- Plus many more!

Complete Kits & Parts

- Classic Cars, Trains & Planes
- Wooden Wheels, Spindles...
- Clock Mechanisms
- "How-To" Books

...And The Tools To Put 'Em All Together!

Circle No 4 for Free Catalog



Quick 'N Easy Projects

Every issue of WEEKEND WOODWORKING PROJECTS™ Magazine is filled cover-to-cover with nothing but projects! You'll build a complete woodworking library with:

- 6-7 projects per issue (more than 36 a year!)
- Step-by-step instructions
- Shop-tested plans
- Plus you can finish these projects in a weekend!

6 issues (1 full year) only \$17.97.

Circle No 5 for \$17.97 Subscription



Countryside Woodworking

Freestanding Backyard Gyms! Eight Master Kits:

- Galaxy
- Enterprise
- Enterprise IV (shown)
- Space Tower Columbia
- Explorer & Explorer IV
- Space Tower Discovery
- Voyager

Eleven Options. Above ground installation, playground tested hardware. Will last a lifetime. Kits contain 40-yr. warranted lumber. All hardware, accessories and instructions.

Circle No 6 for \$1.00 Catalog



Emperor Clock Company

Known for its quality hardwoods and factory direct prices, Emperor Clock Company offers a broad selection of grandfather clocks, mantel clocks, wall clocks as well as furniture accent pieces, in do-it-yourself kit form or completely assembled and finished. Full color catalog.

Circle No 7 for \$1.00 Catalog



The American Clockmaker

Special 30% off sale! Solid cherry desk clock kit – only \$14.95 complete! Includes pre-cut wood parts, quartz movement, ivory dial, convex glass and antique brass handle. Stands 7 1/8" high.

A Wonderful Gift!

Order #1714-081, only \$14.95 (reg. \$21.90) plus \$3.50 shipping/handling (Wisc. res. add 5.5% sales tax).

Circle No 8 for \$1.00 Catalog



Craftplans

Our Catalog Offers Over 75 Projects Including:

- Adirondack Furniture
- Entertainment Centers
- Bird Houses/Feeders
- Computer Furniture
- Whirligigs
- Scroll Saw Patterns
- Children's Playthings

Plus Many More Available in solid cherry, oak, mahogany & walnut. No minimum order.

Circle No 9 for \$1.00 Catalog



Craftsman's Corner

We offer a full selection of outstanding furniture kits featuring top quality materials & outstanding workmanship. Craftsman's Corner Classic Oak Kits offer roll-top desks, file cabinets, oak furniture and accessory kits for your entire home at affordable prices. With these kits, you can build beautiful solid oak pieces with hand tools. Satisfaction guaranteed.

Circle No 10 for Free Catalog

Plans & Kits Order Form

Check the boxes of the catalogs you want to order:

- 1\$1.00
- 2\$1.00
- 3\$1.00
- 4Free
- 5\$17.97
- 6\$1.00
- 7\$1.00
- 8\$1.00
- 9\$1.00
- 10Free

Total for Catalogs: _____

Handling/Processing: \$2.00 _____

Total of check: _____

Make checks payable to:

Better Homes & Gardens®
WOOD Magazine

Mail with payment to:

Better Homes & Gardens®
WOOD Magazine

Dept. #SOPK89
P.O. Box 5103
Pittsfield, MA 01203-5103

(This coupon expires on
October 15, 1990)

Name _____

Address _____

City/State/Zip _____

WADDLES THE DUCK

Continued from page 45



Using the photo above for reference, sand the head and body to shape.

3 With a drum or disc sander mounted to your drill press, sand the head to the shape shown in the photo above. Then, wrap 100-grit sandpaper around felt or foam, and hand-sand the head smooth. Repeat the hand-sanding operation with 150- and 220-grit sandpaper.

4 Drill a pair of $\frac{3}{16}$ " holes $\frac{1}{16}$ " deep in the duck head for the eyes where shown on the Head Pattern Drawing on page 45.

ADD THE WHEELS AND HEAD TO THE BODY

1 From $\frac{1}{2}$ " dowel stock, cut the wheel axle to 4". For ease of insertion into the wheels, sand a slight chamfer on each end of the dowel.

2 Push a thumbtack into each wheel where marked. The tack prevents the wheels from rubbing against the sides of the duck body.

3 From $\frac{1}{4}$ " dowel stock, cut the neck dowel to $2\frac{1}{4}$ " long. Sand a slight taper on one end of the neck dowel. Hold a $\frac{1}{4}$ " nut with a pliers. Slowly rotate the tapered end of the neck dowel into the nut to thread the bottom of the dowel. After you've threaded the end of the dowel, remove the nut; we'll add it back after we've applied the finish. Glue the nontapered dowel end into the hole in the duck head.

4 Apply the finish to the duck body, head, and wheels (we left ours unstained and applied two coats of satin polyurethane). Mask the wheel axle to prevent getting any finish on it.

5 Stick the $\frac{1}{4}$ "-diameter, threaded neck dowel through the body. Holding a $\frac{1}{4}$ " nut with a needle-nosed pliers, thread the nut back onto the tapered end of the dowel. To keep the nut from ever falling off and being accidentally swallowed, add a few drops of instant glue to the nut and dowel.

6 Using white glue to extend working time, glue the axle dowel into the hole in *one* of the wheels. Wipe off excess glue. After the glue dries, stick the axle through the axle hole in the body. Glue the other wheel onto the dowel and immediately (before the glue sets), rotate the second wheel on the dowel until it aligns with the first wheel. Roll the assembly on a flat surface, the duck will roll smoothly and waddle easily once the wheels are aligned. Adjust the wheel alignment if necessary. Remove glue between the wheels and duck body with a damp cloth.

7 Cut a 30" length of $\frac{1}{8}$ " braided nylon. Tie a knot at one end and stick the other end through the rope hole in the duck body. Tie a second knot at the opposite end of the rope. Finally, give Waddles a pull and watch the kids—of all ages—come running.

BUYING GUIDE

• **Turned cherry stock.** $2\frac{3}{8}$ " diameter by $6\frac{1}{2}$ " long, \$10.50 ppd. (\$13 Canadian). Adams Wood Products, 974 Forest Dr., Morristown, TN 37814.

• **Cherry turning square.** 3" cherry turning square 12" long, catalog no. WD989, \$9.50 ppd. (\$12 Canadian). Constantine's, 2050 Eastchester Rd., Bronx, NY 10461. ♣

Produced by Marlen Kemmet
Project Design: Neil Seely, Rochester, NY
Photographs: Hopkins Associates
Illustrations: Kim Downing; Bill Zaun

Compare this offer with any other book club for Price • Quality • Benefits • Selection!

An absolutely no-risk guarantee.



1122P \$11.95



2778P \$14.95



2979 \$22.95



2994P \$12.95



2984P \$12.95



1530P \$15.95



3079 \$23.95



3154 \$24.95
Counts as 2



2964P \$6.95



2789P \$15.95



1675P \$9.95



3014 \$21.95



2829 \$29.95



2863 \$24.95

Select 5 Books for only \$395

(values to \$133.70)
and get a **FREE Gift!**



2878P \$14.95



2944 \$24.95



3053 \$19.95



3051 \$24.95
Counts as 2



2629 \$24.95
Counts as 2

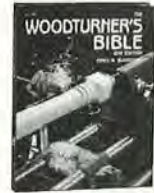

1954P \$16.95



2909P \$12.95



3001P \$23.95
Counts as 2



3064 \$21.95



2858P \$14.95



2774P \$14.95



3149 \$29.95
Counts as 2



3056 \$25.95



2811P \$17.95



1648P \$14.95



1381P \$15.95



HOW-TO BOOK CLUB

FREE
When you join!

15 Practical Woodworking Projects From Percy Blandford

Fascinating projects from master craftsman Percy Blandford include toys, furniture, a go-cart, and more!

15 PRACTICAL WOODWORKING PROJECTS
FROM PERCY W. BLANDFORD

a \$6.95 value!

Membership Benefits • Big Savings. In addition to this introductory offer, you keep saving substantially with members' prices of up to 50% off the publishers' prices. • **Bonus Books.** Starting immediately, you will be eligible for our Bonus Book Plan, with savings of up to 80% off publishers' prices. • **Club News Bulletins.** 14 times per year you will receive the Book Club News, describing all the current selections—mains, alternates, extras—plus bonus offers and special sales, with scores of titles to choose from. • **Automatic Order.** If you want the Main Selection, do nothing and it will be sent to you automatically. If you prefer another selection, or no book at all, simply indicate your choice on the reply form provided. As a member, you agree to purchase at least 3 books within the next 2 years and may resign at any time thereafter. • **Ironclad No-Risk Guarantee.** If not satisfied with your books, return them within 10 days without obligation! • **Exceptional Quality.** All books are quality publishers' editions especially selected by our Editorial Board.

WD939

(Publishers' Prices Shown)
All books are hardcover unless number is followed by a "P" for paperback.

If card is missing use this address to join. HOW-TO BOOK CLUB
Blue Ridge Summit, PA 17294-0800.

© 1989
HOW-TO BOOK CLUB
Blue Ridge Summit,
PA 17294-0800

SYSTIMATIC Blade Bulletin

Try a Budke Blade and see how many jobs a really great combination blade can do.

One of SystiMatic's original founders perfected the Budke Blade nearly twenty years ago. And we still think that this rugged blade does more jobs well than any other one carbide saw blade available anywhere. It rips, it crosscuts, it zips through solid wood, plywood or particleboard. And cuts 'em all

with amazing ease and smoothness. Carefully mounted on a well-tuned machine, the



Budke will give wonderful cuts and wonderful service. The tooth pattern combines four alternate top bevel teeth with one raker. The laser cut Budke Blade is available in 8, 9, 10, 12, 14 and 16 inch diameters. And you can get the ten incher with either 40 or 50 teeth. If you need an all-purpose blade, we heartily recommend the Budke Blade. (If you've never used a SystiMatic, it's a great blade to get started with.) Excellent value too—ask your SystiMatic dealer for prices. We sell only through professional saw shops and industrial tool suppliers. To find the SystiMatic dealer nearest you, just call us toll free at 1-800-426-0000. Extension 80.



professional saw shops and industrial tool suppliers. To find the SystiMatic dealer nearest you, just call us toll free at 1-800-426-0000. Extension 80.

SYSTI MATIC

SystiMatic Company
12530 135th Avenue Northeast
Kirkland, Washington 98034
(206) 823-8200 (800) 426-0000 USA
(800) 663-8001 Canada
FAX (206) 821-0804

Satinwood Products EASY-ONE-STEP TOUCH-UP KIT



FURNITURE
CABINETS
DOORS

- Permanent, invisible repairs
- Assorted colors for a perfect match
- Easy to use brush in each bottle

THE BEST WOOD TOUCH-UP
EVER DEVELOPED
OR YOUR MONEY BACK

Send \$9.95 plus \$2.00 shipping to:

Satinwood Products

9612 Kent Street

P.O. Box 1387

Elk Grove, CA 95759

CALIFORNIA RESIDENTS ADD SALES TAX

WOODWORKERS

Bosch

Orbital Action Jig Saw



1582VS

SALE
\$129.95 ppd

FREE CATALOG SUBSCRIPTION
WITH PURCHASE.

CATALOG ONLY.

2 year subscription (8 issues) \$4.00.

Free \$5.00 gift certificate with catalog order.

R. A. NESS & CO.

THE WOODWORKERS EMPORIUM

8888 N. MILWAUKEE AVE.

NILES, IL 60648

(312) 824-0565



PINT-SIZED PICTURE FRAMES

Continued from page 83

SHAPE THE FRAME SUPPORT

1 Transfer the front-view Support Pattern *below* to $\frac{3}{16}$ " stock. Cut the support to shape. Sand bevels on the support ends where shown on the Side View. (As an option, delete the support, and epoxy a magnet to the frame back for displaying photos on the refrigerator.)

2 Locate and glue the support to the back side of the insert.

3 Sand smooth, and apply finish to the frame, insert, and support.

FULL-SIZED SUPPORT PATTERN

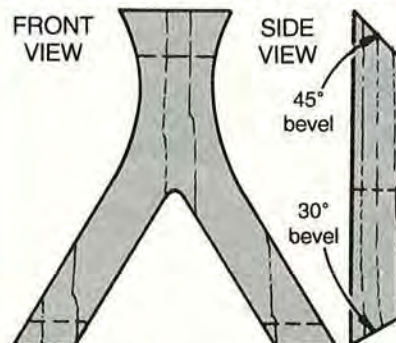

FINAL ASSEMBLY

1 Adhere the photo to the front of the insert with double-faced tape.

2 Slip the clear plastic into the back of the frame. Center the insert in the rabbeted opening and temporarily hold in place with masking tape. As shown in the photo *below*, apply silicone to hold the insert in place. Wipe off excess sealant. If you wish to change the picture later, use a hobby knife to slice through the pliable silicone. ♣



Apply silicone sealant between the frame and insert, and wipe off excess.

Project Design: Jim Boelling

Photographs: Hopkins Associates

Illustrations: Kim Downing; Bill Zaun

EARN \$18 AN HOUR!

Turn Your Spare Time into EXTRA INCOME!!!

Operate your own Profitable Saw & Tool Sharpening Business!



Sharp-All
lets you
easily
Sharpen
Saws, Shop
and Garden-
ing Tools for
Home and
Industry!



Now, use your spare time to generate low risk, high profit income to improve your lifestyle!

With the *Foley-Belsaw Model 1055 Sharp-All* it's easy for you to start your own profitable Saw & Tool Sharpening Business. Yours is a service business...there's no selling involved, no inventory required. You spread the word about your business and people just start bringing in their saws and tools for you to sharpen...it's that easy...and you pocket year 'round profits for the things you want to do.

Manage your own time and reap the rewards of financial success and job satisfaction!

You're your own boss, so you set the hours. Work in your spare time or build into a full time operation right at home in your garage, basement or tool shed. Work as much as you want, as long as you like.

Plenty of business just waiting for you to start your own Sharpening Business!

With all the new residential and commercial building in America today, more than enough business awaits you when you open your shop. Every home and business has saws and tools of all kinds that need sharpening periodically and with your Sharp-All you can service the needs of your community...no matter whether you live in a big city, small town or rural farm area...you'll be the sharpening headquarters for carpenters, builders, manufacturers, craftsmen, hobbyists and homeowners.

It's easy to get started, no experience necessary...and you deal direct with the factory for low prices!

You don't have to invest thousands of dollars to get started in business for yourself. In fact for less than \$2.00 per day, with the low cost Sharp-All and your desire to get ahead, our *Operators Manual and Guide to Profits* will provide all the necessary information and step-by-step illustrated instructions you'll need to get started. With Foley-Belsaw you deal direct with a dependable company with a history of providing independent businessmen and women with quality products and superior service since 1926.

**To get started ... just fill in the coupon TODAY and MAIL IT!
30-DAY FREE HOME TRIAL OFFER!**

We'll rush to you our *FREE "Lifetime Security" Fact Kit* by return mail...First Class! You'll receive full details on how to start your own profitable Saw & Tool Sharpening Business with no risk on our *30-Day FREE Home Trial Offer!* There's No Obligation to buy...and No Salesman will call.

READ WHAT THESE SUCCESSFUL SHARP-ALL OPERATORS SAY...

"Sometimes I make more in a week in sharpening than I do on my regular job. I still have a lot of years before I retire, but I can handle both full and part-time jobs without any trouble."

Don Lollar, Louisiana

"...the thing that impressed me most is that just about everything that Foley-Belsaw claimed turned out to be true. You normally read the ads you know, and tend to look between the lines for what it's really like, but with Foley-Belsaw it was a straight deal and whatever they said was true."

Al Krasnow, Connecticut

"I never sharpened a saw before in my life...only advertised in newspapers for 2 weeks and now I have more work than I am able to do. I have as many as one hundred saws ahead of me at a time."

Frank Sartin, Washington

"I have had excellent results with the Sharp-All...you just can't beat it...it is easy to set-up, doesn't take long to change stones...all in all, it's no trouble to work with."

LaVern Heim, Kansas

**ACT NOW! SEND FOR
FREE FACTS TODAY!**



Foley-Belsaw Company Since 1926
6301 Equitable Road, Dept. 20849
Kansas City, MO 64120

Yes, please rush my FREE "Lifetime Security" Fact kit on starting my own profitable Saw & Tool Sharpening Business!

NAME _____

ADDRESS _____

CITY _____

STATE _____

ZIP _____

PHONE (____) _____



The Woodworkers' Store

New!
35th Anniversary Catalog

- Over 3000 Items.
- Hard-to-Find Products
- Many Exclusives
- Selection Includes: Hardwoods, Wood Parts, Craftplans, Specialty Hardware, Finishing Supplies, Kitchen Accessories, Drawer Slides and much more.
- 24 to 48 Hour Shipment
- Satisfaction Guaranteed



Send Now! \$1.00 (3rd class)
\$2.00 (1st class)

Name _____

Address _____

City _____ State _____ Zip _____

21801 Industrial Blvd., Dept 1401
Rogers, MN 55374

RING MASTER



TEST YOUR IMAGINATION

Create Any Hollow Cylindrical Shape up to 12" dia. Cut flat wood into straight or angle rings, stack rings, glue, sand, & finish, All on your Ring Master.

Now Ring Master Attaches To Your

- SHOPSMITH MARK V
- CRAFTSMAN 12" LATHE

ORDER YOUR **FREE** BROCHURE TODAY

We accept Master Card, Visa, & C.O.D.
Call 1-800-634-9281 in NC 919 762-6334



Porta-Nails, Inc., P.O. Box 1257, Wilmington, NC 28402

WOODCRAFT FULL SIZE PATTERNS

A 16 Country Cat Projects
B. 14 Folkart Shelf Sitters
C. 12 Country Shell Designs
D. 75 Country Miniatures
E. 8 Country Shadowboxes
F. 45 Country Folkart Figures
G. 20 Craft Show Best Sellers
H. 9 Exclusive Folkart Horses
J. 10 Old Fashioned St. Nicks
K. 8 Jointed Figure Designs
L. 24 New Shell Critters

A THRU L—\$5.25 EACH
3 FOR ONLY \$13.50

The Winfield Collection, DEPT. W59
12044 Parkin Lane, Fenton, MI 48430
CATALOG \$1.00—FREE WITH ORDER

SCROLL SAW LETTERS EASILY...



...with Seyco's Layout Guides!

SPECIAL! (Style #RST-001) 1 1/2" (pictured above)

\$25.00 includes brochure and shipping cost.

Make Name Plates, Signs, Gifts and more.

Our unique Lettering Guides are available in many styles and sizes to suit your needs. Upper and Lower Case, Script and Block Styles...and numbers too. Send \$1.00 for brochure and prices to:

SEYCO The Scroll Saw Specialists

1414 Cranford Dr. • Box 472749 • Garland, TX 75047

TOOLS etc PORTER+CABLE BISQUIT JOINER SALE



#555

BISQUIT JOINER w/steel case \$169.95
#ADJF Adjustable fence for 555 \$69.95

0-10-20 Splines (1000) \$29.95
assorted box of bisquits add \$5.00

#555A—#555 Bisquit Joiner with case and adjustable fence. \$229.95

HITACHI 3 H.P. ROUTER KIT SALE

\$60 worth of

FREE Accessories:

- Straight Guide • Roller Guide
- Micro Guide Holder
- Template Adapter • 1/4" Collet
- 3/8" Collet • 1/2" Collet
- Carbide Bit • Template Guide



\$189.95

Freight Prepaid

TR12K with Fine Adjuster \$214.95

CNI Fine Adjustment Crank Only ... \$29.95

New fine adjustment crank allows you to easily adjust router height in router table position or regular position.

TOOLS etc

1567 S. Harbor Blvd., Fullerton, CA 92632

ORDER TOLL FREE

(800) 327-6250



EASY TO BUILD



Lyres
Harps
Banjos
Violins
Psalteries
Dulcimers
Many other
Musical
Instrument
Plans, Kits
& Supplies

Send \$1.00
for catalog

ST. CROIX KITS
Dept. 4B
423 S. Main St.
Stillwater, MN 55082
(612) 439-9120

ORDER TODAY

INSPIRATIONS IN WOOD UNIQUE NEW DESIGNS THAT YOU CAN BUILD

Our plans will help even the beginner create beautiful projects with ease.

- clear, concise, step by step instructions
- only basic hand tools required
- toys, furniture, home improvements and more

• sample plan included FREE with catalogue (\$5.00 value)

Catalogue only \$3.00

For first class, next day delivery of catalogue & sample plan write to:



D & D INSPIRATIONS

D & D INSPIRATIONS

P.O. Box 1852-W, Peterborough, Ont. K9J 7X6

Where Do Ohio's
Serious
Woodworkers Shop?

WOODCRAFTERS
SUPPLY Co

5331 Sinclair Road
Columbus, Ohio 43229
(Off I-71)
(614) 436-6900

CONCERNED ABOUT WORLD WOOD RESOURCES? BE TREESOURCEFUL

See related article on page 46

If you want to do something about any of the issues covered in our article "What's Happening to the World's Wood?" you can turn to a number of citizen-action groups. Those listed below sponsor active programs aimed at solutions.



The American Forestry Association (AFA), with cooperation from the U.S. Department of Agriculture, the U.S. Forest Service, and private conserva-

tion groups, has launched a national campaign to reduce carbon dioxide buildup in the earth's atmosphere by planting trees. The program focuses on urban and rural areas and will assist less developed countries with forest preservation and reforestation. You can support the program financially, with donations starting at \$15, or with involvement. Write: *Global Releaf, The American Forestry Association, P.O. Box 2000, Washington, DC 20013.*



Long the nation's sole promoter of tree planting, the National Arbor Day Foundation will provide you with a free booklet containing advice on how to plant and prune trees

for shade to cut cooling costs, windbreaks, and to offset the greenhouse effect. Order by writing: *Conservation Trees, National Arbor Day Foundation, Nebraska City, NE 68410.*



The EDF fights for national and international legislative action on a number of fronts, including wildlife protection, clean water

and air, and forest preservation. Memberships start at \$10 for seniors and students. For more information, write: *Environmental Defense Fund, 1616 P Street, Washington, DC 20077.*

GREENPEACE Known more for its seagoing efforts to stop the hunting of seals and whales, GREENPEACE actually encourages citizen action on a vast list of issues, including rainforest preservation. The organization's bimonthly magazine comes packed with timely articles and cites efforts you can join. Membership begins at \$20. Write: *GREENPEACE USA, 1436 U Street, NW, Washington, DC 20009.* ♻️

1/2" Shank Carbide-Tipped Router Bits Moulding Plane Profiles

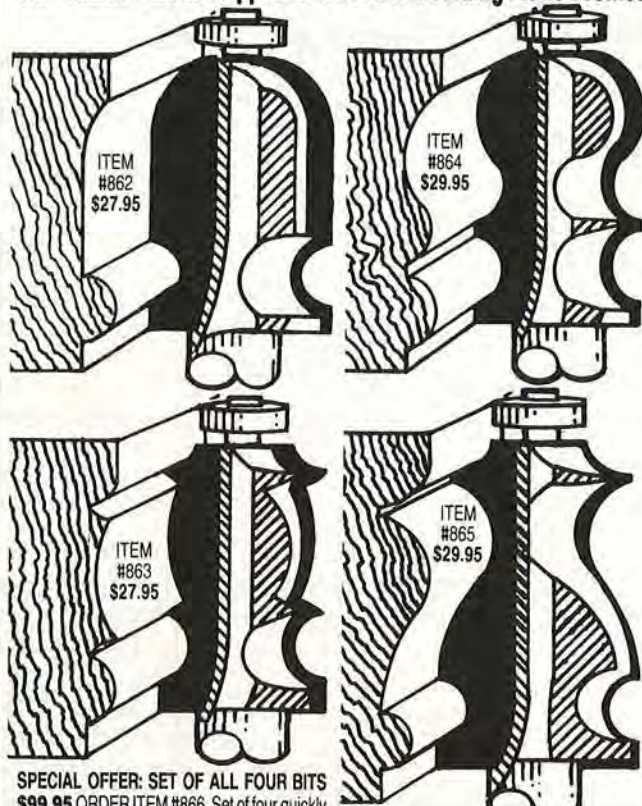

SPECIAL OFFER: SET OF ALL FOUR BITS \$99.95 ORDER ITEM #866. Set of four quickly produce classic traditional mouldings. Bits are shown Full Size - 2 Flute Carbide Tipped. Order by VISA / MasterCard, 7 Day / 24 Hour Service, Call 1-800-533-9298 or send check to: **MLCS Ltd., P.O. Box 4053DD, Rydal, PA 19046**

THE SANDER WITH STRONG APPEAL

POWER

For Abrasive Planing

PRECISION

For Flawless Sanding

SPEED

For Production Woodworking



Made In U.S.A.



SUPER-MAX Heavy Duty Drum Sander

The efficient design of the Super-Max combines the proven features of the Performax S/T Drum Sander and the Power Feed with a 5 HP motor and a heavy duty stand for the most affordable drum sander of its size.

The patented, self-cooling, sanding drum has built-in sandpaper fasteners for quick and easy sandpaper attachment without adhesives or tape.

The innovative Power Feed uses an abrasive conveyor belt for a hard, non-slip surface for precise sanding and a consistent feed rate. These exclusive features will uniformly sand veneers and boards as short as 2-1/4".

Performax Products offers a complete line of affordable and efficient drum sanders for use in cabinet shops, home workshops, custom furniture shops and in musical instrument making.

For a Free Brochure or the Dealer Nearest You Call or Write to:

PERFORMAX PRODUCTS, INC.

1-800-334-4910

12211 Woodlake Dr., SW, Burnsville, MN 55337

NOW! Get in on the PROFITS in

SMALL ENGINE REPAIR!



Start your own money making business!

Work part time, full time—right at home—we help you every step of the way.

No doubt about it... as a small engine pro, you can cash in on the huge demand for qualified men in one of America's fastest growing industries. You'll be able to command top hourly rates of from \$25.00 to \$30.00 per hour—and that's just for labor. A simple tune-up earns as much as \$49.95 for less than an hours work, and parts, engines and accessories will add even more to the profits.

Plenty of business waiting for qualified men. 65,000,000 Small Engines Are In Use Today!

That's the official count from the Engine Service Assn., and one-million new engines are being built each month. With fully accredited Foley-Belsaw training, you can soon have the skills and knowledge to make top money servicing these engines. People will seek you out and pay you well to service their lawnmowers, tillers, edgers, power rakes, garden tractors, chain saws, minibikes, snowmobiles, generators, go-carts, paint sprayers, snowblowers... the list is almost endless.



Professional Tools and Equipment, PLUS 4 H.P. Engine ALL YOURS TO KEEP... All at No Extra Cost. NO EXPERIENCE NECESSARY!

You don't need to be a 'born mechanic' or have any prior experience. You can master this profitable trade right at home in your sparetime. Lessons are fully illustrated...so clear you can't go wrong, and with our famous 'learn-by-doing' method you get practical 'hands-on' experience. We also show you how to get business, what to charge, where to get supplies wholesale...all the inside tricks of the trade you need to assure success right from the start.

Send for FREE Facts—Do It TODAY! NO Obligation—NO Salesman Calls!
You risk nothing by accepting this offer to see how easily you can learn the skills you need to increase your income in a high-profit business of your own. Just fill in and mail coupon below (or send postcard with name and address) to receive full information by return mail.

RUSH COUPON TODAY
 Foley-Belsaw Institute
 6301 Equitable Rd.
 Dept. 51703
 Kansas City, Mo. 64120



FREE BOOKLET!
 Send for your copy today!

FOLEY-BELSAW INSTITUTE
 6301 Equitable Rd., Dept. 51703
 Kansas City, Mo. 64120



YES, please send me the FREE booklet that gives full details about starting my own business in Small Engine Repair. I understand there is No Obligation and that No Salesman will call on me.

NAME _____
 ADDRESS _____
 CITY _____
 STATE _____ ZIP _____

TOOL INDUSTRY INSIDER



SCHEPPACH AIMS TO SERVE IN WAKE OF TOOLS-TO-GO DEBACLE

When Tools-To-Go, a Miami-based distributor of woodworking machinery, suddenly closed its doors for good in the summer of 1988, they left behind a trail of dissatisfied customers. Some woodworkers never received the equipment they ordered. Others who had purchased German-made Scheppach tablesaws, lathes, bandsaws, and other equipment were left wondering where they would find parts.

Now, Scheppach wants to see the needs of these customers served. Scheppach has provided transatlantic service since the downfall of Tools-To-Go and currently seeks an outlet to provide service in the U.S. To contact Scheppach for parts or information, write: Josef Scheppach, Maschinenfabrik GmbH & Co., D-8873 Ichenhausen, West Germany.

"BUYING U.S." ISN'T AS EASY AS IN THE PAST

WOOD® magazine receives a lot of letters from readers interested in buying U.S.-made tools. "Who makes their tools in the U.S.?" they ask. It was a lot easier to answer that question 10 years ago, but in today's global economy, the answer can be mighty elusive.

For example, if you're looking for a tool with only U.S.-made parts, forget it. "It would take a bible-sized book to tell someone where all the parts for power tools come from," says Dennis Huntsman of Porter-Cable. With only one portable woodworking tool in its line made overseas—a 3¼" planer—Huntsman estimates that the Porter-Cable product line "is more U.S. than most."

Gary Compton of Bosch agrees with Huntsman's assessment. "You won't find any tool that's 100 percent sourced in the U.S. For instance, Japan makes nearly all the ball bearings in power tools."

Among complete-line stationary power tool manufacturers, Delta (formerly Rockwell) and Powermatic products were synonymous with U.S. production. Now, because of foreign competition—primarily from the Orient—both firms manufacture some of their less-expensive machines in Taiwan.

One stationary-machine firm—Shopsmith—has resisted the shift to Taiwan. "We took a hard look at having some products built overseas, but we decided against it in order to maintain our quality levels," says Shopsmith's Scott Phillips. "We did see some benefit in exploring the idea, however. When we told the U.S. foundries manufacturing our castings that we were looking abroad for casting sources, their prices suddenly tumbled. Also, both quality and delivery times improved." Shopsmith manufactures its complete line of equipment in Dayton, Ohio. ♣

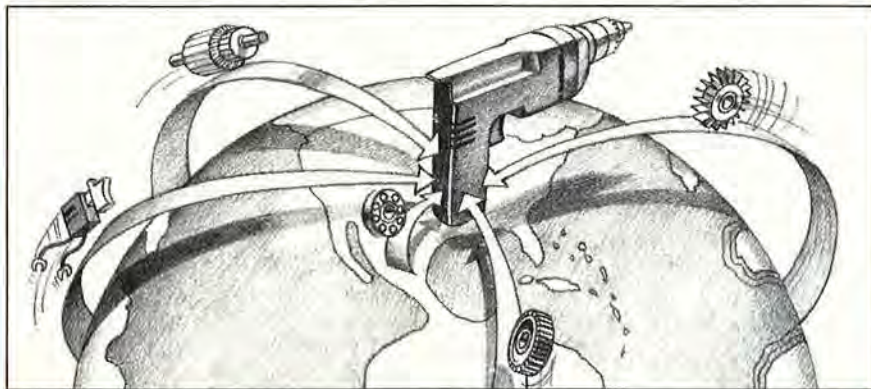

"Jorgensen"®

AND

"Pony"®

CLAMPS

Dependable extra hands for all types of clamping and work-holding jobs:
Woodworking Projects, Home Maintenance, and Furniture Repair.

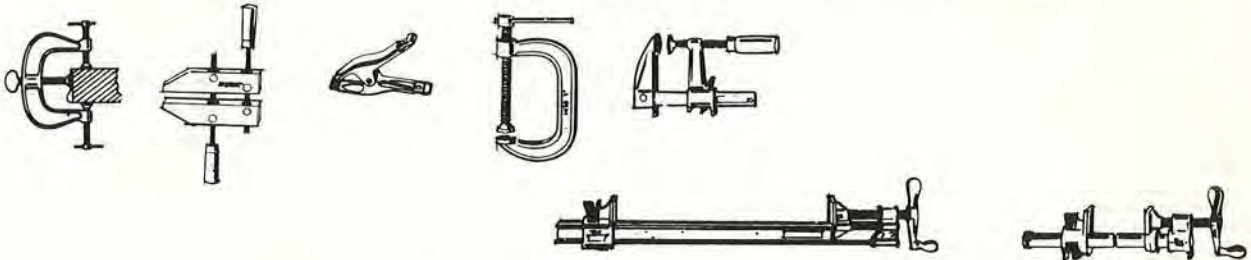

Write for FREE LITERATURE.

For big 32-page "how-to-clamp-it" catalog, send \$1.00.

ASK YOUR DEALER

ADJUSTABLE CLAMP COMPANY

THE CLAMP FOLKS

410 N. Ashland Avenue • Chicago, IL 60622

Special Limited Offer - Expires Oct. 31, 1989

FORSTNER BITS: WHAT THEY CAN DO FOR YOU

WHY OURS ARE BEST AND LEAST EXPENSIVE

Forstners, the only wood bits that can:

- Bore any arc of a circle at any angle
- Make entry holes in veneer, end grain, and knots
- Leave glass smooth walls and a flat bottom hole

Pros use them:

- For starting rabbets or grooves
- To make pocket holes to attach rails to tops, and rods, spindles and stretchers to legs
- To make blind holes for plugs and
- Through holes for locks

Best Because:

- Machined from high-carbon alloy steel
- Precision ground cutting edges, lifters and brads
- Hardened to HRC 50
- Mirror polished head to maintain splinter free entry holes

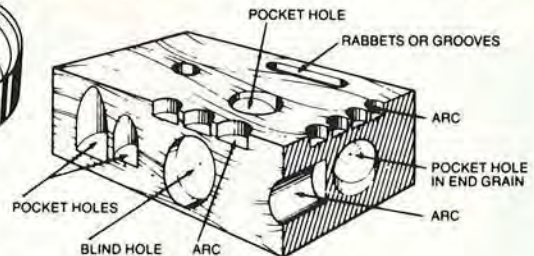

Inexpensive Because:

- Manufactured in China where the US dollar is still king
- Imported directly by us
- Our sincere desire to bring back sensible prices for woodworking tools

SPECIAL INTRODUCTORY OFFERS

BUY A 7-pc FORSTNER BIT SET (1/4, 3/8, 1/2, 5/8, 3/4, 7/8, 1") and we will give you FREE a 7-pc Brad Point Drill Set, a \$12.00 value.

Shp./Hndl. \$4.50
ORDER #10-1426 only **\$ 34.99**

BUY A 16-pc FORSTNER BIT SET (1/4, 3/8, 1/2, 5/8, 3/4, 7/8, 1, 1-1/8, 1-1/4, 1-3/8, 1-1/2, 1-5/8, 1-3/4, 1-7/8, 2, 2-1/8") and we will give you FREE a 25-pc Brad Point Drill Set in Metal Index, a \$29.95 value. Shp./Hndl. \$9.50

ORDER #10-1441 only **\$ 124.99**



All Forstner Bits fit 3/8" chucks and are 3-5/8" overall. FOR A FREE PRICE LIST OF INDIVIDUAL SIZES, SEND NAME AND ADDRESS TO: P.O. BOX 964, RIDGEFIELD, CT 06877

CALL TOLL FREE: 800-447-7770 • VISA / MC / AMEX

Dollar Trading Corp. (Est. 1953) • Dept. WM07C • P.O. BOX 8433 • GRAND RAPIDS, MI 49518
MI and CT Buyers, Please Add Sales Tax • 90 Day, Hassle-Free, Money Back Guarantee



On Jet Orders Over \$ 2000

Nationwide service, \$2,000,000 parts inventory and the most reliable warranty in the business. Jet is unquestionably the best value in woodworking.

CTAS-10 3hp, Sgl Ph + Blesemeyer #50	1299
CTAS-10 3hp, Sgl Ph + Excalibur	1299
CTAS-10 3hp, Sgl Ph + Vega	1249
JWS-18 Woodworking Shaper	335
JWS-34-1 Woodworking Shaper	895
WSS-3 Woodworking Shaper	1289
DC-610 Dust Collector	249
DC-1182 Dust Collector	399
JJ-4 4" Jointer	215
JJ-6 6" Jointer	325
JJ-8 8" Jointer	849
JBS-14MW 14" Bandsaw	335
JWP-15H 15" Woodworking Planer	895
JWP-208 20" Woodworking Planer	1489
JWP-13P 13" x 60" Widebelt Sander	4900
JWB-25P 25" x 60" Widebelt Sander	6395
JWB-37P 37" x 60" Widebelt Sander	9295

Call for quotes on other JET products!!!

Quantities limited at above prices. Order Now. Orders shipped from Santa Rosa, CA., Smyrna, TN. Tacoma, WA.



SANTA ROSA TOOL & SUPPLY, INC.

JET 12" Planer \$ 389



FREIGHT PREPAID

What a great value. This 2 hp JET Planer will handle boards up to 12-1/2". Features rigid steel plate table instead of weaker roller extension, safety key type switch, sturdy handwheel to adjust head. Planer stand \$39.95, rollerstand \$39.95. **New dust chute for planer only \$19.95!!!**

Jet Industrial Sanding Belts



We think Jet's sanding belt line is the best value in abrasives. Try them, and if you don't agree we will refund your money. (Min. Order 10 Belts). Orders over \$50.00 shipped FREE via regular UPS.

1 x 42	\$.65	4 x 24	\$.99
3 x 21	.75	6 x 48	2.95
3 x 24	.79	6 x 89	5.95

36, 60, 80, 100, 120 Grits

WE also stock a full line of AMANA & BOSCH router bits at 30 to 40 % off list price. Call now for FAST SERVICE.

Call for **FREE** catalog - Our 25th Year - CA residents add sales tax
(800) 346-0387 (800) 345-8665 in Calif.
FAX (707) 545-3705
 1651 Piner Road, Santa Rosa, CA 95403

The Japan Woodworker's Catalog is . . .

loaded with the best tools you can get your hands on. In our catalog you will find a complete selection of Japanese tools for the woodcarver, carpenter and cabinetmaker. Send \$1.50 for our catalog and supplements during the next two years.

THE JAPAN WOODWORKER
 1731 Clement Ave., Alameda, CA 94501
 Phone (415) 521-1810



38" High

Solid Wood

Rocking Horse Kit

Build this beautiful 38" rocking horse yourself, and have a family heirloom. Our rocking horse kit includes solid wood parts cut and shaped, with all trim included, for only \$69.99 ppd. Check of M.O. accepted.

Tampa Wood Products, Inc.
 Dept. WD1, P.O. Box 14427, Tampa, FL 33690
 Phone: (813)251-6583

EAGLE AMERICA

ROUTER BITS



Send for the complete mail-order catalog featuring over 700 different router bits and accessories. (Dealer inquiries invited.)

Send me a FREE catalog via 3rd class mail. (Allow 4-6 week delivery.)

RUSH me a copy TODAY via first class mail. I've enclosed a check for \$3.00 for special postage and handling.

BONUS - You will receive with your catalog a \$5.00 refund good towards your first purchase.

MAIL COUPON TO: **Eagle America** BHGW
 BOX 1099 CHARDON, OH. 44024

Name _____
 Address _____
 City _____ State _____ Zip _____

FREE!



OVER 400 TOOLS!

78 full-color pages of exclusive, innovative tools and accessories for the woodworker, do-it-yourselfer and hobbyist, all guaranteed! Mail in the coupon today...or call toll-free

800-654-7817 (Dept. 115)

Please rush my FREE catalog!

Name _____

Address _____

City _____

State _____ Zip _____

Mail to: Leichtung Workshops, Dept. 115
 4944 Commerce Pky. • Cleveland, OH 44128

A forest fire is no picnic.



A Public Service of This Magazine & The Advertising Council

We're looking for men and women who want to start earning an extra \$1,000-\$2,000 a month in their spare time.

HERE'S A WAY YOU CAN BE YOUR OWN BOSS AND MAKE \$55.00/hr. RIGHT FROM THE START...



Diane and John Goodman of Montana enjoy the special rewards of working together in their own chimney sweeping business. "I don't know of any other business with such low overhead, fabulous money and great hours—Thank you August West!" said Diane.

If you want to make big money part-time or full-time in a very serious business, then read on. We're looking for qualified men and women who want to earn upwards of \$55.00 an hour and don't mind getting their hands dirty.

START MAKING MONEY IN 30 DAYS

We'll help you every step of the way and show you how to be your own boss in less than 30 days.

It's a proven system that requires some hard work and dedication on your part. It also requires start-up capital of about \$2,000.

If you've got a few hours a week to invest in your financial future, chimney sweeping is for you.

MILLIONS OF DIRTY CHIMNEYS NEED TO BE CLEANED

Chimneys need to be cleaned and maintained on a regular basis to prevent the dangerous build-up and combustion of creosote. Even the smallest accumulation of soot can be a threat to home safety, and there are millions of dirty chimneys out there just waiting for disaster to occur.

TIME BOMB IN YOUR CHIMNEY

A quarter inch of soot contains a highly flammable substance called creosote. If a spark from your fireplace or woodstove ignites the creosote in your chimney—watch out! The draft gets stronger and stronger, and before you know it, the entire inside of the chimney catches on fire...and this excessive heat of the chimney can ignite the wood framing of your house.

There's really only one way to prevent these disasters from happening, and that's to clean a chimney before it catches fire. This is where you enter the picture...as a professional chimney sweep with the August West System.

The Mother Earth News calls it, "The Height of Technology," and we must admit there's nothing else like the August West System—the professional's choice!

The heart of the August West System is the famous SootSweeper®, a high-powered, high-volume dust collection unit which utilizes state-of-the-art filter technology. This revolutionary SootSweeper® allows you to efficiently clean a chimney in record time and guarantee cleanliness to your customers.

PART-TIME BUSINESS YIELDS FULL-TIME EARNINGS

At \$55.00 per chimney cleaning, usually done in under an hour, your totals for the day would look something like this:

3 chimneys × \$55 ea. = \$165 Monday
3 chimneys × \$55 ea. = \$165 Tuesday
3 chimneys × \$55 ea. = \$165 Wednesday
10 chimneys × \$55 ea. = \$550 Sat./Sun.

Weekly Total = \$1045

NOW HEAR IT FROM THE SWEEPS

When Chimney sweep **Tom Anderson of Irmo, South Carolina** isn't out brushing flues, chances are you'll find him behind a news desk brushing up on the weather forecast he's about to deliver on WIS-TV in Columbia, South Carolina. "In my first year as a sweep, I earned just five hundred dollars less than my yearly radio income...the second year saw a 55% increase in income over the first year." Not bad for a part-timer!

Diane and John Goodman of Montana who said: "Earn \$1,000 a week, right??? **RIGHT!!!** From day one we saw sweeping with the August West System as a fast way to reach our goal to build a house in the mountains. Our hard work has paid off, and the house is now completed." Not bad for a former insurance agent and nurse who traded their ties and titles for top hat and tails.

12 YEARS OF DEPENDABLE SERVICE

Many years and a tremendous amount of devotion have gone into the development of the August West System. We are a strong, national company with thousands of dedicated sweeps in our network! You can join us and count on us to help you build a business you can be proud of. We take pride in the proven quality of our equipment and service to you.

NO STRINGS ATTACHED

We're not selling you a franchise, and we don't take a percentage of your earnings.

August West does provide you with what you need to start making money immediately. That includes equipment, training, newsletters, workshops, advertising and promotion ideas, and even a top hat. MasterCard and VISA are accepted so you can pay in small monthly installments if you wish.

It really is possible to write your own ticket to success and happiness as a chimney sweep using the revolutionary August West System. It's a great way of life, part-time or full-time.

FREE INFORMATION KIT TELLS MORE

Call or write today to find out more about the growing field of chimney sweeping. You'll receive information that will convince you that it will be the best \$2,000 investment you'll ever make.

Call TOLL-FREE 1-800-225-4016 Ask for Extension 726

(In Mass.: 508-753-5544) Yes, please rush me your FREE Information Kit. or write:

August West Systems, Inc.

38 Austin St.
Box 658, Dept. 4408
Worcester, MA 01601

Name _____

Address _____

City _____ State _____

Zip _____ Phone _____

August West



ROBLAND

The Intelligent One Man Shop

- 10" Table Saw
- 12" Jointer
- 12" Planer
- Shaper
- Mortiser
- 50" Sliding Table
- 3 motors 3 HP. ea.

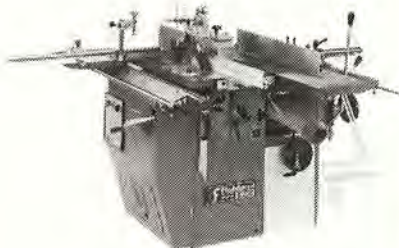

Video: Send \$4 (refundable) + \$2 S+H to Laguna Tools to receive a 40 min. video presentation, and learn why Robland X31 is the most popular one man shop in Europe.

For Information and your nearest dealer call

LAGUNA TOOLS

2081 Laguna Canyon Road
Laguna Beach, California 92651

1-(800) 234-1976

PRO TOOLS

& FASTENERS

725 N. Main St. • Orange, CA 92668

(714) 771-7977 • (800) 533-1630

RYOBI
POWER TOOLS



\$139
BE321
3" x 21" Electronic
Variable Speed
Belt Sander

\$249

RE600
3 H.P. Electronic Variable
Speed Plunge Router

\$329

JP-155
6 1/8" Variable Speed
Jointer-Planer

\$279

RA200
8 1/4" Portable Radial Arm Saw

\$389

AP10
10" Portable Planer

Thin Kerf Japanese Carbide Blades

4 3/8" X 40T = \$19

5 1/2" X 40T = \$19

6" X 40T = \$19

7 1/4" X 60T = \$24

8 1/2" X 60T = \$49



14" X 100T = \$89

15" X 100T = \$79

ASK WOOD

Whether your woodworker's license reads "Beginner," "Intermediate," or "Advanced," you're bound to have a few questions about your favorite hobby. We can help. We'll consult our staff and outside experts for answers. Send questions to:

Ask **WOOD**

Better Homes and Gardens®

WOOD® Magazine

1716 Locust St.

Des Moines, IA 50336



Due to the volume of mail, we can't promise to answer all questions, but we'll try. We may edit letters selected for publication.

LOOKING FOR A FEW FAVORITE WOODS

I have a problem obtaining two favorite woods in 2" thickness or greater. Beech has disappeared except for an occasional board. And, I can't find the other, American mahogany, with the straight grain necessary for carving.

—John Jankowski, Richmond, Va.

Beech—especially in thickness 2" and larger—can be tough to find because it isn't stable when kiln-dried, according to Bob Carr at EDLCO in Asheville, N.C. Bob suggests you try to match maple or birch for furniture repair. If you call Bob at 704/255-8765, he'll remember to keep his eyes and ears out for those thick slabs of beech you desire. But, your best bet may be air-dried beech from a local sawyer.

As for mahogany, hardwood dealers today import much of the genuine mahogany—also known as Honduras or American mahogany—from Brazilian plantations. Ask your lumber dealer to help you find the straightest grain on the market.

After talking with John, we learned he repairs a lot of 18th- and 19th-century furniture. The mahogany he buys—even the premium grades—has a clockwise or counterclockwise twist that John finds objectionable for hand carving.

CHERRY HOTLINE

I am a subscriber to **WOOD** magazine, and I really enjoy your publication. I would like to know how to achieve the deep burgundy of cherry like the furniture in stores. Is this a different type of furniture or is the finish? I want the deep, dark, almost black found in stores.

—Holly Coleman, North Powder, Ore.



Patience, Holly. Light-sensitive cherry darkens with age. Finish and aging will darken the freshly milled cherry you see in hardwood stores. But, the process could take up to two years. Some woodworkers add cherry-colored stain product to speed the darkening.

Continued on page 101

FULL SIZE

CHRISTIAN

Scroll/Band Saw Patterns

Crosses

Doves

Music

Acrostics

& More!



Great for gifts, church bazaars, craft fairs, etc.!

8 Wood Cutout Patterns

For \$6*

1 Peter 2:21

IN HIS STEPS

4089 Via del Bardo

San Diego, California 92073

*CA Residents add 7% Sales Tax

HAND SCREW CLAMPS

*Build Your Own Quality Clamps
For About \$3.00 Each*

- NO SPECIALLY THREADED SCREWS TO BUY
- USES READILY AVAILABLE HARDWARE STORE ITEMS
- NO SPECIAL OR HARD TO FIND TOOLS TO BUY
- BUILD WITH COMMON HOME SHOP TOOLS
- THESE QUALITY CLAMPS OPERATE THE SAME AS ONES COSTING 10 TIMES MORE
- BUILD ANY SIZE CAPACITY YOU NEED

COMPLETE PLANS, INSTRUCTIONS INCLUDING SHOP TIPS AND METAL DRILLING JIG FOR DRILLING BARREL NUTS AND BEARINGS.

PLANS + DRILLING JIG \$19.95. PLANS ONLY \$9.95.
ADD \$3.00 SHIPPING & HANDLING.
TEXAS RESIDENTS, ADD 8% SALES TAX.

CNJ ENTERPRISES

P.O. Box 476234 • Garland, TX 75047-6234

Full-Size Professional Plan ADIRONDACK CHAIR



Make this classic American design. Our special version may be folded for storage by using ordinary hardware available at your local store. Be ready for Summer and get your plan now!

Plan #700 \$12.95
(Catalog free with order)

CATALOG 200 full-size professional furniture plans — \$3.00

FURNITURE DESIGNS, INC. Dept. BA-109

1827 Elm Dale Ave., Glenview, IL 60025
(312) 657-7526

Van Dyke's

Presents a
Catalog

with supplies for upholstery, antique restoration, wood working, caning, brass hardware, carvings and many related trades!

36 Years in Creative Arts & Trades

Many Hard-To-Find Items!

**SEND \$1.00 FOR CATALOG TO:
Van Dyke's Restorers
Dept. D55 - Woonsocket, SD 57385**



CALL TOLL FREE!!



Learn all about combination machine woodworking. Free color catalog and other material available. Tremendous Savings. Expands your workshop area by 90 percent.



Dealer Inquiries Welcome!
1-800-535-4788 USA
1-800-325-8330 CA

National Carvers Museum

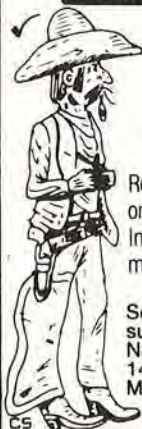

LEARN
WOODCARVING
AT HOME

Receive sample instructional pack on whittling and woodcarving. Includes copy of *Mallet* monthly magazine.

Send \$2.00 — deductible upon subscription payment to The National Carvers Museum, 14960 Woodcarver Rd., Monument, CO 80132.

(719) 481-4737

SPECIAL OFFER

BRANDING IRON

For hard and soft wood

\$24⁰⁰

HAND CRAFTED BY
YOUR NAME HERE

Plus \$2.00 for shipping and handling

Nebr. residents add correct sales tax

SATISFACTION GUARANTEED
or your money back

- Shipped in 1 week
- Solid brass head — deep cut letters
- First Line: HAND CRAFTED BY — as above
- 2nd line: Your choice — 20 characters/spaces max.
- Compact size
- As above but with 3rd line — \$37.00 + \$2.00

ORDER TOLL FREE 1-800-826-7606 (except Nebraska)
In Nebraska 1-402-464-0511

For free brochure, write or call (402) 464-0511

Order by mail from: **NOVA TOOL CO.**

12500 Fingnan Rd., Dept. BH
P.O. Box 29341, Lincoln, NE 68529



Furniture Restoration

Big Money in Small Business

*Stripping * Repairing * Refinishing
Mirror Resilvering * Veneering*

Earn \$200-\$1000 a day!

*At home or in shop * Spare time, full
time * Men or women * Complete
training, no experience necessary
* Simple, fast, safe, fun.*

FREE CATALOG

Video Brochure Available
Send \$2.00 for postage & handling to

**MINUTEMAN, INC., Dept. 17,
115 N. Monroe St., Waterloo, WI 53594**

FULL SIZE Woodcraft PATTERNS



SIMPLE TO MAKE * FUN * PROFITABLE

- 125 pattern packet PLUS "Shop Secrets"
- Over 50 "Folk Art" patterns PLUS projects
- 6 enjoyable "Wind-Action" whirligigs
- 100 yard ornaments, animals, birds and more
- 27 toy cars, trucks, train, ferry and more!
- 17 "Show Stoppers" - craft show best sellers

Send \$7.00 per blueprint packet or
choose any 3 FOR ONLY \$14.00.

Fast Service • Satisfaction Guaranteed!

ACCENTS Dept. MA99, Box 7387, Gonic, NH 03867

Catalog of 1000 patterns \$2.00 (Free with order)

Make a Toy for a Needy Child in Your Community at the WOODWORKING WORLD TOYS FOR TOTS FACTORY!*

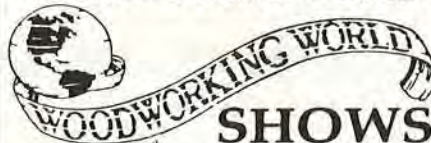

Rescheduled LONG ISLAND SHOW
Sept. 15-17, Nassau Coliseum, Hempstead, NY

THE CAROLINA SHOW
Sept. 22-24, McBenton Conv. Ctr., Winston-Salem, NC

THE CHICAGO AREA SHOW
Oct. 6-8, The Metro Center, Rockford, IL

THE CLEVELAND SHOW
Oct. 13-15, International Exposition, Cleveland, OH

**SAVE \$\$\$ ON EVERYTHING
FOR THE WOODWORKER!**

INFORMATION LINE 800-521-7623, M-TH
Woodworking Association of North America
POB 706 / Plymouth, NH 03264 / 603-536-3768

THE NEW ENGLAND SHOW

Oct. 20-22, Eastern States Exposition, Springfield, MA

THE NEW YORK SHOW

Oct. 27-29, Westchester County Center, White Plains, NY

THE CENTRAL NEW YORK STATE SHOW

Nov. 3-5, New York State Fairgrounds, Syracuse, NY

THE CENTRAL PENNSYLVANIA SHOW

Nov. 17-19, Harrisburg Farm Complex, Harrisburg, PA

Show Hours: Fri.* 5pm-9pm / Sat. 10am-6pm / Sun. 10am-5pm (*Chicago Show: Fri. 12-6pm)

*The Toys for Tots Factory is an officially sanctioned event of Toys for Tots sponsored by the United States Marine Corps Reserve

DMT® Diamond Whetstone™

The answer to
your sharpening needs

A few light strokes
will sharpen knives and
achieve perfect edges
on all tools.

- Durable • Fast
- Versatile • Clean

Available at quality
woodworking stores or

**DIAMOND MACHINING
TECHNOLOGY, INC.**

85-WD Hayes Memorial Drive
Marlborough, MA 01752



The Discerning Craftsman

(ADVERTISEMENT)

LUMBER YARD

- Select a wood species that's compatible with the project you're planning to build (there are several good reference books that list various species' characteristics and preferred uses).
- If you're planning to build several projects in the near future, consider ordering what you need for all of them at one time. That way, you'll have the stock you need when you're ready to build.
- If you or someone you know has a planer, and if you are willing to surface your own lumber, you can save money by ordering stock that's undressed (rough sawn).
- Figure your lumber needs, then add 15% for waste. As you do this, think in terms of the number of boards of a certain size it will take to yield the parts for your project. Make a cutting diagram showing how you plan to cut each of the boards.
- Send along a copy of the cutting diagram with your order, and explain the type of project you're planning to build. Both of these things help us in filling your order.
- Send for our product brochures, and keep them on file in your shop. That way, when you need a particular type of stock, you'll have ready reference.
- Buying in bulk lowers the cost per board foot. Consider going together with some of your woodworking friends, and take advantage of the savings. Some of us have minimum orders.
- Be aware of shipping costs. Is the price quoted a shipped price? How will it be sent? UPS? Trucking firm? Etc.? Ask.
- Upon receipt of your order, please inspect it and report any damaged material to the carrier immediately.



COMPARE
THE
FINEST QUALITY
AT THE
RIGHT PRICE

NORTHEASTERN HARDWOODS

Over 19 species of
domestic hardwoods

including:
RED OAK
CHERRY

HARD MAPLE
WALNUT
WHITE OAK
BIRDSEYE MAPLE
BUTTERNUT

HARDWOOD LUMBER
FLOORING
PANELING
MOLDINGS
THIN STOCK
VENEER

COMPETITIVE PRICES
NO MINIMUM ORDER
Send \$2.00 for Catalog

NORTHEASTERN HARDWOODS

P.O. BOX 365W • SALAMANCA, NY 14779
716-945-1510

Exotic Woods

The Sawmill is an excellent wholesale source for exotic and domestic hardwoods, and musical instrument components.

Call toll free 800-345-3103*
for price lists and information.

For specialty woods, Martin memorabilia, guitar kits or parts, with no minimum order, ask for Woodworker's Dream

*In Pennsylvania, call (215) 759-2064

The Sawmill

THE MARTIN GUITAR COMPANY
Nazareth, Pa. 18064

Thin HARDWOOD—Priced Right

Clear • Kiln Dried • 2 Sides Surfaced
3" to 10" Widths • 2' to 7' Lengths
20 Sq. Ft. Packs • Random Widths & Lengths

Circle wood desired	1/8"	3/16"	1/4"	3/8"	1/2"	3/4"
Red or White Oak	\$32	\$40	\$41	\$42	\$44	\$62
Pecan	30	31	32	34	36	50
Walnut or Cherry	34	42	43	46	50	68
H. Maple or Birch	32	38	39	42	46	62
Poplar or Basswood	30	34	36	38	42	52
Hond. Mahogany	37	39	44	52	62	71
Teak 5" w	62	64	67	72	100	130
Ash Or Sassafras	32	40	41	42	44	62
Purpleheart	65	72	80	90	100	125
Padauk	52	60	66	72	82	100
Aro, Red Cedar 2" to 10" w 12" to 48" L, light knots	32	34	36	40	42	46

Price includes UPS delivery in Continental USA
To order circle wood & dollar amount above.
Send with check or money order to:

HARDWOODS OF ILLINOIS
R.R. 4, Box 618 Mt Vernon, IL 62864



APPALACHIAN HARDWOODS

Beautiful grain and textures. Exceptionally workable. Our Appalachian hardwoods are locally grown, personally selected and kiln-dried... a guarantee of our measure of quality. ■ We handle 21 species of domestic hardwoods, softwoods and hard-to-find imports. ■ Send \$2.00 for our catalogue today (refunded with order). All purchases at delivered prices. **EDLCO**

P.O. Box 5373-A, Asheville, N.C. 28813
For fast service, call 1-704-255-8765

Quality EXOTIC WOOD TURNERS

Burls / Thick Planks / for Bowls / Squares

CABINET MAKERS

Individually Selected Lumber for
Furniture / Boxes / Inlays
OVER 70 SPECIES

All Inquiries Welcome - Call or Write

THE Berea Hard Woods Co.

125 JACQUELINE DRIVE, DEPT. 10
BEREA, OHIO 44017
216-243-4452

"It's a Matter of Pride for Both of Us"

DOMESTIC & FOREIGN HARDWOODS

Quality stock for Cabinet Work
Most all sizes from 1" to 4" in thickness

HARDWOODS

ASH—BASSWOOD—BIRCH
BUTTERNUT—CHERRY
CHESTNUT—EBONY—MAPLE
OAK—POPLAR—ROSEWOOD
TEAK—WALNUT
Also hardwood plywoods

SOFTWOODS

SUGAR PINE—CYPRESS—CEDAR
SPRUCE—DOUGLAS FIR etc.
MAURICE L. CONDON CO., INC.
242 Ferris Ave., White Plains, NY 10603
914-946-4111
Monday through Friday 8 AM to 4:30 PM

SHAKER PEGS CANDLE CUPS MUG PEGS

\$17.95 per 100, prepaid.
Wide selection of other
wood products.

Catalog \$2.00 or free with order.

Benny's Woodworks

P.O. Box 840, Dept. WD17
Shelbyville, TN 37160
1-615-437-2295



Shaker Peg

Mug Peg

If you would like more
information about
advertising in WOOD,
contact:

Terry McIntyre
WOOD Magazine
750 Third Avenue
New York, NY 10017
212-551-7130

ASK WOOD

Continued from page 98

I cut down a cherry tree about a year ago, and decided to save a few limbs for turning on my lathe. I stored the limb pieces in my garage for drying. Later, when I decided to turn a few pieces, I discovered that all the logs were so badly checked that I couldn't use them. How do you prevent wood from checking?

—S.B. Quincy, Bloomington, Ill.

We coat the cut ends of wood with paraffin, although paint works well, too. Sealing the end grain slows the release of moisture and lessens the chances that the wood will check. Remember to leave the bark on the limbs and dry them slowly.

THAT DEVIL, SILICONE

I built a table about a year ago and finished it with polyurethane. Recently, I decided to put on additional coats. To my surprise, the first coat turned out be fish-eyed looking. What did I do wrong? Could it have been the furniture polish?

—Albert Turner, Plano, Texas



In a word, yes. You've been unlucky enough to find out why many people avoid aerosol "polishes" that contain silicones—they're the culprits that cause fish-eyes in finish. Albert, you'll have to remove all the finish and start over. For more information about problems with silicone polishes, see our furniture-waxing article in the June 1989 issue.

CHAIR ON THE LOOSE

I'm looking for advice on tightening some loose legs and rungs on my antique oak plank chairs. I want to take the legs and rungs completely apart so I can properly re-glue all the joints. I tried to loosen the parts by twisting them, but had no success. What method or technique could I use to remove the partially glued parts?



—Daryl Rabert, Chicago

Daryl, an article in our August 1989 issue had some good tips about using bar clamps to gently break glue joints. Also, try dabbing finish stripper around the joint—but be careful if you don't plan to refinish the chair. (It may take a second or third application to make this work.) And, if that doesn't do the trick, flow on a solvent such as acetone or lacquer thinner while working the parts back and forth. We recommend epoxy glue to reassemble the chair. Epoxy fills gaps, dries hard, and cleans up easily.

Continued on page 103

Have a problem with your subscription?

We want to solve it to your complete satisfaction, and we want to do it fast. Please write to: Robert Austin, *Better Homes and Gardens*® WOOD®, P.O. Box 10628, Des Moines, Iowa 50336.

You can help us by attaching your magazine label here, or copy your name and address as it appears on your label. Send this along with your correspondence.

Name _____
Address _____ Apt. # _____
City _____ State _____ Zip _____

Moving?

Simply attach the mailing label from this magazine and write in your new address below. (Please allow 4-8 weeks.)

Name _____
Address _____ Apt. # _____
City _____ State _____ Zip _____

For Fast Service...

...it is better to write us concerning your problem and include the magazine label. Also, address changes are handled more efficiently by mail. However, should you need to reach us quickly the following toll-free number is available:

Subscription Rate:

6 issues — 1 year — \$18. Add \$6 for Canadian, or \$12 for other foreign subscriptions.

Renewal New Order

1-800-678-2666

WOOD
magazine

EO: Box 10628 • Des Moines, Iowa 50336

STEVE WALL LUMBER CO.

Quality Hardwoods and Woodworking Machinery For
The Craftsmen and Educational Institutions

			UPS Special
Ash	4/4	Select 1.90	\$ 53.00
Basswood	4/4	Select 1.30	\$ 43.00
Birch	4/4	Select 1.60	\$ 49.00
Butternut	4/4	Select 1.60	\$ 49.00
Cherry	4/4	Select 2.25	\$ 60.00
Hickory	4/4	Select 1.20	\$ 41.00
Mahogany (Genuine)	4/4	Select 2.50	\$ 67.00
Maple (Hard)	4/4	Select 1.45	\$ 46.00
Maple (Soft)	4/4	1C+Btr. .90	\$ 37.00
Pecan	4/4	Select 1.20	\$ 41.00
Poplar	4/4	Select 1.10	\$ 37.00
White & Red Oak	4/4	Select 1.80	\$ 35.00
Walnut	4/4	Select 2.35	\$ 62.00
Cedar (Aromatic Red)	4/4	1C+Btr. 1.25	\$ 40.00
White Pine	4/4	F.G. .90	\$ 35.00

Above prices are for 100' quantities of kilndried rough lumber sold by the Bd. Ft. FOB Mayodan, NC.
Call for quantity discounts. Other sizes and grades available.

Above prices are 20 bd. ft. bundles of clear kilndried lumber 3"-10" wide • 3'-7' long (Random widths & lengths). Surfaced 2 sides or rough. Delivered UPS—prepaid in the Continental U.S.

Send \$1.00 For Lumber and Machinery Catalog

Call For Best Prices On
RBI - **DELTA** - MiniMax

STEVE H. WALL LUMBER CO.

BOX 287 • MAYODAN, N.C. 27027

919-427-0637 • 1-800-633-4062 • FAX 919-427-7588

TUNGSTEN CARBIDE ROUTER BITS

- Heavy duty industrial quality
- 1/4 by 1-1/4 inch long shafts
- Enclosed Ball Bearing Guides
- Tools exceed AISI standards



Corner Round-over

Radius	Price
1/4 "	\$12.50
3/8 "	\$13.75
1/2 "	\$14.50



Cove Bits

Radius	Price
1/4 "	\$14.50
3/8 "	\$15.50
1/2 "	\$17.00



45° Chamfer Bits

Diameter	Price
1 "	\$12.00
1-1/4 "	\$14.00
1-1/2 "	\$15.50

100% Money Back Guarantee

Order now - Toll free
1-800 767-4747 Anytime

Visa - Master Charge Ok

Or mail check to:

SKYCROFT TOOLS, INC.

P.O. Box 418W1

Myersville, MD 21773-0418

ScrollMate 21" ScrollMate Scrollsaw

NEW MODEL!



- **BIG Capacity**
21" Throat depth, full 2" depth-of-cut.
- **5-Speeds**
—170, 450, 790, 1140 & 1370 strokes-per-minute
- Handles a variety of materials.
- **Built-In Air Bellows** (standard).
- **HUGE, Tilting Table** (14" x 22-1/2").
- **Smooth, Quiet Operation.**
- **Sturdy Steel Stand** (included).
- **Durable Construction**—Made of rugged cast aluminum for a lifetime of dependable service.
- **Value-Priced**—One of the best scrollsaw bargains you'll find!

LIMITED 2-YEAR WARRANTY

SEND TODAY FOR YOUR **Free** FACT KIT



Send your mail-in inquiry to:

P.O. Box 710-CG
Xenia, Ohio 45385
Or call TOLL-FREE — 1-800-533-3728
Dealer Inquiries Invited

RYOBI BEST BUYS!

TS-251U Miter Saw \$178.

AP-10 Planer \$348.

RE-600 Router \$198.

JP-155 6' Jointer \$328.

RA-200 Radial Saw \$238.

TOOL CRIB
OF THE NORTH
DIVISION OF Acme Electric
1-800-358-3096

* FREE FREIGHT * SAME DAY SHIPPING *

WOOD TOY

- ★ Patterns
 - ★ Parts
 - ★ Wheels
 - ★ Many New Patterns to Choose from.
 - ★ Executive toys
- SEND \$1.00 FOR NEW CATALOG & RECEIVE COUPON FOR FREE WHEELS & AXLE PEGS.

toys and joys
Box 628W Lynden, Wash. 98264

MAKE UP TO \$26⁰⁰ an HOUR BE YOUR OWN BOSS

START YOUR OWN MONEY MAKING BUSINESS
Hundreds of FOLEY-BELSAW trained men have succeeded in this fascinating and highly profitable field...

You Can Do It Too! ... BE A **LOCKSMITH** **FREE BOOKLET**

Never before have money-making opportunities been so great for qualified locksmiths. Now lucrative regular lock and key business has multiplied a thousandfold as millions seek more protection against zooming crime. Yet there's only one Locksmith for every 17,000 people! Train FAST at Home — Collect CASH PROFITS Right Away. You're in business ready to earn up to \$26.00 an hour a few days after you begin Foley-Belsaw's shortcut training. Take advantage of today's unprecedented opportunities in Locksmithing for year-round EXTRA INCOME in spare time — or full time in a high-profit business of your own. Hundreds we've trained have done it. So can YOU! All tools plus professional Key Machine given you with course. These plus practice materials and equipment, plus simple, illustrated lessons, plus expert supervision, plus business-building guidance will enable you to KEEP THE MONEY COMING IN! Ideal for retirement — good jobs, too.

SEND FOR EXCITING FACTS — NO OBLIGATION! PRO KEY MACHINE YOURS TO KEEP FREE

This machine can add up to \$200 a month to your income... it won't cost you a penny extra with your training.

FIND OUT ABOUT IT RUSH COUPON TODAY

There is NO OBLIGATION * NO SALESMAN Will Call - ever!

FREE FOLEY-BELSAW INSTITUTE
6301 EQUITABLE RD., DEPT. 11668
KANSAS CITY, MO. 64120
PLEASE RUSH FREE BOOK "Keys To Your Future"

NAME _____
ADDRESS _____
CITY-STATE-ZIP _____

Save on... Band Saw Blades Scroll Saw Blades

Free Catalog from OLSON®

Save up to 50% on the Finest Quality Band and Scroll Saw Blades.



Band Saw Owners...
Hard edge, flex back for general purpose sawing; NEW furniture band for cutting wood faster and smoother; and special thin gauge blades for bench top and 3 wheel saws. Welded to the length you need or in 100' coils.

Scroll Saw Owners...
A huge selection of plain or pin end scroll saw blades; fret, spiral and jewelers (metal piercing) saw blades.

Name _____
Address _____
City _____
State _____ Zip _____

OLSON CATALOG SALES
Route 6, Dept. WM
Bethel, CT 06801(203) 792-8622

Wood Moisture Meter

- Avoid Moisture Problems
- Protect your Masterpiece

MINI LIGNO
Incl. Case, Batteries and Pins for 3/8" and 5/8" Measuring Depth.
only \$110

also from Lignomat: **MINI-LIGNO E** Range: 6%
Easy-to-use, sturdy instruments for the professional woodworker or serious hobbyist. Great for lumber, veneer, fiberboards. Ask for free catalog on the complete line of moisture meters and accessories for kiln drying.

Lignomat USA Ltd. PO. Box 30145bh
503-257-8957 800-227-2105 Portland OR 97230

\$2 Brings you our latest Tool Catalog plus the next 2 issues of Wood News

Our TOOL CATALOG features over 2500 useful woodworking tools, books and supplies.

WOOD NEWS is our popular twice-yearly 48-page magazine chock full of helpful articles on getting the most out of your woodworking tools.

SUBSCRIBE TODAY!
Send \$2 to:

highland hardware
1045 N. Highland Ave, Dept B31
Atlanta, Georgia 30306

ASK WOOD

Continued from page 101

FILLING IN A READER ON FILLERS

I've read several articles advocating the use of special wood filler on porous woods such as walnut and oak.

I've tried repeatedly to find this filler in my area, only to be met with blank stares in paint stores.

I've looked in wood hobby shops, hardware stores, paint-supply stores, and lumberyards. All offer to sell me wood filler (putty used to fill cracks and holes), but only one person admitted to knowing there was another type of filler.

—Larry A. Wolfe,
Pratville, Ala.

Larry, we turned to Jim Boelling, our Project Builder, for an answer: "As I see it, Larry's problem is that he's asked clerks—who might not know a lot about finishing—for the wrong product. And, paste wood filler is not in heavy demand.

"Much of the trend in the last 15–20 years has shifted away wood fillers because open grain has been more popular. Unfilled, open-grained woods absorb more pigment color from stains, and accentuate the grain. On the other hand, filler has a tendency to

uniformly smooth out natural grain contrasts (heartwood and sapwood). Thus, wood fillers have a more subtle overall effect on color and grain.

"Sherwin-Williams Co., with more than 2,000 stores, sells a product called "Fast-Dry Semi-Paste Filler" (catalog no. D70T1). Also, Pratt and Lambert sells a natural paste filler (catalog no. F24)."

WHAT'S THE ACTUAL DIMENSION?

I have a problem. When I want to make a spice rack, jewelry box, or any other project, the plans often call for 1/2" wood. I know that a 2x4 isn't exactly 2" x 4", but a lot less. But how do they measure hardwood?

—Alice Dubamel, Iron Springs, Alberta

This is one of the mysteries of buying wood, Alice. Lumberyards sell dimensional material. Today, a 2x4 actually measures 1 1/2 x 3 1/2". A hardwood lumberyard, however, sells by the board foot (1" thick, 12" wide, and 12" long equals 1 board foot). You should find most 1/2" hardwood boards, for example to measure 1/2". But check carefully: The mill may leave the 1/2" board slightly rough at 1 1/32". If they dress it down to 1/16", they may charge more.

Continued on page 105



USE THIS AD TO ORDER

Our 11th ANNIVERSARY Gift To You!

ACT NOW! Buy 1-Dozen Belts



12
Get 6 Belts FREE!

SANDING BELTS

Available in 36, 40, 50, 60, 80, 100, 120, 150, 180, 220, 240, 320 grit sizes. Please specify when ordering. We will ship an assortment of 24 Fine, Medium and Coarse unless otherwise specified. BELTS - x weight, a/o, cloth.

- 1 1/2" x 21" \$13.50/doz.
- 1" x 30" 15.50/doz.
- 1" x 42" 15.70/doz.
- 1" x 44" 15.75/doz.
- 2" x 48" 19.50/doz.
- 2 1/2" x 16" 16.50/doz.
- 3" x 18" 16.75/doz.
- 3" x 21" 17.75/doz.
- 3" x 23 3/4" 17.90/doz.
- 3" x 24" 18.00/doz.
- 3" x 27" 18.50/doz.
- 4" x 21" 19.95/doz.
- 4" x 21 3/4" 20.00/doz.
- 4" x 24" 21.50/doz.
- 4 1/2" x 26" 21.95/doz.
- 4" x 36" 24.95/doz.
- 4" x 52 1/2" 34.95/1/2 doz.*
- 6" x 48" 32.95/1/2 doz.*
- 6" x 89" 57.95/1/2 doz.*
- 4" x 132" 59.95/1/2 doz.*

STIKY DISC

Stiky Disc, Rugged Cloth. Buy 5, get 1 FREE. Available in 50, 80, 120, 180, 240 grit size.

- 6" diameter \$5.00/pk.
- 8" diameter 6.25/pk.
- 9" diameter 7.50/pk.
- 12" diameter 10.00/pk.

BELT CLEANING STICK \$6.95
Makes your Belts, Discs, Sleeves last 3 x as long.

9" x 11" PAPER SHEETS

A/O Cabinet Paper (Brown)

- | | |
|--|-----------------------------------|
| 40-D ... <input type="checkbox"/> 50/pk. | <input type="checkbox"/> 100/pk. |
| 50-D ... <input type="checkbox"/> \$17/pk. | <input type="checkbox"/> \$31/pk. |
| 60-D ... <input type="checkbox"/> 16/pk. | <input type="checkbox"/> 28/pk. |
| 80-D ... <input type="checkbox"/> 15/pk. | <input type="checkbox"/> 26/pk. |
| 100-C ... <input type="checkbox"/> 14/pk. | <input type="checkbox"/> 24/pk. |
| 120-C ... <input type="checkbox"/> 13/pk. | <input type="checkbox"/> 22/pk. |
| 150-C ... <input type="checkbox"/> 13/pk. | <input type="checkbox"/> 22/pk. |

Garnet Paper (Red)

- | | |
|--|-----------------------------------|
| 40-D ... <input type="checkbox"/> 50/pk. | <input type="checkbox"/> 100/pk. |
| 50-D ... <input type="checkbox"/> \$17/pk. | <input type="checkbox"/> \$31/pk. |
| 60-D ... <input type="checkbox"/> 16/pk. | <input type="checkbox"/> 28/pk. |
| 80-D ... <input type="checkbox"/> 15/pk. | <input type="checkbox"/> 26/pk. |
| 100-C ... <input type="checkbox"/> 14/pk. | <input type="checkbox"/> 24/pk. |
| 120-C ... <input type="checkbox"/> 13/pk. | <input type="checkbox"/> 22/pk. |
| 150-C ... <input type="checkbox"/> 13/pk. | <input type="checkbox"/> 22/pk. |
| 180-A ... <input type="checkbox"/> 12/pk. | <input type="checkbox"/> 20/pk. |
| 220-A ... <input type="checkbox"/> 12/pk. | <input type="checkbox"/> 20/pk. |

No-Load Finishing Paper (White)

- | | |
|---|-----------------------------------|
| 80-C ... <input type="checkbox"/> 50/pk. | <input type="checkbox"/> 100/pk. |
| 100-C ... <input type="checkbox"/> \$16/pk. | <input type="checkbox"/> \$28/pk. |
| 120-C ... <input type="checkbox"/> 14/pk. | <input type="checkbox"/> 24/pk. |
| 150-C ... <input type="checkbox"/> 14/pk. | <input type="checkbox"/> 24/pk. |
| 180-A ... <input type="checkbox"/> 11/pk. | <input type="checkbox"/> 19/pk. |
| 220-A ... <input type="checkbox"/> 11/pk. | <input type="checkbox"/> 19/pk. |
| 280-A ... <input type="checkbox"/> 11/pk. | <input type="checkbox"/> 19/pk. |
| 320-A ... <input type="checkbox"/> 11/pk. | <input type="checkbox"/> 19/pk. |
| 400-A ... <input type="checkbox"/> 11/pk. | <input type="checkbox"/> 19/pk. |

Wet or Dry S/C Paper (Black)

- | | |
|---|-----------------------------------|
| 220-A ... <input type="checkbox"/> 50/pk. | <input type="checkbox"/> 100/pk. |
| 320-A ... <input type="checkbox"/> \$15/pk. | <input type="checkbox"/> \$25/pk. |
| 400-A ... <input type="checkbox"/> 15/pk. | <input type="checkbox"/> 25/pk. |
| 600-A ... <input type="checkbox"/> 15/pk. | <input type="checkbox"/> 25/pk. |

FREE! WITH ANY ORDER OVER \$50.00, CHOOSE A BELT CLEANING STICK OR A "Wooden Memories" PLAN.

Build an heirloom today! Lifelike, full size rockers. Can be ordered Individually.



- \$9.00
 - \$9.00
 - \$9.00
 - \$7.00
- Belt Cleaning Stick Bill E. Goat Ole Grey Mare
 Bessie the Cow Beezer the Burro

INDUSTRIAL
BRASIVES CO.
643 N. 8th STREET
READING, PA 19612

For Fast Delivery Call Toll Free
1-800-428-2222 (U.S.A.)
1-800-222-2292 (PA only)

SHIPPING CHARGES - MIN. ORDER \$25.00

Under \$35 add \$2.75. \$35 or more add \$4.25. PA residents add 6% sales tax.

- MONEY ORDER MASTERCARD VISA CHECK

Acct. # _____ Exp. Date _____
Name _____ DAYTIME PHONE () _____
Street _____ PLEASE PRINT
City _____ State _____ Zip _____

ANYTIME ANYWHERE ANYWOOD

mold plane and edge



Professionals and hobbyists alike know the strengths of the W&H molder-planer. Superior US-made construction and quick two-minute cutter changes make it a snap to cut moldings and plane hardwoods. It's fast, easy, and super-smooth.

Our five-year warranty and free 30-day trial are your assurance that W&H goes the distance.

Mail this ad or call us toll-free today.
1-800-258-1380 in NH 603-654-6828

Williams & Hussey
Riverview Mill
P.O. Box 1149 Dept. 2391M
Wilton, NH 03086



YES! Send your free information kit today.

Name _____

Address _____

City _____ State _____ Zip _____

SAVE MONEY!

KILN DRY LUMBER



MAKE MONEY!

Kiln Dry for others.

As the nation's largest manufacturer of dehumidification Dry Kilns, we can supply you with the same type equipment used by many of the major firms.

Call or write today for free facts that will help you make and save money.



207-989-4335 Nyle Corporation
P. O. Box 1107, Bangor, Maine 04401

1-800-777-NYLE

500 WOOD MOULDING IDEAS!

500 Wood Moulding DO-IT-YOURSELF PROJECTS



This 128-page idea-filled booklet shows how to use wood mouldings for building everything from birdhouses to bookshelves, from door trim to drawer dividers and from planters to picture frames. This book of easy-to-build projects clearly illustrates all the traditional uses, plus hundreds of new ways to use wood mouldings. For your copy send \$4.95 to Wood Moulding & Millwork Producers, Assn., Dept. W89, Box 25278 Portland, OR 97225.



*U.S. funds only. Canadian purchasers add 50¢ for handling & postage.

BUILD A STATIONARY ROCKER

3 MODELS AVAILABLE
ORDER NOW
YOUR PLANS



CLASSIC



CANADIAN



MODERN

PLANS
& PATTERNS

\$7.95 EA.

ALL 3 FOR \$19.95

BALL BEARING
SUSPENSION KIT

(8 sealed ball bearings,
washers, nuts, wood
screws, and bolts plated)

\$22.95 EA.

5 MORE \$20.95

FOOTREST
MECHANISM

(for MODERN style
only)

\$49.95 EA.

5 MORE \$44.95

U.S. FUNDS

All prices include shipping & duty

Tel.: (418) 898-2601

Fax.: (418) 898-2606

VIEL TOOLS INC.

P.O. BOX 660, MADAWASKA, ME. 04756-0660
P.O. BOX 250, ISLE-VERTE, QC., CANADA, G0L 1K0

Full Size Patterns

WOODCRAFT



- 12 WINDOWSILL CATS
- COUNTRY RACKS AND SHELVES
- 6 BIG GAME HEADS
- SMALL COUNTRY FURNITURE
- 7 WHIRLYBIRDS
- 12 JOINTED ANIMALS
- 8 COUNTRY BASKETS
- 6 DINOSAURS

\$7.00 EACH

3 FOR ONLY \$15.00

DAKOTA WIND

DEPT. W109

BOX 866

JAMESTOWN, ND 58402

CATALOG \$1.00 - FREE WITH ORDER

Shophelper®

All Wheels can be Sold Individually and are Interchangeable on Arms

\$69.95

SHOPHELPER Holds it down for a cut above.

Shophelper's unique double wheel configuration gives it the stability required to virtually eliminate kickback and enhance safety. The infeed wheel holds the material down to stabilize the cut. The outfeed wheel controls ripping as narrow as 3/8" x 1/2". Shophelper is the perfect safeguard for professionals and hobbyists alike.

Three Multi-Purpose
Multi-Colored Wheels



Yellow Wheels turn clockwise for table saws and radial arm saws.

Orange Wheels turn counter-clockwise for radial arm saws.

Green Wheels turn both directions for shapes, routers and routers. (No anti-kickback).

Options include aluminum slotted track, auxiliary fence, saw guard

Save time and materials

Options include aluminum slotted track, auxiliary fence, saw guard

Call Toll Free: 800-344-7455 • In California Call: 800-828-8833

WESTERN COMMERCIAL PRODUCTS • P.O. Box 238, Tulare, CA 93275

MU 101762089

MAKE THESE!



WAGNER SAFE-T-PLANER

Fits Drill Press or Radial Arm Saw

ABSOLUTELY SAFE!

Impossible to Grab or Kick Back

PICTURE FRAMES, RAISED PANELS, ROSETTES, PLANES, RABBETS, TENONS, MOULDINGS

KIT INCLUDES: 3 lifetime hi-speed steel cutters, grinding wheel, arbor, wrench, 8 pg. photo instructions.

MONEY BACK GUARANTEE!

DRILL PRESS KIT \$35.00

RADIAL SAW KIT \$40.00

\$2.50 S&H OK ADD TX

(State Make, Model, Shaft Dia)

Order Direct—

Write For Free Literature

G & W Tool, Inc.

P.O. Box 691464

Tulsa, OK 74169

(918)-486-2761



"Quality Planers Since 1956"

SQUARE DRIVE SCREWS

Simply the Best!

- Square Drive Beats Driver Slippage
- Hardened Steel for Extra Strength
- Deep Thread for Superior Grip
- Also Brass & Stainless



Samples and Catalog \$3, Catalog Only \$1

McFEELY
HARDWOODS

P.O. Box 3 • 712 12th St.
Lynchburg • Va • 24505
Toll Free 1-800-443-7937
or FAX (804) 847-7136

ASK WOOD

Continued from page 101

FINALLY, A WOOD SHOW IN DES MOINES

Occasionally, *WOOD* magazine readers from central Iowa will call our office and ask, "Where's the nearest woodworking show I can go to?" Up until now, we've had to shuffle them off to Minneapolis, Chicago, or Kansas City. But now, we're happy to report that the Woodworker's Fair 89 will come to the Iowa State Fairgrounds in Des Moines Oct. 27-29. In addition to exhibitors and a full schedule of seminar speakers, this show will feature several swap tables for antique and collectible tools. For more information, call 800-441-0399 or 515/278-2126.

THE WELL-VENTILATED WORKSHOP

I can't finish what I start! I do my woodworking in the garage and subbasement of our raised-ranch home. When I apply the standard lacquer, varnish, and oil finishes to my projects, the vapors work their way through the upper levels of the house, much to the dismay of my family. I also worry that the gas furnace, which is in the garage, may ignite the lacquer vapors. Please offer suggestions.

—Jack A. Loganbill, Woodridge, Ill.

Jack, we normally turn to our friends at the Center for Occupational Hazards on questions such as these. Their executive director, Michael McCann, suggests that exhausting to the outdoors remains the only effective way to remove fumes. Consider installing an exhaust fan. Michael doesn't recommend using lacquer solvents near gas furnaces or water heaters.

MOISTURE ROUNDUP

We get a couple of letters each month from readers who uncover wood that's been stored for "years and years." Even wood stored for decades, may not be at the optimum 7 to 9 percent for furniture-making. Put a moisture meter to the wood before you saw. 🌲

NEW!
"Quad-Drive"

DRUM SANDER

with Infinitely Variable Power Feed!



At last! A complete power-feed Drum Sander at an affordable price! Choose from 26" and 38" models. SAVES TIME...IMPROVES RESULTS. Use this high-tolerance machine for light dimensioning as well as the finest finish work. Now you can add new beauty to each woodworking project, save hours of tedious hand sanding! In a matter of seconds you can produce a satin-smooth finish impossible to duplicate with hand methods or hand-held power sanders...no more low spots, waves or cross-grain marks! Check these advantages...

FREE FACTS!

Send for complete facts on how you can try this low-cost tool in your own shop for one full month without risk. See how the sander can dimension and finish-sand cabinet pieces, resawn stock, paneling, toys, tabletops, knees, burls, crotches and much, much more! You'll soon find it's one of the most valuable tools in your shop! Made in U.S.A. Easy Terms.

Call Toll-Free 1(800) 538-4200, Ext. RW33

NEW INFINITELY VARIABLE FEED RATE gives you total control in any sanding situation!

EXCLUSIVE QUAD-DRIVE FEED SYSTEM...four, power-fed rollers for maximum traction. Eliminates over-sanding at first and last few inches of a board!

NEW FELT-BACKED ABRASIVE mounts in just seconds to Velcro covered drum. The harder you sand, the tighter it stays! Eliminates stretching...allows fast removal and re-use!



YES! Please rush my FREE INFORMATION KIT and details on your 30-Day Free Trial Guarantee.

Woodmaster Tools, Dept. RW33
2908 Oak, Kansas City, MO 64108

NAME _____
ADDRESS _____
CITY _____ STATE _____ ZIP _____

World's Largest Selling Glue Gun!

Superlax Hot Melt Glue & Guns

Buy the best at below wholesale. Free glue samples — Free Freight. Translucent Sticks 1/2" Diameter 4" or 10" Length.

PRICES — delivered (West Coast add 20¢/lb.)

SUPERTACK 3000 STICKS	PRO-90 TRIGGER GUN
5 lb. \$ 25.00	1 \$18.00 each
10 lb. \$ 43.50	2.3 \$17.00 each
25 lb. \$ 98.75	4.5 \$16.00 each
50 lb. \$182.50	7.12 \$15.00 each
	13.24 \$14.00 each

Supergrip SANDPAPER

PREMIUM QUALITY • DISCOUNT PRICES • FREE FREIGHT most areas

BELTS: BEST RESIN OVER RESIN, "X" WEIGHT 10-Box

1 x 42	\$.70 ea.	4 x 24	\$1.00 ea.
3 x 18	.75	4 x 36	1.25
3 x 21	.80	6 x 48	2.80
3 x 24	.85		

ADHESIVE CLOTH DISCS: BEST RESIN OVER RESIN, "X" WEIGHT

5" Diameter	\$.80 ea.	8"	\$1.65 ea.
6"	.90	10"	1.85
8"	1.30	12"	2.25

Prices quoted 80 grit, other grits available.

GARNET PAPER — ORANGE WATERPROOF PAPER — BLACK

A/O CABINET PAPER — BROWN 180 thru 1200 100 PK \$23.00

40 Grit 50 PK \$15.00 NO LOAD PAPER — WHITE

60 Grit 50 PK 14.00 180 thru 400 100 PK \$20.00

80 Grit 50 PK 13.00

100, 120, 150, 100 PK 22.00 Also Shop Rolls • Cloth Sheets • Drums

180, 220 100 PK 19.00

CLEANING STICKS \$3.50 Small \$6.50 Large

RED HILL CORP., P.O. BOX 4234, GETTYSBURG, PA 17325

CALL TOLL FREE — 1-800-822-4003 or (717) 337-1419 FAX (717) 337-3936

Minimum Order \$25.00 • PA Res. Add 6% • FREE CATALOGUES

GUARANTEED OR YOUR MONEY BACK BAND SAW BLADES

Electro Heat Induction Hardened

Milled Sharp Teeth

Any Length Any Size

FREE INFORMATION

Bi-Metal — M-2/M-42

Flex & Hard Back Band Saw Mill Blades 24 HOUR SERVICE

Mini Business Opportunities — Dealers Wanted

SUFFOLK MACHINERY CORP.

12 Waverly Ave. Ste. 25, Patchogue, NY 11772

Call Toll Free 1-800-234-SAWS Ext. 25

13 YEARS OF GROWTH NATIONWIDE

WOODCARVING IS FUN & PROFITABLE!

Want to carve decoys, statues or gun stocks?

It's easy when you use the Dupli-Carver Series wood carving machines. A patented five axis carving action allows these machines to complete difficult undercuts and contours as no other machine can. Complete machines are available starting as low as \$359.00

SEND \$1.00 FOR OUR FULL LINE BROCHURE AND PRICE LIST AND START PLANNING YOUR FULL OR PART-TIME BUSINESS.

MARLIN INDUSTRIES, INC.

Rt. 70, Box 191, Dept. D910
Cashiers, NC 28717
(704) 743-5551



AMITY®

WIPE-ON/BRUSH-ON POLYFINISH



A break through in Finishing Technology.

A WATER-BASED Finish designed for HAND APPLICATION — WIPE-ON or BRUSH-ON

AMITY Polyfinish is the finish you've been looking for: Safe to use — Non-Flammable, Non-Combustible, and Non-Toxic. The hardness exceeds polyurethane but it dries fast — recoat in 1 hour!

AMITY Polyfinish goes on clear and won't yellow. Clean-up is with soap and water!

AMITY Polyfinish is available in Clear Gloss and Clear Semi-Gloss
1-Qt \$12.95 ea. 1-Gal \$34.95 ea.

Call To Order or For More Information:

US 800-334-4259
WI 608-837-8484

AMITY QUALITY RESTORATION SYSTEMS, INC.
P.O. BOX 148 • 1571 IVORY DR.
SUN PRAIRIE, WI 53590

— DEALER INQUIRIES INVITED —

INTRODUCING PARAGAUGE™

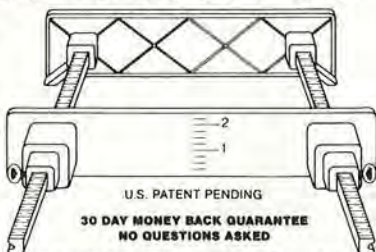

U.S. PATENT PENDING
30 DAY MONEY BACK GUARANTEE
NO QUESTIONS ASKED

The woodworker's solution to accurately producing straight and parallel measurements while setting a table or radial arm saw.

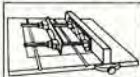

Use Para Gauge as a setting guide for parallel alignment of a rip fence to saw blade and for squaring the saw blade to the work table.

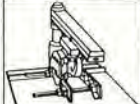

Accurately measures distances from 5/16ths to 10 inches in length and up to 2-1/2 inches in height.

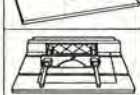

Improves the safety factor by reducing work piece kick back because of binding which occurs when a saw blade and rip fence are not parallel.

These are only an example of the many uses for Para Gauge. For more information write for a free brochure or:

To order yours at the special introductory price of \$29.95 (plus \$3.50 shipping per order) call our order desk at 1-800-343-6129 or mail your payment along with your name and address to:

ACCUSET TOOL CO. INC.
P.O. Box 1088 Dept. D
Troy, Michigan 48099

Charge your purchase using Visa or Mastercard by providing card type, A/C #, expiration date, telephone # and signature. No C.O.D. orders please. Michigan residents add 4% sales tax.

ANTIQUE reproduction furniture HARDWARE



HORTON BRASSES
Nooks Hill Rd. PO Box 120J
Cromwell, Ct 06416 203-635-4400
send \$3.00 for a catalog

TOY WHEEL MAKER WHEELRIGHT

WITH THE WHEELRIGHT AND YOUR DRILL PRESS YOU CAN MAKE 1 3/8" TO 4 1/2" TOY WHEELS.

ROSETTE TOOL

MAKE OLD STYLE ROSETTE TRIM BLOCKS WITH THE ROSETTE TOOL AND YOUR DRILL PRESS.

24 INCH SCROLL SAW

YOU CAN EASILY BUILD YOUR OWN 24" PRECISION SCROLL SAW FROM OUR KIT. VERY AFFORDABLE!

PEDAL POWERED SCROLL SAW

REPRODUCTION OF THE 1870 BARNES VELOCIPED NO. 2 PEDAL SCROLL SAW. GREAT FOR SHOWS!

\$1.00 FOR CATALOG AND FREE TOY PLAN
THE TOOL COMPANY

PHONE 816-537-6308
5271 RAIN TREE PARKWAY, DEPT. W99,
LEE'S SUMMIT, MO 64082

\$200 1 YEAR

CATALOG SUBSCRIPTION



Write today to get your one-year subscription started. Complete selection of all kinds of wood-working tools, competitive prices and fast, friendly service have made Woodworker's Supply of New Mexico the preferred source for professional woodworking tools and supplies.

Please start my one-year subscription.

Name _____
Address _____
City _____ State _____ Zip _____

Woodworker's Supply

OF NEW MEXICO

5604 Alameda Place, NE
Dept. W08
Albuquerque, NM 87113
505-821-0500

1-800-645-9292

FREE 64 PAGE CATALOG



LOWEST PRICES

Let us introduce you and your family to the exciting hobby of clockmaking. It's easy - fun - and a great source for extra income. You'll find our service is fast and friendly, so send for your free catalog today!

(Over 17 years the leader)

Name _____
Address _____
City _____ State _____ Zip _____

KLOCKIT™ Dept. WD99
P.O. Box 542, Lake Geneva, WI 53147

Introducing The Miniature Router Base Attachment For Foredom® And All Flexible Shaft 1" Hand Pieces

The Bollweil is the attachment all craftsmen have been waiting for. Workshop and factory proven - the Boll gets into those little spaces a regular router can't. Made of durable plexy, its great for relief carving, sign making, laminating and inlay work. Regular base/adjustable guide base/instructions. \$34.95 + 3.00 shipping and handling (2-3 weeks for delivery).

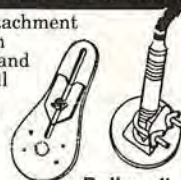

Bollweil

Call 1-(615)-428-6025

or write C & H Enterprises, RT 11, Box 345 B



Sevierville, TN 37862

Visa or Mastercard Accepted



*Foredom® is a registered trademark of the Foreman Electric Company

Avoid delays in the delivery

of your WOOD magazine.

Let us know at least five weeks

before you move, what your

new address will be.

**Find It Fast
with the
All-New
WOOD® INDEX**

A cumulative listing of projects, tips, techniques, and other information in WOOD® Magazine all the way back to issue 1.

You Get:

★ Six Easy-Access Mini Indexes

- Finishing and Refinishing
- Projects
- Tools
- Turning
- Carving
- Wood — From Tree to Board

★ An Extensive General Index

★ A Three-Page Quick-Reference Wood-Species Guide

**Also Included:
The
WOOD®
Reprint Service**

Just fill out one of the handy coupons at the back of the index, and for a nominal charge, we'll send you a high-quality photo-copy of any article we've ever published.

**Order Your All-New
Wood® Cumulative
Index Now!**

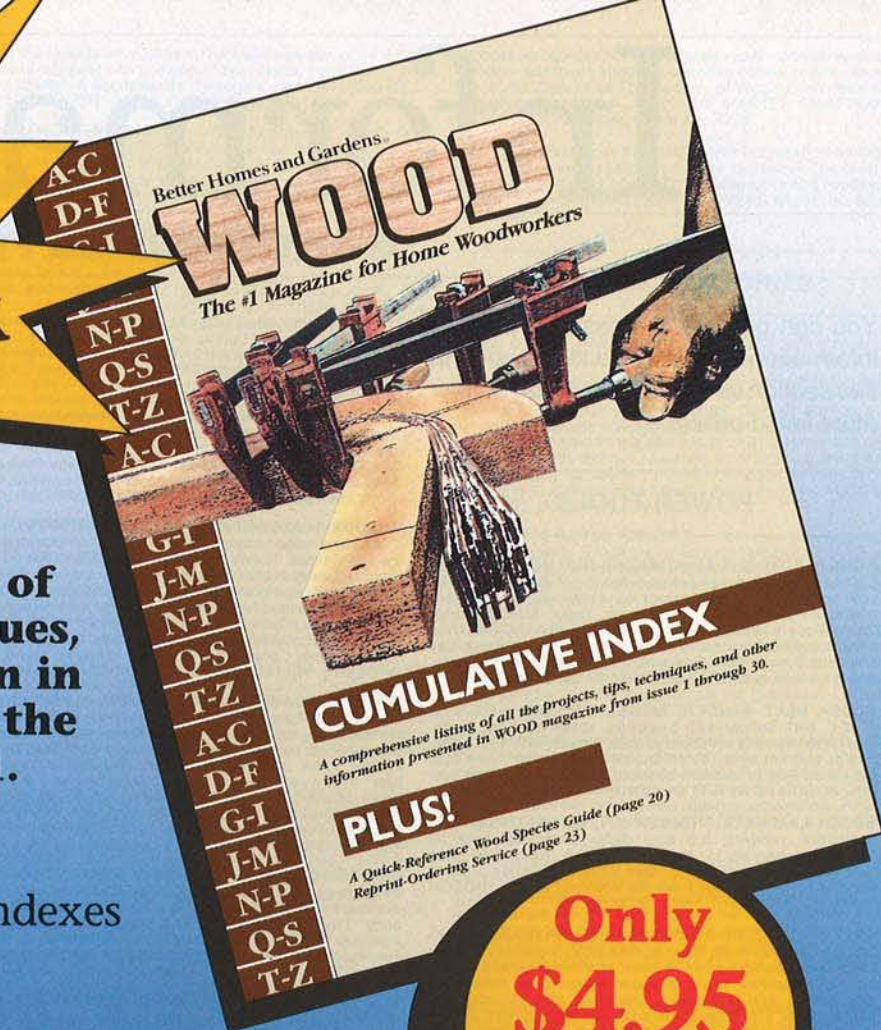

**Only
\$4.95**
Includes postage
and handling!
(Foreign orders \$5.95)

Yes! Please send me the WOOD® Cumulative Index. Here is my check or money order for \$4.95 (Foreign orders \$5.95).
Send to: **WOOD® Cumulative Index**
P.O. Box 11454
Des Moines, IA 50336-1454

My Name _____

Address _____ Apt. # _____

City _____

State _____ Zip _____

MasterCard VISA Expiration Date _____

Card No. _____

Signature _____

We will begin shipping orders about August 30, 1989.

Information



Print this article

WORTH WRITING FOR

You can get useful ideas and product information by mail. Use the coupon in this section to order your choice of literature listed below.

POWER TOOLS

ACME ELECTRIC IS ANNOUNCING OUR NEW 170-PAGE CATALOG—It features a wide selection of merchandise for your home woodworker to your industrial builder. Top manufacturers such as Black & Decker, Delta, Makita, Porter Cable, Bosch, Milwaukee, Ryobi, Freud and many more. We offer competitive prices with quality service and same day shipping. Send today for your new 1989 Acme Electric catalog. It's worth it. **ACME ELECTRIC**. \$2.00. *Circle No. 6.*

BOSCH BELT SANDER, MODEL 1273DVS—10.5 amp 4"x24" Belt Sander with 6 speeds, speed selector guide. Use higher speeds with coarse grits; slower, with finer ones. Faster belt changes, automatic belt tensioning; uses dust collection bag or vacuum-boosted Bosch Air Sweep system. **BOSCH POWER TOOL CORP.** Free. *Circle No. 17.*

BOSCH LAMINATE TRIMMER KIT, MODEL 1608—Trim laminates, veneers; 5.6 amp motor. Complete with all bases; accessories for shop, installation tasks. One base handles routine cuts; tilting base trims odd angles or up to vertical surface; offset base for corners, angles. **BOSCH POWER TOOL CORP.** Free. *Circle No. 18.*

FREE FULL COLOR POWER TOOLS APPLICATION GUIDE/CATALOG—from Dremel describes company's complete line of compact power tools, attachments, and accessories. It features newly designed Moto-Tools, Flex-Shaft attachment, and drill press. Literature also includes descriptions of 170 different bits for cutting, carving, polishing, clearing, routing, grinding, engraving, and more. **DREMEL**. Free. *Circle No. 33.*

MANUFACTURED SINCE 1926—the Foley-Belsaw Model M-14 Circular Sawmill lets you go right to the trees to turn out smooth, true-cut lumber. Available with heavy-duty steel base or with plans and track provided for owner built wood base. Will accurately saw logs up to 14 ft. in length and up to 24 in. in diameter. Complete money-back guarantee. Send for details. **FOLEY-BELSAW CO.** Free. *Circle No. 42.*

POWER TOOLS YOU CAN BUILD AND SAVE—Build sturdy woodworking tools from kits and save—sold for over 40 years—5 year warranty on parts. Simple step-by-step plans with full size patterns for wood base. Plans and patterns can be purchased separately. Send for descriptive brochure. **GILLIOM MFG. INC.** \$1.00. *Circle No. 47.*

LOBO POWER TOOLS—Our lower prices make our fine woodworking machines more affordable for you, "our customers." We sell a complete line of band saw jointers, planers, drum sanders, shapers, and much much more. All of our machines come with a 1-year warranty. Order today for a free catalog. **LOBO POWER TOOLS**. Free. *Circle No. 57.*

MAKITA U.S.A. INC.—offers all new 86-page catalog on their professional line with special emphasis on the entire cordless line. Catalog provides complete information along with available accessories, practical applications at suggested retail prices. **MAKITA U.S.A. INC.** Free. *Circle No. 61.*

SCROLL SAW—Information package available from Penn State Industries describing the specifications and applications of its super 15-inch scroll saw. Special discount pricing available on current promotion. **PENN STATE INDUSTRIES**. Free. *Circle No. 76.*

AFFORDABLE PRECISION SURFACE SANDER—Tired of high and low spots and countless hours of sanding? Now you can buy the components to fit your budget and your needs: The Performax S/T Sander attaches to radial saw or stand, optional power feed conveyor unit, stand hardware kit for a build-your-own stand or all the metal, ready-to-assemble pro stand. Send for informative brochure. **PERFORMAX PRODUCTS**. \$1.00. *Circle No. 78.*

QUALITY AMERICAN-MADE SCROLL SAWS—The RBI Hawk family of Precision Scroll Saws with 6 models, one to fit your needs. Patent pending Camover Quick Blade Change system, 2 way tilting tabletop, 2 speed or variable speed motor, all add up to make the Hawk the best value on the market today. Virtually end sanding forever! Send for the facts. **RBI INDUSTRIES, INC.** Free. *Circle No. 84.*

SAKURA SCROLL SAW INFORMATION—You owe it to yourself to compare the value-priced 14-inch 3-speed

ScrollMate with other units before you make your buying decision. It offers a built-in air bellows; stand; quick, safe speed changes; and a full 2-year limited warranty—all at a price that's tough to beat. **SAKURA USA**. \$1.00. *Circle No. 87.*

THE VERSATILE TOOLMAX T310—woodworking machine solves the common "too small a shop" problem by combining a 10" table saw, 1" spindle shaper, 12" jointer, 12" planer and fully adjustable mortising table. Saves 90% on space and 60% on investment. Send for complete color information pack. **TOOLMAX**. \$1.00. *Circle No. 90.*

MOLDER-PLANERS FROM WILLIAMS & HUSSEY—Mold, plane, and edge, convert from moulder to planer in less than 2 minutes. The W-7 series is available in 3 models for manual, power in feed, or power in feed/out feed. The units plane to a satin, almost sanded finish, produce doll house to crown sized mouldings, raised panels, and virtually any shape profile. Custom knives available up to 7" wide and 3/4" depth of profile. Rugged, well-made, dependable, and transportable. Complete with sturdy movable stand. Send for catalog. **WILLIAMS & HUSSEY**. \$1.00. *Circle No. 93.*

PORTABLE SAWMILLS—Convert logs into valuable lumber—Wood-Mizer® Products manufactures a line of portable bandsaw mills that allows the novice as well as the experienced sawyer to safely convert standing logs into lumber. Then, with the use of our SolaryDry™ Kiln or Vacu-Kiln™ to dry your lumber, you could increase the value of every board you produce. We manufacture some of the most progressive woodworking equipment on the market today. Product videos available. Send for our 44-page catalog. **WOOD-MIZER PRODUCTS**. \$1.00. *Circle No. 94.*

BRIDGEWOOD WOODWORKING MACHINERY—a new 52-page catalog of fine BRIDGEWOOD wood and metalworking machinery is available from Wilke Machinery Company. The BRIDGEWOOD line includes a wide range of products for use in the serious home workshops up through the industrial applications. **WILKE MACHINERY CO.** \$1.00. *Circle No. 96.*

12", 18" and 25" PLANER/MOLDER/SANDER FROM WOODMASTER TOOLS—a size to meet any shop requirement...all with exclusive variable feed rate. Free information kit includes details on 30-day trial period and easy terms. **WOODMASTER TOOLS, INC.** Free. *Circle No. 99.*

COMPACT STROKE SANDER FEATURES BIG CAPACITY—The low-cost, Model 800 features three built-in speeds, a large, 24" x 48" sliding table with automatic elevation, and a travelling, lever-action, pressure platen. Open-ended design accommodates any length material. Long-lasting belts are 6" x 156". 30-day free trial! **WOODMASTER TOOLS, INC.** Free. *Circle No. 100.*

HAND TOOLS

DIAMOND WHETSTONES BY DMT—Discover the ease and speed of sharpening on the finest Diamond Whetstones. Five sizes from 3" to 12" in fine, coarse, and extra coarse. Finest monocrystalline industrial diamonds permanently bonded in nickel. Lubricated with water rather than messy oil. Stays flat, unbreakable. Twelve years of serving sharpening needs. Satisfaction guaranteed. Send for full color catalog. **DIAMOND MACHINING TECHNOLOGY, INC.** \$2.00. *Circle No. 112.*

PERSONAL BRANDING IRONS—Brochure describes branding irons that enable you to put your name on your work quickly and easily. Made especially for branding wood, they are available with 1, 2, or 3 lines of copy or with your logo. Changeable date also available. **NOVA TOOL CO.** \$1.00. *Circle No. 160.*

THE JAPAN WOODWORKER 1989 CATALOG—is loaded with the best tools you can get your hands on. In our catalog you will find a complete selection of Japanese tools for the woodcarver, carpenter, and cabinet maker. Send for catalog plus supplements for next two years. **WOODLINE-THE JAPAN TOOL & SUPPLY**. \$1.50. *Circle No. 190.*

STAINS/FINISHES

ARTI ANILINE DYES—Color chart features 28 aniline colors and 8 toy maker's colors. Price list and ordering instructions included. **HIGHLAND HARDWARE**. \$1.00. *Circle No. 232.*

PLANS

OVER 1000 WOODCRAFT PATTERNS!—Create gifts, toys, whirligigs, lawn ornaments, folk art, bird houses and feeders, magazine racks, household accessories, plus much more! Simple enough for the beginner, fun and profitable for the pro. Catalog plus sample pattern. **ACCENTS IN PINE**. \$2.00. *Circle No. 310.*

WOODWORKERS' PLANS AND SUPPLIES—Wood projects are simplified with the high quality plans, specialty hardware and other supplies offered by Armor Products. Over 100 plans are available for making toys, desks, clocks, pool tables, lamps, chests, and other furniture. Movements, dials, moldings, ornaments, dollhouse kits, door hup supplies and tuning pins are also available. **ARMOR PRODUCTS**. \$1.00. *Circle No. 315.*

CRAFTPLANS CATALOG—Wide selection of ideas, plans, patterns for woodworkers. Simple bird houses, toys, weather vanes, furniture, entertainment centers, computer desks and much more. **CRAFTPLANS CO.** 50¢. *Circle No. 325.*

COUNTRY WOODCRAFT PATTERNS—Enjoy creating gifts, toys, novelties, decorative household accessories, window sill cats, wooden baskets, miniature furniture, jointed animals, bird-mobles, plus more. Full size patterns for simple, fun, profitable woodcrafting. 20-page catalog of over 400 unique country projects. **DAKOTA WIND**. \$1.00. *Circle No. 338.*

PATTERNS BY DESIGN GROUP—Hundreds of interesting, useful and fun items to create for personal use or profitable sale. Our newest catalog contains plans for toys, games, plaques, puzzles, birdhouses, planters, furniture, and much more! All Design Group patterns are professional, "same size" blueprints. No enlarging or reducing is necessary. Simply trace outline of item onto wood and create! Started in 1977, Design Group has sold thousands of patterns to thousands of satisfied customers. Prices start at \$1.00, all patterns come with a full money-back guarantee. Wholesale and bulk prices are available on request. Fully illustrated catalog. **DESIGN GROUP**. \$1.00. *Circle No. 340.*

FULL-SIZE FURNITURE PLANS CATALOG—Illustrates and describes over 200 plans for making furniture of quality found in museums and fine furniture stores. Plans include roltop desk, cradles, dining tables, chairs, buffets, chests, gun cabinets, poker table, children's furniture, rocking horse, spinning wheels, and more. Bill of materials exploded drawings assist the woodworker. **FURNITURE DESIGNS, INC.** \$2.00. *Circle No. 345.*

COUNTRY FURNITURE PLANS—Our catalog features more than 30 designs—from a washstand to a roll top desk. Our new book on finishing and refinishing will show you how to finish projects like the pros. Also included are various products for the home woodshopper. Send for our latest catalog (price of catalog deductible from first order). **HAM-MERMARK ASSOCIATES**. \$1.00. *Circle No. 370.*

CHRISTIAN SCROLL/BAND SAW PATTERNS—Quality full size patterns let you create unique gifts for holiday giving, church bazaars, witnessing, or just to keep! Simple enough for the beginner, challenging for the pro and profitable for all. Send for full size pattern and catalog. 1 Peter 2:21. **IN HIS STEPS**. \$1.50. *Circle No. 375.*

WOODWORKING PLANS—Catalog of full-size plans printed on heavy paper for toys, gifts, novelties, action windmills, shelves, birdhouses, garden furniture, Dutch windmill, lawn ornaments, old-fashioned lawn swing, jigsaw projects for children, and more. **MASTERCRAFT PLANS WEST**. \$1.00 (refunded with first order). *Circle No. 390.*

WOODWORKING TREASURES—Create your own beautiful woodworking masterpieces. All you need is simple tools, and our easy to follow patterns and directions. You will be proud to display these 1/6 scale beauties. Choose from Victorian Riding Toys and Carousel Animals. Send for our latest brochure. **THE MASTER'S WORKBENCH**. \$1.00. *Circle No. 398.*

"KIDDIE KOASTER"—promises miles of smiles. Kids and teenagers will love the excitement of this backyard cable trolley. It will give them hours of fun. Easy to build with scrap wood and standard hardware. Full scale pattern, materials list, and assembly instructions. **VALHALLA & CO.** \$5.00. *Circle No. 472.*

STATIONARY ROCKER PLANS—Build a fine and comfortable rocker with our easy to follow plans & patterns and hardware kit. 3 models available. Also sharpening machines, 12" knife sharpener, profile grinder, sander-grinder. Send for our color brochure. **VIEL TOOLS INC.** \$1.00. *Circle No. 475.*

MAKE TOSELLING COUNTRY WOODCRAFTS—from full size patterns. Turn your scrapwood into decorative, highly profitable projects. Easy to make from our full size patterns and instructions—no enlarging necessary! Over 500 unique designs include popular folk art, old fashioned St. Nicks, nostalgic country furniture, action toys, shelf sitters, country critters, life size yard animals, Christmas yard decorations and more! Fast service, satisfaction guaran-

teed. Send for catalog. THE WINFIELD COLLECTION. \$1.00. Circle No. 480.

LUMBER

QUALITY EXOTIC LUMBER/TURNING WOODS—We offer a comprehensive selection of fine quality exotic woods: Ebony, Kingwood, Tulipwood, Snakewood, African Blackwood, Cocobolo, Bloodwood, Figured Maple, Spaulded Maple, Padauk, etc. Unique and unusual turning woods and burls are also available. Send for catalog. BEREA HARDWOODS. \$1.00. Circle No. 510.

EdLco — WE KNOW OUR LUMBER — Educational Lumber Company is pleased to offer you our new catalog, stacked with excellent buys at delivered prices. Available to you are over 21 species of imported as well as domestic hardwoods, softwoods, turnings, shorts, veneers. All our lumber is kiln dried. As school shop suppliers for 35 years, we know our lumber. It is top-grade. Send today and receive your BONUS GIFT: 4 new furniture designs. EDUCATIONAL LUMBER CO., Inc. \$2.00. Circle No. 530.

THIN LUMBER—Approximately 20 species— $\frac{1}{8}$ " to $\frac{3}{4}$ " thickness. Thinner material sanded, all KD & surfaced—UPS delivery in continental US included in price. Packages of micro-lumber $\frac{1}{8}$ " - $\frac{1}{2}$ " thick. HARDWOODS OF ILLINOIS. 50¢. Circle No. 545.

THE BEST LUMBER AT THE RIGHT PRICE—Located in close proximity to some of the most ideal growing ranges for Red Oak, Pennsylvania grade Cherry, Hard Maple, Ash, Poplar, and other hardwoods, we can supply your needs with the highest quality hardwoods. Our experience in hardwood purchasing and our dedication to keeping our overhead low is your guarantee of low prices. No minimum order. Retail and wholesale. Send for 20-page catalog. NORTH EASTERN HARDWOODS. \$2.00. Circle No. 563.

LUMBER DRYING — Nyle Corp., the largest manufacturer in the United States of dehumidification Dry Kiln Systems, offers *Introduction to Dehumidification Lumber Drying*. NYLE CORP. Free. Circle No. 565.

RARE IMPORTED EXOTIC AND DOMESTIC HARDWOODS—The world renowned Martin Guitar Co. sells wholesale and retail exotic wood (4/4, 6/4, 8/4) and sawn veneers ($\frac{1}{8}$ " & $\frac{1}{4}$ " Sanded Stock), plus guitar parts, kits, accessories and second quality guitars. Send for catalog. SAWMILL/WOODWORKER'S DREAM. \$2.00. Circle No. 578.

STEVE H. WALL LUMBER CO.—Quality hardwoods and woodworking machinery for the craftsman and educational institutions. 22-page catalog lists 15 species of popular hardwoods at wholesale prices. Also dealers for Delta, RBl, MiniMax, Freud and ProCut woodworking machines. STEVE H. WALL LUMBER CO. \$1.00. Circle No. 592.

VIDEOS

SANDING PROBLEM?—One of America's leading manufacturers of abrasive belts, sheets, discs, rolls and other abrasive specialties will help you solve your sanding problem right on your VCR. Send for details. ECON-ABRASIVES. Free. Circle No. 615.

GENERAL WOODWORKING CATALOGS

ADVANCED WOODWORKING—Specialty products catalog from the exclusive distributors of Hegner & Felder woodworking machinery. Includes complete selection of scroll saw blades, accessories, and improvements for almost any scroll saw. Also the Hegner precision scroll saws, lathes & duplicators, Jet clamps, workbenches, Felder systems & more. AMI, LTD. \$2.00. Circle No. 801.

EVERYTHING FOR THE WOODWORKER — Wide selection of woodworking supplies, including candle cups and shaker pegs. Price of catalog is refundable with order. BENNY'S WOODWORKS. \$1.00. Circle No. 810.

CONSTANTINES' CATALOG FOR WOODWORKERS—116 pages packed with over 4,000 products for fine woodworking. Included are 250 kinds and sizes of domestic and imported hardwoods; 150 varieties of exotic veneers; top quality woodworking tools, hard-to-find specialty hardware and accessories; wood finishes, books, plans, and more. 60-day money back guarantee if not fully satisfied. Serving the woodworker since 1812. ALBERT CONSTANTINE AND SON, INC. \$1.00. Circle No. 820.

MASTER TOOLS CATALOG—1988-89 212-page master woodworking tools catalog. Full line of the best hand tools, power tools & accessories, machinery, glues, finishing supplies, and much more. Hundreds of books included. 212 pages. All four-color. Lots of technical information. GARRETT WADE CO. \$4.00. Circle No. 855.

WOODWORKING MACHINERY CATALOG — Planers, jointers, tablesaws, shapers, drill presses, sanders and much, much more. Buy direct from importer at super low prices. Full color catalog. GRIZZLY IMPORTS, INC. Free. Circle No. 860.

THE 1988 HILLER HARDWARE CATALOG—is a comprehensive collection of tools & accessories for you. Select

from the best quality tools in the business at a price only a volume supplier can provide. Power tools, hand tools, cutters, blades, & accessories. 24 pages, over 240 tools! HILLER HARDWARE. \$1.00. Circle No. 875.

TOOL/WOODWORKER'S CATALOG—78 full-color pages. Over 400 practical exclusive and hard-to-find tools and accessories for the woodworker, do-it-yourselfer and hobbyist. Many money-saving specials, and all items guaranteed. LEICHTUNG WORKSHOPS. Free. Circle No. 878.

WOODWORKING TOOL CATALOGS — R.A. Ness & Co., the Woodworkers Emporium, offers a 2-year subscription, a total of eight huge sale catalogs. Thousands of industrial quality items — machinery, hand tools, portable electric tools, and supplies — are featured at super sale prices. The fee is refundable with purchase. R. A. NESS & CO., the Woodworkers Emporium. \$4.00. Circle No. 900.

TOOLS ON SALE—A division of Seven Corners Ace Hardware Inc. offers a comprehensive catalog featuring over 430 pages of the most competitive prices in the industry. If you're looking for savings and fast delivery on over 4000 items, request our catalog. This catalog offers one of the most complete selections of power tools available anywhere from the most respected manufacturers in the industry: Milwaukee, Makita, Porter-Cable, Black & Decker, Freud, Bosch, Delta, and many more. SEVEN CORNERS ACE HARDWARE. \$1.00. Circle No. 920.

A WOODWORKER'S DREAM BOOK!—Power tools...hand tools...machinery...router bits...pneumatic tools...cutting tools...clamps...hardware...wood parts...books...and more! For our new catalog, we've selected the tools woodworkers want most from around the world...at prices that won't hurt your wallet. This is a must reference for every woodworking shop. So give us a try. Price of catalog is refundable with your first purchase. THE SOURCE. \$2.00. Circle No. 935.

TOOL CITY CATALOG HAS THE TOOL OR ACCESSORY FOR YOU—The 500-page 1987-88 Tool City Catalog is the most complete mail order catalog. It features a comprehensive selection of stationary & portable power tools; hand tools, tool accessories, hardware parts, woodworking books, and shop equipment. Priced to save you money in all categories. TOOL CITY. \$5.00. Circle No. 945.

WOODWORKING TOOLS OF EXCEPTIONAL QUALITY—Since 1928, we have searched the world for tools you don't just buy, but adopt; tools made by craftsmen for craftsmen, classics of lifetime quality for people who love to work with their hands...carvers, cabinetmakers, finishers, hobbyists, builders, teachers. Our catalog details over 4,000 tools, each backed by Woodcraft's unconditional guarantee of satisfaction. WOODCRAFT SUPPLY CORP. Free. Circle No. 955.

THE WOODWORKERS STORE—114 pages of domestic and exotic hardwoods, veneers, wood parts, specialty hardware, kitchen accessories, finishing supplies, tools, books, and plans. Catalog filled with hard to find specialties. Orders shipped within 48 hours. Customer satisfaction guaranteed. WOODWORKERS STORE. \$1.00. Circle No. 965.

WOODWORKERS SUPPLY—offers high quality tools and supplies for skilled, amateur, and professional woodworkers. Our complete catalog includes machinery, hand tools, plans, router bits, shaper cutters, wood specialties, and more. For your two year subscription send to WOODWORKERS SUPPLY OF NEW MEXICO. Free. Circle No. 975.

KITS

FREE STANDING BACKYARD GYMS—Countryside Woodworking Inc. (CWI) offers 6 models and 11 options for a wide variety of family fun gyms. The only Backyard Gym you'll ever buy. 4x6 and 4x4 construction, playground rated hardware. Complete kits include all lumber. Hardware only kits also available. Send for complete color catalog. CWI. \$1.00. Circle No. 1005.

OAK FURNITURE AND ACCESSORY KIT CATALOG—features a full range of top quality oak furniture kits and accessory items plus unfinished assembled furniture. Featured items include roll top desks in several styles, stacking barrister's bookshelves, tables, chairs, trunks, file cabinets, bedroom furniture, Mariner's globe, plus many more. Send for full color catalog and enjoy true woodcrafting pleasure. CRAFTSMAN'S CORNER. Free. Circle No. 1017.

FACTORY DIRECT GRANDFATHER CLOCKS—Build a magnificent grandfather clock kit from world's largest manufacturer. Clocks are made of solid $\frac{3}{4}$ " hardwoods, primarily walnut, oak and cherry. West German-made solid brass movements. Send for color catalog showing our selection of grandfather clocks, furniture and home accent pieces. Buy direct from factory and save. EMPEROR CLOCK CO. \$1.00. Circle No. 1030.

MUSIC MAKER'S KEEP BOOK—a 36-page resource catalog for building and learning to play handmade musical instruments. This source book contains plans, blueprints, kits, books, hardware, strings and accessories for building such instruments as guitars, banjos, dulcimers, harps, violins, pipes, and more. ST. CROIX KITS. \$1.00. Circle No. 1080.

PUBLICATIONS

DISCOVER GUILD OF MASTER CRAFTSMAN PUBLICATIONS—Unique books and magazines for those who enjoy working wood. Plans and projects, handbooks on tools and

techniques, guides for woodturners and woodcarvers, etc. Send for our free catalogue of books collected from around the world. Details of The Society of Wood Craftsmen sent with every catalogue. GUILD OF MASTER CRAFTSMAN PUBLICATIONS. Free. Circle No. 1125.

WOOD CARVING — You can obtain information on learning woodcarving by sending for our literature. The offer includes sample copy of *The Mallet Magazine* and two lesson sheets on carving. NATIONAL CARVERS MUSEUM. \$2.00. Circle No. 1140.

SHOP ACCESSORIES

PARA GAUGE, THE WOODWORKER'S SOLUTION TO SETTING A TABLE AND RADIAL ARM SAW—Para Gauge was developed to provide the woodworker a perfectly parallel measurement quickly and accurately to help alleviate the tedious and sometimes inaccurate task of setting a rip fence. Para Gauge accurately measures distances up to 10 in. in length between the saw blade and rip fence and up to 2.5 in. in depth without resetting or relocating the gauge. Para Gauge is completely portable and can be used on just about any tool requiring a parallel measurement. ACCUSET TOOL CO., INC. Free. Circle No. 1205.

RIPSTRATE SAVES FINGERS — for table saw and radial arm saw users. Brochure describes the RIPSTRATE and shows how it gives straighter cuts, speeds, the work, prevents kickbacks, and keeps hands away from the blade. FISHER HILL PRODUCTS. 25¢. Circle No. 1235.

CLASSIC WORKBENCH—This is a space saver's dream. Assembled & knocked down in minutes. Beautifully designed workbench is made of Danish Red Beach with a linseed oil finish. Other features include built-in precision steel spindle rises & dogs. Send for literature. LAGUNA TOOLS. \$1.00. Circle No. 1240.

EASY DOES IT — with HTC's power tool accessories. Discover many unique items, designed only with you, the dedicated woodworker, in mind. Make your machinery safer, increase the working area of your shop and accomplish nearly impossible tasks easily, quickly, accurately. Full-line catalog and price list. HTC PRODUCTS, INC. \$1.00. Circle No. 1245.

BUY YOUR SANDING BELTS DIRECT FROM THE MANUFACTURER — Industrial Abrasives is the company that gives you six free belts with every dozen ordered. But, sanding belts are not the only product we have to offer. In our catalog you will find many specialty items not readily available in your hardware store. Price of catalog refunded with first order. INDUSTRIAL ABRASIVES CO. \$1.00. Circle No. 1248.

WOOD MOISTURE METER — Avoid moisture problems such as cracking, warping, splitting, delamination etc. by using a moisture meter, as described in the latest brochure. Moisture Meter Mini-Ligno is designed for serious hobbyists and woodworkers. Attachments for depth measurements and remote reading during air and kiln drying are available. Available Moisture Range 6-20%, 6-36% or 4-30%, 4-60%. Catalog describes complete line of moisture meters. LIGNOMAT USA, LTD. Free. Circle No. 1250.

ROUTER SPEED CONTROL—Reduces speed electronically without reducing torque. Route at the speed that gives best results with the wood and bit you are using. Speed adjustable from full speed to 0 RPM. Less tear out—stops burning—less wear on bits—easy to use. Send today for information. MLCS LTD. Free. Circle No. 1251.

WHOLESALE SANDPAPER, SANDING BELTS, SANDING DISCS—SUPERGRIT offers its quality line of abrasive products at wholesale prices directly to the consumer. Full or partial box orders welcomed. \$25 minimum order. Prompt, free UPS shipment to most areas. Literature, price list. RED HILL CORP. 50¢. Circle No. 1267.

WEDGE INNOVATIONS' SmartLevel—Digital electronic carpenter level measures all angles with up to 1/10 degree accuracy. Automatically calculates percent of slope and pitch (inches of rise per foot of run), and can be recalibrated into perfect balance with the push of a button. Helps you achieve exact measurements and professional quality with the minimum effort. WEDGE INNOVATIONS. Free. Circle No. 1293.

BITS, BLADES CUTTING TOOLS

CARBIDE TIPPED ROUTER BITS AND SHAPER CUTTERS — Over 400 router bits and shaper cutters displayed in catalog featuring 6 piece cabinet sets, 3 piece 1/2-in. shank router bit panel raising system, and 3 wing industrial shaper cutters. An outstanding selection of top quality shaper cutters available in 1/2-in. - 1 1/4-in. bore, and router bits offered in 1/4-in. and 1/2-in. shank at the industry's best factory direct prices. CASCADE PRECISION TOOL CO. \$1.00. Circle No. 1315.

EAGLE AMERICA CORP.—is proud to announce its all new 1989 Router Bit catalog featuring over 700 items. This factory direct mail order catalog offers the industry's largest selection of the finest quality American made router bits. \$5 refund coupon included with catalog. EAGLE AMERICA CORP. \$3.00. Circle No. 1320.

WOODWORKING TOOLS — Freud provides the finest in hand tools, carbide cutting tools, and hand held power

tools. From drills and sanders to carbide saw blades and router bits. Send for catalog. FREUD. \$1.00. Circle No. 1321.

PRODUCTION QUALITY CARBIDE TIPPED ROUTER BITS—MLCS Ltd. offers a full line of professional production quality carbide tipped router bits at 50-70% lower than retail prices. We sell through the mail and only direct to craftsmen. Send today for information. MLCS LTD. Free. Circle No. 1350.

ROUTER ACCESSORIES CATALOG—Is your router still in the box? Get quality parts to make the router a complete workshop. Make panel doors, dovetail drawers, box joints, picture frames, and much more. Make your router more versatile today with these quality accessories that fit all routers. OAK PARK ENTERPRISES LTD. \$1.00. Circle No. 1360.

SAW BLADE VALUES—Olson Saw's unique "furniture band" is specifically designed to provide fast, smooth cuts in all types of wood. Included in Olson's free literature package are a huge list of resin on resin abrasives and carbide tipped circular saw blades in addition to a growing selection of band scroll (incl. pinned), jewelers and spiral saw blades. OLSON CATALOG SALES. Free. Circle No. 1365.

ROUTER BITS-SHAPER CUTTERS, CARBIDE AND CARBIDE TIPPED—Thick heavy duty industrial grade. Router bits available in either 1/4 or 1/2 in. diameter shafts. Cutters are 3/4 bore supplied with 1/2-in. bushings. Forstner bits 1/4 to 3-in. diameter. Save up to 50% over wholesale prices. Tremendous quality and selection. Write now for large illustrated catalog, comes with \$3 coupon good on first order. SKY-CROFT TOOLS INC. \$1.00. Circle No. 1372.

HARDWARE/WOOD PARTS

OUR READY TO ASSEMBLE KITS—for Queen Anne chairs and occasional tables make it easy for you to make professional looking furniture. We also stock individual Queen Anne legs for every project. Complete information in our brochure packet. ADAMS WOOD PRODUCTS. 50¢. Circle No. 1401.

BRASS FURNITURE HARDWARE—This 36-page catalog shows over 500 items of authentic reproduction hardware from the 1700's and on into this century. This fine quality hardware is a must for the furniture craftsman working on a new project, or the refinisher who needs replacement hardware. HORTON BRASSES. \$3.00. Circle No. 1430.

SQUARE DRIVE SCREWS—Thousands agree—once you try them you will never want to use anything else! The square drive recess virtually eliminates work-damaging driver bit "cam-out," the deep threads result in exceptional holding power, and they are heat treated for strength. Sizes from #4 x 3/8" to #12 x 4", with stainless steel, solid brass, brass plated, and zinc plated available. Quantity discounts. Send for literature. McFEELY HARDWOODS. 75¢. Circle No. 1450.

WOODWORKER'S SPECIALTIES—64-page catalog of plans and hard-to-find hardware for woodworkers. Dozens of door harp plans, wood toy plans & accessories, including wood wheels. Also wood turnings, brass hardware, canister liners, stencil supplies, & wood cutouts. MEISEL HARDWARE SPECIALTIES. \$1.00. Circle No. 1455.

WOOD TOY PATTERNS—Patterns for all ages including children's patterns and executive toys. New catalog has many new patterns to choose from including parts and wheels. Send for new catalog and receive a coupon for free wheels and axle pegs. TOYS AND JOYS. \$1.00. Circle No. 1480.

DESIGN & DECORATE WITH WOOD MOULDINGS—Contains full-color photos of various household rooms showing extensive use of wood mouldings. Profile drawings of all wood mouldings used to create these finished designs are also shown, plus suggested alternative profiles. A simple way to transform an ordinary room into a showplace on a minimum budget. WOOD MOULDING & MILLWORK PRODUCERS ASSN. 75¢. Circle No. 1487.

QUALITY AMERICAN-MADE WOOD TURNINGS—such as shaker pegs, spindles, toy wheels, toy parts, craft items, and dowel rods in birch, oak, walnut, and cherry. Send for complete 32-page catalog. WOODWORKS. \$1.00. Circle No. 1490.

INCOME OPPORTUNITIES

AMITY, NATION'S #1 QUALITY FURNITURE RESTORATION CO. SINCE 1971—New product catalog featuring: Complete restoration systems, Hydrocote non-flammable water based stains and finishes, Permatuff repair products, stripping solvents, chemicals and supplies. Amity 1-2-3 wipe-on finishes and much more. Regional workshops in your area. AMITY. \$1.00. Circle No. 1605.

WOOD CARVING MACHINES AND ACCESSORIES—make all types of wood carving easy, fun and profitable. The machines do the work. Whether for sign carving, flat 3-D, decoys, panels, gun stocks or furniture, we have the proper machine for the job. Professional woodcarving for the hobbyist and superior quality for the professional. Begin your hobby or full or part-time business by ordering our catalog and price list. MARLIN INDUSTRIES. \$1.00. Circle No. 1669.

MAKE MONEY IN FURNITURE RESTORATION THE MINUTEMAN WAY—Earn \$200-\$1000 per day stripping, repairing, refinishing, mirror resilvering, and/or veneering at home or in shop, spare time or full time. We provide complete free training; no experience necessary. Free workshop teaches you latest in furniture restoration. You have to see it to believe it! Send for catalog. MINUTEMAN. \$2.00. Circle No. 1661.

MISCELLANEOUS

FOLEY-BELSAW INSTITUTES' NEW WOODWORKING CORRESPONDENCE COURSE—for people with the desire to learn how to work with wood and the proper use of tools. Create over 20 projects using professional plans and tools like a table saw, router with stand, and more...all included with the course. Complete money-back guarantee. Send for details. FOLEY-BELSAW INSTITUTE. Free. Circle No. 1930.

LEARN ALL THE SKILLS—of professional upholstery and refinishing techniques in the comfort of your own home. The Foley-Belsaw Institute system of "hands on" training provides clear, step-by-step instructions in the use of tools and materials on actual furniture "kits"...all included with the course. Complete money-back guarantee. Send for details. FOLEY-BELSAW INSTITUTE. Free. Circle No. 1931.

BANDSAW OWNERS—A new tool is now available so you can make or repair any length bandsaw blade in minutes. Our splicer enables craftsmen to make up any length blade from economical coil blade stock quickly and easily. Three models are currently available to accommodate blade widths from 1/8 to 1 1/2 in. The tool comes complete with detailed instructions and supplies. We also carry OLSON bandsaw stock at reasonable prices. Send for literature. NEW MILFORD SPECIALTIES CO. 50¢. Circle No. 2025.

ATTENTION! ANTIQUE RESTORERS! WOODWORKERS! COLLECTORS! AND HOBBYISTS!—This 192-page wholesale catalog is loaded with unique, hard to find items! Includes hundreds of essential antique restoration parts, brass reproduction hardware, oil lamps and accessories, wood parts, caning, basketry, upholstery, and art supplies, wood refinishing products, tools, books, etc. VAN DYKE'S RESTORERS. \$1.00. Circle No. 2077.

THE NATURAL CHOICE: SOLID WOOD PLANK PANELING—The paneling choice of the future—here today. For today's home or commercial use. Full color brochure with room paneling applications, some of the standard profiles, installation and finishing recommendations. Design your showcase room with this simple alternative. WOOD MOULDING & MILLWORK PRODUCERS ASSN. \$1.00. Circle No. 2085.

WOODWORKING ASSOCIATION OF NORTH AMERICA—First international association for woodworkers. Benefits include our quarterly magazine *International Woodworking*, specials from selected manufacturers, access to the woodworking network. WOODWORKING ASSOC. OF NORTH AMERICA. 50¢. Circle No. 2092.

CARVING SUPPLIES

DECOY AND WOOD CARVERS WISHBOOK—48-page catalog features wide selection of tools and supplies for decoy carvers, wood carvers, wood turners. Chisels, gouges, sharpening stones, precision grinding tools, Foreman tools, Fire Brush burners, pneumatic sanders, glass eyes, pewter feet, patterns, paints, reference books. P. C. ENGLISH, INC. Free. Circle No. 2115.

WOODCARVING TOOLS—Whittlers and carvers—Warren Tool Co. offers a catalog for you full of whittling and carving hand/power tools, books, stones, wood, and supplies. Since 1927, the finest in woodcarvers tools. WARREN TOOL CO., INC. \$1.00. Circle No. 2185.

CLOCKS

BUILD HEIRLOOM CLOCKS—Now create beautiful heirloom quality clocks right in your own home. Choose from magnificent chiming grandfather clocks to charming wall clocks. 32-page catalog also offers a selection of music boxes, music movements, traditional barometers, and a huge variety of quartz movements and dials for custom clock building. Satisfaction guaranteed. CRAFT PRODUCTS CO. Free. Circle No. 2320.

KLOCKIT'S FREE 64-PAGE COLOR CATALOG—is packed with the largest selection of beautiful wood clock kits for all skill levels, a huge selection of quartz and mechanical clock movements, dials and accessories, turned wood parts, music movements, tools and much more for the craftsman KLOCKIT. Free. Circle No. 2335.

Information

WORTH WRITING FOR

TO ENSURE PROMPT HANDLING OF YOUR ORDER FOLLOW THESE INSTRUCTIONS:

- Circle your choice
- Enclose check or money order for cost of booklets plus \$2.00 service charge (no stamps/foreign)
- Send coupon and remittance to address above
- U.S. FUNDS ONLY
- ALLOW 4-6 WEEKS FOR DELIVERY
- Coupon expires October 15, 1990

WOOD SUBSCRIPTION

1. A 1 year WOOD subscription (6 issues) for \$18.00 (U.S. price) — a \$3.00 savings off newsstand rate. Allow 6-8 weeks for first issue. Canadian price \$24.00. Be sure to include payment with total below. NO FOREIGN ORDERS ACCEPTED ON THIS COUPON; please contact Subscription Dept. directly.

FREE LITERATURE

Circle numbers below corresponding to items in this issue. Please include \$2.00 for handling charge

17.	61.	565.	975.	1251.	1931.
18.	76.	615.	1017.	1293.	2115.
33.	84.	860.	1125.	1350.	2320.
42.	99.	878.	1205.	1365.	2335.
57.	100.	955.	1250.	1930.	

PRICED LITERATURE

Numbers below refer to items on which there is a charge. Please include proper remittance.

6 \$2.00	190 \$1.50	390 \$1.00	592 \$1.00	965 \$1.00	1315 \$1.00	1487 75¢
47 \$1.00	232 \$1.00	398 \$1.00	801 \$2.00	1005 \$1.00	1320 \$3.00	1490 \$1.00
78 \$1.00	310 \$2.00	472 \$5.00	810 \$1.00	1030 \$1.00	1321 \$1.00	1605 \$1.00
87 \$1.00	315 \$1.00	475 \$1.00	820 \$1.00	1080 \$1.00	1360 \$1.00	1659 \$1.00
90 \$1.00	325 50¢	480 \$1.00	855 \$4.00	1140 \$2.00	1372 \$1.00	1661 \$2.00
93 \$1.00	338 \$1.00	510 \$1.00	875 \$1.00	1235 25¢	1401 50¢	2025 50¢
94 \$1.00	340 \$1.00	530 \$2.00	900 \$4.00	1240 \$1.00	1430 \$3.00	2077 \$1.00
96 \$1.00	345 \$2.00	545 50¢	920 \$1.00	1245 \$1.00	1450 75¢	2085 \$1.00
112 \$2.00	370 \$1.00	563 \$2.00	935 \$2.00	1248 \$1.00	1455 \$1.00	2092 50¢
160 \$1.00	375 \$1.50	578 \$2.00	945 \$5.00	1267 50¢	1480 \$1.00	2185 \$1.00

Name (please print) _____

Address _____

City _____

State _____ Zip Code _____

I AM ENCLOSING:

\$ _____ for priced items

\$ 2.00 for handling

\$ _____ total remittance

ORDER TOLL FREE 1-800-328-0457 - MAIL ORDER HOURS 7:00-5:30 C.S.T. MONDAY-FRIDAY

DELTA BENCH TOP TOOLS

Model	Description	List	Sale
23-700	Wetdry grinder	201	159
23-880	6" bench grinder 1/4 H.P.	81	66
23-900	8" bench grinder 1/2 H.P.	136	105
11-950	8" drill press	246	235
14-040	14" drill press	313	309
40-150	15" hobby scroll saw	179	135
28-190	10" hobby band saw	189	144
31-050	1" belt sander 2.0 amp	93	75
31-460	4" belt/buff disc sander	178	135
31-340	"NEW" 1" belt/buff disc sander	226	169

DELTA STATIONARY

Model	Description	List	Sale
34-751	10" unisaw 1/2 H.P.	1715	1339
34-700	Super 10" motorized table saw	909	639
34-429	10" lifting arbor bench saw	1470	1049
	1 1/2" H.P.		
33-990	10" radial arm saw	727	555
11-072	32" radial drill press	487	399
33-280	6" motorized jointer	440	375
50-179	1/4 H.P. 2 stage dust collector	435	339
50-180	1 H.P. dust collector	635	425
50-190	1 1/2 H.P. dust collector	790	615
37-154	Deluxe DJ-15 6" jointer w/1 1/2" H.P.	1288	999

DELTA PORTABLE

Model	Description	List	Sale
33-050	"NEW" 8 1/4" Sawbuck	742	559
34-330	"NEW" 8 1/4" Table Saw	321	245
34-670	10" motorized table saw	437	325
34-965	1/4 H.P. stock feeder	698	545
28-250	18" 3 wheel band saw	546	379

MILWAUKEE TOOLS

Model	Description	List	Sale
0395-1	9.6V cdless. drill w/case	264	159
0219-1	9.6V cdless. drill w/case	277	165
0385-1	7.2V cdless. drill w/case	174	115
0224-1	3/4" drill 4.5A magnum	179	109
0234-1	1/2" drill 4.5A mag 0-850 rpm	189	107
0244-1	3/8" drill 3.5A 0-1000 rpm	185	107
0222-1	3/8" drill 3.5A 0-1000 rpm	154	90
0228-1	3/8" drill 3.5A 0-1000 rpm	154	90
0375-1	3/8" close quarter drill	208	119
0379-1	1/2" close quarter drill	243	139
0539-1	Cordless screwdriver 190 rpm	108	65
	Cdless. screwdriver w/bits & case	137	89
0546-1	Cdless. screwdriver 200 & 400 rpm	120	75
3102-1	Palmox rt angle drill kit	296	175
3002-1	Electronics II angle drill kit	290	175
3399	1 1/2" D-hole hammer drill kit	292	179
1676-1	H.D. Hole Hawg w/case	395	225
6511	2 sp SawZall w/case	209	119
6405	8 1/4" circle saw	209	120
6750-1	Drywall gun 0-4000 4.5A	149	89
6798-1	Trk screwdriver	173	105
6507	TSC SawZall w/case	219	129
6170	14" chop saw	430	295
6012	Orbital sander 3 1/2" x 7 1/4"	179	105
6014	Orbital sander 4 1/2" x 9 1/4"	189	110
6305	6 1/4" cordless circle saw	284	185
6753-1	Drywall gun 0-4000 3.5A	129	83
6977	Vac. temp heat gun	109	70
5397-1	3/4" v. spd. hammer drill kit	227	133
5371-1	1/2" v. spd. hammer drill kit	213	119
3107-1	1/2" v. spd. rt. angle drill kit	305	179
6754-1	Drywall gun 0-4000 4.5A	179	110
6747-1	Drywall driver 0-2500	149	89
0236-1	3/4" drill 0-1700 rpm	199	99
0200-1	1 1/2" v. spd. magnum angle kit	289	179
5650	Router 1 1/2" H.P. - 10 amp	299	179
5680	Router 2 H.P. - 12 amp	350	205
5455	1/4" polisher 1750 rpm	199	125
6215	16" chain saw	280	189
8975	Heat gun	85	55
6385	7 1/4" circular saw	189	107
6356	7 1/4" circ saw w/finest & bid	186	110
6388	7 1/4" circ saw w/finest, bid & case	226	129
0235-1	2 spd cordless drill H-torque	222	145
0235-1	1/2" drill keyless chuck mag	139	85
6016	1/4" sheet pad sander	75	48
6145	4 1/4" grinder 10,000 rpm	149	95
6142	4 1/4" grinder 10,000 rpm w/case & access.	182	114
6141	5" grinder 10,000 rpm	159	99
0239-1	1/2" drill keyless chuck	189	114
6749-1	Drywall gun 0-2500 4.5A	189	115
6377	7 1/4" worm drive saw	275	159

FREUD SAW BLADES

3/8" Bore - Industrial Grade
CARBIDE TIPPED SAW BLADES

Item No.	Description	Dim.	List	Sale
LUT2M018	Gen. Purp. ATB	10" 40	53	39
LUT1M010	Gen. Purp. TCB	10" 40	45	39
LUT3M020	Cut-off	10" 60	77	48
LUT4M011	Combination	10" 50	65	48
LUT5M017	Super Cut-off	10" 80	96	57
LMT2M019	Ripping	10" 24	37	27
LUT2M010	Cut off	10" 60	70	42
LUT7M010	Thin kerf	10" 24	60	40
LUT8M010	Thin kerf	10" 60	74	49
LUT9M010	Ultimate	10" 80	107	79
LUT10M010	Non-ferrous metal	10" 22	67	43
P5203	Gen. Purp.	7 1/4" 24	25	18
P5203	Phenox	7 1/4" 40	38	26
D5206	6" Dado - Carbide	184	109	
D5208	8" Dado - Carbide	184	109	
F8	1 1/4" x 1/4" Biscuits 1000-Qty.	32	25	
F9	2 1/4" x 1/4" Biscuits 1000-Qty.	32	25	
F20	2 1/4" x 1/4" Biscuits 1000-Qty.	34	28	
W504	4 pos. chisel set w/case 1 1/2"	54	35	
WC10	6 pos. chisel set w/case 1 1/2"	73	54	
WC16	10 pos. chisel set w/case 1 1/2"	119	74	
FR100	16 pos. forstner bit set 1 1/2"	284	159	
FR100	5 pos. router bit door system	284	159	
J5100	Biscuit Joiner w/case	300	154	
E9100	"NEW" edge banding machine	358	275	

MAKITA CORDLESS

Model	Description	List	Sale
6070DW	3/8" var. spd. rev. drill, 7.2v	123	75
6071DW	1/2" var. spd. rev. drill, 7.2v	190	105
6090DW	3/4" var. spd. rev. drill, 9.6v	243	129
6090DW	3/4" circular saw, 10.8v	317	175
6010DWK	3/8" cordless drill kit, 7.2v	155	89
6010SDW	3/8" cordless drill, 7.2v	103	65
D43000DW	3/4" angle drill, 7.2v	238	130
4390DW	9.6v vlt. colts. recip saw kit	218	124
4300DW	Jig saw kit comp., 9.6v	220	125
6010DL	3/8" drill w/flashlight, 7.2v	198	113
6710DW	Cordless screwdriver kit, 7.2v	186	103
6021DW	2 spd. driver drill w/ clutch & case, 9.6v	224	115
6092DW	Vsdp. drill, kit complete	237	120
6093DW	Vsdp. drill w/ clutch - complete	248	125
6891DW	Drywall gun 0-1400, 9.6v	285	119
632007A	9.6 vlt. battery	49	30
632002-4	7.2 vlt. battery	42	28

MILWAUKEE TOOLS

Model	Description	List	Sale
5007NBA	7 1/4" saw w/elec. brake	228	125
5008NBA	8 1/4" saw w/elec. brake	276	149
804510	1/4 sheet pad sander	80	50
9900B	3"x21" belt sander w/bag	254	145
9924DB	3"x24" belt sander w/bag	268	155
9035	1/2 sheet finish sander	106	68
9045B	1/2 sheet finish sander	216	125
9045N	1/2 shi fin. sand. w/bag	219	127
4201N	4 1/2" circ. saw 7.5 amp	213	119
5201HA	6 1/2" circ. saw 12 amp	580	290
4301BV	Orb. vsp. jig saw 3.5 amp	274	149
JR3000NL	2 sp recip saw w/case	220	122
JR3000V	Vs. recip saw w/case	224	125
LS1020	New 10" mitre saw	440	235
9820-2	Blade sharpener	354	199
410	Dust collection unit	480	279
3705	Offset trimmer	255	145
1900B	3 1/4" planer w/case	198	115
6031B	3 1/2" planer w/case	288	179
9207SPC	7" sander-polisher	262	148
3601B	1 1/4" H.P. router	242	139
3700B	1/2 H.P. trimmer	180	105
9501B	4" grind. 3.5 amp	137	69
804530	6" round sander	95	60
804550	1/4" sheet pad sander w/bag	85	55
D43000R	3/4" angle drill	256	145
DP4700	1/2" vsp. wire, 4.8 amp	198	119
HP2200W	3 1/4" vsp. hammer drill w/case	285	159
2700W	8 1/4" table saw	478	259
2700W	10" table saw w/bcase	800	459
GV5000	Disc sander 5"	109	69
8000DB	2500 rpm 3.5 amp, drywall	140	89
8000DBV	0-2500 rpm 3.5 amp, drywall	154	95
6801DB	4000 rpm 3.5 amp, drywall	140	89
6801DBV	0-4000 rpm 3.5 amp, drywall	154	95
20010N	12" planer/jointer	2970	1699
2940	15 1/2" planer	2470	1449
1803B	1 1/2" planer kit w/case	545	359
JV1600	var. speed jig saw	220	125
JV2000	var. speed orb. jig saw	242	138
5005BA	5 1/4" circular saw	211	119
9603BH	4 1/2" sander-grinder	153	89
9404B	3/4" drill 0-2100 rpm, 2 amp	102	65
6510LVR	3/4" drill rev. 0-1050 rpm	137	78
6019BR	1/2" drill rev. 6 amp	240	135
5402A	16" circular saw - 12 amp	605	339
9401	3 H.P. plunge router	376	199
9401	4 1/2"x24" belt sander w/bag	302	169
3620	1 1/4" H.P. plunge router w/case	182	105
4302C	Vsdp. orb. jig saw	287	149
5077B	7 1/4" Hypoid saw	248	139
LS1440	14" Mitre saw	624	409
2414	14" cut-off saw AC/DC	350	199
5000WB	7 1/4" circ saw 13 amp	209	119
3812B	3 HP plunge router sq/b	376	199

MILWAUKEE TOOLS

Model	Description	List	Sale
5007NBA	7 1/4" saw w/elec. brake	228	125
5008NBA	8 1/4" saw w/elec. brake	276	149
804510	1/4 sheet pad sander	80	50
9900B	3"x21" belt sander w/bag	254	145
9924DB	3"x24" belt sander w/bag	268	155
9035	1/2 sheet finish sander	106	68
9045B	1/2 sheet finish sander	216	125
9045N	1/2 shi fin. sand. w/bag	219	127
4201N	4 1/2" circ. saw 7.5 amp	213	119
5201HA	6 1/2" circ. saw 12 amp	580	290
4301BV	Orb. vsp. jig saw 3.5 amp	274	149
JR3000NL	2 sp recip saw w/case	220	122
JR3000V	Vs. recip saw w/case	224	125
LS1020	New 10" mitre saw	440	235
9820-2	Blade sharpener	354	199
410	Dust collection unit	480	279
3705	Offset trimmer	255	145
1900B	3 1/4" planer w/case	198	115
6031B	3 1/2" planer w/case	288	179
9207SPC	7" sander-polisher	262	148
3601B	1 1/4" H.P. router	242	139
3700B	1/2 H.P. trimmer	180	105
9501B	4" grind. 3.5 amp	137	69
804530	6" round sander	95	60
804550	1/4" sheet pad sander w/bag	85	55
D43000R	3/4" angle drill	256	145
DP4700	1/2" vsp. wire, 4.8 amp	198	119
HP2200W	3 1/4" vsp. hammer drill w/case	285	159
2700W	8 1/4" table saw	478	259
2700W	10" table saw w/bcase	800	459
GV5000	Disc sander 5"	109	69
8000DB	2500 rpm 3.5 amp, drywall	140	89
8000DBV	0-2500 rpm 3.5 amp, drywall	154	95
6801DB	4000 rpm 3.5 amp, drywall	140	89
6801DBV	0-4000 rpm 3.5 amp, drywall	154	95
20010N	12" planer/jointer	2970	1699
2940	15 1/2" planer	2470	1449
1803B	1 1/2" planer kit w/case	545	359
JV1600	var. speed jig saw	220	125
JV2000	var. speed orb. jig saw	242	138
5005BA	5 1/4" circular saw	211	119
9603BH	4 1/2" sander-grinder	153	89
9404B	3/4" drill 0-2100 rpm, 2 amp	102	65
6510LVR			

We Thank You!

Thanks a lot, readers, for your continued support. On our fifth anniversary, we promise you even better WOOD® magazines in the years ahead.

“Your enthusiasm as readers still inspires us to provide you with the very best wood-working publication available. To continue the tradition we began five years ago, count on me and the rest of the staff to pull out all the stops on your behalf. From top-notch projects to tools, techniques, and features, we’ll aim at *your* interests in every issue. And, if you have a question, we’ll try to answer it. When you have a problem, we’ll solve it. With us, you, our readers, always come first. We want to remain as your favorite woodworking magazine.”

—Larry Clayton, for the WOOD magazine staff



James R. Downing
Design Editor

Bill Krier
Products/
Techniques
Editor

Darlene Reynolds
Administrative
Assistant

Larry Clayton
Editor

Carl Voss
Managing
Editor

Marlen Kemmet
How-to Editor

James E. Boelling
Project Builder

Perry A. McFarlin
Sr. Graphic Designer

C. L. Gatzke
Art Director

Peter J. Stephano
Features Editor

Jodi Downing
Business Office
Clerk

THE ARTISAN'S SAW



\$735

Castors Set and
Stock Pusher shown
on Model 63
are Optional.

Strikingly different. A new standard for the industry.

As "the" producer of top end industrial woodworking machines since 1921, Powermatic now focuses their engineering expertise and resources for the craftsman, contractor and home hobbyist.

- Industrial Quality Vega Fence System provides unsurpassed rigidity for accuracy & speed

- T-Slot Miter Gauge for increased accuracy and flexibility in stock width capabilities

- Built-In Dust Shroud for shop cleanliness

- Cast Iron Grate Extensions provide ruggedness for increased accuracy and longevity

- Unitized Wiring System readily removed for portability

- The Powermatic Name for value and service

You'll find no better quality or value . . . anywhere. For just a little more than you'd spend on a run-of-the-mill machine.

Talk to your Powermatic distributor today. For those who want the

best: the Powermatic 10" Artisan's Saw. Truly a new standard for the industry.

The Artisan's Choice
POWERMATIC 

A Division of Stanwich Industries, Inc.
McMinnville, Tennessee 37110
800/248-0144 □ 615/473-5551
TELEX - 554455
FAX # 615/473-7819

Serious Tools For Serious Work. Or, Just For Fun!



Geauga Lake Park, Aurora, Ohio Photo © Aerial Perspective, Lititz, PA

Dinn Corporation of Cincinnati, Ohio, depends on quality Makita Power Tools to build exciting roller coaster rides all over the United States. When you're working on wooden structures hundreds of feet in the air, you've got to have faith in the tools you use.

That's why more tradesmen use Makita tools than any other cordless. And that's why more and more do-it-yourselfers and home craftsmen are turning to Makita.

Makita offers two complete cordless tool systems, each with its own interchangeable battery. Choose from the extensive 18-tool, 7.2 volt system, or the powerful 9.6 volt system with 12 tools.

But don't forget that Makita also offers over 100 corded power tools in its extensive line.

All our power tools, whether corded or cordless, bear the Makita trademark. Quality and durability.



Makita
IT'S ALL THE POWER YOU NEED.®

14930 Northam St., La Mirada, CA 90638-5753 • (714) 522-8088