

Better Homes and Gardens®

WOOD®

THE #1 MAGAZINE FOR HOME WOODWORKERS

APRIL 1991 • ISSUE NO.42

Display until April 16

**CARVE A TABLETOP
CIGAR-STORE INDIAN**

**WATER-BASED
FINISHES, THE WAVE
OF THE FUTURE**

**WOOD® TESTS 21
CORDLESS DRILLS**

**PROJECT
BONANZA!**

Spice cabinet

Welcome sign

Domed display
case

Wren birdhouse

Marbleized clock

Scrollsawed plaques

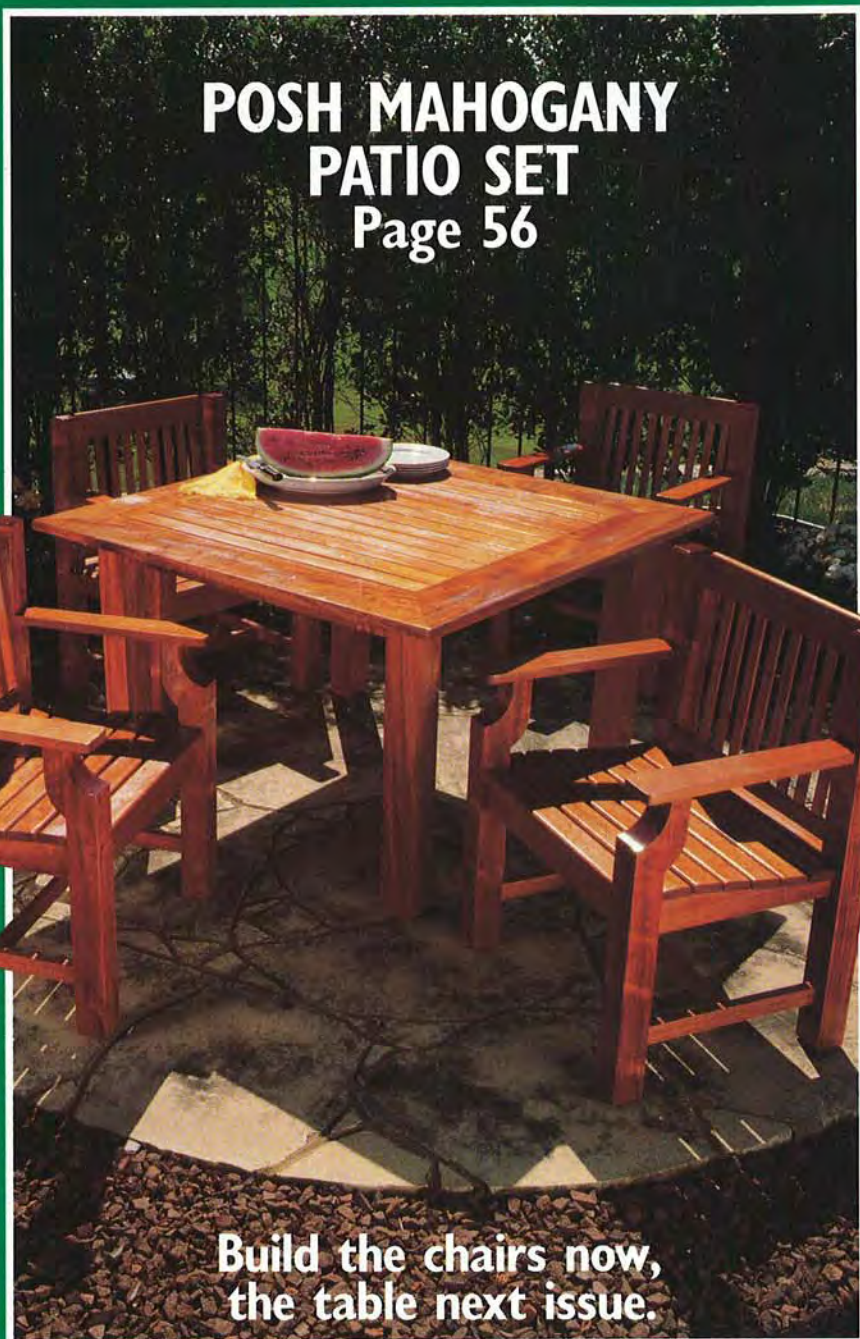

**POSH MAHOGANY
PATIO SET**
Page 56

Build the chairs now,
the table next issue.



U.S. \$3.95



ZAR. Don't let anything else come between you and great wood.

Whether you're restoring a family heirloom or creating one, you're looking for the ideal: a do-it-yourself job that looks professional.

Which is exactly what ZAR® wood stains are all about. ZAR brings wood to life while it brings confidence to you. It wipes on easily. Penetrates evenly. Colors consistently. And covers more surface than leading competitors. Time after time after time.

The ZAR family of fine products is at your hardware store, paint store, home center or lumber yard. Don't put anything else between you and timeless wood.

For a free booklet on how to refinish wood, call 1-800-272-3235

The fine line between you and beautiful wood.

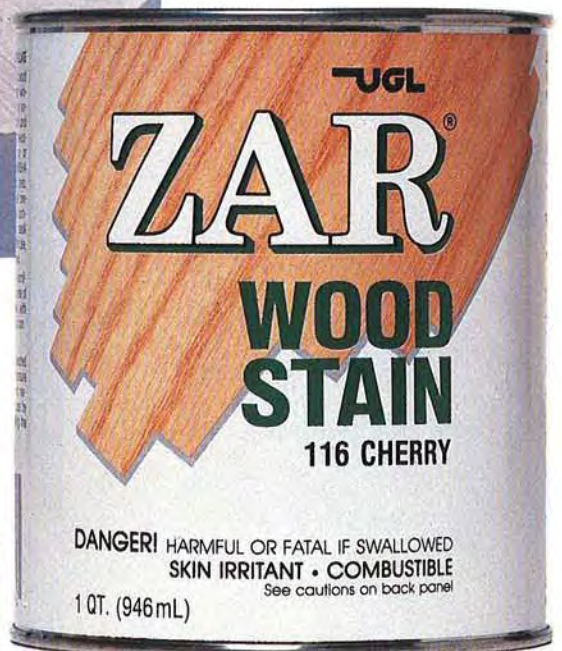

DANGER! HARMFUL OR FATAL IF SWALLOWED
SKIN IRRITANT • COMBUSTIBLE
See cautions on back panel

1 QT. (946 mL)

Test Our Bits & Cutters

At no obligation with our no-risk 30 day trial

Order the tool you want to try out. If it is not exactly to your satisfaction, send it back and we will replace it or immediately refund your money. You pay only a small non-refundable shipping charge on items returned.



Toll Free
1-800-782-6629

AmMax

FREE * Complete catalog sent upon your request
* Plastic caliper for any order (\$4.00 value)

PRECISION TOOLS FOR SKILLFUL WOODWORKERS.
INDUSTRIAL QUALITY CARBIDE TIPPED ROUTER BITS
AND SHAPER CUTTERS.

CUTTER	ORDER #	CUT DIA	CUT L	SNK D.	PRICE
Straight	ST206	1/4	3/4	1/4	5.50
	ST210	3/8	1	1/4	5.50
	ST213	1/2	1	1/4	5.50
	ST413E	1/2	2	1/2	14.00
	ST216	5/8	1	1/4	5.90
Flush Trim	ST219	3/4	1	1/4	8.50
	ST425	1	1 3/16	1/2	8.80
	FT210	3/8	1	1/4	6.50
Flush Trim	FT213	1/2	1	1/4	6.50
	FT413	1/2	1 3/16	1/2	6.50
Dovetail	DV210	3/8	3/8	1/4	4.60
	DV213	1/2	1/2	1/4	4.60
	DV413	1/2	1/2	1/2	4.60
	DV419	3/4	7/8	1/2	6.50
Dovetail	DV425	1	7/8	1/2	7.50
	CB206	1/4	1/4	1/4	8.00
Core Box	CB210	3/8	5/16	1/4	9.00
	CB213	1/2	3/8	1/4	11.00
	CB219	3/4	1/2	1/4	14.00
	CB425	1	5/8	1/2	16.00
45° Chamfer	CH213	1 3/16	1/2	1/4	12.00
	CH216	1 3/8	5/8	1/4	13.00
	CH422	1 7/8	7/8	1/2	18.00
Rabbet	RB232	1 1/4	1/2	1/4	12.00
	RB432	1 1/4	1/2	1/2	12.00
RADIUS					
Rounding Over	CR203	1/8	3/8	1/4	10.00
	CR205	3/16	7/16	1/4	10.00
	CR206	1/4	1/2	1/4	11.50
	CR210	3/8	5/8	1/4	14.00
	CR213	1/2	3/4	1/4	16.00
Roman Ogee	CR419	3/4	1	1/2	20.00
	CR425	1	1 1/4	1/2	32.00
Cove	RO204	5/32	15/32	1/4	15.00
	RO206	1/4	3/4	1/4	16.00
	RO406	1/4	3/4	1/2	16.00
	CV203	1/8	3/8	1/4	11.00
Classical	CV206	1/4	1/2	1/4	11.00
	CV210	3/8	9/16	1/4	12.00
	CV213	1/2	5/8	1/4	13.00
	CV419	3/4	3/4	1/2	25.00
CS206	1/4	5/8	1/4	19.00	
CS406	1/4	5/8	1/2	19.00	

LOCK MITRE
ML470 \$34
1/2" shank



STILE & RAIL
Reversible
RS248
1/4" shank \$37
RS448
1/2" shank \$37



OGEE FILE
OF466
1/2" shank
O.D. 2 1/2"
\$24



KEY HOLE
KH210
1/4" shank
\$6.50



DRAW PULL
DP435
1/2" shank \$29



SLOT CUTTERS
SL204
1/4" shank \$16
SL404
1/2" shank \$16
6 others
in our free catalog



FINGER JOINTER
FJ463
1/2" shank \$53



TONGUE & GROOVE
TG230
1/4" shank \$29
TG444
1/2" shank \$29



MULTI-MOULDING
MM454
1/2" shank \$39



SAVE \$10.00

5PC WOODWORKING KIT

1. AUTO CENTER PUNCH
2. SCRIBER W/MAGNETIC PICK UP
3. STEEL RAFTER & CARPENTER SQUARE
4. PLASTIC STEEL CALIPERS
5. 6" 3 WAY HAND SAW

\$14.99

PANEL RAISER
\$49
EACH

HORIZONTAL PANEL RAISING
5" O.D. 3/4" Bore
3mm Carbide

C931 C984 C985 C986 C987

We stock more than 50 types of 3-wing shaper cutters

Top of the line Made in U.S.A.
Nicholson
10" 60T \$39.99
10" 36T \$18.10
10" 40T \$26.89
Retail values up to \$60

Carbide Tipped

NEW PRODUCTS
2-piece Stile & Rail -- \$69 a set

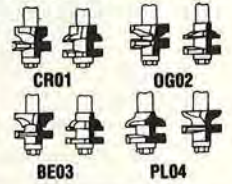

15 PC Router Bits Set

\$109.99

WOOD CASE INCLUDED / \$12.00 Value



1/4" Shank Only

All 2 Flute Carbide Tipped.

Most popular bits are selected in this set
Ideal Gift for woodmakers

SHAPER CUTTERS — Your Choice each

\$29.00

1/4" & 1/2" OR. RD.

FEMALE SASH

OGEE & BEAD



C905



C975



C993

1/8" & 3/8" OR. RD. & 1/4" BEAD

MALE SASH

OGEE

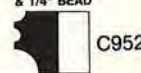

C952



C976



C906

SHAPER CUTTERS / CABINET SETS

3/4" BORE BUSHED TO 1/2"

SAVE \$10.00

FOR TWO SIDES.
Decorative design
work thickness
1 1/8" — 1 3/4"

FOR ONE SIDE
Decorative design

work thickness
1 1/8" — 3/4"

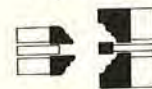

C921

CABINET MOULDING SET

\$150



C940

CONCAVE STILE & RAIL SET



C994

OGEE STILE & RAIL SET



C945

CONVEX STILE & RAIL SET

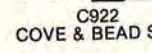

C922

COVE & BEAD SET

\$160

\$140

\$140

\$140

SAME DAY SHIPPING Count on us!

Shipping is FREE for orders over \$60 and is only \$2 for smaller orders.

Call us toll free

1-800-782-6629 or 1-(619) 535-8940 in CA

HOURS: MON thru FRI 7 AM to 6 PM

NEW: SAT 8 AM — 2 PM

Send your check to: 12655 Danielson Court, Suite 310
P.O. Box 520, Poway, CA 92064

Member of the Better Business Bureau

PARAGAUGE™

THE PERFECT SHOP ACCESSORY
FOR ANYONE WHO OWNS A
TABLE OR RADIAL ARM SAW

Designed for both the home and professional shop, Paragauge will accurately set any table or radial arm saw so precise that anyone can now cut wood accurate to within 10/1000" — virtually eliminating binding, burning and dangerous kickback.

Easy-to-follow directions show how to use **Paragauge** for setting a perfectly parallel rip fence (up to 18 inches wide), setting inside bevels and setting blade height. Radial arm saw owners can use **Paragauge** as a square for crosscutting, setting the width for ripping, setting blade depth and even check for table levelness and heel in horizontal position. **Paragauge** is so versatile and accurate everyone can now cut wood with professional quality results.

Paragauge also saves the cost of upgrading to a new saw or adding an expensive parallel-locking fence to your current equipment!

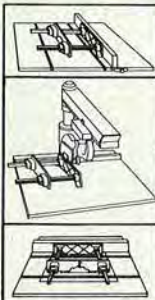

A Proven Performer

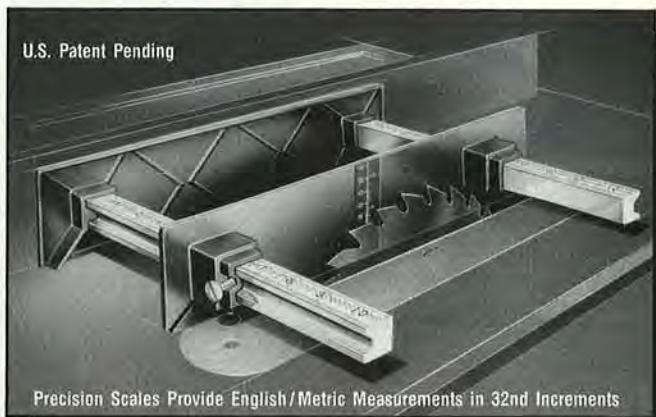

U.S. Patent Pending

Precision Scales Provide English/Metric Measurements in 32nd Increments

NOTE: We suggest that Model PG-18 only be used on table tops measuring at least 36" wide. For smaller saws or when using the gauge on a radial arm saw, Model PG-12 is recommended.

NOW AVAILABLE
IN TWO SIZES

MODEL

Only!

PG-12
(12 inch)

\$34.95 +\$3.50 S&H

PG-18
(18 inch)

\$39.95 +\$5.00 S&H

MI Residents Please Add 4% Sales Tax

"MADE IN THE U.S.A."
For Quality You Can Depend On!



To Order
Call Toll Free



1-800-343-6129

(7 Day - 24 hour service)

- OR -

To order by check or for a FREE BROCHURE write:
Accuset Tool Co., Inc., P.O. Box 1088 Dept. D, Troy, MI 48099
30 Day Money Back Satisfaction Guarantee • SORRY, NO C.O.D.'s

WOOD PARTS FROM MIDWEST DOWEL WORKS

Compare Our Low Prices!



Qty. Cost

3-1/2" Poplar Shaker Peg	\$15/100	___
1-3/4" Mini Shaker Peg	\$7/100	___
3-1/2" Country Wall / Mug Peg	\$15/100	___
2-1/2" Country Shorty Peg	\$12/100	___
Large Bean Pot Candle Cup	\$17/100	___
Brass Inserts	\$9/100	___
1/2" Mini Candle Cup	\$10/100	___
1-1/2" Toy Wheel	\$10/100	___
2" Toy Wheel	\$17/100	___
Axel Pegs	\$4/100	___

SMOOTH SANDED HEARTS

3/4" x 1/8" Hearts	\$2.75/100	___
3/4" x 1/2" Hearts	\$4.50/100	___
1" x 3/16" Hearts	\$4.00/c	___
1" x 3/8" Hearts	\$6.50/c	___
1-3/8" x 1/8" Hearts	\$5.50/c	___
1-3/8" x 1/4" Hearts	\$7.50/c	___
1-3/8" x 1/2" Hearts	\$10/100	___
2" x 1/2" Hearts	\$18/100	___

Great Buys!



Qty. Cost

3/8" x 36" Standard Dowels	\$21/100	___
3/4" x 36" Oak Dowels	\$15/10	___
3/8" Maple Buttons	\$2.15/100	___
1/2" Maple Buttons	\$2.25/100	___
1-1/2" Maple Spindles	\$9/100	___
2-1/8" Maple Spindles	\$18/100	___

ORDER NOW

MC/Visa Check Enclosed

Total Cost

Handling \$3.00

Ohio residents
add 5% sales tax

Final Cost

MC/Visa Number

Expires Phone

Name

Address

City/State/Zip

FREE 16-PAGE CATALOGUE

Circle this section for FREE Dowels
— mixed pack, Maple, Oak, Walnut
Cherry, from 1/4" up to 1"
Approximately 10 LFT. 14" long.
\$5.00 value with any order.

MIDWEST DOWEL WORKS

4631 Hutchinson Road
Cincinnati, Ohio 45248
(513) 574-8488

Same Day Service/Order before Noon
Factory Direct/Satisfaction Guaranteed



WOODCRAFT®

The Leading Edge

in Woodworking Tools

Complimentary Tool Catalog

Our new complete woodworking tool catalog features over 4,500 of the finest quality woodworking tools, books, supplies, and cabinetry hardware available today.

Give us a toll-free call to receive your own catalog FREE!



Order yours today!

Call 1-800-542-9115

Or write: Woodcraft Supply, Dept. 91 WI03Q
#210 Wood County Industrial Park, P. O. Box 1686
Parkersburg, WV 26101

Better Homes and Gardens®
WOOD

THE #1 MAGAZINE FOR HOME WOODWORKERS

April 1991 • Vol. 8, No. 3 • Issue No. 42

Editorial/Art Staff

Editor **LARRY CLAYTON**
 Managing Editor **JIM HARROLD**
 Art Director **C. L. GATZKE**
 Assistant Art Director **PERRY A. McFARLIN**
 Design Editor **JAMES R. DOWNING**
 Senior Editor **PETER J. STEPHANO**
 How-To Editor **MARLEN KEMMET**
 Products/Techniques Editor **BILL KRIER**
 Special-Interest Editor **LARRY JOHNSTON**
 Copy/Production Editor **JOHN D. HOFHEIMER**
 Project Builder **JAMES E. BOELLING**
 Administrative Assistant **DARLENE REYNOLDS**
 Business Office Clerk **MARGARET CLOSNER**
 Secretary **ROSEMARIE BURCH**

Technical Consultants: Product Testing **GEORGE GRANSETH**;
 Products That Perform **STEVE OSWALT**; Wood Technology
PAUL L. McCLURE; Collectible Tools **PHILIP WHITBY**
 Carving **HARLEY J. REFSAL**

Publisher **WILLIAM R. REED**
 Advertising Representatives **PAUL DaCRUZ, CRAIG KAPLAN,**
CHRIS W. SCHAFT, LORIANN DeCIOPPO
 Promotion/Research Director **EILEEN SULLIVAN**
 Marketing Services Manager **NANCY DALY**
 Sales Secretary **ALICIA SANTANA**
 Circulation Manager **ALAN BRUSH**
 Newsstand Circulation Director **MICHAEL SENIOR**
 Business Manager **TERRY UNSWORTH**
 Production Director **ROBERT C. FURSTENAU**
 Public Relations **SONDY DAGGETT**

Magazine Group Officers

Group President **JAMES A. AUTRY**
 Senior Vice President, Publishing Director **ADOLPH AUERBACHER**
 Senior Vice President, Editorial Director **DORIS EBY**
 Senior Vice President, Operations **DEAN PIETERS**
 Group Vice Presidents: Publishing Directors **MYRNA BLYTH,**
BURTON H. BOERSMA, CHRISTOPHER M. LEHMAN
 Group Vice President, Circulation Director **CLEM SEVDE**
 Controller **MAX RUNCIMAN**

WE CARE!

EDITORIAL MAILING ADDRESS: WOOD Magazine, P.O. Box 11454, Des Moines, IA 50336-1454.

SUBSCRIPTION SERVICE (including change of address): WOOD Customer Service, P.O. Box 10628, Des Moines, IA 50336-0628.

Please enclose your address label from a recent issue. If you wish to phone, call toll-free 800-678-2666.

ADVERTISING: WOOD Magazine Advertising, 750 Third Ave., New York, NY 10017. Phone 212/551-6903.

Better Homes and Gardens® WOOD® — the #1 magazine for home woodworkers (ISSN-0743-894X) is published eight times a year in January, February, April, June, August, September, October, and December by Meredith Corporation, 1716 Locust St., Des Moines, IA 50336. Second-class postage paid at Des Moines, Iowa. Better Homes and Gardens trademark registered in Canada and Australia. Marca Registrada en Mexico. **ONE-YEAR SUBSCRIPTION PRICES:** United States and its possessions, \$19.97; Canada, \$29; other countries, \$38. **POSTMASTER:** Send address changes to WOOD, 1716 Locust St., Des Moines, IA 50336.

©COPYRIGHT MEREDITH CORPORATION 1990. ALL RIGHTS RESERVED. PRINTED IN U.S.A.



NEW HEGNER

precision scroll saws

Are you ready for a scroll saw that gives you everything you want? Rated #1 for over a decade, the 1991 HEGNER models are priced as low as \$399, and now are even more



- Convenient
- Precise
- Vibration-free
- Affordable

For **FREE** information call **(302) 322-2226** or send in the coupon!

Please send me free information on HEGNER Precision Scroll Saws.

Name _____
 Address _____
 City, State, Zip _____
 Phone _____

ADVANCED MACHINERY IMPORTS, LTD.
 P.O. Box 312, Dept. 442
 New Castle, DE 19720

A GREAT GIFT IDEA

FOR WOOD® MAGAZINE READERS!
Just Look At These Features:

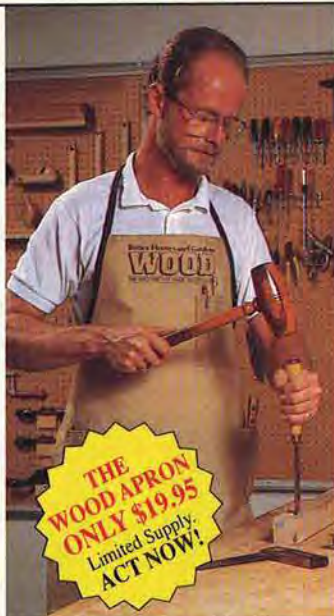

THE WOOD APRON ONLY \$19.95
 Limited Supply. ACT NOW!

- ☆ **Tough, durable nylon** material resists glue and abrasion
- ☆ **3 pockets** designed to hold a tape, folding rule, metal rule, and pencil
- ☆ **Attractive beige color** with a brown border and the WOOD® logo
- ☆ **One size fits all**
- ☆ **Lightweight, comfortable**

YES! Please send me The WOOD® Apron. Here is my check or money order for \$19.95 U.S. Includes shipping and handling. Send to: **WOOD® Apron, P.O. Box 11454, Des Moines, IA 50336-1454, or, call 800-678-2666.**

My Name _____
 Address _____ Apt. # _____
 City _____
 State _____ Zip _____
 MasterCard VISA Expiration Date _____
 Card No. _____
 Signature _____

Mobile Machine Bases

to put your entire shop
on wheels

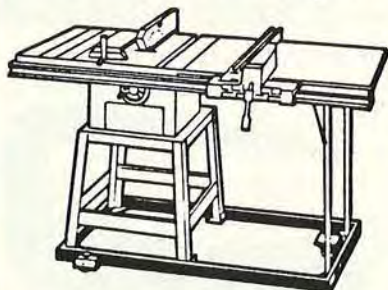

EXPAND WORKING AREA
MAKE CLEAN-UPS A SNAP

- * Hundreds of Models available
- * 3 - 2½" Ø Wheels for Stability
- * Dual wheel locks for Positive Positioning
- * Raises machine only ¾"
- * All Steel & Precision Welded
- * Lifetime Warranty

Work Supports

to do your best
safely & accurately

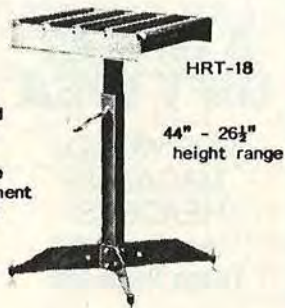

Unique
Tapered
Wedge
for
Positive
Adjustment
Control

DESIGNED TO HELP YOU SUPPORT
AND SAFELY MOVE WORK PIECES
THRU YOUR MACHINES

- * No tools needed for simple, positive height adjustments
- * Top quality, galvanized, ball-bearing Rollers
- * Non-marring Leveling Pads
- * Heavy Gauge Steel Components
- * Lifetime Warranty

All Products - Made in America &
Available at Better Tool Stores

Free Catalog



HTC Products, Inc.
120 E. Hudson • P.O. Box 839
Royal Oak, Michigan 48068-0839

(313) 399-6185 • (800) 624-2027

Better Homes and Gardens.

WOOD®

THE #1 MAGAZINE FOR HOME WOODWORKERS

This issue's cover wood grain: bird's-eye white ash Cover photo: Hopkins Associates

APRIL 1991

ISSUE NO. 42

WOOD PROFILE

Honduras mahogany The classic choice in tropical timber 31

For centuries, furniture designers and woodworkers have prized this red-brown wood's majestic look for tables, cabinets, and more.



CRAFTSMAN CLOSE-UP Whispering giants 33

For two decades, Hungarian-born sculptor Peter Toth has carved and donated a trail of spectacular tree-sized busts across the continental United States, Alaska, and Hawaii in honor of our American Indians.

CARVING

Tabletop cigar-store Indian 38

Enjoy the challenge of shaping this outstanding scaled-down Indian figure—a common storefront sight of the tobacco shops of yore.

SHOP-TESTED TECHNIQUES

Water-based finishes 42

See what's what with this new breed of environmentally safe products while learning how to apply them with shining success.



Spiced-up spice cabinet 48

Parsley, sage, rosemary, and thyme—these are only some of the many spices that you can store in this attractive Early-American project.

Replanting the family farm 52

Three times a year, tree-loving Kevin Kyhl returns to his native Iowa to replant the family farm—in black walnut, red oak, and ash.

Casual classics 56

Spring into summer with this stylish outdoor furniture set, using the chair plans here, and the table plans in issue 43. Made from beautiful mahogany, the chairs include strong mortise-and-tenon joints.



TOOL BUYMANSHIP Cordless wonders 62

Performance and features drive a wedge between mediocre and great cordless drills. Before you shop, make this your first stop.

TURNING PROJECT Exhibition under glass 68

With this decorative turned base and glass dome, you can display anything from floral arrangements to glittering mineral specimens.

THE CRAFT SHOP A warm welcome 70

Our sunny Southwest sign gets its relief details from a spinning 1/8" straight router bit.



Stars and stripes wren house 72

Show a little patriotic spirit by building this all-American home for your fine-feathered warblers.



Marbleized masterpiece 74

It may look like marble, but this modern shelf clock fools the eye with a fantastic faux finish.



SHOP-TESTED TECHNIQUE Painted stone finishes 76

Learn how to create timeless marble- and granite-look finishes on wood and particle-board surfaces with only a few simple tools and materials. The results will amaze you!



SHORT-SUBJECT FEATURES

Editor's Angle	6	Three Scrollsaw Patterns	80
Talking Back	8	Tool Industry Insider	84
Tips from Your Shop	16	Great Ideas for the Shop	87
Products That Perform	22	Ask WOOD®	88
Yesterday's Tools	79	Finishing Touches	96

Winter Sale# B21 Blow-Out



EXPIRES
04-30-91



	Reg.	SALE
3-1/2" Shaker Peg	\$15.00/100	\$11.50
2-7/16" Medium Peg	\$14.00/100	\$11.00
1-3/4" Mini Peg	\$ 7.50/100	\$ 4.50
1-3/8" Candle Cup	\$18.00/100	\$13.00
5/8" Mini Candle Cup	\$10.00/100	\$ 6.00



1" Toy Wheel	\$ 6.00/100	\$ 3.50
1-1/4" Toy Wheel	\$ 8.00/100	\$ 5.00
1-1/2" Toy Wheel	\$10.00/100	\$ 7.00
2" Toy Wheel	\$18.00/100	\$14.00
Axle Pegs for Above	\$ 5.00/100	\$ 3.00
1-1/2" Birch Spindle	\$10.00/100	\$ 7.00
2" Birch Spindle	\$14.00/100	\$10.00
3/8" or 1/2" Birch Button	\$ 2.00/100	\$ 1.50



3/4" Predrilled Door Harp Ball	\$ 9.00/100	\$ 5.00
Tuning Pins	\$16.00/100	\$14.00
Wire-550 Ft. (.013 diameter)	\$13.00/SP	\$ 9.00
3/4" Full Round Ball	\$ 9.00/100	\$ 5.00
1" Full Round Ball	\$12.00/100	\$ 8.00
1-1/2" Full Round Ball	\$ 4.00/10	\$ 2.50
2" Full Round Ball	\$10.00/10	\$ 5.00
2-1/2" Full Round Ball	\$20.00/10	\$10.00
3" Full Round Ball	\$ 3.00/EA	\$ 1.80



Door Harp Parts!		
3/4" x 3/8" Heart	\$ 4.75/100	\$ 4.00
1" x 3/8" Heart	\$ 6.50/100	\$ 5.50
1-1/4" x 3/8" Heart	\$ 8.25/100	\$ 7.00
3/8" Round Bead	\$ 3.25/100	\$ 2.25
1/2" Round Bead	\$ 3.50/100	\$ 2.50
1/2" x 5/8" Spool	\$ 5.00/100	\$ 4.00



5/8" x 7/8" Wren Egg	\$10.00/100	\$ 8.00
1-1/8" x 1-5/8" Pigeon Egg	\$20.00/100	\$16.00
1-3/4" x 2-1/2" Hen Egg	\$12.50/25	\$10.00
2-3/4" x 4-1/4" Goose Egg	\$ 3.00/EA	\$ 2.50
5/8" Picture Hanger	\$ 2.00/100	\$ 1.50
1-5/8" Sawtooth Hanger	\$ 4.00/100	\$ 3.00
#17 Screw Eye 1/2" Long	\$ 2.00/100	\$ 1.50

1-800-722-0311

FREE ALL NEW
With Order WOOD PARTS
CATALOG \$1.00

We accept M/C, VISA, Check, or M.O. All orders add \$4.00 Handling
TX add 7% tax. Canada add 30%
Alaska, Hawaii add 15% for freight.

Woodworks

P.O. Box 14507 Ft. Worth, TX 76117

Exclusively Performax

Precision Drum Sanders

**Revolutionary Component Concept!
It's Versatile....It's Expandable....
and best of all....It's Affordable!**

You select the components to fit your budget and your needs. The Performax S/T Sander attaches to a radial saw or to a Pro Stand.

Patented Drum Design

dissipates heat for hours of steady use, offers greater strength and durability, dimension stock to within .01 of an inch. Cantilevered 22" drum for 44" wide sanding.

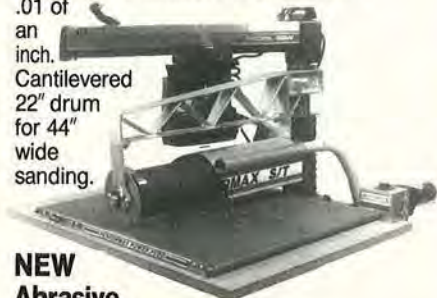

NEW Abrasive Take-Up Mechanism

keeps abrasive tight, accepts any grit of abrasive.



No-Give Power Feed

offers infinitely variable feed rate of 0-10' or 0-20'/minute. Feed multiple pieces as short as 2 1/4" and the thinnest veneer.

NEW Dual Drum Super Max

The only dual drum sander that lets you easily change grits for any abrasive combination.

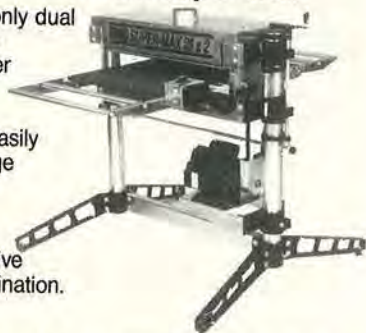

**For Maximum Performance
and Maximum Value
Buy a Performax.
It WILL exceed your expectations.**

For a Free Brochure and the Dealer Nearest You Call
1-800-334-4910

or (612) 895-9922

or write: PERFORMAX PRODUCTS, W3
12211 Woodlake Drive, Burnsville, MN 55337

THE EDITOR'S ANGLE

REINFORCEMENTS HAVE ARRIVED...



...AND JUST IN
THE NICK OF TIME!

In this space in the January issue, I told you how excited we were to be publishing two more issues each year. Here, though, I'd like to share a bit about the three new people we have hired to help make these extra 120 or so pages of woodworking information happen. They've been on board for a few months now, and I'm happy (and relieved) to say that all three appear to be up to the task. Here goes:

Rosemarie Burch, the latest addition to our secretarial corps, told me during her interview that she's highly organized, responsible, honest, and friendly. I knew right away I wanted to hire her. In addition to her secretarial duties, Rosemarie does a great job of filling your orders for back issues, indexes, aprons, and all of our other ancillary products.

John Hofheimer, a former *Arkansas Gazette* bureau chief, joins us as copy/production editor. During the past 10 years, he's been a writer, columnist, editor, and photographer. John, his wife Lea, and their newly arrived baby girl Julia picked up all their belongings in Winchester, Virginia, bid the *Northern Virginia Daily* a hearty good-bye, and came west to be part of the best darned



The three newest members of the Wood magazine team: (l. to r.) Larry Johnston, Rosemarie Burch, and John Hofheimer.

woodworking publication going. Welcome, John!

Larry Johnston, our new special-interest editor, will develop and write material for *The Craft Shop*, as well as for our expanded coverage of carving and turning. Larry comes to us from Aurora, Colorado, where he and his brother owned and operated a tree-trimming business. A successful freelance writer, he's also been the news editor of a daily newspaper, and a field representative for a U.S. congressman. You'll enjoy reading the material that Larry produces. I know I do.

Well, that's the new crew. All seem as committed as we are to continuing to produce the best magazine possible. 🌲

Larry Clayton



**12" PLANER
MODEL G1017**
ONLY \$385⁰⁰

F.O.B. BELLINGHAM, WA or WILLIAMSPORT, PA



IMPORTS, INC.

"IMPORTERS OF FINE MACHINERY"

**...knocks out
the competition!**



**16" BAND SAW
MODEL G1538**
ONLY \$525⁰⁰

F.O.B. BELLINGHAM, WA or WILLIAMSPORT, PA



**6" x 47" HEAVY-DUTY
JOINTER
MODEL G1182**
REG. \$375.00
SALE \$345⁰⁰

F.O.B. BELLINGHAM, WA or WILLIAMSPORT, PA



**10" HEAVY-DUTY
TABLE SAW
MODEL G1022**
REG. \$375.00
SALE \$355⁰⁰

F.O.B. BELLINGHAM, WA or WILLIAMSPORT, PA



**2 H.P. DUST
COLLECTOR
MODEL G1029**
ONLY \$295⁰⁰

F.O.B. BELLINGHAM, WA or WILLIAMSPORT, PA



**20" PLANER
MODEL G1033**
ONLY \$1,295⁰⁰

F.O.B. BELLINGHAM, WA or WILLIAMSPORT, PA



**1-1/2 H.P. SHAPER
MODEL G1035**
ONLY \$495⁰⁰

F.O.B. BELLINGHAM, WA or WILLIAMSPORT, PA



**3 H.P.
SHAPER
MODEL G1026**
ONLY \$850⁰⁰

F.O.B. BELLINGHAM, WA or WILLIAMSPORT, PA



**8" x 65" SUPER
HEAVY-DUTY
JOINTER
MODEL G1018**
ONLY \$695⁰⁰

F.O.B. BELLINGHAM, WA or WILLIAMSPORT, PA



**6" x 48"
COMBINATION
SANDER
MODEL G1014**
ONLY \$195⁰⁰

F.O.B. BELLINGHAM, WA or WILLIAMSPORT, PA



**15" PLANER
MODEL G1021**
ONLY \$735⁰⁰
(STAND OPTIONAL)

F.O.B. BELLINGHAM, WA or WILLIAMSPORT, PA



**SUPER HEAVY-DUTY
TABLE SAW
MODEL G1023**
ONLY \$895⁰⁰

F.O.B. BELLINGHAM, WA or WILLIAMSPORT, PA

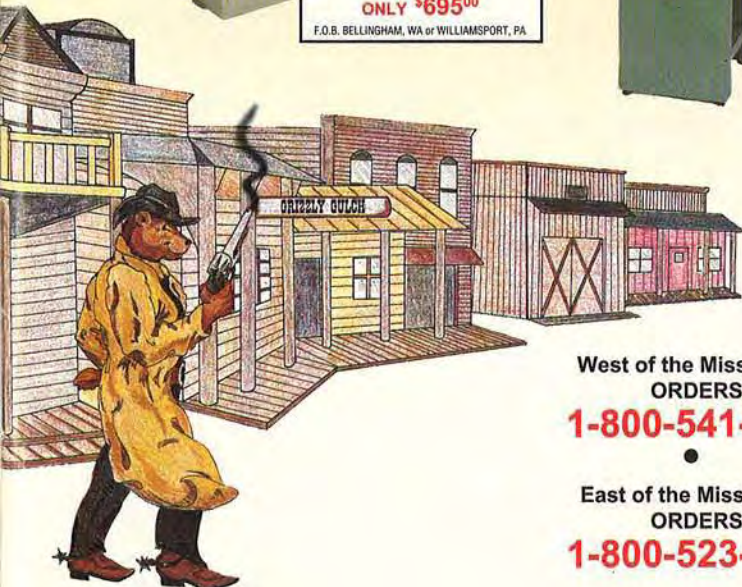

*Order your
FREE 1991
catalog, today.*

West of the Mississippi:
ORDERS:
1-800-541-5537

East of the Mississippi:
ORDERS:
1-800-523-4777



THE FLY-BY-NIGHT GANG

★ SANDPAPER ★

NO GIMMICKS — GREAT PRICES

BELTS: GRITS ASSORTED

SHEETS: (9 x 11) PRICE

UNLESS OTHERWISE SPECIFIED

CABINET PAPER

1 x 30	\$.69 ea	3 x 24	\$.80 ea		50 /pk	100 /pk
1 x 42	.69 ea	3 x 27	.83 ea	40-D	\$16 /pk	\$30 /pk
1 x 44	.69 ea	4 x 21 1/4	.91 ea	50-D	15 /pk	27 /pk
2 1/2 x 16	.73 ea	4 x 24	.94 ea	60-D	14 /pk	25 /pk
3 x 18	.74 ea	4 x 36	1.14 ea	80-D	13 /pk	23 /pk
3 x 21	.77 ea	6 x 48	2.98 ea	100 thru 150C	12 /pk	21 /pk
3 x 23 3/4	.80 ea	2 1/4 x 80	2.47 ea			

OTHER SIZES ON REQUEST

FINISHING PAPER

NO LOAD PAPER			50 /pk	100 /pk
	50 /pk	100 /pk	\$ 9 /pk	\$16 /pk
180-A thru 400-A	\$10 /pk	\$18 /pk	100 thru 280A	8 /pk
				14 /pk

WET / DRY PAPER

PRESSURE SENSITIVE			50 /pk	100 /pk
ADHESIVE DISCS!			\$13 /pk	\$23 /pk
			220 thru 600A	

6"	\$1.06 ea	★ OTHER ITEMS ★	★ JUMBO CLEANING STICK \$8.80 ★
8"	1.99 ea	★ WIDE BELTS	
9"	2.46 ea	★ ROLLS	
10"	3.05 ea	★ FLAP WHEELS	
12"	4.45 ea	★ PUMP SLEEVES	
15"	6.95 ea		

ECON-ABRASIVES
P. O. BOX B865021
PLANO, TX 75086

IN TEXAS 214-377-9779
OUTSIDE TEXAS 1-800-367-4101
TEXAS AND NEVADA RESIDENTS ADD STATE TAX
CONTINENTAL U.S. SHIPPING CHARGES ADD \$4.25

- ★ MINIMUM ORDER \$25.00
- ★ MASTERCARD, VISA OR CHECK
- ★ SATISFACTION GUARANTEED!!
- ★ CALL FOR NEW 1991 CATALOG

TALKING BACK

We welcome comments, criticisms, suggestions, and even compliments. Send your correspondence to: Talking Back, Better Homes and Gardens® WOOD® magazine, P.O. Box 11454, Des Moines, IA 50336-1454.

Scrollsawer frets over lack of patterns

My hobby is fretwork scrollsawing, but I am limited to patterns. My only source is from Patrick Speilman and James Reidle—a really nice man by the way. I have written lots of companies, but no help.

— Boyd Pearson, Amory, Iowa



Boyd, we empathize with your frustration. We published a fairly ambitious scrollsaw hummingbird pattern in January and will generally have one or more such projects per issue, usually in the new Craft Shop section. In our other publication, Weekend Woodworking Projects®, we typically run one or two scrollsaw patterns in each of its bimonthly issues. Also, the spring 1990, woodworking catalog of the American Booksellers Association listed seven books of patterns—all by Speilman. In case they somehow escaped your notice, he published three books in 1990—Scroll Saw Country Patterns, Scroll Saw Fretwork Techniques and Projects, and Spielman's Original Scroll Saw Patterns.

Maybe other readers will send us suggestions.

WOOD magazine brings Desert Shield airman closer to home

I've been meaning to write, but just never found the time. I'm currently deployed in support of Operation Desert Shield and have plenty of time for letters. I've enjoyed your magazine for more than a year now. I built the cabinet you featured on a cover of a recent issue. I don't usually follow plans, but I really enjoyed that project and it looks very nice on the bathroom wall.

Just prior to leaving home, I bought a Powermatic 63 tablesaw, based on the recommendation of your tablesaw feature. My wife sent me the most recent issue of your magazine.

Reading WOOD® has brought me a little closer to home. Any chance of becoming a monthly?

— John E. Stowe, Capt. USAF

Cap'n, we're glad to hear that reading WOOD magazine makes you feel closer to home. As for becoming a monthly, stranger things have happened. Recently we've increased our output to eight issues a year.

Continued on page 10

ROBLAND

The Intelligent One-Man Shop

The Robland X31 features

heavy duty cast iron work surfaces with 3 individual motors of three h.p. each. Full plywood capacity on the 10" table saw, which is equipped with a sliding table that has 50" cutting capacity. The shaper has a cast iron fence system with individually micro adjustable in and outfeed fences, the spindle sizes are 3/4" and 1 1/4". The jointer is 55" long and it features a three knife cutter head. To operate the 12" thickness planer you simply fold the jointer tables out of your way. This process only takes 5 seconds. The thickness planer will accept wood 9" thick. The chuck for the mortiser will self center any bit from 0" to 5/8". The X, Y, Z table is adjustable on all three axes and it will make extremely accurate quality joinery for you in seconds. No function change takes more than 30 seconds.

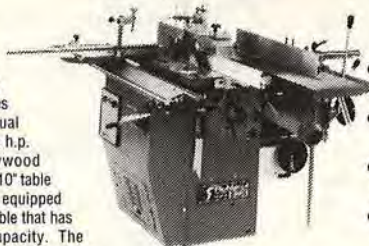

- Heavy Duty
- Cast Iron
- Powerful
- Accurate

CALL TODAY FOR INFORMATION ON HOW TO OBTAIN A 40 MINUTE VIDEO

LAGUNA TOOLS

2081 Laguna Canyon Road
Laguna Beach, California 92651
1-(800) 234-1976

**EASY
Step-By-Step
Plans!**

Build Your Own Professional- Quality Deck

—And Save A Bundle!

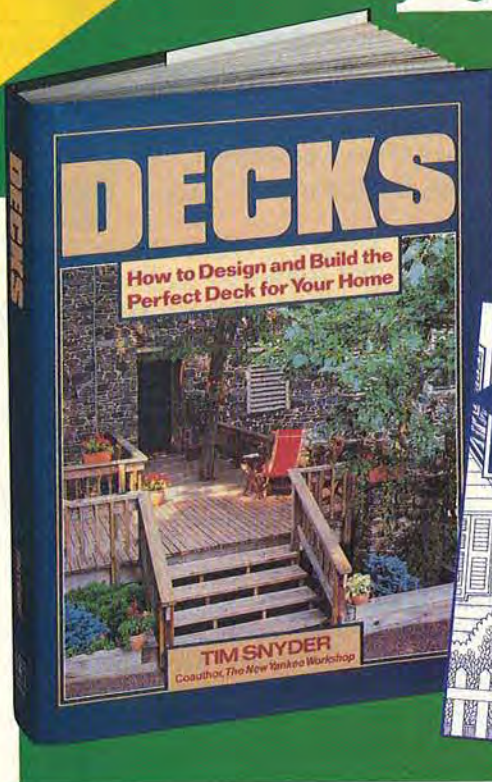

**YOURS
FREE**

Boost the value of your home and maximize your living space with DECKS, the brand-new how-to book from Rodale Press.

From deciding what length nails you need before you start, to applying a protective finish to your completed deck, to hooking up your outdoor deck lights, DECKS will talk you through every step of your project—simply, clearly, thoroughly.

Nail by nail, board by board, we'll help you build the deck of your dreams—with the quality, professional touches and fine details that will set your deck apart from the rest. We'll even show you how to adapt our plans so they custom-fit your property.



- Professional deck-builders' tips, techniques and trade secrets
- 16 full-color pages featuring innovative deck designs
- Detailed information on everything from buying nails to applying finish
- 12 deck projects, each with:
 - Step-by-step instructions
 - Complete lumber and hardware lists
 - Clear, how-to photos and illustrations
- Plus, a free book, *Common Building Materials*

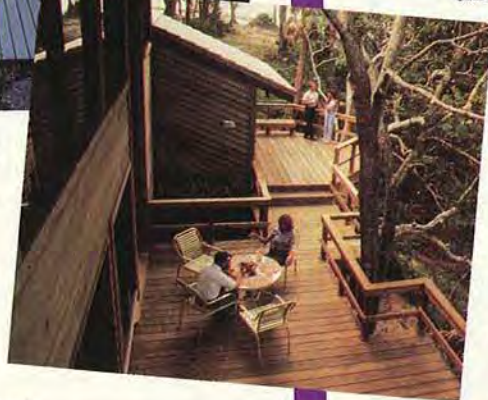

**Try DECKS Free
For 21 Days!**

YES! Please send me a free copy of *Common Building Materials* and a copy of DECKS to examine free for 21 days. If I decide to keep

DECKS, I'll pay for it in **three interest-free installments of \$8.99 (\$10.65 CDN funds) each** plus postage and handling. Otherwise, I'll return the book with the invoice within 21 days and owe nothing. *Common Building Materials* is mine to keep whether I purchase DECKS or not. 42413

Name _____

Address _____

Apt. # _____

City _____

State _____

Zip _____

SEND NO MONEY NOW. THIS IS A NO-RISK FREE LOOK!
Simply clip and mail to: RODALE BOOKS, Emmaus, PA 18098

CASCADE TOOLS, INC.

P.O. Box 3110, Bellingham, WA 98227

ACCESSORIES

BRAD DRIVER

Hold and set brads with this simple but effective tool. Just squeeze and you're done!

PART NO. C3078

ONLY \$7⁹⁵

PUSH BRADS IN
THE EASY WAY!

BEARING LUBRICANT

Made by Dri-Cote, this lubricant protects and lubricates bearings and bearing mechanisms. Especially effective on router bit bearings and rub collars.

- Effective to 550°F!
- Repels dirt and moisture.

PART NO. C3074 ONLY \$3⁴⁵

(1.7 oz. Dropper-tip Bottle)

FENCE FOR INCRA JIGS™

This unique fence system attaches directly to your jig and is used in making all kinds of joints. You'll love it!

PART NO. C3009

ONLY \$54⁹⁵

RIGHT ARM CLAMP

This clamp is a real gem. Its secret is its pivoting arm which squares the work for perfect gluing, joining and fastening.

- Opens up to 1 1/2".
- Clamp is approximately 6" long.

PART NO. C3029

ONLY \$10⁰⁰ or 6 for ONLY \$55⁰⁰

SUPER BRAD NAILER

This light weight pneumatic nailer drives 18 gauge brads from 5/8" to 1-9/16" into almost any kind of wood. Excellent choice!

PART NO. C3082

ONLY \$129⁹⁵

BISCUITS FOR JOINING WITH ROUTER

Why buy a biscuit-cutting machine when a small router will do?

3 sizes in bags of 100...

PART NO. C3021 \$4⁹⁵

(Size "0" - use C1042 bit - \$12)

PART NO. C3022 \$4⁹⁵

(Size "10" - use C1098 bit - \$22)

PART NO. C3023 \$4⁹⁵

(Size "20" - use C1098 bit - \$22)



TO ORDER, CALL TOLL FREE

1-800-235-0272



90C-111

TALKING BACK

Continued from page 8

We call 'em like we see 'em

I've spent many enjoyable hours reading your magazine, but, frankly, your tool comparisons stink! You do a fine job showing the technical differences between the tools, but please tell us which ones work best. Try grading the tools from 1 to 10, or darkening circles like Consumer Reports.

—Bill Malmsten, Dearborn Heights, Mich.



Bill, we strongly disagree with your assessment of our tool comparisons. Several months ago, we started making recommendations. One of many innovations our products editor, Bill Krier, has brought recently to this magazine is the color-coded rating system you'll find used in the six-page cordless-drill comparison, beginning on page 62. When we do power tool comparisons, we take a two-pronged approach. First, we run each tool through a series of woodworking operations to see which tools perform best. (Typically, we rely on people in the woodworking and building trades to give us a thorough helping hand.) And second, we look at all the features the tools provide, including accessories, bearings, working capacities, overall quality, power, price, and other relevant points.

After compiling our information, we organize and write our articles, telling readers which tools do what best, and which may be the best buy. In our February 1990 issue, for example, we looked at 22 routers made by 14 manufacturers. We told readers which models work best for router tables, what buying points to consider, and finally, which routers we liked best.

As always, we provide readers with smart choices, letting them be the final judge. After all, everyone's tool needs are different.



Magazines to fill those arid hours

While working out in the middle of the desert for Operation Desert Shield, my men and I love to read your magazine. We have nothing to read here at night and get to go to the PX [only] once a month. And I haven't seen your magazine for sale out there yet. If you could, please send one or two copies of your magazine to us guys in the desert.

—SSG Ronald A. Johnson, Saudi Arabia

Sarge, thanks for writing. Good luck finding wood to work in the Saudi desert. By now, you should have received the most recent 24 issues of WOOD.

SUPER HEAVY DUTY WOODWORKING EQUIPMENT



250 H.D. Table Saw 12" HP\$350
200A H.D. Table Saw 3HP\$795
200A W BIESEMEYER Fence\$995

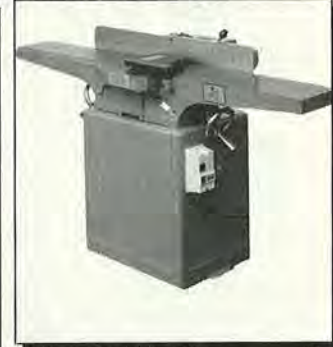

650 H.D. 6" Jointer 1 HP\$295
860 H.D. 8" Jointer 1 1/2 HP\$670
1200 H.D. 12" Jointer 3HP\$1695



150 Shaper Router 1 1/2 HPS298\$328
500 Shaper Router 3HP\$688
660 Tilt Spindle Shaper\$1150
150 Auto Planer 12"\$328
650 Auto Planer 15"\$648
200A Auto Planer 20"\$1195
Dust Collector 1HP\$189
Dust Collector 2HP\$285
Dust Collector 3HP\$385

We also carry complete line of top quality **BAND SAWS, AIR DRUM SANDER, DISC SANDER, BELT SANDERS, AUTO FEEDERS and DRILL PRESS.**

TCM Industries, Inc. 322 Paseo Sonrisa, Walnut, CA 91789
In California (714) 594-0780

WOOD® magazine is welcome in his shop class

I teach shop in our Christian day school and your magazine has been very helpful to me. The projects and instructional information have given me the ability to be more professional in my position. Many of my students have built the projects published in your magazine. I'm really grateful for WOOD magazine. In many ways, it is almost like a text book to me.

—Rev. Howard R. Burnham, Couldersport, Pa.

Thanks for the kind words. We are always happy to hear that our magazine is helping to introduce and teach our favorite hobby to future generations of woodworkers.

We believe you can't beat learning by doing, and we include projects in each magazine that would be suitable for beginning woodworkers, intermediate woodworkers, and advanced woodworkers. Keep up the good work.

Woodworker sings praises of his tools

Here are some lyrics I wrote the other day while out of town and missing my tools. They should be sung to the tune of "I Walk the Line" by Johnny Cash.

The Woodworker's Tool Song

I keep a close watch on these tools of mine.
I keep them bright and shiny all the time.
I keep the sawdust up and in the bin.
Because they're mine—I make them shine.

My rosewood squares are straight and very true.
A little pastewax keeps them looking new.
I put them neatly away when each day's thru.
Because they're mine—I make them shine.

My saw is sharp—the teeth are set just right.
The blade is carbide tipped to give it extra bite.
The sliding rip-fence locks down very tight.
Because they're mine—I make them shine.

My Lufkin tape is always at my side.
My Craftsman plane shaves boards that are too wide.
I drill the holes straight with my Stanley guide.
Because they're mine—I make them shine.

—Don Marshall, Hazelwood, Mo.

*Don:
We're glad you show respect for all your tools,
And keep them polished like they're precious jewels.
Although in some shops chaos often rules,
Because they're thine, you make them shine.*

Continued on page 12

TRIMTRAMP™ SAW TABLE

The most labor efficient, cost effective portable tool for quality cuts available in the market today.

MONEY BACK GUARANTEE.



- Converts your portable circular saw into a precision miter and crosscut sawtable instantly.
- Cutting action is backward, providing unsplinted cuts of cabinet-maker quality.
- Provides: perfect 90° picture-frame quality miter joints everytime, perfect compound miters, variable angles, and crosscuts boards up to 16" wide.

The TRIMTRAMP is convenient! It can be used, clamped in a B & D "WORKMATE," on a bench, on the floor, or you can disengage your saw for use as a handtool.

To obtain a **FREE** brochure or order your **TRIMTRAMP**, call **1-800-267-8776**. (Mon.- Fri. 9 am - 5 pm EST)

To place your order by mail just return this coupon to:
TRIMTRAMP LTD. P.O. Box 740, Buffalo, N.Y. 14213.

Please send me your **FREE** brochure.
 TRIMTRAMP Purchase Price of \$99.95 enclosed, together with a \$10.00 delivery charge.
 Check Visa MasterCard Expiration Date _____
Card Signature _____ Card #: _____
Customer Name (print) _____
Customer Address: _____
State _____ Zip _____ Phone _____

*TRIMTRAMP™ is the registered trademark of TRIMTRAMP LTD, product protected under U.S. pat. 4,909,111.

**"All my tools
should be this
good!"**

The Accu-Miter® is a professional miter gauge that makes perfect angles easily. Shot-pin action assures dead-on accuracy for common angles — plus a precise protractor scale for everything in between!



We do not recommend operating without the saw blade guard, as is shown here.
US Patent Pending

Optional accessories:
manual clamp—
pneumatic clamp—
3/8" x 3/4" miter bar—

**JDS
COMPANY**

Precision Woodworking Equipment

Call or
write for
our free
brochure.

800 Dutch Square Blvd., Suite 200, Columbia, SC
1-800-382-2637 / SC 803-798-1600

\$149

The Image Of Quality



PROFESSIONAL IMAGE —
environmentally safe, water-base
wood stains and finishes for the
woodworker who wants only the
best.



BASIC COATINGS
P.O. BOX 677, DES MOINES, IOWA 50303

TALKING BACK

Continued from page 11

Reader asks pointed question

I just received your December issue (No. 39) and was very interested in the article about the building-block castle. But please, please don't leave it unfinished unless you are absolutely positive it won't fall into the hands of children. Even with the best sanding, it will dent and splinter and can continually "dust off" with a powdery residue. I have made several toys from redwood, and wishing to maintain the natural look as you did, used several coatings of a penetrating Danish oil finish, sanding between coats. I recall reading somewhere of a caution regarding Danish oil on toys, but the polymerizing action of the plastics in the oil will render the finish perfectly safe within a 30-day period.

—Don Honenberger, Los Angeles

Don, your suggestion puts a terrific finish on a great project. We think the blocks are safe for children, but Danish and tung oils would be good choices for anyone wanting to finish the castle.

Unintentional silicone transfer can mar your finish

For a number of years, my wife has used Pledge in a spray can to wax a pair of oak end tables I had made. We kept a brass lamp on each table. The lamps had fuzzy, felt pads on their bottoms to prevent scratching. Recently, while we were moving, one of the lamps was placed temporarily on a walnut table. When I removed it after only a few hours, I noticed a round shiny circle where the lamp had been. A quick touch confirmed my suspicions that the silicone in the spray wax had impregnated the felt bottom of the lamp and was being transferred to any object it was set upon.

Luckily, I was able to remove the silicone right away with mineral spirits, but the lamp's felt bottom needed replacement. The oak tables needed extensive cleaning. I was surprised the pad picked up the silicone and contaminated another object.

—Lenny Nowak, Leola, Pa.

Lenny, we don't know how widespread the silicone-contamination problem is, but it rang a bell with our project builder, Jim Boelling. Jim had a similar problem, also with a felt-bottomed brass item, and has avoided silicone-based furniture treatments since then. It's important to pay attention to which finish is most appropriate for which job in an increasingly chemical environment. Thanks for telling us your problem.

4-H program introduces young women to woodworking, too

Thanks to you, this has been my best year yet in 4-H. This woodworking award pin is my first project award. My father is known as quite a woodworker, and he learned the trade from my grandfather. I hope to carry this tradition on into my adulthood. I have made a birdhouse and a peg-board, rebuilt a washstand and made wooden tray favors for the Fourth of July celebration at the local hospital. Next year I may build a corner china closet or maybe a large shelf with mirror. I am particularly proud of my Iowa State Fair blue ribbon. Thanks!

—Debbie Fitkin, Cedar Falls, Iowa

Thank you for the 4-H pin. Woodworking is fun.

—Amanda Spraggs, Fancy Farm, Ky.

Thank you for sponsoring my woodworking pin at the Sheridan County [Nebraska] Achievement Banquet. My project ideas came from WOOD magazine. I'm now doing another WOOD project for a school industrial arts program.

—Dina Jensen, Hay Springs, Neb.

Debbie, Amanda, and Dina, we appreciate your thank-you notes for the Wood Science Recognition Medals you received recently. Congratulations on having earned them through your involvement in the 4-H Wood Science Program. You are among the 100,000 students who participate each year. We are happy to be a sponsor of this important program—along with DEFT, Inc., and The Society of Wood Science—because we feel that woodworking is one of the most pleasurable of pastimes. It is a fast-growing leisure-time activity for men, women, and youngsters.

When wooden friction is the foe, plastic may put ducks in row

Regarding your October 1989 article on Waddles the Duck, I discovered that threading a nut onto a dowel was easy if I first rubbed paraffin or beeswax on the dowel. I cut a small plastic washer from a margarine container and placed it between the duck's head and body during assembly. Also, I use plastic washers just about any time I have wood rubbing against wood, such as wheels against body.

—M.P. Jacobs, Merrillville, Ind.

M.P., great idea, especially because plastic washers cut easily to size and shape for concealment. 🐥



Super 125 Planer On Sale \$359.95



This machine will pay for itself time and again by planing your own wood. Finishes wood like machines many times its price.

- Portable at 65 lbs • Power feed
- 12 1/2" wide High Speed Steel Knives
- Shipped assembled and ready to run.

SPECIFICATIONS:

Motor: 16Amp, 115V, 8000RPM, 2HP • 26.2 fpm auto feed rate • 16,000 Cuts/min • Thickness of stock: 3/16" - 6" • 1/8" Max depth of cut • 2 HSS knives
Item #PLA \$359.95 (UPS \$15)

Planer Accessories

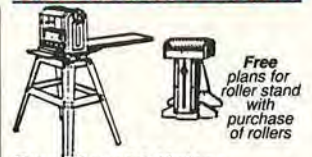

Extra Set of 2 Knives

High Speed Steel, 12-1/2" long.
Item #PKN \$25.00/set (+)

Dust Chute

For vacuum takeoff of wood chips.
#PDS ... (reg \$24), On Sale...\$15 (UPS \$3)

Planer Stand (Heavy duty)

Drilled for Super 125 Planer. 27-1/4" High.
#PST ... (Reg \$44), On Sale...\$39/ea (UPS \$6)

Roller Stand

HTC brand support stand w/heavy duty ball bearing roller. Height adjusts from 25" - 44".
#PRS ... (reg \$40), On Sale...\$35 (UPS \$4)

Ball Bearing Rollers

(Minimum purchase 2 rollers). Build a roller stand, infeed/outfeed table etc. with these 13" X 2" Heavy Duty rollers. Includes FREE plans for roller stand shown above.
Item #BBR \$6.50/ea (\$3 UPS/order)



Two Way Sanders

FREE DISCS & BELTS with Purchase
Save up to \$21

- Dust Collection on both models
- Stand included with 6 x 9 Model

6" x 9" Sander

Model #S69 ... Only \$219.95 (UPS \$30)

Has versatile 9" disc & 6" x 48" belt. Heavy duty design includes stand.
FREE With Purchase : 3 belts, 4 discs (various grits) worth \$21. Motor: 3/4 HP, 1720 RPM, 110/220V. Wt: 100 #

4" x 8" Sander

Model #S48 ... Only \$114.95 (UPS \$8)

A unique design with an 8" disc & 4" x 36" belt. Portable at only 38 #, includes quick release lever for belt changes.
FREE With Purchase - 3 belts, 4 discs (various grits) worth \$14. Motor: 1/3 HP, 1720 RPM, 120V. Wt: 38 #

Features of Both Models:

- Dust collection outlets included.
- Tables: tilt to 45°, includes mitre gauge, moves to vertical belt position.
- Easy belt tracking adjustment.
- Belt table tilts/locks to horiz & vert positions
- Sealed ball bearings

Dust Collectors

FREE HOSE & FITTINGS with PURCHASE
Save up to \$40.00!!



Model #DC1

Model #DC-1 - Only \$199.95 (UPS \$20)

610 CFM flow makes this collector perfect for hookups to almost any single machine.
FREE With Purchase (\$15 Value)
8' of hose • 1 ea. 4" to 3" & 4" to 2" adaptor

Model #DC-2 - Only \$299.95 (UPS \$30)

900 CFM flow allows for use on 2 or more machines & gives improved service for long runs of hose or ducting. Suitable for larger planers, drum & belt sanders
FREE With Purchase (\$40 Value)
30' of hose • (1) 4" to 3" & (2) 4" to 2" adaptors

Specifications:

	DC-1	DC-2
Motor	1 HP, 110/220V	1-1/2 HP, 110/220V
Outlets	1 @ 4"	2 @ 4" or 1 @ 6"
Flow	610 CFM	900 CFM
Bags	2 @ 20 Gal.	2 @ 30 Gal.
Weight	75 pounds	120 pounds

Penn State's Commitment

We unconditionally guarantee your satisfaction with our fine machines. All of our machines carry a Thirty day Money Back Guarantee and One year Warranty.

Quality Woodworking Machines At Affordable Prices from

PENN STATE INDUSTRIES - W

2850 Comly Road • Phila, Pa 19154

Order Toll Free 1-800-288-7297 (Ext 90) Information 1-215-676-7609 (ext 15)

Visa, Master, & Discover Card accepted Pa residents add 6% Sales Tax

When ordering - Add UPS Shipping Charges as noted

(•) No freight charge for accessories ordered with a machine, add \$3 if ordered separately. UPS charges are for Continental U.S. only (Call for shipping charges to other locations)

Call or Write for our NEW 16 Page Color Catalog

We like to think of th

We believe that every tool you buy today should become an heirloom.

Whether it's a fine chisel or that piece of machinery you've been considering, it's an important investment.

And from the first moment you hit the switch on a new Delta machine, it should provide you with pleasure. Precision. Productivity.

And before you stop to think about it, that machine should have taken you well into the future. Still going strong.

At that point, we'd like you to stop and think about all the time you've saved over the years. The problems you've avoided. The hours you've enjoyed.

We build our machines and accessories with that in mind.

We look at it this way, any new product we introduce today has the potential to become an "old standard" in the future.

So we'd better keep building them right.

**Building
On Tradition**
DELTA
A Pentair Company

For additional information on these and other new products or for the name of your Delta distributor, call toll-free: Delta International Machinery Corp., 800-438-2486.



The old-timers say, "You can tell a lot about a man by the company he keeps. And there's no better company in the shop than Delta." Just try to talk one of those old-timers into parting with his 30-year-old Bandsaw. Be a lot easier to pick up a new 14" Bandsaw at your Delta Distributor.



NEW

The New Delta 10" Tilting Arbor Saw. Everything we've learned since we pioneered our Unisaw® some 60 years ago. Cast-iron table, closed base, built-in dust chute, 2-HP motor, at a price that'll fit comfortably into your shop. Even add a Unifence® Saw Guide if you like.

NEW

We've got all the angles covered with this new 32" Radial Drill Press. Angle, horizontal, series or multiple hole drilling become routine operations for it's tilting, swiveling, ram traveling head. A welcome addition to our full line of drill presses.



em as time machines.

We've thrown out all the rules with this one. The Delta Electronic Measuring System virtually eliminates measuring for width of cut. Accurate to .005" with Unifence® Saw Guide, Jet Lock® rip fence or most other fences. Also available for vertical application on thickness planers and drill presses.

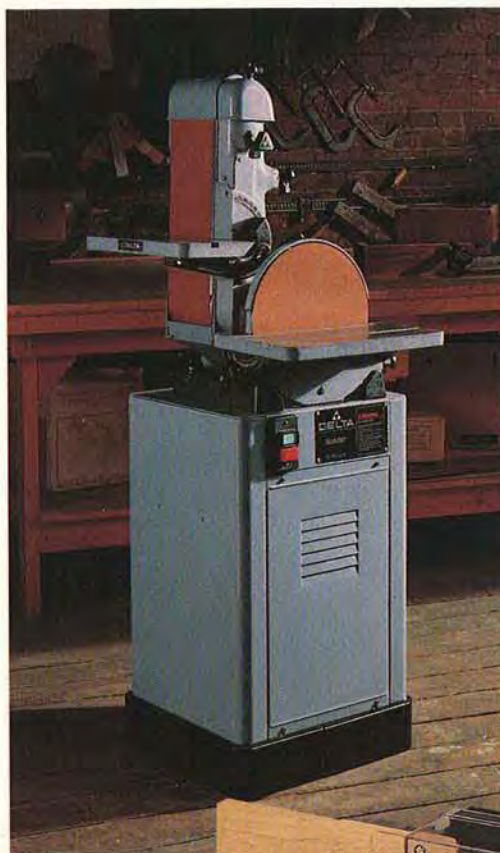

We believe in finishing what we've started. Good example is our Combination 6" Belt/12" Disc Sander. We cover your sanding needs ranging from a tiny 1" Belt Sander all the way up to our large 6" x 132" Edge Sander with edge contour sanding capability.

NEW

Finally an economical alternative to our production shapers. And a world of improvement over an upside down router "rig". The new Delta Router/Shaper handles 1/2" and 1/4" standard router bits. Or 1/2" hole shaper cutters with an accessory spindle. Die-cast aluminum 18" x 20" table and two-piece adjustable fence.



NEW

Four brand new patents redefine the art of woodshaping. Adjustable fence fingers adapt precisely to any cutter profile. No need for auxiliary fences. Our brand new 1-1/2 HP Wood Shaper will reshape the way you work, without reshaping your budget.

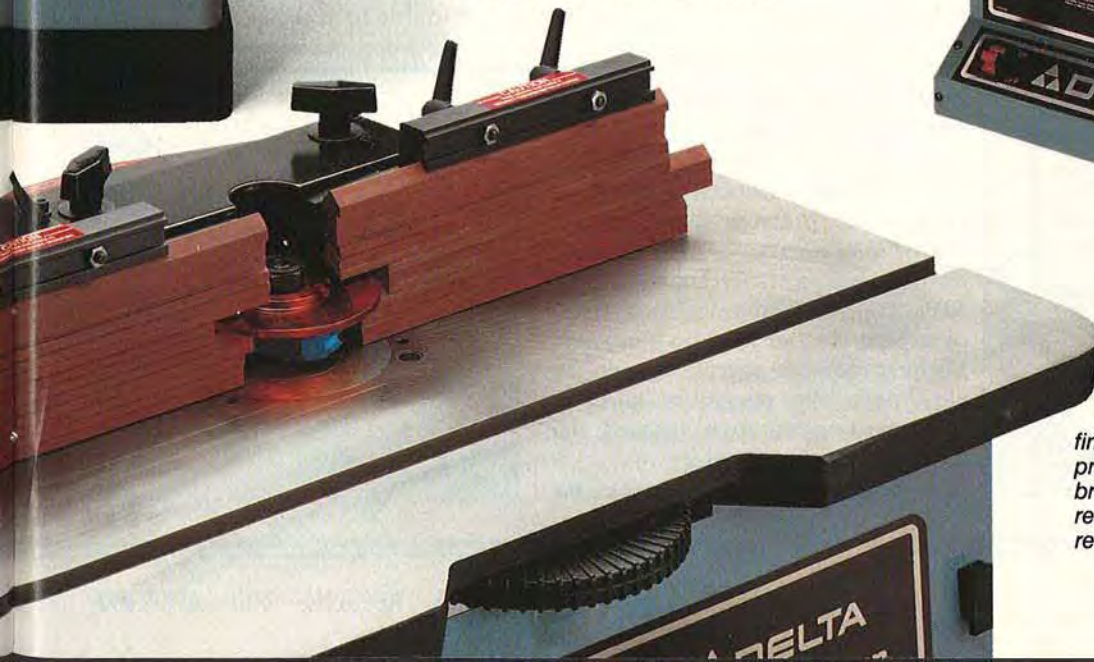



EARN CASH, PRIZES FOR YOUR TOP SHOP TIP

Do you have a great shop tip (or two) you'd like to share with other WOOD® magazine readers? For each published submission, you will get at least \$25 from WOOD magazine (as much as \$200 if we devote a page or more of space elsewhere in the magazine to your idea). You also may earn a woodworking tool for submitting the top shop tip for the issue.

We try not to use shop tips that have appeared in other magazines, so please send yours to only one. We do not return shop tips. Mail your tips, address, and daytime phone number to:

Top Shop Tip
WOOD Magazine
P.O. Box 11454
Des Moines, IA 50336-1454

Simple jig for perpendicular holes

Some projects call for you to drill holes perpendicular to a work surface. But, what do you do if the piece is too large for your drill press, and you don't own a drilling guide for your portable drill?

TIP: Join two blocks of wood at a 90° angle as shown below. By holding your drill bit in the corner of this simple jig, you can accurately bore perpendicular holes with many sizes of twist and brad-point bits.

—Mike Fagan, Elgin, Ore.

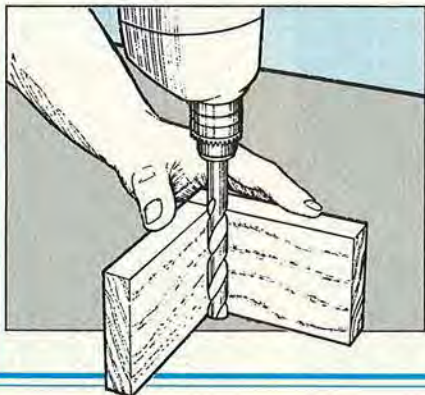

A cam-do carving hold-down

For safe and effective carving of flat workpieces, you must secure the carving in a way that frees both of your hands and doesn't mar your masterpiece. It sure would be nice to have a hold-down that quickly adapts to any carving.

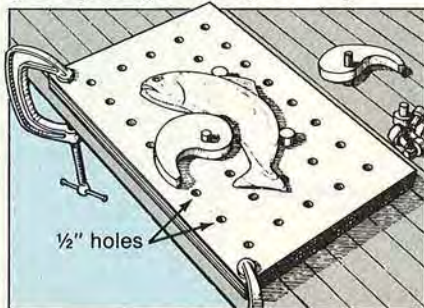

TIP: Drill a series of 1/2" holes, set apart 2" on center, into a piece of 3/4x12x18" plywood (or larger if desired).

Then, make at least two T-shaped pins from 1 1/4" lengths of 1/2" dowel and 3/4" lengths of 1" dowel such as those shown above. Drill a 1/2" hole, 1/2" deep, into the center of the 1" dowel lengths and glue and insert the 1/2" dowel pieces. From 3/4" solid stock, cut a cam according to the full-sized pattern above, and drill a 1/2" hole as indicated. Glue a 1 3/4" length of 1/2" dowel into the hole in the cam so

For his tip, Gordon receives a Freud model CE82 3 1/4" power planer.



1/2" of dowel protrudes from each face. Now, you can hold a carving of most any shape between at least two pins and the cam. Clamp the board to your workbench or hold it in your lap, whatever's most comfortable to you.

—Gordon Humphrey, Victoria, B.C.

How to get glue into those dowel holes

Applying adhesive to the walls of a dowel hole without making a gluey mess of the area around the rim of the hole can be difficult.

TIP: Apply the glue with a bent-over pipe cleaner as shown at right. You can get the correct amount of glue onto the necessary surfaces without a mess, then discard the inexpensive pipe cleaner.

—Ralph A. Sprang, Jr., Columbia, Md.

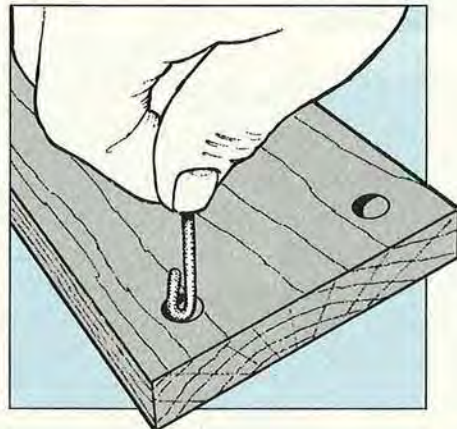

Extendable stop for radial-arm saws

You can purchase or rig all sorts of cut-off stops that clamp to the fence of your radial-arm saw. But, these stops limit the length of your repetitive cuts because they extend no further than the ends of your fence. Here's a better idea.

TIP: Build an extendable stop such as the one below for your radial-arm saw. From a $\frac{3}{4} \times 1\frac{1}{2}$ " length of straight-grain hardwood, cut the ad-

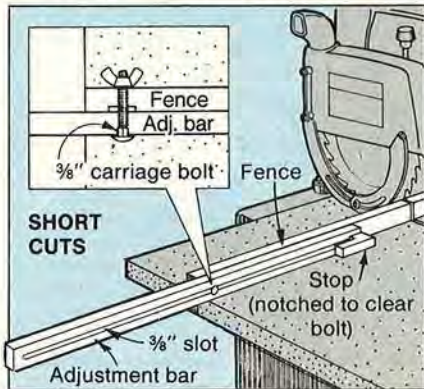

justment bar to a length that suits most of your projects (mine adjusts for cuts from 0-60"). Rout a $\frac{3}{8}$ " slot through the bar, and screw an L-shaped stop to one end. Drill a $\frac{7}{16}$ " hole near the end of your fence, and secure the adjustment bar to the fence with a $\frac{3}{8}$ " carriage bolt as shown in the Short Cuts and Long Cuts drawings, below, left and right.

—Steve Lively, Brainerd, Minn.

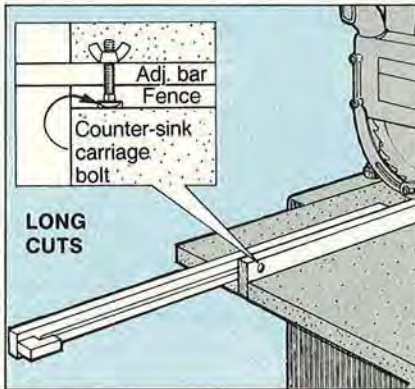

Jig makes for quick adjustment of circle cutter

Circle cutters often require a lot of trial-and-error adjustments.

TIP: Cut a piece of $\frac{3}{4} \times 1\frac{1}{2}$ " stock to a length equaling the maximum diameter of your circle cutter. Mark a line across the width of the block at its midpoint, and drill a $\frac{1}{4}$ "-deep hole with the pilot of your circle cutter at the center of this line. Then, apply two strips of measuring tape. (You can buy the tape from many hardware stores and catalogs. Apply just one strip if your cutter has only one blade). To get a precise reading of your circle cutter's radius, lower the pilot into its hole and align the cutting point with the rule.

—From the WOOD magazine shop

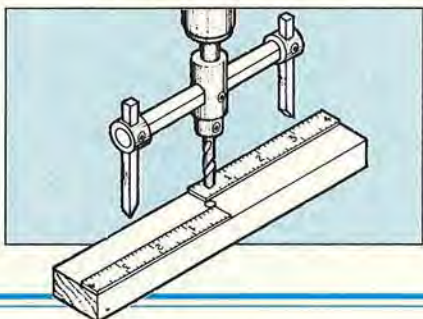

Strap-clamp pointer

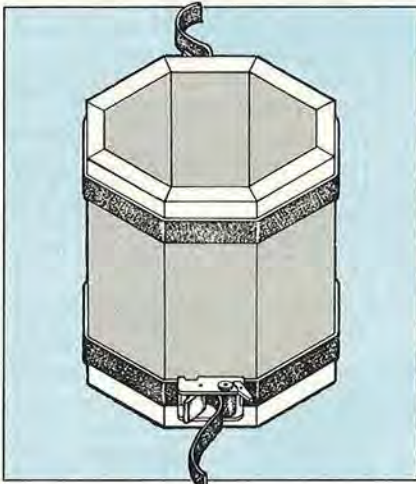

Strap clamps exert more pressure near their ratcheting mechanisms than in the middle of the straps. This uneven pressure can contribute to weak glued joints.

TIP: You can distribute that pressure more evenly by positioning the clamps opposite each other, as shown in the drawing above.

—From the WOOD magazine shop

Continued on page 18

PERFORM WITH THE BEST!

12 VOLT VSR KEYLESS DRILL & DRIVER WITH CASE #EY6205BC **\$189**
15 Minute Charge!

Panasonic 9.6 VOLT VSR CORDLESS DRILL & DRIVER W/KEYLESS CHUCK #EY571B **\$129**

BLACK & DECKER 9.6 UNIVOLT VSR CORDLESS DRILL KIT W/2 BATTERIES #2663K-2 **\$149**

12 VOLT VSR CORDLESS KEYLESS DRILL KIT W/2 BATTERIES #2735-04X **\$138**

SKIL 12 VOLT 3/8" VSR DRILL KIT W/2 BATTERIES #2735-04 **\$125**

12 VOLT VSR KEYLESS DRILL KIT #TFD220VRK **\$165**

RYOBI 9.6 VOLT VSR KEYLESS DRILL KIT #TFD170VRK **\$148**

HITACHI 9.6 VOLT VSR KEYLESS DRILL KIT W/2 BATTERIES #D10DFK **\$169**

Makita 9.6 VOLT VSR DRILL KIT W/KEYLESS CHUCK #6093DWX **\$138**

BOSCH 9.6 VOLT VSR DRILL KIT W/2 BATTERIES #3050VSRK **\$134**

Milwaukee 12 VOLT 3/8" VSR CORDLESS DRILL KIT W/KEYLESS CHUCK #0402-1 **\$169**

Milwaukee 9.6 VOLT VSR 3/8" DRILL KIT #0395-1 **\$149**

PORTER-CABLE 12 VOLT 3/8" VSR KEYLESS DRILL KIT #9851 **\$134**

TOOL CRIB

OF THE NORTH
DIVISION OF **ALCOA**

\$10.00 extra
DISCOVER MasterCard VISA P.O. Box 1716 Grand Forks ND 58206

1-800-358-3096

Free Freight * Limited Offer * Same Day Shipping

Quality

EXOTIC LUMBER

Figured Domestic
Turning Wood
Exceptional Quality
Personal Friendly Service

Whether you are a
Beginner or Professional,
We welcome your inquiries
Call or Write.

BereaHardWoods.co.

125 JACQUELINE DRIVE • BEREA, OHIO 44017
216-243-4452

BUILD YOUR OWN QUEEN ANN FURNITURE



SOLID
CHERRY, WALNUT
OAK, MAHOGANY

FREE
BROCHURE
DESCRIBES
DINING ROOM
AND
LIVING ROOM
PIECES
NO MINIMUM
QUANTITY



Adam's Wood Products, Inc.

DEPT. D03103, 974 FOREST DRIVE, MORRISTOWN, TN 37814

TELEPHONE 615-587-2942
FAX 615-586-2188

WARREN TOOL CO. INC. (10) Piece set of woodcarving tools



ORDER #COMBI-M "WARREN TOOLS GIVE YOU THE EDGE!"

Send \$31.95 Ppd. (USA)
Check or Money Order,
C.O.D. UPS.

Honed Ready To Use
TEL (914) 876-7817



N.Y. res. ADD State Tax
\$3.00 SHIPPING
Foreign orders ADD \$6.00 SHIPPING.

Warren Tool Co. Inc.
2209-1, Rt. 9G,
Rhinebeck, N.Y. 12572

Wood Moisture Meter

- Avoid Moisture Problems
- Protect your Masterpiece

MINI LIGNO

Incl. Case, Batteries
and Pins for 3/8" and 7/16"
Measuring Depth,

only **\$110**

also from Lignomat:
MINI-LIGNO E
Range: 6%

Easy-to-use, sturdy
instruments for the
professional woodworker
or serious hobbyist.
Great for lumber, veneer,
fiberboards. Ask for free
catalog on the complete line
of moisture meters and
accessories for kiln drying.

Lignomat USA Ltd.
503-257-8957 800-227-2105

PO Box 30145bh
Portland, OR 97230



GIVE YOUR
WOOD PRODUCTS
A FRESH LOOK
WITH

Our Pattern Book for bandsaw,
scrollsaw or jigsaw. Contains 50
unique full page patterns. Some
are easy — some are more
challenging — but all are fun to
make. Send only \$10.75 (includes
postage and handling) to:

CUT IT OUT ENTERPRISES

PO Box #404, Dept. W1
Clearfield, PA 16830

(Please allow 4 to 6 weeks for delivery.)

Van Dyke's

Presents a
Catalog

with supplies for
upholstery, antique
restoration, wood
working, caning,
brass hardware,
carvings and many
related trades!



36 Years in Creative Arts & Trades

Many Hard-To-Find Items!

SEND \$1.00 FOR CATALOG TO:
Van Dyke's Restorers
Dept. D55 - Woonsocket, SD 57385

ANTIQUE reproduction furniture HARDWARE



HORTON BRASSES
Nooks Hill Rd. PO Box 120J
Cromwell, Ct 06416 203-635-4400
send \$3.00 for a catalog



NEW GROUND MARKETING
QUALITY & INNOVATION

LOCKWOOD POWER™ Oscillating Spindle Sander

Leaves no sanding lines!
A professional edge on
Contour Sanding.



LOCKWOOD POWER DRIVE™

- 3/4 hp Motor TEFC
- 1 1/2 inch stroke
- 57 Strokes per minute
- 1725 RPM
- 6 inch spindle length
- 8 diameters available,
1/4 inch to 3 inches

MADE IN USA

Write or call for free information!



NEW GROUND MARKETING
P.O. Box 718
Lansdowne PA 19050

(215)622-2445



FIRST CLASS MAILBOXES

It's hard to believe how easy it is to make this
great looking project. You'll find it easy to build
because you'll be getting big blueprint sheets
that show each piece drawn FULL SIZE. You
can make it from 1/2" plywood. Besides the
plans you'll be getting the wheels, axles, axle
caps, smokestack, wooden farmer's head, and
hat. (Note: the mailbox and plywood are not
included in kit.) Order #9630 Pickup Truck
Mailbox Plan & Hdw. Kit for \$26.99/KIT postage
paid. MN residents add \$1.32 sales tax/kit.

TO ORDER: Visa or MasterCard customers call toll free. Mail
order customers send check or money order.

Phone TOLL FREE 1-800-441-9870
(Credit Card Orders Only)



MORE PLANS
See hundreds of additional plans. Order our
72-page catalog for only \$1 or receive
catalog FREE with order.

MEISEL HARDWARE SPECIALTIES

P.O. BOX 70 W 4 MOUND, MN 55364

TIPS FROM YOUR SHOP (AND OURS)

Continued from page 18

A no-squint improvement for your squares

Most combination and try squares are difficult to read. Why? Their blades have stamped markings that don't contrast sufficiently with the rest of the blade.

TIP: Spray or spread a thin coat of black epoxy enamel paint onto the blade, and then wipe away the excess

paint with a squeegee (the type used for auto-body work) or an old credit card as shown below, left. This will leave most of the paint in the indentations, making them more visible. After the paint dries, remove any streaks between the indentations with fine-grade steel wool as shown below, right.

—Raj Chaudbry, Astoria, N.Y.

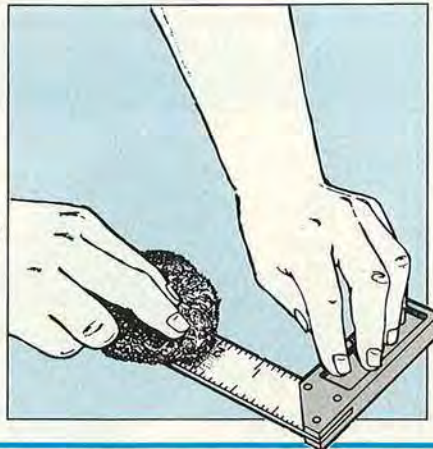
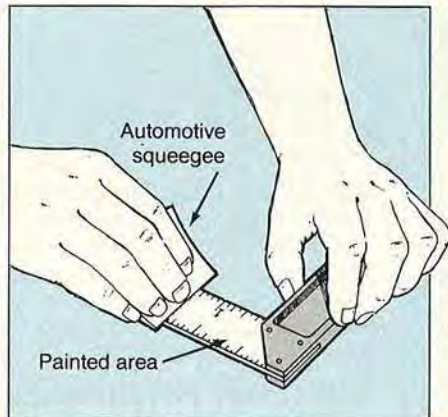

More tips from our woodworking pros

- Some projects require facing pieces with perfectly aligned dados. To accomplish this task, see Steps 1 and 2 and the sketch on page 48.
- For drawer fronts with recessed pulls, see our router jig on page 51. This helper enables you to make multiple, identical recesses.
- Have you looked for a durable outdoor finish lately? Try spar varnish and the application method on page 61.
- You can create the look of a hand-carved sign in just minutes with a router and $\frac{1}{8}$ " straight bit. See pages 70-71. Don't tell your friends, though. Let them think you did it completely by hand.
- For helpful hints on carving a human face, see the cigar-store Indian project on page 40. 🌲

**IF YOU THINK OUR NEW
BAR CLAMP LOOKS GREAT,
WAIT UNTIL YOU GET
YOUR HAND ~~X~~ ON IT.**

Pick up the new QUICK-GRIP™ Bar Clamp. Squeeze the pistol grip handle to tighten clamping pressure. One finger on the quick-release trigger unlocks the clamp.

You've only used one hand.

The revolutionary pistol-grip mechanism puts control of clamping pressure in the palm of your hand. You can work faster, with more precision. ■ Positive locking action holds work tight ■ Quick-release trigger lets go in a snap ■ High-tech resin construction is

strong yet lightweight ■ Instantly adjustable clamping pressure ■ Large, pliable pads won't mar work ■ Available in five sizes – 6"/150mm, 12"/300mm, 18"/455mm, 24"/605mm, 36"/910mm.

Get your hand on the new QUICK-GRIP Bar Clamp wherever quality tools are sold. Yes, it looks revolutionary. And this time, looks aren't deceiving.

QUICK-GRIP™

A UNIT OF **AMERICAN TOOL**
COMPANIES, INC.



MYTHS AND FACTS

ABOUT THE CARE OF YOUR CORDLESS TOOLS

To find out how to get the most from cordless products, we turned to the people at Gates Energy Products, one of the world's largest manufacturers of sealed nickel-cadmium (ni-cad) batteries. The Gainesville, Florida, company provides batteries for Black & Decker, Makita, Porter-Cable, and Sears Craftsman, among many others. C. L. (Red) Scholefield of Gates passed along these pointers:

Forget the myth about battery memory. During the early 1960s, NASA scientists discovered something peculiar about ni-cad cells of that vintage. The batteries "remembered" lower-than-full-capacity charges if not fully drained and recharged for each use. That's no longer true, because numerous improvements in battery technology, yet the myth persists. Today, you can charge batteries at any time, regardless of the amount of power left in the cells, without reducing the batteries' storage capacity.

Ni-cad batteries work best between 50 degrees and 80 degrees Fahrenheit. High temperatures rob a battery of life and performance, so avoid charging a battery that's warm to the touch (95 degrees and up). And, don't charge or store a battery in a hot area such as close to a heating source or in open sunlight.

At the opposite end of the thermometer, you should avoid recharging your batteries at below-freezing temperatures. This could damage the battery's chemistry.

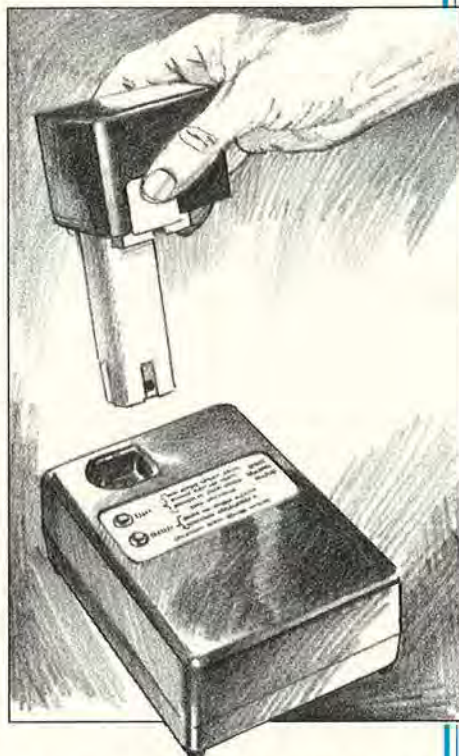

Charge your tools at least once a month. Red's advice here: periodically charge your batteries even if you don't plan to use the tool. Why? Because most battery failure results from electrical shorts that develop between the positive and negative plates inside the cells. And, fully charged plates resist shorts better than discharged plates. Remember that a ni-cad battery loses about one percent of its charge during every day of inactivity, reducing it to less than half power after only two months.

Note: For information about quicker recharging times, see Tool Industry Insider on page 84. 

Illustration: Jim Stevenson

VISIT THE SHOW NEAR YOU!

- Free Workshops • Prizes •
- Hundreds of Products •
- Seminars by Mastercraftsmen •

★ The Woodworking Shows ★

machinery
tools • supplies



See the Widest Variety of
Woodworking Products
All Under One Roof!!

HUNDREDS OF ITEMS! NEW PRODUCTS!!
Machinery • Power & Hand Tools • Supplies

COMING IN 1991

- Atlanta
- Baltimore
- Boston
- Charlotte
- Chicago
- Cincinnati
- Columbus
- Dallas
- Delaware Valley
- Denver
- Detroit
- Indianapolis
- Kansas City
- Milwaukee
- No. California
- Philadelphia
- Portland
- Richmond
- Sacramento
- Seattle
- So. California
- St. Louis
- Tampa
- Twin Cities
- Ventura

1-800-826-8257 or 213-477-8521
Call NOW to be placed on mailing list for
FREE Brochure & Discount Coupons
Phone Hours 8-5 Pacific Time Weekdays

BRIDGEWOOD®

WOODWORKING MACHINERY

The BW-15P PLANER
at \$849. is only one of 60+
Pro Quality, Woodworking
Machinery Values from our
New, 52-PAGE CATALOG!

PRICES F.O.B., YORK, PA
SUBJECT TO CHANGE
WITHOUT NOTICE



To put a BW-15P to work in your shop, PHONE (717) 764-5000 or send \$1.00 for the catalog

TO: WILKE MACHINERY COMPANY
3230 Susquehanna Trail, N.
York, PA 17402

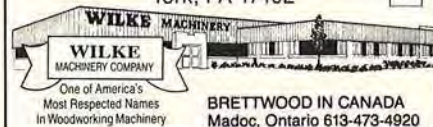

WILKE MACHINERY COMPANY
One of America's
Most Respected Names
in Woodworking Machinery

BRETTWOOD IN CANADA
Madoc, Ontario 613-473-4920

FREE CATALOG

Trend-lines® Discount Woodworking Tools and Supplies

Send today for your **FREE** copy of our 72 page full-color catalog. You'll find the best prices for over 3,000 brand-name products. Included are power tools & accessories, hand tools, screws, hardware, wood components, plans, how-to books, and much more.



To order your **FREE** catalog
call Toll-Free,
1-800-366-6966

Or Write: Dept. WD41 • 375 Beacham St.
Box 6447 • Chelsea, MA 02150

YES YOU CAN!

- make \$18.00 to \$30.00 an hour!
- work full time or part time, right at home.
- operate a CASH business where 90¢ of every dollar is CASH PROFIT!

We'll send you a FREE Lifetime Security Fact Kit — yours to keep with no obligation — that gives you the details on being your own boss with a Foley-Belsaw Full-service Saw and Tool Sharpening Shop.

YES YOU CAN have independence and make good money. But you have to WRITE NOW to get your FREE Lifetime Security Fact Kit.

Mail the coupon below.



**FREE
LIFETIME
SECURITY
FACT KIT**

Foley-Belsaw Co.
6301 Equitable Rd., Dept. 20967
Kansas City, Mo. 64120

Foley-Belsaw Co.
6301 Equitable Rd., Dept. 20967
Kansas City, Mo. 64120

- YES, I want to know more! Please rush my FREE Lifetime Security Fact Kit.

Name _____

Address _____

City _____ State _____ Zip _____

(_____)
Area Code Phone _____



PRODUCTS THAT PERFORM

Print this article

Double-faced tape: just the right amount of tack

The 3M company makes 120 types of tape, so it didn't surprise me when our search for the ultimate double-faced tape turned up two of its products.

What's so good about these tapes? Unlike some double-faced products, 3M's no. 404 and 410 tapes have just enough tack for the task at hand, but not too much. And, they leave little residue on the project surface.

I prefer the no. 404 tape for holding paper patterns on parts. The higher-tack no. 410 tape firmly holds together wooden parts during sawing and sanding operations.

When the tape did hold a little too well, I applied lacquer thinner, just as I do with other brands of "carpet tape." More good news, using thinner with the 3M tape did not result in the excessive slurry of adhesive goo that sometimes accompanies removal of other tapes.

—Tested by Jim Boelling



You can't buy these tapes at your local hardware store. 3M no. 404 and 410 double-faced tapes, are available only through industrial distributors or by mail from Industrial-Kurtz, 2150 Delaware Ave., Des Moines, IA 50317. Call 515/266-4656. Postage-paid prices for 36-yard rolls of these tapes:

No. 404, 2" roll, \$20; no. 410, \$16 for 2" roll.



Portable drafting board does it all

In my job as a freelance technical illustrator for *WOOD*® magazine, I do all of my work on a professional-size drafting machine costing hundreds of dollars. So, I was impressed with the Rotring Portable Drawing Board with optional head, because it does as much as my big machine at a fraction of the cost.

The standard unit has a removable, graduated straightedge with built-in protractor that slides effortlessly up and down the table

and locks securely in place. Although it's made entirely of plastic, the board proved durable in my tests and dust didn't bother it.

I recommend that anybody buying this table also purchase the optional drafting head. This handy accessory slides along the straightedge and locks at any desired angle, with automatic settings every 15°. You can't go wrong with this handy board.

—Tested by Kim Downing

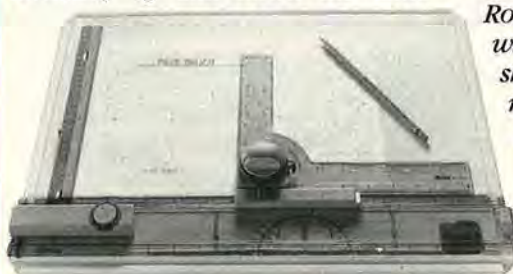

Rotring Portable Drawing Board with case. Item no. G1303, with shipping, \$43.20 (or order item no. G1304, with optional drafting head, \$64.40 with shipping)

Call Grizzly Imports: 800-523-4777, eastern U.S., 800-541-5537 western U.S.

Synthesized exotic woods save you money

Like many exotic hardwoods, Ebon-X doesn't come cheap: \$35-\$45 per board foot for roughsawn stock with its share of defects. You can stain domestic hardwoods black, but that usually yields mixed results, and doesn't work at all for many turning, inlay, and intarsia projects. Now, Supertech Woods has patented a process for treating walnut with nontoxic chemicals to make it look like ebony or rosewood. The process uniformly alters the wood's color throughout its thickness, and makes the walnut 20 percent heavier. The walnut retains its strength and hardness, becoming slightly stiffer. Supertech uses only clear, dimensional walnut, so you obtain a high percentage of usable stock.

I tested a piece of Ebon-X bronze wood that has a tinge of brown in it and bears a striking resemblance to Macassar ebony. The company also makes a jet-black Ebon-X in addition to the rosewood product, and is currently developing a teak substitute. My sample behaved much like walnut during machining. I didn't notice any health irritants. The Ebon-X product also scored well in sanding and gluing. Like most woods, it darkened slightly when I applied a finish.

—Tested by Jim Boelling



Ebon-X woods, about \$36-\$48 per board foot in dimensioned stock from Supertech Woods, 679 Coover Rd., Delaware, OH 43015. Call 614/363-3800.

Continued on page 24

TOULAN 2500 CORNER CAMCLAMP

New From England

The Corner Clamp is an all British invention which has won National acclaim and prizes for its unique design.

How to use your Corner Clamp

- Place cam in hole.
- Clamp by rotating cam.

**SUGGESTED RETAIL \$12.95
SPECIAL INTRODUCTORY OFFER**

4 Corner Camclamps \$ 45.00
10 Corner Camclamps 100.00
20 Corner Camclamps 180.00

CHECK WITH ORDER OR C.O.D.
Freight pre-paid.

Toulan USA 235 Canterbury
Exclusive Importer P.O. Box 12389
Beaumont, Texas 77726

Div. Tech Rep & Associates

WOOD TOY

- ★ Patterns
- ★ Parts
- ★ Wheels
- ★ Many New Patterns to Choose from.
- ★ Executive toys

SEND \$1.00 FOR NEW CATALOG & RECEIVE COUPON FOR FREE WHEELS & AXLE PEGS.

toys and joys

Box 628W Lynden, Wash. 98264

Do-It-Yourself Kits

Factory Direct Clocks and Furniture

Also Assembled and Finished

- Grandfather Clocks, Mantel and Wall Clocks
- Curios, Tables, Chairs, Desks, Cradle...and more!
- Solid 3/4" Black Walnut, Cherry, or Oak
- Heirloom Quality
- Solid Brass West German Movements and Dials
- Money Back Guarantee

I am interested in
 Do-It-Yourself Kits
 Finished Clocks
 Finished Furniture

SEND \$1 FOR COLOR CATALOG

Name _____
 Street _____
 City _____
 State _____ Zip _____
 (Please Print)

EMPEROR CLOCK COMPANY
 World's Largest Manufacturer of Grandfather Clock Kits
 Dept. 3818, Emperor Industrial Park
 Fairhope, Alabama 36532 • Phone 1-205-928-2316

RIP AW

The Portable Sawmill.

The "affordable portable" one man band sawmill. Weighs only 45 lbs. Cuts 20" diameter logs into lumber. Minimum 1/8" to maximum 9" thickness.

Write or call for free brochure.

Better Built CORPORATION
 (508) 657-5636
 845 Woburn Street, Dept. W, Wilmington, MA 01887

The Japan Woodworker's Catalog is...

loaded with the best tools you can get your hands on. In our catalog you will find a huge selection of Japanese saws, waterstones, chisels, planes, carving tools, cutlery and books. Send \$1.50 for our catalog and supplements during the next two years.

THE JAPAN WOODWORKER
 1731 Clement, E9, Alameda, CA 94501
 Phone 1-800-537-7820

ANYTIME ANYWHERE ANYWOOD

mold plane and edge

Professionals and hobbyists alike know the strengths of the W&H molder-planer. Superior US-made construction and quick two-minute cutter changes make it a snap to cut moldings and plane hardwoods. It's fast, easy, and super-smooth.

Our five-year warranty and free 30-day trial are your assurance that W&H goes the distance.

Mail this ad or call us toll-free today.
 1-800-258-1380 In NH 603-654-6828

Williams & Hussey Dept. 231CM
 Riverview Mill, P.O. Box 1149
 Wilton, NH 03086

W&H

YES! Send your free information kit today.
 Name _____
 Address _____
 City _____ State _____ Zip _____

PRODUCTS THAT PERFORM

Continued from page 23

Rock-steady tenoning jig

I've cut my share of tenons, and it's always been a challenge to cut tight-fitting tenons of precisely the same size with square and parallel shoulders. The device from Ru-Barb Tools makes tenon making easier and more reliable than any jig I've tried.



The sturdy, well-machined, and largely cast-aluminum jig holds your workpieces rigidly at 90° or 45° angles. My results: 30 test tenons and each fit perfectly. In addition to making tenons, the jig works well for making tongue-and-groove, lap, and finger joints. The unit adjusts to fit saw fences from 7/8" to 1 1/8" wide and up to 3" high. Its big comfortable handle provides a sturdy grip.

I found it easier to slide the jig along by waxing the rip fence (paraffin, car, or beeswax work fine). And, I scored my layout lines with a knife to reduce chip-out on the saw-blade exit side of the shoulder cut.

—Tested by Lee Gatzke

Tenon device, \$140 ppd. from Ru-Barb Tools, 5-4269-1, Swanton, OH 43558. Call 419/826-8560.



Introduction to marquetry

Here's a marquetry kit that takes you step-by-step through the process. It includes everything: veneer, backing board, design, and instructions. A beginner produced this scene above. The kit is offered in a variety of sizes and designs.

—Tested by Bill Krier

Marquetry kits, available in 12 designs in three sizes: 8×10", \$24 ppd.; 11×14", \$36 ppd.; and 16×20", \$48 ppd. Write to Hardwood Inlays, 16204 92nd Ave. Ct. E, Puyallup, WA 98373. Call 206/848-3019.

Forstner Bit SPECTACULAR

Quality, imported Forstner Bits make glass smooth, flat bottom, clean holes, even through veneer, knots, and end grain, in any direction. Indispensable for furniture making. Will bore any arc of a circle, make pocket and blind holes and even make overlapping holes for mortising.

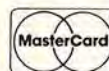

ONLY
\$28⁹⁹ 7-Pc. Set #77571
1/4" to 1" In Wooden Case

- Precision ground, quality bits
- Machined from high-carbon steel
- Hardened to HRC 50-52
- Reusable moulded covers protect rims

22-Pc. Taper Drill Set
Sturdy Wooden Case #12232 **\$27⁵⁰**

- 7 Tapered bits
- 7 Adjustable stop collars
- 7 Countersinks/
- Single-twist design
- Counterbores
- Sizes #5, 6, 7, 8, 9, 10, & 12



Complete 16-Pc. Set
\$88⁹⁹



ONLY
\$33⁹⁹

3" Forstner Bit
1/2" Shank
#77591



25-Pc. Brad Point Drill Set
Fits any 3/8" or larger chuck. Includes FREE metal index.

#77611 **\$28⁰⁰**
2 or more sets **\$25⁰⁰ ea.**



#77581

Call Toll Free:
800-345-2396

Order Mon. through Sat. 8:30 to 5:00
Ask for Tool Order Dept.

Or Mail to:

940 West Maple St., Hartville, Ohio 44632

In state, please add 5% sales tax

\$3.00 Ship/Handling Charge on All Orders; Add'l Shipping Charges Outside Continental U.S.

HARTVILLE TRUE VALUE

Tool and Supply Inc.

Video packages steer you to project completion

Shopsmith's marketing department paid attention when its research revealed that some buyers of new woodworking equipment put off completing a project for a year or more. The reason: the new equipment intimidated some woodworkers. With that in mind, the company now offers a set of 12 comprehensive plans, called Heirloom Projects, designed to give any novice the confidence he needs.

Each package consists of a high-quality, 40-minute VHS tape, a 50-page booklet that includes a cutting diagram, Exploded-View drawing, and full-sized patterns when necessary. The video tape I reviewed detailed construction of a tapered-leg table. I found the instructions for this project clear and easy to follow. The tape and booklet contain a lot of handy tips applicable to any project.

—Tested by Marlen Kemmet



Shopsmith Heirloom Projects, \$29.95 from Shopsmith Inc. Call 800-543-7586 to order or for the location of your nearest store.

Continued on page 26

STEVE WALL LUMBER CO.

Quality Hardwoods and Woodworking Machinery For The Craftsmen and Educational Institutions

Ash	4/4	Select	1.90	UPS	\$64.00
Basswood	4/4	Select	1.30	Special	\$46.00
Birch	4/4	Select	1.60		\$52.00
Butternut	4/4	Select	1.70		\$54.00
Cherry	4/4	Select	2.25		\$65.00
Hickory	4/4	Select	1.30		\$46.00
Mahogany (Genuine)	4/4	Select	2.60		\$72.00
Maple (Hard)	4/4	Select	1.55		\$51.00
Maple (Soft)	4/4	Select	1.25		\$45.00
Pecan	4/4	Select	1.30		\$46.00
Poplar	4/4	Select	1.20		\$44.00
White & Red Oak	4/4	Select	1.80		\$58.00
Walnut	4/4	Select	2.50		\$70.00
Cedar (Aromatic Red)	4/4	C+Br.	1.25		\$45.00
Yellow Pine	4/4	F.G.	.85		\$36.00
		Clear	1.20		\$44.00

Above prices are for 100' quantities of kiln-dried rough lumber sold by the Bd. Ft. FOB Mayodan, NC. Call for quantity discounts. Other sizes and grades available. Delivered UPS prepaid in the Continental U.S.

Call For Best Price On *MiniMax*

STEVE H. WALL LUMBER CO.
BOX 287 • MAYODAN, N.C. 27027
919-427-0637
1-800-633-4062
FAX 919-427-7588

Send \$1.00 For Lumber and Machinery Catalog

SQUARE DRIVE SCREWS

Simply the Best!

- Square Drive Beats Driver Slippage
- Hardened Steel for Extra Strength
- Deep Thread for Super Grip
- Also Brass & Stainless

Send \$3 for Samples and Catalog

McFEELY HARDWOODS

P.O. Box 3 • 712 12th St. Lynchburg • Va • 24505
Toll Free 1-800-443-7937 or FAX (804) 847-7136

RESTORE FURNITURE for SECURE INCOME Perfect 2nd Career

Make \$200-\$2,000 a day! Unlimited market; turn-key business. Free workshops. Set-Up Shop for \$2,999-\$9,999! Part-time or full-time. Great for men, women, families.

Make Molds*Veneer*Resilver Strip*Repair*Refinish

Business Preview Video \$19.95 - Catalog \$2.00

MINUTEMAN, INC., Ste. 17
Box 8, Waterloo, WI 53594
1-800-733-1776



EST. 1974

NATIVE AMERICAN HARDWOODS

Quality, Service and Price, call or write Ed Seeley or Tim Johnston. All Domestic HARDWOODS including

Cherry
Red Oak
Ash
Birch
Basswood
Butternut
Squares

Curley maple
Black Walnut
Tulip/Poplar
White Oak
Wormy Red Maple
Hard Maple
Wide Stock

Send \$1 for catalog (refunded with order) to:

NATIVE AMERICAN HARDWOODS, LTD.
6570 Gowanda State Road, Hamburg, NY 14075
Phone: 716-648-7551—1-800-688-7551
FAX: 716-648-3592

Wood-Mizer®

World's Largest Manufacturer Of Portable Sawmills



OWN YOUR OWN SAWMILL

Four Models To Choose From

BUY DIRECT

1(800)553-0219

In Indiana call: (317) 271-1542
FREE 44-page catalog or use your MasterCard or VISA to order our 50-minute demonstration video—\$10.00
Wood-Mizer Products, Inc. • Dept. QQ53
8180 W. 10th St., Indianapolis, IN 46214-2430

OCTAGON PICNIC TABLES

Plans \$16.75

Easy to follow plans, instruction sheet and step by step pictorial.

Features include, walk through seating, ability to seat eight people in a sociable circle, the strength of a bolted construction.



Specialty Furniture Designs of Michigan

797 West Remus Rd., Dept. W6, Mt. Pleasant, MI 48858
VISA/MC Accepted MI. Res. Add 4%

SPECIAL OFFER

BRANDING IRON
For hard and soft wood

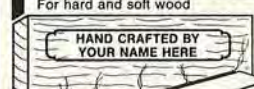

\$2400

Plus \$2.00 for shipping and handling

Nebr. residents add correct sales tax

SATISFACTION GUARANTEED or your money back

- Shipped in one week
- Solid brass head — raised letters
- 1st Line: HAND CRAFTED BY — as above
- 2nd Line: Your choice — 20 characters/spaces max.
- Complete with wood handle
- As above but with 3rd line — \$37.00 + \$2.00

ORDER TOLL FREE 1-800-826-7606

For free brochure, write or call (402) 464-0511

Order by mail from: **NOVA TOOL CO.**

12500 Finigan Rd., Dept. BH
P.O. Box 29341, Lincoln, NE 68529



Tungsten Carbide Router Bits

- INDUSTRIAL GRADE, THICK CARBIDE
- SEALED BALL BEARINGS
- 40 - 60 % BELOW WHOLESALE

COVE BITS



Radius	Price
1/4	\$ 14
3/8	\$ 15
1/2	\$ 17

ROUND-OVER OR BEADING



Radius	Price
3/16	\$ 12
1/4	\$ 13
5/16	\$ 14
3/8	\$ 14
1/2	\$ 15

ROUNDNOSE BITS



Diameter	Price
1/8	\$ 8
1/4	\$ 9
3/8	\$ 11

AMER. EXP. - TOLL FREE - C.O.D.

1-800-767-4747

Or Mail Check to:

SKYCROFT TOOLS, INC.

P.O. Box 418W5

Myersville, MD 21773-0418

FREE MONEY From Scrap Wood



Hawk 20 "	\$949
72 Blades	15
Pattern Pack	39
Foot Switch	33
Reg.	\$1036
Save	\$237
Only	\$799

Turn your hobby and creativity into savings and income.

DON'T WAIT - ORDER TODAY

30 DAY RISK FREE GUARANTEE

TO ORDER CALL

1-800-535-8665

OR MAIL TO

RBI Industries

Box 369

Harrisonville, MO 64701

Send TODAY for

FREE Fact Kit!

Name _____
Address _____
City _____ State _____ Zip _____
Phone () _____

A03

PRODUCTS THAT PERFORM

Continued from page 25

Turn your 5-gallon bucket into a tool carrier

Tradesmen have long used recycled 5-gallon buckets for carrying tools from job site to job site. The buckets are cheap, tough, well-balanced because of their handles (especially handy if you're climbing a ladder), and hold a lot of goodies. Now, Portable Products has come up with a means of organizing those buckets, making them even more useful.

The Bucket Boss slips onto your 5-gallon bucket and has 27 pockets for holding all your tools (11 pockets inside the bucket and 16 pockets on the outside). Because of its heavy, air-textured nylon construction, the Bucket Boss was nearly indestructible in my tests.

—Tested by Bob McFarlin



Bucket Boss, \$27.45 ppd. from Portable Products. (A 10-pocket version is also available for \$22.45 ppd.) Call 800-688-2677 or 612/221-0308.

Would you believe a one-minute epoxy?

We make great use of five-minute epoxy around the *WOOD*® magazine shop for several reasons. It sets up fast, requires no clamping, and creates a strong bond. So, when Devcon put a tube of their new Sure Shot one-minute epoxy into my hands at a recent trade show, I couldn't wait to get back to the shop and give it a try. True to the manufacturer's claims, the product set up in one minute and cured to full strength in one hour. A one-minute working span may be too fast for some projects, but when you're in a hurry, this stuff helps tremendously.

The product comes in a two-part, syringe-type tube that guarantees 1:1 dispensing of the resin and hardener. An attachable nozzle thoroughly mixes the two components. The nozzles are only good for one use, but you can buy extras separately.

—Tested by Bill Krier

Devcon Sure Shot one-minute epoxy, \$4.99 for 1 oz., at hardware and department stores nationwide.



Super-handy featherboard

I can't say enough about the Grip-Tite magnetic feather board. The easy-to-use tool has a strong magnet that holds it securely in place on ferrous tabletops.

It has plastic springblades that exert force down toward the tabletop and against the fence. You can set it up in seconds, and move it easily from your tablesaw to your shaper table, for instance.

When I first saw the tool, I was impressed by its well-machined oak body, but skeptical about how tightly it would hold workpieces against the tables and fences of my machinery. Well, it worked just fine. (The manufacturer says the tool holds against a 20-pound horizontal push, and has over 90 pounds of vertical hold). When it came time to remove the tool, a nudge on the handle does it.

The Grip-Tite sticks to the steel legs or cabinets of your machines for easy storage. Remember, this item will not work with machines having nonferrous tabletops.

—Tested by Bob McFarlin

Grip-Tite magnetic feather board, \$24.95 plus postage from Mesa Vista Design. Call 505/892-2093.



Continued on page 29

THE PERFECT GIFT FOR HOME WOODWORKERS!

Better Homes and Gardens®
WOOD

ONE FULL YEAR (8 ISSUES) ONLY \$19.97

To order, call TOLL-FREE 1-800-678-2666

or write WOOD Magazine, 1716 Locust Street,
P.O. Box 10625, Dept. 385035, Des Moines, Iowa 50336-0625.

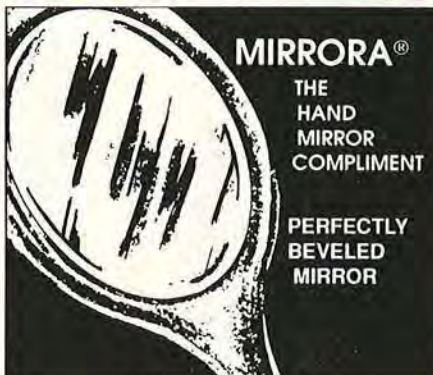

MIRRORA®

THE HAND MIRROR COMPLIMENT

PERFECTLY BEVELED MIRROR

FLORAL
Glass & Mirror, Inc.

895 Motor Parkway, Hauppauge, NY 11788
516/234-2200 • 800-647-7672

Full-Size Professional Plan ADIRONDACK CHAIR



Make this classic American design. Our special version may be folded for storage by using ordinary hardware available at your local store. Be ready for Summer and get your plan now!

CATALOG 200 full-size professional furniture plans — \$3.00

Plan #700 \$12.95
(Catalog free with order)

FURNITURE DESIGNS, INC. Dept. BA-41
1827 Elmdale Ave., Glenview, IL 60025
(708) 657-7526

PENNSYLVANIA HARDWOODS

SATISFACTION GUARANTEED

SIZE	SPECIES	PRICE PER BOARD FT.
15/16	WALNUT	\$1.60
3/4 & 4/4	RED OAK	\$1.75/1.95
3/4 & 4/4	CHERRY	\$1.75/1.95
3/4 & 4/4	WHITE OAK	\$1.05/1.60
3/4 & 4/4	HARD MAPLE	\$1.25/1.30
4/4	POPLAR	\$1.05

NO MINIMUM ORDER.
ALL HARDWOODS KILN DRIED.
For a NEW 24 page catalog featuring over 20 domestic hardwoods, quantity discounts, package deals at delivered prices & much more, send \$1.00 to cover postage & handling to:

TO ORDER CALL:
1-800-235-8317



Northeastern Hardwoods, P.O. Box 365-C, Salamanca, NY 14779

The Finest Quality At The Right Price!

Garrett Wade

161 Avenue of the Americas
New York, NY 10013

(212) 807-1155 for service

(800) 221-2942 for orders



Woodworking Tool Catalog: 212 pages of tools from the USA and around the world. Workbenches; Router Bits and Accessories; Measuring Tools; Carving Tools; Planes; Chisels; Finishing Supplies; and Books. With tips on selecting, using, and maintaining the tools that will serve you best. \$4.00

Classic Hardware Catalog: 64 pages of the finest brass furniture hardware. Hinges; Latches; Locks; Handles; Knobs; Casters; Architectural and Door Fittings. \$2.00

DRY YOUR OWN LUMBER...

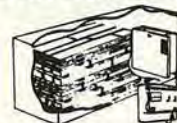

...With an EBAC Wood Drying System

Whether you're a serious home woodworker, small cabinet shop or a large wood retailer, EBAC has a wood drying system that's affordable for you.

EBAC Wood Dryers:

- save you money
- are easy to operate
- are energy efficient
- give you higher quality wood
- give you complete control over your wood's moisture content

CALL OR WRITE TODAY!

EBAC LUMBER DRYERS

106 John Jefferson Rd., Suite 102

Williamsburg, VA 23185

1-800-433-9011 • FAX (804) 229-3321



SAVE BIG Money ONLY \$699⁰⁰ Less Power

Save Like The Pro's With Our 5 in 1 Planer/Sander/Molder/Rip/Joiner
Turn Cheap Unfinished Lumber Into Beautiful Finished Woods, Molding, Picture Frames and More

OUR LOWEST PRICE EVER

- SAVE BIG - EARN BIG -
BIG 12" CUT

\$699 Less Power
MODEL 812

\$999 Motor Switch
MODEL 812

Order TODAY
CALL 1-800-535-8665

Or Mail To
RBI Industries
Box 369

Harrisonville, MO 64701

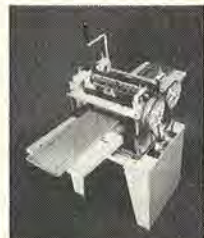

The "ORIGINAL" Model 812

Now In One Handy Volume:

335 GREAT SHOP TIPS

The best ideas collected from our popular column **"TIPS FROM YOUR SHOP"** in WOOD® Magazine

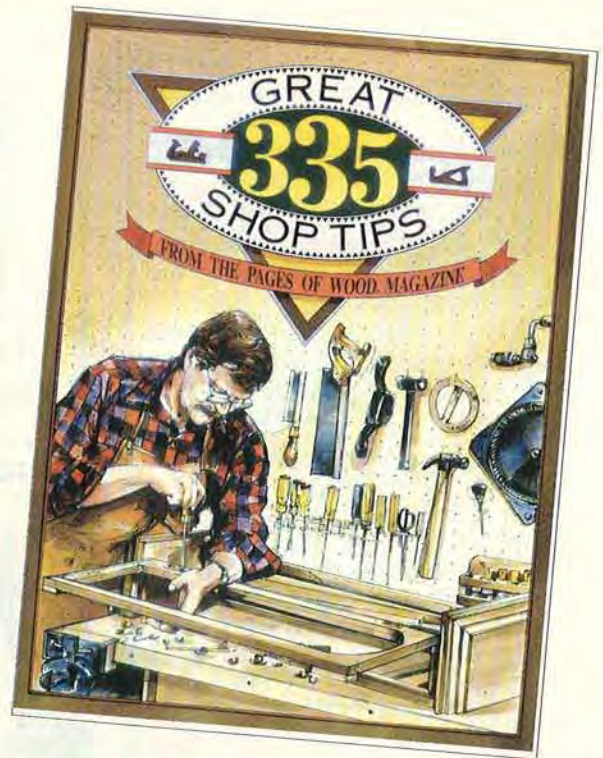

Save \$5.00 with this special advance offer!

335 GREAT SHOP TIPS contains valuable information from the editors and readers of WOOD magazine. **"TIPS FROM YOUR SHOP"** is about their own wood-working experiences—shared knowledge that makes it better, faster, safer and easier to do things in the shop. You've probably used one or more of them yourself!

Now the editors of WOOD have brought together the best tips we know into one publication. **335 GREAT SHOP TIPS** will give you the wisdom of your fellow WOOD readers. We've organized the tips into 24 convenient categories with an index for easy accessibility to any subject.

335 GREAT SHOP TIPS will be available on newsstands nationwide this Spring at a \$9.95 cover price. WOOD, however, offers readers the opportunity to receive **335 GREAT SHOP TIPS** at a special one-time only prepublication price of \$4.95. That's more than 50% off the newsstand price! But you must order now because supplies will be limited. Just fill out the coupon and mail to: **335 GREAT SHOP TIPS, P.O. Box 11454, Des Moines, IA 50336-1454. Allow 6-8 weeks for shipping and handling.**



YES! Please send me your new publication 335 GREAT SHOP TIPS for just \$4.95 (U.S.) plus \$1.00 for postage and handling.

Name: _____

Address: _____

City: _____

State: _____ ZIP: _____

Telephone #: _____

Enclosed is my check or money order for \$4.95 (U.S.) plus \$1.00 for postage and handling made out to WOOD Magazine.

Please bill me at the address listed above.

Please bill my MASTERCARD VISA

Card# _____ Exp. Date _____

Signature _____

Multidiameter countersink handles many drill bits

This countersink does the work of many. It varied in diameter to tenaciously hold all my drill bits from 7/64" to 1/4", when I tested it. Its carbide tips stay sharp for a long time. Two setscrews (one for each half of the clamshell-like tool) securely centered the bit.

—Tested by Steve Oswalt

Amana multidiameter countersink, \$20.90 list price at Amana distributors nationwide. Call 800-445-0077.



Freud's spiral router bits leave straight bits in the dust

After giving Freud's solid-carbide spiral router bits a complete workout, I was thoroughly impressed. Because of their up-cut spiral shape, the bits effortlessly plunge into wood and cut far-smoother surfaces than straight bits, with no chatter, and no burning.

After routing some clean-as-a-whistle mortises, I cut several equally smooth dados. There's more. With my router and a few templates, I cut irregular shapes in 3/4" stock and

1/4" plywood. The end grain and plywood edges were smooth as can be.

Freud claims these solid-carbide bits will last 10 times longer than high-speed steel spiral bits. In my tests, the bits stayed sharp.

—Tested by Jim Downing

Freud solid-carbide spiral router bits, \$16.40-\$46.90 (list) for 1/8-1/2" bits. Call Freud at 800-334-4107 for the location of your nearest dealer.

Now, Add Instant Earning Power To Your Shop!



30-Day Free Trial!

Craftsmen everywhere are using the low-cost Woodmaster to bring in welcome extra cash and to save on all their lumber needs. You can, too!

With the new 18-in. Woodmaster or the standard 12-in. model, you can quickly convert low-cost rough lumber into valuable finished stock. You can turn out perfect picture frame moldings, crown, bed and base moldings, tongue & groove, door and window trim...all popular patterns...any custom design.

You can do custom work for friends, neighbors, lumberyards, picture framers, home remodelers, hobby shops and businesses.

Because it takes just seconds to convert a \$2 rough board into \$10 worth of finished trim, you can see why so many Woodmaster owners enjoy substantial extra incomes!

Variable Speed Makes The Difference!

Just a twist of the dial gives you perfect control for planing, sanding or sawing...from 0 to 1,000 cuts per inch. Creates mirror-smooth molding with no sanding required!

Here's what Woodmaster owner L.C. Griffin of Los Angeles writes: "The shop test article in *Wood Magazine* that said they loved your Variable Feed Rate is what sold me. They were right."

Call or write today for free facts on how you can try this American-made tool in your own shop for one full month. Easy terms.

CALL TOLL-FREE

1-800-821-6651 EXT. PW44



Woodmaster's Quick-Change Molding Head lets you create custom moldings from any stock. Choose from over 250 standard trim and picture frame patterns...or design your own!



Power-fed sanding speeds production and improves the quality of your work. No more waves or cross-grain scratches. Separate sanding head installs in just minutes.



New rip saw attachment lets you gang-rip with power feed in a fraction of the time it takes for multiple hand-fed passes on an ordinary table saw.

FREE FACTS **YES!** Please rush me your **FREE** Information Kit plus details on your **30-DAY FREE TRIAL GUARANTEE!**

WOODMASTER TOOLS, INC., DEPT. PW44
2908 OAK STREET • KANSAS CITY, MO 64108

Name _____
Address _____
City _____ State _____ Zip _____
Telephone (____) _____

CONTROL THE SPEED OF YOUR ROUTER - ROUT AT THE SPEED THAT GIVES THE BEST RESULTS WITH THE WOOD AND BIT YOU ARE USING!

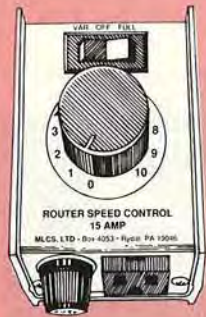

FEATURES:

- Speed Adjustable from Full Speed to 0 RPM
- Full Horsepower and Torque at All Speeds
- Go Back and Forth from Any Pre-Set Speed to Full Speed at the Flip of a Switch
- Works with All Routers 3/4 HP or Less
- 120V 15 Amp
- Gives Your Router a Feature Only Available on Routers Costing Hundreds of Dollars!

- Less Tear Out
- Feed at Comfortable Rate
- Better, Safer Results with Large Diameter Bits
- Less Wear on Bits
- Less Noise and Softer Starts at Lower Speeds
- Stops Burning

EASY TO USE - Simply plug in Speed Control and plug your router into the Speed Control - turn dial for best results. (Speed Control has a clip that can be worn on your belt or hung on wall or left loose.)

• Reduces speed electronically without reducing torque; electronic feed-back maintains speed by increasing voltage to motor as load increases.

NOW ONLY \$39.95 Order Item #200

CARBIDE TIPPED ROUTER BITS PROFESSIONAL PRODUCTION QUALITY GUARANTEED WHEN ORDERING ANY THREE OR MORE DEDUCT \$1.00 EACH. ALL PRICES ARE POSTAGE PAID

ITEM NO.	BEST CUT BEST PRICE	DESCRIPTION	ANGLE/DEPTH/RADIUS CIRCLE DIAMETER	LARGE DIA.	CUTTING LENGTH	SHANK SIZE	PRICE
#601		1/8" Spiral Cutter		1/8"	1/2"	1/4"	\$ 9.00
#602		3/16" Spiral Cutter		3/16"	5/8"	1/4"	\$12.00
#603		1/4" Spiral Cutter		1/4"	3/4"	1/4"	\$12.00
#903		1/4" Spiral Cutter		1/4"	3/4"	1/2"	\$12.00
#904		3/8" Spiral Cutter		3/8"	1"	1/2"	\$24.00
#905		1/2" Spiral Cutter	1/2"	1 1/2"	1/2"	\$29.00	
			*Proper Adaptor Will Be Supplied				
#350		1/8" Round Over	1/8" R	3/4"	3/8"	1/4"	\$11.00
#351		3/16" Round Over	3/16" R	7/8"	1/2"	1/4"	\$11.00
#230		1/4" Round Over	1/4" R	1"	1/2"	1/4"	\$12.00
#353		5/16" Round Over	5/16" R	1 1/8"	1/2"	1/4"	\$14.00
#209		3/8" Round Over	3/8" R	1 1/4"	5/8"	1/4"	\$15.00
#355		1/2" Round Over	1/2" R	1 1/2"	3/4"	1/4"	\$17.00
#656		3/4" Round Over	3/4" R	2"	7/8"	1/2"	\$21.00
#199		Multiform Moulding	Unlimited Patterns	2 1/4"	2"	1/2"	\$40.00
#340		1/8" Cove	1/8" R	5/8"	3/8"	1/4"	\$12.00
#205		1/4" Cove	1/4" R	1"	1/2"	1/4"	\$12.00
#206		3/8" Cove	3/8" R	1 1/4"	5/8"	1/4"	\$13.00
#207		1/2" Cove	1/2" R	1 1/2"	3/4"	1/4"	\$14.00
#208		3/4" Cove	3/4" R	1 7/8"	3/4"	1/2"	\$26.00
#460		1/4" Bull Nose	1/4" Dia. of Circle		3/8"	1/4"	\$14.00
#461		3/8" Bull Nose	3/8" Dia. of Circle		3/4"	1/4"	\$15.00
#462		1/2" Bull Nose	1/2" Dia. of Circle		7/8"	1/4"	\$16.00
#464		3/4" Bull Nose	3/4" Dia. of Circle		1 1/8"	1/4"	\$19.00
#506		1/2" Pattern	Flush Trim	1/2"	1"	1/4"	\$15.00
#507		5/8" Pattern	Flush Trim	5/8"	1"	1/4"	\$16.00
#508		3/4" Pattern	Flush Trim	3/4"	1"	1/4"	\$17.00
#366		1/8" Slot Cutter	3/8" Deep	1 1/4"	1/8"	1/4"	\$14.00
#368		1/4" Slot Cutter	3/8" Deep	1 1/4"	1/4"	1/4"	\$14.00
#204		3/8" Rabbeing	3/8" Deep	1 1/4"	1/2"	1/4"	\$13.00

ITEM NO.	BEST CUT BEST PRICE	DESCRIPTION	ANGLE/DEPTH/RADIUS CIRCLE DIAMETER	LARGE DIA.	CUTTING LENGTH	SHANK SIZE	PRICE
#210		1/4" Core Box	round nose	1/4"	1/4"	1/4"	\$ 9.00
#211		3/8" Core Box	round nose	3/8"	3/8"	1/4"	\$10.00
#212		1/2" Core Box	round nose	1/2"	1 1/2"	1/4"	\$13.00
#418		3/4" Core Box	round nose	3/4"	5/8"	1/4"	\$15.00
#213		1" Core Box	round nose	1"	3/4"	1/2"	\$17.00
#214		1/4" Straight	plunge cutting	1/4"	3/4"	1/4"	\$ 6.50
#215		5/16" Straight	plunge cutting	5/16"	1"	1/4"	\$ 6.50
#216		3/8" Straight	plunge cutting	3/8"	1"	1/4"	\$ 6.50
#217		7/16" Straight	plunge cutting	7/16"	1"	1/4"	\$ 6.50
#474		1/2" Straight	plunge cutting	1/2"	1"	1/4"	\$ 7.00
#775		1/2" Straight	plunge cutting	1/2"	2"	1/2"	\$14.00
#218		5/8" Straight	plunge cutting	5/8"	1"	1/4"	\$ 7.00
#219		3/4" Straight	plunge cutting	3/4"	1"	1/4"	\$ 9.50
#220		1" Straight	plunge cutting	1"	1 1/2"	1/2"	\$11.00
#500		3/8" Flush	Trimming	3/8"	1/2"	1/4"	\$ 7.00
#502		1/2" Flush	Trimming	1/2"	1/2"	1/4"	\$ 7.50
#503		1/2" Flush	Trimming	1/2"	1"	1/4"	\$ 8.50
#221		1/2" Flush	Trimming	1/2"	1 3/16"	1/2"	\$ 8.00
#545		Tongue & Groove	Straight	1 5/8"	1"	1/4"	\$29.00
#845		Tongue & Groove	Straight	1 5/8"	1"	1/2"	\$29.00
#546		Tongue & Groove	Wedge	1 3/16"	1"	1/4"	\$29.00
#846		Tongue & Groove	Wedge	1 5/8"	1"	1/2"	\$29.00
#450		1/8" Beading	1/8" R	3/4"	3/8"	1/4"	\$11.00
#451		3/16" Beading	3/16" R	7/8"	1/2"	1/4"	\$11.00
#233		1/4" Beading	1/4" R	1"	1/2"	1/4"	\$13.00
#453		5/16" Beading	5/16" R	1 1/8"	1/2"	1/4"	\$14.00
#454		3/8" Beading	3/8" R	1 1/4"	5/8"	1/4"	\$15.50
#455		1/2" Beading	1/2" R	1 1/2"	3/4"	1/4"	\$17.00
#530		3/16" Edge Beading	3/16" Dia. of Circle		1/2"	1/4"	\$15.00
#531		5/16" Edge Beading	5/16" Dia. of Circle		1/2"	1/4"	\$15.50

New 24-page catalogue now available, featuring hundreds of bits.

MAKE BEAUTIFUL RAISED PANEL DOORS . . . WITH YOUR 1/4" ROUTER!

Professional production quality bit makes it quick and easy to produce matching rails and stiles — the panel raising bit with ball bearing guide makes the raised panel perfect every time.

Regular value Over \$150.00
SALE PRICE \$69.95 FOR COMPLETE SET

ORDER ITEM # 554 for
 1/4" Shank Set
 (Includes all bits shown below)

RAIL & STILE SHAPER CUTTER
 Item #150 - \$49.95

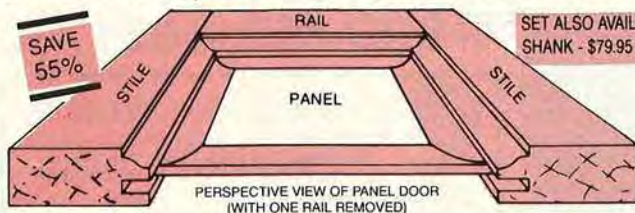

PERSPECTIVE VIEW OF PANEL DOOR (WITH ONE RAIL REMOVED)

SET ALSO AVAILABLE IN 1/2" SHANK - \$79.95 - Item #852

RAISED PANEL BIT

SUPPLIED WITH BALL BEARING
 CARBIDE TIPPED
 1/4" Shank

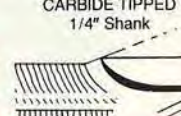

REVERSIBLE COMBINATION RAIL and STILE BIT

(For making matching rails and stiles in raised panel doors, etc.) Works with stock from 11/16" to 7/8" thick

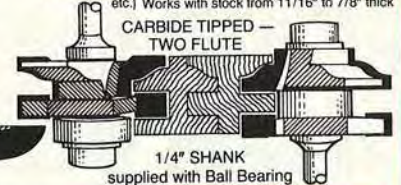

To order by Master Charge or Visa Call Toll Free, 7 Day - 24 Hour Order Service,

1-800-533-9298 or send check to: **MLCS Ltd., P.O. Box 4053DA, Rydal, PA 19046**

Honduras MAHOGANY

The classic choice in tropical timber

The first mahogany to reach England was in the shape of ships—those of the Spanish Armada that later succumbed to the English fleet's cannonballs. That was in 1588, more than 30 years after the Spanish explorer Hernando Cortes discovered mahogany in the Caribbean.

Although English shipbuilders marveled at the new seagoing stock, it was the joiners who really appreciated this New World treasure. They could span greater lengths and widths than with any other wood available, due to the sheer size of the mahogany timbers.

By the late 1700s, the now-famous English cabinetmakers Chippendale, Hepplewhite, and

Sheraton were shaping mahogany into classic furniture styles that kept the wood prominent for 150 years. Today's woodworker still finds delight in working mahogany into elegant cabinets, desks, tables, and other furniture.

Wood identification

Often referred to in the wood trade as Tropical American mahogany, Honduras mahogany (*Swietenia macrophylla*) grows throughout much of Central and South America, including southern Mexico. However, the first mahogany discovered by Spanish explorers was Cuban mahogany (*Swietenia mahagoni*), a species no longer commercially available. Another true mahogany exists in Africa—African mahogany (*Khaya ivorensis*). Philippine mahogany isn't a mahogany at all, but rather a *Shorea* species called lauan.

In the tropical forest, Honduras mahogany sometimes attains 150' heights and diameters of 72". Trees planted and grown for lumber on plantations (found in mahogany's natural range and the South Pacific), run smaller. Honduras mahogany on the stump has a heavily buttressed trunk base, scaly gray bark, and leaves displaying six to eight leaflets arranged on a single stem, much like those of the black walnut tree.

Honduras mahogany wood has straight, semi-open grain and a color that ranges from yellow-brown to dark red, depending



Natural range

on where it grows. With age, though, mahogany of all colors becomes a rich, dark red-brown. The wood also may display exceptional fiddleback, quilt, and ribbon-stripe figure.

A bit lighter than maple at 32 pounds per cubic foot, Honduras mahogany matches oak in strength. The wood also withstands moisture, resists fire and decay, and remains stable in use.

Uses in woodworking

Mahogany claims the qualities that make it the ideal stock for majestic desks, tables, and large cabinets. Both turners and carvers find the wood suited for intricately detailed work. And, today's boatbuilders, like those centuries ago, turn to Honduras mahogany for structural members, decking, and trim.

Availability

Due to the tree's size, Honduras mahogany boards usually run wide and long. Expect to pay about \$4 per board foot. Veneer offers the widest range of figure, but it will cost you \$1 to \$3 per square foot.



Continued

PERFORMANCE PROFILE

Honduras mahogany

(*Swietenia macrophylla*)

Straight-grained

Ribbon-striped

Machining methods

Paul McClure, *WOOD*® magazine's consultant on wood technology, calls Honduras mahogany "the wood by which all other woods are measured." By that, he means you couldn't ask for a better wood to work. And, all the craftsmen we asked agree with him. So, note our advice, and enjoy this singular stock:

- We don't know exactly why, but Honduras mahogany produces extremely fine dust during some machining operations. And, the dust hangs in the air longer than that of other woods. So, wear a respirator.

- Because of this mahogany's hardness and straight grain, it surfaces with minimal tearout. The wood even proves forgiving if you accidentally feed it into the jointer against the grain. Sharp knives leave nearly glass-smooth results free of mill marks. Feed figured stock into a planer slowly and at a slight angle. Otherwise, the wood grain may chip and tear on you.

- You can rip Honduras mahogany equally well with steel or carbide-tipped blades. However, blades with more than 28 teeth increase the chance of burning.

- Don't take chances on the wood splintering while crosscutting. With a handsaw or power tools, always use a fence or backing board as a chip breaker on the exit side.

- Honduras mahogany cuts beautifully with a jigsaw or scrollsaw.

- Rout this wood with sharp bits (and don't forget the dust mask) for mark-free results. The grain "frizzes" with dull bits.

- You won't have problems joining Honduras mahogany, as all types of glue work well.

- Although the wood easily sands smooth, filling its open grain results in the sleekest surface.

- Choose any type of stain or finish for your Honduras mahogany project because the wood accepts them all equally. For outdoor projects, rely on a spar varnish or exterior polyurethane. It also takes and holds paint exceptionally

well, but you'll need a primer coat and several top coats to completely fill the wood's open grain.

Carving cautions

- Honduras mahogany became *the* wood for classic furniture because it was great to carve with knives and gouges and took detail. That holds true today. Power carvers should, however, adopt a light touch because motorized bits can get overly aggressive.

Turning tips

- To avoid chipping, round down Honduras mahogany with a 3/4" gouge at 800–1,000 rpm.

- Turn off the lathe for final sanding, and sand with the grain.

- Don't apply finish to spinning wood because the open grain of Honduras mahogany momentarily collects the material. Then, as it spins, the finishing material flows from the grain to form what looks like wrinkles. ♣

SHOP-TESTED TECHNIQUES THAT ALWAYS WORK

Any exceptions, and special tips pertaining to this issue's featured wood species, appear under headings elsewhere on this page.

- For stability in use, always work wood with a maximum moisture content of 8 percent.

- Feed straight-grained wood into planer knives at a 90° angle. To avoid tearing, feed wood with figured or twisted grain at a slight angle (about 15°), and take shallow cuts of about 1/32".

- For clean cuts, rip with a rip-

profile blade with 24–32 teeth. Smooth cross-cutting requires at least a 40-tooth blade.

- Avoid drilling with twist drills. They tend to wander and cause breakout. Use a backing board under the workpiece.

- Drill pilot holes for screws.

- Rout with sharp, preferably carbide-tipped, bits and take shallow passes to avoid burning.

- Carving hardwoods generally means shallow gouge bevels—15° to 20°—and shallow cuts.

MAHOGANY AT A GLANCE

Cost	\$ \$ \$ \$ \$
Weight	
Hardness	T T T T T
Stability	▲ ▲ ▲ ▲ ▲
Durability	
Strength	
Toxicity	
Workability	
Look-Alike	African mahogany

Compiled with woodworkers Jim Boelling, Jim Downing, Robert St. Pierre, carver Jim Rose, and turner Gary Zeff. Illustrations: Steve Schindler

PETER WOLF TOTH AND HIS TRAIL OF WHISPERING GIANTS

In celebration of the region's Alabama-Coushatta people, Peter carved a red-oak statue in an Interstate 30 rest area outside Texarkana, Texas. Tribal members in their feathered bonnets and other ceremonial finery gather at the statue's dedication.

Peter Toth completes details on his tribute to the native Hawaiians. Carved in 1988, the Douglas-fir sculpture stands 30' tall and measures 6' in diameter. It's located along King Kamehameha Highway, on the island of Oahu's north shore.

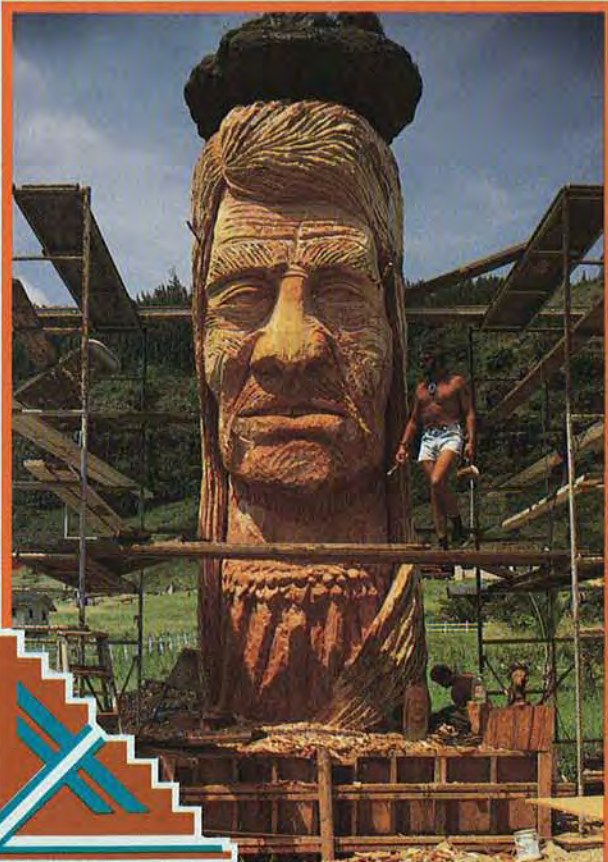

Somewhere, sometime during the last 20 years, you may have spotted the work of Peter Wolf Toth. After all, his massive carvings *are* hard to miss. And once seen, they become etched in your mind.

During the last two decades, the 42-year-old, Hungarian-born sculptor has donated a trail of massive monuments across the continental United States, Alaska, and Hawaii. His tree-sized busts of American Indians number more than 60—at least one in every state. Carved from Douglas fir, oak, cottonwood, Ponderosa pine—whatever happened to be on hand—they represent what Peter calls “The Trail of Whispering Giants.”

A message to America

“All that happened to me early in life led me to making these statues,” explains Peter, in a pause from his work on the upright red-oak carving. In a few weeks it will command public attention in Williamsport, Pennsylvania's Brandon Park, honoring the area's Delaware, Iroquois, Susquehanna, Erie and other Pennsylvania Indian people.

Continued

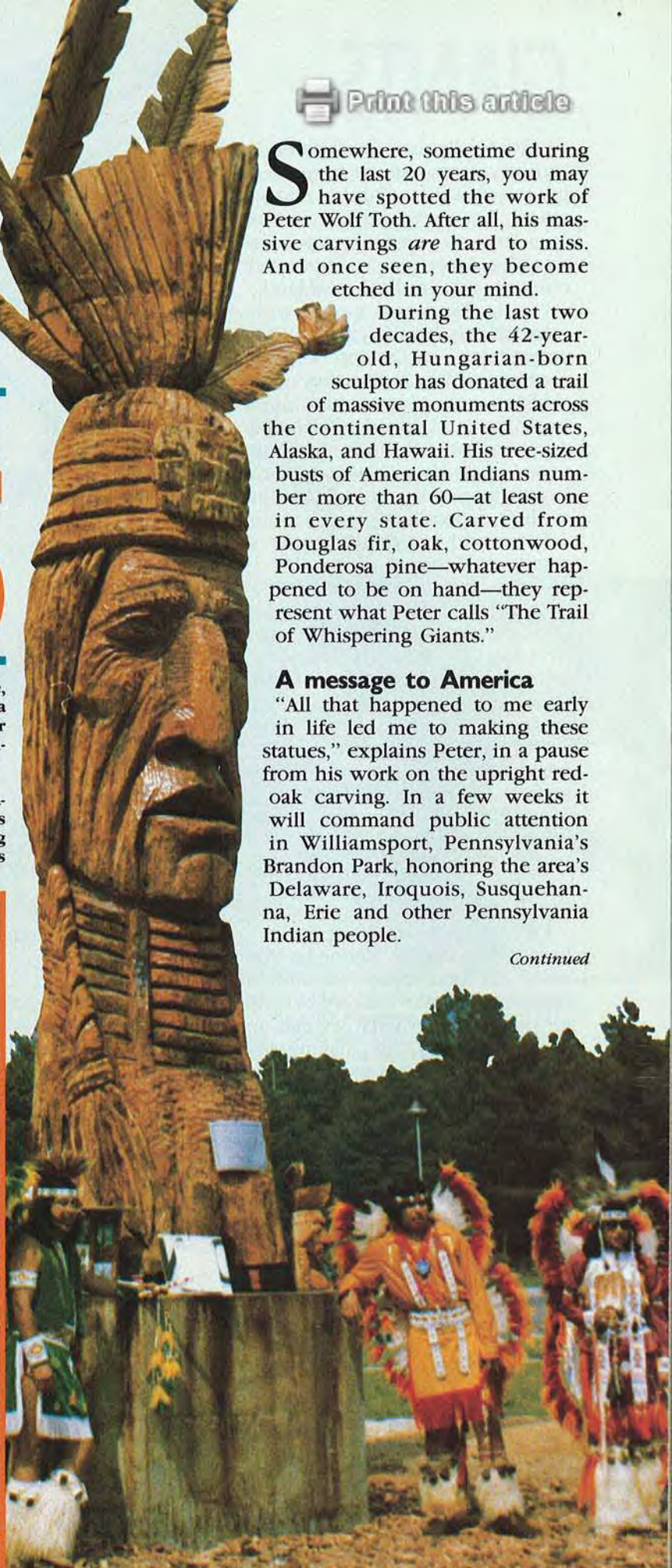

GIANTS

"My family lost their land in Hungary. It was stolen from them by the Russian Communists—twice. We were refugees in our own land, our own country. I feel that the American Indians were refugees, too, in their own land.

"As the Europeans moved westward in this country, the Indians were driven to the interior," he continues. "Eventually, they were shuffled onto reservations, often worthless land, like in Oklahoma. And, you see, this is what happened to us also. That's why I relate to the American Indians, and to their oppression."

Peter and his family escaped war-torn Hungary of the 1950s and fled first to Yugoslavia, then to Austria and Germany before immigrating to the United States in 1958. He was 10 years old when they arrived in Akron, Ohio. And, like any youngster, Peter found heroes in his new land.

"When I was growing up, my heroes were unlike those of other kids," he remembers. "They weren't cowboys, but rather Indians, and specific ones—the Nez Perce's Chief Joseph, Sitting Bull, Chief Crazy Horse, Chief Red Cloud, and others I respected."

One of his more contemporary heroes was John F. Kennedy. "He made the statement 'We should not ask what our country can do for us, but rather what we can do for our country.' By making my statues, I think I am trying to live that—giving a gift of myself to my country in thanks for my freedom. And, with the statues, I bring some attention to the past and present difficulties of the Native American.

"We have such a great, beautiful, and wealthy nation," Peter adds. "Yet, our first people, the ones that are most deserving, are oftentimes living in dire poverty. I have been among them, lived, and taught school. I have seen the poverty. In fact, it was one of my Indian friends who named my series of statues.

He mentioned that they

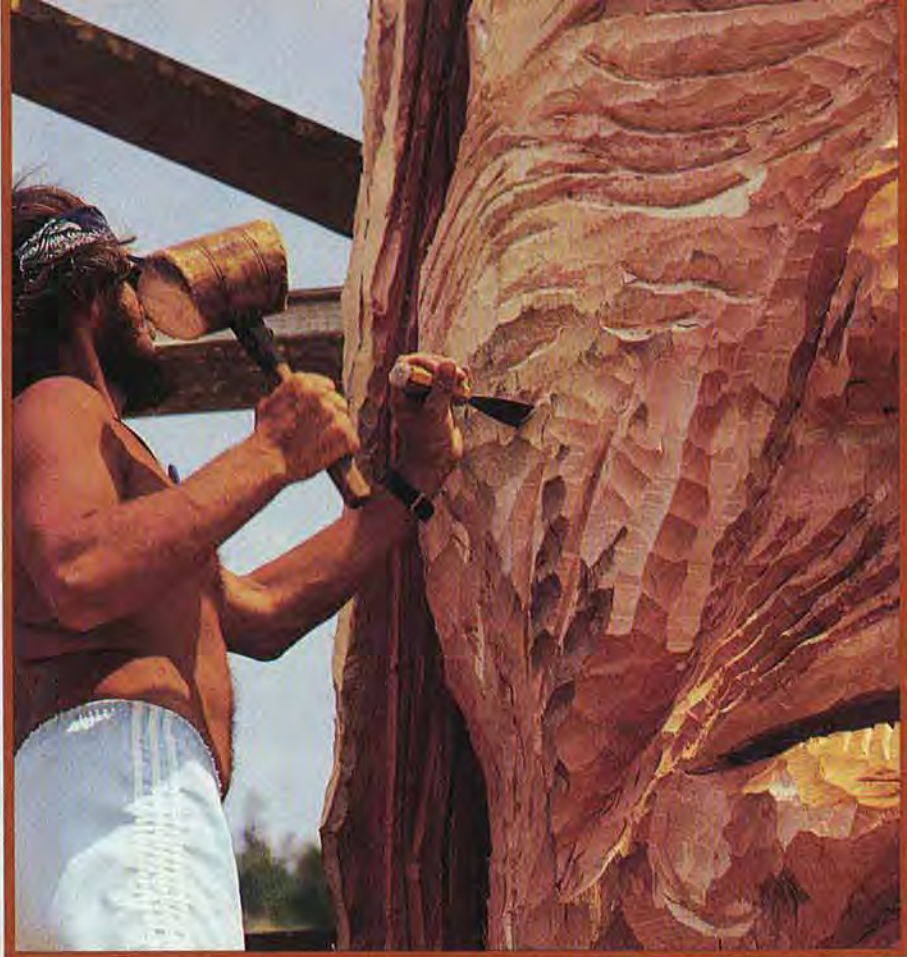

Standing high in the scaffolding, the carver takes off wood with a chisel and mallet. Although Peter owns a chain saw, it's only used for some large undercuts. He does much of the roughing-out with the log on the ground.

Peter's 40th sculpture, *right*, in Valdez, honors Alaska's native American Aleut, Eskimo, Tlingit, Haida, Tsimshian, and other tribes. It's carved from Sitka spruce, the area's most abundant tree.

looked like giants whispering, perhaps about the plight of the Indian people."

Trees along the trail

Peter doesn't claim any formal training in carving or art. His father, however, was a carver, albeit a part-time one.

"I used to watch my father, and most of my ability comes from him, I suppose," he says. "He created a number of carved objects, but he couldn't pursue it as I am able to because he had 11 kids to raise and had to work steady. When I started out, I didn't have any responsibilities except to accomplish a dream. During those five years, I was prepared to live on bread and beans."

Since 1971 Peter has traveled the United States, carving his tributes to the American Indian in tall timber at no charge. But his work

actually began with a face he saw in the rock.

"It was before I was married and I was visiting La Jolla, California," Peter recalls. "I had known for a long time that I wanted to do something for the Indians, but I was unsure of what. Then, on a cliff by the beach, I saw an image of an Indian in the rock. So, I started chiseling away and made the first tribute there. After that, I decided to do more, but in easily accessible areas and with wood.

"The wood I use is not chosen because it is hard or soft, but because it's available," says Peter. "I try to get the best possible wood for the area."

In Hawaii, finding an appropriate tree proved impossible. Koa would have been suitable, but on the island of Oahu it was protected, and the trees were too small in dimension. "I absolutely had to

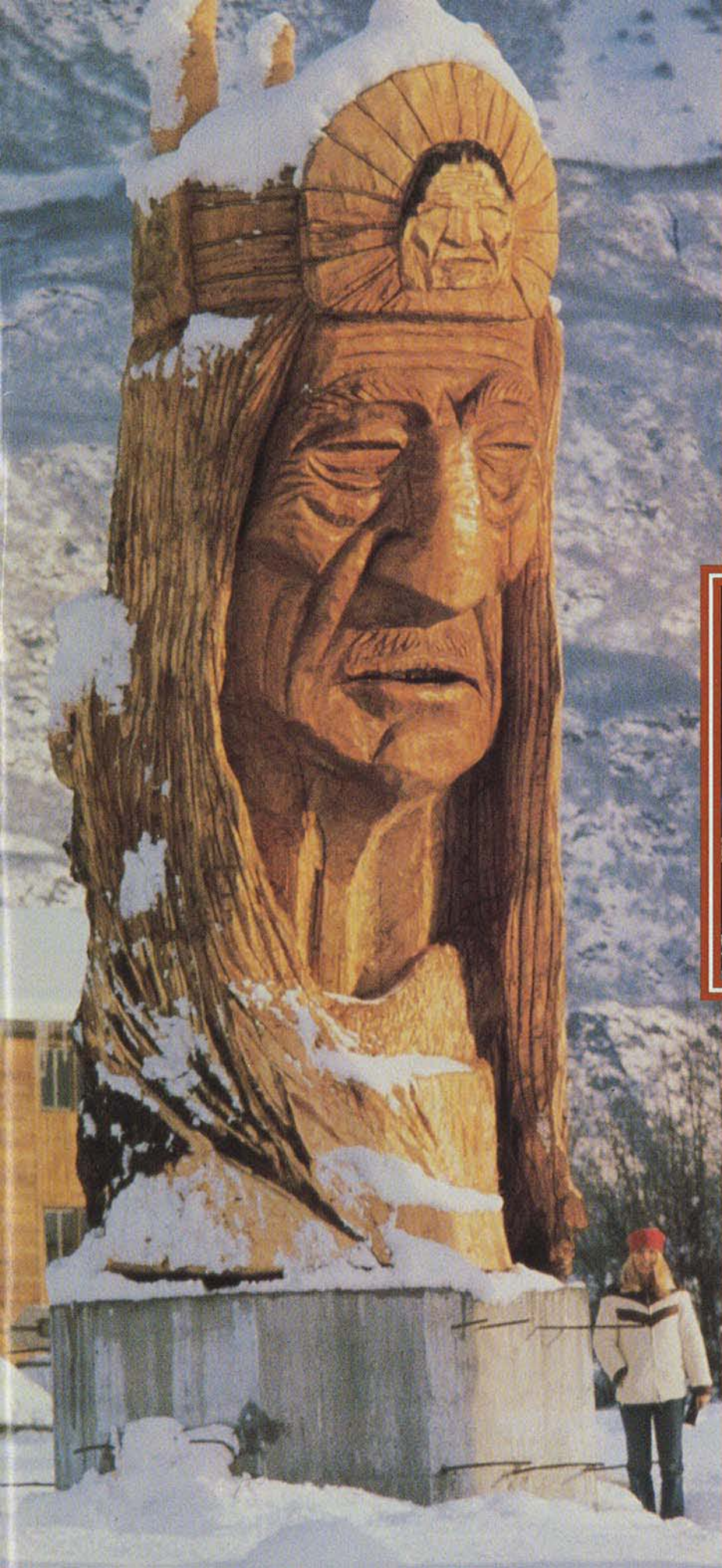

have a tree that was of great diameter," says Peter, "simply because the Hawaiian people have broad faces. They are big people, and to diminish their appearance would be to portray them incorrectly [see photo, *opening page*]."

He solved the problem by importing a large Douglas fir from Oregon. "It was donated, which is often the case, and a friend contributed the shipping. Sometimes, I use my own money for shipping, but fortunately that is not the case in most instances. I am very blessed as far as the communities coming up with the material help that I need."

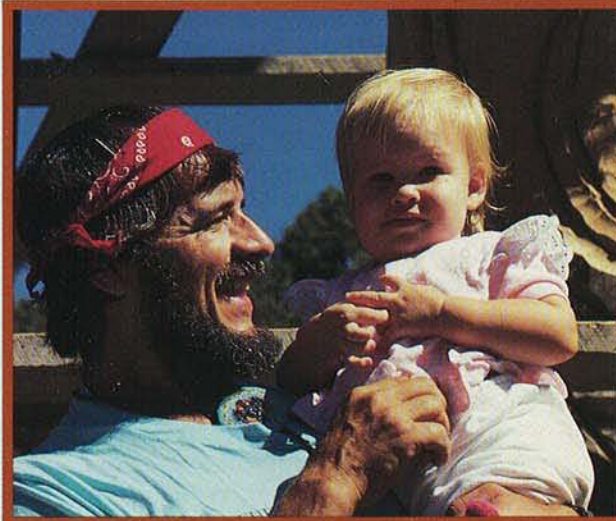

Peter takes a break from his carving to hug his daughter Mendocino, who with his wife, Kathy, accompanies him on the road.

Even after 20 years of carving in many kinds of wood, Peter hasn't developed a fondness for a specific species. His major concern is durability. "I look for the best possible wood, even though it's often the toughest to work. Then, I seal the statue with a preservative, and add sometimes 100 coats of an exterior urethane varnish," he comments. "A wooden statue should last beyond my lifetime if it is protected from termites and ants, standing water, and other things that cause decay. Maybe some year down the road away I can tell you which wood is the

Continued

GIANTS

most durable, but for the time being, it's too early to tell."

Sculpture on a grand scale

Some carvers work from patterns. For Peter, of course, that's impossible. After considerable study of an area's Indian people, his imagination decides the design for his hands to execute.

"Visualization is the most important aspect of carving my statues," Peter says. "I work so close up against them that I have to stand back every so often to see where I'm going."

Because Peter works within the shape of his material, he must alter his carving to the timber. "The log often is very tall and the surface narrow, so there is a certain amount of abstraction required," he says. "Proportion is the first rule of thumb in sculpting—you must divide the anatomy of a human being into balancing parts. But I can't worry too much about that." As a result, viewers frequently equate Peter's statues with totem poles, a comparison he dismisses.

"I honor the American Indian's art, but I don't copy it," he says assuredly. "My statues represent the physical images of the Native Americans as I perceive them to be. And my work is always a composite of the Indian people in a state or region."

At Williamsport, Peter's three-dimensional interpretation began on the 35'-long oak as it lay on the ground. After three months, he supervised the crane and crew who lifted it into place, as shown *opposite page*. Next came the scaffolding that enables him to work the carving round and add detail with his mallet, chisels, and occasionally a small chainsaw.

"Many people think of my work as chainsaw sculpture," he notes, amusement creeping into his voice. "But 90 percent of it is done with hammer and chisel."

A glance into the muscular carver's tool box reveals

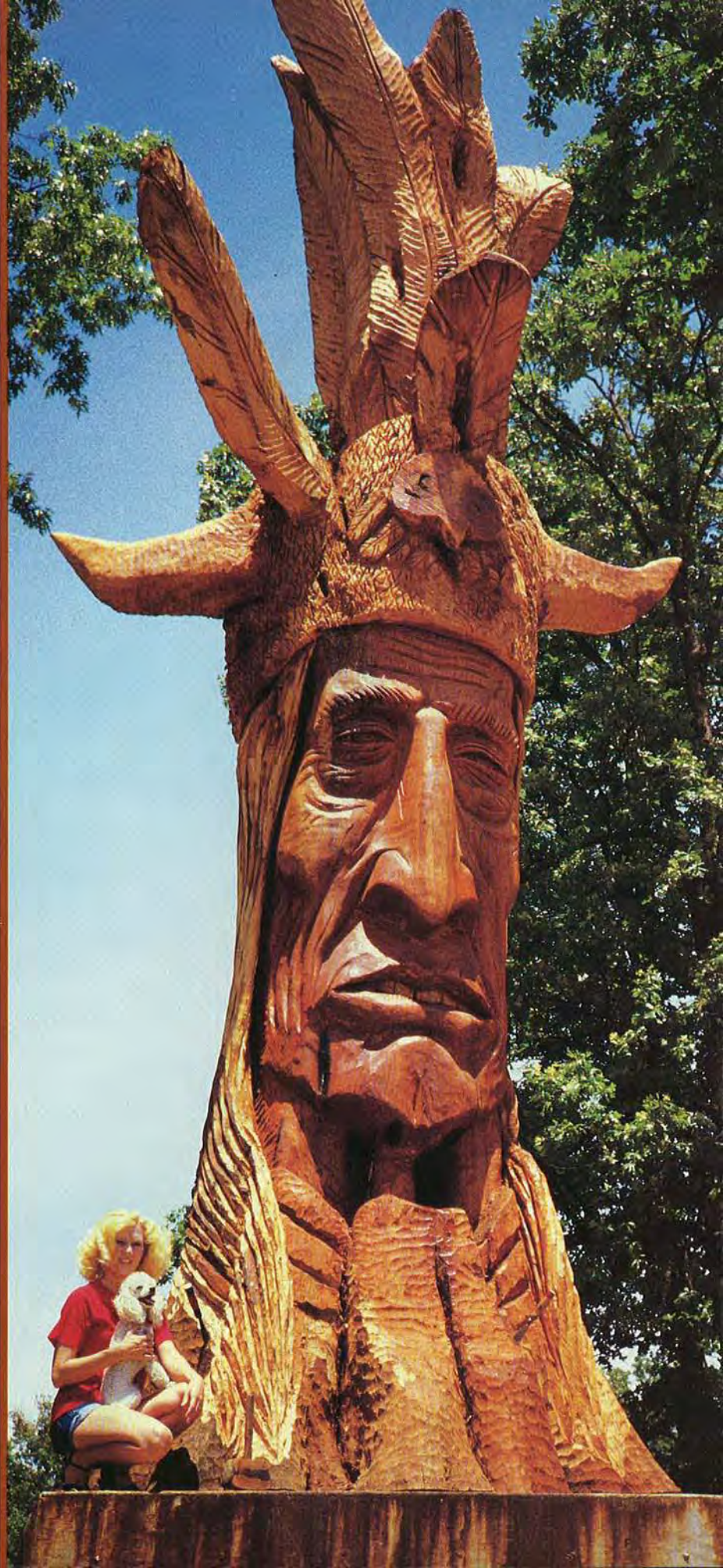

more than 100 chisels, from 1" wide for detail work to 4" for roughing. There's an 8-pound hammer to team up with the largest chisel, a smaller, lighter hammer, and a 2-pound wooden mallet, too. "Of all those chisels," says Peter, "the 4" gets the most use on the wood."

Passing the blanket

All told, Peter, his wife, and young daughter spent nearly five months at the Williamsport site while he worked on his latest whispering giant. Their home on the road was—as it has always been—a 29' trailer pulled by a pickup. Except for a recently purchased Illinois home and the responsibilities of fatherhood, little has changed for Peter in 20 years.

Kathy, Peter's wife, and Caesar pose at the base of a statue carved in Paducah, Kentucky. The headdress represents a compilation of styles worn by the region's Native Americans.

In Williamsport, Pennsylvania's Brandon Park, a crane lifts Peter's latest statue into place. From first cut to dedication, Peter spent nearly five months at the location.

"I charge nothing for my work," he explains. "We get by through the sales of my book [see box, *below*]. I also sell some postcards of the statues, and I sell some of my smaller carved pieces. However, we are not in poverty. We just don't live high on the hog, and we have to watch our money. All in all, we have been

Read about Peter's travels

To see all the carvings and read more about Peter's travels on the Trail of Whispering Giants, order your autographed copy of his 250-page book, *Indian Giver* (\$13.95 ppd.), from: Peter Wolf Toth, Rt. 2, Box 599, Cable, WI 54821.

very fortunate because everything seems to fall into place, so our worries are perhaps less than those of other people."

And Peter has satisfaction, too, in knowing that his Trail of Whispering Giants and their message hasn't gone unnoticed, especially among native Americans. To recognize his efforts, North Carolina's Cherokee tribe made him an honorary member. In acceptance, Peter took the name "Wolf." A Florida Seminole chief equated the importance of his work to that of Michaelangelo. But all recognition pales in comparison to the grass-roots support he receives.

"In 1980, when I was going up to Alaska after finishing my statue in Mandan, North Dakota, I was invited to visit the Standing Rock Reservation of the Sioux, near Bismark," Peter recalls. "That's the tribe of many of my boyhood heroes, such as Sitting Bull.

"Anyway, I attended a powwow there, and after it, the Sioux passed a blanket around and threw money in. That was their way of honoring me. Some people threw in coins, others threw bills, all in my behalf. The money was to help pay my way to do a carving in Valdez. And a lot of the Sioux Indian people were obviously more in need than I, but it would have been dishonorable not to accept their support." ♣

Written by Peter J. Stephano
Photographs: John Troisi; Peter Toth

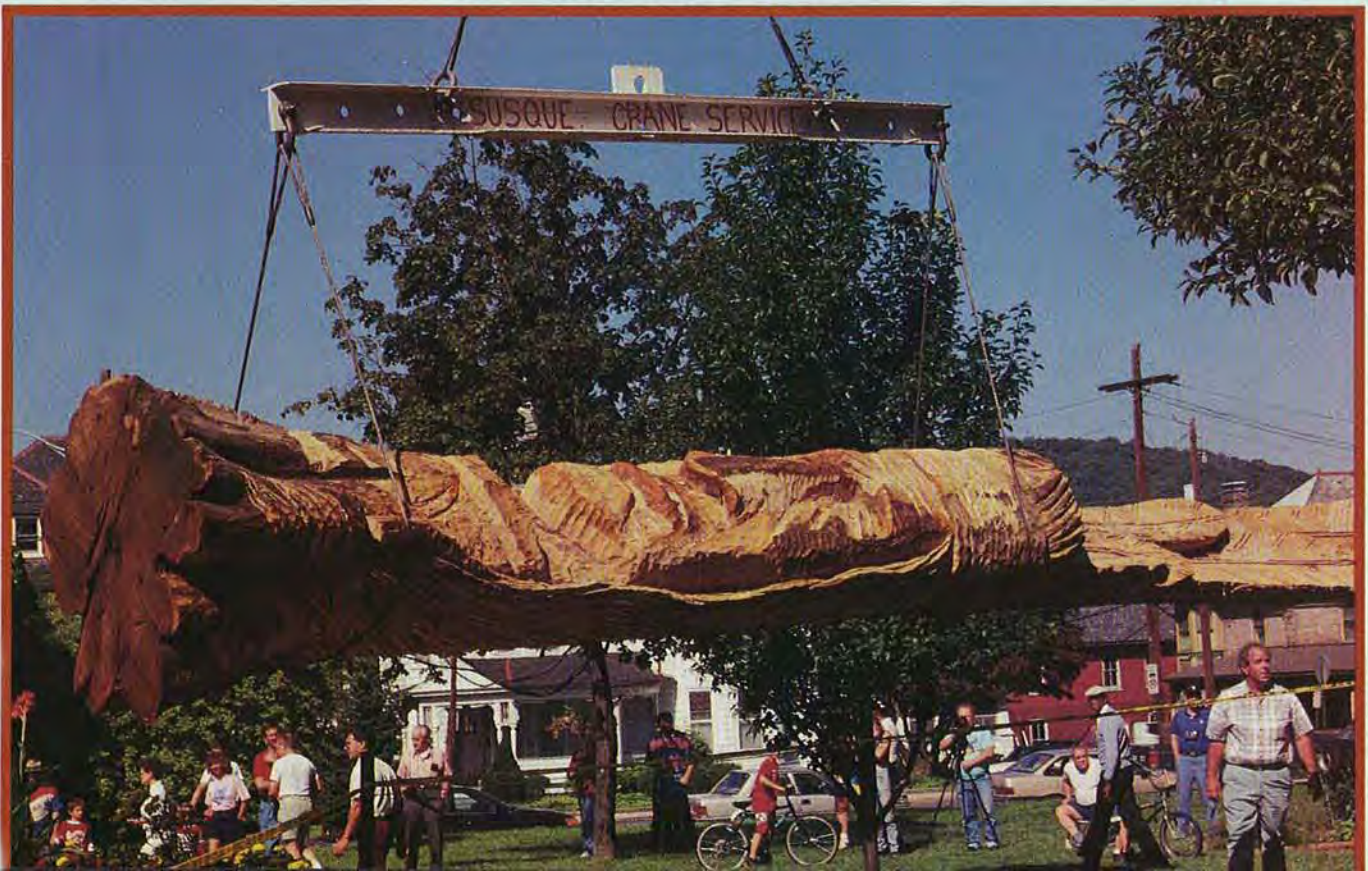

CARVE THIS MOMENTO OF TURN-
OF-THE-CENTURY AMERICA

TABLETOP CIGAR-STORE INDIAN

AN IMAGE WORTH 1,000 WORDS

In the days before public education was guaranteed, many people couldn't read and write. So, to sell their goods and services, merchants and professionals put carved displays and symbolic signs outside their shops and offices to denote what they offered. An optometrist, for example, might hang a large pair of carved eyeglasses; a cobbler a boot; a tavernkeeper a tankard; a dentist a tooth, and so on.

But none of these "shop figures," as collectors call them, has become more recognizable and sought after than the tobacco- or cigar-store Indian. And the account of how the Indian became such a well-known symbol is an interesting tale.

It's said that Sir Walter Raleigh introduced tobacco grown and smoked by the Indians in the Virginia Colony to England in the early 1600s. The popular product became known as "Indian weed" and storekeepers specialized in its sale. However, to cleverly pro-

mote tobacco posed a problem—at least until a pioneer advertising genius thought to associate an Indian figure with the puffable leaf.

As the story goes, few people in England at the time knew what a New-World Indian actually looked like. News from Virginia, though, did tell them that some of the colonists employed black slaves to tend the crops. So, it's said that the first tobacco-store Indian was a black man wearing a feathered headdress and a kilt of tobacco leaves!

It took about 100 years for the carved figure we recognize as a cigar-store Indian to appear in the American colonies. But from 1840 to 1900 (when they began to be replaced by metal signs) the cigar-store Indian was everywhere. It has been estimated that at the turn of the century there were 100,000 of them in use. Fifty years later, the number had dropped to 3,000, and today wooden cigar-store Indians are rare.

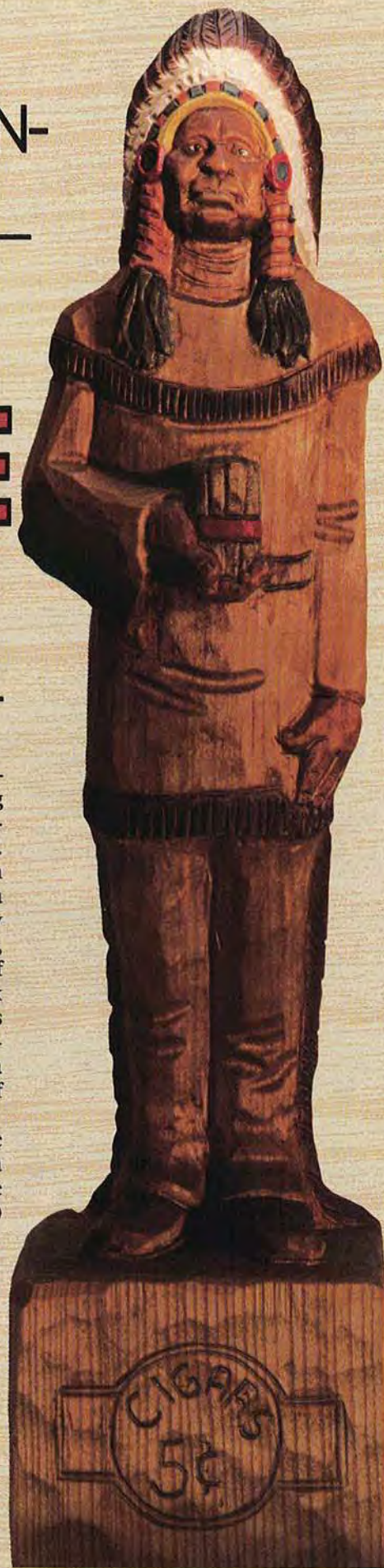

Traditional cigar-store Indian figures were most often life-sized. The one on these pages, however, measures just 19½" tall—a size adaptable to many display possibilities.

Carver Mike Krone of Branson, Missouri, designed this version. In addition to size, he deviated from the traditional by "westernizing" the clothes and headdress to depict clothing worn by the Plains Indians. "This tends to create a more striking carving," notes Mike, who formerly carved nothing

but western figures. He now focuses on carvings of animals and sports figures as an associate of Mountain Woodcarvers, a noted Branson woodcarving shop.

Define your carving

If you have ordered the roughed-out carving, skip down to the next paragraph. If you're starting from scratch, first enlarge the front and side view patterns given on *page 41* to full-size, then trace them on your carving block. Next, bandsaw the block to shape.

Because of the figure's size, it's easy to hold for carving with palm-sized tools by bracing against your thigh. But, the rectangular base also lends itself to clamping in place should you have larger carving tools.

With your knife or a gouge, begin at the base and take off excess wood until you achieve the Indian's rough shape. On a precarved roughout, start surfacing (removing the machining marks) with a knife or gouge. Work on the legs, torso (leave the hands alone for the time being), and arms first, then move to the base.

There, as shown *below*, use your gouge to do the surfacing, and carve deeply enough to shape the feet and give them thickness (about ½" will do).

Now, following the principle that you should work from less-detailed areas to more-detailed areas in order to familiarize yourself with the tools and the wood, work from the feet up to the figure's neck. Carve wood away to define (outline) parts such as the moccasins, the legs, the arms (not hands), braids, and neck with stop cuts from your knife and slices from the gouge.

When you complete defining, go back and carve in details such as fringe and hair with your V-tool. (Novice carvers should save carving the fringe detail around the hand areas until the hands have been shaped.)

Shape the hands from mittens

To carve the left hand with your knife or gouge, don't launch into the fingers right away. Instead, consider the hand's general shape and where the fingers and thumb originate by studying your own hand. You'll notice that the thumb begins down on the side of the hand, as shown in the photo *below*, but not exactly where the fingers do.

Here's an easy way to carve the hand: First draw a mitten on the wood, then carve it. Next, take your pencil and divide the finger

YOU'LL NEED THESE TOOLS AND SUPPLIES

The cigar-store Indian requires a 4¾ × 3¾ × 19½" block of basswood or other carving wood. You can, though, get a quicker start by ordering the 70-percent complete, precarved roughout shown *left*. Send \$19.50 (U.S.) ppd. each, or \$35 for two, to: Indian, Mountain Woodcarvers, Drawer R, Branson, MO 65616. Allow 4 weeks for delivery.

As a minimum, you'll need the carving tools illustrated *below*:



Knife

- bench-type carving knife



Gouges

- ½" No. 3 gouge
- ⅛-¾" 45° V-tool



Finishing materials

- For finishing, you should have:
- 80-120-grit sandpaper
 - Water-soluble, acrylic artist's paints in white, red, blue, orange, brown, and yellow
 - No. 7 or No. 8 brush
 - No. 000 brush
 - Boiled linseed oil
 - Burnt-umber artist's oil color (or walnut oil stain)



Begin surfacing your figure at the base with a No. 3 gouge. Outline the moccasin feet, then define them.



To carve a hand, first draw and shape a mitten, then divide the mitten into fingers with cuts of your V-tool.

Continued

CIGAR-STORE INDIAN

portion of the mitten into separate fingers, noting the different length of each. With your V-tool, carve the fingers, as shown in the photo on *page 39, bottom right*.

Now, start on the right hand, remembering that it, too, should begin as a mitten, but one that surrounds and supports the cigars, as shown *below*. After you have carved the fingers, use your V-tool to make the cigars appear bundled by a ribbon. A simple cross-hatch pattern outlines the top of the cigar bundle.



The right hand holds and supports the cigars. Define individual cigars and the band around them with a V-tool.

The challenge of the head and headdress

Carving the face will be the most critical aspect of your cigar-store Indian. To get a realistic one, you must adhere to the facial characteristics of the American Indian, as shown in the closeup photo of the painted figure, *right*. The nose, for example, should be large and slightly hooked. Carve the cheekbones set wide apart. And make the lips full and rounded, but not overly prominent.

To start the face, pencil it on the wood, as in the photo, *above center*. First, draw a broad oval divided by a vertical center line (this helps you keep the face symmetrical). Next, draw the eyes, noting that they should be widely spaced (about one eye-width apart) and about two-thirds of the way up the face.

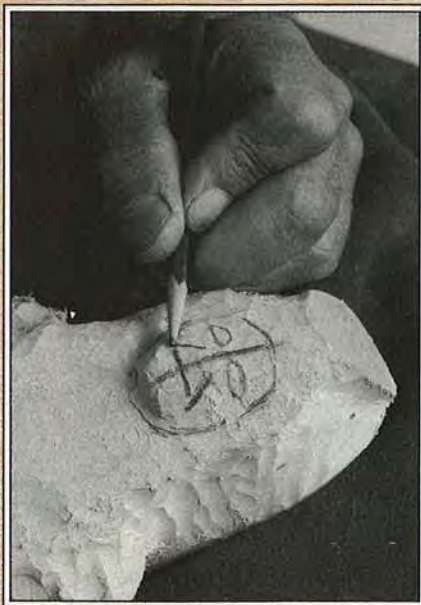

Draw a large oval on the wood for the face, then divide it with a vertical line to help you keep features in balance. Redraw the lines as necessary.

Draw the smile lines of the mouth with two lines forming the legs of the letter A. Begin the lines at the nostrils and run them downward and outward to nearly intersect with the horizontal line of the mouth that falls between the tip of the chin and the tip of the nose. Remember that on the average human face, the width of the mouth equals the distance between the pupils of the eyes.

Now, use your knife and gouges to shape facial features, as in the photo, *below*. As you carve, lightly redraw the vanishing pencil lines.

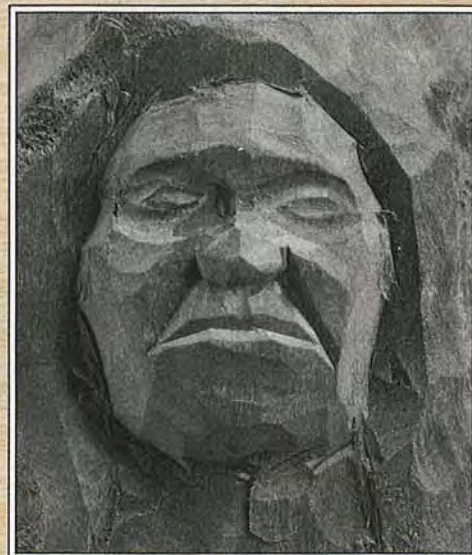

Study the facial features closely. Note that the smile lines come down from the nose like the legs of the letter A.



Refer to the closeup photo of the painted head and the rear view to carve and detail the headdress. Note that the feathers taper out from the head to a thickness of about $\frac{3}{16}$ ". Define the feather outlines, and the quill and barb of each feather, with your V-tool. (See how the feathers appear in the photo of the finished face.)

Complete your carving at the base

Return now to the base of the figure and touch up any rough surfaces you might have missed. Then, draw to size on a piece of paper the logo shown on the base in the opening photograph. With carbon paper, transfer your logo to the front of the base. Carve it with your V-tool (woodburning the design on the base also would be a nice touch).

To complete the carving, use your gouge or knife to add a few wrinkles to the figure's clothing. Generally, wrinkles appear inside the elbows, on the lower front of the shirt, and at the knees, as you can see in the front view of the completed figure.

Now, add the color

For the Indian's buckskin breeches and shirt, thin the paint so that it acts as a stain and lets the grain show through. Use a similar thinned-down mixture on the face, also. For accent, the fringe should be colored with full-strength paint (or use a woodburner to darken it before painting). The headdress, braid trappings, and cigar wrapping all require solid, unthinned paint.

To give your cigar-store Indian an antique look, add a small amount of burnt umber artist's oil color (or walnut oil stain) to boiled linseed oil, then coat the figure. Be sure to first test your antiquing mixture on a piece of scrap wood. ♣

Written by Peter J. Stephano with Mike Krone
and Harley J. Refsal
Photographs: Hopkins Associates;
John Hetherington

CIGAR STORE INDIAN EACH SQUARE = $\frac{1}{2}$ "

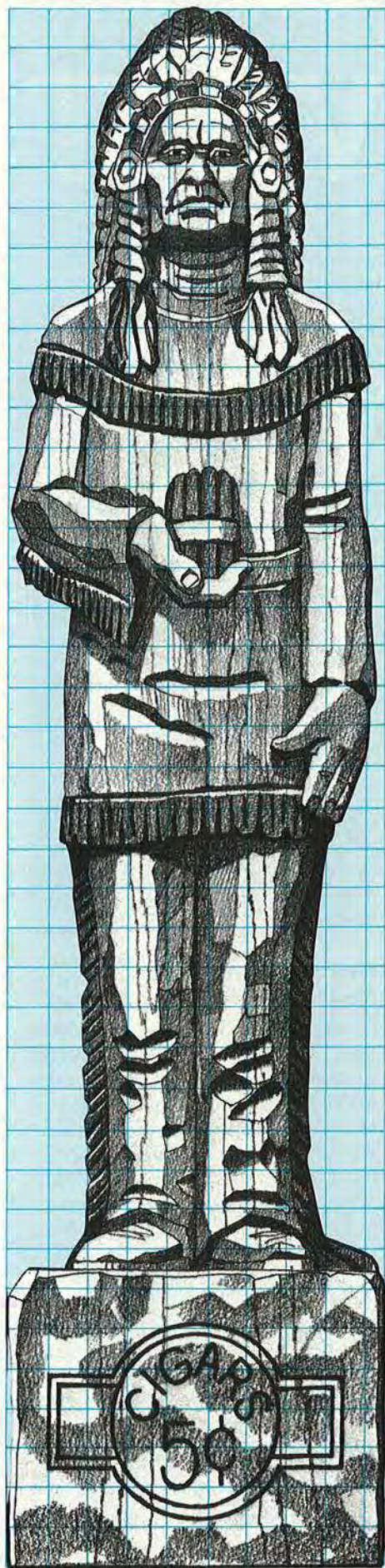
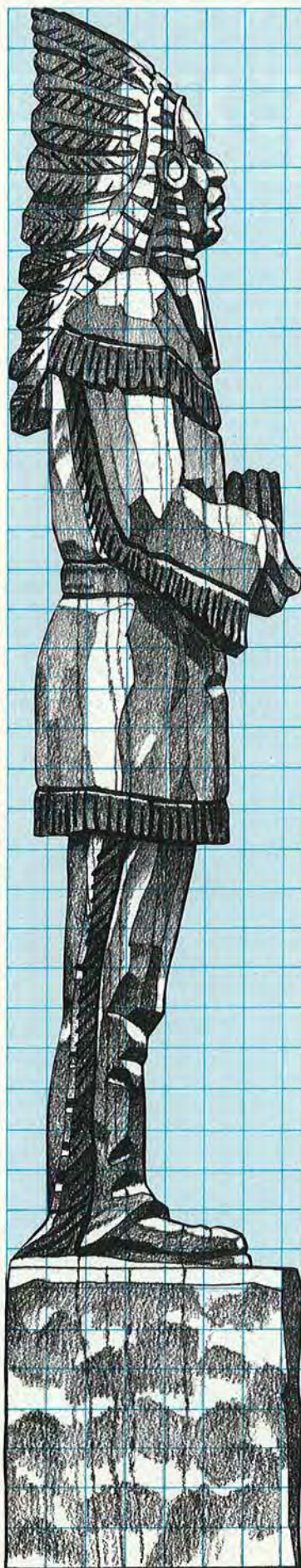

The wave of the future **WATER-BASED**

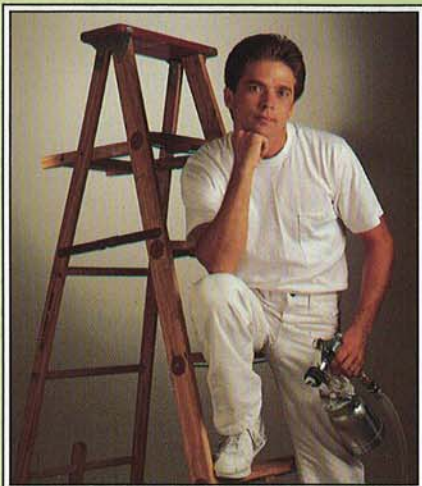
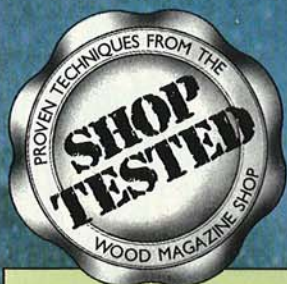

Hey woodworkers, Meet our “finishing fanatic”

Because nobody knows finishing like someone who does it eight hours a day, we asked Wade Sundeen, a professional painter, to try today's water-based finishes and report back to us. Wade's task: tell us if the coatings work, and the best methods of applying them.

A self-described “finishing fanatic,” Wade dug into his assignment with vigor, and came away from his tests impressed. “Once I got used to working with water-based finishes, I achieved great results. And, I know my wife and kids will appreciate not having to breathe lacquer fumes.”

They're fast and environmentally

FINISHES



You say you don't know the first thing about water-based finishes? Well, you're not alone. Until recently, very few people other than professional floor finishers were aware of the easy water cleanup, low odor, clarity, and fast-drying nature of these finishes. That, coupled with two notable drawbacks—grain-rais-

ing and high cost—kept them out of the hands of most home woodworkers. But today, with improvements in the performance and availability of these finishes, and governmental pressure for environmentally friendly coatings, water-based finishes have officially “arrived” for home woodworkers.

In light of these happenings, we decided the time was right for us to take a close look at today's water-based finishes. So, we rounded up most of the major brands and tried them out. Now we're ready to tell you what to expect with these products, and how to make them work for you.

HOW WATER-BASED FINISHES WORK

What makes water-based finishes so different from the solvent-based products you're used to? Two things actually. The first has to do with the makeup of the finishes. Solvent-based finishes contain anywhere from 50 to 80 percent solvents (often referred to as petroleum distillates or mineral spirits) and 20 to 50 percent solids. Solids are the ingredients left on the wood after the solvents evaporate. Water-based finishes, on the other hand, contain more than 60 percent water, about 30 to 40 percent solids, and only 3 to 10 percent solvents. So, when a water-based finish dries, mostly water—and only a small amount of environment-damaging solvents—goes into the air.

The other thing you need to know about water-based finishes is that they dry transparent. The reason: These products don't contain linseed, tung, or other oils that typically give solvent-based coatings an amber coloring as shown *above*. If you want to achieve this warm, yellow look with water-based finishes, you need to stain the surface with light-amber stains.



We finished a red-oak board with a water-based coating (*left*) and an oil-based polyurethane (*right*). Note that the water-based finish left a transparent film on the board surface.

As we found out at an early stage in our research, manufacturers label many water-based products as either *polyurethanes* or *lacquers*, even though the finishes bear little resemblance to solvent-based polyurethanes or nitrocellulose lacquers. Some companies, such as Flecko and Basic Coatings, simply refer to water-based products as *coatings* or *finishes*.

Amity sells both “lacquer” and “polyurethane” water-based finishes. Randy Reek of Amity explains their labeling this way: “We use the terms lacquer and polyurethane so customers can relate to the products they are replacing. Like solvent-based polyurethanes, our water-based

polyurethanes contain urethane, provide a tough finish, and cost a little more than our lacquers.” A gallon of Amity's lacquer retails for \$25, while an equal volume of polyurethane costs \$35. A quart of lacquer sells for \$10.95.

What's behind the move to water-based finishes

Ever since major California air districts limited volatile organic compounds (VOC) in finishing products during the 1960s, manufacturers have researched low VOC coatings.

Today, 35 states have strict requirements for VOC control.

Continued



friendly. Give 'em a try!

WATER-BASED FINISHES

Manufacturers can meet these requirements in one of two ways: Either reduce the level of solvents in their solvent-based finishes, or switch to water-based finishes. Today, manufacturers follow both routes, but most of the company representatives we spoke to felt that only water-based finishes hold the key to meeting ever-tightening VOC regulations.

Our assessment: How the finishes performed

After trying all of the water-based finishes on a variety of projects, we've decided to use these products in the *WOOD*® magazine shop whenever practical. But, we're not ready to entirely drop solvent-based finishes from our shop, yet. Why? On many projects, especially intricate ones, we'll still use lacquers and polyurethanes to completely seal the

wood grain before applying a water-based finish.

To make a personal decision, you need to weigh the advantages and disadvantages against your own needs. To help you out, we've come up with the report card at *right*. If you decide to make the switch to water-based finishes, give yourself a little time to get used to these products, and put in some practice on scrapwood before tackling an actual project. And, don't forget to take the same safety precautions with these products that you would with solvent-based finishes. Once dry, these finishes burn every bit as well as the residues of solvent-based products.

R·E·P·O·R·T C·A·R·D		
WATER-BASED FINISHES		
Subject	Grade	Comments
Clarity	A	Absolutely clear. Great if you want a transparent finish. Not so great if you want a warm glow in the wood.
Cleanup	A+	Enough said.
Cost	E	Expensive—costs nearly twice as much as oil-based finishes.
Drying Speed	A	Fast. Sometimes too fast.
Grain Raising	D	Lots of room for improvement here.
Hardness	A	Finish can be rubbed out and polished after drying for one day.
Odor	A	Little odor.
Bubbling	C	Harder to control than most solvent-based finishes.
Signature		<i>Bill Krier</i>

10 STEPS TO A SUCCESSFUL WATER-BASED FINISH

Before starting our tests, we gathered samples from nine manufacturers including the suppliers of the five products shown *below*.



We also tested finishes from Basic Coatings (Professional Image finishes), Hydrocote, Minuteman Furniture Restoration Systems, and Wood-Kote. All of the coatings performed acceptably. Amity and Hydrocote have the widest ranges of products, including stains, fillers, sanding sealers, and rubbing compounds. At this point, only Hydrocote produces

exterior- and marine-grade water-based finishes.

After two months of testing, we've developed a series of application steps to guide you. We worked mostly with red oak because its open grain structure poses more challenges to the water-based finisher than tighter-grained woods such as walnut or cherry. Here's how to go about it:

1 **Get the right product.** Some finishes are formulated exclu-

sively for spraying, so look for a product intended for brushing if you don't have a spray gun. The brushable coatings have flow-out and debubbling agents not found in the spray-only finishes. For a list of manufacturers and their phone numbers, see page 47. Remember to carefully read the application instructions.

2 **Stir the finish.** This disperses the leveling, debubbling, and flow agents that help the finish



Apply a thin film of water with a sponge or rag to raise the grain.

perform as well as possible. Don't shake the container—you'll just create more bubbles.

3 Wet the wood surface. To help you deal with the tendency of water-based finishes to raise wood grain, wet the wood with plain water as shown *below left* before you put together the project. This way, you can sand the pieces as described in the next step without manipulating the sandpaper into tight spots created by assembly. A sponge or rag works well, but remember to apply just enough water to raise the grain without soaking the surface.

4 Sand the raised grain. With a finish sander or hand block, smooth the surface with a succession of 150- and 220-grit sandpapers as shown at *right*. Thoroughly clean all sanding dust from the surface with an air hose or vacuum. Don't use a tack cloth—it may contain waxes or oils not compatible with water-based finishes.

5 If desired, stain the surface. Even after following the above steps, a water-based stain or finish will still raise the grain, especially on open-grained woods. This increases your odds of sanding off the stain when smoothing successive finish coats. So, if your test pieces reveal a problem here, we suggest you stick to oil-based stains. Several manufacturers, including Deft and Flecto, produce oil-based stains that clean up with water and release negligible odor. These stains will seal the surface partially, reducing or eliminating raised grain on successive coats of clear finish. Gelled stains, such as those sold by Wood-Kote, do an even better job of sealing the wood. However, these products do not clean up with water. And, if you choose an oil-based stain, make certain the stain has dried completely before applying a water-based finish.

Continued



Sand the surface smooth with 150- and 220-grit sandpapers.

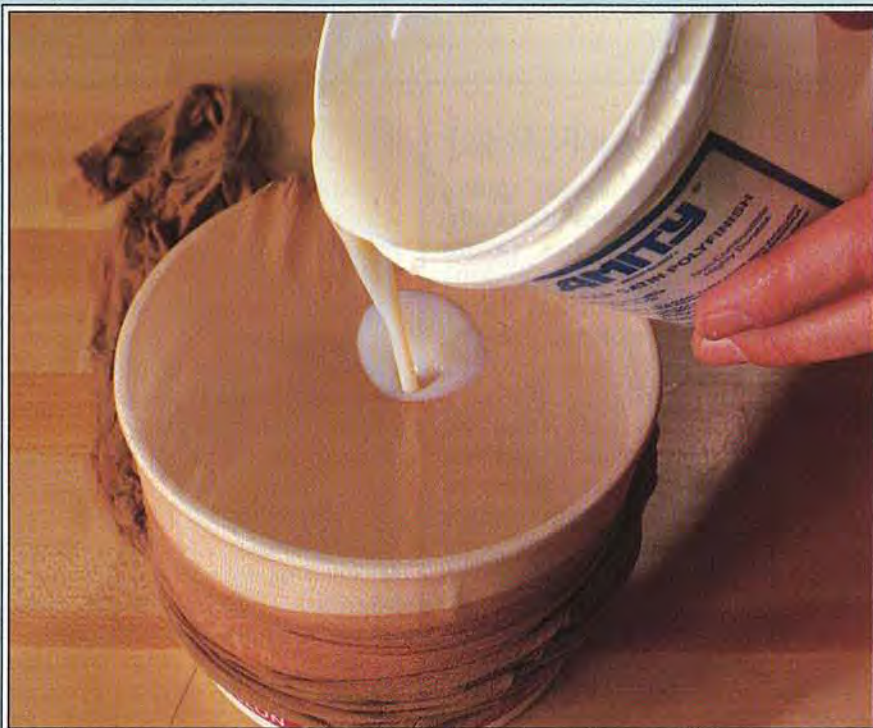

An old nylon stocking helps you strain coagulated chunks and other debris from the finish. You can also purchase cone-shaped strainers just for this purpose.

WATER-BASED FINISHES

③ **Strain the finish.** In our tests, chunks of coagulated coating occasionally accumulated inside the containers of the water-based finishes. These chunks were the No. 1 culprit in surface blemishes. To eliminate this problem, pour the finish into a clean second container through a cone-type strainer or nylon stocking as shown on page 45.

⑦ **If possible, use a sanding sealer.** Amity, Hydrocote, and Minuteman sell water-based sanding sealers, and we highly recommend these for your first coat or two. These sealers build more quickly than the finishes, and also sand much more easily.

⑧ **Brush on the finish.** To keep bubbles to a minimum, use a high-quality, clean, nylon/polyester brush. Dip it no more than 1" or so into the strained liquid to prevent overloading the brush. After completing your work, you can pour any remaining strained finish back

into the container supplied by the manufacturer.

Since heavy coats raise the grain of bare wood more than thin coats, apply a thin first coat. This coat will seal the grain and allow you to apply heavier successive coats. Minimize your brush strokes over already-wetted areas.



On contoured surfaces, smooth the finish with 3M Scotchbrite pads instead of steel wool.

⑨ **Allow the coats to dry thoroughly.** Although the finish may feel dry after only 15 minutes, allow each coat to dry at least one hour before applying the next. Otherwise, you may seal moisture beneath your top coats, leaving the finish with a milky appearance. You can reduce drying times with a fan or hair dryer set on low heat to speed evaporation. Be careful. Overheating may cause blisters.

⑩ **Sand between successive coats.** After sanding your first coat with 220-grit sandpaper, brush on following coats as described in Step 7. Because of the high solid content of water-based finishes, even thin coats build fast and provide a tough protective layer.

For irregular surfaces, such as the table leg shown at left, smooth between coats with a fine 3M Scotchbrite pad. Steel wool does not work because any bits of the steel left on the wood surface will rust. Steel screws will rust, too.

POINTS TO KEEP IN MIND FOR SPRAYING

If you can afford it, a spray system produces the best possible results with water-based finishes. In our trials, the coatings worked equally well with conventional spray guns and the new high volume, low pressure (HVLP) systems designed to minimize overspray.

With a conventional system, we had our best results at 20 PSI and a 6–8" spray pattern. Keep in mind that you must thoroughly clean water-based finishes from all parts of your gun to prevent rusting and finish buildup. We noticed that the coatings formed a skin over the nozzle if the gun was left to sit for just a few minutes. So, do as much spraying as

possible in one session, then immediately clean the gun thoroughly with water.

Conventional spray systems waste more than half of your finish by dispersing it into the air (mostly in the form of overspray), so manufacturers have developed HVLP machines that place 70–80 percent of the finish on the workpiece. The result: less pollution and nearly twice the finish-transfer efficiency. We tried the two HVLP systems shown at right and liked what we saw. If you already own a compressor, you can make the switch to HVLP for about \$350 by replacing your conventional gun with a unit such as the

HVLP 5000 from HVLP Technologies (see the phone number on the opposite page). This unit consumes 6–13 cfm, requiring at least a 2 hp compressor with a 20-gallon tank for most woodworking tasks. Or, you can purchase a stand-alone turbine sprayer such as the Amity model 1000 for about \$725. (More expensive models are also available for extensive-use applications.) The turbine feeds a stream of warm air to the gun at 5 psi. In our tests, the HVLP 5000 produced a better finish than the Amity 1000, but the Amity unit created less overspray.

The Amity 1000 turbine unit (foreground), and HVLP 5000 (in hand). ▶

HOW TO COVER A LARGE SURFACE



After rolling on the finish, smooth it by lightly dragging a brush across the surface.

To quickly and effectively finish tabletops, doors, or other large surfaces, professionals often employ this trick. First, roll a thin, uniform layer of finish onto the surface with a $\frac{1}{4}$ "-nap roller. Then, lightly drag a high-quality brush across the wet finish as shown at *left* to even out the coating and eliminate bubbles.

On surfaces of more than two square feet or so, we also had good luck with short-hair painting pads. These handy applicators quickly put a thin, even layer of finish over a 6–8"-wide surface. Try to simply lay the finish down and not re-pad it.

Water-based products dry quickly, so you won't have time to rebrush the finish. Keeping that in mind, carefully plan how you'll finish the project before getting started. ♣



MANUFACTURERS' LISTING

Amity: 800-334-4259 or 608/837-8484

Basic Coatings (Professional Image finishes): 800-247-5471 or 515/288-0231

Behlen: 518/843-1380

Deft: 800-544-3338 or 714/474-0400

Flecto (Varathane finishes): 800-635-3286 or 415/655-2470

HVLP Technologies: 805/525-5940

Hydrocote: 800-229-4937 or 201/257-4344

Minuteman Furniture Restoration Systems: 800-733-1776

Parks (Carver/Tripp finishes): 800-225-8543 or 508/679-5938

Star Bronze (Zip-Guard finishes): 800-321-9870 (product questions) 800-533-9332 (locations of dealers) or 216/823-1550

Wood-Kote: 800-843-7666 or 503/285-8371

SPICED-UP SPICE



Bill Krier, WOOD magazine's products/techniques editor, and his wife Carrie enjoy hunting for bargain antiques. But when they were unable to find a spice cabinet in good condition for less than \$200, Bill took the initiative and designed his own—the one you see here.



Note: Whole spices such as peppercorn, cloves, allspice, and nutmeg can be stored directly in the drawers. For storing ground spices, keep them tightly sealed in their purchased container or in a plastic bag. Spices lose their freshness, aroma, and flavor over time.

First, build the case

Note: You'll need some thin stock for this project. Plane or resaw thicker stock to size.

1 Cut a $\frac{3}{8}$ "-thick piece of oak to $8\frac{1}{2} \times 12\frac{1}{8}$ " for the case sides (A). Cut the divider (B), and the top

and bottom (C) to the sizes listed in the Bill of Materials.

2 Mark the locations, and cut $\frac{1}{4}$ " dadoes $\frac{1}{8}$ " deep in the case-sides where shown in the drawing on the opposite page, bottom, and where dimensioned on the Exploded View drawing. Cut the same size dadoes in the divider.

3 Rip two 4"-wide pieces from the $8\frac{1}{2}$ "-wide dadoed board to form the 4"-wide side pieces (A).

4 Cut the facing strips (D) to size plus 1" in length.

5 Now, cut $\frac{3}{8}$ " dadoes $\frac{3}{16}$ " deep in the top and bottom pieces where shown on the drawing.

6 With the top and bottom sur-

faces flush and about $\frac{1}{2}$ " of overhang on each end, glue a facing strip (D) onto the front of the dadoed top and bottom pieces. After the glue dries, scrape off the excess and trim the ends of each strip flush with the ends of the top and bottom pieces. Be careful not to shorten the ends of the top and bottom pieces when trimming the ends of the facing strips.

7 Fit your table-mounted router with a $\frac{3}{8}$ " round-over bit. Position the fence where shown on the Round-over detail. The fence prevents the bit pilot bearing from dipping into the previously cut

Continued

CABINET

Our rendition of an Early-American kitchen favorite

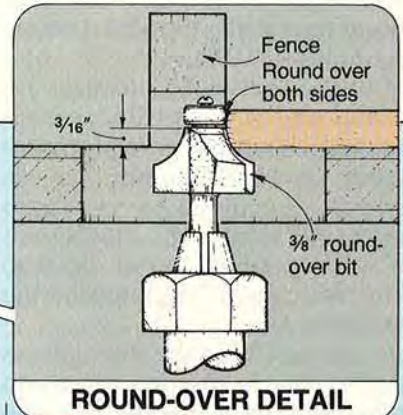
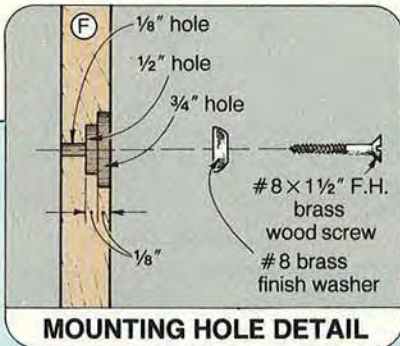

MOUNTING HOLE DETAIL

ROUND-OVER DETAIL

EXPLODED VIEW

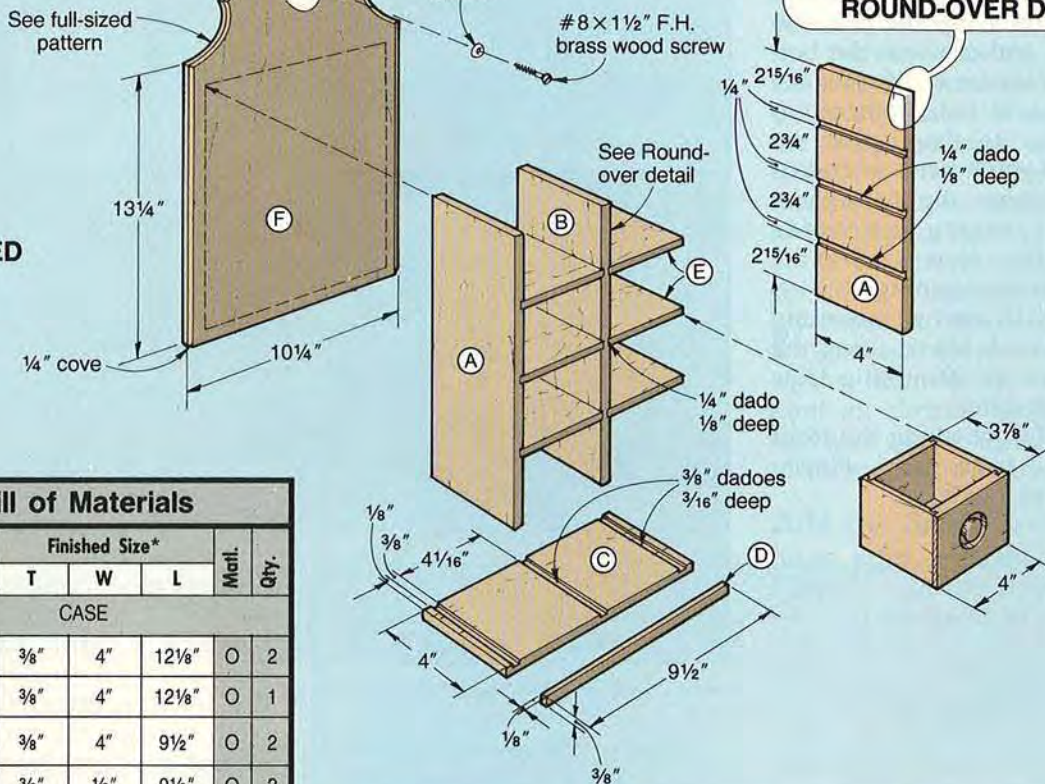

Bill of Materials

Part	Finished Size*			Matl.	Qty.
	T	W	L		
CASE					
A* sides	3/8"	4"	12 1/8"	O	2
B divider	3/8"	4"	12 1/8"	O	1
C top and bottom	3/8"	4"	9 1/2"	O	2
D* strips	3/8"	1/8"	9 1/2"	O	2
E shelves	1/4"	4"	4 5/16"	O	6
F* back	1/2"	10 1/4"	16 7/8"	EO	1
DRAWERS					
G* fronts	1/2"	2 1/16"	4"	O	8
H* sides	1/4"	2 1/16"	3 3/4"	O	16
I* backs	1/4"	2 1/16"	3 3/4"	O	8
J bottoms	1/8"	3 3/8"	3 3/4"	P	8

*Initially cut parts marked with an * oversized. Then, trim each to finished size according to the how-to instructions.

Material Key: O—oak, EO—edge-joined oak, P—plywood

Supplies: #8 x 1 1/2" flathead brass wood screw, #8 brass finish washer, finish.

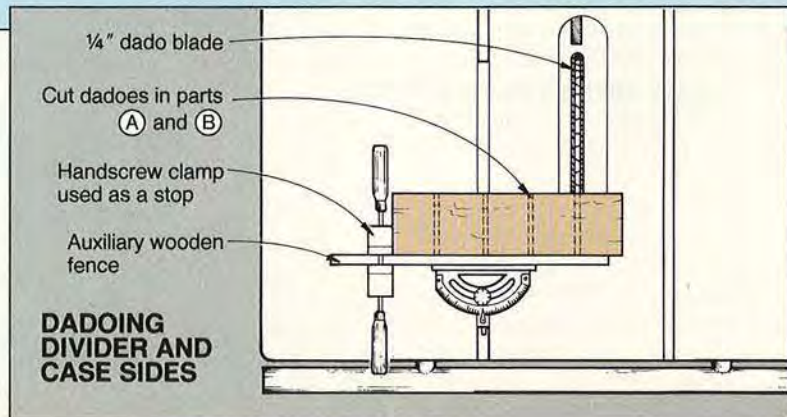

SPICE CABINET

dadoes. Rout the front edge of parts A and B, and the front edge and sides of the top and bottom assemblies (C, D).

8 Cut the shelves (E) to size.

9 Sand all the parts. Glue, assemble, and clamp the case pieces together. Check for square.

Now, let's add the back

1 Cut three pieces of $\frac{1}{2}$ " stock to $3\frac{7}{16}$ " wide by $17\frac{1}{4}$ " long for the case back (F).

2 Glue and clamp the three pieces edge to edge, with the surface and ends flush. Later, rip the panel to $10\frac{1}{4}$ " wide, and crosscut the bottom edge to square it. Transfer the half-pattern and hole centerpoint shown *below* to the top of the back panel (you'll need to do this twice). Bandsaw the back-panel top to shape, cutting just outside the marked line. Now, sand to the line to finish the shaping.

3 Drill the decorative mounting hole in the back blank, using the hole sizes on the Mounting Hole detail for reference.

4 Rout a $\frac{1}{4}$ " cove along the front edges of the back panel. Finish-sand the back piece.

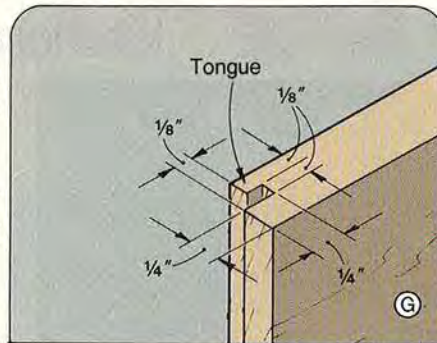

JOINT DETAIL

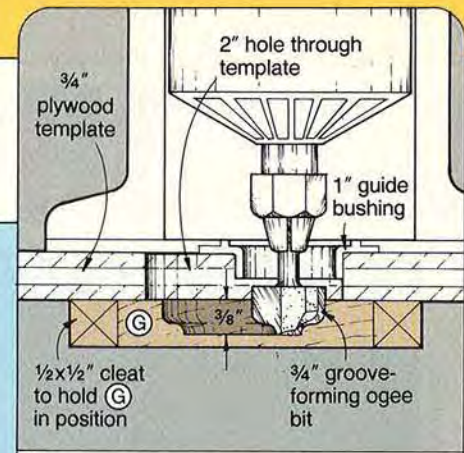

RECESS DETAIL

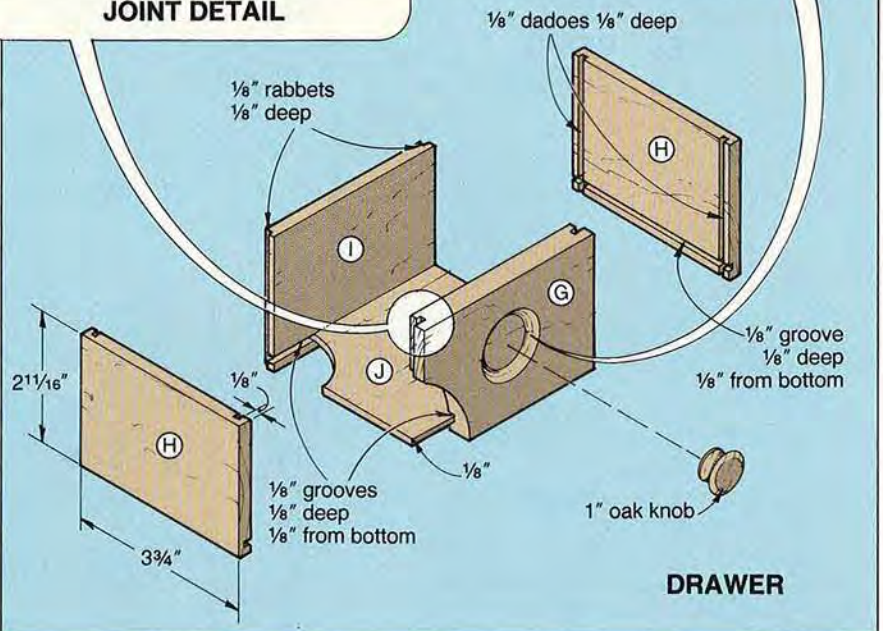

DRAWER

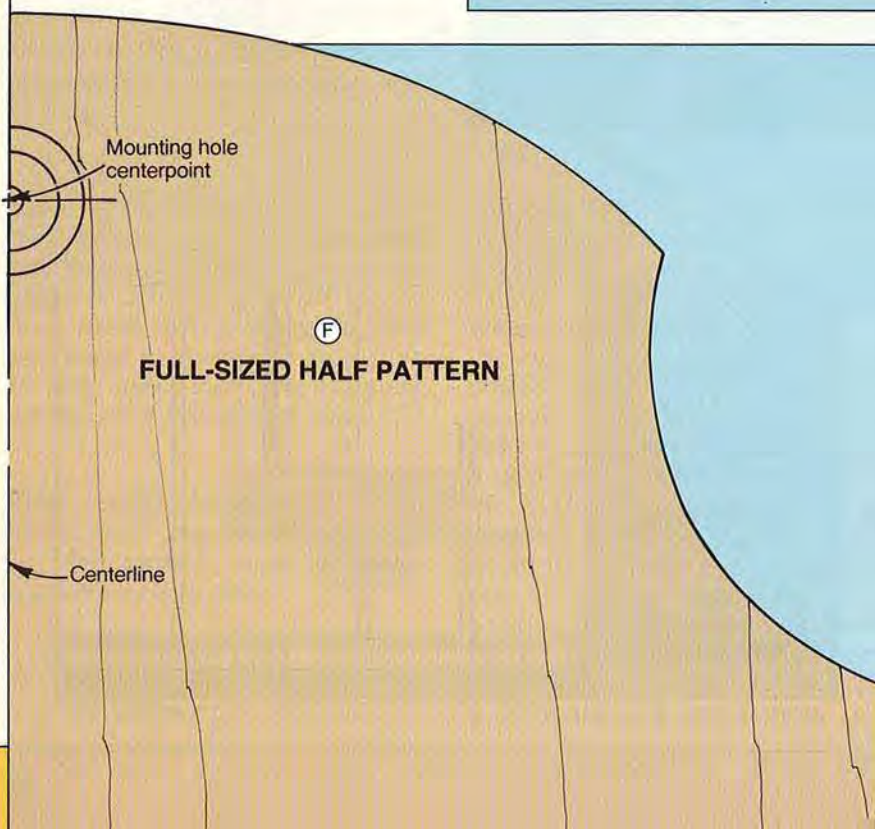

FULL-SIZED HALF PATTERN

5 Apply glue to the back edges of the case. Clamp the front face of the back (F) to the case, centered from side to side and $\frac{3}{8}$ " up from the bottom edge. Use a damp cloth to wipe off excess glue. Be careful to wipe the glue off the wood *and not into the wood*.

Spice up the drawers with recessed pulls

1 From $\frac{1}{2}$ "-thick stock, cut one strip $2\frac{1}{16}$ " wide by 36 " long. Then, from $\frac{1}{4}$ "-thick oak, cut two strips to $2\frac{1}{16}$ " wide by 48 " long. Cut a $\frac{1}{8}$ " groove $\frac{1}{8}$ " deep $\frac{1}{8}$ " from the bottom edge in each strip.

2 Crosscut the drawer fronts (G) to length from $\frac{1}{2}$ "-thick stock. Then, crosscut the sides (H) and backs (I) to length, using the $\frac{1}{4}$ "-thick strips.

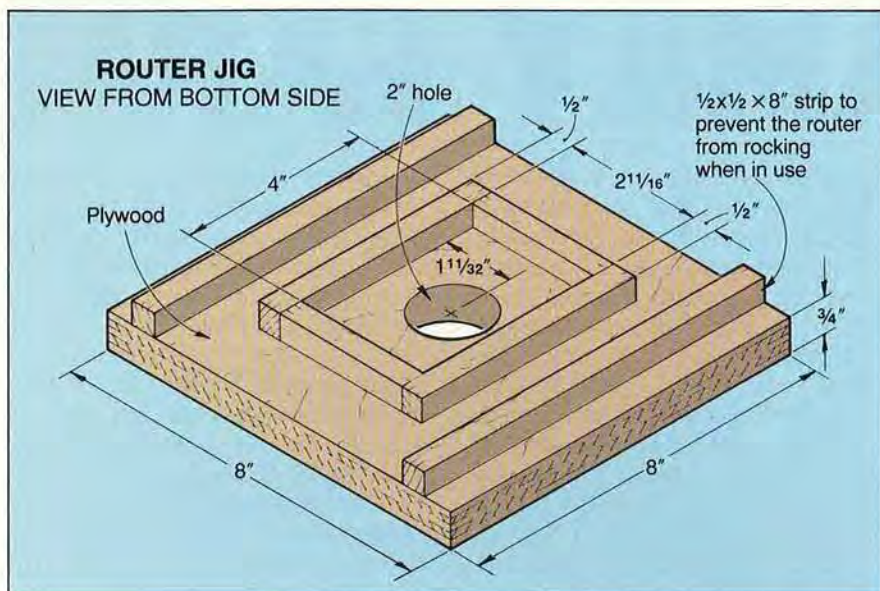

Position a drawer front into the routing jig and rout the depression. A routed front and the router are shown at left.

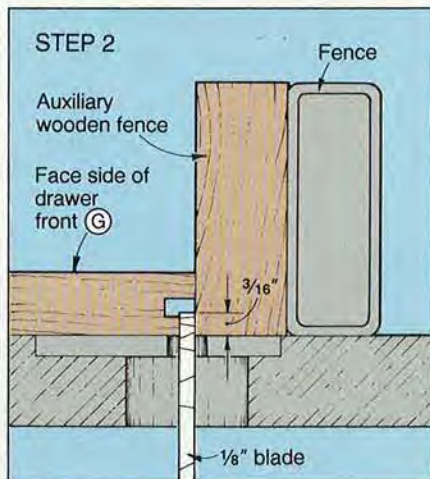
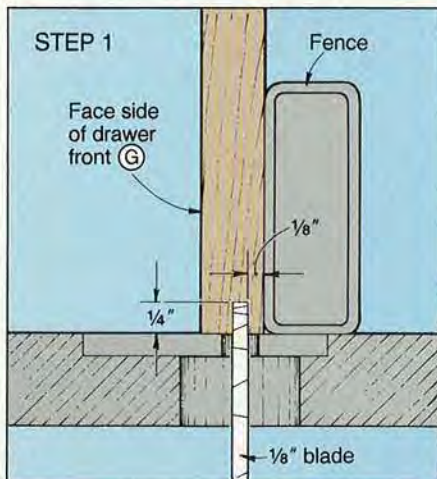

3 Build the routing jig shown at left, and put one of the drawer fronts into the jig. Fit your router with a $\frac{3}{4}$ " groove-forming ogee bit and a 1" guide bushing.

4 Rout a recess into the drawer front as shown in the photo, middle left, and shown in the Recess detail accompanying the Drawer drawing. Remove the piece from the jig, and repeat with the remaining drawer fronts.

5 Follow the two-step drawing, bottom left, to form the joint on both ends of each drawer front. See the Joint detail accompanying the Drawer drawing for dimensions of the finished joint.

6 Cut a $\frac{1}{8}$ " dado $\frac{1}{8}$ " deep $\frac{1}{8}$ " from the front and back edge of each drawer side (H). Then, cut a $\frac{1}{8}$ " rabbet $\frac{1}{8}$ " deep along both ends of the drawer back (I).

7 Cut the drawer bottoms (J) to size from $\frac{1}{8}$ " stock. (We used oak plywood; hardboard also works.)

8 Glue each drawer, checking for square. Remove the clamps and sand all surfaces smooth. Center and glue a knob in the depression in each drawer front.

Add the finish, and hang your cabinet

1 Finish-sand the case and drawers. Add the finish of your choice. (To seal our cabinet and drawers, we started by brushing on a thin coat of satin water-based lacquer. Later, we sanded the assemblies thoroughly with 320-grit sandpaper. Then, we applied two more coats, continuing to sand between coats with 320-grit paper.)

2 Mount the cabinet to the wall with a $\frac{1}{2}$ " countersunk brass washer and a #8x $1\frac{1}{2}$ " flathead brass wood screw.

Buying Guide

- **Oak knobs.** One dozen (minimum order) 1"-diameter oak knobs, catalog no. 803-783, \$6.10 ppd. Woodworker's Supply, 5604 Alameda Place NE, Albuquerque, NM 87113. 🌲

REPLANTING THE FAMILY FARM

Three times a year, one Iowa native returns home from Colorado on a pilgrimage. He's replanting the family farm his way—in black walnut, red oak, white ash, and other species. For his forestry efforts, he'll rescue the soil from erosion, resurrect wildlife habitat, and down the road, reap a respectable return on investment.

Kevin Kyhl loves the land now just as much as when he was growing up on it. The family farm, near Parkersburg in north-central Iowa, was a place to work, sure enough. But it was a place to enjoy the outdoors, too, with a hike through the woodlot or a hunt in the fields. And, as time passed, the land became a thing to improve and preserve.

Now, that affection brings Kevin back year after year from Col-

orado. At the farm, he prepares the ground, then plants the seedlings and tends young saplings. We caught up with him last spring, when he was back at it, planting up a storm.

Stomping in trees

On this cool, dry, spring morning, Albert Jans, 72, a retired farmer from Parkersburg, drives the tractor while Kevin rides the tree planter. Two local high school seniors, Mitch Cashatt and Jon

 [Print this article](#)





“In the Fifties, there were oaks and hickories covering those hills. It’s about time we began to put something back in the ground.”

—Albert Jans, retired Parkersburg, Iowa, farmer

Klinkenborg, walk behind, stomping down the earth around each of the 3,500 trees that will go into the ground—an incredible 500–700 per hour! The trees—12”-tall, year-old black walnut and red oak seedlings—are bare root stock, bought from the state nursery by the thousands at 18 cents a piece—considerably less than a single board foot of either species at the going rate.

Kevin, 37, and his brothers before him, have planted about

77,000 such trees on the 280-acre farm during the last 10 years. Eventually, the land will boast 50 acres of young trees, a complement to the original 40-acre woodland of mature oak, hickory, and walnut. For 27 acres of the new forest—those enrolled in the federal Conservation Reserve Program (CRP)—Kevin will be reimbursed up to half the cost of planting, then be paid about \$100 annually per acre for 10 years (see box, *next page*).

Continued

Bottom: Near Parkersburg, Iowa, Kevin Kyhl and his trio of workers replant rolling farmland with trees. On a spring day such as this, they’ll set 3,500 walnuts and red oaks into the rich soil.

Below: From his seat on the tree planter, Kevin plugs year-old seedlings into the furrowed ground. Now 12” tall, the walnuts and oaks will reach saw-log size in 45 years, veneer size in 60 years.

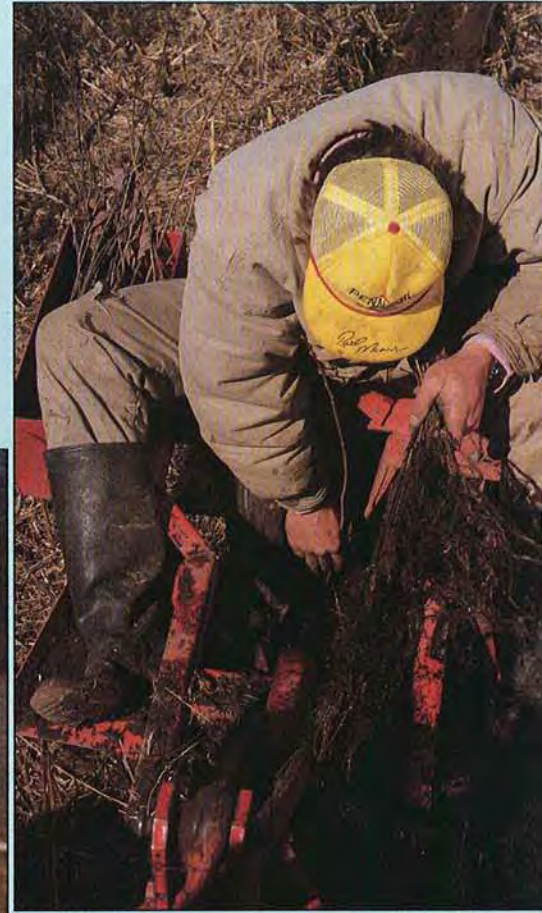

Did you know . . .

•That nearly 60 percent of all timber harvested each year in the United States comes from private, nonindustrial woodlands? Often as small as a few acres, these forests yield wood for paper, lumber, and veneer.

•That trees prevent soil erosion? Cropland with fragile soil can lose up to 30 tons per acre annually. Compare this to the few teaspoonfuls of soil lost when you plant the land to a stand of trees.

THE FAMILY FARM

The walnut entrepreneur bought the land from his two older brothers about five years ago. Now Kevin, who owns and operates a textile-design firm in Fort Collins, Colorado, is in charge. "In the spring, I spend two weeks here planting trees," he says. "Then, I bring my wife, daughters, and son back in the summer for at least a week's vacation, and I follow up in November to combine some pheasant hunting with needed tree maintenance."

A district forester from the Iowa Department of Natural Resources advised Kevin in the turnover of the cropland to trees. "I learned what trees to plant, how to plant, and where to plant them," he comments. "And then, like most people I guess, I picked up a lot of information by trial and error."

Kevin's learn-by-doing approach has resulted in a couple of minor misfortunes: planting a pine species that the local deer herd just loved to nibble, and a costly experiment with hybrid walnut trees that didn't perform. But after the last few years, he knows the tree-growing ropes now, and the amount of work entailed.

Competition down on the farm

It's never an easy life on the farm, even for trees. To become valuable timber, black walnut seedlings require the same protection from takeover weeds as corn and soybeans. Instead of velvet leaf

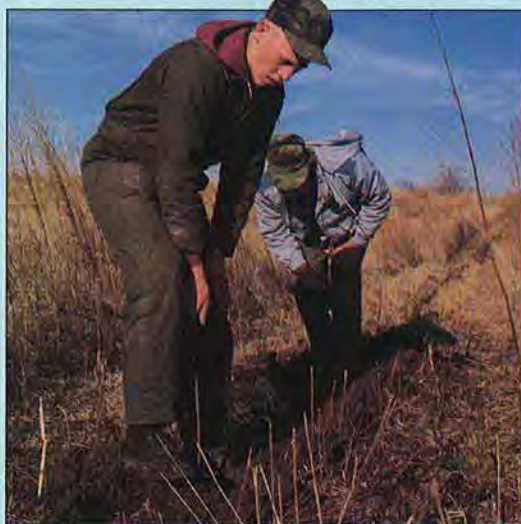

High-school seniors Mitch Cashatt, foreground, and Jon Klinkenborg bend over to straighten each seedling, then tamp down the rich, dark soil around its roots with their heels.

and wild sunflower as enemies, though, trees can succumb to tall and thick brome grass that spreads quickly to strangle seedlings.

"Before planting in the spring, I have to spray the planting area

with Roundup [a defoliating herbicide] to kill ground cover," Kevin says. "Then, until the trees get their heads in the sky [about five years], I keep the brome down by regularly applying Princep [a selective herbicide]."

Tree planting, and managing, requires another important consideration besides start-up competition from wild grasses and weeds. To provide quality lumber and veneer, a mature walnut's trunk must run straight and branch-free for at least 16'. And sunshine can be both enemy and friend.

In a forest setting, black walnut has little competition from ground cover, and the shade provided by surrounding trees limits the development of lower branches. In seeking the necessary sunlight, the young black walnut tree ascends straight, making the perfect veneer log.

In an open farm field, however, sunshine engulfs the baby black walnut. If the tree outgrows the surrounding grasses, it soon shoots out side branches, waylaying nutrients much needed for the preferred vertical growth. Even with pruning, an open-grown walnut may only mature into firewood.

WHAT IT COSTS TO PLANT WALNUT—AND WHO HELPS OUT

Planting trees does require an investment of time and money. Here's the typical cost in Iowa:

- **Seedlings.** A normal planting of 700 per acre costs about \$140 per acre, if stock sells at 20 cents each. State nurseries charge less; private nurseries more.

- **Planting.** Contractors charge \$70 to \$100 per acre. With a tree planter (often loaned free by state agencies), three people can plant an acre an hour. It also can be done by hand.

- **Weed control.** Applying herbicide once a year averages \$30 to \$40 per acre for five years.

- **Mowing.** Between-row mowing averages \$20 to \$30 per acre, necessary two or three times annually for about five years.

And, here's some of the financial and planning help available:

- **Conservation Reserve Program (CRP).** Authorized under the 1985 Farm Bill as a means to control erosion, CRP pays landowners about \$100 per year per acre for 10 years to take acreage out of production. For tree planting on land that qualifies, CRP reimburses a minimum of 50 percent of the costs incurred. Requires five-year program of weed control

on minimum of 10 acres. The national goal is to plant 12 percent of CRP acres to trees.

- **Agricultural Conservation Program (ACP) and the Forestry Incentives Program (FIP).** Both are one-year incentives to plant trees on a minimum of three acres. Each pays 50 to 70 percent of planting costs, not to exceed \$125 per acre.

- **Resource Enhancement and Protection (REAP).** Funds come from state lottery. Pays up to 75 percent of tree-planting costs for a year, or can be coupled with other programs to provide that

"That's why I mix in red oak with the black walnut about 6' apart in the row," Kevin explains. "The oaks have larger, bushier leaves than the walnuts, and more rapidly provide shade to not only hold the grass down, but keep the walnuts from branching out. In forestry, they're called trainers." With rows spaced 10' apart, the trees also receive side protection.

Shaping up prime walnut

Yet, with all this planning, Kevin expects to do annual limb pruning on his walnuts, because if done early and properly, it results in as much as a tenfold value increase at harvest.

According to Kevin, the object in pruning is to maximize the development of the first 16' of trunk to veneer quality. This means removing limbs from the bottom up before they develop heartwood (at about 1" diameter). Taken off early enough, branches will only leave knots in the core of the tree, yielding valuable clear veneer at harvest.

Kevin, of course, won't have to even think about pruning his newly planted trees for at least five years. He can, though, practice pruning techniques on the walnut trees planted by his brothers a decade ago—they're now

6-8" in diameter. He also has about 8 acres of Christmas trees to shear during the 10 years it takes for them to reach maturity. "They're my somewhat immediate cash crop," chuckles Kevin. "They'll help defray other planting costs." 🌲

INVESTING IN TREES

Illinois residents Ron Sippel and Jack Schultz wanted a long-term investment for their heirs that gained in value but wasn't a tax burden. They decided on walnut trees.

The investors purchased 132 acres in Floyd County, Iowa, then asked state forester Gary Beyer to develop a planting and management plan. Here's a look at it:

Costs

Land = 132 acres @ \$700	\$92,400
Planting = Site preparation, trees, planting	\$33,000
Weed control = Spraying @ \$35 per acre over five years.....	\$23,100
Total outlay \$148,500	

Repayments

Federal cost-sharing = ACP and FIP program tree-planting reimbursements @ \$125 per acre.....	\$16,500
CRP enrollment = Payments for non-production of crops, @ \$100 per acre for 10 years	\$132,000
Cash payback \$148,500	

Tax incentive

Non-taxable benefits = After the CRP contract expires (10 years), land qualifies for tax-exempt status under Iowa Forest Reserve law for 55 years to tree maturity.....	\$?
Long-term taxing = At harvest, income from trees taxable at then-current capital-gains rate	\$?

Return from timber sale

(The following are conservative projections based on typical walnut growth, today's timber prices, and do not include returns from trainer-trees such as oak and ash thinned before the walnut harvest.)

Thinning for saw logs at 45 years = 19 walnut trees per acre of at least 16" diameter and containing 100 board feet (bft) per tree, sold at \$1 bft.....	\$250,800.
Final harvest of veneer logs at 60 years = 26 trees per acre of 20" dia., each containing 180 bft, sold at \$3 bft.....	\$1.85 million.

Says forester Gary Beyer, "It's not so much the end value to look at, but the average 15 to 20 percent per year added return from the time the walnuts reach 14" diameter to when they get to 20". The investors' children jump into the earning curve at a 20 percent return."

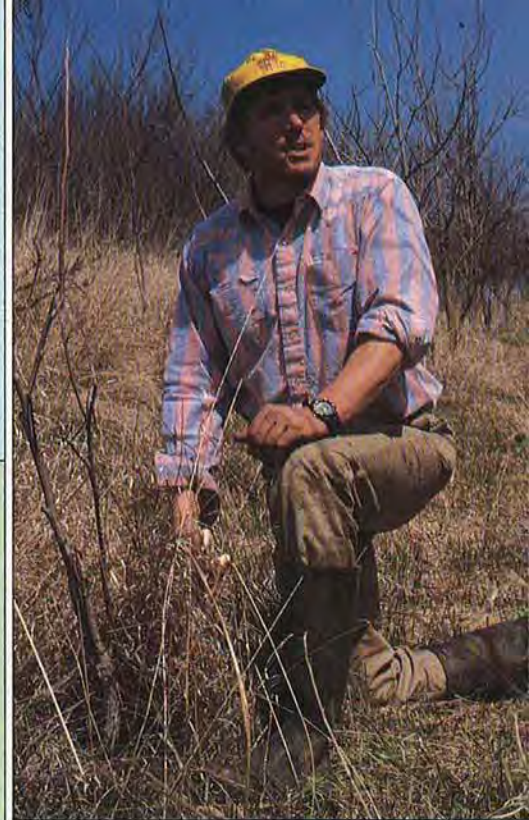

Kevin kneels by a walnut tree planted five years ago. On the edge of the other plantings, it was stunted by brome grass.

amount of reimbursement. Land in program must be maintained in trees for 20 years.

• **Forest Reserve.** This law exempts qualifying woodlands of two acres or more from property tax. Land-use and harvest restrictions apply.

• **Planning help.** Contact a state forester, county conservation board member, local Soil Conservation Service office, or private consulting forester for advice on how you can get started.

**Indicates Iowa state plan, may vary or not exist elsewhere.*

Get a jump
on Summer

CASUAL

MAHOGANY OUTDOOR FURNITURE

Tired of buying bargain-brand outdoor furniture and having it fall apart in a year or two? Are you ready for a table and chair set that will look as good in five years as it does today? Then, have we got a deal for you! Solidly built out of genuine (Honduras) mahogany (see page 32 for machining tips), and stylishly designed, this dynamic project duo spells value.

Here we explain how to make the chairs; in the next issue, we'll cover the table construction.

Start with the legs

Note: You'll need some $2\frac{1}{2} \times 2\frac{1}{2}$ " mahogany for the front and rear legs. We were able to purchase stock this size. If you have trouble locating stock this thick, laminate thinner stock to size. Also, if you plan to use the table and chairs outdoors, use either slow-set epoxy or resorcinol glue.

1 Rip and crosscut the two rear legs (A) and the two front legs (B) to the sizes listed in the Bill of Materials. Chamfer both ends of the rear legs and the bottom end of the front legs. (We chamfered ours on the tablesaw, with the blade at 45° and the miter gauge fitted with an auxiliary wooden fence to support the long stock.)

2 To form the curved sections (C) that attach to each front leg, cut a piece of $2\frac{1}{2}$ " square mahogany to $1\frac{1}{16} \times 2\frac{1}{2} \times 12\frac{3}{4}$ ". Then, lay out the two curved sections (in-



 Print this article



CLASSICS

THAT WILL LAST AND LAST



cluding the tenons) on the stock using the Front Leg grid on the next page as a guide.

3 Attach an auxiliary wooden fence to your tablesaw rip fence. Refer to the six-step drawing on the next page to form the top of each front leg.

Now, form the mortises in the legs

1 Mark the mortise centerpoints on the two rear legs (A) and the two front legs (B) where shown on the Rear and Front Leg drawings. Remember that you are working in pairs of As and Bs. When the legs are in the position shown on the Exploded-View drawing, the corresponding mortises must face each other.

2 Form the mortises, following the four steps in the Mortise Forming detail accompanying the Front and Rear Leg drawings.

Cut the tenons and the other frame members

1 Cut the top seat rails (D) and bottom rails (E) to the sizes listed in the Bill of Materials. Cut the stretcher (F) to size plus 1" in length. Cut the support rails (G, H), seat slats (I, J), armrests (K), backrest bottom rail (L), and backrest top rail (M) to size. (Do not make the contour cuts on parts D and K yet; you'll cut them to shape after tenoning.)

2 Cut tenons on both ends of the seat rails (D), bottom rails (E), and support rails (G, H), using the dimensions on the drawing titled Forming the Tenons. Refer to the Side Rail grid for sizes, and cut the tenons on the side rails (D). Then, referring to the Arm-

Continued



CASUAL CLASSICS

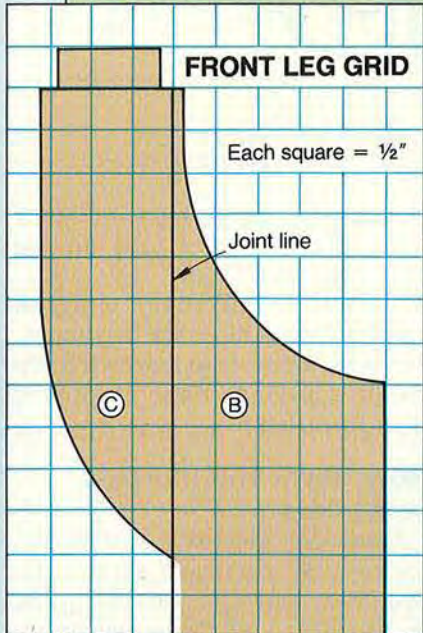

FORMING THE CURVED SECTION OF EACH FRONT LEG

STEP 1.
Cut a $\frac{1}{2}$ " rabbet $\frac{3}{16}$ " deep all the way around each end to form the tenons.

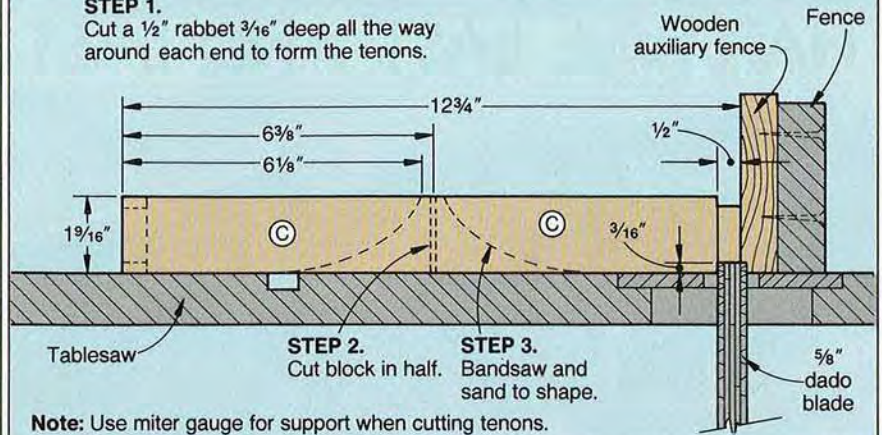

REAR LEG (Left rear leg shown)

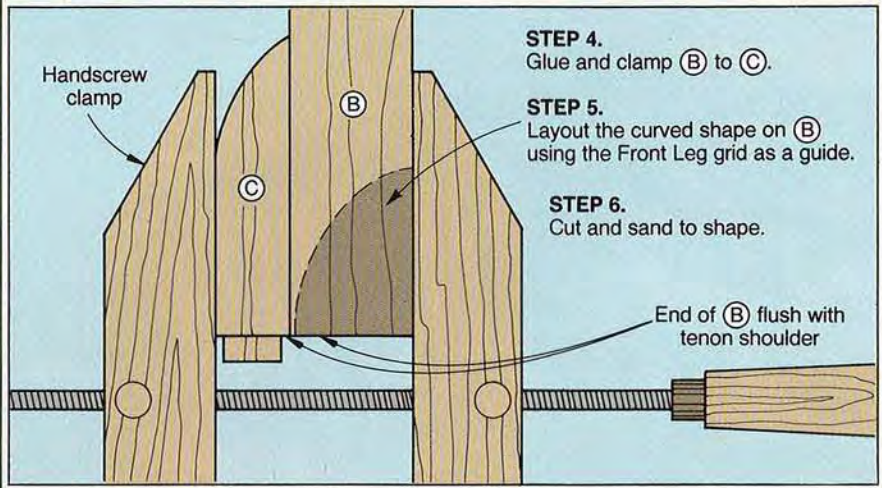
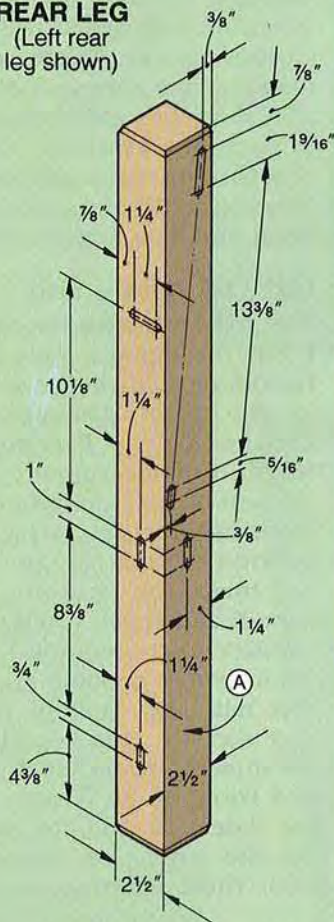

MORTISE FORMING DETAIL

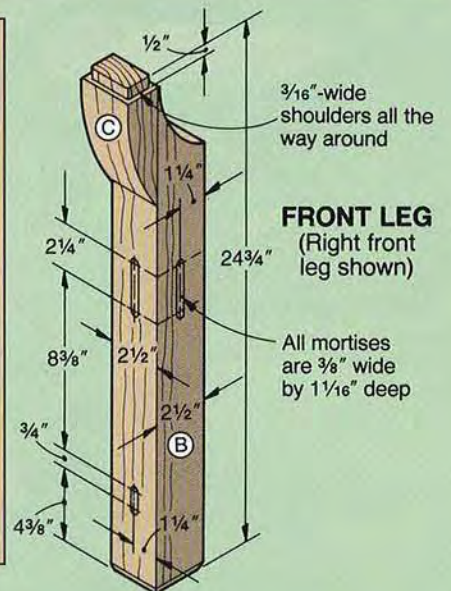
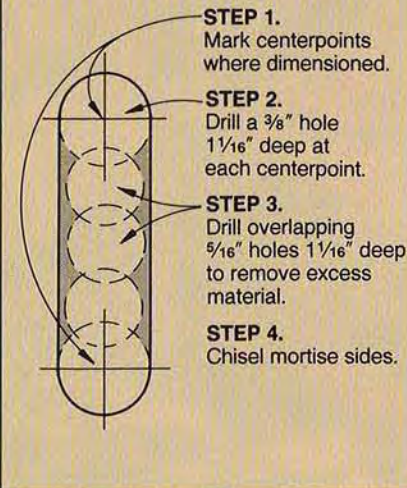

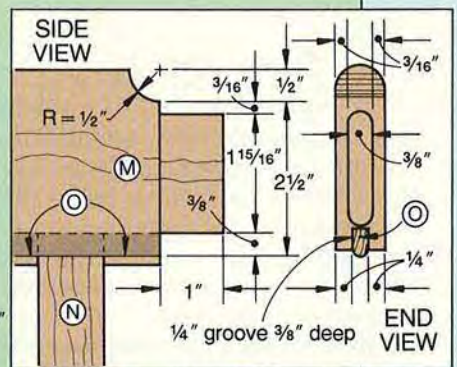
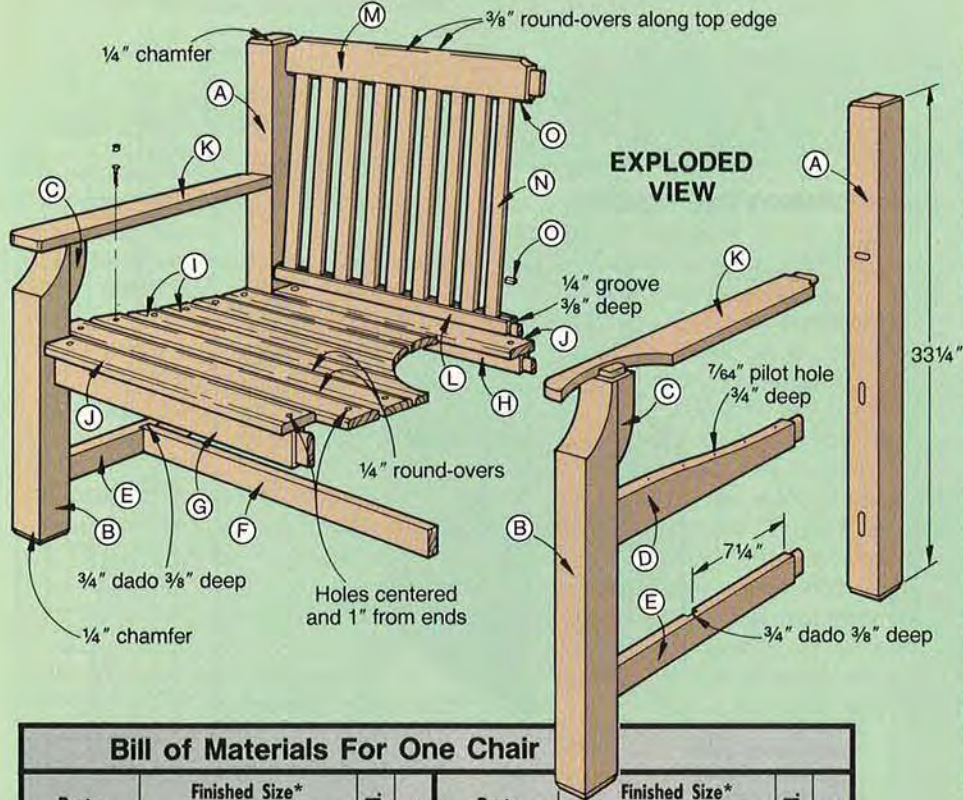

BACKREST TOP RAIL DETAIL

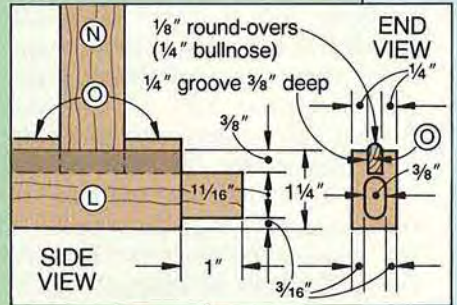

BACKREST BOTTOM RAIL DETAIL

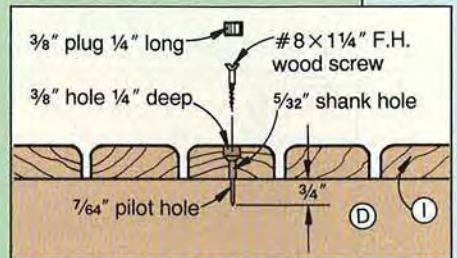

SCREW HOLE DETAIL

Bill of Materials For One Chair											
Parts	Finished Size*			Mtrl.	Qty.	Parts	Finished Size*			Mtrl.	Qty.
	T	W	L				T	W	L		
A rear legs	2 1/2"	2 1/2"	33 1/4"	M	2	K armrests	3/4"	3 1/4"	18 3/4"	M	2
B front legs	2 1/2"	2 1/2"	24 1/4"	M	2	L backrest bottom rail	3/4"	1 1/4"	21"	M	1
C* curved sections	1 9/16"	2 1/2"	.6 1/8"	M	2	M backrest top rail	3/4"	3"	21"	M	1
D rails	3/4"	3"	17 1/4"	M	2	N* splats	1/4"	1 1/16"	13"	M	9
E rails	3/4"	1 1/2"	17 1/4"	M	2	O* spacers	1/4"	1/2"	15 1/16"	M	20
F* stretcher	3/4"	1 1/2"	21 1/2"	M	1	*Initially cut parts marked with an * oversized. Then, trim each to finished size according to the how-to instructions. Material Key: M-mahogany Supplies: #8 x 1 1/4" F.H. wood brass screws, acetone as a solvent for the epoxy, exterior finish.					
G support rail	3/4"	3"	21"	M	1						
H support rail	3/4"	1 3/4"	21"	M	1						
I slats	3/4"	2 1/4"	23 1/2"	M	6						
J front & back slat	3/4"	2 1/4"	19"	M	2						

Cutting Diagram

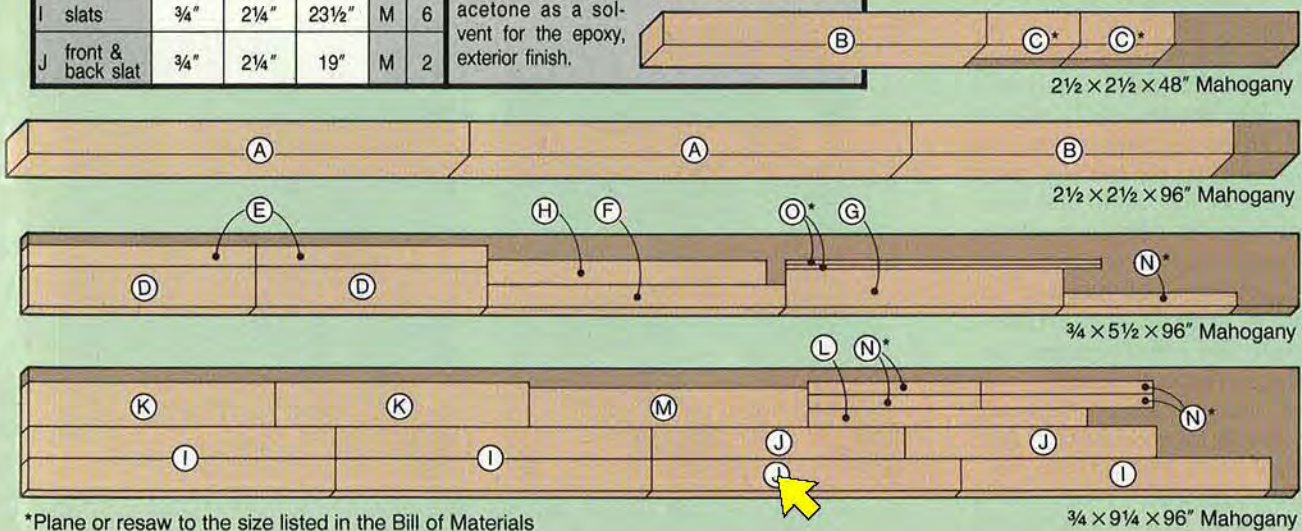

*Plane or resaw to the size listed in the Bill of Materials

Continued



CASUAL

rest drawing for the tenon size, cut the tenon on the back end of the armrests (K). Now, using the details on the Exploded View drawing for tenon sizes, cut a tenon on both ends of the backrest bottom and top rails (L, M).

3 Cut a $\frac{3}{4}$ " dado $\frac{3}{8}$ " deep in each lower rail (E) where shown on the Exploded View drawing.

4 Cut the seat rails (D) to shape, using the Side Rail grid as a guide.

5 Cut the armrests to final shape, using the Armrest drawing below for reference.

6 Rout $\frac{3}{8}$ " round-overs along the top edges of the backrest top rail (M). Then, mark and cut a $\frac{1}{2}$ " radius on each top corner of the backrest top rail (see the Backrest Top Rail detail accompanying the Exploded View drawing for reference). Sand each radius smooth with a 1" drum sander.

CLASSICS

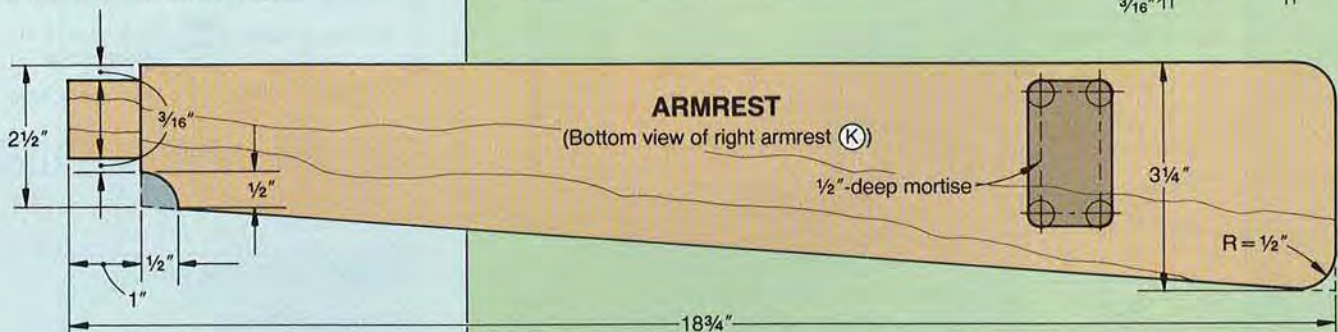
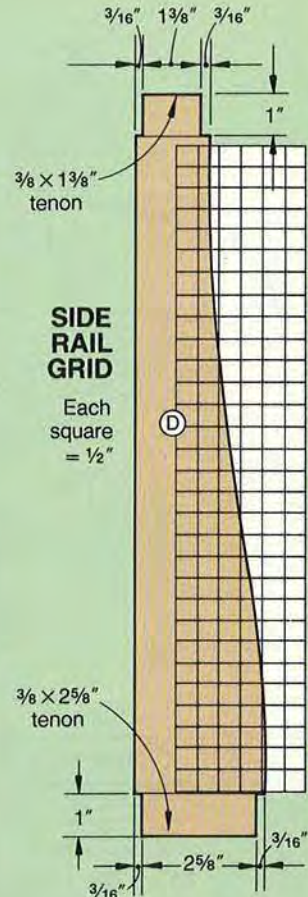
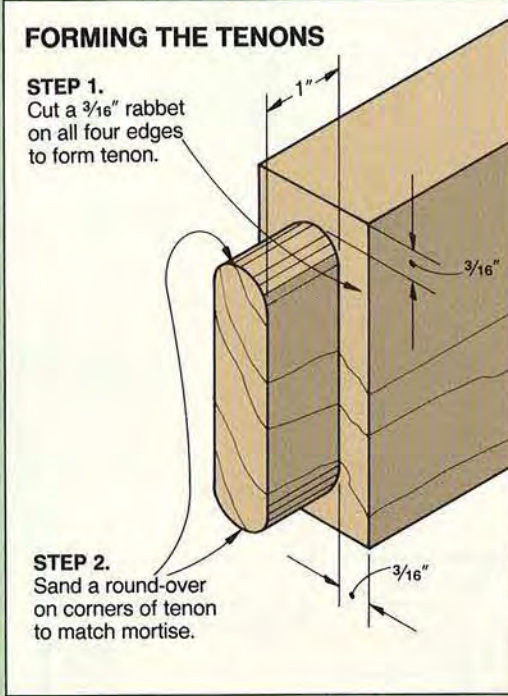

Assemble the end sections

1 Dry-clamp the legs (A, B/C) and rails (D, E). Square each assembly, and slide the tenon on the armrest (K) into its mating mortise in the rear leg. Hold the armrest firmly against the tenoned top of the front leg, and mark the location of the mortise needed on the *bottom* side of the armrest. Repeat with the other armrest. Remove the armrests, leaving the rest of the assembly dry-clamped.

2 To form the mortise on the *bottom* side of each armrest, use a $\frac{3}{8}$ " flat-bottomed bit (we used a Forstner), and drill a $\frac{1}{2}$ "-deep hole at each corner of your layout



To safely cut the short spacers, use the eraser end of a pencil to clear the spacers from the blade.



Brush epoxy into the groove in the backrest lower rail, and then add the spacers and splats.



lines. Now, drill overlapping holes to remove stock, and chisel each mortise clean.

3 Check the fit of the armrests on the dry-clamped end sections. Again, remove the armrests; you'll add them later after you have attached the seat slats.

4 Glue and clamp each end section, checking for square.

Complete the frame, and build the backrest

1 Dry-clamp the support rails (G, H) and backrest top and bottom (L, M) between the end assemblies. Check for square. Remove the clamps and disassemble.

2 Using the Backrest Top Rail detail on the Exploded View drawing as a guide, cut a $\frac{1}{4}$ " groove $\frac{3}{8}$ " deep centered along the top edge of the backrest bottom rail (L) and along the bottom edge of the backrest top rail (M). (We cut the grooves on the tablesaw fitted with a $\frac{1}{4}$ " dado blade. To keep the pieces firmly against the fence, we used a feather board.)

3 Rip five strips $1\frac{1}{16}$ " wide by 13" long from $\frac{3}{4}$ " mahogany stock. Now, resaw each strip to obtain two $\frac{1}{4} \times 1\frac{1}{16} \times 13$ " strips for the splats (N).

4 To form the spacers (O), start by cutting two strips $\frac{1}{4} \times \frac{1}{2} \times 24$ ". Rout or sand an $\frac{1}{8}$ " round-over along one edge of each strip. To prevent the pieces from falling into the gaps in the insert around the saw blade, cover the area with masking tape. Next, clamp a scrap block to the fence about 2" in front of the blade. Raise the saw blade $\frac{3}{8}$ " above the saw table. Position the fence so the block is $1\frac{1}{16}$ " from the inside edge of the blade. Using your miter fence for support, slide one end of one of the strips against the block. Push the piece over the blade to cut a spacer, and move the spacer away from the blade with the eraser end of a pencil as shown in the photo *bottom left, opposite page.*

5 Starting at one end with a spacer, epoxy the spacers and splats into the $\frac{1}{4}$ " groove in the bottom rail as shown in the second photo on the *opposite page.*

6 Once you have all the spacers and splats in position in the bottom rail, apply epoxy to the groove in the top rail. Lay the bottom-rail splat assembly flat on a work surface, and add the top rail to the ends of the splats. Epoxy the spacers in place. With a framing square, check that the splats are square to the rails and that the ends of the tenons are aligned. Wearing vinyl gloves to protect the skin, immediately wipe off excess epoxy with a cloth dampened with acetone.

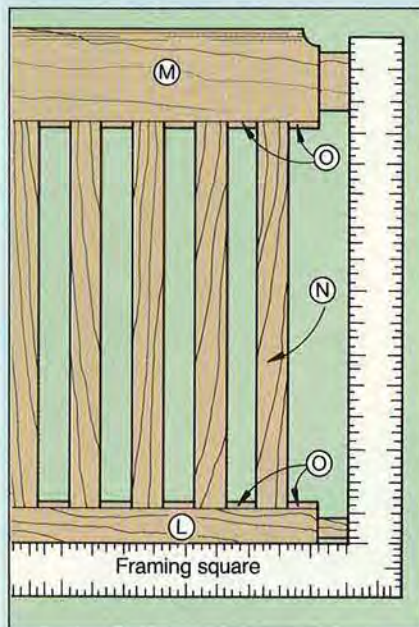

Assemble the chair and add the finish

1 Epoxy and clamp the support rails (G, H) and the backrest assembly between the end sections, checking for square. Measure the distance between the dadoes in the lower rails (E), and cut the stretcher (F) to fit. Epoxy the stretcher in place.

2 Using the Screw Hole detail accompanying the Exploded View

drawing for reference, drill plug and shank holes through the seat slats (I, J).

3 Rout a $\frac{1}{4}$ " round-over along the top edges (not ends) of each seat slat. Clamp the front slat (J) to the chair, centering the predrilled screw holes over the front support rail (G). Drill pilot holes into the seat rails (D), and screw the front slat in place.

4 Cut two strips of scrapwood to $\frac{1}{4}$ " thick for use as spacers. Working towards the back, space the slats (I) $\frac{1}{4}$ " apart with the scrap spacers, and screw the slats to the top seat rails (D). Locate the rear slat (J) and screw it in place.

5 Plane a piece of mahogany to a $\frac{5}{16}$ " thickness and cut sixteen $\frac{3}{8}$ "-diameter plugs from it. With the grain direction on the plugs going in the same direction as the slats, plug the screw holes and sand the plugs flush.

6 Epoxy and clamp the armrests (K) in position.

7 Sand the entire chair smooth. Stain and finish as desired. (For the first coat, we sprayed on spar varnish—reduced 25 percent with mineral spirits. After this dried, we lightly sanded with 320-grit sandpaper, and then applied two additional coats full strength.) To prolong the life of the finish, store the pieces indoors (under cover) over the winter months. Also, if you happen to dent or scratch the finish, touch up the blemish with spar varnish to prevent moisture from getting under the finish.

Buying Guide

• **Tropical hardwood epoxy.** Slow-set epoxy, one 16-oz. can of resin, one 16-oz. can of hardener, and instructions. \$27 ppd. Smith & Co., 5100 Channel Ave., Richmond, CA 94804. Or, call 800-234-0330 to order. 🌳

Produced by Marlen Kemmet
Project Design: James R. Downing
Photographs: Hopkins Associates
Illustrations: Kim Downing; Mike Henry

CORDLESS

INNOVATIONS GALORE



Since we last reported on cordless drills in the June 1986 issue of *WOOD*® magazine, these machines have changed dramatically. Now, most have variable speeds, greater power, faster charging, and keyless chucks—improvements that have greatly increased the practicality of battery-powered drills for the home woodworker.

However, the traditional benefits of these handy tools haven't changed. Go-anywhere portability, freedom from cord hassles, and electrical safety still make cordless drills a smart investment. Small wonder that cordless products (primarily drills) represent the fastest growing product segment in the power-tool industry.

Today, you can choose from hundreds of cordless drills, but we limited our tests to 18 of the newest and best-selling models. This way, we were able to thoroughly test and evaluate every tool. Here's what we learned:

Power: How much do you really need?

Cordless drills get their power from a set of rechargeable nickel-cadmium (ni-cad) battery cells encased in a removable plastic pack. The pack clips partially or completely into the tool handle. Each cell delivers 1.2 volts, so cordless products have voltages ranging from 2.4 volts (two cells)



Milwaukee 0399-1
(we added a Jacobs
keyless chuck)

Panasonic
EY 6205

WONDERS

DISTINGUISH A NEW ERA IN BATTERY-POWERED DRILLS

to 24 volts (20 cells). For this story, we tested models with voltages of 7.2, 9.6, and 12. For a look at the inside of a battery pack, see the photo at *right*.

Before you decide on an individual model, it makes sense to determine how much power you really need, and then steer clear of drills that exceed your requirements. Why? You'll pay \$15-\$30 more for every 2.4-volt jump in comparable models. And, batteries account for about 30 percent of the tool's weight.

In our tests, the 7.2-volt drills proved powerful enough for most woodworking tasks. All were capable of driving 3" deck screws, and drilling 5/8" holes through 2"-thick red oak. As you can see by looking at the chart on page 67, all the 12-volt models bored 1" holes in oak stock. But really, how many times do you call on your cordless drill for such tasks?

High voltage does have its advantages, though, such as added power storage. As shown in the test results at *right*, conducted with some of our favorite 9.6V and 12V models, the 12V machines bored 5-10 more 1" holes per charge than the 9.6V tools. But, we would rather buy the lower-voltage tool and plow our savings into an extra battery pack (\$30-\$50). That way, we can keep a fresh battery on hand.

Continued



During battery-pack assembly, a worker adds a small thermostat that tells a charger when to stop charging, preventing any damage to the battery cells.

BATTLE OF THE BIG BOYS	HOLES BORED*				
	25	30	35	40	45
Black & Decker 1963K (9.6V)					
Hitachi D 10DF (9.6V)					
Panasonic EY6281 (9.6V)					
Panasonic EY6205 (12V)					
Milwaukee 0395-1 (9.6V)					
Milwaukee 0399-1 (12V)					
Porter-Cable 9850 (12V)					

*Number of holes bored with a 1" auger bit by a fully charged drill through a 1 1/2"-thick pine board.



CORDLESS

Handle size and position: vital to your comfort

Most of the drills in the test have slim handles that you can wrap your hand around. A few—such as the Ryobi BD-1020CVR, Makita 6093 DW, and Sears 27132 and 11128—have fat handles. These models, as shown by the Sears 11128 at *left*, have long battery packs contained entirely in the handle. We found these tools harder to grip than models such as the Hitachi D 10DF on page 62, which has most of the battery pack clipped below the handle.

Handle position also influences comfort. Inline-style drills have handles at the rear of the machine. Other models, known as T-handle drills, have handles located closer to the middle of the drill. We prefer the T-handle for most drilling tasks because it makes the machine less nose heavy, thereby improving balance. These tools also put your hand closer to the drilling action, increasing your control.

However, the inline drills have an advantage if you frequently drive long screws or bore large holes. These models allow you to put full forward pressure directly in line with the drill bit with one hand. When taking on heavy-duty tasks with a T-handle drill, you hold the drill with one hand and apply pressure to the rear of the drill with your other hand.

Clutches: nice if you drive a lot of screws

As a group, cordless drills excel at turning screws because of their slow speeds. But, some models

have clutches that add even more control to screw-driving tasks. With these, the clutch slips at predetermined torque levels, preventing you from burying screws in the workpiece or snapping off screwheads. All of the clutches have a drill-only position that bypasses the mechanism.

Most clutches adjust easily with a nose-ring control located just behind the drill's chuck (see the photo at *right*). However, we noticed that some drills such as the Skil 2735 and Ryobi BD-1020CVR have clutch controls on the underside of the body. These dials proved less convenient because you have to turn the drill upside down to make an adjustment.

Keyless chucks: a great way to go

Of the drills tested, only the Hitachi, Panasonic, and three of the four Ryobi models came with keyless chucks. However, nearly all power-tool manufacturers were putting keyless chucks into their product lineups as this story developed. In short, we love these new chucks. With one of them on the business end of your drill, you'll never waste any time looking for a lost key. When it comes time to change a bit, just grab one of the chuck's two rings in each hand as shown on the *opposite page top*, and give a twist.

To our pleasant surprise, the Hitachi, Ryobi, and Panasonic chucks, as well as an aftermarket keyless chuck made by Jacobs, actually have more gripping strength than the keyed variety. As a test, we clamped a 12" long,



The battery pack on the Sears model 11128 had a tendency to fall out of the handle when the tool was jarred.



Bosch 3050 VSR

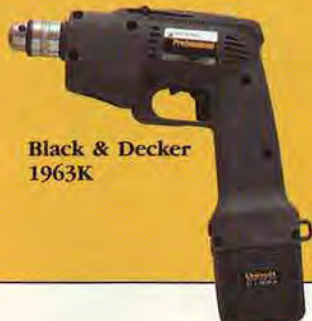

Black & Decker 1963K



Metabo O103

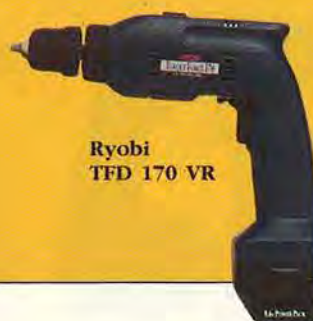

Ryobi TFD 170 VR



The keyless chuck (A) of the Hitachi D 10DF worked smoothly and effortlessly. The clutch control (B) helped make driving screws a breeze.

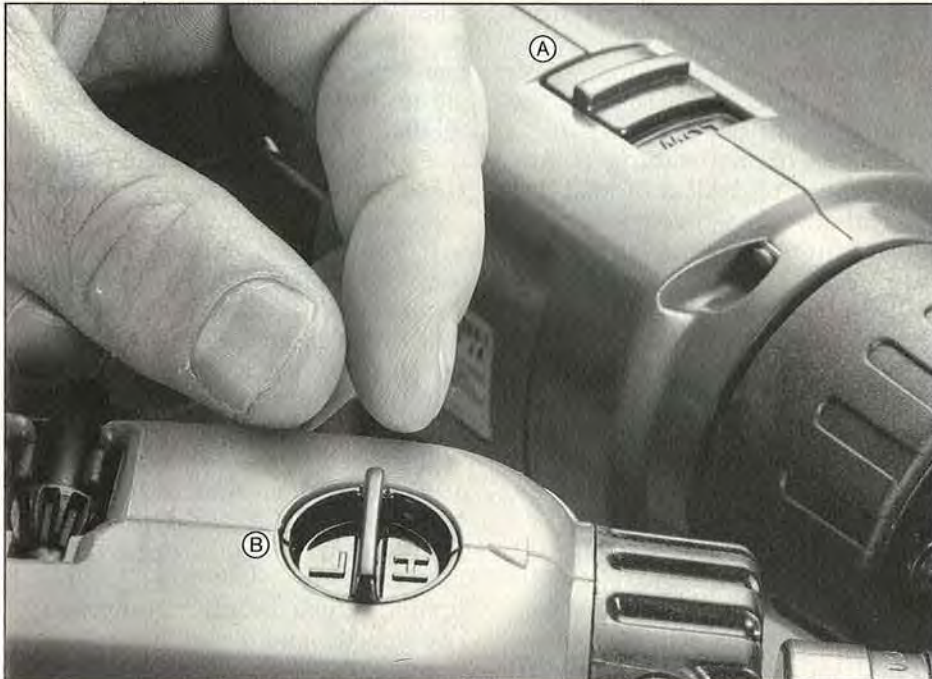

In our tests, sliding gear-reduction switches (A) worked smoother and quicker than rotating switches (B).

$\frac{3}{8}$ "-diameter steel rod into a metalworker's vise, then chucked the other end of the rod into each drill and squeezed the trigger. The rod slipped inside the keyed chucks. The keyless chucks grabbed the rod so tightly that it spun inside the vise. After the tests, the keyless chucks let go of the rod with a firm, but not Herculean, twist.

Of the keyless chucks, we especially liked Panasonic's version because it opens and closes completely in only four revolutions. The other keyless versions require more than 20 revolutions.

You can buy keyless chucks as an accessory from many of the cordless drill manufacturers, or call Jacobs at 800-826-8066 or 803/654-5926 for the location of your nearest dealer. The Jacobs keyless chuck sells for \$17.99 list.

Geared speed changers: some smoother than others

Most drills costing more than \$100 have two speed ranges of about 0 to 400 rpm and 0 to 1,000 rpm. Because the speed changes mechanically through a series of gears, rather than electronically, the tools have more driving torque in the lower range.

Among the different models tested, we liked those that have slide switches such as the Milwaukee 0395-1 shown in the photo at left. One flick of your finger does it. All of the drills with a red dot under the heading "gear-reduction switch" in the chart on page 67 have similar smooth-working mechanisms.

Continued



Makita
6093 DW



Sears 27132



Panasonic
EY 6281

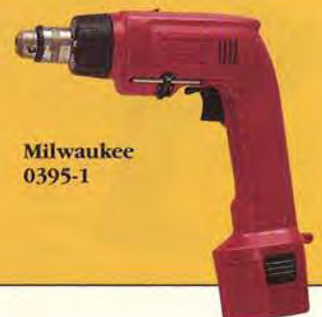

Milwaukee
0395-1

CORDLESS

Those models with a green dot in that column have switches that got stuck between the speed ranges. To complete the speed change, we had to turn on the drill briefly to mesh the gears. The Makita 6093 DW earned a "poor" rating in this category because we had to squeeze our fingers into its small, recessed, rotating switch as shown on the previous page. Once grasped, the switch was difficult to turn.

Reversing switches: handiness counts

These mechanisms were judged according to the ease with which we could switch between forward and reverse without releasing our grip on the drill. Of all the tools, the Panasonic models were tops. As shown at *right*, a button emerges from one side of the drill or the other as you switch between forward and reverse.

A few recommendations about accessories

Only three of the tested drills—the Bosch 3050 VSRK, the Sears 27132, and the Skil 2735—come standard with an extra battery. Batteries cost between \$30–\$50 each, so keep this in mind as you compare prices.

You can purchase many cordless drills with or without a carrying case. This accessory might be worth the extra cost if you do a lot of traveling with your tools.

Which one to buy?

Although TVs and radios have made Panasonic and Hitachi well-known brands, these electronics



Panasonic drills have easy-to-reach reversing switches.

giants could become just as famous for cordless drills. Both companies make well-balanced drills with smooth-working switches and keyless chucks. Along with the AEG ABSE 15, these were the only drills in our test that did a good job of maintaining a constant speed regardless of load. For our money, the 9.6-volt units with 60-minute chargers—the Panasonic EY 571B and the Hitachi D 10DF—have plenty of power and rate as excellent buys.

Several other drills also rate as good buys. All of the Milwaukee tools have excellent features and plenty of power, too, and they're in the same price range as the Panasonic and Hitachi units.

Even though we didn't like some features on the Makita 6093 DW, people who repair all makes of cordless drills tell us that no brand tops Makita for reliability. As one repairman said, "They just don't come back." And, of the

tested drills, only seven of them—the Makita 6093 DW, both Panasonic models, three of the Ryobi models, and the AEG ABSE 15—have electric brakes. This feature allows the tool to come to an immediate stop when you release the ON/OFF button, saving you time and helping you drive screws to precise depths.

If you want maximum power for your dollar, the Porter-Cable 9850 costs less than any other 12-volt drill (about \$145). This tool doesn't have two speed ranges, but Dennis Huntsman of Porter-Cable tells us a two-speed version will be on the market in early 1991. Repairmen told us this tool ranked high in reliability, too.

In the under-\$100 category, we like the Skil 2503. This 7.2-volt drill charges in one hour, has two speeds, and a clutch. ♣

Written by Bill Krier
Technical Consultant: Bob McFarlin
Photographs: Hopkins Associates;
Gates Energy Products



Ryobi
BD-1020CVR



Skil 2503



Black &
Decker 9016

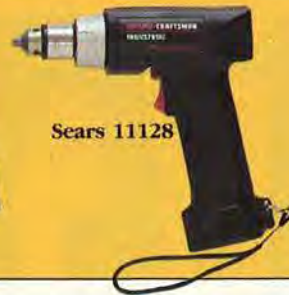

Sears 11128



Milwaukee
0385-1

21 CORDLESS DRILLS: HOW THEY STACK UP

MANUFACTURER	MODEL	BATTERY				CHUCK			CUTTING CAPACITY ²		PERFORMANCE EVALUATION ³							STANDARD EQUIP. ⁴	LENGTH ⁵	WEIGHT OF DRILL (LBS.)	COUNTRY OF ASSEMBLY ⁶	LIST PRICE	SELLING PRICE ⁷
		VOLTS	CHARGE TIME (MIN.)	REMOVABLE (Y, N)	NO-LOAD SPEED(S) (RPM)	KEYLESS (Y, N)	KEY LOCATION ¹	CLUTCH (Y, N)	2"-THICK RED OAK	2"-THICK PINE	BALANCE	HANDLE SIZE AND LOCATION	REVERSING SWITCH	GEAR-REDUC. SWITCH	CLUTCH	CHUCK	CHUCK KEY ACCESSIBILITY						
AEG	ABSE 15	12	60	Y	0-370; 0-1000	N	BH	Y	1	1	•	•	•	•	•	•	•	CC	8	3.5	G	399	300
BLACK & DECKER	1963K	9.6	60	Y	0-350; 0-1200	N	TB	N	¾	1	•	•	•	•	None	•	•	CC, SB	6½	3.8	US	231	159
	9016	7.2	180	N	0-600	N	BH	N	½	½	•	•	•	None	None	•	•	SB	5¼	2.2	US	112	69
BOSCH	3050 VSRK	9.6	60	Y	0-400; 0-900	N	SB	Y	¾	¾	•	•	•	•	•	•	•	CC, EB SB	7¾	3.4	US	235	145
HITACHI	D 10DF	9.6	60	Y	0-400; 0-1,100	Y	None	Y	1	1	•	•	•	•	•	•	None	CC	4½	3.7	J	292	160
MAKITA	6093 DW	9.6	60	Y	0-400; 0-1,100	N	SB	Y	¾	1	•	•	•	•	•	•	•	CC, SB	6¾	3.7	US	261	140
METABO	0103	9.6	60	Y	350; 1,000	N	TB	Y	¾	1	•	•	•	•	•	•	•	SB	7¾	3.7	G	266	250
MILWAUKEE	0399-1	12	30	Y	0-350; 0-1,000	N	SB	Y	1	1	•	•	•	•	•	•	•	CC	6¼	3.8	US	290	170
	0395-1	9.6	30	Y	0-350; 0-1,000	N	SB	Y	1	1	•	•	•	•	•	•	•	CC	6¼	3.7	US	264	155
	0385-1	7.2	60	Y	0-600	N	SB	N	½	¾	•	•	•	None	None	•	•	CC	5¾	2.5	US	174	120
PANASONIC	EY 6205	12	15	Y	50-350; 150-1,000	Y	None	Y	1	1	•	•	•	•	•	•	None	SB	4¼	4.1	J	387	220 ⁸
	EY 6281	9.6	15	Y	50-350; 150-1,000	Y	None	Y	1	1	•	•	•	•	•	•	None	SB	4¼	3.6	J	347	200 ⁸
PORTER-CABLE	9850	12	60	Y	0-400	N	BH	Y	1	1	•	•	•	None	•	•	•	CC, SB	6½	3.9	US	230	145
RYOBI	BD-1020 CVR	7.2	60	Y	0-300; 0-600	N	SB	Y	¾	1	•	•	•	•	•	•	•	SB	5¾	3.4	T	189	120
	TFD 150 VR	7.2	60	Y	0-300; 0-1,100	Y	None	Y	1	1	•	•	•	•	•	•	None	SB	7½	3.4	HK	212	110 ⁹
	TFD 170 VR	9.6	60	Y	0-400; 0-1,200	Y	None	Y	1	1	•	•	•	•	•	•	None	SB	8	3.8	HK	270	140 ⁹
	TFD 220 VR	12	60	Y	0-400; 0-1,300	Y	None	Y	1	1	•	•	•	•	•	•	None	SB	8	4.1	HK	303	160 ⁹
SEARS	27132	9.6	60	Y	0-600	N	SB	Y	¾	¾	•	•	•	None	•	•	•	CC, EB	4¾	3.1	US	None	148.71
	11128	7.2	60	Y	0-600	N	SB	Y	¾	¾	•	•	•	None	•	•	•	--	4¾	2.8	US	None	78.95
SKIL	2735	12	60	Y	0-500; 0-1,650	N	BH	Y	1	1	•	•	•	•	•	•	•	CC, EB	6¾	4	US	210	155
	2503	7.2	60	Y	300; 600	N	BH	Y	¾	¾	•	•	•	None	•	•	•	CC	6¼	3.5	US	80	70

- (BH) Bottom of handle; (SB) Side of body; (TB) Top of body
- Maximum hole diameter in inches
- Excellent
• Good
• Fair
• Poor
(See story for further explanation of criteria).
- In addition to battery and charger. (CC) Carrying case; (EB) Extra battery; (SB) Screwdriving bit
- From tip of chuck to trigger switch
- (G) Germany; (HK) Hong Kong; (J) Japan; (T) Taiwan; (US) United States
- Selling prices based on advertisements, catalogs, and dealer inquiries at time of article's writing.
- Same models available with 60-minute charge as models EY 6005 (12V-\$180) and EY 571B (9.6V-\$150).
- Same models available with 15-minute chargers.

MANUFACTURERS' LISTING

AEG 203/447-4600	Milwaukee 414/781-3600
Black & Decker 800/762-6672	Panasonic 201/348-5334
Bosch Look in your Yellow Pages under "tools"	Porter-Cable 901/668-8600
Hitachi 404/925-1774	Ryobi 803/226-6511
Makita 714/522-8088	Sears Call your nearest store
Metabo 215/436-5900	Skil 312/286-7330



**Ryobi
TFD 150 VR**

EXHIBIT



This clever, inlay-adorned turning project has lots going for it. Not only does it make a terrific gift for anyone who has collectibles to showcase, it's also a snap to turn. And best of all, you can do it all for under \$16.

 Print this article

Form the base lamination, and cut it to shape

1 Rip and crosscut two pieces of $\frac{3}{4}$ "-thick walnut to 8×8 ". With the edges and ends flush, glue and clamp together the two pieces as shown in the drawing at *right*.

2 Mark diagonals to find center on the *bottom* side of the walnut lamination. With a compass, mark one circle the same diameter as your faceplate (we used our 3" faceplate) and a second circle with a $3\frac{7}{8}$ " radius ($7\frac{3}{4}$ " diameter) where shown on the drawing at *right*.

3 Cut the walnut base to rough shape on a bandsaw.

4 Center your faceplate on the smaller-diameter circle, drill pilot holes, and screw your faceplate to the bottom of the lamination.

Turn the base to shape

1 Turn the base to a $7\frac{3}{8}$ " diameter with a gouge and a lathe speed of about 750 rpm.

2 With the lathe running, find and mark the centerpoint on the top face of the walnut base with a pencil. Stop the lathe, and use a compass to mark the inside glass-groove radius ($2\frac{3}{8}$ ") and the outside glass-groove radius ($2\frac{7}{8}$ "). (We set the compass, located the metal point at the marked centerpoint, and then turned the base by hand to mark the two concentric circles to locate the glass groove. See the Buying Guide for our source of the glass dome.) Center the dome between the marked lines to ensure the correct groove location.

3 Use a parting tool to form a $\frac{1}{4}$ " groove $\frac{3}{16}$ " deep. (We cut our groove slightly oversized; a tight fitting dome can crack if the base expands or contracts.) Check the fit of the dome in the groove.

4 Transfer the full-sized template pattern shown *above right* to posterboard. Cut the template to shape (we used an X-acto knife). Using the template as a guide, turn the

UNDER GLASS

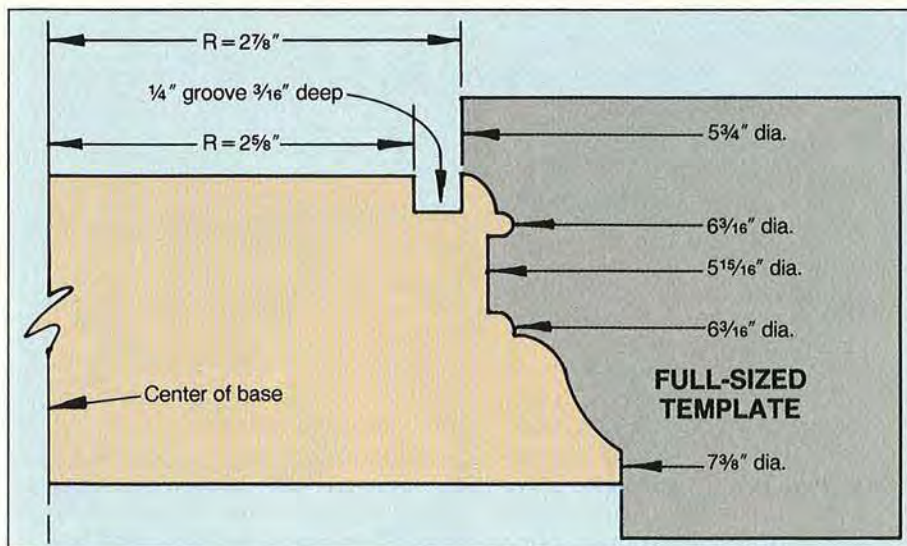
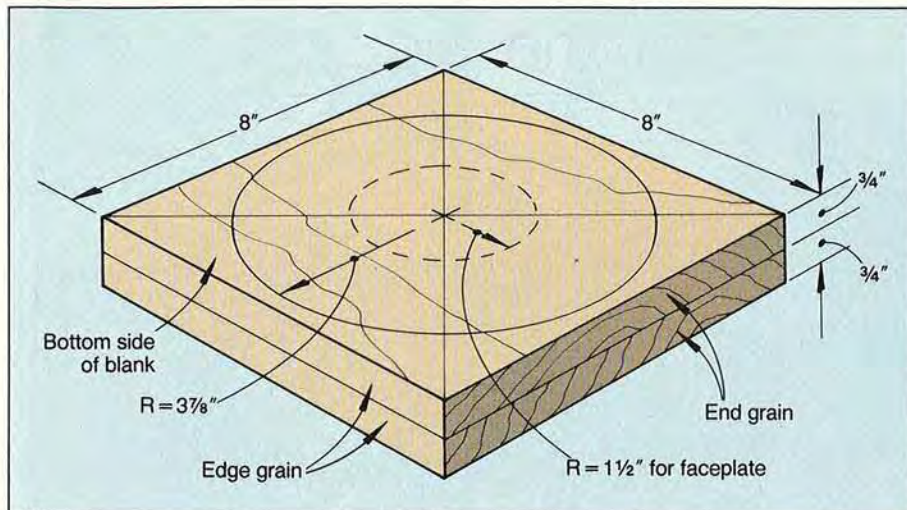

Stop the lathe frequently when turning the inlay-border groove with the parting tool to check the fit of the inlay.

base to shape, checking the diameters with an outside calipers. (We used a $\frac{3}{8}$ " bowl gouge and a parting tool to shape the edge of the base). When forming the groove for the inlay border, stop and check the fit of the inlay in the groove as shown in the photo *above right*.

4 Sand the base smooth, being careful not to widen the groove for the inlay border.

Add the inlay border, and then apply the finish

1 Apply a thin, even coat of glue into the inlay-border groove. Work-

ing your way around the base, fit the inlay border into the groove and hold it firmly in place with masking tape. (We applied tape about every 2".) With a hobby knife (again, we used an X-acto knife), cut the end of the border to fit snugly against the end already glued and taped in place. Wipe off excess glue with a damp cloth. Later, remove the masking tape and lightly sand the inlay smooth with 320-grit sandpaper.

2 Remove the base/faceplate assembly from the lathe, and then remove the faceplate from the base.

With putty or a walnut dust and glue mixture, fill the screw holes in the base bottom. Apply several coats of clear finish to the base (we used spray-on lacquer), being careful not to get an excessive amount in the glass groove.

Buying Guide

• **Dome and inlay.** 5 1/2"-dia. dome 11" high and a 36"-long inlay border. Catalog no. A2738-01, \$13.45 (U.S.) ppd. Mason & Sullivan Co., Dept. 2364, 586 Higgins Crowell Road, West Yarmouth, MA 02673. Call 508/778-1056 to order. ♣

A WARM WELCOME

from the old Southwest



Hey pardner, don't let the hand-carved look of this sign fool ya. Any greenhorn can rout and chisel this ol' doggie in less than 30 minutes flat.

Cut two pieces of $\frac{3}{4}$ "-thick, straight-grained, clear pine to 6" wide by 10" long. Glue and clamp the boards edge to edge with the surfaces and bottom ends flush. Later, scrape off the excess glue from the joint line and sand both surfaces smooth.

Using carbon paper, transfer the full-sized pattern to the wood. (For a bigger sign, enlarge the pattern on a photocopy machine with enlargement capabilities.) The bottom of the pattern should be 1" from the bottom edge of the lamination. Don't mark the detail lines; you'll add them later with a marking pen. Clamp the work piece to your benchtop or stick it with double-faced tape.

Chuck an $\frac{1}{8}$ " carbide-tipped straight bit into your router. Set the bit to cut $\frac{3}{32}$ " deep.



Rout next to the straight lines and borders first. Then, rout around the letters, plants, ground, clouds, and star. Next, rout away the excess material inside the letters. For the areas too small to rout—those marked with a dashed line—cut a V-shaped groove with a crafts knife or a carver's V-parting tool.

Create the hand-carved look by roughing up the flat routed area between the cacti and star, using different-sized bench chisels. Mark a 1" border around the sign, as shown in the sketch *opposite page, top right*.

Cut the perimeter of the sign to shape. Sand the cut edge to remove the saw marks. Rout a $\frac{3}{8}$ " round-over along the front outside edges of the piece. Sand smooth, removing any remaining carbon-paper lines or routing marks. Stain the entire sign, work-

ing the stain into all small corners with a 1"-wide foam brush. Let the stain dry.

To paint the sign, apply enamel or acrylic paints with a fine-tipped brush (we used a #4 sable). Let the paint dry overnight. Depending upon the paint and desired finish, you may want to give the colored areas another coat of paint. After the paint has thoroughly dried, highlight the detail lines on the cacti, letters and ground—where shown on the full-sized pattern at *right*—with a fine-point, black, felt-tip, permanent marker. Don't worry about your highlight lines exactly matching ours; be creative. Spray the front and back of the sign with a clear finish. Drill a mounting hole at a slight angle or nail a sawtooth hanger on the back of the project and hang. 🌵

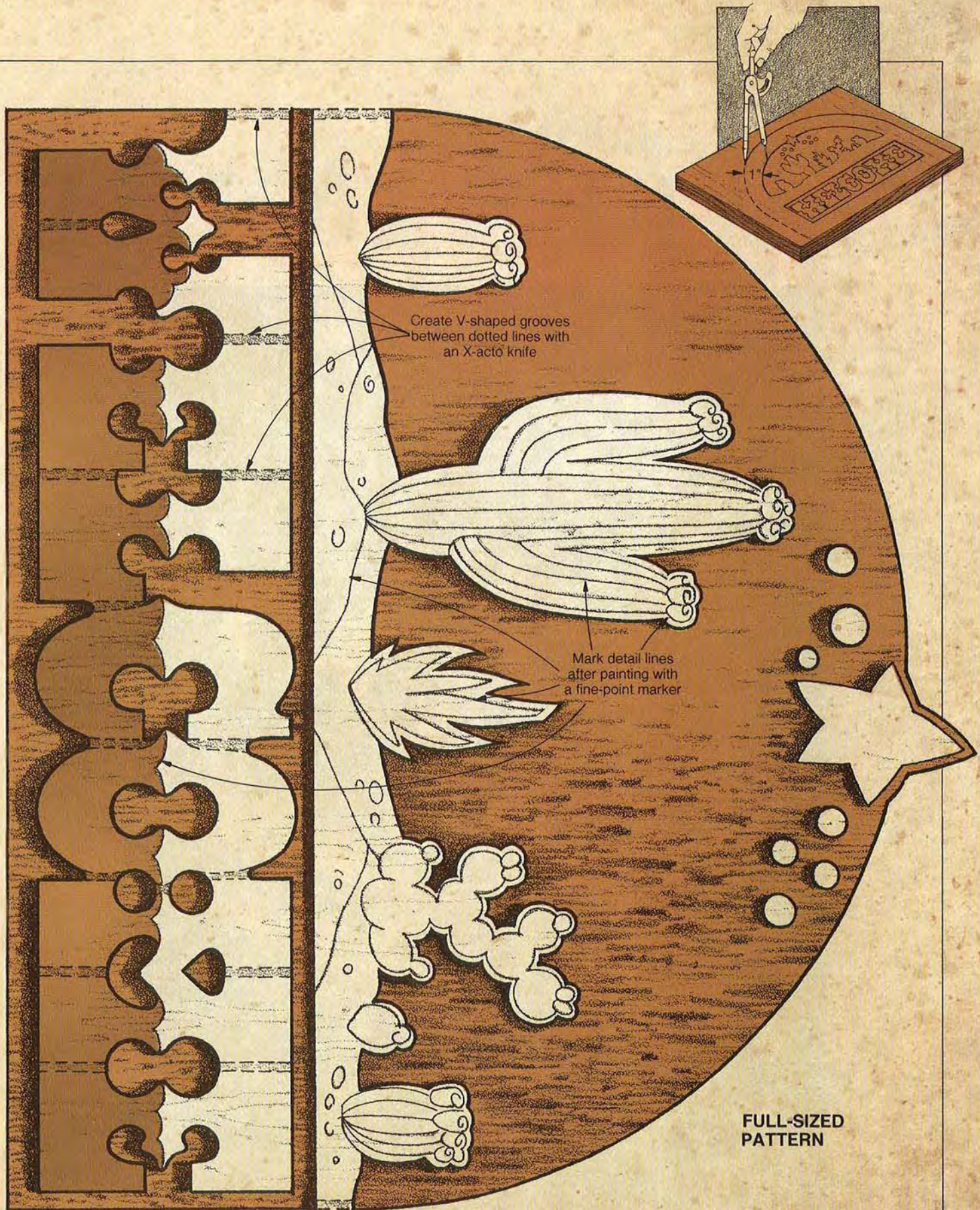

Create V-shaped grooves between dotted lines with an X-act® knife

Mark detail lines after painting with a fine-point marker

FULL-SIZED PATTERN



Stars-and-Stripes

 Print this article

WREN HOUSE



To make the front and back (A), start by cutting a piece of $\frac{3}{4}$ " stock to $5\frac{1}{2}$ " wide by 14" long, bevel-ripping the edges at 45° . Next, cut two $6\frac{1}{2}$ "-long pieces from this board. Place these two pieces on a flat surface, beveled edges down, and lay out the roof-line on each (see the Exploded-View drawing for dimensions). Make the roof cuts.

For the sides (B), cut a piece of $\frac{3}{4}$ " stock to 6" wide by 8" long, bevel-ripping the edges at 45° . From this piece, cut the sides to their $3\frac{3}{4}$ " finished length.

Using $\frac{1}{2}$ " stock, cut the roof pieces (C) to $7\frac{1}{4}$ " wide by 6" long. Bevel one end of each for a 5" finished length. Transfer the full-sized star pattern to $\frac{1}{4}$ " stock, and cut the two stars to shape.

Drill three $\frac{3}{8}$ " ventilation holes in the back piece and a $1\frac{1}{8}$ " entrance hole in the front. With the bottom edges flush, glue and nail the sides between the front and back pieces.

Measure the opening, and cut the bottom (D) to size, less $\frac{1}{16}$ " in length and width. (We made the bottom slightly smaller than the opening, and installed it with screws to make it removable for annual cleaning.) Drill a $\frac{1}{4}$ " drainage hole in each corner of the bottom piece. Drill the shank and pilot holes, and screw the bottom in place.

Paint the house and two wooden stars antique white and the roof soldier blue. Allow the paint to dry. To paint the stripes on the side pieces, adhere $\frac{3}{4}$ "-wide masking tape to the birdhouse, spacing the tape $\frac{3}{4}$ " apart. Paint the stripes barn red. Transfer the full-sized small star patterns to the house front and paint them soldier blue.

Nail the roof pieces to the assembled house. To age the house, lightly sand the edges. Apply medium walnut stain to the birdhouse, and immediately wipe off most of it. Nail the stars to the one side of the roof. 🌿



To perch or not to perch

John Dennis, contributing editor to *Bird Watcher's Digest*, offers the following advice concerning perches: DON'T include them! A bird can easily land on the entrance hole and go into the nesting box from there. Decorating your birdhouse with a perch provides birds such as sparrows and starlings a vantage point from which they can take over the house for themselves. These mischievous birds have been known to destroy the eggs or kill the young nesting inside.

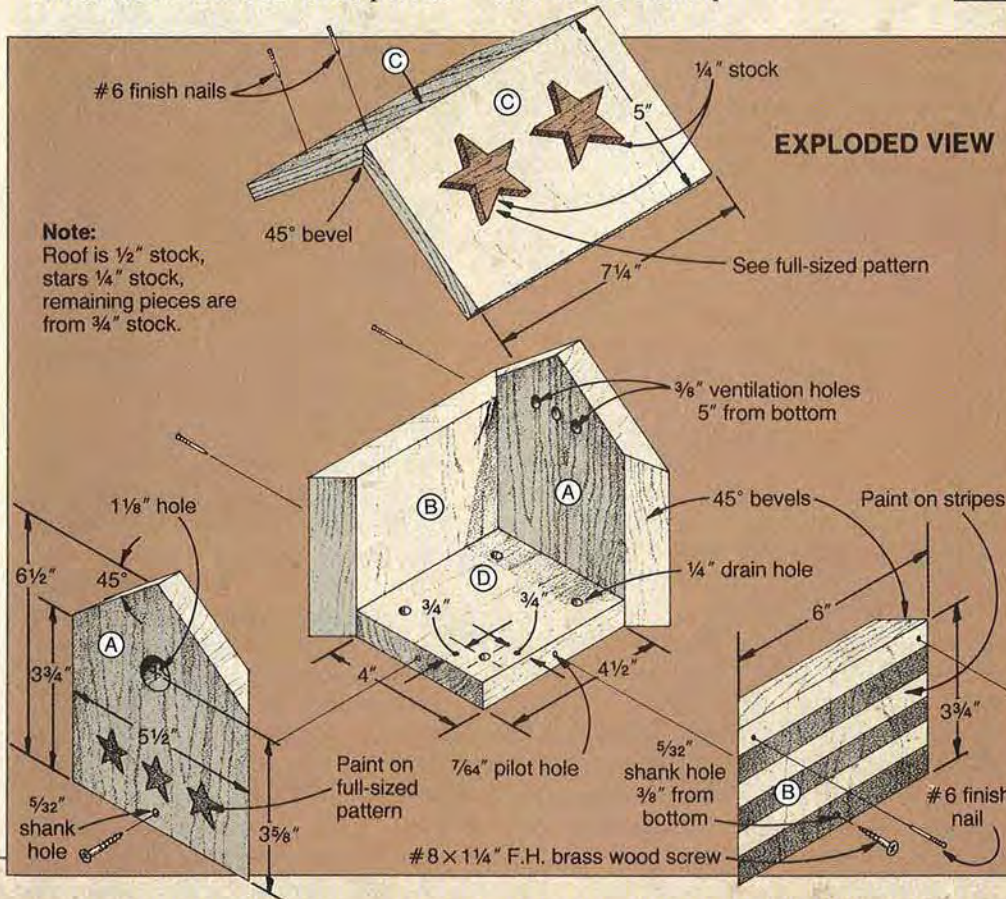

Project Design: Bob and Carolyn Reichert, 100% Pure Country, Waterloo, Iowa. Photograph: Hopkins Associates. Illustrations: Jamie Downing; Jim Stevenson



A mantel clock with classic good looks

MARBLEIZED MASTERPIECE

Coupled with our marbleizing technique on page 76, you can create this stately timepiece from the pauper of woods—particleboard. The finish looks so realistic that only the clock's light weight reveals its true identity.

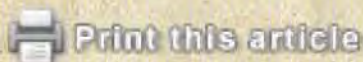

From $\frac{3}{4}$ " particleboard, cut three pieces to $5\frac{1}{4}$ " wide by 12" long. On each piece, mark a centerline between the ends, and then mark a line across the centerline $2\frac{3}{8}$ " from the bottom edge.

Chuck a circle cutter into your drill press, and position the blade where shown in the Cutter detail to cut a $2\frac{7}{8}$ " hole (we test-cut scrap to verify the hole size). Position one of the pieces of particleboard so the pilot bit centers over the marked centerpoint. Clamp it to the drill-press table, and bore a $2\frac{7}{8}$ " hole through it as shown in the photo at *right*. Adjust the cutter and cut a $3\frac{1}{2}$ " hole in each of the two remaining pieces.

Reverse the blade tip so it's on the inside (opposite of that shown in the detail), and then adjust the cutter and cut a $2\frac{7}{8}$ " plug. The plug should fit snugly into the hole in the clock. Enlarge the $\frac{1}{4}$ " shaft hole in the plug to $\frac{3}{8}$ ".

Spread an even coat of glue on the mating surfaces, and glue and clamp the three pieces face-to-face with the edges and ends flush. Check that the two $3\frac{1}{2}$ " holes align and that the $2\frac{7}{8}$ " hole is centered inside the $3\frac{1}{2}$ " hole. Use clamp blocks to prevent denting the particleboard. Later, remove the clamps and sand the bottom surface of the lamination flush.

Transfer the half pattern at *right* to the front of the lamination. Turn the pattern end for end and lay out the other half of the shape. Bandsaw the perimeter of the clock to shape, cutting just outside the marked line. Now, sand to the line to finish the shaping.

Rout a $\frac{3}{8}$ " rabbet $\frac{1}{8}$ " deep on the backside of the clock blank to house the $\frac{1}{8}$ " hardboard backing. Switch bits, and rout $\frac{3}{8}$ " chamfers on the clock where shown on the Exploded View drawing. Carefully mark the location of the four

timing dots on the plug, and drill a $\frac{3}{16}$ " hole $\frac{1}{16}$ " deep at each mark. Glue the plug in place where shown on the Section View detail at *top right*, being careful to position the plug so that the 12 and 6 o'clock marks are straight up and down.

Using a compass, mark a $4\frac{3}{16}$ " circle on a piece of $\frac{1}{8}$ " hardboard, and cut the piece to shape for the movement cover. Next, drill three $\frac{3}{64}$ " shank holes through the hardboard and $\frac{3}{32}$ " pilot holes in the back of the clock.

Fill the edges of the particleboard. (We used Durham's Rock Hard Putty.) Sand the clock body.

Marbleize the clock and backing—see pages 76–77 for how to do this. Add the timing dots and movement, and screw the hardboard back in place. Trim the hands to the lengths stated on the Exploded View drawing and add them to the clock shaft.

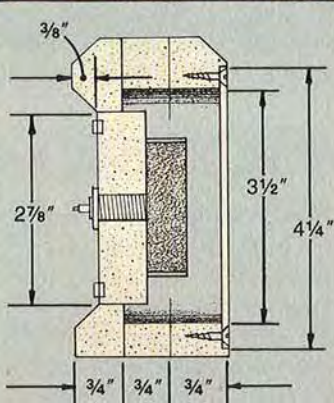

SECTION VIEW DETAIL

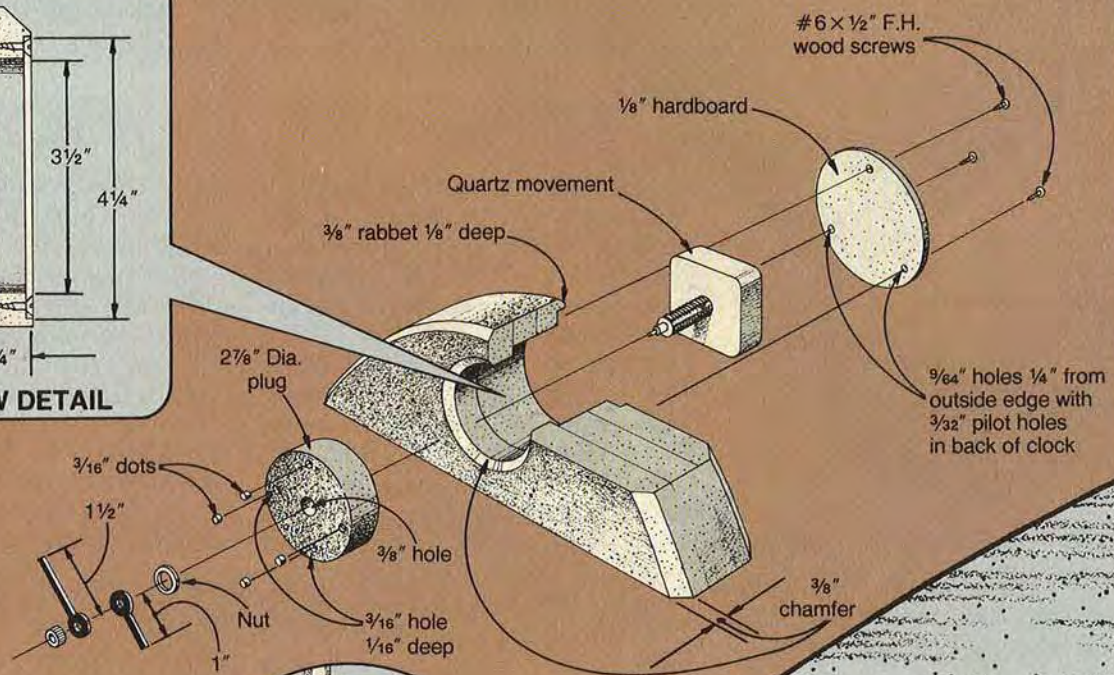

EXPLODED VIEW

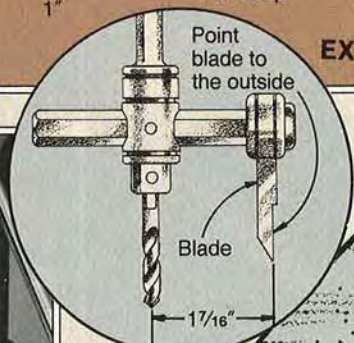

CUTTER DETAIL

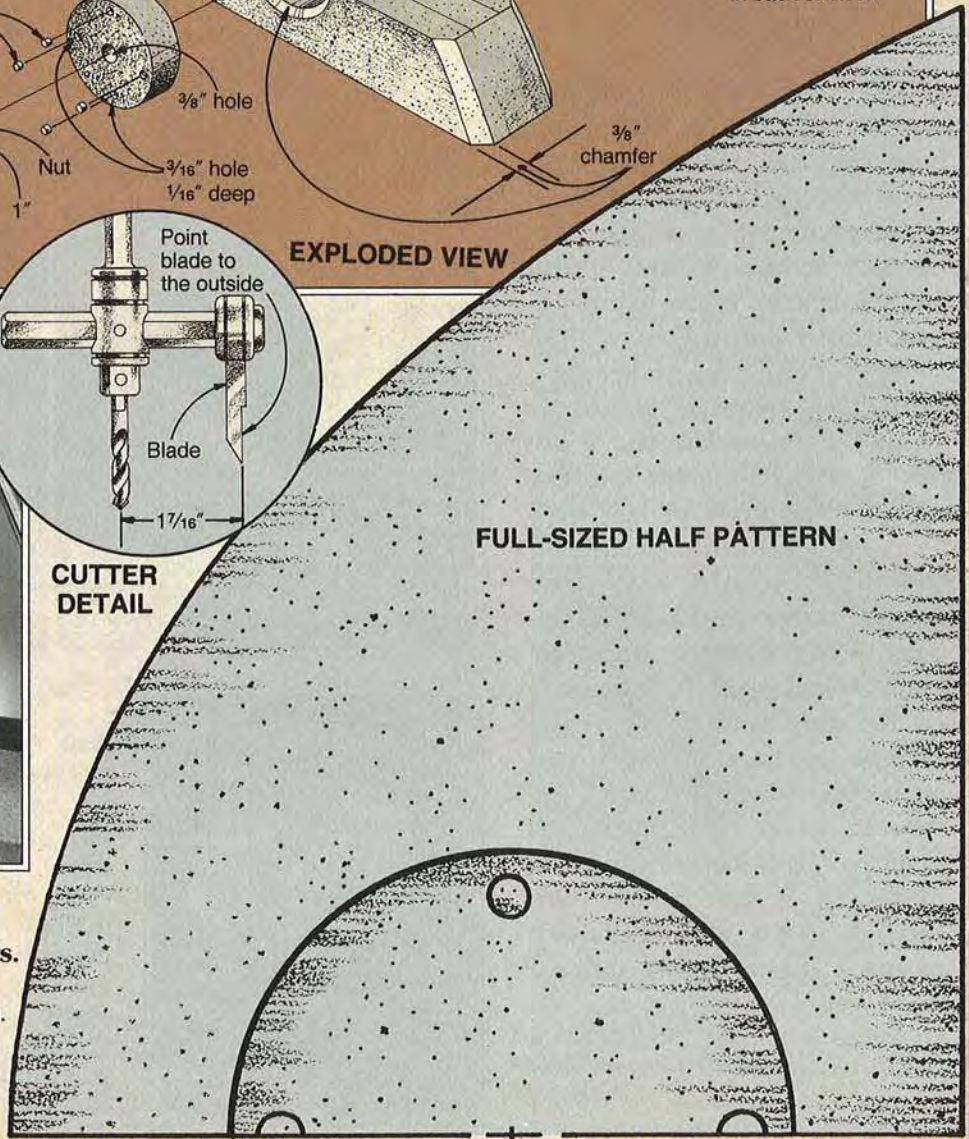
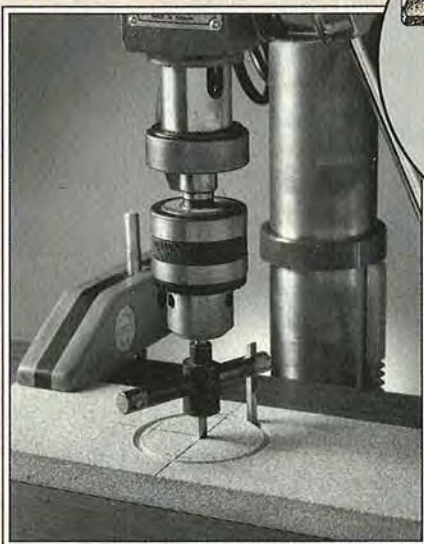

FULL-SIZED HALF PATTERN

Buying Guide

• **Movement, hands, and dots.**
 Mini-quartz movement, black hands, and timing dots. Kit no. 71058, \$9 ppd., Klokit, P.O. Box 636, Lake Geneva, WI 53147. Or, call 800-556-2548 to order. ●

Project Design: James R. Downing

Photograph: Hopkins Associates

Illustration: Jamie Downing; Jim Stevenson

They look so real you can't PAINTED

STEP-BY-STEP TO A ROCK-SOLID

After just three practice pieces, I produced the granite-and-marble tabletop shown at *left above*. After you learn to marbleize, we'll walk you through the steps for a granite like finish.

Because of the strong adhesion qualities of water-based products, these procedures work well on most any material. (For the tabletop *above* and the marbledized clock on page 74, we chose particleboard because it cuts and shapes easily, and has a smooth surface.) After machining your pieces, be sure to fill all cut edges with putty as shown *below*, and sand flat the filled areas with 150-grit sandpaper.

2 With a high-quality nylon/polyester brush, apply successive coats of Amity white primer to the workpiece until the surface appears totally white (See the Buying Guide on page 78 for a source of supplies). Each coat should dry in about one hour, but we decreased the drying time to 15 minutes with the aid of a hair dryer set on *low* as shown *below*. Sand lightly between coats with 220-grit paper.

A few months ago, Chicago woodworker Bill Aitchison sent me the handsome little dish shown *above*. What's most impressive about this project, at least to me, is that he turned it from particleboard and painted it to look like marble and granite. As an experiment, I set the dish on my desk to see how many people it would fool. One after another, mem-

bers of the *WOOD*® magazine staff picked up the dish, only to be amazed at its light weight and particleboard construction. When Bill told me that anybody could learn to perform this wood-into-stone magic in a few hours with fast-drying water-based paints, I had to know more.

Bill Krier

Products/Techniques Editor

 [Print this article](#)



Bill Aitchison with a faux marble-and-granite tabletop.

Our master of deception

In his self-employed occupation as a refinisher/woodworker, Bill Aitchison has painted everything from metal doors to antique furniture, to look like everything from rough cedar to Italian marble. And, more than 30 years of experience have made him a real pro at this craft. Today, Bill passes along many of his secrets in two- and three-day seminars that cover 22 faux finishes. If you would like to attend such a seminar, give Bill a call at 708/422-4456.

tell the difference

STONE FINISHES

MARBLE LOOK

3 With a square stick of soft, compressed black charcoal, draw surface veins that look like concrete cracks or bolts of lightning. Draw the veins at a 45° angle across the surface as shown *below*. For a natural effect, apply light pressure to the charcoal, and try to shake your hand somewhat. Resharpener the charcoal stick now and then by dragging its tip across sandpaper.

This and the following two steps require some practice and patience, but your rate of improvement will amaze you. As you practice, pay attention to the pattern of the veins in the piece of genuine Palomino marble shown in the *bottom* photo.

4 Dip a piece of natural sponge with torn (not cut) faces into a shallow pan of Amity white primer, and lightly dab the entire work surface (in a random pattern) as shown *below*. The sponge will pick up some of the charcoal and spread it around the surface to blend the veins with the background. Lift the sponge straight up and down so you don't smudge the charcoal. Re-wet the sponge after 10 or 12 dabs.

hand and has no wrinkles on its bottom side. With this pad, blot the entire surface as shown *below left* to further blend the charcoal and paint. Again, be careful to lift the rag straight up and down.

Note: Because water-based paints dry quickly, don't waste any time between Steps 4 and 5. It helps to prefold the rag and set it aside before starting Step 4.

6 After the paint dries, again dip the sponge into the white primer and sparingly dab small, random areas of the surface. Try to "bury" portions of the veins and lighten the larger white areas between the veins. This and the following step add depth and realism to the marble. Reblot the surface with a rag as described in Step 5.

7 Accentuate the veins by slightly darkening about half of them with charcoal as shown *below*. Lightly sponge and blot the surface as described earlier in Steps 4 and 5.



5 Fold a clean cotton rag that has little pattern or "weave," (a worn diaper works fine) so it fits into your

8 To make the surface look like polished marble, apply at least three coats of a gloss water-based finish such as Amity gloss lacquer. (For more information on water-based finishes, see page 42.)

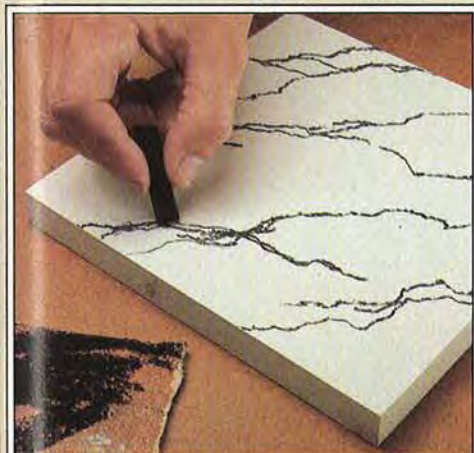
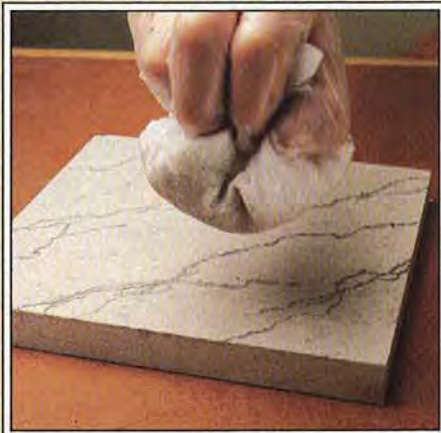

Continued

PAINTED STONE FINISHES

GRANITE: THE PERFECT COMPLEMENT TO THE MARBLE LOOK

The granitelike effect shown on our tabletop makes a great border or trim for a marbleized surface. As you work, strive for a mottled look of black, gray, and white specks. We made the top on page 76 from five separate pieces for a realistic tiled look.

1 Prepare and prime the surface as described in Steps 1 and 2 in the marbleizing section. Into a shallow pan, pour separate pools (about 1 oz. each) of Amity black and white primer.

2 Dip a natural sponge into the black primer and lightly dab the entire surface as shown at *top left*. Apply the black randomly and sparingly, being careful to move the sponge straight up and down.

3 With some black paint still on the sponge, immediately dip it into the white primer and mix the two colors in another area of the pan as shown at *top right*. Dab the surface with this mixture as shown at *bottom right*.

4 Blot the surface as described in Step 5 of the marbleizing procedure. By this point, you should have a surface that appears to be a random mix of black, gray, and white specks. If you're not satisfied, just re-sponge the surface.

5 Add a clear finish as described in Step 8 of the marbleizing technique.

Buying Guide

• **Faux stone kit**, including one pint each of black and white paints, natural sponge, and charcoal, \$15. One quart of brushable clear lacquer (specify satin or gloss) \$10.95. Add \$5 postage per order. Call Amity at 800-334-4259 or 608/837-8484. ♣



Written by Bill Krier

Photographs: Hopkins Associates; John Hetherington

THE DOUBLE-CRANK BRACE

THE TOOL THAT REVOLUTIONIZED DRILLING



Left to right. James Howarth metallic-frame brace, brass with ebony, Sheffield, England, about 1860, \$400; primitive American all-oak brace, late 17th or early 18th century, \$100; American all-metal brace, factory made by John S. Fray Co. about 1900, \$50.

Unlike many tools that evolved from crude predecessors, the double-crank brace mysteriously showed up in early 14th-century Europe as a tool unto its own. Some historians suggest that the Crusaders brought it from the Middle East.

Prior to the brace's appearance, woodworkers used slow-performing, T-handled augers to make large holes, and pump-and-bow drills for smaller ones.

A new concept is born

On some primitive braces, the head (see drawing, *right*) was sometimes a separate piece of wood that the driller strapped to his chest. More often, though, the head attached to the brace and turned independently. The pad, or

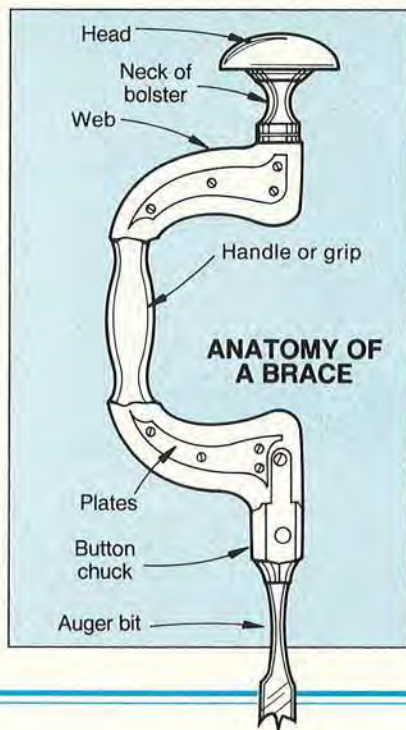

socket, accepted the bit. However, even into the 17th century, the bit was permanently attached to the pad, so a tradesman needed to carry a brace (bitstock) for each size of hole.

Eventually, replaceable bit pads evolved, held in place by brace pressure on the workpiece. By the 1800s, other bit-security mechanisms were invented, including crude chucks with thumbscrews and push-button releases.

Brace bodies, at first made entirely of a stout wood such as beech, were reinforced by the addition of metal plates. Today, collectors call these plated braces.

In 1848, John Cartwright received a British patent for a beautiful and functionally improved brace. It consisted of a heavy, cast-brass frame fitted with wood, with a thrust bearing at the head, a metal chuck for interchangeable bits, and a rotating wrist. William Marples, a Sheffield, England, tool manufacturer, began offering the new brace in 1850, calling it the "Ultimatum." It certainly was. Made of ebony, boxwood, or rosewood, it cost 23 shillings, nearly the weekly wage for a carpenter at the time. Plain wooden braces cost a mere nine shillings.

Improvements by the score

As industrialization enveloped America, new ideas for the brace blossomed. In the second half of the 18th century alone, more than 300 brace designs and improvements were patented. Chucks and other mechanisms for holding bits were improved repeatedly. A monumental innovation in 1859 was the Spofford brace, featuring a split-socket chuck with thumbscrew.

But, topping them all was the invention of the shell-type chuck with adjustable jaws on an all-iron brace. Named the Barber brace, it was first manufactured in 1865 and soon dominated the market. ♣

Written with Philip Whitby
Photograph: Hopkins Associates
Illustration: Jim Stevenson

TRAINS, PLANES, 3 great scrollsaw patterns

Capture the spirit of America on the move with these stylish silhouettes from the past. They're just right for your den or office.



& AUTOMOBILES

NOSTALGIC LOCOMOTIVE

Let's take a ride on the railroad. The steam locomotive expanded commerce and carried the load for the great westward movement starting late in the 19th century.

Ready your stock

Plane or resaw a $3\frac{1}{2} \times 30$ " piece of oak to $\frac{1}{4}$ " thick to make the silhouettes, and a $5\frac{3}{4} \times 36$ " walnut board to $\frac{5}{8}$ " thick for the plaques. Crosscut 8", 10", and 11" lengths from the oak. Then, cut 10", 11", and 12" lengths from the walnut.

Rout along the edges of the three walnut plaques with a $\frac{5}{32}$ " roman ogee bit. Cut a hanging slot in the back of each with a router and keyhole bit. (We cut a centered horizontal slot about 2" long, $\frac{3}{4}$ " from the top edge of the plaque.)

Apply the patterns

Photocopy the full-sized patterns, *right*, and on *pages 82-83*, and then attach them to the $\frac{1}{4}$ "-thick oak stock with spray adhesive. Adhere the biplane pattern to the 8" oak piece, the car to the 10" one, and the locomotive to the 11" one. Insure that the pattern is smooth and secure.

Continued

TRAINS, PLANES, & AUTOMOBILES

OLD-TIME CAR

Packard offered motorists power and prestige when this 1926 model rolled off the line. Their motto: "Ask the man who owns one."

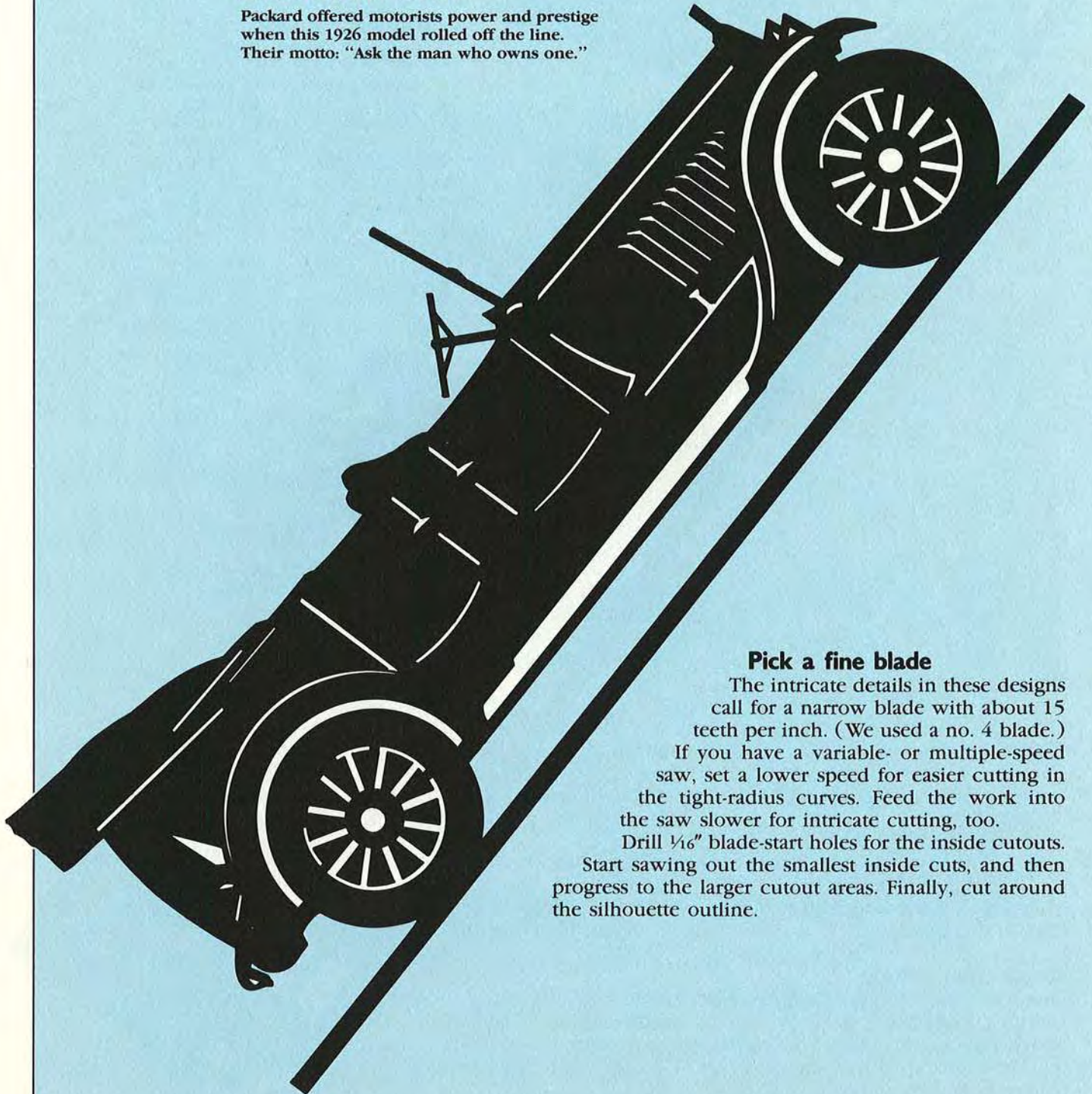

Pick a fine blade

The intricate details in these designs call for a narrow blade with about 15 teeth per inch. (We used a no. 4 blade.)

If you have a variable- or multiple-speed saw, set a lower speed for easier cutting in the tight-radius curves. Feed the work into the saw slower for intricate cutting, too.

Drill $\frac{1}{16}$ " blade-start holes for the inside cutouts.

Start sawing out the smallest inside cuts, and then progress to the larger cutout areas. Finally, cut around the silhouette outline.

EARLY BIRD

The Wright brothers started it all with a biplane, and two wings were the standard for almost four decades of flight.



Put them on plaques

With the cutting completed, carefully remove the paper patterns and sand the silhouettes as needed. Be careful when sanding thin sections such as the car's windshield. Sand the walnut plaques.

Center the locomotive cutout on the 12"-long plaque, mark the location, then apply woodworker's glue sparingly to the back of the silhouette. Clamp it to the plaque with handscrew clamps. Center and attach the automobile to the 11" plaque, and the airplane to the 10" one. When the glue has set, apply a clear oil finish. 🌲

Pattern design: Elaine Hutcheson, Paper Cut Art, Virginia Beach, Va.
Photograph: Hopkins Associates
Illustrations: Mike Henry

SAVE MONEY!

KILN DRY LUMBER



MAKE MONEY!

Kiln Dry for others. As the nation's largest manufacturer of dehumidification Dry Kilns, we can supply you with the same type equipment used by many of the major firms.



Call or write today for free facts that will help you make and save money.

1-800-777-NYLE
Nyle Corporation

207-989-4335
P. O. Box 1107, Bangor, Maine 04401



4 POWER-FED TOOLS IN 1

Plane • Mold • Saw • Sand

FACTORY DIRECT



Now you can use this ONE power-feed shop to turn rough lumber into moldings, trim, flooring, furniture - All popular patterns, Rip-Plane-Mold & Sand ... separately or in combination with a single motor. Low Cost ... You can own this power tool for only \$50 DOWN!

30 DAY FREE TRIAL!

RUSH COUPON TODAY!



Foley-Belsaw Co.
6301 Equitable Rd.
Kansas City, Mo. 64120

YES, Please send me complete facts about your PLANER-MOLDER-SAW-SANDER and details about 30-Day Trial offer and that I will receive your quarterly Woodworking Catalog Dept. 91617

NO, I'm not interested in a Foley-Belsaw PLANER-MOLDER-SAW-SANDER, but please send me your Free Woodworking Catalog. Dept. 44152

Name _____

Address _____

City _____ State _____ Zip _____

TOOL-INDUSTRY INSIDER

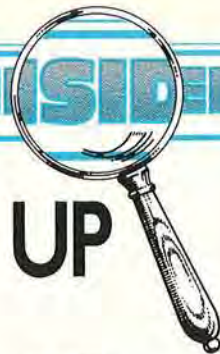

COMING RIGHT UP

SHORTER CHARGING FOR CORDLESS TOOLS



Already, companies here in the United States and abroad offer the new 15-minute charging system. Ten- and 5-minute systems aren't far behind.

If there's one thing that frustrates owners of cordless power tools, it's having to wait—often an hour or more—for recharging. Fear not, help has arrived!

While researching the battery-powered drills article for this issue (see page 62), we talked to several manufacturers who said to expect charging times to come way down. In fact, Panasonic and Ryobi already have 15-minute charging systems for sale in the U.S. market. And, according to Doug Bock of Panasonic, other manufacturers will soon join the club. "Several other companies, including Bosch, Makita, and Hitachi, have 15-minute chargers in overseas markets. It won't be long before we see those here."

Many innovative tools make a later debut in the U.S. because most manufacturers work to list their tools with Underwriters Laboratory. Often, this listing requires the company to make time-consuming modifications.

We also learned that Metabo introduced a 10-minute charger in

January that accepts batteries from older-model Metabo cordless products (Panasonic's system requires 15-minute batteries and chargers). Steve Jost of Metabo tells us the new "cold charger" will triple the life span of batteries from 1,000 cycles (a complete discharge and recharge) to 3,000 cycles. How? Metabo's charger eliminates life-shortening heat during charging.

What's next? "We're working on a five-minute charging system. It's not far away," Panasonic's Bock added. This new technology, wonderful though it is, doesn't come cheap. For example, Panasonic's 15-minute system adds \$40-\$50 to the cost of the same drills with 60-minute chargers and batteries.

What does all this mean to you? Plenty, if you're the type who values quality time spent in the shop, or on the job, with cordless tools. The time you save may very well overshadow the added expense. And if you decide to hold off for now, you may find this technology becoming more affordable in the coming years. ♣

Illustration: Jim Stevenson



P
L
A
N
S



#18 1930 MODEL "A" ROADSTER \$6.95

#10 MONSTER TRUCK \$4.95

STICKLER FOR DETAIL? At last, an exciting new line of REALISTIC Wood Block Models that you can build with your own scrap wood & dowels, and my easy to follow instructions.

ANTIQUE MODEL "A" ROADSTER - (over 12" in length, 8" high) No special wheels or lights required to purchase. Plans include instructions to make all parts. Operational parts include a unique steering with connecting steering wheel, folding luggage rack, an operating rumble set, and turning wheels. Details from 16 spoked wheels (6 each) complete frame assembly, optional top "up" or top "down", kerf-lined seats, door handles (inside & out), lights, license plates, partial engine assembly and much more.

MONSTER TRUCK - measuring over 14" long, 11" high, with 5 1/4" x 4 1/2" monster wheels, 16 shock absorbers, 5 ton military rears, & rear axle supports. Details from engine, transmission, transfer case, & oil pan to K.C. Lights & mirrors.

Send U.S. check or U.S. money order in the above amount to: Gatto Plan Supply, Box 1568, R.D. #1, Hamburg, PA 19526 215-488-6932

ROUTER SHOP II Put Your Router Back to Work

REG \$369

Made To Fit All Saws



Make Your Router Work For You - Thousands of And Hobbyists These Are Two Tools Made

Table Saw Find Out Why Professionals Alike Say Of The Finest Today

YOUR CHOICE \$299

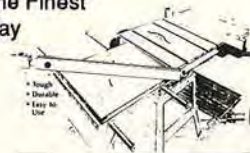

CALL 1-800-535-8665
REG OR MAIL TO \$399 RBIndustries

Box 369 Harrisonville, MO 64701

The **MULE** Sliding Table

Offer Expires 3/29/91

A01

Classic Folding CHAIRS

Set of 3 plans for only \$15.95

(free shipping/handling)



Authentic Civil War Camp Chair

Canvas Sling Deck Chair

Easy to make from our completely detailed, step by step professional plans and full size templates. Each chair designed to fold for convenient storage.

We accept Visa or MasterCard

Send check or money order to: Annapolis Design Group P.O. Box 2790, Dept. B Columbia, MD 21045 (301) 787-7274

Maryland residents add 5% state sales tax

DOMESTIC & FOREIGN HARDWOODS

Quality stock for Cabinet Work Most all sizes from 1" to 4" in thickness

HARDWOODS

ASH—BASSWOOD—BIRCH BUTTERNUT—CHERRY CHESTNUT—EBONY—MAPLE OAK—POPLAR—ROSEWOOD TEAK—WALNUT Also hardwood plywoods

SOFTWOODS

SUGAR PINE—CYPRESS—CEDAR SPRUCE—DOUGLAS FIR etc. MAURICE L. CONDON CO., INC. 242 Ferris Ave., White Plains, NY 10603 914-946-4111 Monday through Friday 8 AM to 4:30 PM

FOR INFORMATION ABOUT PLACING AN ADVERTISEMENT IN

Better Homes and Gardens®

WOOD

PLEASE WRITE:

BILL REED, WOOD MAGAZINE 750 THIRD AVENUE, NEW YORK, NY 10017

OR CALL COLLECT: 212-551-6904

NEW!

MAJOR ADVANCE IN FORSTNER BIT DESIGN

SAW TEETH ELIMINATE OVERHEATING & BURNING AND CUT FASTER WITHOUT ANY LOSS OF FORSTNER BIT FUNCTION



#10-1336	10-pc. Set	1" to 2 1/8"	All Saw Teeth	\$ 84.99
#10-1350	8-pc. Set	2 1/4" to 3 1/8"	All Saw Teeth	139.99
#10-1330	16-pc. Set	1/4" to 2 1/8"	Saw Teeth over 1 1/2"	89.99
#10-1325	7-pc. Set	1/4" to 1"	Conventional Style	29.99

3/8" Shanks up to 2 1/8"; 1/2" Shanks on larger sizes. All Sets In Handsome Wood Cases.

SUPERIOR BRAD POINT DRILLS



#06-1000	High Speed Steel 7-pc. Set w/ Stand/Case, 1/8" to 1/2"	\$19.99
#10-7777	Carbide Tipped 7-pc. Set w/ Wood Case, 1/8" to 1/2"	\$34.99
#06-2004	4-pc. Jumbo Set w/ Vinyl Pouch 5/8", 3/4", 7/8", 1"	\$14.99
#06-2005	5-pc. Jumbo Set w/ Vinyl Pouch add 9/16" to above	\$19.99

22-pc. HSS TAPERED DRILL COUNTERSINK/BORE STOP COLLAR SET



#05-0007

For Screw Sizes #5,6,7,8,9,10,12. Wood case included. \$29.99

"NO HASSLE 30-DAY MONEY BACK GUARANTEE"

VISA/MC TOLL FREE 1-800-666-7227 Dept. WM31 (Incl. Canada)

DOLLAR TRADING CORP., Dept. WM31, P.O. Box 68666, Indianapolis, IN 46268

(Shipping & Handling only \$4.00 first item, \$2.00 each additional. IN and CT Buyers Please Add Sales Tax)



Keep your cordless drill, charger, and bits close at hand—without sacrificing valuable work space—with this wall-hung rack.

Build as shown at right. To fasten the charger to the top shelf, remove the screws securing the feet to the charger case and replace them with longer ones of the same diameter.

Markus Kemmet

How-to Editor

CORDLESS-DRILL ORGANIZER

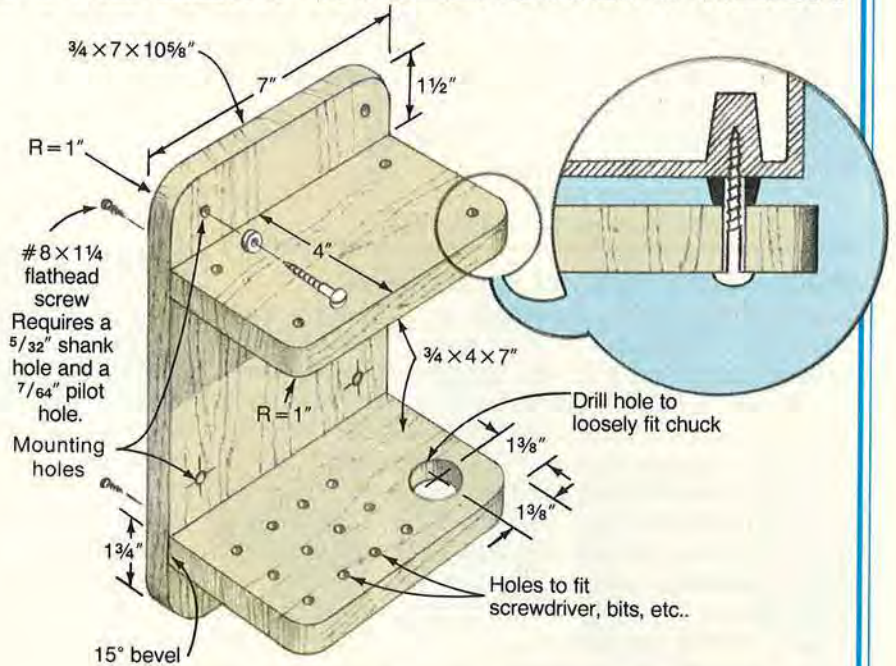

Photograph: Hopkins Associates Illustration: Jim Stevenson

REGGIE RABBIT

This whimsical Door Harp is a 'must' for the rabbit lover. Parts kit includes necessary parts including plywood. No 3/4" stock included.

#01315 Plans 3.00
#04315Z Plans and Parts Kit 8.00



MID-WINTER SALE

Prices good through 4-30-91

TURNINGS

#16001 3-1/2" Shaker Pegs 12.00/100
#16006 3-1/2" Oak Shaker 25.00/100
#16021 2-1/2" Shaker Pegs 11.50/100
#16041 1-3/4" Shaker Pegs 5.00/100
#18031 Lg. Candle Cup 14.00/100
#18036 Lg. Oak Candle Cup .. 27.50/100
#18091 Brass Inserts 8.00/100
#13106 3/4" Ball 6.00/100
#13108 1" Ball 8.00/100
#13112 1-1/2" Ball 2.00/10
#13116 2" Ball 5.00/10
#14013 3/8" Button 1.50/100, 7.00/500
#14014 1/2" Button 1.50/100, 7.00/500
#15801 1-1/8" S1 Spindle 8.00/100
#15711 S11 Spindle 8.00/10, 40.00/50

DOOR HARP PARTS

#13156 3/4" Clapper Balls 7.00/100
#62501 Tuning Pins 14.00/100
#62515 Music Wire, 1/4# 9.95/Roll
#25561 8.5"x12" 1/8" Plywood 8.00/10
#04310 Standard Door Harp Kit 4.95/Ea, 13.50/3, 39.50/10
Includes: 8 tuning pins, 4 clappers balls, nylon cord, 2 pc. 9-1/2" x 12" plywood, music wire and sawtooth hanger.

INDUSTRIAL SCREWS

#S6260 #6x1" 1.10/100, 10.25/1000
#S6261 #6x1-1/4" .. 1.20/100, 11.50/1000
#S6262 #6x1-5/8" .. 1.60/100, 15.00/1000
#S6263 #6x2" 2.00/100, 19.75/1000

TREADED WHEELS Like the real Thing!

#11251 1-1/4", 1/4" hole 1.75/10, 5.75/50
#11252 1-1/2", 1/4" hole 2.00/10, 8.75/50
#11254 2", 3/8" hole 3.15/10, 14.25/50
#11264 2" Dual, 3/8" hi 5.25/10, 23.85/50

DOWELS - 3-FOOT

#15002 1/8" 2.50/25, 8.50/100
#15004 1/4" 4.75/25, 16.00/100
#15006 3/8" 7.50/25, 25.50/100
#15008 1/2" 2.55/5, 11.50/25

BULK PRICES AVAILABLE

WHEELS & AXLE PEGS

#10648 1", 1/4" hole 4.10/100
#10710 1-1/4", 1/4" hole 8.00/100
#10812 1-1/2", 1/4" hole 7.50/100
#10914 1-3/4", 1/4" hole 11.50/100
#11018 2", 1/4" hole 8.00/50
#11018 2-1/4", 3/8" hole 4.50/20
#11020 2-1/2", 3/8" hole 6.50/20
#11022 2-3/4", 3/8" hole 7.50/20
#12001 7/32" AP1 3.10/100
#12004 11/32" AP4 1.50/20

CRAFTER'S MART

P.O. BOX 2342-W • GREELEY, CO 80632

64-Page CATALOG: \$2 with credit towards first order, Free with any order. Check, MasterCard or VISA (include daytime phone, card no., exp. date & signature). CO Res. add 3% tax. No C.O.D.s. PROCESSING CHARGE: Continental U.S. \$4; AK, HI, APO & FPO \$10; Canada \$18; Foreign 20% plus \$10 (U.S. Funds). PHONE ORDERS: 8am-5pm Mon-Fri - Mtn. Time. Info: (303) 351-0678

1 - 800 - 999-3445

Buy Direct From The Manufacturer And **SAVE!**

Buy 12 "EVER-LAST" Belts...
Get 12 Belts
FREE!



Need ROLLS, WIDE BELTS, DISCS, SLEEVES, STROKE BELTS, etc. Write for catalog.

Belts available in 36, 50, 60, 80, 100, 120, 150, 180, 220, 320 grit sizes.

Please specify grit sizes when ordering, otherwise an assortment will be supplied.

1" x 30" ... \$15.50/Doz. + 12 FREE
 1" x 42" ... \$15.70/Doz. + 12 FREE
 2" x 48" ... \$21.50/Doz. + 12 FREE
 2 1/2" x 16" ... \$17.50/Doz. + 12 FREE
 3" x 18" ... \$17.75/Doz. + 12 FREE
 3" x 21" ... \$18.75/Doz. + 12 FREE
 3" x 24" ... \$19.00/Doz. + 12 FREE
 4" x 21" ... \$23.50/Doz. + 12 FREE
 4" x 21 1/4" ... \$23.75/Doz. + 12 FREE
 4" x 24" ... \$24.00/Doz. + 12 FREE
 4" x 36" ... \$26.95/Doz. + 12 FREE
 6" x 48" ... \$35.95/1/2 Doz. + 6 FREE

Other size belts on request.

Belt Cleaning Stick \$4.95 each

For Fast Delivery Call Toll Free
1-800-428-2222 (U.S.A.)
1-800-222-2292 (PA only)

9" x 11" PAPER SHEETS

A/O or Garnet Cabinet Paper

	50 PACK	100 PACK
40-D	\$17.00	\$31.00
50-D	\$16.00	\$28.00
60-D	\$15.00	\$26.00
80-D	\$14.00	\$24.00
100-C	\$13.00	\$22.00
120-C	\$13.00	\$22.00
150-C	\$13.00	\$22.00
No Load Finishing Paper (White)		
120-C	\$14.00	\$24.00
150-C	\$14.00	\$24.00
180-A	\$11.00	\$19.00
220-A	\$11.00	\$19.00
280-A	\$11.00	\$19.00
320-A	\$11.00	\$19.00
400-A	\$11.00	\$19.00

SHIPPING CHARGES: \$4.50 Continental U.S.

MONEY ORDER CHECK
 MASTER CARD VISA

INDUSTRIAL BRASIVES CO.
643 N. 8th ST. • READING, PA 19612

Whether your woodworker's license reads "Beginner," "Intermediate," or "Advanced," you're bound to have a few questions about your favorite hobby. We can help by consulting our staff and outside experts. Send questions to:

Ask WOOD
Better Homes and Gardens®
WOOD® Magazine
P.O. Box 11454
Des Moines, IA 50336-1454

When your shop's not on the level

I love your projects, especially the stationary tools and tables. I'm in the process now of building your workbench featured in the September 1990 issue. I'm already anticipating the same problem that I have with my home-built tools and other stationary benches and tables—that is, they are not stationary.

Probably few of your readers enjoy the luxury of a perfectly flat or level workshop floor. My shop is in the basement, which means that because of a leaky wall, I sometimes get standing water.

Of course, I've tried shims, galvanized pipes, and flanges, all with marginal success. Can someone please come up with an adjustable, high-and-dry idea for making stationary power tools and benches live up to their name?

— Edward Mischnick, Detroit, Mich.

Ed, yours is indeed a familiar problem to many of our readers, particularly, those who have cracked and uneven basement or garage workshop floors. Besides skimming, we have two remedies for dealing with the "rockies"—that annoying and sometimes dangerous condition that causes tools and benches to wobble when in use.

The first and least expensive way involves cutting 2"- to 3"-long pieces of 2" angle iron, drilling holes in them for the needed hardware, and bolting them to the legs or corners of tools and benches where shown, right. Note here that you can adjust a corner's height by turning the slotted shaft of the carriage-head bolt with a screwdriver. You'll need to cut that slot with a hacksaw.

A second method in the case of stationary power tools is to purchase and attach adjustable machine bases. These come with wheels and locking mechanisms, allowing you to roll your tool out when you need it, and then push it alongside a wall when you're through. Two manufacturers make these: HTC Products, Inc. and Delta.

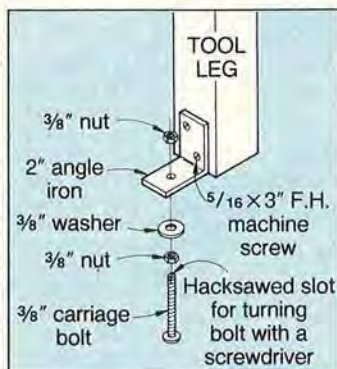

Turned wood that's safe for food

I am retired and work with wood as a hobby. I make bowls and other items as gifts. Could you tell me if there is a list of woods that I can safely use in bowls, goblets, and other containers for food?

— Ralph Easley, Cincinnati, Ohio

Ralph, you really can't go wrong with dense, tight-grained American hardwoods such as maple and cherry. But keep in mind that the application of a



safe sealing finish ranks as equally important. Leading woodturner Dale Nish says in his book Creative Woodturning that

"Kitchenware or other turnings used in contact with foods must have nontoxic finishes." As it turns out, practically all finishes—once fully cured—pose no threat to human health. With our kitchenware turnings, we frequently recommend Behlen's Salad Bowl Finish. This nontoxic product comes with a clean bill of health from the FDA. For one pint, #85006, send \$9 ppd. to Armor Products, Box 445, East Northport, NY 11731. (Orders from Canada, \$11.) Or you can call 516/462-6228.

Can you sell projects made from our designs?

I'm writing to find some answers. It has to do with the business-card box designed by Michael Mikutowski that was featured in your December issue, #39. I've made a small number of these boxes, which has stirred some interest with the people at my workplace. They recommended that I contact a distributor.

My questions are: Can I make and sell these boxes from the plans you've published without causing problems with your magazine or Mr. Mikutowski? And, are there any copyright restrictions preventing me from following through with a distributor?

— Doug Harris, Grand Rapids, Mich.

Doug, it delights us that you've received such high praise for the business-card boxes. Any business person would welcome such an item for a gift. Regarding the mass manufacture and distribution of these boxes for profit, we need to inform you of our policy.

Because this project was designed by an outside designer (someone not on our staff), you will need to negotiate your business interest with him. In a separate letter, we already have sent you Michael Mikutowski's address.

Regarding our own designs—and many of our projects fit into this category—you have our permission to build and sell as many of these projects as you like. Thanks so much for asking before acting. You did the right thing. 🌲

Compare this offer with any other book club for Price • Quality • Benefits • Selection!

An absolutely no-risk guarantee.



3167P \$14.95



3244 \$26.95
Counts as 2

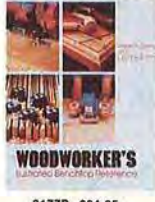

3177P \$24.95
Counts as 2



3255 \$26.95
Counts as 2



1122P \$14.95



3433 \$24.95

Select 5 Books for only \$4.95

(values to \$125.70)
and get a **FREE Gift!**



2704 \$24.95



3079P \$14.95

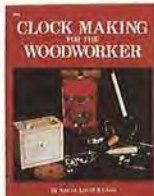

1648P \$14.95



3021P \$14.95

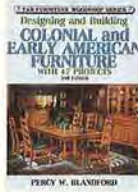

3014P \$12.95

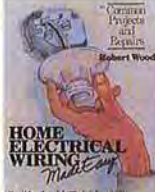

3072P \$16.95



3189 \$25.95



3264 \$24.95



9289 \$40.00
Counts as 3



2789P \$16.95



1971P \$12.95



3500 \$25.95
Counts as 2



3144 \$25.95



3058P \$15.95



3347 \$26.95
Counts as 2



3326 \$26.95
Counts as 2

Membership Benefits • Big Savings. In addition to this introductory offer, you keep saving substantially with members' prices of up to 50% off the publishers' prices. • **Bonus Books.** Starting immediately, you will be eligible for our Bonus Book Plan, with savings of up to 80% off publishers' prices. • **Club News Bulletins.** 15 times per year you will receive the Book Club News, describing all the current selections—mains, alternates, extras—plus bonus offers and special sales, with scores of titles to choose from. • **Automatic Order.** If you want the Main Selection, do nothing and it will be sent to you automatically. If you prefer another selection, or no book at all, simply indicate your choice on the reply form provided. You will have at least 10 days to decide. As a member, you agree to purchase at least 3 books within the next 2 years and may resign at any time thereafter. • **Ironclad No-Risk Guarantee.** If not satisfied with your books, return them within 10 days without obligation! • **Exceptional Quality.** All books are quality publishers' editions especially selected by our Editorial Board.

FREE when you join!

15 Practical Woodworking Projects From Percy Blandford

Fascinating projects from master craftsman Percy Blandford include toys, furniture, a go-cart, and more!



3404 \$26.95
Counts as 2

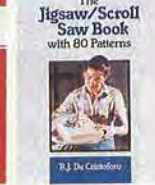

3269 \$27.95
Counts as 2



3064 \$21.95



3134 \$22.95



2994P \$12.95

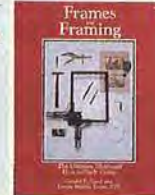

2909P \$12.95



3164 \$26.95
Counts as 2

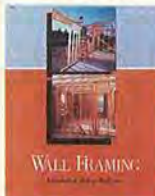

3097P \$14.95

HOW-TO BOOK CLUB

Blue Ridge Summit, PA 17294-0800

Please accept my membership in the How-To Book Club and send the 5 volumes listed below, plus my FREE copy of 15 Practical Woodworking Projects (3124P), billing me \$4.95. If not satisfied, I may return the books within ten days without obligation and have my membership cancelled. I agree to purchase at least 3 books at regular Club prices during the next 2 years, and may resign any time thereafter. A shipping/handling charge and sales tax will be added to all orders.

--	--	--	--

Name _____
 Address _____
 City _____
 State _____ Zip _____ Phone _____
 Signature _____

Valid for new members only. Foreign applicants will receive special ordering instructions. Canada must remit in U.S. currency. This order subject to acceptance by the How-To Book Club. WD391C

(Publishers' Prices Shown)
All books are hardcover unless number is followed by a "P" for paperback.

©1991
HOW-TO BOOK CLUB
Blue Ridge Summit,
PA 17294-0800

Create A
Family Treasure
with
Kuempel Chime
Red-i-Kut Kits



- Each case carefully handcrafted by grandfathers
- ¾" solid walnut, cherry or oak
- Precision movements - chime rods or tubular bells
- Handcrafted pendulums
- Individually hand-painted moonwheels
- Plans, kits, and finished clocks

Write or Call for
Catalog \$2.00

1-800-328-6445

Between
8 a.m. and 4 p.m. CST

Our 75th Year!

Kuempel Chime

Dept. 026, 21195 Minnetonka Blvd.
Excelsior, MN 55331



**APPALACHIAN
HARDWOODS**

Beautiful grain and textures. Exceptionally workable. Our Appalachian hardwoods are locally grown, personally selected and kiln-dried . . . a guarantee of our measure of quality. ■ We handle 21 species of domestic hardwoods, softwoods and hard-to-find imports. ■ Send \$2.00 for our catalogue today (refunded with order). All purchases at delivered prices. **EDLCO**

P.O. Box 5373-A, Asheville, N.C. 28813
For fast service, call 1-704-255-8765

Everybody talks
about the weather.
Now you can do
something about it.

1988 was one of the warmest years on record and global temperatures continue to rise. But instead of just talking about this environmental crisis, you can actually do something about it.

Join other Americans across the country in planting trees. You'll be shading your community and reducing heat-trapping CO₂ build-up in the earth's atmosphere.

For more information on how you can help, write Global ReLeaf, American Forestry Association, P.O. Box 2000, Dept. GR2, Washington, DC 20013.



You can make a world of difference.

Worth writing for...

You can get useful ideas and product information by mail. Use the coupon in this section to order your choice of literature listed below. Each company mails the catalogs or information directly to you.

POWER TOOLS

SCROLL SAW AND LATHE INFORMATION—More than 20 pages of information, including full-color photos, on HEGNER precision scroll saws, HEGNER lathes, and HEGNER duplicators. Find out why these machines are considered state of the art, and what to look for when shopping for scroll saws or lathes. AMI, LTD. \$1.00. *Circle No. 3.*

WOODWORKING PROFESSIONALS ONLY—Now save 50% on machinery, 70% on operating costs! How? By using the world's finest production quality universal machine. Commercial durability, utmost precision, set-up in seconds. No other tool combines usable capabilities like FELDER. Thousands sold all over the world. Now available in America through AMI. Send for brochure. AMI LTD. \$1.00. *Circle No. 4.*

TOOL CRIB OF THE NORTH IS ANNOUNCING OUR NEW CATALOG—It features a wide selection of merchandise for your home woodworker to your industrial builder. Top manufacturers such as Black & Decker, Delta, Makita, Porter Cable, Bosch, Milwaukee, Ryobi, Freud and many more. We offer competitive prices with quality service and same day shipping. Send today for your new Acme Electric catalog. It's worth it. ACME ELECTRIC. \$2.00. *Circle No. 6.*

PORTABLE SAW MILL—a one man saw mill weighing 45 lbs. Gas and electric models will cut dimensional lumber from logs up to 20 in. diameter. Send for brochure. BETTER BUILT CORP. Free. *Circle No. 10.*

175-PLUS USES GUIDE—for Dremel Moto-Tool. Written from the do-it-yourselfer's view, this book shows how to plan and do a variety of everyday projects using the versatile Moto-Tool and cordless Freewheeler. 96-page book with over 275 photos includes tips on using Moto-Tool with flex-shaft, drill press, router attachment, chainsaw sharpening attachment, shaper/router table. DREMEL. \$4.00. *Circle No. 33.*

FREE WOODWORKING POWER TOOL CATALOG—Buy planers, jointers, shapers, table saws, scroll saws, bandsaws, drill presses, wood lathes, sanders, dust collection systems, and more...direct from the factory and save. Foley-Belsaw sells direct to you...so you save on every purchase. You'll find quality power tools, plus hand tools and accessories to meet all of your woodworking requirements. Complete money-back guarantee. Send for details. FOLEY-BELSAW. Free. *Circle No. 41.*

MANUFACTURED SINCE 1926—the Foley-Belsaw Circular Sawmill lets you go right to the trees to turn out smooth, true-cut lumber. Available with heavy-duty steel base or with plans and track provided for owner built wood base. Will accurately saw logs up to 14 ft. in length and up to 24 in. in diameter. Complete money-back guarantee. Send for details. FOLEY-BELSAW CO. Free. *Circle No. 42.*

INCA MACHINERY INFORMATION—Complete information on the famous line of Inca woodworking machines. Designed for precision work by the small to medium sized cabinet shop. Used by thousands of hobbyists and professionals. Table saws, bandsaws, joiner/planers, dust collector, radial arm saw. GARRETT WADE CO. Free. *Circle No. 44.*

MAKITA U.S.A. INC.—offers all new 152-page mini-catalog on its professional line of electric power tools, with special emphasis on the entire cordless line. Catalog provides complete information along with available accessories and practical applications. MAKITA U.S.A. INC. Free. *Circle No. 61.*

WOODWORKING MACHINE CATALOG—New 16-page color catalog introduces many new do-it-yourself woodworking machines. Includes planers, dust collectors, drill presses, sanders, lathes, and specializes in scroll saws and accessories. PENN STATE INDUSTRIES. Free. *Circle No. 75.*

SCROLL SAW—Information package available from Penn State Industries describing the specifications and applications of its super VS-15" variable speed scroll saw. Special discount pricing available on current promotion. PENN STATE INDUSTRIES. Free. *Circle No. 76.*

SURFACE PLANER—Information package available from Penn State Industries describing the specifications and applications of its super 12 1/2-inch surface planer. Special discount pricing available on current promotion. PENN STATE INDUSTRIES. Free. *Circle No. 77.*

PERFORMAX DRUM SANDERS—Exclusive features at an affordable price for precise wide surface sanding. The complete line includes the retrofitting Performax Component Sander, the Pro Max and the Super Max 25, Super Max 25X2, and super brush sander. New accessories for production-mode sanding of pieces as small as 2 1/4" long. Send for brochure. PERFORMAX PRODUCTS. \$1.00. *Circle No. 78.*

THE PRECISION SCROLL SAW FOR THE ENTIRE FAMILY!—The Hawk was designed for beginners and built for expert woodworkers. Learn how to produce creative leisure time projects for fun or to make money...we'll show you how! Make cuts so intricate and smooth they don't require sanding. Over six models to choose from. Send today for all the facts. Send for the facts. RB INDUSTRIES, INC. Free. *Circle No. 84.*

THE VERSATILE RBI WOODPLANNER/MOLDER/SANDER!—It's indispensable! It's 4-in-1. It's RBI's Woodplaner/Molder/Sander/Gang Rip Saw. Find out how the Woodplaner saves you money turning rough stock into beautiful professional quality projects. With 3 models to choose from there's one that fits your needs. It does it all, so you can do it all! Send today. RB INDUSTRIES, INC. Free. *Circle No. 85.*

SKIL CORPORATION—30 page booklet covers the complete line of Skil professional power tools and accessories. Included are saws, cordless drill/drivers, screwdrivers, drills, jigsaws, planes, sanders and the latest addition...a plate joiner. SKIL CORPORATION. Free. *Circle No. 87.*

SKIL CORPORATION—Full color, complete line, power tool catalog. Features cordless screwdrivers, drills and the cordless Skillwrench™. Corded products include circular saws, drills, drywall drivers, sanders, hammer drills, jigsaws, planes, roto hammers, sander/grinders, shears, routers, extra tools, bench top tools and reciprocating saw. All product accessories are also shown. SKIL CORPORATION. \$1.00. *Circle No. 88.*

SCROLL SAWS, ACCESSORIES, PATTERNS, BOOKS—A complete brochure on all kinds of scroll saw accessories. Featuring Excalibur scroll saws and lettering layout guides from Seyco, "The Scroll Saw Specialists." Free pamphlet, "Selecting Your Scroll Saw" included. Send for brochure. SEYCO SALES CO. \$1.00. *Circle No. 89.*

MOLDER-PLANERS FROM WILLIAMS & HUSSEY—Mold, plane, and edge, convert from moulder to planer in less than 2 minutes. The W-7 series is available in 3 models for manual, power in feed, or power in feed/out feed. The units plane to a satin, almost sanded finish, produce doll house to crown sized mouldings, raised panels, and curved molding. Custom knives available up to 7" wide and 3/4" depth of profile. Rugged, well-made, dependable, and transportable. Complete with sturdy movable stand. Send for catalog. WILLIAMS & HUSSEY. \$1.00. *Circle No. 93.*

PORTABLE SAWMILLS—Convert logs into valuable lumber—Wood-Mizer® Products manufactures a line of portable bandsaw mills that allows the novice as well as the experienced sawyer to safely convert standing logs into lumber.

Then, with the use of our SolaryDry™ Kiln or Vacu-Kiln™ to dry your lumber, you could increase the value of every board you produce. We manufacture some of the most progressive woodworking equipment on the market today. Product videos available. Send for our 40-page catalog. WOOD-MIZER PRODUCTS. \$1.00. *Circle No. 94.*

BRIDGEWOOD WOODWORKING MACHINERY—a new 52-page catalog of fine BRIDGEWOOD wood and metalworking machinery is available from Wilke Machinery Company. The BRIDGEWOOD line includes a wide range of products for use in the serious home workshops up through the industrial applications. WILKE MACHINERY CO. \$1.00. *Circle No. 96.*

HAND TOOLS

DIAMOND WHETSTONES BY DMT—Rescue your routers, lap carbide edges; discover the ease and speed of sharpening on Diamond Whetstones. Five sizes from 3" to 12" in the fine, coarse, and extra coarse. Finest monocrystalline industrial diamonds permanently bonded in nickel. Lubricated with water. Stays flat, unbreakable, long life. Fifteen years of serving sharpening needs. Satisfaction guaranteed. Send for full color catalog. DIAMOND MACHINING TECHNOLOGY, INC. \$2.00. *Circle No. 112.*

RADI-PLANE—Profession edge finishing tools. The RADI-PLANE lets you quickly round-over an edge without the time or trouble of routing and sanding. Duel, micro-adjustable cutter provides for a quick, precise rounded edge in just one pass. Send for more information. L. A. MATHERS CO. Free. *Circle No. 142.*

PERSONAL BRANDING IRONS—Brochure describes branding irons that enable you to put your name on your wood quickly and easily. Made especially for branding wood, they are available with 1, 2, or 3 lines of copy or with your logo. Changeable date also available. NOVA TOOL CO. \$1.00. *Circle No. 160.*

THE JAPAN WOODWORKER'S 72-PAGE CATALOG—is loaded with the a huge selection of Japanese saws, waterstones, chisels, planes, carving knives, cutlery and garden tools. See our Tools As Art section for the most expensive hand tools available. Send for 1991 catalog and all supplements for two years. WOODLINE TOOL & SUPPLY. \$1.50. *Circle No. 190.*

STAINS/FINISHES

DEFT SOUTHWEST COLLECTION PAMPHLET—Bring the colors of a desert sunrise into your home with Deft's new Desert Oak White Wood Stain and tint base. Pamphlet shows a wide variety of pastel colors available. DEFT, INC. Free. *Circle No. 215.*

DEFT ACT NOW PAMPHLET—Be environmentally aware during and after your wood finishing projects. Let Deft show you how. DEFT, INC. Free. *Circle No. 216.*

FREE WOOD REFINISHING PRODUCTS—Make wood refinishing easy with products from 3M. Do-it-yourselfers can restore and protect wood like the experts. Send today for free sample. 3M. Free. *Circle No. 268.*

PLANS

OVER 1000 WOODCRAFT PATTERNS!—Enjoy making gifts, toys, lawn ornaments, holiday designs, whirligigs, folk art, bird houses and feeders, household and yard accessories plus much more! Simple enough for the beginner, fun and profitable for the pro. Send for catalog plus sample pattern. ACCENTS IN PINE. \$2.00. *Circle No. 310.*

WOODWORKERS' PLANS AND SUPPLIES—Wood projects are simplified with the high quality plans, specialty hardware and other supplies offered by Armor Products. Over 100 plans are available for making toys, desks, clocks, pool tables, lamps, chests, and other furniture. Movements, dials, moldings, ornaments, dollhouse kits, door harp supplies and tuning pins are also available. ARMOR PRODUCTS. \$1.00. *Circle No. 315.*

SALES TESTED DESIGNS—available as plans only, parts kits, or plans and parts kits. Complete stock of parts, tools and supplies. Door harps to digital electronic/wood projects. Full size plans! Bulk prices on turnings, dowels and music movements. Catalog price refundable on first order. CRAFTER'S MART. \$2.00. *Circle No. 328.*

BUILD MINIATURE HORSE-DRAWN VEHICLES—The Concord Stagecoach symbol of the Old West, the Conestoga Covered Wagon, and the Prairie Schooner are some of the vehicles you can build using our plans in 1/12 and 1/8 scale. Concord Coach and Conestoga are available in full size 1" scale cutting patterns. Also English vehicles, some in 1/20 scale cutting patterns excellent for beginners. Ready-made plastic wheels available for 1/20 scale vehicles. Also books featuring from England, "Making Horse-Drawn Vehicles" by John Thompson, who has done extensive work in this area. CRISS-CROSS CREATIONS. \$1.00. *Circle No. 332.*

INSPIRATIONS IN WOOD—Many new, unique designs of projects never before seen are offered in clear, concise plans. These plans are easy enough for the beginner to follow yet satisfying enough for the expert. Create working toys, furniture and home improvement projects that will amaze your family and friends. Great for gifts. Send for catalog. D&D INSPIRATIONS. \$2.00. *Circle No. 335.*

SEND FOR CATALOG OF FULL SIZE FURNITURE PLANS—all the most popular designs. Early America, Spanish, modern, Queen Anne styles. 270 plans (bill of materials, perspective and exploded view drawings). DALCRAFT, INC. \$1.00. *Circle No. 339.*

PATTERNS BY DESIGN GROUP—Hundreds of interesting, useful and fun items to create for personal use or profitable sale. Our newest catalog contains plans for toys, games, plaques, puzzles, birdhouses, planters, furniture, and much more! All Design Group patterns are professional, "same size" blueprints. No enlarging or reducing is necessary. Simply trace outline of item onto wood and create! Started in 1977, Design Group has sold thousands of patterns to thousands of satisfied customers. Prices start at \$1.00, all patterns come with a full money-back guarantee. Wholesale and bulk prices are available on request. Fully illustrated catalog. DESIGN GROUP. \$1.00. *Circle No. 340.*

FULL-SIZE FURNITURE PLANS CATALOG—Illustrates and describes over 200 plans for making furniture of quality found in museums and fine furniture stores. Plans include rolltop desk, cradles, dining tables, chairs, buffets, chests, gun cabinets, poker table, children's furniture, rocking horse, spinning wheels, and more. Bill of materials exploded drawings assist the woodworker. FURNITURE DESIGNS, INC. \$3.00. *Circle No. 345.*

STICKLER FOR DETAIL?—At last an exciting new line of realistic wood block models that you can build with your own scrap wood and dowels and my easy-to-follow instructions. Highly detailed plans for a 20x8 3/4-in. dump truck. GATTO PLAN SUPPLY. \$8.00. *Circle No. 355.*

COUNTRY FURNITURE PLANS—Our catalog features more than 37 designs—from a washstand to a roll top desk. Our new book on finishing and refinishing will show you how to finish projects like the pros. Also included are various products for the home workshopper. Send for our latest catalog (price of catalog deductible from first order). HAMMERMARK ASSOCIATES. \$1.00. *Circle No. 370.*

MOOSERACK—Full size pattern with easy step by step instructions. A unique design for a one of a kind coatrack. Hangs from a wall or any standard size door. An easy weekend project. Great gift for children. JOBUCK™. \$6.95. *Circle No. 380.*

PROJECT PLANS—Over 400 easy-to-build woodworking project plans. Nation's leading source for door harp plans and parts, holstein cow projects, toy plans, country furniture, etc. Over 3000 hard-to-find specialty items. Send for your big new 72-page catalog. MEISEL HARDWARE SPECIALTIES. \$1.00. *Circle No. 401.*

THE YEAR'S BEST PROJECT PLANS—From the editors of Popular Science® Magazine, 32 easy-to-build and fun-to-do indoor and outdoor woodworking projects you'll be proud to complete. 186-page volume includes materials lists, and complete step-by-step instructions fully illustrated with photos

and diagrams. Hundreds of hours of enjoyment for all skill levels...plus FREE gift for saying "yes" to preview. Send for details. Woodworking Projects Yearbook. POPULAR SCIENCE®. Free. *Circle No. 418.*

NEW QUALITY SCROLLSAW PLANS—Professional quality, from children's toys and country gifts to lawn ornaments and furniture. Cost refundable with first order. RNR SPECIALTIES. \$1.00. *Circle No. 430.*

BACKYARD STRUCTURES—Contains designs for 21 really different storage sheds, 5 cabanas, 13 animal shelters, 3 barns, 13 garbage enclosures, 3 studios, and more, plus 8 plans in book. 66 designs in all, for which plans can be ordered. Full color. SUN DESIGNS. \$10.45. *Circle No. 454.*

MAKING TIMELESS TOYS IN WOOD—contains 40 heirloom-quality designs, with 20 mini-plans in book. Full color, 96 pages. SUN DESIGNS. \$11.45. *Circle No. 455.*

MAKE TOP SELLING COUNTRY WOODCRAFTS—from full size patterns. Turn your scrapwood into decorative, highly profitable projects. Easy to make from our full size patterns and instructions—no enlarging necessary! Over 1000 unique designs include popular folk art, old fashioned St. Nicks, nostalgic country furniture, country shelves and shadowboxes, action toys, shelf sitters, country critters, life size yard animals, Christmas yard decorations and more! Next day shipment, satisfaction guaranteed. Send for our latest catalog. THE WINFIELD COLLECTION. \$1.00. *Circle No. 480.*

WOOD-MET SERVICES CATALOG LISTS SOME 700 PLANS—to build a wide variety of tools and accessories to equip your workshop. They vary from complete machines to hand tools, photo accessories to shop methods. Included are some 80 attachments for your lathes, drill presses & routers, over 60 hand tools, plus sander, welder, shaper, table saw accessories, etc. Others include a portable band sander, metal spinning tools, air compressor, 3/4" spindle wood shaper, wood lathe & chisels & a 12-in. thickness planer. Send for catalog, order plans, build the equipment for your shop and save. WOOD-MET. \$1.00. *Circle No. 496.*

LUMBER

QUALITY EXOTIC LUMBER/TURNING WOODS—We offer a comprehensive selection of fine quality exotic woods: Ebony, Kingwood, Tulipwood, Snakewood, African Blackwood, Cocobolo, Bloodwood, Figured Maple, Spauldted Maple, Padauk, etc. Unique and unusual turning woods and burls are also available. Send for catalog. BEREHA HARDWOODS. \$1.00. *Circle No. 510.*

WOODWORKERS! HELP CELEBRATE OUR 60TH YEAR OF SERVICE—Send for our new 148-page Craftsman 1990-91 Catalog #57. 42 varieties of choice hardwoods 1/64 in. to 4-in. thickness. Fine hardwood veneers, tools, moldings, trim, marquetry inlays, upholstery and lamp supplies, finishes, clock kits, and hard-to-find hardware. 4,000-plus items for your projects. CRAFTSMAN WOOD SERVICE CO. \$1.00. *Circle No. 520.*

EdLco — WE KNOW OUR LUMBER—Educational Lumber Company is pleased to offer you our new catalog, stacked with excellent buys at delivered prices. Available to you are over 21 species of imported as well as domestic hardwoods, softwoods, turnings, shorts, veneers. All our lumber is kiln dried. As school shop suppliers for 35 years, we know our lumber. It is top-grade. Send today and receive your BONUS GIFT: 4 new furniture designs. EDUCATIONAL LUMBER CO., Inc. \$2.00. *Circle No. 530.*

THIN LUMBER—Approximately 20 species—1/8" to 3/4" thickness. Thinner material sanded, all KD & surfaced—UPS delivery in continental US included in price. Packages of micro-lumber 1/8" - 1/2" thick. HARDWOODS OF ILLINOIS. 50c. *Circle No. 545.*

NORTHEASTERN HARDWOODS—We offer over 20 species of the highest quality kiln dried domestic hardwoods. Sold on board footage or cut to order basis. Compare our quality and prices. Unconditional satisfaction guaranteed. Great monthly specials. Super package deal at delivered prices. Attractive quantity discounts. Quick delivery. Send for new catalog. NORTHEASTERN HARDWOODS. \$1.00. *Circle No. 563.*

RARE IMPORTED EXOTIC AND DOMESTIC HARDWOODS—The world renowned Martin Guitar Co. sells exotic woods (4/4, 6/4, 8/4) and sawn veneers (1/8", 1/4", & 1/2" Sanded Stock), plus guitar parts, kits, accessories and second quality guitars. No minimum order. Send for catalog. WOODWORKER'S DREAM. \$2.00. *Circle No. 578.*

STEVE H. WALL LUMBER CO—Quality hardwoods and woodworking machinery for the craftsman and educational institutions. 22-page catalog lists 15 species of popular hardwoods at wholesale prices. Also dealers for MiniMax, Freud and ProCut woodworking machines. STEVE H. WALL LUMBER CO. \$1.00. *Circle No. 592.*

EPOXIES/GLUES

ARE YOU CURIOUS ABOUT EPOXIES?—Our application notes and product literature will tell you how adhesives work, how coating systems are designed, and how to make paint, varnish and fillers stick better and last longer. We are chemists. We make all our own products and write all our own literature. We can answer your questions. SMITH & CO. Free. *Circle No. 760.*

GENERAL WOODWORKING CATALOGS

ADVANCED WOODWORKING—Specialty products catalog from the exclusive distributors of Hegner & Felder woodworking machinery. Includes complete selection of scroll saw blades, accessories, and improvements for almost any scroll saw. Also the Hegner precision scroll saws, lathes & duplicators, Jet clamps, workbenches, Felder systems & more. AMI, LTD. \$2.00. *Circle No. 801.*

CONSTANTINES' CATALOG FOR WOODWORKERS—116 pages packed with over 4,000 products for fine woodworking. Included are 250 kinds and sizes of domestic and imported hardwoods; 150 varieties of exotic veneers, top quality woodworking tools, hard-to-find specialty hardware and accessories; wood finishes, books, plans, and more. 60-day money back guarantee if not fully satisfied. Serving the woodworker since 1812. ALBERT CONSTANTINE AND SON, INC. \$1.00. *Circle No. 820.*

MASTER TOOLS CATALOG—1990-91 220-page master woodworking tools catalog. Full line of the best hand tools, power tools & accessories, machinery, glues, finishing supplies, and much more. Hundreds of books included. 220 pages. All four-color. Lots of technical information. GARRETT WADE CO. \$4.00. *Circle No. 855.*

THE BEST THING THAT EVER HAPPENED TO THE AMERICAN WORKSHOP—You will simply be amazed at the number of new items we have brought on line this year. Our incredible catalog features a huge selection of wood and metal working machinery and accessories. Loaded with tons of goodies you can't resist. GRIZZLY IMPORTS INC. Free. *Circle No. 860.*

SEND FOR JET EQUIPMENT & TOOLS FREE CATALOG—to get details on bandsaws, tablesaws, jointers, shapers, drill presses, lathes, sanders, dust collectors and training videos. All Jet machinery comes with a 1-year limited warranty, replacement parts and repair service availability. JET EQUIPMENT & TOOLS. Free. *Circle No. 876.*

TOOL CATALOG—"Innovation" sets Leichtung apart from the rest! You'll find tools and accessories for the serious woodworker, do-it-yourselfer and hobbyist, many of exclusive design. 78 page full color catalog. 400-plus items. LEICHTUNG WORKSHOPS. Free. *Circle No. 878.*

TOOLS ON SALE—A division of Seven Corners Ace Hardware Inc. offers a comprehensive catalog featuring over 820 pages of the most competitive prices in the industry. If you're looking for savings and fast delivery on over 6500 items, request our catalog. This catalog offers one of the most complete selections of power tools available anywhere from the most respected manufacturers in the industry: Milwaukee, Makita, Porter-Cable, Black & Decker, Freud, Bosch, Delta, and many more. SEVEN CORNERS ACE HARDWARE. \$1.00. *Circle No. 920.*

DISCOUNT WOODWORKING TOOLS AND SUPPLIES—Get your FREE copy of Trendline's new 72 page full-color catalog. You'll find the best prices for over 3,000 brand name products including: power tools and accessories, hand tools, screws, hardware, wood components, plans, books, and much more. TRENDLINES. Free. *Circle No. 950.*

COMPLEMENTARY TOOL CATALOG—Woodcraft offers over 4,000 of the finest quality woodworking tools, books, supplies, and cabinetry hardware in our complete full color catalog. Craftsman, cabinetmakers, carvers, woodturners, and hobbyists have depended on Woodcraft since 1928. Backed by Woodcraft's unconditional guarantee. Free technical assistance. WOODCRAFT SUPPLY CORP. Free. *Circle No. 955.*

THE WOODWORKERS STORE CATALOG—New! The Woodworkers' Store 1990-91 catalog with over 250 new items features 100 color pages of domestic and exotic hardwoods, veneers, wood parts, specialty hardware, kitchen accessories, finishing supplies, tools, books, and plans. Many exclusive items and hard to find specialties. Orders shipped in 24-48 hours. \$1.00 credited toward first purchase. Satisfaction guaranteed. WOODWORKERS STORE. \$1.00. *Circle No. 965.*

WOODWORKERS SUPPLY—offers high quality tools and supplies for skilled, amateur, and professional woodworkers. Our complete catalog includes machinery, hand tools, plans, router bits, shaper cutters, wood specialties, and more. For your two year subscription send to WOODWORKERS SUPPLY. \$2.00. *Circle No. 975.*

KITS

OUR QUEEN ANNE FURNITURE KITS—are ready to assemble and finish. They include dining room table, chairs, hutch, sideboard, a variety of occasional tables, and a personal desk. All are made in solid cherry, oak, walnut, and mahogany. We also stock individual Queen Anne legs for every project. Complete information in our brochure packet. ADAMS WOOD PRODUCTS. Free. *Circle No. 1002.*

FREE STANDING BACKYARD GYMS—Countryside Woodworking Inc. (CWI) offers 6 models and 11 options for a wide variety of family fun gyms. The only Backyard Gym you'll ever buy. 4x6 and 4x4 construction, playground rated hardware. Complete kits include all lumber. Hardware only kits also available. Send for complete color catalog. CWI. \$1.00. *Circle No. 1005.*

POOL TABLE KITS AND COMPONENTS—Save hundreds of dollars in dealer's mark-up and manufacturer's costs by completing a kit or building from scratch. The "Continental Kit" contains all the components and instructions you'll need to build a tournament quality slate pool table at home in a couple of week-ends. The completeness of this kit makes it a practical and enjoyable project for the first time or experienced kit builder. If you are more ambitious, build a pool table from scratch. We supply only the finest Italian slates, leather pockets, billiard cloth, rail cushions and other components. Send for complete information. CONTINENTAL BILLIARDS. \$1.00. *Circle No. 1016.*

OAK FURNITURE AND ACCESSORY KIT CATALOG—features a full range of top quality oak furniture kits and accessory items plus unfinished assembled furniture. Featured items include roll top desks in several styles, stacking barrister's bookshelves, tables, chairs, trunks, file cabinets, bedroom furniture, Mariner's globe, plus many more. Send for full color catalog and enjoy true woodcrafting pleasure. CRAFTSMAN'S CORNER. Free. *Circle No. 1017.*

DO-IT-YOURSELF KITS—Choose from a large selection of grandfather, wall and mantel clocks, as well as elegantly styled accent furniture pieces. Kits are made of solid 3/4" hardwoods, primarily cherry, oak, and black walnut. Buy direct from the factory and save. Send for 36 page color catalog. EMPEROR CLOCK CO. \$1.00. *Circle No. 1030.*

QUALITY CLOCK KITS AND PLANS—Handmade and semi-assembled of carefully selected 3/4 in. cherry, oak, or walnut with beveled glass. Or build from "scratch" using our detailed plans and trim pieces. Choice of quality movements. Established in 1916. KUEMPEL CHIME CLOCK WORKS. \$2.00. *Circle No. 1050.*

MUSIC MAKER'S KEEP BOOK—a 32-page resource catalog for building and learning to play handmade musical instruments. This source book contains plans, blueprints, kits, books, hardware, strings and accessories for building such instruments as guitars, banjos, dulcimers, harps, violins, pipes, and more. MUSICMAKER'S KITS. \$1.00. *Circle No. 1080.*

LOG CABIN DOLLHOUSE—Plans, kits, completed houses. Standard scale 1 in. equals 1 ft. House is 23"x34"x17" high. Stone chimney and fireplace, wood shingle roof. Plans adaptable to any style log house. Send for informational brochure with photos. WOODWORKING UNLIMITED. \$2.00. *Circle No. 1095.*

SHOP ACCESSORIES

PARAGAUZE—NOW ANYONE CAN CUT WOOD ACCURATE TO WITHIN 10/1000 INCH—ParaGauze was developed to provide the woodworker a perfectly parallel measurement quickly and accurately to help alleviate the tedious and sometimes inaccurate task of setting a rip fence. ParaGauze accurately measures distances up to 18 in. in

length between the saw blade and rip fence and up to 2.5 in. in depth without resetting or relocating the gauge. Para Gauge is completely portable and can be used on just about any tool requiring a parallel measurement. ACCUSET TOOL CO. INC. 25¢. *Circle No. 1205.*

WOOD MOISTURE METER—End wood warping nightmares with a high quality precision instrument from Electrophysics. Avoid damage and deformation; eliminate stains, decay, mold, and failed joints. Eight models to choose from in the MT Series of wood moisture meters designed and made in Canada. For moisture contents from 3% to 60%. Accessory probes and custom services available. A wood moisture meter is an essential tool for the home hobbyist, serious enthusiast, professional woodworker, commercial kiln or sawmill operator, wood carver, and everyone who works with wood. Free catalog gives complete information. ELECTROPHYSICS. Free. *Circle No. 1230.*

RIPSTRATE SAVES FINGERS—for table saw and radial arm saw users. Brochure describes the RIPSTRATE and shows how it gives straighter cuts, speeds the work, prevents kickbacks, and keeps hands away from the blade. FISHER HILL PRODUCTS. 25¢. *Circle No. 1235.*

EASY DOES IT—with HTC'S power tool accessories. Discover many unique items, designed only with you, the dedicated woodworker, in mind. Make your machinery safer, increase the working area of your shop and accomplish nearly impossible tasks easily, quickly, accurately. Full-line catalog and price list. HTC PRODUCTS, INC. Free. *Circle No. 1245.*

BUY YOUR SANDING BELTS DIRECT FROM THE MANUFACTURER—Industrial Abrasives is the company that gives you 12 free belts with every dozen ordered. But, sanding belts are not the only product we have to offer. In our catalog you will find many specialty items not readily available in your hardware store. Price of catalog refunded with first order. INDUSTRIAL ABRASIVES CO. \$1.00. *Circle No. 1248.*

WOOD MOISTURE METER—Avoid moisture problems such as cracking, warping, splitting, delamination etc. by using a moisture meter, as described in the latest brochure. Moisture Meter Mini-Ligno is designed for serious hobbyists and woodworkers. Attachments for depth measurements and remote reading during air and kiln drying are available. Available Moisture Range 6-20%, 6-36% or 4-30%, 4-60%. Catalog describes complete line of moisture meters. LIGNOMAT USA, LTD. Free. *Circle No. 1250.*

ROUTER SPEED CONTROL—Reduces speed electronically without reducing torque. Route at the speed that gives best results with the wood and bit you are using. Speed adjustable from full speed to 0 RPM. Less tear out—stops burning—less wear on bits—easy to use. Send today for information. MLCS LTD. Free. *Circle No. 1251.*

WHOLESALE SANDPAPER, BELTS, SHEETS, CLOTH AND PAPER DISCS—for orbital sanders, flexible sanding clocks, pads, tack cloths, pressure sensitive adhesive, wipers, dust mask—Super Grit offers its quality abrasive and refinishing products at wholesale prices directly to the consumer. Try our extra strength hot melt glue sticks for wood. \$25 minimum order, prompt free UPS shipment to most areas. Catalog/Price List. RED HILL CORP. 50¢. *Circle No. 1267.*

LABOR-EFFICIENT, COST EFFECTIVE TRIMTRAMP—Instantly converts your handheld circular saw into a precision miter and cross-cut saw table that provides unsplintered cuts of cabinet maker quality by allowing you to pull the saw backwards through the work. Fixed fences provide perfect 90° picture frame quality miter joints and compound miters, everytime. Also cuts variable angles and cross-cuts up to 15° wide. Send for free brochure. TRIMTRAMP LTD. Free. *Circle No. 1280.*

WEDGE INNOVATIONS' SmartLevel®—Digital electronic carpenters level measures all angles with up to 1/10 degree accuracy. Automatically calculates percent of slope and pitch (inches of rise per foot of run), and can be recalibrated into perfect balance with the push of a button. Helps you achieve exact measurements and professional quality with the minimum effort. WEDGE INNOVATIONS. Free. *Circle No. 1293.*

BITS, BLADES, CUTTING TOOLS

BANDSAW BLADES FOR ALMOST ANY TYPE BANDSAW—both wood and metal cutting. Also circular saw blades, router bits, sanding belts and discs. Send for catalog. BUCKEY SAW CO. \$1.00. *Circle No. 1307.*

BYROM INTERNATIONAL "THE WORLD'S ROUTER BIT SOURCE"—manufactures and offers you over 1,000 industrial quality router bits. Choose from high speed steel, solid carbide,

carbide tipped, and the newest innovation in router bits today, "Byrom Gold Titanium Nitride coated high speed steel." All Byrom router bits are available in English and metric sizes. Send for your new Byrom router bit catalog. Get \$3 back off your first purchase from your dealer. BYROM INTERNATIONAL. \$3.00. *Circle No. 1308.*

CARBIDE-TIPPED ROUTER BIT AND SHAPER CUTTER CATALOG—We have hundreds of styles and thousands in stock ready to be shipped. We specialize in quantity discounts and same day shipping. These are top quality industrial router bits and shaper cutters at super low prices. Send now to receive new giant catalog. CASCADE TOOLS, INC. Free. *Circle No. 1315.*

TIRED OF THE IMPORTS?—All new 1991 router bit catalog featuring over 1100 items. This factory direct mail order 56-page catalog offers the industry's largest selection of the finest quality American made router bits, shaper cutters, and accessories. EAGLE AMERICA CORP. Free. *Circle No. 1320.*

WOODWORKING TOOLS—Freud provides the finest in hand tools, carbide cutting tools, and hand held power tools. From drills and sanders to carbide saw blades and router bits. Send for catalog. FREUD. \$2.00. *Circle No. 1321.*

SUPER-SMOOTH, EXTRA-DURABLE, CARBIDE-TIPPED CIRCULAR SAW BLADES—Get a smooth-as-sanded surface with our all-purpose 40-tooth Woodworker Blade. You will be able to rip and cross-cut 1 - 2 in. rock hards and soft woods with an unbelievably smooth finish. You will also be able to cross-cut oak and birch ply-veneers with no bottom splinters. Send today for our information pack. FORREST MFG. CO., INC. \$1.00. *Circle No. 1322.*

PRODUCTION QUALITY CARBIDE TIPPED ROUTER BITS—MLCS Ltd. offers a full line of professional production quality carbide tipped router bits at 50-70% lower than retail prices. We sell through the mail and only direct to craftsmen. Send today for catalog. MLCS LTD. Free. *Circle No. 1350.*

SAW BLADE VALUES—Olson Saw's unique "furniture band" is specifically designed to provide fast, smooth cuts in all types of wood. Included in Olson's free literature package are a huge list of resin on resin abrasives and carbide tipped circular saw blades in addition to a growing selection of band scroll (incl. pinned), jewelers and spiral saw blades. OLSON CATALOG SALES. Free. *Circle No. 1365.*

ROUTER BITS, SHAPER CUTTERS, FORSTNER BITS—Boring bits, saw blades. All heavy duty industrial grade tungsten carbide. You name it, if it rotates and cuts, we have it. Quality, price, selection, save 50% or more over "wholesale" prices. Catalog comes with a \$3.00 discount coupon. SKYCROFT TOOLS INC. \$1.00. *Circle No. 1372.*

HARDWARE/WOOD PARTS

TURNED WOOD PARTS—Quality shaker pegs, candle cups, spindles, wheels, balls, dowels, screwhole buttons, cargo and much more. High quality. Reasonable prices. Fast service. American made. Free shipping on orders over \$25. 28-page catalog. AMERICAN WOODCRAFTERS SUPPLY. 75¢. *Circle No. 1405.*

HARDWARE CATALOG—A unique 48-page catalog of the very finest in classic, traditional solid brass cabinet hardware. All of British or No. American manufacture. Double & single post handles, knobs, escutcheons, standard & specialty hinges, box hardware, brass screws, castors, latches, catches, locks, and more. GARRETT WADE CO. \$3.00. *Circle No. 1427.*

SQUARE DRIVE SCREWS—Thousands agree—once you try them you will never want to use anything else! The square drive recess virtually eliminates work-damaging driver bit "cam-out," the deep threads result in exceptional holding power, and they are heat treated for strength. Sizes from #4 x 3/8" to #12 x 4", with stainless steel, solid brass, brass plated, and zinc plated available. Quantity discounts. Send for literature. McFEELY HARDWOODS. \$1.00. *Circle No. 1450.*

WOOD TOY PATTERNS—Patterns for all ages including children's patterns and executive toys. New catalog has many new patterns to choose from including parts and wheels. Send for new catalog and receive a coupon for free wheels and axle pegs. TOYS AND JOYS. \$1.00. *Circle No. 1480.*

TRADITIONAL TURNINGS FOR THE HOME CRAFTSMAN—Unique selection of bedposts, table legs (dining, sofa, coffee, and end), hutch, gourmet, and kitchen. American, European, and Contemporary designs, available in Ponderosa Pine. Sanded and ready for assembly and finish. Send for catalog. TRADITIONAL TURNINGS. \$2.00. *Circle No. 1485.*

DESIGN & DECORATE WITH WOOD MOULDINGS—Contains full-color photos of various household rooms showing extensive use of wood mouldings. Profile drawings of all wood mouldings used to create these finished designs are also shown, plus suggested alternative profiles. A simple way to transform an ordinary room into a showplace on a minimum budget. **WOOD MOULDING & MILLWORK PRODUCERS ASSN.** \$1.00. *Circle No. 1487.*

QUALITY AMERICAN-MADE WOOD TURNINGS—such as shaker pegs, spindles, toy wheels, toy parts, craft items, and dowel rods in birch, oak, walnut, and cherry. Send for complete 32-page catalog. **WOODWORKS.** \$1.00. *Circle No. 1490.*

INCOME OPPORTUNITIES

AMITY, NATION'S #1 QUALITY FURNITURE RESTORATION CO. SINCE 1971—New product catalog featuring: Complete restoration systems, Amity non-flammable water based stains and finishes. Permafuse repair products, stripping solvents, chemicals and supplies. Amity 1-2-3 wipe-on finishes and much more. Regional workshops in your area. **AMITY.** \$1.00. *Circle No. 1605.*

MAKE MONEY IN FURNITURE RESTORATION THE MINUTEMAN WAY—Earn \$200-\$1000 per day stripping, repairing, refinishing, mirror resilvering, and/or veneering, at home or in shop, spare time or full time. We provide complete free training; no experience necessary. Free workshop teaches you latest in furniture restoration. You have to see it to believe it! Intro video \$12.95. Send for catalog. **MINUTEMAN.** \$2.00. *Circle No. 1661.*

MISCELLANEOUS

FOLEY-BELSAW INSTITUTES' NEW WOODWORKING CORRESPONDENCE COURSE—for people with the desire to learn how to work with wood and the proper use of tools. Create over 20 projects using professional plans and tools like a table saw, router with stand, and more...all included with the course. Complete money-back guarantee. Send for details. **FOLEY-BELSAW INSTITUTE.** Free. *Circle No. 1930.*

LEARN ALL THE SKILLS—of professional upholstery and refinishing techniques in the comfort of your own home. The Foley-Belsaw Institute system of "hands on" training provides clear, step-by-step instructions in the use of tools and materials on actual furniture "kits"...all included with the course. Complete money-back guarantee. Send for details. **FOLEY-BELSAW INSTITUTE.** Free. *Circle No. 1931.*

THE CUSHION CONTOUR SANDER—is a new concept in pneumatic drum sanding. Sanding sleeves are slid over an air bag (inflated with a hand tire pump) on an arbor to mount it between centers on a wood lathe. Drum effectively takes on profiles, curves, and bevels practically eliminating flat spots and chatter marks. **INDUSTRIAL ABRASIVES CO.** \$1.00 (refunded with first order). *Circle No. 1976.*

IF YOU ARE INTERESTED IN RESTORING ANTIQUES—this 216-page catalog packed with unusual, hard-to-find items is just for you. Included are hundreds of essential items for antique restoration including top quality brass reproduction hardware, oil lamps and accessories, numerous wood component repair parts and kits, caning and basketry supplies, everything needed for wood refinishing, related tools, books, and a complete line of upholstery equipment and supplies. All at wholesale prices. Send for this informative catalog. **VAN DYKE'S RESTORERS.** \$1.00. *Circle No. 2077.*

UNIQUE GREENHOUSE/SCREENHOUSE IDEA—A gardener's paradise during the winter months, a bug-free screen room during the summer months. That's the concept behind the versatile new Sun-Porch. This two-in-one sunspace features sturdy aluminum framing, 1" shatter-resistant glazing, do-it-yourself assembly, and mounts readily on decks, patios, landscape ties. Color catalog includes models, prices; sent first class mail. **VEGETABLE FACTORY, INC.** \$2.00. *Circle No. 2078.*

NEED PARTS!?—If you are having trouble locating parts for your radial arm saw because of recent changes in their availability, Wolfe Machinery could be your answer. We have a full line of parts, including obsolete ones for 10-20" DeWalt radial arm saws. Send today for free information. **WOLFE MACHINERY CO.** Free. *Circle No. 2080.*

HOW TO MAKE PICTURE FRAMES—Instructions for the do-it-yourselfer on how to make picture frames using standard mouldings. Tells what tools to use and how to build and finish

picture frames. **WOOD MOULDING & MILLWORK PRODUCERS ASSN.** 75c. *Circle No. 2085.*

COMPUTER SOFTWARE—Woodworking Magazine Index for *Wood*, *Fine Woodworking*, *Woodwork*, *Woodsmith*, *Today's Woodworker*, and 1987-1990 issue of *Woodworker's Journal and Workbench*. Now you can find the article you remembered, and know the magazine, issue and page without searching through many printed indexes. Yearly updates can be added to the original index. Send for brochure; price refundable with order of *Woodfind*. **WOODFIND.** \$1.00. *Circle No. 2089.*

WOODWORKING ASSOCIATION OF NORTH AMERICA—First international association for woodworkers. Benefits include our monthly bonus packets, Project-Of-The-Month, Group Purchase Opportunity, free woodworking problem solving through full time consultant, 50% discount on regional show admission and more. Send for sample magazine and application. **WOODWORKING ASSOC. OF NORTH AMERICA.** \$3.00. *Circle No. 2092.*

CARVING SUPPLIES

WOODCARVING CATALOG—64-page catalog packed with over 2500 items specializing in woodcarving and decoy carving. Included are carving woods, large selection of hand carving chisels, gouges, knives. Power carving tools and the largest selection of bits, cutters, burrs and abrasives, woodburners, extensive painting supplies and brushes, books and videos. **CRAFTWOODS.** Free. *Circle No. 2110.*

DECOY AND WOOD CARVERS WISHBOOK—48-page catalog features wide selection of tools and supplies for decoy carvers, wood carvers, wood turners. Chisels, gouges, sharpening stones, precision grinding tools, Foreord tools, Fire Brush burners, pneumatic sanders, glass eyes, pewter feet, patterns, paints, reference books. **P. C. ENGLISH, INC.** \$1.00. *Circle No. 2115.*

WOOD CARVING MACHINES AND ACCESSORIES—make all types of wood carving easy, fun and profitable. The machines do the work. Whether for sign carving, flat 3-D, decoys, panels, gun stocks or furniture, we have the proper machine for the job. Professional woodcarving for the hobbyist and superior quality for the professional. Begin your hobby or full or part-time business by ordering our catalog and price list. **MARLIN INDUSTRIES.** \$1.00. *Circle No. 2150.*

WOODCARVING TOOLS—Whittlers and carvers—Warren Tool Co. offers a complete catalog of whittling and carving, hand/power tools, sharpening stones, wood cut-outs and related wood carving supplies. **WARREN TOOL CO., INC.** \$1.00. *Circle No. 2185.*

WOOD CARVERS SUPPLY INC.—OUR 35TH YEAR—Complete 64-page color catalog including over 2,000 carving tools, books & supplies, such as carousel animal kits, gun checkering tools, ship model kits, plus much more. We offer great service, quality products and a 30-day money back guarantee. Send for 2-year subscription. **WOOD CARVERS SUPPLY INC.** \$2.00. *Circle No. 2190.*

CLAMPS

MERLE ADJUSTABLE CORNER CLAMP—Quick & easy to use. Fully adjustable from 2 5/8" to 69x69 in. Perfect for clamping picture frames, cabinets, or anything that requires 90° corner clamping. The Merle Clamp is cast aluminum & steel construction, a true industrial quality tool. Send today for information. **MLCS LTD.** Free. *Circle No. 2250.*

CLAMPING MADE EASY—THE NEW TOULAN 2005 CORNER CLAMP FROM ENGLAND—Introduced at IWF'90, this little award winning clamp was an overwhelming success. Awarded the Britain Engineering award of Excellence and selected to the design Centre of London, the clamp makes clamping easy, fast, efficient. **TECH REP & ASSOCIATES.** Free. *Circle No. 2270.*

CLOCKS

KLOCKIT'S FREE 64-PAGE COLOR CATALOG—is packed with the largest selection of beautiful wood clock kits for all skill levels, a huge selection of quartz and mechanical clock movements, dials and accessories, turned wood parts, music movements, tools and much more for the craftsman! **KLOCKIT.** Free. *Circle No. 2335.*

Worth writing for...



Better Homes and Gardens®
WOOD Magazine, April 1991
Dept. MAW091
P.O. Box 5103
Pittsfield, MA 01203-5103

TO ENSURE PROMPT HANDLING OF YOUR ORDER FOLLOW THESE INSTRUCTIONS:

- Circle your choice
- Enclose check or money order for cost of booklets plus \$2.00 service charge (no stamps/foreign)
- Send coupon and remittance to address above
- ALLOW 4-6 WEEKS FOR DELIVERY
- Coupon expires April 14, 1992

WOOD SUBSCRIPTION

1. A 1 year WOOD subscription (8 issues) for \$19.97 (U.S. price)—an \$11.63 savings off newsstand rate. Allow 6-8 weeks for first issue. Canadian price \$29.00. Be sure to include payment with total below. NO FOREIGN ORDERS ACCEPTED ON THIS COUPON; please contact Subscription Dept. directly.

Circle numbers below corresponding to items in this issue. Please include \$2.00 for handling charge.

3\$1.00	89\$1.00	340\$1.00	578\$2.00	1017Free	1315Free	1931Free
4\$1.00	93\$1.00	345\$3.00	592\$1.00	1030\$1.00	1320Free	1976\$1.00
6\$2.00	94\$1.00	355\$8.00	760Free	1050\$2.00	1321\$2.00	2077\$1.00
10Free	96\$1.00	370\$1.00	801\$2.00	1080\$1.00	1322\$1.00	2078\$2.00
33\$4.00	112\$2.00	380\$6.95	820\$1.00	1095\$2.00	1350Free	2080Free
41Free	142Free	401\$1.00	855\$4.00	1205\$25¢	1365Free	2085\$75¢
42Free	160\$1.00	418Free	860Free	1230Free	1372\$1.00	2089\$1.00
44Free	190\$1.50	430\$1.00	876Free	1235\$25¢	140575¢	2092\$3.00
61Free	215Free	454\$10.45	878Free	1245Free	1427\$3.00	2110Free
75Free	216Free	455\$11.45	920\$1.00	1248\$1.00	1450\$1.00	2115\$1.00
76Free	268Free	480\$1.00	950Free	1250Free	1480\$1.00	2150\$1.00
77Free	310\$2.00	496\$1.00	955Free	1251Free	1485\$2.00	2185\$1.00
78\$1.00	315\$1.00	510\$1.00	965\$1.00	1267\$50¢	1487\$1.00	2190\$2.00
84Free	328\$2.00	520\$1.00	975\$2.00	1280Free	1490\$1.00	2250Free
85Free	332\$1.00	530\$2.00	1002Free	1293Free	1605\$1.00	2270Free
87Free	335\$2.00	545\$50¢	1005\$1.00	1307\$1.00	1661\$2.00	2335Free
88\$1.00	339\$1.00	563\$1.00	1016\$1.00	1308\$3.00	1930Free	

Name (please print) _____

Address _____

City _____

State _____

Zip Code _____

I AM ENCLOSING:

\$ _____ for priced items

\$ 2.00 for handling

\$ _____ total remittance

DELTA BENCH TOP TOOLS			
Model	List	Sale	
23-700	Weld/grinder	201	159
23-680	6" bench grinder 1/4 HP	81	75
23-880	8" bench grinder 1/2 HP	136	119
11-950	8" drill press	164	135
14-400	14" drill press	313	309
40-150	15" hobby scroll saw	178	139
28-160	10" hobby band saw	189	144
31-050	1" belt sander 2.0 amp	93	78
31-460	4" belt/disc sander	176	139
31-340	NEW 1" belt/disc sander	228	175

NEW TOOLS BY DELTA			
40-560	16" 2 speed scroll saw	266	185
23-580	5" Bench grinder 1/5 HP	60	54
11-990	12" drill press	266	185
11-090	32" Radial bench drill press	399	279
43-355	3/4" Shaper 1 1/2 H.P.	950	665
43-505	1/2" Bench router/shaper	399	279

DELTA STATIONARY			
34-761	10" unisaw 1-1/2 HP	1715	1399
33-990	10" radial arm saw	727	565
37-280	6" motorized jointer	440	375
50-179	3/4 HP 2 stg. dust coll.	435	319
50-180	1 HP dust collector	535	415
50-161	2 HP dust collector	760	599
22-667	13" planer w/2 HP motor w/stand & ext. wings	1750	1099
33-050	NEW 8-1/4" Sawbuck	742	545
33-055	Above saw comp w/legs	865	565
34-330	NEW 8-1/4" Tbl Saw 13A	321	195
34-965	1/6 HP stock feeder	698	459
32-100	NEW station plate jointer	645	279
36-040	NEW 8-1/4" compd mitre saw	216	159
34-897	50" Delta unisaw	500	338
36-755	NEW 10" Tbl Arbor Saw	1203	875

MILWAUKEE TOOLS			
6527	NEW SawZall vsp/d 8 amp w/edge & Quick Lock Cord	299	165
0399-1	NEW 12V cd/s vartsp drill w/batt. charger & case	290	155
0395-1	9.6V cd/s drill w/case	270	148
0219-1	3.6V cd/s drill w/case	295	165
0234-1	1/2" drill 4.5A magnum	189	112
0224-1	1/2" drill 4.5A mag-650rpm	209	112
0224-1	3/8" drill 3.5A 0-1000 rpm	189	102
0228-1	3/8" drill 3.5A 0-1000 rpm	209	125
0375-1	3/8" cord quarter drill	243	154
0379-1	1/2" cord quarter drill	243	154
6539-1	Cd/s. scdrv. 190 rpm	119	69
6540-1	Cd/s. scdrv. w/bits & case	159	78
6546-1	Cd/s. scdrv. 200 & 400 rpm	126	75
3102-1	Pimbrs rt angle drill kit	330	185
5399	1/2" D-hole ham drill kit	312	179
1676-1	H.D. Hole Hawg w/case	429	229
6511	2 sp SawZall w/case	224	129
6750-1	Drywall gun 0-4000 4.5A	154	89
6507	TSC SawZall w/case	239	129
6170	1/4" chop saw	430	259
6014	Orbital sander 1/2 sheet	209	118
8977	Var. temp heat gun	114	75
5397-1	3/8" vsp ham. drill kit	232	137
5371-1	1/2" vsp ham. drill kit	335	185
3107-1	1/2" vsp rt angle drill kit	340	189
6754-1	Drywall gun 0-4000 4.5A	179	119
3300-1	1/2" vsp mag rt angle drill	309	179
5660	Router 1-1/2 HP - 10amp	325	195
5680	Router 2 HP - 12 Amp	355	219
5495	7/8" polisher 1750 rpm	219	127
6215	16" chain saw	280	169
6365	7-1/4" circular saw	204	119
6366	7-1/4" circ. saw w/fnc & bid.	214	125
6368	7-1/4" circ. saw w/fence	239	135

FREUD SAW BLADES			
0235-1	1/2" drill klys. chuck mag	215	125
6016	1/4 sheet pad sander	94	49
6145	4.5" grinder 10,000 rpm	159	95
6142	6.45" w/case & access	197	125
6749-1	Drywall gun 0-2500 4.5A	189	125
6377	7-1/4" worm drive saw	295	169

FREUD SAW BLADES			
5/8" Bore - Industrial Grade CARBIDE TIPPED SAW BLADES			
Item	Description	Teeth	List Sale
LJ72M010	Gen Pur. - A.T.B. 10" 40	58	38
LJ82M010	Cut-off 10"	60	44
LJ84M010	Comb 10"	60	55
LJ85M010	Super Cut-off 10"	60	55
LJ72M010	Ripping 10"	24	57
LJ73M010	Cut off 10"	60	44
LJ87M010	Thin kerf 10"	24	60
LJ88M010	Thin kerf 10"	60	44
LJ98M010	Ultimate 10"	80	107
SD306	6" Dado - Carbide	184	105
SD308	6" Dado - Carbide	196	109
F0	1-3/4" x 5/8" Bisc. 1000 Qty.	32	27
F10	2-1/8" x 3/4" Bisc. 1000 Qty.	32	27
F20	2-3/4" x 1" Bisc. 1000 Qty.	34	29
FA	Assor. Biscuits 1000 Qty.	34	29
WC106	6 pc. chisel set w/case 1/4"-1"	73	52
FB100	16 piece forstner bit set	284	159
94-100	5 pc. router bit door system	288	155
JS100	Biscuit Jointer w/case	300	159
CE82	Planer w/case & carb bids	218	135
FT2000	3-1/4 HP plunge router	299	179

THE NEW "TK" BLADE SERIES			
Item	Description	Teeth	List Sale
TK203	7-1/4" Framing	24	29 17.35
TK206	10" Framing	24	33 18.80
TK203	7-1/4" Finishing	40	36 21.80
TK306	10" Finishing	40	40 23.95
TK903	7-1/4" Combo	30	31 18.60
TK906	10" Combo	50	45 26.95

MAKITA CORDLESS			
Model	List	Sale	
60700D	3/8" vsp/d rev. drill, 7.2v	130	78
60710DK	3/8" vsp/d rev. drill w/removable batt, 7.2v	199	115
50900D	3-3/8" saw kit, 9.6v	256	139
60100DK	3/8" cd/s drill kit 7.2v	164	95
60105SD	3/8" cd/s. drill kit, 7.2v	99	59
DA30000D	3/8" angle drill, 7.2v	251	139
84000D	Hammer drill kit, 9.6v	272	149
43900D	9.6 cd/s recip saw kit	230	128
6012HDW	2 spd. driver drill w/clutch & case 9.6v	236	122
60920D	Vsp drill, kit complete	295	125
60930D	Vsp drill w/clutch-complete	261	127
63200T-4	9.6 volt battery	48	30
63200T-4	9.6 volt battery	48	30
5007NBA	7-1/4" saw w/bisc. brake	233	124
5008NBA	8-1/4" saw w/bisc. brake	284	158
604510	1/4 sheet pad sander	85	54
99008	3" x 21" belt sander w/bag	268	144
99240B	3" x 24" belt sander w/bag	282	145
9045N	1/2 sht lin. sand. w/bag	321	129
4200N	4/8" circ. saw 7.5A	225	127
40318V	Orb vsp jig saw 3.5A	289	155
JR3000V	Vs. recip saw w/case	227	124
LS1020	10" mitre saw 3.5A	463	269
9820-2	Blade sharpener	373	195
19008W	3-3/4" planer w/case	209	114
1911B	4-3/8" circ. saw 7.5A	240	139
1100	1-3/8 HP router	401	205
9207SPC	7" sander-polisher	276	149
3601B	1-3/8 HP router	255	139
9501BZ	4" grinder, 3.5 amp	126	69
604530	6" round sander	101	64
604550	1/4 sht pad sander w/bag	86	58
DA3000R	3/8" angle drill	270	146
HP2010N	3/4" vsp hmr. drill w/case	300	165
2708W	8-1/4" table saw	504	249
2711	10" table saw w/brake	841	479
2030N	12" planer/jointer	3120	1665
2040	15-5/8" planer	2995	1459
1805B	5-1/8" jointer w/case	679	359
5005DA	5-1/2" circular saw	223	135
6404	3/8" drill rev. 0-2100 rpm 2A	104	65
6510LVR	3/8" drill rev. 0-1050 rpm	145	75
6013BR	1/2" drill rev. 6 Amp	241	135
5402A	16" circular saw 12 amp	636	325
3612BR	3 HP plunge router	377	189
9401	4" x 24" belt sander w/bag	318	165
4302C	V spd. orb. jig saw	302	159
5077B	7-1/4" Hypoid saw	252	138
LS1440	14" Mitre saw	721	435
LS1030	NEW 10" Mitre saw	414	225
5007NB	7-1/4" circ saw 13A	209	112
3612B	3 HP plunge router sq/base	377	189

SENCO AIR NAILERS			
Model	Description	List	Sale
SNF1	Finishing nailer 1" - 2"	377	275
SNF2	Fin. nailer 1.5" - 2.5"	571	395
SN325	Nailer 1-7/8" - 3-1/4"	665	455
SN4	Gen'l purpose 2" - 3-1/2"	686	475
LS2	Pinner 5/8" - 1"	351	255
SKS	Stapler 5/8" - 1-1/2"	351	255
LS5	Pinner 1" - 1-1/2"	399	285

BOSTICH AIR NAILERS			
Model	Description	List	Sale
N80C-1	Utility coil nailer	845	429
N80S-1	Stick nailer	845	429
T36-S0	Sheath & decking stapler	595	334
N12B-1	Coil roofing nailer	845	429
NE6FN-2	Finishing nailer	625	345
T31	Brad nailer	270	155
CWC100	1 HP Pancake Compressor	445	299

SKIL SIZZLERS			
6850-02	NEW 1/2" EMH hammer drill w/case 4 amp	255	129
3810	10" Mitre saw	263	209
3810K	3810 w/60 tooth carb blade	235	144
77	7-1/4" worm drive saw	230	144
2735-04	12 v vsp cordless drill w/case, 2 batt & xtra special 5 piece bit set.	210	129
1605	NEW Biscuit Jointer w/case	200	119

PANASONIC CORDLESS			
EY6205B	NEW vsp/d. 12 volt drill w/15 minite charger	390	179
EY6005B	12v cd/s drill w/1 hr chgr	315	169
EY6200B	NEW 2 spd. 12 volt drill d-handle w/15 minite charger	350	185
EY6201B	NEW vsp/d. 9.6 volt drill w/15 minite charger	350	169
EY571B	Vsp/d 9.6 volt drill kit	239	128

LEIGH DOVETAIL JIGS			
D1258R-12	List 329.00 Sale 255.00		
D1258R-24	List 390.00 Sale 298.00		
LEIGH INSTRUCTIONAL VIDEO SALE 29.00			
MMT 12"	multiple mort. & tenon attachment for D1258-12	269	155
MMT 24"	multiple mort. & tenon attachment for D1258-24	299	169

HITACHI TOOLS			
Model	Description	List	Sale
CTBD	7-1/4" circular saw	230	129
M12V	NEW 3 HP vsp router	437	235
TR12	Planer/router, 3 HP	354	169
P1000A12	12" Planer/6" jointer	2835	1505
P100F 12"	planer	2005	1259
CI10FA	10" deluxe mitre saw	490	269
C12FA	NEW 12" mitre saw	586	319
CBF8	8-1/2" slide compd saw	859	445
FREUD	LJ81M008 8-1/2" ob/d 48 tooth 58	36	
C15FB	16" mitre saw	745	379
FREUD	LJ85M015 15" ob/d 108 tooth.	181	115

1991 TOOL CATALOG AVAILABLE
 Call Toll-Free 1-800-328-0457 In Minnesota Call (612)224-4859
 FAX: (612)224-8263
 CHECK - MONEY ORDER - VISA - MASTERCARD - DISCOVER
SEVEN CORNERS ACE HDW. Inc.
 216 West 7th St. - St. Paul, MN 55102 - Est. 1938

DELTA TOOLS			
34-444	Table Saw Complete w/1-1/2 H.P. motor & stand	605.00	
34-445-34-444	Table Saw complete w/30" Unifence	779.00	
37-154	DJ15 6" Jointer w/3/4 H.P. motor	999.00	
28-283	14" Band Saw w/encloused stand	675.00	
70-200	NEW 20" Drill Press	729.00	
17-900	15-1/2" Floor Drill Press	385.00	
40-601	18" Scroll Saw w/stand and blades	689.00	

DELTA			
#34-080	10" MITRE BOX		
XTRA SPECIAL			
195.00			
List 289.00			

TOOLS ON SALE!
 AMERICA'S LOWEST PRICED TOOLS
 FREE FREIGHT TO THE 48 CONTINENTAL STATES ON EVERY ITEM.
 PRICES SUBJECT TO CHANGE WITHOUT NOTICE.

PIRANHA By Black & Decker CARBIDE TPOOTH SAW			
Model #	Dia.	Teeth	List

FINISHING TOUCHES

AN ARTIST'S BURNING DESIRE

Daniel Leahy depends on California sunshine. No, he doesn't grow oranges or sell suntan lotion. Leahy creates pictures, laser-style. The woodworking artist accidentally discovered what he calls solar etching a few years back when he wandered outdoors with an 8" spot-projector lens he'd been using as a paperweight. While holding it in the sunlight near a piece of wood, a flame shot up almost instantaneously. "It took less than a second," Leahy remembers. Intrigued, he began burning lines on the wood, and a new career was born. "My solar etchings now outsell my

custom-made furniture," says the 41-year-old Guerneville craftsman. In fact, Leahy's etching on display in the San Jose Public Library has a price tag of \$10,000. Burned on a 7x18' panel of glued-up 2x4s, it depicts the city in the late 1800s. Normally, his work runs from 12" diameter and up and sells for \$75 to \$1000. To learn more about solar etching, write for a copy of Leahy's 24-page, how-to booklet, "Solar Art." Send \$5 (U.S.) ppd. to: Daniel Leahy, P.O. Box 2154, Guerneville, CA 95446.



Solar artist Daniel Leahy uses a magnifying lens to burn intricate patterns into the different woods he's laid up. Dark glasses protect his eyes.

THE PHARAOH'S FINISHERS

Although historians have traced evidence of the woodworking plane to Pompei, the Roman city buried by volcanic lava in 79 A.D., the Greeks may have actually developed and used the tool first. No Greek planes have been un-

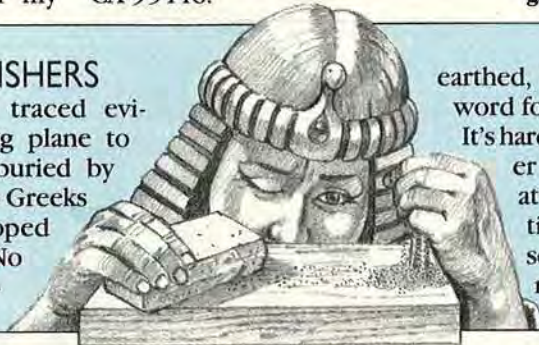

earthed, but the ancient Greeks had a word for it—rhykane.

It's hard to imagine how any woodworker could smooth wood without at least a hand plane, but the inventive Egyptians found a way. They scattered sand on wood, then rubbed it with stone blocks.

TREES: NATURE'S AIR CONDITIONER & HUMIDIFIER

One acre of trees supplies 4 tons of oxygen a year—enough to support 18 people, while using about 2.6 tons of carbon dioxide. That same acre, according to Doug Powell, a U.S. Forest Service researcher, cleans about 13 tons of dust and gases annually from the surrounding environment. An acre of beech or maple trees can give off 8,000 gallons of water—that's transpiration—into the earth's atmosphere during a single growing season.

CHINA'S SORROW: A CLASSIC CASE OF LAND MISMANAGEMENT

"He who fails to plant a tree...shall go coffinless to the grave."—from the proclamation of Chinese Emperor Chin Shih Huang Ti ordering the replanting of the forests along the 2,500-mile long Yellow River about 200 B.C.

Some 2,000 years earlier, the vast forests had been ordered burned by Emperor Shun, who thought the land better suited to farming. Instead, the rich humus in the valley of the Yellow River became depleted, the river annually flooded, massive amounts of soil were carried off, and poverty eventually reigned. Despite Emperor Chin's order to replant, the feudal lords who owned the land refused to do so. Today, the Yellow River still spills over its banks, plaguing the valley with devastation and earning designation as China's Sorrow.

WAY OUT WEST, THE CALL IS "TIMBER!"

In 1989, the 11 contiguous western states plus South Dakota's Black Hills provided 56.4 percent of all softwood lumber produced in the U.S.

WHICH STATES HAVE THE MOST FOREST?

Based solely on the percentage of land covered by forests, the U.S. Forest Service rates Maine (89.8 percent), as the most forested state, followed by New Hampshire (88.1 percent), West Virginia (78.5 percent), Vermont (75.7 percent), and Alabama (66.9 percent). North Dakota (1 percent) is the least forested state, beating out Nebraska (1.5 percent) for the dubious honor. The country as a whole is nearly one-third forested (32 percent).

Illustrations: Jim Stevenson Photographs: Ben Margot, Daniel Leahy

TRULY PERSNIPPITY



Photo: George Duncan

Truly Beautiful

NON-TOXIC

NO ODOR

Wood Stain Concentrate
Mix with Cooking Oil!!
For All Fine Woodwork & Crafts

Furniture, Cabinets, Toys, Clocks, Gun Stocks
Accepts all finishes - Soap & water clean up

8-pack Sampler 14.95 Pint 4.95 Quart 6.95 Gallon 15.95

Eight beautiful colors: Modern Mahogany, Walnut, Classic Oak,
Meadowlark, Azure Blue, Periwinkle Green, Strawberry, and Grape.

Charge or send check or money order + 2.50 shipping & handling

CA residents add 7.25% sales tax

Pat. Pending

Money Back Guarantee!

Unlimited
Shelf Life &
Color Retention

Mail Order
Only



Toys by
Toys from the ♥
4417 Louisiana St.
San Diego, CA 92116
619-291-3066

P.O. BOX 2480, OCEANSIDE, CA 92054 800-878-7859

Engineering A Great Table Saw Wasn't Easy.

Selecting The Name Was. Craftsman!

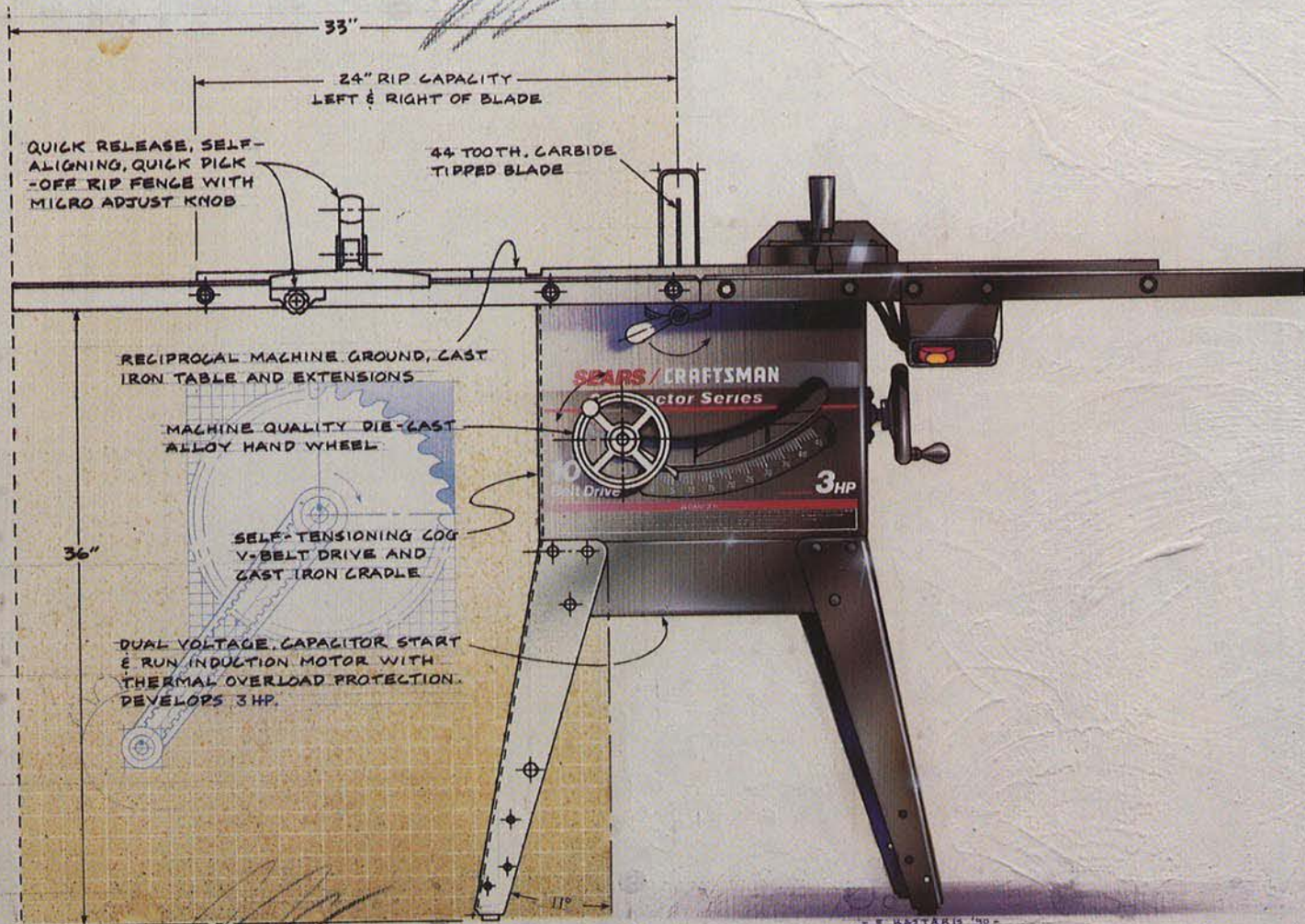

The precision engineering of the Contractor Series table saw was designed specifically for the serious woodworker. From the power of the motor to the accuracy of our patented Exact-I-Cut alignment system, we've spared no effort to ensure all the power and accuracy you'll ever need.

And you don't have to call for the name of your "nearest" distributor to see the many features. Just zip on down to your Sears store to see for yourself.

CRAFTSMAN®
Only at Sears