

Better Homes and Gardens®

# WOOD

**HOT**  
SUMMER PROJECT!  
Mahogany Patio Table  
See page 64

THE #1 MAGAZINE FOR HOME WOODWORKERS

JUNE 1991 • ISSUE NO.43

Display until June 11

**SAY GOODBYE TO DUST:**  
**BUILD YOUR OWN**  
**COLLECTION SYSTEM**

**NORTHWEST INDIAN**  
**CARVING SHOWCASE**

**READING TREE RINGS**  
**TO TELL THE PAST**

**PROJECT PARADE**

Dust collectors for  
portable planers and  
radial-arm saws

Heart music box

Turned balloon mobile

Hollow wooden egg

Whale cutting board

Country pull toys

Woman's purse mirror

## DUCK UNDER GLASS

See page 57





**12" PLANER**  
**MODEL G1017**  
 ONLY \$385<sup>00</sup>

F.O.B. BELLINGHAM, WA or WILLIAMSPORT, PA



IMPORTS, INC.

"IMPORTERS OF FINE MACHINERY"

**...knocks out  
 the competition!**



**16" BAND SAW**  
**MODEL G1538**  
 ONLY \$525<sup>00</sup>

F.O.B. BELLINGHAM, WA or WILLIAMSPORT, PA



**6" x 47" HEAVY-DUTY  
 JOINTER**  
**MODEL G1182**  
 REG. \$375.00  
 SALE \$345<sup>00</sup>

F.O.B. BELLINGHAM, WA or WILLIAMSPORT, PA



**10" HEAVY-DUTY  
 TABLE SAW**  
**MODEL G1022**  
 REG. \$375.00  
 SALE \$355<sup>00</sup>

F.O.B. BELLINGHAM, WA or WILLIAMSPORT, PA



**2 H.P. DUST  
 COLLECTOR**  
**MODEL G1029**  
 ONLY \$295<sup>00</sup>

F.O.B. BELLINGHAM, WA or WILLIAMSPORT, PA



**20" PLANER**  
**MODEL G1033**  
 ONLY \$1,295<sup>00</sup>

F.O.B. BELLINGHAM, WA or WILLIAMSPORT, PA



**1-1/2 H.P. SHAPER**  
**MODEL G1035**  
 ONLY \$495<sup>00</sup>

F.O.B. BELLINGHAM, WA or WILLIAMSPORT, PA



**3 H.P.  
 SHAPER**  
**MODEL G1026**  
 ONLY \$850<sup>00</sup>

F.O.B. BELLINGHAM, WA or WILLIAMSPORT, PA



**8" x 65" SUPER  
 HEAVY-DUTY  
 JOINTER**  
**MODEL G1018**  
 ONLY \$695<sup>00</sup>

F.O.B. BELLINGHAM, WA or WILLIAMSPORT, PA



**6" x 48"  
 COMBINATION  
 SANDER**  
**MODEL G1014**  
 ONLY \$195<sup>00</sup>

F.O.B. BELLINGHAM, WA or WILLIAMSPORT, PA



**15" PLANER**  
**MODEL G1021**  
 ONLY \$735<sup>00</sup>  
 (STAND OPTIONAL)

F.O.B. BELLINGHAM, WA or WILLIAMSPORT, PA

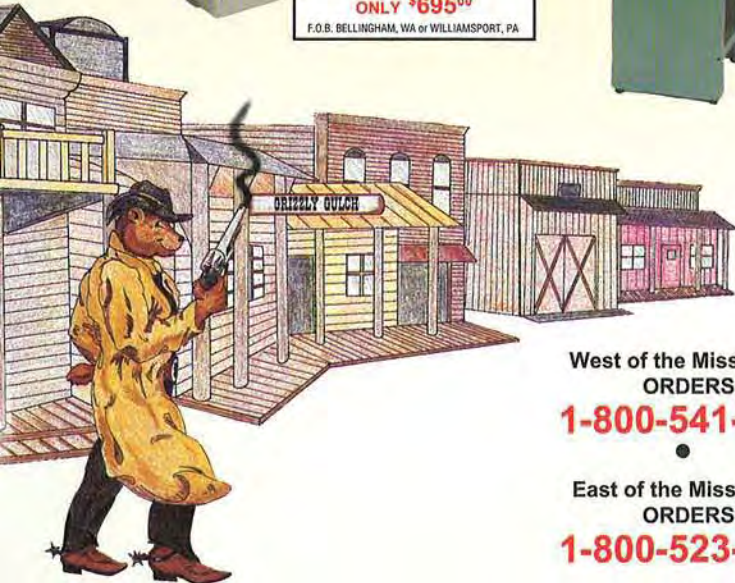

*Order your  
 FREE 1991  
 catalog, today.*



**SUPER HEAVY-DUTY  
 TABLE SAW**  
**MODEL G1023**  
 ONLY \$895<sup>00</sup>

F.O.B. BELLINGHAM, WA or WILLIAMSPORT, PA

West of the Mississippi:  
 ORDERS:

**1-800-541-5537**

East of the Mississippi:  
 ORDERS:

**1-800-523-4777**



**THE FLY-BY-NIGHT GANG**

## THE EDITOR'S ANGLE

# OH, WHAT A RELIEF IT IS!

# DOVE

## READY TO SET SAIL THIS SUMMER

Those of you who have been subscribing to *WOOD*® magazine for some time now may remember that our design editor, Jim Downing, has been building a 30' sailboat—one board at a time. In fact, he's been at it for four years now. But, as you can see, his persistence has paid off handsomely. After some 2,700 hours of his time, and about that many more hours donated by family members, the DOVE is nearly ready to set sail.

Since I'm one of those woodworkers who gets impatient if a project takes more than an evening or two, I was curious to find out how Jim feels now that he's finishing his mammoth undertaking.

Moving day at the Downing's: the DOVE en route to its custom-made trailer.



Captain and Mrs. Downing beaming with pride a few minutes after the big move.

ing. "It turned out to be a much more complex project than I had anticipated, so I'm relieved," Jim says. "There were times when I wished I could get out of the project, but I knew I couldn't."

Our resident sailor credits his family with helping to make the project a reality, especially wife Etta and Jim's father Loyal. "My dad has been at my house every Saturday for the past three years. He's been my steady helper. And Etta tells me that she's looking forward to having a social life again."

What's next for this industrious woodworker? "My projects will be quick and easy for awhile," Jim insists, "though I do want to build a cherry bedroom set after I get rested up."

Congratulations on a job well done, Captain! 🍀

*Larry Clayton*

### WE CARE!

EDITORIAL MAILING ADDRESS: WOOD Magazine, P.O. Box 11454, Des Moines, IA 50336-1454.

SUBSCRIPTION SERVICE (including change of address): WOOD Customer Service, P.O. Box 10628, Des Moines, IA 50336-0628. Please enclose your address label from a current issue. If you wish to phone, call toll-free 800-678-2666.

CUSTOMER SERVICE TEAM: Portia Hallerty, Marjane Cline, Cheryl Leonard, Velma Williams.

## Mobile Machine Bases

to put your entire shop  
on wheels

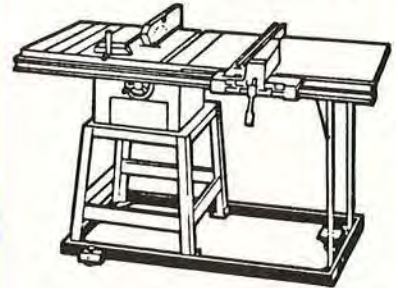

EXPAND WORKING AREA  
MAKE CLEAN-UPS A SNAP

- \* Hundreds of Models available
- \* 3 - 2½" Ø Wheels for Stability
- \* Dual wheel locks for Positive Positioning
- \* Raises machine only 3/4"
- \* All Steel & Precision Welded
- \* Lifetime Warranty

## Work Supports

to do your best  
safely & accurately

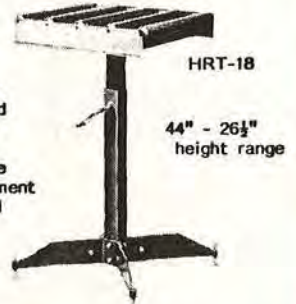

Unique  
Tapered  
Wedge  
for  
Positive  
Adjustment  
Control

DESIGNED TO HELP YOU SUPPORT  
AND SAFELY MOVE WORK PIECES  
THRU YOUR MACHINES

- \* No tools needed for simple, positive height adjustments
- \* Top quality, galvanized, ball-bearing Rollers
- \* Non-marring Leveling Pads
- \* Heavy Gauge Steel Components
- \* Lifetime Warranty

All Products - Made in America &  
Available at Better Tool Stores

Free Catalog



HTC Products, Inc.  
120 E Hudson • P.O. Box 839  
Royal Oak Michigan 48068-0839

(313) 399-6185 • (800) 624-2027

## JUST A PLANE DEAL!

### 10" PORTABLE PLANER

#AP10

**RYOBI**

348

- 13 amps.
- 8,000 RPM.
- 1/8" deep, 10" wide plane.

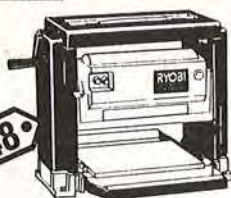

### 12" PORTABLE PLANER

#2012

**Makita**

468

- 12 amps.
- 8,000 RPM.
- 1/8" to 6" deep, 12" wide plane.

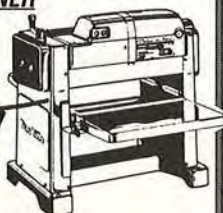

### 12-1/2" PORTABLE PLANER

#JWP-12

**JET**  
EQUIPMENT & TOOLS

358

- 16 amps.
- 8,000 RPM.
- 1/32" to 6" deep, 12-1/2" wide plane.

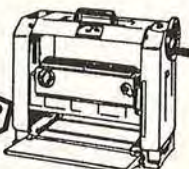

### 12" PORTABLE PLANER

#22-540

**DELTA**

418

- 15 amps.
- 8,000 RPM.
- 1/8" deep, 12" wide plane.

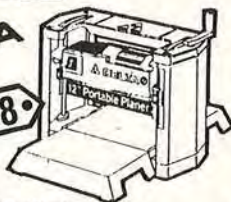

### 12" PORTABLE PLANER

#P12R

**HITACHI**

588

- 14 amps.
- 10,400 RPM.
- 3/32" cutting depth.

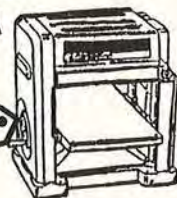

### 12" PLANER/6" JOINTER

#P12RA

**HITACHI**

778

- 14 amps.
- 10,400 RPM.
- 3/32" cutting depth.

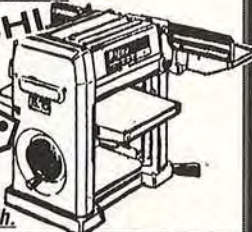

## TOOL CRIB

OF THE NORTH  
DIVISION OF **RAMCO** *Hardware*

P.O. Box 1716  
Grand Forks ND 58206

Send \$2.00 for 186 page catalog

**1-800-358-3096**

Free Freight \* Limited Offer \* Same Day Shipping

Better Homes and Gardens.

# WOOD

THE #1 MAGAZINE FOR HOME WOODWORKERS

This issue's cover wood grain: light avodire

Cover photo: Hopkins Associates

JUNE 1991

ISSUE NO. 43

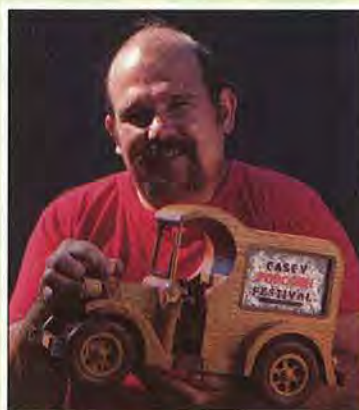

### CRAFTSMAN CLOSE-UP 31

#### Mr. Music Box

A maker of superb music boxes, Richard Gard deserves to wear a good guy's white hat. That's because in Casey, Illinois, his donated projects lift spirits and help worthy causes.

### Northwest coast Indian carvings 36

Take in a showcase of mysterious carved masks, bowls, and boats that marks the artistic peak of a unique North American culture.



### Central dust collection 40

Need an affordable, effective way to rid dust from your shop? Then check out our complete, do-it-yourself system that relies on common PVC pipe and fittings.

### Down-to-business dust collector 46

This homemade louvered box installs behind a radial-arm saw and connects to your collection system for instant local pickup.

### The dust stops here 48

With our easy-to-make hood attachment, you can siphon the shavings from your portable planer and send them to your collection system.

### High-flying balloon mobile 50

Turn and hang our wooden balloons, three in all, and then watch them gently bob up and down in a nifty mobile configuration. We varied the look of each balloon by mixing light and dark woods in laminated blocks prior to turning. To suspend the balloons, we strung each with fishing line, and then we attached them to a pair of birch dowel rods.

## Cumulative index for issues 33-41 53

Find the projects, tool comparisons, techniques, and feature stories for 9 recent issues of *WOOD*® magazine in this easy-to-use reference.

## Duck under glass 57

Scrollsawed pieces sandwiched between panes of glass and forming a wildlife scene make this a must-do project for sportsmen.



## Revelation in the rings 60

Learn how reading tree rings helps a special breed of scientists reconstruct the climatic events of the past.



## Casual classics II 64

Last issue, you received our mahogany outdoor chair plans; here, you'll find the complete design for the striking complementary table.

### TURNING

## Construct-a-chuck 68

Woodturners, you can shape goblets and small boxes with this adaptable lathe chuck. It's made from a wood blank and a hose clamp.

## Lathe-laid eggs 70

Fill a basket with hollow wooden eggs using our novel lathe chuck.

### THE CRAFT SHOP

## One whale of a cutting board 72

## Barnyard favorites 74

## Ladies' cosmetic mirror 76



### DEVELOP YOUR SHOP SKILLS

## How to resaw safely and simply 78

### SHORT-SUBJECT FEATURES

Editor's Angle . . . . .	1	Products That Perform . . . . .	24
Talking Back . . . . .	8	Rain Forest Update . . . . .	79
Four novel napkin rings . . . . .	12	Jelly bean machine . . . . .	80
Tips from Your Shop . . . . .	14	Ask <i>WOOD</i> . . . . .	89
Great Ideas for Your Shop . . . . .	23	Finishing Touches . . . . .	96

# FATHER'S DAY SALE



EXPIRES 6-28-91

	Reg.	SALE
3-1/2" Shaker Peg	\$15.00/100	\$14.00
2-7/16" Medium Peg	\$14.00/100	\$13.00
1-3/4" Mini Peg	\$ 7.50/100	\$ 5.50
1-3/8" Candle Cup	\$18.00/100	\$15.50
5/8" Mini Candle Cup	\$10.00/100	\$ 8.50



1" Toy Wheel	\$ 6.00/100	\$ 3.50
1-1/4" Toy Wheel	\$ 8.00/100	\$ 6.00
1-1/2" Toy Wheel	\$10.00/100	\$ 8.00
2" Toy Wheel	\$18.00/100	\$16.00
Axle Pegs for Above	\$ 5.00/100	\$ 3.00
1-5/8" Pickle Barrel	\$14.00/100	\$12.00
2-3/8" Man	\$18.00/100	\$16.00



3/8" or 1/2" Birch Button	\$ 2.00/100	\$ 1.50
1/4" Birch Dowel	\$18.00/100	\$16.00
3/8" Birch Dowel	\$ 8.75/ 25	\$ 7.00
1/2" Birch Dowel	\$15.00/ 25	\$12.50
1-1/2" Birch Spindle	\$10.00/100	\$ 8.00
5-3/4" Birch Spindle	\$10.00/ 25	\$ 8.75
12" Ramin Spindle	\$12.50/ 25	\$10.00



1/2" Square Block	\$ 8.00/100	\$ 6.00
3/4" Square Block	\$10.00/100	\$ 8.00
1" Square Block	\$12.00/100	\$10.00
3/4" Full Round Ball	\$ 9.00/100	\$ 7.00
1" Full Round Ball	\$12.00/100	\$10.00
1-1/2" Full Round Ball	\$ 4.00/ 10	\$ 3.00
2" Full Round Ball	\$10.00/ 10	\$ 7.00
2-1/2" Full Round Ball	\$20.00/ 10	\$15.00
3" Full Round Ball	\$ 3.00/EA	\$ 2.00



2-1/2" Apple	\$ 2.00/ ea.	\$ 1.50
5/8" x 7/8" Wren Egg	\$10.00/100	\$ 8.00
1-3/4" x 2-1/2" Hen Egg	\$12.50/ 25	\$10.00
2-3/4" x 4-1/4" Goose Egg	\$ 3.00/EA	\$ 2.50
5/8" Picture Hanger	\$ 2.00/100	\$ 1.50
1-5/8" Sawtooth Hanger	\$ 4.00/100	\$ 3.00
#17 Screw Eye 1/2" Long	\$ 2.00/100	\$ 1.50

**1-800-722-0311**

To receive sale prices use Sale #B31



**FREE** ALL NEW  
With Order WOOD PARTS  
CATALOG \$1.00

We accept M/C, VISA  
Check, or M.O. All orders  
add \$4.00 Handling

TX add 7% tax. Canada add 30%  
Alaska, Hawaii add 15% for freight.

**Woodworks**

P.O. Box 14507 Ft. Worth, TX 76117

# FINISHER'S FRIEND®

## THE PERFECT

## GIFT

### FOR EVERY HOME & SHOP

#### HOBBY



**SURFACE PREP. & REFINISHING:** wood, fibre glass, plastic, glass, metal, composition. Eliminates swirl marks of 'rotary' sanding disks. Use **sandpaper**, **sanding screen** (resists 'loading') or **cloth**. Bond to vinyl working surface with **spray adhesive** (can) or feathering disk adhesive (tube). 80 grit through 400 grit up to 2000 micro (wet / dry) pre-polish. **OR... use PSA** (pressure sensitive adhesive) sandpaper rolls. 80 to 400. Standard 9 x 11 sandpaper sheet yields 4 full strips for F.F.

#### RESTORATION



**INTERIOR, EXTERIOR:** Remove / blend cracked, flaking paint / varnish from weathered exterior surfaces; rust from metal surfaces, lawn furniture. Use with sanding screen for dry-wall, plaster or removing paper residue. **Thick, firm & radiused** - one end; **thin & flexible** - other. **Thick & firm along one side; thin, flexible** - other. **WIDE RANGE OF FINGER SAVING PRESSURE CONTROL.** Ends provide **supported access to shallow right angles, "V's" & recesses.** Great for anything with louvers, including metal hot air registers.

#### AUTO / MARINE



Use with 40 grit to 'file' body putty. (Experience permits use of **area directly beneath handle for work requiring a flat surface**). Proper grit selection allows rust & residue removal, paint 'feathering' & **wet finishing** with or without assist from power sanders. Aids surface prep w/o removal of chrome strips or hardware. Follows contours. Accesses hard to reach surfaces. Refer to auto-body supply stores for spray adhesives; heavier & finer grit sandpapers.

### FINISHER'S FRIEND®

Send check or money order to:

**FINISHER'S FRIEND**  
P.O. Box 6146, Dept. W  
Lafayette, Indiana 47903

PLEASE RUSH \_\_\_\_\_ 4-WAY HAND SANDER(S) TO ME AT:

Name: \_\_\_\_\_

Address: \_\_\_\_\_

City: \_\_\_\_\_

State: \_\_\_\_\_ Zip: \_\_\_\_\_

Shipping & Handling:

\$ 0.00 - \$ 15.00 (Excl. tx) \$ 2.00  
15.00 - 30.00 " " 3.00  
over \$ 30.00 3.75

**FINISHER'S FRIEND 4-WAY HAND SANDER**  
State Tax...  
Ship'g/Hndl

Qty	Price	Total
_____	\$14.95	\$ _____
_____	...	_____
_____	_____	_____

**CREDIT CARD ORDERS SPEED DELIVERY**

Fill in lines below ... or Call (toll-free) 1-800-325-4584

Credit Card No.: \_\_\_\_\_

MC  VISA  AM-EX Expiration mo / yr \_\_\_\_\_ / \_\_\_\_\_

100 % MONEY-BACK GUARANTEE IF NOT COMPLETELY SATISFIED

*Flexible, Soft Firm... Comfortable*



*Follows Contours - Wraps Around - Gets in - between - Gets Under and Into.*

Better Homes and Gardens®

# WOOD®

THE #1 MAGAZINE FOR HOME WOODWORKERS

June 1991 • Vol. 8, No. 4 • Issue No. 43

Editorial/Art Staff

Editor **LARRY CLAYTON**  
Managing Editor **JIM HARROLD**  
Art Director **C. L. GATZKE**  
Assistant Art Director **PERRY A. McFARLIN**  
Design Editor **JAMES R. DOWNING**  
Senior Editor **PETER J. STEPHANO**  
How-To Editor **MARLEN KEMMET**  
Products/Techniques Editor **BILL KRIER**  
Special-Interest Editor **LARRY JOHNSTON**  
Copy/Production Editor **JOHN D. HOFHEIMER**  
Project Builder **JAMES E. BOELLING**  
Administrative Assistant **DARLENE REYNOLDS**  
Business Office Clerk **MARGARET CLOSNER**  
Secretary **ROSEMARIE BURCH**

Technical Consultants: Product Testing **GEORGE GRANSETH**; **BOB McFARLIN**; Products That Perform **STEVE OSWALT**; Wood Technology **PAUL L. McCLURE**; Collectible Tools **PHILIP WHITBY**; Carving **HARLEY J. REFSAL**

Publisher **WILLIAM R. REED**  
Advertising Representatives **CRAIG KAPLAN**, **CHRIS W. SCHRAFF**, **LORIANN DeCICOPPO**  
Promotion/Research Director **EILEEN SULLIVAN**  
Marketing Services Manager **NANCY DALY**  
Publisher's Assistant **NANCY LOPEZ**  
**ADVERTISING OFFICES:** 750 Third Ave., New York, NY 10017. Phone 212/551-6903.

Circulation Manager **ALAN BRUSH**  
Newsstand Circulation Director **MICHAEL SENIOR**  
Business Manager **TERRY UNSWORTH**  
Production Director **ROBERT C. FURSTENAU**  
Public Relations **SONDY DAGGETT**  
Special Projects **JAY BURZON**

Magazine Group Officers

Group President **JAMES A. AUTRY**  
SVP, Publishing Director **ADOLPH AUERBACHER**  
SVP, Editorial Director **DORIS EBY**  
SVP, Operations **DEAN PIETERS**  
Group VPs: Publishing Directors **MYRNA BLYTH**, **BURTON H. BOERSMA**, **CHRISTOPHER M. LEHMAN**  
Group VP, Circulation Director **CLEM SEVDE**  
Controller **MAX RUNCIMAN**

Corporate Officers

Chairman of Executive Committee **E.T. MEREDITH III**  
Chairman of the Board **ROBERT A. BURNETT**  
President and Chief Executive Officer **JACK D. REHM**  
Group Presidents: Broadcasting **PHILIP A. JONES**; Magazine **JAMES A. AUTRY**; Real Estate **ALLEN SABBAG**

Better Homes and Gardens® WOOD® — the #1 magazine for home woodworkers (ISSN-0743-894X) is published eight times a year in January, February, April, June, August, September, October, and December by Meredith Corporation, 1716 Locust St., Des Moines, IA 50336. Second-class postage paid at Des Moines, Iowa. Better Homes and Gardens trademark registered in Canada and Australia. Marca Registrada en Mexico. **ONE-YEAR SUBSCRIPTION PRICES:** United States and its possessions, \$19.97; Canada, \$29; other countries, \$38. **POSTMASTER:** Send address changes to WOOD, 1716 Locust St., Des Moines, IA 50336. ©COPYRIGHT MEREDITH CORPORATION 1991. ALL RIGHTS RESERVED. PRINTED IN U.S.A. Canadian GST Reg. #123482887.

MPA

# THE BEST IN THE BITNESS.

When you buy router bits from Freud you're buying carbide precision bits designed to perform at optimum efficiency—bits that deliver finished profiles you'll consider quite simply, the best.

## And we can prove it!

We guarantee the quality of the carbide on over 1000 carbide products, from dados to multi-profile bits.

How?

We produce our own carbide. This gives us closer control on the quality and allows us to formulate carbide to fit the special needs of the woodworker.

A superior cut is also an advantage found on our Freud router bits. Each bit is ground on computer controlled grinding equipment using the finest diamond grinding wheels to provide the sharpest cutting edge available while maintaining durability.

But grinding alone doesn't guarantee the finest finish. When we design a bit we also consider several key factors essential to a bit's performance.

The **relief angle** is the most critical of all angles in achieving smooth burn-free cuts. When wood is cut, the fibers microscopically compress under the cutting edge then return to their normal position. If enough relief angle is not used the friction between the bit and the wood will cause burning. If too much relief angle is used the cutting edge will wear quickly.

Most companies use a less expensive radial grinding for the relief on their bits. This only provides

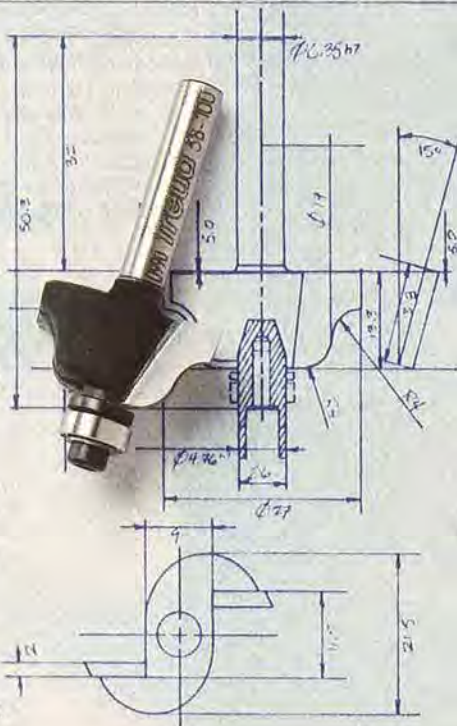

adequate relief on the cutting edges parallel to the shaft. Our computer controlled multi-axis grinding equipment provides exactly 15° of relief on all cutting edges regardless of orientation.

Though it costs more in equipment and time, it's the only way to produce bits of this quality.

The **shear angle** is the angle that the cutting edge makes with the shank of the bit. Our carbide tips are

angled to slice through the wood fibers similar in principle to using a sharp hand plane at an angle to the direction of motion. Bits without shear chop the wood and are more likely to produce tearout and chatter marks.

At Freud we combine advanced engineering with computerized automation to bring you the world's best cutting tools while keeping the cost to you incredibly low. We are so sure of this that we back each bit with a **LIFETIME GUARANTEE\***. And that is why we are "The Best In The Bitness".

As if superior design isn't enough, we offer one of the broadest selections available. Among the most versatile are our 99 Series specialty profile bits available in a wide variety



of shapes and sizes and our 85 Series specifically designed for solid surface materials.

We thought this bit of information would be helpful. If you'd like the number of your nearest Freud dealer, we can help you with that too.

Just call 919-434-3171.

\* Does not constitute entire warranty. For a complete copy of our Freud warranty please send a self addressed envelope to:

Freud Inc., PO Box 7187, High Point, NC 27264

# freud

## Precisely what you need.

High Point, NC • (919) 434-3171

# We like to think of the

We believe that every tool you buy today should become an heirloom.

Whether it's a fine chisel or that piece of machinery you've been considering, it's an important investment.

And from the first moment you hit the switch on a new Delta machine, it should provide you with pleasure. Precision. Productivity.

And before you stop to think about it, that machine should have taken you well into the future. Still going strong.

At that point, we'd like you to stop and think about all the time you've saved over the years. The problems you've avoided. The hours you've enjoyed.

We build our machines and accessories with that in mind.

We look at it this way, any new product we introduce today has the potential to become an "old standard" in the future.

So we'd better keep building them right.

**Building  
On Tradition**  
**DELTA**  
A Pentair Company

For additional information on these and other new products or for the name of your Delta distributor, call toll-free: Delta International Machinery Corp., 800-438-2486.

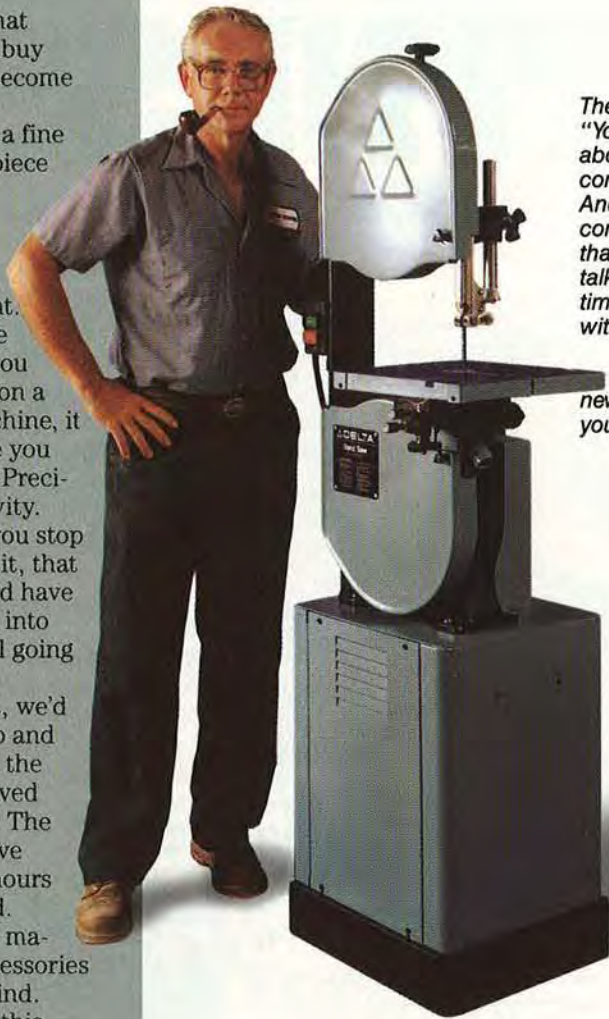

*The old-timers say, "You can tell a lot about a man by the company he keeps. And there's no better company in the shop than Delta." Just try to talk one of those old-timers into parting with his 30-year-old Bandsaw. Be a lot easier to pick up a new 14" Bandsaw at your Delta Distributor.*



## NEW

*The New Delta 10" Tilting Arbor Saw. Everything we've learned since we pioneered our Unisaw® some 60 years ago. Cast-iron table, closed base, built-in dust chute, 2-HP motor, at a price that'll fit comfortably into your shop. Even add a Unifence® Saw Guide if you like.*

## NEW

*We've got all the angles covered with this new 32" Radial Drill Press. Angle, horizontal, series or multiple hole drilling become routine operations for it's tilting, swiveling, ram traveling head. A welcome addition to our full line of drill presses.*





# em as time machines.

We've thrown out all the rules with this one. The Delta Electronic Measuring System virtually eliminates measuring for width of cut. Accurate to .005" with Unifence® Saw Guide, Jet Lock® rip fence or most other fences. Also available for vertical application on thickness planers and drill presses.



We believe in finishing what we've started. Good example is our Combination 6" Belt/12" Disc Sander. We cover your sanding needs ranging from a tiny 1" Belt Sander all the way up to our large 6" x 132" Edge Sander with edge contour sanding capability.

**NEW**

Finally an economical alternative to our production shapers. And a world of improvement over an upside down router "rig". The new Delta Router/Shaper handles 1/2" and 1/4" standard router bits. Or 1/2" hole shaper cutters with an accessory spindle. Die-cast aluminum 18" x 20" table and two-piece adjustable fence.



**NEW**

Four brand new patents redefine the art of woodshaping. Adjustable fence fingers adapt precisely to any cutter profile. No need for auxiliary fences. Our brand new 1-1/2 HP Wood Shaper will reshape the way you work, without reshaping your budget.



# TRIMTRAMP™ SAW TABLE

The most labor efficient, cost effective portable tool for quality cuts available in the market today.

**MONEY BACK GUARANTEE.**



- ◆ Converts your portable circular saw into a precision miter and crosscut saw table instantly.
- ◆ Cutting action is backward, providing unsplinted cuts of cabinet-maker quality.
- ◆ Provides: perfect 90° picture-frame quality miter joints everytime, cuts bevels, compound miters, variable angles, and crosscuts boards up to 16" wide.

The TRIMTRAMP is convenient! It can be used, clamped in a B & D "WORKMATE," on a bench, on the floor, or you can instantly disengage your saw for use as a handtool. Dimensions: 24½" wide x 32½" long x 24½" high. Comes fully assembled, weighs 21 lbs.

To obtain a **FREE** brochure or order your **TRIMTRAMP**, call **1-800-267-8776**. (Mon.-Fri. 9 am - 5 pm EST)

To place your order by mail just return this coupon to: TRIMTRAMP LTD., P.O. Box 740, Buffalo, N.Y. 14213.

- Please send me your **FREE** brochure.  
 **TRIMTRAMP** Purchase Price of **\$139.95** enclosed, together with a **\$10.00** delivery charge.  
 Check  Visa  MasterCard  Expiration Date \_\_\_\_\_

Card Signature \_\_\_\_\_ Card #: \_\_\_\_\_

Customer Name (print) \_\_\_\_\_

Customer Address: \_\_\_\_\_

State \_\_\_\_\_ Zip \_\_\_\_\_ Phone \_\_\_\_\_

\*TRIMTRAMP™ is the registered trademark of TRIMTRAMP LTD. product protected under U.S. pat. 4,909,111.

Buy Direct From The Manufacturer And **SAVE!**

Buy 12 "EVER-LAST" Belts...  
Get 12 Belts  
**FREE!**



Need ROLLS, WIDE BELTS, DISCS, SLEEVES, STROKE BELTS, etc. Write for catalog.

- Belts available in 36, 50, 60, 80, 100, 120, 150, 180, 220, 320 grit sizes. Please specify grit sizes when ordering, otherwise an assortment will be supplied.
- 1" x 30" ... \$16.50/Doz. + 12 FREE
  - 1" x 42" ... \$16.95/Doz. + 12 FREE
  - 2" x 48" ... \$25.25/Doz. + 12 FREE
  - 2½" x 16" ... \$17.95/Doz. + 12 FREE
  - 3" x 18" ... \$18.25/Doz. + 12 FREE
  - 3" x 21" ... \$19.25/Doz. + 12 FREE
  - 3" x 24" ... \$19.75/Doz. + 12 FREE
  - 4" x 21" ... \$23.50/Doz. + 12 FREE
  - 4" x 21¼" ... \$23.75/Doz. + 12 FREE
  - 4" x 24" ... \$24.00/Doz. + 12 FREE
  - 4" x 36" ... \$28.75/Doz. + 12 FREE
  - 6" x 48" \$37.50/½ Doz. + 6 FREE
- Other size belts on request.**  
 Belt Cleaning Stick ..... \$4.95 each

**9" x 11" PAPER SHEETS**

A/O or Garnet Cabinet Paper	
50 PACK	100 PACK
40-D ... \$17.00	<input type="checkbox"/> \$32.00
50-D ... \$16.00	<input type="checkbox"/> \$29.00
60-D ... \$15.00	<input type="checkbox"/> \$27.00
80-D ... \$14.00	<input type="checkbox"/> \$25.00
100-C ... \$13.00	<input type="checkbox"/> \$23.00
120-C ... \$13.00	<input type="checkbox"/> \$23.00
150-C ... \$13.00	<input type="checkbox"/> \$23.00
No Load Finishing Paper (White)	
120-C ... \$14.00	<input type="checkbox"/> \$24.00
150-C ... \$14.00	<input type="checkbox"/> \$24.00
180-A ... \$11.00	<input type="checkbox"/> \$19.00
220-A ... \$11.00	<input type="checkbox"/> \$19.00
280-A ... \$11.00	<input type="checkbox"/> \$19.00
320-A ... \$11.00	<input type="checkbox"/> \$19.00
400-A ... \$11.00	<input type="checkbox"/> \$19.00

SHIPPING CHARGES: \$4.75 Continental U.S.

- MONEY ORDER  CHECK  
 MASTER CARD  VISA

**INDUSTRIAL BRASIVES CO.**  
643 N. 8th ST. • READING, PA 19612

For Fast Delivery Call Toll Free  
1-800-428-2222 (U.S.A.)  
1-800-222-2292 (PA only)

# TALKING BACK Print this article

We welcome comments, criticisms, suggestions, and even compliments. Send your correspondence to: Talking Back, Better Homes and Gardens® WOOD® Magazine, P.O. Box 11454, Des Moines, IA 50336-1454.

## Fire expert warns: Don't build that ventilator

Efforts to vent hazardous vapors out of the shop could blow up in your face—literally—says reader James M. Feld, a Fairfield, California, fire-protection engineer. Feld wrote to warn us that the home-made basement ventilator we featured on pages 72-73 of the December 1990 issue of WOOD magazine increased the risk of fire and explosion. In that article, we told you that the basement-shop ventilator wasn't a substitute for a spray booth, but was intended to dilute light vapors. When a draft of our article passed muster with the Center for Safety in the Arts, in New York—publisher of the book Ventilation—we thought it safe.

We called for clarification. Here's what Feld said:

"Heavier-than-air fumes could accumulate in a basement shop, and electrical arcing in the fan motor could ignite the whole basement." Feld suggests either substituting an [expensive] "intrinsically safe motor," or using a belt-driven fan powered by a motor isolated from the fumes.

"The article is most correct in encouraging the use of a Material Safety Data Sheet for all products used," he says, noting that the sheet reproduced in the article shows that Krylon Fixatif Spray is only a moderate health risk but an extreme fire risk.

In the presence of volatile vapors, simple acts such as turning on a light or using a power tool can spark such uncommon but deadly fires and explosions. A water-heater pilot light can too, Feld warns.

Responding to Feld's concerns, Michael McCann, executive director of the Center for Safety in the Arts, warns against using dilution ventilation to clear high vapor concentrations and against spraying aerosols directly at the fan motor or filter.

**Editor's note:** Many local fire departments will answer questions over the telephone or make home visits to help you spot hazards. Be sure to call on a non-emergency telephone number.



## Tool Issue issue, take two

In January, we ran one of several letters from readers who felt we had let them down by devoting the entire October issue to tool comparisons. Since then, readers have been leaping out of the woodwork to defend our special WOOD® magazine issue that focused on woodworking power tools. Some excerpts follow:



That letter was not necessarily the consensus of WOOD magazine readers.

—Robert Adler, Watertown, N.Y.

We invite concise, unbiased tool comparisons.

—Glenn Clevenger, Hood River, Ore.

I am a "rookie" woodworker trying to set up a shop in my basement. Your issue helped me buy a drill press. Thanks.

—Randy Baker, Ringgold, Ga.

It was especially nice to find out that the issue was free [to subscribers]. Your new eight-issue format is amazing when you consider that most people these days give you less for your dollar.

—Glenn Benjamin, Rome, N.Y.

I hope you will update [the power tool evaluation] at least once a year.

—Richard Weaver, Athens, Ga.

The tool manufacturers know they have competition, especially when experts from WOOD magazine put tools to the test.

—Herman Lavine, Galt, Calif.

## Reader wants pen and pencil innards

Would you know of a source for purchasing mechanics for wood-bodied pen and pencil sets? Have you ever featured a project on making wood pen sets? I also am looking for special stud-type hinges to make wood cases for wood pens—the type where you just drill a hole and push these hinges into them.

—Martin Giesbrecht, Man., Canada

Martin, we will be showing readers how to turn pens on a drill press or lathe in the August 1991 issue. You can get a jump on purchasing pen innards, though. Write to Craft Supplies USA, 1287 E. 1120 South, Provo UT 84606, or call 801/373-0917. As for the pencil mechanisms and hinges, I'm afraid we can't help.

Continued on page 10

# ROBLAND X 31

## THE INTELLIGENT ONE MAN SHOP

90-MINUTE  
DEMO  
VIDEO



- 1100 lbs.
- 3 separate 3HP motors
- 12" jointer
- 12" planer
- 10" table saw
- 50" sliding table
- 3HP shaper
- mortiser
- cast iron

### The Robland X 31

is designed to make maximum use of minimum space ideal for the small professional shop and the demanding hobbyist. Change from one tool to another in 20 seconds or less! Solid, sturdy, reliable.

CALL OR WRITE FOR MORE INFORMATION NOW!

2081 LAGUNA CANYON RD., LAGUNA BEACH, CA 92651

# LAGUNA TOOLS

1-800-234-1976 or 714-494-7006



You asked for it  
here it is!

# WOODTURNING

## A NEW MAGAZINE FOR ALL WOODTURNERS!



Reading *Woodturning* is the next best thing to turning wood! World famous woodturners share their ideas and techniques so you can improve your skills. *Woodturning* is a magazine which is long overdue! It is written with the interests of both experienced and aspiring woodturners in mind. Prepare yourself for a feast! Regular features include Product and Equipment Reviews; variations in turning techniques; ideas, hints and tips. Many easy-to-follow well illustrated projects are included in each issue. *Woodturning* is a magazine you will be proud to call your own!

For further information on *Woodturning* call toll-free (24hrs) on 1-800 225 9262 or return the coupon below to: GMC Publications Ltd., 166 High Street, Lewes, East Sussex BN7 1XU, United Kingdom.

**Yes!** Please send me details on *Woodturning*.

NAME \_\_\_\_\_

ADDRESS \_\_\_\_\_

CITY \_\_\_\_\_

STATE \_\_\_\_\_

ZIP \_\_\_\_\_

TELEPHONE \_\_\_\_\_

2WD

# CASCADE TOOLS, INC.

CALL TOLL FREE!

1-800-235-0272

EXCLUSIVE DISTRIBUTORS OF  INDUSTRIAL CARBIDE TOOLING

## Crown Moulding — Type 1

91C-105

2 Flutes



1/2" SHANK

PART	CUTTER DIAMETER A	CUTTING LENGTH B	OVERALL LENGTH C	PRICE
C1522	1-1/8"	1-1/2"	3"	\$30 <sup>95</sup>
C1521	1-1/8"	1-7/8"	3-3/8"	\$35 <sup>00</sup>
C1520	1-3/16"	2-1/4"	3-3/4"	\$39 <sup>00</sup>

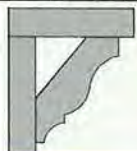

## Window Sash Cutter Sets

Customize your home with these beautiful cutters. Custom windows and french doors are now possible.

1/2" SHANK

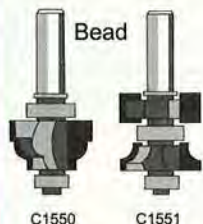

C1550

C1551

PART	CUTTER DIAMETER A	CUTTING LENGTH B	OVERALL LENGTH C	PRICE
C1550	1-1/2"	1-5/8"	3-1/4"	\$49 <sup>95</sup>
C1551	1-1/2"	7/8"	3-1/4"	\$49 <sup>95</sup>

2 - Piece Set C1552 \$95<sup>00</sup>



1/2" SHANK

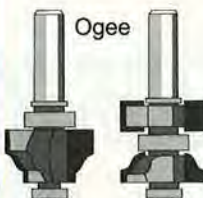

C1553

C1554

PART	CUTTER DIAMETER A	CUTTING LENGTH B	OVERALL LENGTH C	PRICE
C1553	1-1/2"	1-5/8"	3-1/4"	\$49 <sup>95</sup>
C1554	1-1/2"	7/8"	3-1/4"	\$49 <sup>95</sup>

2 - Piece Set C1555 \$95<sup>00</sup>



## Hand Rail Bit Set



We have developed this router bit set for making handrails with your 3 h.p. router. These cutters are a must if your job calls for curved handrails or custom handrail fittings. Use cutters separately to create decorative mouldings and trim.

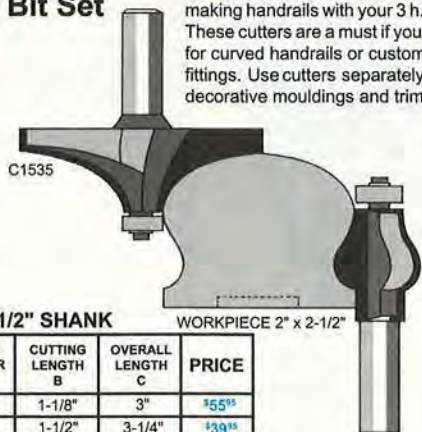

C1535

2 - Piece Set C1542 \$95<sup>00</sup>

1/2" SHANK

WORKPIECE 2" x 2-1/2"

PART	CUTTER DIAMETER A	CUTTING LENGTH B	OVERALL LENGTH C	PRICE
C1535	3-1/8"	1-1/8"	3"	\$55 <sup>95</sup>
C1536	1-1/8"	1-1/2"	3-1/4"	\$39 <sup>95</sup>

SAVE BY ORDERING AS A SET!

C1536



FREE SHIPPING ON ORDERS TOTALING \$100 OR MORE!



## TALKING BACK

Continued from page 9

### Cigar-store Indian, turn around

I would like to carve the cigar-store Indian in your April 1991 issue (p. 38), but in going over the instructions, I discovered no rear-view photograph of the head and headdress as mentioned in the article.

David Price, Rockville, Md.

David, we apologize to you and other carvers for the omission. We trust the photo right will help.



### Prayer of the Woods revisited

I'd like to comment on the January issue, Ask WOOD, page 91, where you quoted the "Prayer of the Woods." The poem quoted for Mr. Dreves of Hillsdale, N.Y. was incomplete to the extent that the first line and original title were absent. Many years ago, I read this poem as a preface to a book and according to the information shown there, this poem was originally translated from a Portuguese inscription posted on timber trees in Portugal. The title of the poem was "To the Wayfarer" and the first line read "Ye who pass by and would raise your hand against me, hearken ere you harm me." Although the beauty of trees has been praised by many poets, the utility of trees and wood has rarely been better expressed than in that poem.

—Wayne B. Morgan, Macon, Ga.

### Reader has burning inquiry

First, let me congratulate you for putting out one of the most comprehensive woodworking magazines I have come in contact with. Regarding your wood profiles, you cover just about every possibility for the featured tree except for its performance in the fireplace. How much ash does it leave, what's its heating capacity, effect on the chimney, average drying time, and approximate cost per cord.

—Stu Wall, Northbrook, Ill.

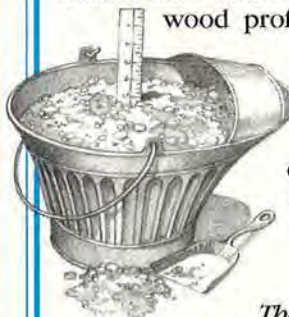

Thanks for writing, Stu. While wood is an important fuel in many areas, we don't have the space to include the data you suggest. We concentrate our efforts on the woodworking aspects of this wonderfully versatile material, letting others deal with the issue you raised. We tracked down for you a good source of information on the heating values of different woods. Write to the USDA Forest Service, 14th and Independence SW, Washington, DC 20250. Mark your request "Attention timber management." Your local Cooperative Extension Service also may be able to help.

## A rose is a rose is...intarsia?

Over the past 10 years, I have noticed the proliferation of interlocking wood pictures and designs. Your article featuring Judy Gale Roberts, August 1988, was perhaps the catalyst for the current explosion. She represents the state of the art in this "new" avenue of woodworking.

In another issue you state that a reader had identified this type of work as "intarsia." Had you checked the library, you would have found that intarsia is Latin for 'inlay'. Tarsia in French, means exotic woods, precious stones, ivory, or metals inserted into another medium, usually wood, and

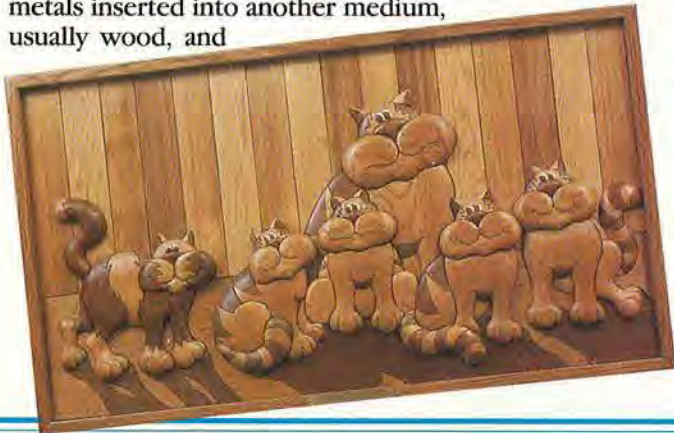

flush mounted, a description which you will agree does not fit.

A rose by any other name would smell as sweet. However, it does not follow that all sweet-smelling flowers are therefore roses.

Ladies and gentlemen of *WOOD*® magazine, however unwittingly it began, you are responsible for the current proliferation of this unique wood technique masquerading under an assumed name.

—John Sedgwick, Stoney Creek, Ont.

*John, thanks for your comments and included reference materials. We are impressed by your research into the name, and perhaps in some technical sense you are correct.*

*But if we misused the term, we did so on good authority. Webster's Ninth New Collegiate Dictionary, printed in 1989, defines intarsia as "a mosaic, usually of wood, fitted into a support." The Complete Dictionary of Wood, published in 1979 by Thomas Corkbill, says intarsia is "Inlays forming pictorial effects. Pictures formed by inlays of differently colored woods." Thanks for writing. We appreciate your interest.*

## WOOD PARTS FROM MIDWEST DOWEL WORKS

### Compare Our Low Prices!

	Qty.	Cost
 3-1/2" Poplar Shaker Peg	\$15/100	—
1-3/4" Mini Shaker Peg	\$7/100	—
3-1/2" Country Wall / Mug Peg	\$15/100	—
2-1/2" Country Shorty Peg	\$12/100	—
Large Bean Pot Candle Cup	\$17/100	—
Brass Inserts	\$9/100	—
1/2" Mini Candle Cup	\$10/100	—
1-1/2" Toy Wheel	\$10/100	—
2" Toy Wheel	\$17/100	—
Axel Pegs	\$4/100	—

### SMOOTH SANDED HEARTS

3/4" x 1/8" Hearts	\$2.75/100	—
3/4" x 1/2" Hearts	\$4.50/100	—
1" x 3/16" Hearts	\$4.00/c	—
1" x 3/8" Hearts	\$6.50/c	—
1-3/8" x 1/8" Hearts	\$5.50/c	—
1-3/8" x 1/4" Hearts	\$7.50/c	—
1-3/8" x 1/2" Hearts	\$10/100	—
2" x 1/2" Hearts	\$18/100	—

### FREE 16-PAGE CATALOGUE

Circle this section for FREE Dowels — mixed pack, Maple, Oak, Walnut Cherry, from 1/4" up to 1" Approximately 10 LFT. 14" long. \$5.00 value with any order.

### Great Buys!

	Qty.	Cost
3/8" x 36" Standard Dowels	\$21/100	—
3/4" x 36" Oak Dowels	\$15/10	—
3/8" Maple Buttons	\$2.15/100	—
1/2" Maple Buttons	\$2.25/100	—
1-1/2" Maple Spindles	\$9/100	—
2-1/8" Maple Spindles	\$18/100	—

### ORDER NOW

MC/Visa  Check Enclosed

Total Cost \_\_\_\_\_

Handling **\$3.00**

Ohio residents add 5% sales tax \_\_\_\_\_

Final Cost \_\_\_\_\_

MC/Visa Number \_\_\_\_\_

Expires \_\_\_\_\_ Phone \_\_\_\_\_

Name \_\_\_\_\_

Address \_\_\_\_\_

City/State/Zip \_\_\_\_\_

## MIDWEST DOWEL WORKS

4631 Hutchinson Road  
Cincinnati, Ohio 45248  
(513) 574-8488

Same Day Service/Order before Noon  
Factory Direct/Satisfaction Guaranteed

## Now, Add Instant Earning Power To Your Shop!



### NOW! Plane, Mold, Sand and Saw with *Infinitely Variable Power-Feed!*

Put this versatile power-feed tool to work in your own shop. See how fast it pays for itself! Quickly converts low-cost rough lumber into valuable finished stock, quarter-round, casing, base mold, tongue & groove...all popular patterns...even custom designs!

**NEW! Variable Feed Rate** — Now, just a twist of the dial adjusts your planer from 70 to over 1000 cuts-per-inch! Produces a glass-smooth finish on tricky grain patterns no other planer can handle.

Phone TOLL-FREE 1-800-821-6651 Ext. PW45



WOODMASTER TOOLS, INC., DEPT. PW45  
2908 OAK, KANSAS CITY, MO 64108

YES! Rush my FREE INFORMATION KIT and details on your 30-Day Free Trial Guarantee.

NAME \_\_\_\_\_

ADDRESS \_\_\_\_\_

CITY \_\_\_\_\_

STATE \_\_\_\_\_

ZIP \_\_\_\_\_

PHONE ( ) \_\_\_\_\_

# MEET THE RINGLEADERS

## FOUR NOVEL NAPKIN RINGS



You'll be amazed at how little effort—and even less material—goes into our distinctive napkin rings. Originally, we ran them in our sister publication, *WEEKEND WOODWORKING PROJECTS*®. To give you a taste of this other dining enjoyment, we now offer the project to you.



*Note: This project requires thin stock. You can resaw or plane thicker stock to the correct thicknesses, or special order it. See the Buying Guide on the next page.*

1 Rip and crosscut two  $\frac{3}{8}$ "-thick outside pieces (A) to  $2 \times 9$ ". For the  $\frac{1}{8}$ "-thick laminate center (B), purchase or resaw stock of a contrasting color. Rip and crosscut to  $2 \times 9$ ". (We used five different kinds of wood for contrasting laminations, but feel free to design your own.) One 9"-inch lamination makes four rings.

2 Glue and clamp the three pieces face-to-face in the arrangement shown on the Laminating and Patterns Layout Drawing below. (We used woodworkers' glue to make up our laminations.)

3 Using carbon paper and the full-sized ring patterns opposite, transfer the patterns you want to

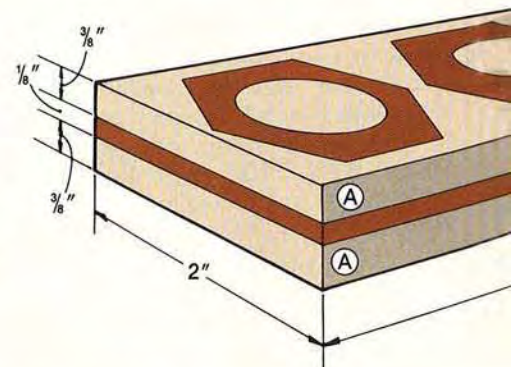

the top surface of the lamination. Be sure to mark the centerpoint of the inner circle for each ring.

**4** Using the marked centerpoints as guides, bore the center hole of each ring with a  $1\frac{1}{4}$ " bit chucked on a drill press. (We used a Forstner bit to ensure a smooth inside cut and minimize sanding. A holesaw would also work if you don't have the correct-size bit.) Back the lamination with a wood scrap as shown in the drawing below. This prevents chip-out on the bottom of the hole. (We also clamped the lamination to the drill press table.)

**5** Cut the rings to shape with a bandsaw or scrollsaw. (We cut outside the line, and then sanded to the line using a belt sander with 180-grit paper.) If you make just one style of ring and want a perfect match, clamp them together and sand all simultaneously.

**6** Sand smooth and round-over the edges, if you wish. (We chucked a 1" drum sander in a drill press to sand the inside of the rings.) Finish as desired. (We strung the rings on a horizontal wire to eliminate handling them, and then applied several thin coats of Deft spray-on lacquer.) ♣

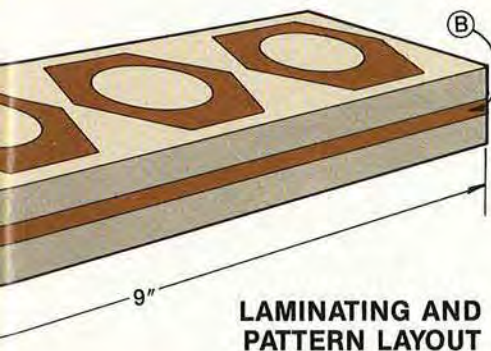
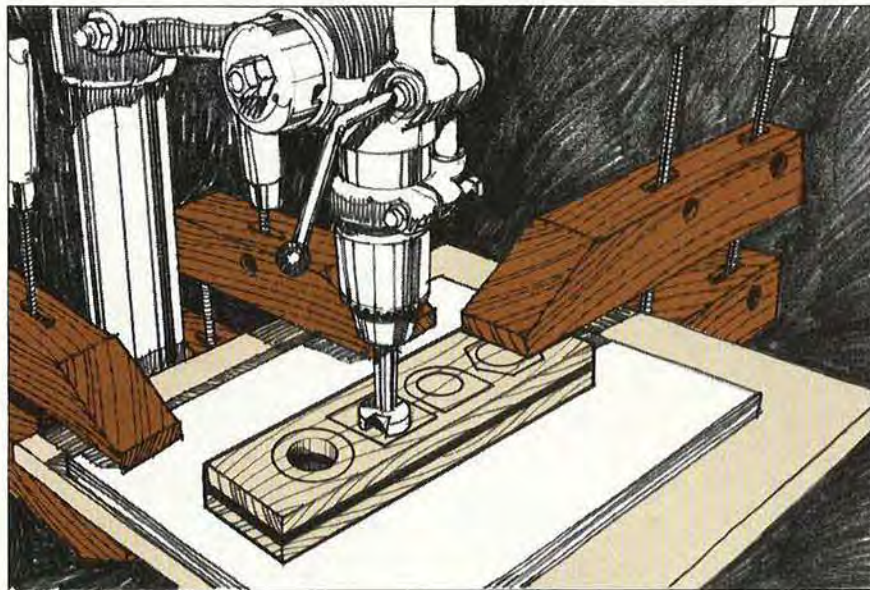

**LAMINATING AND PATTERN LAYOUT**

**Buying guide**

• **Thin stock.**  $\frac{1}{8} \times 3 \times 24$ "-thick oak, catalog no. 12203, \$3.20; walnut, catalog no. 12187, \$3.80; cherry, catalog no. 12161, \$3.80; maple, catalog no. 12146, \$3.45. Minimum order \$10.00 plus \$3.50 handling. The Woodworkers' Store, 21801 Industrial Blvd., Rogers, MN 55374, or 612/428-2199.

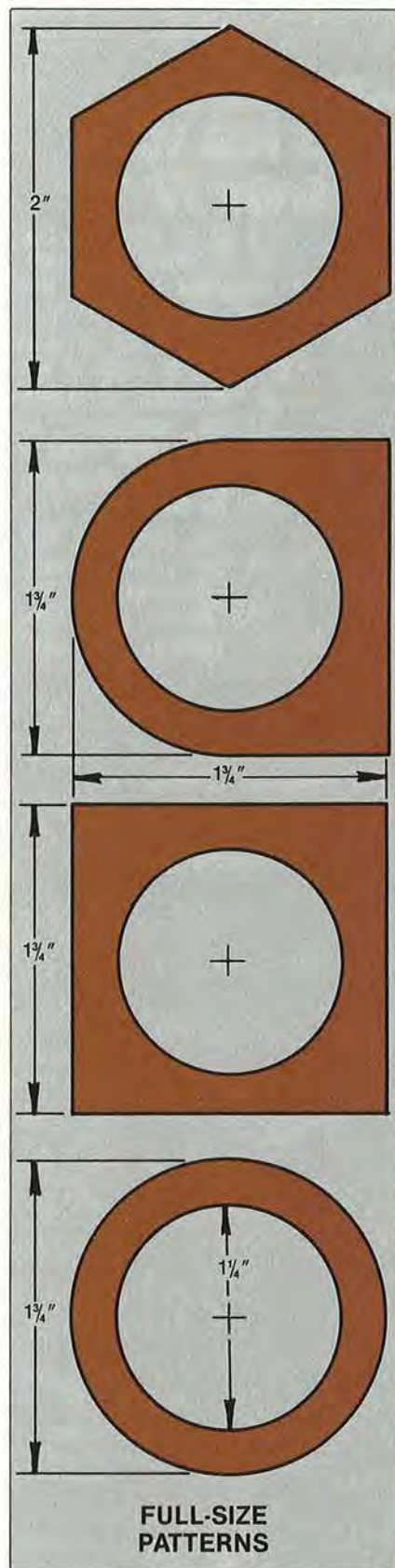

**FULL-SIZE PATTERNS**



For his tip, Walter receives a Delta model 31-070 1" belt sander with flexible shaft shown at right.



## EARN CASH, PRIZES FOR YOUR TOP SHOP TIP

Do you have a great shop tip (or two) you'd like to share with other WOOD® magazine readers? For each published submission, you will get at least \$25 from WOOD magazine (as much as \$200 if we devote a page or more of space elsewhere in the magazine to your idea). You also may earn a woodworking tool for submitting the Top Shop Tip for the issue.

We try not to use shop tips that have appeared in other magazines, so please send yours to only one. We do not return shop tips. Mail your tips, address, and daytime phone number to:

**Top Shop Tip**  
WOOD Magazine  
P.O. Box 11454  
Des Moines, IA 50336-1454

## The rabbit habit makes your vise more versatile

Your workpiece rocks up and down and keeps falling out of the vise whenever you try to work on the face. You need a better grip.

**TIP:** When you make jaw liners for your vise, cut a  $\frac{3}{8} \times \frac{3}{8}$ " rabbet along the top inside edge of each liner. Install the liners flush with the benchtop. The rabbeted edge lets you clamp the workpiece firmly while keeping the face above the bench and vise.

—Bob Colpetzer, Clinton, Tenn.

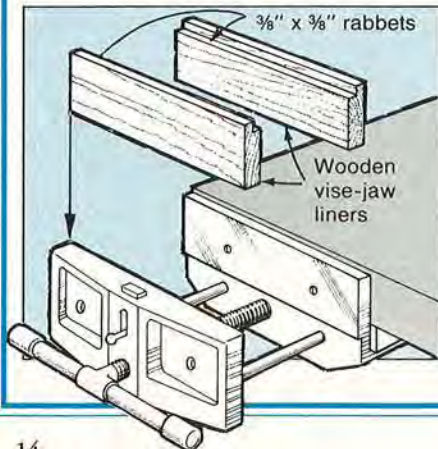

## True rough boards on radial-arm saw

In issue 37, September 1990, we showed you how to cut a straight edge on a rough board using your tablesaw. But, what do you do if you have a radial-arm saw?

**TIP:** Set up your radial-arm saw for ripping, making sure the blade is parallel with the front edge of the table. Clamp a straightedge or guide board to the bottom of your workpiece, parallel with the cutting line and far enough from the cutting edge for stability and safety while cutting. Flip the board over and, guiding the straightedge along the front of the saw table, cut the true edge. The second edge can be cut with the regular rip fence.

—Walter Pleier, Greenville, N.C.

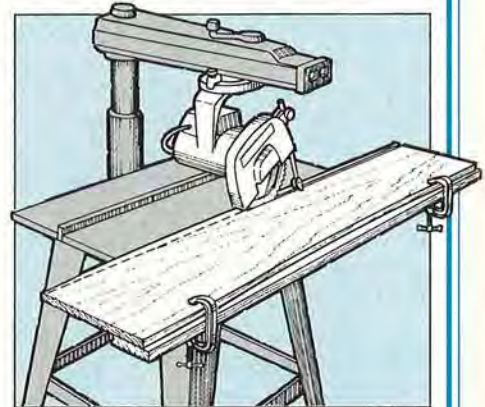

## Remote dust-collector switch saves you time and energy

Dust collectors help you keep the air and the floor of your shop as clean as possible, but it's a hassle to walk over to the collector and turn it on or off each time you operate a power tool.

Simply purchase the appropriate switch, receptacle, two electrical boxes, and wiring, as shown below, from your local hardware store. Enclose the wires in conduit where required. Note that 220-volt and 110-volt collectors require different components and wiring procedures.

—From the WOOD magazine shop

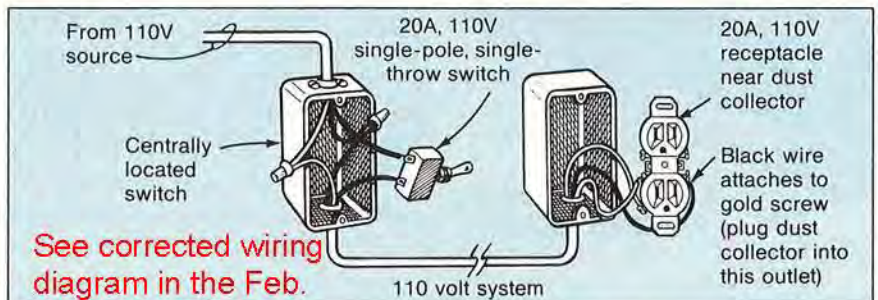
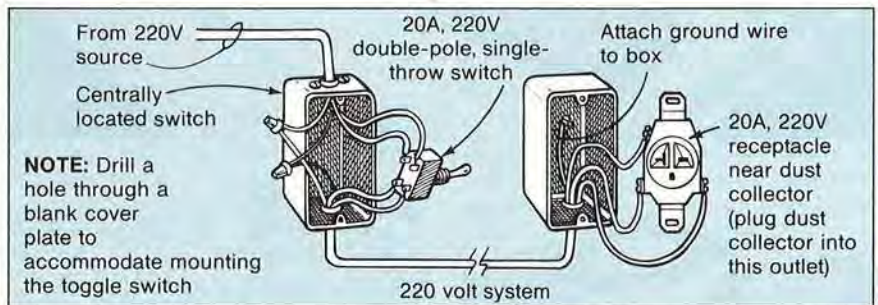

See corrected wiring diagram in the Feb. 1992 (no. 50). Click here to view.

Continued on page 16



RYOBI PRESENTS THE WORKAHOLIC™ OF NEW SANDERS.



INTRODUCING AN INNOVATIVE NEW SANDER THAT'S DRAMATICALLY FASTER AND SMOOTHER THAN CONVENTIONAL SANDERS. IT'S THE RS115 RANDOM ORBIT SANDER. AND IT'S FROM RYOBI. NATURALLY. THE RS115 OFFERS FEATURES SUCH AS VARIABLE SPEEDS FOR BETTER CONTROL, REMOVABLE FRONT GRIP FOR MANEUVERABILITY IN TIGHT SPOTS, ERGONOMICALLY DESIGNED REAR HANDLE TO REDUCE FATIGUE, AND RYOBI'S EXCLUSIVE FILTER-FLO™ DUST REMOVAL SYSTEM TO KEEP THE WORK AREA CLEAN. THE RS115'S RANDOM ACTION COMES CLOSEST TO DUPLICATING THAT OF THE HUMAN HAND, PROVIDING AN EXCEPTIONALLY SMOOTH FINISH, YET REMOVES STOCK UP TO 50% FASTER THAN TRADITIONAL SANDERS. WITH A VARIETY OF OPTIONAL ACCESSORIES, THE RS115 CAN HANDLE ALL YOUR CONTOUR SANDING AND POLISHING NEEDS. SEE THIS WORKAHOLIC AT A TOOL SUPPLIER NEAR YOU.

**RYOBI**®

W O R K A H O L I C S™

RYOBI AMERICA CORPORATION, 1424 PEARMAN DAIRY RD., ANDERSON, SC 29625

© RYOBI AMERICA CORP. 1991

## WOODWORKER'S CATALOG

Over 4000 products to  
**BUILD, REPAIR,  
RESTORE,  
REFINISH**

anything made of wood!

116 pages jam-packed with fine woods, veneers, tools, finishing supplies and much more—all with our 60-day no-questions-asked guarantee. For your 2-year subscription send \$1.00 to:



—CONSTANTINE'S

2054M Eastchester Rd., Bronx, NY 10461

Name \_\_\_\_\_

Address \_\_\_\_\_

City/State/Zip \_\_\_\_\_

Quality

### EXOTIC LUMBER

Figured Domestic  
Turning Wood

Exceptional Quality  
Personal Friendly Service

Whether you are a  
Beginner or Professional,  
We welcome your inquiries

Call or Write.

**The Berea Hard Woods Co.**

125 JACQUELINE DRIVE • BEREA, OHIO 44017  
216-243-4452



### You Can Make This Doll Deacon's Bench in 3 Hours!

It's easy with our big blueprint sheets which show every piece drawn FULL SIZE. A perfect gift for your child or to use for displaying plants in your living room. Besides the plan, you'll be getting all the birch spindles as well as all screws and screw hole buttons needed. (The wood and paint are not included in kit.) Order #9895 Doll Deacon's Bench Plan & Hdw. Kit for \$20.93/KIT postage paid. MN residents add \$.96 sales tax per kit. Visa or MasterCard customers call 1-800-441-9870, or mail your check today! Your satisfaction guaranteed. Absolute 100% money-back guarantee.



For hundreds of exciting plans, order our 72-page catalog for only \$1 or receive a catalog FREE with your order.

MEISEL HARDWARE SPECIALTIES  
P.O. BOX 70 W 6 MOUND, MN 55364

## TIPS FROM YOUR SHOP (AND OURS)

Continued from page 14

### Toothbrushes can clean more than your teeth

Clean tires on your bandsaw wheels can reduce blade breakage and prevent tracking problems. But, cleaning them is easy to overlook, and as soon as you do clean them, they start getting dusty and gritty again.

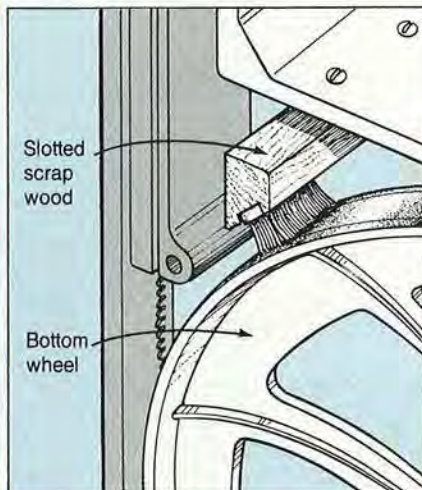

**TIP:** Mount toothbrushes on brackets to clean the tires constantly. The example shown here is for a 14" Delta machine, but would fit most bandsaws with some modifications. Cut the brush handle short and mount the bristle head in a slotted piece of wood with a screw. Or, you could glue a brush to a metal angle bracket with epoxy. Provide slotted mounting holes or add washers for adjustment.

—Laszlo Laczko, San Jose, Calif.

### Plastic jug helps keep air and sprayer clean

When cleaning a sprayer, you can end up filling the air with paint and thinner. This is environmentally shaky and wasteful to boot.

**TIP:** Rinse a one-gallon plastic bleach bottle thoroughly and cut a 4×4" hole in the side. Then, glue a woven dishwashing scrubber over the hole with silicone adhesive. Heavy cloth such as canvas or denim would work also. Now, clean the gun by spraying into the top of the jug. The thinner will stay inside the jug. If vapor does escape through the jug openings, reduce your sprayer pressure. After the thinner sits for a while, the impurities will settle out and you can reuse the clean thinner.

—Tom Haltmeyer, Peoria, Ariz.



### When project painting, not finger painting, is the object

*Painting a small part, especially a ball, often results in a better coat of paint on your fingers than on the thing you're trying to paint. Then, you have to figure out some way to set it down to dry.*

thing aside for drying). Stretch a rubber band around the tongue depressors for more tension.

—Jim Mayer, Lake Lotawana, Mo.

**TIP:** Screw tongue depressors to a scrapwood block. Drill a hole through the other end of each tongue depressor, and drive a screw into each one. Clamp the object between the screw points for painting (and set the whole

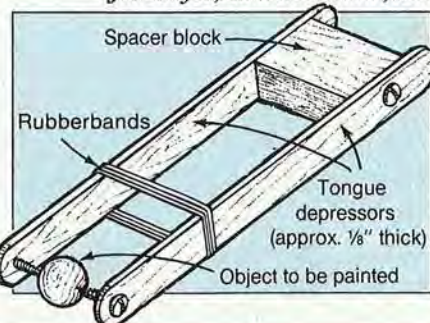

Visit Our Fully Stocked Showroom.  
(Call for easy directions — 8:30-5:00, M-F)

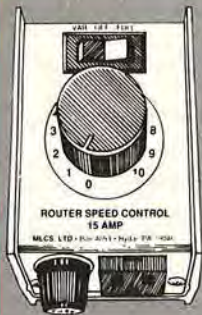

## CONTROL THE SPEED OF YOUR ROUTER ROUT AT THE SPEED THAT GIVES THE BEST RESULTS WITH THE WOOD AND BIT YOU ARE USING!

### FEATURES:

- Speed Adjustable from Full Speed to 0 RPM
- Full Horsepower and Torque at All Speeds
- Go Back and Forth from Any Pre-Set Speed to Full Speed at the Flip of a Switch
- Works with All Routers 3/4 HP or Less
- 120V 15 Amp
- Gives Your Router a Feature Only Available on Routers Costing Hundreds of Dollars!

NOW ONLY

**\$39.95**

Order Item #200

**EASY TO USE** - Simply plug in Speed Control and plug your router into the Speed Control - turn dial for best results. (Speed Control has a clip that can be worn on your belt or hung on wall or left loose.)

• Reduces speed electronically without reducing torque; electronic feed-back maintains speed by increasing voltage to motor as load increases.

## CARBIDE TIPPED ROUTER BITS PROFESSIONAL PRODUCTION QUALITY GUARANTEED WHEN ORDERING ANY THREE OR MORE DEDUCT \$1.00 EACH. ALL PRICES ARE POSTAGE PAID

ITEM NO.	BEST CUT BEST PRICE	DESCRIPTION	ANGLE/DEPTH/RADIUS CIRCLE DIAMETER	LARGE DIA.	CUTTING LENGTH	SHANK SIZE	PRICE
#601		1/8" Spiral Cutter		1/8"	1/2"	1/4"	\$ 9.00
#602		3/16" Spiral Cutter		3/16"	5/8"	1/4"	\$12.00
#603	Solid Carbide	1/4" Spiral Cutter		1/4"	3/4"	1/4"	\$12.00
#903		1/4" Spiral Cutter		1/4"	3/4"	1/2"	\$12.00
#904		3/8" Spiral Cutter		3/8"	1"	1/2"	\$24.00
#905		1/2" Spiral Cutter	*Proper Adapter Will Be Supplied	1/2"	1 1/2"	1/2"	\$29.00
#350		1/8" Round Over	1/8" R	3/4"	3/8"	1/4"	\$11.00
#351		3/16" Round Over	3/16" R	7/8"	1/2"	1/4"	\$11.00
#230		1/4" Round Over	1/4" R	1"	1/2"	1/4"	\$12.00
#353		5/16" Round Over	5/16" R	1 1/8"	1/2"	1/4"	\$14.00
#209		3/8" Round Over	3/8" R	1 1/4"	5/8"	1/4"	\$15.00
#355		1/2" Round Over	1/2" R	1 1/2"	3/4"	1/4"	\$17.00
#656		3/4" Round Over	3/4" R	2"	7/8"	1/2"	\$21.00
#199		Multiform Moulding	Unlimited Patterns	2 1/4"	2"	1/2"	\$40.00
#340		1/8" Cove	1/8" R	5/8"	3/8"	1/4"	\$12.00
#205		1/4" Cove	1/4" R	1"	1/2"	1/4"	\$12.00
#206		3/8" Cove	3/8" R	1 1/4"	5/8"	1/4"	\$13.00
#207		1/2" Cove	1/2" R	1 1/2"	5/8"	1/4"	\$14.00
#208		3/4" Cove	3/4" R	1 7/8"	3/4"	1/2"	\$26.00
#460		1/4" Bull Nose	1/4" Dia. of Circle		3/8"	1/4"	\$14.00
#461		3/8" Bull Nose	3/8" Dia. of Circle		3/8"	1/4"	\$15.00
#462		1/2" Bull Nose	1/2" Dia. of Circle		3/8"	1/4"	\$16.00
#464		3/4" Bull Nose	3/4" Dia. of Circle		1 1/8"	1/4"	\$21.00
#506		1/2" Pattern	Flush Trim	1/2"	1"	1/4"	\$15.00
#507		5/8" Pattern	Flush Trim	5/8"	1"	1/4"	\$16.00
#508		3/4" Pattern	Flush Trim	3/4"	1"	1/4"	\$17.00
#366		1/8" Slot Cutter	3/8" Deep	1 1/4"	1/8"	1/4"	\$14.00
#368		1/4" Slot Cutter	3/8" Deep	1 3/4"	1/4"	1/4"	\$14.00
#204		3/8" Rabbling	3/8" Deep	1 1/4"	1/2"	1/4"	\$13.00

ITEM NO.	BEST CUT BEST PRICE	DESCRIPTION	ANGLE/DEPTH/RADIUS CIRCLE DIAMETER	LARGE DIA.	CUTTING LENGTH	SHANK SIZE	PRICE
#210		1/4" Core Box	round nose	1/4"	1/4"	1/4"	\$ 9.00
#211		3/8" Core Box	round nose	3/8"	3/8"	1/4"	\$10.00
#212		1/2" Core Box	round nose	1/2"	1 1/2"	1/4"	\$13.00
#418		3/4" Core Box	round nose	3/4"	5/8"	1/4"	\$15.00
#213		1" Core Box	round nose	1"	3/4"	1/2"	\$17.00
#214		1/4" Straight	plunge cutting	1/4"	3/4"	1/4"	\$ 6.50
#215		5/16" Straight	plunge cutting	5/16"	1"	1/4"	\$ 6.50
#216		3/8" Straight	plunge cutting	3/8"	1"	1/4"	\$ 6.50
#217		7/16" Straight	plunge cutting	7/16"	1"	1/4"	\$ 6.50
#474		1/2" Straight	plunge cutting	1/2"	1"	1/4"	\$ 7.00
#775		1/2" Straight	plunge cutting	1/2"	2"	1/2"	\$14.00
#218		5/8" Straight	plunge cutting	5/8"	1"	1/4"	\$ 7.00
#219		3/4" Straight	plunge cutting	3/4"	1"	1/4"	\$ 9.50
#220		1" Straight	plunge cutting	1"	1 1/2"	1/2"	\$11.00
#500		3/8" Flush	Trimming	3/8"	1/2"	1/4"	\$ 7.00
#502		1/2" Flush	Trimming	1/2"	1/2"	1/4"	\$ 7.50
#503		1/2" Flush	Trimming	1/2"	1"	1/4"	\$ 8.50
#221		1/2" Flush	Trimming	1/2"	1 3/16"	1/2"	\$ 8.00
#545		Tongue & Groove	Straight	1 5/8"	1"	1/4"	\$29.00
#845		Tongue & Groove	Straight	1 5/8"	1"	1/2"	\$29.00
#546		Tongue & Groove	Wedge	1 3/16"	1"	1/4"	\$29.00
#846		Tongue & Groove	Wedge	1 5/8"	1"	1/2"	\$29.00
#450		1/8" Beading	1/8" R	3/4"	3/8"	1/4"	\$11.00
#451		3/16" Beading	3/16" R	7/8"	1/2"	1/4"	\$11.00
#233		1/4" Beading	1/4" R	1"	1/2"	1/4"	\$13.00
#453		5/16" Beading	5/16" R	1 1/8"	1/2"	1/4"	\$14.00
#454		3/8" Beading	3/8" R	1 1/4"	5/8"	1/4"	\$15.50
#455		1/2" Beading	1/2" R	1 1/2"	3/4"	1/4"	\$17.00
#530		3/16" Edge Beading	3/16" Dia. of Circle		1/2"	1/4"	\$15.00
#531		5/16" Edge Beading	5/16" Dia. of Circle		1/2"	1/4"	\$15.50

New 32-page catalogue now available, featuring hundreds of bits.

## MAKE BEAUTIFUL RAISED PANEL DOORS WITH YOUR . . . 1/4" or 1/2" ROUTER . . . 1/2" or 3/4" SHAPER

Professional production quality bit makes it quick and easy to produce matching rails and stiles — the panel raising bit with ball bearing guide makes the raised panel perfect every time.

**SALE PRICE \$69.95** Regular value over \$150.00!

FOR COMPLETE SET 1/4" Shank set item #554 (includes all bits shown below)

SET ALSO AVAILABLE IN 1/2" SHANK - \$79.95 - Item #852

Shaper Cutters set: Item #1059  
SAVE! only \$99.95  
Set: Rail & Stile & Raised Panel Cutters

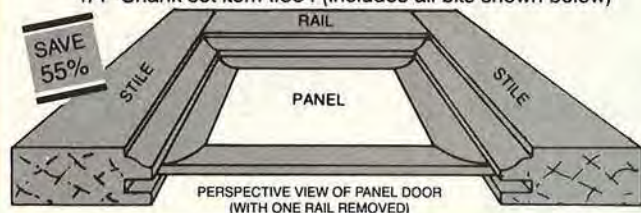

PERSPECTIVE VIEW OF PANEL DOOR (WITH ONE RAIL REMOVED)

RAISED PANEL BIT SUPPLIED WITH BALL BEARING

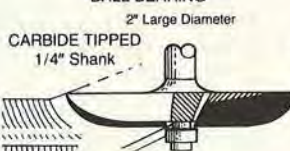

REVERSIBLE COMBINATION RAIL and STILE BIT (For making matching rails and stiles in raised panel doors, etc.) Works with stock from 1 1/16" to 7/8" thick



To order by Master Charge or Visa Call Toll Free, 7 Day - 24 Hour Order Service,  
1-800-533-9298 or send check to: **MLCS Ltd., P.O. Box 4053DA, Rydal, PA 19046**

# PENNSYLVANIA HARDWOODS

**SATISFACTION GUARANTEED**

SIZE	SPECIES	PRICE PER BOARD FT.
1 1/2	WALNUT	\$1.60
3/4 & 4/4	RED OAK	\$1.25/1.95
3/4 & 4/4	CHERRY	\$1.75/1.95
3/4 & 4/4	WHITE OAK	\$1.05/1.60
3/4 & 4/4	HARD MAPLE	\$1.25/1.30
4/4	POPLAR	\$1.05



TO ORDER CALL:  
1-800-235-8317

**NO MINIMUM ORDER. ALL HARDWOODS KILN DRIED.**  
For a NEW 24 page catalog featuring over 20 domestic hardwoods, quantity discounts, package deals at delivered prices & much more, send \$1.00 to cover postage & handling to:



Northeastern Hardwoods, P.O. Box 365-C, Salamanca, NY 14779  
*The Finest Quality At The Right Price!*



## WOODCRAFT PATTERNS

FOR FUN & PROFIT!

SHOP-TESTED FULL SIZE PATTERNS

- 125 Pattern Fun Packet assortment!
- 25 fun, profitable "wind-action" whirligigs.
- Country Critters-100 patterns, decorative projects!
- Attractive Dutch Windmill - 5 feet tall.
- 100 yard ornaments animals, birds, signs, more!
- 200 pattern packet for scroll, band & jigsaws!
- Show stoppers - 22 craft show top-sellers!
- Over 20 easy to make bird houses.

Send \$8.00 per packet. Pick 3 FOR ONLY \$18.00  
Fast Service • Satisfaction Guaranteed!

ACCENTS, Dept MA51, Box 7387, Gonic, NH 03839

WOODCRAFT CATALOG - \$2.00 (Free with order)

**NEW!**

### THROW AWAY THOSE HARD RUBBER DRUM SANDERS... Step up to the Singley "SLEEVELESS SANDERS"!!!

No more expensive sanding sleeves to buy. Singley drums, POLISH out saw marks and do not burn, chatter, or scratch excessively. Simply cut 9x11 sheets of sandpaper, old sanding belts or 3" wide abrasive rolls to fit... lock into drum and you're ready to go!

3/4"x3" Long	\$15.95
1"x3" Long	14.95
2"x3" Long	16.95
3"x3" Long	18.95
Kit of all 4	59.95

Drum Sander Plans	\$10.99
3"x10" Pre-Cut Sandpaper Roll Assortment	\$11.99

#### BONUS

Kit of all 4 drums receive FREE Sleeveless Spindle Sander PLANS and Kit Shipped FREE!



Build this **BENCH TOP SPINDLE SANDER** with our detailed Plans and Instructions for only... **\$10.99**

FINISHED PROJECT  
SIZE: 21"x21"x18" HIGH

Plans describe the sliding motor mount that adjusts drum height for full range sanding application, and the use of the sleeveless sanding drum.

A must for the Drum Sander. ➔

Super Strong "F" weight **SANDPAPER**, pre-cut 3" x 10' rolls that outlast regular 9" x 11" sandpaper 3X or more! Available in assortment pack of 1 each... 80, 120, 220X... **\$11.99**

Phone 1-800-776-5467  
...they are out the next day!

Shipping and Handling: Under \$35 - \$3.75.  Check  MasterCard  
Over \$35 - \$4.75 Pa. residents add 6% tax.  Visa (include expiration date)

**Quaker State WOODWORKING SUPPLY**  
4434 Kutztown Rd. • Reading, Pa. 19560

WARREN TOOL CO. INC.

(10) Piece set of woodcarving tools



ORDER #COMBI-M "WARREN TOOLS GIVE YOU THE EDGE!"

Send \$32.45 Ppd. (USA)  
Check or Money Order,  
C.O.D. UPS.

-Honed Ready To Use  
TEL.  
(914) 876-7817

N.Y. res. ADD State Tax  
\$3.00 SHIPPING  
Foreign orders ADD \$6.00 SHIPPING.

Warren Tool Co. Inc.  
2209-1, Rt. 9G,  
Rhinebeck, N.Y. 12572

## RIP SAW

### The Portable Sawmill.

The "affordable portable" one man band sawmill. Weighs only 45 lbs. Cuts 20" diameter logs into lumber. Minimum 1/8" to maximum 9" thickness.

Write or call for free brochure.



**Better Built CORPORATION**

(508) 657-5636

845 Woburn Street, Dept. W, Wilmington, MA 01887

# FREE CATALOG

## Trend-lines® Discount Woodworking Tools and Supplies

Send today for your **FREE** copy of our 72 page full-color catalog. You'll find the best prices for over 3,000 brand-name products. Included are power tools & accessories, hand tools, screws, hardware, wood components, plans, how-to books, and much more.



To order your **FREE** catalog

call Toll-Free,

**1-800-366-6966**

Or Write: Dept. WD51 • 375 Beacham St.  
Box 6447 • Chelsea, MA 02150

## TIPS FROM YOUR SHOP (AND OURS)

Continued from page 16

### Brush wiper cuts paint mess

Every time you wipe your brush on the edge of a paint can, you get a little more paint into the groove. Pretty soon, you have paint dripping down the side.

**TIP:** Stretch a piece of reinforced strapping tape across the top of the opened can and pinch the sticky sides together to make a terrific brush-wiping edge. Duct tape or masking tape would work, too.

—Herbert Akers, Rockville, Md.



### Scrap plastic laminate solves sticky problem

You're clamping boards across edge-glued stock to keep it flat. But, you don't have enough hands to hold them, tighten the clamps, and slip in waxed paper to keep the boards from becoming a permanent part of your project.

**TIP:** You can save the waxed paper for wrapping sandwiches if, instead, you cement scraps of plastic laminate to the inside surfaces of your alignment boards. Both setup and cleanup will be easier.

—Dan Campbell, Meyersville, N.J.

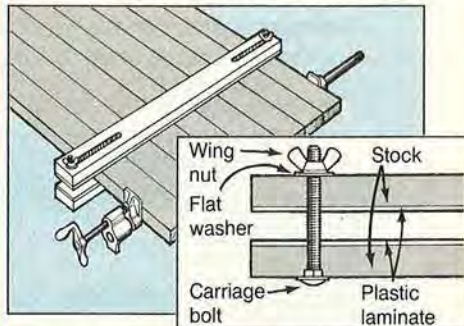

## Sump-pump switch keeps hands free at drill press

Some drill-press operations require both hands, making it difficult to flip the switch, particularly in an emergency. And, looking away from the work to find the switch could cause an accident.

**TIP:** Put a foot-operated control on your drill press. Install a sump-pump switch (available from plumbing-supply dealers) on the machine's base. Mount the switch where it will be easy to reach with your foot but won't be turned on accidentally.

—Raymond Matthews, Port Clinton, Ohio

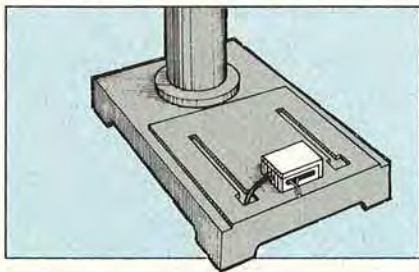

## Clamp gets grip on longer work

Every once in a while, you run across a project that calls for a clamp longer than any in your shop. You figure it's time to go buy longer pieces of pipe.

**TIP:** Instead of running to the plumbing shop, go to your scrapwood bin. Clamp short pieces of scrapwood across the over-long part as shown below. Then, clamp the joint with one jaw pulling against the scrapwood and the other against the opposite side of the joint.

—Jim Morgan, Lafayette, Tenn.

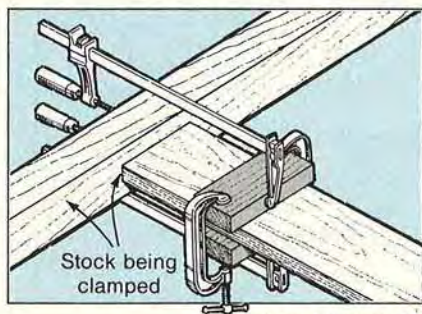

Continued on page 20

## FORSTNER BIT SPECTACULAR



16 Pc. Forstner Bit Set...\$88.99

**HARTVILLE TRUE VALUE**  
1-800-345-2396

- In Ohio add 5% sales tax.
- \$3.00 shipping & handling in continental U.S.
- Additional charge outside 48 contiguous states.

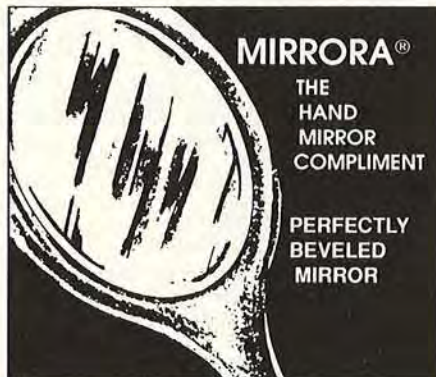

**MIRRORA®**

THE HAND MIRROR COMPLIMENT

PERFECTLY BEVELED MIRROR

**FLORAL**

Glass & Mirror, Inc.

895 Motor Parkway, Hauppauge, NY 11788  
516/234-2200 • 800-647-7672

## 12 SHOWS THIS FALL!

★The Woodworking Shows★  
machinery  
tools • supplies



- Baltimore/Wash.
- Chicago
- Columbus
- Detroit
- No. California
- Philadelphia
- Portland
- Richmond
- Seattle
- So. California
- Twin Cities
- Ventura/S. Barb.

Call for free brochure

Monday - Friday 8 am - 5 pm Pacific Time  
1-800/826-8257 or 213/477-8521

New from McCloskey. Four more Clean Air Formula™ wood finishing products. Low odor. And water-based for easy clean up. Look for them when you want to protect wood...and air. For information, 1-800-767-CLEAN. **McCloskey**





### MERRY CHRISMOOSE!

New for '91 our musical wall moose features a "push" button that plays "Rudolph" while his red nose blinks. Parts kit includes music movement, jingle bells, bow and die-cut letters. #01574 Plans 3.00 #04574Z Plans and Parts Kit 8.50 #04574 Parts Kit 5.95/Ea, 16.75/3, 52.00/10

#### SPRING SALE Prices good through 6-30-91

#16001 3-1/2" Shaker Pegs .....	12.00/100
#16006 3-1/2" Oak Shaker Pegs .....	25.00/100
#16021 2-1/2" Shaker Pegs .....	11.50/100
#16041 1-3/4" Shaker Pegs .....	5.00/100
#18031 Lg. Candle Cup .....	14.00/100
#18091 Brass Inserts .....	8.00/100
#13108 1" dia. Ball .....	8.00/100
#13112 1-1/2" dia. Ball .....	2.00/10
#13116 2" dia. Ball .....	5.00/10
#14013 3/8" Button .....	1.50/100, 7.00/500
#14014 1/2" Button .....	1.50/100, 7.00/500
<b>WHEELS &amp; AXLE PEGS</b>	
#10710 1-1/4" x 7/16", 1/4" hole .....	6.00/100
#10812 1-1/2" x 1/2", 1/4" hole .....	7.50/100
#10914 1-3/4" x 9/16", 1/4" hole .....	11.50/100
#11016 2" x 5/8", 1/4" hole .....	8.00/50
#12001 7/32" Axle Peg .....	3.10/100

### CRAFTER'S MART

Box 2342-W • Greeley, CO 80632

64-Page CATALOG: \$2 with credit towards first order, Free with any order. Check, MasterCard or VISA (include daytime phone, card no., exp. date & signature). PROCESSING CHARGE: Continental U.S. \$4; AK, HI, APO & FPO \$10; Canada \$16; Foreign 20% plus \$10 (U.S. Funds). CO Res. add 3% tax. No C.O.D.s. PHONE ORDERS: 8am-5pm Mon-Fri - Mtn. Time. Info: (303) 351-0676

**1 - 800 - 999-3445**

# WOOD TOY

- ★ Patterns
- ★ Parts
- ★ Wheels
- ★ Many New Patterns to Choose from.
- ★ Executive toys



SEND \$1.00 FOR NEW CATALOG & RECEIVE COUPON FOR FREE WHEELS & AXLE PEGS.

## toys and joys

Box 628W Lynden, Wash. 98264

## Fight Inflation!

Foley-Belsaw can show you how to keep more money in your pocket with our selection of woodworking planer-molders!

Fight back against spiralling lumber and molding costs by:

- Milling your own lumber
- Making your own moldings
- And break lumber yard dependence

It's a FREE call for Full Details!  
Call 1-800-468-4449 TODAY!



Foley-Belsaw Co.—Since 1926  
Dept. 91625  
6301 Equitable Road  
Kansas City, MO 64120-9966

## TIPS FROM YOUR SHOP (AND OURS)

Continued from page 19

### Use dull scrollsaw blades to sand difficult areas

Sometimes, you just can't get into a tight curve or follow an irregular edge very well when sanding.

**TIP:** Grab an old, dull scrollsaw blade and a piece of sandpaper about three-fourths the length of the blade and two inches wide. Wrap it tightly on the blade and secure the ends with thin strips of plastic electrical tape. Use it for hand-sanding or, if you really have some smoothing to do, put it into the scrollsaw and have a power sander for tight places.

—Chris Lyles, Hereford, Texas

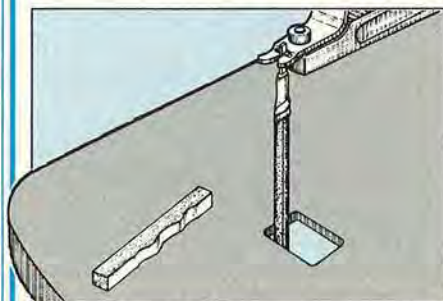

### File card sets spacing for hooks in tight spots

You could go crazy spacing cup hooks in hard-to-reach places or where you don't want layout marks on the finished wood.

**TIP:** Cut a notch in a corner of a file card. Determine the hook spacing and cut another notch that distance from the first one. Then, measure to the shelf edge and fold the card as a depth gauge. Now, slide the card along the shelf to space your hooks.

—Myron Levy, Gold Hill, Ore.

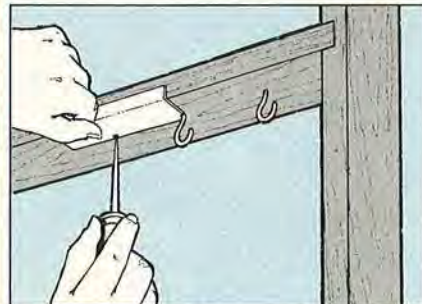

## Wood-Mizer®

World's Largest  
Manufacturer  
Of Portable  
Sawmills



## OWN YOUR OWN SAWMILL

Four Models To Choose From  
**SAVE MONEY—**

### CUT YOUR OWN LUMBER

- Remote hydraulic log handling
- Capacities up to 32" in dia. by 33' long
- Portable—precise—rugged
- Efficient—more lumber per log

CALL FOR FREE CATALOG

**1(800)553-0219**

In Indiana call: (317) 271-1542  
44-page catalog or use your MasterCard or VISA to order our 50-minute demonstration video—\$10.00

Wood-Mizer Products, Inc. • Dept. QQ53  
8180 W. 10th St., Indianapolis, IN 46214-2430

## Van Dyke's

### Presents a Catalog

with supplies for upholstery, antique restoration, wood working, caning, brass hardware, carvings and many related trades!



36 Years in Creative Arts & Trades

Many Hard-To-Find Items!

SEND \$1.00 FOR CATALOG TO:  
**Van Dyke's Restorers**  
Dept. D55 • Woonsocket, SD 57385

## ADIRONDACK CHAIR

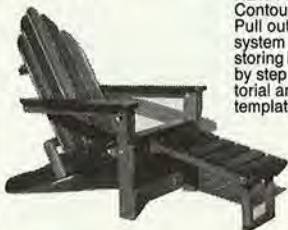

**NEW FEATURES**  
Contoured seat & back. Pull out footrest. New system that folds for storing in seconds. Step by step plan with pictorial and full size templates.

PLANS \$14.95  
Color Cat. \$2.00

FREE with order

### SPECIALTY FURNITURE

797 W. Remus, Dept. W-9  
Mt. Pleasant, MI 48858

Visa/MC MI Res. Add 4%

## A homemade dust collector for your router table

Few workshop tools kick out mounds of wood chips and airborne dust the way a table-mounted router does. It sure would save you cleanup time if you could collect some of that dust at the router.

**TIP:** Build the simple dust collector shown below from 1/4" clear acrylic and 3/4" stock. Size the hole to fit your dust-collection hose. Clamp the collector to your router-table fence and plug your dust-collection hose into the hole in the acrylic, as shown on page 44.

—From the WOOD magazine shop

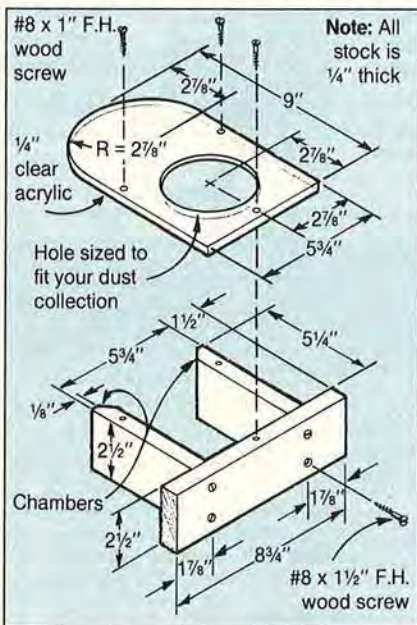

## More tips from our woodworking pros

- Make an old table sturdier or strengthen the corner of a new table with our bracing method, shown and described on page 65.
- Reinforce edge-joined boards by adding splines as described on page 65.
- Cut your own thin stock on the table saw as shown on page 78.
- Create a simple hidden hinge with a screw, washer, and drop of epoxy, as described on page 76.

## BUILD YOUR OWN QUEEN ANN FURNITURE

With Our Kits

SOLID  
CHERRY, WALNUT  
OAK, MAHOGANY



OVAL  
COFFEE



COFFEE



END

FREE BROCHURE DESCRIBES

LIVING ROOM / DINING ROOM PIECES



Adam's Wood Products, Inc.

DEPT. M12, 974 FOREST DRIVE, MORRISTOWN, TN 37814

TELEPHONE 615-587-2942

FAX 615-586-2188

## SQUARE DRIVE SCREWS

Simply the Best!

- Square Drive Beats Driver Slippage
- Hardened Steel for Extra Strength
- Deep Thread for Super Grip
- Also Brass & Stainless

Send \$3 for Samples and Catalog

McFEELY  
HARDWOODS

P.O. Box 3 • 712 12th St.  
Lynchburg • Va • 24505  
Toll Free 1-800-443-7937  
or FAX (804) 847-7136



NEED  
EXTRA  
INCOME?

## SIGNCARVING



IS FUN & PROFITABLE

And it's easy, if you use the Marlin Woodcarvers and accessories. You can carve signs quickly at home or at swap meets. No special training is required. The machines do the work, the operator has the fun and the profits. These machines will also 3-D carve panels and plaques. Our templates work well with other machines.

SEND \$1.00 FOR OUR FULL LINE BROCHURE AND PRICE LIST AND START PLANNING YOUR FULL OR PART-TIME BUSINESS.



MARLIN INDUSTRIES, INC.

Rt. 70, Box 191, Dept D16  
Cashiers, NC 28717  
(704) 743-5551

## FUN & LEARNING!

★The Woodworking Shows★

## ★ SUMMER ★ WOODWORKING CONFERENCE

August 1-4, 1991 • Southern California

★★★★★ ★★★★★

• Education • Demonstrations • Networking

Call for Free Brochure 1-800-826-8257

## Wood Moisture Meter

END WOOD WARPING NIGHTMARES

ONE YEAR  
UNCONDITIONAL  
GUARANTEE

HAND HELD-  
EASY TO USE-  
LARGE DIAL  
RUGGED-  
RELIABLE-  
SOLID-STATE



MT 100  
TESTER  
\$83

BOTH 4% - 16%  
MT 250  
METER  
\$95

EIGHT MODELS IN THE PRECISION MT SERIES FOR MOISTURE CONTENTS FROM 3% TO 60% IDEAL FOR HOME OR INDUSTRIAL DRYING OF ALL KINDS OF WOOD HIGH QUALITY INSTRUMENTS DESIGNED AND MADE IN CANADA Complete detailed information, instructions, and batteries included. Detachable wood probes, accessories, and custom services available. Monitor drying with remote sensing humidity and temperature meters. Above prices in U.S. Dollars to U.S. Customers. Add \$5 shipping. Canadian Residents call or write for Canadian prices. For free catalogue or to order, call or write now to:

Electrophysics  
(416) 470-9522

132 Helen Avenue  
Markham, Ontario  
Canada L3R 1J5

## MAKE WOODEN LAYERED ANIMALS

SO IRRESISTABLE...EVERYONE WANTS THEM!

Unique, new, 3-dimensional animals made from three or more layers of wood. It's easy to make them yourself from our FULL SIZE patterns & instructions ....even if you are new to woodcrafting!



6" TALL

✓ the patterns of interest to you!

- #LAC1 { 14 DESIGNS—COW,PONY,SHEEP,PIG, DAWG,CAT,GOOSE,COON & MORE!
- #LAC2 { 14 MORE DESIGNS—GIRAFFE,CAMEL, RHINO,ZEBRA,MONKEY,LION & MORE!

\$7.50 EACH OR BOTH FOR ONLY \$13.00

The Winfield Collection, Dept W51  
12044 Parkin, Fenton, MI 48430-8726

Catalog of topselling designs \$1.00(free w/order)



9" TALL



# Variable Speed Super V-15" Scroll Saw

- Dial any speed from 400 to 1800 cuts/min!
  - Saws with similar features sell for over \$700
  - Special introductory price...
- only \$189.95**  
(Item #SVS, UPS \$10)



Cut intricate patterns in many different types of materials with this versatile machine. Purchase includes many FREE extras.

This new model features a powerful, high quality electronically controlled universal motor that gives full power and torque at all speeds. Similar in design to our Super-15" model, the cutting action has been re-engineered to give smoother cutting and performance equal to saws many times the price.

Dial any speed from 400 - 1800 cuts/min to set the speed specifically for the job at hand. Use slower speeds for cutting plastics, metals and hardwoods.

### FREE ACCESSORIES:

- Dust blower • 1 dz blades • EZ-Set permanent top-arm blade holder • 4 Standard blade holders • EZ Jig for attaching standard blade holders • Neptune 1-1/2" lettering guides w/6 patterns

### Specifications:

- Motor: Universal motor w/electronic speed control. 110V, 1.3Amp, sealed ball bearings
- Speeds: 400-1800 cuts/min
- Throat : 15" deep • Stroke - 3/4"
- Tilt : 0 - 45° left • Cut Depth: 2"
- Blades: accepts pin and plainend
- Construction - cast iron

## Scroll Saw Products

### Super 15" Scroll Saw

Our most popular model. Same specs as Super V-15 model with single speed 1650 cpm motor, dust blower optional. Same free accessories as listed above.  
#SAW ... Only \$119.95 (UPS \$10)

Dust Blower (option for Super 15" saw)  
#BKT ..... \$15.00/kit (•)

### Variable Speed Motor Upgrade

Convert your saw to variable speed! This quality motor will fit our Super 15" model and other saws of similar design. Also fits Sears<sup>(tm)</sup>16", and "C" arm "Superscroll" styles - 18", 22", and 26" sizes. Limited 90 day warranty on non-Penn State saws.  
#SVM ..... Only \$99.00 (UPS \$4)

### Magnifier Lamp

Great for magnifying scroll work or closeup work of any kind.  
• 175% mag  
• 39" flex arm  
• UL approved  
• 60 Watts Incand.  
#SML (reg 29.95) On Sale ... \$22.95 (UPS \$3)

### Scroll Saw Stand (On Sale)

34" High - the perfect height.  
#STD .. (reg \$39). On Sale \$26 (UPS \$4)

### Foot Switch

For hands free operation. Installs in line w/power cord. Easy hook-up. 7 amp, 6 ft  
#FSW ..... \$20.00 (•)



- 5 Speeds
- 40" Centers
- 16" Swing



(\$20.00 UPS Shipping)

### Wood Lathe XL40-2

Introductory price... **\$259.95**

Includes **FREE** 8 piece Wood Chisel Set.. \$34 Value

New model includes many great new features...

- Standard accessories include: Live tailstock center, Motor, Toolrest, 6" Faceplate, 8 pc chisel set, spur center
- Cast construction for smooth turning
- Turning sizes: 40" Centers, 16" Swing for bowl turning
- Motor: 3/4 HP, 1720 RPM, 110V
- 5 Speeds: From 660 to 2850 RPM
- Headstock thread : 3/4" x 16 tpi
- Drill chuck attaches to tailstock for drilling or boring
- Overall length 60", Wt 105#

### Lathe Accessories

**XL40 Lathe Stand**  
Heavy duty, brings Lathe to 40" working height. Size: 28"H x 56"L x 21"W. Wt. 25Lbs.  
Item #LST.....\$44.00 (UPS \$6)

**1/2" Drill Chuck**  
High quality 1/2" x 20tpi sized to fit XL40-2 tailstock for drilling.  
Item #LDC ..... \$20.00 (\*)

**3 Jaw Chuck**  
Self centering • holds work from 5/16" to 4" outside • Up to 6" inside • 8lbs • Many thread sizes available  
Item #L3J ..... \$85.00 (UPS \$4)

**4 Jaw Chuck**  
4 Independant jaws hold odd shaped work up to 6" OD • 6 Lbs • Many thread sizes available  
Item #L4J ..... \$49.00 (\*)

## Super 125 Planer

On Sale .... \$359.95



This machine will pay for itself time and again by planing your own wood. Finishes wood like machines many times its price.

- Portable at 65 lbs • Power feed
- 12 1/2" wide High Speed Steel Knives
- Shipped assembled and ready to run.

### SPECIFICATIONS:

- Motor: 16Amp, 115V, 8000RPM, 2HP- 26.2 fpm auto feed rate • 16,000 Cuts/min • Thickness of stock: 3/16" - 6"
- 1/8" Max depth of cut • 2 HSS knives
- Item #PLA ..... \$359.95 (UPS \$15)

## Planer Accessories



**Extra Set of 2 Knives**  
High Speed steel, 12-1/2" long.  
Item #PKN ..... \$25.00/set (•)

**Dust Chute**  
For vacuum takeoff of wood chips.  
#PDS ..(reg \$24), On Sale...\$15 (UPS \$3)

**Planer Stand (Heavy duty)**  
Drilled for Super 125 Planer. 27-1/4"High.  
#PST ...(Reg \$44), On Sale...\$39/ea (UPS \$6)

**Roller Stand**  
HTC brand support stand w/heavy duty ball bearing roller. Height adjusts from 25" - 44"  
#PRS ...(reg \$40), On Sale ...\$35 (UPS \$4)

**Ball Bearing Rollers**  
(Minimum purchase 2 rollers). Build a roller stand, infeed/outfeed table etc. with these 13" X 2" Heavy Duty rollers. Includes **FREE** plans for roller stand shown above.  
Item #BBR ..... \$6.50/ea (\$3 UPS/order)

## Two Way Sanders

**FREE DISCS & BELTS** with Purchase Save up to \$21  
• Dust Collection on both models  
• Stand included with 6 x 9 Model

**6" x 9" Sander**  
Model #S69 ... Only \$219.95 (UPS \$30)  
Has versatile 9" disc & 6" x 48" belt. Heavy duty design includes stand.  
**FREE With Purchase** : 3 belts, 4 discs (various grits) worth \$21. Motor: 3/4 HP, 1720 RPM, 110/220V. Wt: 100 #

**4" x 8" Sander**  
Model #S48 ... Only \$114.95 (UPS \$8)  
A unique design with an 8" disc & 4" x 36" belt. Portable at only 38 #, includes quick release lever for belt changes.  
**FREE With Purchase** - 3 belts, 4 discs (various grits) worth \$14. Motor: 1/3 HP, 1720 RPM, 120V. Wt: 38 #

- Features of Both Models:**
- Dust collection outlets included.
  - Tables: tilt to 45°, includes mitre gauge, moves to vertical belt position.
  - Easy belt tracking adjustment.
  - Belt table tilts/locks to horiz & vert positions
  - Sealed ball bearings

## Dust Collectors

**FREE HOSE & FITTINGS** with PURCHASE Save up to \$40.00!!



**Model #DC-1 - Only \$199.95** (UPS \$20)  
610 CFM flow makes this collector perfect for hookups to almost any single machine.  
**FREE With Purchase (\$15 Value)**  
8' of hose • 1 ea. 4" to 3" & 4" to 2" adaptor

**Model #DC-2 - Only \$299.95** (UPS \$30)  
900 CFM flow allows for use on 2 or more machines & gives improved service for long runs of hose or ducting. Suitable for larger planers, drum & belt sanders  
**FREE With Purchase (\$40 Value)**  
30' of hose • (1) 4" to 3" & (2) 4" to 2" adaptors

Specifications:	DC-1	DC-2
Motor	1 HP, 110/220V	1-1/2 HP, 110/220V
Outlets	1 @ 4"	2 @ 4" or 1 @ 6"
Flow	610 CFM	900 CFM
Bags	2 @ 20 Gal.	2 @ 30 Gal.
Weight	75 pounds	120 pounds

**Penn State's Commitment**  
We unconditionally guarantee your satisfaction with our fine machines. All of our machines carry a Thirty day Money Back Guarantee and One year Warranty.

**Quality Woodworking Machines At Affordable Prices from**  
**PENN STATE INDUSTRIES - W**  
2850 Comly Road • Phila, Pa 19154  
Order Toll Free 1-800-288-7297 (Ext 90) Information 1-215-676-7609 (ext 15)  
Visa, Master, & Discover Card accepted Pa residents add 6% Sales Tax  
When ordering - Add UPS Shipping Charges as noted  
(•) No freight charge for accessories ordered with a machine, add \$3 if ordered separately. UPS charges are for Continental U.S. only (Call for shipping charges to other locations)  
Call or Write for our **NEW** 16 Page Color Catalog





# The Japan Woodworker's Catalog is . . .

loaded with the best tools you can get your hands on. In our catalog you will find a huge selection of Japanese saws, waterstones, chisels, planes, carving tools, cutlery and books. Send \$1.50 for our catalog and supplements during the next two years.

**THE JAPAN WOODWORKER**  
1731 Clement E10, Alameda, CA 94501  
Phone 1-800-537-7820

## Unique Childrens Furniture™ With More Than One Use

6 Different Patterns With Materials List  
And Easy To Follow Instructions



- Table/Bench
- Toy Box/Bookshelves
- Bench Toy Box/Desk
- Easel Board/Paper Tray
- Book/Toy Shelves
- Rocking Chair/Desk

**6 Patterns Included**  
With Bonus, Full-Size Pattern  
(Rocking Chair/Desk pictured above.)

Simple Details©  
1317 Industrial Way  
Palmer, AK 99645

**\$8.95** — Postage and Handling Inc.

## ANYTIME ANYWHERE ANYWOOD

mold plane and edge



Professionals and hobbyists alike know the strengths of the W&H molder-planer. Superior US-made construction and quick two-minute cutter changes make it a snap to cut moldings and plane hardwoods. It's fast, easy, and super-smooth.

Our five-year warranty and free 30-day trial are your assurance that W&H goes the distance.

Mail this ad or call us toll-free today.  
1-800-258-1380 In NH 603-654-6828

Williams & Hussey Dept. 231EM  
Riverview Mill, P.O. Box 1149  
Wilton, NH 03086

**W&H**

YES! Send your free information kit today.

Name \_\_\_\_\_  
Address \_\_\_\_\_  
City \_\_\_\_\_ State \_\_\_\_\_ Zip \_\_\_\_\_

## PRODUCTS THAT PERFORM

Print this article

### Foot-pedal tool stands have a leg up on the competition

For those of us who work in tight quarters and need to shuffle our stationary equipment around, mobile stands prove to be a true blessing. Now, Delta has a leg up on the competition with a model featuring a convenient foot pedal for lowering and raising one end. This device allows you to rest the tool firmly on the floor for operation, and then move it out of the way for storage.

With competing mobile bases, you must turn two nuts by hand to stabilize the machine for use, and then turn them again to move it.

The stands come in 11 sizes to fit most Delta stationary power tools, as well as some made by other manufacturers. To see if Delta makes a stand for your stationary tools, take the outside mea-



surements of your tools' bases, and then share them with your local dealer.

—Tested by Bill Krier

*Delta mobile stands, \$94.20 list price at Delta dealers nationwide. Call Delta at 800-438-2486 or 412-963-2400 for the location of a dealer near you.*

### Dremel's entry into flex-shaft carving tools

Versions of Dremel's high-speed rotary tool have served generations of hobbyists. But, they come with certain limitations. Plainly put, the hand-held models lack the power and handling comfort of the flex-shaft tools.

About 18 months ago, Dremel introduced the 732 heavy-duty flex-shaft tool, powered by a gutsy 1/5-hp motor. The one I tested was the heart of carving kit 7390. Included Handpiece 236 accepts 1/8" and 1/4" bits. A footswitch sets motor speeds from 0 to 20,000 rpm.



A flex-shaft maintenance kit, high-speed cutters, a bristle brush, dressing stone, drum-sander bands, aluminum oxide stones, tungsten carbide cutter, silicon carbide stone, and two structured-tooth carbide burrs, used for hogging wood, round out the set.

In my tests, the tool performed flawlessly, with first-class construction evident in all of its components. The motor packs plenty of power for every task from carving hardwood to grinding aluminum.

I was especially impressed by the handpiece, which snapped smartly onto the end of the generous 39" flexible shaft with no alignment problems. I can't say the same for other flex-shaft tools.

You can buy a kit with fewer accessories, or the flex-shaft machine alone.

—Tested by Bob McFarlin

*Dremel model 7390 flex-shaft carving kit, about \$375 at hobby and hardware stores nationwide. For the nearest dealer, call 414/554-1390.*

## Cam-action corner clamps are fast, easy, and versatile

This latest entry in the corner-clamp competition replaces the screw-style corner clamp with a cam-pivot clamp that will hold wood of thicknesses ranging from 1/4" to 2" thick.

The Toulan 2005 makes quick work of clamping corners in box construction or shelf installation. The handles of the cam-action clamp also offer a unique advantage that sets this clamp type apart. You can use the cams with 3/16" perforated hardboard to hold odd sizes and shapes for carving, finishing, or detail work.

—Tested by Bob McFarlin

Toulan 2005 cam-clamps, \$13.95 each, ppd. Ask if introductory offer is still in effect. Mail order only, call 409/838-1386.



## Grip-Tite Correction

We momentarily lost our grip in reviewing the Grip-Tite magnetic feather board (by Mesa Vista's Designs) in Products That Perform, April 1991. The price of the feather board has increased to \$29.95. We also transposed Mesa Vista's telephone number, which is 505/892-0293.

Continued on page 27



## \$300 to replace. \$10 to repair.

Use High Performance Wood Filler by Minwax® for the big jobs, indoors and out. Won't shrink, crack or fall out. Hardens and can be worked on in 15 minutes.

If wood is soft or rotted, use High Performance Wood Hardener first to form a rock solid base.

Free booklet: *Tips on Wood Finishing*  
Minwax Company, Inc., Dept. WO 061  
P.O. Box 426, Little Falls, NJ 07424



## High Performance Wood Filler **MINWAX**

© 1990 Minwax Co., Inc.



## STOP PERFORBOARD HOOK FALLOUT!

**M-CLIPS™** are THE guaranteed perfect solution to this annoying problem! Fit both 1/8" and 1/4" perforboard. Send SASE for free sample or \$5.99 + \$1.50 p&h for pkg. of 50 to: AETECH, P.O. Box 6298, Dept. W10

10 Shadowstone Lane  
Lawrenceville, NJ 08648

## Wood Moisture Meter

- Avoid Moisture Problems
- Protect your Masterpiece

### MINI LIGNO

Incl. Case, Batteries and Pins for 3/4" and 1/2" Measuring Depth,

only **\$110**

also from Lignomat:  
**MINI-LIGNO E**  
Range: 6%

Easy-to-use, sturdy instruments for the professional woodworker or serious hobbyist. Great for lumber, veneer, fiberboards. Ask for free catalog on the complete line of moisture meters and accessories for kiln drying.

Lignomat USA Ltd.

503-257-8957 800-227-2105

P.O. Box 30145b1  
Portland, OR 97230



## STEVE WALL LUMBER CO.

Quality Hardwoods and Woodworking Machinery For  
The Craftsmen and Educational Institutions

Ash	4/4	Select	1.90	UPS	\$64.00
Basswood	4/4	Select	1.30	Special	\$46.00
Birch	4/4	Select	1.60		\$52.00
Butternut	4/4	1C	1.30		\$54.00
Cherry	4/4	Select	2.25		\$65.00
Hickory	4/4	Select	1.30		\$46.00
Mahogany (Genuine)	4/4	Select	2.70		\$72.00
Maple (Hard)	4/4	Select	1.55		\$51.00
Maple (Soft)	4/4	Select	1.25		\$45.00
Pecan	4/4	Select	1.30		\$46.00
Poplar	4/4	Select	1.20		\$44.00
White & Red Oak	4/4	Select	1.80		\$56.00
Walnut	4/4	Select	2.50		\$70.00
Cedar (Aromatic Red)	4/4	1C+Btr	1.35		\$45.00
White Pine	4/4	F.G.	.85		\$36.00
Yellow Pine	4/4	Clear	1.20		\$44.00

Above prices are for 100 quantities of kilndried rough lumber sold by the Bd. Ft. FOB Mayodan, NC. Call for quantity discounts. Other sizes and grades available. Delivered UPS prepaid in the Continental U.S.

Call For  
Best Price On

*MiniMax*

STEVE H. WALL  
LUMBER CO.  
BOX 287 • MAYODAN, N.C.  
27027

919-427-0637  
1-800-633-4062  
FAX 919-427-7588

Send \$1.00 For Lumber  
and Machinery Catalog

# Refinishing School

**Bonus Guide**  
when you  
order now

Introducing  
**REFINISHING FURNITURE**,  
the instructive  
new how-to  
video from  
Better  
Homes  
and  
Gardens®.



Nothing could be a better reflection on you — than your ability to refinish furniture you thought was all but finished.

Now you'll polish these skills to a fine luster with **REFINISHING FURNITURE**, the inspiring new home video from Better Homes and Gardens® magazine.

## Refinishing, from the beginning

Even if you've had no experience restoring or repairing furniture, **REFINISHING FURNITURE** will soon have you rescuing potential heirlooms from the junk pile.

You'll see close up how to revitalize finishes when they are still usable, and repair scratches, water spots, dents — even burns and gouges!

Because it's on video tape, you can replay any section



as often as you need to. And you can actually see a technique demonstrated with your own eyes, to pick up on important subtleties that words sometimes don't convey.

## Stripping made easy

In **REFINISHING FURNITURE**, you'll see, in easy-to-follow close-ups, how to strip old finishes. You'll discover how the pros handle bleaching, restaining, filling, and sealing.

You'll find out how to choose and apply the all important finish coat. And you'll learn how to do professional-calibre oil-and-abrasive polishing.

So if you'd like to master the art of refinishing, the place to start is **REFINISHING FURNITURE**. Order your copy now!



Credit Card Users



Call TOLL FREE  
1-800-678-2699

### MAIL TODAY TO:

Better Homes and Gardens®  
P.O. Box 11430  
Des Moines, Iowa 50336-1430

\*TAX NOTE: We are required to collect and pay STATE taxes in AZ, CO, CT, FL, IL, KS, MA, MD, MI, MN, MO, NM, PA, and WI. We are required to collect and pay STATE/LOCAL taxes in CA, GA, IA, NY, OH, TN, TX, VA, and WA.

## Better Homes and Gardens® REFINISHING FURNITURE ORDER FORM



**YES**, please send me the Better Homes and Gardens® Home Video, **REFINISHING FURNITURE**. I understand the video—and the **BONUS Guide**—are mine for just \$19.95 plus \$3.00 shipping and handling, plus applicable state and local taxes.

### CHECK METHOD OF PAYMENT:

Check or Money Order Enclosed, Payable to Better Homes and Gardens®.

I prefer to bill my:  American Express  VISA  MasterCard

Account Number: \_\_\_\_\_ Expiration Date: \_\_\_\_/\_\_\_\_/\_\_\_\_

Signature: \_\_\_\_\_

NAME \_\_\_\_\_  
(Please Print)

ADDRESS \_\_\_\_\_ Apt. # \_\_\_\_\_

CITY \_\_\_\_\_ STATE \_\_\_\_\_ ZIP \_\_\_\_\_

KEY #280347

Continued from page 25

**TrimTramp miter-cuts and crosscuts with precision**

The TrimTramp, a new, portable tabletop mechanism, tames your 7/4" circular saw, turning it into an extremely accurate miter-saw and crosscut saw.

You pull the saw backward through the wood with a cut-

ting action similar to that of a radial-arm saw. Like any backward cutting saw, it sometimes tends to grab or climb. If doing rough work—say building a deck—I'd probably push the saw through. For trim cuts, however, I'd pull the saw for the smoothest results.

Brian Noble overlooked no detail in the design and construction of this tool. An unlocking mechanism at the end of the smooth-gliding rails allows removal of the saw for other uses.

The table includes three stops—a 90° crosscut fence that cleverly flips out of the way when you're making angle cuts; a fixed 45° fence; and a lock-

ing miter fence, which is adjustable through 135°.

The TrimTramp crosscuts and miter-cuts stock as thick as 1 1/16" and crosscuts stock 16" wide—19" if you flip the board. By setting your blade depth, you can fashion dados by making repeated cuts, moving your stock a kerf's width each time. You can't do this with other mitersaws I've seen. Angle your saw and you can make bevel-cuts and compound miter-cuts.

Accuracy relies on perfect saw alignment and installation, which proved harder and took longer than I wished, but still is achievable by the average woodworker.

—Tested by Bob McFarlin

TrimTramp, \$149.95 ppd., from TrimTramp Ltd., P.O. Box 740, Buffalo, NY 14213, or call to order, 800-267-8776.

Continued on page 28

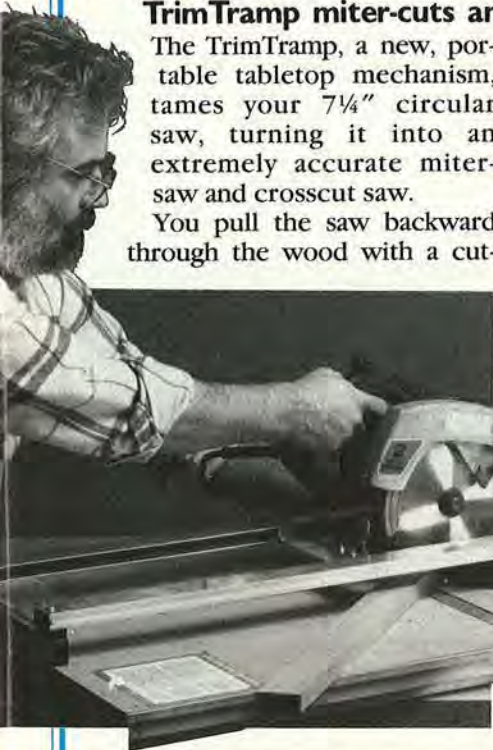

**\*SANDPAPER\***  
IF IT'S ABRASIVE WE'VE GOT IT!

**ABRASIVE SHEETS:**  
(9 X 11)

**CABINET PAPER**

	50/pk	100/pk
40-D	\$17.00	\$32.00
50-D	16.00	28.00
60-D	15.00	26.00
80-D	14.00	24.00
100 thru 150C	13.00	22.00

**FINISHING PAPER**

80-A	\$ 9.00	\$17.00
100 thru 280A	8.00	15.00

**WET/DRY PAPER**

220 thru 600A	\$14.00	\$24.00
---------------	---------	---------

**NO LOAD PAPER**

180-A thru 400A	\$11.00	\$19.00
-----------------	---------	---------

**ABRASIVE BELTS**

Grits assorted if not otherwise specified

1X30	\$.73 ea	3X24	\$.84 ea
1X42	.73 ea	3X27	.87 ea
1X44	.73 ea	4X21 3/4	.96 ea
2 1/2X16	.77 ea	4X24	.99 ea
3X18	.78 ea	4X36	1.20 ea
3X21	.81 ea	6X48	3.14 ea
3X23 3/4	.84 ea	2 1/4X80	3.10 ea

OTHER SIZES ON REQUEST

\* JUMBO CLEANING STICK \$8.80 \*

**OTHER ITEMS**

*WIDE BELTS	*PSA DISCS
*ROLLS	*ROUTER BITS
*FLAP WHEELS	*WOOD GLUE
*PUMP SLEEVES	*VELCRO DISCS

Continental U. S. Shipping Charges add \$5.50.

TX & NV Add Sales Taxes

\*SATISFACTION GUARANTEED!!!  
\*MasterCard, VISA or Check  
\*SUGGESTED MINIMUM: \$25.00  
\*CALL FOR FREE 1991 CATALOG



**Econ-Abrasives**  
P. O. Box B-865021  
Plano, TX 75086-5021

**NATIONAL (800)367-4101**

**THE PERFORMAX COMPONENT DRUM SANDER**

**Revolutionary Component Concept!**  
**It's Versatile....It's Expandable....**  
and best of all.....**It's Affordable!**

The Performax S/T Sander attaches to a radial saw or to a Pro Stand (below).



The Performax Power Feed for an infinitely variable feed rate of 0-10' per minute.

Made in U.S.A.

**YOU SELECT THE COMPONENTS TO FIT YOUR BUDGET AND YOUR NEEDS.**

The Performax Components were designed to fit the needs of all woodworkers. A suspended 22" drum sands up to 44" wide in two passes. An abrasive power feed belt provides a non-skid surface for flawless and effortless sanding. Retrofit the S/T Sander and Power Feed to the Pro Stand for maximum efficiency.

Components require assembly. Factory assembled units available.

**Call or write for a FREE Brochure and the name of your nearest dealer.**



S/T Sander and Power Feed mounted on Pro Stand with extension rollers.

**PERFORMAX**  
PRODUCTS, INC. X

12211 Woodlake Drive  
Burnsville, MN 55337  
PHONE (612) 895-9922  
1-800-334-4910

# PORTER-CABLE

**Random Orbit Disc  
RIOT! BUY 50 ...  
get 50 FREE!**

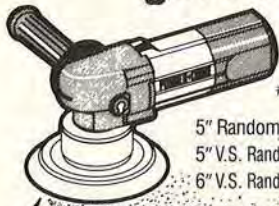

P-C MODEL  
#7334, 7335, 7336

5" Random Orbit... **\$119.99\***

5" V.S. Random Orbit **129.99\***

6" V.S. Random Orbit **134.99\***

\* Sanders Shipped  
Freight FREE!

**BUY 50 5" PSA DISCS  
get 50 FREE (100 Discs)... only \$14.99**

50 Discs per roll. Available in 80, 100, 120, 150, 180, 220, 320 grit. O.K. to Mix and Match Discs. Discs are shipped FREE with Random Orbit purchase, or any Disc order over \$50.00.

**BUY 50 6" PSA DISCS  
get 50 FREE (100 Discs)... only \$18.99**

50 Discs per roll. Available same grit as 5" Discs.

**PHONE  
1-800-776-5467**

...they are out the next day!

Check  MasterCard  
 Visa (Please include exp. date)  
S & H: Under \$35 - \$3.75.  
Over \$35 - \$4.75.  
PA Residents add 6% Sales Tax.

**Quaker State**

**WOODWORKING SUPPLY**

4434 Kutztown Rd. • Reading, PA 19560

## Do-It-Yourself Kits



*Factory Direct  
Clocks and Furniture*

**Also Assembled  
and Finished**

- Grandfather Clocks, Mantel and Wall Clocks
- Curios, Tables, Chairs, Desks, Cradles...and more!
- Solid 3/4" Black Walnut, Cherry, or Oak
- Heirloom Quality
- Solid Brass West German Movements and Dials
- Money Back Guarantee



SEND \$1 FOR  
COLOR CATALOG

I am interested in  
 Do-It-Yourself Kits  
 Finished Clocks  
 Finished Furniture

Name \_\_\_\_\_  
Street \_\_\_\_\_  
City \_\_\_\_\_  
State \_\_\_\_\_ Zip \_\_\_\_\_  
(Please Print)



World's Largest Manufacturer of Grandfather Clock Kits  
Dept. 3915 Emperor Industrial Park  
Fairhope, Alabama 36532 • Phone 1-205-928-2316

## PRODUCTS THAT PERFORM

Continued from page 27

### Seat 35mm Euro hinges with Freud's affordable bit

This Freud boring bit, which simplifies Euro-style hinge installation, has three things going for it. First, its metric diameter allows you to drill to the precise size (35mm) needed for European hinges. Second, the price falls within the "reasonable" range. And, finally, it delivers a quality hole time after time, requiring only minor touch-up.

I tested it on 3/4" oak-veneer plywood while using a drill-press speed of 750 rpm. Accurate boring was effortless thanks to the bit's centerpoint.

A professional woodworker couldn't ask for more.

—Tested by Bob McFarlin



List price is \$24.90. For the location of your nearest dealer, call 919/434-3171.

### Leichtung's new hold-down takes the kick out of ripping

The Leichtung antikickback hold-down works as advertised, employing a two-piece device that clamps firmly to the rip fence of your tablesaw.

I turned the spring-loaded in-feed roller (the one closer to the saw front) 5° toward the fence so that it held the stock down and against the fence. I left the out-feed roller parallel to the fence.

No need for a pushstick, because you can feed the stock in and then walk around the saw and pull it on through. This device holds the wood so securely that it

doesn't burn while you walk around the saw. Not only does this attachment make your sawing operation safer, it's more accurate, too. From now on, I won't rip without it.

—Tested by Jim Downing

Antikickback hold-downs, catalog no. 96974, \$49.99 plus \$5.95 shipping and handling. From Leichtung Workshops, 4944 Commerce Parkway, Cleveland, OH 44128. Call 800-321-6840. ♣

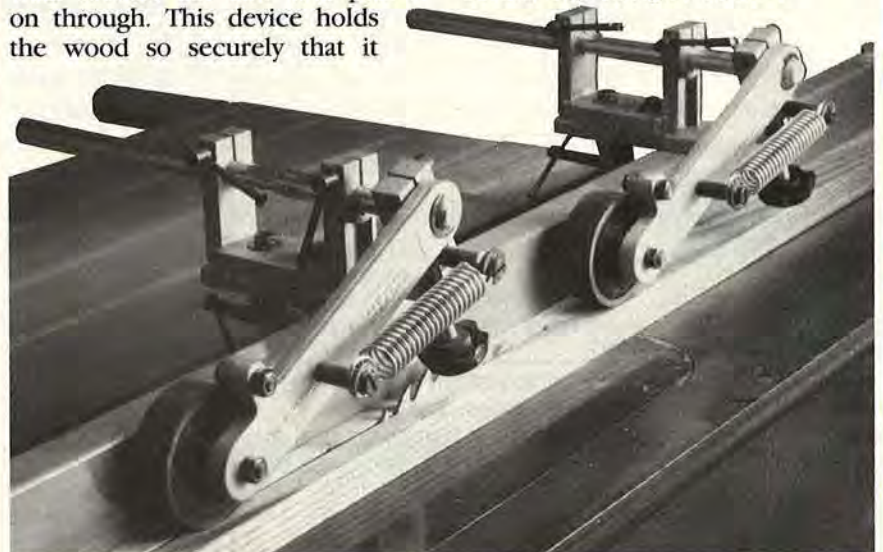

# AmMax

TOOL CO.

FREE

## ANNIVERSARY SPECIAL

\* Complete catalog sent upon order.  
\* Plastic caliper (\$4.00 value) for any order.

## TUNGSTEN CARBIDE TIPPED TOOLS



CALL TOLL FREE  
1-800-782-8629 (NATIONWIDE)  
(619)535-8940 (CALIFORNIA)

Precision tools for skillful woodworkers

CUTTER	TOOL #	CUT DIA.	CUT L.	SNK D.	PRICE
Straight	ST206	1/4	3/4	1/4	5.50
	ST208	5/16	1	1/4	5.50
	ST210	3/8	1 1/4	1/4	5.50
	ST213	1/2	1 1/4	1/4	5.50
	ST216	5/8	1 1/4	1/4	6.25
	ST219	3/4	3/4	1/4	8.95
Flush Trim	FT210P	3/8	1/2	1/4	6.00
	FT210	3/8	1	1/4	6.50
	FT213	1/2	1	1/4	6.95
	FT212L	1/2	1-1/2	1/2	10.50
	FT410	3/8	1-3/16	1/2	6.50
	FT413	1/2	1-3/16	1/2	6.95
Dovetail	DV210	3/8	3/8	1/4	4.95
	DV213	1/2	1/2	1/4	4.95
	DV410	3/8	3/8	1/2	4.95
	DV413	1/2	1/2	1/2	4.95
	DV416	5/8	3/4	1/2	6.50
	DV419	3/4	1	1/2	6.95
Core Box	CB206	1/4	1/4	1/4	8.00
	CB210	3/8	1/4	1/4	9.00
	CB213	1/2	5/16	1/4	11.00
	CB216	5/8	3/8	1/4	12.50
	CB219	3/4	1/2	1/4	14.00
	CB413	1/2	5/16	1/2	11.00
45° Chamfer	CH210	1	3/8	1/4	12.00
	CH213	1-3/16	1/2	1/4	12.00
	CH216	1-3/8	5/8	1/4	13.50
	CH219	1-3/8	5/8	1/2	14.00
	CH419	1-5/8	3/4	1/2	16.00
	CH422	1-7/8	7/8	1/2	19.00
Rabbit	RB232	1-1/4	1/2	1/4	12.00
	RB432	1-1/4	1/2	1/2	12.00
	SL203-2	1-1/4	1/8	1/4	10.00
	SL205-2	1-1/4	3/16	1/4	11.00
	SL206-2	1-1/4	1/4	1/4	11.00
	SL210-2	1-1/4	3/8	1/4	12.00
Rounding Over	CR201	1/16	3/8	1/4	10.00
	CR203	1/8	3/8	1/4	10.00
	CR205	3/16	7/16	1/4	10.00
	CR206	1/4	2/1	1/4	11.00
	CR208	5/16	5/16	1/4	12.95
	CR210	3/8	5/8	1/4	14.00
Roman Ogee	RO204	5/32	1/2	1/4	15.00
	RO206	1/4	3/4	1/4	16.00
	RO404	5/32	1/2	1/2	15.00
	RO406	1/4	3/4	1/2	16.00
	CV203	1/8	3/8	1/4	11.00
	CV205	3/16	7/16	1/4	11.00
Cove	CV206	1/4	1/2	1/4	11.00
	CV208	5/16	1/2	1/4	12.00
	CV210	3/8	1/2	1/4	12.00
	CV213	1/2	5/8	1/4	13.00
	CV406	1/4	1/2	1/2	12.00
	CV410	3/8	1/2	1/2	12.50
Classical	CS203	1/8	5/8	1/4	18.00
	CS206	1/4	7/8	1/4	19.00
	CS403	1/8	5/8	1/2	18.00
	CS406	1/4	7/8	1/2	19.00
	HR203	1/4 D	5/8	1/4	12.50
	HR205	3/8 D	11/16	1/4	13.50
Half Round	HR206	1/2 D	3/4	1/4	14.50
	HR208	5/8 D	1	1/4	16.00
	HR210	3/4 D	1-1/8	1/4	16.00
	HR410	3/4 D	1-1/8	1/2	17.00
	HR413	1 D	1-3/8	1/2	18.00
	HR416	1-1/4 D	1-5/8	1/2	35.00

Top of the line Made In U.S.A.

**Nicholson**

3 WINGS, 9 CUTTING EDGES

**FINGER JOINTER**  
FL463  
1/2" shank \$53

**LOCK MITRE**  
ML470 \$34  
1/2" shank

FOR 5/8" TO 1-1/8" STOCK

Carbide Tipped

Retail values up to \$60

**MULTI-MOULDING**  
MM454  
1/2" shank \$39

**TONGUE & GROOVE**  
1/4" SHANK \$28  
FOR 5/8" TO 3/4" STOCK  
1/2" SHANK \$29  
FOR 5/8" TO 1" STOCK

**FACE MOULDING CUTTERS**  
(1/2" SHANK)

FMC04 FMC03 FMC15 FMC05 FMC07

**BEST BUY GUARANTEED**  
BUY ANY 3 PCS \$ 78.00  
ANY 4 PCS \$ 95.00  
ALL 5 PCS \$ 115.00

**STILE & RAIL**  
Reversible  
RS248  
1/4" shank \$37  
1/2" shank \$37

**OGEE FILLET PANEL RAISING**  
1/2" SHANK ONLY  
OF466 2-5/8" \$24.00  
OF476 3-1/4" \$39.00

**DRAW PULL**  
DP435  
1/2" shank \$29

**KEY HOLE**  
KH210  
1/4" shank \$6.50

BUY TWO OR MORE AND SAVE AN EXTRA DOLLAR ON EACH BIT FROM THE FOUR BITS ABOVE. OFFER EXPIRES: MAY 31, 1993.

**8 PCS FORSTENING BITS SPECIAL**  
ALL BITS ARE CARBIDE TIPPED  
EACH BIT HAS 4 CUTTING EDGES:  
2 STRAIGHT CUTTING TEETH & 2 SCORING TEETH.  
LAST UP TO 25 TIMES LONGER THAN HIGH SPEED STEEL

**SAVE \$25**

**SPECIAL PRICE \$139.00/SET**

TOOL # CUTTING DIA.  
HB419 3/4"  
HB422 7/8"  
HB425 1"  
HB432 1-1/4"  
HB435 1-3/8"  
HB444 1-3/4"  
HB454 2-1/8"

**SLOT CUTTERS --- 4 WINGS ASSEMBLY**

SL	KIRF	SHANK DIA.	PRICE
SL203	1/8"	1/4"	\$16
SL403	1/8"	1/2"	\$16
SL204	5/32"	1/4"	\$17
SL404	5/32"	1/2"	\$17
SL205	3/16"	1/4"	\$18
SL405	3/16"	1/2"	\$18
SL206	1/4"	1/4"	\$20
SL406	1/4"	1/2"	\$20

FOR FLUSH TRIM BITS WITH UPPER BALL BEARING FOR TEMPLATE AND PATTERN ROUTING:  
PUT THE TEMPLATE ON TOP OF THE WORKPIECE USE THE UPPER BALL BEARING GUIDE RIDES AGAINST THE TEMPLATE FOR AN EXACT DUPLICATION.

FT	D	L	PRICE
FT213C	1/2	1	\$12.00
FT213CS	1/2	3/4	\$11.00
FT216C	5/8	3/4	\$12.00
FT219C	3/4	1	\$14.00

BUY ANY 2 PCS FOR \$20.00  
3 PCS FOR \$29.00

(1/4" SHANK ONLY)

**HORIZONTAL PANEL RAISING** \$49 EACH

\* Industrial Quality Grade C3 Tungsten Carbide Tipped  
\* 3 mm Thickness Carbide Offer Longer Life.

3/4" BORE C931 C984 C985 C986 C987  
1-1/4" BORE C1084 C1085 C1086 C1087

REDUCING BUSHING: \$2 / PAIR

**SHAPER CUTTERS / CABINET SETS**  
3/4" BORE BUSHED TO 1/2"

FOR TWO SIDES. Decorative design work thickness 1 1/8" - 1 3/4"

FOR ONE SIDE. Decorative design work thickness 1 1/8" - 3/4"

C921 CABINET MOULDING SET \$150  
C922 COVE & BEAD SET \$160

C940 CONCAVE STILE & RAIL SET \$140  
C994 OGEE STILE & RAIL SET \$140  
C945 CONVEX STILE & RAIL SET \$140

**3/4" BORE 3 WINGS SHAPER CUTTERS**

WEDGE TONGUE WEDGE GROOVE V-GROOVE V-PANELLING LOCK MITRE

C903 \$32 C904 \$32 C966 \$38 C967 \$38 C998 \$42

FINGER JOINT VERTICAL PANEL RAISING DRAWER JOINT REVERSIBLE STILE & RAIL GLUE JOINT

C961 \$69 C901 \$32 C933 \$30 C965 \$45 C911 \$32

STRAIGHT BEAD FLUTE

1/4 C918 \$23 1/4 C973 \$28 1/4 C971 \$26  
3/8 C953 \$25 3/8 C974 \$30 3/8 C972 \$29  
1/2 C954 \$27 1/2 C925 \$32 1/2 C926 \$32  
3/4 C912 \$29 3/4 C927 \$35 3/4 C928 \$34  
1 C955 \$32 1 C929 \$39 1 C930 \$37  
1 1/2 C956 \$39

**3 PCS 1/4" SHANK CABINET MAKER SET**

SAVE YOUR TIME ON ADJUSTMENTS & SET-UP  
ALL 3 BITS COME WITH 2 BALL BEARINGS.  
FOR STABLE AND BALANCE ROUTING.

**2 PC STILE & RAIL SET (#OG01)**  
+  
**2" COVE PANEL RAISING BIT (#CV250)**

**ANNIVERSARY SPECIAL \$85.00/SET**

HOURS: MON thru FRI 7 AM to 6 PM  
NEW: SAT 8 AM - 2 PM  
NET 30 DAYS TO GOVERNMENT AGENCIES, SCHOOLS.  
SAME DAY SHIPPING Count on us!  
Shipping is FREE for orders over \$60 and is only \$2 for smaller orders.  
SEND YOUR CHECK TO: AMMAX TOOLS CO.  
P.O. BOX 520  
POWAY, CA 92074

CALL **1-800-782-6629**  
PRICE GOOD THROUGH MAY 31, 1991

OFFER EXPIRES ON MAY 31, 1993

10% 10%

Mail this Coupon with your Check and Order of \$100.00 or more and you can take 10% OFF your total

10% 10%

\* No Discount for Credit Card Purchases

RYOBI PRESENTS THE WORKAHOLICS™ OF NEW CORDLESS DRILLS.



ENGINEERED TO SET A NEW PERFORMANCE STANDARD FOR CORDLESS DRIVER/DRILLS, THE RYOBI 7.2V, 9.6V AND 12V TORQUEFORCE® SERIES FEATURES BREAKTHROUGH MOTOR TECHNOLOGY TO DELIVER MORE POWER LONGER. A KEYLESS CHUCK, ELECTRIC BRAKE AND BUILT-IN BIT STORAGE ARE STANDARD. NEW ERGONOMIC DESIGN AND PRECISION ENGINEERING MEAN BALANCE, HANDLING EASE AND POWER SECOND TO NONE. SEE THE RYOBI RETAILER NEAR YOU.

**RYOBI**®

W O R K A H O L I C S™

RYOBI AMERICA CORPORATION, 1424 PEARMAN DAIRY RD., ANDERSON, SC 29625

© RYOBI AMERICA CORP. 1991



Woodworker Richard Gard deserves to wear a good guy's white hat because in Casey, Illinois, his donated projects lift spirits and help worthy causes.

# MR. MUSIC BOX



 Print this article

At *WOOD*® magazine, we're always tickled when we hear about woodworkers doing good deeds. Like heroes and heroines of the silver screen, these craftspeople wear the white hats.

Reader Bernie Morgan wrote us about a woodworking friend who helps out lots of people in Casey, a south-central Illinois farming community. We followed up on his tip, and found Richard Gard delightful. And, he sure has found a way to make folks happy—with the sound of music.

That's because when Richard locks up his auto-body repair service in Casey, he heads home to open another door—to his woodworking shop. There, you can find him occupied until the wee morning hours, building projects that not only bring him satisfac-



Casey, Illinois' Mr. Music Box, Richard Gard, along with some of the many townspeople who have benefited from his music box donations.

tion, but spread joy.

Richard, you see, has a fascination with music boxes. Created in a host of shapes—including cars, trucks, bears, and jewelry boxes—his tinkling wooden treasures put smiles on people's faces.

*Continued*

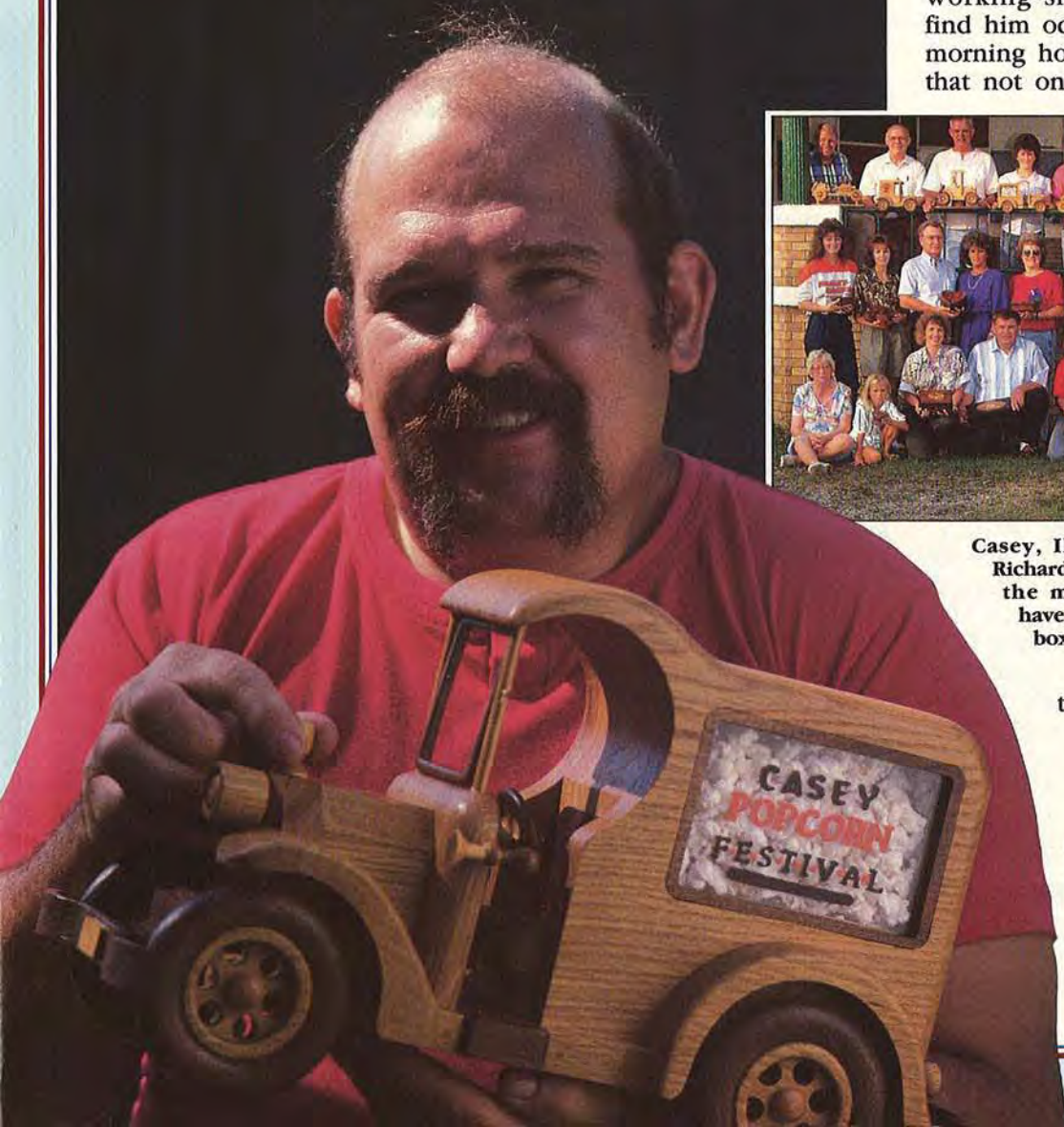

# MR. MUSIC BOX

And, over the last five years, his musical masterpieces have generated about \$7,000 for local charities' fund-raising activities.

## He spreads smiles

"Music boxes are special," Richard explains. "They have a magical quality about them that makes people forget about their troubles and be happy. Whenever someone hears a music box for the first time, there's a long silence, then they smile. For most people, I guess, the sound reminds them of a pleasant time."

The brawny auto-body-man-turned-woodworker has built a lot of music boxes since the time seven years ago when he spotted one in a jewelry store. "It was real expensive," he remembers, "so, I decided to learn how to make one. And that's how I got hooked—on music boxes and woodworking."

Richard is convinced that everyone should have the pleasure of a music box, even men who might think them less than macho. That's why his creations often look quite unconventional.

"Most men probably wouldn't buy one if it looked like a music box," he says. "But, if I put the movement in something more masculine—such as a car or truck—they identify with it."

That's one reason why Richard's unusual music boxes fetch big bucks at fund-raisers. For instance, at the auction to benefit the Shriner's Children's Hospital Burn Center in St. Louis last Fourth of July, his rendition of a Ford Model-A pickup truck that plays "Memories" brought \$500.

Around Casey, though, you don't have to shell out cash to enjoy one of Richard's tuneful whimsies. If you're in need, you'll no doubt get one.

## A loaner to lift spirits

"When I first started making music boxes, I wasn't overwhelmed with how they were turning out,"



Oak Model-A pickup plays "Memories."



Walnut and catalpa Honey Bear

Richard recalls. "To improve them, I had to keep building. But, I didn't want to have them all sitting around, so, I gave them to some people I knew well."

Because Richard knows just about everyone in Casey (pop. 3,000), and what's happening, his giveaways became a no-end situation. "The more I gave away, the more in touch I got with the needs of people," he says. "Finally, I felt I could make music boxes 24 hours a day and still not be able to make everyone happy. Then I thought of The Loaner."

The Loaner has circulated for five years now. It's a basic, durable music box of cherry that plays "Brahm's Lullabye."

"Each person keeps it two weeks," Richard says. "I tell them it's to use, not just for decoration. That way, they enjoy it. And, when I give it to them, I ask who should get it next."

Accompanying The Loaner is a log book, where recipients write in their names and record any comments they want to make. Richard likes to page through the book when it returns. His chance to smile comes with notations like this: *"We may all have a friend in Jesus, but it makes me feel good to know that I have one right here in Casey."*

## Experimenting with the sound of music

There may be magic in a music box, but Richard has discovered that behind every one there must be experimentation, too. But after 100 or so efforts, he's developed a few guidelines for great sound.

"To begin with, I primarily use mechanical—rather than electronic—movements because they have a clearer sound," Richard says. "And an 18-note movement

is the smallest I'll install."

Japanese and Swiss manufacturers produce mechanical music-box movements in 12-, 14-, 18-, 36-, 50-, 72-, and 144-note capabilities. "The higher the number, the better the sound," Richard explains. "At the 144-note end of the range, 72 notes play the melody and 72 notes play the harmony. The result is incredible, but so is the cost—about \$1,500."

After deciding on the movement, Richard selects the style, based on what he wants the music box to look like. "If the movement won't be exposed, I'll use a plastic-covered one," he comments. "If the movement will be visible, I'll insert an open one. They're better looking."

Next, Richard plans how to emphasize the tone. "An inexpensive 18-note movement, on a thin sounding board, will have a high,

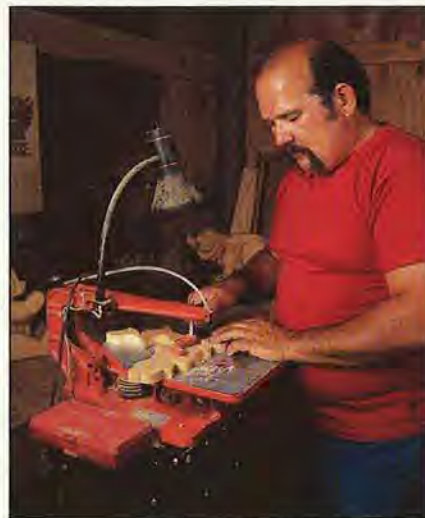

Richard burns the midnight oil in his workshop, building music boxes. Here, a bear takes shape.



A small Teddy bear adorns The Loaner.



This cherry music box displays a Swiss-made movement.

rattling sound,” says the music-box maker. “By using thicker wood for the sound chamber, or by setting the movement deeper, you mellow the tinny sound.

“When it comes to the wood,” he adds, “I’ve found that hardwoods produce a much better sound than softwoods. I get a nice crisp sound with woods like cocobolo, rosewood, or wenge.”

Richard has come up with some dos and don’ts, too. “Always put a dust cover over an open

movement,” he advises. “Also, never, never, never finish a music box with lacquer if you plan to install a 72-note or better movement. The lacquer vapors eventually break down the lubricating oil. For boxes like that, I apply a paste varnish.”

### What the world needs now

Richard says there’s no limit to music-box design. “With an extended arm for the windup key, I can see an airplane music box.

You’d wind it up with the propeller, then the prop would spin as it played,” he explains. In fact, Richard gets so gleeful talking music boxes, it’s certain that the lights in his workshop will burn for years to come. After all, there’s no end to the possibilities.

### How to contact Mr. Music Box

Write Richard Gard at Rural Route No. 2, Box 143A, Casey, IL 62420.



**Richard Gard designed this easy-to-build jewelry/music box just so you, too, can make someone happy. To order the movement, check out our Buying Guide.**

When this issue’s featured craftsman, woodworker Richard Gard, mentioned to us that he’d like to see more people build music boxes because they’re so much fun, we said, “Then design one for WOOD® magazine.” So, a few weeks later, Richard brought us this walnut music box that plays “Memories” when you lift the lid. And, you’ll find that it goes together like a breeze.

# A music box from the HEART

## Step 1. Cut the parts to initial size

You’ll need walnut stock for the body, bottom, and lid, as listed in the Bill of Materials. To get the 1½”-thick material for the body (A), glue together two pieces of ¾” stock, clamp, and let dry.

Cut the parts for the top (C) and the bottom (B) from ¾” stock. See the Exploded-View drawing for referencing parts.

## Step 2. Saw the parts to shape

Trace the heart pattern onto parts A, B, and C. (Refer to pattern notes, because you won’t need the complete pattern for each part.) Then, saw around the perimeter of the pattern, cutting all three pieces to shape.

Now, take the box body (A) and mark the location of the ⅝”

hole for the brass on/off extension pin where shown on the pattern. Drill into the top edge of the box body (A). Then, using the hole as your guide, flip the box body over and drill a ¼” hole ¾” deep into the bottom edge.

Next, drill a ⅛” start hole where shown. Saw out the jewelry compartment, being careful to keep the sawed-out center intact and unmarred—you’ll need it to form the lid bottom (D). Bore out the area to house the music movement with a 3” Forstner-type bit.

To obtain the ¼” material for part D, retrieve the center cutout and bandsaw it to ¼” thickness.

## Step 3. Prepare for the movement

Glue the bottom (B) to the box body (A) and clamp. Then, make a copy of the detailed circular pat-

*Continued*

# MR. MUSIC BOX

tern for the music movement opening and cut it out. Now, place it inside the 3" music movement opening—lining up the cut-out pattern's alignment marks with the on/off lever notch.

Mark the hole locations for the hold-down screws and the move-

ment key with a scratch awl inside the movement opening. Remove the pattern and drill the needed  $\frac{5}{32}$ " and  $\frac{5}{16}$ " inside holes. Now, turn the box body over and complete drilling the holes to the widths and depths indicated on the pattern.

## Step 4. Assemble the box

First, rout a  $\frac{1}{2}$ " roundover around the edge of the box bottom and the top edge of the lid. Then, align the lid bottom (D) on the underside of the lid, as shown in the drawing, *far right*, glue it in place, clamp, and set aside.

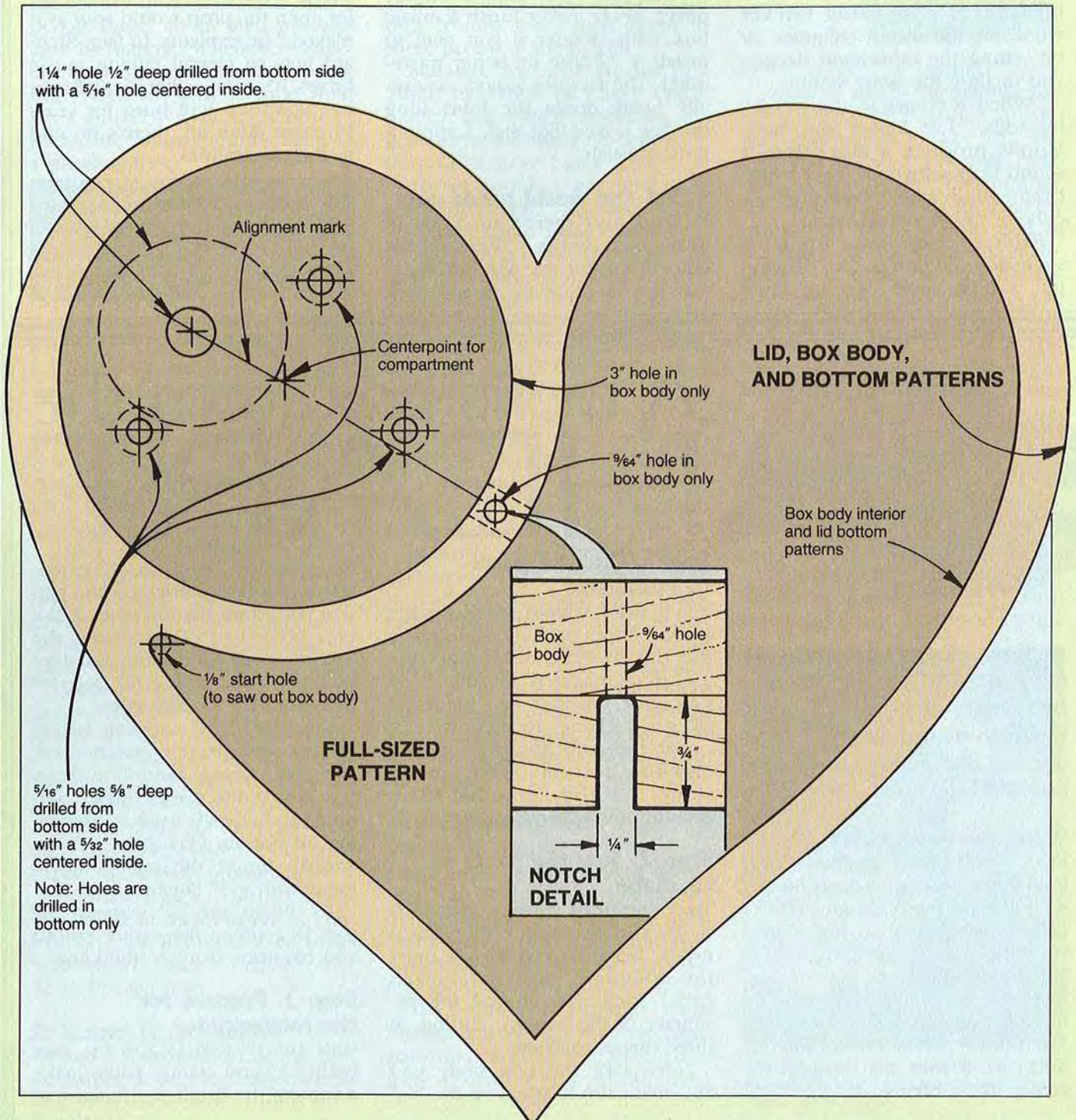

At this time, sand and finish the box and lid, being sure to create a chamfered edge on the hole for the key. This protects fingers when winding.

When the finish dries, insert the movement in the opening, making sure the on/off lever centers in the notch containing the brass pin, as shown in the Section View. Place the brass pin in the hole and couple it with the on/off lever and fasten the movement in place with the screws provided. Next, attach the key.

### Step 5. Add the lining

Refer to the instructions in the Box Lining drawing to line your box with velveteen fabric. Then, to complete your project, add the

3"-diameter, circular glass dust cover (see the Buying Guide) over the movement. It should fit in the recess tightly enough without having to do any gluing.

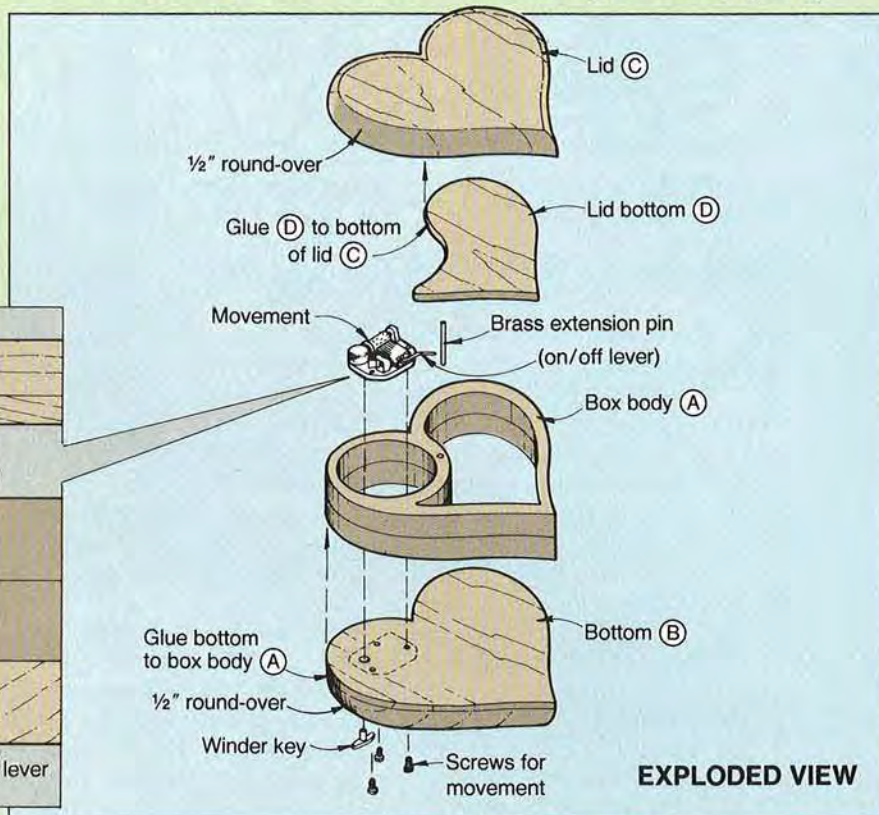
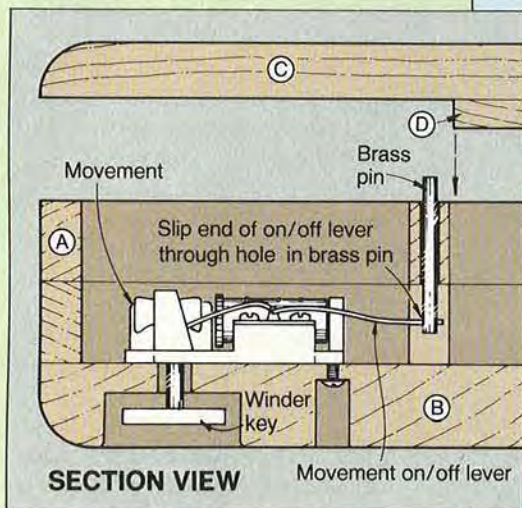

### Buying Guide

• Reuge 18-note music movement (plays "Memories"), brass extension pin, 3"-diameter  $\frac{3}{32}$ " glass dust cover, the entire kit, no. 71063, \$15 (U.S.) ppd., from: Klockit, P.O. Box 636, Lake Geneva, WI 53147. 🌳

Bill of Materials					
Part	Finished Size			Mtrl.	Qty.
	T	W	L		
A*	1½"	8"	8"	W	1
B	¾"	8"	8"	W	1
C	¾"	8"	8"	W	1
D	¼"	6"	6"	W	1

\*Laminated to thickness  
**Material Key:** W-walnut  
**Supplies:** Yellow woodworker's glue, cardboard, velveteen, finish.

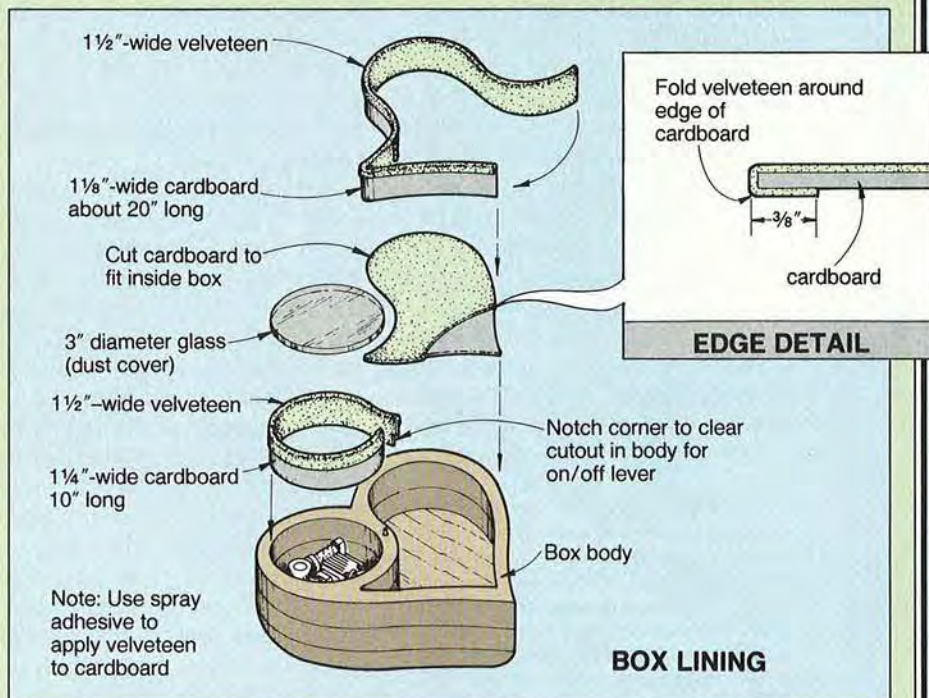

# NORTHWEST COAST INDIAN CARVING

## A SAMPLING OF THE BOLD WOODEN LEGACY FROM ONE OF NORTH AMERICA'S MOST FASCINATING PEOPLE

**N**orthwest Coast defines a distinct geographical area of North America that roughly extends 1,200 miles from Yakutat Bay northwest of Sitka, Alaska, to the Columbia River in Washington state. The native people of the Northwest Coast, from the Tlingit and Tahltan in the far north to the Coast Salish in the south (see map, *right*), shared a life enjoyed by no other.

The area where they lived, with few exceptions, was limited to the narrow coastline where forests met the sea. Warmed by the Japanese Current, the area included lush rain forests. The waters produced seafood in abundance—halibut, salmon, clams, and mussels. There were sea lions and whales, too. Ducks and geese also migrated through the area. And wild berries proliferated.

With their daily necessities so easily attainable, the Northwest Coast tribes developed a leisurely culture rich in mythology and ceremony. Only the Aztecs surpassed it in North America.

The people of the Northwest

Coast also were unequalled as practical woodworkers. But, it was the demand for ceremonial objects and possessions to reflect tribal stature that resulted in skilled artisans—gifted carvers of wooden masks, totems, screens, boxes, furniture, and other artifacts.

### Prestigious symbols

In the society of the Northwest Coast, wealth and prestige were obtained not only by accumulating items of real value, such as canoes, blankets, furniture, and ceremonial trappings like masks, but those without intrinsic value, too. The ownership of specific songs, dances, and symbols contributed equally to status, since these were considered private property.

All the Northwest Coast tribes, and the local groups within them, believed in and identified with myths concerning their origin. One Kwakiutl village group, for instance, claim the thunderbird and halibut as their ancestors. As a result, all their descendants have the right to display the thunderbird and halibut as their “family” crests on totem poles, houseposts, and other items.

Inheritances thus had value. But, there were other ways to obtain this passed-down wealth. When a male married, for instance, he gained his wife’s privileges. Another means was

the *potlatch*.

For example, if a chief wished to claim the crests of a deceased relative, he invited guests to a feast or potlatch. At the event, he erected a totem pole with the deceased’s crests carved on it—those which he was now claiming. By accepting the food and gifts, the guests validated his claim.

### The origins of decoration

Among the Northwest Coast Indians, even the most ordinary objects were decorated. Spoons, canoe paddles, staffs, and clubs received the same artistic attention as ceremonial masks, totem poles, and other large carved objects.

Animal, bird, and fish images reflected the peoples’ origin myths as well as the creatures of the supernatural worlds of sea, sky, and forest that they believed existed. In addition, their carvings carry bold figures of real animals important to their life. But, their designs also reflect a human side that interprets ancestry or legendary people.

### Carvings have similarities

The work of Northwest Coast artisans varies from tribe to tribe, yet has similarities. Haida and Tlingit carvings tend to be less ornate or colorful than those of the Kwakiutl or Coast Salish, but have common, recognizable symbols.



◀ From top to bottom on this Tsimshian ceremonial staff you’ll find a whale, a human, a beaver, a bird, another human, a second beaver, and a whale holding a human figure. Staffs such as this were held by the ceremonial orator. He relinquished the staff only when someone wishing to address the assemblage reached for it. Circa 1895.



HAIDA  
TRIBE



TLINGIT TAHLTAN

TSIMSHIAN

NORTHERN KWAKIUTL

BELLA COOLA

SOUTHERN KWAKIUTL

COAST SALISH

WESTCOAST

VANCOUVER  
★ BRITISH COLUMBIA

WASHINGTON STATE

Northwest Coast carvers used the wood around them—western red cedar, yellow cedar, hemlock, yew, maple, and alder. But, they also turned to other materials, such as soft stone.

Before contact with the white man, pigments for paint came from natural sources. They mixed salmon-egg oil with lignite, iron ore, and copper to get colors.

**Tourist curios**

The Northwest Coast carving culture had flourished before European contact, but it took off in the 18th century when explorers introduced iron tools. Demand for souvenirs was also responsible, and curios became abundant.

However, when British Columbia joined Canada in 1871, officials and missionaries restricted native customs, and aspects of the culture declined. Carving especially suffered because it expressed many of the old practices. Thankfully, some artists passed on their skills.

▲ Depicting the likeness of spirits, masks such as this were worn at the dances that preceded potlatches. Guests would attempt to identify the spirit. Made of wood, fur, and copper, this Tsimshian mask has eyes that open and close. Circa 1900.

*Continued*

# INDIAN CARVING



Elaborately carved ▶ and painted rattles of wood and cedar bark were held by attendants in the Southern Kwakiutl Cannibal Society's *hamatsa* dance. The sound of rattles calms hamatsa, the wild spirit, and prevents him from biting people. Made before 1914, this example depicts a mountain hawk, an unusual subject.



▼ Highly decorated Haida food bowls of this type would have been reserved for use by or as gifts to guests at a potlatch ceremony. Note its rounded sides and shell insets along the rim. Circa 1850.



▲ Carved canoe models were sold as curios to visitors or museums. Sales were an untraditional source of wealth, but helped carving proliferate. This is a Westcoast type, date is unknown.





To find out more about Northwest Coast carving, read *The Legacy, Tradition and Innovation in Northwest Coast Indian Art*, 1984, the University of Washington Press, Seattle. 🌲



▲ Family crests and symbols adorn totem poles lining the shore in this 1884 photograph taken by Richard Maynard at Skidegate, Queen Charlotte Island, B. C. Such displays denoted wealth.

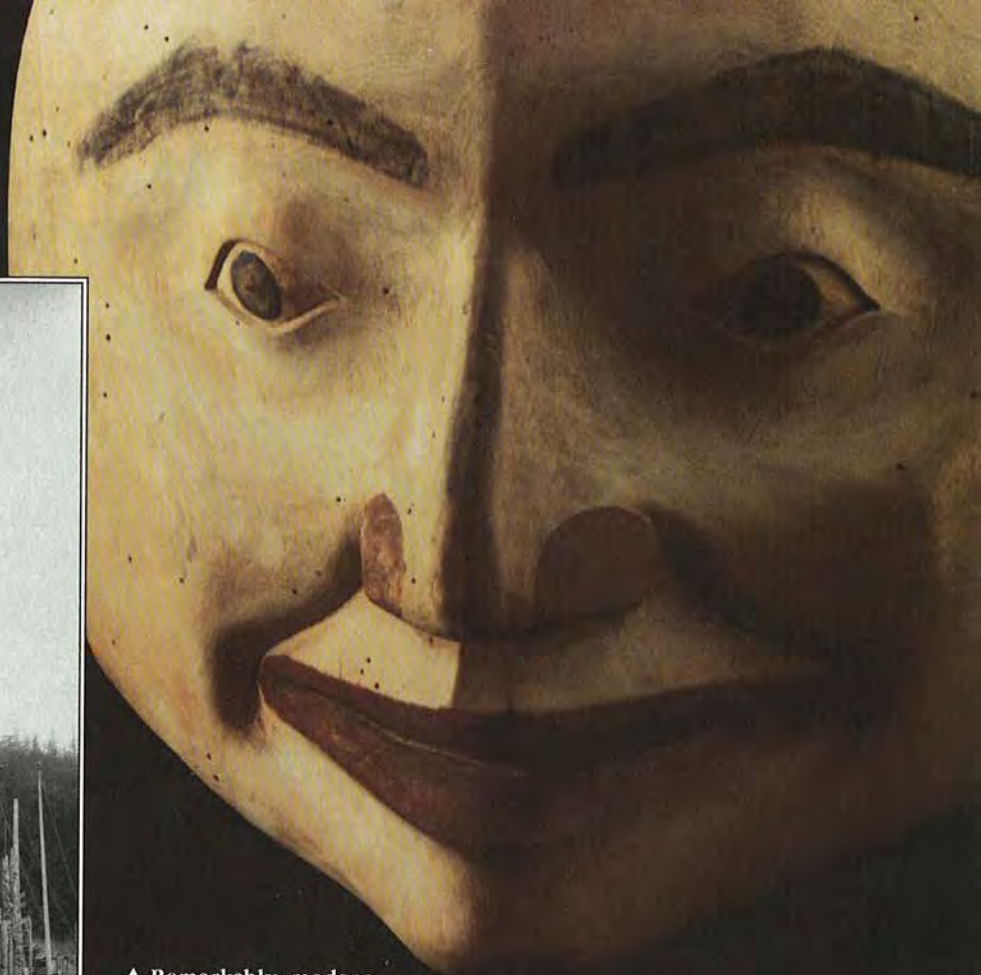

▲ Remarkably modern in appearance, this Tsimshian mask had its place in the ceremonial dramas held in the dance house. Perhaps representing an ancestor, it most likely wasn't worn, but was instead hung as a prop. Circa 1908.

▼ A Haida carved bowl in which soapberries were mixed with water, then whipped to a froth for a confection called *soopallatie*. Note eagle face on left and whale image on right. Circa 1893.



Written by  
Peter J. Stephano  
Graphic design:  
Perry A. McFarlin  
Photographs courtesy of the  
Royal British Columbia  
Museum, Victoria, B.C.

A SIMPLE, AFFORDABLE  
SYSTEM FOR KEEPING  
YOUR SHOP CLEAN

# CENTRAL

**H**ardly a week goes by when I don't receive a reader letter about dust collection. And, it's easy to understand why. Public awareness of the harmful effects of airborne wood dust has grown steadily in recent years. But, what can you do to effectively solve your never-ending dust problem?

With that question in mind, Jim Downing, *WOOD*® magazine's design editor, and I sat down to plan a full-service central dust-collection system. Then, we built the system in my home shop to test out our ideas.

For affordability, safety, and convenience, we decided (1) to use PVC pipe for the main ductwork, (2) to completely ground the piping to prevent buildup of static electricity, and (3) to wire convenient remote switches near major dust-produc-

ing machines for instant, on-the-spot suction.

After having ironed out a few bugs, Jim and I feel confident that we have come up with an efficient, hard-working system.

*Bill Kier*

Products and Techniques Editor

## Planning your system

To get started, sit down with a piece of paper and lay out the perimeter of your shop and the locations of your woodworking machines. Then, plan your dust-collection system with these points in mind:

- Locate your dust collector near machines that produce large chips, such as a thickness planer or router table. By doing this, you reduce the chances of these large chips clogging the ductwork. As you can see by the layout of my shop, *opposite page*, I located the dust collector in a corner and out of my way, but fairly close to both my jointer and to the single hose that serves the tablesaw, thickness planer, and router table. I placed my belt/disc sander near the collector only because that's the most convenient spot for it.

- Run 4"-diameter pipe to major chip producers, and then reduce the pipe diameter to 3" when you start a run to a radial-arm saw or sanding machines.

- Keep the pipe run as short as possible, and the number of elbows and other joints to a minimum. Why? Every foot of pipe lessens air flow, and every elbow reduces efficiency as much as 10' of pipe would. Jim and I hung the main ductwork from joists with pipe straps.

- Position your wye and tee joints for smooth air flow as shown, *opposite page*.



# DUST COLLECTION



**BIRD'S-EYE VIEW OF A CENTRAL DUST-COLLECTION SYSTEM**

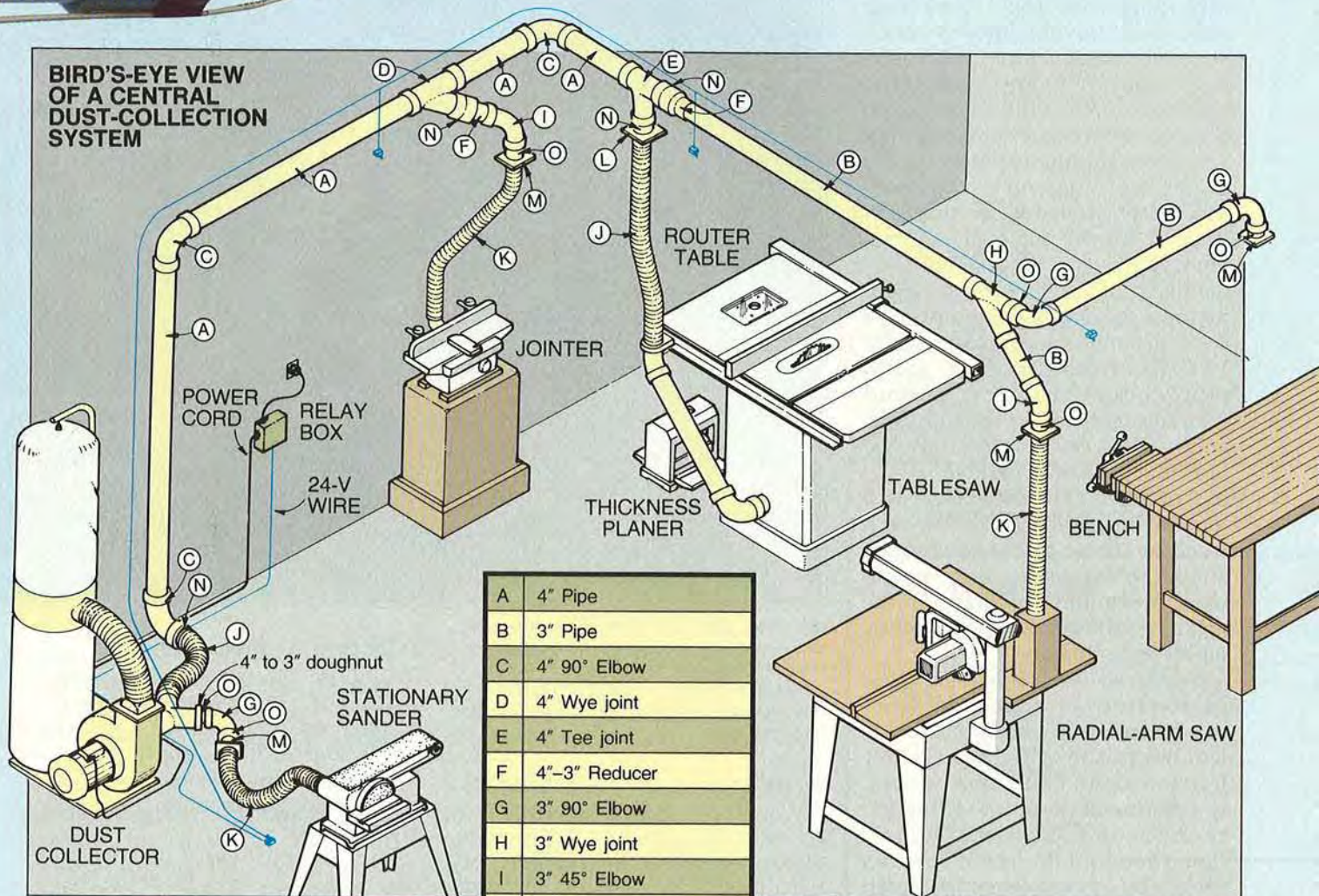

A	4" Pipe
B	3" Pipe
C	4" 90° Elbow
D	4" Wye joint
E	4" Tee joint
F	4"-3" Reducer
G	3" 90° Elbow
H	3" Wye joint
I	3" 45° Elbow
J	4" Hose
K	3" Hose
L	4" Blast gate
M	3" Blast gate
N	Short 4" pipe
O	Short 3" pipe

**CORRECT POSITIONING OF TEE JOINTS**

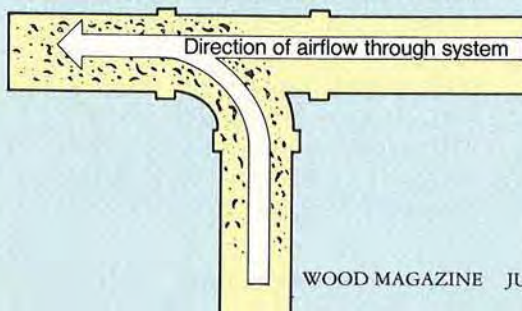

**CORRECT POSITIONING OF WYE JOINTS**

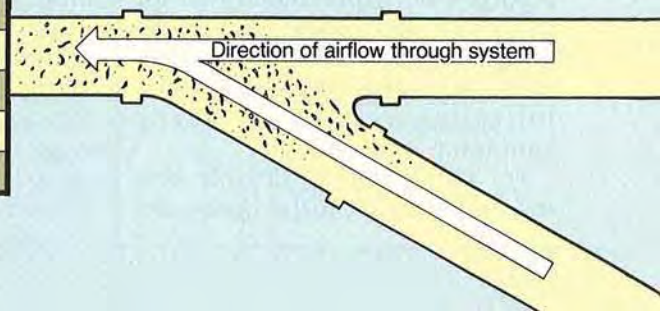

# DUST COLLECTION

## Choosing your ductwork components

We chose rigid PVC sewer-and-drain pipe for our ductwork because of its low price (less than \$4 for 10' lengths in 3" and 4" diameters). This piping has smooth walls for efficient air movement, and accepts radiused tee and wye joints that also aid the smooth flow of air. When you ask for this piping at your local hardware store, don't buy the thicker-walled Schedule 40 PVC pipe. This material weighs more and costs about twice as much while offering no dust-collection advantages over the sewer-and-drain pipe.

You could buy metal ductwork specifically designed for dust collection, but this material will balloon your costs. For example, 4"-diameter metal pipe costs about \$7 for a 30" length, and joints cost 3 to 4 times more than similar PVC fixtures. However, metal pipe doesn't require a ground wire for dissipating the static electricity that builds up from the movement of dust particles.

To control the flow of air, you'll need to install blast gates at each machine. These gates, which open and close manually, allow you to have maximum air draw at the machine you're using. Just close off all the others.

You have two choices in blast gates: plastic or aluminum. With the exception of one gate, my system has plastic gates because they leak less air and don't inadvertently open or close due to vibration as the aluminum ones will do from time to time. The aluminum gates cost about twice as much (\$14-\$16 versus \$8 for 4" plastic models), but I purchased one for the collection point above my table saw. The reason: this often-used gate needs the greater durability inherent in its sturdy aluminum construction.

For the 3" and 4" flexible hoses that leads from the blast gates

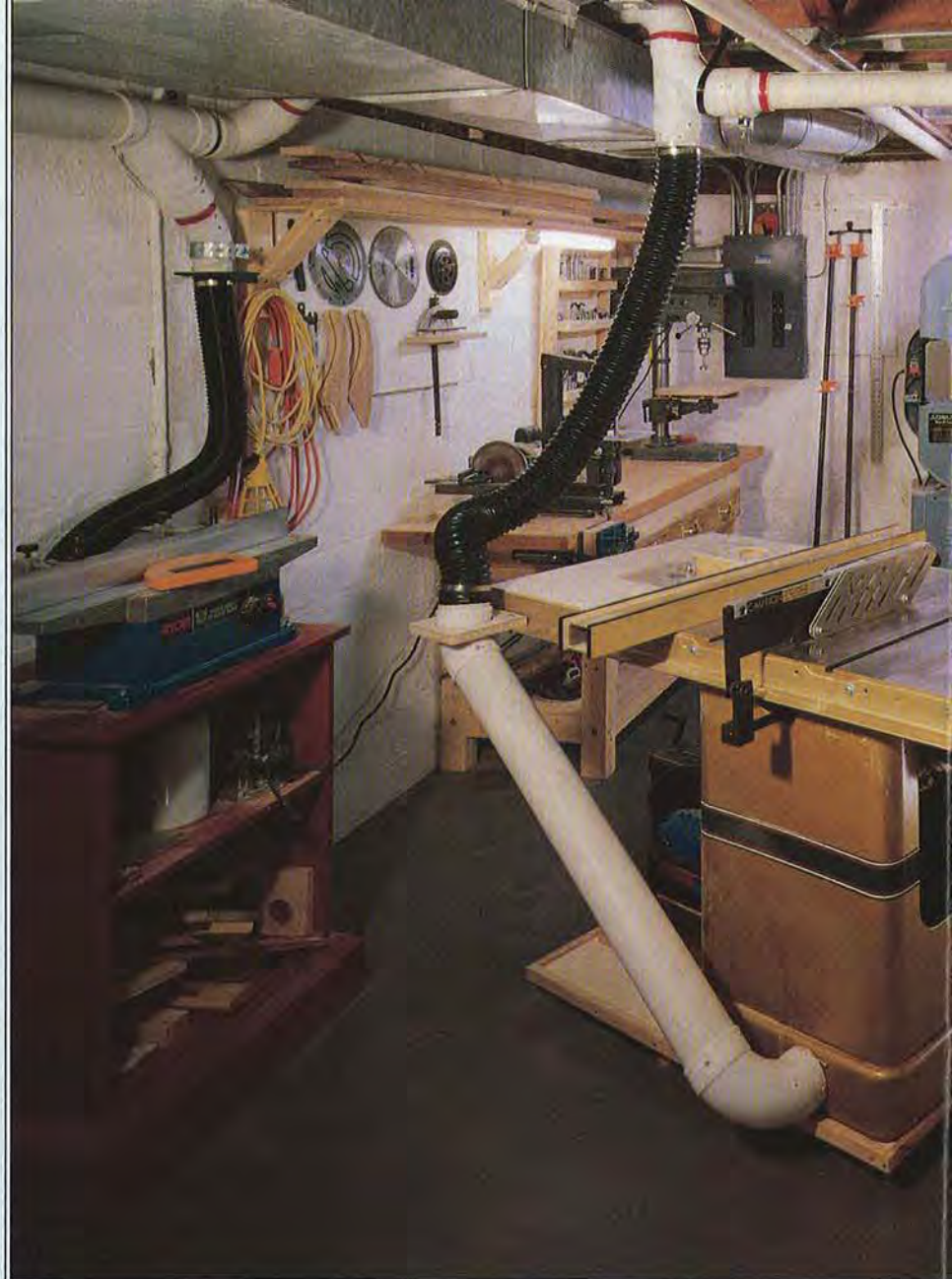

My shop may not always be this neat and clean, but a new central dust-collection system sure helps keep it tidier! A 1-hp dust collector adequately handles this installation, which has a main run of 35' of pipe.

to the woodworking machines, we prefer the type that contains a spring steel wire over those hoses made completely of plastic. The wire models cost about \$3 more per 10' of hose, but they flex more easily.

You can purchase PVC pipe, braided copper ground wire, and all the fasteners for your dust-collection system at your local hardware store. See the Buying Guide on page 45 for two mail-order sources for hoses and blast gates.

## Selecting a dust collector

To choose the ideally sized dust collector for my system, we hooked up a 1-hp Sears model 29978 and a 2-hp Grizzly model G1029 for comparison. Both machines had adequate suction for my installation.

After several trials, I decided to stay with the Sears machine because it took up less space, made slightly less noise, and cost less (\$280) than the Grizzly machine (\$295 plus shipping). But, we suggest you buy a collector of at least 2 hp if you have a system with a main run that's longer than mine. The same holds true for systems with two or more additional

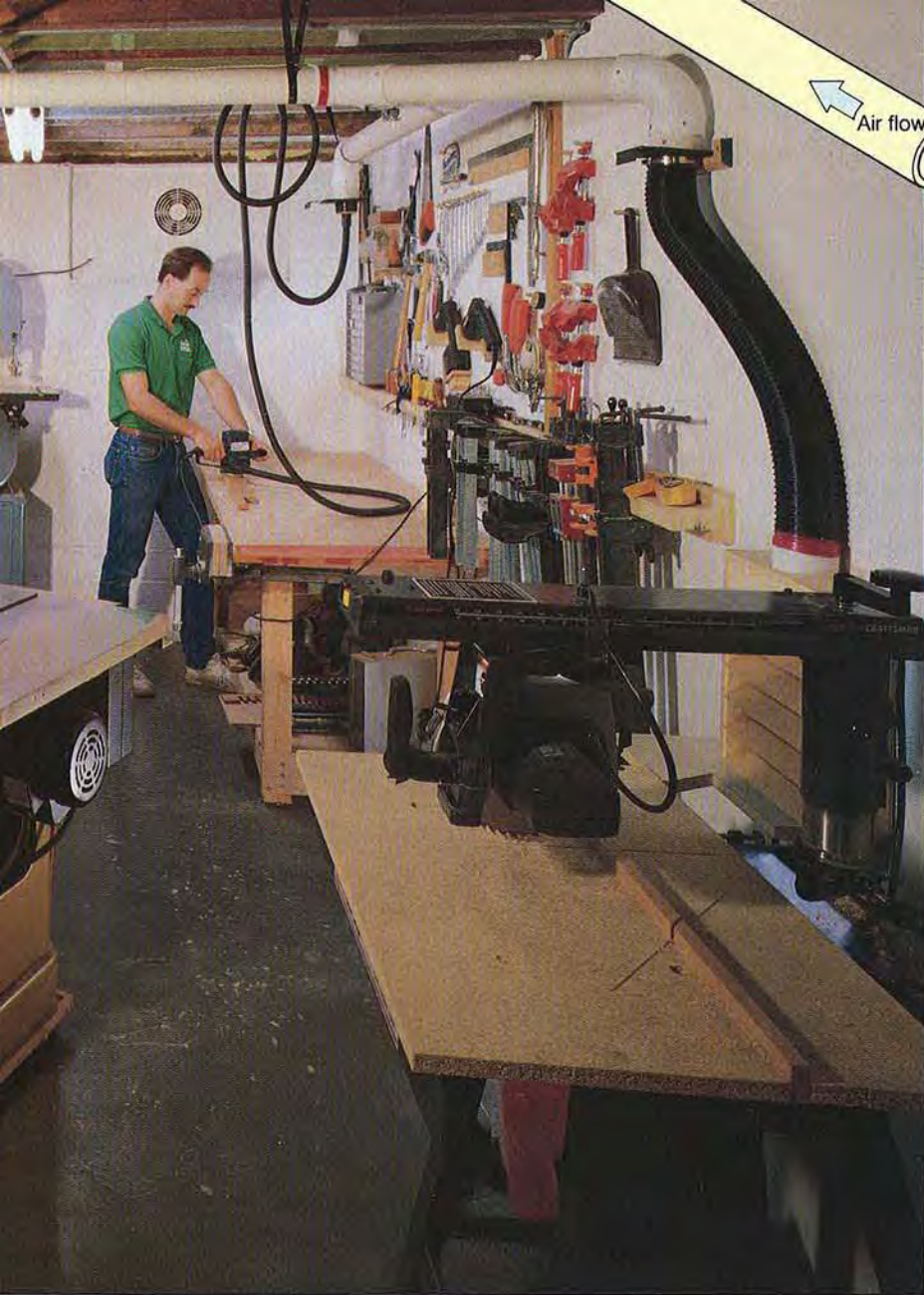

## SYSTEM ASSEMBLY

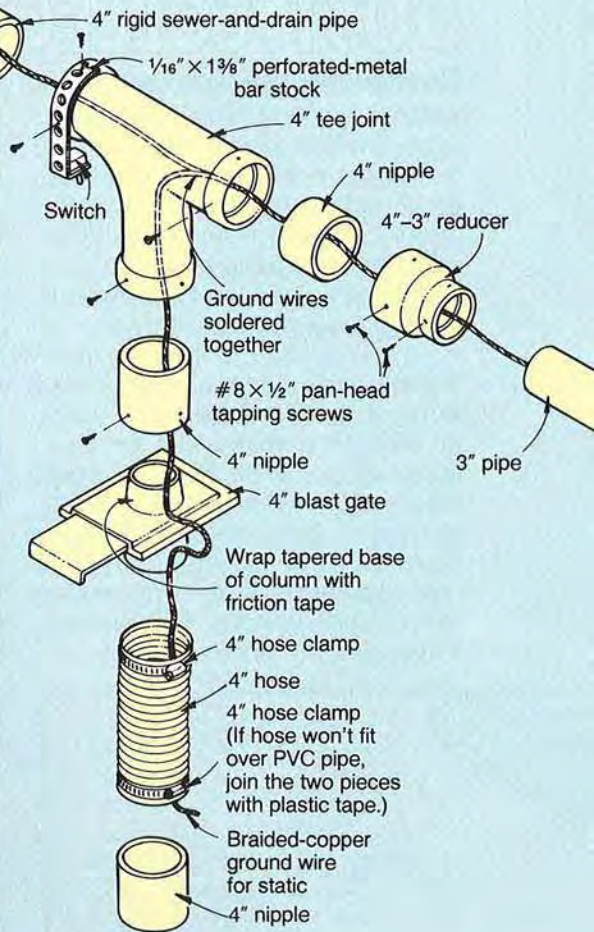

## AVOIDING CLOGS AT SOLDERED GROUND-WIRE CONNECTIONS

### PROPER CONNECTION

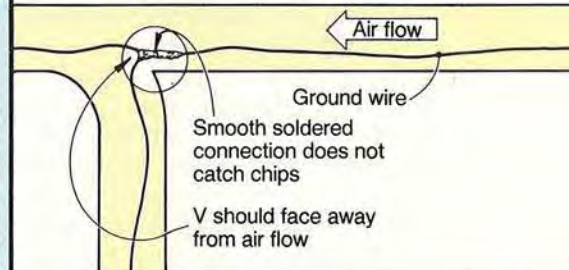

### IMPROPER CONNECTION

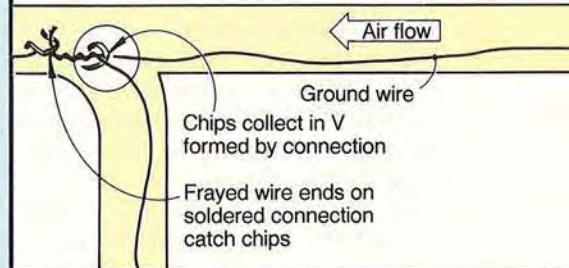

elbows, or those that will have more than one blast gate open at a time. Otherwise, you may experience some clogging and inadequate dust pickup.

### Installing the ductwork

Beginning with the ductwork closest to your dust collector, cut the pipes to length, slip the joints into position, and temporarily mount this ducting to your walls and/or ceiling. *Do not fasten together the ductwork yet.* Cut the PVC pipe to length with a hand-saw, and square the pipe ends with a bandsaw. Scrape burrs from the pipe ends with a pocket-knife. See the drawing *above right*

for help in assembling the joints.

Once you're satisfied with the main ductwork, fish a braided copper ground wire through the pipes and connect it to any grounded object. At wye and tee joints, solder another piece of ground wire long enough to reach the machine it leads to. To avoid clogs at these connections, follow the drawing at *right*.

Now, fasten the PVC pipes together with three #8 x 1/2" pan-head tapping screws at every connection. *Do not glue the connections.* If you do, you'll have to cut the pipe in the event of any clogs. Now, add the blast gates and hoses.

*Continued*

# DUST COLLECTION

## Connecting the system to your woodworking machines

Even the best dust-collection system in the world will do you little good unless it connects to efficient collection ports on your dust-producing machines. To give you a hand, let's look at how Jim and I handled my machines:

• **Stationary sander.** Many versions of this machine have built-in dust ports that make for easy hook up to a 3" hose. If your sander doesn't have such ports, you can fashion collection shrouds from plywood or PVC pipe that surround the drive roller and/or disc bottom. (For an example, see the drawing below).

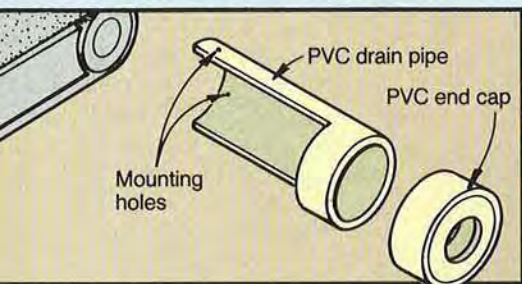

• **Jointer.** These machines create large chips and relatively little airborne dust, so dust collection isn't essential. We hooked up my Ryobi JP-155 because it has a handy collection port. But, I wouldn't have done so if I owned a larger jointer with a chip chute that empties into a box.

• **Bench-collection gate.** Nearly all of my portable sanders have dust ports, so I hung a 3" blast gate above my workbench to which I can hook up these prolific dust makers. To construct this setup, I purchased a 1" Bosch dust-collection hose. Then, I made a wooden doughnut that holds one end of the hose in the blast gate as shown at *top right*. I adapted other tools to this Bosch hose by outfitting them with wooden doughnuts and various plastic and copper-pipe fittings. For information on how to make these doughnuts, see page 23.

• **Radial-arm saw.** The louvered-collector project shown on page 46 efficiently collects dust at 90° or 45° cutting angles.

• **Tablesaw, thickness planer, and router.** I consider this setup the neatest part of my shop. As you can see by the photo on page 42, we ran PVC pipe from the dust port at the base of my table-saw up to a 45° elbow mounted to the back rail of my rip fence. Into this elbow I slipped the flexible hose hanging down from the blast gate. (Using a hose clamp, I secured a 4" length of PVC pipe to the hose for a smooth fit with the elbow). I did not screw together this connection because I wanted the option to connect the hose to my portable planer, which sits on top of my table-saw's extension when in use as shown at *bottom right*. (See page 48 for notes on making this collector).

My table-saw extension serves double-duty as a router table, so when routing I clamp the collector shown at *middle right*, to my fence and plug in the hose. For building notes, see the shop tip on page 22. This helper collects most router chips.

If your table-saw doesn't have a dust-collection port, see the article on building a table-saw base with dust-collection capabilities in the April 1990 issue of *WOOD* magazine. For a reprint of this article, stamped, business-size envelope and \$2 to:

**WOOD Magazine**  
Tablesaw-base reprint  
Box 11454  
Des Moines, IA 50336-1454.

A flexible hose clamped to a PVC nipple quickly switches from the planer to the dust port for the table-saw.



A 3" blast gate outfitted with a wooden doughnut accepts a 1" hose for portable tools such as sanders.

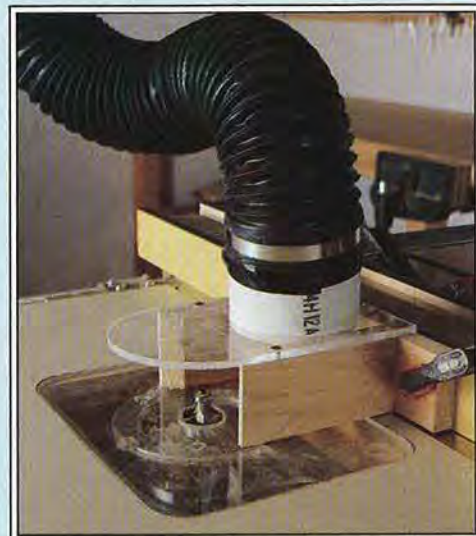

The same hose used for the table-saw and planer also works with the router-table dust collector.

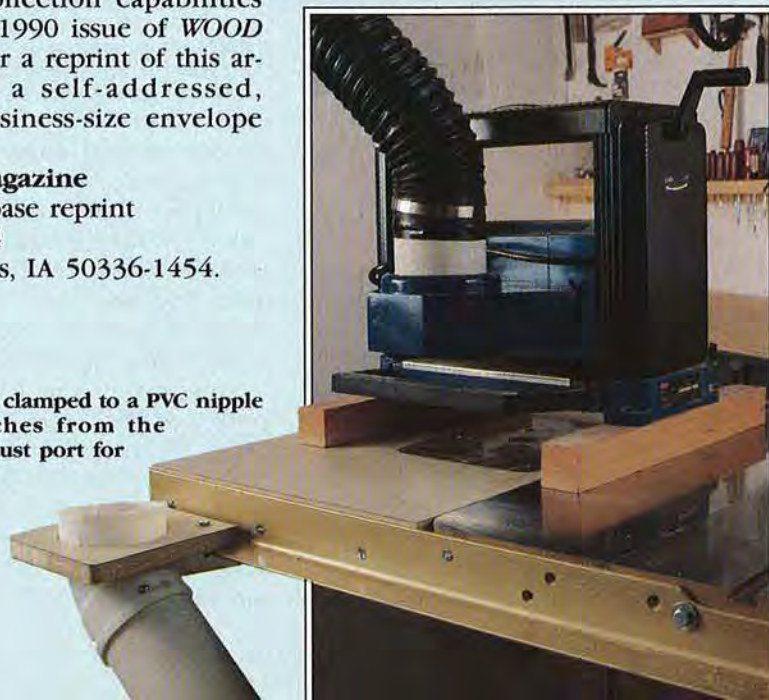



If you decide to install multiple switches, mount the relay box for the low-voltage switching system on a wall near your dust collector.

### HOW TO WIRE THE RELAY BOX

#### 110-VOLT SYSTEM

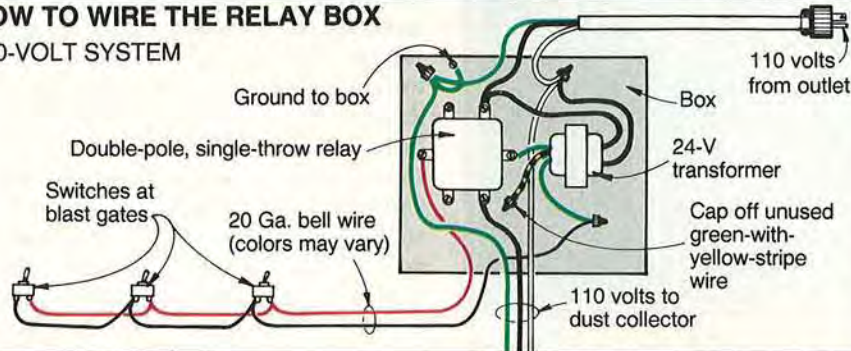

#### 220-VOLT SYSTEM

Note: Drill two 3/4" holes in box. Use Romex connectors to secure wires.

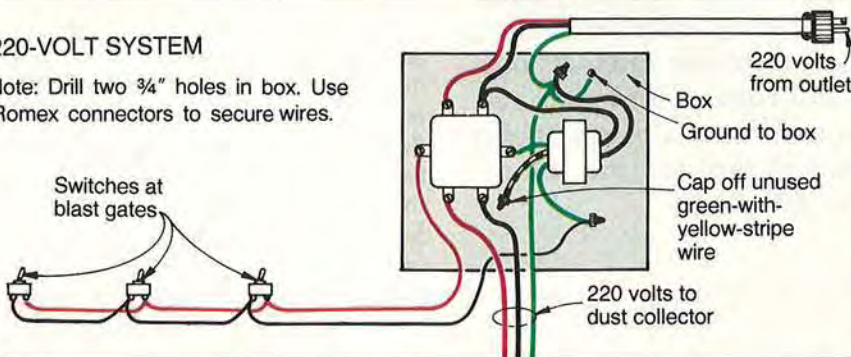

### Buying Guide

• **Low-voltage switching kit.** Relay, 24-volt transformer, and box, \$47 ppd. plus \$3.75 per switch (example: \$62 for a four-switch system). Radio Trade Supply, 1017 High St., Des Moines, IA 50309. Call 515/288-7237. Allow 4-6 weeks for delivery.

• **Blast gates, hoses, and other dust-collection supplies:**

Woodstock International, P.O. Box 2027, Bellingham, WA 98227.

Woodworker's Supply of New Mexico, 5604 Alameda Place NE, Albuquerque, NM 87113.

### Switching setups add to the convenience of your system

Let's face it: no matter how well-conceived your dust-collection system may be, it's still a hassle to walk over to the collector every-time you need to turn it on or off. With that in mind, we've come up with two switching arrangements that allow you to start or stop the dust collector from handier locations in your shop.

**Option 1:** For an investment of less than \$20 at your local hardware store, you can add a switched outlet such as the one shown in the shop tip on page 16. Simply locate the toggle switch at a central location in your shop (I would place this switch near my tablesaw), and plug your dust collector into the switched outlet.

**Option 2:** For the ultimate in convenience, you can have a switch at each of your dust-producing machines, just as we did in my shop. This setup will cost you \$60-\$70 depending on the number of switches, and works with either 110- or 220-volt dust collectors. To install the system as shown in the overall drawing on page 41, you'll need the switching kit listed in the Buying Guide *below left*, enough 20-gauge bell wire to connect the low-voltage switches (about 6¢ per foot at hardware stores), a roll of plastic tape to affix this wire to the ductwork, and a few feet of 1/16 x 1 3/8" perforated-metal bar stock for securing the switches to the ductwork.

With your supplies gathered, mount the switches near your blast gates and wire them together. Mount the relay box that holds the relay and 24-volt transformer near your dust collector as shown *above left*, and wire these components according to the 110- or 220-volt illustrations at *left*. That's it—you're in business! 🌲

Written by Bill Krier with Jim Downing  
Illustrations: Kim Downing; Bill Zaun  
Photographs: Hopkins Associates

# A DOWN-TO-BUSINESS A DOWN-TO-BUSINESS A DOWN-TO-BUSINESS A DOWN-TO-BUSINESS

# DUST

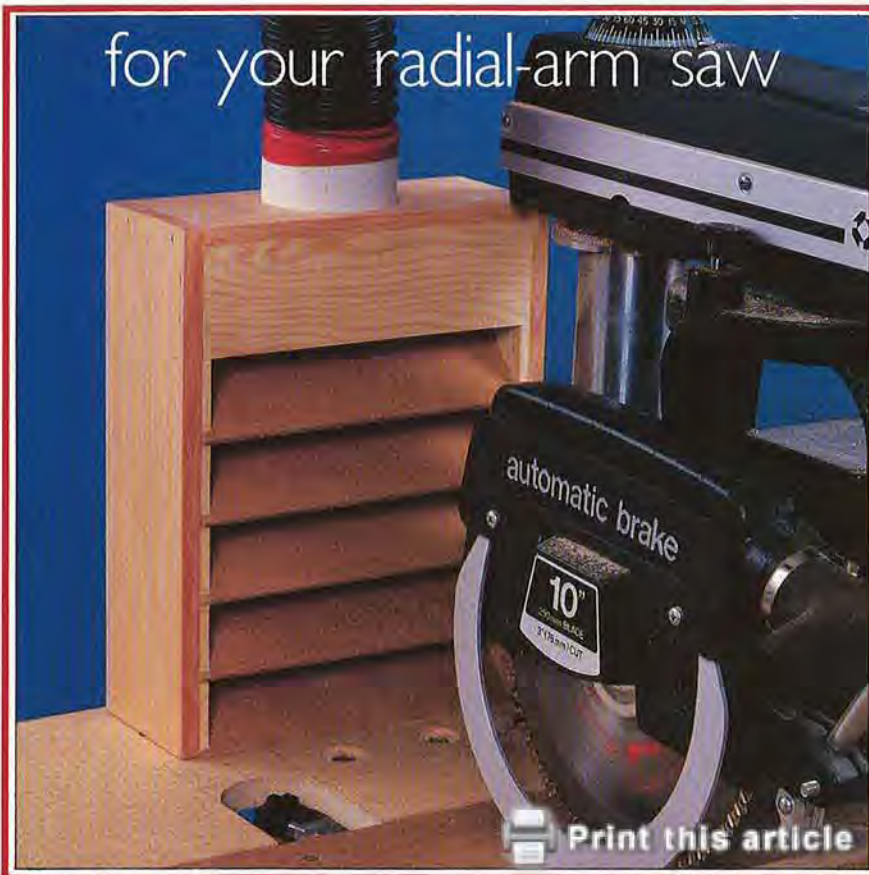

Like a spinning car tire mired in mud, a radial-arm saw blade spews loads of material behind it, spattering walls and filling the air with a torrent of sawdust. But with our catch-all dust collector, you can contain the mess, and route it into your vacuum system. Not only does it give your broom a break, it also lets you breathe a bit easier. Just lift and position the removable louvered box for either a 45° or 90° cut.

*Note: You'll need some thin stock for this project. You can either re-saw or plane thicker stock to size.*

## Start by cutting the collector pieces

**1** From ½" stock, cut the sides (A), top (B), and supports (C) to size, using the dimensions on the Collector drawing, *opposite page*. From the same stock, cut the top front piece (D) to size, bevel-ripping the bottom front edge at 45°.

**2** Measure the outside diameter of your hose coupling (we used 3" PVC pipe). Then, with a compass, mark the same size hole centered on the top surface of the top piece (B). Using a circle cutter in your drill press, cut the hole where marked. You could also drill a blade-start hole inside the marked circle, and cut the hole to shape with your jigsaw or scrollsaw.

**3** Cut a piece of ¼" stock to 1¼" wide by 22" long for the louver

supports (E). Angle your radial-arm saw blade or tablesaw miter gauge to 45° from center, and cut the 10 supports to size. (We used a stop to ensure all supports were the same size.) See the Collector drawing for the layout.

**4** Cut the wide bottom louver (F) to size, bevel-ripping both edges at 45°. Now, cut the four narrow louvers (G) to size.

## Next, assemble the collector

**1** Carefully locate, then glue and nail the louver supports (C, E) to the inside surface of each side piece (A) where dimensioned on the Collector drawing. (When positioning the pieces, we used ¼" hardboard scraps to ensure the correct-sized gap between the louver supports.)

**2** After the glue dries, drill a ⅜" hole ½" deep centered in the bottom end of each A/C assembly. Cut two pieces of ⅜" dowel or ⅜" steel rod to 1" long. If you use dowel stock, sand a chamfer on the bottom ends, and glue the dowels in the holes. If you chose steel rod, file or grind the chamfer, and epoxy the pins in place.

**3** With the ends flush, glue and nail part D onto the bottom front edge of part B.

**4** Position, and then glue and nail the pieces (B/D, F, G) between the side assemblies.

**5** Measure the length and width of the collector, and cut the back (H) to size. Glue and nail the back piece (H) to the collector.

## And finally, add the platform

*Note: The purpose of the platform is to support the collector directly behind the blade when set at either 45° or 90°. This allows you to collect the most sawdust. The size and configuration of your platform will depend on your particular saw. (Our platform conforms to a 10" Delta radial-arm saw.)*



# COLLECTOR

**1** Cut the platform to shape from stock that is as thick as your radial-arm saw table. (Our platform measures  $\frac{3}{4} \times 10\frac{3}{8} \times 20\frac{1}{4}$ .)

**2** Place the platform on top of your saw base where shown in the photo on the *opposite page*. Add a spacer block, if necessary, so the top of the platform is level with the top of the saw table. Mark and cut a notch for both the table clamp and the column.

**3** Position and clamp the platform on the saw base. Drill and counterbore two holes through the platform, spacer block, and metal base frame. Bolt the platform and spacer to the frame.

**4** Center the collector directly behind the saw blade where shown in the photo. For maximum efficiency, position the collector as close to the blade as possible. Mark the locations on the platform for the two  $\frac{3}{8}$ " dowels glued in the bottom of the collector. Drill mating holes in the platform.

**5** Set the radial-arm saw blade to  $45^\circ$ , position the collector directly behind the blade, and repeat the process to locate and drill the holes. (When drilling the holes for the  $45^\circ$  cut, we had to drill one of the holes in the saw table.)

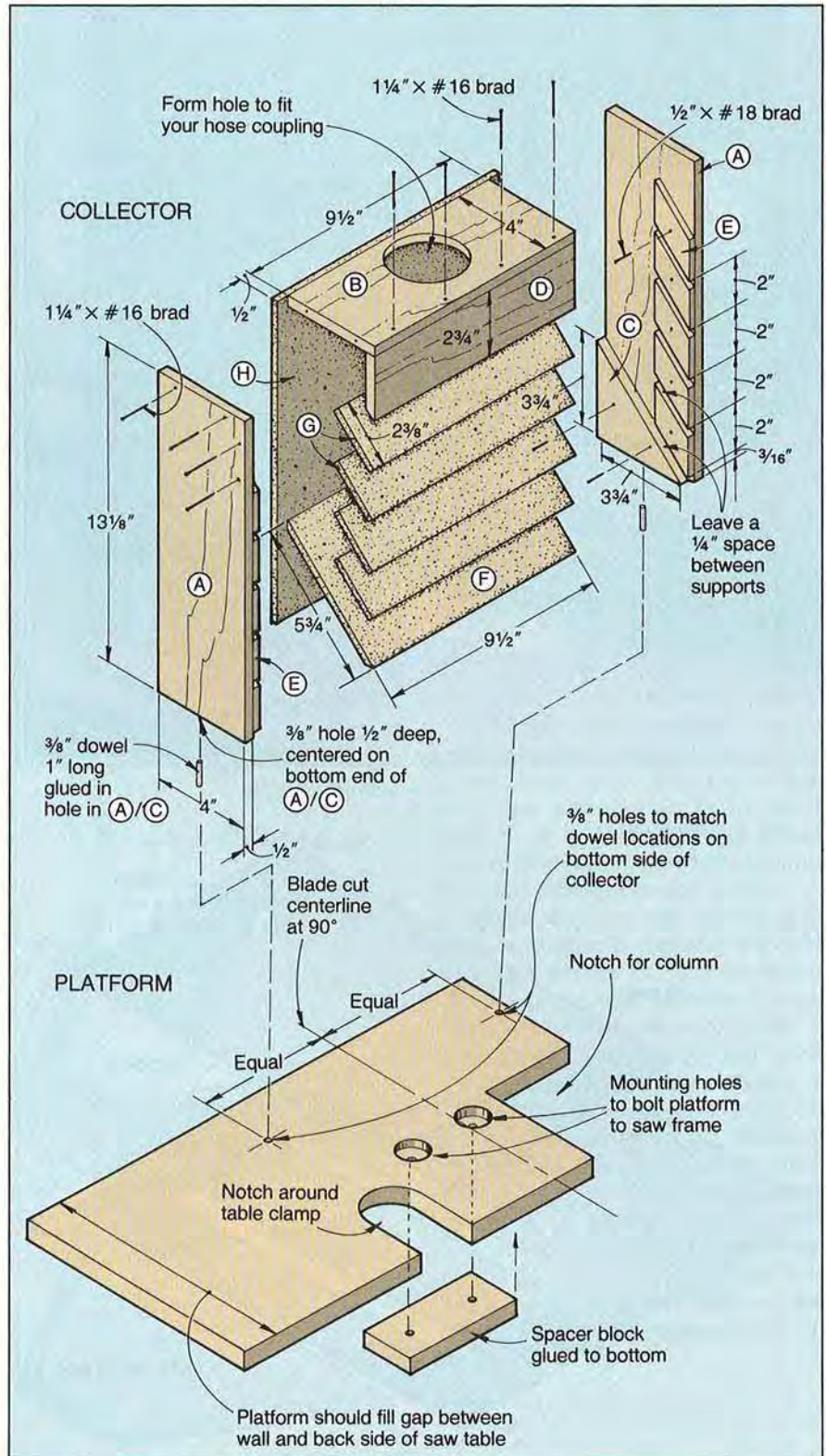
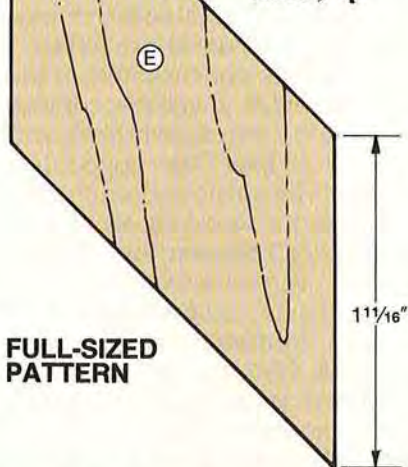

# THE PORTABLE

Attention portable planer owners! If you'd rather spend more time woodworking and less time sweeping up the shop, let this homemade helper come to your rescue. It's our simple-to-make hood that attaches to the rear of your thickness planer and connects to a central dust-collection system or portable shop vacuum. Finally, you can gather your shavings at big savings!

*Note:* We sized our hood to fit a Ryobi AP-10 portable planer, but you can alter the dimensions and  $\frac{1}{4}$ " mounting hole locations to fit the model you own.

To set up a dust-collection system for your shop, see page 40.

 Print this article

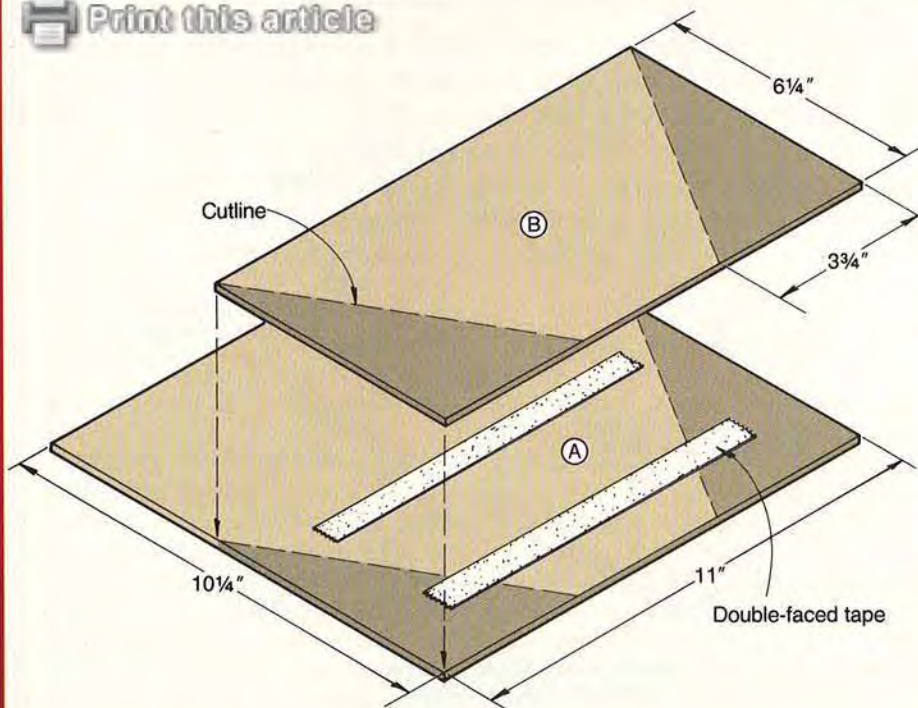

## First, cut the hood pieces

**1** Cut one piece of  $\frac{1}{8}$ " stock to  $10\frac{1}{4} \times 11$ " for the top (A) and another to  $6\frac{1}{4} \times 11$ " for the bottom (B). (We used plywood, but tempered hardboard also would work.) With the edges and one end flush, use double-faced tape to adhere the pieces face-to-face.

**2** Using the dimensions on the drawing at left, mark the cutlines on part B. Bandsaw the hood parts to shape. (We sawed just outside the cutlines, and then sanded to the lines on a stationary belt sander.) Separate the pieces, and remove the tape.

**3** Mark the dust-collection hole and mounting-hole centerpoints on part A. (Because we connected our hood to a whole-shop dust collection system that uses 4" PVC pipe [ $4\frac{1}{4}$ " outside diameter], we

# DUST STOPS STOPS STOPS HERE HERE HERE

## PLANER HOOD

cut a 4¼" dust-collection hole. If you're making the hood for a portable shop vacuum, work off the outside diameter of the plastic adapter at the end of the hose.)

**4** Using a circle cutter in your drill press, center the pilot bit over the marked dust-collection hole centerpoint, and cut the hole in the hood top (A). You also could drill a blade-start hole, and cut the dust-collection hole with a scrollsaw. Finally, switch bits and drill a pair of ¼" mounting holes where shown.

**5** Referring to the dimensions in the Bill of Materials and on the Exploded View drawing, cut the sides (C) and end (D) to size from ¾"-thick stock, beveling the ends of each at 30°.

### Now, let's construct the dust-collector port

**1** Cut a 6" square from ¾"-thick stock for the dust-collector port (E). Mark diagonal lines on the square to find its center.

**2** Next, mark a circle on the blank, using the dimensions for the dust-collection hole cut earlier. Mark a second circle ¾" to the outside of the first.

**3** Drill a blade-start hole and cut just inside the marked inner circle with a scrollsaw or jigsaw. (A circle cutter also works.) After making the cut, sand to the line with a drum sander mounted in a drill press. Check the fit of the PVC pipe or hose adapter in the hole; it should fit snugly. Cut the outside circle to shape on the band-saw and sand smooth.

**4** Rout a ⅜" round-over along the top outside edge of the collection port where shown in the drawing at right.

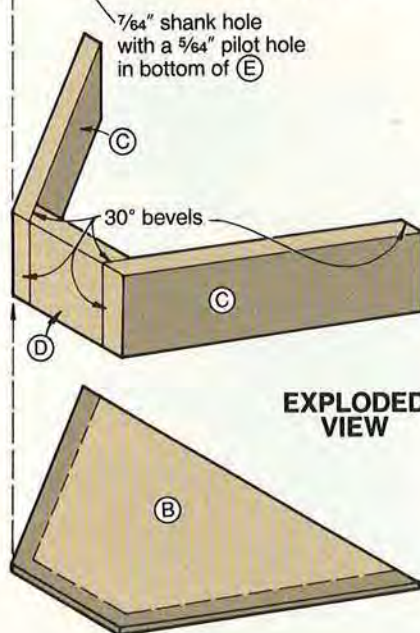
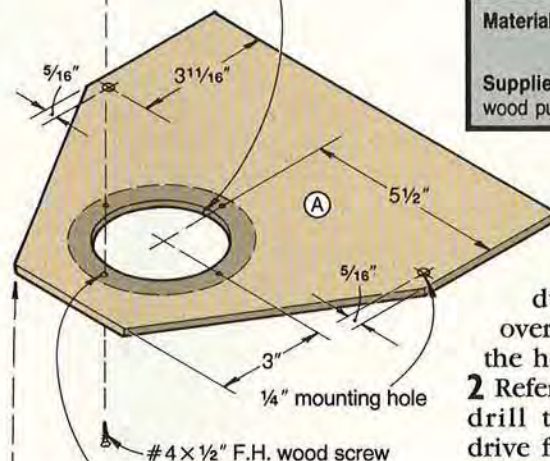
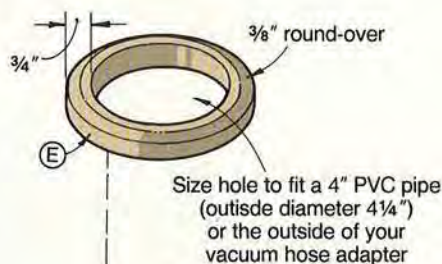

Bill of Materials					
Part	Finished Size			Mater.	Qty.
	T	W	L		
A top	1/8"	11"	10 1/4"	PW	1
B bottom	1/8"	11"	6 1/4"	PW	1
C sides	1/2"	2 1/4"	7 5/8"	P	2
D end	1/2"	2 1/4"	3"	P	1
E port	3/4"	5 3/4"	5 3/4"	PW	1

Material Key: PW-plywood or hardboard, P-pine

Supplies: #4 x 1/2" flathead wood screws, wood putty, sanding sealer, paint.

### It's time to assemble the parts

**1** Glue and clamp the dust-collection port centered over the dust-collection hole in the hood top (A).

**2** Referring to the drawing at left, drill the mounting holes and drive four #4 x 1/2" flathead wood screws through the hood top and into the dust-collection port.

**3** Spread glue on the mating surfaces, and glue and clamp the side and end pieces (C, D) between the hood top and bottom. Check that the outside edges are flush.

**4** Fill gaps with putty and sand the hood smooth. To achieve a glassy finish, apply two coats of lacquer sanding sealer, sanding between coats with 220-grit sandpaper. Apply several coats of spray enamel (we applied four).

**5** Remove the outfeed hood from your planer and set it aside. Use the screws from the hood to fasten the dust-collector hood to your planer. 🛠️

Project Design: James R. Downing  
Photograph: John Hetherington  
Illustrations: Jamie Downing

# HIGH-FLYING BALLOON MOBILE

To “air” is human, to turn these balloons, divine. We’ve turned several, and developed a helpful clamping jig to simplify the laminating process. We also used an auxiliary faceplate to turn the basket. Even after you’ve completed this project, you’ll find these two shop aids helpful.

*Note: The instructions explain how to make the checkered-pattern balloon. Repeat the lamination process aligning the pieces differently to form the top two balloons as in the photo at right.*

## First, form each layer with miter-cut pieces

**1** Cut a piece of  $\frac{3}{4}$ " walnut and a piece of  $\frac{3}{4}$ " maple to  $1\frac{1}{2} \times 40$ ".

**2** Set the miter gauge on your table saw  $30^\circ$  from center, and cut 15 pieces of each species to the shape shown on the Block detail on the opposite page. (We attached a wooden auxiliary fence to our miter gauge, and then clamped a stop to the fence for consistent lengths. We test-cut six scrap pieces to verify the angle.)

**3** Alternate and clamp pieces of walnut and maple, as shown on the drawing on the opposite page. The setup shown helps keep the top and bottom surfaces flush. Use a rubber band to hold the pieces. Then, switch to a band clamp to hold the pieces firmly together. (We placed waxed paper between the particleboard discs and the lamination to prevent them from bonding.) Repeat for each of the five remaining layers.

**4** If necessary to flatten surfaces, lightly sand the top and bottom surfaces of each layer (we did this on a stationary sander).

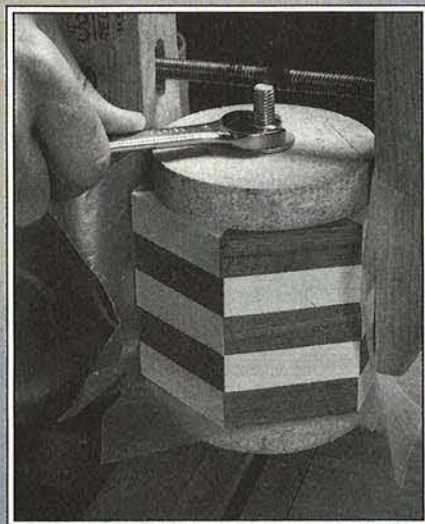

Glue and align the individual laminated layers, and then tighten the  $\frac{3}{8}$ " nut to clamp the layers together.



## The clamping jig helps laminate the layers

1 Spread glue on the mating surfaces. Carefully align the joint lines, and clamp the layers together, using the clamping device.

2 From  $\frac{3}{4}$ " stock, cut four maple discs  $4\frac{1}{8}$ " in diameter. Drill a  $\frac{1}{16}$ " hole centered in each disc. Glue and clamp two discs centered on the top and two centered on the bottom of the lamination.



With the balloon lamination mounted between centers, turn balloon to shape.

## Let's move to the lathe and have some fun

1 Transfer the balloon template pattern shown at right to poster board. Cut the template to shape with an X-acto knife.

2 Mount the balloon between centers on your lathe, using the  $\frac{1}{16}$ " holes in the ends of the lamination to center the headstock and tailstock spindles. Turn the balloon to shape, using the template as a guide. (We used a  $\frac{3}{8}$ " gouge and a  $\frac{1}{2}$ " round-nosed scraper. See the photo above).

3 Sand the balloon. Using a parting tool, part the bottom (basket end) of the balloon from the lathe. Use a hand saw to trim the tenon from the balloon top. Contour-sand the balloon top.

4 Cut a 3" hole in a 1"-thick piece of scrap stock. Place a piece of cloth over the hole, and place the balloon over the hole, as shown in the drawing on the next page. Position the balloon and support under your drill press, and bore a  $\frac{3}{4}$ " hole, centered on the  $\frac{1}{16}$ " hole

*Continued*

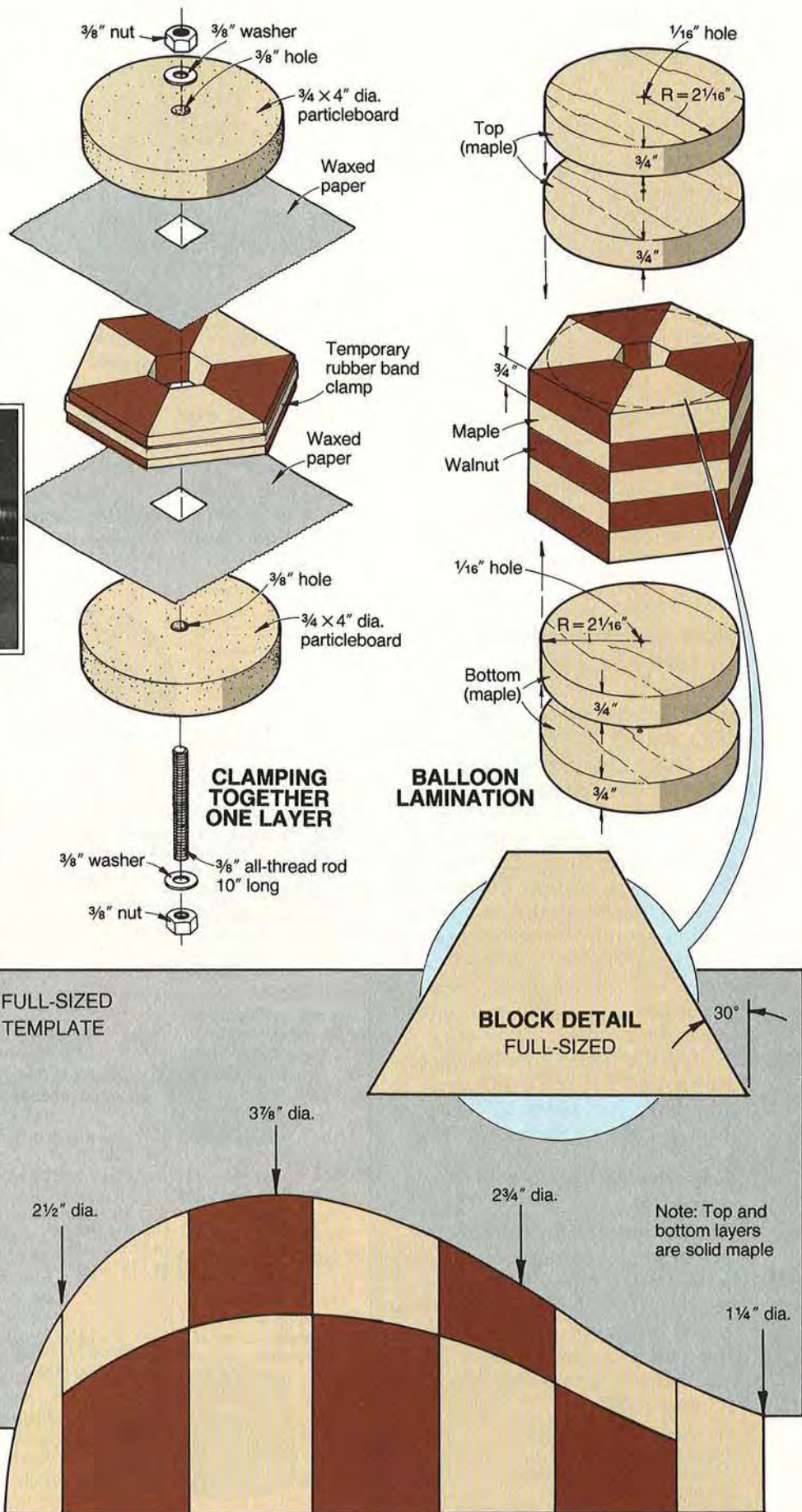



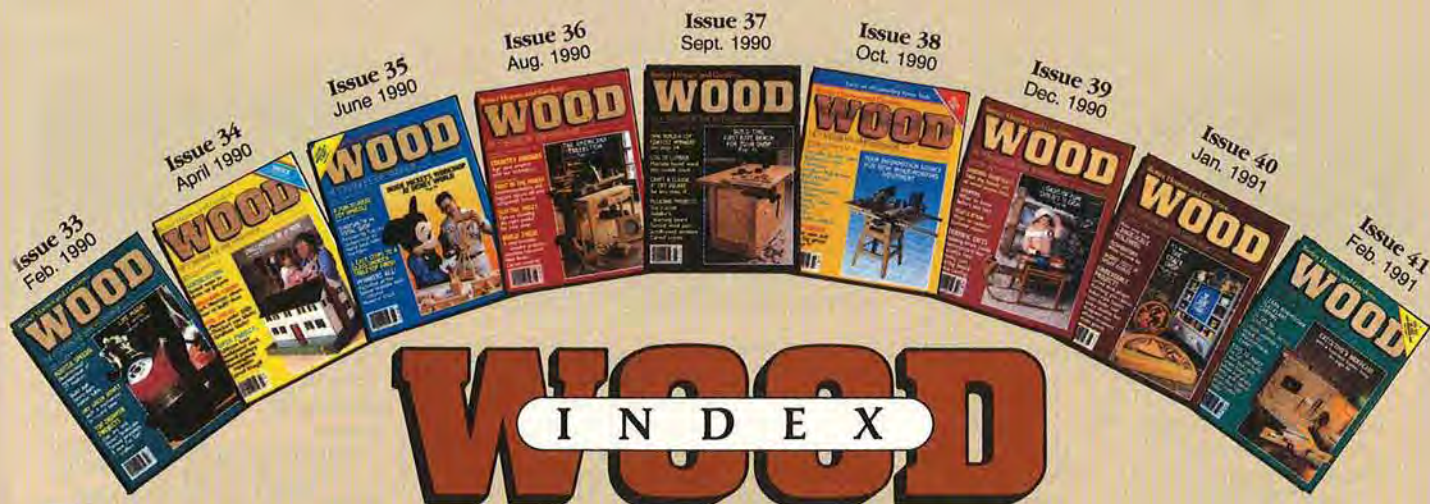

# WOOD

## I N D E X

 **Print this article** Cumulative index for issues 33-41

If you save back issues of **WOOD**® magazine, this index will help you quickly find articles in issues 33-41. You can pull it out easily from the magazine's center. We kept it simple. For instance, after the listing "Painted finishes," you'll find the numbers 36:46-50. This means the article

appears in issue 36, pages 46-50. The Project index is on page 55. The index for issues 1-8 appeared in issue 9 (February 1986), 9-16 in issue 17 (June 1987), 17-24 in issue 25 (October 1988), and 25-32 in issue 34 (April 1990). A cumulative index for issues 1-30 is available for \$4.95, (Canada, \$5.95).

### A-C

**Abrasives. See also Sanders and sanding for sandblasting, 34:36**  
**Air compressors:**  
 as dust blower, 38:24; 40:11  
 maintaining, 34:76, 78  
**Air filters, 36:28**  
**Alder, 37:8**  
**Apron, turtleneck, 36:26-27**  
**Arizona Woodturners Association, 41:62-63**  
**Ball, sawing in half, 39:27**  
**Bandsaws, 38:50-53**  
 blades for, 35:8, 38:50  
 dovetail jig for, 35:13  
 extension table for, 41:15  
 safety with, 37:73  
**Bar clamps, 41:56-57**  
 one-hand, 33:85  
**Bark removal, 34:100; 39:13**  
**Baseball bats, 39:74**  
**Basswood, 38:96**  
**Bearings for rollers, 41:8**  
**Belt sanders:**  
 portable, 38:74-77; 39:64, 66  
 clamping stock for, 34:22  
 homemade belts for, 37:82  
 stationary, 39:64-66  
 cover for, 36:14  
 dust collector for, 38:21  
 safety with, 37:72  
**Bending form, 39:49**  
**Bins, storage, 35:16**  
**Birch, yellow, 39:33-34**  
**Biscuit (plate) joinery, 36:14**  
 with router, 33:38  
**Bluegill, carved, 34:74**  
**Board jack, workbench, 37:86**  
**Bolts:**  
 carriage, no-slip, 38:18  
 hanger, installing, 33:25  
**Books, library loan of, 37:12**  
**Bowed psaltery, 34:68-73**

**Bowls:**  
 dough, 41:25-29  
 green, microwave, 33:46-49  
 sanding, 36:16  
 stack-laminated, 38:15  
 stave, chart for, 36:13  
**Boxes:**  
 lids, cutting off, 35:18  
**Buffer, paint roller as, 40:14**  
**Build-A-Toy contest, 37:54-59,**  
 80-81; 38:78-79  
**Bullnose profile, 40:42**  
**Business-card case, 39:40-41**  
**Butternut, threat to, 34:100**  
**Buymanship, 38:30-77; 40:8,**  
 11, 13  
 bandsaws, 38:50-53  
 belt sanders, 38:74-77  
 circular saws, 38:30-33  
 clamps, 41:56-59  
 drill/drivers, cordless,  
 38:42-45  
 drill presses, 38:46-49  
 drills, electric, 36:66-71  
 Forstner bits, 41:72-73, 89  
 jointers, 38:66-69  
 lathes, 38:70-73  
 multipurpose machines,  
 35:35-39  
 planers, 34:64-67; 38:54-57  
 radial-arm saws, 38:34-37  
 routers, 33:64-70; 38:62-65  
 scrollsaw blades, 34:56-57  
 scrollsaws, 38:58-61  
 shapers, 39:56-61  
 spray enamel, 40:58-59  
 tablesaws, 38:38-41  
 thin-kerf blades, 34:44-45  
 vises, 37:42-45  
**Cabinet, hanging, 33:27**  
 spoon/thimble, 35:68-71  
**Calculators, protecting, 36:19**  
**Calipers, wrench as, 36:16**  
**Canoes, bark, 34:29-33**  
**Carriage bolts, no-slip, 38:18**

**Carvers:**  
 Alvarez, Max, 37:36-39, 78  
 Beyer, Rick, 34:74  
 Boomer, Bob, 40:27-31  
 Pinske, Barry, 33:104  
 Porter, Lindel, 36:74-75  
 Ransom, Ron, 39:78; 41:11  
 Refsal, Harley, 41:30-33, 83  
**Carving:**  
 animals, 37:36-39, 78  
 bluegill, 34:74  
 cardinal, 36:74-75  
 chainsaw, 33:104  
 competition, 33:104; 39:104  
 cupping of wood and, 38:13  
 duck wall plaque, 40:34-37  
 grinder tool for, 36:24  
 Norwegian bachelor farmer,  
 41:30-33, 83  
 safety, 37:70  
 Santa, 39:78; 41:11  
 sidelighting, 33:20  
 walking sticks, 33:58-61  
 Cedar of Lebanon, 41:22  
**Chainsaw carving, 33:104**  
**Cherry, black, 40:25-26**  
 coloring, 34:8  
**Children:**  
 safety, 39:13  
 wood classes, 40:52-53  
**Chucks:**  
 drill, 36:69  
 lathe, 37:28; 39:20  
**Circle cutter, using, 35:40-43**  
 safety, 36:22  
**Circles, making:**  
 with disc sander, 35:16  
 large, compass for, 33:24  
 router template for, 33:34-35  
**Circular saws, portable, 37:71;**  
 38:30-33; 41:9  
**Clamps, 41:56-60**  
 blocks for, 38:18  
 diagonal use of, 37:20  
 framing, Workmate as, 40:14

**Clamps continued**  
 handscrew, 34:22; 35:74-76;  
 37:8; 41:57-58  
 on corners, 36:14; 38:18  
 one-hand, 33:85  
 pipe, 41:56-57  
 for breaking joints, 38:14  
 elevated, 40:16  
 shims for, 34:16  
 to hang cabinets, 33:27  
 strap, 34:18; 41:58  
**Clip art books, 34:84**  
**Cocobolo, 33:33; 37:12**  
**Collectibles, showcase for,**  
 35:68-71  
**Collectible tools, 41:96**  
 combination holders, 38:81  
 hammers, 37:87  
 try squares, 36:80-81  
**Combination machines, 35:**  
 35-39  
**Compass, large-circle, 33:24**  
**Compressors:**  
 as dust blower, 38:24; 40:11  
 maintaining, 34:76, 78  
**Computer systems in home-**  
 centers, 33:30  
**Contour sanding, 37:26; 40:18**  
**Corners:**  
 mitered, clamping, 36:14;  
 38:18  
 sanding, 39:65  
**Cottonwood, 37:31-32**  
 animal carvings, 37:36-39  
**Countersink bits, 36:28; 39:16**  
**Country finishes, 36:46-50**  
**Country projects, 36:33-45;**  
 40:68-69, 86; 41:66-67  
**Coves, cutting, 40:39-41**  
**Crackled finish, 36:48-49**  
**Craftsman Close-ups:**  
 animal carvings: Max  
 Alvarez, 37:36-39  
 bark, canoes: Jack Minchart,  
 34:29-33

*Continued*



**Try square**  
Issue 37  
Page 33

**Santa carving**  
Issue 39  
Page 78



**Duck wall plaque**  
Issue 40  
Page 34



**Craftsman Close-ups continued**

dough bowls: John Sadler, 41:25-29  
furniture restoration: Jim Watson, 39:68-71  
manzanita carvings: Bob Boomer, 40:27-31  
prison-industries furniture: P.J. Jeter, 36:62-65  
trucks, model: Karol Fedoryshyn, 35:52-55  
walking sticks: Theo Fossel, 33:57-61  
Curves, drawing, with hacksaw blade, 33:22

**D-E**

Dadoes:  
enlarging, 38:24  
stop blocks for, 36:23  
Decoys, 39:76  
Dentil profile, 40:43  
Dents, raising, 41:15  
Depth gauge, router-table, 38:20  
Desert landscape, 33:62-3  
Desk, tambour-topped, 33:14  
Diameters, gauge for, 41:17  
Disc sanders, 39:64-66  
circles made with, 35:16  
clamping paper on, 36:22  
removing paper from, 34:16  
tablesaw as, 38:22-23  
Disney World, Orlando, Florida, 35:56-59  
Doors:  
rabbeted frames, 33:38-39  
raised-panel, 36:72-73  
Double-faced tape, loosening, 35:16  
Dough bowls, 41:25-29  
Dovetail jig, bandsaw, 35:13  
Dowels:  
chamfering, 39:66  
grooving, 34:16; 39:16  
jig for making, 39:30  
shrinking, 37:18  
Driftwood, 41:70-71  
Drill bits:  
countersink, 36:28; 39:16  
Forstner, 33:25; 41:72-73, 89  
screw-hole, 41:20-21  
spade, sharpening, 40:18  
Drill, cordless, 38:42-45  
Drill presses, 38:46-49  
hold-downs for, 36:19  
loosened handles, preventing, 37:16  
multipurpose machines, 35:38  
safety with, 37:72  
speed, posting, 38:22-23  
steel drilled with, 33:10  
table, auxiliary, 40:14

Drills:  
as buffing wheel, 40:14  
buymanship, 36:66-71; 38:42-45  
Drivers, cordless, 38:42-45  
Duck calls, 37:12; 39:76  
Dust blower, air compressor as, 38:24; 40:11  
Dust collectors, 38:57  
air filter, 36:28  
lathe, use with, 34:21  
OSHA standards, 40:96  
power controller for, 33:88  
for sanders, 38:21; 39:67  
Easel, tabletop, 34:14; 36:11; 38:11  
Edge-straightening jig, 37:16  
Emergency chart, 37:96  
Enamel spray paint, 40:58-59  
Engine, wooden, 35:96  
Environmental concerns, 36:7  
about finishes, 34:43, 92; 39:7, 72-73  
vs. logging interests, 33:12; 36:57-61; 39:8; 40:72  
Epoxy, 35:21; 36:24  
Extension tables, 37:83; 41:14, 15

**F-G**

Fences, saw:  
aftermarket, upgrading with, 38:41  
auxiliary-fence jig for, 39:20  
holder for, 36:20  
smooth ripping with, 38:26  
stops for, 35:19  
cam-action, 38:17  
Finishes and finishing:  
cherry, coloring, 34:8  
country, 36:46-50  
environmental concerns, 34:43, 92; 39:7, 72-73  
for guitars, 41:52-53  
legs, furniture, 35:16  
from nut oils, 36:24  
polyurethane:  
for curing wood, 33:86  
glass-smooth, 35:50-51  
salad bowl finish, removing odor of, 35:28  
shoe polish as, 41:11  
small parts, 34:19; 41:12  
spray enamel, 40:58-59  
stain, 37:82  
colored, 34:10  
tung oil varnish, 37:14  
turntable for, 38:28  
water-based, 34:92; 39:7  
lacquers, 34:42-43  
First-aid chart, 37:96  
Fish (bluegill), carved, 34:74  
Fishing equipment, 39:77  
Flush-trimming jig, 33:29

Forests, logging in, debate, 33:12; 36:57-61; 39:8; 40:72  
Forstner bits, 41:72-73, 89  
centering, 33:25  
Found wood:  
driftwood, 41:70-71  
machining, 37:60-63  
4-H wood-science projects, 34:10  
Frames:  
door, rabbeted, 33:38-39  
picture, self-hanging, 34:22  
Framing clamp, Workmate as, 40:14  
Furniture, *See also* Finishes and finishing  
candlestand, 36:40-42  
dry sink, 33:40-45; 36:11  
prison-industries, 36:62-65  
restoring/repairing, 38:22-23; 39:68-71; 40:8  
settee, solid-oak, 35:60-67  
sofa table, 36:34-37  
Southwestern, 37:40-41  
Stickley, 34:100  
Glass, sandblasting, 34:35-37  
Glue:  
for dark wood, 34:88  
epoxy, 35:21; 36:24  
hotmelt gun, 36:25  
Golf clubs, 39:75  
Greenheart, 38:88  
Green wood, drying, 33:46-49, 86; 37:63  
Grinders:  
safety with, 37:71  
speed for, 35:26  
woodcarver mounted on, 36:24  
Guide bushings, 35:9  
Guitars, Martin, 41:47-53

**H-I**

Hacksaw blade, drawing curves with, 33:22  
Hammer drills, cordless, 38:45  
Hammers, collectible, 37:87  
Handscrew clamps, 35:74-76; 37:8; 41:57-58  
for edge sanding, 34:22  
Hanger bolts, installing, 33:25  
Hardwood HELPLINE, 36:96  
Hemlock, 33:10  
Hinge screw holes, 39:25  
Hold-downs, 34:16, 18; 36:19  
knobs, turned, 40:22  
Holes:  
Forstner bits for, 33:25; 41:72-73, 89  
in hollow turnings, 38:18  
in post center, 35:26; 38:11  
routing, 33:34-35; 38:20  
Hotmelt glue gun, 36:25  
34:58-59; 40:66-67

Hurricane Hugo, wood  
downed by, 35:96; 41:96  
Indexing jig, 40:43  
Intarsia:  
video about, 36:96  
wall plaque, 41:64-65  
International Wood Collector's Society, 37:83

**J-M**

Jack, workbench, 37:86  
Jewelry:  
bracelets, turned, 33:71  
necklace, 37:76; 40:13  
Jigs:  
for angled ripping, 38:28  
auxiliary-fence, 39:20  
ball-halving, 39:27  
box-joint, 41:42  
clamping, 36:14  
dovetail, for bandsaw, 35:13  
dowel-chamfering, 39:66  
dowel-grooving, 34:16; 39:16  
dowel-making, 39:30  
edge-straightening, 37:16  
flush-trimming, 33:39  
louver, for router, 33:35-37  
for moldings, 40:39, 43  
picture-hanging, 39:23  
screws for fastening, 41:10  
scrollsaw-blade-changing, 35:18  
shooting box, 37:61-62  
V-block, 39:43  
Jigsaws:  
with click-in blades, 36:51  
work support for, 34:21  
Jointers, 38:66-69  
planers with, 38:56-57  
safety with, 37:73  
Joints and joinery:  
box, jig for, 41:42  
dovetail, jig for, 35:13  
loose, correcting, 38:26  
plate (biscuit):  
gauges for, 36:14  
with router, 33:38  
pulling apart, 34:8; 38:14  
sanding, 39:64  
Knobs, hold-down, 40:22  
Lacquers:  
for guitars, 41:52-53  
water-based, 34:42-43  
Landscape, desert, 33:62-63  
Laser cutting, 37:74-75  
Lathes, 38:70-73; 40:13  
chips, collecting, 34:21  
chucks for, 37:28; 39:20  
Delta plan to promote, 37:88  
parts, price list for, 33:16  
working on. *See* Turning  
Level, electronic, 37:29  
Library loans, 37:12





**Hummingbird  
plaque**  
Issue 34  
Page 58

**Fat Cat<sup>™</sup>  
trucks**  
Issue 33  
Page 72



**Portable  
sanders**  
Issue 38  
Page 74



License plates, Woody, 38:16  
Lighting for carving, 33:20  
Lignum vitae, 40:23  
Limed finish, 36:49  
Logging:  
bark removal, 34:100; 39:13  
and environment, 33:12;  
36:57-61; 39:8; 40:72  
Louvers, making, 33:35-37  
Mahogany look-alike, 37:90  
Mail-order products, 35:72-73  
Manufacturers, tool. See Tool  
companies  
Manzanita, 39:104  
carvings, 40:27-31  
Maple, sugar, 36:31-32  
Marquetry, 41:86  
Measuring:  
adhesive-backed tape, 36:24  
saw fence marked for, 35:19  
wrench as calipers, 36:16  
Microwaves:  
drying wood in, 33:46-49  
shrinking dowels in, 37:18  
Mils, 36:13  
Miter gauge holder, 36:20  
Miter joints:  
clamping, 36:14; 38:18  
sanding, 39:64  
Moldings, large-scale, 40:38-43  
Motors:  
for multiple tools, 41:12  
overheating, 34:12; 36:12  
Multipurpose machines, 35:  
35-39  
Musical instruments:  
guitars, Martin, 41:47-53  
psaltery, bowed, 34:68-73

## N-P

Nail holes, plugs for, 39:20  
Norwegian bachelor farmer,  
carved, 41:30-33, 83  
Nuts:  
cap (acorn), 35:9  
wing, custom-made, 33:20  
Oak, red, northern, 34:27-28  
Ohm's law, 34:12  
Old-growth forests, 36:57-61;  
40:72  
Old Hand Ways (Underhill),  
38:84-85; 40:74-75  
Painted finishes, 36:46-50  
spray enamel, 40:58-59  
Panels, raised, made with  
tablesaw, 36:72-73  
Patterns:  
clip art books, 34:84  
photocopy, 33:20; 38:11, 21  
protecting, 37:23  
small templates, 38:26  
from WOOD, 34:8; 36:10  
Pegboard hook fasteners,  
36:26-27

Persimmon, 41:85  
Photocopies:  
of patterns, 33:20; 38:11, 21  
of plans, posting, 37:20  
Picture frames, hanging, 34:22  
Picture-hanging jig, 39:23  
Planers, thickness, 38:54-57  
extension tables for, 41:14  
portable, 34:64-67  
safety with, 37:72-73  
for thin stock, 33:22  
Plaques, wall:  
balloon, 41:64-65  
duck, carved, 40:34-37  
hummingbird, 34:58-59  
Plate (biscuit) joinery:  
gauges for, 36:14  
with router, 33:38  
Plugs:  
aligning, 40:16  
for nail holes, 39:20  
Plunge-router buymanship,  
33:64-70; 38:62-65  
Plywood:  
Asian, 35:96; 37:68-69  
for door harps, 35:28  
safe cutting of, 37:71-73  
sealing edges of, 35:26  
Polyurethane finish:  
for curing wood, 33:86  
glass-smooth, 35:50-51  
Post, center hole, 35:26; 38:11  
Power controller, 33:88  
Power tools. See also Buyman-  
ship; Safety; Drill  
presses; Drills; Grinders;  
Lathes; Planers; Routers;  
Saws  
air-compressor maintenance,  
34:76, 78  
limited number, use of,  
41:84  
motor shared by, 41:12  
plate-joiner gauges, 36:14  
sanders. See also Belt  
sanders; disc sanders  
random-orbit, 36:51;  
39:65  
storage for, 41:16, 54-55  
Prison-industries furniture,  
36:62-65  
Psaltery, bowed, 34:68-73  
Pulleys, tablesaw, 36:26-27  
Pushblocks as sanding blocks,  
40:18  
Putty, wood, 34:86

## Q-S

Quizzes, 37:70-73; 41:78  
Rabbeted doors, 33:38-39  
Radial-arm saws, 38:34-37  
fence stops for, 35:19; 38:17  
safety with, 37:10, 72;  
38:34-35; 40:20

*Radial-arm saws continued*  
smooth rips with, 38:26  
Raised panels, 36:72-73  
Random-orbit sanders, 36:51;  
39:65  
Red-oak, northern, 34:27-28  
Relief-carved plaque, 40:34-37  
Resawing, 41:76  
Respirators, 40:32-33, 84  
Round-overs, cutting, 40:41-42  
Routers:  
basic tips for, 37:77  
buymanship, 33:64-70;  
38:62-65  
cleaning collets on, 33:27  
depth gauge for, 38:20  
dowel-making jig for, 39:30  
guide bushings, 35:9  
holes cut, 33:34-35; 38:20  
plunge, 33:64-70; 38:62-65  
safety, 37:70-71, 77; 41:9  
speed control, 34:12; 36:12  
stile-and-rail cutters, 34:88  
table for, 33:50-56, 68;  
36:10; 37:16; 38:8  
techniques with, 33:34-39

Sabacu, 37:90  
Safety, 37:70-73; 41:9  
with children in shop, 39:13  
circle cutter, 36:22  
circular saw, 37:71; 38:33;  
41:9  
compressor, 38:24; 40:11  
emergency chart, 37:96  
radial-arm saw, 37:10, 72;  
38:34-35; 40:20  
respirators, 40:32-33, 84  
router, 37:70-71, 77; 41:9  
Sandblasting, 34:34-39  
wall clock, 34:40-41  
Sanders and sanding, 39:62-67  
belt. See Belt sanders  
blocks, 38:20; 39:65, 66-67;  
40:18  
bowls, turned, 36:16  
contour, 37:26; 40:18  
disc. See Disc sanders  
random-orbit, 36:51; 39:65  
steel wool sheets for, 35:14  
Sandpaper, 39:62-63  
by sander type, 39:64-65  
for templates, 38:26

## PROJECTS

Balloon plaque, 41:64-65  
Bird feeder, 36:76-78  
Bluegill, carved, 34:74  
Bracelets, turned, 33:71  
Briefcase, 41:40-46  
Business-card case, 39:40-41  
Cabinets, wall-hung, 35:  
68-71; 40:44-51; 41:74-76  
Candle box, 36:38-39  
Candlestand, 36:40-42  
Cardinal, carved, 36:74-75  
Cassette rack, 39:54-55  
Castle, block, 39:36-39  
Center finder, 40:60-61, 80  
Chisel rack, 41:19  
Clocks, wall:  
country, 36:44-45  
sandblasted, 34:40-41  
Coyote, carved, 37:78  
Cutting board, 39:46-47  
Desert landscape, 33:62-63  
Dollhouse, in box, 34:46-48,  
53-55  
Door harp, 41:68-69  
Dry sink, 33:40-45; 36:11  
Duck plaque, 40:34-37  
Fat Cat<sup>™</sup> toys:  
excavator, 36:52-56  
front-end loader, 41:34-37  
trailers, 33:72-76  
Fence stop, cam, 38:17  
Flowers, turned, 41:61  
Gun cabinet, 40:44-51  
Handscrew clamps, 35:74-76

Hummingbirds, scrollsawed,  
34:58-59; 40:66-67  
Jack, workbench, 37:86  
Jewelry case, 39:42-45  
Lathe tool rack, 35:80  
Learning board, 37:58-59  
Napkin holder, goose, 41:  
66-67  
Necklace, 37:76; 40:13  
Norwegian bachelor farmer,  
carved, 41:30-33, 83  
Psaltery, bowed, 34:68-73  
Pushstick, 34:60-61  
Puzzle, relief, 40:70-71  
Router table, 33:50-56; 38:8  
Santa, carved, 39:78; 41:11  
Scrollsaw-blade organizer,  
34:80  
Settee, solid-oak, 35:60-67  
Shadow box, country,  
40:68-69, 86  
Shaker oval carrier, 40:54-57  
Sleigh, child's, 39:48-53  
Table, sofa, 36:34-37  
Tablesaw base, 34:60-63  
Tool cart, 41:54-55  
Tractor, toy, 37:56-57  
Truck, monster, 35:46-49  
Try square, 37:33-35  
Vase, split-turned, 40:64-65,  
88  
Wall box, 36:43  
Weed pots, turned, 37:64-67  
Workbench, 37:46-53

*Continued*



**Turned  
bracelets**  
Issue 33  
Page 71



**Country  
clock**  
Issue 36  
Page 44



**Center  
finder**  
Issue 40  
Page 60

Saw blades. **See also**  
Scrollsaws: blades  
bandsaw, 35:8; 38:50  
thin-kerf, 34:44-45; 39:30-31  
Sawdust in gardens, 38:14  
Saws. **See also** Bandsaws;  
Radial-arm saws;  
Scrollsaws; Tablesaws  
circular, portable, 37:71;  
38:30-33; 41:9  
guide for, 35:22, 36:51  
work support for, 34:21  
Scrapers, 37:27  
Screw chuck, 37:28  
Screwdrivers:  
cordless, 38:42-45  
offset, 35:19; 39:31  
Screw holes:  
drill bits for, 41:20-21  
hinge, 39:25  
Screws:  
loosening, 36:20  
square-drive, 35:8; 38:15  
steading, 37:16  
Scrollsaws, 38:58-61  
blades, 34:56-57; 41:38  
holders, 38:58-59  
jig for changing, 35:18  
organizer for, 34:80  
pins, 41:12  
Delta #40-560, 41:88  
improving skills, 41:38-39  
projects with, 34:58-59;  
37:76; 40:66-67, 70-71  
small parts cut with, 35:21;  
37:18; 41:18  
wheels made with, 35:42-43  
Seascape puzzle, 40:70-71  
Shapers, 39:56-61  
Sharpening stones, 34:88  
Shop skills:  
router basics, 37:77  
scrollwork, 41:38-39  
Shopsmith vs. Total Shop,  
35:35-39  
Shop-tested techniques:  
country finishes, 36:46-50  
found wood, machining,  
37:60-63  
large moldings, 40:38-43  
router tricks, 33:34-39  
sandblasting, 34:34-39  
sanding shortcuts, 39:62-67  
wheels, making, 35:40-45  
Sofa table, 36:34-37  
Southwest-style furniture,  
37:40-41  
Spade bits, sharpening, 40:18  
Spattered finish, 36:48  
Speed controllers, router,  
34:12; 36:12  
Split-turned vase, 40:64-65, 88  
Spoon cabinet, 35:68-71  
Sports, wood in, 39:74-77

Spray finishes:  
enamel, 40:58-59  
turntable for, 38:28  
Square-drive screws, 35:8;  
38:15  
Stack-laminated bowls, 38:15  
Stains, 37:82  
colored, 34:10  
Stave construction, 36:13  
Steel wool sheets, 35:14  
Stickley furniture, 34:100  
Stickmaker, 33:57-61  
Stile-and-rail cutters, 34:88  
Storage:  
bins, 35:16  
scrollsaw-blade, 34:80  
tablesaw-accessory, 36:20  
tool carts, 41:16; 54-55  
tool racks, 35:80; 41:19  
Straightedge, 41:16  
Strap clamps, 41:58  
with pressure pedal, 34:18

### T-V

Tablesaws, 38:13, 38-41; 40:13  
accessory holders, 36:20  
base for, 34:60-63  
carrier, adjustable, 38:28  
dado cuts on, 36:23  
as disc sander, 38:22-23  
extensions for, 37:83  
moldings cut with, 40:38-43  
pulleys for, 36:26-27  
safety with, 37:72-73  
Taiwanese, 34:14  
tilting arbors, 41:85  
Tambour-topped desk, 33:14  
Tape, use of:  
double-faced, 35:16  
masking, 41:14  
Templates, 39:20  
circle, for router, 33:34-35  
for curves, 33:22  
Thimble cabinet, 35:68-71  
Thin-kerf saw blades, 34:  
44-45; 39:30-31  
Tool companies, 33:14; 34:92  
Bosch, new tools from,  
36:51  
computer centers, 33:30  
Delta, 34:14; 37:88; 40:96  
scrollsaw, 41:88  
directory of, 38:82-83  
mail-order firms, 35:72-73  
Penn State Industries, 40:8  
Tools. **Also See** Clamps; Power  
tools  
antique, 40:74-75, 96; 41:96  
combination, 38:81  
hammers, 37:87  
try squares, 36:80-81  
center finder, 40:60-61, 80  
chisels, rack for, 41:19  
compass, large-circle, 33:24

### Tools continued

level, electronic, 37:29  
mail-order, 35:72-73  
scrapers, 37:27  
sharpening stones for, 34:88  
try squares, 36:80-81;  
37:33-35, 41:17  
turning, 37:64  
rack for, 35:80  
small, 34:86  
vises, 37:42-45  
blocks for, 36:25  
Toys:  
castle blocks, 39:36-39  
contest, 37:54-59, 80-81;  
38:78-79  
dollhouse, 34:46-48, 53-55  
Fat Cat™ toys:  
excavator, 36:52-56  
front-end loader, 41:34-37  
trailers, 33:72-76  
learning board, 37:58-59  
puzzle, relief, 40:70-71  
sleigh, 39:48-53  
tractor, 37:56-57  
truck, monster, 35:46-49  
wheels for, 35:40-45  
Trees, 35:96; 38:96; 41:96. **See**  
**also** Wood species  
barking, 34:100; 39:13  
logging, debate over, 33:12;  
36:57-61; 39:8; 40:72  
Trucks:  
scale models, 35:52-55  
toy, 35:46-49  
Try squares, 36:80-81;  
37:33-35  
oversized, 41:17  
Tung oil varnish, 37:14  
Turners:  
Arizona, 41:62-63  
Hart, Don, 41:61  
Hurt, Rus, 37:64-67  
Odnoken, Ab, 33:71  
Panek, Walt, 33:46-49  
Turning:  
birch, yellow, 39:34  
bracelets, 33:71  
cherry, black, 40:26  
drive-spur cure, 37:8  
exhibit, 41:62-63  
flowers, 41:61  
green wood, 33:46-49, 86  
hollow pieces, 38:18  
knobs, hold-down, 40:22  
maple, sugar, 36:32  
oak, red, 34:28  
rack for, 35:80  
sanding of bowls, 36:16  
stave construction, 36:13  
tools, 34:86; 37:64  
walnut, black, 35:34  
Turpentine for drilling steel,  
33:10

### Vacuums:

hose lock for, 37:26; 41:11  
lathe, use with, 34:21  
power controller for, 33:88  
Varnish, tung oil, 37:14  
V-block jig, 39:43  
Vener repairs, 39:70-71  
Ventilation, 39:72-73  
Videos:  
rack for, 39:54-55  
woodworking, 33:60; 36:96  
Vises, 37:42-45  
blocks for, 36:25

### W-Z

Walking sticks, 33:57-61  
Wall cabinets, 35:68-71; 40:  
44-51; 41:74-76  
hanging, 33:27  
Wall plaques:  
balloon, 41:64-65  
duck, carved, 40:34-37  
hummingbird, 34:58-59  
Walnut, 34:100; 35:33-34  
Water-based finishes, 34:42-43,  
92; 39:7  
Weed pots, turned, 37:64-67  
Wheels, toy, making, 35:40-45  
Wing nuts, custom-made,  
33:20  
Wood filler (putty), 34:86  
Wood product, laminated  
(Parallam), 33:104  
Wood samples, 37:28, 83  
Wood species, 33:16; 34:6,  
100; 35:96; 38:96;  
39:104; 40:96  
Wood supply, world's, 33:10,  
12; 34:100; 36:13, 57-61;  
38:96; 40:72  
Woodworkers. **See also**  
Carvers; Craftsman  
Closeups; Turners  
Clausen, Phil and Sam,  
41:70-71  
Dawson, Sheila, 40:52-53  
at Disney World, 35:56-59  
finishers, 34:42-43; 36:46  
Granseth, George, 38:7  
Miller, Andrea, 33:62-63  
Southwest furniture makers,  
37:40-41  
Woodworking bus, 40:52-53  
Woodworking clubs, 40:62-63  
WOODY Award, 37:7  
Woody license plates, 38:16  
Workbenches, 37:46-53  
board jack, 37:86  
hold-downs, 34:16, 18  
vises, 37:42-45  
Workmate as framing clamp,  
40:14  
Workshop consciousness,  
39:88

# DUCK UNDER GLASS

A plaque that points to plenty of possibilities

Seeking a distinctive-looking project? Search no more. We sandwiched this spirited wild-life scene between two contrasting sheets of glass, matted it with oak, and then rimmed the project with a complementary walnut frame. Hang this scene on the wall, or add a pair of walnut feet to stand it on a shelf.

*Note: If you plan to hang the project on the wall, add a picture-hanging wire to the back. For a freestanding unit, add the feet.*

*You'll need some thin stock for this project. You can either resaw or plane thicker stock to size.*

## Let's start with the frame

Have one piece of  $\frac{1}{8}$ " grey tinted glass and one piece of  $\frac{1}{8}$ " clear

*Continued*

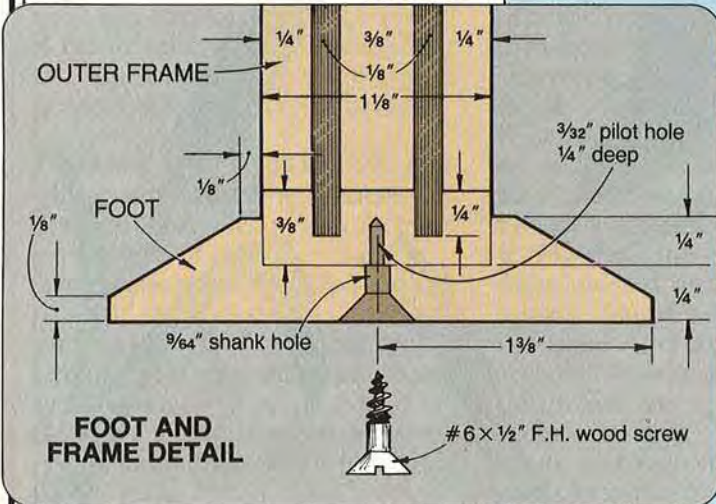
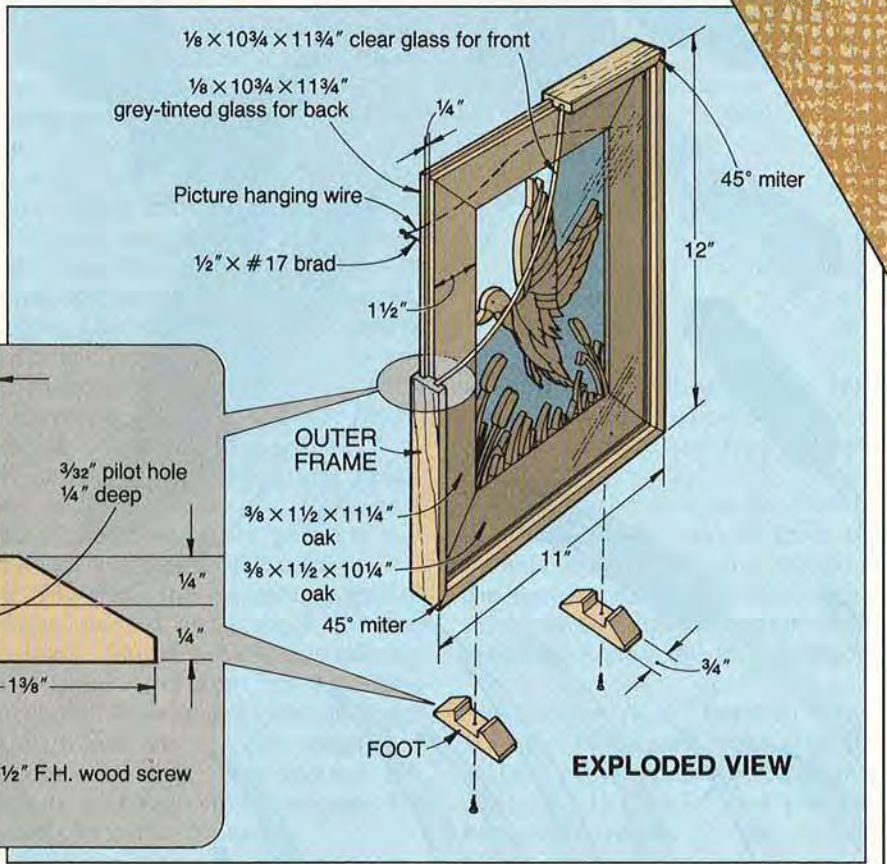

glass cut to  $10\frac{3}{4} \times 11\frac{3}{4}$ ". For a good fit later, double-check that both pieces of glass square up and measure the same size.

**2** From  $\frac{3}{8}$ " walnut (we planed thicker stock), cut two pieces of stock to  $1\frac{1}{8}$ " wide by 26" long for the exterior frame pieces.

**3** Using the Foot and Frame detail accompanying the Exploded View drawing for reference, cut a pair of  $\frac{1}{8}$ " kerfs  $\frac{1}{4}$ " deep along the

### FULL-SIZED PATTERN

#### COLOR KEY

-  Raw umber
-  Parchment
-  Light green
-  Yellow oxide
-  Phthalocyanine green

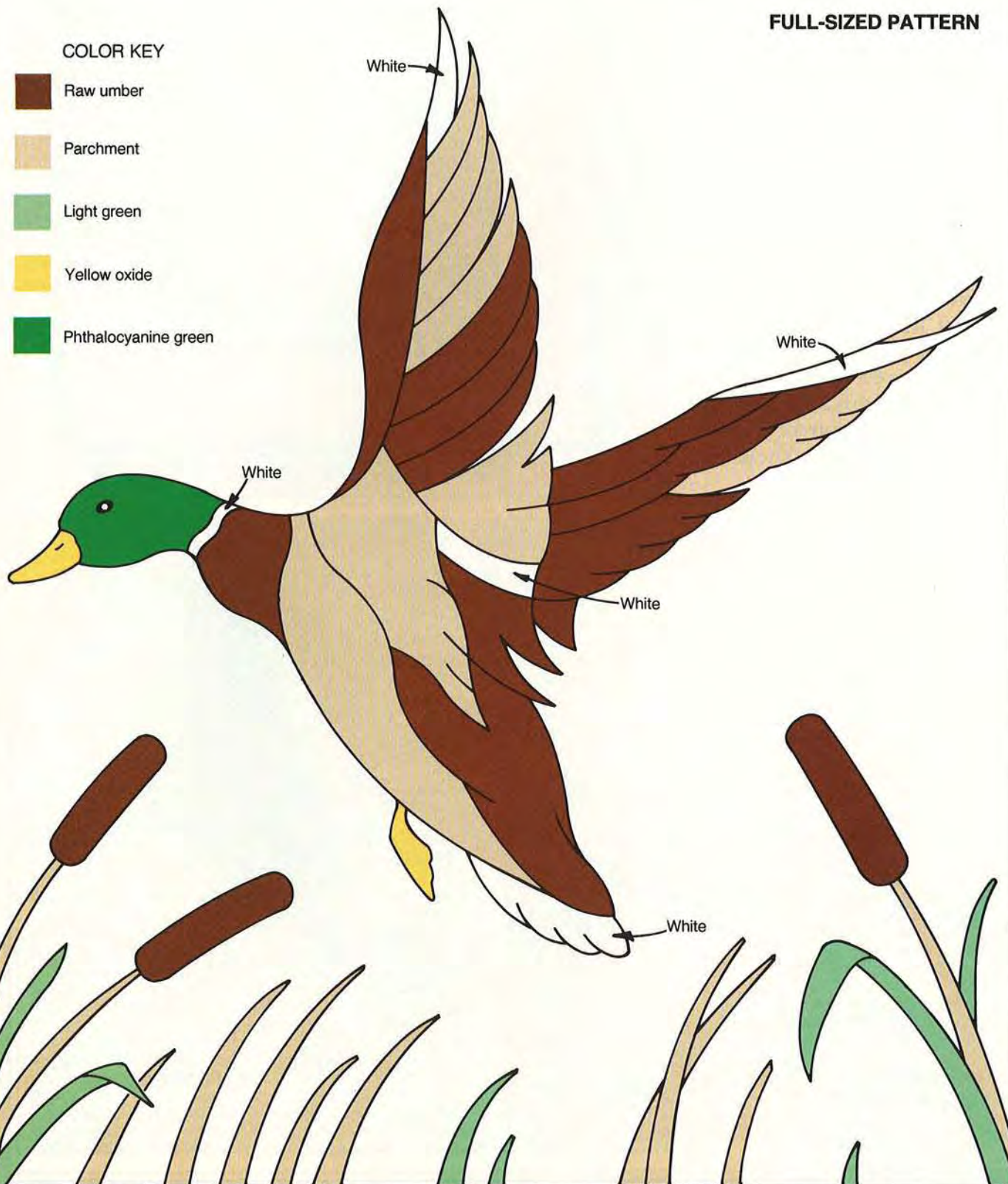

length of each frame strip. Check the fit of the glass in the grooves and widen the grooves slightly if necessary. Sand the two strips.

**4** For the matlike inner frame, rip and crosscut two pieces of  $\frac{1}{4}$ " stock to  $1\frac{1}{2} \times 24$ ". (We used oak.)

**5** Miter-cut the inner frame pieces to length, and position them on one of the glass panels; the outside edges of the pieces should be  $\frac{1}{4}$ " in from the outside edges of the glass panel. Trim if necessary.

**6** Spread waxed paper on a flat surface. Apply woodworker's glue to the mating mitered ends of the inner frame pieces. Assemble the frame on the waxed paper. Drive nails into the work surface next to the frame members to hold the pieces firmly together. Check that the surfaces remain flush. Later, sand the frame.

### Time to fire up the scrollsaw

**1** Make three photocopies of the pattern. Using one of the photocopies and spray adhesive, adhere the paper pattern to  $\frac{1}{4}$ " baltic birch plywood.

**2** Scrollsaw the pieces to shape (we used a #2 blade). Peel off the paper pattern from the scroll-sawed pieces. If the paper pattern resists removal from the wood, add a splash of lacquer thinner to dissolve the spray adhesive. Position the scrollsawed pieces on the second photocopied pattern.

**3** With 220-grit sandpaper, lightly sand the cut edges of each piece.

**4** Brush paint on each piece using the opening photograph as a guide. (We used acrylic paints.)

### Fasten the pieces to the glass, and add the frame

**1** Thoroughly clean both faces of each piece of glass.

**2** Tape the third full-sized pattern to a flat piece of stock. Center the grey-tinted glass over the paper pattern and tape the glass to the work surface.

**3** Using clear silicone sealant, center and adhere the inner frame to the glass.

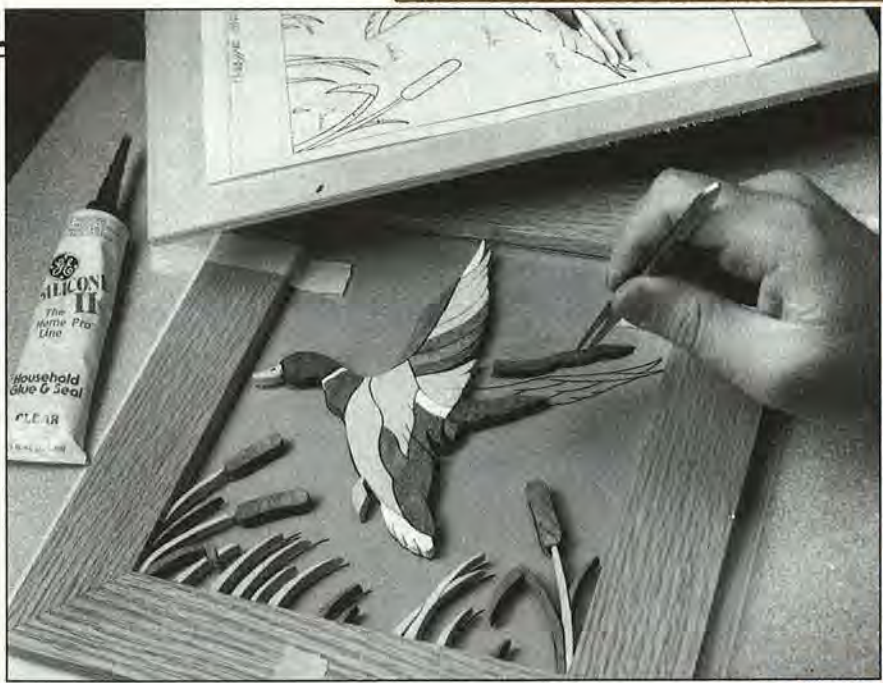

Place a fine bead of silicone sealant on the back side of each piece, and then adhere the pieces to the glass directly above the outline on the photocopied pattern.

**4** Add a dab of silicone to all painted pieces, and adhere them to the glass, positioning them directly over the paper pattern as shown in the photo above. (We used tweezers to accurately locate the smaller pieces.)

**5** Remove the glass and attached parts from the work surface. Place the piece of clear glass on the front of the colored pieces. Set the two pieces of glass aside.

**6** Add the finish to the inner surfaces of each outer frame piece.

**7** Fit the outer frame pieces onto the glass. Being careful not to get glue or dust inside the framework, apply glue to the mitered corners of the frame and clamp them. (We held the pieces together with strapping tape until the glue dried.) Check for square.

**8** Sand the mitered joints flush, mask the glass on the front and back of the assembly, and add the finish to the rest of the frame.

**9** To hang the project, partially drive two  $\frac{1}{2}$ "  $\times$  #17 brads into the outside frame pieces, positioning the brads  $1\frac{3}{4}$ " from the top edge and  $\frac{3}{2}$ " in from the outside edge. Wrap and tie a  $12\frac{1}{2}$ " length of picture-hanging wire around the brads, and then finish tapping the brads into the frame.

### For a freestanding unit, add the feet

**1** Transfer the foot pattern twice to a piece of  $\frac{3}{4} \times \frac{1}{2} \times 12$ " walnut. Cut the dados where shown on the drawing below, and then cut the feet to shape.

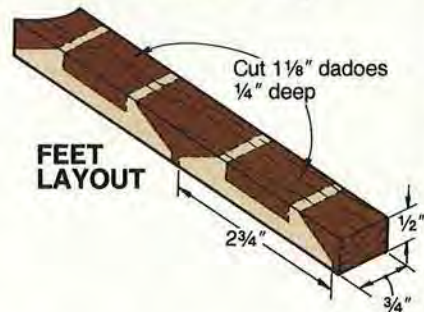

**2** Drill and countersink a hole through the bottom center of each foot. Sand the feet and add the finish.

**3** Position the feet on the bottom of the assembly  $1\frac{5}{8}$ " in from the outside edges. Use the holes in the feet as guides to drill mating holes in the bottom outer frame member. Screw the feet in place.

**Supplies:** #6  $\times$   $\frac{1}{2}$ " flathead wood screws,  $\frac{1}{8}$ " glass, clear silicone sealant, acrylic paints, clear finish, 2— $\frac{1}{2}$ "  $\times$  #17 brads, and picture-hanging wire. ♣

# REVELATION

## AN INSIDE LOOK AT THE TALES

**History—unwritten but not unrecorded—unfolds for those who can read a tree's annual growth rings. Found through a science called dendrochronology, these natural archives tell of droughts, insect infestations, forest fires, erosion, and more.**

**I**n the hellish heat the young soldier staggers under the weight of his pack, then reels, collapsing against his companions. General Stonewall Jackson surveys the scene through the choking dust. "If only the weather would break. The men won't be fit to fight after marching in this," he tells his aide. "Even the jack pines wilt."

—Somewhere in northern Virginia, April 1862.

Without the benefit of a history book, Richard Phipps, a researcher with the U.S. Geological Survey in Urbana, Illinois, knows for certain that Virginia's Rappahannock River nearly ran dry that unseasonably hot spring when General Thomas "Stonewall" Jackson marched his army north. He also can confirm that rain finally came the following September, when the Confederate army wallowed in mud on their retreat. Richard isn't a Civil War buff content with historical journals, though. He's a botanist working in a highly specialized field. And by using a special boring tool, he literally extracts such data from trees.

Forester Paul Krusic measures the rate of soil erosion on hiking trails in New Hampshire's White Mountains for the Forest Service. For this and numerous other tasks, he, too, relies on trees.

Both men work in dendrochronology, the science of dating events and environmental changes in history through the study of a tree's annual growth rings. But, their work represents only two aspects of all the many things that tree rings can tell you.

### History locked in the rings

"Trees in temperate regions undergo an annual cycle composed of a growth period—the spring and summer—and a dormant period," explains botanist Phipps. "Usually, in the early part of the growing season, growth is rapid, resulting in large, thin-walled cells, called *earlywood*. Later in the season, growth slows down, and small, dark, thick-walled cells develop. This is *latewood* [see photo, below]. And, the sharp contrast between earlywood and latewood becomes a distinct line.

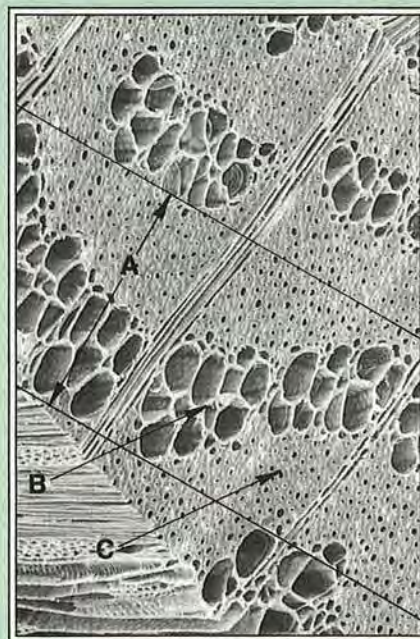

**ANATOMY OF A TREE RING**  
A. Annual growth ring (elm)  
B. Earlywood cells  
C. Latewood cells



1904: In Georgia, a loblolly pine takes root.



1909: At first, the tree grows rapidly. With abundant moisture and light, it produces broad, even rings.



1914: Another tree, pushing against it and making it lean, creates wider "reaction wood" rings.



1924: The pine grows straight, but other trees crowd it, their crowns competing for water and light.



1927: Harvesting surrounding trees provides ample nourishment and light.



1930: A forest fire scars the now almost mature pine, but new wood covers the wound.



1942: A dry spell lasting several years probably caused these narrow rings.



1957: More narrow rings could have been caused by insect attack.

Continued

# IN THE RINGS

TREES TELL

Copyright,  
Champion  
International  
Corporation



# TREE RINGS

"When you look at a tree in cross-section, such as the top of a stump," he continues, "the line looks like a circle. That's the boundary between two annual growth increments, or the ring."

Easy enough, right? Just count the rings and you'll determine the age of a tree. True enough, but, researchers like Richard say there's more to a tree's tale.

"Because various environmental factors, such as drought or insect infestation, can affect the amount of food a tree produces for new wood, the size of the annual ring is related to the growing conditions of that year," he notes (see illustration, page 61).

Stumps and cross-sectional slabs vividly display a tree's annual rings, and have been used by dendrochronologists since the science's infancy around the turn of the century. Today, though, researchers prefer to take core samples of trees with an increment borer because such a wound quickly heals. As shown in photo *below*, the increment borer looks like a T-handled auger. However, the  $\frac{1}{4}$ " bit is hollow so that it col-

lects a plug of wood as it bores to the tree's center. An extractor pulls the plug free before the bore is removed for study.

## Sunspots to earthquakes: tree rings tell it all

During his 30-year career in dendrochronology, Richard has studied tree rings in order to reconstruct stream-flow rates. "It's really *dendrohydrology*," he says. "I collect tree ring samples from species especially sensitive to growing conditions [the types of trees vary by region]. These become pieces of a puzzle. When you add them together, you get a more complete picture of what that stream looked like at a period in time, frequently to the month, often even less."

Dendrochronology came to the forefront around the turn of the century, when astronomer A.E. Douglass was attempting to discover a link between sunspot cycles and changes in the earth's climate. It was the publicity associated with a famous criminal trial, though, that showered the study of tree rings with limelight.

"The usefulness in the regularity of tree-ring patterns was brought to light in the Lindbergh kidnapping case in the 1930s," says the Forest Service's Krusic. "The prosecution proved that the ladder used by the accused to climb into the Lindbergh's second floor window was made out of timbers cut from the floor in his attic. The tree-ring patterns in the ladder's wood matched those found in the cut, attic floorboards of the house."

In his work at the Forest Service's Northeastern Forest Experiment Station in Durham, New Hampshire, Krusic has done some pioneering research with dendrochronology in measuring the effect of recreation on soil erosion. The study, however, involved root rings rather than tree rings.

"When a wound, such as a nick from a hiking boot, occurs at the time a root is first exposed, a scab forms to heal it," Paul explains. "Eventually that scar becomes locked in time within the ring formed that year in the root. Since the healing begins within days, we can also say when it happened during the growing season, then measure the amount of soil lost from the top of the wounded root to the present ground level and that gives us an erosion rate."

Another avenue of dendrochronology has Paul examining thousands of tree-ring core samples taken from sites throughout the northeastern United States. "I calculate which sites prove productive for tree-growing," he says.

## Tracing wood through time

In his leisure hours, the forester enjoys a little investigating with tree rings, too. He probes the countryside pinpointing the construction dates of centuries-old homes and barns.

"It's called cross-dating. The idea is to recognize replicated patterns in tree rings, and identify the years when they were formed. These become signatures," he says. "Cross-dating is finding



To obtain rings for reading, a researcher bores into the center of a tree with a hollow  $\frac{1}{4}$ " auger bit.



matches for those signatures in different wooden artifacts, such as a building. For instance, if you know that a certain pattern was formed in one species of tree in a region only between 1850 and 1855, then every time you see that pattern in an artifact of that species, such as a rafter or beam, you know when the wood was produced. It's like a fingerprint.

"In a 100 years of tree rings," Paul continues, "you might have three or four such definitive signatures [see illustration, right]. When you find one of those signatures, say the one for 1850-1855, you count back the number of years to where you expect to find the next signature, and if you locate it, then you know that you have a time-match. It's a detective type of thing."

### New clues through tree rings

The same clue-seeking with tree rings has resulted in the rewriting of history books. It was the tree rings of ancient bristlecone pines, for instance, that helped archaeologists accurately date the construction of 1,000-year-old pueblos in Arizona and New Mexico. In Europe, tree-ring experts have traced the origins of buildings and artifacts back as far as 193 B.C. Even paintings on wood, carvings, and musical instruments can be authenticated by finding tree-ring chronologies.

Scientists also rely on tree rings to date past volcanic eruptions and earthquakes in order to predict their recurrence. And, by correlating variations in tree rings with weather records, then applying the information back through time, climatologists chart global environmental change and the effects of air-pollution. Says researcher Phipps, "I'm convinced that there are things we could do with trees and tree rings that we haven't even thought about." 🌲

Written by Peter J. Stephano  
 Illustration page 63, Jim Stevenson  
 Photographs: Ripon Microslide; Richard Phipps,  
 U.S. Geological Survey

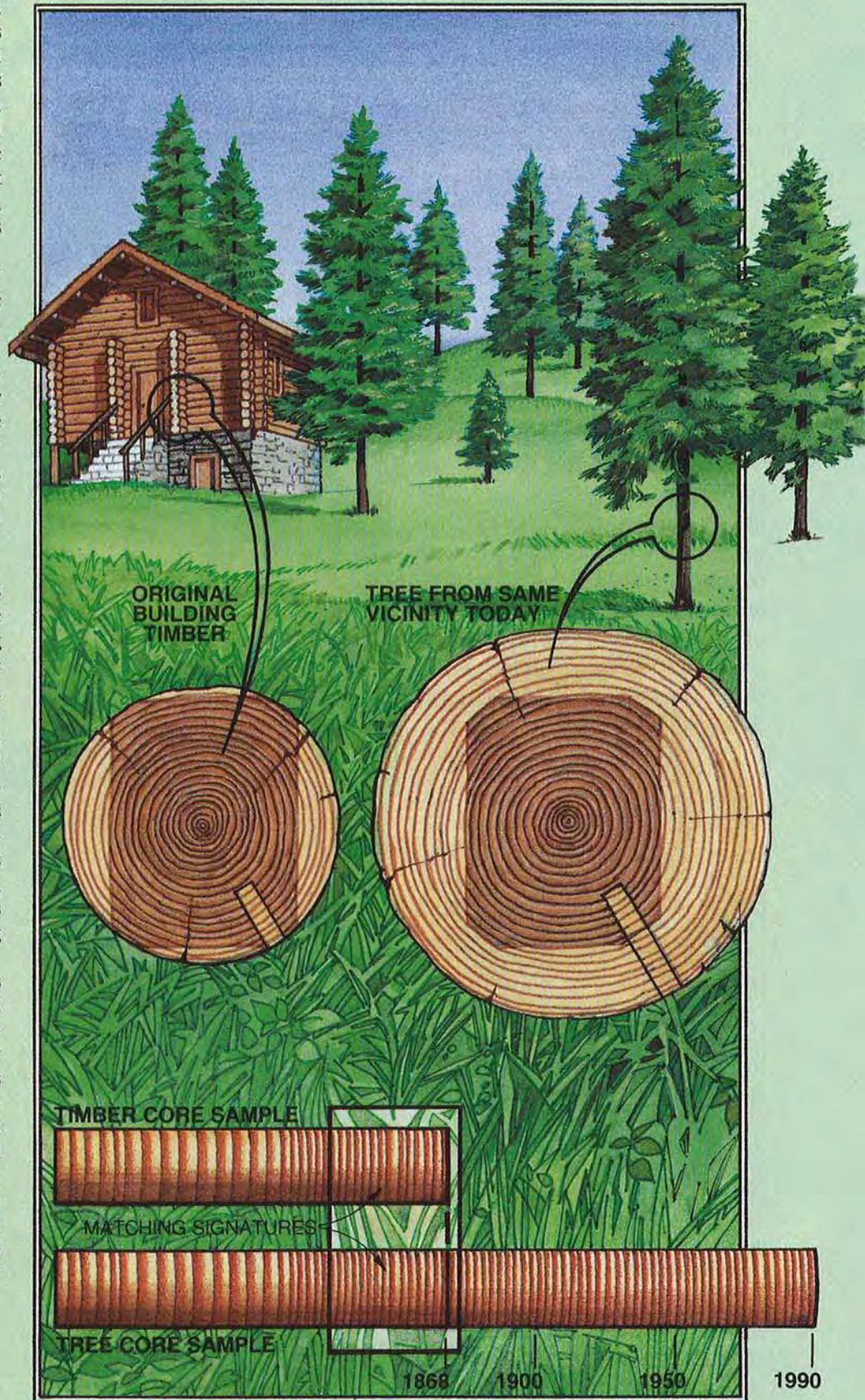

# CASUAL

A DISTINCTIVE AND DURABLE

**L**ast issue we promised you plans for a table to match those good-looking mahogany chairs. Well, here they are. This 48" table, with its mortise-and-tenon joinery and a top featuring splined miter joints, will serve you for years to come.

You say you don't have the issue explaining how to make those mahogany chairs? No problem! For a copy of the plans, send \$2 and a self-addressed business-sized envelope, along with 29¢ postage to What a Chair!, P.O. Box 11454, Des Moines, IA 50336-1454.

*Note: If you plan to use the table outdoors, use either slow-set epoxy or resorcinol glue.*

## Start with the legs

**1** Laminate thinner stock face to face to form the  $3\frac{3}{16}$ "-square legs. (We cut three pieces of  $1\frac{1}{16}$ "-thick stock to  $3\frac{3}{8}$ " wide by 29" long. Then, we glued and clamped the pieces with the edges and ends flush. After scraping off the excess glue from one edge, we planed that edge smooth and then ripped the opposite edge for a  $3\frac{3}{16}$ " finished width. Finally, we crosscut the legs to length.)

**2** Following the four steps on the Mortise detail accompanying the Exploded View drawing, form the mortises on two adjoining faces of each of the four legs.

**3** Cut or rout  $\frac{1}{4}$ " chamfers along the bottom end of each leg.



# CLASSICS II

## MAHOGANY TABLE



### Add the tenoned aprons

**1** Rip and crosscut the four aprons (B) to size ( $1\frac{1}{16} \times 3 \times 3\frac{1}{4}$ ").

**2** Cut the tenons to size on each end of each apron—see the Tenon detail for reference. (To cut the tenons, we mounted a dado blade to our tablesaw and attached a long auxiliary fence to our miter gauge to support the legs when cutting the tenons.)

**3** Dry-fit the tenons in the mortises to check the fit. Spread slow-set epoxy (see the Buying Guide for our source) on the mating surfaces and clamp one apron between two legs. With a framing square, check that the legs are square to the apron. Wearing vinyl gloves, immediately wipe off excess epoxy with a clean cloth dampened with acetone. Acetone will remove uncured epoxy. Repeat with another apron.

Epoxy two aprons between the two leg/apron assemblies to complete the base. Again, check that the legs are square to the aprons.

**4** Cut the four corner braces (C) to size, mitering the ends at  $45^\circ$ . Viewing the Corner detail accompanying the Exploded View drawing for reference, drill and countersink four mounting holes in each corner brace.

**5** Cut a V-shaped notch in four 4"-long pieces of  $2 \times 4$ . As shown in the drawing *above right*, epoxy and clamp each corner brace in place. Wipe off any excess epoxy.

**6** Using the previously drilled holes in the braces as guides, drill  $\frac{1}{8}$ " pilot holes  $\frac{1}{2}$ " into the aprons where shown on the Corner detail on the next page. Drive  $\#10 \times 1\frac{3}{4}$ " screws through the braces and into the aprons to further strengthen the joint.

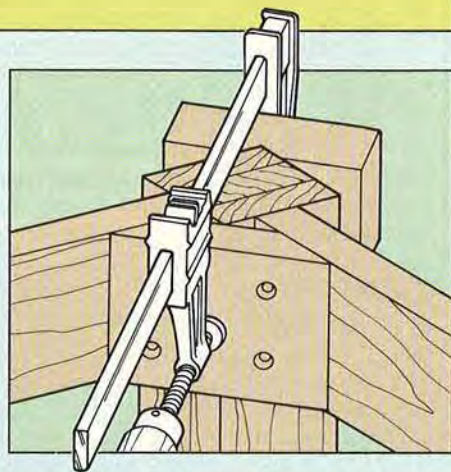

**7** Cut the cleats (D) to size. Drill and countersink four mounting holes in each cleat. With the top edges flush, screw them to the aprons (B).

### Now, let's build and assemble the tabletop

**1** Cut the edging pieces (E) to size, mitering the ends at  $45^\circ$ .

**2** Cut or rout a  $\frac{3}{8}$ " groove  $\frac{3}{8}$ " deep  $\frac{3}{8}$ " from the top surface along the inside edge of *two* pieces of the edging.

**3** Fit your router with a  $\frac{1}{4}$ " slotting cutter. Viewing the Spline and Slot details accompanying the Tabletop drawing and the photo on *page 67* for reference, rout a pair of  $\frac{1}{4}$ " slots  $\frac{1}{2}$ " deep in each mitered end of each edging piece.

**4** From  $\frac{1}{4}$ " stock (we resawed thicker stock), cut eight pieces to  $\frac{7}{8} \times 8\frac{1}{4}$ " for the splines. Before cutting, note the direction orientation in the photo. If the grain runs the length of the spline, the spline will have a tendency to split when the edging expands. Now, cut or sand the ends of each spline to the shape shown on the full-sized Spline pattern. Set the splines aside for now.

*Continued*



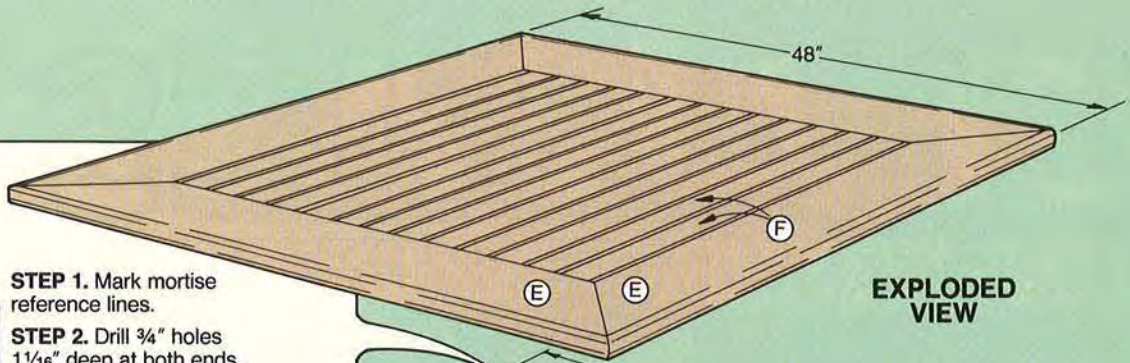

**EXPLODED VIEW**

**FORMING THE MORTISE**

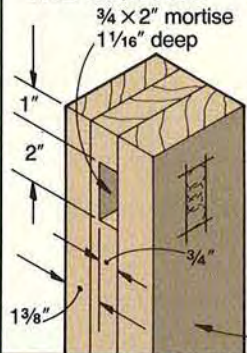

- STEP 1.** Mark mortise reference lines.
- STEP 2.** Drill 3/4" holes 1 1/16" deep at both ends.
- STEP 3.** Drill overlapping 5/8" holes 1 1/16" deep in between the 3/4" holes.
- STEP 4.** Chisel mortise sides.

**MORTISE DETAIL**

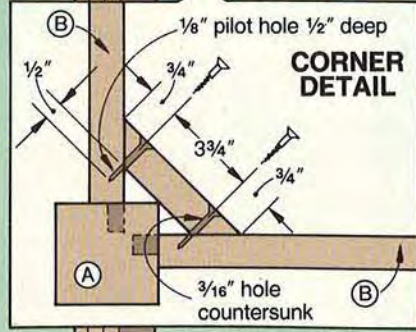
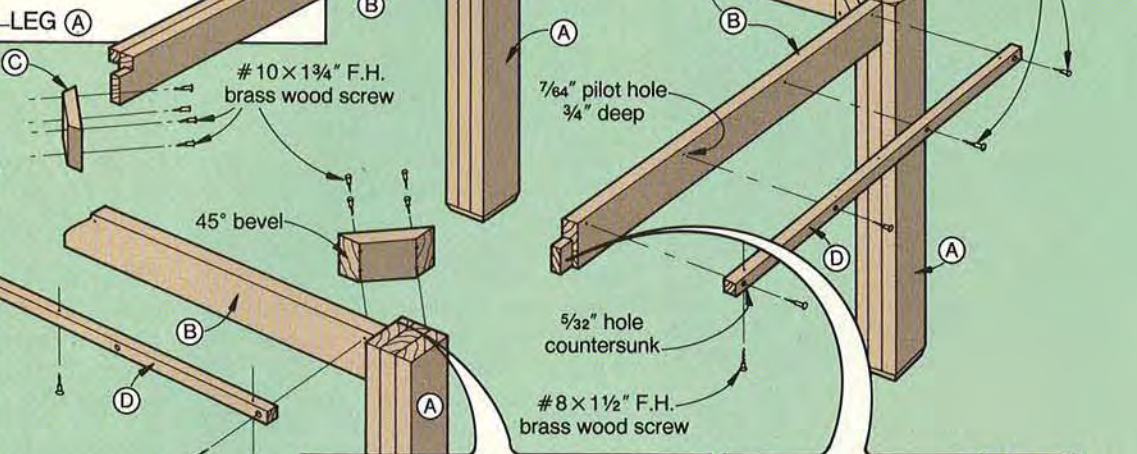

**CORNER DETAIL**

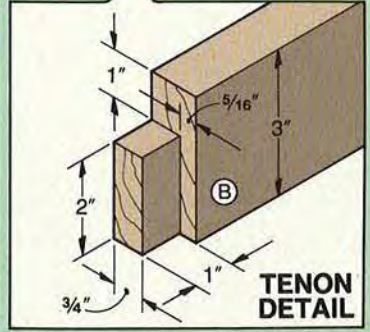

**TENON DETAIL**

**Bill of Materials**

Part	Finished Size*			Mati.	Qty.
	T	W	L		
A* legs	3 3/16"	3 3/16"	28 1/2"	LM	4
B aprons	1 1/16"	3"	34 1/4"	M	4
C braces	1 1/16"	3"	5 1/4"	M	4
D cleats	3/4"	3/4"	32 1/4"	M	4
E edging	1 1/16"	6 13/16"	48"	M	4
F slats	3/4"	2 3/8"	35 1/8"	M	13

\*Initially cut parts marked with an \* oversized. Then, trim each to finished size according to the how-to instructions.

**Material Key:** LM-laminated mahogany, M-mahogany

**Supplies:** slow-set epoxy, #8 x 1 1/2" flathead brass wood screws, #10 x 1 3/4" flathead brass wood screws, acetone as a solvent for the epoxy, exterior finish.

**Cutting Diagram** 1 1/16 x 7 1/4 x 96" Mahogany (two needed)

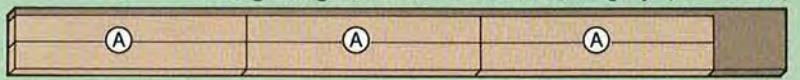

1 1/16 x 7 1/4 x 96" Mahogany

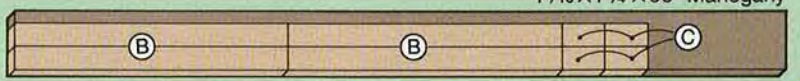

1 1/16 x 7 1/4 x 96" Mahogany (two needed)

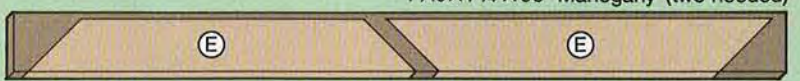

3/4 x 3 1/2 x 36" Mahogany

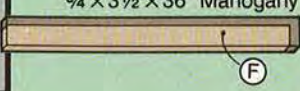

3/4 x 9 1/4 x 72" Mahogany (two needed)

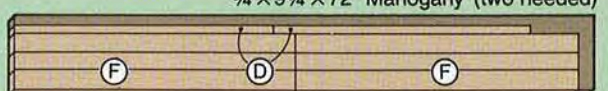

\*Indicates no groove on inside face

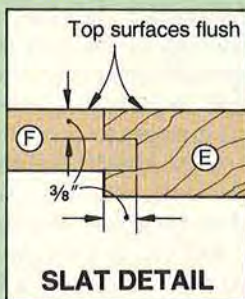
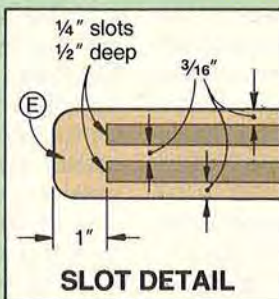
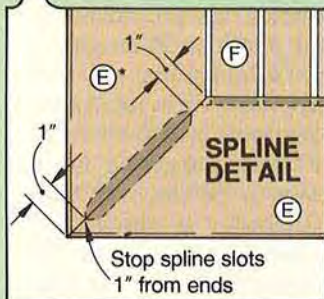
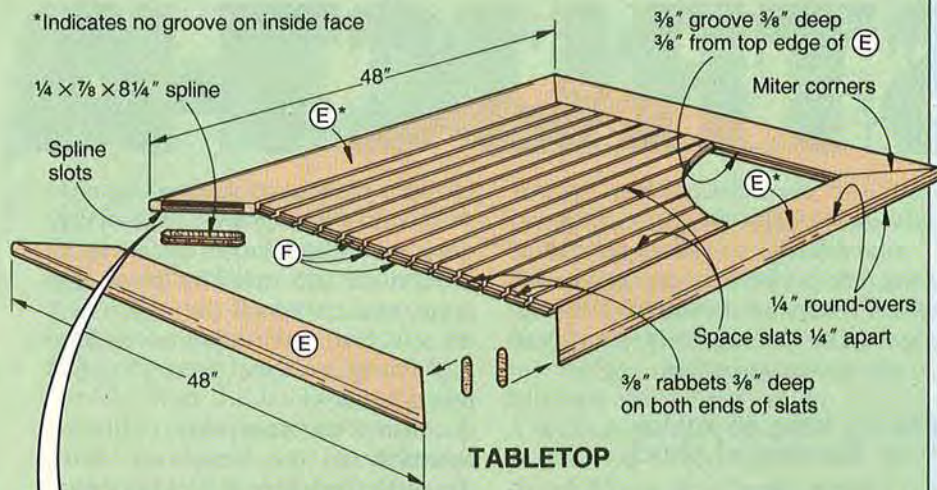

Rout a pair of slots and cut a pair of splines for each mitered corner joint.

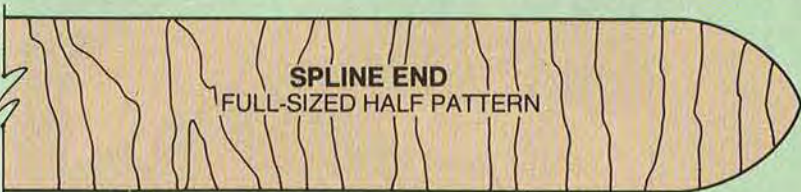

**5** Cut 13 slats (F) to the size listed in the Bill of Materials.

**6** Cut or rout a  $\frac{3}{8}$ " rabbet  $\frac{3}{8}$ " deep across both ends of each slat.

**7** Dry-clamp the tabletop parts (including the splines) to check the fit. Trim if necessary.

**8** Brush epoxy on all mating surfaces and splines, and clamp the tabletop assembly (E, F, and splines), checking for square. Wipe off excess epoxy with an acetone-dampened cloth. (To space the slats  $\frac{1}{4}$ " apart, we used pieces of  $\frac{1}{4}$ " dowel stock as spacers.)

**9** Sand the top of the tabletop smooth and flush.

**10** Rout  $\frac{1}{4}$ " round-overs along the outside edges of the tabletop.

### Sand and finish

**1** Finish-sand the base and tabletop. Stain and finish. (We left the wood natural. For the first coat of finish, we sprayed on spar varnish—reduced with mineral spirits 25 percent. Later, we lightly sanded with 320-grit sandpaper, and then applied a second and later a third coat full strength.)

To prolong the life of the finish, store the table and chairs indoors over the winter months. Also, if you happen to dent or scratch the finish, touch-up the blemish with spar varnish to prevent moisture from getting under the finish.

**2** Set the tabletop upside down on a blanket. Secure the tabletop to the base with #8 x  $1\frac{1}{2}$ " flathead brass wood screws threaded through the cleats (D).

### Buying Guide

• **Tropical hardwood epoxy.** Slow-set epoxy, one 16-oz. can of resin, one 16-oz. can of hardener, and instructions. \$27 ppd. Smith & Co., 5100 Channel Ave., Richmond, CA 94804. Or, call 800-234-0330 to order. 🌲

Produced by Marlen Kemmet  
Project Design: James R. Downing  
Photographs: Hopkins Associates  
Illustrations: Kim Downing; Mike Henry

# CONSTRUCT-A-

Equipping a high-school wood shop on a limited budget can be tough. And, buying lathe chucks, often costing as much as \$200, is almost out of the question. To solve this problem, Dave Hout, an industrial arts teacher at Coventry High School in Akron, Ohio, decided to make his own chuck.

*Note: To prevent the completed chuck from distorting after turning it to final shape, select a piece of kiln-dried, dense hardwood such as cherry or maple.*

*For added holding strength in securing the wood chuck to the metal faceplate, you may want to drill three additional mounting screws through the 3" faceplate*

*and into the chuck. Then, secure with an additional three screws.*

*And finally, to ensure that the faceplate remains centered on the chuck, Dave recommends leaving the chuck permanently attached to the metal faceplate.*

## Here's how to make your hardwood chuck

**1** To make the chuck, you'll need a 3½"-square laminated or solid hardwood block that measures 4" long. Crosscut the ends of the block square. Draw diagonals from corner to corner on each end of the block, and mount it between centers on your lathe.

**2** At a speed of about 800 rpm, turn the block round to a diameter of 3¾" (we used a ½" gouge).

Using a parting tool, turn the tailstock end flat (square to the cylinder) where shown on drawing A.

**3** Remove the cylinder from the lathe, and chisel off the nub. Center and fasten the squared end to a 3" faceplate (we used 1" sheet metal screws).

**4** Mount the faceplate/cylinder assembly to the headstock. Start the lathe and turn the cylinder to a 3¼" diameter. Turn the tailstock end flat for a 3" finished length.

**5** Using the dimensions on the full-sized End View drawing, pencil in the locations of the two recesses. Then, with a parting tool, turn the recesses ⅝"-deep in the end of the cylinder as shown in drawing B. When making the final cuts to form the ⅛"-thick

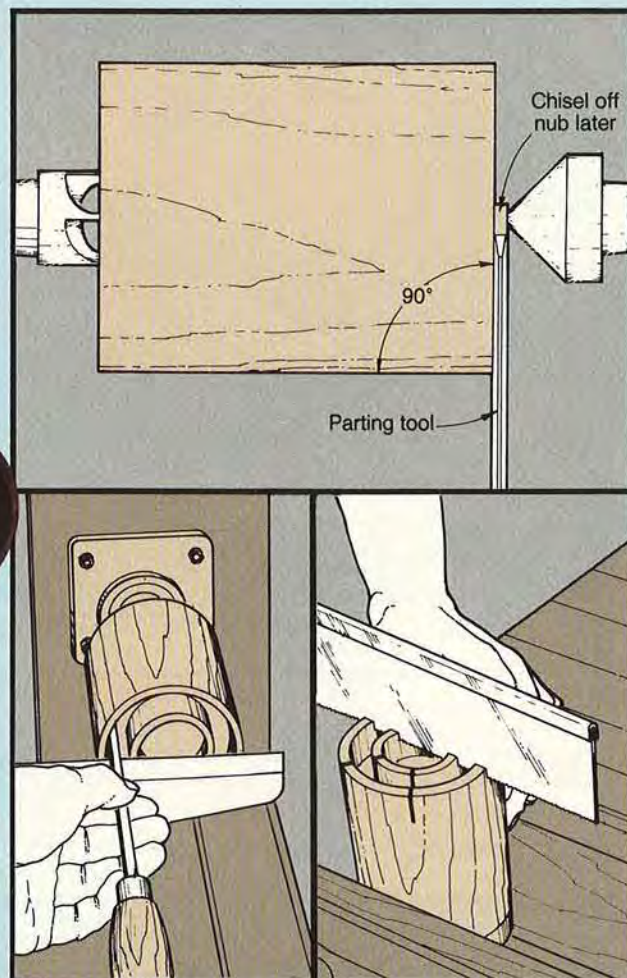

 [Print this article](#)

# CHUCK THE FRUGAL MAN'S LATHE ACCESSORY

inner-jaw wall, hold the parting tool square to the end of the cylinder. For a secure grip on turning projects later, the inner-jaw wall must be perpendicular to the end of the cylinder.

**6** Remove the faceplate/chuck assembly from the lathe, and clamp it into a woodworker's vise as shown in drawing C. Use a back-saw to cut three  $\frac{3}{8}$ "-deep kerfs at 60-degree intervals through the center of the chuck's end where shown on the End View drawing.

**7** Remove a 1"-long section in the outer wall for later access to the hose-clamp adjustment nut. (To do this, we securely fastened the assembly in a large handscrew clamp, chucked a  $\frac{3}{8}$ " Forstner bit into our drill press, and drilled

away 1" of the  $\frac{1}{8}$ " outer wall on one side of a kerf. Then, clean the drilled edge with a chisel.)

**8** For ease in removing turnings from the chuck later with a knockout bar, drill a hole through the center of your faceplate and through the center of the chuck. A knockout bar allows you to push the turning out of the chuck. Trying to pull or twist a project out of the chuck may cause the turning to break. (Our knockout bar measures  $\frac{3}{8}$ " in diameter, so we drilled a  $\frac{7}{16}$ " hole.)

## Tips on how to use your chuck

Mount your workpiece between centers, and turn a  $1\frac{1}{2}$ "-diameter tenon  $\frac{3}{8}$ " to  $\frac{1}{2}$ " long to fit snugly

in the chuck. Stop the lathe frequently to check the fit of the tenon in the recess. Square the surface of the workpiece that fits against the end of the chuck. *Optimum grip is obtained with a tight fit of the tenon in the chuck and flush mating surfaces.*

Next, slip on a #28 hose clamp. Insert the tenoned end of the workpiece into the interior recess. Now, with a screwdriver or hexagonal nut driver, tighten the hose clamp to secure the workpiece. To prevent the turning from coming out of the chuck, take light cuts with your turning tool. As with any chuck, taking large cuts or pressing too hard with a scraper can dislodge the turning from the chuck. 🐿

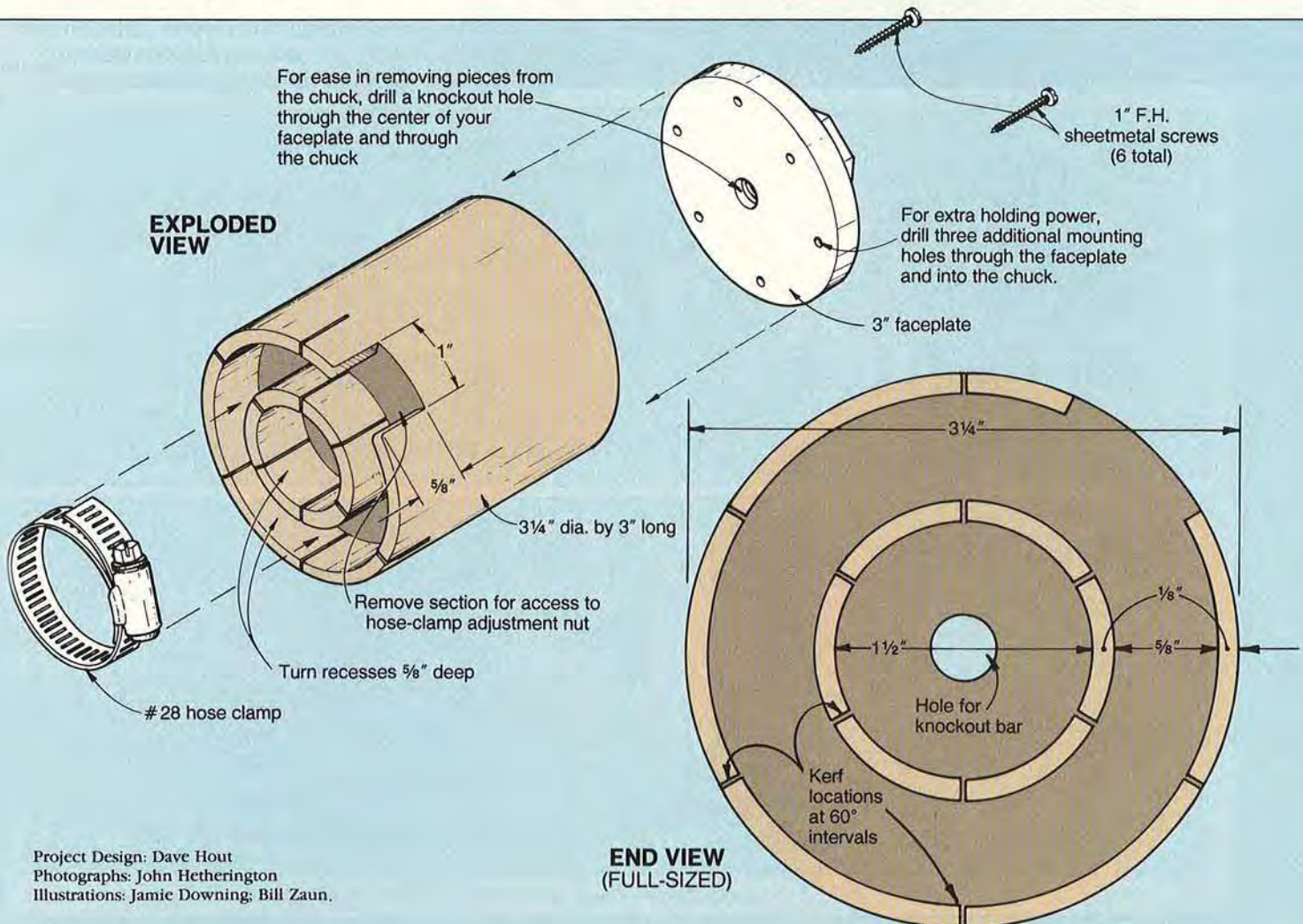

Project Design: Dave Hout  
 Photographs: John Hetherington  
 Illustrations: Jamie Downing, Bill Zaun.



# LATHE-

Be prepared to hear, "How did you do that?" when you show off this nifty hollow-egg container. Our secret (and now it's yours) lies in the use of the handy, home-made lathe chuck featured on the previous two pages.

## OK, let's get going

- 1 Start with a 2½"-square block of hardwood 5" long. If you don't have a kiln-dried turning square this size, laminate thinner stock.
- 2 Draw diagonals from corner to corner on each end, and mount the block between centers on your lathe. At a speed of about 800 rpm, use a gouge or skew to turn the block to a diameter of 2".

A new spin on an old turning favorite

 Print this article

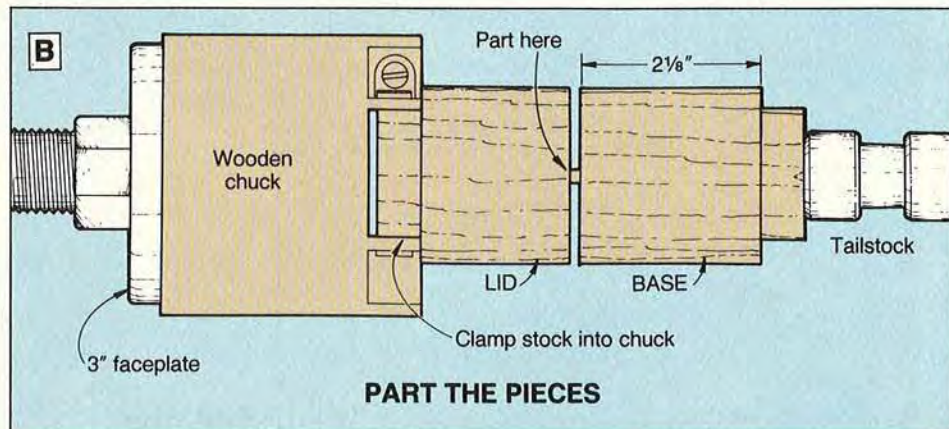
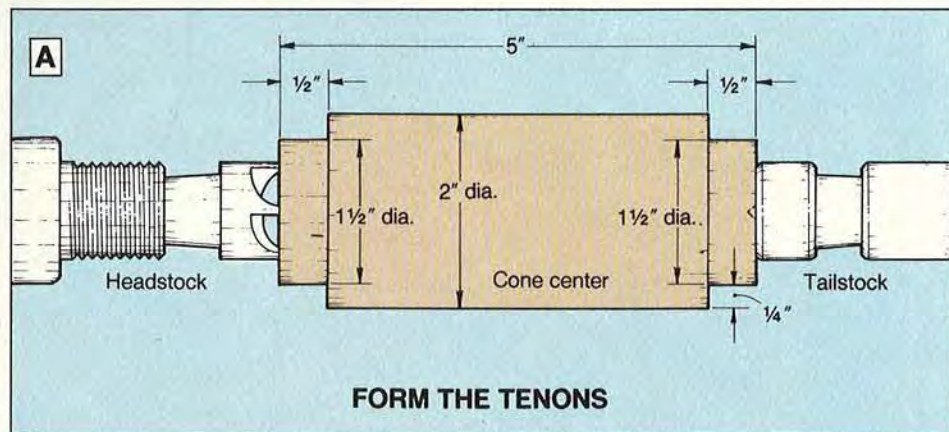



# LAI D EGGS

**3** As shown in figure A, turn a  $\frac{1}{2}$ "-long tenon on each end to a diameter that will fit snugly into your homemade chuck. Our tenons measured  $1\frac{1}{2}$ " in diameter; yours may differ slightly. (We used an outside calipers to measure the diameter, and frequently removed the block to test-fit the tenons in the chuck.)

## Now, you're ready to form the lid and base

**1** Remove the cylinder from between centers, fit one tenoned end into your homemade chuck, and tighten the hose clamp to secure it. Move the tailstock into position, centered on the opposite end. Now, use a parting tool to cut the workpiece in two where shown in

figure B. Set aside the half closest to the tailstock; you'll use this later for the base. Back the tailstock away from the workpiece.

**2** Hollow the lid to the shape shown in figure C. (We used a  $\frac{3}{16}$ " gouge and a round-nosed scraper.) For a tight fit against the base later, turn the first  $\frac{3}{16}$ " of the interior flat where shown on the Interior detail. Sand smooth, being careful not to round the flat area. Add the finish to the lid interior.

**3** Fit the base tenon into the chuck, and use a parting tool or a square-end scraper to form a  $\frac{3}{16}$ " rabbet that will fit snugly into the lid interior where shown in figure D. Make light cuts to avoid removing too much material and making the rabbet too small,

which would result in a sloppy fit. (We stopped frequently to test-fit the lid on the base.) Then, hollow the base interior to the shape shown in figure D.

**4** Fit the lid firmly onto the base where shown in figure E. Turn the lid exterior to shape, sand smooth on the lathe, and add the finish. Pull the lid from the base and set it aside.

**5** Shape a portion of the base exterior to the shape shown in figure E. Part the base from the chuck where shown.

**6** On the waste piece left in the chuck, turn a tenon to fit snugly inside the base piece where shown in figure F. Fit the base onto the waste piece and finish turning the base to shape. Sand smooth and add the finish. ♣

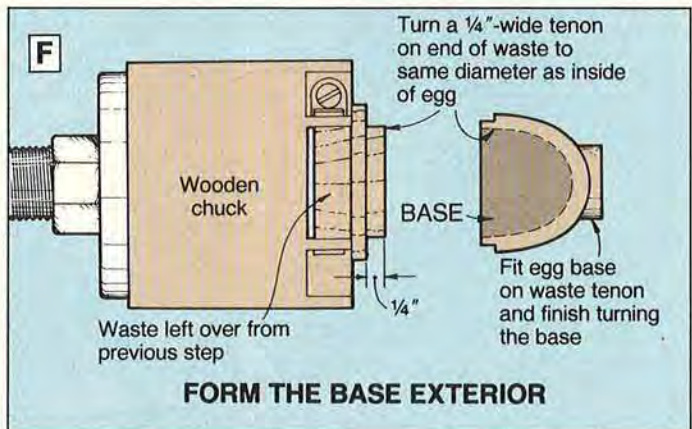
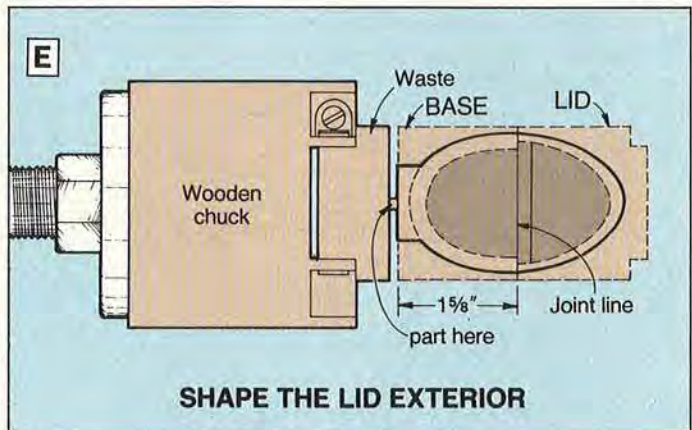
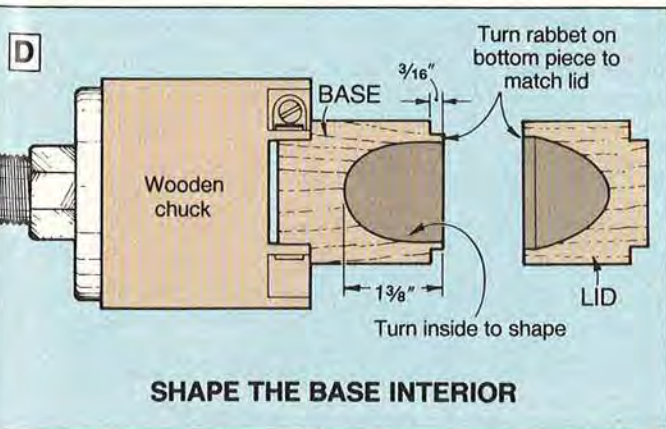
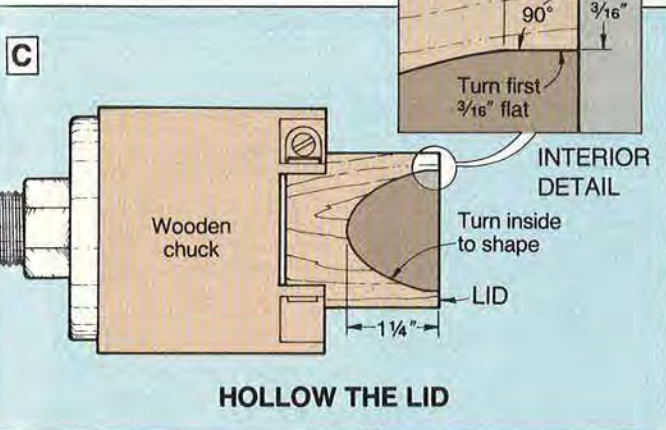

# ONE WHALE

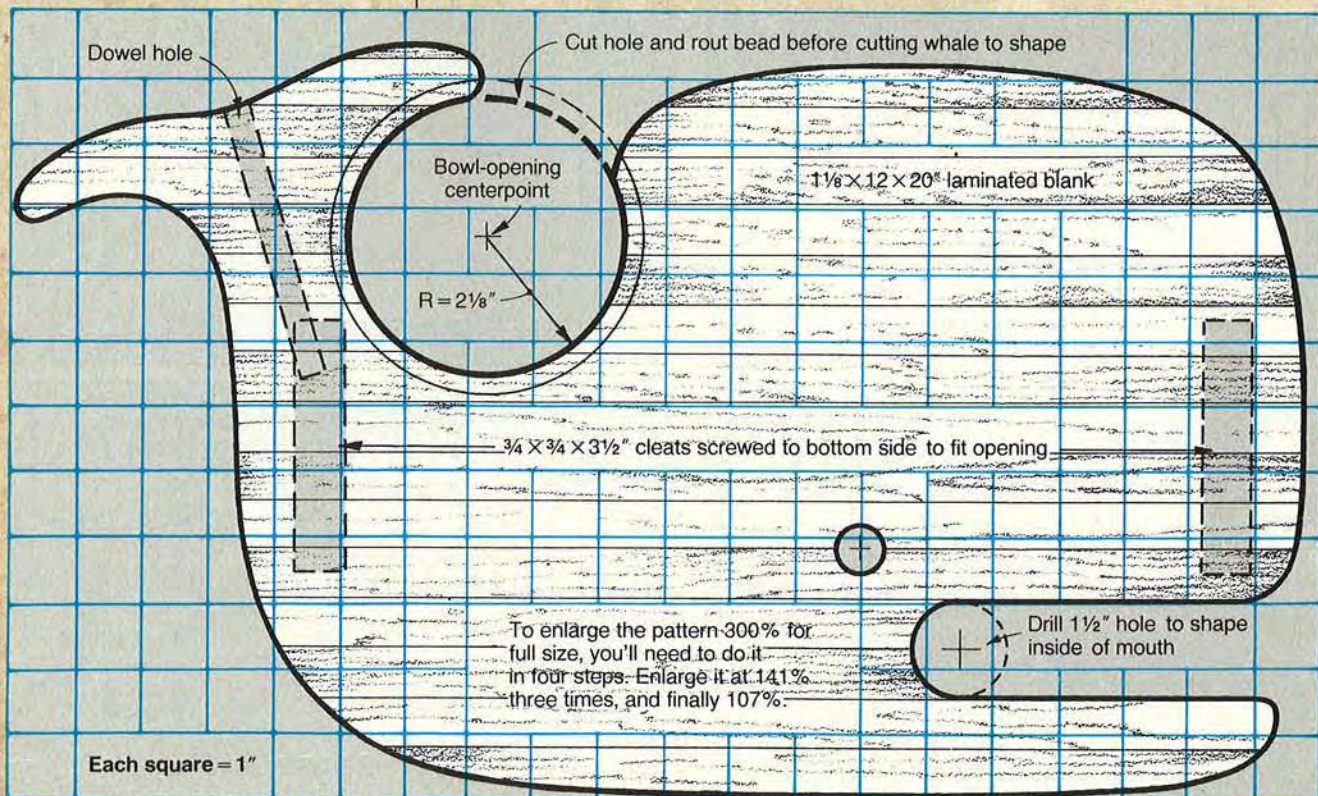
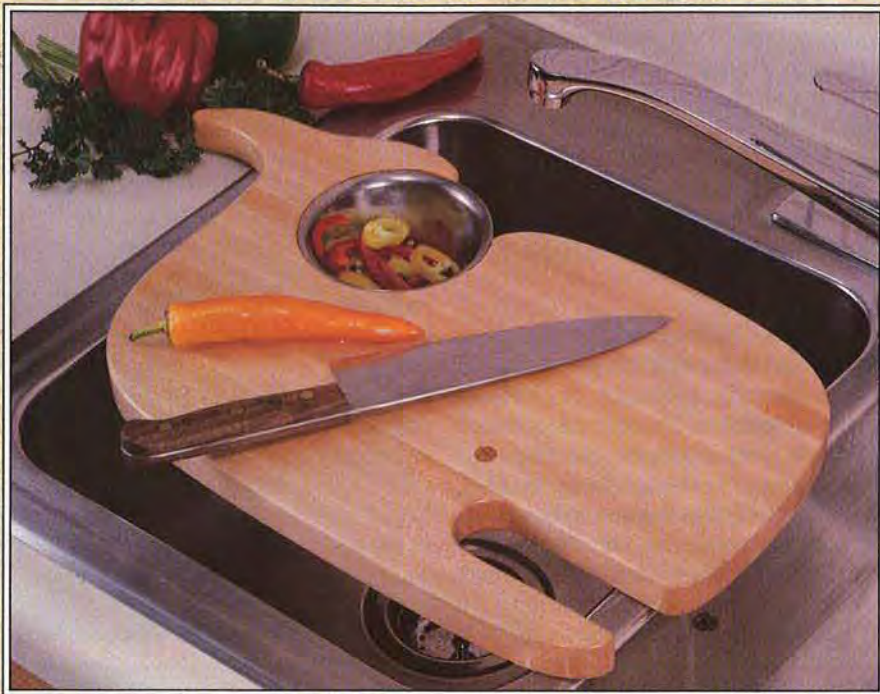

# of a cutting board

Rip and crosscut 16 pieces of  $\frac{3}{4}$ "-thick maple to  $1\frac{1}{8}$ " wide by 20" long. Glue and clamp the pieces face-to-face, with the edge grain facing up and with the edges and ends flush. (We used woodworker's glue.) After the glue dries, remove the clamps, and scrape off the excess glue. Sand the surfaces of the cutting board.

Create a full-sized pattern by redrawing the whale on a 1" grid or enlarging it 300 percent on a photocopier. Or, order our full-sized pattern; see the offer *below right*. Transfer the pattern including the bowl, eye, and mouth center-points, onto your lamination.

To cut the bowl opening to shape, you can either use a circle cutter mounted in your drill press or a bandsaw. *Be sure to test-cut a hole and rout the bead in scrap*

*first to verify the fit of the stainless-steel bowl in the opening.* Using the Bead detail for reference, rout a bead along the top inside edge of the bowl opening.

Drill the mouth opening and eye hole through the lamination.

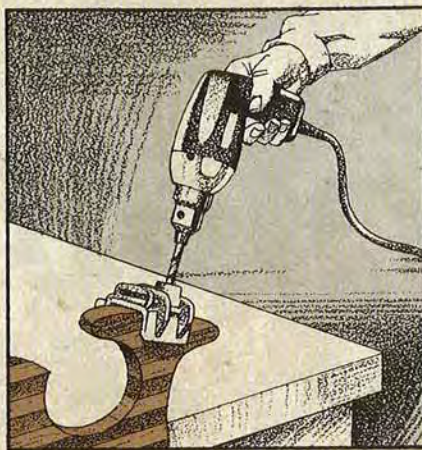

(We first drilled a  $1\frac{1}{2}$ " hole and then cut to it to form the mouth.) Bandsaw the rest of the whale outline to shape, and sand the cut edges to remove the saw marks. To strengthen the tail portion of the whale, use a doweling jig and drill a  $\frac{3}{8}$ " hole into the tail as shown in the drawing *left*. Remove the jig and drill as deeply as you can into the tail section. Cut a  $\frac{3}{8}$ " dowel to 5" long. Sand a flat surface along the dowel where shown in the Dowel detail to allow excess glue and air to escape when driving the dowel into the hole. Tap the dowel into the hole just drilled. Trim the end of the dowel flush with the edge of the tail; sand smooth. Glue a  $\frac{1}{2}$ " dowel in the eye hole. Rout a  $\frac{1}{8}$ " round-over along all edges *except* the beaded bowl opening.

Cut a pair of cleats to  $\frac{3}{4} \times \frac{3}{4} \times 3\frac{1}{2}$ ". Using stainless steel screws, fasten the cleats to the bottom of the cutting board to prevent the board from moving when placed over the sink opening. Sand smooth, and apply several coats of finish. (We used Behlen's Salad Bowl Finish.)

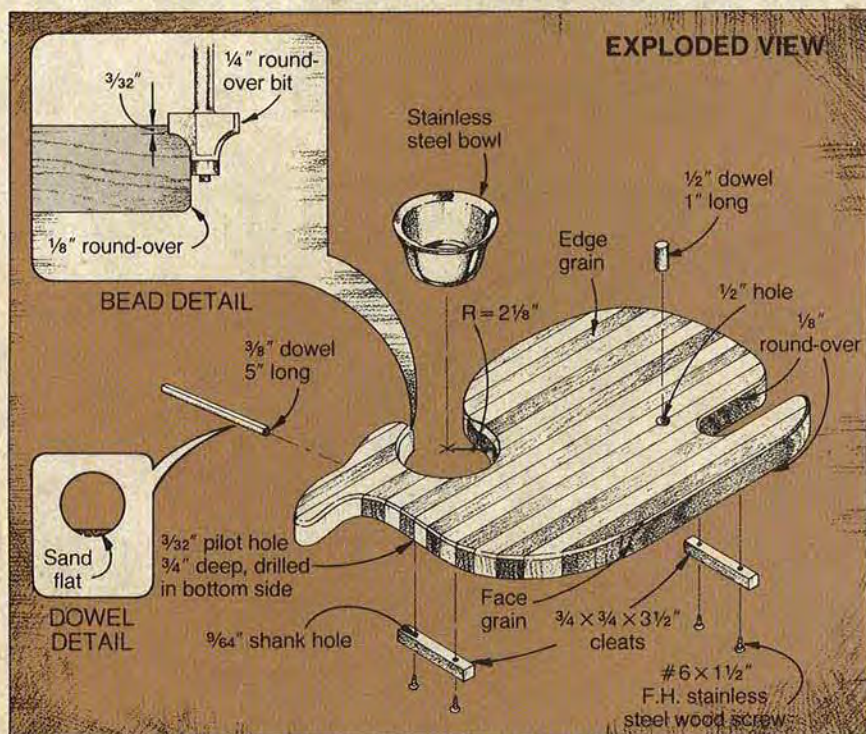

## Buying Guide

• **Bowls.** Three stainless steel bowls, catalog no. 47522, \$9.95 ppd. Sorensen Equipment Co., 2012 Cottage Grove Ave., Des Moines, IA 50312.

• **Behlen's Salad Bowl Finish.** One pint, \$9 ppd. (\$12 U.S. funds for Canadian orders), catalog no. 85006, Armor Products, Box 445, East Northport, NY 11731. ♣

For a full-sized pattern, send \$1 (U.S.) and a self-addressed, stamped, business-sized envelope to: Whale Cutting Board  
P.O. Box 11454  
Des Moines, IA 50336-1454.



# FARMYARD FAVORITES

## on a string

Print this article

Using carbon paper or photocopies and spray adhesive, transfer the full-sized patterns, axle-hole centerpoints, and pull-string and tail reference lines to 1½"-thick stock (we used a 2' length of a fir 2×6). Drill a ⅜" axle hole through each marked centerpoint. Bandsaw the animals to shape. Drill a ⅛" pull-string hole in all three animal shapes, and a ⅛" tail hole in the cow and pig only.

Rout a ¼" round-over along all but the bottom edges of the feet of each animal. Sand the cut and routed edges.

Cut a pair of ⅜" dowels to 2½" long for the axles for each animal. Hold each dowel upright in a handscrew clamp, and drill a ⅝⁄₆₄" pilot hole ½" deep centered in each end. Glue the axle dowels in place, centered from side to side. Resaw thicker stock to ¼" thick for the hearts. Transfer the full-sized heart patterns to the ¼" stock. Cut the hearts to shape and sand smooth. Drill a ⅛" hole ⅜" deep in each heart.

Paint each animal white with a wash coat to allow some grain pattern to show through. Using the photo *above right* for reference, paint the black areas with an acrylic. For the aged look, wipe stain on each animal cutout and immediately wipe off most of the stain. For a worn appearance, lightly sand the edges with 220-grit sandpaper.

Drill a ⅛" hole in the center of each spoked wheel (see the Buying Guide for our source). Soak the wheels in vinegar overnight to dull the finish. Now, using #4×¾" roundhead wood screws, fasten the wheels to each animal.

Project Design: Vickie Rush



Cut the tails, pull strings, and neck cords to length from ⅛" twine. Glue a heart to both ends of the neck twine and one end of the pull string. Then, attach the twine to the animals.

### Buying Guide

• **Wheels and screws.** One dozen metal die-cast spoked wheels and mounting screws. \$10.50 ppd. Wood-N-Wonders, P.O. Box 656, St. Paris, OH 43072. 🍄

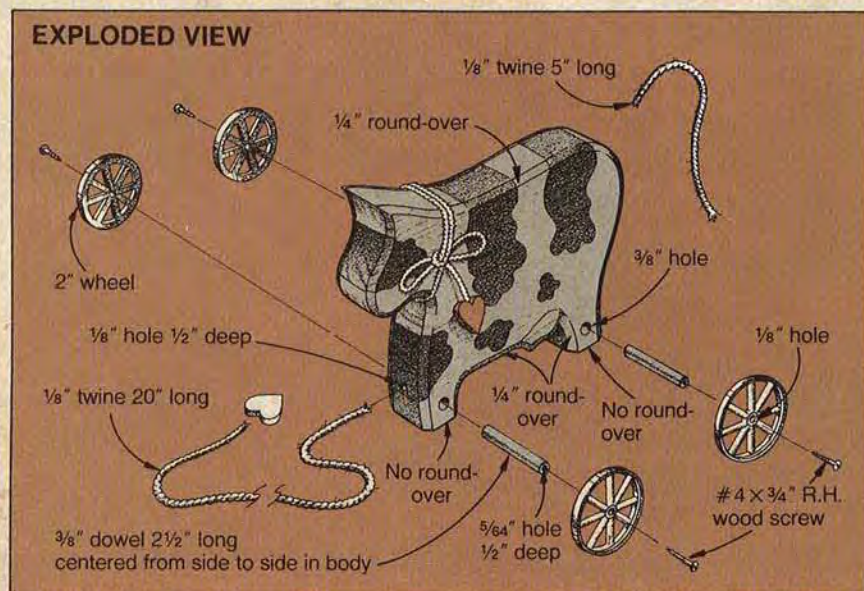

Photographs: Hopkins Associates

Illustrations: Jamie Downing; Jim Stevenson

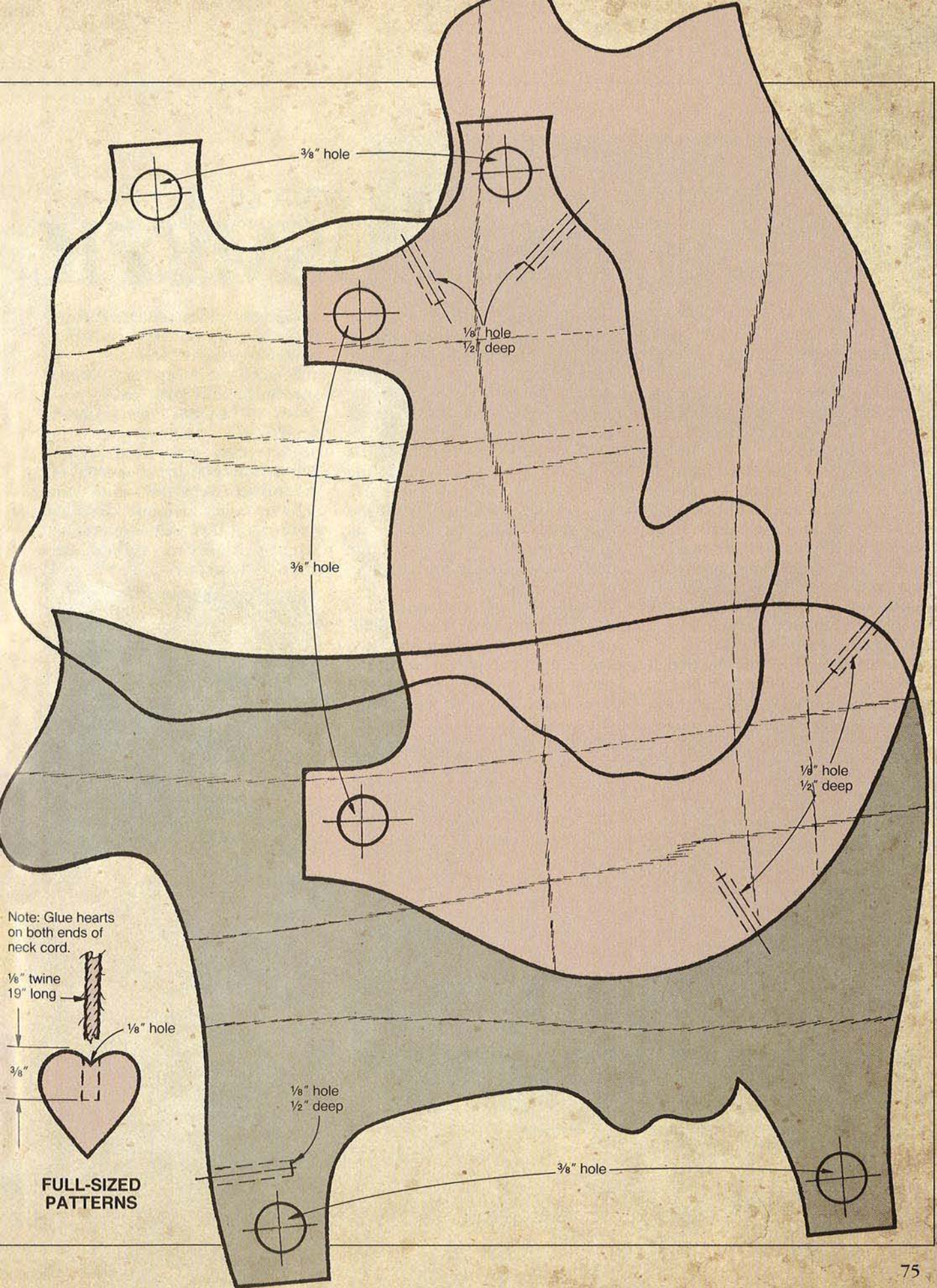



 Print this article

# They won't leave home without it **LADIES' COSMETIC**

Cut one piece of  $\frac{3}{8}$ " stock to 4" wide by 12" long. (See the drawing *below* for the method we used to resaw thicker stock.) Cut the material into two pieces that measure just under 6" long. Stick the two pieces together face-to-face with carpet tape.

Transfer the full-sized pattern and 2" circle location to one of the pieces of stock. Chuck a 2" Forstner bit into your drill press, centering the bit over the marked circle. (See the Buying Guide for our source of bits.) Clamp the stock to the drill-press table. Using a speed of about 250 rpm, bore a  $\frac{3}{16}$ "-deep hole into the stock.

Bandsaw just outside the pencil line on the taped-together pieces. Sand to the line to complete the

teardrop shape (we used a disc sander). With a wooden wedge, pry the pieces apart and remove the tape. Mark an X on the face *opposite* the 2" hole.

Adhere the pieces with carpet tape, making sure that the edges are flush and that the 2" hole is facing in. Locate and mark the hinge-hole centerpoint on the face marked with an X. Drill the plug, shank, and pilot holes to the dimensions shown on the Hinge detail. Pry the pieces apart and remove the tape.

Grind  $\frac{1}{8}$ " off the end of a #6  $\times \frac{1}{2}$ " sheet-metal screw. With the edges flush, fasten the two pieces tightly together with the screw and washer. Resand the edges flush. Rout a  $\frac{1}{4}$ " round-over

along the edges of both pieces. For safety, support the assembled holder as shown *below*.

Remove the screw and washer, and finish-sand both pieces. Add finish to just the *inside face* of each piece. Using a stick pin, place a drop of epoxy or instant glue in the pilot hole, and fasten the pieces with the screw and washer. Later, open and close the holder to test the movement. Slightly loosen or tighten the screw if necessary.

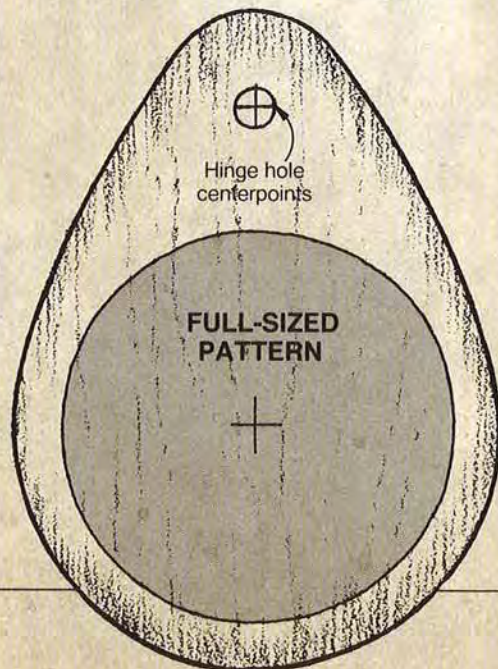
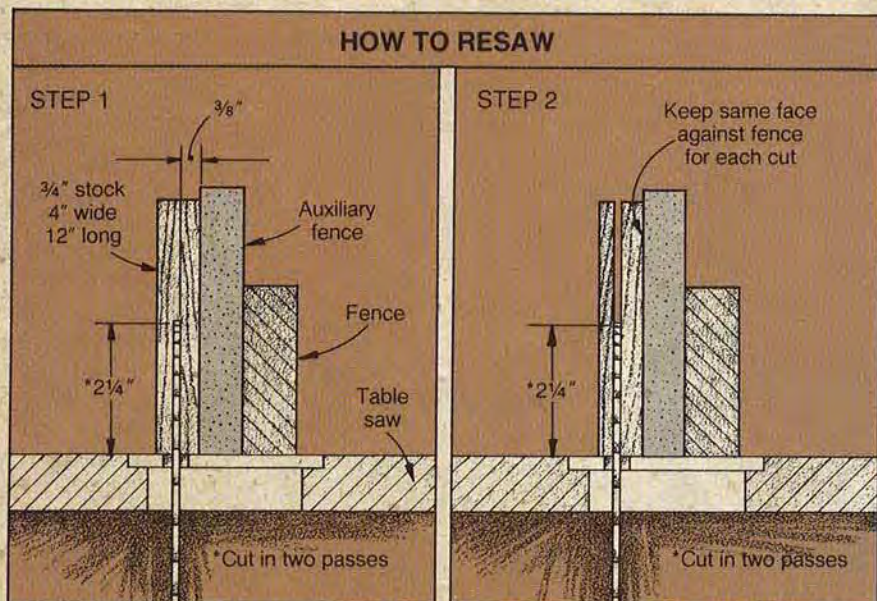
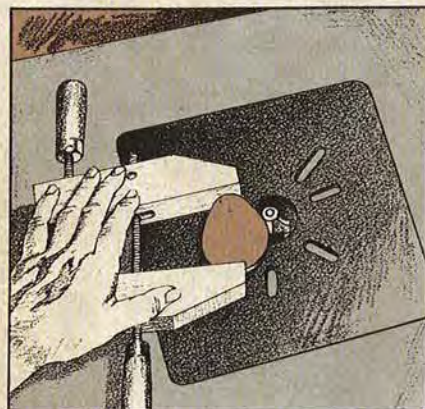

Project Design: Don Bailey Photograph: John Hetherington  
Illustrations: Jamie Downing; Jim Stevenson

# MIRROR

Cut a  $\frac{3}{8}$ " plug, put it in the hole, and sand it flush. Finish the *outside* of the holder. Apply double-faced, foam-core tape to the mirror back, peel off the backing, and place the mirror in the hole.

## Buying Guide

• **2" Forstner bit.** A true Forstner bit with no point,  $\frac{3}{8}$ " shank, catalog no. 57000, \$27 ppd., Connecticut Valley Mfg., P.O. Box 1957, New Britain, CT 06050.

• **Mirror kit.** Six 2mm x 2" mirrors with foam-core tape attached, six #6 x  $\frac{1}{2}$ " panhead sheet-metal screws with washers, \$8.50 ppd. Ennis Mountain Woods, Route 2, Box 222B, Afton, VA 22920. ♣

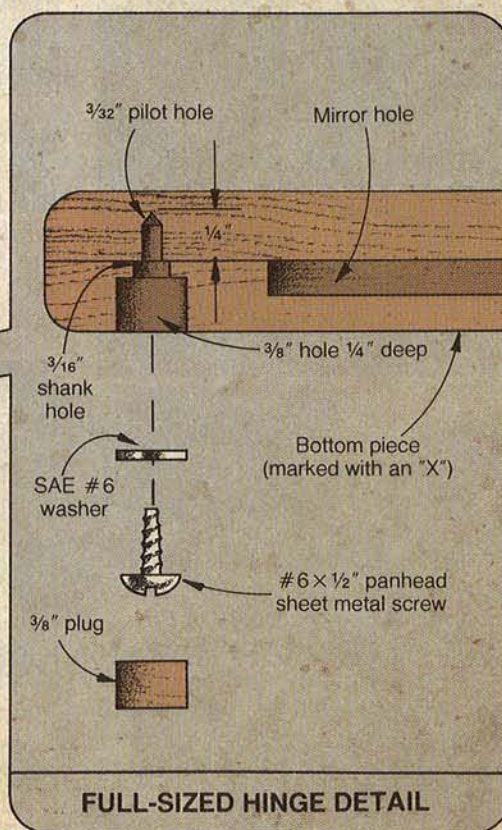
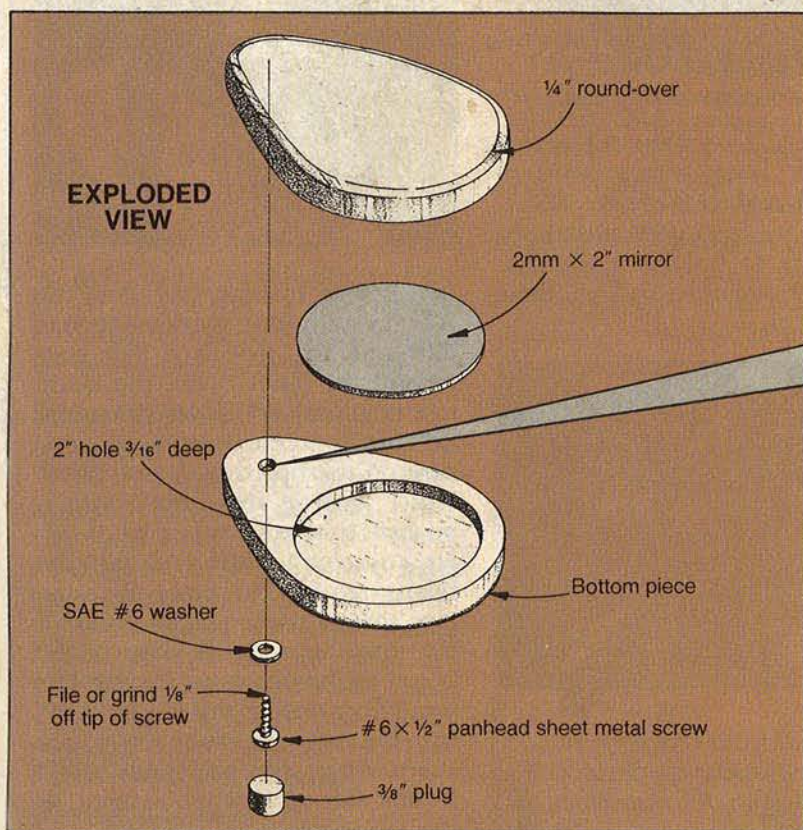
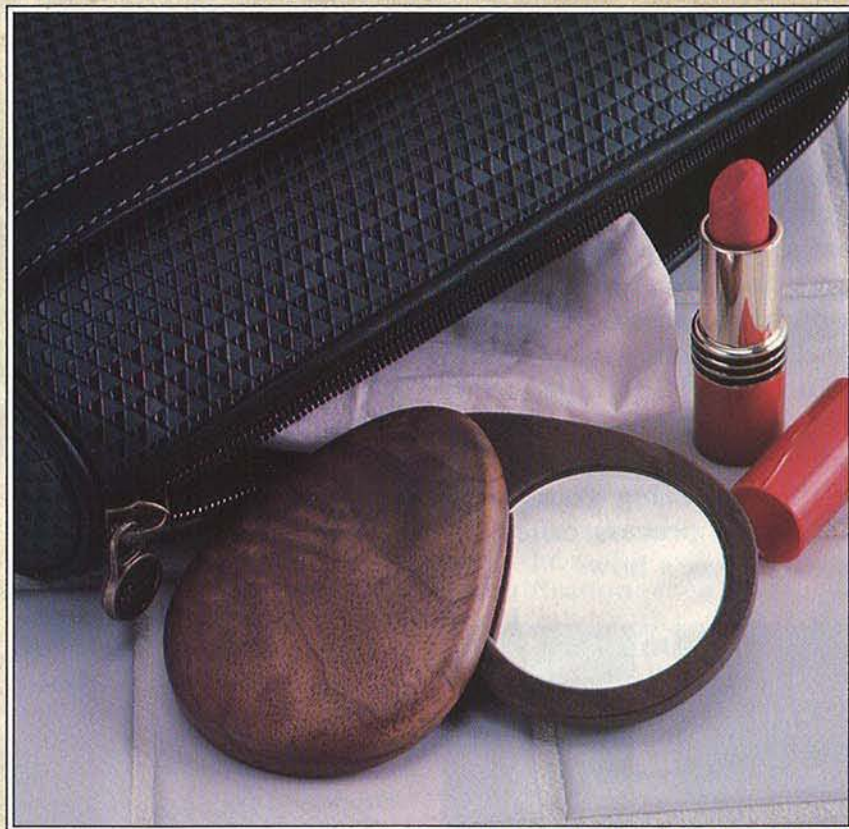



## RESAWING

THE SAFE AND SIMPLE WAY

A surprising number of woodworking projects call for thin stock in dimensions such as  $\frac{1}{8}$ ",  $\frac{1}{4}$ ", or  $\frac{3}{8}$ ". But that shouldn't pose any problems for you, even if you don't have a thickness planer, or don't want to order the material by mail. Just cut what you need from a thicker piece of stock—normally  $\frac{3}{4}$ " or thicker—using your table saw and a process called resawing. Here's how:



To determine how wide a board you can resaw, measure the maximum height of your table saw blade as shown above. Multiply this measurement times two and subtract  $\frac{1}{4}$ " to figure the maximum board width.

Attach an auxiliary  $\frac{3}{4}$ " plywood fence to your table saw rip fence. Cut the plywood as long as the standard fence and 1" higher than the maximum height of the blade as shown above.

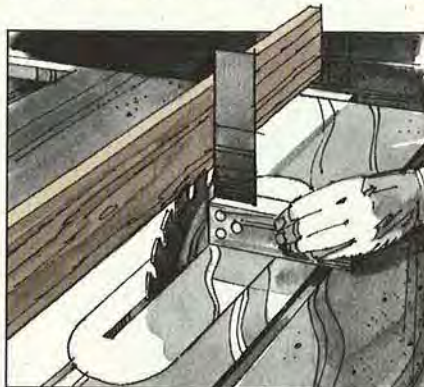

2 With a try square, check that your blade is set at exactly 90° as shown above. Likewise, your fence must be perpendicular to the cutting surface.

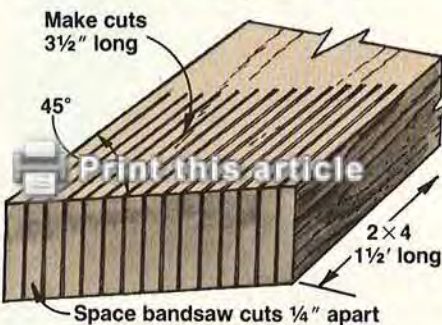

3 From a 2x4 that measures 1½–2' long, cut a featherboard as shown above. Woodworkers have long used these simple helpers to hold a workpiece safely and securely against their saw's fence.

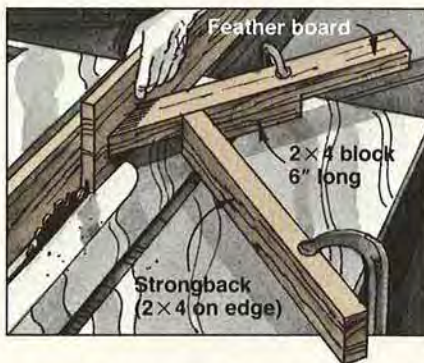

4 Adjust your fence for the desired thickness of stock. For example, set the fence  $\frac{1}{4}$ "

from the blade for  $\frac{1}{4}$ "-thick stock. Then, clamp the featherboard and another 2'-long piece of 2x4—known as a strongback—to the table saw as shown bottom center. The top of the featherboard should be flush with the maximum height of the blade, and positioned just ahead of the blade with all the fingers in contact with the board. We raised the featherboard with a 6"-long block of 2x4 nailed to its underside. Set the strongback, which prevents the featherboard from pivoting toward the rear of the saw, at a 90° angle to the featherboard.



5 Before making any cuts, be certain the workpiece has one flat, true face that goes toward the fence. Raise the blade to a height of  $\frac{3}{4}$ " for your first cut. Be sure to keep downward pressure on the board with one hand, while feeding the board with a pushstick in your other hand. After completing this cut, flip the board end-for-end, place the same face against the fence, and make a cut into the opposite edge of the board as shown above. Repeat this sequence, raising the blade in  $\frac{1}{2}$ " increments. Be sure to use a sharp, rip-profile blade, and stand to one side of it when sawing. ♣

Illustrations: Jim Stevenson



# RAIN FOREST UPDATE

Is logging destroying the rain forest?  
If so, what can be done?



## Woodworkers weigh responsibility at WARP's founding conference

Last November, the Woodworkers Alliance for Rainforest Protection (WARP) gathered craftsmen, suppliers, and top international experts at the University of Massachusetts to ponder the use of rain forest woods. Here are the highlights.

—Peter Stephano, Senior Editor

"The tropical hardwood trade is a \$7 billion a year business," reported speaker Ivan Ussach, director of the Rainforest Alliance's Tropical Timber Project. According to him, Japan and Europe import the most tropical hardwood, although the United States leads in dollar value because it imports more finished products.

Despite this dependence, the U.S. has never paid its \$138,000 membership dues to the International Tropical Timber Organization (ITTO). This revelation came from Donald Thompson, a Philadelphia-based importer. "The ITTO," Thompson explained, "was established in 1985 to develop policies for sustainable utilization of tropical forests." Thompson urged attendees to

campaign for U.S. financial support of ITTO programs (see box below right).

### Will a boycott work?

WARP's collective answer was "NO!" A boycott by woodworkers and other consumers would only lower the value of rain forest species. That's according to keynote speaker John E. Earhart, a forester with years of rain forest experience and representative of the World Wildlife Fund and the Conservation Foundation.

Even selective logging—when harvesters enter the forest to cut only certain trees—damages as much as 60 percent of the remaining trees. So said Robert Siemeone, a tropical forest specialist from Land O'Lakes, Wisconsin.

What then is the answer? One was given by Christopher Cox, director of the Ecological Trading Company (ETC), Newcastle on Tyne, England.

### Certifying the source

"Woodworkers must be certain that tropical woods come from sustainable sources," Cox said. A

cabinetmaker, Cox oversees ETC's purchases of rain forest woods, often visiting South American villages. "For a rain forest community to have its wood certified, it must own the land, inventory the trees, log responsibly, and get a fair price," he said.

Certification, such as required by the ETC, seems a priority. Even now, woodworkers should inquire where stock comes from, and demand responsible sources.

### Here's how to help

To urge more economic support for the International Tropical Timber Organization's efforts, write: U.S. Senate Subcommittee on Foreign Operations Appropriations, Washington, DC 20510.



### Support WARP with a sweatshirt

WARP founding members Scott Landis, Leonard Lee, and John Shipstad display WARP's new sweatshirts. Sweatshirts are pale tan, 100 percent cotton fleece, in M, L, XL for \$29.95 (U.S.) ppd. Cotton T-shirts also available for \$14.95. Order from WARP, Box 133, Coos Bay, OR 97420. Entire proceeds fund WARP and its rain forest wood programs. 🌿

Illustration: Jim Stevenson  
Photograph: David E. Donnelly



# ONE LEAN JELLY BEAN MACHINE

 Print this article

## First, let's cut the parts

**1** Rip and crosscut the sides (A), the cover pieces (B, C), and the base pieces (C, D) to the sizes listed in the Bill of Materials. (We made our jelly bean machine out of  $\frac{3}{4}$ " pine.)

**2** Cut a  $\frac{1}{8}$ " saw kerf  $\frac{3}{8}$ " deep and  $\frac{3}{16}$ " in from the outside edges of each side-piece where shown on the Exploded-View drawing *opposite page*. (These kerfs hold the clear acrylic panels.)

**3** Using the dimensions on the Side-View drawing, *opposite page*, mark the center point locations for the five dowel slides (E, F), the two 1" crank holes, and the exit hole centered from edge to edge, on the inside face of the two sidepieces. Now, as shown *below*, tilt the table on your drill press table  $30^\circ$  from center. (If your table doesn't tilt, make a temporary jig to hold the sidepieces at the desired angle and clamp it in place while you drill the holes.) Using a brad-point bit, carefully drill 1" holes  $\frac{5}{8}$ " deep for the slides, making sure you angle each hole as shown on the Side-View Drawing *opposite*. (We set the stop on our drill press to prevent drilling through the side, and then test-drilled holes in scrap stock.) Next, drill completely through the right hand sidepiece for the angled-exit hole.



From the pages of sister publication **WEEKEND WOODWORKING PROJECTS®**, this clever, fun-to-build project not only fascinates, it also satisfies your sweet tooth in a hurry. Just fill it with jelly beans, turn the crank, and watch your treat tumble down the slides and into your hand.

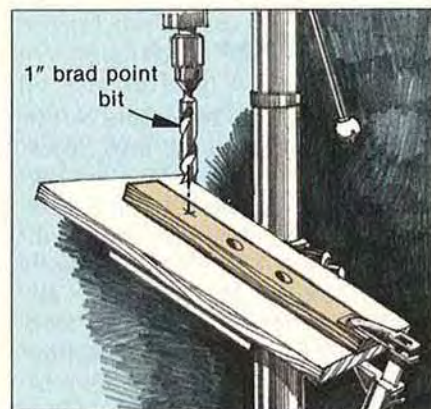

**4** Level the drill press table, and drill the 1" hole in each sidepiece (where marked) for the crank. Now, drill a 2"-diameter hole  $\frac{3}{8}$ " deep, centered from side to side, in the base where located on the Side-View drawing. (We used a forstner bit.)

**5** Cut two pieces of  $\frac{1}{8}$ " clear acrylic to  $4\frac{1}{2} \times 13$ " long. (We cut ours on a bandsaw fitted with a  $\frac{1}{8}$ " fine-tooth blade but you can use a tablesaw.) Leave the protective cover on the acrylic to avoid scratching the surfaces until you're ready to install the panels.

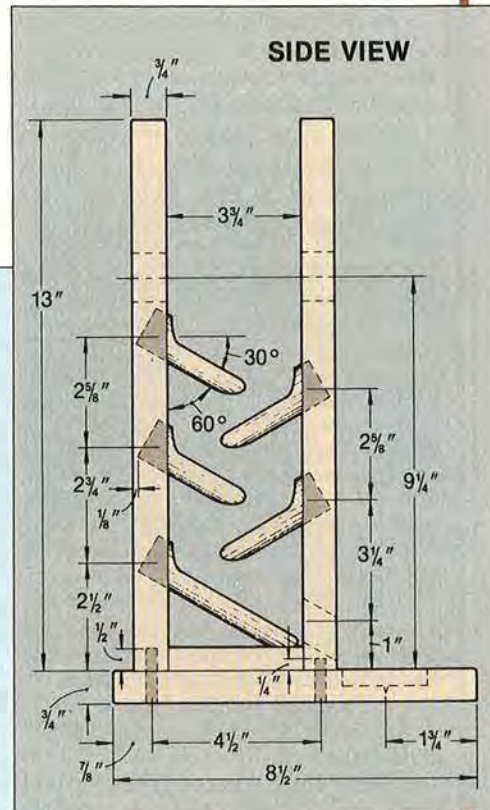
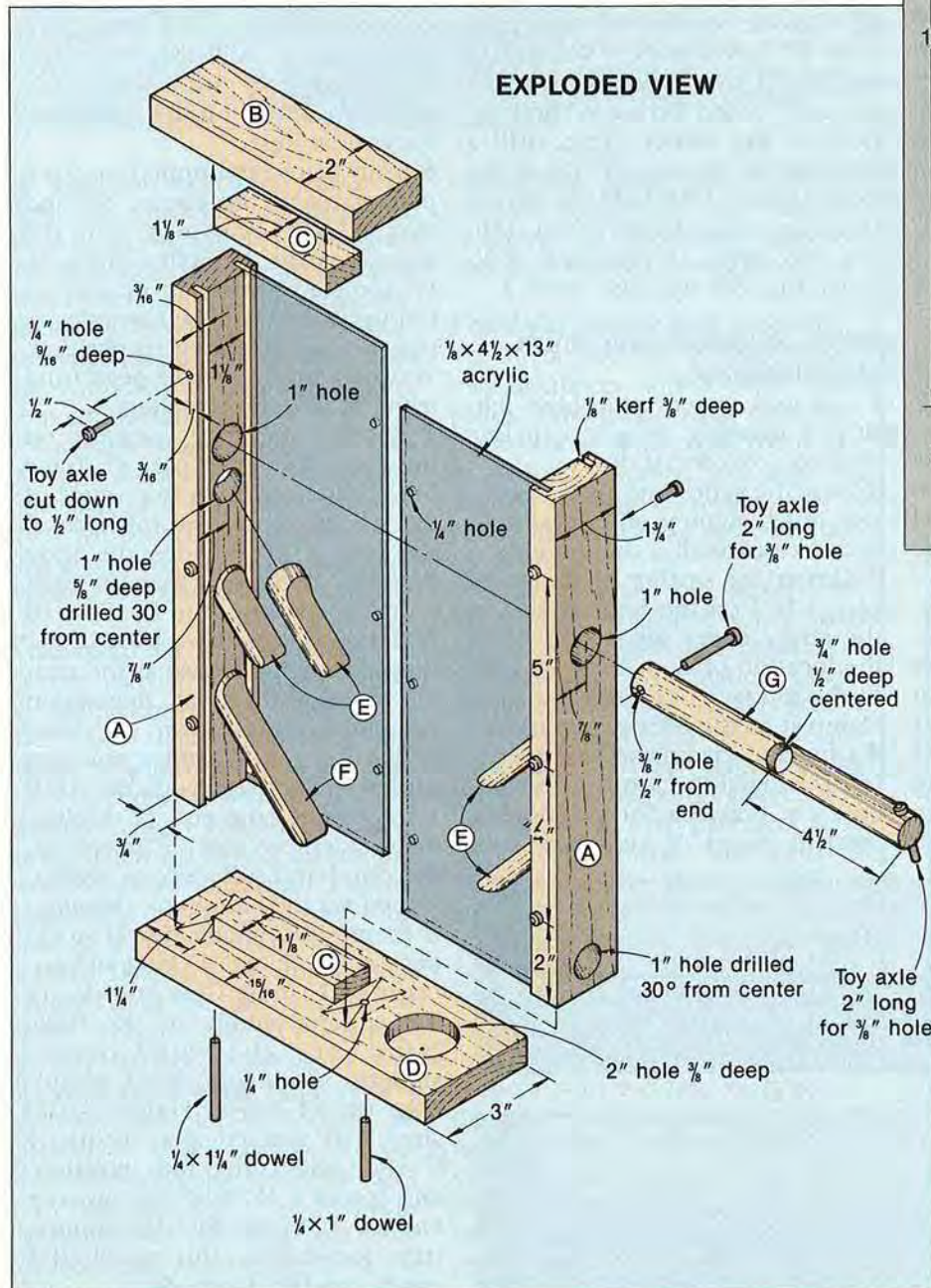

Part	Finished Size*			Material	Qty.
	T	W	L		
A	3/4"	1 1/4"	13"	pine	2
B	3/4"	2"	6"	pine	1
C	1/2"	1 1/8"	3 11/16"	pine	2
D	3/4"	3"	8 1/2"	pine	1
E*	1" diam.	3"		birch dowel	4
F*	1" diam.	4 1/2"		birch dowel	1
G	1" diam.	9"		birch dowel	1

\*Parts marked with an \* are cut larger initially, and then trimmed to finished size. Please read the instructions before cutting.  
**Supplies:** 12—toy axle pegs for 1/4" holes, 2—toy axle pegs for 3/8" holes, 2 pieces of 1/8" x 4 1/2" x 13" acrylic, 1/4" dowel stock, marking pens or aniline dyes for coloring parts.

## JELLY BEAN MACHINE

**6** To form the four short slides (E) shown in the Exploded View drawing, first cut a piece of 1"-diameter dowel stock to 11" long. Then, cut a piece of scrap to 3×4". Position the dowel on scrap so each end extends 3½" beyond the ends (see *below*).

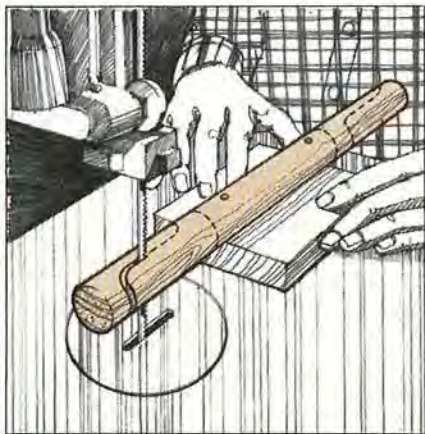

**7** Snip off the head of a 4-penny nail, and use the nail as a bit to drill two holes through the dowel and into the scrap holder. Nail the dowel to the holder.

**8** Using the Full-Size Slide drawing *below* as a pattern, mark cut-lines on each end of the dowel where shown. (We traced two patterns on paper and adhered one to each end of the dowel with spray adhesive.) Then, using a bandsaw fitted with a ⅛" blade, cut the curved lines first. Then,

crosscut the slides to length where shown with the dotted line. (You'll get two slides from each end of the dowel.)

**9** To form the longer bottom slide, cut a 1"-diameter dowel to 9". Then use the full-sized drawing of F and the ¾" scrap holder, and repeat steps 7 and 8.

**10** Cut the crank (G) to length from 1" dowel stock. (We sanded the dowel so it would turn easily in the 1" hole.) Drill a ¾" hole ½" deep at the center. Next, drill a ⅜" hole ½" from each end of the dowel crank. (We held the dowel crank in a handscrew when drilling the holes. If you have a V-block jig, that will also work.)

### Now, assemble and finish the dispenser

**1** Use red, green, and blue felt-tipped marking pens or aniline dyes to color the slides.

**2** Glue the slides into their respective holes, wiping off excess glue squeeze-out with a damp cloth.

**3** Center the smaller of the cover pieces (C) on the bottom face of the larger cover piece (B). Mark the location of C on B, apply glue to the top face of C, and glue and clamp it to the area just marked.

**4** Glue and clamp the base pieces (C, D) together (see the Exploded-View drawing for positioning *opposite page*). If necessary, trim

part C to fit between the saw kerfs in the sidepieces.

**5** Position the acrylic panels in the kerfs between the sidepieces. With the ends of the acrylic flush with the ends of the sidepieces, "clamp" the assembly together with tape or rubber bands. To hold the acrylic panels permanently in place, use a brad-point bit to drill ¼" holes ⅛" from the inside edge of both sidepieces where indicated on the Exploded-View drawing.

**6** Stain or use felt-tipped marking pens to color the twelve ¼" and two ⅜" toy axle pegs. Cut the shanks of the ¼" axles down to ½" long. Apply a dab of glue to the tip and insert the toy axles to peg the acrylic panels in position. You can buy toy axle pegs from many mail-order suppliers.

**7** Position the slide assembly on the base and over part C. Trace the outline of the bottom ends of the sidepieces on the top face of the base (D). Remove the slide assembly. Draw diagonals in each marked rectangular outline to find the center. Now drill a ¼" hole through the base at the center of each diagonal. Reposition the slide assembly on the base, and using the ¼" holes you just drilled in the base as guides, drill ½" deep into the end of the left-hand sidepiece and ¼" deep into the right-hand sidepiece as dimensioned on the Side-View drawing.

**8** From ¼"-diameter dowel stock, cut one piece to 1¼" long and another to 1" long. Glue and dowel the slide assembly to the base. Hand-sand the wood pieces smooth, sanding a slight round-over on all edges. Finish as desired. (We applied spray lacquer.)

**9** Slide the crank into position, and install a ⅜" axle peg at each end of it. Now, fill the hopper, turn the crank, and watch the candy tumble down. ♣

SLIDES  
FULL-SIZE

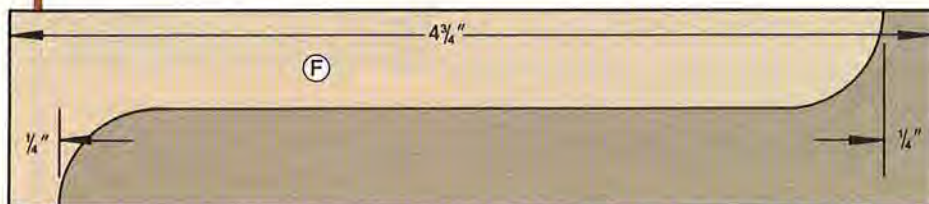
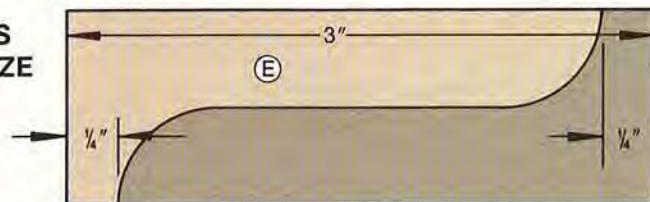

## YESTERDAY'S TOOLS

# MARKING GAUGES

WHEN ONLY FINE LINES WILL DO



Sample this collection of gauges and their present-day values, clockwise from top: Stanley No. 60 iron marking gauge, \$75; William's patent combination gauge, \$300; Stanley double-beam boxwood gauge, \$60; Scholl's patent rosewood marking and mortise gauge, \$250; Blaisdell's patent, \$300.

**E**gyptian craftsmen made do with chalk lines for laying out work on wood. The Romans relied heavily on the compass to trace lines and transfer measurements. But it wasn't until the marking gauge emerged in the mid-1700s that woodworkers could achieve pinpoint accuracy.

The first marking gauges, then as now, were simple tools. They consisted of a hardwood beam or stem with a scribing point at one end and a sliding head that could be fixed in position with a wedge.

### The road to improvement

By the early 19th century, wooden thumbscrews and setscrews in the head began replacing the wedge arrangement. This improvement speeded adjustment and increased accuracy. English toolmakers, though, never adopted the thumbscrew—almost all English marking gauges rely on a flathead screw that must be set with a screwdriver.

Once the head of the marking gauge could be firmly secured, other avenues of development opened up. For instance, by adding a second sliding beam with a scribing point, the tool could accurately and repeatedly lay out both sides of tenons and mortises.

By the mid-1800s other special gauges arrived for laying out door hardware and hinge butts. With the addition of roller spurs at the end of the beam (see the William's patent

combination gauge, above), woodworkers could cut fine lines in workpieces in order to give saws and chisels a foolproof starting place.

### Polished metal and patents

To extend the life of gauge heads, manufacturers added brass wear plates. Some gauge heads were even made entirely of metal. The beam of a gauge took a beating, too, requiring the use of dense hardwood such as beech, cherry, ebony, and rosewood for this piece.

Combinations of wood and brass made attractive tools, such as the rosewood and brass William's patent combination gauge, introduced in 1859 by the Stanley Rule and Level Co. This device featured a mortise gauge, cutting gauge, and marking gauge, and was Stanley's first patented tool. Back then, it sold for a pricey \$1.80. By 1879, Stanley marketed an all-iron gauge.

Special gauges also met the needs of various trades and differing applications. An example is Blaisdell's patent for marking lines parallel to convex and concave surfaces with the help of brass adjusting wings. Scholl's patent gauge of the 1880s, made by the Chapin Tool Company, used three or four stems clamped by one headscrew, enabling the user to lay out intricate joints.

Written with Philip Whitby  
Photograph: John Hetherington

## HARDWOODS

### EXOTIC & DOMESTIC OVER 75 SPECIES

LUMBER • PLYWOOD • VENEERS  
TURNING SQUARES & BLANKS

### COLLECTORS SAMPLE KIT

30 EXOTIC & DOMESTIC WOODS  
1/2" x 3" x 8" SANDED FINISH

**\$29.00** PLUS \$5.00 S&H

Ideal for: Collectors • Schools • Craftsmen • Cabinet  
& Furniture Makers • Architects • Designers



**1-800-423-2450**

**WOODWORKERS** Supply

5402 S. 40th St. • Phoenix, AZ 85040  
(602) 437-4415

## Garrett Wade

161 Avenue of the Americas  
New York, NY 10013

(212) 807-1155 for service

(800) 221-2942 for orders



**Woodworking Tool Catalog:** 212 pages of tools from the USA and around the world. Workbenches; Router Bits and Accessories; Measuring Tools; Carving Tools; Planes; Chisels; Finishing Supplies; and Books. With tips on selecting, using, and maintaining the tools that will serve you best. **\$4.00**

**Classic Hardware Catalog:** 64 pages of the finest brass furniture hardware. Hinges; Latches; Locks; Handles; Knobs; Casters; Architectural and Door Fittings. **\$2.00**

### Cradle Plans

You can easily build this classic cradle which is sure to become a family heirloom. Available in two sizes: Baby & Doll size.

72 pg. catalog  
free with order

### Two Cradle Plans One for Babies One for Dolls



Baby size Plan (21 x 35) **\$11.50**  
Spindle Kit/Rosettes **\$26.25**  
Doll size Plan (10 x 18) **\$5.25**  
Spindle Kit/Rosettes **\$12.95**

M/C Visa orders call toll-free 1-800-292-8296

Frt. 48 States \$3.50. AK, HI add 25% of order. NY add tax. Canada add 50%. Use Visa/MC or M.O. in U.S. funds. Min. order is \$15.00. Catalog \$1.00 or sent FREE with order.

ARMOR, Box 445-E, East Northport, NY 11731

### SPECIAL OFFER

## BRANDING IRON

For hard and soft wood



**\$24.00**

Plus \$2.00 for shipping and handling  
Nebr. residents add correct sales tax

**SATISFACTION GUARANTEED**  
or your money back

- Shipped in one week
- Solid brass head — raised letters
- 1st Line: HAND CRAFTED BY — as above
- 2nd Line: Your choice — 20 characters/spaces max.
- Complete with wood handle
- As above but with 3rd line — \$37.00 + \$2.00

ORDER TOLL FREE **1-800-826-7606**

For free brochure, write or call (402) 464-0511

Order by mail from: **NOVA TOOL CO.**  
12500 Finigan Rd., Dept. BH  
P.O. Box 29341, Lincoln, NE 68529



**TOOLS**

TOOL FORCE

# TOOL

# FORCE

28365 U.S. Hwy 19  
Clearwater, FL  
34621  
813/726-4177

**Let Us Quote You!**

**TOLL FREE 800/553-4177 FAX 813/726-4582**

## SKIL 2735-04

**TOP GUN**  
Drill/Driver Kit  
w/ Extra Battery

Reversible 12V. Super Pack, removable, rechargeable battery. 2 gear ranges: high torque and high speed. Variable torque clutch with five settings and full lock-up. Heavy duty chuck, chuck key storage in handle. Molded carrying case.



**\$124.00**

## HITACHI M12V

Electronically Controlled  
1/2" Plunge  
Router

Super duty 3 1/4HP motor w/soft start & variable speed control. All ball bearing construction. Spindle lock for easy bit change. Depth adjustment mechanism. Comes w/straight guide, bar holder, 2 wing bolts, template guide, wrench, straight bit, chuck sleeve, template adapter.

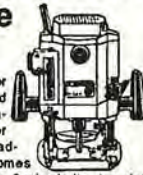

**\$235.00**



UNIQUE TRIANGULAR  
SANDING PAD ALLOWS  
YOU TO SAND IN COR-  
NERS UNLIKE ANY  
OTHER SANDER!

**636**

corner to corner  
3 1/8"



636 Sander w/ metal case \$269.00  
096019 Sandpaper 50pcs.60grit \$17.50  
097013 Sandpaper 50pcs.80grit \$17.50  
098011 Sandpaper 50pcs.100grit \$17.50

## SKIL 1605-02

Plate Joiner  
W/ Case & 1000 Free Mixed Biscuits



Front fence angles 45° and 90°. Precision bevel gears. Dust collection bag. Includes carrying case, wrench, instructions and 1000 biscuits.

**\$139.40**

## RYOBI JP155

Jointer-Planer

6 1/8" Variable speed 8,000 to 16,000 rpm. Adjustable fence can tilt to 45°. 10.5 amp motor has all ball bearing construction. Adapts to 2 1/4" vacuum hose. Comes with blade adjustment gauge, 'T' type wrench, screwdriver, vacuum hose adapter, push block, angle gauge.

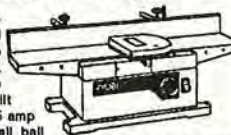

**\$308.00**

## 'Find The Name' Game

Find the names of 7 Manufacturers and you could win \$1000.00 in ToolForce merchandise. Rules: Entries must be received by June 30, 1991. No purchase necessary. Winner will be drawn at random from correct entries on July 10, 1991 and notified by registered mail. Answer must be submitted on any 3" x 5" card or paper to comply with Florida State laws.

DELTAMA  
MILWAUK  
GNIKIVE  
ALIKSAE  
STDUERF  
AAIBOYR  
IHCATIH

## DREMEL



Variable Speed Moto-Tool Kit w/ 40 Accessories, Perfect for Grinding, Drilling, Cutting, Sanding. Speed control to 30,000rpm

**\$64.40**

## SUNGOLD

Sanding Belts

321050	Box of 10 belts 50 grit	\$11.00
321080	Box of 10 belts 80 grit	\$10.20
321100	Box of 10 belts 100 grit	\$9.80
321120	Box of 10 belts 120 grit	\$9.80
324050	Box of 10 belts 50 grit	\$10.80
324080	Box of 10 belts 80 grit	\$10.80
324100	Box of 10 belts 100 grit	\$10.60
324120	Box of 10 belts 120 grit	\$10.60
424050	Box of 10 belts 50 grit	\$16.40
424080	Box of 10 belts 80 grit	\$15.40
424100	Box of 10 belts 100 grit	\$15.00
424120	Box of 10 belts 120 grit	\$19.80

10% off  
on order of 10 boxes or more

## Shophelper

Safety  
Hold-Downs

Safe handling of stock. Completely adjustable, 10 lbs. of pressure in any position. Ratchet bearings turn one way. Anti-kickback. Will not mar work. Material 1/4" square can be run. #211 Clockwise, #212 Counter Clockwise, #213 Free Turning hold down only.

**\$59.80**  
#291 - 2 Pcs 12" Stack 2 gibbs, Hardware \$19.90

## Magna-Set

Jointer Knife Jig

Accurately set Jointer knife in any jointer with this magnetic knife setting jig. tolerance to ± .001". Rugged steel with permanent Alnico magnets. Change knives in minutes.

**\$44.40**

## Trakita

SLIDING  
COMPOUND

10" Blade miter, bevel or compound cutting is easy. 2 1/16" X 12" . 12A. motor with electric brake and shaft lock for easy blade change. Optional LU91M010 10 X 60 Freud Carbide Blade

**\$59.90**  
LS1011

Will even cut nail embedded material !!



TK203	7-7 1/4"	24 teeth ripping	\$17.90
TK204	8-8 1/4"	24 teeth ripping	\$21.40
TK206	10"	24 teeth ripping	\$23.40
TK303	7-7 1/4"	40 teeth Fine Cutting	\$23.40
TK304	8-8 1/4"	40 teeth Fine Cutting	\$25.40
TK306	10"	40 teeth Fine Cutting	\$25.40
TK903	7-7 1/4"	30 teeth combination	\$20.40
TK904	8-8 1/4"	35 teeth combination	\$26.40
TK906	10"	50 teeth combination	\$29.40

## DELTA

12" Planer  
22-540

1.5 A. 2 - knife cutterhead. Cuts up to 6" thick. Feed assembly raises & lowers on 4 steel columns for easy adjustment and unmatched precision. Planer Only \$418.00 Extra Knives only \$26.20. PLANER W/ EXTRA KNIVES

**\$429.40**

## Taper Drill Bit Set

0256-018

22 pieces including 7 bits for screw sizes #5, 6, 7, 8, 9, 10, 12, adjustable stop collars, countersinks and Allen wrench in handsome wooden case.

**\$29.40**

## DELTA

16" Scroll Saw  
40-560

2 Speed 115V. 1/10 HP induction motor. Quik-Set blade changing system. Cutting Capacity 2" thick. Cast iron table tilts to 45°.

**\$184.40**

**We Have Much More Than You See Here**

**FREE FREIGHT IN THE CONTINENTAL USA**



**Your Check Is Welcomed!**

Errors subject to correction

Wood Magazine 5/91

Prices may change without notice

# FATHER'S DAY

# ✓ GIFT LIST

Father's Day is June 16. Check the items you want, tear out this section and casually leave it where your family can find it. They'll get the hint!



- This Craftsman 16-inch variable speed scroll saw will allow Dad to perform intricate curve cutting required on many projects, such as signs, inlays, toys, and crafts. He can select any speed from 500 to 1500 strokes per minute for cutting various materials. Just zip on down to your Sears store to see the many features of this tool for yourself.



- 20 Bd. Ft. Aromatic Red Cedar. Excellent for chests, boxes, or toys. 5'-7" wide, 3'-7" long, S2S 3/4 or rough 1". Shipped UPS prepaid, \$45. Steve H. Wall Lumber Co., Rt. 1, Box 287, Mayodan, NC 27027. 1-800-633-4062 or 919-427-0637.



- Genuine Aladdin® Solid Brass Lamp with Opal Waterfowl scene shade. Functional, beautiful, complete lamp differs little from original 1908 Aladdin design. Choose oil burning #8136C or electrified #8137C, both \$119.95 plus postage and handling. 1-800-843-3320. Van Dykes, Woonsocket, SD 57385.



- New style lounge chair plans \$12.95. Contoured for greater comfort. Has 3 positions and arm rest that automatic adjusts to each. Color catalog \$2.00 Free with order. Specialty Furniture, 797 W. Remus, Mt. Pleasant, MI 48858. Visa/MC. MI 4%.



- Performax Drum Sanders—Exclusive features at an affordable price for precise wide surface sanding. The complete line includes the retrofitting Performax Component Sander, the Pro Max II, Super Max 25, Super Max 25x2, and Super Brush 24 Sanders. New accessories for production-mode sanding of pieces as small as 2 1/4" long. Send for brochure \$1.00. Performax Products, Inc. 12211 Woodlake Drive, Burnsville, Mn 55337. 1-800-334-4910.



- Happy Father's Day from Woodworks! Our 16 piece American made countersink set is in a beautiful hard wood case, regularly \$65.00, is on SALE for only \$49.95. It contains taperpoint drills and countersinks for #6, #8, #10, #12 and #14 screws. It also comes with 3/8" and 1/2" stop collars and matching plug cutters—everything you need. FL-8000, \$49.95. Woodworks, P.O. Box 14507, Fort Worth, TX 76117, 817-281-4447.



- Executive Wood Toys! Now you can create this 1929 Ford van and many others like it from our detailed and easy-to-read patterns. We offer you a complete line of patterns, parts, and wheels. Make this holiday season a time to remember with our Executive Wood Toys. Send \$1.00 for catalog to: TOYS AND JOYS, Box 628 GL. Lynden, WA 98264.



- FREE Woodworking Tool Catalog! Woodcraft offers over 4,500 of the finest quality woodworking tools, books, supplies, and cabinetry hardware in our complete full-color catalog. Cabinetmakers, craftsmen, carvers, woodturners, and woodworking hobbyists have depended on Woodcraft since 1928. Toll free ordering and technical assistance. Woodcraft Supply. 1-800-542-9115. Dept. 91W106T.



Moisture-related problems such as shrinking, warping and cracking can ruin the most beautiful wooden pieces built. Avoid wood moisture problems by checking the wood with a moisture meter! The pocket-size Mini Ligno moisture meter is for the serious hobbyist and professional woodworker. Lignomat, P.O. Box 30125, Portland OR 97230. Call 503-257-8957 or 800-227-2105.



### WOODS OF THE WORLD

Exotic Imported and Domestic Hardwoods—Over 75 species of lumber, bowl blanks, turning squares and veneer. Collectors Sample Kit. 30 exotic and domestic woods. 1/2" x 3" x 6" sanded finish. Ideal for collectors, cabinet and furniture makers, designers and architects. \$29.00+ \$5.00 S&H. Woodworkers Supply, 5402 S 40th Street, Phoenix, AZ 85040 or call toll free 800-423-2450.



Trimtramp™ Saw Table allows your portable circular saw to make unsplintered picture-frame quality miter cuts, 16" wide cross-cuts, bevels and combination cuts up to finished 2x4 thickness with greater accuracy, efficiency, portability (21lb) and safety than a radial arm saw, at a fraction of the cost. Comes fully assembled. Dimensions: 24 1/2"W x 32 1/2"L x 4 1/2"H. Trimtramp Ltd., P.O. Box 740, Buffalo, NY 14213. 800-267-8776.



Fastener Carrying Case with flip-up bins. Now you can carry or store many different items without mixing them up. Extra deep compartments open together for quick selection. Movable dividers let you resize to meet needs. Easy to hang on pegboard. 15 1/2"H x 3 1/2"W x 4"D. \$19.95 each. Call Trend-lines 800-767-9999.



The Porter Cable 7335 Sander is a variable speed random orbit sander which produces a swirl-free finish. The 5" Pad accepts all weights of adhesive backed discs. With a speed of 2500-6000(OPM), the heavy-duty 3.7 amp motor is excellent for any sanding or smoothing job. List price \$225.00 yours for \$129.00. Tools On Sale, 216 W. 7th St. St. Paul, MN 55102. Call 1-800-328-0457. In MN, 612-224-4859.



Here's a complete package for duplicating missing parts and making extra money, too! Anyone can easily make the part shown above. Also makes it easy to replace Victorian carvings, pressed wood ornamentation, turned finials, glass knobs and brass hardware parts. Dupli-Kit is a super add-on business or part-time opportunity for men or women. Everything you need is included. Complete furniture restoration catalog, \$2. FREE workshops. Minuteman, Inc., Dept. 17, 115 N. Monroe, Waterloo, WI 53594. 1-800-733-1776.



Specializing in Abrasives & Refinishing Products for wood working. With Red Hill Corp., you're guaranteed quality, reasonable prices, prompt shipment and free freight. Small orders welcome! Send for information. Red Hill Corp., P.O. Box 4234, Gettysburg, PA 17325. (800) 822-4003.



Remember the car of your dreams. It's offered as a beautiful, yet simple clock kit from the exclusive "Americana" collection from Klockit. There are 21 kits available. See this great '57 Chevy and others in their current full color catalog. Call 1-800-KLOCKIT (That's 556-2548).



Like a third hand. Provides that extra support so often needed. Its rugged, heavy-duty, all-steel construction makes it a tool you'll depend on for years. Roller is 13" long, galvanized and ball bearing. Adjusts in height from 25 3/4" to 45". When you're done it folds flat. #HPR-13, \$39.95+ UPS. HTC Products, Inc. Toll free 1-800-624-2027.

### Armor Products

Since 1967

- Clock Movements
- Toy Plans & Parts
- Furniture Plans
- Wood Goods
- Assorted Hinges
- Door Harp Parts

If you are making toys and other items for craft shows, don't overlook our great selection of patterns for rocking horses, toys, cars, clocks and furniture. Specialty supplies, hardware, tools and gift items also available. Catalog \$1.00. Armor Products, Box 445-FDGL, East Northport, NY 11731.



Ready to assemble and finish kits, include desks, chairs, dining tables, hutches, sideboards, and living room occasional tables. Beautiful Queen Anne style available in Cherry-Oak-Mahogany-and Walnut. Catalog also includes various legs and table bases for the serious woodworker. Adams Wood Products, Inc., Dept. FDGL91, 974 Forest Drive Morristown, TN 37814. 615-587-2942.



Complement your picnic table with our Patio Condiment Holder. The parts kit includes salt & pepper shakers as well as ketchup and mustard dispensers. All you need is a little 1/4" plywood and some bright paint to complete. Umbrella optional. #04275EZ Plans & Parts Kit \$6.00, #78565 Mini Umbrella \$3.99/ea.-add \$4 processing charge. Over 200 other project plans available. Catalog \$2.00, refundable on first order. Crafter's Mart., P.O. Box 2342, Greeley, CO 80632.





Build tomorrow's heirloom today! "Merrilegs", designed to capture the spirit and beauty of a child's loyal steed, also provides pleasure and satisfaction for the woodworker. Full-size, easy-to-make plan #121, \$12.95 ppd. Catalog of 200 professionally designed plans for building furniture \$3.00. Furniture Designs, Inc., 1827 Elmdale Ave., Glenview, IL 60025. Mastercard, Visa. (708) 657-7526.

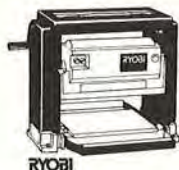

\$348.00 Takes home this Ryobi 10" portable planer for the home craftsman or the serious professional on your gift list. Supplies are limited, so order yours today to assure arrival by Father's Day. We Offer Free Freight and Same Day Shipping. Order now from Tool Crib, P.O. Box 1716, Grand Forks, ND 58206. Toll free 1-800-358-3096.

### Jet Clamp System



Every Dad can use another clamp. You can swivel a Jet Clamp out of your way without loosening it, and without losing your clamp grip! Jet Clamps are extremely versatile and have a lifetime warranty. Father's Day Special—50% off! Sale price \$25.95 plus \$3.95 S/H. AMI, Ltd., P.O. Box 312, Dept. 446, New Castle, DE 19720 or call toll-free 1-800-648-4264.



Create popular and profitable Yard Cows! Includes Full Size patterns plus painting instructions for a 41" tall cow and 24" tall calf. Add a touch of country to your yard and garden! Patterns plus woodcraft catalog only \$8.00. Accents In Pine, Dept. QA51, Box 7387, Gonic NH 03839.



There always seems to be one certain hanger which works best for each different item you need to hang. This 370-piece assortment includes 14 different hangers—140 in all plus 230 fasteners and organizer box. Order #8403 assortment at \$14.99 plus \$4.95 per order for P&H to Meisel Hardware Specialties, P.O. Box 70GS, Mound, MN 55364.



Add beauty and charm to your home with Emperor's Marquis Mantel Clock. This easy to assemble kit is solid 3/4" cherry and features triple chimes and beveled glass. Sale priced at \$219.50. Send \$1.00 for full color catalog. Emperor Clock Company, Dept. 3999, Emperor Industrial Park, Fairhope, AL 36532.



Swedish miter makes easy work of cutting perfect picture frames and mouldings with its thin, tensioned 18tpi blade. Max size of workpiece at 90°; 6 1/2" wide x 4 1/2" high. 5 pre-set stops. \$137.25 ppd. Garrett Wade Co., 800-221-2942.



The Woodworkers' Store 1990-91 catalog with over 250 new items features 100 color pages of domestic and exotic hardwoods, veneers, wood parts, specialty hardware, kitchen accessories, finishing supplies, tools, books, and plans... Many exclusive items and hard to find specialties. Orders shipped in 24 to 48 hours. \$1 credited towards first purchase. Satisfaction guaranteed. The Woodworkers' Store, 21801 Industrial Blvd., Rogers, MN 55374. 612-428-4101.



You're not alone when you do it yourself. Constantine's Woodworkers Catalog is right alongside with whatever you need to build, restore, repair and refinish. Over 4,000 items including hardwoods, brass cabinet hardware, 150 kinds of veneers, inlays, moldings, specialty woodworking tools, wood finishes, plans and books. Catalog \$1.00. Constantine's, 2054 Eastchester Road, Bronx, NY 10461.

OVER  
**1000**  
FULL SIZE  
PATTERNS

Make popular country folkart, wind action whirligigs and mobs, country shelves and shadowboxes, eyecatching yard figures, Christmas decorations, simple furniture, toys, games and much more. Simply trace our full size patterns onto wood and cut out... no enlarging is ever necessary! All of our unique projects are available in our latest Winfield Collection Catalog \$2.00. Winfield Collection, Dept. FDGL, 12044 Parkin Lane, Fenton, MI 48430.



Ryobi's three new "Torque Force™" cordless driver/drills will drive longer screws, drill holes quicker and drive more screws than any other cordless driver/drills. The 3/8" Torque Force drills are available in 7.2-volt, 9.6-volt and 12-volt models. For more information contact RYOBI at 1-800-323-5615.



Stop pegboard hook fall-out forever! M-CLIPS are the guaranteed perfect solution to the annoying problems of pegboard hooks that come loose when a tool is removed. Fit both 1/4" and 1/8" perfbord, lock into adjacent holes and hold hooks tightly in place. Aetech Corp., P.O. Box 6298, Dept. FDGL, 10 Shadowstone Lane, Lawrenceville, NJ 08648.



We offer over 20 species of the highest quality kiln dried domestic hardwoods. Sold on board footage or cut to order basis. Compare our quality and prices. UNCONDITIONAL SATISFACTION GUARANTEED. Very attractive package deals at delivered prices. Quantity discounts available. Send \$1.00 for NEW catalog. Northeastern Hardwoods, P.O. Box 365-C, Salamanca, NY 14779.



One-page brochure from Nova Tool Company describes branding irons that enable you to put your name on your woodwork quickly and easily. Made specially for branding wood, they are available with 1, 2 or 3 lines of copy or with your logo. Nova Tool Company, 12500 Finigan Rd. Dept. FDGL, P.O. Box 29341, Lincoln, NE 68529. 402-464-0511.



"Merle", the adjustable corner clamp, forces your product into square. Full adjustable from 2 5/8" x 2 5/8" to 69" x 69". Perfect for anything that requires a 90 degree corner clamping. Cast aluminum and steel construction; quick and easy to use. \$22.95. MLCS LTD., P.O. Box 4053D, Rydal, PA 19046 or call toll free 1-800-533-9298. Visa/MC.



Father's Day Special. McCloskey introduces Heirloom® Crystal Clear Polyurethane which is ideal for all interior wood surfaces including floors. Part of Mc Closkey's Clean Air Formula™ line, the water-based, non-yellowing formula is low odor, cleans up with soap and water and doesn't require a hardener additive. Call 1-800-767-CLEAN.

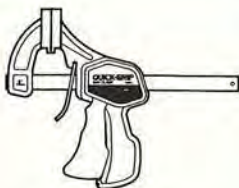

Buy Quick Grip bar clamps and never go back to C-clamps and such!! Fantastic Father's Day Savings. 6"-\$12.75, 12"-\$14.75, 18"-\$15.75, 24"-\$17.75, 36"-\$19.75. 6" Clamp w/corner acc. \$17.75, 7pc. Corner kit. \$5.95. Quaker State Woodworking Supply, Inc., 4434 Kutztown Rd., Reading, PA. 19560 1-800-776-5467. S & H ... Under \$35.00-\$3.75, Over \$35.00-\$4.75, over \$50.00-FREE. Pa. residents add 6% tax.



Delta 16" 2-speed Scroll Saw performs intricate inside curve cutting. Speeds of 850 & 1790 CS/M cut woods, metals, plastics, & compositions. 16" arm to blade & 2" depth of cut. 1 3/4" dia. table tilts 45° for bevel cutting. Quickset blade changing has instant-acting blade tension release lever with patented pivoting chucks & wrench. Frame & table cast iron construction; 1/10 HP 1.6 Amp, single-phase, 115V induction motor, & fingertip blade tensioning control. 2-year limited warranty. Delta International Machinery Corp., 800-438-2486.



Amazing Square Drive Screw virtually eliminates driver bit "Cam-out". Assortment Special includes 100 Flat Head Steel Screws in each of 6 sizes (600 screws in all) from #8 x 3/4" to #8 x 2 1/2", hex shank power driver, 7 1/2" hand driver, and set of 6 storage bins. "Combo Square/Phillips" recess (which uses either driver type) is included along with square recess type in this assortment. Just \$24.00 plus \$3.50 S&H (AK and HI, S&H is \$8.00). Mention this ad when ordering. Offer expires 7/1/91. See ad for catalog and sample pack special. McFreeley's, 712 12th St., Lynchburg, VA. 24505. Toll free 1-800-443-7937.



Flexible 4-way Urethane Hand Sander. Follows contours. Wraps around. Gets into, under and "in-between". Wood, plastic, metal(rust), weathered exteriors/furniture, drywall. Use sandpaper, sanding screen(no loading), cloth abraasive. 80 grit thru 400 grit-up to 2000 micro (wet/dry). Standard 9x11 sheet-4 full strips for F.F. (spray adh.) or use 2 3/4" PSA (pressure sensitive adh.) rolls. Finisher's Friend P.O. Box 6146, Dept. W-2, Lafayette, IN 47903 \$14.95+ \$2.00 P&H or 1-800-325-4584 Visa/MC/Am-Ex.



Give the special Father in your life a gift he can really use. Freud's chisel and carving sets are a great choice for the weekend woodworker to the professional. Each tool is made with chrome vanadium steel, topped with rare boxwood handles. Our chisels are available in a 4, 6 or 10 piece set and our carving sets are available in a 6 and 12 piece set. Any choice of these sets is certain to please even the most difficult to buy for. Item numbers for the chisel sets are WC104, WC106 and WC110. The item numbers for the carving sets are CS106 and CS112. Freud, P.O. Box 7187, 218 Feld Ave., High Point, NC 27264.

## ADVERTISERS:

For information regarding this section, please contact Nancy Lopez, WOOD Magazine, 750 Third Avenue, New York, New York 10017.  
**212-551-6903**

# ASK WOOD

Whether your woodworker's license reads "Beginner," "Intermediate," or "Advanced," you're bound to have a few questions about your favorite hobby. We can help by consulting our staff and outside experts. Send questions to:

Ask WOOD  
Better Homes and Gardens®  
WOOD® Magazine  
P.O. Box 11454  
Des Moines, IA 50336-1454



We'll answer all questions, but due to the volume of mail, we can't publish every letter. We may edit letters selected for publication.

## Getting to know unknown woods

I am sending you samples of wood that I can't find the name of and want to know more about. Folks at the sawmill couldn't tell me anything, and when I ran samples by craftsmen at a woodworker's show, they guessed chestnut and sassafras.



I do know that the tree came from Lancaster County, Pennsylvania. The wood is red, as you can see, light when first cut, but then turns darker. It saws easily, sands well, and takes stain and

varnish. I have subscribed to WOOD magazine since the first issue and like it for its information, patterns, and wood knowledge. I would be grateful for any information you could tell me about this wood.

—John Dupes, Middletown, Pa.

John, you might think that a standing tree, complete with all its leaves and bark, offers the best clues for identification. But with a milled piece of wood, or wood in the raw, the situation changes. Your salvation—a few handy wood-identification books that do wonders helping a novice figure out wood species. Typically, color, density, odor, luster, grain patterns, and growth rings can tell you plenty. Studying the end grain patterns of your samples above, and comparing them with those in our reference books, we quickly arrived at your answer. The mystery wood? Chestnut.

If this subject interests you, check out the following books from your library, or order them from a local bookstore:

### IDENTIFYING WOOD:

Accurate results with simple tools  
by R. Bruce Hoadley,  
The Taunton Press, 1990

### WOOD STRUCTURE AND IDENTIFICATION

H.A. Core, W.A. Cote, A.C. Day,  
Syracuse University Press, 1979

To identify live standing trees, try the Audubon Society's FIELD GUIDE TO NORTHERN AMERICAN TREES by Elbert L. Little, Alfred A. Knopf, 1980.

Continued on page 90

**TRANSPOWER**

SINCE 1953

FOR EXPRESS NEW CATALOGUE CALL

**1-800-654-7702**

## SUPER HEAVY DUTY WOODWORKING EQUIPMENT



250 H.D. Table Saw 1' - 1HP ..... \$350  
200A H.D. Table Saw 3HP ..... \$795  
200A W BIESEMEYER Fence ..... \$995

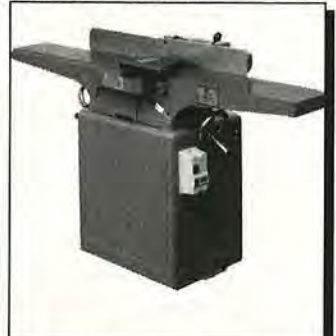

650 H.D. 6" Jointer 1 HP ..... \$295  
860 H.D. 8" Jointer 1' - 1HP ..... \$670  
1200 H.D. 12" Jointer 3HP ..... \$1695



150 Shaper Router 1' - HPS298 ..... \$328  
500 Shaper Router 3HP ..... \$698  
860 Tilt Spindle Shaper ..... \$1150  
150 Auto Planer 12" ..... \$328  
650 Auto Planer 15" ..... \$648  
200A Auto Planer 20" ..... \$1195  
Dust Collector 1HP ..... \$169  
Dust Collector 2HP ..... \$285  
Dust Collector 3HP ..... \$385

We also carry complete line of top quality BAND SAWS, AIR DRUM SANDER, DISC SANDER, BELT SANDERS, AUTO FEEDERS and DRILL PRESSES.

**TCM Industries, Inc.** 322 Paseo Sonrisa, Walnut, CA 91789  
In California (714) 594-0780

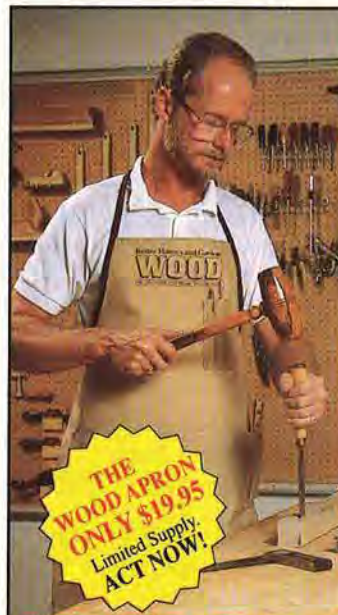

## A GREAT GIFT IDEA

FOR WOOD®  
MAGAZINE  
READERS!  
Just Look At  
These Features:

- ☆ Tough, durable nylon material resists glue and abrasion
- ☆ 3 pockets designed to hold a tape, folding rule, metal rule, and pencil
- ☆ Attractive beige color with a brown border and the WOOD® logo
- ☆ One size fits all
- ☆ Lightweight, comfortable

**THE WOOD APRON ONLY \$19.95**  
Limited Supply. ACT NOW!

**YES!** Please send me The WOOD® Apron. Here is my check or money order for \$19.95 U.S. Includes shipping and handling. Send to: WOOD® Apron, P.O. Box 11454, Des Moines, IA 50336-1454, or, call 800-678-2666.

My Name \_\_\_\_\_

Address \_\_\_\_\_ Apt. # \_\_\_\_\_

City \_\_\_\_\_

State \_\_\_\_\_ Zip \_\_\_\_\_

MasterCard  VISA Expiration Date \_\_\_\_\_

Card No. \_\_\_\_\_

Signature \_\_\_\_\_

# ASK WOOD

Continued from page 89

## Love those materials lists!

The changes you made in the new, improved WOOD magazine are super. However, in the Craft Shop, you make it difficult to build the "easy-to-build" projects by excluding the bill of materials. Each of your other, larger projects has a bill of materials. Your magazine has always stood out from others with clear directions, so why not include a bill with each Craft Shop project?

—Chuck Hopkins, La Center, Wash.



Chuck, thanks for your concern. Providing readers with everything they need to know to build a featured project remains a constant goal in the magazine. With the Craft Shop section, we opted for flexibility. We plan to include a bill of materials only for those projects having several parts. Simple scrollsawed projects cut from a single piece of wood don't really require one. For projects that fall somewhere in between, we intend to include an introductory note telling what wood you'll need to complete the project. We hope this helps.

## Making rosewood rosy

I am having a problem finishing the rosewood trim around my fireplace. I have tried polyurethane with no success. What do you suggest?

—Larry D. Bruck, Logansport, Ind.

Larry, Project Builder Jim Boelling says he has used both polyurethane and lacquer on rosewood and come away with a fine finish. He's developed a process that you may want to try. Because of rosewood's oily nature, Jim advises first wiping the surfaces down with thinner. Then, he applies two coats of sanding sealer thinned at 50 percent. He applies a third coat thinned at 25 percent, and then a final coat full strength.

## The meaning behind MDF

During a visit to a woodturning exhibit, I found several mentions of a material referred to as MDF. Could you inform me what it is and its usage?

—Jaime Corbett, Buenos Aires, Argentina

Jaime, as a well-trained employee at a lumberyard service center would tell you, the letters representing the product you mentioned, MDF, stand for medium-density fiberboard. It's a 4×8 sheet good product purchased in 1/2", 3/8", and 3/4" thicknesses, and made up of a blend of western softwoods and glue. The smooth surfaces of medium-density fiberboard, along with its built-in weather resistance, make it ideal for high-quality outdoor paint finishes. Outdoor signs serve as one of the more common uses of this product.

## The incredible shrinking dowels

Whatever happened to standard sizes in wood dowels? In years past when you bought a 1/2" or 3/4" dowel rod, it measured 1/2" or 3/4" in diameter. No more! Recently, I needed 3/4" dowel for a wood shaft. I shopped at several stores, including Home Depot, Ace Hardware, and True Value Hardware. The so-called 3/4" dowels were from 1/64" to 1/32" undersized, which would result in a sloppy fit. Fortunately, I had enough 3/4" dowel I bought four or five years ago to finish the job. What can I do the next time this happens? Needless to say, I'm plenty confused and don't know where to turn.

—Lee E. Warren, Sun City, Ariz.

Lee, thanks for bringing up this frustrating concern. We did a little investigating at lumberyards and hardware stores here in the midwest and found the problem of undersized dowels to be rampant in our neck of the woods as well. That discovery launched us into a second investigation to find how and why this is happening.

Talking to H.A. Stiles Company in West Brook, Maine, a major manufacturer of dowels that consistently measure to specified diameters, we learned that differences lie in whether the dowels have been kiln- or air-dried, and whether they're made here or abroad. Those air-dried, it turns out, all hail from overseas, from Taiwan, the Philippines, and Malaysia. During shipping or storage, these same dowels undergo slight shrinkage, which results in their undersized diameters. The diameters of kiln-dried dowels, on the other hand, remain stable and consistent from dowel to dowel.

Now, you're likely wondering, "Who can I trust? What lumberyard or hardware store can I go to for actual-sized dowels?" Because so many such places buy in volume and at the lowest prices, your chances of buying undersized dowels seem, unfortunately, pretty good. For this reason, we recommend drilling a hole in scrap to the desired diameter and taking it to your retailer for test-fitting before you buy.

We also recommend calling your favorite mail-order suppliers to find out from whom they purchase their dowels and whether their stock is kiln- or air-dried. We called Dorothy Constantine Dockerty, president of Constantine's, a large mail-order house for woodworking supplies, and found that her buyers ordered dowel stock from Cincinnati Dowel and Wood Products Company, as well as H.A. Stiles. To date, Constantine's has not had a single complaint on dowel diameters. If interested in their catalog, call 800-223-8087. Once you find a reliable source, stick with it.



## The WOOD® magazine textbook

I am a teacher at Roosevelt Middle School and teach technology education. My question is this: Do you publish any educational material that I could use in my classes?

—Ken Eckelberry, Coffeyville, Kan.

Ken, how about "yes" and "no" as answers to your question? Though we do not produce special material for schools, we do produce a ton of highly instructive stories each year in WOOD magazine and sister publication, Weekend Woodworking Projects®. If you've subscribed to WOOD for several issues, then you know that we handle each project as an opportunity to teach readers about some aspect of woodworking. Even if students avoid hands-on woodworking, our features provide lots of opportunities for them to grow.

## Stuck on gluing

My humble woodworker's license reads BEGINNER. Right now, I'm interested in gluing tongue-and-groove strips that measure 1½ × 18" for a breadboard. Could you tell me where the glue needs to go and how I can get it there?

—Roy Mac Nair, Colchester, Vt.

Roy, knowing the secret to successful gluing can do wonders for your woodworking confidence. But how you seal and clean your completed cutting board may have more to do with preserving it for a long, useful life.

Our project builder, Jim Boelling, relies on yellow woodworker's glue for the cutting boards you see in WOOD magazine. When working with tongue-and-groove strips, he says he first stands the joining pieces on their tongues and face-



to-face, holding them together with a clamp. Next, using a ½" acid brush or 1" foam brush (both found at hardware stores), he applies the glue in the grooves and on the shoulders of the grooves. Then, he releases the clamp and quickly coats the tongues of the pieces, placing them one by one in their joining order on a sheet of waxed paper. Finally, he applies hand pressure to bring the pieces together, and rests the lamination on a pair of well-spaced bar clamps. He places a third bar clamp on top of the lamination, midway between the two bottom clamps, and applies pressure evenly to all three.

After trimming the laminations to finished dimensions, and scraping and sanding the surfaces, Jim seals his cutting boards with a nontoxic salad bowl finish. 🌿

**Sleeveless DRUM SANDER**  
Uses regular sandpaper — no pre-made sleeves to buy!



**Lifetime Guarantee**

USE ON:  
Drill press, motor, lathe, combo-tools, radial saw, drills.

Twist of key tightens sandpaper to drum. Rubber backing insures long sandpaper wear.

1" x 3" long	\$14.95
2" x 3" long	\$16.95
2½" x 3" long	\$17.95
3" x 3" long	\$18.95
1" and 2½" above	\$29.95
Set of 4 above	\$59.95
¾" x 3" long	\$15.95
2½" x 4½" long	\$22.95
3" x 4½" long	\$23.95
2½" x 6" long	\$27.95
3" x 6" long	\$29.95

Add \$2.50 per order for shipping.

AVAILABLE WITH:  
\*½" bore with ½", ¾", or 1" shaft  
\*½-20 RH thread (except ¾" x 3")  
\*¾" bore (except ¾" x 3" and 2" x 3")

MC, Visa, Check or Money order to:  
**SINGLEY SPECIALTY CO. INC.**  
P.O. BOX 5087B, GREENSBORO, N.C. 27403  
CALL: (919) 852-8581

**RESTORE FURNITURE for SECURE INCOME Perfect 2nd Career**

Make \$200-\$2,000 a day! Unlimited market; turn-key business. Free workshops. Set-Up Shop for \$2,999-\$9,999! Part-time or full-time. Great for men, women, families.

Make Molds\*Veneer\*Resilver Strip\*Repair\*Refinish

Business Preview Video \$19.95 - Catalog \$2.00  
**MINUTEMAN, INC., Ste. 17**  
Box 8, Waterloo, WI 53594  
**1-800-733-1776**



Full-Size Professional Plan  
**ADIRONDACK CHAIR**

Make this classic American design. Our special version may be folded for storage by using ordinary hardware available at your local store. Be ready for Summer and get your plan now!

CATALOG 200 full-size professional furniture plans — \$3.00  
Plan #700 . . . . . \$12.95 (Catalog free with order)

**FURNITURE DESIGNS, INC. Dept. BA-61**  
1827 Elmdale Ave., Glenview, IL 60025  
(708) 657-7526



**NEW "FINGER RELEASE" BLADE CLAMPS FOR SCROLL SAWS**

Designed to fit most constant tension scroll saws (except far east imports).

CATALOG \$1.00 with details and information on--  
BLADES - BOOKS - PATTERNS

**EXCALIBUR SCROLL SAWS**

**SEYCO "The Scroll Saw Specialist"**  
1414 Cranford Dr • Box 472749  
Garland, TX 75047 - 2749  
**1 800 462-3353**



**WOODWORKERS**  
Save on Wood - Tools - Supplies!

OVER 4000 ITEMS

Send for New 1991 148 Page Money Saving CATALOG

Finest Dimensioned HARDWOODS and Quality VENEERS  
42 VARIETIES  
1/64" to 4" Thickness

Fast service on choice kiln dried Wood and Veneers, Moldings, Trim, Hand and Power Tools, Lamp Parts, Upholstery Supplies, Clock Movements and Kits, Hard-to-Find Hardware, Finishing Materials, Books . . . over 4000 items in stock! Craftsman — Woodworker's best friend.

**CRAFTSMAN WOOD SERVICE**

Dept. WM691, 1735 W. Cortland Ct., Addison, IL 60101  
Please enclose \$1.00 to help pay postage and handling.



**STOP Before You Shop!!**

Foley-Belsaw now carries everything for your woodworking needs!

Before you shop anywhere else, be sure to check out our NEW Woodworkers Outlet Catalog for the best products at the best prices!

It's a FREE call to get your FREE COPY!  
Call 1-800-468-4449 TODAY!

Or write us at-

Foley-Belsaw Co.—Since 1926  
Dept. 44166  
6301 Equitable Road  
Kansas City, MO 64120-9966



# Worth writing for...

You can get useful ideas and product information by mail. Use the coupon in this section to order your choice of literature listed below. Each company mails the catalogs or information directly to you.

## POWER TOOLS

**TOOL CRIB OF THE NORTH IS ANNOUNCING OUR NEW CATALOG**—It features a wide selection of merchandise for your home woodworker to your industrial builder. Top manufacturers such as Black & Decker, Delta, Makita, Porter Cable, Bosch, Milwaukee, Ryobi, Freud and many more. We offer competitive prices with quality service and same day shipping. Send today for your new Acme Electric catalog. It's worth it. ACME ELECTRIC. \$2.00. *Circle No. 6.*

**PORTABLE SAW MILL**—a one man saw mill weighing 45 lbs. Gas and electric models will cut dimensional lumber from logs up to 20 in. diameter. Send for brochure. BETTER BUILT CORP. Free. *Circle No. 10.*

**FREE WOODWORKING POWER TOOL CATALOG**—Buy planers, jointers, shapers, table saws, scroll saws, bandsaws, drill presses, wood lathes, sanders, dust collection systems, and more...direct from the factory and save. Foley-Belsaw sells direct to you...so you save on every purchase. You'll find quality power tools, plus hand tools and accessories to meet all of your woodworking requirements. Complete money-back guarantee. Send for details. FOLEY-BELSAW. Free. *Circle No. 41.*

**MANUFACTURED SINCE 1926**—the Foley-Belsaw Circular Sawmill lets you go right to the trees to turn out smooth, true-cut lumber. Available with heavy-duty steel base or with plans and track provided for owner built wood base. Will accurately saw logs up to 14 ft. in length and up to 24 in. in diameter. Complete money-back guarantee. Send for details. FOLEY-BELSAW CO. Free. *Circle No. 42.*

**INCA MACHINERY INFORMATION**—Complete information on the famous line of Inca woodworking machines. Designed for precision work by the small to medium sized cabinet shop. Used by thousands of hobbyists and professionals. Table saws, bandsaws, joiner/planers, dust collector, radial arm saw. GARRETT WADE CO. Free. *Circle No. 44.*

**WOODWORKING MACHINE CATALOG**—New 16-page color catalog introduces many new do-it-yourself woodworking machines. Includes planers, dust collectors, drill presses, sanders, lathes, and specializes in scroll saws and accessories. PENN STATE INDUSTRIES. Free. *Circle No. 75.*

**SCROLL SAW**—Information package available from Penn State Industries describing the specifications and applications of its super VS-15" variable speed scroll saw. Special discount pricing available on

current promotion. PENN STATE INDUSTRIES. Free. *Circle No. 76.*

**SURFACE PLANER**—Information package available from Penn State Industries describing the specifications and applications of its super 12 1/2-inch surface planer. Special discount pricing available on current promotion. PENN STATE INDUSTRIES. Free. *Circle No. 77.*

**PERFORMAX DRUM SANDERS**—Exclusive features at an affordable price for precise wide surface sanding. The complete line includes the retrofitting Performax Component Sander, the Pro Max II, Super Max 25, Super Max 25X2, and Super Brush 24 Sanders. New accessories for production-mode sanding of pieces as small as 2 1/4" long. Send for brochure. PERFORMAX PRODUCTS. \$1.00. *Circle No. 78.*

**SCROLL SAWS, ACCESSORIES, PATTERNS, BOOKS**—A complete brochure on all kinds of scroll saw accessories. Featuring Excalibur scroll saws and lettering layout guides from Seyco, "The Scroll Saw Specialists." Free pamphlet, "Selecting Your Scroll Saw" included. Send for brochure. SEYCO SALES CO. \$1.00. *Circle No. 89.*

**MOLDER-PLANERS FROM WILLIAMS & HUSSEY**—Mold, plane, and edge, convert from moulder to planer in less than 2 minutes. The W-7 series is available in 3 models for manual, power in feed, or power in feed/out feed. The units plane to a satin, almost sanded finish, produce doll house to crown sized mouldings, raised panels, and curved molding. Custom knives available up to 7" wide and 3/4" depth of profile. Rugged, well-made, dependable, and transportable. Complete with sturdy movable stand. Send for catalog. WILLIAMS & HUSSEY. \$1.00. *Circle No. 93.*

**PORTABLE SAWMILLS**—Convert logs into valuable lumber—Wood-Mizer® Products manufactures a line of portable bandsaw mills that allows the novice as well as the experienced sawyer to safely convert standing logs into lumber. Then, with the use of our SolaryDry™ Kiln or Vacu-Kiln™ to dry your lumber, you could increase the value of every board you produce. We manufacture some of the most progressive woodworking equipment on the market today. Product videos available. Send for our 40-page catalog. WOOD-MIZER PRODUCTS. \$1.00. *Circle No. 94.*

## HAND TOOLS

**THE PERFECT GIFT**—Flexible urethane 4-way hand sander—Finisher's Friend®. Use with sandpaper, cloth and/or sanding screen; 80 grit through 400 grit—up to 2000 micro (wet or dry). Standard 9" X 11" sheet yields 4 full strips of sandpaper to fit F-F. Or use 2 3/4" wide PSA (pressure sensitive adhesive) rolls of grit choice. Follows contours—wraps around—gets in between, under and into...saves fingers. FINISHER'S FRIEND®. 75c. *Circle No. 120.*

**PERSONAL BRANDING IRONS**—Brochure describes branding irons that enable you to put your name on you work quickly and easily. Made especially for branding wood, they are available with 1, 2, or 3 lines of copy or with your logo. Changeable date also available. NOVA TOOL CO. \$1.00. *Circle No. 160.*

**THE JAPAN WOODWORKER'S 72-PAGE CATALOG**—is loaded with the huge selection of Japanese saws, waterstones, chisels, planes, carving knives, cutlery and garden tools. See our Tools As Art section for the most expensive hand tools available. Send for 1991 catalog and all supplements for two years. WOODLINE TOOL & SUPPLY. \$1.50. *Circle No. 190.*

## STAINS/FINISHES

**PROFESSIONAL IMAGE WOOD FINISHING PRODUCTS**—For the woodworker concerned about quality, Professional Image water-base, environmentally safe stains and finishes enhance the natural beauty of your wood finishing project and provide many other advantages. Send for a free brochure. BASIC COATINGS. Free. *Circle No. 205.*

## PLANS

**OVER 1000 WOODCRAFT PATTERNS!**—Enjoy making gifts, toys, lawn ornaments, holiday designs, whirligigs, folk art, bird houses and feeders, household and yard accessories plus much more! Simple enough for the beginner, fun and profitable for the pro. Send for catalog plus sample pattern. ACCENTS IN PINE. \$2.00. *Circle No. 310.*

**WOODWORKERS' PLANS AND SUPPLIES**—Wood projects are simplified with the high quality plans, specialty hardware and other supplies offered by Armor Products. Over 100 plans are available for making toys, desks, clocks, pool tables, lamps, chests, and other furniture. Movements, dials, moldings, ornaments, dollhouse kits, door harp supplies and tuning pins are also available. ARMOR PRODUCTS. \$1.00. *Circle No. 315.*

**SALES TESTED DESIGNS**—available as plans only, parts kits, or plans and parts kits. Complete stock of parts, tools and supplies. Door harps to digital electronic/wood projects. Full size plans! Bulk prices on turnings, dowels and music movements. Catalog price refundable on first order. CRAFTER'S MART. \$2.00. *Circle No. 328.*

**FULL-SIZE FURNITURE PLANS CATALOG**—Illustrates and describes over 200 plans for making furniture of quality found in museums and fine furniture stores. Plans include rolltop desk, cradles, dining tables, chairs, buffets, chests, gun cabinets, poker table, children's furniture, rocking horse, spinning wheels, and more. Bill of materials exploded drawings assist the woodworker. FURNITURE DESIGNS, INC. \$3.00. *Circle No. 345.*

**PROJECT PLANS**—Over 400 easy-to-build woodworking project plans. Nation's leading source for door harp plans and parts, holstein cow projects, toy plans, country furniture, etc. Over 3000 hard-to-find specialty items. Send for your big new 72-page catalog. MEISEL HARDWARE SPECIALTIES. \$1.00. *Circle No. 401.*

**POPULAR CHILDREN TESTED FURNITURE**—16 pages of unique, dual purpose furniture. Keep toys together, off the floor and conserve space. Construct seating that's fun and efficient. Provide little artists with a neat work space. Organize meal time. Plans contain complete material list, pictures, drawings and easy-to-follow instructions. Send for more details. \$2.00. **SIMPLE DETAILS.** *Circle No. 440.*

**MAKE TOP SELLING COUNTRY WOODCRAFTS**—from full size patterns. Turn your scrapwood into decorative, highly profitable projects. Easy to make from our full size patterns and instructions—no enlarging necessary! Over 1000 unique designs include popular folk art, old fashioned St. Nicks, nostalgic country furniture, country shelves and shadowboxes, action toys, shelf sitters, country critters, life size yard animals, Christmas yard decorations and more! Next day shipment, satisfaction guaranteed. Send for our latest catalog. **THE WINFIELD COLLECTION.** \$1.00. *Circle No. 480.*

---

## LUMBER

---

**QUALITY EXOTIC LUMBER/TURNING WOODS**—We offer a comprehensive selection of fine quality exotic woods: Ebony, Kingwood, Tulipwood, Snake-wood, African Blackwood, Cocobolo, Bloodwood, Figured Maple, Spaulted Maple, Padauk, etc. Unique and unusual turning woods and burls are also available. Send for catalog. **BEREA HARDWOODS.** \$1.00. *Circle No. 510.*

**WOODWORKERS! HELP CELEBRATE OUR 60TH YEAR OF SERVICE**—Send for our new 148-page Craftsman 1990-91 Catalog #57. 42 varieties of choice hardwoods 1/4 in. to 4-in. thickness. Fine hardwood veneers, tools, moldings, trim, marquetry inlays, upholstery and lamp supplies, finishes, clock kits, and hard-to-find hardware. 4,000-plus items for your projects. **CRAFTSMAN WOOD SERVICE CO.** \$1.00. *Circle No. 520.*

**NORTHEASTERN HARDWOODS**—We offer over 20 species of the highest quality kiln dried domestic hardwoods. Sold on board footage or cut to order basis. Compare our quality and prices. Unconditional satisfaction guaranteed. Great monthly specials. Super package deal at delivered prices. Attractive quantity discounts. Quick delivery. Send for new catalog. **NORTHEASTERN HARDWOODS.** \$1.00. *Circle No. 563.*

**STEVE H. WALL LUMBER CO**—Quality hardwoods and woodworking machinery for the craftsman and educational institutions. 22-page catalog lists 15 species of popular hardwoods at wholesale prices. Also dealers for MiniMax, Freud and ProCut woodworking machines. **STEVE H. WALL LUMBER CO.** \$1.00. *Circle No. 592.*

---

## GENERAL WOODWORKING CATALOGS

---

**CONSTANTINES' CATALOG FOR WOODWORKERS**—116 pages packed with over 4,000

products for fine woodworking. Included are 250 kinds and sizes of domestic and imported hardwoods; 150 varieties of exotic veneers, top quality woodworking tools, hard-to-find specialty hardware and accessories; wood finishes, books, plans, and more. 60-day money back guarantee if not fully satisfied. Serving the woodworker since 1812. **ALBERT CONSTANTINE AND SON, INC.** \$1.00. *Circle No. 820.*

**MASTER TOOLS CATALOG**—1990-91 220-page master woodworking tools catalog. Full line of the best hand tools, power tools & accessories, machinery, glues, finishing supplies, and much more. Hundreds of books included. 220 pages. All four-color. Lots of technical information. **GARRETT WADE CO.** \$4.00. *Circle No. 855.*

**THE BEST THING THAT EVER HAPPENED TO THE AMERICAN WORKSHOP**—You will simply be amazed at the number of new items we have brought on line this year. Our incredible catalog features a huge selection of wood and metal working machinery and accessories. Loaded with tons of goodies you can't resist. **GRIZZLY IMPORTS INC.** Free. *Circle No. 860.*

**TOOLS ON SALE**—A division of Seven Corners Ace Hardware Inc. offers a comprehensive catalog featuring over 820 pages of the most competitive prices in the industry. If you're looking for savings and fast delivery on over 6500 items, request our catalog. This catalog offers one of the most complete selections of power tools available anywhere from the most respected manufacturers in the industry: Milwaukee, Makita, Porter-Cable, Black & Decker, Freud, Bosch, Delta, and many more. **SEVEN CORNERS ACE HARDWARE.** \$1.00. *Circle No. 920.*

**DISCOUNT WOODWORKING TOOLS AND SUPPLIES**—Get your FREE copy of Trendline's new 72 page full-color catalog. You'll find the best prices for over 3,000 brand name products including: power tools and accessories, hand tools, screws, hardware, wood components, plans, books, and much more. **TRENDLINES.** Free. *Circle No. 950.*

---

## KITS

---

**OUR QUEEN ANNE FURNITURE KITS**—are ready to assemble and finish. They include dining room table, chairs, hutch, sideboard, a variety of occasional tables, and a personal desk. All are made in solid cherry, oak, walnut, and mahogany. We also stock individual Queen Anne legs for every project. Complete information in our brochure packet. **ADAMS WOOD PRODUCTS.** Free. *Circle No. 1002.*

**DO-IT-YOURSELF KITS**—Choose from a large selection of grandfather, wall and mantel clocks, as well as elegantly styled accent furniture pieces. Kits are made of solid 3/4" hardwoods, primarily cherry, oak, and black walnut. Buy direct from the factory and save. Send for 36 page color catalog. **EMPEROR CLOCK CO.** \$1.00. *Circle No. 1030.*

---

## SHOP ACCESSORIES

---

**WOOD MOISTURE METER**—End wood warping nightmares with a high quality precision instrument from Electrophysics. Avoid damage and deformation; eliminate stains, decay, mould, and failed joints. Eight models to choose from in the MT Series of wood moisture meters designed and made in Canada. For moisture contents from 3% to 60%. Accessory probes

and custom services available. A wood moisture meter is an essential tool for the home hobbyist, serious enthusiast, professional woodworker, commercial kiln or sawmill operator, wood carver, and everyone who works with wood. Free catalog gives complete information. **ELECTROPHYSICS.** Free. *Circle No. 1230.*

**EASY DOES IT**—with HTC'S power tool accessories. Discover many unique items, designed only with you, the dedicated woodworker, in mind. Make your machinery safer, increase the working area of your shop and accomplish nearly impossible tasks easily, quickly, accurately. Full-line catalog and price list. **HTC PRODUCTS, INC.** Free. *Circle No. 1245.*

**BUY YOUR SANDING BELTS DIRECT FROM THE MANUFACTURER**—Industrial Abrasives is the company that gives you 12 free belts with every dozen ordered. But, sanding belts are not the only product we have to offer. In our catalog you will find many specialty items not readily available in your hardware store. Price of catalog refunded with first order. **INDUSTRIAL ABRASIVES CO.** \$1.00. *Circle No. 1248.*

**WOOD MOISTURE METER**—Avoid moisture problems such as cracking, warping, splitting, delamination etc. by using a moisture meter, as described in the latest brochure. Moisture Meter Mini-Ligno is designed for serious hobbyists and woodworkers. Attachments for depth measurements and remote reading during air and kiln drying are available. Available Moisture Range 6-20%, 6-36% or 4-30%, 4-60%. Catalog describes complete line of moisture meters. **LIGNOMAT USA, LTD.** Free. *Circle No. 1250.*

**ROUTER SPEED CONTROL**—Reduces speed electronically without reducing torque. Route at the speed that gives best results with the wood and bit you are using. Speed adjustable from full speed to 0 RPM. Less tear out—stops burning—less wear on bits—easy to use. Send today for information. **MLCS LTD.** Free. *Circle No. 1251.*

**LABOR-EFFICIENT, COST EFFECTIVE TRIMTRAMP**—Instantly converts your handheld circular saw into a precision miter and cross-cut saw table that provides unsplintered cuts of cabinet maker quality by allowing you to pull the saw backwards through the work. Fixed fences provide perfect 90° picture frame quality miter joints and compound miters, every time. Also cuts variable angles and cross-cuts up to 15" wide. Send for free brochure. **TRIMTRAMP LTD.** Free. *Circle No. 1280.*

---

## BITS, BLADES, CUTTING TOOLS

---

**AmMax TOOL CO.**—offers "Professional Quality" tungsten carbide tipped router bits, shaper cutters, saw blades, and 16" scroll saw machine, at lower "wholesale prices." 16" scroll saw featuring light load, cutting without blade breakage. UL and CSA approved. Nicholson carbide tipped saw blades from \$6.90; woodworking files from \$6.95. **AMMAX TOOL CO.** 50¢. *Circle No. 1304.*

**CARBIDE-TIPPED ROUTER BIT AND SHAPER CUTTER CATALOG**—We have hundreds of styles and thousands in stock ready to be shipped. We specialize in quantity discounts and same day shipping. These are top quality industrial router bits and shaper cutters at super low prices. Send now to receive new giant catalog. **CASCADE TOOLS, INC.** Free. *Circle No. 1315.*

**WOODWORKING TOOLS**—Freud provides the finest in hand tools, carbide cutting tools, and hand held power tools. From drills and sanders to carbide saw blades and router bits. Send for catalog. FREUD. \$2.00. *Circle No. 1321.*

**PRODUCTION QUALITY CARBIDE TIPPED ROUTER BITS**—MLCS Ltd. offers a full line of professional production quality carbide tipped router bits at 50-70% lower than retail prices. We sell through the mail and only direct to craftsmen. Send today for catalog. MLCS LTD. Free. *Circle No. 1350.*

## HARDWARE/WOOD PARTS

**HARDWARE CATALOG**—A unique 48-page catalog of the very finest in classic, traditional solid brass cabinet hardware. All of British or No. American manufacture. Double & single post handles, knobs, escutcheons, standard & specialty hinges, box hardware, brass screws, castors, latches, catches, locks, and more. GARRETT WADE CO. \$3.00. *Circle No. 1427.*

**SQUARE DRIVE SCREWS**—Thousands agree—once you try them you will never want to use anything else! The square drive recess virtually eliminates work-damaging driver bit "cam-out," the deep threads result in exceptional holding power, and they are heat treated for strength. Sizes from #4 x 3/8" to #12 x 4", with stainless steel, solid brass, brass plated, and zinc plated available. Quantity discounts. Send for literature. McFEELY HARDWOODS. \$1.00. *Circle No. 1450.*

**WOOD TOY PATTERNS**—Patterns for all ages including children's patterns and executive toys. New

catalog has many new patterns to choose from including parts and wheels. Send for new catalog and receive a coupon for free wheels and axle pegs. TOYS AND JOYS. \$1.00. *Circle No. 1480.*

**QUALITY AMERICAN-MADE WOOD TURNINGS**—such as shaker pegs, spindles, toy wheels, toy parts, craft items, and dowel rods in birch, oak, walnut, and cherry. Send for complete 32-page catalog. WOODWORKS. \$1.00. *Circle No. 1490.*

## INCOME OPPORTUNITIES

**MAKE MONEY IN FURNITURE RESTORATION THE MINUTEMAN WAY**—Earn \$200-\$1000 per day stripping, repairing, refinishing, mirror resilvering, and/or veneering, at home or in shop, spare time or full time. We provide complete free training; no experience necessary. Free workshop teaches you later in furniture restoration. You have to see it to believe it! Intro video \$12.95. Send for catalog. MINUTEMAN. \$2.00. *Circle No. 1661.*

## MISCELLANEOUS

**FOLEY-BELSAW INSTITUTE'S NEW WOODWORKING CORRESPONDENCE COURSE**—for people with the desire to learn how to work with wood and the proper use of tools. Create over 20 projects using professional plans and tools like a table saw, router with stand, and more...all included with the course. Complete money-back guarantee. Send for details. FOLEY-BELSAW INSTITUTE. Free. *Circle No. 1930.*

**LEARN ALL THE SKILLS**—of professional upholstery and refinishing techniques in the comfort of your own home. The Foley-Belsaw Institute system of "hands on" training provides clear, step-by-step instructions in the use of tools and materials on actual furniture "kits"...all included with the course. Complete money-back guarantee. Send for details. FOLEY-BELSAW INSTITUTE. Free. *Circle No. 1931.*

**THE CUSHION CONTOUR SANDER**—is a new concept in pneumatic drum sanding. Sanding sleeves are slid over an air bag (inflated with a hand tire pump) on an arbor to mount it between centers on a wood lathe. Drum effectively takes on profiles, curves, and bevels practically eliminating flat spots and chatter marks. INDUSTRIAL ABRASIVES CO. \$1.00 (refunded with first order). *Circle No. 1976.*

**IF YOU ARE INTERESTED IN RESTORING ANTIQUES**—this 216-page catalog packed with unusual, hard-to-find items is just for you. Included are hundreds of essential items for antique restoration including top quality brass reproduction hardware, oil lamps and accessories, numerous wood component repair parts and kits, caning and basketry supplies, everything needed for wood refinishing, related tools, books, and a complete line of upholstery equipment and supplies. All at wholesale prices. Send for this informative catalog. VAN DYKE'S RESTORERS. \$1.00. *Circle No. 2077.*

## CARVING SUPPLIES

**WOOD CARVING MACHINES AND ACCESSORIES**—make all types of wood carving easy, fun and profitable. The machines do the work. Whether for sign carving, flat 3-D, decoys, panels, gun stocks or furniture, we have the proper machine for the job. Professional woodcarving for the hobbyist and superior quality for the professional. Begin your hobby or full or part-time business by ordering our catalog and price list. MARLIN INDUSTRIES. \$1.00. *Circle No. 2150.*

**WOODCARVING TOOLS**—Whittlers and carvers—Warren Tool Co. offers a complete catalog of whittling and carving, hand/power tools, sharpening stones, wood cut-outs and related wood carving supplies. WARREN TOOL CO., INC. \$1.00. *Circle No. 2185.*

## CLAMPS

**MERLE ADJUSTABLE CORNER CLAMP**—Quick & easy to use. Fully adjustable from 2 5/8" to 69x69 in. Perfect for clamping picture frames, cabinets, or anything that requires 90° corner clamping. The Merle Clamp is cast aluminum & steel construction, a true industrial quality tool. Send today for information. MLCS LTD. Free. *Circle No. 2250.*

**QUAKER STATE WOODWORKING SUPPLY INC.**—one of the largest "Quick-Grip" and "Jorgensen" dealers on the EAST COAST. Great prices along with expert service and advice will make QUAKER STATE your supplier of woodworking clamps and acc. Information and price list. QUAKER STATE. Free. *Circle No. 2260.*

*Worth writing for...*



Better Homes and Gardens®  
WOOD Magazine, June 1991  
Dept. MJWO91  
P.O. Box 5103  
Pittsfield, MA 01203-5103

### TO ENSURE PROMPT HANDLING OF YOUR ORDER FOLLOW THESE INSTRUCTIONS:

- Circle your choice
- Enclose check or money order for cost of booklets plus \$2.00 service charge (no stamps/foreign)
- Send coupon and remittance to address above
- ALLOW 4-6 WEEKS FOR DELIVERY
- Coupon expires June 16, 1992

### WOOD SUBSCRIPTION

1. A 1 year WOOD subscription (8 issues) for \$19.97 (U.S. price)—an \$11.63 savings off newsstand rate. Allow 6-8 weeks for first issue. Canadian price \$29.00. Be sure to include payment with total below. NO FOREIGN ORDERS ACCEPTED ON THIS COUPON; please contact Subscription Dept. directly.

Circle numbers below corresponding to items in this issue. Please include \$2.00 for handling charge.

6 .....\$2.00	89 .....\$1.00	328 .....\$2.00	820 .....\$1.00	1248 .....\$1.00	1450 .....\$1.00	2185 .....\$1.00
10 .....Free	93 .....\$1.00	345 .....\$3.00	855 .....\$4.00	1250 .....Free	1480 .....\$1.00	2250 .....Free
41 .....Free	94 .....\$1.00	401 .....\$1.00	860 .....Free	1251 .....Free	1490 .....\$1.00	2260 .....Free
42 .....Free	120 .....75¢	440 .....\$2.00	920 .....\$1.00	1280 .....Free	1661 .....\$2.00	
44 .....Free	160 .....\$1.00	480 .....\$1.00	950 .....Free	1304 .....50¢	1930 .....Free	
75 .....Free	190 .....\$1.50	510 .....\$1.00	1002 .....Free	1315 .....Free	1931 .....Free	
76 .....Free	205 .....Free	520 .....\$1.00	1030 .....\$1.00	1321 .....\$2.00	1976 .....\$1.00	
77 .....Free	310 .....\$2.00	563 .....\$1.00	1230 .....Free	1350 .....Free	2077 .....\$1.00	
78 .....\$1.00	315 .....\$1.00	592 .....\$1.00	1245 .....Free	1427 .....\$3.00	2150 .....\$1.00	

Name (please print) \_\_\_\_\_  
Address \_\_\_\_\_  
City \_\_\_\_\_  
State \_\_\_\_\_ Zip Code \_\_\_\_\_

### I AM ENCLOSING:

\$ \_\_\_\_\_ for priced items  
\$ 2.00 for handling  
\$ \_\_\_\_\_ total remittance



DELTA BENCH TOP TOOLS			
Model	Description	List	Sale
23-700	Wetdry grinder	201	159
23-680	6" bench grinder 1/4 HP	81	75
23-880	8" bench grinder 1/2 HP	136	115
11-950	8" drill press	164	148
40-150	hobby scroll saw	178	139
25-160	1" hobby band saw	189	144
31-050	1" belt sander 2.0 amp	93	78
31-460	4" belt/disc sander	178	139
31-340	NEW 1" belt/disc sander	226	184
31-980	NEW 1" belt/disc sander	134	95

NEW TOOLS BY DELTA			
40-560	16" 2 speed scroll saw	266	185
23-580	5" Bench grinder 1/5 HP	60	54
11-980	12" Bench Drill Press	266	185
11-490	32" Radial Band Drill Press	399	279
43-355	3/4" Shaper 1 1/2 h.p.	950	685
43-305	1/2" Bench router/shaper	399	279
22-540	12" Bench top jointer	595	389

DELTA STATIONARY			
34-761	10" unsway 1 1/2 HP	1715	1325
33-890	10" radial arm saw	727	575
37-280	6" molder jointer	440	375
50-175	3/4 HP 2 slg. dust coll.	435	345
50-180	1 HP dust collector	535	415
50-181	2 HP dust collector	760	599
22-667	13" planer w/H.P. motor		
	w/stand & ext. wings	1750	1099
33-050	NEW 8-1/4 Sawbuck	742	545
33-055	Above saw w/legs	885	589
34-330	NEW 8-1/4" Tol Saw	312	235
34-985	1/6 HP stock feeder	698	459
32-100	NEW station plate jointer	645	285
36-040	NEW 8-1/4" compd mitre saw	216	165
34-997	50" Delta uniface	500	349
36-755	NEW 10" Tilt Arbor Saw	1203	885

MILWAUKEE TOOLS			
6527	NEW SawZall vsp/d 8 amp		
	w/wise & Quick Loc Cord	299	165
0399-1	12V cdss: drill kit complete	290	155
0402-1	same as 0399-1 w/kylix chuck	290	165
0395-1	9.6V cdss: drill w/wise	270	148
0219-1	9.6V cdss: drill w/wise	295	165
0224-1	3/8" drill 4.5A magnum	189	112
0234-1	1/2" drill 4.5A mag 850rpm	209	112
0222-1	3/8" drill 3.5A 0-1000 rpm	179	102
0228-1	3/8" drill 3.5A 0-1000 rpm	169	99
0375-1	3/8" close quarter drill	208	125
0378-1	1/2" close quarter drill	243	154
6539-1	Cds. scrdrv. 190 rpm	119	69
6540-1	Cds. scrdrv. w/bits & case	159	108
6545-1	Cds. scrdrv. 200 & 400 rpm	126	75
3102-1	Pimbrs rt angle drill kit	330	185
5399	1/2" D-hole ham drill kit	312	179
1676-1	H.D. Hole Saw w/wise	429	229
6511	2 speed SawZall w/wise	224	129
6750-1	Drywall gun 0-4000 4.5A	154	89
6507	TSC SawZall w/wise	239	129
6170	1/4" chop saw	430	259
6014	Orbital sander 1/2 sheet	209	118
8977	Var. temp heat gun	114	75
5397-1	3.8" vsp ham. drill kit	232	137
5371-1	1/2" vsp ham. drill kit	335	185
3107-1	1/2" vsp rt angle drill kit	340	189
6754-1	Drywall gun 0-4000 4.5A	179	119
3300-1	1/2" vsp mag it angle drill	309	179
5660	Router 1-1/2 HP - 10amp	325	189
5680	Router 2 HP - 12 Amp	355	219
5455	7/8" polisher 1750 rpm	219	127
6216	16" chain saw	280	169
6365	7-1/4" circular saw	204	119
6366	7-1/4" circ. saw w/fin & bid	214	125
6368	7-1/4" circ. saw w/fin		
	blade & case	239	135
0235-1	1/2" drill w/kylix chuck mag	215	125
6016	1/4 sheet pad sander	84	49
6145	4.5" grinder 10,000 rpm	159	95
6142	5.145 w/blade & access	197	125
6749-1	Drywall gun 0-2500 4.5A	189	125
6377	7-1/4" worm drive saw	295	169

FREUD SAW BLADES			
5/8" Bore - Industrial Grade			
CARBIDE TIPPED SAW BLADES			
Item	Description	Teeth	List Sale
LUB2M010	Gen Pur. A.T.B.10'40"	58	38
LUB2M010	Cut-off 10'	60	77
LUB4M010	Comb 10'	50	65
LUB8M010	Super Cut-off 10'	80	96
LUB7M010	Ripping 10'	24	37
LUB3M010	Cut off 10"	60	70
LUB7M010	Thin kerf 10"	24	60
LUB8M010	Thin kerf 10"	60	74
LUB9M010	Ultimate 10"	80	107
SD306	6" Dado - Carbide	184	109
SD308	6" Dado - Carbide	196	115
F0	1-3/4" x 5/8" Bisc. 1000 Qty.	32	27
F10	2-1/8" x 3/4" Bisc. 1000 Qty.	32	27
F20	2-3/4" x 1" Bisc. 1000 Qty.	34	29
FA	Assor. Biscuits 1000 Qty.	34	29
WC108	6 pc. chisel set w/wise 1/4" - 1"	73	52
FB100	16 piece forstner bit set	284	159
C74-100	5 pc. router bit door system	288	158
JS100	Biscuit jointer w/blade	300	159
FT2000	3-1/4 HP plunge router	299	179

THE NEW "TK" BLADE SERIES			
Item	Description	Teeth	List Sale
TK203	7-1/4" Framing	24	29 18.25
TK206	10" Framing	24	33 20.75
TK303	7-1/4" Finishing	40	33 22.65
TK306	10" Finishing	40	40 25.10
TK903	7-1/4" Combo	31	19.49
TK906	10" Combo	50	45 28.25

MAKITA CORDLESS			
Model	Description	List	Sale
6070DW	3/8" vsp/eed rev. drill, 7.2v.	130	78
6071DWK	3/8" vsp/eed rev. drill		
	w/removable batt, 7.2v.	199	115
5090DW	3-3/8" saw kit, 9.6v.	256	139
6010DWK	3/8" cds. drill kit 7.2v.	164	95
6010SDW	3/8" cds. drill kit, 7.2v.	99	59
DA3000DW	3/8" angle drill, 7.2v.	251	139
4390DW	9.6 cds recip saw kit	230	128
6012HDW	2 spd. drill w/ clutch-comp	236	122
6092DW	Vsp drill, kit complete	250	125
6093DW	Vsp drill w/ clutch-complete	251	127
632007-4	9.6 volt battery	49	30
632002-4	7.2 volt battery	40	28
5007NBA	7-1/4" saw w/elec. brake	233	124
5008NBA	8-1/4" saw w/elec. brake	284	158
604510	1/4 sheet pad sander	85	54
9900B	3" x 21" belt sander w/bag	248	144
9924DB	3" x 24" belt sander w/bag	282	145
9045N	1/2 sh lin. sand. w/bag	231	129
4200N	4-3/8" circ. saw 7.4A	225	127
4301VB	Orb. vsp jig saw 3.5A	289	155
JR3000V	Vs. recip saw w/wise	227	124
LS1020	10" miter saw 3.5A	463	289
9820-2	Blade sharpener	373	195
1900WB	3-3/4" planer w/wise	209	114
1911B	4-3/8" circ. saw 7.5A	240	139
1100	3-1/4" planer w/wise	401	205
92075PC	7" sander-polisher	276	149
3601B	1-3/8 HP router	255	135
9501BZ	4" grinder, 3.5 amp	126	69
604530	6" round sander	101	64
604550	1/4 sh pad sander w/bag	86	58
DA3000R	3/8" angle drill	270	148
HP2010N	3/4" vsp hmr. drill w/wise	300	165
2708W	6-1/4" table saw	504	249
2711	10" table saw w/brake	841	479
2030N	12" planer/jointer	3120	1689
2040	15-5/8" planer	2955	1375
1005B	6-1/8" planer kit w/wise	678	359
5005BA	5-1/2" circular saw	223	135
6404	3-8" drill rev. 0-2100 rpm 2A	104	65
6510LVR	3/8" drill rev. 0-1050 rpm	145	83
6013BR	1/2" drill rev. 0-1050 rpm	241	135
5402A	16" circular saw-12 amp	636	325
3612BR	3 HP plunge router	377	189
9401	4" x 24" belt sander w/bag	318	165
4302C	V spd. orbital jig saw	302	159
5077B	7-1/4" Hypoid saw	252	138
LS1440	14" Miter saw	721	435
LS1030	NEW 10" Miter saw	414	225
5007NB	7-1/4" circ saw 13A	209	112
3612B	3 HP plunge router sq/base	377	189
2012	12" portable planer	695	465

MIL-ROUTE			
MR1/MR-R1	System	329	279
MR1/T1	Router table	139	109

SENCO AIR NAILERS			
Model	Description	List	Sale
SNF1	Finishing nailer 1"-2"	377	275
SNF2	Fin. nailer 1.5" - 2.5"	571	395
SN325	Nailer 1-7/8" - 3-1/4"	665	455
SN4	Gen'l purpose 2" - 3-1/2"	685	475
LS2	Finmer 5/8" - 1"	351	255
SKS	Stapler 5/8" - 1-1/2"	351	255
SS5	Finmer 1" - 1-1/2"	399	285

BOSTICH AIR NAILERS			
N00C-1	Utility coil nailer	845	419
N805-1	Stick nailer	845	419
T36-50	Sheath & decking stapler	595	334
N12B-1	Coil roofing nailer	845	419
N60FN-2	Finishing nailer	625	339
T31	Brad nailer	270	155
CWC100	1 HP Pancake Compressor	445	299

SKIL SIZZLERS			
6850-02	1/2" EMH hammer drill w/wise	255	135
3810	10" Miter saw	263	209
3810S	3810 w/60 tooth carb blade	235	165
77	7-1/4" worm drive saw	230	144
2735-14	12 v vsp/d cordless drill, w/wise 2 batt		
	& extra special 5 piece bit set	210	129
1605-02	NEW Biscuit Jointer w/wise	200	119

PANASONIC CORDLESS			
EY6205BC	NEW vsp/d. 12 volt drill		
	w/15 minute charger & case	390	179
EY6005B	12v cds drill w/rt. charger	315	169
EY6200B	NEW 2 spd. 12 volt drill q-handle		
	w/15 minute charger	350	185
EY6281B	NEW vsp/d. 9.6 volt drill		
	w/15 minute charger	350	169
EY571B	Vsp/d 9.6 volt drill kit	239	128

LEIGH DOVETAIL JIGS			
D1258R-12	List 328.00-Sale 255.00		
D1258R-24	List 399.00-Sale 299.00		

LEIGH INSTRUCTIONAL VIDEO SALE 29.00			
MMTA 12"	mort. & tenon attachment	269	155
MMTA 24"	mort. & tenon attachment	299	169

HITACHI TOOLS			
Model	Description	List	Sale
C7BD	7 1/4" circular saw	230	129
M12V	NEW 3 HP vsp router	437	235
TR12	Plunge router. 3 HP	354	169
P1000A12	Planer's/jointer	2835	1505
F1000V	12" Planer	2005	1259
C10FA	10" deluxe miter saw	490	269
C12FA	NEW 12" miter saw	586	319
C8FB	8-1/2" slide compd saw	859	445
FREUD LUB8M09	8-1/2" c/bld 48 tooth	58	38
C15FB	15" miter saw	745	379
FREUD LUB5M015	15" c/bld 108 tooth	181	115

**1991 TOOL CATALOG AVAILABLE**  
 Call Toll-Free 1-800-328-0457 in Minnesota Call (612)224-4859  
 FAX: (612)224-8263  
**SEVEN CORNERS ACE HDW. Inc.**  
 216 West 7th St. • St. Paul, MN 55102 • Est. 1933

DELTA TOOLS			
34-444	Table Saw Complete w/1-1/2 H.P. motor & stand	605.00	
34-445-34-444	Table Saw complete w/30" Uniface	849.00	
37-154	DJ15 6" Jointer w/3/4 H.P. motor	1049.00	
26-283	14" Band Saw w/enclosed stand 3/4 H.P. motor	735.00	
70-200	NEW 20" Drill Press	739.00	
17-800	16-1/2" Floor Drill Press	385.00	
40-601	18" Scroll Saw w/stand and blades	699.00	

DELTA #34-080 10" MITRE BOX XTRA SPECIAL			
		195.00	
		List 289.00	

JORGENSEN I-BAR CLAMPS</			
--------------------------	--	--	--

## NO SHAGGY DOG, THIS TALE

Eerie faces peer out at Herb Fausch from log jams. He extracts figures of shaggy dogs, jumping fish, and horses, found among tangles of twisted, bone-white root wood, broken tree trunks, limbs and branches. Where others see firewood, the retired Sheldahl, Iowa, postman spots elves.

Herb, you see, scouts local riverbanks, lakes, and reservoirs for driftwood in the shape of nature's creatures. Armed with a hatchet and a walking stick, he collects samples, then hauls them home in his van for cleanup. He might even carve an eye here or shape a mouth there, just to get the right effect, but mostly he just cleans the wood, then coats it with a protective polyurethane finish.

"I call these critters 'natural phenomena', and the best thing about them is that they're free," he says. Herb has stacks of free figures he's found locally, and even more from his vacations in the West and Southwest. "I have carver friends out there to direct me to ponderosa pine knots as well as driftwood," Herb comments, as he stuffs new finds into the cargo area of his van.

**Right:** An afternoon stroll along the lake produces a few prime specimens of natural phenomena to load in the van.

**Below:** Herb sees a shaggy sheepdog in the light-colored piece of wood at center. Can you see the gnome in the lower left?



## SQUIRRELS SEEDIER IN THE WEST?

Western squirrels are a seedy bunch. Food caches scrounged up by Western squirrels have been found to contain as much as eight bushels of conifer seeds! That's a lot of gathering, true, but in a good year a single white pine can produce a bushel of seeds, a ponderosa pine about four bushels, and an old-growth Douglas fir three-and-one-half bushels.



## FIR FOR ONE-TIME USE

Soldiers have long relied on bangalore torpedoes to breach enemy fortifications. Made of an explosive charge attached to one end of a long pole, these weapons could be pushed to the target by means of extensions, then detonated with a remote trigger.

But even in peacetime, bangalore torpedoes have found a place, making some lumber suppliers happy.

According to the Western Wood Products Association, miners use similar assemblies, called bomb sticks, to blast ore in difficult-to-reach situations. One U.S. mine has ordered 2,400 pieces of 1"×2"×14' clear Douglas fir for just that purpose. Each stick will be capped with a 2½-pound charge. Of course, the sticks are one-time use.

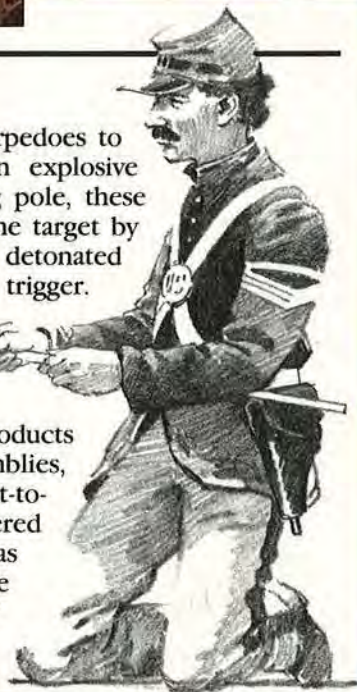

## TEAK TACTICS

As much as 80 percent of the world's teak grows in Burma, wood experts say. Some are concerned, however, that rather than steward this valuable resource, the country's military government apparently is exporting vast quantities of the wood —and fish, too—to help

finance its regime. The U.S. Senate and House of Representatives are considering banning the sale of this imported teak, reports the National Forest Products Association. If passed, the bills would help isolate the Burmese government, widely accused of human rights violations. 🌲

Photographs: Bob Calmer Illustrations: Jim Stevenson

Now In One Handy Volume!

# 335 GREAT SHOP TIPS

The best ideas collected from our popular column **"TIPS FROM YOUR SHOP (AND OURS)"** in WOOD® Magazine

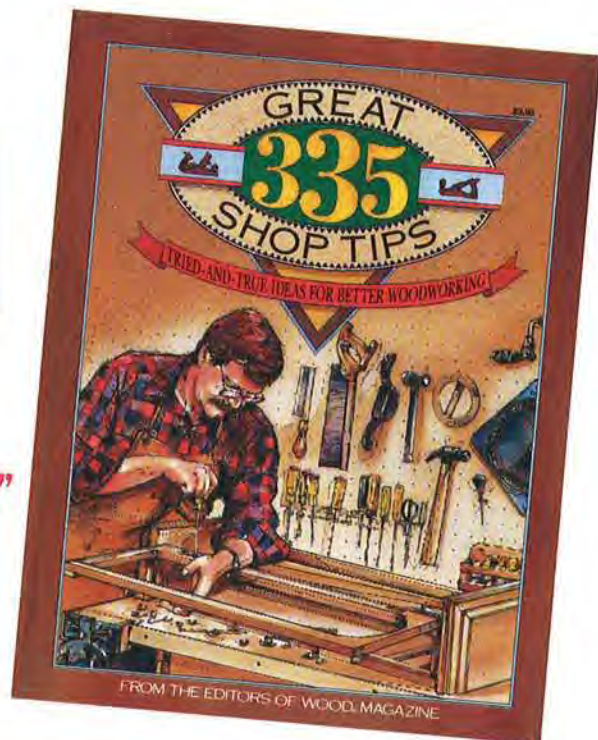
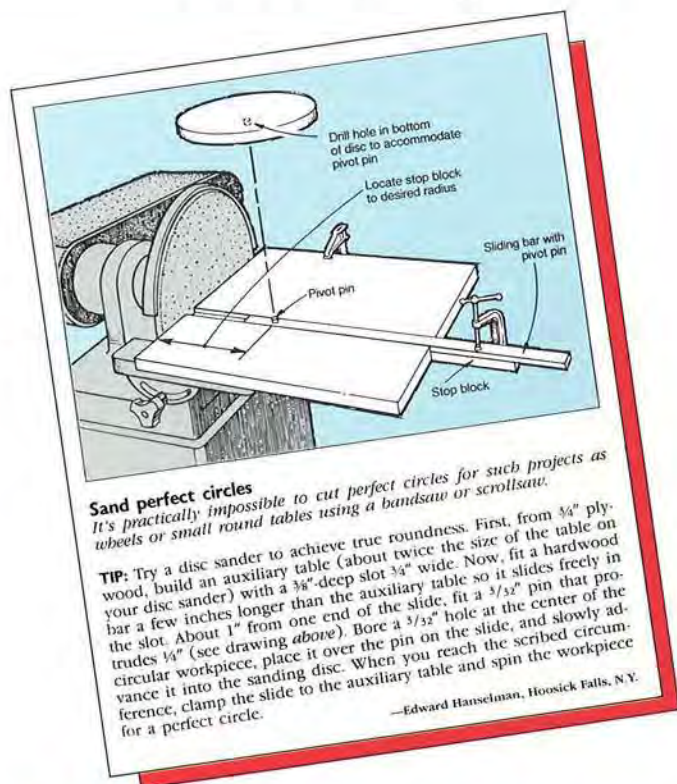

**Save \$5.00 with this special advance offer!**

**335 GREAT SHOP TIPS** contains valuable information from the editors and readers of WOOD magazine — shared knowledge that makes working in your shop better, faster, safer, and easier.

The editors of WOOD have brought together the best shop tips we know into one publication. **335 GREAT SHOP TIPS** will give you the wisdom of your fellow WOOD readers. We've organized the tips into 24 convenient categories with an index for easy accessibility to any subject.

**335 GREAT SHOP TIPS** will be available on newsstands nationwide this Spring at a \$9.95 cover price. WOOD, however, offers readers the opportunity to receive **335 GREAT SHOP TIPS** at a special one-time only prepublication price of \$4.95. That's more than 50% off the newsstand price! But you must order now because supplies will be limited. Just fill out the coupon and mail to: **335 GREAT SHOP TIPS, P.O. Box 11454, Des Moines, IA 50336-1454. Allow 6-8 weeks for shipping and handling. To order by phone, call 1-800-678-2666 (9 a.m. to 5 p.m. CST).**

**YES! Please send me your new publication 335 GREAT SHOP TIPS for just \$4.95 (Canadian residents add \$1.00) plus \$1.00 for postage and handling.**

Name: \_\_\_\_\_

Address: \_\_\_\_\_

City: \_\_\_\_\_

State: \_\_\_\_\_ ZIP: \_\_\_\_\_

Telephone #: \_\_\_\_\_

Enclosed is my check or money order for \$4.95 (Canadian residents add \$1.00) plus \$1.00 for postage and handling made out to WOOD Magazine.

Please bill my  MASTERCARD  VISA

Card # \_\_\_\_\_ Exp. Date \_\_\_\_\_

Signature \_\_\_\_\_

# CRAFTSMAN®

## All You'll Ever Need in a Power Tool.



From project start to a perfect finish,  
you can always count on Craftsman to pull you through.

Sure, you could pay more for a tool, but you'll never need to. Because the tools in our Contractor Series are engineered to handle the most demanding projects.

Rigorous life testing on every tool backs up our promise of Craftsman reliability. For example, we ripped 40,000 feet of 2" x 6" stock in just four working days with our Contractor Series tablesaw. We repeatedly jam-tested our 10" compound miter saw for 2,000 cycles. The motor was then cycle-tested at 150% of its rated amperage for 167 hours. The ability of both tools to withstand this abuse was rated excellent. They continue to be used daily in our engineering workshop.

There's more about every one of the tools in the Contractor Series that will impress you. And you don't have to call your nearest distributor to see for yourself. Just zip on down to your Sears store.

# CRAFTSMAN®

Only at Sears