

Better Homes and Gardens®

WOOD

THE WORLD'S LEADING WOODWORKING MAGAZINE
AUGUST 1997 ISSUE NO. 98
<http://www.woodmagazine.com>

Check out our stylish GARDEN ARBOR

Plus

- Cigar-lover's humidior
- Curvacious hand mirror
- Trammel/marking gauge
- Easy-to-turn wall clock & mirror



Display until July 28



INSIDE
See our special
HOME-SHELVING GUIDE
Page 68

Editor **LARRY CLAYTON**

Managing Editor **JIM HARROLD**

Art Director **C. L. GATZKE**

Design Editor **JAMES R. DOWNING**

Senior Editor/Features **PETER J. STEPHANO**

Senior Editor/How-To **MARLEN KEMMET**

Assistant Managing Editor/Products **BILL KRIER**

Senior Editor/Special-Interest **LARRY JOHNSTON**

General-Interest Editor **KERRY GIBSON**

Associate Art Director **PERRY A. McFARLIN**

Assistant Design Editor/Project Builder **JAN HALE SVEC**

Project Builder **CHARLES I. HEDLUND**

Graphic Designer **CHERYL A. CIBULA**

Production/Office Manager **MARGARET CLOSNER**

Administrative Assistant **NATALIE COOLEY**

Art Business Office Secretary **BARBARA HELPS**

Contributing Editors **KIM DOWNING, DAVE HENDERSON,**

LORNA JOHNSON, ROXANNE LeMOINE, BOB McFARLIN,

MIKE SATTERWHITE

©Copyright Meredith Corporation 1997
All rights reserved. Printed in the U.S.A.

Better Homes and Gardens® **WOOD**® magazine (ISSN-0743-894X) is published nine times a year in January, February, March, April, June, August, October, November, and December by Meredith Corporation, 1716 Locust St., Des Moines, IA 50309-3023. Periodicals postage paid at Des Moines, Iowa, and additional mailing offices. *Better Homes and Gardens* trademark registered in Canada and Australia. Marca Registrada en México. **ONE-YEAR SUBSCRIPTION PRICES:** U.S. and its possessions, \$25; Canada, \$36; other countries, \$45. Canadian GST Reg. #BN 12348 2887 RT. **POSTMASTER:** Send address changes to *Better Homes and Gardens* **WOOD** Magazine, P.O. Box 55050, Boulder, CO 80328-5050.

CUSTOMER SERVICE INFORMATION: For service on your magazine subscription including change of address, phone toll-free **800/374-9663**. Or, write to *Better Homes and Gardens* **WOOD** Magazine, P.O. Box 55050, Boulder, CO 80328-5050. Please enclose your address label from a recent issue.

EDITORIAL INFORMATION: Address letters and questions to THE EDITOR, **WOOD** Magazine, 1912 Grand Avenue, Des Moines, IA 50309-3379.

ATTENTION RETAILERS: To carry **WOOD** magazine in your store, call 800/659-5990, or write: Select Title Program, **WOOD** Magazine, 902 Paramount Parkway, Batavia, IL 60510.



Better Homes and Gardens®

WOOD Online™

at <http://www.woodmagazine.com>

At **WOOD ONLINE**, you can check out 11 brand-new additions to our wide selection of **WOOD PLANS**®. Just click on the **WOOD PLANS** link at the lower right-hand corner of the **WOOD ONLINE** home page.

On the plans list, you'll find some brand-new yard ornaments you can build now for Christmas. We've also added great outdoor-living projects you can use right now, as well as a couple of shop jigs and two terrific furniture plans. To see a photo of a project, just click on the project's name on the listing. 🌿

THE EDITOR'S ANGLE

Coming in November

Smart Solutions For Your Basement Shop



Jan Svec, Chuck Hedlund, and Jim Downing (in the **WOOD** magazine shop) showing off some early prototypes of the goodies they've created for **IDEA SHOP 3**.

Of all the projects we involve ourselves in here at **WOOD**® magazine, our **IDEA SHOP**® series clearly ranks no. 1 in complexity. Think about it. First, we have to erect a space in which to locate the shop. Then comes the arduous task of selecting and ordering all of the tools and supplies.

Once these things are done, we design and build cabinetry, work centers, tool stands, and all the other items needed to complete the project. Finally, we photograph the shop and everything in it, write the how-to directions for the various projects, and present the completed shop to you in the magazine. Whew!

Those of you who have been readers for several years remember **IDEA SHOP 1** (the 14×28' outbuilding in issue 54) and **IDEA SHOP 2** (the garage shop in issue 72). From your letters we know you like this type of editorial, so we've decided to take on the biggest challenge yet—**IDEA SHOP 3** (the 12×16' basement shop). Why the biggest challenge, you ask? Because the smaller the shop, the more resourceful you must be in setting it up.

At this point, we're in the process of moving everything into the shop. And if all goes according to plan, the November issue (no. 100) will feature one of the most creative, space-efficient, and innovative basement shop layouts ever devised.

Of course, behind every project of this magnitude stand a dedicated band of people who transform dreams into reality. And **IDEA SHOP 3** is no exception. Once again, Jim Downing, **WOOD** magazine's design editor, captained this herculean effort. Jim's steady, confident presence always seems to make the process go much smoother.

But Jan Svec, our project builder/assistant design editor, and Chuck Hedlund, **WOOD** magazine's project builder, played mighty roles in the creation of this shop, too. In fact, many of the project ideas you'll see in **IDEA SHOP 3** were developed by these talented gentlemen.

Thanks, guys. The readers are going to love your handiwork. 🌿

Larry Clayton

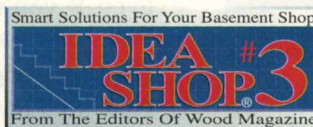

Better Homes and Gardens®

WOOD

THE WORLD'S LEADING WOODWORKING MAGAZINE

CONTENTS

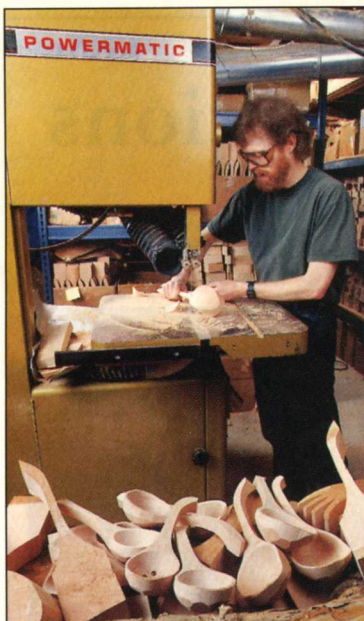

Page 39

37 Northern white cedar
This species serves numerous outdoor uses, from fences and decks to boats and furniture.

39 Success by the spoonful
Meet a Pennsylvanian who reaps a tidy profit crafting kitchen utensils from cherry.

58 Cabinet-style tablesaws
If you don't own one of these, maybe it's time. Check out the eight shop-tested models inside.

68 Home-shelving planner
Solve storage problems around the home with our complete guide for designing shelves.

78 The WOOD gang builds kit boats
Add to your summer fun by building a boat. We test-built five from kits and had a blast doing it.



Page 58



Page 47

Woodworking projects

44 A great-looking looking glass
Rout and bandsaw a stylish handheld mirror. See our buying guide for the beveled glass.

47 Grand humidor
Even if you're not a cigar smoker, you'll find other uses for this showy box.

52 Gardener's retreat
Perk up a favorite outdoor space with our arched-top arbor/bench design.

64 Contemporary clock and mirror
Take a turn for the better by giving these two lathe projects a whirl.

74 Collector's edition marking gauge/trammel
Scribe circles, arcs, and straight lines on workpieces with this homemade tool.

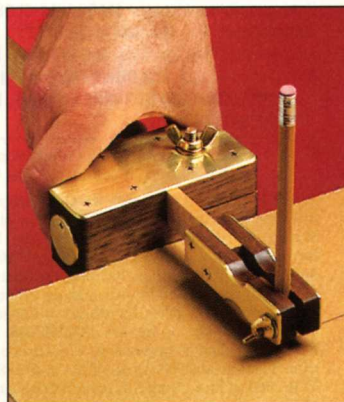

Page 74

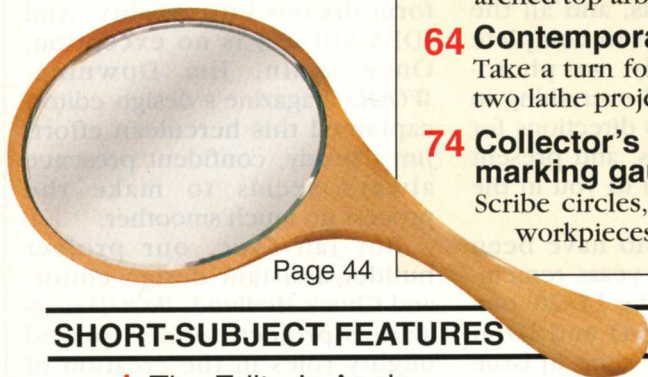

Page 44



Page 78

SHORT-SUBJECT FEATURES

- 1** The Editor's Angle
- 4** Talking Back
- 18** Tips From Your Shop (And Ours)
- 24** Tool Buyer's Update
- 28** What Woodworkers Need To Know

- 32** Router Bit Review
- 85** Wood Anecdote
- 94** Products That Perform
- 101** Ask WOOD
- 110** How To Cut Perfect Arches

112 Finishing Touches

This issue's cover wood grain: Mineral-streaked aspen

BED POSTS

IN STOCK

NO
MINIMUM

VARIOUS
WOODS



PENCIL CANNON BALL RICE

FREE COLOR CATALOGUE

Adams Wood Products™ L.T.D., L.P.
974 Forest Drive, Dept. M40
Morristown, TN 37814
Phone 423-587-2942 • Fax 423-586-2188

Circle No. 1002

Better Homes and Gardens®

WOOD Advertising & Marketing

THE WORLD'S LEADING WOODWORKING MAGAZINE

Publisher **WILLIAM R. REED**
Advertising Director **MARK HAGEN**

Display Advertising: 333 N. Michigan Ave., Suite 1101, Chicago, IL 60601 Phone: 312/853-2890 FAX: 312/580-7906
Eastern Advertising Manager **JAMES N. FORD**
Western Advertising Manager **WILL MURPHY**

Direct Response Advertising: 1912 Grand Ave., Des Moines, IA 50309-3379 Phone: 515/284-3785 FAX: 515/284-3343
Direct Response Advertising Manager **LISA WIEMKEN**
Direct Response Advertising **CINDY ANDERSON,**
PATRICK MADDEN

Administrative Assistant **MICHELLE GLOWACKI**
Classified Advertising: Phone: 800/424-3090 FAX: 312/464-0512

Ancillary Sales Director **MAUREEN RUTH**
Marketing Manager **RICK PALLISTER**
Marketing/Ad. Services Supervisor **PAT HENDERSHOTT**

Circulation Director **LIZ BREDESON**
Associate Circulation Director **KATHI PRIEN**
Business Manager **JANET DONNELLY**
Senior Product Manager **RICK GROW**

Publishing Director **MAX RUNCIMAN**
MEREDITH PUBLISHING GROUP

CHRISTOPHER M. LITTLE, President
BILL MURPHY, Custom Marketing; **JERRY KAPLAN**, Group Sales;
MAX RUNCIMAN, Controller; **BRUCE HESTON**, Manufacturing;
HAL ORINGER, Circulation; **DEAN PIETERS**, Operations



JACK D. REHM, Chairman of the Board
WILLIAM T. KERR, President and Chief Executive Officer

E. T. MEREDITH III, Chairman of the Executive Committee 

TALKING BACK

Lamp wiring revisited

In the November 1996 issue, the wiring diagram for the "Stenciled Country Lamp" will result in the lamp's threaded socket bottom cap being hot, even with the switch off. The silver colored screw is indeed the neutral, but it should be attached to the ribbed conductor. In addition, the broadest blade on the plug is neutral, not hot as originally shown.

—*Scott M. Hart, Clyde, N.C.*

Scott, you're right! The drawing below shows the correct wiring.

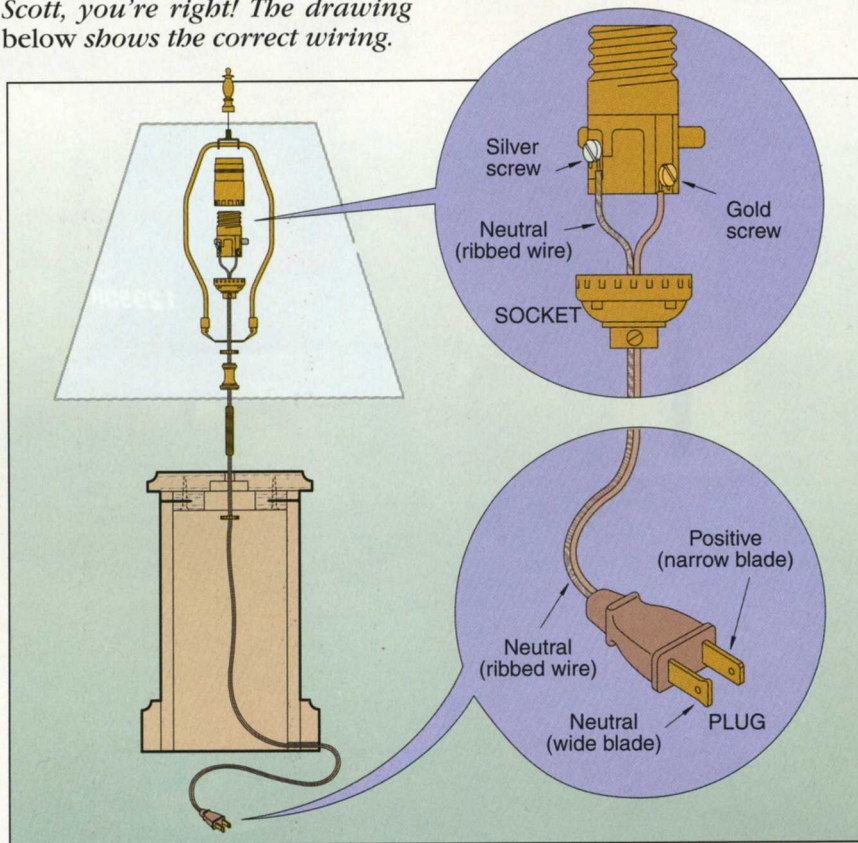

How to reach us

We welcome comments, criticisms, suggestions, and even compliments. We'll do our best to respond, perhaps even on this page! You can "talk back":

• **Via mail.** Send your letter to Talking Back, *WOOD*® magazine, 1912 Grand Ave., Des Moines, IA 50309-3379.

• **Via computer.** Send e-mail to: woodmail@woodmagazine.com

A bit over a barrel

Your article, "The Cooper of Cambridge" (April 1997), about barrel maker Ken Knox, came as great news. My husband and I have been looking for barrels for a year now to use for landscaping. Will you please tell me how I can contact Ken so we can buy some of his barrels?

—*Terry Bobinko, Wellsboro, Pa.*



Terry, you can contact Ken at Brooks Barrel Company, Inc.,

P.O. Box 1056, 5228 Bucktown Rd., Cambridge, MD 21613-1056. Or call 800/398-2766 (Fax: 410/221-1693).

Continued on page 6

Continued from page 4

I like your magazine, but...

In the January 1997 issue, page 92, the Ryobi biscuit joiner is rated. The rating sounded good so I thought I might buy one, but then I saw an ad on the back cover for another Ryobi biscuit joiner.

The back cover is probably the most expensive ad page in your magazine. And, even if the person rating this product is not an employee, he is listed as a contributing editor. So, it seems to me that the magazine could not give a poor rating to a major advertiser's product. Other readers must have a problem with this, too.

—William S. Grove, Weston, W. Va.

Bill, we're not surprised that you might have questions about what impact, if any, advertising has on our tool reviews. In fact, we've heard similar comments from other readers. So, we want to explain some things about our tool tests.

We recognize that woodworkers consider their tools an investment. And, we understand that owning the right tools makes a big difference in how much you enjoy woodworking. We also know that you, our readers, demand honest reporting in our tool reviews. You want no-holds-barred observations from our testers, not just a rephrasing of manufacturer-supplied information. That's why we test every product before it appears in our editorials.

Occasionally, advertisers know in advance what products will be reviewed in an upcoming issue. Then, they might run an ad for the product being reviewed, knowing that potential buyers of that product will be paying special attention to that issue. This can lead to the impression that the advertised brands received special treatment, but that simply isn't the case.

Because we test products about 4-12 months before they appear in the magazine, we have no idea if an ad for a product will appear in the same issue as its review. Typically, our advertising department confirms ad orders just weeks, or even days, before the magazine goes to press.

Of course, several manufacturers advertise in nearly every issue of the magazine, and others don't advertise at all. But, we assure you that no company receives preferential treatment in our tool reviews based on the amount of advertising it places.

Like you, we just don't see any point in running reviews that don't serve our readers' best interests. Believe it or not, most advertisers understand and respect this approach. They only ask that we test all of the products on a fair and level playing field—something our testers and editors constantly work to achieve.

—Bill Krier, Assistant Managing Editor

Separate bus bars in a subpanel

In the "Wiring Your Shop" article in the February 1997 issue, the wiring diagram of the subpanel won't work. A subpanel requires two separate bus

bars—one for the ground wires and one for the neutral wires. The ground bus bar mounts directly to the panel box, and the neutral bus bar should rest on an insulating block to keep the neutral wires from contacting the panel box.

Also, in a subpanel, the ground wire must come from the main service entrance panel to provide a "least resistance" ground path for any fault current. Remember, don't take chances with electricity. Always consult local codes and get the advice of a certified electrician before beginning any do-it-yourself electrical work.

—Rusty Nelson, El Cajon, Calif.

Rusty, even though we checked our facts with one professional engineer and two certified electricians, we still managed to get it wrong. Obviously, we're better as woodworkers than as electricians. The illustration at left shows the correct wiring for a subpanel.

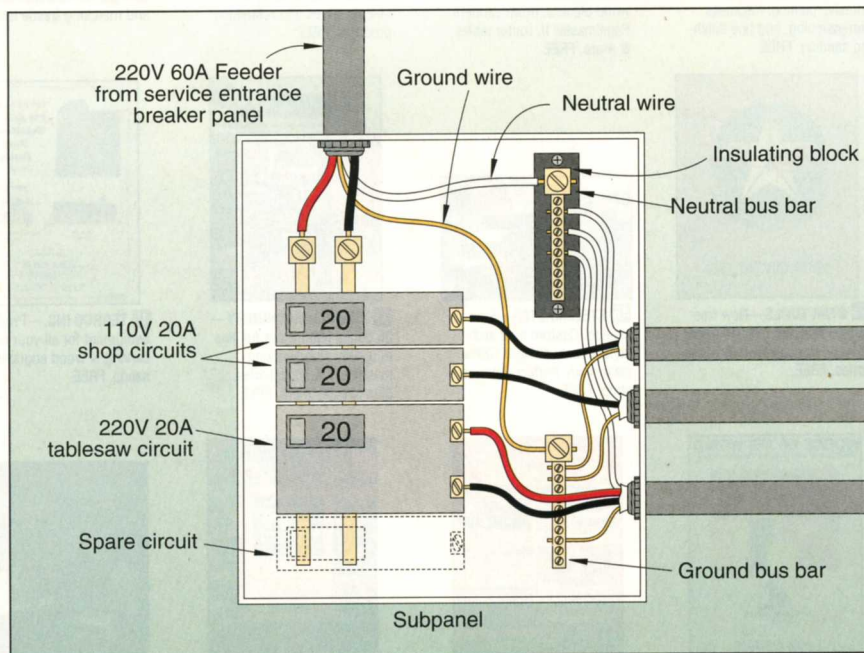

Continued of page 12

"All my tools should be this good!"

The Accu-Miter® is a professional miter gauge that makes perfect angles easily. Shot-pin action assures dead-on accuracy for common angles — plus a precise protractor scale for everything in between!

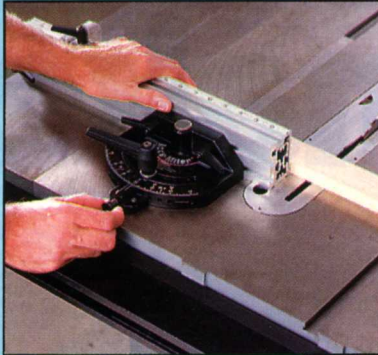

We do not recommend operating without the saw blade guard, as is shown here. US Patent #5,038,486

Optional accessories:
manual clamp—
pneumatic clamp—
3/8" x 3/4" miter bar—

**JDS
COMPANY**

Precision Woodworking Equipment

Call or write for our free brochure.

800 Dutch Square Blvd., Suite 200, Columbia, SC 29210
1-800-382-2637 / SC 803-798-1600

\$149

**DAD
ALERT!**

Unless you want another tie, cut out ad on the facing page and place conspicuously where your wife or kids will find it.



CRAFTSMAN

EXCLUSIVELY AT SEARS AND SEARS HARDWARE STORES

TALKING BACK

Continued from page 10

How did you figure that?

In the article, "Waste Not, Want Not," in the December 1996 issue, you claim that today's thinner kerf blades will recover about 1,200 board feet of lumber from a log that would only yield 695 board feet in 1920—almost double. According to my math, comparing the $3\frac{9}{128}$ " kerf of the old blade to the $1\frac{1}{128}$ " kerf of the thin-kerf blades would increase production only 21½ percent—not exactly double the production.

—Paul Medkeff, Akron, Ohio

You make a good point, Paul. Other factors, also discussed in the article, contribute to the increase in productivity. For example, loggers now process the flared butt of the tree instead of letting it go to waste. Sophisticated computer programs help increase cutting efficiency by analyzing individual logs and determining the best way to saw each one. And, because finished dimensions have decreased over time (a 2x4 used to be 2x4", but now measures 1½x3½", and some manufacturers even produce a 1¼"-thick stud), even narrow treetops become usable.

Largely out of necessity, the lumber industry has become vastly more efficient. Today, by using almost every part of a tree, the industry has nearly doubled the board foot production of what the same raw material yielded in 1920.

A better cordless detail sander

The "Cordless Detail Sander" that appeared in the October 1995 issue is a handy little helper that can be even better as a two-handed tool. To provide a place for my free hand, I replaced the wing nut and washer that secure the pad to the handle with a 1½" wooden knob as shown below. The knob gives me a great place to add extra pressure with my index finger to make the work go faster.

—Stan Valley, Normal, Ill.

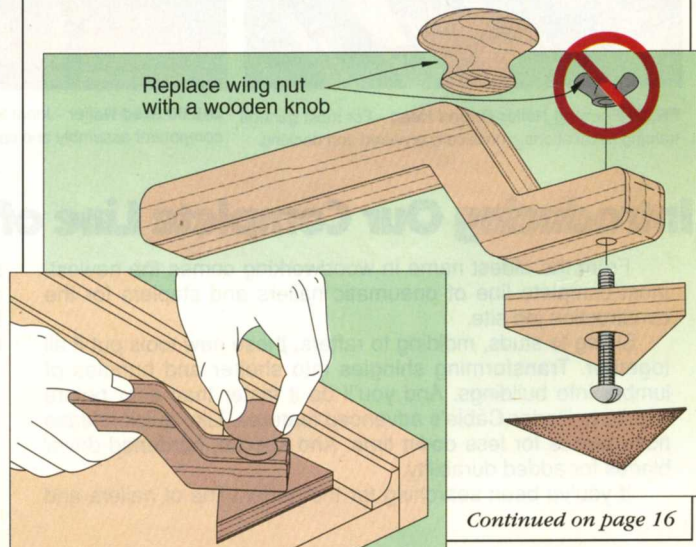

Continued on page 16

OK, Hold It.



Now Spread 'Em.



The innovative POWER PRESS™ Pipe Clamp, from the makers of QUICK-GRIP® Bar Clamps, is more than just a pipe clamp.

By simply reversing the two movable clamping sections, it quickly becomes a spreader. Perfect for all kinds of woodworking applications, the POWER PRESS Pipe Clamp can do anything a regular pipe clamp can do, only faster. It works on both threaded and unthreaded pipe.

And two rubber pads keep gripping surfaces from marring your work.

The most versatile pipe clamp to hit the shelves, the POWER PRESS

Pipe Clamp is going to revolutionize the way you work.

Look for it wherever quality tools are sold.



FROM THE MAKERS OF QUICK-GRIP® BAR CLAMPS

© 1995 AMERICAN TOOL COMPANIES, INC. U.S. and Foreign Utility and Design Patents Issued and Pending.



TALKING BACK

Continued from page 12

Low-tech watchmaking

I made the project shown in "Watchmaking on a Large Scale" featured in the September 1996 issue, but I used a different method to compensate for my lack of tools. Not having a 2³/₈" Forstner bit for cutting out the center, I instead used a router, guide bushing, and a circular template to form this hollow (see drawing below). This could also be done by cutting the hole in a piece of 1/2" hardwood, and gluing a piece of 1/4" hardwood to the project back.

—Charles C. Smith, Townsend, Mass.

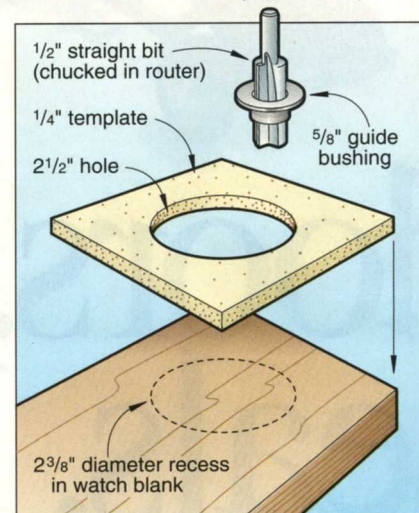

Charles, your technique suggests an additional method for making the clock-mechanism hole. Chuck an adjustable circle cutter in your drill press, and cut to the desired depth. Remove the remaining wood with a router and straight bit.

Good-bye September issue, hello March

Effective immediately, we are changing the publishing schedule for WOOD® magazine. Yes, you'll still be receiving nine incredible issues per year. But instead of doing a September issue, we'll be publishing a March issue. So, don't panic when you don't get a September issue, OK? Thanks much! ♣

—The WOOD magazine circulation department

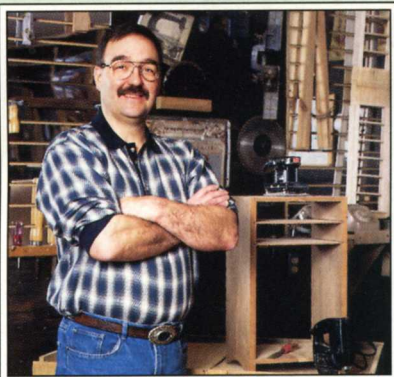

Woodworker Denny Feller submitted several useful tips, including the Top Tip at right.

Denny Feller constantly looks for new ways to do things. Take, for example, the unusual, but effective, way he disposes of his sawdust. "My workshop is on the second story of a barn. The sawdust goes down a chute to serve as bedding for our horses."

Denny and his family live in the house he built in the countryside near Strasburg, Ohio. "When we started building this house, I hadn't even built a doghouse," he said.

If you, like Denny, enjoy solving a woodworking problem, send us your solution. It may be worth \$40. If it's selected as the Top Shop Tip, you'll win a tool prize valued at \$250 or more and be featured in this column. If you would like to submit a tip, send a letter, including your daytime phone number, with a photo or drawing of your idea, to:

**Tips from Your Shop
(And Ours)**

**WOOD® Magazine
1912 Grand Ave.**

Des Moines, IA 50309-3379

Our goal is to publish original shop tips, so please send your idea only to WOOD magazine. Also note that we cannot return submissions. Thanks!

Kerry Gibson

GENERAL-INTEREST EDITOR

Motion detector offers no-hands light switch

When I walk into my workshop at night, I need light to see where I'm going. But it's not easy to get to the switch with an armload of lumber or tools. The answer was simple and didn't cost much, either. I bought a basic motion sensor light—mine cost \$8.99—and positioned it on the wall so that it flips on every time I enter the room.

And here's a tip about tips: Keep some 3×5" note cards in your shop, and whenever you



For submitting the Top Shop Tip for this issue, Denny receives Delta's new 22-560 12" portable planer. Nice going!

think of a better way to do something, write it down before you forget it.

—Denny Feller, Strasburg, Ohio

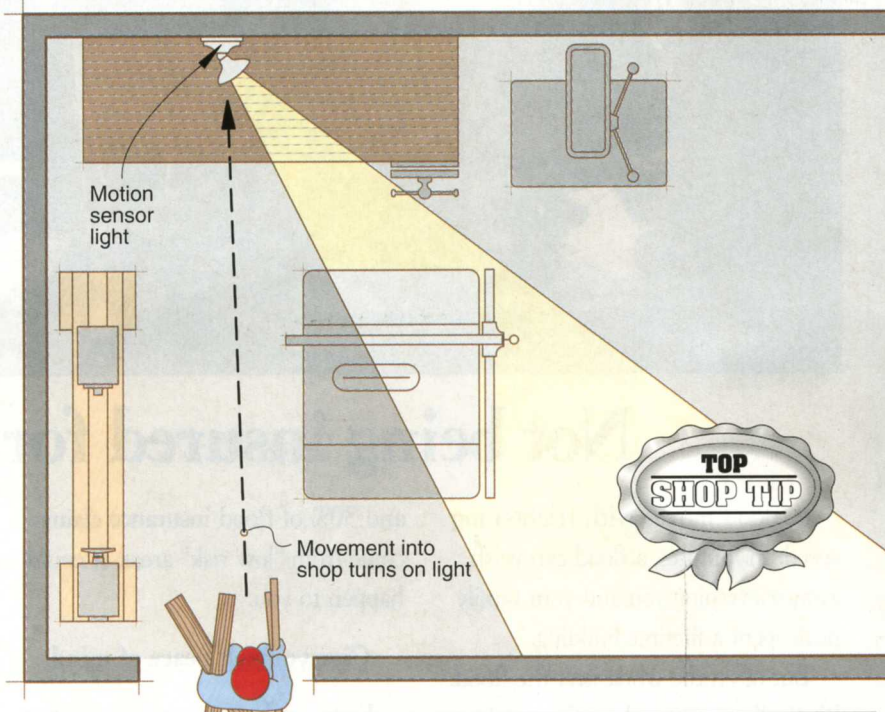

Felt furniture glides protect wood from clamps

I always worry about marring the wood with my clamps during dry assembly or glue-up of a project. Rather than buying the costly custom pads available for most clamps, I purchased some hard felt chair glides. They have self-adhesive backing and come in various sizes and shapes, so it's easy to find some just the right size for your clamps.

—Sonny Rains, Carbondale, Colo.

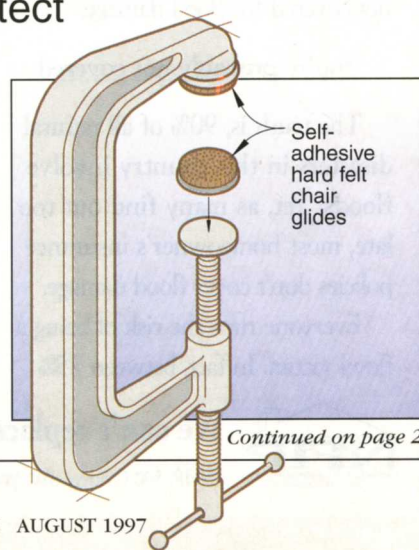

Continued from page 18

A kerf marks the spot on radial-arm saws

I got tired of always hauling out a protractor or adjustable triangle when I wanted to set my radial-arm saw at an angle. So, I notched the most frequently used angles on the saw's particleboard top to make setting up the saw a snap.

To mark a particular angle, I raise the blade above the table and pull it forward as far as it will go. Then, I set the angle of the

blade with an adjustable triangle and lock the arm. With the saw running, I lower the blade until it makes a $\frac{1}{8}$ "-deep kerf in the tabletop. Whenever I need to repeat that angle, I pull the blade forward and turn the saw arm until the blade lines up with the kerf. I lock the arm and push the carriage back before making my cut.

—Rob Nusbaum, Toledo, Ohio

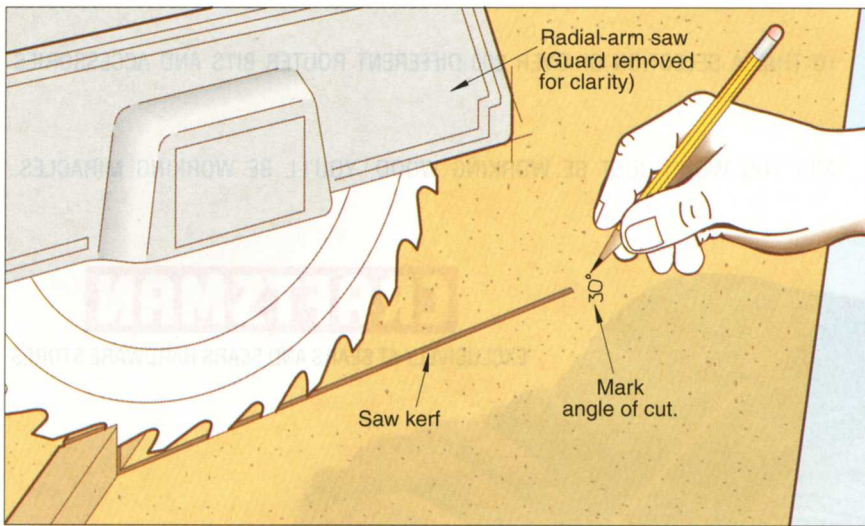

Ironing board steadies long workpieces

When crosscutting a long piece of stock or sheet goods on a tablesaw, I use a handy substitute for expensive roller stands—an ironing board. The legs on most ironing boards adjust to the height of a tablesaw. I put a piece of $\frac{1}{4}$ " tempered hardboard on top

of the ironing board to give the workpiece a slick surface to ride on and to protect the fabric cover on the ironing board. Don't attempt this technique with heavy workpieces that might tip over the ironing board.

—Frank Lucca, Saratoga, Calif.

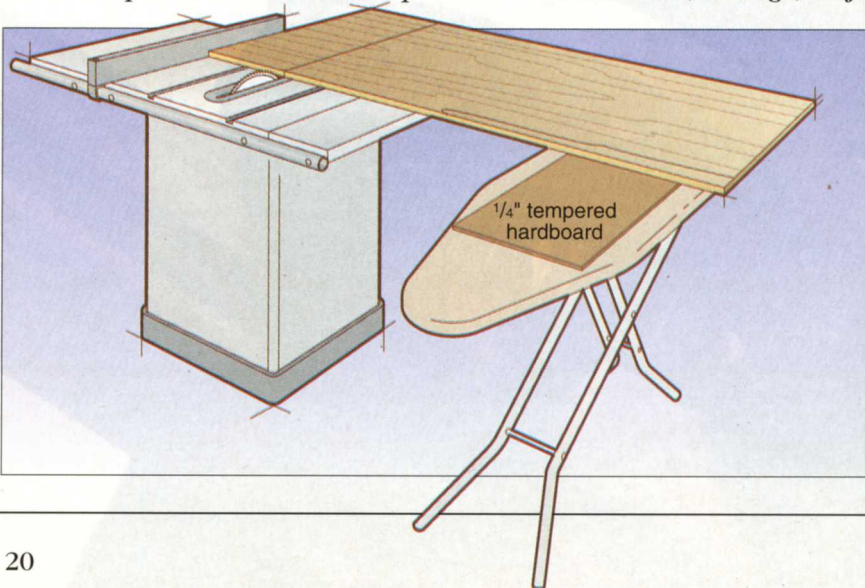

Tapered blocks help clamp sloped sides

I always had a tough time clamping a tapered project, until I made some tapered clamping blocks. To make the blocks, I cut a few $\frac{3}{4}$ " scrapwood blocks 2" wide and about 1" longer than the height of the item to be clamped. (Sometimes I need one per side, although one for every other side works for the splined joints in the glue-up shown.) I rip an angle on one edge of each block to match the slope on the side of my project. Next, I attach a stop of scrapwood or sheet metal to the narrow end of each block. After dry-fitting the clamping setup, I glue and clamp the project as shown.

—Eugene Cockeram, Florence, Ore.

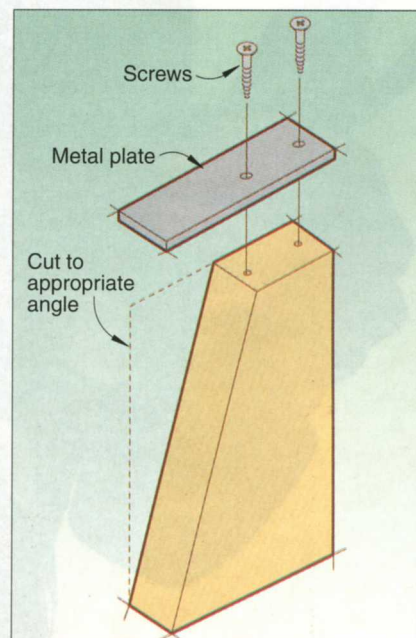
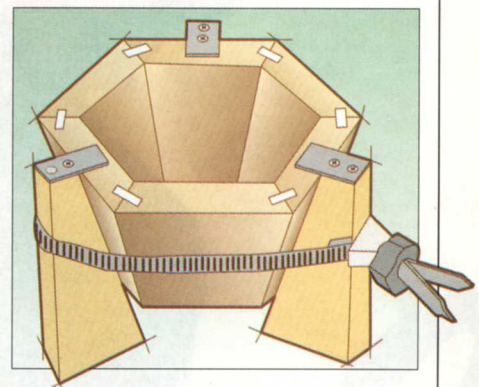

Continued on page 22

FREE SANDING BELTS

BUY A DOZEN GET A DOZEN FREE

FULL MONEY BACK GUARANTEE!!

| | | | | |
|------|-------|--------------|---|---------|
| 1x30 | | 17.95/doz | + | 12 free |
| 1x42 | | 18.50/doz | + | 12 free |
| 3x18 | | 18.95/doz | + | 12 free |
| 3x21 | | 19.95/doz | + | 12 free |
| 3x24 | | 21.95/doz | + | 12 free |
| 4x21 | | 24.95/doz | + | 12 free |
| 4x24 | | 25.95/doz | + | 12 free |
| 4x36 | | 35.95/doz | + | 12 free |
| 6x48 | | 40.95/1/2doz | + | 6 free |
| 6x89 | | 66.95/1/2doz | + | 6 free |

Grits available: 36X to 320X
All belts A/O Resin Bond Cloth
w/bi-directional butt splice

Full Line of 9x11 Sheets

ALSO AVAILABLE: Stroke Sanding Belts; Belt Cleaning Sticks; Inflatable Drums and Sleeves; Cloth/Paper Discs (PSA/Hook & Loop) Drum Sanding Rolls; Wide Cloth and Paper Belts or any size belt you may require and MUCH MUCH MORE!!

Call For Price Quotes • Orders • Free Catalog

Please add \$5.00 S & H / PA Residents add 6% Sales Tax

• • • • • Money Orders • Checks

1-800-428-2222

Mon. - Fri. 8am - 4:30pm EST

Fax: 1-610-378-4868

Anytime

INDUSTRIAL
ABRASIVES CO.

642 N. 8th St. Dept. W
P.O. Box 14955
Reading, PA 19612

Circle No. 1976

TIPS FROM YOUR SHOP (AND OURS)

Continued from page 20

Modified triangle solves corner problem

It's tricky to check a leg-and-rail project for squareness during glue-up when the corner leg posts stand in the way of your try square. I bought a plastic draftsman's triangle—available at drafting and business supply stores—and cut a notch out of the right-angle corner so it fits around the legs.

—Russell G. Clausing, Overland Park, Kan.

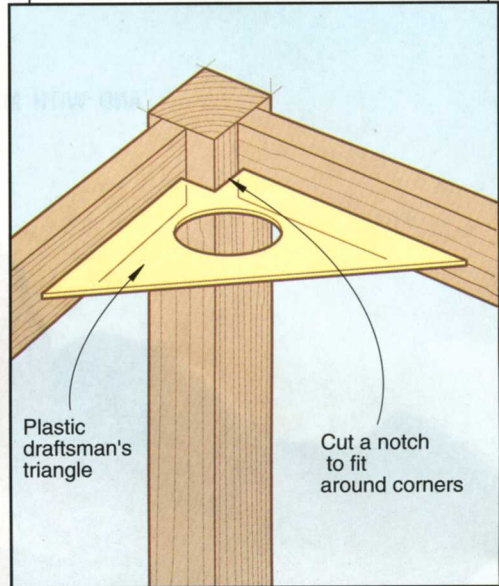

A FEW MORE TIPS FROM OUR WOODWORKING PROS

- Want to try your hand at making a wooden spoon? Follow spoonmaker Jonathan Simone's advice on *page 39* to learn how to take advantage of the wood's grain for sturdy spoons.
- Don't have a biscuit joiner? See the humidor article (*page 50*) for the method we used to make biscuit-style reinforcements and fit them into slots cut with a router bit.
- See our procedure for cutting wide coves with a tablesaw. We used the setup shown in the Cutting the Coves drawing on *page 50*, for the top and bottom of the humidor. ♣

DEFT'S REVOLUTIONARY WAY TO STAIN AND FINISH IN ONE EASY CLEAN STEP

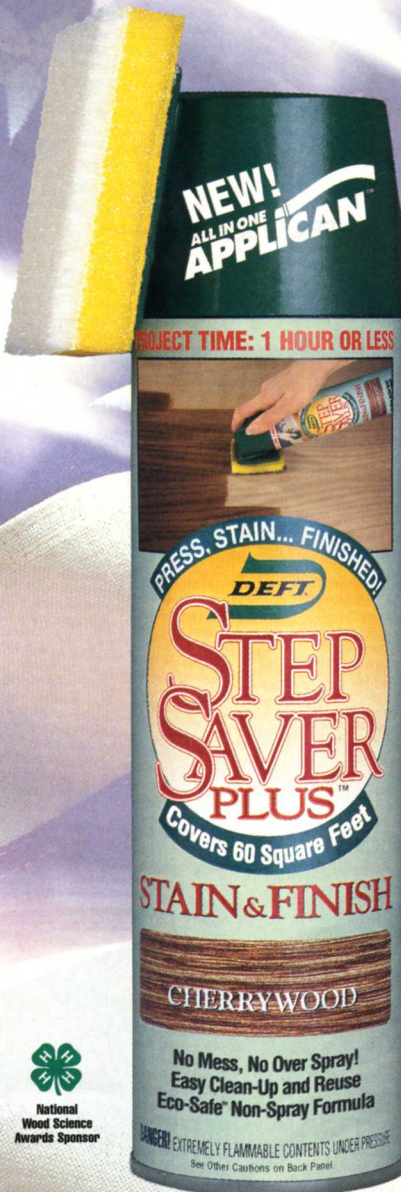

Join the APPLICAN™ Revolution

Try Step Saver Plus™—
One Step Stain & Finish

Now—the fastest way
to stain and finish. No
brush, no rags, no spills.
One application with
easy water clean up.



America's Wood Finish Family

Irvine, CA (800) 544-DEFT

Alliance, OH (800) 458-DEFT

<http://www.deftfinishes.com>

THE NEWEST CORDLESS DRILLS

Getting more powerful all the time

Shortly after we published our test of 43 cordless drills in the August 1996 issue, we learned about some new models from Black & Decker, Milwaukee, Porter-Cable, Skil, and Wagner. So, we got our hands on these new tools and ran them through the same tests we conducted for the initial article. (See the charts below and on page 26 for full test results. We suggest that you compare this information to the charts in the earlier issue before making a purchase decision.)

As we expected, these new models push the "power envelope" for cordless drills ever higher. For example, the Milwaukee and Porter-Cable models both sport 2.0 ampere-hour (Ah) ratings. In our last test, only two models—both from Hitachi—were available with 2.0 Ah batteries. We expect Ah ratings to continue to climb.

Continued on page 26



HOW THE NEW KIDS ON THE BLOCK COMPARE

| VOLTS | MANUFACTURER AND BRAND | MODEL | AMP-HOURS | NUMBER OF BATTERIES INCLUDED | CHARGE TIME (HOURS) | KEYLESS CHUCK (YES, NO) | CHUCK CAPACITY (INCHES) | CLUTCH SETTINGS | ELECTRIC BRAKE (YES, NO) | NO-LOAD SPEEDS (RPM) | LOADED SPEEDS (RPM) (1) | FAN-COOLED MOTOR (YES, NO) | LENGTH FROM TRIGGER TO CHUCK TIP (INCHES) | OVERALL LENGTH TO NOSE OF CHUCK (INCHES) | OVERALL HEIGHT (INCHES) | HANDLE STYLE (2) | DRIVER-BIT STORAGE (YES, NO) | CARRYING CASE (YES, NO) | WEIGHT (POUNDS) | COUNTRY OF ASSEMBLY (3) | SELLING PRICE (4) |
|-------|------------------------|-----------|-----------|------------------------------|---------------------|-------------------------|-------------------------|-----------------|--------------------------|----------------------|-------------------------|----------------------------|-------------------------------------------|------------------------------------------|-------------------------|------------------|------------------------------|-------------------------|-----------------|-------------------------|-------------------|
| 9.6 | BLACK & DECKER | PS3200 | 1.0 | 2 | 3 | Y | 3/8 | 5 + DRILL | Y | 350, 700 | 550 | Y | 4 3/4 | 9 1/2 | 9 | T | Y | Y | 2.90 | C | \$ 80 |
| | PORTER-CABLE | 830 | 2.0 | 2 | 1 | Y | 3/8 | 20 + DRILL | Y | 0-350, 0-1250 | 0-250, 0-800 | Y | 4 1/4 | 9 1/4 | 9 1/4 | T | N | Y | 3.90 | U | 140 |
| 12 | BLACK & DECKER | PS3500 | 1.0 | 2 | 3 | Y | 3/8 | 5 + DRILL | Y | 0-800 | 0-650 | Y | 4 3/4 | 9 1/2 | 9 | T | Y | Y | 3.22 | C | 100 |
| | MILWAUKEE | 0501-02 | 2.0 | 2 | 1 | Y | 1/2 | 19 + DRILL | Y | 0-360, 0-1100 | 0-300, 0-900 | Y | 8 1/4 | 10 3/8 | 9 3/8 | P | N | Y | 4.39 | G | 230 |
| | MILWAUKEE | 0502-02 | 2.0 | 2 | 1 | Y | 3/8 | 19 + DRILL | Y | 0-360, 0-1100 | 0-350, 0-900 | Y | 3 1/2 | 9 | 9 3/8 | T | N | Y | 3.93 | G | 220 |
| | PORTER-CABLE | 826 | 2.0 | 2 | 1 | Y | 3/8 | 20 + DRILL | N | 0-350, 0-1250 | 0-250, 0-800 | Y | 4 1/4 | 9 1/4 | 9 1/4 | T | N | Y | 4.26 | U | 180 |
| | SKIL | HD2745-04 | 1.3 | 2 | 1 | Y | 3/8 | 15 + DRILL | Y | 0-400, 0-1100 | 0-325, 0-850 | Y | 4 3/8 | 9 1/4 | 10 | T | N | Y | 4.03 | M | 135 |
| 14.4 | WAGNER | PG144 | 1.7 | 2 | 1 | Y | 3/8 | 5 + DRILL | Y | 0-300, 0-1100 | 0-300, 0-900 | Y | 5 3/8 | 9 7/8 | 10 1/4 | T | Y | Y | 4.41 | C | 180 |



BLUE BARS INDICATE TOOLS THAT PERFORMED BEST REGARDLESS OF PRICE



RED BARS INDICATE TOOLS THAT OFFER THE BEST BLEND OF PERFORMANCE AND PRICE



PURPLE BARS INDICATE TOOLS THAT EARNED BOTH AWARDS



NOTES:

1. Loads applied were 35 inch-pounds in low gear and 10 inch-pounds in high gear.
2. (P) Pistol-grip (T) T-shaped
3. (C) China (G) Germany (M) Mexico (U) United States
4. Lowest selling prices based on advertisements, catalogs, and manufacturer inquiries at time of article's production.

MANUFACTURERS' LISTING

Black & Decker 800/762-6672
 Milwaukee 414/781-3600
 Porter-Cable 800/487-8665
 Skil 773/286-7330
 Wagner 800/727-4023

TOOL BUYER'S UPDATE

Continued from page 24

When you shop, you may find models similar to those here, but in voltages that were not available at the time of our test. For example, Black & Decker markets 14.4- and 18-volt models in the same series as the models we tested. Porter-Cable also makes a 14.4-volt model. And, Wagner sells models with 13.2, 12, 10.8, and 9.6 volts in the "Pro Gold" series that we tested. We did not test Wagner models that fall outside of the "Pro Gold" series. Those have fewer features, less power, and lower prices.

In the end, the Milwaukee products proved to be the musclemen of this group—but at a high price. The Porter-Cable models, in our opinion, delivered the best combination of high performance and moderate cost. If you're an occasional woodworker, the Skil and Wagner products deliver a lot of value for your cordless dollar. 🐿️

TOTAL REVOLUTIONS: A good measure of work output

| VOLTS | | | THOUSANDS | | | | | | | | | | |
|-------|----------------|-----------|-------------------------------------------------------------------|---|---|---|---|---|---|---|---|---|----|
| | | | 0 | 1 | 2 | 3 | 4 | 5 | 6 | 7 | 8 | 9 | 10 |
| 9.6 | BLACK & DECKER | PS3200 | [Bar chart showing low speed revolutions at 35 inch-pounds load] | | | | | | | | | | |
| | PORTER-CABLE | 830 | [Bar chart showing high speed revolutions at 10 inch-pounds load] | | | | | | | | | | |
| 12 | BLACK & DECKER | PS3500 | [Bar chart showing low speed revolutions at 35 inch-pounds load] | | | | | | | | | | |
| | MILWAUKEE | 0501-02 | [Bar chart showing high speed revolutions at 10 inch-pounds load] | | | | | | | | | | |
| | MILWAUKEE | 0502-02 | [Bar chart showing low speed revolutions at 35 inch-pounds load] | | | | | | | | | | |
| | PORTER-CABLE | 826 | [Bar chart showing high speed revolutions at 10 inch-pounds load] | | | | | | | | | | |
| | SKIL | HD2745-04 | [Bar chart showing low speed revolutions at 35 inch-pounds load] | | | | | | | | | | |
| 14.4 | WAGNER | PG144 | [Bar chart showing low speed revolutions at 35 inch-pounds load] | | | | | | | | | | |

■ BLUE--LOW SPEED REVOLUTIONS AT 35 INCH-POUNDS LOAD
■ RED--HIGH SPEED REVOLUTIONS AT 10 INCH-POUNDS LOAD

TORQUE: It tells how much muscle a drill has

| VOLTS | | | MAXIMUM INCH-POUNDS | | | | | | | | | | |
|-------|----------------|-----------|------------------------------------|----|----|----|----|-----|-----|-----|-----|-----|-----|
| | | | 0 | 20 | 40 | 60 | 80 | 100 | 120 | 140 | 160 | 180 | 200 |
| 9.6 | BLACK & DECKER | PS3200 | [Bar chart showing maximum torque] | | | | | | | | | | |
| | PORTER-CABLE | 830 | [Bar chart showing maximum torque] | | | | | | | | | | |
| 12 | BLACK & DECKER | PS3500 | [Bar chart showing maximum torque] | | | | | | | | | | |
| | MILWAUKEE | 0501-02 | [Bar chart showing maximum torque] | | | | | | | | | | |
| | MILWAUKEE | 0502-02 | [Bar chart showing maximum torque] | | | | | | | | | | |
| | PORTER-CABLE | 826 | [Bar chart showing maximum torque] | | | | | | | | | | |
| | SKIL | HD2745-04 | [Bar chart showing maximum torque] | | | | | | | | | | |
| 14.4 | WAGNER | PG144 | [Bar chart showing maximum torque] | | | | | | | | | | |

NOTES: 1. Tools were run at full speed in lowest gear. We slowly increased the applied load until the tool stopped.
 2. Our test gauge measures only to 200 inch-pounds of torque.



Howard Packer, Newtown, CT, General Contractor

“Every time I build something, I’m building a reputation. That’s why I use ProBond.”

Often, even on the biggest projects, it’s the smallest details that make or break the job. That’s why I insist on ProBond’s line of professional products.

ProBond is designed by professionals to have unsurpassed performance. From the strongest formulas to the most functional packaging, ProBond products are created for experienced contractors like me. It took years for me to build my reputation and that’s why I only trust ProBond’s quality products made by Elmer’s®. And we’ve always been known to be the best.

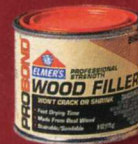
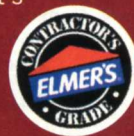

© Elmer's Products, Inc., 1997

ProBond. Pro Results.

WORKING OUT THE WRINKLES

HOW TO GLUE WAVY VENEER TO A FLAT PANEL

There was never any question: Beautiful burlwood was just the ticket to highlight the lid of our humidior (*page 47*). But burls aren't the easiest veneers to work with. Here's how Project Builder Jan Svec worked out the kinks.

Start with crinkly wood

Potato chips and burl veneer have a lot in common. Flat, moist slices at first, they're wrinkly and crispy by the time they get to you. And if you take either one straight from the package and try to flatten it out, you end up with crumbs.

But, when you want to incorporate burl veneer into a project, it usually needs to lie flat. Here's a simple way to flatten burl veneer and glue it to a flat panel.

First, select the section of the burl you want to display on your project. To visualize what it will look like, cut a window the size of the desired piece in a sheet of paper or cardboard. A pair of cardboard L-shapes works great, too, as shown *top right*.

Mark the selected area, allowing about 1/2" extra on the length and width. Then, cut the piece to this rough size. (You'll need two pieces for the humidior lid.) Cut the veneer with a fine-toothed dovetail saw or a utility knife. Cut with light strokes to prevent cracking the brittle veneer. Don't attempt to press the veneer down flat for cutting.

Iron out the kinks

Cut two pieces of flat, smooth scrapwood slightly larger than the dimensions of the veneer piece. (We used melamine-faced particleboard.) These will be the platens

for flattening the veneer. Later, you'll use them for clamping the veneer to the panel.

Now, soak the veneer in hot water until it softens. Remove it from the bath, and blot the surfaces. Lay several thicknesses of clean, absorbent paper on the bottom platen. (Brown kraft paper or heavy paper towels work well. Unprinted newsprint is good, but don't put printed newspaper pages in contact with the veneer.)

Lay the damp veneer on top of the paper. Cover it with several more layers of paper, shown *below*, then put the top platen in place. Clamp the platens together, as shown *below right*.

After four hours, unclamp the stack and replace the paper with dry sheets. Reclamp. Change the

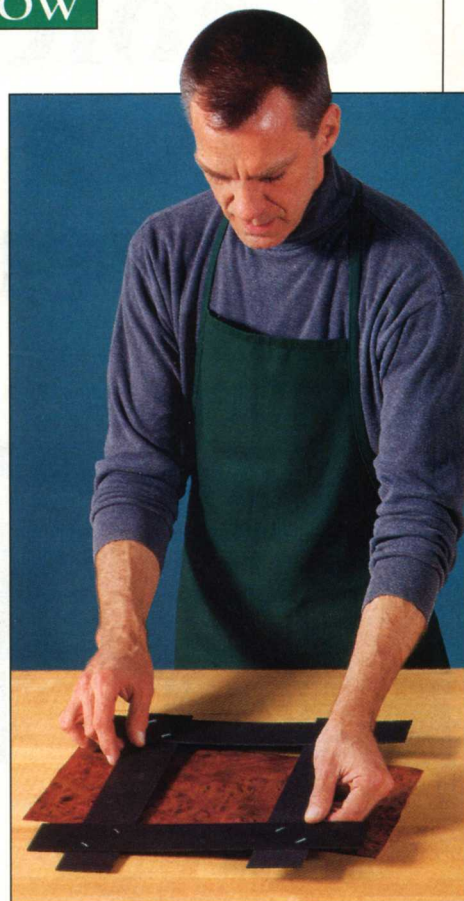

paper three times at intervals of at least four hours. Change the paper a fourth time, and leave the stack clamped overnight. (You can press several pieces of veneer at once, as long as you separate them with paper.)

After the veneer dries, store it clamped between the platens with clean, dry paper until you're ready to use it.

Continued on page 30



Continued from page 28

WORKING OUT THE WRINKLES

**Glue the burl to a base**

Cut the base panel for the veneer about $\frac{1}{2}$ " larger in length and width than finished size. (For the panel in the humidor lid, we chose $\frac{1}{4}$ " plywood.) Sand the surface smooth for the veneer.

Clean out the dust bag on your portable belt sander. Then, turn the tool upside down and clamp it to your workbench. Grind some veneer scraps to dust with the sander. Carefully empty the veneer dust into a cup.

Now, mix enough epoxy to cover the panel. (To veneer both sides of the approximately 6x8" humidor panel, we mixed about $\frac{2}{3}$ of a 1-oz. package.) Slow-setting resin—often labeled as 2-ton epoxy—is better for this job than the five-minute variety. As you mix the epoxy, stir in an equal amount of veneer sanding dust.

Lay waxed paper on one platen, then place a piece of veneer (best face down) on top of it. Spread the epoxy/wood dust mixture on the back of the veneer. Lay the base panel on the veneer, as shown *above*.

If you're veneering both sides of the panel, cover its back with the epoxy/wood dust mix, and position the other veneer on it, best face up. Cover the veneer with waxed paper, then place the other platen on top. Clamp the sandwich together, and allow the epoxy to cure overnight.

Fill the faces

Remove the panel from between the platens. You'll notice that the

epoxy has squeezed through many of the holes in the burl. To fill the remaining ones and any surface cracks, mix another batch of epoxy and veneer dust. (We mixed the remaining $\frac{1}{3}$ of the package with an equal volume of veneer sanding dust.)

Spread some of the mixture on one face of the panel. Then, using a putty knife or plastic spreader, force the epoxy into any voids in the surface. Place the panel face-down on a clean sheet of waxed paper, and repeat the operation on the other side, if veneered. Allow the epoxy to cure.

Using double-faced tape, adhere the panel to one of the platens. Secure the platen to your bench, and scrape the excess epoxy from the surface with a cabinet scraper as shown *below*. Sand the face smooth with 220-grit abrasive, taking care not to cut through the thin veneer at the edges. Repeat on the back, if veneered. Finally, trim the panel to finished size, and install. ♣

Photographs: John Hetherington



You deserve
a vacation...
Our bandsaws
will give you one

Who needs civilization when you have a Laguna Tools Bandsaw on a desert island? We give you more power, more re-saw and more Bandsaw for your money. Our European Bandsaws give you dynamically balanced cast iron wheels, professional guides, large blade capacities and heavy duty cast iron tables. Models range from 13" to 36".



Call now
(800)
234-1976
for your
FREE
demonstration
video
getting
you closer
to your
vacation.

LAGUNA TOOLS

2265 Laguna Canyon Road
Laguna Beach CA 92651
800-234-1976 • FAX 714-497-1346
lagunatools@earthlink.net

Circle No. 615

FINGER

These bits help you make super-strong joints, but setting one up properly can prove tricky. So, we've come up with a method that ensures your success time after time.

Advantages of and uses for a finger-joint bit

It's usually a simple matter to glue edge or face surfaces together, but gluing boards end-to-end is another matter. That's because the hollow fibers of end grain work like straws to draw adhesive away from a joint. And, the ends of these "straws" provide little surface area for the glue to adhere to. Fortunately, a finger-joint bit solves both of these problems by exposing face grain and greatly increasing the surface area of the joint.

With one of these bits you can make good use of your scrap stock by end-joining short pieces to make longer ones. But, because the edge-grain view of a finger joint (shown *above*) can be less than appealing, we suggest you use it only for project pieces that will be painted. Some outdoor projects, such as the garden arbor on *page 52*, look okay with clear-finished finger joints.

A 7-step process for great results

You can buy several types of finger-joint bits, including those with variable-spaced cutters and bearings. For this article we'll show you how to use a no-frills version like the one shown *above*—a one-piece cutter without a bearing. With this eight-finger bit you can finger-joint stock up to 1 1/8" thick in one pass.

1 Set the bit upright and rotate it so the cutting edge with the highest finger faces you. With a permanent, felt-tip pen, mark the third finger down on the side facing you as shown in the drawing at *right*. This will be your reference finger for the following steps.

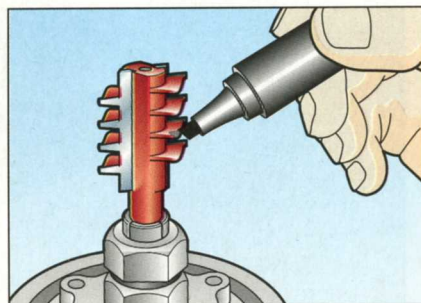

2 Mark a centerline along the edge of a scrap piece of stock of the same thickness as your workpiece. With the bit in your router table, adjust its height so the point of the reference finger aligns with the centerline as shown at *right*.

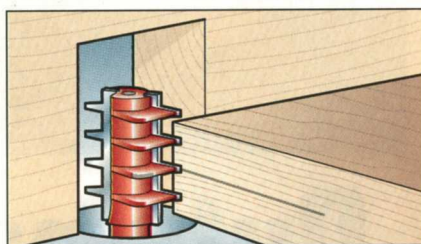

3 With the router unplugged, rotate the bit by hand to the point where it makes the deepest possible cut into the workpiece. Then, use a straightedge to align the fence flush with the innermost cutting edge of the fingers (the "web" of the fingers, so to speak). Also, the fence should be parallel to your router table's miter-gauge slot.

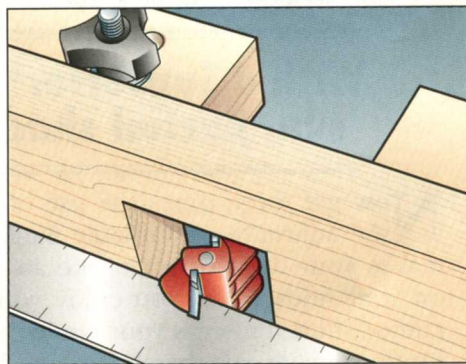

4 Test the fence position by making a test cut into the edge grain of your scrap stock. If the fingers that you just cut into the workpiece do not contact the exit side of the fence, you need to decrease the depth of the cut by bringing the fence forward. If the workpiece fingers contact the fence, but are not smooth and rounded on their ends, you need to increase the cutting depth. Do this by adjusting the fence back.

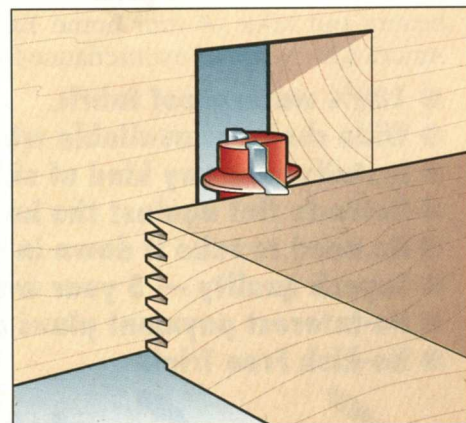

JOINT BITS

You can't beat 'em for joining end-to-end

5 Cut the edges of two pieces of scrap stock, flip one piece over, and place together the finger-jointed edges. The faces should align flush. If they don't, you will need to adjust the bit's height up or down by $\frac{1}{2}$ of the misalignment between the faces of the scrap stock.

In the example *right*, the faces are misaligned by about $\frac{1}{16}$ ". So, we *lowered* the bit $\frac{1}{32}$ ". On the other hand, if the piece on the right side of the illustration was too high by $\frac{1}{16}$ ", we would *raise* the bit $\frac{1}{32}$ ".

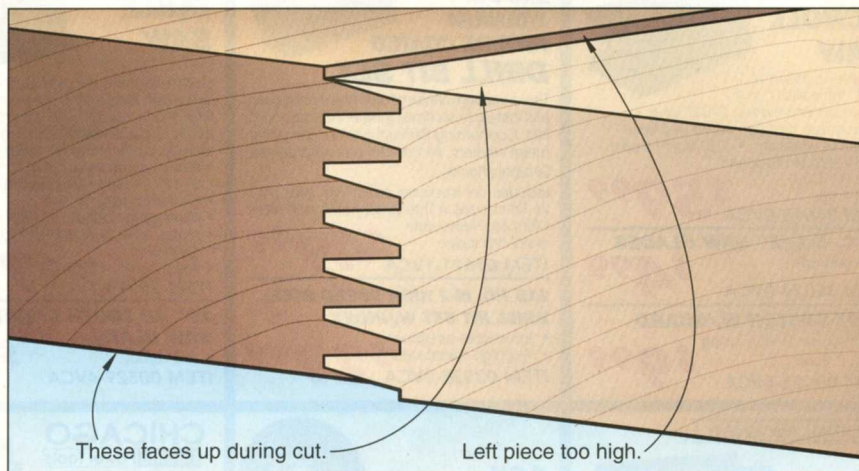

6 Now, you're ready to cut your actual workpieces. First, attach an auxiliary wooden face to your miter gauge. The end of the face should contact the router-table fence without preventing you from pushing the miter gauge smoothly through its complete travel.

Place one edge of a workpiece against the auxiliary face, butt the end of the workpiece against the router-table fence, and make a cut by slowly but steadily pushing the miter gauge forward. (The face side of the workpiece can be up or down.) The auxiliary face backs up the workpiece to prevent edge-grain chipping on the exit end of the cut.

To cut the other end, flip the workpiece *end for end* and repeat the procedure described above. *Do not* simply rotate the piece and keep its same face down for the second cut. By flipping the workpiece, you ensure that the face sides of your workpieces will be on the same side of your completed assembly.

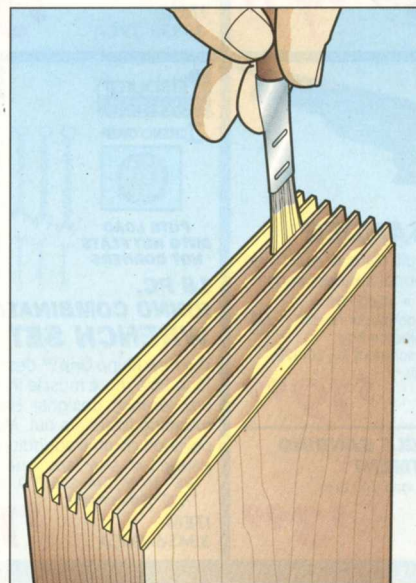
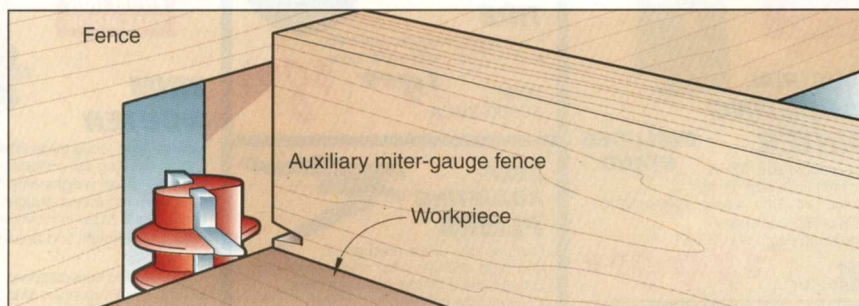

7 Apply glue to the finger-jointed ends by running a thin bead of woodworker's glue between each finger. Work the glue into the fingers as shown at *left* so it covers all surfaces.

It does not pay to apply glue to both surfaces of a finger joint. This just creates excessive glue squeeze-out.

After applying the glue, join the two workpieces and rub them back and forth to ensure that all surfaces of the joint receive glue.

If your longest clamps aren't long enough for your longest workpieces, or part of your assembly is curved, try the clamping arrangement on *page 54*.

Written by Bill Krier with Chuck Hedlund Illustrations: Kim Downing Photograph: John Hetherington

NORTHERN WHITE CEDAR

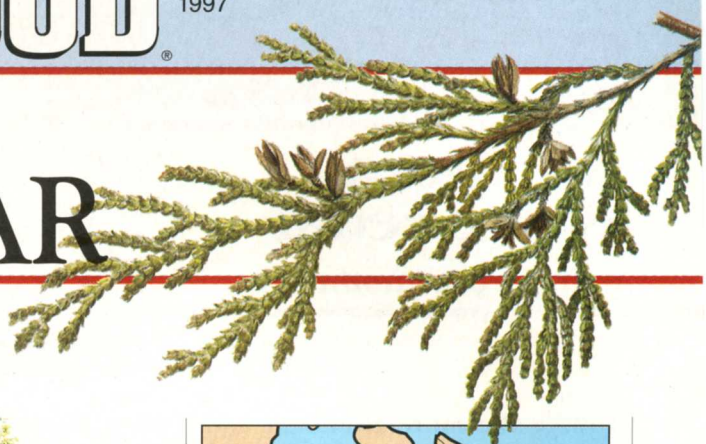

Call this tree the canoe conifer

Native Americans of the Great Lakes region knew northern white cedar's value. Its wood was light yet strong enough for canoe ribs, and easily split along the growth rings to form the thin planking that was covered by birch bark. The tree also provided an oil that they extracted from twigs and foliage to relieve chest congestion.

When lumbermen first entered the vast forests where the northern white cedar grew, they instead harvested the abundant white pine. Except for furnishing decay-resistant wood to shingle bunkhouses, the northern white cedar was ignored. But by the turn of the century, as its use for cooperage, posts, poles, and shingles became appreciated, northern white cedar reached record harvest levels of nearly 100 million board feet per year.

Loggers in the northern Great Lakes states, Maine, and Canada still harvest northern white cedar. Like more familiar cedars, it is durable for everything outdoors, from fences and decks to boats and furniture.

Wood identification

Northern white cedar (*Thuja occidentalis*), sometimes called arborvitae, or "tree of life," grows in a range from eastern Manitoba to Maine and New Brunswick and south through Michigan to New York. In little more than shrub form, it occasionally appears in other regions.

The tree flourishes in company with hemlock, larch, alder, and balsam fir. In the moist soil that it



frequently grows in thick stands. Favorable conditions produce trees 70' tall and up to 6' in diameter. Normally, northern white cedars grow to about 50' with a diameter of 2-3'.

No matter its size, the tree has an attractive pyramidal shape, often with twin trunks. Northern white cedar's orange-brown bark features fissures that break into twinlike strings.

Rather than having needles like most conifers, northern white cedar has tiny, scaly leaves that overlap on the twigs and branchlets. By late summer, reddish cones up to ½" long appear.

Northern white cedar's aromatic wood is a light tan and weighs about 19 pounds per cubic foot air-dried. Although quite stable and easy to work, it is soft, brittle,

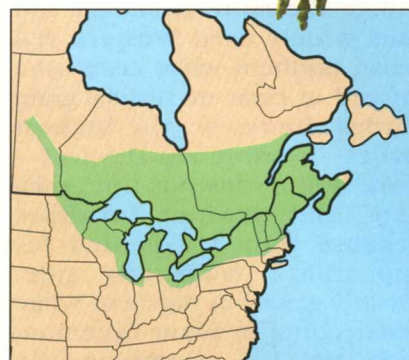

Natural range

and coarse-grained. However, the wood is durable in contact with soil and water, and strong for its weight. The fact that it easily splits along its growth rings was a blessing to the Native Americans, but is rated a defect called "ring shake" by the lumber industry.

Uses in woodworking

Traditionally destined for posts, utility poles, shingles, siding, and boats, northern white cedar's lightness and durability make it ideal for outdoor furniture, too. The wood is still a favorite for strip canoes. And because it holds paint and stain well, it's used for decks and fencing.

Availability

In New England and the Great Lakes states, you'll find northern white cedar at small local mills as well as lumber outlets. Elsewhere, it's replaced in the marketplace by Western red cedar, which is logged in far greater volume. Where you find it, expect to pay about \$1 per lineal foot in thicknesses up to 4".

Continued

PERFORMANCE PROFILE

northern white cedar (*Thuja occidentalis*)



Clear northern white cedar



Common northern white cedar

Unlike the more abundant and thus widely used Western red cedar, northern white cedar isn't offered in clear or vertical-grain grades. However, the highest grades—C Select and D Select—work well for interior trim, cabinets, and outdoor furniture because they are graded for appearance from one side. "Board" grades of northern white cedar come in plain Common, and Nos. 1-5 Common (in descending order of quality). You also can buy the wood in construction grades.

Air-dried northern white cedar should be stickered when stored. If not, moisture that works its way between the boards can sometimes cause a surface mold.

Machining methods

Users of northern white cedar, one of the lightest of the softwoods, also find it among the most stable, especially when kiln-

dried. However, the wood's brittleness, which results in splits, splinters, and tearout, requires some care in machining with sharp cutting edges.

- Plane northern white cedar with a shallow pass, and joint it so that you remove $\frac{1}{16}$ " or less.
- You won't have problems ripping this straight-grained wood if you feed it slowly.
- Reduce splintering when cross-cutting by using a fine-toothed crosscut blade.
- Avoid tearout while routing across the grain by applying a backing board along the edge where the bit will exit.
- Saw or rout thin stock slowly to avoid breakage.
- Northern white cedar's lack of sticky pitch allows you to join it with little trouble using your choice of adhesives. Screws, though, require pilot holes, and should be noncorrosive aluminum, brass, or silicon bronze.

Nails also should be zinc-coated. And, use screws and nails about one-third longer than normally required so they won't pull out.

- Exposure to weather will eventually turn the wood a silver-gray. Some people like the look, but it can turn out uneven. A clear protective finish will slow the graying process if occasionally recoated. Pigmented stain or paint best protects the wood from damaging ultraviolet rays.

Carving comments

- Tighter grained, the wood takes detail well.
- Watch out for the northern white cedar's softness and brittleness that leads to breakage.

Turning tips

- Use sharp gouges. For end grain, which easily tears out, sand to final shape.

SHOP-TESTED TECHNIQUES THAT ALWAYS WORK

Any exceptions pertaining to this issue's featured wood species appear under bold-face headings elsewhere on this page.

- For stability in use, always work wood with a maximum moisture content of 8 percent.
- Feed straight-grained wood into planer knives at a 90° angle. To avoid tearing, feed figured or twisted grain at a slight angle (about 15°), and take shallow cuts of about $\frac{1}{32}$ ".
- For clean cuts, rip with a rip-profile blade having 24-32 teeth.

Smooth crosscutting requires at least a 40-tooth blade.

- Avoid using standard twist-drill bits. They tend to wander in the wood and cause breakout. Use brad-point bits and a backing board under the workpiece.
- Drill pilot holes for screws.
- Always rout with sharp, preferably carbide-tipped, bits and take shallow passes to avoid burning.
- Carving softwoods generally means fairly steep gouge bevels—20° or more—and deeper cuts.♣

N. WHITE CEDAR AT A GLANCE

| | |
|-------------|---------------------|
| Cost | \$ \$ \$ \$ \$ |
| Weight | ⚖ ⚖ ⚖ ⚖ ⚖ |
| Hardness | T T T T T |
| Stability | ▲ ▲ ▲ ▲ ▲ |
| Durability | 🕒 🕒 🕒 🕒 🕒 |
| Strength | 💪 💪 💪 💪 💪 |
| Toxicity | ☠ ☠ ☠ ☠ ☠ |
| Workability | 🔪 🔪 |
| Look-alike | Eastern white cedar |

Compiled with woodworkers Jon Olson and Bill Krier

Success by the Spoonful

Jonathan Simons discovered how to make spoons over lunch. Now, this Pennsylvania craftsman just can't stop.



Wooden spoons. There's nothing like them for gently stirring a sauce or nudging a sauté to perfection. And when they're not in use, they create a great decorative accessory. Without a doubt, wooden spoons are among the oldest dinner-table implements, too. Among pioneer folk crafts, treenware was the name for the ladles, spoons, and other utensils whittled from tree branches. The only investment was time.

Jonathan Simons, a 42-year-old craftsman and entrepreneur, knows about spoons and time. He's spent more than 18 years developing his line of wooden spoons, spatulas, scoops, spreaders, and forks. And from his three-story, chalet-type shop nestled in the eastern Pennsylvania hills near Lenhartsville, he ships his solid cherry utensils to wholesale accounts in nearly every state, as well as Europe and Japan. Yet, reaching a level of success that allows top-notch equipment, several employees, a constant \$100,000 inventory, and time to call his own, was a somewhat harrowing trip.

The birth of a spoon

"I can say that this was probably my first spoon," says Jonathan with an amused grin as he points at a small, roughly hewn, gouged out, shallow bowl on his office

Continued

Jonathan's spoons

desk. "I made that in seventh grade and gave it to my father."

But the path that led him to his successful business—naturally called Jonathan's Spoons—wasn't a simple progression. After graduating from college in Illinois with a degree in art and design, Jonathan returned to his home state of Pennsylvania in search of a job.

"In the fall of 1978 I was selling environmental calendars. One day I was walking the streets of New Hope, Pennsylvania, when I stumbled upon the studio of furniture-maker Geoffrey Green," Jonathan recalls. "A sign on the the door read 'Apprentice Wanted.' I felt the Hand of Providence pushing me."

According to Jonathan, he and Geoffrey Green had been cast from the same mold—intensely creative and independent. That resulted in an abbreviated apprenticeship. Yet it was a learning experience. Says Jonathan: "With

Geoffery, I was able to take all this smattering of art and design that I had studied and focus it on the one material that I had always loved, wood."

While working in Green's studio, Jonathan also accidentally discovered the path to his eventual success. "I usually brought soup or stew to work for lunch, and as we ate, we talked about the different wholesale products that we might develop," notes Jonathan. "One day I forgot my spoon, so I cut one out of scrapwood on the bandsaw. It was really flat and thick. But I said to myself, 'Hey, I could make and sell spoons.' After I left, I set up a little woodshop in a spare room of my rented house."

Without a job, but with a table-saw, a jigsaw, and a disk sander, Jonathan began to make spoons, putting them out on consignment to gift shops in the area. He managed to sell enough to get excited about the possibilities. Then he ran into a chilly detour.

At the bandsaw, Jonathan cuts a spoon freehand from 2"-thick cherry. He stands at the side of the table for better vision and control of the wood as it moves against the blade.

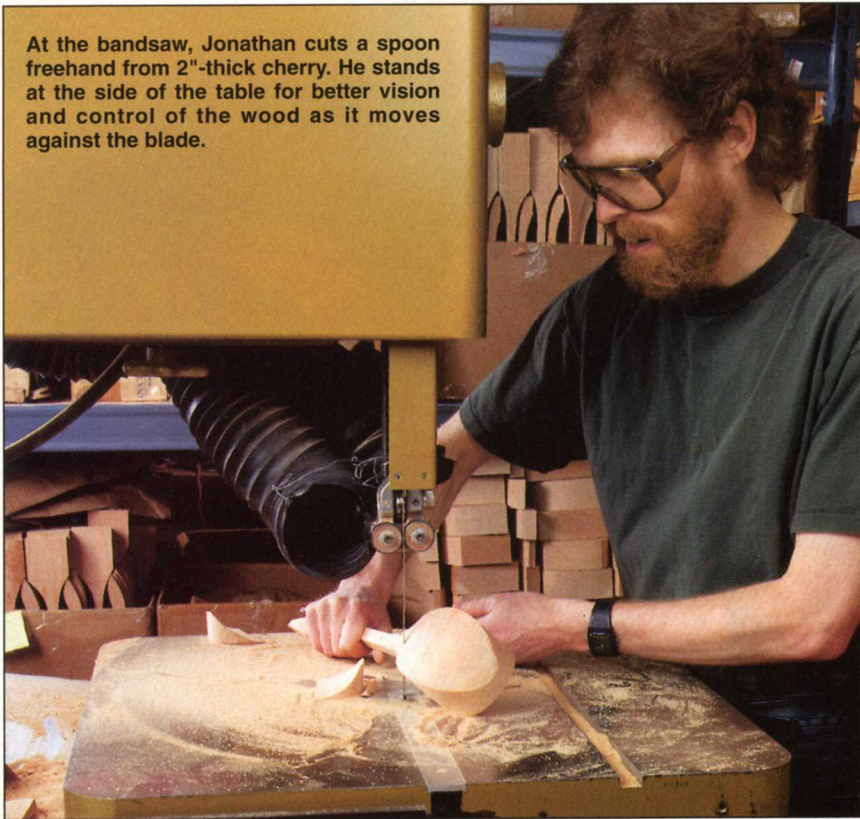

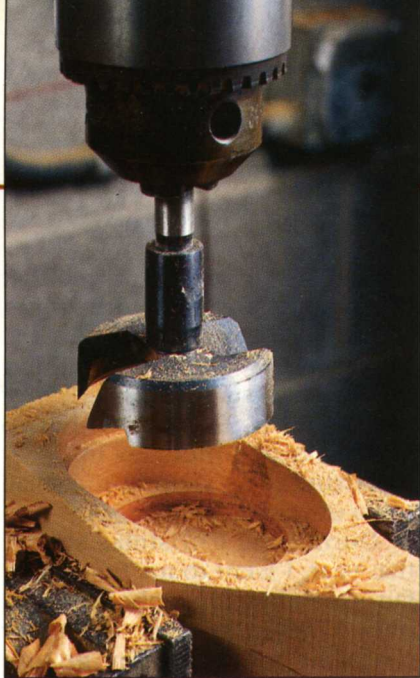

After sawing a ladle to shape, the bowl is roughly bored out at the drill press with overlapping bites of a Forstner bit.



To make the depression in the bowl of a spoon, Jonathan modified a special belt sander. The abrasive of the extra-long belt doesn't clog with sanding dust as easily as a shorter belt.

Woodworking at 20 below

Just as Jonathan was crafting his spoonmaking into a going business, his fiancée, Julie, decided to take a job in Maine. The fledgling woodworker decided that he needed a change, too, and joined her. They were soon married.

In his new environment, Jonathan kept busy doing home repair work, and in his off hours set up a workshop. "I created a tiny shop about 10x15' in a corner of the garage where I could make some furniture and spoons. But then the repair jobs ran out," he recalls, "and I had to go to work for minimum wage in a shop that made ash canoe seats."

Hindsight proves that was valuable experience. The developing craftsman learned the elements of production by spending days on a drill press, next a week with a router, then a spell at the inflatable drum sander ("That's what was missing in my spoon making, a professional-looking sanding job!"). It was the discipline he needed, even if it was at low pay. And there was another fringe benefit—he hauled scrapwood home.

Then came the unexpected. Jonathan recalls it vividly. "One February night the furnace in the canoe-seat shop overheated and all the ash seats we'd worked on

cracked. The owner had to lay everybody off. I couldn't find another day job, so I had to work at home in an unheated shop. It was about 20 degrees below zero. And my dust collection system was a fan in the window that blew out onto the train tracks. It was so cold that I couldn't glue furniture. I had to make single-piece items like the spoons. But I really wanted to work for myself."

In Jonathan's words, he spent that winter "traipsing around Maine" trying to sell his spoons, even trading them for food. He was barely eking out a living when he got a break.

"I met an elderly greeting-card salesman who liked my work," says Jonathan. "I really wasn't set up for mass production, but he took the 100 or so spoons I gave him and sold them wholesale to gift shops. Eventually, he brought me in a couple hundred dollars worth of orders a week, and 'Jonathan's Spoons' was born."

Continued



Jonathan's spoons

The system that creates

The Pennsylvania shop of Jonathan's Spoons today hums with the sounds of bandsaws cutting cherry, drill presses boring it, and various sanding machines smoothing it. Jonathan walks about, sidestepping cardboard boxes filled with spoons in different stages of completion, as he describes how his business gradually evolved.

"In Maine, I was making spoons out of scraps or chunks from firewood piles," he explains. "But that was one of the things that attracted me to making them. I loved to cut open the wood and see something that no one had ever seen before. My work was to take what I saw as being beautiful in the wood and to cut it into a form that someone would find a useful item. And the spoons were so simple. I could show the variety, grain, and texture of the wood without having to do something elaborate with joinery, as with furniture. And by following the grain a certain way, they were

still strong." (See illustration, *opposite page*.)

Jonathan eventually realized that the climate for his work might actually be better in Pennsylvania. The weather was much milder, and there was a greater variety of hardwood trees from which to make his product. So in 1979 Jonathan set up shop in the small town of Lenhartsville.

"During the Christmas season that year, I went to my first crafts' fair," Jonathan remembers. "I sold over \$700 in spoons. I'd never had that much money at one time! It definitely got my business on its feet."

The first five years he spent in Pennsylvania saw the business grow nearly 50 percent annually. Jonathan even began selling his wares at American Crafts Council wholesale shows and other professional events. Business was great, but there were some growing problems, too.

"I was still making all my spoons without a pattern—every one was designed from scratch," explains



This ladle serves as a strainer, too. A rubber baseball on the sander arbor perfectly fits the ladle's bowl. Hot glue adheres the abrasive disc to the ball.

Jonathan. "To make my work pay off, I kept raising prices. That seemed okay until I attended a retail show at Harrisburg. There were 35,000 people there and I didn't sell a thing the first day. What was the matter? I arrived at the conclusion that a spoon retailing for \$12 was just too expensive. People didn't want all this quality that I was putting into them. That night I went home and worked all night to see how I could cut corners."

Jonathan concluded that four changes would lower prices:

- Select only one variety of wood to take advantage of quantity prices for the stock. (That turned out to be cherry, which is easier on blades and abrasives than the apple, plum, hickory, osage orange, and other woods that he had been using.)
- Make templates of the best designs for easier and more consistent reproduction.
- Switch to thicker stock so three spoons could be bandsawn to shape at once.
- Cut the final wet-sanding step, which added little to the finish.

The next day, Jonathan returned to the crafts fair with a handful of the spoons he had made the new way. Priced at \$6 each, they sold immediately, and encouraged him to take economy of scale further and hire help. In 1984 Jonathan hired the first of what has now become 10 employees.

Concluding his story, Jonathan stops by one of the employees sitting at the inflatable drum sander. "All along I've wanted to build a system, a production like this that allows me to create. That's still a driving force—to get my ideas out there. The more people in my shop that I can teach to make the items I already have to market, the more I will be able to take the new things that I visualize and create them."

As he surveys the small company that he's built—the employees chatting as they work, the piles of



All of the cherry utensils get a final smoothing with 220-grit at one of two inflatable drum sanders. Ian Keal works in the background behind Jonathan. For a finish, the utensils receive a coat of high-grade mineral oil.

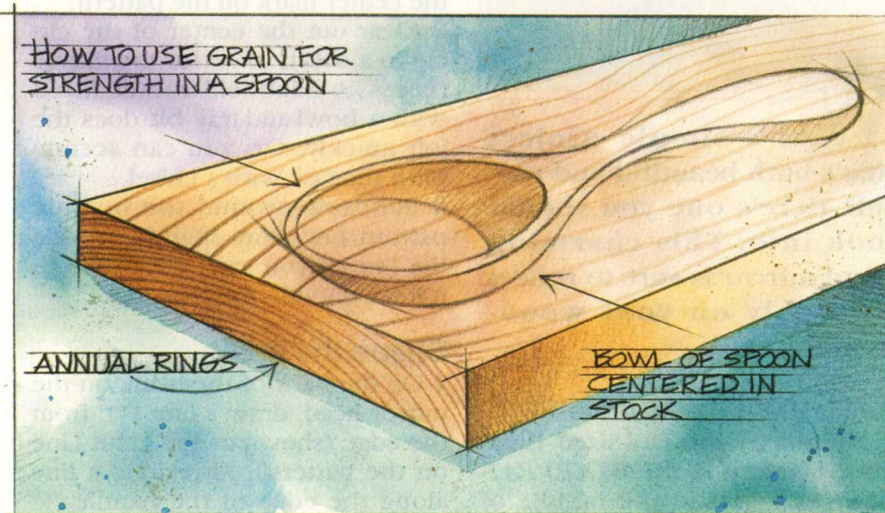

solid cherry boards, the machines—Jonathan smiles. "I do miss the excitement of opening up a new piece of wood, something I've not seen before, and I intend to someday bring that aspect back into my woodwork-

ing life. Responding to the grain of the wood and making it into a spoon is simply a great experience. Today, I can get maybe 10,000 spoons out of a typical cherry tree, but there's not the old romance to it." ♣

Written by Peter J. Stephano Photographs: Steve Uzzell Illustration: Brian Jensen

A GREAT-LOOKING LOOKING GLASS

This old-style mirror boasts up-to-the-minute beauty



Want a simple project that's both beautiful and useful? Here's one you should look into. This charming hand mirror is sure to reflect favorably on your woodworking skills.

First, machine the blank

1 Photocopy the Full-Sized Hand Mirror pattern in the *WOOD PATTERNS*® insert in the middle of the magazine. With spray adhesive or rubber cement, attach the pattern to a piece of $\frac{3}{4}$ "-thick stock about 6" wide and 12" long. The wood grain should run lengthwise on the narrow handle.

2 Set your circle cutter to a radius of $2\frac{1}{32}$ " ($5\frac{1}{16}$ " diameter). Adjust the pilot bit so its tip extends only

$\frac{1}{8}$ - $\frac{3}{16}$ " beyond the cutting blade tip. Chuck the circle cutter in your drill press, and bore $\frac{1}{8}$ " deep at the center mark on the pattern.

3 Clear out the center of the circle to a depth of $\frac{1}{8}$ " for the mirror recess. A handheld router fitted with a bowl-and-tray bit does the job quickly. Or, you can accomplish the task with a chisel.

4 Bandsaw around the outside pattern line. Stay slightly outside the line as you saw, then sand to it for a smooth, flowing edge.

Shape the back

1 On the back of the blank on the mirror head, draw a line $1\frac{1}{2}$ " from the edge (shown as the Limit Line on the pattern). Also draw a line along the edge of the handle $\frac{1}{8}$ " from the back (the flat side).

2 Shave or sand the handle down to the line, blending it into the mirror head. Shape the back edges of the handle to the profile indicated by the cross-section drawings. A rasp, drum sander, or rotary power-carving tool with a Kutzall bit will do the job.

3 As you shape the handle, curve the back edge of the mirror head. Refer to the cross-section illustration as you stretch the curve from the front edge to the Limit Line on the back. Notice in the photo of the mirror's back *below left* how the lines blend and flow together.

4 Employing progressively finer grits from 100-220, finish-sand the back and handle. Blend the contours, and sand out any file or grinding marks remaining after the shaping.

Finish up the front

1 Sand a slight round-over around the outer edge of the mirror head. It should be just enough to eliminate the sharp edge, but not enough to look round.

2 Where the handle meets the mirror head, shape the round edges to match those on the back of the handle. Blend the handle into the mirror head. The surface along the front of the handle remains flat and on the same plane as the rim around the front of the mirror head.

3 Finish-sand the front, starting with 100-grit abrasive and ending with 220-grit. Then, sand the entire mirror with 320-grit sandpaper. Apply semigloss lacquer or a finish of your choice.

4 Install a 5"-diameter beveled mirror glass in the recess. (Many craft supply stores or glass dealers sell suitable mirror glass, or see our Buying Guide.) Cement it in place with silicone adhesive/sealer. But just use a few dabs so it won't squeeze out past the glass. ♣

Buying Guide

Mirror. Beveled mirror glass, 5" diameter. Order no. 17T03. For current price and shipping costs, call Woodcraft Supply Co., 800/225-1153.

Project Design: Erik Jorgenson
Photographs: John Hetherington
Illustrations: Roxanne LeMoine; Lorna Johnson

GRAND HUMIDOR

A handsome home for fine cigars

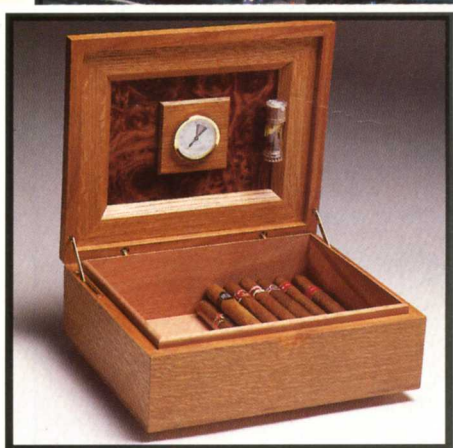

With the cigar craze comes another wood-working opportunity—the humidor. Our exquisite oak version features a beautiful burl-accented lid. You nonsmokers can build it as a handsome accessory for the desk or dresser.

Start with the box shell

1 Rip $\frac{1}{2}$ "-thick quartersawn white oak stock to the width shown for the sides (A) and ends (B) in the Bill of Materials. Crosscut each piece to about $\frac{1}{2}$ " longer than the length shown. For best appearance, cut the pieces from one length of stock in sequence (end, side, end, side), and mark them for assembly order.

2 Tilt your tablesaw blade to 45° . Bevel-cut each piece to finished length, beveling both ends on each one (refer to the Box Assembly drawing, *page 49*).

3 To saw the spline slots shown in the drawing, first attach an auxiliary fence to the saw's miter gauge. Leave your blade tilted to

45° , and lower it to about $\frac{3}{16}$ " above the surface. Saw through the auxiliary fence. Then, using that kerf as a guide, position a piece of bevel-cut scrapwood against the fence so the blade will cut into the beveled end $\frac{1}{8}$ " from the heel (see the Sawing Spline Slots in the Sides and Ends drawing). Clamp a stopblock to the auxiliary fence at the toe of the bevel. Adjust the blade elevation to saw a slot $\frac{1}{4}$ " deep. Test the setup on scrapwood, then saw a slot in each end of each part.

4 Plane a piece of $3\frac{1}{4}$ "-wide scrapwood to about $\frac{1}{8}$ " thick to fit into the spline slots. Saw four $\frac{1}{2}$ "-long pieces from it (the grain will run across the $\frac{1}{2}$ " dimension).

Continued

GRAND HUMIDOR

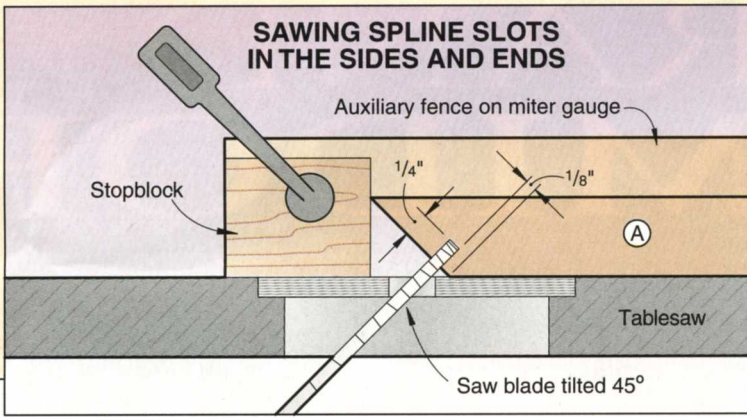

| Part | Finished Size | | | Mati. | Qty. |
|-----------------------------|---------------|---------|----------|-------|------|
| | T | W | L | | |
| A* side | 1/2" | 3 1/4" | 11 1/8" | WO | 2 |
| B* end | 1/2" | 3 1/4" | 9 1/8" | WO | 2 |
| C* top panel | 1/4" | 5 3/4" | 7 3/4" | OP | 1 |
| D* top/bottom surround side | 3/4" | 2" | 11 1/8" | WO | 4 |
| E* top/bottom surround end | 3/4" | 2" | 9 1/8" | WO | 4 |
| F bottom panel | 1/4" | 5 7/8" | 7 7/8" | OP | 1 |
| G meter base | 1/4" | 3" | 3" | WO | 1 |
| H bottom liner | 3/16" | 8 1/16" | 10 1/16" | SC | 1 |
| I* side liner | 3/16" | 2 7/8" | 10 1/8" | SC | 2 |
| J* end liner | 3/16" | 2 7/8" | 8 1/8" | SC | 2 |

*Initially cut parts oversized. Then, trim to finished size in accordance with the how-to instructions.

Materials Key: WO—white oak, OP—oak plywood, SC—Spanish cedar

Supplies: Elm burl (see Buying Guide for veneer), invisible hinges, lid supports, hygrometer, humidifier (see Buying Guide for hardware), walnut stock, slow-set epoxy adhesive, Deftoil Classic Danish Oil Finish—clear natural.

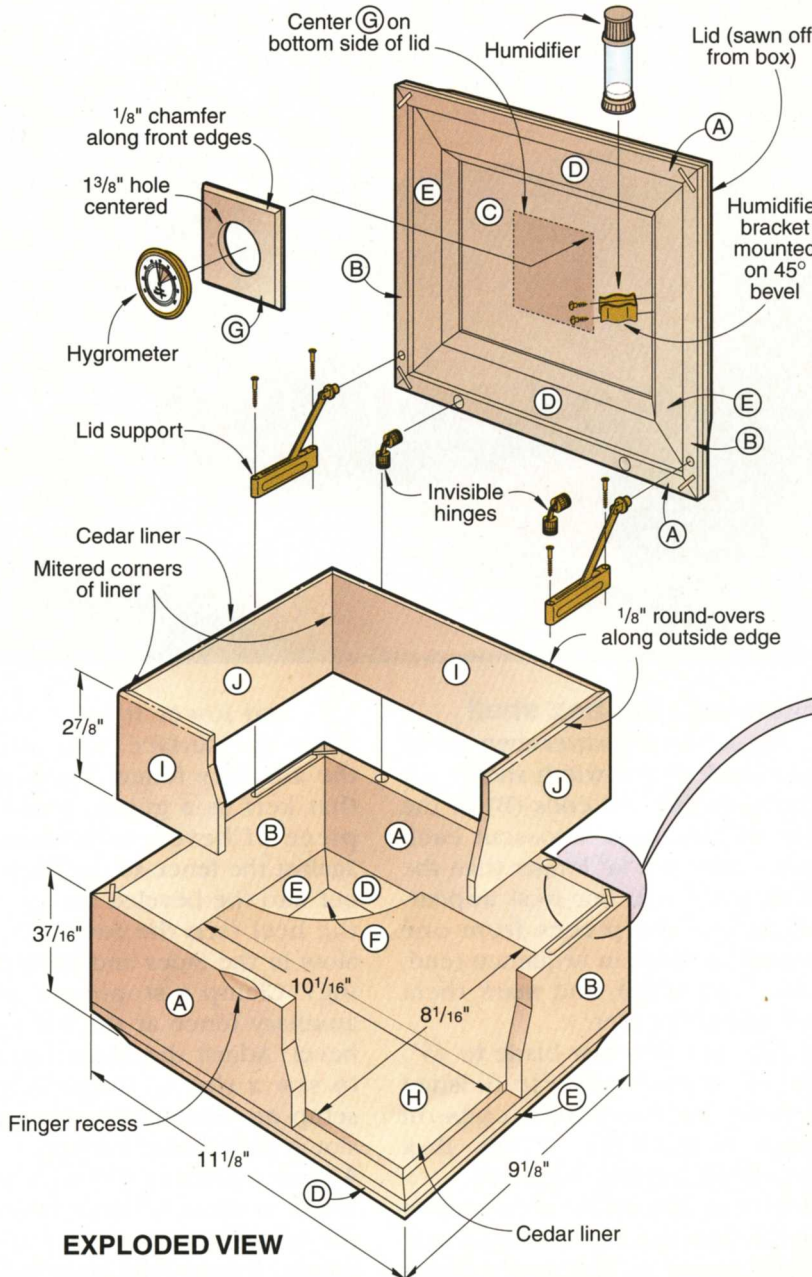

Referring to the Box Assembly drawing, assemble the sides and ends, applying glue to the splines and to the bevels on the sides and ends. Clamp the box, and measure the diagonals to check for square. Clamp the assembly to a flat surface until the glue dries.

5 Lay out the centers for the hinge holes in the side (A) that

will be the back of the box. Refer to the Hinge Hole and Lid Support Mortise detail with the Exploded View drawing for the location. Chuck a 10mm bit in your drill press. (Woodcraft Supply sells a 10mm bit for the hinges; address in Buying Guide.) Drill the holes 1" deep. (Cutting the lid from the box later will result in the $\frac{7}{16}$ "

depth specified in the drawing.) The side is only about 12.7mm thick, so drilling a 10mm hole into it leaves little margin for error.

Add the top and bottom

1 Construct the veneered panel for the top. To do this, start with a piece of $\frac{1}{4}$ "-thick oak plywood about $\frac{1}{2}$ " wider and longer than the dimensions shown for the top panel (C) in the Bill of Materials. Veneer both faces of the panel. (For instructions on veneering the panel, see page 92.)

2 From $\frac{3}{4}$ " stock, cut the sides (D) and ends (E) for the top and bottom frames to the width shown and about $\frac{1}{2}$ " longer than the length shown.

3 Install a 45° chamfer bit in a table-mounted router, and set it to cut a $\frac{3}{8}$ " chamfer. Rout the bottom inside edge of two parts D and two parts E for the top frame. (See the Frame detail.)

4 Install a $\frac{3}{8}$ " dado blade on your tablesaw, and adjust the cutting depth to match the thickness of your veneered top panel. With

Continued

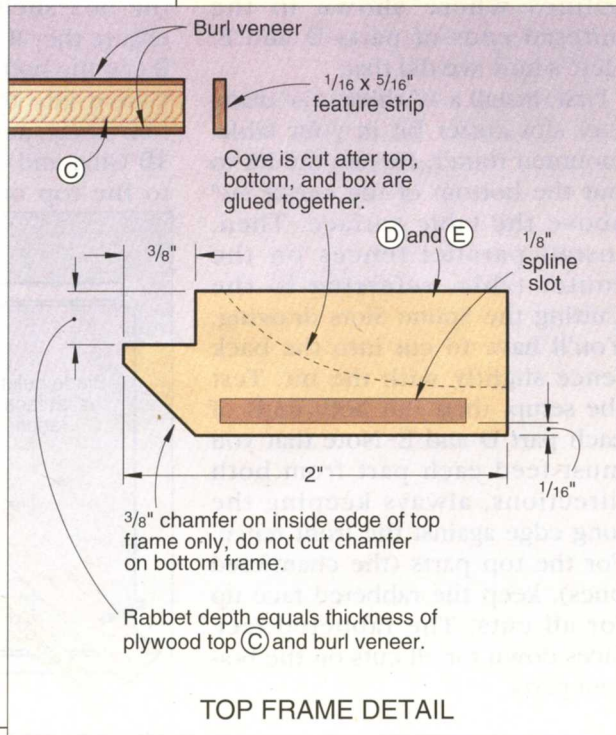
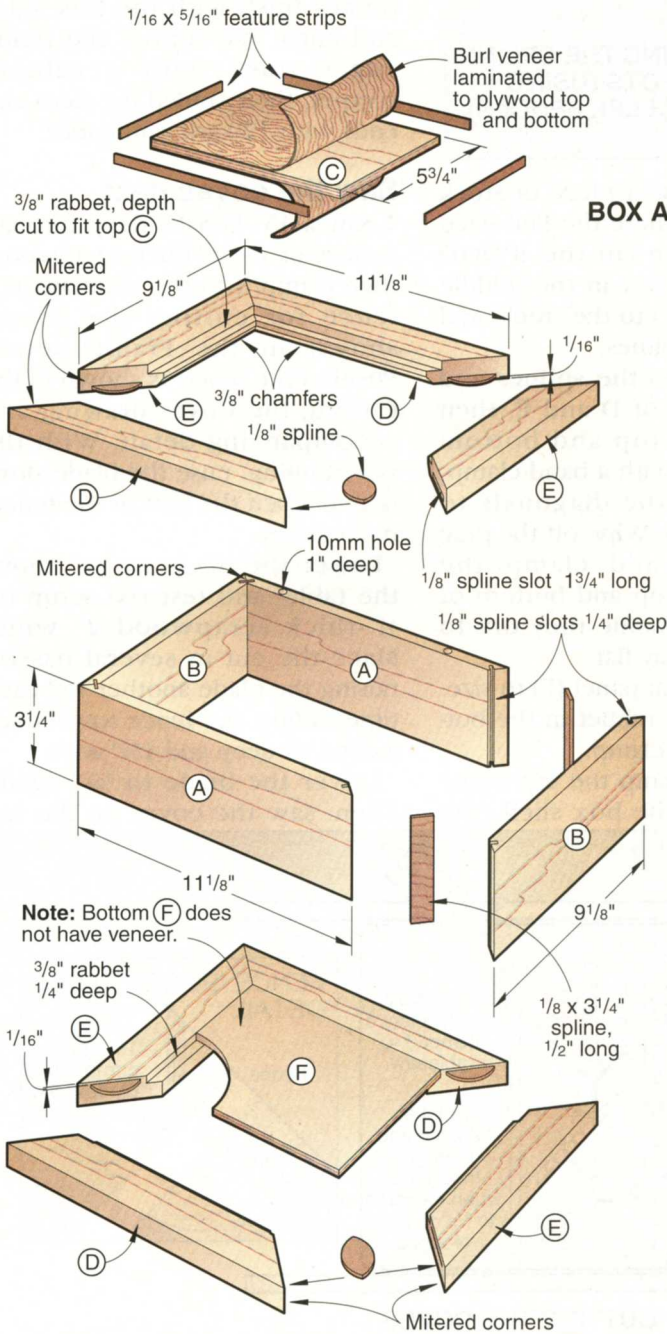

GRAND HUMIDOR

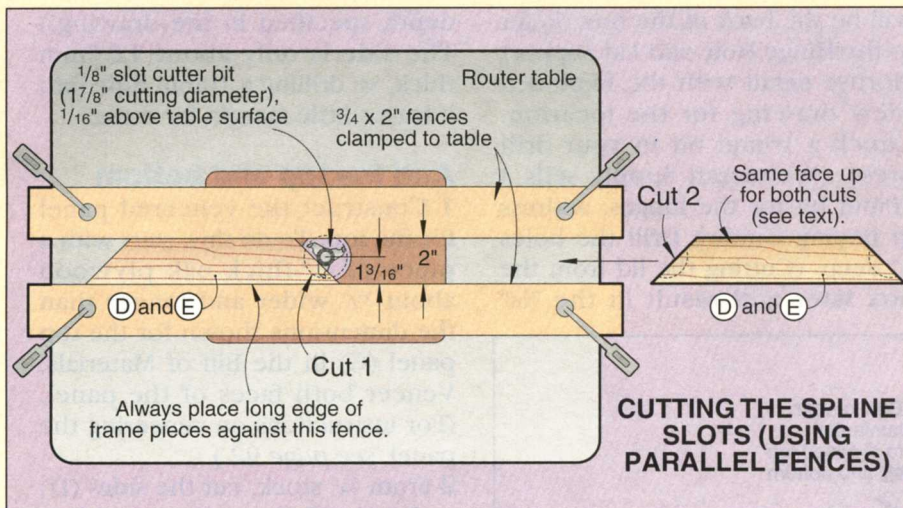

this setup, saw a rabbet on the top inside edge of the top frame parts, shown in the detail. Adjust the cutting depth to $\frac{1}{4}$ " , and rabbet the top inside edge of parts D and E for the bottom frame.

5 Miter-cut the sides and ends for the top and bottom frames. Cut each piece $\frac{1}{32}$ " longer than shown in the Bill of Materials. Later, you'll sand the assembled frames flush with the sides and ends of the box.

6 Cut slots for biscuit-shaped splines where shown in the mitered ends of parts D and E. Here's how we did that:

First, install a $\frac{1}{8}$ "-thick, $1\frac{7}{8}$ "-diameter slot cutter bit in your table-mounted router. Elevate the bit to put the bottom of the cutter $\frac{1}{16}$ " above the table surface. Then, install parallel fences on the router table, referring to the Cutting the Spline Slots drawing. You'll have to cut into the back fence slightly with the bit. Test the setup, then slot both ends of each part D and E. Note that you must feed each part from both directions, always keeping the long edge against the front fence. For the top parts (the chamfered ones), keep the rabbeted face up for all cuts. The rabbeted face faces down for all cuts on the bottom parts.

7 Plane and saw a piece of stock to $\frac{1}{8} \times 2 \times 12$ ". Adhere the Full-Sized Splines pattern (in the *WOOD PATTERNS*[®] insert in the middle of the magazine) to the stock, and scrollsaw the splines.

8 Apply glue to the splines and miter-cut ends of D and E, then assemble the top and bottom frames. Clamp with a band clamp, and measure the diagonals to square them up. Wipe off the glue squeeze-out, and clamp the frames to the top and bottom of the box shell while they dry to ensure they'll stay flat.

9 Cut the bottom panel (F) to size. Glue it into the rabbet in the bottom frame, and clamp.

10 Glue and clamp the top frame to the top of the box shell (the

edge with the hinge holes drilled in it). The frame should overhang both sides and both ends equally. Remove glue squeeze-out on the inside of the box.

11 Glue and clamp the bottom frame and panel to the box shell. As with the top, equalize the overhang around the box, and remove glue squeeze-out.

12 Trim the top and bottom frames flush with the box sides and ends. We shaved the frame edges flush with a cabinet scraper, then sanded the sides and ends with 120-grit sandpaper.

Saw the coves next

1 Saw a 45° kerf $\frac{1}{2}$ " deep through a piece of 1- $\frac{1}{2}$ "-thick scrapwood, then clamp it to the tablesaw as a fence for cutting the coves, shown in the Frame detail. Position the fence as shown in the Cutting the Coves drawing and accompanying detail. With the saw running, raise the blade slowly to deepen the kerf in the fence, if necessary.

Lower the blade to $\frac{1}{16}$ " above the table, and test the setup on $\frac{3}{4}$ "-thick scrapwood 2" wide. Make the cut in several passes, raising the blade another $\frac{1}{16}$ " each time. Adjust the fence to produce a cove $\frac{1}{2}$ " deep and 1 $\frac{1}{2}$ " wide.

Lower the blade to $\frac{1}{16}$ " again. Then, saw the coves on the top

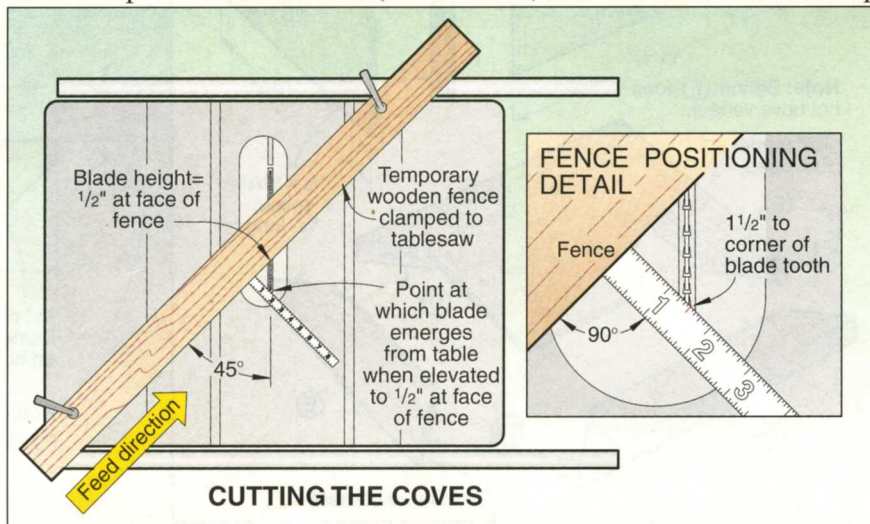

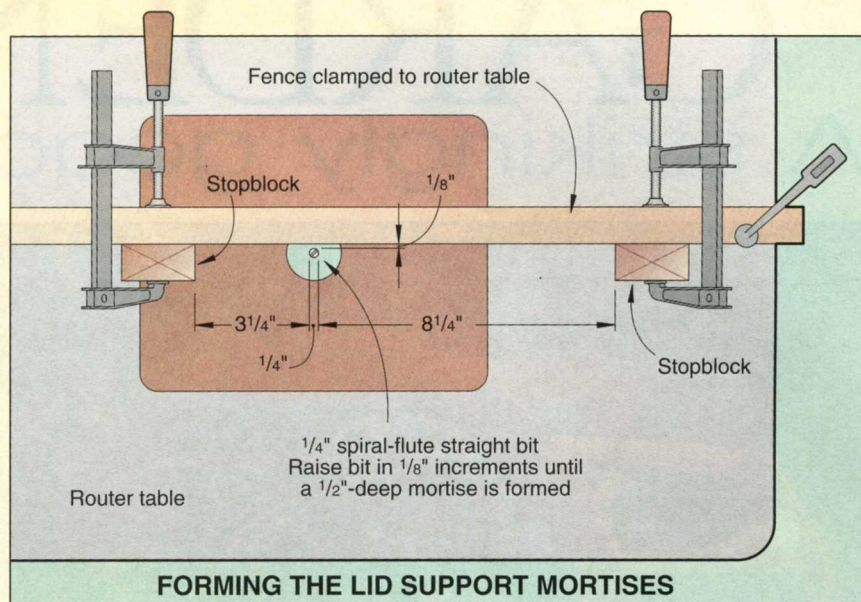
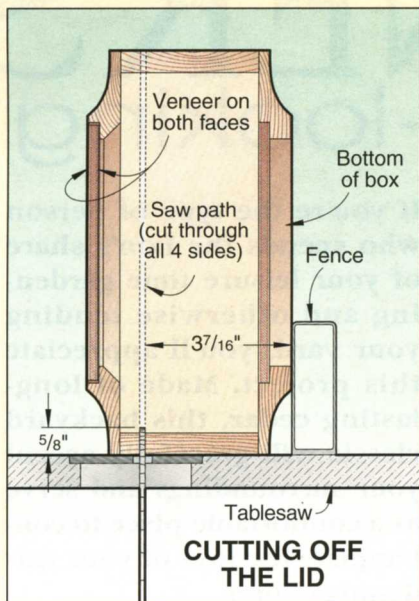

Complete the basic box

1 Now, form the mortises for the lid supports. Begin by installing a $\frac{1}{4}$ " spiral-flute straight bit in your table-mounted router. Position the fence $\frac{1}{8}$ " from the bit. Clamp stopblocks to the fence where shown by the Forming the Lid Support Mortises drawing. Set the cutting depth to $\frac{1}{8}$ ".

Hold the box just above the router bit, with the left end of the box against the fence and the front (the side without hinge holes) against the stopblock at the right end of the fence.

Start the router, and lower the box straight down onto the bit. Slide the box along the fence to the other stopblock, lift it straight up, and shut off the router. Repeat the process three more times, raising the bit $\frac{1}{8}$ " each time to make a mortise $\frac{1}{2}$ " deep. Reverse the stopblock positions, and rout the mortise in the other end of the box.

2 Chuck a $\frac{1}{4}$ " brad-point bit in your drill press. Position a fence $\frac{1}{8}$ " from the side of the bit (this will center the $\frac{1}{4}$ " hole on the $\frac{1}{2}$ "-thick material). Mark the position for the lid support hole at each end, shown in the Hinge Hole and Lid Support Mortise detail. Drill the holes $\frac{1}{4}$ " deep.

3 Lay out the finger recess on the face and edge of the box front, shown in the Finger Recess detail. Form it with a 3"-diameter sanding drum. Sand the recess at a 45° angle to the front of the box and $\frac{3}{16}$ " deep at the center.

4 Rip four $\frac{1}{16}$ "-thick dark walnut strips 12" long and slightly wider than the thickness of the veneer panel (C). Trim them to fit inside the rabbet as a liner. Butt joints work fine for the corners.

5 With the walnut feature strips in place, measure the length and width of the opening. Cut the veneered panel (C) to these dimensions. Keep the top face of the panel up while sawing; this confines any chipout caused by sawing to the bottom, where it will be hidden by the rabbet.

6 Dry-fit the walnut strips and veneer panel in the rabbet. Then, glue the strips to the ends and sides of the rabbet, and glue the panel in place. Clean off glue squeeze-out.

7 Sand the walnut strips flush with the top of the lid. Finish-sand the box and lid, starting with 120-grit sandpaper and progressing to 220- and 320-grit. Take care not to sand through the veneer on the lid insert panel.

Continued on page 92

Project Design: James R. Downing Illustrations: Kim Downing; Lorna Johnson Photographs: Dean Tanner

and bottom of the box. Make the cuts in $\frac{1}{16}$ " steps, going all around the top and bottom at each blade setting. Sand off the blade marks with 120-grit sandpaper.

2 Now, separate the lid from the box. To do so, first position the tablesaw's rip fence $3\frac{7}{16}$ " from the blade, shown in the Cutting Off the Lid drawing. Set the blade height to $\frac{5}{8}$ ". To minimize splintering at the corners, place a strip of masking tape around the box at the parting line. Before sawing, make about six spacers the same thickness as your blade's kerf.

Saw along the front of the box, and insert a spacer about 1" from each end of the kerf. Tape the spacers in place. Then, stand the box on one end, make that cut, and insert spacers. Cut the other end, and insert spacers. Then, carefully cut the lid free by sawing along the back. The spacers will help prevent binding and gouging the mating surfaces.

3 Using spray adhesive, adhere two sheets of 150-grit sandpaper to a flat 11x18" surface. Invert the body onto the sanding surface, and move it in a flat, circular motion to sand the saw marks from the mating surface. Similarly sand the lid.

GARDENER'S

A strikingly good-looking



If you're the type of person who spends the lion's share of your leisure time gardening and otherwise tending your yard, you'll appreciate this project. Made of long-lasting cedar, this backyard classic will gracefully accent your surroundings and serve as a comfortable place to contemplate the joys of your gardening chores.

Let's begin with a pair of arches

1 From $1\frac{1}{16}$ " stock, cut the arch-top segments (A) and arch uprights (B) to the sizes listed in the Bill of Materials plus 1" in length. (We cut our pieces from $1\frac{1}{16}$ "-thick cedar deck boards. If your stock is thicker, you'll need to plane it to $1\frac{1}{16}$ " thick to work with the finger-joint bit. Redwood, mahogany, white oak, or teak would also work well for this project. We also recommend cutting a couple extra arch-top segments. They'll come in handy when testing the finger-joint bit setup in Step 3.)

2 Using the Arch-Top Segment drawing for reference, miter-cut the arch-top segments (A) to length. (We test-cut scrap stock first to verify an accurate 22.5° miter-cut.)

3 Fit your table-mounted router with a finger-joint bit. See the article on this handy bit on *page 32*. Then, rout finger joints across the miter-cut ends of the arch-top segments and across the top ends of the uprights (B). (We cut $1\frac{1}{16}$ "-thick scrap stock first to verify the settings.) Crosscut the uprights to final length.

Continued

RETREAT

arbor with a built-in bench

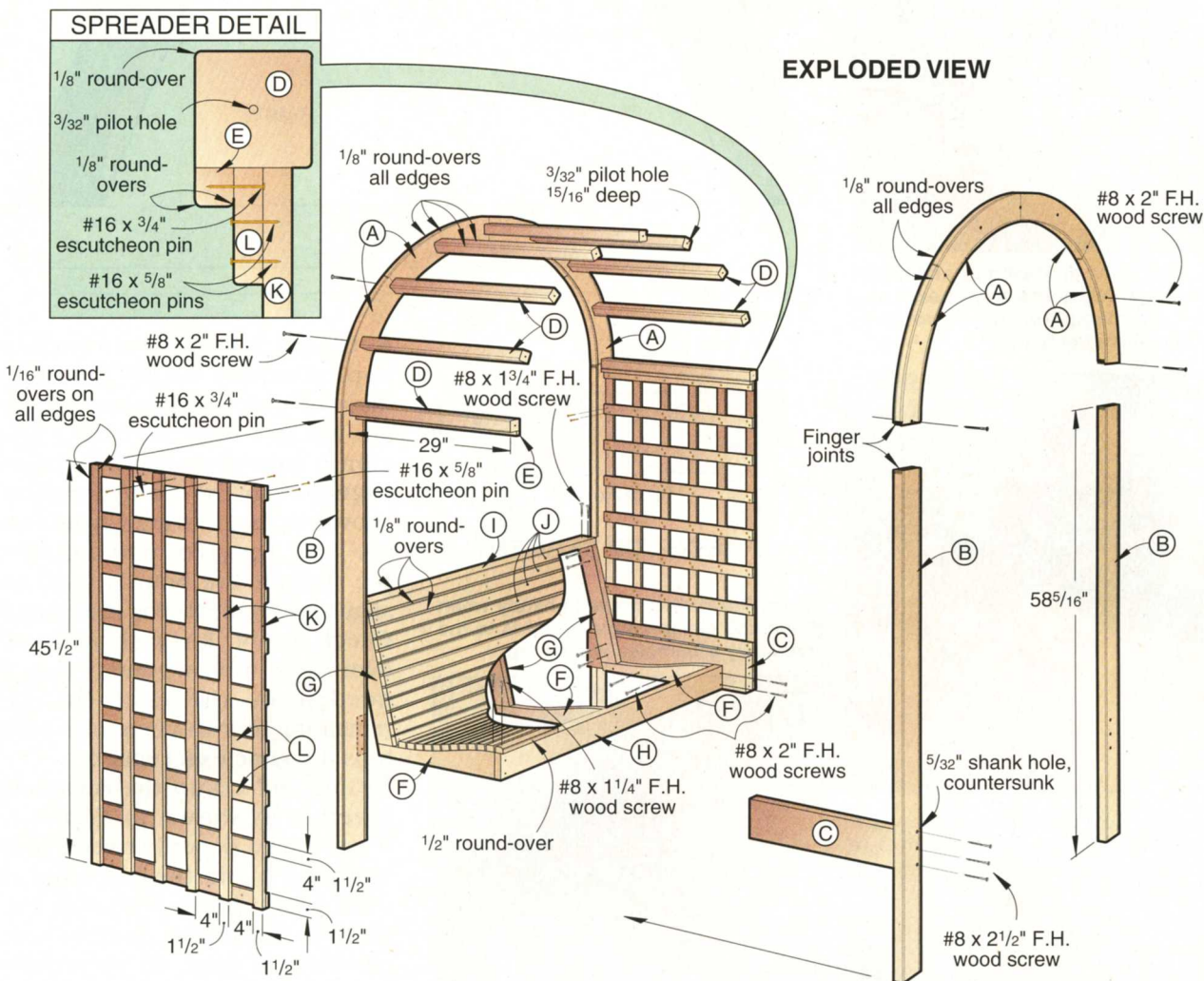

| Bill of Materials | | | | | | | | | | | |
|-------------------|---------------|--------|----------|-------|------|----------------------|---------------|--------|---------|-------|------|
| Part | Finished Size | | | Matl. | Qty. | Part | Finished Size | | | Matl. | Qty. |
| | T | W | L | | | | T | W | L | | |
| ARCHES | | | | | | SEAT | | | | | |
| A* arch segments | 1 1/16" | 5 1/2" | 20 5/16" | C | 8 | F* supports | 1 1/16" | 3 1/2" | 21 5/8" | C | 3 |
| B* arch uprights | 1 1/16" | 3 1/2" | 58 5/16" | C | 4 | G backrests | 1 1/16" | 3" | 20 1/2" | C | 3 |
| SPREADERS | | | | | | H front rail | 1 1/16" | 3 1/2" | 41" | C | 1 |
| C seat spreaders | 1 1/2" | 5 1/4" | 29" | C | 2 | I top rail | 1 1/16" | 3 1/2" | 41" | C | 1 |
| D spreaders | 1 1/2" | 1 1/2" | 29" | C | 9 | J slats | 3/4" | 1 3/8" | 41" | C | 24 |
| E cleats | 1/2" | 1/2" | 29" | C | 2 | LATTICE | | | | | |
| | | | | | | K vertical members | 3/8" | 1 1/2" | 45 1/2" | C | 12 |
| | | | | | | L horizontal members | 3/8" | 1 1/2" | 29" | C | 18 |

*Initially cut parts marked with an * oversized. Trim to finished size according to the how-to instructions.

Materials Key: C—cedar

Supplies: #8x1 1/4", #8x1 3/4", #8x2", #8x2 1/2" flathead wood screws (preferably stainless steel), #16x5/8" brass escutcheon pins, #16x3/4" brass escutcheon pins, clear exterior finish.

Buying Guide

Finger-joint bit. Carbide-tipped cutters with 1/2" shank. Will cut finger joints in stock from 1/2" to 1 1/4" thick. Bit no. 7861, \$55 ppd. (contiguous U.S.). MLCS, P.O. Box 4053, Rydall, PA 19046. Or call 800/533-9298 to order.

GARDENER'S RETREAT

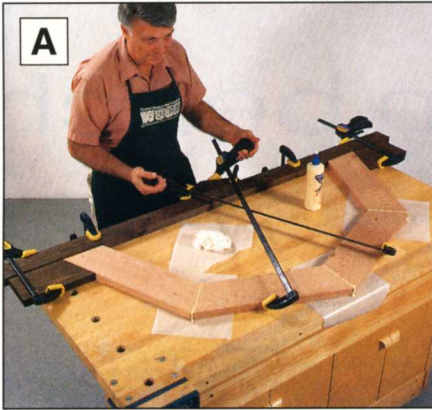

Above: Check the fit, then glue and clamp the arch-top segments together. Long clamps and clamping boards come in handy to pull the joints tight.



Above: After sanding the glued-together finger joints smooth, use a trammel to mark a pair of arcs on one face of each arched top.

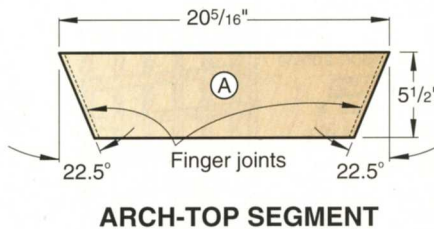
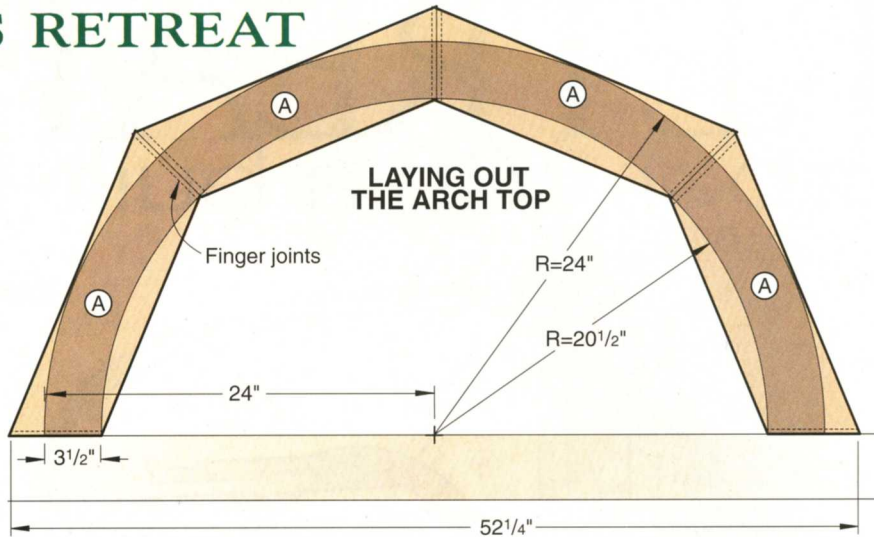

Below: Sawhorses come in handy when gluing and clamping the uprights to the previously assembled arched top.

4 Clamp a board measuring approximately $\frac{3}{4} \times 4 \times 72$ " to one edge of your workbench where shown in *Photo A*. Now, dry-clamp four arch-top segments together in the configuration shown in the drawing *Laying Out the Arch Top*. (For photo clarity, we stained the boards used to align the segments for clamping.) Check the fit. Remember, if you trim these four segments, you'll need to do the same for the remaining four to keep both arch tops the same exact shape.

5 Glue and clamp the segments together as shown in *Photo A*. Place waxed paper between your workbench and the segments at each glue joint to prevent the arch top from being glued to your workbench. Wipe off the excess glue with a damp cloth.

6 After the glue has dried (we used Titebond II and left the arch-top pieces clamped up overnight), sand the joints smooth. Use a trammel (see the home-made trammel on *page 74*) to mark two arcs on the clamped-together arch top as dimensioned on the *Laying Out the Arch Top* drawing and shown in *Photo B*. Repeat the process in steps 4, 5 and 6 to form and mark the second arch top.

7 Bandsaw the archs top to shape, cutting just outside both marked arcs and then sanding to the line.

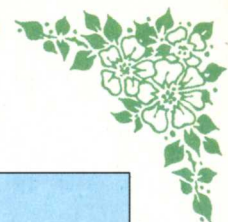

CUTTING DIAGRAM

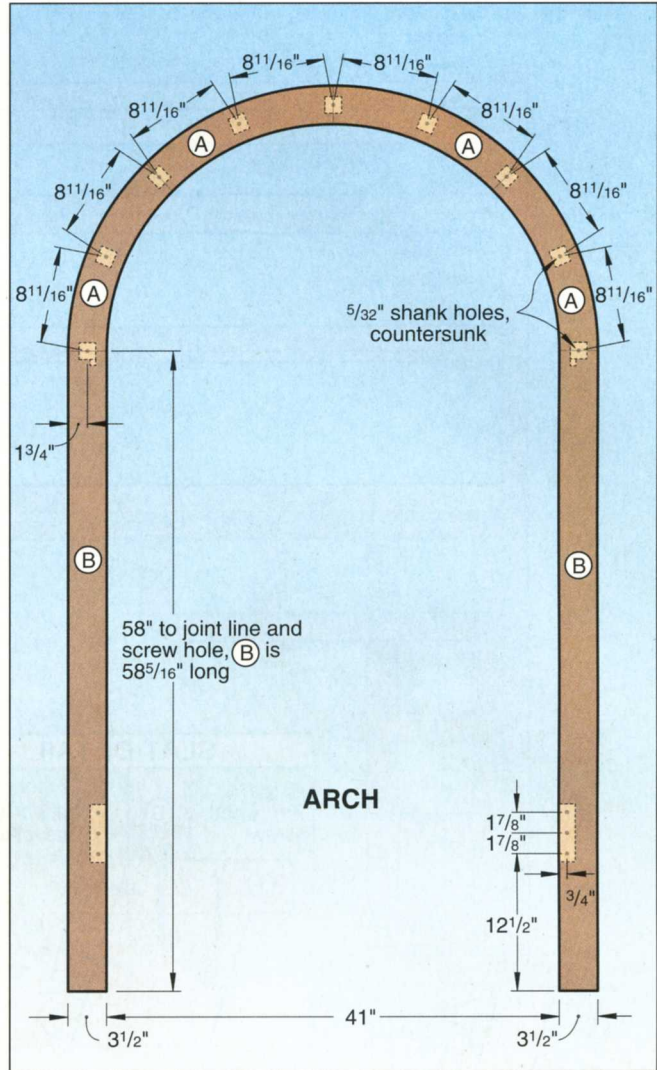
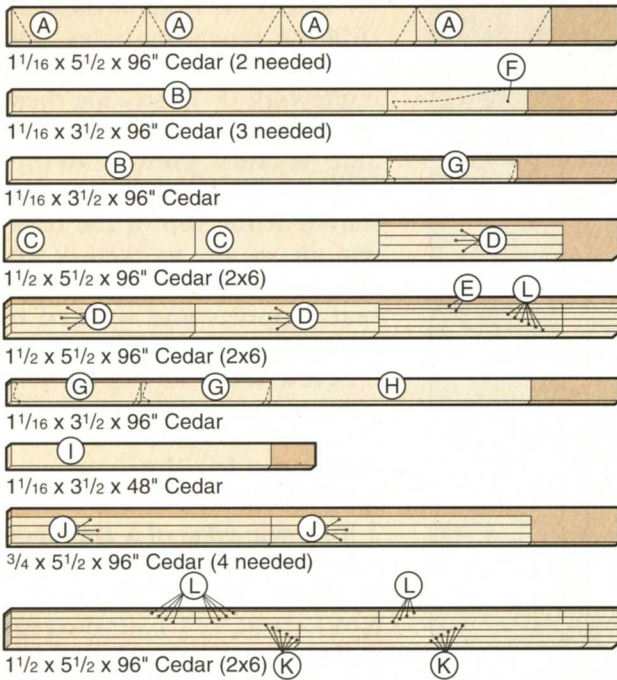

See our method on page 110 for cutting the arch tops to shape.

8 Using a pair of sawhorses with extra-long tops, glue and clamp the uprights to the arch tops as shown in *Photo C*.

9 Sand the arches, and clamp them together surface-to-surface with the edges flush. Mark the hole centerpoints on the top arch where dimensioned on the Arch drawing. Drill a $\frac{5}{32}$ " shank hole through both arches at each mark. Separate the arches and countersink the shank holes on the *front side of the front arch* and on the *back side of the rear arch*.

10 Rout a $\frac{1}{8}$ " round-over along all edges (except for the bottom ends) of each arch.

Add the spreaders

1 Cut the spreaders (C, D) and cleats (E) to size.

2 Glue and clamp the cleats (E) to the bottom side of two of the spreaders (D) where shown on the Spreader detail accompanying

the Exploded View drawing.

3 Rout $\frac{1}{8}$ " round-overs along all edges of the spreaders and combination spreader/cleats.

4 Mark centerpoints on the ends of each spreader (D). Drill a $\frac{3}{32}$ " pilot hole at each marked point. Using exterior screws (we used stainless steel), screw the spreaders (C, D) between the arches (A, B).

Next, add a contoured seat for comfortable sitting

1 To form the seat supports (F), cut three pieces of $1\frac{1}{16}$ " stock to $3\frac{1}{2}$ " wide by $22\frac{1}{8}$ " long. Then, cut the backrests (G) to the size listed in the Bill of Materials.

2 Using the Forming the Seat Supports and Forming the Seat Backrests drawings, machine the supports and backrests to fit in the configuration shown on the

Joint detail accompanying the drawings. Transfer the full-sized seat support pattern on the *WOOD PATTERNS®* insert in the center of the magazine to the seat supports (F). Cut them to shape.

3 Glue and clamp the three supports (F, G) together.

4 Cut the front rail (H) and top rail (I) to size. Bevel-rip the front edge of the top rail at 15° . Rout $\frac{1}{8}$ " round-overs, drill the mounting holes, and screw the rails to the seat supports (F/G) where shown on the Exploded View and Side Section View drawings.

5 Cut the seat slats (J) to size. Rout $\frac{1}{8}$ " round-overs along the top edges of each. Then, rout a $\frac{1}{2}$ "

Continued

GARDENER'S RETREAT

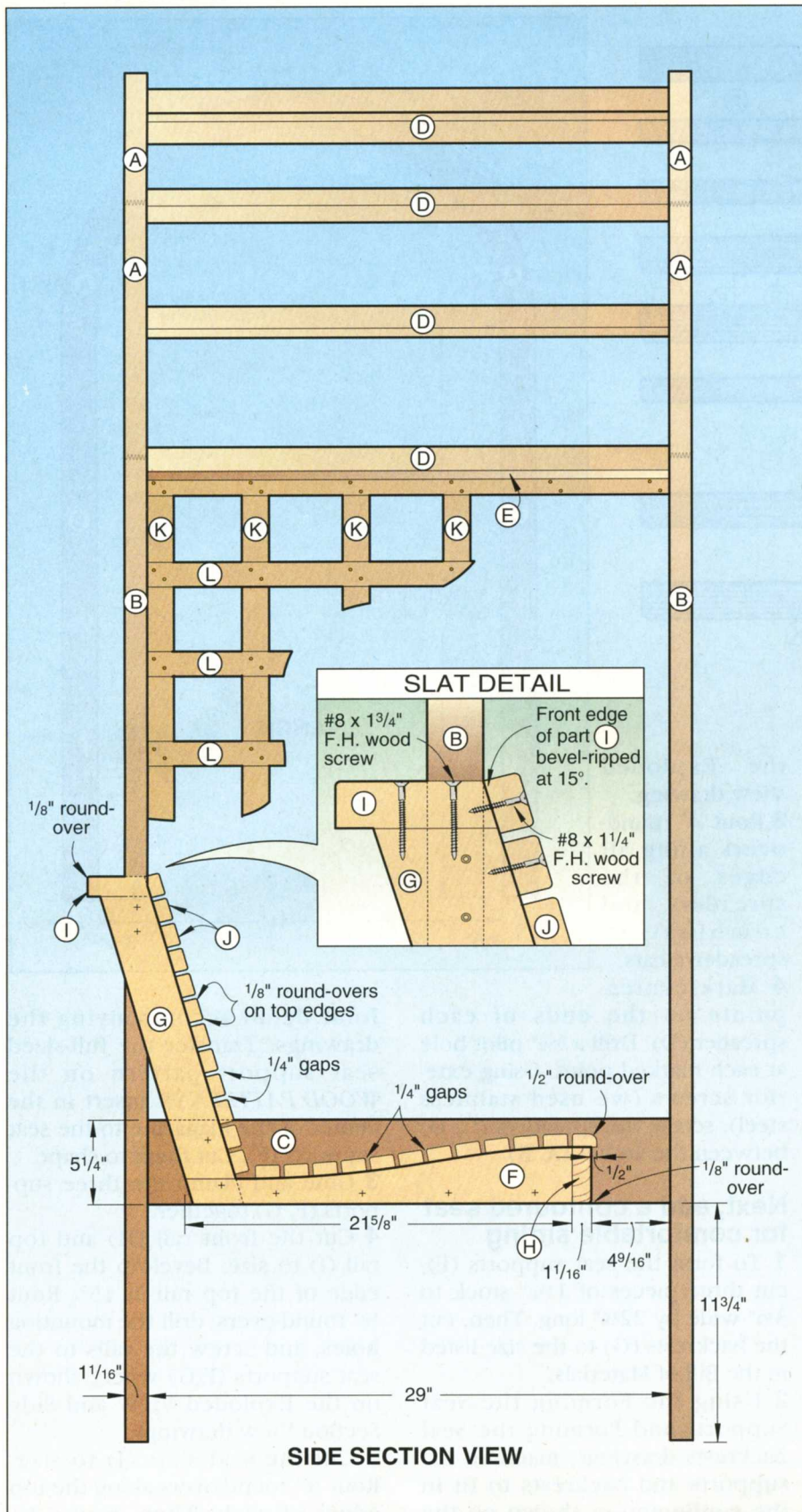

round-over on the slat you'll use across the front of the seat. Drill the mounting holes, and screw the slats to the seat framework (F-D), spacing them $\frac{1}{4}$ " apart where shown on the Side Section View drawing. (When adding the slats, we started at the top of the backrest pieces and worked down, and started at the front of the seat supports and worked to the back.)

6 Screw the seat assembly in place between the arches.

And now for the lattice sides

1 Joint one edge of a 2x6, then rip $\frac{3}{8}$ x1 $\frac{1}{2}$ " strips from the stock for lattice pieces (K, L). Next, rout $\frac{1}{16}$ " round-overs along all edges of each strip.

2 Use two Ks and two Ls to form the perimeter framework to fit between the uprights (B). Glue and nail these four pieces together. Repeat for the other side of the arbor.

3 Cut a scrap piece of stock 4" wide by about 45" long. Use this as a spacer to position the Ls on the framework when gluing and nailing them in place. Repeat with the Ks.

4 Glue and nail the lattice assemblies to the arbor.

Sand the surfaces, and add the finish

1 Check all surfaces, and sand where necessary.

2 Apply a quality exterior finish to the entire project. (We brushed on Flood CWF-UV Clear Wood Finish. We also placed a small amount of finish in pie tins, and put one under each upright. This allowed the finish to slowly wick into the end-grain upright ends to enhance the rot resistance of the wood.)



FORMING THE SEAT BACKRESTS

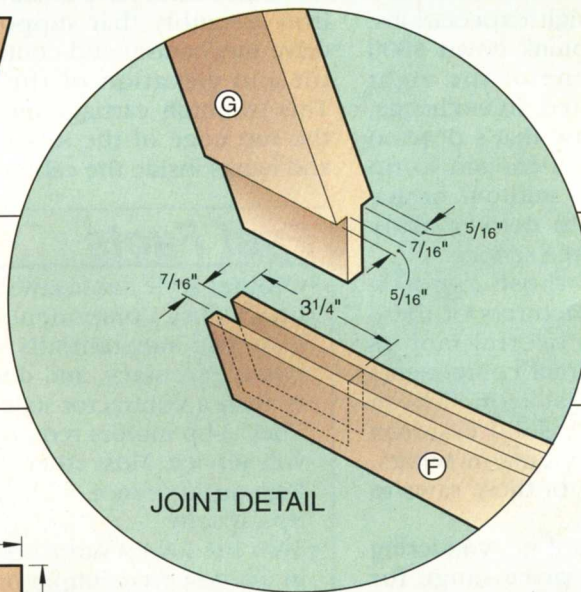
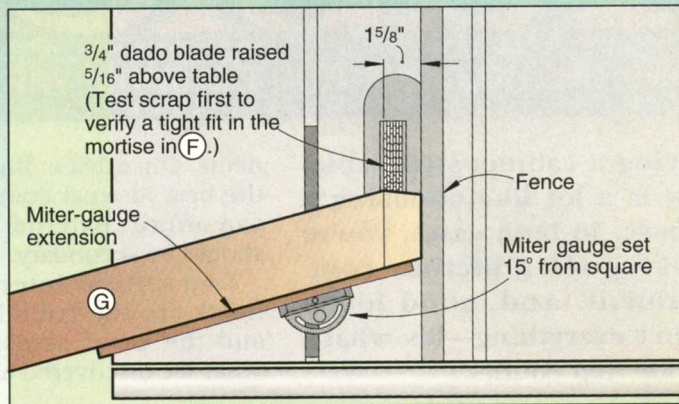
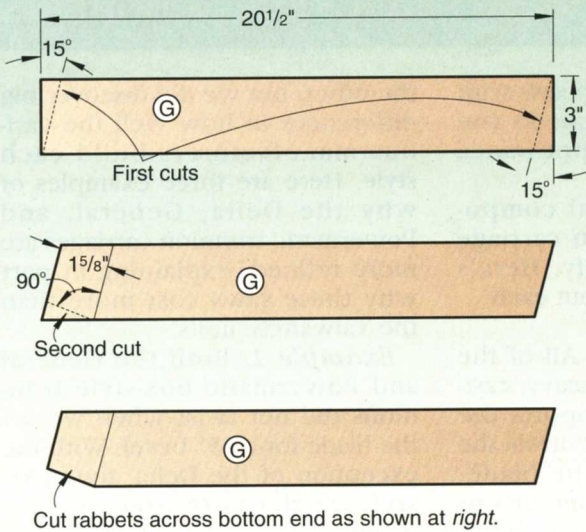

FORMING THE SEAT SUPPORTS

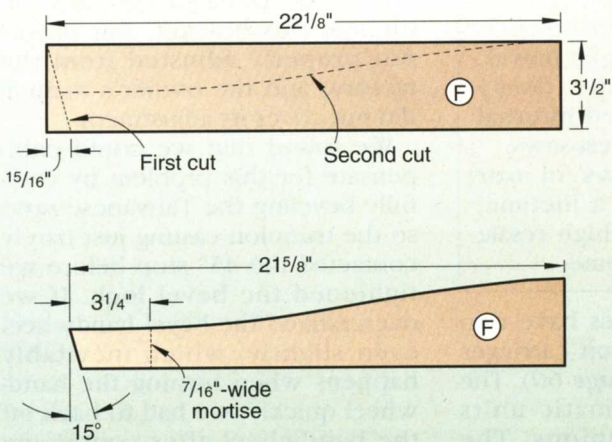

SEE THE
WOOD PATTERNS®
INSERT FOR
FULL-SIZED PATTERNS

CUTTING THE MORTISE

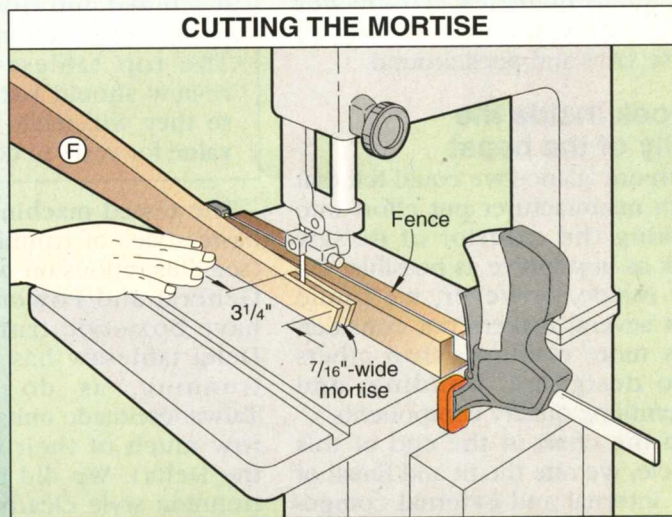

Written by Marlen Kemmet Project Design: Jerry Tedrow Illustrations: Roxanne LeMoine; Lorna Johnson Photographs: Dean Tanner; Hetherington Studio

Table Cabinet-Style Tablesaws

We get up close and personal with these heavy-duty performers

Buying a cabinet-style table-saw is a lot like choosing a spouse. In both cases, you're looking for a lifetime commitment. And, good looks aren't everything—it's what's inside that counts.

The tablesaws shown in this article come with high expectations. After all, you'll plunk down \$800 to \$2,000 for one of the eight machines we tested. In exchange, you deserve a saw that's dead-on accurate, powerful enough to rip thick hardwoods without hesitation, and built to deliver many years of trouble-free service.

To help meet those expectations, the manufacturers of these saws build in powerful motors and massive internal components machined of cast iron. These parts, along with solid cast-iron tabletops and extension wings, boost the weight of these saws to over 400 pounds.

By now you might be wondering about the wide price range for tablesaws that seem to possess the same qualities. To answer that mystery, let's take the top off these saws and peek around.

A look inside the belly of the beast

With one glance we could tell that each manufacturer put effort into making the exterior of its saw look as impressive as possible. On the inside, however, we found that several makers put considerably more resources than others into designing, building, and assembling quality components.

In the chart at the end of this article, we rate the fit and finish of the internal and external compo-

nents. Our advice: Buy a saw with the best internal components you can afford. External appearance should be secondary.

Two critical internal components are the trunnion carriage and the arbor assembly. Here's what we discovered about each:

•**Trunnion carriage.** All of the rated machines have a heavy, cast-iron assembly that supports the drive mechanism and controls the tilt and elevation of the blade. This trunnion carriage mounts to the top edge of the saw cabinet, and hangs inside the cabinet.

Fast Facts

- Cabinet-style tablesaws have heavy-duty components that give you substantially more power, accuracy, and durability than a contractor-style saw. Their 3-hp motors require 220-volt service. Most come with a high-quality fence with 50" of rip capacity.
- Even the lowest-priced models in our test have ample power. But, they lack the finely machined and fitted internal parts found in the best saws.
- The top tablesaws in our review should last a lifetime, so they will retain high resale value for years to come.

The tested machines have two basic styles of trunnion carriages (see illustrations on page 60). The General and Powermatic units have box-style trunnions. The Delta tablesaw has a yoke-style trunnion, as do all of the Taiwanese-made units (which borrow much of their design from the Delta). We did not find one trunnion style clearly superior to

the other, but we did discover big differences in how well the various manufacturers build each style. Here are three examples of why the Delta, General, and Powermatic trunnion carriages are more refined, explaining in part why these saws cost more than the Taiwanese units.

Example 1: Both the General and Powermatic box-style trunnions did not twist when we set the blade for a 45° bevel. With the exception of the Delta, the yoke-style carriages twisted slightly when we beveled them for a 45° cut. This twisting throws the blade out of parallel alignment with the miter-gauge slot.

As shown in *Photo A* on page 60, the Delta has an L-bracket that helps prevent the twisting by keeping the trunnion gears in alignment. Most of the other yoke-style trunnions, including the Grizzly gearing shown in *Photo B* on page 60, do not have this bracket. The Jet saws most closely mimic the Delta design, and do include this bracket. But it was not properly adjusted from the factory, and the owner's manual did not cover its adjustment.

We found that we could compensate for this problem by carefully beveling the Taiwanese saws so the trunnion casting just barely contacted the 45° stop before we tightened the bevel lock. If we overcranked the bevel handwheel even slightly, which inevitably happens when turning the handwheel quickly, we had to back off the handwheel after contacting the 45° stop. This relieves the pressure that twists the trunnion.

Example 2: Now, compare gearing *Photos A and B* to *Photo C* on page 61, shot inside of the Powermatic. Only the Powermatic

Continued



Product tester Bob McFarlin gets “under the hood” of a Powermatic 66 to check the amount of motor and arbor bracket shaft play with the aid of a dial indicator. It was one of several key checks we used to rate the eight cabinet-style saw reviewed in this article.

DANGER
MOTOR EQUIPPED WITH MANUAL OVERLOAD.
WHEN RESET BUTTON ON MOTOR IS
DEPRESSED IT WILL START IMMEDIATELY
IF MACHINE IS EQUIPPED WITH MANUAL
STARTER IN ON POSITION.
WITH MAGNETIC STARTERS MOTORS MAY
NOT BE RESTARTED UNTIL RESET BUTTON
IS DEPRESSED AFTER AN OVERLOAD.

MADE IN USA
PARTS 807225
MATIC 66
MATIC 66
MADE IN USA

Cabinet-Style Tablesaws

has concave-ground gear teeth on the arbor bracket and front trunnion castings.

The concave teeth are more complex and expensive to machine, but have advantages. They better match the worm gear, so they should wear much better than straight-cut gears. Not surprisingly, the Powermatic was the smoothest and easiest saw to make blade height and bevel adjustments.

The worm gears on the Delta, General, and Powermatic were more nicely finished than the others, with square-cut ends. The Grizzly, Star Tools, and Sunhill worm gears were rougher, and not absolutely square on their ends. The Jet worm gears fell somewhere in between.

Example 3: In the chart at the end of this article, you will find a column titled "Change in fence-to-blade distance with blade at 90° and 45°." Here, we measured the difference in rip capacity when we changed the blade bevel from 90° to 45° with the fence in a stationary position. Only the General registered no difference in this test. To accomplish this neat feat, General precisely adjusts the fit between the trunnion and the ways that support it.

Why is this important? Because of the price of these saws, it makes sense to invest in a high-quality fence (most of the saws come standard with such a fence with 50" of rip capacity). These fences have tape measures on their rails that tell you the exact

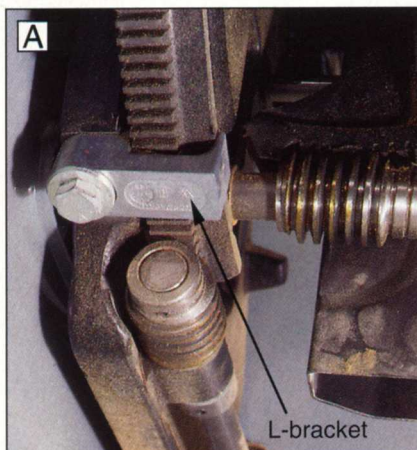

An L-bracket on the Delta prevents its yoke-style trunnion carriage from twisting when adjusted for 45° bevel cuts.

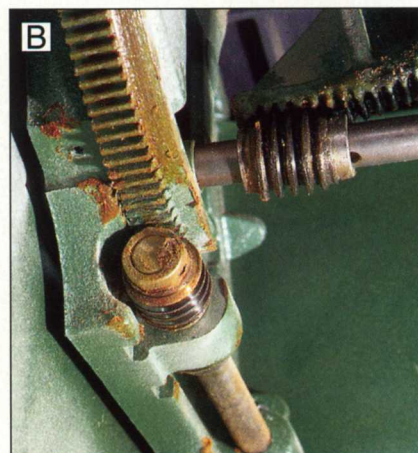

Most Taiwanese-made saws imitate the Delta design, but lack an L-bracket to prevent trunnion-carriage twisting.

blade-to-fence distance, saving you the hassle of measuring from the blade to the fence with a handheld tape measure. Since you can trust the General's built-in tape measure at 90°, 45°, and all bevels in between, you don't need to haul out a handheld tape measure for bevel cuts as you do with the other tested saws.

• **Arbor assembly.** This component consists of the turned-steel arbor that you mount the blade to, the bearings that hold the arbor, and the arbor flange that contacts the blade body. High-quality parts and construction in this assembly ensure that a blade will spin true, free of the "runout" that contributes to poor-quality cuts. We measured runout with a dial indicator, and the Jet JTAS-10XL and Powermatic topped this test (see chart for complete results).

All in all, the Powermatic impressed us more than the other saws in this area. One reason it has almost no runout is its thick, accurately machined inner and outer blade flanges. And, the Powermatic is the only machine with a 3/4"-diameter arbor shaft (milled to 5/8" at the threaded end to accept blades with 5/8" bores). The other machines have 5/8" arbors supported by 5/8" bearings.

Most of the tested saws have high-quality, rubber-sealed bearings that support the arbor. The Star Tools and Sunhill models have bearings with metal shields instead of seals. This makes the bearings more susceptible to damage from dust, necessitating quicker replacement. (Randy Shepherd of Star Tools tells us he will switch to rubber-sealed bearings, and these saws should be available by the time you read this.)

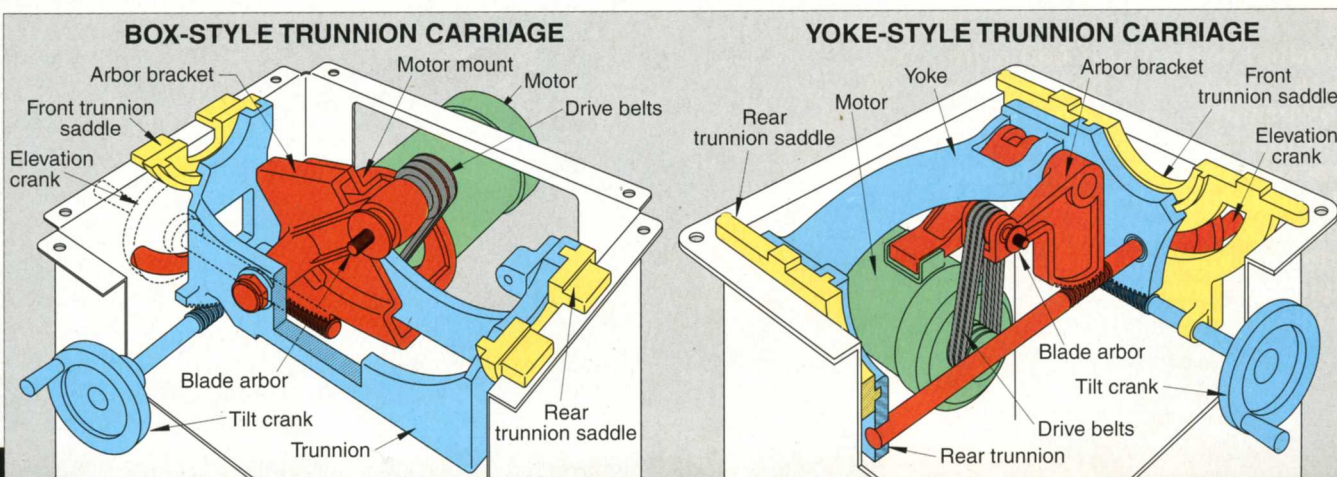

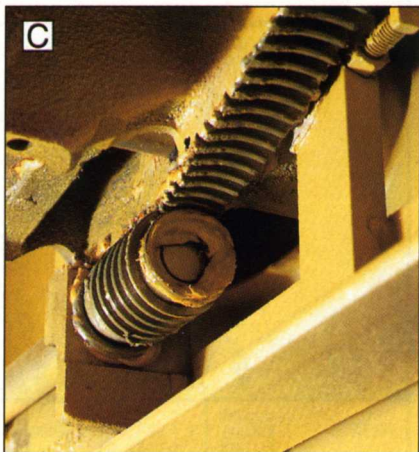

Only the Powermatic has concave-ground gear teeth for longer wear and smoother operation.

Drive mechanisms: the muscle in these machines

All of the tablesaws have motors with ample power for every woodworking task we could throw at them, including ripping 3"-thick oak. However, only three of the tested machines had U.S.-made motors labeled as being continuous duty: the Delta (Marathon motor), General (Leeson motor), and Powermatic (Baldor motor). After the testing, representatives of Grizzly told us that they were switching to a U.S.-made Reliance motor for their "Z" version of the model G1023. The motors on the tested machines mount to the saw in one of three ways:

- The Powermatic model 66 saw has a *face-mount* motor. Here, the shaft end of the motor mounts directly to a large piece of cast iron bolted to the casting that supports the arbor. This makes for a super-solid, nearly vibration-free connection.

- The Delta, Grizzly, and Star Tools motors have a special mounting bracket welded to them. If you need to replace the motor, you have to buy the tablesaw manufacturer's motor.

- The General, Sunhill, and both Jet saws accept motors with standard 56 frames.

In the chart we show the price of a replacement motor. Keep in mind that a high-quality motor may outlive you if not abused.

Level facts about tabletops

As you can see by looking at the diagram and chart *below*, none of the tested tabletops were more than .017" out of flat in any of the three directions we measured. All of them were within what we consider acceptable tolerances.

Besides being the flattest tabletops in our test, the Jet tops were also the most smoothly machined. All of their edges were nicely chamfered and burr-free.

In the main chart at the end of this article, we've listed the sizes of the tables. Most of the tables are 27" deep, but the Powermatic and General saws give you an extra inch in this dimension. Not

surprisingly, these two saws give you about an inch more of table surface in front of the blade. That extra inch helps you hold long workpieces flat on the top as you feed them.

Unlike the tops on contractor-style saws, the tabletops on these saws do not bolt directly to the trunnion castings. You can easily adjust or remove them by loosening four bolts that attach them to the top of their base (three bolts in the case of the Powermatic). That makes aligning the miter slots with the blade a snap, and helps ease the burden of transporting these behemoths.

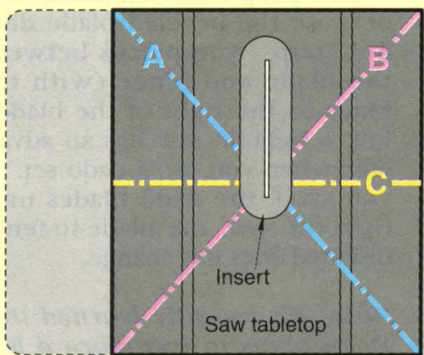

| Saw | TABLE FLATNESS | | |
|------------------|----------------|-------|--------|
| | Flatness | | |
| | A | B | C |
| Delta Unisaw | .004" | .005" | .005" |
| General 350 | .002" | .004" | .002" |
| Grizzly G1023Z | .006" | .003" | .0015" |
| Jet JTAS-10X | .002" | .002" | .0005" |
| Jet JTAS-10XL | .002" | .003" | .0005" |
| Powermatic 66 | .007" | .006" | .005" |
| Star Tools S3202 | .016" | .001" | .003" |
| Sunhill MBS-250 | .017" | .007" | .004" |

The Inca 290: in this price range, but totally different

You won't find the Inca 290 in the chart at the end of this article, but we did take a look at it because its price (\$1,895 on sale) falls into the range of this article. However, we found the saw so different from the other models discussed here that a direct comparison would not be fair.

The Inca has nearly the power of the other tested saws, but weighs only 175 pounds because of extensive use of aluminum instead of cast iron. Although this tool's price approximates that of the Powermatic 66, we did not find the Inca comparable to the model 66 in terms of accuracy,

power, durability, or capacity. But, because of its low weight and small size, the saw may make sense if you have a cramped workshop, do your woodworking on an upper floor, or require portability.

For additional versatility, the 290 accepts a mortising attachment that drives off the arbor shaft, and a router table that mounts to the fence rails.



All of the tested saws have three drive belts except for the General and Powermatic, which have two belts. We could find no performance advantage to having three belts instead of two. Three belts just complicate changing them.

Tip: To extend the life of an induction motor, run it on a heavy power cord that's as short as possible. As much as possible, avoid turning the machine on and off frequently.

Continued

Cabinet-Style Tablesaws

More points you need to consider before buying

• **Fences.** See the February 1997 issue of *WOOD*® magazine for our review of the fences that come with these saws. In that article, Paralok, Powermatic, and Delta received our top ratings for commercial-duty fences.

In the chart *right*, we list the available fences for these saws. If you don't want the manufacturer's fence, some companies offer you the option of buying the saw without a fence, or with a less-expensive standard-quality fence that you can replace (see the "selling price" columns).

• **Switches.** All of the saws have magnetic switches that shut off in the event of an interruption in power. The Delta, General, both Jets, and Powermatic saws have UL-listed switches.

• **Blade access.** Large blade openings (throats) make blade changing as easy as possible. Most of the saws have adequately sized throats about 3¾×13¼" in size.

We found the Powermatic the easiest saw for blade changes, thanks to its 4×14¾" throat. The General proved the most difficult for changing blades because of its 3¼×13¾" throat. The tight quar-

ters formed by the General's casting surrounding the blade further complicate blade changes.

• **Ease of maintaining.** You should periodically clean your saw's internal components and apply grease as needed. We found it easier to access these components on the yoke-style trunnions.

• **Left or right tilt.** All of the tested saws have blades that tilt to the right except for the Powermatic 66 and Jet JTAS-10XL. We don't prefer one direction of tilt over the other, and consider this largely a matter of personal preference.

Some people like left-tilting saws because the beveled blade does not "trap" workpieces between the blade and fence (with the fence to the right of the blade). But, a right-tilt saw has an advantage when you use a dado set. As you stack the dado blades on a right-tilt saw, the blade-to-fence distance does not change.

Note: We recently learned that Delta plans to introduce a left-tilting version of the Unisaw. It should be available for \$1,499 (including \$100 rebate) by the time you read this.

| BRAND | MODEL TESTED | LISTED HORSEPOWER OF MODEL TESTED | CAPACITORS (1) | CONTINUOUS-DUTY RATED (YES, NO) | MOTOR | |
|------------|------------------------|-----------------------------------|----------------|---------------------------------|-------------------------------|------------------|
| | | | | | COUNTRY OF MOTOR ASSEMBLY (2) | REPLACEMENT COST |
| DELTA | UNISAW SPECIAL EDITION | 3 | SR | Y | U | \$498 |
| GENERAL | 350 | 3 | SR | Y | U | 316 |
| GRIZZLY | G1023Z | 3 | S | Y | U | 250 |
| JET | JTAS-10X | 3 | SR | Y | T | 320 |
| | JTAS-10XL | 3 | SR | Y | T | 320 |
| POWERMATIC | 66 | 3 | SR | Y | U | 381 |
| STAR TOOLS | S3202 | 3 | S | N | T | 275 |
| SUNHILL | MBS-250 | 3 | S | N | T | 220 |

NOTES:
 1. (SR) Start-and-run capacitors (S) Start capacitor only
 2. (C) Canada (T) Taiwan (U) United States
 3. (B) Box (Y) Yoke
 4. Cursor on fence was set to read correct fence-to-blade distance with blade at 90°. Then, blade was set at 45° and the change in fence-to-blade distance was measured.

And now, the envelope please

All of the machines in this hotly competitive category are worth pretty much what you pay for them. So, we chose what we considered to be the top machine in four \$200 price ranges.

So, what price range should you be looking at? That depends on your needs, budget, and mechanical skills. Here's what we mean.

In our tests, all of the saws made good cuts in thick hardwoods—once we adjusted them. The difference: the best machines required little or no tinkering with their internal components. That's something to consider if you're much more comfortable with woodworking tools than you are with gears and wrenches.

Also, the higher-priced saws should hold up better, and retain higher resale value, over time. But, if you're an occasional woodworker, you'll probably never wear out any of these saws.

If you want the best and can pay for it, look at the Powermatic 66 or General 350. You can buy the General for about \$200 less than



CABINET-STYLE TABLESAWS: HOW THEY RATE

| TYPE (3) | TRUNNION ASSEMBLY | | | | TABLE | | PERFORMANCE (5) | | | | | | | | | | SELLING PRICE (8) | | COMMENTS | |
|----------|--------------------------|----------------------------------------------------|------------------------------------------------|--------------------------------------------------------------------------|--------------------------------|-----------------------------------------------|-------------------------|-------------------------|------------------|------------------------------------|-------------------------|--------------------|-----------|-------|------------------|-------------------------|-------------------|---------------------------------|-----------------------------------------------------------------------------------------|-----------------------------------------------------------------------------------------------------------------------------------------------------|
| | BLADE TILT (LEFT, RIGHT) | HANDWHEEL REVOLUTIONS FOR COMPLETE BLADE ELEVATION | HANDWHEEL REVOLUTIONS FOR COMPLETE BLADE LEVEL | CHANGE IN FENCE-TO-BLADE DISTANCE WITH BLADE AT 90° AND 45° (INCHES) (4) | NUMBER OF CAST-IRON EXT. WINGS | TABLE SIZE WITH CAST-IRON WINGS ONLY (INCHES) | INTERNAL FIT AND FINISH | EXTERNAL FIT AND FINISH | ARBOR RUNOUT (6) | MOTOR/ARBOR BRACKET SHAFT PLAY (7) | EASE OF BLADE ELEVATION | EASE OF BLADE TILT | VIBRATION | POWER | WARRANTY (YEARS) | COUNTRY OF ASSEMBLY (2) | TABLESAW ONLY | SAW WITH STANDARD-QUALITY FENCE | | TABLESAW WITH HIGH-QUALITY FENCE |
| Y R | 13 | 30 | -1/16 | 20 x 27 | 1 | 28 x 27 | E | E | G | E | E | E | E | E | 2 | U | \$ N/A | \$ N/A | \$1,499 With 52" Unifence or 50" Biesemeyer commercial fence. Includes \$100 rebate. | This saw has stood the test of time since its introduction in 1937. Today, it's still a finely made machine. |
| B R | 9 | 30 | 0 | 20 x 28 | 2 | 36 x 28 | E | E | G | E | E | E | E | E | 2 | C | 1,600 | 1,630 | \$1,800 With General 50" fence nearly identical to Biesemeyer commercial model. | Impeccable fit and finish on the inside and outside of this table saw make it a quality machine. Distribution is limited. |
| Y R | 16 | 29 1/2 | -3/16 | 20 x 27 | 2 | 36 x 27 | F | F | F | E | G | G | G | E | 1 | T | N/A | 800* | \$1,095 Includes Shop Fox 25" fence. | If you're looking for an affordable cabinet-style table saw, here it is. |
| Y R | 13 1/2 | 30 1/2 | -1/8 | 20 x 27 | 2 | 40 x 27 | G | E | G | F | E | E | E | E | 2 | T | 1,299 | N/A | \$1,399 With 50" Xacta fence, ext. table, and legs. | A close copy of the Delta Unisaw. |
| Y L | 13 | 30 1/2 | +1/16 | 20 x 27 | 2 | 40 x 27 | G | E | E | E | E | E | E | E | 2 | T | 1,599 | N/A | \$1,699 With 50" Xacta fence, extension table, legs, carbide blade, and dado insert. | A lower-cost option for those who prefer a left-tilting saw. Internally, it doesn't match the bulk and high-quality machining of the Powermatic 66. |
| B L | 7 | 32 | -1/8 | 21 1/2 x 28 | 2 | 38 x 28 | E | G | E | E | E | E | E | E | 1 | U | N/A | N/A | \$2,000 With 50" Powermatic Accu-Fence similar to Biesemeyer fence. | The biggest, baddest, best-made machine in this test. |
| Y R | 13 | 27 1/2 | -1/8 | 20 x 27 | 2 | 36 x 27 | F | F | G | F | G | G | G | E | 1 | T | 750 | 825 | \$1,180 With 56" Star fence, extension legs, work shelf hardware, and Freud blade. | Nearly identical to the Grizzly G1023. Its best-quality fence was disappointing. Available with 3- or 5-hp motor for same price. |
| Y R | 12 1/2 | 31 1/2 | -1/16 | 21 1/4 x 27 | 2 | 36 1/2 x 27 | G | F | G | E | G | G | G | E | 1 | T | 1,195 | 1,254 | \$1,524 With Paralok 50" fence. | A good saw, but only slightly better than the Grizzly or Star Tools models. |

5. **E** Excellent 6. Measured 5" from arbor 7. **E** .000 - .001" 8. Prices current at time of article's production and may change. Shipping is additional for models purchased mail-order.
G Good **E** .001 - .002" **G** .002 - .004" (*) This model, the G1023, comes with a Taiwanese motor and cast-metal pulleys.
F Fair **G** .003 - .005" **F** .005 - .008"
F .006 - .007"

WHERE TO CALL FOR MORE INFORMATION:

| | | | |
|----------------------------|-------------------------|-------------------------------------------------------------------------------------------|-------------------------|
| Delta 800/438-2486 | Jet 800/274-6842 | Star Tools 888/678-8777 | General 819/472-1161 |
| Powermatic 800/248-0144 | Sunhill 800/929-4321 | Grizzly West of the Mississippi: 800/541-5537 East of the Mississippi: 800/523-4777 | |

the Powermatic, but it doesn't come with a table board and legs as the Powermatic does. And, General has few dealers in the U.S., so you may have to drive a long way to pick up the saw or pay for shipping.

Among the saws in the \$1,400-\$1,700 range, you can't go wrong with the Delta or Jet

units. Delta offers slightly better fences and internal machining, but the Jet saws come with more standard equipment (such as a table board, legs, and two cast-iron table wings instead of one). The Jets had the best-machined tabletops in the test.

The Delta, as well as the Powermatic, have proved them-

selves for decades. And, if it matters to you, only the Delta and Powermatic saws are U.S.-made.

If you're looking for a bargain, buy the Grizzly G1023Z, its less-souped-up version, the G1023 (see chart above for differences), or the Star Tools S3202. These saws are quite similar, so it makes sense to call each importer and deal with the one you feel most comfortable with. Neither brand

offers a great fence, so we suggest you buy the saw in its most basic form and outfit it with a high-quality aftermarket fence. 📌

Written by Bill Krier
 Product Testing: Bob McFarlin
 Illustrations: Kim Downing
 Photographs: John Hetherington



GENERAL 350



POWERMATIC 66



CONTEMPORARY

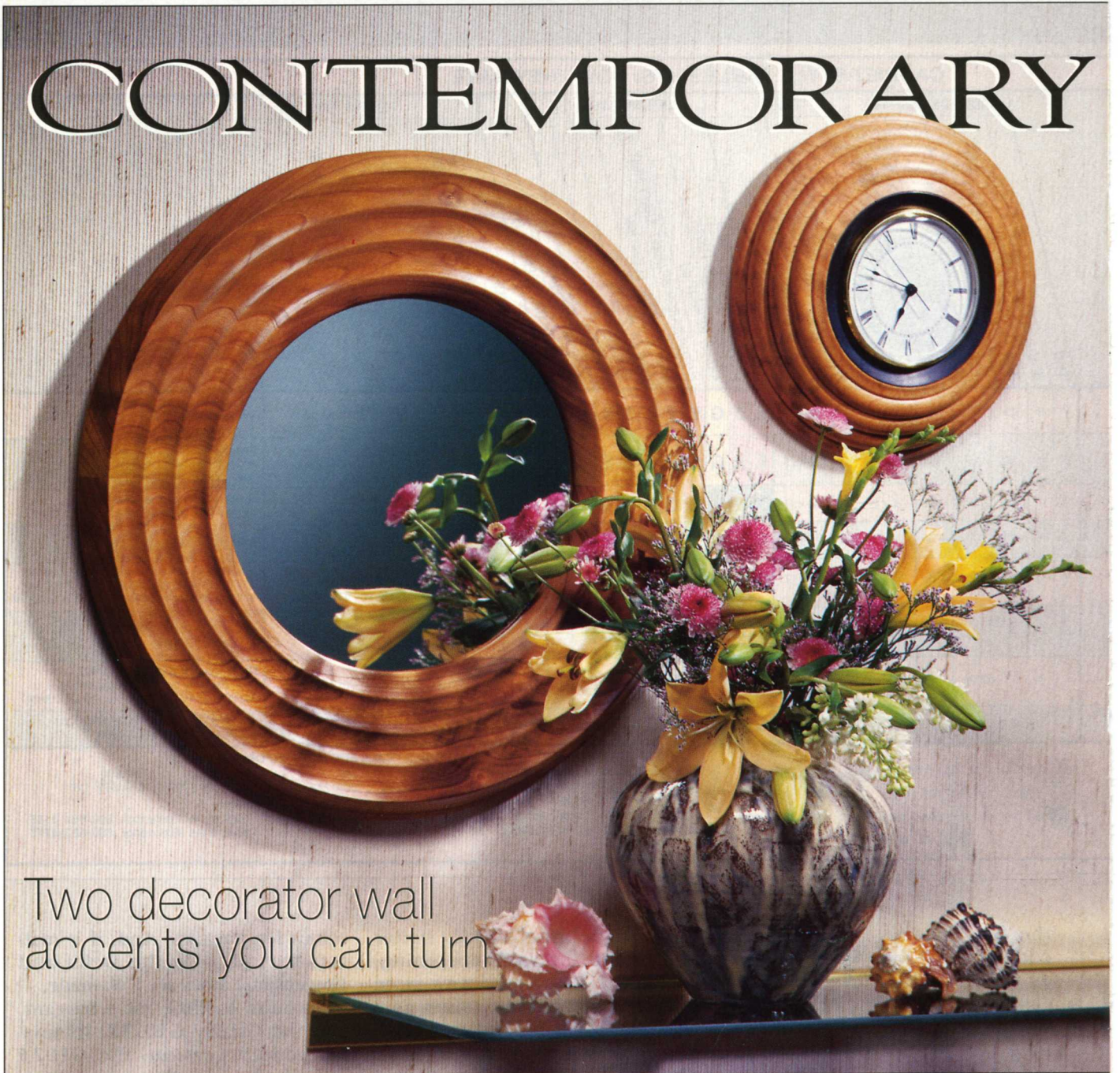

Two decorator wall accents you can turn

For beauty, you can't beat simplicity, as this mirror and clock so clearly illustrate. Turn them both, or pick your favorite as the focus for a deserving wall in your home.

Project prep

Stock: Cherry or other hardwood 2×9¼×9¼" for clock, 1¼×16×16" for mirror.

Lathe equipment: 3-4" faceplate, rotating tail center, expanding chuck (optional).

Tools: ½" bowl gouge, ½" skew, parting tool.

First, turn the clock back

Draw diagonal lines to locate the center on a 2×9¼×9¼" piece of cherry or other hardwood. Lay out the lines on the surface that will be the front of the completed clock. Draw two circles around the center, one 9" diameter and another the diameter of your 3-4" lathe faceplate.

Cut out the clock blank by band-sawing around the larger circle. Fasten the faceplate to the front of the blank, attaching it inside the

CLOCK & MIRROR

smaller circle you drew. You can screw the faceplate directly to the blank using 1-1/4"-long screws, as long as the diameter of the screw circle is less than 3 3/4".

True the face and edge of the blank. Turn the blank to 8 1/2" diameter. Then, by holding a pencil against the spinning workpiece, draw a circle on the face 1/8" in from the edge. In the same way, mark another circle on the edge of the workpiece, 1/8" from the face, as shown *below right*. With a skew or gouge, round over the corner between the two lines. With the point of a parting tool, mark the center of the turning.

Dismount the faceplate and turning. Remove the faceplate from the front of the blank.

Bore a hole, build a chuck

Chuck a 2 3/8" Forstner bit, hole-saw, or circle cutter in your drill press. Bore through the blank at the center mark you made with the parting tool. This hole, which will ultimately receive the clock insert, now provides a convenient means of holding the blank while turning the front of the clock.

If you have an expanding-jaw chuck, such as a Nova chuck, grip the turning by the center hole. (You may need to reattach the turning to the faceplate, and dovetail the rim of the hole for a firmer grip—consult the instructions for your chuck.)

Otherwise, build a jam chuck for the clock blank. To do so, first bandsaw a disc the size of your 3-4" faceplate from a piece of scrapwood 1 3/4-2" thick. Attach the disc to the faceplate, using screws that penetrate less than 3/4" into the wood.

Then, mount the assembly on the lathe, and true the face and edge. Mark the edge 3/4" from the joint between the scrapwood disc

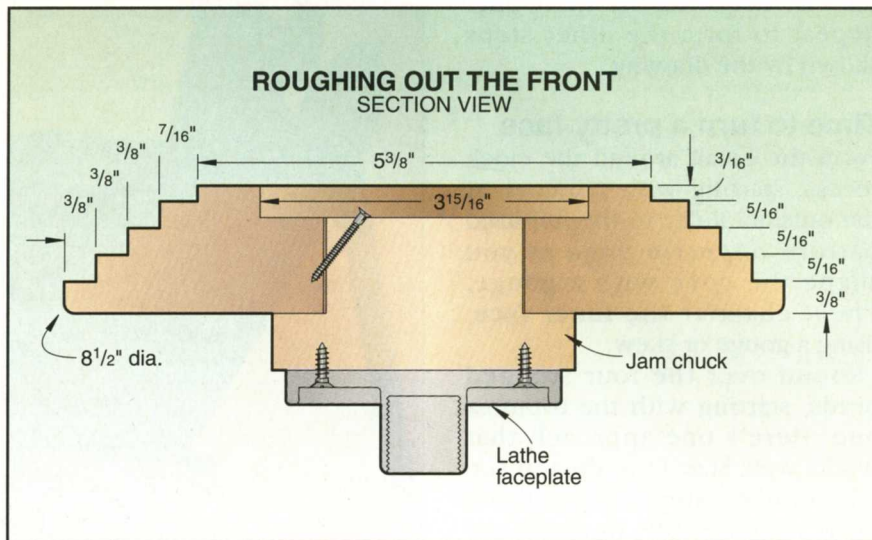

Draw pencil lines on the face and rim of the blank as guidelines for rounding over the clock's back edge.

and the faceplate—this will serve as a reminder not to cut into the screws. Turn a 2 3/8"-diameter tenon 1" long. The tenon must fit snugly into the hole bored in the blank, so test it frequently.

Mount the turning on the jam chuck's tenon, with the front of the clock facing out. For extra mounting security, drive one or two screws through the tenon into the workpiece, shown in the *Roughing Out the Front* drawing.

Rough out the front

True the front surface, and turn the blank to 1 1/2" thick. Verify that the edge runs true—you can take

a light cut, if necessary, but keep the outside diameter as close to 8 1/2" as possible.

Draw a 3 15/16" circle on the face for the clock recess. With a parting tool, cut straight in to a depth of 3/8" just inside the line. Then, with a gouge remove the waste to form a flat-bottomed recess. To avoid burning, make the cut in small increments, clearing out the waste as you go. (If you drove a screw in through the chuck's tenon, beware of the screw head as you work inside the recess.) Make a clean cut to the line with a gouge or skew.

Draw another circle on the face, this one 5 3/8" diameter. Just outside the line, cut straight in 3/16" deep with the parting tool. At the rim of the turning, cut 3/16" deep with the parting tool, then make a similar cut about midway between the other two.

With a gouge, turn the surface between the 5 3/8" circle and the rim to the level of the parting cuts. This establishes the first of the step-downs shown in the *Roughing Out the Front* drawing.

Draw another circle 7/16" out from the step. Following the same procedure as previously, turn the

Continued

CONTEMPORARY CLOCK & MIRROR

surface down $\frac{5}{16}$ ", establishing another step. Mark $\frac{3}{8}$ " out, and cut $\frac{5}{16}$ " deep for the next one. Repeat to form the other steps shown by the drawing.

Time to turn a pretty face

Form the detail around the clock recess, starting with the cove at the outside. Refer to the full-sized pattern *opposite page* as you shape the cove with a gouge. Then, chamfer the inner face, using a gouge or skew.

Round over the four stepped beads, starting with the topmost one. Here's one approach that works well: Start from the top surface of each step, then roll the skew or gouge 90° down to the vertical face.

Turn all four beads to the same curvature. At the same time, ensure that each one meets the next at a sharp, right angle, as shown on the pattern.

Inspect the turned details. They should be sharp and crisp, creating distinct separations from one step to the next.

Sand the completed turning with progressively finer abrasives from 100- to 220-grit.

Make a mirror frame next

Note: The finished mirror frame measures 15 $\frac{5}{8}$ " in diameter. To turn it you'll need a lathe with at least 8" between the center of the headstock spindle and the bed (or gap) or one that you can rig for outboard turning, as shown above right.

Glue up the blank

Edge-glue three or four 1 $\frac{1}{16}$ "-thick pieces of stock to make a 16×16" panel. (Cherry is shown.)

Mark the center on the face that will be the front of the mirror frame. With a compass, draw a circle around the center the same diameter as your 3-4" lathe faceplate. Also draw a 16" circle around the center.



The mirror frame is too large to turn over the bed on most home-shop lathes. The job calls for one that can be set up for outboard turning.

Bandsaw around the larger circle. Attach the faceplate inside the smaller one, using screws that penetrate about halfway into the wood. Mount the faceplate and blank on the lathe.

If you're able to turn over the bed, bring up the tailstock for extra support as you true the edge. For large-diameter work such as this, set your lathe to a slow speed, perhaps 500-750 rpm. Turn the blank to 15 $\frac{3}{4}$ " diameter, $\frac{1}{8}$ " larger than the finished dimension. Slide back the tailstock, and turn the face (the back of the frame) true. Round the outer edge to the radius shown on the half pattern.

Pencil a 10 $\frac{1}{8}$ "-diameter circle on the face. Inside the circle, form a flat-bottomed, square-edged recess $\frac{1}{2}$ " deep. This will later form the rabbet to hold the mirror glass in the frame.

Dismount the faceplate and workpiece. Remove the faceplate from the front of the blank.

Construct another chuck

Mark the center on a piece of $\frac{3}{4}$ "-thick scrapwood about 11" square. (Plywood or particleboard would be a good choice.) Scribe a 10 $\frac{1}{2}$ " circle and one the same size as your faceplate around the center. Bandsaw the larger circle.

Attach the disc to the faceplate, and mount on the lathe. True the face. Turn the disc to 10 $\frac{1}{8}$ " diameter, making sure it fits snugly into the recess in the back of the workpiece. This will be the jam chuck for completing the frame.

Press the mirror frame onto the jam chuck. Ensure that it runs true. Then, drive a #10×1" pan-head sheet-metal screw through the center of the turning into the jam chuck.

Turn the front of the frame

True the front of the blank, and turn it to 1" thick. (Leave a nubbin an inch or so in diameter around the center screw as you work on the frame face.)

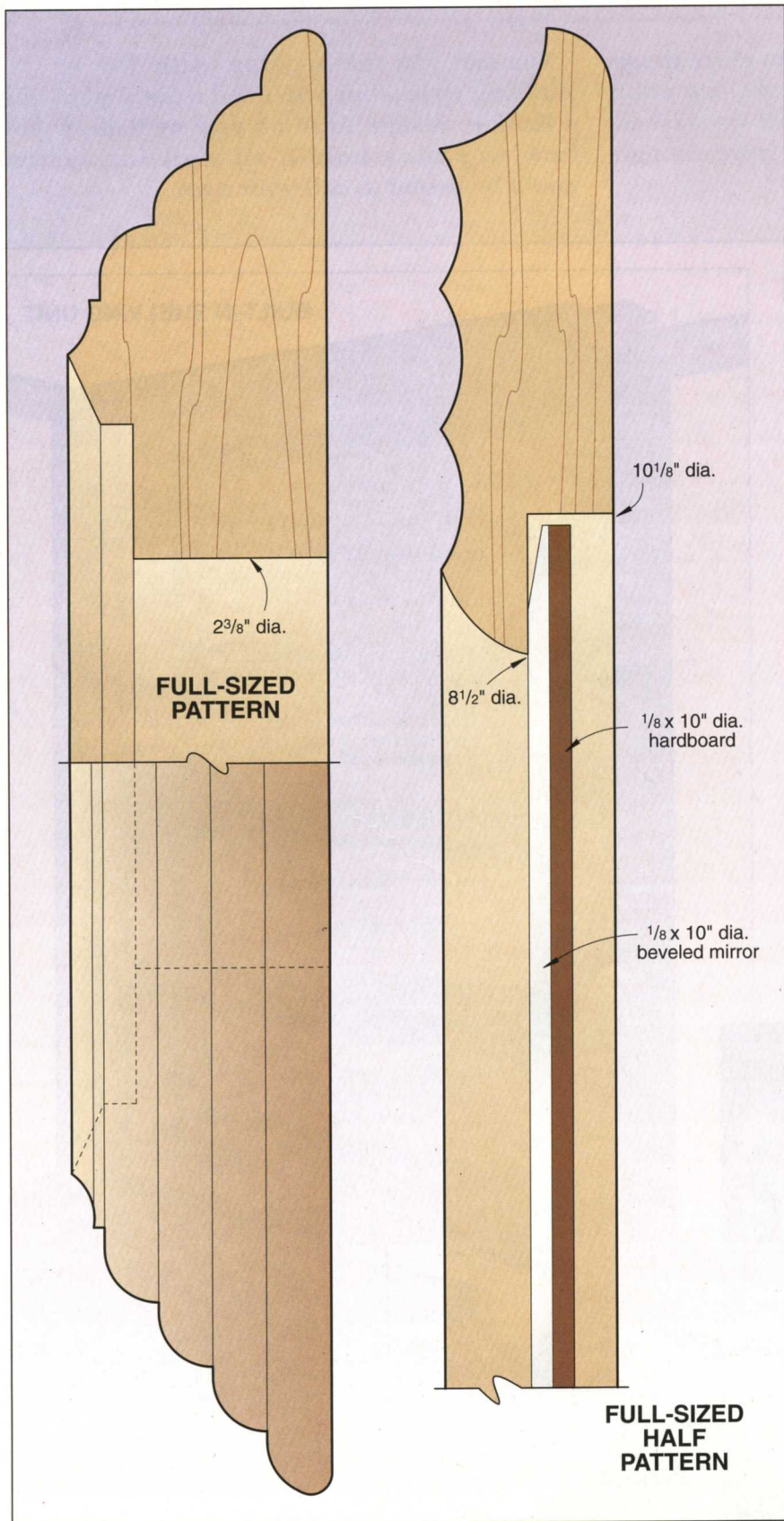

Mark two circles on the face, one $14\frac{3}{8}$ " in diameter and another $8\frac{1}{2}$ " in diameter. Between the outermost line and the outer edge of the blank, form the cove shown on the half pattern.

Working toward the center from the $14\frac{3}{8}$ "-diameter line, lay out three sections, each $\frac{13}{16}$ " wide. Turn each section to a shallow cove (about $\frac{1}{8}$ " deep). Leave about a pencil line's width between the coves. Sand the turned features with progressively finer abrasives from 100- to 220-grit, but don't sand the raised edges to sharp ridges.

To create the mirror opening, remove the $8\frac{1}{2}$ "-diameter center section. Here's one way to do that: With a series of gouge cuts, taper the center disc from the surface near the tail center to about $\frac{3}{8}$ " deep just inside the line. With the parting tool, cut straight in to separate the center section.

Make sure the workpiece is secure on the jam chuck before restarting the lathe. Then, form the curvature on the inside of the opening. Sand the opening, then apply a clear finish overall.

Install the looking glass

Place a $\frac{1}{8}$ "-thick mirror glass $10\frac{1}{8}$ " in diameter in the rabbet. (We chose a 10" beveled mirror for the $8\frac{1}{2}$ " opening because it is a stock size, less expensive than a smaller, custom-cut flat mirror. The bevel doesn't show.) Peel the foam feet from the back of the mirror.

Cut a 10" disc of $\frac{1}{8}$ " hardboard. Place it behind the mirror in the frame, and drive in glazier's points. Attach a hanger. 🌟

Buying Guide

Clock, mirror. Quartz clock insert, item no. 200950, and 10" beveled mirror, both \$31.45 ppd. in U.S. Available separately. Schlabaugh and Sons, 720 14th St., Kalona, IA 52247, or 800/346-9663 to order.

Project Designs: Brad Warstler, Floyd, VA Illustrations: Roxanne LeMoine; Lorna Johnson Photographs: Dean Tanner; John Hetherington Written by Larry Johnston

Home-Shelving

Have you run out of shelf space to store those books you plan to read someday? Are your fine collectibles crammed together or stashed away in boxes because you don't have enough space to showcase them properly?

You can win the ongoing battle for shelving space, but you need a good plan and a flexible design. Read on and we'll show you how to plan a hold-it-all shelving system you'll be proud to call your own.

Select a type of shelving

Shelving falls into two basic categories—**open** and **closed**. Generally, open shelving consists of shelves that extend beyond the shelf supports and have no back. Without these viewing obstructions, open shelves lend themselves particularly well to display purposes.

Closed shelves typically fit between two solid or closed sides and have a back. Attaching a back adds considerable strength to a shelving unit and helps prevent racking.

Each category has three basic types—built-in, freestanding, and wall-hung. Here's what you need to know about each type.

Built-in shelving units, as shown *right*, let you take advantage of interior or wall space or other niches that normally go to waste. They blend smoothly into a home's interior, and as permanent fixtures, they add value to the property. Because they're tied directly into a home's framing, built-ins get high marks for stability and strength. However, they offer the least flexibility when it comes to expansion, and they stay with the house if and when you move.

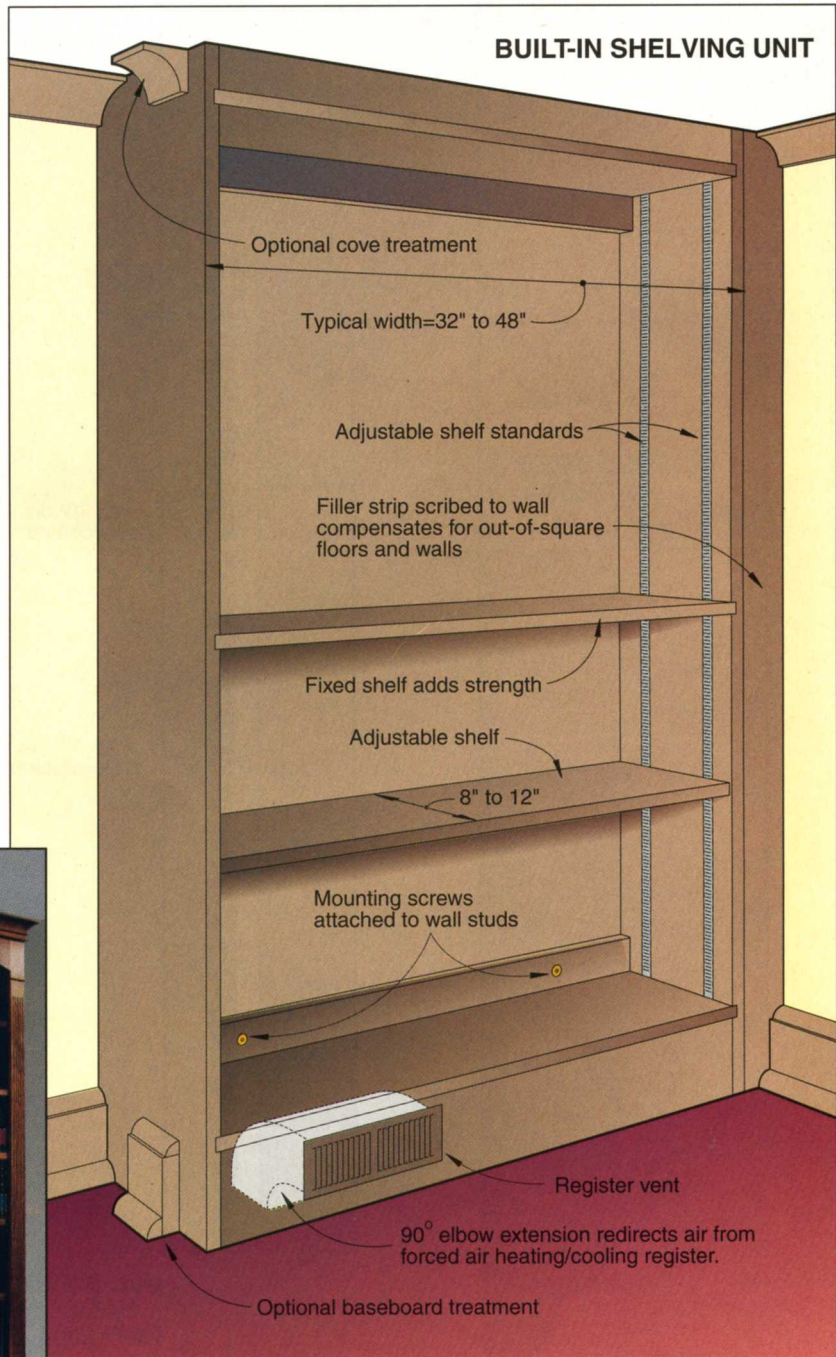
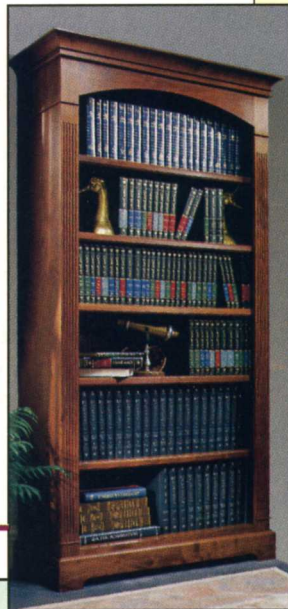

Planner

WOOD® magazine's guide to basic storage

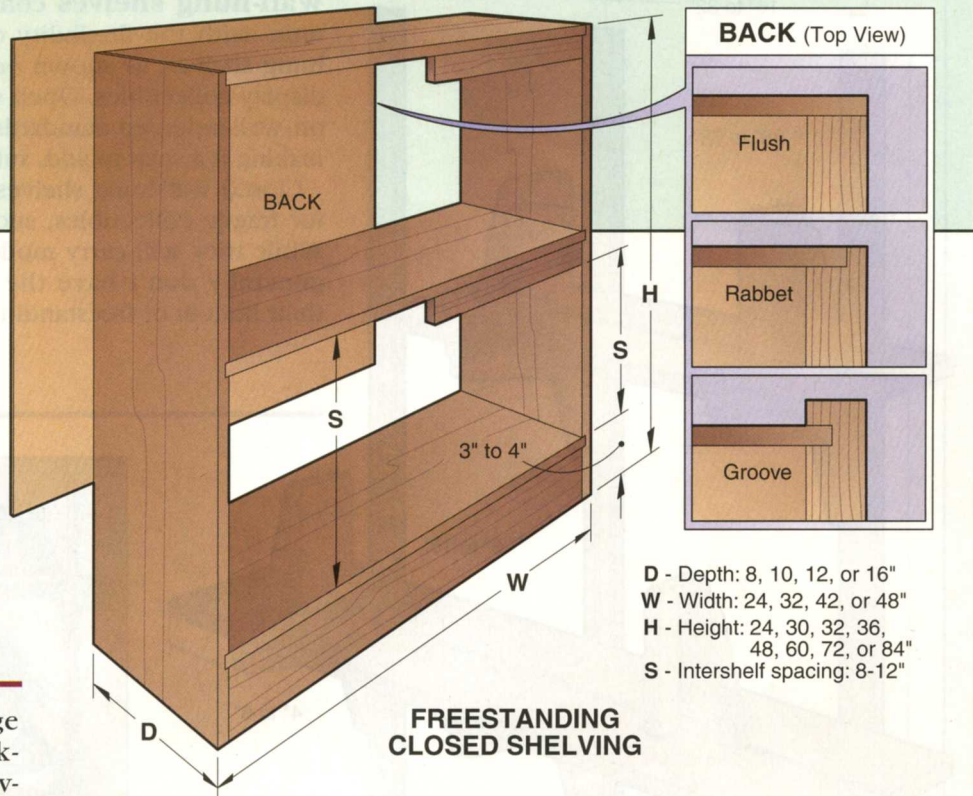
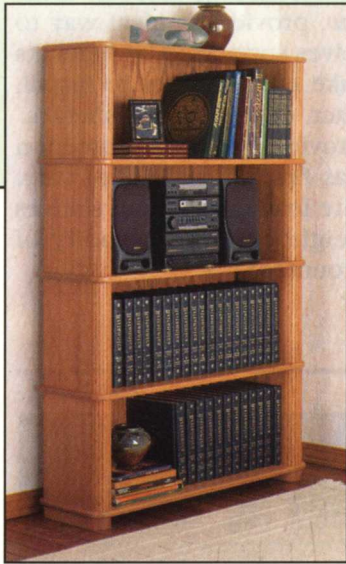

Freestanding shelves range in size from two-shelf bookstands to floor-to-ceiling shelving units. Stacking shelves, as shown *lower right*, can function as a room divider because they provide shelf access on both sides. Closed bookshelves, shown *upper right*, work well backed up to walls or furniture so their unadorned plywood backs don't show. And, like any piece of furniture, they can go with you when you move.

Continued

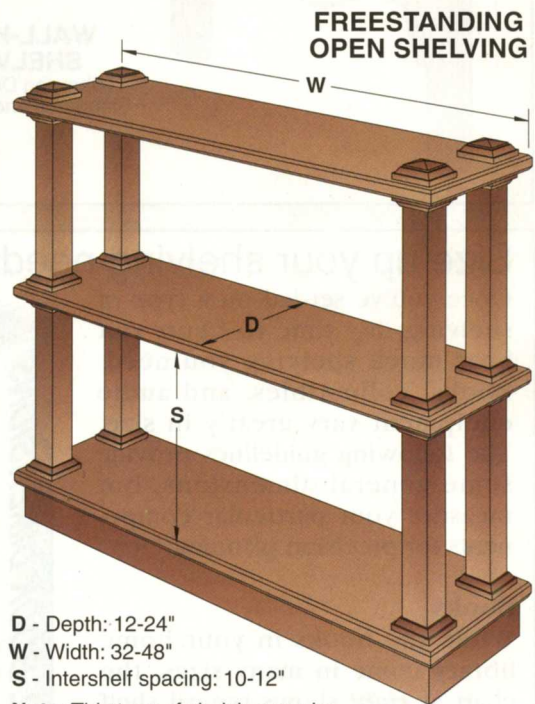
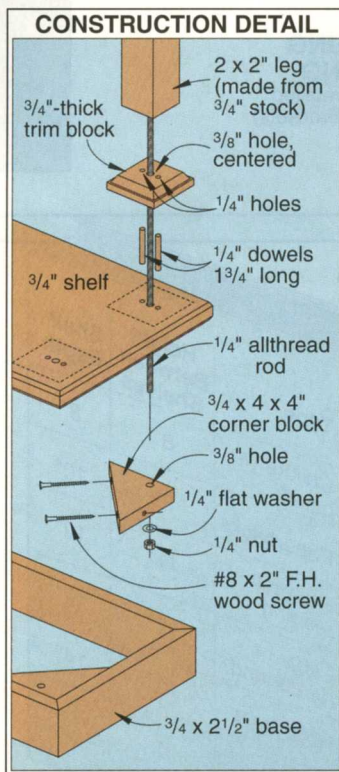

Note: This type of shelving can be stacked up to four units high for narrow-width shelves; five high for 24"-wide shelves.

Home-Shelving Planner

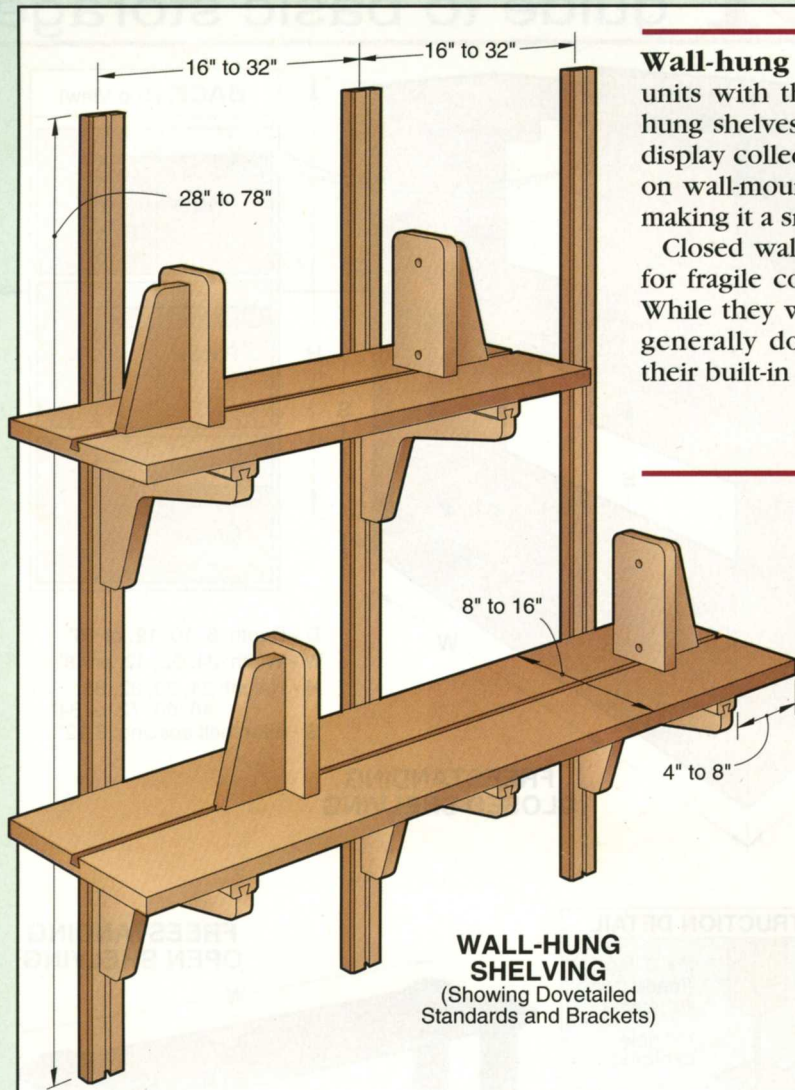

Wall-hung shelves combine the stability of built-in units with the flexibility of freestanding shelves. Wall-hung shelves, as shown *below*, provide an ideal way to display collectibles. Open shelves supported by brackets on wall-mounted standards take only minutes to install, making it a snap to add, subtract, or reconfigure shelves.

Closed wall-hung shelves provide enclosed protection for fragile collectibles, such as fine china or glassware. While they will carry moderate loads, wall-hung shelves generally don't have the weight-carrying capacity of their built-in or freestanding counterparts.



Size up your shelving needs

Once you've settled on a type of shelving, it's time to figure out how much shelving you need. Books, collectibles, and audio equipment vary greatly in size. The following guidelines provide some general dimensions, but measure your particular components for precision planning.

Books

While the books in your home library come in many sizes, the chart at *right* shows typical shelf depth and height requirements for the different types.

| Type | Height Between Shelves | Shelf Depth |
|------------------|------------------------|-------------|
| Children's books | 8" | 8" |
| Paperbacks | 8" | 10" |
| General reading | 11" | 12" |
| Large hardbound | 15" | 12" |
| Reference | 10" | 14" |

As a general rule, a running foot of shelf space holds 8-10 books. That same space will hold 10-12 children's books, but plan on fitting only five reference books per foot of shelving.

Collectibles

Take a detailed inventory of your particular collection, including the width, depth, and height of each piece. To help get a better feel for spacing between pieces, try different arrangements by laying them out on a carpeted floor. If your collection's still growing or part of an ongoing series, allow

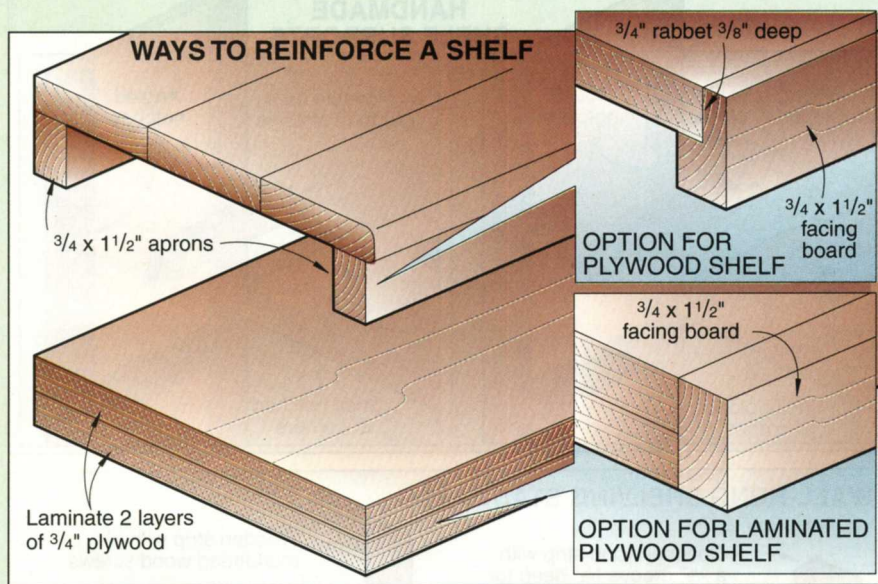
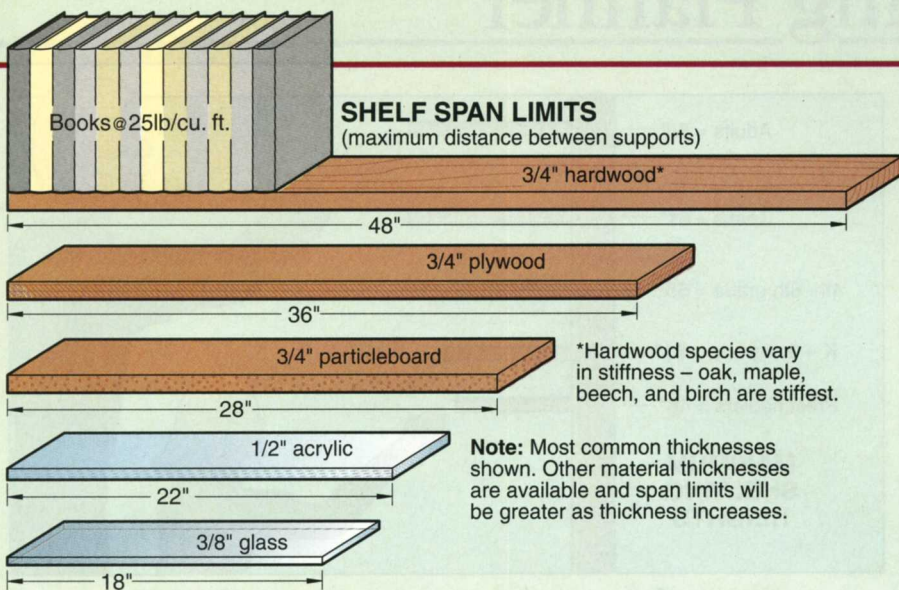

adequate room for future additions to the set.

To showcase a particularly prized piece, provide extra space to set it off from the rest of the collection. You may want to include protective features, such as a plate groove, partitions between pieces, or a lip along the front edge of the shelves.

Audio equipment

Many stereo components measure 17 1/8" wide and 14" deep, but stack together in different configurations, so check the size of your equipment for a custom

fit. You'll need to conceal electrical cords and wiring between components, too. A minimum 1 1/4"-diameter hole provides clearance for electrical plugs.

Note: No matter what you're storing, give some thought to "overbuilding" your shelves by a factor of 10–25 percent in terms of both overall running footage and the weight they can carry. "Extra" shelf space has a way of filling up quickly, and shelves built heavy enough to hold encyclopedias will carry practically anything else.

Consider strength, cost, and appearance of shelf materials

Any shelf will sag if you overload it. A shelf's span limit—the distance it can span between supports without sagging or breaking—varies depending on the material used.

Architects use books—at 25 pounds per cubic foot—as the standard for determining span limit. Span limits for some typical shelf materials appear at left.

As noted in the comparison chart, hardwood shelves sag less than other materials, but the amount of sag varies between hardwood species. Oak, maple, beech, and birch rank as the stiffest, followed by ash, cherry, walnut, and mahogany. By comparison, 3/4" softwoods such as white pine can usually span 36" underload without sagging.

To span longer distances, you need to use thicker material—solid or laminated—or reinforce the shelves by one of the methods shown at left. Reinforcing both edges can boost spans up to 40 percent. Similarly, small aluminum channels fitted over the edges of glass or acrylic shelves add strength without affecting the limited visual impact of clear display shelving.

While solid hardwoods provide you with longer spans, they cost considerably more than veneered plywood. And, plywood reacts less to seasonal humidity changes than solid wood, making it less likely to warp and twist.

Plywood also saves you from edge-joining solid boards to achieve greater widths. And, by applying veneer tape or gluing facing strips to exposed plywood edges, you still get the look of solid wood.

Medium density fiberboard (MDF) provides a stable, inexpensive alternative to veneer plywood

Continued

Home-Shelving Planner

for shelves you plan to paint. It will span nearly the same distance and you can machine and sand its edges smooth, but be sure to use an oil-based primer coat prior to painting MDF, since the water in latex primer causes the fibers to swell and separate.

Particleboard provides an even lower-cost option, making it ideal in utility applications where appearance isn't as critical. Many home centers carry "prefinished" particleboard shelving—in 8", 10", and 12" widths—that has a rounded front edge and a thin, wood-grained or white, vinyl covering. These same outlets also stock this material predrilled for shelf-support pins for use as shelving unit sides.

Glass and acrylic work well for display shelving because they allow light to pass through, and their thin, transparent edges don't detract from the object on display. Use glass at least 1/4" thick and have the edges seamed—or sanded—to make the glass safer to use and handle. For longer spans, or to hold heavier objects, use 1/2"-or-thicker glass, but expect to pay substantially more.

Acrylic provides a lightweight alternative to glass where breakage could present a hazard to small children. However, it scratches easily and costs as much as or more than comparably sized glass.

Iron out a few more details

Before you start building, you need to finalize a few more shelving system details. For example, shelves need to be placed within easy reach of family members who use them most. Your shelves shouldn't be higher than the heights—shown at *top right*—for the various ages listed.

For display shelving, mirrored back or side panels add depth

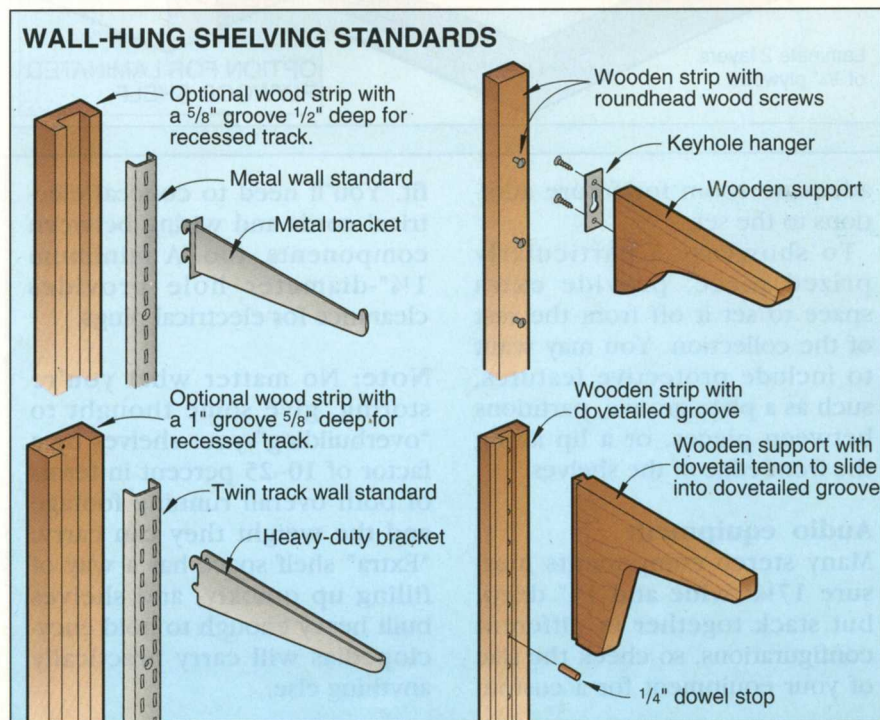
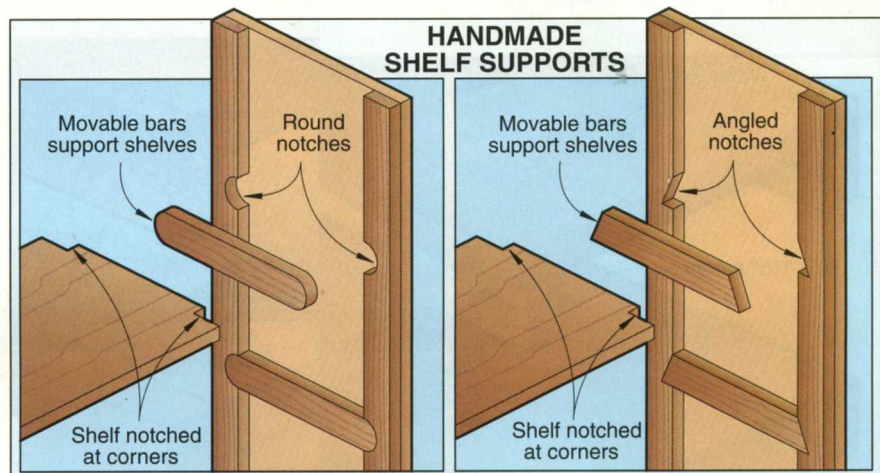
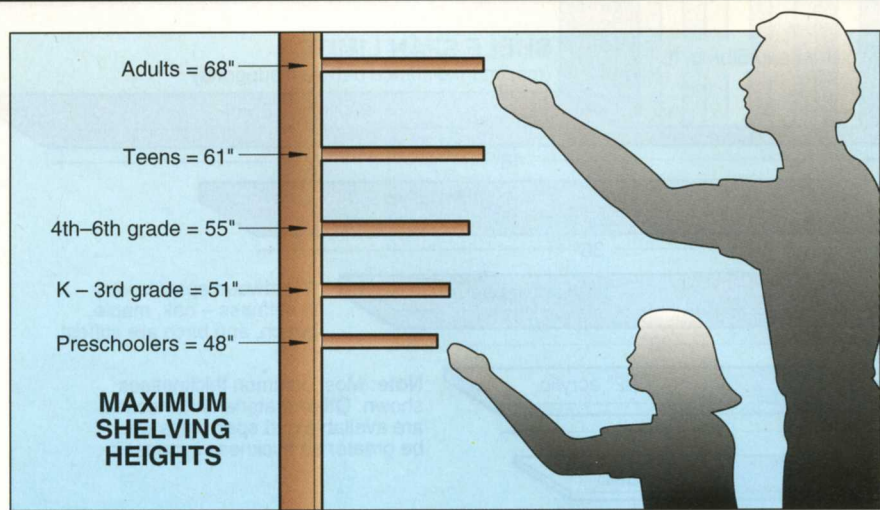

TOP AND SHELF JOINERY OPTIONS

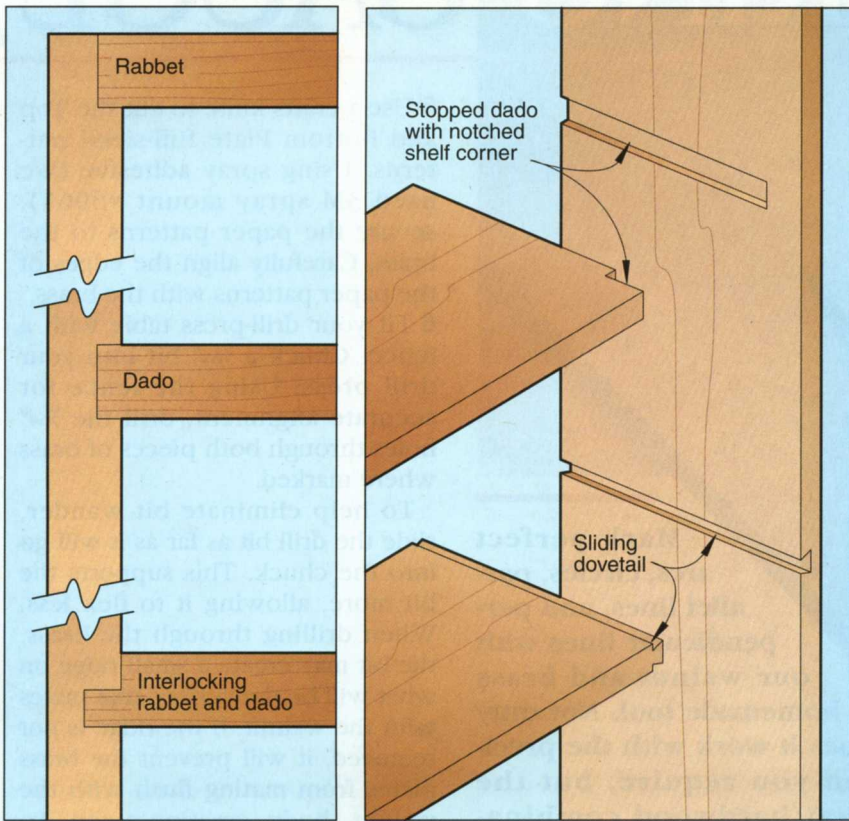

SHELF STANDARDS

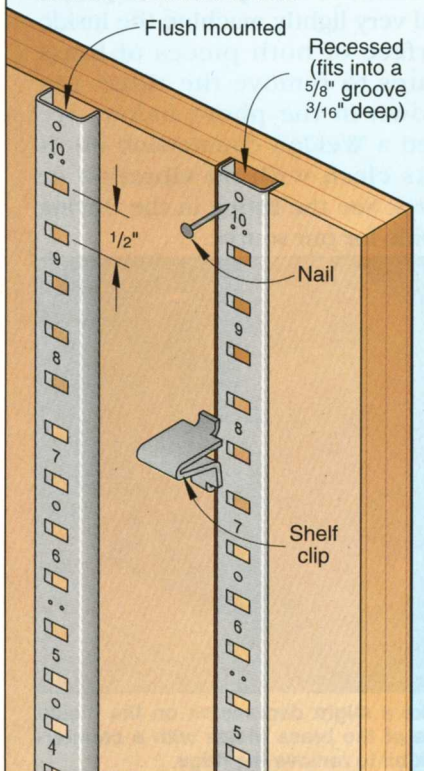

SHELF SUPPORT OPTIONS

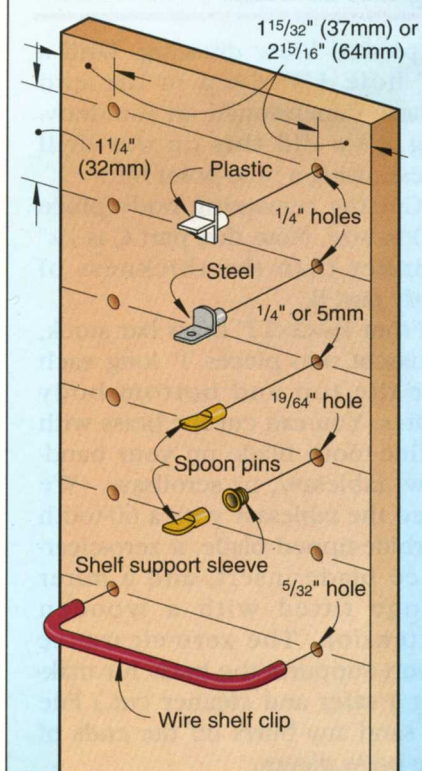

and dimension. Recessed lights—available in 110-volt or low-voltage models—focus attention on key elements you put on display. Some fixtures swivel or have movable reflectors to help you direct the light just where you need it.

If you plan to use plywood or other sheet goods, choose shelf widths and lengths that make maximum use of material. For example, a 4×8' sheet of plywood yields 24 shelves approximately 8×24" or 12 shelves 12×32" and wastes only the wood lost to the saw kerfs.

Spacing between shelves varies, but typical spacing is 8–12". By using adjustable shelves, you can fine-tune the spacing to maximize the amount of space available within a unit.

To support adjustable shelves, you have dozens of options, a number of which appear in the drawings at *left*. Most employ standards—either metal or wood—that hold pins, clips, or brackets which support the shelf.

Some shelf-support brackets or pins have holes so shelves can be held firmly in place with screws. To protect glass shelves and keep them in place, use clips with vinyl or rubber pads.

To dress up metal wall-hung standards, insert them in a groove cut into a wooden mounting strip, as shown *lower left* on the opposite page. Any wall-hung unit must be firmly attached with screws driven into the wall studs. Commercial metal standards usually come with #12×2 1/2" or longer mounting screws.

While they limit flexibility, fixed shelves add strength and stability to closed shelving units. A number of options for joining fixed shelves to the case sides appear at *top left*.

Written by Kerry Gibson, with Jim Downing, Jan Hale Svec, and Chuck Hedlund
Photographs: Hopkins Associates; John Hetherington
Illustrations: Kim Downing

*
Collector's Edition

MARKING GAUGE /

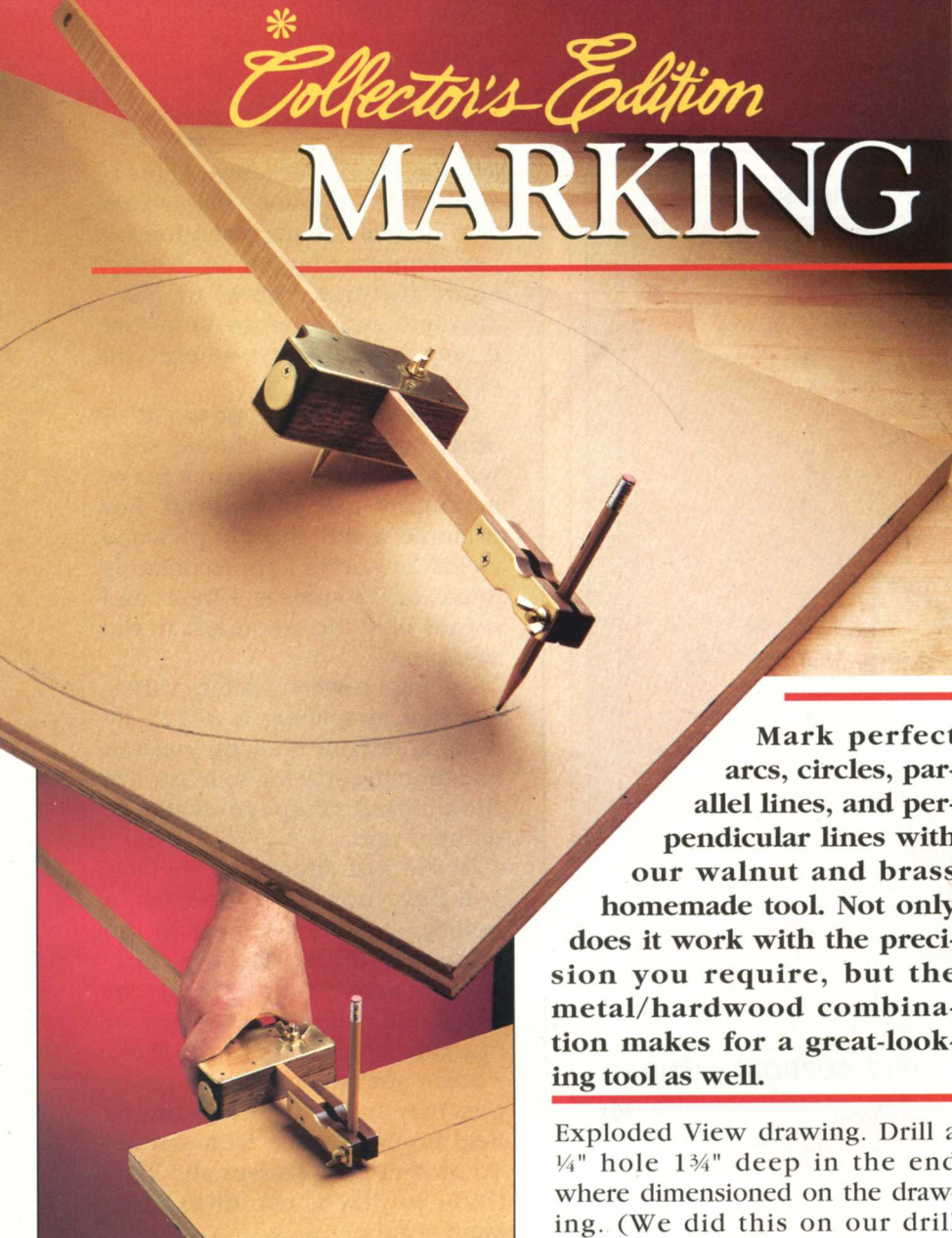

Mark perfect arcs, circles, parallel lines, and perpendicular lines with our walnut and brass homemade tool. Not only does it work with the precision you require, but the metal/hardwood combination makes for a great-looking tool as well.

Exploded View drawing. Drill a $\frac{1}{4}$ " hole $1\frac{3}{4}$ " deep in the end where dimensioned on the drawing. (We did this on our drill press, using a brad-point bit.)

3 Cut the remaining body piece (C) to size. Note that part C is $\frac{1}{16}$ " thinner than the thickness of body part B.

4 From $\frac{1}{16} \times 2 \times 12$ " brass bar stock, crosscut two pieces 4" long each for the top and bottom body plates. You can cut the brass with a fine-tooth blade on your hand-saw, tablesaw, or scrollsaw. (We used the tablesaw with a 60-tooth carbide-tipped blade, a zero-clearance blade insert, and a miter gauge fitted with a wooden extension. The zero-clearance insert supports the brass for making a safer and cleaner cut.) File or sand any burrs off the ends of the brass pieces.

5 Use a crafts knife to cut the Top and Bottom Plate full-sized patterns. Using spray adhesive (we used 3M spray mount #6065), secure the paper patterns to the brass. Carefully align the edges of the paper patterns with the brass.
6 Fit your drill-press table with a fence. Chuck a $\frac{3}{64}$ " bit into your drill press. Using the fence for accurate alignment, drill the $\frac{3}{64}$ " holes through both pieces of brass where marked.

To help eliminate bit wander, slide the drill bit as far as it will go into the chuck. This supports the bit more, allowing it to flex less. When drilling through the brass, the bit may create a small ridge on what will be the surface that mates with the walnut. If the ridge is not removed, it will prevent the brass plates from mating flush with the walnut body, creating a gap. To remove the ridge, mount a countersink bit into your drill press, and very lightly machine the inside surface of both pieces of brass plates to remove the ridge. (As shown in the photo *below*, we used a Weldon countersink bit. It cuts clean with no vibration or burrs. See the listing in the Buying Guide for our source.)

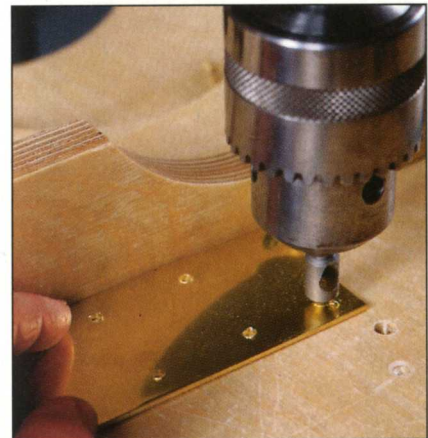

Make a slight depression on the inside face of the brass plates with a countersink bit to remove the ridge.

Note: Although the brass we used measures .064", it is often referred to as $\frac{1}{16}$ "-thick brass. See our source for a kit containing all the necessary hardware in the Buying Guide at the end of the article.

Let's start by building the trammel body

1 Cut the trammel body parts (A, B) to the sizes listed in the Bill of Materials from $\frac{3}{4}$ " walnut. With one end and both edges flush, glue and clamp the pieces together face-to-face.

2 Remove the clamp, mark the centerpoint for the pivot-pin hole where dimensioned on the

TRAMMEL

EXPLODED VIEW

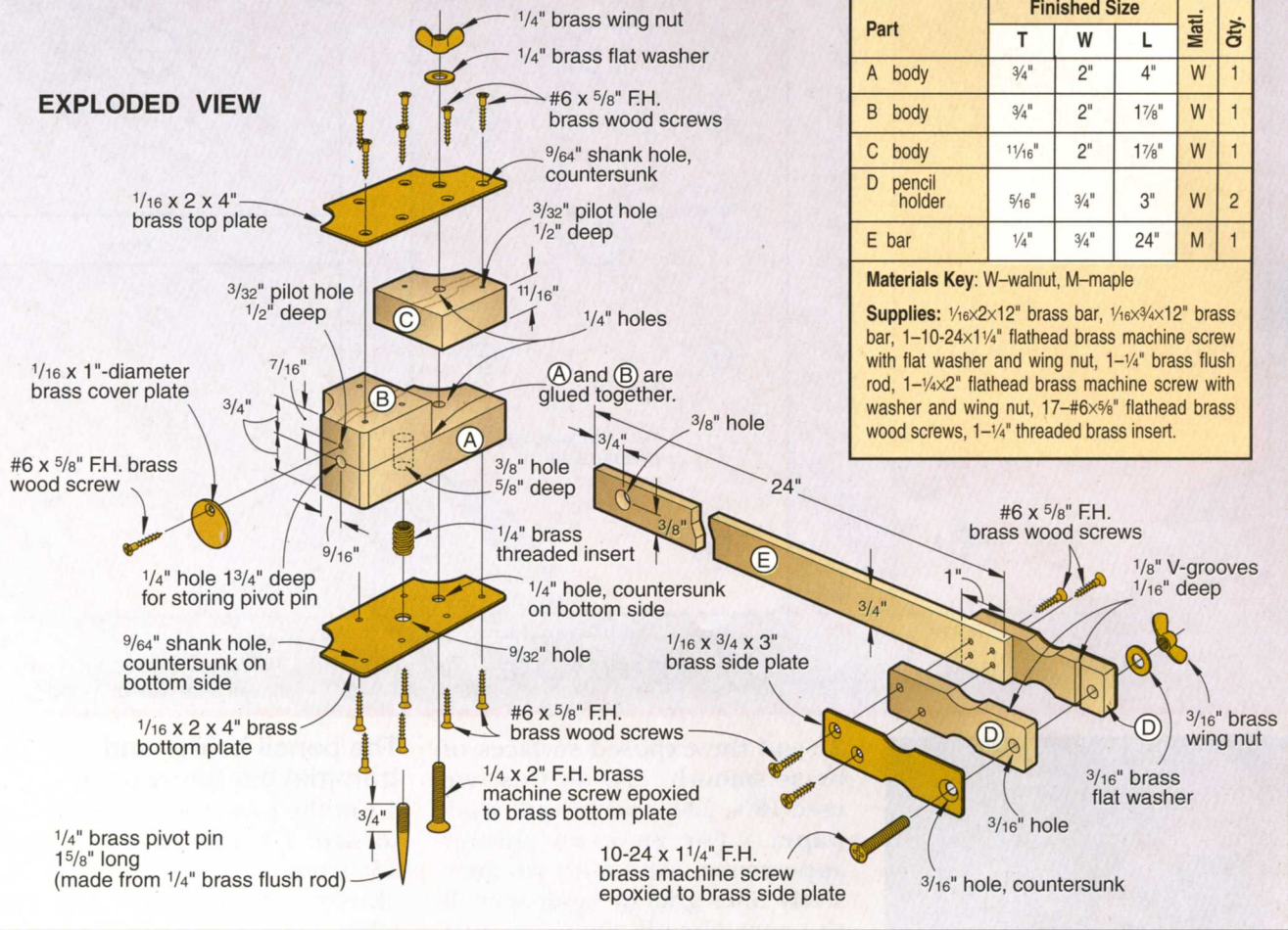

Bill of Materials

| Part | Finished Size | | | Matl. | Qty. |
|-----------------|---------------|------|--------|-------|------|
| | T | W | L | | |
| A body | 3/4" | 2" | 4" | W | 1 |
| B body | 3/4" | 2" | 1 7/8" | W | 1 |
| C body | 1 1/16" | 2" | 1 7/8" | W | 1 |
| D pencil holder | 5/16" | 3/4" | 3" | W | 2 |
| E bar | 1/4" | 3/4" | 24" | M | 1 |

Materials Key: W—walnut, M—maple

Supplies: 1/16x2x12" brass bar, 1/16x3/4x12" brass bar, 1-10-24x1 1/4" flathead brass machine screw with flat washer and wing nut, 1-1/4" brass flush rod, 1-1/4x2" flathead brass machine screw with washer and wing nut, 17-#6x5/8" flathead brass wood screws, 1-1/4" threaded brass insert.

7 Turn the brass pieces over (pattern side up), and countersink each 3/64" hole. (We test-countersunk holes in the remaining brass stock first, allowing us to accurately set the depth stop on our drill press. The screwheads need to seat flush in the countersunk holes later.)

8 Using double-faced tape, adhere the bottom plate to the walnut body. Drill a 1/16" guide hole through the brass at the threaded-insert location, giving you an accurate centerpoint for drilling the 3/8" hole into the wood later.

9 Separate the brass and wood, and drill a 3/8" hole 3/8" deep into the wood and a 3/32" hole through the brass for the threaded insert.

10 Install the 1/4" brass threaded insert in the 3/8" hole in the walnut (A). (To do this, we double-nutted a 1/4" roundhead machine screw and threaded the insert onto the machine screw and against the nuts. Then, we used a wrench and a screwdriver to drive the insert squarely into the hole. We used the screwdriver to press the insert downward and the wrench to thread the insert into the hole. Doing this is more accurate than trying to drive the insert in place with just a screwdriver.)

11 Chuck a self-centering 7/64" Vix bit into your drill press, and position the fence to align the bit over the countersunk holes. (See the Buying Guide for our source of

this bit.) Drill the pilot holes for the brass screws into the walnut as shown in the photo on the *next page*. To help hold part C in place, use a 1/4" spacer as shown in the photo.

12 Drive #6x5/8" brass flathead wood screws through the brass and into the trammel body. Continue using the 1/4" spacer between parts B and C for support. Bandsaw the radii to shape. (We used a 1/4" skip-tooth blade.)

13 Drill a 1/4" hole through the trammel body (A, C). Countersink one end of the hole where shown on the Exploded View drawing to house the head end of a 1/4x2" flat-head brass machine screw.

Continued

MARKING GAUGE/ TRAMMEL

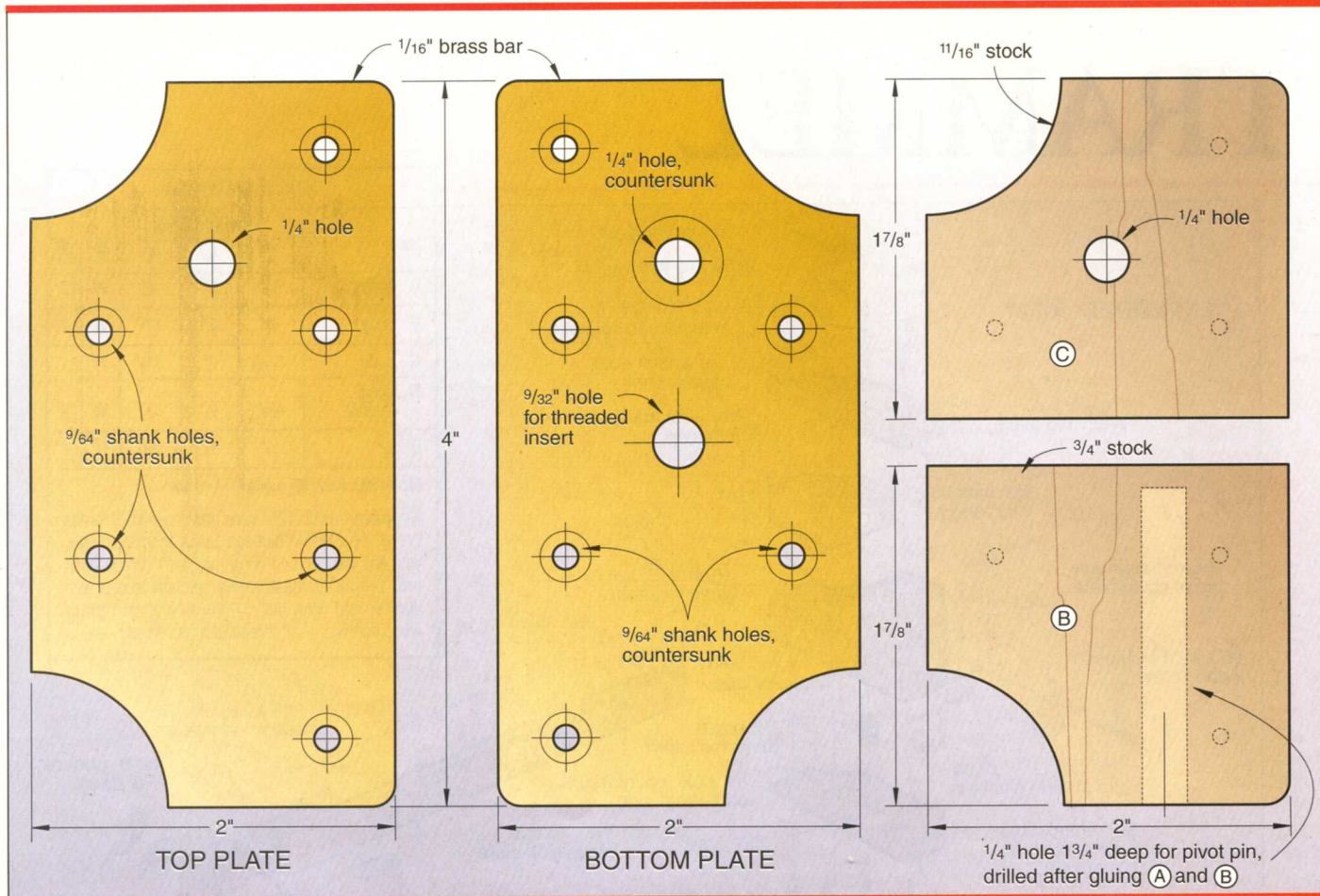

Use the fence on your drill-press table to align the bit over the previously countersunk holes in the brass.

14 Drum-sand the two radii. Then, lightly sand the edges and ends of the trammel body.

Now, clean up the brass and make it shine

1 Using a round and a flat file (we used an 8" mill file and an 8" round file), file a $\frac{1}{16}$ " round-over along the edges of the brass top and bottom plates.

2 Sand the exposed surfaces of brass smooth. (To do this, we used 180-, 220-, and 320-grit sandpaper.) For an even shinier appearance, sand with progressively finer grits of sandpaper. If the screwheads protrude just slightly, they can be sanded flush; if they protrude too much, remove them and drill the countersinks deeper.

3 Mix quick-set epoxy (5-minute epoxy), and epoxy the $\frac{1}{4} \times 2$ " brass machine screw in place. After the epoxy has cured, sand the bottom plate again to remove any excess epoxy and to smooth the head of the screw flush with the brass bottom plate. The $\frac{1}{4} \times 2$ " brass screw and mating wing nut allow you to secure the trammel bar in the body later by simply tightening the wing nut slightly.

4 Finish-sand the trammel body, and apply an oil finish to the wood. Immediately wipe any finish off the brass.

The pencil holder and trammel bar come next

1 Cut the pencil-holder pieces (D) to size. Tilt your tablesaw blade 45° from center, and raise it $\frac{1}{16}$ " above the surface of the saw table. Using a wooden extension on your miter gauge for support, cut a V-groove in each pencil holder (D) where shown on the Full-Sized Patterns and the Exploded View drawing.

2 Cut the trammel bar (E) to size. Check the fit of the bar into the body (A, B, C). The bar should slide smoothly, yet clamp securely in the trammel body.

3 For hanging the completed trammel, drill a $\frac{3}{8}$ " hole through the bar where shown.

4 Glue and clamp the pencil holders to the bar, aligning the V-grooves. See the Exploded View for particulars.

5 Cut two pieces of $\frac{1}{16} \times \frac{3}{4}$ " brass bar to 3" long to cover the outside face of the pencil holders.

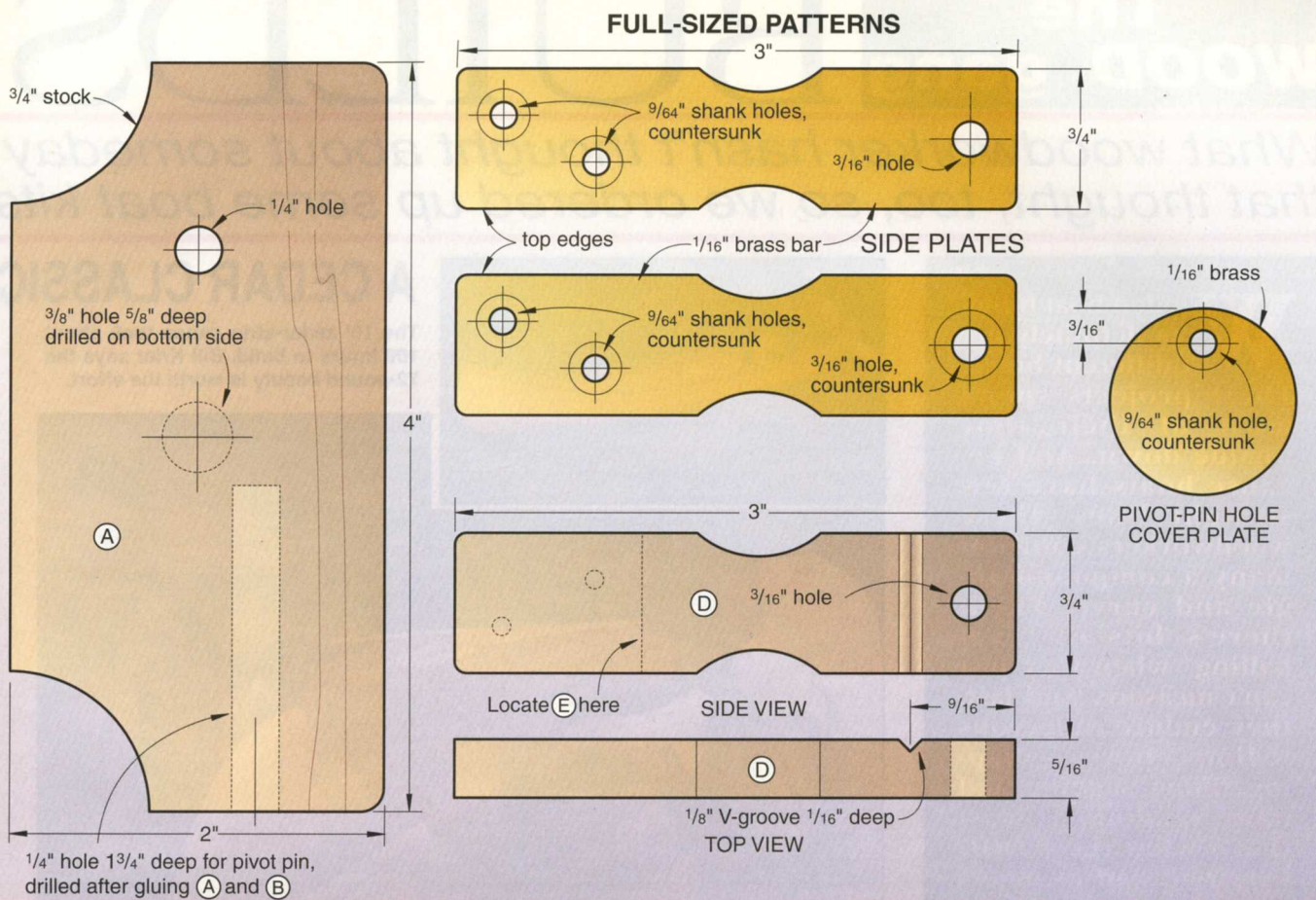

Transfer the paper patterns, and drill and countersink the holes like you did earlier with the brass on the body. Note that the two screws on one brass plate are offset from those on the opposite plate. Secure the two pieces of brass to the pencil holders with #6 screws.

6 Using your drillpress and a $\frac{3}{16}$ " bit, drill a hole through the brass-covered pencil holders to house a 10-24 \times 1 $\frac{1}{4}$ " machine screw. To reduce the chance of chip-out, place a $\frac{1}{4}$ "-thick spacer between pencil holders when drilling the hole. Countersink the hole.

7 With the spacer still in place, bandsaw the radii on the pencil holders, and drum-sand each radius smooth. File and sand the brass as before.

8 Epoxy the 10-24 \times 1 $\frac{1}{4}$ " brass machine screw in place, being careful not to get any epoxy on the exposed threaded end. Finish-sand the pencil holder and bar.

Add the cover plate and pivot pin

1 Transfer the 1"-diameter cover plate pattern to $\frac{1}{16}$ " brass. Drill and countersink the hole where marked. Cut the cover plate to shape, cutting just outside the marked line. The cover is used to cap the end of the $\frac{1}{4}$ " storage hole for the brass trammel pivot pin.

2 Using double-faced tape, secure the cover plate to the end of a 1"-diameter dowel. Using the previously drilled hole in the cover plate as a guide, drill a pilot hole into the dowel, and further secure the brass cover plate to the end of the dowel with a screw. Clamp the dowel in your workbench vise with the brass end up. File the edges of the cover plate flush with the edges of the dowel. Then file and sand the round-overs on the cover plate.

3 Drill a $\frac{3}{32}$ " pilot hole in the trammel body (B) for mounting the cover with a #6 screw.

4 To form the pivot pin, cut a 1 $\frac{5}{8}$ "-long piece off the threaded end of a brass flush (toilet) rod. If the threaded end is longer than $\frac{3}{4}$ ", cut the threaded end to length and then crosscut to 1 $\frac{3}{4}$ " long. Chuck the threaded end into your drill press. Start the drill press and use a file to sharpen the end of the pivot pin. Sand the point until it shines. Assemble the project in the configuration shown. 🌟

Buying Guide

Hardware kit. All the pieces listed in the Supplies listing (brass not cut to length). Catalog no. MGT2000, \$20 ppd. For a Weldon countersink bit, add \$9.10. For a self-centering #5, $\frac{7}{64}$ " Vix bit, add \$8.80. Puckett Electric Tools, 841 Eleventh St., Des Moines, IA 50309, or call 800/544-4189 or 515/244-4189 to order.

Written by Marlen Kemmet
Project Design: James R. Downing
Illustrations: Kim Downing; Lorna Johnson
Photographs: Wm. Hopkins; John Hetherington

What woodworker hasn't thought about someday that thought, too, so we ordered up some boat kits

Wooden-boat builders definitely are a different breed. Their projects spend most of their time upside down. And because boats have few straight lines, these woodworkers confront many a compound angle and curve. Then, there's lots of "eyeballing" when they just can't measure. And last, they endure numerous tedious chores—shaping, filling, sanding, and more sanding. At least that's what the **WOOD** magazine staff members who agreed to build the boats described in this article discovered.

They also found out that building a boat from a kit saves time over building a boat from plans and searching for all the materials. A kit also costs up to 50% less than a comparable stock boat.



A CEDAR CLASSIC,

The 16' cedar-strip canoe took about 100 hours to build. Bill Krier says the 72-pound beauty is worth the effort.



In his garage workshop, Bill staples the edge-glued $\frac{1}{4} \times \frac{3}{4}$ " white cedar strips to the building form of the canoe hull. When the glue dries, he'll pull the 1,000 or so staples from the wood before sanding it smooth and fiberglassing.

Jim Harrold's plywood kayaks—the Queen Charlotte XL 17'6" in clear finish and the Cape Charles 18' with white hull—required a construction process called stitch-and-glue.



STITCH-AND-GLUE

I built kayaks because they offer the best way I know to explore America by water. Kayaks require only a few inches to float in, and the sleek designs are things of beauty. Better still, the construction processes are geared to the beginner and intermediate woodworker. Anybody can build them, and you don't need a lot of tools. That's why I tackled two boat kits from two different manufacturers.

KIT BOATS

building a boat? At WOOD® magazine we had to give us a taste of what it's like.

FROM SCRATCH *By Bill Krier, assistant managing editor*

A friend of mine in Wisconsin owned a cedar-strip canoe that I've long admired and dreamed of building for myself some day. So when it came time to select a kit, I didn't hesitate.

Building the canoe: To succeed with this kit you need intermediate woodworking skills. It was fun to apply the cedar strips I'd ripped to the canoe forms, and I learned some new woodworking tricks along the way. Then came the work. First, I pulled each of the 1,000 or so staples that hold the strips to the forms as the glue dries. Next, I sanded the outside and inside of the hull with a belt sander and random-orbit sander. Of the 100 hours that I worked on it, at least half involved sanding.

I also was intrigued by fiberglassing the hull, although I'll admit that I'm not anxious to do it again soon. But attaching the gunwales, gluing up and installing the decks, then adding the seats and yoke made me a happy woodworker.

The finishing process did not go quite as I had planned. First, I

wiped down the outside of the hull, as I usually do unfinished wood, with a cloth dampened in lacquer thinner, then applied the first coat of varnish. I waited and waited for it to set up. After two weeks in a dry, 70° environment, the finish was still tacky.

Finally, I telephoned the finish manufacturer and found out that I should have washed the hull with soapy water, then rinsed it with clear water, before applying the finish. As it cures, epoxy releases a water-soluble but oily substance called amine. The resultant surface film can't be removed with solvents. Resigned to the fact that the amine film would never let the finish dry, I stripped off the varnish, washed and rinsed the hull, then reapplied another coat that dried overnight. The kit supplier now furnishes a warning about washing down the hull with soapy water.

The kit critique: All of the items supplied with the kit, including the wood, epoxy, and fiberglass, were high quality. A step-by-step

video proved helpful, although the package could be improved with the inclusion of a few simple diagrams and instructions that would have saved me some time.

The beauty of the finished canoe is undeniable, and the years of use that I will get from it more than make up for the hours that went into making it. I can't wait to take my beauty on a long excursion.

16' cedar-strip canoe kit

Components: 4"-wide white cedar in 10' lengths for ripping, redwood for accent strips, red oak for gunwales, walnut for fore and aft decks, epoxy mix, fiberglass cloth, screws, nails, building-form patterns, ash seats and carrying yoke, application supplies, instructional video. **Cost:** \$720 plus shipping. Available 14' canoe kit, \$645 plus shipping. Video and building-form patterns only, \$43.95 ppd. All kit components also sold separately. **Manufacturer:** Paleo Canoe Co., Box 491, Bedford, MA 01730. 617/275-3004.

KAYAKS FROM PRECUT PLYWOOD *By Jim Harrold, managing editor*

Building the kayaks: For the most part, the construction processes of the two kayaks—the Queen Charlotte XL by Pygmy Boats, Inc. and the Cape Charles 18' by Chesapeake Light Craft, Inc.—are similar. First, light pre-cut plywood parts for the sides, bottom, and (in the case of the Queen Charlotte XL) deck need to be butt- or scarf-joined with epoxy to get the needed panel

lengths. Then, I joined these lengths together by stitching and gluing. This process requires drilling small holes along the mating edges of the pieces, running lengths of wire through opposing holes, and finally twisting the wire ends to snug the plywood pieces together. Following the joining, I applied epoxy and fiberglass tape over the seams and permanently bonded the pieces.

With the Cape Charles 18', I glued and nailed the deck in place to a cypress sheer clamp, which gave added support. The resulting brass nailheads dotting the deck create a different look by standing out against the wood. Both boats got added strength and protection with applications of fiberglass cloth and epoxy. Finally, I sanded and finished the boats—the

Continued



The stitch-and-glue boatbuilding process involves joining panels together with wire, filling the seams with epoxy, then applying fiberglass tape and more epoxy over the tape.

Right: Jim rolls and squeegees epoxy onto the fiberglass cloth laid on the Queen Charlotte XL's hull bottom.



KIT BOATS

Jim and brother-in-law Dave Durden team up nailing and gluing the deck panels to the sheer clamp on the Cape Charles 18'.



THE CHINE TECHNIQUE FOR A SQUARE-STERN CANOE

By Pete Stephano, features editor

A 16' square-stern canoe can easily handle a small outboard for fishing lakes and large rivers. And if I learned chined plywood construction, I could use it to build other boats.

Building the square-stern: Before I started building the kit, I made a canoe-shaped assembly jig of two 13'11½"-long 2×4s built up by laminating ¾" plywood to set atop three sawhorses. Erecting the canoe's frame members along the building jig required precise spacing from stem to stern, checking for square and plumb, as well as the height of each member. First, though, I had to bevel the frames closest to stem and stern to hopefully match the bend of the plywood planking.

Following the installation of the upright frame members, I added the 16'-long longitudinals—the keelson, inner gunwales, and

chines—that completed the canoe's wooden skeleton. At times, I hung them from my shop ceiling in approximate position. This kept them off the floor so I could glue and screw them to the frame members.

To ensure that the canoe's plywood skin would completely contact the frame pieces, I "faired" the wood frame. With a hand plane, wood rasp, and belt sander, I tapered the wood of the chines, keelson, frames, stem, and transom. I'd lay a 1×2 over the keelson and the chine. If it didn't lie flat, I took off more wood.

A friend helped me handle and add the plywood side panels by gluing, clamping, and screwing. Once secured, the oversized panels were trimmed and faired to accept the bottom panels.

Next, I filled all the countersunk screw holes, sanded the hull smooth, and added a layer of

epoxy and fiberglass cloth. I then varnished the interior and painted the exterior.

The kit critique: As a kid, I made model airplanes from kits with parts printed on balsa wood that I cut out. This was a level up from that. Step-by-step instructions and better drawings certainly would have helped, and greatly reduced construction time. As it was, the full-sized plans were a lifesaving visual reference. What I didn't expect from this kit was all the necessary problem-solving, and the amount of handwork. Yet, those 150 or so hours were meaningful and satisfying woodworking time to me.



Queen Charlotte XL with a clear marine varnish, and the Cape Charles with two-part marine paint on the hull and clear marine varnish on the deck.

The kits' critique: Working with precut plywood panels saved me loads of time. Both sets of instructions seemed clear, with only a few small glitches. When I had a technical problem, I called the manufacturer and got help.

Total construction time ran over the estimated time stated in the instructions, taking about 70 hours per boat. But working with fiberglass and epoxy added a new dimension to my woodworking. And a person can save over \$1,000 by building his or her own kayak. I'd say that building these boats ranks among my favorite woodworking experiences.

Queen Charlotte XL 17'6" kayak

Components (full kit): Precision precut 4mm mahogany marine plywood, coaming, epoxy, fiberglass and tape, foot braces, seat, wire, instruction booklet, misc. hardware. **Cost:** \$660 (plus shipping charge). **Accessories:** Deck rigging pack, \$20; hatch kit, \$162; bulkheads (two pieces), \$18; rudder kit with pedals (helpful for all kayakers when paddling against stiff wind or in swift river currents), \$150.

Manufacturer: Pygmy Boats, Inc., P. O. Box 1529, Port Townsend, WA 98368. 360/385-6143. Boat kit catalog and plans available. Internet: www.pygmyboats.com

Cape Charles 18' kayak

Components (basic kit): Precut 3mm and 4mm okoume marine plywood, cypress sheer clamps, coaming, epoxy, fiberglass cloth, tape, foot braces, seat, wire, hardware, deck rigging, instruction booklet, blueprint plans, and miscellaneous. **Cost:** \$594 (plus shipping).

Accessories: ; hatch and bulkhead kit (for storage), \$60; rudder kit with pedals, \$165; creature comfort seat, \$75.

Manufacturer: Chesapeake Light Crafts, Inc., 1805 George Avenue, Annapolis, MD 21401. 410/267-0137. Boat kit and supplies catalog, plans, and book available.



The frame members of the canoe are positioned on the building jig as Pete adds a gunwale. Far right: Dry-fitting a panel to the canoe frame indicates where more fairing needs to be done.

With the inside varnished to contrast with the black hull, Pete Stephano's chined plywood canoe is ready to hit the water.



16' Niagara square-stern canoe

Components (basic kit): Precut Philippine mahogany frame parts, chines, keel, gunwales, and seat boards, 3/4" fir plywood foredeck, stem, and transom, and precut (oversized) 1/4" fir marine plywood panels for sides and bottom, plus floorboards, screws, plastic-resin glue, full-sized frame patterns, and instructions with sketches.

Cost: \$395 plus shipping. **Optional upgrades:** Silicon-bronze screws, \$55; fiberglass covering, \$120; two gallons Epoxy-plus, \$88.

Manufacturer: Clark Craft, 16-97 Aqua Lane, Tonawanda, NY 14150. Call 716/873-2640. Kit and plan catalog with 200 designs, \$3. Boatbuilding supplies catalog, free.

Continued

KIT BOATS



Jim Downing's lapstrake sailing pram kit from The Wooden Boat Store took him 60 hours to build. "Small but stable, it handles like a dream," he says.

Lapstrake construction involves fastening overlapping panels (planks) to a minimal frame. Jim started with the bottom panel, added the broadstrake, and then worked up the hull.



LAPSTRAKE CONSTRUCTION FOR A PRAM THAT PERFORMS

By Jim Downing, design editor

I've sailed for decades. Now my sons sail. And it's time for my grandsons to learn. That's why I picked the nutshell pram to build. The boat is just the right size.

Building the pram: The first step in building the boat was to set up a temporary platform (a strongback) to hold the stem, laminated frame, a couple of plywood forms, and the bow and stern transoms in position. Using straight stock and a level is essential to building a boat that is true to the design.

Next, I glued the 1/2" plywood bottom to the transom, stem, and the laminated frame. After the glue dried, I beveled the edges of the plywood to match the angle of the broadstrakes (lower plywood panels). A hand plane or a belt sander fitted with a coarse belt is the best way to shape these important bevels.

But I somewhat over-beveled the joint. That made a tight-fitting seam on the inside of the boat and a slightly open joint on the outside. Since I planned to varnish the interior of the boat, I wanted the best fit there. Using epoxy thickened with silica, I filled the slightly open, outer side of the joint. That produced a stronger

joint than a perfectly beveled one.

After I cut the bevels, I dry-fitted the broadstrakes, then glued and screwed down. Alternating sides, I added the remaining strakes until I reached the final sheer strake. Then, I filled the screw holes and open joints while the boat was still upside down.

That done, I turned the hull over to install the sheer rail and corner knees. Because it is a sailing model, I added a daggerboard trunk inside the hull.

After the keel, daggerboard, and rudder were completed, I varnished the interior. Then, I primed the outside of the boat with DuPont Corlar Epoxy and painted it with marine paint.

The kit critique: The materials were all of appropriate woods—Sitka spruce for the spars, for example. The single frame used for the boat and the three spars were prelaminated. The spars were also tapered and machined to an octagonal shape that left only a little hand-planing and sanding to get round spars.

Building the Nutshell pram was a pleasant 60 hours. I was amazed how well all the parts fit. And in the few times I've had the pram out, it performed wonderfully.

7'7" Nutshell pram

Components (basic kit):

Precut, machined parts, silicon-bronze fasteners, marine-grade mahogany plywood, pre-cut and laminated spars, rowing hardware, plans, step-by-step instructions. **Cost:** Sailing model #600-002, \$895 plus shipping. Rowing model kit, \$700 plus shipping. Available in 9'6" version. Plans only, \$75.

Options: White Dacron sail, \$200. Video, \$59.95.

Manufacturer: The Wooden Boat Store, P.O. Box 78, Brooklin, ME 04616. Call 800/273-7447.

Tough finishes for boats of all kinds

We coated all painted boats in this article with Interthane Plus, a two-part brushable polyurethane marine enamel. Varnished surfaces received Plus-5 Varnish, a clear gloss, phenolic-resin marine finish with ultraviolet protection. For more information, write Interlux, 2270 Morris Ave., Union, NJ 07083. Call 800/468-7589. Fax 908/686-8545, or www.interlux.com.

BUSERA The elephant tree

Although quite common throughout all of northern Mexico, what has come to be called the elephant tree grows only in isolated areas of the American Southwest and West. In fact, the tree's whereabouts were known only to adventurous prospectors and other desert rats until the early 1900s.

Then, a wandering scientist heard a tale concerning a strange white-barked tree with limbs like an elephant's trunk and wood that bled red when cut. Determined to find this tree, the scientist set out into the desert of eastern San Diego County, California. Near a place called Split Mountain, he came upon the tree just as described. It wasn't until the late 1930s, though, that enough trees

were found to credit *Busera microphylla* as native to the U.S. Today, the elephant tree's range is known to extend along the coast of the Gulf of California in Mexico, north to Arizona's Gila Desert, and into the Imperial Valley of California. The largest specimens in the United States—20' tall—grow in Arizona.

Called toroto or copal in Mexico, the strangely attractive trees yield a gum that is used there as a base for varnish and a preservative for wood. The gum also works as an adhesive. And the incense burned in Mexican churches has its source in the wood of the elephant tree, a member of the same botanical family that provided the frankincense mentioned in the Bible. ♣

Illustration: Jim Stevenson

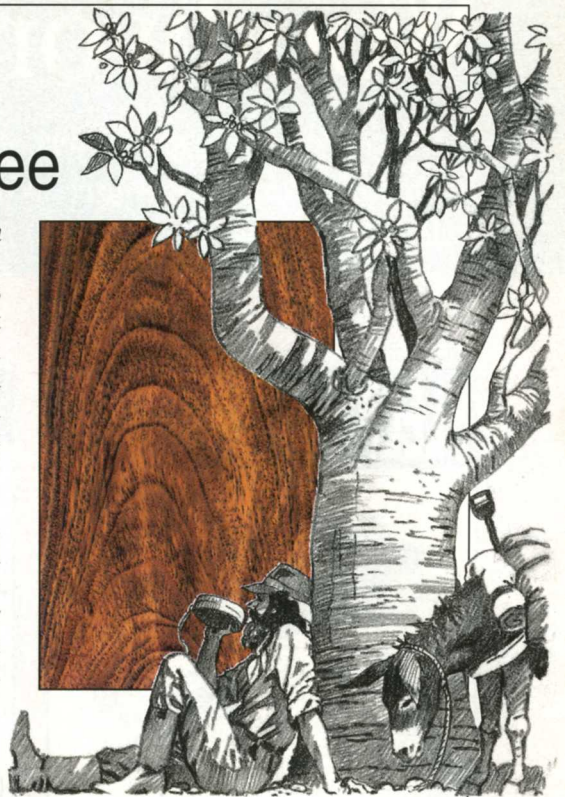

In its desert habitat, the bizarre elephant tree with its spindly leaves offers some shade to the weary traveler.

The hottest
woodworking
project...
humidors

FREE
CATALOG!

Build a humidior with our complete line of plans and supplies including: exclusive hardware and fine woods like spanish cedar!



Department 73111

Call 1-800-403-9736

<http://woodworkerstore.com>

Since 1954

The Woodworkers' Store

Hardware, Wood, Tools & Know How

Circle No. 965

"ASK ME HOW TO GET A FREE SAW!"

Visit the RBI Home page at
<http://www.rbiwoodtools.com>

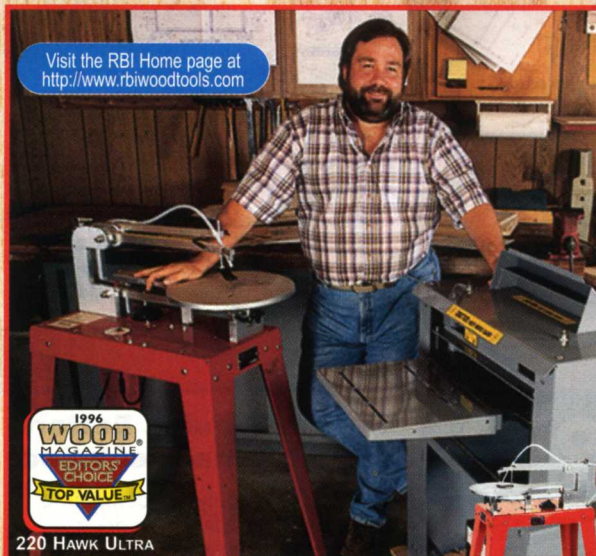

220 HAWK ULTRA

"QUALITY PERFORMANCE...WIDE RANGE OF DESIRABLE FEATURES...AT A FAIR PRICE."

BETTER HOMES AND GARDENS® WOOD® OCTOBER, 1996

rbindustries, inc.

America's Woodworking Machinery Manufacturer

1801 Vine Street • PO Box 369 Harrisonville, MO 64701

Call 1-800-487-2623 for info!

Being the leader in scroll saws, we offer the 30 day money back guarantee. Enjoy your new RBI Hawk Ultra Saw FREE FOR 30 DAYS!* During this time, make money, create projects that sell, and if you're not totally satisfied return your saw for a refund. RBI even offers 180 days same as cash with our simple credit plan. This gives you 6 whole months to pay for your new saw with the projects you create. Now that is a FREE saw offer!

*Must pay for unit with credit for your FREE for 30 days offer! This offer excludes shipping.

G108

Copyright-1997 rbindustries. All rights reserved

**WOOD®
CLASSIFIED MART**
For rates: 1-800/424-3090 Fax 312/464-0512

BUSINESS OPPORTUNITIES

BUNK BEDS. Clear \$300/day making Bunk Beds. Start at home in your spare time. Low startup cost. 1-800/382-3180, ext 1131.

KITCHEN SAVERS INSTITUTE. Video courses on Cabinet Restoration and Refacing. Low Cost! Complete "Business Start-up" package. 1-800/905-3980.

FINISHING/RESTORATION

LINE BOXES EASILY. Spray-on suede. 31 colors. Free Brochure. DonJer Products, Ilene Court-Bldg. 8W, Bellemead, NJ 08502. 1-800/336-6537.

HELP WANTED

EASY WORK! EXCELLENT PAY! Assemble Products at Home. Call Toll Free 1-800-467-5566 EXT. 11856.

HARDWOODS/LUMBER

4 RARE OAK SLABS! 4' x 7' x 2 1/2" thick. From 900 year old oak tree. Cured and sanded. 916/644-4731. <http://www.applehill.com/xmastrees>

BALTIC BIRCH PLYWOOD. Void Free. Ultimate for scrollsaw projects 1/8"-3/4". Call for info/pricing: "All Cut Up" 1-800/303-3090 Ext. 20.

HENDERSONVILLE HARDWOODS OF NC! 25 years lumber expertise. Family management team emphasizes top quality Appalachian Hardwoods/Softwoods, professional service, best prices. Small UPS specials, or large carrier orders. Send for our brochure: Hendersonville Hardwoods, PO Box 268, Hendersonville, NC 28793. For information call: 704/697-2929.

INSTRUCTION/EDUCATION

BE AN ELECTRICIAN. Train at home for an exciting new career with ICS-Accredited Member of the Distance Education and Training Council. Call today for free information with absolutely no obligation: 1-800/595-5505, ext. 1198.

BE A LOCKSMITH. Train at home for an exciting new career with ICS-Accredited Member of the Distance Education and Training Council. Call today for free information with absolutely no obligation: 1-800/595-5505, Ext. 1113.

MUSIC/SUPPLIES

PLANS, KITS, SUPPLIES for musical instruments: harps, dulcimers, psalteries, banjos, guitars, more. Musicmaker's Kits, Dept. B97, PO Box 2117, Stillwater, MN 55082. 612/439-9120.

PLANS/KITS/PATTERNS

LOOKING FOR SOMETHING COMPLETELY DIFFERENT? Unique Scrollsaw designs based on original artwork. All skill levels. Send \$1.00 for information: Drew Phillips, PO Box 4384, Carson, CA 90749.

CORNER SHELVES, FOOTSTOOLS, SHADOWBOXES! Complete kits, easy assembly! Color brochure \$2.00, circle shelf \$9.99 delivered! Craftkits-W, 122 Homing Road, Palatine Bridge, NY 13428.

WOOD PLANS, PATTERNS. Over 50 years of plans, some scroll, desk. Send \$6.00: George Rochier, 2101 Jean, Springdale, AR 72762.

THE FRAMER: Our company has a newly designed and patent pending product that can easily be constructed of available hardwood. This product will provide any woodworker, using a table saw and a router, the ability to make picture frames, bulletin boards, or the framework for kitchen cabinets and doors, including the slotting for biscuit joinery. Plans and construction instructions are available now. For pricing and further information send \$2.00 to: The All Wood Co., Salem Bend Dr. P. O. Box 26520, Troutwood, OH 45426 / 937-837-0252. Allow 2-3 weeks for delivery.

TOOLS/EQUIPMENT

CUSTOM BRANDING IRONS - Any logo, design, signature. Absolutely lowest custom prices. VISA/MC. Brochure \$1.00: BRANDNEW, 6125 Pederal, Goleta, CA 93117.

DRY YOUR OWN LUMBER. Ebac's user friendly dry kilns 200BF-40,000BF. Mix species in same load. Great 3-year warranty. Over 6000 systems worldwide. Call Today. 1-800/433-9011.

BAND SAW BLADES: Low Tension Swedish Silicon Steel "TIMBER WOLF" Bands. 1/16" thru 1 1/4". FREE CATALOG 1-800/234-7297. Email-timberwolf2@worldnet.att.net HOME PAGE - timberwolf1.com

SAWMILLS

CALL SAWMILL EXCHANGE to buy/sell used portable sawmills (Wood-Mizer, TimberKing, etc.). Also, "Portable Sawmill Encyclopedia," only \$14.95! 205/969-3963. <http://www.sawmill-exchange.com>

WOODTURNING

NEWSPAPER FOR TURNERS, monthly, \$30.00/year, \$3.75/Sample, VISA/MasterCard Accepted. MORE WOODTURNING, 950 South Falcon, Camano Island, WA 98292.

**ATTENTION
CLASSIFIED ADVERTISERS**

Now you can reach over 1,100,000 responsive woodworkers and do-it-yourselfers in the **WOOD® Classified Mart** section.

The next closing date is **June 7, 1997** for the September 1997 issue.

For rates and information call:
1-800/424-3090 • Fax: 312/464-0512
or write

WOOD® Classified Mart
500 N. Michigan Avenue • Suite 2010
Chicago, IL 60611

GRAND HUMIDOR

Continued from page 51

NOTE: If you are not constructing the box for use as a humidor, skip the next section. Start again at "Wrapping up the details."

Add the accessories

1 To complete the box as a humidor, first cut the hygrometer base (G) to size. At the center, bore a 1 3/8" hole through the block. We gripped the block with a handscrew clamp while we bored the hole with a Forstner bit chucked in a drill press. Chamfer the ends and edges on one face.

2 Center the block inside the lid, and mark the position. Glue and clamp the block in place.

3 Hold the humidifier bracket against the bevel on the inside of the lid where shown, and mark the screw holes. Drill pilot holes for the bracket screws. Insert the lid supports in their mortises, drill the 3/32" pilot holes, and remove the supports.

4 Cut two pieces of 3/16"-thick Spanish cedar to fit inside the bottom of the box. You do not need to edge-glue the pieces.

5 Rip and crosscut four pieces of the same material to the width shown and slightly longer than the length shown for the side and end liners (I, J). Miter-cut the pieces to fit snugly inside the box. Rout a 1/8" round-over on the top outside edges.

Wrapping up the details

1 Apply a clear finish overall. We put on two coats of Deftoil Classic Danish Oil Finish, clear natural. Our method: Apply a heavy first coat and let it sit, touching up any spots that dry or become dull. When the finish starts to thicken, wipe it off. Let the parts dry overnight, then rub out with a gray Scotch-Brite pad. Apply a sec-

ond coat, wipe it off when it starts to thicken, and let dry overnight. Rub out the second coat with a white Scotch-Brite pad.

2 Press the hinges into the holes in the body, aligning them carefully. (They can be difficult to remove for resetting once installed.) Place the holes in the lid over the hinges, and press the lid straight down until the hinges seat in the holes. Tighten the hinge setscrews.

3 Install the lid supports in the body mortises, and drive in the screws. Spread a small amount of epoxy inside the 1/4" holes in the lid, then press the support-arm ends into them. Carefully clean up any glue squeeze-out.

4 If you're making a humidor, press the hygrometer into the mounting block. Screw the humidifier bracket into place, and snap the humidifier into it.

5 Lay the bottom liner (H) in the box; gluing isn't necessary. Slide the end and side liners into place. Again, no glue is needed. If the Spanish cedar lining has a strong odor when you install it, leave the box open for a while to let it air out. Too much cedar odor, those in the know tell us, could impart unwanted flavor to cigars stored in the humidor. ♣

Buying Guide

Veneer. Carpathian elm burl veneer, 3 sq. ft., item V16. Call for current price. Constantine's, 2050 Eastchester Road, Bronx, NY 10461, 800/253-8087.

Hardware. Invisible hinges, item 27C11 (order 2); mortised lid supports, item 16B34 (order 2); 50mm hygrometer, item 125111; humidifier, item 125113; Spanish cedar, item 125872 (order 3). Call for current prices. Woodcraft, P.O. Box 1686, Parkersburg, WV 26102-1686, 800/225-1153.



Inkra scores again with its precision steel rules

Have you ever struggled to draw closely spaced parallel lines on a board? Or maybe you've become frustrated while trying to transfer a mark accurately from the edge of a board to an adjoining surface. Let me introduce you to some relief for these headaches courtesy of Taylor Design Group, the Incra Jig folks.

Made from ultra-thin stainless steel, the products shown at *right*—the T-rule, bend rule, pocket rule, and marking rule—all feature precision, engraved scales that help you mark and measure with incredible precision. At each dimension there's a slot and a hole. You select the proper slot or hole, insert a 0.5mm mechanical pencil, and mark the measurement with dead-on accuracy.

While the other rules work fine on flat surfaces, the unique bend rule shines when it comes to marking two faces of a board at once. It has slots every $\frac{1}{16}$ " that wrap around the 90° bend, and

make it virtually impossible to mismark your workpiece.

Except for the 3×2" pocket rule, all the rules come in 6-, 12-, and 18-inch lengths. You can buy any of the rules separately or in a three-piece set that includes the T-rule, bend rule, and marking rule for the three lengths listed.

—Tested by Dave Henderson

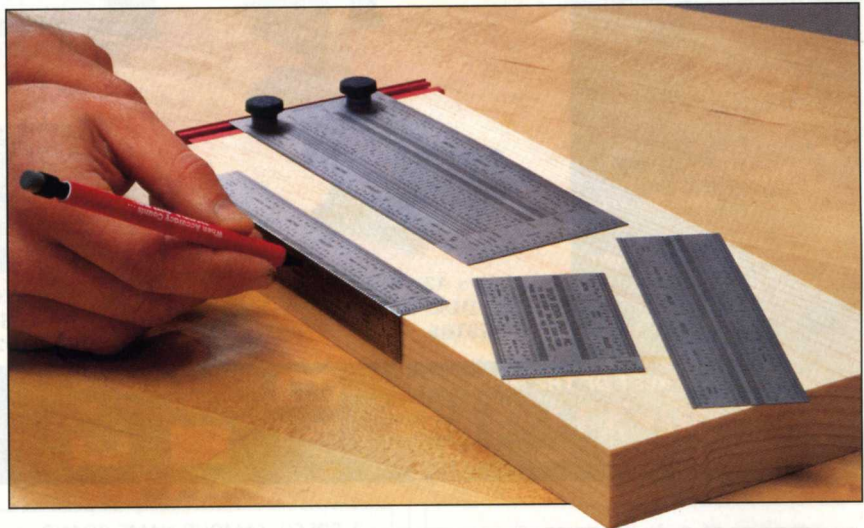

PRODUCT SCORECARD

Inkra Rules

| | |
|-------------|-------------------------|
| Performance | ★ ★ ★ ★ ★ |
| Price | \$47.95 for 6" set of 3 |
| Value | ★ ★ ★ ★ ☆ |

Taylor Design Group, Inc., P.O. Box 810262, Dallas, TX 75381. Call 972/484-5570.

Sears benchtop drill press also an oscillating spindle sander

Oscillating spindle sander attachments have been available as drill press accessories for some time. But a new benchtop drill press from Sears comes with the oscillating action and a sanding table built right in.

As a drill press, the Craftsman Model 21331 comes equipped



with a $\frac{1}{2}$ " keyed chuck, and five speeds ranging from 620 to 3,100 rpm. The maximum distance between the chuck and table measures 8½" and the machine has a 4¼" throat depth (distance from column to table center).

To convert to spindle-sanding mode, you install a rubber O-ring belt between an extra pulley on the drill spindle and the oscillation mechanism, as shown at *left*. This set-up also keeps the oscillations—ranging from 13 to 62 strokes per minute—matched to the speed of the spindle to help prevent glazing of the sandpaper.

Sanding with a $\frac{1}{2}$ "-diameter sanding drum, I found the machine performed well. However, I needed to use lighter pressure when sanding with a 2" drum, to allow the return spring to fully retract the quill. I measured the stroke at just over $\frac{5}{8}$ "—adequate for most spindle sanding.

The 6¼"×6½" cast-iron drill press table has a 2⅜" hole that accepts 1", 1⅜", and 1⅞" spacer rings. The rings fit snugly and flush with the tabletop. A 2" dust-collection port accepts standard shop vacuum hoses.

The table spacer rings and sanding drums store in the cast-iron base. The 21331 accepts optional 4½"-long spindle-sanding drums—available from Sears for \$3.99-\$9.99—up to 2" in diameter. The $\frac{1}{3}$ hp motor has ample power for both drilling and sanding operations.

—Tested by Bob McFarlin

PRODUCT SCORECARD

Sears Craftsman model 21331 8½" Multifunction Drill Press

| | |
|-------------|-----------|
| Performance | ★ ★ ★ ★ ☆ |
| Price | \$159.99 |
| Value | ★ ★ ★ ★ ★ |

Available at Sears stores nationwide. Call 800/377-7414.

Continued on page 97



Continued from page 94

The POWERPLATE performs many feats

When I first saw this product and its \$69.95 price tag, I thought to myself, "Can a 3/8"-thick piece of acrylic that measures 8x17", plus a couple of ball handles, possibly be worth that much?" But that was before I started working with it. Now, I'm convinced that it's worth the money.

The POWERPLATE extends the versatility of your router in several ways. The large plate gives you lots of control, particularly with the router mounted over the off-set hole for edge-routing.

I especially appreciate the two screw-in mortising pins that thread into both sides of the center hole, as shown *below*. With these in place, I accurately mortised boards up to 3" wide.

The POWERPLATE also helps you cut 6- to 24-inch circles in 1/8" increments, cut dadoes and grooves, duplicate shapes, and trim wooden parts flush.

Too complicated, you say? I've got good news for you. It comes with mounting instructions, a positioning template, and a video showing the POWERPLATE performing all of its operations.

—Tested by Bob McFarlin

PRODUCT SCORECARD

8-in-1 Router POWERPLATE

| | |
|-------------|-----------|
| Performance | ★ ★ ★ ★ ☆ |
| Price | \$69.95 |
| Value | ★ ★ ★ ★ ☆ |

America's Best Tool Co., P.O. Box 203, West Milton, OH 45383. Call 513/698-4317.

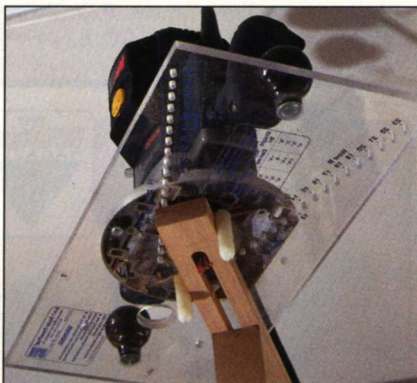

Continued on page 98

STEVE WALL LUMBER CO.

Quality Hardwoods and Woodworking machinery For The Craftsman and Educational Institutions

| | | | | | |
|----------------------|-----|---------|------|--|---------|
| Ash | 4/4 | Select | 2.15 | | \$73.00 |
| Basswood | 4/4 | Select | 1.80 | | \$59.00 |
| Birch | 4/4 | Select | 2.25 | | \$75.00 |
| Butternut | 4/4 | 1C | 2.00 | | \$65.00 |
| Cherry | 4/4 | Select | 3.40 | | \$92.00 |
| Hickory - Pecan | 4/4 | Select | 1.85 | | \$67.00 |
| Mahogany (Genuine) | 4/4 | Select | 3.60 | | \$92.00 |
| Maple (Hard) | 4/4 | Select | 2.50 | | \$77.00 |
| Maple (Soft) | 4/4 | Select | 1.80 | | \$65.00 |
| Poplar | 4/4 | Select | 1.55 | | \$60.00 |
| Red Oak | 4/4 | Select | 2.35 | | \$76.00 |
| Walnut | 4/4 | Select | 3.25 | | \$91.00 |
| White Oak | 4/4 | Select | 2.35 | | \$75.00 |
| Cedar (Aromatic Red) | 4/4 | 1C+Btr. | 1.60 | | \$62.00 |
| Cypress | 4/4 | Select | 2.15 | | \$70.00 |
| White Pine | 4/4 | F.G. | 1.10 | | \$51.00 |
| Yellow Pine | 4/4 | Clear | 1.60 | | \$61.00 |

Above prices are for 100' quantities of kilndried rough lumber sold by the Bd. Ft. FOB Mayodan, NC. Call for quantity discounts. Other sizes and grades available.

Above prices are 20 bd. ft. bundles of clear kilndried lumber 3"-10" wide x 3'-7' long (Random widths & lengths) Surfaced 2 sides or rough. Delivered UPS prepaid in the Continental U.S.

Circle No. 592

CUSTOM CABINET DOORS
Custom Raised Panel Doors and 1 Piece MDF Now Available.

4/4 Log Run Walnut
100 Bdft. \$145

STEVE H. WALL LUMBER CO.

BOX 287
MAYODAN, N.C. 27027
910-427-0637
1-800-633-4062
FAX 910-427-7588

Send \$1.00 For Lumber Catalog



Introduces

The New Improved T50[®] Staple Gun Tacker

All Steel Construction.
Long-Lasting Reliability.
Hard-Driving Power.
And Now...



Easier to Squeeze THAN EVER BEFORE!

Beneath the T50's solid steel housing is ARROW's most advanced double leverage mechanism. That's why it's now designated the T50[®]P and why this new, improved powerful staple gun tacker is easier to squeeze and so comfortable to use.

The ARROW T50P has no plastic parts. It's all steel.

It is built to deliver years of trouble-free performance with no loss of driving power.

You can rely on the T50P to tackle almost any job. And to add versatility to durability, ARROW's

T50P uses 6 different size staples: 1/4", 5/16", 3/8", 1/2", 9/16" and 17/32" Ceiltile.

All ARROW staple guns and staples are built in the USA under the strictest standards of quality assurance. *It's been that way for over 68 years!*

ARROW products are available at home centers, lumber yards, hardware stores and wherever fine tools are sold. You work hard for your money. So, spend it wisely. The all-steel T50P will last and last....



ARROW FASTENER COMPANY, INC., 271 Mayhill Street, Saddle Brook, N.J. 07663
ARROW FASTENER (U.K.) LTD., 14 Barclay Road, Croydon, Surrey CRO 1JN
JARDEL DISTRIBUTORS, INC., 6505 Metropolitan Blvd. East, Montreal, Quebec H1P 1X9

© 1997 ARROW FASTENER CO., INC.

One Stop Wood Shop

- Plywood & Veneer made to order (no min.)
- 30 species
- Custom Cutting
- Competitive Pricing
- We bundle & ship to U.S. & Canada
- Over 65 years of personal service

For catalog & quote: (617) 666-1340

Boulter Plywood Corp.

24-WD Broadway, Somerville, MA 02145

Where the finest cabinetmakers select & blend domestic & exotic hardwood in plywood, veneer & lumber.

WOOD

Circle No. 512

Having Fun Making Money...

A Dream Come True for Woodworkers.



For Keith Hone, a Utah native, making money and having fun go hand in hand. Using the new ultra high speed engraving technology developed by the Paragraphics Corporation, Keith can engrave beautiful designs on virtually any surface. The demand for this type of work is tremendous!

It's fast... and easier than you might think!

With an easy-to-use stencil system, you can transfer any design, artwork, or logo to any hard surface. By simply tracing lines using the Paragrave handpiece spinning at speeds of over 300,000 rpm, you can create beautiful carvings and engravings and the system does the work for you. It's that simple!



Call 1-800-624-7415 and get your demonstration video today to learn more about how you can make money and have fun too!

Paragraphics
CORPORATION

1-800-624-7415

Circle No. 2160

1455 W. Center Orem, Ut 84057

PRODUCTS THAT PERFORM



Continued from page 97

Rattleshake keeps spray paint all shook up

Have you ever gotten a sore arm trying to shake loose the mixing ball in a can of spray paint? I know I have, and that's why I was excited to find a product that offers a solution.

The Rattleshake spray can shaker consists of a two-piece canister. The bottom half contains a camshaft that attaches to a cordless drill. An acrylic cam rotates against the bottom of the paint can to push it up and down inside the canister. A spring in the top of the canister holds the spray can firmly against the cam. The rapid up-and-down action shakes up the paint inside the can.

You run the drill at slow speed (800 rpm or less), so a variable speed cordless drill works best. You need to hold it tightly because it really does shake.

I tried the Rattleshake on several cans of spray paint, including a partially used one that had sat on a shelf in my garage for a couple of years. I shook it by hand first, and the paint barely sputtered out. After a minute in the Rattleshake, the same can sprayed a fine, even mist with no sputtering. By salvaging such "unusable" spray paint, the Rattleshake quickly paid for itself. ♣

—Tested by Jan Svec

PRODUCT SCORECARD

Rattleshake spray can shaker

| | |
|-------------|-----------------------|
| Performance | ★ ★ ★ ★ ★ |
| Price | \$14.95 plus shipping |
| Value | ★ ★ ★ ★ ★ |

Doug Sharp Enterprises, P.O. Box 3907, Pagosa Springs, CO 81147-3907. Call 970/264-6755.



The Professional's Choice

Since 1935, Titebond® has gained a reputation of solving woodworkers' needs... and doing it first.

- 1st ready-to-use, liquid ground-hide glue
- 1st aliphatic wood glue for general applications
- 1st Type II water-resistant glue for exterior use

Today, Titebond offers a complete line for every woodworking application, introducing:

NEW! Titebond Polyurethane Glue

- Versatile—bonds almost anything
- 100% waterproof for exterior projects
- No-run, no-drip formula

To find out where you can purchase Titebond Glues, call our Technical Service Team at 1-800-347-GLUE.



ASK WOOD

Winning the war against rust

Some of my tools have developed a layer of rust on their cast-iron tables. How can I remove this corrosion, and how can I keep it from happening again?

—Tom Boyer, East Lansing, Mich.



You're not alone, Tom. Virtually everyone working in an unheated shop has to deal with this problem. Radically changing temperature and humidity levels cause condensation to form on cast-iron tabletops. To remove the resulting rust, try one of these two popular methods.

Some woodworkers remove the rust by using a few drops of machine oil and a steel wool pad. In our shop, Chuck Hedlund prefers to use a shop-grade Scotch-Brite

pad placed underneath an orbital sander. The Scotch-Brite pad doesn't leave a messy residue (like steel wool does), and it doesn't leave a layer of oil that might later transfer to your workpiece.

Have a question for our woodworking experts? Here's how to reach us.

No matter how simple or perplexing a woodworking problem you're faced with, we would love to hear from you. We'll do our level best to solve your mystery, and you might even find your question and our reply on this page. You can reach us either by letter or through your computer:

- **Letters:** Send your letter to Ask WOOD®, 1912 Grand Ave., Des Moines, IA 50309-3379.
- **E-mail:** Send your question to us at woodmail@woodmagazine.com
- **Internet:** Visit our home page and discuss your questions with other woodworkers by joining our discussion group at: <http://woodmagazine.com>

pad placed underneath an orbital sander. The Scotch-Brite pad doesn't leave a messy residue (like steel wool does), and it doesn't leave a layer of oil that might later transfer to your workpiece.

To preserve the surface, apply a coat of paste or liquid car wax in the same way you would to your car. The wax provides a temporary protective layer, and it reduces friction when you feed workpieces over the surface.

Continued on page 106

Econ-Abrasives

WE MAKE ABRASIVE BELTS ANY SIZE, ANY GRIT!

Standard Abrasive Sheets

CABINET PAPER

| | 50/pk | 100/pk |
|---------------|---------|----------|
| 60D | \$16.70 | \$30.00C |
| 80D | 15.60 | 27.80C |
| 100 thru 150C | 14.50 | 25.60C |

FINISHING PAPER

| | | |
|---------------|----------|----------|
| 80A | \$ 11.15 | \$18.90C |
| 100 thru 280A | 10.00 | 16.70C |

NO LOAD PAPER(white)

| | | |
|---------------|---------|----------|
| 100 thru 400A | \$12.25 | \$21.25C |
|---------------|---------|----------|

"C" = 100 SHEETS

Velcro® Vacuum Discs

8 Hole pattern for Bosch sanders

| Dia. | Grit | Price |
|------|--------------|---------|
| 5" | 60 | \$.48ea |
| 5" | 80 | .46 |
| 5" | 100 thru 320 | .45 |

* Available in 5 hole pattern *

*Wide Belts*Rolls*Flap Wheels
*Pump Sleeves*PSA Discs
*Router & Wood Bits*Wood Glue

*MasterCard, VISA, C.O.D. or Check

*SATISFACTION GUARANTEED!!!

*CALL FOR FREE CATALOG

- TX & NV add appropriate sales tax

- Continental U. S. shipping add \$5.50

ABRASIVE BELTS

Belts are resin bond cloth with a bi-directional splice, specify grits.

| | | | |
|----------|----------|----------|----------|
| 1X30 | \$.81 ea | 3X24 | \$.93 ea |
| 1X42 | .81 ea | 3X27 | .96 ea |
| 1X44 | .81 ea | 4X21 3/4 | 1.06 ea |
| 2 1/2X16 | .85 ea | 4X24 | 1.10 ea |
| 3X18 | .86 ea | 4X36 | 1.35 ea |
| 3X21 | .90 ea | 6X48 | 3.50 ea |
| 3X23 3/4 | .93 ea | 6x89 | 6.24 ea |

OTHER SIZES ON REQUEST

HEAVY DUTY SPRING CLAMPS

Clamps come w/PVC tips and grips.

| Size | Price |
|------|-----------|
| 4" | \$1.75 ea |
| 6" | 2.25 |
| 8" | 3.50 |

JUMBO ROUTER PAD(24" x 36")

It will not allow small blocks of wood to slip out under router or sanding applications. ROUTER PAD ONLY \$8.95ea.

JUMBO BELT CLEANING STICK ONLY \$8.80

Econ-Abrasives

P. O. Box W865021

Plano, TX 75086

(214)377-9779

TOLL-FREE ORDERING LINE (800)367-4101

Circle No. 1229

TORMEK for WOOD TURNERS

NEW PATENTED Fingernail Gouge Jig

... permits woodturners to select cutting edge angle and length of side bevel on bowl or spindle gouges.

Plus other jigs for ●Skew chisels ●Roughing gouges
●Parting tools ●Scrapers (curved or straight)

THE ONLY COMPLETE WATER COOLED GRINDING AND SHARPENING SYSTEM

● for plane irons, chisels, spoke shaves, planer/jointer blades, knives, scissors, axes, turning tools and carving tools.

For full information and nearest stockist:

| | | |
|-----------------|------------|----------------|
| United States: | TORMEK | 1-800-5-TORMEK |
| United Kingdom: | BriMaxc | 01926 493389 |
| Australia: | PROMAC | 07-3279-4811 |
| New Zealand | W & R JACK | 03-546-7479 |
| South Africa | RECORD | 011-422-2340 |



Circle No. 101

ASK WOOD

Continued from page 101

Don't give powder post beetles a free lunch

Recently, I've noticed dust under the beams in the building where I store my lumber, indicating that I might have a problem with powder post beetles. What should I do to rid myself of these varmints before my lumber gets infested? Will the treatment stain my lumber, making the cure as bad as the disease?

—Clarence Zimmerman, Petroleum, Ind.

To answer your question, Clarence, we spoke with Les Fergy of the Forest Products Laboratory in Madison, Wisconsin (phone 608/231-9200), and Dr. Donald Lewis, an entomologist at Iowa State University in Ames, Iowa. They explained to us that, like the termite, the powder post beetle lives just about everywhere.

Of the three varieties of powder post beetle (lyctids, anobiids, and bostrichids), each prefers a different kind of wood. For woodworkers, the lyctid variety presents the greatest danger because it prefers the open grain found in many of our favorite hardwoods such as walnut, oak, hickory, and ash. Yet powder post beetles don't care much for tighter-grained woods, such as hard maple, because the beetle works by laying its eggs in the pores of the wood.

When the larvae hatch, from one to five years later, they begin chewing their way through the wood, leaving behind the telltale powder from which their name springs. The larvae thrive on the high starch content found in sapwood, so the heartwood usually doesn't suffer the same shotgun-like damage. And, as lumber ages and the starch content goes down, it becomes less desirable. After about five years, the beetle will consider your wood an empty wasteland with nothing to eat.

To avoid powder post beetle problems, start by buying kiln-dried lumber. Drying at temperatures above 120°F kills any eggs or larvae already in the wood. Also be sure to store the lumber in a space where it will remain dry, ventilated, and at least 12" off the ground. If you suspect you already have beetle problems, call an exterminator to treat the area with a borate solution, such as Bora-Care or Tim-Bor, before storing lumber. These insecticides are nontoxic to mammals, and any staining that might occur should be superficial and easily removed by planing and sanding.

Continued on page 108

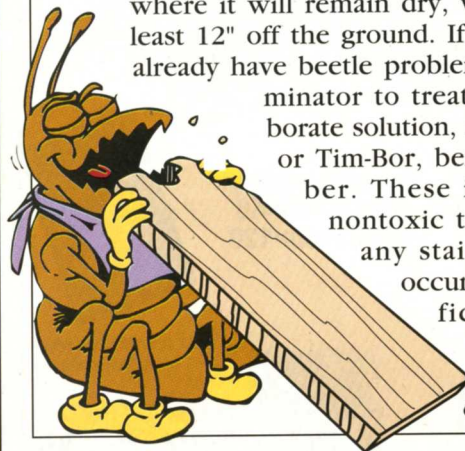

ASK WOOD

Continued from page 106

What's blind about a blind dado?

I am building a bedroom chest that calls for blind dadoes where the drawer guide frame assemblies join the sides. Unfortunately, the plans (not WOOD® plans) don't show a blind dado, or explain why I should use it instead of a regular dado. Can you help me?

—Elmer Glasmeier, Cincinnati, Ohio

We sure can, Elmer. Blind dadoes, also known as stopped dadoes, serve several purposes. First, stopping a dado eliminates having to worry about chipping problems at exposed dado ends. But more important, a stopped dado makes it possible for the joints to have the clean lines of a simple butt joint while providing the strength of a dado.

Basically, a stopped dado stops short ($\frac{1}{2}$ -1") of going all the way across the material. To make the mating piece fit into a stopped dado, you need to remove material equal to the depth of the dado and the length of the stop. If the dado has a depth of $\frac{1}{4}$ ", and the stop is 1" long, the mating piece needs a $\frac{1}{4}$ "x1" shoulder cut. If you make the dado with a router, don't worry about shaping the mating piece to fit the dado exactly. However, if you

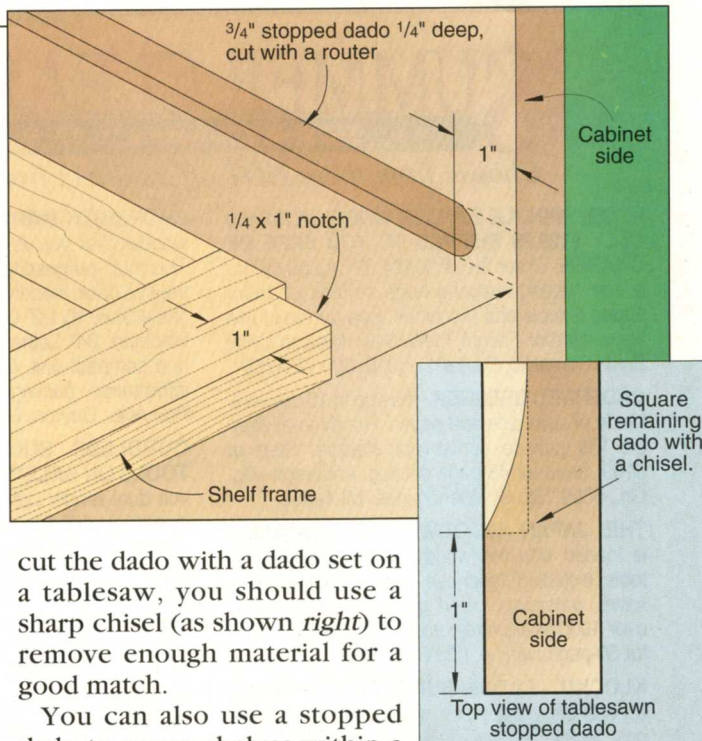

cut the dado with a dado set on a tablesaw, you should use a sharp chisel (as shown right) to remove enough material for a good match.

You can also use a stopped dado to recess shelves within a carcass. This technique is helpful when the project calls for recessed doors or even because you think the project will just plain look better. ♣

If you were stranded on an island... What is the one machine you couldn't live without? The X3!

Gilligan would have made it back to civilization sooner, if he had our X31 Combination machine.

- 38" Rip Capacity Saw
- 10" Table Saw
- 50" Cross Cut
- Mortiser

- 20 seconds to change functions
- 12" Jointer/Planer
- Cast Iron Tables
- Three 3HP German Motors
- 3HP Reversible Shaper

Don't get left stranded in the sand...call (800) 234-1976 today, for your FREE demonstration video.

LAGUNA TOOLS

2265 Laguna Canyon Road • Laguna Beach CA 92651
800-234-1976 • FAX 714-497-1346 lagunatools@earthlink.net

Circle No. 615

CHOICE OF PROS NOW AVAILABLE AT 40% LESS!

THE NEW WAGNER L609
MOISTURE METER...



L 4.5" x
W 2.75" x H 1.0"

- Pin-Free Narrow Sensor Deep Penetrating
- Features Wagner's Proven electromagnetic wave Technology
- Accuracy Verified by Independent Studies

Our Lowest Price Was: \$225

Now: **\$129**

WAGNER
ELECTRONICS

"The Choice of the Pros"

1-800-581-3301

326 Pine Grove Road
Rogue River, OR 97537
Phone: (541) 582-0541 Fax: (541) 582-4138

© 1997 Wagner Electronic Products, Inc.

Circle No. 1285

Shops • Garages • Storage

**Buy Manufacturer Direct -
SAVE THOUSANDS!**

Limited Offer



30'x36' \$8,555 Value
NOW \$4,379

36'x48' \$13,400 Value
NOW \$6,855

- Easy Do-It-Yourself Construction
- Toll Free Technical Support
- Immediate Delivery or Free Storage

Pkgs. include steel frames & endwalls,
sheeting & trim. Some other sizes available.

 **MIRACLETRUSS®**

1-800-843-8275

FAX 612-544-1835

WOOD

HOW TO CUT PERFECT ARCHES

Chuck Hedlund, *WOOD*® magazine's project builder, makes easy work out of cutting arches, using the process shown here. It'll work for you, too.



After laminating and marking the arcs on the arch blank as described on page 54, carefully bandsaw just outside the marked line on the outside arc of the blank as shown in Photo A. Save at least one section of scrap—you'll use it later. Now, carefully sand to the line with a disc sander or portable belt sander to finish forming the top of the arc.

Clamp a piece of the scrap to the top surface of your bandsaw table.

Position and clamp the scrap to the bandsaw table so the bandsaw blade aligns with the inside marked arc on the arch blank as shown in Photo B.

Now, as shown in Photo C, slowly feed the blank into the blade, holding the top arched edge against the curved scrap piece. Keep these two pieces flush while cutting the entire bottom edge of the blank. Finally, sand the bottom edge of the blank smooth. ♣

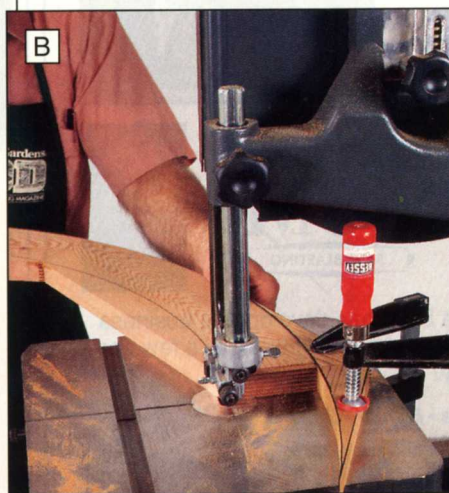

WOOD TOY



- ★ Patterns
- ★ Parts
- ★ Wheels

★ Many New
Patterns to
Choose
From.



- ★ Executive
Toys

SEND \$1.00
FOR NEW
CATALOG



toys and joys

Box 628w
Lynden, Wash. 98264

Sound sources for special stock

Good Wood Alliance



The massive conversion of tropical hardwood forests to other uses threatens the very existence of some exotic species (such as Brazilian rosewood), according to John Shipstad, a Coos Bay, Oregon, professional furnituremaker and board member of the Good Wood Alliance. That's because natural reforestation is interrupted, and the favorable conditions that certain species require no longer exist.

But John and hundreds of other woodworkers, wood and tool suppliers, and manufacturers believe there's a solution: Good Wood. That's what they call wood from a certified source—whether in the U.S. or elsewhere—that ecologically manages the forest for a continual supply of wood. Some species from these sources may be familiar, such as good old sugar maple from Menominee Tribal forests in Wisconsin. Many others from the tropics, such as the two species shown below, are practically unknown outside their native land.

You'll find these species and more, and their suppliers, listed in the "Good Wood Directory." For a copy of the 32-page publication, send \$10 (includes postage) to: Good Wood Alliance, 289 College St., Burlington, VT 05401. Or, send \$25 for annual membership and you'll get a free directory as well as the quarterly journal *Understory*.

Katalox, far left, and the wood called machiche are Good Wood species that come from Quintana Roo, Mexico.



Photographs: Rich Shelton; Dean Tanner; Mary Sue Traynelis

Treated wood on wheels

For group activities, most car clubs stage caravans, fund-raisers, and rallies. But the Rollin' Oldies car club of Oskaloosa, Iowa, chose to do something quite different last year. Members pooled their variety of talents to create a 1930s Ford pickup—of sturdy, CCA-treated wood!

Their project, above, took a bit more than 14 weeks to build. And except for wheels, tires, and steering wheel, it's all wood. After display at different affairs



The Rollin' Oldies car club of Oskaloosa, Iowa, built this wooden pickup from over 600 board feet of treated wood and 10 pounds of screws.

and parades around the state, the wooden pickup found a permanent parking place at Oskaloosa's Edmunson Park, where the city's children now clamber over it.

Woodworking piece by piece

Without a doubt, Californian Robert Traynelis has developed a highly unique form of woodworking, along with lots of patience. Over the last six years, he has refined a process for creating mosaics that requires hundreds of tiny pieces of wood, each glued down to form intricate pictures of people and places.

Bob's mosaics began as a way to utilize the scrapwood he generated in his Cupertino woodworking shop. "Now, I have to go around and collect scrapwood from other sources," he laughs.

At local woodworking shows, his wooden "canvases" always draw a crowd, and he sometimes demonstrates. Requests for classes—and even kits—keep mounting. "I'm finding out that there's a pretty big audience for this type of detailed project," Bob adds. ♣



"Ballet" measures 16x20" and required about 500 pieces of wood and 30 hours.



Robert Traynelis collects and uses pieces of native and exotic woods to render the different colors in his large mosaics.

Better Homes and Gardens®

WOOD PATTERNS™

Full-sized for your woodworking convenience

AUGUST 1997

ISSUE 98

Dear Reader: As a service to you, we've included full-sized patterns on this insert for irregular-shaped and intricate project parts. You can machine all other project parts using the Bill of Materials and the drawings accompanying the project you're building.

Looking Glass • Cigar Humidor • Garden Arbor

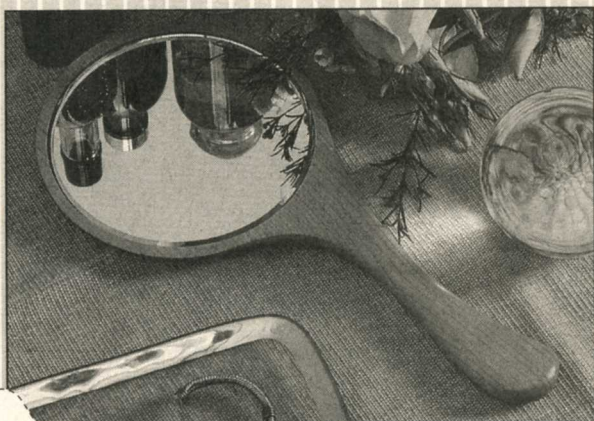

Page 44



Page 47

Page 52



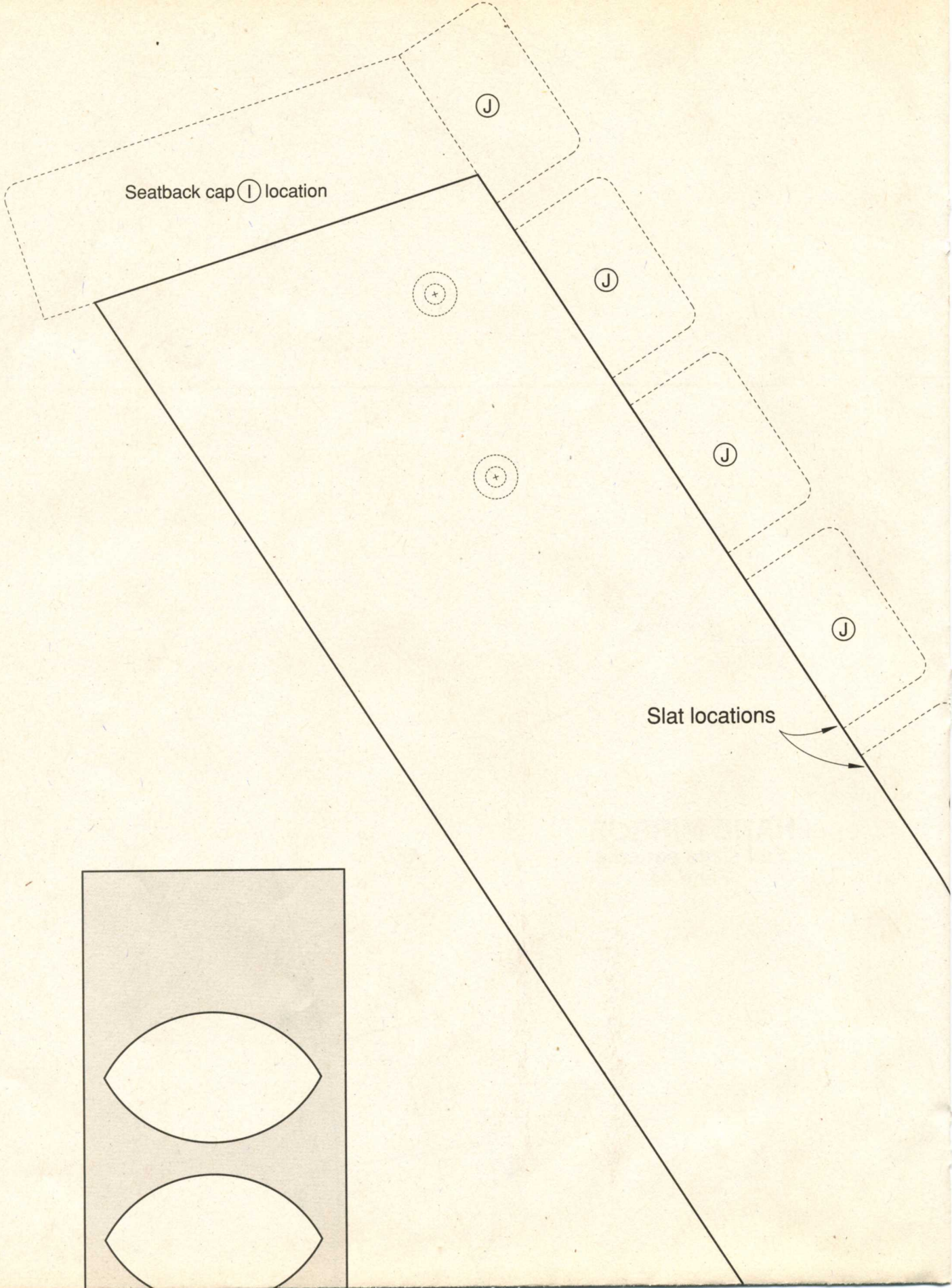

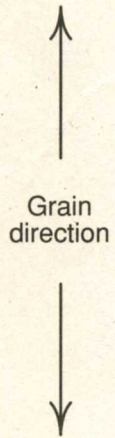
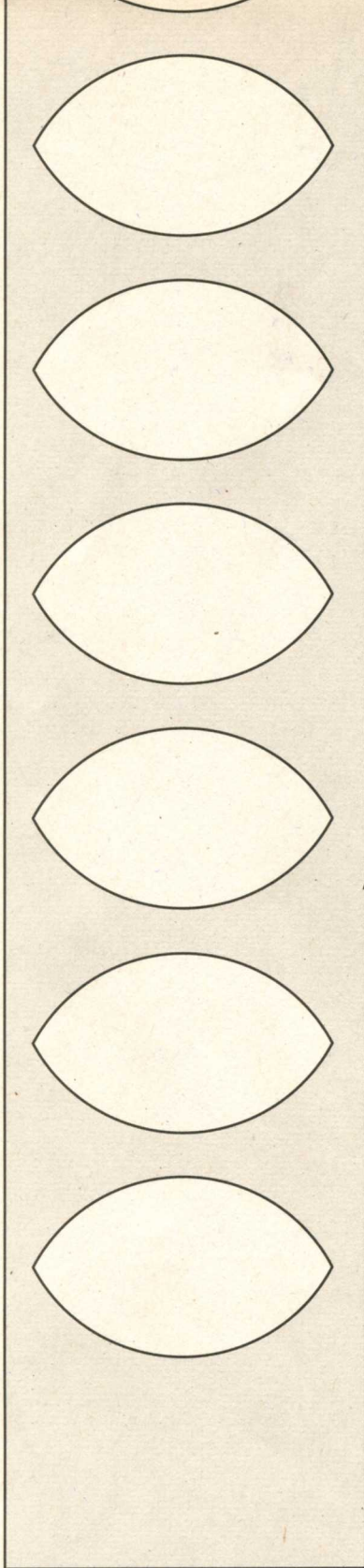

1/8" stock

**GRAND HUMIDOR
SPLINES**
Full-sized pattern
Page 47

GARDEN ARBOR
BACKREST SUPPORT ©
Full-sized pattern
Page 52

J

J

J

J

J

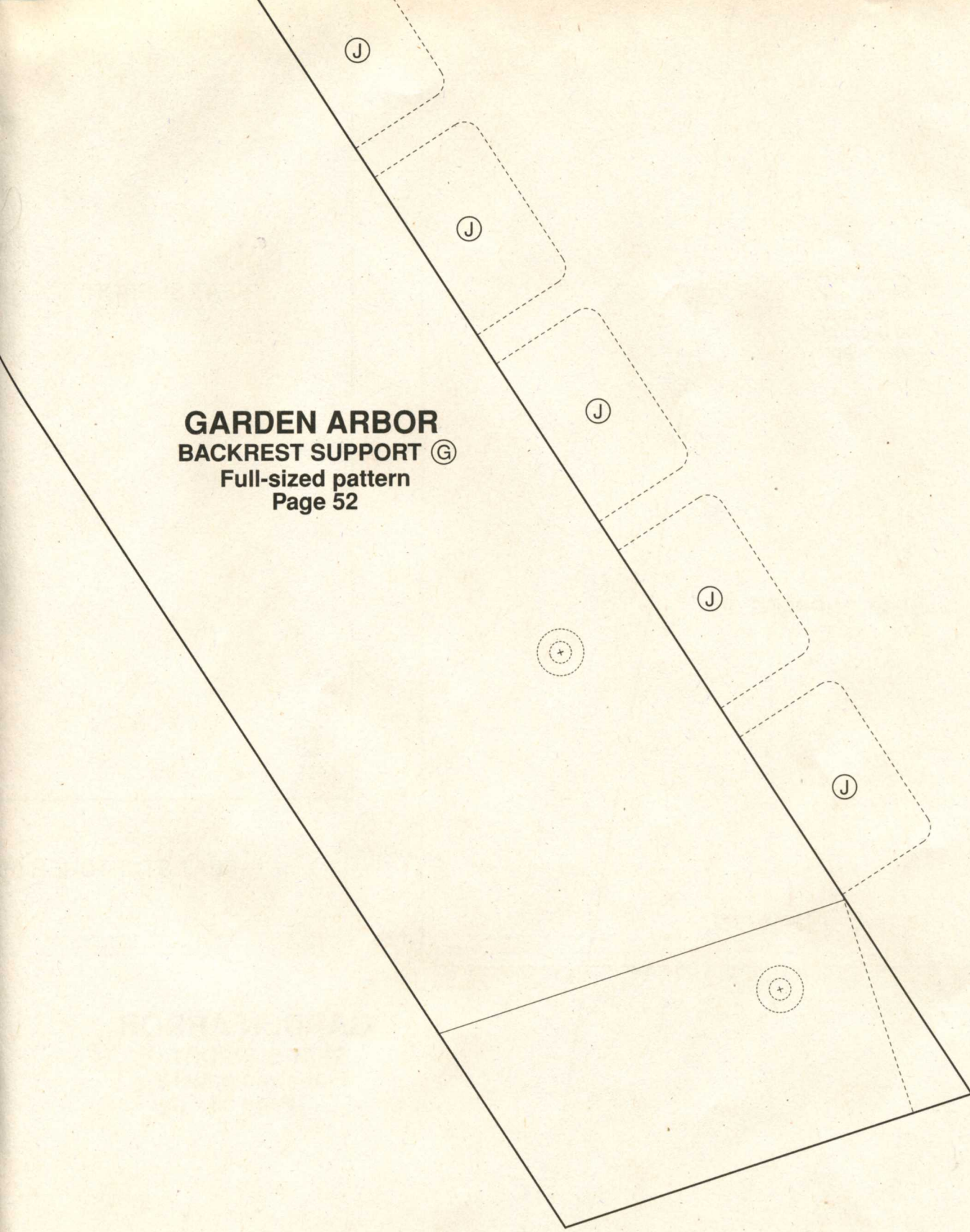

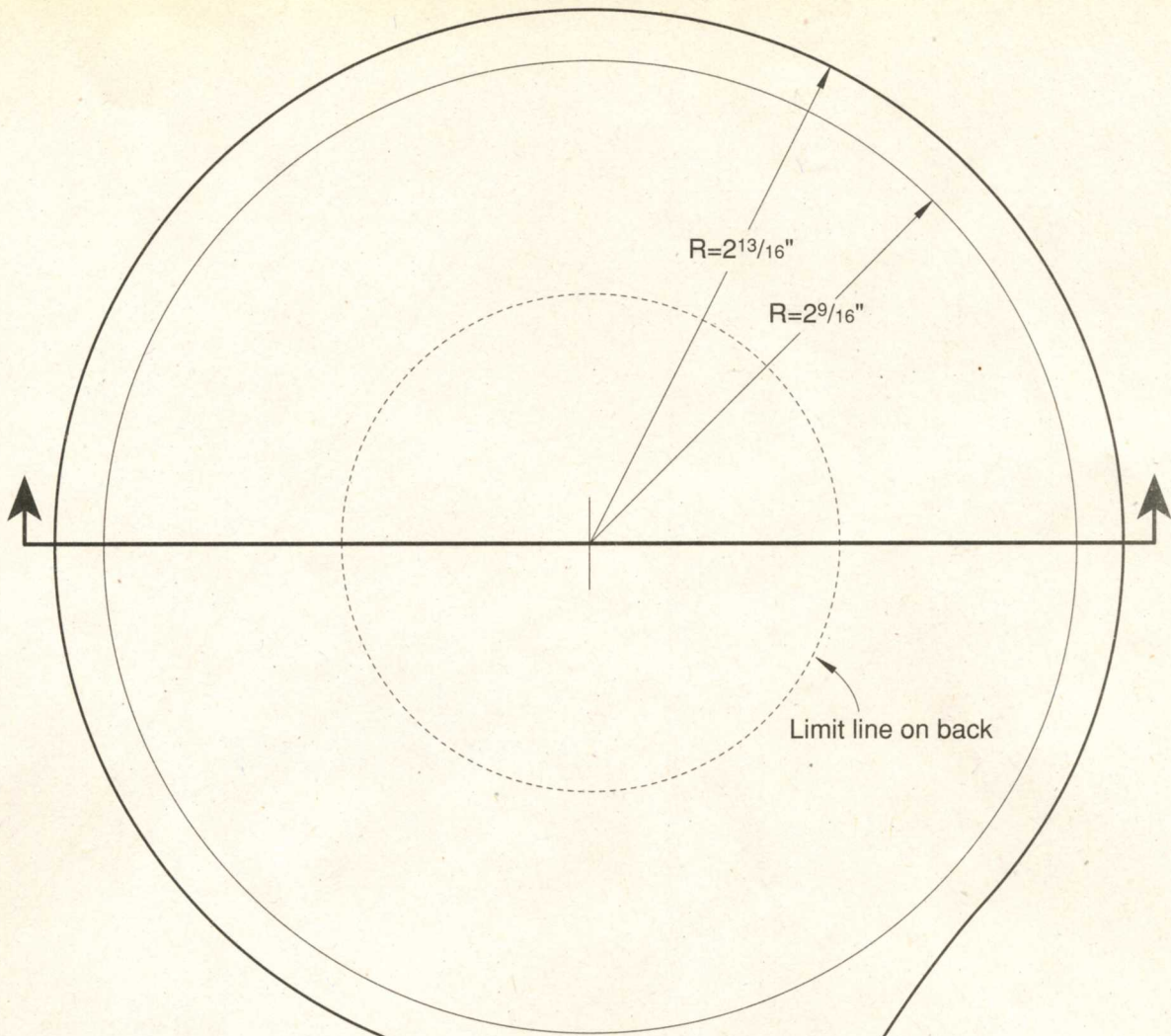

HAND MIRROR
Full-sized patterns
Page 44

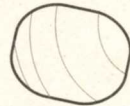
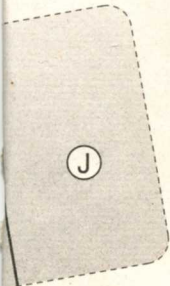

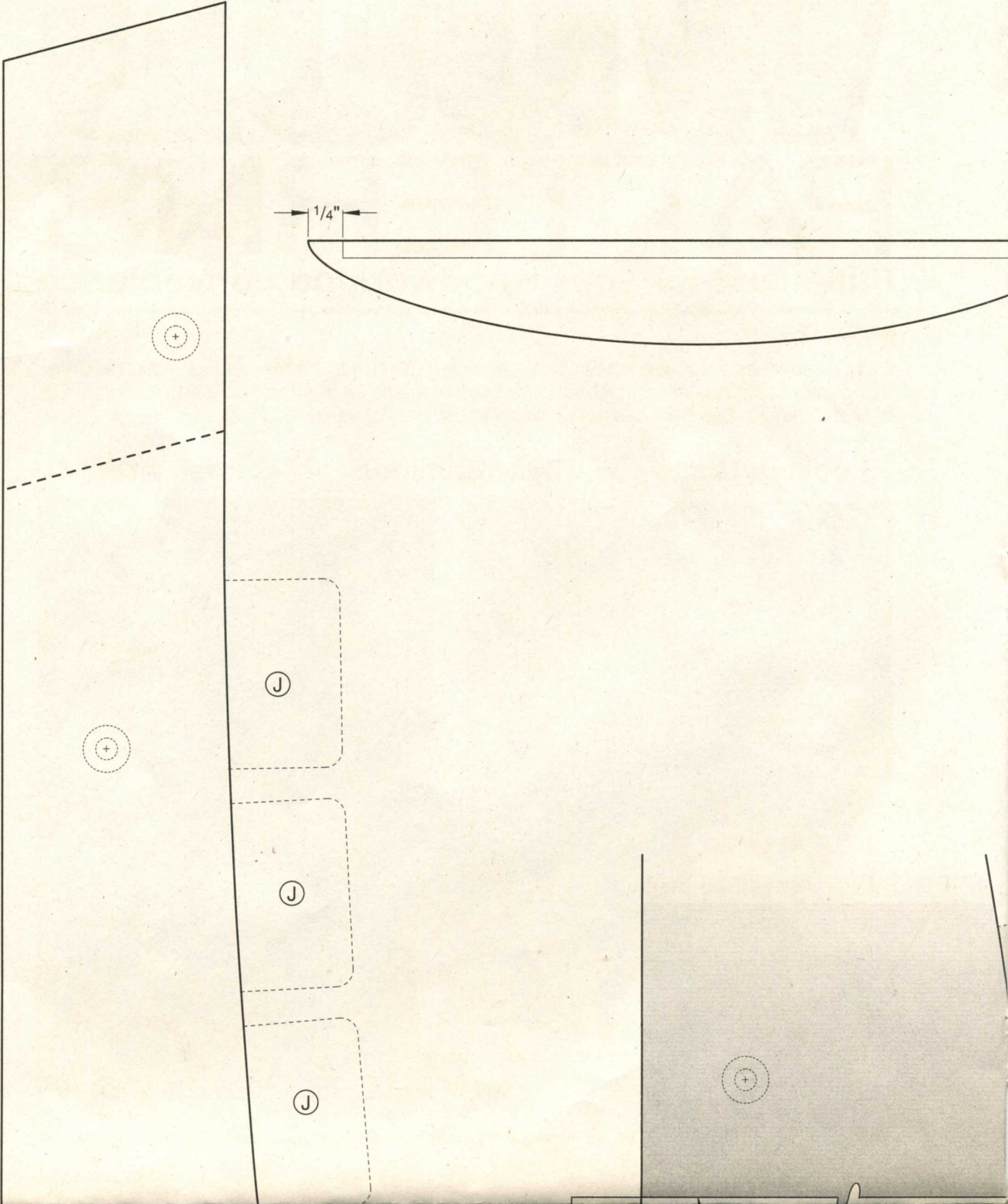

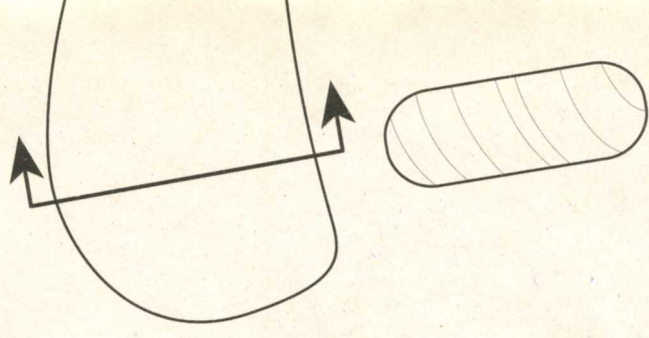
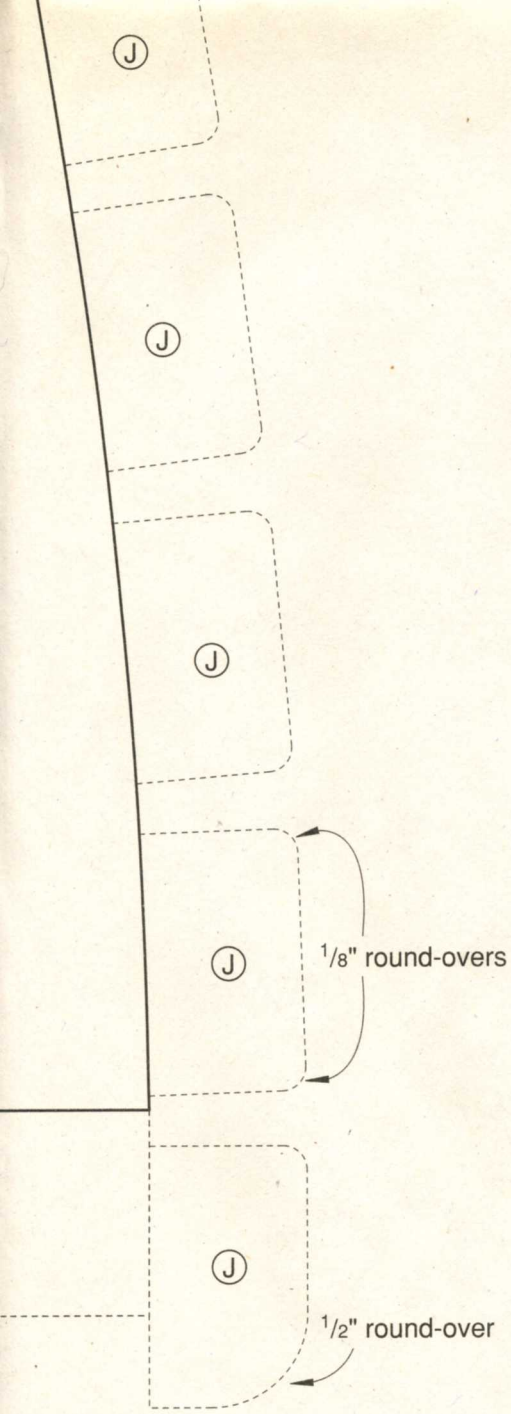

Slat locations

Join patterns here

5/32" shank hole,
countersunk on
inside face of
the two outside
seat supports

SEAT SUPPORT (F)

SEAT SUPPORT (F)

SEAT STRETCHER (H)

Join patterns here

GARDEN ARBOR
SEAT SUPPORT (F)
Full-sized pattern
Page 52

