

We put **10 moisture meters** to the test See page 66

WOOD[®]

ISSUE 127 October 2000

www.woodmagazine.com

Build this heirloom Shaker blanket chest

Page 60

3 workshop projects
to improve your skills

**Construct perfect
solid-stock panels** Page 43

Display until October 3

U.S.A. \$5.95





Bill Hug, the first guest expert in our new series of articles, really knows his way around the wood lathe.

a new article series we think you're gonna' like

Beginning with this issue, we're introducing a brand-new column titled "Be Our Guest (Expert)." To kick things off, we're featuring Bill Hug, a talented guy who has turned more than 5,000 vessels in the last 18 years, many of them using wonderful-looking exotic woods.

We thought that with all of Bill's experience, he'd be a natural to share some of his turning wisdom with you (and us). If you take a look at *page 18*, you'll find out what his seven favorite turning woods are as well as four types of woods that give him trouble. In addition, he lists woods that often give woodworkers a rash, and tells about several woods that start out beautiful, but then disappoint when they oxidize.

If you have expertise in a particular woodworking subject, or you know someone who has, write to "Be Our Guest (Expert)," *WOOD*® magazine, 1716 Locust Street, GA310, Des Moines, IA 50309-3023. We'd be glad to hear from you.



renew your subscription

and get five free project plans!

Those of you who have access to the Internet can now eliminate the hassle of mailing in a renewal notice and check each time you renew your subscription to *WOOD* magazine. Simply log onto www.woodonline.com and click SUBSCRIPTIONS. Upon renewing, you get to print five free downloadable project plans as a gesture of our appreciation.

When at *WOOD ONLINE*®, sign up for our bi-monthly newsletter filled with the latest online happenings and register for our monthly tool sweepstakes or our free downloadable woodworking plans. Finally, check out our online searchable *WOOD* magazine index for a complete listing of our projects, techniques, and tool reviews. ♣

Larry Clayton

Customer Service Information: For service on your subscription, including change of address, contact www.wood-magazine.com/service or call 800/374-9663. **Subscription mailing address:** *Better Homes and Gardens WOOD* magazine, P.O. Box 37439, Boone, IA 50037-0439. Please enclose your address label from a recent issue. **Editorial mailing address:** The Editor, *WOOD* magazine, 1716 Locust Street, GA310, Des Moines, IA 50309-3023. For questions for our editorial staff, questions about how to reach an advertiser, or to place an advertisement in our magazine call 800/374-9663. To order back issues call 800/346-9663. For article reprints, write to the editorial address and enclose \$5 per article.

WOOD®

OCTOBER 2000 • Vol. 17, No. 7 • Issue No. 127

Editor **LARRY CLAYTON**
Managing Editor **JIM HARROLD**
Assistant Managing Editor/Features **PETER J. STEPHANO**
Senior Design Editor **JAMES R. DOWNING**
Projects Editor **BILL KRIER**
Projects Editor **JAN HALE SVEC**
Products Editor **DAVE CAMPBELL**
Techniques Editor **JIM POLLOCK**
Shop Manager/Project Designer **CHARLES I. HEDLUND**
Assistant Design Editor/Project Builder **KEVIN BOYLE**
Production/Office Manager **MARGARET CLOSNER**
Administrative Assistant **SHERYL MUNYON**
Art Business Office Secretary **BARBARA HELPS**
Reader-Contact Specialist **BEN VONRUDEN**
Contributing Editors **KIM DOWNING, LORNA JOHNSON, ROXANNE LeMOINE, CARSON ODE, BOB McFARLIN, DAVE HENDERSON**
Contributing Craftsman **JIM HEAVEY**

Creative Director **DANIEL MASINI**
Assistant Art Director **CHERYL A. CIBULA**

Publisher **MARK HAGEN**
Advertising Director **WILL MURPHY**
Ancillary Sales and Internet Manager **MARLEN KEMMET**

Advertising Office: 333 N. Michigan Ave., Suite 1500,
Chicago, IL 60601 Phone: 312/853-2890 FAX: 312/580-7906
Direct Response Advertising **CAROLYN DAKIS**
Account Executive **YUWEI LEE**
Account Executive **RON GOLMINAS**
Advertising Manager **JIM HUGHES**
Marketing Manager **GERALLIE LEGASPI**
Sales Assistant **MARGARET TRAVIS**

Publishing Director **WILLIAM R. REED**

Advertising Services Manager **PAT HENDERSHOTT**
Consumer Marketing Director **LIZ BREDESON**
Associate Consumer Marketing Director **KATHI PRIEN**
Assistant Consumer Marketing Manager **DAVE HONOLD**
Business Manager **CRAIG FEAR**
Senior Product Manager **RICK GROW**

MEREDITH PUBLISHING GROUP

President **CHRISTOPHER M. LITTLE**
Vice President Publishing Director **JERRY WARD**
Creative Services **ELLEN DELATHOUER**
Manufacturing **BRUCE HESTON**
Consumer Marketing **KARLA JEFFRIES**
Group Sales **JERRY KAPLAN**
Operations **DEAN PIETERS**
Finance and Administration **MAX RUNCIMAN**



WILLIAM T. KERR, President and Chief Executive Officer

E. T. MEREDITH III, Chairman of the Executive Committee

©Copyright Meredith Corporation 2000
All rights reserved. Printed in the U.S.A.

Better Homes and Gardens® *WOOD*® magazine (ISSN-0743-894X) is published nine times a year in February, March, April, May/June, July/August, September, October, November, and December by Meredith Corporation, 1716 Locust St., Des Moines, IA 50309-3023. Periodicals postage paid at Des Moines, Iowa, and additional mailing offices. *Better Homes and Gardens* trademark registered in Canada and Australia. Marca Registrada en México. **ONE-YEAR SUBSCRIPTION PRICES:** U.S. and its possessions, \$27; Canada, \$39; other countries, \$47. Canada Post Publications Mail Sales Product Agreement No. 1369350. Canadian BN 12348 2887RT. **CANADIAN RETURN ADDRESS:** *Better Homes and Gardens WOOD* magazine, 2744 Edna Street, Windsor, Ontario, N8Y 1V2. **POSTMASTER:** Send address changes to *Better Homes and Gardens WOOD* magazine, P.O. Box 37439, Boone, IA 50037-0439.



this issue's highlights

WOOD® magazine

October 2000 Issue 127

www.woodmagazine.com

woodworking projects

- 16 great ideas: ball-drilling jig**
Use this simple project to bore perfectly centered holes in wooden balls.
- 54 sliding table add-on**
Improve your tablesaw's crosscutting capacity with this well-engineered workshop accessory.
- 60 Shaker-style blanket chest**
Create a family heirloom with this handsome, full-size storage piece. Features include eye-catching box joints, two accommodating drawers, and a wraparound profile molding along the base.
- 66 big-time box-joint jig**
Machine clean, accurate, box joints in large solid stock or plywood panels with this handy clamp-on router fixture.
- 74 clockwork under glass**
Apply your craftsmanship to this exquisite tall clock. Large glass panels framed in walnut provide a clear view of the brass movement within.
- 80 toy floatplane**
Take off with this classic design, then give your favorite junior pilot something to smile about.



page 74

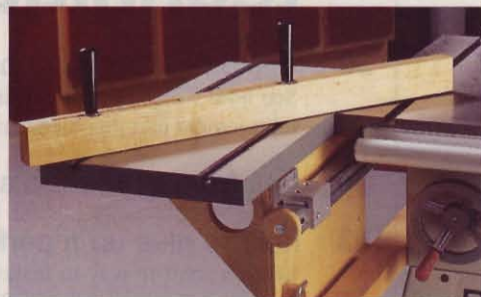

page 54



page 66



page 80

tools & materials

- 22 dovetail bits**
Rout snug-fitting dovetail joints with these special cutters.
- 70 dampness detectives**
Get an accurate reading on the moisture content of your hardwoods and softwoods with one of the 10 shop-tested meters found here.
- 86 quick-change artists**
Speed the process when changing drill bits by souping up your portable drill with one of these shop-tested add-on chucks.
- 90 products that perform**



page 86

Continued on page 6

This issue's cover wood grain: buckeye

Cover photograph: Baldwin Photography

tips & techniques

- 30** make new furniture parts from old
See how we copied an existing furniture part to make a new replacement part that blends right in.
- 34** tips from your shop and ours
- 43** how to glue up a perfect panel
Learn a surefire way to make long-lasting, solid-stock panels from contributing craftsman Jim Heavey.
- 68** how to cut large box joints
See how easy it is to rout sizeable box joints using the jig featured on *page 66*.



page 43

features

- 2** the editor's angle
- 8** talking back
- 14** business side of woodworking: wood-wide web
Discover the many ways in which the internet and having an online store can help you sell your hand- and machine-made goods.

page 84



- 18** insights from a woodturning master
Find out from an expert which turning woods work best.
- 20** WOOD ONLINE®
- 26** hot off the internet
- 49** segmented bowls from Sedona
See Arizona woodturner Galen Carpenter's approach for forming beautiful creations from wedges of wood.

- 84** masterful walking sticks
Meet five folk artists who began their craft by providing help for others.
- 97** wood anecdote: red alder
When this wood goes up in smoke, there's usually fish nearby.

112 finishing touches



page 68



page 49

Letters Comments And Updates

We welcome your comments, criticisms, suggestions, and yes, even compliments. We select and publish only letters of the greatest benefit to our readers. Write to:

Talking Back
WOOD magazine
1716 Locust St., GA310
Des Moines, IA 50309-3023

Mobile mitersaw center update

Several readers noted an error in the Bill of Materials for the Mobile Miter Saw Center in Issue 119. The thickness of the saw tables (Q) should be $\frac{13}{16}$ " as shown below.

Readers also have requested assistance in laying out the two sheets of plywood for this project. Here's a complete cutting diagram.

Part	Finished Size			Mater.	Qty.
	T	W	L		
Q saw tables	$\frac{13}{16}$ "	$10\frac{1}{16}$ "	$31\frac{3}{16}$ "	B/L	2

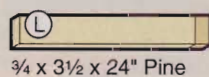

$\frac{3}{4}$ x $3\frac{1}{2}$ x 24" Pine

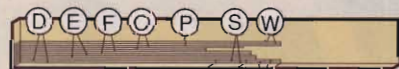

$\frac{3}{4}$ x $5\frac{1}{2}$ x 48" Birch

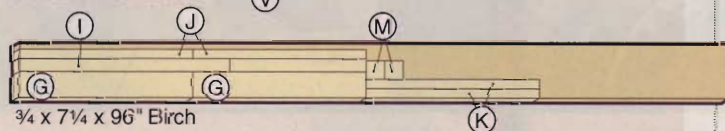

$\frac{3}{4}$ x $7\frac{1}{4}$ x 96" Birch

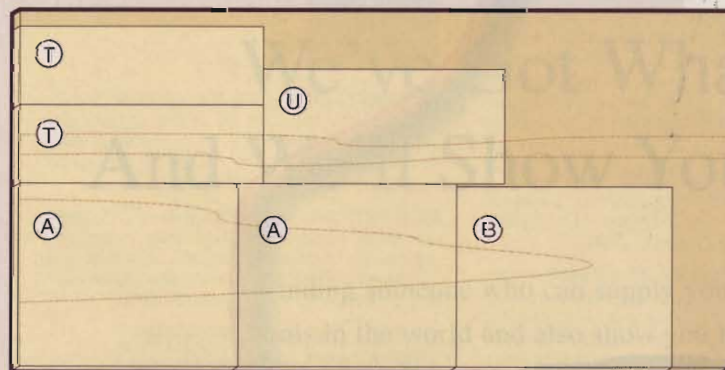

$\frac{3}{4}$ x 48 x 96" Birch plywood

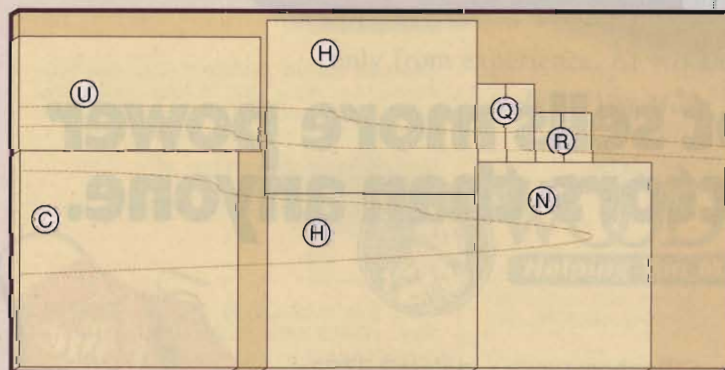

$\frac{3}{4}$ x 48 x 96" Birch plywood

A safer grooving cut

In building the Nesting Knockouts in Issue 121, I followed the directions as given except for cutting the slot groove in the rails (B). The rails for the small table are only $6\frac{3}{8}$ " long, and I was not comfortable passing these pieces over the dado insert on my tablesaw. I cut the grooves in all the rails first, using two $\frac{3}{4}$ x 2 x 24" pieces for the small table rails. After forming the grooves, I cut these pieces to length.

—Robert Mueller, Menominee, Mich.

Clock finish revealed

After receiving a number of inquiries, we asked Senior Design Editor Jim Downing to elaborate on the finish used on the maple Shaker tall clock kit he built in Issue 123. Here is his process.

Sand the wood with 150-grit sandpaper. Make 16 oz. of dye, mixing one part TransTint Dark Mission Brown no. 128486 and two parts TransTint Reddish Brown no. 128483, according to the directions. TransTint aniline dyes are available from Woodcraft, call 800/225-1153.

Thin 4 oz. of the dye mixture, 1 part dye to 3 parts water, and apply with a foam brush. This raises the grain and shows any glue smudges. Let the thinned coat dry overnight and sand with 220-grit sandpaper. Now coat the wood with the full-strength mixture, wiping up any excess dye with a clean rag. Let dry overnight and sand with 320-grit sandpaper. Finish with two coats of Olympic Antique Oil no. 41004, following the directions on the can. Let the finish dry for 24 hours, apply paste wax with 0000 steel wool, and buff with a clean cotton cloth.

MORTISE DETAIL (right rear leg)

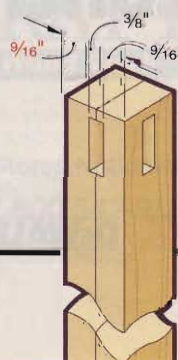

Table dimensions don't add up

A reader called to tell us that $\frac{1}{8}$ " went AWOL from the Mortise detail on the Nesting Knockouts in Issue 121. See the corrected detail at left.

Continued on page 12

The great metric debate, part two

With reference to Melvin Brzostek's letter in Talking Back, Issue 122, many people advocate use of the metric measurement system to facilitate mathematical manipulation. Conversions of measurements in inches are not a problem if you work in decimals and not fractions. It does not take much effort to become familiar with the decimal equivalents of fractions. You must think of dimensions in inches and deci-

imals, rather than inches and fractions, which are, by their nature, hard to manipulate.

—William Dettmer, Crescent, Ga.

Our designers know what you're talking about, Bill, because they use decimal equivalents when drawing with their CAD program. Here's the conversion chart they keep handy.

DECIMAL AND MILLIMETER EQUIVALENTS													
4ths	8ths	16ths	32nds	64ths	Decimal	Millimeters	4ths	8ths	16ths	32nds	64ths	Decimal	Millimeters
				1/64	.0156	.397					33/64	.5156	13.097
			1/32		.0312	.794				17/32		.5312	13.494
				3/64	.0469	1.191					35/64	.5469	13.891
		1/16			.0625	1.588			9/16			.5625	14.288
				5/64	.0781	1.984					37/64	.5781	14.684
			3/32		.0938	2.381				19/32		.5938	15.081
				7/64	.1094	2.778					39/64	.6094	15.478
	1/8				.1250	3.175		5/8				.6250	15.875
				9/64	.1406	3.572					41/64	.6406	16.272
			5/32		.1562	3.969				21/32		.6562	16.669
				11/64	.1719	4.366					43/64	.6719	17.066
		3/16			.1875	4.762			11/16			.6875	17.462
				13/64	.2031	5.159					45/64	.7031	17.859
			7/32		.2188	5.556				23/32		.7188	18.256
				15/64	.2344	5.953					47/64	.7344	18.653
1/4					.2500	6.350	3/4					.7500	19.050
				17/64	.2656	6.747					49/64	.7656	19.447
			9/32		.2812	7.144				25/32		.7812	19.844
				19/64	.2969	7.541					51/64	.7969	20.241
		5/16			.3125	7.938			13/16			.8125	20.638
				21/64	.3281	8.334					53/64	.8281	21.034
			11/32		.3438	8.731				27/32		.8438	21.431
				23/64	.3594	9.128					55/64	.8594	21.828
	3/8				.3750	9.525		7/8				.8750	22.225
				25/64	.3906	9.922					57/64	.8906	22.622
			13/32		.4062	10.319				29/32		.9062	23.019
				27/64	.4219	10.716					59/64	.9219	23.416
		7/16			.4375	11.112			15/16			.9375	23.812
				29/64	.4531	11.509					61/64	.9531	24.209
			15/32		.4688	11.906				31/32		.9688	24.606
				31/64	.4844	12.303					63/64	.9844	25.003
1/2					.5000	12.700						1.0000	25.400

Two tips on wrestling with rust

As a retired millwright and part-time farmer, I've had a few experiences with rusty bolts. My best solution is pouring white vinegar on the bolt. The vinegar quickly penetrates the threads and rust.

—Gordon Greniger, Grand Rapids, Minn.

Ask WOOD® in Issue 123 gives advice on freeing rusted bolts. I own a construction company that specializes in steel buildings and reinforced concrete and run into this predicament often. To loosen a rusted bolt, I heat it with a torch until it is red hot, then quickly cool it with cold water.

—Roy Hester, Macon, Ga.

Wood-Wide Web

The internet opens a world of options for selling your woodworking

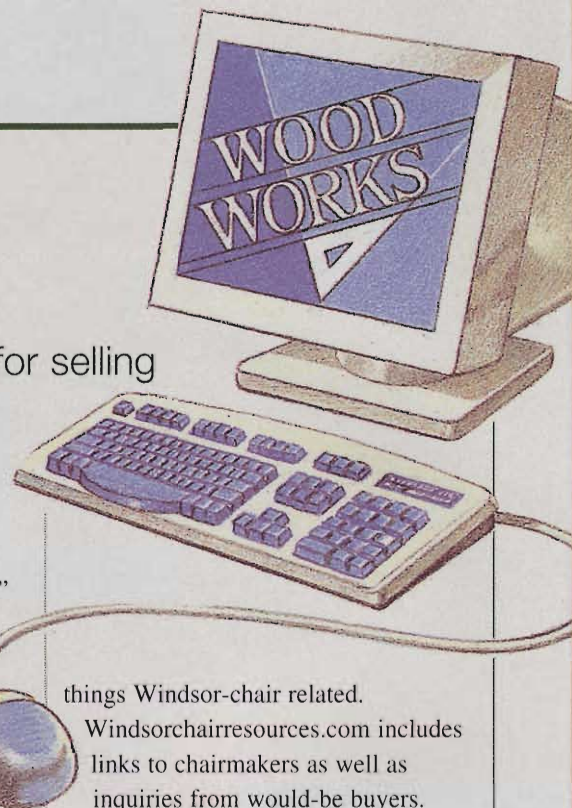

Marty Barker may just be a part-time woodworker in Charlotte, North Carolina, his home town, yet the market for what he makes is the world. With a little moxie and a lot of research, he turned his website, MartyWoodshop.com, into the primary outlet for his sideline business of selling wooden writing sets, boxes, shelves, humidors, and other small gift items. Besides operating a booth at one outdoor craft fair each year, he makes all the rest of his sales online.

A crafts show that never closes

For woodworkers like Marty, the World-Wide Web has turned into a sort of non-stop crafts show. Even woodworkers who make expensive furniture and don't take orders online find the Web a valuable marketing tool. For as little as \$200 to \$300 to start, and \$20 to \$50 a month to maintain, a website can be an interactive brochure that never gets outdated and doesn't require any postage to reach thousands of people.

Marty got about 8,000 visits to his website in the first year following setup in April 1999. Because many visitors simply e-mail questions to him about different woods and woodworking, he's added a section to his site on wood selection to help answer them. Yet, he also has sold several thousand dollars worth of goods. And Marty monthly resubmits new information about his site to internet search engines, such as Yahoo and Altavista.

That has paid off by putting him among the top 50 sites when visitors enter search terms like "woodworkers" or "humidors." Marty learned about site promotion mainly online, he says, entering the term "site promotion" into search engines, and surfing the results.

Expand new business horizons

For Marty Barker, the web serves mainly as a convenience. But for Beth Antonsen, an art-furniture maker in Ketchikan, Alaska, it's more a matter of keeping her business going. After selling all the furniture she could to doctors, lawyers, and other professionals in the hill-hugging coastal town of 13,000, she launched her site, bethantonsen.com, last January to find new markets. Her first inquiry came from Korea, and she thinks her furniture style actually may play better in Asia than Alaska.

Pennsylvania Windsor chair builder Peter Wallace sees his site, Windsorchair.com, mainly as an online brochure. "With traditional advertising, it's very time consuming to answer a response by sitting down, writing a letter, and then enclosing a brochure," Peter comments. "Every year I probably change my line about 60 percent with new pieces. It's much easier—and less costly—to put new photographs on the website than to redo a brochure."

Peter also utilizes a reference website, a sort of online encyclopedia of all

things Windsor-chair related.

Windsorchairresources.com includes links to chairmakers as well as inquiries from would-be buyers.

Credit cards cost money

Surprisingly, Peter doesn't accept credit cards, as do most all websites in e-commerce. Instead, he collects a check as deposit when someone orders and another as payment in full before shipping the purchase. But woodworkers like Marty Barker, who take orders for smaller-ticket items bought on impulse, usually need to accept credit cards for electronic payment, even though it costs them a little money.

Credit card companies generally charge fees ranging from two to five percent of the transaction amount, according to Marty. And despite losing \$200 to one fraudulent transaction from Eastern Europe, the North Carolina craftsman says the site and credit cards are still worthwhile. "I tried a print catalog, but my products kept changing all the time," he adds. "So even if I just use my website as a catalog, it pays to have it." ♣

Written by Jack Neff, a Batavia, Ohio, business writer and author of *How to Make Your Woodworking Pay for Itself*.

Illustration: Jim Stevenson

ball-drilling jig

a simple design for a special task

The tall clock project on page 74 calls for drilling perfectly centered holes in hardwood balls. While you can hold a ball securely in a wood handscrew, centering it under the bit on your drill press is difficult.

Solve both problems with this quick-to-build jig. To make it easy to clamp the jig to your drill press, make the length of the base the same as the width of your drill-press table.

Drill the counterbored holes for the carriage bolts and the large holes in the

base and cap. (See the Jig Hole Guide on the drawing.) Insert the bolts and center the jig by lowering the bit back into the hole, and holding it there while you clamp the jig to your drill-press table. Place the ball over the hole, slide the cap down on the protruding carriage bolts, and tighten it onto the ball with washers and wing nuts. Chuck in the proper bit and drill away. 🛠️

Illustration: Kim Downing; Lorna Johnson
Photograph: Baldwin Photography



JIG HOLE GUIDE	
Ball dia.	Hole Dia.
3/4"	1/2"
1"	3/4"
1 1/4", 1 1/2"	1"
1 3/4", 2"	1 1/2"
2 1/4", 2 1/2"	1 3/4"
2 3/4", 3"	2"

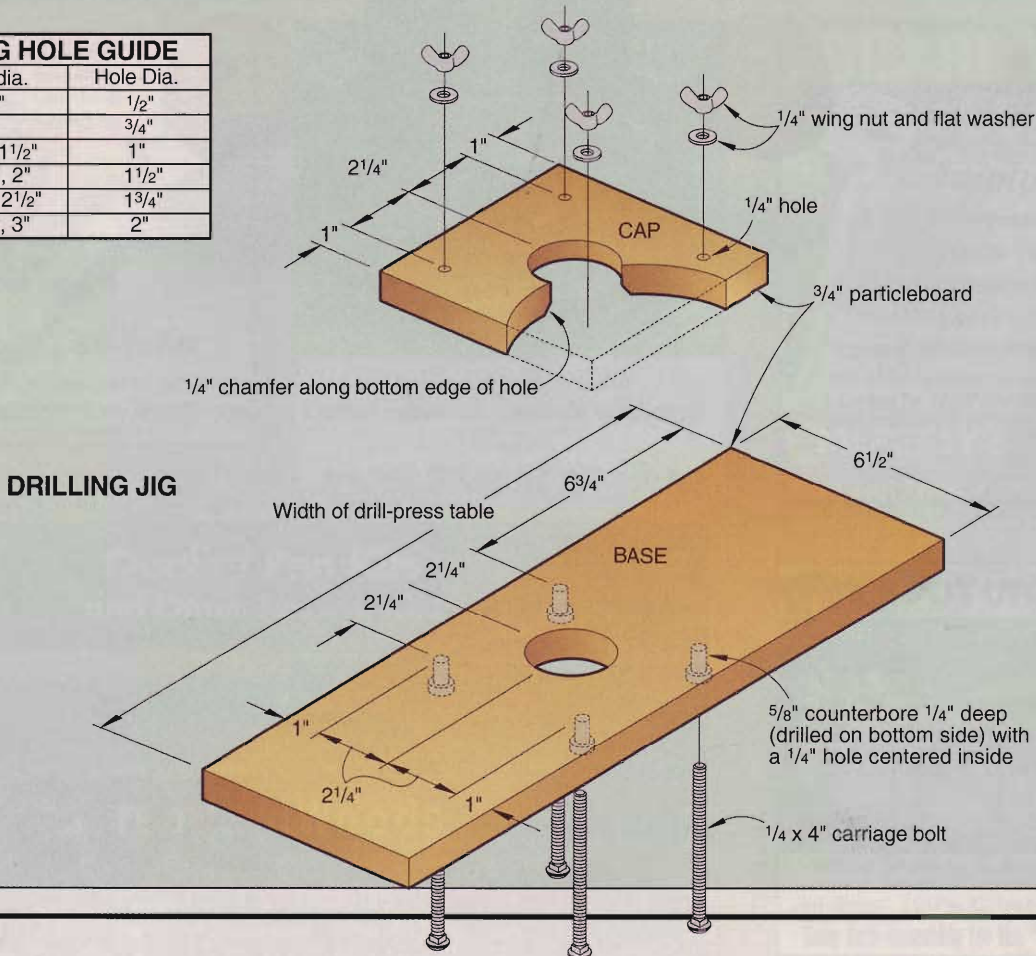

insights from a woodturning master



Woods that can give you a rash (or worse)

Species	May cause
Camphorwood	Skin irritation, reaction to strong odor
Douglas Fir	Skin, eye, and throat inflammation
Imbuaya	Sore eyes, nose, and throat
Redwood	Skin irritation, breathing problems
Rosewoods (Cocobolo, Kingwood, African blackwood, etc.)	Acute dermatitis, lung problems, sneezing
Teak	Skin irritation, nausea, eye problems
Walnuts (Black, Claro, European)	Irritation to the eyes, nose, and throat



There's no other way to say it: The turnings from Bill Hug's lathe are breathtakingly beautiful. Since 1979, this Athens, Georgia, woodturner has created more than 5,000 pieces from more than 100 species of wood, many of them exotic.

As Bill works with different kinds of wood, he keeps notes on the characteristics of each one and takes photos. According to him, some species, such as lignum vitae and some ebonies, are impossible to cut on a tablesaw or with hand tools, but work successfully on a lathe. In the accompanying tables, Bill shares some of his discoveries. 🌲

Bill's magnificent seven turning woods

Species	Origin	Characteristics
Black limba	Zaire	Prized for many uses, especially well-figured pieces.
Camphorwood	Japan, China, Formosa	Has rich red, yellow, and gray colors, deep, iridescent figure.
Imbuaya	Brazil	Looks like black walnut with fine grain and great stability.
Oregon myrtle (California laurel)	Oregon	Color and grain vary widely; ages beautifully.
Santos rosewood	Brazil	More brown than other rosewoods, with a somewhat wider stripe.
Sissoo	India	Ranges from rich, deep brown heartwood to light golden brown sapwood.
Spanish Olive	Southern Europe	Hard and heavy, yet easy to work. Can display a tangle of dark stripes against a tan background.

(These woods can be hard to find. Try Woodworkers Source in Phoenix, Arizona, 800/423-2450, or Berea Hardwoods in Brook Park, Ohio, 440/234-7949.)

Troublesome timbers and how to turn them

Problem	Solution
Highly figured wood	Rough-turn the piece and turn it again. If the piece tears out or warps, let it sit and turn it again when it's stable.
Burls with defects	Turn with a natural rim at top and leave defects to add interest. Bill likes to turn green burls.
Extremely hard wood	Use utmost care and patience, keep tools sharp, and avoid gouging wood.
Spalted wood	To kill fungi and bacteria that cause the beautiful black lines and unusual color in early stages of decay, rough-turn the piece and slowly dry it in a microwave oven. Keep the oven at its lowest setting and never let the wood get too hot to handle. Stabilize soft spots with instant glue. (See <i>WOOD</i> ® magazine issue 116, pages 58-59.)



Lovely colors that just fade away

Species	Unwanted change
Vermillion (padauk)	Starts as bright orange with black and white spots, changes to a uniform deep burgundy.
Cordia (Bocote)	Glamorous black brown with golden stripes turns boring brown.
Osage orange	Spectacular clear yellow dims to yellow orange or yellow brown.
Cocobolo	Beautiful red, purple, and black streaks darken and lose their brilliant color with age.

"Be Our Guest Expert" gives accomplished woodworkers a chance to share insights into their particular areas of expertise. If you'd like to be our guest, or know someone who would, write to "Be Our Guest Expert," *WOOD Magazine*, 1716 Locust Street, GA310, Des Moines, IA 50309-3023.

How to make friends and influence other woodworkers



Members of the Des Moines (Iowa) Woodworking Club participate in an annual potluck dinner and show-and-tell in addition to regular meetings, seminars, and field trips.

Although woodworking is a solitary hobby for most of us, there are ways to enjoy your hobby with others. Hundreds of woodworking clubs across the country offer folks like us the opportunity to share tips, learn from experts, and even have some good old-fashioned fun.

If you're interested in joining a club, starting a club, seeing projects from other clubs, or promoting the meeting dates and activities of your own club, check out the WOODworking Clubs section under COMMUNITY at the WOOD ONLINE home page. Nearly 200 clubs have built a free home page in this section—it's easy to do.

www.woodmagazine.com/scgi/woodclub/

Free tools? You'll find them here

Each and every month we give away a free power tool at WOOD ONLINE. To be eligible for a prize, all you have to do is stop in and register. You can take part in the sweepstakes every month by simply re-entering your user name and password.

Over the past few years, between our monthly giveaways and special woodworking-show sweepstakes, we've made over a hundred woodworkers quite happy with everything from tablesaws to cordless drills. Here are just a few recent winners:

January:

Tim Anderson,
Maplewood, Minn.,
Bosch Jigsaw.



February:

William Croft,
Wooster, Ohio,
Bosch Random-Orbit Sander.



March:

Mike Sistek,
Scott Air Force Base, Ill.,
Bosch Power Handsaw.



www.woodmagazine.com/members/toolsweeps.html

Get on the Internet where tool reviews are a two-way street

If you would like to offer your own feedback to the reviews of moisture meters or quick-connect drill accessories in this issue, you're in luck. Now you can share your tool experiences with us and other woodworkers immediately and directly. No letters, no postage.

And if you have tool-related questions for other online participants, you'll most likely get a response within a day. We'll also encourage manufacturers to share their opinions of our reviews, and add any information on new or updated tools.

www.woodmagazine.com/talk/



Have an opinion on moisture meters or quick-connect drill accessories, or our reviews of them in this issue? Then be heard online.

Here's a tip: Learn and earn in this web group

It's a fact—woodworkers love shop tips. No wonder then, that one of the most-frequently visited spots at WOOD ONLINE is the



Woodworking Tips Discussion Group. You can read hundreds of woodworking tips posted by folks just like yourself. Or, you might line your pocket with some cash if we publish your online tip in WOOD® magazine. We pay \$75 for published tips, and if your tip is chosen as the Top Shop Tip, you'll win a tool prize worth at least \$250. 🍀

www.woodmagazine.com/talk/

dovetail bits

think outside the box joint

For centuries, the hand-cut dovetail joint has stood as a testament to the quality of the case, box, or drawer that beheld it. These days, thanks to routers and dovetail bits, even a beginning woodworker can incorporate this joint to enhance the simplest projects.

Dovetail bits come in an array of cutting angles—usually 7–14°—and heights (see photo, *below*), on both ½" and ¼" shanks. Generally speaking, the greater the cutting angle, the stronger

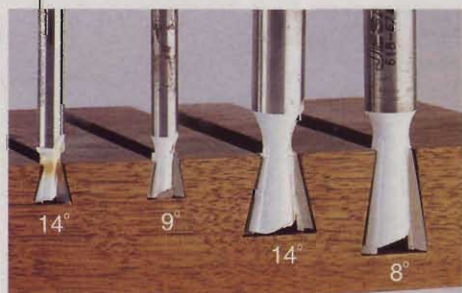

the joint. But beware: The acute angles on the tails make them more fragile as the cutting angle increases, and they can break more easily along the grain.

Because of its opposing-wedge action, a properly fitted dovetail joint self-tightens. This means you can use it to eliminate fasteners, such as screws or nails. You should still glue the joint, but you won't need clamps.

How to tell your pins from your tails

You'll see the three basic parts of every dovetail joint in the Parts of a Dovetail Joint drawing at *right*. The *pin* is the part that fits into the *socket*,

which is formed by two *tails*. Pins and tails are often confused, but there's an easy way to remember which is which. If you look at the face of the workpiece and see birdtail-shaped protrusions, those are tails; if you see rectangles, you're looking at pins.

The tails bear the brunt of the joint's stress, so when planning your project, point the tails in the direction of the stress. For example, opening and closing a drawer creates front-to-rear stress on the drawer. Therefore, point the tails front and rear, which means cutting the sockets in the drawer sides.

Here in the *WOOD*® magazine shop, we like to cut the sockets first, about 1/32" deeper than the thickness of the pins, using a dovetail bit in our router

table. Then, using a straight bit, we form the pins, leaving them just a hair wider than the sockets. This lets us gradually remove more stock from the pins until we get a good fit. Once the joint is complete, we sand the tails flush with the pins.

Making well-fitting dovetail joints in boxes or drawers requires a high degree of precision. That's why you'll find a covey of commercial jigs on the market today, each designed to simplify cutting the pins and sockets with bearing-guided bits. Less-expensive jigs make only half-blind joints, where the dovetails are visible only from one side of the joint. With pricier models, you can cut through-dovetails, where

Continued on page 24

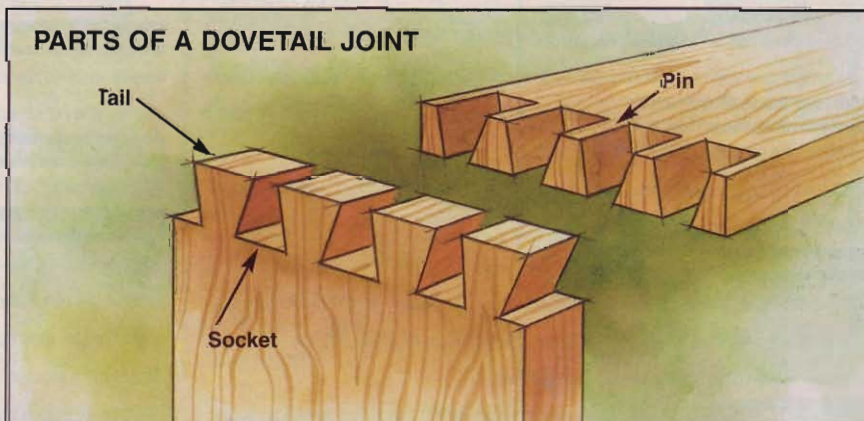

dovetail bits

both sides show (see Common Corner Joints drawing, *below*).

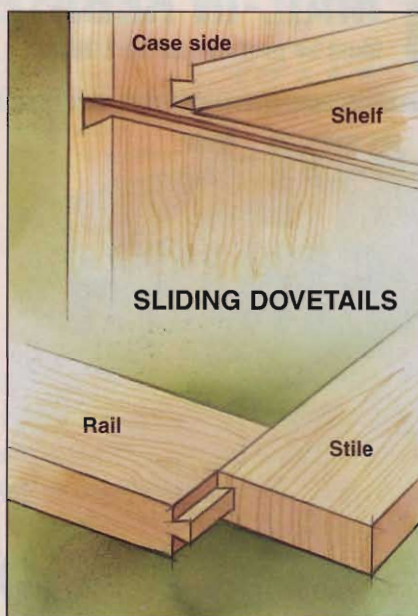
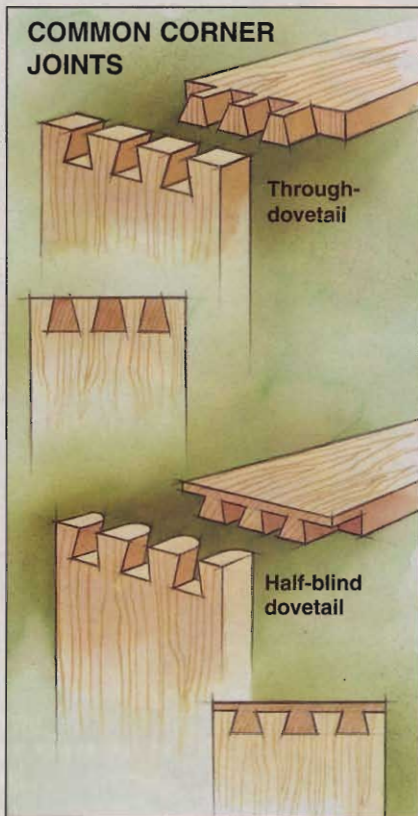

Beyond the box: Let it slide

Even without the use of expensive jigs, you can use dovetail bits to make other strong and attractive joints. For example, use a long dovetail slot (socket) inside a bookcase or entertainment center, then machine a long tail on each end of a shelf, as shown *below left*. The resulting joint, besides adding beauty to the case, also keeps the case sides from bowing. And, if you don't glue the shelf in place, you can remove or replace it at any time.

Or, use a sliding dovetail joint instead of a stub tenon for making rail and stile panels, as shown *below left*. You'll still want to glue the joint, but again, you won't need clamps for this assembly. Just be sure your panels are in place prior to gluing the frame.

One tip for cutting sliding dovetails: The tapered sides of the dovetail slot tend to trap chips in the slot as you cut. So precut the slot with your tablesaw, or a router and a straight bit, as shown *below*, to remove as much material as you can before routing the dovetail. If pre-cutting proves impractical, proceed slowly with the dovetail bit, backing it completely out of the cut frequently to clear chips and debris from the slot.

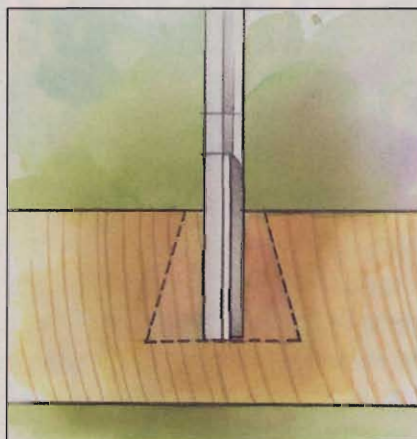

A couple more key uses

As you can see from the drawing *below*, dovetail keys add decoration and function to any number of joints. The key is an hourglass-shaped piece of stock, often made from a contrasting species, that creates a mechanical joint between two flat surfaces.

Before cutting the key sockets, mill a long key blank using the same dovetail bit. Then, set up the socket cuts in scrap to ensure a good fit. Slice individual keys from the blank (about 1/32" longer than the socket), assemble the joint, tap the keys into place, then sand them flush with the workpiece. 🛠️

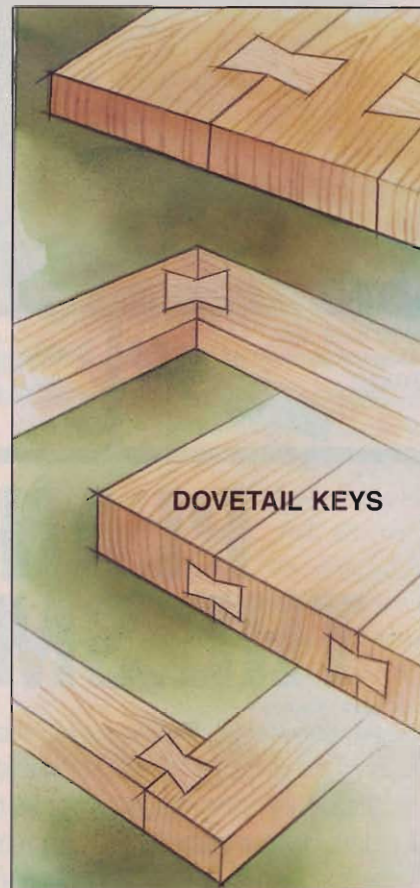

Written by **Dave Campbell** with **Chuck Hedlund**
 Photographs: **Baldwin Photography**
 Drawings: **Brian Jensen**



Comments, answers, and ideas from our
WOOD ONLINE® discussion groups at
www.woodmagazine.com

Note: We have edited all entries in the interest of brevity and clarity while preserving the intent of the original message. Opinions expressed here are those of our online participants.

What is whitewood?

Lowes and Home Depot sell what they call whitewood. Just what is this? I bought some to make shelves for my wife and picked the straightest boards I could find. By the time I made the shelves, they were crowned even more than those that I rejected at the home center.

—W. C. Turner, Hopkinsville, Ky

● W.C., at my local Home Depot, the whitewood section contains lumber that is stamped with its species name. It will

be either LP (lodgepole pine) or PP (ponderosa pine). I have never seen unstamped softwood at this store.

The grade of wood is something else you need to be aware of when purchasing wood. Read R. Bruce Hoadley's *Understanding Wood* from Taunton Press. You can order this book at your local book store. At www.amazon.com the book sells for \$24.46, plus shipping. It will tell you all you need to know about purchasing wood. Incidentally, Lowes' whitewood, according to a spokesperson, is a form of white pine

that could be any number of pine softwoods featuring a light color.

—Howard Acheson, Asheville, N. C.



What's the best way to stop burn marks in cherry?



Someone told me I should adjust my table-saw fence so the back of the blade is $\frac{1}{32}$ " further away than the front of the blade to keep it from burning cherry as I cut it. Should I

always make cuts with the fence on the same side of the blade? Which should I adjust: the blade or the fence to be $\frac{1}{32}$ " further away? By the way, I have the Ridgid tablesaw, the one with the cast-iron wings.

—Phil Peterson, Crown Point, Ind.

● I use a Freud Glue Joint rip blade and it leaves an edge that has no marks whatsoever. It cuts hardwoods effortlessly and almost noiselessly, too. It does not crosscut well, but is not designed for this, either. I have cut a lot of cherry on my Craftsman contractor saw and have had only a few instances of burning. I think your blade is the cause, or you are feeding the wood too slowly, or both. Try replacing your blade with a dedicated ripping blade of high quality and see if the burning stops.

—Hugh Hatfield, Fairview Heights, Ill.

● First make sure the fence is parallel with the blade. Lock the fence in place and measure the distance from the fence to one of the miter slots at sever-

al locations. Now do the same with the saw blade. Crank the blade all the way up, then measure from the miter slot to just inside the teeth on the front and back of the blade. Turn the blade a quarter of a turn and measure from the miter slot to the front and back of the blade again. Keep doing this until you complete a full rotation of the blade. If there is variation in the measurement, then the blade might be bent or the arbor is out of alignment. Now run a piece of cherry or other wood through the saw; if the wood burns again check to see if the fence is still parallel. Sometimes the fence will move when you rip a piece because it is not anchored properly. If the wood still burns, then get a dedicated rip blade.

—John Minichiello, Fairport, N.Y.

Continued on page 28

Urgently seeking a way to remove candle wax

My daughter burned some candles and left wax on my wood dresser—no finish, just stained—and I'm afraid to scrape it off for fear of leaving scratch marks. I have a large area of dried candlewax. Any suggestions?

—Corinne Davidson, Palos Verdes, Calif.



● Try putting ice on the wax. The cold will make it hard and shrink it slightly. This may be enough to loosen it so that you can merely pop it off.

—Jim Kull, San Ramon, Calif.

● Use some turpentine to soften the wax so you can take it off. It won't harm any finish, except a "wax finish."

—Mac Simmons, Massapequa, N.Y.

Build a serviceable router table from materials you have on hand

I just completed constructing a router table and wanted to share my procedure. If you have ever wanted a router table, but thought everything out there was too small or too expensive, here's what I did. First, I made the carcass out of 2x4s to give it strength and mass. This cost about \$18. Next, I made a double-thick top out of ¾" plywood 27x40" with a nice yellow Formica surface. I just happened to have these materials lying around. Most woodworkers will have access to these or get them free. Let's say the cost of these are \$25. I wanted a quality router insert that hinged for ease of changing bits. I recommend the Excalibur model EXRTA. [Sommerville Design has discontinued this product but a company representative says they plan to reintroduce a modified version by the time this article appears. Call 800/357-4118.]

The next step was to have a miter slot. I bought an aluminum miter track for \$15. My fence is

home-constructed from scrap materials. That's it! A huge router table that doubles as a tablesaw extension table for \$150. I looked for six years before building this project in only a weekend.

—David B. Gessner, Seattle

● I made my router table last year for about \$10 in materials. The tabletop was a dumpster-diving find, so my costs were for the 2x4s to hold it together, screws and a few bucks paid to a glass shop for a ¼" acrylic base plate for the router. It is definitely of the "glue and screw" side of woodworking—no fine casework there. And it ain't pretty, but it does a good job. Looking back, I would buy ½" acrylic plastic instead of the ¼". I have a small router so it isn't a problem, but if I buy something bigger, it won't support it.

—Bill Schreiber, Litchfield, N.H.

● I used an old microwave stand/cabinet for a support structure. It saved a lot of time and provided storage. My top is two layers of ¾" MDF capped with laminate and edged with some oak strips. I used the Rousseau insert

(800/635-3416), installed an external power switch, and added dust collection. There are lockable casters on the stand that let it move in my small shop and also be used like yours as a tablesaw extension table. I did build my fence from some oak lumber I purchased. The fence is faced with sliding panels made from double layers of ½" Baltic birch plywood faced with the same laminate as the top. They slide on T-Bolts. I took the basic fence design from one of the router books in my library and made small changes to accommodate my 36x24" table.

—Jim Becker, Bensalem, Pa.

● My shop is small (12x20'), so everything has to be mobile. I built my router table into my tablesaw assembly. First, I moved the right table extension to the extreme left where it fits nicely. In its place, I built my router table of two ¾" MDF sheets with Formica top, and fitted an external switch. This arrangement allows me to use my tablesaw fence and miter slots. It also gives me a full 70" of tabletop surface, and saves me room in the shop. ♣

—Glyn Howell, Fernie, B.C.



make new parts from old

With basic tools and patience,
you can re-create what time
and wear have stolen away

You catch a glimpse of a wonderful old rocking chair at an auction or in the back room of an antique store, and you get excited. When you look closer, disappointment sets in: One of the rockers is gone, or a slat, or a stretcher.

Don't despair. A woodworker can find a way to replace most standard furniture parts and some specialized ones, too.

In many cases, the piece of furniture will have surviving parts that match the missing one. That's often true with rockers, chair arms, knobs, or drawer pulls. Use one of those originals as a pattern for tracing or measuring, as we've done with the chair arm in the photos here.

Sometimes you can trace a part without removing it. But if you have to take it off, remember that denatured alcohol dissolves hide glue, commonly used in pre-World War II furniture. Vinegar or warm water helps dissolve the white or yellow glue found in newer joints.

If the missing part was the only one of its kind, that's another story. You'll have to make an educated guess about its dimensions and appearance. The design of the furniture should offer some clues.

Varnish lines can suggest the missing part's basic shape. Also, you might find photos or illustrations of similar pieces in furniture reference books.

Here's one example of how to copy a part that still exists. We made an arm to replace the one that was missing from the simple rocking chair shown *above*. These basic steps and similar procedures will get you through many such repair jobs.

First, mill a piece of stock that's very close to the right thickness and slightly

oversized in the areas where you'll cut it to shape. Next, form the tenon that joins the arm to the chair's back. You can drill into mating pieces and join them with a dowel, but you'll get a stronger joint by cutting a tenon. We drilled into the end of our blank with a $\frac{5}{8}$ " plug cutter mounted in the drill press, then cut away the waste at the bandsaw, as shown *below*.

Carefully trace the shape of your template piece onto your stock with a sharp pencil. Cut close to that line with a band-

Continued on page 32

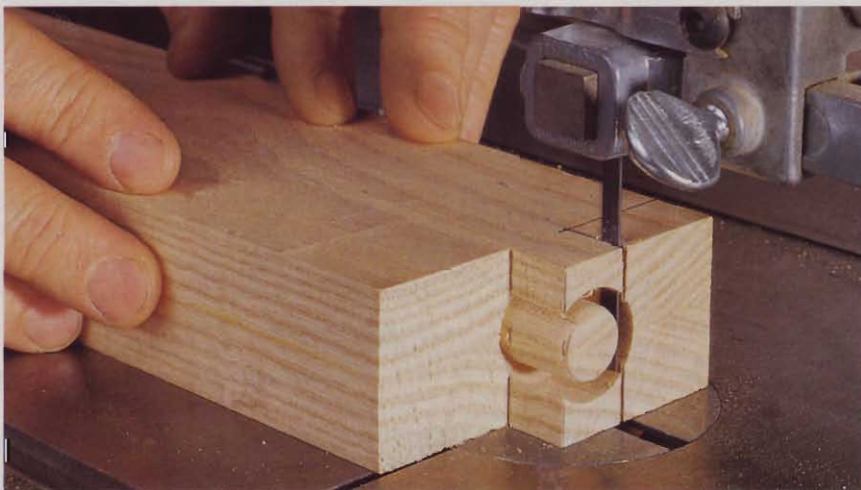

Once you've pinpointed the right location for a tenon, the milling work goes quickly.

Dust free woodworking

Oneida Air 1.5 hp



Clean Air

Filter Inside

FOR ONLY

\$659⁰⁰

FOB
Syracuse
New York

Flex Hose & 35 gal. Barrel \$29⁰⁰

Optional wall mount brackets \$28⁰⁰

- 1400 cfm fan/blower
- 700 cfm@8" W/C system

Filter Efficiency

- 1-2 microns 99%
- 2-5 microns 100%
- over 5 microns 100%



Free Ductwork Design



Call 1-800-732-4065

www.oneida-air.com

U.S.A.
made

1001 W. Fayette St. Syracuse, NY 13204 Phone (315) 476-5151 Fax (315) 476-5044

Just ask a HAWK ScrollSAW owner

Meet Danny Ferrington who uses his Hawk to create one of a kind guitars for stars like Waylon Jennings, Emmy Lou Harris, Eddie Van Halen and Eric Clapton to name a few. Don't let your tools limit you in creating your project of a lifetime. Learn why craftsmen like Danny choose the Hawk Scroll Saw for their shop.

Call for your
FREE Fact Kit

- ▶ Variable cutting action gives more control
- ▶ Smooth vibration-free performance
- ▶ Cuts so smooth, no sanding required
- ▶ Blade changes in seconds
- ▶ Save money buying factory direct
- ▶ 3 models to choose from

MADE IN USA

Call about our
**No Risk
in the Shop
30 Day Trial**



Call Toll Free!

1-800-487-2623

RB Industries PO Box 369 Harrisonville, MO 64701

www.rbiwoodtools.com

K112

the furniture
repair shop

Continued from page 30

make
new parts
from old



Bandsaw close enough to traced lines to keep your sanding time to a minimum.

saw, as in the photo above, then sand to the line with a drum sander. We tapered the arm at the stationary belt sander.

The biggest challenge in this repair was finding the correct angle for the hole that receives the support post. Again, we relied upon the surviving arm. We placed it on a tilting table on the drill press, and kept adjusting the table angle until a 5/8" Forstner bit ran smoothly in and out of the hole. Then we put the new arm on the table and drilled a hole, as seen below. If you don't have an adjustable table, cut a wedge of wood at the appropriate angle to support the workpiece.

All that remained was to ease the edges with a 1/4" round-over bit in a router. A rubber mat on the workbench held the arm in place during that operation.

Written by Jim Pollock with Ben Von Ruden
Photographs: Baldwin Photography



It takes a properly sized, properly angled hole to produce a long-lasting tenon joint.



As proof of his performance, Top Shop Tip winner Paul Parker receives a Hitachi C10FCD dual-bevel compound miter saw. Thanks for the tip, Paul!

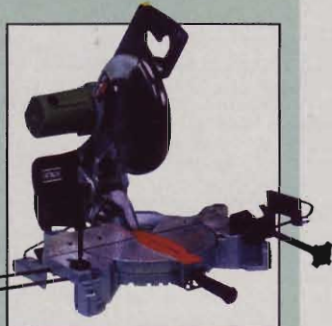

Paul Parker crossed a bicycle seat post with a router and came up with this issue's Top Shop Tip honors.

After earning his bachelor's degree from the University of Southwestern Louisiana and his master's from Texas A&M, Paul Parker's education is about to pay off. Sure, his job as a mechanical stress analyst at Boeing in Houston, Texas, probably has its perks. But it was his senior project at USL—building a bicycle—that inspired the tip (at right) that won him this issue's Top Shop Tip tool prize.

"I don't do much woodworking myself, but when I do, I go over to my dad's place. He's got all the tools," he chuckles. Well, Paul, here's a miter saw to get you started on your own shop. Thanks for the tip.

You don't need to have a fancy diploma to win our Top Shop Tip honors, just a darned good idea. If we like your suggestion, we'll pay you \$75 for it. If we really really like it, we could award you a tool prize worth at least \$250. Send your tips, along with photos or sketches and a daytime phone number to:

Tips From Your Shop (and Ours)
WOOD® Magazine
1716 Locust St., GA-310
Des Moines, IA 50309-3023

Or submit your tips online by posting them to our Top Shop Tip discussion group at www.wood-magazine.com. Sorry, but we can't return the materials you submit. And, we try to publish only original tips, so please send them only to *WOOD* magazine. Thanks!

Dave Campbell
WOODWORKING PRODUCTS EDITOR



Seat-post haste inspires rapid router release

While using my father's table-mounted router recently, I grew frustrated with the height-locking knob. The router uses a wing-bolt and nut that clamps the router base to the motor, and I had to use a pliers to tighten and loosen the bolt. Not an easy task, especially under the table.

So I replaced the wing bolt and nut with a seat-post quick-release from a bicycle store, as shown below. (If you do this, make sure you specify a seat-post quick-release, because the models designed for attaching wheels are too long.)

Slip the quick-release's skewer into the base, and finger-tighten the nut until the handle sticks straight out in the unlocked position. That orientation is important, because if the handle is too high, locking it down could damage your router; if it hangs, the cam won't hold fast.

—Paul Parker, Webster, Texas

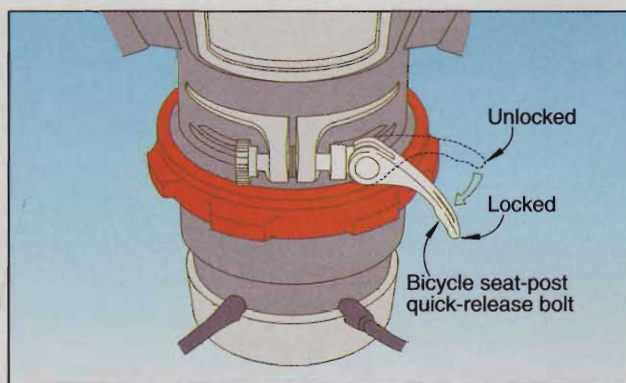

This tip doesn't even begin to scratch the surface

When tacking the stops around a fragile pane of glass (in a cabinet door, for instance), it's not hard to scratch the glass, or worse yet, break it. To overcome this potential problem, I attach a piece of card stock to one side of my tack hammer with double-faced tape (as shown below). Not only does the card stock protect the glass, but by using different thicknesses, I can make the face of the hammer parallel to the nail head, lessening the likelihood of bending the nail.

—R.B. Himes, Vienna, Ohio

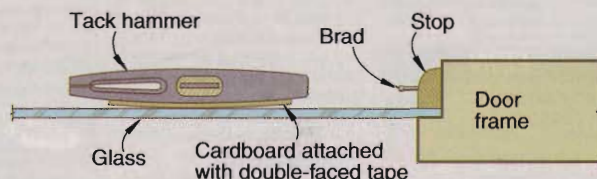

Continued on page 36

CRAFTSMAN

SO VERSATILE, YOU CAN CUSTOMIZE IT TO ALL TYPES OF PROJECTS

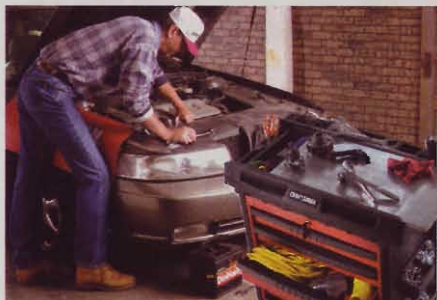

Automotive work. Small parts trays are thoughtfully placed on pegboard sides and under the sliding galvanized steel worktop.

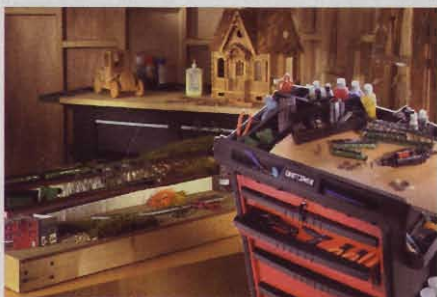

Hobbies and crafts. Two craft projects are rarely the same. The movable side trays are designed to adapt to best suit your current project.



Home fix-up projects. You never know which tools you'll need for the next fix-up job. So we've provided 5 drawers and 9,846 cu. in. of space to hold a wide variety of tools, parts and supplies.

SEARS

THE GOOD LIFE
AT A GREAT PRICE
GUARANTEEDSM

tips from your shop and ours

Continued from page 34

Auxiliary miter saw fence goes beyond 45°

While installing cabinets, I needed to miter-cut some pieces to a 57° angle. Unfortunately, my miter saw only goes to 45°, so I had to find another way to get the angle.

I made a jig in the shape of a speed-square from 3/4" plywood, and clamped it to my miter saw fence, as shown below. My new auxiliary fence now allows me to cut angles over 45°.

The new fence is at a right angle to the saw's miter scale, so to get the correct angle, I subtracted 57° (the angle I needed) from 90°. I then set the miter angle to that difference (33°), clamped the stock to the auxiliary fence, and cut.

—Steve Hodge, Alexander City, Ala.

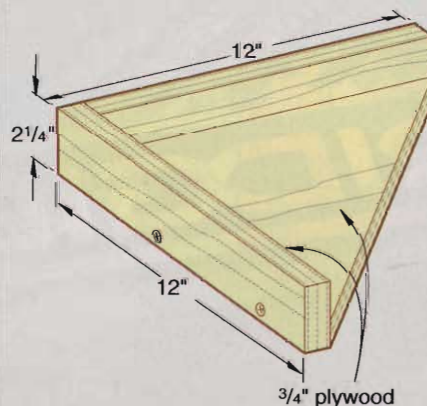
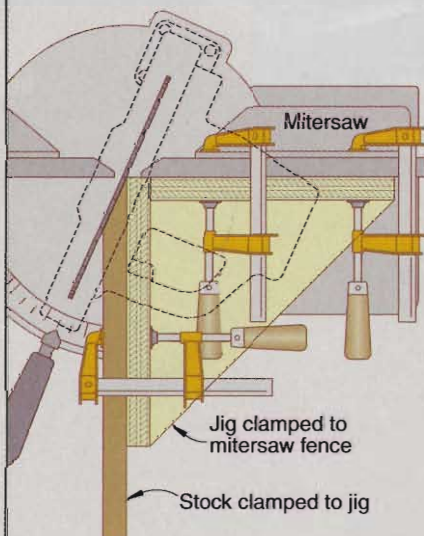

A neat way to fill nail dimples

After I milled some custom oak molding, then stained and finished it to match the existing woodwork, I wanted to avoid the inevitable blemishes from wood filler used to hide countersunk finish nails.

My solution: Place a small piece of masking tape at each point you want to nail. Drive and countersink nails through the tape, then apply wood filler. When you peel off the tape, you'll find a perfectly round spot, with no dulling of the surrounding area. This technique works anytime you need to nail prefinished wood.

—James Vasi, Williamsville, N. Y.

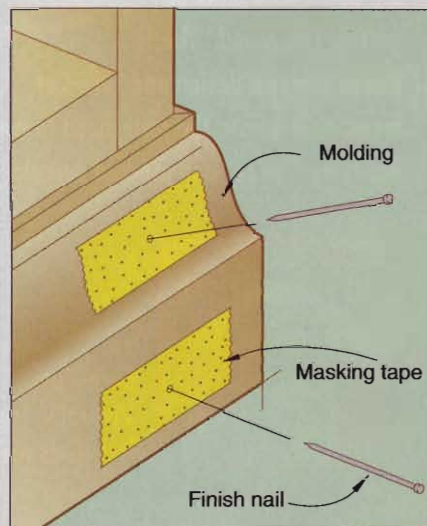

Continued on page 38

Continued from page 36

Scrollsaw patterns from the office supply store

For making your own self-adhesive scrollsaw patterns, buy pressure sensitive label sheets at the office supply store. They come in sizes from small mailing-labels up to 8½x11" solid sheets. Simply transfer your pattern to the label sheet (by hand, photocopier, or computer printer), cut it out, and affix it to your workpiece.

And, if you have a computer, make sure you take a look through the office-supply store's bargain bin while you're there picking up the labels. You're bound to find dozens of clip-art CD-ROMs chock-full of scrollsaw-ready drawings for next to nothing.

—Ron Seto, from the WOOD ONLINE®
Top Shop Tip discussion group

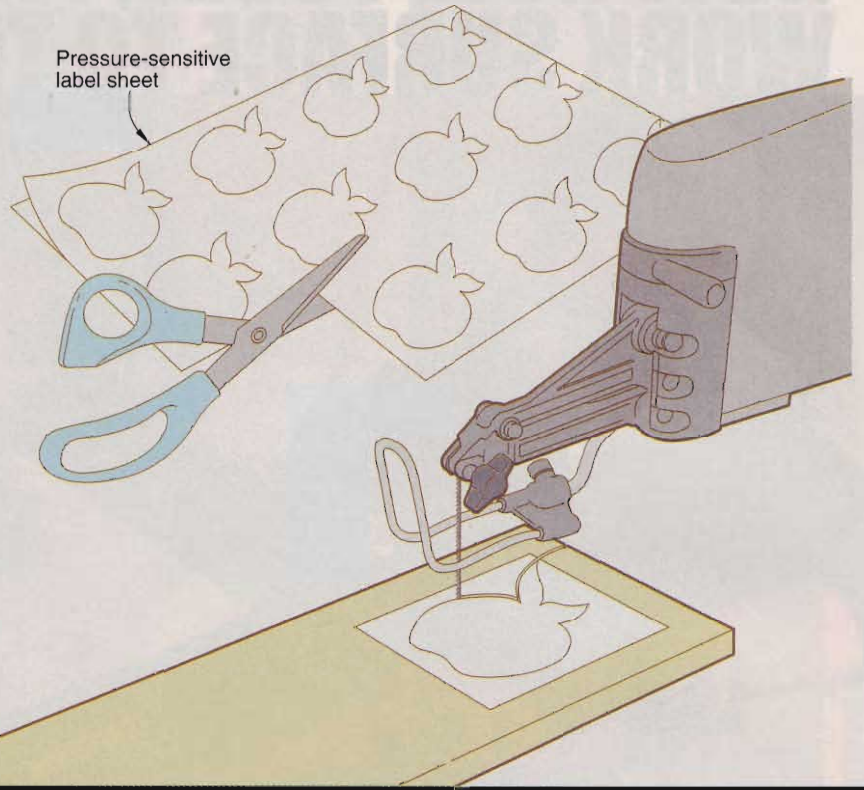

Let's Clear the Air...

JDS AIR-TECH 2000™

Model 750, Still the Best!

- Variable Speed Control for unlimited air flow settings
- Highest Maximum air flow in its class - 1,050 CFM
- Convenient On/Off pull chain
- Ultra Quiet
- 1/4 H.P. Motor for heavy duty performance
- Antimicrobial 1 Micron Internal bag filter
- UL Listed
- Lifetime Warranty

The National Institute for Occupational Safety and Health (NIOSH) recommends limiting wood dust exposures. The JDS Air-Tech 2000 will dramatically improve the quality of the air you breathe. Our new model 750 variable speed allows you to dial in your desired air flow, from a whisper quiet 200 cfm to an ultra performance 750 cfm. This will clean the air in a 30'x30'x8' shop every ten minutes. For larger areas our models 8-12, 10-16 and 2400 are available. The JDS systems will remove 99% of particles as small as five microns and 80% of particles as small as one micron. For the removal of odors, fumes and smoke, our optional charcoal filter is available. To place an order or for the dealer nearest you call us toll-free.

\$259.00
Model 750



Another quality product from
1-800-382-2637

Manufactured in the U.S.A. www.thejdscompany.com



*Better Homes and Gardens®
WOOD® Magazine (Nov. '95)

JDS AIR-TECH 2000™

Smooth sinking in close quarters

Sometimes you need to countersink a hole drilled into an area where a countersink won't fit (in the bottom of a steel channel, for example). But using a big twist-drill bit for a countersink rarely gives you a smooth round countersink. Instead, it often leaves a ragged, five-sided sink. Here's how to get a clean countersink in a close quarters every time.

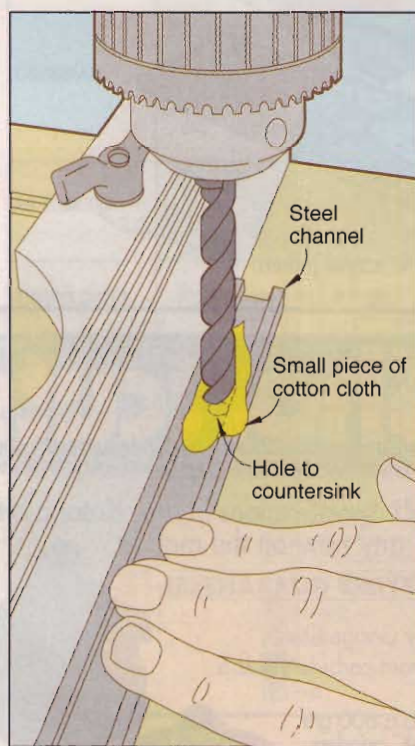

Place a small scrap of cotton cloth—no more than an inch or two square—over the hole you want to countersink. Now use your oversize drill bit as if you're trying to drill through the cloth. The cloth cushions the cutting edges so they both make contact with the metal at the same time, leaving you with a clean, round countersink. Be careful: The cloth will twist with the bit, so don't try to hold onto it.

—Klass Oterdoom, Bentveld, The Netherlands

Continued on page 40

NO MORE DUST



Introducing Microplane® Rotary Shaper Power Tool Attachments for low-speed shaping. The razor-sharp teeth create tiny shavings that fall to the surface instead of clouding your air.

Call 501-968-5455 or

1-800-555-2767

* dealer inquiries encouraged

www.microplane.com

email: info@microplane.com

Microplane
A Product of Grace Manufacturing

Circle No. 2145

The missing
Link Between
man AND
CRAFTSMAN.



Gorilla Glue® makes serious woodworkers more successful. It's incredibly strong, 100% waterproof and excellent for hardwoods, softwoods and hard-to-glue exotics. You'll get nearly invisible glue lines and stable joints. Plus, Gorilla Glue won't gum up your tools like yellow glue does. Discover a higher form of creation. Call 800-966-3458 for a dealer, or find out more at www.gorillaglue.com.



THE TOUGHEST GLUE ON PLANET EARTH™

Continued from page 39

Doubled cord is half the trouble

When storing a long extension cord, I like to double the cord first, then start it on the reel from the middle. This keeps both ends of the cord free so I can use a long cord for short distances without unspooling the whole thing. One word of caution though: unwrap the cord completely before using with high-power tools. Pulling lots of current through a coiled cord can quickly cause it to overheat.

—A. Young Brown, Jr. (from the WOOD ONLINE® Top Shop Tip discussion group)

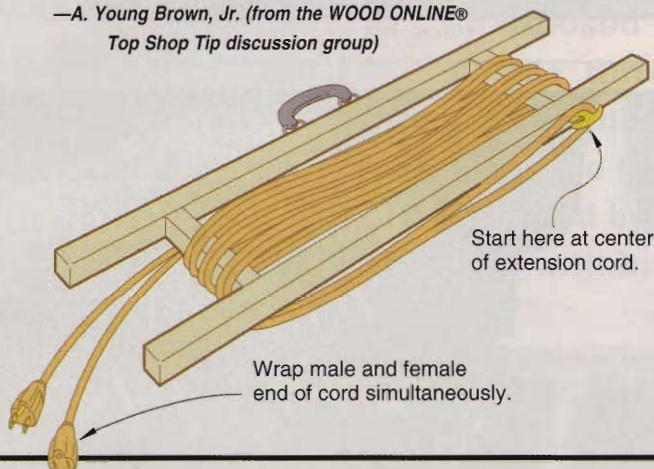

Clear-cut idea for picking grain

When I find an intarsia pattern I like, I first cut all of the parts from a piece of 1/8" clear acrylic. (I use my scrollsaw on its lowest speed to keep the acrylic on both sides of the kerf from fusing back together.) Besides giving me a perfect pattern for tracing out multiple projects, the clear pieces also allow me to choose the best grain orientation for each part.

—Dave Beaune (from the WOOD ONLINE Top Shop Tip discussion group)

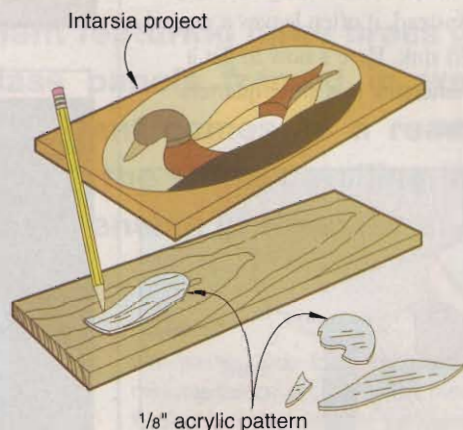

No Matter How You Cut It, These Tenryu Blades Are Winning Combos

Tenryu Gold Medal 10" x 40t and Rapid-Cut 10" x 50t blades give you splinter-free cuts in all woods—even chip-free cuts in melamine. Both feature extra hard carbide teeth that stay sharp longer, even when cutting abrasive materials.

Gold Medal: "A top performer offering a very smooth cut edge and glass-smooth feeding"... "the quietest-cutting blade in our test"

Rapid-Cut: "The smoothest cutting of all the ATB/R blades tested"
—WOOD Magazine, February 2000

For exceptionally clean and accurate cross, rip and miter cuts in all woods, ask for Tenryu Gold Medal or Tenryu Rapid-Cut blades at your favorite dealer.

Making quality saw blades since 1910

TENRYU

4301 Woodland Park Dr., Ste. 104 West Melbourne, FL 32904
1-800-951-SAWS • 321-951-2400 • Fax: 321-951-2250 • www.tenryu.com



No Shortcuts

NEW DESIGN! Specifications in new Katana bits equal or exceed any now on the market.

INCLUDES A LIFETIME GUARANTEE!

- 1 Unique new Safety Gauge Shank™.
- 2 Premium micro-grain carbide yields a longer cutting life.
- 3 Diamond honed to a 600 grit mirror finish on CNC grinders.
- 4 Non-stick coating baked on to prevent residue build up.
- 5 Precision ground to a tolerance of +/- .005".
- 6 High hook and shear angles produce a clean cut.
- 7 Anti-kickback design forces smoother entry into stock.
- 8 Balanced in excess of 25,000 RPM for smooth routing.



FREE SHIPPING

FREE CATALOG!
1-800-533-9298

KATANA™

3 PIECE RAISED PANEL
DOOR SET • 1/2" SHANK
\$129⁹⁵
ORDER ITEM - #14502
WOOD BOX INCLUDED

KATANABITS.COM • AN MLCS COMPANY P.O. BOX 4053, RYDAL, PA 19046

PVC gives TLC to turned bowls

Here's an idea that will make a lot of wood turners (and their spouses) happy. To part a turned bowl from my lathe's faceplate all by myself, I use a 12" length of PVC pipe with a rubber cap slipped over one end. I put the other end of the pipe over the tailstock, and move the tailstock in until the rubber presses on the bottom of the bowl. Then, I part the bowl from the faceplate. I've never lost a bowl using this device.

—Norbert Heckler, Fort Meyers, Fla.

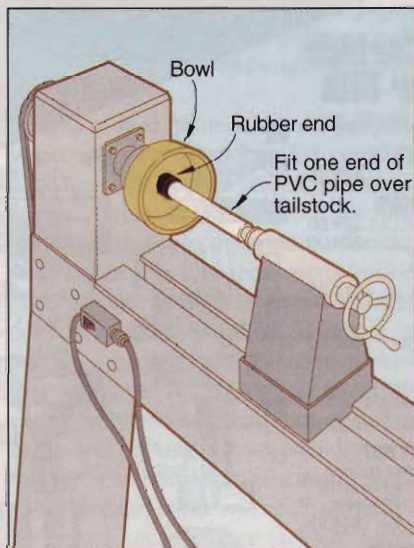

A few more tips from our woodworking pros

- Matching wood grain is half the battle when making beautiful panels. Learn the tricks on *page 44*.
- On *page 52*, woodturner Galen Carpenter offers some tips for gluing and reinforcing segmented- or stack-laminated bowls.
- Looking for an easy way to drill angled holes? Simply saw a jig that holds your workpiece at the prescribed angle, as we did on the Toy Float Plane on *page 82*. ♣

STEVE WALL LUMBER CO.

Quality Hardwoods and Woodworking machinery For The Craftsman and Educational Institutions

Ash.....	4/4	Select	2.25
Basswood.....	4/4	Select	1.95
Birch.....	4/4	Select	2.50
Butternut.....	4/4	1C	2.20
Cherry.....	4/4	Select	4.20
Hickory - Pecan.....	4/4	Select	2.30
Mahogany (Genuine).....	4/4	Select	3.70
Maple (Hard).....	4/4	Select	3.15
Maple (Soft).....	4/4	Select	2.20
Poplar.....	4/4	Select	1.75
Red Oak.....	4/4	Select	2.40
Walnut.....	4/4	Select	3.45
White Oak.....	4/4	Select	2.40
Cedar (Aromatic Red).....	4/4	1C+Btr.	1.65
Cypress.....	4/4	Select	2.25
White Pine.....	4/4	F.G.	1.15
Yellow Pine.....	4/4	Clear	1.80

Above prices are for 100' quantities of kilndried rough lumber sold by the Bd. Ft. FOB Mayodan, NC. Call for quantity discounts. Other sizes and grades available.

UPS	\$77.00
Specials	\$63.00
	\$81.00
	\$69.00
	\$98.00
	\$72.00
	\$98.00
	\$85.00
	\$72.00
	\$64.00
	\$80.00
	\$95.00
	\$80.00
	\$66.00
	\$74.00
	\$55.00
	\$65.00

Above prices are 20 bd. ft. bundles of clear kilndried lumber 3"-10" wide • 3'-7' long (Random widths & lengths) Surfaced 2 sides or rough. Delivered UPS prepaid in the Continental U.S.

Circle No. 592

NOW AVAILABLE

Custom Made Raised Panel Doors

4/4 Log Run Walnut 100 bd. ft. \$155

Also Available Exotic Lumber

STEVE H. WALL LUMBER CO.

BOX 287
MAYODAN, N.C. 27027
336-427-0637
1-800-633-4062
FAX 336-427-7588

Email: wood@walllumber.com
Website: www.walllumber.com

Send \$1.00 For Lumber Catalog
Prices Subject to Change Without Notice

Prototype



ARROW ELECTRO-MATIC

New!

Finished Product



HEAVY DUTY ET100™ Nail Master™ ELECTRIC BRAD GUN

Grab hold of the all-new ARROW ET100™ and experience the beauty of ergonomically designed comfort. Its non-slip cushioned grip and superb balance assures effortless work, even during long jobs.

In addition to performing routine nailing jobs, this powerful 10 amp brad nailer is specially angled to handle difficult corner, edging and framing jobs. No scratched or damaged surfaces.

The ET100™ provides nail driving muscle without the burden of an air compressor. It shoots 3 different size brads.

Solid state circuitry, a hardened carbon steel delivery system for jam-proof performance, and both trigger and surface contact safety locks combine to offer increased years of safe, accurate, trouble-free service.

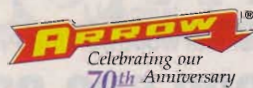

The ET100™ is available wherever fine tools are sold.

Arrow Fastener Co., Inc., 271 Mayhill Street, Saddle Brook, New Jersey 07663
Canada: Jardel Distributors, Inc., 6505 Metropolitan Blvd. East, Montreal, Quebec H1P 1X9
United Kingdom: Arrow Fastener (U.K.) Ltd., 14 Barclay Road, Croydon, Surrey CR0 1JN
www.arrowfastener.com © 1999 Arrow Fastener Company, Inc.



how to glue up a
perfect panel
it's easy with straight, flat stock

If you're a beginning woodworker, master this basic technique before you move on to the fancy stuff. You'll start with a few boards, and end up with a panel worthy of a tabletop.

All boards are not created equal. Some boards follow the rules and stay straight and flat. Others rebel. If you take time to find the cooperative ones when you set out to make a panel, the task will be much easier.

Here's what you need to consider when you visit the lumber rack at the home center or wood supplier: straightness, color, and grain figure.

Sight down the edge of a board and you'll quickly spot any bowing. Look down the face to check for twist.

Once you've found some boards that you might like to take home, stand them up side by side to make sure they get along with each other visually. We used red oak for this project, and found significant color variations. Some boards showed a pink tinge, others looked brown, and a couple were almost white. Stick with boards of the same color.

Grain matching isn't as straightforward as color matching, but think ahead. Can you see similar patterns on all the boards? If so, you'll have an easy time making joints that seem to disappear instead of standing out.

Cut them down to size

If you buy lumber that has been stored inside a store, you can start to work it as soon as you get it into your shop. Lumber that's been stored outdoors or in an unheated, uncooled warehouse

Continued

will need a few days to adjust to your shop's humidity.

Before making any cuts, double-check your tablesaw and jointer to make sure they're set at exactly 90°. You might have been told that a slightly rough surface glues better. Not so. Smoother is

better. Still, if you use a high-quality ripping blade on your saw, you can produce edges suitable for gluing without even going to the jointer.

You'll probably buy stock that's surfaced on both sides and one or both edges. If it has one rough edge, rip that

away on the tablesaw. Then crosscut the boards to length plus a few extra inches. That allows for planer snipe and also comes in handy when you're searching for the best grain match.

Now take those wide boards and rip them into pieces no wider than 4". It seems like a shame, but doing this virtually eliminates a wider board's natural tendency to cup. Even if you rip a board in half and wind up gluing those two halves right back together again, you have relieved tension within the stock. That will help keep your panel flat.

reading the grain

It's not a jigsaw puzzle, it's a lumber puzzle. Here's an example of nice matching grain and an example of a match that would annoy you for years to come.

GO WITH THIS ONE

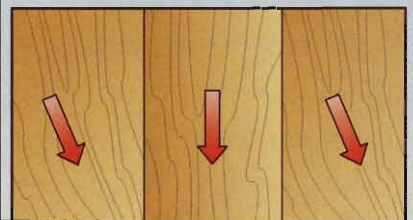

These boards feature grain lines of similar direction and width, so they blend well.

LET THIS ONE GO

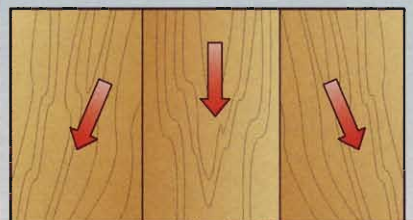

Different grain directions and shapes doom these boards to a jarring visual effect.

Get ready to glue

Now comes your chance to imitate nature. Lay the boards on your workbench, as you see in the photo at left. Look for an arrangement in which the grain on each piece seems to flow visually into the adjacent piece. (See "Reading the Grain" at left.)

Again, consider color. For example, you'll get a better-looking result by placing a couple of light boards at the sides of the panel, rather than alternating them with darker pieces.

Some woodworkers swear by flipping every other board to alternate the growth rings that you see on the end grain. However, you can ignore that factor once you've ripped the boards to 4".

After you've decided how the boards will go together, mark them in alphabetical order with chalk, as in the photo at the top of the *opposite page*. The chalk rubs off easily after glue-up.

Check the fit one last time. If any gaps show, go back to the tablesaw or to the jointer, or get out a long, sharp jointer plane. Make the edges as straight as you can along the length of the board and keep them square with the face, too.

When the boards fit tight, place waxed paper on your workbench to catch any stray glue drips. Set bar clamps or pipe clamps on the paper, spaced about 12" apart. It wouldn't hurt to put waxed paper directly on the clamps, too. The waxed paper will keep the clamps clean and won't stick to your glued-up boards.

We used four Bessey K Body bar clamps from the American Clamping Corp. (800/828-1004) underneath our 36x24" assembly. The jaws stay parallel to the workpiece and keep the boards flat. Other kinds of clamps might need



After cutting your stock to size, lay the boards on your workbench and begin looking for the perfect match, as *WOOD* magazine's contributing craftsman Jim Heavey does here.



Here's another marking method: Jim pencils in X's and O's "because I love my work." Write them on masking tape and you won't have to sand them off.

When you've figured out the best arrangement, mark the boards with chalk.

alignment help from two more clamps placed on the top side of the assembly.

Our finished panel ended up six boards wide. But we glued up just half of the panel—three boards—at a time. Otherwise, it takes some scrambling to keep all of the joints in perfect alignment. This method also allows you to run each three-board assembly through a 12" planer after the glue dries.

Lay the three sequentially marked boards on the clamps between the jaws and reach for the glue bottle. We recommend yellow woodworker's glue. It does set up quickly, though, so be prepared to work fast.

You don't need special tools to spread the glue. Simply lay down a bead from your glue bottle, then spread it into an even coat with a finger, as shown in the photo at right—you'll develop a feel for the right amount. And you only need to apply glue to one of two mating edges. If you put glue on both boards, you're certain to overdo it.

Rub the glue joints together and line up the boards for the grain effect you planned. Don't worry about getting the ends exactly even; that's one reason you cut them a little long. Snug up all of your clamps, but don't apply much pressure yet.

Start at one end, make sure the joints are flat on top, and tighten that clamp. Overtightening will just force glue out

Continued



Apply a bead of yellow glue on just one board per joint, and spread it evenly with your finger. All it takes is enough to coat the surface. Anything more gets squeezed out.

how to glue up a perfect panel

of the joint, so take it easy. You're making a panel, not arm-wrestling.

Work toward the other end of the assembly, checking the joints and tightening the clamps as you go, as shown in the photo at *right*. If you applied the perfect amount of glue, it will show up as tiny beads along each joint.

Clean up, repeat, trim

Let the glue set up until it's rubbery. Then skim it off the wood with a putty knife or a scraper, as shown in the inset photo. Leave the clamps in place for an hour or so.

For a panel 24" wide, we glued up another three-board piece, then ran both pieces through our 12" planer to take down any high spots. Then we joined the two halves with the same gluing and clamping procedures as above.

The final panel won't fit through the planer, but that's not a problem. You can easily clean up that single, middle joint with a scraper or a random-orbit sander.

Trim the ends square on the table saw, if your panel isn't too wide for comfort. A crosscut sled makes that job easier and safer. Otherwise, clamp a straightedge across the panel and use it as a guide for your circular saw or router. ♣



Rather than make a mess trying to wipe up wet glue, let it set up for a while, then scrape it off.

Working quickly, jockey the boards up and down as necessary to get them flat all along each joint. You can clamp a troublesome joint to the bar clamp sitting underneath.

Written by **Jim Pollock**
Photographs: **Baldwin Photography**
Illustrations: **Roxanne LeMoine**

4 other ways to align edges



biscuit

A plate joiner, or biscuit joiner, rates as the easiest and quickest way to line up mating pieces.



spline

Equip your router with a slot cutter to make short grooves along both mating edges, then use your table saw to rip wood splines to fit. That's easier than dealing with one long slot.



dowel

Oh-so-convenient biscuits are pushing dowels out of the picture. If you still prefer dowels, make sure they're straight and fit the holes perfectly.



routed profile

You can rout a tongue on one piece and a matching groove on its mate. Two drawbacks: the cost of a special bit and the challenge of keeping long stock perfectly flat as you run it across your router table.



segmented bowls

from Sedona

Arizona woodturner Galen Carpenter uses rich color and spectacular grain to entice customers to his bowls

A dry streambed outside Sedona provides the backdrop for Galen's turnings of exotic wood and unconventional materials. The one at top center, for example, is black palm with antler rim. A tall vessel of oriented strand board (OSB) stands at bottom center.

In his Sedona, Arizona, workshop, Galen Carpenter attempts to explain the consumer appeal of his segmented, turned bowls: "I base all my work on the theory that I would rather give somebody a really good taste of the wood instead of a little piece of it." And for that taste of wood, people pay upward of \$500 for one of Galen's bowls, usually made from colorful exotic wood, highly figured stock, or quite unusual materials.

"You just can't get the colors out of domestic wood that you can out of exotics," he explains. "And they're intriguing because they're new to people. I don't use American black walnut, for instance, because everyone in the world can see walnut in a furniture store. Most people buy the work because they like the color. They're drawn to them." With that theory in mind, a walk through Galen's shop becomes a journey through the world of wood, and much more.

Come into the wood candy store

"There are a lot of woods I don't use out of respect for their endangered status, such as Brazilian rosewood," notes Galen. "Why use it when there are other woods that will work just as well?"

Then the woodturner begins to recite the names of his favorite materials. "Royal palm. That comes from Florida. There's black palm, ramon, and bulletwood from Belize." Galen pauses, then continues.

Continued

segmented bowls from sedona

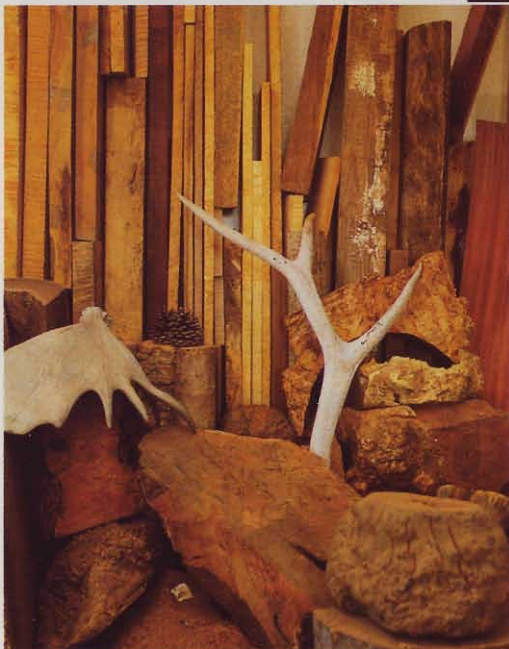

Madrone burl, moose and elk antler, and exotic wood species from around the world make up the raw materials for Galen's turnings.



Can you guess what this bowl's made of? Pine cones joined with epoxy! Galen uses a sanding disc fastened to a metal plate to perfectly flatten its bottom.

"Rhodesian teak. Indian and Belize rosewood. Australian myrtle and tabari. African oil palm. Alexander palm. Corkscrew palm. Tulipwood and pernambuco out of Brazil. From Mexico, I get chocte and cocobolo.

"About the only native American woods I turn are bird's-eye maple and madrone," he adds. "In all, I use maybe 175 species. Then I've employed oriented strand board [OSB], plus corn and other oddities epoxied together. Of course, there are people who have a sentimental tie to a wood species, so they'll commission me to make a bowl from it."

Looking around Galen's large material-storage area, you'll spot other things seemingly foreign to a woodworker's shop. There are chunks of semi-precious stones, such as turquoise and lapis lazuli. "When a bowl calls for it, I'll use it, but not to get the Southwest look," he says. A few moose antlers lay about. "They come from friends in Alaska. I can only use the outside layer because the inside is porous. I cut out a thick piece for a bowl rim, then resaw it into two thin rims. I don't put it on everything," Galen notes.

The long trail to success

Confident in his design sense and choice of materials, and skilled as a turner, Galen has developed a following of collectors everywhere he sells. He's also won numerous art-fair awards and best-of-show titles across the country. This national reputation, however, has been nearly 30 years in the making.

In 1974, Galen and his wife, Ann, ran a furniture repair and stripping business in Florence, Kansas. Galen taught himself woodturning because he had to turn rings for broken chairs. "I would go into the shop at 5 a.m. and turn until 8 a.m., then get on with the other work," he recalls. "I've always worked long hours because I enjoy what I'm doing—or I don't do it. Back then, I'd never seen anyone's woodturnings to compare mine to, but we had a little showroom, and every once in awhile I'd turn a jewelry box or a bowl and put it out marked at \$30. When people came to pick up their furniture, they would sometimes buy."

Galen was enjoying his work and his turnings. Then a different opportunity knocked. "One day a customer came in

accompanied by a woman who was the curator of the Wichita Art Museum," he remembers. "She was interested in my bowls for an upcoming exhibition. So I made about 15 of them for the show."

That experience got Galen off and running. He began taking his woodturning more seriously, and started accenting the native woods of his bowls with horn and other adornments. "Very Southwestern," he says. Yet, his turnings were getting better and better. At the time, though, Kansas was in an economic downturn. No one wanted to pay what he thought his work was worth.

Following a winter vacation to Sedona in 1983, Galen and Ann decided on a move. "Oil, agriculture, and aircraft made up the economy in Kansas back then, and none of them were doing well," he remembers. "People at home weren't happy. But they were in Sedona, so we sold everything and moved here."

Galen was hired by a Sedona building contractor, but continued turning nights and weekends "I was making bowls on a Craftsman lathe. I had a Craftsman tablesaw, jointer, and sander—enough

tools to make a living with if I had to," he recalls.

"Eventually I met a local woodworker who used exotic woods exclusively for his intricately inlaid boxes," says Galen. "He gave me a bunch of scraps. It was great. I'd never in all my life seen such beautiful wood!"

Over time, the woodworker also told Galen the ropes of selling at art fairs, a market for his work that he was unfamiliar with. Before long, Galen got accepted at his first one. He and Ann had to travel to California in a rented station wagon, but he surprisingly sold most of the bowls he brought at from \$250 to \$300 apiece. Encouraged, Galen exhibited at another fair in Florida, and did well. "Ann and I were so excited that we decided that full-time woodturning was the direction I should take," says Galen.

Continued

Proportioning a bowl with the golden mean

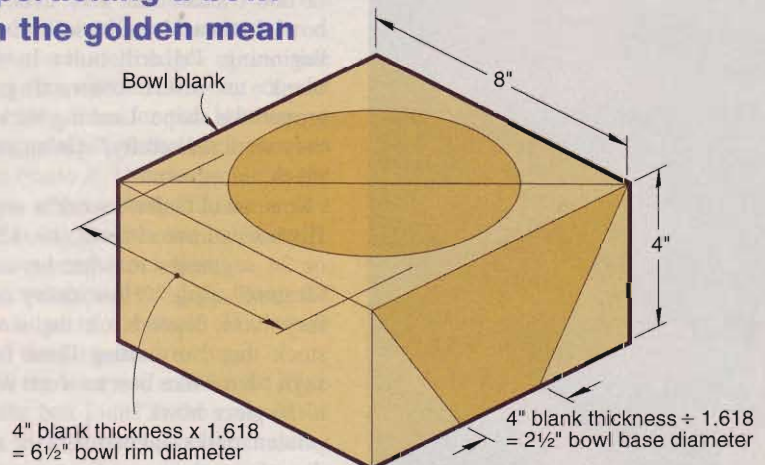

Bowls by the golden mean

"When a bowl sits on a mantle, you can't tell its wall thickness or how heavy it is. It should simply be aesthetically pleasing," says the woodturner. "And that's a combination of the material and the shape."

To get an eye-appealing bowl shape requires a sense of proportion. An ancient Greek formula called the Golden Mean frequently guides Galen. "It's really about using the ratio 1:1.618 to find the length of the long side in relation to the short side of a rectangle," he explains. "But in bowl turning, it's used to calculate the diameter of the rim in relation to the height of the bowl, or of the base diameter to the height." (See the drawing *above*.)

Galen, though, sometimes turns to a design method somewhat less sophisticated than that of the Greeks. Snatching a used auto fan belt from the shop wall, the lanky turner strides outside, into the sunlight. Holding the belt in the air, he twists and turns it. Looking down at the belt's shadow on the driveway, he says, "That shape would make a nice bowl." Then, while holding the twisted belt in configuration with one hand, he traces the shadow onto the cement with chalk.



Woodturner Galen Carpenter leans against a deck railing that he crafted of local juniper branches and western red cedar.

segmented bowls from sedona

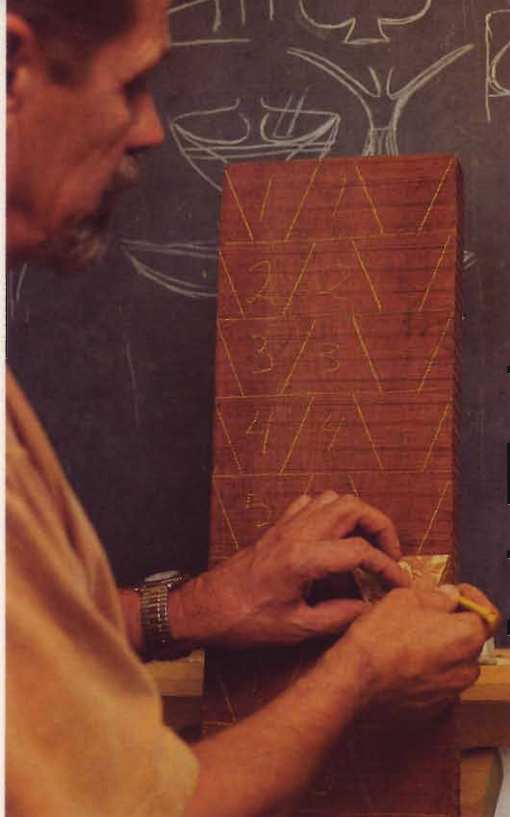

The segments of a turning begin as triangular markings across the face of a board. Galen numbers them in order down the board for bookmatching.

What's the angle, anyway?

A full circle contains 360°. So to make a glued-up blank of segments for turning out of straight pieces, the corner angles must add up to 360°. For example, in a simple blank with six equal-length sides, the six 60° corners add up to 360°. But 60° is not the angle you need to cut on the ends of each segment. Because two segments join to make the angle, each segment must be miter-cut to exactly half the total corner angle, or 30°.

Here's the rule:

To determine the corner angle for a figure with any number of equal-length sides, divide 360° by the number of sides. To find the miter angle, divide the corner angle by two.

corner and miter angles for various numbers of sides

No. of sides	corner	miter
6	60°	30°
8	25°	22½°
10	36°	18°
12	30°	15°
16	22½°	11¼°

He works segments two by two

"I don't know that I've ever turned a bowl that wasn't multi-piece. Even in the beginning, I'd drill holes in the bowl blank to insert contrasting dowels around the shape. Looking back, I guess they were real crafty," Galen says with much amusement.

Now, all of Galen's work is segmented. His bowls have either 8, 10, 12, 16, 20, or 24 segments in what he calls their "feature" ring. "How many segments they have depends on the size of the stock that I'm cutting them from," he says, "but I like best to work with a 12- to 16-piece bowl."

Galen marks and numbers the segments directly on the board from which they'll be sawn, as shown in the photo left. "Then, I cut them on the miter saw, keeping them numbered for use in sequence. (For how to calculate angles, refer to "What's the angle?" below left.)

I always work with paired segments," he notes. "Like numbers 1 and 2, 3 and 4, and so on. I sand them at the belt sander with 60-grit in pairs, too. I use coarse paper because the glue grips the wood better."

When he has sanded all the paired segments, the woodturner glues up the ring with yellow glue. But he defies tradition by not clamping. "That freaks people out," he says. "But I don't clamp because a clamp always puts the wood in stress. You see, wood always wants to go back to the way it was. When you add stress with a clamp, the wood's eventually going to go somewhere. There's no stress in my bowls."

On gluing, Galen offers some advice: "You never want to glue up the segments right after sanding. The wood gets hot from it and sucks up the glue. Then, what you get is a starved joint that will eventually separate.

"Remember, too, that if you want to insert veneer accents between each of the segments," he adds, "run the grain perpendicular to that of the segments. That way, the veneer acts just like crossbanding in plywood and gives the bowl lots more strength."

Galen's bowls also grow stronger with additions. "The rim, of antler or solid wood, helps strengthen the segments below it just as the solid wood base holds the segments above it in place," he points out.



The segments, cut to the correct angle at the miter saw, are glued up to form rings. Veneer accents between the rings act as crossbanding to strengthen the bowl.



Chucked onto his 5-speed Woodfast lathe, the segmented ring presents solid end grain to Galen's turning tool.

Tools to shed end grain

Because of the way Galen lays out and cuts the segments, he ends up turning end grain for the bowl body. "Most woodturners say that's harder to do, but if you're turning a solid-piece bowl, every 180 degrees of rotation you're hitting hard end grain," he comments. "But if you begin with a blank that's entirely end grain, it's harder all the way through and thus more predictable."

As unconventional as Galen's end-grain turning are the tools he employs to do it. Rather than a traditional gouge, he prefers hollow-handle turning tools with replaceable high-speed steel cutting tips in straight and bent versions. "They were designed by noted woodturner David Ellsworth," he notes. "The tips are held on with cyanoacrylate glue. Want to change a dull tip? Just heat it up with a propane torch, then tap it against something solid, and it pops out. But I do use a Sorby parting tool, too. And for hollowing, I go to a Thompson tool. With those four, I can make about anything."

Galen strives to turn all his bowls with 1/8"-thick walls, but some of his chosen materials won't allow it. "Like black palm, for instance. If I turn that very thin, it becomes a border-line explosion because it's fibrous. I can break out a big hole with my turning tool for no apparent reason," he says. "I can stabilize the material with cyanoacrylate, but if I happen to cut myself out of the area where the cyanoacrylate has penetrated, I might blow out a big hole. So the material can limit what I'm able to do with it." ♣

Written by **Peter J. Stephano**
Photographs: **Tom Brownold**



"The high-speed steel cutting tip actually shears the end grain, although it looks as if I'm scraping because there are no long curls," says Galen.



With the outside of the bowl turned to shape, Galen turns his attention to the inside with a Thompson hollowing tool. After the bowl has been finely sanded, he'll finish it with three or four coats of Waterlox, a tung-oil based clear finish.

sliding table add-on

make your tablesaw a
high-capacity crosscutter



You can buy a multitude of accessories for making crosscuts on tablesaws. Everything from souped-up miter gauges to platforms that sit atop the tablesaw. But none of these gadgets tops a sliding table for convenience, control, and capacity. Here's one you can build in your own shop.

Note: This sliding accessory fits on tablesaws with left sides unobstructed by cranks or tilting motors, such as most Craftsman and Ridgid models. In this article we mounted the attachment to a Ridgid model TS2424. You may need to make modifications to the design presented here depending on the construction of your tablesaw.

If your saw is not a candidate for this add-on, you may want to purchase a manufactured sliding table. Delta sells one for under \$350 (800/438-2486, in Canada 519/836-2840); Laguna Tools carries two models priced at \$795 and \$945 (800/234-1976); and you can purchase Excalibur sliding tables priced from \$580 to \$800 (800/357-4118).

By the numbers: How this slider provides a big assist in the shop

With this attachment pulled completely forward, you can place workpieces up to 28" wide between a tablesaw's fully raised blade and the sliding-table's fence set for a 90° cut. The sliding-table surface extends 22" to the left of the blade, and its fence is 38" long, so trimming the end of a 4'-long piece should be manageable without the help of an assistant or other support.

First, let's build the accessory table

1 Cut the table upright (A), table supports (B), and table panels (C) from birch plywood according to the dimensions in the Bill of Materials on page 57.

2 Mark, drill, and countersink the $\frac{5}{32}$ " holes in A, where shown in the Table Upright Parts View drawing. Mark and pre-drill the $\frac{1}{4}$ " and $\frac{5}{16}$ " hole locations with a $\frac{1}{32}$ " bit in a drill press. (You'll drill these holes to full size later.)

3 Secure part A in your bench vise and clamp the aluminum guide blocks and guide rail to A, as shown in the Marking the Tapped Holes in the Guide Blocks drawing. Use a hand drill and $\frac{1}{32}$ " bit to mark the locations of the $\frac{1}{4}$ " and $\frac{5}{16}$ " holes onto the guide blocks.

4 Mark the location and orientation of the guide blocks on part A, and unclamp them. Also mark the guide blocks and the plastic UHMW wear blocks within them that's closest to A. Your marks will enable you to remove and replace the UHMW wear block in its same location later.

5 Drill the $\frac{1}{4}$ " and $\frac{5}{16}$ " holes in part A, where shown at right.

6 Remove the marked UHMW wear blocks. On your drill press, bore the $\frac{1}{32}$ " holes, where marked on the guide blocks. Tap these holes with a $\frac{1}{4}$ -20 tap. Use threading lubricant for best results. Remove any burrs with a file, and replace the UHMW wear blocks.

7 Lay out and cut the table supports (B) using the Parts View drawing as a guide. Cut the holes with a circle cutter, or mark them with a compass and cut with a jigsaw.

8 Align and clamp the supports to A. Drill $\frac{7}{64}$ " pilot holes into the supports using the $\frac{5}{32}$ " holes in A as guides. Unclamp the supports, and attach them with glue and screws.

9 Cut two pieces of $13\frac{1}{2} \times 27\frac{1}{2}$ " plastic laminate for the table panels (C). (The $27\frac{1}{2}$ " dimension will vary for saws with tops that aren't 27" deep. Make this dimension $\frac{1}{2}$ " larger than the table depth.) Adhere one piece to each side of the table panels (C) with contact adhesive, and trim flush with a router.

10 Drill and countersink holes in the bottom table panel, where shown on the Table Exploded View.

11 Attach the bottom table panel to the uprights (B) with screws driven into piloted holes.

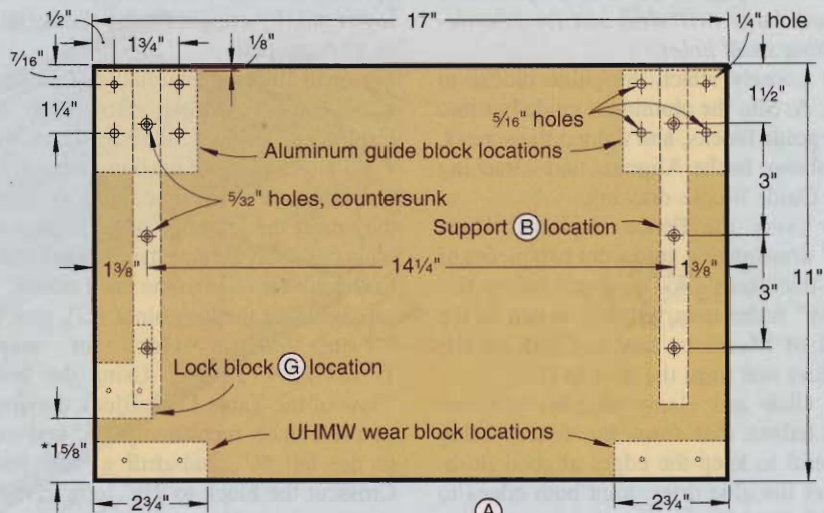

*Determined by location of (F).

TABLE UPRIGHT

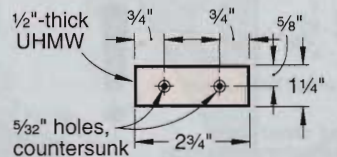

UHMW WEAR BLOCK
(2 needed)

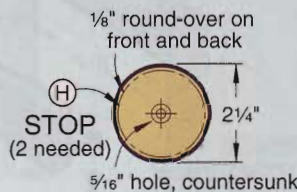

STOP
(2 needed)

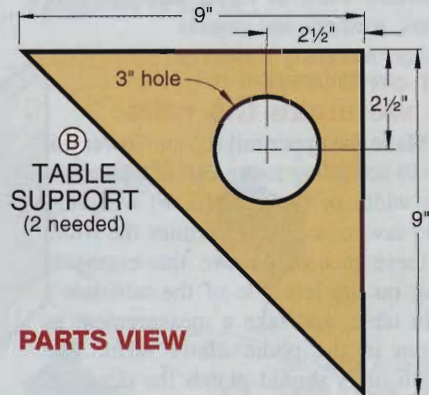

PARTS VIEW

12 With a dado set, cut the grooves for the mini channel in the remaining table panel where shown.

13 Glue and clamp the two table panels together, being careful to keep the edges flush. Sand a $\frac{1}{4}$ " radius on the four corners. Fill the edge voids with automotive body filler, and sand smooth.

Add the heavy hardware and fence

1 Cut two pieces of mini channel to 27" long. Align your drill-press fence to keep its $\frac{3}{16}$ " bit centered on the channel. Drill holes into the channel spaced $1\frac{1}{2}$ " from both ends and 4" apart from each other. Countersink the holes, and remove any burrs with a file. Secure the mini channel with screws.

Continued

MARKING THE TAPPED HOLES IN THE GUIDE BLOCKS

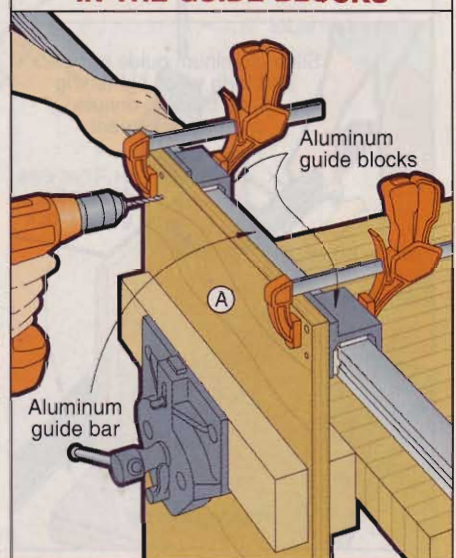

sliding table add-on

Note: See page 39 for a nifty tip on how to use large twist drill bits for countersinking small holes.

2 Loosely attach the guide blocks to A. Slip the aluminum guide bar into the guide blocks, and tighten the screws, as shown in the Aligning and Attaching the Guide Blocks drawing.

3 Using the Fence Exploded View drawing as a guide, cut two pieces of $\frac{3}{4}$ "-thick maple for the fence halves (D) to $\frac{1}{8}$ " wider than the size shown in the Bill of Materials. Lay out and cut the dados that form the slots in D.

4 Glue and clamp together the two halves that form the fence, being careful to keep the edges aligned flush. After the glue dries, joint both edges to finished width.

5 Grind the heads of two carriage bolts, as described in the Fence Exploded View at right. Add the long knobs, washers, and gaskets.

All on board as we make the rails

1 Make the upper rail (E) and lower rail (F) according to the Bill of Materials. The width of the rails (E, F) will vary from saw to saw. To determine the width of these pieces, remove the extension wing on the left side of the tablesaw's main table, and take a measurement as shown in the photo above right. The length of E should match the depth of your tablesaw cabinet.

We used 8/4 maple to make these parts, but you could laminate $\frac{3}{4}$ " stock to make

up the thickness. Be sure to joint the lower rail (F) straight for the sliding table to work properly.

2 Drill and countersink the $\frac{3}{8}$ " holes in E and F, where shown on the Exploded View and Side View drawings.

3 Place a piece of masking tape on the tablesaw's rip-fence rail(s) where they meet the left edge of the tablesaw's main table. On the tape make a mark that's flush with the edge of the main table.

4 To make the lock block (G), glue up and cut a block of maple $1\frac{1}{2} \times 1\frac{1}{2} \times 2\frac{3}{4}$ " in size. Using the Front View of the Table Lock Block drawings as a reference, measure up $2\frac{1}{2}$ " and over to the left $\frac{3}{8}$ ", and drill a $\frac{1}{16}$ " hole. Crosscut the block to $2\frac{1}{2}$ " long to make a radiused notch.



Use a framing square held tight against the table edge, along with a rule, to determine the width of the rails (E, F).

Continued

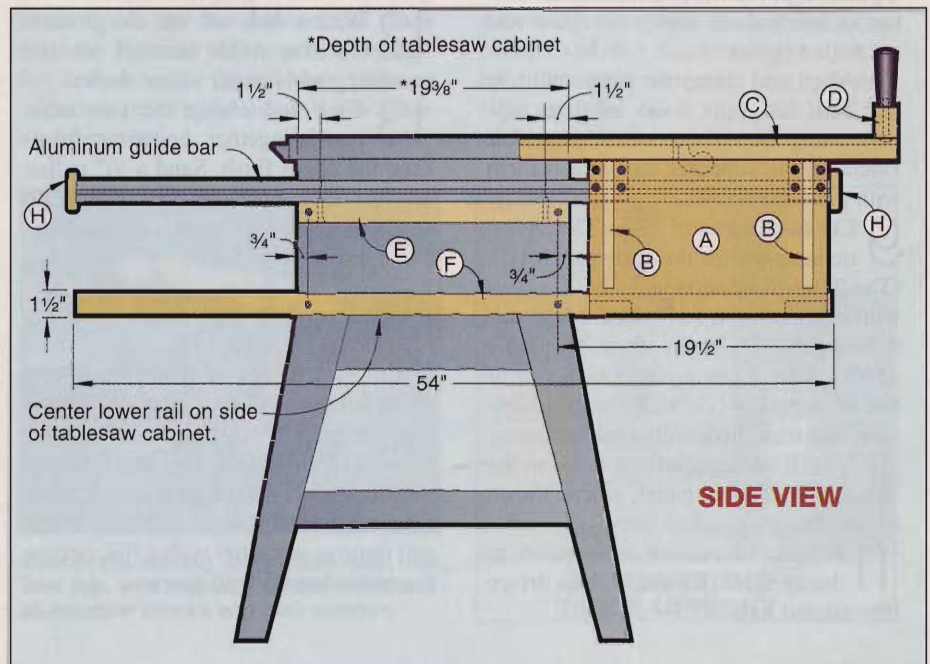
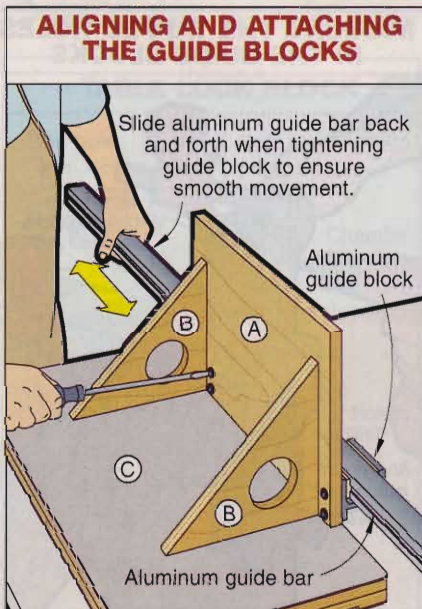
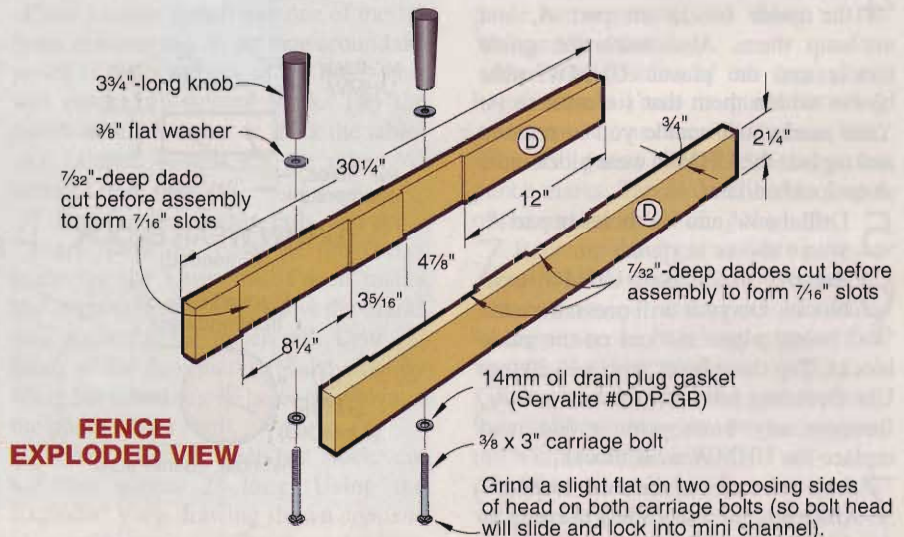

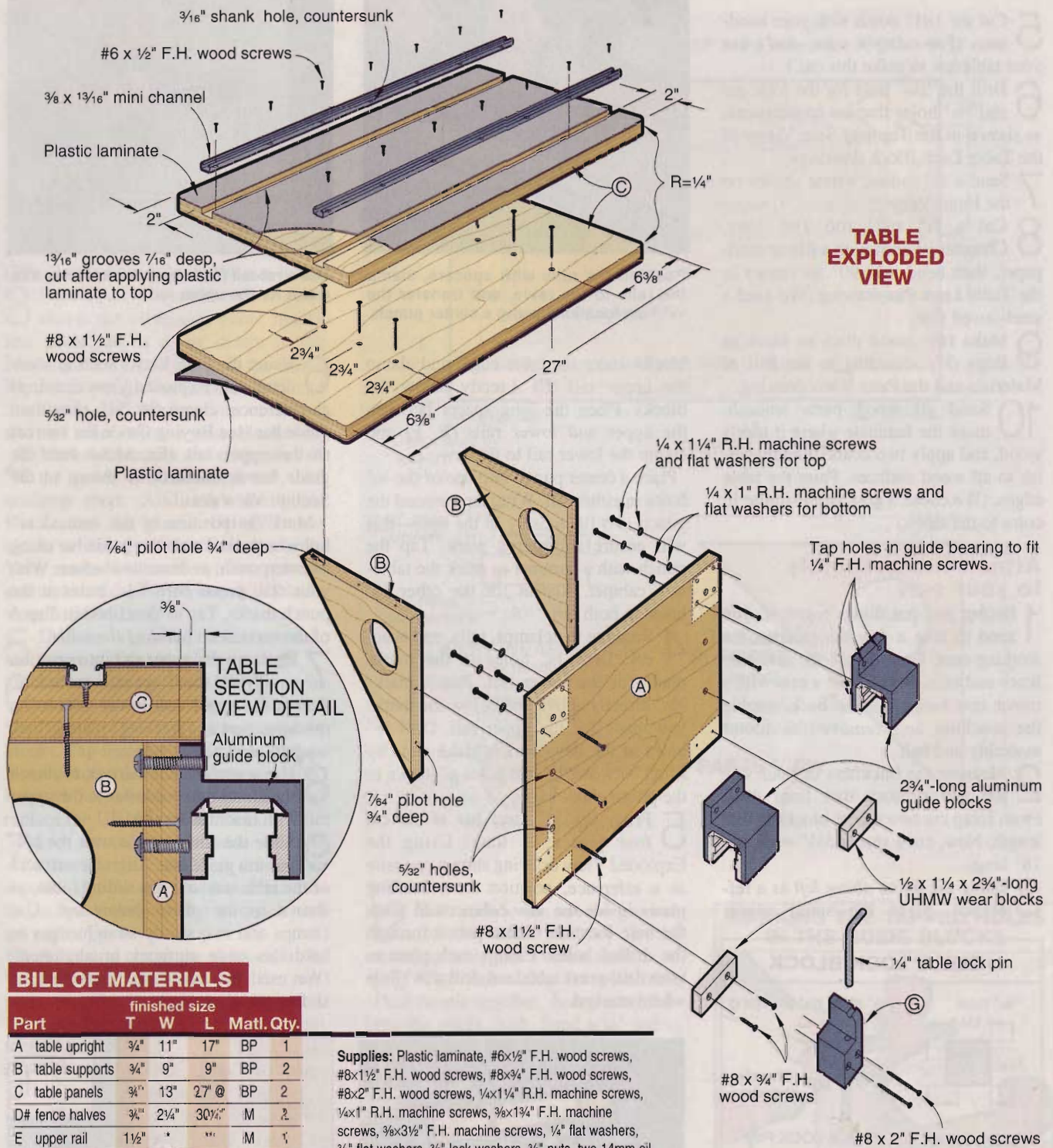

BILL OF MATERIALS

Part	finished size			Matl.	Qty.
	T	W	L		
A table upright	3/4"	11"	17"	BP	1
B table supports	3/4"	9"	9"	BP	2
C table panels	3/4"	13"	27" @	BP	2
D# fence halves	3/4"	2 1/4"	30 1/2"	M	2
E upper rail	1 1/2"	*	**	M	1
F lower rail	1 1/2"	*	54"	M	1
G# lock block	1 1/2"	1 1/2"	2 1/2"	M	1
H stops	3/4"	2 1/4" dia.		M	2

Supplies: Plastic laminate, #6x1/2" F.H. wood screws, #8x1 1/2" F.H. wood screws, #8x3/4" F.H. wood screws, #8x2" F.H. wood screws, 1/4x1 1/4" R.H. machine screws, 1/4x1" R.H. machine screws, 3/8x1 1/4" F.H. machine screws, 3/8x3 1/2" F.H. machine screws, 1/4" flat washers, 3/8" flat washers, 3/8" lock washers, 3/8" nuts, two 14mm oil drain plug gaskets, 1/4" steel rod 3 1/2" long, two 3/8x3" carriage bolts, 5/16x1" F.H. machine screws, 1/4x1 1/2" steel bar stock 1' long, contact adhesive, threading lubricant, oil finish, paint.

Buying Guide

Aluminum guide bar 54" long, two guide blocks, two pieces of 1/2x1 1/4x2 3/4" UHMW, two 27"-long pieces of mini channel, and two long knobs, \$75 ppd. from Kreg Tool Co., 201 Campus Drive, Huxley, IA 50124. Call 800/447-8638.

@This dimension should match the depth of your tablesaw top. Some tables are not 27" deep.
 *Width varies. See instructions.
 **Length varies. See instructions.
 #Initially cut part oversized and trim to finished size according to instructions.
Materials Key: BP—birch plywood, M—maple

sliding table add-on

5 Cut the 1x1" notch with your band-saw. (For safety's sake, don't use your tablesaw to make this cut.)

6 Drill the 1/64" hole for the lock pin and 5/32" holes that are countersunk, as shown in the Top and Side Views of the Table Lock Block drawings.

7 Sand a 1/8" radius, where shown on the Front View.

8 Cut a 1/4" steel rod 3 1/2" long. Chamfer its ends with a file or sandpaper, then bend it at 90°, as shown in the Table Lock Pin drawing. We used a steel-jawed vise.

9 Make two round discs to serve as stops (H) according to the Bill of Materials and the Parts View drawing.

10 Sand all wood parts smooth, mask the laminate where it meets wood, and apply two coats of an oil finish to all wood surfaces. Paint the table edges. (We chose a gray paint similar in color to the table.)

Attach the assembly to your saw

1 Before you put things together, you need to take a few things apart for working ease. First, detach the saw's rip fence and rails. If you have a saw with a motor that hangs out the back, unplug the machine and remove the motor assembly and belt.

2 Measure the thickness of your saw top and subtract that from 4 1/4". From scrap cut two spacer blocks to that length. Now, cut a spacer 5 1/4" wide and 18" long.

3 Using the photo *above left* as a reference, place the small spacer



Position the rails with spacers, clamp the rails to the table, and transfer the 3/8" hole locations using a center punch.

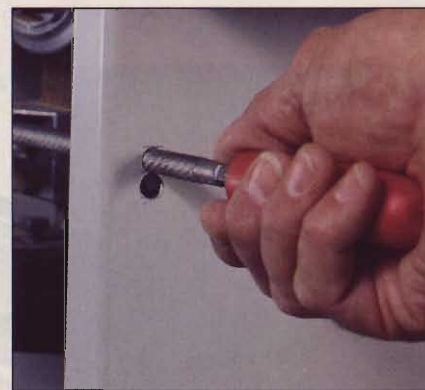

Use a rat-tail file to turn the 3/8" holes into a slot for the upper rail.

blocks under the table edge, and clamp the upper rail (E) directly below the blocks. Place the long spacer between the upper and lower rails (E, F) and clamp the lower rail to the saw.

Place a center punch into one of the 3/8" holes in either rail. Wrap tape around the punch if it fits loosely in the hole—this will ensure a centered mark. Tap the punch with a hammer to mark the tablesaw cabinet. Repeat for the other 3/8" holes in both rails.

4 Remove the clamps, rails, and spacers. Drill 3/8" holes at the marks made for the lower rail. Punch marks 3/16" directly above and below the marks you made for the upper rail. Drill 3/8" holes at the new marks. Make slots by filing between the two holes as shown in the photo *above right*.

5 From 1/4x1 1/2" steel bar stock, cut four pieces 2" long. Using the Exploded View drawing shown *opposite* as a reference, position these backing plates inside the saw cabinet and mark the hole location with a pencil through the drilled holes. Clamp each plate to your drill-press table and drill a 3/8" hole where marked.

6 Using the Side View, Section View detail, and Exploded View drawings as reference, clamp the 54" aluminum guide bar (see Buying Guide for source) to the upper rail (E). Make sure the guide bar is oriented, as shown in the Section View detail.

Mark the position of the vertical 3/8" holes in the rail onto the guide bar using a centerpunch, as described before. With your drill press, bore 1 3/64" holes at the punch marks. Tap as described in *Step 6* of the section on *building the table*.

7 Reclamp the upper rail into position using the small spacers as before. Attach the upper and lower rails using machine screws, backing plates, lock washers, and nuts.

8 Use a stubby screwdriver to attach the aluminum guide bar to the upper rail with machine screws.

9 Slide the sliding table over the aluminum guide bar. Align the surfaces of the tablesaw and the sliding table, as shown in the photo *below left*. Use clamps and two sturdy straightedges to hold the table surfaces in alignment. (We used the saw's rip fence and the sliding table's fence.)

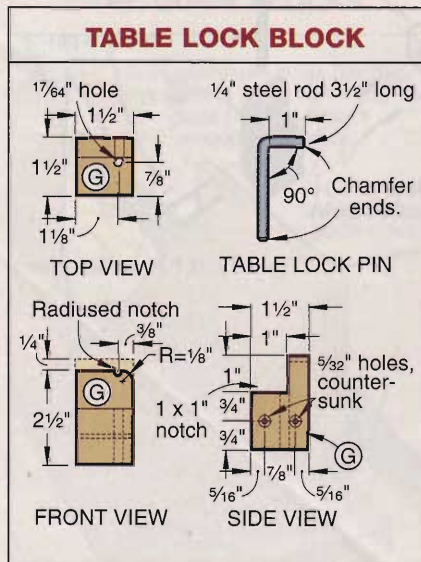

Clamp the sliding table flush with the saw top, and measure for the thickness of the wear blocks and their spacers.

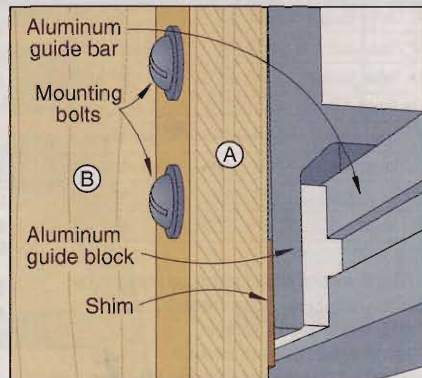

SHIMMING THE TABLE UPRIGHT

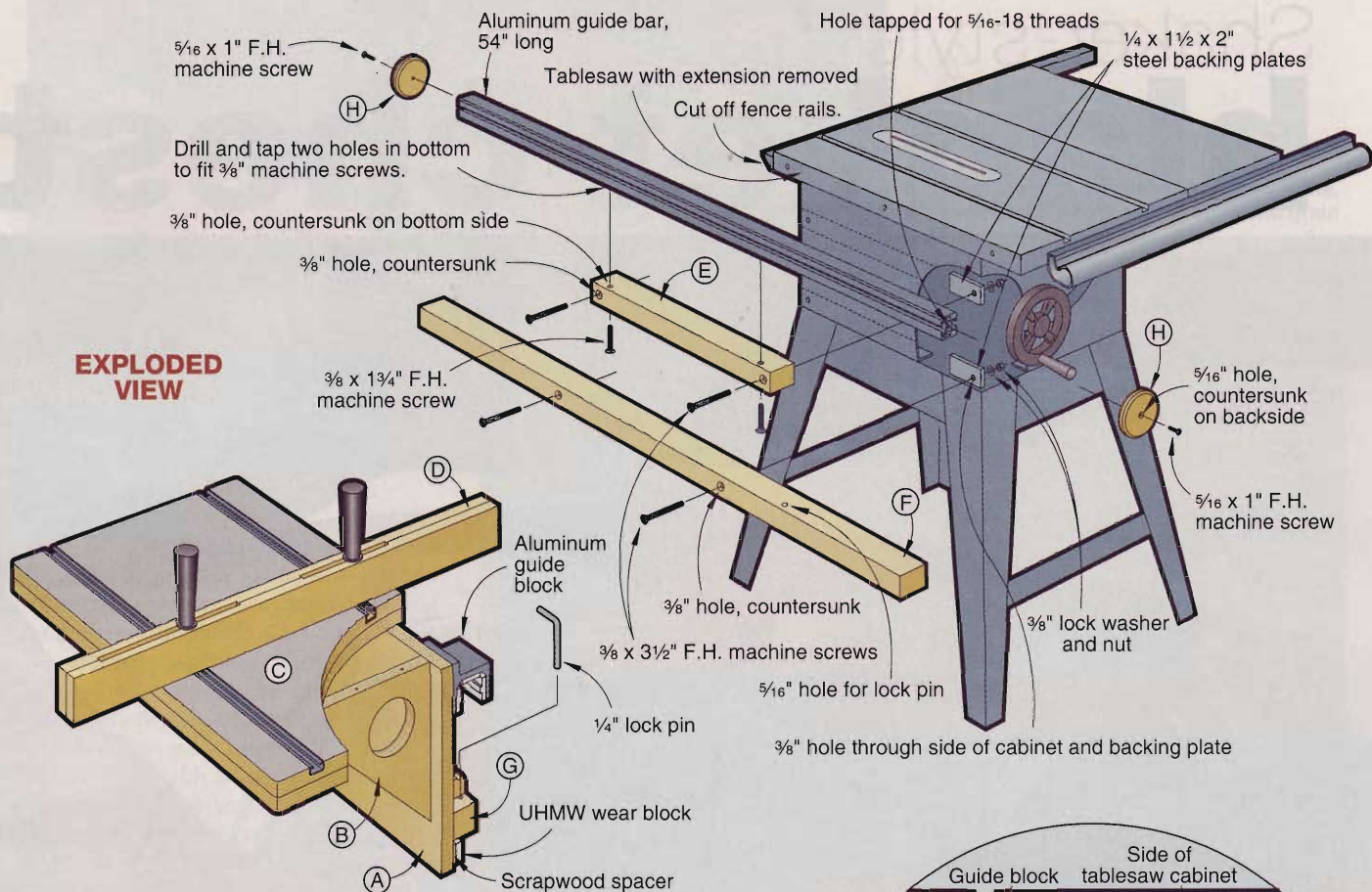

EXPLODED VIEW

Measure the distance between the lower rail and the table upright. From this distance subtract the thickness of the UHMW wear block ($\frac{1}{2}$ "). Make scrapwood spacers that thick and the same width and length of the wear blocks. (We used our bandsaw because of the tablesaw's dismantled state.)

10 Position the lock block $\frac{1}{8}$ " above the rail, and secure it in place with screws. Remove the table, and attach the wear blocks and spacers, as shown in the Section View detail and Table Upright Parts View drawings.

A few final touches, and you're done

1 If the table does not slide easily, you may have to shim it. Before doing this, double-check that the table surfaces still are aligned. Fine-tune the alignment by adding shims (slices of wood, paper, or metal) between the guide blocks and table upright (A) where necessary through trial-and-error. Our table worked best when we added a shim in the spot shown in the Shimming the Table Upright drawing.

2 Align the sliding table and saw table edges flush front and back, and clamp them there. Place a $\frac{1}{4}$ " brad-point bit into the hole in the lock block, and tap the bit to make a mark on the lower rail.

3 Remove the sliding table and lower rail, then drill a $\frac{5}{16}$ " hole where you marked. Use a countersink to cut a $\frac{1}{16}$ " chamfer on the top rim of the drilled hole. Reinstall the sliding table and lower rail.

4 Attach the wood fence (D) with $\frac{3}{8}$ " carriage bolts, knobs, and washers, as shown in the Exploded View and Fence Exploded View. The oil drain plug gaskets shown raise the fence off the sliding table slightly.

5 Tap the holes in the ends of the guide bar with a $\frac{5}{16}$ -18 tap. Screw the stops (H) to the ends of the aluminum guide bar.

6 Cut the rip-fence rails where marked previously with tape. Reattach the rails, and check for interference with the sliding table. You may need to shorten the front rail further.

7 Reattach the motor and put your new sliding table to work! You'll love its velvety-smooth action and increased cutting capacity. 🌲

Written by **Bill Krier** with **Chuck Hedlund**
Project Design: **James R. Downing**
Illustrations: **Kim Downing; Lorna Johnson**
Photographs: **Wm. Hopkins, Hetherington & Associates, Hetherington Photography**

Shaker-style

blanket chest

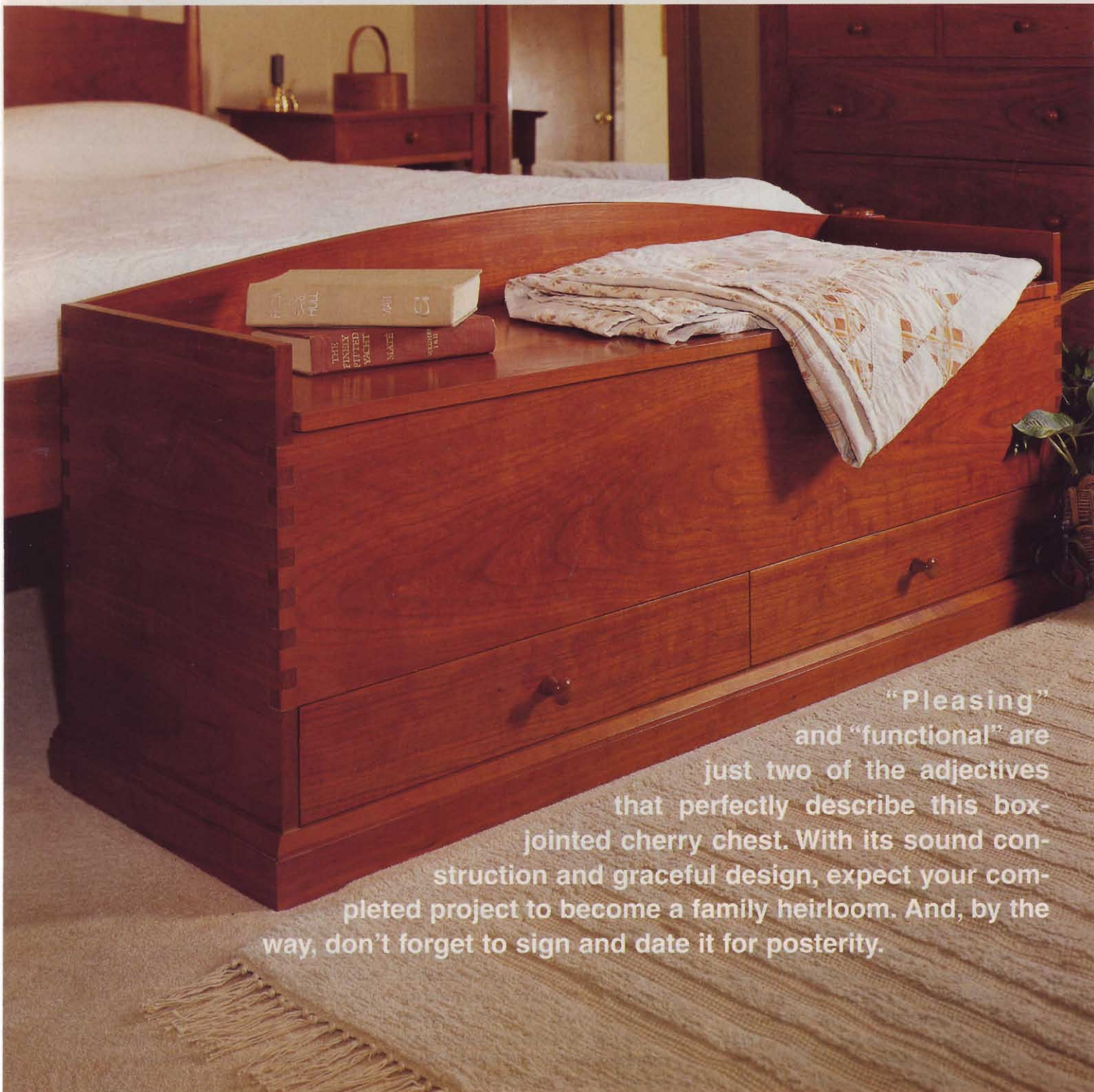

“Pleasing” and “functional” are just two of the adjectives that perfectly describe this box-jointed cherry chest. With its sound construction and graceful design, expect your completed project to become a family heirloom. And, by the way, don’t forget to sign and date it for posterity.

Start with the edge-joined cherry panels

1 Edge-join $\frac{3}{4}$ " cherry to form slightly oversized panels for the back (A), sides (B), front (C), shelf (D), bottom (E), and the lid (F). Use biscuits or splines to join the boards, keeping them several inches from the ends of the glued-up panels and along the top edge of the back (A) that will be cut later. This is to prevent an exposed spline or biscuit later. For more on gluing up solid stock, see *page 43*.

2 Sand the surfaces smooth, and cut the back (A), sides (B), and front panel (C) to the finished size listed in the Bill of Materials.

3 Mark and rout the notch along the bottom edge of the back panel (A), where shown on the Parts View and Routing the Notch drawings.

4 To form the box joints along the ends of the back (A), sides (B), and front (C), start by building the box-joint

jig on *page 66*. Then, see the article on *page 68* for using the jig.

5 Lay out and cut the box joints along the back edge of each side (B), where noted with numeral 1 on the Carcase and Parts View drawings.

6 Align the bottom edges of one side panel (B) with the bottom edge of the back (A). Transfer the location of the mating notches to the back panel as shown in *Photo A*. Use the jig to cut the box joints, where noted with numeral 2 on the drawing and shown in *Photo B*. (We test-cut scrap stock first.)

7 Cut a $\frac{1}{2}$ " rabbet $\frac{1}{4}$ " deep along the front edge of the shelf (D), where shown on the Carcase drawing.

8 Mark the location, and use the jig to cut the box joints in the ends of the front (C). See numeral 3 on the drawing for reference.

9 Using the Parts View as a guide, transfer the notch locations from the front panel (C) to the front edge of

the sides (B). Remove the pin from the jig, and cut the first notch in the front edge of a side (B). Position the pin back in place and finish routing the joints, where noted with numeral 4 on the drawing. Repeat for the front edge of the other side panel.

Form the grooves and cut the curved back next

1 Mark and cut $\frac{3}{4}$ " grooves $\frac{3}{8}$ " deep in the back (A) and sides (B) to fit the shelf (D), bottom panel (E), and lid support (G). To locate the grooves use the dimensions on the Parts View, *being careful to align the grooves with the notches and fingers*, where shown on the drawing. Cut the grooves on the inside face of each panel, keeping the good face out.

2 Repeat the process in step 1 above to cut the $\frac{1}{4}$ " groove $\frac{1}{4}$ " deep along the inside face of the front panel (C) for the shelf (D).

Continued

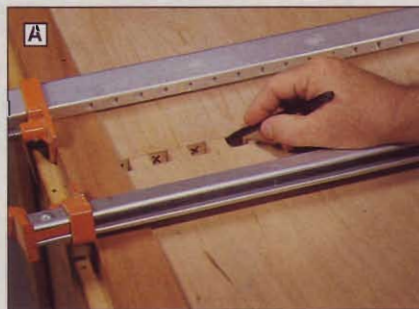
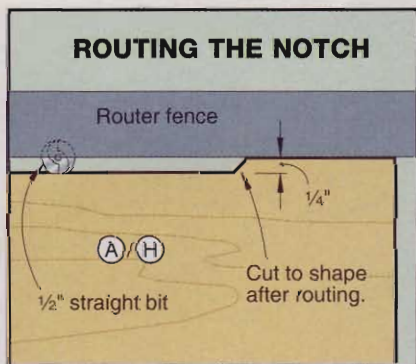

With the bottom edges aligned, mark the notch locations on the back panel.



Use the jig to rout the notches in the ends of the back panel.

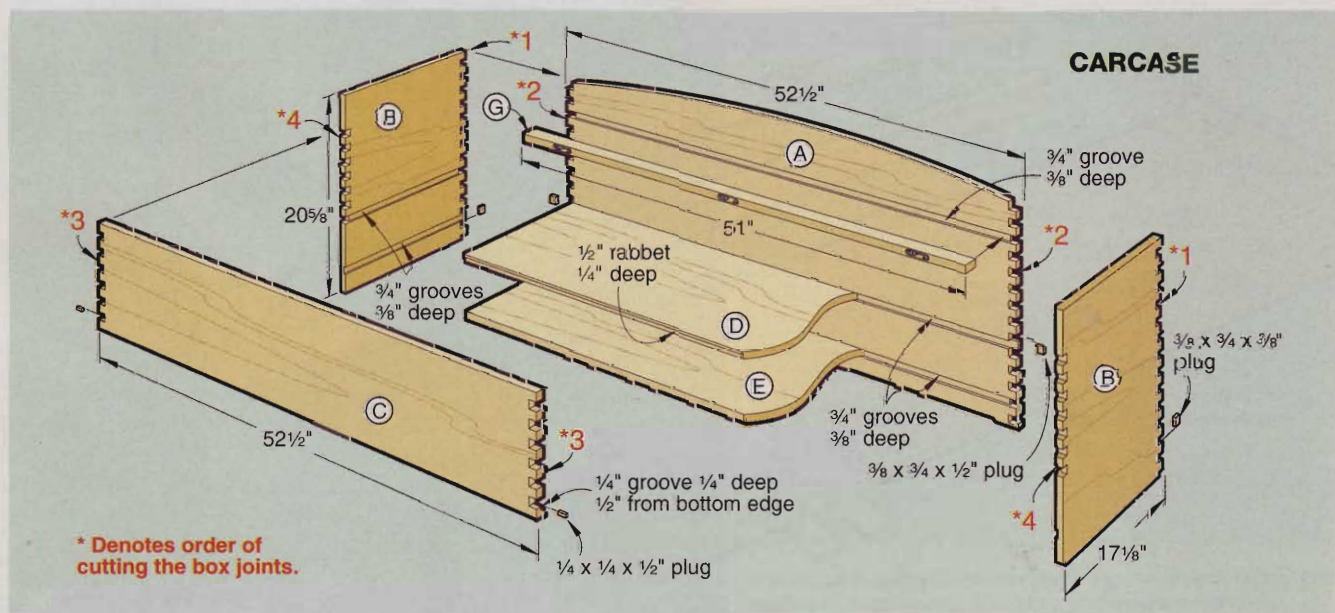

blanket chest

BILL OF MATERIALS

Part	finished size			Matl.	Qty.
	T	W	L		
CARCASE PANELS					
A* back panel	3/4"	22 5/8"	52 1/2"	EC	1
B* side panels	3/4"	20 5/8"	17 1/8"	EC	2
C* front panel	3/4"	9 3/4"	52 1/2"	EC	1
D* shelf	3/4"	16 1/8"	51 3/4"	EC	1
E* bottom panel	3/4"	16 5/8"	51 3/4"	EC	1
F* lid	3/4"	15 1/4"	50 3/4"	EC	1
G lid support	3/4"	1 7/8"	51"	C	1

Part	finished size			Matl.	Qty.
	T	W	L		
BASE TRIM					
H* front	3/4"	2 5/8"	54"	C	1
I* sides	3/4"	2 5/8"	17 7/8"	C	2
DRAWERS					
J fronts	3/4"	4 3/8"	25 1/16"	C	2
K sides	1/2"	4 7/16"	16"	B	4
L backs	1/2"	3 13/16"	24 13/16"	B	2
M bottoms	1/4"	14 9/16"	24 13/16"	BP	2
N guides	1/4"	1 1/2"	14 1/16"	B	4
O guides/stops	1/4"	1 1/2"	15 5/8"	B	2

Note: Cut parts labeled with an * oversize. Trim to finished size according to the how-to instructions.

Materials Key: EC—edge-joined cherry, C—cherry, B—birch, BP—birch plywood.

Supplies: #16x1/2" brads, clear finish.

Buying Guide

Hardware. Three Soss "invisible" hinges, 1/2x2 3/8", catalog no. 140472; two Shaker cherry knobs, 1 1/4" diameter with 1/2" tenon, catalog no. 125437. Woodcraft, 800/225-1153.

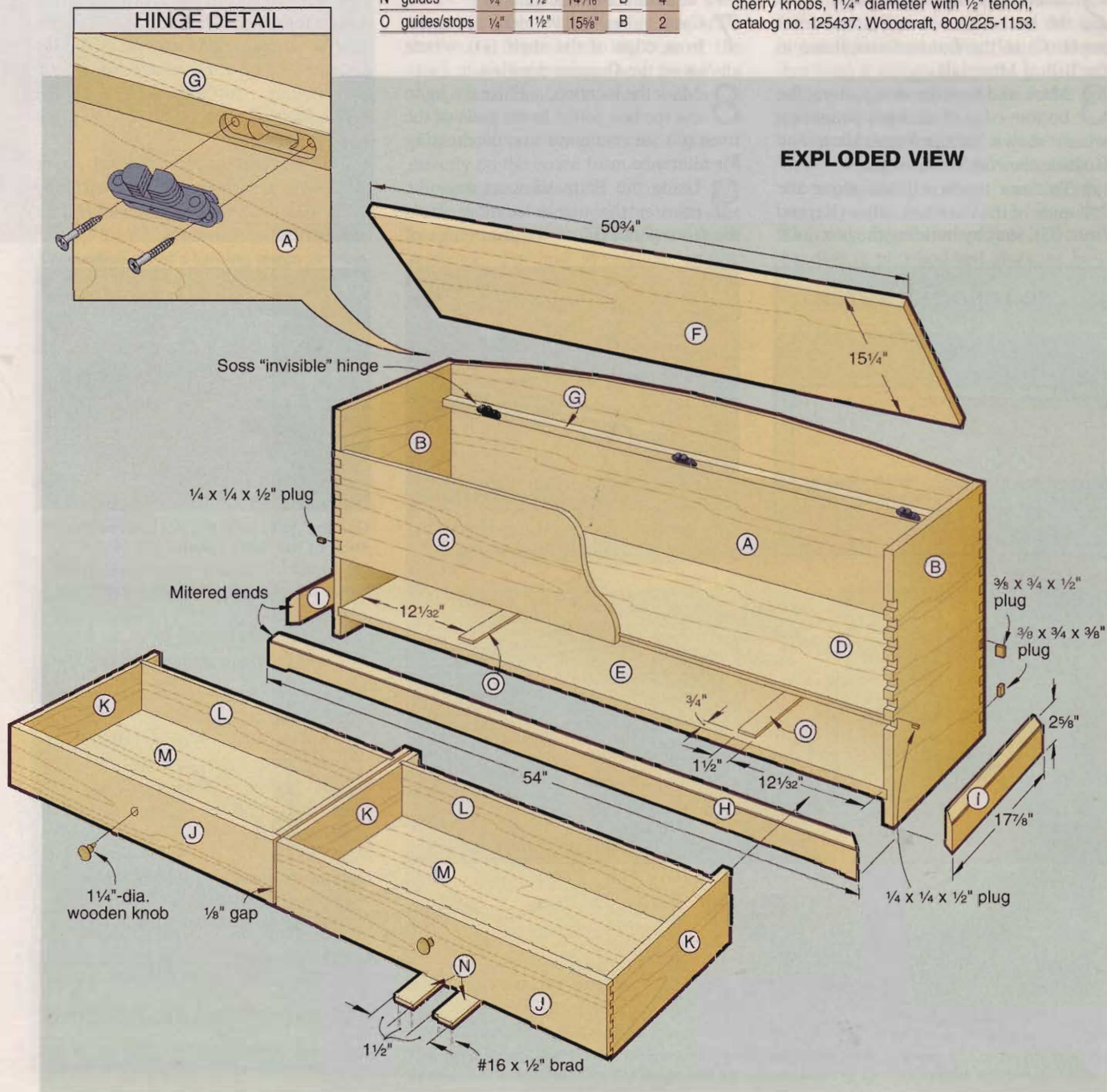

CUTTING DIAGRAM

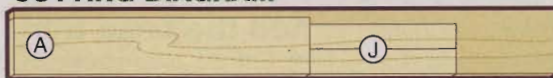

3/4 x 11 1/4 x 96" Cherry

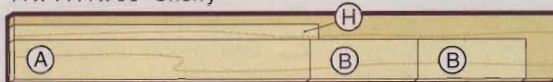

3/4 x 11 1/4 x 96" Cherry

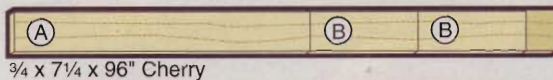

3/4 x 7 1/4 x 96" Cherry



3/4 x 11 1/4 x 96" Cherry



3/4 x 7 1/4 x 60" Cherry (3 needed)



3/4 x 7 1/4 x 60" Cherry (3 needed)

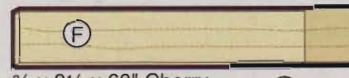

3/4 x 9 1/4 x 60" Cherry



3/4 x 11 1/4 x 60" Cherry



1/2 x 9 1/4 x 96" Birch

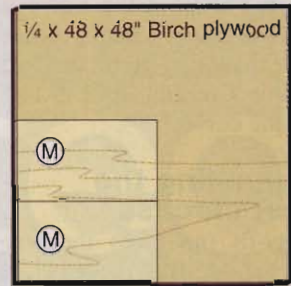

1/4 x 48 x 48" Birch plywood

*Plane or resaw to the thickness listed in the Bill of Materials.

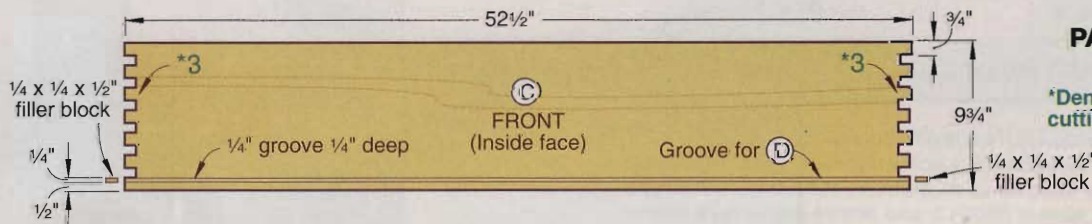
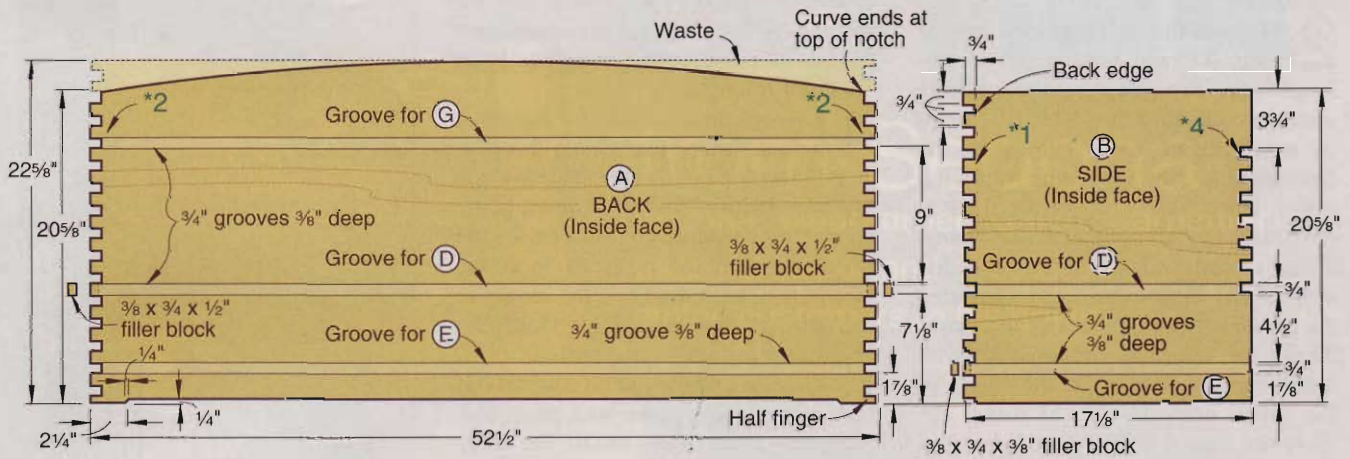

PARTS VIEW

*Denotes order of cutting the box joints.

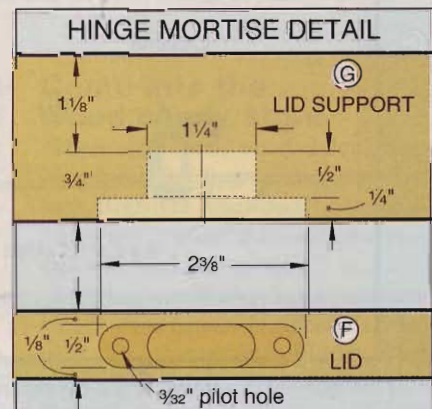
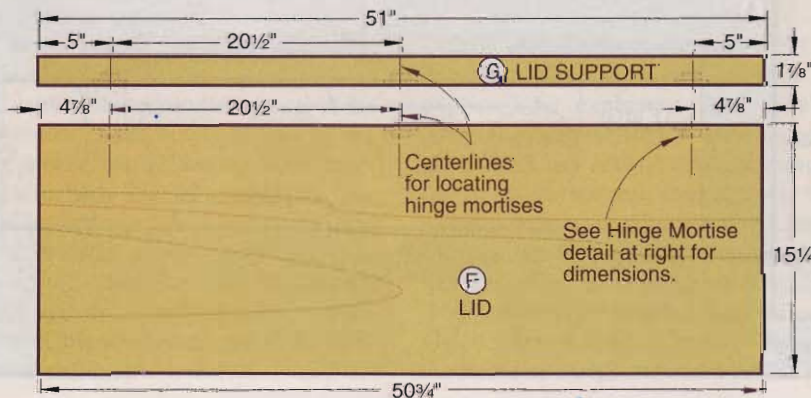

Continued

blanket chest

3 To fill the voids created in the fingers when cutting the grooves, cut filler blocks to the sizes noted on the Parts View drawing. Glue the blocks in place, and later sand smooth.

4 Lay out the curve along the top edge of the back panel (A). (We used a $\frac{1}{4} \times \frac{3}{4} \times 60$ " fairing stick to ensure a smooth curve.) Be careful to align the ends of the curve with the top of the top box joints, where shown on the Back pattern on the Parts View drawing. Cut and sand to the line to form the curve.

Assembling the chest carcase

1 Dry-fit (no glue) the box-jointed panels (A, B, C) together, checking for square.

2 Measure the openings, and cut the shelf (D) and bottom (E) to finished size. (To measure the opening width, we clamped two $\frac{1}{4} \times 2 \times 12$ " strips of wood together, as shown in the Determining the Opening drawing below. Once both strips bottomed out in the grooves, we tightened the clamp. Then, we removed the clamped-together strips from the carcase, and measured the distance from the ends of the strips. Then, we repeated the process with longer strips to determine the length of the panels needed.) Cut the panels (D, E) to the size of the measured openings less $\frac{1}{8}$ " in width. This is to allow for expansion and contraction.

3 Dry-fit (no glue) the assembly (A–E) to double-check the fit of all the pieces. Once satisfied with the fit, glue and clamp the entire assembly together, checking for square. (We used white glue to lengthen assembly time.) When gluing the shelf (D) in place, apply glue only along the front edge of the panel to allow for movement.

Add the lid pieces

1 Measure and cut the lid support (G) to fit snugly between the sides (B) where shown on the Carcase drawing.

2 Cut the lid (F) to finished size, allowing $\frac{1}{8}$ " clearance on each end and $\frac{3}{8}$ " overhang along the front.

3 Position the lid (F) and the lid support (G) on your workbench. Center G behind F, and clamp the two pieces together. Lay out the centerlines for the invisible hinges using the Parts View for reference.

4 Lay out the mortises for the three hinges using the Hinge Mortise detail accompanying the Parts View drawing. Drill $\frac{1}{2}$ " holes as shown in the Hinge Mortise drawing, and chisel the waste between the holes to form the mortises. Check the fit of the hinges in the mortises. See the Buying Guide for our source for hinges and pulls.

5 Glue and clamp the lid support (G) in the groove in the back panel (A). After the glue dries, install the three hinges to connect the pieces and check the fit.

Add the base trim

1 Cut the base pieces (H, I) to size plus 1" in length.

2 Shape the top front edge of the base pieces using the Forming the Base Trim drawings for reference.

3 Miter-cut the base pieces to length. Mark and cut the bottom edge of the front piece (H) using the same procedure as used to form the bottom edge of the back (A).

4 Glue and clamp the trim pieces (H, I) to the chest.

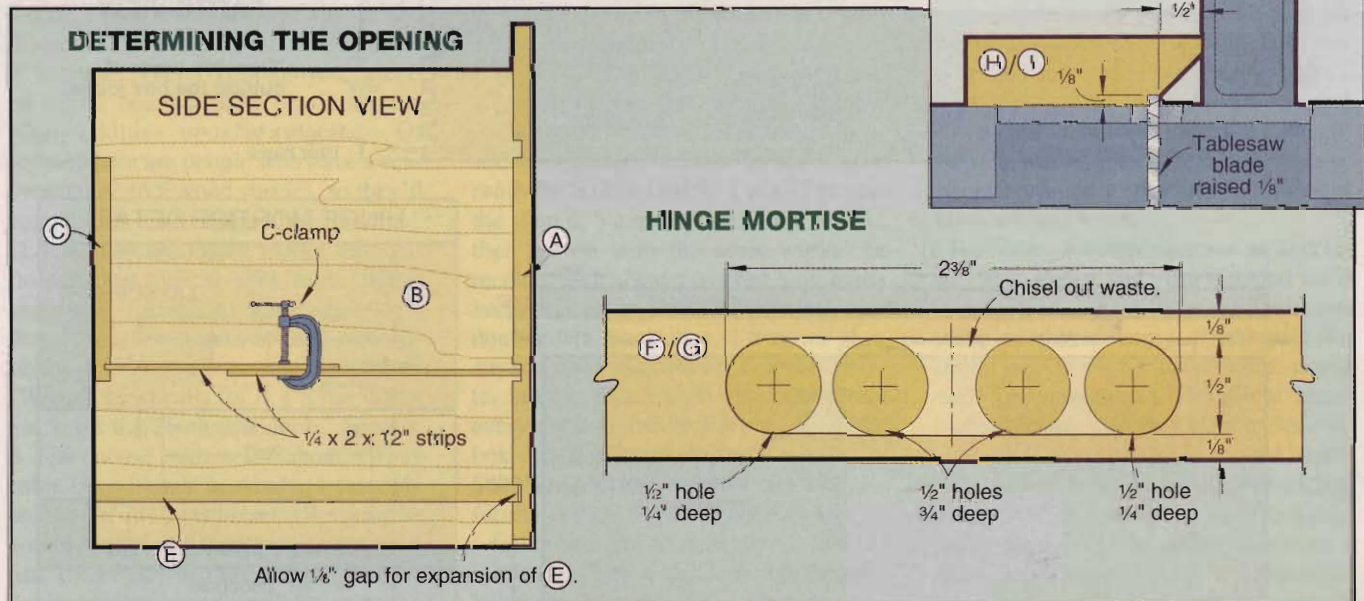

Build a pair of drawers next

1 Cut the drawer fronts (J), sides (K), and backs (L) to the sizes listed in the Bill of Materials.

2 Using a standard 1/2" half-blind dovetail jig, cut the dovetails for the joint between the sides (K) and the front (J). Refer to the instructions that came with your jig for proper setup.

3 Using the same dovetail bit, cut the dovetail dado in the drawer sides (K) to house the back (L). See the Dovetail Top View detail accompanying the Drawer drawing at right for reference. Now, use the same bit in a table-mounted router to cut a dovetail-shaped tenon along the ends of the drawer back (L) to fit tightly into the dovetail groove in the drawer sides. (We cut scrap stock first to verify the fit of the tenon in the dovetail groove before cutting the drawer backs.) Note that while the top edge of the drawer sides (K) and front (J) are flush, the bottom edge of the drawer front sits 1/16" above the bottom edge of the sides.

4 Cut the groove in the drawer sides and fronts for the drawer bottoms.

5 Temporarily clamp each drawer assembly to check the fit. Measure the opening (see the Tip on page 39 for reference), and cut the drawer bottoms (M) to size. Disassemble the drawers, and drill a 1/2" hole into each drawer front (J) for the pull.

6 Glue and clamp each drawer together, checking for square.

7 From 1/4" stock, cut the drawer guides (N, O) to size. Glue and brad-nail the drawer guides (N) to the bottom of the drawer, being careful to keep the guides square with the front of the drawer. Space the guides so part O slides easily between them.

8 Attach the lower drawer guides (O) to the carcass with double-faced tape to ensure proper location and clearance. Once satisfied with the way the drawers slide, nail the guides in place. 🌲

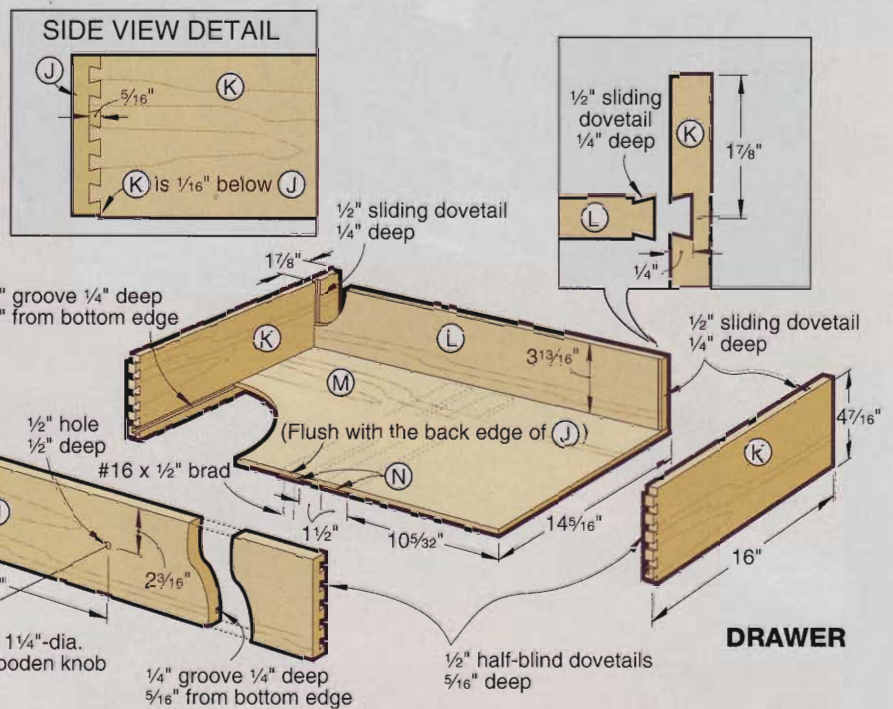

Downloadable Shaker Plans

Looking for even more great Shaker projects? If so, visit the Downloadable Plans section in the WOOD STORE® at WOOD ONLINE®. With the capabilities of today's electronic transmissions and commerce, we are able to offer the finest quality downloadable plans on the Internet.

Visit our Plans Section at <http://woodstore.woodmall.com>

or our Magazine Website at <http://www.woodmagazine.com>

Quilt Stand



Hall Mirror



Hall Table



Written by **Marlen Kemmet**
 Project Design: **James R. Downing**
 Photographs: **Hetherington Photography**
 Illustrations: **Roxanne LeMoine;**
Lorna Johnson



big-time box-joint jig

We cut most box joints on a tablesaw, but large projects like the blanket chest on *page 60* require a different approach. For this big box, we developed a clamp-on jig that works with a hand-held router. It's simple to build and still easier to use.

First, let's make the large parts

1 From $\frac{3}{4}$ " plywood cut parts A, B, and C according to the Bill of Materials. On the plate (A) mark the position of the $\frac{1}{4}$ " carriage-bolt holes and radiused front corners, as shown on the Exploded View drawing. Also mark the location of the $1 \times 3\frac{3}{8}$ " guide-bushing slot shown on the Plate drawing.

2 On the bottom surface of the plate, mark the location of the $\frac{3}{4}$ "-wide, centered groove that runs the length of the plate. Then, mark another $\frac{3}{4}$ "-wide groove on the vertical fence (B) located $\frac{7}{32}$ " from its top edge, as shown on the Exploded View drawing.

3 Fit your router with a 1" straight bit. As shown on the Plate drawing, clamp a straightedge parallel to the marked slot and distanced from the center of the slot by half of the diameter of the router base. Rout the slot completely through the plate in several $\frac{1}{8}$ " passes for best results. The sides of the slot must be smooth, straight, and parallel.

4 Set up a dado blade to cut a groove that's $\frac{1}{4}$ " deep and matches the thickness of your plywood. Cut the marked grooves on the plate (A) and vertical fence (B). You may need to slightly increase the width of the groove in part A so the edge of part B slides smoothly, but not loosely, in it.

A little assembly and you're almost there

1 Glue and clamp the horizontal fence (C) into the groove in part B. Be sure the parts form a 90° angle. After the glue dries, drill and countersink $\frac{3}{32}$ " pilot holes, and secure the parts with $\#8 \times 1\frac{1}{4}$ " flathead wood screws.

2 Clamp the B/C assembly in your bench vise and place the plate (A) on top of it with the top edge of part B sitting in the groove in the plate. Align the part ends and clamp them together. Drill the marked $\frac{1}{4}$ " carriage-bolt holes. Remove the plate, and elongate the two holes in part C $\frac{1}{8}$ " in both directions along the length of the jig.

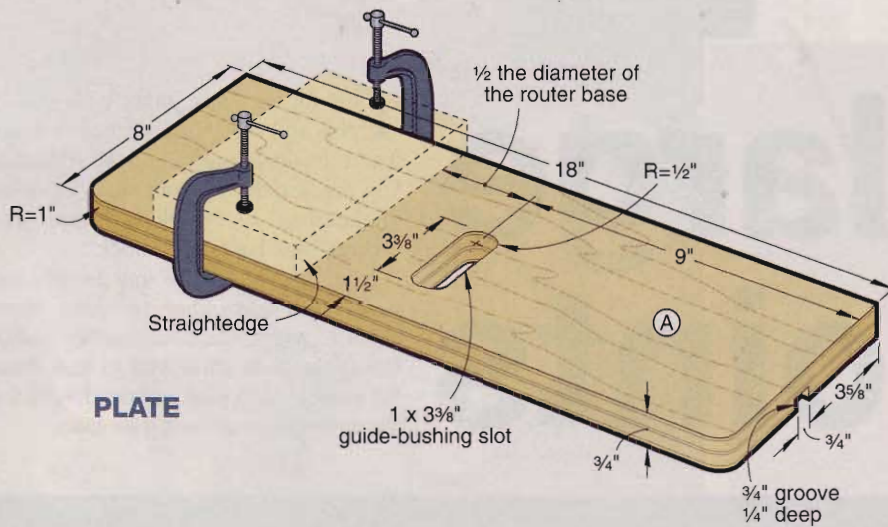

PLATE

BILL OF MATERIALS

Part	finished size			Matl.	Qty.
	T	W	L		
TOP					
A plate	3/4"	8"	18"	P	1
B vert. fence	3/4"	6 1/4"	18"	P	1
C horiz. fence	3/4"	3 3/8"	18"	P	1
D guide pin	3/4"	3/4"	2"	M	1
E key attachment	3/4"	1 1/2"	2 1/2"	P	1

Materials Key: P-plywood, M-maple or other dense wood.

Supplies: #8x1 1/4" flathead wood screws (6), 1/4x2" carriage bolts (2), 1/4" flat washers (2), 1/4" wing nuts (2).

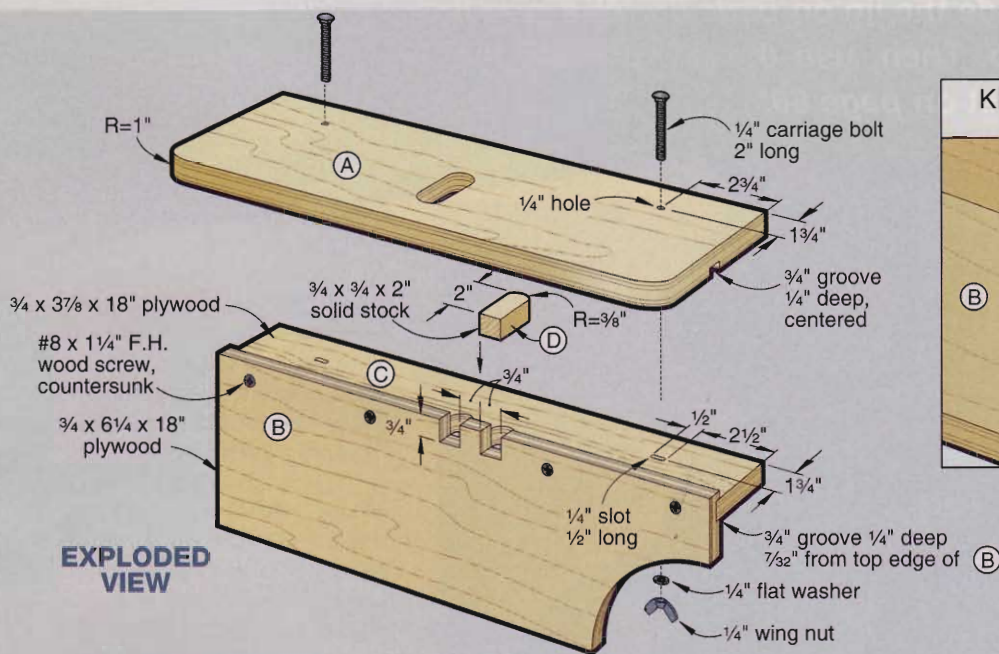

EXPLODED VIEW

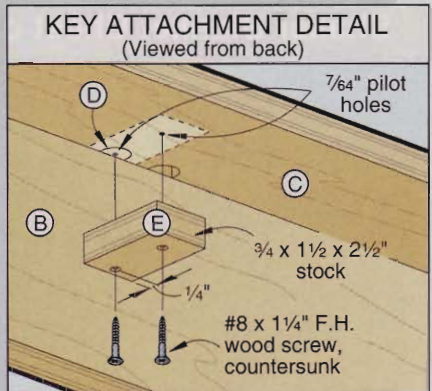

3 Place the plate (A) atop the B/C assembly again, flush their ends, and tap the carriage bolts into their holes. Add the flat washers, and tighten with wing nuts.

4 Mount a 1"-O.D. guide bushing to the baseplate of your router. Add a 3/4" straight bit (we recommend using one with a 1/2" shank), and adjust it so it sticks 1/4" out of the guide bushing. Position the guide bushing in the slot in the plate (A), and rout through assembly B/C. Make progressively deeper cuts until the cut in the assembly is 3/4" deep.

5 Remove the carriage bolts and plate (A). Mark on C the position of the slot that holds the guide pin (D) exactly

3/4" from the slot you cut in the previous step (see Exploded View drawing). Align the slot in the plate (A) atop assembly B/C so your router will cut a 3/4"-deep slot on your marks. Clamp the plate to the assembly, and rout the slot just as you did in the previous step.

Add the guide pin and you'll be cutting joints in no time

1 From solid stock (we used maple), cut a 3/4x3/4x2" guide pin (D). Check its side-to-side fit in the second slot you cut in assembly B/C. It needs to be snug. Now, mark and cut its radiused end to fit in the slot. Place the pin in its slot. Do not glue it.

2 Cut part E according to the Bill of Materials. Flip the jig over and position E over the radiused end of D. (See the Key Attachment Detail.) Drill and countersink 7/64" pilot holes in E that go 1/2" deep into C and D. Attach E to C and D with #8x1 1/4" wood screws.

3 Sand all surfaces and sharp edges. That's it. Now, turn the page to find out how to put this jigstastic joint maker to work. Once you have this jig set up, you'll find it a breeze to make large boxes of many sizes and shapes.

Written by **Bill Krier** with **James R. Downing** and **Jim Boelling**
 Photograph: **Baldwin Photography**
 Illustrations: **Roxanne LeMoine**

perfect panel
LEARN HOW TO USE
how to cut **large**
box joints

This jig cuts box joints with $\frac{3}{4} \times \frac{3}{4}$ " pins and matching notches in stock that's ideally about $\frac{3}{4}$ " thick. Although you can use the jig with stock of other thicknesses, we think $\frac{3}{4}$ " pins and notches look best in $\frac{3}{4}$ " stock.

Your panels can be any length and width, just remember to make them about 1" wider than their finished width. Doing that will allow you to trim them for evenly sized pins and notches at the top and bottom of each joint later.

Now that you've made the jig on *page 66*, let's give it a trial run on scrap. Then, use the jig to make the Shaker Blanket Chest on *page 60*.

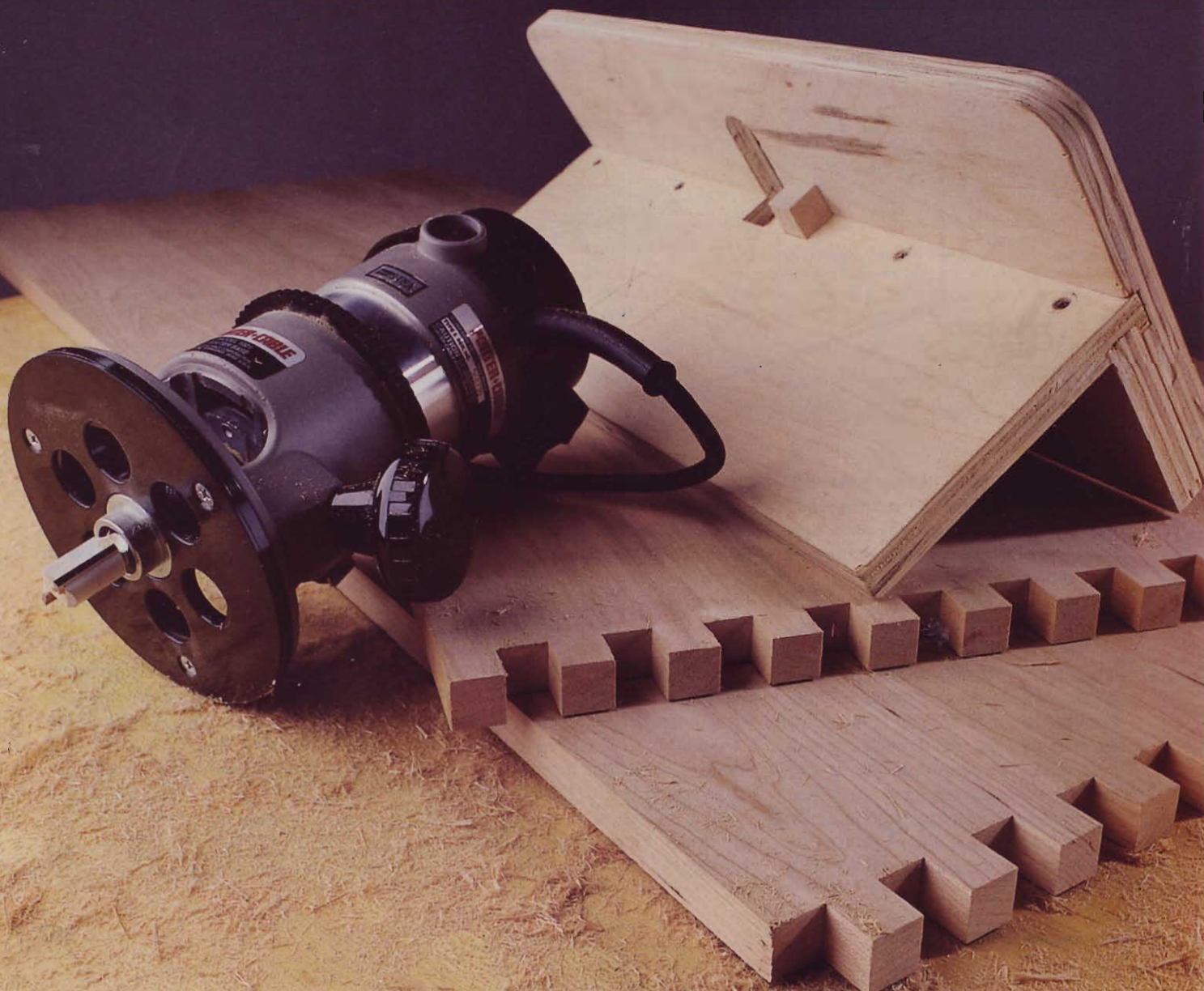

1 Prepare your project panels

Mark the top edges and face sides (the surfaces that will face outward in the assembled box) on each of the four panels. Number each of the adjoining panel ends so that you can match up your adjoining pieces at any point in this machining process.

Grab two panels with adjoining ends. Position the panels face side-to-face side, top edges facing the same direction. Align their ends flush and offset one panel $\frac{3}{4}$ ". (See the Offset Panels drawing *below* that shows two panels after being cut for box joints.) Clamp the panels together and stand them upright so the ends are about chest high. (For the blanket chest panels, we stood the longer of the two clamped panels on the floor and held them upright in a bench vise.)

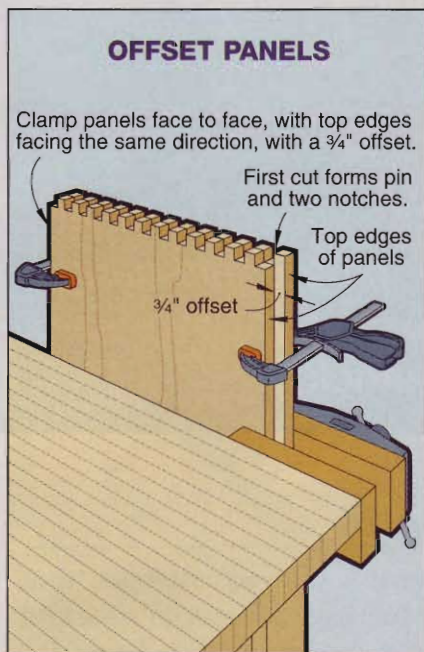

2 Ready your router

Put a 1"-O.D. guide bushing in your router's base, and install a $\frac{3}{4}$ " straight bit. Turn the router upside-down and set the jig on the router's base. Now, adjust the height of the bit using a scrap block that matches the thickness of your panel stock, as shown *below*. Then, raise the bit $\frac{1}{32}$ ".

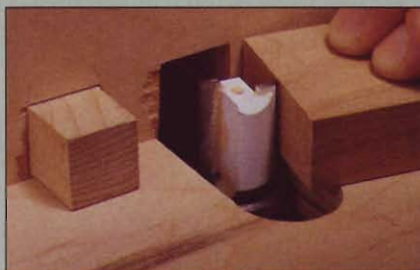

Match the height of the router bit to the thickness of a scrap piece from your panel stock, then raise the bit $\frac{1}{32}$ ".

Now, set the distance between the bit and the jig's guide pin to exactly $\frac{3}{4}$ ". A scrap of $\frac{3}{4}$ "-thick stock works well for doing this, as shown in the photo *below*. To adjust this spacing, loosen the wing nuts, and slide the two horizontal plates of the jig ever so slightly. Retighten the wing nuts.



The bit-to-guide-pin distance should exactly match a $\frac{3}{4}$ "-thick piece of scrap.

3 Rig the jig

Place the jig on top of the clamped panels with its guide pin touching the edge of the workpiece that's offset to your left. Clamp both ends of the jig to the panels. Place the router bit and guide bushing into the end of the jig's slot closest to you. Turn on the router, hold it against the left side of the slot, and push it forward to the other end of the slot to cut a pin and matching notches. Turn off the router and wait for the bit to stop spinning before lifting the router off the jig.

Remove the debris from the jig and panel notches. Place the guide pin into the notch you just cut, and repeat the process, as shown at *right*, until you cut all the way to the other edge of the panel. For all of the cuts, remember to hold the bushing against the left side of the jig slot to help ensure consistent holes.



Work from your left to right when cutting the pins and matching holes across the ends of two clamped panels.

4 Check your results

You should be able to tap the box joints together by hand. If you have to force them together with a mallet, you may break a pin and the joints will be too tight to hold enough glue. Sloppy joints will prove weak and unattractive.

To fine-tune the box-joint fit, loosen the wing nuts and slide the guide pin closer to the bit in the case of too-tight

joints. Sliding the guide pin further away from the bit will result in tighter joints. Be patient with this step; it may take several trials with very slight adjustments to get things right.

Also check that the ends of the pins stick slightly out of the notches so you can sand the joints flush. If the pins are short, increase the depth of the router-

bit cut. In the event the pins are too long, decrease the cutting depth.

Trim the panels to width, being careful to leave evenly sized pins and matching notches at both panel edges. Add some glue and clamp two panels at a 90° angle, then glue and clamp the other two panels. After the glue dries, glue and clamp these two assemblies. ♣

dampness detectives



We test the waters with ten moisture meters that gauge the dryness of your wood-working stock.

Wood that's too wet when you work it can wreak havoc with your projects. Too much moisture warps tabletops, checks the ends of boards, cracks legs, and results in loose-fitting joints. Stock that's too dry also causes problems: When relative humidity climbs, the wood swells, causing doors and drawers to stick. In extreme cases, this swelling can even blow apart your fine joinery.

To prevent such catastrophic results, your stock's *equilibrium moisture content* (EMC) must be in sync with your climate (see box at right). The job of measuring EMC falls to a moisture meter. And to help you choose the right one for your needs, we tested the ten models shown at right, ranging from \$60 to \$285.

How dry is dry enough?

For building indoor projects in most of the U.S., you'll get best results when your stock's EMC lies in the 7–10 percent range. However, in areas with higher or lower average relative humidities, you could see EMCs as high as 11 percent or as low as 6 percent.

So what's the optimum moisture content for your project wood? The best way to find out is to take an EMC reading on a piece of wooden furniture that has been around your home for a while, and use this as a benchmark for checking new stock.

Once your stock reaches that benchmark, it has acclimated to the environment where it will be used, and you can begin working it. Sure, it's hard to resist the excitement of starting a new project, but waiting before you dive in beats watching your project self-destruct before your eyes.

Pin-pointing EMC: One way to get the story

Seven of the meters we tested detect moisture content via a pair of pins, spaced 3/4–1" apart, that you push or drive into the wood. Activating a switch sends a slight electrical charge down one pin, through the wood, up the other pin and back to the meter (as shown in the photo at right). Internal circuitry then measures the electrical conductance between the pins (wet wood conducts electricity more readily than dry wood), and converts that measurement to an EMC reading.

Pin-type moisture meters have lots of going for them. First, wood dries from the outside in, and the pins read moisture below the surface where its average content usually is located. With a pinned meter you also can take readings on the edges of thin boards or moldings, or even end grain.

Some pinned models provide jacks for you to add external probes that you place at different points in a stack of wood and connect with leads to the meter. Or, plug in a hammer electrode (an accessory with longer pins than the meter's built-in pins) to take readings at several different depths. This process helps detect an uneven drying condition called a *moisture gradient*. A moisture gradient can cause problems when machining exposes a wetter interior, especially with thicker material, such as turning stock. (See the chart at the end of this article to see which models have jacks to accept external probes.)

Pin-type meters have one drawback—they make small holes that mar the surface of the wood. Usually you can plan a project so that the holes end up on the back or inside of a piece. But we can't recommend that you take a pin-type meter to an exotic hardwoods dealer and punch a bunch of holes in stock you haven't paid for yet.

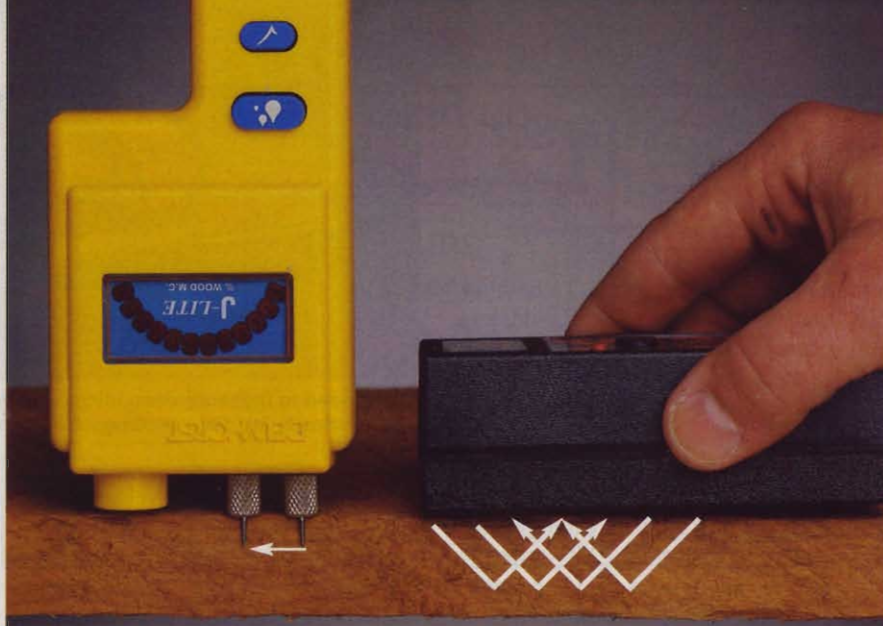

Meters with pins, such as the Delmhorst J-Lite at left, are sometimes called "resistance" meters, although they measure the wood's conductivity. Pinless meters, such as the Wagner L606 at right, are also known as electromagnetic meters because they use radio waves to measure wood moisture.

Pinless meters: Look ma, no holes

The three pinless moisture meters in our tests operate on a different principle. These broadcast electromagnetic radio waves, such as those shown in the photo above, and measure the rate at which the waves bounce back to the meter, a process akin to radar. This determines the board's density, and—within the same species—the denser a board, the more moisture it contains.

Pinless meters have two advantages over pin-type sensors. First, they don't leave any holes behind after testing. An emitter pad simply contacts the surface of the wood. And, by moving a pinless meter along the entire surface of a board, you'll quickly learn its moisture content at many different points, rather than just in a small area.

Trouble is, pinless-meter readings can be affected by tight grain, hidden knots, or the smoothness of the wood surface. (On rough-sawn lumber, the emitter rests on the tops of the "hills" left by the sawmill; tiny air spaces between the

emitter and the "valleys" effect a pinless meter's accuracy.) Even another piece of stock directly below the piece you're testing can throw off the reading. That's why the meter's instruction manual warns you to keep at least 1" of clear air space below the test area.

Also, because the meter's emitter pad requires more surface area than just a couple of pins, pinless meters don't read thin edges or small pieces well. And you can't connect an external probe to a pinless meter, so you're limited to testing boards outside a stack, or pulling a board out of a stack for scanning.

Hot from the oven: How we tested the meters

For our tests, we cut dozens of samples of air-dried red oak, and kiln-dried red oak and cherry, then took moisture readings of the samples with each meter. To determine the actual moisture content of each sample, we used an oven-drying test developed by the U.S. Department of Agriculture's Forest Products Laboratory. *Continued*

MEET THE METERS IN OUR TEST



dampness detectives

This procedure involves weighing each sample on a jeweler's scale, slowly baking the moisture out of the wood, then weighing the samples again. (To be sure we'd removed all the water we could, we baked the samples an additional 4 hours, and weighed them a third time.) A simple calculation gave us the true initial moisture-content of each sample.

As the Rating The Readings chart below shows, all of the meters read our kiln-dried red oak samples within about 0.5 percent of the actual EMC—plenty accurate in the crucial 7–10 percent range. On the other hand, none of the meters did well with our wetter air-dried oak, reading 5–8 points off the mark.

On our kiln-dried cherry samples—around 6 percent EMC—all the meters did better. But some, such as the Timber Check, can't even display readings below 6 percent. Remember, though, that from a woodworker's point of view, readings above 20 percent and below 6 percent are moot because you want material with 7–10 percent EMC to ward

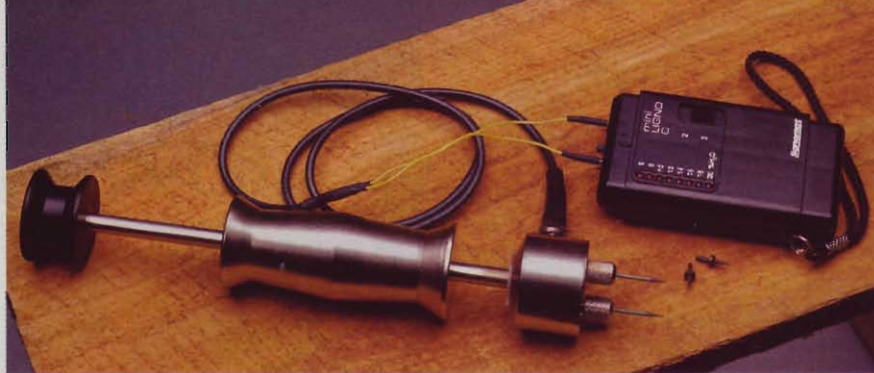

If you need to measure deep into a workpiece, consider a meter that will accept a hammer electrode for deep readings, such as the Lignomat shown.

off shrinkage or swelling-related defects in your projects.

We found that readings taken with external probes (such as the hammer electrode shown in the photo above) were every bit as accurate as those taken with built-in probes. But keep in mind: The external probes can read deeper, and most are insulated except at their tips, so they can give you a picture of moisture levels at different depths.

Other considerations besides accuracy

- **Pin penetration.** All of the pin-type meters have pins at one end of the case.

Remove the cover, grasp the case, and press the pins into the wood. We had no trouble seating the pins on any of the models in our test, but we especially liked the Lignomat meters because the contoured cap, when placed on the other end of the meter, becomes a comfortable push handle.

Besides built-in pins, the Protimeter BLD-5700 comes with an external probe, but because of the probe's small size we had trouble pushing its thick pins into wood samples. (If you often work with thick hardwoods that resist hand-driven pins, we suggest equipping your meter with a hammer electrode.)

- **Reading the results.** Moisture meters display readings in one of three ways—digital; analog; or as a light-emitting diode (LED) bar display, with each LED representing a percentage range. We liked the digital meters because their displays leave no room for interpretation or guessing what the meter is telling you. Analog meters require a little more attention than digital versions because their meters slowly sweep back and forth before settling on a final reading.

If you're going to be using your meter outdoors, you'll find the liquid-crystal (LCD) digital and analog displays easiest to read in direct sunlight. All of the LED-based displays were impossible to read in such conditions, unless shaded by a hand.

- **Species correction.** All but one of the meters in our test are calibrated to the meter-industry standard of Douglas Fir at 70°F. The lone exception is the Timber Check meter, which comes calibrated for red oak.

To account for different wood temperatures, densities, and resistance, most of the meters come with a correction chart you must consult to calibrate the meter to the species you're testing. This can be time-consuming, and some meters come with graph-style charts that are difficult

RATING THE READINGS

MANUFACTURER/ IMPORTER	MODEL	RED OAK #1			RED OAK #2			CHERRY		
		ACTUAL EMC	MEASURED EMC (1)	DIFFERENCE	ACTUAL EMC	MEASURED EMC (1)	DIFFERENCE	ACTUAL EMC	MEASURED EMC (1)	DIFFERENCE
DELMHORST	J-Lite	24.9	18	-6.9	8.7	8.5	-0.2	6.0	7	1.0
	J-4	24.1	18	-6.1	9.0	8.5	-0.5	6.4	<6.5	unknown
ELECTROPHYSICS	MT270	23.8	18.5	-5.3	8.7	9.5	0.8	6.1	6	-0.1
	CT100	23.2	19	-4.2	8.5	8	-0.5	6.1	10	3.9
LIGNOMAT	Mini-Ligno C	24.7	16	-8.7	8.5	8	-0.5	5.7	6	0.3
	Mini-Ligno DXC	23.4	18	-5.4	8.6	8.6	0.0	5.5	5.2	-0.3
PROTIMETER	BLD5700	25.0	18	-7.0	8.7	9.3	0.6	5.6	*	unknown
TIMBER CHECK	B350	23.8	16	-7.8	8.6	8	-0.6	5.4	<6	unknown
WAGNER	L606	20.8	18	-2.8	8.7	9	0.3	5.6	6.5	0.9
	L609	21.1	18	-3.1	8.6	11	2.4	5.8	10	4.2

NOTES:

1. All readings taken with materials at 70°F. Measured EMC readings reflect species correction.

(*) Reading out of meter's range.

HOW THE MOISTURE METERS MEASURE UP

MANUFACTURER/ IMPORTER	MODEL	TYPE	BATTERY TYPE	AUTO SHUT-OFF (1)	DISPLAY STYLE (2)	SPECIES CORRECTION METHOD (3)	CAPACITY			PERFORMANCE RATINGS (5)					ACCESSORIES		WARRANTY (YEARS)	COUNTRY OF ASSEMBLY (7)	SELLING PRICE (8)	COMMENTS
							RANGE (PERCENT)	DEPTH OF PENETRATION (INCHES) (4)	MINIMUM SAMPLE AREA (L x W, INCHES)	CRITICAL RANGE (7-10% ACCURACY)	UPPER RANGE (11-30% ACCURACY)	EASE OF PENETRATION	DISPLAY READABILITY	SPECIES CORRECTION	STANDARD (6)	OPTIONAL (6)				
DELMHORST	J-Lite	pin	9V	Y	BAR	C	6-30	5/16	5/8 x 1/4	E	F	E	G	E	C, P	E	1	USA	\$135	This mid-priced unit will accept an external probe. Though the LED bar display leaves room for guesswork between the steps, it proved plenty accurate in our tests.
	J-4	pin	9V	Y	ANA	C	6-30	5/16	5/8 x 1/4	E	F	E	G	E	C, P	E	1	USA	185	Identical to the J-Lite, but with analog display to remove any guesswork.
ELECTROPHYSICS	MT270	pin	9V	Y	ANA	C	4-30	7/16	3/4 x 1/4	G	G	E	G	G	F, W		2	CAN	110	This meter took longer than other analog meters to settle on a reading. Does not come with case or pin protectors.
	CT100	pinless	9V	N	LCD	I	0-30	1	2 x 2 3/4	E	G	N/A	E	E		F	2	CAN	198	User must manually set species density with a difficult to use chart. Digital LCD readout is a big plus. No auto-shutoff could shorten life of battery.
LIGNOMAT	Mini-Ligno C	pin	9V	Y	BAR	I	6-20	3/16*	1 1/4 x 1/4	G	P	E	G	E	C, P	E, H, R	1	USA	122	A good value that provides internal species-correction, external probe capability, and LED bar display in an affordable, pocket-size package.
	Mini-Ligno DXC	pin	9V	Y	LED	I	5-65	3/16*	1 1/4 x 1/4	E	G	E	G	E	C, P	E, H, R, W	1	USA	199	Our pick of the pinned meters, with digital LED readout that shows EMC in 0.1 increments in the critical range. Other features include internal species-correction and external probe capability.
PROTIMETER	BLD-5700	pin	9V	Y	LCD	C	8-90	7/16	5/8 x 1/4	G	F	E	E	G	C, E, F, P	H, R, T	1	UK	159	A pocket-size meter with long pins for deep measurements and digital LCD display for good readability, even in direct sunlight. Comes with a small external probe that we found hard to drive into hard woods.
TIMBER CHECK	B350	pin	9V	N	ONE	C	6-25+	1/2	1 x 1/4	G	F	E	G	G	P		3	CAN	60	Inexpensive meter seemingly designed with woodworkers in mind. The only meter in the test calibrated to red oak. No auto-shutoff could shorten battery life.
WAGNER	L606	pinless	9V	Y	ANA	C	5-30	3/4	1 1/2 x 2 1/2	E	E	N/A	G	G	C		1	USA	285	Tops of the pinless meter pack, with high accuracy in the critical and non-critical ranges. Also the most expensive in our test.
	L609	pinless	9V	Y	BAR	C	4-22+	1/2	1 x 2 1/2	F	E	N/A	G	E	C		1	USA	135	Least expensive pinless meter in the test, but its accuracy, especially in the critical range, seems to reflect the price.

NOTES:

- (N) No (Y) Yes
- (ANA) Analog (BAR) LED bar (LCD) Liquid-crystal digital (LED) LED digital (ONE) Single LED
- (C) Chart (I) Internal
- For pinned meters, equals length of the pins. For pinless meters, indicates depth of penetration of electromagnetic signal. * 7/16" pins also shipped with meter.
- E** Excellent **G** Good **F** Fair **P** Poor
- (C) Carrying case (E) External probe (F) Field-calibration kit (H) Hammer electrode (P) Extra pins (R) Remote electrode (T) Touch sensor (W) Wires for external probe
- (CAN) Canada (UK) United Kingdom (USA) United States
- Prices accurate at time of article's production.

Where to get more information:

Deilmhorst 800/222-0638 www.deilmhorst.com	Protimeter North America 800/321-4878 www.moisture-meter.com
Electrophysics 800/244-9908 www.electrophysics.on.ca	Timber Check (ComProTec) 613/256-5437
Lignomat 800/227-2105 www.lignomat.com	Wagner Electronics 800/634-9961 www.moisturemeters.com

to read (and easy to lose!). The Electrophysics CT100 and Lignomat meters have species-correction built in. You "tell" the meter what species you're going to test, and the meter automatically adjusts for it.

Now then, which one should you buy?

If you're a turner or the kind of person who likes to mill, stack, and dry your own lumber (or can't pass up a barn full of bargain lumber at an auction), we recommend the Lignomat Mini-Ligno DXC. At \$199 it's one of the higher-priced models, but we feel the DXC's accuracy, internal correction, and exter-

nal-probe capability for checking deep into the material make it worth the extra bucks. If you don't need the external probe and don't mind using a correction chart, the Timber Check—for only \$60—delivers no-frills accuracy.

On the other hand, if you primarily need to ensure the kiln-dried stock you're buying is ready to machine, go pinless. Here, the Wagner L606 showed us a higher degree of accuracy across the broad range of wetness we tested. But that accuracy comes at a price (\$285). For about \$85 less, the Electrophysics CT100 gives near-equal accuracy in the critical range and provides internal species correction. 🍌

Here's your chance to respond to this review

You've heard what we have to say about these moisture meters. Now, log onto the **WOODMALL**® website at www.woodmall.com, and respond to our review. Does your experience with these meters agree with ours? Click on the "Interactive Tool Reviews" button and join the dialogue with the manufacturers and other **WOOD**® magazine readers.

Written by **Jim Hufnagel** with **Dave Campbell**
 Technical consultant: **Dave Henderson**
 Photographs: **Baldwin Photography**

clockwork under glass

Here is a graceful tall clock that looks at home in both traditional and contemporary surroundings. An exposed movement featuring large brass gears gleams through glass panels framed in walnut. Better still, the movement comes as a ready-to-assemble kit. Thanks to the spare detailing, focus is shared by the craftsmanship of the case and the jewel within.

Getting started: Organization is essential

Note: Our clock case consists of two types of frames. For the top, base, and backs, we chose stub-tenon and groove frames with plywood panels glued in place. For the sides and doors, we opted for rabbeted frames fastened with pocket screws. The rabbeted frames house glass panels. Both types of frames have members that are 3/4" thick and 1 1/2" wide.

Parts B, C, E, and F are the same size, but require different milling, depending upon where they are used. For consistent results, do all similar operations at the same time.

1 Prepare enough 3/4x1 1/2" stock for parts A–G. Cut all these parts about 1" longer than listed on the Bill of Materials, and set aside some extra material to use for test cuts. As you cut parts A–G, lay them out on the floor, and mark them with chalk indicating the parts to be grooved for plywood panels and the ones to be rabbeted for glass. Also, mark the edges that get grooved or rabbeted. Note that in the lower case top frame (A, E, L), shown on the Frame Assembly drawing, the two rails (E) have stub tenons but no groove or rabbet.

2 Gather all the parts A–G marked for grooves, and cut the grooves. To get a square-bottom, centered groove of the proper width, use a single blade (not a chipper) from your stack dado set. Make

two passes, one from each side. When making the cuts, control the pieces with feather boards to insure grooves of uniform width and depth.

3 Clamp an auxiliary fence to your tablesaw rip fence. Gather all the parts A–G marked for rabbets and cut the rabbets in the edges. As before, control the pieces with feather boards to insure rabbets of uniform depth and width.

4 Crosscut all the parts A–G to finish length. Attach an auxiliary fence to your tablesaw miter gauge, and use a stopblock to set the length. To insure squareness of the frames, cut all like-lettered pieces at the same time.

5 Form the stub tenons on the grooved case/side rails (E), door/back rails (F), base rails (G), and the two ungrooved case/side rails (E). To allow use of the same setup regardless of the length of the piece, cut the tenons as shown on the Forming the Tenons drawing.

6 Cut the upper case top panel (H), upper case back panel (I), lower case back panel (J), and base panel (K) to the sizes listed on the Bill of Materials. Glue (we used a dark woodworker's glue), assemble, and clamp the upper case top frame (A, E, H), upper case back frame (C, F, I), lower case back frame (B, F, J), and base frame (G, D, K). Glue and clamp the lower case top frame (A, E), cut the filler strips (L), and glue them in the grooves, as shown on the Frame Assembly drawing.

FRAME ASSEMBLY

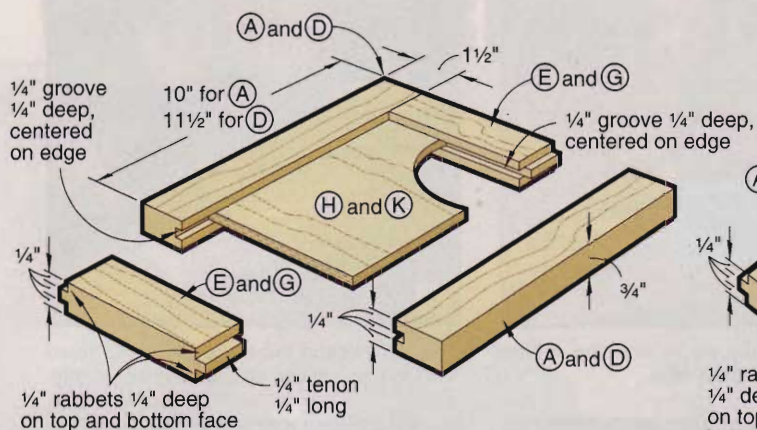

TOP AND BASE FRAMES

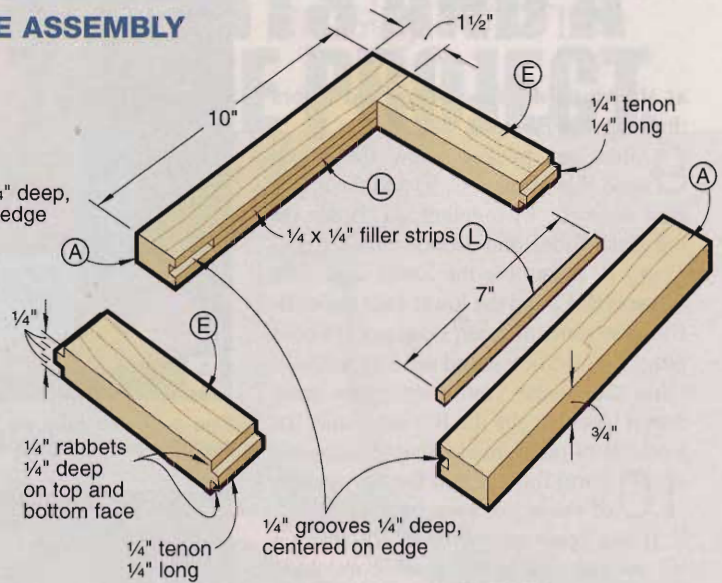

LOWER CASE TOP FRAME

See page 110 for full-size pattern.

FORMING THE TENONS

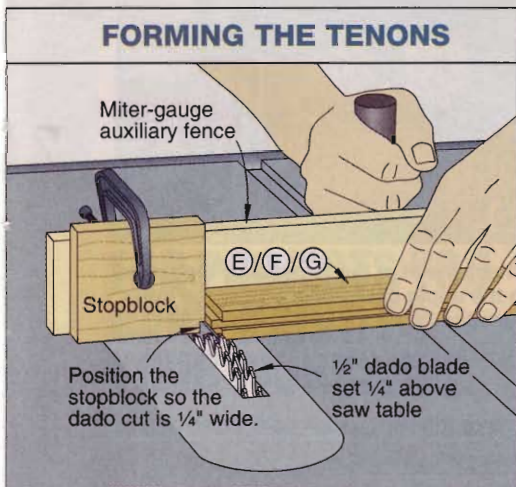

7 Rabbet the ends of the remaining case/side rails (E) and door/back rails (F), as shown on the Case Sides and Doors drawing. Use a setup similar to that shown on the Forming the Tenons drawing. As in Step 5, cut all end rabbets using the same setup. Test-fit this rabbeted rail-to-stile joint carefully. The depth of the rabbets on the ends of the rails must mate with the rabbets on the stiles so the faces of the rails and stiles are flush. The width of the rabbets on the rails and stiles must be equal so the stile doesn't rotate slightly when the joint is pulled together by the pocket screw.

8 Drill the pocket holes in the inside faces of the rabbeted rails (E) and (F),

Continued

CASE SIDES AND DOORS

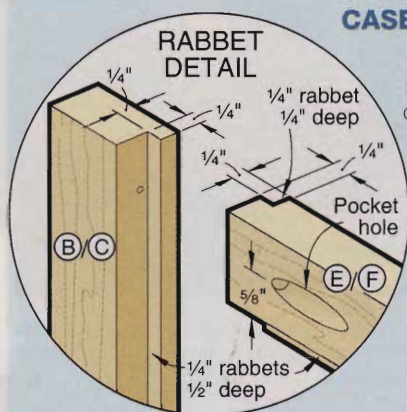

(upper case door shown)

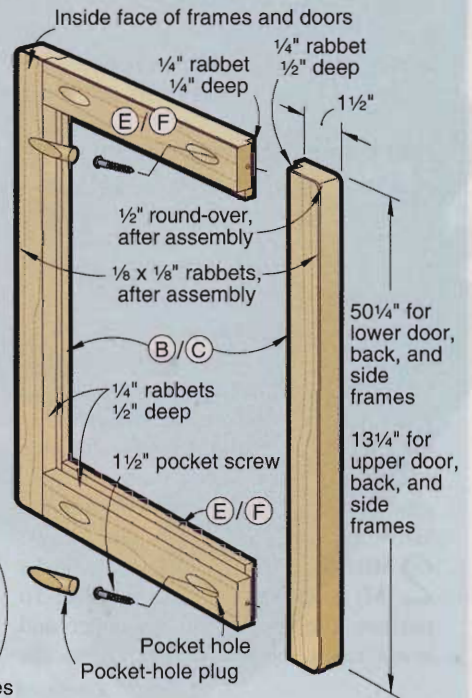
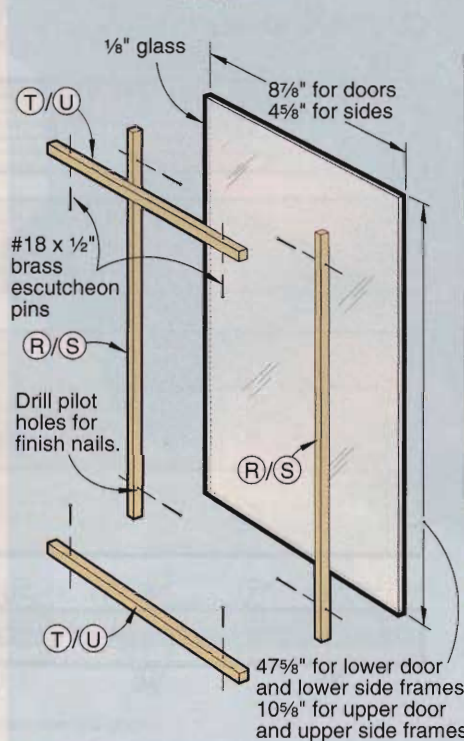
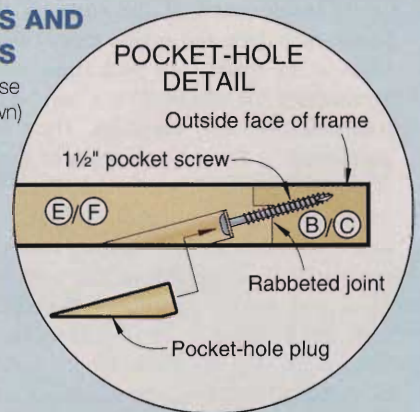

clockwork under glass

as shown on the Case Sides and Doors drawing and *Photo A*.

9 Glue and pocket screw the upper case side frames (C, E) and the upper case door (C, F) together, as shown on the Case Sides and Doors drawing and *Photo B*. Assemble the lower case side frames (B, E) and the lower case door (B, F) in the same manner. Glue pocket-hole plugs into the holes, and sand them flush. (You can make your own plugs from dowel stock, or see the Buying Guide for a source of ready-made plugs.)

10 Form the radii on the top corners of the upper case back panel (C, F, I) and upper case door (C, F), using a 1/2" round-over bit in a table-mounted router, as shown in *Photo C*.

11 Form the 1/8x1/8" rabbets on the inside faces of the stiles of the lower case door and inside faces of the stiles of the lower case back frame with a rabbeting bit mounted in a hand-held router. Rabbet only the stiles. There are no rabbets at the top or bottom of these frames. Rout the 1/8x1/8" rabbet on the inside faces of the stiles, and across the top of the upper case door. Rout the same rabbet on the inside faces of the stiles and across the top of the upper case back frame. The radius corners formed in *Step 10* allow the rabbet to flow around the top corners. Do not rout rabbets in the bottom edges of these frames. When the case is assembled, the rabbets create a visual break between the backs and sides, and the doors and sides.

Flat frames make the case

1 Dry assemble the upper and lower cases, as shown in *Photo D*. Joint or trim the frames as necessary to achieve flush outside edges. Now, glue and clamp the upper side frames to the upper back frame and the lower side frames to the lower back frame, keeping the ends and edges flush. Glue and clamp the top frame in place in the upper case with its top edges flush with the tops of the side and back frames. Clean up any excess glue from the inside corners and the 1/8x1/8" rabbets.

2 Miter-cut the reveal fronts/back (M) and reveal sides (N) to size. To position the reveals in the upper and lower cases, clamp four blocks to the

Continued



A Use a pocket-hole jig to drill the inside faces of the rabbeted rails.



B A square keeps the edge of the rail flush with the end of the stile during assembly.

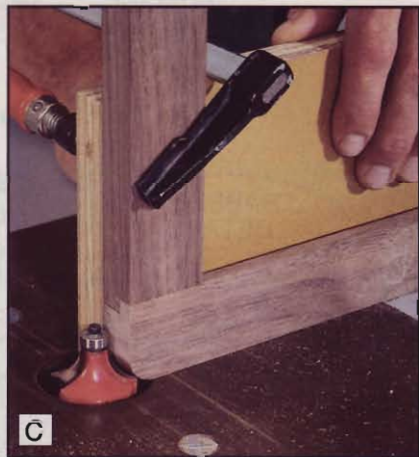

C To prevent tear-out on the trailing faces of the stiles, use an auxiliary fence attached to the miter gauge.



D Check the fit of the upper case top frame in the upper case and the fit of the lower case top frame in the lower case.

CUTTING DIAGRAM

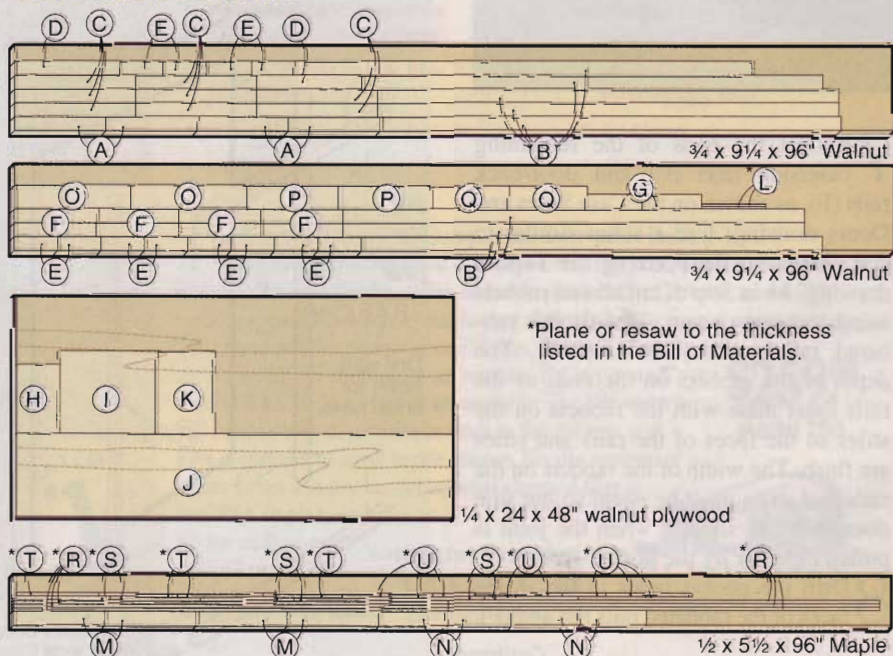

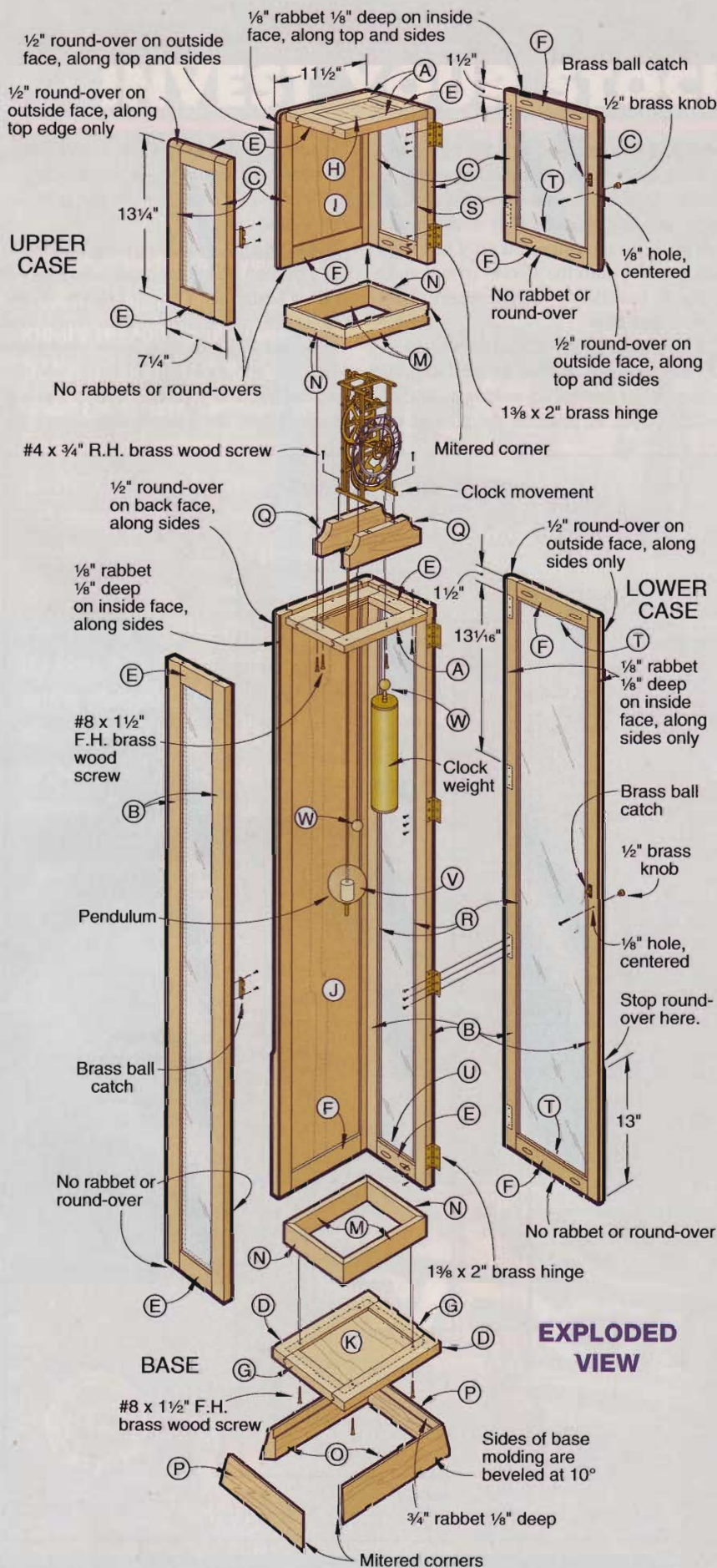

BILL OF MATERIALS

Part	finished size			Matl.	Qty.
	T	W	L		
A* case stiles	3/4"	1 1/2"	10"	W	4
B† lower stiles	3/4"	1 1/2"	50 1/4"	W	8
C† upper stiles	3/4"	1 1/2"	13 3/4"	W	8
D* base stiles	3/4"	1 1/2"	11 1/2"	W	2
E† case/side rails	3/4"	1 1/2"	4 3/4"	W	12
F† door/back rails	3/4"	1 1/2"	9"	W	8
G* base rails	3/4"	1 1/2"	6 1/4"	W	2
H upper case top panel	1/4"	7 1/2"	4 3/4"	WP	1
I upper case back panel	1/4"	9"	10 3/4"	WP	1
J lower case back panel	1/4"	9"	47 3/4"	WP	1
K base panel	1/4"	9"	6 1/4"	WP	1
L filler strips	1/4"	1/4"	7"	W	2
M reveal fronts/back	1/2"	1 5/8"	10"	M	4
N reveal sides	1/2"	1 5/8"	7 1/4"	M	4
O* molding front/back	3/4"	2 1/2"	12 3/4"	W	2
P* molding sides	3/4"	2 1/2"	10"	W	2
Q movement supports	3/4"	2 3/8"	8 1/2"	W	2
R lower vertical stops	1/4"	3/8"	47 1/4"	M	6
S upper vertical stops	1/4"	3/8"	10 1/4"	M	6
T door horiz. stops	1/4"	3/8"	9"	M	4
U side horiz. stops	1/4"	3/8"	4 3/4"	M	8
V bob cover	3" diameter			B	1
W knot covers	1" diameter			B	2

*Parts initially cut oversized. Trim to finished size according to instructions.

†Parts of the same size, but requiring different machining operations. See the illustrations.

Materials Key: W—walnut, WP—walnut plywood, M—maple, B—hardwood ball.

Supplies: 1 1/2" pocket screws (24), walnut pocket-hole plugs (24), #18x1/2" brass escutcheon pins, #8x1 1/2" flat-head brass wood screws (10), #4x3/4" brass roundhead wood screws (4), 1 3/8x2" brass hinges (6), brass ball catches (2), 1/2" brass knobs (2), single-strength glass, oil finish.

Buying Guide

Movement: Brass Clock Kit Movement, \$299.00 plus \$15.00 shipping, MT residents add tax, The Clock Shop, 311 Cottonwood St., Anaconda, MT 59711. Or call 406/563-2498 to order.

Weight: complete polished brass weight shell (caps, rod, hook), #087053, \$12.25, 9lb.-12oz. lead weight, #087055, \$12.98, add shipping, NC residents add tax, S.LaRose, Inc. Call 888/752-7673 to order.

Pocket-hole plugs: walnut pocket-hole plugs, #P WAL, \$5.95 (pack of 50), plus shipping, IA residents add tax, Kreg Tool Co. Call 800/447-8638 to order.

clockwork under glass

cases, where shown in the Side Section View details and in *Photo E*.

Apply glue to the case, position the reveal backs and sides against the blocks, and clamp them in place. Apply glue to the miters, and clamp the reveal front in place. Remove the blocks as soon as the reveals are in place, and clean up any excess glue.

3 Glue and clamp the lower case top frame in place at the top of the lower case, as shown on the Side Section View detail. Clamp blocks to the case as in *Step 2* for accurate positioning.

4 Clamp the door to the lower case and rout the stopped round-overs on the vertical edges, as shown on the Exploded View drawing. Use a block clamped to the case to stop the router.



Use a combination square to accurately position the blocks. A spacer clamped across the case keeps it from spreading when the reveal fronts are glued in place.

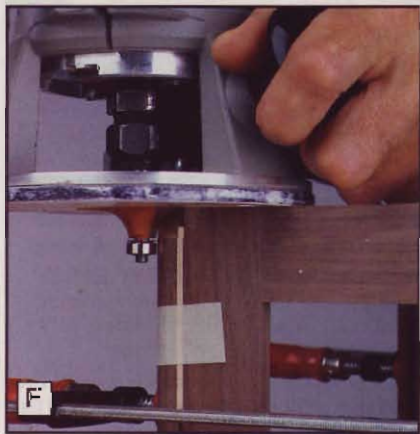

When routing the top of the upper case, $\frac{1}{8} \times \frac{1}{8}$ " strips of wood taped into the rabbets keep the pilot bearing from dropping into them.

Turn the case over, and rout the edges of the back frame in the same manner. Rout all the stopped round-overs with the router base riding on the side of the case. This prevents the router bit pilot bearing from slipping into the $\frac{1}{8} \times \frac{1}{8}$ " rabbet and forms a consistent shape where the round-overs stop.

5 Clamp the upper door to the upper case with the clamps at the top and bottom. Rout the round-overs on all the vertical edges. Reposition the clamps to

the sides, and rout the top round-overs, as shown in *Photo F*. When routing is complete, each top corner has a three-way round-over.

6 Cut the base moldings (O) and (P) to size but 1" longer than listed on the Bill of Materials. Cut the rabbets on the top edges, as shown on the Exploded View and Side Section View drawings. Miter-cut the moldings to fit around the base frame, and glue and clamp them in place. When the glue is dry, bevel the

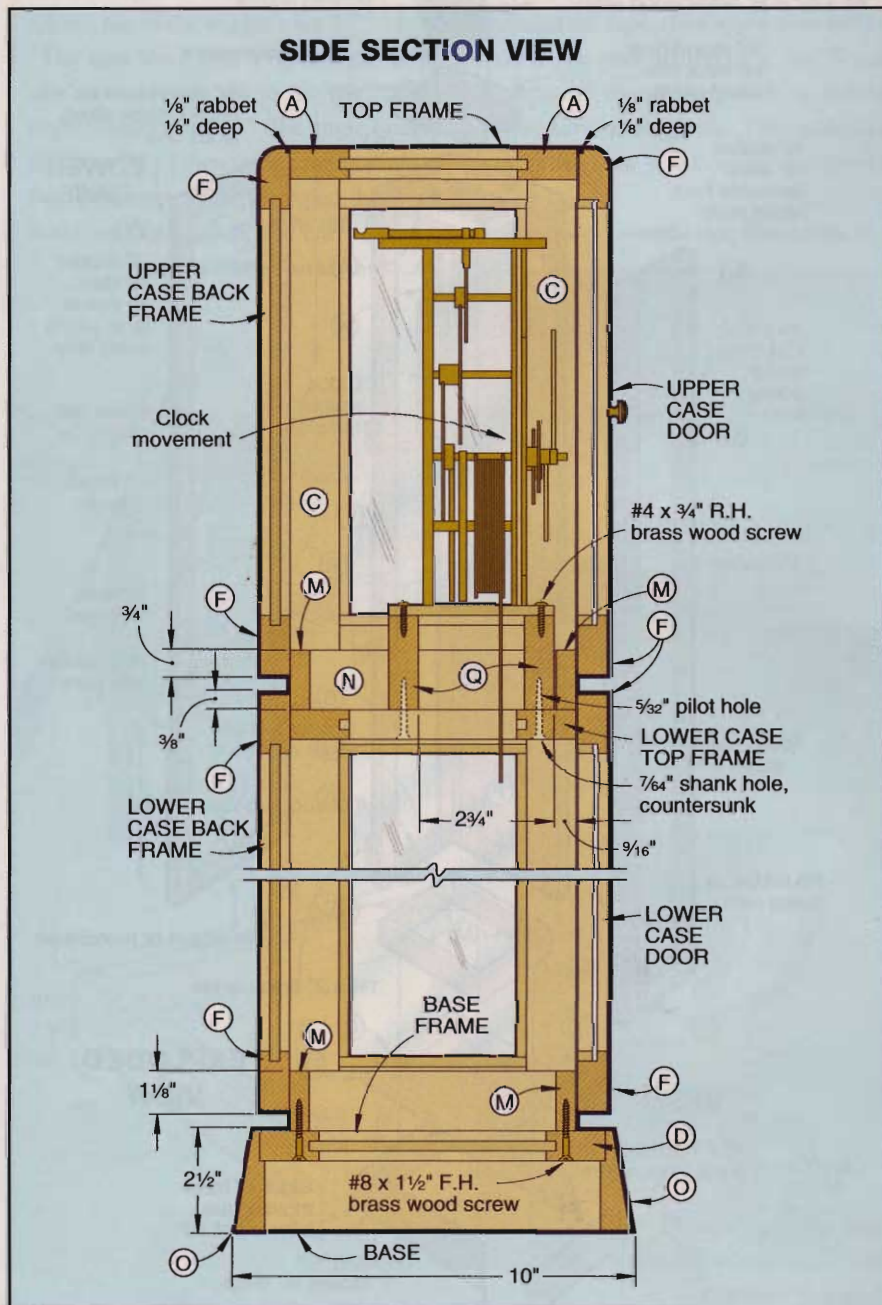

moldings on the tablesaw, then sand away the saw marks. Clamp the completed base to the bottom of the lower case, centered front-to-back and side-to-side. Drill pilot and shank holes, and screw the base to the lower reveal, as shown on the Side Section View detail.

7 Fasten two pieces of stock $\frac{3}{4} \times 2\frac{3}{8} \times 8\frac{1}{2}$ " together with double-faced tape. Copy the Movement Support (Q) from page 110, and adhere it to the top piece with spray adhesive. Bandsaw the corner radii, and sand away the saw marks. Clamp the movement supports to the lower case top frame at the top of the lower case, centered side-to-side and spaced where shown on the Side Section View detail. Drill the pilot and counter-sunk shank holes, and drive the screws.

8 Clamp the upper case to the lower case. The upper case is removed to mount and adjust the movement so this must be an easy fit. If the fit is too tight, sand the exposed surfaces of the upper reveal. Drill the pilot and shank holes through the lower case top frame into the upper reveal sides (N), as shown on the Exploded View drawing, and drive in the screws.

9 Lay out the locations of the hinges on the doors, as shown on the Exploded View drawing. Mortise the hinges to the same depth as the rabbet in the edges of the doors. Mount all the hinges, clamp the doors to the case, and transfer the hinge locations to the case stiles. Make the case mortises $\frac{1}{16}$ " deep. This allows $\frac{1}{32}$ " between door and stile when the door is closed. Mount the doors on the case, and install the catches and knobs.

10 Cut and fit the glass stops (R, S, T, U). Drill all the glass stops for #18 $\times\frac{1}{2}$ " brass escutcheon pins, as shown on the Case Sides and Doors drawing. Space the escutcheon pin holes about

11" apart on the lower vertical stops (R). Set the stops aside.

11 Drill the holes in the wood balls for the pendulum bob cover (V) and the knot covers (W), as shown on the Bob and Knot Covers drawing. *Great Ideas For Your Shop*, page 16 shows you how to make ball drilling jigs for this chore. After drilling, chuck the balls into the drill press, and finish sand them. Use a $\frac{1}{4}$ " bolt as a mandrel for the 3" ball and a $\frac{1}{4}$ " dowel as a mandrel for the 1" ball.

Final assembly: One step back, four steps forward

1 Remove the doors, movement mounts, and all hardware. Mark the movement mounts so they can be reassembled in the same locations. Separate the upper case and base from the lower case. Finish sand all parts and assemblies to 320-grit. Apply two coats of a penetrating oil finish, following the instructions on the can. (We used Olympic Antique Oil Finish no. 41004.)

2 Refasten the base and the movement mounts to the lower case. Have single-strength glass cut $\frac{1}{8}$ " less in length and width than the rabbeted openings in the doors and sides. Install the glass with the stops, driving the escutcheon pins through the pre-drilled holes into the frames. Hang the doors on the cases and reinstall the knobs and catches.

3 Now it's time to build the movement. See the Bill of Materials for our source. All parts are pre-cut and only require de-burring and polishing before assembly. Detailed instructions are included, and no special tools are needed. The movement kit does not include the weight that powers it, but the instructions include a method for making your own wood-encased weight. We used a



G The removable upper case makes mounting and adjusting the movement easy.

lead weight in a decorative brass shell to power our movement. (See the Buying Guide for our source.)

Note: Direct all questions concerning assembly or adjustment of the kit movement to: Mike Kovacich, The Clock Shop, 311 Cottonwood St., Anaconda, MT 59711, phone (406)563-2498.

4 Center the movement side-to-side on the movement supports (Q), and mark and drill pilot holes for the mounting screws, as shown on the Exploded View and Side Section View drawings. Screw the movement to the supports, as shown in Photo G. Slide the bob cover (V) and the bob onto the pendulum rod, and thread the knurled nut onto the rod. Hang the pendulum on the movement. Thread one knot cover (W) onto the weight end of the cord, and tie a loop. Hang the weight on the loop, and slide the cover down over the knot. Thread the other knot cover over the free end of the cord, tie a knot, and slide the cover down over the knot.

5 Level the clock case with shims and adjust the beat of the movement according to the instructions that come with the kit. Fasten the upper case to the lower case. Correct for slow or fast running by adjusting the pendulum bob up or down with the knurled nut. When it reaches the end of its travel, reset the weight by lifting it while pulling down on the free end of the cord. To avoid tarnishing the brass shell, wear a glove or use a cloth when handling the weight.

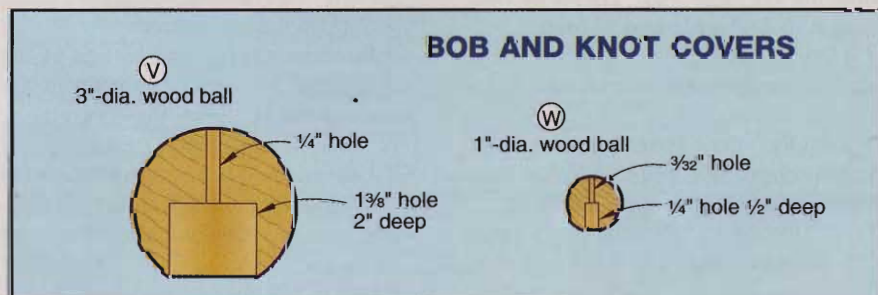

Designed, built, and written by Jan Hale Svec
 Illustrations: Kim Downing; Lorna Johnson
 Photographs: Hetherington Photography;
 Andrew & Co. Photography

toy floatplane



Build this little puddle-jumper for any flying enthusiast, and you'll see their spirits soar. Or, give this toy to a child, and watch an imagination take flight. Either way, you'll be an aviation hero.

Begin your flight by building the fuselage

- 1 Follow the Bill of Materials to make the fuselage laminates (A-D) but cut them $\frac{1}{4}$ " oversized in width and length. Laminate the parts together, as shown in the Fuselage Side pattern drawing on *page 107*. Trim this lamination to $1\frac{1}{2}$ " wide and 9" long.
- 2 Drill a centered $\frac{1}{4}$ " hole, $\frac{3}{8}$ " deep, for the propeller on one end of the fuselage lamination.
- 3 Apply the Fuselage Top and Fuselage Side patterns to the fuselage lamination with spray adhesive.
- 4 To cut the $\frac{3}{16}$ " elevator slot, set your tablesaw blade $1\frac{1}{2}$ " high and stand

the bottom end of the laminated fuselage on the saw table and against the adjusted saw fence. In two cutting passes, saw the slot where shown on the Fuselage Side pattern.

- 5 Drill the two $\frac{5}{8}$ " window holes through the lamination.
- 6 Bandsaw the top and bottom of the fuselage to shape, as shown in the photo at *right*. Save the sawn-away pieces for the next step.
- 7 Using double-faced tape, reattach the sawn-away pieces from the previous step, and saw the sides to shape by

Continued

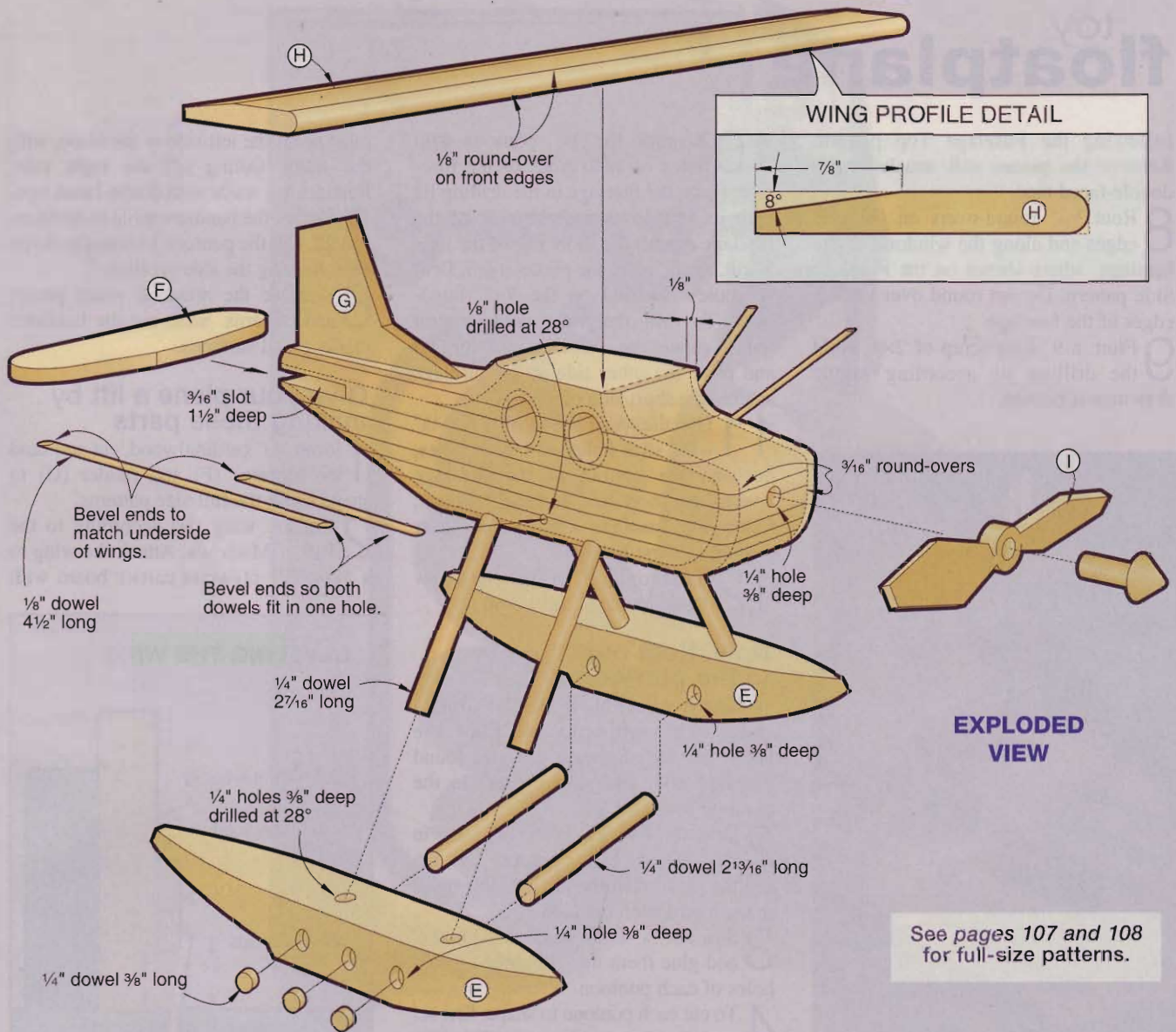

See pages 107 and 108 for full-size patterns.

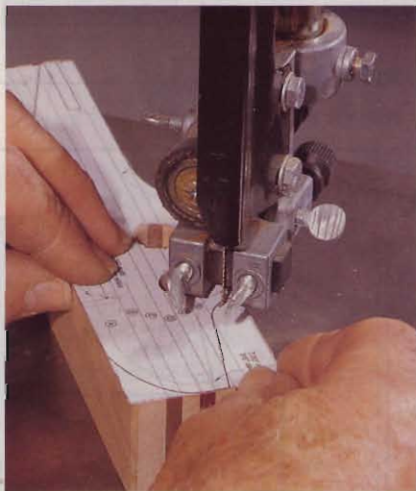

Bandsaw the fuselage side profile to shape carefully, and save the scraps.

BILL OF MATERIALS

Part	finished size			Matl.	Qty.
	T	W	L		
FUSELAGE LAMINATE					
A*	1/2"	1 1/2"	9"	M	2
B*	3/16"	1 1/2"	9"	W	2
C*	1/4"	1 1/2"	9"	M	2
D*	3/16"	1 1/2"	9"	C	1
PONTOONS					
E	7/8"	1 1/8"	7 1/2"	W	2
ELEVATOR					
F	3/16"	1 1/2"	4"	C	1
RUDDER					
G	3/16"	1 1/16"	3 3/8"	C	1
WING					
H	1/4"	2"	10 3/4"	C	1
PROPELLER					
I	1/4"	3/4"	4"	C	1

* Cut parts labeled with * oversized. Trim to finished size according to instructions.

Materials Key: M—maple, W—walnut, C—cardinalwood.

Supplies: 1/4" dowel 2' long, 1/8" dowel 2' long.

Buying Guide

Hardwood kit. All the parts cut slightly oversized from the thickness and species listed in the Bill of Materials. This includes the fuselage laminates glued up in a block. Also includes 2' of 1/8" and 1/4" dowels. Kit no. W127, \$18.95 ppd. Quantity discounts available. Heritage Building Specialties, 205 N. Cascade, Fergus Falls, MN 56537. Or call 800/524-4184 to order.

toy floatplane

following the Fuselage Top pattern. Remove the pieces still attached with double-faced tape.

8 Rout $\frac{3}{16}$ " round-overs on the side edges and along the windows of the fuselage, where shown on the Fuselage Side pattern. Do not round over the top edges of the fuselage.

9 From a 9"-long scrap of 2x4, build the drilling jig according to the drawings at *bottom*.



Use the drilling jig to bore the angled pontoon-strut holes (shown here) and wing-strut holes.

10 Remark the $\frac{1}{4}$ " pontoon-strut holes on both sides of the fuselage. Place the fuselage in the drilling jig with its top down and the side of the fuselage against the short side of the jig's V-cut, as shown in the photo at *left*. Drill $\frac{1}{4}$ " holes centered on the $\frac{3}{16}$ " round-over. To drill the other pontoon-strut holes, rotate the fuselage end-for-end and place the other side of the fuselage against the short side of the jig.

11 Use the same jig to drill the $\frac{1}{8}$ " wing-strut holes. For both holes, position the bottom of the fuselage against the short side of the jig. Again, rotate the fuselage end-for-end after drilling the first hole.

12 Sand out all of the bandsaw marks made to this point.

Now, float over to the pontoons

1 Cut two pieces of $\frac{7}{8} \times 1\frac{1}{8} \times 7\frac{1}{2}$ " walnut for the pontoons (E). Fold the Right and Left Pontoon patterns, found on *page 108*, and adhere them to the pontoon stock.

2 Drill the five $\frac{1}{4}$ " holes $\frac{3}{8}$ " deep in the sides of each pontoon. Use the drilling jig to drill the angled strut holes in the top of each pontoon.

3 Saw six $\frac{3}{8}$ "-long plugs of $\frac{1}{4}$ " dowel and glue them into the three outside holes of each pontoon.

4 To cut each pontoon to shape, first set your bandsaw table at an 8° angle. Cut along the pattern lines on the tops of the pontoons. During the cut, the pontoons

must be on the left side of the blade, with the waste falling off the right side. Reattach the waste with double-faced tape.

5 Return the bandsaw table to horizontal. Cut the pontoon bottoms to shape by following the side profiles.

6 Remove the attached waste pieces and patterns. Sand out the bandsaw marks on all surfaces.

Give your plane a lift by making these parts

1 From $\frac{3}{16}$ " cardinalwood, cut and sand the elevator (F) and rudder (G) to shape using the full-size patterns.

2 Cut the wing (H) according to the Bill of Materials. Attach the wing to a $\frac{3}{4} \times 4 \times 12$ " plywood carrier board with

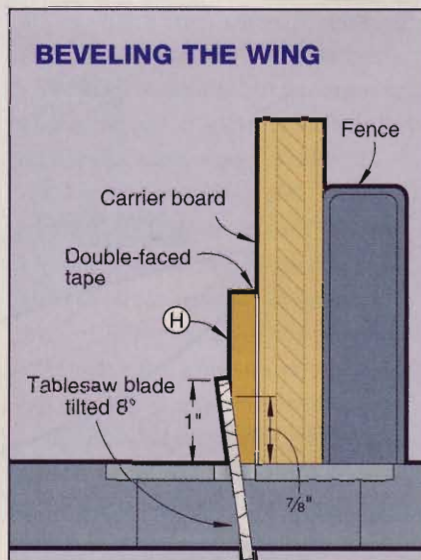

DRILL JIG

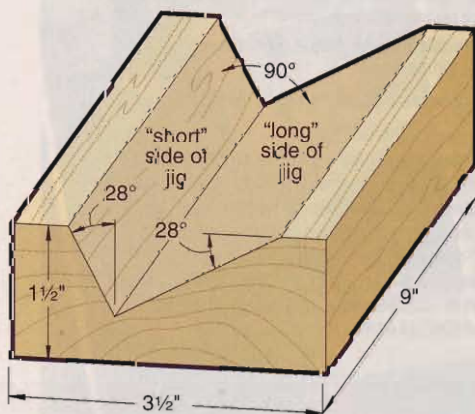

CUTTING THE DRILLING JIG

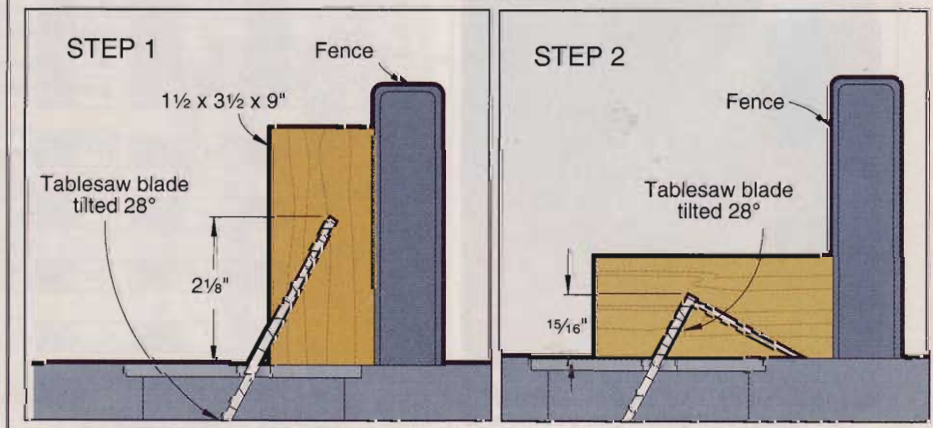

double-faced tape and bevel the wing at 8°, as shown in the Beveling the Wing drawing. Rout 1/8" round-overs along the top and bottom of the front edge of the wing. Sand any saw or router-bit marks.

3 Cut the propeller blank (I) according to the Bill of Materials. Fold and adhere the Propeller pattern to the blank.

4 Set your bandsaw for an 18° cut. Stand the propeller on edge and cut along the pattern line starting at the hub

and cutting toward the propeller tip. The propeller must be on the left side of the blade, as shown in the photo *below left*. Repeat this cut for each of the four propeller edge cuts, and save the scrap.

5 Use double-faced tape to reattach the scrap pieces. Return the bandsaw table to a horizontal position, lay the propeller on its side, and cut the face of the propeller to shape. Drill the 5/16" hole for the propeller axle, remove the paper pattern, and sand the propeller smooth.

6 To make the propeller axle, first drill a 1/4" hole, 1/8" deep, into the end of a 1/2"-length of 1/2" dowel. Cut a 1" length of 1/4" dowel, and glue one end into the hole in the 1/2" dowel.

7 After the glue dries, chuck the shaft of this axle into your drill press. Sand the 1/2" dowel portion to a point, as shown on the Propeller Axle drawing.

8 To make the various struts, cut four pieces of 1/4" dowel 27/16" long, two pieces of 1/4" dowel 2 13/16" long, and four pieces of 1/8" dowel 4 1/2" long.

side of the wing. (See photo *below*.) Use instant glue to attach the struts to the undersides of the wings.

3 Insert the propeller axle through the propeller, and attach both to the plane by gluing the shaft of the axle into the 1/4" hole on the front of the fuselage.

4 Final-sand the project, and apply the finish of your choice. (We sprayed on three coats of aerosol lacquer.) That's it, you're set to take flight.✈

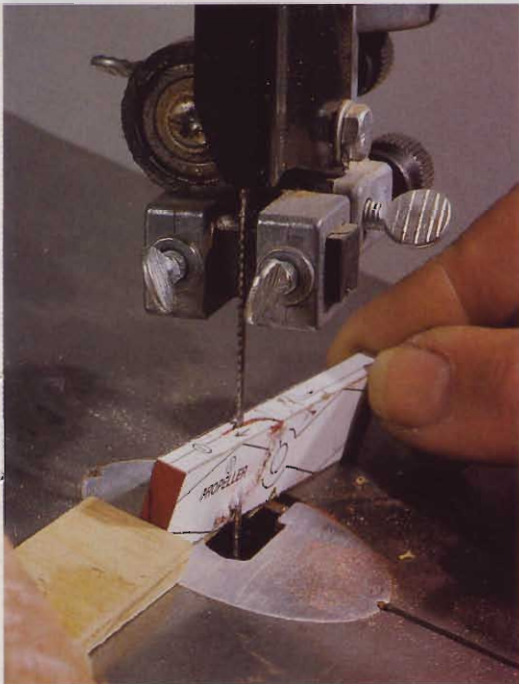

For safety's sake, use a scrap of wood to help guide the propeller cuts.



Sand the ends of the wing struts at an angle so they match the wing underside.

Prepare the plane for final approach and landing

1 Using the Exploded View drawing as a guide, glue together the pontoons, fuselage, and the struts that connect them. Be sure the plane sits level and parallel with the pontoons. Glue on the elevator, rudder, and wing.

2 Sand the ends of the wing struts so they fit into the hole on each side of the fuselage. Sand the opposite ends of the wing struts so they match the under-

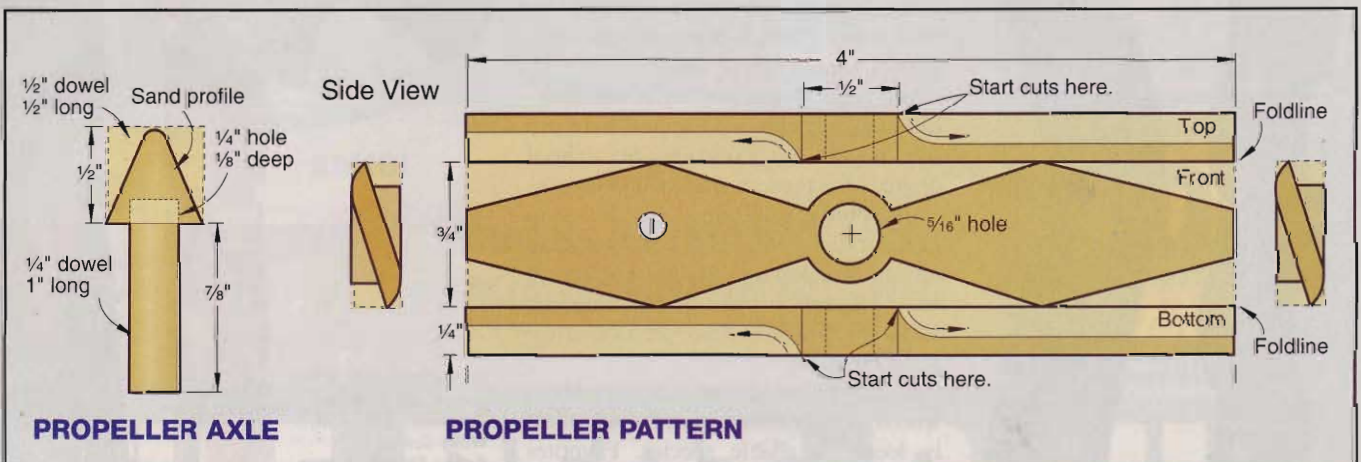

masterful walking sticks

one-of-a-kind carvings that have a human side to them

About 18 months ago, the Telfair Museum of Art in Savannah, Georgia, staged an exhibition featuring some extraordinary, African American-inspired, carved walking sticks. We were so taken by the beauty of these folk-art canes that we decided to share photos of them, and a bit about their creators, with you.

Interestingly, some of the artists represented here began their walking stick carving careers for humanitarian reasons. John Hall, of Clyo, Georgia, for example, recalls, "There were a number of old people around here who didn't have walking sticks, so I carved some for them. They wanted them, so I made them and gave them away."

Similarly, Arthur Dilbert, who estimates that he's carved over 2,000 pieces in his career, says he knows for sure some people need walking sticks. He offers something different from the ordinary canes they can buy at the mall.

Many of the carvings shown on these pages depict snakes, alligators, and other reptiles. And that's not surprising because they all were created by Savannah, Georgia-area carvers who grew up around these creatures.

And believe it or not, all of the walking stick makers represented here are self-taught. No exclusive art school degrees for these men. Their down-to-earth approach to things also shows up in the tools they use. They rely mainly on pocket knives and chip-carving sets, chisels, broken glass scrapers, and a power tool or two thrown in for good measure.

In case you're wondering what kinds of woods these craftsmen use, they're mostly locally available species. Favorites include cedar, oak, mahogany, and gum.

And they're always on the lookout for stock that has bulges, bends, and other interesting features to work around.

We hope you enjoy your tour of these exquisite American-crafted originals. They're a sight to behold. And if you're interested in learning more about walking sticks, we've included several books in the box at right to get you going.

Editor's Note: Our thanks go to Harry DeLorme, senior curator of education at the Telfair Museum of Art in Savannah, Georgia, for providing us with the background information, photographs, and contacts for this article.

Written by **Larry Clayton** and **George Brandsberg**
Photographs: **Courtesy of Telfair Museum of Art; Erwin Gaspin**

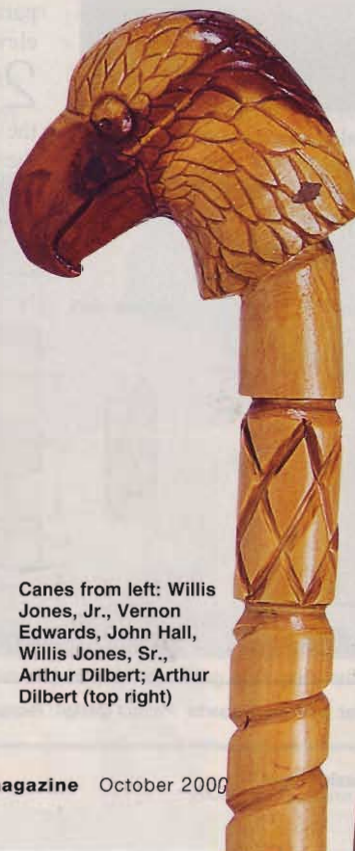

Canes from left: Willis Jones, Jr., Vernon Edwards, John Hall, Willis Jones, Sr., Arthur Dilbert; Arthur Dilbert (top right)



To learn more about walking sticks, read:

Meyer, George H. with Meyer, Kay *White American Folk Art Canes: Personal Sculpture*, (New York: Museum of American Folk Art, 1992).

Dike, Catherine, and Stein, Kurt (Introduction), *Canes in the United States: Illustrated Mementoes of American History* (Cane Curiosa, 1996).



about the artists

Vernon Edwards

This talented craftsman, who passed away this past year, learned about the joys of woodworking from his father, a carpenter and craftsman. But it was an elderly African American woodcarver who Vernon watched making canes with reptilian motifs who inspired him to this art form. Vernon carved off and on for most of his life in Philadelphia, where he earned his living as a meat cutter and race car driver. His signature works are his walking sticks resembling snakes.



Willis (Hakim) Jones, Jr.

Born in 1953, this talented carver of canes first learned of the beauty of wooden items as a youngster while playing with carved wooden ships his dad, Willis, Sr., had carved while he was at sea. For a short period of time, Willis built furniture for a local decorative artist. But he eventually gravitated to cane making. Most of his work features geometric designs—diamonds, spirals, checkerboards, and lengths of chain.



Arthur Peter Dilbert

Born in 1928, Arthur got his start in woodworking by making simple toys, such as slingshots and wooden boats. A longshoreman by trade (now retired), he began carving walking sticks in the '60s. The Smithsonian Institution, the Atlanta History Center, and Savannah's Telfair Museum of Art all feature this craftsman's work.



Willis Jones, Sr.

Raised within a block of the Savannah River, one of America's great seaports, Willis' first exposure to woodworking and crafts was watching men making boats, fishnets, and carved canes. As a teen, he began making and selling twig furniture. After a stint in the Army, Willis went to sea, traveling to ports in South America and elsewhere. It was during this time that he worked alongside a carver from Trinidad, and got serious about carving.



John Hall

This talented carver (born in 1954) began making walking sticks just for the fun of it when he was a teenager. And like many other talented woodworkers, John gave away most of his work to family, friends, and those in need. He's carved around 300 walking sticks, many of which tell stories, as well as numerous in-the-round human and animal figures. John currently lives in Clio, Georgia, where he has a studio in an abandoned school building. ♣

quick-change artists

We test nine add-on drill chucks perfect for woodworkers who find a keyless chuck just too slow.

You don't have to be graying at the temples to remember when a drill was used only for boring holes, and its chuck key was lashed to the power cord with a thick tourniquet of electrical tape. Most of today's cordless drill/drivers lost their chuck keys long ago, thanks to the invention of the keyless chuck. But it's a new century and our need for speed is greater than ever, so we examined nine quick-change chucks that allow you to swap bits in half the time of traditional keyless chucks.

All of the models in our test accept bits, drivers, and accessories with a standard 1/4" grooved hextail, as shown on the drill bit *left*. Inside each connector, a ball-bearing (or bar, in the case of DeWalt's Rapid Load) engages the groove to hold the bit fast. The bearing/bar releases the bit when you push or pull the connector's collar. (Throughout this article, we'll use the word *pull* to describe the action of moving the collar toward the drill body; *push* means to move the collar away from the drill.)



Bosch Clic-Change



Craftsman Speed-Lok

Black & Decker QuickConnect



DeWalt Rapid Load



Hanson Lock 'N Load



The drill/sink/drive alternative

Because of the huge variety of 1/4" hex-tailed accessories on the market today, from nut drivers to masonry bits, you'll find them handy all over the house. But if your drilling and driving duties are almost exclusively performed in the woodshop, consider a drill/sink/drive unit. These accessories bore and countersink a pilot hole, quickly convert to drive home a screw, then just as speedily return to bore-and-sink mode.

The most common style you'll find—we call it a "flipper"—has a reversible insert with a drill bit and countersink on one end and a screwdriver tip on the other. This insert locks into the holder that chucks into your drill. (Some flippers, such as Makita's Quad-Driver, bottom unit in photo at *right*, also fit in a quick connector.)

Jack be nimble, chuck be quick

The manufacturers of these quick connectors tantalize you with the offer of one-handed bit changes. But most of the models required a fair amount of manual dexterity to release, remove, and replace the bit with only one hand.

Seven of the nine connectors in our test release the bit when you pull a spring-loaded collar. You can do it with one hand, as shown at *right*, but pulling the collar one way with your pinky finger while pulling the bit the other way with your thumb and forefinger feels awkward. Of those seven models, Makita's UltraLok and Stanley Jorettech's STC1629 also will release on the push stroke. We liked these better because the collar and bit are moving in the same direction regardless of whether you're removing or inserting a bit.

However, for true one-handed release, the collars on Bosch's Clic-Change and Craftsman's Speed-Lok lock in the open position, which means you don't have to fight spring tension to remove bits. Just

To use a flipper, you set the drilling depth by means of a hexhead set screw, load the insert, and bore and countersink your hole. Now remove the insert, flip it end for end, reinsert it, and drive the screw. One source of frustration with flippers: Drilling debris falling from the bits' flutes tended to collect in the holder, preventing us from properly seating the insert until we cleaned it out.

The Jack Rabbit (800/445-5969, or www.jackrabbittool.com) takes a different approach. Instead of requiring a special holder, the drill bit and countersink mount to a sleeve that fits over a standard 1/4" hextail-shank screwdriver bit.

Slip the sleeve over the driver, bore and sink, then remove the sleeve with a quick tug of the sleeve's collar, freeing the driver



Jack Rabbit (top) parts, left to right: drill bit, countersink/collet, sleeve, driver bit. Flipper parts, left to right: drill bit/countersink, insert, driver bit, holder.

bit to do its job. The four-fluted countersink acts as a collet on the drill bit, so you loosen the countersink/collet to set the drilling depth.

Changing from drill/sink to drive with the Jack Rabbit definitely takes less time than rotating a flipper, and can be easily done with one hand. But the system's tight tolerances occasionally made it difficult to mate the sleeve to the driver.

push the collar until it snaps open, then remove the bit.

To insert a new bit, we liked the mechanisms in the Bosch Clic-Change, DeWalt Rapid Load, and Make It Snappy 40011, where bits lock in place without any collar action. Merely push the hextail shank into the chuck until it clicks. Craftsman's Speed-Lok is next best, requiring only that you snap the collar back to its locked position after inserting the bit. The rest of the chucks require the same collar motion to load a bit as to unload it.

A few more things to consider

●**Getting a grip.** As you can see from the photos *below* and *left*, the collars of these quick-connectors come in all colors, shapes, and grip materials. Only you can decide which one feels best in your hand, so we encourage you to do a hands-on try before you buy.

We gave a slight edge to the soft-grip collars, not only because of their comfort, but also because they tend to be of



One-handed bit removal on most connectors, such as DeWalt's Rapid Load, is possible, but uncomfortable. The hand-stretching motion required may be difficult for those with limited dexterity.

a larger diameter. Knurling helps on the metallic collars, but we found the meager cross-hatching on Hanson's Lock 'N Load hard to hold onto with wet or sweaty hands.

●**Bit retention after release.** We were surprised to find that two of the quick-connectors—Bosch's Clic-Change and Insty-Bits—held the bit loosely in the chuck even after being released. When used in a drill press, this feature could save the bit's cutting flutes from the ravages of a concrete shop floor. On the other hand, a connector that lets the bit drop free might be a plus if you need to replace a hot bit, so decide which is most important to you.

Continued



●**Runout and tolerances.** Some of the units in our test have looser hextail-to-connector tolerances than others. But for handheld drilling, we simply couldn't make ill-mating bits an issue. Why? Because the pressure you put on the bit when you place it on your mark tends to tighten everything up. However, when mounted into a drill press (where you start the bit spinning before it enters the workpiece), we found it difficult to hit our mark consistently. The Bosch Clic-Change and Insty-Bits proved the best in the test here.

●**Dealing with broken bits.** The drill bits that come with most quick connectors are permanently mounted in their hextails. So, when a bit breaks—which only seems to happen when the hardware store is closed—what do you do? You could go back to the old-fashioned method of using your drill's chuck. Or,



If you break a Make It Snappy bit (top), you can loosen the collet and replace only the bit. With other manufacturers' single-piece bits, you toss it away and buy another.

if you have the Make It Snappy 40011, you simply free the busted bit from its collet-type hextail (top, in photo above), and replace it with another bit that you already have on hand.

The pick of the quick

Hands down, we liked Bosch's Clic-Change best. With its lock-open/insert-to-close collar, bit retention when released, and low runout, we can't think of a good reason to buy anything else. But when it came time to replace a broken bit, we'd buy a set of Make It Snappy's, owing to their collet-style hextails. 🍌

Now, you can rate our performance

You've heard what we have to say about these quick-release chucks. Now, log onto the WOODMALL® website at www.woodmall.com and respond to our review. Are we right on the money, or way off the mark? Click on the "Interactive Tool Reviews" button and join the dialogue with the manufacturers and other WOOD® magazine readers.

Written by **Dave Campbell**
 Technical consultant: **Raleigh Rubenking**
 Photographs: **Baldwin Photography**

A QUICK LOOK AT SPEEDY DRILL CHUCKS

MANUFACTURER / IMPORTER	MODEL	SHANK SHAPE (1)	SHANK DIAMETER (INCHES)	SHANK LENGTH (INCHES)	TOTAL LENGTH (INCHES)	ACTION REQUIRED TO LOAD (2)		ACTION REQUIRED TO RELEASE (2)			GRIP MATERIAL (3)	LOCKING MECHANISM (4)	BIT RETAINED WHEN RELEASED?	RUNOUT	BIT LOADING EASE	BIT RELEASING EASE	WARRANTY (6)	COUNTRY OF ASSEMBLY (7)	PRICE - CONNECTOR ALONE (8)	PRICE - SMALLEST SET (includes connector) (8)	COMMENTS
						PULL	PUSH	PULL	PUSH	K											
BLACK & DECKER	QuickConnect	H	3/16	3/4	1 1/16	PULL	PULL	K	B	N	F	G	G	L	C	N/A			\$10 (8 pc.)	\$10 (8 pc.)	Connector available only in sets with bits. Collar is better-knurled than Hanson's collar.
BOSCH	Clic-Change CC 2300	H	3/8	7/8	2 1/4	INS	PUSH	R	B	Y	G	E	E	1 yr.	U	\$10	13 (5 pc.)	\$10	13 (5 pc.)	Our favorite, with tight tolerances and the easiest one-handed bit loading and unloading in the bunch.	
CRAFTSMAN	Speed-Lok	H	3/16	1	2 1/4	PUSH	PULL	K	B	N	F	E	E	1 yr.	U	9	20 (16 pc.)	20 (16 pc.)	20 (16 pc.)	Easy one-hand operation. Bit run out high for drill press operation, but fine for hand drill work.	
DEWALT	Rapid Load	H	3/16	7/8	2 5/16	INS	PULL	R	R	N	F	E	G	1 yr.	U	9	20 (13 pc.)	20 (13 pc.)	20 (13 pc.)	Simply push bit to load, but it's awkward to remove bits with only one hand. Wide, tapered collar provides plenty of gripping area.	
HANSON	Lock 'N Load	H	1/4	1 1/8	2 1/2	PULL	PULL	K	B	N	F	G	G	L	U	9	30 (13 pc.)	30 (13 pc.)	30 (13 pc.)	Smooth collar finish may make it more difficult to operate with wet or sweaty hands.	
INSTY-BITS	80032	F	3/8	7/8	2	PULL	PULL	K	B	Y	G	G	G	L	U	10	28 (8 pc.)	28 (8 pc.)	28 (8 pc.)	Heavy knurling makes for sure handling of collar. Tight tolerances allow for good drill press operation.	
MAKE IT SNAPPY	40011	H	3/8	1	2 3/16	INS	PULL	K	B	N	F	E	G	L	U	9	19 (4 pc.)	19 (4 pc.)	19 (4 pc.)	Only connector system with collet-style hextails to replace broken bits.	
MAKITA	UltraLok	H	3/16	1	2 3/8	P/P	P/P	R	B	N	F	G	G	1 yr.	U	9	15 (7 pc.)	15 (7 pc.)	15 (7 pc.)	Comfortable concave soft-grip collar releases bit on push or pull stroke for maximum flexibility.	
STANLEY JORETECH	STC1629	H	3/16	1	2 5/8	P/P	P/P	R	B	N	F	G	G	L	U	8	20 (15 pc.)	20 (15 pc.)	20 (15 pc.)	Push/click collar operation allows for personal preference. Barrel-shaped, soft-grip collar easy to grasp.	

NOTES:

- (F) Three flat sides
(H) Hex
- (INS) Bit locks with no collar action
(PUSH) Move collar away from drill body
(PULL) Move collar toward drill body
(P/P) Push or pull
- (K) Knurled metal
(R) Rubber
- (B) Ball bearing
(R) Rod
- E** Excellent
G Good
F Fair
- (L) Lifetime warranty against factory defects
- (C) China
(U) United States
- Prices current at time of article's production.
(N/A) Connector not sold separately.

For more information, contact:

- | | | |
|---|--|--|
| Black & Decker
800/544-6986
www.blackanddecker.com | DeWalt
800/433-9258
www.dewalt.com | Make It Snappy
(Poly-Tech Industries)
800/334-7472 |
| Bosch (S-B Power Tools)
877/267-2499
www.boschtools.com | Hanson (American Tool)
612/832-5000
www.americantool.com | Makita
800/462-5482
www.makitatools.com |
| Craftsman
www.sears.com/craftsman | Insty-Bits
612/381-1060 | Jore Corporation (Stanley)
888/809-5673
www.jorecorporation.com |

Fumble-free router-raising? Crank it up!

As useful as router tables are, adjusting the cutting depth can be a royal nuisance. You either have to climb underneath and fidget with the plunge mechanism, or pull the whole works out—plate, router, and all—to change the depth. The folks at JessEm Tools have come up with a nifty solution to the age-old problem with the Rout-R-Lift.

Instead of using your router's depth-setting mechanism, the Rout-R-Lift has its own, operated by a removable crank on top of the anodized aluminum table plate. Set your router to maximum cutting depth, mount it to the Rout-R-Lift's carriage (which rides up and down on a pair of guide rods, shown inset), drop the plate in the table, and you're ready to roll.

I was worried that the carriage and guide rods would deflect under the weight of a router, so I loaded up the heaviest router I know of—my 15-pound Porter-Cable 7518—and

checked under the table for deflection. I found only .005" under load.

Adjusting cutting height with the Rout-R-Lift is not only more convenient than under-the-table fumbling, it's also more accurate. Each full turn of the crank raises or lowers the cut by .050", with .005" increments marked around the crank's path. And, as an unexpected bonus, I found I could change router bits from above the table by raising the router all the way up and inserting the collet wrenches through the throat opening. (However, this may not work with every router.)

The instructions are a little skimpy when explaining how to center your router in the carriage (I used a 1/2"-diameter pin and a 1/2" throat insert) and how to precisely machine your tabletop to accept the plate. (A template would be helpful here.) And the plate has no provisions for leveling the plate in the tabletop, so I had to shim it with masking tape.

—Tested by Bob McFarlin

PRODUCT SCORECARD

Rout-R-Lift

Performance	★★★★★
Price	\$199
Value	★★★★☆

Call JessEm Tools at 800/436-6799, or visit www.jessem.com.



Sawhorses sturdy as... well, a Clydesdale

For temporary work space in the shop, nothing beats a pair of sturdy sawhorses. But non-collapsible horses take up a lot of storage area, and I worry that knockdown horses will get knocked down when I'm still using them.

I had no such worries when using Clyde and Dale's sawhorses, because each heart-shaped leg assembly is made from a single piece of tempered aluminum tubing. It can't splay under duress like most four-legged sawhorses. And, the user-supplied beam fits into a piece of rigid box-tubing welded to the leg assembly.

Any 2x4 fits into the box-tubing, but I cut slots in both ends of a 2x6 instead. Besides making a stronger horse, it raised the working height from 32" to 34" and gave me plenty of room to cut through the beam without fear of hitting hardware.

At 3 pounds per leg assembly, it's easy to haul the legs and beams for two horses just about anywhere. And all four legs nest nicely together for compact wall-hung storage. Despite their light weight, a pair of Clyde and Dale's sawhorses are rated to hold 3,000 pounds.

—Tested by Dave Henderson

PRODUCT SCORECARD

Clyde and Dale's Sawhorses

Performance	★★★★★
Price	\$90 (legs for two horses)
Value	★★★★☆

To locate a dealer, call 800/390-5303 or visit online at www.clydeanddales.com.

Continued on page 94

Continued from page 90

Banish knuckle-bash with Kwik-Crank

To me, changing the cutting height of a table-mounted router is about as much fun as sticking my hand in the mouth of an ill-tempered dog: Both administer pain, and usually result in a bloody knuckle. But Eagle America's Kwik-Crank height-adjustment crank keeps my fingers clear of the router body while making height changes painless.

Available for virtually every major brand of plunge router, this anodized aluminum tube threads onto the router's threaded rod, replacing the standard height-adjustment mechanism. (For the DeWalt 621 and Porter-Cable 7529, 7538, and 7539 routers, the Kwik-Crank mounts to the depth-stop rod by means of special hardware that comes with the crank.)

Under table, the Kwik-Crank performed as advertised. It allowed me to

quickly raise and lower the cutting height of the bit without the annoyance of constantly regripping my router's small factory knob.

However, when I dismantled my router for handheld use, it was a different story. Without the weight of the router to hold the depth setting, vibration caused the crank to rotate down. So by the end of my plunge cut, I couldn't raise the bit high enough to clear the workpiece. For this reason, the Kwik-Crank performs best on a table-mounted router.

Eagle America also sells a height knob that's identical to the Kwik-Crank, but with a knurled knob instead of a crank handle. I didn't find it to be any faster than my router's OEM knob, but the additional length of the tube saved my knuckles. The knurled-knob

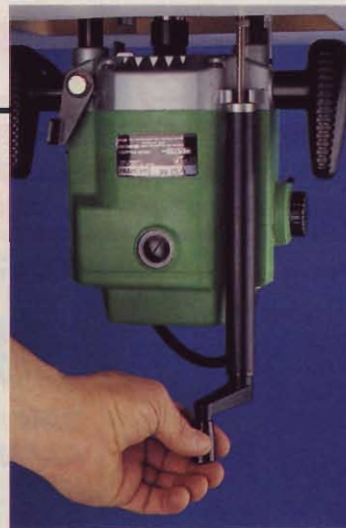

version sells for \$10 less than the Kwik-Crank.

—Tested by Bob McFarlin

PRODUCT SCORECARD

Kwik-Crank

Performance	★★★★★
Price	\$30 plus shipping (\$35 plus shipping for DeWalt 621 and Porter-Cable 7529, 7538, and 7539 routers)
Value	★★★★★

Call Eagle America toll-free at 888/872-7637, or order online at www.eagle-america.com.

Put the pinch on miter joints

I've tried various jigs, both shop-made and commercial, for clamping mitred joints, with limited success. But, when I noticed the Gross Stabil MCX Mitre Clamping System at a recent wood-working show, I decided I had to try it out myself.

The system consists of a pair of two-piece clamps connected by a steel rod. Loosely position a clamp over one workpiece (it'll work with stock up to 4" wide) so that the small piece of the clamp is slightly behind the large

piece, as shown at *right*, and lock the rod with the knurled knob. At this point, it's okay for the clamp to be a little loose. Repeat with the other clamp and workpiece.

Now use a bar clamp (not included) on the 45° adapter pads, as shown, to pull the joint together. This action tightens the clamps on the workpieces while simultaneously pulling the joint together. The MCX Mitre Clamping System also comes with easy-to-replace 22.5°, 30°, and 60° adapter pads for clamping other than right-angle joints.

The system puts all of its pressure on those 1"-wide clamping jaws, so I found it more difficult to use with

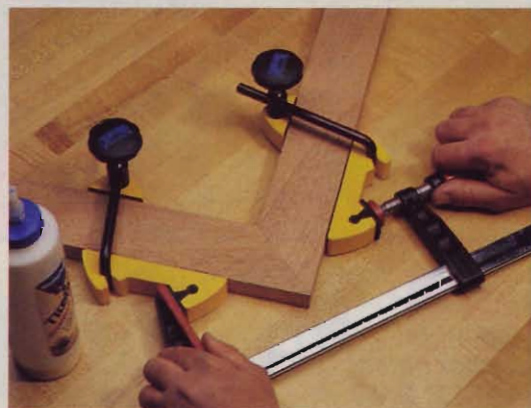

stock less than 1/2" thick, including thicker stock with edge treatments that reduced the amount of flat clamping surface to 1/2" or less. And, because the MCX Mitre Clamping System does nothing to ensure face alignment, the manufacturer suggests aligning the pieces with biscuits or dowels, which I found to be valuable advice.

—Tested by Randy Zimmerman

PRODUCT SCORECARD

Gross Stabil MCX Mitre Clamping System

Performance	★★★★★
Price	\$26 (bar clamp not included)
Value	★★★★★

For more information, call Gross Stabil at 800/671-0838.

DeWalt puts its spin on the circ saw

Worm-drive circular saws offer superior torque and side-to-side balance over helical-gear saws, but they tend to be heavier—and front-heavy at that—than their side-winding brothers. Leave it to the engineers at DeWalt to come up with the DW378G: a 7¼" circ saw with the power of a worm-drive and the lighter weight of a sidewinder.

Like a right-angle grinder, the shaft of the DW378G's 15 amp. motor turns perpendicular to the blade arbor by means of spiral-bevel gearing. But, instead of lying flat at full blade-depth like a worm-drive saw, the motor angles up and back at about a 45° angle. These moves put the tool's center of gravity just behind the center of the blade, resulting in an overall better-balanced saw.

Looking beyond its rather unorthodox appearance, I found some nice features on the DW378G. The blade-depth indicator shows markings not for the depth of cut, but for the thickness of stock you're working with. In other words, to cut ½" sheet goods, I set the blade depth to the "½" ply" mark, and the blade bottomed ¾" below the cast-aluminum base shoe—just enough to clear the blade gullets. The indicator also denotes settings for ¼", ⅜", ⅝", 1× (¾"), and 2× stock.

If you use your circ saw for more than breaking down sheet goods, you'll like the dual blade indicator, which showed me exactly where to put the saw to take the line or leave the line, in both 90° and 45° bevel-cuts. And I appreciated the DW378G's retractable tool hanger that let me hang it on any convenient chunk of 2× stock, such as a rafter or joist, without a bunch of jury-rigging.

—Tested by
Dave Henderson

PRODUCT SCORECARD

DeWalt DW378G Framing Saw

Performance	★★★★★
Price	\$160
Value	★★★★★

For more information, call 800/433-9528, or visit www.dewalt.com.



Continued on page 96

Woodworking, craft and home improvement projects?

Get AccuSet!



A200BN Brad Nailer

A100MP Micro Pinner

DRIVES STAPLES AND BRAD NAILS
2 IN 1



New AccuSet A2N125 drives 5/8" to 1¼" brads and ½" to 1" staples.

Are you a woodworker, hobbyist or home improver? Have you experienced the precision and speed of pneumatic nailing and stapling? Professionals use pneumatic fastening in applications from small bird feeder production to cabinet building and finish and trim work. Now SENCO®, the brand of choice of professionals, has a new line of tools, fasteners and accessories just for you! Check out AccuSet® brand finish nailers, brad nailers and staplers from the pros at SENCO. They're loaded with power, great features and have a two year warranty – the best in the business! To find the retail outlet nearest you, call 1-888-222-8144, or click on the dealer locator on our newly expanded website: www.accuset.com

ACCUSET

THE TOOLS YOU NEED FOR THE WORK YOU DO.

SENCO®

1-888-222-8144

Visit our newly expanded website: www.accuset.com



Woodworking
TOOL OF THE YEAR
1998

TESTED & RECOMMENDED

Better Homes and Gardens
WORLD
5 Year Rating
For Performance

Quickly becoming one of America's most preferred woodworking tools.

©2000 Senco Products, Inc. 8485 Broadwell Road, Cincinnati, Ohio 45244-1699 Safety First. The only way to work.



Continued from page 95

Two ways to power a three-tool combo

Few things in life equal the frustration of getting psyched-up to tackle a big project, only to find that you forgot to charge your cordless drill battery. By the time the battery gets up to speed, you've gotten sidetracked. If only you could use that drill while the battery was charging.

One solution: Skil's Dual-Source power system. Replace the exhausted 12-volt battery pack with a corded adapter, plug the adapter into an AC power inverter, and you're back in business. The inverter doubles as a charger, so you can still drill while you recharge the pack.

I liked the flexibility of the power system, especially for DIY and home-shop use. The drill will drive deck screws, but I wouldn't recommend it for construction work. It's strictly a low-performance tool by today's cordless stan-

dards. However, I found the 10' cord gave me lots of room to move without adding any weight.

The Skil Dual-Source 12-volt kit also comes with a flashlight and air gun. The light boasts a flat base, 360°-rotating head, and adjustable beam. But the air pump took nine minutes to inflate my truck tire to only 22 psi—and I had to hold the trigger the whole time. Still, it's handy to have around for topping off bicycle tires, air mattresses, and such. ♣

—Tested by Bob McFarlin

PRODUCT SCORECARD

Skil Dual-Source combo kit (120VXT-ALK)	
Performance	★★★★★
Price	\$99, 12-volt kit; \$89, 12-volt drill only
Value	★★★★★

Call S-B Power Tools toll-free at 877/754-5999, or visit online at www.skiltools.com.



Free to a Good Home

\$131 Accessory Package

Accept no imitations! Buy the Performax 16-32 Plus Drum Sander, the industry's original drum sander, and receive the accessory package absolutely FREE!



- Package includes:**
- Infeed/outfeed tables
 - Conveyor belt tracker set
 - Box of ready-to-wrap sandpaper sized to fit
- \$131 accessory package FREE**

The power to shape your ideas **PERFORMAX**

JET, Performax and Powermatic — A Family Of Brands

Offer effective September 1, 2000 through March 31, 2001 • 800-334-4910 • www.PerformaxProducts.com

Econ-Abrasives

WE MAKE ABRASIVE BELTS ANY SIZE, ANY GRIT!

Standard Abrasive Sheets

CABINET PAPER		
	50/pk	100/pk
60D	\$17.58	\$31.58C
80D	\$16.42	\$29.26C
100 thru 150C	\$15.26	\$26.95C
FINISHING PAPER		
80A	\$11.74	\$19.89C
100 thru 280A	\$10.50	\$17.58C

NO LOAD PAPER(white)		
100 thru 400A	\$12.90	\$22.40C
"C" = 100 SHEETS		

Velcro® Vacuum Discs
8 Hole pattern for Bosch Sanders

Dia.	Grit	Price
5"	60	\$.48 ea
5"	80	.46
5"	100 thru 320	.45

* Available in 5 hole pattern *

*Wide Belts*Rolls*Flap Wheels
*Pump Sleeves*PSA Discs
*Router & Wood Bits*Wood Glue

ABRASIVE BELTS

Belts are resin bond cloth with a bi-directional splice, specify grits.

1X30	\$.81 ea	3X24	\$.93 ea
1X42	.81 ea	3X27	.96 ea
1X44	.81 ea	4X21 3/4	1.06 ea
2 1/2X16	.85 ea	4X24	1.10 ea
3X18	.86 ea	4X36	1.35 ea
3X21	.90 ea	6X48	3.50 ea
3X23 3/4	.93 ea	6x89	6.24 ea

OTHER SIZES ON REQUEST

HEAVY DUTY SPRING CLAMPS

Clamps come w/PVC tips and grips.

Size	Price
4"	\$1.75 ea
6"	2.25
8"	3.50

JUMBO ROUTER PAD/24" x 36"

It will not allow small blocks of wood to slip out under router or sanding applications. ROUTER PAD ONLY \$8.95ea.

JUMBO BELT CLEANING STICK ONLY \$8.80

*MasterCard, VISA, Discover, Am. Express
*SATISFACTION GUARANTEED!!!

*CALL FOR FREE CATALOG
-TX add appropriate sales tax
-Call for shipping charges

Econ-Abrasives

P. O. Box W1628
Frisco, TX 75034
(972)377-9779

TOLL-FREE ORDERING LINE (800)367-4101

Red Alder

the Northwest's most abundant hardwood likes having wet feet

In the Pacific Northwest, almost wherever you find water you'll discover red alder. From southeastern Alaska into California, this cousin of the birch tree grows best where its roots get wet, and seldom more than 125 miles from the ocean.

Trout fishermen know it well because the tree shades the deep, clear pools where the big fish lay. Along the streams and rivers, its roots steady banks against erosion and keep the water running clear. And when salmon begin their run from the ocean, they do it amidst stands of red alder because nowhere does it grow more abundantly and to greater size than in boggy areas near salt water. In those favored condi-

tions, it can attain 100' heights with diameters to 3'.

Once considered by lumbermen as a nuisance tree, red alder today rates as the most commercially important hardwood in the Pacific Northwest.

Increasing 20-fold since the 1920s because it swiftly appears on burnt or cutover land, red alder's current standing volume represents 60 percent of the region's hardwood inventory.

Early loggers only cut red alder for firewood, for which it excels. (Its smoke gives salmon a distinct flavor, too). But 75 years ago or so, Northwest furniture manufacturers began giving the tree well-deserved attention.

Because its evenly textured, moderately



Red alder was once cut almost exclusively for firewood, and today still serves to give salmon unique flavor with its smoke.

hard, and heavy wood seasons well and works easily, it rivaled more costly eastern hardwoods for modestly priced furniture, cabinets, and turnings. Now, much red alder also becomes veneer for plywood cores as well as high-grade face. And logs find a ready market in Asia and Europe. 🌲



Laguna Tools Band Saw Now Only \$995*

No more excuses, you will never have a better time to purchase a Laguna Tools LT16 band saw. Due to the high volume of band saws that we sell, we can now give you the best band-saw value in the market. Manufactured in Italy exclusively for Laguna Tools, this powerful, swift piece of Italian ingenuity has high-quality, performance and your name written all over it.

Don't wait. Call today to get your free demonstration video.

- 12" resaw capability
- Easy blade change with 1/16 to 1" blade capacity
- 1.5 HP motor
- All-welded steel frame construction
- Cast-iron flywheels with snap on rubber tires
- Electrostatically balanced
- Large 16" x 19" cast iron table
- Cast-iron rip fence
- 3/8" x 3/4" miter gage slot
- Two dust ports for excellent dust collection
- Blade tension indicator
- Table tilt from -10 to 45 degrees. Steel trunions
- Bearing Euro guides, both upper and lower
- Mobility kit, power feeder and 110-volt motor available

*Excludes sales tax and freight. Limited offer, while supplies last.

LAGUNA TOOLS

You Build With Wood, We Build With Trust.

800-234-1976

E Mail: mail@lagunatools.com Web: www.lagunatools.com
17101 Murphy Avenue Irvine, CA 92614 (949) 474-1200 • FX (949) 474-0150
100 Central Avenue South Kearny, NJ 07032 (973) 491-0102 • FX (973) 491-0591

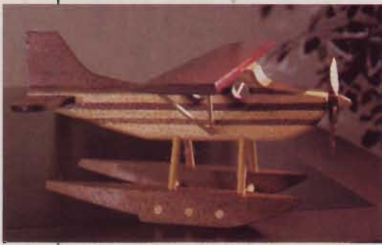

Continued from page 83

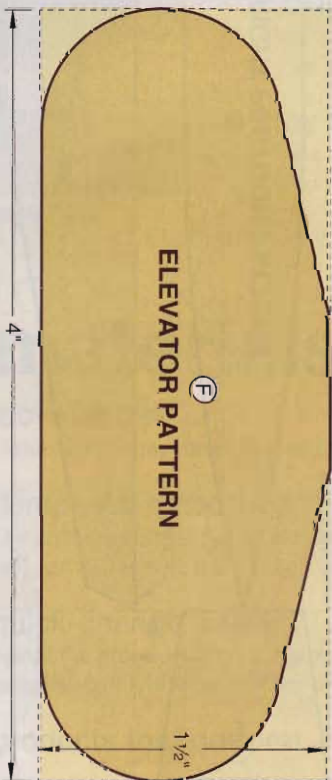
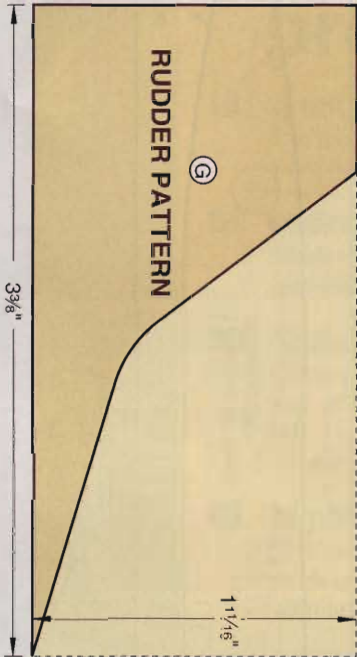
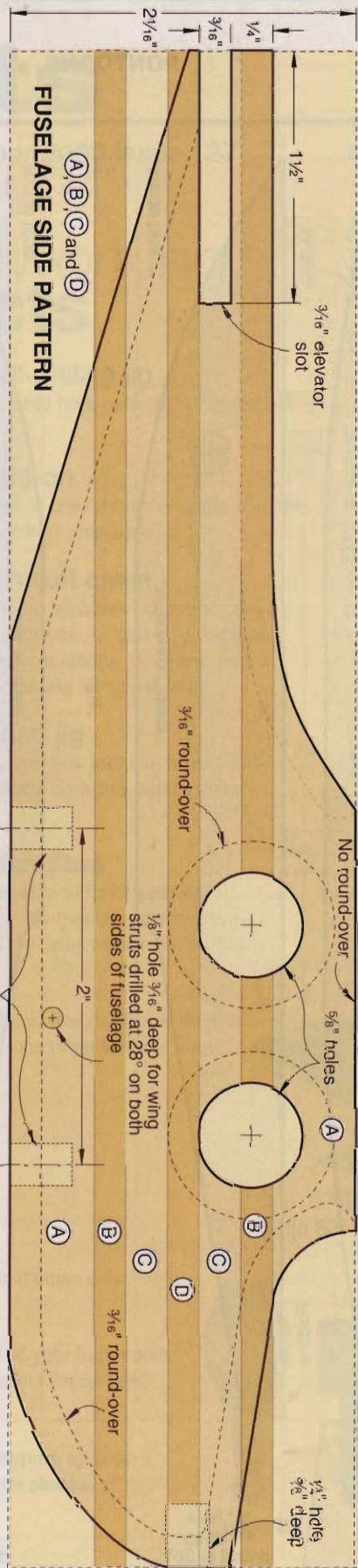
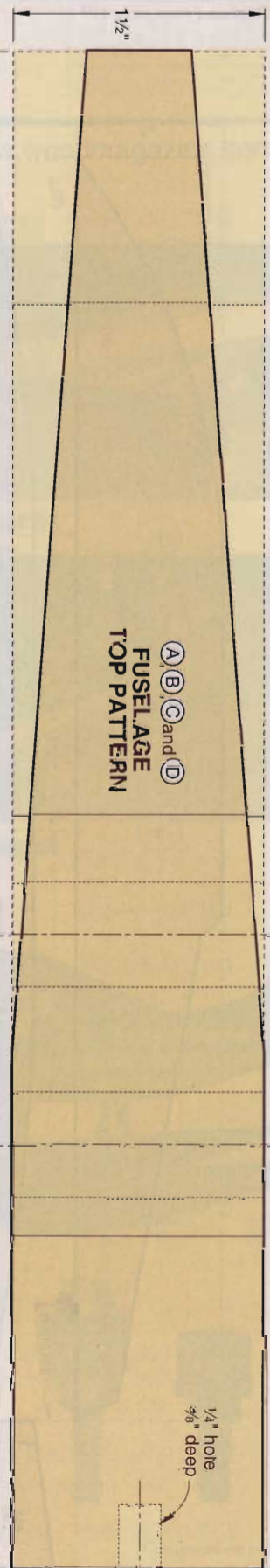

Continued on page 108

PONTOONS

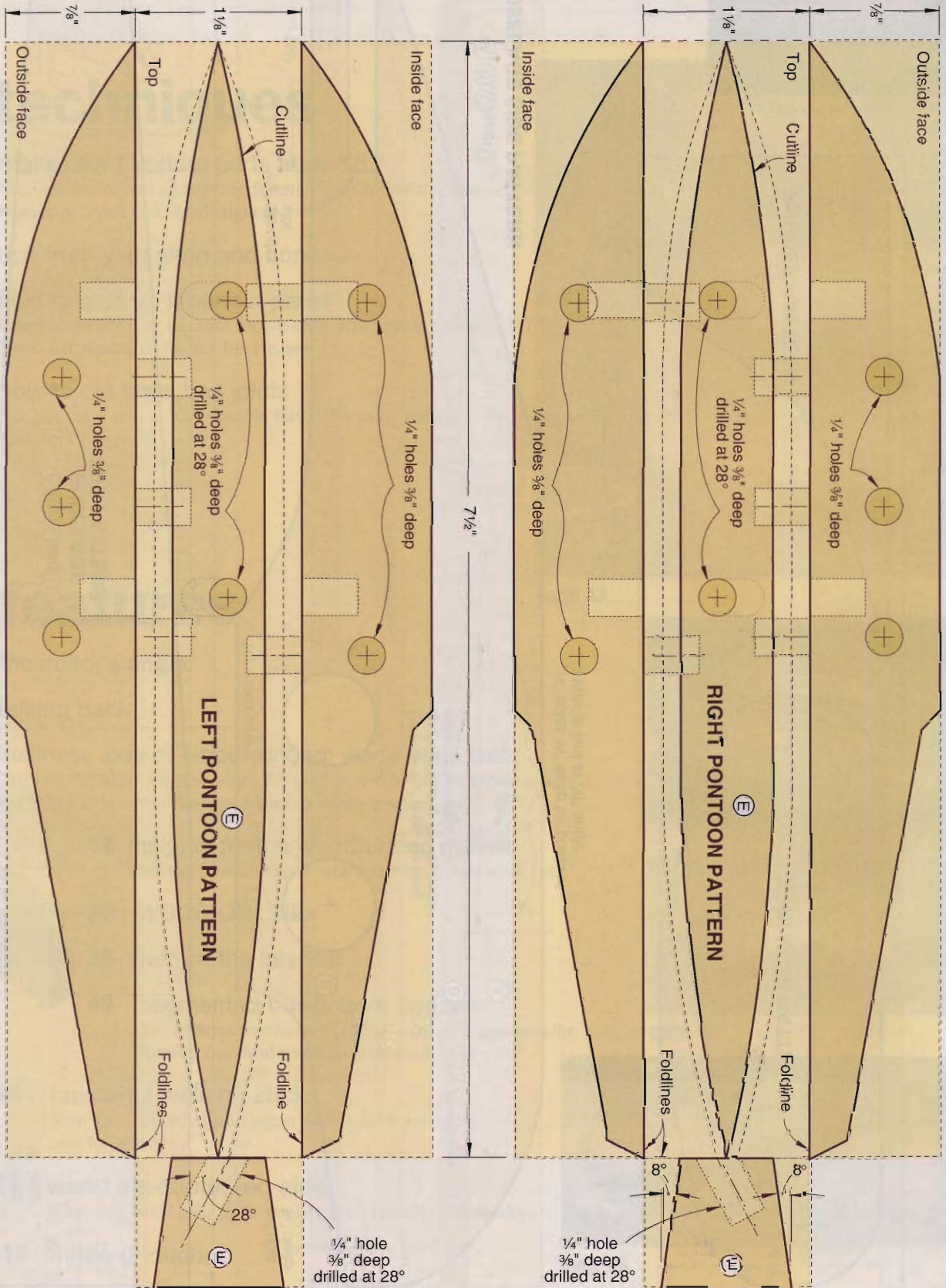

"All my tools should be this good!"

The Accu-Miter® is a professional miter gauge that makes perfect angles easily. Shot-pin action assures dead-on accuracy for common angles — plus a precise protractor scale for everything in between!

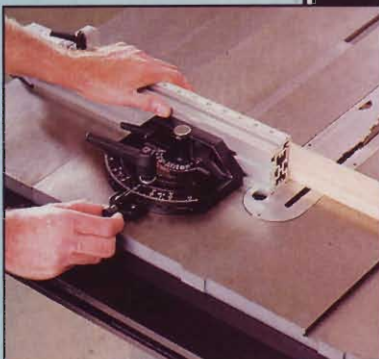

We do not recommend operating without the saw blade guard, as is shown here.
US Patent #5,038,486

Optional accessories:
manual clamp-
pneumatic clamp-
3/8" x 3/4" miter bar-

**JDS
COMPANY**

Precision Woodworking Equipment

Call or write for our free brochure.

800 Dutch Square Blvd., Suite 200, Columbia, SC 29210
1-800-382-2637 / SC 803-798-1600
www.thejdscompany.com

\$149

clockwork

under glass *Continued from page 79*



- Turns on the vacuum only to machines in use
- Shuts dust collector down (& regulates power)
- Saves energy (industrial users up to 76% !)
- Motorized 4"- 12" blast gates and controller
- Your shop is cleaner, and noise is reduced
- Self installing and industrial systems

Call 1-888-ECOGATE for a free brochure. www.ecogate.com

ECOGATE®

French build **Europe's second longest wooden bridge**



The all-wood Merle bridge spans a valley 100' above France's Maronne River.

short of the world's longest wooden one, Pennsylvania's 328' MacCalls Ferry bridge.

According to the French Technology Press Office, the Merle bridge replaced a steel structure that became obsolete due to a 12-metric-ton load limit and insufficient width. For a new bridge, the local government wanted one designed in harmony with the surrounding countryside. Sodeteg, the French architectural firm entrusted with the bridge's design, decided on glue-laminated, French-grown Douglas fir for the structural material. (The species was introduced to England and Europe from the United States' Pacific Northwest in the 1800s.)

Although Douglas fir, stripped of all its sapwood, proves naturally decay resistant, the bridge's design eliminated all possible water traps. The reinforced concrete decking of the roadway above also protects the wood. Due to its strong material and careful engineering, the new bridge has a no-weight-limit, Class 1 rating.

Opened last December, the 189'-long Merle bridge over France's Maronne River ranks as the second longest wooden bridge on the European continent. Only an arched one in Austria has a greater span. Yet both bridges fall

Oldest "Hole-Shooter" surfaces



To celebrate its 75th year of business, the Milwaukee Electric Tool Corporation conducted a nationwide search contest for the oldest "Hole-Shooter" during 1999. The electric drill so named was first produced in 1923 by the A.H. Peterson Company of Milwaukee, the forerunner of Milwaukee Electric Tool.

From more than 100 entrants, the winner was Barney Straus of Elm Grove, Wisconsin. He turned up an operational Hole-Shooter manufactured in 1923 with the production number 84. For his effort, Straus was awarded a collection of special 75th anniversary tools that included a Super Sawzall, a Magnum Hole-Shooter, a Milwaukee Tool leather jacket, a cordless Power-Plus drill, and a Magnum 10" mitersaw.

Elm Grove, Wisconsin's Barney Straus holds the 1923 Hole-Shooter drill that earned him a host of prizes in Milwaukee Electric Tool's "Search for the Oldest Hole-Shooter" contest.

Help for **storm-damaged trees**

Do the chainsaws start humming after a severe storm where you live? Maybe, with a little help, those wind-damaged trees could survive rather than come down. For pointers on saving trees instead of felling them, visit the National Arbor Day Foundation's website (www.arborday.org) to view and download its Storm Recovery—Trees Media Kit. Then pass it along to your town's tree maintenance department. No computer? Request a kit by writing The National Arbor Day Foundation, 100 Arbor Ave., Nebraska City, NE 68410. Phone 402/474-5655. 🌳

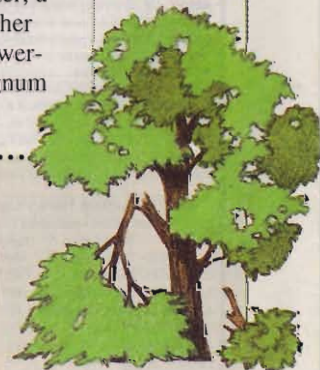

Illustration: Jim Stevenson Photographs: Bridge, courtesy of the French Technology Press Office; Milwaukee Electric Tool Corp.