

WOOD

November 2000 ISSUE 128

www.woodmagazine.com

Tablesaw Trials

We put seven mid-priced models to the test

Page 68

**Winners
Take All!**

See the top clocks from our contest

Page 14

PLUS

**5 Exciting
Projects**

FOR YOUR HOME

Display until November 7

USA \$5.95



0 72440 14072 1

11 >

another great success story!



How about these terrific-looking clocks! I still can't believe how many great entries we had in our "It's About Time" Clock Contest.

well. *WOOD* magazine readers have proven to be some of the most generous (and genuine) people I've ever met, and I knew I could count on you.

As the first entries arrived sometime in mid-December, I could tell that the contest had captured the imagination of many of you. A few more clocks arrived nearly every day, and as we unpacked each of them, I could sense that the rest of the *WOOD* staff was catching clock fever, too. By the time the last 15 clocks were delivered to us on April 3, 2000 (the final day of the contest), we had people from all around the building coming by to take a look at your handiwork.

Yes, these clocks are that good! I've never seen more creativity expressed in any of the contests we've sponsored.

To all of you who took the time to make a difference for the Marine Corps Reserve Toys for Tots program, thank you, thank you, thank you. And a big round of applause for Titebond Glues and Adhesives for their generous support.

For a look at the five top prizewinning clocks, see page 14. To view several of the other Certificate of Accomplishment award winners, please turn to page 16. And check out www.woodmagazine.com for even more of the entries in the clock contest. I guarantee that you'll be impressed. I know we are. 🌲

Larry Clayton

WOOD® magazine readers donate 242 incredible clocks

When I announced the "It's About Time" Clock Contest in the December 1999 issue, I really didn't have any idea how you would react to it. After all, we hadn't done anything like this before, and as with anything new, there's always an element of risk involved.

But I did know two things that made me feel a bit more confident that the contest would work. First, I know that most everyone has a fascination with clocks. And second, after 16 years at the editorial helm of this magazine, I know you pretty

WOOD®

NOVEMBER 2000 • Vol. 17, No. 8 • Issue No. 128

Editor **LARRY CLAYTON**
Managing Editor **JIM HARROLD**
Assistant Managing Editor/Features **PETER J. STEPHANO**
Senior Design Editor **JAMES R. DOWNING**
Projects Editor **BILL KRIER**
Projects Editor **JAN HALE SVEC**
Products Editor **DAVE CAMPBELL**
Techniques Editor **JIM POLLOCK**
Shop Manager/Project Designer **CHARLES I. HEDLUND**
Assistant Design Editor/Project Builder **KEVIN BOYLE**
Production/Office Manager **MARGARET CLOSNER**
Administrative Assistant **SHERYL MUNYON**
Art Business Office Secretary **BARBARA HELPS**
Reader-Contact Specialist **BEN VONRUEN**
Illustrators **KIM DOWNING, LORNA JOHNSON, ROXANNE LeMOINE, CARSON ODE**
Consultants **BOB McFARLIN, DAVE HENDERSON**
Contributing Craftsman **JIM HEAVEY**

Creative Director **DANIEL MASINI**
Associate Art Director **JOHN W. MEEK**
Assistant Art Director **CHERYL A. CIBULA**

Publisher **MARK HAGEN**
Advertising Director **WILL MURPHY**
Ancillary Sales and Internet Manager **MARLEN KEMMET**

Advertising Office: 333 N. Michigan Ave., Suite 1500,
Chicago, IL 60601 Phone: 312/853-2890 FAX: 312/580-7906
Direct Response Advertising **CAROLYN DAKIS**
Account Executive **YUWEI LEE**
Account Executive **RON GOLMINAS**
Advertising Manager **JIM HUGHES**
Marketing Manager **GERALLIE LEGASPI**
Sales Assistant **MARGARET TRAVIS**

Publishing Director **WILLIAM R. REED**

Advertising Services Manager **PAT HENDERSHOTT**
Consumer Marketing Director **LIZ BREDESON**
Associate Consumer Marketing Director **KATHI PRIEN**
Assistant Consumer Marketing Manager **DAVE HONOLD**
Business Manager **CRAIG FEAR**
Senior Product Manager **RICK GROW**

MEREDITH PUBLISHING GROUP

President **CHRISTOPHER M. LITTLE**
Vice President Publishing Director **JERRY WARD**
Creative Services **ELLEN DELATHOUDER**
Manufacturing **BRUCE HESTON**
Consumer Marketing **KARLA JEFFRIES**
Group Sales **JERRY KAPLAN**
Operations **DEAN PIETERS**
Finance and Administration **MAX RUNCIMAN**

Meredith
CORPORATION

WILLIAM T. KERR, President and Chief Executive Officer

E.T. MEREDITH III, Chairman of the Executive Committee

©Copyright Meredith Corporation 2000
All rights reserved. Printed in the U.S.A.

Better Homes and Gardens® *WOOD*® magazine (ISSN-0743-894X) is published nine times a year in February, March, April, May/June, July/August, September, October, November, and December by Meredith Corporation, 1716 Locust St., Des Moines, IA 50309-3023. Periodicals postage paid at Des Moines, Iowa, and additional mailing offices. Better Homes and Gardens trademark registered in Canada and Australia. Marca Registrada en México. **ONE-YEAR SUBSCRIPTION PRICES:** U.S. and its possessions, \$27; Canada, \$39; other countries, \$47. Canada Post Publications Mail Sales Product Agreement No. 1369350. Canadian BN 12348 2887RT. **CANADIAN RETURN ADDRESS:** *Better Homes and Gardens WOOD* magazine, 2744 Edna Street, Windsor, Ontario, N8Y 1V2. **POSTMASTER:** Send address changes to *Better Homes and Gardens WOOD* magazine, P.O. Box 37439, Boone, IA 50037-0439.



Customer Service Information: For service on your subscription, including change of address, contact www.woodmagazine.com/service or call 800/374-9663. **Subscription mailing address:** *Better Homes and Gardens WOOD* magazine, P.O. Box 37439, Boone, IA 50037-0439. Please enclose your address label from a recent issue. **Editorial mailing address:** The Editor, *WOOD* magazine, 1716 Locust Street, GA310, Des Moines, IA 50309-3023. For questions for our editorial staff, questions about how to reach an advertiser, or to place an advertisement in our magazine call 800/374-9663. To order back issues call 800/346-9663. For article reprints, write to editorial address and enclose \$5 per article.

this issue's highlights

WOOD® magazine

November 2000 Issue 128

www.woodmagazine.com

woodworking projects

- 28 great ideas: drill-press pocket-hole jig**
Bore dead-on screw holes for your pocket-hole joints with this easy-to-make jig.
- 56 elegant scrollsawn wall shelf**
Rely on our full-size patterns to ensure your success when making this ornate home accent.
- 60 well-composed compote**
Serve nuts, candy, or other tasty treats in this attractive wood turning. We made ours from three separate pieces that glue-assemble into the glowingly handsome raised dish *above right*.
- 64 "music on file" cd cabinet**
Store as many as 160 cds in this well-organized, five-drawer furniture piece. Large brass pulls and traditional design give it a look that will work with just about any home decor.
- 74 bentwood accent table**
Learn how to work with forms while shaping the legs of this clean, unaffected table design.
- 78 empire state streamlined train**
Relive the days of luxury rail travel by crafting this authentic-looking 1940s display model.

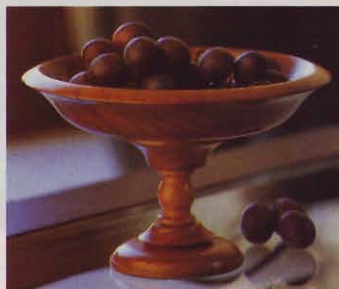

page 60



page 74



page 64

tools & materials

- 68 big-time tablesaws**
You'll be pleasantly surprised by the quality and costs found in this roundup of seven shop-tested machines.
- 90 products that perform**



page 68

Continued on page 6

This issue's cover wood grain: poplar

Cover photograph: D.E. Smith

tips & techniques

- 20** a pro's tips for matching grain
Discover six surefire tricks for achieving the best look from the boards you select for projects.
- 30** how to flush a mounted door
Follow our seven-step process for creating even reveals when hanging flush-mounted cabinet doors.
- 38** tips from your shop (and ours)
- 85** how to get started in biscuit joining
Become hands-on familiar with this quick-and-easy method for joining wood as we cover the basics.

page 30

features

- 2** the editor's angle
- 8** talking back
- 12** WOOD ONLINE®
- 14** top clocks from our contest
Marvel at the winners from our "It's About Time" contest that included hundreds of imaginative and well-crafted entries.
- 24** hot off the internet
- 34** be safety savvy around your tablesaw
Before you cut your next piece of wood, run through our checklist to ensure your tablesaw safety habits are in good order.
- 46** what makes wood rare
Why are some woods so difficult or impossible to get hold of? The reasons may surprise you.
- 51** master of time and space
When Minnesota craftsman James Borden builds a clock, it becomes something more—an expression of art and philosophy in grand style.
- 108** ask wood
- 112** finishing touches



page 85



page 14



page 51

Letters, Comments, And Updates

We welcome your comments, criticisms, suggestions, and yes, even compliments. We select and publish only letters of the greatest benefit to our readers. Write to:

Talking Back
WOOD magazine
 1716 Locust St., GA310
 Des Moines, IA 50309-3023

It's deer season; keep 'em standing up

Well, it's Christmas time and there are more white deer in front yards than ever before. The problem is, after a storm,

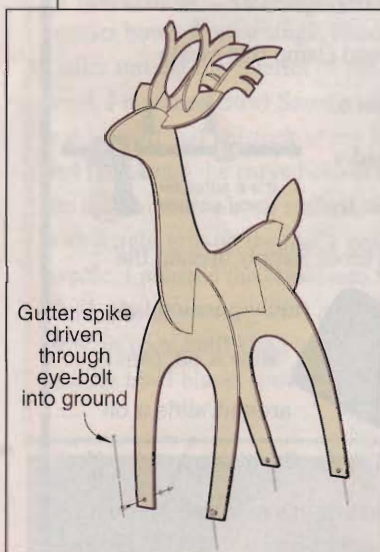

many of them are flat on the ground. The ones that aren't have unsightly wires or poles holding them up. Mine have never fallen; the drawing shows my simple and almost invisible method. Just use an eye bolt whose eye is smaller than the head of the gutter nail, and push or pound the nail into the ground.

As an added touch, when painting the deer, I sprinkle on glitter while the paint is still wet. It gives a nice effect.

—Rob Kurtz, Lorain, Ohio

Thanks from The Homestead for helping the autistic

Thanks for including the story on The Homestead in Issue 119's "FINISHING TOUCHES" column. Woodworkers from across the United States and several from Canada contacted us. Dan Long of Jacksonville Beach, Florida, e-mailed us to see if we were interested in some tools. A few weeks later we received from him seven hand sanders (five of them brand new), several jigsaws, saw blades, rechargeable drills, a package of new bits, and other miscellaneous tools. Your willingness to share The Homestead story has helped us reach new friends. Thanks again.

—Steve Muller, executive director, The Homestead, Runnells, Iowa.

Plunge-router jig alert

An important piece of information is missing from the plunge-router jig article in Issue 123. Building to the dimensions given in the Bill of Materials results in a jig that fits the DeWalt router shown in the article. To make the jig fit any other router, modify the ends (A, B) and fence rail (G) as shown in the drawing.

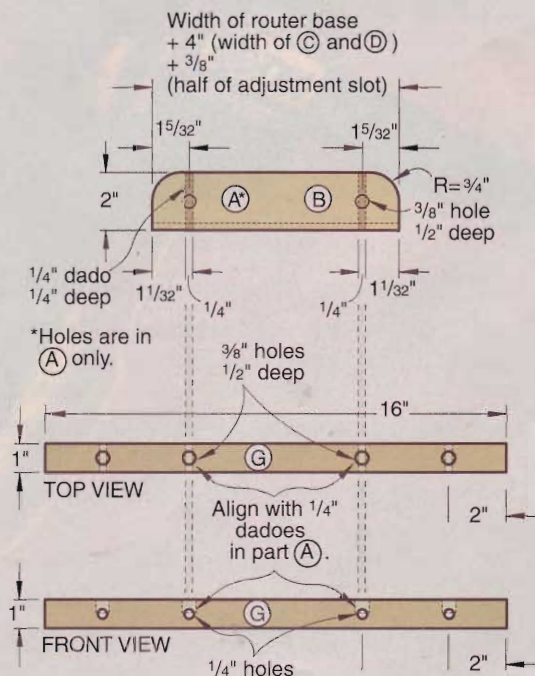
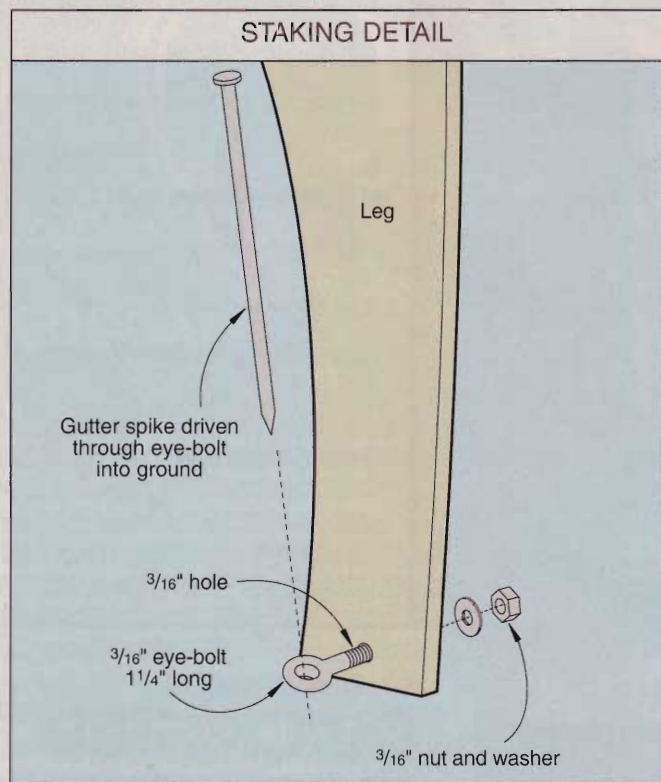

Continued on page 10

A correction and an addition to the keyhole-routing jig

In Issue 123, page 59, you show a keyhole-routing jig. The length of the rabbeted side rails is indicated as, "Length of router base + 3/8". This is not the overall length; it is the inside length. The overall length is the length of the router base plus 3 3/8".

—Charles Krauss, Augusta, Kan.

You are right, Charles. We apologize for the mistake. Luther Williamson, who helped develop the jig, wrote to alert us to the error and pass along another suggestion as well. He drilled more holes in the rails and offset the insert in the moveable stop, as shown in the drawing. This allows him to center a keyhole in the top member of a narrow frame. Luther also advises clamping the jig to the workpiece.

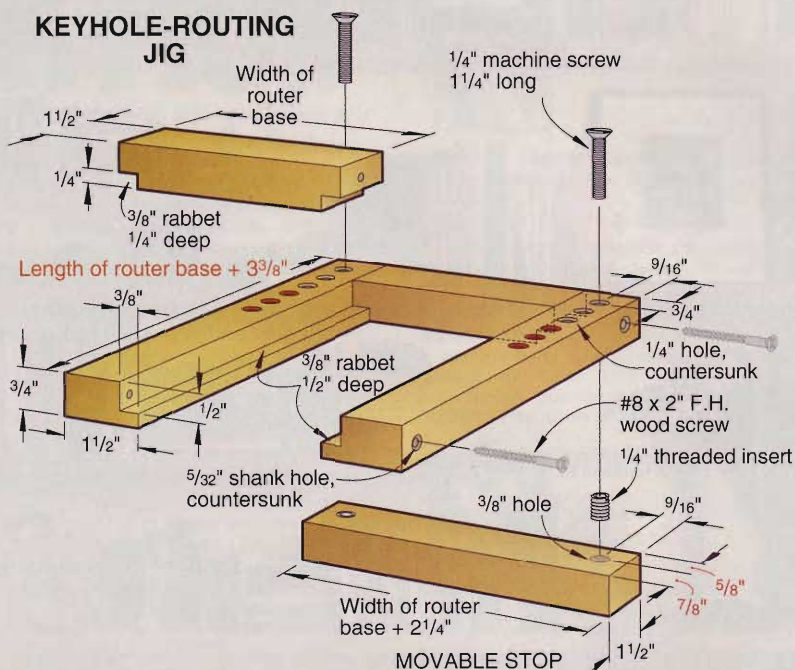

More on the worldwide supply of wood

Peter Stephano's article in Issue 124, page 84, "Wood Worldwide," made me proud to be a subscriber. Who says a hobby magazine cannot practice responsible journalism?

For those interested in more information, the UN released the summary findings of the report, "A Guide to World Resources 2000-2001: People and Ecosystems: The Fraying Web of Life." Copies of the summary can be downloaded from www.wri.org/wri/wrr2000.

Also, note the correct spelling of "taiga," defined as a moist subarctic forest dominated by conifers.

—David R. Cory, Lake Oswego, Ore.

(David is a consulting arborist for Pruett Tree & Landscape in Lake Oswego.)

"Wood Worldwide" in Issue 124 overlooked an organization that makes an important contribution to sustainable forest management: the American Tree Farm System. The System was established in 1941, and has grown to a U.S. membership of over 70,000 private, non-industrial forest owners. The organization's mission is to promote the development of renewable forest resources on private lands, while protecting the environment and increasing public awareness of the benefits of productive forestry. The Tree

Farm System continually modernizes its standards, aligning them with other international certification bodies and national programs, such as the U.S. forest industry's Sustainable Forestry Initiative Program.

—Mickey Hallum, Fayetteville, Tenn.

Mickey is the chairman of the Tennessee Tree Farm Committee. The American Tree Farm System is a program of the American Forest Foundation, 1111 19th St. NW, Suite 780, Washington, DC 20036. Call 888/889-4466 or visit www.treefarmssystem.org.



Home Depot's good deed noticed

On March 8, a tornado touched down in St. Francis, Wisconsin (near Milwaukee). Within hours, Home Depot had a truck in the area with free plywood and tarps for people who needed them to prevent further damage from rain and snow. Our thanks to Home Depot.

—Ken Jaeger, Milwaukee, Wis.

TimberKing sawmill improvements

Thanks for the article on low-cost sawmills in Issue 125. We felt that the review was fair in reflecting a brief experience with each sawmill. I would like to point out that since April 1, we have equipped the TimberKing 1200 with a 15 hp, electric-start Kohler motor. This motor has the integrated clutch and throttle, and pull-start override favored by your reviewer.

The reviewer had some valid criticisms, most of which are addressed by changes effective August 31: hinged blade covers, cutting head feed system disengages on return, hairline depth indicator, and a guide roller moveable from the operating position.

—Will Johnson, President, TimberKing, Inc.



THE RIGHT TOOL

WOODWORKING 101

FOR THE JOB

German Made,
Superior Quality,
Woodworking
Clamps And
Accessories

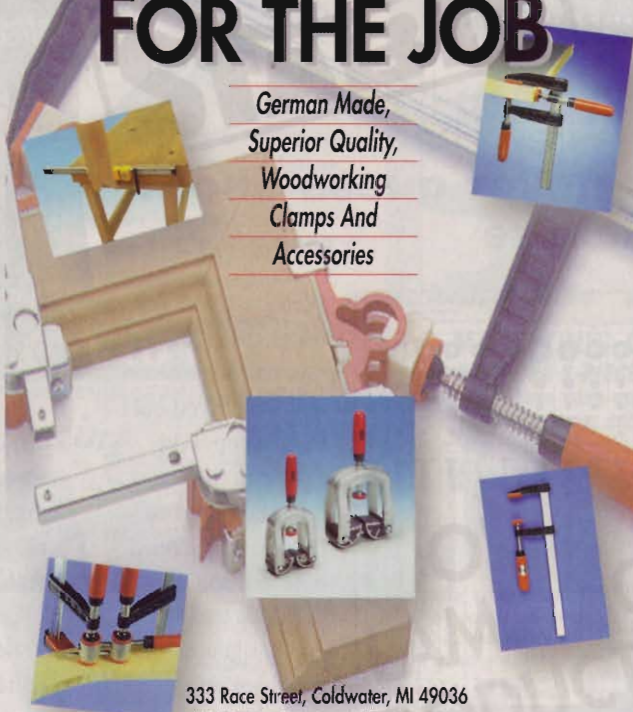

Gross Stabil manufactures woodworking clamps and accessories for every project imaginable. Sliding Arm Clamps, Parallel Clamps, Mitre Clamps, Spring Clamps, Pipe Clamps and Edge Gluing Clamps are made of the finest materials ensuring you a lifetime of dependable use.



333 Race Street, Coldwater, MI 49036
(517) 278-6121 Fax (517) 278-5523
800-671-0838

©Gross Stabil, 2000

Circle No. 2230

Just ask a HAWK ScrollSAW owner

Meet Danny Ferrington who uses his Hawk to create one of a kind guitars for stars like Waylon Jennings, Emmy Lou Harris, Eddie Van Halen and Eric Clapton to name a few. Don't let your tools limit you in creating your project of a lifetime. Learn why craftsmen like Danny choose the Hawk Scroll Saw for their shop.

Call for your FREE Fact Kit



- ▶ Variable cutting action gives more control
- ▶ Smooth vibration-free performance
- ▶ Cuts so smooth, no sanding required
- ▶ Blade changes in seconds
- ▶ Save money buying factory direct
- ▶ 3 models to choose from

MADE IN USA

Call about our No Risk in the Shop 30 Day Trial



Call Toll Free!
1-800-487-2623

RB Industries PO Box 369 Harrisonville, MO 64701
www.rbiwoodtools.com

K114

With this free chart, you'll never guess about pilot-hole size

TRADITIONAL WOOD SCREWS (Actual Sizes)														PRODUCTION SCREWS (Actual Sizes)										
Gauge	3	4	5	6	7	8	9	10	11	12	13	14	4	5	6	8	10	12	14	16	18	20		
Head Size	1/8"	1/8"	1/8"	1/8"	1/8"	1/8"	1/8"	1/8"	1/8"	1/8"	1/8"	1/8"	1/8"	1/8"	1/8"	1/8"	1/8"	1/8"	1/8"	1/8"	1/8"	1/8"		
Shank-Hole Size	+	+	+	+	+	+	+	+	+	+	+	+	+	+	+	+	+	+	+	+	+	+		
Head-Hole Size	•	•	•	•	•	•	•	•	•	•	•	•	•	•	•	•	•	•	•	•	•	•		
Head-Hole Type	Hardwood	•	•	•	•	•	•	•	•	•	•	•	Softwood	•	•	•	•	•	•	•	•	•	•	
Head-Hole Size	1/8"	1/8"	1/8"	1/8"	1/8"	1/8"	1/8"	1/8"	1/8"	1/8"	1/8"	1/8"	1/8"	1/8"	1/8"	1/8"	1/8"	1/8"	1/8"	1/8"	1/8"	1/8"		
Available Lengths	1 1/2"	1 3/4"	2"	2 1/4"	2 1/2"	2 3/4"	3"	3 1/4"	3 1/2"	3 3/4"	4"	4 1/4"	1 1/2"	1 3/4"	2"	2 1/4"	2 1/2"	2 3/4"	3"	3 1/4"	3 1/2"	3 3/4"		
Phillips-Head Point Size	#1	#1	#1	#1	#1	#1	#1	#1	#1	#1	#1	#1	#1	#1	#1	#1	#1	#1	#1	#1	#1	#1		
Square-Drive Bit Size	#0	#0	#0	#0	#0	#0	#0	#0	#0	#0	#0	#0	#0	#0	#0	#0	#0	#0	#0	#0	#0	#0		

Well-designed and information-packed reference charts can really help you out in the shop. For example, the screw reference chart at left shows the head-bore and shank-hole size for all popular gauges of woodworking screws. It even lists

separate pilot-hole sizes for hardwoods and softwoods, and the screw lengths available in various gauges. The editors at WOOD® magazine refer to this chart everyday when preparing project instructions.

You can download and print this chart, as well as others covering drill-press speeds and lumber sizing, absolutely free of charge. Just go to the page listed here.

www.woodmagazine.com/woodbasics/pages/aboutscrews.htm

Want a free woodworking plan? Just subscribe or renew online

We love online subscriptions. They save us money in paper, postage, and handling, and you often can get your first copy of the magazine sooner.

In fact, to show our appreciation for your online business, we'll provide you with access to five free mini plans when you subscribe or renew through our internet site. Within minutes of getting your order, we'll e-mail you the address of an internet page where you can request the free plans. It's easy, and ordering online is 100 percent safe and secure.

www.woodmagazine.com/subscribe/



In search of the missing article

It happens to all of us. We seem to remember seeing an article, perhaps years ago, that had just the information we need to build a project today. But how on earth do we find the article? Now there's help—a single, up-

to-date, comprehensive index of all WOOD magazine articles. You'll find projects, techniques, tool reviews, and everything else that's been published since issue No. 1.

And if the article you're looking for is in an issue you don't have, we most likely can help you there, too. Many of the back issues of WOOD magazine are still available through the online WOOD STORE®—but only until the limited supplies run out.

www.woodmagazine.com/scgi/index/wdindex.html

Sign up now for our free, new-and-improved newsletter

It can be a challenge trying to keep up with all of the current project plans, tools, and other goodies given away at WOOD ONLINE, as well as the latest special programs, tool sales, and seminars. To help you out, we've come up with a newsletter that will be e-mailed to you automatically every month. All you have to do is register for it at the web page listed below. You can unsubscribe at any time.

The newsletter now has color graphics, including photos and illustrations, to go along with the shop tips that have always been popular. The thousands of readers who already receive it tell us they love it. We think you will, too.

www.woodmagazine.com/members/index.html

from over 200 entries, here are the

top clocks

You would never believe the fantastic array of clever time-pieces that showed up in *WOOD*® magazine's Year 2000 "It's About Time" clock contest. Take a look at the winners.

The *WOOD* staff never quite knows what to expect after a new contest announcement. Eleven years ago, readers responded with hundreds of wonderful, handcrafted entries in the first-ever toy contest. Although the entry numbers fluctuated like river levels from then on, the quality and creativity never did. What would happen with a clock contest?

February of the new millennium brought a trickle of entries. By mid-March they grew stream-size. April 1 marked a deluge.

And what clocks there were! Tiny clocks cased in burl. Wall clocks in all

shapes and sizes. Mantle models, both carved and machined. Desk-top delights in a host of woods. You sent clocks that chimed, buzzed, and ticked. A few featured animation. All proved amazing.

The clocks now have new homes. Sold at auction during the fall, they generated funds to benefit the U.S. Marine Corps Reserve's Toys for Tots program. That'll mean lots of happy kids at Christmas. Thanks to all of you who entered and to Titebond Glues and Adhesives for sponsorship. Now for a look at the winners. (See the honorable mentions on *page 16*, and view all the entry finalists at www.woodmagazine.com.)



Grand Prize \$5,000

David German of Grand Rapids, Minnesota, dumbfounded the judges with his ingenious, 74"-tall, red oak grandfather clock. Why was it so special? David cleverly engineered and crafted his hinged clock to fold and nestle one part into another. Closed up, it easily fit inside a 2x2x2' box (as shown *left*), as required by contest rules.

To assure non-breakage, the craftsman and his wife personally delivered the entry to Des Moines. And such care paid off.





First Prize \$4,000

But which way is up? Kentwood, Michigan's Charles Bowman had a story to tell with his 24x24" intarsia clock. His timepiece represents the moment when his grandpa's pocket watch plopped into the old fishing hole. The reversed face on the bottom watch is a reflection on the water. He used purpleheart, maple, and walnut.



Second Prize \$3,000

Woodworker Mike Jagielo from Almond, Wisconsin, might have named his animated clock "Row, row, row, your boat." When running, the oars move and the fish pop in and out behind the clock face. Mike fashioned the 21x15x9" clock from cherry, walnut, mahogany, basswood, curly maple, pine, and baltic birch plywood.



Third Prize \$2,000

Christopher Kroup of Friendship, Tennessee, held the judges' interest with his black widow spider clock. When its articulated legs were spread out to full "crawling" position, Chris' creation measured 32" in diameter. The painted spider's legs were made of balsa, and the case of an unidentified hardwood.



Fourth Prize \$1,000

It was simple beauty, use of wood, and a fine finish that drew applause for James Peluso's 14"-tall mantle clock. Inlaid with cardinal wood, the figured maple case was satin to the touch. The Rowland Heights, California, craftsman provided access to the clock's battery by making its top slide up like a drawer by pulling on the handle.

Continued on page 30

Contest Judging

There's nothing better about a contest than watching the judging. And our judges were great fun to observe. They smiled, frowned, laughed, and grimaced as they went room to room and clock to clock making their selections.



Entries in the contest filled two rooms in the Des Moines offices of *WOOD* magazine. Shown is just a partial room full of clocks that were entered.



Contest judges Scott Mitchell of Titebond and assistant design editor Kevin Boyle scrutinize a clock held by editor Larry Clayton.



Clock contest judges, from left: Sheryl Munyon, administrative assistant; USMC sergeant Searcy Hollis; Jeff Seivers, Titebond; Kevin Boyle, assistant design editor; and Scott Mitchell, Titebond.

still more amazing clocks!

These finalists deserve a round of applause

When the five "It's About Time" Clock-Building Contest judges finally selected the prize winners, they had a field of 46 finalists remaining. Although the contest was set up for only 25 honorable mentions, the judges said, "So what? These are all great, wonderful clocks. Let's award all of them Certificates of Accomplishment." That's how the decision was made, and judges' decisions are always final. The following clock-contest finalists were so awarded:



Shirley Mensch of Center Ossipee, New Hampshire, exhibited her carving skills with "Father Time." Her hand-crafted clock measures 14" tall with a face enclosure mimicking stonework.



This chest-of-drawers clock of figured mahogany built by Larry Cardingley of Maridian, Idaho, was a unique design. Standing 23½" high, it features drawers lined with red fabric.

Shiraz Balolia, Bellingham, Washington. Ebony-trimmed round bear clock.

Bruce Boyd, Carbondale, Kansas. Sculpture with suspended clock.

Roy Braley, Brentwood, New Hampshire. Queen Anne-footed mantel clock.

Gene Buehrer, Cornville, Arizona. Pocket-watch clock with stand.

Larry Cardingley, Maridian, Idaho. Chest-of-drawers clock (shown left).

Jim Caughran, Lodi, California. Laminated circular clock with stand.

Raymond Champine, Clinton Township, Michigan. Walnut-hull clock (see page 18).

Jimmy Clark, Brown Summit, North Carolina. Log cabin fireplace clock.

Howard Clements, Knox, Pennsylvania. "Mark Twain" stern-wheel riverboat clock.

Richard Cox, Norwich, Connecticut. Round scrollsawn clock.

Adam Cunha, Graveland, Massachusetts. Wood beam-boxed mantel clock.

Jack Dalton, Jackson, South Carolina. Brass and laminated-wood pedestal clock.

Dan Demmer, Fairfax, Iowa. Carriage bolt wall clock.

Ralph DiAmore, Queens Village, New York. Padlock wall clock.

Robert Drumm, San Antonio, Texas. Marquetry mantel clock.

Kathleen Escobar, West Jordan, Utah. Segmented egg clock with base.

Henry Freidenberger, Jr., Rocky Ford, Colorado. Scrollsawn scene wall clock.

James Gauntt, Arkville, New York. Carousel mantel clock.

Continued on page 18

amazing clocks!



Henry Schulz, a woodworker from Burnaby, British Columbia, also happens to be a mechanic. That's why he built this 10" wenge clock as a model of a magnetic dial gauge, with a quartz movement replacing the gauge.



There's no doubt about the material that Raymond Champine, a reader from Clinton Township, Michigan, used for his mantel clock. Walnuts! Ray gathered countless black walnut hulls, and epoxied them together for his 10½"-tall clock's fascinating case. Unopened hulls form the pillars.

Mel Gullickson, Hancock, Wisconsin.
Relief-carved picture wall clock.

Donald Harden, Wyerhaeuser, Wisconsin. Fishing rod and reel clock.

Rod Hildahl, Brooklyn Park, Minnesota. C-clamp music-box clock.

Lowell Hudson, Jacksonville, Florida. Classic mantel clock.

George Kempf, Seattle, Washington. Square, dovetailed teapot clock.

Glenn Kerr, Grand Rapids, Michigan. Turn-of-the-century train station clock.

Robert Lamson, Leesburg, Florida. Teardrop rearview mirror clock.

Sam Lay, Baker City, Oregon. Sculptural clock.

Steve Leonard, Palatine Bridge, New York. Rustic birch-bark clock.

Leland Marean, Tucson, Arizona. Sculptural purpleheart clock.

Neal McAfee, Summerfield, Florida. World time zone wall clock.

Paul McFadden, Rock Springs, Wyoming. Mantel clock with trout.

Shirley Mensch, Center Ossipee, New Hampshire. "Father Time" carved clock (see page 16).

Charles Myers, Clinton, Tennessee. Laminated wall clock.

Mario Padilla, Plainfield, Illinois. Square mantel clock with four faces.

Kenneth Parker, West Palm Beach, Florida. Saltwater fishing-reel clock.

Victor Pasturczak, East Moline, Illinois. Victorian wall clock.

Glenn Poole, Winnipeg, Manitoba. Mantel clock with weather gauges.

Cindy Radle, The Woodlands, Texas. Built-up triangle mantel clock.

William Roskop, Austin, Minnesota. Arched-top mantel clock.

Dennis Roussel, Delta, Colorado. Log cabin clock with furnished interior.

Jim Rubach, Waterford, Wisconsin. Round-turned clock on pedestal.

Henry Schulz, Burnaby, British Columbia. Magnetic dial-gauge clock (shown above left).

Glenn Schworm, Millersburg, Ohio. Pulley-and-belt clock.

Gil Steele, State College, Pennsylvania. Intarsia frog clock.

Michael Vander Wall, Williamston, Michigan. Carved/scrollsawn clock.

John Willis, Savannah, Missouri. Horsefly-shaped clock and micrometer desk clock.

Wayne Wollersheim, Fond du Lac, Wisconsin. U.S. Navy destroyer clock.

To see all the finalists' clocks, visit www.woodmagazine.com.

Photographs: Baldwin Photography

a pro's tips for matching grain

I've met a lot of woodworkers who have a good handle on the mechanical part of their craft. They build projects that are square and sturdy, with parts that fit precisely.

Yet, many woodworkers overlook the more subtle art of matching grain direction and color. As a result, their well-machined and finely fastened projects fall short in the appearance department.

While building the CD cabinet on *page 64*, and the accent table on *page 74*, the importance of grain matching really hit home. For both projects I carefully selected, cut, and joined workpieces for best appearance.

In this article I'll share some tips for grain- and color-matching. You can use these same tricks when building many of your own projects.

—Chuck Hedlund, Shop Manager/Project Designer



For the best grain match, Chuck Hedlund often cuts workpieces at a skewed angle to the board edge.

1 Single out one board for small projects

When selecting stock for a small project, say a keepsake box or picture frame, try to use wood from the same board. Although grain and color can vary even in a single board, with careful selection you should be able to cut parts that match closely.

2 For large work, choose compatible stock

For larger projects, I like to use boards cut from the same log. And that's possible if you have your own tree custom sawn. Because most of us have to buy wood from a lumberyard or home center, here's how I go about finding matching boards at these outlets. It takes a little time, but pays off in good-looking projects.

First, I cull the boards that are free of warp and have as few defects as possible. Then, I stand them up side-by-side, and take a step back. Next, I reshuffle their order for best color match.

Finally, I select the boards with similar color that have grain that I can envision being matched as I build the project.

Grain refers to the pattern of lines on the surface of a board produced by the orientation of the wood's annual growth rings. I look for boards with grain lines spaced equally apart and oriented in the same direction.

3 Go straight when looking at grain pattern

For most project parts, especially those I cut from oak, ash, or hickory, I like to use straight-grained boards. That's because wavy grain can give a project, particularly a tall one like the

CD cabinet, an unbalanced feeling. Wavy grain can create an optical illusion where a perfectly constructed piece of furniture appears out of square or plumb.

To get straight-grained pieces for projects, I choose the widest boards available. Why? Most boards are flatsawn at the mill today, meaning they typically have cathedral-grain figure toward their center, and straight-grain figure toward their edges as shown *below*. It's been my experience that wide flatsawn boards yield a higher percentage of straight-grained stock than narrow boards.

Continued on page 22

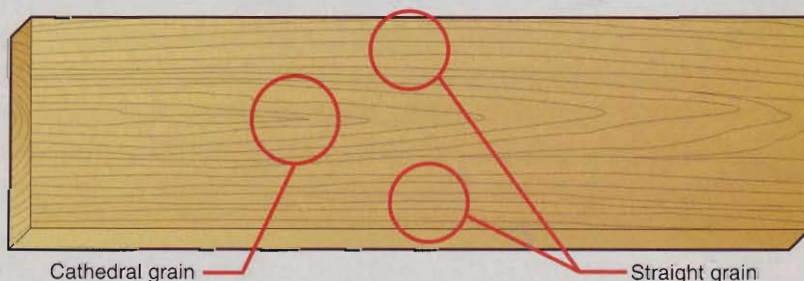

matching grain

4 Save cathedral-grain stock for hidden parts

After reading the last tip, you may be wondering what I do with the leftover cathedral-grained stock. I'm as frugal as the next guy, so cathedral-grained stock goes into parts that aren't visible, such as internal components.

5 Try this angle for wavy-figured woods

Certain woods, such as cherry, walnut, and maple, don't have a lot of straight grain. Much of their beauty comes from wavy-figured grain patterns. That's why mills saw these species to yield as many wavy-grained boards as possible.

When working with these woods, I use chalk to mark the location of project parts on the boards. I orient the chalk marks for the best grain match as shown on page 20. Doing this, the

pieces often come out of the stock at an angle to the board edges. I cut out these marked pieces with a handheld circular saw or jigsaw, then joint one edge. The remaining material goes for parts that aren't conspicuous in the finished project.

6 Cut your drawer fronts from large glue-up

There are a number of differences between the architectural-grade projects that we feature in *WOOD* magazine and the factory-grade furniture you find in stores. For example, on the CD cabinet you'll see that the grain seems to flow without visual interruption from one drawer to another. On the same furniture piece made in a factory, the grain of one drawer likely won't match the one adjoining it, and a single drawer may have both cathedral- and straight-grain.

To make a series of matching drawer fronts, I glue and clamp matching pieces into an oversized panel as shown in *Step 1* of the drawing below. Its length (measured with the grain) should be 1" longer than the length of the drawers to allow for trimming. The width of the panel (across its grain) should equal the combined widths of the drawers, plus 1/8" for each saw kerf, plus 1" for trimming. I crosscut this large panel into drawer fronts as shown in *Step 2, below*.

This procedure not only makes for great-looking drawer fronts, but you can economize by using narrow pieces (that might otherwise end up as scrap) to make the panel. For example, most of the drawer fronts on the CD cabinet are made of two or three pieces of wood, some as narrow as 1".

Photograph: Baldwin Photography
Illustrations: Kim Downing, Brian Jensen

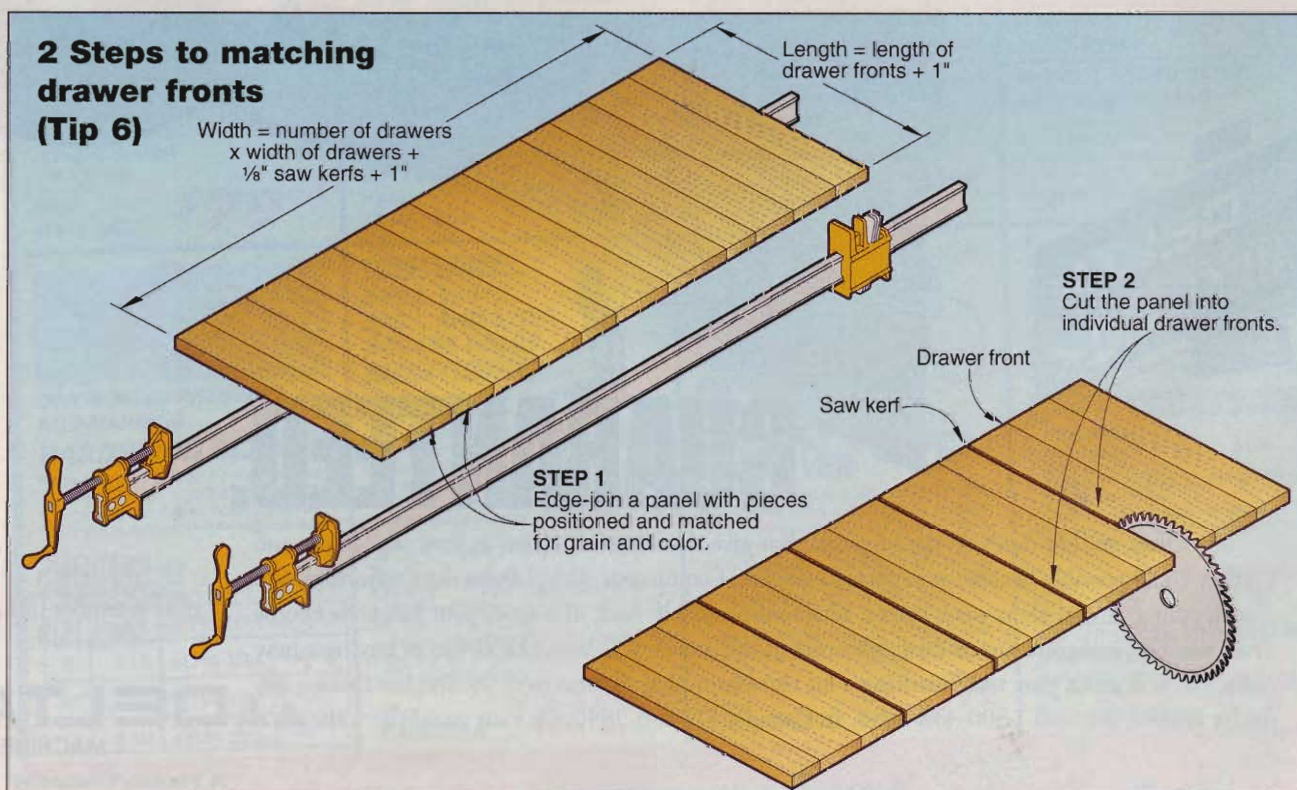



Comments, answers, and ideas from our WOOD ONLINE® discussion groups at www.woodmagazine.com

Note: We have edited all entries in the interest of brevity and clarity while preserving the intent of the original message. Opinions expressed here are those of our online participants.

What finish works on top of shellac?

Can I successfully apply polyurethane or lacquer over a sealer coat of shellac?

—Ben Licata, New Orleans, La.

There's no problem putting lacquer over shellac. But polyurethane just plain will not stick to shellac that has wax in it. For that, you need a dewaxed shellac. Do not trust any shellac labeled as dewaxed until you are absolutely sure. Some shellacs say they are dewaxed, and all that means is that they have taken out some or most of the wax. "Some" is not good enough. Completely dewaxing shellac is not difficult, but it takes time. It is worth the effort.

—Jim Kull, San Ramon, Calif.

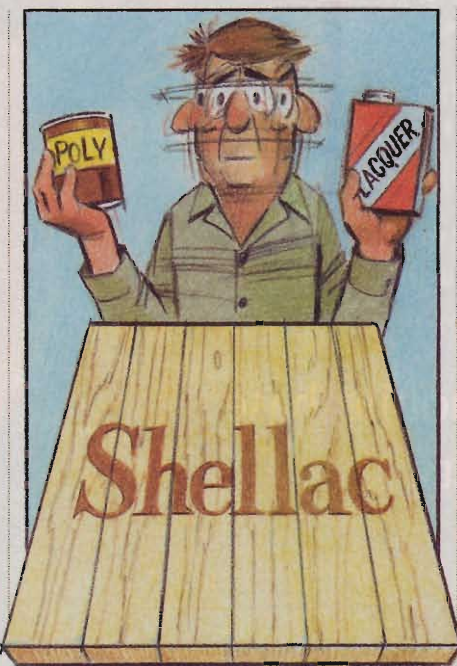

The traditional dewaxing method is to put the shellac in a clear glass jar and let the wax settle to the bottom. This can take place overnight or in a few weeks, depending on temperature and other factors. Then siphon or pour out the clear shellac, taking care not to stir up the wax at the bottom. Or you might try the method used by WOOD ONLINE regular Jim Frye: Place three regular coffee filters in the basket of an old iced tea or coffee maker, set the basket on a glass jar, pour the shellac into the filters, cover the basket with its original cover or some plastic wrap to slow the evaporation of alcohol, and let it drip all night.

—WOOD® magazine

Gluing a through tenon

I am a novice woodworker, and want to know the best way to glue a mortise-and-tenon joint that goes completely through the leg of a chair. Is there a way I can do this without displacing the glue as I push the tenon through the mortise, especially when the fit needs to be so tight?

—Bill Van Gilst, Harwinton, Conn.

The tenon should not be a "hammer fit." Good milling, jiggling, cutting, and practice will make for consistent "slop" of 2 to 4 millimeters in joinery. Paint the mortise and tenon

with yellow glue, and you'll get a uniform glue line. You'll get a mess, too, but a wet rag will clean that up.

—Pat Warner, Escondido, Calif.

Another way to get the look of a through tenon is to cut the mortise approximately halfway through the piece, then on the opposite side make a mortise about 3/8" deep. The wood left in the middle will hold glue in the joint, and you can make it even stronger with a hidden wood screw. Then glue a short tenon plug in the other side. I like to use a contrasting wood.

—Mark Metko, Larsen, Wis.



Continued on page 26



**THERE'S A QUALITY
CRAFTSMAN AIR POWER
FASTENING TOOL TO
SOLVE MOST ANY PROJECT**



Craftsman 16-gauge 2 1/2-in. finish nailer with case. Ideal for installing window, door trim. Drives nails 3/4 to 2 1/2-in. long. 150 nail capacity. #18441. **149.98**



Craftsman 18-gauge brad nailer with case drives 5/8 to 2-in. brads. Ideal for molding and finished trim work. 110 nail capacity. #18433 **99.99**



Craftsman 18-gauge 1/4-in. crown stapler with case drives 1/2 to 1 1/2-in. staplers. 130-staple capacity. #18434 **99.99**

SEARS

THE GOOD LIFE
AT A GREAT PRICE
GUARANTEEDSM

Will shellac fully protect end tables?

I'm almost ready to finish some mission end tables. Using some white oak scraps, I found a combination of orange shellac over aniline dye that gives me a great color. I'm wondering if just spraying on the shellac is durable enough to handle spills and normal use. Or should I just go with the dye and a polyurethane topcoat?

—Joel Matteson, Clovis, N.M.

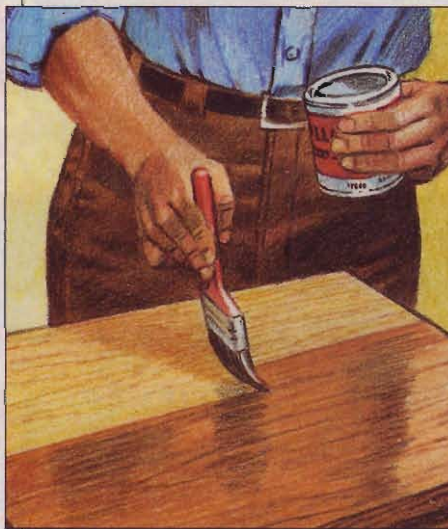

● Polyurethane varnish is more durable, but shellac will handle occasional spills. A coat of paste wax after the shellac has cured is good insurance. If the shellac is fresh and the wax has been removed, the level of resistance to water damage is raised significantly.

—Dave Macfee, Topeka, Kan.

● Commenting on Dave's reference to the water resistance of shellac, according to Michael Dresdner, if shellac is completely dewaxed it is completely water resistant. I found this very interesting.

—Gretchen Allen, Charlotte, N.C.

● Yes, shellac is resistant to water if it is dewaxed, but resistance is subjec-

tive. It offers far less resistance than lacquer or any varnish finish. A wet glass on it will quickly leave a ring. If the glass has scotch in it and the scotch gets on the finish, the shellac is gone. Also, literally any commercial cleaning product will harm it. For example, many cleaning services use Windex as a general cleaner. The ammonia in it will destroy a shellac finish. Most dishwashing detergents will harm it. Shellac has a wonderful place in finishing, but I do not feel it is a good general finishing product.

—Jim Kull, San Ramon, Calif.

● For another opinion on this topic, we turned to Bob Flexner, author of *Understanding Wood Finishing*. Here's what Bob had to say:

"Almost all furniture made from the 1820s to 1920s was finished with shellac, usually with its wax still included, and the finish has held up quite well for many decades. Shellac is a perfectly appropriate finish for end tables as long as you don't abuse them.

"Paste wax reduces scratching but gives little or no protection against spills. The shellac is quite resistant to spills, even highly diluted alcohol like that in alcoholic drinks.

"Though condensation on a cool glass will eventually work its way through a shellac film and cause it to peel, the water won't cause water marks on shellac that is only a few years old. Very hot water, or a very hot coffee cup, may do damage though, as they also will do to lacquer.

"Dewaxed shellac is more resistant to the penetration of water than shellac with the natural wax still included, but it isn't more resistant to heat. I have confirmed all of this many times through testing." 🍀

on-the-money

drill-press pocket hole jig

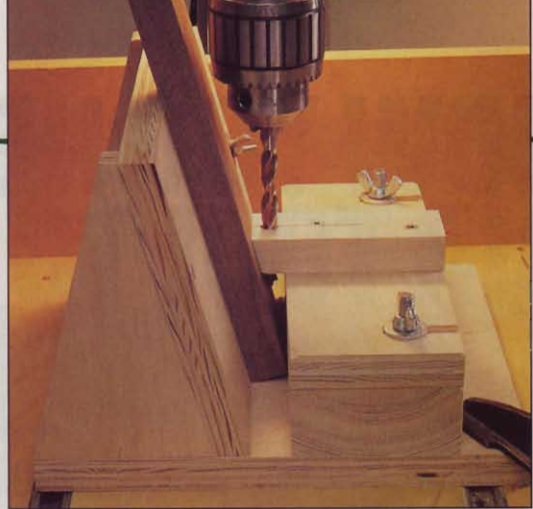

No need for a store-bought jig with this shop aid. We built ours out of $\frac{3}{4}$ " plywood and a few pieces of solid stock cut to the dimensions shown on the Exploded View drawing.

Build and assemble the jig as shown. Mark the hole-location centerline on the face of the workpiece, and place the workpiece against the angled fence.

Slide the guide assembly firmly against the workpiece, as shown in the Front Section View drawing below, aligning the centerline on the guide with the one marked on the workpiece. The slots in the guide block allow you to adjust the guide for different thicknesses of wood. Slide the stopblock up to the edge of the workpiece, and tighten it in place. (Because most stiles and rails require a pair of pocket holes, we drill the first set of holes at one setting, loosen the wing nut, move the stopblock, and drill the second set of holes at the next setting.)

Chuck a $\frac{3}{8}$ " brad-point bit into your drill press (longer bits allow more clearance). Align the $\frac{3}{8}$ " hole in the guide with the $\frac{3}{8}$ " bit. Clamp the base of the jig firmly to your drill-press table. Drill the hole into, but not through the stock, as shown on the Front Section View drawing. Once the right depth has been determined, set the stop on your drill press to drill to the exact depth each time. Later, use a portable drill and a $\frac{1}{8}$ " bit to drill a

pilot hole through the center of the angled $\frac{3}{8}$ " counterbore to finish creating the pocket hole for the screw. 

Note: We used our jig on a heavy-duty benchtop drill press with a spindle travel of $3\frac{1}{4}$ ". But, we found it wouldn't work on a small benchtop model with a 2" spindle travel or models with limited clearance on the side where the drill-press stop juts out.

Project Design: Robert Taugher
Illustrations: Kim Downing
Photograph: Hetherington Photography

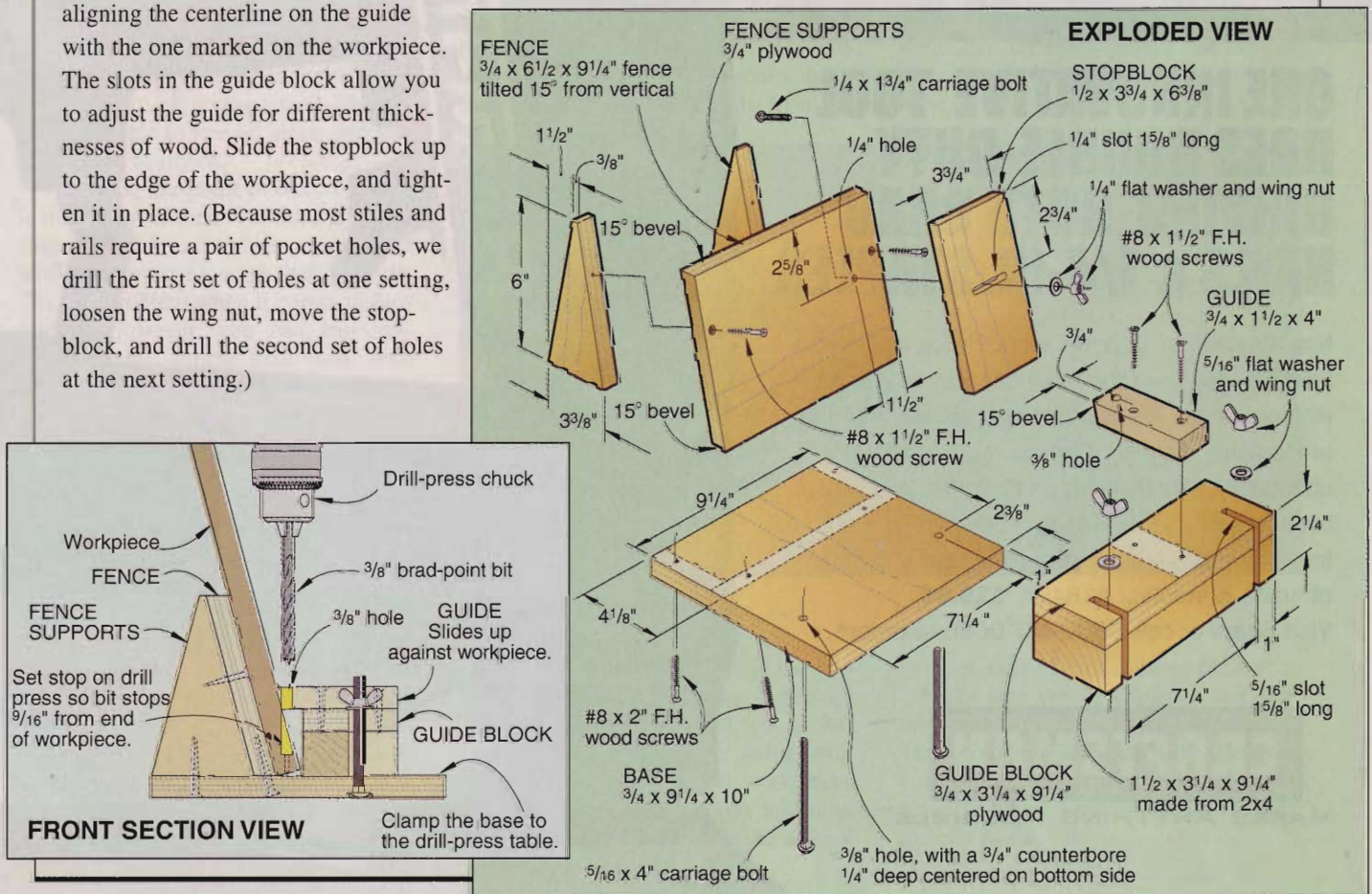

7 steps to perfectly fitted, flush-mounted doors

When you install a flush-mounted door, you simply place one rectangle inside another, right? Well, we all know that looks can deceive in the world of woodworking. Door installation can quickly zoom past “simple” and go all the way to “frustrating.”

Ideally, your carcass has perfectly square corners, so does each door, and you fit them together with a perfectly even gap, or “reveal,” all the way around. But don’t count on it. Almost always, you’ll have to compensate for small flaws that can add up to big problems. Here’s how to handle the all-too-typical problems in a common two-door cabinet.



1 First, build the doors to the exact size of the carcass opening.

That gives you some extra wood to work with in the fitting process.

Set the cabinet up on your workbench, if possible, and make sure it’s sitting level. Measure it carefully and, using a crosscut sled on your table saw, trim one door to a length $\frac{1}{16}$ " less than the height of the opening. Now set the door in place, as shown *above*. Does the hinge-side stile sit tightly against the carcass? If so, you’re off to a great start. But if you see space at one end, use cardboard or folded paper to make a shim that fits the gap an inch from the end of the stile. You’ll use this shim in the next step.

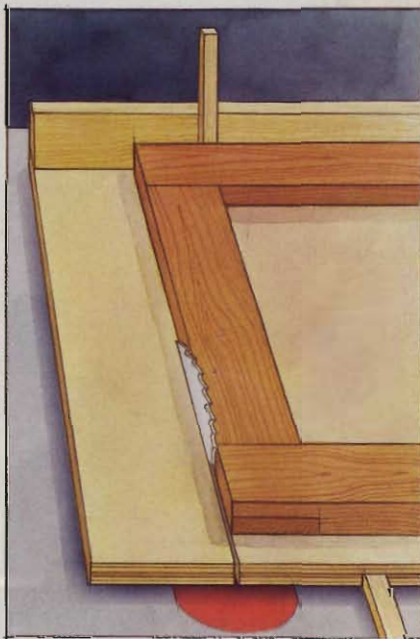

2 Go to the table saw to shave a bit off the bottom rail at a very slight angle. This will let you align the hinge stile, but won’t ruin the look of the door as long as you don’t have to trim off too much. To get the right trim angle, place your shim an inch from the end of the door that did not show a gap, as shown *above*. Test-fit the door again, and trim some more if necessary. Be careful to remove very little stock with each trim.

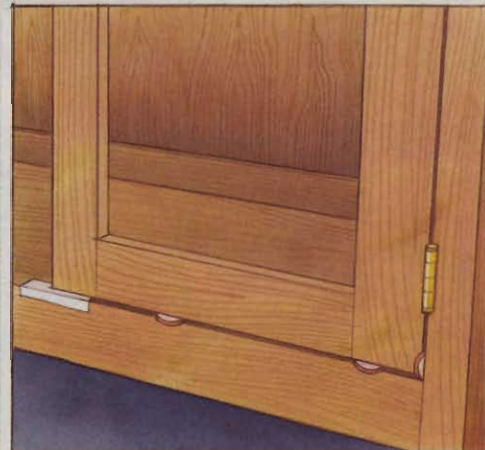

3 Place the door in the opening with pennies as $\frac{1}{16}$ " spacers on the bottom, as shown *above*. Trim the top rail until you have a $\frac{1}{16}$ " reveal there, too. Then stick a penny along the hinge stile and mark the knob stile’s location on a piece of masking tape, also shown in the drawing. Now follow these first three steps again for the second door. When you mark the second door’s knob stile on the masking tape, it probably will fall slightly beyond the first one. Mark halfway between the two to locate the center of the carcass opening. The doors should meet at that point before you make the final trim on the knob stiles.

Continued on page 32

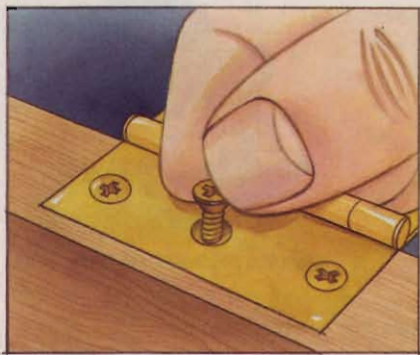

4 Establish the locations for your hinges, then cut mortises in your cabinet doors. Install the hinges, as shown *above*. Here again, you want a $\frac{1}{16}$ " reveal, so set your mortise depths accordingly. The surest method is to mortise a couple of pieces of scrap, install one of your hinges, and check the resulting gap. Caution: Even though you've found the perfect mortise depth for one hinge, that doesn't assure the same result for every other hinge. The dimensions can vary slightly, especially with handmade hardware.



5 To find the correct hinge locations on the carcass, put the door in place again with pennies underneath. Mark lightly with a sharp pencil at both ends of both hinge barrels, as seen *above*. Remove the door, hold a loose hinge at each set of marks, and mark around the hinge plate. Using those marks as guides, cut mortises and install the door with just one screw in each carcass-side leaf. Repeat with the second door. If everything looks perfect, add the rest of the screws.



6 Sometimes, after all that careful work, you still might find yourself looking at imperfect reveals. If the gap is too large at one end, you'll have to chisel a thin layer of wood out of the nearest mortise, as shown *above*. When a reveal is too slight, loosen the screw in the carcass-side hinge and slip a piece of paper, sandpaper, or cardboard into the mortise to bump the hinge out just a bit, as shown *below*. Tighten the screw and check the reveal again.

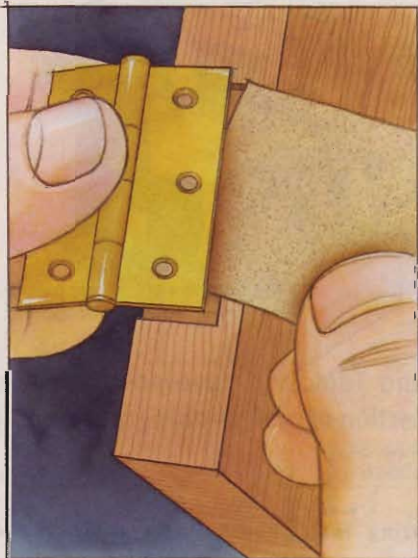

7 Another common problem: The reveal turns out fine, but the plane of the door doesn't line up with the face frame, as shown *above*. Loosen the single screw placed in each carcass-side leaf and place screws as shown in the *inset*. To shift the door out, put each screw against the outer edge of its hole. To pull the door in, put the screws against the inner edge. Once the door is lined up, remove the original screw entirely, fill the hole with toothpicks and glue, and drill a pilot hole after this plug hardens.

Finally, when everything is lined up just right, trim the knob stiles to produce a $\frac{1}{16}$ " reveal down the middle. Take the same amount off each door, using your tablesaw or a handplane, and bevel them slightly toward the inside. The bevel lets them swing open and shut without banging together at their inside edges. ♣

Written by **Jim Pollock** with **Charles I. Hedlund**
Photograph: **Baldwin Photography**
Illustrations: **Brian Jensen**

be safety savvy
around your

tablesaw

Of the 720,000 injuries per year associated with woodworking, 42 percent happen at the tablesaw. Yet common sense, proven practices, and tried techniques will keep you out of harm's way.

That tablesaws rank high as the cause of many woodworking accidents shouldn't be surprising. What woodworker doesn't have one? And it's probably the most frequently used power tool in the shop. Because of that use, it'll pay you healthy dividends to always be on guard around this indispensable machine.

A multi-toothed blade whirling at 8,000 rpm should spur a sense of caution and respect. It shouldn't instill fear. Armed with the advice, rules, and techniques you'll find here, you'll have the confidence to get the best out of your tablesaw, and safely, too.

Begin a habit-forming checklist to follow before sawing

California Polytechnic Institute has developed a Code of Safe Practice for a number of woodworking machines as a guide for operators and supervisors in the industry. We've added to it, and suggest you always follow the checklist before doing any cutting with your tablesaw in the shop.

- Remove from the saw table all scrap materials, tools, fasteners, and other debris. Also clear a 2' perimeter all

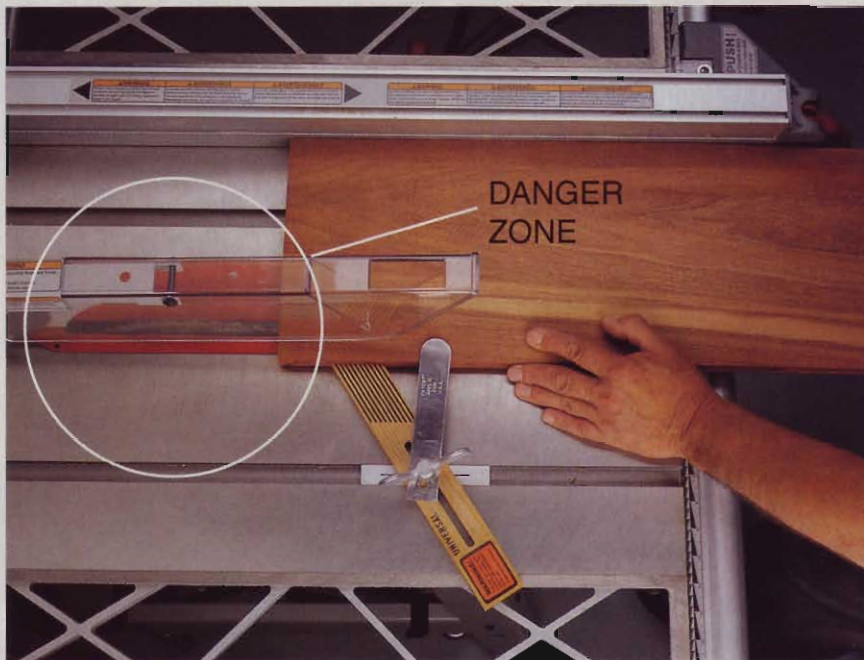

around the saw (more where you'll stand if ripping long stock).

- Use the blade that best suits the job (never a crosscut blade for ripping or vice versa), and make sure it's sharp. Check the arbor nut for tightness and the blade itself for chipped teeth, cracks, and other defects. Do all of this with the machine unplugged.
- Set the blade height. Flat-ground blades should extend no more than 1/4" above the wood. Hollow-ground or planer blades must be raised as high as possible to avoid binding.
- Inspect all of your saw's safety devices (the blade guard, splitter, and anti-kickback device, if present) for proper operation. The blade guard must move up and down freely to accommodate different wood thicknesses.
- Double-check the location and condition of the on/off switch.

- Realign the electrical cord to avoid tripping over it.
- Set the fence to align parallel to the blade at the width of the cut.
- Have safety glasses ready to wear, or if cutting material that tends to chip, a full-face shield.

Because a tablesaw gets so much use in woodworking, turning it on to make a cut becomes as automatic as flipping on a light switch. But it shouldn't. Ponder this advice:

- Never run your tablesaw when you're tired. Fatigue leads to errors in judgment and mistakes. In fact, studies have shown that many serious tablesaw injuries occur to woodworkers when most other people are getting ready for a good night's sleep. Also stay away from the saw if you're on medication or have been drinking alcohol.
- Don't rush. Plan all your cuts.

Continued on page 36

be safety savvy around your **tablesaw**

- When ripping stock, always anticipate the possibility of kickback. Plan to minimize any damage from it to you or the workpiece. For instance, don't stand directly in line with the blade, but off to the side of it. To make sure your pushing hand won't accidentally run into the blade, hook the small and ring fingers of the your pushing hand over the fence to slide with the wood.
- If you're planning to rip boards longer than 3', get a helper to support the wood after it passes through the blade (or use an off-feed table or roller).
- All cuts should incorporate either the fence or the miter gauge. Never attempt freehand sawing. Turning the stock on the blade even slightly causes it to bind in the wood and kick back.

On the other hand, never use the fence and miter gauge together. If you try to crosscut with the miter gauge using the fence as a stop, for example, the cutoff piece trapped by the blade may fly back at you.

- Don't remove the blade guard from your saw unless absolutely necessary to make a specific cut.
- Make sure you have a pushstick handy for any cuts that require your hand to pass within 6" of the blade. See designs at *right* for two tried-and-true pushsticks you can make easily.
- If you have doubts about making a cut, don't do it.

You've thought it through, now get in position to saw

You've got everything on hand, you've gone through the checklist and you've thought through all your cuts. You're set to saw. And as you do, keep the following in mind.

- Stand with your weight equally balanced on both feet. If the board should

suddenly give, you don't want to run into the blade.

- Be absolutely sure that the blade never comes between your body and your hands, either front to back or side to side.
- Use a featherboard to hold stock against the fence. And make sure you have a firm pushing grip on it.
- As you saw, don't reach over the blade to push stock. Always keep your hand as far away from the blade as practical. If need be, use a pushstick.

- If you're making repetitive cuts, stop frequently to take a break. Many accidents happen after boredom lulls a person into carelessness.
- After completing the cut, let the blade come to a complete stop on its own. Don't push scrap wood against the blade to stop its rotation.
- When you've finished sawing, turn off the tablesaw and lower its blade below table height. 🌲

Drawings: **Roxanne LeMoine**
Photograph: **Baldwin Photography**

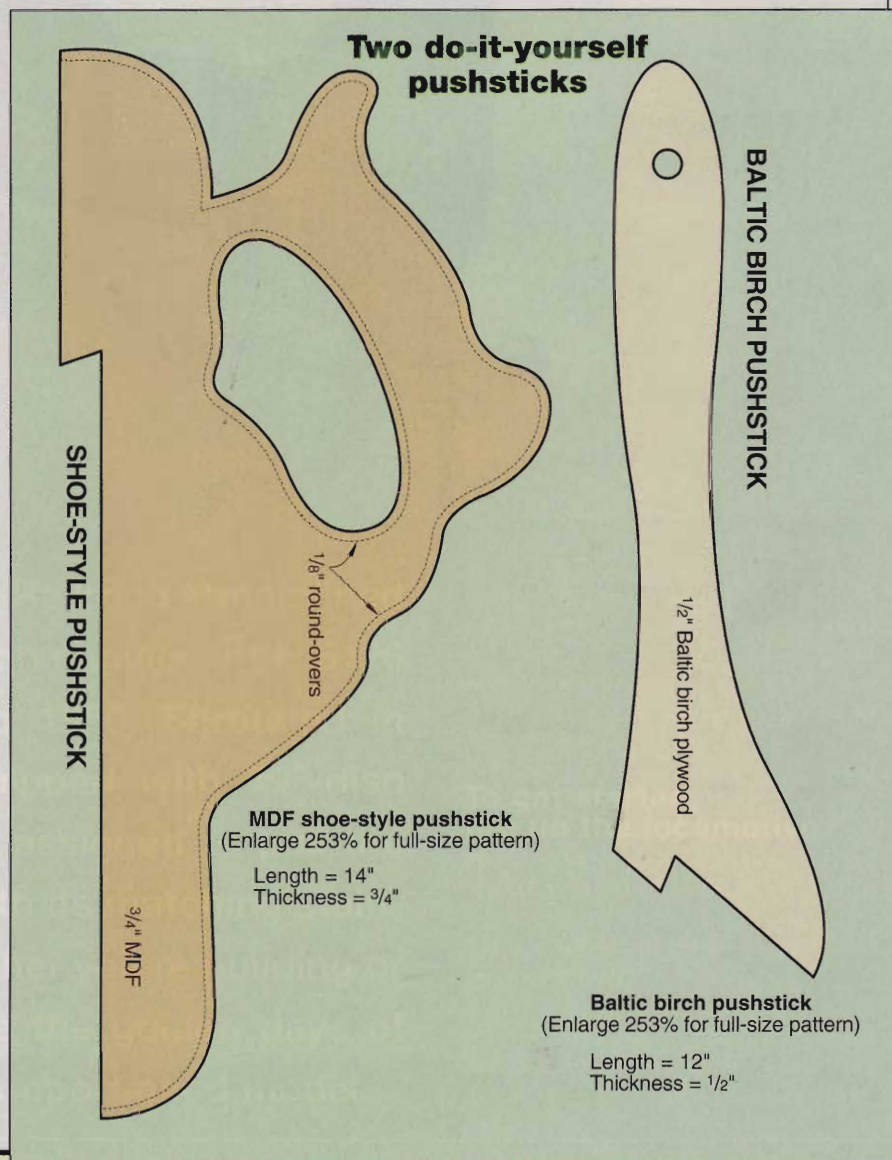



Here's our Top Shop Tip winner, Allen Abell, showing off his prize-winning tip and a few of his favorite projects.

While watching TV one Saturday morning, Allen Abell saw a guy using C-clamps that had a knob where the dog bone-shaped tightening pin should be. Our Top Shop Tip winner thought the knob might give better grip and leverage than the pin, and promptly filed the idea in the back of his head.

Then one day, he was puttering around the shop when he stumbled onto a box of old golf balls. One thing led to another, and before he knew it, Allen had come up with this issue's Top Shop Tip, shown at right.

Perhaps you, too, have found a practical use for sporting goods in your shop. Or maybe you've just come up with a simple solution to a shop problem.

Either way, your idea is worth \$75 if we print it. And, if we deem it the best tip of the issue, we'll also throw in a tool prize worth at least \$250.

You can post your suggestions to our WOOD ONLINE® Top Shop Tips discussion group at www.woodmagazine.com. Or send them, along with drawings or photographs and your daytime telephone number, to:

Tips From Your Shop and Ours
WOOD Magazine
 1716 Locust St., GA-310
 Des Moines, IA 50309-3023

Sorry, but we can't return your submissions. And, because we try to print only original shop tips, please send them only to WOOD magazine. Thanks!

Dave Campbell

WOODWORKING PRODUCTS EDITOR



Improve your grip with a little forethought

After bending the flimsy metal tightening pin on a C-clamp for the umpteenth time, I decided to get a grip on the problem. So I replaced the pin with an old solid-core golf ball.

I started by cutting off the pin with a hacksaw. I then measured the diameter and length of the remaining shaft, and bored a hole slightly larger and deeper in the center of a golf ball. Finally, I epoxied the ball onto the shaft, as shown below.

The ball-grip fits in the palm of my hand, and gives me more torque than I could get with the old pin. Plus, it's easier to make large changes in clamping depth by holding the ball and spinning the clamp.

—Allen Abell, Lilburn, Ga.



Cooler hands prevail when sanding small turnings

I like to sand my small turnings while they're still on the lathe, but with sandpaper alone the paper heats up quickly. And if I back the paper with padding, I can't control the sheet of abrasive. It invariably ends up on the floor behind my lathe or gets sucked into my dust collector.

So, I bought an extra-fine 3M sanding sponge (part no. 916NA). But instead of sanding with the pad itself, I use it to back my sandpaper, as shown below. The grit on the sponge grips the paper and keeps it from flying away, while the sponge itself insulates my fingers from the heat generated by sanding. And, although you'll still wear out a lot of sandpaper, the sponge will last forever.

—Bruce Hoover, Bloxom, Va.

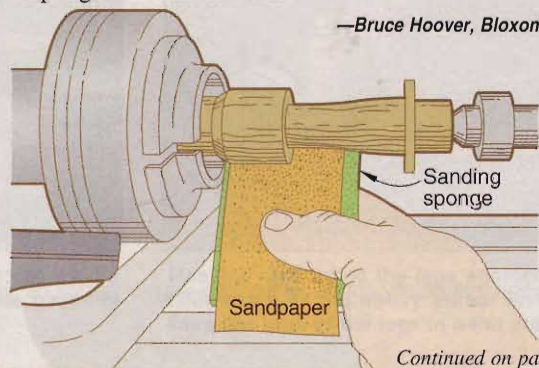

Continued on page 40

Woodworking, craft and home improvement projects?

Get AccuSet!



A200BN Brad Nailer

A100MP Micro Pinner



DRIVES STAPLES AND BRAD NAILS
2 IN 1



New AccuSet A2N125 drives 3/8" to 1 1/4" brads and 1/2" to 1" staples.

Are you a woodworker, hobbyist or home improver? Have you experienced the precision and speed of pneumatic nailing and stapling? Professionals use pneumatic fastening in applications from small bird feeder production to cabinet building and finish and trim work. Now SENCO, the brand of choice of professionals, has a new line of tools, fasteners and accessories just for you! Check out AccuSet brand finish nailers, brad nailers and staplers from the pros at SENCO. They're loaded with power, great features and have a two year warranty – the best in the business! To find the retail outlet nearest you, call 1-888-222-8144, or click on the dealer locator on our newly expanded website: www.accuset.com

AccuSet

THE TOOLS YOU NEED FOR THE WORK YOU DO.



1-888-222-8144

Visit our newly expanded website: www.accuset.com



Quickly becoming one of America's most preferred woodworking tools.

©2000 Senco Products, Inc. 8485 Broadwell Road, Cincinnati, Ohio 45244-1699 Safety First. The only way to work.

tips from your shop and ours

Continued from page 38

Finish your projects backless or bottomless

When I build drawers or cabinets with plywood backs, I finish the drawer bottoms or case backs separately before assembly. Whether spraying or brushing, I have better access to all sides of the workpiece, and never have to worry about finish collecting in three-sided corners.

—Don Eisenhardt, from the WOOD ONLINE®

Top Shop Tip discussion group

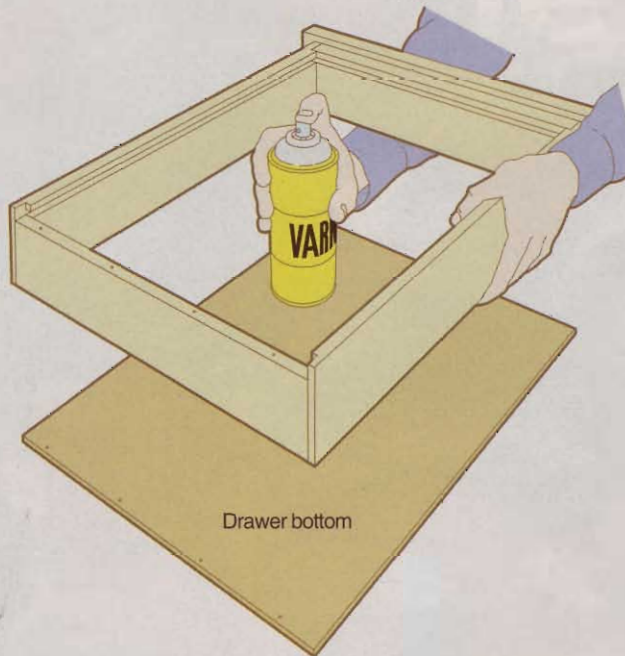

Do-it-yourself crown molding: Rip, rout, and bevel

I like to make my own moldings using a full-profile molding bit. For crown molding, I first rip my blank 1/4" wider than

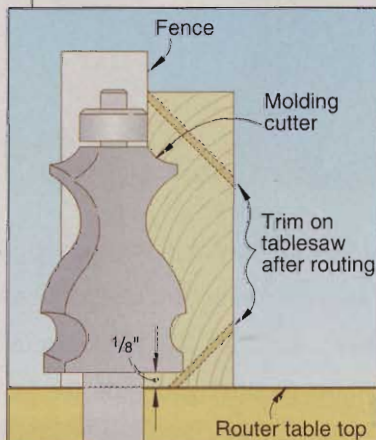

the final width, then rout the profile on my router table with the bit raised 1/8" above the tabletop, as shown at left. The square corners (and a pair of feather boards) keep the stock snug against the fence and tabletop through the cut. Finally, it's back to the tablesaw, where I bevel-cut the waste away.

—Dick Rose, Portland, Maine

Clamps from household objects, revisited

While building a doll house recently, I needed a bunch of small clamps, so I fashioned my own from wire coat hangers. I built the bending jig shown *below* (and in the Full-Size pattern) out of scraps of plywood and a short piece of $\frac{3}{4}$ " dowel. Each finish nail stands about $\frac{1}{4}$ " proud of the bending jig.

Cut a piece of coat hanger wire (or $\frac{1}{8}$ " welding rod) about 14-18" long and wrap it around the dowel, starting from the middle. Then wrap each loose end of the wire around the form, as shown in the Full-Size pattern. The wire will want to flex back on you, so finish each bend with a pliers.

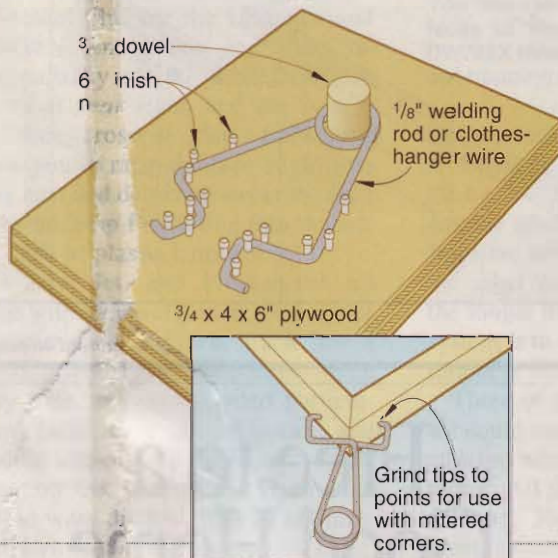

While the arms of the clamp are still separated, cut the ends to length, and grind or file the tips flat. (For clamping mitered corners on small frames, grind each tip to a point to pull the joint together as shown.) Once you have the jig built, you can crank out as many mini-clamps as you like at no cost.

—Ian Beaton, Kamloops, B. C.



Shop puzzle: Can you draw the parallels?

By itself, my table saw's fence just isn't reliable when it comes to locking it parallel to the blade. So I transferred the graduations of a ruler to the front and back edges of the tabletop, as shown in the drawing at *right*. Here's how.

I attached an auxiliary fence to the miter gauge, then cut a kerf in the fence. Using this indexing kerf, I scribed "zero" marks on my tabletop at the front and rear edges. (Remember, there are "zeros" for both sides of the blade.)

Next, I stretched strips of masking tape along the front and rear of the table and transferred the graduations from a steel rule to the tape. I used my engraver to trace through the graduations, then removed the tape and lightly sanded the sharp edges left by the engraver.

Now, I can align my fence parallel to the blade, front and rear, without a lot of fussing and test-cutting. As a bonus, the marks work even if I have an auxiliary face attached to my fence.

—Barry Brimor, Gadsden, Ala.

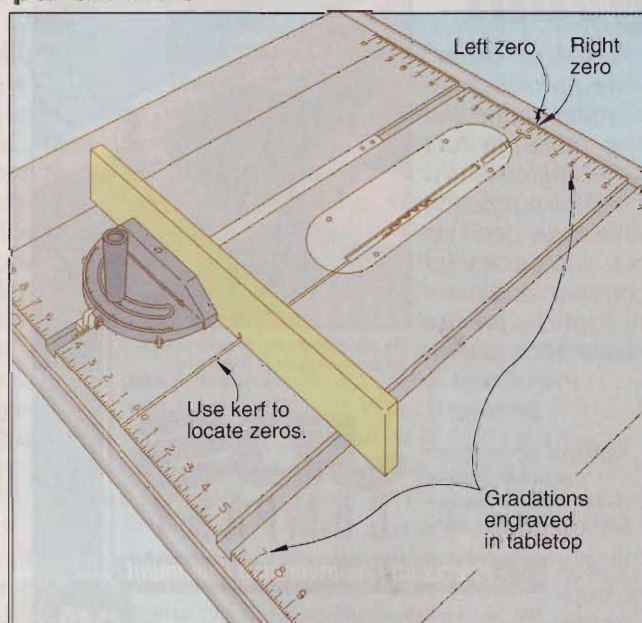

Continued on page 42

Continued from page 41

Don't fence your benchtop in

Like a lot of woodworkers, I inset my mitersaw lower into my benchtop so I could use the bench as stock support. I wanted to be able to use a workstop for repetitive cuts, but I didn't want to sacrifice usable bench space by running a fence down the middle of it, so here's what I did.

Instead of a fence, I routed a $\frac{3}{4}$ " slot $\frac{3}{8}$ " deep where the fence would have been and placed a self-sticking, left-reading measuring tape in the bottom of it. For a workstop, I tighten my table-saw's feather board—the kind that clamps into the miter-gauge slot—in the fence slot as shown at right. On those occasions when I need a fence, I simply drop a $\frac{3}{4}$ "-thick fence in the slot.

—Larry Niehus, Sioux City, Iowa

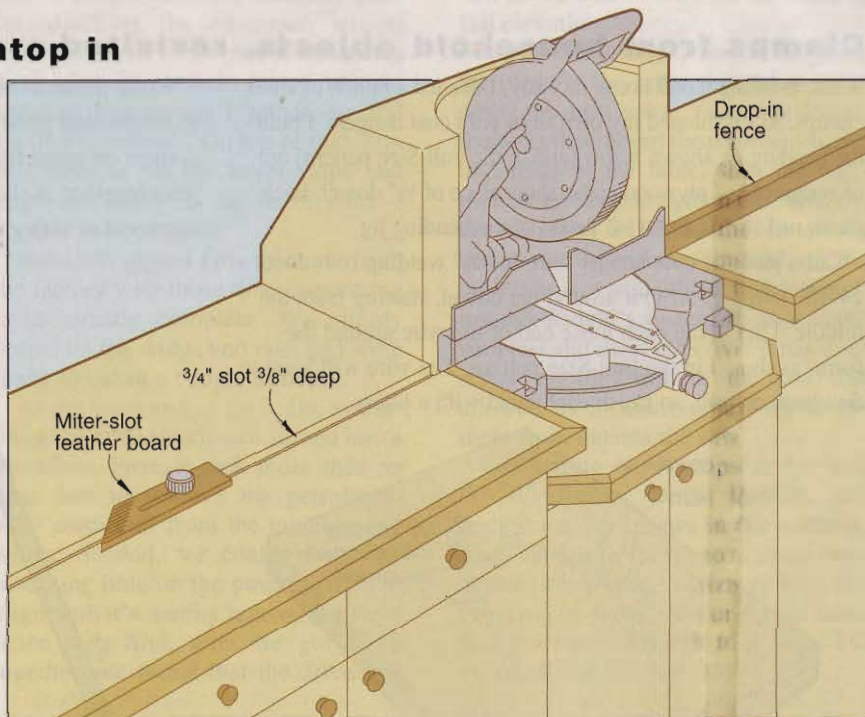

Continued on page 44

"All my tools should be this good!"

The **Accu-Miter**[®] is a professional miter gauge that makes perfect angles easily. Shot-pin action assures dead-on accuracy for common angles — plus a precise protractor scale for everything in between!

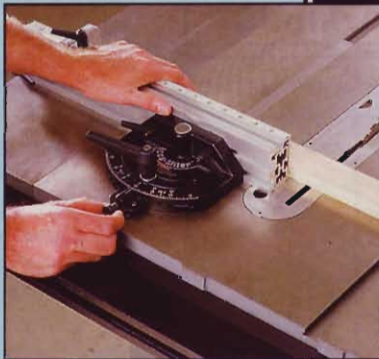

We do not recommend operating without the saw blade guard, as is shown here.
US Patent #5,038,486

Optional accessories:
manual clamp—
pneumatic clamp—
 $3/8$ " x $3/4$ " miter bar—

JDS COMPANY

Precision Woodworking Equipment

Call or write for our free brochure.

800 Dutch Square Blvd., Suite 200, Columbia, SC 29210
1-800-382-2637 / SC 803-798-1600
www.thejdscompany.com

\$149

Free to a Good Home

\$131 Accessory Package

Accept no imitations!
Buy the Performax 16-32 Plus Drum Sander, the industry's original drum sander, and receive the accessory package absolutely FREE!



Package includes:
Infeed/outfeed tables
Conveyor belt tracker set
Box of ready-to-wrap sandpaper sized to fit
\$131 accessory package FREE

The power to shape your ideas **PERFORMAX**

JET, Performax and Powermatic — A Family Of Brands

Offer effective September 1, 2000 through March 31, 2001 • 800-334-4910 • www.PerformaxProducts.com

Circle No. 78

MAKE YOUR BED.



PACE EDWARDS

Pace Edwards offers the most innovative and stylish truck accessories on the market, like our Roll-Top-Cover™ and our new BedLocker™ electric retractable cover.

Pace Edwards ... products for today's trucks!

1-800-413-8378

www.pace-edwards.com

Circle No. 1985

The missing
Link Between
MAN AND
CRAFTSMAN.



Gorilla Glue® makes serious woodworkers more successful. It's incredibly strong, 100% waterproof and excellent for hardwoods, softwoods and hard-to-glue exotics. You'll get nearly invisible glue lines and stable joints. Plus, Gorilla Glue won't gum up your tools like yellow glue does. Discover a higher form of creation. Call 800-966-3458 for a dealer, or find out more at www.gorillaglu.com.



THE TOUGHEST GLUE ON PLANET EARTH™

Circle No. 650

tips from your shop and ours

Continued from page 42

Mini-scraper gets right to the point

For removing glue squeezeout from inside corners of your projects, make a mini-scraper. Remove the blade from your hobby knife, and replace it with a triangular glazing point, as shown below. (They're normally used to hold window glass in place before glazing.)

Because the manufacturer stamps them from sheet-steel, one face of each point has a small burr around the edges. Scrape with that face down. With three edges on each point and dozens of points in a box, one box lasts a mighty long time.

—Mark Williams, Rockford, Ill.

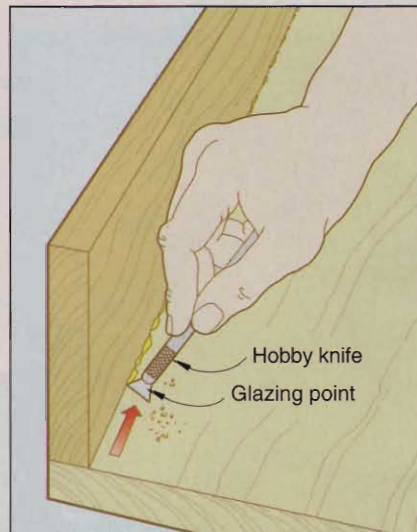

A few more tips from our woodworking pros

- Need to scrollsaw a piece that's so large you can't spin it completely around on your saw without hitting the upper-arm support? See how we worked around this problem in the scrollsawn-shelf on page 56.
- When you need to clamp the center of an assembly but don't have a deep enough clamp, turn to your drill press or lathe, as shown in the photo on page 63. 🐼

what makes wood rare

Some stock costs a bundle. Some you can hardly find at all. Yet scarcity results for many reasons.

Pink ivory has been called the world's rarest wood. It's never been available in commercial quantity. That's because the relatively small trees that produce it grow sparsely in their arid, South African range. It's also because the Zulu tribe holds the tree sacred and only a chief can fell one. As a result, little pink ivory ever got out into the rest of the world. Today, chances are that any pink ivory you'll find comes from a number of trees cleared a decade or so ago during a major dam construction. Because that limited supply has dwindled, you'll pay dearly for any of it. That's just one of the stories behind rare wood.

Endangered trees don't fall

Some tree species have been overcut to near extinction.

Endangered species of trees, such as the ones that produce Brazilian rosewood and pernambuco, end up on a list generated by the Convention on International Trade in Endangered Species (CITES). Signed by 144 countries, the CITES treaty bans a listed species from world trade.

Sorry, no boards available **Government restrictions often can limit the supply of certain woods in world trade.**

Indian rosewood isn't allowed to leave India in board or log form. Before the wood enters the world market, value has to be added that economically benefits the country. That "value added" may consist of sawing the lumber into part blanks for musical instruments or some other form of machining that creates more jobs for the nation's people.

Some governments also control all logging and pricing. Indonesia, for instance, presently has set high prices for teak. Buyers then go elsewhere.

Trees bow to expansion

As populations grow and towns and cities spread, humanity encroaches on the land until few trees remain.

Wild pear trees once grew throughout Switzerland. But as the small country's population expanded, the pear began to disappear. It happened in Great Britain, too, with the English yew. If you can find any wood from these trees at all, it will be in small pieces and quite costly.



Quality not quantity

Extensive processing to get perfect stock reduces availability and drives up the cost.

Gaboon ebony, at about \$70 per board foot, may be the most expensive wood dealers regularly carry. And its price doesn't reflect any scarcity of the tree from which it comes. It grows plentifully in Gaboon and Nigeria. The reason it costs so much: Users demand jet black, dense wood. Anything less, although still good stock for many uses, has become unacceptable for projects, at least to American woodworkers.

Sometimes, trees succumb

At times in history, man or government has had nothing to do with the disappearance of a wood from the marketplace.

In the United States, the mighty American chestnut disappeared from the nation's forests and byways in but a few decades. It succumbed to the chestnut blight. And although scattered examples of the stately American elm still exist, its sweeping destruction by Dutch elm disease began in the 1950s.

Import not export A country may choose to allocate its wood for national use.

Japan has much well-managed forest land, and the wood from it has time-honored uses. However, to Japan's consumers the cost of native wood, such as figured tamo, a species of ash that frequently displays "peanut" figure, runs high. To satisfy the demand, tamo often is sliced into very thin veneer and then applied to imported Douglas fir or other softwood. Uses like that explain why the Japanese import 70 percent of their wood and export little except extremely thin veneer.

Top dollar gets the logs A type of wood may owe its rarity to temporary popularity.

Sometimes, a wood you'd like to use just isn't available in any large quantity as boards. Why not? When the "look" of a certain wood becomes popular with designers and architects, logs of that wood head for veneer mills rather than sawmills. And the veneers end up as architectural paneling and other products in demand. Because they get so much product from them, the veneer mills can pay 10 to 20 times more for logs than sawmills. That's the case, at this writing, with quartersawn anigre from Africa.

World banking stops the flow

A country sometimes quits exporting wood when the International Monetary Fund puts its foot down.

When the International Monetary Fund discovers that a developing nation it's planning to fund is selling off natural resources, including logs, restrictions go into effect. And the wood species from that country vanishes from the marketplace.

Victims of war Civil war and other internal unrest limit logging and slow world trade.

Wenge comes from Zaire. Indian ebony and Ceylon satinwood originate in Sri Lanka. But unless those countries' civil wars come to an end before you read this, those woods are in limited supply. What there is carries a hefty price tag.

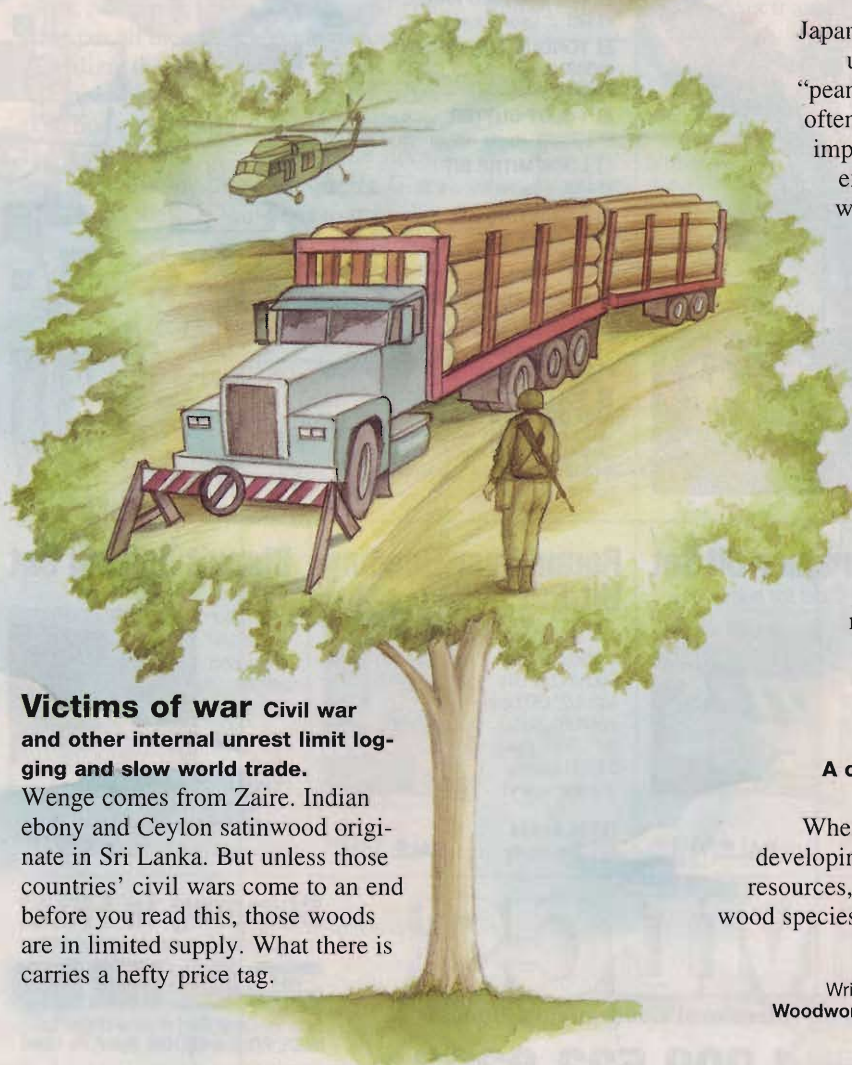
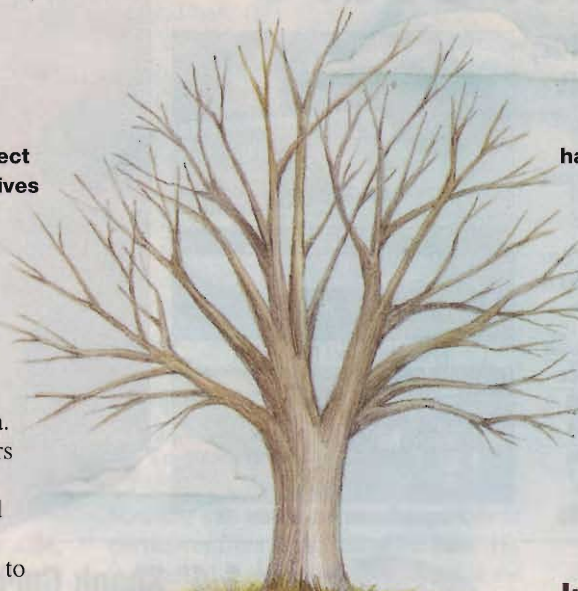



master of
time & space

When it comes to clocks, Minnesota craftsman
James Borden has the timely touch

Zumbrota, Minnesota, lies 20 miles to the north of bustling Rochester, home of the world-renowned medical facility, the Mayo Clinic. There's little of great note in this typical town of 2,000 people. It seems a great place to live and raise a family—tidy, quiet, and with just enough businesses to supply daily needs. To clock-maker James Borden, its small-town pace perfectly reflects his view of time.

"Time isn't a cold calibration of the passage of seconds, minutes, hours, days, and years, but a progression from one event to another," says Jim, his boyish face flashing a smile. "That's why my clocks have only hands. No face. No numerals. I think of them as living things, a type of creature sculpted of wood that happens to tell time."

A big creature lives on the lawn

Jim calls his clocks "Timeshapes." Crafted of solid woods for the most part native to Minnesota, they first capture your eye with size and form, then mesmerize you with graceful movement. "The clocks are strictly my design, and the process I've developed to make them is more that of a freehand woodworker than that of a precision machinist," he comments. "Right from the beginning I had a problem keeping the works boxed in like a traditional clock. I'll show you what I mean."

Although Jim stores his clock inventory in a loft gallery on the second floor of his converted-barn workshop, he jumps from his workbench and motions outside. He strides across the vast lawn to a windmill-type structure rising 26' into the air.

"This was an experiment that I built two years ago," he almost exclaims in excitement. "I wanted to see how a clock would work outdoors, unprotected. It's all made of white oak, with a gear wheel 10' in diameter and a 5' escapement wheel. The pendulum weight is 70 pounds of cast concrete."

Jim clammers up the weathered structure, intending to start the mechanism moving. Then he stops to call down, "It won't run for long. Too windy. A sudden gust catching the pendulum will stop it dead." And after a few moments, one does exactly that.

Back on the lawn, Jim puts his hands on his hips, looks up at the clock, and says, "I think I'm on a scale that no one else is doing. I started making clocks small, then they got larger and larger. But this may be the limit, for now."

From humanities to timepieces

Raised in Rockford, Illinois, Jim did little actual woodworking as a youngster. It wasn't until he was enrolled at Blair, Nebraska's Dana College in the late 1970s that his latent craftsmanship started ticking.

"I was a humanities major," he starts to explain. "But there, you were always encouraged to do work outside your major. So one semester, a classmate, Tom Kendall, and I took independent study and built a tall clock with wooden works. An old man in the area gave us advice. It was pretty tough. Because of money constraints, we used salvaged wood, and spent hours filing gear teeth that we'd cut on a bandsaw. Finally, though, we had a towering 12'-tall grandfather clock built in kind of a classical Greek style.

"To this day," Jim continues, "I credit that school for communicating to me that anything is possible. It was that type of study that helped me to arrive at the connection between timekeeping and woodworking art. That clock back in college got the ball rolling."

After the first timepiece, Jim started picking up old clocks at garage sales to tinker with, fix up, and resell. "I had plans to go to the seminary after college graduation, but I became obsessed with clocks," he recalls. "So the summer after graduation, Tom and I tried to go into production from my parents' home in Rockford. We thought we could get commissions for clocks from large corporations in the Chicago area. Well, we never got any. And in retrospect, I'm glad that we didn't because we really didn't know what we were doing!"

Not discouraged, Jim continued to build clocks alone. "In 1981, it seems that I made clocks 12 hours a day, seven days a week, I was so inspired," he remembers. "But I didn't sell many of the ones I made."

Finally, Jim decided to shelve his tools and pursue his original plan by enrolling



A clock begins as a pile of wheels and boards on the shop floor because Jim doesn't sketch his designs on paper.

in a Lutheran seminary in Dubuque, Iowa. For a few years he had little to do with clocks. But he couldn't keep his mind off of them, and eventually started collecting antique ones and working on them. Then he met Barbara, also a seminarian, and they married. "We moved downtown and I opened a clock shop in a historic tourist district," Jim recounts. "I had maybe 100 antique clocks for sale, and did repair work. It became my full-time occupation as I was finishing up my classwork."

When in 1988 Jim's wife was offered a job as pastor in Wykoff, Minnesota, they moved. Because the mostly rural area wasn't conducive to an antique clock business, Jim once again began creating his own. "The sand shifted from antiques to my own ideas," he says. "I didn't sell much there, but fortunately Barb had a steady income and I



At his bandsaw, Jim freehands stock through the blade to rough-shape a new pendulum for a clock.



Much like decorating a Christmas tree, Jim hangs sculpted bits of wood to a clock in progress to properly balance it.



"Timeshapes" all-wooden clock sculptures start at \$5,000. All feature pendulums, and some self-wind.

had the opportunity to follow my own thoughts. Some of the designs I'm working on now are the result of that time."

Events that shaped time

Zumbrota beckoned in 1992. Barbara became the town's Lutheran pastor and Jim continued his clockmaking. This time there was a new twist. His clocks were actually beginning to sell.

At an American Crafts Council show in St. Paul that year, Jim sold a 25'-tall timepiece to a medical systems company for display in its corporate headquarters. "It had an 8' gear wheel," he says. "I had to take it there to install, and go back a few times. It needed a lot of adjustment because it was surrounded by windows in an atrium, so the wood had some movement." Jim sold three other clocks at that show, which marked his first real entry into commercial crafts.

As consumers began taking notice of Jim's timepiece sculptures, so did the experts. Entries in two clock-building contests sponsored by the National Association of Watch and Clock Collectors (NAWCC) Museum in Columbia, Pennsylvania, resulted in back-to-back first-place awards. In 1994, some of Jim's clocks formed a special, half-year-long exhibit at the NAWCC Museum that drew raves.

Even though he's mingled with the experts, Jim admits to little knowledge of the language of horology (timekeeping science). "There are a lot of terms that I don't know or use much. Clockmaking has its own jargon," he says. "Yet, it doesn't matter about the terms, as long as I understand what they describe and how a clock works. And I've always been pretty good at understanding mechanical things and physical

laws. With a calculator I can figure out the gear ratios and the number of teeth on a gear. Knowing how to apply it is the real challenge."

Woodshop horology

Most of the wood for Jim's clocks comes from the hardwood forests of southeast Minnesota. He buys it direct from a mill that custom-saws for him. And he often visits there to find just the right stock.

In storage, you'll find ash, cherry, hickory, maple (some carrying the dark lines of spalting), walnut, and a smattering of red and white oak and other woods.

Many of the rough-sawn boards approach 20" in width, and there's an explanation. "I don't like edge-joining wood," says the clockmaker. "So I try to make each part in a clock out of one piece of wood. And for that part, let's

Continued



Jim's clocks never have numerals because he likes the simplicity of telling time only by the position of the hands.



To make his own dowels, Jim invented a simple jig that mounts to his stationary belt sander. Pressure from the adjustable wooden platen holds the wood against the belt as he turns it with his fingers.



In this clock, built in the early 1990s, Jim used a mix of walnut, maple, and cherry for contrast.



Shaping the gear wheels' faces adds to the sculptural effect of the clocks.

say it's a curving pendulum, I'll use a board with sweep. It's stronger and more stable that way."

Jim even goes so far as to make a clock from the wood of a single log, if possible. "I don't usually worry about dimensional change because I'm mostly working with lengths, and shrinkage is less along the grain," he adds. "And I leave enough spacing between parts to allow for swelling without binding up the works. The hand shaft, where one rod goes through another, is about the only place I worry about change. The wood I use there—usually ironwood—has to expand and contract at the same rate."

Most of the challenge Jim faces with his timepieces is balance. He explains, "A traditional escapement will be much smaller than those I build. Because my clocks are so large, I'm always battling to decrease friction by balancing it as perfectly as possible so that I don't have to use 50 pounds of weight to get the works moving. To help reduce the

weight size, I use a slow pendulum. You see, the length of a pendulum, depending on type, can determine its speed. My compounded ones run from a second and a half to four seconds per arc, like a metronome. The weight above the pendulum hub, in the escapement, tends to slow the pendulum down.

"And when you slow it down, there are so many fewer ticks per minute that the gear ratio doesn't have to be so high and you only need one main gear wheel," he further explains, pointing to the mechanisms on the wall. "That decreases the amount of power needed to run the clock, and takes away a lot of the friction you'd otherwise have. There's a trade-off, though. A slow, compounded pendulum, is less accurate. And with wood, you have to consider humidity. When wood picks up moisture, it adds weight. So depending on humidity, a wooden clock can run alternately fast and slow."

To Jim, though, timekeeping accuracy isn't foremost. It's the way it's viewed.

Cutting teeth in timely fashion

Not long after building his first wooden clock—and filing all the gear teeth—Jim devised a faster, more precise method. With the indexing jig shown *center, opposite page*, he can shape the teeth (or the slots for teeth) on a wheel up to 8' in diameter. Wheels over 4' in diameter always get separate teeth, usually of a contrasting wood.

"I normally rout 12 to 15 wheels at a time," Jim notes. "All I have to do is slide the router along its track to cut the same tooth in every wheel. It takes about a minute, then I shut off the router, and turn the wheels to the next tooth. Usually, I'll have to stop about halfway through all the teeth and sharpen the bit. But I grind my own profiles in high-speed steel, so I'm used to it."

In addition to his indexing jig, Jim has come up with another dandy device. Because his clocks require dowels of varying sizes, made of woods not readi-



At the lathe, Jim drills out a dowel that the hand shaft will pass through. He prefers iron-wood for those parts.



A mantel-size clock like this one of maple that stands about 24" high requires more work to make than a large one. It sells for \$8,000.



A router mounted on a sliding track cuts the teeth for gear wheels. The fixture will take a wheel up to 8' in diameter.

ly available, he fashioned a doweling jig that clamps to his stationary belt sander. "My clocks are doweled together, and they use dowels for hand shafts. I found that I couldn't buy the right sizes in the woods that I needed, so I built this," Jim says as he demonstrates making a dowel (see top, opposite page). "If I'm making a thin dowel, I can do it in one pass."

The clock a month club

Although the time spent working on a clock can vary with its size and complexity, Jim estimates that he averages one clock a month. And every one gets the same finish.

"I've come to trust a mix that I came up with several years ago," says the craftsman. "It's a mixture of polyurethane and linseed oil. After the last fine-sanding with 400-grit, I wipe on a three part linseed oil, one part polyurethane mix, wipe off the excess, then let it dry for a day or so. For the final finish, I use a 50/50 mix, and put on two coats."

Jim's finish gives the wood a satin glow. "At one time, I mixed the woods I'd use in a clock, such as maple to contrast with walnut. But now I want a uniform look, so except for the teeth of large gear wheels, I usually use only one type of wood in a clock," he says,

His customers, now mostly individuals rather than companies because his clocks are now of a size that fits in a home, seem to appreciate the look, too. "Customers are interested in what they see in front of them," he observes. "I guess that's why I've not had any requests for clocks made in an unusual wood. If I do get a commission, it's normally for a larger size. And thank goodness people seldom ask for a smaller version. Making a clock smaller is harder than making one larger because it gets very complex. And I don't need any more complexity than I have." 🌲

Written by Peter J. Stephano
Photographs: Layne Kennedy



How a clockwork works

A clockwork is a train of intermeshed gears and pinions—a transmission machine—set in rotary motion by the kinetic energy of a falling weight. At the top, the escapement mechanism divides the weight's long fall to the floor into tiny increments as a swinging pendulum regulates the weight's rate of fall, stretching the energy into brief, uniform, and countable bits.

While you can trace toothed wheels back to the ancient Greeks who used them to compute relative positions of the sun, moon, and planets, clocks as we know them didn't appear in Europe until the 14th century, when monks developed weight-driven clocks to signal prayer times. Clock faces with hour hands came about in the 16th century. They were not accurate enough, though, to have a minute hand. Clocks became accurate only when the pendulum was added 100 years later.

The swinging pendulum attracts the most attention, but it performs only as a regulator. All energy comes from the falling, suspended weight. The wheel train transmits this kinetic energy to the time-computing motion works for display by the hands, and also to the escapement. The energy going to the escapement induces its release/relock sequence which relays regular impulses to the pendulum to keep it swinging. Each swing lets the escapement unwind, creating a tick.

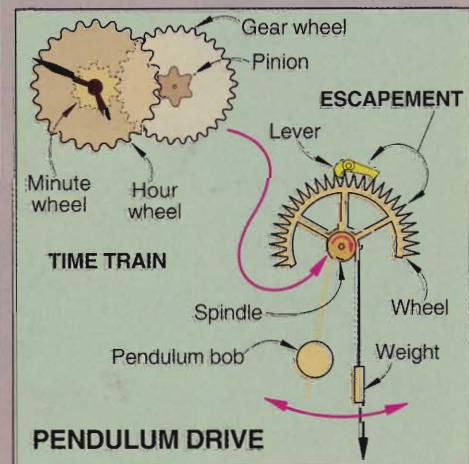

easy elegance

scrollsawn wall shelf

Now here's a shelf that's easy to make, yet fully befitting of your fanciest collectibles. So fire up the old scrollsaw—after a little bit of cutting and assembly you'll have a shelf sized to suit most any wall.



Let's cut the parts to shape

1 From 1/2" mahogany cut all of the parts listed in the Bill of Materials on the next page. Use a stopblock to cut the shelves (B), bottom apron (C), and top apron (E) to the same length. (See the Exploded view on page 59.)

2 Make and adhere two complete side patterns to the sides (A), using the Full-Size Side Pattern and instructions in the *WOOD PATTERNS*® insert. With spray adhesive, mount the other patterns for the bottom apron (C), top apron (E), and top trim (F).

Note: You may be tempted to stack-cut the sides (A), meaning you only need one copy of the pattern. We tried this, but didn't find much time savings in doing so. We also discovered that scrollsawing the sides individually yielded more-accurate cuts and less burning.

3 Drill all start holes and saw the patterns to shape. Chances are the throat on your scrollsaw is not deep enough to allow you to swing the sides completely around while cutting. As we discovered, you can tackle this problem in one of two ways as described in the boxed information below.

Time to assemble your top-shelf project

1 Mark the back edges of the sides (A) for the locations of the shelves (B), as indicated on the side pattern. Drill 1/8" guide holes at each of the hole locations on the side patterns.

Designate one of the side pieces for the right side of the shelf. On this piece, counterbore and drill shank holes into the pattern face at the guide-hole locations. On the other side piece (for the left side of the shelf), counterbore the face that's opposite the pattern face. (If in doubt, arrange the pieces in their

Continued

How to cut workpieces too long for your saw's throat

The sides of this shelf measure 26 1/2" long—significantly longer than the throat depth (the distance from the blade to the cutting-arm support) of most commonly available scrollsaws. This situation presents a challenge because for most of the cuts in the sides (A) you can't spin the workpieces in a 360° circle.

Nevertheless, with a little ingenuity, you can make these cuts with any scrollsaw. Here are two methods.

First, you can make a series of cuts like those shown in the Cutting Sequence for Sides drawing below left. This can prove a little confusing, to say the least, for the beginning scroller. And, stopping a cut midway

along a line often leaves a telltale irregularity in the cut.

We had our best results by making part of the cut in the typical fashion with the teeth facing forward, then reversing the blade so its teeth point away, as shown below right. Getting use to pulling the workpiece through the blade takes a little practice.

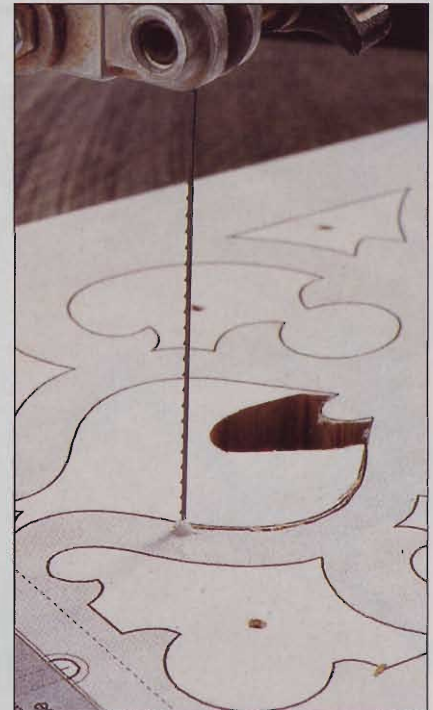
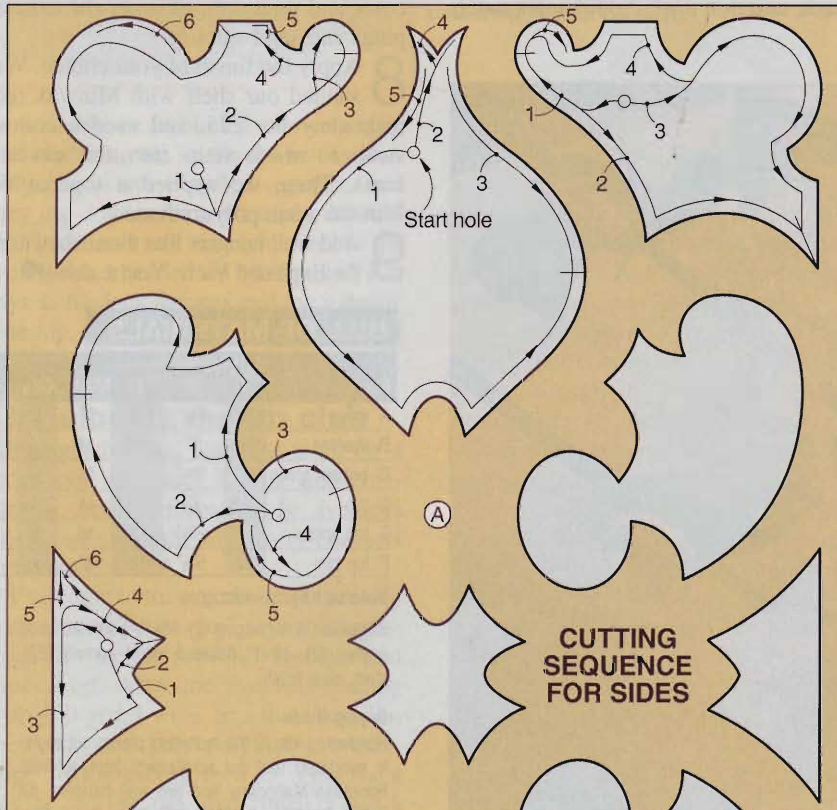

You can make the cuts in the sides by sawing a part of the pattern with the teeth facing forward, then finishing the cut with the teeth facing backward.

scrollsawn wall shelf



Align the shelves with a square, clamp them in place, and drill the $\frac{7}{64}$ " pilot holes using the shank holes as guides.

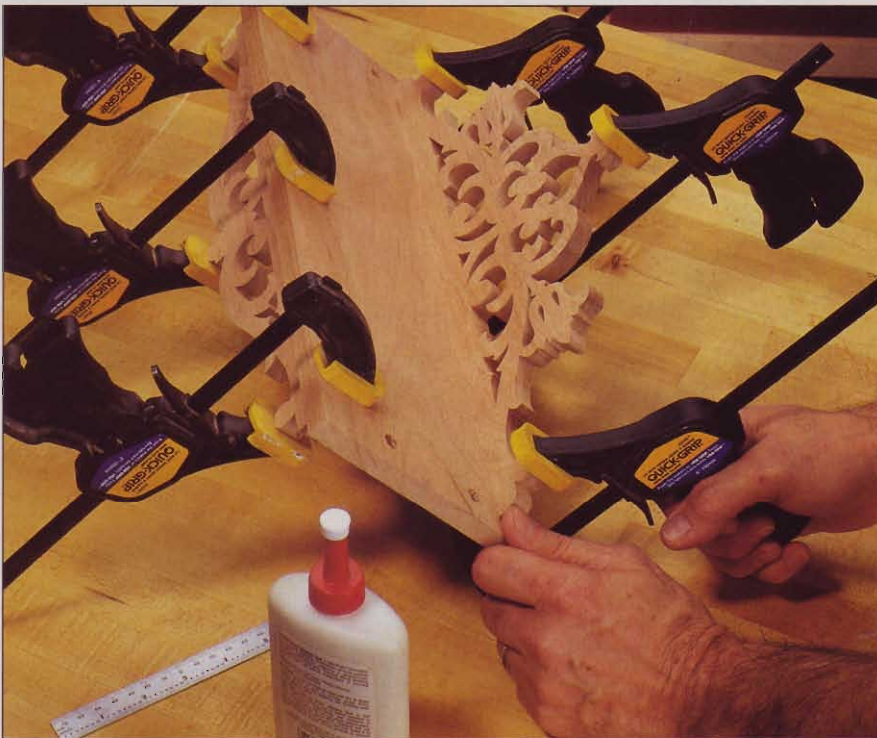

Space the top trim $\frac{1}{4}$ " from the back edge of the top, and position the top apron $\frac{1}{2}$ " from the front edge of the top.

assembled positions—the counterbores must be on the outside faces of the sides.) Remove all patterns and adhesive. Sand smooth.

2 With a square align the shelves (B) at their marked locations on the sides (A). Dry-clamp them together and drill pilot holes using the shank holes as guides. (See the photo at left, top.) Screw the shelves in place.

3 Apply glue to the straight edge of the bottom apron (C). Position it between the sides, and clamp it to the bottom shelf. Drill pilot holes, and screw in place.

4 Counterbore and drill shank holes in the top (D), according to the Exploded View drawing.

5 Apply glue to the straight edges of the top apron (E) and top trim (F). Clamp E and F to D, where shown in the Top Side View detail and depicted in the photo at left, bottom.

6 After the glue dries, position the D/E/F assembly atop the sides. Drill pilot holes, and secure with screws.

7 From scrap mahogany, cut $\frac{3}{8}$ " plugs. Glue the plugs into the counterbores, being careful to match grain color and direction. Saw off the excess plugs and sand smooth.

8 Apply the finish of your choice. We stained our shelf with Minwax red mahogany no. 225, and used a cotton swab to work stain into the cut-out areas. Then, we applied a topcoat of Minwax satin polyurethane.

9 Add wall hangers like those shown in the Exploded View. You're done! 🛠️

BILL OF MATERIALS

Part	finished size			Matl.	Qty.
	T	W	L		
A sides	$\frac{1}{2}$ "	$5\frac{1}{2}$ "	$26\frac{1}{2}$ "	M	2
B shelves	$\frac{1}{2}$ "	5"	15"	M	3
C bottom apron	$\frac{1}{2}$ "	$3\frac{1}{8}$ "	15"	M	1
D top	$\frac{1}{2}$ "	6"	17"	M	1
E top apron	$\frac{1}{2}$ "	$2\frac{5}{8}$ "	15"	M	1
F top trim	$\frac{1}{2}$ "	$5\frac{3}{8}$ "	16"	M	1

Material Key: M—mahogany

Supplies: Wall hangers (2), #6 $\times\frac{1}{2}$ " panhead wood screws (2), #8 \times 1" flathead wood screws (22), stain, clear finish.

Buying Guide

Hardwood kit. All the individual pieces cut slightly oversized (but not scrollsawn) from $\frac{1}{2}$ "-thick Honduras Mahogany and two wall hangers. Kit W128, \$64.95 ppd. Heritage Building Specialties, 205 N. Cascade St., Fergus Falls, MN 56537. Or call 800/524-4184 to order.

EXPLODED VIEW

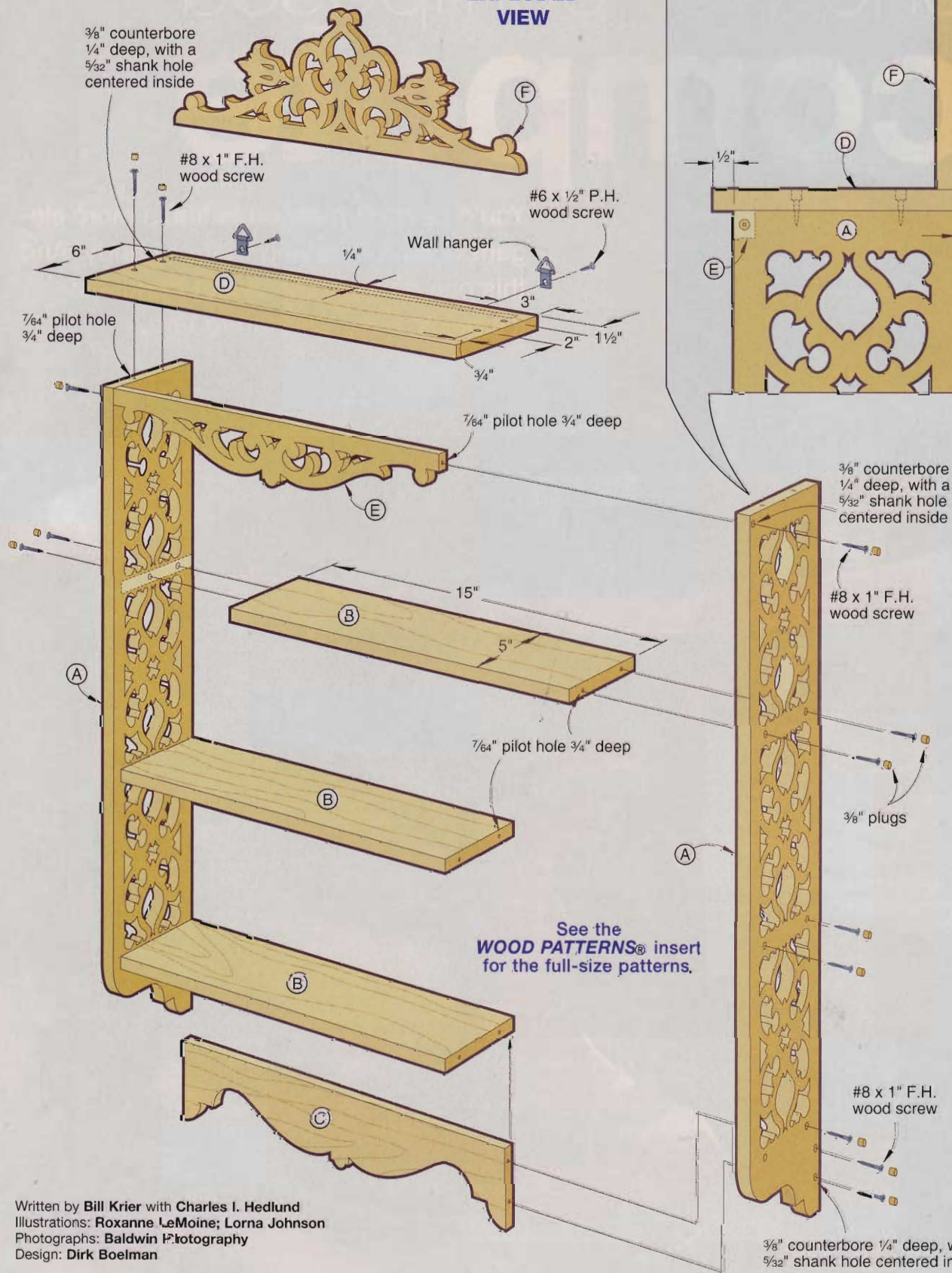

Written by Bill Krier with Charles I. Hedlund
 Illustrations: Roxanne LeMoine; Lorna Johnson
 Photographs: Baldwin Photography
 Design: Dirk Boelman

one well-composed
compote

You'd be hard-pressed to find a more elegant bowl for serving fruit or candy. And this one offers some sweet bonuses: It's quick, easy, and fun to turn.



Build a blank for the top bowl

1 Locate the center on the bottom face of a $1\frac{1}{2} \times 8\frac{1}{2} \times 8\frac{1}{2}$ " blank.

(We made all parts of our compote from cherry. If necessary, you could edge-glue or laminate stock to make the blank.) With a compass, draw two circles around the center, one $8\frac{1}{4}$ " in diameter and the other $3\frac{1}{4}$ ".

2 Locate the center on the bottom face of a $1 \times 3\frac{1}{2} \times 3\frac{1}{2}$ " blank of the same wood. Draw a $3\frac{1}{4}$ " circle around the center. Drill a pilot hole of the size required for your screw chuck through the center.

3 Bandsaw around the $8\frac{1}{4}$ "-diameter circle on the $1\frac{1}{2}$ "-thick stock. Bandsaw the $3\frac{1}{4}$ " disc from the 1"-thick stock.

4 Glue the smaller disc inside the small circle you drew on the larger disc. Orient the grain on the small one to match the grain on the larger blank.

Note: A lathe screw chuck will hold the stock to turn the compote bowl and base. Turning the center post calls for a spur-type drive center and a rotating tail center.

Turn the bowl first

1 Mount the screw chuck on your lathe. Thread the hole in the small face of the blank assembly onto the chuck. Mark a center for a screw-chuck pilot hole on the larger face of the blank. You can do this by bringing up the tailstock and marking the wood with the tail center's point. Then, dismount the blank and drill the pilot hole. Don't drill any deeper than the depth of the bowl.

If you have a drill chuck and an arbor to mount it on your lathe's tailstock, you can drill the pilot hole on the lathe. After drilling the hole to depth, dismount the blank.

2 Rechuck the blank with the large face against the chuck. Install a revolving cone center in the tailstock, and slide it up to support the workpiece firmly for turning.

3 True the edge of the larger disc, and turn it to 8" in diameter. True the smaller disc, and turn it to 3". (We used a $\frac{1}{2}$ " gouge for this.)

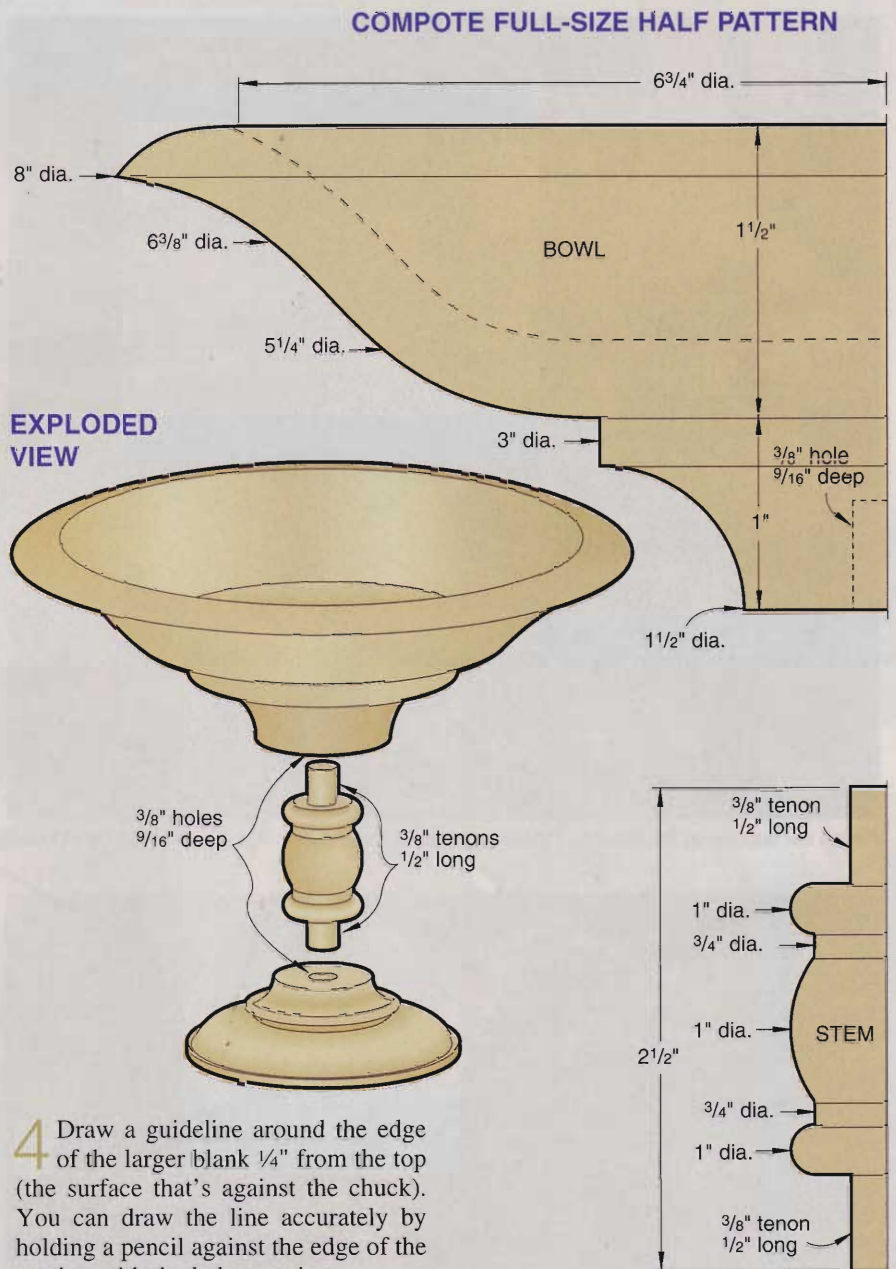

EXPLODED VIEW

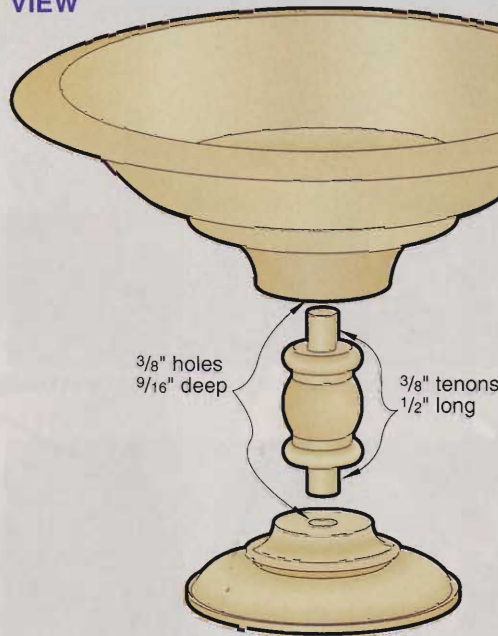

4 Draw a guideline around the edge of the larger blank $\frac{1}{4}$ " from the top (the surface that's against the chuck). You can draw the line accurately by holding a pencil against the edge of the turning with the lathe running.

Draw a similar line on the edge of the smaller disc, $\frac{1}{4}$ " from the glue joint. Draw a $1\frac{1}{2}$ "-diameter circle on the bottom of the smaller disc.

5 Turn the exterior of the top bowl to shape, referring to the full-size half patterns. Grab a $\frac{1}{2}$ " bowl gouge to cut the curves easily. For increased stability, you can bring the tailstock up for support during most of the operation. Maintain a flat surface where the bowl mates with the stem. That guarantees a tight-fitting, almost invisible joint.

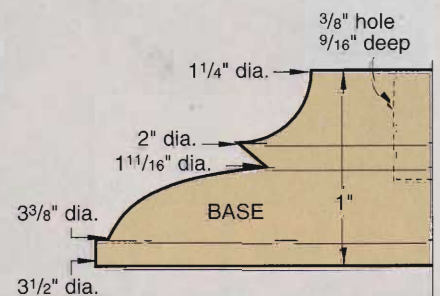

Continued

compote



Finish the outside of the bowl on the lathe before reversing it on the chuck to turn the inside.



Remount the bowl on the screw chuck to turn the inside. Take light cuts with a sharp gouge to prevent knocking the workpiece off the chuck.

6 Finish-sand the exterior with progressively finer sandpaper grits from 120 to 220. Take care to keep the square edges crisp.

7 You can apply a lathe finish to the exterior at this point, or wait until the compote is completed and finish it all at once. If you finish the bowl now, leave an unfinished spot about $\frac{3}{4}$ " in diameter on the mating surface for gluing. (For on-lathe finishing, we like Briwax Original or French polish, both available from Craft Supplies USA, 800/551-8876.)

8 Dismount the turning, and reverse it on the screw chuck. Turn the bowl interior and rolled top edge. Turn the bowl to about $\frac{1}{4}$ " wall thickness. Finish-sand the interior and edge. If you've already finished the bowl exterior, finish the inside now. Dismount the turning.

Another blank becomes the base

1 Locate the center on a $1 \times 4 \times 4$ " blank of the same wood. Draw a 4" circle around the center, and bandsaw the blank. Drill a pilot hole for the screw chuck all the way through the blank at the center.

BASE PARTIALLY TURNED

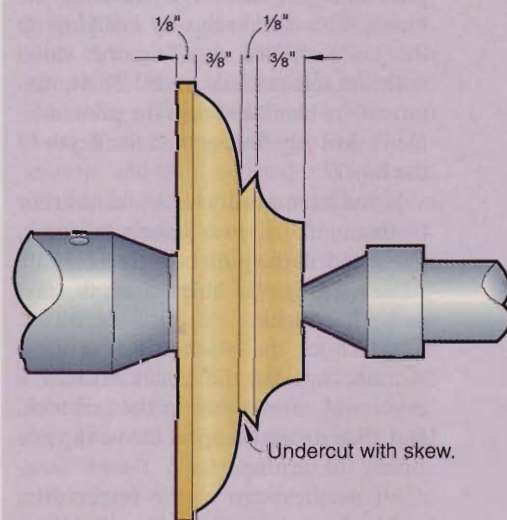

2 Mount the blank on the lathe, placing the surface that will be the bottom of the base against the chuck. Bring up the tailstock to support the workpiece. True the edge, and turn the blank to 3½" diameter.

3 Draw one guideline around the edge ⅛" from the bottom and another one ½" from the bottom. Turn the portion between the second layout line and the tailstock face of the blank to 2" in diameter.

Draw a line ⅛" from the shoulder of the resulting tenon. That line will be the top of the undercut feature shown on the pattern. (See the Base Partially Turned illustration.)

4 Turn the base to shape, leaving the undercut feature for last. To form the undercut feature, first shape the curve from the top of the tenon to the guideline, using the bowl gouge. Then cut in at the base of the tenon (shown on the illustration) with the tip of a ¾" or 1" skew chisel. True the top surface, which will mate with the stem.

5 Finish-sand the base, taking care not to dull the sharp features. If you're finishing as you go, apply the finish to the base.

6 Enlarge the pilot holes in the bottom of the bowl and the top of the base to ⅜" diameter. A twist drill chucked in a drill press will do this most accurately. Drill each hole to a depth of ⅞".

Now turn a spindle for the stem

1 Replace the screw chuck on the lathe headstock with a standard spur drive center.

2 Locate the center on each end of a 1½×1½×5½" piece of stock.

3 Mount the stock between centers, and round it down to 1¼" diameter.

4 Mark guidelines ¾" and 1¼" from the tailstock end of the blank. At the headstock end, draw lines 2¼" and 2¾" from the end. Turn a ⅜"-diameter tenon between each pair of marks. (See the Turning the Stem illustration.)

5 Lay out the stem features on the blank. Turn the stem to shape, relying on a ½" spindle gouge and a 1" skew chisel.

6 Finish-sand the stem. When sanding a turning between centers, shut

off the lathe after sanding with each grit, and sand in the grain direction. This will help minimize circumferential sanding scratches. Apply finish to the stem. Part or saw off the waste ends, leaving the tenons ½" long.

Put the parts together

1 Dry-assemble the bowl, stem, and base to test the tenons' fit and determine the best orientation for each part in relation to the others.

2 Glue the parts together, and remove glue squeeze-out. To clamp the assembly, first mark the center on a flat ¾×9×9" piece of scrapwood. Then hold the scrapwood's center against the point of the lathe drive center.

Next, engage the hole in the compote's base on the point of the tail center. Slide the tailstock up until the rim of the bowl contacts the scrapwood squarely. (If you've already finished the bowl, put cardboard between the rim and the scrapwood.) Extend the tailstock ram to clamp the compote.

3 If you haven't already finished the compote, do so now. After the finish cures, apply paste wax and buff it. Add felt to the base bottom. (We pressed double-faced tape to the felt, cut it to shape, then pressed it onto the base.)

Project designed and turned by **Ray Wilber**
 Illustrations: **Roxanne LeMoine; Lorna Johnson**
 Photography: **Baldwin Photography**
 Written by **Larry Johnston**

TURNING THE STEM

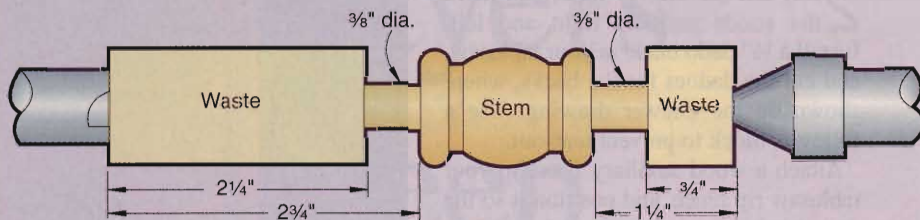

Glue the bowl, stem, and base together, and clamp them to complete the project. For a clamp, you can't beat the lathe.

music *on* file

Designed to accommodate up to 160 CDs, this attractive storage cabinet keeps your collection organized and neatly behind closed drawers.

Start your cabinet by building the drawers

1 Plane stock to $\frac{1}{2}$ " thick, then cut the drawer fronts (A), drawer sides (B), and drawer backs (C) to the sizes listed in the Bill of Materials. Make one extra drawer side to use later when positioning the drawer guide dadoes in the sides (G).

2 Lay out the drawer sides, and mark the inside surfaces right and left. Install a $\frac{1}{2}$ " dado blade in your tablesaw, and cut the dadoes for the backs, where shown on the Drawer drawing. Use a follower block to prevent tear-out.

Attach a wood auxiliary fence to your tablesaw rip fence, and position it so the dado blade just grazes its surface. Now, cut the rabbets in the edges of the drawer fronts, once again using a follower block. Drill the counterbored holes for the pulls.

3 Change to a $\frac{1}{4}$ " dado blade, and cut the dadoes for the dividers first, then the grooves for the drawer bottoms in the fronts, sides, and backs. Shim the dado blade to $\frac{3}{32}$ ", and cut the drawer guide grooves in the outside surfaces of the drawer sides.

4 Cut the drawer bottoms (D) to the size listed in the Bill of Materials. Dry-assemble one drawer to check the fit of the drawer bottom, and make any necessary adjustments. Glue and clamp the drawer backs into the dadoes in the sides, slide the drawer bottoms into their grooves, then glue and clamp the fronts in place. Check the drawers for squareness, and place them on a flat surface while the glue dries.

5 Check the dado-to-dado lengths for the dividers (E, F), then cut them to size. Chuck a $\frac{1}{4}$ " straight bit in your table-mounted router, and rout the slots in the dividers, as shown in *Photo A*. Interlock the two dividers, and slide





A Center the bit between two fences that capture the dividers. A stopblock controls the length of the slot.

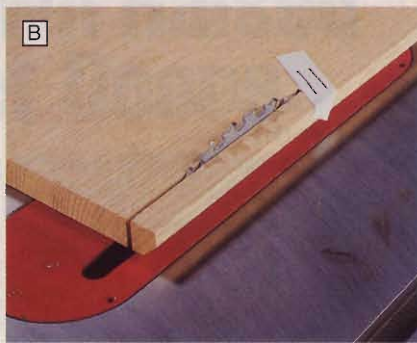

B Index marks on a piece of tape in the path of the cut ensure proper reassembly later.

them into the mating dados in the drawers for compartmentalized storage.

Now, make a carcass to fit the drawers

1 Cut the sides (G) to an oversize width of $11\frac{3}{4}$ ", and the top and base (H) to an oversize width of $12\frac{1}{4}$ "; both to the length shown in the Bill of Materials. Chuck a chamfer bit in your router. Then rout $\frac{3}{8}$ " chamfers on the front inside edges of the sides and both ends and front edges of the top and base, as shown on the Exploded View drawing.

2 Rip off the chamfered edges of the sides (G) to the width listed for the side trim (I), and those of the top and base (H) to the width listed for the top and base trim (J). Mark the mating pieces for reassembly later, as shown in Photo B.

With the edges just ripped against your table saw fence, cut parts (G) and (H) to final width.

3 Install a $\frac{1}{4}$ " dado blade in your table saw, and cut dados for the sides in the top and base (H), where shown on the Parts View drawing.

Note: Measure the outside width of your drawers. The dimension between the dados in the top and base (H) must be $\frac{1}{8}$ " greater. Make any necessary adjustments to the location of the dados for a good fit.

Cut the rabbets for the back (N) in the inside back edges of the sides (G). Next, cut the rabbets on the ends of the sides so they fit snugly into the dados in the top and base. Finally, rout a stopped rabbet between the side dados in the top and base. See the Top and Parts View.

4 Prepare to cut the drawer guide dados in the sides (G) by making an indexing strip $\frac{3}{8}$ " wide and $10\frac{1}{2}$ " long that fits snugly in a $\frac{1}{4}$ " dado and a

$3\frac{5}{16}$ " long spacer block. Install a $\frac{1}{4}$ " dado blade in your table saw, and adjust it to cut $\frac{1}{4}$ " deep. Position the rip fence $3\frac{9}{16}$ " to the right of the blade. Fit your miter gauge with an auxiliary fence to support the workpiece and reduce tearout. Using the rip fence as a stop, cut the top drawer guide dado in each side.

5 Fit the indexing strip in one of the dados you just cut, and place the extra drawer side over the strip, engaging the groove in the drawer side. Push the drawer side toward the bottom end of the side (G) to take up the $\frac{1}{32}$ " play in the groove, and clamp it in place. Position the $3\frac{5}{16}$ " spacer

Continued

A Tip From Our Builder



To prevent tearout when making a dado cut, back your workpiece with a scrap softwood follower block.

DRAWER

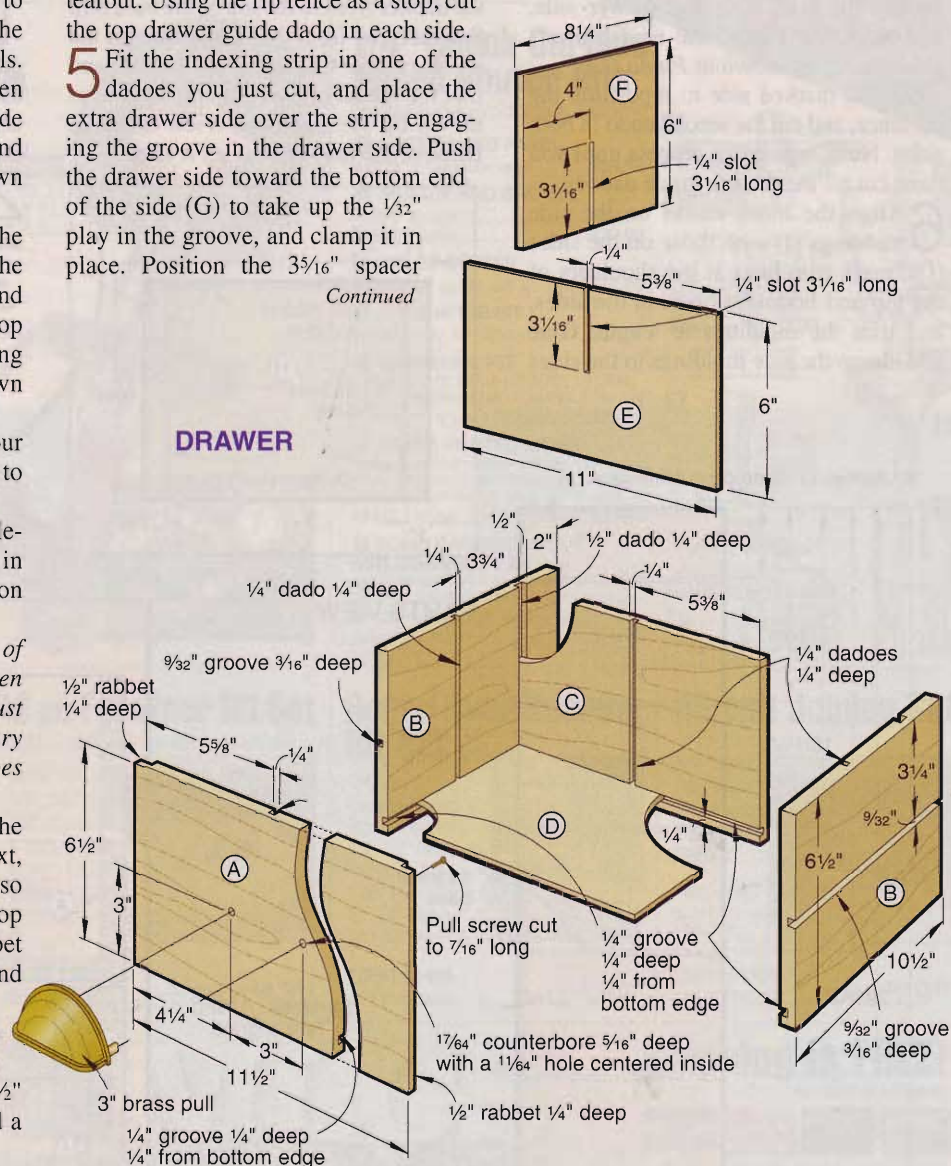



Use a craft or utility knife to mark the location of the top of the next dado in the carcass side.

against the bottom of the drawer side, and mark the top of the next drawer-guide dado, as shown in *Photo C*.

Use the marked side to reposition the rip fence, and cut the second dado in both sides. Now, repeat this process until you have cut all the drawer-guide dados.

6 Align the index marks on the side moldings (I) with those on the sides (G), mark trim lines at the shoulders of the top and bottom rabbets in the sides, and trim the moldings to length. Glue and clamp the side moldings to the sides

and the top and base moldings (J) to the top and base (H).

7 Cut the drawer guides (K) to size, as shown on the Exploded View drawing. Chamfer one end of each, and glue and clamp them in the side dados, centered front-to-back.

Note: To allow for seasonal wood movement, the guides are $\frac{1}{8}$ " shorter than the sides. Glue only 1" at the center of each guide.

8 Glue the tongues on the ends of the sides into the dados in the top and base. Clamp the assembly, check it for square, and place it on a flat surface to dry.

9 To check the width of the front (L), slide the bottom drawer into place. Measure the distance from the bottom of the drawer front to the top of the base (H). Subtract $\frac{1}{16}$ " from this dimension for the width of (L). Cut the front to size, and rout the rabbet in the ends and bottom, as shown on the Exploded View drawing. Remove the drawer, and set it aside.

10 Cut the cleats (M) to size. The length of the cleats is the same as the width of the front. Drill the countersunk shank holes in the cleats. Using the shank holes as guides, drill pilot holes into the front, and screw the cleats to the front. Again, using the shank holes as guides, drill pilot holes into the sides, and screw the front to the sides, where shown on the Side Section View drawing below.

11 Measure the rabbeted opening, and cut the back (N) to size. With the back in place, drill pilot and countersunk shank holes. Now, screw the back firmly in place.

Winding it up: Finishing and final assembly

1 Remove the dividers from the drawers. Finish-sand all surfaces and edges through 220-grit. Remove sanding dust and apply stain, following the manufacturers directions. We used Minwax Provincial no. 211.

2 When the stain is dry, apply two coats of satin polyurethane, sanding with 220-grit sandpaper between coats.

3 Let the finish dry for 24 hours, trim the screws, and install the pulls. We bought ours from a local home center. See the Supplies list for the ones we

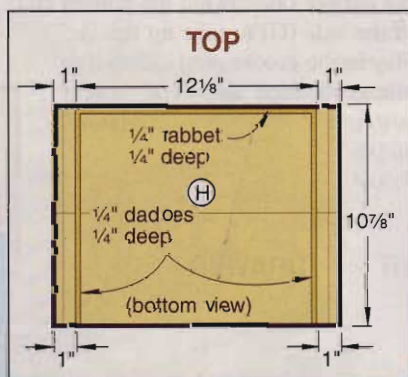

SIDE SECTION VIEW

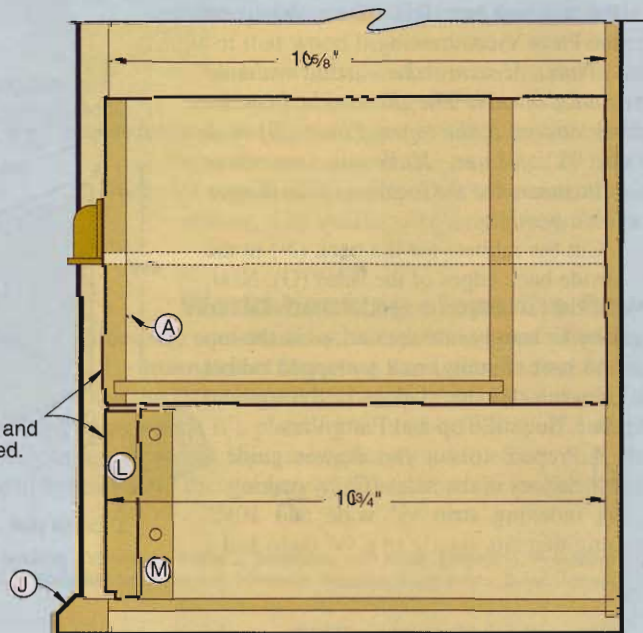

PARTS VIEW

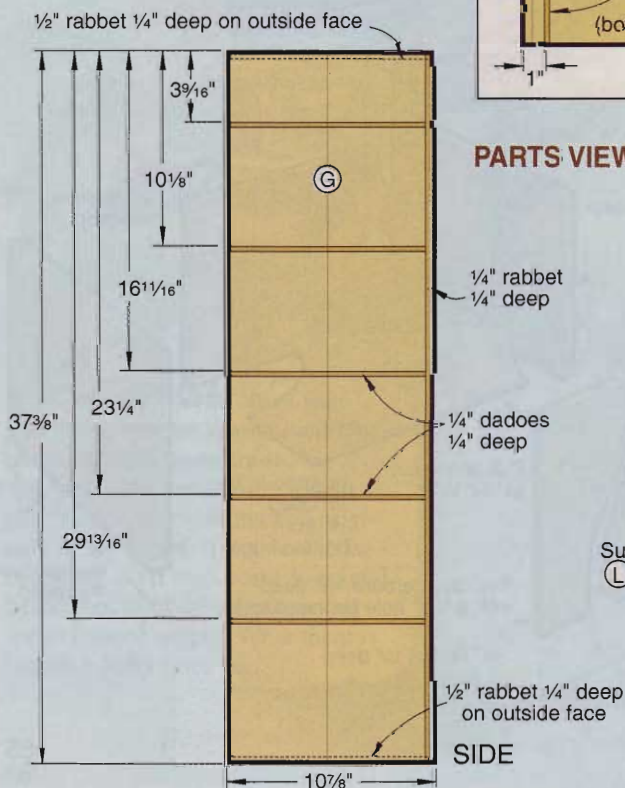

used. Reinstall the dividers, and slide the drawers in place.

4 Fill the drawers with CDs. Store eight in each compartment for easy retrieval. Now, place the cabinet near your stereo and enjoy a happy tune.

BILL OF MATERIALS

Part	finished size			
	T	W	L	Matl. Qty.
A drawer fronts	1/2"	6 1/2"	11 1/2"	O 5
B drawer sides	1/2"	6 1/2"	10 1/2"	O 10
C drawer backs	1/2"	6 1/2"	11"	O 5
D drawer bottoms	1/4"	8 3/4"	11"	H 5
E dividers	1/4"	6"	11"	H 5
F dividers	1/4"	6"	8 1/4"	H 5
G* sides	3/4"	10 7/8"	37 3/8"	EO 2
H** top/base	3/4"	10 7/8"	14 1/8"	EO 2
I** side molding	3/4"	5 5/8"	36 7/8"	O 2
J** top/base molding	3/4"	1 1/8"	14 1/8"	O 2
K drawer guides	1/4"	1/2"	10 1/2"	O 10
L front	3/4"	4"	11 5/8"	O 1
M cleats	3/4"	3/4"	4"	O 2
N back	1/4"	12 1/8"	37 3/8"	H 1

* Parts initially cut oversize, see instructions.

**Parts cut from oversize parts (G,H).

Materials Key: O—red oak, H—tempered hardboard, EO—edge-joined oak.

Supplies: #8x1 1/4" flathead wood screws (8), #6x3/4" flat-head wood screws (18), Amerock no. BP4235-B pulls (5), stain, finish.

CUTTING DIAGRAM

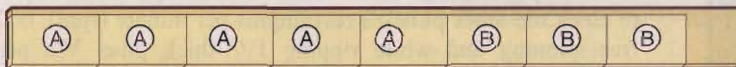

1/2 x 7 1/4 x 96" Oak

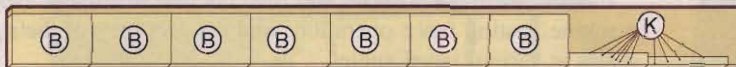

1/2 x 7 1/4 x 96" Oak



1/2 x 7 1/4 x 96" Oak



3/4 x 7 1/4 x 96" Oak

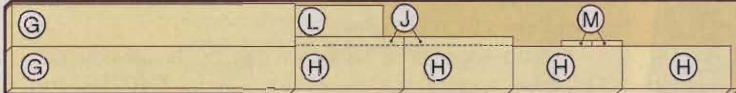

3/4 x 11 1/4 x 96" Oak

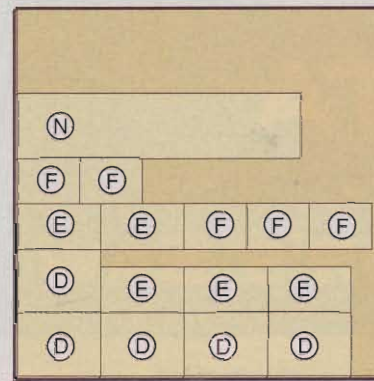

1/4 x 48 x 48" Tempered hardboard

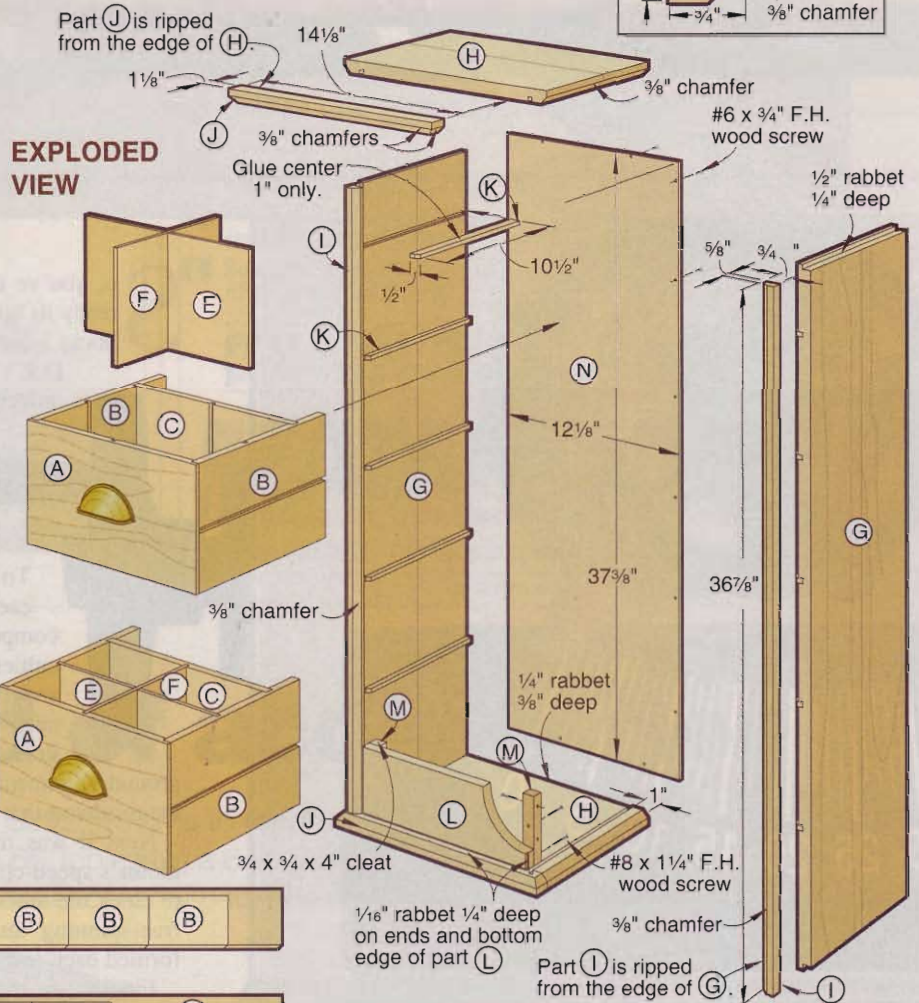
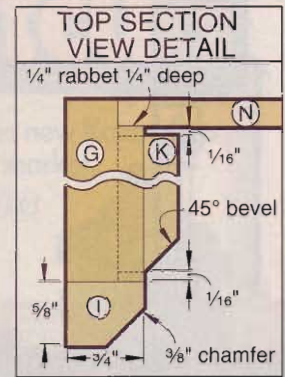
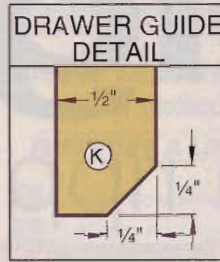

Written by Jan Hale Svec with Charles I. Hedlund Project Design: James R. Downing; Dave Ashe
Illustrations: Roxanne LeMoine; Lorna Johnson Photography: Baldwin Photography

big-time

at a ripping good price



So, you've outgrown your "starter" tablesaw, and you're ready to upgrade. But you don't have a lot of extra sawbucks lying around to spend on a costly cabinet-style saw. Don't despair—we tested seven popular tablesaws priced between \$600 and \$900 that suit both your woodworking needs and your budget.

Table manners: How we treated our guests

To get our testing underway, we first assembled each of the saws, examining internal and external components for fit and finish, and noted any difficulties in the assembly process. We then checked and, if necessary, adjusted each machine's blade-to-miter-slot parallelism, fence alignment, and bevel stops, again noting any problems. Using a precision-ground alignment plate, we checked arbor runout. You'll find the results of that test in the chart on pages 72-73.

Next it was time to plug in the saws. To measure each motor's speed-change under load, we used a phototachometer to clock the arbor pulley's revolutions per minute (rpm), both free-spinning and while ripping 1½"-thick pine. We performed each test three times and averaged the results.

Finally, we made a series of crosscuts and rips using each machine, testing fence operations and the accuracy of the rip scales at various bevel angles.

Fast facts

- Although most of the saws in our test are open-stand, contractor-style saws, the Grizzly G1023S closed-stand, cabinet-style saw falls in the same price range.
- When shopping for a tablesaw, don't overlook the fence. Since our last test (*WOOD* magazine, issue 98), saw makers have made more improvements in this vital component than anywhere else.
- Putting together a tablesaw can be an all-day job. However, two of the saws—the Grizzly G1023S and DeWalt DW746X—come mostly assembled, so you can start cutting after only a few hours.

tablesaws

The seven saws we tested promise you high-quality cuts without breaking the bank.

Find out which ones deliver.



Motors, speed, and torque: The power struggle

Tell a fellow woodworker that you just bought a new table saw, and after he or she stops salivating, the first question will be, "How many horsepower?" That's because a powerful saw makes ripping and crosscutting a joy rather than a tedious task.

Call us jaded, but over the years, we've learned to take manufacturers' claims about horsepower with a grain of salt. (Does it make sense to buy a 6-hp shop vacuum to clean up after your 1½-hp table saw?) So we measured power the way you do: by seeing how each saw responded while cutting wood.

With proper setup, all of the saws in our test performed well when ripping stock at a comfortable 10–12' per minute feed rate. If you look at the Power Ratings chart, below, you'll see that five of the

tablesaws slowed an average of only 175 rpm in our ripping test. However, the Jet and Powermatic saws slowed significantly during the test, losing about twice as much as the other saws. Why?

First off, speed and torque have an inverse relationship: As speed goes up torque goes down, and vice versa. The Jet and Powermatic arbors turn about 1,000 rpm faster than the other saws, so you'd expect them to bog down more when being pushed to their limits. Both did.

More importantly, though, the Jet and Powermatic motors lack a run capacitor. All of the saws in our test use a start capacitor that, like the first cup of coffee in the morning, provides an extra boost of energy to kick-start the motor from a dead stop. Once the motor gets up to speed, the start capacitor kicks out. The run capacitor is more like a mid-morning coffee break. It patiently waits until the motor

bogs down, then jumps in with another boost to get you through the tough spots. Without that extra kick, we found it easy to stall both saws when ripping.

Like the Jet and Powermatic machines, Grizzly's motor lacks a run capacitor and turns the arbor at about 4,200 rpm. But with twice the rated horsepower, we found we could cut material at nearly twice the rate of the other saws with no significant drop in rpm.

Here's our slant on blade tilt and elevation

When you set up to make a bevel cut with a table saw, you're really tilting the motor and arbor assembly in unison. To accomplish this, the entire assembly hangs on a pair of cast trunnions that bear the weight of the arbor assembly. (See photos on the next page.)

These trunnions ride on saddles at the front and rear of the saw housing, and connect to each other by means of a cast yoke (Grizzly) or a pair of steel bars (Delta, Jet, and Powermatic). Or, both trunnions and the connector simply may be one cast piece (Craftsman, DeWalt, and Ridgid). Of the methods for keeping the trunnions moving in unison, we found none any better or worse than the other.

To change blade elevation, all of the saws we tested use a rack and worm gear. Compared to the other saws, the fine rack teeth and threads on the Craftsman and Ridgid elevation mechanisms require an arm-numbing 36 and 35 turns of the crank to raise or lower

Continued

POWER RATINGS: MEASURING THE MUSCLE

MANUFACTURER	MODEL	VOLTS	RATED HORSEPOWER (1)	RATED AMPERAGE (110/220V)	CAPACITORS (2)	ARBOR SPEED (RPM) (3)		
						NO LOAD	UNDER LOAD (4)	SPEED LOSS
CRAFTSMAN	22859	110/220	1½	13/6.5	2	3,578	3,392	186
DELTA	36-475	110/220	1½*	12.8/8.6	2	3,117	2,951	166
DeWALT	DW746X	110/220	1¾	15/7.5	2	3,187	3,009	178
GRIZZLY	G1023S	220	3	18	1	4,174	4,011	163
JET	JWTS-10CW2-PF	110/220	1½	18/9	1	4,202	3,864	338
POWERMATIC	64A	110/220	1½	15/7.5	1	4,231	3,810	421
RIDGID	TS2424	110/220	1½	13/6.5	2	3,146	2,960	186

- NOTES: 1. (*) Rated 2hp at 220V. 3. Measured by phototachometer on arbor pulley.
 2. (1) Start capacitor only. (2) Start-and run-capacitors. 4. Ripping 1½" pine at 12' per minute feed rate. Results shown are average of three tests.

big-time tablesaws

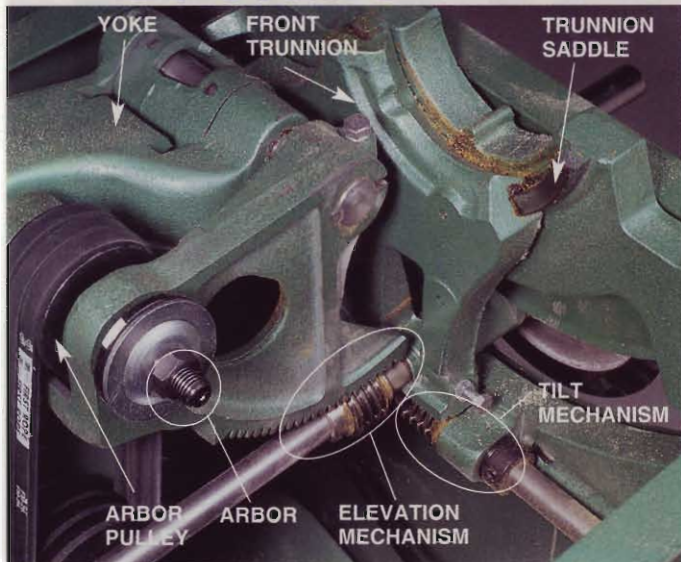

Note the sturdy internal components of the Grizzly G1023S, which includes the rack-and-worm-gear tilt and elevation mechanisms.

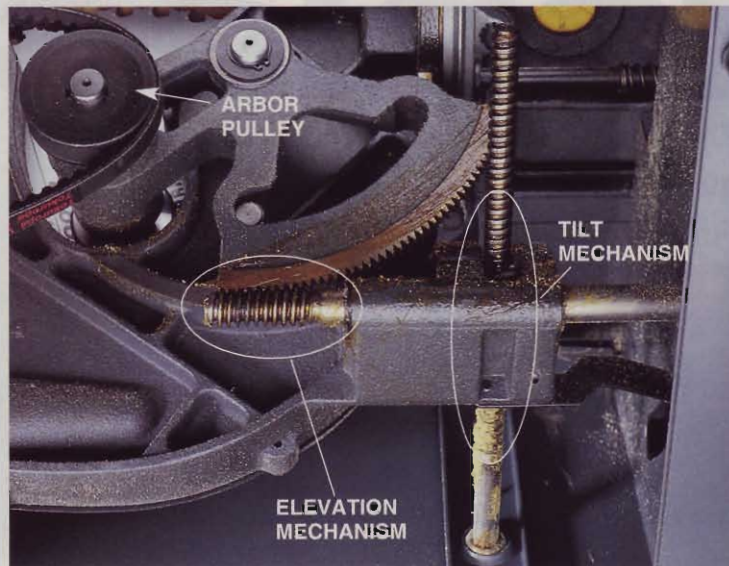

In contrast, the Craftsman 22859 (viewed from below) uses a threaded-rod-and-nut tilt mechanism attached to the side of the saw housing (bottom of photo).

the blade completely. But on the positive side, those same threads are less likely to vibrate out of adjustment, so they don't require an elevation lock like the other saws.

Craftsman and Ridgid also differ from the other models in their blade-tilt mechanisms. Five of the saws use a durable rack and worm gear, such as that shown *above left*. Craftsman and Ridgid, on the other hand, employ a long threaded rod that threads into a nut on the arbor bracket, as shown *above right*. One end of that threaded rod mounts to the saw's stamped-steel housing, which deflects easily, making the bevel stops feel mushy. In fact, we turned the crank more than one full turn past the stop while watching the housing bulge.

DeWalt engineers really did their homework when designing their tilt mechanism. For one thing, they've geared the system so that one-half turn of the crank changes the tilt exactly 1°. And, this is the only saw in the test—and only the second table saw we've ever seen—that pivots the mechanism in such a way as to keep the fence scale accurate at any bevel angle. (See the "Change in Fence-to-Blade Distance" column in the chart on page 72.)

The fence can make or break the table saw

We don't ask too much of a table saw fence—only that it glide smoothly, lock securely and parallel to the blade

Left-tilt vs. right-tilt arbors: Which way do you lean?

If you frequent the *WOOD ONLINE*® (www.woodmagazine.com) Tools and Tool Buying discussion group, you'll often read about somebody who wants to know whether to buy a left- or right-tilting arbor table saw. Intelligent people on both sides argue passionately for their preference, but each has advantages and disadvantages.

Left tilt. Most woodworkers run their fence to the right of the blade; so if you do a lot of bevel-cutting, a left-tilting blade is safer. The blade tilts away from the fence so the workpiece can't get trapped and launched. And, on narrow workpieces, there's more room between the fence and blade for a pushstick.

Right tilt. On a right-tilting saw, the arbor flange—from which you calibrate your fence's rip scale—is on the right. This means that with full-kerf, thin-kerf, or dado blades, your rip scale will always be accurate. On a left-tilting saw, the scale's accuracy changes with the thickness of the blade.



Dual cursors keep Delta's scale accurate regardless of the fence orientation. But from some viewing angles, we couldn't tell one increment marking from another.



Some of the tapered increment markings on the Ridgid TS2424's rip scale don't reach the cursor.

throughout its travel, remain parallel if bumped hard, and have an easy-to-read rip scale and cursor. For the most part, we were very pleased with the fences on these saws.

However, our favorite in the test is Delta's Unifence with its dual-height, extruded-aluminum fence. In its "flat" orientation (as seen in the photo on page 69), it's only 1/2" high. So for narrow workpieces, you can keep your hand safely away from the blade. Loosen the T-nuts on the fence body, remove the fence, rotate it 90°, and you have a 3 1/2" high fence for better vertical support of tall workpieces.

Another plus for the Unifence and DeWalt's fence: You can slide the face partially off the fence body, as shown at *near right*, and use it as a bind-free crosscut stop. Both also allow you to raise the face slightly to clear dust and debris, or lower the face to the tabletop for cutting thin materials, such as plastic laminate.

Grizzly, Jet, and Powermatic all come with their version of the popular Biesemeyer-style fence. Each has a sturdy rectangular tube-steel fence body with melamine-coated particle-board faces, easy-to-read scales, and hairline cursors. Speaking of scales, those on the Craftsman, Delta, and Ridgid were difficult to read at times, as shown in the photos *opposite left*.

Craftsman and Ridgid each have a microadjust knob for fine-tuning their fences. Ridgid's rubber nipple works well, but we had trouble getting Craftsman's pinion gear to engage the rack on the rail.

More things to think about before you buy

Arbor runout and length. Runout describes the wobbling caused by a misaligned blade arbor. We're happy to report that all of the saws performed impressively in our test. Measured 5" from the center of the arbor on a flat metal plate, we consider any runout less than .003" to be excellent. Delta, Grizzly, Jet, and Powermatic all beat that standard at less than .002". Even Craftsman's and Ridgid's .004" and DeWalt's .005" are well within the acceptable range of runout.

The shortest arbors in our test, found on the Delta and Ridgid, are long enough to use a 29/32" stacked dado set.



You can use the sliding aluminum fence faces of the Delta 36-475 and DeWalt DW746X (shown) as a crosscut stop without trapping the workpiece.

But we couldn't fit a Freud 29/32" Dial-A-Width dado set on either.

Vibration. All of the saws we tested employ a belt or belts to transfer power from the drive pulley on the motor to the arbor pulley. Generally speaking, the longer the belt, the more prone the system is to vibration caused by pulley runout or belt irregularities.

Three of the saws vibrated so little we could stand a penny on edge on the tabletop while we ran and stopped the motor. All three succeeded for different reasons. The Grizzly G1023S, like most cabinet-style saws, uses three short belts (which tend to smooth out any minor variance in pulleys) and a very heavy cast-iron tabletop and trunnions to dampen vibration.

DeWalt and Ridgid both drive with a single belt. DeWalt's unique motor placement—below the blade—shortens the belt and places the weight beneath the arbor to reduce motor bounce. And Ridgid uses a thin, flat ribbed belt (similar to an automotive serpentine belt) and nicely machined, solid steel pulleys (see photo *top right*) for vibration-free operation.

Tabletops and extensions. All seven saws have cast-iron tables that are flatter than most wood you'll cut on them. (See chart, *above right*, for details.) Except for Ridgid and DeWalt, the saws use solid cast-iron extension wings. Ridgid's webbed cast-iron wings can pinch your fingers as you slide the fence from side to side, and don't give you a place to put small workpieces while you work.



The Ridgid TS2424's machined steel pulleys and flat, ribbed drive belt made it one of the smoothest operators in our test.

THE FLATNESS FACTOR

MANUFACTURER	MODEL	A*	B*	C*
CRAFTSMAN	22859	.023	.012	.001
DELTA	36-475	.012	.030	.001
DeWALT	DW746X	.008	.009	.004
GRIZZLY	G1023S	.022	.004	.002
JET	JWTS-10CW2-PF	.009	.012	.002
POWERMATIC	64A	.043	.022	.001
RIDGID	TS2424	.010	.006	.001

(* Inches out of flat, measured in direction shown on drawing below.)

Delta and Jet add a medium-density fiberboard (MDF) table to the end of the right extension wing, widening the work surfaces to 62" and 56 3/8", respectively. You

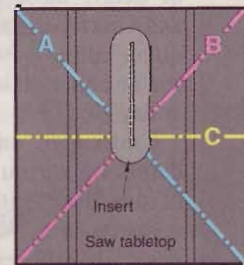

also could mount a router in the MDF table, and use the tablesaw fence for both sawing and routing chores.

Throat plates. First, we want throat plates to be easy to remove. The inserts on the Craftsman, DeWalt, and Ridgid saws fall short here because each attaches to the saw with a screw. (DeWalt goes one worse, using a Torx-head screw to secure the plate, without including a Torx driver with the saw.)

We also like throat plates that can be easily duplicated to make our own zero-clearance inserts. The plates on the Delta, Grizzly, Jet, and Powermatic can be cut from 1/2" plywood, and don't require securing to the saw. Grizzly and Powermatic, anticipating your need for dadoes, package two inserts with the saw—one for a full-kerf blade, and one for a dado set.

Blade guards and splitters. Once removed, most safety devices are such a nuisance to replace that they never get put back on. That's a shame. But Ridgid's guard/splitter comes completely off the saw with a few turns of a thumbscrew and goes back on just as simply. Bravo.

Continued

big-time tablesaws

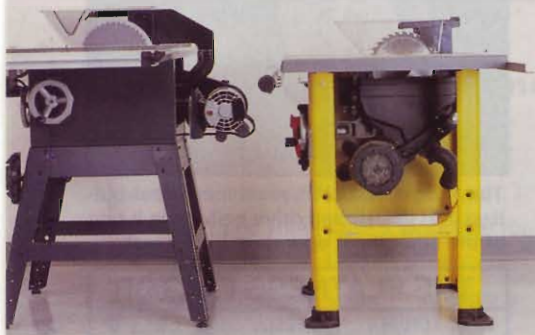

Contrary to a typical contractor-style tablesaw (left), DeWalt hangs the motor of the DW746X inside the saw housing, making the whole machine more compact.

Dust collection. With an open-stand tablesaw, it's tough to contain the piles of debris these saws generate. Delta and Grizzly use a slanted dust chute to direct falling dust to one side where it can be collected in a box or swept away at day's end.

Craftsman and DeWalt capture debris by surrounding the lower half of the blade with a dust shroud that connects to a 2½" port, but with dramatically different results. Even when not connected to a vacuum hose, DeWalt's design directs dust out through the port. The Craftsman shroud is supposed to route the debris to a fine-mesh collection bag. But the poor location of the exhaust port sends most of the dust past the port and onto the tabletop. Even with a vacuum attached to the port, we observed a disproportionate amount of dust building up on the table.

Portability. If you're the kind of woodworker who doesn't have enough space in your shop, you'll appreciate the compact nature of the DeWalt DW746X. You see, the motor of a typical contractor-style saw hangs off the back of the machine (see photo above), meaning you can't store the saw flat against a wall. DeWalt's motor-under design saves 10–13" in saw width. Grizzly's G1023S, a cabinet-style saw, also will store flat against the wall.

You can buy a mobile base for any saw in our test, but Ridgid includes a built-in mobile base as standard equipment—a big plus for the small shop. The outboard legs on Delta's MDF extension wing require an extra-long mobile base to save levelling the legs every time you move the machine.

Assembly. All of the saws require at least a couple of hours assembly time for attaching the extension wings, fence rails, and blade guard. Most also must have their stands, motor mounts, and belt guards put together, so add another few hours. On top of that, you still have to set the bevel stops and align the blade to the miter slots—another tedious chore.

But DeWalt and Grizzly came from the factory with those time-consuming tasks already complete. We simply bolted on the wings and rails and were ready to cut in a couple of hours.

At the other end of the scale, assembling the Powermatic saw turned into a marathon. First, it took more than an hour just to remove the petroleum-jelly protectant from the tabletop and wings. Second, we couldn't get the mounting hole on the power switch to align with its mating hole on the front fence rail. And, after we got it all together, we found that the drive belt

on our saw dragged on the forward bolt of the belt cover with the blade at full elevation.

Adjustment and alignment. Aligning the blade to the miter slots takes some doing on most saws. You must loosen the bolts that mount the trunnions to the underside of the table, shift the trunion assembly and tighten the bolts. On the Grizzly G1023S, the trunnions mount to the cabinet instead of the tabletop, so you shift the tabletop instead. Ridgid's system, though, is the simplest and most effective: It has a set screw on the back of the saw that allowed us to micro-adjust the alignment from outside the saw.

For setting bevel stops at 45° and 90°, Craftsman, Delta, DeWalt, and Ridgid use set screws in the tabletop. They're quite easy to access and adjust. Meanwhile Grizzly, Jet, and Powermatic have bolts under the table that are more difficult to access, but every bit as effective.

MID-PRICED MADNESS:

MANUFACTURER	MODEL	VOLTS	MOTOR		CAPACITY (INCHES)				CONSTRUCTION							
			RATED HORSEPOWER (1)	MOUNTING STYLE (2)	THICKNESS		WIDTH		BEVEL							
					90° BEVEL	45° BEVEL	LEFT OF BLADE	RIGHT OF BLADE	PULLEY MATERIAL (3)	BELT MATERIAL (4)	TRUNNION TYPE (5)	TILT DIRECTION (LEFT OR RIGHT)	DRIVE MECHANISM (6)	NUMBER OF CRANK ROTATIONS, 45-90°	CHANGE IN FENCE-TO-BLADE DISTANCE BETWEEN 90° AND 45° (INCHES)	DRIVE MECHANISM (6)
CRAFTSMAN	22859	110/220	1½	ST	3¾	2¼	24	30	CI	RV	CI	L	TN	31	¼	WG
DELTA	36-475	110/220	1½*	ST	3⅞	2⅞	9¼	32¼	CI/MS	V	TB	R	AW	29	¼	AW
DeWALT	DW746X	110/220	1¾	SS	3⅞	2⅞	16	30½	PM	RV	CI	L	WG	22½	0	WG
GRIZZLY	G1023S	220	3	SS	3⅞	2⅞	8¾	26	CI	V	CY	R	WG	30	⅞	WG
JET	JWTS-10CW2-PF	110/220	1½	ST	3⅞	2⅞	12⅞	29⅞	AL	V	TB	R	AW	29	⅞	AW
POWER-MATIC	64A	110/220	1½	ST	3⅞	2	11¾	30¼	CI	RV	TB	L	WG	30	⅞	WG
RIDGID	TS2424	110/220	1½	ST	3⅞	2¼	24¾	24¾	MS	RF	CI	L	TN	28	⅞	WG

NOTES: 1. (*) Rated 2hp at 220V
 2. (SS) Saw-specific welded mount (ST) Standard 56 frame 4-bolt mount
 3. (AL) Aluminum (CI) Cast Iron (MS) Machined steel (PM) Powdered metal
 4. (RF) Ribbed flat belt (RV) Ribbed V-belt (V) V-belt
 5. (CI) One-piece cast-iron (CY) Cast-iron yoke (TB) Twin bar
 6. (AW) Adjustable worm gear (TN) Threaded nut (WG) Worm gear
 7. (CI) Solid cast-iron (I/M) Cast iron and medium-density fiberboard (SS) Stamped steel (WI) Webbed cast-iron
 8. (BT) Steel box-tube (EA) Extruded aluminum (RT) Steel round-tube
 9. (BT) Steel box-tube with bolt-on faces (EA) Extruded aluminum
 10. (F) Fence locks at front only. (FR) Fence locks at front and rear.

It's time to put our cards on the tablesaw

You won't find a more solid performer than the Grizzly G1023S for under \$1,000. You'll never get bogged down cutting with this 3-hp animal, but you will need to have a shop wired for 220 volts to use it.

If you don't have 220-volt service but have plenty of space, you can't go wrong with Delta's 36-475. It has all the power and tabletop real estate you

could ask for in the price range, and a great fence to boot.

For the small shop, DeWalt's feature-packed DW746X offers great power in a compact machine. But if the \$900 price tag is too rich for your blood, save \$250 and get the Ridgid TS2424—an easy-to-adjust saw with excellent mobility.

Written by **Dave Campbell**
 Technical consultant: **Bob McFarlin**
 Illustration: **Kim Downing**
 Photographs: **Baldwin Photography**

You're welcome to review our review

Do you have one of the tablesaws in our test? If so, why not let your fellow readers know what you think about the tool. We've set up a discussion group on our web site for you—and the saw manufacturers—to do just that. Just click on the "Interactive Tool Reviews" button, at www.wood-mall.com to discuss our findings.



Grizzly G1023S
(with optional motor cover)



Delta 36-475



DeWalt DW746X



Ridgid TS2424

TWO TOOL UPDATES

After we completed our testing, we learned that the Craftsman 22851 will be replaced shortly with the 22859. Craftsman's Bryan Whiffen said the 22859 will be identical to the saw we tested except that they've replaced the right cast-iron wing with a wider MDF extension wing, added soft-grip control knobs, and incorporated a T-slot miter track. The chart below reflects the new model.

And Grizzly Industrial will launch a new edition of the G1023S saw that runs on either 110V or 220V current. Bill Crofutt of Grizzly told us the G1023S110 will sport a 2-hp motor and a different power switch, but otherwise will be exactly the same as the 220V-only version we tested. Crofutt also said he expects the price to be "comparable" to the 3-hp model we tested.

HOW SEVEN SAWS STACK UP

ELEVATION	TABLE		FENCE		PERFORMANCE RATINGS (11)														EASE OF ADJUSTMENT	WARRANTY (13)	COUNTRY OF ASSEMBLY (14)	WEIGHT, POUNDS	SELLING PRICE (15)	COMMENTS		
					NUMBER OF CRANK ROTATIONS, LOWEST ELEVATION TO HIGHEST	TABLE SIZE WITH EXTENSION WINGS (WIDTH X LENGTH, INCHES)	EXTENSION WING MATERIAL (7)	RAIL MATERIAL (8)	MATERIAL (9)	LOCKING STYLE (10)	BLADE ELEVATION	BLADE BEVEL	PARALLEL BLADE TO MITER SLOT	45° AND 90° BEVEL STOPS ASSEMBLY	BEVEL STOP QUALITY	ARBOR SHAFT RUNOUT	VIBRATION	SMOOTHNESS OF FENCE SLIDE							FENCE DEFLECTION	FENCE SCALE READABILITY
36	53 x 27	CI	EA	EA	FR	E	G	G	E	G	F	F	G	E	F	F	F	F	G	E	1 yr.	TAI	332	\$800	Powerful saw with left-tilting blade. We found the 90° and 45° bevel stops mushy. This model replaces the 22851 we tested.	
12	62 x 27	I/M	EA	EA	F	E	E	G	E	G	E	E	G	E	E	G	E	G	F	E	E	2 yr.	USA	271	\$850	Our top pick with outstanding construction throughout. Powerful and quiet with an excellent fence and large extension table.
22½	40¾ x 27	SS	RT	EA	F	E	E	G	E	E	E	F	E	G	E	G	G	G	G	E	2 yr.	USA	254	\$900	Center-hung motor makes this saw more compact. Only saw in our test where the rip scale remains accurate for all bevel angles.	
16	36¾ x 27	CI	BT	BT	F	E	E	E	G	E	E	E	E	G	E	E	F*	G	G	E	1 yr.	TAI	360	\$840*	If you have 220V service in your shop, this saw gives a whole lotta bang for your buck. 2-hp version that runs on 110 volts is coming soon.	
13	56¾ x 27½	I/M	BT	BT	F	E	E	G	G	G	E	E	G	G	E	E	G	E	G	E	2 yr.	TAI	300	\$750	A well-built saw with a good fence and large extension table. Slightly underpowered if you do a lot of ripping.	
12	40½ x 27	CI	BT	BT	F	G	E	G	P	F	E	E	G	G	E	E	G	F	F	G	1 yr.	TAI	310	\$750	Similar to the JET, but without the fit and finish.	
35	44 x 27	WI	EA	EA	FR	F	G	E	E	F	F	F	E	F	F	F	P**	F	G	E	LIFE	USA	245	\$650	The best buy in the test with lots of power and low vibration. Mobile base (\$100 value) comes included, even at this low price.	

11. **E** Excellent
G Good
F Fair
P Poor

12. (*) Improved to "Excellent" with optional motor cover.
 (**) Improved to "Excellent" with optional dust hood.

13. (LIFE) Warranted against factory defects for the life of the tool.

14. (TAI) Taiwan
 (USA) United States

15. All prices current at time of article's production and include shipping, if applicable.
 * Does not include optional motor cover (G9223, \$30.) shown.

For more information, contact:

Craftsman
 Visit your local store.
www.sears.com/craftsman

Delta
 800/438-2486
www.deltamachinery.com

DeWalt
 800/433-9258
www.dewalt.com

Grizzly
 800/523-4777
www.grizzly.com

Jet
 800/274-6848
www.jettools.com

Powermatic
 800/248-0144
www.powermatic.com

Ridgid
 800/474-3443
www.ridgidwoodworking.com

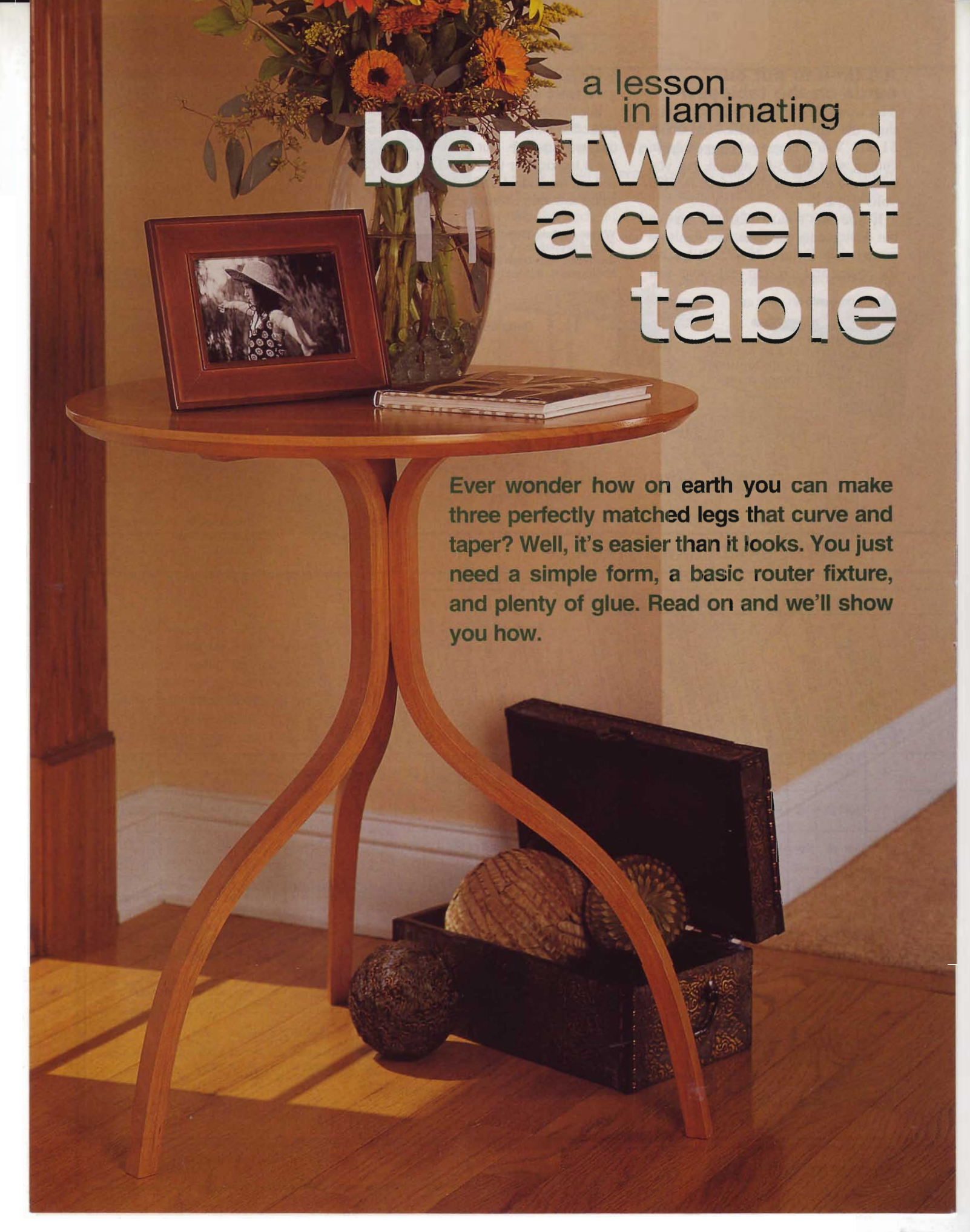

a lesson
in laminating

bentwood accent table

Ever wonder how on earth you can make three perfectly matched legs that curve and taper? Well, it's easier than it looks. You just need a simple form, a basic router fixture, and plenty of glue. Read on and we'll show you how.

A good form helps this table function

1 To make the leg-bending form parts, cut two pieces of $\frac{3}{4}$ "-thick medium-density fiberboard (MDF) to $16\frac{3}{4}\times 27$ ". Laminate the two pieces face-to-face, keeping the edges flush.

Note: Each leg must stay in its form for 48 hours for the glue to dry properly, meaning it will take six days to make the three legs. If you want to work faster, make three sets of the form parts described here.

2 Make an extra copy of the full-size form pattern found in the *WOOD PATTERNS*® insert. (You'll need the extra copy for reference later.) With spray adhesive, attach a full-size form pattern to the MDF lamination.

3 With your bandsaw, cut just outside the curved lines of the three form parts. Sand up to the lines with a drum sander for smoothly curving edges.

4 Transfer the positions of the two $\frac{5}{32}$ " shank holes onto the edges of the form parts. Also transfer the alignment marks for the filler block, and the reference mark that will help you align the $\frac{1}{16}$ " strips.

5 Drill starter holes, and cut the three 3" holes with a jigsaw.

6 As you remove the pattern, mark the form with the numbered positions of the five clamps. Transfer the edge marks made in *Step 4* onto the faces of the form parts, and make a note of what they represent.

7 Apply a coat of oil finish to the faces of the form parts. Allow the finish to dry, then cover the inner edges with clear packaging tape. This will prevent glue and leg laminations from sticking to the form parts.

It's time to cut thin strips for the legs

1 Cut 12 pieces of cherry to $\frac{3}{4}\times 1\frac{1}{2}\times 36$ ". Laminate these face-to-face to make a $1\frac{1}{2}\times 9\times 36$ " block. Square one end, and mark a "V" like the one shown in *Photo A*.

2 Straighten one edge of the cherry block on a jointer, and rip the other edge so it's parallel.

3 Rip the block into $\frac{1}{16}$ "-thick strips as described in the boxed information at *right*. Test your cuts in scrap stock to make sure that 12 of your ripped pieces stacked together make up a $\frac{3}{4}$ " lamination. You will need 36 good strips. (The

block is wide enough to afford you extra strips.) Keep the strips in the order that you sawed them from the block, referencing off the "V."

The legs are just around the bend

1 Stack 12 strips jointed-face-down (the "V" will help you keep them in the sawn order), and make a reference mark on them 8" from one end of the stack. Get prepared for the next step by placing an 18×28 " piece of cardboard or other stiff scrap material under your forms to protect your bench from glue squeezeout. Have five clamps with 12" jaws ready,

too; you'll need to work quickly once you spread the glue. Clamp form part 1 onto your bench with its long edge aligned with your bench edge.

Note: Contrary to typical clamping wisdom, do not attempt to dry-clamp the form parts and strips to check your setup. The strips will not be pliable enough to bend without the moisture they pick up from the glue.

2 Apply a layer of slow-setting glue, such as Titebond Extend Wood Glue, to one face of each strip. (We used a foam brush to speed things along.) Restack the strips as you apply the glue.

Continued

improve your woodworking skills

How to safely and effectively rip thin strips

Sure, you could cut the $\frac{1}{16}$ " strips required for this project by simply adjusting the fence $\frac{1}{16}$ " from the blade, and ripping away. But there's a better way. By using the setup in the photos *below*, you'll get strips of consistent thickness while maximizing your margin of safety.

Here's how to go about it. First, set up your tablesaw with a splitter and zero-clearance insert (a throat plate with an opening that's only as wide as the teeth of the blade). Place the ripped edge of your workpiece against your saw fence. (The other workpiece edge is jointed.) Adjust the fence to cut a $\frac{1}{16}$ "-thick strip on the outboard side of the blade (the side *away* from the fence).

Make a "stop guide" by jointing one edge of a flat scrap board that's at least as long as the depth of your tablesaw top. Set up a router table or your table-

saw to remove $\frac{1}{8}$ " of material from one end of the jointed edge to the midpoint of the edge. Position the stop guide against the jointed edge of your workpiece, as shown in *Photo A*, and clamp both of its ends to your tablesaw top.

Place the ripped edge of your workpiece against the fence, slide the fence over until the jointed edge of the workpiece contacts the stop guide, and rip the first strip. As the end that you're pushing approaches the blade, use your free hand to press the strip against the workpiece at a point just beyond the splitter, as shown in *Photo B*. (We used the end of a pencil eraser to keep distance between the blade and fingers.) This allows the strip to completely exit the blade area without damage.

Lightly joint the workpiece edge you just ripped. Repeat the procedure described in the previous paragraph.

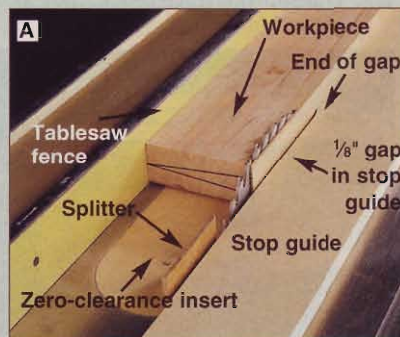

Position the end of the sawn or routed gap in the stop guide with the leading edge of the saw blade.

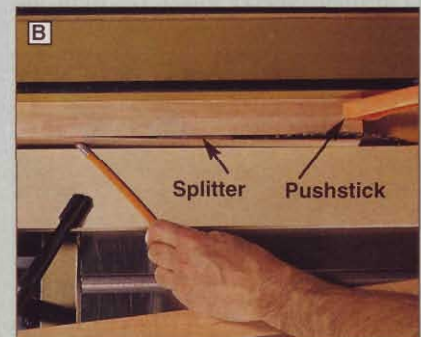

Move the strip safely past the blade by using the eraser-end of a pencil to contact the strip after it passes the splitter.

bentwood accent table

3 Place the stack of strips on edge between the three form parts, aligning the mark you made in *Step 1* of this section with the reference mark for aligning $\frac{1}{16}$ " strips on form part 1. Position and tighten the clamps in their numbered order. You'll have to muscle form part 3 into position, as shown in *Photo C*, before securing clamp 5.

4 With a mallet tap down any strips that slide up during the glue-up. You may need to tap the forms and retighten the clamps to ensure air-tight joints between the strips. Wipe off excess glue with a damp cloth. Because of the high stresses in this glue-up, allow the glue to dry for 48 hours.

5 With a handsaw cut the leg to length, even with the ends of the form parts. Remove the leg from the form, and chamfer one end, as shown on the pattern. Remove any glue from the form parts. Repeat the process for the other two legs.

Tapering the legs: Your router makes it easy to do

1 Place a piece of masking tape on both leg ends, and mark a centerline that runs across the laminations. On the chamfered end mark lines $\frac{5}{8}$ " on both sides of center. At the other end, mark lines $\frac{3}{8}$ " on both sides of center.

2 Place the leg back into the form with the clamps placed underneath. Align the top line on both ends with the top of the form, and clamp the leg in place. (See *Photo D*.)

3 Set up your handheld router with a bottom-cutting bit. We used a $1\frac{1}{4}$ "-diameter dish-carving bit (Freud item no. 99-026—others make similar bits).

Build a router sled with two $\frac{3}{4}\times\frac{3}{4}\times 6$ " scrapwood runners glued $\frac{1}{2}$ " from the

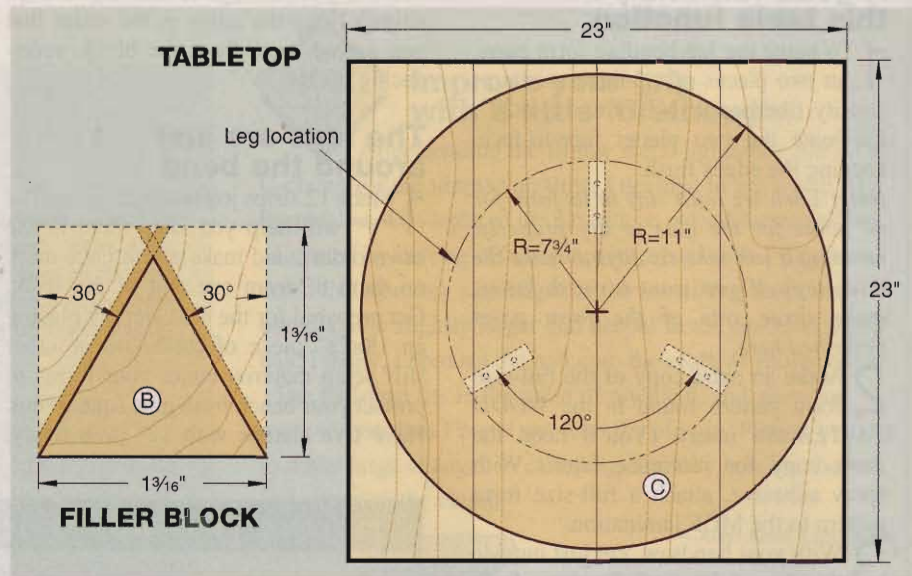

outer edges of a $\frac{1}{4}\times 6\times 6$ " piece of plywood with a $1\frac{1}{2}$ " diameter hole drilled in its center. Attach the runnerless side of the sled to your router baseplate with cloth-backed double-faced tape. Lower the bit so it sits $\frac{1}{64}$ " above the surface that the sled sits on.

4 Place the router sled on the form, and remove the leg material sticking above the form surface, as shown in *Photo D*.

5 Loosen the clamps, and adjust the leg so the other $\frac{5}{8}$ " and $\frac{3}{8}$ " marks align with the other side of the form. Switch the clamps, one at a time, to the other side of the form, and rout the legs as before.

6 Before removing the leg from the form, mark the alignment lines for the filler block. Mark, drill, and countersink the $\frac{5}{32}$ " shank holes, as shown on the pattern. Sand the tapered sides of the leg. Transfer the filler-block lines to the

surface of the leg that will face inward after assembly. Sand the edges smooth.

Assemble the legs to give your table something to stand on

1 Cut the 4"-long filler block (B) to shape according to the Filler Block drawing. Glue and clamp the filler block to one leg.

2 After the glue dries, screw the leg to a scrap sheet of $\frac{3}{4}\times 18\times 18$ " material. Place gel-type epoxy on the two exposed faces of the filler block, and hold the other legs to the filler block with masking tape, as shown in *Photo E*. Note that we placed masking tape on the inside of



Use arm force to bend the laminations and draw form part 3 into position so you can clamp it to form part 1.

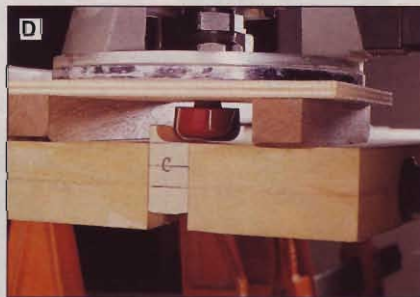

We chamfered the end bottoms of the leg so the other $\frac{5}{8}$ " and $\frac{3}{8}$ " marks align with the other side of the form during the leg tapering.

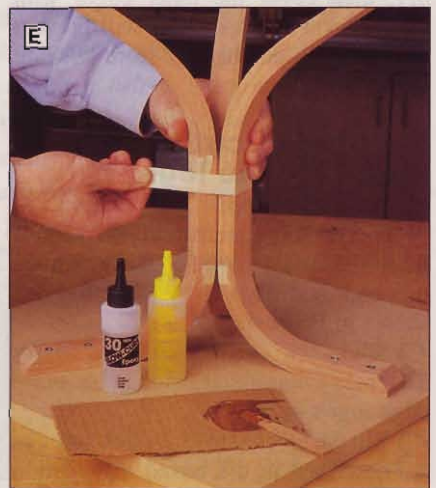

Masking tape holds the legs against the filler block as the epoxy cures. Screws keep the tops of the legs in a flat plane.

the legs to keep any runny epoxy off the legs. Screw the legs to the scrap sheet before the epoxy sets up.

3 After the epoxy cures, sand off any corners of the filler block that stick out from the legs.

Top off your project with a table

1 Edge-glue 3/4"-thick, 23"-long pieces of cherry to make a 23x23" tabletop panel. Sand the panel flat.

2 Place the panel face down, and mark the radii shown on the Tabletop drawing. (Mark the 7 3/4" line lightly so you can easily erase it later.)

3 Bandsaw along the 11"-radius line. Sand the circle edge smooth.

4 Chamfer the edge of the tabletop with a router bit. (See the Tabletop Profile detail drawing.)

5 Place the tabletop face down, align the chamfered ends of the legs along the 7 3/4" radius, and attach them

with #8x1 1/4" flathead wood screws in 1/2" deep, 7/64" pilot holes.

6 Stand the table upright on a flat surface and measure from the edge of the table straight down to the bottom of each leg. Cut the leg(s) to the same length to eliminate wobble.

7 Finish-sand and remove all dust. We brushed on two coats of Minwax gloss polyurethane, followed by an aerosol coating of Minwax satin polyurethane. ♣

BILL OF MATERIALS

Part	finished size			Matl.	Qty.
	T	W	L		
A* legs	1/16"	1 1/4"	36"	C	36
B filler block	1 3/16"-triangular	4"		C	1
C tabletop	3/4"	22"-round		C	1

*Ripped from a 1 1/2x9x36" block made up of 12 pieces of 3/4x1 1/2x36" stock.

Material Key: C—cherry

Supplies: #8x1 1/4" flathead wood screws, Titebond Extend Wood Glue, gel-type epoxy, clear finish.

EXPLODED VIEW

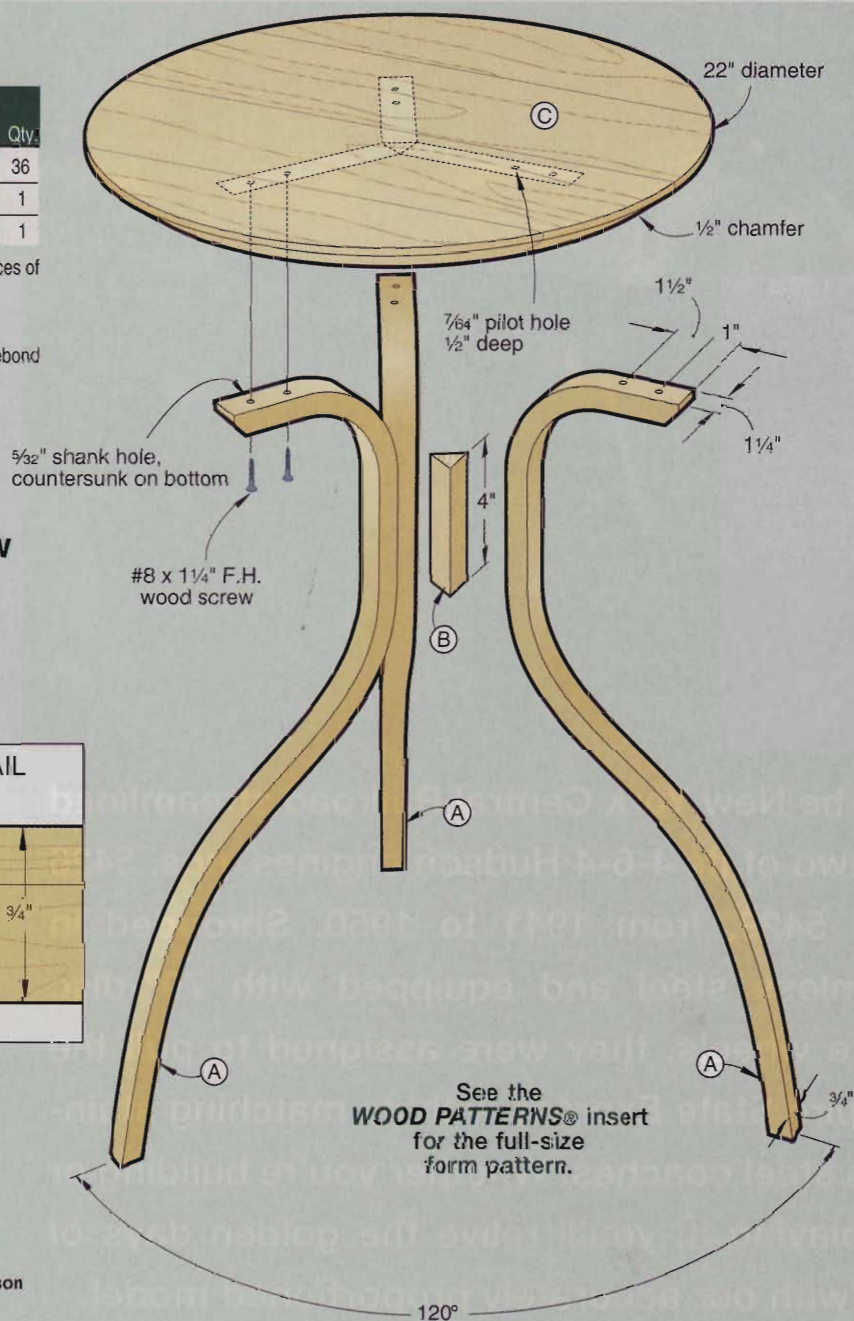
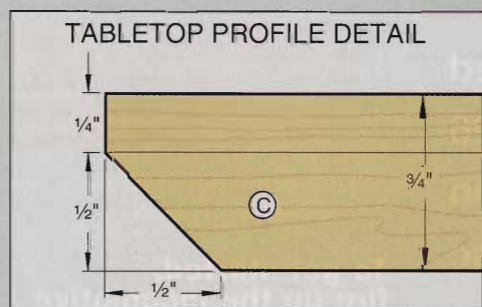

See the WOOD PATTERNS® insert for the full-size form pattern.

Written by Bill Krier with Charles I. Hecklund
Photographs: Baldwin Photography
Illustrations: Roxanne LeMoine; Lorna Johnson

the empire state



The New York Central Railroad streamlined two of its 4-6-4 Hudson engines, nos. 5426 and 5429, from 1941 to 1950. Shrouded in stainless steel and equipped with 79"-disc drive wheels, they were assigned to pull the Empire State Express with its matching stainless steel coaches. Whether you're building or displaying it, you'll relive the golden days of rail with our accurately proportioned model.

Note: This project calls for parts anywhere from 1/4" to 27/8" thick. We used 5/4 lumber, planing the thin pieces and laminating the thick ones. For best results, we finish-sanded each part to 220-grit before assembly.

To get started, fire up the locomotive

1 Laminate a 2x3x12" blank for the boiler (A), then plane and trim it to the size listed in the Bill of Materials. Make a copy of the Boiler (Front View) on the *WOOD PATTERNS*® insert, adhere it to the blank front with spray adhesive, and make a punch mark at the center of the radius. Draw pencil lines the length of the blank to define the tops

express

beauty, speed, and luxury on the
New York-Buffalo-Cleveland-Detroit route

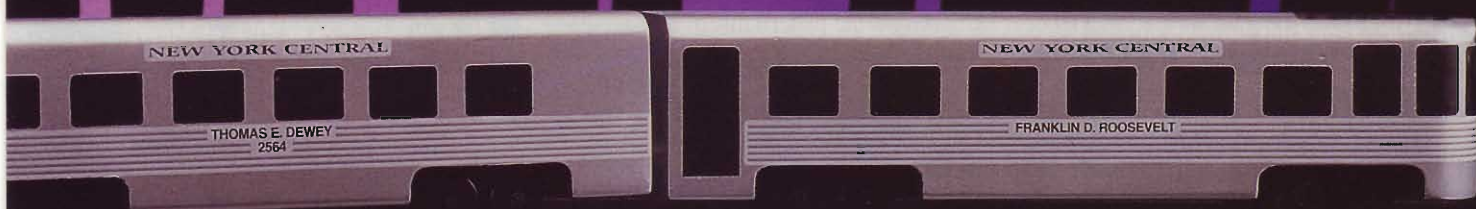

and bottoms of the curved sides. Rough out the boiler shape on your tablesaw by making six bevel rips, three on each side, in the waste area of the blank, that come within $\frac{1}{16}$ " of the pattern lines.

2 Make a copy of the Boiler Template on the pattern insert, adhere it to a piece of $\frac{1}{8}$ " hardboard, then saw and sand it to shape. Now, shape the sides of the boiler with a block plane and sandpaper, using the template to check your progress. Do not sand beyond the pencil lines drawn in *Step 1*.

3 Cut the running board (B) to the size listed, and sand the $\frac{1}{4}$ " radii on the front corners. Glue and clamp the boiler (A) to part B, centering A on the width of B, keeping the ends flush.

4 Laminate a $1\frac{1}{8} \times 2\frac{1}{2} \times 2\frac{1}{2}$ " blank for the nose (C). Mark the center, draw a $2\frac{1}{4}$ " circle using a compass, and band-saw just outside the line. Drill a $\frac{3}{8}$ " counterbore, $\frac{1}{4}$ " deep at the center, then drill a $\frac{3}{16}$ " hole, as shown on the Parts View drawing on the pattern insert.

5 Insert a #10x2" machine screw in the hole, and secure it at the back of the nose with a washer and nut. Chuck the protruding end of the machine screw into your drill press. Make a copy of the Nose Template on the pattern insert, adhere it to a piece of $\frac{1}{8}$ " hardboard, and saw and sand it to shape. Now, spinning the nose blank on your drill press, use a file and sandpaper to shape the nose, as shown in *Photo A*.

Continued



As you form the nose (C), check your progress with the template.



Use a handsaw to trim the nose (C) flush with the bottom of the running board.

6 Remove the machine screw arbor from the nose. Drill a pilot hole in the end of the boiler at the punch mark, apply glue, and screw the nose to the boiler, as shown on the Engine Exploded View drawing. The oversized shank hole in the nose allows for some adjustment of its position on the boiler.

7 When the glue is dry, trim the nose close to the surface of the running board, as shown in *Photo B*, then sand it flush. Glue a piece of $\frac{3}{8}$ " dowel, $\frac{7}{16}$ " long, into the counterbore.

8 Cut stock for the top shroud (D) to thickness and width, but $\frac{1}{4}$ " longer than the size listed. Drill the smokestack holes and radius the front end, as shown on the Parts View drawing on the pattern insert. Position the shroud (D) on top of the boiler (A) with the rounded end against the protruding back of the nose (C), mark the length of D flush with the rear of A, and trim it to final length. Glue and clamp D to A.

9 Cut a blank for the chassis (E) to the size listed. Make a copy of the



Form the pilot bumper (G) from a long blank, then cut it to length.

Chassis on the pattern insert, then adhere it to the blank. Drill the axle holes using your drill press. Cut the notches for the engine trucks (H) with your tablesaw using a dado blade, then cut the angle at the front. Set the chassis aside.

10 Laminate a $3 \times 3\frac{1}{2} \times 3\frac{1}{2}$ " block for the cab (F), and trim it to the size listed. Make copies of the Cab Side and Cab Front Views on the pattern insert, and adhere the patterns to the blank. Cut the centered groove. Start with a $\frac{1}{2}$ " dado blade in your tablesaw adjusted to cut $\frac{1}{8}$ " deep. Position the fence $\frac{1}{16}$ " from the blade and make two passes, one from each end of the blank. Check the fit of this groove on the chassis (E), then "sneak up" on the exact groove width by making small adjustments to the position of the fence, cutting from both ends of the blank with each adjustment. When you are satisfied with the fit, cut the groove to full depth, proceeding carefully in $\frac{1}{8}$ " increments.

11 Shape the curved roof of the cab by sanding to the pattern line with

your disc sander. Chuck a chamfer bit in your handheld router, and form the chamfers on the cab front, following the pattern.

12 Form the cutout at the back of the cab by bandsawing, then sanding to the pattern line. Sand the radii on the back edges of the roof. Now, glue and clamp the back end of the chassis, making certain the back end of the chassis is flush with the back of the cab.

13 Drill the pilot and countersunk shank holes, where shown on the Engine Section View drawing, and glue and screw assembly A/B/C/D to assembly E/F, aligning the edges of the running board with the sides of the cab. Center the front of the chassis on the width of the running board.

14 Prepare a blank for the pilot bumper (G) the thickness and width listed in the Bill of Materials, but for safe handling, make it 10" long. Rout $\frac{1}{2}$ " round-overs on the top edges. Using a 1"-diameter sanding drum, form two radius-end notches, as shown on the Parts View drawing on the pattern insert. Cut a 30° bevel at this end, then bevel-cut the pilot bumper to length, as shown in *Photo C*. Glue and clamp G to the front of E.

15 Cut the engine trucks (H) to size, and drill the axle holes, where shown on the Engine Exploded View drawing. Drill the pilot and countersunk shank holes, and glue and screw the trucks in place.

16 Cut a $1\frac{1}{16} \times 1 \times 6$ " blank for the cylinder mounts (I). Bevel rip it to the profile shown on the Parts View drawing on the pattern insert, then cut off two 1" lengths. Glue and clamp one mount to each side of the chassis, as shown on the Engine Exploded View drawing, centered above the front truck.

Continued

ENGINE SECTION VIEW

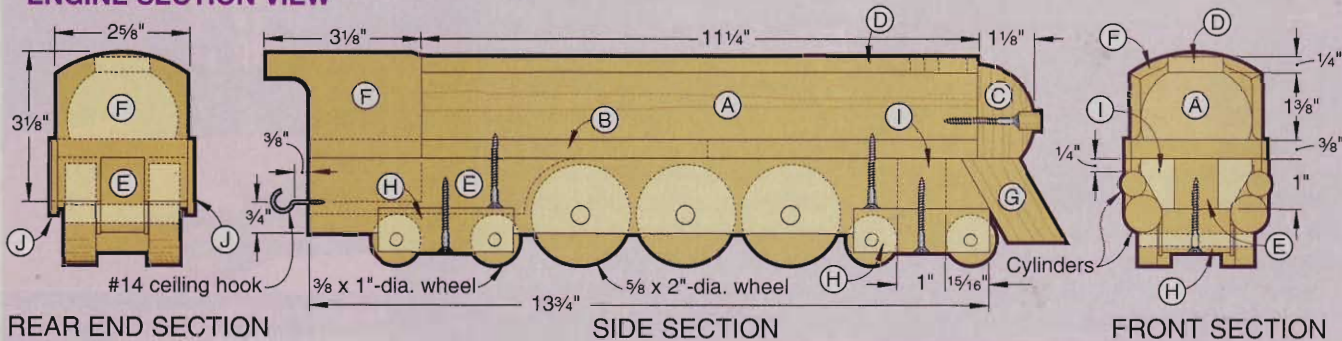

ENGINE EXPLODED VIEW

3/8" counterbore 1/4" deep with a 5/32" hole centered inside

#8 x 1 1/2" F.H. wood screw

3/8" dowel 7/16" long

30° bevel
1/2" round-overs
30° bevel

1/16" chamfers on both ends

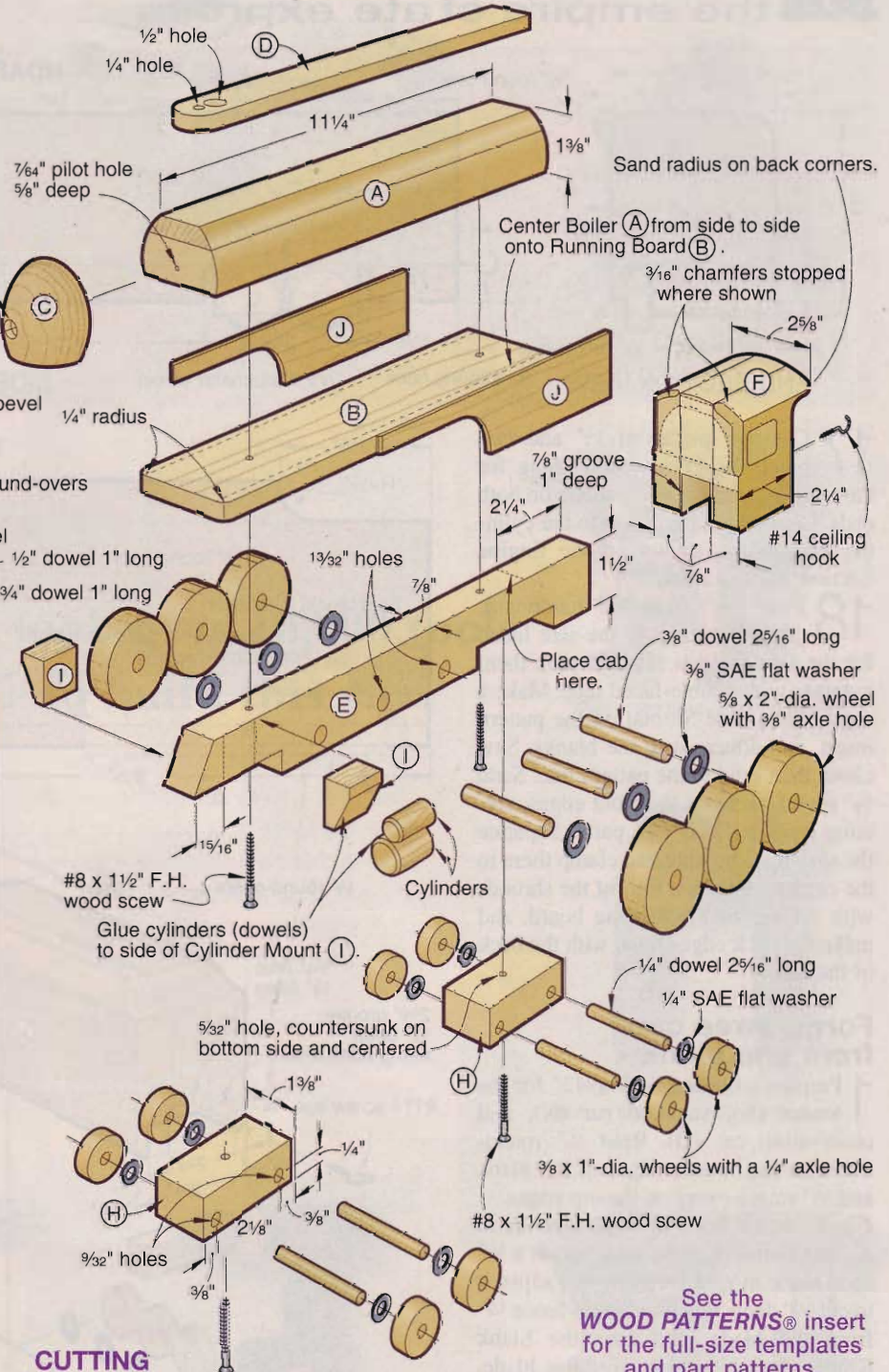

BILL OF MATERIALS

Part	finished size			Mtrl.	Qty.
	T	W	L		
A boiler	1 3/8"	2 1/4"	11 1/4"	LP	1
B running board	3/8"	2 5/8"	11 1/4"	P	1
C nose	1 1/8"	2 1/4" diameter		LP	1
D* top shroud	1/4"	1 1/8"	11 1/4"	P	1
E chassis	7/8"	1 1/2"	13 3/4"	P	1
F cab	2 5/8"	3 1/8"	3 1/8"	LP	1
G* pilot bumper	1"	2 5/8"	2 1/2"	P	1
H engine trucks	7/8"	1 3/8"	2 7/8"	P	2
I* cylinder mounts	1 1/16"	1"	1"	P	2
J side shrouds	1/8"	1 1/2"	8"	H	2
K** tender	2 1/8"	3 1/4"	9 7/8"	LP	1
L tender skirt blocks	1/2"	5/8"	2 3/8"	P	2
M tender trucks	7/8"	1 3/8"	3 3/4"	P	2
N** standard car	2 1/8"	3 1/4"	14"	LP	1
O** observation car	2 1/8"	3 1/4"	15"	LP	1
P** car skirt blocks	5/8"	1 1/2"	2 3/8"	P	8
Q** car trucks	7/8"	1 3/8"	2 1/2"	P	4

*Parts initially cut oversize.

**Multiple parts cut from a longer blank.

Materials Key: LP—laminated poplar, P—poplar, H—tempered hardboard

Supplies: 1/4" dowel (48"), 3/8" dowel (12"), 1/2" dowel (6"), 3/4" dowel (6"), 1/4" SAE flat washers (36), 3/8" SAE flat washers (6), #8x1 1/2" flathead wood screws (13), National #14 ceiling hooks (3), National #114 screw eyes (3), spray primer and paint, masking tape.

Buying Guide

Hardware kit: 1x3/8x1/4"-bore flat wood wheels (36), 2x3/8x3/8"-bore flat wood wheels (6), 1x3" adhesive labels (4), 7/8x1 1/4" adhesive labels (33), 1/4" round adhesive labels (18), water-transfer decals. Order kit #TRN, \$19.95 ppd. from Schlaubaugh and Sons Woodworking, 720 14th Street, Kalona, IA 52247, or call 800/346-9663.

CUTTING DIAGRAM

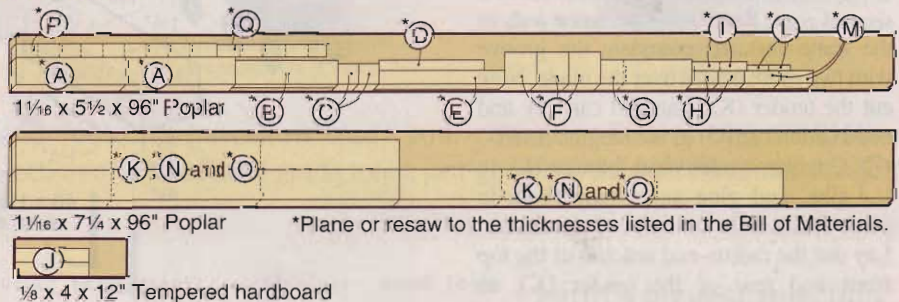

See the **WOOD PATTERNS®** insert for the full-size templates and part patterns.

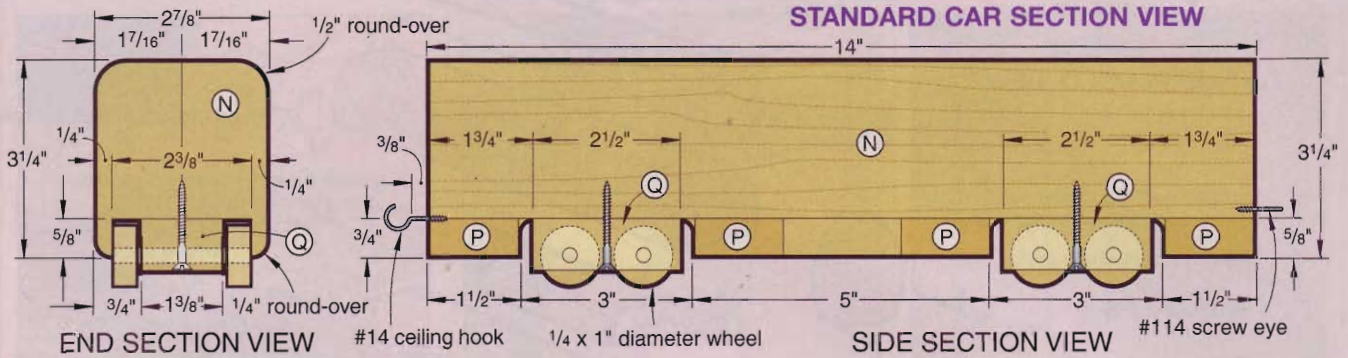

17 Cut two pieces of 1/2" and two pieces of 3/4" dowel 1" long for the cylinders, and sand chamfers on both ends. Glue and clamp them to the cylinder mounts, as shown on the Engine Section View drawing.

18 From 1/8" tempered hardboard, cut two blanks to the size listed for the side shrouds (J), and stick them together with double-faced tape. Make a copy of the Side Shroud on the pattern insert, and adhere it to the blanks. Saw close, then sand to the pattern line. Sand 1/8" round-overs on the front edges, creating right and left side parts. Separate the shrouds, and glue and clamp them to the engine. Align the tops of the shrouds with the top of the running board, and make the back edges flush with the back of the cab.

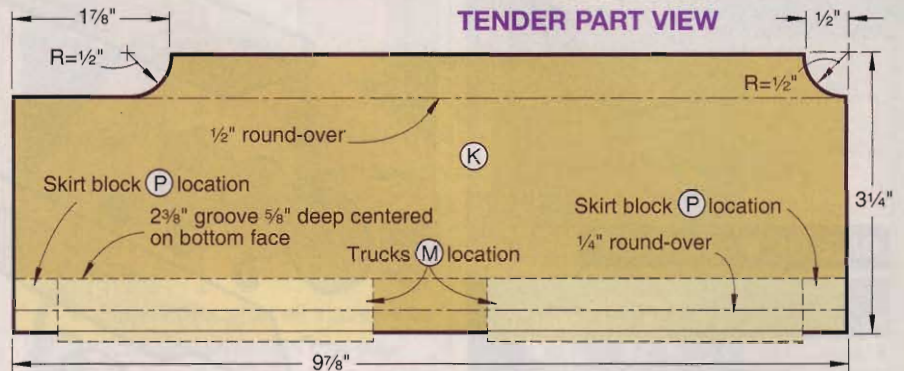

Forge three cars from one blank

1 Prepare a blank 2 7/8 x 3 1/4 x 42" for the tender (K), standard car (N), and observation car (O). Rout 1/4" round-overs on the bottom edges of the blank and 1/2" round-overs on the top edges.

2 To make the 2 3/8" wide grooves in the bottoms of the cars, install a 3/4" dado blade in your table saw and adjust it to cut 5/8" deep. Position the rip fence 1/4" from the blade, and pass the blank K/N/O, bottom down, over the blade. Rotate the blank end-for-end and make a second pass. Reposition the fence and, in the same manner, complete the groove with two more passes over the blade. Now cut the tender (K), standard car (N), and observation car (O) to the lengths listed.

3 Cut the tender skirt blocks (L) to size, and glue and clamp them in place flush with the ends of the tender. Lay out the radius-end notches at the top front and rear of the tender (K), as

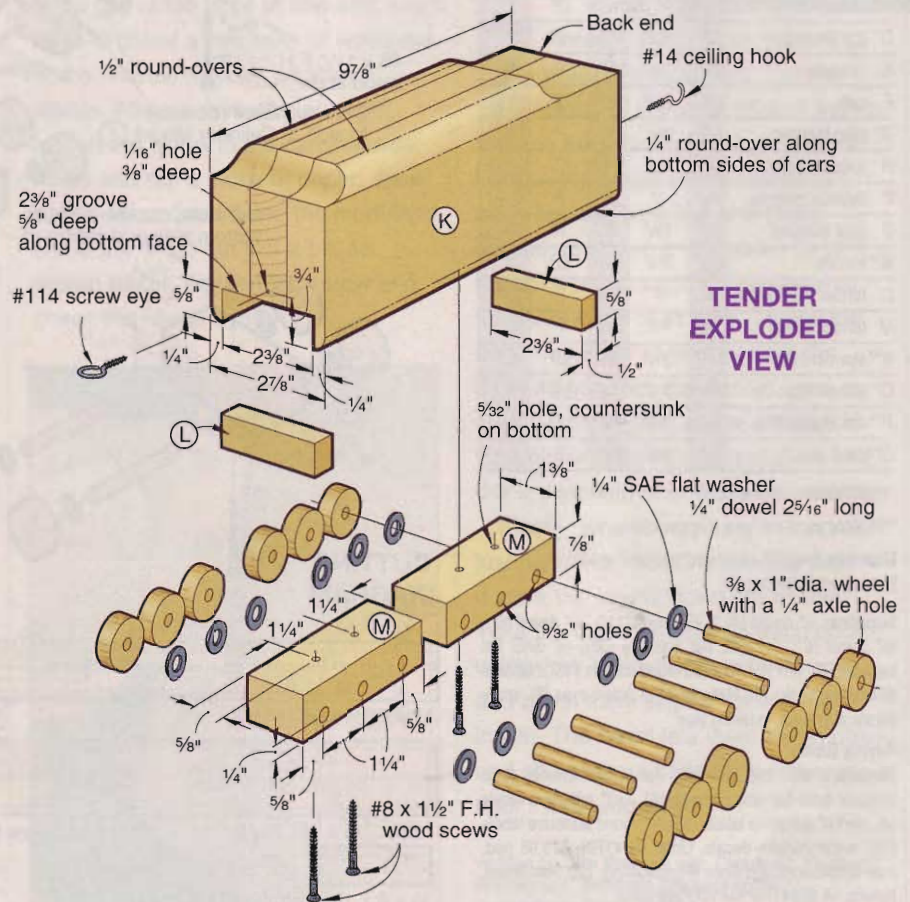

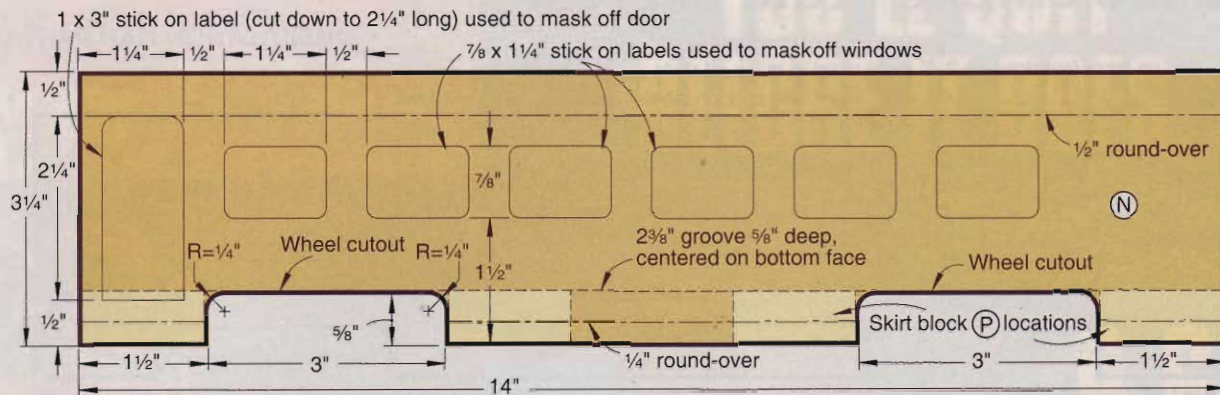

STANDARD CAR PART VIEW

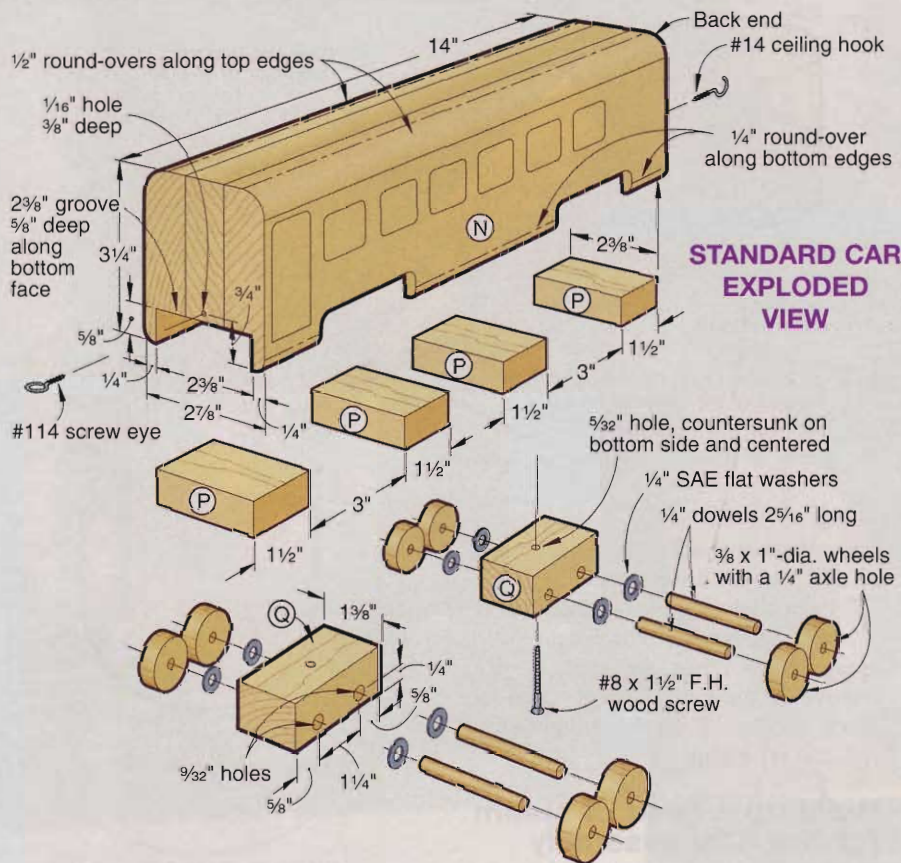

STANDARD CAR EXPLODED VIEW

shown on the Tender Part View drawing. Bandsaw the waste, then clean up the cuts with a 1" sanding drum.

4 Cut the tender trucks (M) to size, and drill the axle holes, where shown on the Tender Exploded View drawing. Position the trucks centered side-to-side in the bottom groove, as shown on the Tender Part View drawing. Drill the pilot and countersunk shank holes, and set the trucks aside.

5 Prepare a $5/8 \times 1 1/2 \times 22$ " blank for the car skirt blocks (P), then cut eight

blocks to length. Glue and clamp a block in each end of the bottom groove in the standard (N) and observation (O) cars, where shown on the Standard Car Section View drawing. Cut 3"-long spacers to position the inboard pair of skirt blocks on each car, then glue and clamp these skirt blocks in place.

6 Rough out the wheel cutouts, defined by the bottom of the groove and the two skirt blocks, on the standard and observation cars with your bandsaw. Clean up the rough cut, and neatly

form the radius corners with a $1/2$ " sanding drum.

7 Prepare a $7/8 \times 1 3/8 \times 12$ " blank for the car trucks (Q), then cut four trucks to length. Drill the axle holes, where shown on the Standard Car Exploded View drawing. Center the trucks in the width and length of the wheel cutouts, drill pilot and countersunk shank holes, and screw the trucks in place.

8 Draw the radius at the end of the observation car (O), where shown on the Round-Over detail of the Observation Car Exploded View drawing. Bandsaw, then sand to the drawn line. Mark the centerline for the tail light and the flanking lines, where the round-overs stop. Extend the top round-overs to the marked lines and the bottom round-over all the way around the end. Drill the hole for the taillight.

9 Cut 18 pieces of $1/4$ " dowel and three pieces of $3/8$ " dowel $2 5/16$ " long for the axles. Round the end of the left-over piece of $3/8$ " dowel, cut a $7/16$ "-long piece for the taillight, and set it aside. Drill the pilot holes for the ceiling hooks and screw eyes, where shown on the Engine and Car Section View drawings.

To the roundhouse for paint

1 Prime all parts and assemblies. We used Krylon 1314 Platinum spray primer. Before painting, glue one wheel onto each axle so the ends of the axles and the faces of the wheels are flush. (See the Buying Guide for our wheel source.) Dry fit wheels in the same manner on the other end, and mask the axles between the wheels. After the primer and each successive coat of paint is dry, rotate the dry-fit wheel to make sure the paint does not seal it in place.

Continued



OBSERVATION CAR PART VIEW

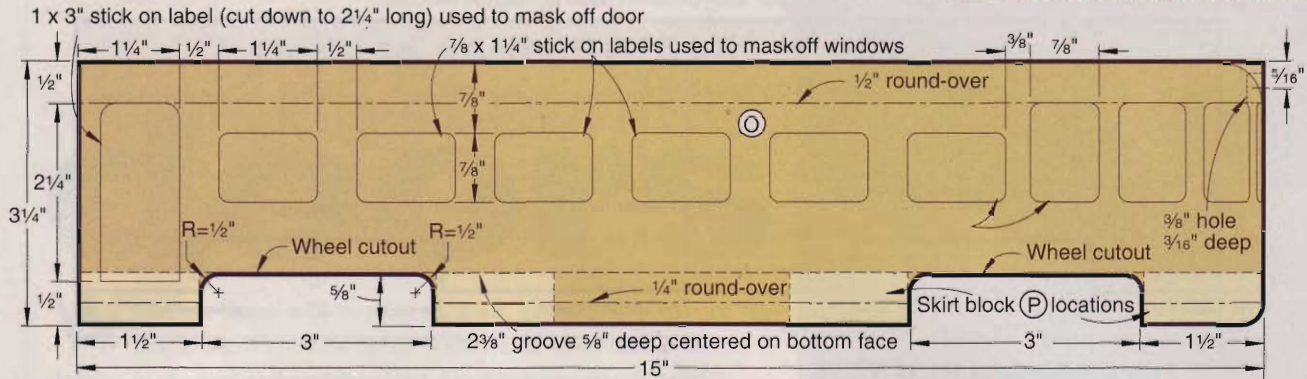

2 Paint the entire engine, sides and wheel areas of the cars, tender trucks, and all the wheels black. We used Krylon 1613 Semi Flat Black spray paint. Before masking the parts with tape and labels in the following steps, allow the paint to dry for 24 hours.

3 Cut four 1x3" labels to 2 1/4" long, and adhere them to the standard and observation cars, where shown on the Standard and Observation Car Part View drawings. (We used Avery 06603/ES-1648 removable adhesive labels purchased from an office supply store, or see the Buying Guide.) The opposite sides are mirror images of the ones shown.

4 Apply a strip of masking tape to the sides of the cars so the top edge of the tape is 1 1/2" from the bottom. Now, mark the locations of the windows on the tape, and adhere 7/8x1 1/4" labels (Avery 05432/SI420). To evenly space the vertical windows that wrap around the end of the observation car, adhere the first vertical label at each side, and one label centered at the rear. Divide the remaining spaces evenly, and adhere the last four labels, two on each side. Mask the wheel areas of the cars.

5 Mask the top shroud (D); the bottom half of the boiler (A), going under the bottom half of the headlight; the top surface of the running board (B), leaving the edges exposed; the pilot bumper (G); and the entire undercarriage of the engine, including the cylinders. Apply one label on each side of the cab, where shown on the pattern insert.

6 Wrap masking tape around the "tread" surface of the large drive wheels. Make a copy of the Driver Template on the pattern insert, and cut out the three small circles. Use this copy

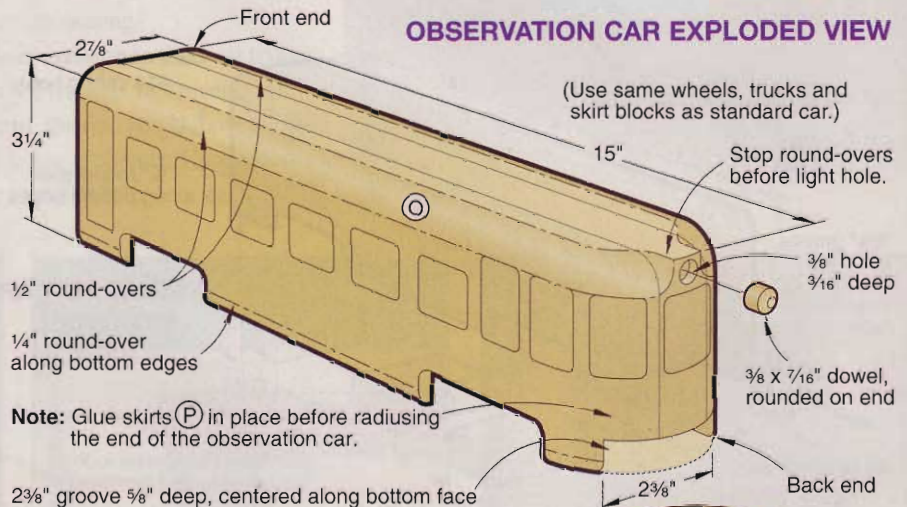

for positioning adhesive dots (Avery TD5737) on the drive wheels.

7 Paint all the exposed surfaces silver. We used Krylon 1406 Bright Silver spray paint. When the paint is dry, remove the masking and peel off all the labels and dots. Paint the taillight gloss red, and set it aside.

Build up a head of steam for the final assembly

1 Remove the dry-fit wheels from the axles. Slide washers onto the axles, insert them in the trucks, add another washer, and glue the second wheel onto each axle. (We used SAE washers for a better fit on the axles and smaller outside diameters.) Screw the completed tender trucks to the bottom of the tender. Glue the taillight to the observation car.

2 Screw the ceiling hooks and screw eyes into the previously drilled pilot holes in the engine, tender, and cars. Let 3/8" of the straight shank of the hook protrude from the rear of the engine, but

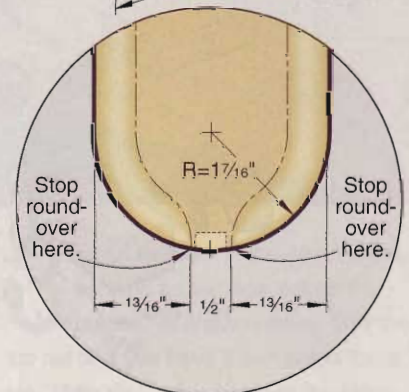

ROUND-OVER DETAIL (TOP VIEW)

run the hooks in the tender and standard car in all the way to the bend of the hook. Screw the eyes in all the way to the loop.

3 If you purchased the decal set (see Buying Guide), apply them according to the instructions.

Written by Jan Hale Svec with Jim Boelling
Project Design: Jan Hale Svec
Illustrations: Kim Downing; Lorna Johnson
Photographs: Hetherington Photography; Baldwin Photography

how to get
started in

biscuit joining

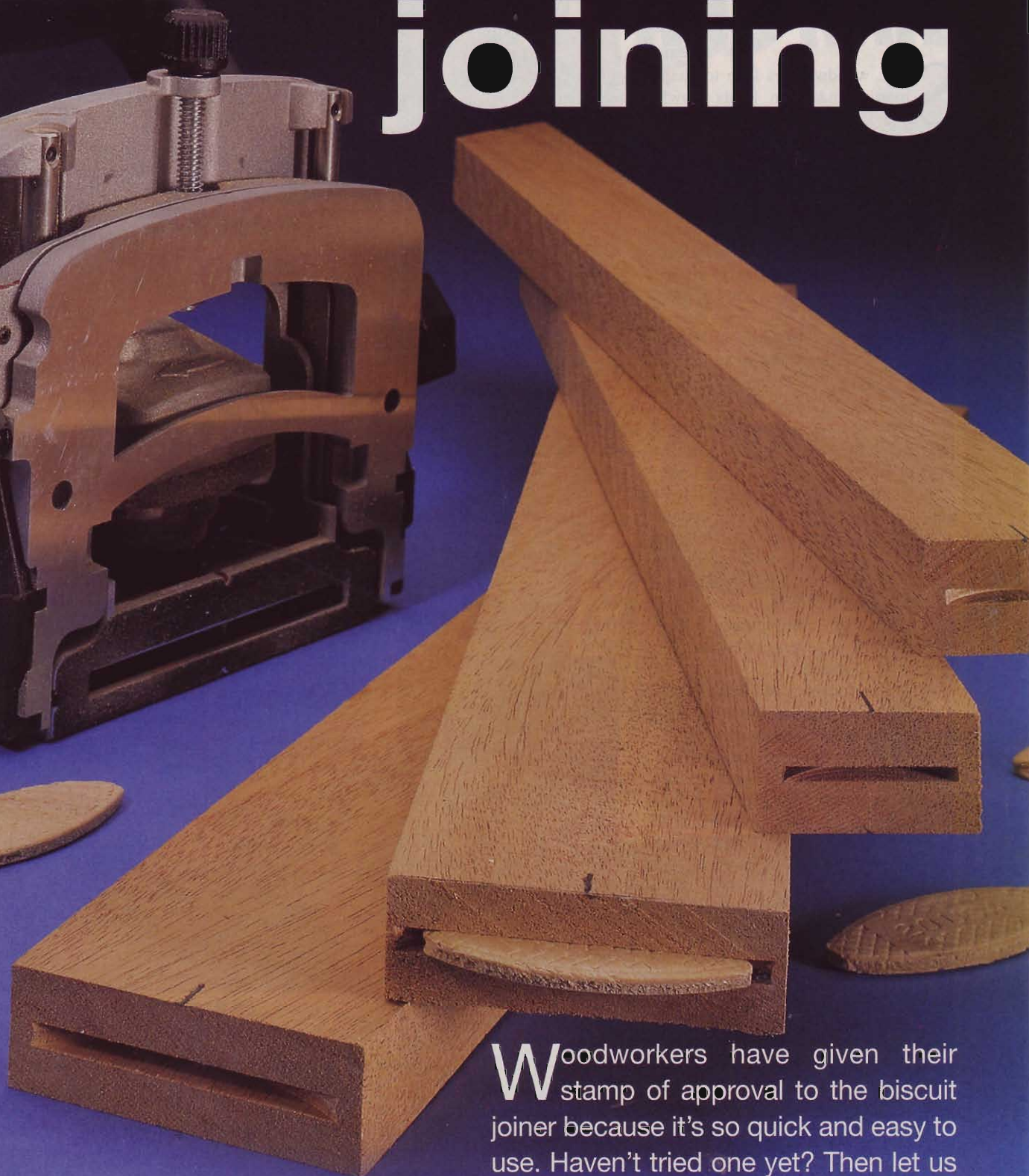

Woodworkers have given their stamp of approval to the biscuit joiner because it's so quick and easy to use. Haven't tried one yet? Then let us show you how it can become one of the handiest tools in your shop.

biscuit joining

Some woodworkers love to shape mortise-and-tenon joints slowly and lovingly. Some could never give up their doweling jig because it's the one Dad taught them to use. But an awful lot of woodworkers grab hold of the biscuit joiner at every opportunity.

The biscuit joiner, or plate joiner, does two things, and it does them in a hurry. It helps you align parts as you glue them together, plus it adds strength to the joint.

With its fence in the vertical position, a biscuit joiner can cut in the middle of a large workpiece. With the fence extended at a right angle, you set it to cut slots that match exactly from one board to the next. Or you can set the fence at other angles for mitering tasks.

A 4" circular blade cuts a half-oval slot when you switch on the power and push the tool body forward into your workpiece. Then cut an identical slot on a mating piece and you've created a football-shaped opening to hold a biscuit made of compressed beech. Biscuits come in several sizes, and you set the tool to match.

The major drawback of biscuit joiners is that many of them can't use a biscuit shorter than $1\frac{3}{16}$ ", which means your workpiece must be more than 2" wide. That's a problem when it comes to face frames. However, you can buy full-sized biscuit joiners that work with $1\frac{1}{2}$ "-wide stock, or smaller "detail" biscuit joiners that are designed to install biscuits as short as $\frac{3}{8}$ ".

A good biscuit joiner plunges smoothly into the workpiece, has plenty of power to make the cut, and blows the chips and dust into an attached cloth bag. Its blade cuts a slot that's precisely the right size for the biscuits. Its fence adjusts quickly and accurately on a rack-and-pinion mechanism.

See the tool review in *WOOD* magazine issue 117 for our ratings of several models. In the meantime, let's look at the basics of biscuit joinery.



Go right to the edge

Many woodworkers start right here with their biscuit joiners: edge-joining boards to make a wider workpiece. Just place the two boards together, making sure you have flat edges and a good grain match. Then draw lines across the joint to mark the locations for biscuit slots. They don't have to be evenly spaced or drawn with any great precision. The only caution: Keep the biscuits back from the ends if you plan to trim the

glued-up piece or put an edge profile on it. Biscuits are utilitarian, not decorative; you don't want them showing on a completed project.

A rubber pad on your workbench, as shown in *Photo A*, helps hold long boards in place. We pressed down on the joiner's extended fence with a jointer pushblock for extra safety. Use No. 20 biscuits, the largest size available for most of these tools.

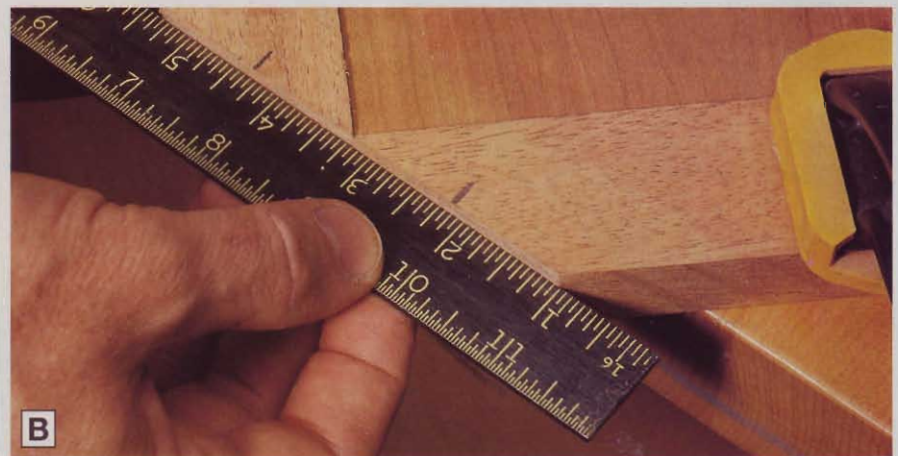

Mighty fine miters

For flat mitered joints, arrange the two halves as shown *Photo B*. A thinner piece of wood or plywood, cut at 90° and placed behind them, helps with alignment. Place your two workpieces against that guide with points touching, clamp them in place, and make a mark

in the middle of each mitered surface.

Make sure you've chosen a slot size that will stay within the workpiece. Then go ahead and cut your slots. As you work on one piece, the adjacent piece provides support for the biscuit joiner's fence.

Modify your joiner for 45° cuts

You say your biscuit joiner fence can't "capture" a 45° angle, but you wish it could? *WOOD*® magazine Senior Design Editor Jim Downing whipped up a quick and easy solution for you. Check it out in *Photo C*.

The drawing, *bottom*, shows you how to make a 45° adapter that attaches to your joiner's fence with two machine screws. We used Baltic birch, but any sort of plywood or solid wood will serve the purpose.

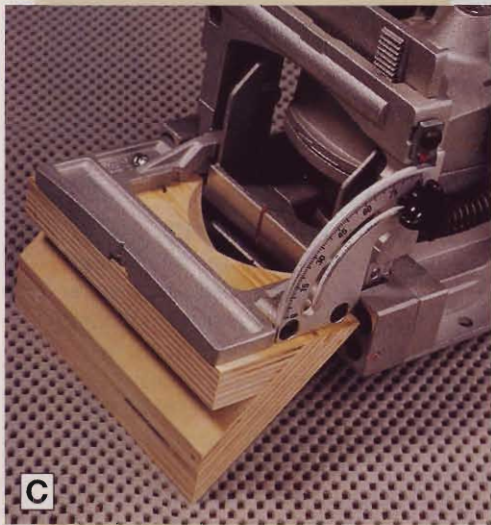
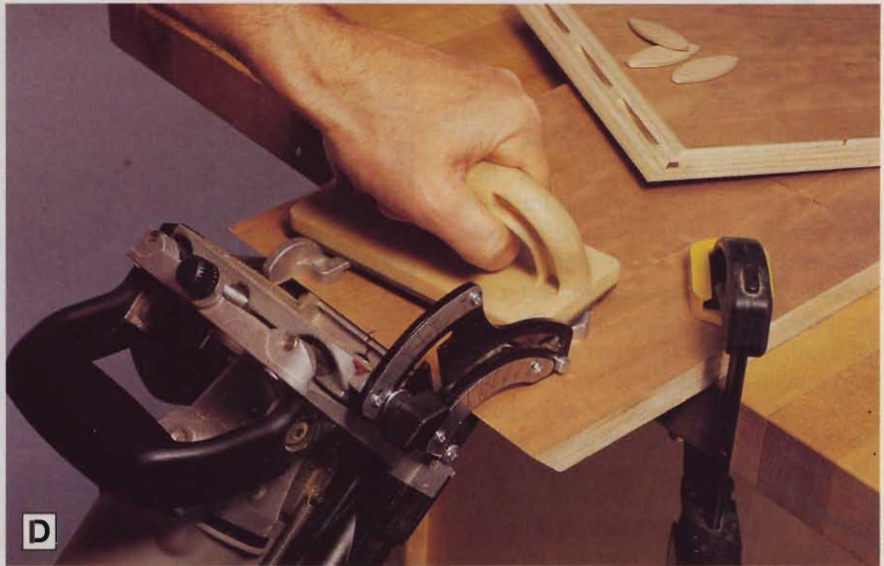

45° BEVEL ADAPTER

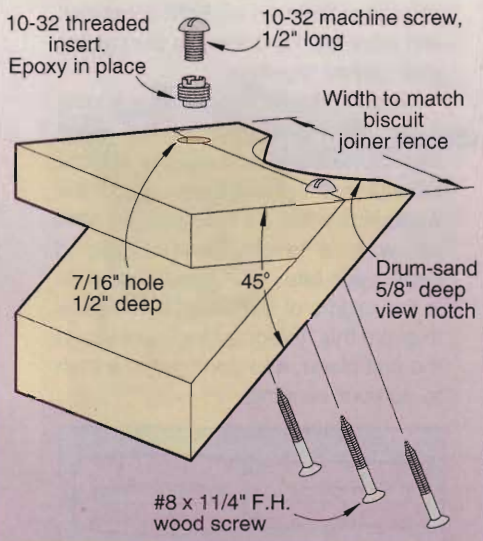

Make the vertical leap

Many a butt joint comes into existence because somebody lacked the confidence to assemble a vertical miter joint. The biscuit joiner can supply some of the necessary confidence.

This would be an excellent time to double-check your table saw's 45° setting and make sure the fence sits exactly parallel with the blade. Once you have cut the miters as accurately as possible on your saw, hold the two sides of the joint together and make your guide marks on the outside surfaces.

Some biscuit joiners are designed to hold a 45° angle between the solid front and the adjustable fence. If your model fits that category, clamp one side of the joint as shown in *Photo D*. The inside surface of the joint faces down.

Adjust your biscuit joiner to cut the slots near the inside of the joint, not in the middle of the workpiece as usual. Doing this eliminates the risk of cutting clear through the wood.

Some biscuit joiners cut into miters with their fence set at 135°. In this case, make your guide marks on the inside of the joint and clamp the workpiece with the inner surface of the joint facing up, as shown in *Photo E*.

This rates as a less precise arrangement than the previous one, so apply extra pressure to the fence with a push block and proceed carefully. If you'd like to modify your tool to cut the other way, see the sidebar at *left*.

Continued

biscuit joining

No-fuss face frames

A mortise-and-tenon joint might offer more strength when it comes to face frames, but biscuits supply all the holding power you need for most projects. Unfortunately, the small work surface can cause problems when you cut a slot near the end of a stile or in the end grain of a rail. Your biscuit joiner must sit flat and remain in position to cut neat slots.

We not only clamped a block against the workpiece to hold it in place, as seen in *Photo F*, we also clamped the biscuit joiner's fence directly onto the rail and the workbench underneath. The workpiece stays put and so does the tool.



Outstanding in the field

This technique helps you lay out biscuit joints in the field of your workpiece, well away from the edge. In the example shown in *Photo G*, we've prepared to place a leg and rail assembly in the mid-

dle of a board. Set the assembly in place, then use masking tape and a square to make your guide marks. Cut the field slot with the biscuit joiner held vertically, fence retracted.

Allow for swelling

Biscuits are made of compressed beech wood, and something happens to them when they contact moisture: They swell up, as shown in the drawing *below*. Nestled in their slots, absorbing moisture from glue while the joint dries, they create a tighter, stronger joint.

Problems arise, however, if biscuits take in enough moisture from humid air to swell before you get the joint assembled. Make it a habit to keep your biscuits in an air-tight container, and work quickly once you start gluing your project together.

When a biscuit swells inside a joint, it can lift the surface of the wood slightly. As the glue dries, the surface flattens out again. If you sand the workpiece while it's swollen, you wind up with a slight, biscuit-shaped depression later on. So cut your slots in the middle of the board's thickness to avoid this "telegraphing" problem in the first place, and don't get in a rush to do your sanding.

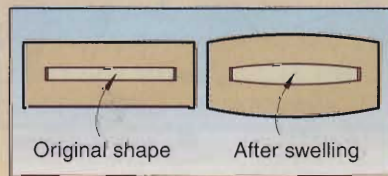



Slick shelves, quick carcases

Biscuits really speed the assembly of shelves or plywood carcases, especially when you use the simple layout technique shown in *Photos H and I*. After deciding the spacing of your shelves, hold one shelf in place and mark its position on the carcass, making your mark against the far side of the shelf. Tilt the

shelf away from yourself and lay it on the carcass, keeping its edge right at the pencil mark.

Align the two pieces exactly, then clamp them together and to your workbench. Mark the biscuit locations on the exposed side of the shelf. Now cut matching slots in both pieces, using your

pencil marks as guides for both the horizontal and vertical actions.

Your biscuit joiner should have a guide mark on the front and bottom of its fence. If the mark on the bottom is too short to show above the board, extend it with a square and a felt-tip marker or a sharp grease pencil. 🌲

Take care of every little detail

The detail joiners we've tested can't deliver the performance quality of the best full-sized tools, but they can come in handy. *Photo J* shows just how small you can go with biscuit joinery; the R1 biscuit between the mitered corners measures $\frac{5}{8}$ " , and so does the stock. Keep that in mind when you set out to make delicate picture frames or lids for jewelry boxes.

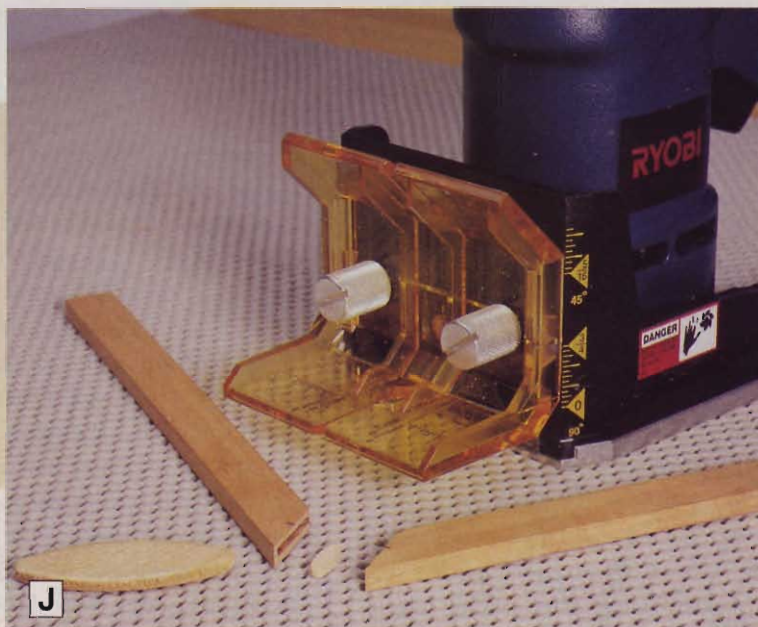

Written by **Jim Pollock**
 Photographs: **Baldwin Photography**
 Illustrations: **Roxanne LeMoine**

The power of a spindle sander in the palm of your hand

You know how the up-and-down motion of the drum makes an oscillating spindle sander more aggressive than a drill-press mounted drum. Thanks to Porter-Cable's model 121 sander, shown at *right*, you can now take that tenacity to a large or fixed workpiece.

Like the table of a benchtop sander, the 5 $\frac{1}{8}$ ×9 $\frac{5}{8}$ " base of the model 121 keeps the spindle perpendicular to your workpiece for sanding edges squarely. In fact, you can mount the 121 in your router table and use it as a benchtop spindle sander. (For \$15, Porter-Cable sells an adapter to bolt the tool to their model 698 router table; the adapter's mounting-hole pattern matches their 690-series routers.)

We attached the model 121 to a 11 $\frac{1}{4}$ ×8 $\frac{1}{4}$ " blank phenolic insert with only one hitch: We had to bore the spindle hole off-center in the insert so that the body of the sander would fit through the hole in our router table.

Whether you table-mount the model 121 or use it handheld, its 6-amp motor offers something I've not seen on any spindle sander: variable speed. The body-mounted dial controls both drum speed (2400–3600 rpm) and stroke speed (40–60 oscillations per minute) simultaneously. I got very good results at any speed, but at low speed, I found the model 121 more controllable than benchtop units I've tested.

Besides helping smooth curves, the model 121's split fence also helps you sand straight. Like the tables of a jointer, I offset the outfeed end of the fence slightly to remove a very small amount of material and smooth-up and straighten a rough edge.

The model 121 also comes with a dust-collection nozzle that mounts to the snout of the machine and fits a 1" vacuum hose. I was skeptical of its effectiveness, but it did a surprisingly good job of gathering up the dust.



If you already have 4 $\frac{1}{2}$ " sanding drums and sleeves, you can use them on the model 121. The base opening accommodates drums up to the 2"-diameter drum that comes with the sander. You may need to borrow the drum-changing wrench from your benchtop spindle sander as well: The model 121 doesn't come with one.

—Tested by Dave Henderson

PRODUCT SCORECARD

Porter-Cable model 121 Oscillating Spindle Sander

Performance	★★★★★
Price	\$250
Value	★★★★☆

Call Porter-Cable at 800/487-8665 or visit www.porter-cable.com.

Smooth convex and concave surfaces with 3D Sander



Let's get this out of the way right off the top: Craftsman's 3D Sander looks like an electric shaver. I just wish my razor left my face as smooth as the 3D Sander leaves my workpiece.

This German-made, variable-speed sander features three sanding platens

that pivot independently to conform to convex, concave, or even compound curves. In theory, you can sand any concave surface with a 4" or more radius. But that tight a curve pushes the sanding discs to their edges.

Although designed for curves, I was surprised to find how smooth and scratch-free the 3D Sander left flat workpieces. Each 1 $\frac{5}{8}$ " hook-and-loop abrasive ring has a $\frac{3}{4}$ " hole in its center. With no grit in the middle of the pad, where it moves slowest, this sander simply does not leave swirl marks. And, with three rotating pads, each pad tends to wipe out any scratches from the pad before.

So how aggressive is this lightweight tool (it tips the scales at just

over a pound)? Using 240-grit discs, I was amazed at how quickly and controllably the 3D Sander flattened flush-sawn dowel plugs.

I found the same speed and control sanding the curved feet of a workbench I'm building. And, as a bonus, the 3D Sander's smaller-diameter discs allowed me to sand much closer to inside corners than my 5" random-orbit sander.

—Tested by Bob McFarlin

PRODUCT SCORECARD

Craftsman 3D Sander 11633

Performance	★★★★★
Price	\$50; \$6 for 21 abrasive rings in 240-, 150-, or 100-grit (28253).
Value	★★★★★

Available in November at Sears, or at 800/377-7414.

Continued on page 94

Continued from page 90

Get every last drop with Drip-It

Call me impatient, but when I'm in the middle of a project I find it easier to open a new bottle of glue than to wait for the last of the glue in the old bottle to crawl out. Eventually, I either throw away the old bottle (and the glue inside) or try to top off the new bottle with the remainder of the old glue. The latter invariably requires an elaborate system of props to keep the bottles from falling and spilling glue all over my benchtop.

PRODUCT SCORECARD

Drip-It No Waste Funnel

Performance	★★★★★
Price	\$7
Value	★★★★★

Call Cumberland Concepts toll-free at 877/437-4748. Or visit www.cumberlandconcepts.com.

But the Drip-It No Waste Funnel makes transferring liquids a virtual no-brainer. I clipped this simple gadget to the slightly used (bottom) glue bottle as shown at *right*, positioning Drip-It's funnel in the bottle neck. Next, I clipped the nearly-empty bottle over the funnel. Within a few minutes, the glue from the top bottle had drained into the bottom, cleanly and completely.

For refilling small bottles from an economy-size bottle, I clipped the funnel to the small bottle, swung the top clip out the way, and filled through the funnel. The clip kept the funnel out of the glue, while keeping both of my hands free to manhandle that big bottle.

For the price, I'd keep a couple on hand in the garage for transferring



motor oil and such. I expect you'd want one in the kitchen, too, to get the last of the ketchup or salad dressing.

—Tested by Randy Zimmerman

Continued on page 96

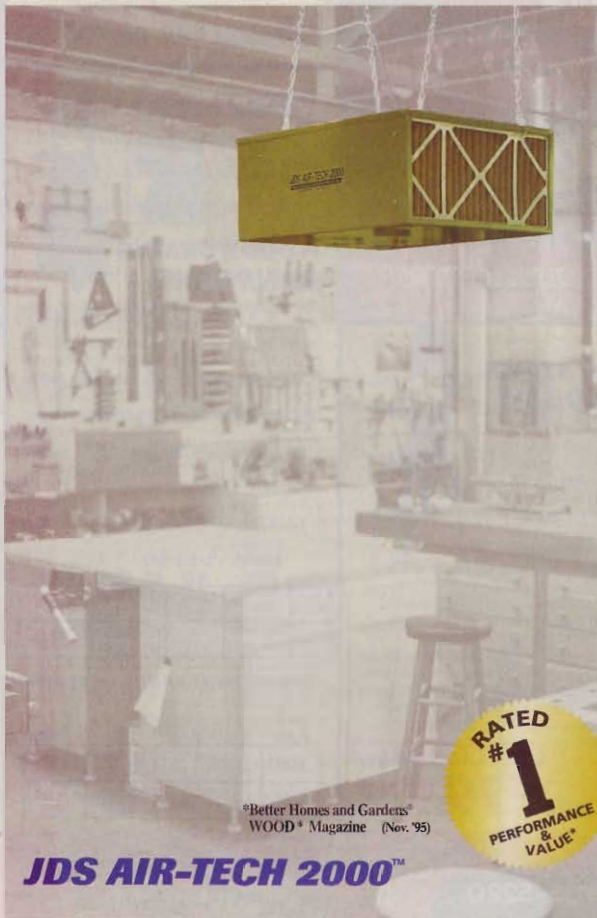

Let's Clear the Air...

JDS AIR-TECH 2000™

Model 750, Still the Best!

- Variable Speed Control for unlimited air flow settings
- Highest Maximum air flow in its class - 1,050 CFM
- Convenient On/Off pull chain
- Ultra Quiet
- 1/4 H.P. Motor for heavy duty performance
- Antimicrobial 1 Micron Internal bag filter
- UL Listed
- Lifetime Warranty

The National Institute for Occupational Safety and Health (NIOSH) recommends limiting wood dust exposures. The JDS Air-Tech 2000 will dramatically improve the quality of the air you breathe. Our new model 750 variable speed allows you to dial in your desired air flow, from a whisper quiet 200 cfm to an ultra performance 750 cfm. This will clean the air in a 30'x30'x8' shop every ten minutes. For larger areas our models 8-12, 10-16 and 2400 are available. The JDS systems will remove 99% of particles as small as five microns and 80% of particles as small as one micron. For the removal of odors, fumes and smoke, our optional charcoal filter is available. To place an order or for the dealer nearest you call us toll-free.

\$259.00

Model 750

Another quality product from

1-800-382-2637

Manufactured in the U.S.A.

www.thejdscompany.com



®Better Homes and Gardens®
WOOD® Magazine (Nov. '95)

JDS AIR-TECH 2000™

VAN DYKE'S RESTORERS

SUPPLIES FOR WOODWORKERS AND ANTIQUE RESTORERS



Visit us at www.vandykes.com



Over 8,000 Items

- Featuring the industries largest selection of:
- Furniture Components
 - Veneers, Carvings and Moldings
 - Furniture Kits
 - Hardware

Free catalog!

Call 1-800-558-1234
Or Write

Dept. 60040 PO Box 278 Woonsocket, SD 57385

Circle No. 2077

Fisch BENCH TOP MORTISER

From the company that provides the highest quality mortising chisels & bits, comes a mortising machine with the same outstanding quality, precision and accuracy you have come to expect from Fisch Precision Tools. This heavy duty dedicated mortiser will handle all your mortising jobs with the ease.

- Double post columns add stability
- Adjustable cushioned grip handle
- Indelible metal lock knobs
- Micro adjustable fence
- Adjustable depth stop
- Spring loaded return
- Convenient tool holder
- 1/2 hp motor
- 2-year warranty

Patents Pending



Dealers Welcome!

Another Great Innovation From



Fisch Precision Tools Inc.
Claysville, PA 15323
Phone: 724-663-9072 • Fax: 724-663-9065
fischusa@pulsenet.com
Website: www.fisch-woodworking.com

Call Fisch Precision Tools for the dealer nearest you.

products that perform



Continued from page 94

MasterGage steps up to the Plate

When you check the blade-to-miter slot alignment on your tablesaw (you do check it, don't you?), you probably use the blade itself as a reference, right? But if your blade isn't perfectly flat—and many aren't—you can't be sure you've aligned your machine accurately. With a Master Plate in place of that blade, you can be certain.

A 10" blade, raised to its full height in a tablesaw, provides only about 6" of width from which to align. When mounted lengthwise on your saw's arbor (Master Plate has both 5/8" and 1" arbor holes), this 1/4x6x10" double-ground aluminum plate offers a full 10" of dead-flat surface for your dial indicator to contact. Now, that additional 4" may not mean much on the tablesaw, but on my mitersaw and radial arm saw, Master Plate's extra length gave me unequalled confidence when truing the blade arbor 90° to the fence.

Even if you're a "set it and forget it" kind of woodworker, you can still use Master Plate. Mount it to your table-saw's arbor in its vertical orientation and match the bevel angle to a bevel gauge or square (or a MasterGage, from the same manufacturer). You'll never again have to account for a

blade's teeth or a hollow-ground plate when setting up a bevel cut.

—Tested by
Bob McFarlin

PRODUCT SCORECARD

Master Plate

Performance	★★★★★
Price	\$55 ppd.
Value	★★★★★

For more information, call MasterGage Corp. toll-free at 888/893-8300, or visit www.mastergage.com.

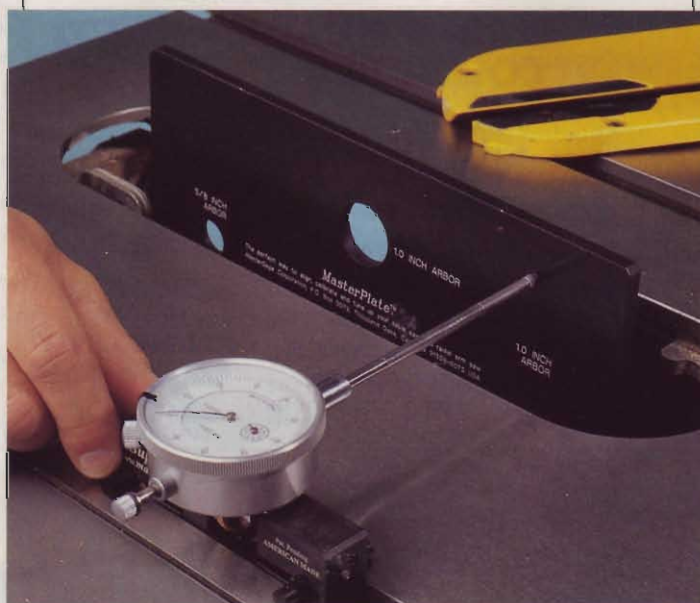

Continued on page 106

Continued from page 96

More bowls, less waste

As a turner, nothing gets me more excited than finding a big chunk of highly figured stock, such as spalted maple. Yet, few things sadden me like reducing most of that beautiful block to chips as I turn out a bowl. Woodcut's Bowl Saver spares most of that agony by removing several, progressively smaller bowls from a single blank.

After turning the exterior of the largest bowl, I mounted Bowl Saver to the tool rest support and tailstock of my lathe and positioned the curved chisel to cut the rough interior bowl surface. Then, with a tight grip on the tool's generous handle, I plunged the chisel into the blank (as shown *top right*) applying firm pressure until I had turned out a smaller bowl blank, (*inset*). I then

mounted that smaller blank to my faceplate, and turned another smaller bowl out of it.

The initial setup process is time-consuming, and the instructions were vague in places, but after using the tool a few times, setup became quicker and easier. You can start with a blank up to 5" thick and 12-14" in diameter.

Bowl Saver doesn't leave you with a finish-ready surface, so you still need to clean up the interior and exterior of each piece. And, although I still ended up with a pile of chips at the end, I also had three gorgeous spalted-maple bowls where once I would have had only one.

—Tested by Ray Wilber

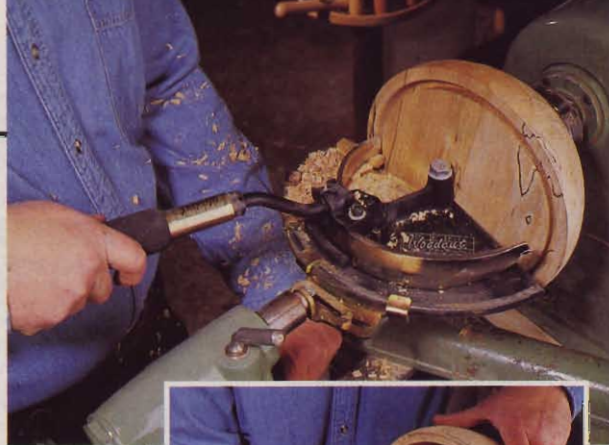

PRODUCT SCORECARD

Woodcut Bowl Saver

Performance	★★★★★
Price	\$220
Value	★★★★★

Call Craft Supply at 800/551-8876, or visit www.craftusa.com.

Fully automatic dust collection system's

ECOGATE

The ECOGATE System is a revolutionary idea in dust collection. When a machine is turned on, a sensor signals the controller to open the appropriate gate and turns on the dust collector. When the machine stops, the gate closes. Our larger model monitors the usage of all machines in your shop and continually optimizes the amount of power supplied to your dust collector. And that generates dramatic savings. We are going to demonstrate the ECOGATE System at IWF 2000 in Atlanta (on August 24th through the 27th). Our booth number is 26421.

Call 1-888-ECOGATE for a free brochure. www.ecogate.com

Circle No. 1230

Visit WOOD® magazine on the World Wide Web

at <http://www.woodmagazine.com>

Better Homes and Gardens®

WOOD Online™

Buy WOOD® PLANS on the Internet in our company store

A WOODWORKING INFORMATION SERVICE FROM THE EDITORS OF WOOD® MAGAZINE

- **Discussion Groups** — Talk with other woodworkers
- **Woodworking Sources** — Comprehensive database of woodworking sources for tools, supplies, and lumber
- **Tour Our Workshops** — A "virtual" tour of the WOOD magazine workshops
- **Current Issue** — Overview of the latest issue of WOOD
- **Company Store** — WOOD products for sale
- **Index** — Search through past issues of WOOD
- **Software Library** — Download valuable wood-working software

<http://www.woodmagazine.com>

Make diminutive, yet distinguished panels

Have you ever wanted the distinguished look of raised panels on a small project, such as a humidor? Ordinary raised panel sets can give a disproportionate,



clunky look to very small panels, and rail-and-stile bits aren't designed for use with 1/2" stock, so they don't work well on pint-sized projects.

But the Sommerfeld Junior Raised Panel Set answers those needs in a big way. Designed to work with stock from 7/16-1 1/16" thick, this downsized version of CMT's classical raised panel set comes with a 2 1/2" panel-raising bit (complete with integral back-cutter for flush panel backs), and 1 1/4" matching rail and stile cutters, all of which you can shim for fine-tuning the fit.

I didn't need to do any tweaking, though, because out of the box these babies cut like a dream. The raised-panel bit left a 5/32" tongue that mated perfectly with the slot left by the stile cutter.

Although the Sommerfeld Junior Raised Panel Set costs less than a comparable full-size set, don't negate your savings with a trip to the ER. Working with thin, narrow stock, even around these elfin cutters, can be dangerous. So before you begin, jig-up with hold-downs and pushsticks to keep your fingers clear. CMT provides some helpful safety suggestions in their catalog. 🐿

—Tested by Dave Henderson

PRODUCT SCORECARD

Sommerfeld Junior Raised Panel Set

Performance	★★★★★
Price	\$190
Value	★★★★☆

Call CMT USA toll-free at 888/268-2487, or visit www.cmtusa.com.



Laguna Tools Band Saw Now Only \$995*

No more excuses, you will never have a better time to purchase a Laguna Tools LT16 band saw. Due to the high volume of band saws that we sell, we can now give you the best band-saw value in the market. Manufactured in Italy exclusively for Laguna Tools, this powerful, swift piece of Italian ingenuity has high-quality, performance and your name written all over it.

Don't wait. Call today to get your free demonstration video.

- 12" resaw capability
- Easy blade change with 1/16 to 1" blade capacity
- 1.5 HP motor
- All-welded steel frame construction
- Cast-iron flywheels with snap on rubber tires
- Electrodynamically balanced
- Large 16" x 19" cast iron table
- Cast-iron rip fence
- 3/8" x 3/4" miter gage slot
- Two dust ports for excellent dust collection
- Blade tension indicator
- Table tilt from -10 to 45 degrees. Steel trunions
- Bearing Euro guides, both upper and lower
- Mobility kit, power feeder and 110-volt motor available

*Excludes sales tax and freight. Limited offer, while supplies last.

LAGUNA TOOLS
You Build With Wood, We Build With Trust.

800-234-1976

E Mail: mail@lagunatools.com Web: www.lagunatools.com

17101 Murphy Avenue Irvine, CA 92614 (949) 474-1200 • FX (949) 474-0150
100 Central Avenue South Kearny, NJ 07032 (973) 491-0102 • FX (973) 491-0591

Solving Workshop Mysteries

If you're looking for an answer to a question that you think would interest lots of other readers, write to:

Ask WOOD®, 1716 Locust St., GA310, Des Moines, IA 50309-3023.

For an immediate answer to your question, get help from fellow woodworkers by posting it on one of our internet discussion groups at: www.woodmagazine.com

Can green lumber and veggies be neighbors?

Q I'm using treated lumber to build pieces for the garden. Some of the wood will be below ground. Will the chemicals used on the wood leak into the soil? My wife insists that our garden be organic.

—Jim Still, Eagle Nest, N.M.

A The debate continues, Jim, but several studies by universities and the Environmental Protection Agency indicate that treated lumber is safe for garden use. The most common wood preservative,

chromated copper arsenate (CCA), contains arsenic, a toxic element. Gardeners worry that it will leach into the soil, and it does, to some extent. But a three-year study at North Carolina State University found no evidence of CCA uptake by grapes growing three inches from treated posts. Mississippi State University researchers have sampled soil surrounding CCA-treated stakes for 30 years without finding harmful levels in the soil.

Direct personal contact is another matter. Always wear a dust mask when

sawing treated lumber and gloves when handling it.

You do have some other options. You can ask your lumber supplier about wood that's treated with less questionable chemicals. For example, the Northern Crossarm Company in Chippewa Falls, Wisconsin (715/723-4100) treats wood with a copper and ammonia mixture called ACQ. Or, you can really put your wife's mind at ease by using redwood or cedar.



Continued on page 110

Econ-Abrasives

WE MAKE ABRASIVE BELTS ANY SIZE, ANY GRIT!

Standard Abrasive Sheets

CABINET PAPER

	50/pk	100/pk
60D	\$17.58	\$31.58C
80D	\$16.42	\$29.26C
100 thru 150C	\$15.26	\$26.95C

FINISHING PAPER

80A	\$11.74	\$19.89C
100 thru 280A	\$10.50	\$17.58C

NO LOAD PAPER(white)

100 thru 400A	\$12.90	\$22.40C
---------------	---------	----------

"C" = 100 SHEETS

Velcro® Vacuum Discs

8 Hole pattern for Bosch sanders

Dia.	Grit	Price
5"	60	\$.48ea
5"	80	.46
5"	100 thru 320	.45

* Available in 5 hole pattern *

*Wide Belts*Rolls*Flap Wheels
*Pump Sleeves*PSA Discs
*Router & Wood Bits*Wood Glue

*MasterCard, VISA, Discover, Am. Express

*SATISFACTION GUARANTEED!!!

*CALL FOR FREE CATALOG

-TX add appropriate sales tax

-Call for shipping charges

ABRASIVE BELTS

Belts are resin bond cloth with a bi-directional splice, specify grits.

1X30	\$.81 ea	3X24	\$.93 ea
1X42	.81 ea	3X27	.96 ea
1X44	.81 ea	4X21 3/4	1.06 ea
2 1/2X16	.85 ea	4X24	1.10 ea
3X18	.86 ea	4X36	1.35 ea
3X21	.90 ea	6X48	3.50 ea
3X23 3/4	.93 ea	6X89	6.24 ea

OTHER SIZES ON REQUEST

HEAVY DUTY SPRING CLAMPS

Clamps come w/PVC tips and grips.

Size	Price
4"	\$1.75 ea
6"	2.25
8"	3.50

JUMBO ROUTER PAD(24" x 36")

It will not allow small blocks of wood to slip out under router or sanding applications.

ROUTER PAD
ONLY \$8.95ea.

JUMBO BELT CLEANING STICK
ONLY \$8.80



Econ-Abrasives
P. O. Box W1628
Frisco, TX 75034
(972)377-9779

TOLL-FREE ORDERING LINE (800)367-4101

Introducing, the Kreg Jig® K2000 ProPack...



Featuring...

-Simple, three-step adjustability for nearly all material dimensions.

Pocket hole joinery, think outside the frame.



Kreg Tool Company
201 Campus Drive
Huxley, IA 50124

www.kregtool.com
1-800-447-8638

NO MORE DUST



Introducing Microplane® Rotary Shaper Power Tool Attachments for low-speed shaping. The razor-sharp teeth create tiny shavings that fall to the surface instead of clouding your air. Call 501-968-5455 or

1-800-555-2767

• dealer inquiries encouraged

www.microplane.com email: info@microplane.com

Microplane
A Product of Grace Manufacturing

Circle No. 2145

Prototype



New!

ARROW
ELECTRO-MATIC

Finished Product



HEAVY DUTY ET100™
Nail Master™
ELECTRIC BRAD GUN

Grab hold of the all-new ARROW ET100™ and experience the beauty of ergonomically designed comfort. Its non-slip cushioned grip and superb balance assures effortless work, even during long jobs.

In addition to performing routine nailing jobs, this powerful 10 amp brad nailer is specially angled to handle difficult corner, edging and framing jobs. No scratched or damaged surfaces.

The ET100™ provides nail driving muscle without the burden of an air compressor. It shoots 3 different size brads.

Solid state circuitry, a hardened carbon steel delivery system for jam-proof performance, and both trigger and surface contact safety locks combine to offer increased years of safe, accurate, trouble-free service.

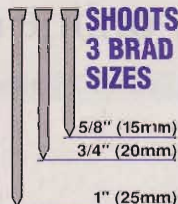

The ET100™ is available wherever fine tools are sold.

Arrow Fastener Co., Inc., 271 Mayhill Street, Saddle Brook, New Jersey 07663
Canada: Jardel Distributors, Inc., 6505 Metropolitan Blvd. East, Montreal, Quebec H1P 1X9
United Kingdom: Arrow Fastener (U.K.) Ltd., 14 Barclay Road, Croydon, Surrey CR0 1JN
www.arrowfastener.com © 1999 Arrow Fastener Company, Inc.

ask wood

Continued from page 108

A little help with cypress knees, please!

Q I have access to a number of live cypress knees, and would like to harvest some to make a lamp. What's the best way to remove the bark?

C. Walls, Winter Springs, Fla.

A For the sake of our non-Southern readers, we should probably first explain that cypress trees, which grow in swamps and wetland areas in the deep South, sometimes develop slender conical growths that sprout vertically off their root base. These "knees" come up through the soil or water. Their uniform grain, density, and resistance to checking make them a favorite of carvers.

Pennsylvania woodworker Bill Evans, who carves a lot of cypress knees, says you must boil them in water as soon as possible after harvesting. After 30 to 45 minutes, the rough outer bark and the inner bark (phloem) will loosen enough to be peeled off. You have to do this while the knees are still steaming hot, though, which requires working quickly with thick gloves and a pair of wide-jaw pliers (the kind sporting goods stores sell for skinning catfish).

Before you fire up the kettle, check with local officials of the Florida Department of Environmental Protection. Harvesting of cypress knees is regulated heavily on all state property, and water-quality issues affect allowable harvesting techniques even on some privately held lands. To avoid doing environmental harm or paying a stiff fine, comply with any legal requirements.



new auction sales record for decoys



Carved by Elmer Crowell in 1917, this sleeping Canada goose decoy sold at auction for a world record \$684,500.

Last January, the decoy collection of Dr. James M. McCleery brought nearly \$11 million at a Sotheby auction in New York City. The sale, an effort of Sotheby's and Guyette & Schmidt, Inc., set a world record for decoys,

and gave strong indication that collectible decoys have achieved a significance in American folk art.

The decoy attracting the highest bid was a sleeping Canada goose carved in 1917 by Elmer Crowell of Massachusetts. It went to a Boston dealer for \$684,500, a record in itself as the world's most expensive decoy. The previous highest price for a single decoy was \$335,500.

houses sailed around the Horn

San Diego was settled in the late 1700s, and with its natural bay, soon became a bustling seaport. The area called Old Town represents the original development of the city. And many of the early 19th-century structures in it were prefabricated houses shipped unassembled from Maine. With no heavy forest in the region, it apparently was more practical to bring kit houses by sailboat around South America's Cape Horn than haul logs from distant mountains.

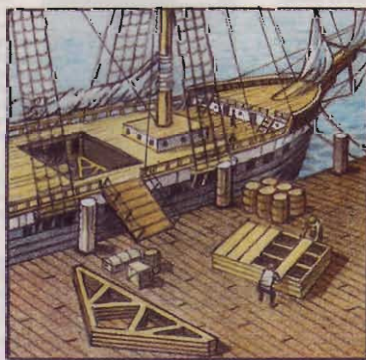

Illustration: Jim Stevenson Photographs: courtesy The Ward Museum of Wildfowl Art; TimberTech, Ltd.

plastic lumber

now even smells like wood



Perhaps you've seen a sleek deck or park bench made of recycled plastic material. Sure, projects made from composites won't decay, and you don't have to renew their protective finish annually. But do woodworkers want to build with anything but real wood?

If you've had that thought, you might want to think again. Companies that produce deck planking and other components mix everything from sawdust and wood chips to rice hulls with recycled plastics to obtain their composites. Now, one company has even added aromatic red cedar to its mix so your plastic deck will smell like wood! ChoiceDek (800/951-5117) uses 48 percent recycled polyethylene and 52 percent wood waste fiber, principally cedar chips left over from the manufacture of perfume.

For more information about plastic lumber, try the American Plastics Council, 1300 Wilson Blvd., Suite 800, Arlington, VA 22209. (800/243-5790, or visit www.plastics.org). You can find dealers through the Plastic Lumber Trade Association, P.O. Box 80311, Akron, OH 44308-9998. Or call 800/886-8990.

Decking material made of recycled plastic and wood-waste works like wood and now can even smell like it.