

WOOD

December 2000 ISSUE 129

www.woodonline.com

An Arts & Crafts Classic

Build this elegant oak sofa and a matching chair. Page 42

technique

Faux Finishing

Create figured wood with a brush! Page 78

bonus

8 WORKSHOP PROJECTS

BE A BETTER WOODWORKER

Display until January 9

U.S.A. \$5.95



129

0 72440 14072 1

this issue's highlights

WOOD® magazine

December 2000 Issue 129

www.woodonline.com



page 62

woodworking projects

28 great ideas: leg stand for stationary tools

Got a heavy-duty tool that needs legs? Let this sturdy stand handle the load. By altering the dimensions, you can make it fit any machine in your shop.

42 prairie sofa and chair

Create an Arts and Crafts showroom in your home with this true-to-form duo. Our designs feature quartersawn oak and allow you to make both pieces at once without changing sawing operations. We even tell how to make the cushions.

54 all-purpose router station

Take your routing to new heights with this handy shop project. It allows you to operate your table-mounted tool either horizontally or vertically for a wide range of machining assignments.

62 an Oriental-styled beauty

Display flowers in the traditional Japanese way with this finely crafted Ikebana stand.

72 marquetry mirages

Now you can use your woodworking skills to perform an illusion. Thanks to designer John Russell, all you need are a few pieces of select veneer, a basic box, and simple instructions.

88 precision jigs you can make

Have your tools and shop work harder with this selection of six quick-and-easy projects.



page 42



page 66

tools & materials

115 products that perform

66 lean, mean cleaning machines

See which of five new shop vacuums, all priced at or below \$150, outperform the pack.



page 16

This issue's cover wood grain: sugar maple

Continued on page 4

Cover photograph: Baldwin Photography

tips & **techniques**

- 18 router bit review: drawer-lock bit**
See how to fashion strong, long-lasting drawer joints with just a few machinings.
- 32 tips from your shop (and ours)**
- 49 no-sew upholstery**
Try our woodworker-friendly technique for making furniture cushions using common workshop tools.
- 78 how to faux finish like a pro**
Let expert Tim Vander Well show you how to create the look of highly desirable expensive woods on less-expensive materials.
- 106 mortising with chisels**
Learn the basics as we show how to make mortises the old-fashioned way.



page 18



page 49



page 78

features

- 6 the editor's angle**
- 8 talking back**
- 22 wood anecdote: Osage orange**
Discover why many Native Americans preferred bows made from this species.
- 24 WOOD ONLINE®**
- 84 jukebox journey**
Marvel at the spectacular designs of Wurlitzer's jukeboxes and learn about their history as we visit with Ed Jones, owner of Jukebox Junction, a small restoration company in Iowa.
- 112 finishing touches**

page 184





Phil Brennon talking the fine points of burl turning with projects editor Bill Krier.

a turn for the better

Woodworkers, just like anyone else, are creatures of habit. Take me, for example. More often than not, when I venture into the shop and don my shop apron, it's to make a gift for someone special. Usually the project is small, relatively quick to build, and decorative rather than functional.

Why do I do what I do? I don't really know, except that the recipients, usually the women in my family, always seem appreciative, and often display the gifts in their homes. That's enough for me.

Even though I am predictable in my building habits (and maybe you are, too), I get pumped up when I see others who have woodworking skills that I'd love to possess. People like scrollsawyer Roy King, finishing expert Bob Flexner, intarsia expert Judy Gale Roberts, master chip carver Wayne Barton, hatmaker Johannes Michelsen, and many others have been an inspiration to me.

That's why when anyone on the *WOOD* staff asks to have a recognized expert come in to share some wood-working specialty, I say, "Yes, let's do it." Such was the case recently when projects editor

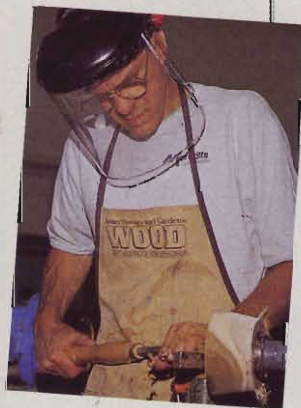

Projects editor Jan Svec begins hollowing out a green-wood bowl.

Jan Svec asked to have Phil Brennon in for a three-day turning seminar. After all of the wood chips settled, those participating staff members agreed that their experience at the lathe really gave them a creative shot in the arm. It opened up new woodworking vistas while adding to their skills.

If you're looking for some woodworking excitement, you, too, may want to enroll in an adult-education class, plan a woodworking vacation, or attend a woodworking seminar. I guarantee that broadening your woodworking horizons will add greatly to your enjoyment of this multifaceted craft we all enjoy. 🌲

Larry Clayton



Shop manager/project designer Chuck Hedlund cleaning the inside of a wide-mouthed vessel.

Customer Service Information: For service on your subscription, including change of address, contact www.wood-magazine.com/service or call 800/374-9663. **Subscription mailing address:** Better Homes and Gardens *WOOD* magazine, P.O. Box 37439, Boone, IA 50037-0439. Please enclose your address label from a recent issue. **Editorial mailing address:** The Editor, *WOOD* magazine, 1716 Locust Street, GA310, Des Moines, IA 50309-3023. For questions for our editorial staff, questions about how to reach an advertiser, or to place an advertisement in our magazine call 800/374-9663. **To order back issues call 800/346-9663.** For article reprints, write to the editorial address and enclose \$5 per article.

WOOD®

DECEMBER 2000 • Vol. 17, No. 9 • Issue No. 129

Editor **LARRY CLAYTON**
 Managing Editor **JIM HARROLD**
 Assistant Managing Editor/Features **PETER J. STEPHANO**
 Senior Design Editor **JAMES R. DOWNING**
 Projects Editor **BILL KRIER**
 Projects Editor **JAN HALE SVEC**
 Products Editor **DAVE CAMPBELL**
 Techniques Editor **JIM POLLOCK**
 Shop Manager/Project Designer **CHARLES I. HEDLUND**
 Assistant Design Editor/Project Builder **KEVIN BOYLE**
 Production/Office Manager **MARGARET CLOSNER**
 Administrative Assistant **SHERYL MUNYON**
 Reader-Contact Specialist **BEN VONRUDEM**
 Illustrators **KIM DOWNING, LORNA JOHNSON, ROXANNE LEMOINE, CARSON ODE**
 Consultants **BOB McFARLIN, DAVE HENDERSON**
 Contributing Craftsman **JIM HEAVEY**

Creative Director **DANIEL MASINI**
 Associate Art Director **JOHN MEEK**
 Assistant Art Director **CHERYL A. CIBULA**

Publisher **MARK HAGEN**
 Ancillary Sales and Internet Manager **MARLEN KEMMET**

Advertising Office: 333 N. Michigan Ave., Suite 1500, Chicago, IL 60601 Phone: 312/853-2890 FAX: 312/580-7906
 Direct Response Advertising **CARDLYN DAKIS**
 Account Executive **YUWEI LEE**
 Account Executive **RON GOLMINAS**
 Advertising Manager **JIM HUGHES**
 Marketing Manager **GERALLIE LEGASPI**
 Sales Assistant **MARGARET TRAVIS**
 Sales Assistant **THERESA COOKS**

Publishing Director **WILLIAM R. REED**

Advertising Services Manager **PAT HENDERSHOTT**
 Consumer Marketing Director **LIZ BREDESON**
 Associate Consumer Marketing Director **KATHI PRIEN**
 Assistant Consumer Marketing Manager **DAVE HONOLD**
 Business Manager **CRAIG FEAR**
 Senior Product Manager **RICK GROW**

MEREDITH PUBLISHING GROUP

President **CHRISTOPHER M. LITTLE**
 Vice President Publishing Director **JERRY WARD**
 Creative Services **ELLEN DELATHOUDER**
 Manufacturing **BRUCE HESTON**
 Consumer Marketing **KARLA JEFFRIES**
 Group Sales **JERRY KAPLAN**
 Operations **DEAN PIETERS**
 Finance and Administration **MAX RUNCIMAN**

Meredith
CORPORATION

WILLIAM T. KERR, President and Chief Executive Officer
E.T. MEREDITH III, Chairman of the Executive Committee

©Copyright Meredith Corporation 2000
 All rights reserved. Printed in the U.S.A.

Better Homes and Gardens® *WOOD*® magazine (ISSN-0743-894X) is published nine times a year in February, March, April, May/June, July/August, September, October, November, and December by Meredith Corporation, 1716 Locust St., Des Moines, IA 50309-3023. Periodicals postage paid at Des Moines, Iowa, and additional mailing offices. Better Homes and Gardens trademark registered in Canada and Australia. Marca Registrada en México. **ONE-YEAR SUBSCRIPTION PRICES:** U.S. and its possessions, \$27; Canada, \$39; other countries, \$47. Canada Post Publications Mail Sales Product Agreement No. 1369350. Canadian BN 12348 2887RT. **CANADIAN RETURN ADDRESS:** Better Homes and Gardens *WOOD* magazine, 2744 Edna Street, Windsor, Ontario, N8Y 1V2. **POSTMASTER:** Send address changes to Better Homes and Gardens *WOOD* magazine, P.O. Box 37439, Boone, IA 50037-0439.



Letters Comments & Updates

We welcome your comments, criticisms, suggestions, and yes, even compliments. We select and publish only letters of the greatest benefit to our readers. Write to:

Talking Back
WOOD Magazine
1716 Locust St., GA310
Des Moines, IA 50309-3023

The right coating for cast-iron tool tops

I noticed contradictory advice on preventing rust on tablesaw tops in Issue 124 of WOOD® magazine. On page 55, Mike Gililand says to apply paste-type auto wax; on page 10, Jack Understeller cautions against the use of auto wax because it contains silicone that can get onto wood and cause finishing problems.

Indeed, I have experienced fisheyes in my finish caused by using auto wax. It is a difficult problem to overcome. I use a beeswax and turpentine paste on my machine tops.

—Christine Demers, Telkwa, B.C.

We heard from several readers on this one. Anything with silicone in it should

be kept off surfaces that come in contact with your wood. Verne Anderson of Okmulgee, Oklahoma, wrote to tell us he uses a mixture of equal parts kerosene, paraffin, and machine oil. We use a paste floor wax on the cast-iron

tool tops in the WOOD shop. A couple of years ago, Project Builder Chuck Hedlund was impressed when he used Bostick Top Coat (Woodworker's Supply, 800/645-9292) on his jointer. He claims that its surface is still slick and rust-free.

Entry suite ruled out of order

The cutting diagram for the Entry Suite hall table in Issue 122 disagrees with the instructions. In order to achieve a continuous grain pattern across the front rails (C) and the drawer front (J), the parts should be

cut in the sequence C-J-C. In addition, I would flank the front rails with the end rails (B), (as shown in the drawing), resulting in a continuous grain pattern on all the visible sides. ♣

—Richard Peabody, Jr., Naperville, Ill.

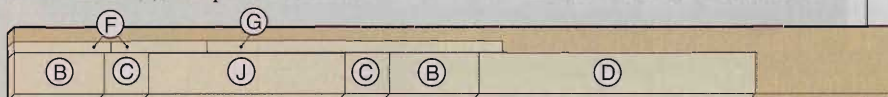

NEW CUTTING DIAGRAM 3/4 x 7 1/4 x 96" Walnut

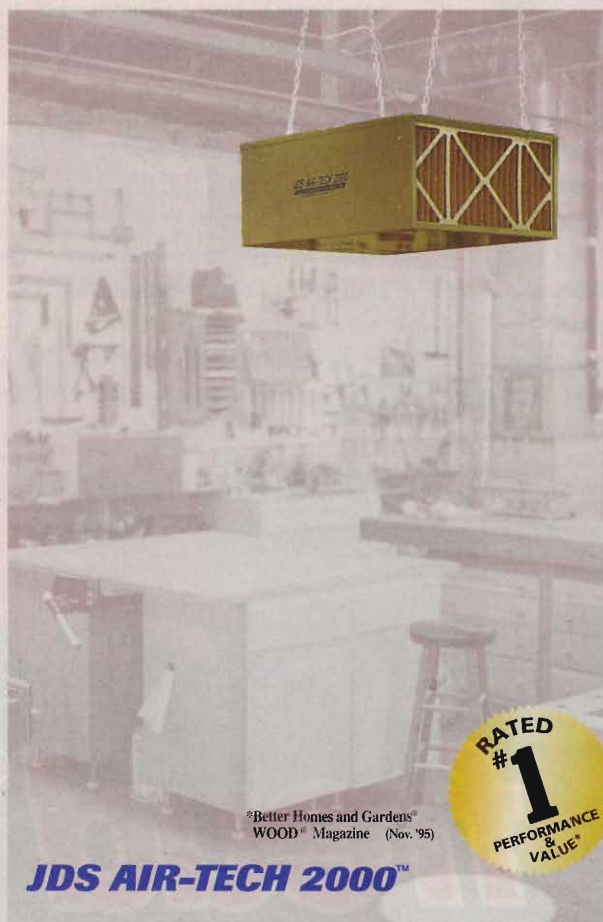

Let's Clear the Air...

JDS AIR-TECH 2000™

Model 750, Still the Best!

- Variable Speed Control for unlimited air flow settings
- Highest Maximum air flow in its class - 1,050 CFM
- Convenient On/Off pull chain
- Ultra Quiet
- 1/4 H.P. Motor for heavy duty performance
- Antimicrobial 1 Micron internal bag filter
- UL Listed
- Lifetime Warranty

The National Institute for Occupational Safety and Health (NIOSH) recommends limiting wood dust exposures. The JDS Air-Tech 2000 will dramatically improve the quality of the air you breathe. Our new model 750 variable speed allows you to dial in your desired air flow, from a whisper quiet 200 cfm to an ultra performance 750 cfm. This will clean the air in a 30'x30'x8' shop every ten minutes. For larger areas our models 8-12, 10-16 and 2400 are available. The JDS systems will remove 99% of particles as small as five microns and 80% of particles as small as one micron. For the removal of odors, fumes and smoke, our optional charcoal filter is available. To place an order or

for the dealer nearest you call us toll-free.

Another quality product from
1-800-382-2637

Manufactured in the U.S.A.

www.thejdscompany.com

\$259.00
Model 750

JDS
COMPANY



®Better Homes and Gardens
WOOD® Magazine (Nov. '95)

JDS AIR-TECH 2000™



No more crying over spilled juice with Guardian

When finishing a woodworking project, such as the mission-style sofa on page 42, stain can be a good thing. But on the upholstered cushions of that same project, a stain from a spilled drink or coffee cup can ruin the fabric. Guardian Fabric Protector keeps the spill from penetrating the upholstery.

The concept isn't new: 3M's "Scotchgard" has been an industry standard stain-blocker for years. However, 3M recently stopped making the product because it contains perfluorooctane sulfonate (PFOS), that has been shown to persist in the human blood stream. (A 3M press release indicates that the presence of PFOS at very low levels does not pose health or environmental risks.) Guardian Fabric Protector works without PFOS.

How well does it work? Following the manufacturer's directions, I applied

one coat of the product to different swatches of nearly white upholstery. Then, I dribbled on two of the worst stain-makers I could think of—grape juice and a red Kool-Aid brand drink. After letting the spills stand for a few minutes, I blotted them with an absorbent towel, and found some light staining of the upholstery.

Next, I sprayed two coats of Guardian Fabric Protector on some new swatches of the same upholstery, and let them cure for 48 hours. When I repeated the spill tests, both came out completely—no stains. In my testing, I also found that the longer a spill stays on the fabric, the less likely you'll be able to completely remove it. And, the more textured the upholstery, the more likely it is to stain.

Currently, you can buy Guardian Fabric Protector at better furniture



stores. However, a company spokesperson told me they hope to have it available soon at home centers.

—Tested by Randy Zimmerman

PRODUCT SCORECARD

Guardian Fabric Protector

Performance	★ ★ ★ ☆ ☆
Price	\$15, 16 oz.
Value	★ ★ ★ ★ ☆

Call Guardian Products at 800/527-8487, or visit www.guardianproducts.net.

Give yourself a medal for your hard work

Woodworkers as a whole are a modest bunch. We perform our craft in an



area (the shop) that's mysterious to our friends and family, and are usually the first to point out our mistakes. Even those "flawed" pieces will be cherished for years as they get passed down, but will anyone remember who made them, or when?

That's the purpose behind these laser-engraved plastic medallions: to proudly give credit to the craftsman and the year the project was built. Simply bore a 1/16"-deep hole with a 1" Forstner bit in an inconspicuous place on your project (on the back panel, or inside a door or drawer), and glue the identification medallion in place. The manufacturer suggests cyanoacrylate adhesive ("super glue"), but for indoor pieces, I found that double-faced carpet tape worked just as well.

The Gold Series medallions show your name and the year, plus one of four standard phrases: "Handcrafted by," "Hand made by," "Custom made by," or "From the shop of." You can be more creative on the Platinum/Signature series medallions, shown at left, even adding your own autograph for an additional charge. Gold medallions are sold in lots of 40; Platinum medallions come in lots of 80.

—Tested by Randy Zimmerman

PRODUCT SCORECARD

Identification medallions

Performance	★ ★ ★ ★ ★
Price	\$38.90 ppd., Gold series (40 pcs.); \$79.90 ppd., Platinum/Signature series (80 pcs.)
Value	★ ★ ★ ☆ ☆

Call The Wooden Post at 417/852-7126, or visit www.woodenpost.com.

Continued on page 16

Use this slot support for safer sawing

Frankly, I think my wife resents it when I use her as a sawhorse. Here's how it usually goes: I need to rip a

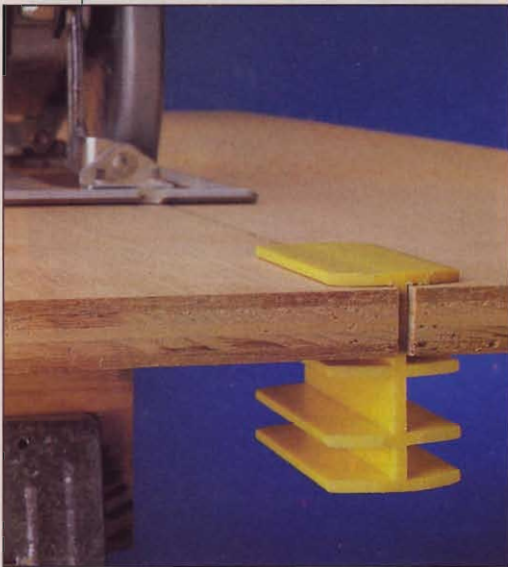

long piece of sheet goods with my circular saw. But if I try to do it myself, the offcut piece invariably sags about halfway through the cut, and I risk pinching the blade in the kerf and having the saw kick back. I don't have enough hands to support the stock, so she drops everything she's doing to hold the offcut. No more.

The Tri-Size Kerf Support slips into the kerf behind the saw, as shown at left. By holding the "keeper" and waste pieces together, as if they weren't cut at all, this neat little shop aid prevents dangerous blade binding and kickback.

The Tri-Size Kerf Support has three pairs of slots to hold 1/4", 1/2", and 3/4" sheet goods. I used it with full-kerf and thin-kerf 7/4" circular saw blades, and with my cordless trim saw's ultra-thin

blade. With the thinner blades, I found I had to cut well into the sheet before the kerf opened enough for me to insert the device.

The only complaint I have—and it's a minor one—is that I found it distracting to stop part way into the cut to slip the Tri-Size Kerf Support into the slot. But the few dollars it costs already have saved me a time or two in the doghouse, and kept me safe. 🐶

—Tested by Randy Zimmerman

PRODUCT SCORECARD

Tri-Size Kerf Support

Performance	★★★★★
Price	\$4
Value	★★★★★

Call Safe-T-Products at 253/826-0516 to find a dealer near you.

Introducing the New Delta Store. Tap into the Power of the Pros.



The new Delta store has over 500 products from a complete line-up of unisaws from a complete line-up of unisaws to those hard-to-find machinery attachments.

Extensive product information including customer ratings and reviews will help you choose the right tool for the job. We'll even deliver to your door for only \$5.99.

Visit the Delta store at

www.amazon.com/delta

table saws radial saws miter saws
scroll & band saws planers the Delta store
drilling machines jointers wood shapers



Introducing, the **Kreg Jig** K2000 ProPack...



Featuring...

-Simple, three-step adjustability for nearly all material dimensions.

Pocket hole joinery,
think outside the frame.

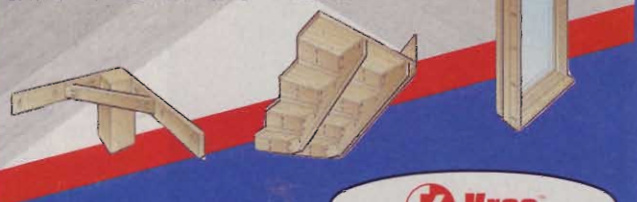

Kreg Tool Company
201 Campus Drive
Huxley, IA 50124

www.kregtool.com
1-800-447-8638

drawer-lock bit

the one-bit solution to strong interlocking joints



The unique geometry of a drawer-lock bit creates a strong bond between perpendicular pieces. And the joint is not only functional, but attractive as well.

Unlike stub tenons made on a tablesaw, the wedge-shaped tenons created by a drawer-lock bit self-align both workpieces for a perfectly mating joint. Furthermore, once you've

set the bit to the correct height, you need only adjust your router-table fence to make a variety of mating cuts.

One safety note before we get into using this bit: Remember that a drawer-lock bit should always be used in a router table, never in a handheld router.

Start by setting up your router table and milling the fronts

1 If your router table doesn't have a split fence, you'll need to build out the fence almost the full diameter of the bit. That's because most of the bit must be captured inside the fence when milling drawer or box sides.

Close up the opening around the bit by making an auxiliary face for your router table fence. For our 2"-diameter bit, we cut a $\frac{5}{8} \times 2\frac{1}{4}$ " dado in a scrap of $\frac{1}{2}$ " medium-density fiberboard (MDF), then clamped it to the router table fence with the dado centered over the bit, as shown at left.

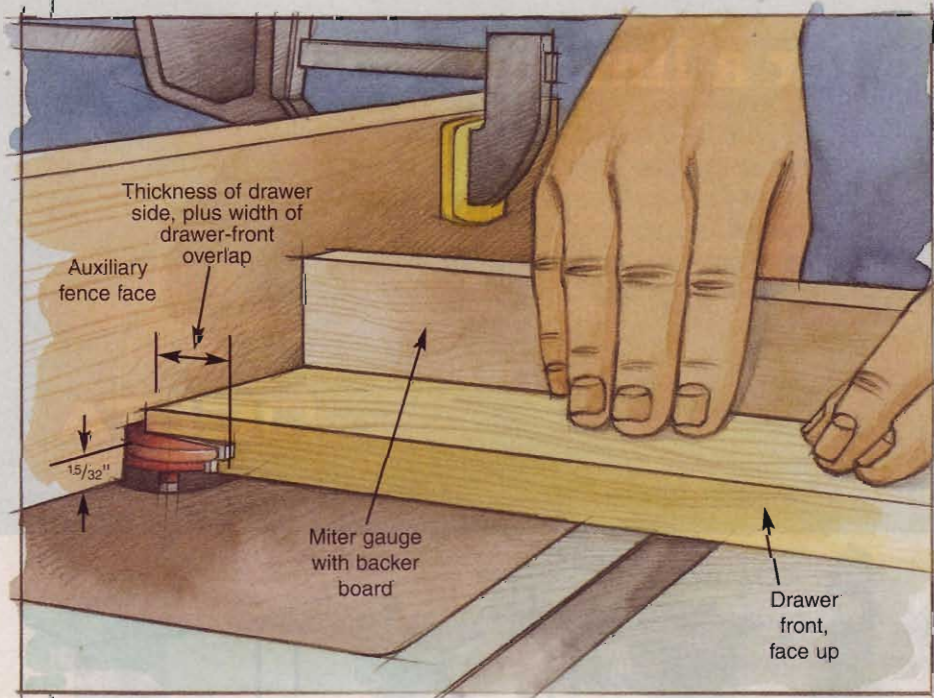

2 Mount the drawer-lock bit in your table-mounted router, and set the top of the cutter so that it's $\frac{15}{32}$ " above the tabletop.

3 Calculate the fence position by adding your drawer front's intended overlap (if any) and the thickness of your drawer side. Position your router table fence that distance back from the lower cutting edge of the bit.

For example, if your drawer front will overlap the sides by $\frac{3}{8}$ ", and the sides are $\frac{1}{2}$ "-thick, put the fence $\frac{7}{8}$ " back from the lower part of the bit. For flush-mount drawers, or drawers to which you'll add a false front, place the

Continued on page 20

"All my tools should be this good!"

The Accu-Miter® is a professional miter gauge that makes perfect angles easily. Shot-pin action assures dead-on accuracy for common angles — plus a precise protractor scale for everything in between!



We do not recommend operating without the saw blade guard, as is shown here. US Patent #5,038,486

Optional accessories:
manual clamp—
pneumatic clamp—
3/8" x 3/4" miter bar—

**JDS
COMPANY**

Call or write for our free brochure.

Precision Woodworking Equipment
800 Dutch Square Blvd., Suite 200, Columbia, SC 29210
1-800-382-2637 / SC 803-798-1600
www.thejdscompany.com

\$149

Jet...the Power to Shape Your Ideas.
And the Store to Make Them a Reality.



The Jet store is now open with over 150 Jet products in stock, including best sellers and hard-to-find attachments. Complete product information including customer reviews make comparing products quick and easy. Visit the Jet store and see why Jet is one of the fastest growing brands in the industry.

Visit the Jet store at
www.amazon.com/jet

dust collectors jointers planers
saws wood lathes the Jet store
shapers sanders planer-molders



router bit
review

drawer-lock bit

Continued from page 18

fence only the thickness of the drawer side from the bit's lower cutting edge.

(You also could use this dimension for milling the drawer backs. But here in the *WOOD*® magazine shop, we like to cut the backs with the same overlap as the fronts, then trim them to size. This ensures that the inside dimensions of the drawer remain constant.)

4 To prevent tearout while milling the fronts, attach a backer board to your miter gauge so that the backer board just touches the auxiliary fence face, as shown on the *previous page*.

5 With your drawer front already cut to finished size, place it faceup on the router table. Keep one end of the drawer front against the router table fence and mill the workpiece using the miter gauge as a guide. Turn the workpiece around, keeping it face-up, and mill the other end. If you're making more than one drawer, machine all of the drawer fronts (and backs, if you like) using this setup.

Now, it's time for a little action on the sides

1 Without changing the cutting height of the bit, move the fence so that it's flush with the lower cutting surface of the drawer-lock bit. We like to rotate the bit so the cutting edge is forward, then lay a straightedge against it for reference, as shown *below*.

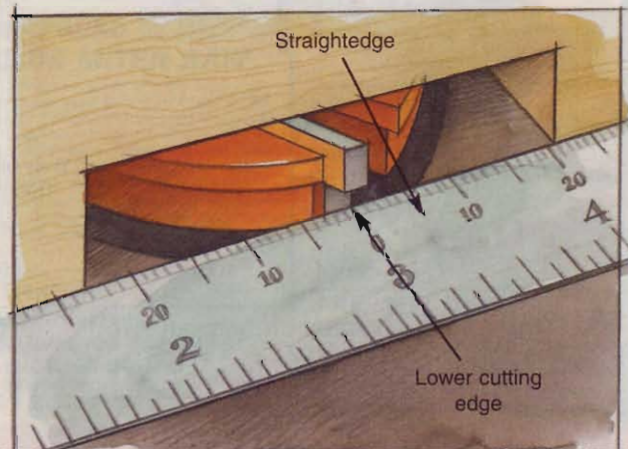

2 To prevent tear-out, make a pushblock from scrap and an extra piece of drawer-side stock (or scrap of the same thickness), as shown *below*. Make certain that the two pieces form a 90° angle, and that the screws are high enough to clear the cutting path of the bit.

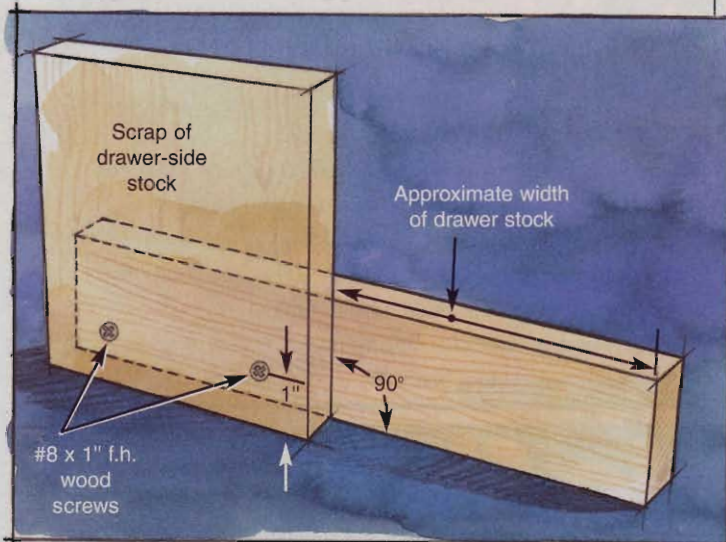

3 Cut the drawer sides to size. Stand the drawer side on end, placing the inside face against the fence. Use the pushblock, as shown *below*, to guide the drawer side through the bit. ♣

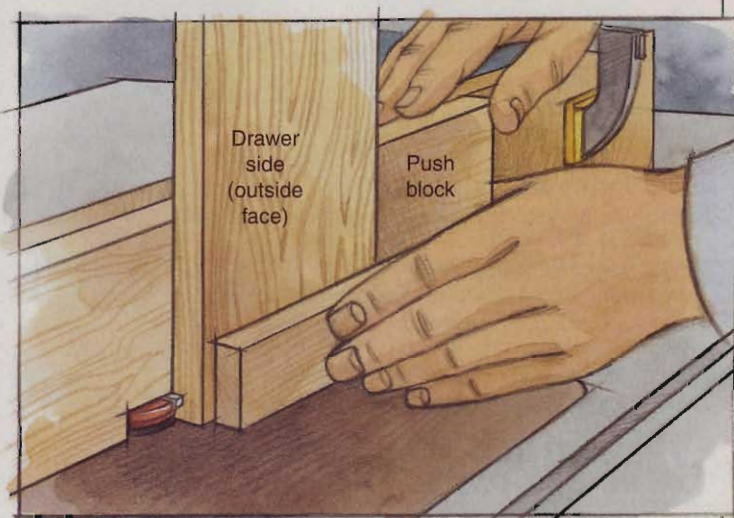

Written by Dave Campbell with Chuck Hedlund
Illustrations: Brian Jensen
Photograph: Baldwin Photography

No Matter How You Cut It, These Tenryu Blades Are Winning Combos

Tenryu Gold Medal 10" x 40t and Rapid-Cut 10" x 50t blades give you splinter-free cuts in all woods—even chip-free cuts in melamine. Both feature extra hard carbide teeth that stay sharp longer, even when cutting abrasive materials.

Gold Medal: "A top performer offering a very smooth cut edge and glass-smooth feeding"... "the quietest-cutting blade in our test"

Rapid-Cut: "The smoothest cutting of all the ATB/R blades tested" —WOOD Magazine, February 2000

For exceptionally clean and accurate cross, rip and miter cuts in all woods, ask for Tenryu Gold Medal or Tenryu Rapid-Cut blades at your favorite dealer.

Making quality saw blades since 1910

TENRYU

4301 Woodland Park Dr., Ste. 104 West Melbourne, FL 32904
1-800-951-SAWS • 321-951-2400 • Fax: 321-951-2250 • www.tenryu.com



If you Want the Best, Go for the Gold. Powermatic Gold.

You don't have to go to the end of the rainbow to find the gold. The new Powermatic store has gold shapers, gold sanders, gold jointers, gold planers, and more. We have the biggest selection with over 80 Powermatic machines and accessories to choose from. Powermatic sets the Gold standard for woodworking and metal-working machinery.



Visit the Powermatic store at
www.amazon.com/powermatic

blades bits shapers dust collectors
jointers sanders the Powermatic store
table saws portable planers band saws



Osage orange

the tree that has stood the test of time

In early geologic time there were many species in the Osage orange family. Today, however, it stands alone as the only tree in the world that is the sole species in a genus.

Fossils indicate that Osage orange (*Maclura pomifera*) once grew naturally well outside its native range of Texas, Oklahoma, Louisiana, Missouri, and Arkansas. Then it retreated, perhaps ahead of advancing glaciers. Thousands of years later, because it was cultivated and planted by settlers as inexpensive fencing, it once again spread. Now, you may even find Osage orange growing in the eastern states and well into the Great Plains.

Wherever Osage orange grew, it had many a use. At one time, a Plains

Indian brave would gladly trade a horse and blanket for a bow made of the wood. The reputation of such bows spread widely from the land of their makers—the Osage Indians of Arkansas and Missouri. Bows of this hard, strong wood even were found by explorers in use as far north as Montana. That's why in many parts of the nation the wood carries the name bois d'arc, French for wood of the bow. Americanized, the term becomes bowdork.

Harder and stronger than even white oak, Osage orange was once cut for railroad ties. While other woods for ties lasted but a few years, Osage orange served for 20! And many a Midwestern farm still has fence posts of the wood in place after a century.

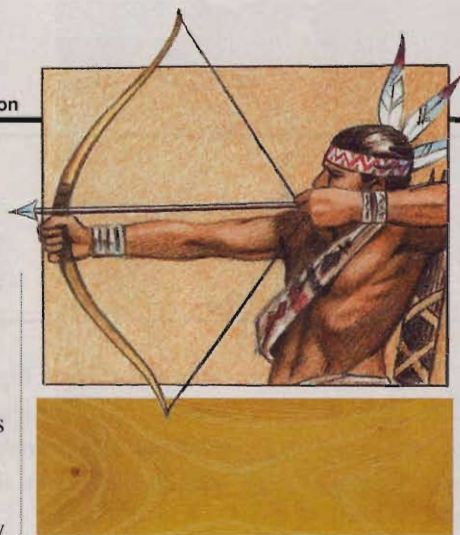

Made into a bow, Osage orange grows stronger with age and smoother to draw.

Because of Osage orange's hardness and durability, it often was used for wagon wheels. Highly decay-resistant, it was even laid as paving blocks. In today's world, however, the wood is scarce as lumber. Yet sanded smooth and oiled, Osage orange beats all others for cutting boards that will stand up to a blade. ♣

Heavy Duty, Rugged, and Reliable. A Web Site That's Built Like A DEWALT Tool.



The new DeWALT store has a complete DeWALT selection of over 1300 products. See the newest cordless tools and the hard-to-find wood-working accessories. Our heavy-duty product information including customer ratings and reviews will help you select the right products.

Visit the DeWALT store at
www.amazon.com/dewalt

chop saws drills grinders hammer
drills planers routers the DeWALT store
screw guns vacuums saw blades



No Shortcuts

NEW DESIGN! Specifications in new Katana bits equal or exceed any now on the market.

INCLUDES A LIFETIME GUARANTEE!

- 1 Unique new **Safety Gauge Shank™**.
- 2 **Premium micro-grain carbide** yields a longer cutting life.
- 3 **Diamond honed** to a 600 grit mirror finish on CNC grinders.
- 4 **Non-stick coating** baked on to prevent residue build up.
- 5 **Precision ground** to a tolerance of +/- .005".
- 6 **High hook and shear angles** produce a clean cut.
- 7 **Anti-kickback design** forces smoother entry into stock.
- 8 **Balanced in excess of 25,000 RPM** for smooth routing.



FREE CATALOG!
1-800-533-9298

KATANA™

3 PIECE RAISED PANEL
DOOR SET • 1/2" SHANK
\$129⁹⁵
ORDER ITEM #14502
WOOD BOX INCLUDED

KATANABITS.COM • AN MLCS COMPANY P.O. BOX 4053, RYDAL, PA 19046

You'll profit by visiting the WOODMALL[®] Fall Show 2000

If you make all or part of your living through woodworking—or would like to—then consider the WOODMALL Fall Show a must-see event. The special event runs only from noon on Friday, November 17, until the end of the day (midnight) on Monday, November 27.

In addition to all of the other great things always going on at the WOODMALL, such as special prices and closeouts on major-brand tools, you'll find numerous attractions available only during the 11-day Fall Show. They include:

- Interviews with fellow woodworkers who can tell you first-hand about their personal experiences with a product, service, woodworking school, or franchise they've used to generate income.
- Five new woodworking seminars free of charge to show attendees.
- A Grand-Prize drawing for woodworking machinery.
- A free downloadable plan, different from the November one already available at WOOD ONLINE.
- Articles on the business side of woodworking.

www.woodmall.com

Here's what woodworkers are saying about WOOD ONLINE

From Geneva, Illinois . . .

I'm a charter subscriber to WOOD[®] magazine and just want to say thanks to you and the magazine staff for providing a top-quality product. The online discussion groups complement the magazine so well that I feel almost like I'm picking up a new issue every day when I log on. I've recently purchased several shop tools, including an 18-gauge brad nailer, portable planer, and dust collector. I can very honestly say that without both your magazine and the tool discussion group, I wouldn't have had a clue as to comparing one brand versus another. Keep up the good work.

Jack Francis

From a WOOD PLANS[®] customer in Napanee, Ontario . . .

Great job. I received my plans in about four days—excellent considering I live in Canada. Thanks a million.

Michael J. Pilon

Michael Pilon and son Mitchell enjoy the crib that Michael and his father built from a WOOD PLANS project plan.

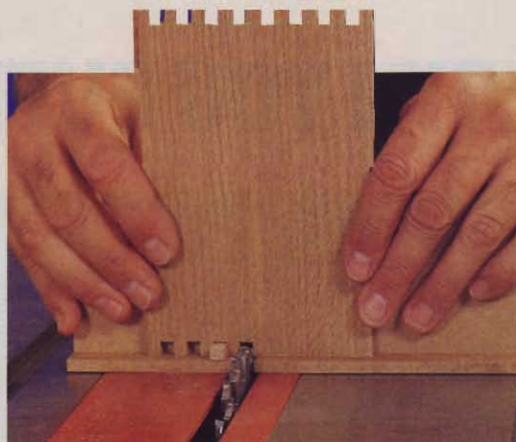

Looking for basic woodworking instruction?

Check this out

As editors at WOOD magazine, we're often asked where a beginning woodworker should turn for basic instruction. To meet this need, we've developed a Woodworking-Basics section on our internet site. You'll find over two dozen free, instructional pieces covering such subjects as gluing, basic joints, safety, finish identification, and wood selection. In one class, Making Box Joints, we'll even show you how to make and use a no-frills box-joint jig like the one being used in the photo above. To find Woodworking Basics, go to www.woodonline.com, click on WOOD MAGAZINE, then go to Woodworking Basics on the drop-down menu.

You can try the same software we use at WOOD magazine

By going online you can review over a dozen software programs that have proven useful in the WOOD magazine shop. You can download these "shareware" programs for free, and give them a try. Some cost nothing, others ask for a modest fee after you try them out, and some provide expanded versions after a trial period.

www.woodmagazine.com/software/

leg stand for stationary tools

A leg stand, with its tapered and slightly splayed legs, makes a sturdy, yet good-looking base for any machine. In fact, the router table on page 54 rests squarely on one. Use the dimensions shown here in the Bill of Materials to make one for the router table or, alter the lengths of the parts and make one to fit a machine in your shop. To size the parts for any machine, follow these guidelines: 1) Subtract $1\frac{1}{8}$ " from the length of the machine for the length of the side rails (A). 2) Subtract $3\frac{1}{4}$ " from the width of the machine for the length of the end rails (B). 3) Subtract 3" from the length of the side rails (A) for the length of the cleats (C). 4) Multiply your desired height by 1.074 for the length of the blanks for the leg halves (D). Screw a piece of plywood to the cleats and bolt your machine to it. Now, here's how to put your leg stand together.

After cutting the rails (A) and (B) to the dimensions shown on the Parts View drawing, screw them together to form a rectangular frame. Fit the cleats (C) into the rail frame and screw them in place. Set the frame aside.

Cut blanks for the leg halves (D) to size, and before forming the legs, drill

the holes where shown. Remember to make mirrored pairs. Bevel-rip the mating edges. Then, with the saw blade tilted at the same angle, cut the spline slots in the bevels. Next, make the angled and beveled cuts at the top and bottom of each leg half. Do not cut the leg tapers until the halves have been glued together.

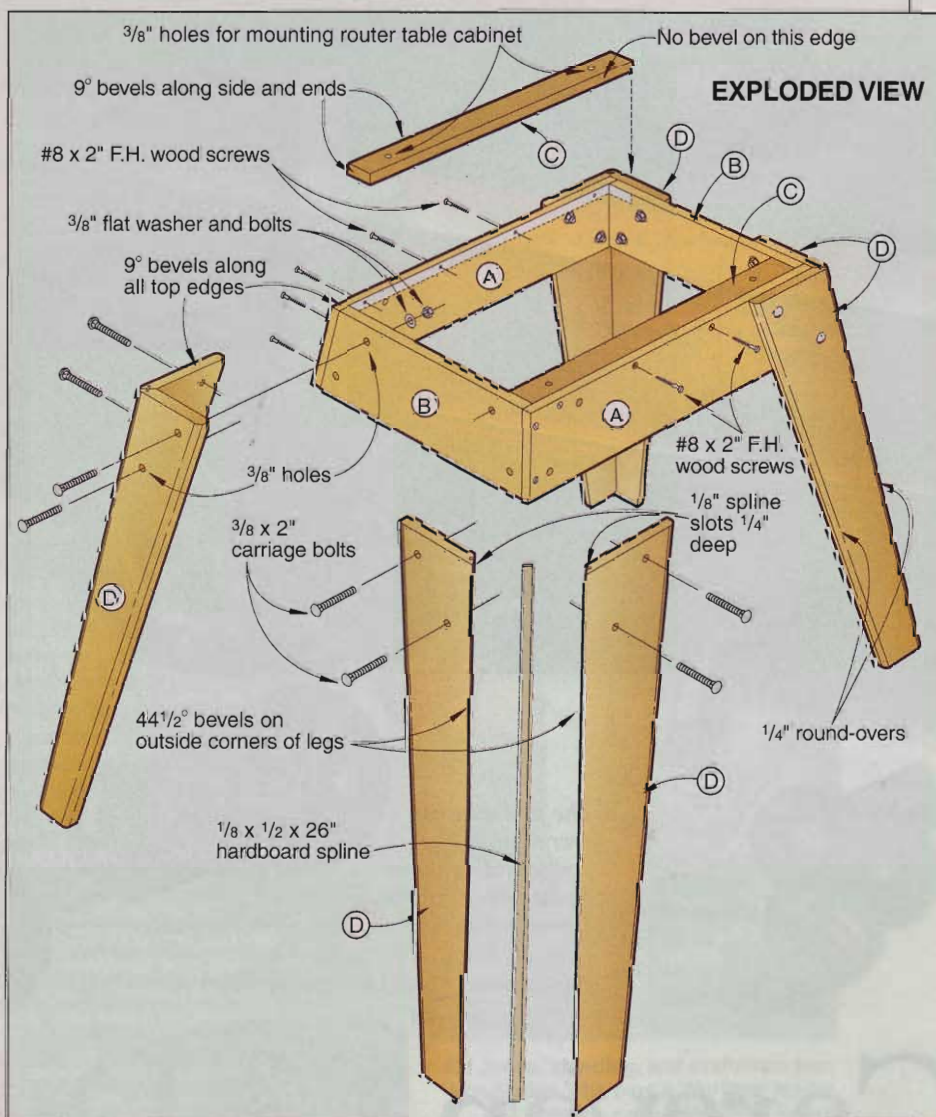

BILL OF MATERIALS

Part	finished size				Matl.	Qty.
	T	W	L	Matl.		
A side rails	$\frac{3}{4}$ "	5"	25 $\frac{1}{4}$ "	M	2	
B end rails	$\frac{3}{4}$ "	5"	20"	M	2	
C cleats	$\frac{3}{4}$ "	1 $\frac{1}{2}$ "	22 $\frac{1}{4}$ "	M	2	
D leg halves	$\frac{3}{4}$ "	6 $\frac{1}{2}$ "	27 $\frac{1}{8}$ "	M	8	

Materials Key: M—maple

Supplies: $\frac{1}{8}$ " tempered hardboard, $\frac{3}{8}$ "x2" carriage bolts, flat washers and nuts (16), #8x2" flathead wood screws (16), finish.

Continued on page 30

leg stand

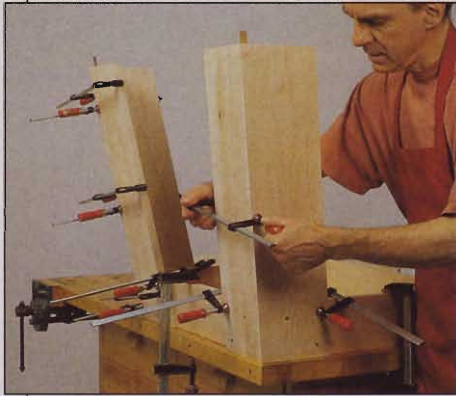

Clamping the legs (D) to the frame (A/B/C) holds them at the proper angle while you finish clamping their length.

Clamp the frame upside down on your workbench. Apply glue to the mating bevels of the leg halves, and insert the splines. While holding the halves together by hand, clamp the legs to the frame. This holds the halves at the proper angle while you finish clamping the length of the leg, as shown in the photo at left. When the glue is dry, mark the tapers on the legs, and cut with a jigsaw or band-saw. Clean up the cuts with a couple of passes over your jointer. Rout the round-overs, and using the holes

drilled in the legs as guides, drill the holes in the frame.

Bolt the legs in place, and if needed, cut a piece of plywood and screw it to the cleats. Place your tool on the stand, and mark the locations of the mounting bolts with a pencil.

Drill the holes and apply the finish of your choice. When the finish is dry, bolt your machine in place and enjoy safe, rock-solid woodworking. 🌲

Written by Jan Hale Svec with Erv Roberts
Project Design: James R Downing
Illustrations: Kim Downing; Lorna Johnson
Photographs: Baldwin Photography

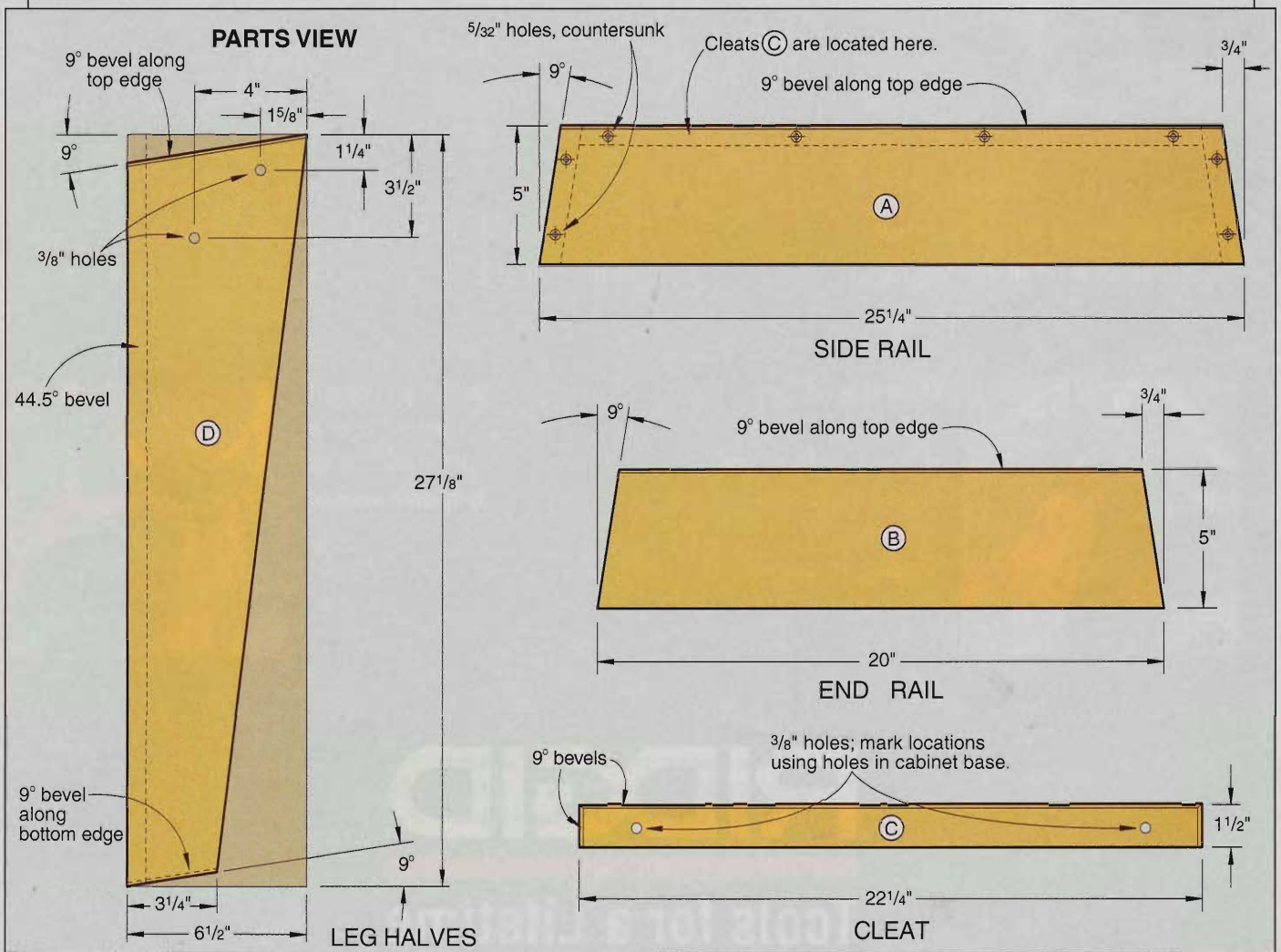

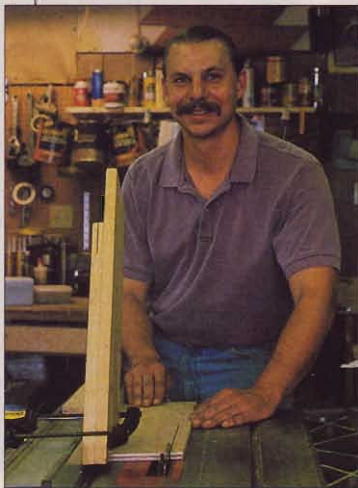

Top Shop Tip winner Todd Rogalla will breathe easier in his shop, thanks to this Jet AFS-1000 ambient air filter and extra filter. Thanks for the tip, Todd!

Once he was bitten by the woodworking bug, Todd Rogalla wasted no time getting going. Five years ago, he bought his first woodworking magazine, followed soon by his first tool: a router he needed to build the jewelry-box project he found in the magazine. Since then he's designed and built everything from small boxes to custom cabinetry.

About his relatively new-found hobby, Todd says, "My father-in-law was a woodworker, but he passed away before I even met my wife. But I sometimes wonder if he's not up there watching and guiding me along."

Whatever your source of inspiration, you've no doubt come up with a great solution to a problem in your shop. Tell us about it, and if we print your idea, we'll pay you \$75. Your shop tip might even be judged the best of the issue, in which case we'll also give you a tool prize worth at least \$250, just as we did for Todd.

Send your best ideas, along with a drawing or photograph of each, and your daytime telephone number, to:

Tips from Your Shop and Ours
WOOD® Magazine
1716 Locust St., GA-310
Des Moines, IA 50309-3023

Or, share your tip with us (and the online world) by posting it to our Top Shop Tip discussion group at www.woodonline.com.

Sorry, but we can't return submitted materials. And, we try to publish only original shop tips, so please send them only to WOOD magazine. Thanks!

Dave Campbell
WOODWORKING PRODUCTS EDITOR



One-pass milling for drawer sides cuts setup time in half

Recently, I was asked to construct five built-in dressers and a set of kitchen cabinets: I had a lot of drawers to make, all of different depths. And I wasn't looking forward to setting everything up twice—once to cut the drawer parts to width, and again to dado for the drawer bottom. The one-step method I came up with works great.

I first stacked my dado set to the thickness of the drawer-bottom material. Next, I made a 1/4"-hardboard spacer and bored a 5/8" arbor hole in the center of it. (This spacer determines the distance between the bottom edge of the sides and the dado for the drawer bottom.)

Finally, I sandwiched the spacer between the dado set and my 10" saw blade, as shown *below*, and slipped the whole thing onto the saw arbor. If you try this technique, make sure you arrange the parts so that the dado set is on the same end of the arbor as your fence.

I used the dado depth to set my blade height, then went to town cutting drawer parts. For each drawer, I only had to measure between the fence and the blade to set the width of the pieces.

—Todd Rogalla, Wahpeton, N.D.

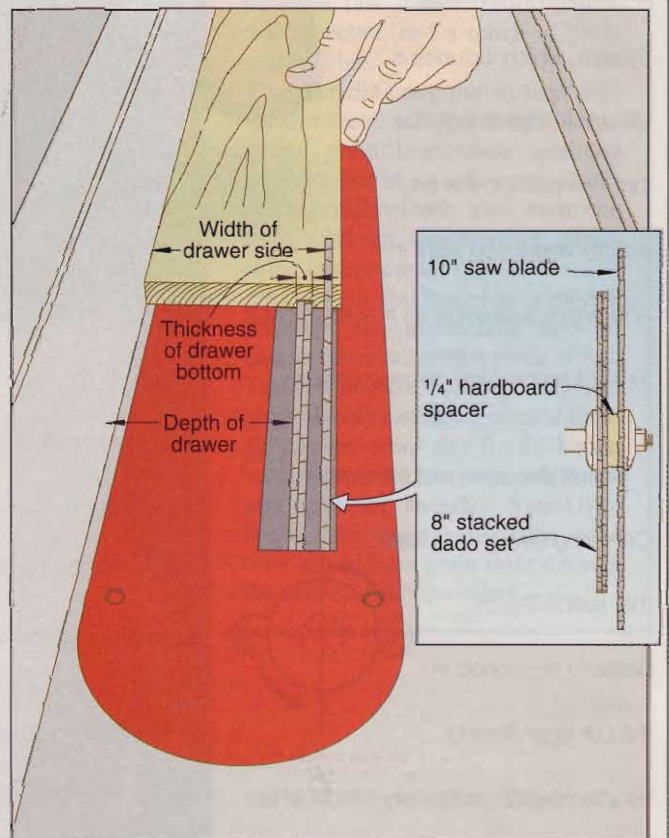

Continued on page 34

Continued from page 32

Cut perfectly pointed post caps in a snap

While building a deck recently, I wanted to cap the 4x4" posts. Precuts were expensive, so I decided I'd make my own. However, I quickly found it difficult and unsafe to try and cut all four sides of a 4x4x6" blank on a tablesaw. I switched to my miter saw, and using the jig shown at right, I was able to cut the caps uniformly, and without putting my hands at risk.

I first ripped the 3/4x12" plywood backboard to the same width as the cap blanks. Next, using one of the blanks as my pattern, I plotted the center point on the backboard, drilled a 5/32"-shank hole through it, and attached a blank to the backboard as shown.

After setting the miter saw to cut a 15° angle, I clamped the backboard against the fence, and made the first cut. To

shape the three remaining sides, I simply rotated the blank a quarter-turn and repeated the procedure. For the last cut,

I supported the cap from beneath with the first wedge I cut off.

—Conrad Savoy, Jr., St. Amant, La.

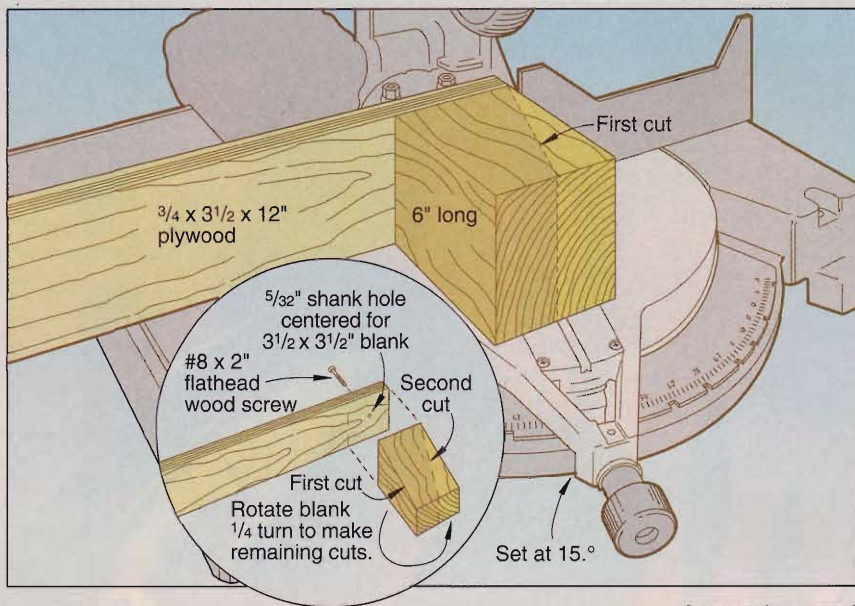

Continued on page 38

INTRODUCING

MAGNESIUM

A Strong Case for a New Tape...



Nobody else makes a 1" x 25' tape with a real metal case, no less magnesium. And nobody else (totally) makes a tape within the U.S. anymore. Nobody except Starrett. No tape except the Starrett Magnesium.

- ◆ 100% MAGNESIUM CASE
- ◆ 100% AMERICAN MADE
- ◆ Compact ergonomic shape & non-slip rubber grip
- ◆ Heavy duty UV-coated blade is 3x more wear resistant
- ◆ Smooth-action reel & rust-resistant return spring
- ◆ Soft touch cam-activated positive lock
- ◆ Tough-Tip® stainless steel blade protector
- ◆ NEW shock absorbing blade bumper

Ask your supplier/retailer or contact Starrett for more information.

AMERICAN MADE
Starrett

Rugged, lightweight magnesium
Tomorrow's Metal, Today!

121 Crescent St., Athol, MA 01331 • (800) 541-8887 • Fax: (978) 249-4745 • www.starrett.com

The fence your table saw dreams about!

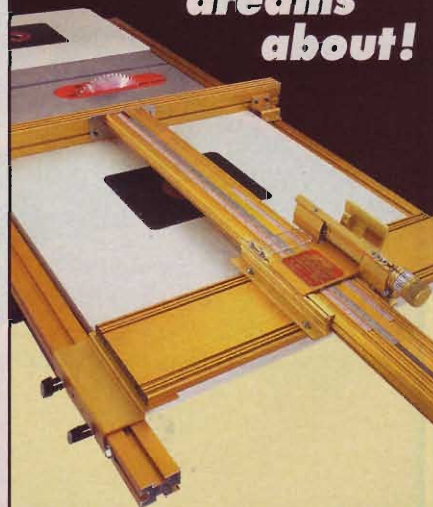

THE NEW INKRA TS-III

Call for your FREE Video Brochure
1-800-752-0725



Woodpeckers Inc.
The Inkra Tool Source

www.woodpeck.com

CRAFTSMAN

INNOVATIVE FEATURES MAKE THIS OUR MOST USER-FRIENDLY VAC!

Perhaps someday, we'll design a vac that makes clean-up fun. For now, we're perfecting wet/dry vacs that make it quick and easy.



The 7-ft. Pos-I-Lok™ hose swivels 360° & snaps in place so it won't pull loose, even when you drag the vac across the room.



Big 16-gal. oval drum with removable drain cap that is flush with the bottom, allowing for complete emptying of liquids.



6.25-peak HP motor detaches from vac to convert into a powerful 210-mph velocity blower for garage & yard clean-up.



SEARS

THE GOOD LIFE
AT A GREAT PRICE
GUARANTEEDSM

tips from your shop and ours

Continued from page 34

Safely secure small parts for crosscutting

You can't beat a stopblock for making repetitive cuts on a miter saw. But small parts, such as the spindle spacers in our mission-style sofa on *page 45*, can get pinched between the stop and the blade. At best, this ruins the workpiece; at worst, it can cause serious injury.

To keep the workpiece in place while I raised the miter saw blade, I made a part-holding device from a scrap strip of $\frac{3}{4} \times \frac{3}{4}$ " stock. In one end of the strip, I drove in a $1\frac{1}{4}$ " screw so it just protruded through the strip, as shown in the drawing at *right*.

With the stopblock to the left of the blade, I placed the spindle-spacer stock against the saw fence and stop block. Then, before starting the saw, I captured the future spindle-spacer against the fence with the screw end of my device. After cutting the piece off, I

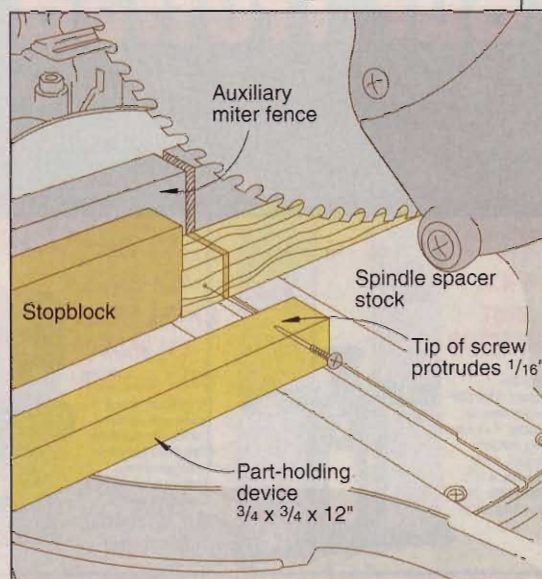

raised the saw, allowed the blade to stop, then removed the workpiece and repeated the process until I had more than enough spindle spacers to complete the project.

—Jim Downing, *WOOD*® magazine
senior design editor

Microadjust plunge depth without an on-board scale

For setting precise plunge depth on my router, I often use a gauge of the same thickness as the desired routing depth. You can use almost anything for a gauge: a piece of scrap, or a drill bit that's the desired thickness or diameter.

First, I lower the motor and bit until the bit just touches the benchtop, then lock it in position. Next, I place my gauge on top of the turret stop, lower the router's plunge stop-rod down to the gauge, then lock the rod in place. When I remove the gauge and unlock the plunge mechanism, the router is ready to plunge to the correct depth.

Need to rout just a smidgeon deeper? I reset the stop rod using the same gauge and an automotive feeler-gauge to fine-tune the depth.

—A. C. Bouchard, Peabody, Mass.

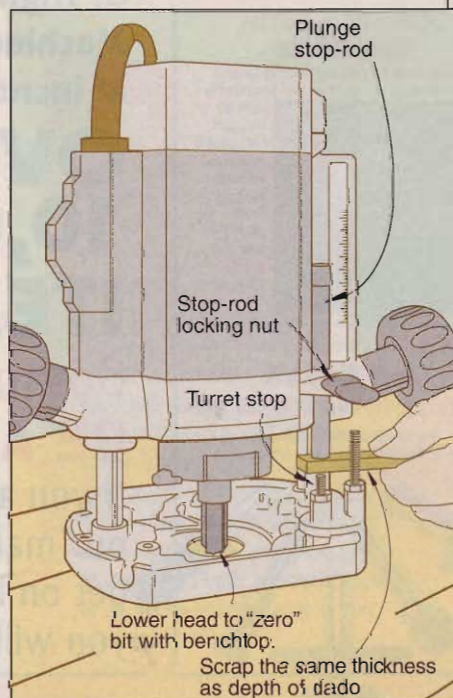

Continued on page 40

Continued from page 38

Quick reference for depth-setting a dado set

Here's a way to quickly set the cutting depth of your dado set without reaching for a ruler every time. Mount your dado blade and throat plate on your tablesaw, then set its cutting depth to $\frac{1}{4}$ ". Rotate the nearest tooth on the dado set to where the tip of the tooth aligns with the top of the throat plate. Scribe a line and mark it $\frac{1}{4}$ ", as shown below. Then do the same for $\frac{3}{8}$ ", and $\frac{1}{2}$ ", $\frac{5}{8}$ ", and whatever other depths you commonly use.

Next time you need a $\frac{1}{2}$ "-deep dado, raise your dado blade until a tooth aligns with the $\frac{1}{2}$ " mark on the throat plate. Make a test cut in scrap and fine-tune if necessary. I can usually get the precise depth with only a couple of test cuts, and without a ruler.

—Chuck Hedlund, WOOD® magazine
shop manager

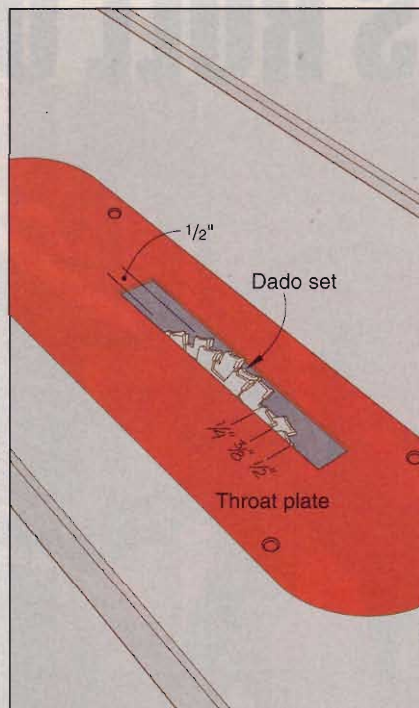

A few more tips from our woodworking pros

- Want face grain on all four sides of a furniture leg? In the Prairie Sofa article, on page 43, we show you a nifty way to do just that.
- Cutting tenons on the end of a long workpiece, such as a bed rail, can be a challenge. On page 44, we show two safe options for performing the task.
- Sometimes a jig or machine setup requires you to feed stock in a different direction than you normally would. See how we marked our horizontal/vertical router table for safety on page 60. 🌲

Free to a Good Home

\$131 Accessory Package

Accept no imitations!
Buy the Performax 16-32
Plus Drum Sander, the
industry's original drum
sander, and receive the
accessory package
absolutely FREE!



- Package includes:**
- Infeed/outfeed tables
 - Conveyor belt tracker set
 - Box of ready-to-wrap sandpaper sized to fit
- \$131 accessory package
FREE**

(Stand optional)

The power to shape your ideas **PERFORMAX**

JET, Performax and Powermatic — A Family Of Brands

Offer effective September 1, 2000 through March 31, 2001 • 800-334-4910 • www.PerformaxProducts.com



ECOGATE

The ECOGATE System is a revolutionary idea in dust collection. When a machine is turned on, a sensor signals the controller to open the appropriate gate and turns on the dust collector. When the machine stops, the gate closes. Our larger model monitors the usage of all machines in your shop and continually optimizes the amount of power supplied to your dust collector. And that generates dramatic savings.

Call 1-888-ECOGATE for a free
brochure. www.ecogate.com



Circle No. 1230

Circle No. 78



prairie sofa

make it your mission
to build this comfy couch

It's easy to show you how great this mission-style sofa looks, but you'll have to build one yourself to find out how incredibly comfortable it is. And by just shortening a few of the parts, you can use these plans to build a matching chair.

In this article we'll build the sofa shown at left. To make the chair at right, simply shorten parts E, F, G, L, M, P, and R according to the chair's length dimensions in the Bill of Materials. If you plan to build both the sofa and chair, machine their matching parts at the same time.

Authentic mission-style furniture from the early 1900s was made mostly of quartersawn white oak. For this project we chose quartersawn red oak because it's easier to cut and machine. To economize on materials, you can make the parts that don't show (L, M, N, R, S, and the inner laminations of D and F) from plainsawn red oak.

First, let's wrap up the legs

1 From $\frac{3}{4}$ " stock 30" long, cut 16 leg outer wraps (A) to $2\frac{1}{2}$ " wide and four leg cores (B) to $\frac{3}{4}$ " square. Set your tablesaw blade at a precise 45° angle and bevel-rip one edge of each part A face-side up.

Note: You may want to practice the next two steps with scrap stock.

2 Using the setup shown at right in Photo A, bevel-rip the other edge for a final width of $2\frac{1}{4}$ ".

3 Surround each core (B) with four part As, and check the miter fit, as shown in Photo B. Cut the core equally across its width and thickness until the miters close up.

4 Apply glue to the beveled edges and inside face of each part A, assemble them to the leg cores, and wrap masking tape around them to hold everything in place. Clamp all four sides, using clamp pads to avoid marring the wood. When dry, cut each leg to $29\frac{1}{4}$ " long.

5 Lay out the mortise locations on the legs according to the Legs and Exploded View drawings. Note that the

Continued

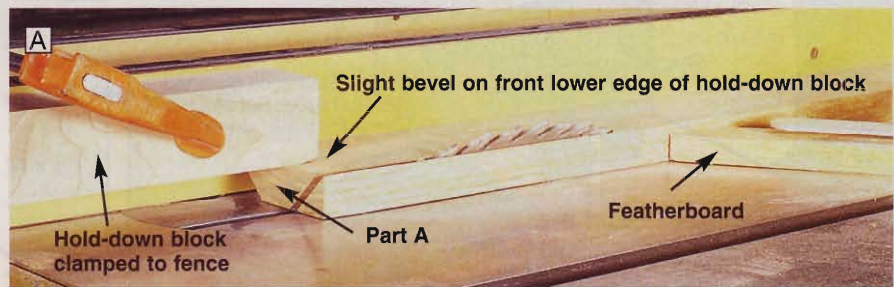
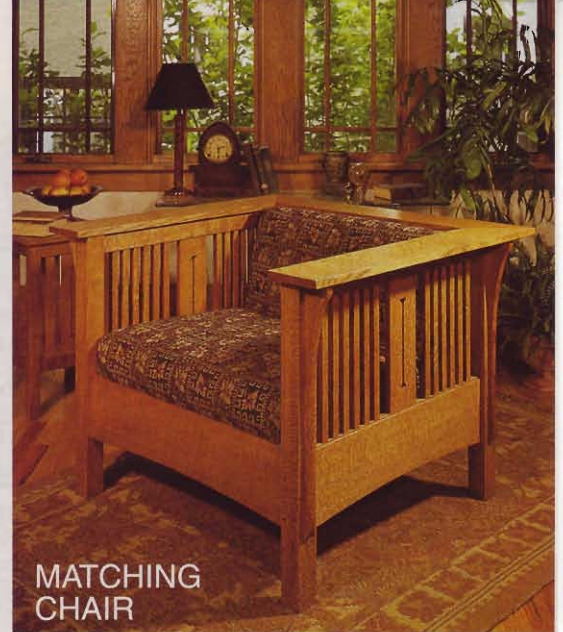

To rip the second beveled edge on the leg outer wraps (A), clamp a hold-down block in back of the blade and a featherboard in front of the blade.

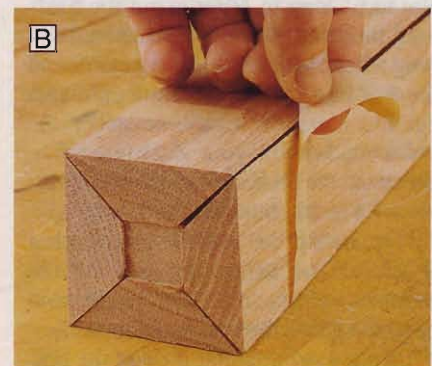
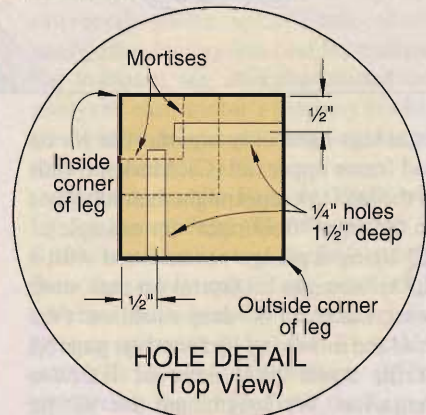
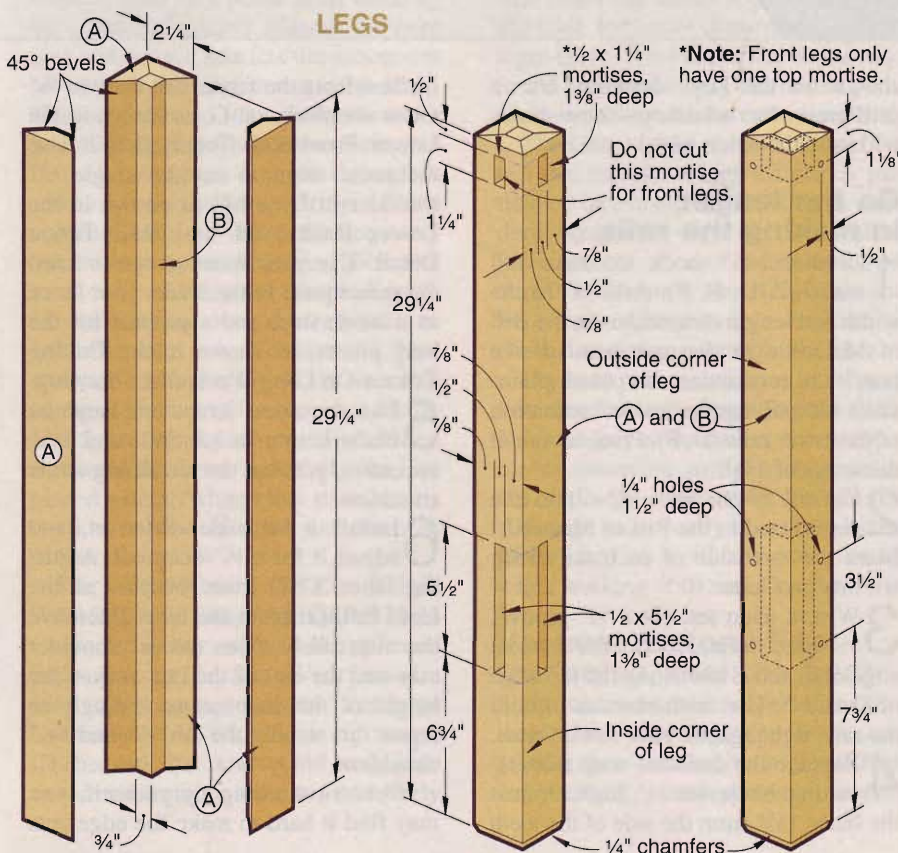

Wrap masking tape around the leg assemblies (parts A, B) to check the fit of the miters. This core is too big.

prairie sofa

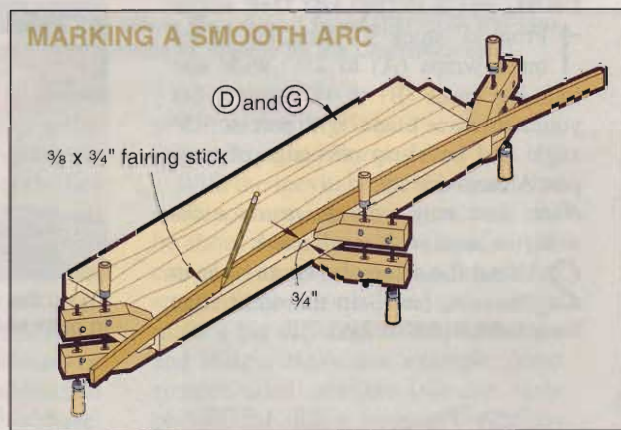
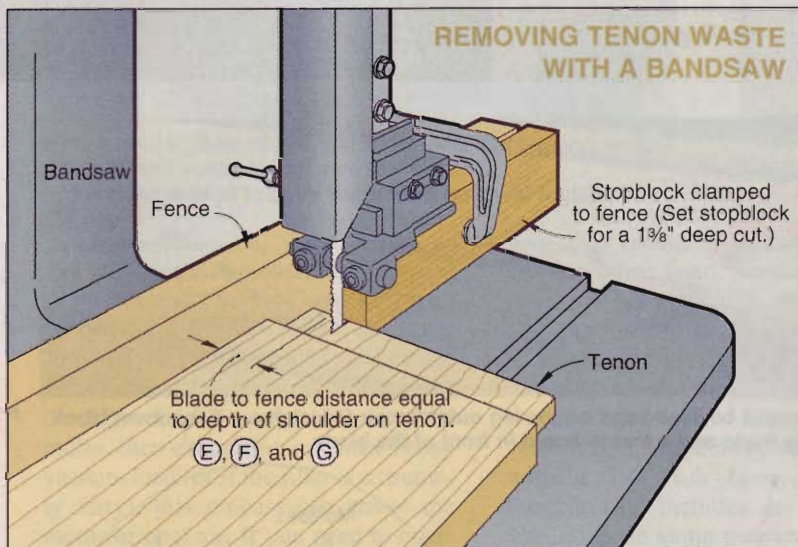
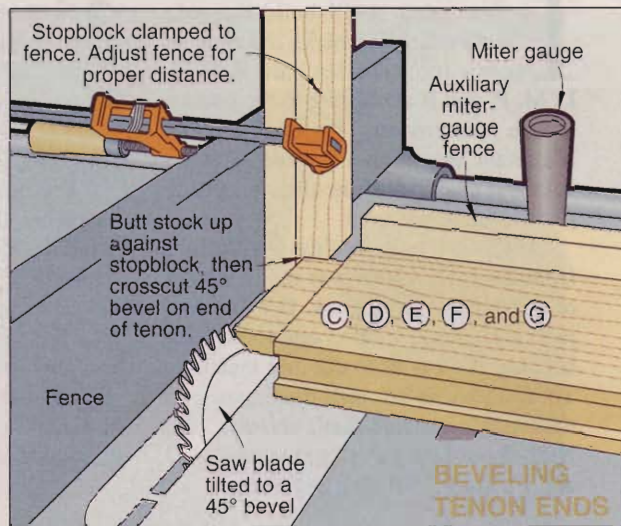
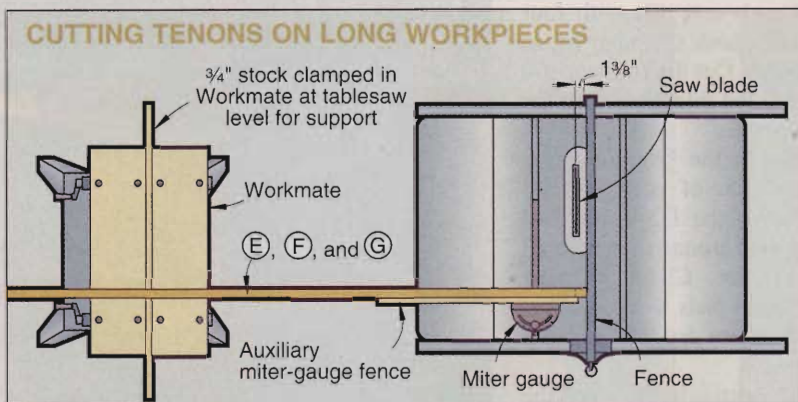

front legs have only one mortise for an end frame upper rail (C). Mark the ends of the legs to keep straight their locations on the sofa ("front/right" for example).

6 Using a plunge router fitted with a 1/2" straight bit (spiral up-cuts work best), cut the 1 3/8"-deep mortises. (We used the mortising jig found on page 58 of the April 2000 issue of *WOOD* magazine. We lengthened the 3/4" jig slot to 6" long in order to cut the 5 1/2"-long mortises. Then, we placed a 4 1/4"-long filler block in the 3/4" jig slot to cut the 1 1/4"-long mortises. You could also cut the mortises with a series of 1/2" holes made with your drill press. Or, check out the process on page 106 of this issue for hand-chopping the mortises.)

7 Square up the mortise ends with a chisel and mallet. (If you cut the mortises with a drill bit, you'll also need to square the mortise sides.)

8 Rout a 1/4" chamfer around the bottom ends of the legs.

9 Mark and drill the 1/4" holes through the mortise wall where

shown on the Legs drawing. Use a drill-press for accuracy—these holes will hold the tenon pins.

Go the length in making the rails

1 Laminate 3/4" stock to make rail stock (C, D, E, F). Add 1/4" to the width and length dimensions in the Bill of Materials so you can trim to size later. To economize, we used plain-sawn red oak for the inside lamination of the lower rails (D, F). Plane to a final thickness of 1 1/4".

2 Cut all of the rails (C–G) to the sizes listed in the Bill of Materials. Mark the face side of each rail along with its part letter.

3 With a dado set, cut a 3/4" groove, 1/2"-deep, centered on the bottom edge of C and E and along the top edge of D and F. Use featherboards to hold the rails tight against your saw's fence.

4 Replace the dado set with a cross-cutting blade set 1/4" high. Adjust the fence 1 3/8" from the side of the teeth

furthest from the fence. Cut the two 1/4" tenon shoulders on G, as shown in the Lower Front Rail Tenon Detail. Use the same setup to cut the single 1/4" shoulder in D and F, as shown in the Lower Back And End Rail Tenon Detail. Use your miter gauge to keep the rails square to the blade, your fence as a work stop, and a support for the long pieces, as shown in the Cutting Tenons On Long Workpieces drawing.

5 Use the same setup, but vary the blade height to 3/8", 1/2", and 1 1/4" accordingly, to cut the remaining tenon shoulders.

6 Install a 3/4"-wide dado set, and adjust it for a 1/4"-deep cut. Adjust the fence 1 5/16" from the side of the teeth furthest from the fence. Remove the material between the 1/4" shoulder cuts and the end of the rail. Adjust the height of the dado set accordingly to repeat this step for the 3/8", 1/2", and 1 1/4" shoulders.

If you're working by yourself, you may find it hard to make the edge cuts

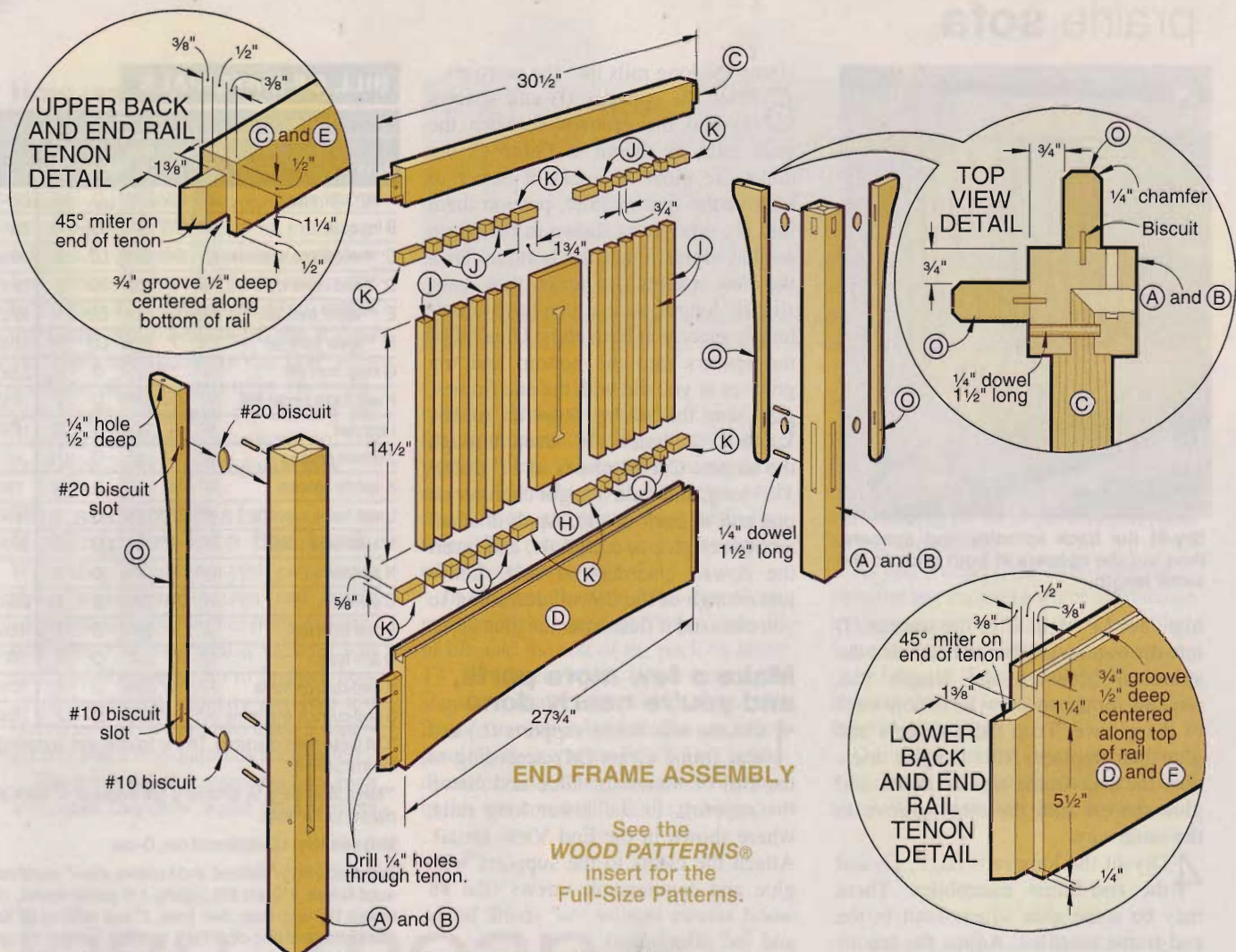

in the long rails. In that case, use your bandsaw and the setup shown in the Removing Tenon Waste With A Bandsaw drawing.

7 With the blade bevel set at 45°, cut beveled ends on the tenons. Use a gauge block, as shown in the Beveling Tenon Ends drawing. *The bevel cut should not shorten the length of the tenon.*

8 Angle your tablesaw blade to 17°, adjust your fence 3/8" from the blade, and cut the chamfer along the top edge of G. Use a featherboard to keep the back face of G tight against the fence.

9 Make a mark 3/4" up from the bottom edge at the center of each of the lower rails. Use a fairing stick to lay out an arc, as shown in the Marking a Smooth Arc drawing. Saw just outside this line with a jigsaw or bandsaw, and sand up to it with a drum sander.

10 Dry-clamp the legs and rails to check for fit. Fine-tune the tenon sizes as required. Leave the assembly clamped together for now.

Let's saw the slats, spindles, and spacers

1 Cut the end frame center slats (H) to thickness and width according to the Bill of Materials. Determine their length by measuring between the bottoms of the end-rail grooves and subtracting 1/16". Now cut the center slats to length.

2 Center and apply or trace the full-size I-beam slat pattern found in the *WOOD PATTERNS®* insert to the slats. We used a 1/4" straight bit in a router table for the straight part of the pattern, and scrollcut the ends.

3 Cut a 3/4×3/4×14 1/2" spindle (I). Adjust its width so it fits loosely and slides back and forth in the rail grooves. Adjust its length so you can tip it into the grooves in the upper and lower rails. Cut 71 more spindles just like it.

4 Cut two 6' lengths of 5/8×3/4" stock for the spacers (J, K). Cut 118 spacers (J) to 3/4" long. Be careful not to cut them too long—it's best to err on

the side of being a hair short. (See the shop tip on page 38 for a means of safely cutting these small blocks.)

5 Finish-sand all of the parts you've made so far.

It's time to assemble everything we've made

1 Disassemble the dry-clamped frame, and glue and clamp the end frames (A/B, C, D). See the End Frame Assembly drawing. Put the center slats (H) into place during the assembly, but do not glue them.

Note: Perform the next two steps on both end frames.

2 After the glue dries, stand the end frame upright and clamp it to your bench to keep it from falling over. Tip into position six spindles on both sides of the slat.

3 Center the slat and place glued spacers (K) on both sides of the slat, in the bottom groove only. Be sure to orient the spacers so they stand 5/8"

Continued

prairie sofa

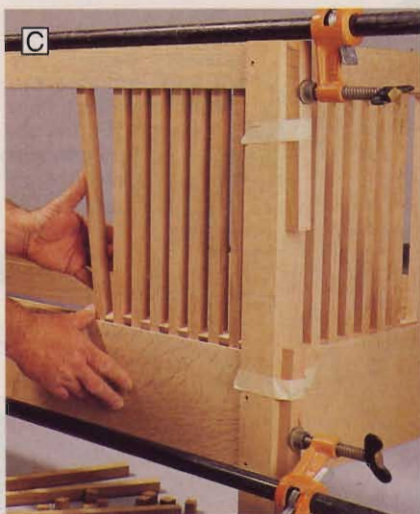

Dry-fit the back spindles and spacers, then cut the spacers at both ends to the same length.

high, not $\frac{3}{4}$ " high. Glue the spacers (J) into the bottom groove and between the spindles. Measure the length that remains for the spacers (K) at both ends of the groove. Trim these spacers and glue them in place. After the glue dries, turn the end frame upside down and glue spacers into the other groove in the same way.

4 Dry-fit the long rails (E, F, G) and the end-frame assemblies. There may be some glue squeeze-out in the end-frame mortises. Adjust the tenons on the long rails for a tight fit. Glue and

clamp the long rails into the mortises.

5 Place the spindles (I) and spacers (J) into the grooves between the back rails, as shown in *Photo C*, but don't use glue. To make it easier to remove the spacers later, position them into the groove, as shown in the photo so they don't touch the bottom. Trim the end spacers, or make new ones slightly longer, so that you have equal-length spacers at both ends. Glue all of the spacers into the bottom and top grooves as you did with the end frames.

6 Using the $\frac{1}{4}$ " leg holes as guides, drill $\frac{1}{4}$ " holes $1\frac{1}{2}$ " deep through the tenons. Cut 22 pieces of $\frac{1}{4}$ " dowel $1\frac{1}{2}$ " long, and sand a slight chamfer on one end of each dowel. Apply a small amount of glue to each hole, and insert the dowel, chamfer-end first. Leave just enough of the dowel protruding so you can sand it flush after the glue dries.

Make a few more parts, and you're nearly done

1 Cut the seat frame supports (L) and seat frame cleats (M) according to the Bill of Materials. Glue and clamp the supports to the lower long rails, where shown in the End View Detail. Attach the cleats to the supports with glue and countersunk screws (the #8 wood screws require $\frac{5}{32}$ " shank holes and $\frac{7}{64}$ " pilot holes).

BILL OF MATERIALS

Part	Sofa				Chair	
	finished size	T	W	L	Matl.	Qty.
A leg outer wraps*	$\frac{3}{4}$ "	$2\frac{1}{4}$ "	$29\frac{1}{4}$ "	O	16	$29\frac{1}{4}$ " 16
B leg core*	$\frac{3}{4}$ "	$\frac{3}{4}$ "	$29\frac{1}{4}$ "	O	4	$29\frac{1}{4}$ " 4
C** end frame upper rail	$1\frac{1}{4}$ "	$2\frac{1}{4}$ "	$30\frac{1}{2}$ "	LO	2	$30\frac{1}{2}$ " 2
D** end frame lower rail	$1\frac{1}{4}$ "	7"	$30\frac{1}{2}$ "	LO	2	$30\frac{1}{2}$ " 2
E** upper back rail	$1\frac{1}{4}$ "	$2\frac{1}{4}$ "	$75\frac{1}{2}$ "	LO	1	$33\frac{1}{2}$ " 1
F** lower back rail	$1\frac{1}{4}$ "	7"	$75\frac{1}{2}$ "	LO	1	$33\frac{1}{2}$ " 1
G lower front rail	$\frac{3}{4}$ "	7"	$75\frac{1}{2}$ "	O	1	$33\frac{1}{2}$ " 1
H end frame center slat	$\frac{3}{4}$ "	$4\frac{1}{4}$ "	$14\frac{1}{2}$ "	O	2	$14\frac{1}{2}$ " 2
I spindles	$\frac{3}{4}$ "	$\frac{3}{4}$ "	$14\frac{1}{2}$ "	O	72	$14\frac{1}{2}$ " 44
J spindle spacers	$\frac{3}{4}$ "	$\frac{5}{8}$ "	$\frac{3}{4}$ "	O	118	$\frac{3}{4}$ " 82
K spindle spacers	$\frac{3}{4}$ "	$\frac{5}{8}$ "	$1\frac{3}{4}$ "	O	16	$1\frac{3}{4}$ " 16
L seat frame supports	$\frac{3}{4}$ "	$2\frac{1}{2}$ "	$72\frac{3}{4}$ "	O	2	$30\frac{3}{4}$ " 2
M seat frame cleats	$\frac{3}{4}$ "	$\frac{3}{4}$ "	$72\frac{3}{4}$ "	O	2	$30\frac{3}{4}$ " 2
N spreaders	$\frac{3}{4}$ "	2"	$27\frac{5}{8}$ "	O	3	0
O corbels	$\frac{3}{4}$ "	$2\frac{3}{4}$ "	$22\frac{3}{4}$ "	O	6	$22\frac{3}{4}$ " 6
P seat back rest	$\frac{3}{4}$ "	6"	$83\frac{3}{4}$ "	O	1	$41\frac{3}{4}$ " 1
Q arm rests	$\frac{3}{4}$ "	6"	37"	O	2	37" 2
R seat-cushion frame	$\frac{3}{4}$ "	$1\frac{1}{2}$ "	$72\frac{1}{2}$ "	O	2	$30\frac{1}{2}$ " 2
S seat-cushion end frame	$\frac{3}{4}$ "	$1\frac{1}{2}$ "	$28\frac{7}{8}$ "	O	2	$28\frac{7}{8}$ " 2

*Cut these parts oversized. Trim to finished size according to the instructions.

**Make these parts by laminating two pieces of $\frac{3}{4}$ " stock and planing to $1\frac{1}{4}$ " thick.

Materials Key: LO—laminated oak, O—oak

Supplies: #8x $1\frac{1}{4}$ " flathead wood screws, #8x $\frac{3}{4}$ " roundhead wood screws, #10 and #20 biscuits, $1\frac{1}{2}$ " pocket screws, $\frac{1}{4}$ " dowels $1\frac{1}{2}$ " long, stain, clear finish, 2" seat webbing 52' long, and 46 seat-webbing clips. For a complete listing of the upholstery supplies, see the article on page 50.

Continued

CUTTING DIAGRAM - SOFA

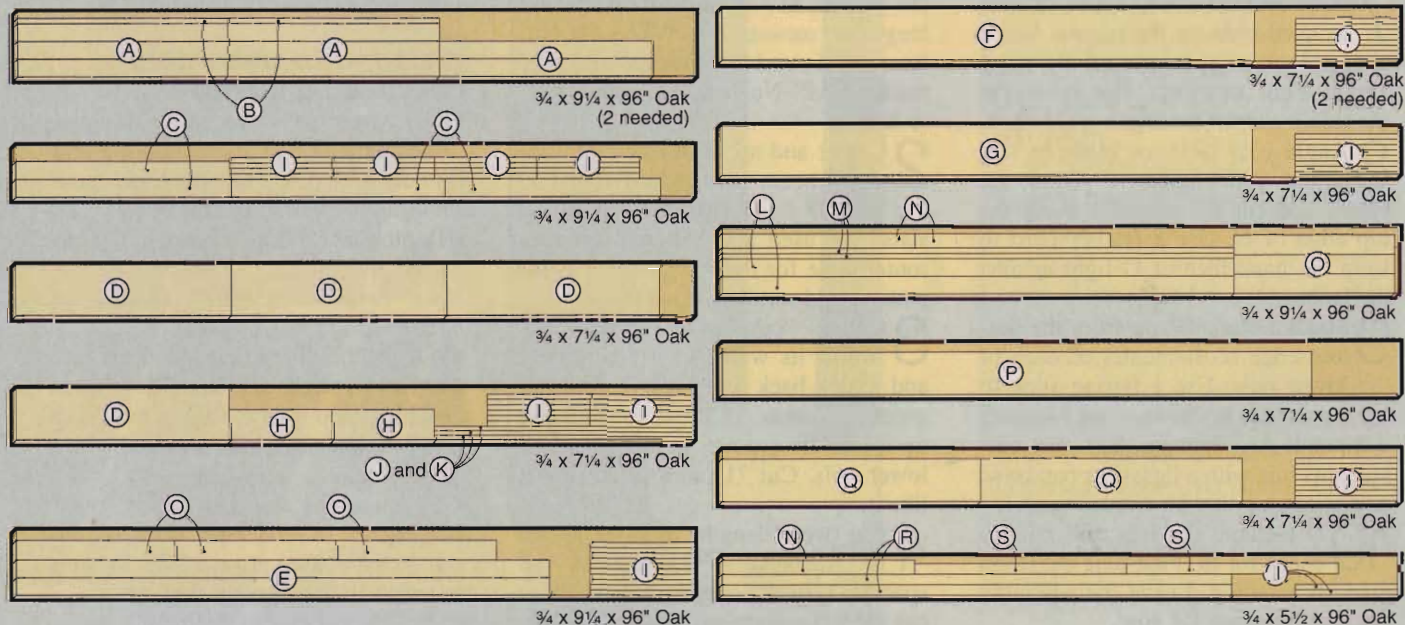

EXPLODED VIEW

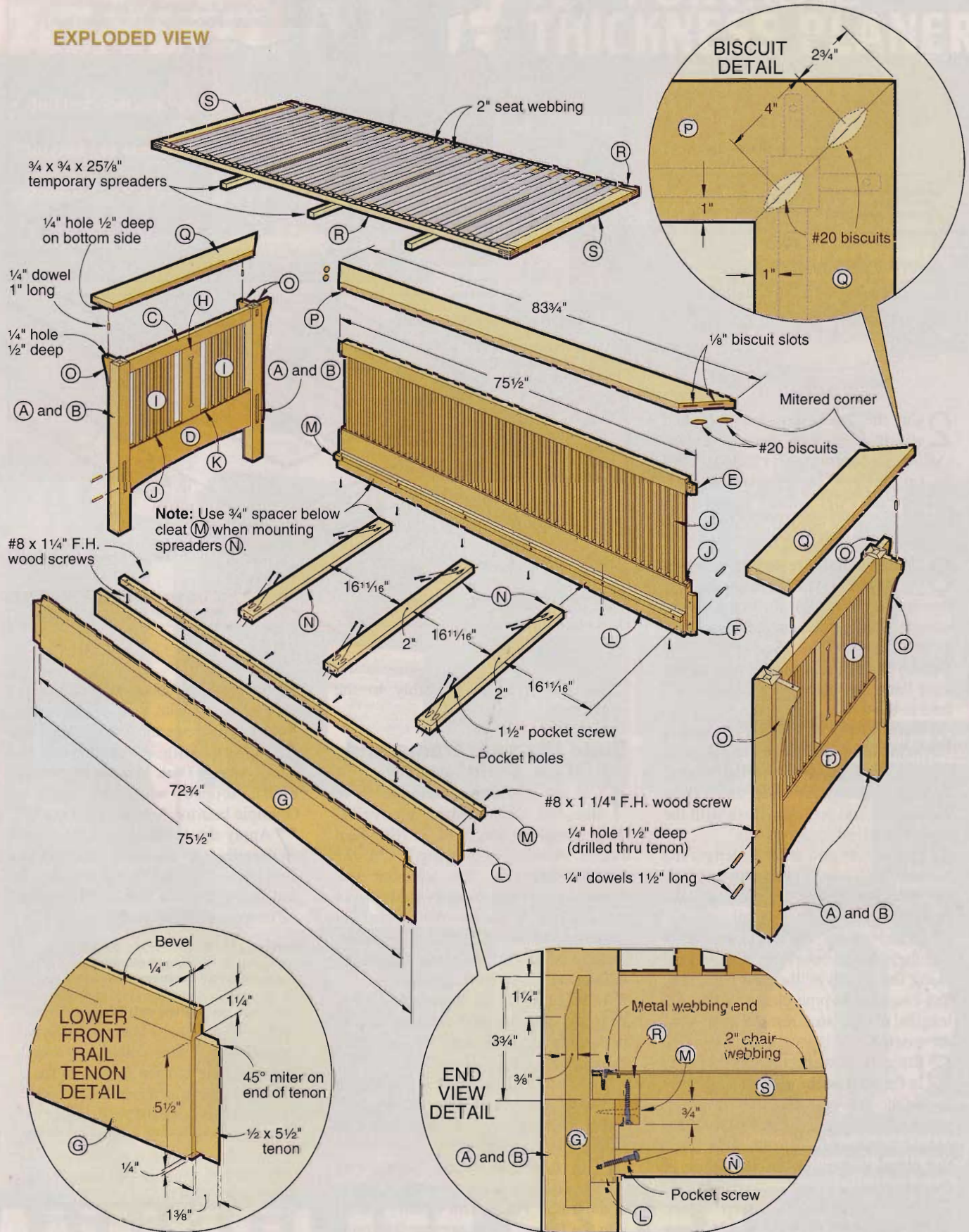

prairie sofa

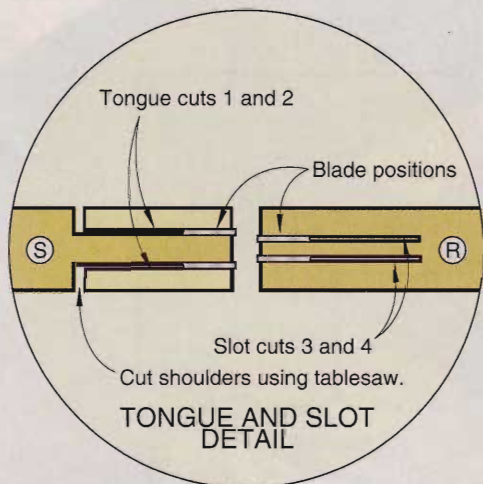

2 Cut the three spreaders (N), and attach them with pocket screws. (Most woodworking catalogs sell pocket hole jigs. The company we purchased our jig from, Kreg Tool Company, sells several models. Call 800/447-8638.)

3 Using the full-size corbel pattern in the *WOOD PATTERNS*® insert, cut the six corbels (O) to shape. Sand smooth, and rout the curved edges with a 1/4" chamfer bit. (See Top View Detail.) Cut centered biscuit slots on the long flat edge, and drill a centered 1/4" hole in the top.

4 Transfer the biscuit-slot locations to the legs, and cut centered biscuit slots in the legs. (See the End Frame Assembly drawing.) Glue and clamp the corbels into position, flush with the tops of the legs.

5 Cut to size and miter to length the seat back rest (P) and arm rest (Q). Cut biscuit slots into the mitered ends, as shown in the Biscuit Detail drawing. Glue and clamp the back and arms together using one long pipe clamp along the length of the seat back rest, and two shorter pipe clamps along the lengths of the arm rests. Finish-sand the assembly.

6 Place 1/4" dowel centers in the holes in the ends of the corbels. Carefully locate the arm-rest assembly in place, again referring to the Biscuit Detail for exact positioning. Tap down to mark the dowel centers on the underside of the arm rests.

7 Drill 1/4" holes 1/2" deep at the dowel-center marks. Place 7/8"-long glued dowels into each hole. Glue and

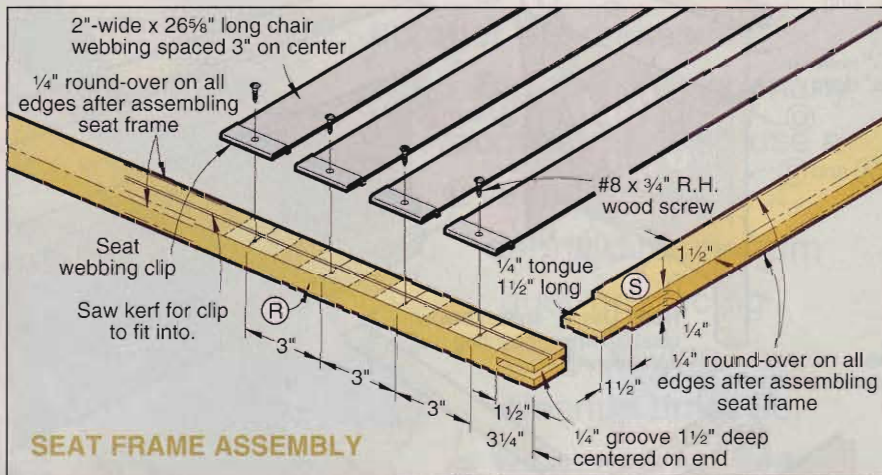
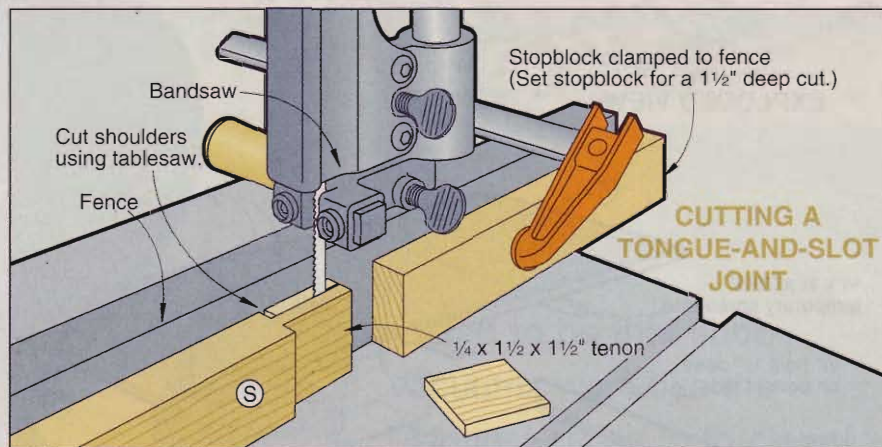

clamp the arm-rest assembly to the upper rails.

Build the seat frame and you'll be sittin' pretty

1 Cut the seat frame parts (R, S) to size. Cut a centered 1/8" groove 1/8" deep along the length of R. (See Seat Frame Assembly drawing.) Cut the tongues and slots that join the seat frame using your bandsaw, as shown in the Cutting A Tongue-And-Slot Joint drawing. Glue and clamp together, making sure the frame is square by measuring across its diagonals.

2 Cut 23 pieces of 2" webbing 26 5/8" long. Install a seat-webbing clip to both ends of each piece by squeezing them together with a bench vise.

3 Locate, drill, and screw one end of all of the webs along the length of one R, making sure the tab of each clip is in the 1/8" groove.

4 Cut three 3/4x3/4x25 7/8" temporary spreaders to fit between the R pieces of the frame. Place them equally spaced into the frame. These prevent the frame from bowing during the next two steps.

5 Stretch each rubber web and clamp it to the opposite side of the frame. Attach with screws and remove the clamp.

6 Finish the sofa. We applied one coat of Watco Dark Walnut Danish Oil Finish topped with two coats of Olympic Interior Antique Oil Finish.

7 Apply the upholstery to the seat as described in the next article. Place the upholstered seat frame into the sofa and screw it to the cleats (M). Remove the temporary spreaders. ♣

Written by **Bill Krier** with **Jim Downing**
Photographs: **Baldwin Photography**
Illustrations: **Kim Downing; Lorna Johnson**

In past issues we've shown how to build a matching Arts-and-Crafts bookcase, coffee table, recliner, ottoman, set of three nesting tables, wall shelf, and nightstand. To order article reprints, send \$5 per project to *WOOD*® Magazine reprints, 1776 Locust St., GA-310, Des Moines, IA 50309-3023. You can purchase most of these projects as downloadable plans online at: woodstore.wood-mall.com/misfur.html

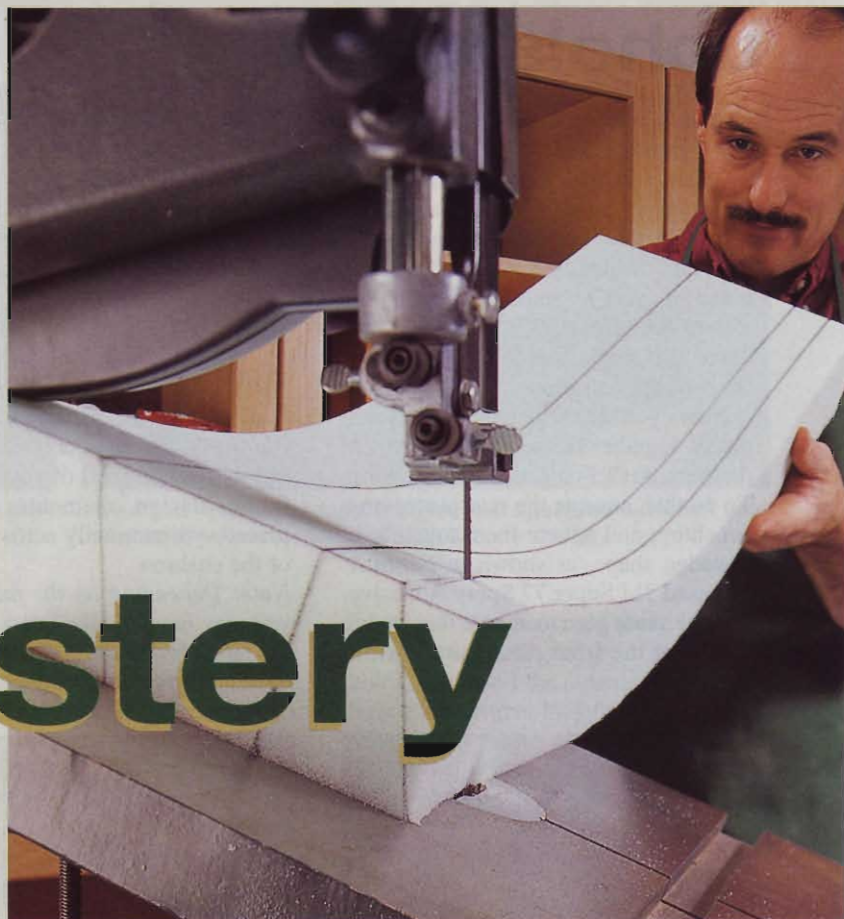

no-sew upholstery

the easy way to cover
your furniture
with cushy comfort

As woodworkers, we know how to operate most any tool made for cutting, shaping, or fastening wood. But if you put many of us in front of a sewing machine, we might as well be at the controls of the space shuttle.

With that in mind, Design Editor Jim Downing came up with a solution. Here's his method for assembling good-looking, comfortable cushions using only tools and techniques that us woodworkers can quickly master.

Note: In this article we'll show you step-by-step how to make a back cushion for the Mission-style sofa or chair on page 42. After making the back cushion, you'll find it a breeze to make the seat cushion.

A little planning ensures you of a smooth start

Your woodshop probably contains all of the tools you'll need, such as a bandsaw for slicing through high-density foam. A pneumatic wide-crown stapler and brad nailer are mighty helpful, but not essential. You'll find the fabric, foam, and batting at fabric and upholstery shops.

When selecting the fabric, which typically comes in rolls 54–55" wide, keep in mind how you will orient it on the seat and back cushions. For example, with the sofa on page 42, the pattern of the fabric allowed us to run the material length-wise on the seat cushion. As a result, we didn't have to stitch the fabric together to span the length of the seat. But with the fabric shown on the following pages of this article, which has a striped design running along its length, the stripes need to be oriented across the width of the upholstered seat cushion for best appearance. So, if you select a fabric like this, you will need to find someone who can stitch two pieces of fabric together to span the length of the seat.

First, cut and assemble the foam

For the sofa and chair cushions we chose a high-density foam purchased at an upholstery-supply shop. It provides a firm cushion, and holds up better over time than a lower-density foam.

To cut the foam, mark its width and length dimensions according to the list shown on the next page. Use a permanent marker and straightedge.

Although the foam pieces for the seat cushion require only square cuts, the back cushions call for some angle cuts. The foam offers little cutting resistance, so even a low-powered bandsaw will help you get the job done. Here's how to go about it.

For the sofa backs, lay out the edge and face marks shown in the Seat Back (Rear Pieces) drawings on a piece of 3×9½×36" foam. (If you're building the chair, make the same marks on the 3×9½×30" piece.) Angle your bandsaw table to 22° and make the beveled cuts, as shown above. Slow the feed rate as you exit the cut—this helps prevent the blade from "grabbing" the foam at the

Continued

upholstery

end of the cut and pulling it into the saw's throat plate.

Also cut the long edges of the 3×14¼×36" piece at a 22° angle, as shown in the Seat Back (Front Piece) drawing. (Substitute the 3×14¼×30" piece if you're making the chair.) Return the table to 0° (horizontal) and make the single cut that's 90° to the faces of the rear piece.

Now, you need to glue these foam pieces together in the shape shown in the Seat Back Foam Glue-up drawing. To do this, arrange the rear pieces on a benchtop, and adhere them together in a wedge shape, as shown in *Photo A*. We used 3M Super 77 Spray Adhesive. Use the same glue to adhere this wedge on top of the front piece, as shown in *Photo B*.

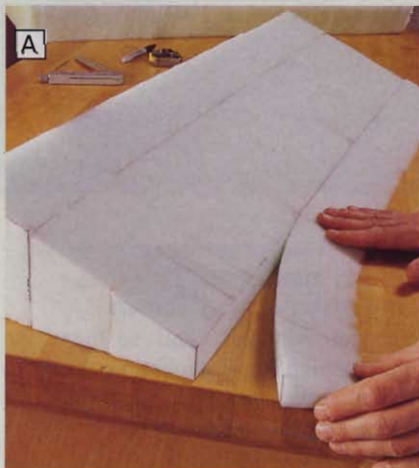

A Arrange the rear pieces for the seat back in a wedge shape, and adhere them with a spray adhesive compatible with foam.

Now, cover the foam with batting and fabric

Cut the ½×12×36" plywood cushion panel. Sand a ½" radius on each corner, and mark the stapling guidelines, centerline, and bottom edge, as shown in the Panel Views drawing.

Cut a 30×60" piece of upholstery fabric and staple one long edge along the stapling guideline on the bottom edge of the cushion panel, as shown in *Photo C*. Use the centerline to center any design elements of your fabric. The fabric design elements should be placed symmetrically across the length of the cushion.

Note: Depending on the fabric design, you may have to take into account how the fabric will be positioned on the seat cushion before determining its best posi-



B Align and adhere the front piece of the seat back to the glued-up rear pieces.



C Stop your staples 2" from the end of the ½" plywood cushion panel when tacking the fabric in place.



D Enlist the help of a friend to pull the fabric uniformly taut along the length of the cushion as you staple the fabric.

tion on the back cushions. The design elements on the seat and backs should align in the finished sofa or chair.

Place the ⅜" staples every inch or two, and keep them at least ¼" from the edge of the plywood panel. Keep the end staples about 2" from the ends of the panel.

Now, arrange the foam, three pieces of upholstery batting, and the cushion panel, as shown in the Back-Cushion Assembly drawing. Place this assemblage, cushion-panel-up, on a clean benchtop.

This is a good time to call in a helper if you have one. Have the helper pull the fabric taut as you staple it along the top edge of the cushion panel, as shown in *Photo D*. Place the first staple in the

Continued

CUSHION MATERIALS FOR THE SOFA AND CHAIR

Part	T	W	L	Matl.	Qty.
------	---	---	---	-------	------

SOFA

SEAT CUSHION (1 REQUIRED)

	6"	28⅞"	72½"	HF	1
	1"	36"	73"	UB	3
	—	46"	92"	UF	1

BACK CUSHIONS (2 REQUIRED)

	3"	9½"	36"	HF	2
	3"	14¼"	36"	HF	2
	1"	14"	36"	UB	4
	1"	19"	36"	UB	2
	—	30"	60"	UF	2
	—	15"	42"	UF	2
	½"	12"	36"	PW	2
	⅛"	11½"	35½"	PW	2

CHAIR

SEAT CUSHION (1 REQUIRED)

	6"	28⅞"	30½"	HF	1
	1"	36"	31"	UB	3
	—	46"	50"	UF	1

BACK CUSHION (1 REQUIRED)

	3"	9½"	30"	HF	1
	3"	14¼"	30"	HF	1
	1"	14"	30"	UB	2
	1"	19"	30"	UB	1
	—	30"	50"	UF	1
	—	15"	33"	UF	1
	½"	12"	30"	PW	1
	⅛"	11½"	29½"	PW	1

Material key: HF—high-density foam, UB—upholstery batting, UF—upholstery fabric, PW—plywood.

Other supplies: ⅜" staples, ⅝" brads, spray adhesive for foam, cloth-backed double-faced tape.

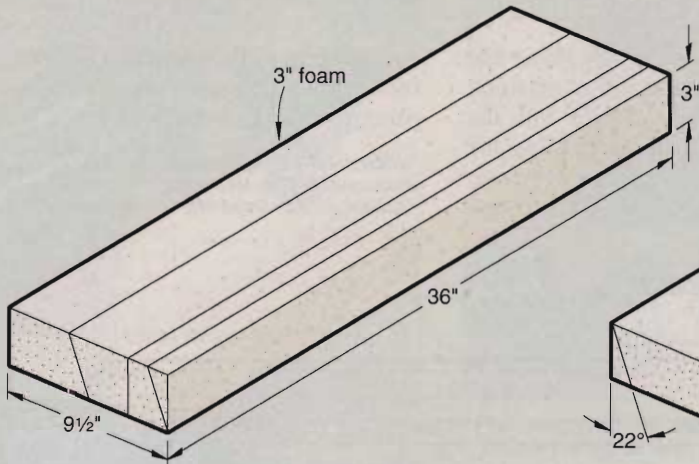

**SEAT BACK
(REAR PIECES)**

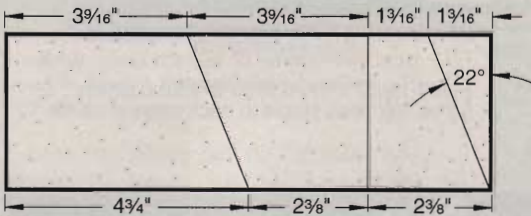

END VIEW

**SEAT BACK
(FRONT PIECE)**

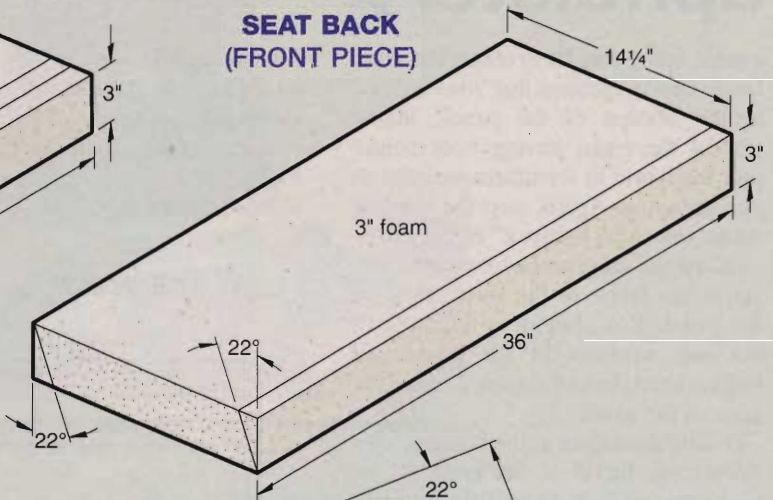

**SEAT BACK
FOAM GLUE-UP**

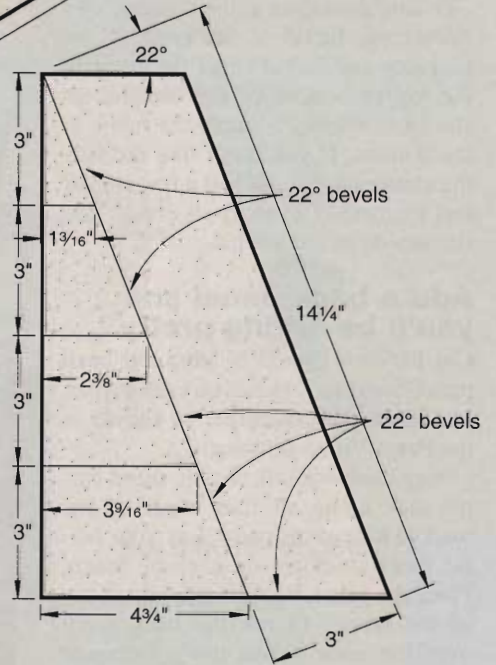

PANEL VIEWS

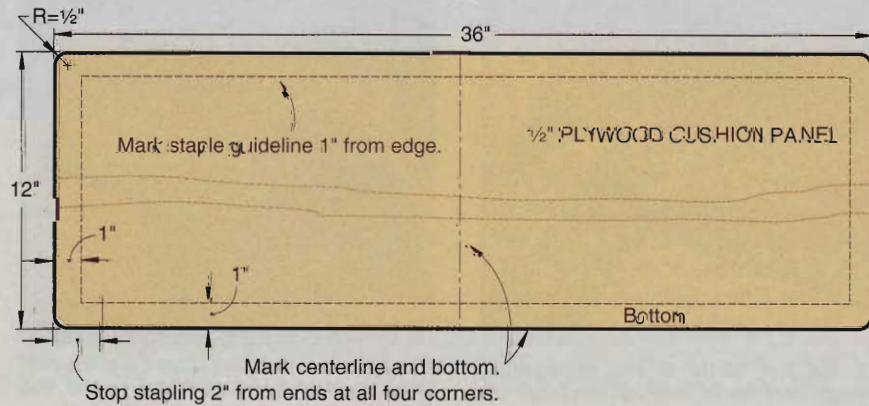
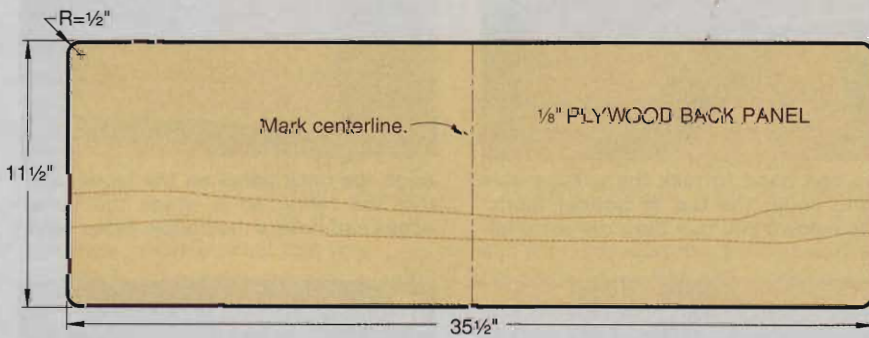

BACK-CUSHION ASSEMBLY

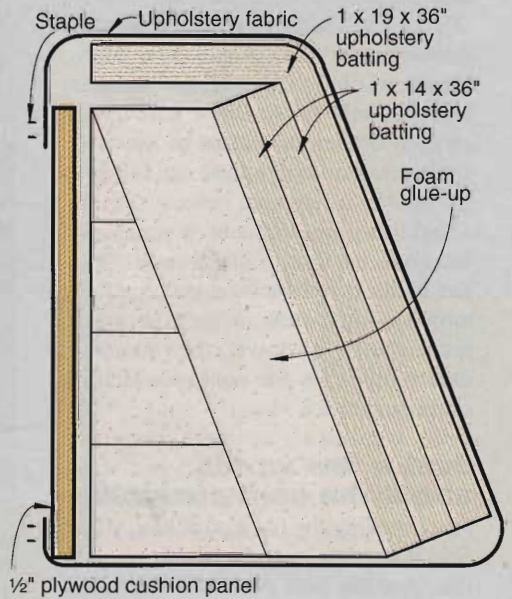

upholstery

center, being careful to center the same fabric design element that you centered at the bottom of the panel. Staple toward the ends, having your helper pull the fabric to a uniform tautness as you go along. Again, stop the stapling when you come within 2" of the ends.

Follow the same procedure to pull and staple the fabric to the short edges of the panel. You should be able to pull out any wrinkles in the fabric. As before, keep the end staples 2" from the edge of the panel.

To fold the fabric at the corners, take the excess fabric at the ends of the cushions and tuck it under the fabric at the top or bottom of the cushion, as shown in *Photo E*. Staple the fabric at the corners. If you don't like the way the corner looks, just pull a few staples and try again. Cut away all excess fabric outside of the staples.

Add a back panel and you'll be sitting pretty

Cut the $\frac{1}{8} \times 11\frac{1}{2} \times 35\frac{1}{2}$ " plywood back panel. Sand a $\frac{1}{2}$ " radius on each corner, and mark the centerline, as shown in the Panel Views drawing.

Place cloth-backed, double-faced carpet tape along all four edges of the marked side of the panel. Lay your fabric face-side-down on a clean bench. Place the panel, marked side up, on top of the fabric. Center the back panel over the same fabric design element that you previously centered on the cushion panel. Cut the fabric to width and length, as shown in *Photo F*.

Pull the fabric taut and adhere it to the double-faced tape along all four edges. Miter-cut the fabric at the corners, leaving some excess fabric at the point of each corner, as shown in *Photo G*. Press down and stick the extra fabric to the double-faced tape.

Nail this panel to the back panel with $\frac{5}{8}$ " brads, as shown in *Photo H*. Place the brads every inch or two, and put three or four brads in each corner to securely hold down the wrinkled excess fabric on the nonexposed sides of the panels.

Just a few words about the seat cushions

After making the back cushions, you'll find it easy to assemble the seat cushions (see the Seat Assembly drawing).

Simply use the seat-cushion frame and its webbing in place of the $\frac{1}{2}$ " plywood cushion panel that you used with the seat back. The article on building the Prairie Sofa, beginning on *page 42*, shows how to make the webbed seat-

cushion frame. Be careful to position the fabric so its pattern aligns with the pattern on the back cushions. 🍀

Written by **Bill Krier** with **Jim Downing**
Photographs: **Wm. Hopkins**
Illustrations: **Kim Downing; Lorna Johnson**

SEAT ASSEMBLY

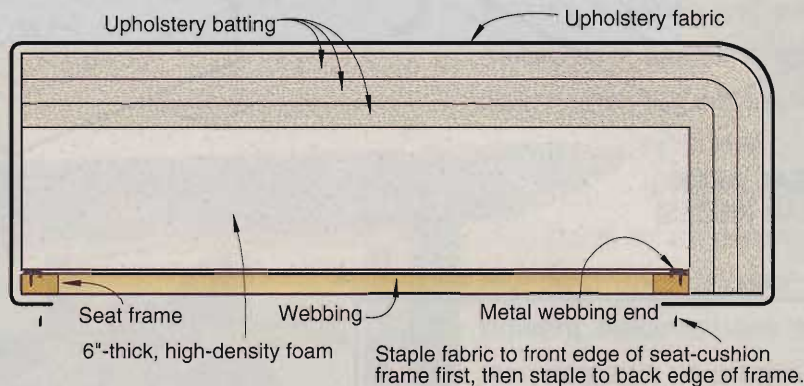

E Use one hand to tuck the excess side fabric under the top or bottom fabric. Staple down and trim the extra material.

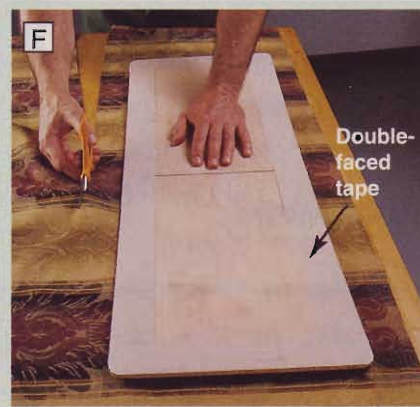

F Align the back panel on the fabric, and trim the fabric so it wraps the panel edges and covers the double-faced tape.



G Miter-cut the fabric at the back-panel corners, and leave enough material to fold over the point of the corner.



H Brads hold the upholstered back panel to the upholstered cushion panel. The brad heads disappear below the fabric.

all-purpose router stat

In its horizontal configuration, this router table is great for mortise and tenon work. A crank makes vertical adjustment convenient and accurate. For operations requiring traditional vertical orientation, the router table converts quickly without tools. The same crank that adjusts the vertical table now raises and lowers the plunge router.

Note: To use the pivoting arm and crank for raising and lowering the router, you must install a plunge router whose motor housing top is flat and unobstructed.

Start with the cabinet and the tables

1 Because you need the four studded knobs already fabricated for use later in the project, make them now. To make the knobs, cut four $2\frac{1}{2}$ " lengths of $\frac{3}{8}$ " threaded rod and epoxy them into four plastic knobs. See the Buying Guide for our source for the knobs. Set the knobs aside while the epoxy cures.

2 Cut the base (A) and sides (B) to the sizes listed in the Bill of Materials. Drill four $\frac{3}{8}$ " holes in the base, where shown on the Parts View: Base drawing on the *WOOD PATTERNS*® insert. Cut the rabbets in the bottom edges of the sides, drill the $\frac{3}{8}$ " holes, and form the $\frac{3}{8} \times \frac{3}{4}$ " slot, where shown on the Parts View: Side drawing. The slot is located only on the right side. Glue and screw the sides to the base as shown in the Cabinet Assembly drawing, keeping the sides square to the base.

3 Cut the table front/back skirts (C), side skirts (D), auxiliary side skirts (E), and auxiliary back skirt (F) to size. Form the rabbets in the ends of the front/back skirts (C), rout the stopped slots in the side skirts (D), and drill the $\frac{7}{16}$ " holes in the side skirts (D) and aux-



ion



iliary side skirts (E), where shown on the Table Assembly, and Auxiliary Table Assembly drawings. To form the stopped slots in the side skirts (D), chuck a $\frac{3}{8}$ " straight bit in your table-mounted router and raise it to cut $\frac{1}{8}$ " deep. Position the fence to center the bit on the width of the skirts. Limit the cut by clamping stopblocks to the fence. With one end against the right stopblock, lower the skirt onto the running bit and rout the length of the slot. Repeat this process, raising the bit $\frac{1}{8}$ " with each pass until you rout the slot through. Install the T-nuts in the side skirts (D) and auxiliary side skirts (E).

4 Drill pilot and countersunk shank holes, and screw the frames together, as shown on the Table Assembly and Auxiliary Table Assembly drawings. Cut the top (G) and auxiliary top (H) to the size listed, and clamp them to the frames C/D and C/E/F, making certain the frames are square. Drill pilot and countersunk

Continued

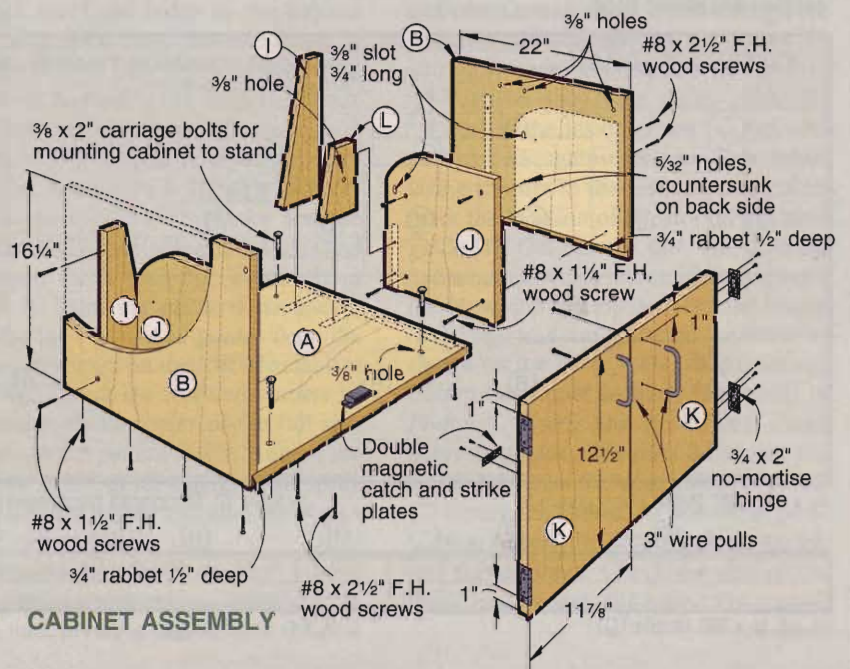
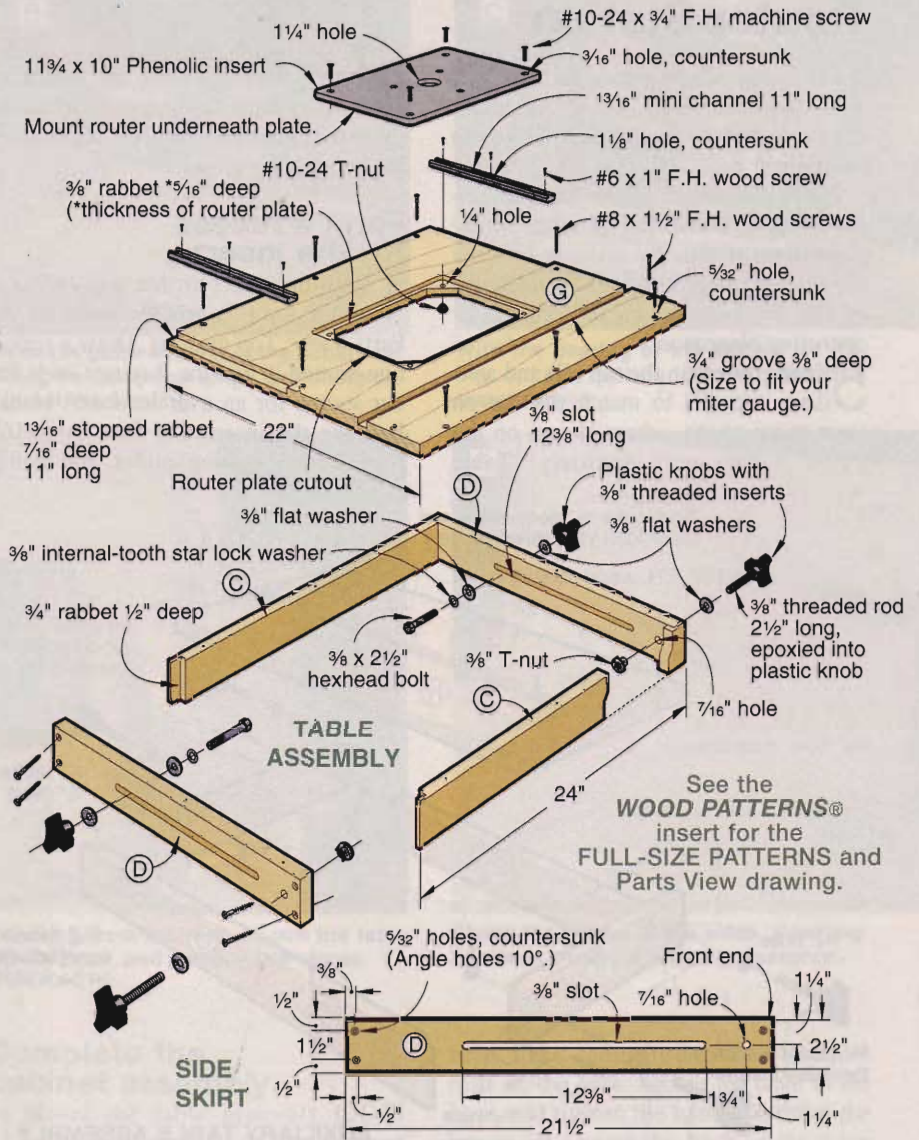

Router Station

shank holes, where shown on the Parts View and Auxiliary Table Assembly drawings, and screw and glue the tops to the frames.

Note: The length of the table assemblies C/D/G and C/E/F/H must be the same dimension as the distance between the cabinet sides (B), minus the thickness of two business or playing cards for operating clearance.

5 Rout grooves in the top (G) and auxiliary top (H) to match the bar on your miter gauge, where shown on the Parts View and Auxiliary Table

Assembly drawings. Set the auxiliary table aside. Rout the stopped rabbets in the rear edges of the top (G), and square the ends with a chisel.

Form a recess for the insert

1 Trim the insert to size, and center it on the top (G), where shown on the Parts View: Top drawing. Draw a pencil line around it. See the Buying Guide for our source for an oversize insert blank. Remove the insert. Cut four 3/4x6x16" particleboard routing guides, and clamp

two of them in place aligned with two adjacent sides of the marked outline. Replace the insert, and position and clamp the other two guides in place, as shown in Photo A. Remove the insert.

BILL OF MATERIALS

Part	finished size			Matl.	Qty.
	T	W	L		
A base	3/4"	22"	25"	BB	1
B sides	3/4"	22"	16 1/4"	BB	2
C front/back skirts	3/4"	2 1/2"	24"	M	3
D side skirts	3/4"	2 1/2"	21 1/2"	M	2
E auxiliary side skirts	3/4"	2 1/2"	13 1/4"	M	2
F auxiliary back skirt	3/4"	2 1/2"	22 1/2"	M	1
G top	3/4"	22"	24"	BB	1
H auxiliary top	3/4"	13 1/2"	24"	BB	1
I* braces	3/4"	4 1/2"	12 3/4"	BB	2
J* table guides	3/4"	12 3/4"	12 3/4"	BB	2
K doors	3/4"	11 7/8"	12 1/2"	BB	2
L arm block	3/4"	3 3/4"	6"	BB	1
M** lift arms	3/4"	7 7/8"	12 5/8"	BB	2
N wrist pin	1" diameter	2 1/8"	D	D	1
O** crank	3/4"	2 1/8"	6"	BB	1
P discs	3/4"	2 1/8" diameter	BB	BB	4
Q fence face	3/4"	3"	24"	BB	1
R fence base	3/4"	2 5/8"	24"	BB	1
S fence blocks	3/4"	2 1/8"	2 1/8"	BB	2
T vac port	1/4"	3 3/4"	4"	H	1
U stop bases	3/4"	1"	1 1/2"	M	2
V stopblocks	5/8"	1 1/2"	4"	M	2

* These pieces are cut from the same blank.

** Part initially cut oversize.

Materials Key: BB—Baltic birch plywood, M—maple, D—hardwood dowel, H—tempered hardboard.

Supplies: #6x1" flathead wood screws (15), #8x1 1/4" flathead wood screws (14), #8x1 1/2" flathead wood screws (50), #8x2 1/2" flathead wood screws (5), 3/8x2 1/2" hexhead bolts (2), 3/8x3" hexhead bolt, 3/8x4 1/2" hexhead bolt, 3/8x2" carriage bolts (4), #10-24x3/4" flathead machine screws (4), 3/8" T-nuts (6), #10-24 T-nuts (4), 3/8" lock nuts (5), 3/8" hex nuts (4), 3/8" coupling nut, 3/8" flat washers (26), 3/8" nylon washer, 3/8" internal-tooth star washers (2), 3/4x2" no-mortise hinges (4), 3" wire pulls (2), double magnetic catch and strike plates, 1 1/4" wood knob, epoxy, clear finish, primer, paint.

Buying Guide

Hardware kit: 1 3/32x1 3/16" mini channel (2 @ 11", 1 @ 24" long), plastic knobs with 3/8" threaded inserts (11), 3/8" threaded rod (4 @ 2 1/2", 1 @ 9" long), 3/8x1 1/2" square-head bolts (5), 3/8x1 1/4x1 1/4" phenolic sheet. Order WOOD KIT RTS-1, \$47.95 ppd., Schlabaugh and Sons Woodworking, 720 14th Street, Kalona, IA 52247 or call 800/346-9663.

Lumber pack: 3/4" Baltic birch plywood cut slightly larger than the sizes listed on the Bill of Materials. Order WOOD KIT LP-3, \$95.00 ppd., from the same address or phone listed above.

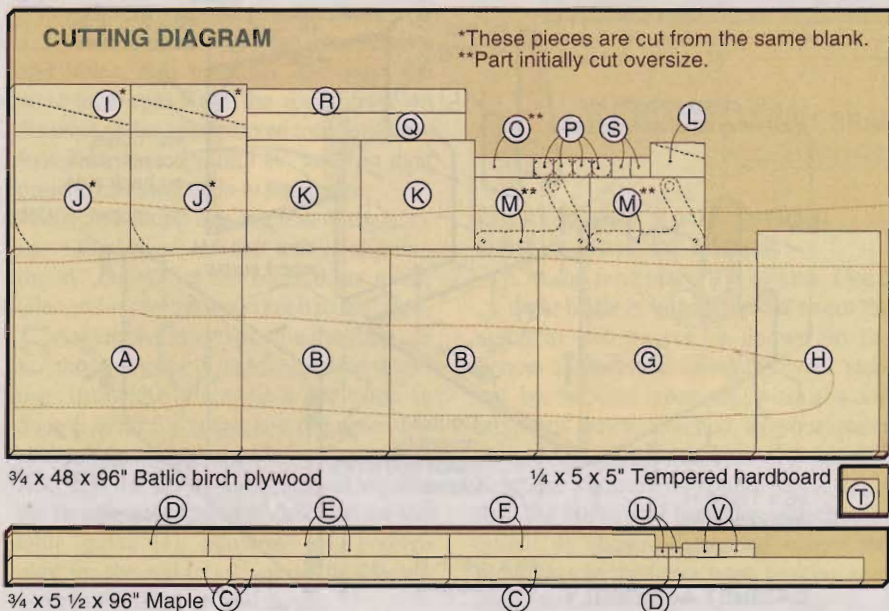
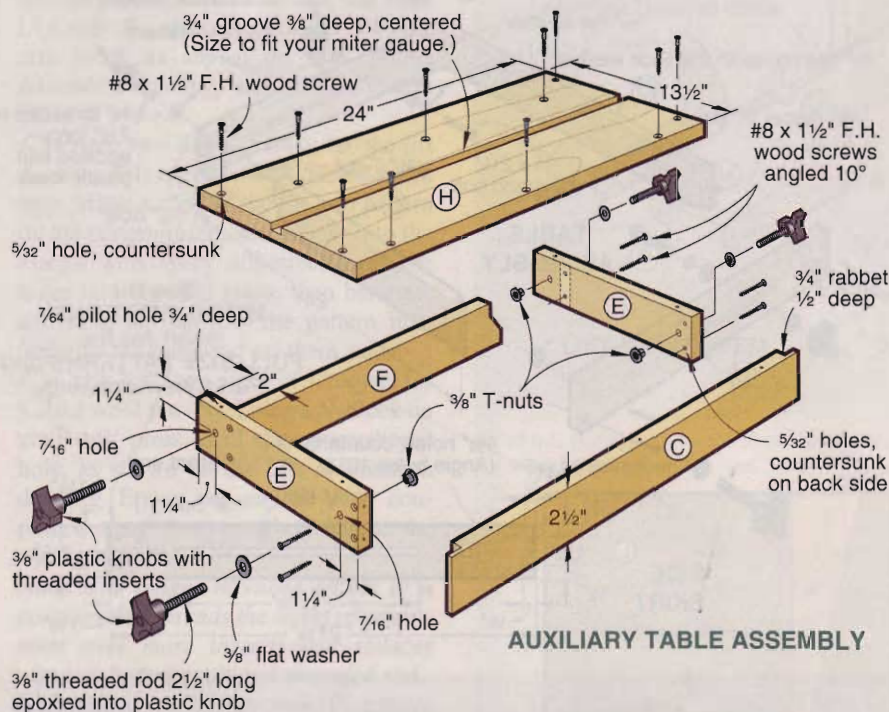

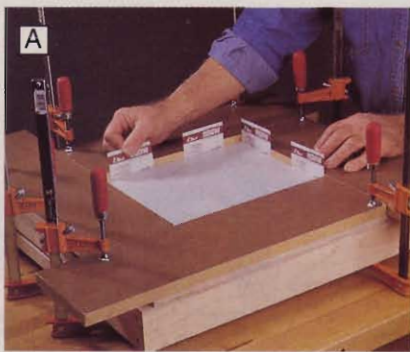

A Use business or playing cards as spacers to provide working clearance for the insert.



B With the guide bearing of the pattern bit riding on the spacer strips and triangles, cut out the opening.

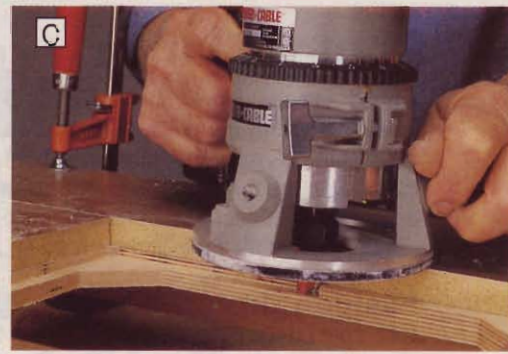

C With the bearing of the pattern bit riding on the routing guides, form the insert recess.

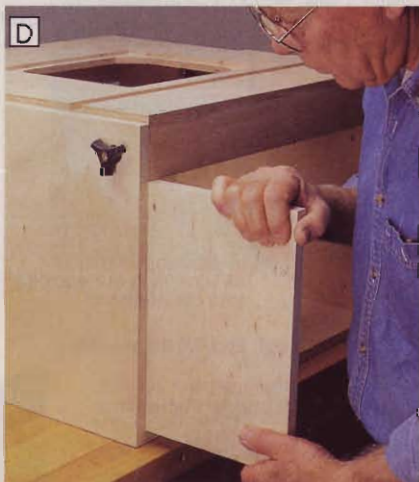

D Inserted from the front, the blanks for I and J make a snug fit between the base and the bottom of the table.



E Working from the rear, square the table to the base, and position the braces.



F Clamp the guides to the sides, inserting business cards for working clearance.

2 Position $\frac{3}{8}$ " thick, $\frac{3}{4}$ " wide spacer strips around the inside of the opening formed by the routing guides. Secure $\frac{3}{4}$ "-thick, 45° triangles, 2" long on the diagonal, in the corners with double-faced tape. Chuck a $\frac{1}{2}$ " top-bearing pattern bit in your handheld router. Starting with the depth of cut set at $\frac{1}{8}$ ", and increasing the depth of cut $\frac{1}{8}$ " with each pass, make repeated passes to cut out an opening in the center of the top, as shown in *Photo B*. Remove the spacer strips and triangles.

3 Place the insert on top of the routing guides and the router on top of the insert. Adjust the depth of cut so the pattern bit just grazes the exposed edge of the tabletop. Remove the insert, and rout the exposed lip of the tabletop, as shown in *Photo C*.

4 Round the corners of the insert to match the corners of the recess, and drill countersunk $\frac{3}{16}$ " holes, where shown on the Table Assembly drawing. Use the insert to mark the locations of the T-nut holes in the corners of the recess and drill the holes.

Complete the cabinet assembly

1 Mount the table assembly C/D/G between the sides of the cabinet assembly A/B. Insert studded knobs through the front holes in the cabinet sides, and screw them into the T-nuts at the front of the side skirts, as shown on the Table Assembly drawing. Insert hex bolts from the inside through the slots in the skirts and the rear holes in the cabinet sides. Secure the bolts with knobs.

2 Cut two $18 \times 12\frac{3}{4}$ " blanks for the braces (I) and table guides (J), and test them for a snug fit, as shown in *Photo D*. Trim the blank if necessary, then cut the braces and guides from the blanks, as shown on the Lift Mechanism drawing. To cut the rounded corners of the guides, make copies of the full-size pattern on the pattern insert. Adhere the patterns to the guide blanks with spray adhesive, and jigsaw and sand the blanks to the pattern lines.

3 Remove the front studded knobs; loosen the rear knobs; slide the table back; and, pivoting the table on the rear

bolts, flip it vertically and lower it until it rests on the base. Square the table to the base, and tighten the knobs. Position the braces (I) against the back of the table skirts, as shown in *Photo E*. Drill pilot and countersunk shank holes through the base (A) and sides (B) into the braces (I), and screw them in place.

4 Position the right table guide (J) against the inside of the cabinet, and push it back against the top of the table. Using the slot in the side (B) as a guide, mark the location of the slot on the table guide (J). Cut out the slot, and drill the countersunk shank holes in both guides (J). Now, pin the top between the braces in the rear and the guides in the front, as shown on the Parts View: Side drawing. Clamp the guides in place, as shown in *Photo F*. Using the pre-drilled shank holes as guides, drill pilot holes into the sides, and screw the table guides in place.

5 Return the table to its horizontal position, insert the front studded knobs, and tighten them. Check the size of the front opening and, allowing a $\frac{1}{16}$ " gap all

Continued

Router Station

around, cut the doors (K) to size. Drill holes and install the pulls, as shown on the Cabinet Assembly drawing. Mount the hinges on the doors, and hang the doors on the cabinet. Install the magnetic catch. Remove the table and set it aside.

Fashion the lift mechanism

1 Form the arm block (L), as shown on the Lift Mechanism drawing. Position it inside the cabinet, centered underneath the slot in the right table guide (J), as shown. Drill pilot and countersunk shank holes through the base (A), side (B), and table guide (J) into the arm block, as shown on the Cabinet Assembly drawing, and screw the arm block in place.

2 Fasten two 8x13" blanks for the lift arms (M) together with double-faced tape. Make a copy of the lift arm pattern on the pattern insert, and adhere it to the blanks with spray adhesive. Drill the holes on your drill press, then bandsaw and sand the parts to the pattern line. Separate the parts and set them aside.

3 Cut a 2 1/8" long piece of 1" dowel for the wrist pin (N). Using a V-block on your drill press, drill the counterbored hole, as shown on the Lift Mechanism drawing. Epoxy one end of a 3/8" coupling nut into the counterbore and set the wrist pin aside.

Note: The longer threaded length of a coupling nut spreads the stress of adjustment over more threads and reduces wear on both the nut and threaded rod.

4 Make a copy of the crank (O) pattern on the pattern insert, and adhere it to a 2 1/8x6 1/2" blank. Drill the counterbore and holes, and bandsaw and sand the ends to shape. Rout the round-over on the edge of the counterbored face. Bandsaw four 2 1/8" discs (P), drill 3/8" holes in their centers, and sand them to finish size.

Glue and clamp one of them to the back (no round-over) of the crank, aligning the 3/8" holes. Set the other discs aside. Glue and screw the wood knob to the crank.

5 Assemble the lift mechanism as shown on the Lift Mechanism drawing, using the three discs set aside in Step 4. With the crank and rod assembly protruding through the slot in the cabinet side, run the inside lock nut and washer up the threaded rod to the face of the table guide (J), allowing just enough play for the rod to swivel as the mechanism is adjusted up and down.

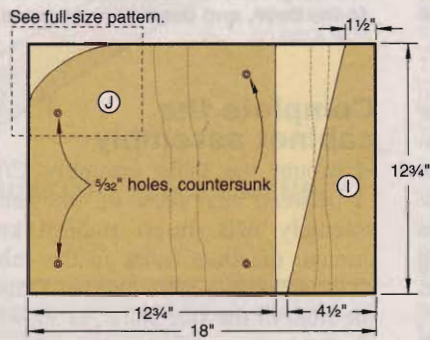
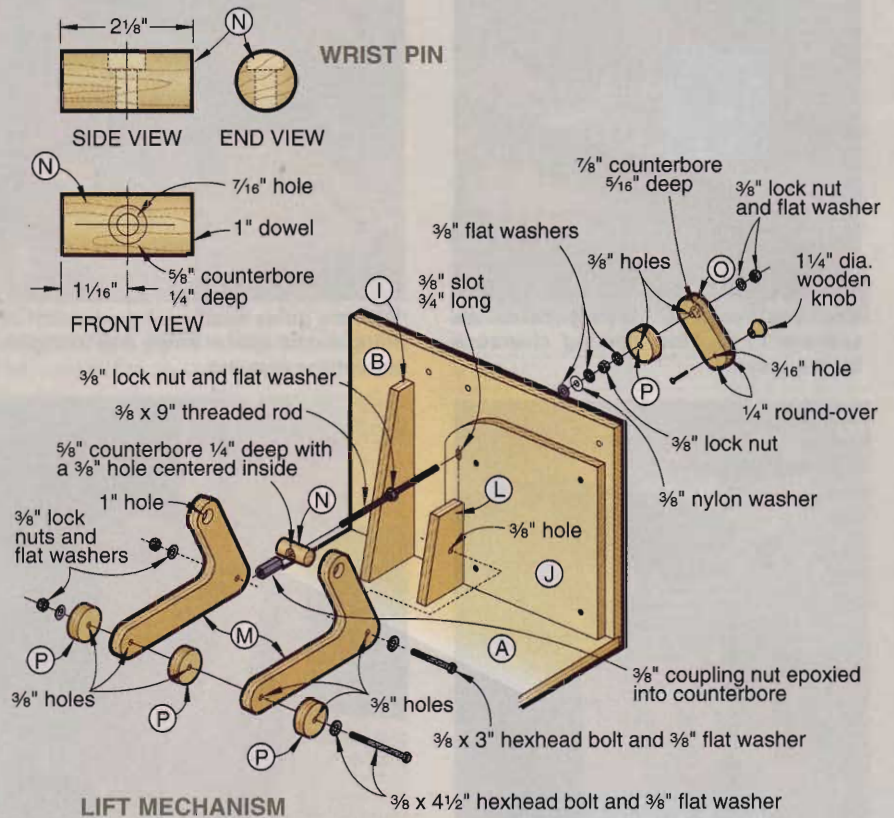
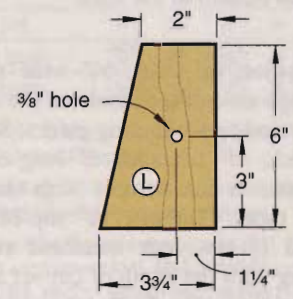

TABLE GUIDE/CABINET BRACE



ARM BLOCK

Next build your fence and a pair of stops

1 Cut the fence face (Q) to size. Use a dado blade in your tablesaw to cut the notch in two passes, as shown on the Fence Assembly drawing. Prevent tear-out by backing your cut with a wood auxiliary fence attached to your miter gauge. Cut the fence base (R) to size. Rout the chamfer along the back edge, drill the holes, and form the semicircular cutout as shown. Glue and clamp the fence face to the fence base, making sure they form a 90° angle.

2 Form the triangular fence blocks (S), as shown on the Fence Assembly drawing. Glue and clamp them to assembly Q/R, where shown. Cut a length of mini channel 24" long, and drill and countersink it for #6 flathead screws. The Buying Guide lists a source for this channel. Position it on the top edge of the fence, with the front of the channel flush with the face of the fence. Drill pilot holes and screw the channel in place. Cut a 3 3/4x4" piece of 1/4" hardboard for the vac port (T), and form a hole in it to fit your shop vacuum hose.

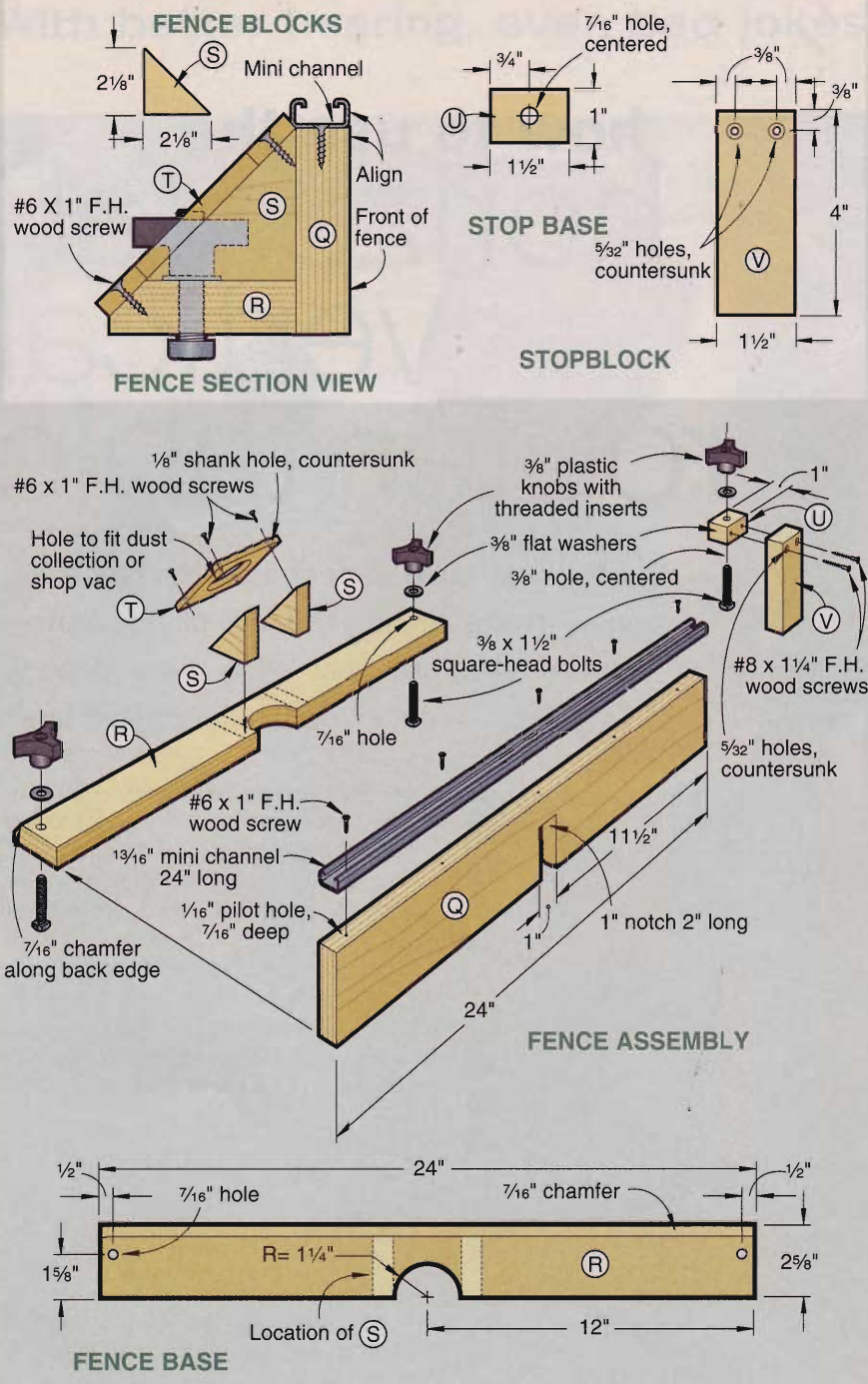

Screw the vac port to the fence, as shown on the Fence Section View.

3 Cut the stop bases (U) and stopblocks (V) to size. Drill holes in the bases, as shown on the Fence Assembly drawing. Secure the bases to the channel with square head bolts and knobs. Position the stopblocks on the bases, using a square to align them perpendicular to the length of the fence. Clamp the stopblocks to the fence, and drill pilot and countersunk shank holes through the blocks into the bases. Unclamp the blocks, apply glue, and drive the screws.

Finishing and final assembly

1 Remove the doors and door hardware. Disassemble the lift mechanism, leaving only the arm block (L) in place. Remove the bolts and knobs from the stops and the channel from the fence. Finish-sand all parts and assemblies through 220-grit. Apply two coats of satin polyurethane to the inside of the cabinet, and all surfaces of the table, auxiliary table, lift arms, crank, rollers, fence, and stops. Sand between coats with 220-grit sandpaper.

2 Prime and paint the outside of the cabinet, including the edges of the base and sides, and all surfaces of the doors. We masked off the interior of the cabinet, and used Krylon 2012 Clover Green/Safety Green spray paint as our finish coat.

3 Reassemble the lift mechanism, greasing the threaded rod where the coupling nut runs. Mount the hinges and pulls, rehang the doors, and reinstall the magnetic catch. Cut two 11" lengths of channel, drill and countersink them for #6 flathead screws, and screw them to the top, as shown in the Table Assembly drawing. Install T-nuts in the corners of the insert recess. Screw the previously cut piece of channel to the fence.

4 Remove the subbase from your router, center it on the insert, and use it to mark the locations of the router mounting screws. Drill and countersink the holes, and mount the insert to the router. Chuck a 1/4" brad-point drill bit in the router, and turning the collet by hand, mark a center point. Remove the router, and drill a 1/4" hole in the insert. Remount the insert to the router, then mount the combination in the top, fastening the insert in place with flathead machine screws.

5 Position the table in its vertical configuration by sliding it, front (T-nut end) first, into the slot between the braces and table guides and letting it come to rest on the rear disc of the lift mechanism. Fasten it in place, through the slots in the side skirts, with hex head bolts, lock washers, flat washers, and knobs. Position the auxiliary table between the sides, resting on the table guides. Fasten it in place with four studed plastic knobs and washers.

6 Install square head bolts, washers, and knobs on the fence and stops, as shown on the Fence Assembly drawing. Slide the heads of the bolts in the stops into the channel on the fence, and tighten the knobs. Slide the heads of the bolts in the fence into the channels on the table, and tighten the knobs.

Note: For instructions on using the router station, see the following article. To build the leg stand, see Great Ideas For Your Shop on page 28. 🌟

Written by Jan Hale Svec with Erv Roberts
Project Design: Conway Dobbs; James R. Downing
Illustrations: Kim Downing; Lorna Johnson
Photographs: Baldwin Photography



how to use the horizontal/ vertical router table

Our two-way table, described in the preceding pages, makes already versatile plunge routers even easier to use. Just follow these steps to get smooth results every time.

You already know how useful your router can be with the bit pointed straight up or straight down. But have you ever thought about what woodworking feats you could accomplish with it mounted horizontally? You'll find that several operations, such as raising panels, mortising, and tenoning, become much easier and safer with the bit parallel to the work surface and the workpiece lying flat.

Get the horizontal advantage

Vertical panel-raising bits and some edge profile bits work great with the back table upright and the router horizontal. You'll have to cut an opening in the auxiliary table that's big enough to accommodate the largest bit that you plan to use. See the photo *below*.



Only part of the bit extends above the work surface in the horizontal setup, so you'll have to cut an opening to accommodate the rest of it. We made ours 2" long and 1 3/4" wide, big enough to let this panel-raising bit spin freely.

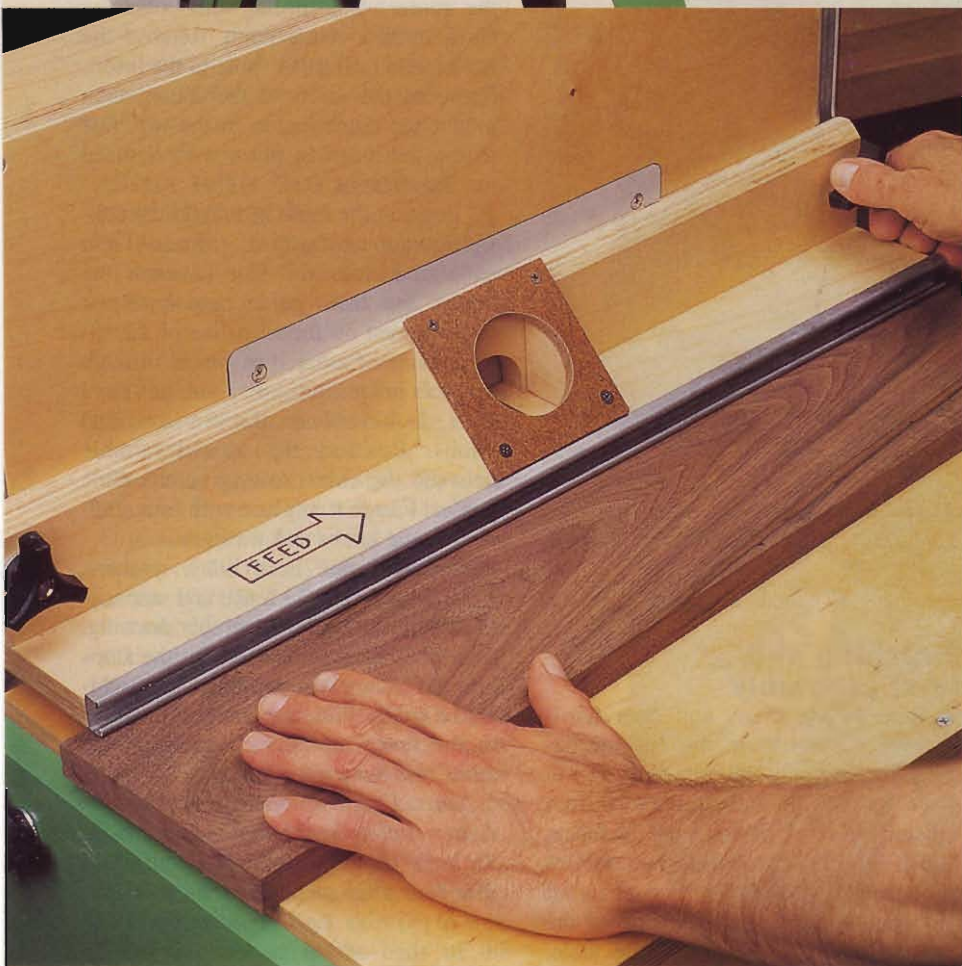

Use the workpiece to set the fence as a hold-down. The stock must slide smoothly through from end to end for safety and a precise cut.



Slide the hold-down block into the fence channel, and center it whenever you need to keep a narrow piece in place.

Raise the fence out of the way, and loosen the knobs holding the vertical table. Turn the crank on the side of the cabinet to adjust the depth of cut, then retighten the knobs. Note that you'll feed stock from left to right. The photo *opposite* shows our handy reminder, printed and drawn right on the fence with a dark, permanent marker.

In this position, your fence serves as a long hold-down. Place the workpiece flat on the front table. Then lower the fence until it contacts the piece lightly and evenly, from end to end. Again, see the photo *opposite*.

Take several light cuts to shape a profile, finishing up with a setting that just skims the surface. You'll get the smoothest possible result that way.

We built one more accessory, a hold-down block, to use for mortise and tenon work at the end of a narrow board, or on the side of a narrow stile. See the drawing *above right* for the dimensions and details. It fits into the channel on the fence and keeps the workpiece secure while providing a clear view.

An upcut spiral bit excels at mortise and tenon tasks. Install one in your router, use a couple of test pieces to set the height and depth, and transfer your layout lines from the workpiece to the auxiliary table. When working on a short stile, use both stop blocks to control the cut. You'll be limited to one stop block

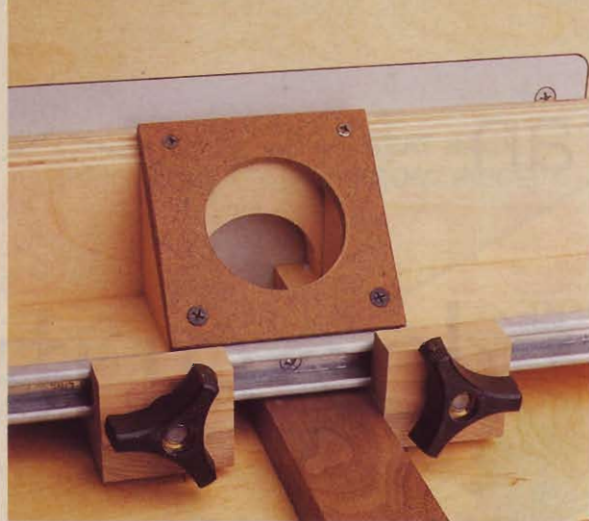

For mortising, set both stop blocks whenever possible. Guide the stock with your miter gauge.

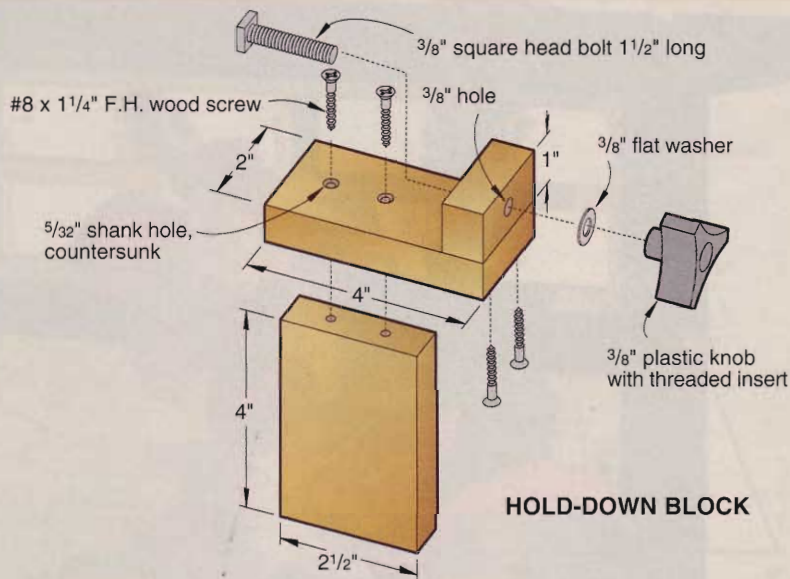

with longer workpieces. As shown in the photo *above right*, you can even cut into the end of a rail for loose tenons.

To form standard tenons, set the depth of cut, place the hold-down block in contact with the workpiece face, as shown in the photo *above left*, and cut the tenon's side shoulders in one or more passes. Use the miter gauge to support the workpiece. Loosen the fence knobs and reset the height of the hold-down block when you flip the rail on edge to cut the final two shoulders.

Go vertical when necessary

Now let's say you want to reset the router to its vertical position so you can use a large-diameter panel-raising bit. Loosen the bolts that hold the auxiliary table in place and remove it. Loosen the bolts that hold the main table and crank

the lift mechanism as low as it will go. Slide the table up and out of its slots, pivot it back and down, and fasten it with the knobs and bolts.

Now you're back to the more familiar router table arrangement. Take advantage of the miter gauge slot to guide wide pieces with your tablesaw miter gauge. Use the stop blocks to make accurate stopped dados.

Remember, the design calls for a plunge router, and you must keep the plunge mechanism unlocked to adjust cutting height. Now the crank forces the router up along its plunge rods for a deeper cut or lowers it for a lighter cut.

Make sure to tighten the knobs on the fence every time you reposition it. Feed stock from right to left in this setup, and use a featherboard when possible. 🐿️

Photographs: **Baldwin Photography**
Illustration: **Roxanne LeMoine**

an Oriental-styled beauty

Ikebana, the art of arranging cut stems, leaves, and flowers in vases and other containers, has evolved in Japan over the past seven centuries.

While western floral arrangements use layer upon layer of flowers, ikebana uses as few elements as possible in composing elegant contours that highlight the flowers' beauty. In Japan, arranged flowers traditionally decorated a small niche in rooms where guests were received. Our vase incorporates a serene background for a few carefully selected blooms.





A Use a $\frac{3}{16}$ "-thick strip of wood with a $\frac{5}{16}$ " hole to gauge the projection of the dowels.



B When you remove the tape, the glue that squeezed out when you inserted the dowels comes off with it.

Base and top begin as one

1 Cut a $\frac{3}{4} \times 6\frac{1}{4} \times 11\frac{1}{2}$ " blank for the base (A) and top (B), and plane it to $\frac{5}{8}$ " thick. We used wenge, but any wood that contrasts with the birch dowels and lattice screen will work. To keep the blank from accidentally slipping into the blade slot in the throat plate of your tablesaw when cutting the end bevels, clamp it to a carrier board at least 12" long. Attach a tall auxiliary fence to your rip fence, tilt the blade to 20° , and cut the bevels on the ends of the blank, where shown on the Base: Front View, of the Parts View drawing on the **WOOD PATTERNS**® insert. Rip the blank to form the base (A) and the top (B), cutting each piece $\frac{1}{32}$ " wider than listed in the Bill of Materials. Then, joint the extra $\frac{1}{32}$ " off the cut edges to remove the saw marks.

2 Install a $\frac{1}{2}$ " dado blade in your tablesaw, and attach a wood auxiliary fence to your miter gauge. Clamp a stopblock to the auxiliary fence, locating the notches in the base (A) where shown on the Parts View drawing. Cut the shallow front notches first, then the deeper back notches. Cutting the notches in this order preserves the backing of the auxiliary fence and reduces tearout.

3 Mark the location of the hole for the flanged flower arranger. Chuck a Forstner bit or an adjustable hole cutter in your drill press, and drill the hole.

4 Tilt your tablesaw blade to 45° , and using a tall auxiliary fence and clamping the base (A) to a carrier board as in *Step 1*, cut the bevel along its front bottom edge.

Raise the base on legs and uprights

1 Plane $\frac{3}{4}$ " stock to $\frac{1}{2}$ " thick for the legs (C), uprights (D), and beam (E). As you plane the stock, test the thickness for a snug fit in the base notches. Cut the legs and uprights to size. Set a piece of stock aside for the beam. Apply small pieces of masking tape to the outside faces of the top (B), legs (C), and uprights (D) at the cross-grained $\frac{1}{4}$ " hole locations, as shown on the Parts View and Upright drawings. Mark the centers of the holes on the tape and, using a brad-point bit chucked in your drill press, drill the holes. *Do not drill the end-grain holes in the tops of the uprights or the ends of the beam.* Leave the tape in place until the dowels are glued in.

2 Chuck a $\frac{1}{8}$ " straight bit in your table-mounted router, and adjust it to rout $\frac{1}{4}$ " deep. Position the fence to center the uprights (D) on the bit. Clamp a stopblock to the fence, and rout the grooves, where shown on the Uprights drawing on the insert.

3 Install a $\frac{5}{8}$ " dado blade in your tablesaw, and adjust it to cut $\frac{1}{8}$ " deep. Make test cuts to check that the width of the cut is the same as the thickness of the base (A). As in *Step 2*, use an auxiliary fence and stopblock to cut the notches in the legs (C) and uprights (D), where shown on the Parts View and Upright drawings on the pattern insert.

4 Cut eight pieces of $\frac{1}{4}$ " dowel $1\frac{1}{4}$ " long. Position the legs and uprights in the notches in the base, as shown on the Exploded View drawing. Using the previously drilled holes as guides, drill

holes into the base, as shown on the Parts View drawing. Spread glue in the holes, and insert the dowels through the legs and uprights into the base, letting the ends of the dowels protrude $\frac{3}{16}$ ", as shown in *Photo A*.

Remove the tape before the glue is completely dry, as shown in *Photo B*.

Set the other four dowels aside.

Make a screen of lattice and dowels

1 Measure the distance between the bottoms of the grooves in the uprights, subtract $\frac{1}{16}$ ", and cut 45 pieces of $\frac{1}{8}$ " dowel to this length. To avoid splintering the dowels, we used a utility knife. Stack these dowels in the upright grooves.

2 Mill a piece of birch stock to $\frac{3}{16} \times \frac{1}{2} \times 36$ " for the rails (F) and stiles (G). Measure the distance between the uprights. Using a wood auxiliary fence attached to your miter gauge and a stopblock clamped to the fence, cut the beam (E) and rails (F) to this length. Reset the stopblock and cut the stiles (G) to length.

3 Adjust your saw blade to cut $\frac{1}{4}$ " deep, and making two passes at each location, cut the notches in the rails and stiles, as shown on the Parts View drawings. To ensure accuracy, bundle the parts together with masking tape before cutting. Glue and clamp the grill together.

4 Glue and clamp the grill to the beam, centered on the width, with the ends flush. When the glue is dry, glue and clamp the beam/grill assembly

Continued

an Oriental-styled beauty

to the top (B), centered on its length and width. Clamp the beam/grill/top assembly between the uprights with the sides of the beam flush with the uprights, and the grill centered on them. Using the 1/4" holes in the top and uprights as guides, drill holes into the beam and uprights. Glue the 1/4" dowels previously cut in the holes, letting them protrude 3/16" as before.

5 Because water spills are inevitable, we applied two coats of semigloss polyurethane from a spray can. Place the flower arranger in its hole (see the *Bill of Materials* for our source), fill it with water, and insert your flowers. 🌸

Written by **Jan Hale Svec** with **Charles I. Hedlund**
 Project Design: **James R. Downing**
 Illustrations: **Kim Downing; Lorna Johnson**
 Photographs: **Andrew & Co. Photography; Baldwin Photography**

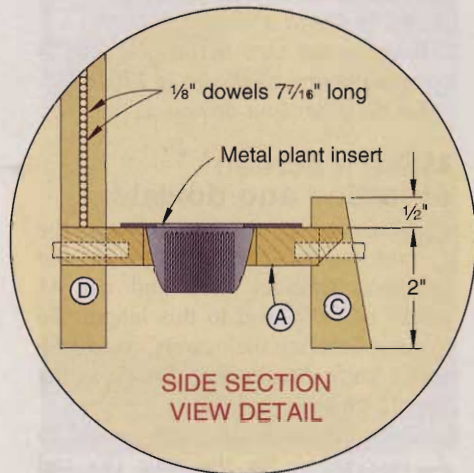

BILL OF MATERIALS

Part	finished size			Matl.	Qty.
	T	W	L		
A* base	5/8"	4 5/8"	11 1/2" W		1
B* top	5/8"	1"	11 1/2" W		1
C legs	1/2"	1"	2 1/2" W		2
D uprights	1/2"	3/4"	10 1/4" W		2
E beam	1/2"	3/4"	7" W		1
F rails	3/16"	1/2"	7" B		3
G stiles	3/16"	1/2"	2" B		5

* Parts cut from the same blank. Trim to finished size according to the instructions.

Materials Key: W—wenge, B—birch.

Supplies: 1/4x12" dowel (1), 1/8x36" dowel (12).

Buying Guide

Flanged flower arranger: Item no. 183-0100, \$6.99 plus shipping. Utah residents add sales tax. Call Craft Supplies USA, 800/551-8876.

EXPLODED VIEW

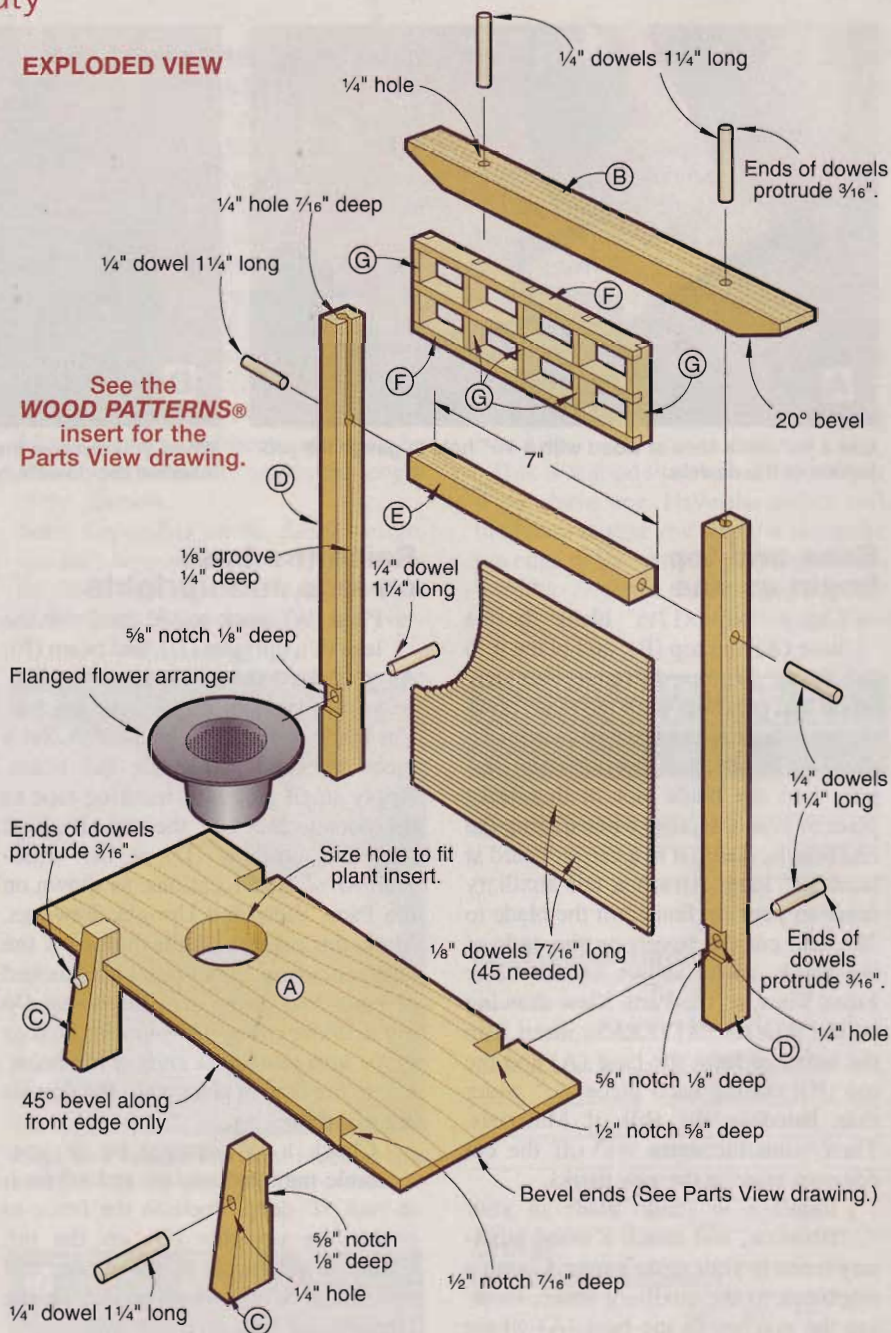

CUTTING DIAGRAM

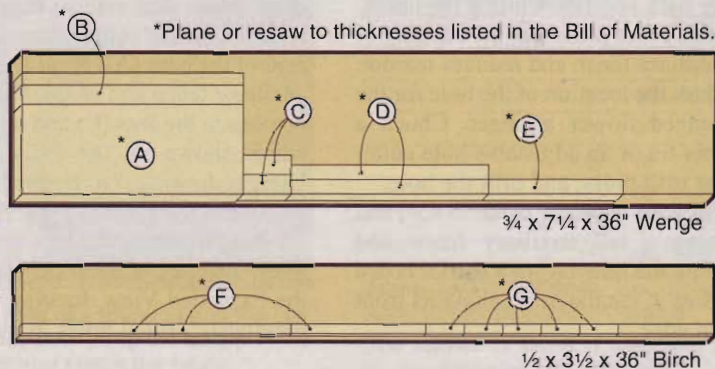

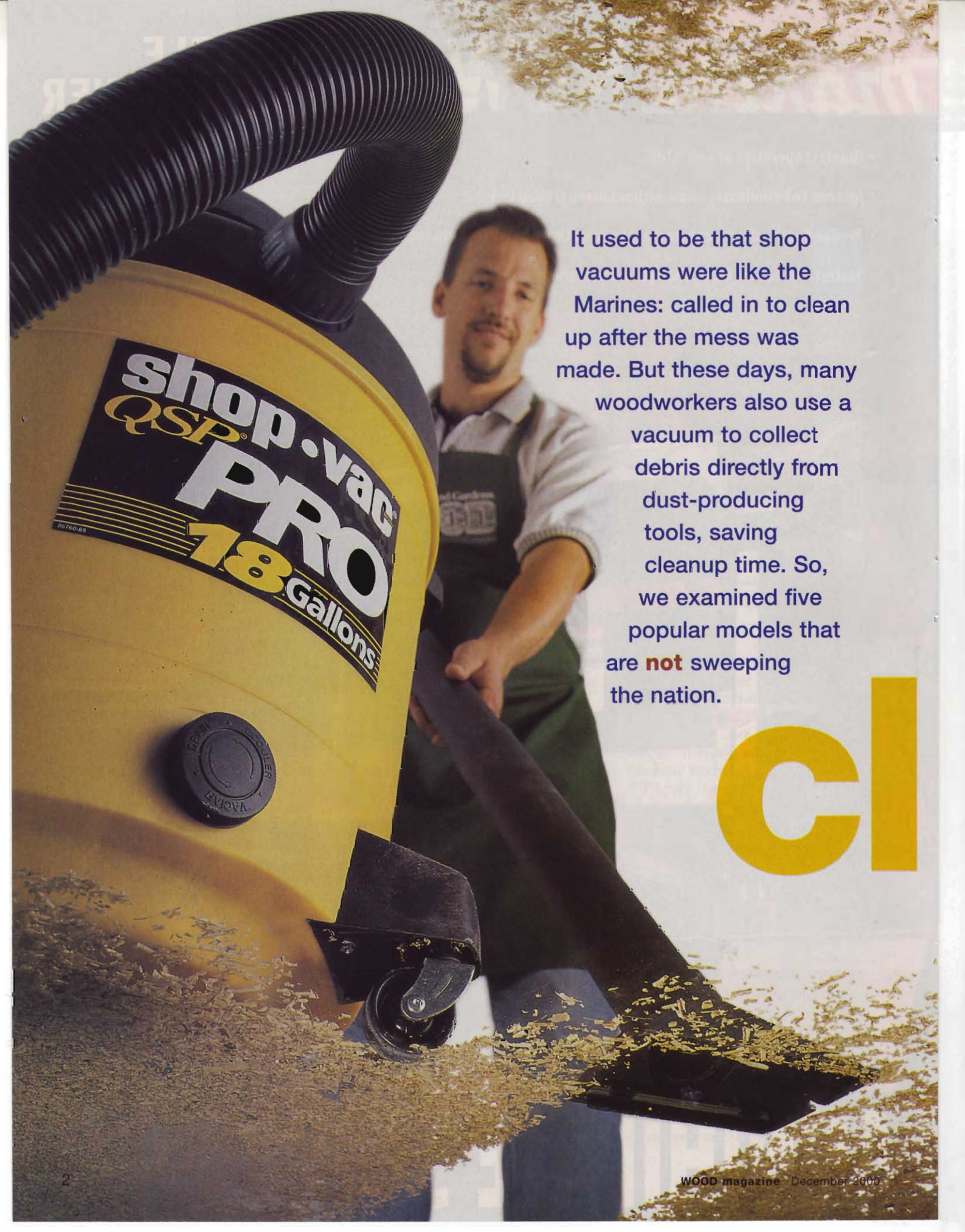
A man in a workshop setting is using a yellow Shop-Vac PRO 18 Gallons vacuum. The vacuum is the central focus, with a large black flexible hose extending from the top. The man is wearing a white shirt and green overalls, and is holding the black handle of the vacuum. The floor is covered with wood shavings, and the vacuum is actively sucking up some of them. The background is a bright, slightly blurred workshop environment.

It used to be that shop vacuums were like the Marines: called in to clean up after the mess was made. But these days, many woodworkers also use a vacuum to collect debris directly from dust-producing tools, saving cleanup time. So, we examined five popular models that are **not** sweeping the nation.

CI

How we chose the five vacuums in our test

You can buy a full-blown dust collector these days for \$200-300, so we don't believe you should pay more than \$150 for a vacuum. With that in mind, we selected five popular models at or below that price point for our test: the Craftsman 17026, the Fein Mini-Turbo, the Genie PRO16-6026QH, the Ridgid WD1660, and the Shop-Vac QSP 925-33. Most of the models offer 16- or 18-gallon tanks, designed for holding the wet or dry materials you vacuum up. The Fein Mini-Turbo has a 5-gallon tank.

The suction tests: Getting dirt into the tank

With shop vacuums, you can forget about horsepower ratings and motor amperage ratings. Neither of those numbers tells you how well a vacuum will suck up shop waste. So to find out how much suctioning capacity our five test machines had, we ran two tests: a water-lift test and a dry-materials suction test.

The water-lift test measures how high a vacuum can draw water up a vertical

Fast Facts

- Unless you have some unique requirements, you don't have to spend more than \$150 to get a shop vacuum that will handle all common workshop chores.
- Since our last test (*WOOD* magazine #78), shop-vacuum mufflers—to reduce the ear-ringing effects of using a vacuum—have become more widely available.
- If you're buying a vacuum only for gobbling dust from portable power tools, consider instead a so-called "tool vac." Priced about the same as the larger-capacity models in our test, these small-tank vacuums offer tool-triggered convenience.

tube, as shown on *page 68*. The higher the vacuum can lift the water, the more suction it has. We ran this test six times on each machine—three times with clean filters and three times with dirty filters. The results of each test are reported in the chart on *page 71*.

In this test, the Fein Mini-Turbo outperformed the next-best Shop-Vac by 9" of lift, and the rest of the pack by about 17". However, in actual use around the shop, we didn't notice a significant difference in suction between the machines, possibly owing to the Fein's 1¼" inside-diameter (i.d.) hose. (The other vacuums in this test come with 2½" i.d. hoses.)

The 3" water-lift variance between the Craftsman and Ridgid surprised us because they're essentially identical machines. The difference may be due to variations in the fit of gaskets and joints on the two units.

As you'd expect, the dirty-filter static-pressure test showed a slight degradation in performance from the clean-filter. Interestingly, the two best-performing units initially (Fein and Shop-Vac) also showed the the least change in suction from clean to dirty.

Our dry-materials suction test simulated in-shop-vacuuming conditions. We timed how long it took each

Continued

lean, mean cleaning machines

**Get the most suction for your buck
without spending a tidy sum.**

lean, mean
cleaning machines

We tested vacuum pressure the way the manufacturers do: by measuring how high the vacuum could lift water in a column.



machine to suck up three gallons of cat litter from a five-gallon bucket. Four runs were made; the best three were then recorded and averaged.

Again, the performance difference between the units with large-diameter hoses was insignificant, with just a few seconds variation between them. The Fein Mini-Turbo, even with its high water-lift rating, took about twice as long to complete the task. This difference can be attributed directly to the machine's smaller-diameter hose. When we put a 2¼" i.d. hose on the Fein, it pulled up the cat litter in half the time of the other machines.

Shop vacuum or dust collector?
Why you should have both

Shop vacuums, like the models we tested, have considerable lifting power and move relatively small volumes of air at high speed through hoses 2" or so in diameter. They work best for general shop cleanup and for directly collecting the small volume of debris generated by portable power tools and some stationary machines, such as a bandsaw, scrollsaw, or oscillating-spindle sander.

This high-pressure, low-volume system tends to lose suction as the distance between the vacuum and the dust source increases (and as the volume and weight of the debris increases). Their universal motors tend to be very noisy and offer comparatively short running life. A vac can cost anywhere from \$100 to about \$500, depending on its capacity and features.

On the other hand, dust collectors use powerful induction motors, high-capacity blowers (or impellers), and large ducts and hoses (3–6" diameter). This combination of features moves higher volumes of air at a lower pressure, but at speeds high enough to transport the dust and chips a considerable distance. While this high-volume, low pressure suction works great for large debris makers, such as tablesaws, planers, and jointers, it's less effective on power tools with small dust ports, such as portables. A shop vacuum proves more useful on these tools.



Fewer chalk-dust particles escaped Genie's HEPA filter (left) than Craftsman's pleated-paper filter (right).

Filters separate the dust from the air

A filter must trap dust particles, yet still allow the air to pass through and exit the machine. That's no small task. Most filters actually improve with use—at least to a point. Dust building up on and in a filter reduces the pore size and in turn, restricts the movement of smaller particles through the filter. This dust cake, as it's called, works for you until the filter becomes so clogged that not enough air can pass through it.

The pleated-paper cartridge filters supplied with the vacuums adequately handle most general cleaning jobs. But most can't contain the ultrafine particles of sanding dust, drywall dust, or cold fireplace ash. To find out how well these filters really work, we sifted an equal amount of neon-orange chalk-line dust through each machine's filter. Between the hose and the filter, we placed a damp white cloth to snare any chalk dust that escaped the filter, as shown above.

The Craftsman 17026, Ridgid WD1660, and Shop-Vac QSP 925-33 vacuums come with basic pleated paper filters. The Shop-Vac passed a very small amount of the dust; the Craftsman and Ridgid, a bit more. Unchecked, that dust would have been exhausted from the vacuum, and likely

ended up in your lungs. (See "The Particulars of Particle Size," above.)

Fein supplies the same type of a pleated paper filter, but supplements it with a paper-bag filter, similar to those used in home vacuums. That disposable paper bag makes it easier to empty the tank, but more importantly, acts as a pre-filter. The bulk of the waste stays in the bag, while only the tiniest particles get through to the cartridge filter.

The Genie is the only vacuum in our test that includes a high-efficiency particulate arrester (HEPA) filter as standard equipment. It's rated to collect 99.7 percent of dust particles larger than 0.3 microns in size. The Genie and Fein showed little visible evidence of chalk dust passing through the filter.

If you expect to collect a lot of very fine dust, consider upgrading the filter. You can buy after-market filters capable of removing particles as small as 0.3 microns for most machines. Although more costly than the standard filters, they're worth the extra money when working with very fine dust.

Vacuum motors: Feel the noise, feel the heat

Shop vacuums use universal motors that run at very high speed—around 10,000 rpm—and emit a high-pitched, ear-piercing, nerve-grating scream

The particulars of particle size

Examine a handful of shop dust and you'll find it made up of variously sized wood particles—from sizable chips to extremely fine powder-like particles. Engineers size dust particles in *microns*, a measurement equal to $\frac{1}{1000}$ of a millimeter, or about 40-millionths of an inch. To put these teeny tiny fractions into perspective, our eyes can't see individual particles smaller than 100 microns in size.

Why does size matter? Well, after flying off the tablesaw blade, that barely visible 100-micron particle falls quickly, at about 16 inches per second. But it takes almost 30 minutes for a 5-micron particle to fall to the floor if there's no air movement. With air movement, these particles can stay suspended indefinitely.

Dust particles sized between 10 and 0.3 microns pose the greatest health hazard. They're easy to inhale, and they tend to collect in our lungs. Particles smaller than 0.3 microns are small enough to be exhaled, so they're less of a threat.

that can really stress you and affect your hearing.

Most humans can detect a 1-decibel (dB) difference in loudness. But, beyond mere loudness, the whine of a universal motor contributes to its annoyance factor. So, besides measuring loudness, we also determined and analyzed each motor's pitch by finding the loudest frequency range or ranges that it generates.

In our tests, the Fein, at 77dB, was by far the quietest. The Shop-Vac, at 81dB, was also several decibels quieter than the other units, and perceptibly quieter. That's because the primary frequency generated by the Shop-Vac motor is lower—1 kilohertz (kHz), rather than the 2 kHz from the Fein or the 4 kHz we heard from the rest. (A sustained 1-kHz noise sounds like a low, rushing roar; 4 kHz sounds more like a high-pitched scream and is much more discomforting.)

To minimize noise, consider adding an aftermarket muffler, such as the Craftsman/Ridgid muffler we tested previously (Products That Perform, *WOOD* magazine #115). We found that such accessories cut the level of some key frequencies without affecting the machine's suctioning power. A similar device can be purchased from Leichtung (800/321-6840).

Continued



With a quick flick of the wrist, the Craftsman and Ridgid (shown here) vacuums become leaf blowers.



The mouth of the Genie tank (right) is smaller than the tank itself, so it didn't empty as cleanly as the Craftsman (left).

While we're on the subject of motors, universal motors are designed to run for short periods, and long run-times may cause them to heat up, shortening their life. Most of the vacuums in our test cool their motors by drawing the filtered air from the hose over the motor, then exhausting it. Under heavy vacuum load (or if the filter is extremely dirty), this process can starve the motor of cool air. If you need to operate the vacuum continuously, the Fein Mini-Turbo is the only machine we tested with a bypass fan—a separate auxiliary fan to pull in outside air to cool the motor when it's running.

As a DIYer's bonus, the motors on the Craftsman 17026 and Ridgid WD 1660 detach from the vacuum body, as shown in the *top left* photo, to convert into a leaf blower for lawn and garden cleanup. Attach the wand to the motor's exhaust port and blast away. (We don't, however, recommend blowing woodworking debris out of even a garage shop.)

Other things to consider before you buy a vacuum

• **Hoses.** Large-diameter vacuum hoses move higher volumes of workshop debris than smaller hoses. And, the larger chips generated by portable planers and jointers are less likely to plug a large hose. (Note: We're talking cleanup after the fact here. Planers and jointers can generate chips faster

than most vacuums can keep up with.) On the other hand, smaller-diameter hoses create very high air velocities and work great at picking up water and transporting fine dust particles, even directly from the port of a dust-making woodworking tool.

Most of the models in our test come with a 2 $\frac{1}{8}$ " i.d. hose. Shop-Vac thoughtfully includes an additional 1 $\frac{1}{4}$ " i.d. hose along with its 2 $\frac{1}{8}$ " hose. The Fein Mini-Turbo's 1 $\frac{1}{4}$ " i.d. hose felt much more pliable than the hoses on the other models. That makes it less susceptible to kinking and cracking under the crush of a foot.

Few things frustrate us more in the shop than inadvertently pulling the hose out of the tank while vacuuming. So, we appreciate the hose locks on the Craftsman, Ridgid, and Fein machines. However, after several weeks of general use, the hose on the Ridgid test unit started coming apart at the snap-in connector.

• **Tank capacities.** Although the 16- or 18-gallon ratings aren't their true capacity (the motor housing and filter use about a gallon of the space inside the tank), the tanks on most of the models are adequate for shop cleanup, and for collecting sawdust and small shavings from woodworking tools without necessitating frequent dumping. The 5-gallon tank on the Fein will be more than adequate for collecting fine sawdust from a sander or band-

saw, but limiting if you're collecting larger chips and shavings.

With the inevitable debris cloud that ensues, emptying a vacuum tank can be about as unpleasant a chore as you can get. However, we found that even small differences in the tank design make a big difference. The Craftsman and Ridgid tanks, for example, have smooth-sided interiors (see *top right* photo) that didn't impede the debris being dumped. By contrast, the Shop-Vac and Genie tanks have a large lip around the top of the tank. It took a fair amount of shaking to completely empty the Genie.

• **Accessories.** All of the models in our test come with a hose, wand, and an array of attachments. And except for the Fein, all have some manner of on-tank storage for those accessories.

Tool storage built into the bases of the Craftsman and Ridgid vacuums worked well for keeping the attachments with the machine. The deep pocket on the Shop-Vac keeps the attachments handy, but collects considerable dust and debris, too. Although the accessory shelf on the Genie was meant to be helpful, we found it flimsy, and the lone screw that held it to the tank soon failed.

• **Mobility.** Because vacuums of this type often get used outside the shop, we subjected the test machines to a battery of tests, including towing them around vehicles and stationery power

tools and over cracked, cratered drive-ways and power cords. The test vacuums proved to be quite stable. The Craftsman and Ridgid machines, with their fixed rear wheels, generally trailed nicely behind as we moved them about.

However, when all wheels swivel, you can easily push or pull the machine in any direction. The five casters on the Fein, for example, made it very stable and smooth-rolling. And, although small, they traversed the cracked and uneven driveway test surface with no problems.

It's time for our pick of the vacuum pack

The durability, suction, and quietness of the Fein Mini-Turbo makes it an excellent choice for continuous duty where you want to grab small quantities of debris. It's the only vacuum in the test we would have been comfortable with in our home as well as shop.

For general in-shop use, we'd buy the Shop-Vac QSP 925-33, primarily because of its big 18-gallon tank, good suction, and quiet-running motor. The additional small hose and accessories that come with it are a nice bonus.

You've read our opinions; now we'd like to read yours

Chances are, you've had your hands on one of the vacuums in our test, and we'd like to know if you agree or disagree with our evaluation. Log onto our Interactive Tool Review at www.woodonline.com, and tell us about your experience. You'll hear not only from your fellow WOOD® magazine readers, but the manufacturers themselves.

Written by **Charles Sommers** and **Dave Campbell**
 Technical consultant: **Raleigh Rubenking**
 Photographs: **Baldwin Photography**



RATING A QUINTET OF POPULAR SHOP VACUUMS

MANUFACTURER/ IMPORTER	MODEL	MOTOR TYPE (1)	CAPACITIES				FILTER TYPE (3)	PARTICLE SIZE RATING (MICRONS) (4)	WATER-LIFT TEST (6)		PERFORMANCE RATINGS (5)							MOTOR NOISE (8)	WHEEL CONFIGURATION (9)	CORD LENGTH	STANDARD ACCESSORIES (10)	WARRANTY (YEARS) (11)	COUNTRY OF ASSEMBLY (12)	SELLING PRICE (13)	COMMENTS
			RATED AMPERAGE	TANK CAPACITY (GALLONS)	TANK INLET DIAMETER (INCHES)	HOSE INSIDE DIAMETER (INCHES) (2)			HOSE LENGTH (FEET)	WITH CLEAN FILTER	WITH DIRTY FILTER	OBSERVED SUCTION	TIME TO VACUUM 3 GALLONS OF DRY MATERIAL (SECONDS) (7)	FILTER EFFECTIVENESS	TANK TIP RESISTANCE	EASE OF EMPTYING DRY MATERIALS	NOISE LEVEL (DECIBELS)								
CRAFTSMAN	17026	D	12	16	2 3/4	2 1/4	7	P	NA	54	48	E	14.82	F	E	E	85	F	FR	20'2"	B, E, P, U, W	1	US	\$139	Squat tank design resists tipping, and detachable blower is handy for outdoor cleanup.
FEIN	Mini-Turbo	F	8	5	2 1/4	1 1/4	10	B	1	73 1/2	69	G	34.70	E	G	G	77	G	SW	16'2"	D, E, F, H, P, W	1	IT	150	Quiet, small capacity vacuum with excellent filtration. Suitable for fine-dust applications.
GENIE	PRO16-6026QH	F	12	16	2 1/4	2 1/4	6	H	.3	56	48 1/2	E	15.49	E	G	F	85	F	SW	10'1"	R, S, U, W	3	US	100	An average vacuum with an excellent standard-equipment filter.
RIDGID	WD1660	D	12	16	2 3/4	2 1/4	7	P	NA	57	50 1/2	E	14.28	F	E	E	84	F	FR	20'2"	B, E, P, U, W	L	US	129	Virtually identical to Craftsman 17026, but with a lifetime warranty.
SHOP-VAC	QSP 925-33	F	9.5	18	2 1/4	2 1/8*	6	P	1	64 1/2	60	E	12.88	G	G	F	81	G	SW	18'	P, R, S, W, X	4	US	109	Plenty of suction, quiet operation, and lots of attachments. Our top choice for general use.

NOTES:

- (D) Detachable
(F) Fixed
- (*) Also comes with 1 1/4" i.d. hose.
- (P) Pleated-paper cartridge
(B) Paper bag and pleated-paper cartridge
(H) HEPA (High-efficiency particulate arrester) cartridge
- (NA) Filter not rated.

- E** Excellent **G** Good **F** Fair
- Inches of water lifted through 2 1/2" i.d. clear plastic tubing.
- Using original-equipment hose. Average of three tests.
- Measured 36" from motor.
- (FR) Fixed rear wheels/front swivels
(SW) All swivel casters

- (B) Blower nozzle
(D) Paper dust bag
(E) Wet nozzle
(F) Floor brush
(H) Hose handle
(P) Upholstery/car nozzle
(R) Crevice nozzle
(S) Floor nozzle with removable squeegee
(U) Utility nozzle
(W) Wand
(X) Extra 1 1/4" i.d. hose and wand

- (L) Lifetime warranty against factory defects.
- (IT) Italy
(US) United States
- Prices current at time of article's production.

For more information:

- Craftsman
 Visit local Sears store
www.sears.com/craftsman/
 Fein
 800/441-9878
www.feinusa.com
 Genie
 800/354-3643
www.geniecompany.com
- Ridgid
 800/474-3443
www.ridgidwoodworking.com
 Shop-Vac
 570/326-0502
www.shopvac.com



Marquetry Mirages

John Russell, who designed the examples shown above and on page 77, uses carefully selected veneers and a unique shading process to yield small boxes that fool the eye.

Kevin Boyle, assistant design editor/project builder, walks you through the construction of one such box, shows you the basics of veneering, and shares tips he picked up along the way.

See the
WOOD PATTERNS®
insert for
FULL-SIZE PATTERNS.

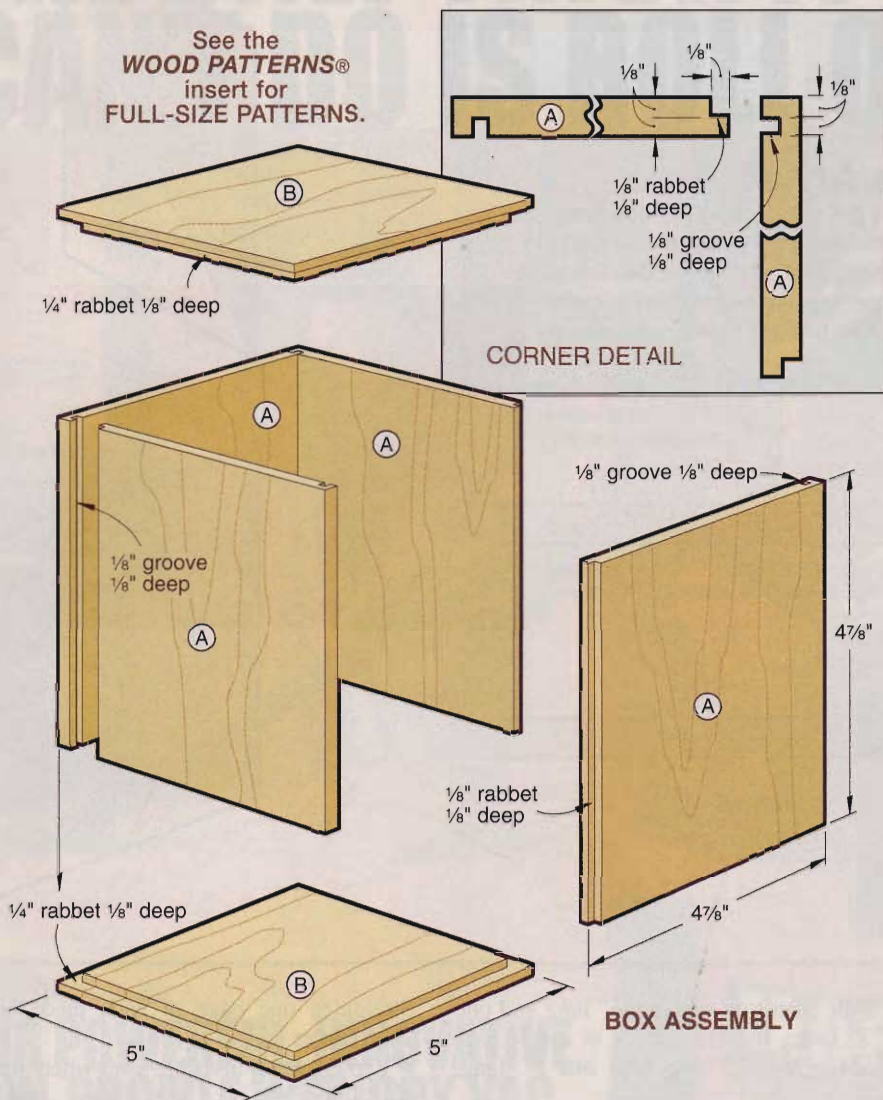

BILL OF MATERIALS

Part	finished size			Matl.	Qty.
	T	W	L		
A sides	1/4"	47 7/8"	47 7/8"	M	4
B ends	1/4"	5"	5"	M	2
C liners	1/8"	3 1/4"	4 1/2"	M	4

Material Key: M—mahogany

Supplies: glue, silica sand, finish

Buying Guide

Veneer: Veneers are priced by the square foot. The minimum order for each species is 3 sq. ft. We used the following: maple V48, \$.90/sq. ft., tulipwood V87, \$2.75/sq. ft., wenge V100, \$1.20/sq. ft. Add shipping, NY residents add sales tax. Call Constantine's, 800/223-8087, or go to www.constantines.com.

Filler: J.E. Moser's Grain-Fill, no. 922-828, \$17.95/qt. Add shipping, NM, WY, NC residents add sales tax. Call Woodworker's Supply, 800/645-9292.

Patterns: Full-size veneer patterns for the four box designs shown on page 77, as well as additional tips on how to achieve the desired results, are available for \$20 each. Write to John Russell, 201 W. 86th St., New York, NY 10024. Be sure to include the name(s) of the pattern(s) desired.

Start by building a hollow cube

- 1 From a 3/4x5 1/2x36" piece of stock, resaw and plane a blank to 1/4" thick for the sides (A) and ends (B). Plane a 22"-long piece of the remaining stock to 1/8" thick for the liners (C), and set it aside.
- 2 Cut the sides (A) to the dimensions listed on the Bill of Materials. With

shop tip

Use a single blade (not a chipper) from your stack-dado set to make flat-bottomed grooves and rabbets.

a single blade from your dado set in your tablesaw, cut grooves with the grain in the edges of the sides (A), as shown on the Corner Detail of the Box Assembly drawing.

- 3 Attach an auxiliary fence to your tablesaw rip fence, position it so the blade just grazes it, and form the tongues by cutting rabbets on the edges opposite the grooves as shown. Make test cuts in scrap to ensure a snug fit of the tongues in the grooves.

- 4 Dry-assemble the four sides. Check the dimensions for the ends (B), then cut them to size. Install a 1/4" dado blade in your tablesaw, and cut the dados in the ends where shown. A snug fit of the

shop tip

Mark light pencil lines on each face of the box. Any high or low spots will disappear along with the pencil lines as you sand.

ends in the assembled sides keeps the box square.

- 5 Glue and clamp the sides and ends together. When the glue is dry, sand the outside of the box to 120-grit. To keep the sides flat and the edges crisp, adhere a sheet of sandpaper to a flat surface, and move the box in a circular motion on the sandpaper. Set the box aside.

Continued

How To Be a Cutup Artist

When cutting veneer, use a fresh blade. A dull blade tears the wood fibers and makes rough, inaccurate edges. Guide your cut with a steel ruler, and to avoid tearing the veneer, cut in from both edges toward the middle. Complete the cut in several passes. Most hardwood veneers require two or three passes; exotic woods, such as wenge, can take up to five or six swipes with a knife.

To get super-tight joints, always position the veneer face-side-down when cutting. This way, the knife edge creates a "plow" on the back side of the veneer, as shown on the Knife Plow drawing. The plowing action creates beveled edges that make for nearly invisible joint lines when you tightly butt together two edges as shown on the Veneer Joint drawing.

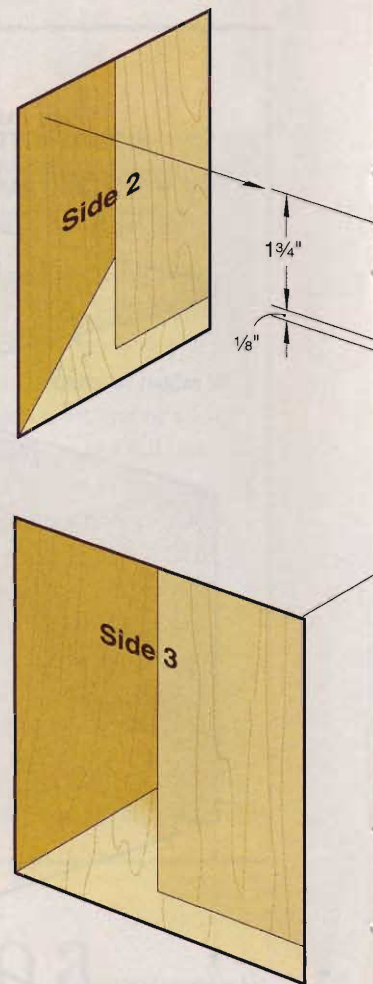
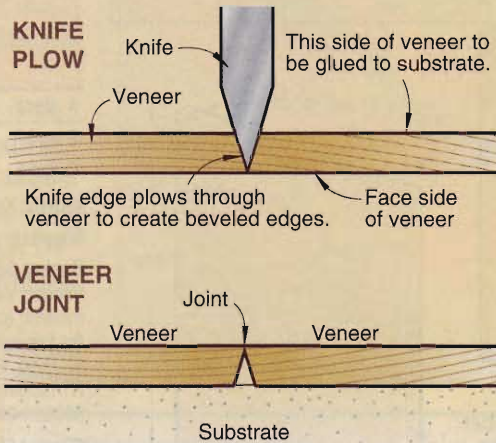

Construct an illusion in veneer

1 For our featured box you will need one 3 1/2 x 36" strip each of tulipwood, wenge, and maple veneers. See the Buying Guide for our source. Rough-cut the veneer to the following: four pieces of tulipwood 5 1/2" long and one 7" long;

four pieces of wenge 6 1/2" long and one 7" long; and two pieces of maple 6 1/2" long, two 7" long, and one 5" long.

Straighten one edge of each piece on your jointer.

2 To create an invisible joint where the jointed edge of the veneer abuts another piece, bevel the back edge. To do this, hold the veneer at an angle and sand a slight bevel, as shown on the Sanding a Bevel drawing. Use a sheet of 120-grit

shop tip

To get a perfectly straight edge on several pieces of veneer at once, sandwich the veneer between two clamped blocks of wood and joint the edge of this sandwich, as shown in Photo A. Orient the veneer grain as you would when jointing a board. Set the jointer for a light cut—about 1/32" or so.

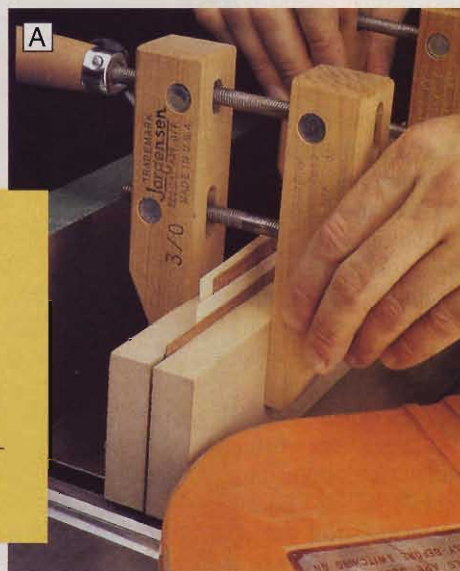

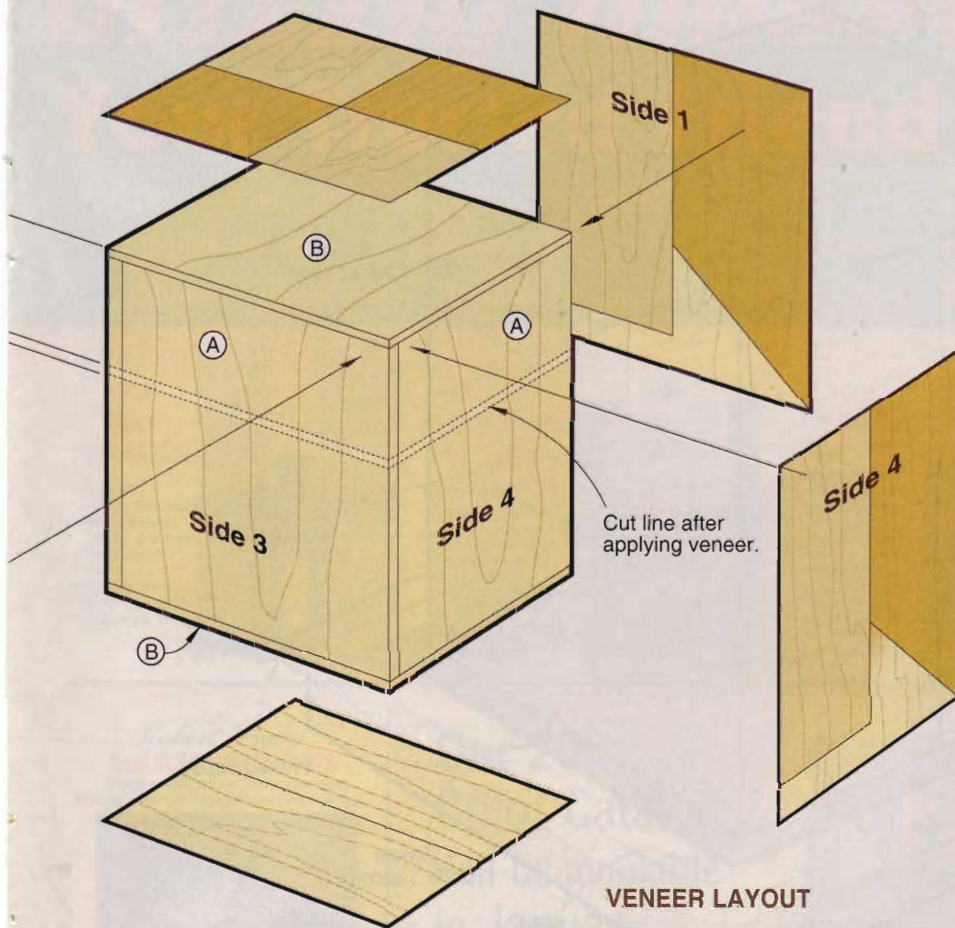

The Secret's in the Sand

For shading the veneer, purchase silica sand, intended for sandblasting, from your local home center.

Hot sand causes the veneer to shrink and distort slightly, so cut your project pieces oversize and trim them after shading. You can trim each piece so as to precisely position the shading on it.

Use extra veneer to experiment. The shading effect can vary considerably depending on heat intensity and the thickness and species of your veneer. Be careful not to burn the veneer by leaving it in the sand too long or letting it touch the bottom of the pan.

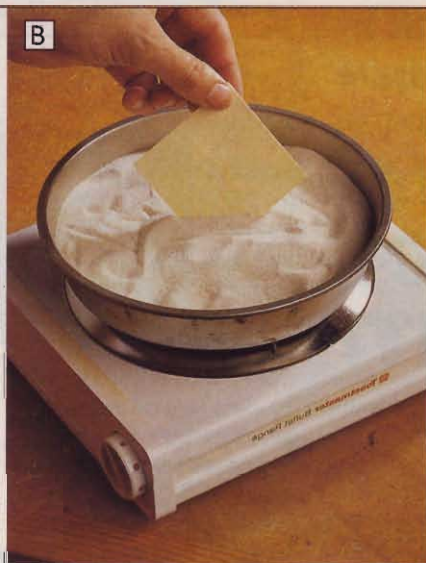

The hot sand sings the veneer, creating a shaded effect.

sandpaper adhered to a flat surface. To avoid confusion as you assemble the veneers, mark the jointed and beveled

edges on the back of each piece. The back is the side with the heel of the bevel.

3The three-dimensional illusion on this box depends heavily on a shadow effect created on one corner of each of the maple triangles. This shading is the result of singeing the veneer in hot sand. (See the sidebar, "The Secret's in the Sand," above, right.) Put 1" of sand in a steel cake pan and place it on a burner over medium heat for about 10 minutes. Slice the 7"-long pieces of maple cut in *Step 1* into 3½" squares. Immerse one corner of each square in the hot sand, as shown in *Photo B*, until you achieve the desired amount of shading.

4Referring to the full-size patterns on the *WOOD PATTERNS®* insert, and using a utility knife, metal ruler, and combination square, cut the veneers to final size. (See the sidebar, "How To Be a Cutup Artist," opposite page, top left.) Cut the squares of tulipwood and wenge from the 7" pieces cut in *Step 1*. Mark the

shop

tip

You can buy tapes made especially for veneer, but for small projects like this box, you'll get by just fine with drafting tape (available from art-supply stores) or safe-release (blue) masking tape (available from paint or hardware stores). I prefer these products over regular masking tape because, when removed, they leave little adhesive residue on the veneer.

backs of the pieces as you cut them. The backs are the sides with the knife plow.

5Assemble the veneers for each side of the box, placing them with their marked sides down, on a flat surface. Tape them together, as shown on the Veneer Layout drawing above. Make certain all the mating edges are straight, and the veneer joints are tight.

Continued

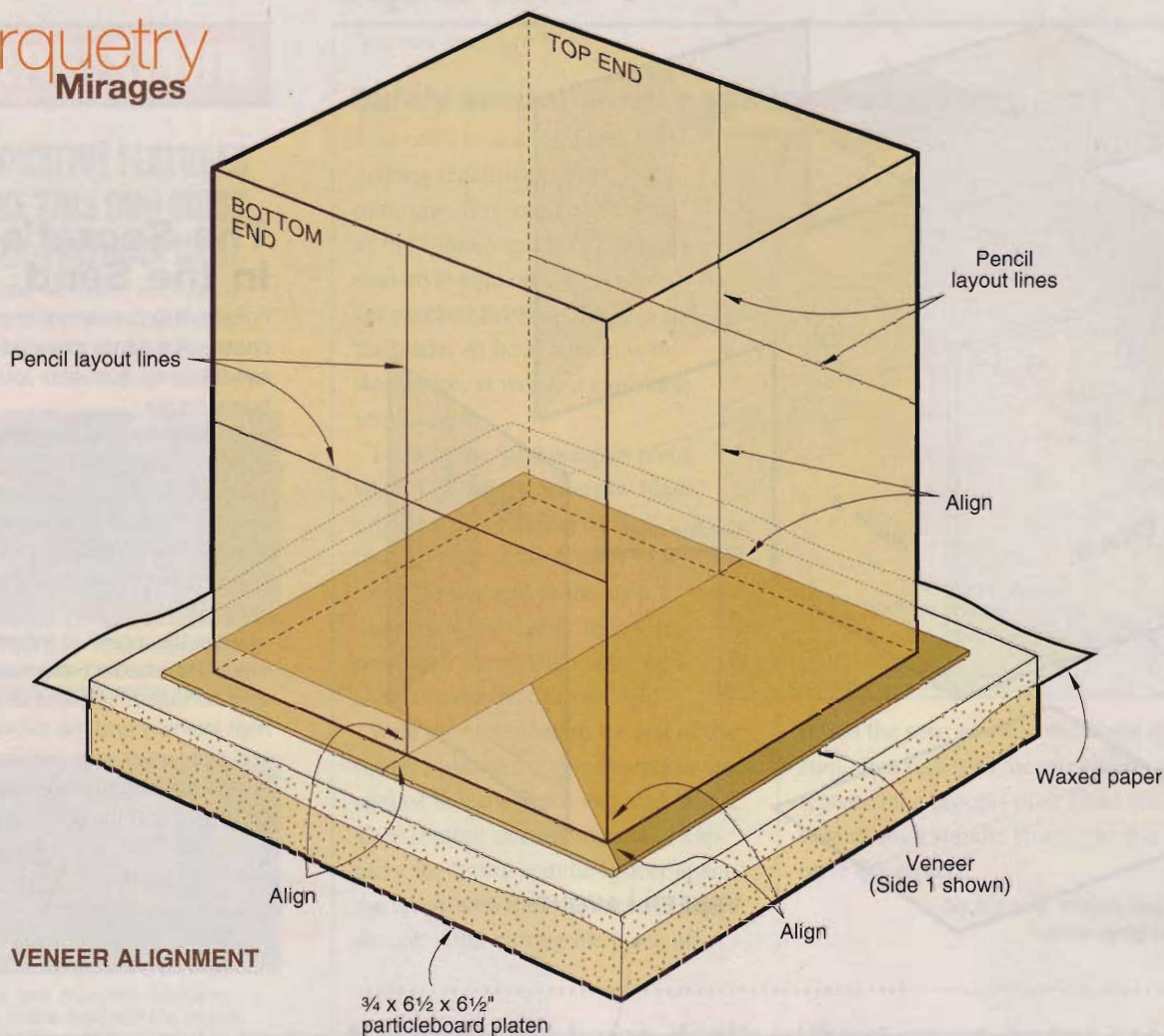

VENEER ALIGNMENT

Give your illusion substance

1 Draw center lines both ways on the top and bottom of the box. Cut a $\frac{3}{4} \times 6\frac{1}{2} \times 6\frac{1}{2}$ " piece of particleboard for a

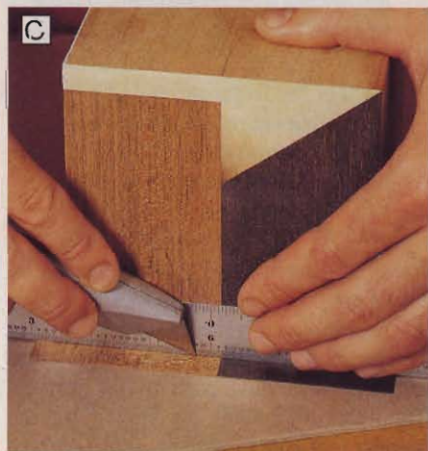

Place your metal ruler on edge against the box, and cut away the extra veneer.

clamping platen; cover it with a piece of waxed paper; and place the first side veneer assembly, face down, on it. Spread a thin coat of glue on one side of the box, and position it on the veneer, as shown on the Veneer Alignment drawing. Because the veneer has a tendency to shift when pressure is applied, we used yellow glue for a fast grab. Clamp the box to the platen.

2 After the glue dries, place the box, veneer-side-down, on a piece of cardboard and trim the excess veneer, as shown in Photo C. Be sure to cut from both edges to the center. Sand the edge flush with a firm sanding block.

3 Repeat the veneering sequence in Steps 1 and 2 for the other three sides, then for the top and bottom, as shown on the Veneer Layout drawing. Sand the box lightly, and soften the corners with 320-grit sandpaper, taking care not to sand through the veneer.

shop tip

Excess glue isn't such a big deal when it squeezes out of typical woodworking joints, but too much glue can ruin a veneering project. That's because the excess adhesive will squeeze right through the pores of veneers. Even if you succeed in sanding the extra glue off the surface without sanding through the veneer, the glue will still be visible in the pores.

To avoid this calamity, apply just a thin layer of glue to one surface—the substrate. Move the glue around with a plastic spreader or an ink roller to get a thin, uniform coating.

Some other designs

Shown below, clockwise from upper left, are four other veneer illusions created by John Russell: Celtic, Picture Window, Pillars, and Fold. To order patterns of these designs, see the Buying Guide. To see more of John's veneered box designs, visit his gallery on the internet at www.wood-veneers.com/gallery14.htm.

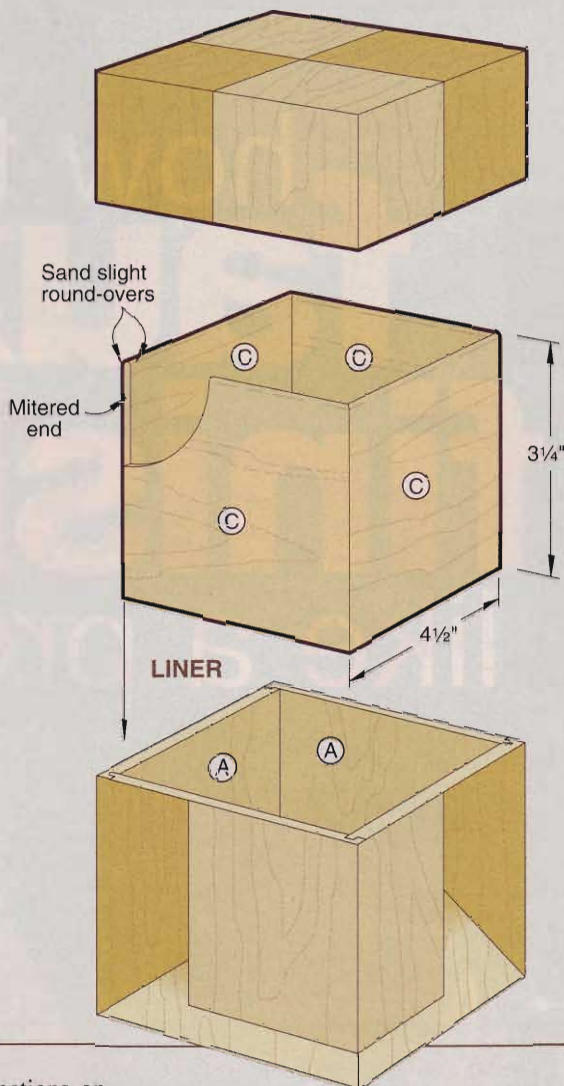
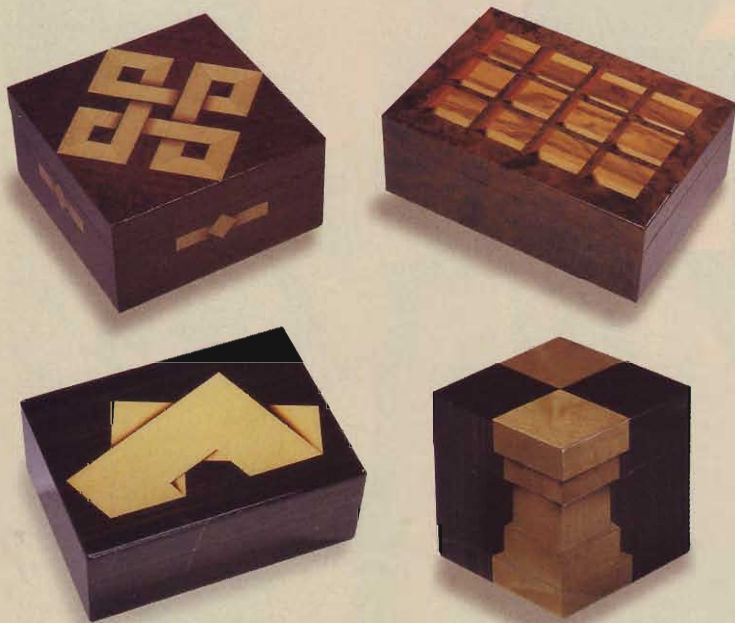

Turn your veneered cube into a box

1 Raise your tablesaw blade to cut $\frac{7}{32}$ " deep, and position the rip fence $1\frac{3}{4}$ " from the blade. With the box top against the fence, cut all the way around. Apply masking tape to the box in the path of the blade, and back your cuts with a follower block to avoid chipping the veneer as the blade exits the back of the cut.

2 Separate the lid from the box as shown in *Photo D*. Remove the remaining waste from the saw kerf with your sanding block.

3 Rip your $\frac{1}{8}$ " stock to $\frac{3}{4}$ " wide. Miter cut four pieces to fit tightly inside the box for the liner (C), as shown on the Liner drawing. Sand round-overs on the top edges, and slide the liners into place. The liner protrudes $\frac{1}{4}$ " to provide a lip for the lid.

4 Because the tulipwood and wenge veneers are porous, apply a paste

wood filler following the directions on the container. (We used a transparent, water-based filler; see the Buying Guide



Carefully slice through the last $\frac{1}{2}$ " by cutting down the center of the saw kerf with a utility knife.

for our source.) Top off with two coats of gloss spray finish, sanding lightly with 320-grit sandpaper between coats. We finished only the outside of the box. ♣

Written by Jan Hale Svec and Bill Krier with Kevin Boyle

Illustrations: Roxanne LeMoine; Lorna Johnson
Photographs: Bob Barrett; John Russell;
Baldwin Photography; Wm. Hopkins

Show off your stuff

Inspired? Design and execute your own veneer illusion, and send us a picture. We'll post it in a gallery on our web site. Just take a standard snapshot of your creation against a neutral background, and send it to: WOOD magazine, Marquetry Mirages Gallery, 1716 Locust St., GA-310, Des Moines, IA 50309-3023.

how to
**faux
finish**
like a pro

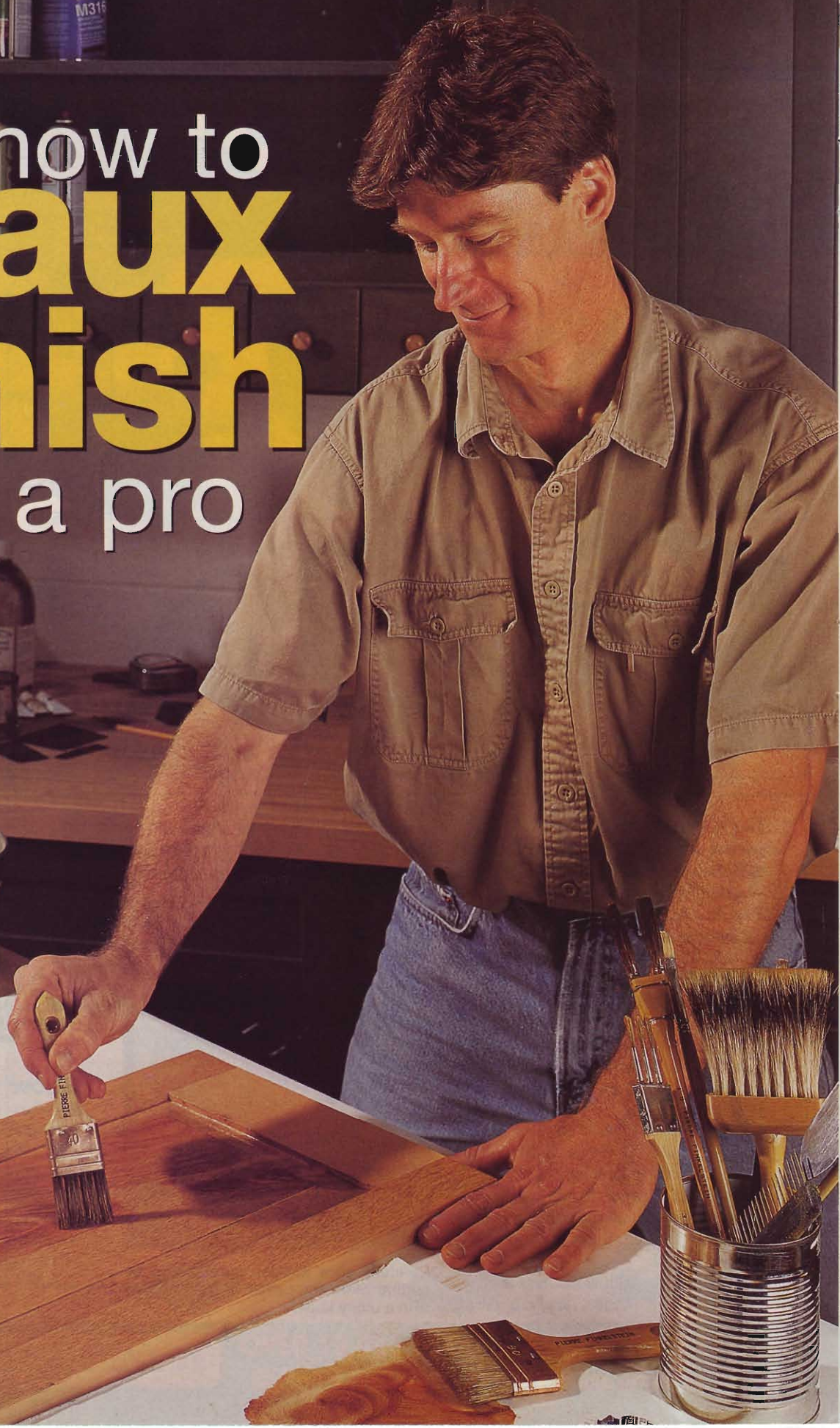

When we found out about Tim Vander Well's skill as a decorative artist, we asked him to show us his wood graining technique. You'll be impressed with the results. Take a peek at his secrets, then have a go at it yourself.

You're a woodworker, so naturally you like to build projects with beautiful wood. But once in a while, it would be fun—and even useful—to know how to fake it.

What if you could take a humdrum piece of medium-density fiberboard and make it look like satinwood? That would accomplish a couple of things: It would save you a chunk of money, and protect an exotic wood at the same time.

Or what if you were remodeling your home, and wanted to turn a well-made but dull door into a richly figured walnut showpiece? That would be worth some effort, don't you think?

Faux (pronounced "foe," it's French for "false") finishing began long ago as a means of imitating wood, stone, and various kinds

of finishes on common materials. Faux bois, or wood-graining, was all the rage in the 19th century, when European status-seekers wanted to give the impression that they could afford the finest woods even though they couldn't. The idea made it across the Atlantic, too. Go to Thomas Jefferson's Monticello home in Charlottesville, Virginia, and you'll find faux woodwork right alongside expensive furniture that Jefferson imported from France.

No doubt about it, faux wood graining is an art, requiring practice and patience. But we think you can find lots of fun in the learning.

Tim Vander Well, a master at this sort of thing, just happens to work in a loft not far from *WOOD*® magazine headquarters. What he can accomplish in one short session will set you to wondering what you might be able to create in your own workshop.

Gather your equipment

The first key to faux finishing lies in the glazing you use. A glaze is like a thin paint that can be manipulated while wet to create effects you can't get with paint or stain alone. See the box at right for two glaze recipes.

You'll need the right kind of paint to do this work the way Tim does it. We recommend buying a few small tubes or cans of artist's oils at an art supply store. You can find the basic colors you need—raw sienna, burnt sienna, raw umber, burnt umber, Van Dyke brown—and their heavy-bodied consistency will help you create the striking effects you want.

A wood-graining expert, such as Tim, brings out one specialized brush after another, in sizes and shapes that you'd never find in a house painter's toolbox. Wood graining calls for a

Continued

You can use the basic graining techniques to imitate many kinds of wood. Check out these samples of faux satinwood, walnut, and two pieces of quartersawn oak.

Two easy glaze recipes

You need the right blend of ingredients to get the best results.

Tim uses this recipe:

- 1 part linseed oil
- 2-4 parts turpentine
- not more than 10 percent Japan drier
- artist's oil colors, as needed



Or, if you want to simplify the process and avoid mixing paint, you can use this recipe:

- 1 part premixed glaze
- 1 part interior oil-based satin paint (off the shelf or mixed by the retailer)
- 1 part paint thinner

Either recipe makes an oil-based glaze that you'll use in two ways as you produce a faux finish:

- (1) Apply it by itself as a base coat for wood graining.
- (2) Pour out a small amount on wax paper to mix with individual colors of artist's oil as you add the various graining details.

You also can use water-based glazing, which requires you to work more quickly. Check the resources for more about that approach.



how to faux finish



Want to go faux in a big way? There's no shortage of special brushes and tools.

series of effects, and you can find a brush to help you achieve each one.

But you don't have to lay in a box full of brushes just to experiment with wood graining. You can give it a try with just a few brushes and tools similar to the ones shown in the array above. If you want to take your efforts a step further, visit an art store or contact the sources listed in the box below to buy the kinds of brushes you see Tim using in this article.

Prepare the surface

Pick out a piece of material to practice on. It can be wood, MDF, plywood, or just heavy card stock or poster board. Also, round up a good-looking sample of hardwood to use as your model, and apply a coat of oil to highlight its grain.

Start with a primer coat of paint on your sample board. The test of your art savvy begins now, as you choose the

lightest background color that you see in the wood species you want to imitate, then select an alkyd paint that's a shade lighter than that. Apply two coats of this paint over the primer.

Brush on the paint in the direction of the grain, if any. Lightly sand each coat with 220-grit sandpaper after it dries.

Where to learn more

Tim looks to New York City decorative artist Pierre Finkelstein as a great teacher of wood graining. You can learn much more from Finkelstein's book, *The Art of Faux*, which you can order from his website, www.pfinkelstein.com, for \$45 plus \$5 shipping. Or call the Pierre Finkelstein Institute of Decorative Painting at 888/328-9278.

Here are some other sources:

• *Professional Painted Finishes, A Guide to the Art and Business of Decorative Painting*; Watson-Guption Publications; \$45.

• *The Catalog of Artists' Materials*; Daniel Smith, 4150 First Ave. South, P.O. Box 84268, Seattle, WA 98124-5568; www.danielsmith.com.

• Pearl Paint Company, 308 Canal St., New York, NY 10013; 800/221-6845.



SIX STEPS to walnut grain

1 After you paint the surface, make it resemble wood pores with a technique called flogging. To do this, apply a coat of glazing. Then add some Van Dyke brown to a brush with long, stiff bristles—it helps to have a special flogging brush for this step—and begin working up the surface, one brush-width at a time.

Grip the brush just above the ferrule, and tap the glazed surface with the heel of the bristles. Keep tapping your way up the surface in a single row from bottom to top, then repeat. Overlap each succeeding row. The more times you go over the glaze, the finer the pores.

2 Mix glaze, burnt umber, and burnt sienna, plus small amounts of Van Dyke brown, ultramarine blue, and black. While the glaze from *Step 1* is still wet, use this mixture to sketch in the figure grain with a brush—ideally, a tooth spalter.

3 Still working in the glazing, define the heart grain with a three-headed pencil grainer brush, dipped in burnt umber and burnt sienna. Shape a series of peaks, but don't make them too sharp or regular. This is your chance to make wood look the way you want it to look.

4 Next, make the straight grain, using a two-headed brush loaded with glazing mixture and dabbed in black glaze. The ideal piece of lumber for building a piece of furniture might consist of arrow-straight grain from end to end, but it's more fun, and still natural, to make something showy. Start off-center, and put in a gentle curve or two.

5 Define knots and heart grain details with a small, flat brush. This step requires a good eye, a deft touch, and lots of practice.

6 Let the piece dry for 24 hours, then apply an overglazing tinted with Van Dyke brown. To add the subtle, rippling, moiré patterns you see in quilted wood grain, hold a wide brush in a V shape and dab the surface, moving down the surface and dragging down slightly with each stroke.



Continued

how to faux finish

1

2

3

4

5

FIVE STEPS to quartersawn oak grain

1 After painting a flat surface, apply a coat of glaze. You'll need a blend of raw sienna, raw umber, and burnt umber.

2 Dip a tooth spalter brush in a tinted glaze and create color contrasts. The example you see here includes raw umber, burnt sienna, yellow ochre, and a touch of ultramarine blue.

3 After dragging the surface with lint-free burlap, comb it to define grain lines. Steel graining combs come in various tooth widths and overall widths. You even can start with an inexpensive, three-sided rubber comb.

4 Using a real board as a model, draw the distinctive rays of quartersawn oak with a piece of felt. The felt absorbs some glazing and gives the rays a muted, natural look.

5 Let the piece dry for 24 hours, then brush on a coat of "over-glazing" that includes Van Dyke brown and raw sienna. This is the time to add light grain lines through the rays and subtle moires.

AN ADVANCED technique

Butterfly and cat's eyes

After you've practiced the basics, try adding these beautiful markings that tend to appear in heartwood around a knot. Do this step in the final coat of glazing. Holding a soft blending brush in a V shape, draw the glaze toward the knot from above and below to make the butterfly wings. Then add the cat's eyes by removing dabs of glaze with the corner of a short-haired brush.



This faux artist is for real

Tim Vander Well, 41, went to Iowa State University to study industrial engineering, not art. Later, he added two years of art studies at the University of Texas, and now his work as a decorative painter and renovation project manager takes him all over the world.

Among many memorable assignments, he has worked on a high-rise hotel in Barcelona, Spain; a department store in Singapore; a ceiling mural in South Africa; and during his recent stay in his hometown of Des Moines, he helped to re-gild the gold dome high atop the venerable Iowa State Capitol building.

If you travel through Iowa on Interstates 80 or 35, you have the opportunity to see

a wonderful example of faux wood grain at Living History Farms in Urbandale, on the west side of Des Moines. Tim, his twin brother Terry, and Richard Davis of Los Angeles worked their magic in the Tangen House in 1995. They created mahogany, walnut, light oak, and dark oak finishes for the house, built to represent the home of a business owner in the 1875 village of Walnut Hill. Call Living History Farms at 515/278-5286 or e-mail lhf@netins.net for hours and admission prices. 🌳

Tim Vander Well's artistry is transforming buildings around the world. Here's some of his faux woodwork at Living History Farms in Urbandale, Iowa.



From 1940, the Model 800 still used the plastic that was later prohibited.



Stroll down memory lane to the melody of wooden Wurlitzers

The first jukebox was engineered in 1927 by the Automatic Music Instrument Company of Detroit, Michigan. Not surprisingly, the machine was an immediate hit with Prohibition's speakeasy proprietors who couldn't afford bands to draw customers. For but one nickel, the electronically amplified, multi-selection phonograph, or jukebox, could practically reproduce the full sound of an entire orchestra.

The Rudolph Wurlitzer Company entered the jukebox business in 1933 with musical experience. In Cincinnati, Ohio, the company had manufactured theater organs, dubbed Mighty Wurlitzers, and sold them to movie houses around the nation to provide the music for silent films.

Wurlitzer's first jukebox, the Debutante, was produced by highly skilled designers and craftsmen in its new North Tonawanda, New York,

manufacturing facility. The model's highly decorated walnut-faced plywood cabinet was only the beginning of what was to become the Golden Age of dazzle.

Glitz and glitter replace grief

The Great Depression of the 1930s saw growth in the new jukebox industry, but it wasn't until after the economic slump that jukebox sales really took off. Trying to attract customers' newly loose change, the top manufacturers

jukebox



Model 780 reflects Wurlitzer's switch to practically all-wood construction in wartime. It was made from 1940-42.

The 1940 Model 700 played 24 selections. More than 9,000 were produced.

A classic of design and detail, the Model 42-Victory was built during the material constraints of 1941.

journey

depended on visual enhancement of their machines. Wurlitzer, though, became the acknowledged leader in quality and visual appeal, creating spectacular machines made of wood, metal, and phenolic resins.

"The Wurlitzer machines had all the visual effects to catch your eye before you ever put money in them," says Ed Jones, owner of Jukebox Junction, a Cumming, Iowa, business that buys, restores, and resells collectible jukeboxes, primarily Wurlitzer. (See "Return to glory: jukebox restoration," *next page*.)

"Wurlitzer used veneers of mahogany, cherry, walnut, quilted maple, acacia, Carpathian elm—they used it all.

"The veneer, a full 1/8" thick, was given particular attention in how it was placed on the cabinet," Ed continues. "For effect, their craftsmen laid it down in eye-catching patterns. Then, the natural wood color was accentuated with aniline dye. Wurlitzers were made like fine furniture."

Because of this attention to detail, Wurlitzer controlled 60-70 percent of

the jukebox market during the 1930s and 1940s. Models from those years became classics due to their sophisticated, artistic employment of plastic, glass, and outstanding wood.

When war broke out in 1941, the United States government mandated that the Wurlitzer factories primarily produce war-related materials and severely restricted the use of metal and plastics. The company's response was to release models that relied heavily on wood and glass, a factor that makes them now quite rare and highly col-

jukebox journey

lectible because few survived, according to Ed.

Goodbye to wood

As the 1950s approached, less and less wood was used in the manufacture of jukeboxes. "The emphasis on design that incorporated details began to leave the picture," comments the jukebox dealer.

Return to glory: jukebox restoration

In 1973, Ed Jones paid \$200 for his first jukebox. Five years later he turned his part-time restoration hobby into a full-time business, Jukebox Junction. Since that time, he's shipped restored jukeboxes to practically all parts of the globe from his shops in Cumming, Iowa. "We're not a volume type of business," he says, "but the only countries I haven't shipped to are the former Iron Curtain ones and what used to be the Soviet Union." The company also offers 2,000 different parts manufactured for restoration as well as reprints of service manuals and memorabilia.

Ed likens jukebox restoration to restoring an antique automobile. "If you find one with good sheet metal, the upholstery is probably shot. So what do you do? Pull the upholstery, and redo it as close to the original as possible," he explains. "But you don't take liberties. It's the same with jukeboxes. We don't change anything in terms of their original components or design. We just put them back as close as possible to the way they were when they left the factory."

And doing that takes expert woodworking skills. According to Ed, you could find a jukebox with all the mechanical components but with damaged wood, then you either have to have the skills to rebuild and restore it or know someone who does. And Ed knows some skilled craftsmen to supplement what he can do.

"When a machine might be worth \$25,000, you can't take shortcuts," he advises. "There are cabinet components on some of these machines that are difficult to remake, even with today's improved woodworking machines."

From experience, Ed has found that missing and broken doors are the most common problem with old jukeboxes. "Every machine had both front and back doors. The front ones were to get to the records; the ones in back to service light bulbs and such. And on them they ran veneers vertically, diagonally, every which way. Their craftsmen were extremely talented as well as clever. So we fix it or make it new," he says. "And that in no way detracts from its collectible value. But I'll tell my customer what part was fixed or replaced."

In addition to repairing parts or making replacements, jukebox restoration often requires extensive refinishing. "You can tell an amateur restoration because the finish won't be rubbed out," Ed comments. "With wooden jukeboxes, the grain was always filled before dyeing, then they were sprayed with lacquer and rubbed out so that the cabinet reflected light like a mirror."

Does the selling price of a restored jukebox justify all the work? "Most of the jukeboxes from the 1940s run between \$7,000 and \$30,000 in restored condition," Ed replies. "And the most valuable of all is the Wurlitzer 950 because only 3,000 were made in 1942. The machine didn't survive well because there was comparatively little metal bracing. So five-figure prices aren't unusual."

For a colorful brochure with several jukebox models not shown here, as well as memorabilia, send a business-size SASE to Jukebox Junction, P.O. Box 70, Cumming, IA 50831. Phone 515/381-4019. To learn more about Wurlitzers, visit the internet at www.wurlitzer-jukebox.com.

A machine named for dancing

Contemporary wisdom has it that the term jukebox originated in the word "jook." In the South during the 1930s, jook was African-American slang for dancing. Places to dance, such as roadhouses and speakeasies, came to be called jook or juke joints, and it was in those places that the earliest coin-operated music machines appeared. The name jukebox was a natural evolution. However, its use was frowned on by the Wurlitzer company because it was thought degrading. Until 1972, Wurlitzer described its machines as "automatic, coin-operated phonographs."

"The main manufacturers—Wurlitzer, Seeburg, and Rock-Ola—became cost conscious. They discovered particle-board, and plastic veneer decal sheets, particularly after the Korean War.

"Music technology also determined jukebox design," Ed notes. "When manufacturers developed mechanisms that could play 50 two-sided 45-rpm records to replace the two dozen 78s that played only one side, they could no longer keep the vertical cabinet. To hold records and the new mechanism that changed them required a squatty, wide cabinet. And part of the draw of the new 45-rpm machines was watching what happened inside as the records changed. That meant bigger glass windows and less wood—big differences in just 10 years. That's why a jukebox from 1942 is a world apart from one of 1952. And worth more, too." 🌳

Written by Peter J. Stephano
Photographs: jukeboxes courtesy of Jukebox Junction; Baldwin Photography
Photo illustration: Carlos Alejandro



Ed Jones, standing, and craftsman Ben Von Ruden look over a Wurlitzer Model 850 from the early 1940s that needs woodworking attention. Restored, it'll carry a \$20,000 price tag.

precision jigs

you can make
in a jiffy

We're big on jigs here at *WOOD*® magazine—over the years, we've published plans for nearly 50 of them! Here's a collection of some of our all-time favorites—six quick-and-easy ways to make your power tools more versatile and accurate.

Router straightedge

Line it up and go

If you've ever put off building a project because it called for extra-long or tough-to-do dados, wait no longer. Instead, let our router straightedge come to your rescue. With it, you easily can rout one or a dozen dados, stopped or not. Edge-joining with your router also becomes a snap.

Note: The finished width of the base (A) will depend on the size of the plastic subbase of your router and the size of the straight bit you use. We cut our base extra wide and then trimmed it to finished width later with a $\frac{3}{4}$ " straight bit.

Project Design: James R. Downing; Jim Boelling

Continued

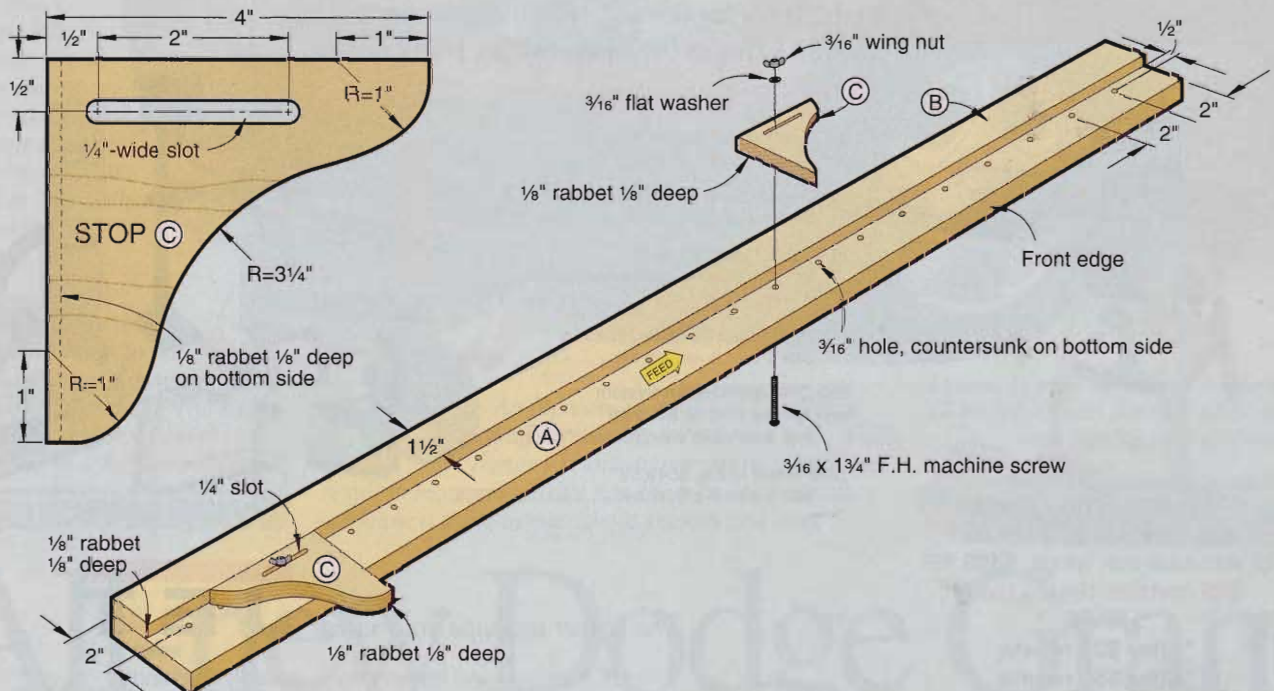

precision jigs



Tablesaw miter jigs

Cut those angles right

Cutting accurate 45° miters becomes a whole lot easier with these angled table-saw-miter jigs. The key, of course, is to lay out the fences with precision while making the jigs. The jig marked R on the drawing fits on the right-hand side of the blade, as shown *above left*. The

jig marked L, shown *above right*, fits into the miter-gauge slot on the left-hand side of the table-saw blade. Use either jig for miter-cutting 45° angles. Or, turn the jig marked L end for end, and use that fence when crosscutting at 90°, as shown in the photo *above right*.

Project Design: **Loyal Downing**

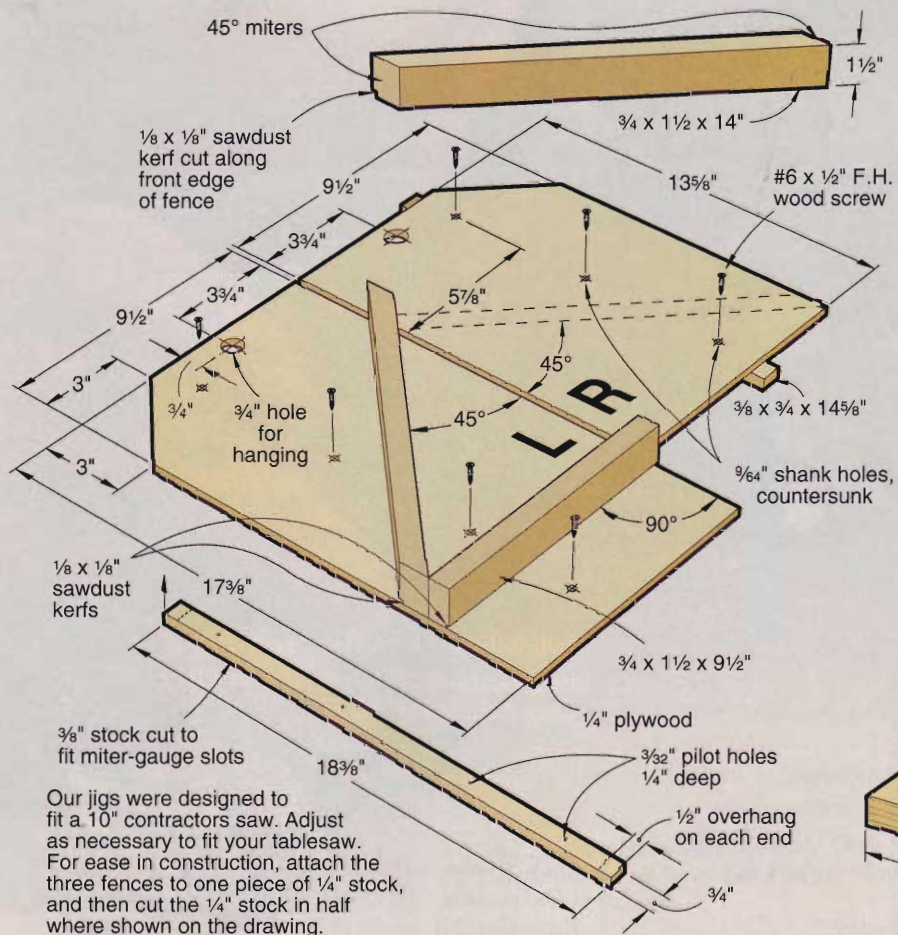

Disc sander circle jig

Make circles without holes

Rough-cut two circles 1/4" larger in diameter than the disc you want. Drill a hole through the center of one disc, which will serve as a model for the hole-free disc. Clamp a block to the sliding bar so it will stop the bar's nail at a distance from the sanding surface equal to the desired radius of your circle. Slip the model disc's hole over the nail in the bar, and sand it to size by rotating and feeding it into the sanding disc until the stopblock contacts the jig's base. Attach the second roughed disc to the top of the model with cloth-backed carpet tape, and sand the second disc the same way you sanded the model.

Project Design: **Jan Hale Svec**

Continued

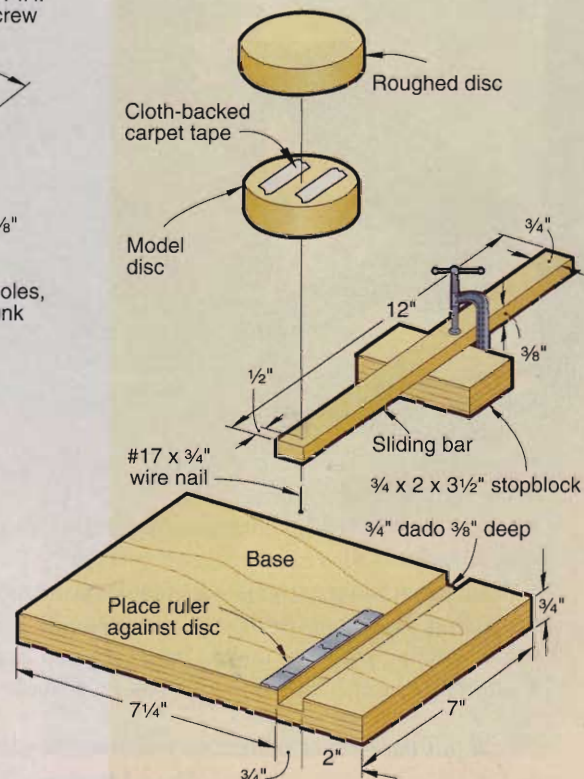
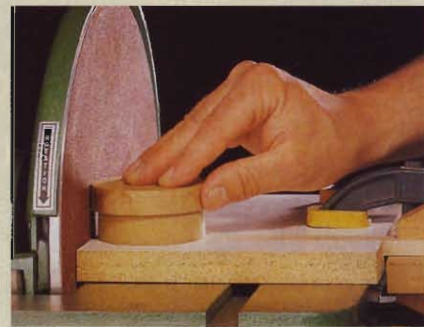

precision jigs



Router trammel

Create perfect circles

For a few dollars and in just an hour or so, you can turn your router into a motorized compass. To adjust the size of circles it can cut, just move the pivot hole. Size the hole at the router end to accommodate the bit you'll be using.

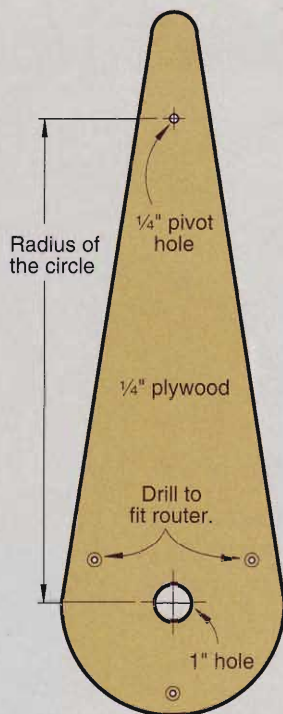

ROUTER TRAMMEL

Tablesaw taper jig

Put a good slant on things

Taper jigs don't get much more basic than this clever hold-down helper. Build the plywood base and hardware hold-downs, as shown on the drawing. Then mark the angled cutline(s) on your workpiece. Position the rip fence so the inside edge of the jig base sits against the fence and the outside edge of the base is flush with the blade. Align the marked cutline on the workpiece with the outside edge of the jig next to the blade. Secure in place, and make the cut, as shown in the photo at right.

Project Design: Jan Hale Svec

Continued

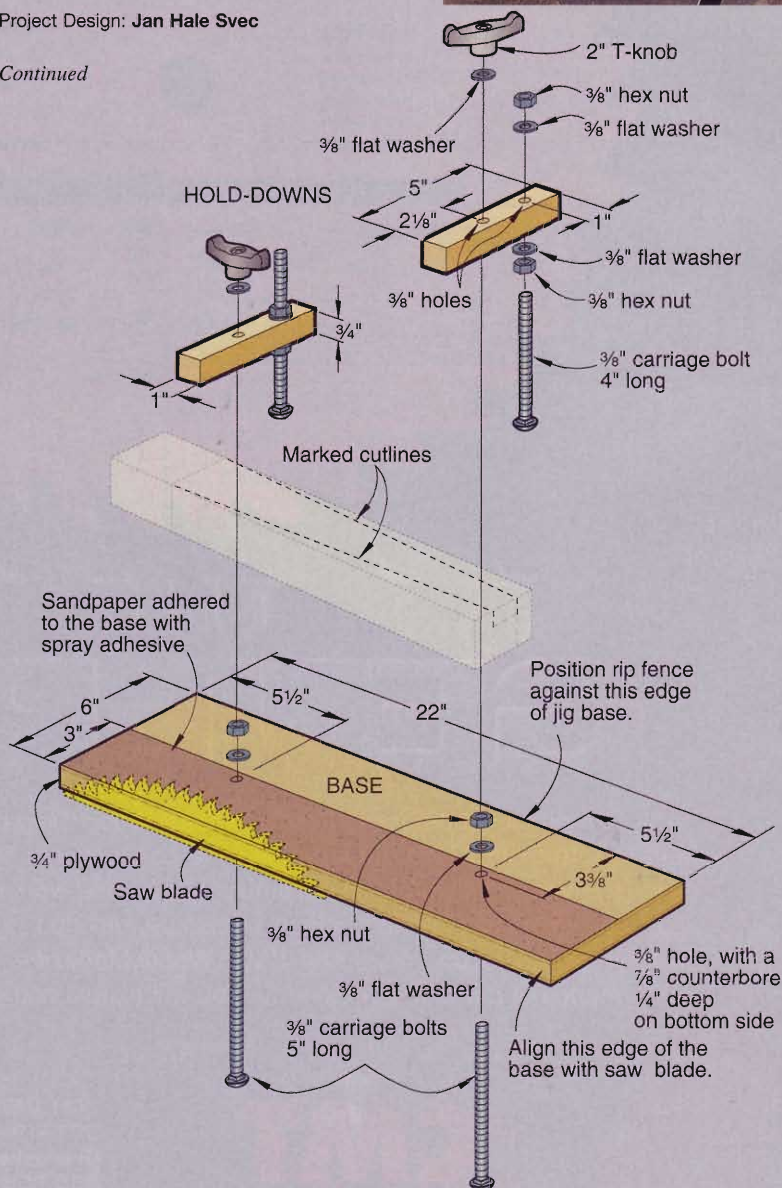
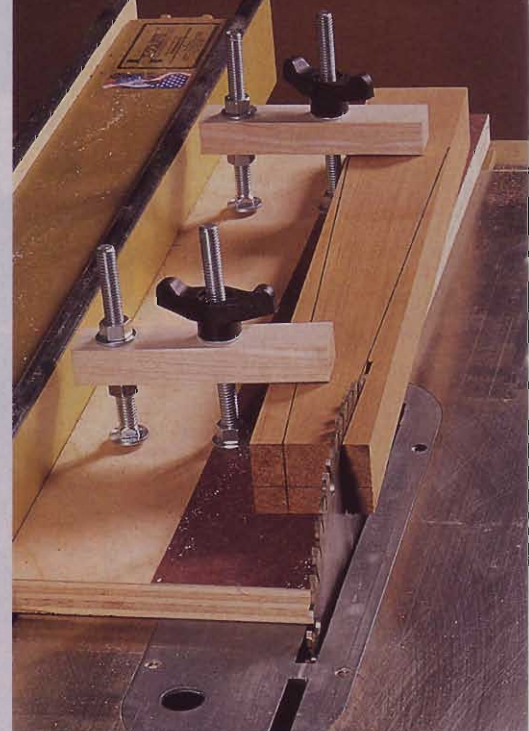

precision jigs

Bandsaw fence

Keep your blade on track

Bandsaws are like after-dinner speakers: They're a lot more enjoyable if they don't wander too far off course. Here's the jig you need to produce nice, straight cuts. Begin by cutting the pieces and assembling them as shown in the drawings below. Once you have all the parts assembled, position the fence on your bandsaw, and tighten the $\frac{3}{8}$ " handle to secure the fence in place. Test-rip on a piece of scrap, and alternately loosen one machine screw and tighten the other until the fence is parallel to the cutting track of the blade. Be sure to loosen and tighten the screws the same amount to avoid bowing the fence. 🐿

Project Design: Charles I. Hedlund

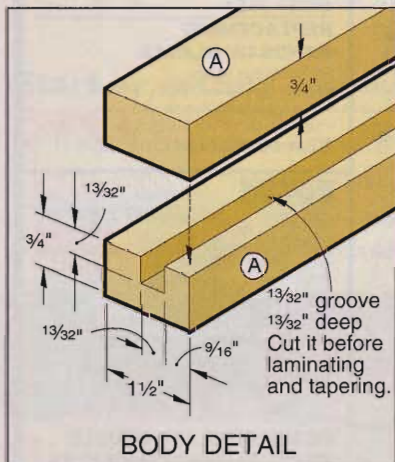

#6 x $\frac{3}{4}$ " panhead sheet-metal screws

Note: Do not screw the aluminum plate tight against the beveled end of (A). Leave a $\frac{1}{32}$ " gap between the plate and (A).

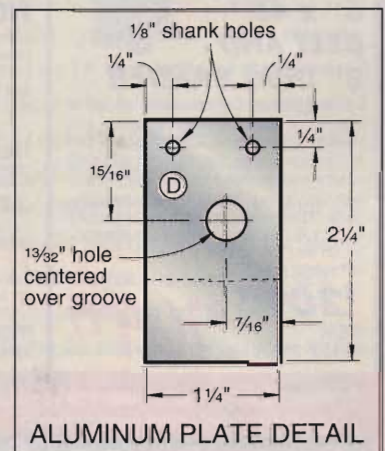
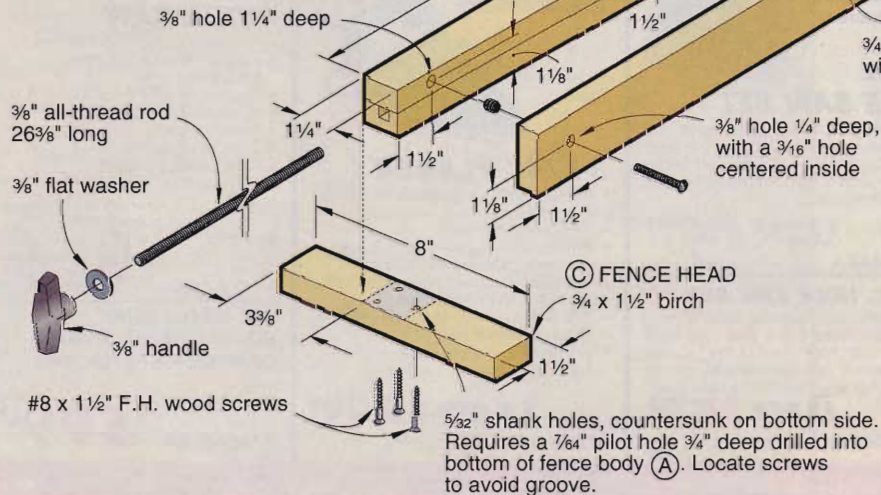
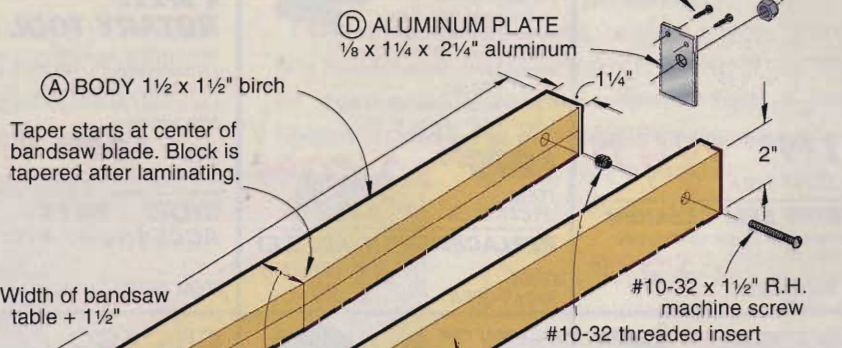

mortising with chisels

a no-nonsense alternative to jigs and machines

You need to cut a mortise; so which power tool will you switch on? The router, the drill press, maybe a mortising machine? Before you start setting up a power tool and searching for jigs and fixtures, consider this: You can make a fine mortise in a couple of minutes with a hammer and chisel.

You'll need the right kind of chisel, of course. Thick, sturdy mortising chisels are designed specifically to do this job. Mortising chisels come in sets of various widths, or you can just buy one and try it. We used a $\frac{3}{8}$ " heavy-duty mortising chisel from Robert Sorby (Woodcraft, 800/225-1153).

1 Carefully lay out the dimensions of your mortise, choosing a width that matches one of your chisels. Clamp the workpiece securely to a solid surface. Then set the cutting edge squarely within the lines and $\frac{1}{8}$ " from the far end, as shown in the illustration *below*. Strike the chisel with a mallet or dead-blow hammer, and drive it $\frac{1}{4}$ " into the wood.

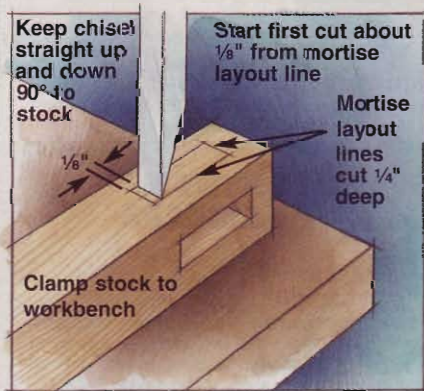

2 Keep the bevel down, incline the chisel handle toward yourself, and begin to chop out material to a depth of $\frac{1}{4}$ ", as shown *below*. Pull the chisel edge back $\frac{1}{8}$ " for each new cut. Be careful not to angle the chisel left or right.

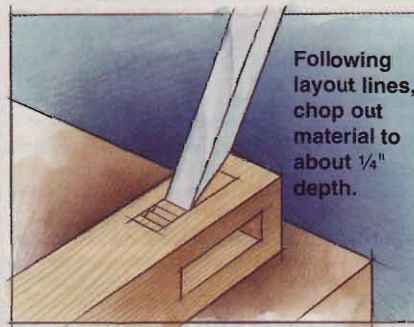

3 When you reach the near end of the mortise, turn the bevel edge away and set the chisel vertically $\frac{1}{8}$ " from the end line, as shown *below*. Make a 90° cut. Then go back to the other end and repeat step one. Continue in this way, checking the depth with a ruler or combination square, until you've reached the desired mortise depth.

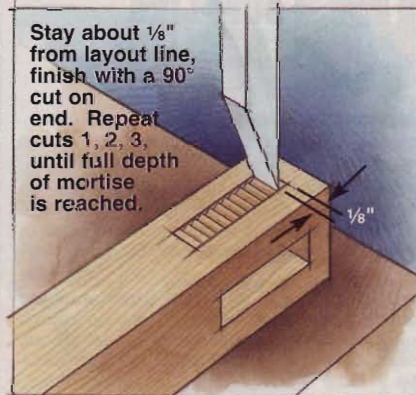

4 Here's the key to cutting perfectly smooth, straight ends in a mortise—the kind of accuracy that results in a strong, tight fit for the tenon. If your mortise is close to the end of the workpiece, find or cut a spacer block of the same thickness as your workpiece, and place it at the end, as shown *below*. Clamp a 90° guide block on the layout line that marks the mortise end. Hold the flat side of the chisel firmly against this guide with one hand, and drive the chisel straight down to the bottom of the mortise. 🌲

Illustrations: Brian Jensen

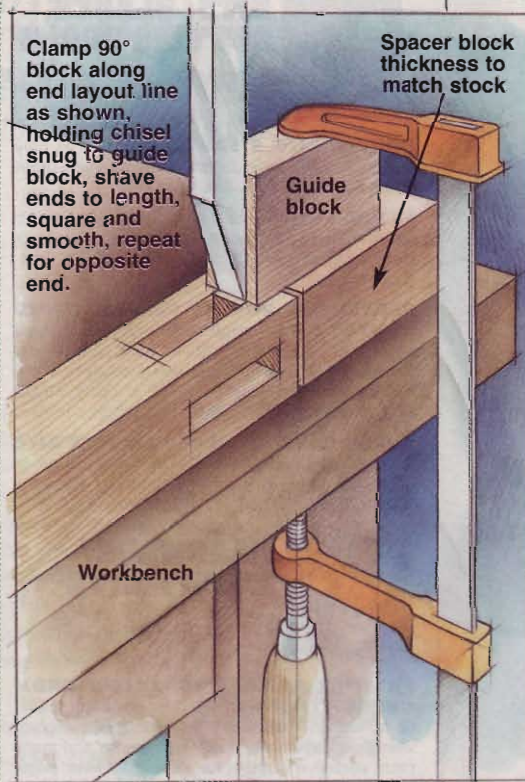

Learn intarsia on a mountaintop

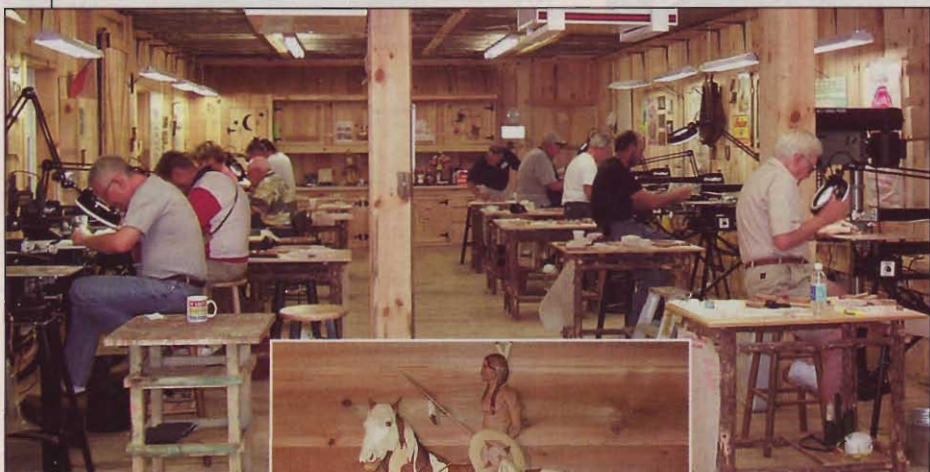

Projects such as the one, right, are designed especially for the intensive intarsia classes.



At Judy Gale Roberts' Tennessee studio, intarsia students cut away at their scrollsaws, above, in hands-on classes.

Now, you can learn intarsia from the best. Artist Judy Gale Roberts and husband Jerry Booher (See "She paints with wood," issue #24, August 1988) began offering hands-on intarsia workshops last May at their mountaintop studio in Sevierville, Tennessee.

Dubbed "The Intarsia Experience," the three-day workshops—at both beginner and intermediate skill levels—are limited to 10 students and held during May, June, July, September, and October. The \$300 fee includes materials and lunches, with a farewell barbecue that features Jerry's special recipes brought from Texas.

Judy had the new classroom space designed in a comfortable old-barn theme appropriate to the Smoky Mountain setting. Sevierville lies just a short drive from Dollywood theme park, Pigeon Forge, Gatlinburg, and Great Smoky Mountains National Park.

For more information on The Intarsia Experience, call 800/316-9010. Or write Roberts Studio, P.O. Box 4718, Sevierville, TN 37864. Visit Judy and Jerry on the internet at www.intarsia.com.

Used lumber becomes rediscovered wood

According to John Landis, writing in the SmartWood newsletter, an old warehouse with one million board feet of reusable lumber can offset the harvest of a 1,000-acre forest.

At a time when global forests face increasing pressures, such wood sources shouldn't be ignored, believe officials of SmartWood, a program of the Rainforest Alliance that certifies sound environmental wood sources.

To encourage wood recycling, SmartWood has launched the Rediscovered Wood Program. At this writing, more than a dozen companies in four countries have received certification for their reclaimed wood products.



SmartWood calculates that billions of board feet of reusable wood exist in the United States and Canada alone. For more information on Rediscovered Wood, write SmartWood at Goodwin-Baker Bldg., 61 Millet St., Richmond, VT 05477. Call 802/434-5491. Or visit www.smartwood.org.

Illustrations: Jim Stevenson
Photographs: Jerry Booher

Calculations to find a tree's age

Normally, you'd count the annual rings of a fallen tree to find its age. The International Society of Arboriculture (ISA), however, has developed a formula to estimate age without cutting or boring into the trunk.

With a tape measure, find the circumference of the tree 54" above the ground. From this, determine its diameter by dividing the circumference by 3.14. Next, multiply the diameter in inches by the factor assigned to the tree's species by the ISA. In the case of black walnut, it's 4.5. So for a black walnut tree of 18" diameter, the age would be approximately 81 years. The cal-

culations aren't exact, of course, because soil, moisture, location, and other factors influence tree growth. But just for the fun of it, here are some factors for some other trees:

Basswood	3	Sugar maple	5.5
Black cherry	5	White ash	5
Douglas fir	3	White oak	5
Red oak	4	White pine	5
Shagbark hickory	7.5		