

Better Homes and Gardens®

WOOD

**FULL-SIZE
PULL-OUT PATTERNS**

December 2001
ISSUE 138

Tips, Tools, Techniques, and Projects for the Home Woodworker

make your own **benchtop router table**

PLUS:
5 router-table tricks
6 routers tested

You-can-build projects:

- Raised-panel dresser and mirror
- Arched-top mantel clock
- Stylish window valance

QUICK-and-EASY
Holiday Tabletop Reindeer



www.woodonline.com

Display until January 8, 2002



U.S.A. \$5.95

contents

WOOD® magazine

December 2001, Issue 138

projects & techniques

- 44 benchtop router table**
Build a feature-packed workstation that offers portability, as well as dead-on accurate machining.
- 50 five router-table techniques**
Rout with templates, cut biscuit and spline slots, shape dowels, and joint with the hardworking how-to here.
- 58 valancing act**
Create a simple, stylish box over windows to hide drapery hardware.
- 66 arched-top clock**
Learn to cut and join staves as you make this award-winning design.
- 72 tabletop reindeer**
This year, scrollsaw your way to holiday cheer with our full-size patterns.
- 74 dresser with mirror**
Add elegance and storage to your bedroom with this fashionable pair of raised-panel projects.

Cover Photos: Baldwin Photography

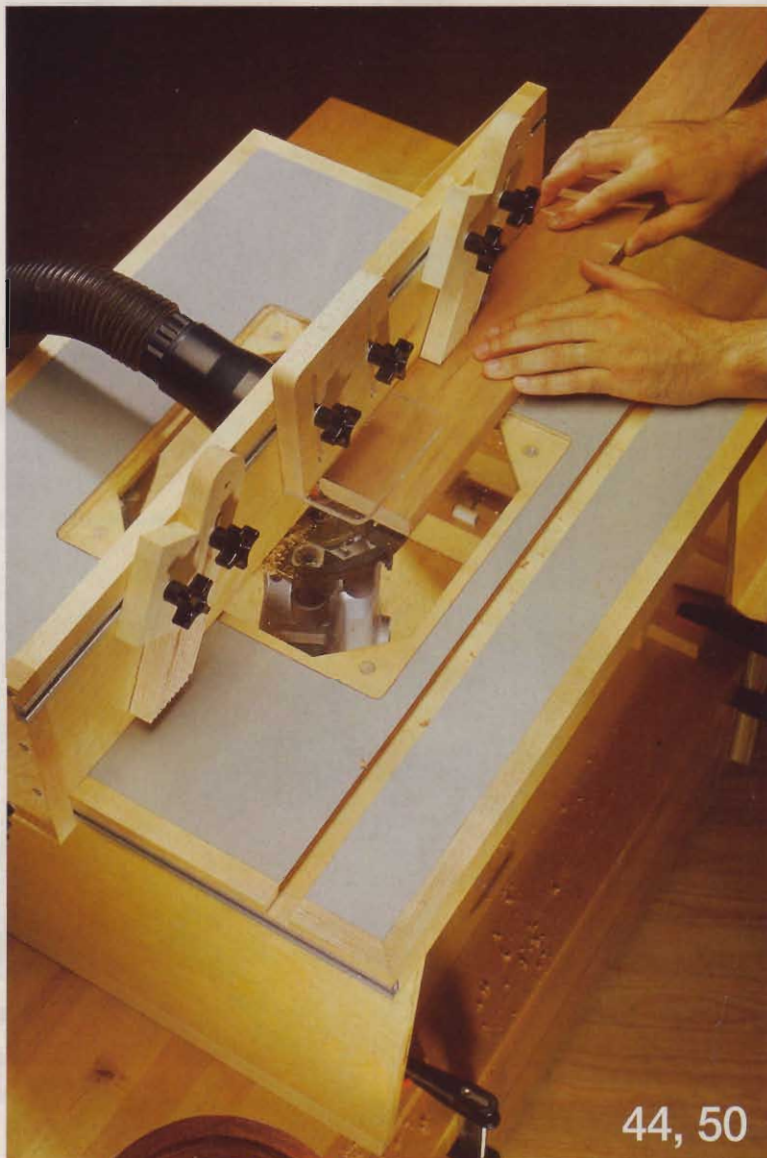

44, 50



66



74



72

contents

December 2001, Issue 138

tools & materials

- 62 healthy woodworking**
Protect your sight, hearing, and lungs with these safety-gear options.
- 84 mid-size routers**
Six 1½- to 2¼-horsepower tools compete in a series of merciless, take-no-prisoners shop tests.

departments

- 6 editor's angle**
- 12 WOOD ONLINE®**
- 14 talking back**
- 20 tool industry insider**
See the hottest new woodworking products from this year's trade shows.
- 24 ask wood**
- 34 router bit review: slot cutters**
Try one of these specialists to cut variably sized slots, grooves, or rabbets on workpiece edges.
- 36 shop tips**
- 42 great ideas: drum sander**
Use PVC pipe and scrap to make an extra-long, drill-press sanding fixture.
- 90 products that perform**
- 104 what's ahead in our next issue**



Better Homes and Gardens® WOOD® magazine (ISSN-0743-894X) is published nine times a year in February, March, April, May/June, July/August, September, October, November, and December by Meredith Corporation, 1716 Locust St., Des Moines, IA 50309-3023. Periodicals postage paid at Des Moines, Iowa, and additional mailing offices. Better Homes and Gardens trademark registered in Canada and Australia. Marca Registrada en México. ONE-YEAR SUBSCRIPTION PRICES: U.S. and its possessions, \$28; Canada, \$41; other countries, \$49. Canada Post Publications Mail Sales Product Agreement No. 40049562. Canadian BN 12348 2887RT. CANADIAN RETURN ADDRESS: Better Homes and Gardens WOOD magazine, 2744 Edna Street, Windsor, Ontario, N8Y 1V2. POSTMASTER: Send address changes to Better Homes and Gardens WOOD magazine, P.O. Box 37439, Boone, IA 50037-0439.

we break a few eggs so you don't have to

At times, you just have to try something new to see if it will work. Your idea might fizzle, but it's also possible you will hit upon a great innovation.

Whenever we present a project, we're faced with many possible ways to go about building it. Take the approaches we tinkered with for assembling the arched-top cabinet clock on page 66.

Design Editor Kevin Boyle quickly realized that the trickiest part of building the clock would be forming its arched top. Basically, he had two choices. He could clamp-up the top from several staves of solid wood and join this arched assembly to the sides with biscuits. Or, he could build the top and sides in one continuous, curving lamination of eight 3/32"-thick veneers pressed around a tall, arched-top gluing form.

The second option especially appealed to Kevin because it would result in a top and sides with no joint lines. And, there would be little sanding of the clock case.

Never one to shy away from a challenge, Kevin set about building the forms by laminating sheets of medium-density fiberboard. Jaw-holding spots for 18 bar clamps were built into the forms, which weighed in the vicinity of 50 pounds all together. Then, he resawed the clock's 5"-wide veneers, planed them, applied glue, and clamped the layers face to face between the inside and outside forms.

Although his forms were shaped perfectly, getting the veneers to conform to that shape, and adhere to each other without gaps, required a tremendous amount of clamping pressure. In fact, one of his first forms broke under the considerable stress.



Design Editor Kevin Boyle learned a lot about cold-lamination techniques in his experiments on building the arched-top cabinet clock carcass.

A subsequent reinforced form held up fine, and resulted in the curved carcass Kevin is holding in the photo above.

Now, if you read the clock project, you may be wondering why, after all of that hard work, we elected to abandon the laminated top/sides and go with a staved top. Well, in the final analysis, we determined that the lamination process was just too unpredictable. You might find success with it, but you might also waste a lot of good stock in the process.

Still, I commend Kevin for this experiment, and encourage all of our editors, designers, and builders to keep trying new techniques. It's through these efforts that we are able to bring you innovative and easier ways to work in the shop. We'll keep trying, come success or failure.



Bill Krier

Editor-in-Chief **BILL KRIER**
Executive Editor **JIM HARROLD**
Managing Editor **MARLEN KEMMET**
Products Editor **DAVE CAMPBELL**
Projects Editor **JAN HALE SVEC**
Projects Editor **DAVID STONE**
Techniques Editor **JIM POLLOCK**
Design Editor **KEVIN BOYLE**
Design Editor **KENT WELSH**
Master Craftsman **CHARLES I. HEDLUND**
Production/Office Manager **MARGARET CLOSNER**
Administrative Assistant **SHERYL MUNYON**
Illustrators **LORNA JOHNSON, ROXANNE LEMOINE, TIM CAHILL, MIKE MITTERMEIER**
Contributing Photographer **MARTY BALOWIN**
Technical Consultants **RICH BRIGHT, JEFF HALL, KIRK HESSE, GARRY SMITH**
Contributing Craftsman **JIM HEAVEY**
Proofreader **JIM SANDERS**
Art Director **TIM ALEXANDER**
Associate Art Director **JOHN MEEK**
Assistant Art Director **CHERYL A. CIBULA**

Publisher **MARK HAGEN**

Advertising Office: 333 N. Michigan Ave., Suite 1500, Chicago, IL 60601 Phone: 312/853-2890 Fax: 312/580-7906

Sales Assistant **THERESA COOKS**

Mail Response Manager **CAROLYN DAKIS**

Account Executive **RON GULMINAS**

Account Executive **NEIL WIRBY**

Account Executive **JOHN THORNBURG**
(Detroit, Phone: 248/356-1149 Fax: 248/356-8930)

Account Executive **PAT TOMLINSON**

(Northeast, Phone: 212/551-7043 Fax: 212/551-7192)

Southeast: Lagomarsino, Dempsey & Dennis, Inc.

2951 Piedmont Rd., NE, Suite 100, Atlanta, GA 30305

Phone: 404/261-5400 Fax: 404/261-5404

Marketing Services Director **CATHY E. SMITH**

Phone: 212/551-7178 Fax: 212/551-7192

Group Publisher **STEPHEN B. LEVINSON**

Associate Business Director **CRAIG FEAR**

Senior Product Manager **RICK GROW**

Advertising Services Manager **PAT WENDERSHOFF**

Consumer Marketing Director **KATHY PHILLEN**

Consumer Marketing Manager **DAVE HUNOLD**

Vice President/Publishing Director **WILLIAM R. REED**

Meredith Publishing Group

President **STEPHEN M. LACY**

Magazine Group President **JERRY KAPLAN**

Group Sales **MICHAEL BROWNSTEIN**

Creative Services **ELLEN DELATYJDER**

Business Development **TINA GEORGEU**

Manufacturing **BRUCE HESTON**

Consumer Marketing **KARLA JEFFRIES**

Finance and Administration **MAJ RUNCAMAN**

Meredith
CORPORATION

WILLIAM T. KERP, President and Chief Executive Officer

E.T. MEREDITH III, Chairman of the Executive Committee

©Copyright Meredith Corporation 2001

All rights reserved. Printed in the U.S.A.

Customer Service Information: For service on your subscription, including change of address, contact us at www.woodmagazine.com/service or call 800/374-9663. **Subscription mailing address:** Better Homes and Gardens WOOD magazine, P.O. Box 37439, Boone, IA 50037-0439. Please enclose your address label from a recent issue. **Editorial mailing address:** The Editor, WOOD magazine, 1716 Locust Street, GA310, Des Moines, IA 50309-3023. For questions on editorial, questions about how to reach an advertiser, or to place an advertisement in our magazine call 800/374-9663. **To order back issues call 800/346-9663.** Article reprints, send \$5 per article (no phone orders). Include issue and name of article, to WOOD Article Reprint Service, P.O. Box 349, Kalona, IA 52247, check or money order made payable to WOOD magazine.



wood online®

How you benefit by going to www.woodonline.com



WOOD ONLINE—where no tool review is ever final

Have you ever read a tool review in *WOOD*® magazine and thought, "I've got that tool, and it's even better than rated?" Or maybe you thought our review was too kind. Share your hands-on experience with thousands of woodworkers, or see what they have to say. The Interactive Tool Comparisons Discussion Groups on WOOD ONLINE let you do just that—instantly and directly. There's no better place to talk shop about the tested tools—their features, date, and performances. Check it all out at www.woodmagazine.com/woodmall/charts/

C'mon. Share our shareware

The Internet is full of shareware—specialized programs you can download for free, try out at your leisure, then purchase for a modest fee if you like them (in some cases, the shareware is free). Here at WOOD ONLINE, we've field-tested lots of them, like Snap-It, the Sheet Goods Layout program shown *below*, and posted links to the best of the best on our site so you can see if they'll work for you, too.

Check out our current picks by going to www.woodmagazine.com/software/

Qty	Width	Length	Description
4	18.00	30.00	Top
6	16.00	38.00	Side
4	4.25	14.50	Brace
8	8.50	40.00	Support
8	7.00	38.00	Shelf

Hot tips? Get 'em here first!

You've probably read a gazillion woodworking tips in the pages of *WOOD* magazine (and in our popular special newsstand publications), but we have to admit—most of them came straight from readers and site visitors like you. But here's a hot tip of our own: Why wait for the valuable tips you can use today to show up in print weeks or months from now? Check out our online Top Shop Tip discussion group for an advance look. And while you're there, why not post your own favorite shop tip that saves work, time, or money?

Just go to www.woodonline.com, click on WOOD TALK on the left-hand navigation bar, WOOD Talk Home, then on Top Shop Tip.

Get back! (Issues, that is.)

On this page a couple of issues ago, we trumpeted our comprehensive online index, complete with search capabilities, that lets you zero in on just about every single feature and project we've ever published. (And that's a lot, folks—remember, we've been at this since 1984.) What if you want to order a back issue to get your hands on a specific project or technique? No problem. Order the issues you're missing online. (But hurry—supplies are limited, and they're going fast!)

Go to www.woodonline.com, and click on WOOD MAGAZINE in the left-hand navigation bar and on Back Issues in the drop-down menu. Then, select the year the issue appeared.



talking back

Our bulletin board for letters, comments, and timely updates

Spring action makes the simple taper jig better

You featured a tablesaw taper jig in the article "Precision jigs you can make in a jiffy" in issue 129. I build a lot of Adirondack chairs with tapered back slats, so I built the jig and use it often. It works great, but I did make one small improvement. Compression springs slipped over the two front bolts, as shown in the drawing, below,

keep the hold-down arms elevated so you easily can insert your workpieces. The springs I used are $2\frac{3}{4}$ " long and about $\frac{1}{2}$ " in diameter. Because they have a wide pitch and are made from fairly thin wire, the springs compress to hold even thin stock.

—Clarence Jaynes, Midwest City, Okla.

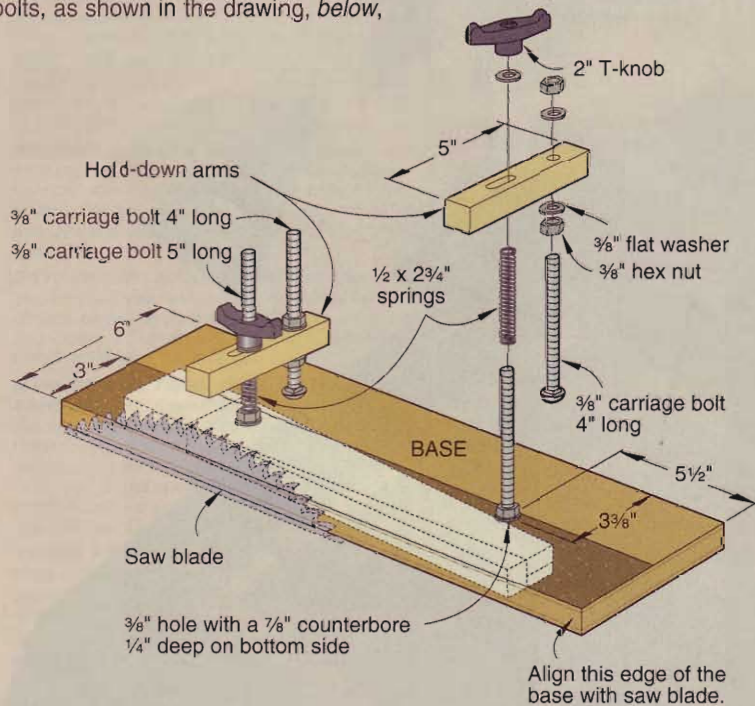

Project Designer Wanted

Are you a creative individual with the ability to design projects like those found in *WOOD* magazine? We're looking for a full-time project designer to join our staff in Des Moines, Iowa. You'll work in a team-oriented environment with other professionals dedicated to producing the world's leading woodworking magazine. Woodworking skills and a knowledge of computer-aided design programs a must. Send cover letter, resume, and work samples to:

Marlen Kemmet, Managing Editor
WOOD Magazine
 1716 Locust St., GA-310
 Des Moines, IA 50309
 Fax: 515/284-2115

Centerline layout increases accuracy

In the "Pivoting picture frames" in issue 132, the mating dowel holes in the pediment assembly (A/B), the base center (C), and the upright (D) are located by measuring from the edges of the parts. As a machinist with 30 years of experience, I know that this layout method leads to problems. If any of the parts are cut slightly oversize or undersize, the holes won't line up. The proper method, shown in the drawing, below, is to mark the centerline of each part, then locate the holes the same distance on each side of the centerline. This way, even if the parts are a little off, the dowel holes still line up.

—Ralph Willis, Barnwell, S.C.

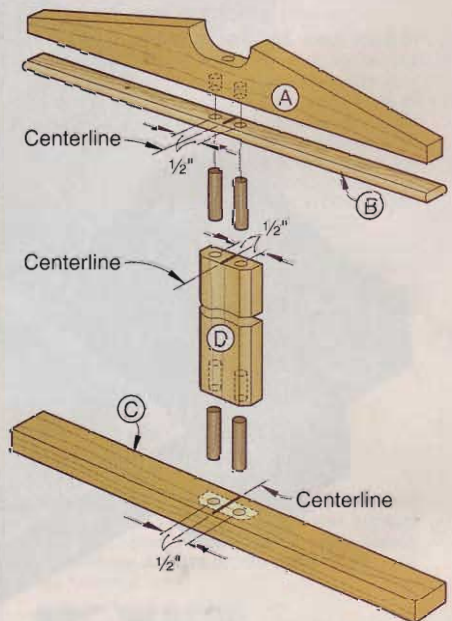

"Drilling" long holes with your router

Your solution for the reader whose drill bits were too short for the long, straight holes he needed in his turned lamp bases was right on the money. In issue

Continued on page 18

**JET...the Power to
Shape Your Ideas.
And the Store
to Make
Them a Reality.**

The JET store is now open with over 200 JET products in stock, including best sellers and hard-to-find attachments. Complete product information including customer reviews make comparing products quick and easy. Visit the JET store and see why JET is one of the fastest growing brands in the industry.



Visit the Jet store at
www.amazon.com/jet

Call for your FREE Tool Crib catalog
1-800-635-5140

dust collectors jointers planers
saws wood lathes the Jet store
shapers sanders planer-molders



talking back

131, page 20, you recommended ripping the stock lengthwise, sawing or routing a groove down the center, and gluing the halves back together.

I've been "drilling" with my router for years, and it sure saves time and frustration. But for my turning projects, I stop my groove about 3" from each end. That way I don't lose my centers. When I'm finished turning, I just drill out the last part with a hand drill or my drill press.

—Gary Brophy, Colorado Springs, Colo.

Raising the stakes on our popular reindeer

My hat's off to the reader who came up with a way to use inconspicuous eye bolts and gutter spikes to stake down the legs of his white lawn reindeer (issue 128 Talking Back). The winds here in Florida can get pretty strong, and my

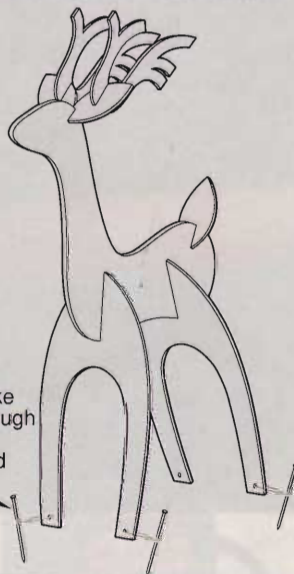

Gutter spike driven through wire loop into ground

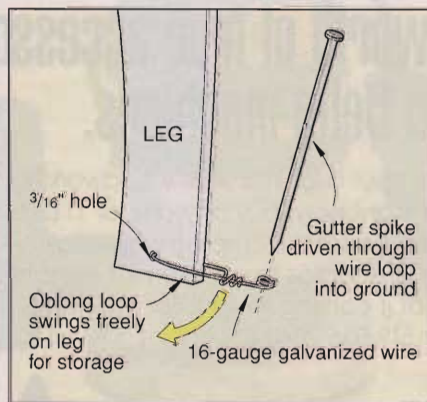

reindeer have blown down more times than I can remember.

But in the off-season, I'm afraid those protruding eye bolts in the legs would keep me from storing the pieces in neat, flat stacks. (Most Floridians don't have a basement, and storage space can be tight.) So I used long-nose pliers to make my own "staking eyes", shown in the drawings, *below left*, out of 16-gauge galvanized wire. They're even harder to detect than eye bolts, and they swing out of the way for storage, letting me stack the parts without a hitch.

—James B. Trushell, Port Charlotte, Fla.

Tool test integrity

I read with great interest the comments on your Web site from numerous **WOOD**® subscribers who were surprised that in the issue 135 jointer review, the Grizzly G1182HW was the best tested. It was rather unfortunate that some of the comments accused **WOOD** magazine of favoring Grizzly because we are one of their advertisers. I trust that the pounding we took in the drill-press review in issue 136 put to rest any question of favoritism.

Although we sell thousands of drill presses every year and the depth stop hasn't been an issue, we plan to switch to the threaded, three-nut system. **WOOD's** comments in the drill-press article were taken seriously and positively, and let there be no doubt—Grizzly intends to be the best.

—Shiraz Balolia, president, Grizzly Industrial, Inc.

Write Us!

Do you have comments, criticisms, suggestions, or maybe even a compliment specifically relating to an article that appeared in **WOOD**® magazine? Please write to:

Talking Back
WOOD magazine
1716 Locust St., GA310
Des Moines, IA 50309-3023

or e-mail us at talkingback@mdp.com.
Due to the volume of letters and e-mails we receive, we only can respond to and publish those of the greatest interest to our readers.

this year's hot new tools

I recently scoured two enormous trade shows in search of the latest and greatest woodworking products. Here are six I judged most innovative.

Dave Campbell

Woodworking Products Editor

Every summer, tool manufacturers from around the world gather to show off new gadgets they hope will capture the hearts (and wallets) of tool junkies. At the Association of Woodworking and Furnishings Suppliers Fair in Anaheim, Calif., and the National Hardware Show in Chicago, I got a chance to see and handle literally hundreds of new tools, gizmos, and accessories. You read about Porter-Cable's cordless router in our last issue, and you'll learn about the Record QuickVise on page 90, but here are six more of the best products I saw.

**Titebond HiPURformer
Advanced Bonding System**
800/347-4583
www.titebond.com

Titebond's waterproof polyurethane adhesives apply like hotmelt glue and bond like epoxy on virtually any material. I put a dab of the stuff on the end grain of a piece of oak, and pressed another piece of oak end grain to it. After a couple of seconds I didn't need to hold the pieces anymore. Within 5 or 6 minutes, I couldn't break the two pieces apart. The cordless applicator, base, and three cartridges of adhesive sell for around \$100; replacement cartridges cost \$6-\$8.



Delta 22-580 Portable Planer
800/438-2486
www.deltamachinery.com

Delta's 22-580 13" portable planer is the first portable planer with two feed rates. In "dimension" mode, the feed rollers haul lumber under the knives at 22.4 feet per minute (fpm). Switch to "finish" mode, and the rate slows to 14.8 fpm for a silky smooth surface. The 22-580 also boasts a depth stop that can be set anywhere from 1/8" to 6 1/2". A price hasn't been established yet for the planer, but a source at Delta says it will be "under \$500."



Tool Dock Modular Workshop

866/866-5362
www.tooldock.com

These modular cabinets and tops come in a myriad of configurations so you can build your shop one piece at a time. Interchangeable inserts allow you to mount, dismount, and store benchtop tools quickly and securely. And casters make the system flexible to your space. To see how versatile this system can be, drop by the Tool Dock Web site. I was impressed by the sturdiness of the 18-gauge steel cabinets that support the MDF work surfaces. Equally impressive are the prices: Most pieces cost less than \$200; the Router Station and Shop Bench sell for around \$300 each.



Continued on page 22

Laguna Tools LT14 Bandsaw

800/234-1976
www.lagunatools.com

I've long admired the stationary tools imported by Laguna Tools, but such quality demands a higher price than I can easily afford. Laguna's new Belgian-made 14" bandsaw is more modestly priced—under \$900. Rather than clone existing models, Laguna designed the LT14 from the ground up with a large table sitting on double cast-iron trunnions; machined cast-iron wheels; ceramic blade guides; and two tall, extruded-aluminum fences—one for resawing and the other on the miter guide.



Porter-Cable BN200V12 Cordless Brad Nailer

800/487-8665
www.porter-cable.com

I've searched for years for an electric brad nailer that works like a pneumatic, but I never thought it would come without a cord attached. The BN200V12 uses a 12-volt rechargeable battery to power an air compressor built into the nailer, and can drive 3/4–2" 18-gauge brads at a rate of about one per

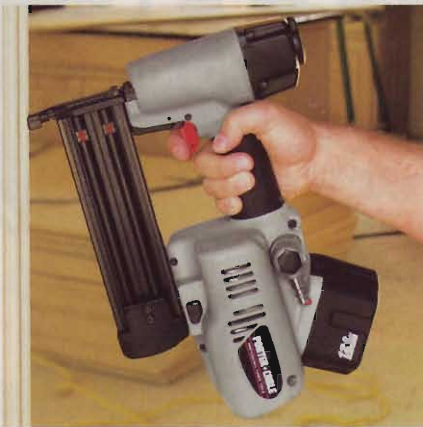

second. You also can remove the battery and power the tool with an air compressor. I found the BN200V12 heavier than a pneumatic nailer, though its balance isn't much different from the feeling of dragging an air hose. It sells for about \$280, including one battery pack.

Hear & Protect Electronic Hearing Protectors

631/673-5975

Now hear this: Avoid the hassle of on-again, off-again hearing protection with Hear & Protect from Power Aisle, Inc. You simply leave these muffs on your ears all the time. A built-in microphone allows you to hear what's going on under normal workshop circumstances. But when the noise level exceeds 85 decibels (dB), electronic circuitry turns off the mic, and Hear & Protect protects. The set sells for about \$60.



SOMMERFELD'S TOOLS FOR WOOD
8 East Third Street Remsen, IA 51050

CMT's New Industrio™ Routing System
Designed by Marc Sommerfeld

This system combines the performance and design of a shaper with the versatility of a router.

Check out our complete on line catalog at www.sommerfeldtools.com

ORDER TOLL-FREE 1-888-2BUY-CMT
1-888-228-9268

Circle No. 1366

NEW! Adjustable Bar! Micro Adjusting Flip-Stop

"All my tools should be this good!"

Accu-Miter® shown with optional manual clamp.

The Accu-Miter® is a professional miter gauge that makes perfect angles easily. Shot-pin action assures dead-on accuracy for common angles. Our new adjustable bar insures a perfect fit in your table saw's slot.

\$179 Model 18-34

Call or write for our free brochure.

JDS COMPANY
800 Dutch Square Blvd., Suite 200
Columbia, SC 29210
1-800-382-2637 www.thejdscompany.com

Introducing the
New Delta Store.
**Tap into the
Power of the Pros.**

The new Delta store has over 1000 products from a complete line-up of unisaws to those hard-to-find machinery attachments. Extensive product information including customer ratings and reviews will help you choose the right tool for the job. We'll even deliver to your door for only \$6.99.



Visit the Delta store at
www.amazon.com/delta

Call for your FREE Tool Crib catalog:
1-800-635-5140

table saws radial saws miter saws
scroll & band saws planers the Delta store
drilling machines jointers wood shapers



ask wood

Answers to your questions from
letters, e-mails, and WOOD ONLINE®

Get good grades as a novice plywood buyer

Q I always ask for "cabinet grade" plywood when buying for projects, because I don't know the actual grade names. Can you tell me what the grades are, and what they mean, so I can at least sound like I know what I'm talking about?

—Bill Martin, Lewisburg, Tenn.

A You're not alone, Bill. Plywood comes in a staggering array of grades, but the short answer is that top-quality cabinet plywood is called the "A" or "number 1" grade. According to the American National Standards Institute, the splices in "A" grade face veneer should be matched in some fashion for an attractive appearance, there should be very little contrast in color or grain, and each 4x8' sheet can have no more than a handful of pin knots no larger than 1/4".

You can get by with less-expensive "B" grade material for workshop or garage projects. "B" grade plywood can have

more pin knots and up to four larger knots, but still no glaring contrasts in color or grain. The "C" grade has unlimited pin knots and up to eight larger knots, and might display grain contrasts at the splices. The photos *below* show the kinds of defects you should avoid in your best projects. Remember that you can buy plywood with an "A" face and an "A," "B," or "C" grade back.

If you don't see the grade printed on the end of the sheet, ask the dealer. Even better, buy where you can easily look through the plywood and pick the pieces you like best, whatever their grade. You'll find that some home centers don't carry "A" material. A more specialized lumber company should have the good stuff.

—WOOD® magazine

Limit the load on MDF shelves

Q I'm thinking about using medium-density fiberboard to make the shelves for a bookcase. What's the maximum recommended length for 3/4" MDF shelves?

—Chris Terhune, Austin, Texas

A We found an answer from The Composite Panel Association, Chris. Check the chart, *page 26*, and match your design to the load you expect the shelves to carry. For example, a linear foot's worth of WOOD magazines weighs roughly 22 pounds. The numbers in the chart apply to a shelf that simply rests on a support at each end. However, if the shelf is 12" or less in width, and has continuous

Continued on page 26



Knot

Mismatched
Veneer

Mineral
Streaks

The Plane Truth

While these may look and feel like your Grandfather's planes, truth is, when it comes to performance, all but sentiment is left behind. We kept the look and feel part and applied modern design, manufacturing and material concepts to create classic planes that truly work better. You can see, hear and feel the difference.



Low-Angle Block Plane

#4 1/2 Smoothing Plane

#5 1/4 W Bench Plane

The new Veritas® line of planes – classic evolution.
Affordably priced from \$89.00-\$175.00

1-800-871-8158 or customerservice@leevalley.com

Lee Valley & Veritas®

Lee Valley Tools Ltd., 12 East River St., Ogdensburg, N.Y. 13669

Shop online:
www.leevalley.com

ask wood

support along its back edge, you can double the span. Solid-wood edging along the front will boost the shelf's strength, too, as well as improving its appearance.

—WOOD® magazine

Maximum Span for MDF Shelves

Load lbs./sq. ft.	1/2" thickness	3/4" thickness
50	15"	22"
40	16"	24"
30	18"	26"
20	20"	30"
10	25"	36"

These woods can be downright irritating

Q I've been building a table out of walnut, and the sawdust seems to be irritating. As a novice woodworker, I'm wondering which woods are most likely to produce unpleasant reactions. Can you help?

—Carl Bretzke, Hutchinson, Minn.

A Carl, some woods affect almost anyone, given enough exposure, while others create an allergic reaction only in certain people. Species that commonly create breathing problems or skin rashes include cocobolo, ebony, myrtle, padauk, rosewoods, satinwood, teak, wenge, and western red cedar. It's more

The Selection is Huge.

We Built a Porter-Cable Store to Show it all.

See the complete line-up of Porter-Cable products in the new Porter-Cable store. Over 1,000 items including pneumatics and cordless tools to the hard-to-find woodworking accessories. See the entire fleet of this year's new Porter-Cable products at the store that has it all.



Visit the Porter-Cable store at

www.amazon.com/portercable

Call for your FREE Tool Crib catalog 1-800-635-5140

routers sanders cordless tools
generators the Porter-Cable store
nailers & staplers air compressors

VISIT THE



Continued on page 28

Serious Woodworkers
Rely On Freud

For The Sharpest Router On The Shelf.

Get precisely what you need from Freud. Visit Freud's new web site and choose from more than 1,500 items, including router bits, saw blades, power tools, dado sets, and shaper cutters. Extensive product information, including customer ratings and reviews, help you stay on the cutting edge.



Visit the Jet store at
www.amazon.com/freud

Call for your FREE Tool Crib catalog
1-800-635-5140

dado sets hand tools power tools
router bits router sets the Freud store
saw blades shank sets shaper cutters



ask wood

rare to run into trouble with bald cypress, balsam fir, beech, birch, black locust, boxwood, elm, gonzalo alves, mahogany, maple, red oak, purpleheart, redwood, spruce, walnut, and zebra-wood. No matter what woods you use, we hope that you have a good dust-collection system, wear a dust mask, and keep your shop well ventilated.

—WOOD® magazine

The truth about wood countertops

Q I want to install a solid-wood countertop in the kitchen, around the sink. What kind of wood and finish should I use to avoid water damage?

—Jim Kieffer, Summit, N.J.

A White oak is one of the more moisture-resistant woods, Jim, but it's the finish that will make or break a kitchen countertop. Unfortunately, it's difficult to find a product that will stand up to the demands over a long period of time. According to finishing expert Bob Flexner, conversion varnish (which requires an acid catalyst) and catalyzed lacquer (conversion varnish plus nitrocellulose lacquer) would be the most durable film-forming finishes for this application, but their use is problematic for most of us. Next in durability comes polyurethane varnish, which is easy to handle. But any film finish will start to peel if water makes its way through a

Bob Flexner's Finish Ratings

On a rising scale of 0-5, here's how some finishes resist kitchen challenges.

	water	wear	heat
Wax	0-2	0	0
Oils	0-2	0	3
Nitrocellulose lacquer	3	3	2
Water-base Polyurethane varnish	3	5	2
Conversion finishes	5	5	5

crack or scratch. Bob says your other choices are to apply a non-curing oil, such as mineral oil, and recoat often; apply an oil that cures, such as linseed oil, or an oil-varnish blend, and recoat often; or leave the wood unfinished, and wash it periodically to clean it. All in all, you can see why wood doesn't show up in many kitchen countertops, except as edging.

—WOOD magazine

Is it safe to burn manufactured wood?

Q I produce lots of scrapwood in my shop, and use most of the scraps as kindling or firewood in my fireplace or woodstove. I've always considered it unsafe to burn CCA-treated wood, composition board, and MDF. Is that correct?

—Frank Krieger, Patchogue, N.Y.

A Frank, the U.S. Forest Products Laboratory in Wisconsin says treated lumber may produce toxic chemicals when burned, so don't throw it in a fireplace or stove. As for composite materials, a few scraps in a fire won't create a personal health hazard, according to a chemical engineer at the Weyerhaeuser Company. Victor Dallons, of the lumber giant's environmental technical services department, says a normally burning fire will consume the formaldehyde contained in composite board adhesives. But the urea in those adhesives does produce more air pollution in the form of nitrogen oxides, so we hope you'll take most of those scraps to the landfill.

—WOOD magazine

Help! Workshop dust is invading my house!

Q My shop occupies part of our walkout basement. When I built it, I tried to isolate the sawdust from the upper level by drywalling the whole shop and adding wipers to the bottoms of the two shop doors, and I have three dust collectors. However, some of the fine sawdust still infiltrates to the upstairs. Any ideas on how to really

Continued on page 30

seal the doors while still allowing them to open and close?

—Larry Jenkins, Shellsburg, Iowa

A Install exterior door units that have integral weather stripping and threshold with a sealing sweep under the door. You could try to retrofit the existing interior doors with foam stick-on weather stripping but the add-on type is not as good as the type that comes on insulated steel door units. A threshold and rubber bulb type sweep could be added to the existing doors, but it's pretty tough to get a tight fit that still allows the door to close nicely. If you are not using an air filtration unit, you might want to install one.

—Hugh Hadfield, Fairview Heights, Ill.

A Filter any and all return air ducts in the basement.

—Gene Broseus, address unknown

How to cut plywood with a circular saw

Q I have a 4x8' sheet of red oak lumber core plywood and only a Skilsaw to cut it. Any recommendations for getting straight, clean cuts? What about blade type? I have a Black & Decker 73-147 hollow-ground plywood blade that works fine on 1/4" plywood, but I don't know if it will make it through 3/4" lumber core.

—Charles Brozek, Zion, Ill.

A Place the wider, heavier part of your saw on the "keeper" side of your cut when you remove a narrow strip, as shown at right. You'll want the straightedge on the left in this situation. If your plywood has a good face and a lesser-quality face, place the good side down when you cut it with a circular saw. That way, the leading edge of the blade cuts into the veneer instead of



It's The World's Only Cordless Brad Nailer That's Also Pneumatic.

Cordless. Pneumatic. Our new cordless brad nailer gives you the option of both, using exclusive **TPS Technology™** (Twin Power Source System). It's cordless, thanks to a mini-compressor powered by our rechargeable, interchangeable 12-volt battery. It's also pneumatic, courtesy of a 1/4" valve that allows you to use it with traditional compressors. To get one of your own, visit your Porter-Cable dealer or call 1-800-487-8665 (519-836-2840 in Canada).



PORTER-CABLE
PROFESSIONAL POWER TOOLS

breaking out of it. Any splintering will be on the back side. Also, Tru-Grip makes a bar clamp/straightedge that you might like. The Woodworker's Supply catalog carries the 48" model. Call 800/645-9292 to order part number 868-717, priced at \$39.95 plus shipping.

—WOOD® magazine

A Yes, your blade will handle the 3/4" just fine, provided it is reasonably sharp. If you've used it for several years, you probably should replace it with a good, general-purpose carbide blade. The Black & Decker Piranha is an excellent choice. To cut a straight line with a circular saw, use a straightedge guide clamped or screwed to the plywood. The straightedge can be a piece of factory-edge, 3/4" plywood about 6" wide by 8' long, which your lumber provider will cut for you. Place enough 2x2s or 2x4s across a pair of sawhorses to make a sta-

ble platform, put the plywood on top, and clamp or screw the straightedge in a carefully measured position to the right of your saw's table (to the left, if you're a lefty). Set the depth of the cut for the blade to extend about 1/4" through the plywood. Move the saw slowly and carefully, always keeping some pressure against the straightedge.

—Sam Sayger, Hernando, Miss.

A I cut furniture-grade plywood with a top-of-the-line Black & Decker saw and a 40-tooth, ATB, carbide-tipped Jesada blade, and I have essentially no splintering. I do have a couple of gimmicks, however. First, I use a Penn State Portable Panel Saw System, which allows you to fasten your saw to a ball-bearing guide carriage. [It's part PPS-B, priced at \$89. Call 800/377-7297.] Second, I saw all my panels on the floor by placing them on a sheet of 1" struc-

tural foam. I set the blade so that it just penetrates the foam.

—Clint Chamberlain, Madison, Wis.

Do power tools cause carpal tunnel woes?

Q What is the thinking on using handheld power tools and carpal tunnel syndrome? Every time I use my random-orbit sander, I get a pain on the back of my hand.

—Bruce Dissel, Moab, Utah

A Bruce, you should visit your doctor and get the problem checked out. Bill Fellows, a physical therapist at the Iowa Clinic in Des Moines, says handheld power tools can contribute to a variety of painful conditions. The vibration, long-term gripping, and repetitive motion involved in using a sander, for

Continued on page 33

It's The World's Only Pneumatic Brad Nailer That's Also Cordless.



Pneumatic. Cordless. Our new cordless brad nailer gives you the option of both, using exclusive **TPS Technology™** (Twin Power Source System).

It's pneumatic, courtesy of a 1/4" valve that allows you to use it with traditional compressors. It's also cordless, thanks to a mini-compressor powered by our rechargeable, interchangeable 12-volt battery. To get one of your own, visit your

Porter-Cable dealer or call 1-800-487-8665 (519-836-2840 in Canada).

Proud sponsor of
THE NEW YANKEE
WORKSHOP on
Public Television



PORTER-CABLE
PROFESSIONAL POWER TOOLS

WWW.PORTER-CABLE.COM

example, can lead to problems such as carpal tunnel syndrome, tendinitis, or nerve irritation. Bill suggests stretching your hands, wrists, and forearms before settling in to use a tool for any length of time. Bend and straighten them, move them from side to side, and pump your hands open and shut a few times to improve blood flow and flexibility. He also suggests trying to find a more comfortable way to hold the tool, and recommends buying tools that are ergonomically designed to fit the human hand. But when pain becomes a regular and significant factor, get a medical opinion. If these ailments become chronic, eventually you have no choice but surgery.

—WOOD® magazine

Going around the bend with plywood

Q I'm making a sleigh, and need to bend a sheet of 3/8" plywood. What's the best way to go about it? Also, would exterior plywood work or is marine-grade plywood necessary?

—Rand Foss, Tomahawk, Wis.

A Exterior plywood will serve the purpose, Rand. Tom Millsap, a Paxton Lumber salesman in Des Moines, says marine-grade plywood is necessary only for projects that will be submerged in water. Remember, of course, that it's the glue that makes plywood "exterior." The wood itself is as susceptible to the elements as the interior version.

If you'll be bending your plywood to a tight radius, we suggest using three lay-



www.woodonline.com

ers of 1/8" material, rather than one 3/8" piece. Use epoxy to laminate the three thicknesses into the required shape, and expect some "springback." We don't recommend saw kerfs as a bending aid for outdoor projects. The kerfs create entry points for water to get inside and cause damage. For indoor projects, try a sheet of "bending plywood," available from the larger lumberyards. It comes in 1/8" and 3/8" thicknesses, and you can form it into a tight radius with ease.

—WOOD magazine

Seeks an end to curly maple tear-out

Q When I send curly maple through the thickness planer, there is always tear-out. How can I avoid this? Is there a better way to bring it to dimension?

—olgrngo@aol.com

A Curly maple is a tough wood to power-plane. When I've got to dimension this wood, I run it through the planer at a slight angle and take light cuts until I get close to the thickness I want. Then I go to the hand plane and scraper. Check in your area for someone with a wide belt sander, and see if you can rent time on it or have the owner do the work. If you have a lot of material to run, it could be worth the money.

—Robert Phillips, San Antonio, Texas

Got a question?

If you're looking for an answer to a woodworking question, write to Ask WOOD, 1716 Locust St., GA 310, Des Moines, IA 60309-3023 or send us an e-mail at askwood@mdp.com. For immediate feedback from your fellow woodworkers, post your question on one of our discussion groups at www.woodonline.com.

Discover the NEW RouterShop™

"the router tool with a brain"



L416

See it, to Believe it!
Call for your FREE Video and Catalog



Discover how the Hawk RouterShop™ can help you unlock your woodworking potential.

- No fancy bits required- with a simple straight bit you can create a complete set of cabinets.
- Patented tilting table- set your cutter vertically and horizontally for a safe, new way to make cuts.
- Solid steel construction- no flimsy chipboard to warp.
- Patented Router Carriage
- No time consuming set ups, the tool does it automatically with it's unique built in "brain".



Please rush my FREE L416 Catalog and Video to: www.rbiw.oodtools.com

Name _____
 Phone _____
 Address _____
 City _____
 State _____ Zip _____
 Email _____

ROUTERSHOP
 HAWK
 RBI Industries, Inc.
 1801 Vine Street
 P.O. Box 369
 Harrisonville, MO 64701-0369

Optional—occasionally require special offers, via email

Call 1-800-487-2623

stacked slot cutter

Get into the groove with this slot-cutting specialist

If you need a slot, groove, or rabbet on the edge of a workpiece, you can't beat a stacked slot-cutting bit in your router or router table. This set of cutters with a single arbor gives you the flexibility to cut a range of widths, and you can micromanage the fit with a series of shims, much like a stacked dado set on your tablesaw.

But a stacked slot cutter can do things your dado set can't, such as rabbeting a curved surface, as shown *above right*. In the arched-top cabinet clock project on *page 66*, we machined the groove to accept the clock back using a stacked slot-cutter—a task impossible for a dado set.

Mounted in a router table, use a stacked slot cutter to rout a spline groove in the edge of wide workpieces without jiggling up a tall fence. And for large projects, such as a built-in bookcase, mount the bit in your handheld router to cut slots for T-moldings or biscuits. (In the Router-Table Techniques article on *page 50*, learn how to use your router table as a biscuit joiner.)

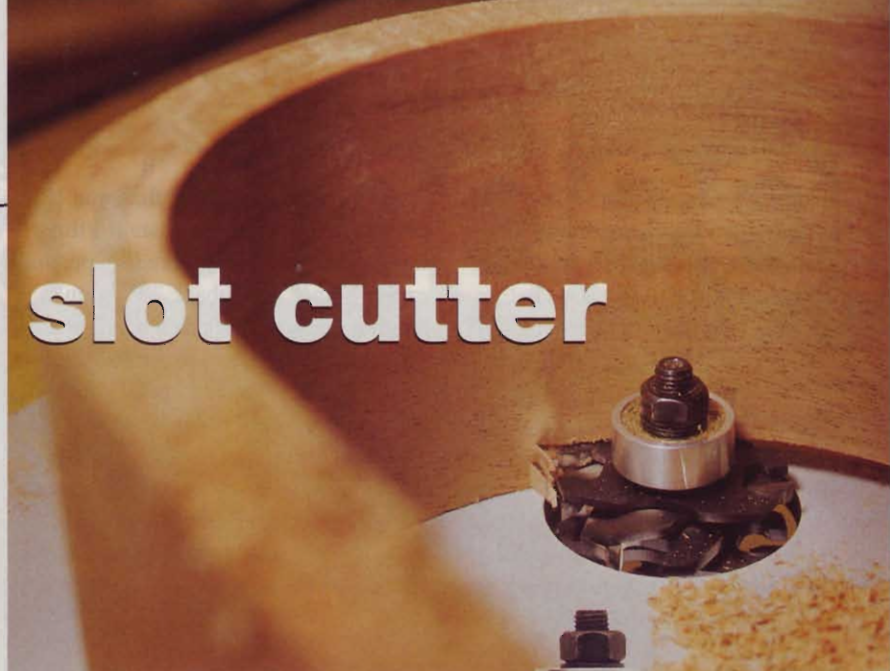

How the set stacks up

A typical stacked slot cutter consists of four cutters of different thicknesses ($\frac{1}{8}$ ", $\frac{5}{32}$ ", $\frac{3}{16}$ ", and $\frac{1}{4}$ "), an arbor on which they mount, and a bearing that fixes the depth of cut (usually $\frac{1}{2}$ ", although other bearing sizes are available). The set also comes with about 20 shims ranging from .1 millimeter (mm) to 1 mm for fine-tuning the cutting width.

The cutters themselves have two, three, or even four "wings," each with a carbide tooth on its end. Four-wing cutters afford the cleanest cuts, but are more expensive; three-wing cutters offer the best combination of performance and value.



One stacked slot-cutting set can cut grooves ranging from $\frac{1}{8}$ " to nearly $\frac{3}{4}$ ".

and make a test cut in scrap stock. Add or remove shims as needed for a perfect fit.

Setting up the bit

To use a stacked slot cutter, figure the combination of cutters and shims you'll need to achieve your final cut width. The chart at *left* shows the range of widths for each combination of cutters and shims. You must use at least a 1 mm shim between cutters, and the narrowest cut shown for each combo includes that shim.

Because the arbor isn't threaded along its entire length, you'll also need to add enough extra shims to reach the threads on the end of the shank. Put the extra shims on the empty arbor first, then add the cutters and shims, and finally the bearing and arbor nut.

Remember to orient the cutters properly: When viewed from the threaded end of the arbor, the cutters should point counterclockwise. Mount the bit in your router

Beyond the basics

Here are a few more tips to get the most out of your stacked slot cutter:

- Forget to cut the rabbet to accept a drawer bottom or case back? Rout the rabbet in the completed box using a stacked slot cutter. The rabbet's corners will be rounded, but you can square them up with a chisel or radius the corners of the bottom/back to match.
- The bearing also can be mounted on the arbor between cutters (say, to create the tongue of a tongue-and-groove joint) or before the cutters on the arbor for guiding from the top with a handheld router.
- Although it's safe to use these bits in a handheld router, we prefer the stability and security of a router table, whenever possible. 🛠️

Written by **Dave Campbell** with **Kevin Boyle**
Photograph: **Baldwin Photography**

Cutter combos for lots of slots

Standard cutter(s)	Slot width*
$\frac{1}{8}$	$\frac{1}{8}$
$\frac{5}{32}$	$\frac{5}{32}$
$\frac{3}{16}$	$\frac{3}{16}$
$\frac{1}{4}$	$\frac{1}{4}$
$\frac{1}{8} + \frac{5}{32}$	$\frac{1}{4} - \frac{9}{32}$
$\frac{1}{8} + \frac{3}{16}$	$\frac{9}{32} - \frac{5}{16}$
$\frac{1}{8} + \frac{1}{4}$	$\frac{11}{32} - \frac{3}{8}$
$\frac{5}{32} + \frac{3}{16}$	$\frac{5}{16} - \frac{11}{32}$
$\frac{5}{32} + \frac{1}{4}$	$\frac{3}{8} - \frac{13}{32}$
$\frac{3}{16} + \frac{1}{4}$	$\frac{13}{32} - \frac{7}{16}$
$\frac{1}{8} + \frac{5}{32} + \frac{3}{16}$	$\frac{13}{32} - \frac{15}{32}$
$\frac{1}{8} + \frac{5}{32} + \frac{1}{4}$	$\frac{15}{32} - \frac{17}{32}$
$\frac{1}{8} + \frac{3}{16} + \frac{1}{4}$	$\frac{1}{2} - \frac{9}{16}$
$\frac{5}{32} + \frac{3}{16} + \frac{1}{4}$	$\frac{17}{32} - \frac{19}{32}$
$\frac{1}{8} + \frac{5}{32} + \frac{3}{16} + \frac{1}{4}$	$\frac{5}{8} - \frac{23}{32}$

Note: Dimensions are inches.

*Variable widths result from adding shims.

shop tips

Helping you work faster, smarter, and safer

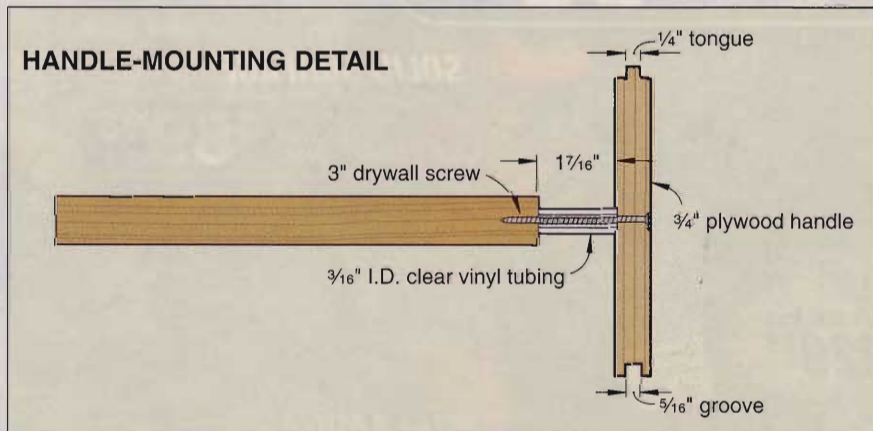

See how well this tip stacks up

While building a small bookcase recently, I again stumbled on an age-old problem: how to apply finish to all six sides and edges of the shelves in one sitting. (And, how to handle and store the freshly finished pieces until they dried.) This time, though, I figured out a solution.

I built a pair of "handles" for each shelf from scraps of 3/4" plywood with loosely matching tongues and grooves on the top and bottom edges, as shown *above*. After drilling a pair of 1/8" holes in each handle, I pushed 3" drywall screws through the holes and slipped a 1 7/16" length of clear vinyl tubing (about 5¢ a foot at the hardware store) over each screw. Finally, I attached a pair of the handles to the shelf by driving the screws 3/4" into each end of the shelf.

With the handles attached, I can apply finish or paint to all sides of the shelf—the tubing gives me plenty of brush clearance even for the ends. And, I can stack the shelves while they dry without having them spread out all over the shop.

—Don Klimesh, Brownstown, Pa.

Continued on page 38

our winner



Ask Don Klimesh how he got into woodworking, and he cuts right to the chase: "Because I wanted nice things, and I'm frugal." Be that as it may, our Top Shop Tip winner also is pretty clever, as you can see from his prize-winning tip at *left*.

And frugality has paid off for the retired mechanical engineer. He and his wife, Mary Ann, divide their time between their home in Brownstown, Pennsylvania, and their recently acquired cottage in Spillville, Iowa, where Don is setting up a second shop.

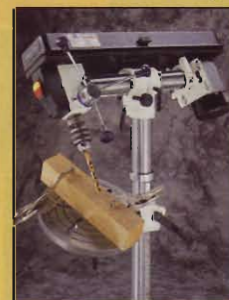

For sending in this issue's Top Shop Tip, Don Klimesh wins a Shop Fox W1670 radial drill press. Great work, Don!

You can win a free tool, too!

Tell us how you've solved a workshop puzzler, and we'll send you \$75 if we print your solution. And, if we choose your tip as the Top Shop Tip of the issue, we'll also send you a tool prize worth at least \$250.

Send your best tips, along with photos or illustrations and your daytime telephone number, to: **Shop Tips, WOOD Magazine, 1716 Locust St., GA-310, Des Moines, IA 50309-3023.** Or post your best suggestions at www.woodonline.com on our Top Shop Tip discussion group.

Because we try to publish only original tips, please send your tips only to **WOOD®** magazine. Sorry, but we can't send back the items you send in.

Tin-punching jig works smooth as silk

I finally got around to building the Punched-Tin Pie Safe project that appeared on the cover of *WOOD* magazine issue 53. But I had problems punching consistent-sized holes using a wood backer for the tin. My solution: a drill-press mounted punch and anvil.

The jig, shown at right, consists of a $\frac{3}{8}$ " bolt mounted in an auxiliary table on my drill press. I drilled a $\frac{5}{32}$ " hole about

$\frac{1}{16}$ " deep into the end of the bolt, then ground a bevel on the outside edge.

To use the jig, I chuck a 6-penny finish nail into the drill press and center the bolt (and jig) under the tip of the nail. Placing the tin between the nail and bolt, I simply lower the drill-press quill to push the nail through the tin. The beveled edge of the bolt allows me to punch holes close together without interference from below.

—Kenneth Cook, Plattsburgh, N.Y.

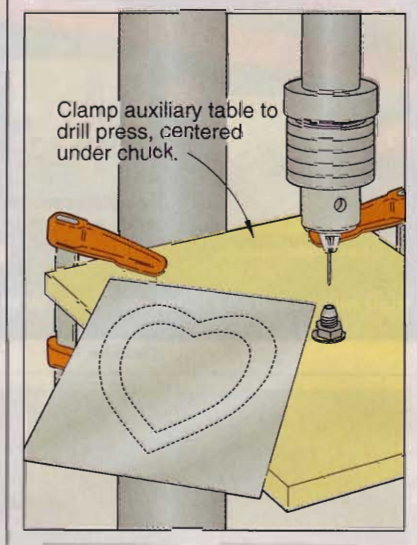
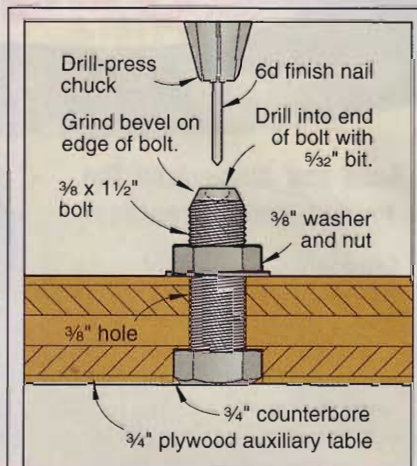

Board feet's secret agent: .007

I marvel sometimes at how the guy at the hardwoods store uses his ruler to quickly calculate the number of board feet in any given board. But here's an easy-to-remember formula that helps you make the calculations without a bunch of mental gymnastics.

Multiply the board's thickness (for boards less than 1" thick, just use 1") times its width, times its length, times .007 (T×W×L×.007). If one dimension is in feet, use .084 instead of .007.

Although there's a very small error due to rounding, for most purposes the difference is insignificant.

—Robert Reynolds, Birchwood, Wis.,
via *WOOD* Online®

Continued on page 40

Incra MITER 1000

- ◆ 41 Indexed Angle Stops over ± 90° range
- ◆ 18" Incra Track Fence with Slide Stop
- ◆ Steel GlideLOCK™ Miter Bar with 6 Width Adjustment Points

SALE \$89

Incra MITER 3000

- ◆ 364 Indexed Angle Stops over ± 90° range
- ◆ 27" Miter Fence + Dual-Flip Stop
- ◆ Steel GlideLOCK™ Miter Bar with 8 Width Adjustment Points

SALE \$219

Incra MITER 5000

- ◆ 364 Indexed Angle Stops over ± 90°
- ◆ 36-64" Miter Fence + Dual-Flip Stop
- ◆ Steel GlideLOCK™ Miter Bar with 10 Width Adjustment Points
- ◆ Integral Hold-down Clamping System
- ◆ Renewable Zero Clearance Right Panel

SALE \$299

Produce perfect gap-free hairline glue joints on the mitered corners of any multi-sided object on your first try without trial-and-error setups.

Woodpeckers Inc.
The Incra Tool Source
www.woodpeck.com

All models include: Adjustable GlideLOCK Miter Bar, Incra Specified Fence with Stop Positioner, and FREE Video Brochure. **1-800-752-0725**

Under-table drawer stores accessories

I recently installed an aftermarket rip fence on my tablesaw. While I had the saw apart, I decided to add a drawer

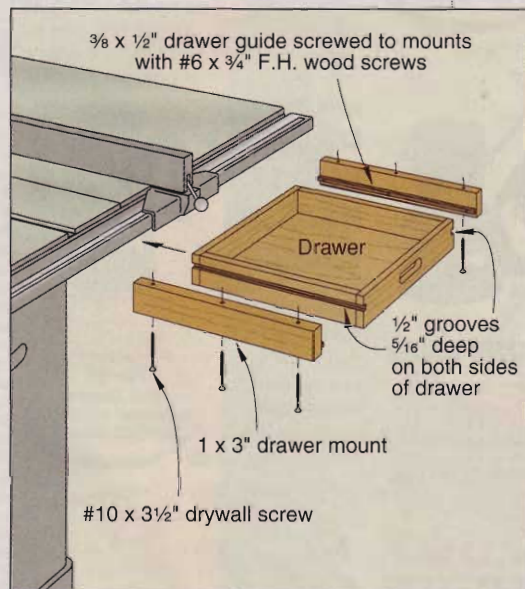

under the table, as shown *below left*. I find it very handy for storing items I use with the saw—wrenches, pushsticks, feather boards, and so on. Sure enough, it saves steps and space in my tool chest.

—Jerry Kloppenborg, Davenport, Iowa

Squeeze bottle into storage duty

Saving leftover paint and other finishes is a great idea, both for the environment and your wallet. But air trapped inside a half-full can will shorten the life of these products. I dodge this problem by eliminating the air from the storage container.

After washing and air-drying a resealable plastic soft-drink bottle, I use a funnel to transfer the



finish. I squeeze out the air, then cap the container. To save time, I keep a few bottles of various sizes washed and ready for storage duty. Be sure to label the contents with a permanent marker, and keep all of these chemicals away from children.

—Art Ransom, Lancaster, Texas, via WOOD ONLINE®

I N T E R O D U C I N G

PC²

Gross Stabil Corporation, a leading manufacturer of woodworking clamps and accessories proudly introduces a new woodworking clamp product.

PC² is a revolutionary new Parallel Clamp for woodworking professionals. Manufactured in Germany of the highest quality materials and craftsmanship, the PC² will clamp wood pieces with up to 1100 lbs. of clamping pressure.

The PC² is made of polyamide 6.6 (nylon) grade 1A plastic, reinforced with 50% long-fiber fiberglass, malleable cast iron locking mechanism, and galvanized steel rail. The clamping jaws are wrapped around steel inserts for added strength and support. With a clamping area of 5-1/2" x 1-3/4" and clamping length from 12" to 100", the PC² will handle the largest of clamping projects. This easy to use clamp quickly and easily slides up and down its galvanized steel rail to accommodate virtually any size pieces of wood.

Woodworkers are assured of perfectly squared up clamping of wood products with this hand held unit.



WOOD WORKER'S PARALLEL CLAMP



Close-quarters clamps? Socket to 'em

Sometimes, such as when gluing up a cold-bent lamination, the clamps can get so close together that you can't get a good grip on the handles to tighten them. That's why I epoxied lag screws into the ends of my clamp handles, as shown *below*. In tight situations, I can use a socket wrench with an extension to close the clamps.

—Dave Campbell, *WOOD*® magazine products editor

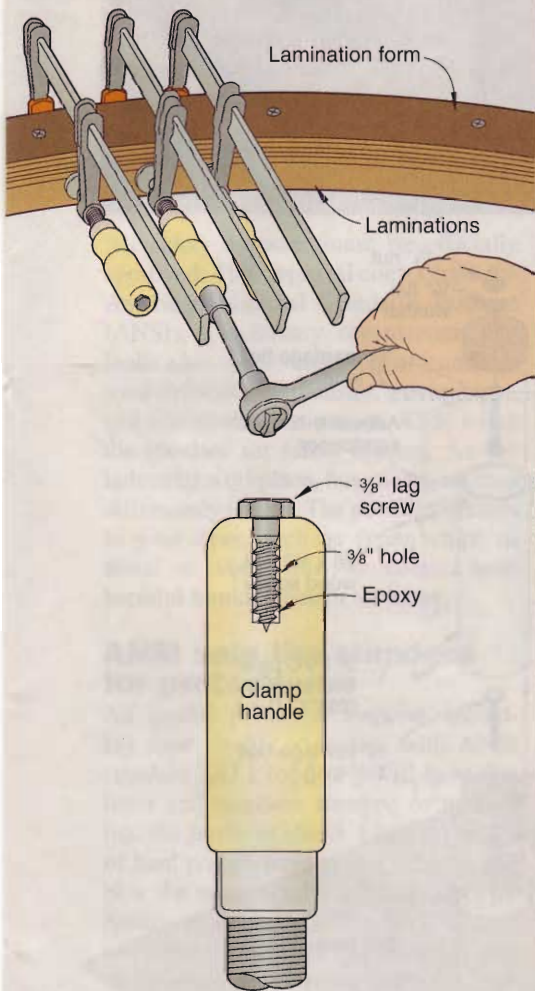

shop TIP

You'll find more great Shop Tips throughout every issue of *WOOD*® magazine. Look for boxes like this one nestled among the project and technique articles.

Quality Pen Kits and Other Turning Kits



- Designers & Manufacturers
- Wholesale & Retail

THE BereaHardWoods CO. Inc.

Manufacturer of quality writing instruments, components and kits.

CALL FOR FREE CATALOG

6367 Eastland Rd. • Brookpark, Ohio 44142 U.S.A.
Ph: 440-234-7949 • Fax: 440-234-7958 • bereahard@aol.com

Circle No. 510

Measure Twice. Glue Once.

Hardwoods, softwoods, pressure-treated or exotics – Gorilla Glue® is tough enough to hold them all. Incredibly strong, nearly invisible glue lines, and 100% waterproof. Just the way serious woodworkers demand it. Call 800-966-3458 for a dealer near you, or visit www.gorillaglu.com to find out more.



The Toughest Glue
on Planet Earth™



extra-long drum sander

building this sander is just plumb easy



When he started building the Arched-Top Clock (see the how-to-build article on page 66), *WOOD* magazine Design Editor Kevin Boyle was faced with a plan that looked as if it would require hours of tedious hand sanding. Dreading this, Kevin created a drill-press attachment using parts he scrounged in the shop. The spindle itself is a length of 2" PVC plumbing pipe, a size that worked well for the clock's curves, but you can easily adapt this idea to other diameters of pipe.

Use a circle cutter to make slightly oversized wood plugs for the top and bottom of the spindle. Add the carriage bolts and nuts, chuck them into your drill press, and power-sand the plugs to fit perfectly into the pipe. Be sure that you fully countersink the PVC for the wood screws that secure the plugs so the heads don't protrude and scratch your work. Trim the sandpaper so the ends just meet or have a slight gap—overlapping the paper would make a bump.

Construct the base assembly by cutting a piece of 1/4" hardboard and 3/4" MDF to identical size. Drill a 2 1/2" hole through the hardboard, and a 1/4" hole through the MDF. When you set up the sander, carefully check that the spindle is square to the table. Run the sander at 500 rpm or slower. Because of the low cost of building these spindles, you may want to make one for each grit you frequently use. ♣

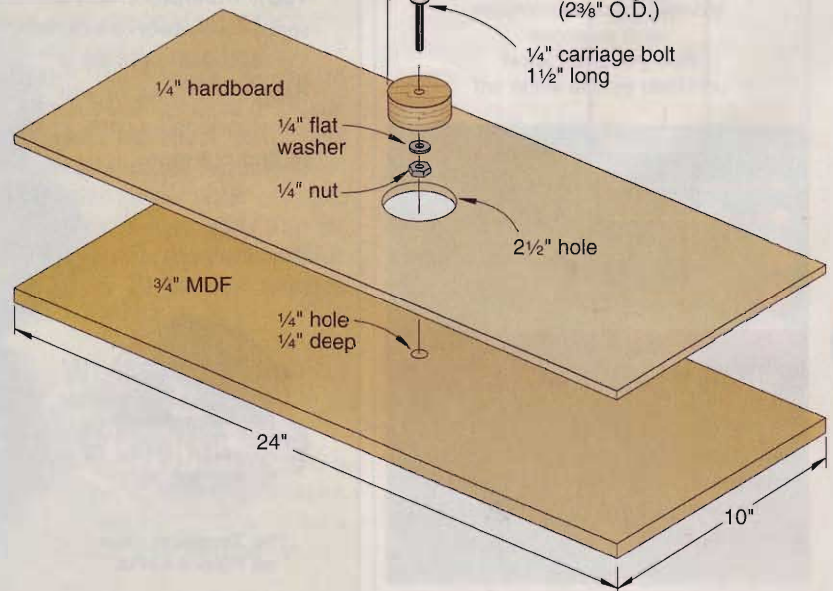
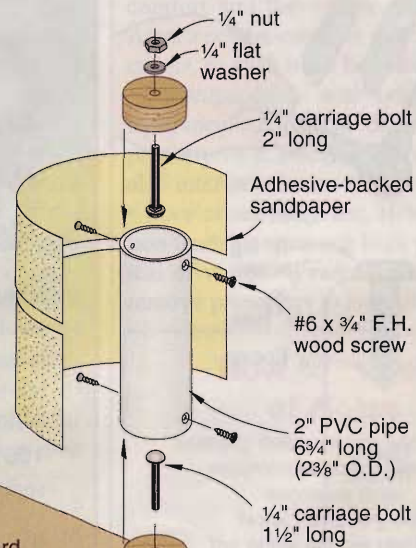
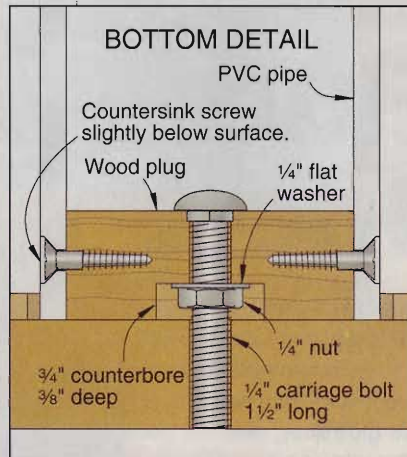

Illustrations: Mike Mittermeier; Lorna Johnson
Photograph: Baldwin Photography



full-service benchtop router table

Why this project belongs in your shop

- You can put it together in a weekend for less than \$100 plus the cost of your own wood.
- Its fence adjusts in a flash and locks into T-slotted mini tracks with the quick twist of two knobs.
- A mini-track built into the fence makes for lightening-fast and solid positioning of homemade featherboards and a bit guard.
- Insert-plate levelers ensure a perfectly aligned tabletop.
- The built-in dust-collection port keeps debris at a minimum.
- It's easily portable, weighing only 36 pounds (without router), and you can grip the the tabletop edges for comfortable carrying.

1 TABLE EXPLODED VIEW

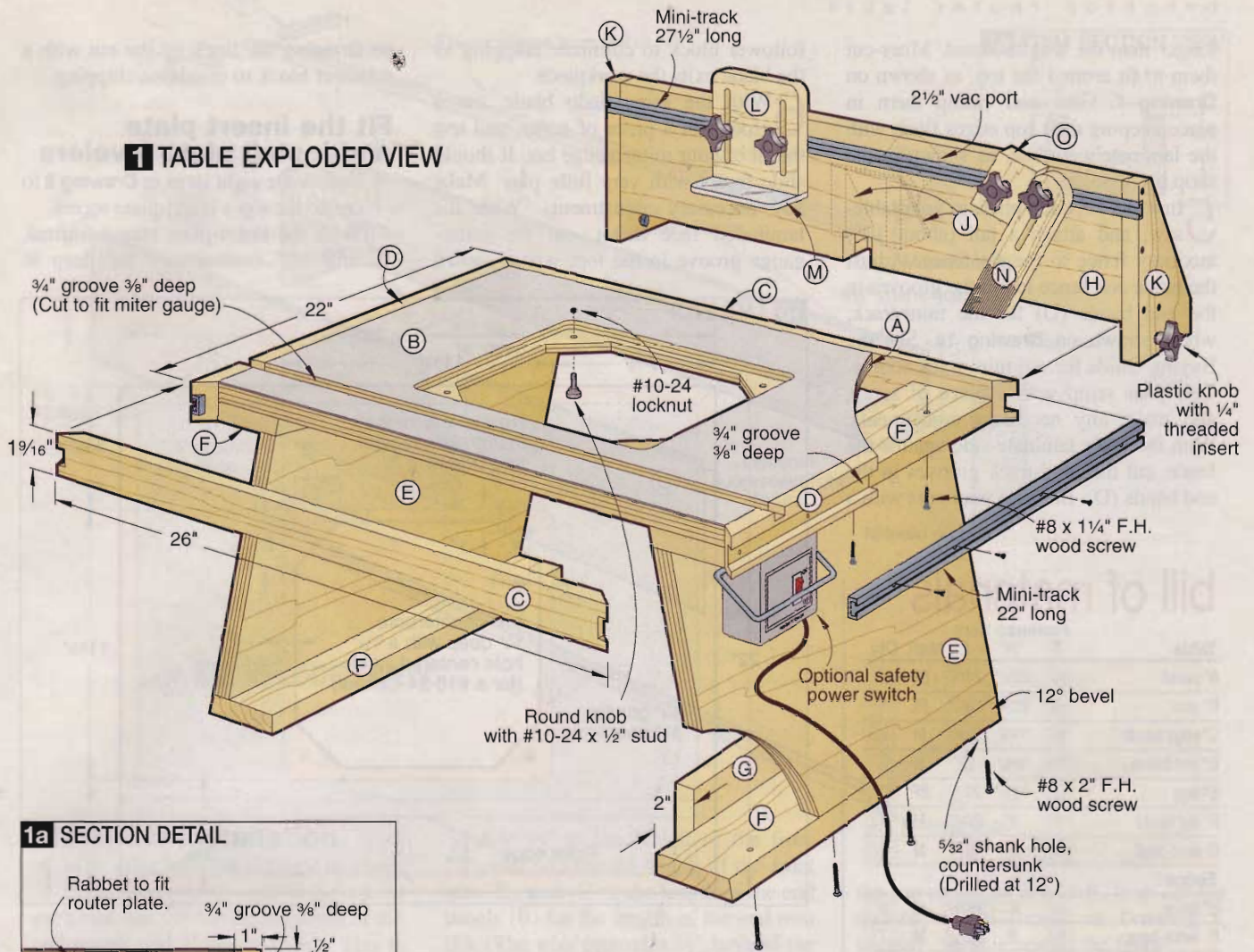

1a SECTION DETAIL

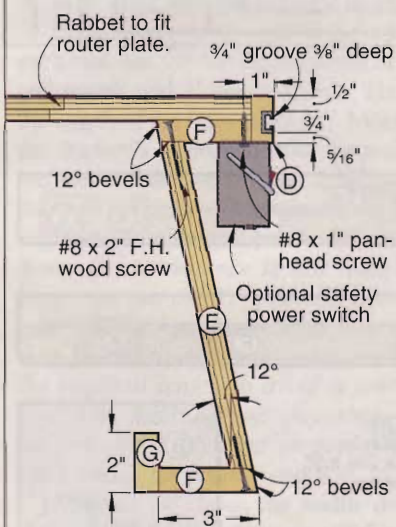

Start at the top

1 Cut both a piece of birch plywood for the panel (A) and a piece of plastic laminate for the skin (B) an inch larger in length and width than the sizes listed in the Bill of Materials.

2 Following the directions on the can, apply contact adhesive to the back of

shop TIP

Flush trimming with your tablesaw

When applying plastic laminate to a part like the router-table top's panel, start with oversize pieces of plywood and laminate. Apply contact cement to the laminate and the plywood. Position the laminate just shy of one edge and end of the plywood, as shown in the photo. Run these edges, free of overhanging laminate, against your tablesaw fence first when trimming the top to its finished size. Cutting both plywood and laminate at the same time avoids router flush trimming.



the laminate and the face of the plywood. Bond the laminate to the plywood, holding the laminate about 1/8" back from one edge and one end of the plywood, as shown in the shop tip above. Apply pressure with a rubber laminate roller.

3 With the plywood's exposed end and edge in turn against your tablesaw's

rip fence, trim about 1/4" off the panel's opposite end and edge, cutting through both the plywood and laminate. Now with the just-trimmed end and edge in turn against the fence, cut the panel/skin (A/B) to finished size.

4 Cut the edge bands (C) and the end bands (D) to width, but about 1"

longer than the lengths listed. Miter-cut them to fit around the top, as shown on **Drawing 1**. Glue and clamp them in place keeping their top edges flush with the laminate's surface, as shown in the shop tip *opposite*.

5 Install a 3/4" dado blade in your table-saw, and attach a tall (about 10") auxiliary fence to the rip fence. Adjust the blade and fence to cut the grooves in the end bands (D) for the mini-track, where shown on **Drawing 1a**. See the Buying Guide for our mini-track source. Test your setup with a piece of scrap, and make any necessary adjustments. With the top's laminate side against the fence, cut the mini-track grooves in the end bands (D). Back up your cuts with a

follower block to eliminate chipping as the blade exits the workpiece.

6 With the same dado blade, cut a groove in a piece of scrap, and test the fit of your miter-gauge bar. It should slide freely with very little play. Make any necessary adjustments. With the laminated face *down*, cut the miter-gauge groove in the top, where shown

on **Drawing 1b**. Back up the cut with a follower block to eliminate chipping.

Fit the insert plate and install plate levelers

1 Follow the eight steps in **Drawing 2** to create the top's insert-plate recess.

2 With the insert-plate recess formed, drill 7/16" counterbores 1/4" deep in

bill of materials

Table	FINISHED SIZE				Matl.	Qty.
	T	W	L			
A* panel	3/4"	20 1/2"	24 1/2"	BP	1	
B* skin	1/16"	20 1/2"	24 1/2"	PL	1	
C* edge bands	3/4"	1 1/16"	26"	M	2	
D* end bands	3/4"	1 1/16"	22"	M	2	
E* legs	3/4"	11 1/2"	20 1/2"	BP	2	
F* leg cleats	3/4"	3"	20 1/2"	M	4	
G cord cleat	3/4"	2"	16 1/2"	M	1	
Fence						
H* fence	3/4"	6"	26 1/32"	M	1	
I* fence base	3/4"	3"	26 1/32"	M	1	
J vac port mounts	3/4"	2 1/2"	3 1/8"	M	2	
K fence brackets	3/4"	4 3/4"	7 1/2"	M	2	
Guard & Feather board						
L guard base	3/4"	5"	5"	M	1	
M guard	1/4"	2 3/4"	5"	A	1	
N*feather boards	3/4"	1 3/4"	8"	M	2	
O jam blocks	3/4"	1 3/4"	3"	M	2	

*Parts initially cut oversize.

Materials Key: BP—birch plywood, PL—plastic laminate, M—maple, A—acrylic.

Supplies: #8x1 1/4" flathead wood screws, #8x1 1/2" flathead wood screws, #8x2" flathead wood screws, #8x1" panhead screws, #8x1" brass flathead wood screws (2), 1/4" SAE flat washers, contact adhesive, 5-minute epoxy, #10-24 locknuts (4).

Buying Guide

Hardware: 1/4" hexhead bolts 1 1/2" long (8), knobs with 1/4" threaded inserts (8), miniature knobs with #10-24x1/2" studs (4), 36" mini-track with screws (1), 24" mini-tracks with screws (2), 2 1/2" vac port (1), 3/8x12x12" acrylic insert plate (1), order kit no. 131238, \$59.99 plus shipping, from Woodcraft. Call 800/225-1153 to order.

Switch: Safety power switch no. 141938, \$34.99 plus shipping, from Woodcraft. Call 800/225-1153 to order.

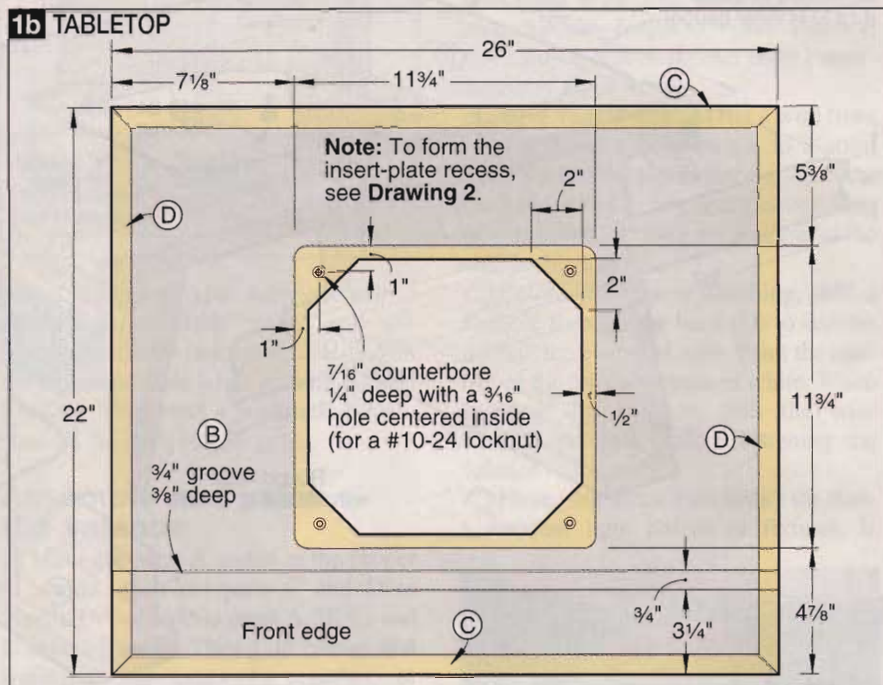

cutting diagram

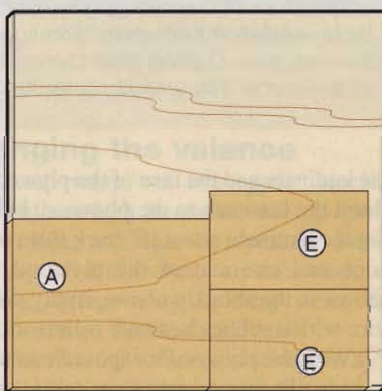
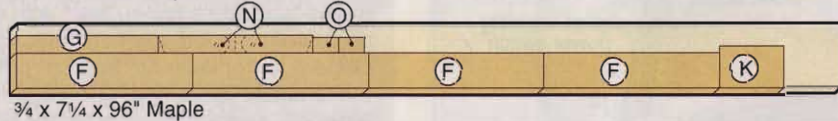
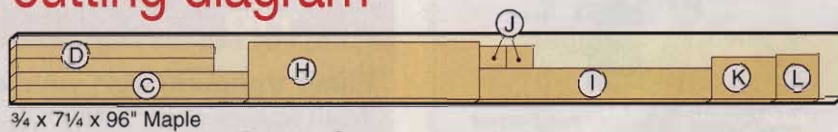

(M)
1/4 x 2 3/4 x 5"
Acrylic

(B)
21 1/2 x 25 1/2"
Plastic laminate

each corner for #10-24 locknuts, where shown on **Drawing 1b**. Make sure that, when placed in the counterbores, the locknuts are flush with the surface of the recess. Drill $\frac{3}{16}$ " holes through the centers of the counterbores.

3 Referring to the sidebar "How to add insert-plate levelers to your table" on page 49, epoxy locknuts into the counterbores. Finish-sand the bands (C, D) to 220 grit. Ease the sharp laminate edges of the miter-gauge slot and insert-plate recess with a cabinet scraper.

Build a sturdy base

1 Cut the legs (E) and leg cleats (F) to length, but about 1" wider than listed. Tilt your tablesaw blade 12° , and bevel-rip the edges of the legs and leg cleats, where shown on **Drawing 1a**. Cut the cord cleat (G) to size.

2 Glue and clamp the leg cleats (F) to the legs (E). Then drill pilot and countersunk shank holes through the leg cleats into the legs. Drive in the screws, and remove the clamps. Glue and clamp the cord cleat to the leg cleat. Finish-sand the leg assemblies to 220 grit.

Note: When storing the router table, coil the router and switch cords and stow them under the table, wedging them between the leg and the cord cleat.

3 Place the top assembly upside down on your bench. Glue and clamp the leg assemblies to the top. Drill pilot and countersunk shank holes through the leg cleats into the top. Drive in the screws.

Build an accurate fence

1 Forming straight, square edges on your fence parts is essential for making a straight fence. Start by cutting the fence (H) and the fence base (I) $\frac{1}{2}$ " wider and 1" longer than the sizes listed. Joint one edge of each board. Next set the fence on your tablesaw $\frac{1}{32}$ " over the finished width, and rip the parts. Set your jointer's depth to $\frac{1}{32}$ " and joint the freshly cut edge. Check the length of your tabletop and add $\frac{1}{32}$ " to this measurement. Cut the fence and fence base to this length. (The added $\frac{1}{32}$ " allows the fence to slide easily.) Bandsaw centered $1\frac{1}{2} \times 1\frac{1}{2}$ " bit-clearance notches in both parts. Glue and clamp the fence and fence base together.

2 Cut two $\frac{3}{4} \times 4\frac{3}{4} \times 7\frac{1}{2}$ " blanks for the fence brackets (K). Fasten the two blanks together with double-faced tape.

2 FORMING THE INSERT-PLATE RECESS

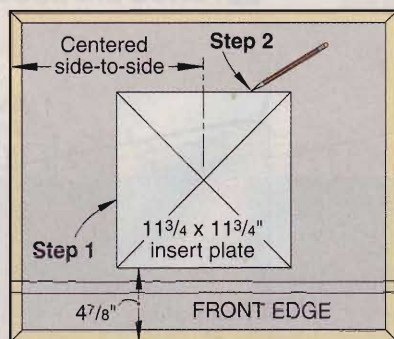

STEP 1 Trim the insert plate to size, and position it $4\frac{7}{8}$ " from the tabletop's front edge and centered side-to-side.
STEP 2 Trace outline of plate onto the tabletop.

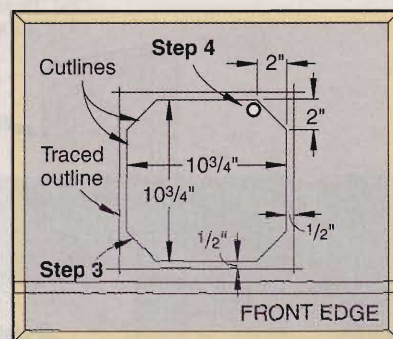

STEP 3 Lay out and mark the opening cutlines inside the traced outline.
STEP 4 Drill a blade start hole, and use your jigsaw to cut the opening.

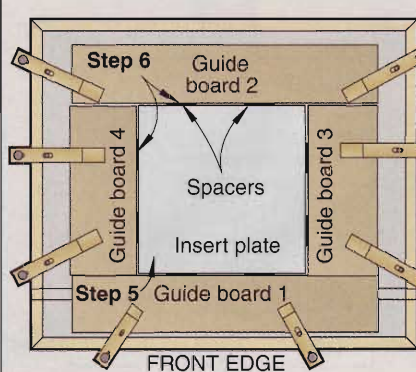

STEP 5 Secure insert plate inside traced outline with double-faced tape.
STEP 6 Clamp the guide boards around the plate, spacing each board away from the plate with business-card shims.
STEP 7 Remove the insert plate and shims. Chuck a straight bit with a top-mounted pilot bearing (pattern bit) into your handheld router. With its base rest-

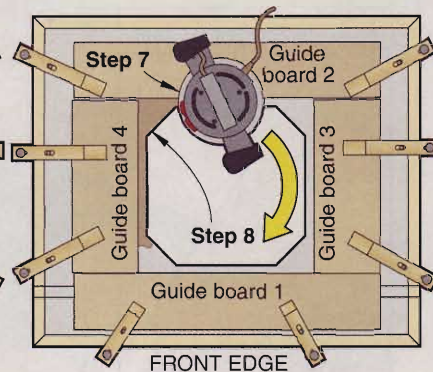

ing on top of the guide boards, adjust the router to cut $\frac{1}{8}$ " into the tabletop.
STEP 8 Guiding the bit's pilot bearing along the guide board's inside edges, begin routing the recess. Make additional passes, lowering the bit each time until you reach a depth of about $\frac{1}{32}$ " greater than the thickness of the insert plate.

shop TIP

Keep your banding flush and corners aligned

Make alignment blocks by cutting 2×2 " notches out of four 4×4 " pieces of $\frac{3}{4}$ " plywood. (The notches let you see the mitered corners.) Clamp them to the top, as shown in the photo. Use scrap blocks underneath the top to space the clamps away from the banding. Now, glue and clamp the banding to the top, keeping it tight against the alignment blocks.

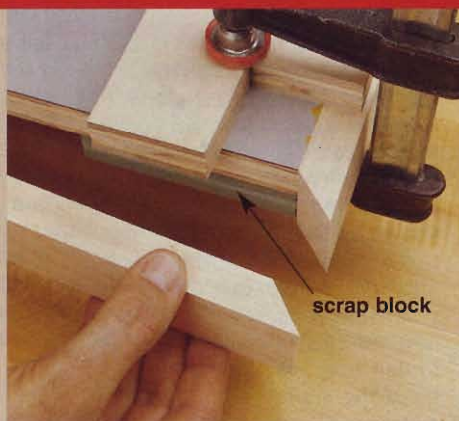

3 FENCE EXPLODED VIEW

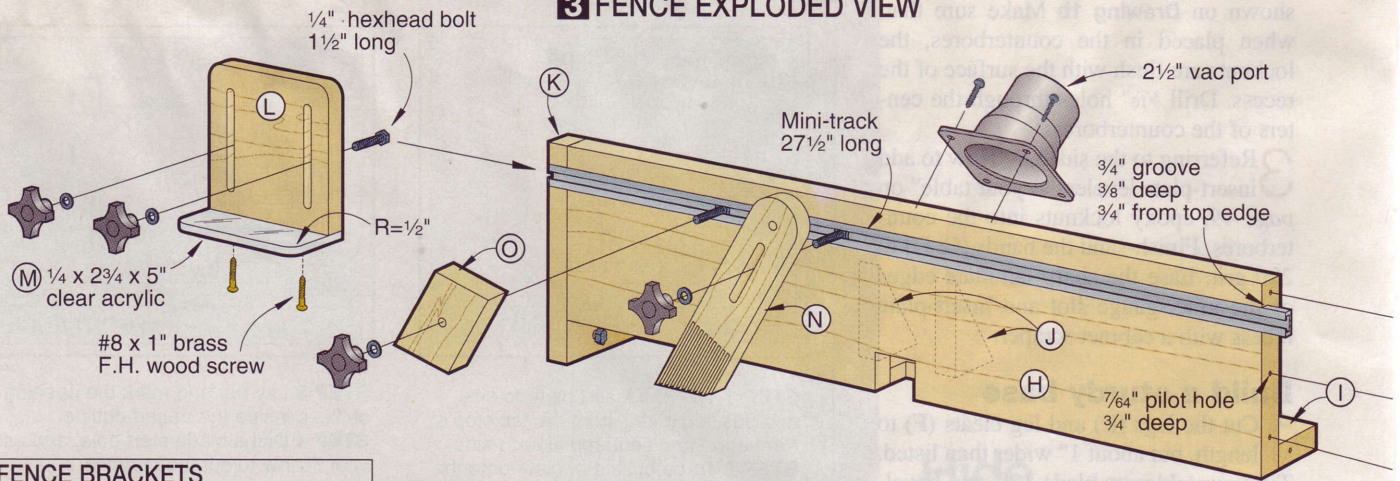

3a FENCE BRACKETS

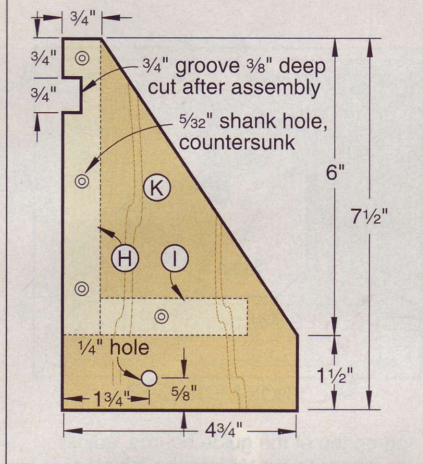

Mark the diagonal cut and the location of the 1/4" hole on the top blank, where shown on **Drawing 3a**. Bandsaw and sand to the marked line, and drill the hole. Separate the brackets.

3 Glue and clamp the fence brackets (K) to the fence (H/I), making sure the brackets' edges are flush with the

3c GUARD

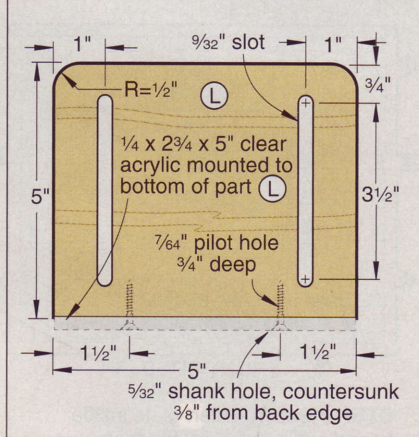

fence's face. Drill pilot and countersunk shank holes through the brackets into the fence, where shown, and drive in the screws. With your dado blade adjusted to the width of the mini-track, cut the dado in the fence (K/H/K), where shown on **Drawing 3**. Finish-sand the fence assembly to 220 grit.

4 Cut the vac port mounts (J) to the size and shape shown on **Drawing 3b**. Dry-position the mounts and check their placement with your vac port. See the Buying Guide for our vac port source. Glue and

clamp the mounts in place. With the glue dry, use the port to mark the mounting screw locations. Drill screw pilot holes and set the vac port aside.

Now, get your guard up

1 Cut the guard base (L) to size. Sand the 1/2" radii on the top corners, where shown on **Drawing 3c**. To form the mounting slots, drill 9/32" holes where shown, draw lines from hole to hole, and scrollsaw along the lines. Finish-sand the base to 220 grit.

2 Cut 1/4" acrylic to size for the guard (M). Disc-sand 1/2" radii on the outside corners, where shown on **Drawing 3**. Adhere the guard to the base with double-faced tape, keeping the back edges flush. Drill pilot and countersunk shank holes through the guard (M) into the base (L). Remove the guard, and set it aside.

Make the feather boards

1 Select a straight-grained piece of 3/4"-thick maple, and cut a 3/4x2x18" blank for the feather boards. Using your table-saw and miter gauge, trim 30° angles on both ends of the blank, where shown on **Drawing 4**. Mark angled lines across the

shop TIP

Make a self-gauging feather board

Here's a quick way to set your feather board to apply the proper pressure. Trim the first feather 1/8" shorter than the others, where shown on **Drawing 4**. When you use your feather board, place this short gauging feather on top of your workpiece. Now, keeping the other feathers parallel to the router-table top, tighten the mounting knob.

4 FEATHER BOARDS & JAM BLOCKS

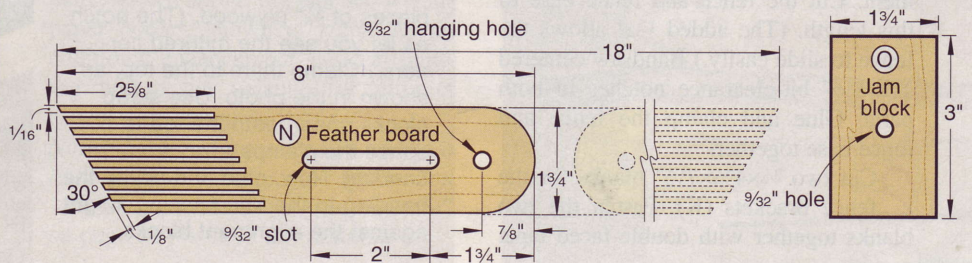

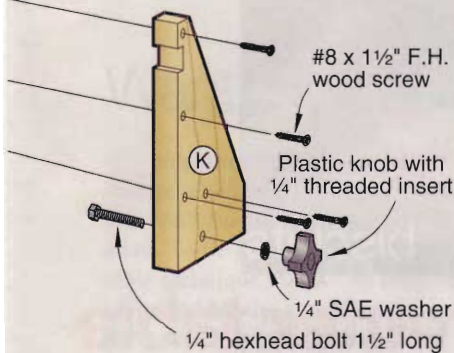
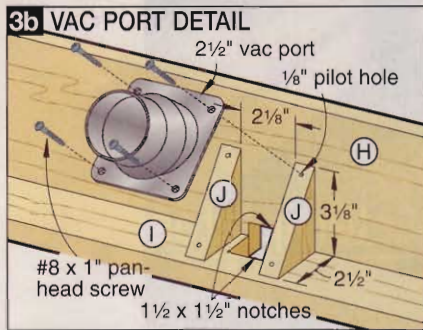

blank's width, 2⁵/₈" from each end, then mark the feather boards' radius ends.

2 Install a regular (1/8" wide) blade in your tablesaw and raise it 2" high. Set the rip fence 1/16" from the blade. With the long edge of the blank against the fence, cut in to the marked line, then *carefully* pull the board straight back from the blade. A padded jointer push-block works well for this operation. Flip the board end for end and repeat. Reset the fence at 1/4" and repeat the cut on each end. Repeat cutting the feathers at 3/16" intervals up to 1 3/4". With the fence set at 1 3/4", lower the blade to 1", and cut the blank to finished width.

3 Drill the 3/32" hanging and slot-starting holes in the feather boards (N), where shown on **Drawing 4**. Mark and scrollsaw the slots, and bandsaw the rounded ends. Finish-sand the feather boards to 220 grit.

4 Cut the jam blocks (O) to size and drill the centered 3/32" holes. Finish-sand them to 220 grit.

Note: The jam blocks are positioned against the feather boards to prevent them from pivoting when applying pressure to a workpiece.

Apply a finish, and install the hardware

1 Touch up the finish sanding where needed. Apply two coats of a pen-

How to add insert-plate levelers to your table

Adjusting your router table's insert plate perfectly flush with the top is as easy as installing locknuts in the corners of the plate's recess. Once you've drilled counterbored holes to accept #10-24 nuts in all four corners, here's how to proceed.

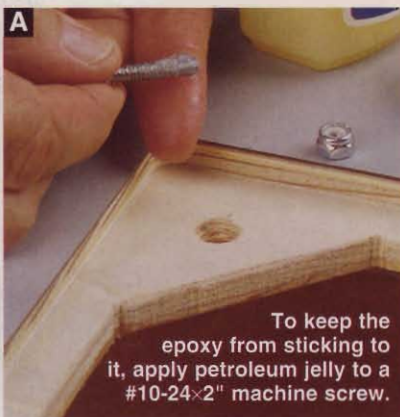

To keep the epoxy from sticking to it, apply petroleum jelly to a #10-24 x 2" machine screw.

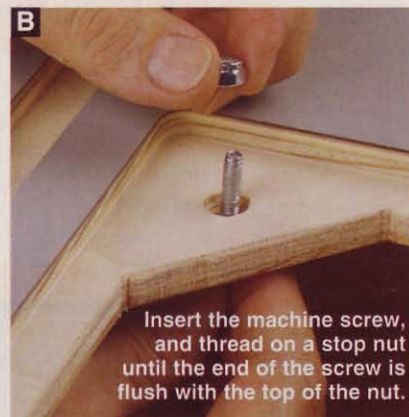

Insert the machine screw, and thread on a stop nut until the end of the screw is flush with the top of the nut.

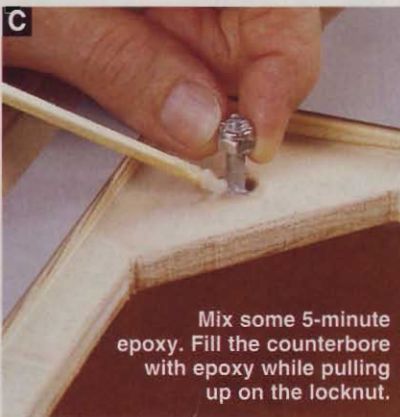

Mix some 5-minute epoxy. Fill the counterbore with epoxy while pulling up on the locknut.



Pull down on the machine screw to seat the nut in the counterbore. Scrape off the excess epoxy.

When the epoxy hardens, replace the 2"-long machine screw with a 1/2"-long one. For no-tool adjustment, use a knob with a 1/2"-long threaded stud. See the Buying Guide for our knob source.

trating oil finish to all the wood parts, including the miter-gauge slot and the insert-plate recess, following the instructions on the can. We used McCloskey Tung Oil Finish. An oil finish is easier to reapply after the finish is worn than paint or varnish. It also seals the miter-gauge slot and insert-plate recess without building up and interfering with the fit.

2 Hacksaw mini-track to the lengths of the table ends and fence. You'll have to drill and countersink new mounting holes at the cut ends. Using the holes in the mini-track as guides, drill pilot holes into the table and fence, and screw the track in place.

3 Mount the optional switch, where shown on **Drawings 1** and **1a**. See the Buying Guide for the source of the safety power switch we used.

4 Screw the guard (M) to the guard base (L) with #8 x 1" brass flathead wood screws. Attach the assembled guard, feather boards, and jam blocks to the fence and the fence to the table with hexhead bolts, washers, and knobs, as shown. See the Buying Guide for our source of bolts and knobs. Screw the vac port to the mounts.

5 Screw the insert-plate leveling knobs into the locknuts. Sand the insert plate's corners to match the corners of the insert recess. See the following article, "5 ways to get the most out of your router table," for instructions on mounting your router on the insert plate. 🐿

Written by **Raymond L. Wilber** with **Charles I. Hedlund**
Project design: **Charles I. Hedlund**
Illustrations: **Roxanne LeMoine; Lorna Johnson**
Photographs: **Baldwin Photography;**

to add...
your...
as...
to...

5

ways to get the most out of your **router table**

When you mount a router on a table, you expand your shop's potential. To help you take advantage of this potential, we assembled five router table techniques guaranteed to make you a better woodworker. You'll see that a well-equipped router table not only saves you time, it can save you money by standing in for other tools.

Don't have a router table? Think you don't have room for one? Take a look at our plans for a handy bench-top model in the article beginning on *page 44*. It's easy to build and a breeze to use.

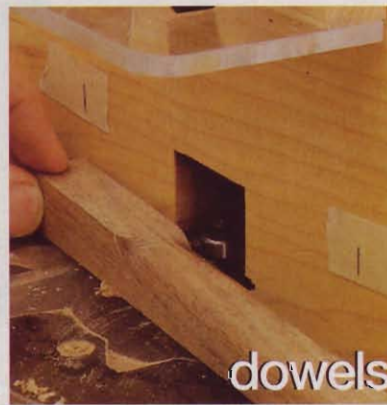

A **template** means never having to say “oops”

Let's say you want to make four table legs with matching curves. A table-mounted router and template enable you to produce as many identical legs as you want.

Using 1/4" hardboard or medium-density fiberboard, make a template to the shape you want. Use a bandsaw or scrollsaw to cut close to the line, then sand right up to it. Attach the template to your stock with cloth-backed, double-faced tape, orienting the grain for best effect. Bandsaw within 1/8" of the template, all the way around.

Turning to your router table, you have two choices for router bits—a flush-trim bit and a pattern-cutting bit. In some situations, you might need both.

A flush-trim bit has a ball-bearing pilot mounted at the tip. To use it, place your workpiece on the table with the template on top. Adjust the bit's height so the pilot runs on the edge of the template.

On pattern-cutting bits, the pilot sits between the shank and the cutter. Your template rests on the table.

Whichever bit you use, ease the workpiece into the bit until it contacts the pilot, then move the piece from right to left, as shown *above*. If you've left more than 1/8" of excess material in some spots, trim it to size with a couple of shallow passes. Don't pause too long in any spot, or you'll burn the wood.

Double-check the surfaces you've just routed before you remove the template. Sometimes another pass will smooth out a rough spot. Finally, slide a putty knife blade between workpiece and template, pop them apart, remove the tape, and you're done.

When you have a workpiece that's thicker than the cutting length of your bit, use a pattern-cutting bit and a flush-trim bit in sequence, as shown in **Steps 1, 2, and 3**. Make one pass with the pattern-cutting bit, template side down. Remove the template, then make another pass with the pilot bearing riding on the surface you just machined. Finally, flip the workpiece over and use the flush-trim bit, with the pilot bearing riding on the previously milled surface.

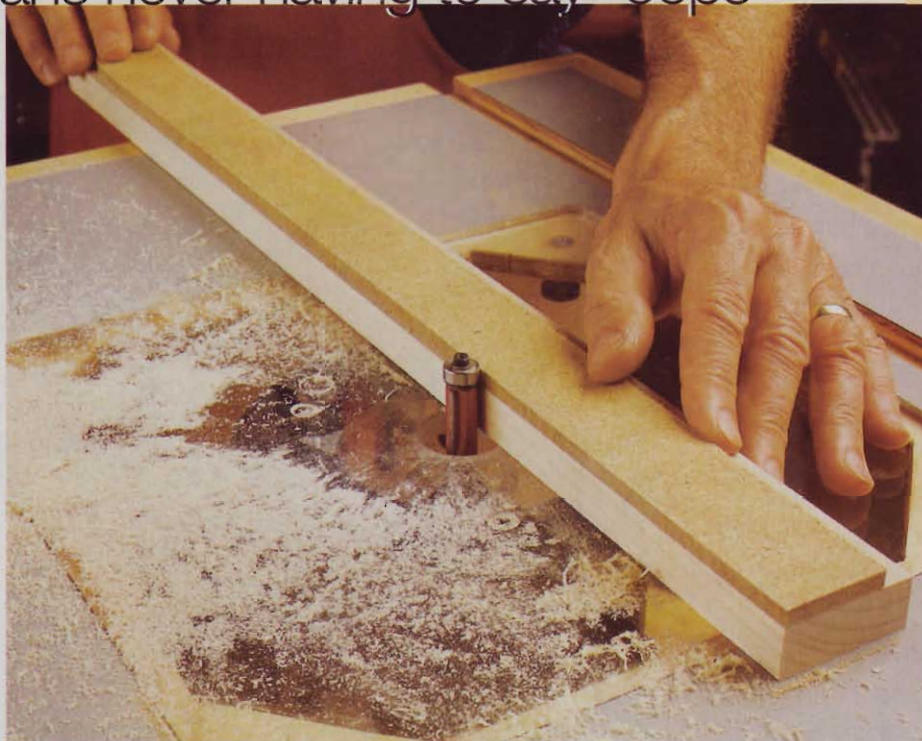

Cut the workpiece close to your template with a bandsaw before going to the router table. Trim bits are designed to handle light cuts only.

Continued on page 54

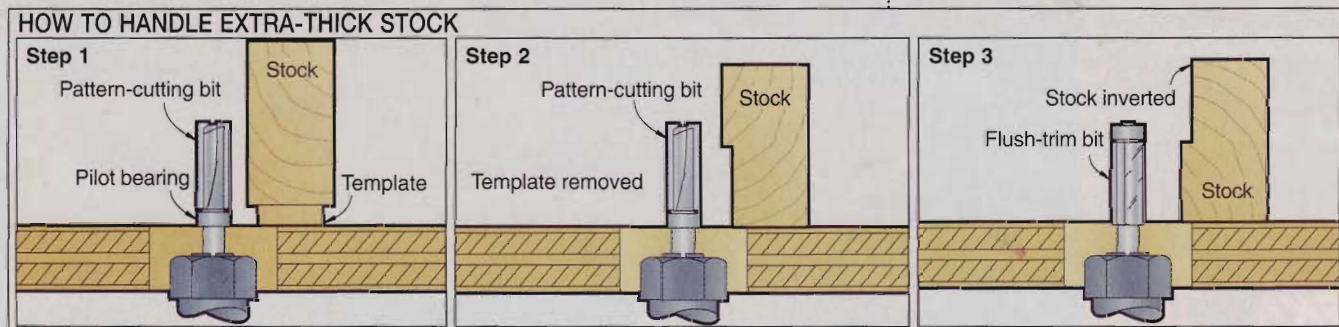

2

Sink your teeth into some biscuits

Biscuit joiners are great tools, but you also can do a lot of biscuit joinery right on your router table. All you need is a slot-cutting bit that matches the standard biscuit thickness of $\frac{5}{32}$ " (see the router bit review on page 34) and a miter gauge with an auxiliary fence.

Every time you set up to make a joint, center the cutter on the thickness of your stock, and make a test cut to double-check. To further reduce the risk of misalignment, mark the face of each component, then keep that side up.

Plunging a workpiece into a standard slot-cutting bit produces a slot that's shorter than a standard biscuit. You can lengthen the slot by moving the workpiece and making additional cuts. However, if you're going to make only a few joints, it's quicker and easier to shorten the biscuits. Here's how to cut slots for a rail-and-stile frame.

Use a steel rule to align the face of your router table fence with the front of the bit's pilot bearing. Place a piece of masking tape on the fence above the bit. Then, use a square and a pencil to mark the center of the bit on the tape. Now, mark the center of a rail. Hold the length of the rail against your miter gauge, equipped with an auxiliary fence that nearly touches the router table fence, as shown in **Photo A**. Align the two center marks, and clamp a stopblock on the router table fence so it meets the back of the miter-gauge fence. Using the miter-gauge fence as a support, plunge the workpiece squarely into the bit. Cut until it contacts the bearing.

Mark a biscuit at both ends, making it slightly less than the slot length. Slice off the ends with a bandsaw. Test the fit, as shown in **Photo B**, to make sure that at least half of the biscuit's width slides into the slot.

To cut a matching slot on a stile, leave the miter gauge and stopblock in place. Carefully push the workpiece into the cutter, as shown in **Photo C**.

You can cut a slot in the other end of the stile with the same setup, but you have to flip the stock over, putting the face side down. If the slots are perfectly centered in the stock's thickness, that will work fine. The alternative is to measure the distance from the center of the bit to the miter gauge, then clamp a stopblock at that same distance to the left of the bit. Remove the miter gauge and right-hand stop, then cut a slot at the opposite end of the stile, still keeping the face side up.

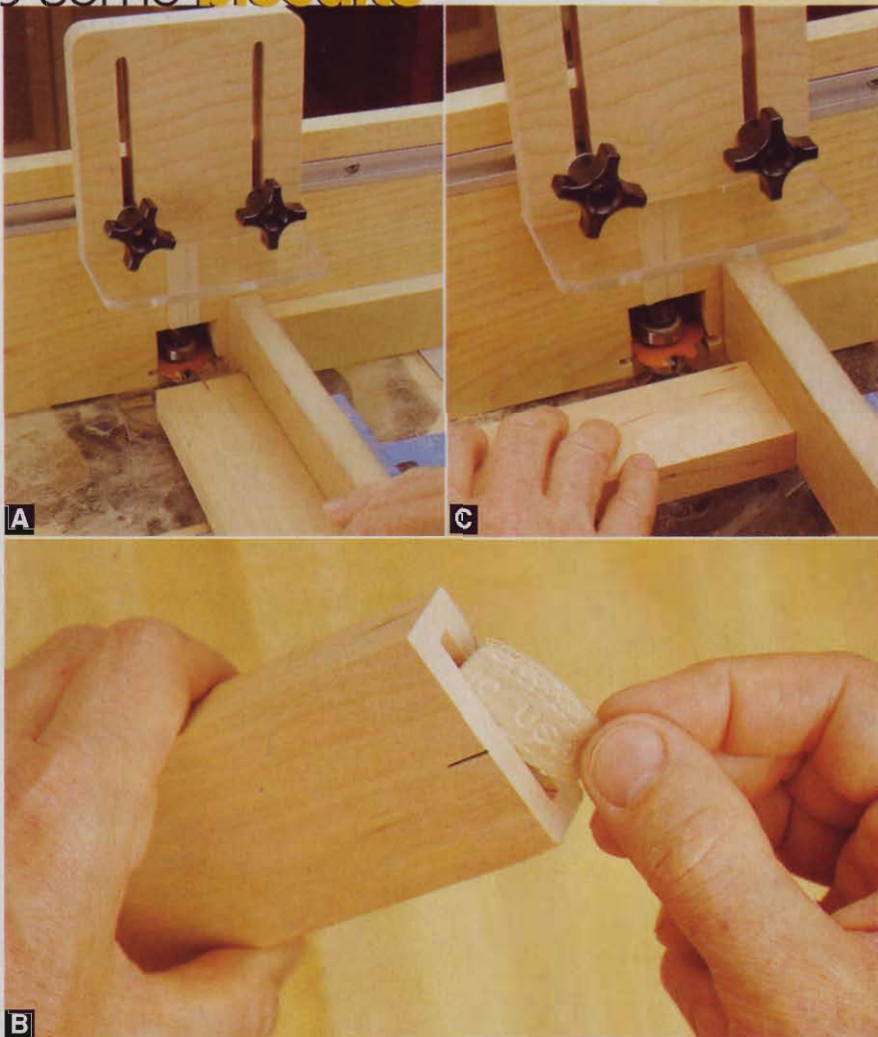

STEP A: Your miter gauge, backed by a stopblock, provides a solid, square guide as you push the end of a rail into the spinning slot-cutting bit.

STEP B: Trim the biscuit, slip it into the slot, then test the fit before gluing. If a gap shows, take just a bit more material off each end of the biscuit.

STEP C: Your setup remains the same when you cut a biscuit slot for a stile. This slot will match perfectly the slot in the previously milled rail.

Want to super-size those **dowels**?

Sometimes you need big dowels that match the wood of your project, but you can't find what you need at the store. To help you out, here's a router table technique that we've used for quilt racks and for the handle on the patio party center featured in issue 134.

You'll need a round-over bit with the same radius as the dowel's radius. For example, use a 1/2" round-over bit to make a 1" dowel. Chuck the bit in the router, and position the fence flush with the pilot bearing. Put two pieces of masking tape on the fence, one on either side of the bit, and mark two points 3" from the bit's center.

On the tablesaw, rip each dowel blank to a square profile equal in thickness to the desired diameter of the dowel.

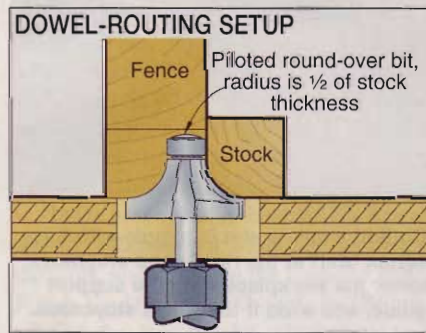

Crosscut it 6" longer than the finished dowel length.

Place your workpiece as shown in the drawing above. Align the left end with the left-hand fence mark, as shown in the photo at right, hold the end firmly against the fence, and begin routing any edge. Ease the workpiece into the bit, and move the blank across the bit until the right end reaches the right-hand mark. Repeat the procedure for each of the three remaining edges. The flat surfaces left at each end not only prevent the blank from rotating, but also keep your fingers at a safe distance from the bit.



We raised the guard for clarity in this photo. Keep it low while you're making dowels, to ensure that your fingers stay well away from the router bit.

4

Keep that miter in line with a spline

Here's a handy method for beefing up long, mitered joints in jewelry boxes and the like. You can make slots for hidden splines with a straight bit, two stopblocks, and a simple support block.

Set your $\frac{1}{8}$ " straight bit to project $\frac{1}{4}$ " above the router table. Clamp an auxiliary fence to your router table fence, so that your workpiece won't slide into the bit-clearance notch. Set this fence the same distance from the bit's center as the thickness of your stock, or slightly farther. In the drawing below, we're cutting spline slots in $\frac{1}{2}$ "-thick pieces.

Miter-cut your box sides to length. Take the two ends of the box, or the

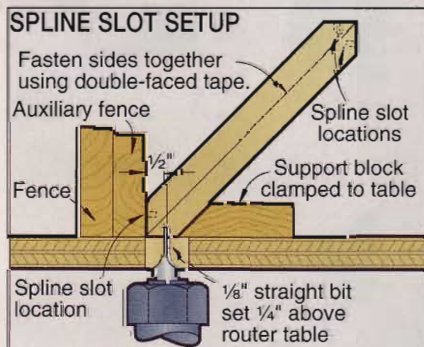

front and the back, place them face-to-face, align the edges, and join them with cloth-backed, double-faced tape.

Bevel-rip a scrap piece at 45° to make a support board. Hold the taped-together assembly in the corner formed by the router table and fence, and use it to place the support board parallel to the fence. Clamp both ends of the support board to the router table.

Now, mark the ends of the planned slot on the workpiece. Use those marks, matched with the cutting edges of the bit, to set stopblocks on the fence to the left and right of the bit.

Turn on the router, hold the workpiece firmly against the fence, and lower it onto the spinning bit, as shown in the photo above. Keep the right side of the workpiece against the right-hand stopblock. Carefully slide the workpiece across the table to the left-hand stopblock, and raise it straight up the fence.

After cutting eight slots for a rectangular box, cut matching splines. Hardboard and plywood work great for this, or you can cut splines from the same wood used for the box. In that case, the grain of the splines should run in the same direction as the sides, to avoid problems with wood movement.



Cutting a spline slot is simple with this setup. Start at the right-hand stopblock, lower the workpiece onto the support guide, and slide it to the left stopblock.

Make your router think it's a jointer

You can equip your table with a split fence for edge-jointing, or you can take the low-tech route shown here. We simply clamped a piece of plastic laminate on the left-hand, outfeed end of the fence. Use sandpaper to ease the edge nearest the router bit, so it won't catch your workpiece as the board slides past. As seen in the photograph at *right*, we used a steel rule to align the laminate with the cutting edge of a straight bit mounted in the router.

Set the bit high enough to trim the entire edge of the board in one pass. Then, turn on the router, and move the board across the table from right to left. You'll remove $\frac{1}{16}$ " with each pass, and leave a perfectly straight, square edge. Repeat the procedure with a second board, and the two pieces can be glued together without a gap anywhere. 🐿

Written by **Jim Pollock** with **Charles I. Hedlund**
 Illustrations: **Roxanne LeMoine**
 Photographs: **Baldwin Photography**

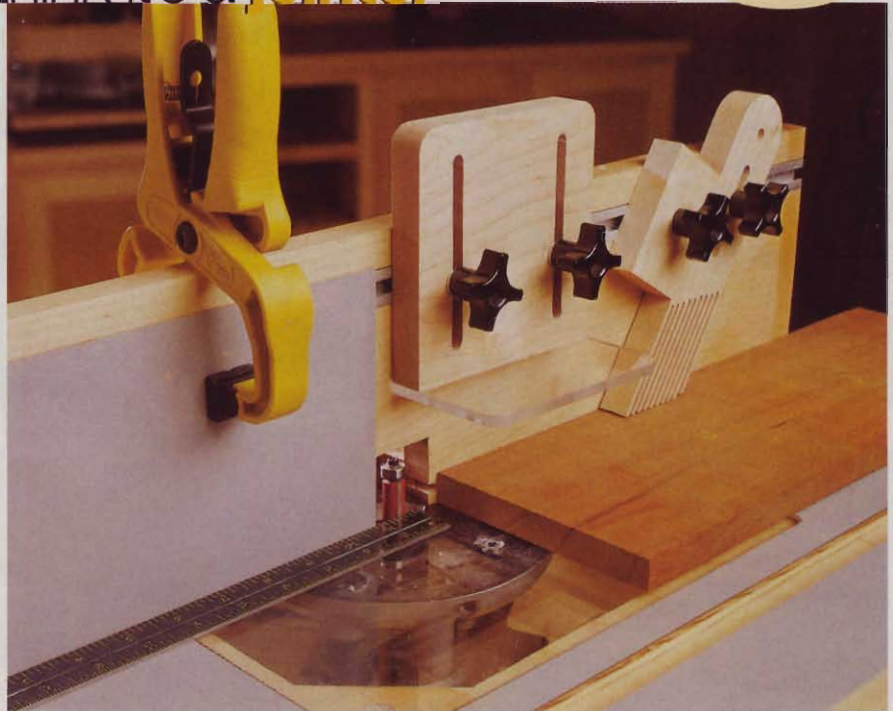

Place your laminate piece at the left-hand edge of the bit-clearance notch in the router table fence. The solid backing will keep it from flexing.



Clamp your insert-plate blank and a backer board to your drill-press table, centered under the bit of your holesaw. Drill slowly, and you'll get a clean cut.

Set your table with custom plates

Router table work goes smoother and more safely when the hole in your insert plate is only slightly larger than the diameter of the bit. You can buy a plate with removable rings, which gets you close enough in most situations—or you can make a custom plate to match a bit exactly. Use Baltic birch plywood for the least expensive plate, or choose polycarbonate for a clear plastic plate. You can buy a 12×12" piece of $\frac{3}{8}$ " polycarbonate for \$15.99 from Woodcraft. Call 800/225-1153 to order part number 16L72.

Place the insert plate faceup on a flat surface. Remove the subbase from your router, and adhere it to the plate, faceup, with double-faced tape. Be sure it's centered, and oriented so that your router will be convenient to operate once it's mounted under the table. Select a drill bit the same size as the holes in the subbase, and chuck it in your drill press. Using the holes in the subbase as guides, drill matching holes through the insert plate. Remove the subbase, and countersink the holes.

Now, attach the insert plate to your unplugged router and set it flat on your workbench. Chuck a $\frac{1}{4}$ " drill bit in the router, and lower it until the bit touches the insert plate. Turn the collet by hand to mark the centerpoint.

Remove the insert plate from the router. Chuck a holesaw or adjustable circle cutter in your drill press to cut a center hole of the diameter needed, as shown at *left*.

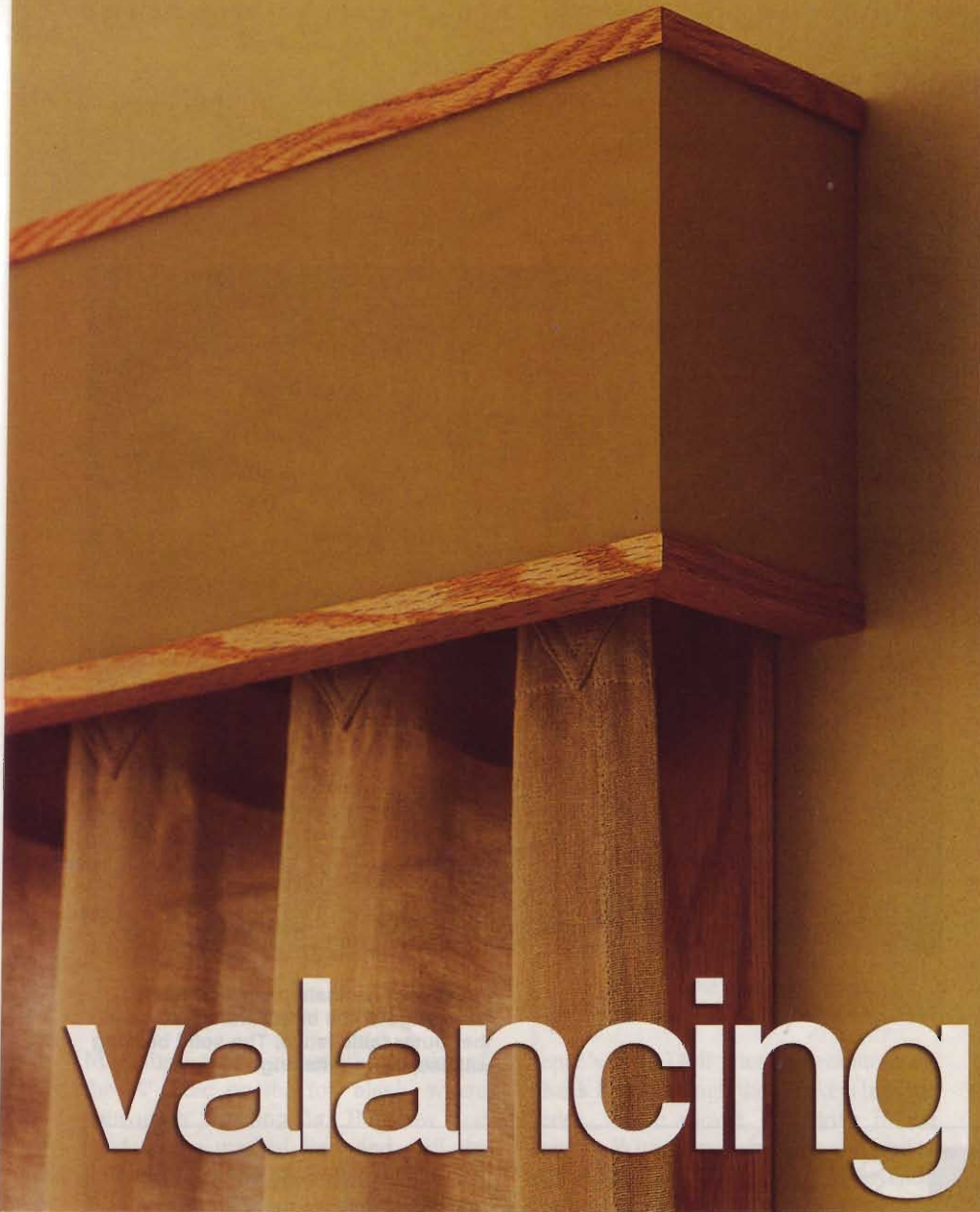

Hide
drapery
hardware
with style

balancing act

A window valance brings elegance to any room while performing a valuable service—hiding the rods and brackets that support curtains and blinds. Want a few more pluses? A valance is simple to make and you can customize it to your home's interior with a clear finish and paint, shown *above*, or paint and a wallpaper border, shown at *right*. As an additional enhancement, conceal lighting within the valance for indirect accent illumination.

Note: If you are interested in adding a light to your valance, see the section "Lighten up! Illuminate your valance" on page 60 for more information.



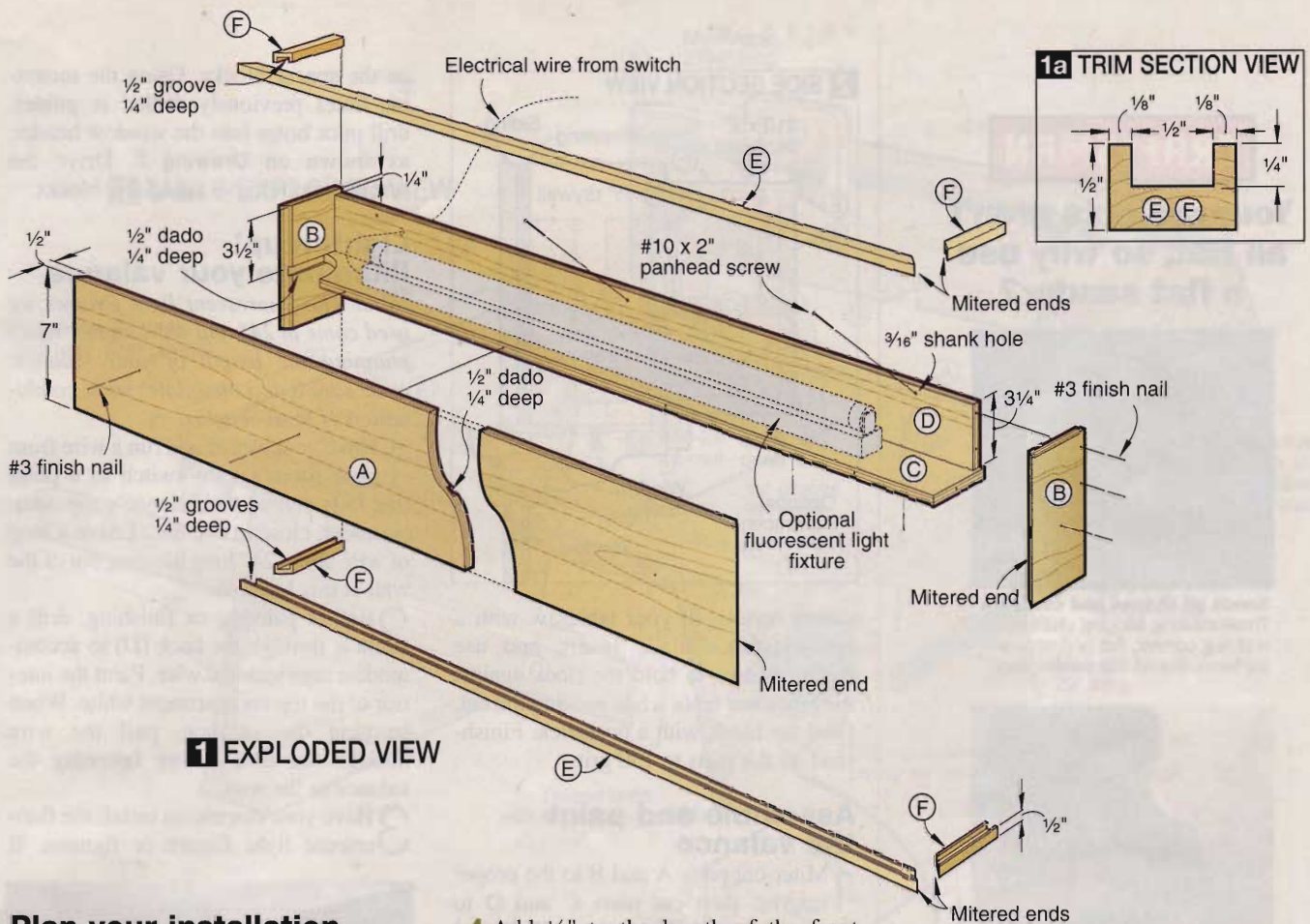

1 EXPLODED VIEW

Plan your installation

1 With your window drapery in place, measure its overall width at the rod. At each end, add 1/2" for the thickness of the end panels and 1" for clearance. This is the length of the front panel (A). Measure the drapery's projection from the wall at the rod, and add 1/2" for the thickness of the front panel plus 1" for clearance. This is the length of the end panels (B).

Note: If your valance is less than 96" long, you can use 1/2" plywood and not worry about butt joints. If it is longer than 96", consider using solid wood of the required length to avoid a joint. If you are painting or papering the valance, birch plywood or poplar is a good choice for parts A and B.

2 Subtract 1/4" from the width determined for the end panels (B) for the width of the bottom (C), and 1/2" from the length determined for the front panel (A) for the length of the bottom (C). (The bottom fits into 1/4"-deep dadoes in the front and ends.)

3 For the length of the back (D), subtract 1" from the length determined for the front panel (A). (The bottom butts against the ends.)

4 Add 1/4" to the length of the front panel (A) for the length of the front trim (E), and 1/8" to the length of the end panels (B) for the length of the end trim (F). (The trim protrudes 1/8" beyond the panels at the ends and front.)

Now, cut your parts

1 Cut the front panel (A), end panels (B), bottom (C), and back (D) to the widths listed in the Bill of Materials, or determined by measuring, but make them all about 1" longer than determined. Cut two pieces of stock for the trim pieces (E, F) to the thickness and width listed, but make them about 4" longer than the total length for each of the two trim sets (F, E, F).

Note: If your valance is longer than 96" and you decide to use plywood to get the required lengths for parts A, C, and D, stagger the joints in the front, bottom, and back when assembling them. This will avoid a weak spot in your valance.

2 Install a 1/2" dado blade in your table-saw, and adjust it to cut 1/4" deep. Test the cut on scrap to get the precise depth and a snug fit on your 1/2" plywood. Set the rip fence 3 1/2" from the blade. Mark

the top edges of A and B, then cut the dadoes, where shown on **Drawing 1**, keeping the tops next to the fence.

3 Using the same dado blade, reset the fence and dado the blanks for the trim pieces (E, F), making the profile shown on **Drawing 1a**. For safe and con-

bill of materials

Part	FINISHED SIZE			Matl.	Qty.
	T	W	L		
A* front panel	1/2"	7"	†	BP	1
B* end panels	1/2"	7"	†	BP	2
C* bottom	1/2"	†	†	BP	1
D* back	1/2"	3 1/4"	†	BP	1
E* front trim	1/2"	3 1/4"	†	O	2
F** end trim	1/2"	3 1/4"	†	O	4

*Parts initially cut oversize.

**Parts cut from two long blanks.

†See the instructions in the section "Plan your installation" for the lengths of these parts.

Materials Key: BP—birch plywood, O—oak.

Supplies: #10x2" panhead screws, #3 finish nails, glue, clear finish, primer, paint, optional fluorescent light fixture(s).

CRAFTSMAN

Your projects aren't all flat, so why use a flat sander?



Sands all shapes and contours
Three rotating sanding discs wrap and hug convex, flat and concave surfaces like no flat sander can.



Let the 3-D sander do the work
Requires very little pressure to remove rust, paint and stain from a variety of materials and surface contours.



Precise fingertip control
The 3-D sander's compact design fits comfortably in your palm for one-hand operation. Turn the dial to adjust sanding speeds of 800 to 2600 rpm.

Available at Sears, Sears Hardware, and the Craftsman Catalog at 800-437-9686

SEARS
Where else?

valance

2 SIDE SECTION VIEW

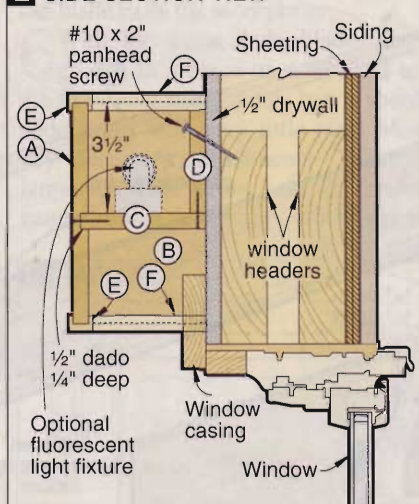

sistent results, fit your table saw with a zero-clearance blade insert, and use feather boards to hold the stock against the fence and table while making the cut. Feed the blank with a pushstick. Finish-sand all the parts to 150 grit.

Assemble and paint the valance

1 Miter-cut parts A and B to the proper lengths, then cut parts C and D to length. Dry-assemble parts A, B, C, and D to check the fit. Then glue, clamp, and finish-nail the assembly together, as shown on **Drawing 1**.

2 Miter-cut the trim (E, F) to fit the top and bottom edges of parts A and B. Glue and clamp the trim in place. Drill one mounting-screw shank hole through the back (D) for every 2' of valance length, where shown on **Drawing 2**.

3 Fill all the nail holes with wood filler, and sand them smooth. Finish-sand the valance to 220 grit. Mask around the trim, and give it two coats of clear finish. With the finish dry, mask the trim, and prime and paint the rest of the valance, including the bottom interior (where the curtains or blinds will hang), the desired color.

Hanging the valance

1 From scrap, cut two spacer blocks wide enough to rest on the top window casing and clear the top of the drape-ry by 1". Place them on the window casing, temporarily holding them in position with double-faced tape.

2 Position the valance, centered on the window, with the bottom (C) resting

on the spacer blocks. Using the mounting holes previously drilled as guides, drill pilot holes into the window header, as shown on **Drawing 2**. Drive the screws, and remove the spacer blocks.

Lighten up! Illuminate your valance

Note: The fluorescent light fixtures we used come in 24" and 48" lengths. When planning the length of your valance, make sure it accommodates some combination of these lengths.

1 Have your electrician run a wire from your room's light switch to a point that falls behind the valance's top compartment, close to one end. Leave a loop of wire about 24" long hanging out of the wall at this location.

2 Before painting or finishing, drill a hole through the back (D) to accommodate the electrical wire. Paint the interior of the top compartment white. When hanging the valance, pull the wire through the hole before fastening the valance to the wall.

3 Have your electrician install the fluorescent light fixture or fixtures. If



Light fixtures concealed in the valance provide soothing indirect illumination.

your valance is longer than the total length of the light fixtures, have them installed to leave equal spaces at each end and between fixtures. 🌿

Written by **Raymond L. Wilber** with **Charles I. Hedlund**
Project design: **Charles I. Hedlund**
Illustrations: **Roxanne LeMoine; Lorna Johnson**
Photographs: **Baldwin Photography**

healthy woodworking



Know what you need to protect your sight, hearing, and lungs. We'll help you choose the right gear, keeping you on the cutting edge of shop safety.



Safety glasses that fit over corrective eyeglasses

Shop safety includes a whole lot more than leaving the guard in place on your tablesaw. There's your eyes, ears, and lungs to think about. To protect these, select the right gear, then make a habit of using it.

Don't let hindsight become blind sight

All safety eyewear must be officially approved. That approval comes from the American National Standards Institute (ANSI), a voluntary organization that looks after the development of standards used in business, industry, government, and educational institutions. ANSI wrote the standard for safety eyewear for the industrial workplace, but your workshop differs only in size. The possible hazards to your eyes, such as flying chips of metal or wood, dust, or contact with harmful liquids, remain the same.

ANSI sets the standard for protection

All quality protective eyewear, including face shields, complies with ANSI standard Z87.1 (of 1989) will have that letter and numbers stamped or molded into the frame or shield. Lenses (usually of hard polycarbonate) that comply will bear the manufacturer's initials (AO for American Optical, X for UVEX, etc.) somewhere out of the line of sight. Any manufactured protective eyewear you consider purchasing should bear both inscriptions.

What does the ANSI standard mean to you? For one thing, the frames and lenses work together for protection. Industrial safety glasses have lenses that withstand nearly four times the impact of regular impact-resistant lenses. Compliant frames have inner retention

lips that keep unshattered lenses from being driven into your eyes under the force of heavy impact. They also meet the standards for pressure and impact that regular frames do not. And for complete protection, all industrial safety glasses should have side shields.

You'll find, though, some contemporary styles of one-piece, wraparound safety glasses that might not carry the ANSI Z87.1 imprint or the initials of the maker. They may meet or exceed the standard, but due to their one-piece construction, they don't comply with ANSI's lens-and-frame stipulations.

Your eyes determine your eyewear options

Depending on your eyesight, you have several options in safety eyewear. If you don't require corrective lenses (or wear contact lenses), you may select prefabricated safety glasses with clear lenses in place, safety frames in which safety lenses are inserted, or goggles. (There's also a combination eye-glass/goggle available.) If you have to wear corrective lenses while woodworking, you can don prefabricated safety glasses or goggles over your normal eyewear; use a flip-up face shield; or have prescription safety glasses made.

How much does ANSI-compliant eyewear cost? Not much, considering what you're protecting. You can buy a pair of prefabricated Z87-level

safety glasses for as little as \$5 or as much as \$30 (lens quality gets better as the price goes up). Goggles run from about \$8 to \$20; face shields, \$15 to \$20. The cost of prescription safety glasses varies with the fashion and quality of the frame, as it does with regular corrective lenses.

With safety glasses, always check (or ask) for ones with scratch-resistant lenses. And to prevent them from fogging when you're wearing a dust mask, have them treated with an antifog coating. Many companies offer permanent antifog coating on nonprescription safety glasses.

Antifog coating



Flip-up face shield

You say you've lost your hearing?

If there is one thing to remember from reading this, it's that hearing loss is cumulative and permanent. Hearing protection can't restore what you've already lost, but it can halt further deterioration.

If you value your hearing, you'll want to wear ear protection for any noise over 85 decibels (dB), and for very loud noise, such as that made by a chain saw,

you'll need added protection, such as earplugs under earmuffs. (See the chart, *opposite page*, for tool loudness ratings.)

Permanent damage to your hearing ability can result from exposure to over 100 dB for two hours or even less.

Note: The decibel scale by which sound is measured happens to be logarithmic, not linear. As demonstrated in the chart, below right, that means that a 100 dB noise is 10 times as loud as a 90 dB noise. And 90 dB is 10 times as loud as 80 dB.

In industry, the federal Occupational Safety and Health Administration (OSHA) helps reduce noise at its source by doing site-specific studies and giving recommendations to manufacturers for quieting operations. You can do a similar thing in your home shop by purchasing low-noise power tools and equipment. *WOOD* magazine's tool comparison tests usually provide noise ratings when applicable.

Even with quieter tools, though, you'll still need hearing protection when noise exceeds dangerous exposure levels, such as when you're routing. So how much do you need?

You first must understand how hearing protection is rated.

Manufacturers of hearing protectors assign each of their products a laboratory-based Noise Reduction Rating (NRR), and by law, it must be shown on the label of each hearing protector sold.

The NRR supposedly equals the drop in decibels (attenuation) provided by the device. For example, an NRR of 20 would reduce a 100 dB noise to an audible 80 dB. In the real world of your shop, however, the actual NRR proves to be somewhat less. That's why you should select hearing protection with an NRR of at least 25.

The best protection is what you'll wear

According to a 1997 study by the National Institute of Occupational Safety and Health (NIOSH), laboratory data show that earmuffs provide the highest real-world noise attenuation values, followed by foam earplugs. However, other data from OSHA and industrial sources, such as 3M, find that properly fitted foam or flexible plastic earplugs offer the greatest protection—from an NRR rating of about 29 to 33. NIOSH, more generally speaking, states that "the best hearing protector is the one that the worker will wear."

Basically, you'll find three types of hearing protectors. Foam earplugs that mold to fit your ear canal offer the highest NRR and cost the least (about 15 cents a pair). Band plugs, similar to foam ones but made of flexible plastic and joined with a head/neck band, come next, and cost a bit more. Earmuffs, usually with the lowest NRR (17–23), have prices around \$15. Top-of-the-line models can have an NRR as high as 29, but cost as much as \$25 a pair.

What happens when hearing protection fails

Researchers at 3M, which manufactures several styles of hearing protectors, have studied why hearing protec-



Earmuffs



Foam earplugs

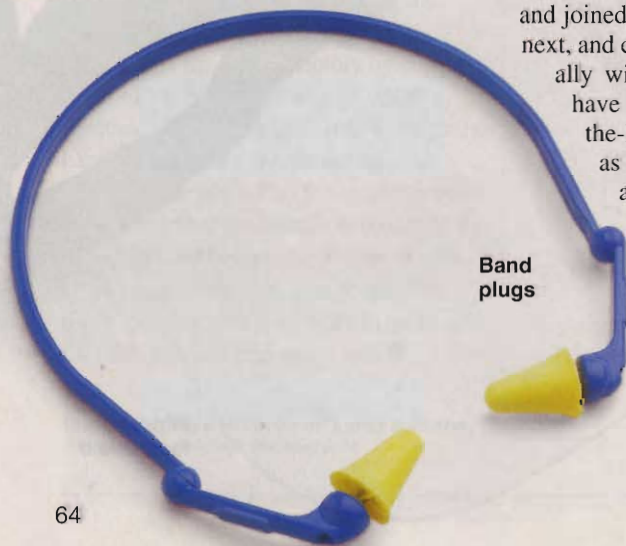

Band plugs

tion frequently fails in the industrial workplace. Some of their findings follow:

- **Improper sizing and insertion.** The wearer tends to fit plugs too loosely, even though they're available in various sizes. If fit too tightly, they are a discomfort and the wearer removes them. Also, a person can have different size ear canals, so each must be sized separately.
- **Incompatibility with other protective equipment.** Earmuffs often don't seal properly over safety glasses. Long hair also interferes.
- **Poor communication.** Hearing protection tends to attenuate high pitches, typical of voices. Wearers loosen, alter, or remove protectors to hear others.

How to "Look" at Noise

Intensity comparisons with NIOSH recommended permissible exposure time.

Note: For every 3dB the noise energy doubles.

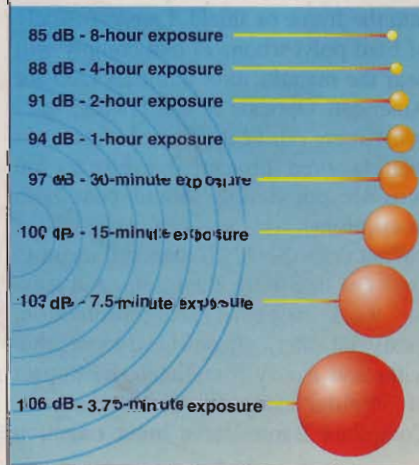

Woodworker's Noise Exposures

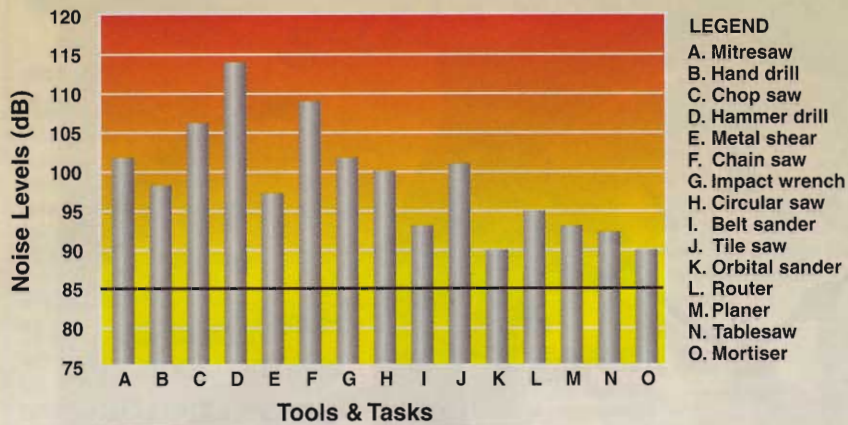

• **Wear and tear.** Seals wear down on muffs. Foam plugs become less flexible and unable to properly mold to the ear canal. Premolded plugs shrink. Ear wax and perspiration also build up on them. Earplugs should be checked frequently and pushed in. Even chewing gum can shift them out of position.

Finally, here's a test to see if earplugs fit properly: After inserting the plugs, cup your hands over your ears, then take them away. If you hear a difference, they're not being worn correctly. Remove them, refit, then try again. And don't forget to wash them in mild soap and water after a few wearings.

Dust can take your breath away

Exposure to wood dust in excess of five milligrams per cubic meter of air is hazardous to your health, says OSHA. It's even more so from western red cedar. Because that very common wood has been linked to respiratory problems, OSHA limits its dust to 2.5 milligrams per cubic meter.

How much is five milligrams? It's actually less than two ten-thousandths of an ounce. (A dime weighs eight-hundredths of

an ounce!) So according to OSHA standards, a woodshop measuring 15x30' with a 10' ceiling would reach the exposure limit when there are two-hundredths of an ounce of wood dust in the air. Granted, that's not much dust. But OSHA cares about it because exposure to wood dust has been associated with a variety of adverse health effects that include dermatitis, nonallergenic and mucosal respiratory effects, allergic respiratory ailments, as well as cancer. You and your home shop don't fall under OSHA's scrutiny, but for your own well-being, you'll want to do all that you can to cut down your exposure to dust.

What to do when you can't collect all of it

The highest degree of dust control consists of a three-pronged approach. Of primary importance is the installation of a dust-collection system that captures it at the source. The second prong is an air-filtration system that pulls out air-borne particles. And the third is the use of personal dust protection. Of course, most woodworkers typically start with the latter, then add the rest as their shop activity and hobby grow. So we'll look at dust masks as your first line of lung protection.

Protection for your respiratory system has two categories: nuisance protection masks and respirators.

For occasional light sanding that won't generate heavy dust, you can opt for the common paper throwaways with the single elastic band and the metal nose clip. These nuisance masks run about 30 cents each. The next step up is the woven cloth or

polyester mask with two elastic bands and an exhaust port. Although they're still disposable, they're NIOSH approved and can cost around \$2 apiece. Costlier variations of these are washable for years of wear.

For prolonged exposure to fine dust, mist, and dangerous fumes you'll need an air-purifying respirator with changeable filters that remove specific, unhealthy contaminants from ambient air. These half masks, because they're made of rubber or silicone, are flexible to fit your facial contours. Several straps ensure a tight fit. This type of protection can run you \$30 or more. And you'll have a choice of filters, depending on the kind of protection needed.

High-efficiency particulate air (HEPA) filters are 99.97% efficient in removing particles of 0.3 micrometer in diameter. A set of them may cost as much as the respirator itself. NIOSH (standard 42 CFR84) designates them as follows:

- *N100*, not resistant to oil particulates;
- *R100*, resistant to oil particulates;
- *P100*, oilproof.

Here's a tip concerning air-purifying respirators: Never simply store one on a shelf. Keep it in a sealed plastic bag; otherwise it will filter the ambient air and clog the filters while it just sits there.

To test the respirator, put it on and cover the air outlet with one hand. Then blow gently. Anywhere your other hand can feel air escaping around the mask is where it will leak when you inhale, so readjust for fit. ♣

Dust mask with exhaust port



Note: All equipment shown in this article was provided by Woodcraft. For more information on these products call 800/225-1153.

Written by Peter J. Stephano
Photographs: Baldwin Photography



www.woodonline.com



Here's a winning clock design...literally. Originally built by reader Larry Cardingley of Mardian, Idaho, this beauty was one of the finalists in our "It's About Time" Clock-Building Contest.



Arched-top clock with drawers

As soon as we opened the shipping box containing this contest entrant, we knew we were looking at something many of you would be interested in building. It was unique, well-detailed, and a real eye grabber. So, we obtained the design rights, tweaked a few of its proportions and construction details to better suite your needs, and asked staff designer/builder Kevin Boyle to construct another one. Now, without taking any more of your time, here's how to build one just like it.

Make the blanks for the staves and sides

Note: To get the appearance of continuous grain up the sides of the clock and over the arch, we cut all the pieces in sequence from a single board, as shown on the **Cutting Diagram**. **Photo A** shows the sides and staves lined up in their original position after we cut the $22\frac{1}{2}^\circ$ angle at each end of the staves.

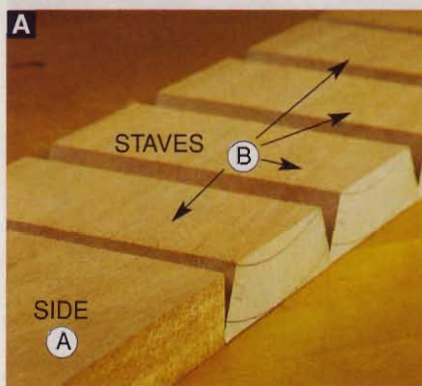

Cutting all of the sides and staves from a single length of lumber will ensure consistent color and continuous grain in the completed clock.

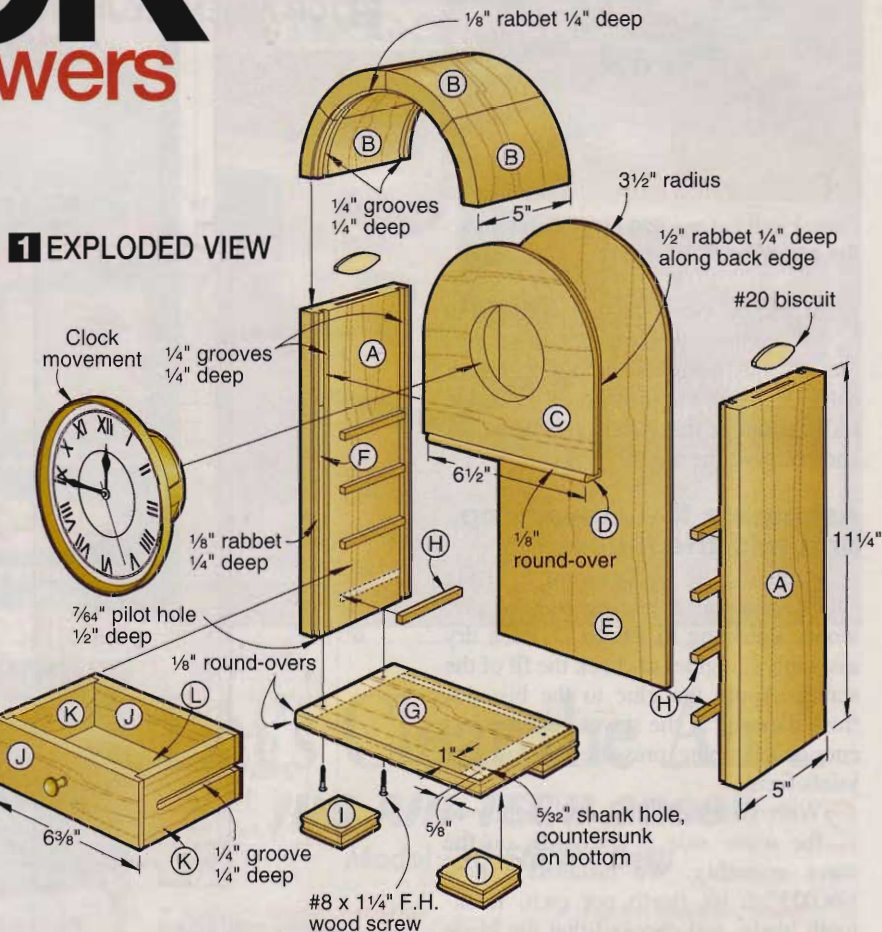

1 Starting with a piece of $1\frac{1}{4}$ "-thick mahogany that's at least 40" long, face joint and plane it to $1\frac{1}{8}$ "-thick to flatten both sides, and rip it to 5" wide.

2 Square one end of the board, and crosscut one side (A) to the length listed in the Bill of Materials. Mark a "1" on the lower end of this part, and draw an arrow pointing to the face that will be inside the completed clock. Crosscut four blanks $3\frac{3}{16}$ " long for the staves (B), numbering them in sequence on the inside face. Cut the other side (A) to length, and mark its lower end "2" with an arrow pointing to its inside face.

3 Referring to the **WOOD PATTERNS**® insert, make four photocopies of the

stave full-size pattern. Using spray adhesive, adhere a pattern to the front edge of each stave blank.

4 To cut the $22\frac{1}{2}^\circ$ ends of the staves (B), attach a stopblock to your miter-saw, and cut the same end on each block. After repositioning the stopblock and blade, make all of the other end cuts.

5 Referring to **Photo B**, set your biscuit joiner's fence to $22\frac{1}{2}^\circ$, and adjust the cutter so that the #20 slot will be centered in the final thickness of the stave (B). (This centerline is shown on each end of the full-size pattern.) Make certain that you center the slot side-to-side, and cut a slot into both ends of each stave.

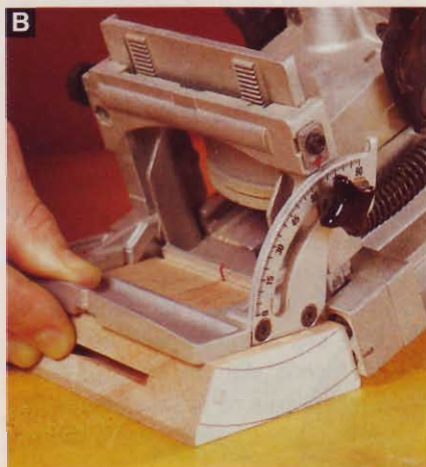

B Center and cut the #20 biscuit slot into the end of each stave.

6 Thickness-plane the two sides (A) to $\frac{3}{4}$ ", removing stock from both surfaces. Adjust your biscuit joiner, and cut a #20 slot into the top end of each side (A), centering the slot in the thickness and width of the stock.

Assemble the staved top, and add the sides

1 Build the jig in **Drawing 2**, using medium-density fiberboard or plywood. Referring to **Photo C**, do a dry assembly (no glue) to check the fit of the staves. Apply the glue to the biscuits, flush the ends of the staves, and use just enough clamping pressure to close the joints firmly.

2 With your bandsaw, cut slightly to the waste side of each line on the stave assembly. We installed a new $\frac{1}{4} \times .025 \times 6$ tpi (teeth per inch) hook-tooth blade, and checked that the blade was square to the table.

3 Next, using 80-grit sandpaper, sand the arch to the line, leaving a smooth curve that's $\frac{3}{4}$ " thick. Although you could sand the arch by hand, you can easily make the custom sanding drum shown in the Great Ideas From Your Shop article on *page 42*.

4 Do a dry assembly to check the fit of the sides (A) against the arched top assembly (B). Referring to **Photo D**, cut two $5 \times 6\frac{1}{2}$ " scrapwood spacers to hold the sides parallel when you snug up the band clamps. After the glue dries, sand the arch-to-side joints smooth.

5 Note the location of the grooves cut $\frac{3}{8}$ " from the front and $\frac{1}{4}$ " from the rear inner perimeter of the arch/side

2 TOP-ASSEMBLY JIG

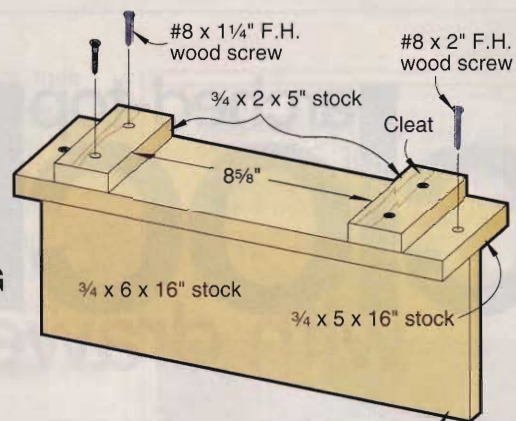

To use this jig, clamp this upright in your bench vise.

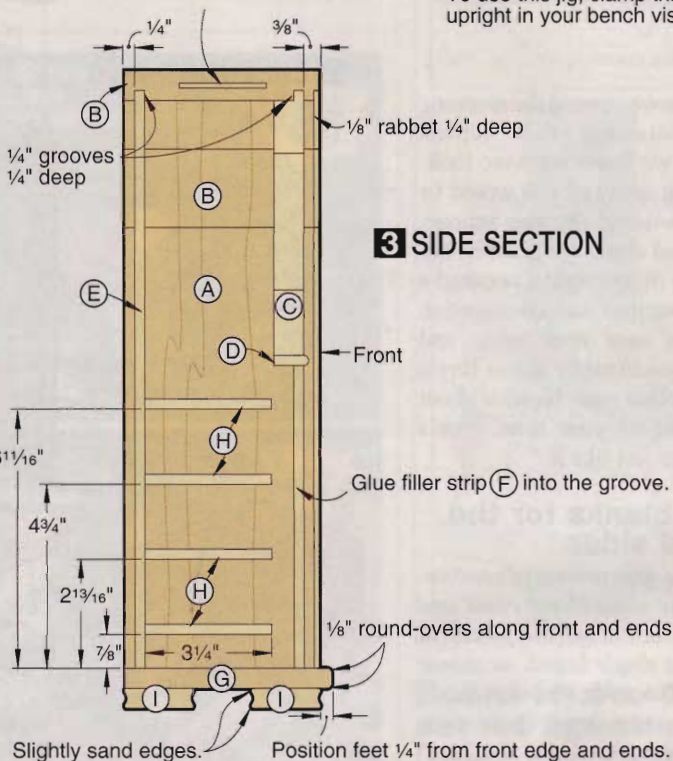

3 SIDE SECTION

shop TIP

A trick to keep things straight

Ideally, the ends of the stave assembly that join to the sides should come out of the clamping jig flat and perfectly aligned with each other. If not, the sides won't be vertical and parallel. If the ends of the staves require adjustment, spray-glue a sheet of 80-grit sandpaper onto a flat surface, and rub the ends of the stave assembly on the sandpaper to flatten them. Check your progress by putting the stave assembly on a flat reference surface, such as your saw table, and look for gaps that allow light to pass between the wood and the table.



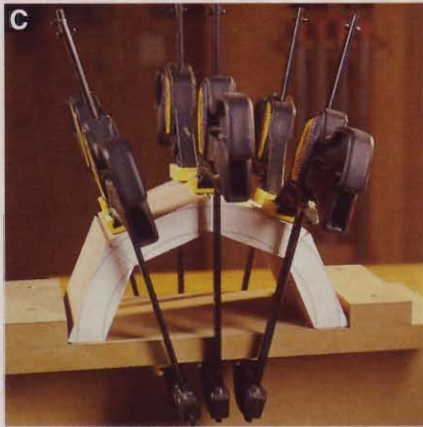

C When clamping the staved top, apply the clamps symmetrically, and use just enough muscle to close the joints.

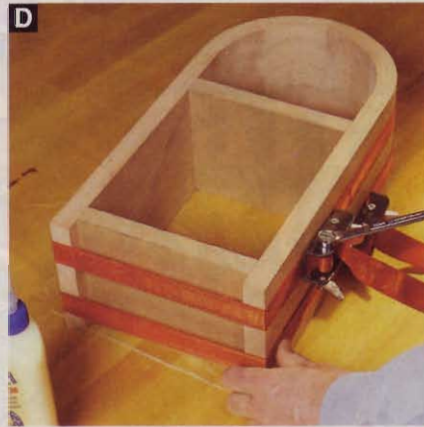

D A pair of band clamps snugs the staved top to the sides while the scrapwood spacers keep the sides parallel.

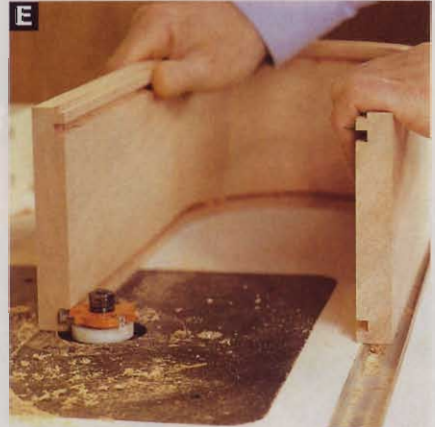

E Rout the grooves with a slot cutter by moving the top/side assembly in a counter-clockwise direction.

assembly (A/B) in **Drawing 3**. Cut these grooves with a 1/4"-wide 3-wing slot cutter chucked into your table-mounted router. (Our bit uses a bearing under the cutter to limit the depth of cut to 1/4", as shown in **Photo E**.)

6 Chuck a rabbeting bit into your table-mounted router, and cut the 1/8" rabbet, 1/4" deep along the front edge of the case assembly.

The case grows as you add the front, back, and base

1 From 3/4"-thick mahogany, cut a blank 6 3/4"x7" for the front (C). Referring to **Drawing 4**, lay out the

radius at the top of this part and the 3 1/8"-diameter hole for the clock movement. Referring to **Photo F**, use a circle cutter in your drill press to cut the hole in the front (C). Bandsaw and sand the upper radius of the front to the layout line.

Note: If you use a movement different from the one specified in the Buying Guide, it may require a different hole.

2 Chuck a rabbeting bit into your table-mounted router, and rout the 1/2" rabbet, 1/4" deep where shown on **Drawing 4**.

3 Referring to the Bill of Materials, cut a piece of mahogany to size for the front trim (D). Using a 1/8" round-over bit in your table-mounted router, rout along the top and bottom front edges of

the front trim, forming the profile shown in **Drawing 3**. Glue the front trim to the lower edge of the front, flushing the back edges of these parts and centering the front trim end-to-end.

4 Referring to the Bill of Materials and **Drawing 1**, cut the back (E) to shape from 1/4"-thick plywood. Test-fit the back into the groove of the top/sides assembly (A/B), making sure that the lower end of the back is flush with the bottom ends of the sides (A). You don't need to glue this part into position.

cutting diagram

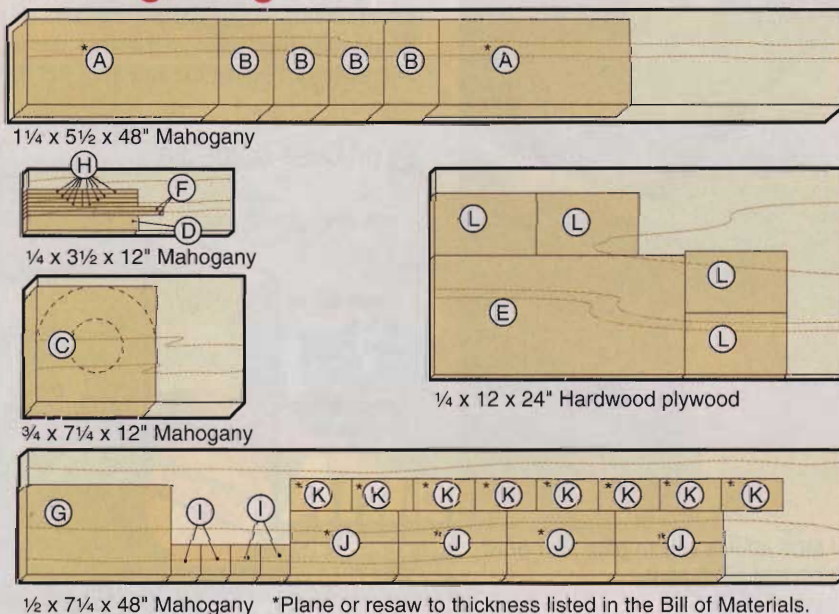

bill of materials

Part	FINISHED SIZE			Matl.	Qty.
	T	W	L		
A sides	3/4"	5"	11 1/4"	M	2
B* staves	1 1/8"	5"	3 3/4"	M	4
C front	3/4"	6 3/4"	7"	M	1
D front trim	1/4"	7 3/8"	6 1/2"	M	1
E back	1/4"	7"	14 3/4"	HP	1
F filler strips	1/4"	1/4"	8"	M	2
G base	1/2"	5 1/4"	8 1/2"	M	1
H drawer guides	1/4"	1/4"	3 1/4"	M	8
I feet	1/2"	1 3/4"	1 3/4"	M	4
J drawer fronts/back	3/8"	1 7/8"	6 3/8"	M	8
K drawer sides	3/8"	1 7/8"	3 5/8"	M	8
L drawer bottoms	1/4"	3 5/8"	6"	HP	4

* The dimensions given are for the stave blanks. The parts are shaped after assembly.

Materials Key: M—mahogany, HP—hardwood plywood.

Supplies: #8x1 1/4" flathead wood screws, AA battery, #20 biscuits, 1/4" hardboard, spray adhesive, glue, stain, clear finish.

Buying Guide

Brass knobs no. 39499, \$1.45 each (4); 5/8"-diameter press-in clock movement no. 15343, \$11.95. Order from Klockit, PO Box 636, Lake Geneva, WI 53147, or call 880/556-2548, or go to www.klockit.com.



F For safety, run the circle cutter at the slowest speed on your drill press, and use a fence and stopblock to secure the blank.

5 Slide the front assembly (C/D) into the groove in the case assembly. Referring to the Bill of Materials, rip and crosscut the filler strips (F), and glue them where shown on **Drawing 3**.

6 Cut the base (G) to the size listed. Chuck a $\frac{1}{8}$ " round-over bit in your table-mounted router, and rout round-

overs along the top and bottom of both ends and the front edge. To prevent tearout, rout the ends first, then rout the front edge.

7 Referring to **Drawing 1**, drill the $\frac{5}{32}$ " countersunk shank holes through the base (G) where dimensioned. Lay the

case assembly on its back on your workbench, and center the base side-to-side against it. Using the holes in the base as guides, drill $\frac{7}{64}$ " pilot holes $\frac{1}{2}$ " deep into the bottom ends of the sides (A). Drive the #8x $\frac{1}{4}$ " flathead wood screws through the base into the sides.

8 Cut the drawer guides (H) to size. For safety, we used a zero-clearance tablesaw insert and a pushblock when cutting the narrow strips.

9 Make the drawer-guide jig shown in **Drawing 5**. Mark an arrow on each edge pointing to the top of the jig so you don't accidentally use it upside down. Referring to **Photo G**, load the jig with four drawer guides (H), and lightly coat their open edge with glue. Flush the lower end of the jig against the base (G) inside the clock case, and clamp the jig into position against the side (A). Let the

5 DRAWER-GUIDE JIG

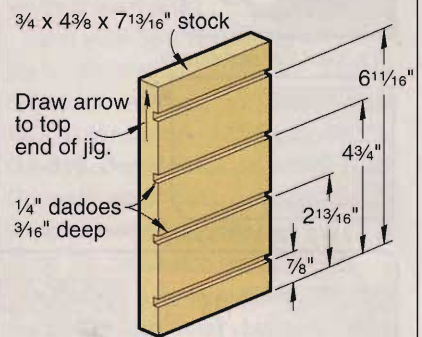

G A simple jig made by cutting dadoes in a scrap of MDF allows you to glue four drawer guides inside the clock case at one time and in perfect alignment.

6 FOOT ROUTING DETAIL

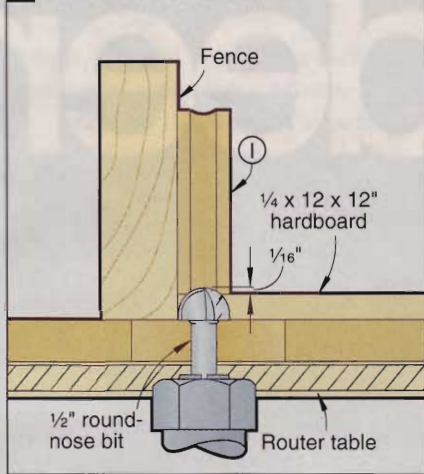

glue dry for a couple of hours, then repeat the process on the other side.

10 Rip the feet (I) to size. To safely route the ends and edges of the feet, create a zero-clearance surface on your router table. To do this, chuck a 1/2" roundnose bit into your table-mounted router, and raise the bit above the table. Referring to **Drawing 6**, position the fence so that it just touches the bit's cutting edge. Lower the bit below the surface of the table, and put a 12" square of 1/4" hardboard over the router table's opening. To keep the hardboard flat to the table, secure it with a couple of pieces of double-faced tape. Turn on your router, and slowly raise the running

bit through the hardboard until 1/16" projects above its surface, as shown in **Drawing 6**. Rout the profile along the ends and edges of each foot (I).

11 Sand a slight curve along the upper and lower perimeters of the feet, where shown in **Drawing 3**. Glue the feet to the base (G), positioning them flush with the back edge of the base, and 1/4" from its front edge and ends.

Gear up for drawer production

1 Cut the drawer fronts/back (J) and the drawer sides (K) to size. Put a 3/8" dado blade into your table saw, and attach a scrapwood face to your saw's rip fence. Slide the fence until it just touches the blade, and lock it in place. Adjust the blade for 3/16" depth-of-cut, and cut the rabbets into the drawer fronts/back (J), where shown on **Drawing 7**.

2 Put a 1/4" dado blade into your table saw, adjust your fence, and cut the grooves into the lower inner faces of the drawer fronts/back (J) and the drawer sides (K) where shown on **Drawing 7**.

3 Cut the drawer bottoms (L) to size. **4** Dry-assemble the drawers to check the fit of the parts. Glue and clamp the drawer assemblies, and check that they sit flat and are square.

4 To cut the stopped grooves into the drawer sides, chuck a 1/4" straight bit into your table-mounted router, and set it

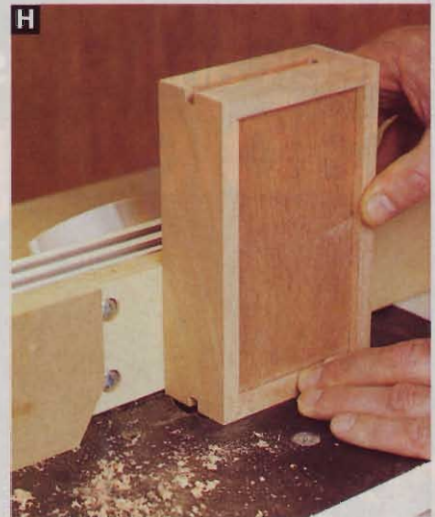

H Carefully centering the bit in the drawer's side, rout grooves into both sides with this one setup.

for a 1/4"-deep cut. Position your router-table fence so that the bit is exactly centered in the width of the drawer side (K). Test your setup with scrap that is the same width as your drawer sides. Referring to **Photo H**, clamp a stopblock to the fence on the left side of the bit to stop the groove at 3 5/16" long. After you groove the first side of each drawer, turn the drawer over, and push it up to the stopblock to cut the groove into the other side.

5 Test-fit each drawer, and sand the drawer guides, if necessary, to get a smooth-sliding fit. Drill the pilot holes for the knobs, centered top-to-bottom and side-to-side in each drawer front (J).

The finish is fast and easy

1 If desired, stain the mahogany to slightly darken it. (We used Antique Cherry stain from General Finishes. To find a dealer, call 800/783-6050, or go to www.generalfinishes.com)

2 With the stain dry, spray on two coats of aerosol semigloss Deft Clear Wood Finish. Between coats, lightly sand with 220-grit sandpaper, and remove the dust with a tack cloth.

3 After the finish dries, attach the knobs. Rub a little paraffin wax on the drawer guides to ease the sliding of the drawers. Install the battery in the clock movement, and press it into place. 🌲

Written by **Robert J. Setlich** with **Kevin Boyle**
Project design: **Larry Cardingley**; **Kevin Boyle**
Illustrations: **Roxanne LeMoine**; **Lorna Johnson**
Photographs: **Baldwin Photography**

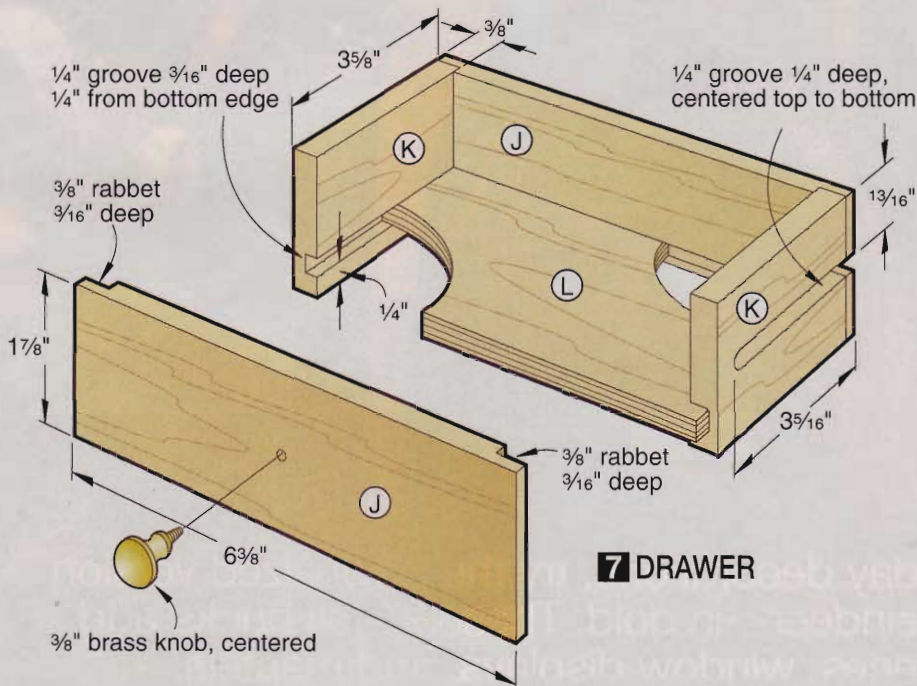

7 DRAWER

sleek and stylish
tabletop reindeer



For some upscale holiday decorations, try the downsized version of our popular lawn reindeer—in gold. These 9"-tall bucks add dash to centerpieces, window displays, and mantels.

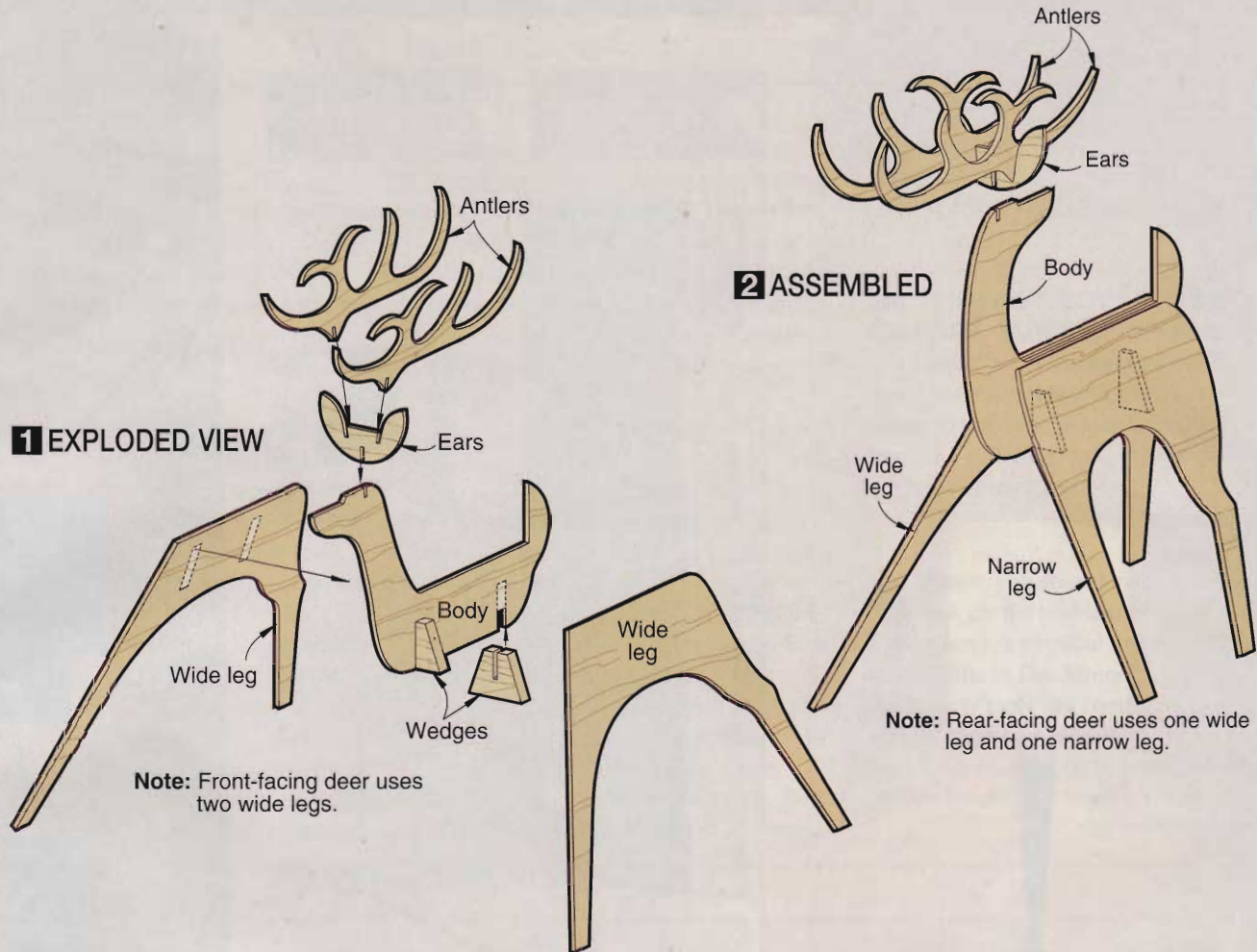

1 EXPLODED VIEW

2 ASSEMBLED

Note: Front-facing deer uses two wide legs.

Note: Rear-facing deer uses one wide leg and one narrow leg.

Transfer the patterns, and cut out the deer

- 1 Using carbon paper or photocopies of the patterns and spray adhesive, transfer the full-size body patterns on the *WOOD PATTERNS*® insert to poster-board. Cut the patterns to shape to form templates. (If you're making just a set or two of reindeer, skip the templates and transfer the full-size patterns directly onto 1/8" stock.)
- 2 Use the templates to trace the patterns onto 1/8" stock. (See the Buying Guide below for our source of void-free birch plywood.)
- 3 Cut the pieces (we used a scrollsaw and a #4 blade -.033x.014" - with 15 teeth per inch; you also could use a band-saw equipped with a 1/8" blade). When cutting the notches in the parts, remem-

ber that the notch width needs to be the same as the thickness of the stock.

Sand, assemble, and spray—that's it!

- 1 Scrollsawing or bandsawing the tabletop figures causes the plywood edges to "fuzz up" slightly. Left unsanded, the fuzz becomes more noticeable after spray painting. So, lightly hand-sand the edges and surfaces smooth with 220-grit sandpaper.
- 2 Assemble each deer. We used a drop of instant glue at each joint to hold the pieces together.
- 3 Spray on several light coats of gold gloss enamel. To avoid runs, apply light coats rather than trying to paint the deer with a heavy coat or two. We used Rust-Oleum American Accents #7954

Metallic Gold. If the painted surfaces get a bit rough, sand lightly with 320-grit sandpaper before applying the final coat of spray paint. 🦌

Project design: © Meredith Corporation/Lee Gatzke
 Photograph: Baldwin Photography
 Illustrations: Roxanne LeMoine

cutting diagram

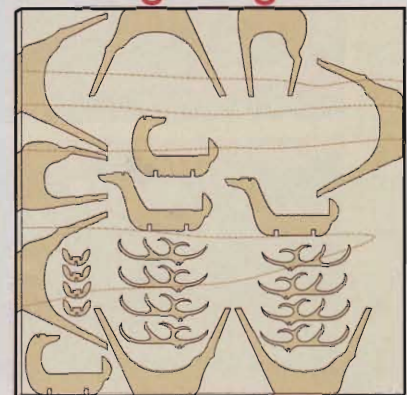

1/8 x 24 x 24" Birch plywood

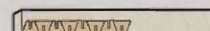

3/8 x 1 1/2 x 12" Plywood

Buying Guide

Void-free 1/8x12x30" birch plywood. Two pieces (enough for five deer) for \$10.95 ppd., five pieces (enough for 12 deer) for \$18.95 ppd. Heritage Building Specialties, 205 North Cascade, Fergus Falls, MN 56537. Call 800/524-4184 to order.

Plan for 52" Pair. Woodworking plan with full-size patterns for the yard-size, 52"-tall, yard-sized pair, order plan no. OFS-1068. Send \$13.95 ppd. to WOOD PLANS, P.O. Box 349, Dept. WD1201, Kalona, IA 52247, call toll free 888/636-4478, or see our full line of woodworking plans at <http://woodstore.woodmall.com>



eight-drawer dresser with mirror

bedroom storage never looked better

The final installment of our maple-and-cherry bedroom ensemble, this chest of drawers, along with its matching mirror, provides a stunning conclusion to the set that began with the sleigh bed featured in issue 135. Its combination of raised-panel drawer fronts and contrasting woods makes it a good fit in any setting—contemporary or traditional. *Note: In addition to ease of assembly, the biscuit-joiner construction of this project makes finishing a breeze. We finish-sanded the parts before gluing up the various sub-assemblies, applied the finish, then glued up the final carcass. To further speed construction, we banded 96"-long plywood panels, then crosscut the carcass parts from these prebanded panels.*

Shape the flared legs

1 Laminate two $\frac{1}{4} \times 2\frac{3}{4} \times 32\frac{1}{4}$ " pieces of hardboard to make a $\frac{1}{2}$ "-thick template blank for the legs (A). Joint one edge. Make a copy of the leg pattern from the *WOOD PATTERNS*® insert. Use spray adhesive to adhere the pattern to the blank, aligning the pattern with the hardboard's jointed edge as indicated. Saw and sand the template to the pattern line.

2 Prepare two $1\frac{1}{2} \times 4\frac{1}{2} \times 38$ " blanks for the legs (A). (We planed down $1\frac{3}{4}$ " stock. You can also laminate the blanks from $\frac{3}{4}$ " stock.) Joint

both edges, then use the template to trace the leg outlines on the blanks, aligning the template's and the blanks' jointed edges. To conserve lumber, nest the parts, as shown on the Cutting Diagram. Bandsaw the legs from the blanks keeping close to the pattern lines. Clean up the legs' bandsawn edges with a drum sander chucked into your drill press. We built the simple pattern-sanding jig shown in issue 136, page 20, for this task, using double-faced tape to adhere the template to each leg.

3 With the legs complete, arrange them for the best appearance and mark their locations, front and back, left and right. Finish-sand the legs to 220 grit.

In case you missed the rest of the set...



Interested in building the entire ensemble? You can order back issues with complete plans for \$6.95 each. Call 800/346-9663 and ask for the following issues: 135 (sleigh bed), 136 (nightstand), 137 (armoire).

Make the carcass parts, and glue up assemblies

1 Cut two $\frac{3}{4} \times 15\frac{7}{8} \times 27\frac{1}{4}$ " maple plywood blanks for the side panels (B). Finish-sand the outside faces.

2 Resaw in half a $\frac{3}{4} \times 4\frac{1}{2} \times 34$ " maple board and plane the two pieces down to $\frac{1}{4}$ ". From this stock cut two $2 \times 15\frac{3}{4}$ " blanks for the upper side rails (C), and two $3\frac{1}{2} \times 15\frac{3}{4}$ " blanks for the lower side rails (D). To avoid a tricky cleanup task when gluing the rails onto the side panels, cut $\frac{1}{8}$ "-deep saw kerfs $\frac{1}{8}$ " from the edges of the rails, as shown on **Drawing 1a**. Glue applied to the surface between the grooves squeezes into the grooves instead of oozing onto the panels. Finish-sand the pieces.

3 Glue and clamp the rails to the panels, where shown on **Drawing 1**, centering the rails on the panels. The rails' ends fall $\frac{1}{16}$ " short of the oversize panels' edges. This keeps the rails from interfering with the cut when the panel assemblies are trimmed to final size.

4 With the glue dry, cut the side panel assemblies (B/C/D) to the width listed in the Bill of Materials for part B, trimming both edges. Cutting panels and

rails together ensures straight, flush edges and crisp, tight glue joints between the panels and the legs.

5 Adjust your biscuit joiner to cut a slot centered in the thickness of your $\frac{3}{4}$ " plywood. Plunge the biscuit slots in the legs and the mating edges of the side panel assemblies, where dimensioned on **Drawing 1**. Index your biscuit joiner on the inside surfaces of the legs and panels. Apply glue, insert biscuits, and clamp the legs to the sides.

6 Rip a full sheet of $\frac{3}{4}$ " maple plywood into three $15\frac{7}{8} \times 96$ " panels for carcass parts E through J, and cut a fourth $15\frac{7}{8} \times 61$ " panel from another sheet for the carcass bottom (K). From solid maple, cut three pieces $\frac{3}{4} \times 1\frac{1}{2} \times 96$ " for the edge bands (L) and two $\frac{3}{4} \times 1\frac{1}{2} \times 61$ " blanks for the carcass rails (M).

7 Pair up each of the three 96"-long plywood panels with a 96"-long edge band. Mark biscuit locations at 10–12" intervals along the mating edges. Plunge the biscuit slots, and glue, biscuit, and clamp the bands to the panels, as shown in **Photo A**. With the glue dry, trim one end of each panel/band assembly. Now cut carcass parts E through J in the order



Clamp the panel/band assemblies, band-to-band, in pairs.

shown on the Cutting Diagram to the lengths listed in the Bill of Materials.

Note: Cut two scrapwood spacers to the same dimensions as the center divider (I). Set them aside to use when assembling the carcass.

8 Mark biscuit locations along the mating edges of the carcass bottom blank (K) and the carcass rail blanks (M) where shown on **Drawing 2**. Plunge biscuit slots, and glue, biscuit, and clamp the assembly. With the glue dry, cut the carcass bottom to finished length, trimming both ends.

9 Mark the biscuit locations on the ends of the banded carcass parts F through J, where shown on **Drawing 2**. Plunge the slots. Mark the biscuit locations on the surfaces of the banded carcass parts E, F, G, and K. Plunge the end rows of slots in the carcass top (E/L) and bottom (K/M), indexing your biscuit joiner on the panels' ends. To guide your biscuit joiner when plunging the other slots, clamp a straightedge to the panel. (See the shop tip *opposite*.) Offset the straightedge so the biscuit slots fall on the location centerline. Finish-sand the panels to 220 grit.

10 Lay out and drill the counterbored screw shank holes and slots in the carcass top (E/L), where shown on **Drawing 2**. To form the slots' counterbores, drill $\frac{3}{16}$ "-deep holes with your $\frac{1}{2}$ " Forstner bit, and chisel out the center, where shown on **Drawing 2a**. Then drill overlapping shank holes to form the slot.

11 Edge-join stock to form a blank for the top (N) about 1" longer and wider than the size listed. With the glue dry, trim the blank to size. Rout a $\frac{1}{2}$ " round-over on the top's ends, then the front edge, where shown on **Drawing 3**. Finish-sand the top.

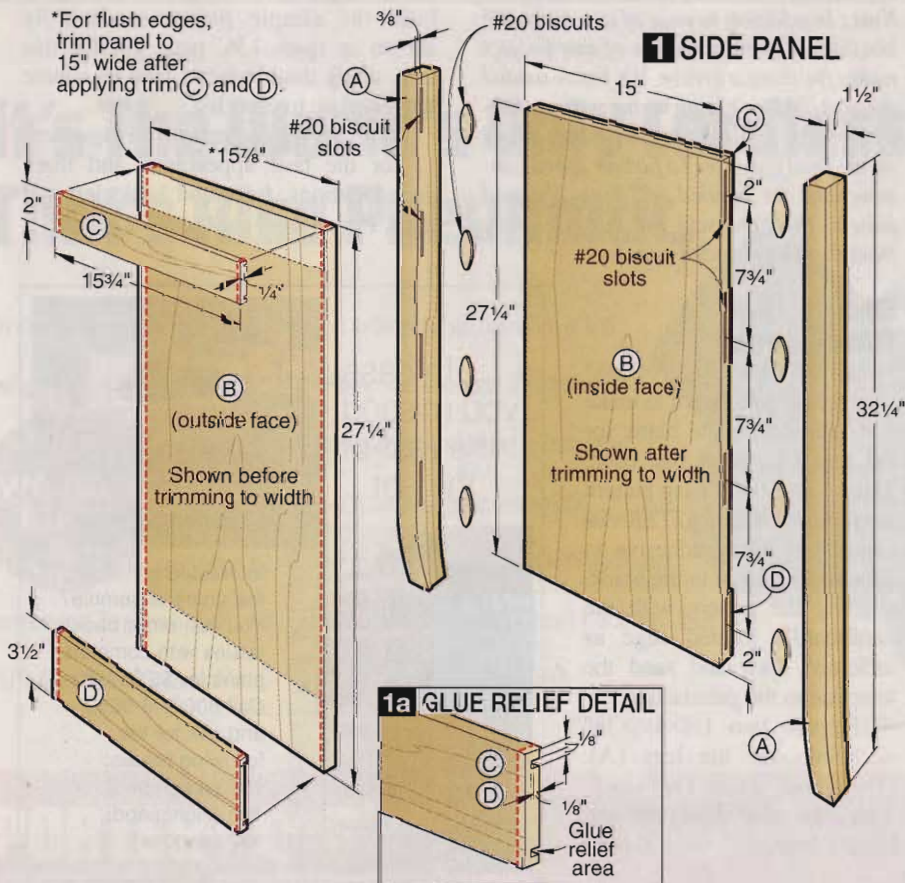

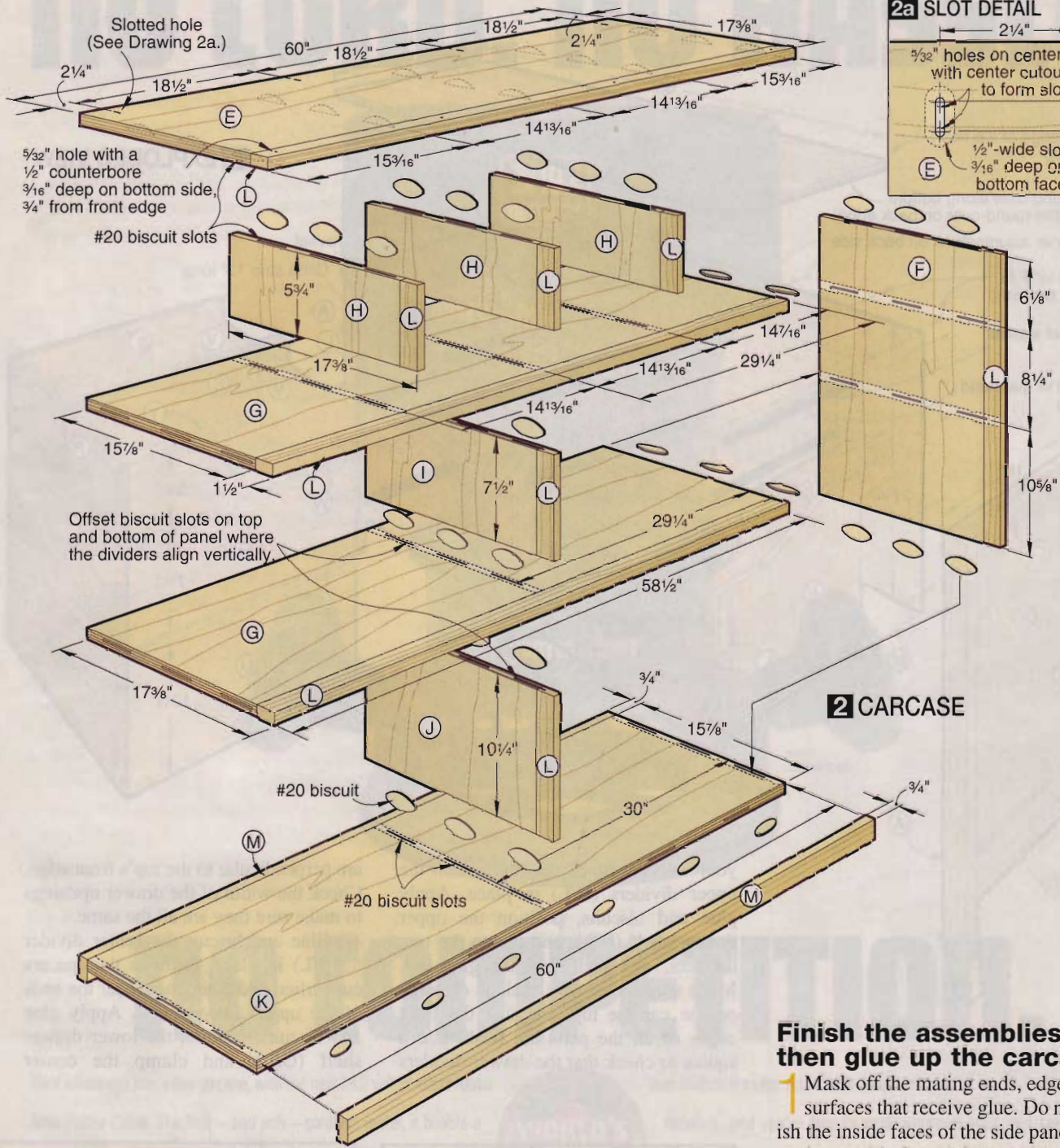
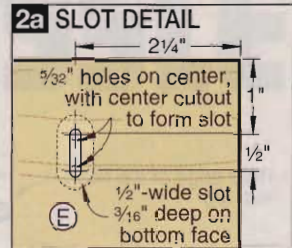

Finish the assemblies, then glue up the carcass

1 Mask off the mating ends, edges, and surfaces that receive glue. Do not finish the inside faces of the side panels (B) or the outside faces of the carcass sides (F/L). Apply a coat of gloss polyurethane to all other parts. With the finish dry, sand lightly with 220-grit sandpaper. Remove the dust and apply a coat of satin polyurethane. With the finish dry, remove the masking tape.

2 Place the carcass top (E/L) bottom side up on your workbench. Raise it with blocking thick enough to make room for your clamp heads, as shown in Photo B. Using white glue to extend

shop TIP

Production biscuit joining

Use a simple T-square made of 1/4" hard-board and 3/4" plywood for plunging biscuit slots in the face of a panel. For quick alignment, mark the required centerline offset on the T-square's head. Mark repeating slot locations on a strip of masking tape.

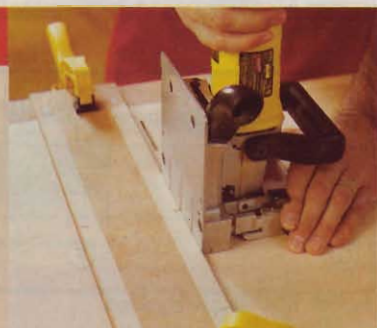

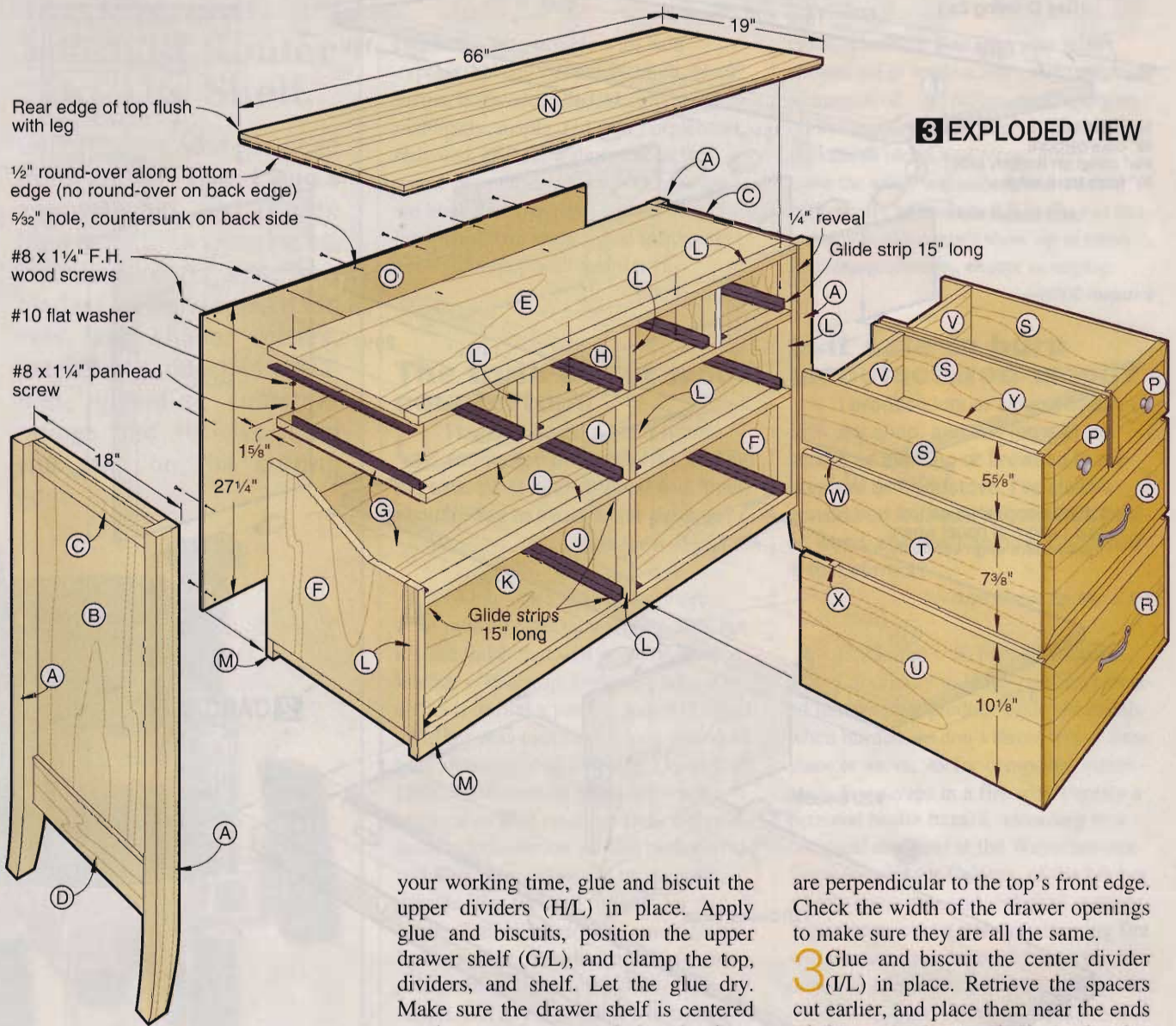

3 EXPLODED VIEW

your working time, glue and biscuit the upper dividers (H/L) in place. Apply glue and biscuits, position the upper drawer shelf (G/L), and clamp the top, dividers, and shelf. Let the glue dry. Make sure the drawer shelf is centered on the carcass top, and that the front edges of all the parts are flush. Use a square to check that the drawer dividers

are perpendicular to the top's front edge. Check the width of the drawer openings to make sure they are all the same.

3 Glue and biscuit the center divider (I/L) in place. Retrieve the spacers cut earlier, and place them near the ends of the upper drawer shelf. Apply glue and biscuits, position the lower drawer shelf (G/L), and clamp the center

cutting diagram

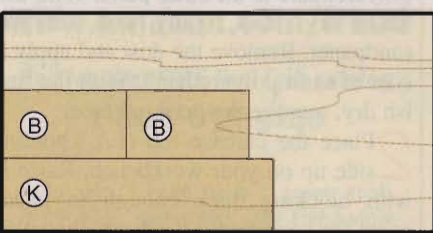

3/4 x 48 x 96" Maple plywood

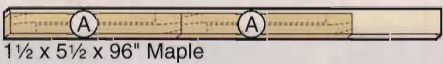

1 1/2 x 5 1/2 x 96" Maple

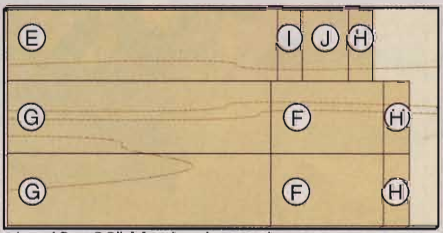

3/4 x 48 x 96" Maple plywood

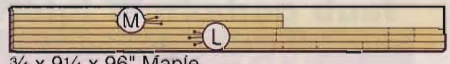

3/4 x 9 1/4 x 96" Maple

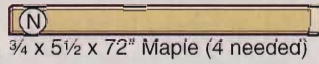

3/4 x 5 1/2 x 72" Maple (4 needed)



3/4 x 9 1/4 x 72" Cherry

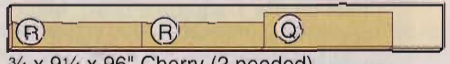

3/4 x 9 1/4 x 96" Cherry (2 needed)

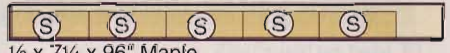

1/2 x 7 1/4 x 96" Maple



Scrap 4x4s make room for clamp heads underneath the assembly, while spacers keep the lower drawer shelf aligned.

divider, spacers, and lower drawer shelf to the previous assembly, as shown in **Photo B**. Let the glue dry.

4 Apply glue and biscuits, and add the carcass sides (F/L) to the previous assembly, as shown in **Photo C**. Clamp the sides in place until the glue dries.

5 Apply glue and biscuits and position the lower divider (J/L). Add more glue and biscuits, position the carcass bottom (M/K/M), and clamp the divider and bottom to the larger assembly.

6 Retrieve the side panel assemblies (A/B/C/D) and glue and clamp them to the carcass assembly, where shown on **Drawing 3**. The side panel assemblies' top edges are flush with the carcass top (remember, you're working with the carcass upside down), and the legs protrude beyond the carcass sides $\frac{1}{4}$ " at the front and $\frac{3}{8}$ " at the back.

7 Turn the carcass right side up, and clamp the top (N) in place, flush with the legs at the rear and centered side-to-side. Use an awl to mark the locations of the mounting screws. Remove the top, drill the screw pilot holes, and fasten the



Leave the spacers in place while gluing and clamping the carcass sides. With the glue dry, remove the spacers.

top to the carcass with #8x $\frac{1}{4}$ " panhead screws and washers, where shown on **Drawing 3**.

8 Adhere self-adhesive glide strip to the lower inside corners and the tops of the drawer cavities, where shown on **Drawing 3**. Hold the strips $\frac{3}{4}$ " back from the carcass's front edge. For a good bond, press them in place with a wood block. See the Buying Guide for a source of glide strip.

9 Cut the back (O) to fit side-to-side between the protruding legs, and top-to-bottom from the top of the carcass top (E) to the bottom of the lower rail (M). Clamp the back in place and drill pilot and countersunk shank holes, where shown on **Drawing 3**. Remove the back and set it aside.

Now build the drawers

Note: Because the complete bedroom suite involves making fifteen drawers, we used a drawer-lock router bit to speed this task. These bits form the mating halves of the joint in the drawer front and side with a single setup. (See the

bill of materials

Sides	FINISHED SIZE			Matl. Qty.
	T	W	L	
A* legs	1½"	2½"	32¼"	M 4
B**side panels	¾"	15"	27¼"	MP 2
C**upper side rails	¼"	2"	15"	M 2
D**lower side rails	¼"	3½"	15"	M 2

Carcass

E**carcase top	¾"	15⅞"	60"	MP 1
F**carcase sides	¾"	15⅞"	25"	MP 2
G**drawer shelves	¾"	15⅞"	58½"	MP 2
H**upper dividers	¾"	15⅞"	5¾"	MP 3
I**center divider	¾"	15⅞"	7½"	MP 1
J**lower divider	¾"	15⅞"	10¼"	MP 1
K**carcase bottom	¾"	15⅞"	60"	MP 1
L edge bands	¾"	1½"	96"	M 3
M**carcase rails	¾"	1½"	60"	M 2
N**top	¾"	19"	66"	EM 1
O back	¼"	27¼"	60"	BP 1

Drawers

P upper fronts	¾"	5⅝"	13⅝"	C 4
Q center fronts	¾"	7⅞"	28¼"	C 2
R lower fronts	¾"	10⅞"	28¼"	EC 2
S upper sides	½"	5⅝"	17¼"	M 8
T center sides	½"	7⅞"	17¼"	M 4
U lower sides	½"	10⅞"	17¼"	EM 4
V upper backs	½"	5⅝"	13⅝"	M 4
W center backs	½"	6⅞"	28¼"	M 2
X lower backs	½"	9⅝"	28¼"	EM 2
Y upper bottoms	¼"	13⅞"	15⅝"	BP 4
Z center and lower bottoms	¼"	15⅝"	28¼"	BP 4

*Parts nested in pairs on two blanks. See the Cutting Diagram.

**Parts initially cut oversize. See the instructions.

Materials Key: M—maple, MP—maple plywood, EM—edge-joined maple, BP—birch plywood, C—cherry, EC—edge-joined cherry.

Supplies: ¼" hardboard, spray adhesive, #20 biscuits, #8x $\frac{1}{4}$ " flathead wood screws, #10 flat washers, #8x $\frac{1}{4}$ " panhead screws, masking tape, glue, finish.

Buying Guide

Vertical raised-panel bit. Jesada no. 690-602, \$59.90, call Jesada at 800/531-5559.

Drawer-lock joint bits. Use any one of the following bits: Freud no. 99-240 (order catalog no. 800-486), \$49.95, call Woodworker's Supply at 800/645-9292; Jesada no. 655-512, \$71.90, call Jesada at 800/531-5559; Katana no. 18850, \$39.00, call MLCS at 800/533-9298.

Hardware. Self-adhesive glide strip no. 464, \$4.55/10-foot roll (6 rolls), call Meisel Hardware Specialties, 800/441-9870. 1¼" satin chrome knobs, Amerock no. BP1466G10 (4); 3" satin chrome pulls, Amerock no. BP1590G10 (4), check your local hardware store or home center, or call Woodworker's Hardware, 800/383-0130. Order knobs no. AO1466G10, \$4.83, pulls no. AO1590G10, \$3.68.

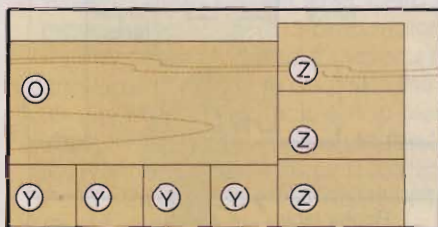
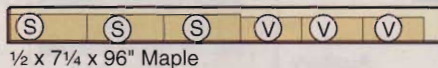

¼ x 48 x 96" Birch plywood

*Resaw and plane to thickness listed in the Bill of Materials.

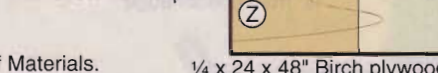
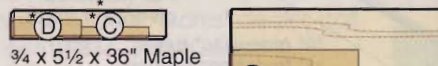
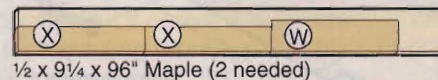
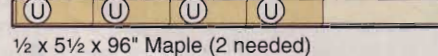
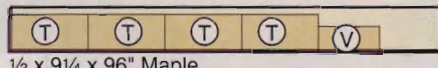

¼ x 24 x 48" Birch plywood

Buying Guide for router bit sources.) If you wish, you can substitute a lock-rabbit joint, as shown on **Drawing 4a**, and cut them on your tablesaw.

1 Check the dimensions of your drawer openings. (Ours are, top-to-bottom, $5\frac{3}{4} \times 14\frac{1}{16}$ "", $7\frac{1}{2} \times 28\frac{7}{8}$ "", and $10\frac{1}{4} \times 28\frac{7}{8}$ ". If yours are different, adjust your drawer part dimensions to leave a $\frac{1}{16}$ " gap all around.) Cut the drawer fronts (P, Q, R) and drawer sides (S, T, U) to size. We edge-joined stock for the lower drawer fronts (R) and the lower drawer sides (U). Set aside extra pieces of drawer front and side stock to use when setting up the drawer-lock bit.

2 Chuck the drawer-lock bit in your table-mounted router and attach a tall auxiliary fence to the router table fence. Position the bit and fence as shown in **Drawing 4b**. Using the extra pieces you set aside, test your setup. Rout the drawer front piece flat on the router table with its outside face up, and the drawer side piece upright with its inside face against the fence. Make any necessary adjustments to get a tight, flush joint. We let the fronts protrude a hair beyond the sides, then sanded them flush after assembling the drawers.

Note: We used a Freud no. 99-240 bit. If you use another manufacturer's bit, your setup may differ slightly.

3 Now, rout the ends of the drawer fronts (P, Q, R) and the drawer sides (S, T, U) just as you did the setup pieces. Use a follower block to steady the parts and eliminate chipping.

4 Switch to a vertical raised-panel bit and position it and the fence as shown in **Drawing 4c**. We used a Jesada no. 690-602 bit. See the Buying Guide for our bit source. Rout the bevels, first on the drawer fronts' ends, then the edges. Use a follower block to steady the fronts when routing their ends.

5 Install a $\frac{1}{2}$ " dado blade in your tablesaw and cut dadoes in the drawer sides (S, T, U) to receive the drawer backs (V, W, X), where shown on **Drawing 4**. Change to your regular blade and cut the drawer bottom grooves in the drawer fronts and sides. Match the thickness of your plywood by cutting the groove in two passes.

6 Cut the drawer backs (V, W, X) and drawer bottoms (Y, Z) to size. We edge-joined stock for the lower drawer backs (X). Dry-assemble the drawers to check the parts' fit. Because the drawers

fit closely in their recesses, make sure they are the same width front and back. Disassemble the drawers, and drill machine screw holes in the fronts for the knobs and pulls. Finish-sand all the parts. To give the raised-panel fronts a soft look, we slightly rounded the bevel/field transitions with our random-orbit sander.

7 Glue and clamp the drawers together, gluing the bottom panels into the front and side grooves. Measure diagonally to check for squareness. Set the drawers on a flat surface until the glue dries. Remove the clamps and drill pilot and countersunk shank holes through the sides and bottoms into the backs, as shown. Drive the screws.

8 Retrieve the back (O). As with the carcass parts, apply two coats of polyurethane to the back and drawers. With the finish dry, screw the back in place. Install the drawers' knobs and pulls, and slide them into place. ♣

Written by **Jan Hale Svec** with **Charles I. Hedlund**
 Project design: **James R. Downing**
 Illustrations: **Kim Downing; Roxanne LeMoine; Lorna Johnson**
 Photographs: **Baldwin Photography; Douglas E. Smith; Andy Lyons**

4 DRAWER

(CENTER DRAWER SHOWN)

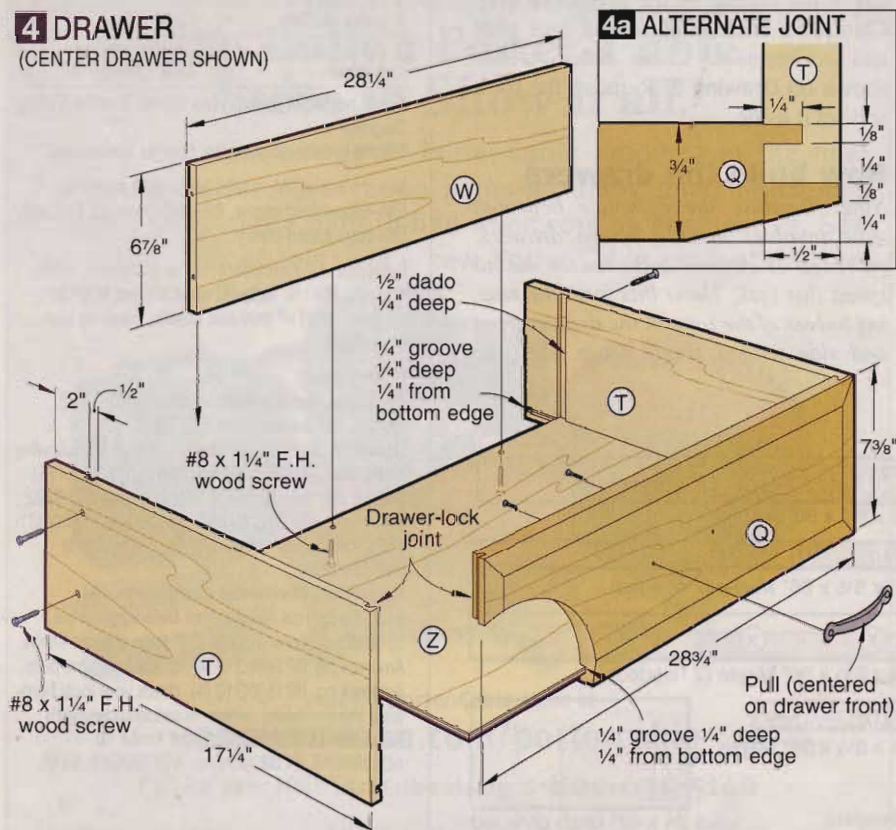

4a ALTERNATE JOINT

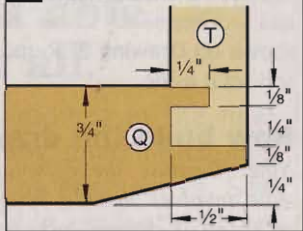

4b DRAWER JOINT DETAIL

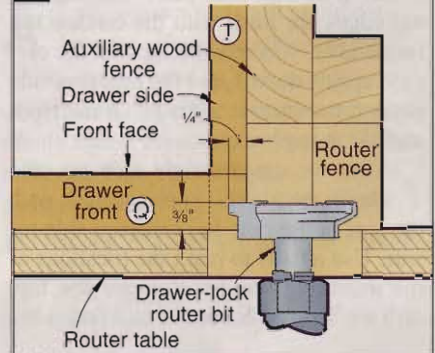

4c BEVELED EDGE

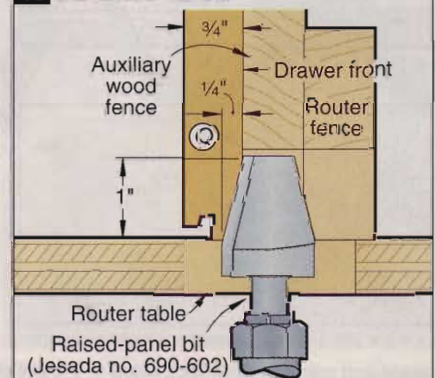

suite reflections

A matching mirror for the eight-drawer dresser

Simple stub-tenon-and-groove joinery, plus a pair of raised panels, make a mirror that harmonizes beautifully with the bedroom ensemble shown on pages 74-75.

Start with the stiles and rails

1 From $\frac{3}{4}$ "-thick stock, cut the center stile (A), upper rail (B), center rail (C), lower rail (D), and stiles (E) to the sizes listed in the Bill of Materials. As you cut the parts, lay them out in their frame configuration, shown on **Drawing 1**. Letter each part and mark their groove and tenon locations. Cut some extra pieces for testing your groove and tenon setups.

2 Install a $\frac{1}{4}$ " dado blade in your table-saw and adjust it to cut $\frac{1}{2}$ " deep. Center the blade in the thickness of your $\frac{3}{4}$ " stock, as shown on **Drawing 2**. Cut the grooves in parts A, B, C, D, and E, where shown on **Drawing 1**. To ensure that the grooves are dead center, pass the parts over the blade twice, turning them end-for-end between passes.

3 Without moving the fence, lower the blade to $\frac{1}{4}$ ". Fasten an auxiliary

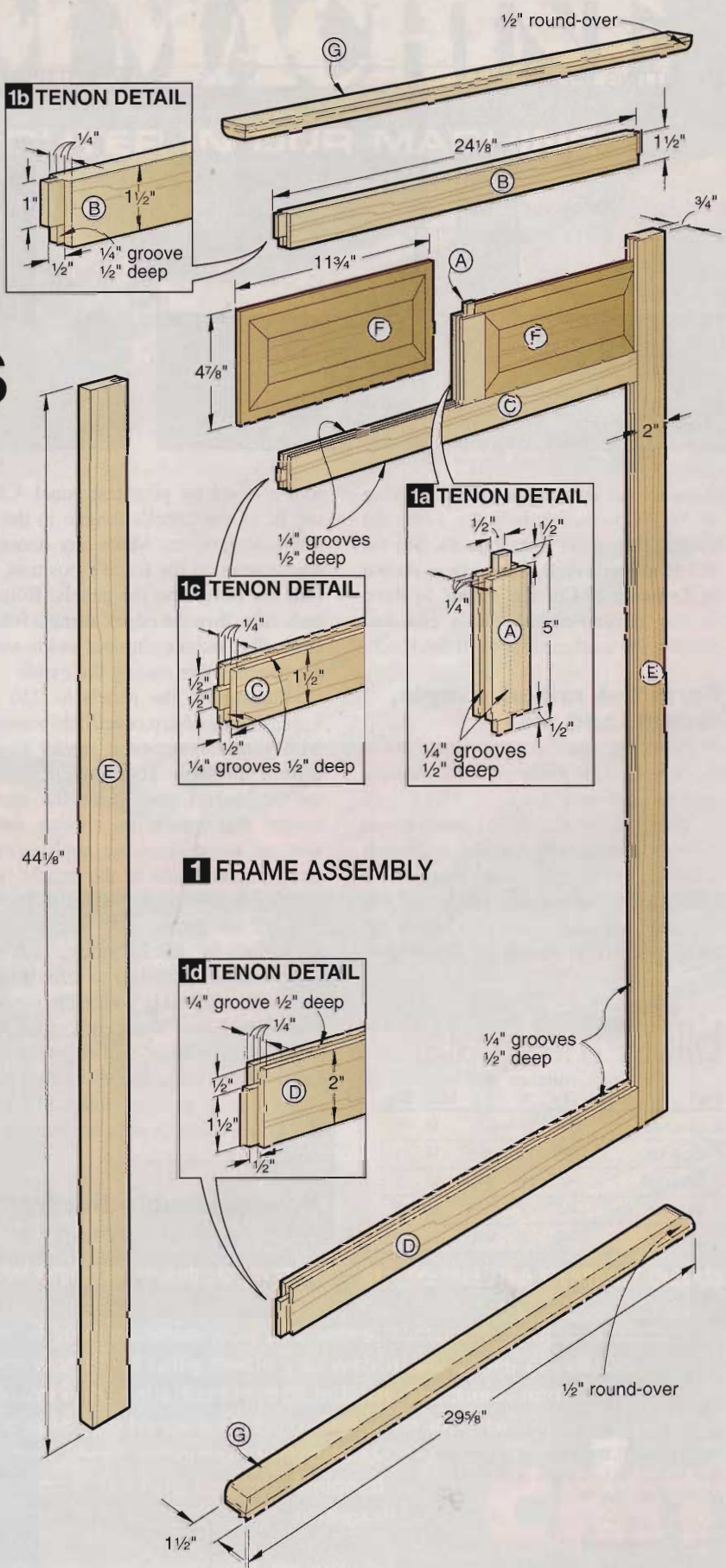

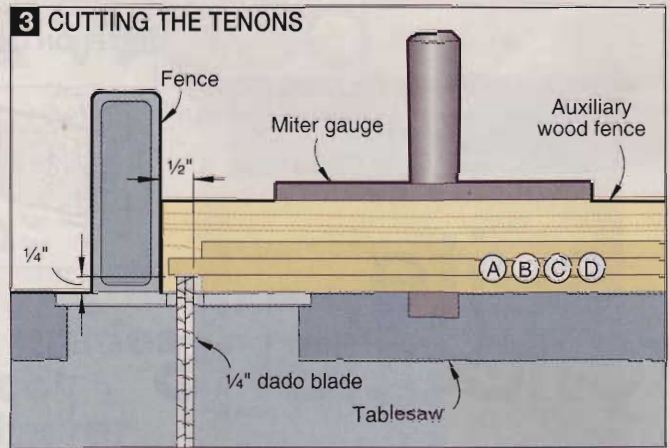
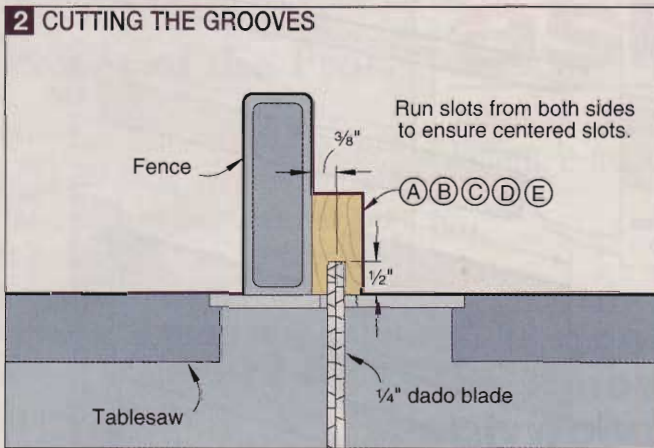

extension to your miter gauge, leaving its end 1/8" from the rip fence. Form the tenons, shown on **Drawings 1a, 1b, 1c,** and **1d** on parts A, B, C, and D, as shown on **Drawing 3.** Cut the tenons in three passes, starting at the part's end and moving the workpiece toward the fence.

Form the raised panels, crown, and sill

- 1 From 1/2" stock, cut the panels (F) to size. Cut an extra piece for testing your panel-raising setup.
- 2 Install a vertical raised-panel bit in your table-mounted router, and attach a tall auxiliary fence to the router table fence. (See the Buying Guide for the source of our raised-panel bit.) With the bit positioned as shown on **Drawing 4,**

route a bevel on your test panel. Check the fit of the panel's tongue in the rail and stile grooves. Make any necessary adjustments to the fence's position, and rout the bevels on the panels. Rout the ends first, then the edges, using a follower block to reduce chip-out and to steady the panels when routing their ends.

- 3 Finish-sand the panels to 220 grit, easing the sharp bevel/field transition with your random-orbit sander to give them a soft look. To eliminate showing the unfinished portion of the panels' tongue that sometimes appears due to seasonal wood shrinkage, apply a coat of gloss polyurethane to the panels. With the finish dry, lightly sand them with 220-grit sandpaper.

- 4 From 3/4"-thick stock, cut the crown/sill parts (G) to size. Install a 1/2" round-over bit in your table-mounted router, and rout their ends, then front edges. To eliminate chip-out when routing the parts' ends, use your miter gauge fitted with an auxiliary fence whose end just grazes the bit's pilot bearing. Finish-sand the crown and sill.

ed working time, glue the center stile (A), centered side-to-side, between the upper rail (B) and the center rail (C).

- 2 Without gluing them, slip the panels (F) in from each side. (The panels fit loosely in length and width.) Glue one stile (E) to the assembly, keeping its top end flush with the upper rail's top edge.

- 3 Now glue the lower rail (D) and the other stile (E) to the assembly, again keeping the corners flush. Clamp the frame, and wipe off any glue squeeze-out. Check the frame for squareness, and leave it on a flat surface to dry. With the glue dry, remove the clamps and finish-sand the frame to 220 grit.

- 4 Glue and clamp the crown and sill (G) to the frame, flush at the back and centered side-to-side.

Rout a recess for the mirror

- 1 To form a rabbet for the mirror, remove the rear lip of the frame's open groove. Chuck a 1/2" rabbeting bit in your handheld router, and adjust it to cut 5/16" deep. Cut 1/2"-wide filler strips from 1/4" hardboard, and place them in the frame's open grooves. Rout away the groove's back lip, running the rabbeting bit's pilot bearing on the hardboard filler strips, as shown in **Photo A.** Remove the

bill of materials

Part	FINISHED SIZE			Matl.	Qty.
	T	W	L		
A center stile	3/4"	1 1/2"	5"	M	1
B upper rail	3/4"	1 1/2"	24 1/8"	M	1
C center rail	3/4"	1 1/2"	24 1/8"	M	1
D lower rail	3/4"	2"	24 1/8"	M	1
E stiles	3/4"	2"	44 1/8"	M	2
F panels	1/2"	4 7/8"	11 3/4"	C	2
G crown/sill	3/4"	1 1/2"	29 5/8"	M	2
H vertical stops	1/4"	1/4"	36 1/8"	M	2
I horizontal stops	1/4"	1/4"	23 5/8"	M	2

*Parts initially cut oversize. See the instructions.

Materials Key: M—maple, C—cherry.

Supplies: Brass hangers (2), #5x1/2" brass roundhead wood screws (4), braided mirror-hanging wire (capacity at least 22 lbs.), 1/8" mirror, 1/8" poster board, #16x5/8" brads, glue, finish.

Buying Guide

Vertical raised-panel bit: Jesada no. 690-602, \$59.90, call Jesada at 800/531-5559.

Now assemble the frame

- 1 Lay out the frame parts on a flat surface in the configuration shown on **Drawing 1.** Using white glue for extend-

cutting diagram

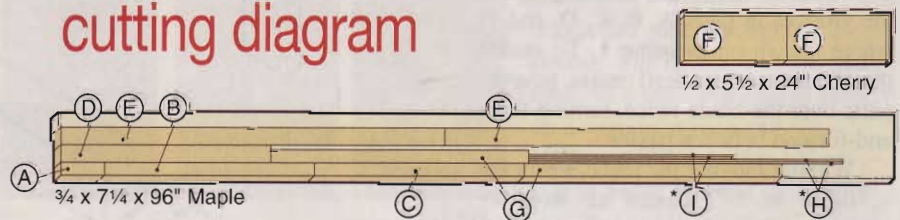

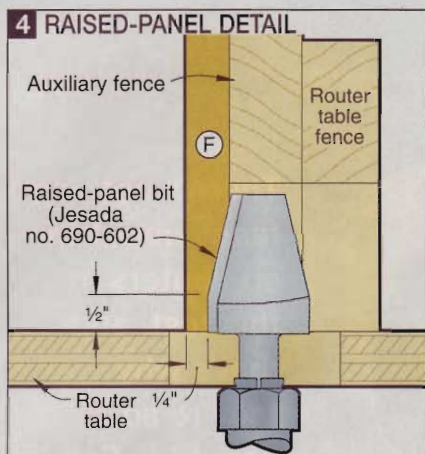

hardboard strips and square the corners with a chisel.

2 Plane or resaw stock for the vertical and horizontal stops (H, I), and cut them to length. The horizontal stops fit between the vertical ones. Clip the head off a #16 brad and use it to drill brad shank holes through the stops, where shown on **Drawing 5**.

Apply the finish and install the mirror

1 Touch up the finish sanding where needed, and remove the dust. Apply a coat of gloss polyurethane to the frame. When dry, lightly sand the frame with 220-grit sandpaper. Apply a coat of satin polyurethane to the frame and panels.

2 Drill pilot holes and screw the hangers in place, where shown on **Drawing 5**. Attach braided mirror-hanging wire capable of supporting 22 pounds.

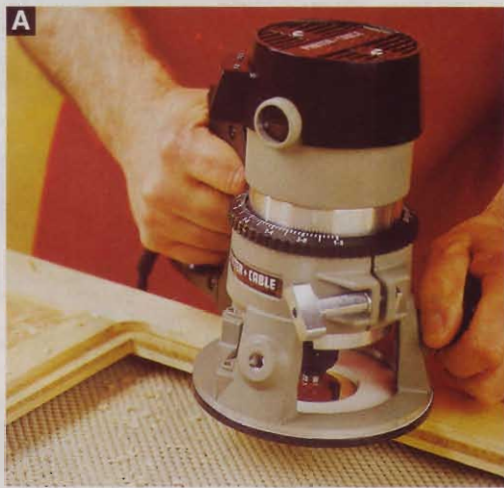

To form the mirror recess, rout away the frame groove's back lip. The rabbeting bit's pilot bearing runs on hardboard filler strips.

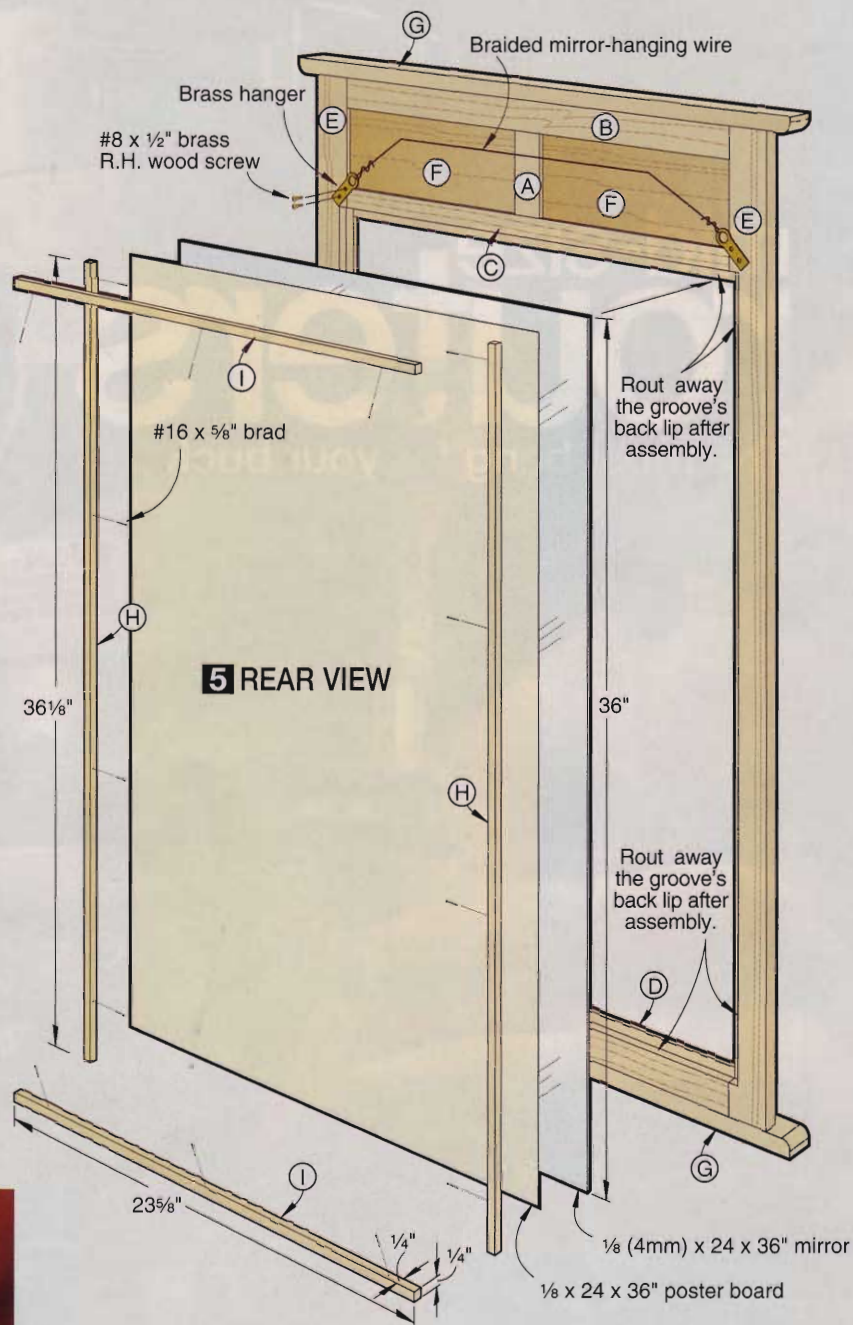

3 Have a piece of $\frac{1}{8}$ " mirror cut $\frac{1}{8}$ " smaller in length and width than the rabbeted opening. (Or look in your local home center or discount department store. We found a 4mm \times 24 \times 36" polished-edge vanity mirror for about \$20.) Set the mirror in the frame, covering it with a piece of $\frac{1}{8}$ " poster board. Nail the stops in place with #16 \times $\frac{5}{8}$ " brads.

4 Hang the mirror centered over the dresser. We installed two hooks in the wall, placing them so they protrude into the space behind the frame's raised panels. Adjust the wire so the mirror just clears the dresser's top. 🌿

Written by Jan Hale Svec with Charles I. Hedlund
Project design: James R. Downing
Illustrations: Kim Downing; Roxanne LeMoine;
Lorna Johnson
Photographs: Baldwin Photography;
Andy Lyons

mid-size routers

The most bang for your buck

There's nothing fancy about the six routers in this test, and that's why they're so beautiful. For value, simplicity, and all-around usefulness, you just can't top this group.

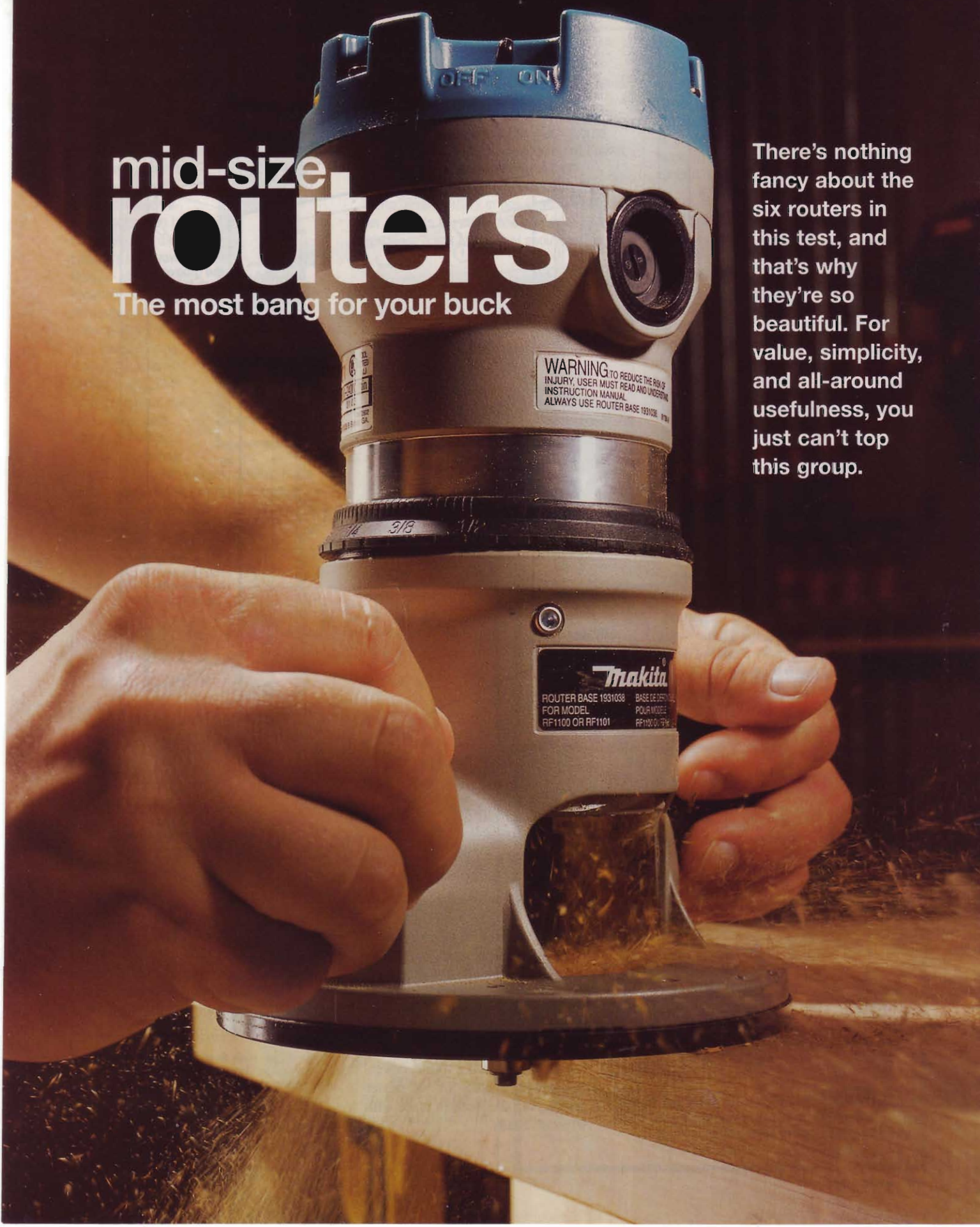

WARNING TO REDUCE THE RISK OF INJURY, USER MUST READ AND UNDERSTAND INSTRUCTION MANUAL. ALWAYS USE ROUTER BASE 1931038. RF1101

Makita
ROUTER BASE 1931038 BASE 1931038
FOR MODEL RF1100 OR RF1101 POUR MODELE RF1100 OU RF1101

To test for vibration, we double-face taped a 6" square of high-density foam to a cast-iron table saw top, and placed the router on top. With the stylus of a dial indicator zeroed on one of the router's handles, as shown, we turned the machine on and noted the amount of movement.



We chose the contestants for this article according to some basic ground rules: All of them have mid-size motors, drawing 9 to 12 amps, with horsepower ratings in the 1½ to 2¼ range. Each has a fixed base as opposed to routers with a plunging mechanism. And, all of them are widely available. Where possible, we tested the variable-speed version of routers that come that way or with a single speed. The question, of course, is which one best suits your needs. Read on and find out.

First, a bit about our testing process

After unpacking the routers, we chucked a 3½"-long, precision-ground ½" steel rod into each router's collet. Using a dial indicator, we measured for runout (wobble caused by an imperfect arbor) 2" from the collet. Severe runout contributes to inaccuracy and vibration in a router. We made three measurements on each machine, then averaged the results.

Next, we familiarized ourselves with each router and its controls, and went to work. While routing a smorgasbord of dadoes, dovetails, and round-overs in a variety of materials, we observed each motor's power and how well it main-

tained its speed in heavy cuts. Each cut required changing bits and adjusting the cutting depth, and we noted any difficulties with either process.

To quantify vibration, we used a dial indicator, as shown and described in **Photo A**, above. During this test, we measured the tool's noise level using a sound-level meter mounted on a tripod about 3' above the router.

We also tested each machine's base concentricity. A concentric base means that the distance between the bit and the edge of the base is consistent, regardless of which point on the base is being guided against a straightedge. For this test, we screwed a flat steel bar to a piece of plywood, and routed a 24" groove while turning the base 360°. We then checked for consistent distance between the groove and bar along the length of the cut.

Motor matters

All the routers in our test handled full-depth test cuts with a ½" straight bit, ¾" dovetail bit, and ½" round-over bit easi-

ly, whether in pine, maple, or walnut. Only the Bosch 1617EVS and Makita RF1101 routers recovered quickly from the initial load without us having to slow our feed rate.

That's because these two routers have electronic speed control, which is like cruise control for the motor. When it detects an increased load, the speed-monitoring circuitry pours more power to the motor to maintain its speed—a big plus in our book.

With all of that power in hand, we also appreciated the soft-start motors in the Bosch and Makita tools. This feature "ramps" the motor up to full speed, rather than lurching it to full power, when the switch is turned on. This is especially important on routers where the switch location dictates temporarily removing one hand from the router to turn it on. (More on that subject later.)

Most of the fixed-base routers we tested are single-speed routers. The Bosch 1617EVS and Makita RF1101 have variable-speed motors, which we prefer

Why not take the plunge?

Comparing a plunge router to a fixed-base router is like comparing actors Pamela Anderson and Julia Roberts: The former is kind of exciting with all of those moving parts, but in reality, the latter gets most of the work. Unless you're routing a lot of mortises or making signs, the bulk of your

router chores (rabbets, grooves, dadoes, edge-treatments, and even dovetails) are handled easily by a fixed-base model.

Generally, plunge routers are larger and heavier—and top-heavy, at that—than routers that don't plunge. With fewer moving parts, fixed-base

routers tend to be more reliable and accurate, too.

And you get more muscle for your money with a fixed-base router. For example, Makita's RP1101 plunge router, at \$240, has the same motor and collet as the fixed-base RF1101 that sells for only \$210.

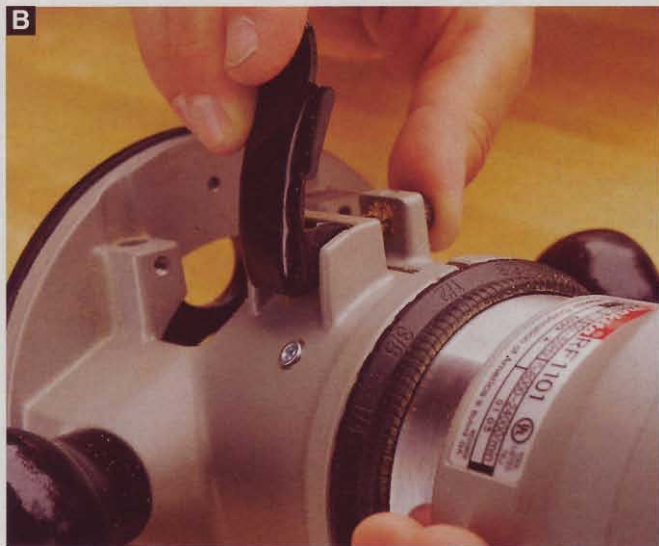

B We found lever locks, such as this one on the Makita RF1101, simple, fast, and secure.

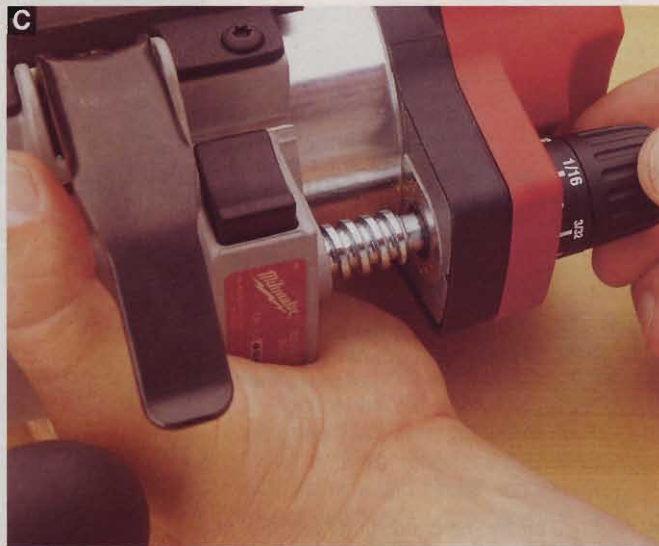

C Tiny changes to cutting depth are easier and more accurate on a router with a threaded-rod depth system.

because we can slow the tool for safety when using large bits. These two routers also come in fixed-speed versions (the 1617 and RF1100, respectively) for about \$20 less. Porter-Cable's Mark Woodlief says a variable-speed 690LR also is in the works.

Knee-deep in depth-setting systems

To set the cutting depth of the bit, the routers in our test employ almost as many different systems as there are machines. We prefer lever locks (**Photo B**) for fixing the cutting depth, and threaded-rod systems (**Photo C**) for accuracy. The Bosch and Milwaukee machines have both.

We give the edge to Milwaukee's system because of the spring-loaded, half-

nut release that allows you to instantly set the depth anywhere along the threaded rod. Once you're in the ballpark, you hone in the precise cutting depth by turning the rod. On the Bosch, you press a release lever and step to the nearest 1/2" detent, then turn the rod to adjust. It gets you close, but not necessarily as close as the Milwaukee.

The Porter-Cable 690LR and Makita routers rank next. Release the lever lock, rotate the motor in the base (like a bolt in a nut), and secure the base. While quick—one-half turn of the motor nets 1" of cutting depth—a very slight rotation can quickly put you 1/64" off your mark. And, tolerances between the pins and the spiral slot that guide the motor can affect the cutting depth by .050" (Makita) and .036" (Porter-Cable). To avoid this error, make a habit of always setting your depth of cut the same way, with the pin against either the top or bottom of the groove.

The Craftsman and DeWalt systems both fall a little short, but for different reasons. Craftsman's twist-ring mechanism gets tedious for large depth changes, and we found ourselves banging our knuckles on the tool's handles (**Photo D**). DeWalt's rack-and-pinion system works fine, but the wing-nut lock is harder on the fingers, and tiny, black-on-black increments on the depth scale are difficult to read (**Photo E**).

Speaking of which, the scales on all of the machines can be "zeroed" to set the depth of cut without any figuring.

Craftsman provides two independent scales: one that reads from the top of the router, and one that reads from the bottom to use when looking at the machine base-up.

Bits in, bits out

Most of the tested routers require two wrenches to tighten or loosen the collet nut. The Craftsman has a spindle lock: a knob you turn to secure the spindle so you need only one wrench for the collet nut. All of the collets released easily with a half-turn or less of the nut, and all of the machines come with both 1/2" and 1/4" collets. That's not to say, though, that there aren't differences when it comes to changing bits.

First, you have to get wrenches on the motor-shaft and collet nut. For unfet-



D One full turn of Craftsman's twist ring yields only 1/4" change in cutting depth, so large changes take longer.



E The tool's weight makes it difficult to make fine adjustments using DeWalt's rack-and-pinion depth mechanism.



F Removing the motor from the base of the Bosch (shown), DeWalt, Makita, or Porter-Cable routers provides unlimited wrench room when changing bits.

tered access, the bases on the Bosch, DeWalt, Makita, and Porter-Cable routers remove completely, as shown in **Photo F**. Without removeable bases, wrench room through the bases of the Craftsman and Milwaukee routers is smaller, but adequate.

However, we found big differences in the collet wrenches. Usually, the shaft and collet nut are slightly different sizes—a source of frustration, figuring which wrench goes where. Makita solved the puzzle by making both the shaft and collet nut the same size. On the Bosch and Milwaukee routers, a greater size difference makes the choice of wrench more obvious.

And, the cast wrenches from Bosch and Milwaukee felt better in our hands—especially when loosening a really tight



G A D-handle base puts the power switch at your fingertips and helps you control the lateral pressure for bearing-guided cuts, such as round-overs.

collet nut—than the thin, stamped-steel wrenches from the other manufacturers. The cast wrenches also won't become deformed over time.

Of handles and switches

We can't tell you how a router will feel in your hands, so we encourage you to try before you buy. A pair of ball-shaped knobs are typical of this class of router, but many of the models in our test also come in a D-handle version, as shown in **Photo G**. The chart on *page 89* lists model numbers and prices for D-handle machines from the manufacturers that offer them.

We like D-handle routers for a couple of reasons: First, the handle-mounted power switch means you can start and stop the router without having to let go of the router with one hand. (Craftsman's trigger-switch in the pistol-grip handle does the same thing.) Second, a D-handle gives you better side-to-side control when cutting edge treatments with bearing-guided bits.

Speaking of control, it took some getting used to, but we quickly grew to like Milwaukee's unique "body-grip" design, shown in **Photo H**. Plastic molding wrapped around the router's motor provides the gripping surface, while a woven strap keeps your hand in position, much like the grip on a camcorder. (The strap can be positioned for either right- or left-handed operation.) In body-grip position, the power switch is within thumb's reach.

The rest of the routers have toggle or rocker switches located at or near the top of the motor. In most cases, these require taking one hand off the router to turn it on or off.

Table service

So far, we've only discussed the merits of these machines when handheld. But mid-size models have enough power and large enough openings in their subbases for many router-table tasks, with the exception of running large bits, such as horizontal panel-raisers.

For a table-mounted router, a threaded-rod depth-setting system normally wouldn't be our first choice. On the Bosch, for example, the weight of the router and the fineness of the threads slow the process. And, we could only rotate the adjustment knob one-half turn

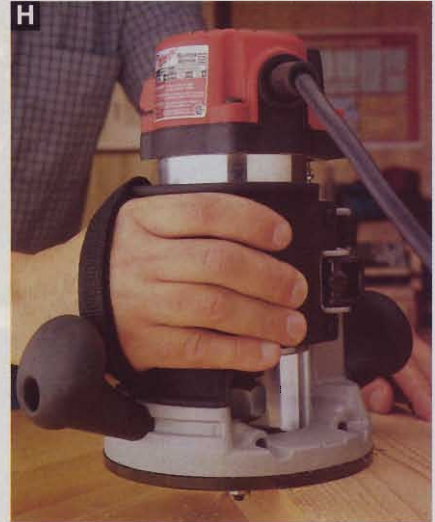

H The tool becomes an extension of your body when you strap on Milwaukee's unique palm-grip router.

at a time because the knob is very close to the router's body. (Bosch sells an extension that reduces the nuisance.)

Although the Milwaukee also uses a threaded rod, the rod has a hex shank on the base end, accessible through a hole in the router's base. You can buy an accessory T-handled wrench to turn the rod, but we found a $\frac{3}{8}$ " socket on a speed wrench, as shown in **Photo I**, also works well. This feature alone helps make it our favorite model under the table.

The Makita and Porter-Cable routers also allow easy bit-height adjustments when mounted in a table. Because the motor itself is the height control, it's



I Milwaukee's built-in, through-the-base depth adjustment is a big plus if you plan to table mount your router. (Shown out of table for clarity.)

easy to find without having to stick your head under the table. Downside: Unless you're using a D-handle version or a table-mounted switch, the power switch moves with every height change.

We really can't recommend the DeWalt for in-table use. If you forget to support the motor when loosening the height-adjustment thumbscrew, the motor will drop to the floor, possibly damaging the machine. Even being aware of the problem, we were surprised at how often this happened during our test.

More points to ponder prior to purchase

•**Noise.** At 91 decibels (dB), the Makita is the quietest of the bunch, earning it an Excellent rating. In fact, with the router on and under no load, we could carry on a conversation without raising our voices, but there is a whiny quality to the sound. Though slightly louder at 94 dB, the Bosch router's sound is easier on the ears: more like a whoosh than a whine. It also earned an Excellent rating. The Craftsman and Milwaukee machines, even with their 94 dB readings, have that high-pitched whine, so we downgraded them to Good. We recommend the use of hearing protection any time you use any

router, but especially with the DeWalt, which measured 104 dB at 3'.

•**Runout.** Measured 2" from the collet, we found no significant difference between the machines. All of the routers were within .0004" of .003" runout.

•**Vibration.** None of the routers vibrated enough to make our fingers tingle. But for the record, the Makita and Porter-Cable machines vibrated the least at $\frac{1}{8}$ -.001"; Craftsman in the middle at $\frac{1}{8}$ -.002"; and Bosch, DeWalt, and Milwaukee the most at $\frac{1}{8}$ -.003".

•**Consider your options.** With some routers in the test, you're buying only a router; with others, you're buying a router with lots of versatility. As we mentioned, four of the routers also come in D-handle versions. You can buy three of those four—the Bosch, Makita, and Porter-Cable—with a traditional fixed base, then add a D-handle base or plunge base later on. The same motor fits in all three bases, so it's like getting an extra router for only a little more money.

So, who's on top in the middle?

For primarily handheld use, we like the Bosch 1617EVS and the Makita RF1101 because both provide powerful, quiet,

soft-start, variable-speed motors. Both manufacturers also offer interchangeable bases to add versatility for little extra cost. We give a slight edge to Bosch because we like the threaded-rod depth adjustment, but wouldn't argue if you prefer the twisting motor-style instead.

If you plan to use the router both in and out of a router table, go with the Milwaukee 5615-20 or the Makita RF1101. Milwaukee's through-the-table height adjustment is hands down the best of the bunch in a router table. The Makita is still easy to adjust, even under the table, and the variable-speed motor is a plus for running larger bits.

Now, tell us what you think

We'll bet you've had your hands on at least one of these routers, and if you have, we'd like to hear your opinions as well. So we've set up an Internet discussion group where you can talk with your fellow woodworkers about mid-size routers. Log on to www.woodmall.com, then click on the Tool Comparisons tab. While there, you can also see how the manufacturers responded to our test. 🐘

Written by **Dave Campbell** with **Rich Bright**
Photographs: **Baldwin Photography**



Bosch 1617EVS

One of our favorite routers for handheld use, it offers everything we like in a router: a powerful, quiet, soft-starting, variable-speed motor, and accurate depth-setting. Also available in fixed-speed and D-handle configurations.
877/267-2499
www.boschtools.com

Craftsman 27500

The twist-ring depth-adjustment proves time-consuming for large depth changes. The least-expensive model in the test, it features a bit-illuminating light and spindle lock.
Visit your local Sears store.
www.sears.com/craftsman



DeWalt DW610

This former contender in the mid-size router category is in need of updating. Not recommended for use in a router table, as the motor can drop out of the base when changing the depth setting.
800/433-9258
www.dewalt.com

SIX FIXED-BASED, MID-SIZE ROUTERS, UP CLOSE AND PERSONAL

MANUFACTURER	MODEL	MOTOR		BASE OPENING		COLLET	CUTTING DEPTH	PERFORMANCE RATINGS (8)										ROUTER-TABLE USE	CORD LENGTH	WARRANTY (9)	WEIGHT (POUNDS)	SELLING PRICE (10)	D-HANDLE MODEL/PRICE			
		AMPS	SPEED RANGE (RPMs x 1,000)	SWITCH TYPE (1)	HANDLE TYPE (2)			WITH SUBBASE (3)	WITHOUT SUBBASE	MOUNTING METHOD (4)	SPINDLE LOCK (Y)es (N)o	RANGE (5)	ADJUSTMENT MECHANISM (6)	LOCK TYPE (7)	OBSERVED POWER	SWITCH LOCATION	DEPTH-SCALE READABILITY							EASE OF LOCKING	DEPTH OF CUT	BIT CHANGING EASE
BOSCH	1617EVS	12	8-25	R	WB	2" **	3 3/4"	N	N	1 1/16"	TR	L	E	G	E	E	E	E	G	E	G	9'6"	1 yr.	7.7	\$195	1618EVS / \$200
CRAFTSMAN	27500	9	25	TR	PP	3"	3 3/4"	S	Y	2"	R	C	E	E	G	E	E	G	G	F	10'	1 yr.	7.8	130	N/A	
DEWALT	DW610	9	25	TO	PB	1 1/4" *	3 5/8"	N	N	2 1/4"	RP	W	G	G	G	F	G	G	F	F	8'4"	1 yr.	7.3	150	N/A	
MAKITA	RF1101	11	8-24	TO	WB	1 1/4" *	3 5/8"	N	N	1 1/2"	TW	L	E	F	G	G	E	E	E	E	G	8'7"	1 yr.	7.1	210	RD1101 / \$220
MILWAUKEE	5615-20	11	24	R	PM*	2 1/2" ***	3 21/64"	N	N	1 3/8"	TR	L	E	G	E	E	E	E	G	G	E	8'	LIFE	8.3	160	5619-20 / \$170
PORTER-CABLE	690LR	10	23	R	PM	1 1/4" *	3 5/8"	N	N	1 1/2"	TW	L	E	G	G	E	E	G	E	G	G	7'	1 yr.	8.0	160	691 / \$170

NOTES:

- (R) Rocker
(TO) Toggle
(TR) Trigger
- (PB) Plastic, ball-shaped knobs
(PM) Plastic, mushroom-shaped knobs
(PP) Plastic pistol-grip knobs
(WB) Wooden, ball-shaped knobs
(*) Also palm grip with strap

- (*) Accepts Porter-Cable guide bushings.
(**) Accepts Porter-Cable guide bushings with included adapter.
(***) Accepts Porter-Cable guide bushings with accessory subbase.
- (N) Mounts to arbor with collet nut.
(S) Mounts to arbor with screw.

- Vertical range of bit measured with motor fully raised and fully lowered.
- (R) Ring
(RP) Rack and pinion
(TR) Threaded rod
(TW) Twist motor in base
- (C) Cam
(L) Lever
(W) Wing bolt

For specifications on other types of tools, click on "Tool Comparisons" at www.woodmall.com

- E** Excellent
G Good
F Fair
- (LIFE) Lifetime warranty against factory defects.
- Prices current at time of article's production.

Makita RF1101

About equal to the Bosch 1617EVS in power, precision, and performance. We give it a slight edge for router table use, owing to its twist-base depth-setting. Also available in fixed-speed and D-handle configurations. 800/462-5482 www.makitatools.com



Milwaukee 5615-20

Unique system makes large or small changes in cutting depth easy and accurate, whether hand-held or mounted in a table. Body-grip design took some getting used to, but we grew to like it. 877/279-7819 www.mil-electric-tool.com

Porter-Cable 690LR

This upgraded version of the classic P-C 690 router brings welcome improvements, including more power, a lever lock for fixing the cutting depth, and a dust-protected rocker switch. Fits existing 690 plunge and D-handle bases; variable-speed version coming soon. 800/487-8665 www.porter-cable.com



products that perform

These woodworking wares passed our shop trials

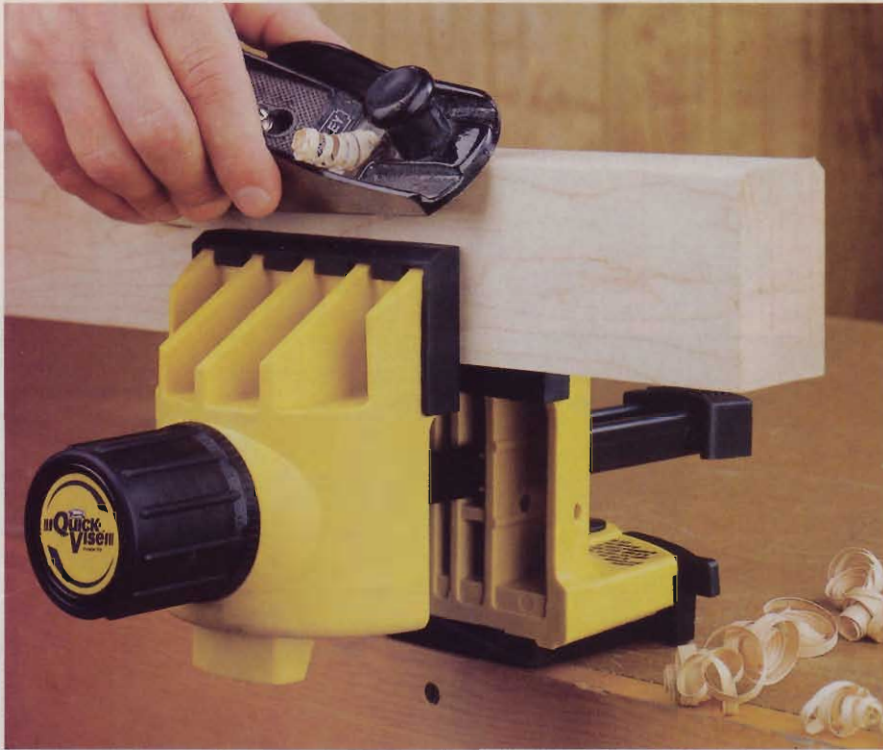

Quick-Vise has many virtues

Even with the venerable Record brand name attached to it, I didn't expect much of a bite from a yellow plastic, portable vise. Boy, was I wrong. There's a lot to like about the Record Quick-Vise.

First, to set the record straight, it's made of glass-filled nylon—a lightweight and strong material. Second, this vise is the fastest I've ever used, with a pair of smooth steel bars to guide the moveable jaw instead of long screw.

I put a chunk of 3/4" oak between the Quick-Vise's open jaws, slid the jaw until it touched the workpiece, and a half-turn of the large knob on the front locked the workpiece in as solid as granite. The vise released easily by turning the knob back.

The soft, removable jaw covers provide a good grip on smooth workpieces. When

Record Quick-Vise, Portable Vise

Performance	★★★★★
Price	\$30, vise; \$4, additional bases
Value	★★★★★

Call American Tool at 800/866-5740, or visit www.quickvise.com.

removed, they reveal matching V-grooves in each jaw face for holding round workpieces, such as doweling or pipe, at three angles: 0°, 45°, and 90°.

So, what about the portable part? Well, the Record Quick-Vise comes with a base that mounts to your benchtop with four screws. A lever on the back of the vise securely locks it onto the base. Buy an extra base or two, mount them in different places around the shop and move the vise from one place to another. The manufacturer also offers an accessory base for mounting the Quick-Vise in the dog holes of a portable workstation, such as a Black & Decker Workmate.

Continued on page 94

Statement of Ownership, Management, and Circulation (Required by 39 USC 3685) 1. Publication Title: Better Homes and Gardens® WOOD®. 2. Publication No. 724-890. 3. Filing Date: October 1, 2001. 4. Issue Frequency: Nine times per year in February, March, April, June, August, September, October, November, December. 5. No. of Issues Published Annually: 9. 6. Annual Subscription Price \$28. 7. Complete Mailing Address of Known Office of Publication: 1716 Locust Street, Polk County, Des Moines, IA 50309-3023. 8. Complete Mailing Address of Headquarters or General Business Office of Publisher: 1716 Locust Street, Polk County, Des Moines, IA 50309-3023. 9. Full Names and Complete Mailing Addresses of Publisher, Editor, and Managing Editor: Publisher: Mark Hagen, 333 N. Michigan Ave., Suite 1500, Chicago, IL 60601; Editor-in-Chief: Bill Krier, 1912 Grand Ave., Des Moines, IA 50309-3379; Managing Editor: James V. Harrold, 1912 Grand Ave., Des Moines, IA 50309-3379. 10. Owner: Meredith Corporation, 1716 Locust Street, Des Moines, IA 50309-3023. The Names and Addresses of Stockholders Owning or Holding 1 Percent or More of the Total Amount of Stock: Bank of New York (The), 925 Paterson Plank Road, Secaucus, NJ 07094; Bankers Trust Company, c/o BT Services Tennessee Inc., 648 Grassmere Park Drive, Nashville, TN 37211; Barclays Global Investors, N.A., 45 Fremont St., 33rd Floor, San Francisco, CA 94105; Boston Safe Deposit & Trust Co., c/o Mellon Bank N.A., Three Mellon Bank Center, Room 153-3015, Pittsburgh, PA 15259; Charles Schwab & Co., Inc., c/o ADP Proxy Services, 51 Merced Way, Edgewood, NY 11717; Chase Manhattan Bank Iowa, Four New York Plaza, 13th Floor, New York, NY 10004; Chase Manhattan Bank, Four New York Plaza, 13th Floor, New York, NY 10004; Investors Bank & Trust/MF Custody, 200 Clarendon Street, 15th Floor, Hancock Tower, Boston, MA 02116; Merrill Lynch, Pierce, Fenner & Smith Safekeeping, 4 Corporate Place, Corporate Park 287, 2nd Floor, Piscataway, NJ 08855; Morgan Stanley & Co. Incorporated, One Pierrepont Plaza, 7th Floor, Brooklyn, NY 11201; Northern Trust (The), 801 S. Canal C-In, Chicago, IL 60607; PNC National Association, 8800 Tincum Boulevard, Philadelphia, PA 19153; Salomon Smith Barney Inc., 333 West 34th St., New York, NY 10001; State Street Bank and Trust Company, 1776 Heritage Drive, Global Corporation Action Unit JAB 5NW, No. Quincy, MA 02171; Wells Fargo Bank Minnesota, N.A., 733 Marquette Avenue, Minneapolis, MN 55479-0056.

Through some of the nominees listed above, the E. T. Meredith and Bohen families and family foundations own, directly or beneficially, approximately 25% of the issued and outstanding stock of the corporation. Each nominee listed above holds stock for one or more stockholders. 11. Known Bondholders, Mortgagees, and Other Security Holders Owning or Holding 1 Percent or More of Total Amount of Bonds, Mortgages, or Other Securities: None. Item 12 of PS Form 3526 not applicable. 13. Publication Title: Better Homes and Gardens® WOOD®. 14. Issue Date for Circulation Data: October 2001. 15. Extent and Nature of Circulation: A. Total No. of Copies (Net Press Run): Average No. Copies Each Issue During Preceding 12 Months, 684,045; No. Copies of Single Issue Published Nearest to Filing Date, 679,325. B. Paid and/or Requested Circulation: 1. Paid/Requested Outside-County Mail Subscriptions Stated on Form 3541. (Include advertiser's proof and exchange copies): Average No. Copies Each Issue During Preceding 12 Months, 486,012; No. Copies of Single Issue Published Nearest to Filing Date, 474,897. 2. Paid In-County Subscriptions Stated on Form 3541 (Include advertiser's proof and exchange copies): Average No. Copies Each Issue During Preceding 12 Months, none; No. Copies of Single Issue Published Nearest to Filing Date, none. 3. Sales Through Dealers and Carriers, Street Vendors, Counter Sales, and Other Non-USPS Paid Distribution: Average No. Copies Each Issue During Preceding 12 Months, 64,000; No. Copies of Single Issue Published Nearest to Filing Date, 71,000. 4. Other Classes Mailed Through the USPS: Average No. Copies Each Issue During Preceding 12 Months, none; No. Copies of Single Issue Published Nearest to Filing Date, none. C. Total Paid and/or Requested Circulation [Sum of 15b (1), (2), (3), and (4)]: Average No. Copies Each Issue During Preceding 12 Months, 550,012; No. Copies of Single Issue Published Nearest to Filing Date, 545,897. D. Free Distribution by Mail (Samples, complimentary, and other free): 1. Outside-County as Stated on Form 3541: Average No. Copies Each Issue During Preceding 12 Months, 4,710; No. Copies of Single Issue Published Nearest to Filing Date, 4,741. 2. In-County as Stated on Form 3541: Average No. Copies Each Issue During Preceding 12 Months, none; No. Copies of Single Issue Published Nearest to Filing Date, none. 3. Other Classes Mailed Through the USPS: Average No. Copies Each Issue During Preceding 12 Months, none; No. Copies of Single Issue Published Nearest to Filing Date, none. E. Free Distribution Outside the Mail (Carriers or other means): Average Number Copies Each Issue During Preceding 12 Months, none; Actual No. Copies of Single Issue Published Nearest to Filing Date, none. F. Total Free Distribution (Sum of 15d and 15e): Average No. Copies Each Issue During Preceding 12 Months, 4,710; No. Copies of Single Issue Published Nearest to Filing Date, 4,741. G. Total Distribution (Sum of 15c and 15f): Average No. Copies Each Issue During Preceding 12 Months, 554,722; No. Copies of Single Issue Published Nearest to Filing Date, 550,638. H. Copies Not Distributed: Average No. Copies Each Issue During Preceding 12 Months, 129,323; No. Copies of Single Issue Published Nearest to Filing Date, 128,687. I. Total (Sum of 15g and h): Average No. Copies Each Issue During Preceding 12 Months, 684,045; No. Copies of Single Issue Published Nearest to Filing Date, 679,325. J. Percent Paid and/or Requested Circulation (15c/15g×100). Average No. Copies Each Issue During Preceding 12 Months, 99.15%; No. Copies of Single Issue Published Nearest to Filing Date, 99.14%. 16. Publication of Statement of Ownership will be printed in the December 2001 issue of this publication. 17. Signature and Title of Editor, Publisher, Business Manager, or Owner (Signed) William N. Krier, Editor-in-Chief. Date: August 6, 2001. I certify that all information furnished on this form is true and complete. I understand that anyone who furnishes false or misleading information on this form or who omits material or information requested on the form may be subject to criminal sanctions (including fines and imprisonment) and/or civil sanctions (including civil penalties).

My only knock against the Record Quick-Vise is that the mounted base stands proud of my bench so that it's not flush. I got around this by mounting the base to a plywood subbase, then clamping the subbase to my bench. If the protrusion bothers you, American Tool's Paul Hemingfield suggests mortising your benchtop to accommodate the base.

—Tested by Garry Smith

B&D debuts tough 10" compound mitersaw

After focusing mainly on consumer-grade power tools for a number of years, Black & Decker beefs up its lineup with a pair of 10" mitersaws. The BT1500 I tested is the compound-miter version of the BT1000, a straight mitersaw.

With features like a sliding left fence, a slotted blade guard for aligning the blade prior to the cut, and a horizontal D-handle, the BT1500 compares favorably with

some of the established mitersaws on the market today. Add in a bevel scale that's easy to read from either side of the saw, large soft-grip handles on the bevel and miter locks, and a price tag about \$50 less than similar saws, and you've got an affordable winner.

I teach home construction techniques at a local high school, so I brought the BT1500 to the jobsite where my students are framing up a house. (It lacks a carrying handle, but at only 30 pounds, that was no big deal.) While the students worked, I played with the saw and found myself impressed with how firmly and accurately the miter detents lock in the angle. And the BT1500 had plenty of power for any cut I threw at it.

To make it into a true woodworking tool, you'll want to replace the blade with

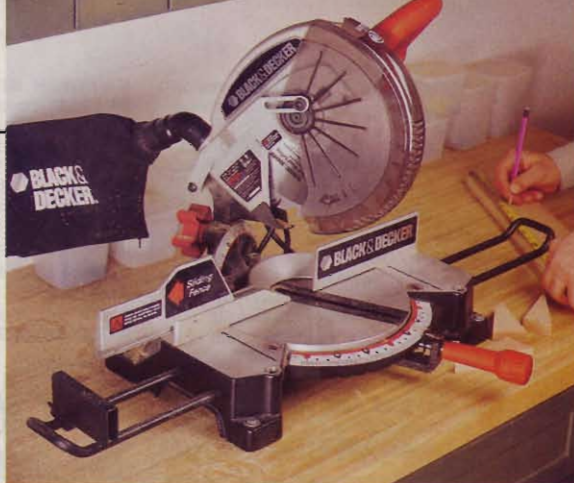

Black & Decker BT1500 10" compound mitersaw

Performance	★★★★☆
Price	\$180
Value	★★★★★

For more information, call 800/544-6986, or visit www.blackanddecker.com.

a 40-tooth or better blade. The 28-tooth factory-issued blade is just too coarse for most woodworking tasks.

Dust collection is no better or worse than on any other mitersaw. The BT1500

Continued on page 96

TOP PICK in WOOD Magazine! June, 2001

The **OSBORNE** by **Excalibur** Miter Guide

ORDER TODAY
FOR ONLY \$ **179.99**

COVERED BY EXCALIBUR LIFETIME GUARANTEE!

**So Simple...
So Stable...
So Accurate!**

OSBORNE EB-3 by Excalibur

THE GREATEST INNOVATION IN MITER GUIDE DESIGN IN OVER 100 YEARS!
Solid triangular configuration keeps the guide absolutely rigid, even at the outermost end of the fence. No movement in the fence, no movement in the work piece, no gaps in the miter joint.

Want more info? See our website...
www.osbornemfg.com
Want to own one? CALL 1-800-357-4118
EXCALIBUR • 940 BROCK ROAD, PICKERING, ONTARIO L1W2A1

Fully automatic dust collection systems

ECOGATE

- Directs air-flow only to machinery in operation - your existing system is dramatically improved
- Computer controls blast gates and regulates dust collector

Call 1-888-ECOGATE for a free brochure. www.ecogate.com

ECOGATE®

comes with a dust bag, but within a few minutes of using the saw, I broke the bag's internal support rod while retrieving an errant offcut. A wire support rod would be better than the plastic one.

—Tested by Kirk Hesse

Support stand doubles as a clamping fixture

If your roller stand only supports workpieces on the tablesaw or mitersaw, your stand isn't working hard enough. Once you get your hands on a Multi-Stand, your roller stand may find itself mothballed.

Like a roller stand, the Multi-Stand's primary job description includes supporting outfed workpieces on your tablesaw or mitersaw. But instead of a roller that can steer your workpiece, this shop aid uses a pair of low-friction polyethylene skids that let the material move in any direction.

Between those skids, the manufacturer placed a slot that accommodates 2x lum-

ber, and a clamping jaw to hold that material in place. That 2x can extend the width of the support well beyond the width of the skids. Or, it also can serve as a sacrificial rail so you can cut sheet goods on it without fear of cutting into the Multi-Stand's head.

If you need to plane a little off that sticky bedroom door, tilt the head so it's perpendicular to the floor and clamp a door in the jaw instead. Be careful, though: The jaw isn't really designed for protecting the finish on a workpiece and can leave a pretty severe bite mark.

As an outfed stand, though, the Multi-Stand shines. It adjusts in height from 25–37", and its wide three-point stance proved very stable.

—Tested by Kirk Hesse

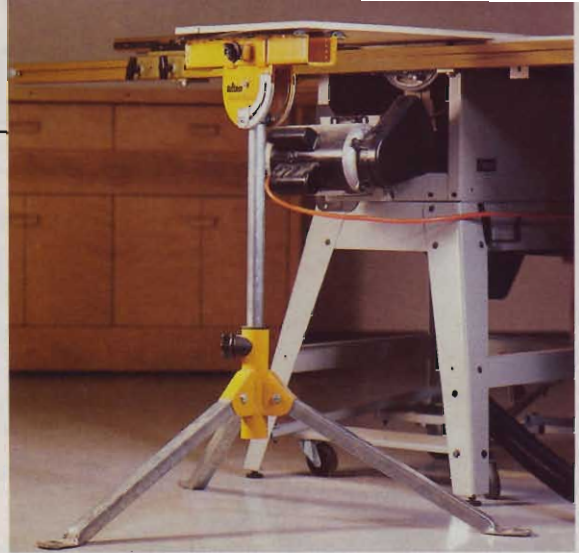

Multi-Stand Work Support

Performance	★★★★☆
Price	\$75
Value	★★★★☆

Call Triton Woodworking Systems toll-free at 888/874-8661, or visit www.multi-stand.com.

About our product testers

Kirk Hesse teaches woodworking and other technical skills to high school students in Des Moines, Iowa.

Garry Smith is a tool-and-die maker and an avid woodworker.

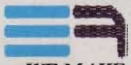

Econ-Abrasives

WE MAKE ABRASIVE BELTS ANY SIZE, ANY GRIT!

<p>Standard Abrasive Sheets</p> <p style="text-align: center; font-size: small; color: blue;">CABINET PAPER</p> <table border="0" style="width: 100%; font-size: x-small;"> <tr> <td></td> <td style="text-align: center;">50/pk</td> <td style="text-align: center;">100/pk</td> </tr> <tr> <td>60D</td> <td style="text-align: right;">\$17.58</td> <td style="text-align: right;">\$31.58C</td> </tr> <tr> <td>80D</td> <td style="text-align: right;">\$16.42</td> <td style="text-align: right;">\$29.26C</td> </tr> <tr> <td>100 thru 150C</td> <td style="text-align: right;">\$15.26</td> <td style="text-align: right;">\$26.95C</td> </tr> </table> <p style="text-align: center; font-size: small; color: blue;">FINISHING PAPER</p> <table border="0" style="width: 100%; font-size: x-small;"> <tr> <td>80A</td> <td style="text-align: right;">\$11.74</td> <td style="text-align: right;">\$19.89C</td> </tr> <tr> <td>100 thru 280A</td> <td style="text-align: right;">\$10.50</td> <td style="text-align: right;">\$17.58C</td> </tr> </table> <p style="text-align: center; font-size: small; color: blue;">NO LOAD PAPER(white)</p> <table border="0" style="width: 100%; font-size: x-small;"> <tr> <td>100 thru 400A</td> <td style="text-align: right;">\$12.90</td> <td style="text-align: right;">\$22.40C</td> </tr> </table> <p style="text-align: center; font-size: x-small;">*C* = 100 SHEETS</p> <p style="text-align: center; font-size: x-small; color: blue;">Velcro® Vacuum Discs</p> <p style="text-align: center; font-size: x-small; color: blue;">8 Hole pattern for Bosch sanders</p> <table border="0" style="width: 100%; font-size: x-small;"> <tr> <th style="text-align: left;">Dia.</th> <th style="text-align: left;">Grit</th> <th style="text-align: left;">Price</th> </tr> <tr> <td>5"</td> <td>60</td> <td style="text-align: right;">\$.48ea</td> </tr> <tr> <td>5"</td> <td>80</td> <td style="text-align: right;">.46</td> </tr> <tr> <td>5"</td> <td>100 thru 320</td> <td style="text-align: right;">.45</td> </tr> </table> <p style="text-align: center; font-size: x-small; color: blue;">* Available in 5 hole pattern *</p> <p style="font-size: x-small;">*Wide Belts*Rolls*Flap Wheels *Pump Sleeves*PSA Discs *Router & Wood Bits*Wood Glue</p> <p style="font-size: x-small;">*MasterCard, VISA, Discover, Am. Express *SATISFACTION GUARANTEED!!! *CALL FOR FREE CATALOG -TX add appropriate sales tax -Call for shipping charges</p>		50/pk	100/pk	60D	\$17.58	\$31.58C	80D	\$16.42	\$29.26C	100 thru 150C	\$15.26	\$26.95C	80A	\$11.74	\$19.89C	100 thru 280A	\$10.50	\$17.58C	100 thru 400A	\$12.90	\$22.40C	Dia.	Grit	Price	5"	60	\$.48ea	5"	80	.46	5"	100 thru 320	.45	<p style="text-align: center; font-size: small; color: blue;">ABRASIVE BELTS</p> <p style="font-size: x-small;">Belts are resin bond cloth with a bi-directional splice, specify grits.</p> <table border="0" style="width: 100%; font-size: x-small;"> <tr> <td>1X30</td> <td style="text-align: right;">\$.81 ea</td> <td>3X24</td> <td style="text-align: right;">\$.93 ea</td> </tr> <tr> <td>1X42</td> <td style="text-align: right;">.81 ea</td> <td>3X27</td> <td style="text-align: right;">.96 ea</td> </tr> <tr> <td>1X44</td> <td style="text-align: right;">.81 ea</td> <td>4X21 3/4</td> <td style="text-align: right;">1.06 ea</td> </tr> <tr> <td>2 1/2X16</td> <td style="text-align: right;">.85 ea</td> <td>4X24</td> <td style="text-align: right;">1.10 ea</td> </tr> <tr> <td>3X18</td> <td style="text-align: right;">.86 ea</td> <td>4X36</td> <td style="text-align: right;">1.35 ea</td> </tr> <tr> <td>3X21</td> <td style="text-align: right;">.90 ea</td> <td>6X48</td> <td style="text-align: right;">3.50 ea</td> </tr> <tr> <td>3X23 3/4</td> <td style="text-align: right;">.93 ea</td> <td>6X89</td> <td style="text-align: right;">6.24 ea</td> </tr> </table> <p style="text-align: center; font-size: x-small; color: blue;">OTHER SIZES ON REQUEST</p> <p style="text-align: center; font-size: x-small; color: blue;">HEAVY DUTY SPRING CLAMPS</p> <p style="font-size: x-small;">Clamps come w/PVC tips and grips.</p> <table border="0" style="width: 100%; font-size: x-small;"> <tr> <th style="text-align: left;">Size</th> <th style="text-align: left;">Price</th> </tr> <tr> <td>4"</td> <td style="text-align: right;">\$1.75 ea</td> </tr> <tr> <td>6"</td> <td style="text-align: right;">2.25</td> </tr> <tr> <td>8"</td> <td style="text-align: right;">3.50</td> </tr> </table> <p style="text-align: center; font-size: x-small; color: blue;">JUMBO ROUTER PAD(24" x 36")</p> <p style="font-size: x-small;">It will not allow small blocks of wood to slip out under router or sanding applications. ROUTER PAD ONLY \$8.95ea.</p> <p style="text-align: center; font-size: x-small; color: blue;">JUMBO BELT CLEANING STICK</p> <p style="text-align: center; font-size: x-small;">ONLY \$8.80</p>	1X30	\$.81 ea	3X24	\$.93 ea	1X42	.81 ea	3X27	.96 ea	1X44	.81 ea	4X21 3/4	1.06 ea	2 1/2X16	.85 ea	4X24	1.10 ea	3X18	.86 ea	4X36	1.35 ea	3X21	.90 ea	6X48	3.50 ea	3X23 3/4	.93 ea	6X89	6.24 ea	Size	Price	4"	\$1.75 ea	6"	2.25	8"	3.50
	50/pk	100/pk																																																																				
60D	\$17.58	\$31.58C																																																																				
80D	\$16.42	\$29.26C																																																																				
100 thru 150C	\$15.26	\$26.95C																																																																				
80A	\$11.74	\$19.89C																																																																				
100 thru 280A	\$10.50	\$17.58C																																																																				
100 thru 400A	\$12.90	\$22.40C																																																																				
Dia.	Grit	Price																																																																				
5"	60	\$.48ea																																																																				
5"	80	.46																																																																				
5"	100 thru 320	.45																																																																				
1X30	\$.81 ea	3X24	\$.93 ea																																																																			
1X42	.81 ea	3X27	.96 ea																																																																			
1X44	.81 ea	4X21 3/4	1.06 ea																																																																			
2 1/2X16	.85 ea	4X24	1.10 ea																																																																			
3X18	.86 ea	4X36	1.35 ea																																																																			
3X21	.90 ea	6X48	3.50 ea																																																																			
3X23 3/4	.93 ea	6X89	6.24 ea																																																																			
Size	Price																																																																					
4"	\$1.75 ea																																																																					
6"	2.25																																																																					
8"	3.50																																																																					

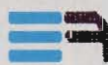

P. O. Box W1628
Frisco, TX 75034
(972)377-9779

TOLL-FREE ORDERING LINE (800)367-4101

Dust



Collector

- Flexible design options
- Perfect for the small shop
- Compact 2' W x 2' L x 7'2" H footprint
- 1.5 hp delivers 700 CFM @ 8" static pressure
- Internal pleated spun bond polyester filter cartridge
- High efficiency filtration 99% on .2-2.0 micron material

Engineered ductwork design & parts list provided

"If you have a small shop this is the perfect dust collector, I put mine in a 2x2' corner space and connected it to five woodworking machines. I love it!" Lloyd Diamantis, Albany NY.

Call for a free brochure!



1-800-732-4065

www.oneida-air.com

1001 W. Fayette St. Syracuse, NY 13204

Proudly made in America

Dust collection systems & components 1.5 hp & larger

what's ahead

in our next issue

Coming in February

Projects



Contemporary futon

Build this versatile bed/sofa, then add the matching TV stand and modular shelving system featured in two upcoming issues.



Shelves with flair

Despite its sophisticated look, this Meier brothers design goes together quickly and economically.



Turn on this lamp

Based on the Biedermeier style of furniture, this lamp combines eight separate turnings into one classic shape.



Coaster set

Let this attractive scrapwood project grace and protect your wooden table-tops for years to come.



Stars and Stripes: forever

Show your patriotism by making and displaying America's quintessential symbol of freedom, Old Glory.

Tools, Techniques & Features



WOOD's guide to finishing, part I

The kick-off to this three-part series covers proper sanding, grain filling, and defect repair.



A new star in the West

From her secluded workshop in Montana, Amber Jean produces unique, Western-themed pieces fetching up to five figures.

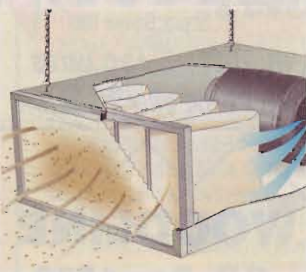

Tool reviews

We test two types of woodworking tools in this issue: lung-saving air-filtration units (*shown*) and quick-action, one-handed bar clamps.



Wood-buying basics

There's no getting around it: Wood costs plenty. Here's the scoop on getting the best deal every time you shop for hardwoods or softwoods.