

Better Homes and Gardens®

Scrollsaw a Flag!
Full-Size Pattern Inside



WOOD

February 2002
ISSUE 139

Tips, Tools, Techniques, and Projects for the Home Woodworker

build a handy
fold-down

work center

for only \$150

SPECIAL!
GUIDE
TO
FINISHING
SUCCESS

PLUS:
Contemporary futon sofa
Classic turned lamp
Quick-and-easy coaster set

Product Tests:

- One-handed clamps
- Air-filtration systems



www.woodonline.com
Display until February 5, 2002

U.S.A. \$5.95

0 72440 14072 1

02 >

Swim At Home contents

WOOD® magazine

February 2002, Issue 139

projects & techniques

36 sleeping-beauty futon
Add to the versatility of your family room or den with this contemporary sofa/sleeper.

44 eye-catching coasters
Try a project that is simple to make and will be used again and again.

48 space-saving work center
Build the project featured on the cover that combines cabinet storage with a fold-down workbench.

56 well-rounded table lamp
Turn a classic Biedermeier-style lamp base step by step.

60 prepare for a great finish
Learn to fix flaws and smooth surfaces before you finish in this first of a three-part series.

74 patriot's plaque
Scrollsaw and paint a dramatic rendition of the American flag.

features

53 wood-buying basics
Cut through the lingo when purchasing lumber with this tell-all guide.

68 meet a master craftswoman
Montana's Amber Jean makes big-ticket furniture in the western style.

82 wood close-up: sugar maple
See why this species is one of the premier woodworking woods.

Cover Photos: Baldwin Photography



36



44



56



60



74



68



53

contents

February 2002, Issue 139

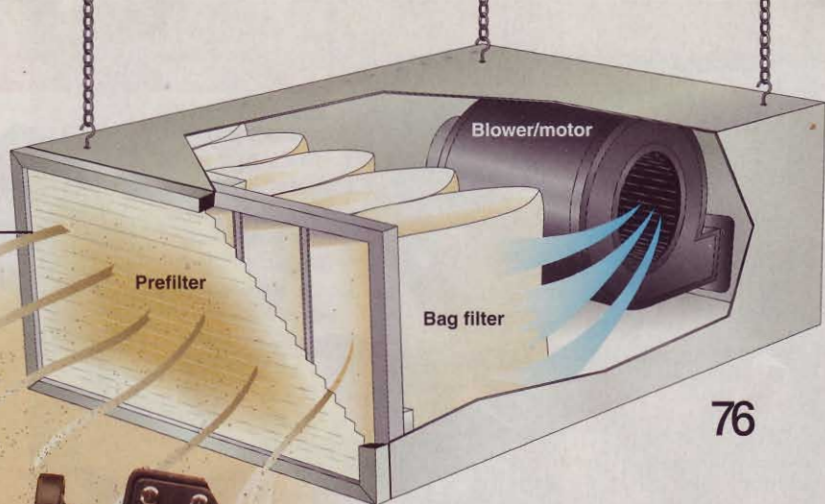

tool tests

- 66 one-handed clamps**
We put the squeeze on five models, and pick the top buys.
- 76 air-filtration systems**
Six dust-munching units suck it up in our side-by-side shop tests. With the dust settled, here now are the results.



departments

- 6 editor's angle**
- 10 talking back**
- 16 WOOD ONLINE®**
- 18 furniture repair: fixing cracks**
See how to fill thin openings in old furniture and make them disappear.
- 20 wood anecdote: bigleaf maple**
This wood, from America's Northwest, is sought by woodworkers for its outstanding figure.
- 22 just-right joinery: squeeze-out**
Use the tricks shown here to put the kibosh on excess glue.
- 24 great ideas: accessory shelf**
Store router bits, sanding drums, and drill bits with this organizer.
- 25 short cuts**
- 26 ask wood**
- 30 shop tips**
- 86 find a fitting futon**
Find out what's what when shopping for futon mattresses.
- 88 products that perform**
- 104 what's in the next issue**



Better Homes and Gardens® *WOOD*® magazine (ISSN-0743-894X) is published nine times a year in February, March, April, May/June, July/August, September, October, November, and December by Meredith Corporation, 1716 Locust St., Des Moines, IA 50309-3023. Periodicals postage paid at Des Moines, Iowa, and additional mailing offices. Better Homes and Gardens trademark registered in Canada and Australia. Marca Registrada en México. **ONE-YEAR SUBSCRIPTION PRICES:** U.S. and its possessions, \$28; Canada, \$41; other countries, \$49. Canada Post Publications Mail Sales Product Agreement No. 40049562. Canadian BN 12348 2887RT. **CANADIAN RETURN ADDRESS:** *Better Homes and Gardens WOOD* magazine, 2744 Edna Street, Windsor, Ontario, N8Y 1V2. **POSTMASTER:** Send address changes to *Better Homes and Gardens WOOD* magazine, P.O. Box 37439, Boone, IA 50037-0439.

Become a woodworking mentor

Think back to your youth, and I'll wager you can remember a person or two who had the patience to help spark your interest in woodworking. Thank goodness they did! Consider all of the pleasure you've received and given through woodworking.

Today, a lot of tool manufacturers and retailers, furniture suppliers, cabinetmakers, and contractors are asking the same question: "Who will teach tomorrow's woodworkers?"

This concern stems largely from the slow but steady disappearance of woodshop classes from high school curricula. The reasons are many, including an increase in the number of required credit hours for math, English, science, and foreign languages at many schools. Kids have fewer hours to devote to elective courses, and when they do, they're more apt to enroll in a computer-related class than in woodshop.

Why does this matter to you? Well, I believe all of us who have enjoyed woodworking, and been enriched by it for so long, have an obligation to pass our appreciation and skills to the next generation. High schools won't do it in the future, so it's up to us. Besides, sharing your love for woodworking with another person will just plain make you feel good.

So, how do you become a mentor to an aspiring woodworker? It's not a big deal, and won't take up much of your time. Simply invite your child, grandchild, or perhaps that bored kid next door to spend a little time with you in the shop. Do



When my 8-year-old daughter, Nicole, needed a new dresser, we teamed up to repair and refinish an antique. Will she be a woodworker some day? I hope so.

something that's safe, simple, and enjoyable. Perhaps a scrollsawn ornament or basic birdhouse. Or, just allow the youngster to glue scrap pieces into shapes conjured from their imagination. The two of you will be best buddies forever.

And remember, little girls are just as fascinated by your workshop activities as little boys. I have three daughters, and all but the youngest—who's excused because she's less than a year old—have an intense curiosity about their dad's woodworking activities.

I'm guessing that you, too, are surrounded by inquisitive kids dying for a peek inside your workshop. Go ahead—invite them in. Be a woodworking mentor. The world will be a more beautiful place for it.

Bill Krier

Editor-in-Chief **BILL KRIER**
Executive Editor **JIM HARROLD**
Managing Editor **MARLEN KEMMET**
Products Editor **DAVE CAMPBELL**
Projects Editor **JAN HALE SVEC**
Projects Editor **OWEN DUVALL**
Features Editor **DAVE STONE**
Techniques Editor **JIM POLLOCK**
Senior Design Editor **KEVIN BOYLE**
Master Craftsman **CHARLES I. HEDLUND**
Production/Office Manager **MARGARET CLOSER**
Administrative Assistant **SHERYL MUNYON**
Illustrators **LORNA JOHNSON, ROXANNE LeMOINE, TIM CAHILL, MIKE MITTERMEIER**
Contributing Photographer **MARTY BALDWIN**
Technical Consultants **RICH BRIGHT, JEFF HALL, KIRK HESSE, GARRY SMITH**
Contributing Craftsman **JIM HEAVEY**
Proofreaders **JIM SANDERS, BARBARA KLEIN**

Art Director **TIM ALEXANDER**
Associate Art Director **JOHN MEEK**
Assistant Art Director **CHERYL A. CIBULA**

Publisher **MARK HAGEN**

Advertising Office: 333 N. Michigan Ave., Suite 1500, Chicago, IL 60601 Phone: 312/853-2890 Fax: 312/580-7906

Sales Assistant **THERESA COOKS**

Mail Response Manager **CAROLYN DAKIS**

Account Executive **RON GOLMINAS**

Account Executive **NEIL KIRBY**

Account Executive **JOHN THORNBURGH**

Detroit, Phone: 248/356-1149 Fax: 248/356-8930

Account Executive **PAT TOMLINSON**

Northeast, Phone: 212/551-7043 Fax: 212/551-7192

Southeast: Lagomarsino, Dempsey & Dennis, Inc.

2951 Piedmont Rd., NE, Suite 100, Atlanta, GA 30305

Phone: 404/261-5400 Fax: 404/261-5404

Group Marketing Director **CATHY E. SMITH**

Phone: 212/551-7178 Fax: 212/551-7192

Senior Marketing Services Manager **ALEXANDER D. CLARKSON**

Group Publisher **STEPHEN B. LEVINSON**

Associate Business Director **CRAIG FEAR**

Senior Product Manager **RICK GROW**

Advertising Services Manager **PAT HENDERSHOTT**

Consumer Marketing Director **KATHI PRIEN**

Consumer Marketing Manager **DAVE HONOLD**

Vice President/Publishing Director **WILLIAM R. REED**

MEREDITH PUBLISHING GROUP

President **STEPHEN M. LACY**

Magazine Group President **JERRY KAPLAN**

Group Sales **MICHAEL BROWNSTEIN**

Creative Services **ELLEN DELATHOUDER**

Business Development **TINA GEORGEU**

Manufacturing **BRUCE HESTON**

Consumer Marketing **KARLA JEFFRIES**

Finance and Administration **MAX RUNCIMAN**

Meredith
CORPORATION

WILLIAM T. KERR, President and Chief Executive Officer

E.T. MEREDITH III, Chairman of the Executive Committee

©Copyright Meredith Corporation 2002

All rights reserved. Printed in the U.S.A.

Customer Service Information: For service on your subscription, including change of address, contact us at www.woodmagazine.com/service or call 800/374-9663. **Subscription mailing address:** Better Homes and Gardens WOOD magazine, P.O. Box 37439, Boone, IA 50037-0439. Please enclose your address label from a recent issue. **Editorial mailing address:** The Editor, WOOD magazine, 1716 Locust Street, GA310, Des Moines, IA 50309-3023. For questions on editorial, questions about how to reach an advertiser, or to place an advertisement in our magazine call 800/374-9663. **To order back issues call 800/346-9663.** Article reprints, send \$5 per article (no phone orders), include issue and name of article, to WOOD Article Reprint Service, P.O. Box 349, Kalona, IA 52247, check or money order made payable to WOOD magazine.

talking back

Our bulletin board for letters, comments, and timely updates

A double-duty drilling jig

You're right—it can be tough drilling perfectly centered holes in a hardwood ball. But your ball-drilling jig in issue 127 (Great Ideas for Your Shop on page 16) takes the long way around the barn.

I've been using the simplified version shown in the drawing, *below*, for years and it's never failed me. Instead of tightening the stock in place with a small screw clamp, you also could use a carriage bolt and wing nut. I use various-size threading dies for my projects and have had trouble holding the dowels to thread them, but this jig works great for that purpose, too.

—Jim Kreisel, Yakima, Wash.

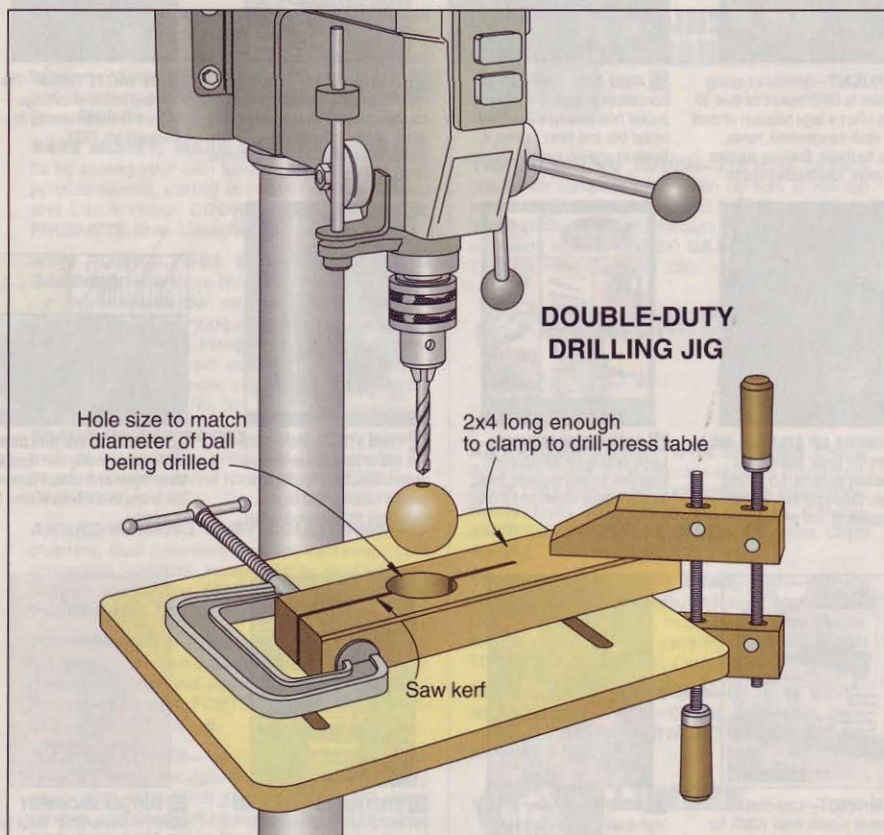

Boring long holes on your lathe

A reader wrote to *WOOD*® Forum in issue 131 asking for help with boring long holes in lamp bases. If you do enough of this work to warrant it, you can purchase a special accessory set that allows you to drill these holes on your lathe. Consisting of a special drive spur, a hollow tail center, and a boring tool

called a shell auger, it allows you to bore into one end of your lamp base to half the total length, then flip the piece end-for-end and finish the hole from the other end. Bases up to 60" tall can be drilled. The point on the shell auger is designed to drill without wandering off center.

The long hole boring accessories can be ordered online from Craft Supplies UK at www.craft-supplies.co.uk, or their

North American distributor, Wood Chucker's Supplies in Weston, Ontario, at www.woodchuckers.com. Call 800/551-0192 to request a catalog.

—Harold Nancekivell, Thunder Bay, Ont.

Stray dimension in patio party center

Building this project in issue 134 was very enjoyable, and I learned some things that will help me out on future projects. There is one minor error in the leaf supports, shown *below*, and I thought other readers would like to know.

—Larry Larsen, Ivins, Utah

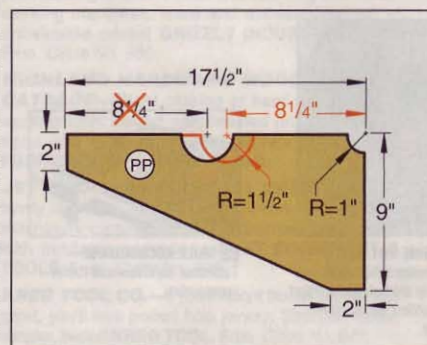

Do the math

"If I'd known I was going to be a woodworker, I'd have paid more attention in math class." That seems to be the problem for the reader who was scrambling to find a good geometry book (issue 132 *WOOD* Forum on page 98).

Here's a good one: *Mathematics Made Simple* by Abraham Paul Sperling and Monroe Stuart. It's a classic.

—Dr. H. M. Smith, Napanee, Ont.

Thanks, Dr. Smith. And here are a couple more, courtesy of Marvin Morgan of San Antonio, Texas: *Workshop Math* by Robert Scharff and *The Woodworker's Guide to Shop Math* by Tom Begnal.

Continued on page 14

Another look at parts views

Reader Matt Gauntt of Geneva, Illinois, alerted us to errors in the Parts Views drawing for the side-draft workbench in issue 133. Please note the corrections to the left divider (A), right drawer support (E), left end panel (H) and right end panel (I). To clarify another point, the optional channel grooves shown in the top (JJ) are routed in only the top layer. Thanks, Matt, for taking the time to write.

Use same dimensions when locating new opening.

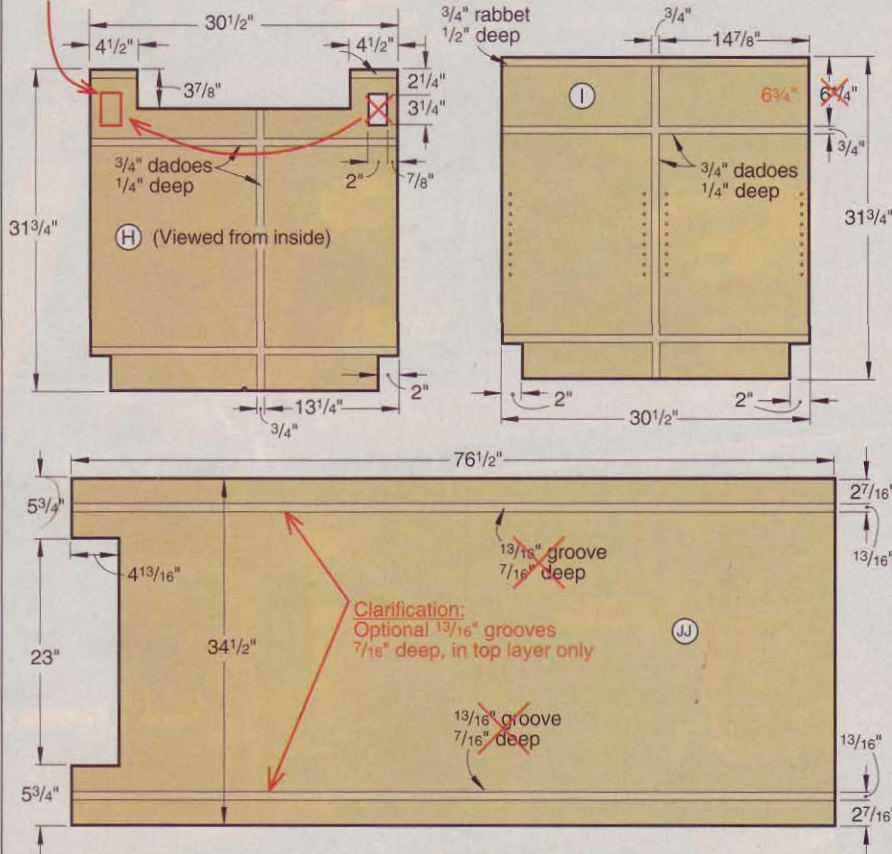

Getting grounded (once again)

I was knocked out by the Family Room Renovation in issue 132. You can be sure I'll be going back to that issue when it's time to redo our basement rec room.

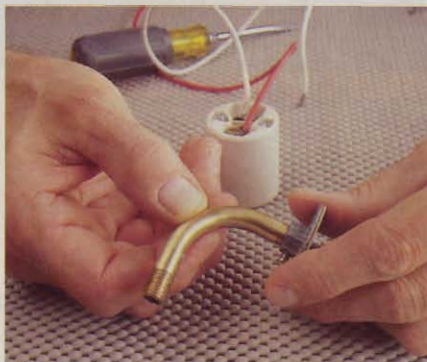

I noticed, though, that to make the light fixtures for the wall sconces, you tell folks to epoxy together the various parts (the copper pipe, copper elbow, reducing bushing, and metal cap). Although epoxy will work fine for joining the parts, it won't conduct electricity, making the fixture's ground wire useless. To keep everything up to code, you'd be better off using the appropriate-size stock lamp-fitting elbow and threading it directly into the socket cap and nipple.

—Harvey McLean, Cambridge, Ont.

Thanks, Harvey. You're absolutely right. We found the solid brass threaded lamp

elbow shown in the photo, left, at a lamp shop that specializes in repairs.

Write Us!

Do you have comments, criticisms, suggestions, or maybe even a compliment specifically relating to an article that appeared in *WOOD* magazine? Please write to:

Talking Back
WOOD magazine
 1716 Locust St., GA310
 Des Moines, IA 50309-3023

or e-mail us at talkingback@mdp.com.

Due to the volume of letters and e-mails we receive, we can only respond to and publish those of the greatest interest to our readers.

wood online®

How you benefit by going to www.woodonline.com



WOOD STORE affiliate makes a difference

Jim Barry is a hobbyist woodworker who runs a great Web site called www.woodworkersworkshop.com. The site is filled with photos of Jim's projects, links to products, and an amazing selection of links to woodworking plans.

Jim's site is also part of our WOOD STORE affiliate program. That means he earns money every time someone links from his site to www.woodstore.woodmall.com and purchases a plan or product. Jim uses the money, along with money from a couple other affiliate programs, to support his woodworking endeavors.

On September 11, 2001, as terrorists attacked America, Jim's small hometown of Gander, Newfoundland, became the temporary home of about 6,700 airline passengers that were forced to land short of their destinations. Like everyone in town, Jim, who owns a local bakery, did his part to house, comfort, and feed the passengers. He even baked 216 American flag cakes, shown below. But Jim felt

he should do more. That's when he realized most of the people who have purchased goods by linking from his site to the WOOD STORE and his other affiliate sites are Americans. On Wednesday, September 12, Jim was at the bank bright and early, where he drew out over \$1,800 (U.S.), which was practically all the money he had in his "online account." He presented the money to his local Red Cross representative as a donation to the American disaster relief fund. 🇺🇸



Jim Barry used his hands and heart to help out on September 11, 2001. He baked 216 American flag cakes for stranded airline passengers, and donated woodworking income to disaster relief.

Three great ways to get woodworking plans

Choice is the name of the game when you order woodworking plans online from the WOOD STORE®.

The WOOD PLANS® page guides you to over 100 blueprint-style paper woodworking plans in eight categories. Click on the plan you like, place an order, and we'll mail the plan to you on the double.

The Downloadable and Mail-Direct Plans page features two easy ways to order 125 terrific plans in 15 categories: Click on

"Downloadable Plan," and the file transfers to your computer immediately. Or click "Mail-Direct Printed Plan," and we'll send you a full-color, printed copy.

Any way you go, you get the plans you need. And you receive the detailed how-to steps, photos, and illustrations you expect from WOOD® magazine.

Go to www.woodstore.woodmall.com, then click one of the two plans buttons on the left-hand side of the page.

Find the tools you need FAST at WOODMALL®

You know the drill. When it's time to buy a new tool, you have to sift through a stack of catalogs or jump from one Web site to another just to compare features and prices. It's a hassle.

Make it easy on yourself with the alphabetized product index at WOODMALL. It groups products in categories, so you quickly can locate the online retailers that sell the products you need without having to click through pages of things you don't want.

Go to www.woodmall.com, and click on Product Index at the top of the page.

how to make small furniture cracks **disappear**

Plagued by cracks in a piece of old furniture?

Unless it's a museum piece, this simple repair might fill the bill.

Quite often, cracks in old furniture arise from failed glue joints. Repairing these becomes a matter of cleaning out loose fibers and old glue, fitting the parts, and gluing them back together. In many instances, a crack that doesn't occur at a joint can be repaired readily by cleaning, gluing, and clamping, too.

But the two cracks in the edge of the small table shown below defied gluing and clamping because the tabletop was veneered both top and bottom. Pulling the cracks' edges together would require removing the veneer.

Since the table isn't a valuable antique, the repair could lean more toward the serviceable and less toward a museum-quality restoration. So, we decided to simply fill the cracks.

Build a base of shavings

Generally, it's better to apply filler materials in thin layers. Wood movement and other factors can crack filler that's been applied too heavily.

To minimize the amount of filler in the crack, we glued some wood into the split first, then smoothed a thin coat of filler over the repaired surface. Plane shavings proved a workable choice for wood packing, as shown in **Photo A**. After block-planing some fairly thick curls from a piece of walnut—chosen to match the table's dark finish—we moistened a few and stretched them out flat to dry under weights on the workbench.

The curls didn't press completely flat, but came out straight enough that we

could coat some with liquid hide glue and slide them into the crack. We alternated layers of glue-coated and uncoated shavings, then dribbled glue along the top of the wood-packed crack, letting it ooze down through the gaps.

After the glue dried, we trimmed the shavings flush with the table edge, using a small chisel. We sanded the repair and the surrounding area with 100-grit sandpaper.

Top it off with wood filler

The repaired area showed numerous surface irregularities after sanding. To level and smooth the surface, we applied wood filler, as shown in **Photo B**.

For filler, we mixed epoxy wood rebuilder, following the manufacturer's

instructions. (We bought the two-part putty at a home center.) Other types of wood filler would work, too.

Then, using a flexible plastic applicator, we spread a layer of filler over the repair and surrounding area. An old kitchen spatula or expired credit card will work fine for a spreader. If nothing suitable is at hand, buy plastic spreaders for auto-body filler at an auto-supply store.

After the filler cured, we sanded it smooth with 100-grit sandpaper, feathering it into the adjacent wood. Finally, we block-sanded with grits from 150 to 320, which left the surface suitable for staining and finishing. 🌲

Photographs: Hetherington Photography



A Glue plane shavings into the crack to provide a base for the filler. A knife helps push the thin pieces into place. The crack to the left of the knife has been trimmed and sanded already.



B Smooth wood filler onto the repaired area after trimming the glued-in plane shavings flush with the surface. Make sure to use a filler that will take stain. We chose a two-part epoxy product.

bigleaf maple

the Northwest tree with a ton of figure

When it comes to trees, the Pacific Northwest boasts some great ones. Think of California, Oregon, and Washington, and grand specimens come to mind: Douglas fir, coast redwood, and western red cedar. Yet these trees, no matter how large and abundant, don't produce the boards of woodworkers' dreams. They're primarily the softwoods of home and deck builders, not the stock of fine furniture.

There is, however, a tree native to the region worthy of craftsmen's dreams—the bigleaf maple. And its sap, like that of its eastern cousin the sugar maple, can be used to make syrup and sugar. Bigleaf maple wood, although not quite as heavy

or hard as sugar maple, displays figure equally dazzling to the eye. Perhaps even more frequently, its normally straight-grained, light pinkish brown heartwood shapes itself into wavy, quilted, fiddleback, and bird's-eye patterns. Even in pioneer times, this figured wood—so sought after by today's veneer manufacturers—was highly prized for gunstocks.

In a geographic area not known for its hardwoods, bigleaf maple ranks second only to red alder in abundance for commercial use. In fact, the tree accounts for about 18 percent of the Pacific Northwest's total volume of standing hardwood timber. Although lumber production of bigleaf maple falls far below

that of the region's softwoods, the wood does become furniture; turnings; musical instruments; paneling; and, of course, sheet veneer. But it's for the bigleaf maple tree's exquisite burls, frequently more than 4' in diameter, that local and distant craftsmen pay premium prices. ♣



SOMMERFELD'S TOOLS FOR WOOD

8 East Third Street

Remsen, IA 51050

CMT's New Industrio™ Routing System

Designed by Marc Sommerfeld

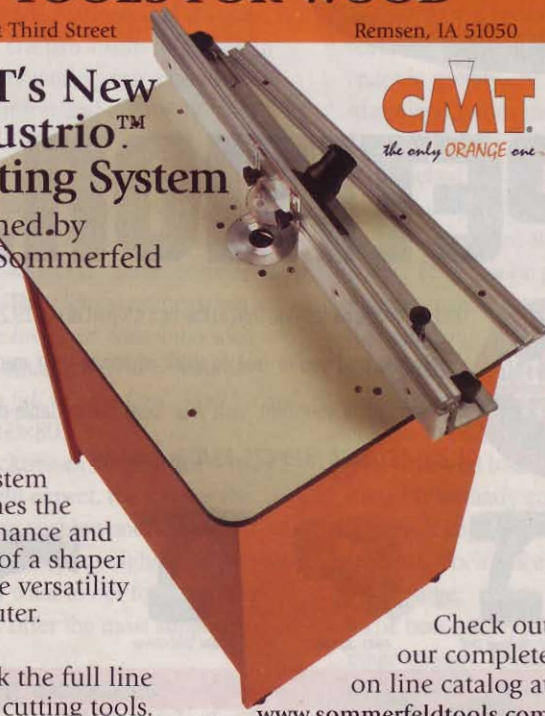

This system combines the performance and design of a shaper with the versatility of a router.

We stock the full line of CMT cutting tools.

Check out our complete on line catalog at

www.sommerfeldtools.com

ORDER TOLL-FREE 1-888-2BUY-CMT

1-888-228-9268

Circle No. 1366

Rockler.com
WOODWORKING SUPERSTORE

JET

Win a Saw!

3 HP XACTA Saw™ with 50" Fence



Register to win at www.rockler.com/jet and receive Rockler's email newsletter for free!

No purchase necessary. See official rules at www.rockler.com/jet for details. Enter online at www.rockler.com/jet or send your name, address, phone and e-mail address on a postcard to: Rockler/ JET XACTA Saw Drawing, 4365 Willow Drive Medina, MN 55340. One entry per household. Void where prohibited by law. Entries must be received by April 30, 2002.

Circle No. 900

put the squeeze on **excess glue**

Miss a spot and your project loses style points. Here's what to do before and after glue-up.

A little bit of glue squeeze-out is a good thing. It shows that you used enough glue to produce a strong joint. However, it's also a potential finish wrecker, so be sure to remove every bit of it before you proceed.

Effective glue removal is a matter of timing. If you wait and scrape the glue off after it hardens, you might pull out chunks of wood. You're also more likely to miss a spot, only to see it show up when you apply the first coat of stain or finish. If you wipe squeeze-out with a damp rag immediately after glue-up, you might smear glue into the surrounding wood pores, which makes your cleanup task much more challenging.

The easy, effective way to deal with squeeze-out is to assemble and clamp your

Masking tape along joints will keep glue from the wood. Peel off the tape after the glue is partially or completely dry.



B

project, then wait 30 minutes and check the glue. When it has reached a rubbery consistency all the way through, you can quickly take it off with a scraper, as shown in **Photo A**.

It pays to take extra steps before you apply glue in areas that will be tricky to scrape. **Photo B** shows masking tape being applied to both sides of a butt joint, and the same technique works on the inside corners of a box, for example.

Or, for really tight areas, go ahead and apply finish to those surfaces that will be visible in the completed project. Yellow or white glue won't adhere to the finish, so you can let the squeeze-out harden, then easily pop it loose with a putty knife.

Photo C shows a special technique that you'll appreciate. When you're building

Cut glue-stopping grooves $\frac{1}{8}$ " deep with your tablesaw or with a straight bit and router table, then apply glue as shown.



C

up pieces by gluing them face-to-face, cut a pair of shallow saw kerfs near each edge of the piece that will receive glue. Apply glue only between the kerfs, and they'll capture any excess before it can ooze to the edge and squeeze out. If the ends will be visible in the completed project, use your router table and a $\frac{1}{8}$ " straight bit to make stopped grooves.

Finally, despite all of your precautions, always double-check for dried squeeze-out before moving on to your finishing procedures. Wipe mineral spirits over the project's surface, as shown in **Photo D**, and any dried glue will show up. Remove it carefully with a chisel or a well-sharpened cabinet scraper. ♣

Photographs: **Baldwin Photography**

Mineral spirits, or paint thinner, will reveal any dried glue. It evaporates quickly, and won't affect the finish.



D

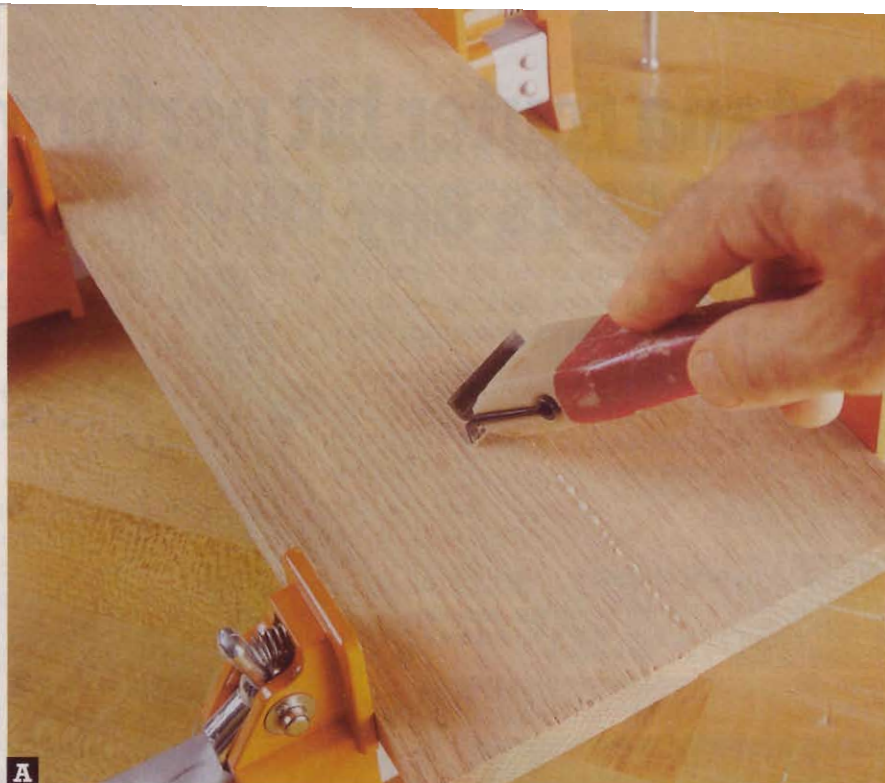

A

Use a common paint scraper to remove glue squeeze-out; just make sure it's sharp.

**JET...the Power to
Shape Your Ideas.
And the Store
to Make
Them a Reality.**

The JET store is now open with over 200 JET products in stock, including best sellers and hard-to-find attachments. Complete product information including customer reviews make comparing products quick and easy. Visit the JET store and see why JET is one of the fastest growing brands in the industry.



Visit the JET store at
www.amazon.com/jet

Call for your FREE Tool Crib catalog
1-800-635-5140

dust collectors jointers planers
saws wood lathes the Jet store
shapers sanders planer-molders



great ideas for your shop

at-the-ready bit shelf

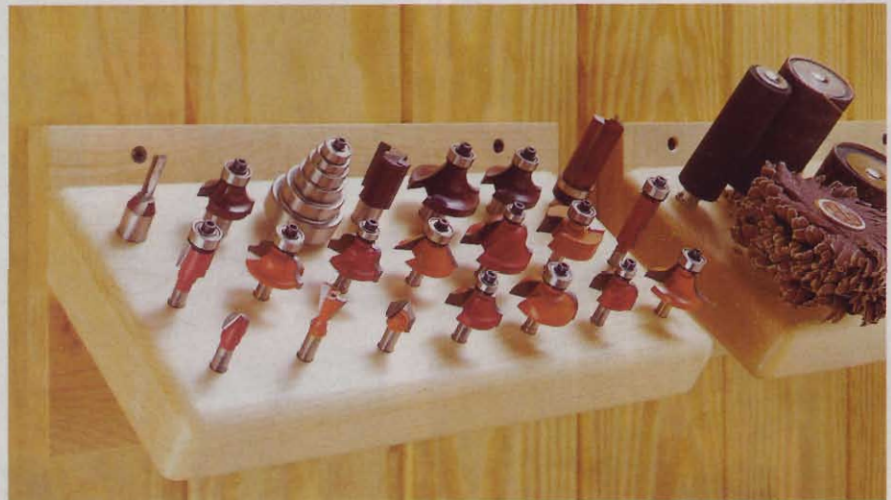

Here's an easy-to-build organizer you can customize to hold as many bits and shanked accessories as you need by simply varying the length and number of holes in this handy project. Angled for better accessibility and visibility of your accessories, our shelves hold router bits, sanding drums, flap sanders, and other drill-press and shanked

accessories from our shop. Use either thick hardwood or 2x6 stock for the angled shelf and 3/4" stock for the back-board. We routed a 3/8" round-over on all but the back edges of the shelf where shown below, and finished each project with a clear finish. ♣

Illustration: **Roxanne LeMoine**
Photograph: **Baldwin Photography**

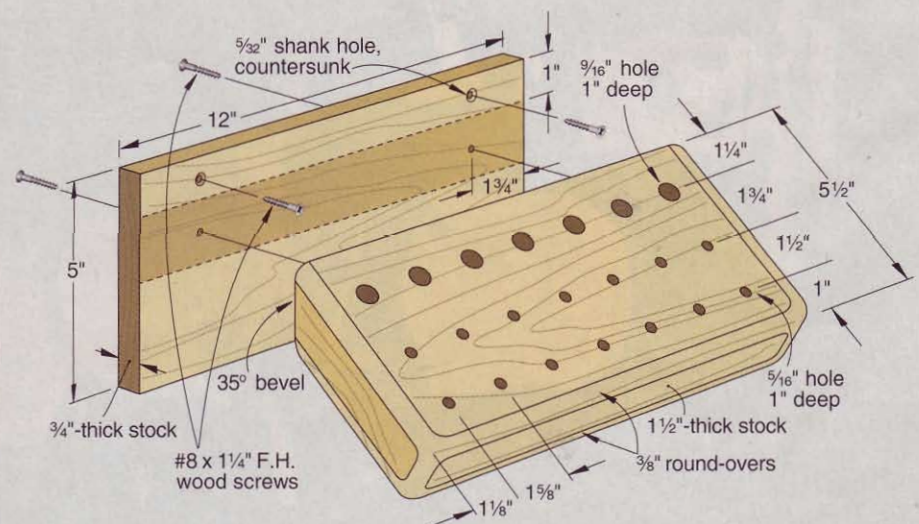

short cuts

News and notes from the woodworking world

\$500 WOOD® magazine prize goes to San Diego woodworker

Russ Filbeck's beautiful youth rocking chair, *below*, earned him the "Excellence in Craftsmanship" award and a \$500 check from *WOOD* magazine at the 2001 Del Mar Fair Design in Wood Show. The annual event, conducted by the San Diego Fine Woodworkers Association, showcased 353 judged entries from southern California woodworkers.

The winning chair, made of walnut, features a woven hickory-bark seat, ebony pins that secure the mortise-and-tenon joints, and a hand-applied oil finish. Described as an Appalachian ladder-back rocking chair, the piece includes Filbeck's own adaptations, such as the Sam Maloof-inspired arms and rockers. Show coordinator and judge Bob Stevenson said he awarded the prize based on the rocking chair's "high degree of difficulty and absolute perfection in every detail."

Filbeck is a woodworking instructor at Palomar Junior College in San Marcos, California, where he



teaches beginning and intermediate woodworking, chairmaking, finishing, tool sharpening, and wood bending. To see other outstanding entries from the Design in Wood Show, go to www.sdfwa.org.

Free CD-ROM helps you test stains on 21 woods

It's always a good idea to test a stain on a scrapwood sample before applying it to your finished project. Now, The Hardwood Council has developed a CD-ROM that enables you to apply stain variations to photos of 21 North American hardwood species, such as oak, maple, hickory, and cherry, to name a few. You also can apply stain hues to room photos that include hardwood flooring, millwork, molding, and cabinetry.

Called *The Finishing Touch*, the CD also contains physical and working properties for the 21 species, a photo gallery, and photos of lumber in three grades for seven species. You'll also find major sections on finishing specifications, how to specify lumber by grade and species abundance, and tips and techniques for building hardwood projects.

To get your free copy of *The Finishing Touch*, visit www.hardwoodcouncil.com, or contact The Hardwood Council, P.O. Box 525, Oakmont, PA 15139. Call 412/281-4980. Minimum system requirements to run the CD-ROM include Windows 95, 98, NT4, 2000; Pentium 166MHz or better; Macintosh: 120MHz PowerPC, MacOS 8.1 or better; Memory: 32MB RAM. ♣



The Toughest Glue On Planet Earth

You're beyond simple yellow glues and you don't want a different bottle of glue for every project. You want Gorilla Glue.® Bonds wood, stone, metal, ceramic, plastics and more. Incredibly strong and 100% waterproof.

Goes on Dark Neutral When Dry

GORILLA BRAND
Gorilla Glue®
PREMIUM GLUE

The Toughest Glue on Planet Earth™

GORILLA BRAND
Gorilla Glue®
PREMIUM GLUE

for retailers near you:
www.gorillaglu.com
1-800-966-3458

Introducing the New Delta Store.
**Tap into the
Power of the Pros.**

The new Delta store has over 1000 products from a complete line-up of unisaws to those hard-to-find machinery attachments. Extensive product information including customer ratings and reviews will help you choose the right tool for the job. We'll even deliver to your door for only \$6.99.



Visit the Delta store at
www.amazon.com/delta

Call for your FREE Tool Crib catalog
1-800-635-5140

table saws radial saws miter saws
scroll & band saws planers the Delta store
drilling machines jointers wood shapers



ask wood

Answers to your questions from letters,
e-mails, and WOOD ONLINE®

What's the best fastener for deck boards?

Q I plan to build a deck with cedar lumber and galvanized screws. Is this the right way to go about it?

—Don Miner, Port Orchard, Wash.

A Cedar makes a great-looking deck, Don, and you definitely want to use screws rather than nails—but use the stainless steel variety. Darin Lawrence, technical manager for McFeely's Square Drive Screws, recommends stainless fasteners for decks built with cedar or redwood. The tannic acid in those woods will cause stains if it gets through the zinc-based coating of a galvanized screw and reacts with the iron underneath.

Galvanized screws work fine with decks made from pressure-treated lumber or Trex polymer wood. For anybody who goes all-out and spends a lot of money for teak or ipe, Darin suggests using stainless steel screws so the screws will last as long as the extremely durable lumber. By the way, he says a deck near the ocean needs stainless steel screws no matter what kind of lumber you use.

Buy 3" screws to fasten standard 2x4 or 2x6 boards. They'll provide enough holding power to withstand the force exerted by seasonal wood movement. That force

is the reason for not using nails, which have a tendency to pop up.

—WOOD® magazine

Attics keep lumber high and dry

Q I have some lumber that was air-dried outdoors for at least a year, then stored in an attic. The temperature in that attic gets as high as 120° during the summer. Some cabinetmakers have told me they never use attic-dried lumber. So I'm wondering: Is it good for woodworking projects?

—David Mattichak, Port Republic, Va.

A We can't pass judgment on that particular stack of lumber, Dave, but a hot attic should dry wood just fine. Bill Simpson, a wood technologist at the U.S. Forest Products Laboratory in Madison, Wisconsin, notes that farmers with their own woodlots traditionally used this method to remove more moisture than air-drying alone can accomplish. A summer high of 120° isn't terribly hot for drying lumber—the temperature inside a kiln can reach as high as 180°. And if the lumber was air-dried properly, the danger of surface-checking has passed. When you're going to use some of that lumber in a project, move it

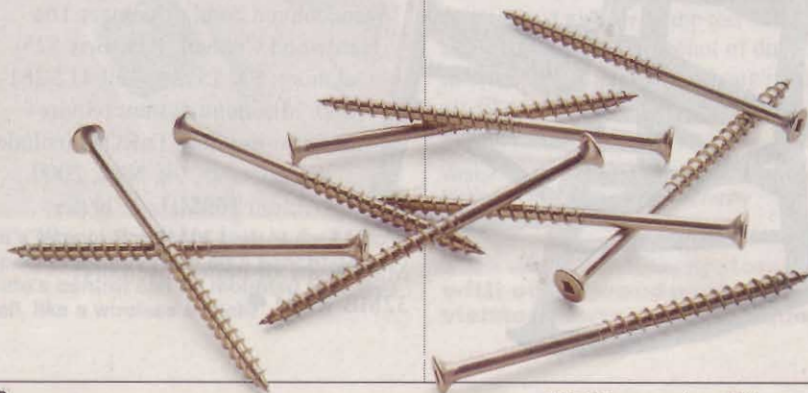



from attic to workshop, and let it sit for a few weeks to reach the appropriate moisture content before machining.

—WOOD® magazine

A new angle on long tabletops

Q I have some walnut that has been aging since 1971. I would like to make a table that is 12' long, but most of my planks are about 6'. Can I glue up the panel with the grain running the width of the table rather than the length? Will I have expansion problems with a panel this big?

—John Dunbar, via woodonline.com

A Yes, you can run them in the direction of the width. I would use a couple of heavy stiffening "ribs" underneath the top to keep it flat. Of course, you need to allow for expansion when fastening the top to the ribs.

—Henry Anderson, Yaocolt, Wash.

A I recently built a countertop 14' long from solid cherry. I couldn't get cherry that long, so I glued up my boards in a bricklaid pattern. I dry-fitted all boards to make sure the ends would match up. It looked great and the customer was happy.

—Randy Schaefer, Gillette, Wyo.

Here we go 'round the mulberry tree

Q Lots of mulberry trees grow around here, almost like weeds. I know that mulberry is a pretty wood, similar in color to cherry. What else can you tell me about it?

—Richard Pilvin, Beltsville, Md.

Continued on page 28

Discover the NEW RouterShop™

"the router tool with a brain"

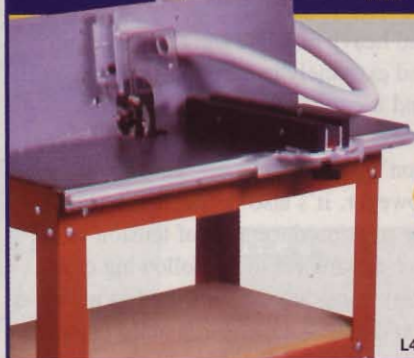

L417

See it, to Believe it!
Call for your FREE Video and Catalog



Discover how the Hawk RouterShop™ can help you unlock your woodworking potential.

- No fancy bits required- with a simple straight bit you can create a complete set of cabinets.
- Patented tilting table- set your cutter vertically and horizontally for a safe, new way to make cuts.
- Solid steel construction- no flimsy chipboard to warp.
- Patented Router Carriage
- No time consuming set ups, the tool does it automatically with its unique built in "brain".



Please rush my FREE Catalog and Video to:

L417

www.rbiwoodtools.com

Name _____
Phone _____
Address _____
City _____
State _____ Zip _____
Email _____



RB Industries, Inc.
1803 Vano Street
P.O. Box 389
Harrisonville, MO 64701-0389

(Optional—occasionally receive special offers via email)

Call 1-800-487-2623

Bird's-Mouth Router Bits



Bird's-mouth 6 or 12

Bird's-mouth 16

Bird's-mouth 8

A bird's-mouth joint (traditionally used in making masts, booms and spars) vastly simplifies making multi-sided items such as columns, buckets and planters. — in both tapered and parallel-sided forms. **\$26.50 each**

To see a selection of project ideas and tips on how to use these bits, visit our Web site and look at our 14-page instruction booklet for this product.

1-800-871-8158 or customerservice@leevalley.com

Lee Valley & Veritas®

Lee Valley Tools Ltd., 12 East River St., Ogdensburg, N.Y. 13669

Shipping and N.Y. sales tax extra.

Shop online:
www.leevalley.com

A Richard, mulberry doesn't show up very often in lumber yards or woodworking stores, but it is used now and then for crafts and furniture. The red mulberry, which thrives up and down the East Coast and in other parts of the United States, is approximately as hard

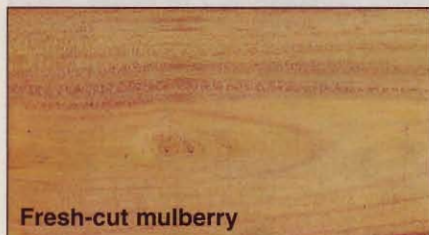

Fresh-cut mulberry



Aged mulberry

and heavy as white ash or yellow birch and extremely resistant to decay. You'll find it easy to work with hand and power tools, and easy to glue. You won't find many good-sized boards, however. It's also brittle, and because the trees produce a lot of tension wood (see the answer to the following question), some areas won't sand as nicely as you'd like. And, unfortunately, the nice color of a fresh-cut piece darkens to brown with age and exposure to light.

—WOOD magazine®

Narrow boards warp after he saws them

Q When ripping a long, narrow board—2x48", for example—on my tablesaw, the board is the same width at all points along the 48", but it has a bow. What am I doing wrong?

—Ronald Stewart, Franklin, N.C.

A It's not you, Ron, it's the lumber. Ripping a board can release internal stress and produce the kind of bowing that you describe. This stress results when a tree leans as it grows, creating reaction wood inside the trunk in response to the pull of gravity. Reaction wood exists in two forms: softwoods form compression wood on the underside of a leaning tree, while hardwoods form tension wood, mostly on the top side of the trunk.

It's hard to spot reaction wood ahead of time, but you can take steps to avoid some of it, and allow for the rest. Choose clear lumber with straight, consistently spaced grain, and buy it rough-cut, which is thicker than a completely surfaced piece. Cut the workpiece slightly longer and wider than needed, then surface one face on your jointer. Smooth the other face with your planer, then alternate the faces as you run the piece

It's The World's Only Cordless Brad Nailer That's Also Pneumatic.

Cordless. Pneumatic. Our new cordless brad nailer gives you the option of both, using exclusive **TPS Technology™** (Twin Power Source System). It's cordless,



thanks to a mini-compressor powered by our rechargeable, interchangeable 12-volt battery. It's also pneumatic,

courtesy of a 1/4" valve that allows you to use it with traditional

compressors. To get one of your own, visit your Porter-Cable dealer or call 1-800-487-8665

(519-836-2840 in Canada).



PORTER-CABLE
PROFESSIONAL POWER TOOLS

through the planer until it's the right thickness. Joint one edge flat and square, rip the other edge just slightly over-width, and joint that edge to the final dimension. This sequence gives you every chance to compensate for bowing and twisting.

—WOOD® magazine

Pine-ing for a beautiful finish

Q I'm going to use pine wainscotting and trim in a house addition. I plan to stain it, but I want to avoid the blotchy look that sometimes occurs with pine. Any advice?

—Marshel Rossow, Mankato, Minn.

A That's a common concern, Marshel, and you have a couple of good options. The trouble with pine is that the earlywood, produced by the tree

in the spring of the year, is quite soft, but the late-wood is extremely dense. Stain readily soaks into the soft spots but doesn't get very far with the hard spots.

You'll get much better results with a gel stain than with other types of pigment or dye stains. Gels don't penetrate much, no matter what the wood. Or, you can finish pine without any stain at all. Finishing expert Bob Flexner likes to use several coats of varnish, lacquer, or water-based finish. As the pine ages, its yellow-orange color shows through and looks great. Orange shellac creates a nice effect, too.

—WOOD magazine



Got a question?

If you're looking for an answer to a woodworking question, write to Ask WOOD, 1716 Locust St., GA 310, Des Moines, IA 50309-3023 or send us an e-mail at askwood@mdp.com. For immediate feedback from your fellow woodworkers, post your question on one of our discussion groups at www.woodonline.com.

It's The World's Only Pneumatic Brad Nailer That's Also Cordless.



Pneumatic. Cordless. Our new cordless brad nailer gives you the option of both, using exclusive *TPS Technology™* (Twin Power Source System). It's pneumatic, courtesy of a 1/4" valve that allows you to use it with traditional compressors. It's also cordless, thanks to a mini-compressor powered by our rechargeable, interchangeable 12-volt battery. To get one of your own, visit your Porter-Cable dealer or call 1-800-487-8665 (519-836-2840 in Canada).

Circle No. 80

Proud sponsor of
THE NEW YANKEE
WORKSHOP on
Public Television



PORTER-CABLE
PROFESSIONAL POWER TOOLS

WWW.PORTER-CABLE.COM

shop tips

Helping you work faster, smarter, and safer

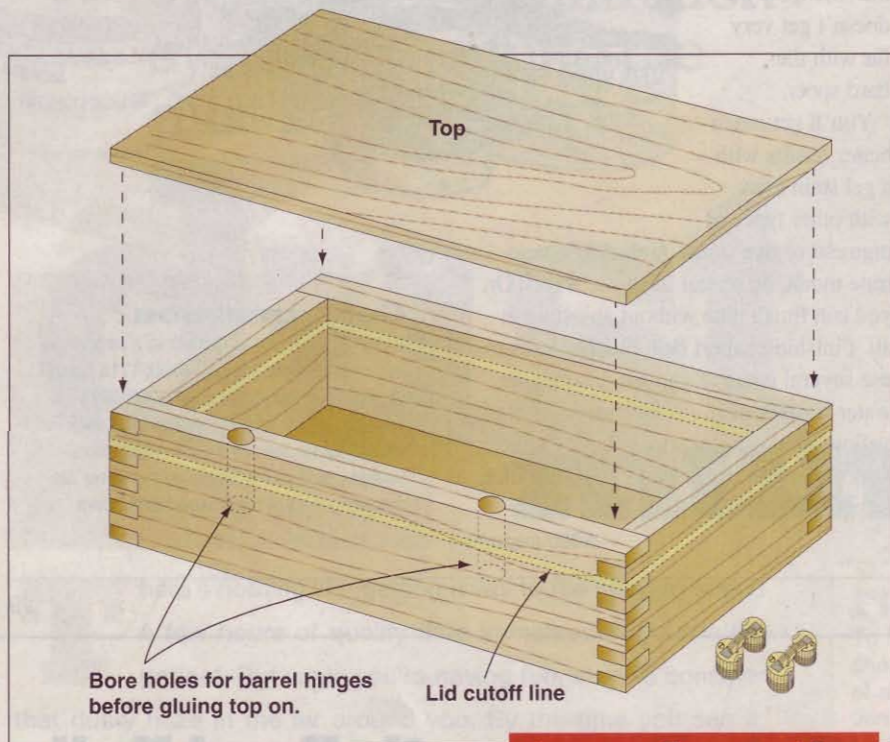

Boring for barrels

top shop tip

If you've ever used those hidden barrel-style hinges on a box, you've probably ruined a box or two trying to get the mounting holes between the box and the lid perfectly aligned. I solved the problem by boring the holes for the hinges before I glue the box top on, as shown *above*. Then, when I cut the lid off the box, the holes can't help but line up.

—Gerry Hill, Tucson, Ariz., via WOOD ONLINE®

Put your legs up on stilts

When finishing the legs of chairs or tables, I like to have a little "stilt" under each leg to keep the finish from sticking the project to my workbench. Pushpins from an office-supply store fill the bill. They're easy to install and remove, and they stay in place when I need to move the project.

—William Clark, Douglas, Mich.

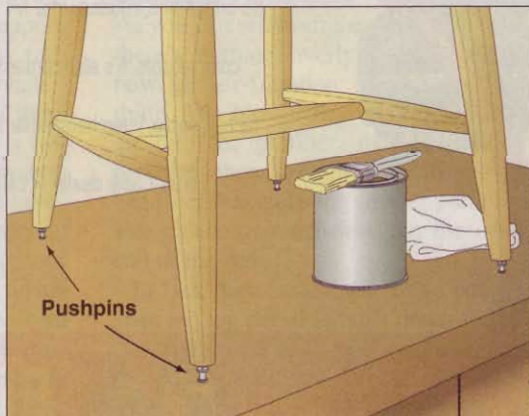

our winner



As an avid woodworker for the past 25 years, Gerry Hill gets a lot of requests to build projects. In most cases, he's happy to accommodate. But our Top Shop Tip winner has a rule about such requests: "I'll build just about anything—but only once."

Gerry's no-repeat rule leaves him open to learn new techniques. After honing his carving skills on an 8' armoire (shown *above*), he's now tackling three-dimensional carving. When he's not working in the shop, Gerry shares his love of the hobby at a nearby woodworking store.



A Ridgid MS1250 compound miter saw goes out to Gerry Hill for sending in this issue's Top Shop Tip. Great job, Gerry!

You can win a free tool, too!

Tell us how you've solved a workshop puzzler, and we'll send you \$75 if we print your solution. And, if we choose your tip as the Top Shop Tip of the issue, we'll also send you a tool prize worth at least \$250.

Send your best tips, along with photos or illustrations and your daytime telephone number, to: **Shop Tips, WOOD Magazine, 1716 Locust St., GA-310, Des Moines, IA 50309-3023.** Or post your best suggestions at www.woodonline.com on our Top Shop Tip discussion group.

Because we try to publish only original tips, please send your tips only to WOOD® magazine. Sorry, but we can't send back the items you send in.

Bamboo: great on the grill and in the joint

While restoring a couple of century-old family heirlooms recently, I wanted to strengthen the mortise-and-tenon joints by pinning them with $\frac{1}{8}$ " dowels. Rather than use hardwood dowels, which can become fragile at that size, I used bamboo skewers that I bought from a local discount store.

The skewers I found are exactly $\frac{1}{8}$ " in diameter, and bamboo's long grain makes it exceptionally strong. And, for less than \$2, I got 100 10" skewers (which should keep me pinning joints well into the 22nd century).

—Gerald Hastings, Fredericton, New Brunswick

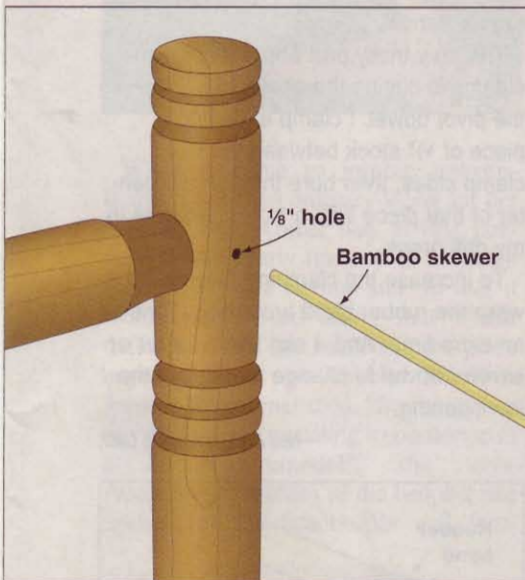

Let your hardboard be your guide

Sure, glue sticks things together, but it can be awfully slippery when wet. So, when gluing two or more workpieces of the same width together (as you might when laminating hardwood for butcher block), I keep the workpieces under control with temporary guides.

To the first piece in my lamination, I clamp a pair of hardboard strips at both ends, as shown below. The strips guide the next piece (and subsequent pieces)

into proper alignment, so I can focus on tightening clamps without worrying about slippage. A good coating of paste wax on the inside of the guides keeps them from becoming part of the glue-up.

—Ralph Roberts,
Thompsonville, Mich.

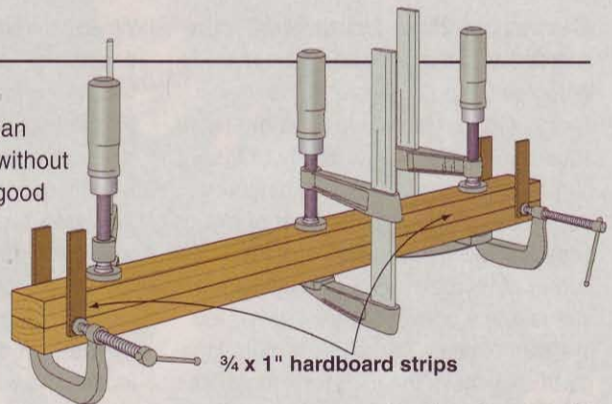

Continued on page 32

DREAM MACHINE

PUT YOUR ROUTER IN OUR MACHINE



Check out our demo at www.woodshopdemos.com



CMT INDUSTRIO™
PIVOTING FENCE



CMT INDUSTRIO™
ROUTING SYSTEM



REPLACEABLE ZERO
CLEARANCE INSERTS

Imagine the ultimate routing system for all your woodworking pleasures. Picture a spacious table top made of solid phenolic that will never warp and will provide you with many years of reliable service. Add on a heavy-duty anodized aluminum fence that pivots in both directions and makes set-ups fast and easy. Yes, and a split sub-fence with zero clearance inserts made of slick UHMW that your prized wood glides across almost effortlessly. Imagine your shop with CMT's New Industrio™ Routing System designed by Marc Sommerfeld. This system will make all your routing dreams real!

MADE IN ITALY

Router, feather boards, dust hose
and denim shirt not included.

CMT
the only ORANGE one™

CMT USA, Inc. • 307-F Pomona Drive • Greensboro, NC 27407 • 888-268-2487
Check out our NEW website at www.cmtusa.com

Corner the market on square assemblies

When gluing up a picture frame, I've always found it helpful to have a reliable square to ensure the accuracy of the angles. So, I added a pair of height-adjustable cleats to one corner of my assembly table, as shown at *right*. The corner of my bench is perfectly square, so the angle between the cleats is, too.

With the cleats raised, I can dry-fit the parts and check the joint for squareness.

When I'm ready to assemble, I protect my tabletop with waxed paper, apply glue to the joint, and clamp the workpieces to the cleats. This works especially well when assembling miter joints because the workpieces can't slip past each other.

When I'm done with the project, I loosen the wing nuts and lower the

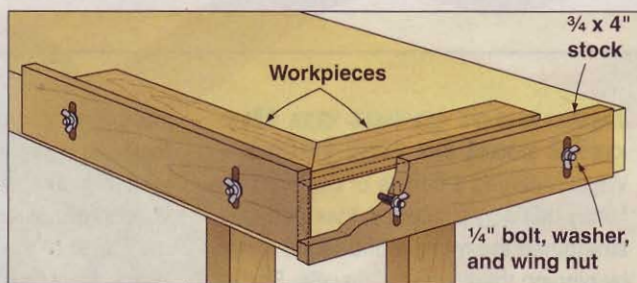

cleats. That way they don't interfere with the assembly of my next project.

—Eli Kopperud, Ely, Minn.

Adjustable clamps on a rubber-band budget

I build small wooden models, and find that most woodworking clamps are too heavy and bulky for fragile work. So, I made my own clamps, shown *below*, from scraps of hardwood, dowels, and rubber bands.

The only tricky part about making the clamps is cutting the shallow cove for the pivot dowel. I clamp a sacrificial piece of 1/2" stock between the two clamp sides, then bore through the center of that piece with a 3/4" Forstner bit in my drill press.

To increase the clamping pressure, I wrap the rubber band around the jaws an extra time. And, I can use a larger or smaller dowel to change the size of the jaw opening.

—Neil Rigby, Fremont, Calif.

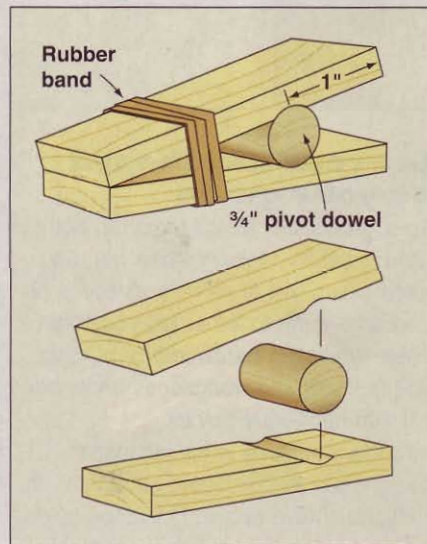

When the Sawdust Settles...

Premium Quality ZAR® Rises Above the Rest!

Whether you're creating your own masterpiece or want to give new life to a treasured family heirloom only the best wood stain will do. ZAR Wood Stain is formulated using only the finest ingredients. ZAR Wood Stain's controlled penetration formula allows you to work at your own pace. ZAR wipes on easily and penetrates evenly for uniform color tone without streaks, lapmarks or blotches. ZAR Wood Stain's extra rich formula makes it ideal for all types of wood; from Oak to Aspen to Poplar to Pine with beautiful results every time. So whether you're a professional or just want professional looking results - use ZAR Wood Stains and Clear Finishes.

ZAR
The Best Thing That Ever Happened to Wood!

For a free brochure and the name of your nearest dealer call 1-800-272-3235, or visit us at www.ugl.com.

YOU CONTROL THE STAIN IT DOESN'T CONTROL YOU!

ZAR Wood Stain wipes on evenly. Its controlled penetration gives you a uniform color tone without streaks or lap marks.

ZAR
Wipes on Evenly!

ZAR's controlled penetration allows you to apply the same stain to different species of wood and get matching color tones.

Pine Birch Oak Maple

Match Color Tone on Different Kinds of Woods.

Sparring with tool rust

When I turn on the heat in my uninsulated shop, you can almost watch the rust form on the machined surfaces of my tablesaw, jointer, etc. I tried commercial rust preventers, but they didn't last long or transferred to my project materials.

Purely by accident, I found that spar varnish, sprayed on my machine tabletops, effectively prevents rust. After a light sanding with 400-grit paper, the surfaces are shiny and smooth, with no transfer to my workpieces. It's been more than 6 months since the treatment and I've not seen a speck of rust.

—John Gaeler, Keswick, Ont., via WOOD ONLINE®



Hidden hangers for hefty projects

I made a couple of heavy oak corbels and a shelf for my wife last Christmas, but that was only half the battle: I also had to figure out how to securely mount those beasts to the wall. After I slept on it a few nights, the answer came to me as if in a dream.

I bought some mortise-style bedrail fasteners (Rockler Woodworking, 800/279-4441, part no. 28597 or 28589) and mounted one half to the wall, and the other half to the corbel, as shown *above right*. The shallow mortise is as deep as both brackets together. That allowed me to surface-mount the male bracket to the wall, yet the corbel really hugs the wall when mounted.

There's an added bonus to this method: As long as the bracket is plumb, your corbel will be. If you try this at home, make sure the male-bracket mounting screws bite into a stud. Otherwise, all of your hard work may come crashing down.

—Steve Keller, Galveston, Ind.

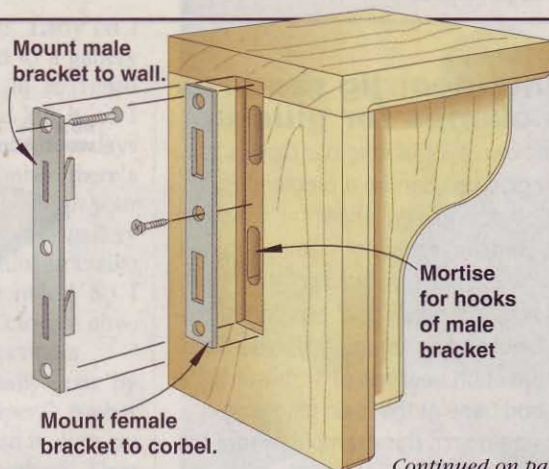

Continued on page 34

Refinish Your Future.



Own your own business.

Let your passion for furniture lead you into a new business with a Furniture Medic franchise. We're a complete on-site repair and restoration-refinishing business servicing homes and companies as well as handling moving and insurance claims. We offer extensive training and support with a low initial investment and manageable overhead. Financing is available to qualified candidates and franchises are offered nationwide. Call today to brush up on the details.



FURNITURE MEDIC®
"the prescription for damaged furniture"

www.furnituremedicfranchise.com



1-800-RUN YOURS

Panel-door jig requires no clamps for glue-up

I don't own a lot of long bar clamps, so large glue-ups can be a problem. But I created a simple jig, shown at right, that uses wedges instead of clamps to provide the clamping pressure.

Basically, it consists of two perpendicular fences attached to a plywood base. I mount short sections of 1" dowel to the plywood base at the main clamping-pressure points (for example, where the

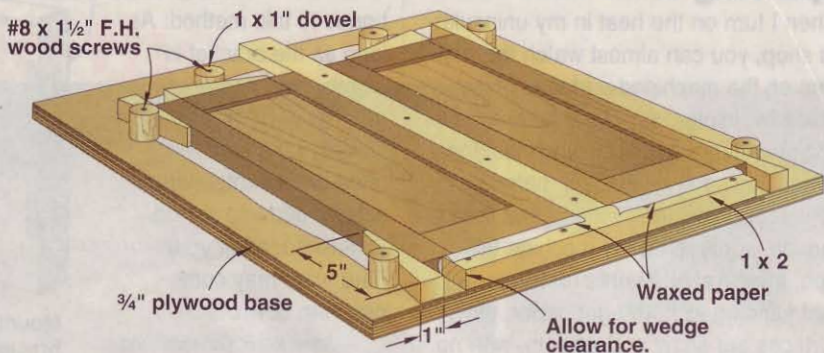

stiles meet the rails). With the dowels in place, I lay waxed paper over the base to protect it from glue squeeze-out, glue the door together, and tap in hardwood wedges, as shown in the drawing.

You can use this same jig for gluing up odd-shaped pieces simply by adding and/or moving the dowels and wedges wherever needed. It also works great for edge-joining pieces to make solid-stock panels.

—Roland Oesterle, St. Louis

Incra MITER1000

- ◆ 41 Indexed Angle Stops over ± 90° range
- ◆ 18" Incra Track Fence with Slide Stop
- ◆ Steel GlideLOCK™ Miter Bar with 6 Width Adjustment Points

SALE \$89

Incra MITER3000

- ◆ 364 Indexed Angle Stops over ± 90° range
- ◆ 27" Miter Fence + Dual-Flip Stop
- ◆ Steel GlideLOCK™ Miter Bar with 8 Width Adjustment Points

SALE \$219

Incra MITER5000

- ◆ 364 Indexed Angle Stops over ± 90°
- ◆ 36-64" Miter Fence + Dual-Flip Stop
- ◆ Steel GlideLOCK™ Miter Bar with 10 Width Adjustment Points
- ◆ Integral Hold-down Clamping System
- ◆ Renewable Zero Clearance Right Panel

SALE \$299

Stay, pencil, stay!

Invariably, round pencils and pens roll off my bench and do one of two things: Either they land point down, or they wind up where I can't reach them. To put the brakes on my writing utensils, I create a "flag," as shown below, from masking tape, sticky side in.

—Jay Wallace, Ashland, Ore.

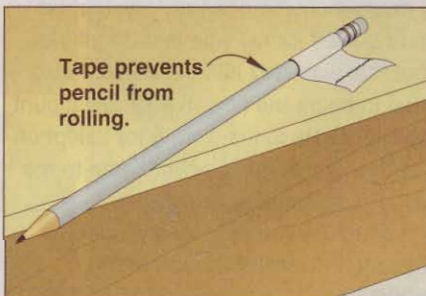

shop TIP

You'll find more great Shop Tips throughout every issue of WOOD magazine. Look for boxes like this one nestled among the project and technique articles.

Produce perfect gap-free hairline glue joints on the mitered corners of any multi-sided object on your first try without trial-and-error setups.



Woodpeckers Inc.

The Incra Tool Source

www.woodpeck.com

All models include: Adjustable GlideLOCK Miter Bar, Incra Specified Fence with Stop Positioner, and FREE Video Brochure.

1-800-752-0725



This sofa/sleeper is a great addition to the den, family room, or home office that gets pressed into service as a guest room. Or build it as the first piece of a living room set, adding the matching pieces to be featured in future issues of *WOOD*® magazine. A television stand (issue 141) and a knockdown modular shelving unit (issue 143) round out the set, sharing the same crisp lines and simple construction.

Note: Our sofa/sleeper uses a standard futon mattress. For more information on these mattresses, see the article "Futon hunting," on page 86.



sleeping
beauty

futon

Your garage isn't the only place to park a classy convertible.

Start at the ends

1 From $\frac{3}{4}$ " poplar, cut the frame tops/bottoms (A), and frame ends (B), to the sizes noted in the Materials List. Glue and clamp the frames (A/B) together, keeping the ends flush, where shown on **Drawing 1**. Make sure the frames' outside dimensions are $15 \times 30\frac{1}{2}$ ", the same as the panels (D). Measure the frames' diagonals to check for squareness, and place them on a flat surface to dry. With the glue dry, remove the clamps, drill pilot and countersunk shank holes, and drive in the screws.

2 Cut the blocking (C) to size. (The blocking provides solid anchoring for the bedrail fasteners' mounting screws.)

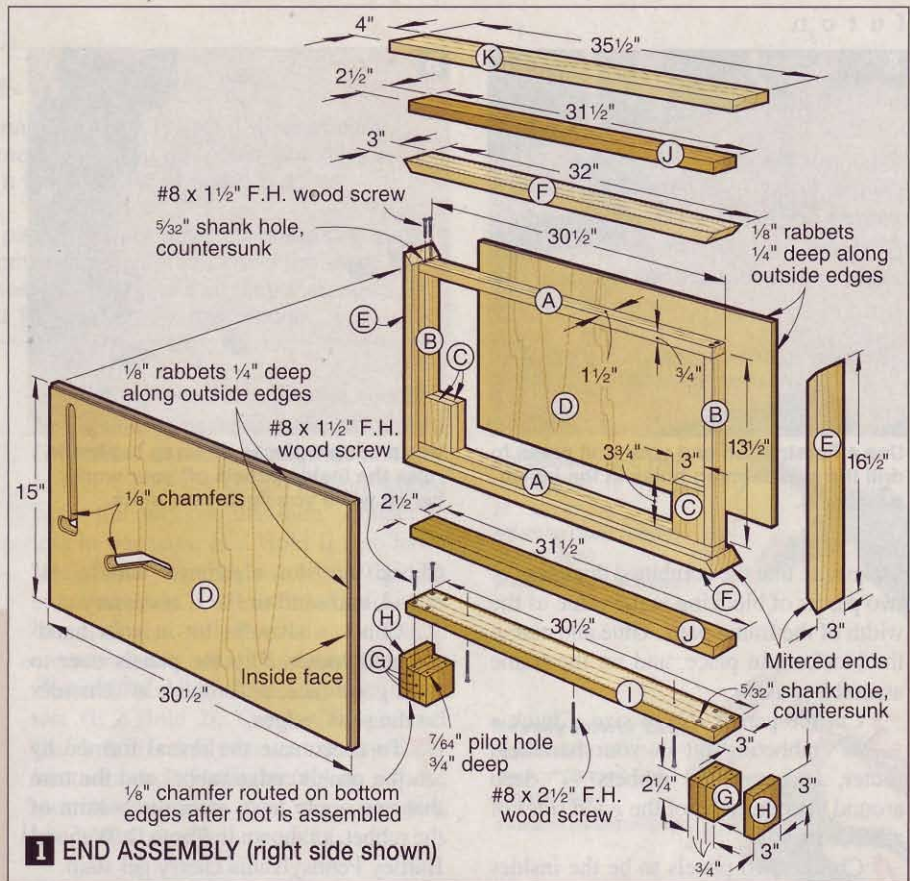

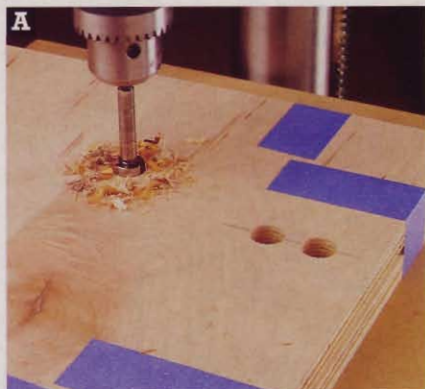

A Use a Forstner bit and your drill press to drill the slot-defining holes in the inside panels (D).

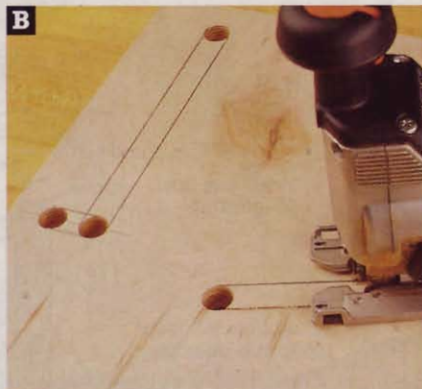

B Use a couple pieces of scrap lumber to raise the inside panels off your workbench while you jigsaw the slots.



C Mask the rabbet's edge to keep the stain from accidentally bleeding onto the panel's surface.

Make sure that the combined thickness of two pieces of blocking is the same as the width of the frame parts. Glue and clamp the blocking in place, and set the frame assemblies aside.

3 Cut the panels (D) to size. Chuck a $\frac{1}{8}$ " rabbeting bit in your handheld router, and rout $\frac{1}{8}$ " rabbets $\frac{1}{4}$ " deep around the perimeter of the good sides of all four panels.

4 Choose two panels to be the insides of the sofa's end assemblies, and tape them together face-to-face. Mark centerpoints on the back of the top panel for the $\frac{3}{4}$ " holes that define the slots, where shown on **Drawing 2**. Drill the holes through both panels, as shown in **Photo A**.

5 Draw lines on both panels connecting the holes to form the slots' shapes, where shown on **Drawing 2**. Separate the panels, and use your jigsaw to cut the slots, as shown in **Photo B**.

Check the slot clearance with a $\frac{3}{4}$ " dowel, and sand or file if necessary.

6 Chuck a chamfer bit in your handheld router. Flip the panels over to their good face, and rout a $\frac{1}{8}$ " chamfer on the slots' edges.

7 To accentuate the reveal formed by the panels' edge rabbet and the trim that you apply next, stain the bottom of the rabbet, as shown in **Photo C**. We used Bartley Pennsylvania cherry gel stain.

8 Glue and clamp the panels to the frame assemblies, where shown on **Drawing 1**. Be sure that the panels' edges are flush with the frame.

9 Cut the end trim (E) and the top/bottom trim (F) about 1" longer than noted in the Materials List. Fit the trim around the end panels, miter-cutting it to length. Glue and clamp the trim to the panels. With the glue dry, remove the clamps and finish-sand the end assemblies to 220 grit.

Add the feet and arms

1 Cut the foot bodies (G), foot faces (H), stretchers (I), and reveal trim (J) to size. Laminate the feet (G/H), as shown on **Drawing 1**, keeping the bottoms and sides flush. With the glue dry, clamp the feet to the stretchers (I), and drill the pilot and countersunk shank holes. Spread glue, and screw the stretchers to the feet. With the chamfer bit still in your router, rout a $\frac{1}{8}$ " chamfer around the bottom edge of each foot.

2 Finish-sand the foot assemblies (G/H/I) and parts J to 220 grit. If you wish to stain these mahogany parts, do it now, before assembly. We stained ours using the same Bartley stain as before. Let the stain dry thoroughly.

3 Glue and clamp the reveal trim (J) to the end assemblies, centering them front-to-back and side-to-side. With the glue dry, clamp the foot assemblies in place. The edges of the foot assemblies are flush with the edges of the bottom trim (F). Drill pilot and countersunk shank holes through the stretchers (I) into the end assemblies. Spread glue, and screw the foot assemblies in place.

4 Cut the arms (K) to size, and finish-sand them to 220 grit. Glue and clamp them to the end assemblies. The arms are flush with the inside end panels and protrude equally at front and rear.

Now for the backrest and seat

1 Cut the backrest uprights (M), top rail (N), bottom rail (O), seat ends (Q), fillers (R), rear rail (S), and front rail (T) to size. We planed down $\frac{3}{4}$ " stock for these parts. You can laminate them from $\frac{1}{2}$ " stock as well. You'll cut the

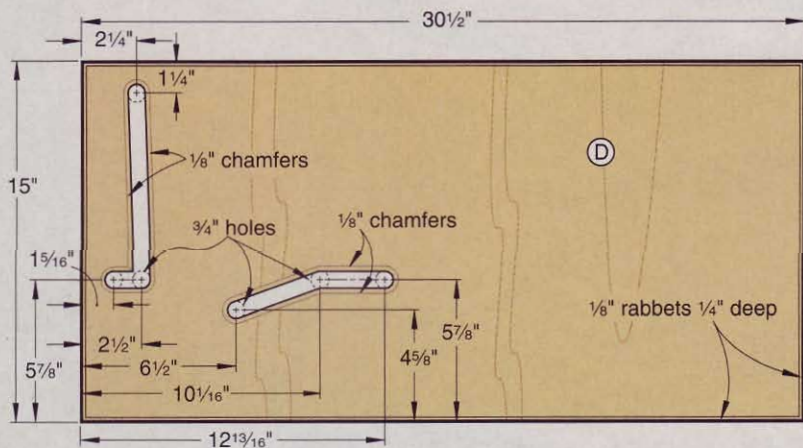

2 INSIDE PANEL

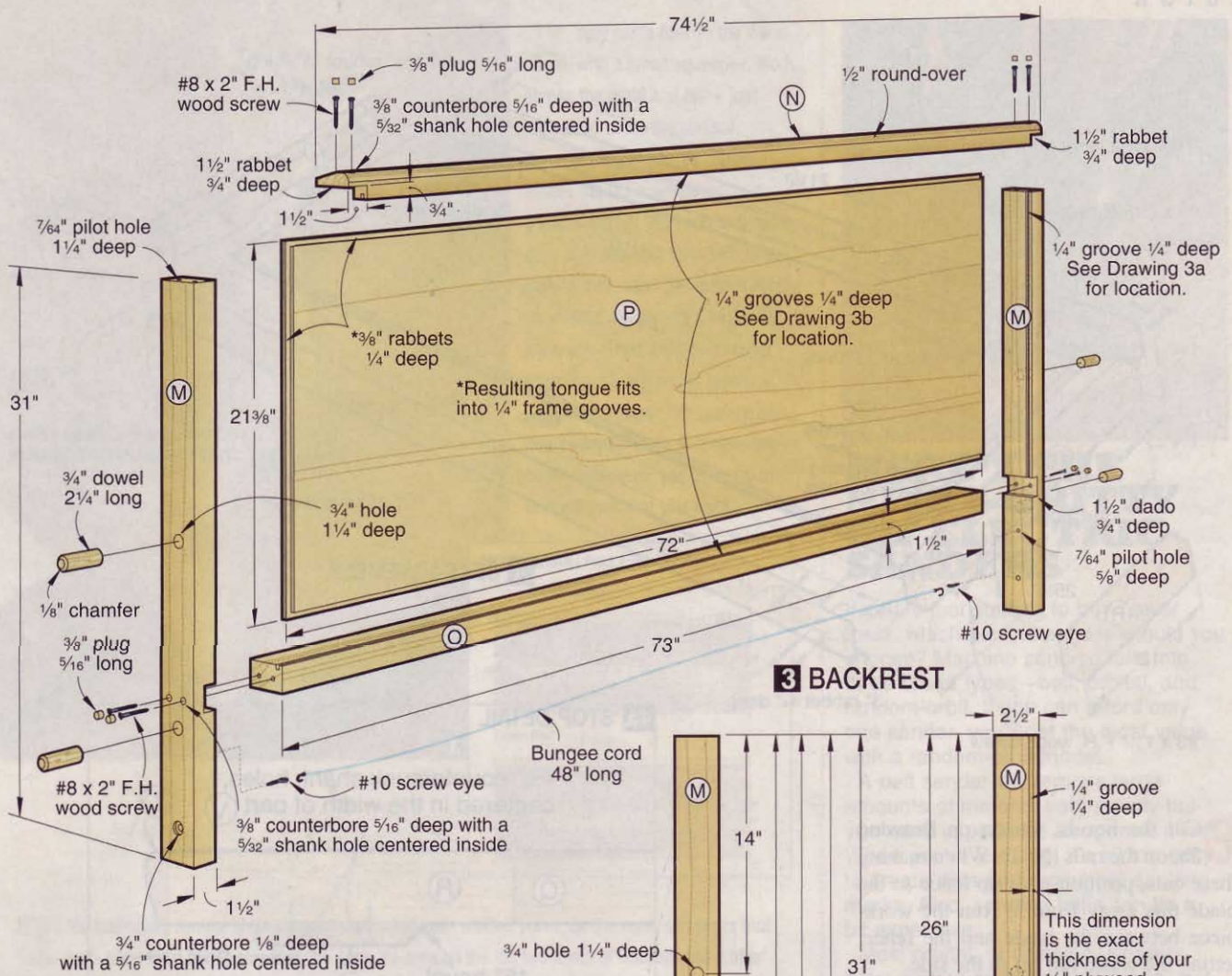

3 BACKREST

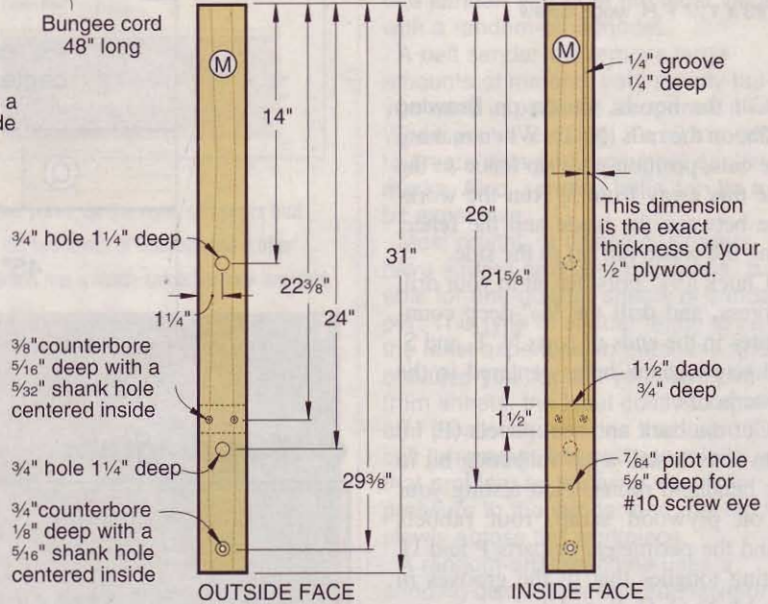

3a UPRIGHT (RIGHT SIDE SHOWN)

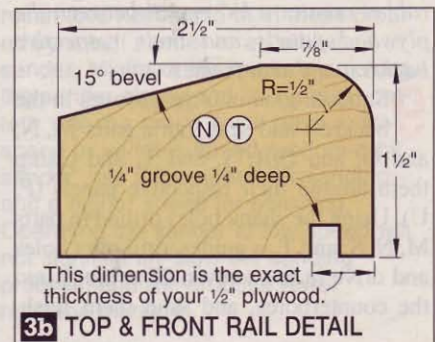

3b TOP & FRONT RAIL DETAIL

backrest panel (P) later when you cut the seat panel (U).

2 Drill the counterbores and holes in the uprights (M) and ends (Q), where shown on **Drawings 3a** and **4**. Then glue and clamp the fillers (R) to the ends (Q), where shown on **Drawing 4**.

3 Install a 3/4" dado blade in your table-saw, and adjust it to cut 3/4" deep. To prevent chip-out, attach an auxiliary extension to your miter gauge. Positioning the rip fence as an end stop, cut the 1 1/2" dados in the uprights (M), the 1 1/2" rabbets in the ends of the top rail (N) and rear rail (S), and the 3" rabbets in the ends of the front rail (T), where shown on **Drawings 3, 3a**, and **4**.

4 Chuck a 1/4" slot cutter in your table-mounted router. Lay a piece of the 1/2" plywood for the back and seat panels (P, U) next to the cutter. Adjust the cut-

ter so its top edge matches the plywood's thickness. Position the fence to make a 1/4"-deep cut. Rout the grooves in parts M, N, O, Q, S, and T where shown on **Drawings 3, 3a**, and **4**.

5 Replace the slot cutter in your table-mounted router with a 1/2" round-over bit. Rout round-overs, shown on **Drawing 3b**, on the top and front rails (N, T), where shown on **Drawings 3** and **4**.

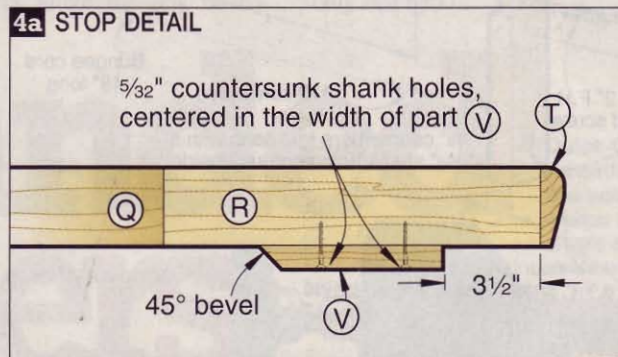
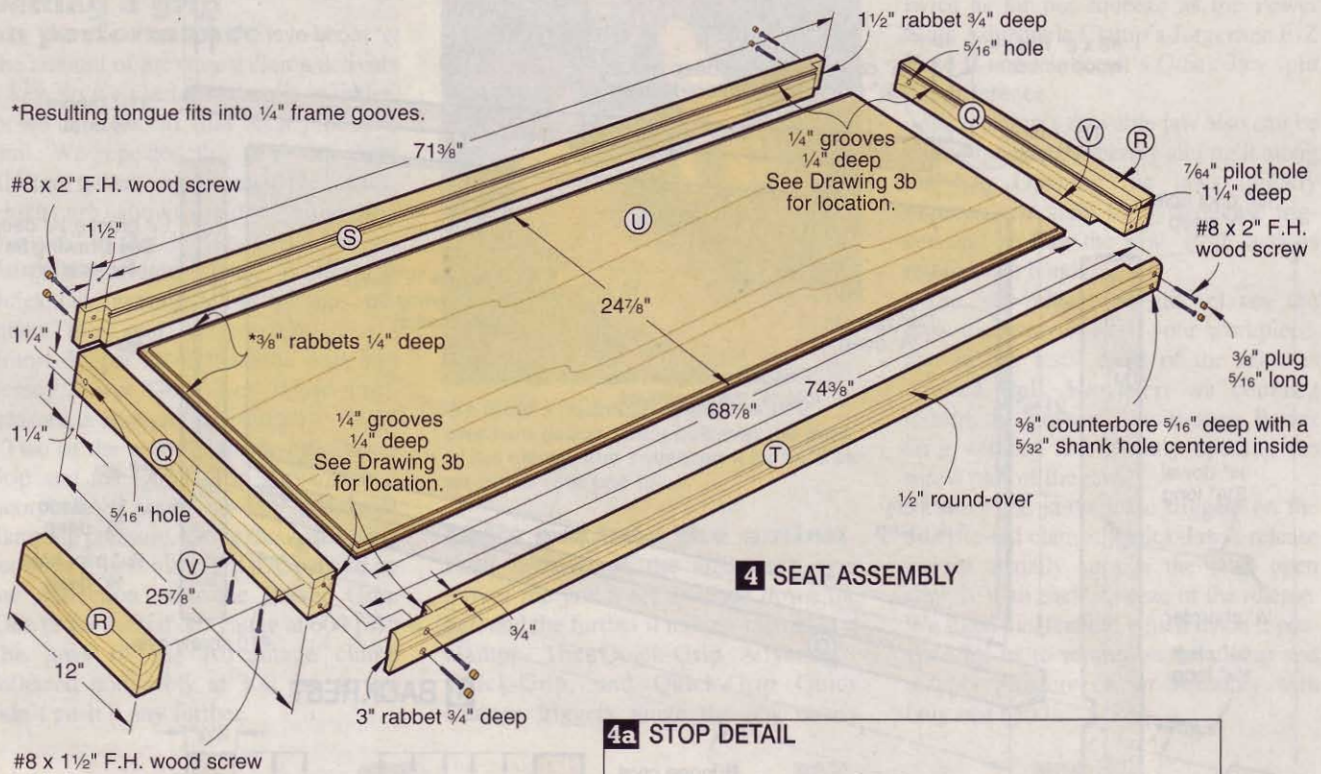

6 Cut the bevels, shown on **Drawing 3b**, on the rails (N, T). When making these cuts, position your rip fence so the blade tilts away from it. Run the workpiece between the blade and the fence, letting the waste fall off to the side.

7 Chuck a 3/8" Forstner bit in your drill press, and drill the 5/16"-deep counterbores in the ends of parts N, T, and S. Drill screw shank holes centered in the counterbores.

8 Cut the back and seat panels (P, U) to size. Install a 3/8" rabbeting bit in your handheld router. First testing your cut on plywood scrap, rout rabbets around the perimeters of parts P and U, creating tongues that fit the grooves in parts M, N, O, Q, S, and T.

Note: When assembled, the 3/8"-wide rabbet creates a 1/8" reveal between the plywood panels and their respective backrest and seat frames.

9 Squeeze glue into the grooves in the backrest and seat frame parts M, N, and O, and Q/R, S, and T, and clamp them around their respective panels (P, U). Using the shank holes drilled in parts M, N, S, and T as guides, drill pilot holes and drive in the screws. Glue plugs into the counterbores, and sand them flush.

cutting diagram

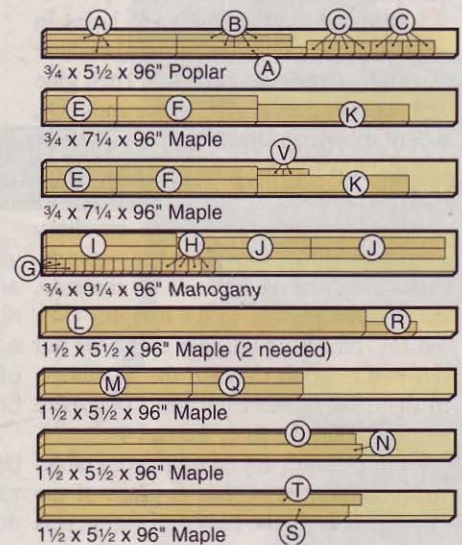
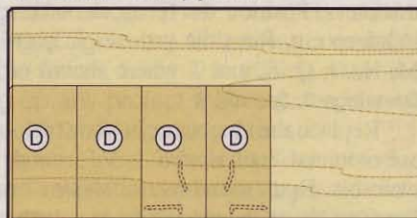
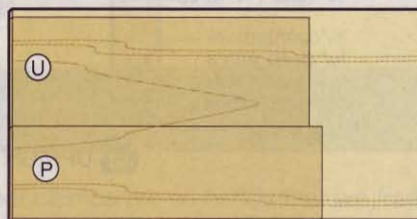

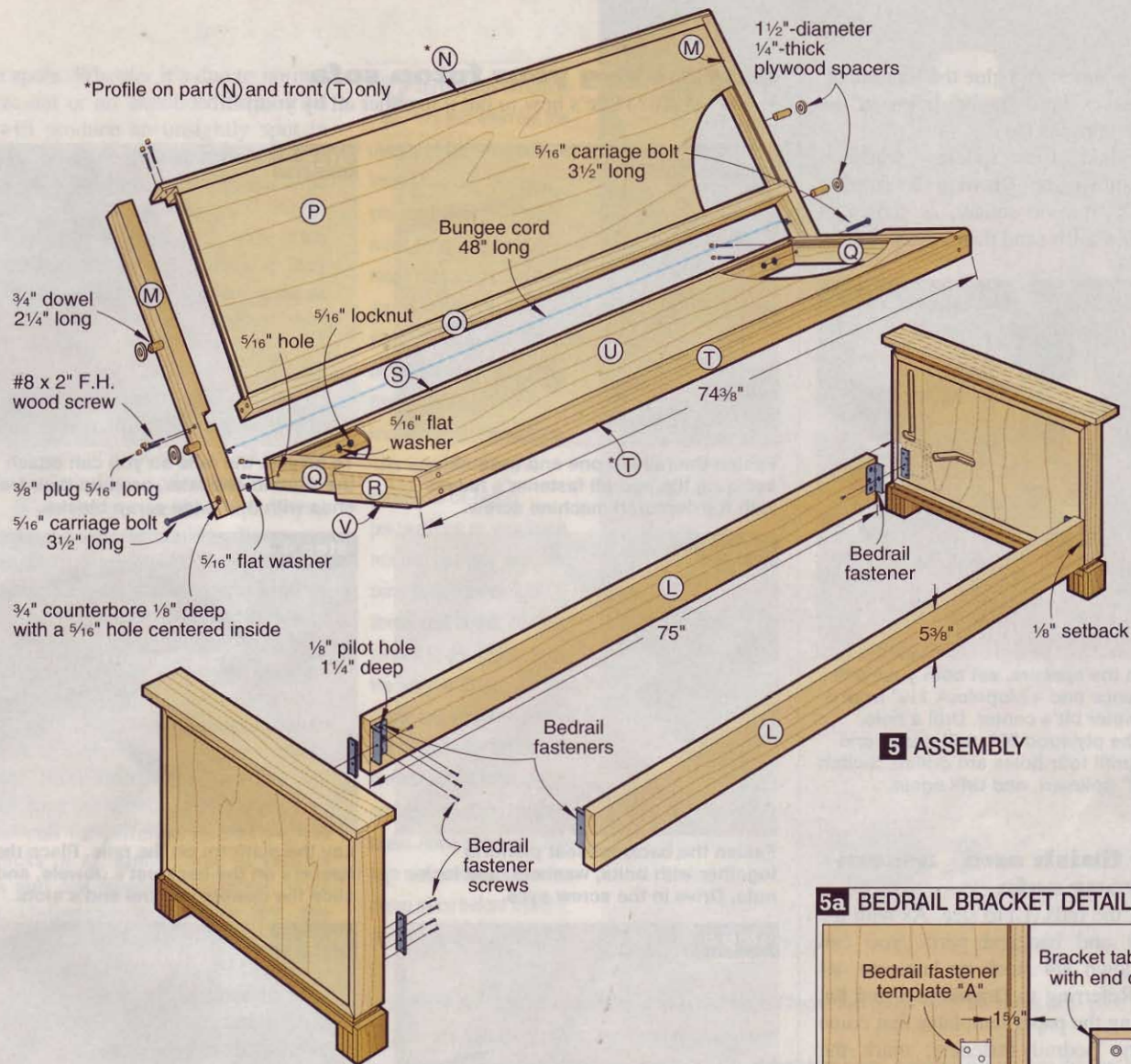

5 ASSEMBLY

5a BEDRAIL BRACKET DETAIL

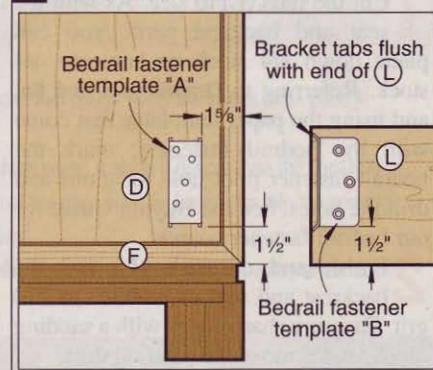

materials list

Ends and Rails	FINISHED SIZE			
	T	W	L	Matl. Qty.
A frametops/bottoms	3/4"	1 1/2"	30 1/2"	P 4
B frame ends	3/4"	1 1/2"	13 1/2"	P 4
C blocking	3/4"	3"	3 3/4"	P 8
D panels	3/4"	30 1/2"	15"	MP 4
E* end trim	3/4"	3"	16 1/2"	M 4
F* top/bottom trim	3/4"	3"	32"	M 4
G foot bodies	3/4"	3"	2 1/4"	MY 12
H foot faces	3/4"	3"	3"	MY 4
I stretchers	3/4"	3"	30 1/2"	MY 2
J reveal trim	3/4"	2 1/2"	31 1/2"	MY 4
K arms	3/4"	4"	35 1/2"	M 2
L rails	1 1/2"	5 3/8"	75"	M 2
Backrest				
M uprights	1 1/2"	2 1/2"	31"	M 2
N top rail	1 1/2"	2 1/2"	74 1/2"	M 1
O bottom rail	1 1/2"	2 1/2"	73"	M 1
P backrest panel	1/2"	21 3/8"	72"	BP 1

Seat	FINISHED SIZE			
	T	W	L	Matl. Qty.
Q ends	1 1/2"	2 1/2"	25 7/8"	M 2
R fillers	1 1/2"	2 1/2"	12"	M 2
S rear rail	1 1/2"	2 1/2"	71 3/8"	M 1
T front rail	1 1/2"	2 1/2"	74 3/8"	M 1
U seat panel	1/2"	24 7/8"	68 7/8"	BP 1
V stops	3/4"	1 1/2"	6"	M 2

*Parts initially cut oversize. See the instructions.

Materials Key: P—poplar, MP—maple plywood, M—maple, MY—mahogany, BP—birch plywood.

Supplies: #8x1 1/2" flathead wood screws (36), #8x2" flathead wood screws (16), #8x2 1/2" flathead wood screws (6), 5/16" carriage bolts 3 1/2" long (2), 5/16" flat washers (4), 5/16" locknuts (2), #10 screw eyes (2), 1/2" diameterx48" bungee cord, 3/4" birch dowel, 1/4x5x5" plywood, glue, stain, finish, standard futon mattress.

Buying Guide. Bedrail fasteners no. 953-817, \$9.95/set of four with screws. Woodworker's Supply, 1108 North Glenn Road, Casper, WY 82601-1698. Call 800/645-9292 to order.

(We made our own plugs with a plug cutter chucked in our drill press, allowing us to match wood color and grain.)

10 Cut the stops (V) to size and bevel one end, where shown on **Drawing 4a**. Lay the seat facedown and clamp the stops in place. Drill the pilot and countersunk shank holes. Remove the clamps, spread glue, and screw the stops in place.

11 Use your disc sander to sand a 1/8" chamfer on the end of a 3/4" dowel, then cut off a 2 1/4" length. Repeat

this three times, and glue the four chamfered pieces into the $\frac{3}{4}$ " holes in the backrest uprights (M).

12 Make four spacing washers, shown on **Drawing 5**, from a $\frac{1}{4}$ "x5x5" plywood square, as shown in **Photo D**. Finish-sand their edges.

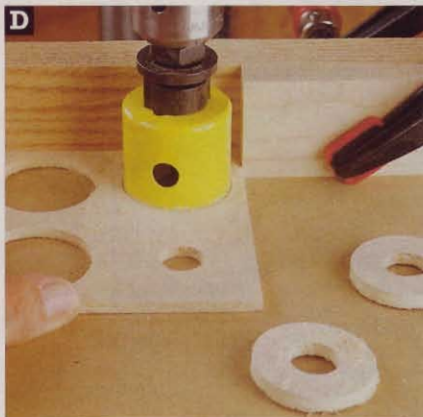

To form the spacers, set both your drill-press fence and a stopblock $\frac{1}{4}$ " from a $\frac{3}{4}$ " Forstner bit's center. Drill a hole, rotate the plywood 90°, drill again, and repeat until four holes are drilled. Switch to a $\frac{1}{2}$ " holesaw, and drill again.

Now finish and assemble your sofa

1 Cut the rails (L) to size. As with the seat and backrest parts, you can plane down $\frac{3}{4}$ " stock or laminate $\frac{1}{4}$ " stock. Referring to **Drawings 5** and **5a**, and using the paper templates that come with the bedrail fasteners, mark the bedrail fastener pilot hole locations and drill the holes. See the Buying Guide for our bedrail fastener source.

2 Finish-sand the rails (L) and the backrest and seat assemblies to 220 grit. Ease any sharp edges with a sanding block, and remove the sanding dust.

3 Apply two coats of clear finish. We used a gloss polyurethane for the first coat and when dry, sanded it lightly with 220-grit sandpaper. We then top-coated with a satin polyurethane.

4 Screw the bedrail fasteners to the end assemblies and rails (L), driving the provided screws into the previously drilled pilot holes.

5 To assemble your sofa, see the step-by-step instructions at *right*. ♣

Written by **Jan Hale Svec** with **Charles I. Hedlund**
Project design: **Kevin Boyle**
Illustrations: **Roxanne LeMoine**; **Lorna Johnson**
Photographs: **Baldwin Photography**

Assembling your futon sofa

Working solo? Here's how to put it together all by yourself.



step 1
Fasten the rails to one end assembly, securing the bedrail fastener's halves with the captured machine screw.



step 2
To elevate the rails so you can attach the second end later, prop up their free ends with $\frac{3}{4}$ "-wide scrap blocks.

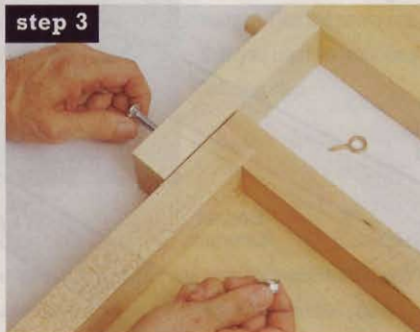

step 3
Fasten the backrest/seat platform together with bolts, washers, and lock-nuts. Drive in the screw eyes.



step 4
Lay the platform on the rails. Place the spacers on the backrest's dowels, and slide the dowels into the end's slots.



step 5
Bring the second end into position, engaging the backrest's dowels in its slots, and aligning the bedrail fasteners.



step 6
Pivot the seat up, and rest it on the backrest. Secure the front bedrail fastener to the second end.



step 7
Fold the platform into its seat mode, and secure the back bedrail fastener to the second end. Remove the prop blocks.



step 8
Secure the mattress with a 48"-long heavy-duty ($\frac{1}{2}$ " diameter) bungee cord, hooking its ends into the screw eyes.

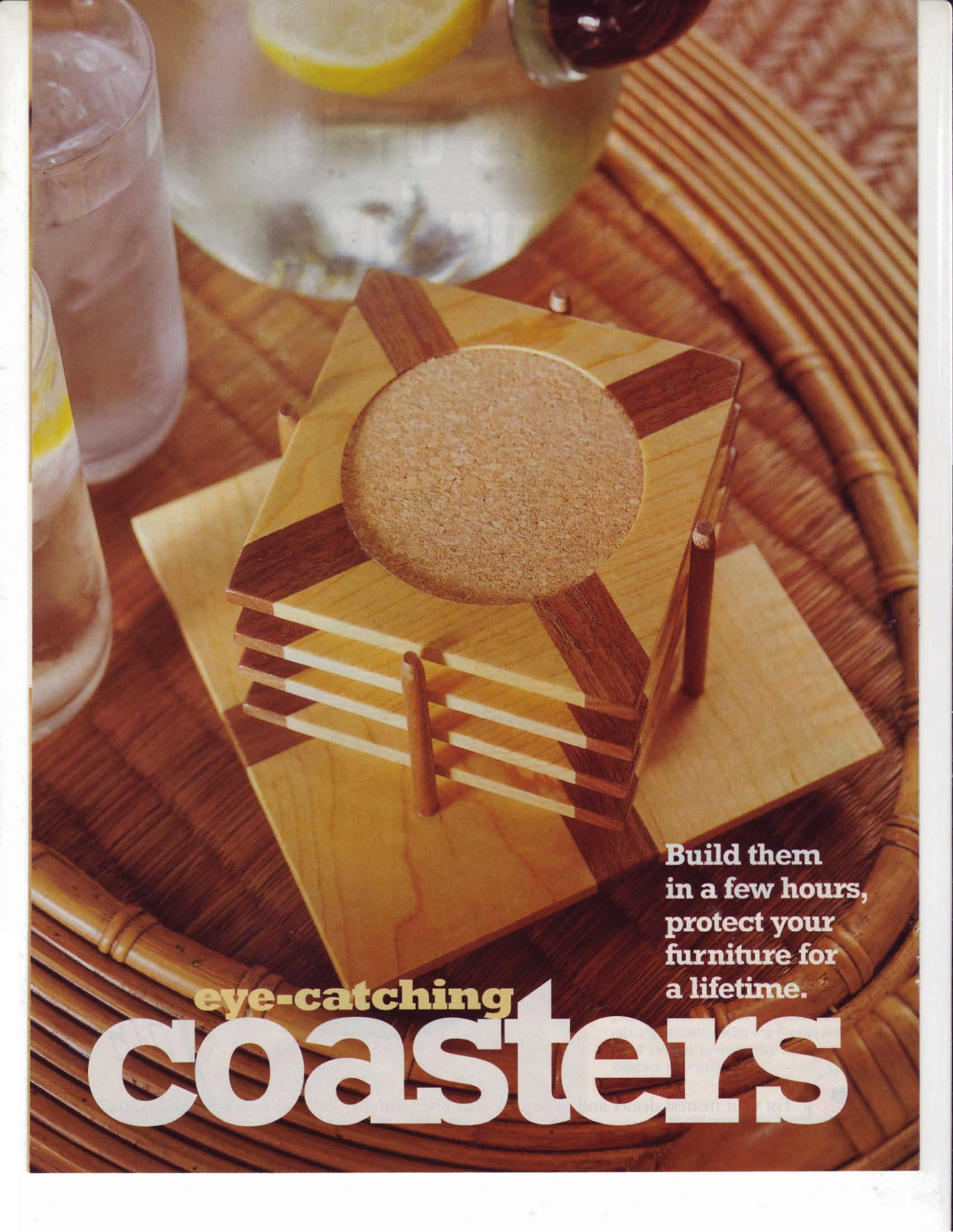

Build them
in a few hours,
protect your
furniture for
a lifetime.

eye-catching
coasters

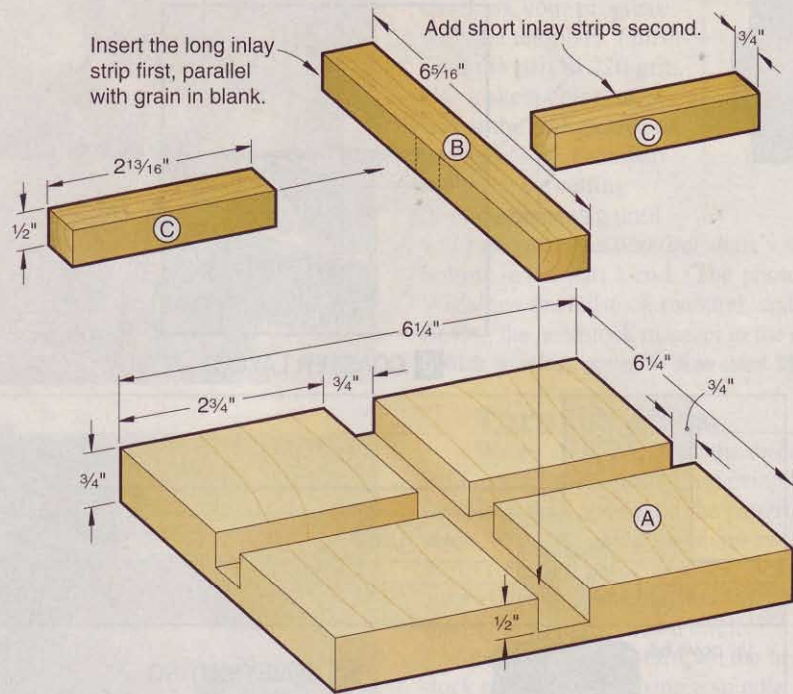

1 BASEPLATE AND COASTER BLANKS

This great-looking coaster set scores high points as a project for two reasons: It's simple to build and very useful. The whole set is made up of just a few pieces of scrap lumber, plus some cork discs and hardwood dowels. Follow our easy steps to coast through the construction, then relax, have a beverage, and enjoy the fruits of your labor.

Start by making blanks

1 Cut five pieces of $\frac{3}{4}$ " maple to $6\frac{1}{4} \times 6\frac{1}{4}$ " to create the baseplate and coaster blanks (A), shown in **Drawing 1**.

2 Chuck a $\frac{3}{4}$ " straight bit in your table-mounted router and set the fence, where shown in **Drawing 2**, to center the bit on each baseplate blank (A). Rout the intersecting grooves in multiple passes, raising the bit by about $\frac{1}{8}$ " after each pass until you get to the final depth of $\frac{1}{2}$ ". To save time, make cuts in all five blanks before changing router settings.

3 Cut two $\frac{1}{2} \times \frac{3}{4} \times 36$ " strips for parts B and C, making sure they snugly fit in the blanks' grooves. Then crosscut the

five long inlay strips (B) and ten short inlay strips (C) to the sizes shown on **Drawing 1**.

4 Apply glue to the grooves in the baseplate and coaster blanks (A). Then glue the inlay strips (B, C) in place, orienting the long inlay strips parallel to the grain in each blank. Because the coasters may get wet, we used exterior glue (such as Titebond II). Note that the ends of the inlay strips extend slightly beyond the edges of the blanks.

5 After the glue sets, sand the ends of the inlay strips (B, C) flush with the edges of the blanks, as shown in **Photo A**. Set one blank aside for the baseplate.

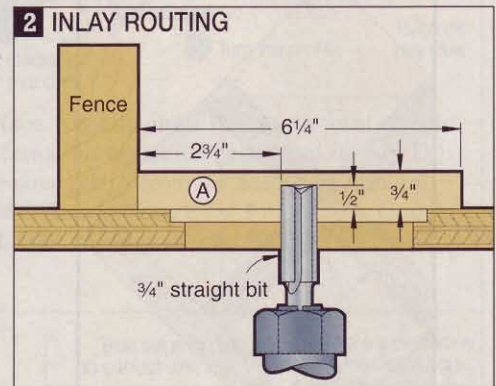

Use 80- or 100-grit sandpaper on a block to remove excess inlay. Choose one blank to use as the baseplate, sand its edges to 150 grit, and set it aside.



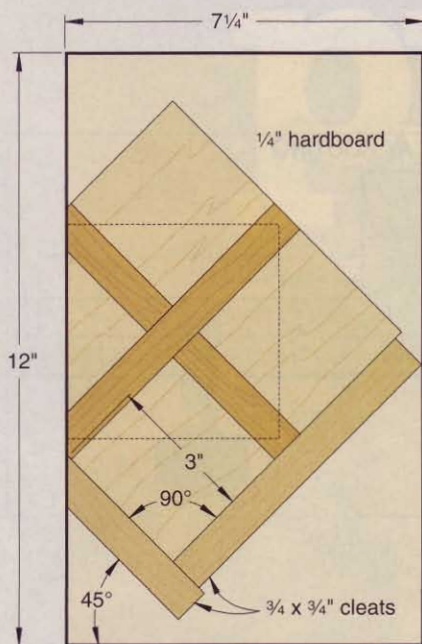

3 CORNER-CUTTING JIG

Cut the coasters to size

1 Trim the corners off the remaining four blanks to form the coasters. To do this, make the jig shown in **Drawing 3** by gluing short cleats to a piece of 1/4" hardboard. This jig ensures each coaster will be the same size, and that their corners are centered on the inlay strips.

2 Position your tablesaw fence 7 1/4" from the blade, then use the jig to cut the first three corners from each coaster, as shown in **Photo B** and **Drawing 4**.

3 Reposition the rip fence 4 1/4" from the blade and cut the final corner from each of the four coaster blanks, as shown in **Photo C**.

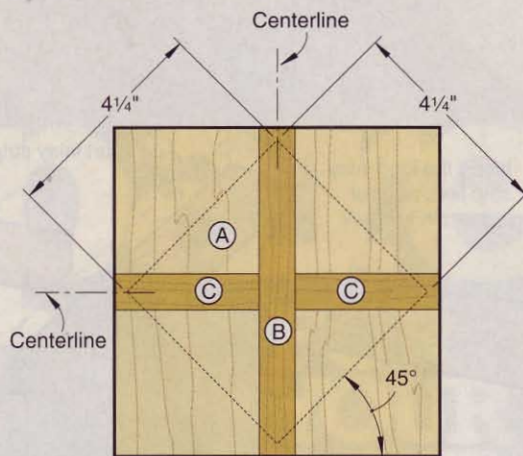

4 COASTER LAYOUT

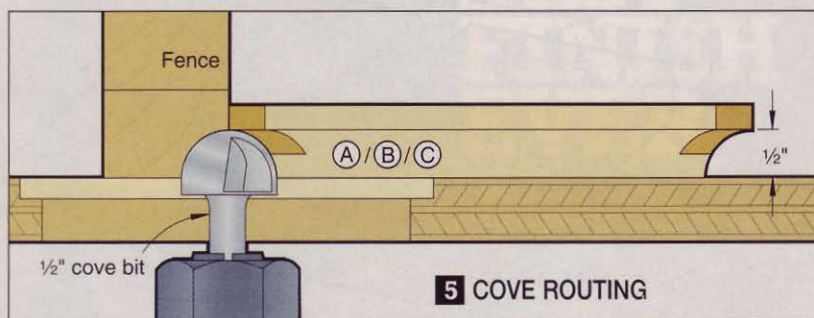

5 COVE ROUTING

Route the coves and cork recess

1 Chuck a 1/2" cove bit in your table-mounted router, and rout the cove on both ends and edges of each coaster, as well as on the baseplate, where shown in **Drawing 5**. Make multiple passes to achieve the final 1/2" depth. To reduce

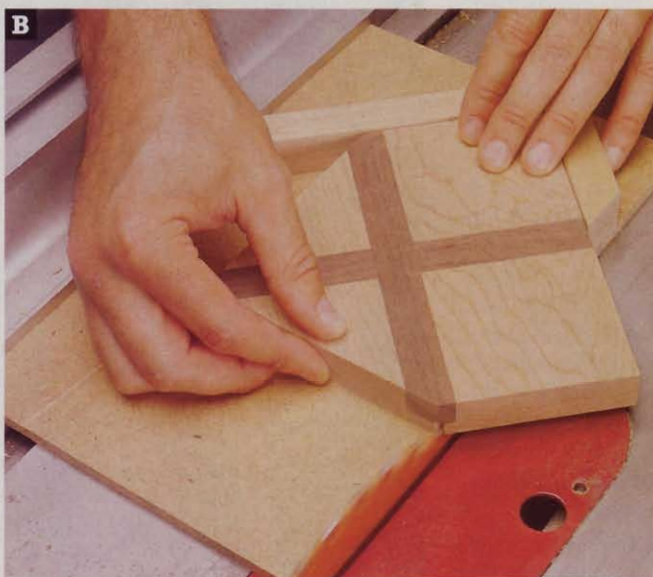

Position the tablesaw fence so the corner-cutting jig just slips past the blade. Hold each blank securely against the jig cleats as you cut four of the blanks down to 4 1/4 x 4 1/4".



To reduce the chance of kickback when cutting short pieces, keep the blade low and hold each coaster securely against the fence as you make the cut.

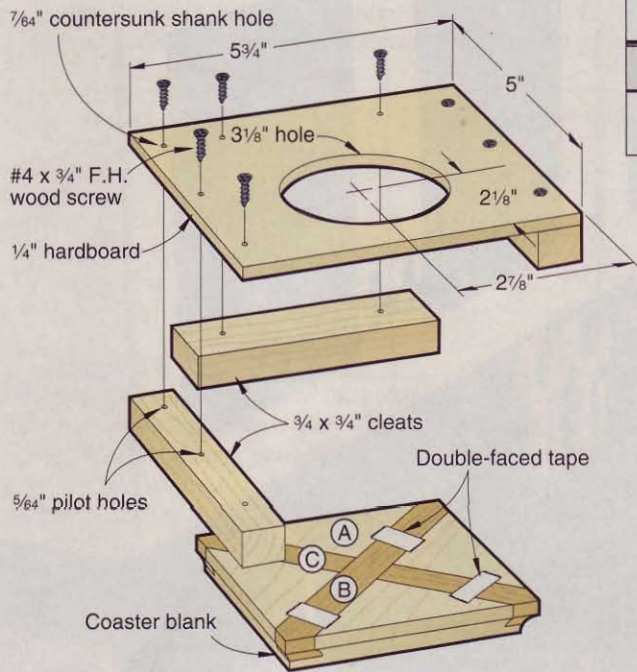

6 RECESS-ROUTING JIG

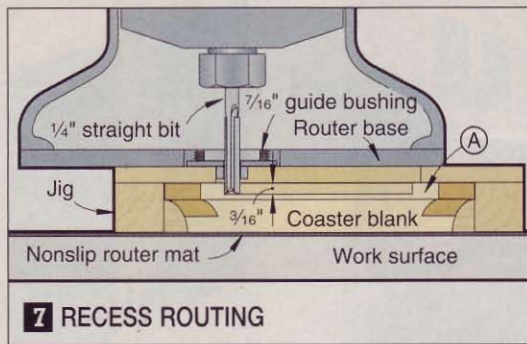

7 RECESS ROUTING

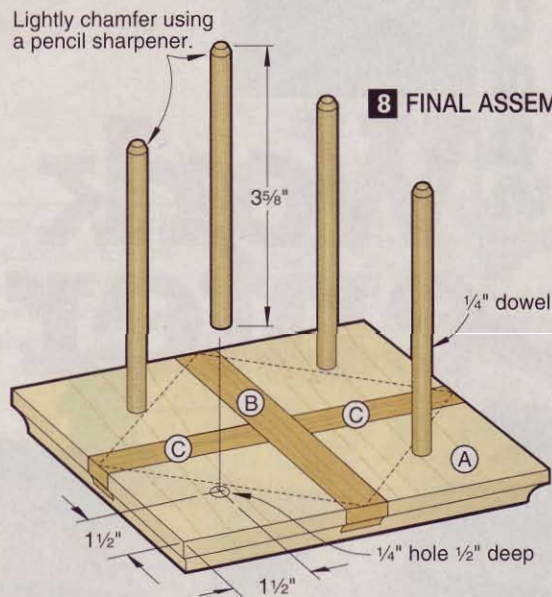

8 FINAL ASSEMBLY

chip-out, rout end grain first, then work your way around the piece.

2 Each coaster has a small recess to accept a precut, adhesive-backed cork disc. To create the recess, start by making the recess-routing jig shown in **Drawing 6**. The jig is simply a piece of 1/4" hardboard with scrapwood cleats screwed to the underside and a 3 1/8" hole bored at the location shown.

3 Install a 7/16" guide bushing and chuck a 1/4" straight bit in your handheld router, setting the bit to make a 3/16"-deep cut. Temporarily secure a coaster to the jig with small pieces of double-faced tape, then rout the recess, where shown in **Drawing 7**. (Lay the jig and attached workpiece on a nonslip router mat to keep them from moving around as you rout.) Rout the edge of the recess first, following the jig. Then rout away the interior by moving the router back and forth across the field. Repeat this procedure with each of the three remaining coasters.

Add dowels and finish

1 Drill four 1/4" holes 1/2" deep in the baseplate assembly (A/B/C), where dimensioned on **Drawing 8**, to accept the 1/4" dowels.

2 Cut four dowels to 3 5/8" long. We used walnut dowels, which are available through woodworking supply stores and the source listed in the Buying Guide. To dress up the ends, add a slight chamfer at the top. You can sand to create the chamfer, but a simpler way is to just give each dowel a few turns in a handheld pencil sharpener.

3 Glue the dowels into the baseplate with the chamfered ends up.

4 Finish the completed baseplate and coasters with a couple coats of polyurethane. As you apply the finish, take care to not let too much build up around the edges of the cork recesses. Excess finish will prevent the cork disc from sitting flat.

5 Double-check the fit of each cork disc, and sand the edge if necessary

to fit into the recess. Then peel off the backing and stick a cork disc into each coaster to complete the project. 🍷

Written by **David Stone** with **Kevin Boyle**
Project design: **Kevin Boyle**
Illustrations: **Mike Mittermeier**; **Lorna Johnson**
Photographs: **Baldwin Photography**

materials list

Part	FINISHED SIZE			Matl. Qty.
	T	W	L	
A baseplate and coaster blanks	3/4"	6 1/4"	6 1/4"	M 5
B* long inlay strips	1/2"	3/4"	6 5/16"	W 5
C* short inlay strips	1/2"	3/4"	2 13/16"	W 10

*Pieces initially cut oversize; see the instructions.

Materials Key: M—maple, W—walnut.

Supplies: exterior glue, finish.

Buying Guide: 1/4x3/8" walnut dowel, no. 7512, \$1.89; 1/8x2 1/16" cork coaster disc, no. 832, \$3.12/8. Order both from Meisel Hardware Specialties, PO Box 70, Mound, MN 55364; 800/441-9870; www.meiselwoodhobby.com

Space-Saving

Work Center

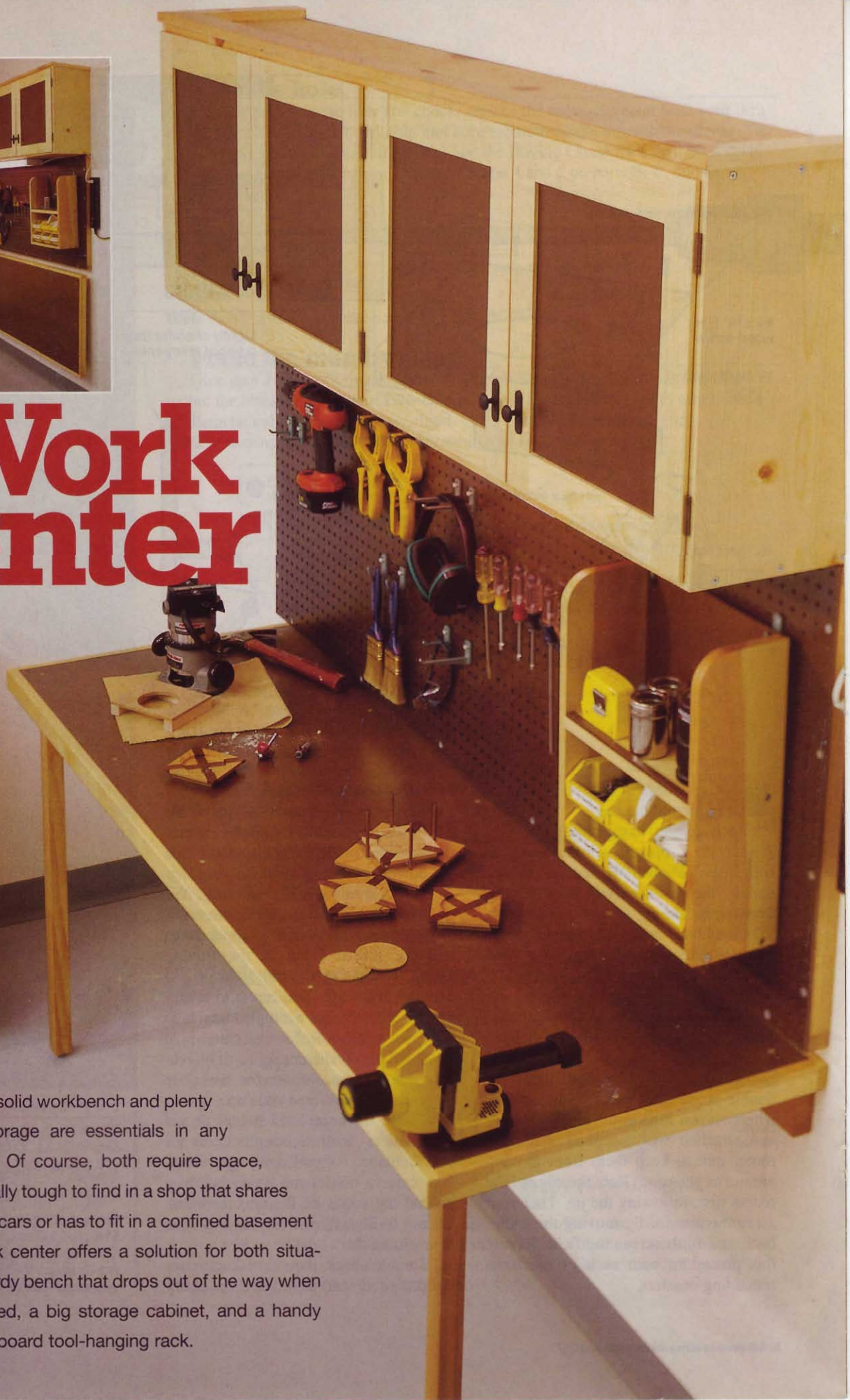

A rock-solid workbench and plenty of storage are essentials in any shop. Of course, both require space, which is especially tough to find in a shop that shares the garage with cars or has to fit in a confined basement room. This work center offers a solution for both situations, with a sturdy bench that drops out of the way when no longer needed, a big storage cabinet, and a handy perforated-hardboard tool-hanging rack.

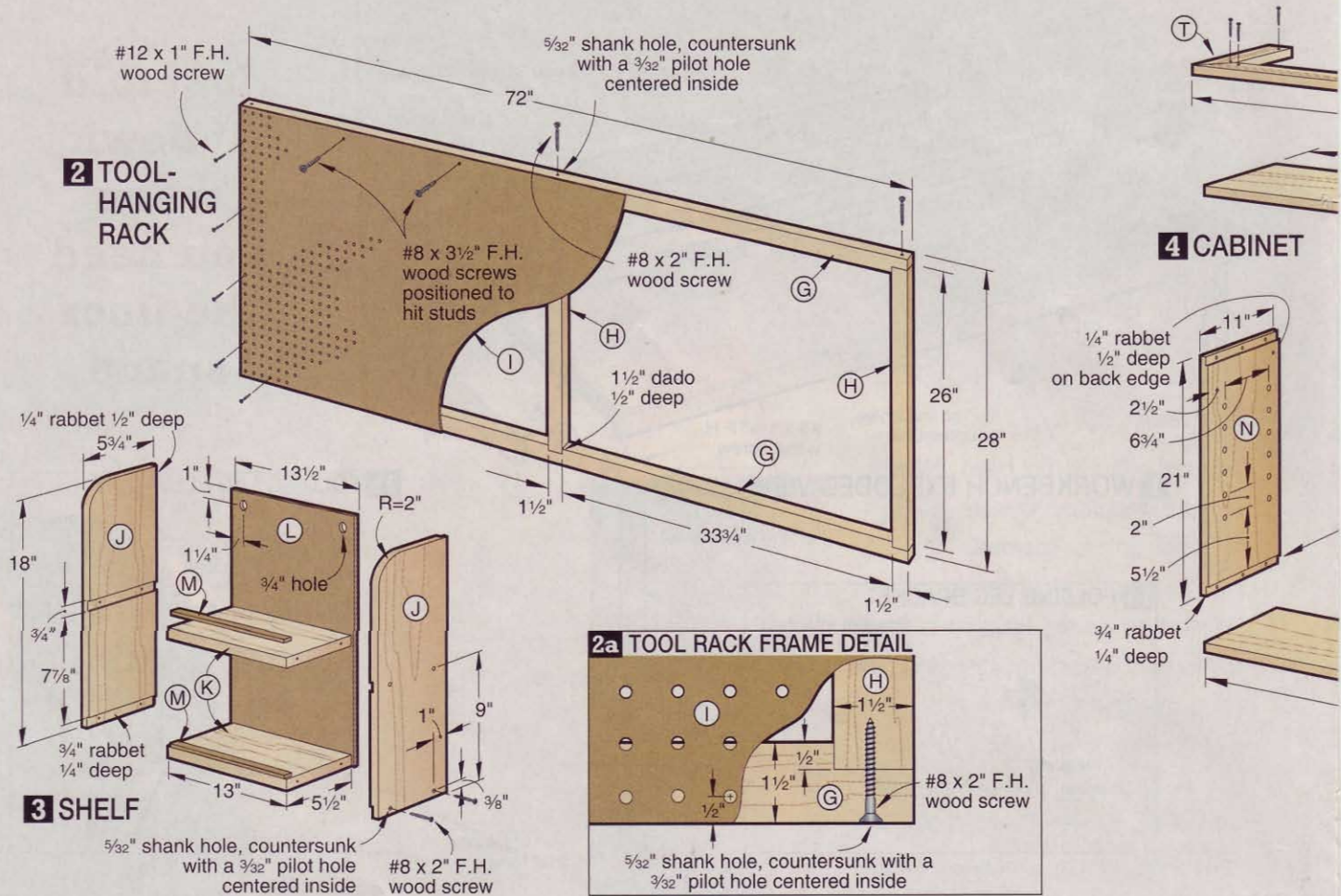

Mount the bench

1 Locate the studs in the wall where you'll mount the bench, and attach the wall cleat (F), where shown in **Drawing 1b** and **Photo A** on the *previous page*. The cleat is long enough to span up to five studs. Make sure it is secured to at least three.

2 Lock the leg brackets open and rest the bench assembly (A through E) on the floor and wall cleat, as shown in **Photo B**. Attach the hinges, where dimensioned on **Drawing 1**. Adjust the lag screws in the legs to level the bench.

Make a tool-hanging rack

1 Cut the frame top/bottom rails (G) and frame stiles (H) to size. Then install a 3/4" dado blade in your tablesaw, and attach an auxiliary extension to your miter gauge to help support the long workpieces. Now machine the rabbets at the ends of the top/bottom rails, where dimensioned in **Drawings 2** and **2a**.

Also center a 1 1/2"-wide dado on each top/bottom rail.

2 Glue and screw the frame assembly (G/H) together. Next, cut the perforated hardboard hanging panel (I) to fit on the frame assembly (G/H), making sure the outermost rows of holes are 1/2" from each edge, where shown in **Drawing 2a**. Attach the panel to the frame by driving flathead wood screws through the holes around the perimeter as shown.

3 Mount the tool rack (G/H/I) to the wall 1" above the workbench. Just as with the workbench, make sure the mounting screws reach into wall studs.

Add optional bin shelves

1 Cut the sides (J) and shelves (K) to the sizes shown in **Drawing 3**. Now lay out and cut a 2" radius on one corner of each side, and sand to the line. (We cut the radii with a bandsaw and sanded to the outline with a disc sander.)

2 Next, reinstall the 3/4" dado blade and auxiliary fence, and machine the rabbet and dado in each side (J). These will receive the shelves (K).

3 To create the rabbet in each side (J) that receives the back (L), bury all but 1/4" of the dado blade in the auxiliary fence, and set the blade for a 1/2"-deep cut. With these rabbets complete, use a drill press to bore countersunk shank holes for the screws where indicated. Then glue the sides (J) and shelves (K) together. After the glue sets, use the shank holes as guides to drill 3/32" pilot holes, then add the screws.

4 Cut the tempered hardboard back (L) and retainer strips (M) to size. Bore hanger holes through the back, where shown, then attach it to the shelf assembly (J/K) with glue and 1" brads. Sand a slight round-over on the top edges of the retainer strips, and glue them to the shelves. Remove all glue squeeze-out after it first hardens, using a chisel.

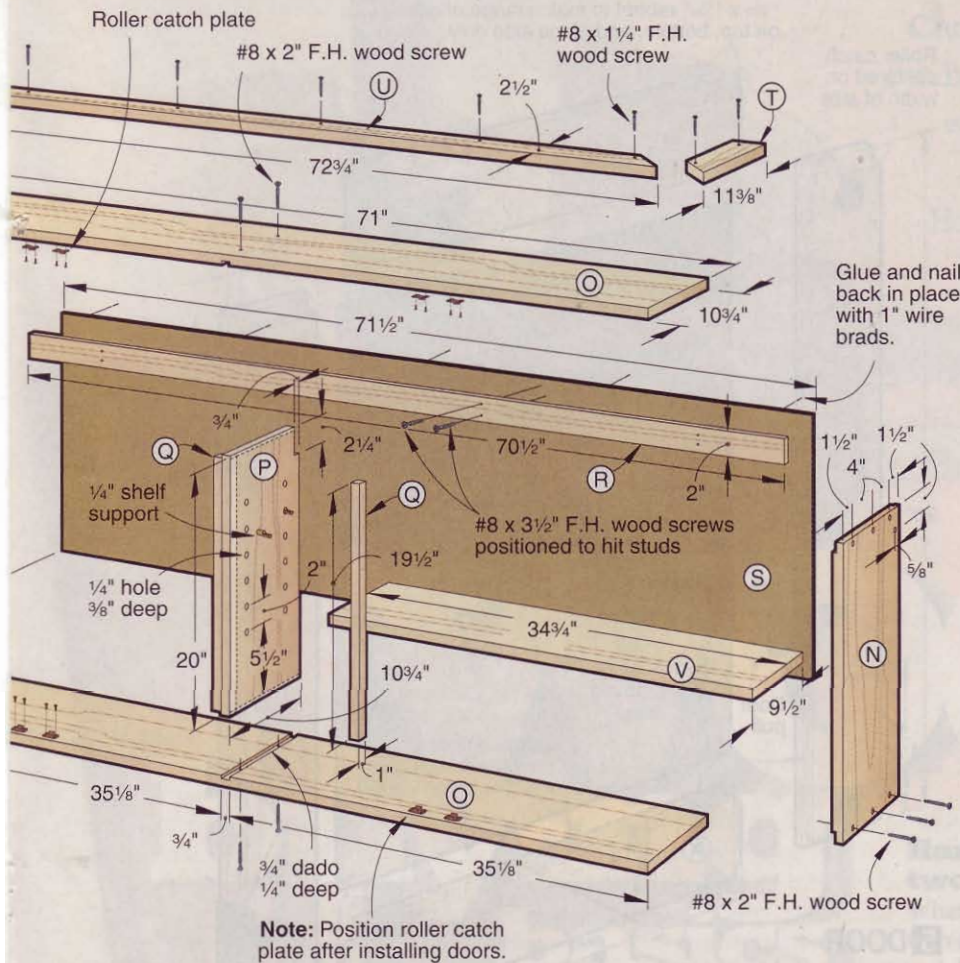

cutting diagram

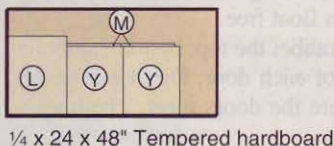
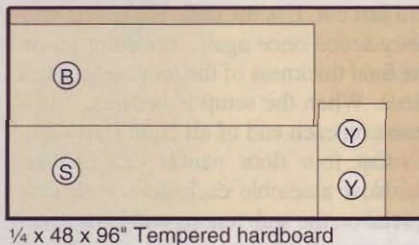
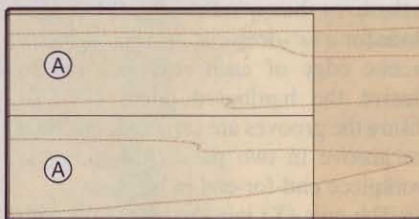
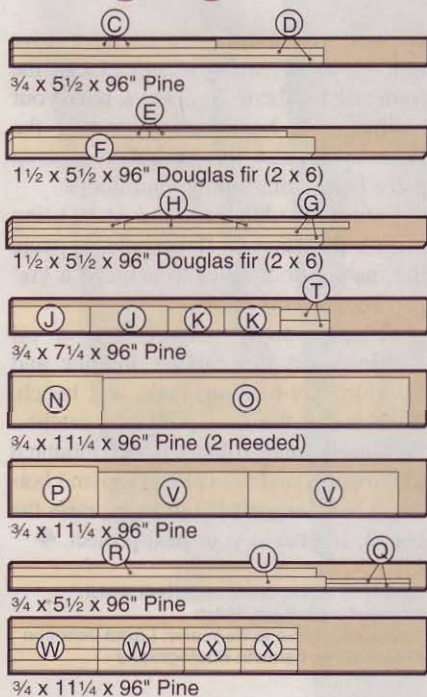

materials list

Folding Bench	T	W	L	Size	Matl. Qty.
A* substrates	3/4"	23 1/2"	70 1/2"	FP	2
B* skin	1/4"	23 1/2"	70 1/2"	TH	1
C end edging	3/4"	19 1/4"	23 1/2"	P	2
D front/back edging	3/4"	19 1/4"	72"	P	2
E legs	1 1/2"	1 1/2"	31 3/4"	DF	2
F wall cleat	1 1/2"	3 1/2"	70"	DF	1
Tool-Hanging Rack					
G top/bottom rails	1 1/2"	1 1/2"	72"	DF	2
H stiles	1 1/2"	1 1/2"	26"	DF	3
I hanging panel	1/4"	28"	72"	PH	1
Storage Shelf (optional)					
J sides	3/4"	5 3/4"	18"	P	2
K shelves	3/4"	5 1/2"	13"	P	2
L back	1/4"	13 1/2"	18"	TH	1
M retainer strips	1/4"	5/8"	12 1/2"	TH	2
Cabinet					
N ends	3/4"	11"	21"	P	2
O top/bottom	3/4"	10 3/4"	71"	P	2
P center divider	3/4"	10 3/4"	20"	P	1
Q hinge spacers	3/4"	1"	19 1/2"	P	2
R hanging cleat	3/4"	2"	70 1/2"	P	1
S back	1/4"	21"	71 1/2"	TH	1
T top trim—ends	3/4"	2 1/2"	11 3/8"	P	2
U top trim—front	3/4"	2 1/2"	72 3/4"	P	1
V shelves	3/4"	9 1/2"	34 3/4"	P	2
W door stiles	3/4"	2 1/2"	20"	P	8
X door rails	3/4"	2 1/2"	13 1/8"	P	8
Y door panels	1/4"	13 1/16"	15 1/16"	TH	4

*Parts initially cut oversize. See the instructions.

Materials Key: FP—fir plywood, TH—tempered hardboard, P—pine, DF—Douglas fir, PH—perforated hardboard.

Supplies: #8x1 1/4" flathead wood screws (25), #8x1" brass flathead wood screws (14), #8x2" flathead wood screws (30), #8x3/4" roundhead wood screws (12), #8x3 1/2" flathead wood screws (~25), #12x1" flathead wood screws (20), #4x1/2" flathead wood screws (48), 5/16x2 1/2" galvanized lag screws (2), 3x2" butt hinges (1 pair), #17x1" wire brads (26), glue, finish. Optional: Record Quick-Vise from American Tool Companies, Inc. (800/866-5740), 36" fluorescent shop lamp, surge-protected outlet strip.

Buying Guide

Hardware. Folding leg bracket no. 00T16.01 (2); lipped door overlay hinge no. 00H59.01 (4 pr.); 2 1/2" BZ door pull no. 01W33.11 (4); spring roller catch no. 01L03.01 (2 four-packs); brass paddle shelf support no. 63Z06.04 (pack of 20). You can order these items individually, or order item no. 05KWOOD for \$33.00, which includes shipping, from Lee Valley Tools Ltd., PO Box 1780, Ogdensburg, NY 13669-6780; 800/871-8158; www.leevalley.com.



Choosing stock for a project can be a delightful walk in the wood store—or a mumbo jumbo of lumber lingo. Here's a primer to sharpen your buying eye and help you talk the talk the next time you shop for boards.

WOOD

buying basics

Hardwood and softwood: two ball games

What makes a wood “hard” or “soft”? Carvers love the softness of basswood and butternut under their knives. Sure, they’re soft in that respect, but technically they’re hardwoods. That’s because hardness isn’t what spells the difference between hardwood and softwood lumber. Instead, it’s the type of tree that the wood comes from.

Hardwood is produced by mostly broad-leaved deciduous trees that—in the world’s temperate zone—lose their leaves each fall. Softwood, on the other hand, refers to the product of evergreen, cone-bearing, needle-leaved trees called conifers. Neither term has anything to do with hardness, although the wood from deciduous trees generally proves to be harder than that from coniferous trees.

Because of its beauty, stability, strength, predictability when machined, and resistance to denting, hardwood is the choice for most furnituremaking. Few softwoods offer the same positive characteristics. Baldcypress, redwood, and western red cedar are occasional exceptions. See the sidebar, *next page*, for a selection of the most commonly used hardwoods and softwoods.

Hardwood grade school

Because hardwood trees are less abundant than softwood and their lumber more valuable, great care is taken to minimize waste from a log. That means you'll find boards of differing quality—even if they came from the same log. For this reason, the National Hardwood Lumber Association (NHLA) assigns specific quality grades to all hardwood boards. Each grade reflects a classification according to the percentage of clear material the grade is expected to yield. The greater the percentage, the higher the grade and value of the board. Let's look at the top four standard grades of hardwood lumber.

•**Firsts & Seconds (FAS).** This grade features long and wide cuttings. The board sizes measure from 6" and wider to 8" and longer. Graded from the poorer side, FAS boards produce minimum cuttings of 4"×5' or 3"×7'. Clear-face cuttings must yield no more than 16% waste. These highest-quality boards are most often used in tabletops, moldings, or where long, clear boards are required.

•**FAS 1-Face (FAS1F) or Selects.** FAS1F is graded like FAS, except that the boards are graded from the better side, or the clearer face of the board. The back side of the board will grade no lower than No. 1 Common grade.



Guide to key woods and uses

Where 20 hardwoods and softwoods find their greatest application

	PRIMARY USES	OTHER USES
Alder (red)	cabinets, simple furniture	
Ash (white)	cabinets	sporting goods
Basswood	carved items	
Birch (yellow)	cabinets, furniture	flooring
Butternut	carved items	
Cherry	cabinets, fine furniture	moldings
Hickory	chairs	tool handles, cabinets
Mahogany	classic furniture	outdoor furniture
Maple (hard)	durable tables & chairs	cabinets, moldings
Oak (red)	cabinets, furniture	moldings
(white)	outdoor & indoor furniture	barrels
Poplar	utility furniture	painted items
Teak	furniture	boat decks & trim
Walnut (black)	fine furniture	moldings
Baldcypress	outdoor & indoor furniture	
Cedar (western red)	outdoor furniture	decks, fences
Pine (ponderosa)	country furniture	
(white)	country furniture	
(southern yellow)	flooring	treated for outdoor use
Redwood	outdoor furniture	decks, fences

No difference exists between FAS1F and selects except for minimum dimensions. The minimum board size for FAS1F boards is 6"×8'. Selects measure at least 4"×6'. The select grade applies to woods, such as birch or hickory, that yield narrower and shorter boards.

•**No. 1 Common.** Graded from the poorer side, common boards measure 3"

and wider, 4' and longer, with minimum cuttings of 4"×2' or 3"×3'. Clear-face cuttings must yield two-thirds or more usable wood. You'll find the grade in the shorter pieces of cabinets or furniture.

•**No. 2A.** Most often found in flooring, boards of this grade yield at least 50 percent clear wood in cuttings at least 3" wide and 2' long.



Basic yields for three grades of hardwoods

The examples below show the minimum clear yield (shaded areas) needed to make each grade. The unshaded areas contain defects and are not used in calculating the yield. Woodworkers possibly could rip and crosscut the lumber in a different way, and use portions of the boards in the unshaded areas.

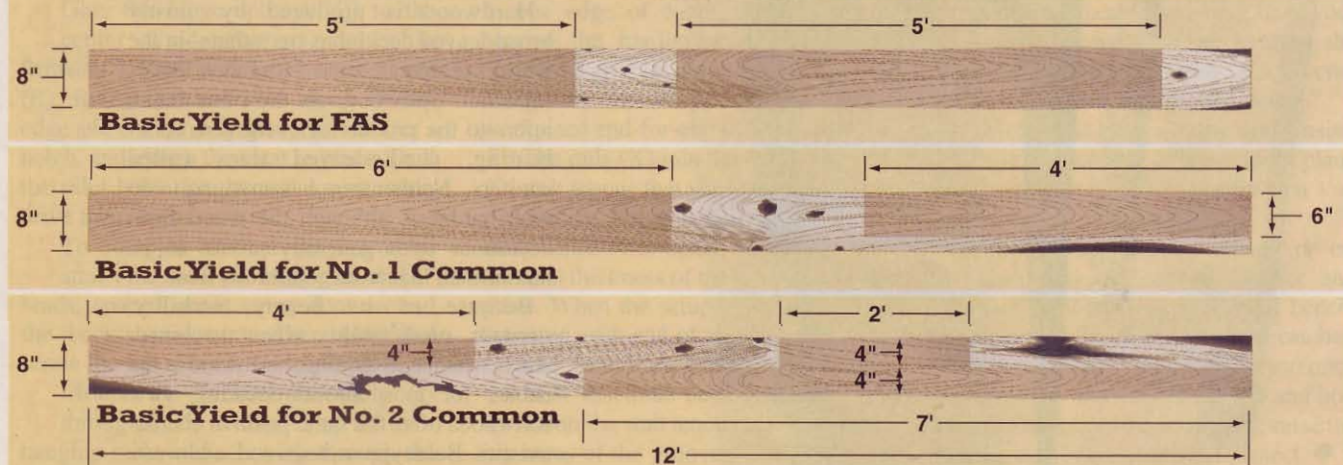

TIP If you're looking for consistent color and grain in long boards, say for a piece of fine furniture or cabinetry, go with a Select or Better grade. If, however, you're building a small project that you plan to paint or stain, a lesser grade will save you 30 to 50 percent in wood cost.

Softwood grade school

Like hardwood, softwood lumber of furniture and cabinet quality (not building construction) is graded on the number of cuttings a board will yield. Softwood grades fall into three main categories—select, shop, and common. A board's best side determines the grades for all but 5/4 (1 1/4") and thicker shop grades. One-inch lumber generally is sold in 2" width increments (1x2, 1x4, etc.), and 1 1/4" lumber comes in random widths and lengths. Several rules and regulations govern softwood grades. Here's a simplified rundown.

•**C and Better Select.** The clearest grade available from most American mills, many C and Better Selects have a B and Better face with backs of a slightly lower grade that have minor imperfections, but no knots.

•**D Select.** A good practical grade for many projects, D Selects have

separately. Instead, it's included with No. 2 Common and sold as No. 2 & Better Common. Referred to as the knotty or shelving grade, No. 2 Common is the most popular utility grade. Similar to No. 1 Common, No. 2 Common allows more pronounced knots and other defects. No. 3 Common includes boards of less uniform appearance than the higher grades. Common grades include the designation "S-Dry," meaning they have 18–20% moisture content. All higher, more expensive softwood grades are kiln-dried to less than 10%.

Air-dried vs. kiln-dried

Both hardwood and softwood lumber begin as "green" boards sawn at mills



Effects of planing

When you buy lumber, you pay for its rough thickness before surface planing on two sides (S2S). Here's how planing affects the thickness of purchased boards. You can save money by buying full-thickness rough stock from mills that offer it.

Hardwood thickness after S2S	Lumber Rough Thickness	Softwood thickness after S2S
1 3/16"	4/4 = 1"	3/4"
1 1/16"	5/4 = 1 1/4"	1 5/32"
1 5/16"	6/4 = 1 1/2"	1 13/32"
1 3/4"	8/4 = 2"	1 13/16"
2 1/4"	10/4 = 2 1/2"	2 3/8"
2 3/4"	12/4 = 3"	2 3/4"

won't absorb moisture readily, which means more stability.

Calculating board feet

Dealers typically price softwoods by the running (lineal) foot and hardwoods by the board foot, a volume measurement. A board foot includes thickness, width, and length measurements that equal 144 cubic inches. The box at left provides some sample calculations.

The thickness of lumber, especially hardwoods, is referred to in quarters of an inch, such as 4/4 ("four/quarters" or 1"), 5/4 (1.25"), 6/4 (1.5"), 8/4 (2"), and so on. However, these hardwood thicknesses are designated and the board footage calculated before surfacing. Although you'll pay for the full designated thickness, what you'll actually get in lumber surfaced two sides (S2S) is shown in the chart above. Also, in a lumber store, the board footage is rounded up or down to the nearest one-half board foot, except for more costly exotic or imported wood. Exotic wood is calculated to the inch, and will be rounded to the nearest hundredth of an inch. 🌲

Written with **Raymond L. Wilber**
Photographs: **Marty Baldwin**
Illustrations: **Tim Cahill**

For more information
National Hardwood Lumber Assoc.
P.O. Box 34518
Memphis, TN 38184-0518
901/377-1818
Western Wood Products Assoc.
522 SW 5th Avenue #500
Portland, OR 97204-2190
503/224-3930

How to determine board feet

Whether you measure a board's length in inches or feet, calculating board footage for that piece of lumber is simple math.

$$\frac{T \times W \times L}{144} = \text{board feet}$$

$$\frac{1 \times 6 \times 96}{144} = 576$$

$$576 \div 144 = 4 \text{ board feet}$$

$$\frac{T \times W \times L'}{12} = \text{board feet}$$

$$\frac{1 \times 6 \times 8'}{12} = 48$$

$$48 \div 12 = 4 \text{ board feet}$$

only minor defects, such as small, tight knots.

•**Molding stock.** A special grade offered by a few mills, molding stock yields more than 70% clear rippings 1" and wider, 6' and longer. As the name implies, this grade is used to make moldings because of its narrow yields.

•**Shop grades.** The highest shop grade, in 1 1/4" and thicker dimensions, No. 3 Clear offers only a few well-placed defects, allowing for a very high yield of clear, two-faced stock.

Beyond No. 3 Clear, shop lumber falls into three other categories: No. 1 Shop, No. 2 Shop, and No. 3 Shop. Widths run 5" and wider, lengths 6' to 16'.

No. 3 Clear yields 70% clear cuttings. In contrast to this, No. 1 Shop yields 50% clear cuttings and No. 2 Shop yields just 33 1/3% clear cuttings.

•**No. 2 and No. 3 Common.** No. 1 Common is no longer graded and sold

from the logs of freshly felled trees. The moisture content of a green board runs 28% or greater. This makes it unsuitable for woodworking because all wood shrinks, warps, and splits as it dries.

To remove moisture from green boards, most manufacturers air-dry then kiln-dry them. Air-drying lumber reduces moisture content to 12–19% naturally—workers stack and separate the boards so that air circulates between them. Moisture content in the teens is okay for outdoor construction, but is inadequate for interior projects, such as furniture and cabinets. Why is that? Because the wood will shrink in a drier interior environment, playing havoc with project glue joints and finishes.

Kiln-drying takes over where air-drying leaves off. Large ovenlike kilns with carefully controlled temperatures reduce the moisture to 6–9%, the ideal range for interior projects. Kiln-dried lumber

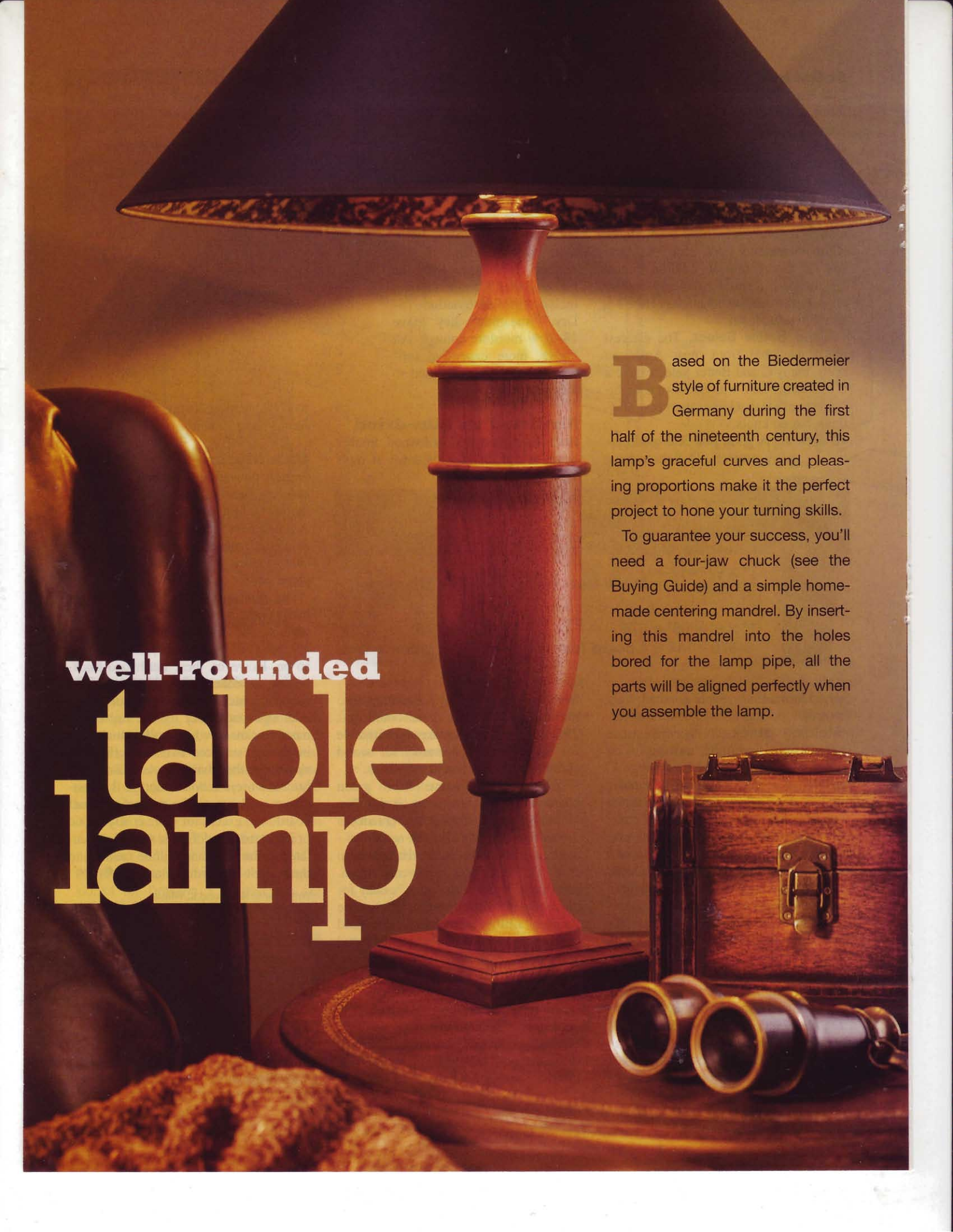

well-rounded
**table
lamp**

Based on the Biedermeier style of furniture created in Germany during the first half of the nineteenth century, this lamp's graceful curves and pleasing proportions make it the perfect project to hone your turning skills.

To guarantee your success, you'll need a four-jaw chuck (see the Buying Guide) and a simple homemade centering mandrel. By inserting this mandrel into the holes bored for the lamp pipe, all the parts will be aligned perfectly when you assemble the lamp.

Turn a European classic, step by step

1 Create the templates.

Make a copy of the full-size patterns from the *WOOD PATTERNS*® insert. Use spray adhesive to adhere them to 1/8" hardboard. Cut and sand the templates to the pattern lines.

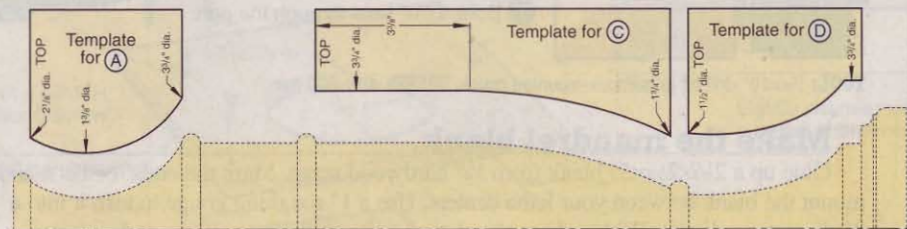

2 Prepare the blanks.

Mark diagonals on each of the turning square's ends to find the centers, and mount it between your lathe centers. (See "The wood you'll need" on page 58 for lumber requirements.) Use a roughing gouge to turn it into a 3 15/16"-diameter cylinder. Remove the cylinder, and bandsaw it into blanks for parts A, B, C, and D, where shown below. Mark the top of each piece so you can maintain its original orientation in the finished piece.

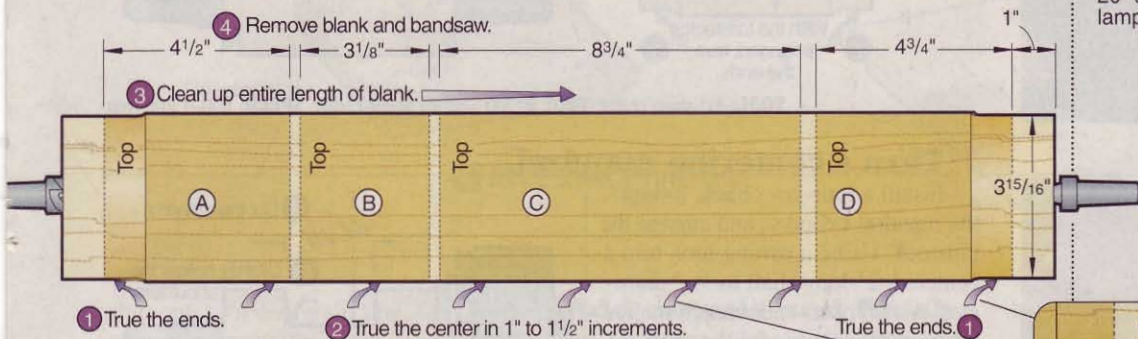

TOOL: 1" roughing gouge. **TOOL REST:** Slightly below center. **SPEED:** 600–800 rpm.

3 Turn dovetail tenons.

Mark centers on the ends of the blanks for parts A, B, C, and D. Mounting each blank in turn between your lathe centers, use a skew chisel to form dovetail tenons to fit your four-jaw chuck. Turn the tenons on the tops of the blanks for A, B, and D, and the bottom of the blank for C. This way, the bulk of the waste is removed close to the chuck.

TOOL: 3/4" skew chisel. **TOOL REST:** Slightly above center. **SPEED:** 800–1,200 rpm.

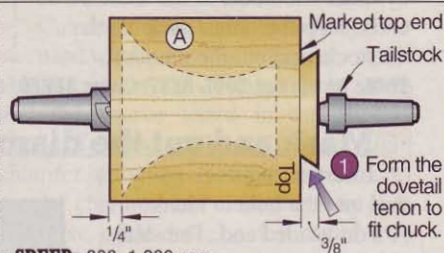

4 True and finish one end.

Loosely mount the tenon of blank A in a four-jaw chuck. Engage the tailstock to help center and support the blank, then tighten the chuck. True the blank's tailstock end with a skew chisel, forming a slight hollow. The hollow ensures a tight fit between the parts. Cut as close to center as possible, then back off the tailstock and part the waste.

TOOL: 3/4" skew chisel. **TOOL REST:** Slightly above center. **SPEED:** 800–1,200 rpm.

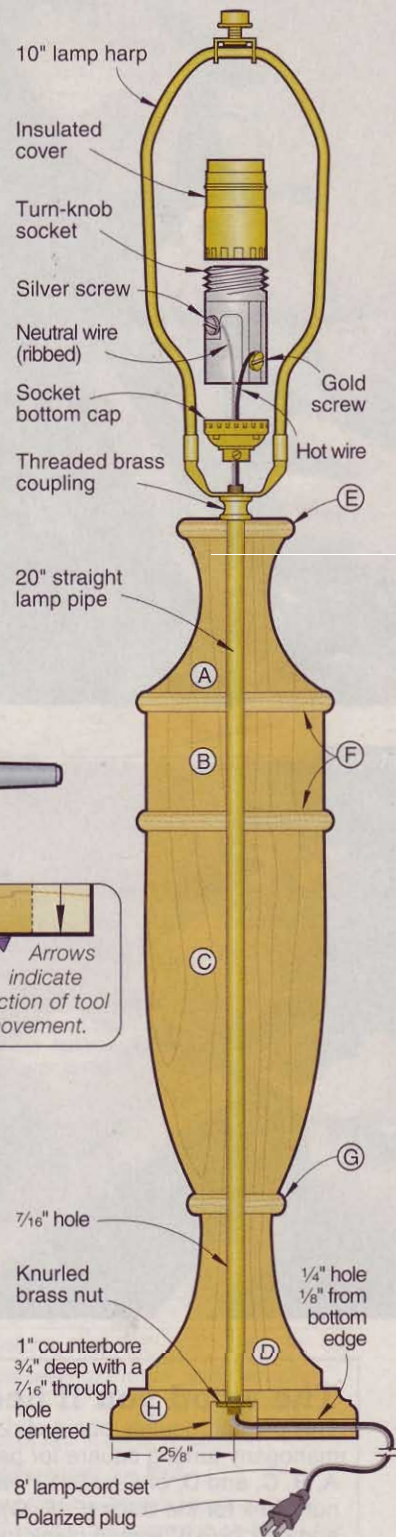
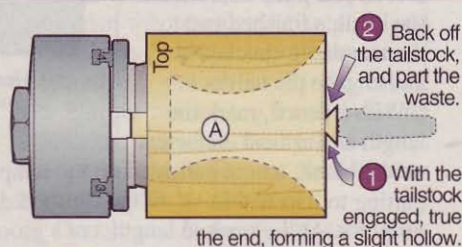

SECTION VIEW

step 5



5 Bore the hole.

Leaving part A in the four-jaw chuck, replace the tailstock center with your drill chuck. Chuck in a $\frac{7}{16} \times 10$ " drill bit, and bore a centered hole through the blank. (The photo shows boring the hole in part C.) See the Buying Guide for a drill-bit source. Repeat **Steps 4** and **5** on parts B, C, and D.

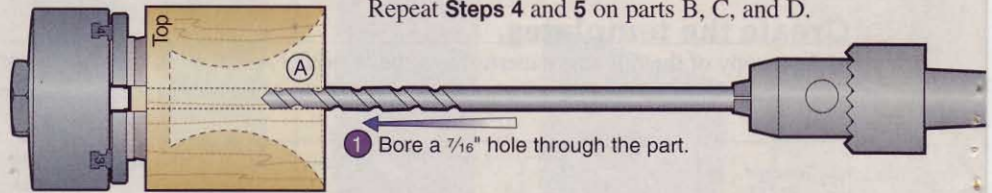

TOOL: $\frac{7}{16} \times 10$ " drill bit in tailstock-mounted chuck. **SPEED:** 400–600 rpm.

6 Make the mandrel blank.

Glue up a $2\frac{1}{4} \times 2\frac{1}{4} \times 5$ " blank from $\frac{3}{4}$ " hardwood scrap. Mark the ends' centers, and mount the blank between your lathe centers. Use a 1" roughing gouge to turn it into a 2"-diameter cylinder. With a skew chisel, turn a dovetail tenon on one end.

TOOL: 1" roughing gouge. **TOOL REST:** Slightly above center. **SPEED:** 600–800 rpm.

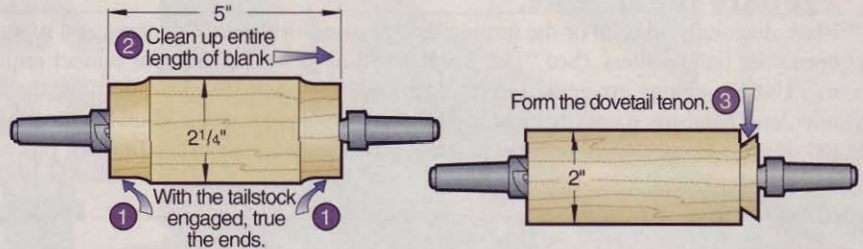

TOOL: $\frac{3}{4}$ " skew chisel. **TOOL REST:** Slightly above center. **SPEED:** 800–1,200 rpm.

step 7



7 Turn a centering mandrel.

Install a four-jaw chuck, mount the mandrel cylinder, and engage the tailstock. Using a parting tool, turn a centered, 2"-long shaft to $\frac{7}{16}$ " diameter. A $\frac{7}{16}$ " open-end wrench makes a handy calipers to size the shaft, as shown in the photo. The wrench should fit tightly. Slightly hollow the cylinder shoulders at the shaft's ends. Stop the lathe, back off the tailstock, and cut the mandrel.

TOOL: Parting tool. **TOOL REST:** Center. **SPEED:** 800–1,200 rpm.

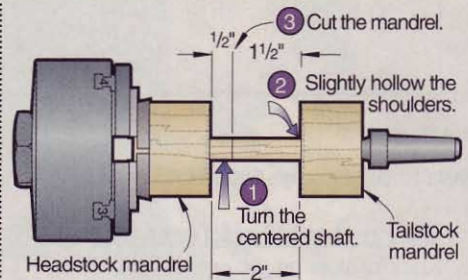

8 Mark and cut the diameters.

Insert the tailstock mandrel into the hole in blank A's dovetailed end. The shaft should fit snugly, and you may have to twist the mandrel as you push it in. Mount the blank's finished end to the mandrel's chucked half, and engage the tailstock.

With a pencil, mark the length and critical diameters on the blank, where indicated on the template. Cut grooves in the blank with your parting tool to within $\frac{1}{8}$ " of the finished diameters. Use calipers to check your progress. At the marked length, cut a groove to within $\frac{1}{4}$ " of the mandrel's shaft.

TOOL: Parting tool. **TOOL REST:** Center. **SPEED:** 800–1,200 rpm.

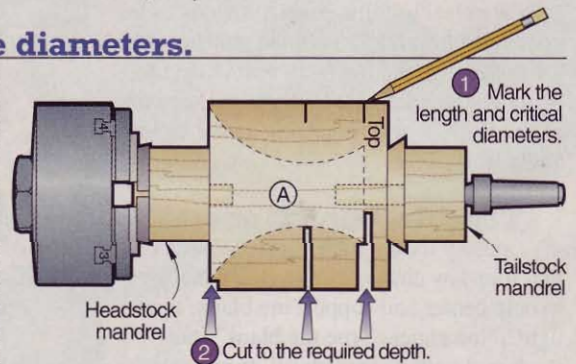

The wood you'll need

This project requires one $4 \times 4 \times 24$ " mahogany turning square for parts A, B, C, and D; one $\frac{3}{8} \times 6 \times 12$ " walnut blank for the discs (E, F, G); and one $1 \times 6 \times 6$ " walnut blank for the base (H). See the Buying Guide for a lumber kit.

step 9**9 Shape the parts.**

Turn part A's profile with a spindle gouge, checking your progress with the template. Finish-sand the part to 220 grit. Use a skew chisel to widen the end groove on its waste side, then part the piece by cutting through the waste until

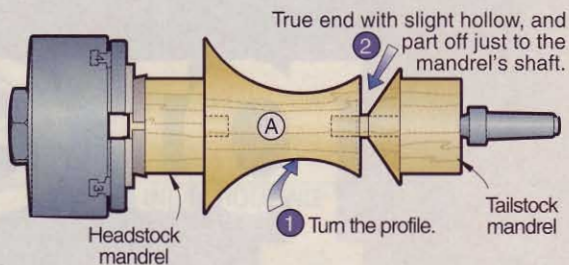

you just graze the mandrel shaft's surface. Slightly angle this cut to form a slight hollow in the part's end. (The photo shows this operation performed on part D.) Withdraw the tailstock mandrel, and remove part A from the headstock mandrel, leaving the headstock mandrel in the chuck. Repeat **Steps 8 and 9** on parts B, C, and D.
TOOLS: $\frac{3}{8}$ " spindle gouge, $\frac{3}{4}$ " skew chisel. **TOOL REST:** Slightly above center. **SPEED:** 800–1,200 rpm.

step 10**10 Turn the discs.**

With a compass, draw the discs (E, F, G) on $\frac{3}{8}$ "-thick walnut, referring to the dimensions shown on the pattern insert. Mark the centers with an awl, and using your drill press, bore $\frac{7}{16}$ " holes at the awl marks. Then bandsaw the discs, staying outside the drawn circle.

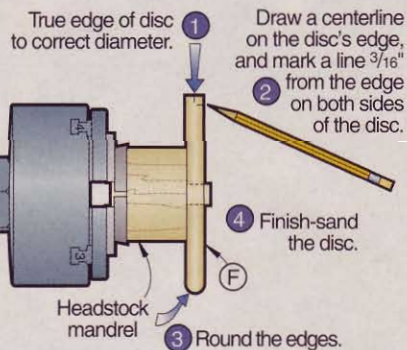

Mount the discs, in turn, on the headstock mandrel half. Using a spindle gouge, true the disc to finished diameter. Mark a centerline on the disc's edge and another line $\frac{3}{16}$ " from the edge on both of its faces. Round the edges from centerline to face line using the same spindle gouge. Finish-sand the disc to 220 grit. **Note:** When rounding the small discs (E, G), as shown in the photo, the mandrel interferes with the back edge. Round the front edge, flip the disc over, and round the opposite edge. Repeat for sanding.

TOOL: $\frac{3}{8}$ " spindle gouge. **TOOL REST:** Slightly above center. **SPEED:** 800–1,200 rpm.

11 Make a square base.

Cut a piece of 1" walnut stock to $5\frac{1}{4} \times 5\frac{1}{4}$ ". With a Forstner bit, drill a 1" counterbore $\frac{3}{4}$ " deep, centered in the bottom face. Then drill a $\frac{7}{16}$ " through hole, centered in the counterbore. Drill a $\frac{1}{4}$ " hole that intersects the counterbore through the base's edge, where shown on **Drawing 1**.

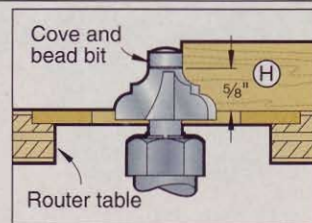

Chuck a cove and bead bit in your table-mounted router and rout the profile on the base's top edges. See the Buying Guide for a router-bit source. Finish-sand the base to 220 grit.

12 Finish and assemble.

Apply a penetrating oil finish to all the parts, following the instructions on the can. (We used General Finishes Seal 'n Finish oil/urethane blend.)

With the finish dry, assemble the lamp in the configuration shown on the **Section View** drawing. See the Buying Guide for our lamp hardware source. Screw in the bulb, and mount the shade. (Our shade is $11\frac{1}{2}$ " tall with upper and lower diameters of 7" and 18".) Click the switch, and bask in the warm glow of your new creation. 🌟

Written by **Raymond L. Wilber** with **Jan Svec**
Project design: **Raymond L. Wilber; James R. Downing**
Illustrations: **Raymond L. Wilber; Roxanne LeMoine; Lorna Johnson**
Photographs: **Baldwin Photography**

Buying Guide

Four-jaw chuck. A wide variety of four-jaw chucks (also called scrolling chucks) are available from Craft Supplies USA (call 800/551-8876 for a catalog), or Packard Woodworks, Inc. (call 800/683-8876 for a catalog). Prices range from \$140 to \$270.

Lumber. 4x4x24" mahogany turning square, $\frac{3}{8} \times 6 \times 12$ " walnut, 1x6x6" walnut. Kit no. W139-1, \$45.95 ppd., Minnesota residents add sales tax. Heritage Building Specialties, 205 N. Cascade, Fergus Falls, MN 56537. Call 800/524-4184.

Drill bit. $\frac{7}{16} \times 10$ " high-speed brad-point drill bit no. 140056, \$11.99. Call Woodcraft, 800/225-1153.

Cove and bead bit. $\frac{1}{2}$ "-shank French provincial classic bit no. 788, \$25. Call MLCS, 800/533-9298.

Hardware. 1 each: 20" straight lamp pipe, turn-knob socket, threaded brass coupling, 8" lamp-cord set, 10" lamp harp with finial and nut. Kit no. 6353, \$9.99 plus \$3.99 shipping, Minnesota residents add sales tax. Meisel Hardware Specialties, PO Box 70W, Mound, MN 55364-0070. Call 800/441-9870; outside the U.S. call 952/471-8550.

prepare

**FOR
YOUR
BEST
FINISH
EVER**

Get that wood surface as smooth and perfect as possible; it paves the way for a great result.



Author Jim Kull also monitors the discussion group on wood finishing at our www.woodonline.com Web site.

FIRST OF A THREE-PART SERIES

If you'd like to get a handle on the basics of finishing wood, here's your opportunity. In the March issue of *WOOD*®, we'll talk about staining, then conclude with a look at clear finishes in the June issue.

You chose a terrific design, you did some outstanding joinery, and your project went together just perfectly. Now you're ready to apply a finish. Or are you? A second-rate job of preparing the surface can make the finish look like it was applied with a broom, ruining the look and feel of the whole project. Get the preparation right, and you're on your way to a finish that will make people say, "Wow!"

Let us help you take your projects to the next level with the procedures and insider's tips accumulated over the years by veteran finisher and instructor Jim Kull.

Sand it smooth

The first step in a good sanding job is to choose the right sandpaper. Buy good-quality paper, because the inexpensive kind will dull quickly, and can load very rapidly with sanding dust.

The caption with **Photo A** provides a brief introduction to your sandpaper choices. Start with 100 grit in most cases; use 150 next; and stop at 220. Sometimes you might want to use even finer paper on end grain, but remember that higher grits can create a burnished surface that won't accept stain properly.

Make simple sanding blocks, like the one in **Photo B**, to smooth flat surfaces. You can sand concave and convex areas, such as molded edges, without a block. However, a backing material that matches the desired shape makes the job neater and easier. Dowels, profiles made of rubber, and countless other shapes will work just fine.

Sanding dust—the technical term for it is "swarf"—must be removed as you sand, and between grits. The cleaner you keep your surface, the more effective your sanding will be. Grit and dust that

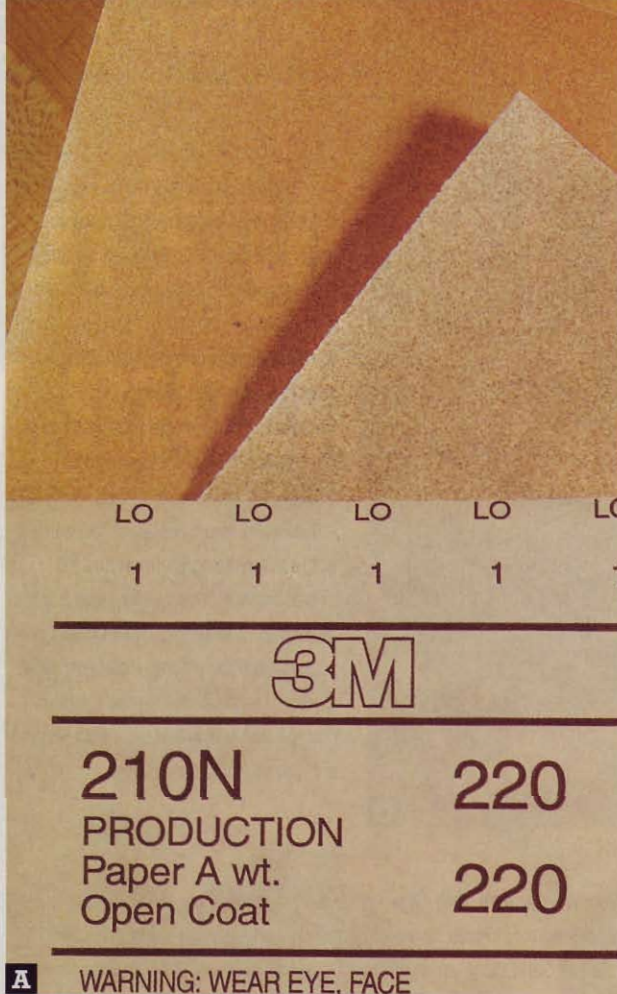

A WARNING: WEAR EYE, FACE

Rely on garnet paper, easily identified by its orangish color, for most pre-finishing sanding. Tan-colored aluminum oxide sandpaper will do the job, too. Choose "open coat" paper, which has more space between the grit particles than the "closed coat" type. The sanding dust can escape temporarily into these open spots, so your sanding is more effective and produces smoother results.

Good sandpaper carries a grit number on the back of each sheet, such as 100, 150, 180, or 220. A larger number means finer grit, which produces smaller scratches on the wood. "A" weight paper is the lightest, most flexible kind. It's a good choice for most jobs.

Hand sanding produces the best results with a block of hard rubber or cork backing the paper to give it just a bit of flexibility. If you hold the sandpaper with your fingers, you'll remove more material from softer areas, creating valleys. Buy a sanding block from a catalog or woodworking outlet.

For a quick and easy alternative, you can use a block of wood, as shown here. Glue felt or cork on one face to serve as a slightly flexible pad between the block and the paper. Size it to fit your hand, and use it with a quarter sheet of paper.

Heat is the enemy when you sand wood. It causes resin to ball up and create "corning" on your sandpaper. So sand slowly, and don't create excess pressure by bearing down too hard.



B



A vacuum with a hose and a brush attachment, as shown here, does a good job of cleaning dust from your project. Blowing compressed air also takes the dust off the wood, but it's best done outdoors. If you do it in your shop, the dust goes into the air, creating a mess and a health hazard.

A commercially made tack cloth, or a rag or paper towel dampened with paint thinner, will remove dust fairly well. Turn it frequently to a fresh side, so you're not just spreading the dust around.

Paint thinner dries quickly, and a trace of it left on the surface won't affect any further finishing efforts. However, some commercial tack cloths may leave a residue that will affect the finish, especially water-based coatings.

remain on the surface tend to ball up and clog your paper. This "coming" will create broad, deep scratches that are difficult to remove.

If your electric sander includes a dust-collection bag or vacuum attachment outlet, be sure to use it. (When we tested random-orbit sanders in issue 123, we found that hooking up the shop vacuum does improve dust control.) Check **Photo C** for more about other options.

Spot problems early

As you prepare to finish, you'll find that paint thinner is one of your best friends. What you see with a wet coat of paint thinner is what you will see with a finish, as shown in **Photo D**. Blotches, scratches, glue spots, and other flaws will leap out at you, just begging to be fixed.

Paint thinner evaporates fairly quickly and leaves no contaminant on the wood. You can use any kind of finish without problems, after the thinner dries. Here's how to handle three typical defects:

Scratches. If you see scratches or machine marks from sanding, you might not have sanded adequately with your last grit of paper. Resand, and check again. If you still find prominent scratches, go to the next finer grit, and sand the wood thoroughly once again.

Blotches. If you examined a board with a microscope, you would see many tiny holes called "pores." Woods with fine pores, including pine, cherry, birch, and maple, tend to blotch when stained. This uneven coloration is a result of variations in the density of the wood. Anything put on the surface tends to absorb more in the softer areas than in the harder areas of the wood. The greater the absorption, the darker the color. Your paint thinner will reveal potential blotching problems.

To avoid blotching, make a homemade conditioner, as described with **Photo E**. Most commercial conditioners, as well as homemade mixes using lacquer or varnish, will leave a slight amber cast.

For a colorless conditioner, or one that will be coated with a water-based finish, use a thin coat of clear shellac. You'll find premixed, canned shellac at most home centers and hardware stores. This product is too thick for a conditioner, so mix 1 part shellac with 4 to 5 parts denatured alcohol to make the amount you need for your project.

Plywood and dimensional lumber may take stain differently even though they are the same species of wood. When you wipe on paint thinner to look for sanding and gluing flaws, you'll spot this difference, too. Softer areas will look darker. Sand those areas with a higher grit—the smaller scratches won't capture as much stain.

For the same reason, use a higher grit on softer woods if you have mixed woods in your project. For example, in a project that combines oak and soft maple, sand the oak to 150 and the maple to 180.

The same is true for end grain with any wood. Sand the end grain with a paper one grit higher than the last one used on the face grain, to compensate for the end grain's tendency to soak up more stain or finish.

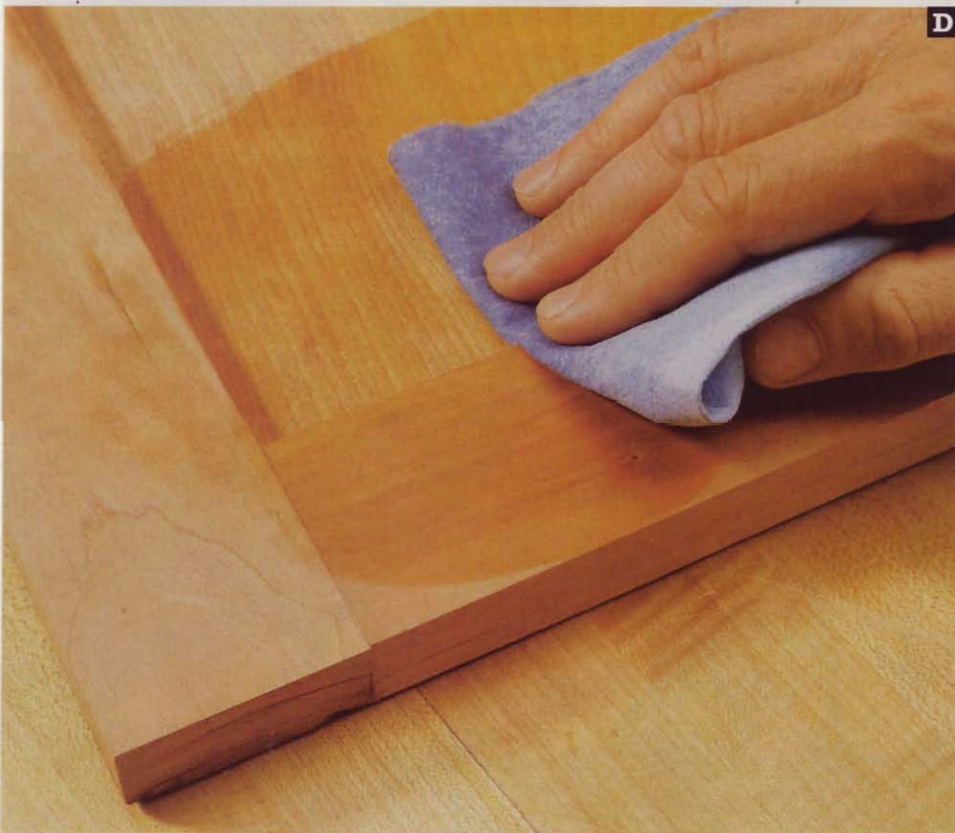

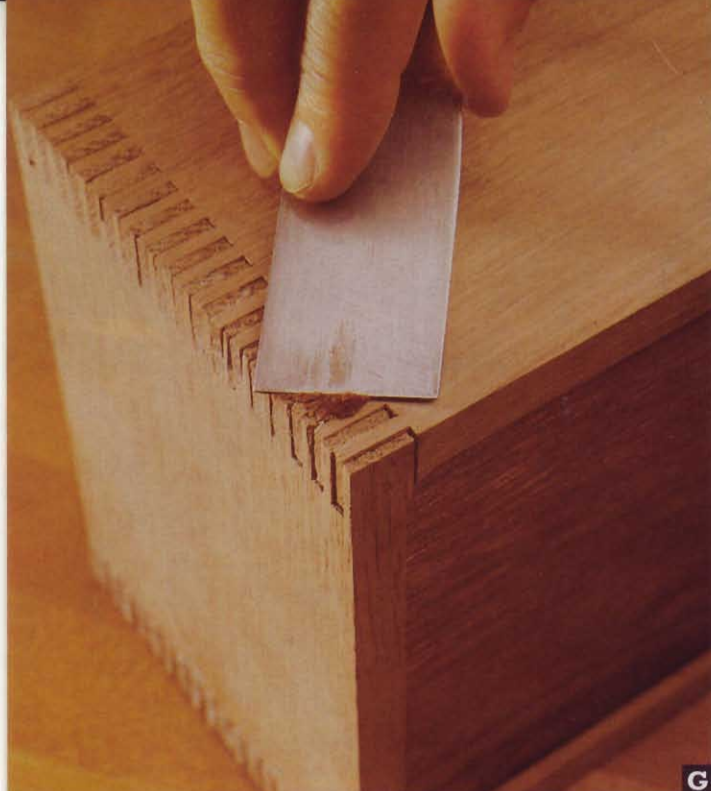

G

To fix gaps, cracks, and small holes, make your own filler by mixing sanding dust with hide glue, linseed oil, or a bit of your final finish. Here, we used polyurethane varnish and powdery dust that we reclaimed from the bag of our belt sander.

Make your filler into a thick paste, and force it into the gap with a putty knife. Sand it to aid in drying and to level the surface. Use the same grit that you used for your final sanding step.

Here you see the sanding slurry from a wide area, scraped into one spot for visibility. You don't need to do that when you wet sand, just sand thoroughly, forcing the slurry into the pores. The next day, sand again. The oil/varnish mix won't be dry yet, so some of the new sanding dust will blend with the original slurry and further fill the pores. Let the piece dry for a couple of days before proceeding to the final sanding and finishing.



H

remain, preventing you from attaining a perfectly smooth base for your finish. The finish itself will solve the problem in fine-grained woods, but if you're working with a coarse-grained species, such as oak, walnut, or mahogany, filling the grain makes a big difference. After filling, it's much easier to produce a glass-smooth surface that's a pleasure to look at and delightful to touch. Here are four choices for filling grain.

Filling with finish only. You can fill the grain with repeated applications of a finish. Sand after each coat has dried, leaving finish only in the pores. Traditional varnishes, polyurethane varnish, and lacquer will work, but shellac excels. After two or three applications, you should have a smooth surface as a base for a hard, film-forming finish.

Sanding with a finish. Apply an oil/varnish mix to the wood—tinted to highlight the pores, if you choose—then sand this liquid with 220-grit sandpaper. You'll produce a slurry like that shown in **Photo H**.

Applying paste filler. Some oil-based paste fillers come from the can as thick as peanut butter. Thin them to the consistency of heavy cream with paint thinner or naphtha, then proceed as shown in **Photo I**. You can see in **Photo J** the difference that filling makes in the first coat of finish.

A dark filler will serve to highlight the grain. You can buy colored fillers, but it's easy to make your own by adding stain to the filler.

If a filler is a different color than the stain you plan to use, the wood must be stained first, sealed, then filled. When sanding the filler, take great care to avoid sanding through the stain.

Water-based paste fillers. These fillers dry quickly, and will take a water-based stain, but possess some disadvantages, too. Because they dry so rapidly, you're limited to a small work area. It's tough to remove water-based filler that has dried.

If you plan to stain over water-based fillers, note that oil-based or varnish-based stains won't work. You have several other choices, though, and we'll talk more about that in next issue's article about staining.

Written by **Jim Kull** with **Jim Pollock**
 Photographs: **Baldwin Photography**
 Illustration: **Roxanne LeMoine**



Apply paste filler to the wood with a small squeegee. Work across the grain and leave just enough to cover the surface. Remove any streaks by rubbing across the grain with a rag or a piece of burlap. Wait two or three days until the filler has dried completely, then sand the surface lightly. Or, instead of sanding a large, flat area, you might want to consider scraping. It's faster and leaves a smoother surface. The surface is now ready for stain or a clear top-coat—whichever will give you the finished look that you want.

HOW GRAIN FILLERS WORK

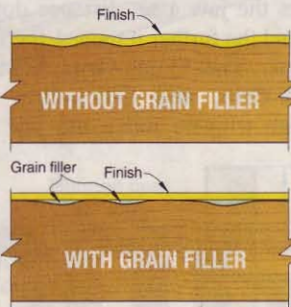

This mahogany sample shows the difference between unfilled pores, on the right, and pores that have been filled with paste filler. We gave the area on the left two coats of filler, sanded it after each coat, and sprayed lacquer on the entire board. The filled portion has a much smoother look and feel.

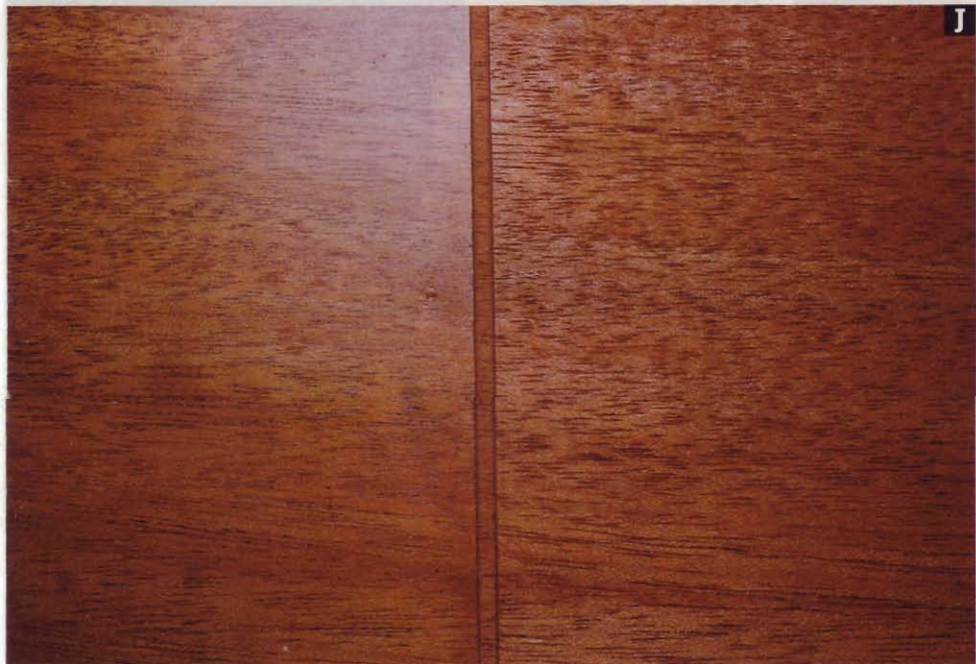

HERE'S THE NITTY-GRITTY ON ELECTRIC SANDERS

If you're just starting to buy power tools, which electric sander should you choose? Machine sanding falls into three broad types—belt, orbital, and random-orbit. If you can afford to buy only one sander, you'll get the most value with a random-orbit model.

A belt sander will remove large amounts of material very rapidly but you need experience to operate it well. When you're learning, it's all too easy to create dips and prominent sanding marks. Also, sanding belts can be a bit expensive.

Most orbital, or finishing, sanders have square or rectangular pads, suitable for one-quarter sheets of sandpaper. This type of sander tends to be the least expensive to purchase and, because you can cut your own paper from sheets, the least costly to operate. It can create swirls that are difficult to remove, but you can minimize that problem by applying very little pressure to the sander and moving it slowly across the workpiece.

A random-orbit machine uses a sanding disc, either self-adhesive or hook and loop. These machines leave sanding marks, but the scratches are much less noticeable than those created by a belt sander or an orbital sander. Minimize the marks by moving the sander slowly and in a regular pattern with the grain. If you have a two-speed or variable-speed random-orbit sander, use a low speed for sanding and a higher speed for polishing. Operating the sander at low speed will not significantly slow the sanding process, and will produce fewer machine marks. ♣

Getting a grip on performance

The amount of pressure a clamp delivers is key, so we used a hydraulic cylinder, shown at *right*, to find each product's limit. We repeated this test with three different testers and averaged the results, which are shown under "Clamping Pressure" in the chart, *opposite bottom*. Using the trigger alone, Wolfcraft's Quick-Jaw averaged 144 pounds per square inch (psi) of pressure. That's almost 35 psi more than the next-best Bessey Power Grip. (See "How much pressure is enough?" *opposite*.)

Two of the tested clamps—the Power Grip and the Quick-Grip Advantage—incorporate a screw jaw for additional clamping pressure. Using this screw jaw, our three testers averaged 470 psi and no jaw deflection with the Power Grip. (One tester maxed our gauge at 600 psi.) The jaws of the Advantage clamp deflected noticeably at 300 psi, so we didn't push it any further.

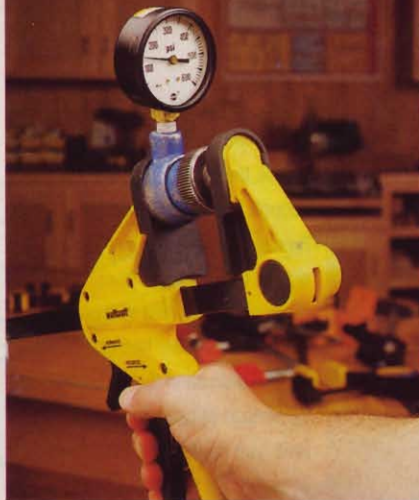

We fitted a hydraulic cylinder with a pressure gauge, put it between the jaws of the clamp, and squeezed it as hard as we could with one hand.

Let's get into the action

Each squeeze of the clamp's trigger moves the jaw a set distance down the bar, and the further it moves, the faster it clamps. The Quick-Grip Advantage, Quick-Grip, and Quick-Grip Quick Change triggers move the jaw nearly

twice as far per squeeze as the Power Grip. Adjustable Clamp's Jorgensen E-Z Hold II and Wolfcraft's Quick-Jaw split the difference.

Each clamp's movable jaw also can be closed quickly by merely sliding it along the bar. Opening the jaws quickly requires activating the jaw-release trigger and sliding the jaw. Both actions require two hands.

The jaw-release trigger relaxes the jaws for removal from your workpiece, and in our tests, most of the releases worked well. However, we couldn't loosen the jaws of the Bessey Power Grip without first slightly opening the screw part of the jaw.

Unlike the jaw-release triggers on the other tested clamps, Quick-Jaw's release trigger actually springs the jaws open slightly with each squeeze of the release. We liked this feature, which made it possible for us to reposition the clamp and reapply pressure on an assembly with only one hand.

one-handed wonders

Quick clamps single-handedly changed the way we assemble projects. We uncover which ones do it best.

Quick-Grip Advantage

Sizes available: 6", 12", 24"
American Tool Companies
800/866-5740
www.americantool.com



One-handed bar clamps are so handy that we frankly don't know how we'd get by without them in the **WOOD**® magazine shop. Their versatility shows in myriad ways: attaching a jig to the drill press, mounting a stop to the router-table fence, fixing a mortising machine to the bench, and gluing up any project that requires one hand to steady the workpieces while applying pressure.

It's been a dozen years since American Tool introduced Quick-Grip clamps and revolutionized the way we hold our work. Since that time, other manufacturers have jumped on the bandwagon with their own products, so we think it's time for a hand-to-hand showdown.

How much pressure is enough?

Dale Zimmerman of Franklin International, maker of Titebond woodworking glues, says, "In a perfect world, with precisely mating materials, you'd need only enough force to press the glue to a thin, consistent layer. But," he reminds us, "nobody's perfect."

Bowed, crooked, or poorly machined pieces require more clamping pressure than well-machined parts because, Zimmerman says, "You need the extra force to bend the wood to fit." He advises woodworkers that they may need up to 100–150 psi to clamp softwoods and 175–250 psi for hardwoods.

Other considerations

•**Jaws.** The jaw faces on most of the tested clamps are parallel, so they're less likely to pull a slippery glue joint out of alignment when you apply pressure. The E-Z Hold II jaws start off toed in at the top (see photo, at right top), but become parallel as you increase clamping pressure. We found it difficult to keep pieces aligned when using these clamps. The jaws on the Advantage pivot or swivel, which aids in holding odd-shaped assemblies, such as when clamping crown molding to a case.

•**Pads.** All of the clamps have soft pads on their jaw faces to protect your workpieces. Most of them stayed secure during our testing, but we found the pads on the E-Z Hold IIs and the Quick-Grips slipped off from time to time. The Quick Change clamps, although similar to the Quick-Grips, use a pad that completely captures the jaw face, preventing such slippage.

•**Quality of materials.** Except for their handles, triggers, and pads, the Power Grip and Advantage clamps are all steel. In fact, the Power Grip's I-beam-shaped bar is the only one that didn't deflect an iota in our tests. E-Z Hold II also has a steel fixed jaw, but it isn't as rigid as either of those. The rest have solid-steel bars and glass-filled nylon jaws, which are remarkably strong and durable.

•**Versatility.** Half of the clamps in our test (E-Z Hold II, Quick Change, and Quick-Jaw) readily convert to a spreader for tasks such as disassembling a loose mortise-and-tenon joint for repair—a handy feature if you need it.

Give a hand to our picks

If you're after unbridled pressure, or if you have limited hand strength, you'll like the clamps with a screw jaw: the Bessey Power Grip and the Quick-Grip Advantage. The Advantage costs less, and you can release and reclamp without having to turn the screw. But, if you frequently torque your clamps to heavy pressures, you'll appreciate the Bessey's no-bend bar.

On the other hand, Wolfcraft's Quick-Jaw delivered enough clamping pressure for most any woodworking task for about half the price of the screw-jaw models. Compared to the other non-screw models, it provides 50 percent more clamping pressure, convertibility to a spreader, and that nice spring-loaded jaw release. ♣

Written by **Dave Campbell** with **Rich Bright**
Photographs: **Baldwin Photography**

Jorgensen E-Z Hold II

Sizes available: 10", 16", 22", 28", 36", 40", 54"
Adjustable Clamp Company
312/666-0640
www.adjustableclamp.com



Bessey Power Grip

Sizes available: 12", 24"
American Clamping Corp.
800/828-1004
www.americanclamping.com



Quick-Grip

Sizes available: 6", 12", 18", 24", 36", 50"
American Tool Companies
800/866-5740
www.americantool.com



Quick-Grip Quick Change

Sizes available: 6", 12", 24"
American Tool Companies
800/866-5740
www.americantool.com



Quick-Jaw

Sizes available: 6", 12", 24", 36"
Wolfcraft
630/773-4777
www.wolfcraft.com



GET A GRIP ON ONE-HANDED BAR CLAMPS											
MANUFACTURER	MODEL	HANDLE DESIGN (1)	SCREW JAW? (Y)es (N)o	JAW TRAVEL PER SQUEEZE (PSI) (3)	PERFORMANCE RATINGS (2)		WARRANTY (4)	COUNTRY OF ASSEMBLY (5)	WEIGHT (12" CLAMP, POUNDS) (6)	SELLING PRICE (6, 7)	
					CLAMPING PRESSURE	EASE OF RELEASING JAWS					
ADJUSTABLE CLAMP	Jorgensen E-Z Hold II	I	N	5/16"	78	G	G	1yr.	U	2.0*	\$15*
AMERICAN CLAMPING	Bessey Power Grip	I	Y	7/32"	110*	G	E	5yr.	G	2.7	44
	Quick-Grip	P	N	13/32"	97	E	G	LIFE	U	1.9	19
AMERICAN TOOL	Quick-Grip Quick Change	P	N	13/32"	97	E	E	LIFE	U	2.0	22
	Quick-Grip Advantage	P	Y	13/32"	87*	E	E	LIFE	U	3.4	37
WOLFCRAFT	Quick-Jaw	P	N	5/16"	144	E	E	LIFE	S	2.1	20

NOTES:

For specifications on other types of tools, click on "Tool Comparisons" at www.woodmall.com.

1. (I) In line (P) Pistol grip
2. (E) Excellent (G) Good
3. Average, using three persons of varying hand strengths. (*) Does not include pressure from screw jaw.
4. (LIFE) Lifetime warranty
5. (G) Germany (S) Slovakia (U) United States
6. (*) 16" clamp (12" clamp not available.)
7. Mail-order price of 12" clamp at time of article's production.

Talk one-handed bar clamps with other woodworkers at www.woodmall.com.



a new star rises in the west

At 34, she's an artist, a carver, a designer, a woodworker, and all Montana. Petite, golden-haired Amber Jean worked her way through Montana State University as a Forest Service firefighter and wilderness ranger. She apprenticed in a cabinet shop to get a handle on power tools. Today, Amber Jean (she dropped her last name after graduation) lives modestly in a mountaintop cabin, daily driving her 4x4 pickup to and from her spacious, sunlit studio in Livingston.

As a blossoming artist, Amber's sees her star continue to rise with each passing day. Her reputation for creating unique, massive, western-themed furniture and accessories has spread beyond the Rockies. A consistent award winner at the Western Design Conference in Cody, Wyoming, Amber can command five figures for her pieces. She gets commissioned work, too, such as the five custom-made, 2¼"-thick guest-room doors she was bestowing with western motifs when we visited.

They're slated for a Coloradan's mansion under construction.

Following those, she'll begin work on a life-size carved buffalo bench made entirely of walnut.



In her never-ending search for pleasing shapes of deadfall juniper, Amber Jean, *above*, searches among promising trunks for an upcoming project. Pieces such as these form the massive posts in her mustang bed, "Spirits Untamed," shown *below*.

Here, carved panels of mahogany capture scenes that symbolize the West.





Inspiration abounds in the beautiful Montana landscape, left, where Amber Jean finds sculptural pieces of juniper for her projects. Below, she fleshes out a concept for an upcoming assignment on paper.



Beauty beneath the dust

Amber Jean's award-winning juniper and mahogany bed that she named "Spirits Untamed" took shape from an experience. "The mustang bed actually



A carved floral motif extends—as if growing—beyond the frame of this custom door by Amber Jean.

began in the Pryor Mountains of eastern Montana," she recalls. "I spent a college summer there working with Native American children. We lived in tepees, slept under the stars, and ate around a campfire. And there are wild horses in the Pryors, running amidst all the twisted juniper. So when I started thinking about doing a piece that represented the West—the power, the harshness, the beauty, the gracefulness—the juniper to me symbolized that. And the mustangs are dusty and dirty, not like Hollywood wild horses. You can see some color, but there's all this grime on them. The juniper is that way, too, weathered gray. But underneath the weathering are wonderful colors—reds, rusts, white. Because of that, I had to bring the two together—the wood and the horses. Since part of my remembrance was of sleeping in the outdoors, it just had to be in the form of a bed."

But why such a doggone huge bed? The headboard posts alone are 8' tall! "People often ask that," replies Amber. "I tell them it's because of that whole

overwhelming feeling that I get from the West—the mountains, the sky, the clouds, just the vastness. It's majestic. After all, in Europe there's a lot of huge, oversize furniture. But here in America we have huge things like the Jolly Green Giant and Paul Bunyan, super domes, and skyscrapers, yet all our furniture remains small. It seems that big hunks of furniture would be part of the American attitude. Despite that, my big pieces haven't had any trouble finding homes."

Found wood: gems in the rough

Amber began working with wood in the rough during her last semester of college, through necessity. "I was holding

down a number of jobs, doing the starving artist thing," she explains. "My art assignments reflected my lack of money. So for my final sculpture class, I needed material. I heard that the local Forest Service district was selling dead standing trees as firewood for \$5 a cord, and it dawned on me that I could buy a whole tree for five bucks! So some friends from my fire fighting job went with me to do some harvesting of dead lodgepole pine. We ended up bringing a whole truckload of trees back to Bozeman!"

That wood was the beginning of a career. With \$200 worth of Swiss-made chisels and a mallet that she bought on a bus trip to Seattle, Amber began chipping away. Today, she favors juniper, marrying it with mahogany or walnut, as in the mustang bed.

"Working with juniper is like what happens when people polish stone," she says. "They have an idea of what they want to get, but they're sometimes surprised. With juniper, you've got this rough, gray, weathered exterior. But once you start getting below the surface, it's like finding a gemstone."

Although Amber could obtain a permit to gather dead and down wood on the vast federal lands surrounding her, she favors private ranch land. "I just ask the owners for permission," she notes. "Then I go looking for interesting pieces. Some pieces I pull aside because they look special, even if I have no idea where they're going to go. But if I have a project that I've started and generally know what I need to add—like so big around and with a crook or something—then I try to find a piece that fills that need. The old fence posts that I use for my lamps have a whole other history and meaning, and usually their history does not lend itself to power tools very well, with nails and staples and all."

The juniper Amber finds does have hidden defects, and she usually won't discover them until she starts working the piece. "With found wood, you can't be rigid. You have to be open to the fact that this most beautiful, perfect bed corner post has rot or decay in a section that makes it unusable. Sometimes you can remove it, and the resulting curve or depression adds to the look. Sometimes I like to leave some of the old, weathered wood on the piece because I don't want people to forget what it was."

Critters are another story. "Early on I had a piece that I delivered to a gallery and it had a little worm in it. I had thought the finishing would kill it, so I just left it," she remembers. "A few days later I got a call saying, 'Amber, there's these little things coming out of your piece.' I had to go back to the gallery with a can of Raid and a thin, strawlike nozzle and spray into the holes! So I check out the wood more closely now, and throw it out if I suspect critters."

"Most of the bark is usually gone by the time I get to the juniper," Amber continues, "but I power-wash it all to get the dirt and any remaining bark off. Then I go directly to sanding with a portable sander. To clean out crevices, I'll use a carving burr on a pneumatic rotary tool. Then, I do some hand-sanding, usually with 220-grit. But if there's a neat touchy-feely spot, I take it up to 440 grit. Then people will just pet it and pet it."

Moisture content is never a problem with juniper, according to Amber. Montana's low humidity, sun, and wind have stabilized it by the time it's found.

A marriage of wood

By the time the juniper joins with the machined stock in a piece, Amber has it gleaming. Streaks of red portray the setting sun; whitish yellow provides contrast. And any remaining gray balances the two, much as the Montana mountains separate the sky from the valleys.

Amber got her introduction to fine wood rather than found in Jacksonville, Florida, where she designed and carved an entry door in mahogany for an art collector. She used more of the wood in a 12'-tall Mayan-themed totem for the same gentleman. "It carves so well,"



To give her relief carvings depth, Amber routs the background around the central figures 1/2" deep.

says Amber, "and the color complements the rugged juniper. It's a perfect marriage."

Because she freehand-routs the backgrounds of her images to a 1/2" depth, Amber orders 1 1/4"-thick stock. Large items, such as the headboard on the mustang bed, require edge-joining several boards to obtain the needed width. "People have this thing about something being made from one piece of wood," Amber comments. "So when they ask me, 'Is that just one big piece of wood?' I say 'Yes, a big piece of wood made from smaller pieces.'" Laughing, she mocks their surprised expression.

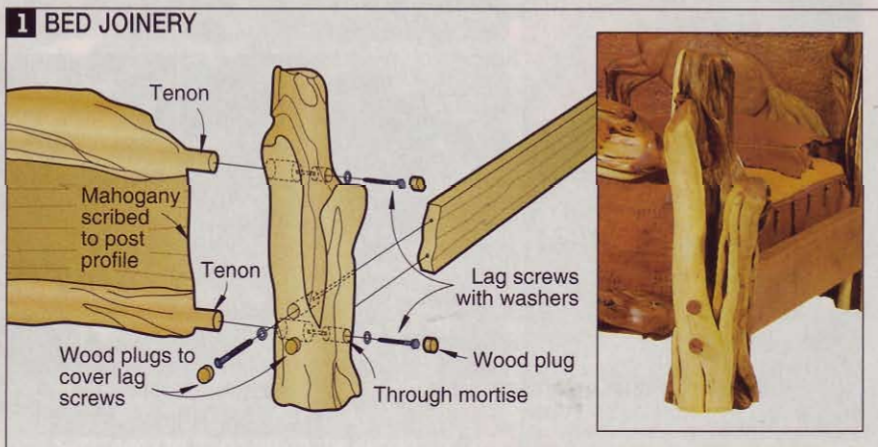

Chip away on furniture: 6 tools to do the job

Amber Jean recognizes that not all woodworkers wish to become carvers. Still, she believes that bits of selected carving can enhance the surface of some pieces of furniture, such as a border treatment on a tabletop. Here are her six favorite tools with photos of the marks each will leave.

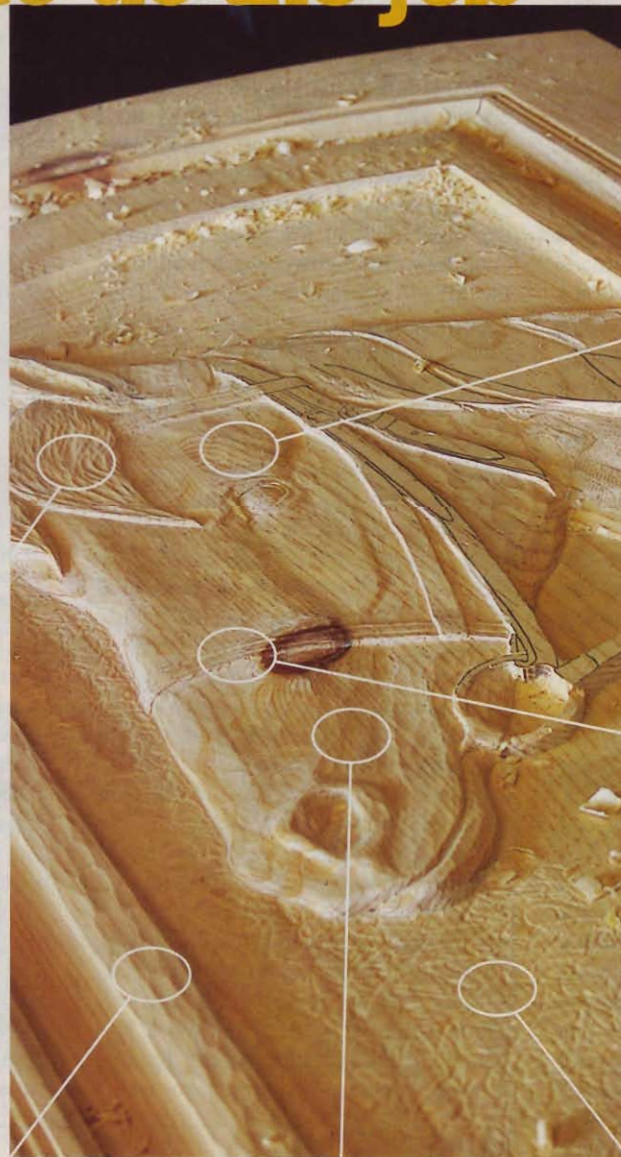

#9 sweep, 13mm gouge
This blade digs shallow trenches.



#8 sweep, 25mm gouge
Make deep, rounded cuts with this.



#9 sweep, 5mm palm gouge
This blade carves canyons.

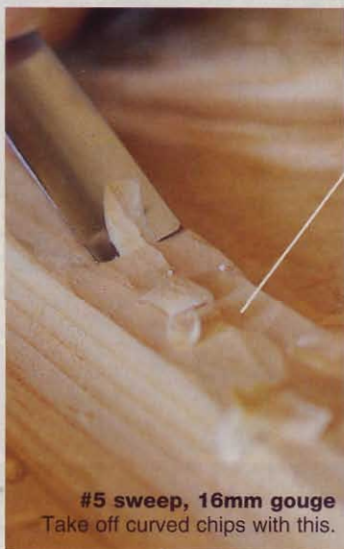

#5 sweep, 16mm gouge
Take off curved chips with this.



#3 sweep, 35mm gouge
This one cuts wide swaths.

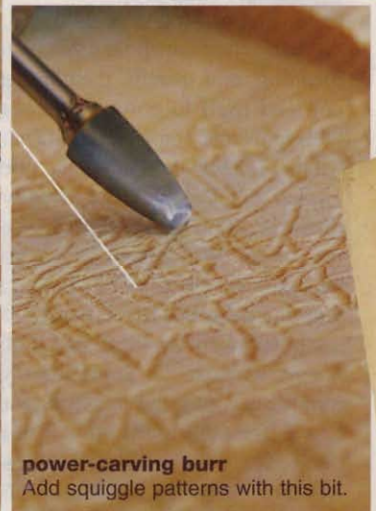

power-carving burr
Add squiggle patterns with this bit.

At her cabin near Livingston, Amber Jean, *right*, carves details into what will be a trout-motif table. *Below*, artist's oil colors mixed with stains work to brighten up the fish image while letting the wood grain show through.



When it came to joining uneven-shaped juniper to ordinary wood for her mustang bed, Amber was at first puzzled. It was nearly impossible to flatten the found wood on one side so that it would mate. And doing that would defeat the look she wanted in the piece anyway. Then, she recalled her time spent in the cabinet shop. "Scribing! Just as you do when installing a countertop in a kitchen remodel," she says. Accordingly, profiles of the bedpost and frames for the headboards and foot-

boards were traced onto the edges of the mahogany panels. Then they were cut to shape with a jigsaw and further profiled with a detail sander.

Drawing 1 on page 71 shows in an exploded view how the footboard assembly was done. The bed's massiveness required heavy-duty lag screws.

Finishing to fit the West

The shelves carrying Amber's finishing supplies reflect her artist's approach to woodworking. Dozens and dozens of small cans of different colored Minwax stains occupy several. A box of artist's oil colors fills another. Tried then discarded finishes sit here and there, beaten out by her now favored ones.

"My staining is more like traditional oil painting on a canvas," Amber explains. "I put down areas of oil color first—I call them under colors—then lay glazes of oil-based stains over them. And I usually mix in pigmented oils to get the color I want. It's more tinting than painting, letting the colors build up.

"I've even burned wood to get it black," she continues. "For

a large clock I built, I had farmed out the juniper sanding because I was so busy. Well, the guy had done it all wrong, and I thought I'd have to throw it out. Then, I was working late one night, and a friend stopped in. I was upset about the juniper. He just said 'Burn it' and grabbed a propane torch. Well, both of us got going on the wood with the torch. We'd char it, then wet it, then burn it again. And sometimes things just happen, you know? It was incredible—the charred black against the white streaks and against the red. The piece became ten times better than first conceived because the black was so powerful. I wanted it to look as if the black areas would get you black if you touched them. So it took some experimenting with finishes, but I settled on Danish oil applied with a mister, like for plants. The charred wood soaks it up."

To keep the natural colors of the wood bright, as well as the applied colors, Amber has settled on a two-part finishing process. She first sprays on several coats of Danish oil (by Menco), and lets them dry. Then she follows with two coats of Minwax Helmsman's spar varnish, creating a look of lasting beauty. 🌲

Amber Jean applied several layers and colors of oil-based stains to achieve the final look of this custom-carved door.

Written by Peter J. Stephano
Photographs: Lynn Donaldson
Illustration: Roxanne LeMoine



patriot's plaque

Show your
true colors
every day



Just as our 50 states are united in one nation, the parts of this intarsia flag come together to form a symbol of the unity and spirit of America.

Our door-mounted version measures $9\frac{1}{2} \times 13\frac{1}{2}$ ", but you can enlarge or reduce it to any size for other purposes.

***Note:** For this project you'll need one $\frac{1}{8} \times 10 \times 15$ " piece of Baltic birch plywood; one $\frac{1}{4} \times 10 \times 15$ " piece of solid poplar; water-resistant glue; a can of semigloss white spray paint; a can of satin spray lacquer; red, white, and blue acrylic craft paints; and a sawtooth-style picture hanger or double-stick foam mounting tape. (See the Buying Guide for a kit that includes the wood and the red, white, and blue craft paint.)*

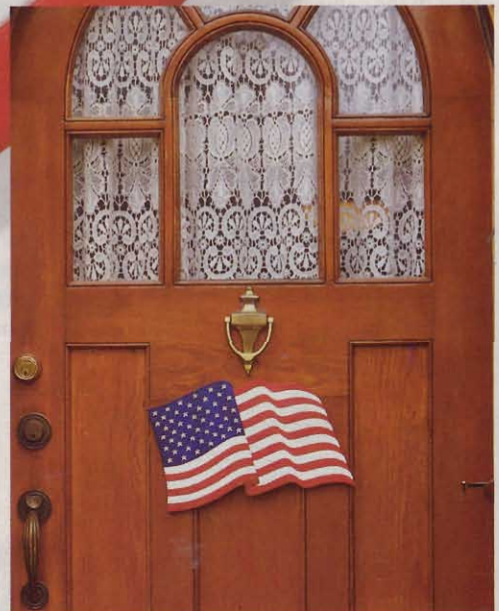



Scrollsaw the stars and stripes

1 Make two copies of the full-size flag pattern in the *WOOD PATTERNS*® insert. Use spray adhesive to adhere one to the piece of Baltic birch plywood and the other to the poplar.

2 Install a #2R blade (.014x.032" with 20 teeth per inch, reversed teeth at

the bottom) in your scrollsaw. Cut the plywood along the dashed lines to make the backer, and the poplar along the solid lines to make the flag. Drill 1/16" blade start holes, and saw the star cutouts.

3 Mark the pattern's stripe numbers and color letters on the back of each piece. Remove the pattern from all the pieces, and sand a 1/16" round-over on the front edges.

Paint and assemble the parts

1 Separate the stripes into red and white groups, and paint their fronts and edges. To make a small amount of slightly darker red for stripe no. 7 (the "back" of the bottom red stripe), squeeze a small pool of red paint onto a scrap of cardboard. Add a drop of blue and mix it in. Paint the part's front and edges.

2 Spray-paint the insides of the field's star cutouts semigloss white, as shown in **Photo A**. Then spray the back and edges of the backer and the portion

of the front that will be behind the stars when the flag is assembled.

3 Lightly sand the field's front to remove any fuzz from the stars' edges. Squeeze a pool of blue paint onto a cardboard scrap and *lightly* load a 4" foam mini-roller. To keep excess paint from dripping into the star cutouts, first run the roller back and forth on the cardboard, evening out its coating. Roll the paint onto the field, as shown in **Photo B**. Paint the field's edges.

4 With the paint dry, organize the stripes in numerical order. Glue the field to the backer, with its top and left-hand edges overhanging the backer by 1/8". Now glue the stripes to the backer, as shown in **Photo C**. Use a water-resistant glue. (We used Titebond II.)

5 With the glue dry, apply a couple coats of clear satin spray lacquer.

6 Display your flag. For indoor wall hanging, attach a sawtooth-style picture hanger to the back, centered where indicated on the pattern. For front door display, mount your flag with double-stick foam tape. (We used 3M Scotch mounting tape.) ♣

Written by Jan Svec

Project design: Kevin Boyle

Photographs: Baldwin Photography

Buying Guide

1/8x10x15" Baltic birch plywood, 1/4x10x15" poplar, craft paint (Delta Ceramcoat artist's acrylic paint, 2-oz. bottles: tompete red no. 2107, white no. 2505, opaque blue no. 2508). Material for five flags, \$34.95 ppd.; material for 10 flags, \$56.95 ppd. Order kit no. W139-2, and specify either a five-flag or 10-flag kit. Heritage Building Specialties, 205 N. Cascade, Fergus Falls, MN 56537, or call 800/524-4184.

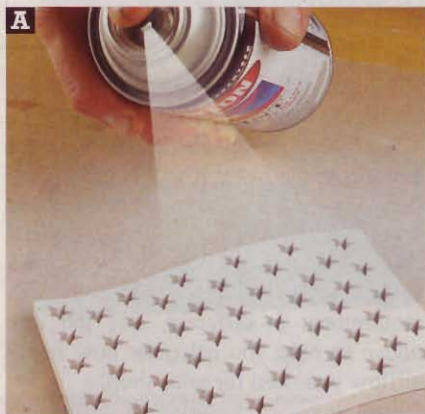

To paint the stars, spray at an angle from all directions. With the paint dry, flip the part over and repeat.

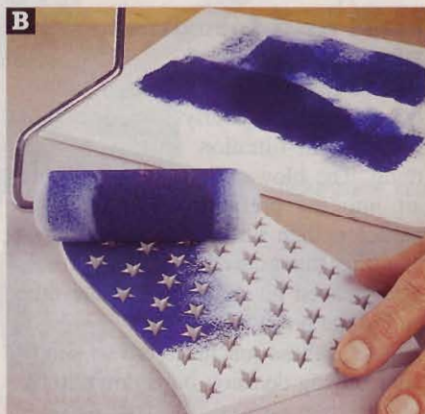

With an even, light coating on the roller, use moderate pressure to roll the paint onto the part.



Working down on the left from the field to the flag's bottom edge, then back up on the right, glue the stripes in place.

We test six air-filtration systems that bite the dust so you don't

dust munchers

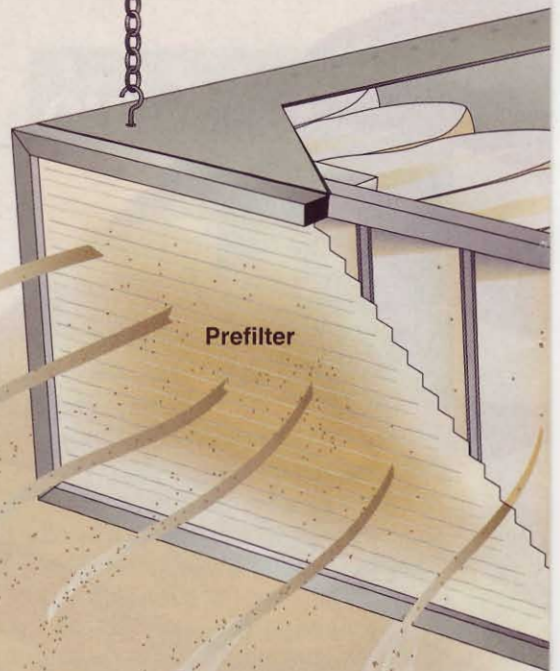

There's nothing like getting away to the shop to spend a few hours of quality time immersed in your latest project. But while you're having fun, stop to consider that dusty haze in the air around you. By the time you see it, microscopic debris already has bypassed your body's natural filtering mechanisms and lodged in your lungs. An air-filtration system not only adds quality to your time in the shop, it could add time to your life.

Your first and best line of defense in the war against workshop dust is to collect the debris at its source before it has a chance to go airborne. But, because no method is 100 percent effective, an air-filtration system provides air support, trapping floating debris before it falls and minimizing the amount you inhale.

Keep in mind that using one of these systems doesn't negate the use of a respirator. Employ an air-filtration system regularly, though, and you'll find yourself spending less time under the mask.

The last time we tested this type of unit, there were only a few models on the market. Today, you can choose from many brands in sizes ranging from near-industrial-size units to torpedo-style benchtop units. For this article, we limit-

ed the test to ceiling-hung units priced between \$150 and \$300.

First and foremost: air movement

As you can see from the drawing above, there's nothing overly complex about how an air-filtration system does its thing. The blower first pulls dust-laden air into the prefilter, removing larger particles, then through a tightly woven bag filter that grabs the smaller particles. The cleaned air exhausts out the other end of the box.

In fact, these machines are so simple, your buying decision boils down to two key factors: airflow (the volume of air the blower can pull through the filter, measured in cubic feet per minute, or

Figuring flow

To find the minimum cfm requirement for your shop space, you first need to know the volume of air in that room. To do that, use this calculation (round dimensions to the nearest foot):

$$\text{Length} \times \text{width} \times \text{ceiling height} = \text{volume}$$

Now, multiply the volume by 6 (air exchanges per hour), and divide by 60 (minutes in an hour) to find how much airflow you need in your shop.

$$\text{volume} \times 6 \div 60 = \text{minimum cfm requirement}$$

For example, a 12x20' shop with a 10' ceiling has a volume of 2,400 cubic feet. $2,400 \times 6 \div 60 = 240$, so the air-filtration system for this shop should move at least 240 cfm.

cfm), and the effectiveness of that filter. Let's start with airflow.

The more air an air-filtration system can move, the faster it will clean the air. At a minimum, the model you choose should change the air in your shop at least six times an hour. Because everyone's shop is a different size, every shop's cfm requirement is different. See the box above to help you calculate how much airflow you need for your shop.

The photos opposite show the testing procedure we used to ensure that our airflow tests simulated real-shop conditions.

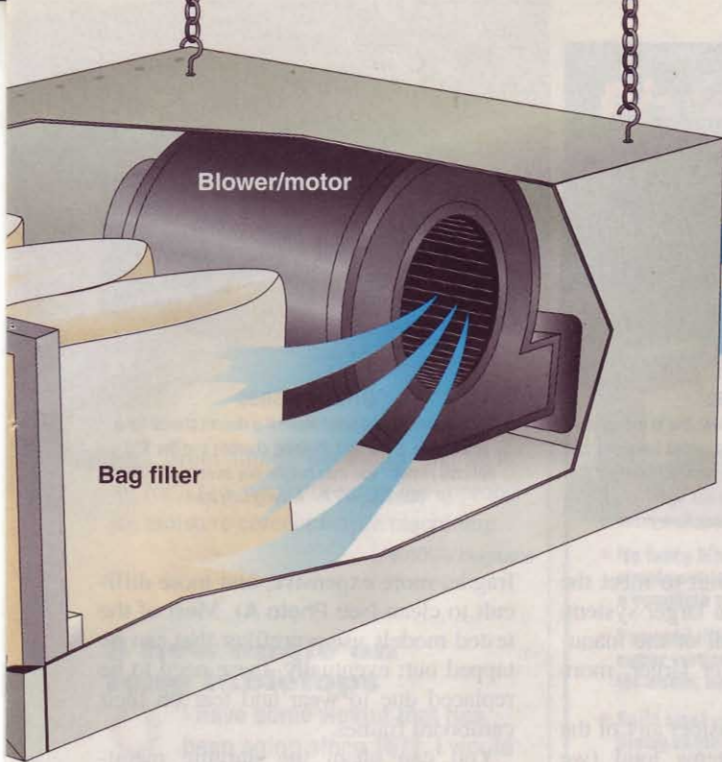

STEP 2

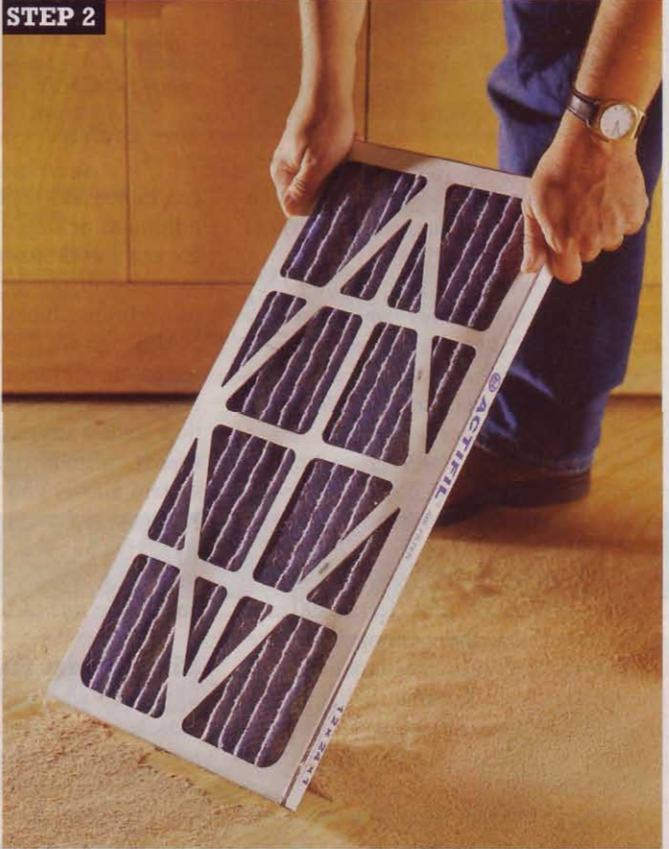

3 steps to measuring real-world airflow in these systems

STEP 1



STEP 3



A filter is new only once, so to get a more realistic measurement of airflow, we first set each machine to its highest speed, then sifted nine cups of sawdust into the filter end (above). After removing the prefilter and tapping out the dust (above right), we reinstalled the prefilter and used an air-capture hood to measure the air-filtration system's volumetric airflow (right).



Craftsman 29972

A single-speed unit with no remote control, but it has pretty good airflow. However, plan to clean the bag filter frequently, as the prefilter does little to protect it from debris.
800/377-7414 (catalog orders only)
www.sears.com/craftsman



Delta 50-868

In the middle of the pack for airflow, this is the most expensive unit in the test. We like the sealed touchpad controls and off-timer, and Delta has promised to correct the dust bypass we found in our tests.
800/438-2486 www.deltamachinery.com

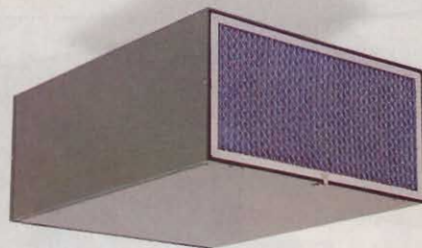

Grizzly G5955

The low airflow and price make it a decent choice for a small shop. If you add shipping charges and the \$30 optional remote, you may negate any savings, though.
800/523-4777 www.grizzly.com

The air-capture hood we used is the same type used by heating and cooling professionals to measure airflow.

Note: Due to differences in testing procedures, our cfm ratings may not match those quoted by the manufacturers. Because we tested all of the machines identically, our numbers provide a fair head-to-head comparison of the tested models. However, don't compare our numbers to the published specs of air-filtration systems not in this test.

As you can see from the Airflow column on the chart on page 80, airflow ratings range from 490 cfm (Jet) to 190 cfm (Grizzly). Using the example from the "Figuring flow" box, the Jet would turn the air over twice as often as that shop's minimum requirement, while the Grizzly would be appropriate for a slightly smaller shop.

If you have a large shop, you may need more airflow than any of the tested machines can provide. In that case, you

can either add another unit to meet the minimum or step up to a larger system. Except for Craftsman, all of the manufacturers in our test offer larger, more powerful machines.

Although we don't consider any of the tested air-filtration systems loud (we could easily carry on normal conversation under any model running at full speed), a multispeed or variable-speed system allows you to quiet the machine by slowing the motor. Obviously, doing so also reduces airflow, so lower speeds should be used only when you're not generating lots of fine dust.

Filtration facts

If the blower and motor provide the muscle in an air-filtration system, the filters provide the finesse. After all, it takes a fine touch to handle near-microscopic-size dust particles.

The prefilter's main purpose is to protect the bag filter, which is finer, more

fragile, more expensive, and more difficult to clean (see Photo A). Most of the tested models use a prefilter that can be tapped out; eventually, these need to be replaced due to wear and tear on their cardboard frames.

You can clean the durable metal-framed prefilters on the Craftsman, Grizzly, and Penn State models by spraying them with water. But you must let the prefilter dry thoroughly before using it again. (To get back to work sooner, temporarily insert a pleated furnace filter while the foam prefilter dries.)

But how well do they work? A filter's efficiency is expressed as a percentage of a certain size particle removed from the air passing through it. (Dust particles from 0.5 to 10 microns in size are the most damaging to your health.)

Some manufacturers claim their units remove 95% of the 5-micron particles, while others are listed as removing 80-85% of smaller 1-micron particles.



Craftsman's relatively coarse prefilter allowed large particles into the bag filter. Note that to take out the prefilter, you must first remove two screws and an access panel.

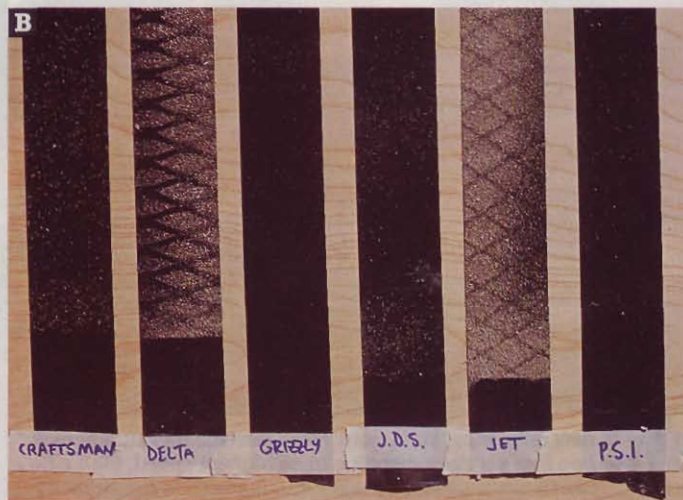

The Delta and Jet machines let more dust around or through their filters than others in the test. Since our test, both manufacturers have pledged to reduce the amount of bypass dust.



JDS 750

This variable-speed unit moves a lot of air while letting very little dust back into the room. One of our top picks, but wait for the remote-control version due out later this year.
800/382-2637 www.thejdscompany.com



Jet AFS1000B

There's a lot to like about this unit: the best airflow in the test, an 8-hour off-timer, and a fair price. Check the model you buy to make certain it has a seal behind the bag filter.
800/274-6848 www.jettools.com



Penn State AC620

Low airflow makes it a good choice for a small shop, and good seals prevent dust from getting back into the shop air. Speed control and off-timer operate by remote control only.
800/377-7297 www.pennstateind.com

Manufacturers don't give efficiency ratings for both 1- and 5-micron particles. So which is better: a smaller percentage of small particles or a higher percentage of large particles? Truth is, there's just no way of knowing.

Nevertheless, in our tests, we found that filter specs alone don't tell how much debris gets back into the air. To quantify the amount of dust that bypasses the filters completely, we placed a strip of black adhesive tape over each machine's exhaust, sticky side in, and sifted nine cups of sawdust into each machine running at its highest speed. **Photo B** shows the actual test strips.

The best performers in the bypass test, Grizzly and Penn State, have a seal (**Photo C**) around the prefilter; the other models do not. This seal keeps larger

dust particles from skirting past the prefilter, and makes a tight fit between the prefilter, bag filter, and the machine's metal case. Of the models with unsealed filters, the JDS performed best, with only a little more dust bypassing its filters than Grizzly or Penn State.

The test strips from the Jet AFS1000B and Delta 50-868 showed visible dust particles. Upon learning of our test results, John Otto of Jet Equipment told us they immediately would begin adding a foam seal to the case behind the bag filter to reduce the amount of bypass dust. Delta's Angie Shelton says the 50-868 also will now come with a similar seal, and that current 50-868 owners can get a free retrofit seal by calling Delta (800/223-7278) and asking for part no. 400-06-416-0002.

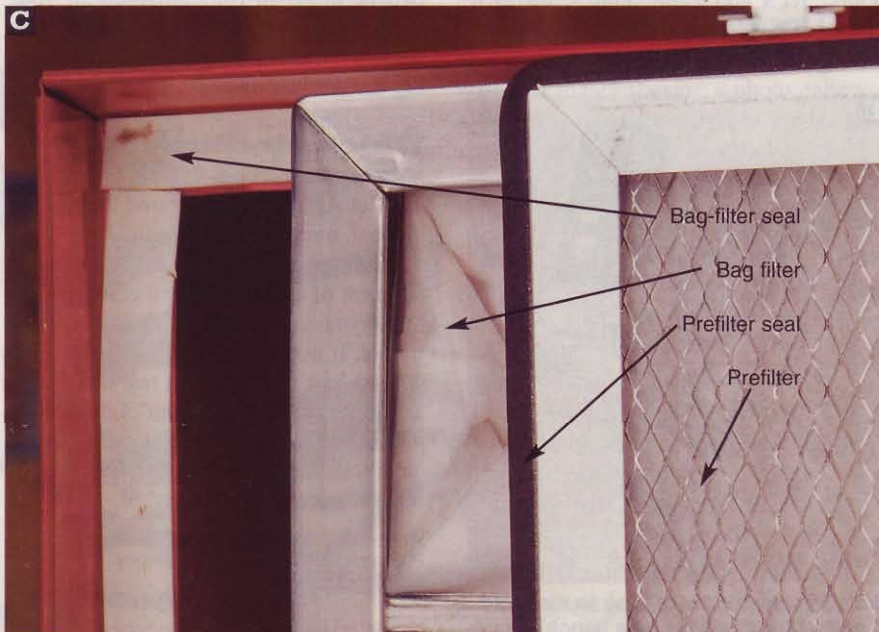

To reduce the amount of dust bypassing the filters, Penn State puts a foam seal around the prefilter and another behind the bag filter.



Touchpad controls are sealed from the outside to reduce dust penetration to the switches.

Most prefilters pop out easily for changing or cleaning. However, to remove the Craftsman prefilter, you need a screwdriver to open an access panel on the side of the unit.

Still up in the air? More considerations

•Power and speed controls. Three of the tested units have a simple pull-chain power switch for turning the machine on and off. But, we like the smooth, dust-resistant touchpads (**Photo D**) found on the Delta and Jet systems. Besides turning the fan on and off, the touchpad also controls the speed and off-timers (which we'll discuss shortly).

Speaking of speed controls, Delta and Jet offer three speeds, which seems like plenty to us. Penn State's system has five

SIX AIR-FILTRATION SYSTEMS UNDER \$300

MANUFACTURER / IMPORTER	MODEL	AIRFLOW (CFM) (1)	AMPS	MOTOR			CONTROLS			CABINET SIZE (HxWxL, INCHES)	EXHAUST TYPE (4)	WASHABLE PREFILTER (Y/yes (N)/no)	FILTERS		PERFORMANCE RATINGS (6)		CORD LENGTH (FEET)	OPTIONAL ACCESSORIES (7)	WARRANTY (YEARS) (8)	COUNTRY OF ASSEMBLY (9)	WEIGHT (POUNDS)	SELLING PRICE (10)
				NUMBER OF SPEEDS (2)	SWITCH TYPE (3)	REMOTE CONTROL (Y/yes (N)/no)	OFF-TIMER (Y/yes (N)/no (2))	BAG-FILTER EFFICIENCY (MICRONS) (5)	DUST BYPASS				EASE OF CHANGING/REMOVING FILTERS	EFFICIENCY (MICRONS) (5)								
CRAFTSMAN	29972	300	2.2	1	P	N	N	11 x 20 x 33	D	Y	95% @ 5	G	F	8		1	C	45	\$ 260			
DELTA	50-868	390	3.0	3	T	Y	Y	12 x 24 x 30	M	N	91% @ 1	F	E	7	CF, EF	2	U	50	299			
GRIZZLY	G5955	190	2.5	1	R	N	N	12 ^{3/16} x 24 x 30 ^{5/16}	L	Y	95% @ 5	E	E	5	RC	1	T	35	170			
JDS	750	420	3.9	V	PR	N	N	12 x 24 x 34	D	N	80% @ 1	G	G	7	CF, EF	LIFE	U	62	260			
JET	AFS1000B	490	4.5	3	T	Y	Y	12 x 24 x 30 ^{1/4}	M	N	85% @ 1	F	E	6	CF	2	T	54	240			
PENN STATE	AC620	200	2.5	5*	P	Y	Y*	12 x 24 x 30	L	Y	85% @ 1	E	E	6	SF	2	T	40	229			

NOTES:

- Airflow measured in cubic feet of air moved per minute (cfm) at highest fan speed, using air-capture hood. Prior to test, filters were fed equal amounts of wood dust then tapped clean to simulate workshop use.
- (V) Infinitely variable speed
(*) Using remote control only.

- (P) Pull chain
(PR) Pull chain with rotary speed control
(R) Rocker switch on case
(T) Touchpad on case
- (D) Diffused
(L) Directable louvers
(M) Mesh outlet

- Percentage of particles of the size shown removed from air passing through the filter. Rating from manufacturer.
- E Excellent
G Good
F Fair

- (CF) Charcoal filter for removing odors
(EF) Electrostatic filter
(RC) Remote control
(SF) Smoke filter

- (LIFE) Lifetime warranty against factory defects, 1 yr. warranty on motor.

For specifications on other types of tools, click on "Tool Comparisons" at www.woodmall.com.

discrete speeds, but you can change them only with the remote control. Lose the remote, and you lose control. Rather than stepping from speed to speed, JDS's infinitely variable control lets you fine-tune the fan speed from low to high.

•**Remote control.** If you mount your air-filtration unit on a high ceiling, a remote control may be important to you. Delta, Jet, and Penn State all come with remote controls (Photo E), while Grizzly offers one as a \$30 option. Most remotes require line-of-sight to the air-filtration system, much like your TV remote.

Neither Craftsman nor JDS currently offers a remote, but Doug Roder at JDS tells us that later this year they'll offer a radio frequency (RF) remote control with a digital speed display for their air-filtration system. Besides having greater range than line-of-sight models, Roder says the remotes will be addressable, which means that if you have more than one JDS air-filtration system in your shop, you can set them to the same or different frequencies.

•**Off-timers.** The air-filtration systems from Delta, Jet, and Penn State have timers that can be set to scrub the air for up to 8 hours, then power down automatically. We love this feature—we set the timer when we first entered the shop,

and never worried about remembering to turn it off.

Even here, there are differences in the tested models. Off-timers on the Delta and Jet units can be set by remote control or by the touchpad on the machine; Penn State's can be set only with the remote control. Delta's timer runs up to 7½ hours; Jet's and Penn State's, up to 8 hours. JDS plans to offer an off-timer with their new remote package.



Jet's remote control is easy to tuck into a pocket (or misplace on a bench). Penn State's control can be mounted to a wall, like a wireless switch.

•**Exhaust.** A diffused airflow out the back of the machine prevents stirring up already-settled dust, and Craftsman and JDS are the only air-filtration systems in our test to diffuse the exhaust. Directable louvers on the Grizzly and Penn State allow you to steer the exhaust to create an airflow pattern—especially handy with two or more air-filtration units in your shop. Delta's and Jet's mesh outlet keeps fingers out of the blower without directing the outflow of air.

Which air-filtration system rises to the top?

The Jet AFS1000B delivered the most airflow, a remote control, and handy off-timer at a reasonable price. If the addition of a bag-filter seal corrects the dust-bypass problem, we'd choose this model. If not, the JDS 750 delivered the second-best airflow in the test while allowing a minimal amount of dust back into the air. At this stage, though, this air-filtration system doesn't offer a remote control or off-timer.

Written by Dave Campbell with Kirk Hesse
Photographs: Baldwin Photography
Illustration: Tim Cahill

Talk air-filtration systems with other woodworkers by visiting www.woodmall.com.

sugar maple

Even to
lumbermen,
it's one
of the
sweetest
of North
American
hardwoods.



Growth range



Typical bark

Illustration: Steve Schindler
Photographs: Baldwin Photography

plain sawn

bird's-eye

curly

quartersawn

fiddleback

Try to picture a New England village in the fall without images of arching maples in brilliant hues of crimson, gold, and orange. That's hard, and rightly so, for the sugar maple (*Acer saccharum*) thrives in such a setting, lending its shade to lawns and streets. An ideal small-town tree, the sugar maple does, however, suffer when moved to the city and its accompanying pollution.

Throughout its range from the Great Plains eastward and into Canada, the sugar maple historically has provided man with not only beauty, but sustenance. For in the early spring, the tree's sap rises in such amounts that it always has been tapped for an annual yield of syrup and sugar. In Vermont, Michigan, and other northern states where it grows in stands, the trees in these "sugarbushes" each can produce 15-20 gallons of sap per season—approximately enough to boil down to a half-gallon of syrup or four pounds of valuable sweet sugar.

The sugar maple, though, is no less sweet to the lumberman. In the wilds of the woods, the tree can grow to 120' tall with a diameter of 3-4', frequently with two-thirds of its trunk free of branches. This presents the opportunity for the clearest of lumber for a myriad of traditional uses.

Finding the tree afield

In its range, you'll find the best sugar maples in gravelly, somewhat alkaline soil that drains easily. Unlike some hardwoods, it doesn't like wet feet.

With its symmetrically rounded shape, the sugar maple is recognizable enough at first glance. Yet, there are 13 maples native to the United States, so making positive identification means looking to the leaves. Sugar maple leaves are up to 6" long, dark green above with pale green beneath, and have five lobes, each carrying delicate points. By late summer, winged keys (fruits) joined at an acute angle hang amid the leaf stems. And it's this sharp angle of the keys that helps distinguish the sugar maple from others in its family.

Barks helps, too. As a sugar maple tree matures, its smooth, silvery bark

Sugar Maple at a Glance

Price: Because of its surge in popularity in recent years, maple prices have shot up. Lumber suppliers we surveyed charged \$3.50 per board foot (bf) in the Midwest, \$5.50 in the Northeast, and \$8 on the West Coast for F&S, the best grade.

Everywhere, curly figure will add \$2 per bf. Expect to pay more than \$12 per bf for boards with fiddleback or bird's-eye figure.

Pros: Hard, stable, strong, and durable. Excellent for any surface that takes abuse—tables, chairs, flooring, and cutting boards.

Cons: Requires power tools and sharp cutting edges; burns easily during machining. Prone to chip-out. Stain may blotch unless wood is conditioned first.



heartwood



mineral streaks

Heartwood (top) or mineral streaks have little effect on the pricing of sugar maple. Be careful in your selection.



spalted

Maple left in wet conditions will attract fungi that create fanciful patterns in the grain. This "spalting" process must be stopped, however, and the wood dried before it becomes too soft and punky to be usable.

becomes dark gray and breaks into deep fissures or grooves. Frequently, outer portions of the bark on older trees become noticeably scaly.

The wood and its uses

At times and in different places sugar maple is called "rock" or "rock-hard" maple. That name came about due to an Early American craftsman named Rock who made a line of sugar maple furniture that he dubbed "Rock's Hard Maple Furniture." The name lives on in the language today.

Sugar maple may not be rock hard, but it ranks higher than red oak in that category. It's also stable, strong, stiff, and durable to indoor punishment. In fact, sugar maple gets smoother, not rougher, with age and wear. And at 44 pounds per cubic foot air dry, it rivals beech and teak in weight.

Light tan to nearly white in color (particularly the desirable sapwood), sugar maple normally has straight, close grain. To woodworkers' delight, though, highly figured wood appears perhaps more admirably in this stock than in any other commercial species. You'll enjoy the sight of curly or tiger; the closer-striped fiddleback; quilted; and bird's-eye.

Sugar maple is most closely associated with its use for Early American or Colonial style furniture. But it doesn't end there. You'll find it taking a pounding as bowling lanes (the pins, too), school desks, tool handles, and ladder rungs, as unglamorous as these may be. Yet, it's a mainstay for cabinetry, butcher block, cutting boards, and flooring, too. Turners find the figured and spalted varieties a treat for bowls and other vessels. Instrument makers treasure it for violin backs (hence "fiddleback"). And even during the days of Kentucky long rifles, it made the grandest of stocks.

Abundant in supply, you'll find sugar maple readily available coast to coast at a bit more than red oak. (See prices above middle.) Although color doesn't come under grading rules, some dealers sort out and mark up the price of the whiter sapwood boards. At most dealers, the presence of mineral streaks (shown left) and heartwood

does not lessen the price you pay for a board, so select carefully, and choose clear boards that match closely in color. You'll occasionally find curly figured boards mixed in with straight-grained ones. You also can buy sugar maple plywood and veneer. In fact, if you're looking for fiddleback or quilted varieties, veneer sellers may be the first place to look because boards carry an extremely high price.

Sugar maple in the shop

As wonderfully clear, straight- and close-grained as sugar maple is, you can still have problems with it in your workshop. Heed the following to lessen them.

- Due to its hardness, always use carbide cutters and blades.
- Because it's hard as well as close-grained, use a rip-profile blade with fewer than 28 teeth. And avoid burning with sawblades or router bits by using a fast feed rate.
- Avoid jointing tear-out with sharply honed knives. At the planer, take light cuts. With figured stock, plane at a slight (15°) angle and never to finished thickness; always leave some for sanding, or use a cabinet scraper.
- Use a backing board when crosscutting to reduce chipping.
- When joining, if slippage occurs, switch to white glue with a longer open time. Coat both sides, then rub together and let the glue set up slightly before clamping.
- Never oversand. Excessive sanding with 400- or 600-grit burnishes the wood and causes staining problems.
- Maple can blotch when traditionally stained. To avoid it, first prepare the wood with a wood conditioner or thinned sealer (such as shellac). Using aniline dye or gel stains reduces the problem, too. You also can tint a clear finish to obtain the right shade. Remember, if you use clear, water-based finishes the wood will look whiter and brighter. See the difference in the photos *below*.



Maple with a water-based finish (left) is whiter than the amber-toned sample coated with an oil-based finish shown at right.

Hard maple vs. soft maple

In addition to sugar maple, the wood products industry includes black maple (principally from the lower Midwest) and bigleaf maple (from the West Coast and marketed there as western maple) under the hard maple heading. Grouped under and sold as soft maple are red maple, silver maple, and occasionally boxelder. All other maples are not commercially important due to their smaller size. Here's how the two groups generally compare:

	Hard maple	Soft maple
Weight (lbs. per cu. ft.)	44	35
Testing values (higher numbers reflect more favorable ratings):		
Strength	106	80
Stiffness	178	106-158
Hardness	115	70
Stability	147	120

Note: Soft maple costs at least \$1 less per board foot than hard maple. And boards with figure, especially curly, occur more frequently in soft maple than in hard maple. In fact, it's said that you'll find figure in 2-5 percent of soft maple trees, but only in .05 percent of hard maples!

Is there a substitute?

Due to current demand, sugar maple prices are relatively high. If cost is a factor—and you're willing to accept some trade-offs—you may want to consider the less costly alternative woods featured *below* when you're looking for the light-colored appearance of sugar maple. 🌲



soft maple

Almost as heavy, but not as strong or hard. Best choice as a substitute. See more at *left bottom*.

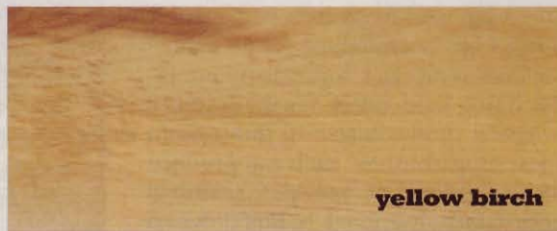

yellow birch

Nearly the same in weight, strength, and hardness. But discolorations make it hard to find clear boards.

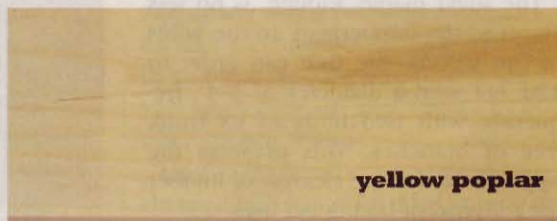

yellow poplar

A lighter, weaker, and softer substitute. Greenish discoloration is prevalent. Good for painted projects.

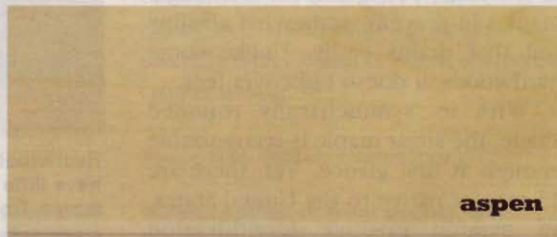

aspen

Half as strong and a third as hard as sugar maple. Difficult to stain. Routing can fuzz wood fibers.



basswood

Less than half the weight and strength. One-third as hard. A great wood for carving.

futon hunting

While designing our sofa/bed on page 36, we shopped for a futon mattress with good looks and long-lasting comfort. Here's what we discovered.

Whether at a furniture or specialty mattress store, or online, we found the world of futon mattresses to be a diverse community, with prices ranging from \$60 to \$400. In every case, prices rose as quality improved and mattress thickness increased. But if you spend the time and money to make our sturdy sofa/bed, you'll want to fit your project with a comfortable, well-made mattress that complements your craftsmanship. We chose a standard-size, innerspring mattress 8" thick for comfort and durability.

Sizing up your futon purchase

Made by such manufacturers as Simmons, Wolf, and Goldbond, futons come in four basic sizes. The *chair* size measures 28x54"; the *love seat* combined with a separate ottoman mattress measures 54x75"; the *full* or *standard*, 54x75"; and the *queen*, 60x80".

Futon thicknesses range from 4" to 12". As you might expect, the thinner the mattress, the less cushion and comfort. If your plans are for sleeping nightly on the mattress, you'll want to opt for the thicker models that offer the most support.

Quality counts

How a futon mattress goes together says a lot about its quality, comfort, and durability.

FOAM-CORE MATTRESS (LOW-END QUALITY)

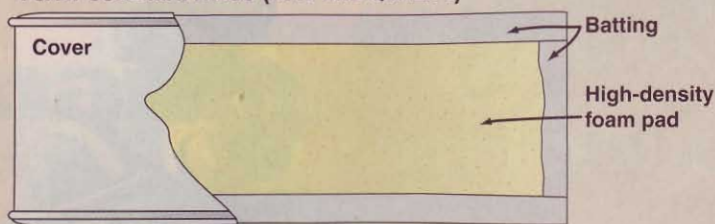

CONVOLUTED FOAM-CORE MATTRESS (BETTER QUALITY)

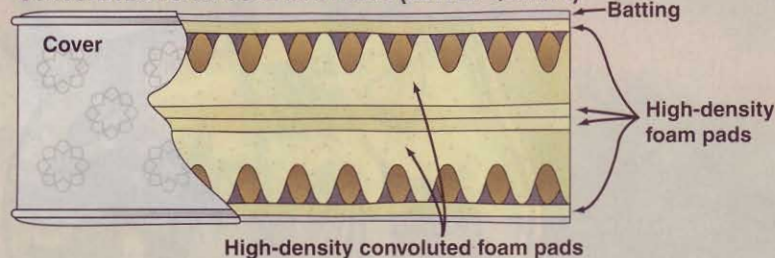

INNERSPRING MATTRESS (BEST QUALITY)

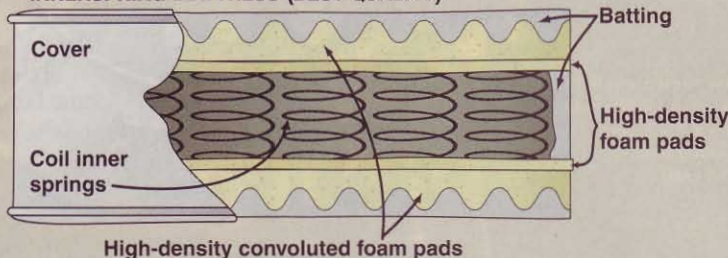

ty. Though many variations on futon mattress construction exist, the illustrated cross sections *above* help point out the differences in quality.

- Low-end futons range in thickness from 4" to 12", and consist of a large foam core sandwiched between thinner layers of cotton and polyester fiber (called batting), all wrapped in a hard-wearing muslin outer cover. They can be priced as low as \$60.
- Better-quality foam futon mattresses feature opposing layers of egg-crate or convoluted foam and provide stiffer, more resilient support. The downside of a foam-core mattress is that the foam breaks down over time and loses its resilience. The good thing? It instantly conforms to any seat/back angle while offering acceptable comfort. Their prices fall in the \$100 to \$200 range.
- The best-quality futon mattresses include inner springs. These start at 8" thick and go up to 12". The spring core is additionally layered with flat and convoluted foam, batting, and a muslin cover. These mat-

tresses tend to be stiffer, and when we installed ours, we needed to string a bungee cord from one end of our sofa to the other to maintain the fold. However, from a support and comfort standpoint, innerspring futons proved superior, with the springs warranted to outlast a foam core (one year versus five years). They also weighed more, with the largest tipping the scale at 80 pounds. Expect prices here to run from \$200 to \$400.

Going under cover

Though we chose not to cover our futon mattress, you can add style and protect yours with an attractive slipcover. One store we visited offered 300 different styles from colored muslins to plaids to tapestries and ranging in price from \$40 to \$200. You also can mail-order a standard futon slipcover from JCPenney, or order one online, searching the Web under "futon." ♣

Written by **Jim Harrold**
Illustrations: **Tim Cahill**

products that perform

These woodworking wares passed our shop trials

Big plunge router is so Fein

Fein power tools have a worldwide reputation for quality and durability at a premium price. Everything about the RT1800 3¼-hp router builds on that well-deserved perception.

Without a lot of flashy gimmicks, the RT1800 looks like a simple plunge router, and it is. All of the controls operate simply and smoothly, from the rack-and-pinion depth stop, to the handle-mounted trigger switch, to the plunge-lock lever.

The RT1800's maximum 3" plunge depth is the deepest I've seen, equalled only by the Porter-Cable 7539. And, that plunge mechanism operates as smooth as a baby's bottom, with no stuttering on the downstroke.

I made some stout cuts with the RT1800, plunging ½" and more into solid walnut with a ½" spiral-cutting bit, and the variable-speed, soft-start motor barely flinched. In fact, I purposely tried to find ways to bog it down, even hogging away a 1"-



Fein RT1800 Plunge Router

Performance	★★★★★
Price	\$299
Value	★★★★☆

Call Fein Power Tools at 800/441-9878, or visit www.feinus.com.

radius round-over in walnut, but the machine's electronic speed control simply wouldn't allow it.

Another unheralded feature of the RT1800 is its solid-steel insert plate, shown in the foreground of the photo at left. Attached to the router base, it fits Porter-Cable guide bushings; removed, it opens the base to accept bits up to 3½" in diameter. A clear plastic dust-collection shroud adds icing to the RT1800's cake, although it makes bit changing a little more difficult.

—Tested by Rich Bright

Continued on page 90

Dust Collector

- Flexible design options
- Perfect for the small shop
- Compact 2' W x 2' L x 7'2" H footprint
- 1.5 hp delivers 700 CFM @ 8" static pressure
- Internal pleated spun bond polyester filter cartridge
- High efficiency filtration 99% on .2-2.0 micron material

Engineered ductwork design & parts list provided

"If you have a small shop this is the perfect dust collector, I put mine in a 2x2' corner space and connected it to five woodworking machines. I love it!" Lloyd Diamantis, Albany NY.

Call for a free brochure!



1-800-732-4065

www.oneida-air.com

1001 W. Fayette St. Syracuse, NY 13204

Proudly made in America

Dust collection systems & components 1.5 hp & larger

Circle No. 1264

Safe stripper cuts even water-based poly

If you've ever refinished a piece of furniture or the wood trim in your house, you've run into one of two problems: Either you resorted to noxious chemical strippers that created an explosion hazard, or you met up with a water-based finish that had to be sanded off because even the nastiest solvent wouldn't remove it. Motsenbocker's Lift Off Lacquer Remover solves both problems.

I tested Lift Off on an old door from my 1931 house that had clear-finished panels surrounded by painted rails and stiles. Using a paint brush dipped in the stripper, I kept the door surface wet and slightly agitated. Within minutes, six layers of paint disappeared before my eyes with only gentle persuasion from a putty knife.

When I could see bare wood, I switched to a synthetic abrasive pad dipped in Lift Off. Even though the paint originally had been applied directly to the wooden door,



**Motsenbocker's Lift Off
Lacquer Remover**

Performance	★★★★★
Price	\$40, gallon
Value	★★★★☆

Call Motsenbocker's Lift Off at 800/346-1633, or visit www.liftoffinc.com.

the stripper easily floated the paint residue out of the pores.

On the clear-finished portion of the door, the finish offered almost no resistance to the stripper. And Lift Off removed the finish without dissolving it into a sticky mess.

Next, I turned my attention to a cabinet door that we'd finished with water-based polyurethane a couple of years ago in the *WOOD* magazine shop. Although it took a little longer for Lift Off to get under the finish (it breaks up like river ice in spring), the end result was just as impressive.

I wore gloves when applying Lift Off, but the occasional accidental splash onto my bare arms yielded no irritation at all. And using the product in an unvented room didn't offend my nose or create a health hazard.

My house also has brass switch plates that had been painted over umpteen times. I poured a little Lift Off into a shallow dish, dropped the plates in, and 15 minutes later, they shed their paint "skin" in one layer without discoloring the brass.

—Tested by Jan Hale Svec

Continued on page 93

ARROW

THE SURVIVOR

THE ALL-STEEL ARROW T50®PBN

ARROW's Professional T50®PBN is steel inside and out. Beneath its durable housing, carbon hardened steel working parts add years of precision performance to the T50®PBN. There are no internal plastic parts to quickly wear out.

This all-steel ARROW tool won't let you down during a rough day on the job. It's simply built to last. And, the fact that the T50®PBN shoots 6 different size staples, plus brad nails too, means that it will tackle a wide range of fastening jobs.

Available at lumberyards, home centers, and neighborhood hardware stores wherever fine tools are sold.

MADE IN USA
HECHO EN E.U.A.

Arrow Fastener Co., Inc., 271 Mayhill Street, Saddle Brook, New Jersey 07663
Canada: Jardel Distributors, Inc., 6505 Metropolitan Blvd. East, Montreal, Quebec H1P 1X9
United Kingdom: Arrow Fastener (U.K.) Ltd., 14 Barclay Road, Croydon, Surrey CRO 1JN
www.arrowfastener.com © 2001 Arrow Fastener Co., Inc.

products that perform

Sturdy, stowable router table

I hear a lot of woodworkers pooh-poohing the idea of buying a router table, saying they can build their own cheaper. That may be, but for those of us with small shops, the last thing we need is another cabinet eating up precious floor space. That's one good reason to look at Bosch's RA1200 Deluxe Router Table: It folds up for storage.



Bosch RA1200 Deluxe Router Table

Performance	★★★★★
Price	\$370
Value	★★★★☆

Call S-B Power Tools toll-free at 877/267-2499, or visit www.boschtools.com.

That's not to imply, though, that this router table is small. On the contrary, the RA1200 offers a lot of working surface—44x24" of 1 1/2"-thick, plastic-laminated medium-density fiberboard. The phenolic router-mounting insert plate comes pre-drilled for Bosch routers, and includes two insert rings for use with larger bits.

And, you don't sacrifice performance for portability. The RA1200's machined aluminum split fence has adjustable wooden faces and comes with two feather boards: one that rides in the miter slot, and another that mounts to the fence. I also like the acrylic bit guard and large adjustment knobs on the fence.

None of the adjustments on the RA1200—including leveling the insert plate—require tools. And except for attaching the guard to the fence and the remote power switch below the table

Continued on page 94

WOODLINE ARIZONA, INC. OFFERS YOU MORE... Super Sets AT Great Prices!!!

30-Piece Professional Set



- Includes:
5 Straight bits
3 Dovetail bits
3 Core Box
3 Cove Bits
6 Roundovers
2 Flush Trim
1 Panel Bit
2 Roman Ogee
2 Slot Cutters
1 "V" Groove
1 Chamfer
1 Bevel Trim Bit

WL-2010 OUR PRICE ONLY \$109 set

15-Piece 1/2" Shank Set



- Includes:
Chamfer
Cove -
1/2"R, 3/8"R, 1/4"R
Roundover -
1/2"R, 3/8"R, 1/4"R
Roman Ogee -
1/4"R
Straight Bits -
3/4"R, 1/2"R, 1/4"R
Roundover -
1/2"R, 3/8"R, 1/4"R
1/2" Dovetail
1/2" Roundover
1"CL Flush Trim
Rabbit Bit

WL-2022
OUR PRICE ONLY \$59 set

15-Piece 1/4" Shank Set

same as WL-2022 except 1/4" shank

WL-2022 OUR PRICE ONLY \$59 set

5-Piece Cabinet Door Set



- Includes:
3/4" Bore Shaper Cutter
1-pc Rail & Stile (Roman Ogee)
4 5/8" Panel Raiser (Ogee)
Door Lip
Glue Joint
Drawer Locker

WL-1505 OUR PRICE ONLY \$179 set

6-Piece Cabinet Door Set



- Includes:
2-pc Rail & Stile (Roman Ogee)
2 3/4" D Panel Raiser (Ogee)
Door Lip
Glue Joint
Drawer Locker

WL-2020 OUR PRICE ONLY \$119 set



- 8-Piece Classical Set
Includes:
2 Classical - 5/32"R & 1/4"R, 1 Wavy
2 Ogee - 5/32"R & 1/4"R, 1 Filet
2 Roman Ogee - 5/32"R & 1/4"R
(1/2" Shank Router Bits)

WL-2016 OUR PRICE ONLY \$99 set



- 5-Piece Cove Set
1/2" Shank Router Bits
1/4"R, 3/8"R, 1/2"R,
5/8"R, 3/4"R

WL-2015 OUR PRICE ONLY \$49 set

5-Piece Roundnose (Core Box) Set



- 1/2" Shank Router Bits
3/8"D, 1/2"D, 3/4"D, 1"D, 1 1/2"D

WL-2012
OUR PRICE ONLY \$49 set

13-Piece Dovetail Set



- 1/2" Shank Router Bits
3 Straight bits
10 Dovetail bits

WL-2014 OUR PRICE ONLY \$49 set



- 6-Piece Bullnose Set
1/2" Shank Router Bits
1/4"D, 3/8"D, 1/2"D,
5/8"D, 3/4"D, 1"D

WL-2013 OUR PRICE ONLY \$89 set

3-Piece Cabinet Door Set



- 1/2" Shank Router Bits
2-Piece Roman Ogee Rail & Stile
2 3/4" Ogee Panel Raiser

WL-2019 OUR PRICE ONLY \$65 set



- 5-Piece Moulding Set
1/2" Shank Router Bits

WL-2011 OUR PRICE ONLY \$99 set

All Woodline Arizona Sets are packaged in a beautiful wood box (a \$10.00 value).



- 5-Piece Carbide-Tipped Forstner Bit Set
3/8" Shank for Drill Press
35mm, 1 1/4", 1", 3/4", 5/8"

WL-2018 OUR PRICE ONLY \$39 set



- 5-Piece Dovetail Set
1/2" Shank Router Bits
8 - 1/2"
14" - 3/8", 1/2", 5/8", 3/4"

WL-2017 OUR PRICE ONLY \$19 set



WOODLINE ARIZONA, Inc.
P.O. Box 1530 • Payson, AZ 85547
Great Router Bits & Shaper Cutters!
Best Selection... Best Price

Order Toll Free

1-800-472-6950

Get your FREE catalog and see our great selection of Bits and Cutters

Most items in stock • All major credit cards accepted
Same-day shipping!! • Shipping \$3.75/\$100 + \$4.75

WOODLINE's Quality Bits and Cutters feature:

- Tough Micro-Grain Carbide
- Euro Anti-Kickback Design
- Super-slick Non-stick finish

• **Super Low Prices**

Check our website for new products:
www.woodbits.com
E-mail:
cuttersaz@cybertrails.com

products that perform

(another nice feature), the RA1200 comes completely assembled. I had the table up and ready to rout in less than 20 minutes.

If your shop floor is uneven (and whose isn't?), you'll like the leveling foot on the RA1200. A few quick spins of the leveling foot keep the table from rocking.

—Tested by Rich Bright

Scalloped bits cut fast while keeping cool

“Wow.” That’s the first note I made after plunging a 2” bit called “The Edge Forstner” into a piece of oak. With little pressure on the drill-press feed lever, this bit spat out mounds of thick shavings without leaving so much as a smoky smudge in the hole.

Similar to a sawtooth bit, The Edge Forstner bit has a series of scallops around the perimeter of the cutting edge that make an exceptionally clean entry into



The Edge Forstner bits

Performance	★★★★★
Price	\$4-26
Value	★★★★☆

To locate a dealer near you, call The Mibro Group at 800/221-4040.

both plywood and solid-stock workpieces. These scallops also help keep the bit from overheating. In fact, when I bored a 2” hole in a piece of hickory, the bit barely got warm.

Less obvious benefits of The Edge are the bit shank, which is ground flat on three sides to prevent slipping in the drill chuck, and the titanium coating, which should keep the bits sharp a good deal longer than uncoated bits. The Edge Forstner bits come in diameters ranging from 1/4 to 2 1/8”.

—Tested by Garry Smith

About our product testers

Rich Bright teaches woodworking and other technical skills to high-school students. Jan Hale Svec is a WOOD® magazine projects editor. Garry Smith is a tool-and-die maker and avid woodworker.

Fully automatic dust collection systems

ECOGATE

- Directs air-flow only to machinery in operation - your existing system is dramatically improved
- Computer controls blast gates and regulates dust collector

Call 1-888-ECOGATE for a free brochure. www.ecogate.com

ECOGATE®

POCKET HOLE SYSTEMS

Have you discovered the Pocket Hole Advantage?

Experience the joinery technique everyone's talking about...

Kreg offers solutions to all of your joinery needs with Pocket Hole Systems from \$20 to \$3,000, including our most popular tool the **Kreg Jig ProPack**.

- 1** Cut wood square.
- 2** Drill pocket holes.
- 3** Clamp and drive self-tapping screws.

Visit our website to learn more. www.kregtool.com

what's ahead

in our next issue

Coming in March

Projects



One classy computer center

Let's face it, computers and the things that go with them don't do much for your home's interior. This simple yet stylish furniture piece hides all of that stuff when not in use, but makes it readily accessible when needed.



Gardener's at-the-ready potting bench

Get your planting gear organized and placed at arm's length with this easy-to-make project. It will stand up to most anything you, or Mother Nature, throws at it.



Mission CD case

Store CDs, cassettes, or DVDs by simply changing the shelf spacing of this accommodating piece. It matches our previously published mission furniture.



Desktop TV clock

With just a few pieces of scrapwood and our complete hardware kit, you can build this retro clock so reminiscent of the '50s.

Tools, Techniques, & Features



Shops to die for

The judges have spoken. Now you'll see the winning entries in the Great American Workshops Contest cosponsored by **WOOD**® and DeWalt.



Buy the best dust collector

Looking for a machine that will clean your shop and not your wallet? We test and review 10 dust collectors having 1- or 1½-hp motors.



WOOD magazine's guide to finishing, part II

Finishing pro Jim Kull teaches foolproof ways to creatively stain and dye all of your projects.