

Build the ultimate bandsaw table jig pp. 50, 56, 64

Better Homes and Gardens®

# WOOD

JUNE/JULY 2003  
ISSUE 149

Tips, Tools, Techniques, and Projects for the Home Woodworker

heirloom-quality  
**barrister's  
bookcase** p. 42

**GET YOUR TOOLS  
RAZOR SHARP**  
In 10 minutes for pennies! p. 68

**29 workshop  
time-savers**  
pp. 16, 34, 92

**3 GREAT  
OUTDOOR  
PROJECTS**  
pp. 74, 78, 80



Display until July 22, 2003



www.woodonline.com



# WOOD®

June/July 2003, Issue 149

## PROJECTS

- 10 fast-forming faring stick
- 42 barrister's bookcase  
Build this classic modular storage piece, and discover an innovative way to hang the doors.
- 50 the ultimate bandsaw table system  
Ramp up your bandsaw for precision resawing, circle cutting, tapering, and cutting curved parts.
- 64 bandsaw table accessories  
Taper jig, pattern guide, and feather board.
- 74 adirondack chair and footrest
- 80 gardener's tuteur for training plants

## TECHNIQUES

- 34 marking tips for better woodworking
- 36 perfect plugs in 6 easy steps
- 56 put your bandsaw system to work
- 68 low-tech, foolproof sharpening  
Use sandpaper and our shop-made jig to give chisels and plane irons a razor edge.
- 92 13 workshop shortcuts
- 100 6 dead-on drilling tricks

## TOOLS & MATERIALS

- 12 the hard facts on Forstner bits
- 86 mid-size plunge routers  
See the top-tool and top-value winners in this test of seven feature-packed models.
- 102 9 shop-proven products

## FEATURES

- 9 collecting classic old tools
- 33 lacewood: a figured favorite
- 61 guide to choosing sheet goods
- 84 yellow poplar: a valued hardwood
- 96 birdhouses/feeders contest winners

## DEPARTMENTS

- 4 editor's angle
- 6 sounding board
- 8 at your service
- 16 shop tips
- 26 ask WOOD
- 38 short cuts
- 120 what's ahead in our next issue



42



12



86



74



Ultimate  
Bandsaw  
Table  
System

50



80



This seal is your assurance that we build every project, verify every fact, and test every reviewed tool in our workshop to guarantee your success and complete satisfaction.

Visit our Web site at [www.woodonline.com](http://www.woodonline.com) for free woodworking plans, tips, shop tours, and more.



## editor's angle

# Woodworkers: a breed apart

I recently had the enjoyable task of calling the winners in our first birdhouse/bird feeder contest, letting them know of their good fortune. The ensuing conversations only reinforced my firm belief that woodworkers are among the most generous people anywhere.

**L**ike other contests we've had, in which readers sent in their best toys, clocks, and workshop layouts, the recently completed "For the Birds" competition just blew us away. The number of entries (271), and the quality and originality of the designs (see page 96 for photos), was simply staggering.

As impressed as I and the other judges were with the winning entries, I was especially touched by my conversations with their makers. All were thrilled to have won, but none of them expected it. They just enjoyed the chance to contribute to a good cause (more on that later), and the opportunity to put in some enjoyable shop time in the process.

For example, Donald Berard of Mission Viejo, Calif., who built "The Best Birdhouse from Existing Plans," told me he worked "4 to 6 hours a day, 5 to 6 days a week, for 4 weeks" preparing his entry. Looking at the intricate and perfectly executed copper panels on his entry's roof, I fully believe his time estimate.

Then there's John Styga of Elmhurst, N.Y., whose incredibly detailed "Mother Hubbard's Boot" took the \$5,000 grand prize. Said John, "A lot of time went into it, more than I can calculate. I was just having fun."

Inspecting all of the entries, it's easy to see that readers devoted thousands of hours to this competition to benefit The National Wildlife Federation's Backyard Wildlife Habitat Program. So, on behalf of the NWF, *WOOD* magazine, and, of course, the birds, I want to say a big "Thank You" to all who entered.

I must add that there were many outstanding entries that did not receive a prize, but which nevertheless enabled us to raise more than \$8,000 for the program. Based on my phone conversations, I'm guessing that the news of this generous donation is reward enough for the winners and nonwinners alike.

### We've hatched a new column.

Readers have told us that the woodworking terms we use in articles occasionally can throw them for a loop. So, on page 110 you'll find the first installment of "Wood words" to help you better understand every article in the magazine. Let me know how you like it.

*Bill Krier*

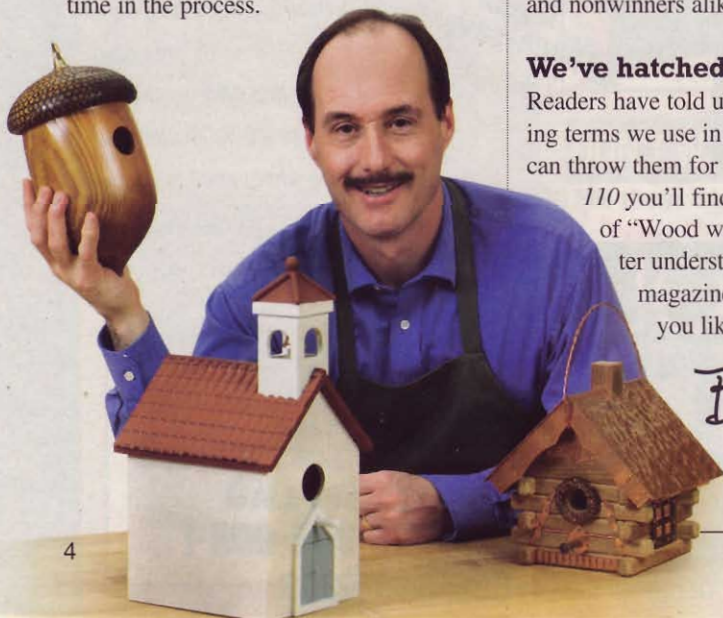

Editor-in-Chief **BILL KRIER**  
Executive Editor **JIM HARROLD**  
Managing Editor **MARLEN KEMMET**  
Features Editor **DAVID STONE**  
Products Editor **DAVE CAMPBELL**  
Projects Editor **JAN SVEC**  
Projects Editor **OWEN DUVALL**  
Techniques Editor **JIM POLLOCK**  
Senior Design Editor **KEVIN BOYLE**  
Design Editor **JEFF MERTZ**  
Master Craftsman **CHUCK HEDLUND**  
Production/Office Manager **MARGARET CLOSNER**  
Administrative Assistant **SHERYL MUNYON**  
Illustrators **LORNA JOHNSON, ROXANNE LEMOINE, TIM CAHILL, MIKE MITTERMEIER**  
Technical Consultants **JEFF HALL, GARRY SMITH, PHILLIP GOODWIN, JOHN CEBUCHAR**  
Contributing Craftsman **JIM HEAVEY**  
Proofreaders **JIM SANDERS, BARBARA KLEIN**  
Art Director **KARL EHLERS**  
Associate Art Director **GREG SELLERS**  
Assistant Art Director **CHERYL A. CIBULA**  
Publisher **MARK HAGEN**

Advertising Office: 333 N. Michigan Ave., Suite 1500, Chicago, IL 60601 Phone: 312/853-2890 Fax: 312/580-7906  
Sales and Marketing Assistant **NEILLE MORRIS**  
Account Executive **RON GOLMINAS**  
Direct Response Manager **CAROLYN DAKIS**  
Direct Response Sales Representative **SANDY ROBINSON**  
Account Executive **JOHN THORNBURGH**  
Detroit, Phone: 248/356-1149 Fax: 248/356-8930  
Account Executive **PAT TOMLINSON**  
Northeast, Phone: 212/551-7043 Fax: 212/551-7192  
Southeast: Lagomarsino, Dempsey & Dennis, Inc.  
2951 Piedmont Rd., NE, Suite 100, Atlanta, GA 30305  
Phone: 404/261-5400 Fax: 404/261-5404

Group Marketing Director **CATHY E. SMITH**  
Senior Marketing Services Manager **ALEXANDER D. CLARKSON**  
Phone: 212/551-7090 Fax: 212/551-7192  
Senior Promotion Designer **SARAH DEBELLA**

Group Publisher **STEPHEN B. LEVINSON**

Associate Business Director **CRAIG FEAR**  
Advertising Operations Manager **PAT HENDERSHOTT**  
Consumer Marketing Director **JULIE MARTIN**  
Consumer Marketing Manager **DAVE HONOLD**

Vice President/Publishing Director **WILLIAM R. REED**

### Meredith PUBLISHING GROUP

President **STEPHEN M. LACY**  
Magazine Group President **JERRY KAPLAN**  
Group Sales **MICHAEL BROWNSTEIN**  
Creative Services **ELLEN DELATHOUDER**  
Manufacturing **BRUCE HESTON**  
Consumer Marketing **KARLA JEFFRIES**  
Finance and Administration **MAX RUNCIMAN**

**Meredith**  
CORPORATION

**WILLIAM T. KERR**, Chairman and Chief Executive Officer  
**E.T. Meredith III**, Chairman of the Executive Committee

©Copyright Meredith Corporation 2003  
All rights reserved. Printed in the U.S.A.

*Better Homes and Gardens*® *WOOD*® magazine (ISSN-0743-894X) is published seven times a year in March, May, June/July, September, October, November, and December by Meredith Corporation, 1716 Locust St., Des Moines, IA 50309-3023. For subscription questions call 800/374-9663. Letters to Editor: *WOOD* magazine, 1716 Locust St., GA-310, Des Moines, IA 50309-3023, or woodmail@mdp.com. Periodicals postage paid at Des Moines, Iowa, and additional mailing offices. *Better Homes and Gardens* trademark registered in Canada and Australia. Marca Registrada en México. **ONE-YEAR SUBSCRIPTION PRICES:** U.S. and its possessions, \$28; Canada, \$41; other countries, \$49. Canada Post Publications Mail Sales Product Agreement No. 40069223. Canadian BN 12348 2887 RT. **CANADIAN RETURN ADDRESS:** *Better Homes and Gardens* *WOOD* magazine, 2744 Edna Street, Windsor, Ontario, N8Y 1V2. **POSTMASTER:** Send address changes to *Better Homes and Gardens* *WOOD* magazine, P.O. Box 37439, Boone, IA 50037-0439.





# sounding board

Our bulletin board for letters, comments, and timely updates

## A simple formula reveals the radius

Reading "A Short Course on Making Curves" in issue 147 reminded me of a mathematical formula I learned years ago for finding the radius of an arc. This method is handy for creating a smooth layout after you've drawn a freehand arc.

As shown at *right*, all you need to know is the height of the arc and its length. Then plug those numbers into this simple formula in the drawing to find the radius, and you're done.

Once you have this number, it's simple to set up a trammel and draw a perfectly smooth arc.

For example, if you want to draw an arc that's 24" long and 3" tall at the center, here's what to do:

- First, plug the numbers into the formula. In this case,  $L=12$ ,  $H=3$ , so:

$$\begin{aligned} & (12^2 + 3^2) \div (2 \times 3) \\ & = (144 + 9) \div 6 \\ & \text{or } 153 \div 6 \\ & = 25.5 \text{ or } 25\frac{1}{2}'' \end{aligned}$$

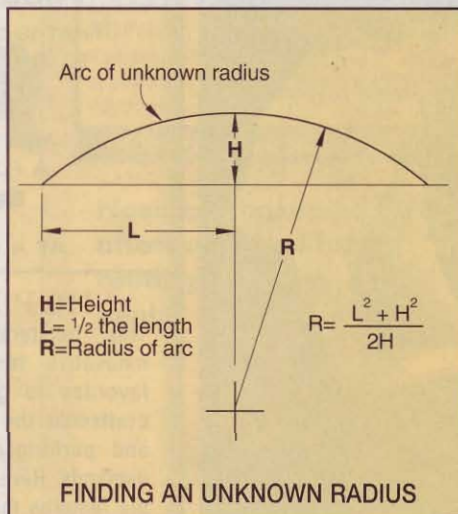

- Now, make a trammel, as shown *below*, that's  $25\frac{1}{2}''$  long. Align one end with the midpoint of the arc on your workpiece. Anchor the other end at a point that's in line with the midpoint, and draw your arc.

Harold F. Leister, Chambersburg, Pa.

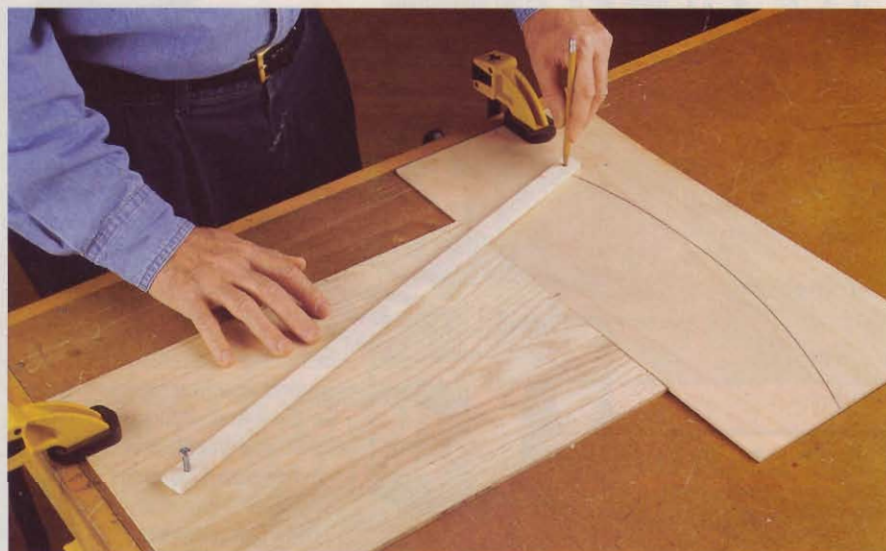

## Project update

- Baker's Trio (issue 147, p. 56):  
The  $\frac{1}{8}''$  dowel used in this project is birch, not walnut.

## Article information online

You'll find a listing of all known updates to past *WOOD* magazine projects at [www.woodmagazine.com](http://www.woodmagazine.com). Just click on *WOOD* magazine on the left side of the screen, and then select Editorial Extras.

## Protect tools with organized records

In one of your online forums (*WOOD Talk* at [www.woodonline.com](http://www.woodonline.com)) I read about a man whose tools were stolen out of his truck. I have a system to help recover my tools if they get stolen and found by police.

When I get a new power tool, I first write its serial number in the owner's manual. Then I engrave my driver's license number on the tool in an inconspicuous spot. I also engrave expensive hand tools. (I don't engrave rare or collectible tools, though, because it decreases their value.)

Next, I take a picture of the tool so I have something to show the police or insurance company should the need ever arise. I mark each photo to indicate the engraving location on the tool.

Now I place these records, along with the owner's manual and purchase receipt, in a fire safe inside my house, instead of out in the garage with the tools. Doing this also gives me a record for insurance purposes, and forces me to keep track of all of my manuals and warranty information.

**Note:** Many law enforcement agencies suggest using your driver's license number because stolen tools are often pawned for cash. (Note: If your driver's license number is your Social Security number, don't use it. Request a new driver's license number.) Most pawnshops collect the driver's license number of anyone who brings in merchandise. If this number doesn't match the one on the tool, store personnel should refuse to buy the tool, then alert authorities.

Bruce Moore, Eugene, Ore.

## Write us!

Do you have comments, criticisms, suggestions, or maybe even a compliment relating to a *WOOD* magazine article? Please write to:

Sounding Board  
*WOOD* magazine  
1716 Locust St., GA-310  
Des Moines, IA 50309-3023

or e-mail [soundingboard@woodmagazine.com](mailto:soundingboard@woodmagazine.com).

Due to the volume of letters and e-mails we receive, we can respond to and publish only those of the greatest interest to our readers.



at your **service**

# we're here to help

assistance is just a click (or two) away

## ■ Find the right article, right now

We've just completed the re-indexing of all issues of **WOOD**® magazine, including over 2,400 articles. You can enter a keyword search for any word or group of words, drawing from our keyword files that contain nearly 40,000 terms. Just go to [woodmagazine.com/search](http://woodmagazine.com/search)

## ■ Get past issues and articles here

Order past issues of **WOOD** magazine at [woodstore.woodmall.com](http://woodstore.woodmall.com) or by calling 800/346-9663. Be aware that many early issues are sold out. For reprints, send \$5 per reprint (no phone orders), including issue and name of article, to **WOOD** Article Reprint Service, P.O. Box 349, Kalona, IA 52247; make check or money order payable to **WOOD** magazine.

8

## ■ Our editors are listening

Have a comment about something you've seen, or would like to see, in **WOOD** magazine? E-mail your suggestions to [woodmail@mdp.com](mailto:woodmail@mdp.com), call 800/374-9663 and press option 2, or write: Editor-in-Chief, **WOOD** Magazine, 1716 Locust St., GA-310, Des Moines, IA 50309-3023.

## ■ Learn more about woodworking basics

From abrasives to shop safety, the info-packed **Woodworking Basics** section at **WOOD ONLINE**® delivers dozens of informative articles. We add new features and projects every two weeks, making it the site that keeps giving. Find it at [woodmagazine.com/basics](http://woodmagazine.com/basics)

## ■ Subscription assistance

Need to notify us of an address change, or get help with your subscription? Visit us at [woodmagazine.com/service](http://woodmagazine.com/service), call 800/374-9663 and press option 1, or write to **WOOD** Magazine, P.O. Box 37439, Boone, IA 50037-0439. Please enclose your address label from a recent magazine issue.

## ■ Woodworking advice available around the clock

Post your most perplexing questions to thousands of woodworkers eager to help you in one of the 20+ online forums at [talk.woodmagazine.com/forums](http://talk.woodmagazine.com/forums)

**WOOD** magazine June/July 2003



# Extremely Affordable/Unbelievable Quality

Discover why these European crafted machines from Rojek are fast becoming the tools of choice for America's finest woodworkers.

### PK 300V CABINET SAW

- Professional sliding table
- Scoring unit built in
- European riving knife safety
- Superior dust collection

### KPS 300 COMBINATION MACHINE

- Table saw/Shaper/Planer/Jointer/Mortiser
- Choice of sliding tables
- Professional precision & accuracy
- Ideal for small shops & basements

### MSP 310M PLANER/JOINTER COMBINATION

- 12" Jointer & thickness planer
- Fixed jointer tables means no flipping!!
- Reduced changeover & setup

### VDA 316 SLOT MORTISER

- Cut deep mortises with ease
- One-handed 360° operation
- 3.6HP motor & reversing switch
- Over 8" lateral travel

Let us make you a believer! Call toll-free:

**800-787-6747**

for a lifetime of  
woodworking



Exclusive Distributor  
in the United States

7901 Industry Dr., North Little Rock, AR 72117  
Fax: 501-945-0312 • Website: [www.tech-mark.com](http://www.tech-mark.com)

COMBINATION MACHINES • SHAPERS • JOINTERS • PLANERS • SLIDING TABLE SAWS • SLOT MORTISERS



the pros **know**

# collecting classics

Tips on finding and buying old tools



**G**ot an eye out for old tools? Whether

you're looking to buy your first antique tool or add a few more to your collection, you need to know the ins and outs of smart buying. Martin J. Donnelly, an internationally renowned antique tool dealer of Avoca, New York, really knows his stuff, and now shares his best tips.



Martin J. Donnelly

## 4 surefire ways to hunt down old tools

■ **Check tool organizations.** Looking for a specific tool? Get in touch with any of the dozens of regional and national tool-collecting organizations. (See below for a list of several.) Their members sell and trade thousands of tools and share knowledge about them.

■ **Try an antique tool auction.** Want access to a mind-boggling number of tools in one place? Then attend the ultimate classic tool extravaganza—an antique tool auction. Chances are you'll find what you want in multiples. For a schedule of such auctions, go to [www.mjdtools.com](http://www.mjdtools.com).

■ **Search the Internet.** Online auction services, such as eBay ([www.ebay.com](http://www.ebay.com)), list thousands of tools for sale every day, and have become hot spots for tool sellers and seekers. Martin says they're worth looking into, but be sure to check the online buyers' feedback on the seller. Also, ask the seller about the completeness and condition of the tool if the listing doesn't clearly state it.

■ **Look locally.** Many fine antique tools show up at garage and yard sales, Martin says, so your treasure could be next door. Also, check out area flea markets, and antiques shops and shows. No matter if you find a tool, you'll undoubtedly make valuable contacts along the way.

## What tools should be left on the shelf?

It's okay to put the majority of antique tools to use. But certain tools are best kept unused when:

- Their primary value is based on their unused condition or rarity.
- The tools are fragile.
- There are "modern" tools or less-expensive antique tools that can do the same job.



Martin's comprehensive "Catalogue of Antique Tools" contains descriptions and photographs of more than 6,500 tools. It sells for \$25 at [www.mjdtools.com](http://www.mjdtools.com).

## 3 golden rules for a successful purchase

■ **Know the tool's value.** To be sure you're getting a fair deal, determine the tool's value up front. You can find help on the Internet by searching for "antique tool values" or going to tool dealers' Web sites. Also, check out tool catalogs, like the one shown in the photo, above, that identify tools and establish their values.

■ **Find out the tool's condition.** Don't be afraid to ask a collector or dealer to point out any problems with a tool. The antique tool business holds itself to a high standard of integrity, Martin notes, and most dealers will reveal any flaws to you. Should you be wary of reproductions? No, Martin says. That's because tool values are quite low in relation to other antique items, so counterfeiters don't find it worth the effort, at least for now.

■ **Ask for the best price.** Before you buy a tool, always ask the seller for his or her best price. A discount will certainly follow. ♣

## Contacts for major tool organizations

Organization	Web site	Telephone
■ Mid-West Tool Collectors Association	<a href="http://www.mwtca.org">www.mwtca.org</a>	919/828-2754
■ Early American Industries Association	<a href="http://www.eaiainfo.org">www.eaiainfo.org</a>	508/993-9578
■ South-West Tool Collectors Association		888/889-3340
■ Rocky Mountain Tool Collectors Association		505/344-9272
■ The Tool Group of Canada		416/487-0995
■ New England Tool Collectors Association		413/586-2114



# fast-forming fairing stick

The only thing simpler than making this bowlike layout tool is using it.

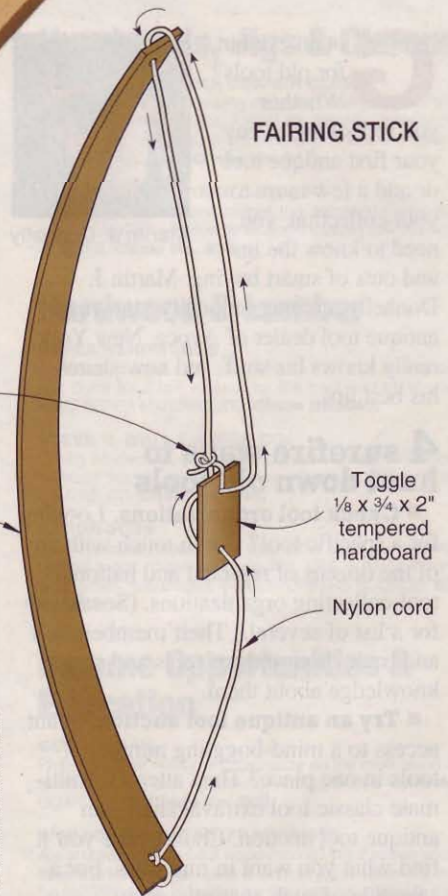

**Note:** All holes are  $\frac{1}{8}$ " diameter, located  $\frac{1}{4}$ " from ends of piece.

**W**hen he needed to lay out smooth arcs on the Adirondack chair on *page 74*, *WOOD*® magazine Master Craftsman Chuck Hedlund turned to his shop-made fairing stick. Chuck's version, shown *here*, features an adjustable cord with a sliding "toggle" that locks in the desired arc for hassle-free use.

To make your own, start with a  $\frac{3}{4}$ "-wide piece of  $\frac{1}{8}$ " tempered hardboard. The length is up to you; but at 24", this one handles most layout chores. Also cut a piece to size for the toggle. Now drill the four  $\frac{1}{8}$ " holes, as dimensioned, through the ends of both pieces.

Next, thread a length of #18 nylon mason's cord (ours measured 38"), following the arrows in the drawing. The cord gets tied to one end of the fairing

stick, then goes through the holes in the toggle, loops through the other end of the fairing stick, and ties back to the toggle.

To use the fairing stick, start by figuring out the endpoints and midpoint of the arc you want to create. Here's where you'll appreciate Chuck's toggle device. Instead of using clamps or nails to hold the ends of the stick in place, just slide the toggle to flex the stick until it matches your desired arc. Friction locks the toggle in place, retaining the correct shape. Now align the stick on your workpiece and trace. If you have multiple pieces to mark, you can pick up the stick and move it without losing your setting.

When you're not using the fairing stick, slide the toggle to release tension on the stick. That minimizes any

"memory" setting in. If this happens, just adjust the cord and flex the stick in the opposite direction.

Also, if you need a fairing stick greater than 3' long, increase the stick's width to about  $1\frac{1}{2}$ " to keep it from twisting sideways under tension. For a really long stick, switch to  $\frac{1}{4}$ "-thick hardboard. ♣



What you need to know about

# Forstner bits

**W**hen it comes to boring holes, woodworkers have lots of options at their fingertips. You can cover the gamut of hole diameters with inexpensive twist-drill bits, spade bits, and—for the *really* big holes—a drill-mounted holesaw. So, why spend more money on Forstner bits that cover many of the same hole sizes as the others?

There are two reasons, really. First, Forstners equal finesse: The cutting rim scores the circumference of the hole first so the bit enters the wood with a minimum of tear-out, resulting in smooth walls and a flat bottom. And that's important when, for example, you're boring holes to hold candles or counterboring screw holes that will be plugged.

Second, a Forstner bit is guided by its rim, rather than by a center point like a spade or twist-drill bit. So it bores accurately in situations where other bits can't, such as overlapping holes, in end grain, at an angle, into the edge of a workpiece, or wherever grain direction or surface orientation would deflect the point of a non-Forstner bit.

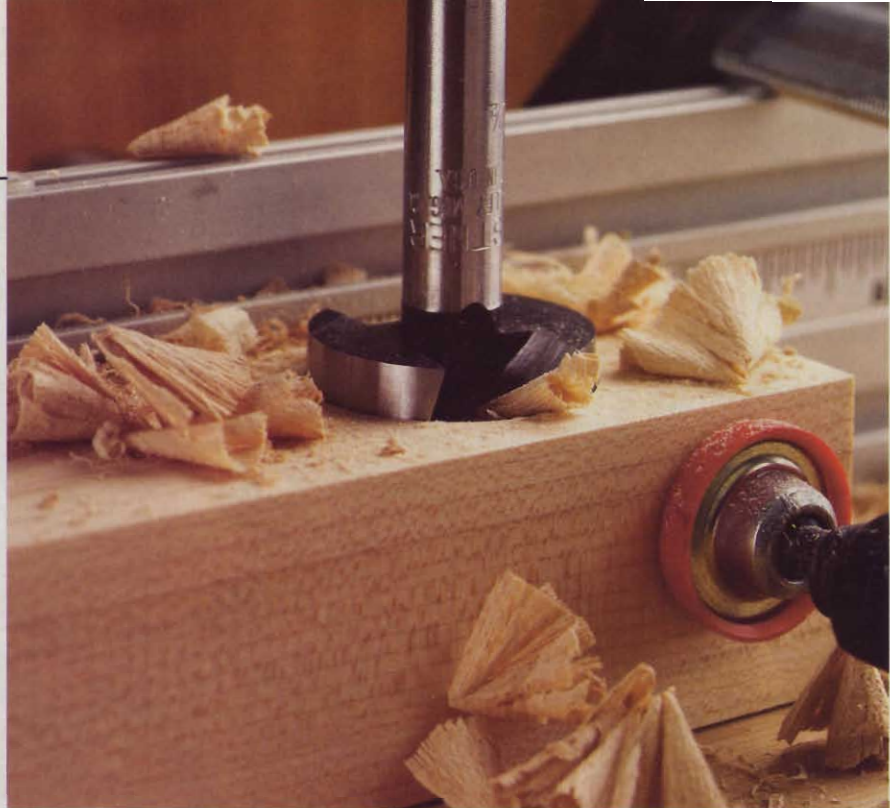

## When is a Forstner bit not a true Forstner bit?

Most of the so-called Forstner bits on the market today are really variations on the original designed by Benjamin Forstner almost 120 years ago. All, though, cut in a similar way. As the outer rim scores the circle, lifters radiating from the center of the bit act like tiny hand planes, slicing away material and ejecting the waste. The drawing *below* shows the four basic Forstner-style bits available today.

**True Forstner** bits, with an outer rim interrupted only twice by hand-sharpened lifters, have a virtually nonexistent center spur, and are made in the U.S. exclusively by Connecticut Valley Manufacturing Company, or CONVALCO (860/827-

0823, or [www.convalco.com](http://www.convalco.com)). Machined from solid carbon steel rather than cast and forged like other bits, a true Forstner's beefy body absorbs heat, reducing workpiece burning and the bit overheating that can keep a bit from holding a sharp edge. It also makes this style among the most expensive bits you'll find (\$26 plus shipping for a 1" bit).

These bits are as aggressive as any other Forstner-style bit we've tried, yet they cut cleanly. The lack of a prominent center spur (see photo on *page 14*) makes them good for boring into thin materials. However, it also makes it more difficult to center the bit on a mark—you must peek between the lifter and the bit body, or

*Continued on page 14*

## 4 TYPES OF FORSTNER BITS

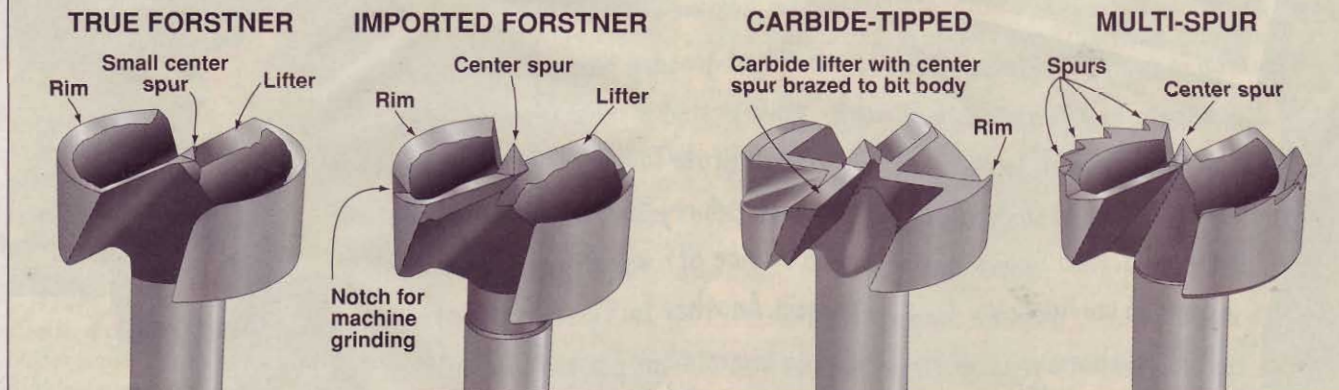



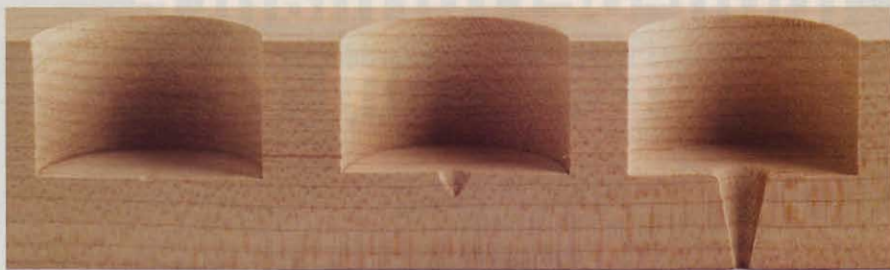

We bored these 1"-deep holes with (from left to right) true Forstner, imported Forstner, and spade bits. Note that the center spur of the spade bit broke through the bottom of the 1 3/4"-thick board.

mark the outside dimensions of the hole rather than the center.

**Imported Forstners** differ from true Forstners by the long center spur and tell-tale notch in the rim behind the lifter. This notch facilitates machine sharpening of the lifter—a less costly method than hand sharpening—helping make them the least expensive style of flat-bottomed bit (\$5–\$10 for a 1" bit).

**Carbide-tipped** bits resemble imported Forstners, but have a carbide lifter brazed onto the bit body, much like a router bit. About as expensive and cool running as true Forstners, they should outlast steel bits many times over. However, as you can see from the drawing on page 12, the cutting rim comprises only about one-fourth of the bit's circum-

ference—so it chatters more than other styles of Forstners when boring at an angle or into the edge of a workpiece.

**Multi-spur** bits are similar to imported Forstners, but with sawlike teeth on the cutting rim. Without a long rim continuously contacting the workpiece, they're less prone to overheating than other styles of bits. That's especially important on large-diameter holes, which is why you'll often find this design on bits larger than 1" in diameter. Like carbide-tipped bits, they tend to chatter in angled and partial-hole cuts.

### The steel spiel

Most imported Forstner bits today are made of high-speed steel (HSS)—a relatively inexpensive material that keeps the

bits affordable. If you've ever "blued" a bit, you overheated it to the point where the steel softens and won't hold a sharp edge. That occurs at a lower temperature in HSS than other materials.

Some makers coat their bits with titanium, which helps the bits run cooler. We found that Titanium-coated bits tend to cut less aggressively than uncoated bits, but you can apply more pressure without fear of overheating them.

### Speed kills

The larger the bit, the slower it must turn to prevent overheating. If the manufacturer provides a maximum speed limit, don't exceed it. And remember, you can run the bit slower with no loss of quality or control. To be safe, follow these guidelines:

FORSTNER BIT SPEED LIMITS	
Softwoods (such as pine)	
Bit diameter	Maximum rpm
1/4–5/8"	2,400
3/4–1"	1,500
1 1/8–1 1/4"	1,000
1 3/8–2"	500
Hardwoods (such as maple)	
Bit diameter	Maximum rpm
1/4–3/8"	700
1/2–1"	500
1 1/8–2"	250

### Sharpening Forstners

Perhaps nobody knows more about sharpening Forstner bits than Tony Garro, president of CONVALCO, who offers these tips:

■ **Forget sharpening the rim.** The cutting edge of the rim has to stay on the same plane, and that's nearly impossible without special machinery. CONVALCO resharpenes its own bits (rims and all) for \$9 per bit if you return them to the factory.

■ **Focus on the lifter.** Use a small, fine file, a thin stone, or a strip sander. Sharpen the flat face of the lifter, as shown at right, then remove the burr on the cutting edge with a stone.

■ **Go easy.** Don't abrade away too much of the lifter, especially near the rim. Forstner bits have a slight back taper, and if you sharpen too much, you can change the geometry of the bit, which may cause it to overheat.



A strip sander quickly renews a dulled Forstner bit. Use 100-grit abrasive and a light touch, and keep the lifter flat against the sander's platen.

### Which should you buy?

If you need only a few sizes of bits, and you'll use those a lot, true Forstners are your best bet. CONVALCO makes them in diameters ranging from 1/4" to 3" in 1/16" increments. They bore fast and clean, but they're not for the checkbook challenged.

If you need a variety of sizes for occasional use, and you have more patience than money, opt for a set of imported Forstners. You can buy a 7-piece set that covers the most common hole sizes (1/4" to 1" by 1/8" increments) for about the same price as a 1" CONVALCO bit. Clockmakers and others who routinely bore larger-diameter holes will be well served by multi-spur bits at proportionally higher prices. ♣



# shop tips

Helping you work faster, smarter, and safer

## Mega dust bag for miter saws

Collecting sawdust from some miter saws is about as efficient as catching a thunderstorm in a shot glass. But the "big ol' bag" dust catcher that I built for my miter saw collects about 90 percent of the debris.

I started by making a 1¼×10×32" frame out of ½" hardwood, glued and screwed together, and stiffened by corner blocks. To install the frame, I made a couple of hardwood mounting brackets that tilt the frame back 20°, and attached them to the bottom of the frame.

If you decide to make one of these for your shop, you'll have to figure out the best method to install the frame behind your saw. For example, I C-clamped the brackets to my miter saw's plywood subbase, as shown at right, back when I mounted the saw on my portable clamping workstation. Now that I have a dedicated miter saw stand, I permanently attached the frame.

The frame should be centered behind the saw, and installed as close to the back of the saw as possible without interfering with the saw's operation. To catch the dust, I drape an ordinary

## top shop tip

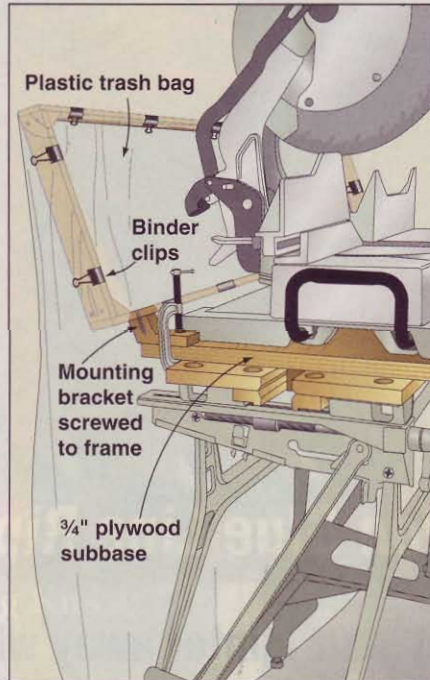

33-gallon trash bag through the frame and secure it with binder clips from the office-supply store.

—Joe Godfrey, Forest City, N.C.

## Simple router bit storage anyone can tackle

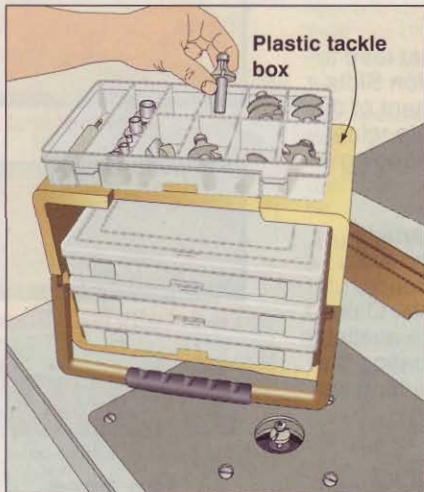

I use a plastic fisherman's tackle box to hold my router bits, with one bit in each compartment to protect the cutters. Actually it's more of a "routing center" because it holds pretty much everything I need for several routers: bearings, allen wrenches, screws for mounting subbases, etc.

Larger tackle boxes have a big open area beneath the compartmentalized trays, and that's perfect for storing wrenches, template guides, and oversize bits that won't fit into the compartments. Some boxes even have enough room below to stow a trim router. My advice: Buy a big box and fill 'er up!

—Wayne Van Coughnett, New Milford, Conn.

## Our Winner

Joe Godfrey's passion for woodworking goes back to his father, who built a lot of furniture in his day.

Although our Top Shop Tip winner's first love is carving decoys, he,

too, likes making furniture. Joe has crafted a Sam Maloof-inspired rocking chair, and recently completed the Hal Taylor-designed rocker, above.



Joe Godfrey wins a Laguna Tools LT14 14" bandsaw for submitting this issue's Top Shop Tip. Way to go, Joe!

## You can win a free tool, too!

Describe how you've solved a workshop dilemma, and you'll earn \$75 if it appears here. And, if your tip garners Top Shop Tip honors, you'll also win a tool prize worth at least \$250.

Send your best tips, along with photos or illustrations and your daytime telephone number, to: **Shop Tips, WOOD® Magazine, 1716 Locust St., GA-310, Des Moines, IA 50309-3023.** You can also e-mail tips to [shoptips@woodmagazine.com](mailto:shoptips@woodmagazine.com), or post them on the Top Shop Tip forum at [www.woodonline.com](http://www.woodonline.com).

Because we try to publish only original tips, please send your tips only to WOOD magazine. Sorry, but submitted materials can't be returned.



## Time to untie the apron strings

I'm in and out of the shop all of the time, so I'm constantly putting on and taking off my shop apron. To make it faster and easier, I attached a 4-ounce sinker from my fishing-tackle box to one apron string, and an old shower-curtain ring to the other. Now instead of tying knots behind my back, I just slip the sinker through the ring, as shown, and I'm ready to go to work.

—Gordon Van Roekel, Mission, Texas

Inspired by your tip, Gordon, we noticed a box of inexpensive aluminum snap clips called "carabiners" at the hardware store. When coupled with a 2" key ring,

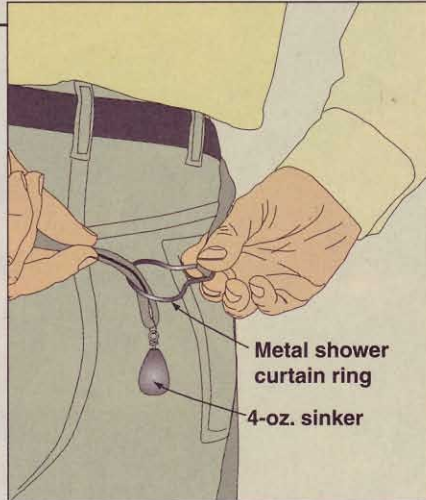

Metal shower curtain ring

4-oz. sinker

a carabiner also makes a dandy quick-release for apron strings.

—WOOD® magazine

## Detachable mount makes filling feeder easy

Hanging a bird feeder high where our feathered friends can feel safe using it makes it more difficult for us earthbound creatures to fill it. But I devised a mounting system that you can make in a few minutes, and that permits easy removal of a birdhouse or feeder for cleaning, refilling, or storage.

I tilted my bandsaw table 15° when cutting the wedge from the holder. I

then attached the wedge—wide face out—to the feeder.

—Joe Lehosky, Eldred, Pa.

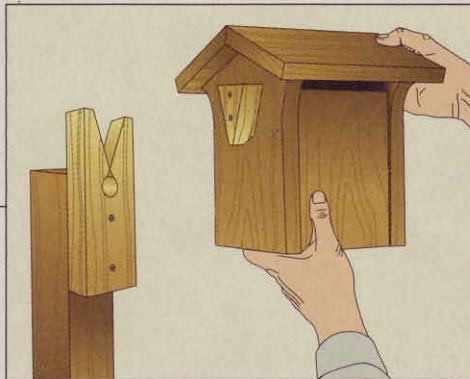

STEP 1. Drill 1" blade-clearance hole.

Attach this side to post.

Determined by length of feeder or birdhouse

Determined by roof overhang

STEP 2. Start saw cut, and cut to clearance hole.

Attach this side to feeder or birdhouse.

STEP 3. Rotate workpiece and make exit cut.

# The Toughest Glue On Planet Earth

Gorilla Brand Premium Glue is the all purpose, interior/exterior glue ideal for most repair and bonding needs. It's great for indoor/outdoor furniture repair, woodworking projects, as well as general repairs around the house. Bonds wood, stone, metal, ceramic and more! Incredibly strong and 100% waterproof.



for retailers near you:  
[www.gorillaglu.com](http://www.gorillaglu.com)  
 1-800-966-3458



### A jig for rounding turning squares

Before turning narrow pieces, such as chess pieces or dowels, between centers, it's easier on the workpiece (and the woodworker) to knock off the four corners, making the square spindle into an octagon. This simple guide clamps to your bandsaw table to do the job.

—Franklin Zia and Arthur Mendel, Richmond, Calif.

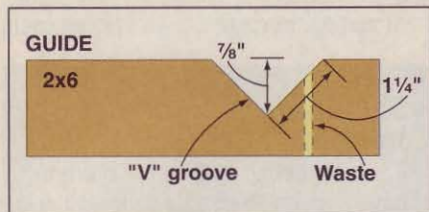

### Use bevel blade for tablesaw tuneup

After months of saving (and pleading), I finally got my new tablesaw. But late in the assembly process, I accidentally knocked the blade out of parallel with the miter slot. I started digging through drawers, trying to jury-rig some kind of alignment tool, when I stumbled upon my sliding bevel gauge. It was then that the solution hit me.

I took the blade out of the bevel gauge and the washer off the bottom of the saw's miter-gauge bar, and mounted the blade to the bar, as shown in the draw-

ing below. I raised the tablesaw blade fully and set the bevel-gauge blade so that its point was touching one saw tooth near the back of the slot. Then I rotated the saw blade by hand so that the same tooth was near the front of the slot. By sliding the bar/bevel blade assembly forward to that tooth, I quickly saw how much I needed to adjust the blade to make it parallel. The process is easy, accurate, and, best of all, didn't cost me a penny!

—Ray Vojtash, North Plainfield, N.J.



Continued on page 20

is coming.

**DELTA X<sup>5</sup>**

A new line of woodworking tools from Delta Machinery.



## shop tips

### Hang 'em high—your project plans, that is

When building a project, I like to keep my plans close at hand, which means dragging them from tool to tool for different operations. It also means having to hunt them down from time to time when I forgot where I left them.

The "bright idea" lightbulb went on one day when I found a spring-clip-style pants hanger in the closet. Now, I clip my plans to the hanger, and hook the

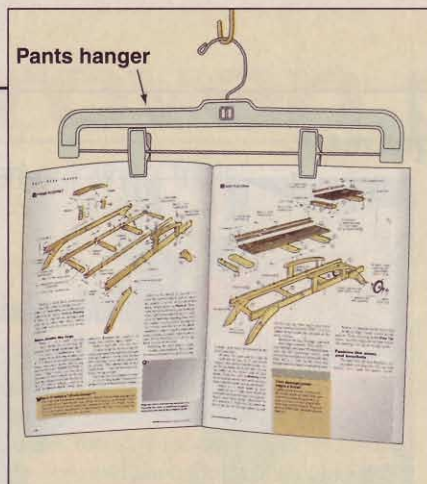

hanger onto a wire hung from the ceiling (or a nail on the wall) near each of my workstations.

This method has two other advantages: My plans never get buried in dust or tools on the workbench, and they hang closer to eye level, making them easier to read.

—Chris Smith, Clackamas, Ore.



## DRIVES 4 SIZES OF NAILS WITH NO EFFORT

■ Comfortable Ergonomic Styling with Cushioned Non-Slip Grip.

■ Trigger and Surface Safety Locks.

■ Non-Marring Bumper.



DRIVES 4 DIFFERENT SIZE BRAD NAILS UP TO 1 1/4" LONG

14 AMPs

■ New Heavy Duty Nail Driving Power with Built-in 10' Cord.



Available at home centers, lumber yards and hardware stores, wherever fine tools are sold.



Arrow Fastener Co., Inc., 271 Mayhill Street, Saddle Brook, New Jersey 07663  
 Canada: Jardel Distributors, Inc., 6505 Metropolitan Blvd. East, Montreal, Quebec H1P 1X9  
 United Kingdom: Arrow Fastener (U.K.) Ltd., Unit 5 ZK Park, 23 Commerce Way, Croydon CR0 4ZS, Surrey  
 www.arrowfastener.com Rev.1002

### Save benchtop space by going up

If you're like me, you never seem to have enough shelf space, so you end up keeping more things than you'd like on your benchtop. I store lighter things, such as boxes of tissue, latex gloves, and garbage bags, up under my wall cabinets. Hotmelt glue makes it easy to stick them up there, and easy to pop them loose when it's time to replace an empty box with a full one.

—Jeff DiBattista, Edmonton, Alta.





## Have a face-to-face with biscuits

While laminating two pieces of  $\frac{3}{4}$ " medium-density fiberboard (MDF) to make a router-table top recently, I ran into the problem I always run into when gluing two large pieces face-to-face: The slippery glue makes it hard to keep the pieces aligned during clamping.

I solved the problem with my biscuit joiner. I made matching index marks on two adjacent edges of the stacked workpieces, as shown below, then cut biscuit

slots in the mating faces of the pieces. After spreading glue on the surface, I put a little glue in each biscuit slot, dropped a biscuit in each slot in the bottom piece, and put the top piece in place, fitting it over the biscuits.

Using this technique, there was no slippage during assembly. And I saved time by not having to retrim the edges with my tablesaw.

—Jim Morgan, Dickson, Tenn.

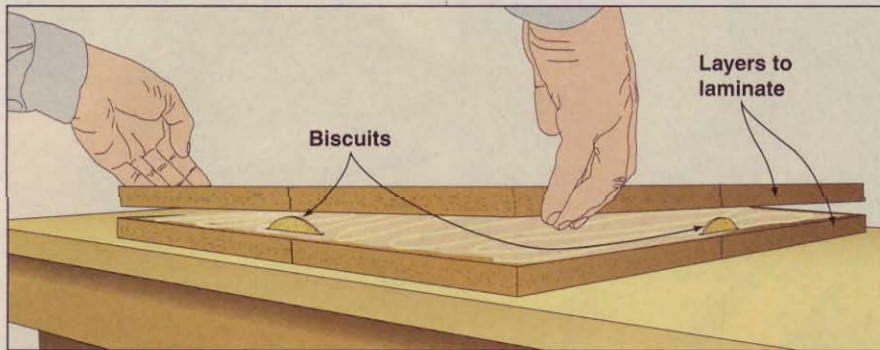

## Make a clean break

I had to trim about 1" from a piece of glass I was installing in a cabinet door, but even after scoring the glass with a cutter, it kept breaking off in small pieces. I wasn't getting the snapped-clean edge I see on professionally cut glass.

I figured if I could snap the whole length at once, I'd get a nice clean break. So I sandwiched the waste piece of glass

between two scraps of hardwood as long as the scored line and clamped them in place as shown in the drawing below. Using the clamp as a handle, I gave a quick downward snap, and the piece broke off perfectly. I've used this technique with narrower strips of glass and it has worked every time.

—Allan Fanjoy, Saint John, N.B.

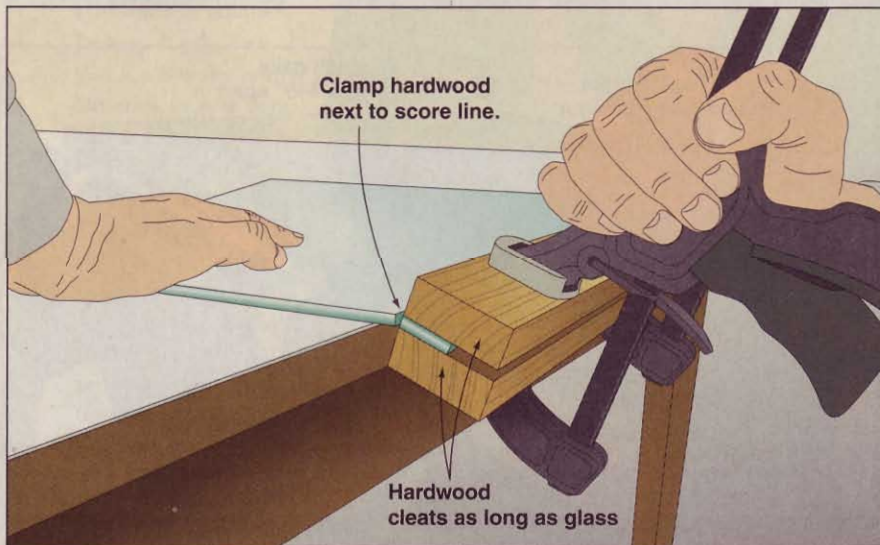

Continued on page 22

NEW



# Ultimate Glue

from the adhesive experts!

Nothing works better!



Elmer's Ultimate Glue is a Polyurethane that bonds metals, wet woods, rubber, plastics, glass...virtually anything! It's waterproof so use it outside. Paint or stain over it. This solvent-free product is as strong as it gets.

Visit our website at  
[www.elmers.com](http://www.elmers.com)

For store locations call  
1-888-435-6377



# SOME PROJECTS REQUIRE A WHOLE HOW-TO BOOK. YOU'LL JUST NEED THIS LITTLE AD.

Protect and add luster to your wood floors.  
Do-it-yourself, and do-it-with-ease.



Sand floors quickly and easily with Varathane's revolutionary, dust-free ezV™ Sander.

## 1. Sand



If you wish to add color to your floors, apply the stain color of your choice.

## 2. Stain (Optional)



Apply Varathane Premium Polyurethane for Floors; over twice as durable as other finishes for the ultimate in wood floor protection.

## 3. Protect

Floors this beautiful have never been so easy.

For a free brochure, go to [www.varathane.com](http://www.varathane.com).

# Varathane



## shop tips

### Sanding-disc shim cuts plugs close

I like to use wooden plugs to hide screws in my projects, but tediously sanding the plugs flush with the surface around them isn't high on my list of fun things to do. Even when I saw the plugs off first, no matter how careful I am, the teeth of the saw often mar the workpiece, which means even more sanding.

I minimize both damage and sanding time by slipping a well-worn random-orbit sander disc, grit side down, over the plug, as shown *below*, before sawing it off. The disc protects the workpiece from the saw's teeth and leaves just the shallowest nub on the plug that sands away quickly.

—John Hell, Inver Grove Heights, Minn.

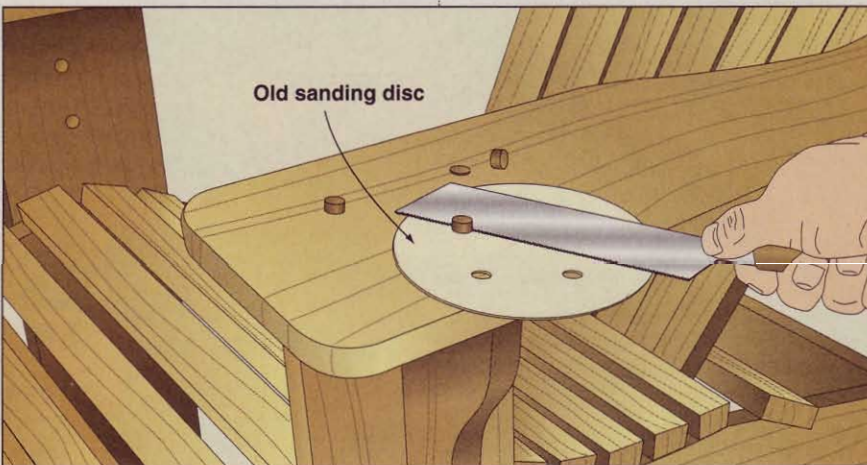

### Scrap strips form a finish line

At the end of nearly every project, I end up with strips of stock ripped from the edges of workpieces. I drive 4d finish nails spaced at 4–5" intervals through these scraps, place them points-up on my finishing table, and use them to support a project while I apply finish. For large panels, I'll sometimes tape these

strips to the top of a pair of sawhorses, as shown in the drawing *below*.

I recently had a huge project with lots of doors and panels. So I stretched my 20' extension ladder across sawhorses, taped the strips end to end on the ladder rails, and finished 12 panels at a time!

—Robert Reed, Roaming Shores, Ohio

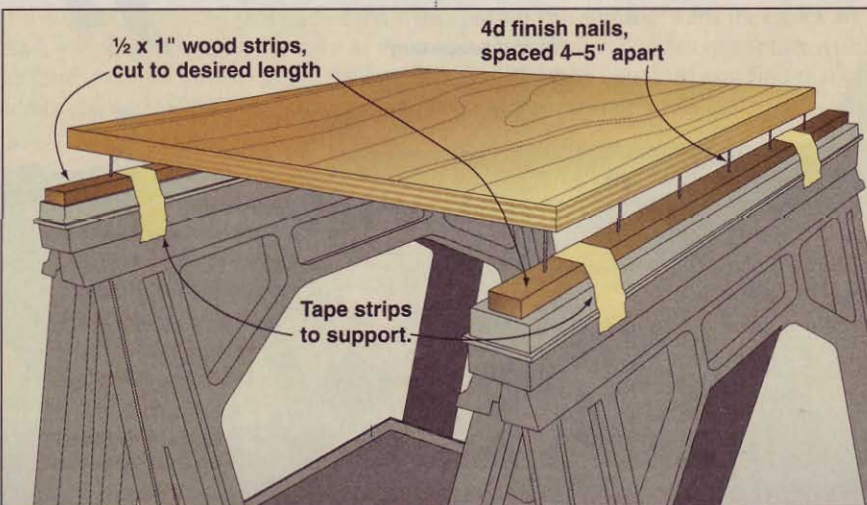

Continued on page 24



## STOP HAND-HOLDING YOUR ROUTER

Prices good through August 1st, 2003

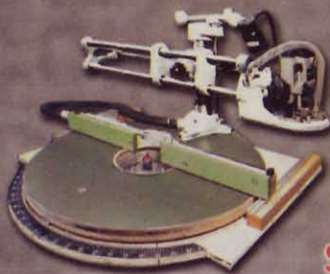

RAMR™ \$725 + Shipping  
Routers not included

Think  
Safety

### Radial Arm Mill Router "RAMR"™

#### Features

- Multiple built-in vacuum systems
- Cuts dados and louvers (angled slots)
- Cuts mortises
- Cuts tenons
- Pin routing
- Milling of wood and soft metals
- Panel relief
- Molding when using the lower system (router-shaper portion)
- Milling on complex shapes
- Dovetail cutting with purchase of accessory
- Reversible multi-function work surface

#### Accessories sold separately

- Radial Arm Clamps (ARMS™)
- Vacuum fence for Molding
- Work light
- A variety of changeable work surfaces WITHOUT losing alignment
- New dovetail fixture.

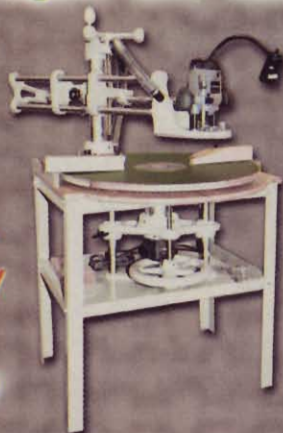

RAMR-S™ \$1095 + Shipping  
Routers not included



Ten Fingers Corp.™

1-866-458-9673 (toll free)

www.tenfingerscorp.com

Patents Pending

## shop tips

### Enlarge a hole of almost any shape accurately

Have you ever cut a hole in a workpiece only to find it needed to be just a little bit bigger? Here's a way to resize that opening while still keeping its shape.

Let's say you need to enlarge a hole's diameter by 1/2". Install a rabbeting bit in your router using the bearing for a 1/4" rabbet (1/4" on both sides of the hole yields a total enlargement of 1/2"). Rout a rabbet around the hole as deep as you can while still keeping the router bit's bearing in contact with the edge of the hole. Finally, flip the workpiece over and finish the cut using a flush-trim bit, with the bearing riding on the rabbet you cut first.

My rabbeting bit limits me to 1/2" rabbets maximum, so I can enlarge almost any hole by 1". If I need more, I simply repeat the rout-flip-rout-again process until the hole is sized the way I want it.

—David Kantor, East Meadows, N.Y.



New!  
Mite R Slide™

## Precious Metals

Get into JessEm for Fine Production Grade Routing Solutions from the Inventor and #1 Maker of Router Lifts. If you're into the coolest CNC machined tools with the highest level of precision performance, look no further. We make tools that are all about pure accuracy, reliability, and meeting the demands of Custom Woodworkers around the World.

See JessEm products in use at  
[www.woodshopdemos.com](http://www.woodshopdemos.com)

**JessEm**  
Tool Company

Barrie, Ontario  
Canada, North America

Visit us at [www.jessem.com](http://www.jessem.com)

Or call 866-272-7492

Distributor Inquiries Are Highly Recommended

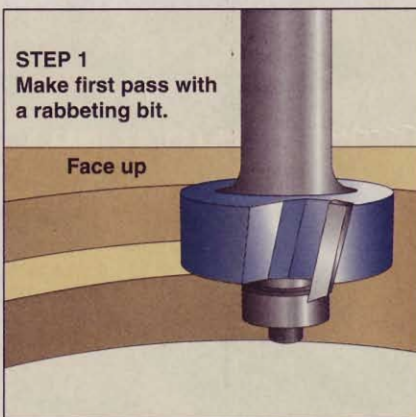

STEP 1  
Make first pass with a rabbeting bit.

Face up

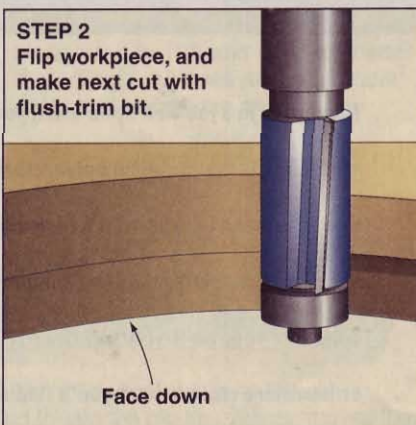

STEP 2  
Flip workpiece, and make next cut with flush-trim bit.

Face down



## Use a little glue, hold a little screw

Two things I love to do in the woodshop are carving small figures and building small treasure or jewelry boxes. I get frus-

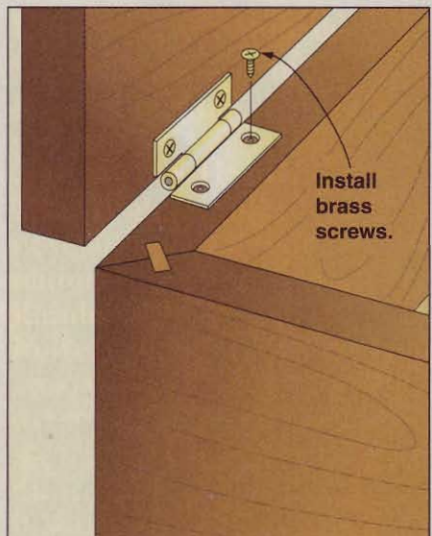
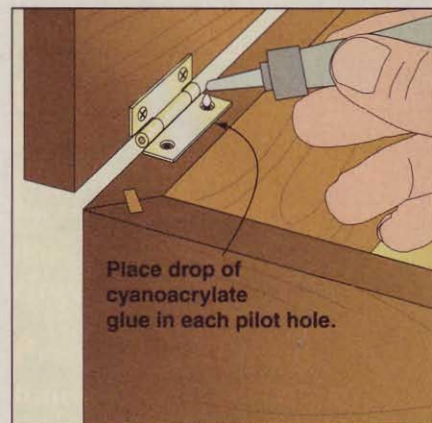
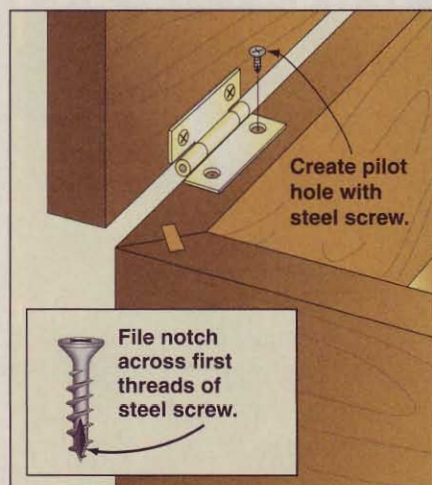

trated when attaching hinges to a box (or a basswood figure to its base) because the screw can strip or split the wood.

To prevent this, I first drill a pilot hole, then "tap" the hole with a steel screw the same size as the brass screw I'll install permanently. (I file a small notch in the screw threads to make it cut like a self-tapping screw.)

When it's time to install the brass screws, I first add a drop or two of cyanoacrylate (CA) glue to the hole, then insert

and tighten the screw. This really sets the screws in place. I find I still can back the screws out, but it's definitely more work. I've also used this method successfully to screw into the edge of plywood.

—Ed Twilbeck, Ocean Springs, Miss.

See a new . . .

...shop tip daily at  
[www.woodmagazine.com/tips](http://www.woodmagazine.com/tips)



# WANT THIS?

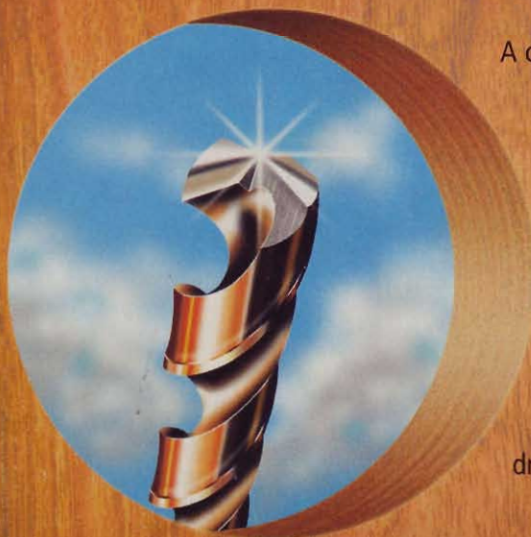

A clean, sharp hole every time. No chips, no splits, no errors. It takes skill and a sharp drill bit. And *that* takes the **Drill Doctor®** drill bit sharpener.

# GET THIS.

- Restores bits to factory sharp
- Fast and easy to use
- Sharpens most bits—even split point
- Diamond sharpening wheel
- Powerful 20,000 rpm motor

**Drill Doctor®**  
The Drill Bit Sharpener

Drill bits are meant to be sharpened

[www.DrillDoctor.com](http://www.DrillDoctor.com) • 1-888-MYDRILL



"I have never recommended a product that was so easy to use and so effective. This is one of the best tools I've ever purchased."

—Stephen Bierhorst  
Patterson, Louisiana

Available at Home Depot, Lowe's, Sears and wherever fine tools are sold



# ask wood

Answers to your questions from letters, e-mails, and WOOD ONLINE®

## Drawer insides need finish, too

**Q:** I bought a chest at an auction, cleaned it up, and plan to varnish the insides of the drawers. But I've seen lots of factory-built drawers left unfinished on the inside. Which way is best?

—Keith Andrepont, Lafayette, La.

**A:** Go ahead and start varnishing, Keith. A drawer that's finished inside looks better, resists wear, and is less likely to snag its contents. Some furniture factories skip this step to save time, which just gives hobbyists one more opportunity to outshine the professionals when it comes to small details. After you've finished the drawers inside and out, allow them to dry and cure before slipping them into the chest, and you won't have a problem with a lingering finish odor.



To avoid puddles and runs, first brush finish into the four vertical corners of the drawer. The next step is to coat the bottom, then complete the job by doing the sides.

## Choose the right spiral router bit

**Q:** Would a spiral router bit give me a cleaner cut than a straight bit when I make circles and ovals in solid wood? If so, should I buy an upcut or a downcut bit?

—Boyd Ash, St. John's, Newfoundland, Canada

**A:** Boyd, you do get a slightly cleaner cut with a spiral bit. A straight bit chops at the wood with its vertical flutes, but a spiral bit's corkscrew-shaped cutting edges stay in continuous contact with the workpiece, shearing the wood fibers.

An upcut bit shears toward the router base, and a downcut bit shears in the opposite direction. Combine the two designs, and you get an upcut/downcut or compression bit, which shears upward and downward at the same time. Spiral bits are made of solid carbide, and any of

the three styles can handle the task you mention, as long as you orient the workpiece appropriately. For future reference, here's a brief guide.

■**Upcut:** Use this bit for making mortises in solid stock because it pulls out the chips as it cuts. You also can use it for edge treatments with the face of the stock away from the router base.

■**Downcut:** This bit style produces a clean cut on the face closest to the router base, so it works well on rabbets, dadoes, grooves, and shallow mortises. Make several shallow passes, though, because the

downcut bit tends to pack the waste material into the cut.

■**Upcut/downcut or compression:** Here's the best choice for cleaning up the edges of hardwood plywood or melamine-coated particleboard. It prevents chipping on both faces.

### The ups and downs of spiral bits



Upcut



Downcut



Compression

Here's a look at the way spiral bits cut wood. The arrows show the direction of each bit's shearing action.

Continued on page 28



**Push a slider, pull a radial-arm**

**Q:** The experts tell you to push a sliding mitersaw through the workpiece, but pull a radial-arm saw toward you to make a cut. Why are they used differently?

—Chris Satow, Walnutport, Pa.

**A:** It's a safety issue, Chris, based on one essential difference in design: The sliding mitersaw head pivots up and down, and the radial-arm saw head doesn't. Let's consider the radial-arm first. As you noted, the proper way to crosscut with this machine is to place your workpiece tightly to the fence, line up the cutline with the blade edge, turn on the saw, and pull the blade slowly toward you, as shown in the top photo at right. All through the cut, the teeth force the workpiece down on the table and back against the fence. The head of the saw can't jump upward in response, because it operates in a fixed horizontal plane. However, if you started with the saw head on the near side of the workpiece, and pushed the saw blade through the cut, the teeth would tend to pick up the front edge of the board.

Now, for the sliding mitersaw. Some models allow you to lock the head in various positions while cutting, but there's always the chance that it will be left unlocked. If so, the blade would tend to climb up the workpiece if you started your crosscut on the far side of the workpiece and pulled. The proper method is to place your workpiece on the table and against the fence, secure it with a hold-down, center the arbor above the front edge of the workpiece, turn on the saw, and lower the blade into the wood, as shown in the bottom photo at right. The teeth force the

board forward upon the initial contact. Note, however, that the cutting action from that point on creates a lifting force. That's why you use a hold-down. (We removed the hold-down in the photo for clarity.) Also use a blade with negative-hook teeth to reduce the lifting force.

Here's one more detail to consider: Because the teeth on a radial-arm saw blade cut down as they contact the workpiece, any tear-out will be on the bottom. To compensate, place your workpiece on the saw table with its good face up—our preferred way to cut wood. However, the sliding mitersaw blade cuts up at the point of contact, so any tear-out will be on the top, and the good face should rest on the table.



Just follow the arrows shown here for safe results on the radial-arm saw, top, and sliding mitersaw, bottom.

*Continued on page 30*

Take a look at the premier web site for buying and selling works in wood; antique and collectible tools

**WOODCRAFT**  
auction.com



**WOODCRAFT**

For your local woodcraft store, visit [www.woodcraft.com](http://www.woodcraft.com), or for a free catalog, call 800 542-9115

Dept.03WI06BB

Circle No. 700



From tired  
to inspired.



**IF YOU'RE READY** for a change around the house, don't buy new...renew! With Painter's Touch<sup>®</sup> by Rust-Oleum, it's easy. You can breathe new life into any room just by adding a little color. Take a look around. Who says wicker has to be white? Picture a chair and table in a soft shade of Sage Green. Or, try Painter's Touch in inviting colors like Warm Yellow or Terra Cotta. Whether it's an ordinary piece or a vintage treasure, Painter's Touch can make it look new and exciting. It'll change the way you look at your home!



Painter's Touch by Rust-Oleum is available at home centers, hardware, discount and craft retailers.

For a free Dream Spaces inspirational booklet, visit [rustoleum.com](http://rustoleum.com)

Find more inspiration at [paintideas.com](http://paintideas.com)

**RUST-OLEUM**  
BRANDS

stopping rust is just the start.™

Circle No. 115

## ask **wood**

### Keep your projects clean, not tacky

**Q:** I was taught to clean off sanding dust with a tack cloth before finishing, but some of my fellow woodworkers disagree with that advice. Can you shed some light on the subject?

—Larry Hall, Independence, Mo.

**A:** You're better off avoiding a tack cloth, Larry. For one thing, it won't pull dust out of the pores. Also, the sticky, varnish-like substance that picks up sanding dust can leave a gummy residue that interferes with the bonding and smoothness of your finish. That's a particular problem when you use waterborne finishes.



Naphtha evaporates quickly and won't interfere with your finishing steps, so it works well for giving your sanded project a final wipe-down.

For better results, vacuum the surface, or blow it out with compressed air outdoors or in a well-ventilated area. Then, moisten a cloth with mineral spirits or naphtha and wipe the wood. As you remove the last specks of sawdust, you'll also highlight any missed scratches or glue splotches.

### How to safely table-rout without a fence

**Q:** I notice that a lot of woodworkers rout "freehand" on router tables, using a guide-bearing bit and no fence. Is this safe?

—Louis Rebideaux, Sparks, Nev.

**A:** With the right techniques, Louie, it's a safe procedure. But it does call for caution, because a spinning router bit can throw a piece of wood or yank your fingers toward it in an instant. We checked with Rick Rosendahl, who appears on public television's "The Router Workshop" with his dad, Bob, and got his advice.

Rick recommends the use of a safety guide pin, or starter pin, when you rout freehand. Use a 1/4" rod or dowel made of steel, brass, or a dense hardwood, and drill a hole of the same size in your table, located about 2" from the bit, as shown below. The pin must fit snugly in the hole, and project above your workpiece. Push the workpiece against the pin, and use the pin as a fulcrum point to support the wood as you carefully ease it into the spinning bit.

Rick suggests that a novice practice first with a good-sized scrap of wood and a nice,

small, 1/4" roundover bit. That will give you a feel for the forces at work before you try a larger bit that generates much more torque. Always grip the workpiece well away from the router bit.

Finally, Rick encourages the use of a plastic shield like the one shown, to keep your fingers out of harm's way. Use a screw to mount acrylic or polycarbonate plastic on a piece of wood that's slightly thicker than your workpiece. Make this wood base large enough so that you easily can clamp it to your router table. Position the plastic over the bit, and tighten your clamp. Now your fingers can't touch the bit from above.

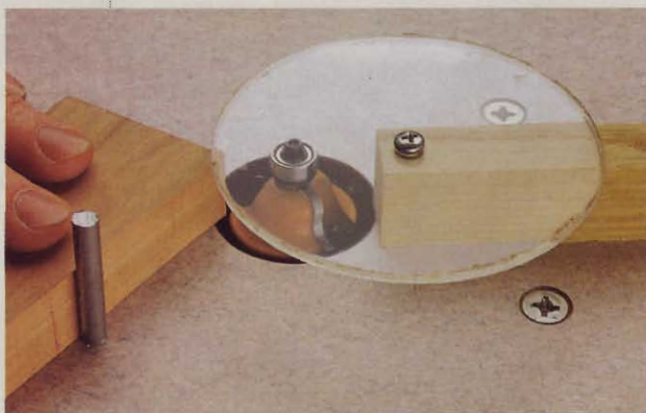

We cut a safety guide pin from a 1/4" steel rod, and fitted it into a hole we drilled into our router table insert. We used a hole saw to cut a shield from 1/8" acrylic plastic.

Continued on page 32



## Good woods for cutting boards

**Q:** Which woods work best for making cutting boards, and which ones should I avoid? I've heard

that some species can con-taminate food and make people sick.

—Barbara McKay, St. Louis

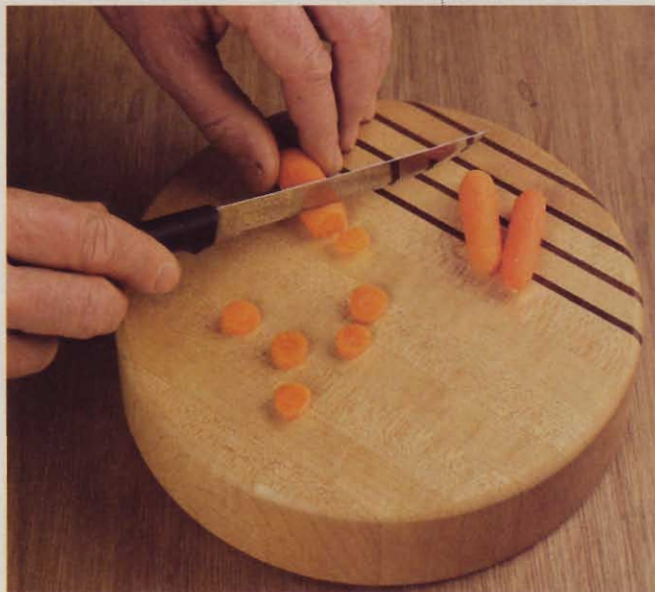

**A:** Barb, you don't have to worry about that kind of toxicity with any species of wood. However, some woods are better candidates than others for cutting boards. Choose a dense

For a handsome and durable cutting board, try hard maple. Add details with darker wood, like these walnut stripes.

one, such as maple, rather than an open-pored species, such as oak. The lack of large pores means fewer places for food particles to lodge, making the cutting board easier to clean. Also, avoid oily exotics, which might affect the flavor of food.

We recommend boiled linseed oil or mineral oil as a finish for cutting boards. Allow the finish to dry and cure before using the board. When you want to remove scratches, just sand and apply more oil.

### Got a question?

If you're looking for an answer to a woodworking question, write to Ask WOOD, 1716 Locust St., GA-310, Des Moines, IA 50309-3023 or send us an e-mail at [askwood@mdp.com](mailto:askwood@mdp.com). For immediate feedback from your fellow woodworkers, post your question on one of our woodworking forums at [www.woodonline.com](http://www.woodonline.com).

*Talented Creator. Skilled Hobbyist.*

# BUSINESS OWNER.

You're already two. With Guardsman FurniturePro®, you can become all three!

*Guardsman FurniturePro is a network of franchises specializing in furniture-related services. Guardsman FurniturePro has available territories throughout North America.*

#### TRAINING AND SUPPORT PROGRAMS:

- Comprehensive initial training
- Ongoing regional workshops
- Web-based support programs
- 24-hour technical assistance
- Access to fellow FurniturePro franchisees

#### GUARDSMAN FURNITUREPRO CUSTOMERS:

- Homeowners
- Furniture retailers

- Restaurants and Hotels
- Professional office buildings
- Moving and storage companies

#### NOT TO MENTION:

- Protected territories
- Affiliation with the most established and respected name and presence in the marketplace
- The support of a \$2.2 billion company, and the largest manufacturer of furniture finishes in the world.
- Affordable franchise entry fees, as low as \$9,500
- Home based with low overhead!



For Franchise Information Call  
800.496.6377  
[www.guardsmanfurniturepro.com](http://www.guardsmanfurniturepro.com).

**GUARDSMAN**  
**FurniturePro**  
*The most trusted name in furniture repair*

## Profit Centers



**Furniture Repair** - gouges, scratches, burns, water marks, dents and more

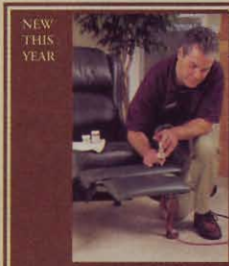

**Leather Cleaning and Repair** - stain removal, recoloring, and more



**Upholstery Services** - spot cleaning, panel replacement, seat re-upholstering



**Cabinet Refurbishing** - cleaning, degreasing, repairing and polishing



**Refinishing** - complete stripping and refinishing using an eco-friendly, water-based system



# lacewood

The down-under lumber with over-the-top figure

**W**ith its striking flecked figure, pinkish hue, and lustrous sheen, lacewood (*Cardwellia sublimis*) makes a great choice for creating knock-'em-dead small projects, or for adding accents on furniture and cabinetry. The wood machines easily, holds a crisp edge, and accepts glue well.

Lacewood's famous flecks run throughout the log, and are visible however it is sliced. Quartersawing, however, produces the tightest, most uniform pattern. Choose your boards carefully and examine the grain on both faces to get the best figure.

To achieve a surface free from tear-out, sand lacewood to final thickness using 60- or 80-grit paper. Proceed through 220 grit to impart a high luster. Oil finishes bring out the best in the grain, and aniline dyes can be used to color the wood. 🌲

## At a glance

- **Color:** Pink to light brown with a silvery sheen. Fairly colorfast over time.
- **Availability:** Many hardwood dealers carry an excellent supply of 4/4 and 8/4 boards. Find small pieces through mail-order and online suppliers.
- **Price:** Varies widely by supplier from \$8 to \$13 per board foot for 4/4 FAS stock.
- **Density:** Moderate
- **Workability:** Good
- **Growth range:** Australia, Europe
- **Uses:** Decorative accents, door panels, small projects, veneer.
- **Special considerations:** Tear-out can be a problem when planing. Lacewood sawdust is an irritant, so wear a dust mask when sanding and machining to avoid respiratory problems.
- **Other names:** Silky oak

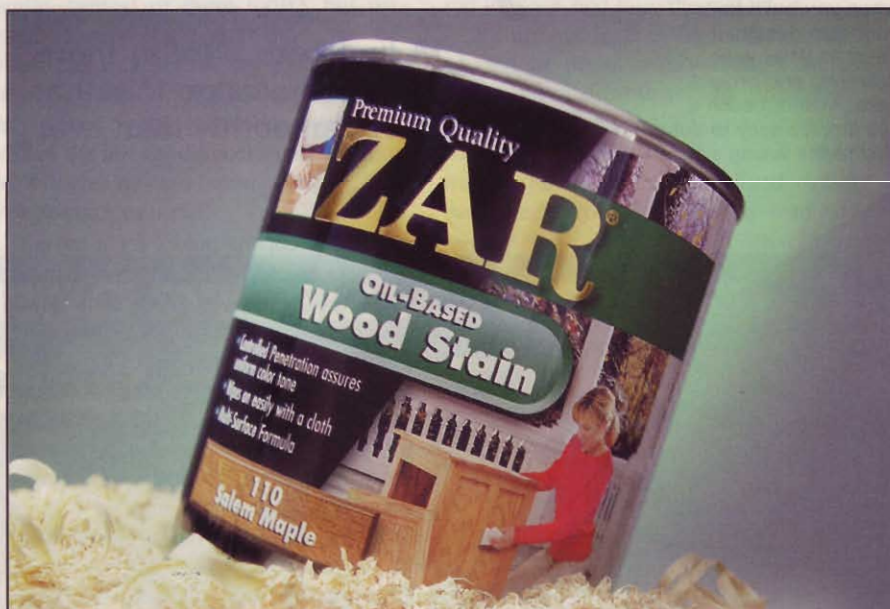

## When the Sawdust Settles... Premium Quality ZAR® Rises Above the Rest!

Whether you're creating your own masterpiece or want to give new life to a treasured family heirloom only the best wood stain will do. ZAR Wood Stain is formulated using only the finest ingredients. ZAR Wood Stain's controlled penetration formula allows you to work at your own pace. ZAR wipes on easily and penetrates evenly for uniform color tone without streaks, lapmarks or blotches. ZAR Wood Stain's extra rich formula makes it ideal for all types of wood; from Oak to Aspen to Poplar to Pine with beautiful results every time. So whether you're a professional or just want professional looking results - use ZAR Wood Stains and Clear Finishes.

### CONTROLLED PENETRATION YOU CONTROL THE STAIN IT DOESN'T CONTROL YOU!

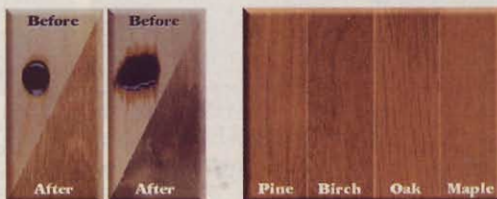

ZAR Wipes on Evenly!

Match Color Tone on Different Kinds of Woods.

**ZAR**  
The Best Thing That Ever Happened to Wood!

For a free brochure and the name of your nearest dealer call 1-800-272-3235, or visit us at [www.ugl.com](http://www.ugl.com).



# make your mark

**1** For projects with alphabetized pieces, use letters to match the materials list and drawings in the article. Even when you build from your own design, it helps to letter your drawings and project parts. Without such a system, it's easy to cut a part to the wrong size.

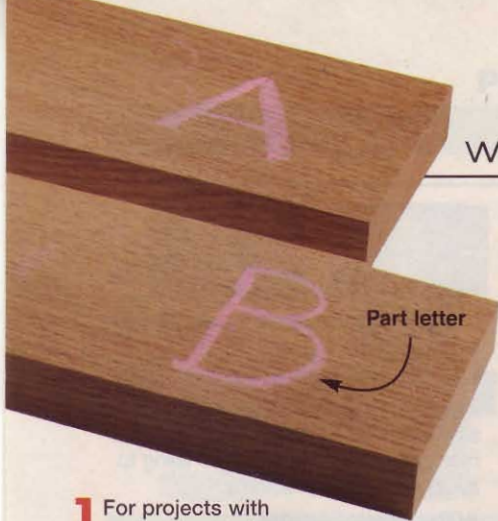

A line here, a letter there, and projects go together more smoothly than ever.

**A**s you cut the pieces for a project, you often lay them down around the workshop, and sometimes don't return to them for a day or two. The result? You forget which pieces have been planed, which board you intended to become Part A, and so on. To avoid this problem, develop a surefire system for marking your pieces as you work. That way, you eliminate any confusion whatsoever.

Here's a selection of useful marking methods, the same ones we use when building projects in the *WOOD*® magazine shop. You can use a pencil on surfaces still to be sawn, planed, or jointed. Because chalk removes more easily, it ranks as a better choice for fully machined parts prior to final sanding. 🌲

**2** Sometimes, the grain pattern dictates the best orientation for planing or jointing a board. After you determine which face or edge you wish to machine, make a pencil mark on the end grain near the face slated for removal by the planer or jointer.



**3** When squaring up a workpiece, keep track of your progress with a few quick marks. Make a distinctive mark on the first jointed face, such as the pigtail shown here. With that face against the fence, joint an edge and draw two lines to indicate the 90° intersection. Now, you're set to rip and plane the remaining surfaces.

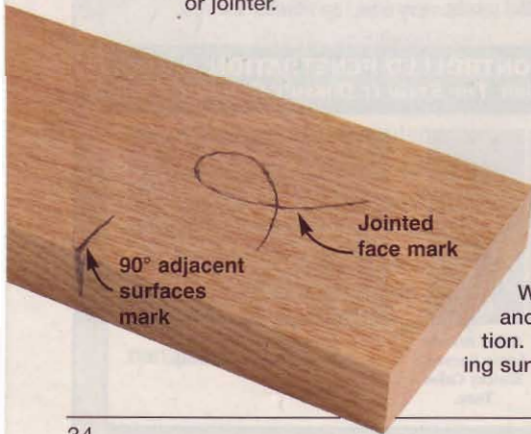

**5** Each of these chalked arrows points to the face side of a part. Work with the face up during all machining operations, and everything (such as these mortises) will align during assembly.

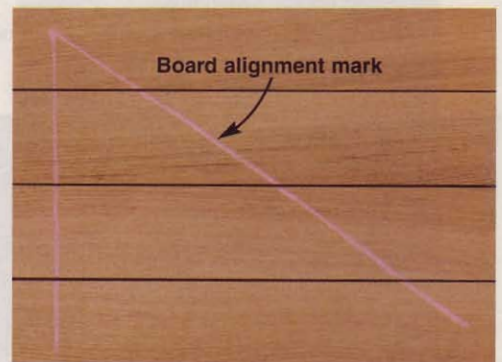

**4** After jointing and planing your boards, arrange them to get the best grain match when you prepare to glue up a panel. Then, mark them as shown *above* to avoid an assembly mix-up. If you're sorting stock for more than one panel, mark the second grouping with a double line, as shown *below*, a triple line for a third panel, and so on.

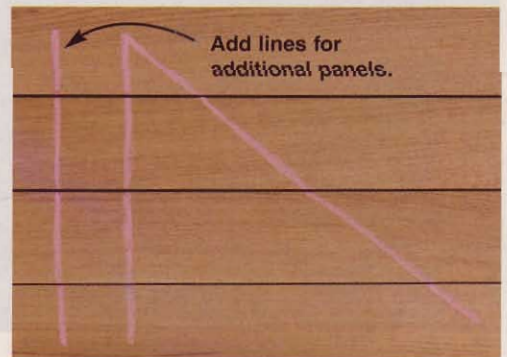





www.amazon.com/bosch

See over 200 BOSCH tools online.

## BOSCH 2-1/4 HP Electronic Plunge Router



#1613AEVS



*This is likely one of the nicest tools I've ever used. It is so smooth and quiet, I don't even have to wear earplugs.*

—An Amazon.com customer from Concord, CA

- Micro-fine bit-depth adjustment can be made after setting plunge position
- Variable speed, soft-start, constant response circuitry maintains desired rpm
- 3-5/16-inch base opening with 2-inch sub-base opening for large bits and improved visibility
- Exclusive precision-centering design for centering template guides
- Includes dust hood, 1/2- and 1/4-inch self-releasing collets, and comfortable drop-forged wrench



*\*We will match our competitors price plus beat it by 10% of the difference. Find out more at [www.amazon.com/price-match](http://www.amazon.com/price-match).*

Call for your FREE Tool Crib catalog

1-800-635-5140

**amazon.com**  
tools & hardware

just-right **joinery**

# 6 steps to perfect plugs

Visible screwheads really detract from any woodworking project; here's the easy way to hide them.

**S**hopmade wood plugs are quick and fun to make, and do a great job of dressing up your projects by hiding screwheads. See the photos and captions at *right* for the keys to this technique.

To get started, you need to choose among several styles of plug cutters. We prefer those that produce tapered plugs (like corks), which are more likely to give you a perfect fit than straight plugs. After cutting the plug and removing it from the cutter, flip it over and insert the small end into the screw hole.

You can buy a set of three Veritas Snug-Plug cutters (for 1/4", 3/8", and 1/2" holes) from Lee Valley Tools for \$27.95, plus shipping. Call 800/871-8158, and order item number 05J05.10.

Prepare a home for each plug by counterboring a hole centered on the marked pilot hole location for the screw. A countersinking drill set drills a pilot hole and a counterbore in one operation. Or you can use a Forstner or brad-point bit. Drill the counterbore first, then drill the pilot hole in the counterbore's center. The counterbored hole must match the inside diameter of your plug cutter. Drill it at least 1/4" deep, but no deeper than the capacity of your plug cutter.

Cut a plug from your project's scrap-wood to match grain and color. Spread yellow glue in the hole, and tap the plug into place. Use a mallet, or place a wood block on the plug and use a hammer. 🪵



**STEP 1** Find a spot on your scrap-wood with the grain lines you need, and clamp the workpiece to the drill-press table. Select a plug cutter, and bore at about 1,250 rpm.



**STEP 2** After drilling your plugs, mark the grain direction on each one with a pencil or pen. Cut them free on your bandsaw, and then transfer the line to the newly exposed "top" end.

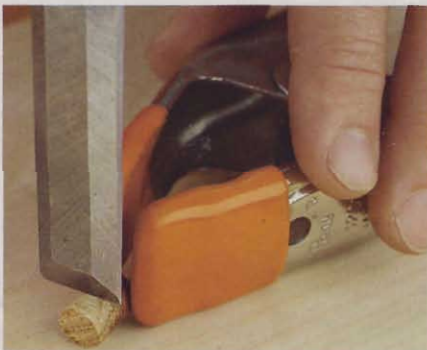

**STEP 3** You might not get a tight fit when inserting a tapered plug into a shallow hole. In that case, hold the plug with a spring clamp and trim off the smaller end with a chisel.



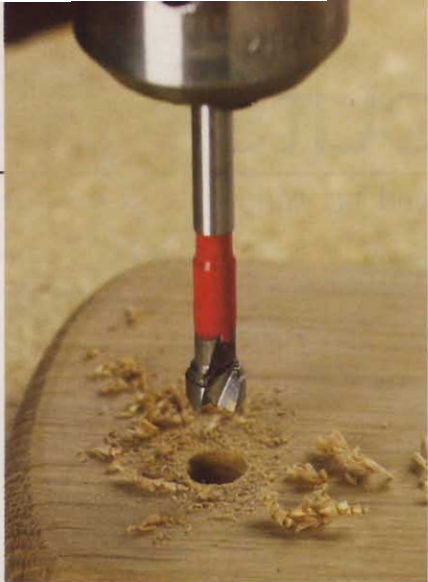

**STEP 4** Tear-out ruins the look of a plug hole, so drill a clean counterbore. A Forstner bit works best. Next, drill the pilot hole, install a screw, and glue the plug in place.

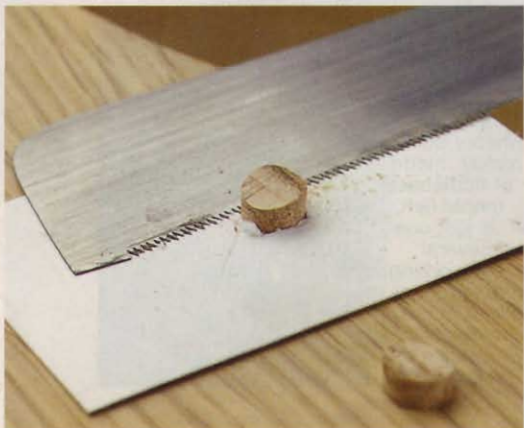

**STEP 5** After the glue dries, trim the plug with a flexible flush cutting saw. To protect the surface, make a hole in cardboard (a business card, for example) and fit it over the plug.



**STEP 6** Sand the plug flush with 100-grit sandpaper, using a random-orbit sander or a handheld block. Continue with finer grits to match the surrounding surface.

# WOODLINE USA™ OFFERS YOU MORE... LIFETIME WARRANTY / GUARANTEED LOWEST PRICE

All Woodline USA Products Feature  
Tough Micro Grain Carbide

## 30 Piece PROFESSIONAL SET

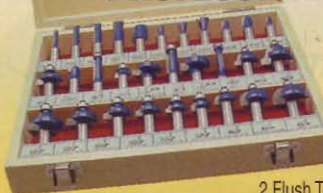

Includes:  
5 Straight Bits  
6 Roundovers  
3 Dovetails  
3 Core Box  
3 Cove Bits  
2 Flush Trim, 1 Panel Bit  
2 Roman Ogee, 2 Slot Cutters, 1 "V" Groove  
1 Chamfer and 1 Bevel Trim Bit

**SUPER BUY**  
WL-2010 **OUR PRICE ONLY \$109** set

## 15 Piece 1/2" SHANK SET

Includes:  
• Chamfer • Cove = 1/2" R, 3/8" R, 1/4" R  
• Roundover = 1/2" R, 3/8" R, 1/4" R  
• Roman Ogee = 1/4" R  
• Straight Bits = 3/4" R, 1/2" R, 1/4" R  
• 1/2" Dovetail • 1/2" Roundover • 1" CL Flush Trim • Rabbet Bit

WL-2022 for 1/2" or WL-2021 for 1/4" SHANK SET  
**OUR PRICE ONLY \$59** each set

## 5 Piece DOVETAIL SET

• 14° 3/4" • 14° 5/8"  
• 8° 1/2" • 14° 1/2"  
• 14° 3/8"  
1/2" Shank Router Bits

WL-2017  
\$30 VALUE  
**OUR PRICE ONLY \$19** set

## 8 Piece PICTURE FRAME SET

Perfect for making great looking picture frames. Bits can be combined to form complex mouldings or simple decorative frames.

WL-2008 \$189 VALUE

**OUR PRICE ONLY \$75** set



## 3 Piece CABINET DOOR SET

1/2" Shank Router Bits • 2-pc Roman Ogee Rail & Stile  
• 3 1/4" Panel Raiser

WL-2019-1 \$129 VALUE  
**OUR PRICE ONLY \$69** set



1/2" Shank Router Bits



## 6 Piece CABINET DOOR SET

1/2" Shank Router Bits  
• 2-pc Rail & Stile (Roman Ogee) • Drawer Lock  
• 3 1/4" D Panel Raiser (Ogee) • Door Lip • Glue Joint

WL-2020-1 \$175 VALUE  
**OUR PRICE ONLY \$119** set

## 5 Piece CABINET DOOR SET

3/4" Bore Shaper Cutter  
• 1-pc Rail & Stile (Roman Ogee)  
• 4 5/8" Panel Raiser (Ogee)  
• Door Lip  
• Glue Joint  
• Drawer Lock

WL-1505 \$279 VALUE  
**OUR PRICE ONLY \$179** set

## 5 Piece MOULDING SET

1/2" Shank Router Bits

WL-2011 \$175 VALUE  
**OUR PRICE ONLY \$99** set

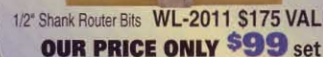

## 13 Piece DOVETAIL SET

1/2" Shank Router Bits  
• 3 Straight Bits  
• 10 Dovetail Bits

WL-2014  
\$125 VALUE  
**OUR PRICE ONLY \$49** set



## 9 Piece MASTER DADO SET

Includes Undersize for Plywood, Standard for Hardwood and Oversize for Melamine or Veneered Materials.  
In 3 Popular Sizes: 1/4", 1/2" and 3/4".

WL-2030  
\$89 VALUE

**OUR PRICE ONLY \$39** set



## 5 Piece COVE SET

1/4" R • 3/8" R • 1/2" R • 5/8" R • 3/4" R

WL-2015 \$99 VALUE  
**OUR PRICE ONLY \$49** set



**WOODLINE USA™**

GREAT ROUTER BITS AND SHAPER CUTTERS  
BEST SELECTION / BEST PRICE!  
ORDER TOLL FREE

**1-800-472-6950**

WOODLINE USA • P.O. BOX 298 • TEMECULA, CA 92593

• INDIVIDUAL BITS ALSO AVAILABLE • ALL MAJOR CREDIT CARDS  
• PRIORITY SHIPPING: \$3.75 FOR UP TO \$99. / \$4.75 FOR \$100.+  
• MOST ITEMS IN STOCK • SAME DAY SHIPPING

PREMIUM  
CARBIDE

ALL WOODLINE USA  
SETS ARE PACKAGED IN  
BEAUTIFUL WOOD BOXES

QUALITY Guaranteed

E-mail: woodline@woodbits.com

Visit us **WOODBITS**  
at our Web site: **WOODBITS.COM**

• Tough Micro Grain Carbide  
• Euro Anti-Kickback Design  
• Super-Slick Non-Stick Finish  
• Super Low Prices

FREE CATALOG  
See our great selection of  
Bits and Cutters  
1-800-472-6950



CHANGE THE ENGINE OIL  
 REPLACE THE SPARK PLUG  
 REPLACE THE BLADE  
 REPLACE THE AIR FILTER  
 By properly addressing these maintenance points, not only are you keeping your lawn healthy, but you may also be prolonging the life of your mower.  
 Sears has parts and repair expertise for all major brands of lawn equipment—no matter where you bought them.  
 THREE WAYS TO BUY PARTS FROM SEARS:  
 • CALL 1-800-4-MY-HOME®  
 • CLICK SEARS.COM & VISIT THE PARTS PAGE  
 • VISIT A PARTS & REPAIR CENTER NEAR YOU  
 FOR LOCATIONS, CALL 1-800-488-1222

**You're not the only one who puts effort into making your lawn look good. Your mower works hard too. Just an hour of simple preventative maintenance once a year assures smooth operation and actually extends the life of your mower.**

## 4 STEPS TO A HEALTHY MOWER

### CHANGE THE ENGINE OIL

Clean oil coats and protects engine components and can prolong the life of your mower. Check the owner's manual for the right SAE viscosity grade.

### REPLACE THE SPARK PLUG

A worn plug will make your mower hard to start.

### REPLACE THE BLADE

A bent, chipped, or dull blade not only cuts your grass poorly, but can even ruin your lawn.

### REPLACE THE AIR FILTER

A dirty filter can allow dirt to get inside the carburetor and may restrict air flow.

*By properly addressing these maintenance points, not only are you keeping your lawn healthy, but you may also be prolonging the life of your mower.*

*Sears has parts and repair expertise for all major brands of lawn equipment—no matter where you bought them.*

### THREE WAYS TO BUY PARTS FROM SEARS:

- CALL 1-800-4-MY-HOME®
- CLICK SEARS.COM & VISIT THE PARTS PAGE
- VISIT A PARTS & REPAIR CENTER NEAR YOU

FOR LOCATIONS,  
CALL 1-800-488-1222

**SEARS** Where else?™

# short cuts

News and notes from the woodworking world

## Have a capital time at the Renwick

The next time you find yourself in Washington, D.C., schedule time to see the special permanent furniture collection at the Smithsonian American Art Museum's Renwick Gallery. In addition to exhibits featuring items made of clay,



fiber, glass, and metal, you'll be pleased to know that wood is

equally well represented. The museum's curator, Kenneth Trapp, says that visitors typically will see between 75 to 90 exquisite furniture pieces by post-World War II craftsmen.

You'll find the Renwick on Pennsylvania Avenue at 17th Street, NW. Admission is free with visiting hours from 10 a.m. to 5:30 p.m. every day except December 25. For more information, call 202/357-2700, or go to [www.AmericanArt.si.edu](http://www.AmericanArt.si.edu).

This Sam Maloof double rocker made of fiddleback maple (left) is just one of several woodworking masterpieces found at the Smithsonian's Renwick Gallery (right).



## Windmills of the mind

During the final days of *WOOD*® magazine's "For the Birds" Birdhouse/Bird Feeder Contest, we received a well-made entry from a 74-year-old woodworker who faced one challenge that other participants did not. Ed Pritchard of Fallbrook, California, is blind.

Due to unsuccessful cataract surgery, coupled with a stroke, Ed's vision deteriorated to a complete loss of sight by 1997. But thanks to his supportive family, and their purchase of a tape measure for the blind, mitersaw, drill-press, router, and sander, Ed was able to ply his favorite hobby.

Ed started making numerous styles of small birdhouses, using a miniature birdhouse as his model, something he could feel. To work safely, he made jigs to keep his fingers away from the bits and blades when machining parts. Assembly involved spreading glue with his fingers



Over 13" wide and 15" tall, this windmill birdhouse was made by blind woodworker Ed Pritchard of Fallbrook, California.

and holding parts together with rubber bands and pins. When the small birdhouses were no longer challenging, he turned to making windmill birdhouses from memory, based on plans he had purchased some 15 years before.

*Continued on page 40*



### Does your state have a champion tree?

While not every state can lay claim to having the biggest tree in a selected species, most can. According to the National Register of Big Trees, Georgia has 15, for instance. Kansas, on the other

hand, has none. To discover the giants in your neck of the woods, or to report a giant, go to the Web, and look up [www.americanforests.org](http://www.americanforests.org), and find out how to proceed.



Photograph: Whit Bronough Photography

This magnificent Maryland tree, named the "Wye Oak" after the surrounding town of Wye Mills, was the largest white oak, until tipping over in June of 2002. It stood 96' high, measured 31'10" around, and lived for more than 450 years.

### Yes, Virginia, there is more than one Santa

For the past five years, the 46-member Livingston County Woodcraft Guild of Michigan has pulled its talents together to make toys and other items for patients at children's hospitals. This past year alone, the Guild crafted and distributed more than 1,000 wooden toys and 15,000 wooden silhouettes to such locations as the children's hospitals in Detroit and Philadelphia, as well as Give Kids The World in Orlando, Florida.

Word of these wise men's gifts have traveled fast and afar. Guild vice president Bob Penfil says that additional requests have come in from hospitals across the country. To learn how you can help contribute to this worthy cause, contact

Bob at Livingston County Woodcraft Guild, P.O. Box 1165, Brighton, MI 48114. He has blueprints of the toys and a catalog of the silhouettes that he can pass along, as well as other key information.



Photograph: Livingston County Daily Press and Argus, Michigan

From left: Gary Saum, Bob Penfil, and Tod Kovach display a sampling of the thousands of wooden toys and silhouettes made by their guild for children's hospitals.

### A contest you can bond with



Have you tried or regularly use Franklin International's HiPURformer Advanced Bonding System in your shop or around the home? If so, you qualify to enter a new contest where monthly winners will come away with a HiPURformer Advanced Bonding System (worth \$100) or two cases of HiPURformer cartridge adhesives of your choice (retail value, \$160.) What a deal!

A product of Titebond Glues & Adhesives, HiPURformer is a polyurethane hot-melt adhesive that lends itself to countless applications in woodworking, crafts, and home improvement and repair assignments. Judges will evaluate entries based on "practicality, clarity, creativity, and sincerity." Go to [www.titebond.com](http://www.titebond.com) to enter and click on the HiPURformer link to the contest. Here you'll find the entry form and detailed instructions. Then, fill out the entry form and submit it electronically, or make a copy of it and send it to: HiPURformer Contest Entry, Franklin International, 2020 Bruck Street, Columbus, OH, 43207. Good luck.

### Hard facts on hardwood usage

According to the United States Department of Agriculture (USDA), red oak leads the pack as the most produced hardwood lumber in the country. Here's a look at the total hardwood production picture:

SPECIES	PERCENTAGE
Red Oak	37
White Oak	15
Poplar	11
Ash	5
Cherry	4
Soft Maple	4
Hard Maple	4
Alder	3
Other Species*	17

\*Other species include basswood, beech, birch, cottonwood, elm, hackberry, hickory, pecan, tupelo, sap gum, walnut, and other hardwoods.



# barrister's bookcase

This early  
example of  
modular  
office furniture  
still makes  
its case.

You may stack the bookshelf units up to five high. With two units, as shown below your barrister's bookcase does double duty as a sideboard or hall table.





**B**uild a base, a top, and as many bookshelf cases as you wish to go in between. All the parts simply stack up and screw together. You'll make your own wood door guides, and, aside from wood screws in various sizes, the only hardware needed is the knobs.

*Note: The Materials List and Cutting Diagram show the number of parts needed for a one-bookshelf-case bookcase. Multiply the number of case parts and door parts by the number of bookshelf cases you wish to make.*

### Build the case

**1** Cut the upper and lower panels (A) to width, but about 1" longer than listed in the **Materials List**. Rip the banding (B) to width, but about 1" longer than listed. Glue and clamp the banding to the panels. With the glue dry, sand the banding flush with the panels, and cut the assemblies to length, trimming both ends.

**2** With the panels oriented so their good sides will face into the case, rout  $\frac{1}{16}$ " chamfers on the banding, where shown on **Drawing 1**. Finish-sand the assemblies to 220 grit.

**3** For the case sides, cut the stiles (C), rails (D), and mullions (E) to the sizes listed. Install a  $\frac{3}{8}$ " dado blade in your tablesaw, and cut the centered grooves, where shown on **Drawing 2**.

**4** To form the tenons on the ends of the rails and mullions, switch to a  $\frac{1}{4}$ " dado blade. To set the tenons' length, position the fence to the right of the blade, and  $\frac{3}{8}$ " from the blade's left side. Attach an auxiliary extension to your miter gauge so it just grazes the fence. First testing your cuts in scrap, form the tenons, where shown on **Drawings 2** and **2a**, making two passes over the blade.

#### 1 CASE EXPLODED VIEW

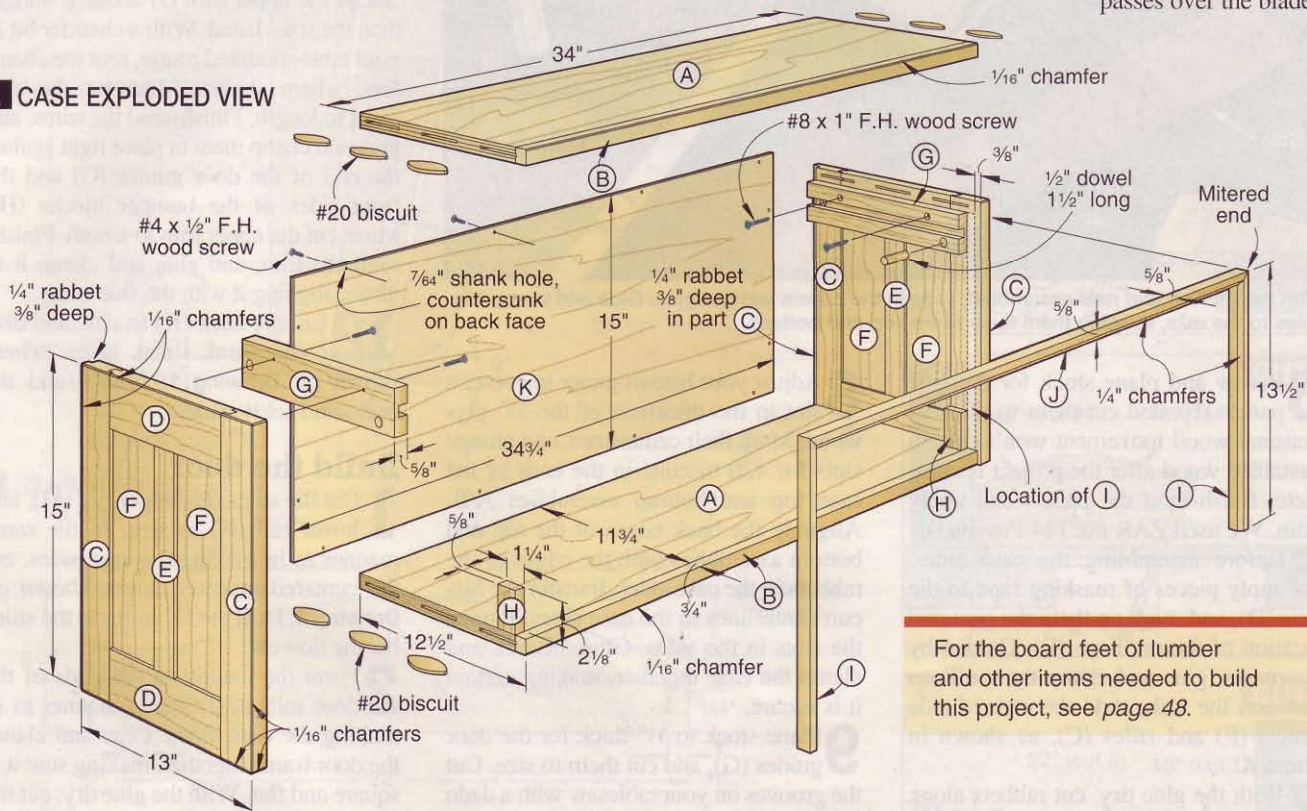

For the board feet of lumber and other items needed to build this project, see page 48.

#### 2 SIDE (Inside face shown)

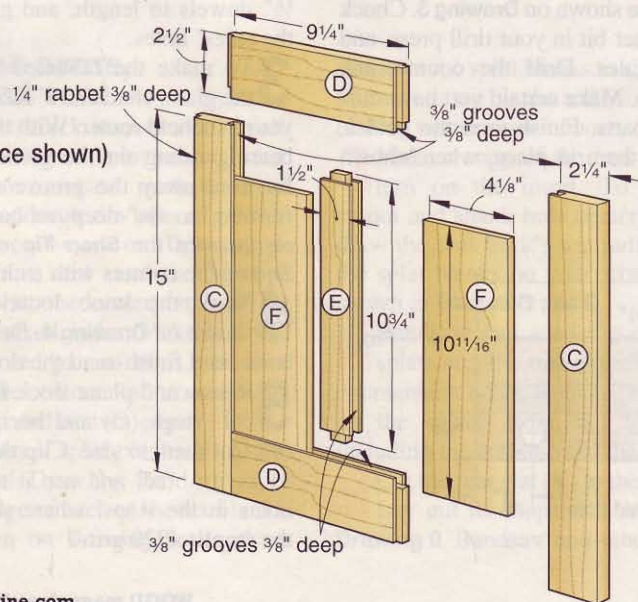

#### 2a TENON DETAILS (Case side shown)

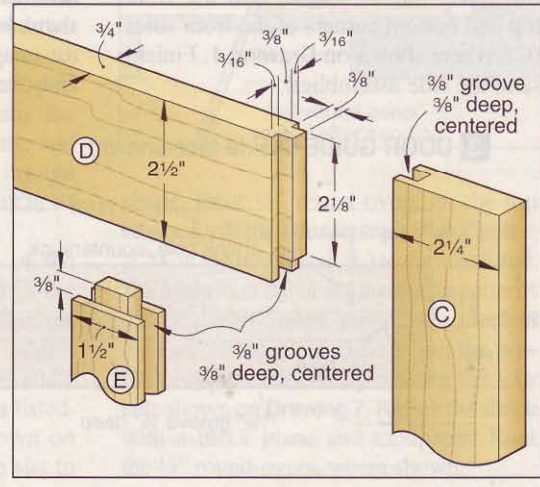



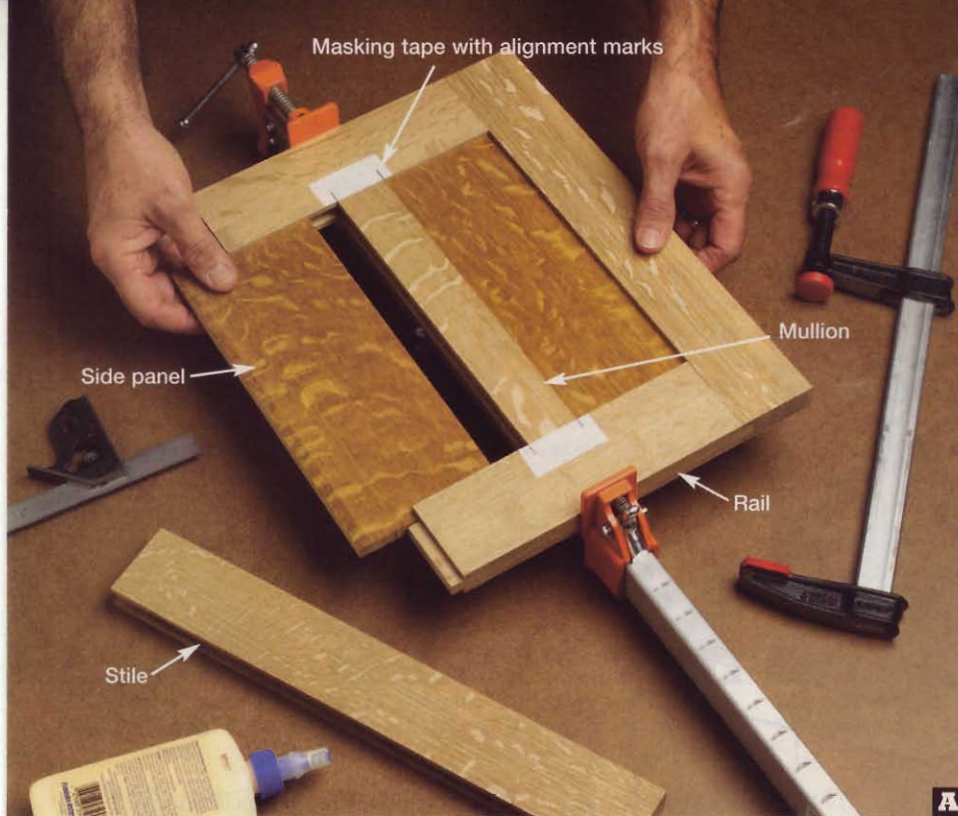

With the mullion and rails assembled, slide in the panels without glue. Glue and clamp the stiles to the rails, keeping them flush at the top and bottom.

**5** Resaw and plane stock for the side panels (F), and cut them to size. So seasonal wood movement won't expose unstained wood after the project is complete, finish-sand the panels and apply stain. We used ZAR no. 114 Provincial.

**6** Before assembling the case sides, apply pieces of masking tape to the rails (D), and mark on them the centered location of the mullions (E). Guided by the marks, glue and clamp the mullions between the rails. Add the stained side panels (F) and stiles (C), as shown in **Photo A**.

**7** With the glue dry, cut rabbets along the case sides' inside back edges, for the back (K). Rout  $\frac{1}{16}$ " chamfers along the sides' outside edges, and the front top and bottom corners of the front stiles (C), where shown on **Drawing 1**. Finish-sand the side assemblies.

**8** Adjust your biscuit joiner to center a slot in the thickness of the  $\frac{3}{4}$ " plywood. Mark their centerlines, and plunge slots for #20 biscuits in the ends of the case top and bottom assemblies A/B. Aligning the back edges of the top and bottom assemblies with the edges of the rabbets in the case sides, transfer the biscuit centerlines to the case sides. Plunge the slots in the sides. Glue, biscuit, and clamp the case together, making certain it is square.

**9** Plane stock to  $\frac{5}{8}$ " thick for the door guides (G), and cut them to size. Cut the grooves on your tablesaw with a dado blade, where shown on **Drawing 3**. Chuck a  $\frac{1}{2}$ " Forstner bit in your drill press, and drill the holes. Drill the countersunk shank holes. Make certain you have mirror-image parts. Finish-sand the guides, and clamp them in place, where shown

on **Drawing 1**. The ends of the guides are flush with the edge of the sides' back rabbets. Using the shank holes as guides, drill pilot holes into the case sides, and drive in the screws. Cut four  $1\frac{1}{2}$ "-long oak dowels and glue two of them in the guides' front holes. Set the other two aside for the stops that will later be installed in the rear holes.

**10** Plane stock for the bumper blocks (H), and cut them to size. Finish-sand the blocks. Glue and clamp them in place, where shown on **Drawing 1**.

**11** Cut blanks for the side trim (I) and the upper trim (J) about 1" longer than the sizes listed. With a chamfer bit in your table-mounted router, rout the chamfers, where shown. Miter-cut the side trims to length. Finish-sand the trims, and glue and clamp them in place tight against the end of the door guides (G) and the front sides of the bumper blocks (H). Miter-cut the upper trim to length. Finish-sand the trim, and glue and clamp it in place, aligning it with the side trims.

**12** Cut the back (K) to size, and drill countersunk shank holes, where shown on **Drawing 1**. Finish-sand the back, and set it aside.

## Build the door

**1** Cut the stiles (L), upper rail (M), and lower rail (N) to size. In the same manner as in making the case sides, cut the centered grooves, where shown on **Drawing 4**. Drill the  $\frac{1}{2}$ " holes in the stiles for the dowels.

**2** Form the tenons on the ends of the door rails in the same manner as in making the case sides. Glue and clamp the door frame together, making sure it is square and flat. With the glue dry, cut the  $\frac{1}{2}$ " dowels to length, and glue them in the stiles' holes.

**3** To make the rabbeted opening for the glass, chuck a  $\frac{3}{8}$ " rabbeting bit in your handheld router. With the bit's pilot bearing riding on the groove's outside lip, rout away the groove's inside lip, forming a  $\frac{1}{16}$ "-deep rabbet. For best results, see the **Shop Tip** on page 46. Square the corners with a chisel.

**4** Mark the knob locations, where shown on **Drawing 4**. Drill the screw holes, and finish-sand the door.

**5** Resaw and plane stock for the vertical stops (O) and horizontal stops (P). Cut them to size. Clip the head off a #17 wire brad, and use it to drill pilot holes in the stops, where shown. Sand the stops to 220 grit.

### 3 DOOR GUIDE (Inside face shown)

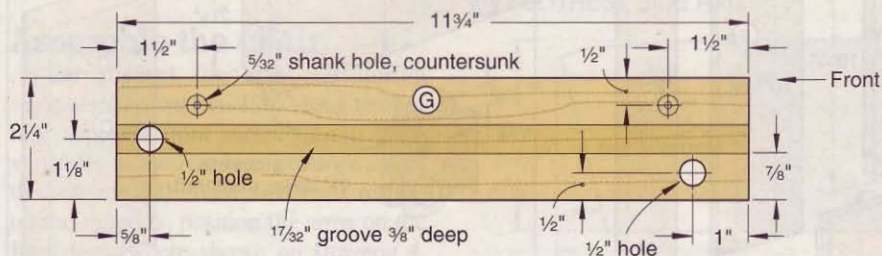



#### 4 DOOR (Viewed from back side)

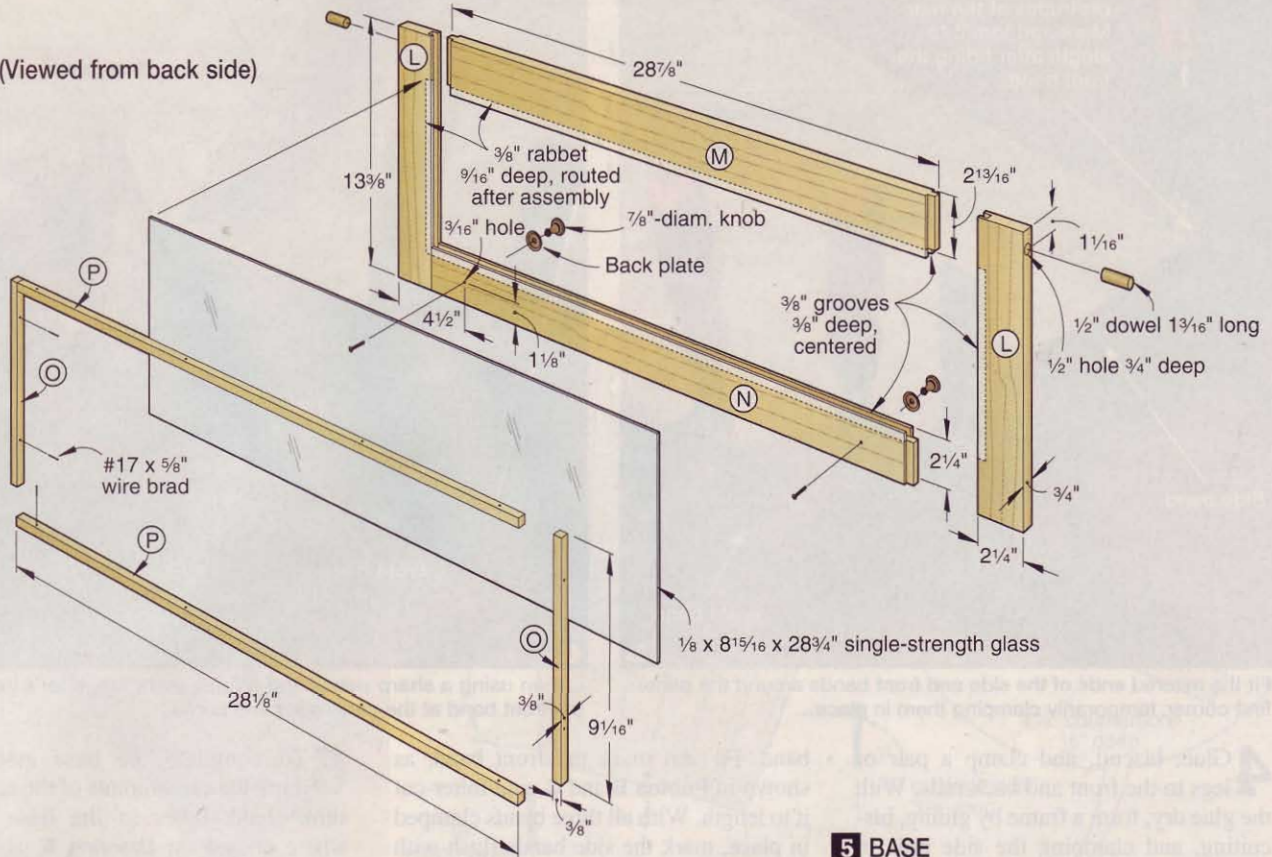

*Note: The vertical and horizontal stops (O, P) are butted at the corners, rather than mitered. Once mitered stops are nailed, one piece locks the other in place, making them difficult to remove without breakage. Butted stops avoid interlocked corners for easy removal.*

#### 5 BASE

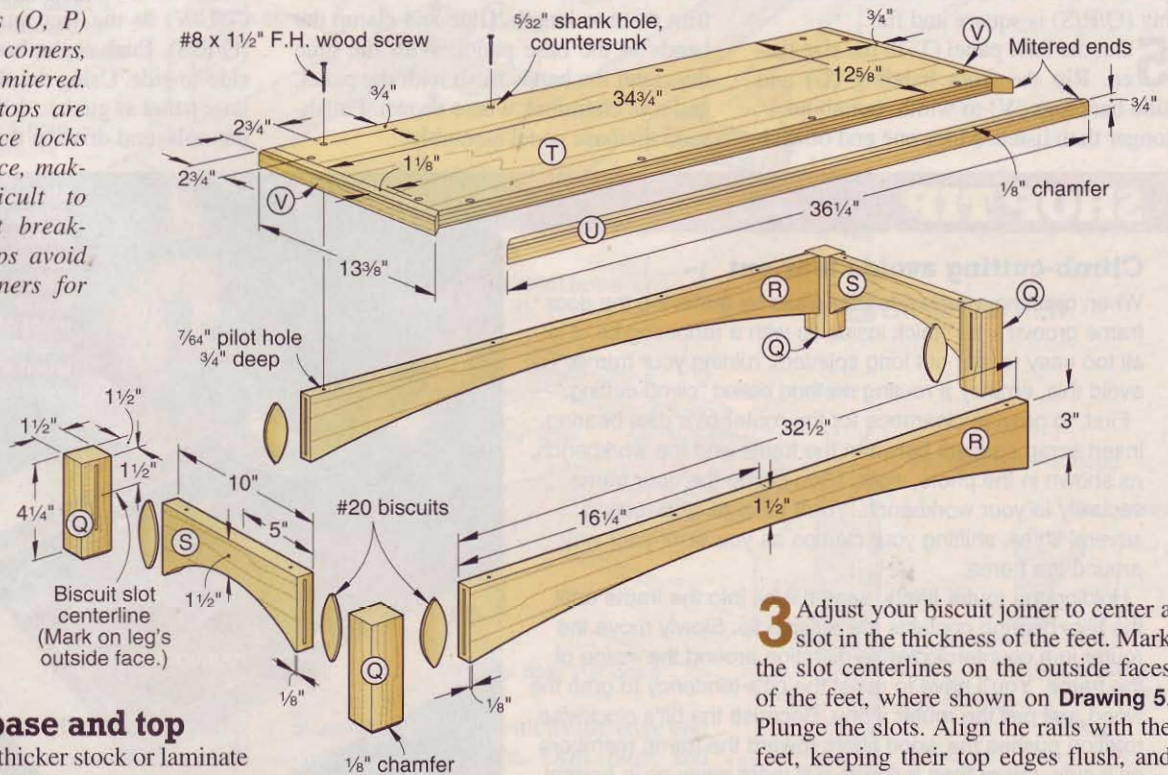

#### On to the base and top

**1** Plane down thicker stock or laminate thinner stock for the feet (Q), and cut them to size. Rout 1/8" chamfers on their bottom edges.

**2** Cut the front and back rails (R) and the side rails (S) to size. Mark the

ends and centers of the arches, where shown on **Drawing 5**. Bend a fairing stick to these points, and draw the arches. Bandsaw and sand them to shape.

**3** Adjust your biscuit joiner to center a slot in the thickness of the feet. Mark the slot centerlines on the outside faces of the feet, where shown on **Drawing 5**. Plunge the slots. Align the rails with the feet, keeping their top edges flush, and transfer the slot centerlines to the outside faces of the rails. Readjust your biscuit joiner to center a slot in the thickness of the rails, and plunge the slots. Finish-sand the feet and rails.



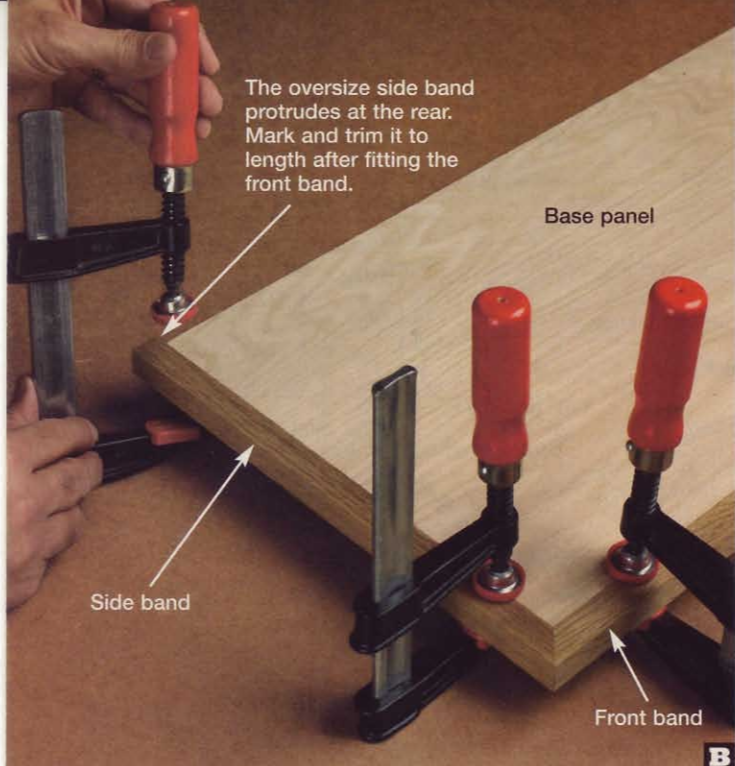

Fit the mitered ends of the side and front bands around the panel's first corner, temporarily clamping them in place...

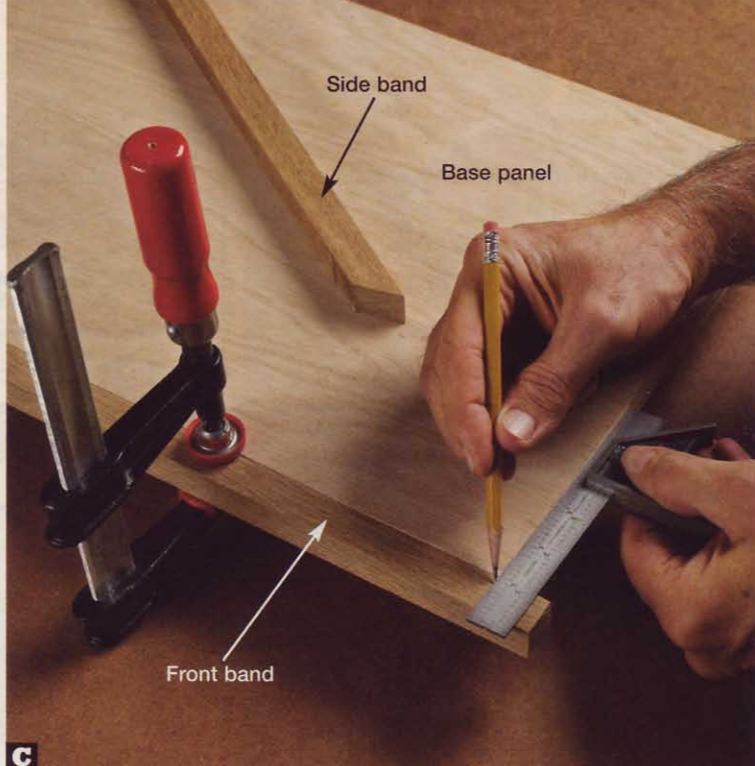

...then using a sharp pencil and a ruler, mark the miter's heel on the front band at the panel's second corner.

**4** Glue, biscuit, and clamp a pair of legs to the front and back rails. With the glue dry, form a frame by gluing, biscuiting, and clamping the side rails in place. Make certain the feet/rails assembly (Q/R/S) is square and flat.

**5** Cut the base panel (T) to the size listed. Rip the front banding (U) and side bandings (V) to width, but about 1" longer than listed. Miter one end of each

band. Fit and mark the front band, as shown in **Photos B** and **C**, and miter-cut it to length. With all three bands clamped in place, mark the side bands flush with the back edge of the base panel (T), and trim them to length. Glue and clamp the bands to the base panel. With the glue dry, sand the bands flush with the panel, and rout chamfers, where shown. Finish-sand the base panel assembly.

**6** To complete the base assembly, mark the centerpoints of the countersunk shank holes in the base panel, where shown on **Drawing 5**, and drill them. Clamp the base panel assembly (T/U/V) to the feet and rails assembly (Q/R/S), flush at the back, and centered side-to-side. Using the shank holes in the base panel as guides, drill pilot holes into the rails, and drive in the screws.

## SHOP TIP

### Climb-cutting avoids tear-out

When creating a rabbet for the glass by removing the door frame groove's  $\frac{3}{16}$ "-thick inside lip with a rabbeting bit, it is all too easy to tear out long splinters, ruining your frame. To avoid this, employ a routing method called "climb-cutting."

First, to provide clearance for the router bit's pilot bearing, insert scrap spacers between the frame and the workbench, as shown in the photo, *right*. Then clamp the door frame securely to your workbench. You'll have to stop routing several times, shifting your clamps as you work your way around the frame.

Holding the router firmly, ease the bit into the frame until the pilot bearing contacts the outside lip. Slowly move the router in a counterclockwise direction around the inside of the frame. You'll have to resist the bit's tendency to grab the wood and pull the router along. Because the bit's clockwise rotation pushes the wood fibers toward the frame members as it cuts, rather than trying to pull them away as in normal routing, tear-out is eliminated.

Once you've worked your way around the frame, make a second counterclockwise pass to clean up the edge.



Although it may appear otherwise, this photo shows climb-cutting only a  $\frac{3}{16}$ "-thick  $\frac{3}{8}$ "-wide lip from the door frame. That's because most of the material was removed earlier when a centered groove was cut in the parts.







## Apply the finish, and assemble

**1** Examine all the parts and assemblies, and resand any areas that need it. If you wish, apply a stain, and let it dry. We used ZAR no. 114 Provincial.

**2** Apply a clear finish. To add an amber tone to the stain's color, we brushed on oil-based satin polyurethane.

**3** Lay the bookshelf case on its back on your workbench. Clamp the base to it, flush at the back and centered side-to-side. Drill pilot and countersunk shank holes through the base panel (T) into the case's lower panel (A), where shown on **Drawing 7**, and drive in the screws. Clamp the top assembly to the case, flush at the back and centered side-to-side. Drill pilot and countersunk shank holes through the

case's upper panel (A) into the top (W), where shown, and drive in the screws. Stand the assembly upright.

**4** Have single-strength glass cut  $\frac{1}{8}$ " smaller in width and length than the door's rabbeted opening. Lay the door facedown, and install the glass. Position the stops (O, P), and drive brads through the previously drilled pilot holes. Set the brads, and fill the holes with a matching color putty stick.

**5** Apply wax to the grooves in the door guides (G) and their dowels. Install the door from the rear, sliding it over the door guide dowels at the front, and engaging the door's dowels in the guides' grooves. Retrieve the two door-stop dowels, and tap them into the guides' rear holes. Do not glue them in.

**6** Clamp the back (K) in place. Using the previously drilled shank holes as guides, drill pilot holes into the case. Drive in the screws.

**7** Install the knobs. Drill pilot holes for the tack bumpers, positioning them to leave  $\frac{3}{4}$ " between the bumpers and the bumper blocks' front edges. Tap in the tack bumpers. ♣

Written by **Jan Svec** with **Chuck Hedlund**

Project design: **Kevin Boyle**

Illustrations: **Roxanne LeMoine**

## Materials List

Case	FINISHED SIZE			Matl.	Qty.
	T	W	L		
A* upper and lower panels	$\frac{3}{4}$ "	11 $\frac{3}{4}$ "	34"	OP	2
B* banding	$\frac{3}{4}$ "	$\frac{3}{4}$ "	34"	QO	2
C stiles	$\frac{3}{4}$ "	2 $\frac{1}{4}$ "	15"	QO	4
D rails	$\frac{3}{4}$ "	2 $\frac{1}{2}$ "	9 $\frac{1}{4}$ "	QO	4
E mullions	$\frac{3}{4}$ "	1 $\frac{1}{2}$ "	10 $\frac{3}{4}$ "	QO	2
F side panels	$\frac{5}{8}$ "	4 $\frac{1}{8}$ "	10 $\frac{1}{16}$ "	QO	4
G door guides	$\frac{5}{8}$ "	2 $\frac{1}{4}$ "	11 $\frac{3}{4}$ "	QO	2
H bumper blocks	$\frac{5}{8}$ "	1 $\frac{1}{4}$ "	2 $\frac{1}{8}$ "	QO	2
I* side trim	$\frac{5}{8}$ "	$\frac{5}{8}$ "	13 $\frac{1}{2}$ "	QO	2
J* upper trim	$\frac{5}{8}$ "	$\frac{5}{8}$ "	34"	QO	1
K back	$\frac{1}{4}$ "	15"	34 $\frac{3}{4}$ "	OP	1
<b>Door</b>					
L stiles	$\frac{3}{4}$ "	2 $\frac{1}{4}$ "	13 $\frac{3}{8}$ "	QO	2
M upper rail	$\frac{3}{4}$ "	2 $\frac{1}{16}$ "	28 $\frac{7}{8}$ "	QO	1
N lower rail	$\frac{3}{4}$ "	2 $\frac{1}{4}$ "	28 $\frac{7}{8}$ "	QO	1
O vertical stops	$\frac{3}{8}$ "	$\frac{3}{8}$ "	9 $\frac{1}{16}$ "	QO	2
P horizontal stops	$\frac{3}{8}$ "	$\frac{3}{8}$ "	28 $\frac{1}{8}$ "	QO	2
<b>Base and Top</b>					
Q feet	1 $\frac{1}{2}$ "	1 $\frac{1}{2}$ "	4 $\frac{1}{4}$ "	LQO	4
R front and back rails	$\frac{3}{4}$ "	3"	32 $\frac{1}{2}$ "	QO	2
S side rails	$\frac{3}{4}$ "	3"	10"	QO	2
T base panel	$\frac{3}{4}$ "	12 $\frac{5}{8}$ "	34 $\frac{3}{4}$ "	OP	1
U* front band	$\frac{3}{4}$ "	$\frac{3}{4}$ "	36 $\frac{1}{4}$ "	QO	1
V* side bands	$\frac{3}{4}$ "	$\frac{3}{4}$ "	13 $\frac{3}{8}$ "	QO	2
W* top	$\frac{3}{4}$ "	14 $\frac{5}{8}$ "	38 $\frac{3}{4}$ "	EQO	1
X crest	$\frac{3}{4}$ "	2 $\frac{1}{2}$ "	35 $\frac{1}{2}$ "	QO	1

\*Parts initially cut oversize. See the instructions.

**Materials key:** OP—oak plywood, QO—quartersawn white oak, LQO—laminated quartersawn white oak, EQO—edge-joined quartersawn white oak.

**Supplies:** #20 biscuits;  $\frac{1}{2}$ " oak dowel; #8x1", #8x1 $\frac{1}{4}$ ", #8x1 $\frac{1}{2}$ ", and #4x $\frac{1}{2}$ " flathead wood screws; #17x $\frac{5}{8}$ " wire brads; single-strength glass;  $\frac{1}{2}$ "-diameter tack bumpers; putty stick; paraffin wax.

**Blades and bits:** Stack dado set,  $\frac{1}{2}$ " Forstner bit, chamfer router bit,  $\frac{3}{8}$ " rabbeting router bit.

## Buying Guide

**Knobs.** Antique brass  $\frac{7}{8}$ "-diameter knobs with 1" back plates no. MS-8, \$4.75 each (2 per door). Horton Brasses, call 800/754-9127, or go to [www.horton-brasses.com](http://www.horton-brasses.com).

## Cutting Diagram

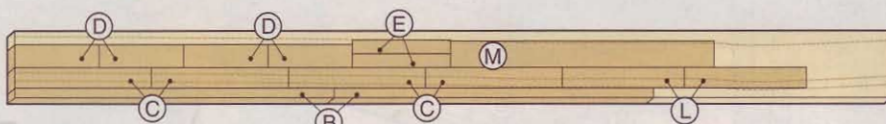

$\frac{3}{4}$  x 7 $\frac{1}{4}$  x 96" Quartersawn white oak (5.3 BF)

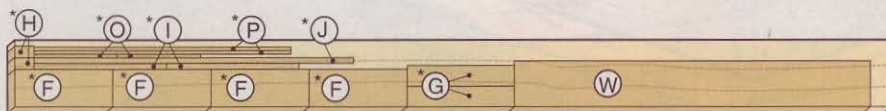

$\frac{3}{4}$  x 7 $\frac{1}{4}$  x 96" Quartersawn white oak (5.3 BF)

\*Plane or resaw to the thicknesses listed in the Materials List.

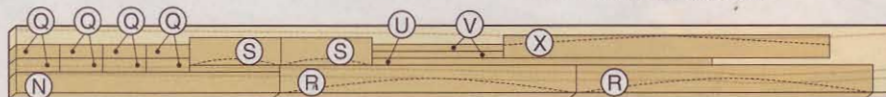

$\frac{3}{4}$  x 7 $\frac{1}{4}$  x 96" Quartersawn white oak (5.3 BF)

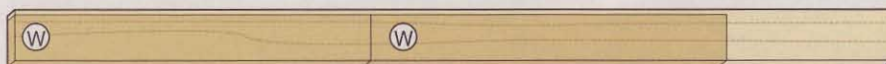

$\frac{3}{4}$  x 5 $\frac{1}{2}$  x 96" Quartersawn white oak (4 BF)

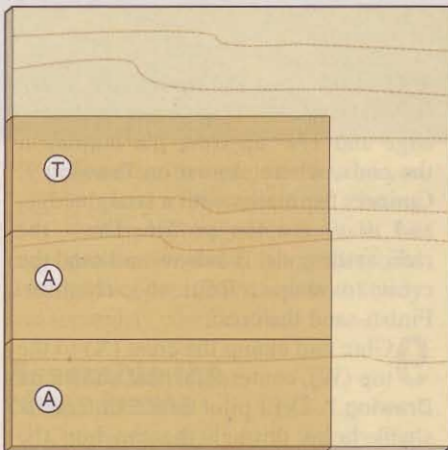

$\frac{3}{4}$  x 48 x 48" Oak plywood

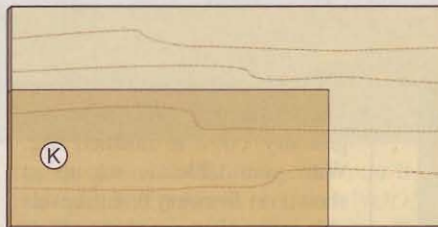

$\frac{1}{4}$  x 24 x 48" Oak plywood

See more . . .

...mission furniture plans at

[www.woodstore.woodmall.com/misfur.html](http://www.woodstore.woodmall.com/misfur.html)





the ultimate shop-made  
**bandsaw  
table  
system**

**CROSSCUT**  
parts to length  
using your miter  
gauge in one of  
these dual,  
smooth-gliding  
T-tracks.

**RIP**  
stock to width with this rock-  
solid, self-aligning fence.

**CUT CIRCLES**  
up to 32" in diameter  
with this adjustable  
slider and pivot pin.

**RESAW  
VENEERS**  
from wide  
and narrow  
stock with  
this bolt-on  
resaw fence,  
which lets  
you lower  
the blade  
guide to suit  
the work-  
piece.

Fits most 14" and 16" bandsaws.

**CHANGE  
BLADES**  
by removing only  
the slider—not  
the table!

19 $\frac{3}{8}$ "x27"  
table safely  
supports  
large work-  
pieces.

**It does it all!**

**Add these accessories for maximum versatility (see page 64 for plans):**

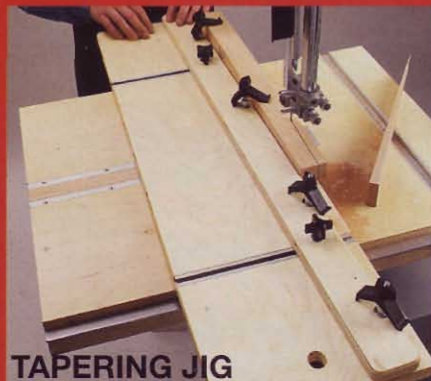

**TAPERING JIG**

Cut consistent tapers on parts such as table legs with ease.



**DUPLICATING JIG**

Produce identical curved parts quickly and accurately.



**FEATHER BOARD/  
SINGLE-POINT FENCE**

Resaw thick and narrow stock with this dual-function jig.



Looking to take your bandsaw to a whole new level of performance and versatility? Here's your chance. After you build the jigs, see page 56 for tips on putting the system to work in your shop.

*Note: Because the bandsaw table system's hardware comes from several suppliers, we've listed convenient kits in the Buying Guide on page 55 so you can purchase all of the items from a single source, saving you time and money. You won't find the hardware listed in the supplies section due to the number of pieces and sources.*

## Start with the table

**1** Cut the table (A) to the size listed in the Materials List. On the table's top, lay out the  $1\frac{3}{8} \times 18\frac{5}{16}$ " slot, where dimensioned on **Drawing 1**. Jigsaw the slot to within  $\frac{1}{16}$ " of the lines.

**2** Chuck a top bearing pattern bit with a 1" cutter length in your router. Align a straightedge with one of the slot's long layout lines, and clamp it to the table (A). Next, rout along the edge of the slot. Repeat the process to trim the slot's end and other long edge.

**3** Refit your router with a  $\frac{3}{8}$ " rabbeting bit. Rout a  $\frac{3}{8}$ " rabbet  $\frac{1}{8}$ " deep along the slot's edges on both faces of the table, where shown on **Drawing 1**, to receive the

## How to determine if the jig will fit your bandsaw

Take four measurements on your bandsaw where shown on the drawing, right. The table will fit your saw provided your measurements stay within the limits shown.

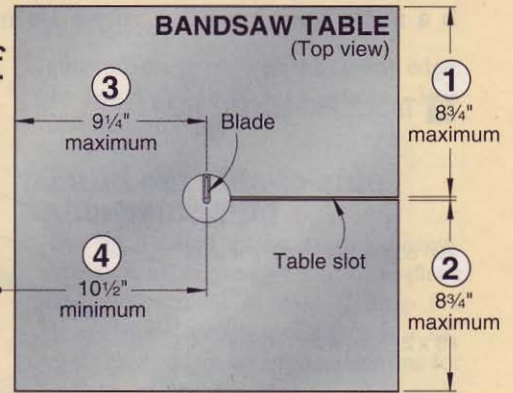
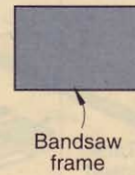

$\frac{1}{8}$ "-thick aluminum bars, where shown on **Drawing 2** on the next page. Square the rabbet corners with a chisel.

*Note: For safe operation when using the system's jigs, ensure that all of the aluminum parts fit flush with the table's top surface.*

**4** Lay out the  $1\frac{3}{4} \times 2$ " enlarged throat area at the end of the slot, where dimensioned on **Drawing 1**. (This provides clearance to facilitate blade changes.) Jigsaw the opening to shape.

**5** Using a dado blade in your tablesaw, cut the  $1\frac{5}{32}$ " dados  $\frac{1}{2}$ " deep in the table's top, where dimensioned, to receive the T-tracks shown on **Drawing 2**.

## Cut the aluminum parts

**1** From a 48"-long piece of  $1\frac{5}{32}$ "-wide aluminum T-track, hacksaw a  $19\frac{3}{8}$ "-

long piece and two 9"-long pieces to fit the exact length of the table's dados, where shown on **Drawing 2**. Cut the  $\frac{3}{8}$ " notches  $\frac{1}{8}$ " deep in the inboard ends of the 9"-long pieces, where shown. Position the notched pieces in the dados.

**2** From a  $\frac{1}{8} \times 2 \times 12$ " aluminum bar, cut four 2"-long pieces for the table clamp plates and a  $2\frac{1}{8}$ "-long piece for the table insert, where shown on **Drawings 2** and **2a**. Drill a  $\frac{5}{16}$ " hole through each clamp plate where dimensioned. Set the plates aside. Place the insert in the table. (You'll cut the slot in the insert later.)

**3** Position a  $\frac{1}{8} \times \frac{1}{2} \times 36$ " aluminum bar in the rabbet along one edge of the slot on the top of the table (A), flush against the table insert, as shown in **Photo A**. Mark the bar for the exact lengths of the pieces, where shown on **Drawing 2**, so they'll fit flush with the

### 1 TABLE

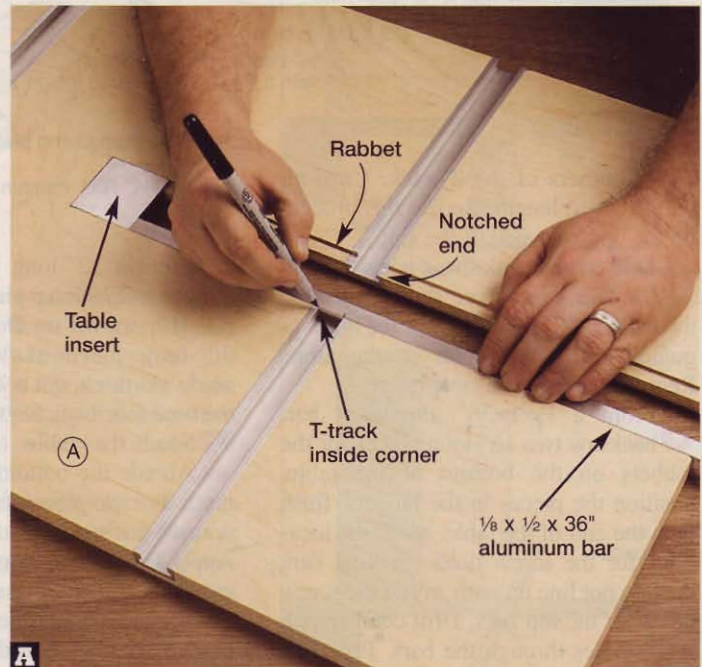
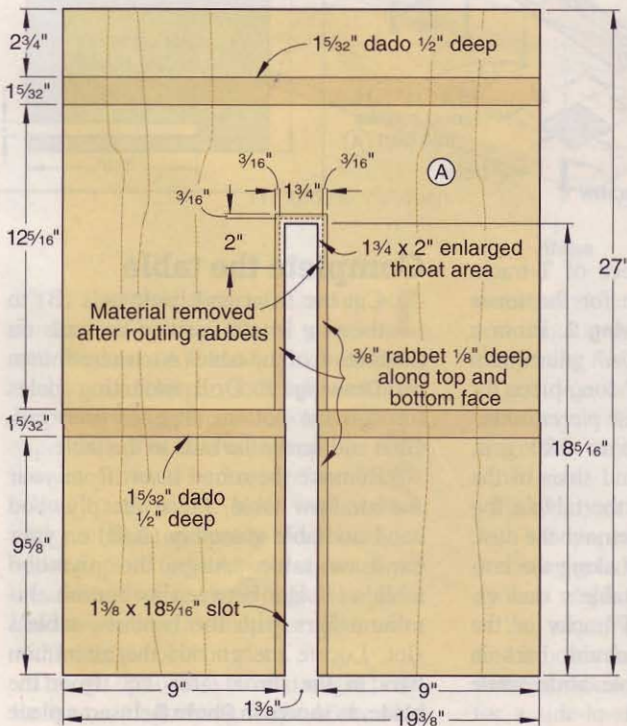

Using a fine-tip permanent marker, mark the bar exactly at the inside corners of the T-track and at the table's end and crosscut to length.



**2** TABLE EXPLODED VIEW

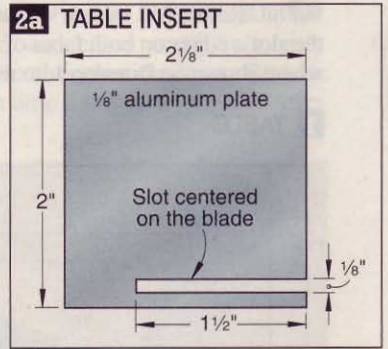
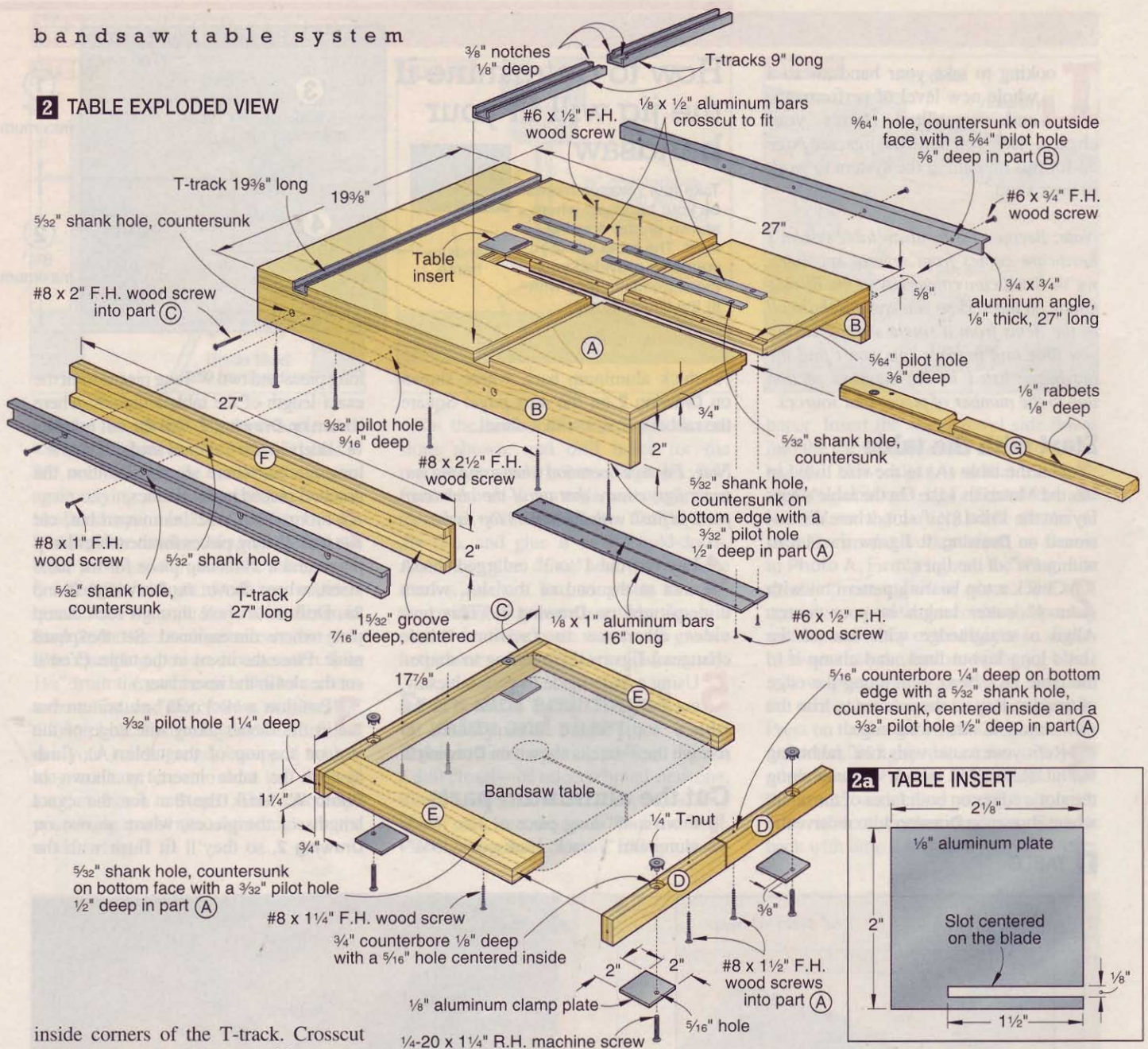

inside corners of the T-track. Crosscut the pieces to length. Repeat this process on the opposite side of the slot.

**4** Drill countersunk shank holes through the four bars where shown. Position the bars in the rabbets. Using the holes as guides, drill pilot holes in the table. Remove the bars and table insert.

**5** From a 1/8x1x36" aluminum bar, hacksaw two 16"-long pieces for the rabbets on the bottom of the table. Position the pieces in the rabbets, flush with the end of the table. Mark the locations for the screw holes, making sure they do not line up with any of the screw holes for the top bars. Drill countersunk shank holes through the bars. Place the bars in position, and drill the pilot holes. Remove the bars.

**6** From a 32"-long piece of T-track, cut a 27"-long piece for the fence rail (F), shown on **Drawing 2**. From a 36"-long piece of 3/4x3/4" aluminum angle 1/8" thick, cut a 27"-long piece for the back fence rail. Set these pieces aside.

**7** Sand the table (A) to 180 grit. Abrade the bottom and sides of the three T-track pieces for the table's top with 40-grit sandpaper. Remove the dust. Apply five-minute epoxy along the bottom and sides of the table's dadoes. Install and clamp the T-tracks in the dadoes. Screw the aluminum bars in their rabbets. Set the table aside while the epoxy cures.

**Complete the table**

**1** Cut the front and back rails (B) to the size listed. Position the rails on the bottom of the table (A), where shown on **Drawing 2**. Drill mounting holes through the bottom edge of each rail. Glue and screw the rails to the table.

**2** Remove the round insert from your bandsaw table. Place the plywood bandsaw table assembly (A/B) on your bandsaw table. Align the plywood table's 1/8" slot between its bottom aluminum bars with the bandsaw table's slot. Locate the end of the aluminum bars in the throat area 3/16" from the blade, as shown in **Photo B**. Insert a piece



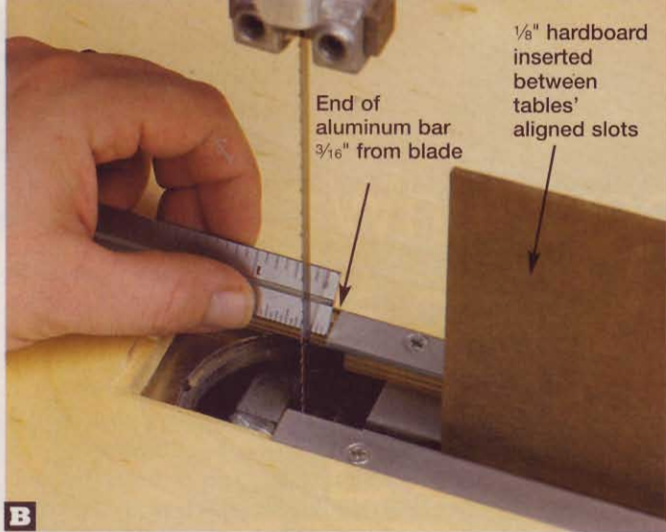

**B**

With the plywood table correctly positioned on the bandsaw table, insert a 1/8" hardboard scrap between the tables' aligned slots.



**C**

Find the width for the fillers (E) by measuring the space between the front and back rails (B) and the bandsaw table.

of 1/8" hardboard between the tables' slots, as shown, to keep them aligned. On the plywood table's bottom, scribe along the bandsaw table's sides.

**3** Measure the thickness of your bandsaw table. (Ours measured 1 1/4".) Cut the side rail (C) and split side rails (D) to the lengths listed and width equal to your measured table thickness. Position the side rail (C) under the plywood table, tight against the side of the bandsaw table, where shown on **Drawing 2**. Make a mark across the bottom edge of the rail 1" in from the front and back edges of the bandsaw table. These marks locate the centerlines for the clamp-plate screw holes. Repeat the process to mark the split side rails (D), holding them tight against the front and back rails (B). Remove the plywood table.

**4** At the marked centerlines on the rails (C, D), drill a 3/4" counterbore 1/8" deep with a 5/16" hole centered inside, where shown. Install a 1/4" T-nut in each counterbore.

**5** With the plywood table bottom side up, place the side rail (C) and split side rails (D) in position, aligning their inside edges with the scribe marks. Drill counterbored mounting holes through the rails, where shown. Drive the screws. Use a screw length appropriate for the width of your rails. Note that if the rails directly align with the T-tracks in the table's top, you'll need to attach them from the top by drilling countersunk shank holes through the T-tracks.

**6** Drill pilot and countersunk shank holes through the front and back rails (B) into the side rails (C, D), where shown on **Drawing 2**. Drive the screws.

**7** Reinstall and align the plywood table on the bandsaw table. Measure

between the side rail (C) and split side rails (D) for the length of the fillers (E). Measure for their widths as shown in **Photo C**. (The widths may be different.) Cut the pieces to size. Place each filler in position. Drill mounting holes through the fillers where shown. Drive the screws.

**8** Cut the fence rail (F) to size. Cut a 1 5/32" groove 1/16" deep centered along the front face of the rail, where shown, to receive the 27"-long piece of T-track. Drill countersunk shank holes through the T-track where shown. Place the T-track in the rail's groove. (The T-track sits 1/16" proud of the rail's face.) Position the rail/track assembly against the front rail (B) with the bottom edges flush. Using the holes in the T-track as guides, drill mounting holes through the fence rail and into the front rail. Glue and screw the assembly to the front rail.

**9** Retrieve the aluminum-angle back fence rail. Drill countersunk shank

holes, where shown. Position it on the back rail (B) 5/8" below the top of the plywood table, where dimensioned on **Drawing 2**. Drill pilot holes in the back rail. Screw it in place.

**10** Apply two coats of satin polyurethane to the completed plywood table. When the finish dries, fit the table on the bandsaw. Screw the aluminum clamp plates to the side rails (C, D) with 1/4-20 roundhead machine screws. You may need to use a different length screw than shown to suit your rails' width.

### Add the slider

**1** To enable your system to cut circles, you need to make the slider (G). Cut the part to size. Chuck a rabbeting bit in your table-mounted router. Cut a 1/8" rabbet 1/8" deep along the top edges of the slider, where shown on **Drawing 3**.

**2** Insert the slider in the plywood table's slot, flush with its right end.

### 3 SLIDER

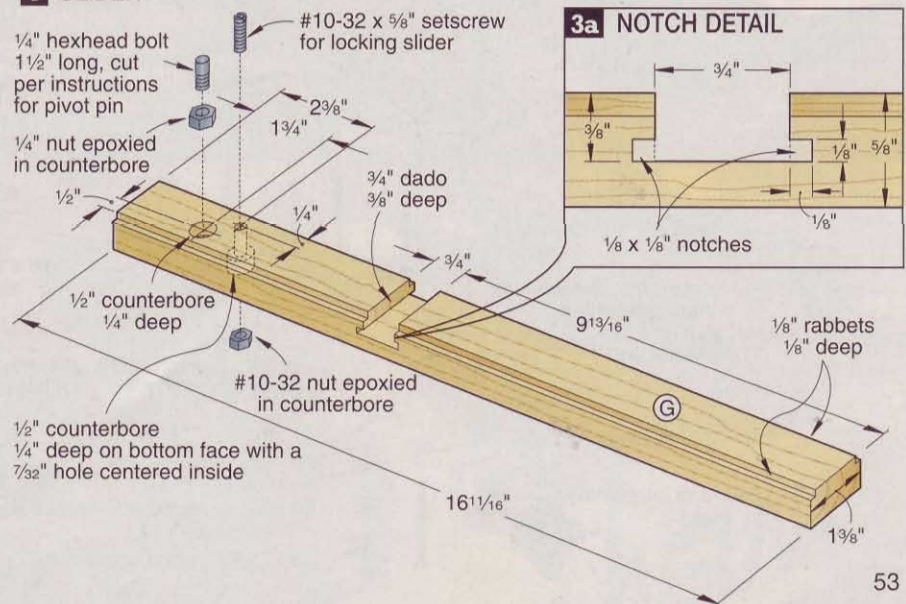



## bandsaw table system

Scribe along the inboard ends of the  $\frac{1}{8} \times \frac{1}{2}$ " aluminum bars to mark the location for the slider's dado. Remove the slider. Cut the  $\frac{3}{4}$ " dado  $\frac{3}{8}$ " deep. Bandsaw, with the slider resting on its edge, the notches in the sides of the dado at the bottom, where dimensioned on **Drawing 3a**.

**3** Mark the centerpoints for the  $\frac{1}{2}$ " counterbores on the top and bottom of the slider, where dimensioned on **Drawing 3**. Note that the center of the top counterbore and the front of the bandsaw blade must be the same distance from the plywood table's front edge for proper circle-cutting operation. (You may need

to adjust the counterbore's location from the dimension shown to suit your saw.) Using a  $\frac{1}{2}$ " Forstner bit, drill the counterbores  $\frac{1}{4}$ " deep at the centerpoints. Then, drill a  $\frac{7}{32}$ " hole centered inside the bottom counterbore.

**4** Epoxy a  $\frac{1}{4}$ " nut in the top counterbore and a #10-32 nut in the bottom counterbore. When the epoxy cures, sand the slider. Apply two coats of finish.

**5** Thread a #10-32 $\times\frac{5}{8}$ " setscrew (for locking the slider) into the #10-32 nut. To make a pivot pin, mark a  $\frac{1}{2}$ " length on a  $\frac{1}{4}$ " hexhead bolt  $1\frac{1}{2}$ " long that includes  $\frac{1}{4}$ " of thread and  $\frac{1}{4}$ " of smooth shank. Cut the length from the bolt, and file its ends and edges smooth. Thread it into the  $\frac{1}{4}$ " nut. Now, insert the slider in the table.

**PATTERNS**® insert. Mark the angled end on the stiffener, where dimensioned, and cut it to shape. Sand the parts smooth. Do not drill the holes in them yet.

**2** Position the stiffener against the fence, where shown on **Drawing 4**. Drill mounting holes where shown. Glue and screw the parts together.

**3** Cut the fence plate (J) to size. Lay out and cut the plate's angled sides, where dimensioned on **Drawing 5**.

**4** Position the fence/stiffener assembly (H/I) on the fence plate (J), where shown on **Drawing 4**. Square the fence to the plate's back edge. Clamp the assembly together. Drill two mounting holes through the bottom of the plate into the fence where shown. Drive the screws.

**5** Cut the clamp plate (K) to size. Drill a  $\frac{5}{16}$ " hole, centered side-to-side and top-to-bottom, through the part. Set the fence assembly (H/I/J) on the plywood table with the back edge of the fence plate (J) flush against the table's front edge. Position the clamp plate under the fence

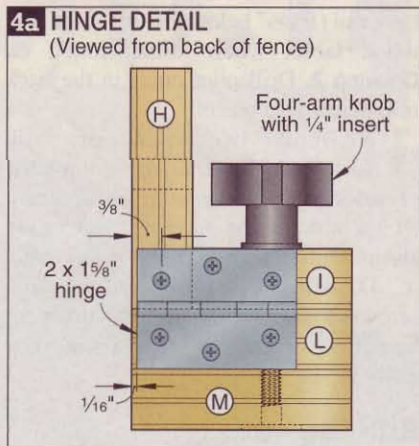

### Time for the fences

**1** Cut the fence (H) and stiffener (I) to size. Bandsaw and sand the  $\frac{1}{2}$ " radii on the fence, where shown on **Drawing 4**, and the stiffener, where shown on **Drawing 5** on the **WOOD**

### 4 FENCE ASSEMBLY

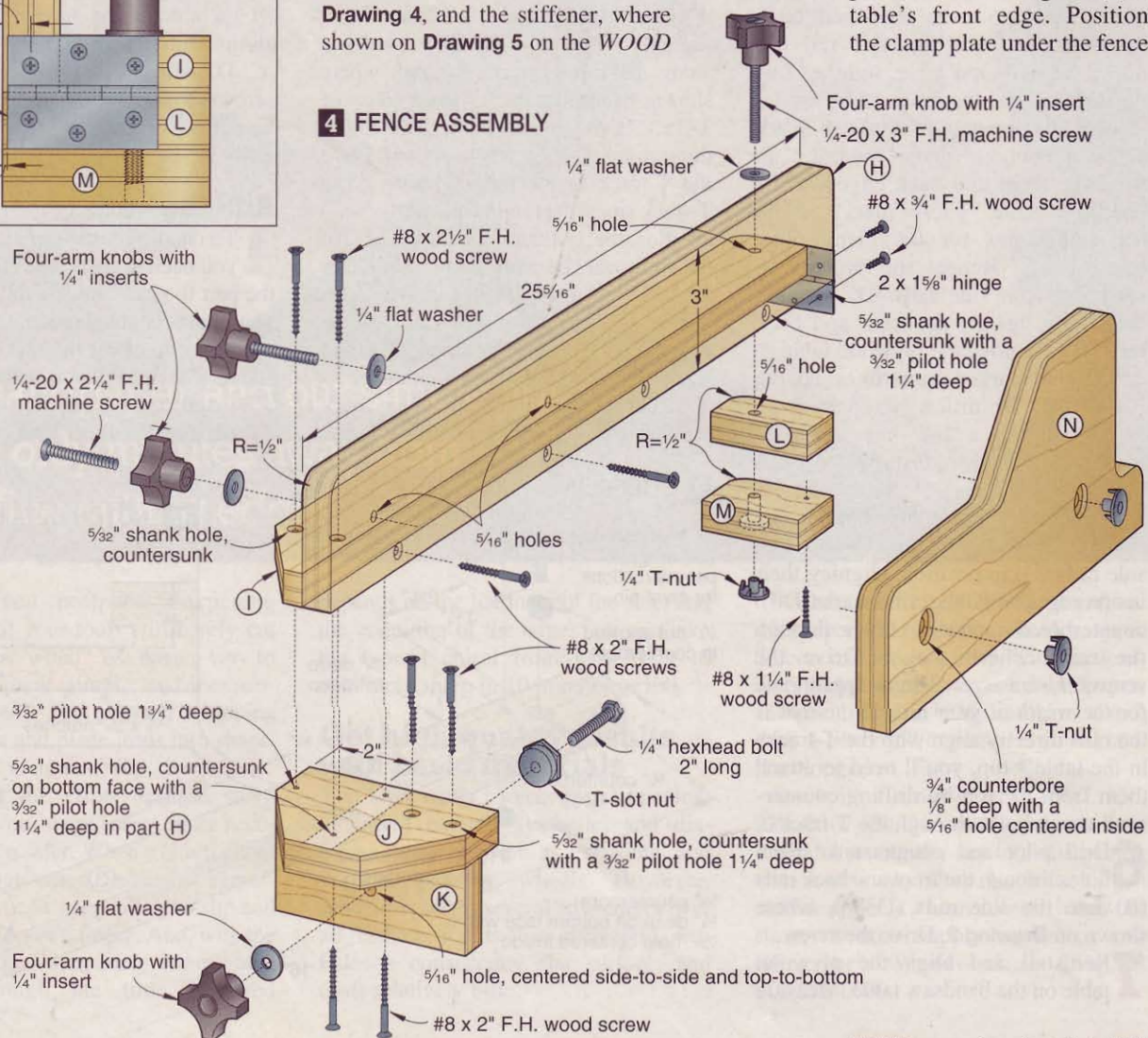



## SHOP TIP

### This stud's for you

Finding knobs with custom-length threaded studs can be a challenge. Here's an easy way to make your own. Thread a 1/4-20 flathead machine screw of sufficient length (cut it if needed) completely into the knob. Mark the threads immediately below the knob with a permanent marker. Back out the screw until you see the mark. Apply five-minute epoxy to the threads above the mark. Tighten the epoxied screw in the knob, and wipe off any squeeze-out.



plate, flush against the T-track in the fence rail (F). Clamp the plates together. Drill mounting holes through the top of the stiffener (I) and fence plate where shown. Glue and screw the plates together. Insert a 1/4" hexhead bolt 2" long with a T-slot nut through the hole in the clamp plate from the rear. Secure with a 1/4" flat washer and four-arm knob having a 1/4" insert as shown.

**6** Cut the rear top and bottom clamps (L, M) to size. Place clamp L on top of clamp M, aligning their back edges. Drill a pilot and countersunk shank hole through the bottom clamp, where shown on **Drawing 5**. Glue and screw the parts together. When the glue dries, mark the 1/2" radius on the assembly. Bandsaw and sand the radius to shape.

**7** Position the clamp assembly (L/M) at the rear of the fence assembly, where shown on **Drawing 4**, aligning their back edges and 1/2" radii. Clamp the parts together. Screw a 2x1 3/8" hinge to the back of the fence and clamp assembly, where shown on **Drawing 4a**. Drill a 3/4" counterbore 1/8" deep in the bottom clamp (M), where dimensioned on **Drawing 5**. Now, drill a 5/16" hole centered inside through the clamp assembly and stiffener (I), where shown on **Drawings 4** and **5**. Install a 1/4" T-nut in the counterbore.

**8** Make a four-arm knob with a 1/4-20x3" threaded stud for the rear clamp assembly. See the **Shop Tip**, above right. Install the knob with a 1/4" flat washer in the 5/16" hole in the stiffener (I), where shown.

**9** Cut the resaw fence (N) to size. Lay out its contour, where dimensioned on **Drawing 5**. Bandsaw the fence to shape, and sand it smooth. Drill the needed holes, where dimensioned. Position the resaw fence against the right side of fence H, with their front ends and bottom edges aligned. With a backer board placed against the left side of the fence to prevent tear-out, and using the centered holes in the counterbores as guides, drill 5/16" holes through the fence. Apply two coats of finish to the fences.

**10** Install 1/4" T-nuts in the resaw fence's counterbores. Epoxy two 1/4-20x2 1/4" flathead machine screws in two four-arm knobs. Secure the resaw fence to the fence with the knobs and 1/4" flat washers.

**11** Finally, place the aluminum table insert in the table opening against

## Cutting Diagram

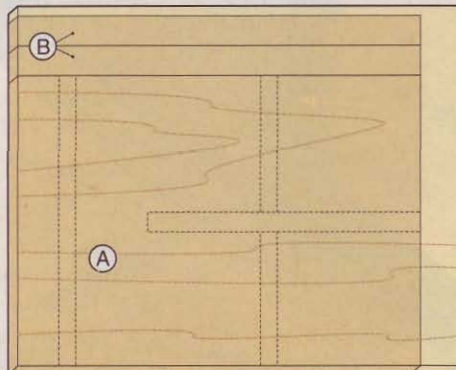

3/4 x 24 x 30" Baltic birch plywood

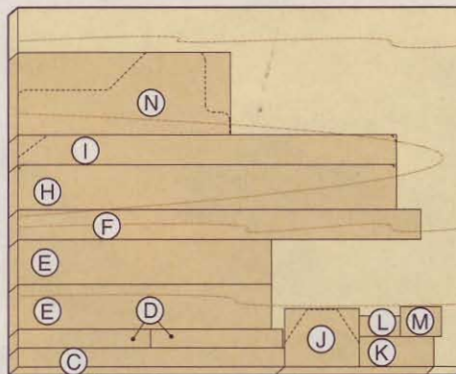

3/4 x 24 x 30" Baltic birch plywood



3/4 x 1 1/2 x 24" Maple

\*Plane or resaw to the thickness listed in the Materials List.

the blade's cutting edge. Referring to **Drawing 2a**, mark a 1/8" slot 1 1/2" long, centered on the blade, on the plate. Hacksaw or scrollsaw the slot, and install the plate. Now, it's time to put this awesome system to work. ♣

Written by **Owen Duvall**  
Project design: **Jeff Mertz**  
Illustrations: **Roxanne LeMoine**

## Materials List

Bandsaw table	FINISHED SIZE			Matl.	Qty.
	T	W	L		
A table	3/4"	19 3/8"	27"	BB	1
B front and back rails	3/4"	2"	27"	BB	2
C side rail	3/4"	†	17 7/8"	BB	1
D split side rails	3/4"	†	8 7/8"	BB	2
E fillers	3/4"	†	†	BB	2
F fence rail	3/4"	2"	27"	BB	1
G slider	5/8"	1 3/8"	16 1/16"	M	1
Fence assembly					
H fence	3/4"	3"	25 5/16"	BB	1
I stiffener	3/4"	2"	25 5/16"	BB	1
J fence plate	3/4"	3 13/16"	5"	BB	1
K clamp plate	3/4"	2"	5"	BB	1
L rear top clamp	3/4"	1 3/8"	2 3/4"	BB	1
M rear bottom clamp	3/4"	2"	2 3/4"	BB	1
N resaw fence	3/4"	5 1/2"	14 1/4"	BB	1

†Dimensions determined by your bandsaw measurements. See the instructions.

**Materials key:** BB—Baltic birch plywood, M—maple.

**Supplies:** Five-minute epoxy.

**Blades and bits:** Dado-blade set, top bearing pattern bit with a 1"-long cutter, 1/2" Forstner bit, 1/8" and 3/8" rabbeting bits.

## Buying Guide

**Hardware kit for ultimate bandsaw table.** Contains all hardware (screws included) required for one table. Order kit no. UBT, \$39.95 ppd., from Schlabaugh and Sons Woodworking. Call 800/346-9663, or go to [www.schsons.com](http://www.schsons.com) to order.

**Lumber kit for ultimate bandsaw table.** Enough Baltic birch plywood for one table. Order kit no. LP-UBT, \$39.95 ppd. See above for Web address and telephone number.

**Master hardware kit for ultimate bandsaw table and accessories.** Contains all hardware (screws included) required for one table and all accessories. Order kit no. MAS-BAN, \$74.95 ppd. Address and telephone above.

**Master lumber kit for ultimate bandsaw table and accessories.** Enough Baltic birch plywood for one table and all accessories except the duplicating jig. Order kit no. LP-MAS-BAN, \$49.95 ppd. Address and telephone above.



# put your **bandsaw system** to work



Feather board/  
single-point  
resaw fence

Feather board end

Bolt-on  
resaw  
fence

Fence

## **Slice** veneers accurately and easily

The bandsaw table and fence system on page 50 makes your bandsaw super versatile. But you'll unlock its full potential if you build the accessories found on page 64. Here's a guide to getting the most from them.

To resaw a thin slice ( $\frac{1}{8}$ " or less) from any board, you need rock-solid support on both sides of your stock to hold it in position vertically. This system's bolt-on resaw fence and feather board deliver, especially when you're working with stock more than about 5" wide, such as you'd use when creating your own veneer.

First, position the fence and lock it down with the front and rear knobs. Slide the feather board end of the feather board/single-point resaw fence into the T-slot to support the outside face of the stock. Now lock in the feather board so the workpiece contacts the laminate just in front of the blade, and flexes the laminate to provide support without binding. Make sure to crank up the blade tension to keep the blade taut, and push the workpiece slowly as you cut.



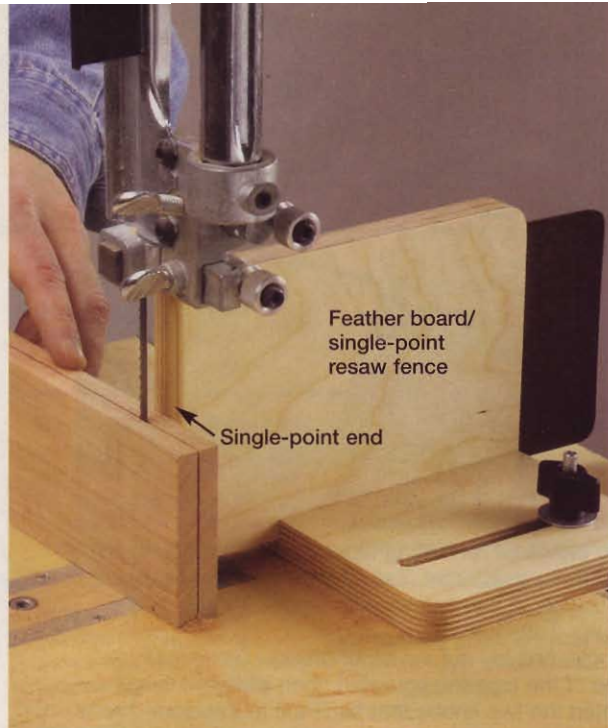

## Resaw confidently

When resawing thicker slabs ( $\frac{1}{4}$ " or greater), or when working with narrow stock, vertical support isn't as important as keeping the workpiece running true. Bandsaw blades sometimes twist slightly as you push the workpiece, meaning you'll have to angle the workpiece slightly to compensate for this "drift." You can do this by guiding your stock against the bullnose end of the feather board/single-point resaw fence.

Align the bullnose end with the blade's teeth, leaving a gap equal to the thickness of the piece you wish to cut. Tighten the knobs to lock the fence in the T-slot. Mark a layout line on the top edge of your workpiece, and push the piece through the cut while pressing one face against the bullnose. Note that the standard fence does not get used in this resawing technique. (To learn more about resawing successfully, see issue 147.)

## Rip stock cleanly with this standard fence

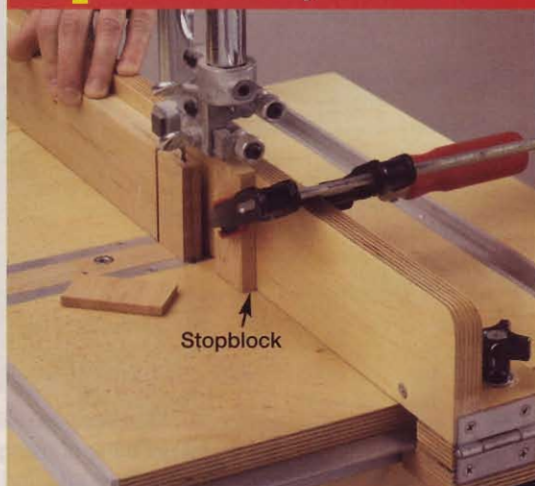

The standard fence provides sturdy support for ripping boards to width, or other precise operations, such as cutting tenons. Just loosen the front and rear locking knobs, slide the fence into place, then tighten the front knob. This locks the fence and automatically aligns it with the blade. Then lock the rear knob for sure-footed cuts.

## Duplicate patterns easily



Need to cut multiple curved pieces to the exact same size and shape? This duplicating jig is just the ticket, with its hardboard guide that's notched to fit snugly around the blade. Attach a hardboard pattern, cut in the exact shape you require, to your workpiece using double-faced tape. Then just feed the workpiece into the blade with the pattern riding against the duplicating jig. Adjust the position of the jig to control how close the blade cuts to the pattern. You can then sand right up to the line using a drum sander, or rout to the pattern using a flush-trimming bit.

## Cut circles using this handy accessory

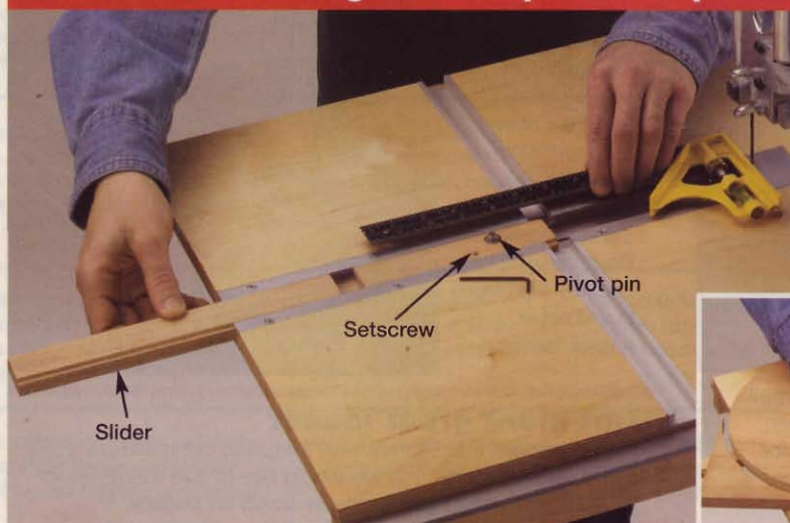

This system feature takes the hassle out of cutting circles from 6" to 32" in diameter, thanks to its adjustable slider and pivot pin.

To use the circle cutter, start by cutting a square workpiece about  $\frac{1}{16}$ " larger than the diameter of the circle you want to create. Carefully mark the exact center of the square, on the underside, by placing a straightedge from corner to corner in each direction. Then drill a  $\frac{1}{4}$ "-diameter hole  $\frac{1}{4}$ " deep.

Next, loosen the setscrew that locks the slider in place, pull the slider to position the pivot pin, and retighten the setscrew. Now lower your workpiece onto the pivot pin so one edge is against the blade, and turn on the saw. Rotate the workpiece to clip off the corners and create a perfect circle.





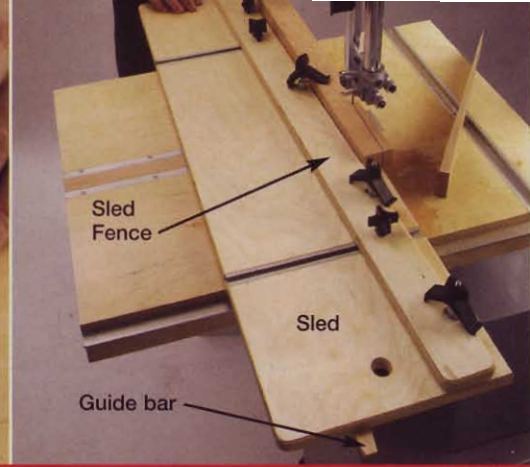
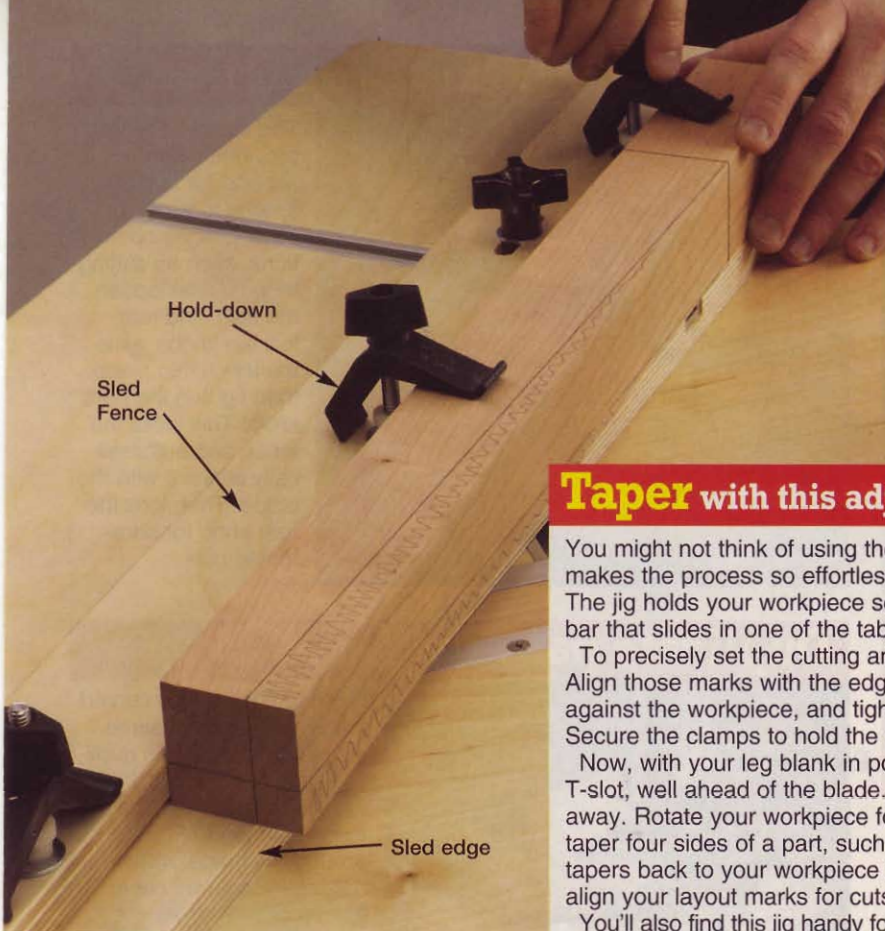

## Taper with this adjustable jig

You might not think of using the bandsaw for cutting tapers, but this tapering jig makes the process so effortless that you'll forget about tapering on the tablesaw. The jig holds your workpiece securely in place, and rides smoothly on a guide bar that slides in one of the table's T-track slots.

To precisely set the cutting angle, first lay out the taper on your workpiece. Align those marks with the edge of the tapering jig's sled, then slide the fence against the workpiece, and tighten the two knobs that secure it to the sled. Secure the clamps to hold the workpiece in place.

Now, with your leg blank in position, lower the jig's guide bar into the right-hand T-slot, well ahead of the blade. Then simply slide the jig forward to cut the waste away. Rotate your workpiece for the second taper, and cut again. If you need to taper four sides of a part, such as a table leg, tape the cutoffs from your first two tapers back to your workpiece as shims. Now readjust the fence as necessary to align your layout marks for cuts three and four, and make the cuts.

You'll also find this jig handy for putting a straight edge on rough-cut stock.

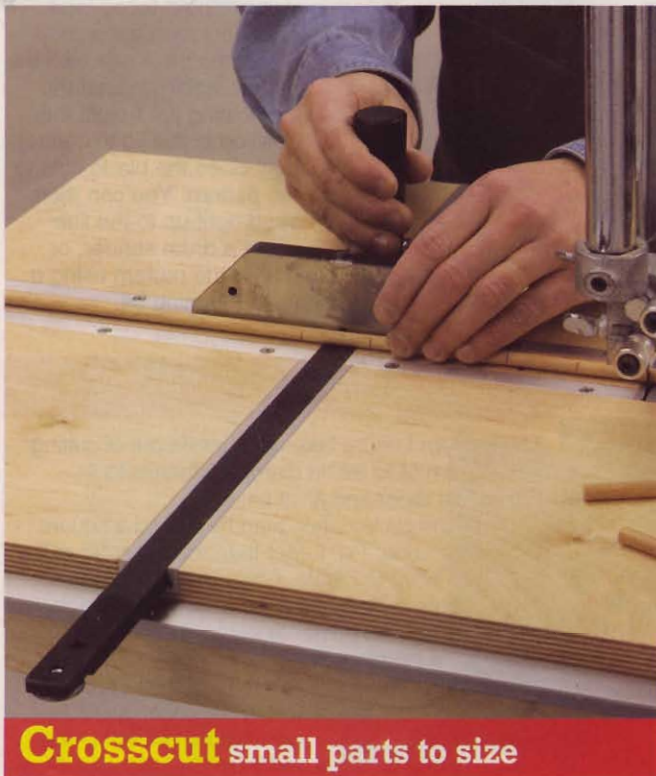

## Crosscut small parts to size

A bandsaw is the perfect tool for safely crosscutting small parts to size. The table system makes the process even easier by offering two slots—the aluminum T-tracks—for your miter gauge to slide in.

Written by **David Stone**

## Change blades in no time

It's plain to see that this bandsaw table system offers gobs of features you just can't get with a bare-bones stock saw. In addition to all of those great accessories, there's one important feature that's a little harder to see: You can change blades without removing the table! Just pop the blade insert out of the table and remove the slider. This exposes the slot in the stock bandsaw table, allowing you to easily slip blades in and out in normal fashion.

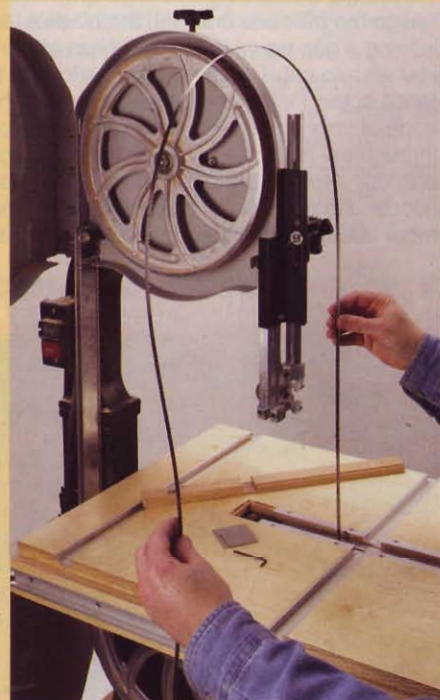

## Got more great ideas?

We've packed this system with features, but we know you'll come up with more, and we would like to see them! Send your submissions to the address listed on page 4. 🌲





# woodworker's guide to choosing sheet goods

**Do you know what sheet goods work best for shop fixtures? Or which ones excel in furniture construction? Armed with our chart, you'll be an instant expert.**

**M**ost woodworkers know the major virtues of plywood: strength, stiffness, size, and stability. You may not be nearly as familiar, though, with the wide array of other sheet goods available today. No matter the project, you'll find a type of sheet stock ideally suited for the task at hand.

## Enhanced performance through engineering

All sheet goods, including plywood, fall into a broad category called "engineered wood." Unlike solid lumber, which is simply cut from the tree and dried, engineered products are further altered during the manufacturing process to enhance or suppress certain properties.

Plywood, for example, consists of multiple thin layers glued together with the grain of one layer running at a right angle to the neighboring layer. This enhances strength, decreases dimensional changes, and allows desirable wood to be placed only on the visible outer faces.

While plywood remains prevalent, more and more sheet goods are produced from ground wood chips or wood pulverized into powder, mixed with adhesives and additives, then pressed into sheets. This, in turn, becomes such products as medium-density fiberboard (MDF) and particleboard. Even traditional plywood has changed, with the addition of new core materials, face coverings, and increasingly popular

"high density" varieties made up of ultra-thin plies.

You can familiarize yourself with the uses, properties, costs, and sources of 10 contrasting sheet goods using the handy chart on the following two pages.

*Note: We purposely excluded some materials, such as oriented strand board (OSB) and pressure-treated plywood, which are designed for building construction and have limited usefulness in the shop.*









## SHOP TIP

### Surefire steps to sheet goods success

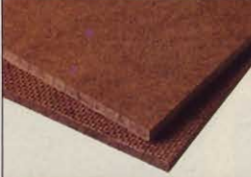
1. Always measure the thickness of sheet goods before machining mating pieces. Plywood, for example, is  $\frac{1}{32}$ " thinner than its stated thickness.
2. When cutting sheet goods on the tablesaw, place the good face up to prevent tear-out. Place the good face down if using a handheld circular saw.
3. If you work with particular sheet goods often, invest in saw blades designed for that material to get the smoothest cuts and least chip-out.
4. Rather than wrestle a sheet onto the tablesaw, lay 2" rigid foam insulation on the floor, place the sheet on it, and rough-cut using a circular saw.

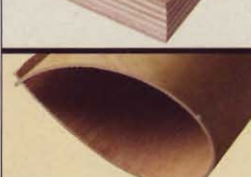
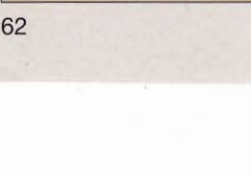

# Sheet Goods Selector: Match the Product to the

Material	Description	Uses	Available sizes
 <b>PARTICLEBOARD</b>	Wood shredded into tiny chips (essentially sawdust, often from waste wood), combined with adhesives, then heated and compressed to form sheets.	Widely used as a substrate for flooring and countertops, and for building inexpensive knockdown furniture and cabinetry. Also suitable for some shop fixtures.	Sold in 1/4", 1/2", 5/8", 3/4", 1", and 1 1/8" thicknesses. Half and quarter sheets are often available.
 <b>MELAMINE</b>	Particleboard faced with paper impregnated with melamine resin, a type of plastic. Paper on low-cost types is simply adhered. Higher-cost sheets are thermally fused (essentially melted together).	Great for making cabinet carcasses because it wipes clean easily. Use it, as well, for shop fixtures or to make an economical router-table top.	Sold in 49x97" oversize sheets in 1/4", 1/2", 5/8", and 3/4" thicknesses.
 <b>HARDBOARD</b>	Ground wood pulp combined with resins and pressed into sheets. May be smooth on one or both faces.	Excellent for shop fixtures and jigs (especially the variety with two smooth faces) and benchtops. Use perforated hardboard for hanging tools.	Available in two thicknesses: 1/8" and 1/4" in 4x8' sheets.
 <b>MEDIUM-DENSITY FIBERBOARD (MDF)</b>	Cellulose fibers combined with synthetic resin and formed under heat and pressure.	Excellent for shop jigs and fixtures, cabinets, painted projects, molding and millwork, furniture, and as a substrate under veneer and plastic laminate.	1/4", 3/8", 1/2", 5/8", 3/4", and 7/8" thicknesses in both 4x8' and 49x97" sheets.
 <b>SOFTWOOD PLYWOOD</b>	Face-glued layers of thin softwood veneer.	Outdoor projects (exterior rated), carpentry and construction, shop cabinets, substrates, underlayment for floors and countertops.	1/4", 5/16", 11/32", 1/2", 5/8", 23/32", and 3/4" thicknesses in 4x8' sheets.
 <b>MEDIUM-DENSITY &amp; HIGH-DENSITY OVERLAY PLYWOOD (MDO/HDO)</b>	Exterior-rated softwood plywood covered on both faces with resin-impregnated fiber (paper).	Used extensively for highway signs, great for outdoor projects, siding, painted projects, watercraft, cabinets, shop fixtures, and concrete forms.	1/4", 5/16", 3/8", 1/2", 5/8", and 3/4" thicknesses in 4x8' sheets.
 <b>HARDWOOD PLYWOOD</b>	Veneers (soft- or hardwood) glued in layers with alternating grain, and covered with hardwood veneer.	The traditional sheet good of choice for everything from furniture and cabinets to wall paneling and boxes.	1/4", 1/2", and 3/4" are most common. Occasionally, you'll find 1/8", 3/8", and 5/8" in some species.
 <b>BALTIC AND FINNISH BIRCH</b>	Made from ultra-thin (1/16"), void-free birch veneers. Finnish birch is like Baltic, but is made with exterior adhesive for outdoor use.	Use to create shop jigs and fixtures, cabinets, drawer sides, furniture, and as a substrate.	In millimeters: 4 (1/8"), 6.5 (1/4"), 9 (3/8"), 12 (1/2"), 15 (5/8"), and 18 (3/4") in 60x60" sheets.
 <b>APPLEPLY</b>	American version of Baltic birch with alder and birch core plies and quality veneer faces. Birch face is standard, other woods available.	Same uses as Baltic above, plus applications where a fine-hardwood face veneer is needed.	Available in 1/4", 3/8", 1/2", 3/4", 1", and 1 1/4" thicknesses, in 4x8' sheets.
 <b>BENDABLE PLYWOOD</b>	Plywood with a single face veneer and core plies with all grain running perpendicular to face to allow cross-grain bending.	Used mostly as a substrate for building cabinets, etc. with rounded corners. Sheets with clear face veneers are suitable for furniture.	1/8" and 3/8" are common, though thicker sheets are produced. Sold in 4x8' sheets.



# Project, as Well as Your Budget

Common grades	Pros	Cons	Where to find it	Price ( <sup>3</sup> / <sub>4</sub> "x4'x8' sheet unless noted)
PBU—for floor underlayment. M-S, M-1, M-2, M-3 industrial grades are best for making shelving and countertops.	PBU grade is readily available and inexpensive. Particleboard cuts easily and is fairly stable.	Low stiffness, heavy, holds fasteners poorly, not moisture resistant.	Home centers carry <sup>1</sup> / <sub>4</sub> – <sup>3</sup> / <sub>4</sub> " PBU grade. "M" grades (mostly M-2) are found at building-material and millwork suppliers.	\$12+ per sheet for PBU grade. "M" grade prices range about 20 percent higher.
There are no standard grades for melamine, but there are "vertical" and "horizontal" types. Higher-priced sheets generally feature thermally fused coatings and are made with thicker paper.	Inexpensive, readily available, easy-clean surface, available in a variety of colors and in wood-grain patterns. Also available with kraft paper or real-wood veneer on one face.	Not moisture resistant, heavy, edges chip easily when cutting unless you use blade designed for cutting laminates.	Home centers carry <sup>1</sup> / <sub>2</sub> " and <sup>3</sup> / <sub>4</sub> " sheets, shelves, and closet parts. Colors other than white and patterned papers are available by special order.	\$25+ for adhered-surface, vertical-grade white sheets common in home centers. Colors and wood-grain patterns cost slightly more. \$40+ for thermally fused sheets.
Service (2 green stripes) Standard (1 green stripe) Service-tempered (2 red stripes) Tempered (1 red stripe) S1S (smooth one side) S2S (smooth two sides)	Readily available, easy to cut, relatively stable, available with two smooth sides or one, takes paint well.	Standard and Service grades are susceptible to moisture, can't sand faces, flexible, edges easily damaged, holds fasteners poorly.	Home centers carry 4x8' sheets plus half and quarter sheets in standard and tempered grades. Look for the edge stripes.	\$10 ( <sup>1</sup> / <sub>4</sub> " 4'x8', tempered). Perforated sheets are also available at a similar price.
One main grade: Industrial. Lower grades, which aren't commonly available, carry "B" or "shop" grade. Also classified by density: Medium-density (MD) is standard; low-density (LD) is a lightweight version.	Flat, no face or core voids, consistent thickness, glues easily, has machinable edges.	Heavy [100 lbs. per sheet in MD grade; low-density version (LD) weighs approximately 60 lbs.], standard wood screws hold poorly.	Home centers carry medium-density (MD) <sup>3</sup> / <sub>4</sub> " sheets. Low-density (LD) is available through millwork suppliers and some hardwood retailers.	\$20+ for both MD and LD.
Veneer grades: A, B, C, D. Panel grades: include sheathing and "Sturd-I-Floor." Exposure: Exterior, Exposure 1, Exposure 2, Interior.	Cheaper than hardwood ply, readily available, face veneers can have a nice appearance in higher grades.	Built more for performance than appearance; thick plies reduce stiffness; interior plies may have voids, face veneers often patched.	All home centers and building-supply stores carry an array of softwood plywood for construction.	\$25+ for A–C sanded, varies by type and material.
Follows softwood plywood grading. Face and back plies (which are covered with paper) rate as B grade or better, inner plies are C grade.	Resistant to weather and water; flat, smooth, surface is easily paintable, machines easily, and is very durable.	Not widely available, heavy.	Some home centers, wood specialty stores, sign shops.	\$35+ for MDO, HDO costs slightly more.
Face: AA, A, B, C/D/E, Special. Back: 1, 2, 3, 4. Core: J, K, L, M. Panel types: Technical type, Type I, Type II (Type II most common for interior use.)	More stable and less expensive than solid wood, widely available, made in a variety of species, and with many choices for veneer matching on faces.	Thick sheets are heavy, exposed ply edges may mean you'll have to band with solid wood, thin face veneers ( <sup>1</sup> / <sub>32</sub> ") are easy to sand through and damage.	Home centers carry a few species, such as oak, birch, maple. Turn to building suppliers and hardwood retailers for other species.	\$35 to \$100+ Prices vary greatly due to species, face and back grades, ply count, and cut of veneer. A/2 or B/2 is reasonably priced and suitable for furniture.
No standardized grades, but manufactured with void-free plies and face veneers carrying a grade of B or better.	Stiff, stable, consistent thickness, no voids, nice-looking edge, holds screws.	Hard to find, costly, odd (60x60") size sheet, available only with birch face.	Woodworking-supply stores, hardwood retailers, mail-order catalogs (small sizes).	\$45+ for standard-size 60x60" sheets.
No standardized grades, but manufactured with void-free plies and face veneers carrying a grade of B or better.	Stiff, stable, void-free, nice-looking edge, holds screws, offers a variety of face veneers.	Difficult to find, costly, requires large order to get optional veneers.	You'll find distributor information at <a href="http://www.statesind.com">www.statesind.com</a> .	\$50+
Able to conform to tight radii without splitting or cracking with no need for kerf-bending or steaming.	Flexibility allows radiused corners, decorative shapes.	Not designed for structural use, quality of face veneer varies greatly.	Building-supply stores and hardwood retailers.	\$35+ ( <sup>1</sup> / <sub>8</sub> " 4'x8' sheet)



# 3 accessories

## for the bandsaw table system

Add even more versatility with these hardworking jigs.



Tapering Jig

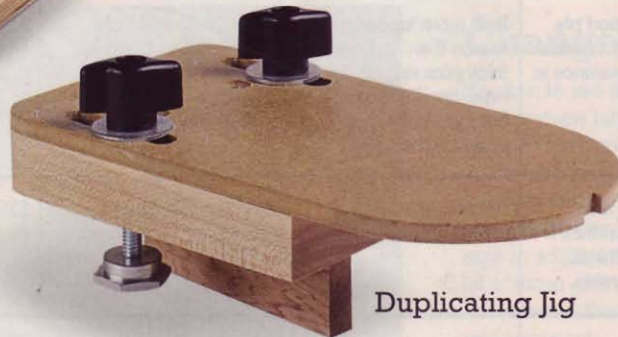

Duplicating Jig



Feather Board/  
Single-Point Fence

**Note:** To build the bandsaw table, see page 50; for instructions on using the accessories with the table, see page 56.

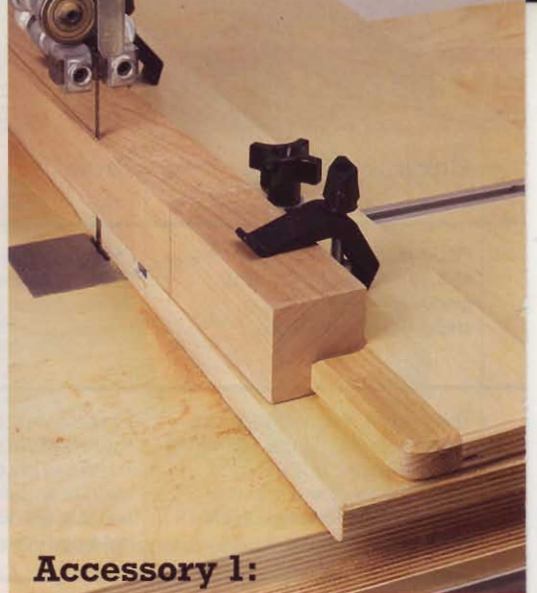

### Accessory 1: TAPERING JIG

#### Start with the sled

Cut the sled (A) to size from Baltic birch plywood. Drill a  $\frac{3}{4}$ " hanging hole, where shown on **Drawing 1**. Bandsaw and sand  $\frac{1}{2}$ " radii on two corners, and rout  $\frac{1}{8}$ " chamfers along one side and both ends of both the sled's faces and around the hanging hole, where shown. Cut dadoes, where dimensioned, to accept the T-tracks.

Measure the distance from the side of your bandsaw's blade to the edge of the miter-gauge slot in which the jig's miter guide bar will run. Cut a  $\frac{3}{4}$ " groove  $\frac{1}{16}$ " deep at this location in the sled's bottom face. Resaw and plane the guide bar (B) to size, and shape its end, as shown on **Drawing 1a**. Clamp the guide bar in the groove. Drill pilot and countersunk shank holes through the guide bar and into the sled. Drive in the screws.

**Note:** Do not glue the guide bar in place. By removing the guide bar, you also can use the taper jig on your tablesaw, using the saw's fence to guide the jig.

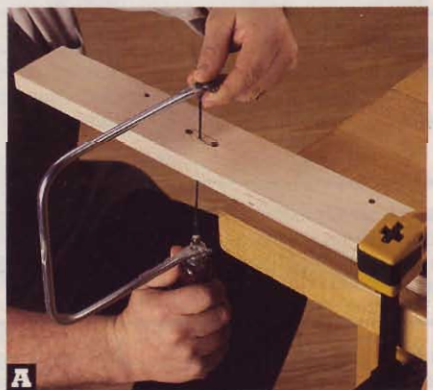

Draw lines tangent to the two  $\frac{5}{16}$ " holes, and saw out the slot with a coping saw.



## 1 TAPERING JIG

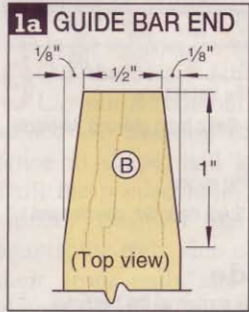
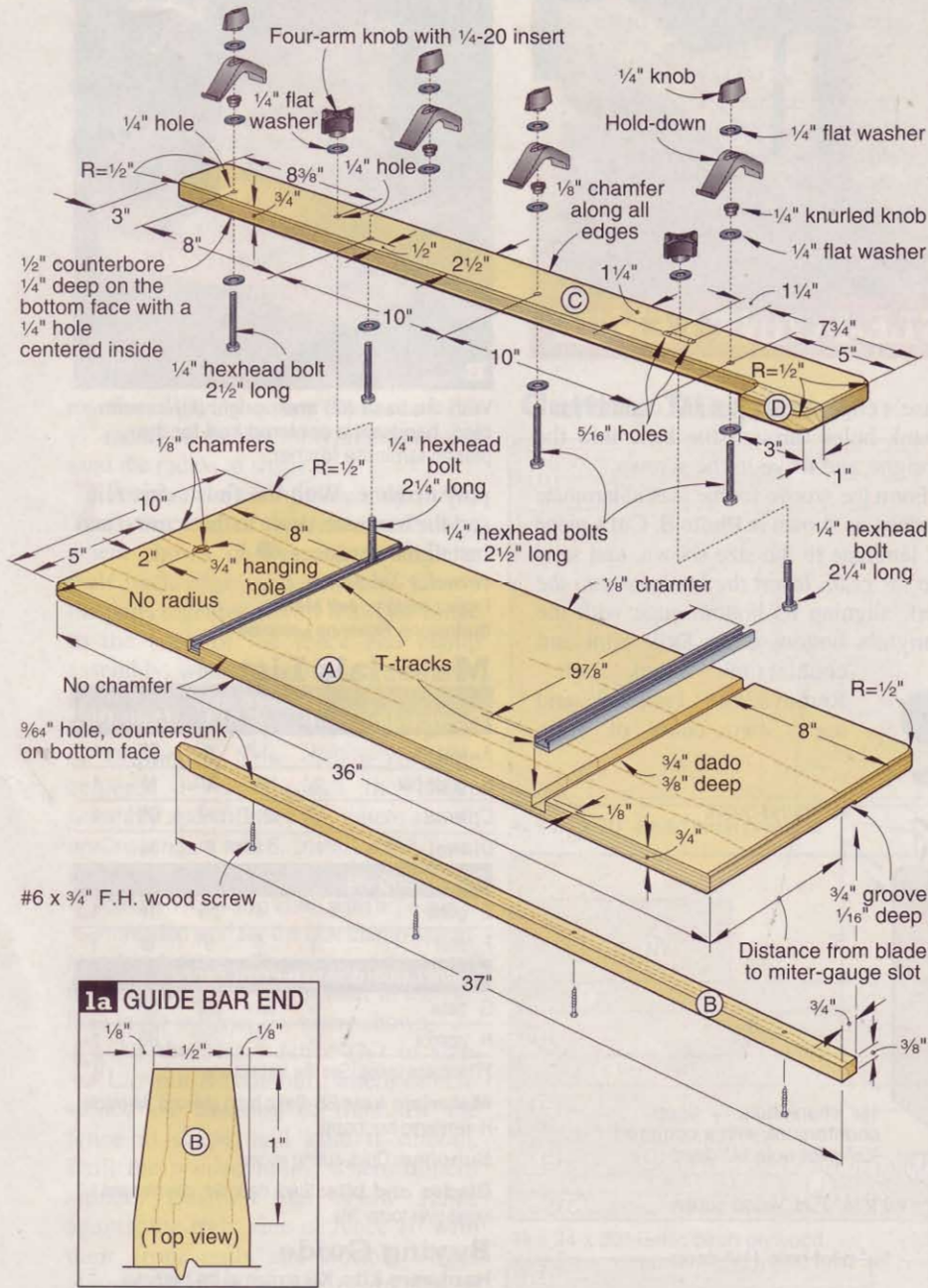

Cut two pieces of aluminum T-track to the length shown. Mix quick-setting epoxy, and epoxy and clamp the tracks into the dados. To prevent the possibility of the blade coming in contact with the tracks, position the tracks flush with the sled's chamfered edge.

### Add the fence

Cut the fence (C) to size. Mark the centers of the four counterbored holes for the hold-down clamps on the *bottom* of

the fence. Drill the counterbores and holes. Mark and drill a 1/4" hole for the first clamp knob. Drill two 5/16" holes for the second clamp knob's slot. Form the slot, as shown in **Photo A**. Cut the stop (D) to size, and glue and clamp it to the fence. Bandsaw and sand 1/2" radii, where shown, and then rout 1/8" chamfers along all the top and bottom ends and edges.

Sand the sled and fence to 220 grit. Apply two coats of satin polyurethane to the parts. Install the hardware.

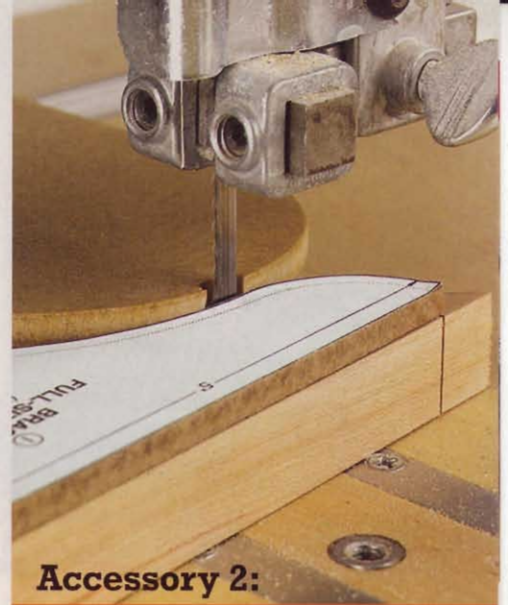

## Accessory 2:

## DUPLICATING JIG

Cut the guide (E) to size. Bandsaw and sand the 2" radius, where shown on **Drawing 2**, then file the blade notch. Cut the riser (F) from stock that is 1/16" thicker than the parts you will be sawing with the duplicating jig.

*Note:* You may want to make several duplicating jigs to accommodate common stock thicknesses.

Glue and clamp the guide to the riser, keeping their ends and edges flush. Drill pilot and countersunk shank holes, and drive in the screws. Drill 3/8" holes to form the ends of the slots. Saw them out in the same manner shown in **Photo A**. Bandsaw and sand the 1/2" radii. Apply polyurethane. Install the hardware.

## 2 DUPLICATING JIG

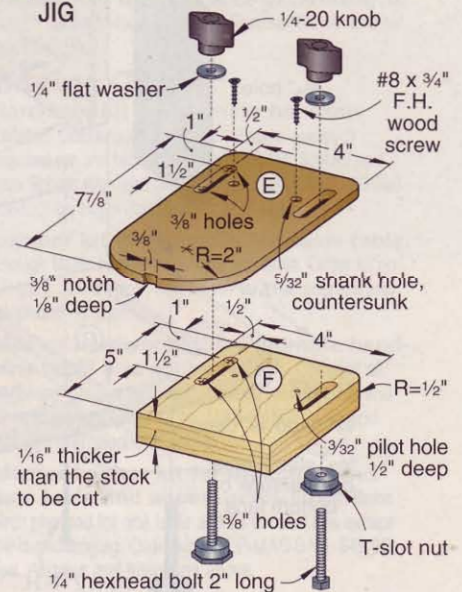



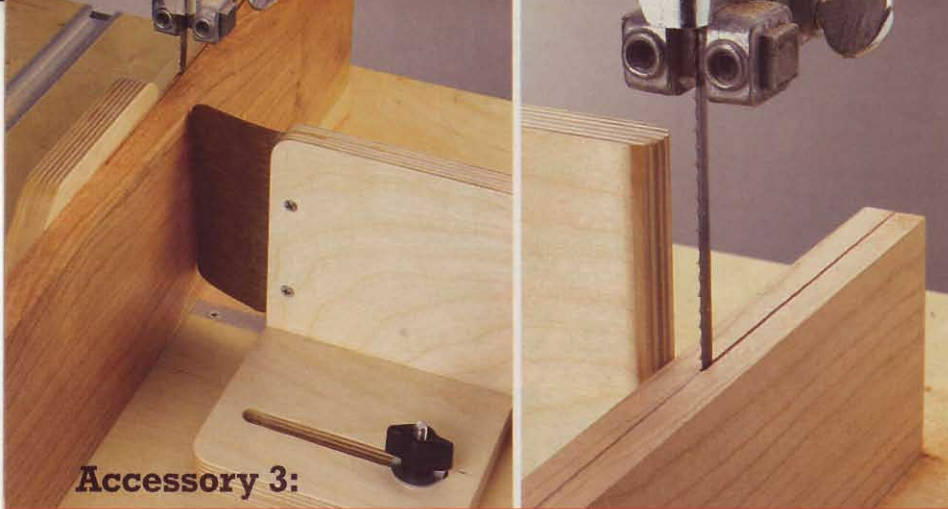

### Accessory 3:

## FEATHER BOARD/SINGLE-POINT FENCE

Cut the base (G) to size, and plow the centered dado, where shown on **Drawing 3**. Drill  $\frac{3}{8}$ " holes to form the ends of the slots, and saw out the waste. Bandsaw and sand  $\frac{1}{2}$ " radii on all four corners. Cut the upright (H) to size. Rout a pair of  $\frac{3}{8}$ " round-overs on one end, forming a full round. Bandsaw and sand the  $\frac{1}{2}$ " radius, where shown, then finish-sand the parts. Glue and clamp the upright into the base's dado with the feather board end flush with the

base's edge. Drill pilot and countersunk shank holes through the base into the upright, and drive in the screws.

Form the groove for the plastic-laminate feather, as shown in **Photo B**. Cut a piece of laminate to the size shown, and sand the  $\frac{1}{2}$ " radii. Insert the laminate into the kerf, aligning its bottom edge with the upright's bottom edge. Drill pilot and countersunk shank holes. Remove the laminate and apply two coats of satin

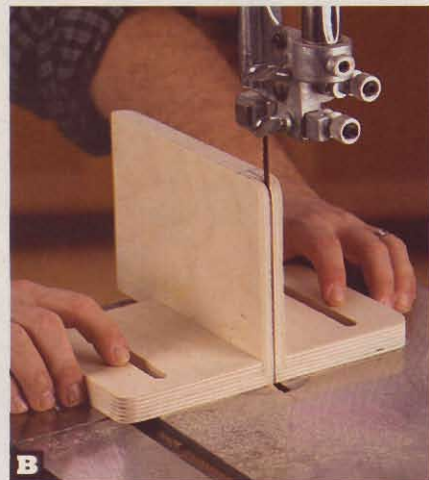

polyurethane. With the finish dry, reinsert the laminate, drive in the screws, and install the hardware. 🌲

Written by **Jan Svec**  
Project designs: **Jeff Mertz**  
Illustrations: **Roxanne LeMoine**

### Materials List

Tapering Jig	FINISHED SIZE			Matl.	Qty.
	T	W	L		
A sled	$\frac{3}{4}$ "	10"	36"	BB	1
B guide bar	$\frac{3}{8}$ "	$\frac{3}{4}$ "	37"	M	1
C fence	$\frac{3}{4}$ "	2 $\frac{1}{2}$ "	36"	BB	1
D stop	$\frac{3}{4}$ "	1"	3"	M	1
Duplicating Jig					
E guide	$\frac{1}{4}$ "	4"	7 $\frac{7}{8}$ "	H	1
F riser	†	4"	5"	M	1
Feather Board/Single-Point Fence					
G base	$\frac{3}{4}$ "	5 $\frac{1}{4}$ "	8 $\frac{3}{4}$ "	BB	1
H upright	$\frac{3}{4}$ "	5"	7 $\frac{1}{2}$ "	BB	1

†Thickness varies. See the instructions.

**Materials key:** BB—Baltic birch plywood, M—maple, H—tempered hardboard.

**Supplies:** Quick-setting epoxy.

**Blades and bits:** Stack dado set, chamfer and  $\frac{3}{8}$ " round-over router bits.

### Buying Guide

**Hardware kits.** Kits contain all the hardware shown on **Drawings 1, 2, and 3**, including the plastic laminate for the feather board. Tapering jig hardware kit no. BTJ, \$18.95 ppd.; duplicating jig hardware kit no. DUP, \$13.95 ppd.; feather board/single-point fence hardware kit no. FB-SPF, \$15.95 ppd. Schlabaugh & Sons Woodworking, 720 14th Street, Kalona, IA 52247. Call 800/346-9663.

**Hardware plus lumber kits.** Kits contain all the hardware shown on **Drawings 1 and 3**, including the plastic laminate for the feather board, plus enough Baltic birch plywood and maple lumber to build the tapering jig and the feather board/single-point fence. Tapering jig hardware plus lumber kit no. LP-BTJ, \$24.95 ppd.; feather board/single-point fence hardware plus lumber kit no. LP-FB-SPF, \$16.95 ppd. See the address and telephone number listed above.

### 3 FEATHER BOARD/SINGLE-POINT FENCE

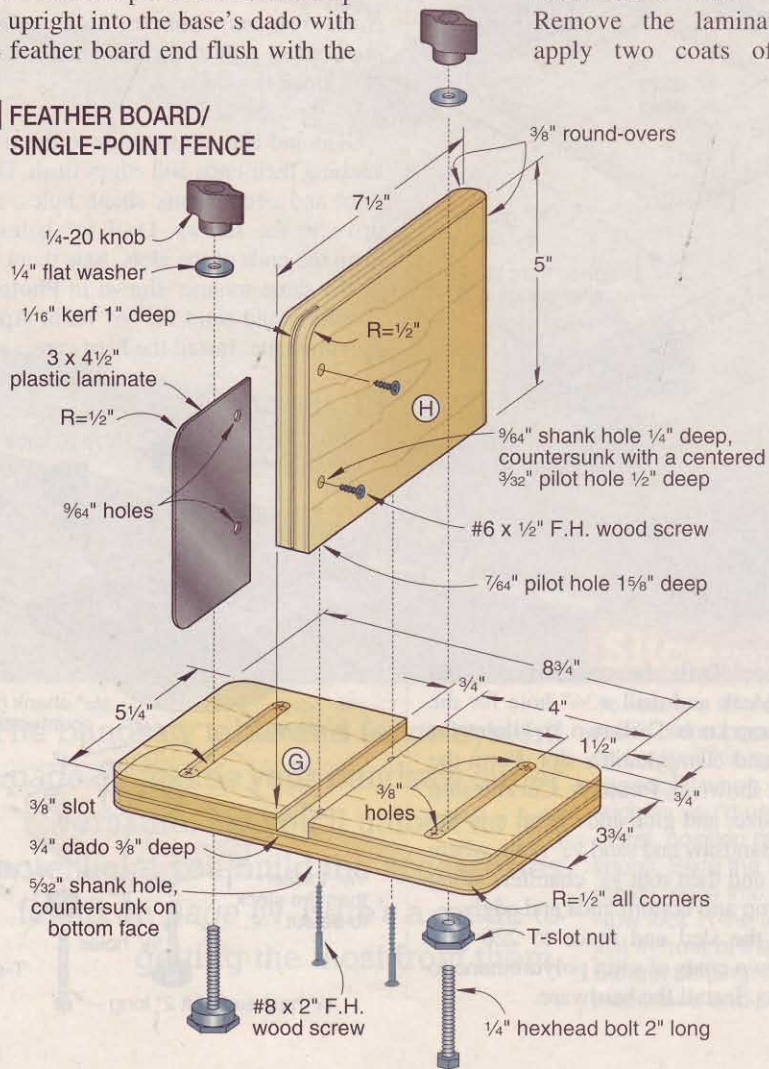





# low-tech foolproof sharpening

With sandpaper and our simple jig, you're only minutes away from razor-fine cutting edges.

**D**o you postpone sharpening until your tools will barely cut balsa wood? We have a way to make it so quick, simple, and inexpensive that you'll find yourself whipping those chisels and plane irons into shape, and keeping them that way.

It's worth the effort because sharp tools make your work easier, more accurate, and even safer. When a chisel slices neatly through wood, instead of requiring brute force, it's less likely to slip and nick the project or a finger. And, with the right technique, sharpening doesn't take long. Although the time involved

depends on the hardness of the steel and the condition of the edge, you can take the typical chisel from banged-up to extremely sharp in 10 minutes or less.

### Get high-quality results with basic materials

You have many choices for sharpening, including natural, synthetic, and diamond stones, as well as horizontal and vertical grinding wheels. However, sandpaper offers several advantages over all of these. It cuts steel efficiently, provides a consistently flat surface, and costs relatively little.

For best results, rely on silicon carbide sandpaper, the black, wet/dry type. Silicon carbide is harder than the abrasives found on other types of sandpaper, such as aluminum oxide and garnet, so it does a better job of removing steel, and lasts longer.

Stockpile a series of grits—100, 150, 220, 320, 400, and 600—and you'll be ready for practically any tool-sharpening task in your workshop. Look for silicon carbide paper at a home center, hardware store, or auto supply outlet, or call Klingspor's Woodworking Shop at 800/228-0000.



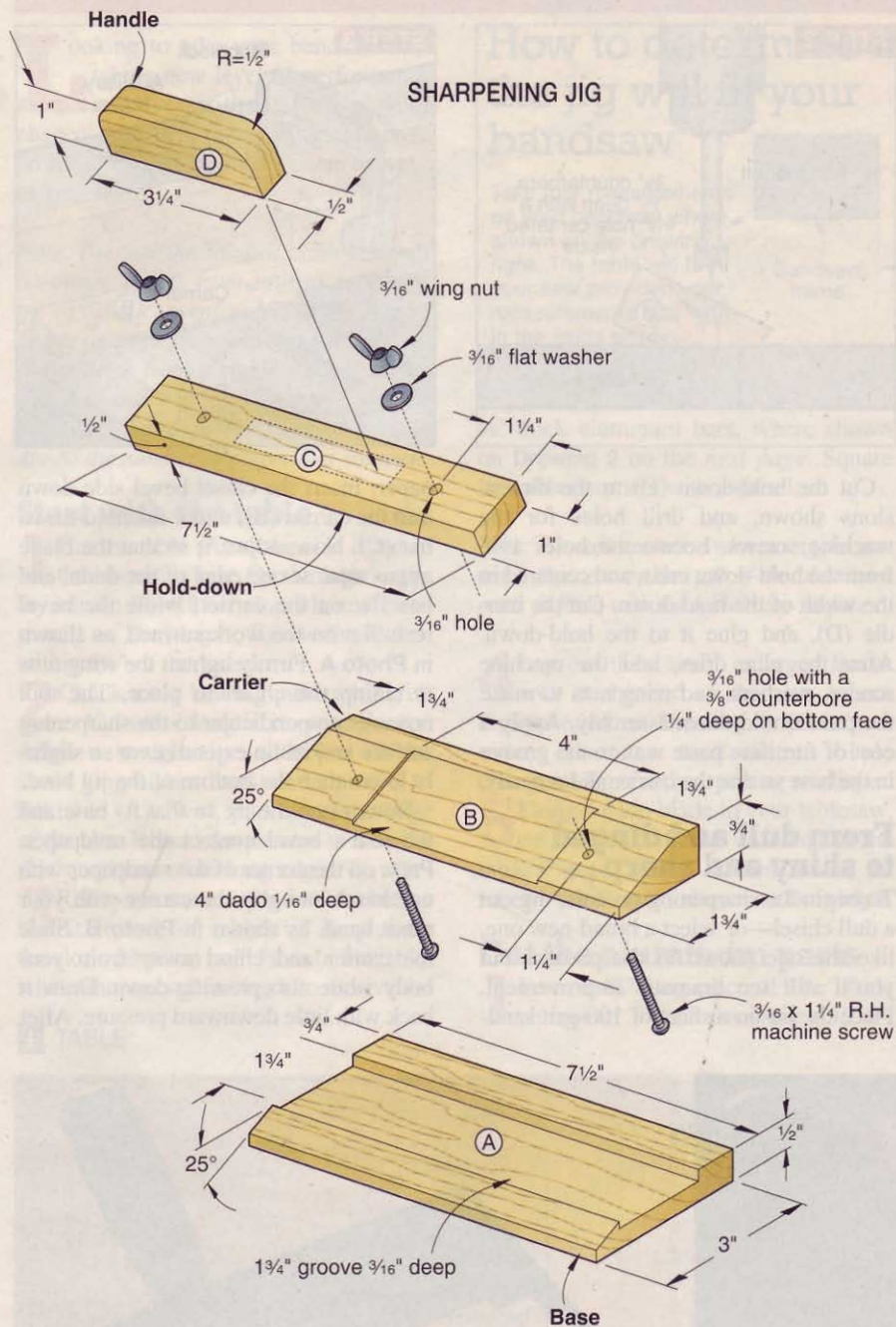

You also need a can of scouring powder for final honing. We got great results with Barkeepers Friend, which contains oxalic acid, feldspar, soda ash, and other proprietary ingredients. Look for it at a supermarket or hardware store, or order it online at [www.barkeepersfriend.com](http://www.barkeepersfriend.com).

You'll need a flat, hard, work surface, such as medium-density fiberboard, on which to place the sandpaper sheets. If you use a slicker surface, such as glass or plastic laminate, and your sandpaper slips, wet it with water to hold it in place.

Though optional, you also might benefit from a magnifying loupe of the kind

commonly used to examine photographs and negatives. Use it to check your sharpening results as you move from grit to grit. We stopped by a camera store, and for just \$7.95 bought a loupe that magnifies objects to eight times their actual size.

Finally, because sharpening tool edges with sandpaper on a flat surface requires precision grinding, we developed a sturdy hard maple jig to help you every step of the way. When using the jig, you'll find it holds the tool at the perfect angle without rocking or tipping. And it allows for a side-to-side motion to avoid dig-

ging into the paper with the cutting edge. To begin the sharpening process, let's first make the jig.

## Build our side-to-side sharpening jig

The jig detailed in the exploded view, left, is suitable for any chisel or plane iron with a blade at least 3" long. It's designed to sharpen tool edges at a 25° angle. You might decide to make one for each angle that you need.

To build one for yourself, first make the base (A) from a piece of hard maple longer than the completed jig. Start with a workpiece measuring approximately 1/2 x 3 x 10". Install a dado set in your tablesaw, and cut a groove 3/16" deep and 1 3/4" wide, 3/4" from the rear edge, where shown in **Step 1** of the **Making the base** drawing. Now, install a ripping blade, and set it at 25°. Use double-faced tape to fasten your workpiece to a slightly larger backer board. Now, place this assembly as shown in **Step 2**, and rip a bevel. Return the blade to 90°, and cut the base to its finished length of 7 1/2".

### MAKING THE BASE

#### STEP 1

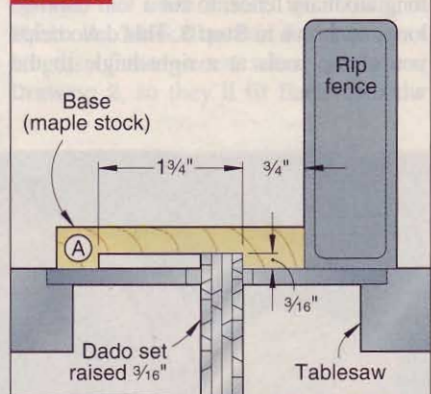

#### STEP 2

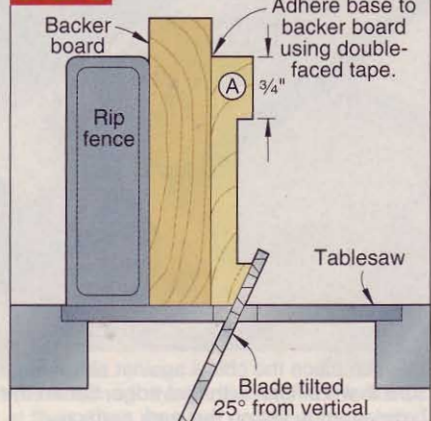



## MAKING THE CARRIER

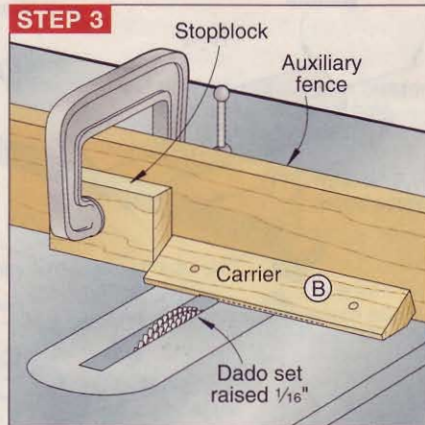
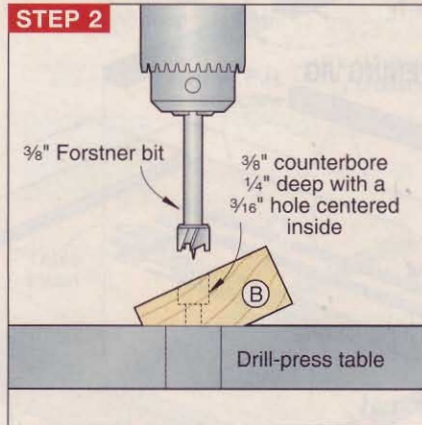
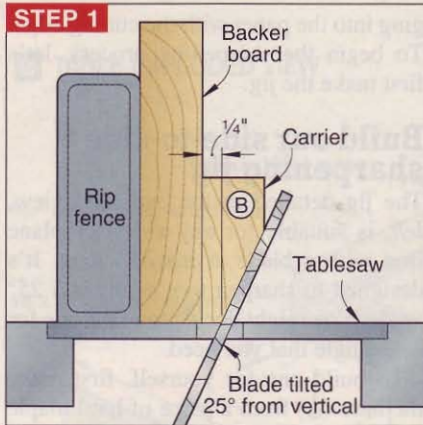

Make the carrier (B) from a piece of  $\frac{3}{4} \times 1\frac{1}{4} \times 10$ " hard maple. Tilt your blade to  $25^\circ$ , and bevel-rip the bevel on the carrier, again relying on a backer board and double-faced tape, as shown in **Step 1** of the **Making the carrier** drawing. Return the blade to  $90^\circ$ , and crosscut the carrier to its finished  $7\frac{1}{2}$ " length. Drill two counterbored holes from the bottom, as shown in **Step 2**, for the machine screws that provide clamping power. Locate each hole  $1\frac{1}{4}$ " from the carrier end. Drill the counterbore first, and then follow with the  $\frac{3}{16}$ " through hole. Reinstall your dado set, and use your miter gauge, equipped with a long auxiliary fence, to cut a  $\frac{1}{16}$ " dado 4" long, as shown in **Step 3**. This dado helps you clamp tools at a right angle to the work surface.

Cut the hold-down (C) to the dimensions shown, and drill holes for the machine screws. Locate the holes  $1\frac{1}{4}$ " from the hold-down ends, and centered in the width of the hold-down. Cut the handle (D), and glue it to the hold-down. After the glue dries, add the machine screws, washers, and wing nuts to make the carrier/hold-down assembly. Apply a coat of furniture paste wax to the groove in the base so that the carrier slides easily.

### From dull and dinged to shiny and sharp

To begin the sharpening process, dig out a dull chisel—or select a brand-new one, like the one shown in the photos, and you'll still see dramatic improvement. Place the jig on a sheet of 100-grit sand-

paper. Insert the chisel bevel side down into the carrier (B), under the hold-down bar (C). Now, adjust it so that the blade aligns against one edge of the dado, and lies flat on the carrier, while the bevel rests flat on the work surface, as shown in **Photo A**. Firmly tighten the wing nuts to clamp the chisel in place. The tool now sits perpendicular to the sharpening surface and its tip extends ever so slightly lower than the bottom of the jig base.

Now, place the jig so that its base and the tool's bevel contact the sandpaper. Press on the corner of the sandpaper with one hand, and grip the carrier with your other hand, as shown in **Photo B**. Slide the carrier and chisel away from your body while also pressing down. Draw it back with little downward pressure. After



**A** You can place the chisel against either edge of the dado. Just make sure that it's flush with that edge, flat on the carrier, and has its beveled edge flat on the work surface.



**B** As you begin to remove steel from the chisel, a line appears on the sandpaper. Move the jig away from the line to place the chisel on fresh abrasive. Your pressure on the jig helps keep the sandpaper in position.



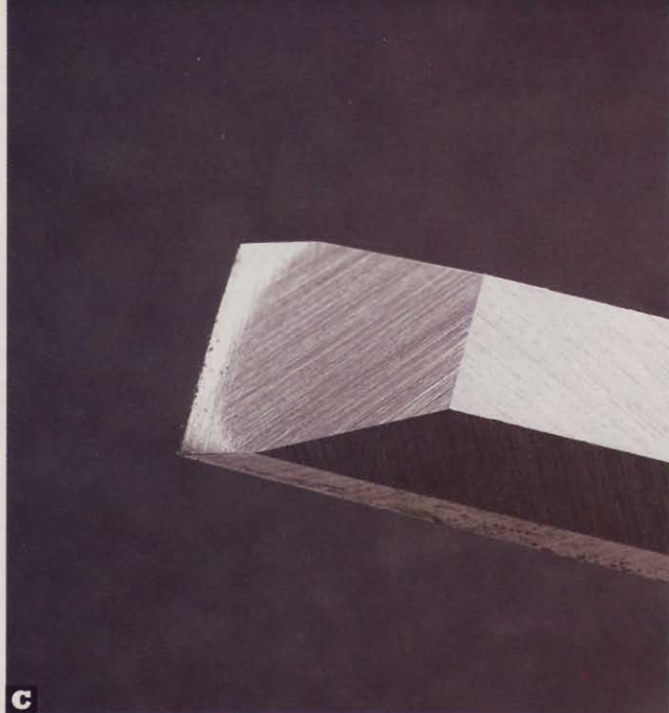

**C**

After only a few strokes on 100-grit paper, the scratches left by the manufacturing process begin to disappear. Keep working at the same grit until the entire bevel shows an equal shine.

several such strokes, lift the carrier from the base and inspect the chisel bevel, as shown in **Photo C**. Whether the chisel is new or used, your goal is the same. You want to place a fresh, uniform pattern of fine scratches parallel to the cutting edge across the entire bevel. If more strokes are necessary to accomplish that, move the jig back slightly to place the bevel on an untouched surface.

Remove the chisel from the jig, lay its face flat on the sandpaper, as shown in **Photo D**, and rub it from side to side. Again, you want to replace coarse scratches with finer ones. Also, many chisels come from the factory with a slightly dished face, so spend some time on the coarser grits to make it flat.

Repeat these two steps with each grit that you use, refining both facets of the

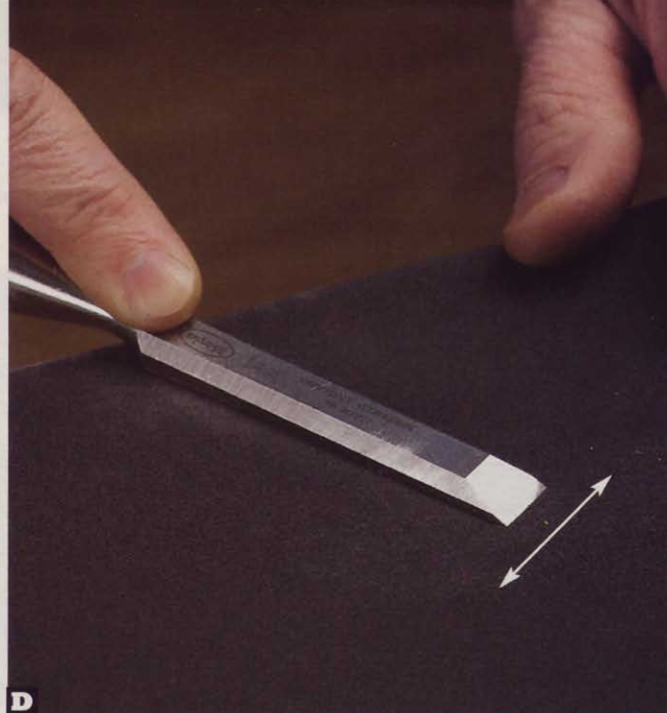

**D**

Before changing to the next grit of sandpaper in your sequence, rub the flat side of the chisel on the paper. This step helps to assure that the cutting edge is sharp as can be, with no burr.

cutting edge equally. Rely on your loupe to inspect the steel for a uniform scratch pattern, as shown in **Photo E**, and decide whether it's time to move to the next grit.

Of course, you can keep going with finer and finer grits—consider 2,000 as the maximum—but we suggest stopping at 600 grit and honing the edge. You'll have a chisel that's plenty keen enough for all of your woodworking needs.

## High-tech analysis of low-tech sharpening

We sharpened some chisels with our jig and sandpaper, and took them to Iowa State University. John Verhoeven, retired professor of metallurgical engineering, photographed the edges with a

scanning electron microscope. As a final step, he stropped the samples on leather charged with abrasive compound. One of those samples is shown *below left*. Verhoeven also sharpened one of the

chisels on an expensive hollow-grind system, and then stropped it. That result is shown *below right*. The final verdict: our low-tech method produced comparable results at a fraction of the cost.

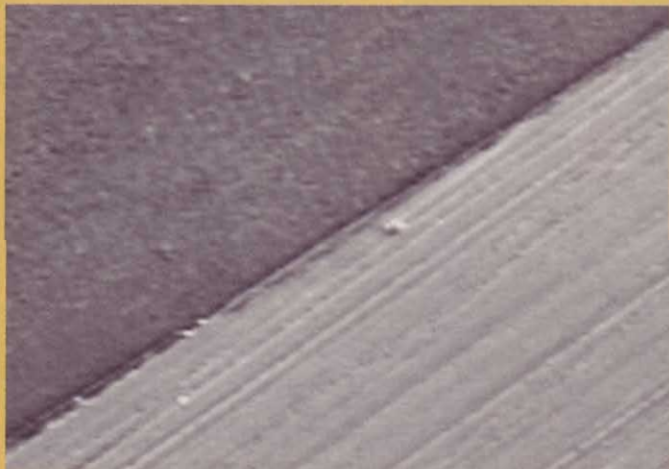

Here's one tiny section of a chisel edge that was sharpened with the side-to-side method. The view is magnified 150 times. At that extreme, you can see slight scratches left even after stropping.

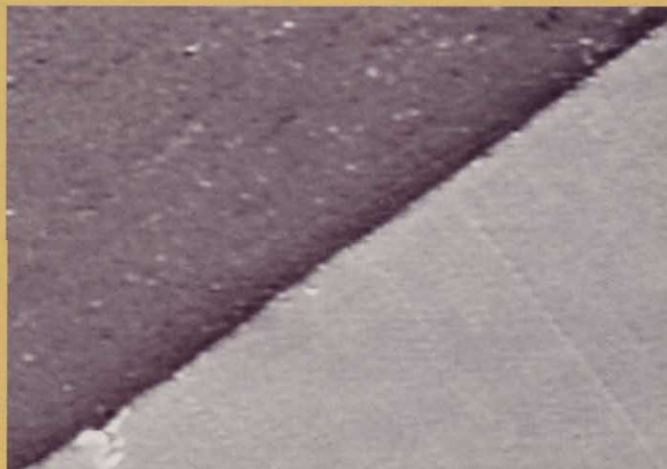

Also magnified 150 times, this chisel was sharpened on a high-end system. The scratches run perpendicular to the edge, and are less prominent than those at *left*, but there's little difference in sharpness.



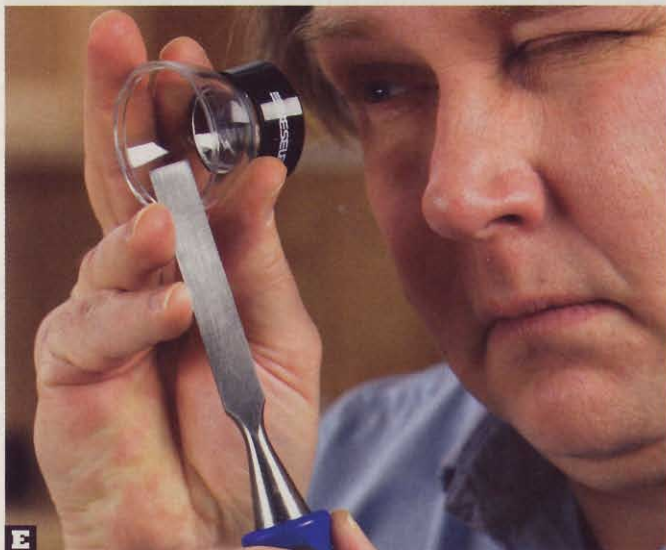

**E** Most of us need a little magnification to examine the chisel edge for a consistent scratch pattern. This simple loupe allows plenty of light to reach the subject, and magnifies it eight times.



**F** Sprinkle some scouring powder on a flat surface, such as this medium-density fiberboard, and proceed as you did on the sandpaper. It doesn't take many strokes to thoroughly hone the edge.

## Now you're in the hone stretch

Honing removes the last tiny sandpaper scratches, and gives you the smoothest possible cutting edge. We honed our sample chisels on a leather strop charged with green chromium oxide compound. You can buy both items from Woodcraft by calling 800/225-1153. A 2x8" leather strop mounted on maple is item 18H21 and costs \$22.99; a 6-ounce bar of compound is item 85H28 and costs \$6.95. Or,

you can substitute any piece of available leather for a strop, and use household scouring powder as the abrasive.

We also got fine results with an even simpler approach. Sprinkle scouring powder on a flat piece of dense wood, such as maple, or a piece of medium-density fiberboard (MDF). Now, as shown in **Photo F**, use the jig one more time. Remove the chisel from the jig, and hone the face, too. The fine abrasives in the powder remove most of the remaining

scratches to produce a gleaming edge. Store each sharpened chisel in its own slot or compartment, so the edge can't get dinged. Put each plane iron back in its plane with the edge above the sole.

Once you have your cutting tools up to snuff, get in the habit of keeping them that way with frequent resharpener. You won't have to start at 100 grit; you might be able to start at 320, and go from there. 🌲

Written by **Jim Pollock** with **Steve Oswalt**  
Illustrations: **Roxanne LeMoine**

## To grind, or not to grind?

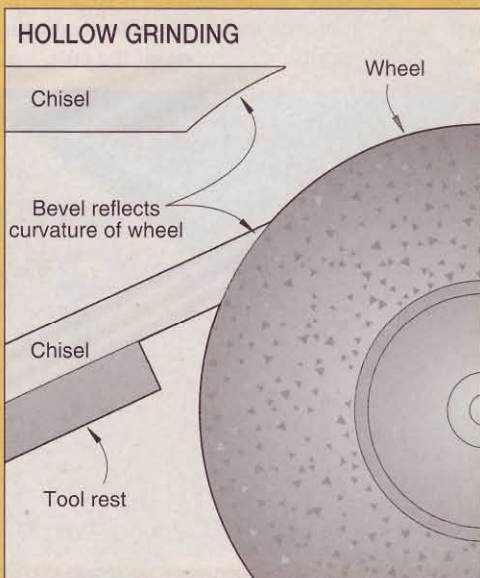

By itself, the sandpaper sharpening method creates a flat bevel. Every time you sharpen, you have to remove steel from the entire bevel. As long as you resharpen on a regular basis, that's really not a problem.

If you start the sharpening process with a grinding wheel, you produce a hollow-ground edge, as shown in the drawing at left. You can go this route, then follow your grinding with the sandpaper method. But we recommend doing all of the work on sandpaper. A hollowed-out bevel results in a weaker edge.

## Our cutting-edge expert

Steve Oswalt has been honing his sharpening and wood-working skills since his first high school shop class more than 30 years ago. He has tested products for **WOOD®** magazine for more than 15 years.



See more . . .

...shop-tested techniques at

[www.woodstore.woodmall.com/dow.html](http://www.woodstore.woodmall.com/dow.html)





simply made summer classics

# adirondack chair & footrest



If you like the chair, *left*, you may be interested in a matching double settee that appeared in issue 125. To obtain the plans, see the Buying Guide on page 79.

For the lumber and other items needed to build this project, see page 79.

**H**ere are two projects that let you spend a lot more time relaxing than building. But don't let the easy deck-screw-and-bolt-together construction fool you. This duo is both sturdy and supremely comfortable.

## Assemble the chair frame

**1** Cut the rear legs (A) to the size listed in the **Materials List**. Make two

copies of each half of the chair rear leg full-size half pattern on the **WOOD PATTERNS®** insert. Adhere them to the legs with spray adhesive, mating the halves where shown on the small-scale drawing on the pattern. Bandsaw and sand the rear legs to shape. Rout the chamfers.

**2** Cut the rear rail (B) and front rails (C) to the size listed. Lay out the centerpoints of the shank holes and the endpoints and midpoints of the arcs, where

shown on **Drawing 1**. Use a fairing stick to draw the arcs, as shown in **Photo A**. To make the adjustable fairing stick shown, see page 10. Drill the counter-sunk shank holes, and bandsaw and sand the rails to shape. Set aside one front rail for the footrest.

**3** Glue and clamp the rear and front rails (B, C) to the rear legs (A), where shown on **Drawing 2**. (The front edge of the rear rail aligns with the end







### 3 SPLAT RAIL ASSEMBLY

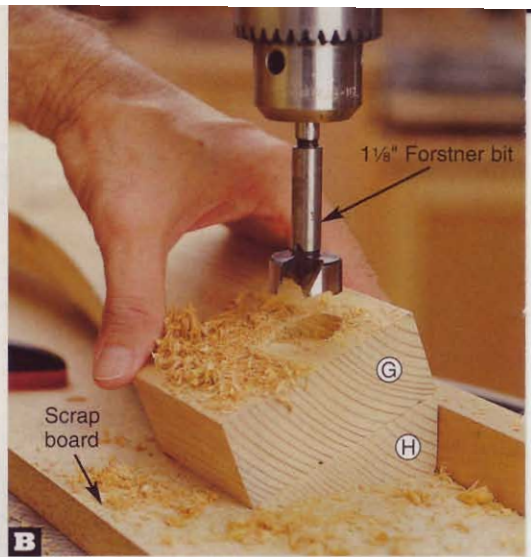
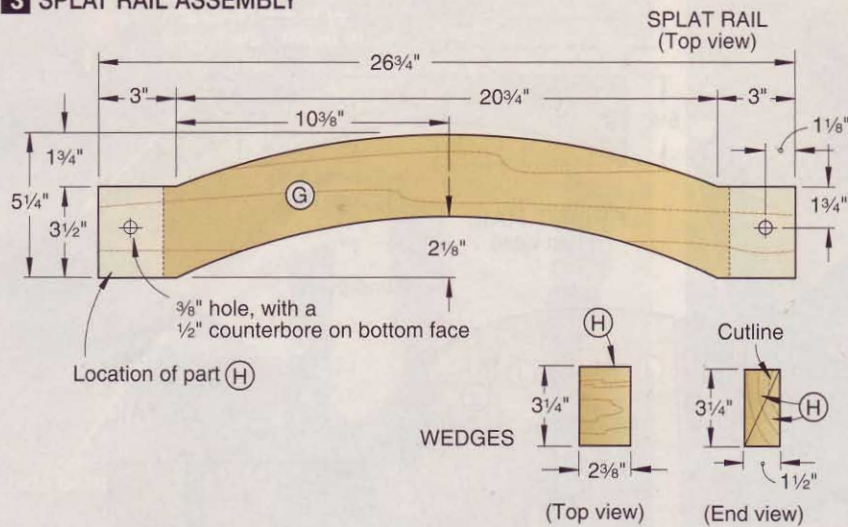

**B** Position your drill-press fence  $1\frac{3}{4}$ " from the bit's center. With assembly G/H supported on a scrap board, drill the  $\frac{1}{2}$ "-deep counterbores.



**C** Clamp a scrap stock straightedge to your workbench. Apply double-faced tape to the back of one center splat, and stick it to the bench so it is square to the scrap.

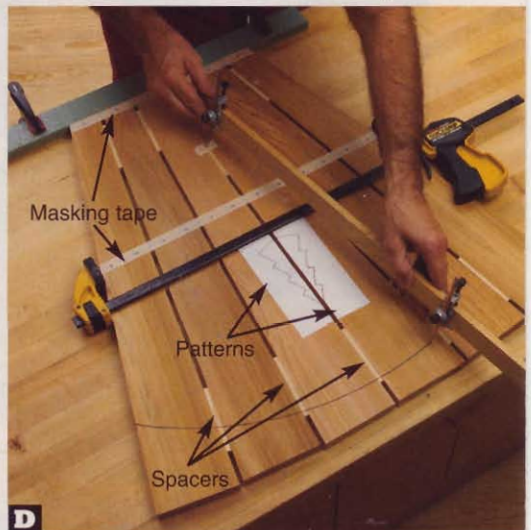

**D** Inserting  $\frac{3}{8}$ " spacers, position the other splats. Adhere the tree patterns with spray adhesive. Apply masking tape, and mark the hole locations. Draw the radius.

### 4 ARM

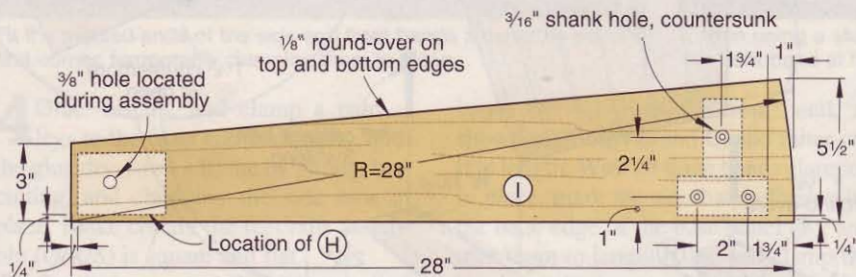

**Drawing 2.** Make sure you have a mirrored pair. Rout the chamfers.

*Note:* Chamfers at the bottoms of the front and rear legs prevent their edges from splintering as the chair is moved around on your patio, porch, or deck.

**6** Make two copies of the brackets (F) on the pattern insert. Adhere them to  $1\frac{1}{2}$ "-thick stock, and bandsaw and sand them to shape. Drill countersunk shank holes, where shown. Glue and clamp the brackets to the legs' outside faces, flush at the top and centered side-to-side. Using the shank holes in the brackets as guides, drill pilot holes into the legs, and drive in the screws.

**7** Measure up  $12\frac{1}{4}$ " from the bottom of each front leg (E), and make a mark on its inside face. Working on a flat surface, glue and clamp the front legs to the rear legs and rails assembly (A/B/C/D). Position the face of the front rail (C)  $\frac{1}{2}$ " back from the front legs' front edges, and align the top of the front rail with your marks, where shown on **Drawing 2**. Using the shank holes in the

front legs as guides, drill pilot holes into the front rail, and drive in the screws. Using the  $\frac{3}{8}$ " holes as guides, drill  $\frac{3}{8}$ " holes through the rear legs. Insert carriage bolts, and fasten them with washers and nuts.

**8** Cut the splat rail (G) to the size listed. Once again using your fairing stick, lay out the curves, where shown on **Drawing 3**. Bandsaw and sand the splat rail to shape.

**9** Cut a  $1\frac{1}{2}\times 3\frac{1}{4}\times 2\frac{3}{8}$ " piece of stock for the two wedges (H). Draw the diagonal on one end, where shown in the **End View** on **Drawing 3**. Bandsaw on the line to separate the two wedges, and sand the sawn faces smooth. Apply glue to the wedges' sawn faces, and clamp them to the splat rail (G), where shown on **Drawings 2** and **3**.

**10** Chuck a  $1\frac{1}{8}$ " Forstner bit in your drill press, and drill counterbores in the splat rail for the bolts that hold the splat rail and wedges assembly to the arms (I), where shown on **Drawings 2** and **3**, and as shown in **Photo B**. Switch to a  $\frac{3}{8}$ " brad-point bit and drill holes centered in the counterbores.



## 5 BACK SPLATS

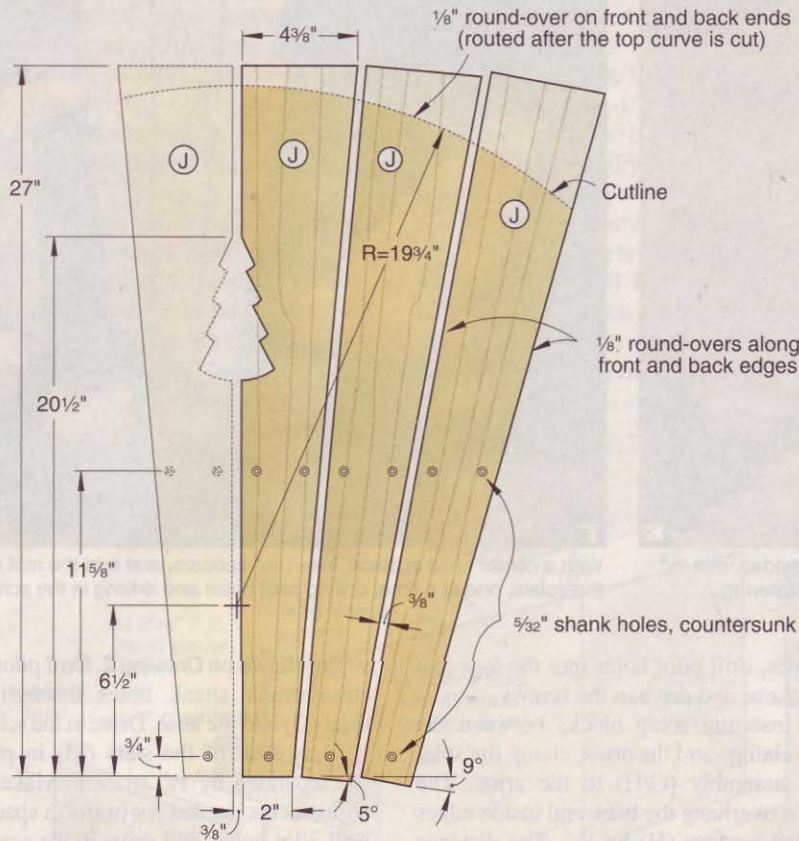

## 6 REAR SLAT (Top view)

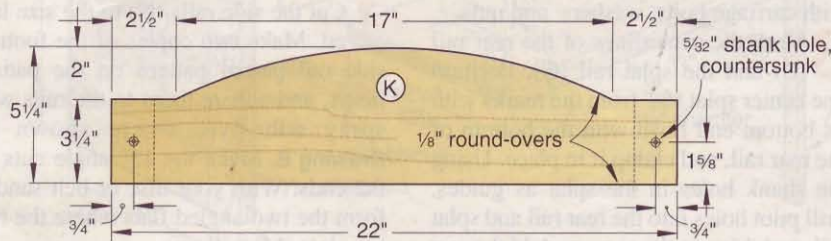

## Make the arms, back, and seat

**1** Plane 1/2"-thick lumber to 1" thick, and cut the arms (I) to the size listed. Using a beam compass, mark the front radii, and then mark the tapered outside edges, where shown on **Drawing 4**. Bandsaw, joint, and sand the arms to shape. Lay out the centerpoints of the countersunk shank holes. Make sure you have a mirrored pair of arms, and then drill the holes. Rout 1/8" round-overs along the top and bottom edges.

**2** Cut the back splat blanks (J) to the size listed. Draw the 4 3/8" to 2" taper along one edge of each of the six blanks, where shown on **Drawing 5**. Bandsaw

and joint the splat blanks to shape. Make 5° cuts on two blanks and 9° cuts on two blanks, where shown *above*.

**3** Make a copy of the tree cutout pattern on the insert. To locate the cutout and shank hole centerpoints, and draw the seat back's top radius, lay out the splat blanks on your workbench, as shown in **Photos C and D**.

**4** Bandsaw and sand the ends of the splats and the tree cutouts. Drill the countersunk holes. Rout 1/8" round-overs on the splats' front and back edges, including the cutouts, and their top ends.

**5** Cut the rear slat (K) to the size listed. Lay out its shape, where shown on **Drawing 6**. Bandsaw and sand the slat to

## 7 SHAPING THE NOSE

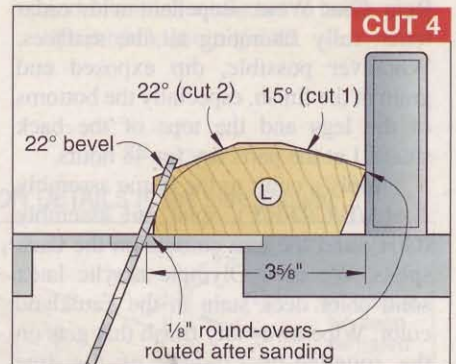
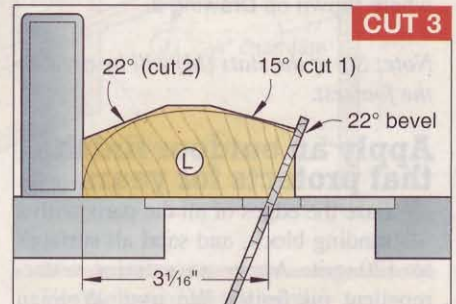
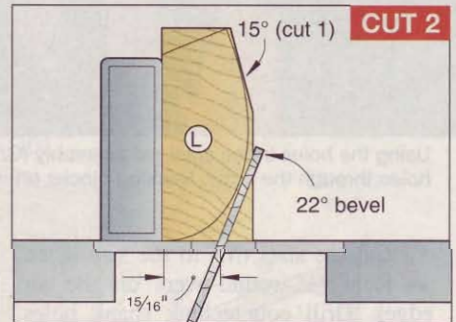
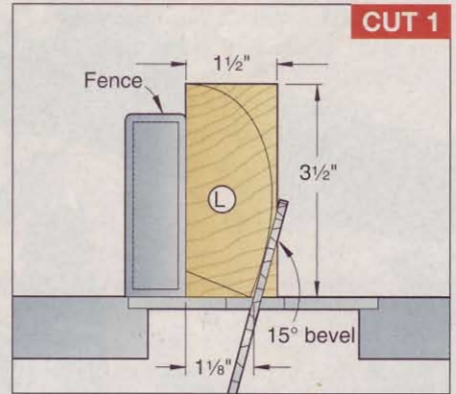

shape. Rout 1/8" round-overs on the top edges. Drill the countersunk shank holes.

**6** Cut the nose blank (L) to the size listed. Make a copy of the two nose patterns on the pattern insert, and adhere them to the ends of the blank. Rough out the profile on your tablesaw by making the four cuts shown on **Drawing 7**. Refine the shape with a block plane and sandpaper. Rout the 1/8" round-overs, where shown.



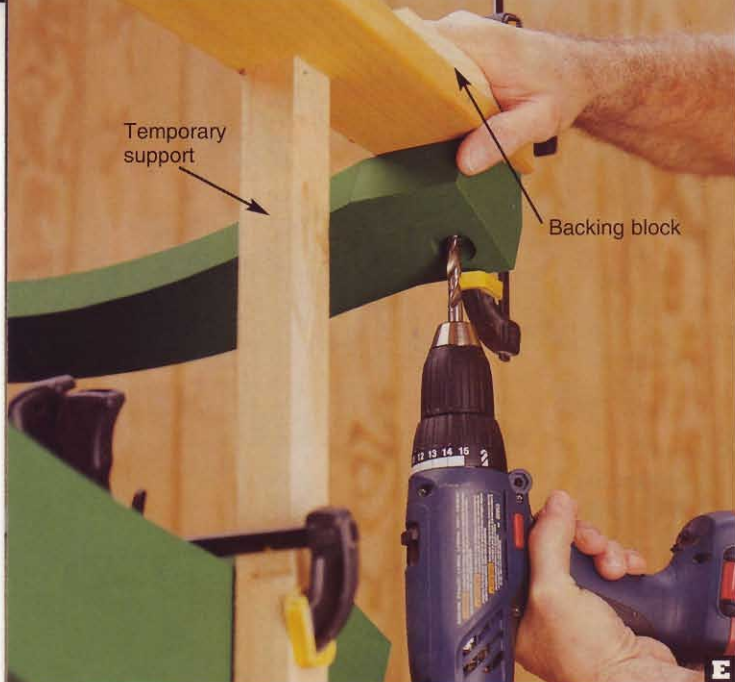

Using the holes in the splat rail assembly (G/H) as guides, drill  $\frac{3}{8}$ " holes through the arms. Backing blocks prevent splintering.



With a center splat in place, insert  $\frac{3}{8}$ " spacers, and add the rest of the slats, one at a time, drilling pilot holes and driving in the screws.

**7** Cut the slats (M) to the size listed. Rout  $\frac{1}{8}$ " round-overs on the top edges. Drill countersunk shank holes, where shown on **Drawing 2**.

*Note:* Six of the slats (M) will be used on the footrest.

### Apply an outdoor finish that protects for years

**1** Ease the edges of all the parts with a sanding block, and sand all surfaces to 120 grit. Apply an exterior water-repellent oil finish. We used Wolman Rain Coat Water Repellent with cedar toner, fully saturating all the surfaces. Wherever possible, dip exposed end grain in the finish, especially the bottoms of the legs and the tops of the back splats. Let the parts dry for 48 hours.

**2** Apply a color to the frame assembly (A/B/C/D/E/F), splat rail assembly (G/H), and the tree cutouts on the back splats. We used Olympic acrylic latex solid color deck stain in the Faulkland color. Wipe away any finish that gets on the rounded-over edges of the tree cutouts. Set the parts aside to dry.

### Assemble the chair

**1** To support the arms (I) during assembly, cut two  $19\frac{3}{4}$ "-long temporary supports from scrap. Clamp them vertically to the rear legs just forward of the rear rail (B). With their ends resting on the supports, position the arms on the front legs, where shown on **Drawing 4**. Using the shank holes in the arms as

guides, drill pilot holes into the legs and brackets, and drive in the screws.

**2** Inserting scrap blocks between the clamps and the arms, clamp the splat rail assembly (G/H) to the arms. The arms overhang the back and inside edges of the wedges (H) by  $\frac{1}{4}$ ". The distance between the arms is  $21\frac{1}{2}$ ". Drill  $\frac{3}{8}$ " holes through the arms, as shown in **Photo E**. Fasten the arms to the splat rail with carriage bolts, washers, and nuts.

**3** Mark the centerlines of the rear rail (B) and the splat rail (G). Position one center splat  $\frac{3}{16}$ " from the marks with its bottom end flush with the bottom of the rear rail, and clamp it in place. Using the shank holes in the splat as guides, drill pilot holes into the rear rail and splat rail, and drive in the screws. Add the rest of the splats, as shown in **Photo F**.

**4** Insert  $\frac{3}{8}$ " spacers between the back splats and the rear slat (K). Drill pilot holes into the rear legs (A), and drive in the screws.

**5** Clamp the nose (L) in place, overhanging the front rail (C) by  $\frac{1}{4}$ ",

where shown on **Drawing 2**. Drill pilot and countersunk shank holes through the cleat (D) into the nose. Drive in the screws.

**6** Lay four of the slats (M) in place, separated by  $\frac{3}{8}$ " spacers. Make any adjustments needed for uniform spacing, drill pilot holes, and drive in the screws.

### Assemble and finish the footrest

**1** Cut the side rails (N) to the size listed. Make two copies of the footrest side rail partial pattern on the pattern insert, and adhere them to the rails with spray adhesive, where shown on **Drawing 8**. Make the  $15^\circ$  angle cuts on the ends. With your disc or belt sander, form the two angled flats where the two top slats (M) will rest.

**2** Retrieve the previously cut front rail (C). Glue and clamp the side rails (N) to the front rail, flush at the sides and top, where shown on **Drawing 9**. Using the shank holes in the front rail as guides, drill pilot holes into the side rails. Drive in the screws.

### 8 FOOTREST SIDE RAIL

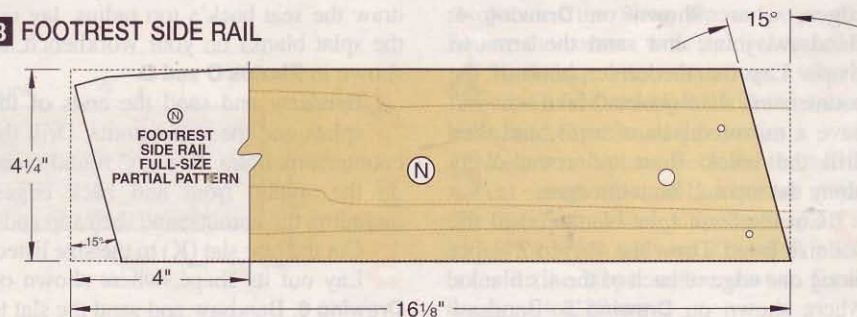







# flower-tower tuteur

Build a great pyramid for your garden in just a day or two.



**C**reate a unique garden focal point and give climbing plants an upscale home with this geometric gem. The roughly 50"-tall tuteur can be used freestanding or mounted atop its companion planter, featured in the May 2003 issue and shown on the *opposite page, bottom*. Need suggestions for suitable plants? See the sidebar, "Vine ideas."

For the lumber and other items needed to build this project, see [page 82](#).

## Start with the sides

**1** From a 1½×5½×48" cedar board (2×6) planed to 1" thick, cut the legs (A) to the size listed in the Materials List. Mark the locations for the rail blanks (B, D, E, F) on the legs, where dimensioned on **Drawing 1**.

**2** Plane a 1½×5½×24" cedar board to 1" thick. Rip sixteen ¼"-thick, 1"-wide strips from the edge of the board for the rail blanks (B through F), referring to the Cutting Diagram for layout. Crosscut the strips to the listed lengths.

**3** From scrap ¾" plywood, make a 5×19¾" spacer, and miter-cut its ends at 11½°, where shown on **Drawing 1**.

**4** Lay two legs (A) on your workbench with the markings visible, and position the spacer between them with the bottom edges flush. Clamp the legs to the spacer.

**5** Glue and nail a rail blank (B) to the legs, where shown on **Drawing 1**, aligning it with the marks and roughly centering it end to end. Use an exterior-type adhesive, such as Titebond II or polyurethane glue. In the same way, attach a rail blank (C) to the legs with the top edges flush and the legs spaced 3" apart at the rail's bottom edge, where shown on **Drawing 1a**. Now, attach the other rail blanks (D, E, F) to the legs. When the glue dries, trim the rails' ends flush with the legs' outside edges, as shown in **Photo A**.

**6** From a 1½×3½×32" cedar board, rip four ⅛"-thick, 1½"-wide strips for

## What is a tuteur?

"Tuteur" is a French word meaning guardian or tutor. It also describes structures or props used to "tutor," or train, climbing plants. Tuteurs aren't new. They're based on designs found in European gardens as early as the 17th century.





**A**

Place the side assembly facedown on scrap boards. Using a fine-tooth saw, trim the rails' ends even with the legs.

the vertical trim (G). Face-join the strips together using a few pieces of double-faced tape. Make two copies of the vertical trim pattern on the *WOOD PATTERNS*® insert. Adhere the patterns to the ends of a strip, and draw lines to connect them, where shown on **Drawing 2**. Bandsaw the strips to shape, and sand the curved edges smooth. Carefully separate the strips, and remove the tape.

**7** Glue a vertical trim strip (G) to the side assembly, where shown on **Drawings 1** and **3**. Center it side-to-side in the assembly with an equal overhang above rail F and below rail D. Note that the trim fits behind rail E and in front of rails D and F.

**8** Repeat the process to assemble the opposing side.

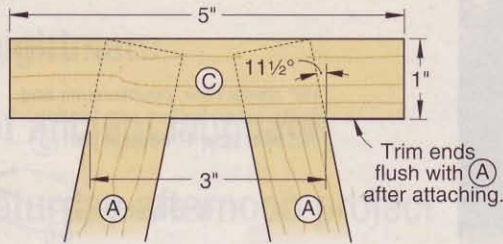

**1a** TOP RAIL DETAIL

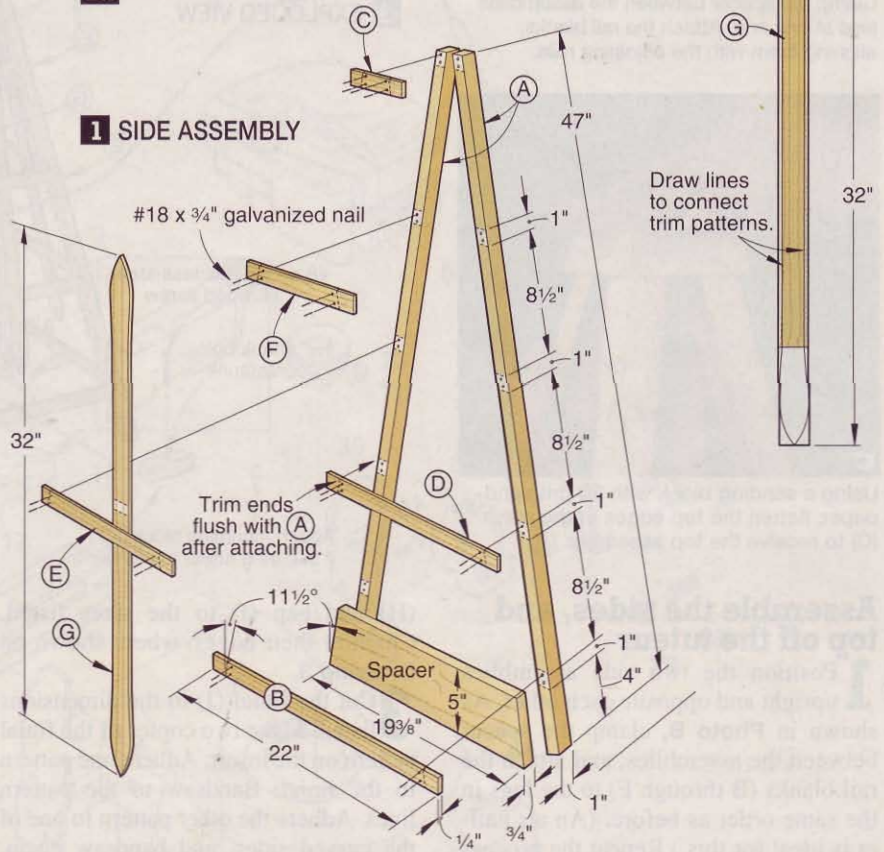

**1** SIDE ASSEMBLY

**2** VERTICAL TRIM

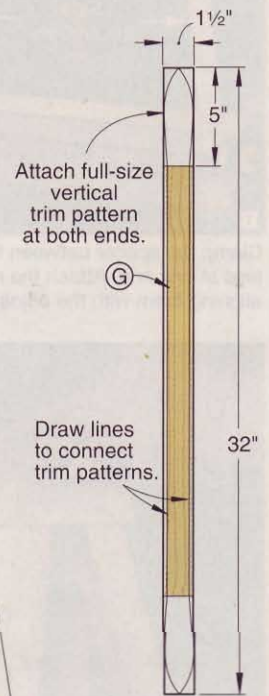

## Add the tuteur to the planter

For a winning combination, consider mounting the tuteur on the planter featured in the previous issue (May 2003, page 94), as shown at *right*. First, trim the tuteur's legs (A) flush with the bottom edge of the rails B. Then, cut two mounting blocks (K) to the size listed in the Materials List. Glue the blocks to the inside face of two opposing rails B, where shown on **Drawing 3**. With the tuteur placed on the planter, drill a countersunk shank hole in each mounting block, and screw the blocks to the planter's top trim.



## Vine ideas

Wondering what vines will work best with this tuteur? The selections *below* enjoy full sun and do well in most areas of North America. You'll want to tie miniature climbing roses and clematis to the tuteur for support, and help vines that have tiny rootlets, such as ivy, get a foothold by twining them around the structure. In areas with cold winters, bring tender vines indoors in fall before the first frost.

**Annuals:** Sweet pea, hyacinth bean, climbing snapdragon, moonflower (specifically *Ipomoea alba*), morning glory, cardinal climber, Spanish flag, cypress vine, and nasturtium.

**Perennials:** Clematis, miniature climbing roses, and English ivy.

**Tender vines:** Mandevilla, passionflower, black-eyed Susan, and jasmine.



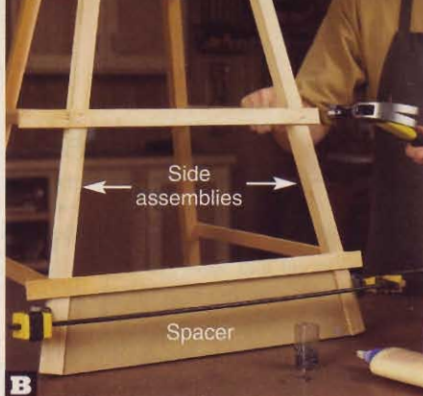

**B** Clamp the spacer between the assemblies' legs at one end. Attach the rail blanks, aligning them with the adjoining rails.



**C** Using a sanding block with 80-grit sandpaper, flatten the top edges of the rails (C) to receive the top assembly.

## Assemble the sides, and top off the tuteur

**1** Position the two side assemblies upright and opposite each other. As shown in **Photo B**, clamp the spacer between the assemblies, and attach the rail blanks (B through F) to the legs in the same order as before. (An air nailer is ideal for this.) Repeat the process on the opposite side. Trim the rails' ends, and install the remaining vertical trim (G).

**2** From a  $\frac{3}{4} \times 5\frac{1}{2} \times 12$ " cedar board planed to  $\frac{1}{2}$ " thick, cut the base

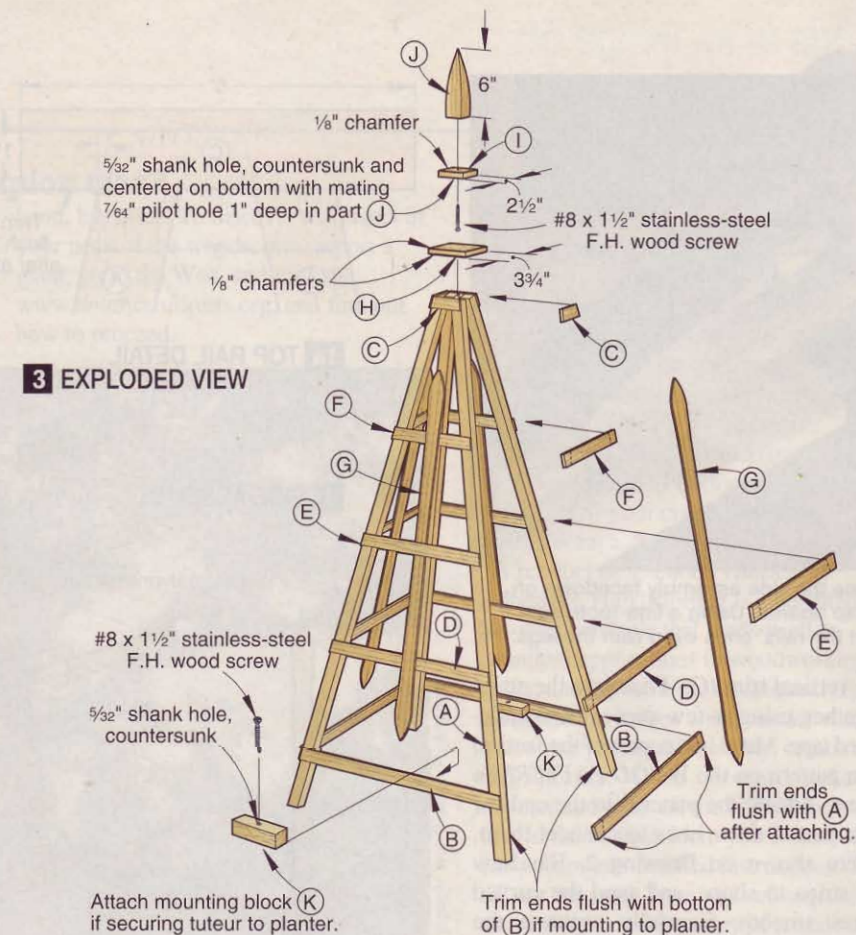

**3** EXPLODED VIEW

(H) and cap (I) to the sizes listed. Chamfer their edges, where shown on **Drawing 3**.

**3** Cut the finial (J) to the dimensions listed. Make two copies of the finial pattern on the insert. Adhere one pattern to the finial. Bandsaw to the pattern lines. Adhere the other pattern to one of the curved sides, and bandsaw again. Sand the finial smooth.

**4** Center and glue the finial to the top of the cap (I). Drill a pilot and countersunk shank hole through the bottom of the cap, where shown, and drive the

screw. Center and glue this assembly to the base (H).

**5** Sand the top of the tuteur flat, as shown in **Photo C**. Then center, glue, and clamp the top assembly H/I/J to the rails (C). 🌲

Written by **Owen Duvall**  
Project design: **Kevin Boyle**  
Illustrations: **Mike Mittermeier**

## Materials List

Part	FINISHED SIZE			Matl.	Qty.
	T	W	L		
A legs	1"	1"	47"	C	4
B* rail blanks	$\frac{1}{4}$ "	1"	22"	C	4
C* rail blanks	$\frac{1}{4}$ "	1"	5"	C	4
D* rail blanks	$\frac{1}{4}$ "	1"	18"	C	4
E* rail blanks	$\frac{1}{4}$ "	1"	14"	C	4
F* rail blanks	$\frac{1}{4}$ "	1"	10"	C	4
G vertical trim	$\frac{1}{8}$ "	$1\frac{1}{2}$ "	32"	C	4
H base	$\frac{1}{2}$ "	$3\frac{3}{4}$ "	$3\frac{3}{4}$ "	C	1
I cap	$\frac{1}{2}$ "	$2\frac{1}{2}$ "	$2\frac{1}{2}$ "	C	1
J finial	$1\frac{1}{2}$ "	$1\frac{1}{2}$ "	6"	C	1
K mounting blocks	$\frac{3}{4}$ "	$\frac{3}{4}$ "	$3\frac{1}{2}$ "	C	2

\*Parts initially cut oversize. See the instructions.

**Material key:** C—cedar.

**Supplies:** #18 $\times\frac{3}{4}$ " galvanized nails, #8 $\times\frac{1}{2}$ " stainless-steel flathead wood screws (3), spray adhesive, exterior-type adhesive.

## Cutting Diagram

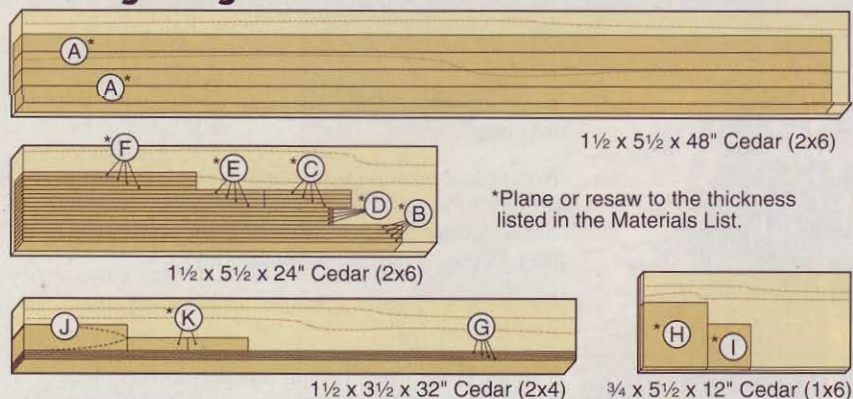



# yellow poplar

A supporting player among today's cast of hardwoods

Sapwood

Heartwood

Drawer side

Drawer front

Compared to the well-known American hardwoods, yellow poplar (*Liriodendron tulipifera*) doesn't get much respect. It doesn't have striking grain to awe the eye, nor is it lauded as a fine furniture wood. In the shop, though, poplar proves economical, versatile, and very workable. See "Poplar at a glance" for more details.

The tree isn't actually a "true" poplar. It's a member of the Tuliptree family. But if you hear a woodworker speak the name, know that he is referring to just one species: the yellow poplar.

## A towering tree that yields loads of lumber

Poplar is native to much of the eastern United States, as shown on the growth-range map, and ranks among North America's tallest hardwoods, reaching 150' or taller with trunk diameters commonly measuring 6' to 8'. A mature poplar produces astounding quantities of high-quality lumber.

Poplars often bear no branches for over half their height, meaning no knots to cut around. A thick layer of sapwood—the preferred part of the log—yields creamy-white wood with subtle grain, *above left*. The heartwood exhibits more color—a greenish cast sometimes laced with tinges of purple, black, blue, and brown.

Poplar makes a perfect choice for unseen furniture parts. It machines cleanly to produce tight-fitting joinery.

## An important player behind the scenes

Poplar doesn't receive much recognition, but is used commonly for making everyday items, such as toys, kitchen utensils, implement handles, and boxes. When used in furniture and cabinetry, though, it's usually hidden or disguised, so the wood remains less known than other hardwoods.

Homebuilders, though, know poplar very well. They have discovered that the wood produces high-quality millwork at a competitive price.

## A workable wood at a popular price

Though softer than the hardwoods with which it's often paired, poplar undergoes similar seasonal movement, which gives it great stability and joint-holding power. At 28 pounds per cubic foot dry, it's just over half the weight of red oak. These attributes suit the wood extremely well for use on such furniture parts as internal frames, carcasses, and drawers.

You can expect excellent results when machining poplar. It rips and crosscuts cleanly, and holds joinery and decorative details well. Use of dull bits may cause the wood's surface to "fuzz," as will rough sanding, but you can knock it down to a smooth finish by keeping tools honed and sanding through 220 grit.

Millwork makers love the way poplar takes paint, and so will you. The wood's consistent, unobtrusive grain doesn't





Poplar moldings and millwork are becoming increasingly popular as low-cost upgrades from paint-grade pine.



Poplar easily accepts decorative profiles and crisply holds machined edges. The wood rarely suffers tear-out or burn.

telegraph through, leaving a silky-smooth finish without need for special surface preparation.

Poplar takes stain easily, and the sapwood's neutral color makes it somewhat of a color chameleon, as shown in "Create color" at right. Blotching, though, presents challenges. The sample board shown in "Combat the blotches" shows that you can combat the problem with wood conditioner or gel stains. Cabinetmakers, who sometimes substitute poplar in place of costlier cherry, use toners and glazes to minimize blotching.

Poplar's price adds to its merits as a woodworking wood. Its per-board-foot cost may run one-third that of cherry, and half that of red oak. 🌲

Written by David Stone



Natural Growth Range

### Create color with various finish treatments



### Combat the blotches using conditioners and gel stains



## Poplar at a glance

**Price:** We surveyed lumber dealers for their prices on 4/4 firsts-and-seconds (FAS), random-width-and-length boards. In the East and Midwest, expect prices from less than \$2 per board foot to \$2.75. West Coast prices may be twice as high. Home centers also carry poplar that is machined to 3/4" thick, cut to standard widths, and surfaced on four sides (S4S). You'll pay close to \$4 per board foot at these stores.

**Pros:** Economical price; easily worked; readily available; stable; reasonably strong; no toxicity.

**Cons:** Limited grain figure; blotchy appearance when stained; grain may "fuzz" when worked with dull tools or rough sandpaper; not suited to wet areas or exterior use.

**Other names:** Tulip poplar, tuliptree, whitewood.



# mid-size plunge routers

We challenged seven tools to see which ones deserve Top Tool and Top Value honors.

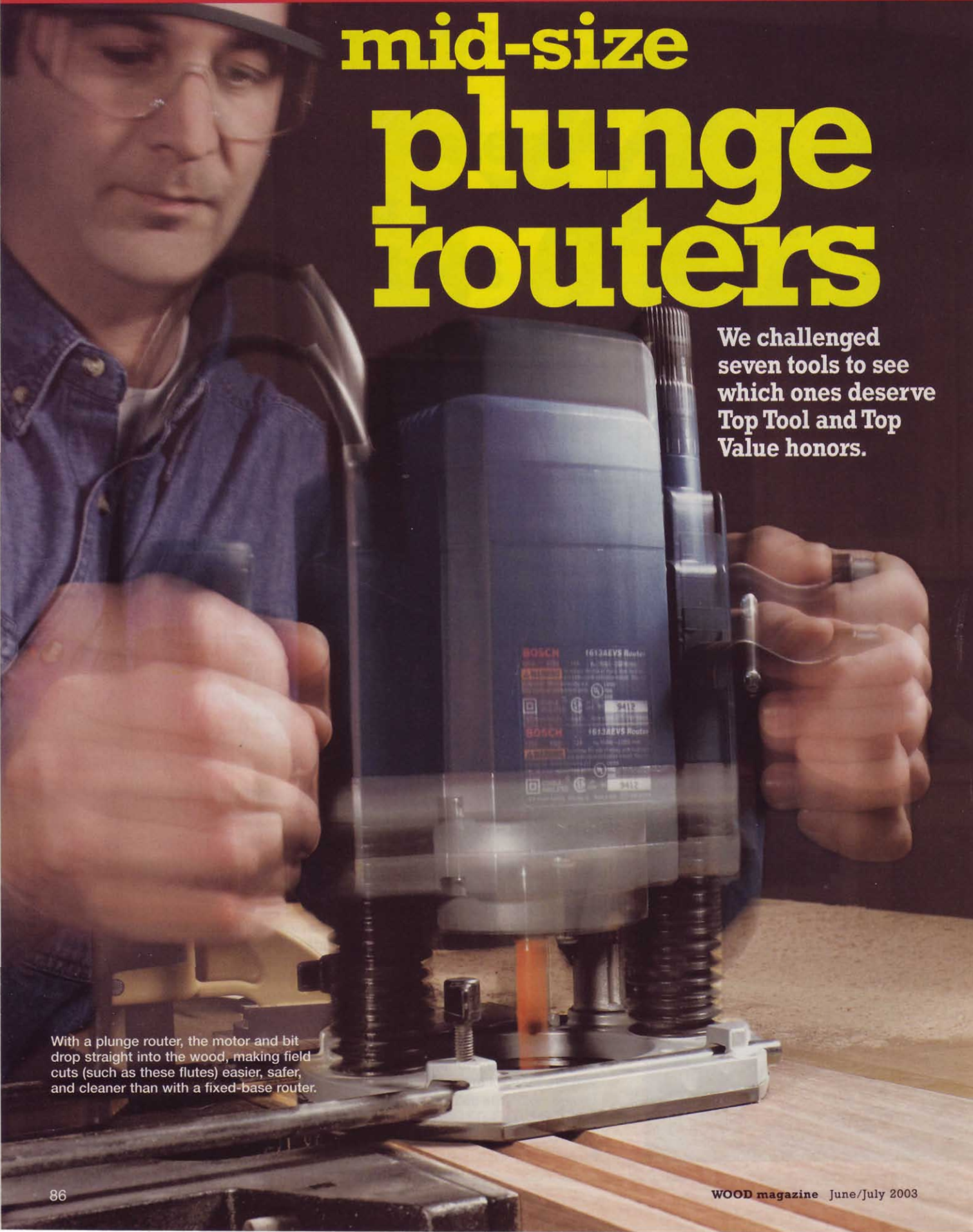

With a plunge router, the motor and bit drop straight into the wood, making field cuts (such as these flutes) easier, safer, and cleaner than with a fixed-base router.



**M**id-size routers—those that draw from 10 to 12 amps—pack enough punch to knock off all but the most daunting duties in your shop, such as full-depth cuts with big panel-raising bits. Add plunging capability for making field cuts (see “7 Reasons to Take the Plunge,” on the next page), and you wind up with the ultimate wood-machining tool without busting the budget.

In preparation for this article, we gathered up a raft of mid-size plunge routers with prices ranging from \$100 to \$250, and put them through a battery of tests. All offer variable-speed, soft-start motors, and most accept both 1/4"- and 1/2"-shank bits in self-releasing collets (with these, an extra turn of the collet pops the bit loose, preventing both stuck and free-falling bits). But that's where the similarities end, as you'll soon see when we separate the best from the rest.

## Key comparisons of performance

■ **Controls.** When you have a razor-sharp bit spinning at 23,000 rpm, you want total control of the router at all times, which means keeping your hands on its handles. On almost all of the tested routers, we could reach the critical controls—the power switch and plunge lock—without letting go of the tool. Makita's switch, though, located on top of the motor, proved unreachable without removing one hand from a handle.

The DeWalt DW621's controls are a mixed bag: We like the location of the power switch (it's a trigger on the right handle, typical of these tools), but we found cumbersome the sequence of events required to lock the switch “on.” On the other hand, DeWalt's unique plunge lock is the easiest to engage. A twist of the left handle locks and unlocks the plunge motion—you needn't lift even a finger to use it.

■ **Depth-setting ease.** Here's where these routers differ the most, and the photos below show three depth-setting systems we like. Use them as a reference while we refresh your memory on setting the cutting depth with a plunge router.

With the bit in the router and the motor off, lower the motor gently until the bit just touches the work surface. Unlock the stop rod and lower it until it touches the stop (usually, but not always, a turret with a series of steps for making progressively deeper cuts), then slide the movable cursor to “zero” on the depth scale, lock the stop rod in place, and raise the motor.

All are accurate as far as their scales go, but we prefer depth-setting systems with a microadjust feature for fine-tuning the depth. Our least favorite system is found on the Skil 1845-02: It lacks microadjustability, and its fixed cursor can't be “zeroed,” so you have to add

## 3 DEPTH-SETTING SYSTEMS COMPARED

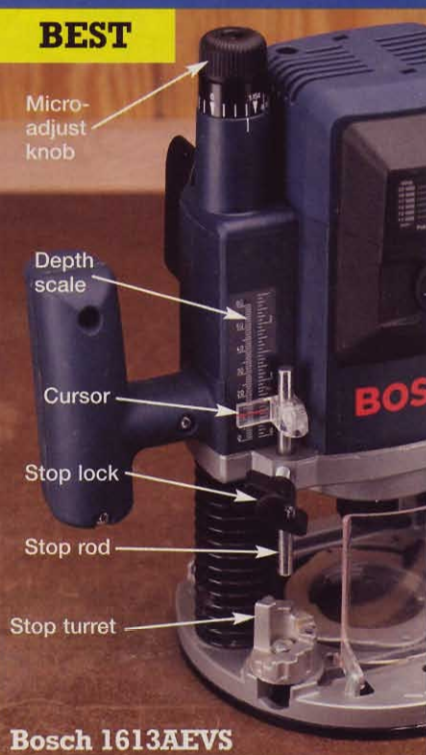
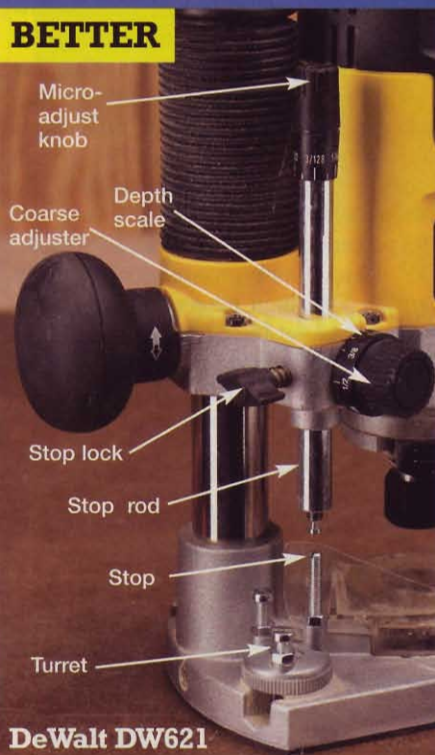

Ryobi's engineers one-upped the other models having simple stop rods by adding a microadjust mechanism on the stop itself (left). Each quarter turn of the stop clicks in a 1/64" adjustment. DeWalt's rack-and-pinion system (center) requires two steps to set the cutting depth: Turning the coarse-adjustment knob gets you to the nearest 1/16"; the microadjust knob threads the tip of the stop rod in or out, and its scale is marked in 1/256" increments for making superfine changes in depth. We like the depth-setting system on the Bosch 1613AEVS (right) best for a couple of reasons. First, the microadjust knob works even with the plunge lock engaged, and, like the DeWalt, shows .004" (1/256") increments. Second, the turret stop offers eight 1/8" steps—the most of any router in the test.



## PRESSURE REQUIRED TO PLUNGE

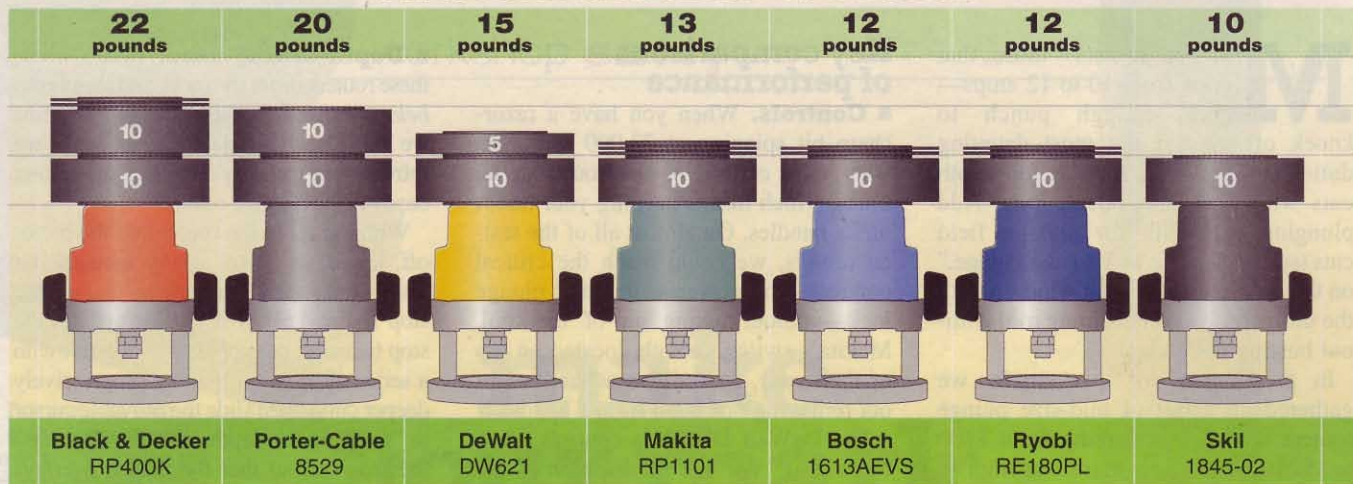

We tested the ease of plunging each router by gradually adding sand to a container attached to the top of each router. When the motor dropped 1", we removed the container and weighed it. This chart shows the weight required.

your cutting depth to the reading shown on the scale when the bit is bottomed out. (Quick—add  $\frac{1}{2}$ " to  $\frac{3}{16}$ "!)

■ **Plunge action.** Overly stiff return springs on a plunge router only increase the difficulty of already challenging field cuts. To learn how much pressure it takes to plunge each router, see the "Pressure Required to Plunge" chart, *above*. We found that routers requiring 12–15 pounds of pressure gave us the best control.

Also, a sloppy fit between the plunge posts and the motor housing contributes to inaccurate cuts if the bit doesn't come down in the exact same spot every time. Although some routers felt looser than others, the best strayed  $\frac{1}{64}$ " at most (Bosch and DeWalt), while the worst were off  $\frac{1}{32}$ " (Skil and Ryobi). Remember, these numbers are the extremes: You can minimize the effect by always plunging with equal pressure on both handles.

■ **Power.** To measure the mettle of the tested routers, we plowed 3'-long  $\frac{1}{2}$ "

grooves  $\frac{1}{2}$ " deep in red oak in a single pass, pushing the motor as hard as we could. After timing the cuts and averaging the results, we discovered only a few seconds' difference in the time it took each tool to complete the cut, proving that even the lowest-priced routers in this category are up for tough tasks, if only occasionally.

■ **Dust extraction.** Once considered a luxury, four of the tested routers now include dust-collection ports as standard equipment; one manufacturer sells it as an accessory; and two make no provision at all. By far, the most effective is the through-the-post collection system on the DeWalt: When connected to a shop vacuum, it gathered a spectacular 93 percent of the debris from a  $\frac{1}{2}$ "-wide,  $\frac{1}{2}$ "-deep, 3'-long groove (see photos at *right*). That high number leaves the 70 percent rate of the Bosch and the 40-ish percentages of the Black & Decker RP400K, Makita RP1101, and Porter-Cable 8529 in its (ahem) dust.



You'll spend less time cleaning up after cuts made with the DeWalt DW621 hooked up to a vacuum (top photo). Compare that to the mess left after making the same cut (bottom photo) with a router that lacks a dust-extraction port.

## 7 reasons to take the plunge

Waffling between a plunge and fixed-base router for your next portable power-tool purchase? It's true that a fixed-base router costs and weighs less than the same size plunge router, and will handle at least 80 percent of your routing chores. But for only a little more money, a plunge router can do everything a fixed-base machine can do and more.

A plunge router is worth the extra money if you want to:

- 1 Make stopped flutes and dados.
- 2 Cut mortises with a router.
- 3 Use keyhole slots in your projects.
- 4 Routinely rout deep slots requiring several progressively deeper cuts.
- 5 Create signs with recessed letters.
- 6 Add an inexpensive through-the-table lift to your router. (See "Table tenants" on page 90.)
- 7 Buy only one router.



# Plunge routers, point by point

**Black & Decker RP400K, \$105** [www.blackanddecker.com](http://www.blackanddecker.com), 800/544-6986



## High points

- ◆ Low price—about half that of the “premium” routers in this category—includes carrying case.
- ◆ Large pistol-grip handles.

## Low points

- ◆ Requires 22 lbs. of force to plunge 1"—the most in the test.
- ◆ Accepts only 1/4"-shank bits, and collet runout (wobble) measured 7/1000", the highest of the tools we tested.
- ◆ The chip shield is difficult to remove for changing bits, discouraging its use.

- ◆ Dust-collection port doesn't fit snugly to router and fell off repeatedly, especially when connected to a vac hose.
- ◆ No self-releasing collet.
- ◆ In a router table, the only height-adjustment mechanism is the plunge itself, which is difficult to set accurately.

## More points

- ◆ Large 3" subbase opening allows excellent view of bit, but won't accept guide bushings and offers reduced support on corners of workpieces.
- ◆ Easy-to-use rack-and-pinion depth scale, but no microadjustment system.

**Bosch 1613AEVS, \$200** [www.boschtools.com](http://www.boschtools.com), 877/267-2499



## High points

- ◆ Spring-loaded plunge lock returns automatically to locked position, so you always know where to find it.
- ◆ Satin-smooth plunge action.
- ◆ Our favorite depth-setting system with micro-adjustability to 1/256", and functionality even with the plunge lock engaged.
- ◆ Hinged chip guard flips out of the way for bit changes.



## Low points

- ◆ Dust-extraction port mounts on the flat side of the D-shaped base, so you'll need to remount it for fence-guided cuts (or use a fence lower than 5/8").
- ◆ Plunge lock can't be defeated for router-table use.

## More points

- ◆ Guide-bushing adapter comes with the router, but accepts only Bosch quick-release guide bushings (or Porter-Cable bushings—the industry standard—with an optional accessory).

**DeWalt DW621, \$200** [www.dewalt.com](http://www.dewalt.com), 800/433-9258



## High points

- ◆ Best in the test for dust extraction with a shop vacuum attached.
- ◆ Rack-and-pinion depth-setting system with microadjust works well and is adjustable to 1/256".
- ◆ Left handle rotates to engage and disengage plunge lock, so hands remain in full grip of router at all times.
- ◆ Very smooth plunge action.
- ◆ The quietest router in the test, at 88dB.

## Low points

- ◆ Locking power switch requires a clumsy three-step process that takes some getting used to, and is difficult to engage with router table-mounted.

- ◆ Mushroom-shaped handles are less comfortable to our hands than pistol-grip style.
- ◆ The clear plastic dust hood tends to cloud with dust, even when used with a vacuum, limiting view of the bit. You can easily remove it.

## More points

- ◆ If you turn off the motor, and then start it again before it stops turning, it won't restart until it slows to a low rpm. This feature may add life to the motor but we found it annoying, especially when combined with the already awkward power switch.
- ◆ This router runs a close second to the Bosch for Top Tool.

**Makita RP1101, \$250** [www.makitatools.com](http://www.makitatools.com), 800/462-5482



## High points

- ◆ All-metal construction (except for cap on motor) makes this a durable tool.
- ◆ Spring-loaded plunge lock returns automatically to locked position, so you always know where to find it.
- ◆ Very smooth plunge action.
- ◆ Externally replaceable motor brushes for easy maintenance.

## Low points

- ◆ Threaded stop rod is microadjustable, but the micro-scale and zero point both turn with each adjustment, so you can't tell how much you've changed.
- ◆ The quick-release button for the stop rod requires 1 turn to release, but with 1 1/2 turns, it falls off.
- ◆ Painted, mushroom-shaped handles are less

comfortable to our hands than pistol-grip style, and contribute to this router feeling top-heavy.

- ◆ Round base lacks a flat edge for guiding along a fence.
- ◆ Plunge lock can't be defeated for router-table use.

## More points

- ◆ Requires two wrenches for changing bits.
- ◆ Toggle power switch on top of motor can't be reached with both hands on the router's handles, but works well with the router table-mounted.
- ◆ Small subbase opening fits P-C guide bushings, but restricts view of bit.
- ◆ Dust hood is an optional accessory.
- ◆ Motor also fits in Makita's accessory fixed-base and D-handle bases. This interchangeability leads to many of the RP1101's shortcomings as a dedicated plunge router.



Porter-Cable 8529, \$220 [www.porter-cable.com](http://www.porter-cable.com), 800/487-8665



#### High points

- ◆ Spring-loaded plunge lock returns automatically to locked position, so you always know where to find it. It also can be defeated for router-table use.
- ◆ Toggle-style power switch works well both handheld and with router table-mounted. Though not on the handle, it's within an easy thumb's reach.
- ◆ Externally replaceable motor brushes for easy maintenance.
- ◆ When used with the optional router-table accessory kit (shown *bottom right*), you can adjust cutting height from above the table, making this router uniquely suited for router-table use.

#### Low points

- ◆ Although this router has a microadjust system, it requires a lot of knob turning and is so confusing that the six steps to use it are written on the router.

- ◆ It takes 20 lbs. of pressure to plunge the bit 1"—the second most in the test.
- ◆ The clear plastic dust hood tends to cloud with dust, even when used with a vacuum, limiting view of the bit. You can easily remove it.

#### More points

- ◆ Instead of a rotating turret stop, the stop rod rotates to select which of the three stops you'll use. The knob for turning the stop is so snug to the router body that we found it easier to rotate it using the "foot" on the bottom of the rod.
- ◆ The features that make this a good router for table mounting seem to work against it in handheld mode. If you'll primarily use your router in a table, this is the best in the test.

Ryobi RE180PL, \$100 [www.ryobitools.com](http://www.ryobitools.com), 800/525-2579



#### High points

- ◆ At \$100, this is the least-expensive router in the test that accepts 1/2"-shank bits.
- ◆ Microadjustable stop changes cutting depth 1/64" for every 1/4 turn. Its full range is 1/2".
- ◆ Externally replaceable motor brushes for easy maintenance.

#### Low points

- ◆ 15,000 rpm low speed is significantly faster than the other tested routers.

- ◆ No dust extraction or self-releasing collet.
- ◆ Slop in plunge action can cause bit to be off its mark by as much as 1/32".
- ◆ In a router table, the only height-adjustment mechanism is the plunge itself, which is difficult to set accurately.

#### More points

- ◆ Large 3" subbase opening allows excellent view of bit, but won't accept guide bushings and offers reduced support on corners of workpieces.
- ◆ Plunge lock and power switch are both activated by the right hand, which may cause confusion in an emergency.
- ◆ Instead of 1/4" collet, Ryobi provides an adapter sleeve to accommodate 1/4" bits.



## Table tenants

So, how well does this class of machine work when hanging upside down in a router table? Frankly, the answer in many cases is a qualified "not very well."

One major factor prevents most plunge routers from working as well in a router table as fixed-base machines: the ability to accurately adjust cutting depth. In fact, on four of the seven tools in our test, the only height adjustment you have when table-mounted is the plunge action itself.

Of the three models that do allow for fine height adjustments when table-mounted, Porter-Cable's system (shown at *right*) is arguably the best, with its through-the-table adjuster. (Bosch and Skil require fiddling beneath the table with a small knob; DeWalt's below-table adjuster is optional.) You can also add through-the-table adjustability to two of the

Porter-Cable's router-table accessory kit (part no. 75301, \$30) includes a height-adjustment knob for through-the-table settings, and an offset wrench that permits bit changes through the table's bit opening. (One of the two offset wrenches shown comes with the router.)



tested routers—DeWalt and Makita—with a relatively inexpensive router-lifting accessory called RouterRaizer (\$90, 515/266-1293 or [www.routerraizer.com](http://www.routerraizer.com)).





**High points**

- ◆ \$100 price tag includes a carrying case and an adapter that fits Porter-Cable-style guide bushings.
- ◆ Large pistol-grip handles.
- ◆ Onboard storage for bit-changing wrench.

**Low points**

- ◆ No dust extraction.
- ◆ Collet accepts only 1/4"-shank bits and is not self-releasing.
- ◆ Slop in plunge action can cause bit to be off its mark by as much as 1/32".
- ◆ Depth scale can't be "zeroed," so you have to add your cutting depth to the fraction shown on the fixed scale.
- ◆ The "fine-adjustment knob" cited in the 1845-02's owner's manual overrides the ability to plunge the router, effectively making it a fixed-base router with

microadjustability. And the knob itself crowds the router body, making it difficult to adjust with the tool table-mounted.

**More points**

- ◆ Although it requires the least amount of weight to plunge 1", the plunge action felt a little too loose to us. Just placing our hands on the unlocked router caused it to plunge.
- ◆ Just before we went to press, we learned of a new line of routers slated to be in stores by early this fall, one of which will replace the 1845-02. According to Skil product manager Marcus Burzynski, the new 1820 plunge router will add a turret stop, "zeroing" capability on the depth stop, and a work light, and will sell for around \$80. However, it will only be offered in a fixed-speed version.

**HEAD-TO-HEAD COMPARISON OF SEVEN MID-SIZE PLUNGE ROUTERS**

BRAND	MODEL	MOTOR AMP RATING	COLLET SIZE (INCHES) (1)	SPEED RANGE (RPM)	MAXIMUM PLUNGE DEPTH (INCHES)	NUMBER OF DEPTH STOPS	SIZE OF SUBBASE OPENING (INCHES) (2)	SIZE OF BASE OPENING (INCHES)	COLLET RUNOUT	PERFORMANCE GRADES (3)										ACCESSORIES (6)		CORD LENGTH (FEET)	WARRANTY (YEARS)	COUNTRY OF ASSEMBLY (7)	WEIGHT (POUNDS)	SELLING PRICE (8)
										EASE OF PLUNGE AND PLUNGE LOCK	EASE OF SETTING CUTTING DEPTH	EASE OF FINE-TUNING CUTTING DEPTH	BIT-CHANGING EASE	DUST-COLLECTION EFFECTIVENESS (4)	POWER SWITCH	VIBRATION	EASE OF USE IN ROUTER TABLE	NOISE LEVEL (DB) (5)	STANDARD	OPTIONAL						
BLACK & DECKER	RP400K	10	1/4	8,000-25,000	2	1	3	3	D	C	A-	C	B-	C	A	B	D	96	CC, D, X	CG, E	10	2	C	8.8	\$105	
BOSCH	1613AEVS	12	1/4, 1/2	11,000-22,000	2 1/4	8	2 1/2	3 3/8	A	A-	A	A	A	B	A	A	C	93	C, D, G	CC, CG, E	9	1	U	10.4	200	
DEWALT	DW621	10	1/4, 1/2	8,000-24,000	2 1/8	3	2 1/2	2 1/2	B	A	A-	A-	A	A	C	A	D	88	C, D, G	BT, E	8	1	E	9.1	200	
MAKITA	RP1101	11	1/4, 1/2	8,000-24,000	2 19/32	3	1 1/4	3	A-	A	B	A-	B	C+	C	A	D	92	C	D, E, SB	8 1/2	1	U	10.3	250	
PORTER-CABLE	8529	12	1/4, 1/2	10,000-23,000	2 1/2	4	3 1/2	3 1/2	A	B+	A-	C	A	C-	A	A	A	94	C, D, G	E, AT	10	1	U	10.8	220	
RYOBI	RE180PL	10	1/2"	15,000-23,000	2	1	3	3	C	C	A	B+	A-	N/A	A	B	D	100	S		10	2	U	8.6	100	
SKIL	1845-02	10	1/4	8,000-25,000	2	1	3 1/2	3 1/2	C	C	C	D	B	N/A	A	B	C	98	CC, G	E	6	2	U	7.9	100	

**NOTES:**

1. (\*) Adapter sleeve provided for 1/4"-shank bits.
2. Without guide-bushing adapters if so equipped.
3. A Excellent  
B Good  
C Average  
D Below average  
N/A Feature not available on this router.
4. (\*) Tested with optional dust hood.
5. Measured 2' above and 1' behind router running at top speed.
6. (AT) Through-the-table height adjuster  
 (BT) Below-the-table height adjuster  
 (C) 1/4" collet  
 (CC) Carrying case  
 (CG) Circle-cutting guide  
 (D) Dust-collection port  
 (E) Edge guide  
 (G) Guide-bushing adapter  
 (S) Adapter sleeve for 1/4" bits  
 (SB) Clear subbase  
 (X) Extra 1/4" collet
7. (C) China  
 (E) England  
 (U) United States
8. Prices current at time of article's production and do not include shipping, where applicable.

**And now, the top picks from our test**

It was neck and neck between the Bosch 1613AEVS and DeWalt DW621, but in the end, Bosch wins by a nose. Although DeWalt's dust collection proved superior, the 1613AEVS is easier to use in a router table, so we ultimately named it our Top Tool. If you're buying a mid-size router specifically for table-mounting, opt instead for the Porter-Cable 8529 and its optional router-table accessory kit.

The Top Value award goes to the \$100 Ryobi RE180PL. Good power, microadjustability, replaceable motor brushes, and the 1/2" collet are features typically found only on routers costing twice as much. 🍌

**Share your opinion of these tools in our Plunge Routers forum at**

[www.woodmagazine.com/plungerouters](http://www.woodmagazine.com/plungerouters)

Written by **Dave Campbell** with Phillip Goodwin  
 Illustration: **Tim Cahill**



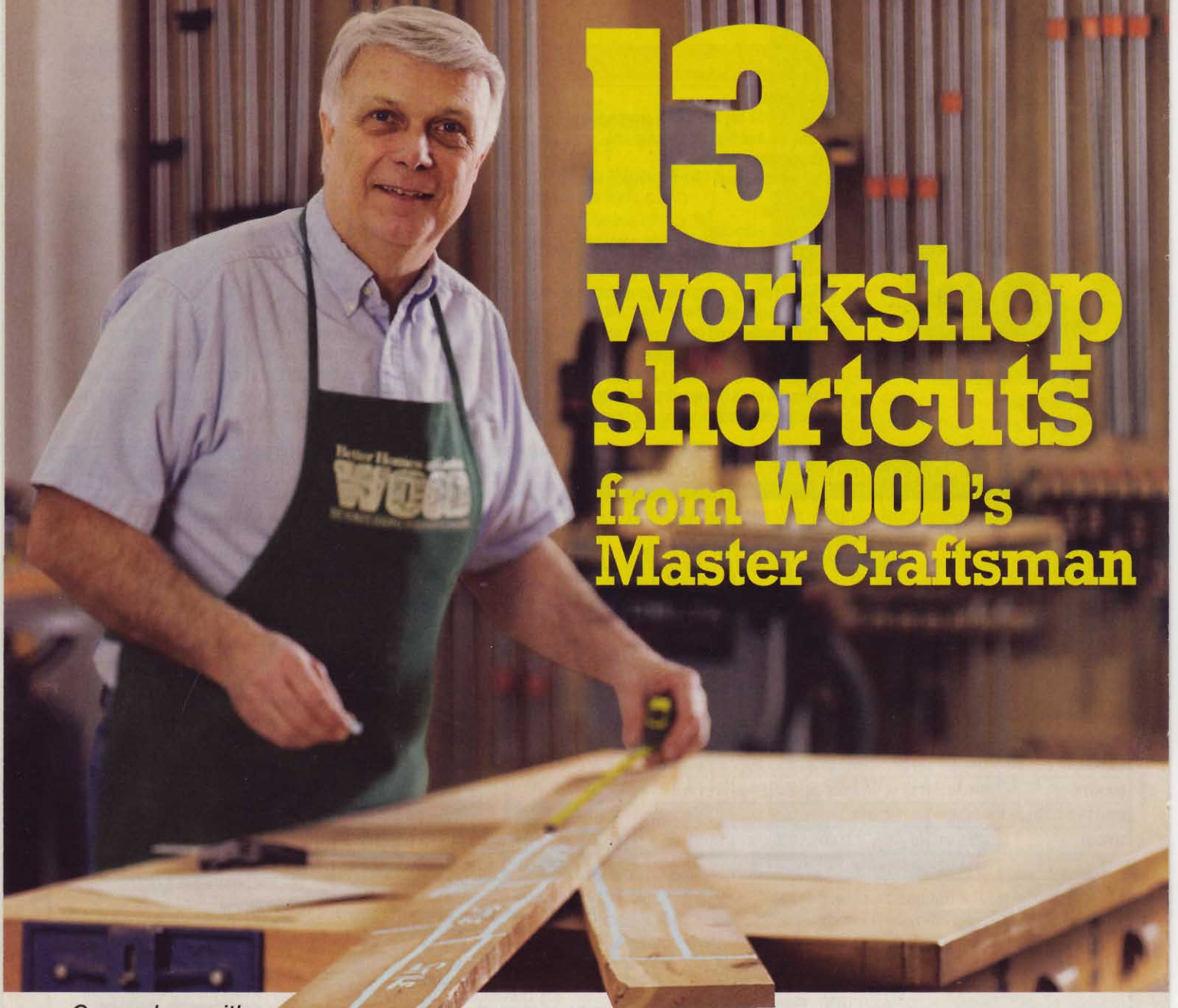

# 13

## workshop shortcuts

from **WOOD's**  
Master Craftsman

Come along with me and learn the simple timesaving techniques I use in the **WOOD®** magazine shop every day. I guarantee they'll make you more productive and help you build every project better.

*Chuck Hedlund*

**W**hether you spend an hour a week or every waking hour in the shop, chances are you feel like it's never enough time. While I can't create more time for you, I can maximize your woodworking time. You won't need fancy tools or complicated jigs. As you'll see, you just need to effectively set up your shop, and approach projects with a plan.

### 1 Lay out your shop for effective workflow.

This 12x20' shop makes the most of every square foot with logically located workstations and tuck-away tool storage. Machines are positioned with infeed and outfeed room, and can be moved to accommodate working with long boards.

Mount machines on mobile bases to simplify adding a new tool or temporarily relocating equipment while working on a big project. You can build your own bases, or buy models to fit most any tool.

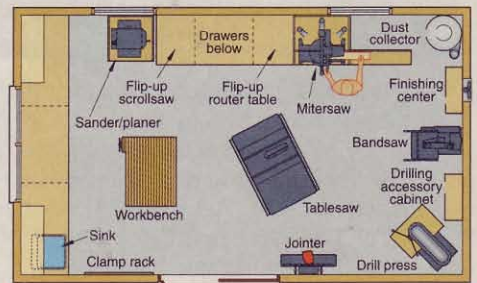





**2 Get organized and stay that way.** Few things cause more frustration than being unable to find a particular tool or bit when you need it. Router bits, as an example, seem to sneak away easily, so I give them dedicated storage. This holder (found in issue 139) mounts to the wall near your router table to cradle bits safely within easy reach.

Not all tools and accessories need to be in plain view all the time. To prevent losing track of those you store behind cabinet doors or in drawers, apply labels for instant recognition.

Cleaning isn't a chore most of us enjoy, but you'll reap great rewards if you spend just 10 or 15 minutes tidying up at the end of each shop session. It lets you collect your thoughts as you organize your tools, and gives you a head start when you return to the shop.

**3 Collect dust at its source.**

A dust collector removes most, if not all, of the dust and chips, meaning you don't have to. This results in huge time savings by drastically reducing the time you spend cleaning up. You can create a centralized dust-collection system with ducts to every machine, or just move a collector from tool to tool as needed.



**4 Take time to tune.** Don't wait until you cut into your precious project stock to find out your table saw blade is misaligned. Check all your machines before you get under way. Also check the condition of your chisels, blades, and bits, and sharpen any that need it.



**5 Buy another router.** If there's any tool you can justify two of, it's a router. With two routers, you won't have to undo setups or waste time swapping parts. For maximum versatility, get both a fixed-base model and plunge router.

If you have a router table, you can dedicate one machine to it. A fixed-base model works great in most tables. This leaves the plunge router available for freehand work. Some manufacturers offer an extra base, which you can mount to the table, then simply swap the motor.



**6 Study the plan before you start.** Even if you're proficient at all the operations involved in a project, read

through any plan completely, and take notes as you read. Doing this helps you to translate someone else's plans into the way you work.

Record and locate all of the tools, lumber, and supplies you'll need. Study the materials list (where the sizes of all the individual parts are stated) and jot down the common measurements for quick reference when it comes time to set up your machines.



**7 Have your lumber on hand when you begin.** Go

through the plan's materials list, or make one up for projects you design, and add everything up to determine your lumber needs. Then, get all of your lumber, plus at least 20 percent extra, at one time. Doing this allows you to match grain and color.

Don't think of the extra you buy as waste. I don't discard any decent-size cut-offs until all the parts of a project are cut and assembled. This wood is perfect for testing setups and techniques, and trying out finishes. Plus, having identical stock on hand can save a project if you need to re-create a spoiled piece or make an inconspicuous patch.







**8 Go with what you know.** You need to experiment in order to learn new skills. But if you're working with a deadline, it may not be the time to try something new. Go with techniques you know, such as simple biscuit joinery, instead of making this the time you learn how to hand-cut dovetails.

**9 Have your hardware when you start.** The last thing you want is to cut all your project parts based on specific hardware, only to find it unavailable. You may have to substitute if you can't find the exact item specified. If so, expect to alter dimensions accordingly.

**10 Plan your steps before each session.** Before you head for the shop, plan what you want to accomplish. This reduces errors by focusing your concentration on specific tasks, and reduces setup changes by grouping similar operations (more on this later). Plus, planning eliminates time wasters, such as finding out one piece isn't sanded to final grit when you have wet finish on everything else.

**11 Build a prototype.** If the project includes new techniques or a modified plan, or if you need to get a glimpse at a new design of your own creation, prototype it, as I did with the candle lantern in issue 148. You'll keep the mistakes off your real project. Your cut-off bin is a great place to find prototype stock, but if you need to buy wood, try poplar. It's inexpensive and easy to work.



Finished project

Prototypes

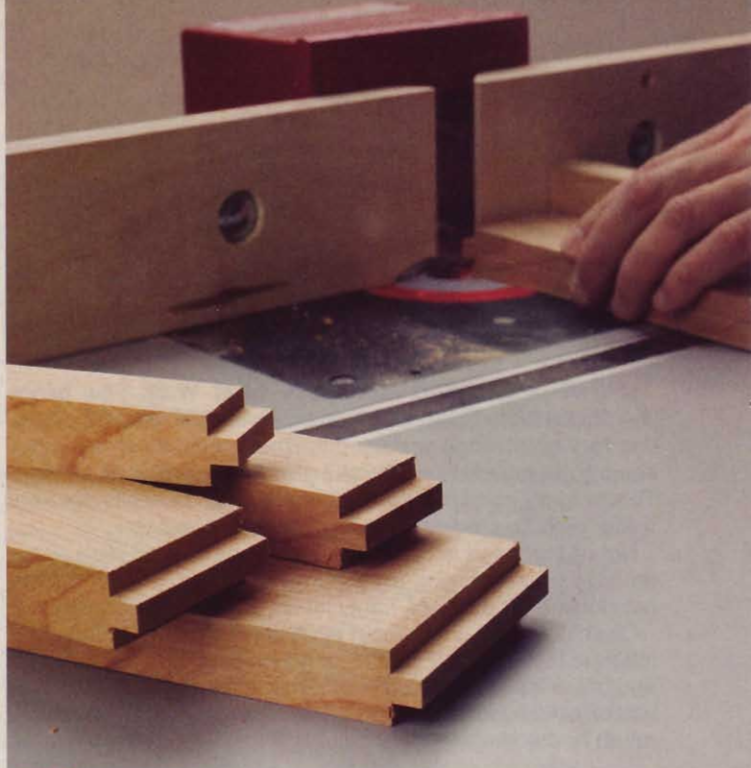

**12 Minimize setups on similar operations.** When you begin a project, start by thickening all your stock at the same time to make sure your parts match exactly. Then determine which parts require similar joinery.

Tenons, for example, often share the same dimensions throughout a project, even if the pieces they're cut into are of different sizes. Perform those cuts at one time so you're not constantly redoing the same setup.

Even with careful planning, duplicating setups is inevitable on some projects. Make it easier on yourself by taking notes and keeping your test pieces to use as templates. These approaches don't only save time, they increase accuracy.

**13 Cut lumber to size early.** Double-check measurements (and whether any parts need to start out oversize), and then pre-cut all the parts you can. This saves you from tripping over long boards while you work. While you're at it, cut an extra of any piece that requires testing tool setups.

Mark each part with its name or letter using chalk. It shows well, yet sands away easily without staining.

If parts will sit for a long time before being used, bind them with plastic stretch wrap, found in about any office-supply store. This organizes the parts and inhibits wood movement caused by changing moisture content. 🌲

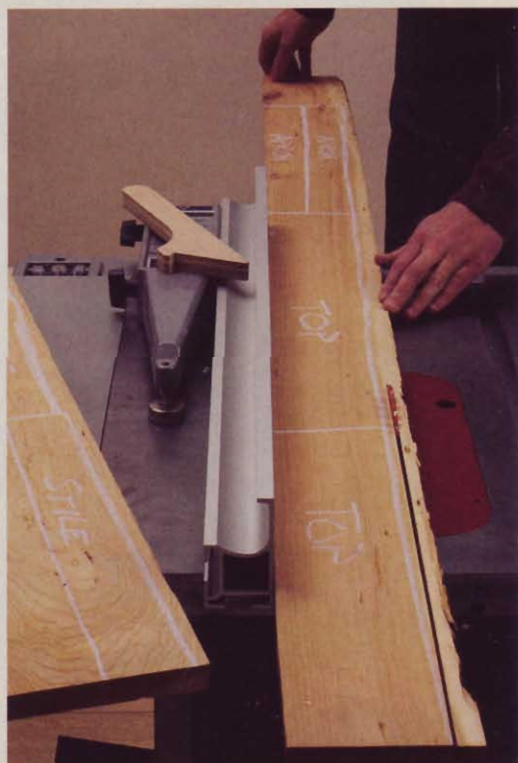



the judges have spoken ...

# INTRODUCING THE 2003 "FOR THE BIRDS" birdhouse/bird feeder CONTEST WINNERS

Readers let their woodworking talents soar in a contest that helps our fine feathered friends.

**F**ew things spark a woodworker's creativity as much as being issued a challenge. And challenge we did when we asked our readers to build the best birdhouses and bird feeders in America for the *WOOD*® magazine/Chevy Silverado 2003 "For the Birds" contest.

Sure, we expected a big response. There were, after all, \$8,000 worth of cash and prizes on the line. But the contest also offered participants a way to help out birds and other wildlife. How so? After the contest ended, we auctioned off all 271 amazing entries and turned the proceeds (more than \$8,000) over to the National Wildlife Federation's "Backyard Wildlife Habitat Program." (Visit [www.nwf.org](http://www.nwf.org) to learn more about the program.)

We were overwhelmed by the variety and creativity exhibited in the birdhouses and bird feeders we received. Our judges (see the sidebar, *opposite page*) praised the workmanship displayed. "I just wish we had about 50 more prizes to give away," said Editor-in-Chief Bill Krier, as they sorted through the field.

Now, in honor of the best of the best, we give you the winners.



## Best Overall Birdhouse/ Bird Feeder

**\$5,000 Grand Prize Winner**

John Styga of Elmhurst, N.Y., wowed the judges with "Mother Hubbard's Boot," a 2'-tall masterpiece of birdhouse fun and function. "I'm an artist and have illustrated a lot for children," John says. "To me, the theme was a natural." The realistic boot features three separate dwellings under its arched, shingled roof. Latched doors hinge open for cleaning. More impressive details include the partially laced front, with the tongue hanging out to serve as a perch. The carved brick chimney, and "windows" with hand-painted curtains complete the design.

## Best Original Outdoor Species-Specific Birdhouse

**A \$425 Freud router setup**

Mike Jagielo of Almond, Wis. created his "Wren Castle" from recycled old-growth redwood, and finished it to a satiny luster using spar urethane over tung oil. To complete the theme, each tower is topped by a brass flagpole and copper flag. Several windows feature vents to keep the residing birds comfortable, and an opening in the bottom makes cleaning the birdhouse a breeze.





### Best Original Outdoor Birdhouse

\$700 worth of Campbell-Hausfeld air tools

The "Purple Martin Hotel," made by Michael Sosebee of Newton, N.C., provides first-class accommodations for eight martin families. The main case, made from redwood staves, is impeccably finished with high-gloss enamel. A painted finial tops the cedar-shingle roof, while decorative brackets underneath grip a 4x4 mounting post. A removable base allows the interior dividers to be removed for easy cleaning.



### Best Original Turned Outdoor Birdhouse/Bird Feeder

A \$650 14" Delta lathe

It's easy to see the beauty of the turned acorn house crafted by J. Stan Johnson of Lexington, S.C. Its spalted maple body and walnut cap (with realistic texture courtesy of a chatter tool) display faultless quality. Even the stem (made from a 1/2" bolt) is hammered and colored to look real. But what pushed this entry to the top was the clever threaded cap that allows for cleaning and the vent holes under the cap and at the bottom to provide climate control for the home's lucky residents.



### Best Bird Feeder from Existing Plans

\$300 worth of Gorilla Glue and Lutz Tools

Donald Hopkins of Salem, Ore., likes his "Pyramid Canopy" feeder so much that he built eight of them. "Two hang in my yard," says Donald. "The others went to grandchildren and friends." This one features a cedar roof with compound-angle-cut panels suspended over a handcrafted copper tray.



### Best Outdoor Birdhouse from Existing Plans

A \$330 DeWalt router from Woodcraft

Donald Berard of Mission Viejo, Calif., worked about 100 hours to craft his award-winning entry. His effort and unique skills appear everywhere, but especially in the copper roof. "I sandwiched each copper sheet between blocks shaped like the shingles, and then carefully pounded the edges with a polished ball-peen hammer. Then I glued each to a wooden shingle," Donald says. The results are a study in perfection.

## A little bit about our judges

Picking a few winners from all the great entries wasn't easy, but our judges proved up to the task. Editor-In-Chief Bill Krier and Senior Design Editor Kevin Boyle were joined by another seasoned woodworker: Scott Phillips, the host of "The American Woodshop" on PBS. Joe Wilkinson, President of the Iowa affiliate of the National Wildlife Federation, brought his insight into what birds like.



Contest judges (from left to right) Joe Wilkinson, Bill Krier, Scott Phillips, and Kevin Boyle are all smiles as they pose with the eight winning entries after a long day of judging.



The 271 entries filled this room and another to overflowing with every imaginable type of birdhouse and bird feeder.





### Best Original Bird Feeder

**A \$520 1/2" hammer drill from Makita**

Russ Deiter of Omer, Mich., incorporated loads of convenience features into his beautiful, functional "Rusty Bridge" bird feeder. Most notable—the easy-loading bin accessed by removing the top of the roof. Seeds pour into both sides at once and spread below for access from either outside or within the bridge. "The best feature is the copper-screen base, which allows snow and rain to run off without causing rot," Russ says.



### Best Original Indoor (decorated/painted) Birdhouse

**\$300 worth of Rust-Oleum paint products**

Johnny Johnson of Lindale, Texas, used old cast-iron parts left over from his days in the fencing business, cut nails, and even a door-knob perch to lend a distinctive thematic look to his church birdhouse. With its towering spire and patinaed shingles, this entry has the look and charm of an antique right out of the box.



## More high-flying entries

There's no way to show you every creative, well-crafted entry in this contest. While only eight could win prizes, many more thoroughly impressed the judges. Here are just a few:



Jaime Fusko of Canton, Ohio, made and assembled 1,358 wooden bricks, 343 stone-look blocks, and 380 cedar shingles, and then added 1,450 shrubs and flowers to create his vision of a bird's dream cottage.



Richard Starr of Burton, Mich., crafted this whimsical entry almost entirely from scraps. The roof is glued up from pieces of floor joist, the worm-holed trunk was cut from a 2x12 header, and the bases are from cedar trim boards.

The message over the door of this charming birdhouse reads "home sweet home" in Japanese characters. Charles Chaplin of Waynesboro, Miss., created it by gluing up small pieces of mahogany, fir, and spanish cedar, and then turning the assemblies to create the body and roof.



Bill Oakley of Rancho Santa Margarita, Calif., threw a variety of woodworking skills into the pot to create this stunning birdhouse. The teapot body is a hollow turning made up of stacked rings and painted to resemble an old-style enameled finish.



Three uniquely-styled houses perch on a "grass" base in this birdhouse colony entered by Lawrence Jenkins of Shellsburg, Iowa. He formed the lap siding using a dado blade tilted to 10°, and cut each cedar roof shingle. All three houses feature vents and removable roofs.



William Fischer of Norfolk, Va., made a big hit, literally, with this hammer birdhouse. It features two separate homes. One has a clean-out door. Access to the other comes by releasing a spring-loaded retainer and removing the head from the handle.



Howard Clements of Knox, Pa., created this Noah's Ark that springs to life with a battery-driven homemade works that raises and lowers the giraffes' heads, moves the rooftop owl up and down, and makes Noah and his wife wave.

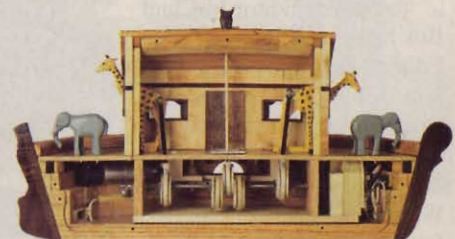



# dead-on drilling

Get accurate, trouble-free results from your drill press by following these simple guidelines.

**T**he drill press seems simple compared to a workshop's other stationary machines. But when it comes to setup and use, many of the same operating principles apply: You need to align it properly; add some basic accessories; and stick with safe, sensible procedures.

To help you along, we've collected six surefire tips and techniques to guarantee your drill-press success. They're simple, quick, and require only items that you already have in your workshop.



## 1 Line it up at 90°

Because we tilt drill-press tables for angled drilling from time to time, or because they may not be perfectly set at 90° when purchased, we sometimes must reset the table for perfect right-angle boring.

To do this, get hold of a 10" piece of heavy wire like that found in a coat hanger. Bend each end into a right angle, and chuck one end in the drill press. Set the height of the table so that the free end of the wire contacts the surface. Turn the chuck by hand, keeping an eye on the wire to make sure it maintains consistent contact with the table without flexing. If so, the table sits at 90° to the chuck. If you find that one side is lower than the other, adjust it as shown in your owner's manual.

## 2 Call for backup

Protect your bits while expanding your work surface with a 3/4" plywood auxiliary table clamped or bolted to the metal table, as shown in the photo at the *top of this page*. When you need to drill several through holes, go one step further—place a backer board on top of the auxiliary table. Use any handy scrap, such as the particleboard shown at *right*. The backer board prevents tear-out on the bottom of your workpiece by supporting wood fibers around the hole, while keeping your auxiliary table intact. Move the backer board to place solid material beneath the next hole.





### 3 Set the depth

After you mount the bit and adjust the table height, set the depth stop to control the depth of the hole. On the typical depth-adjustment assembly shown here (your drill press might have a different stop design), lower the bit alongside your workpiece to the chosen depth, hold it there, turn the depth-stop nut until it contacts the top of the bracket, and then tighten the jam nut against it.

If the depth-stop rod is calibrated, like the one shown here, you have another choice. Lower the bit until it contacts the workpiece, note the location on the gauge, and then move the depth-stop nut up the desired distance and hold it in place by turning the jam nut against it.

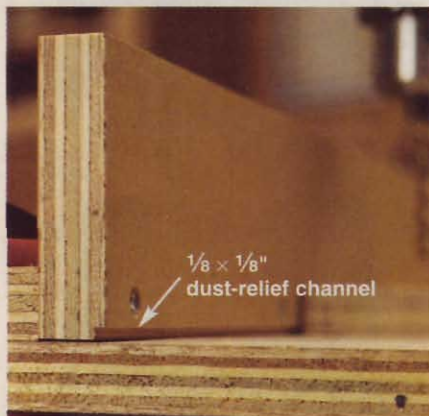
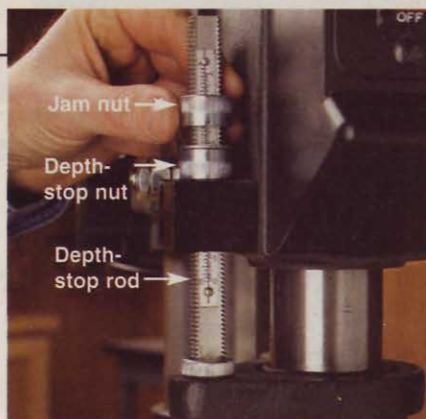

### 4 Add a dust-relieving fence

A simple fence comes in handy when you need to drill more than one hole at the same distance from the edge of the workpiece. Make a fence by cutting two straight pieces of  $\frac{3}{4}$ " stock to a length that matches the width of your auxiliary table. Use your tablesaw to cut a  $\frac{1}{8} \times \frac{1}{8}$ " dust-relief channel at the edge of one piece. This channel preserves accuracy by keeping sawdust and wood chips from lodging between fence and workpiece. Screw the pieces together at a right angle, as shown, and you have a fence that's easily clamped to the table.

### 5 Get a grip

Twist bits can drift off course when drilling into irregular grain, especially small-diameter bits like the  $\frac{1}{16}$ " bit shown here. Limit this tendency by inserting the bit well into the drill-press chuck when you mount it. Leave enough of the bit exposed to bore the hole to the desired depth—and make sure that it's centered in the chuck, not trapped between just two of the three jaws. You also can improve your accuracy by using brad-point bits.



TWIST BIT



BRAD-POINT BIT



### 6 Drill a dowel end

One of the trickiest drill-press tasks is boring a centered hole into the end of a dowel. Try this quick and neat solution.

Clamp a  $2 \times 3$ " scrap of  $\frac{3}{4}$ " wood to your drill-press table, and bore halfway into it with a Forstner bit that's the same diameter as your dowel. Leave the scrap in place, replace the Forstner with a bit the size of the hole you want to drill in the dowel, and drill the rest of the way through to make the centering guide shown at left. Place the larger hole on the end of the dowel, and clamp the dowel onto a holding jig, such as the V-groove version shown. Lower the bit to align it with the smaller hole. Clamp the holding jig to your drill-press table, and carefully drill your hole, as shown above. ♣

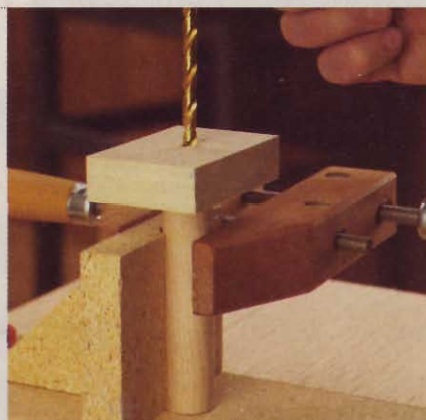



# shop-proven products

These woodworking wares passed our shop trials

## \$375 bandsaw delivers big-time

After testing a whole bunch of bandsaws priced from \$500 to \$900 for a recent issue of *WOOD*® magazine (issue 144), I didn't expect too much out of a stationary saw costing only \$375. But the Grizzly G0555 isn't some stripped-down, under-powered, ugly machine. In fact, it's quite the opposite.

Standard features include ball-bearing blade guides, 4" dust port, a quick-release tensioner that allowed me to change blades in about 8 minutes, a miter gauge, and a really good rip fence. You'd have to spend hundreds of dollars more to find another bandsaw with this many standard accessories.

The fence is probably the best I've seen on a 14" bandsaw. It adjusts to compensate for blade drift, and features a magnified cursor for easy reading. And, unlike many other bandsaws, it lifts right off the rail without having to partially disassemble the saw.

As for power, the G0555's 1-hp dual-voltage motor packs enough punch to resaw 6"-wide red oak boards easily. If I'd had this saw for the test a few months ago, it would have finished about in the middle of the pack for resawing power.

You can run 92–93½" blades from ⅛" to ¾" wide on the G0555. Its 6" resaw capacity bumps up to 12" with the addition of a riser block (\$50). Add that and an optional mobile base for \$70, and you're still paying less—a lot less—than I paid for a 14" bandsaw just two years ago with none of the features. Is it too late to get my money back?

—Tested by Jeff Hall

### Grizzly G0555 14" bandsaw

Performance	★★★★☆
Price	\$375, plus \$55 shipping where applicable
Value	★★★★★

Call Grizzly Industrial at 800/523-4777, or visit [www.grizzly.com](http://www.grizzly.com).



## Rout dadoes that fit first time, every time

As the years go by, I've noticed that I keep getting fatter while plywood keeps getting thinner. That means that routing dadoes to fit ¾" plywood (actually about 23/32" thick) requires a ½" bit and two passes for each dado. And if you don't measure, calculate, or clamp your fence correctly for the cleanup cut, you can

wind up with ill-fitting joints. But with the Accurate Guide, you can rout perfectly fitting dadoes for ¼–1" materials with only half as many fence setups (and no lousy math!).

Let's say you're building a bookcase with ¾"-thick plywood shelves. After installing the Accurate Guide in your router's edge-guide mounting holes, lay out the shelf location and clamp on a fence to guide the router. With the two halves of the Accurate Guide closed and held against the fence, make your first cut using a ½" straight (or downcut spiral) bit. For ½" or thinner stock use a ¼" bit.

Next, spread the two halves of the Accurate Guide and insert a couple of scraps of shelf stock between the two halves, as shown at left. Without moving the fence, make the cleanup cut. The shelf scraps index the guide precisely for a dead-on dado.

The Accurate Guide works equally well and in the same manner for routing slots for perfectly fitting sliding dovetails. If you have a Makita 1100- or 1101-series, or Porter-Cable 100- or 690-series router (except for the D-handle base), order model no. P2001. The B1001 model fits all Bosch routers and DeWalt's 600-series routers.

—Tested by Garry Smith

### Accurate Guide

Performance	★★★★★
Price	\$60
Value	★★★★☆

Call Accurate Woodworking Tools at 920/589-4010, or visit [www.accuratewoodtools.com](http://www.accuratewoodtools.com).

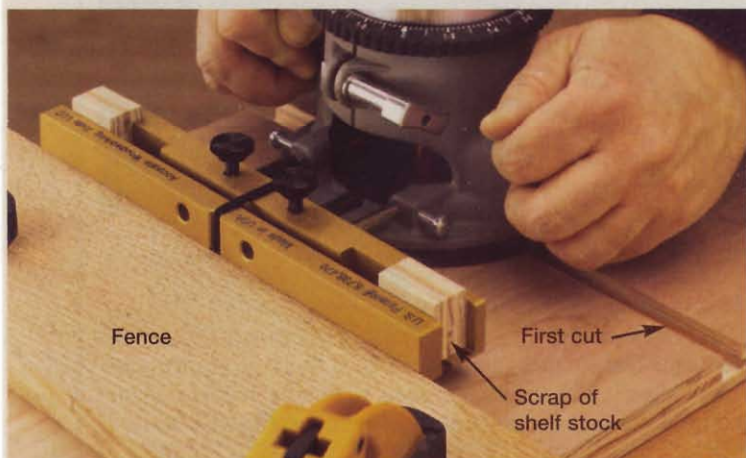



## Caster set puts wheels where you want them

No matter how large or small your shop, you'll benefit from the flexibility of having heavy stationary tools on mobile bases. But some mobile bases are a pain to assemble (can you say "bag of bolts"?). More important, you can't change the wheel locations to best serve the tool they'll hold.

If you own closed-base stationary tools, there may be an answer. Jet's Clamp-on Castors mount individually to such tools so you can place them anywhere around the base. The installation instructions make several suggestions about where to best place the wheels for tools with different centers of gravity, whether low (jointer), high (bandsaw), or off-center (cabinet saw or shaper).

The Clamp-on Castors installed easily on both my bandsaw and jointer, especially because I only needed to tilt those heavy tools slightly during installation, rather than muscle them onto a mobile base. The casters' magnetic faces held them in place while I tightened the J-shaped clamps that grip the wrap-under flange on most closed-base tools. (Oddly, my Jet 14" bandsaw lacks that flange, but the casters held fast anyway, although the cabinet flexed more than on my jointer, which has a flange.)

In use, the casters locked and rolled easily, even over broken concrete. Clamp-on Castor sets come in two configurations: Model JMB-CTR includes two fixed and two swivel casters; the JMB-CTR2 set comes with four swivel casters. Neither set works with open-stand tools.

—Tested by Dave Stone

### Jet Clamp-on Castors

Performance	★★★★☆
Price	\$60, model JMB-CTR; \$70, model JMB-CTR2
Value	★★★★☆

Call Jet Equipment & Tools at 800/274-6848, or visit [www.jettools.com](http://www.jettools.com).

Continued on page 104

## ITK Blade Packs from CMT: Your best value on the best blades!

CMT's new ITK Blade Packs are the perfect way to add the finest thin-kerf performance to your shop at incredible prices! Each of these five special packages includes one of our most popular 10" or 12" blades, plus our 7-1/4" Framing/Decking or Finishing blade and an 18 oz. bottle of CMT's super 2050 Blade & Bit Cleaner.



### CMT's ITK Blades feature:

- ◆ Micrograin carbide teeth
- ◆ Premium steel plate
- ◆ Anti-kickback design
- ◆ Laser-cut plate & arbor
- ◆ Tri-Metal brazing, precision balancing & more!

### Call your CMT Distributor for a super deal on ITK Blade Packs

SBP001	General Purpose 10" Table Saw Pack 10" x 42 General Purpose, 7-1/4" x 24 Framing/Decking
SBP002	General Purpose 12" Miter Saw Pack 12" x 45 General Purpose, 7-1/4" x 24 Framing/Decking
SBP003	Fine Cut 10" Miter Saw Pack 10" x 60 Compound Miter, 7-1/4" x 24 Framing/Decking
SBP004	Fine Finish 12" Miter Saw Pack 12" x 72 Compound Miter, 7-1/4" x 24 Framing/Decking
SBP005	Fine Finish 10" Premium Pack 10" x 80 Fine Finish, 7-1/4" x 40 Finish



Each pack includes CMT's 2050 Cleaner, the perfect way to keep blades & bits in tip top shape!

Ask your CMT Distributor for the full story about CMT blades, router bits, shaper cutters and more. Or contact CMT for your free 2003 catalog, and the name of a distributor in your area.

888-268-2487 • [www.cmtusa.com](http://www.cmtusa.com)





**Psoriasis? Eczema? Seborrheic Dermatitis?  
Stubborn Dandruff? Red, Scaly, Itchy Skin?**

**Acadia Skin Care® can help restore  
your skin to its normal, healthy state.**

**WE GUARANTEE IT!**

Here's what some of our 80,000  
customers are saying!

"It just works miracles. I couldn't  
ask for anything better."

"I can finally sit down and enjoy a  
meal with my family without  
scratching."

"I can wear a skirt again. I'm  
totally cleared up."

"I've tried just about everything  
on the market and nothing  
works like this."

"Within 10 days of receiving  
my order, the itching had  
completely gone away."

*(Individual Results May Vary.)*

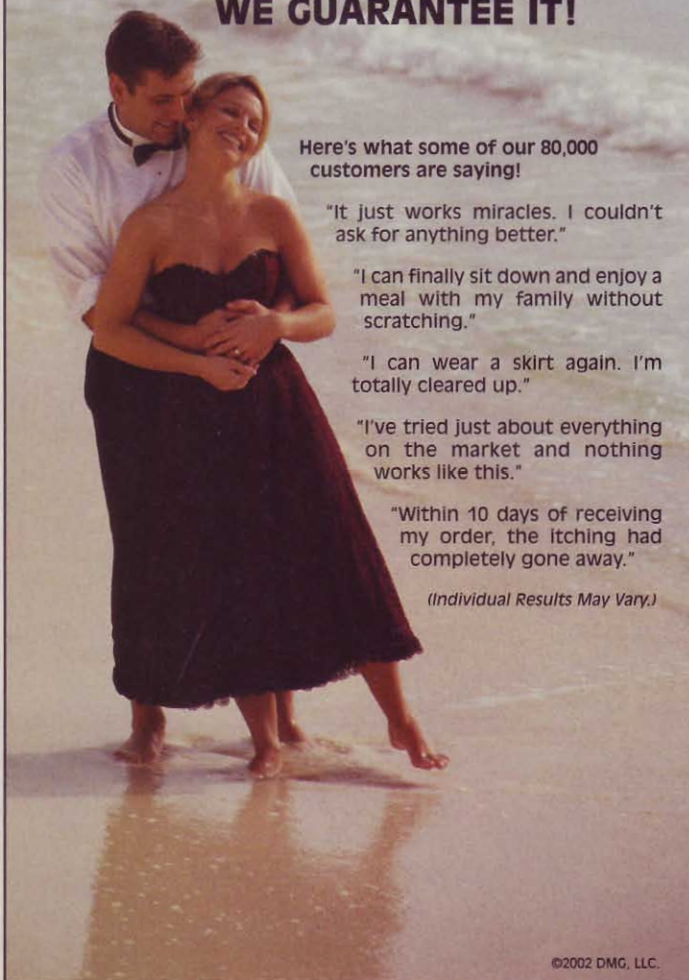

©2002 DMG, LLC.

If you're tired of ointments and creams that are messy, hard to apply and, worst of all, don't get results, then you owe it to yourself to try Acadia Skin Care.® Acadia will help relieve the irritation and embarrassment of Psoriasis, Eczema, Seborrheic Dermatitis, rough, dry skin and Dandruff.

No burning, no prescriptions, no steroids, no alcohol and best of all, it's easy to apply, even in those hard to reach areas.

**Call now and put Acadia Skin Care to work for you.**

Acadia Skin Care's active ingredients are FDA approved and dermatologist recommended, so you know it's safe, and it works. Don't suffer any longer. Acadia Skin Care is odorless, easy to apply and very effective.

**Isn't it time you looked and felt your best? All it takes is a phone call!**

**Call Now For Your 30-Day Risk-Free Trial!**

**1-800-840-8020 Ext. S-6578**

Mention this ad and receive a FREE bottle of our therapeutic body wash with your purchase. (Active Ingredient FDA Approved)

ACADIA ALSO OFFERS REVOLUTIONARY NEW PRODUCTS FOR BOTH ACNE AND ROSACEA.

**shop-proven** products

**Spiff up your hardwood floor in a day**

If you've ever wished you could put a new face on your lightly worn hardwood floor, but didn't want to endure the hassle and expense of sanding and recoating, here's another option: the Renewal system from Varathane.

To start the process, I scrubbed the surface of my 75-year-old oak dining-room floor with a woven-abrasive pad dipped in Renewal's "no-sanding formula." The manufacturer says this liquid removes wax and "chemically etches" the existing flooring. This step was easy enough, but mopping up with rags and clean water gave me about an hour on my hands and knees. After letting the floor air dry for about half an hour, I applied Renewal's "interloc bonding formula," in the same manner as step one. After 30 minutes of scrubbing, another hour of mopping, and 30 minutes of drying, I applied the top coat.

Using the lambs-wool applicator that comes with the product left me with a lot of bubbles in the water-based finish, even after following the manufacturer's stir-and-let-settle instructions to the letter. I ended up sanding the entire floor with a random-orbit sander—only about a 20-minute chore in my 12x12' room—and reapplying the finish. This time, I used my own painter's pad, and reduced the number of bubbles to an acceptable level. Besides the bubbling problem, the lambs-wool applicator isn't very precise. Fortunately, I had masked off all of the base molding around the room to protect it from steps one and two, and that saved me from slopping fresh finish on the old molding.

Eight hours later, I could walk on the floor in stocking-feet, but we waited 72 hours before replacing the heavy furniture or walking on it with hard-soled shoes.

Renewal isn't designed for use on floors with stains, deep scratches, or gouges that go all the way through the finish: You'll still need to sand and refinish those floors. But, armed with a painter's pad and a full day, you can rejuvenate your gently worn hardwood floor for about what it costs to rent a floor sander.

—Tested by Bill Krier

**Varathane Renewal**

Performance	★★★★☆
Price	\$70 (restores 225 square feet)
Value	★★★★☆

Call Varathane at 800/635-3286, or visit [www.varathane.com](http://www.varathane.com).





## Slash knife-changing time by 70 percent

Nothing cuts like a new blade, but few things frustrate like changing knives in a jointer or stationary planer. I've long been a fan of Esta-USA's Dispoz-A-Blade system that brings the convenience of quick-change, self-indexing knives to stationary planers and jointers. But, unless your tool's cutterhead came equipped with jackscrews (screws in each blade pocket that you raise or lower to adjust the knife height), you couldn't really take advantage of the system until now.

For jackscrew-less jointers and planers, Esta-USA now offers Posi-Set magnets—rare-earth magnets, custom-sized for your tool—that rest in the bottom of the cutterhead's knife pocket to fix the height of the Dispoz-A-Blade blade holder. You simply measure the depths of your knife pockets and give the measurements to the manufacturer. (Or, Esta-USA will send you a free measuring card if you call.) Then, they'll send the right magnets.

Once installed, the knives drop in at the perfect height every time. Using the Dispoz-A-Blade system with Posi-Sets, I swapped the three knives in our Jet 8" jointer in less than 10 minutes—a job that previously required nearly an hour and a few unprintable expletives.

At about \$150 to equip a 6" jointer with the Dispoz-A-Blade system, plus another \$45 for the Posi-Set magnets, the startup cost isn't for the faint of heart. Once you bite the bullet, though, it costs about the same to replace the double-edged knives as it would to have conventional knives sharpened twice. But how much is your time—and sanity—worth?

—Tested by Chuck Hedlund

### Posi-Sets and Dispoz-A-Blade

Performance ★★★★★

Price Posi-Set, \$7.50 per magnet; Dispoz-A-Blade system: \$153 for 6" jointer, \$180 for 8" jointer, \$223 for 15" planer

Value ★★★★★

Call 800/557-8092 or visit [www.estausa.com](http://www.estausa.com).

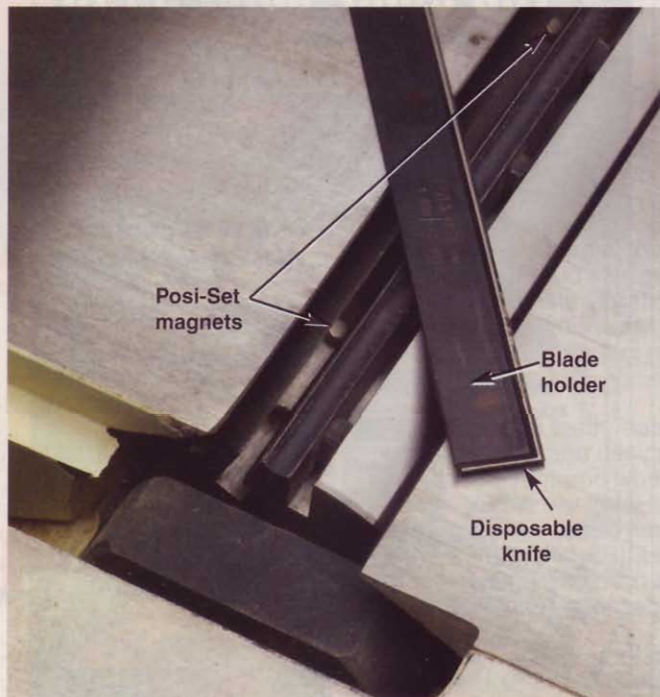

Continued on page 106

NEW!

# Router Mania

by Rockler.com  
WOODWORKING SUPERSTORE

## Enjoy one-stop shopping for your router!



Rockler's new web site has everything for your **router** needs, including router tables, bits, accessories and more.



### Exclusive Router Table Package Only \$369.99

Includes:

- Porter Cable 2 H.P. Plunge Router with Micro-Height Adjustment
- Table & Fence System
- Aluminum Router Plate

Legs & accessories sold separate. Price Expires 7/31/03

Visit [www.RouterMania.com](http://www.RouterMania.com) now!

Circle No. 661



## POCKET HOLE SYSTEMS

Have you discovered the Pocket Hole Advantage?

Visit [KREGTOOL.COM](http://KREGTOOL.COM) today to learn how the speed, strength and simplicity of pocket hole joinery can greatly enhance your woodworking experience. Our "Virtual Trade Show" features a **FREE** video demonstration of our tools and techniques in action!



1



Drill pocket holes.

2



Drive screws.

Two simple steps for perfect joints.

Contact us today to learn more!



The **BLUE** Mark of Quality.

[www.kregtool.com](http://www.kregtool.com)  
800.447.8638

Circle No. 635



## Powermatic 54A: A longer, stronger 6" jointer

As a rule of thumb, you can successfully straighten a board up to twice the length of your jointer's bed (the combined infeed and outfeed tables). With the Powermatic Model 54A, its 66"-long bed—the longest of any 6" jointer on the market today—allows you to work stock up to 11' in length. I rarely joint stock that long, but welcome the extra support it provides shorter workpieces.

While bed length is important, it means little if the jointer lacks sufficient power. That's not a problem with the Model 54A. After edge-jointing some stock at a 1/8" cutting depth, I face-jointed some 5"-wide cherry, forgetting to reset the cutting depth to a more reasonable 1/64". The 1-hp, dual-voltage motor slowed when making this brutal cut, but didn't stall.

Speaking of cutting depth, the Model 54A has a unique system that combines the quick-and-dirty action of a lever with



the fine control of a handwheel. Raise or lower the lever to set the rough cutting depth, then push the lever's handle in and twist it to fine-tune the depth.

In my tests, the Model 54A's fence proved both flat (within .004" from end to end) and rigid, with a massive center trunnion. And the tilt stops at 45°, 90°, and 135° angles are positive, accurate, and repeatable: I switched from one to the other and back with complete confidence.

—Tested by Garry Smith

### Powermatic Model 54A 6" jointer

Performance	★★★★★
Price	\$750
Value	★★★★☆

Call Powermatic at 800/248-0144, or visit [www.powermatic.com](http://www.powermatic.com).

## Unique Woodworking Kits 800-847-4947



**Authentic Wagon**  
\$109.00\*  
\*(\$8.00 shipping, USA)



**Buckboard Bench**  
\$49.00\*  
\*(\$6.00 shipping, USA)



**Wheelbarrow**  
\$59.00\*  
\*(\$5.00 shipping, USA)

We offer many build-it-yourself kits: buckboard bench, irish mail handcar, wheelbarrows, halltree, sleigh, baker's cart, garden cart, & park bench. All kits come with complete hardware, detailed instructions and full size patterns.

### Items shown:

#### 1901 Buckboard Wagon

Measures 36"x16"x18" Tall  
Build your 1901 wagon with these authentic looking plastic wagon wheels, which are very sturdy and look great.

#### Buckboard Bench

Measures 42"(long) x 22"(wide) x normal seat height  
Authentic reproduction seats two adults comfortably. Great for indoors or on the patio.

#### Antique Wheelbarrow

Measures 56"(long) x 24"(wide) x 29" Tall  
Build this nostalgic Antique Wheelbarrow, for use in your backyard or a display piece.

- All Items Shipped UPS
- All Items US currency required
- Indiana Sales add 6% sales tax

Many More Items Available!  
Call for Catalog: 800-847-4947

**The Roudebush Company**  
PO Box 348  
Star City, IN 46985

Visa & Mastercard Accepted  
[www.woodkitsandplans.com](http://www.woodkitsandplans.com)

Maintain the beauty of outdoor wood furniture for years.

## The clear solution to outdoor wood finishing.



\* \$5.00 rebate on purchases of System Three Marine, Inc. products over \$25.00 (cash rebates) 2/1/03 and 6/30/03 Limit 1 per customer. Instructions on rebate coupon must be followed.

### Designed for the exacting standards of boatbuilding.

For over 2 decades we've been providing boatbuilders with the highest quality epoxy resins & spar varnishes for their "furniture quality", clear-finished watercraft. These wooden boats continue to look great after several years of extreme outdoor exposure.

### Get it right. Get the brochure.

The same techniques can be used to finish many other outdoor wood projects. Your wooden furniture can be exposed to the elements for months without fear of the finish failing. Get an info-packed brochure at: [www.systemthree.com/outdoor](http://www.systemthree.com/outdoor) & create beautiful, lasting, outdoor wood masterpieces

Download the brochure. It's filled with tips & a \$5.00 rebate\* towards your next purchase.

**SYSTEMTHREE**

Find a dealer near you: 1.800.333.5514

©2003 System Three Resins, Inc. All Rights Reserved.



## These circle jigs cut no corners

When it comes to cutting perfect circles in wood, I've resorted to shop-made router jigs with mixed success. (Frankly, I usually spend more time building the jig than using it.) That's why I was intrigued with the Jasper Circle Jigs that boast accuracy through a wide range of circle sizes.

The concept isn't new: Replace your router's subbase with an oversized auxiliary plate and put a pivot pin in the center of your workpiece. Mark the radius of the circle on the auxiliary plate, drill a hole there for the pivot pin, and start cutting.

Instead of a one-off jig, though, each Jasper jig has a series of pivot-pin holes at precise increments from the router-bit hole. For example, the Model 200 jig allowed me to rout any diameter circle from 2¼–18¾" in ¼" increments. That's 256 different sizes, and every hole I cut was right on the money.

Because many of the Model 200's pivot holes are for diameters smaller than the router's base, all of the increments are marked on the bottom of the jig. That makes it more difficult to locate the pin for any diameter. But Bill Jasper of Jasper Audio, the maker of the jigs, suggests putting the pivot pin into the jig first, then using it to find the center hole in the workpiece.

For cutting circular tabletops, or other large arcs, the Model 300 jig provides the same accuracy in ¼" increments from 7–52¾". In such cases, you also will want Jasper's Model 350 pivot pin. It's a short pin on a thin plate that attaches with double-faced tape, so you needn't drill a hole in your workpiece.

Model 600 (shown below, and the best value in the bunch at \$31) cuts circles from 7–18¾" in ¼" steps, and the smaller Model 400 provides ¼" increments ranging from 1–7½". Each Jasper Circle Jig comes pre-drilled with countersunk holes for mounting virtually every major brand of plunge router, so within a minute or so of opening the package, I was ready to make circles.

—Tested by Kirk Hesse

### Jasper Circle Jigs

Performance	★★★★☆
Price	\$46, Model 200; \$54, Model 300; \$36, Model 400; \$31, Model 600 (all prices include shipping)
Value	★★★★★

Call Jasper Audio toll-free at 877/229-7285, or visit [www.jasperaudio.com](http://www.jasperaudio.com).



Continued on page 108

# Finally... a COMPLETE Pocket-Hole Jig Kit!

OUR COMPLETE KIT INCLUDES:

- Pocket Jig with Clamp
- 3/8" Step Drill Bit
- Stop Collar for Drill
- Hex Wrench for Collar
- Square Drive Screws
- 6" Square Drive Bit

ALL THIS FOR ONLY \$39.95 sugg. ret. SEND FOR DEALER LIST

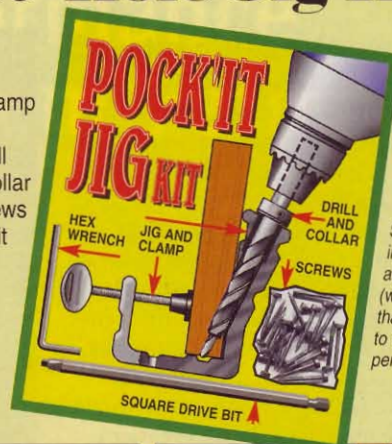

Shown here in our kit, are all the pieces (with your drill) that you'll need to execute perfect joinery.

USE THIS POCKET JIG KIT TO MAKE:

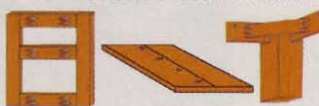

Face frames, table leg braces, flush joints plus corner and angle joints.

Heavy-duty aluminum extrusion with hardened steel drill bushings.

Shown here in use, the jig's built-in clamp holds the wood firmly in place for accurate drilling.



## SIMP'L PRODUCTS Inc.

21 Bertel Avenue, Mount Vernon, NY 10550

Web Site: [woodjigs.com](http://woodjigs.com) E-Mail: [info@woodjigs.com](mailto:info@woodjigs.com)  
Available through most fine woodworking outlets.

Circle No. 2085

# Get Rid of the Dust!

## 1.5hp to 20hp Systems



2hp Component External Filter

Let us design your complete dust collection system.

**FREE System and Ductwork Catalog!**

**FREE Duct Design** with \$50 Order



**Buy Direct and Save!**  
**1.800.732.4065**

**Order Online!**  
[www.oneida-air.com](http://www.oneida-air.com)

See us at AWFS 2003 Booth # 738



Proudly Made in the USA

Oneida Air Systems, Inc. 1001 W. Fayette St. Syracuse, NY 13204

Circle No. 2039



### Meet the self-centered pen-boring clamp

If you're a pen turner, chances are you've let a few choice words slip after blowing through the side of a pen blank while accidentally drilling the center hole off-center. The Drilling Center Vise helps eliminate the heartbreak of bungled blanks.

Before using the vise, I first centered it under the drill-press chuck, and clamped it to the drill-press table. (A larger wooden base would have made the job a little easier.) Once secured, all I had to do was drop in a piece of pen-blank stock, and turn the crank to center and clamp. Both jaws open or close simultaneously, automatically centering the blank beneath the bit.

I used the Drilling Center Vise to hold various size blanks while boring 7mm and 10mm holes. I even bored holes in odd-shaped blanks, such as 3/4x1", all without fail and without repositioning the vise.

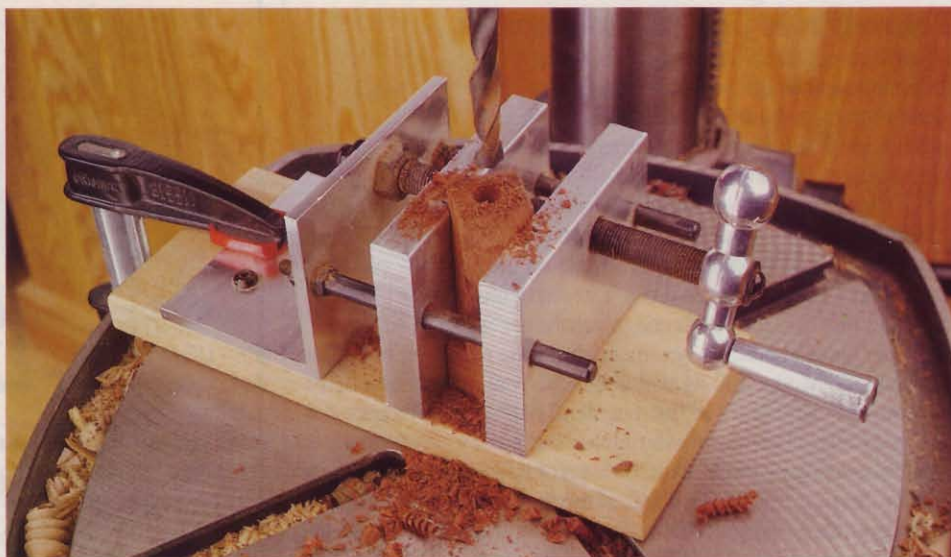

The money saved from botched boring (and from being able to salvage marginal-size scraps of exotic woods and burls) will help this accessory pay for itself in no time flat.

—Tested by Rich Bright

#### Drilling Center Vise

Performance	★★★★★
Price	\$49 ppd.
Value	★★★★★

Call Penn State Industries at 800/377-7297, or visit [www.pennstateind.com](http://www.pennstateind.com).

Osborne Wood Products, Inc. offers an impressive line-up of Kitchen Island legs in a variety of wood species. Custom turnings are also available.

8116 Highway 123 North • Toccoa, GA 30577  
 Call for a catalog: 1-800-746-3233  
 Order line: 1-800-849-8876 • Español: 1-877-445-6034  
 email: [turn@alltel.net](mailto:turn@alltel.net)  
[www.osbornewood.com](http://www.osbornewood.com)

## 4-WAY MONEY-MAKER! • MOLDS • PLANES • SANDS • SAWS

Now, turn a \$5 rough board into \$75 worth of straight or curved molding in just minutes! Make over 500 standard moldings, tongue & groove, picture frame stock, any custom design. Quickly Converts from Planer/Molder to Drum Sander or Power-Feed Multi-Blade Saw!

**FREE 30-DAY TRIAL!**  
 12", 18" & 25" Models

#### Variable Feed Rate!

Just a twist of the dial adjusts the Woodmaster from 70 to over 1,000 cuts per inch. Produces a glass-smooth finish on tricky grain patterns no other planer can handle. Plenty of American-made "muscle" to handle low-cost, "straight-from-the-sawmill" lumber. **5-Year Warranty, MADE IN USA!**

Call Today for Free Facts  
**1-800-821-6651 ext. P302**  
[www.woodmastertools.com](http://www.woodmastertools.com)

Woodmaster Tools, Inc. 1431 N. Topping Ave. Dept. P302, Kansas City, MO 64120



## No-dust chalk line is on the level

Chalk lines don't always mark well on uneven surfaces and sometimes require a helper to hold the other end, not to mention the dusty mess they leave behind. Strait-Line's Laser Line Generator (LLG) gives you a temporary line, even on rough surfaces, for hanging cabinets or pictures, or laying out floor tile.

Rather than creating a single dot like a laser level, the LLG casts an actual line from the center of its height, allowing it to "look" around many objects in its path, such as a window casing, a wave in the wall, or my finger, as shown in the photo below.

Although the 1/8"-wide beam generated by the Laser Line Generator is clearly visible indoors, full daylight easily overwhelms it. I measured the width of the beam 10' away from the unit, and found it had spread to 1/4"; at 30', the beam was 3/4" wide. Even at those distances, the beam was clearly defined, and still accurate as long as I remembered to mark in the center of the beam.

Spirit-level vials mounted on the case show both level and plumb, and their tight markings make it easy to assure a dead-level line. A pair of steel pins pop out the bottom of the LLG's case to affix it to drywall, flooring, or a wooden wall stud for hands-free operation.

—Tested by Kirk Hesse

### Strait-Line Laser Line Generator

Performance	★★★★★
Price	\$45
Value	★★★★★

Call American Tool Company at 800/838-7845, or visit [www.strait-line.com](http://www.strait-line.com).



## About our testing

We test hundreds of tools and accessories, but only those that earn at least three stars for performance and value make the final cut and appear in this section. Our testers this issue include: high-school industrial arts and woodworking teachers **Rich Bright**, **Jeff Hall**, and **Kirk Hesse**; machinist **Garry Smith**; and *WOOD*® magazine staff members **Chuck Hedlund** (master craftsman), **Bill Krier** (editor-in-chief) and **Dave Stone** (features editor). All are avid woodworkers. 🌲

# 9 Nights of Pleasure 1 Incredible Price

GUARANTEED  
FRESH

Limited Time Offer  
9 Premium Cigars

\$19<sup>95</sup>  
Retail Value  
\$58.00



[www.famous-smoke.com/specials](http://www.famous-smoke.com/specials)

key code  
ZMA0810

## Great cigars at Famous savings since 1939!

No matter what you pay for it, a fine cigar is worth every penny. But finding a cigar that suits your taste can get expensive! From the mild Macanudo to the savory Sancho Panza to the hearty Cohiba, there's a cigar for every preference. **Order Now...Offer good through July 31, 2003.**

Since 1939  
**FAMOUS**  
SMOKE SHOP

**1-800-656-2101**

Offer limited to one per household/customer.  
Please use key code ZMA0810 when ordering.

Yes! Please rush my 9 premium Cigars for only \$19.95 (plus \$4.95 S&H), a savings of \$38.05 off suggested retail and send me information on great Famous Smoke Shop values. (PA residents add 6% sales tax.)

Mail to: **FAMOUS SMOKE SHOP - PA, INC.**  
1100 Conroy Place, Easton, PA 18040

Name \_\_\_\_\_

Company Name (if applicable) \_\_\_\_\_

Address \_\_\_\_\_ Apt./Suite \_\_\_\_\_

City \_\_\_\_\_ State \_\_\_\_\_ Zip \_\_\_\_\_

Home Phone (required) \_\_\_\_\_

Work Phone (required) \_\_\_\_\_

E-Mail \_\_\_\_\_

Date of Birth (required) \_\_\_\_\_

\$24.90 Enclosed  \$26.39 PA residents  Just send free catalog

Charge:  Visa  Master Card  Amex  Discover Card

Signature \_\_\_\_\_

Credit Card No. \_\_\_\_\_ Exp. Date \_\_\_\_\_

Only good in the USA. No gifties. Originals only—no photocopies.  
Offer limited to one per household/customer. Not available to minors.

key code ZMA0810



I'm Bill Carroll,  
call me & I'll show  
you how you can  
own a Woodcraft  
franchise



When I  
think about  
owning my own business ...

Bring your woodworking skill, your love of tools, and your expertise and we'll show you how you can turn your passion for woodworking into your life's work.

...I think of Woodcraft



**WOODCRAFT**  
Helping You Make Wood Work®

800 344-3348 or e-mail:  
bill\_carroll@woodcraft.com

1177 Rosemar Road  
P.O. Box 1686  
Parkersburg, WV 26102-1686 Dept.F03WI06Q

Circle No. 924

**SUPERSHOP 10-IN-1 WOOD & METAL SHOP**

Own a Complete,  
PRO-QUALITY WOOD SHOP  
In Just 12 SQUARE FEET!

Stand-alone machines  
take TOO MUCH ROOM!



All the QUALITY of premium  
"stand-alone" shop machines  
in LESS FLOOR SPACE...  
and at LOWER COST!

10 TOOLS  
IN JUST  
12 SQ. FT.!

- Equal or **BETTER QUALITY** than one-function shop equipment.
- **COSTS LESS** than buying several one-function machines.
- **10 MOST-USED TOOLS IN 1:** table saw, lathe, drill press, router, sander, more!
- **Rock solid, 2½ times MORE MASSIVE** than other combo machines.
- State-of-the-art **ELECTRONIC SPEED** controls, powerful DC motor.
- Perfect for both **HOME & PROFESSIONAL** woodworkers.
- **30-Day RISK FREE** Buy-Back Offer & Industry-Leading Warranties.



Get complete details  
& SAVINGS OFFER:

ON SALE  
FOR A LIMITED  
TIME ONLY!



CALL TOLL FREE  
**1-800-476-4849**

Or this Mail to: **SuperShop**® Dept. WOOD, P.O. Box 1517, Ann Arbor, MI 48106-1517

**YES!** RUSH me all the details on the HIGH QUALITY, AFFORDABLE alternative for TIGHT SPACE wood shops!

Name \_\_\_\_\_  
Address \_\_\_\_\_  
City \_\_\_\_\_ State \_\_\_\_\_ Zip \_\_\_\_\_

Circle No. 1766

## wood words

### A quick guide to must-know terms used throughout **WOOD**® magazine.

**Auxiliary fence:** A temporary (sometimes sacrificial) fence attached to a table-saw rip fence or miter gauge, or to some other machine table, to protect a cutter or bit while providing full workpiece support.

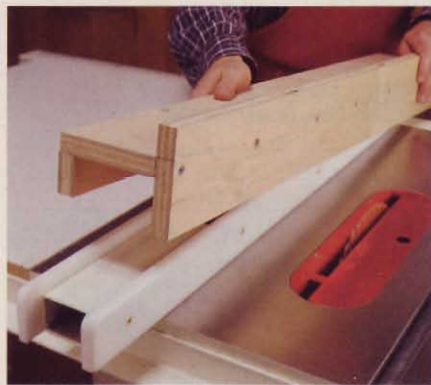

**Blade runout:** Runout in circular-saw blades is measured by the amount of side-to-side movement in the blade body.

**Collet runout:** The amount of deviation from center (wobble) in a router collet, measured in thousandths of an inch.

**Climb cut:** A routing operation during which the router moves in the same direction as the bit's rotation, rather than against the rotation, as is normal. The result is a cleaner, but harder-to-control, cut. Always make light cuts when climb-cutting.

**FAS:** An abbreviation used in hardwood-lumber grading for Firsts-and-Seconds: the best boards cut from a log. An FAS board measures at least 6" wide by 8' long, and yields a minimum of 83 percent clear cuttings (areas free of knots and defects). These areas must be at least 4"×5' or 3"×7'.

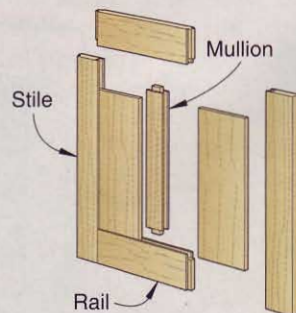

**Mullion:** A vertical member of a cabinet or door frame that forms a division between two units, such as panels.

**Rail:** A horizontal member, most typically in a cabinet's face frame or door, and running between two vertical pieces.

**Stile:** A vertical member of a cabinet or door frame.

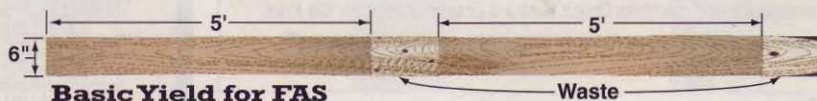



# what's ahead

Your preview of the September issue of WOOD® magazine on sale July 22

## FEATURED PROJECT



### Heirloom curio cabinet

It's all here: classic design, ample room for collectibles, and two-level lighting. Plus, its full-view glass front *slides* open for easy access.

## Just some of the projects you'll find



### Turned box with lid

Fast and fun-to-make describes the turning of this little beauty. Enjoy!



### Cookbook holder

Delight your favorite chef with this functional kitchen accessory. After the meal's prepared, the holder folds up for easy storage.



### Accent table

A stylish cherry base and smooth-as-glass bird's-eye maple top make a woodworking statement wherever you place this stunning piece.

## Tools, Techniques, & Features

### TOOL TEST



### Tune-up tools for your woodworking machines

We cut through the myriad of choices to let you know which gauges you really need to adjust your table saw, miter saw, jointer, and planer for top-notch results.

### William H. Macy: Actor, woodturner



Visit the workshop of one of Hollywood's finest and star of *Fargo*, *Pleasantville*, and *Jurassic Park III*. We guarantee you'll learn a thing or two about lathe-tool sharpening and bowl turning.

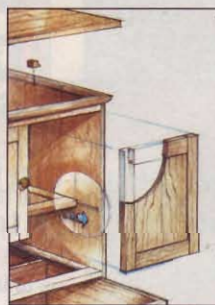

### How to deal with wood movement

It's a fact: Wood expands and contracts with seasonal changes in humidity. Discover the keys to building furniture that allows for that inevitable movement.

### Dado sets

Find out which give you the cleanest cuts without emptying your wallet.

