

WOOD

The Shop-Proven Woodworking Magazine

adirondack glider **plus 6** more super projects

Build it in a weekend

p.34

RATED:
18
Accessories to
BEEF UP your
TABLESAW

**Custom Oak
Sideboard** p.66



Sharpen Your Skills

- polyurethane glue secrets p.112
- installing European hinges p.58
- make projects from free wood p.42
- low-cost vs. premium router bits p.18

Display until May18, 2004

USA \$6.99

9 2567 14072 5

WOOD

May 2004, Issue 155

PROJECTS

- 14 workshop light support
- 34 Adirondack glider
- 48 collector's torpedo level
- 66 traditional oak sideboard
- 78 three fun-filled kid's room projects

TECHNIQUES

- 22 working with sheet brass
Learn the secrets for cutting and drilling brass parts for wear plates and other project accents.
- 42 fancy woods, unlikely sources
Turn tree limbs, scrapwood, and job-site cutoffs into awesome projects.
- 58 how to install concealed hinges
Hang cabinet doors quickly and accurately with these six can't-fail steps.
- 90 just-right joinery: waterfall joint
- 110 success with sanding sealers
Prep wood surfaces to perfection.
- 112 polyurethane glue how-to

TOOLS & MATERIALS

- 16 wise buys: powered dust hoods
- 18 premium vs. low-cost router bits
- two tablesaw accessory reviews
- 52 rip fences
- 60 splitters
- 116 rated: four shop-proven products

FEATURES

- 26 wood close-up: black walnut
- 62 the ultimate cheap guy's workshop
Count the ways you can create a fully-loaded work area on a shoestring budget.
- 74 wood structure and appearance
See how cell structure translates into impressive color, grain figure, and strength.
- 84 high school shop-class revival
Discover how four unique programs have excelled at capturing students' interest.
- 108 golf club pro
Meet a craftsman who putters making putters.

DEPARTMENTS

- 6 masthead
- 8 editor's angle
- 10 sounding board
- 30 ask WOOD
- 92 shop tips
- 100 wood words
- 102 short cuts
- 122 workshop woods: ipe
- 128 what's ahead



42

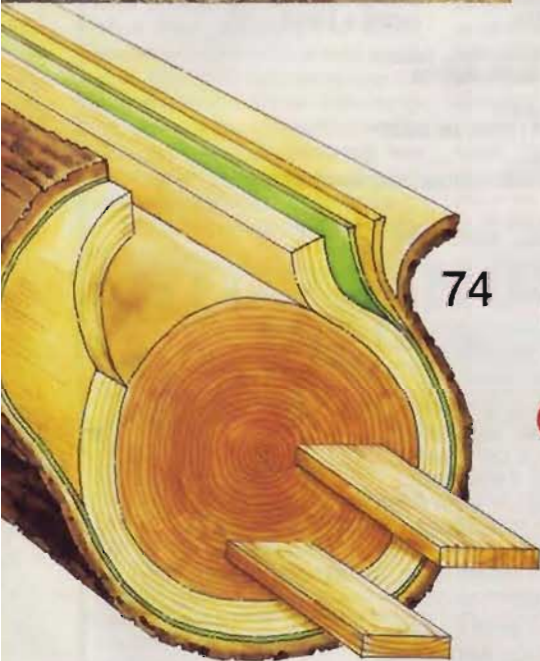

74



112



This seal is your assurance that we build every project, verify every fact, and test every reviewed tool in our workshop to guarantee your success and complete satisfaction.



34



48



66



78

The Toughest Glue On Planet Earth



Bonds:
Wood, Stone, Metal,
Ceramic, & More!

Gorilla Glue is the versatile, interior/exterior adhesive ideal for most household fixes and building projects: furniture repair, crafts, woodworking, and general repairs around the house. **Bonds wood, stone, metal, ceramic & more! Incredibly strong and 100% waterproof.**



**REQUEST YOUR FREE
INFORMATION KIT!**
www.gorillaglu.com
1-800-966-3458

Circle No. 50

Better Homes and Gardens® WOOD®

May 2004

Vol. 21, No. 2

Issue No. 155



Jim built this divided jewelry box for his daughter, Hollis.



Jeff and Owen show off items they made during a session with master turner Mike Mahoney.



David recently designed and built this addition to his home.

EDITOR-IN-CHIEF
BILL KRIER

Executive Editor **JIM HARROLD** Managing Editor **MARLEN KEMMET**

Senior Design Editor **KEVIN BOYLE** Products Editor **DAVE CAMPBELL**

Techniques Editor **JIM POLLOCK** Features Editor **DAVID STONE**

Projects Editor **OWEN DUVAL** Projects Editor **JAN SVEC**

Design Editor **JEFF MERTZ** Master Craftsman **CHUCK HEDLUND**

Art Director **KARL EHLERS** Associate Art Director **GREG SELLERS** Assistant Art Director **CHERYL A. CIBULA**

Production/Office Manager **MARGARET CLOSNER** Administrative Assistant **SHERYL MUNYON**

Photographers
MARTY BALDWIN, SCOTT LITTLE, JAY WILDE

Illustrators
TIM CAHILL, LORNA JOHNSON, ROXANNE LeMOINE, MIKE MITTERMEIER

Technical Consultants
JOHN CEBUHAR, JEFF HALL, GARRY SMITH

Contributing Craftsman
JIM HEAVEY

Proofreaders
BARBARA KLEIN, JIM SANDERS

Publisher **MARK HAGEN**

ADVERTISING OFFICE: 333 N. Michigan Ave., Suite 1500, Chicago, IL 60601 Phone: 312/853-2890 Fax: 312/580-7906

Sales and Marketing Assistant **NEILLE MORRIS**

Account Executive **JACK A. CHRISTIANSEN**

Direct Response Manager **CAROLYN DAKIS**

Direct Response Sales Representative **SANDY ROBINSON**

Account Executive **JOHN THORNBURGH** Detroit, Phone: 248/356-1149 Fax: 248/356-8930

Account Executive **PAT TOMLINSON** Northeast, Phone: 212/551-7043 Fax: 212/551-7192

Southeast: Lagomarsino, Dempsey & Dennis, Inc. 2951 Piedmont Rd. NE, Suite 100, Atlanta, GA 30305
Phone: 404/261-5400 Fax: 404/261-5404

Group Marketing Director **CATHY E. SMITH**

Senior Marketing Services Manager **MARY M. WRIGHT**

Senior Promotion Designer **SARAH MASSIMO**

Group Publisher **STEPHEN B. LEVINSON**

Associate Business Director **CRAIG FEAR**

Consumer Marketing Director **ROBIN HUTCHINSON**

Consumer Marketing Manager **LESLIE SHAEFFER**

Newsstand Product Manager **LISA TROM**

Advertising Operations Manager **PAT HENDERSHOTT**

Sr. Production Manager **MICHAELA LESTER**

Vice President/Publishing Director **WILLIAM R. REED**

MEREDITH PUBLISHING GROUP

President **STEPHEN M. LACY**

President, Magazine Group **JACK GRIFFIN**

Corporate Solutions **MICHAEL BROWNSTEIN**

Creative Services **ELLEN DELATHOUDER**

Manufacturing **BRUCE HESTON**

Consumer Marketing **KARLA JEFFRIES**

Finance and Administration **MAX RUNCIMAN**

Meredith
CORPORATION

WILLIAM T. KERR, Chairman and Chief Executive Officer

In Memoriam — E.T. Meredith III (1933-2003)

©Copyright Meredith Corporation 2004
All rights reserved. Printed in the U.S.A.

Better Homes and Gardens® WOOD® magazine (ISSN-0743-894X) is published seven times a year in March, May, June/July, September, October, November, and December by Meredith Corporation, 1716 Locust St., Des Moines, IA 50309-3023. For subscription questions call 800/374-9663. Letters to Editor: WOOD magazine, 1716 Locust St., GA-310, Des Moines, IA 50309-3023, or woodmail@woodmagazine.com. Periodicals postage paid at Des Moines, Iowa, and additional mailing offices. Better Homes and Gardens trademark registered in Canada and Australia. Marca Registrada en México. ONE-YEAR SUBSCRIPTION PRICES: U.S. and its possessions, \$28; Canada, \$41; other countries, \$49. Canada Post Publications Mail Sales Product Agreement No. 40069223. Canadian BN 12348 2887 RT. CANADIAN RETURN ADDRESS: Better Homes and Gardens WOOD magazine, 2744 Edna Street, Windsor, Ontario, N8Y 1V2. POSTMASTER: Send address changes to Better Homes and Gardens WOOD magazine, P.O. Box 37439, Boone, IA 50037-0439.

B

6

MPA

WOOD magazine May 2004



TURN OFF
THE LIGHTS.
TURN ON
THE SUN.



It's the ultimate light switch. By installing Solatubes in your home, you'll be able to capture and redirect sunlight to the areas that need it most.

Let Solatube fill your home with beautiful, natural daylight. Switch to the sun. Call for free information or a dealer near you. Code 1004.

1 - 8 0 0 - 9 6 6 - 7 6 5 2
www.solatube.com



editor's angle

Free wood, it's all around you

Would you like to spend little or nothing for wood that's more spectacular than any store-bought stock? And have lots of fun in the process? Here's how.

While recently cutting down a gnarly old box elder tree for firewood, the chainsaw suddenly spewed a stream of crimson-red chips that covered my pants. "You're bleeding!" exclaimed my father-in-law working beside me. Fortunately, this was no accident; my chainsaw had struck a rich vein of the red-streaked grain often found in distressed box elder trees. Pay dirt!

Much of the tree still wound up in the firewood pile, but I cut the reddest sections into turning blanks. Jeff Mertz, our talented design editor, turned one of those blanks into the beautiful vessel at *right*.

Of course, you can saw such found wood into boards too. The options are several. You can haul the log to a local sawmill or have a portable mill come to you. Typical charge: about 15 cents per board foot (bf) at a sawmill (portable mill operators might charge 5 to 10 cents more per bf). You even can convert firewood-size log sections into short boards, as demonstrated in issue 37, page 60. (If you don't have that issue, go to woodmagazine.com/foundwood to obtain a copy of "How to Transform Found Wood into Usable Stock.")

Of course, you'll need to sticker and dry the stock for about a year, and then plane it. An investment in time and effort for sure, but what a payoff!

And you don't have to go into the woods to find really interesting, super-cheap wood. For example, I once spotted a severely warped, pressure-treated 1x4 on a pile of other hopelessly defective, bargain-priced boards at a local home center. Something about that ugly board caught my eye, though: It was loaded with an amazing bird's-eye figure. The price: 50 cents. I snapped it up, and gleefully tolerated the "can't-you-see-how-warped-this-board-is" look I received from the checkout clerk. I



Photo: Larry Schmitz

To my surprise, this twisted, multi-trunked box elder tree yielded hundreds of board feet of incredibly red-streaked stock, including the wood used to make this bowl.



dried and cut that 1x4 into short, straight lengths for the lid and sides of the keepsake box, *below* (plans found in issue 143).

These experiences tell me that the possibilities for finding and converting free or extremely cheap wood into usable stock are nearly endless. I've heard from readers who build beautiful projects from discarded crates, pallets, house trim, barn siding, and salvaged beams. For a few more ideas on using workshop scraps, construction debris, and even narrow tree limbs, check out the article starting on *page 42*.

Now, I'm not suggesting that these tips will save you from ever having to make another expensive trip to the lumber store. But I do guarantee that using found stock will help you save a few bucks, stretch your creativity, and put more personality into your projects than ever before.



Bill Krier

sounding board

Our bulletin board for letters, comments, and timely updates

Adding safety brakes to a crosscutting sled

Your crosscutting sled on page 84 of the October issue is a great idea. I suggest adding a simple stopblock system, shown in the photo *below*, that stops the sled's forward movement at the end of each cut. This prevents pushing the sled too far forward and exposing the blade behind the guard.

Start by cutting a sled stop and saw stop, as shown in the drawing, *right*, from a piece of $\frac{3}{4} \times 1\frac{1}{4}$ " scrap. Now, place the

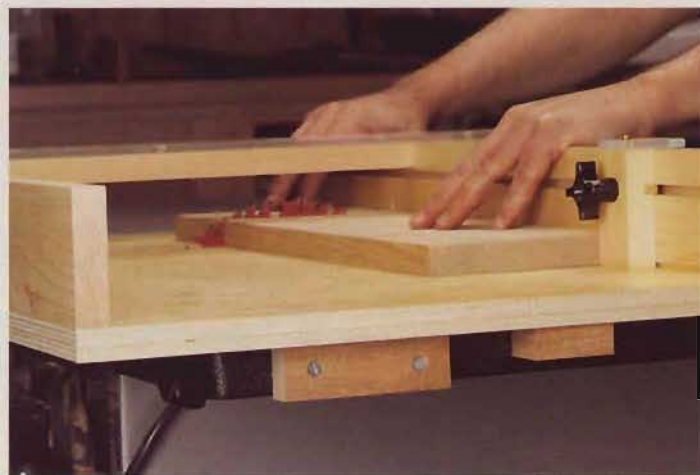

crosscutting sled on your saw table, and push forward as far as you would when completing your cut.

Using double-faced tape, temporarily attach the sled stop and saw stop approximately where shown. Next, remove the crosscutting sled and permanently secure the sled stop with a couple of screws. Mount the saw stop by drilling through it and the edge of the saw table, and attaching the stop with machine screws, lock washers, and nuts.

James E. Connolly, West Union, Ohio

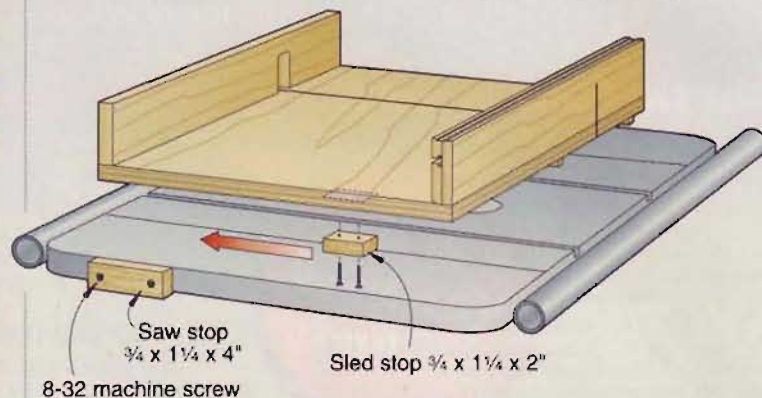

How to "make do" with smaller Forstner bits

While building the Galileo Thermometer (issue 151, page 94), I realized I didn't have the $2\frac{3}{8}$ " Forstner bit necessary to bore the recess in the base (B). Instead of buying a new bit, I made the recess in two steps, as shown at *right*, using equipment I already had in my shop.

First, I drilled all the way through the base using my $1\frac{5}{8}$ " Forstner bit. Then, I chucked a $\frac{3}{8}$ " rabbeting bit in my router, set it for a $\frac{1}{4}$ " deep cut, and routed a perfect "shelf" with a diameter of $2\frac{3}{8}$ ". This worked very well, and with the thermometer in place, you can't even see the hole.

Fred Kamp, Rittman, Ohio

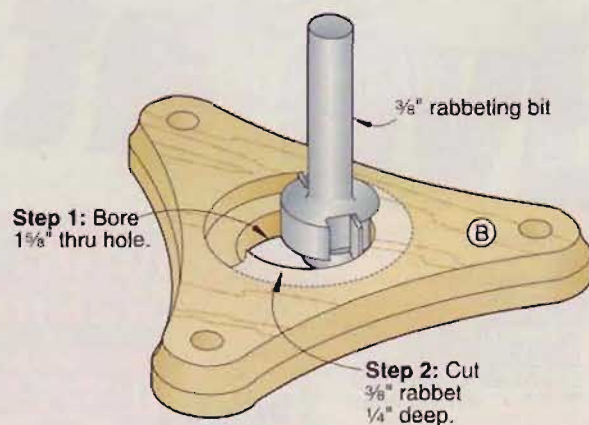

Continued on page 12

HOW TO REACH US

■ Editorial questions and feedback:

E-mail woodmail@woodmagazine.com; call 800/374-9663 and press option 2; or write to WOOD magazine, 1716 Locust St., GA-310, Des Moines, IA 50309-3023.

■ Subscription assistance:

To notify us of an address change, or to get help with your subscription, go to woodmagazine.com/service; call 800/374-9663 and press option 1; or write to: WOOD magazine, P.O. Box 37439,

Boone, IA 50037-0439. Please enclose your address label from a recent magazine issue.

■ To find past articles:

Go to our continuously updated online index at woodmagazine.com/index.

■ To order past issues and articles:

Order past issues of WOOD® magazine and our newsstand special issues at woodstore.woodmail.com, or by calling 800/346-9663. Be aware that many early issues

are sold out. For reprints, send \$5 per article (no phone orders), including the article name and issue number, to: WOOD Article Reprint Service, P.O. Box 349, Kalona, IA 52247; make check or money order payable to WOOD magazine.

■ Updates to previously published projects:

For a complete listing of known changes in dimensions and buying guide sources from issue 1 through today, go to woodmagazine.com/editorial.

Manufacturer offers our six must-have router bits

I really enjoyed your article on "6 must-have router bits" (issue 151, page 38). After reading that you couldn't find these bits ($\frac{1}{8}$ " and $\frac{1}{4}$ " round-over bits, a $\frac{1}{2}$ " straight bit, a $\frac{1}{2}$ " flush-trim, a 45° chamfer, and a rabbeting bit with interchangeable bearings) as a set. I decided to do something about it.

Infinity Cutting Tools now offers this set of American-made bits, which we call "the essential six," at an introductory price of \$99.90 for *WOOD* magazine readers. To purchase them or find a dealer in your area, call 877/872-2487, or visit www.infinitytools.com.

David Venditto, President, Infinity Cutting Tools

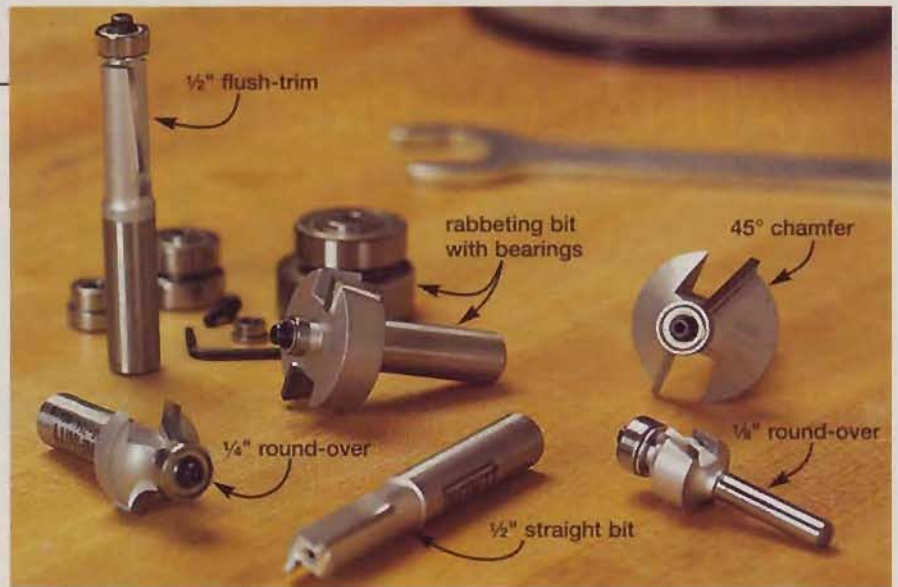

Good garden structures make great neighbors

I recently started woodworking and subscribing to your magazine, which led to my first major project: the garden structure, shown at left.

My neighbor and I built the structure to replace a hedgerow that had separated our properties. We came up with the idea by combining the plans for your pergola (issue 141) and arbor (issue 148), then throwing in a few touches of our own. Those include the bamboo trellis for plants to climb, and the low stone base that hides containers, which house the plants. We also built the structure in two sections to follow the slope of the property. Best of all, we built it using just a circular saw, jigsaw, drill, router, and palm sander, and we did it in only a few weekends and evenings.

Jeff Perry, Charlottesville, Va.

Article updates

Slant-front secretary (issue 153, p. 50): The shank holes in the rails (F) should be spaced $1\frac{9}{16}$ " apart. The upper edge of the desk-case side (N) measures $10\frac{3}{4}$ ".

Cyclone dust collectors (issue 153, page 94): Additional information for the "Report Card" chart on pages 98–99:

Brand	Model	Inlet Diam. (inches)
Bridgewood	BW-CDC3	8
Grizzly	G0525	8
Oneida	Comp-Sys 1.5EXT35	6
	Comp-Sys 2EXT35	7
	2 Commercial	7
Penn State	Tempest	5
	Tempest142CX	6
Woodsucker	Woodsucker II	6

What a pyramid point tool can do for you (issue 153, page 122): Here is the correct image for **Photo B**:

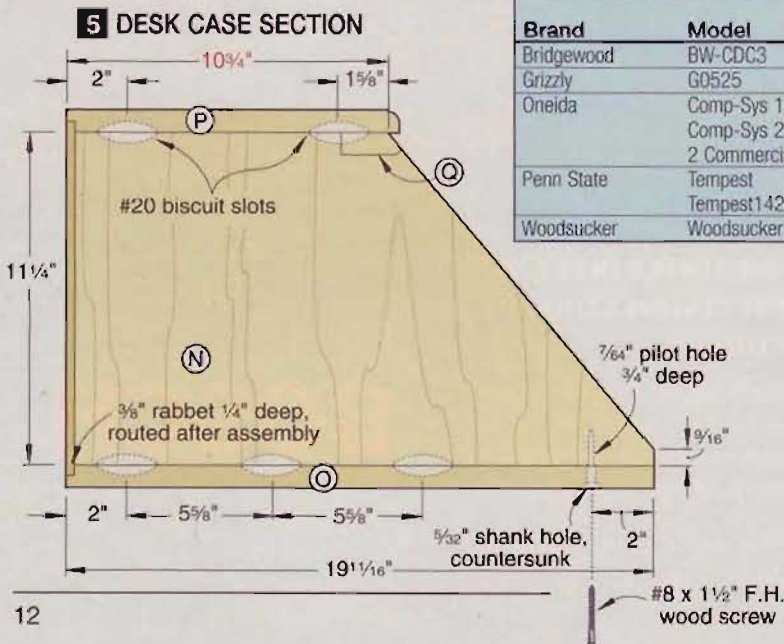

workshop light support

Place it anywhere you need it



Project Design: Kevin Boyle
Illustrations: Roxanne LeMoine

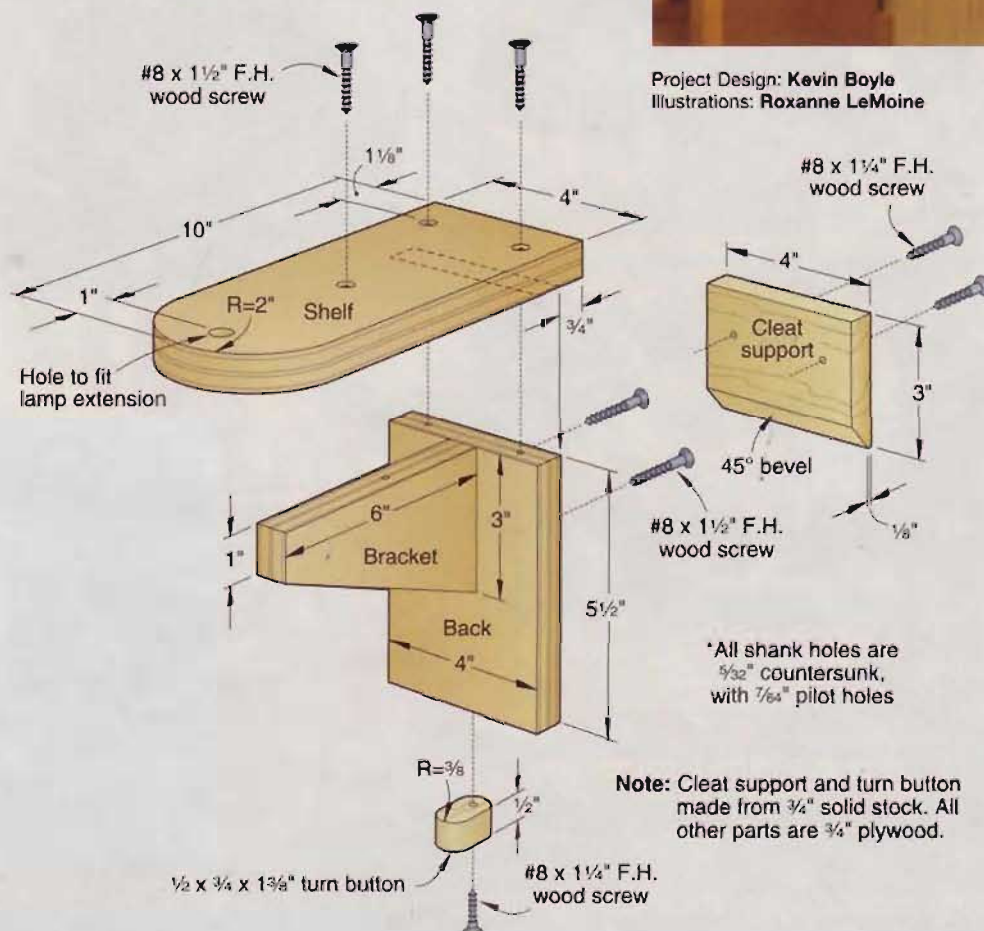

Rotate the turn button to secure the light support to the wall cleat.

Get the full scoop . . .
 ...on the Idea Shop 5 Wall Storage System at
www.woodmagazine.com/IS5

The Idea Shop 5 wall cleat system featured on page 86 of the November 2003 issue of *WOOD* works great for supporting more than cabinets and tool racks. This easy-to-build light support fits and locks onto the same cleat, and can be located near any number of machine operations.

To make this shop helper, cut the cleat support and turn button from solid stock

and the shelf, bracket, and back from ¾" plywood. Drill the countersunk screw mounting holes and a hole in the shelf to fit your light bottom. Screw (but don't glue) the support together. The bottom edge of the back needs to be flush with the bottom edge of the wall-hung cleat when in place. Adjust if necessary. Glue and screw the support together, and then position the assembled light support where you need it. Add the

light, and swivel the turn button, as shown on the inset photo, to secure the support to the wall cleat.

For use in a shop without the cleat system, construct the project so the back edge of the shelf is flush with the back surface of the back. Omit the turn button and cleat support, and screw the assembled support to the wall, centered over a stud. Then slip the lamp extension into the hole in the shelf. ♣

our editors test powered dust hoods

Why buy?

Low-cost paper dust masks offer some protection from breathable dust created when sanding, routing, or turning; but they don't catch all the dust, and they often fog your face shield or safety goggles, causing potentially hazardous visibility restrictions. For a price, battery-powered dust hoods solve both problems. These units deliver clean, filtered air to the mask for easy breathing and fog-free viewing. As an added benefit, the moving air keeps your face cool—a welcome change from sweaty masks and respirators. Note that **these units filter particulates only**, so they don't protect you from solvent vapors, such as those present when using oil-based finishes.

Aircap 2, \$170



Editor test-drive:

The filter system of the Aircap 2 is built into the brim of the cap, eliminating the need for a cumbersome air-supply hose. Yet the battery pack—a major contributor to hood weight—either slips into a pants pocket or clips onto your belt. This hood operates on four ordinary C-cell batteries, making it affordable and allowing you to get back to work without waiting for a battery pack to recharge. The manufacturer claims 30–40 hours of run time with good quality alkaline cells; I ran it continuously for 30 hours before the batteries died.

I slipped Aircap 2 on after rough-turning a bowl, and started sanding. The visor has a nice field of

vision, and there was ample airflow to keep the inside of the visor—and my glasses—fog-free.

There is one caveat, and the Aircap 2's manual states it up front: "The visor...does provide a high degree of eye protection." That makes it fine for sanding, bandsawing, and general woodworking, but pretty much rules it out for use as a protective face shield.

—Tested by Jeff Mertz, Design Editor

To learn more:

www.aircap2.com (Available at Woodcraft, 800/225-1153; or www.woodcraft.com)

Trend Airshield, \$275



Editor test-drive:

Using a paper mask, I've frequently found myself congested from inhaling dust, especially while sanding turnings. However, after several hours at the lathe, both turning and sanding, while wearing the Airshield, I wasn't the least bit congested. I also noticed a lot more particulate on the pre-filter than I ever did on the surface of a paper dust mask.

The Airshield integrates the battery, motor, fan, and filter into the hood itself and does away with the awkwardness of an air-supply hose. So, although my neck felt a bit stiff after the first couple of long turning sessions, I found the added hood

weight a reasonable compromise. The Ni-Cad battery pack recharged in 14 hours and ran more than 6 hours on a charge—plenty for most woodworkers. The face shield is rated for low-impact protection only, so I'd hesitate to use it in place of a high-impact shield when, for example, turning out-of-round bowls or using a tablesaw. Overall, I am impressed with this unit.

—Tested by Marien Kemmet, Managing Editor

To learn more:

859/485 2080; www.trend-usa.com

Triton Powered Respirator, \$270



Editor test-drive:

This unit combines air filtration with hearing, head, and high-impact facial protection. The hard hat may be overkill for woodworkers, but the Triton hood features a comfortable, lightweight, gasketed visor and a well-designed shroud that effectively eliminates inhaled dust. The hearing-protection earmuffs are also comfortable and easy to adjust, and clicking them outward holds them away from your head when hearing protection is not needed.

Triton's fanny-pack-like air filtration unit connects to the visor with an air-supply hose. Although this design makes for a light and comfortable hood, the somewhat stiff hose tipped the helmet forward

when I looked upward, and I could feel its influence when turning my head side-to-side. It also transmits vibration from the blower to the helmet and earmuffs, resulting in an annoying hum. A Triton spokesman says a new, more supple hose will solve both problems on future hoods. The rechargeable Ni-Cad battery pack powered the hood for about 5 hours (more than adequate for most shop tasks); it recharges overnight.

—Tested by Jan Svec, Projects Editor

To learn more:

888/874-8661; www.tritonwoodworking.com

are premium-priced router bits worth the money?

Or is low-dough the way to go? We milled more than a mile and a half of material to find the differences between the highest- and lowest-priced router bits.



These bundles of 4'-long workpieces represent a mere fraction of the oak and MDF we machined to learn what separates premium- and low-cost router bits.

When shopping for router bits, we've all been tempted by low-cost cutters, wondering what differences exist between them and ones that cost three times as much. A 1/2" round-over bit is a 1/2" round-over bit, right?

To get to the bottom of this burning matter, we purchased 36 1/2"-shank router bits—three each of 1/2" straight, 1/2" cove, and 1/2" round-over—from four manufacturers (two that sell premium-priced bits, and two that sell low-cost bits). Then we put them all to the test.

Tests in red oak gave us real-world results

After weighing each bit, we chucked it into a table-mounted router, fired up the tool, and measured vibration using a dial indicator on the body of the router. We found no discernable difference in weight or vibration between premium- and low-cost bits.

Next we made a cross-grain cut in red oak with each bit, looking for fuzzing and signs of burning on the freshly cut edges. Out of the box, almost all of the premium-priced bits delivered clean, burn-free cuts. On the other hand, most of the low-cost bits fuzzed, with three round-over bits burning slightly, and all low-cost coves burning to some degree on the first cross-grain cut.

With an out-of-the-box benchmark for cut quality established, we went to work routing full-depth profiles with the cove and round-over bits, and ripping 3/8"-deep grooves in red oak. We cut 100 linear feet with each bit, and at the end of each 100' run, we again made cross-grain cuts in red oak, looking for signs of dulling.

Most of the bits made it through this test with flying colors, but we deemed four of the low-cost straight bits unusable by the time we were done. On three of these bits, a carbide cutter broke before we hit the 100' mark. There's no way of knowing what caused these bits to fail—it could be the quality of the carbide, the width of the carbide cutter, inadequate brazing, or something else—but our pre-test inspection showed no visible flaws.

The fourth failed bit slipped in the router's collet regardless of how much we tightened, causing it to change cutting height at random during the test cut. A fifth low-cost bit—this one a cove—lost its bearing at 82' into the test cut, so we removed it from further testing.

As the trials progressed, some of the low-cost bits dulled to the point where feeding material became quite difficult. (In a few instances, we had to push so hard the router table moved.) We suspect that one reason these bits dulled faster than their higher-priced counterparts was because the shear angles of the cutters (see drawing on page 20) are closer to vertical, causing them to chop into the wood more than slice through it. By the end of this test, about half of the

Continued on page 20

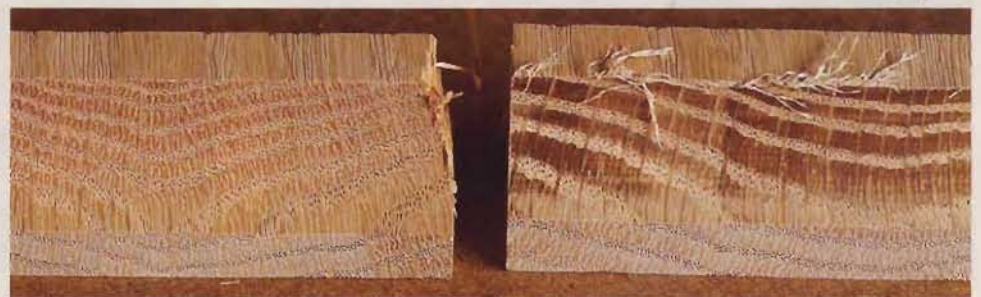

The first cuts with each bit varied widely, from the fuzz-free cut of a typical premium cove bit (left) to the burning and fuzzy edges caused by a low-cost cove (right).

blades and bits

premium straight bits fuzzed on cross-grain cuts, and one cove bit showed a slight burn.

Next stop on the test track: MDF

To accelerate wear, we next subjected the surviving bits to 100 linear feet of medium-density fiberboard (MDF), a material that dulls cutters faster than domestic hardwoods because of the adhesives in it. During this test, we observed grittiness in the bearings on many of the low-cost bits—something we didn't find on the premium bits.

Why did this happen? The more costly bits have a washer-like shield below the bearing (see the drawing, at right) that seems to prevent even superfine MDF dust from penetrating the bearing and robbing it of its lubrication. Diligent cleaning and lubrication of the bearings on the low-cost bits may have extended their lives, but we didn't perform these maintenance tasks.

By the time we'd wrapped up our run of MDF, seven bearings on low-cost bits had seized, and three others were gummy beyond repair. In comparison, all of the

bearings on the premium-priced bits still spun freely.

We again put the surviving bits through our acid test—cross-grain routing in red oak—and found that all of the straight bits fuzzed some, two premium round-over bits burned slightly, and two low-cost round-overs burned badly.

Should you own low-cost bits?

Yes, but with some conditions. Although premium bits clearly outperformed low-cost bits in this punishing test, inexpensive bits represent a terrific value for occasional use, especially when purchased in large sets where you may pay as little as \$3 per bit. Besides being economical, these sets also allow you to keep a large number of bits on hand for occasional use. The trade-off is that you may have to sand more

and spend a little more time maintaining low-cost bits. For bits that endure regular and heavy use or stressful forces, such as straight or panel-raising bits, you'll be money ahead if you start with a premium-priced bit. ♣

LOW-COST BITS

PREMIUM-PRICED BITS

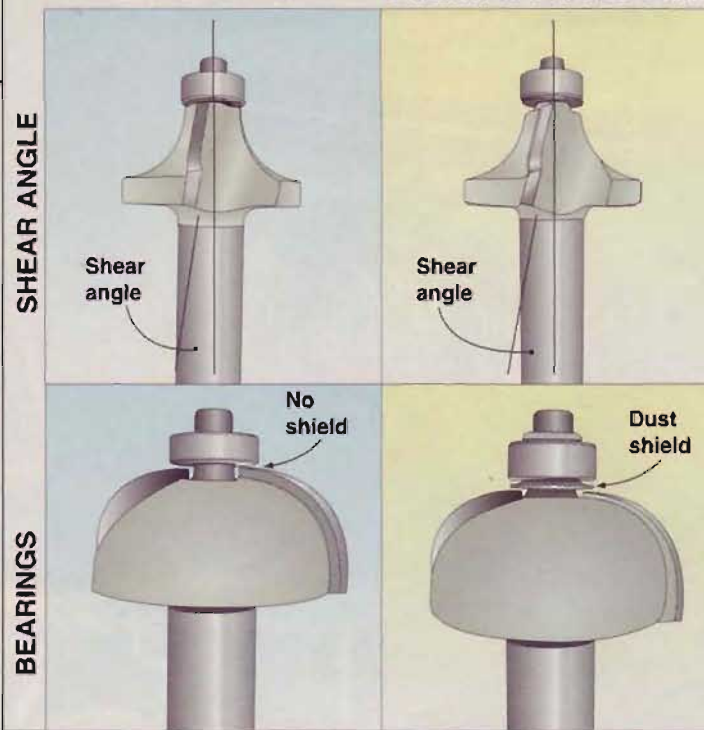

LAGUNA TOOLS

*Simply
the Best!*

Call for **FREE Video!**

1.800.234.1976

www.lagunatools.com

The new Laguna TS table saw is setting a new high standard by which all others will be measured. With all the features of a traditional cabinet saw, the TS also comes with its own line of bonus 'Laguna' features.

The X31 multi-task machine has a lineage second to none. This third-generation combination machine is a best seller, with updated fences and increased cutting capacity.

Meet our latest award-winning machine, the LT 14 bandsaw. Packed with outstanding features for powerful performance. 1.7 HP motor - 13 1/4" throat - 1/16" to 1" blade - 8" resaw.

mail@lagunatools.com

17101 Murphy Avenue
Irvine, CA 92614

working with sheet brass... the short course

Properly cut, installed, and polished, brass will add a classy touch to many of your projects. Here's the skinny on how to cut, fit, and finish this thin, easy-to-work material.

Reluctant to meddle with brass? Don't be. Using common woodworking tools and the simple five-step process that follows, you can easily make eye-catching brass accents, such as the wear plates for the torpedo level shown *below* and featured on *page 48*.

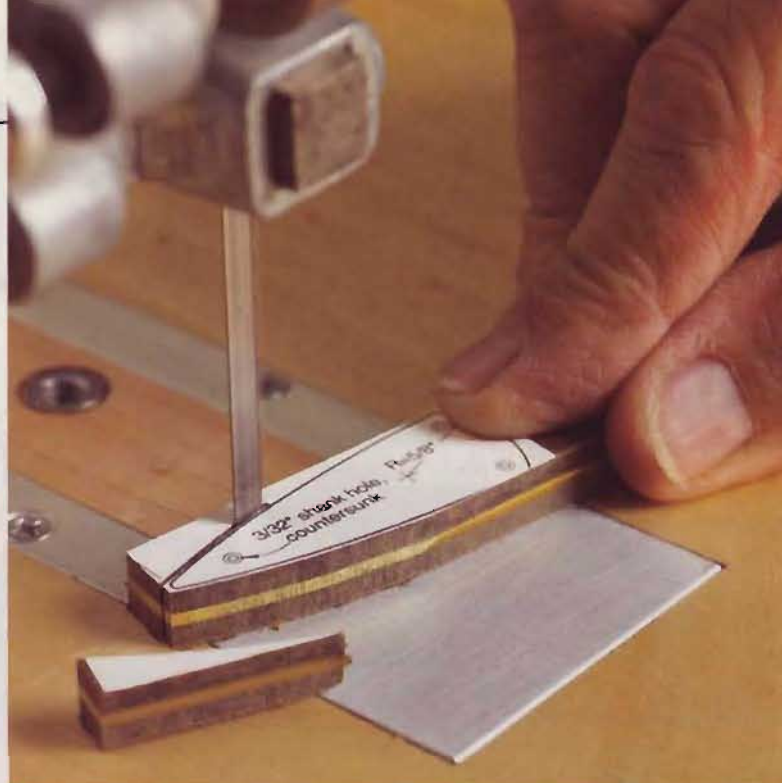

1 Sandwich the brass to keep it rigid, and cut it to shape

Sheet or strip brass, found at hobby stores, comes in thicknesses ranging from .016" ($\frac{1}{64}$ ") to .063" ($\frac{1}{16}$ "). To support this thin metal and prevent it from chattering when you machine it, sandwich it between two pieces of $\frac{1}{8}$ " hardboard using spray adhesive.

Apply a pattern to one of the hardboard pieces or mark the part's shape and any hole centerpoints using a fine-point permanent marker. Cut the brass to shape, staying just outside the lines, as shown in the photo *above*. When cutting with a bandsaw, use a $\frac{1}{4}$ " or smaller blade with a minimum of 10 teeth per inch (tpi) for a smooth cut. When cutting with a scrollsaw, use a #5 blade with 16 tpi. Then, drill any screw shank holes through the brass.

You also can cut the sandwiched brass using a tablesaw or table-mounted router with carbide-tipped blades or bits. Just be sure to use a zero-clearance insert, which closes the throat opening around the blade or bit for safe workpiece support and clean cuts.

2 Then, simply sand to the pattern lines

To precisely fit the brass, first sand its edges to the pattern/layout lines using a disc sander with 120-grit sandpaper. For safety, ensure the gap between your table and sanding disc is less than $\frac{1}{8}$ ". If not, clamp on an auxiliary plywood or hardboard table to reduce the space. After sanding, remove the top hardboard piece, and clean off the adhesive from the brass with a solvent-moistened cloth.

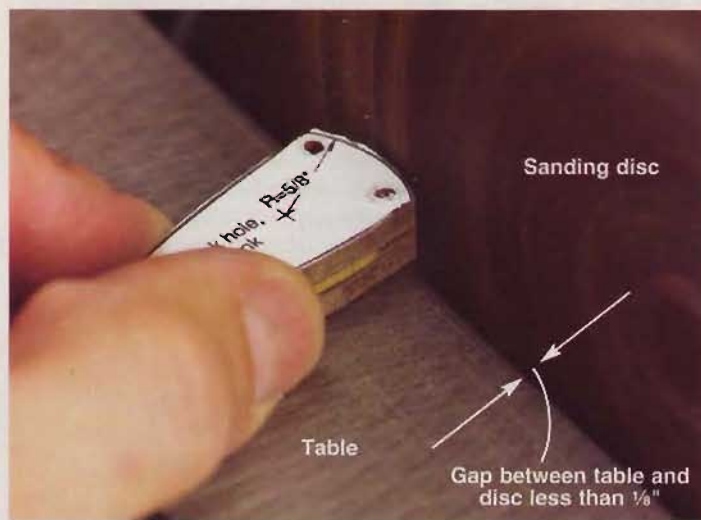

3 Now's the time to countersink holes

Countersink any screw holes so the screwheads will sit flush with the brass. You can use a high-speed steel bit, but a titanium nitride-coated countersink, as shown, will cut faster and smoother and last about four times longer. To ensure a clean cut and prevent overheating the bit, set your drill speed at 500 rpm. Also, use a depth stop for hole-to-hole consistency.



Continued on page 24

4 Fine-tune the brass for a perfect fit

Next, remove the bottom hardboard piece, and test-fit the brass. If necessary, remove small amounts of material by sanding or filing the edges with a flat bastard file until the piece fits correctly. To ensure you remove only a whisker of material at a time, mark the edges with a felt-tip marker, as shown. Sand just until you remove the marks. Note that for some projects, such as the level, you may find it easier to mount the brass and then sand or file its edges flush with the surrounding material.



24

5 Finish up with a shine

Mount the brass with screws and/or epoxy, as appropriate. Then, sand its face and any exposed edges with 220-grit sandpaper to an even sheen. For a highly polished look, sand the brass with progressively finer sandpaper up to 600 grit. If any surrounding wood blackens as you sand the brass, simply rub the wood with a cloth moistened with denatured alcohol to remove the discoloration, as shown.

Finally, to protect the brass, coat it with a finishing wax. For longer-lasting protection and to preserve the brass's luster, spray it with a lacquer-based finish, such as Staybrite Clear Gloss Brass Lacquer, no. CK-02012466, available from Van Dyke's Restorers. Call 800/558-1234 or go to www.vandykes.com. A 6-ounce can of the finish sells for less than \$8. ♣



Discoloration removed using denatured alcohol

www.woodmagazine.com

ROCKLER®
WOODWORKING AND HARDWARE

THE WORLD'S
BEST
SELECTION
OF HINGES

50
years
1954-2004

Call or go online to get your **FREE** catalog today! Code 14032

1-800-403-9736 -or- rockler.com/go/V4343

Circle No. 661

The **BLUE** Mark of Quality.

Kreg

POCKET HOLE SYSTEMS™

Quality tools, education, service and value.

Expect this and more from **KREG**, the leader in Pocket Hole technology.

Kreg Jig® ProPack

A better way to join wood.

Faster... No waiting for the glue to dry.
Stronger... Screws put unmatched clamp pressure on the joint line.
Simpler... Drill pocket holes in only one workpiece. Align for assembly with a single clamp.
Better! Faster assembly, stronger joints, fewer headaches. Give it a try today!

Two simple steps to wood joinery...

Drill pocket holes. Drive screws.

www.kregtool.com **Kreg** **800.447.8638**

Circle No. 802

black walnut

A storied hardwood that's dark, handsome, and oh-so-distinctive

Black walnut (*Juglans nigra*) ranks as one of America's great woods, serving for years as a top choice for creating fine furniture. Today, we see the wood less often, as trends favor the lighter tones of oak, cherry, and maple. Walnut, though, remains a favorite of clockmakers, who employ the wood to create stately heirlooms. Crafters of gunstocks, too, favor no wood as highly, thanks to walnut's weather resistance, stability, figure, and deep, dark color.

As a woodworker, you, too, will appreciate walnut's positive attributes. It's a perfect wood for building projects with luster, figure, and an undeniable air of quality such as the table, *bottom right*.

A producer of good wood from trunk to top

Walnut trees grow in abundance over the eastern half of the United States, both in open areas and in great deciduous forests. The trees commonly achieve heights of

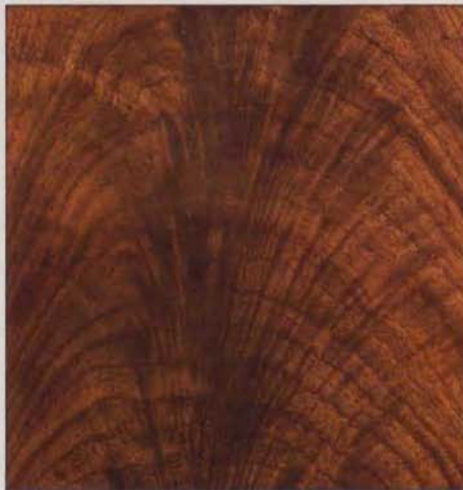

With amazing regularity, the crotches in walnut trees yield V-shaped "flare" and "flame" patterns with contrasting colors and dazzling grain.

100' with trunks 3' across. In ideal conditions, 6'-diameter trunks can be found. Walnuts that grow in the open branch out low, while those that compete with neighboring trees climb many feet before sprouting major appendages.

These forest-grown trees yield superior straight-grained lumber, which is prized in any species. Where branches and trunk intersect, though, walnuts produce some of their most spectacular grain, *above left*. Gunstock makers fetch up these crotch pieces, and create blanks that sell for \$300 and more. Locate a tree with bumps and bruises, and you'll find amazing burls, as shown *above right*.

Walnut heartwood, *top*, bears warm tones of brown, sometimes tinged with purplish hues. All walnut trees wear thick rings of creamy-white sapwood. Rather than waste this wood, many mills steam walnut boards during the drying process, which darkens the sapwood to match the



Walnut trees commonly bear craggy protrusions, known as burls, that produce grain with tight swirls. Much of this wood becomes veneer.

heartwood more closely. A lot of woodworkers believe this process dulls the tones in heartwood, and seek air-dried stock instead. Examine kiln-dried walnut at your lumber dealer, though, and you'll

Continued on page 28





Walnut machines almost flawlessly with carbide-tipped bits and blades. The wood will blunt edges, so keep tools sharpened.

discover plenty of colorful boards. Those boards carry a price, in most regions, similar to other premium hardwoods. See "Walnut at a glance" for more details.

A very workable wood

If anything can surpass walnut's beauty, it may be its workability. For starters, walnut remains relatively stable once dried, and suffers little seasonal movement. Build projects with confidence. They won't split apart over time.

Walnut is rated as moderately hard, so it machines reasonably well without being too hard on tools. The wood holds crisp details, *above*, whether decorative or for joinery. Hand tools perform well in walnut, too. Examine the checkering and carving that adorn gunstocks to see why carvers crave the wood.

Walnut trees produce earlywood and latewood with pores of similar size and color. This yields visible, but not sharply contrasting, grain. By comparison, oak's earlywood and latewood differ dramatically, resulting in its distinct grain.

This wood also sands well, with little effort. Work through 180 or 220 grit, using a random-orbit sander, to produce a smooth, scratch-free surface.

Figured walnut requires the same care exercised with any patterned grain: light cutting passes and additional sanding.

Machining and sanding the wood evoke a trait only the woodworker may appreciate, too—a sweet aroma. Just don't breathe it too much, or it could irritate your lungs.

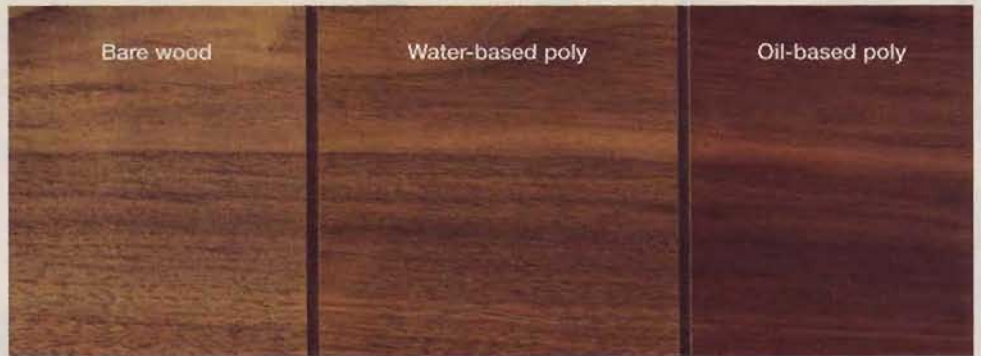

Unfinished walnut, *left*, has a beautiful color, but may not reveal the wood's intriguing grain. Water-based topcoats, *middle*, help enhance the grain, but leave color lifeless. To bring out the best of both, coat the wood with an oil-based finish, *right*.

Faultless finishing

No matter how versed you are at finishing, walnut yields great results. Because of the wood's dark tone, it's rare to stain it to completely alter its color. You may want



To re-create the look of ebony, brush on black aniline dye. Flood the surface, and then wipe away the excess to reveal the grain. Apply multiple coats if necessary.

to stain walnut, though, to better match boards with differing hues, or to even out the tone of heartwood and sapwood. A simple clear finish imparts a beautiful sheen, as shown *above*.

One final note: Walnut is wonderful for the technique of ebonizing—tinting the wood with black dye to replicate the look of rare, expensive ebony, *left*. Certainly lesser species can take on the black color using the same process, but the grain, color, and pore structure of straight-grained walnut lend themselves to an effective impersonation. ♣

Written by David Stone

Learn more about

different wood profiles at

woodmagazine.com/woodprofiles



Walnut at a glance

Price: Expect to pay from about \$4.50 to \$6.50 per board foot for 4/4 firsts-and-seconds (FAS), random-width-and-length boards. Highly figured stock can bring twice the price, or more, of straight-grained wood. Veneers sell for \$6 or more per square foot.

Pros: Very workable; excellent finishing properties; widely available; stable; makes a great accent wood when combined with lighter woods; moderate price; often exhibits interesting grain figure.

Cons: Dark tone may obscure some details or appear nondescript without good lighting; color-matching boards can be difficult.

Special considerations: Wear a dust mask when sanding to prevent lung irritation. The tree's wood, leaves, bark, and roots contain a substance called juglone, which is toxic to roots of other plants and to animals. Don't use chips as bedding for plants or animals.

Related species: Butternut (lighter but has similar grain); hickories; and a variety of other walnuts, such as European and English.

ask wood

Answers to your questions from letters, e-mails, and WOOD ONLINE®

Use the right tools for water-base success

Q: What's the best way to apply water-based finish when you don't have spray equipment?

—Al Joslin, Evanston, Ill.

A: A 100 percent synthetic brush works great, Al, and paint pads really speed up the process on large, flat surfaces. Natural-bristle brushes tend to splay as they absorb the water that's present in the finish, and rollers leave bubbles. Once you have the right tool or tools, follow these tips for great results:

- Weather affects water-based more than solvent-based finishes, so take temperature and humidity into account. Make sure your finishing area is 65° F or higher so the finish flows out properly. If high humidity prolongs the drying time, set a fan to blow air over the project. (Be sure you do this in a dust-free environment.)

- Stir the container thoroughly to bring solids off the bottom and back into solution. Then, pour the amount you need into a jar or pan, straining it through a paper or plastic filter or pantyhose to remove any remaining lumps.

- Apply a thin coat, let it dry (in normal conditions, water-base dries in 10 minutes or so), and sand away the raised grain with 320-grit sandpaper. You may need to sand again if the second coat also raises the grain. Keep subsequent coats thin to avoid bubbles.



When finishing with water-based coatings, cover a lot of surface quickly with a clean paint pad. Always work with a light source reflecting off the surface at a low angle so you don't miss any spots.

Save money with this edge-clamping method

Q: I want to apply edging to a countertop. Because it's fastened in place against a wall, I can't use my pipe clamps. Do I need specialized clamps of some kind, or can you suggest another solution?

—William Barton, Covington, Ky.

A: Bill, manufacturers make several models of edging clamps, and they could be a good investment if you planned to do a lot of similar projects. But we have a cost-free, shop-made solution as well. All you need are wood scraps tapered at about 10°, handscrews or other suitable clamps, and a hammer. Apply glue to the edging, and hold it in place with help from an assistant. Use as many clamps as necessary to hold the entire edging strip in place, spaced at regular intervals, and adjust each clamp to keep the edging flush with the top surface. Insert a pair of wedges, with the tapered edges together, between each clamp and the edging. Gently tap one wedge, then the other, as shown at right, until you see glue squeeze-out along the joint.

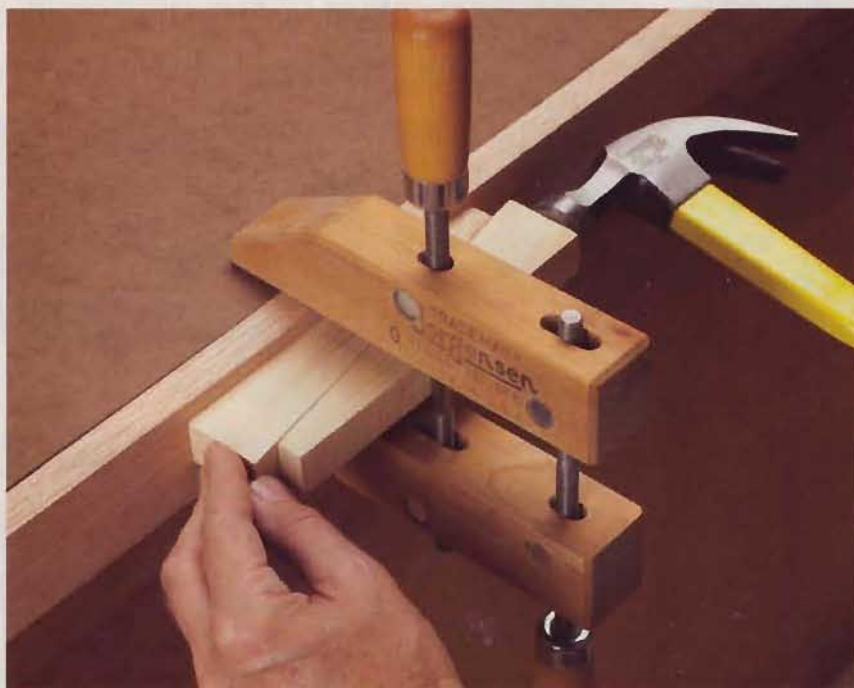

Other kinds of clamps will work, but this style gives you plenty of room for wedges. Remove the clamp after 30 minutes so squeeze-out doesn't glue it to the surface.

Continued on page 32

“Rock the bit” to elongate screw holes

Q: I’m looking for a quick, simple way to elongate screw holes when I attach a solid-wood top to a piece of furniture.

—Jon Toft, Overland Park, Kan.

A: Here’s how we made ½”-long slots to receive #8 screws for a recent project, Jon. With a 3/16” twist bit mounted in the drill press and a fence in place to keep the holes aligned, we drilled three holes for each slot: one in the center and one at each end. Then, we chucked the same bit into a portable drill, placed the part on scrap, pulled the trigger, and rocked the bit against the remaining waste until we had a complete slot. Work carefully, and you’ll get a clean, straight result.

Align each slot so that it runs perpendicular to the top’s grain lines. All significant wood movement occurs across the grain.

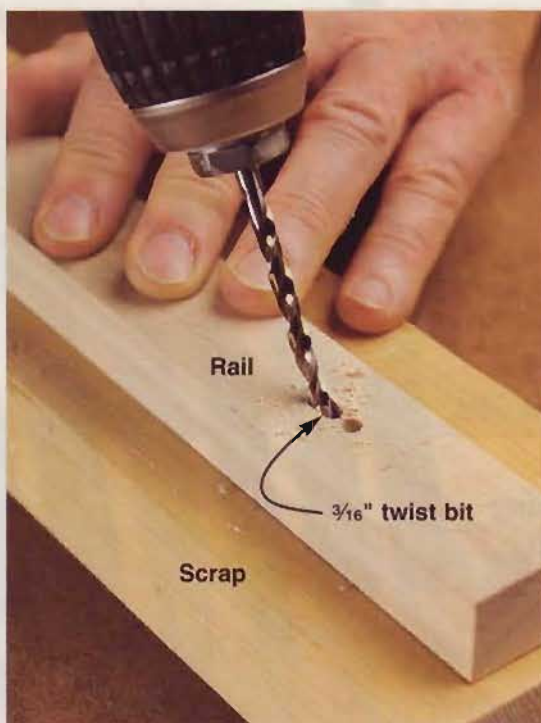

Use a sharp twist bit to hog out wood for a screw slot. Make sure to keep it in line with the starter holes so the screw can slide easily as the solid-wood top swells and shrinks.

Consider safety when selecting contact cement

Q: I’ve always used solvent-based contact cement, but I’m wondering if I should switch to a water-based version to avoid the fumes. What do you recommend?

—Paul Allen, Anaheim, Calif.

A: Go with the water-based product, Paul. It provides the same bonding strength, reduces your exposure to toxic chemicals, and cleans up easily. In one solvent-based contact cement, the hazardous material toluene accounts for as much as 60 percent of the product by weight. In a comparable water-based contact cement, toluene is no more than 5 percent of the total. Apply the cement with a foam roller, notched trowel, or utility brush, and then clean your tools with soap and water. Wait 30 to 45 minutes before assembly—about twice as long as you would with the solvent type—until the cement looks glossy and feels tacky. In cool (below 65° F) and humid weather, plan to wait even longer.



Spread water-based contact cement evenly on your substrate. When the adhesive becomes tacky, apply the plastic laminate, and then press it down firmly with clamps and cauls.

Add weathering to sawn edges of old barn boards

Q: I make picture frames from old barn boards, and you know the problem: When I saw a piece to size, I expose light-colored wood that looks like it just came from a store. Is there a way to create a rustic, weathered look on fresh-sawn wood?

—Robert Kirkpatrick, Oregonia, Ohio

A: Start by scrubbing the sawn area with a stiff steel brush to create texture, Bob, and then take care of the color. Several products promise “instant weathering.” We’ve had success with one called Age-It Easy (Gray). It creates a chemical reaction that turns light wood gray in minutes. Brush on a thin coat, wait a few minutes, and compare the treated area to the weathered portion. If the result isn’t dark enough, brush on a bit more. We bought a 3.5-ounce bottle of Age-It Easy for \$6.75 from Micro-Mark, a company that sells a wide variety of hobby supplies. Phone 800/225-1066 to place an order, or visit www.micromark.com.



When you build with weathered wood, brush on Age-It Easy to disguise freshly sawn surfaces. Keep the liquid right where you want it by using a small brush.

Got a question?

If you're looking for an answer to a woodworking question, write to Ask WOOD, 1716 Locust St., GA-310, Des Moines, IA 50309-3023, or send us an e-mail at askwood@woodmagazine.com. For immediate feedback from your fellow woodworkers, post your question on one of our forums at www.woodmagazine.com.

Easy glider

COVER PROJECT



Float off into the summer sunset on this comfy addition to our Adirondack-style outdoor seating ensemble.



Bring a touch of the north woods to your backyard

Furnish your outdoor living space with matching Adirondack-style pieces, including a settee (issue 125), planter (issue 148), and chair and footrest (issue 149). If you don't have these issues, see *Sources* on page 40 to obtain the plans.

1 SEAT SIDE ASSEMBLY (Right end shown)

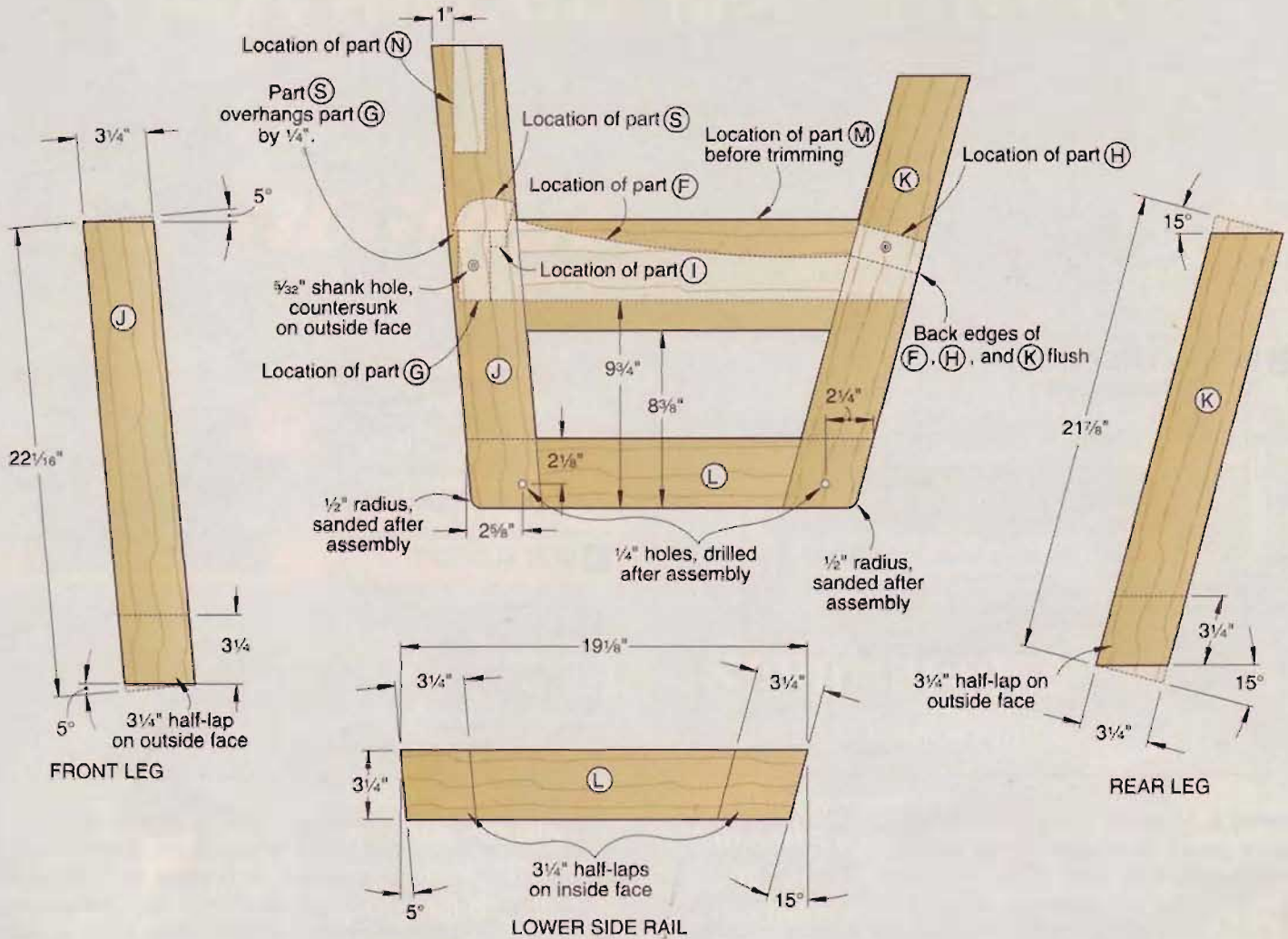

Among childhood memories of visiting my grandparents was the scramble for a place on a glider that occupied their breezeway. Even as an adult, that glider was my favorite seat for iced tea and conversation. Child or adult, the soothing motion of a glider is hard to resist. The traditional design shown at left, reminiscent of summers in the woods, will surely become your favorite outdoor retreat.

Jan Svec
Projects Editor

Start with the half-laps and offset tenons

1 Cut the stiles (A), rails (B), stretchers (D), front legs (J), rear legs (K), and lower side rails (L) to the sizes listed on the **Materials List**. Then cut the 5° and 15° angles on the ends of the front legs (J), rear

legs (K), and lower side rails (L), where shown on **Drawing 1**.

Note: The half-laps on parts A, B, J, K, and L require making test cuts in scrap to accurately set your dado-blade height. And you'll use this same blade height to cut the offset tenons on parts D. By machining all these joints now, you'll save time by eliminating repetitive trial-and-error setups.

2 To set up your table saw for cutting half-lap joints, adjust your $\frac{3}{4}$ " dado blade to make a $\frac{3}{4}$ "-deep cut. Rabber the ends of two pieces of $\frac{1}{2}$ "-thick scrap. Fit the pieces together, check if their surfaces are flush. Then make any necessary adjustments, and retest the fit.

3 To cut the laps, first position the table-saw fence to act as a stop, as shown in **Photo A**. To prevent chip-out, attach an auxiliary extension to your miter gauge, positioning it so the dado blade cuts through it. Now, cut the half-laps in the stiles (A) and rails (B), where shown on

SETTING THE LAP LENGTH

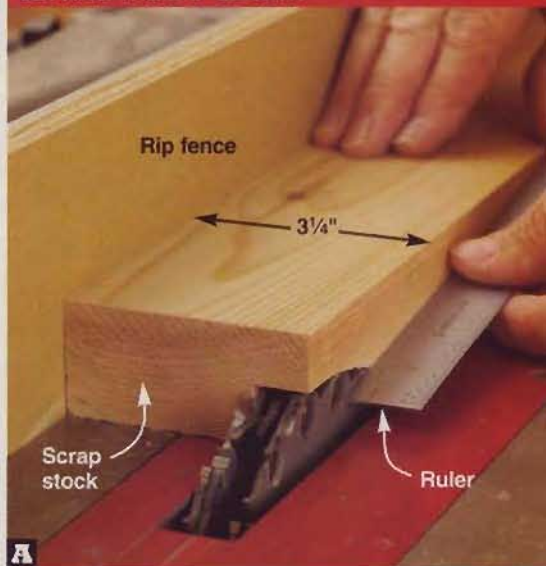

A Cut into a piece of scrap stock the same width as the parts to be half-lapped, and adjust the fence so the outside edges of the scrap and the blade are flush.

2 BASE

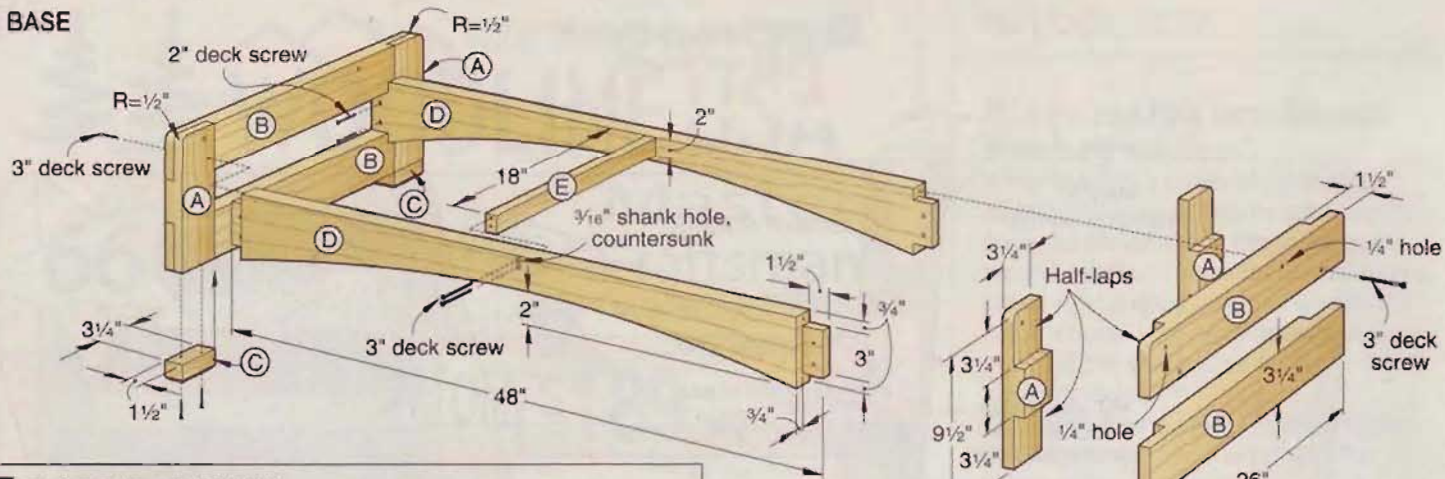

2a BASE END ASSEMBLY (Outside face shown)

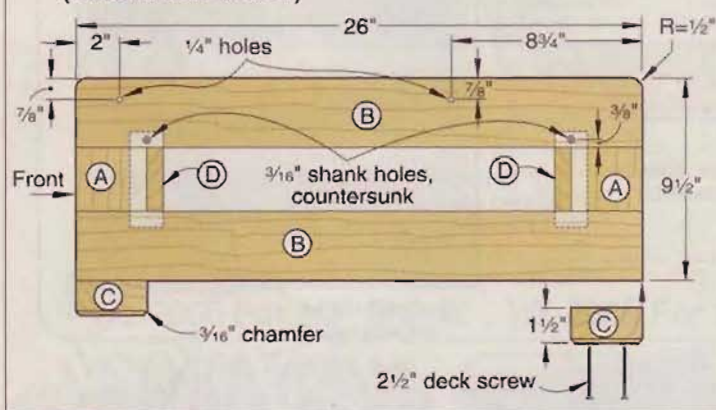

3 SEAT SUPPORT

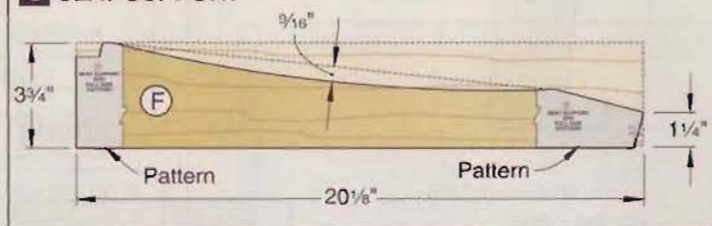

Drawing 2. Make the cuts in several overlapping passes, stopping when the ends of the parts contact the fence.

4 Lay out the side assembly parts J, K, and L. Mark an "X" on the face of each part that will be removed when cutting the half-laps. Make sure the assemblies are mirror images. Adjusting your miter gauge to match their 5° and 15° ends, cut the half-laps in the front legs (J), rear legs (K), and lower side rails (L), as shown in **Photo B**.

CUTTING THE ANGLED LAPS



With your miter gauge adjusted to the proper angle (a 15° cut is shown), cut the angled half-laps. Make multiple passes until the end of the part contacts the face of the rip fence.

5 Set the miter gauge back to 90°, and reposition the fence to the right of the dado blade, 1 1/2" (the thickness of part A) from its left side. Once again using the fence as a stop, cut offset tenons on the stretchers (D), where shown on **Drawing 2**.

Build the base

1 Glue and clamp the base end assemblies (A/B) together. (We used polyurethane glue. For more on using

polyurethane glue, see *page 112*.) Then drill two 1/4" holes in each assembly, where dimensioned on **Drawing 2a**. Cut the feet (C) to size, and chamfer their bottom edges, where shown. Drill screw holes, countersinking them so the screw heads will be about 1/8" below the surface. Screw the feet in place. Finally, sand 1/2" radii on the assemblies' top corners.

2 Mark the midpoint of each arc on the stretchers (D), where dimensioned on **Drawing 2**. Draw the arcs, as shown in **Photo C**, and then bandsaw and sand the arches. For instructions on making the simple fairing stick shown, see *issue 149, page 10*, or go to woodmagazine.com/fairing. Glue and clamp the stretchers (D) to the end assemblies, drill the countersunk screw holes, and drive the screws.

3 Cut the crossbar (E) to size. Clamp it between the stretchers at their midpoint and flush with their top edges. Drill countersunk screw holes, and drive the screws. Sand the base assembly smooth, and ease any sharp corners with your sanding block.

DRAWING ARCS ON THE STRETCHERS



Make a simple fairing stick from a thin strip of wood and some string, and flex it to connect the endpoints and midpoint of the arcs on the stretchers (D). Then draw the arcs.

Make the seat frame

1 Cut the seat supports (F) to size. Copy the seat support end patterns on the *WOOD Patterns* insert, and adhere them to

4 EXPLODED VIEW

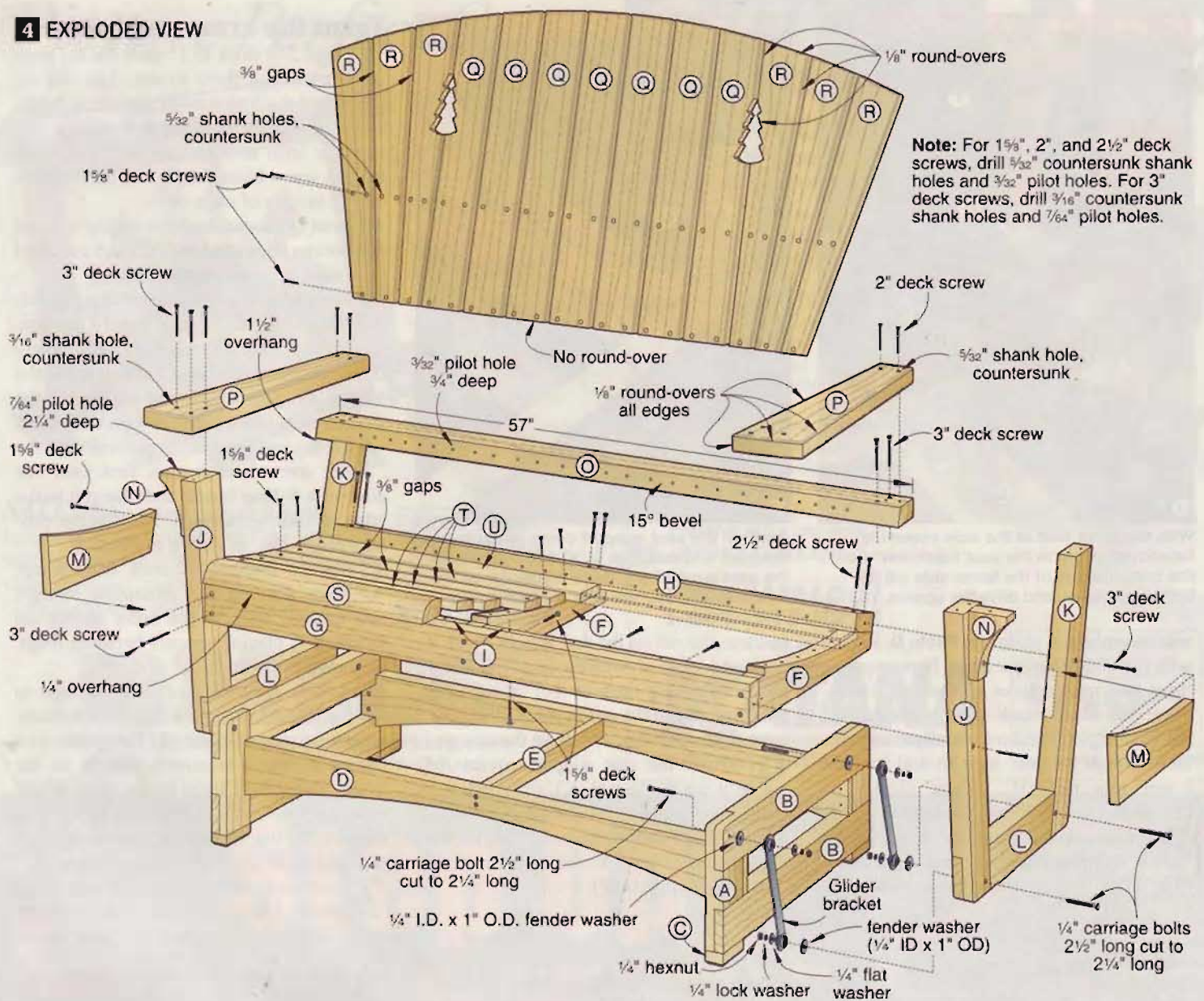

5 SEAT SUPPORT COVER

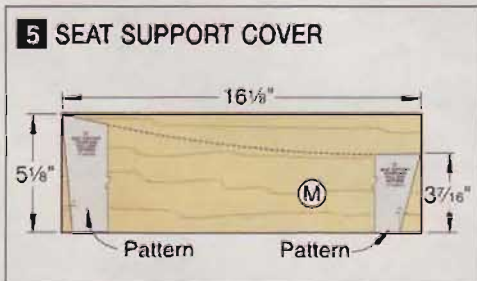

one of the supports with spray adhesive, where shown on **Drawing 3**. To complete the curve of the seat, connect the pattern halves with a straight line, where shown on the drawing, and then mark the curve center-point ⅜" below this line. Now bend a fairing stick to connect the curve endpoints and midpoint, and draw the curve. Cut the 15° angles on your tablesaw. Then bandsaw and sand the other areas of the seat supports to shape. Using this completed seat support as

a template, trace outlines on the other two supports, and cut and sand them to shape.

2 Cut the front rail (G) and lower rear rail (H) to size. Then glue and clamp the seat frame (F/G/H) together with parts F and H flush at the rear, where shown on **Drawing 1** and **4**. Drill countersunk screw holes, and drive the screws.

3 Cut the cleats (I) to size, and glue and clamp them to the inside face of the front rail (G), flush with its top edge. Drill countersunk screw holes through the cleats and into the rail, and drive the screws.

4 Cut the seat support covers (M) to size. Copy two sets of the seat support cover ends on the pattern insert, and adhere them to the seat support covers, where shown on **Drawing 5**. Cut the end angles on your tablesaw. Do not cut the curve at this time.

5 Retrieve the front legs (J), rear legs (K), and lower side rails (L). Glue and clamp

the seat side assemblies together in the configuration shown on **Drawing 1**. To make certain the assemblies are accurately aligned when gluing, temporarily clamp the seat support covers (M) between the legs, where shown. With the glue dry, drill the ¼" holes, and sand the ½" radii on the assemblies' bottom corners.

6 Cut the brackets (N) to size. Make two copies of the bracket in the pattern insert, and adhere them to the brackets. Bandsaw and sand them to shape. Glue and clamp the brackets to the front legs (J), where shown on **Drawing 1**. Drill the countersunk screw holes, and drive the screws.

7 Place one side assembly (J/K/L/N) outer side facedown on your workbench. Position the seat frame (F/G/H/I) with the back edges of parts F and H flush with the back edge of part K, where shown on **Drawing 1**. Fasten the seat frame to the

ATTACHING THE SEAT FRAME

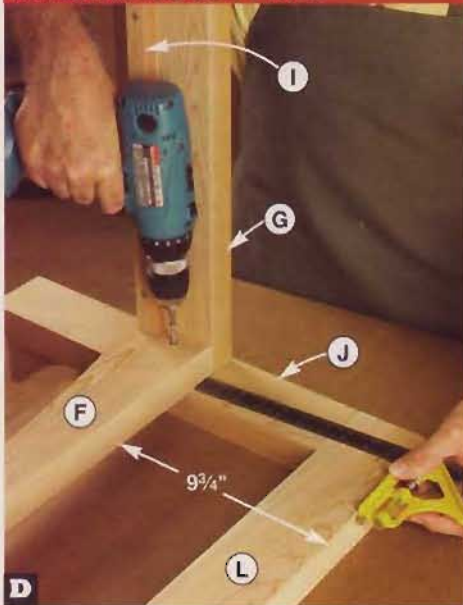

With the outer side of the side assembly facedown, position the seat frame $9\frac{3}{4}$ " from the bottom edge of the lower side rail (L). Drill screw holes, and drive the screws.

side assembly, as shown in **Photo D**. Repeat with the other side assembly. Now working from the outside faces of the end assemblies, drill countersunk screw holes through the front legs (J) and into the front rail (G), and through the rear leg (K) and into the lower rear rail (H), where shown on **Drawings 1 and 4**. Drive the screws.

8 Cut the upper rear rail (O) to size. Then tilt your saw blade 15° , and bevel-rip its front edge, where shown on **Drawing 4**.

6 ARM

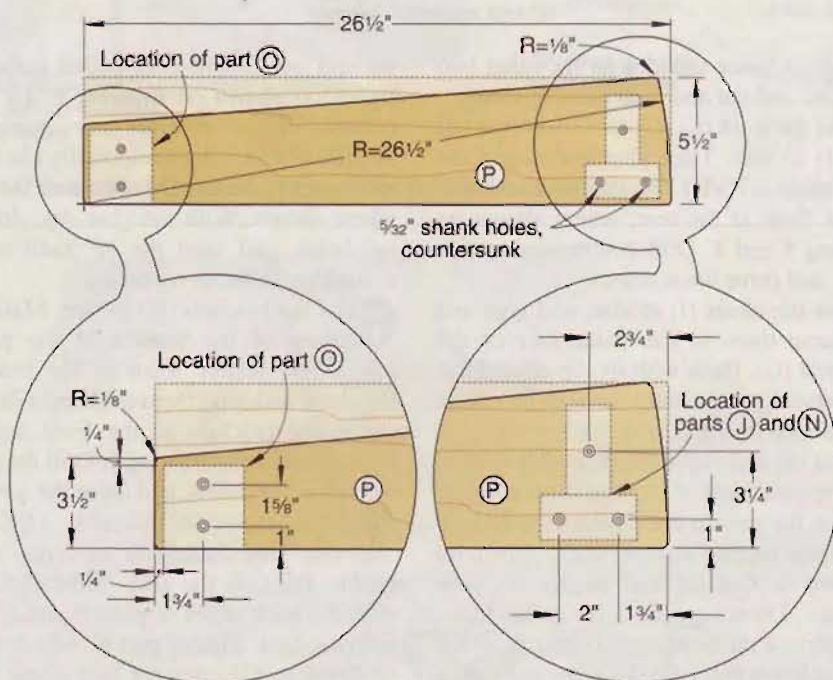

MARKING THE SEAT SUPPORT COVERS

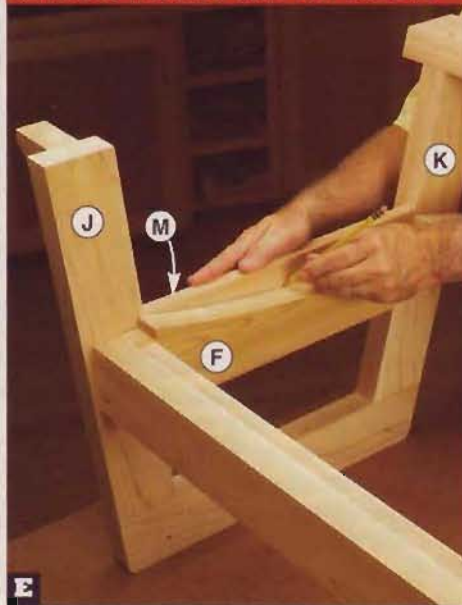

Position the seat support cover (M) between the front and rear legs (J, K) and tight against the seat support (F). Trace the profile of the seat support onto the seat support cover.

Position the rail on the rear legs (K) with its beveled edge flush with the legs' front edge, and overhanging them by $1\frac{1}{2}$ " at each end. Glue and clamp the rail in place, drill countersunk screw holes, and drive the screws.

9 Position the seat support covers (M) between the legs (J, K), and mark their curved top profiles, as shown in **Photo E**. Bandsaw and sand to the marked lines, and then glue and clamp the seat support covers to the seat supports (F).

Form the arms and back

1 Plane 2×6 stock to $1\frac{1}{2}$ " thick for the arms (P), and cut them to size. Lay out the shape and the locations of the screw holes, where shown on **Drawing 6**. Bandsaw and sand the arms to shape, and drill the countersunk screw holes. Make sure the parts are mirror images of each other.

2 Rout $\frac{1}{8}$ " round-overs along the top and bottom edges and ends of each arm, and then sand $\frac{1}{8}$ " radii on the corners.

3 For the back, cut the seven straight slats (Q) and the six tapered slats (R) to size. Taper one edge of the slats (R), where dimensioned on **Drawing 7**. Then make the 5° cuts on the bottom end of two of the tapered slats and the 10° cuts on two more.

4 To lay out the back top curve and the slat screw hole centers, first joint one edge of a 5'-long board, and clamp it to the edge of your workbench. Position the center straight slat, as shown in **Photo F**.

5 Cut 24 spacers $\frac{3}{8}$ " thick from scrap. Then position the remaining straight and tapered slats in the order shown on **Drawing 7**, placing spacers between them, as shown in **Photo G**.

6 Adhere two strips of masking tape to the slats, and mark screw hole centers, where shown on **Drawing 7**. Then make two copies of the tree cutout pattern in the insert, and adhere them to the slats, where shown. Now mark the centers of the top arcs $1\frac{1}{2}$ " below the top corners of the slats (R), and draw them as shown in **Photo H**.

7 Slice the masking tape and the tree patterns between the slats with a utility knife. Drill the countersunk screw holes.

ALIGNING THE CENTER SLAT

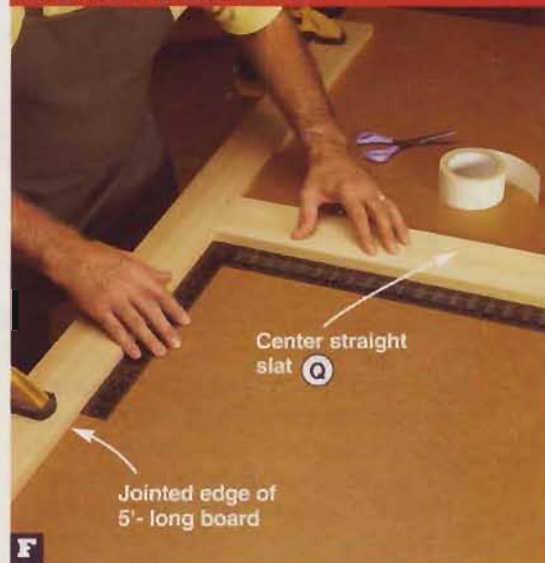

Apply double-faced tape to the back of a straight slat (Q). Center it on the jointed edge of a 5'-long board, align it with a framing square, and stick it to your workbench.

7 BACK SLATS

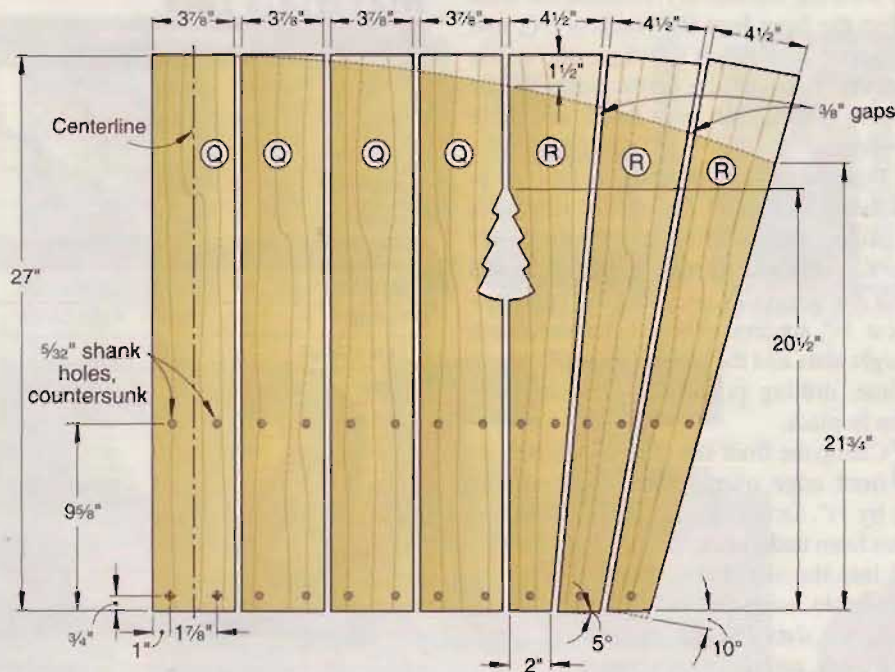

Bandsaw and sand the tree cutouts and the top arcs of the slats. Stain the edges of only the tree cutouts. (We gave ours two coats of Olympic Wood Protector solid color latex stain in a color called Faulkland.)

8 With the stain dry, rout 1/8" round-overs on the front and back edges of the slats, including around the tree cutouts. Rout the top ends of the slats, but not the bottom ends. Finish-sand the slats.

Now make the seat slats

1 Cut the front slat (S) to size. Make a copy of the front slat end patterns in the

insert, and adhere them to the ends of the front slat. Aligning your tablesaw blade with the cuts indicated on the pattern, rough out the slat by making the four cuts in the order shown on **Drawing 8**. Finish the profile by sanding, and then routing, the 1/8" round-overs, where shown on the patterns.

2 Cut the center slats (T) and rear slat (U) to size. Drill countersunk screw holes that are centered in the widths of the slats and on the thickness of the seat supports (F), where shown on **Drawing 4**.

3 Rout 1/8" round-overs on the top edges of all of the slats. Finish-sand the slats.

SPACING THE SLATS

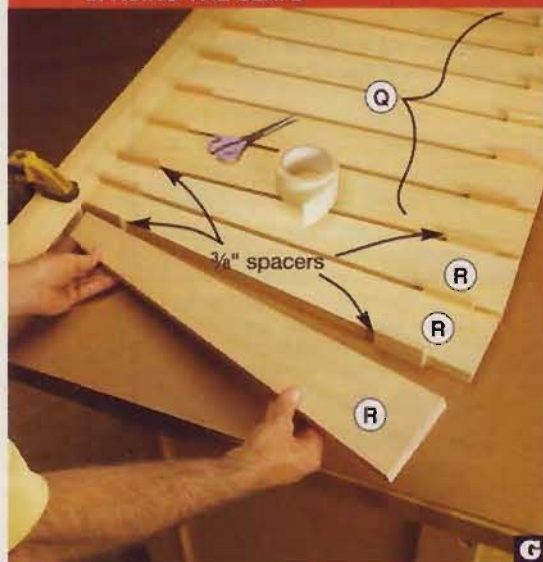

With the center slat (Q) affixed to the workbench, position the remaining slats, inserting 3/8" spacers. Stick the outer tapered slat to the workbench with double-faced tape.

LAYING OUT THE BACK

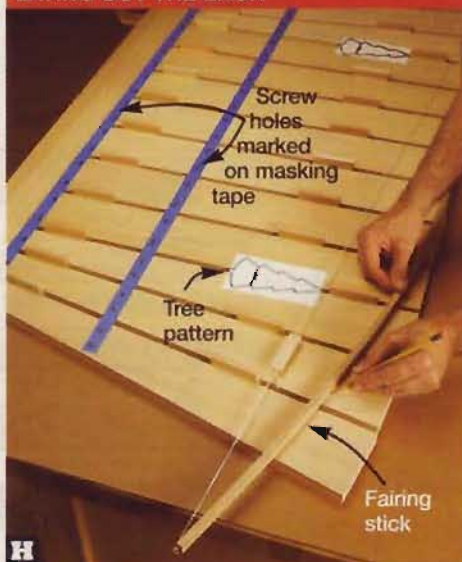

After marking screw hole centers on masking tape and adhering the tree cutouts to the slats, adjust your fairing stick to the end-points and center of the arc, and draw it.

Apply finishes and assemble

1 Inspect all the parts and assemblies, and resand any areas that need it. Ease any sharp edges with a sanding block.

2 Apply two coats of the same stain used on the tree cutouts to the base and the seat frame assembly. Coat the arms, back slats, and seat slats with a clear wood preservative. (We used Wolman Raincoat Water Repellent in a tint called Cedartone.) Avoid getting finish on the stained edges of the tree cutouts.

8 FORMING THE FRONT SLAT

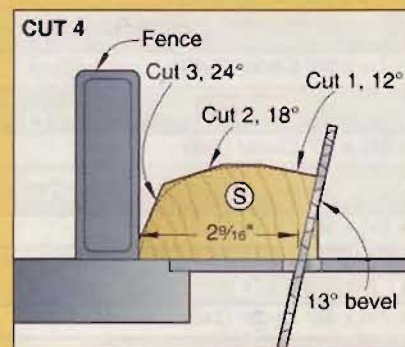
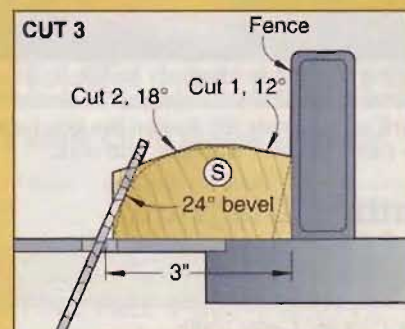
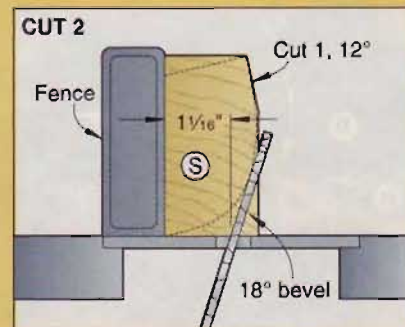
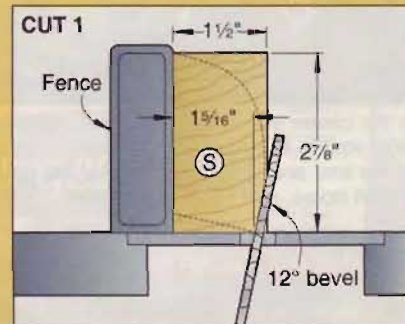

FASTENING THE BACK SLATS



With the center slat (Q) centered side-to-side on and square to the lower rear rail (H), align its lower end and the lower edge of the rail. Drill pilot holes, and drive the screws.

ATTACHING THE GLIDER BRACKETS

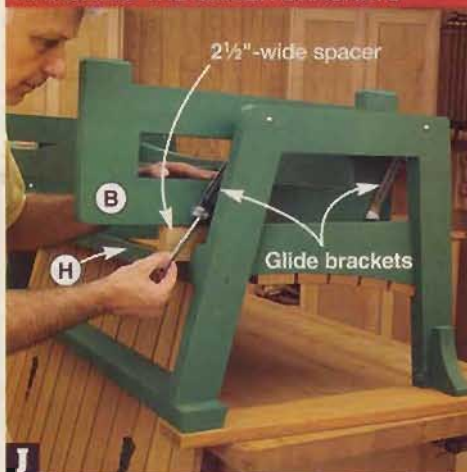

With the front glider brackets installed, insert a 2 1/2"-wide spacer between the lower rear rail (H) and the rails (B). Fasten the brackets with carriage bolts, washers, and nuts.

Cutting Diagram

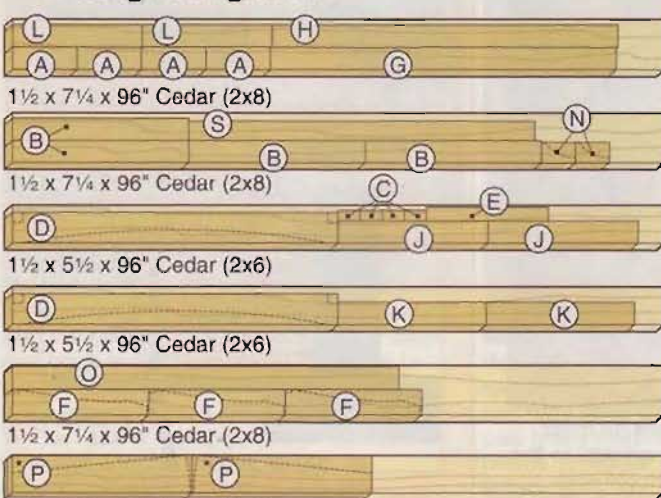

*Plane or resaw to the thickness listed in the Materials List.

3 With the finishes dry, position the arms on the front legs (J), brackets (N), and the upper rear rail (O), where shown on **Drawing 6**. Using the screw holes in the arms as guides, drill pilot holes, and drive the screws.

4 Position the center straight slat (Q), as shown in **Photo I**. Using its screw holes as guides, drill pilot holes into the lower rear rail (H) and upper rear rail (O), and drive the screws. Now, using the previously cut 3/8" spacers, position the remaining straight slats and the tapered slats (R) one at a time, drilling pilot holes and screwing them in place.

5 Clamp the front slat (S) in place with its front edge overhanging the front rail (G) by 1/4". Drill angled countersunk screw holes from underneath through the cleats (I) and into the slat. Drive the screws. Then, once again using the 3/8" spacers, position the center slats (T) and rear slat (U). Drill pilot holes, and drive the screws.

6 To install the glider brackets, place the completed seat upside down on your workbench, resting on its arms. Hacksaw eight 1/4" carriage bolts 2 1/2" long to 2 1/4" long. Then use four of them along with fender washers, flat washers, lock washers, and nuts to fasten the glider brackets to the seat, where shown on **Drawing 4**. Position the base between the seat's end assemblies. Note the position of the 1/4" holes in the base relative to its front face, shown on **Drawing 2a**. Attach the front glider brackets to the base. To align the rear mounting holes, insert 2 1/2"-wide spacers, as shown in **Photo J**, and fasten the rear glider brackets to the base. Place the glider on the floor, and take it for a test glide. 🪜

Written by **Jan Svec** with **Chuck Hedlund**
 Project design: **Jeff Mertz**
 Illustrations: **Roxanne LeMoine**

Materials List

Base	FINISHED SIZE			Matl.	Qty.
	T	W	L		
A stilts	1 1/2"	3 3/4"	9 1/2"	C	4
B rails	1 1/2"	3 3/4"	26"	C	4
C feet	1 1/2"	1 1/2"	3 3/4"	C	4
D stretchers	1 1/2"	4 1/2"	48"	C	2
E crossbar	1 1/2"	2"	18"	C	1
Seat Frame					
F seat supports	1 1/2"	3 3/4"	20 1/8"	C	3
G front rail	1 1/2"	3 3/4"	51"	C	1
H lower rear rail	1 1/2"	3 3/4"	51"	C	1
I cleats	3/4"	3/4"	23 1/8"	C	2
J front legs	1 1/2"	3 3/4"	22 1/8"	C	2
K rear legs	1 1/2"	3 3/4"	21 7/8"	C	2
L lower side rails	1 1/2"	3 3/4"	19 1/8"	C	2
M seat support covers	3/4"	5 1/8"	16 1/8"	C	2
N brackets	1 1/2"	3"	5"	C	2
O upper rear rail	1 1/2"	3 3/8"	57"	C	1
Arms and Slats					
P arms	1"	5 1/2"	26 1/2"	C	2
Q straight slats	3/4"	3 3/8"	27"	C	7
R tapered slats	3/4"	4 1/2"	27"	C	6
S front slat	1 1/2"	2 7/8"	51"	C	1
T center slats	3/4"	2 1/2"	52 1/2"	C	4
U rear slat	3/4"	3 3/4"	52 1/2"	C	1

Material key: C—cedar.

Supplies: 1 1/2", 2", 2 1/2", and 3" deck screws; 1/4" carriage bolts 2 1/2" long (8); 1/4" I.D. x 1" O.D. fender washers (8); 1/4" flat washers (8); 1/4" lock washers (8); 1/4" hexnuts (8); spray adhesive; polyurethane glue; masking tape; double-faced tape.

Blades and bits: Stack dado set; chamfer and 1/8" round-over router bits.

Sources

Hardware. Glider brackets no. 58330, \$19.99 for a set of four. Rockler Woodworking and Hardware. Call 800/279-4441, or go to www.rockler.com.

Plans. To obtain plans for the matching pieces, call 888/636-4478, and ask for the settee from issue 125, planter from issue 148, or the chair and footrest from issue 149, or shop online at www.woodmagazine.com/store.



do you see beautiful projects here?

Workshop scraps, construction debris, and even tree limbs contain the seeds of great-looking projects.

Ready to try something different? We're here to remind you that not every woodworking project has to start with a stack of surfaced lumber from the store. As you'll soon see, you're surrounded by other choices all of the time.

When *WOOD* magazine editors scour crafts shows around the country, we're often impressed by the innovative use of unconventional materials by some artisans. We've seen exquisite projects made from the kind of material that usually winds up in the landfill.

In this article, we'll introduce you to fresh-faced materials bound to enhance projects. We'll include tips and suggestions that will help you successfully incorporate these and similar materials into your work.

As you make and machine creative woods, pay particular attention to the safety reminders, and remember to keep your tools sharp.

now you do!



Turned vessel
by Dick Codding
16" Diameter x 32" Tall



2 5/8 x 4 1/8 x 5 7/8"



2 x 3 1/2 x 3 1/2"

9 steps to making flat squares from a round branch

Any tree branches lying in your lawn? The small box shown *opposite, bottom right* demonstrates a delightful way to put them to use in your workshop. Its unique look is created by concentric juvenile rings from cedar branches. However, juvenile wood can be tricky to handle because it has a high tendency

to move and split as it dries. Work carefully and you can tame it to make panels suitable for small projects such as boxes, trays, and picture frames.

Stay with cedar and other lightweight woods, such as pine, apple, and mulberry. These woods move less with changes in moisture than heavy, dense woods do.

Look for a straight length that's at least 1½" in diameter and 1' long. You'll cut away much of that material as you prepare your workpieces.

A word of advice as you follow the sequence *below*: Make more pieces than you need in case you have to discard some due to cracking.



1 Begin with a 1'-long branch and bandsaw off a slab from one side to establish a face. Use pushblocks to feed this surface over your jointer. Your goal is to end up with blocks about ½" square and ⅜" thick.

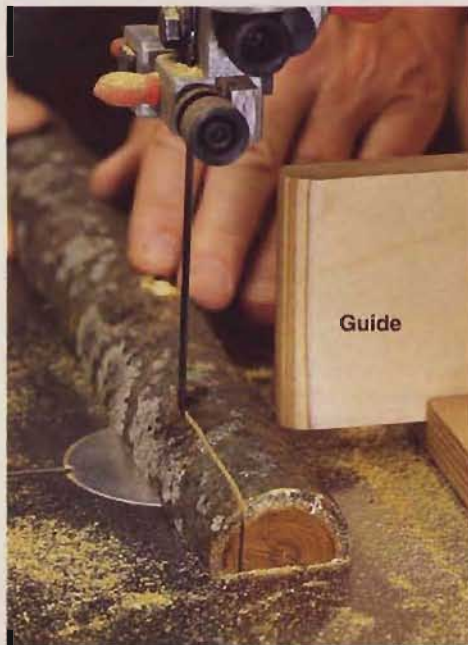

2 With the jointed surface down, cut an adjacent face. If the branch is straight enough to allow it, clamp a single-point guide to the bandsaw table. After cutting, joint this face.



3 Set your guide to cut the blank to the desired final width plus ½". With one flat surface on the table and one against the guide, make your third cut and joint it to the final width.



4 Bandsaw away most of the remaining waste, and once again clean up the cut on the jointer. Now you have a dimensioned workpiece suitable for sawing and clamping in the subsequent steps.



5 Fasten an auxiliary wooden fence to your bandsaw miter gauge. We clamped a stop-block ¾" from the blade to make blocks twice as thick as our intended panel. Next, crosscut as many blocks as possible from your 1' blank.



6 Arrange blocks edge-to-edge in rows of the desired length, apply yellow glue, and clamp. Keep the row flat as you tighten the clamps, then let the glue dry. Fill end-grain cracks with cyanoacrylate glue.

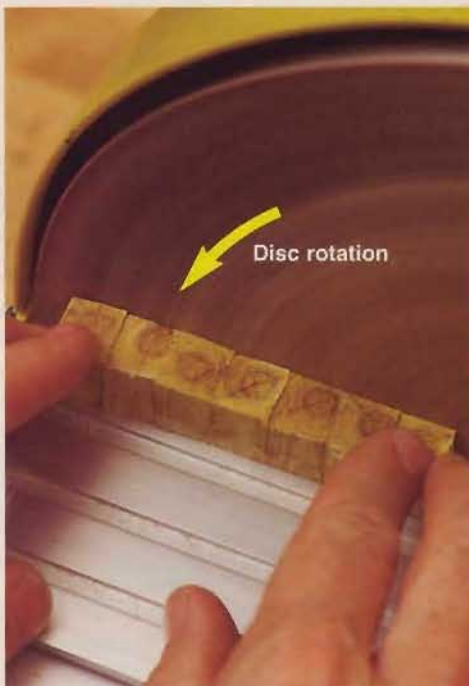

7 Unclamp the rows and smooth one face and one adjacent edge on each row with a disc or stationary belt sander. Edge-glue the rows in pairs with the sanded edges together and the sanded faces down.

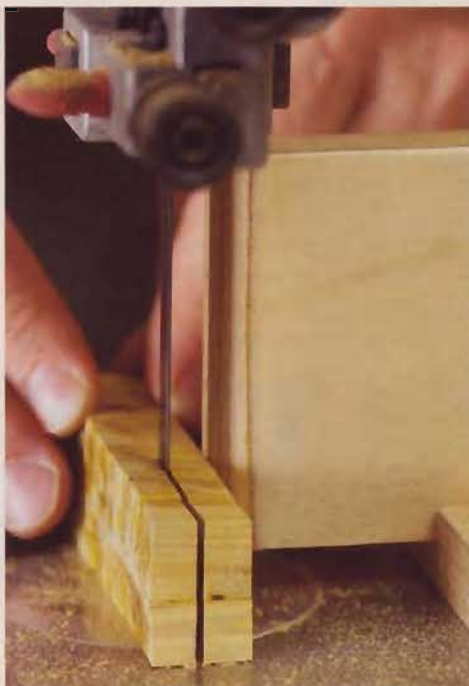

8 Set your single-point guide so the blade cuts down the center of the glue-up. Place the sanded face against the guide and saw through the glue-up to make two pieces at the planned thickness.

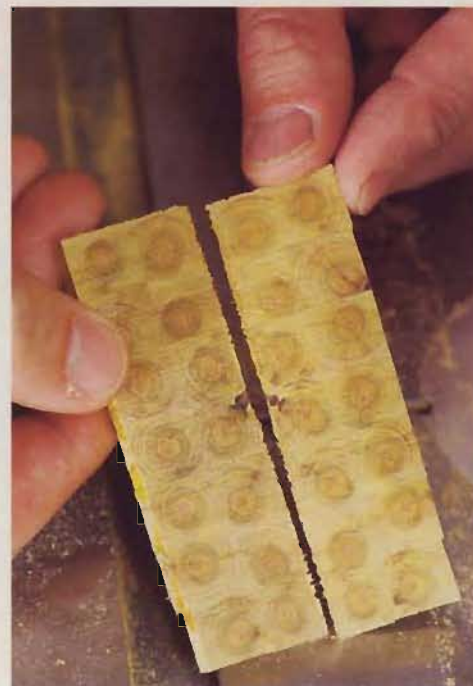

9 Sawing a row produces a pair of book-matched mini-panels. Edge-glue these to form a larger panel. Make as many panels as you need for your project and sand all rough surfaces smooth.

Quilting without cloth — how to transform scraps into eye-

If you hate to throw away wood, as most woodworkers do, you eventually wind up with an unwieldy pile of scraps. Here's a nifty way to turn them into projects like the small box shown *below*, with a lid that's a patchwork quilt of end grain. To build panels like those used to make the box lids, just follow the sequence starting at *right*.



1 Gather contrasting wood scraps of various widths and species, and run them through a planer to make them equal in thickness. If you don't have a planer, saw and sand them to approximately equal thickness and take care of any slight variations in the next step.

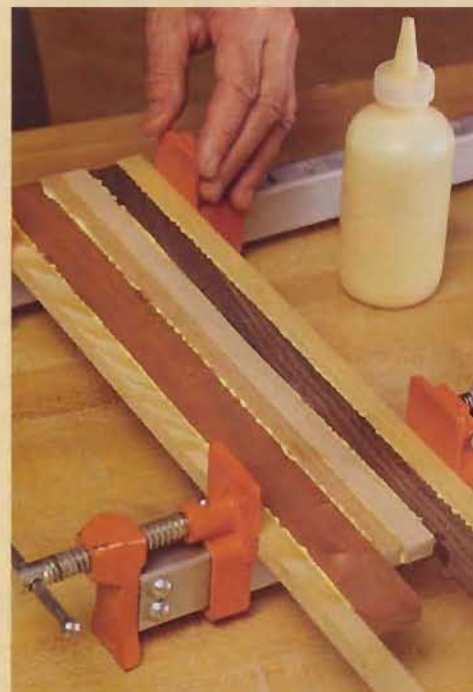

2 Select enough pieces to equal the length of your planned panel. Arrange them to emphasize their contrasts. Now, glue and clamp them as shown. When the glue becomes rubbery, remove it with a sharp scraper. If the surface is uneven, plane and/or sand it flat.

Go wild with OSB

Out on the job site, builders like to use oriented-strand board (OSB) because of its versatility and price, not its appearance. However, if you sand a piece of OSB (also known as wafer board or flake board), its random, varied shapes suddenly look a lot better, as shown in the photo *right*—nice enough to use as a small panel or lid.

Feel like taking this unlikely stock one step farther? Dye the sanded OSB a bright color. (Water-soluble dye gives good results.) As you wipe dye onto the OSB, different chunks in the material accept dye at different rates, so you get subtle variations in color on a lively, textured surface.

We smoothed these OSB samples on a drum sander. Then we sprayed shellac on the top panel and applied water-soluble dyes to the others.



pleasing project components



3 Take the panel out of the clamps and square the ends on the tablesaw. Make several panels and then face-glue them into a block no more than 2" thick so you'll be able to cut it with one pass on your table-saw. Stagger the joint lines to give the end grain a random appearance.

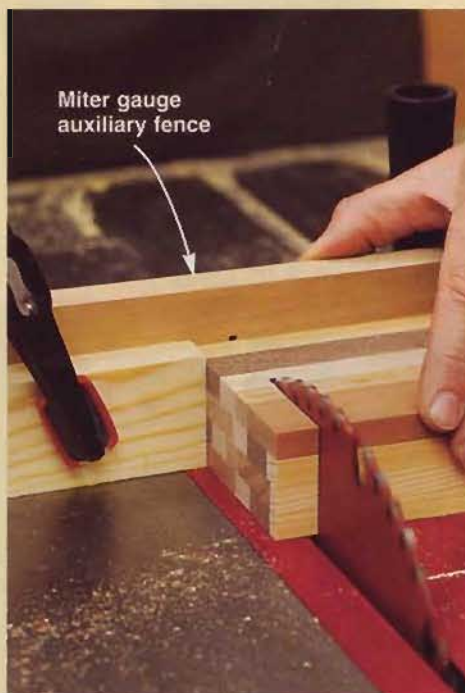

4 After the glue dries, rip-cut a flat surface along each edge of the block. Crosscut the ends square with a combination blade in your tablesaw. Now, add an auxiliary fence to your tablesaw miter gauge, clamp a stop-block approximately $\frac{3}{8}$ " to the right of the blade, and crosscut to make pieces.



5 Edge-glue as many pieces together as necessary to make a panel, then shape them according to your project plan. End grain absorbs more stain and finish than other grain, resulting in a darker color. If you want to minimize that difference, seal the end grain with dewaxed shellac.

High-class results from high-tech lamination

You can do great things with the right type of glue-laminated beams, such as Parallam®, a structural product that's made by Trus Joist, a Weyerhaeuser business. It contains long strands of fir, pine, and poplar, glued and pressed together. Unlike other types of glue-lam beams, with Parallam you see roughly parallel lines on all four faces, as shown in the shelves at *far right* and furniture *below, right*. And when you crosscut it, you expose a lively pattern of wavy shapes, as shown in the photo at *right*. Whether ripped or crosscut, Parallam gives you an interesting choice for small lids and panels in jewelry boxes and wall cabinets.

If you can find scraps of Parallam or other glue-lam at a building site, free for the asking, give this material a try. Otherwise, order a piece through a lumber dealer. As a ballpark figure, a 4x6" piece costs about \$3 per lineal foot, and you might have to order a piece at least 8' long. To find a Parallam distributor, visit www.trusjoist.com.

To make boards for such projects, just rip or crosscut pieces to the desired thickness ($\frac{1}{2}$ – $\frac{3}{4}$ " in most cases) with your tablesaw or bandsaw. Such boards have less strength than solid wood of the same thickness, especially the crosscut version. Design adequate support for any surface that will bear weight, or glue the boards to a backer made of plywood or medium-density fiberboard (MDF).

Keep in mind that you're cutting through a lot of glue when you work with this type of material. Glue quickly dulls your cutting tools, so we recommend sanding or scraping rather than using your planer and jointer.

To deal with the many voids that are part of Parallam, you have two choices: Leave them as is, or fill them with clear or tinted



Crosscut Parallam to expose a pattern unlike anything else in woodworking. The voids you see here are holes that require filling.



Shelving and furniture by **Parallel Lines**

epoxy. Remember, however, that epoxy doesn't absorb stain.

Parallam also works wonders as a turning material, as shown by the vessel on *page 42*. The photos *below* show you what to expect. Spindle turning produces striking lines all around the project. Faceplate turning exposes the wavy end-grain figure.

Filling large voids with epoxy as you work helps avoid large blow-outs but consumes an awful lot of time. Your best bet: Wait until your project is virtually complete and then fill any problem areas with epoxy. After the filler dries, follow with a finish coat of epoxy or a clear topcoat. ♣

Written by **Jim Pollock**

TURN PARALLAM FOR THE MAXIMUM "WOW" FACTOR



Fibers rip and chunks break loose as you rough-turn a piece of Parallam, but don't worry. We had no trouble achieving a generally smooth result aside from the material's inherent voids.

plumb-easy torpedo level



Add this handy, brass-accented beauty to your fine tool collection.



BUILDER'S NOTE

As *WOOD*'s master craftsman, I enjoy the challenge of finding simple, dependable ways to build projects so you're ensured a trouble-free and satisfying woodworking experience. Although small in size and made from a single piece of wood, this level made me reach deep into my bag of woodworking tricks. First, I had to find an easy way to form the radii at the ends of the level's recesses for the brass wear plates. Then, I needed to come up with a clever method for leveling the bubble vials. Finally, there was the issue of how to cut and precisely fit the brass plates.

To solve all three mysteries, I had to do a little workshop thinking. You'll discover the solutions in this article and the "working with sheet brass" article on page 22. Now, let's get busy.

Chuck Hedlund

For the items needed to build this project, including a handy level kit, see page 51.

Prepare a blank, and bore the bubble-vial view holes

1 From $\frac{3}{4}$ "-thick hardwood stock of your choice (we used figured cherry), cut a 2x10" blank for the level body. Make two copies of the level full-size patterns on the *WOOD Patterns* insert. Spray-adhere the level side-view pattern to a face of the blank.

2 Chuck a $\frac{7}{8}$ " Forstner bit in your drill press. Using a fence to position the level body and a backer board to prevent tear-out, bore a view hole at the top edge for the 1 $\frac{1}{2}$ "-long bubble vial, where shown on

the pattern and on **Drawing 1**. Switch to a $\frac{3}{4}$ " Forstner bit, and bore a view hole for the 1"-long bubble vial, where shown. Now, rout a chamfer on the holes' edges on both faces, as shown in **Photo A**.

3 Using your tablesaw, rip the blank to $1\frac{1}{16}$ " wide, cutting along the top edge.

Form the recesses for the brass plates

1 Spray-adhere the bottom-view and top-view patterns to the blank, aligning the $\frac{3}{4}$ " view-hole centerlines.

2 To form the recesses for the .063" ($\frac{1}{16}$ ")-thick brass wear plates, where shown on **Drawing 1**, first chuck a $1\frac{1}{4}$ " Forstner bit in your drill press. Centering the bit on the centerpoints for the $\frac{5}{8}$ " radii, where shown on the top- and bottom-view patterns, drill $\frac{1}{32}$ "-deep counterbores, as shown in **Photo B**. (Because a Forstner bit's outer cutting edge makes a groove slightly deeper than the hole depth, we drilled the counterbores to only one-half the recesses' $\frac{1}{16}$ " finished depth to prevent the grooves from showing on the level's faces.)

3 To complete the recesses, chuck a $\frac{3}{4}$ "-diameter straight bit in your table-mounted router. Place a piece of .063"-thick brass on the table, and adjust the bit height to match the brass's thickness. Then, using your miter gauge with an auxiliary extension to prevent tear-out, rout the recesses,

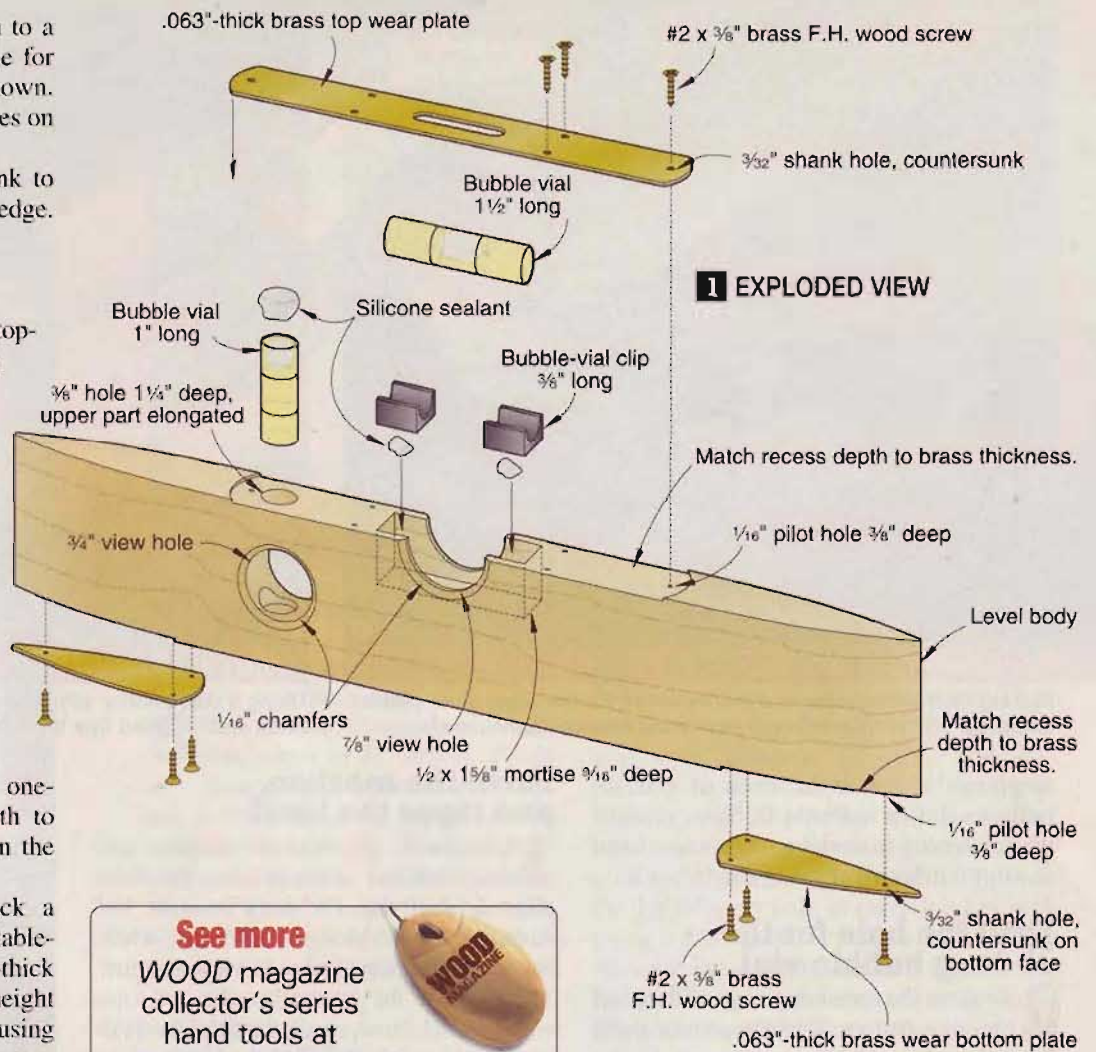

See more
WOOD magazine
collector's series
hand tools at
woodmagazine.com/handtools

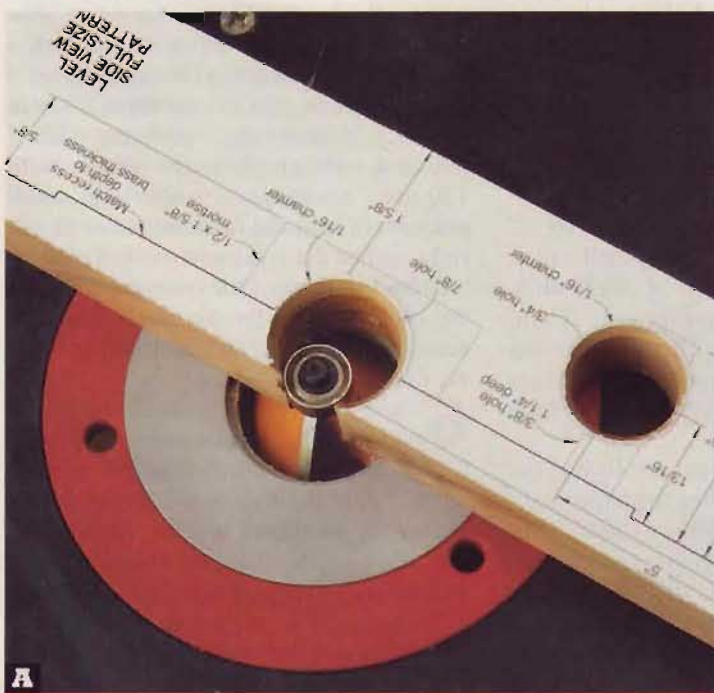

A ROUT CHAMFERS ON THE BUBBLE-VIAL HOLES' EDGES

Using a piloted 45° chamfer bit in your table-mounted router, rout $\frac{1}{16}$ " chamfers along the edges of the $\frac{7}{8}$ " and $\frac{3}{4}$ " holes.

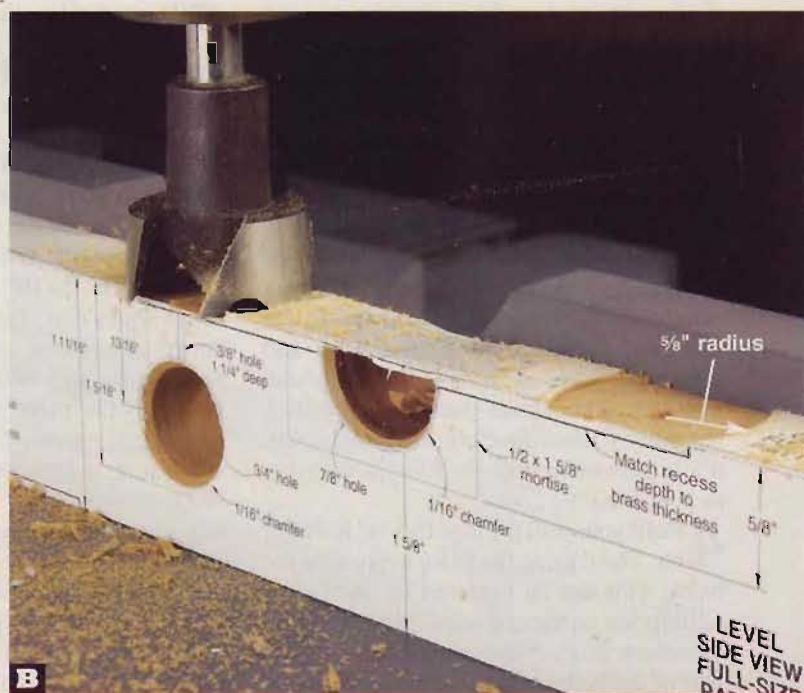

B CREATE THE RECESSES' RADIUSED ENDS

Using a $1\frac{1}{4}$ " Forstner bit, drill $\frac{1}{32}$ "-deep counterbores in the blank's top and bottom edges to establish the recesses' $\frac{5}{8}$ " radii.



ROUT THE RECESSES

Making multiple passes, rout the recesses for the brass wear plates, stopping $\frac{1}{8}$ " from the $\frac{3}{8}$ " radii to prevent damaging their ends.

stopping $\frac{1}{8}$ " from the ends of the $\frac{3}{8}$ " radii, as shown in **Photo C**. Now, remove the remaining material using a chisel and a utility knife to cut along the $\frac{3}{8}$ " radii.

Drill the hole for the 1"-long bubble vial

1 Retrieve the remaining copy of the level top-view pattern. Trim the pattern along the $\frac{3}{8}$ " radii, and spray-adhere it in the blank's top recess.

2 To create the $\frac{3}{8}$ " hole $1\frac{1}{4}$ " deep (from the recessed surface) for the 1"-long bubble vial, where shown on the top- and side-view patterns, first cut a $\frac{3}{4}$ " dowel $\frac{3}{4}$ " long. Insert the dowel in the $\frac{3}{4}$ " view hole to prevent tear-out when drilling the $\frac{3}{8}$ " hole. (After drilling the hole, you'll elongate the upper part to allow for leveling of the bubble vial later.)

3 Chuck a 6"-long piece of $\frac{1}{4}$ "-diameter steel rod in your drill press. Using a square, check that your table is 90° to the rod front-to-back and side-to-side, and adjust the table as necessary. (Although you can compensate for minor drilling inaccuracy when leveling the bubble vial, it's important to drill the hole as squarely as possible.)

4 Refit your drill press with a $\frac{3}{8}$ " Forstner bit. Then, using the fence to position the blank with the bit centered on the hole's centerpoint on the top-view pattern, drill a $1\frac{1}{4}$ "-deep hole. Now, elongate the upper part of the hole by moving the level to one side, rebor-ing to the outer pattern line, and then repeating with the level moved to the other side. Remove the dowel.

Form the mortise, and taper the level

1 Using a $\frac{1}{2}$ " Forstner bit in your drill press and the fence to keep the holes aligned, drill the $1\frac{1}{2}$ "-long mortise $\frac{1}{16}$ " deep for the $1\frac{1}{2}$ "-long bubble vial, where shown on the top- and side-view patterns. Then, square the mortise's sides and ends with a chisel. Now, check the fit of the $1\frac{1}{2}$ "-long bubble-vial clip along the length of the mortise. Pare away any material that interferes with the clip's insertion.

2 Taper the level's ends by bandsawing just outside the lines on the top-view pattern. Then, sand to the lines, as shown in **Photo D**. Remove the patterns.

Add the brass wear plates for the top and bottom

1 Cut two $\frac{3}{4}\times 10$ " pieces from scrap $\frac{1}{8}$ " hardboard. Using spray adhesive, sandwich a $\frac{3}{4}\times 10$ " piece of .063"-thick brass between the hardboard. Then, spray-adhere one copy of the brass top wear plate and two copies of the brass bottom wear plate patterns to one of the hardboard pieces.

2 Using a bandsaw or scrollsaw, cut the sandwiched plates to shape, staying just outside the pattern lines. (For more on working with brass, see the article on *page 22*.) Next, drill $\frac{3}{32}$ " shank holes through the plates, where shown on the patterns. Then, drill $\frac{1}{4}$ " holes through the top plate at the ends of the $\frac{1}{4}\times 1$ " slot. Insert your scrollsaw blade through one of the $\frac{1}{4}$ " holes, and cut the slot to shape.



SAND THE LEVEL'S TAPERED ENDS

Using a disc sander with 120-grit sandpaper, sand the level's tapered ends and rounded tips to the pattern lines.

3 Sand the brass/hardboard pieces to the pattern lines using a disc sander. Then, remove each of the top hardboard pieces to expose the brass plates. Now, countersink the shank holes so the head of a $\#2\times\frac{3}{8}$ " brass flathead wood screw sits flush with the plates' top (outside) surfaces.

4 Separate the brass from the bottom hardboard pieces. Using a clean rag moistened with a solvent, remove the adhesive residue from the brass. Then, smooth the edges of the top plate's slot using a flat bastard file.

5 Check the plates' fit on the level. (It's okay if the plates overhang the level's sides a little as you'll sand them flush in step 7.) If necessary, sand the plates' radiused ends on your disc sander with 120-grit sandpaper, removing small amounts of material until the plates fit just right against the level's $\frac{3}{8}$ " radii. To maintain the locations of the bottom plates and the orientation of the top plate, mark the plates' bottom faces and the level's recesses. Reposition the plates.

6 Using the plates' shank holes as guides, drill $\frac{1}{16}$ " pilot holes $\frac{3}{8}$ " deep in the level. Then, attach the plates with $\#2\times\frac{3}{8}$ " steel flathead wood screws. (This prethreads the holes to prevent breaking the soft brass screws you'll use for final attachment of the plates.)

7 Clamp the level faceup in your vise. Using a sanding block with 150-grit sandpaper, sand the edges of the brass plates flush with the level's face. Repeat on the opposite face. Then, remove the plates.

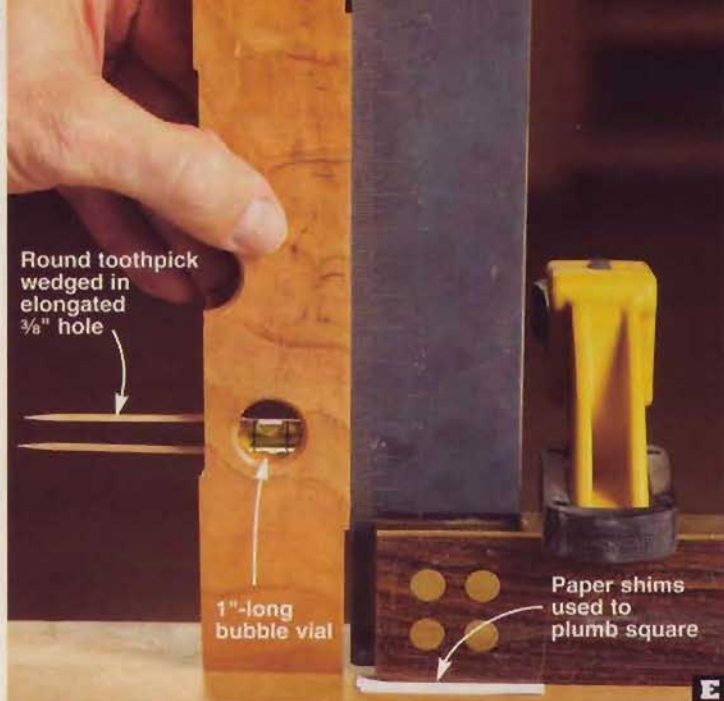

Round toothpick wedged in elongated $\frac{3}{8}$ " hole

1"-long bubble vial

Paper shims used to plumb square

E

LEVEL THE 1"-LONG BUBBLE VIAL

With the level held tight against the plumbed square, wedge round toothpicks in the elongated hole's ends to level the 1"-long bubble vial.

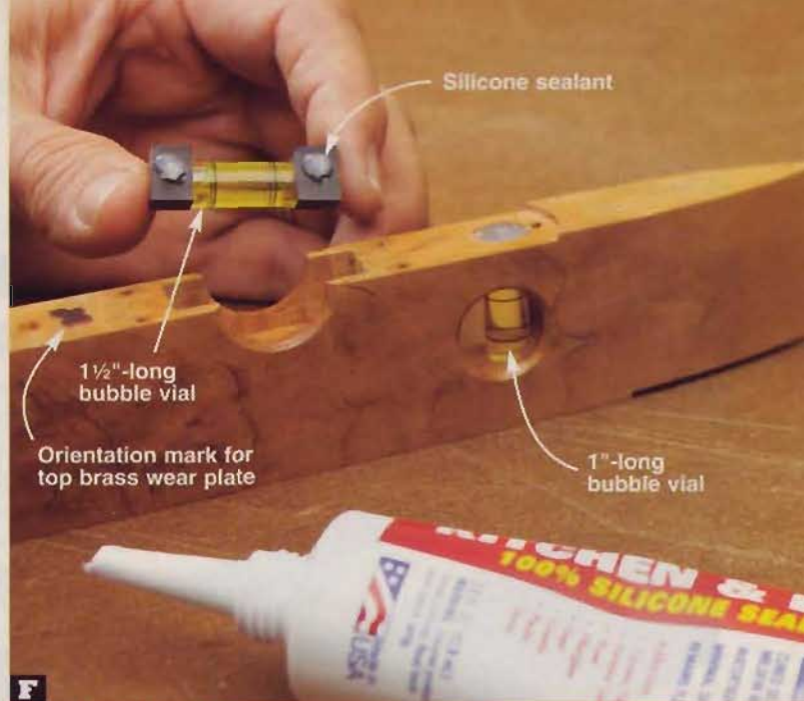

Silicone sealant

1 1/2"-long bubble vial

Orientation mark for top brass wear plate

1"-long bubble vial

F

APPLY SILICONE SEALANT TO THE BUBBLE-VIAL CLIPS

Squeeze a dab of silicone sealant on the bottom of each bubble-vial clip. The sealant allows you to level the vial in the mortise.

Install the bubble vials, and finish up

1 While you have access to them, sand the bubble-vial openings with 220-grit sandpaper, and remove the dust. Mask the level, and apply a clear finish to the openings. (We used Deft Gloss Clear Wood Finish.) Because you'll use silicone sealant when installing the bubble vials, ensure the finish is wax-free for proper sealant adhesion.

2 Insert a 1"-long bubble vial through the level's elongated $\frac{3}{8}$ " hole. To level the vial, first clamp a square, positioned vertically, to your workbench. Place another level of known accuracy against the square, and check it for plumb. If necessary, adjust the square by placing paper shims under it.

3 Next, holding the torpedo level tight against the square, level the bubble vial using round toothpicks, as shown in **Photo E**. Then, place the level on your workbench and, without moving the toothpicks, fill the elongated hole with clear silicone sealant. When the sealant cures, flush-trim the toothpicks and sealant using a utility knife.

4 To install the 1 1/2"-long bubble vial, first hacksaw two $\frac{3}{8}$ "-long pieces from the 1 1/2"-long vial clip. Snap the pieces onto the vial flush with its ends. Next, find a surface where the vial reads level. Then, apply silicone sealant to the bottom of the vial clips, as shown in **Photo F**. With the torpedo level on the same level surface, place the vial in the mortise, centering it side-to-side.

Now, level the vial, as shown in **Photo G**. (To double-check the leveling, we turned the torpedo level end for end and verified that the vial read the same.) Avoid moving the level until the sealant cures.

5 Attach the brass plates to the level with #2x $\frac{3}{8}$ " brass flathead wood screws. If necessary, file the screwheads flush with the plates using a flat bastard file. Then, sand the face of the plates to an even sheen and

flush with the level using a sanding block with 220-grit sandpaper. Now, sand the level and plates using progressively finer sandpaper up to 600 grit. Remove the metal and wood dust.

6 Finally, using a clean cloth and avoiding the bubble-vial openings, apply two coats of a finishing wax to the level and brass. (We used Mylands Clear Wax.) When dry, buff-shine. Now, remember that picture you promised to hang? Time to get busy again. ♣

Supplies: Spray adhesive, $\frac{3}{4}$ " dowel $\frac{3}{4}$ " long, $\frac{1}{4}$ "-diameter steel rod 6" long, round toothpicks (2), clear silicone sealant, two $\frac{3}{4}$ x10" pieces of $\frac{1}{8}$ " hardboard.

Blades and bits: $\frac{3}{8}$ ", $\frac{1}{2}$ ", $\frac{3}{4}$ ", $\frac{7}{8}$ ", and $\frac{1}{4}$ " Forstner bits; countersink bit; piloted 45° chamfer and $\frac{3}{4}$ "-diameter straight router bits.

Sources

Level kit: #2x $\frac{3}{8}$ " steel and #2x $\frac{3}{8}$ " brass flathead wood screws (12 each); .063x $\frac{3}{4}$ x10" brass; bubble vials 1" long (1) and 1 1/2" long (1); bubble-vial clip 1 1/2" long. Order kit no. TL, \$11.95 ppd. Add \$6.00 for each additional kit. Call Schlabaugh and Sons Woodworking, 800/346-9663, or go to www.schsons.com.

Written by Owen Duvall with Chuck Hedlund

Project design: Kevin Boyle

Illustration: Roxanne LeMoine



G

LEVEL THE 1 1/2"-LONG BUBBLE VIAL

With the torpedo level on a level surface, lightly press on the appropriate end of the 1 1/2"-long bubble vial to level it.

See more photos of the level coming together in the **WOOD** magazine shop at woodmagazine.com/level



tablesaw rip fences

Can't trust the fence that came with your saw to deliver dead-on cuts? Wish you could set your fence in seconds? Consider upgrading to one of the models reviewed and rated here.

FIVE KEY ELEMENTS OF A GOOD RIP FENCE

1 Consistently lock parallel to the blade. A fence that veers away from the blade when locked results in a wider kerf and requires more power; one that pulls *toward* the blade pinches the workpiece between the fence and blade causing poor-quality cuts, burned edges on your stock, and, at worst, dangerous kickback.

2 Minimal deflection. If the fence strays from parallel when the pressure's on—when ripping large sheet goods, for example—your cuts may not be straight, and may exhibit scoring from the blade teeth. Worse, the fence may spring back when you relax the pressure momentarily, burning the cut edge and raising the risk of kick back.

3 Faces are perpendicular to the tabletop. For thick workpieces, or those cut on edge (such as tablesawn raised panels), the fence face must be square to the table. Fewer than half of the tested fences provide a mechanism for this alignment; most of the rest, though, were perfect out on the box.

4 Flat faces. Again, it comes back to poor cut quality and kickback if the face bows toward the blade. If it bows away, your cut may be curved instead of straight and true. None of the fences in our test bowed more than .0005" in either direction, which we think is very good.

If you're still measuring between your tablesaw's blade and fence before every cut, *just to be sure*, a new rip fence may be in your future. A high-quality fence gives even an inexpensive contractor-style saw the precision and convenience of a saw costing nearly twice as much. But with a head-spinning number of models to choose from, how do you decide?

Manufacturers offer multiple fence configurations and rail lengths, so we chose the models with 50"-ish rails whenever more than one rail length was available. Many of the fences we tested come in both home shop (also called "contractor" or "utility") and commercial (or "pro") versions, and we opted for the home-shop models in those cases. The commercial versions of these fences typically have longer faces (by about 5") and beefier bodies and rails. And they cost \$30-\$70 more than their home-shop brethren. If you frequently work with heavy sheet goods, or use your tablesaw all day every day, consider going commercial.

Three tests for accuracy

Because the chief responsibility of a rip fence is keeping your workpiece traveling parallel to the tablesaw blade, we started (as you should) by aligning each fence's left face to the blade. We then moved the fence to the right 6" at a time, double-checking for parallelism

at each stop. All of the fences remained perfectly parallel throughout their full range.

You may want to slide the fence to the left of the blade for some cuts, so, without making any adjustments, we moved the fences with a right face (all but the Delta Unifence and Inca LS32-TS have one) to the left of the blade and again measured parallelism. In the Right Face Parallel To Left Face column in the chart on page 56, fences that angled toward the blade here earned a D performance grade because of the increased chance of kickback; those that angled away earned a C; and fences within .002" of parallel scored an A.

To test deflection, we ripped a 96-lb. sheet of medium-density fiberboard (MDF) against each fence using normal feed pressure. With a dial indicator against the right fence face and positioned in line with the blade arbor, we measured how much the fence moved during this operation. We also observed whether the indicator returned to zero with the cut completed.

Deflection varied from a test-best of .002" for the Excalibur EXTT45/78 and Inca, to the Delta T250's .032". The latter deflection resulted in obvious blade scoring on the cut edge of the MDF. (The Mule Accusquare and Wazee WonderRip also caused scoring.)

One more note about deflection: We found we could adjust the front-locking fences to completely eliminate deflection, but on some, doing so tightened the fence on the rail so that, even unlocked, it became difficult to slide. Our grades reflect deflection with the fences set for acceptably smooth travel.



5 Easy-to read scale. Most of the scales in our test have large print and are marked in $\frac{1}{32}$ " increments for the first 12", with $\frac{1}{16}$ " increments for dimensions above 12". A dual-hairline cursor tells you when your eye is properly aligned for precise reading. See the photos, above, for two examples of notable scales.



Delta T250



Jet Deluxe

GOOD SCALES MAKE SALES

The $\frac{3}{16}$ " distance between the Delta T250's scale and its stamped-steel cursor (top) invites error: Viewed slightly from the left, you can't tell that the cursor is set on the 10" mark. Dual hairline cursors—one above the other—on the Jet Deluxe (bottom) become one when you look straight down.

Three more considerations

■ **Microadjustability.** Six tested fences have microadjusters for fine-tuning their location. With most of these systems, you temporarily hold the fence in place with its microadjuster lock, tweak the fence's location by rotating a knob or thumbwheel, then secure the primary fence lock. Inca's microadjuster moves the fence in precise .001" increments for repeatable accuracy; the others employ a screw drive for continuous adjustment. Of these, we found the Vega U50's system intuitive and easiest to use; Craftsman's proved difficult to engage.

■ **Smoothness of travel.** The Excalibur and Shop Fox Heavy Duty W1411/1413 float effortlessly over the table, running on pulley-like wheels. The Vega also slides smoothly. Lower-graded front-locking fences can be adjusted for smoother travel, but, as we mentioned, this must be balanced with the resulting increase in deflection.

■ **Installation.** All of these fences will fit any contractor- or cabinet-style saw—it just depends on how much work you want to do. The most common fence mounting-hole spacing on today's tablesaws is 16" on center, and more than half of the fences bolt onto such a saw without drilling the saw top. The rest may require boring holes into the top, the mounting rails, or both.

If you already have $1\frac{1}{2} \times 2\frac{1}{2}$ " or 2×3 " tube-steel rails on your saw, you can save time and serious money (\$100-\$150) on some models by buying the fence only and using your saw's existing rails. Call the manufacturer or visit its Web site to see whether this is an option.

Rating the fourteen fences



Biesemeyer 52" Home Shop, \$300

800/782-1831, www.biesemeyer.com

High points

- ◆ Earned high marks across the board, with low deflection.
- ◆ "Universal" mounting bracket comes predrilled to fit a variety of saws, making it one of the fastest to install. (Call the manufacturer or visit its Web site for specific models.)
- ◆ Fence faces are dead flat, and the right face is within .002" of parallel to the left face.

More points

- ◆ There's no way to adjust the face perpendicular to the tabletop, but we didn't need to—it was perfectly square to the table out of the box.
- ◆ Also available in a beefier commercial version.



Craftsman Align-A-Rip XRC, \$280

Visit Sears or www.craftsman.com

High points

- ◆ T-slots on the top and face allow for easy attachment of jigs and fixtures.

Low points

- ◆ Rack-and-pinion microadjuster is difficult to engage.
- ◆ Wide cursor hides the fine markings of the measuring scale, so we couldn't tell a "dead-on" $\frac{9}{16}$ " from a "shy" $\frac{9}{16}$ " or a "strong" $\frac{9}{16}$ ".

- ◆ When we moved the fence left of the blade, the out-of-parallel right fence face caused stock to pinch between the fence and blade.



Delta T²50, \$200

800/438-2486, www.deltamachinery.com

High points

- ◆ The lowest priced 50" fence system in the test.

Low points

- ◆ Aluminum body yielded the highest deflection in the test (.032" when ripping MDF).
- ◆ Stamped-steel cursor (photo on *previous page*) sits too far above the scale to read reliably.
- ◆ You must hold the fence-locking lever in the up position when moving the fence. If you don't, it falls, causing extra drag.

More points

- ◆ When moved to left of the blade, right face was out of parallel, but didn't pinch the workpiece against the blade.



Delta Unifence, \$330

800/438-2486, www.deltamachinery.com

High points

- ◆ Unique L-shape fence body easily switches from a tall fence (as shown here) to a low fence for safer ripping of narrow stock. The fence face can also be pulled toward the operator, to a spot ahead of the blade to act as a crosscut gauge.
- ◆ Parallelism adjustments are made with the fence in place, so there's no trial-and-error setting.

Low points

- ◆ Face must be removed and reinstalled on right side of body to use the fence on the left side of the blade.



Excalibur EXTT45/78, \$340

800/357-4118, www.excalibur-tools.com

High points

- ◆ Tied with the Inkra for the least deflection (.001") in the test.
- ◆ Glides smoothly across the tabletop, yet locks securely and parallel to the blade.

Low points

- ◆ When we moved the fence left of the blade, the out-of-parallel right fence face caused stock to pinch between the fence and blade.
- ◆ Light-color cursor can be difficult to read.

More points

- ◆ Drilling into your saw's cast-iron table is required for installation, but the factory-supplied gauge makes locating and drilling the mounting holes simple.
- ◆ Our fence was .007" out of square with the tabletop, and there's no adjustment to correct it. Excalibur's Graham Wray says that's outside of their acceptable tolerance and that the fence would be replaced under warranty.

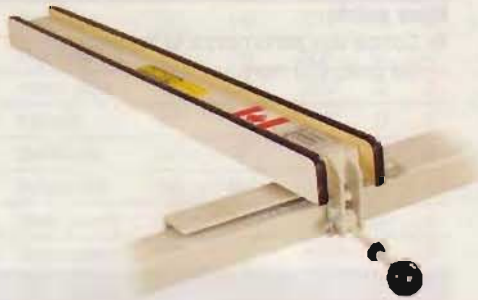
**High points**

- ◆ Strikingly similar to the Biesemeyer Home Shop fence, and a strong performer in most key areas.
- ◆ The right face is within .002" of parallel to the left face.

Low points

- ◆ This fence deflected twice as much as the Biesemeyer in the MDF test due to a slight design difference in the locking mechanism.

- ◆ Light-color cursor can be difficult to read; and the smallish scale is marked only in 1/16" increments.

More points

- ◆ There's no way to adjust the face perpendicular to the tabletop, but we didn't need to—it was perfectly square to the table out of the box.
- ◆ Also available in a beefier commercial version.

HTC 850, \$370

800/624-2027

**High points**

- ◆ Easy installation on saws with 16" on-center mounting holes.
- ◆ Accurate, smooth, microadjuster moves the fence 1/16" with each full turn of the knob.

Low points

- ◆ As one of the highest-priced fences in the test, we expected little deflection, but found it was about average.

- ◆ When we moved the fence to the left of the blade, the out-of-parallel right fence face caused stock to pinch between the fence and blade.

More points

- ◆ Available without microadjuster and/or rails, and in a beefier commercial version.

Inkra LS32-TS, \$450

800/752-0725, www.inkra.com

**High points**

- ◆ The best of the test with little deflection (.001") and an exceptionally flat face.
- ◆ T-slots on the top and face allow for easy attachment of jigs and fixtures.
- ◆ Microadjuster shifts fence in precise .001" increments for controlled repeatability.

Low points

- ◆ Scale goes to only 32"; for wider rips, you must move the main carriage farther down the rails and measure to the blade, then recalibrate the scale when you move the carriage back.

- ◆ Assembly is more time-consuming (more than 4 hrs.) than with the other fences (1–2 hrs).
- ◆ Some disassembly and reassembly is required to move the fence to the left of the blade.

More points

- ◆ Excellent accuracy for cuts up to 32"-wide, but such precision comes at a price \$70 higher than the next most expensive fence system.

Jet Deluxe (708957DK), \$340

800/274-6848, www.jettools.com

**High points**

- ◆ The right fence face is within .002" of parallel to the left face.
- ◆ Magnified dual cursor (see photo on page 53) gives user high confidence in scale readings.

More points

- ◆ Virtually identical to the HTC 850, except for the better cursor and right-face parallelism.

- ◆ Jet also sells a lower-cost version of this fence without the magnified cursor and microadjuster (708957K, \$300). Both models also available in a beefier commercial version and without rails.

Mule Accusquare, \$210

877/684-7366, www.mulecab.com

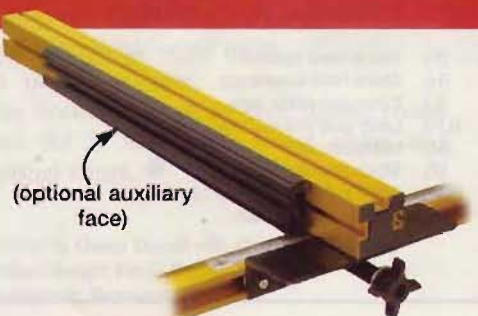
**High points**

- ◆ T-slots on the top and face allow for easy attachment of jigs and fixtures.
- ◆ The right face is within .002" of parallel to the left face.

Low points

- ◆ Among the highest deflection in the test (.025" when ripping MDF).
- ◆ Rails must be drilled to fit your saw.

More points

- ◆ There's no way to adjust the face perpendicular to the tabletop, but we didn't need to—it was perfectly square to the table out of the box.
- ◆ Optional auxiliary fence face (Euro Jig, \$30) acts as a crosscut gauge.



High points

- ◆ Earned high marks across the board, with low deflection.
- ◆ The right fence face is within .002" of parallel to the left face, for easy transitions to cut left of the blade.

More points

- ◆ Comparable performance to the Biesemeyer, but costs \$50 more.

Shop Fox Heavy Duty W1411/1413, \$335



High points

- ◆ This "fence on wheels" rolls easily on its rails, yet locks down securely at the front and rear resulting in low deflection.
- ◆ Two easily accessible screws make parallel and perpendicular adjustments simple.

Low points

- ◆ Rear rollers bump into the saw's splitter/guard mount, preventing the fence from getting closer than 1/2" to the blade.
- ◆ Some disassembly and reassembly is required to move the fence to the left of the blade, and the out-of-parallel right fence face caused stock to pinch between the fence and blade.

RIP FENCE RATINGS

BRAND	MODEL	CONSTRUCTION										PERFORMANCE GRADES (7)																						
		DESIGN (1)	T-SLOT LOCATIONS (2)		INSTALLATION REQUIREMENTS (3)		RAIL MATERIAL (4, 5)		RIP CAPACITY (RIGHT OF BLADE, INCHES) (4)		FACE MATERIAL (6)		FACE HEIGHT (INCHES)		FACE LENGTH (INCHES)		MICROADJUSTABLE? (YES/NO/OPTIONAL)		LACK OF DEFLECTION TO BLADE		LOCKS PARALLEL TO BLADE		EASE OF ADJUSTING TO BLADE		RIGHT FACE PARALLEL TO LEFT FACE (8)		FACE FLATNESS TO TABLETOP		EASE OF ADJUSTING FACE PERPENDICULAR TO TABLETOP (9)		SCALE READABILITY		EASE OF SLIDE	
BIESEMEYER	52" HOME SHOP (BHS52W)	F	16OC	TS	51	PLY	2 ¹⁷ / ₃₂	41 ³ / ₄	N	B	A	B	A	A	A	N/A	A-	A-	A															
CRAFTSMAN	ALIGN-A-RIP XRC	F/R	T,F	CR	AL	30	AL	3	36	Y	B	A	B	D	A	C	N/A	B-	C+	B-														
DELTA	T ² 50	F	16OC	TS	50	AL	2 ¹ / ₂	37	N	D	A	B	C	A	A	A	C+	A-	A															
	UNIFENCE	F	ANY	AL	50	AL	2 ¹⁷ / ₃₂	43	N	C	A	A	N/A	A-	A	A	A-	B-	A-															
EXCALIBUR	EXTT45/78	F/R	T	DR	AL	62	AL	2 ¹ / ₂	44 ¹ / ₂	O	A	A	C	C	A-	C	N/A	B	A	B														
GENERAL	F36T52	F	DR*	TS	50	PLY	2 ⁵ / ₃₂	36 ¹ / ₈	N	C	A	B	A	A	A	N/A	B	B+	B-															
HTC	850	F	16OC	TS	52	HDPE	1 ¹⁹ / ₃₂	37 ¹ / ₄	Y	C	A	B	D	A-	A	A	A-	A-	A															
INCRA	LS32-TS	C	T, F	ANY	AL	32	AL	2 ⁹ / ₈	36	Y	A	A	B-	N/A	A	A	N/A	B+	B	C														
JET	DELUXE (708957DK)	F	16OC	TS	52	HDPE	1 ²⁹ / ₃₂	37 ³ / ₁₆	Y	C	A	B	A	B-	A	A	A	A-	A															
MULE	ACCUSQUARE	F	T, F	DR	AL	50	AL	2 ¹ / ₂	35 ¹ / ₂	N	D	A	C	A	A	A	N/A	B	C	C														
SHOP FOX	CLASSIC W2006	F	16OC	TS	54	HDPE	2 ¹ / ₂	41 ³ / ₄	N	B	A	B	A	B-	A	A	A-	A-	A-															
	HEAVY DUTY W1411/1413	F/R	T	16OC	SA	50	AL	3 ¹ / ₂	39 ³ / ₄	Y	B+	A	A	D	B+	A	A	B	A	B														
VEGA	U50	F	ANY	TS	50	AL	2 ¹ / ₂	36	Y	B	A	B	D	A-	A	N/A	A-	A	A-															
WAZEE	WONDERIP	F	F	BIES	N/A	N/A	AL	2 ¹ / ₂	38	N	D	B	C	D	B-	A	N/A	A-	C	C+														

NOTES:

- (C) Center-mounted
(F) Front locking
(F/R) Front/rear locking
- (T) Top of fence
(F) Fence face
- (16 OC) Fits saws with 16" on-center fence mounting holes, or requires drilling saw table.
(ANY) Fits any saw.
(BIES) Fence rails not included; fits 1 1/2 x 2 1/2" tubular steel rails, such as Biesmeyer.
(CR) Fits Craftsman saws, or requires drilling saw table.
(DR) Requires drilling the mounting rail or saw table.
(*) Fits General tablesaws without drilling.
- (N/A) Rails not included.
- (AL) Extruded aluminum
(SA) Steel angle
(TS) Tubular steel
- (AL) Extruded aluminum
(HDPE) High-density polyethylene
(PLY) Plastic-laminated plywood
(SS) Stamped steel
- A** Excellent **C** Average
B Good **D** Below average
- (N/A) No right fence face.
- (N/A) No adjustment for perpendicular.
- (F) Stock-feed system
(H) Stock hold-downs
(L) Extension-table legs
(LR) Long rails (45-62" rip capacity)
(M) Microadjuster
(P) Stock pusher
(SR) Short rails (25-38" rip capacity)
(X) Auxiliary fence face



Vega U50, \$260

800/222-8342, www.vegawoodworking.com

High points

- ◆ Very smooth slide on its round steel rail, and leveling screws aid in setting the rail to the correct height.
- ◆ Lever-locking microadjuster is more intuitive and easier to use than ratcheting knobs on the Jet and HTC fences.
- ◆ Fence faces come predrilled for mounting accessories, and the back of the fence hooks on the rear rail to keep it from lifting off the table when using vertical feather boards.

Low points

- ◆ When we moved the fence left of the blade, the out-of-parallel right fence face caused stock to pinch between the fence and blade.

More points

- ◆ Also available in a beefier commercial version.

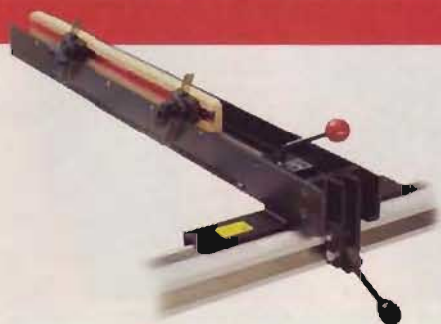

Wazee Wonderip, \$370

559/297-0351, www.wonderip.com

High points

- ◆ Built-in "feeder tab" pushes workpiece through the blade for the last 12", keeping your hands far from the blade.

- ◆ Feeder tab doesn't work on stock thinner than 3/8" without optional adapter, or narrower than 3/8" without filing or cutting off the tab.

Low points

- ◆ A splitter must be used behind the blade to prevent kickback, because the single point of contact from the feeder tab tends to steer the workpiece to the left.

More points

- ◆ There's no way to adjust the face perpendicular to the tabletop, but it was perfectly square to the table out of the box.
- ◆ Available without rails for \$100 less. There's a version to fit 1 1/2x2 1/2" Biesemeyer-style rails and another for the larger 2x3" rails.

		ACCESSORIES (10)				
	STANDARD	OPTIONAL	COMMERCIAL VERSION AVAILABLE? (YES/NO)	COUNTRY OF ASSEMBLY (11)	WARRANTY (YEARS) (12)	PRICE AS TESTED (13)
	L, LR	SR	Y	U	2	\$300
			N	T	1	280
	LR	SR	N	T	2	200
	L, LR	SR	N	U	2	330
	LR	M, P, SR, X	N	C	L	340
	LR	SR	Y	C	2	290
	LR	L, SR, X	Y	U	L	370*
	SR	LR	N	U	1	450
	LR	L, SR	Y	U	L	340
	LR	L, SR, X	N	C	L	210†
	L, LR	SR	N	T	1	350
	L, LR	H, SR	N	T	1	335
	LR	F, L, P, SR	Y	U	1	260
	SR		N	U	1	370**

11. (C) Canada
(T) Taiwan
(U) United States

12. (L) Lifetime warranty against factory defects.

13. Prices current at time of article's production and do not include shipping, where applicable.

- (*) Sold without rails for \$220.
(**) Sold without rails for \$280.
(†) Price includes shipping.

Here's where we sit on the fences

Only two of the fences in our test earned A grades for both lack of deflection and locking parallel to the blade—the Inca LS32-TS and Excalibur EXTT45/78. That alone might make them Top Tools, except that neither is a particularly good choice for use left of the blade, and the Inca's rip capacity is limited to 32".

So, we awarded Top Tool honors to the Biesemeyer 52" Home Shop fence. Its lack of deflection wasn't the best in the test, but at .008", it's certainly within the acceptable range (up to .010"). The faces are very flat and parallel to each other, so it works equally well left or right of the blade, and it installs easily on most saws thanks to its predrilled mounting bracket.

The Vega U50 earned grades similar to the Biesemeyer, has a great microadjust system, and costs \$40 less, so we dubbed it the Top Value. Its only downfall: The right face isn't parallel to the left (it's .007" wider at the rear), but we can live with that, or shim the face, at this price. 🐿

Written by Dave Campbell with John Cebuhar

Share your opinion

of these rip fences in our Interactive Tool Review at www.woodmagazine.com/fences



how to install concealed hinges

Also called "European-style" or 35mm hinges, they give you three-way adjustability that makes cabinet door installation a breeze.

They might look bulky and clumsy, but don't let that fool you. European-style hinges offer some great advantages when hanging cabinet doors. They install easily, make it simple to nudge doors into perfect alignment, and remain out of sight when the doors are closed.

These hinges are part of a standardized cabinet system developed decades ago in Germany for efficient production. One end of a European hinge fits snugly into a hole that you drill in the door. The other end connects to a mounting plate attached inside the cabinet; with most models, you

simply snap it in place. It's just that easy to disconnect the hinge, too.

Be sure to choose a hinge style that suits your application. European hinges come in various models for inset and overlay doors, frameless and face-frame cabinets, and also in a range of opening-angle options. Any model works with either frame-and-panel or slab doors.

To get you started, we'll show how to hang overlay doors with medium-priced hinges that we bought at a home center for \$6.88 per pair. Be sure your hinge purchase includes templates for locating the mounting holes. Otherwise you'll have to experiment

To attach a snap-on hinge to its mounting plate, open it to its full extension. Engage the end nearer the door, and then press down on the other end.



on scrap to determine hole locations. The only tools you need include a drill press and portable drill; a Forstner drill bit that's either 35mm or 1 3/8" in diameter; a bit to drill pilot holes (we used a 7/64" bit to match #8 screws); and, as an option that makes the job go more smoothly, a 7/64" self-centering Vix bit.

If you buy a Forstner bit to use with European hinges, make sure it has a short lead point that won't penetrate the outer face of your door when you drill a 1/2"-deep cup hole. If you already have a bit of the correct diameter, test it on scrap the same thickness as your door to make sure.

Follow these steps to install this common hinge

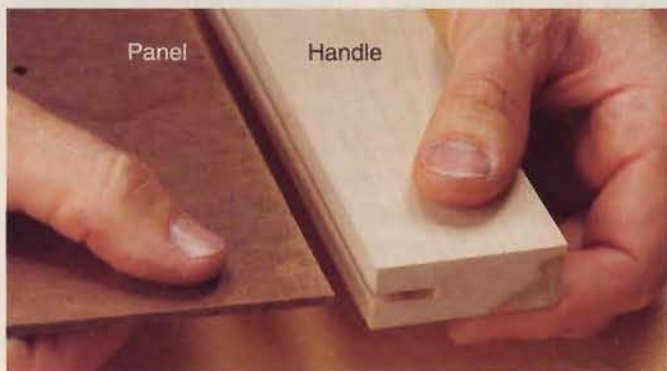

1 For convenience and consistent results, make a drilling guide to help you locate the mounting plates. With a standard blade mounted in your tablesaw, rip a single kerf approximately 1/2" deep centered on one edge of any handy scrap piece (ours measured 3/4x2x10") to make a handle. Cut a piece of 1/8"-thick hardboard to approximately 3x6" to make the panel. Slip a long edge of the panel into the saw kerf, as shown here, with one short edge flush with the top end of the handle.



2 Now, tape the paper template for mounting plates to your drilling guide, using the 3 3/8" dimension shown here for a door that's about 24" long. (Use a smaller measurement for short doors, and a longer one for long doors.) Place the guide next to your finished door, as shown, with its top edge 1/8" beyond the door's top edge to produce a door reveal of 1/8". (This dimension also can be changed to create a larger or smaller reveal or to accommodate inset doors.) Use a square to align the two template centerlines and then tape the door template to the door.



3 Using the marks on the paper template as entry points, drill $\frac{7}{64}$ " pilot holes through your drilling guide. Now, place the door facedown on your drill-press table. Lower the Forstner bit until its lead point touches the cup hole center marked on the paper template and then lock the quill. Slide your fence against the door and lock it in position. Then place a stopblock against the end of the door and clamp it to the fence. Measure and record the distance from the bit's lead point to the stopblock. Finally, drill the cup hole to the required depth, as shown. To mount hinges on several doors, drill one hole in each door before changing the setup.



4 To drill the second cup hole at the opposite end of the door, switch your stopblock to the other end of the drill-press fence at the recorded distance. Now clamp it in place, position the door, and drill. Place and align the hinge on the door and then drill the screw pilot holes. Screw the hinge to the door and repeat the process for the other hinge or hinges. If you get serious about using European hinges, and build a fair number of cabinets, step up to models that are even handier to install on the door. Some mount without screws by squeezing against the walls of the cup hole. Call Woodworker's Hardware at 800/383-0130 for a catalog.

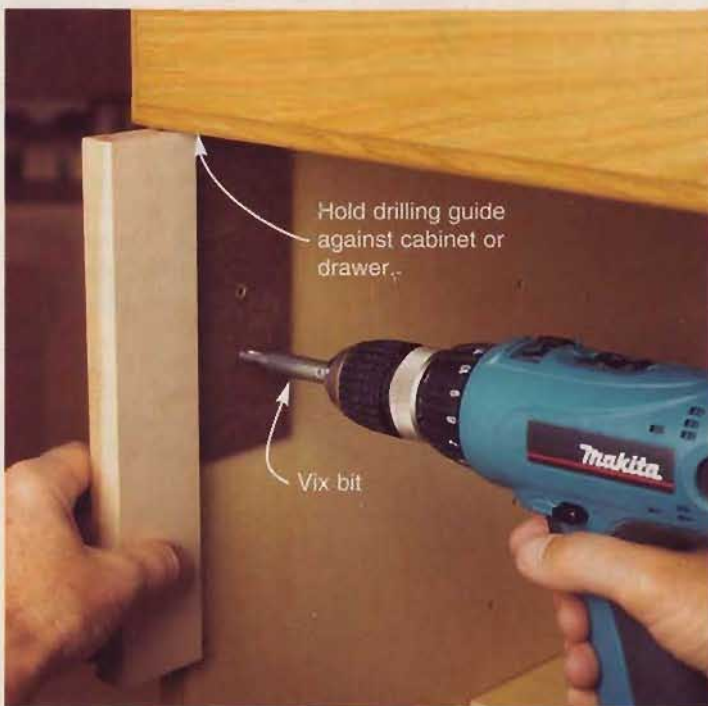

5 To drill holes inside the cabinet for the mounting-plate screws, hold your drilling guide with its top end against the drawer edge, as shown, or the top of the cabinet. Drill the holes and then attach the mounting plate with the supplied screws. Use the drilling guide in this orientation for top corners and then flip it upside down to handle bottom corners.



6 You'll find adjustment variations among different brands and models of European hinges. Here's how to tweak this common design: (1) Loosen both mounting-plate screws on both hinges to nudge the door up or down. (2) Turn this screw to bump the door left or right. (3) Loosen this screw to move the door in or out and make it flush with the cabinet front. ♣

tablesaw splitters

Safety made so simple, you'll actually want to use it.

Anti-creep pawls

Splitter

A splitter keeps the saw kerf open and prevents the workpiece from pinching the trailing edge of the blade. Anti-creep pawls restrict backward movement of the workpiece that can lead to kickback.

TOOL TIP

When I bought my first tablesaw 15 years ago, I dutifully installed the saw's combination splitter/blade guard and promised myself I'd use it faithfully. That lasted until I had to remove it to make a dado cut. I always meant to put it back on the saw, but the contraption was such a nuisance to reinstall, I never did. Now, I have a dust-collecting blade guard—it sits on a shelf and collects dust!

These days, you don't need to sacrifice safety for convenience, thanks to a batch of tablesaw splitters that dismount and—more important—mount to your saw faster than you can say "kickback." While they're a good start, you should still supplement any of these splitters with an aftermarket overarm blade guard, increasing your investment by \$200 to \$300.

Dave Campbell

Dave Campbell
Woodworking Products Editor

Every tablesaw needs a splitter

If you've never experienced the thrill of watching your tablesaw turn into a pitching machine, you probably know someone who has. Kickback occurs when a workpiece pinches against the back of the blade, creating enough force to lift it off the table. In an instant, the piece goes airborne, flying back at the operator at about 100 miles per hour.

Kickback results most commonly from trapping a short but wide workpiece between the fence and the blade, and from ripping wood with internal stresses that cause the kerf to close up during the cut. The photo and caption, *above*, describe how a splitter puts the kibosh on kickback.

We tested these splitters seven ways from Sunday

After installing the splitters on different tablesaws, we made rip cuts in 3/4"-thick red oak, deliberately trying to cause kickback. During these tests, we also observed the effectiveness of each device's anti-creep pawls. Here are the tests performed on each splitter:

1 Normal rip. Unaided by feather boards or hold-downs, we completed the cut with a pushstick.

2 Partial rip, then stop. After cutting 2' into our workpiece, we stopped the saw, released the workpiece, and then restarted the saw.

3 Partial rip, then release. Like cut #2, we ripped 2' into the workpiece, but then released it with the saw still running.

4 Push partway, pull the rest. Same as cut #3, and then we walked behind the saw and pulled the workpiece through to complete the cut.

5 Clamp the kerf. Ripping until 6" of the workpiece overhung the back of the tablesaw, we then shut off the machine. After clamping the kerf closed, we completed the cut.

6 Wood under stress. In a move that made the lumberyard man very happy, we bought the most twisted, cupped, and warped 1x6 pine boards we could find. We then repeated cuts #1 and #4 with those gnarly boards.

7 Thin-kerf blade. Without adjusting the splitters, we repeated cut #1 using a thin-kerf blade.

Despite our best efforts, none of the four splitters allowed kickback in any of the tests, proving that these accessories are *far* better than nothing. The chart at *right* summarizes other key findings from our test.

QUICK-CHANGE TABLESAW SPLITTERS



		BIESEMEYER	DELTA	EXCALIBUR	GRIP-TITE
		SNAP-IN SPREADER	DISAPPEARING SPREADER	MERLIN	ANTI-KICKBACK SPLITTER
FITS THESE 10" SAWS (1)	DELTA CONTRACTOR SAWS	X	Right-tilt only		Any tablesaw with a 1/4" or thicker throat plate
	DELTA UNISAW	X	Right-tilt only	X	
	GENERAL CABINET SAW	Right-tilt only		X	
	GENERAL INTL. CONTRACTOR			X	
	GRIZZLY CABINET SAW	Right-tilt only			
	JET JTWS CONTRACTOR SAW	X		X	
	JET XACTA CABINET SAW	X		X	
	POWERMATIC 64	X			
POWERMATIC 66	X		X		
PERFORMANCE GRADES (2)	EASE OF INITIAL INSTALLATION	The receiver installs in the same holes as your saw's original splitter/guard. Excellent instructions ease the job.	This splitter installs in the same holes as your saw's original splitter/guard. Excellent, easy-to-follow instructions.	Although we ordered the correct splitter for our saw, we had to grind away part of the mounting bracket (on the advice of the manufacturer) to install it. It takes a little longer to align than the other splitters.	Install the splitter's mounting disc into a counterbored pocket you drill into a shop-made insert. Install the included pin in one of the disc's holes and rotate the disc to make the pin flush with the edge of the blade, then lock it in place with the center screw.
	GRADE	A	A	C	A-
	EASE OF MOUNTING AND DISMOUNTING THE SPLITTER	Remove the saw's throat plate, reach into the blade opening, and pull out on the spring-loaded knob. Lift the splitter out. No need to pull the knob to remount the splitter.	Unlike the removable models in this test, this splitter simply drops down below the tabletop when not needed. The anti-creep pawls must be properly aligned before retraction, which we found bothersome.	Use a pencil or screwdriver to push the release button located under the throat plate, then tip the splitter back and lift it off its rear mount. You can drill your throat plate to access the release, or simply remove it.	Insert the pin into the disc to mount; pull it out with a pliers to dismount. Or, you could install the disc in a shop-made throat plate and simply change throat plates when you need to use it. (For the price, you could buy separate splitters for each insert plate.)
	GRADE	A	B	A-	A
	RIGIDITY	A	B	A	A
	ANTI-CREEP PROTECTION	A	C	A	N/A
	EASE OF USE WITH THIN-KERF BLADES	C	C	A	A
	PERFORMANCE SUMMARY	A pair of anti-creep pawls flank this splitter so test pieces didn't creep back despite our best efforts. It's stout and rigid, but its beefiness makes it difficult to use with a thin-kerf saw blade. See the manufacturer's Web site to find the correct model number for your saw.	This device's biggest selling point is its self-storing design. Despite four anti-creep pawls of varying lengths (for different thicknesses of wood), our 3/4"-thick test pieces crept back about 2". Also, the splitter itself isn't as rigid as the Biesemeyer or Excalibur, and didn't always hold the workpiece snug against the tablesaw fence.	This very thin splitter works well with thin-kerf blades. However, because it affixes to the saw in two places—under the throat plate and at the back of the saw—it proved plenty rigid. Except for the initial installation, we liked this splitter best. See the manufacturer's Web site to find the model number for your saw.	In our tests, the Grip-Tite splitter worked as well as the others that cost more than 10 times as much, and it works with virtually any tablesaw. However, with no pawls, our test workpieces tended to creep back. Put the money you save toward an overarm blade guard.
OVERALL GRADE	A	B-	A-	A-	
PRICE (3)	\$130	\$160	\$115	\$7 (or \$20 with throat plate)	
FOR MORE INFORMATION:	800/782-1831 www.biesemeyer.com	800/438-2486 www.deltamachinery.com	800/357-4118 www.excalibur-tools.com	800/475-0293 www.grip-tite.com	

NOTES: 1. (X) Fits both left-tilt and right-tilt versions of this saw.

2. **A** Excellent
B Above average
C Average
N/A No anti-creep pawls

3. Prices current at time of article's production and do not include shipping, where applicable.

Written by Dave Campbell with Paul McClannahan

The best of the test

The Biesemeyer and Excalibur splitters came out on top in our testing, both being rigid, easy to mount and dismount, and with effective anti-creep pawls. We give the slight edge to Biesemeyer, based on its

ease of initial installation. However, it doesn't work well with a thin-kerf blade, so if you use one occasionally, it's worth the extra installation work to get the Excalibur.

If the price tag is too high on those models (or if they don't make a model to fit your saw) opt for the Grip-Tite. At only \$7 a pop, it provides an extra margin of safety on any tablesaw. 📌

The ultimate cheap guy's workshop...

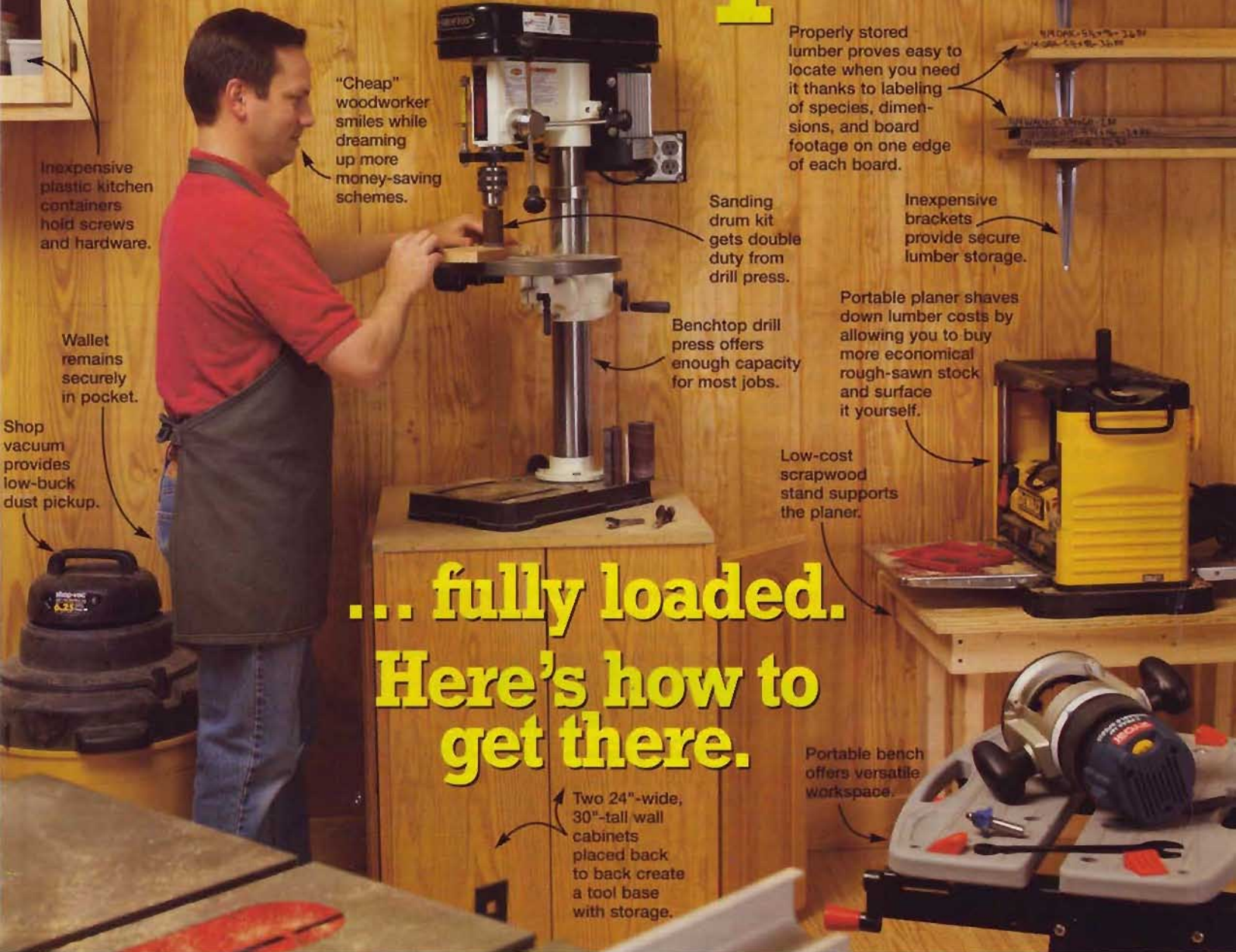

Inexpensive plastic kitchen containers hold screws and hardware.

"Cheap" woodworker smiles while dreaming up more money-saving schemes.

Properly stored lumber proves easy to locate when you need it thanks to labeling of species, dimensions, and board footage on one edge of each board.

Sanding drum kit gets double duty from drill press.

Inexpensive brackets provide secure lumber storage.

Wallet remains securely in pocket.

Benchtop drill press offers enough capacity for most jobs.

Portable planer shaves down lumber costs by allowing you to buy more economical rough-sawn stock and surface it yourself.

Shop vacuum provides low-buck dust pickup.

Low-cost scrapwood stand supports the planer.

... fully loaded. Here's how to get there.

Portable bench offers versatile workspace.

Two 24"-wide, 30"-tall wall cabinets placed back to back create a tool base with storage.

Convinced that you have to spend big bucks on industrial-quality gadgets and shop furnishings to get great results? Think again. When you make smart choices you really can outfit your shop on a shoestring budget.

The secret: buy what you need, when you need it, and don't spend money on unnecessary luxuries. Take a look at a pro's woodworking shop if you want proof. There, every tool has to earn its keep. Read on to see how you can make yours do the same, and how to squeeze the most from every cent without scrimping on quality.

Start with the essentials

Woodworkers often debate which tools to buy when setting up shop. Here's our take on prioritizing your purchases. The list includes stationary machines, portable tools, and other essentials. (We'll assume you already have such common tools as a cordless drill, a jigsaw, and a shop vacuum.)

✓ **Anchor your shop with a tablesaw.** This versatile tool sits at the heart of most shops. It rips and crosscuts, dados, rabbets, cuts tenons, and does much more. Because

this is your core tool, invest a few bucks. Stay away from ultra-low-end benchtop saws (priced from about \$100 to \$200). They offer little power or precision.

At minimum, buy a basic contractor-style saw or a high-end benchtop model for \$300 to \$500. They offer reasonable power and accuracy, and accept accessories.

Up the ante to around \$900, and you're in cabinet saw country, *opposite top*. Or, for that same money, get a contractor's saw equipped with a 1.5-hp, 120/240-volt motor, and a 50" fence. A saw in either of these categories may be the only one you'll ever buy.



Tablesaw bargains abound at several price levels. As an example, less than \$900 buys this Grizzly G1023GS, a saw we've tested and admire. It has a 240-volt, 3-hp motor, an accurate fence, and cast-iron wings.

An accurate rip fence is worth its weight in gold, so make sure you get a good one. See our review of top models on *page 52*.

When you set your saw budget, allow at least \$50 for a high-quality 40- to 60-tooth combination blade. Doing this means you won't sacrifice wood to chip-out and burns.

After you get that saw, sink a router-table insert into its extension table. By doing this, you eliminate the cost of a separate stand, and save floor space. You can even get double duty from your tablesaw rip fence by building a slip-on router-table fence.

✔ **Multi-base routers play many roles.**

The router is one of the most versatile shop tools. And today, you get more router for your money than ever, as shown, *below*.

A router is useless alone, of course, but you can buy bits in batches to save money. If you use a bargain-priced bit enough to wear it out, replace it with a higher-dollar version that will yield longer service.



\$175 to \$250 buys a full-featured router with multiple bases (fixed, plunge, and, in some kits, a D-handle base). Table-mount one base, and use the others for freehand work. Add a bargain bit set—this 66-piece pack costs less than \$200—and you're ready to rout.

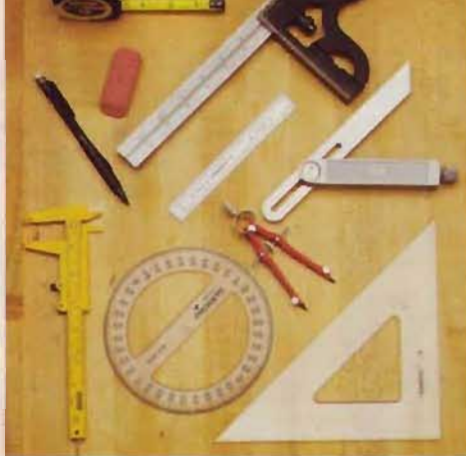

You can tackle most layout chores with a tape measure, combination square, 6" steel rule, compass, and a mechanical pencil. To handle tougher tasks, add a sliding bevel gauge, dial caliper, protractor, and a 45° triangle.

✔ **Pay out for layout tools.**

You can only cut as accurately as you mark, so devote a few dollars to good quality measuring and marking tools. Many elaborate gadgets exist, but skip them. You can get by with a few basics, *above*.

✔ **Work out a work surface.**

Now that you can transform lumber into project parts, you need a place to work with them. A full-blown cabinetmaker's bench would be ideal, but you can do a lot with a folding work station; a solid core door thrown on sawhorses; or a simple shop-built bench, such as the one shown *below*.



A workbench must be flat, sturdy, and stable. To make yours more useful, incorporate a vice and bench-dog holes that ease holding chores. Get plans for this easy-to-build bench at www.woodmagazine.com/workbench.

✔ **Get a grip on good clamps.**

A woodworker can never have enough clamps, but just a few will get you started. Bar or pipe clamps still rule for versatility, and are the favorite for gluing panels. Build an inexpensive but expandable set by getting a half dozen pipe clamp heads plus some 24" sections of pipe and pipe couplers. That way, you can arrange the clamps' lengths to suit your needs.

One-handed clamps are handy, too, so augment your arsenal with a few of these in the 12" to 24" size range. As your budget allows, pick up more clamps to fill your set.

✔ **Sail into smooth sanding.**

If you can only have one sander in your shop, make it a random-orbit model, *right*. Fit it with coarse paper to remove stock aggressively and with fine-grit paper to leave a smooth, scratch-free finish. You can pick one up for as little as \$35.



The pad on a random-orbit sander rotates and moves in an orbital motion to blend the scratches into a hard-to-see pattern.

✔ **A drill press comes next.**

Modern hand drills are wonders of power and versatility, but for ultimate accuracy and control, you need a drill press. For 90 percent of projects, a benchtop model will do, which can save \$100 or more over buying a floor model.

Devote those savings to a set of twist bits, imported Forstner-style bits, and a sanding drum kit. You even can get a mortising attachment that bolts on when you need it.

✔ **Next pointer, get a jointer.**

You may think you need a jointer, *below*, only if you purchase rough stock. Or you might be tempted to buy one of those gadgets that's supposed to joint edges using your router. But a jointer is no luxury item.

With one you can remove saw-blade burn marks, dress edges for perfect glue-ups, and, on many models, cut rabbets. Most important, though, a jointer is the *only* tool that can reliably flatten the face of a board.

Even if you don't take full advantage of a jointer's abilities, you'll appreciate how quickly it prepares boards for perfect ripping and gap-free glue-ups.



Still ready to spend? Now consider these contenders

With the tools on the previous pages, plus your jigsaw and drill, you have all you need to build most projects. Eventually, though, you'll want two more machines.

✓ Plan for a planer.

A planer, *below*, saves money on lumber because you can buy rough-sawn boards, then mill them to finished dimension. Plus, owning one allows you to work with lumber thicknesses unavailable at your retailer.

Be aware that a planer will create a huge mess of flying chips. Some newer models, though, offer built-in chip collectors that will save you the expense of a dust collector until your shop budget allows for it.



A portable planer offers ample power and enough width capacity (usually 12–13") to handle all of your lumber surfacing needs. This model collects its own chips in a bag.

✓ Now bring on a bandsaw.

Not all woodworking involves making straight cuts. A handheld jigsaw can negotiate many curves, but, eventually, you'll want a bandsaw, *below*. In our opinion, a 14" model offers the most bang for your buck to handle home-shop needs.



A bandsaw shines at cutting curves, and can also rip, resaw, cut circles, and even mill short, small diameter logs into lumber.

With all of these tools and machines on hand, you'll be set for most tasks. Now you can add specialized tools as your budget permits and projects require. Read "The next wave," *right*, to see what you may want to purchase next.

Time to get Organized

Getting the most from any workshop requires keeping it clean by creating places to stash all your stuff. But don't assume that storage has to be fancy or costly to be effective. Try these pointers.

✓ Scrounge up some cabinets.

You can create great storage without spending a dime if you keep your eyes open for discarded kitchen cabinets. Neighbors, friends, or contractors working on a remodeling project are often happy to get rid of them.

Once you get the cabinets in the shop, use them creatively. The drill press in the photo on *page 62*, for example, sits on two wall cabinets. They position the drill press at working height and provide about eight cubic feet of enclosed, dust-free storage. Kitchen base cabinets serve well as workbench bases.

Make the cabinets more functional for shop use by building in cubbies or extra shelving, or adding perforated hardboard to the inside of the doors. Throw on a coat of gloss paint to lend a finished appearance to tattered or mismatched cabinets.

✓ Keep your lumber in line.

Lumber leaned against walls or stacked underfoot quickly becomes disorganized or falls victim to damage. Store those boards right by mounting simple metal shelf brackets, as shown on *page 62*. (We purchased ours at a hardware store for a meager 75 cents each.) Use four or five brackets—screwed into the wall studs—for each shelf, and space the shelves about 8" apart. Lay particleboard over the brackets, and each shelf will easily support six to eight boards.

These short stacks prove easy to sort through when you need a board, especially if you mark the stacks as shown.

The next wave

Obviously, many more tools and accessories exist to make your woodworking easier, faster, and more refined. After securing the tools covered in this article, buy these next:

Hand tools:

Bench chisels
Block plane
Dead-blow mallet
Japanese-style handsaw
Cabinet scraper

Portable power tools:

Biscuit joiner
Belt sander
Handheld circular saw
A second router

Stationary tools:

Dust collector and air filter
Compound mitersaw
Belt/disc sander
Oscillating spindle sander
Scrollsaw
Lathe

Accessories:

Mobile tool bases
Roller stand/outfeed support
Pocket-hole jig
Dovetail jig
Marking gauge

More ways to squeeze the most from your budget

✓ Save some coin on clamps.

Want to reduce your need for clamps? Try securing glued-up assemblies with a few air-nailed brads, *below*.

You can get a compressor and brad nailer kit for under \$200, the price of just a few decent-quality bar clamps. If you already have a compressor, the investment for a nailer may be as little as \$40.



A pneumatic air nailer drives a brad into joints without splitting the wood, and holds the assembly while the glue sets.

✓ Add lumber purchasing power.

Buying lumber doesn't qualify, strictly speaking, as part of shop setup. But building anything in a shop proves pretty tough without boards. Why not make them less expensive by purchasing in lots of 100, 250, or even 500 board feet? Pros do it, and so can you, by getting a group of friends or club members together. You may be able to mix species and still earn discounts. ♣

Written by David Stone

at-your-service

traditional sideboard





If you prefer a fully enclosed sideboard, simply make an additional door.



Add these optional easy-to-make wine racks to hold 12 of your favorite vintages.

Looking for a handsome, versatile serving piece with plenty of storage for fine dinnerware and linens? This traditional oak beauty, with three spacious cupboards and drawers and seven adjustable shelves, may be just the ticket. Using straightforward half-lap joinery for the face frame, stub-tenon-and-groove construction for the doors, and super-simple locking joints for the drawers, you'll find building this unit a snap. If you wish, you can add wine racks and/or a door to the center cupboard, as shown in the photos above.

AT A GLANCE

- Overall dimensions are 55" wide × 19¼" deep × 41" high.
- For the board feet of lumber and other items needed to build this project, see page 73.

Start with the sides

1 Cut the front stiles (A), rear stiles (B), center stiles (C), top rails (D), center rails (E), bottom rails (F), lower panels (G), and upper panels (H) to the sizes listed in the **Materials List** on page 73. Save the rail cutoffs to make test tenons. For a continuous grain flow from the lower to upper ¼" plywood panels (G, H), lay them out in the configuration shown on the **Cutting Diagram**. Sand the panels with 220-grit sandpaper.

2 Using your tablesaw, cut a ¼" groove ⅝" deep centered along one edge of parts A, B, D, and F, and along both edges of parts E, where shown on **Drawing 1**. (We cut the grooves with a standard blade in two passes to exactly fit the thickness of our plywood panels.) Then, cut a ¼" groove 1⅛" deep centered along both edges of the center stiles (C).



Interested in making the matching table and chairs for the sideboard? You'll find the plans for the table in the November 2003 issue and the chair in the March 2004 issue. If you need to order these issues, see page 10.

1 SIDE ASSEMBLY

(Inside face shown)

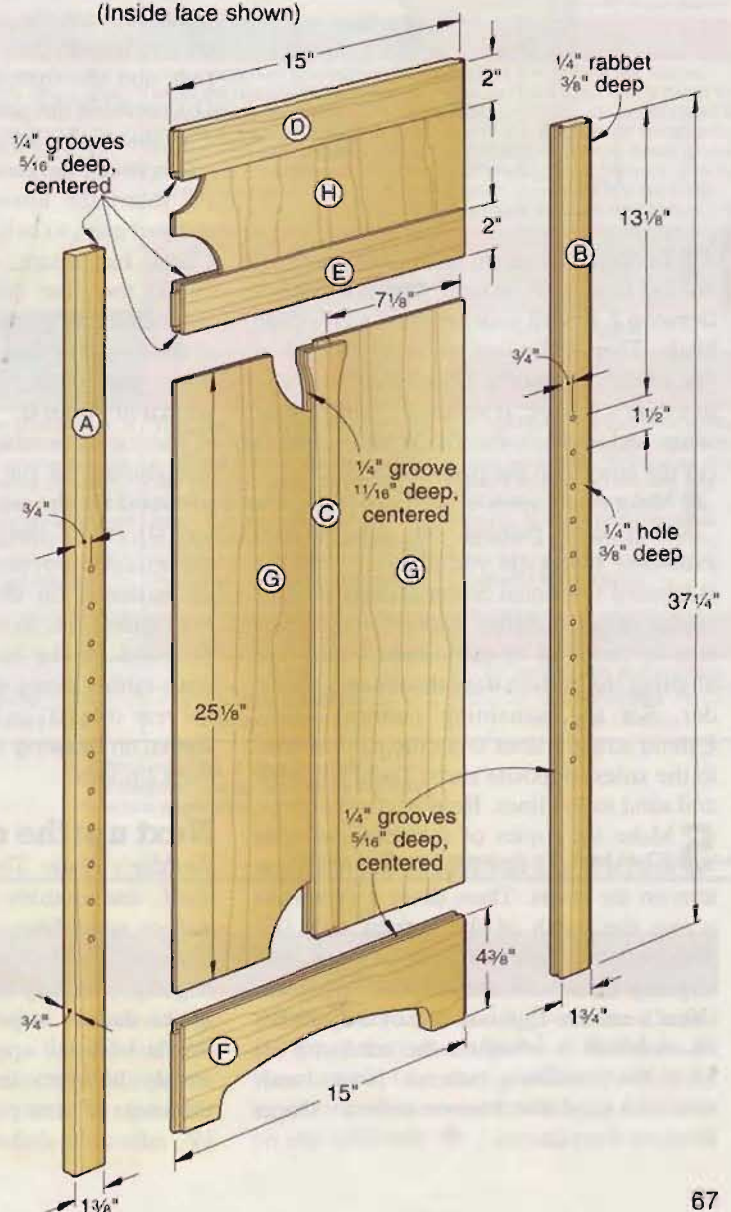

2 TENON DETAILS

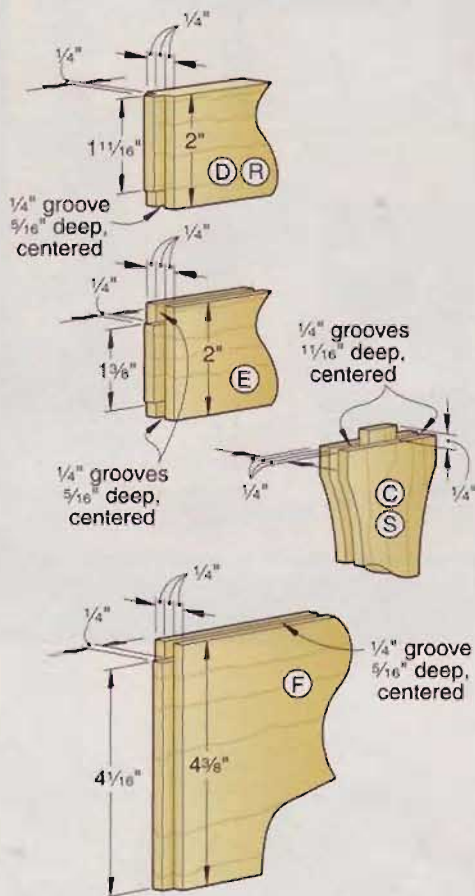

3 To form tenons on the ends of parts C, D, E, and F, where dimensioned on **Drawing 2**, first fit your tablesaw with a dado blade. Then, cut a test tenon on the end of one of the rail cutoffs. Check the tenon's fit in a stile's groove. If necessary, adjust your setup and recheck the fit. When satisfied, cut the tenons on the parts' ends.

4 Make four copies of the full-size center stile end pattern on the *WOOD Patterns* insert. (If you plan to make the sideboard's optional center door, make five copies of the pattern.) Spray-adhere a pattern to one end of each center stile (C), aligning the pattern with the tenon's shoulder. Set the remaining patterns aside. Extend straight lines from the pattern lines to the stiles' opposite ends. Then, bandsaw and sand to the lines. Remove the patterns.

5 Make six copies of the combined side assembly and face frame bottom rail pattern on the insert. Then, draw a centerline across the width of the bottom rails (F). Spray-adhere two patterns to each rail, aligning them with the marked centerline. (You'll need to flip over one of the patterns on each rail to complete the contour.) Set aside the remaining patterns. Now, bandsaw and sand the bottom rails to shape. Remove the patterns.

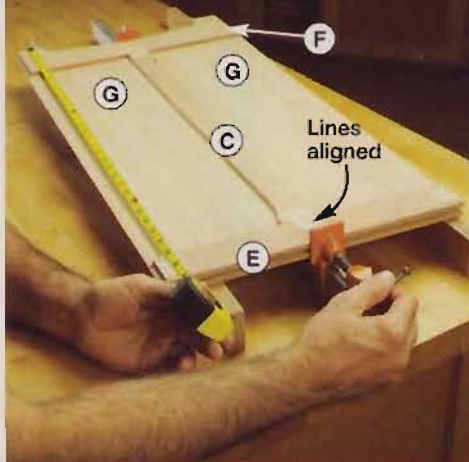

A GLUE THE RAILS AND CENTER STILE

With the lines on the center stile (C) and center and bottom rails (E, F) aligned, check for equal 31" measurements on each side of the assembly to verify square.

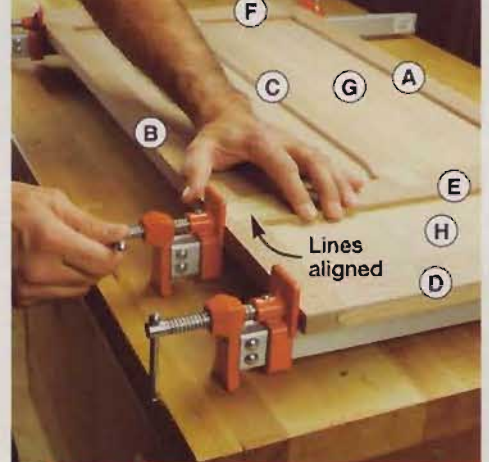

B COMPLETE THE SIDE ASSEMBLY

With the lines on the center rail (E) and front and rear stiles (A, B) aligned and the top rail (D) and bottom rail (F) flush with the stiles' ends, clamp the side assembly together.

6 Dry-assemble parts A through H to form the two side assemblies, centering the center stiles (C) to the center and bottom rails (E, F). Verify that the parts fit together correctly. Then, to make it easy to realign the parts, draw alignment lines across the joints between the center stiles and the center and bottom rails and between the center rails and the front and rear stiles (A, B). Disassemble the parts.

7 Glue and clamp the center stiles (C) between the center and bottom rails (E, F). Insert the lower panels (G) in place, without glue, to help square each assembly. Check for square, as shown in **Photo A**. When the glue dries, complete the side assemblies by gluing and clamping together the front and rear stiles (A, B), lower and upper panels (G, H), and top rails (D), as shown in **Photo B**.

8 Using your tablesaw and a dado blade adjusted to the thickness of your 3/4" plywood for the top, center shelf, and bottom (I), cut 1/4"-deep dadoes and rabbets on the *inside* face of each side assembly, where dimensioned on **Drawing 3**. Then, adjust your dado blade to the thickness of your 1/4" plywood for the back (L), and cut a 3/8"-deep rabbet along the back inside edge of the rear stile (B) on both assemblies, where shown on **Drawing 1**. Now, sand the assemblies smooth.

Next up: the case

Builder's Note: The plywood top, center shelf, and bottom (I) are located in the dadoes and rabbets in the side assemblies. Because the thickness of plywood varies slightly, you may need to adjust the depth of the dadoes in parts I so that the lower dividers (J) and upper dividers (K) will fit snugly between the parts. Measure the thickness of your plywood. If it's less than 3/4", adjust the dadoes' depths as needed.

1 From 3/4" plywood, cut the top, center shelf, and bottom (I); lower dividers (J); and upper dividers (K) to the sizes listed. From 1/4" plywood, cut the back (L) to size. Sand the back smooth, and set it aside. Using your dado blade adjusted to the 3/4" plywood's thickness, cut 1/4"-deep dadoes on the *inside* faces of the top and bottom (I) and on *both* faces of the center shelf (I), where dimensioned on **Drawing 3**.

2 Mark the locations for 3/16" shank holes and 3/16" slots 1/2" long on the top (I), where shown. Drill the holes and slots.

3 Mark the locations for 1/4" holes for shelf supports on the inside face of the side assemblies' front and rear stiles (A, B), where dimensioned on **Drawing 1**, and on one face of the lower dividers (J), where dimensioned on **Drawing 3**. Then, drill the holes 3/8" deep in the stiles and through the dividers.

4 To assemble the case, first glue and clamp the lower dividers (J) between the bottom and center shelf (I) on a flat surface, checking for square. When the glue dries, glue and clamp to this assembly the upper dividers (K) and top (I), again verifying square. Now, glue and clamp the side assemblies to the case, as shown in **Photo C**. You can avoid using extra-long clamps by clamping the side assemblies to the dividers, as shown.

Add the face frame

1 Cut the outer stiles (M), inner stile blanks (N), top and center rails (O), and bottom rail (P) to the sizes listed, saving the cutoffs.

2 Lay out the half-lap joints on the parts, where dimensioned on **Drawing 4**. Using a dado blade in your tablesaw, cut half-laps in two of the cutoffs. Put the pieces together, and check for a flush-fitting joint. Adjust your setup and retest as needed. When the fit's acceptable, cut the half-laps.

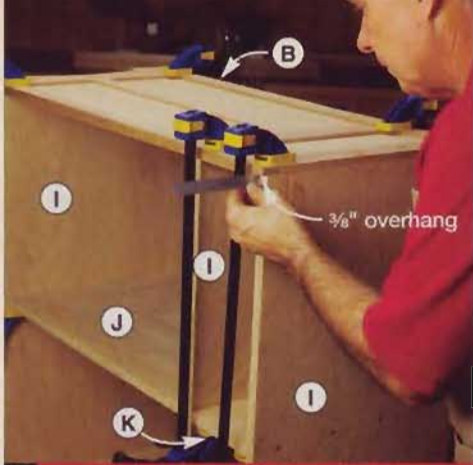

C GLUE THE SIDE TO THE CASE
Position the side assembly so that it overhangs the case's front edge by $\frac{3}{8}$ " while the rabbeted edge of the rear stile (B) is flush with the case's back edge.



D RABBET THE FACE FRAME
Keeping the face frame (M/N/O/P) tight against the saw's rip fence and supporting the frame with a stand, rabbet the back edges of the outer stiles (M).

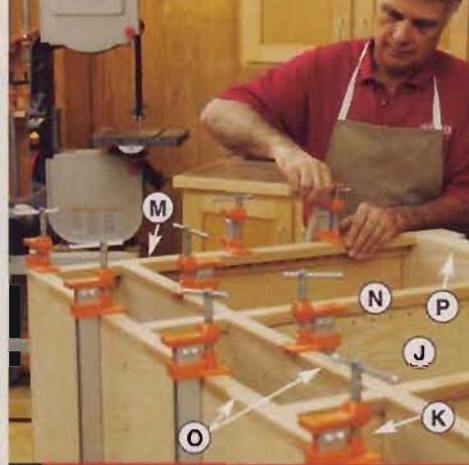

E ATTACH THE FACE FRAME
Clamp the face frame (M/N/O/P) to the case around the perimeter and on the inside to ensure it's securely attached to the lower and upper dividers (J, K).

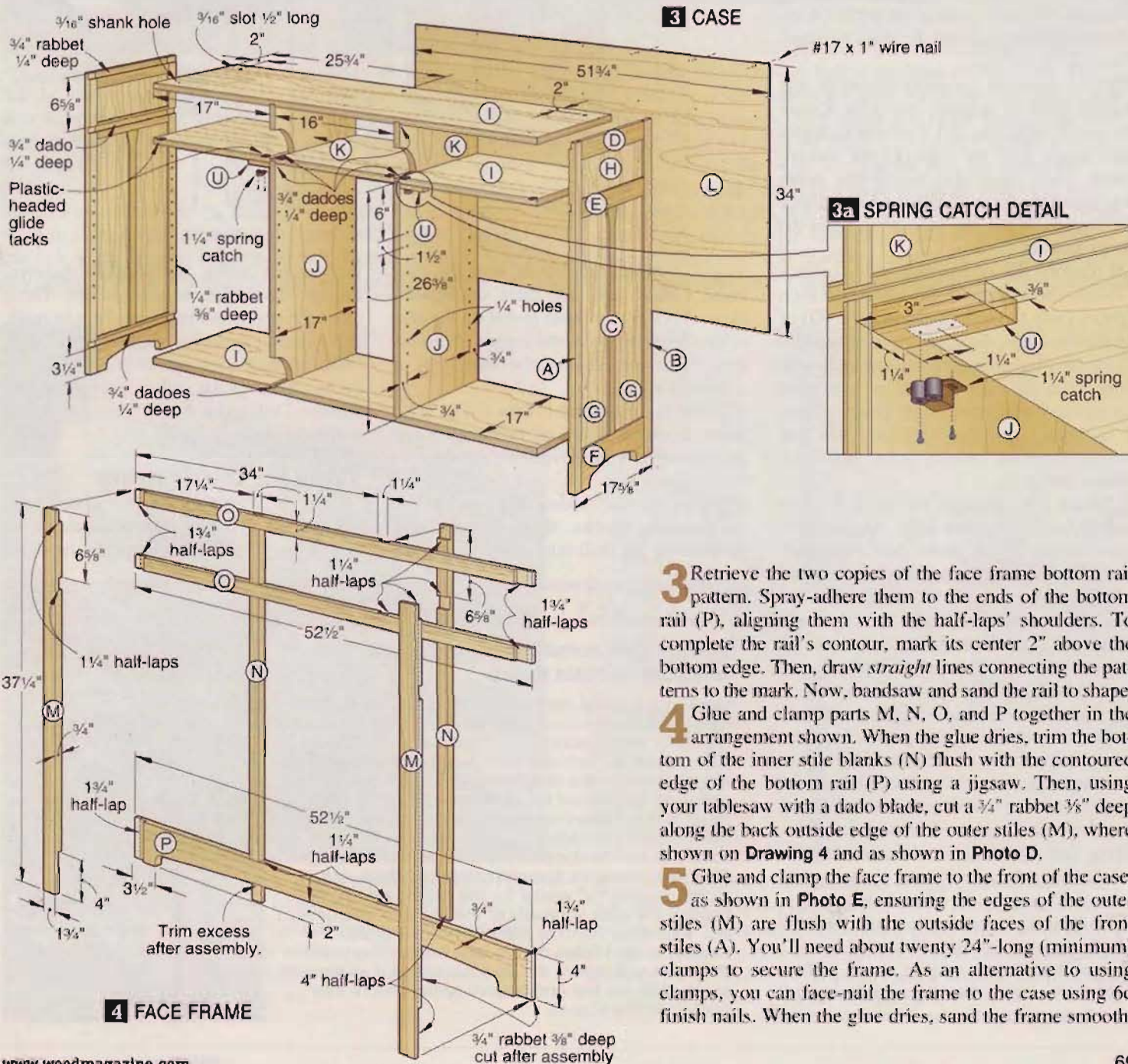

3 Retrieve the two copies of the face frame bottom rail pattern. Spray-adhere them to the ends of the bottom rail (P), aligning them with the half-laps' shoulders. To complete the rail's contour, mark its center 2" above the bottom edge. Then, draw *straight* lines connecting the patterns to the mark. Now, bandsaw and sand the rail to shape.

4 Glue and clamp parts M, N, O, and P together in the arrangement shown. When the glue dries, trim the bottom of the inner stile blanks (N) flush with the contoured edge of the bottom rail (P) using a jigsaw. Then, using your tablesaw with a dado blade, cut a $\frac{3}{4}$ " rabbet $\frac{3}{8}$ " deep along the back outside edge of the outer stiles (M), where shown on **Drawing 4** and as shown in **Photo D**.

5 Glue and clamp the face frame to the front of the case, as shown in **Photo E**, ensuring the edges of the outer stiles (M) are flush with the outside faces of the front stiles (A). You'll need about twenty 24"-long (minimum) clamps to secure the frame. As an alternative to using clamps, you can face-nail the frame to the case using 6d finish nails. When the glue dries, sand the frame smooth.

Swing over to the doors

Note: The **Materials List** shows the quantities of parts for two doors. If you wish to add the optional center door, increase the quantities of parts Q through U accordingly.

1 Cut the stiles (Q), rails (R), center stiles (S), panels (T), and mounting blocks (U) to the sizes listed. Sand the $\frac{1}{4}$ " plywood panels smooth. As you did for the side assemblies, cut a $\frac{1}{4}$ " groove (sized to fit the panels) $\frac{5}{16}$ " deep centered along one edge of parts Q and R, where shown on **Drawing 5**. Then, cut a $\frac{1}{4}$ " groove $\frac{11}{16}$ " deep centered along both edges of parts S. Now, form tenons on the ends of parts R and S, where dimensioned on **Drawing 2**.

2 Retrieve the center stile (S) end patterns. Spray-adhere them to the ends of the center stiles. As before, extend the pattern lines. Then, bandsaw and sand the stiles to shape. Remove the patterns.

3 Dry-assemble the doors to ensure that the parts fit together correctly. Center the center stiles (S), and draw marks across their joints with the rails (R) for realignment. Then, glue and clamp the doors together with the stiles centered, and check for square. When the glue dries, sand the doors smooth.

4 Identify the doors' best sides to face out. Then, drill an $\frac{11}{64}$ " screw hole for a 25mm knob through the inner stile (Q) of each door, where dimensioned on **Drawing 5**. (You can hinge the optional center door to open from the right or left, so locate the knob screw hole where appropriate.) Using a hacksaw, trim the $\frac{1}{4}$ "-long machine screws (supplied with the knobs) to 1" long. Mount the knobs.

5 Mark the locations for the $2\frac{1}{4}$ " inset hinges on the outer stiles' edges, where dimensioned. (The outer doors use full-wrap hinges, and the optional center door uses partial-wrap hinges.) While holding the hinges in position, mark the screw-hole locations on the edge and back face of the stiles using an awl. Then, drill pilot holes, and screw the hinges in place.

6 Position a door, centered vertically, in the face-frame opening. (For an easy way to support the door in the opening, see the **Shop Tip, right**.) Mark the centers of the hinges' vertical screw adjustment slots on the face-frame edge. Remove the door. Then, drill pilot holes, and mount the door to the face frame without snugging the screws. Repeat for the other door(s).

7 Adjust the doors for an equal reveal at the top and bottom. (It should be $\frac{1}{16}$ ", the same as the door-hinge reveal.) Then, tighten the screws. For the outer doors, drill pilot holes centered in the screw holes in the

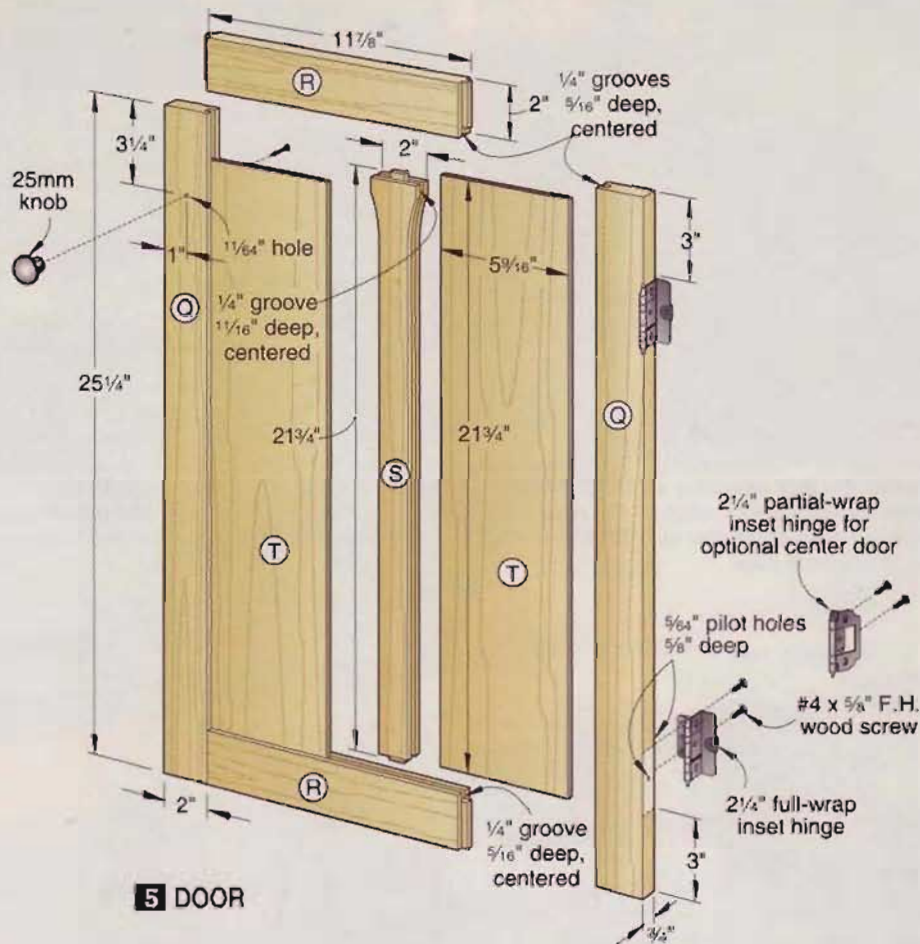

hinges' wraparound leaves into the face frame's back side, and drive the screws. Now, check for an equal reveal on the side of the doors opposite the hinges. If necessary, plane the edge of the stiles (Q) to match the reveal.

8 Glue the mounting blocks (U) in position, where shown on **Drawings 3** and **3a**, tight against the dividers (J) and the face frame's back face.

9 Position $\frac{1}{4}$ " spring catches on the mounting blocks, where dimensioned on **Drawing 3a**. Drill pilot holes, and fasten

the catches using the supplied screws. Engage the strikes in the catches. Then, close the doors and press on them to mark the strikes' locations. (The strikes have barbs on their back sides.) Now, open the doors, and align the strikes with the indentations. Drill pilot holes, and screw the strikes in place.

Time for the drawers

1 Cut the fronts (V), sides (W), backs (X), bottoms (Y), and drawer-slide spacers (Z) to the sizes listed. Center the fronts in

SHOP TIP

A steel rule comes in handy when hanging cabinet doors

Holding a cabinet door in position while marking the hinge mounting-hole locations on the face frame can be tricky. When mounting a door that uses hinges with vertical adjustment slots, such as the inset hinges used for the sideboard's doors, here's an easy way to support the door approximately centered in the cabinet opening. Simply clamp a steel rule from an adjustable square to the cabinet bottom, and set the door on the rule, as shown at *right*. (The rule measures approximately $\frac{3}{32}$ " thick—close to the desired $\frac{1}{16}$ " reveal for the sideboard.) While holding the door vertically at the top with one hand, use your other hand to mark the center of the hinges' slotted holes on the face frame. Then, drill the holes and mount the door, adjusting it as needed to equalize the top and bottom reveal before fully tightening the screws.



6 DRAWER

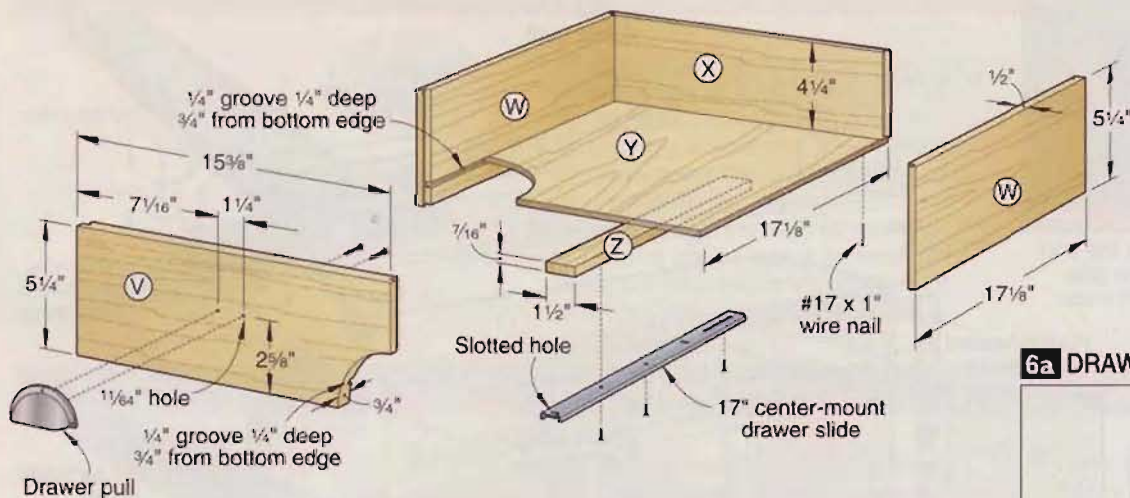

Drawer pull

the face-frame openings, and check for a $\frac{1}{16}$ " reveal all around that matches the doors' reveal. If necessary, trim the fronts, and adjust the size of the sides, backs, and bottoms accordingly.

2 Mark centerpoints on the fronts (V) for the drawer-pull screw holes, where dimensioned on **Drawing 6**. Then, drill $\frac{1}{16}$ " holes through the fronts at the marked locations.

Note: As an alternative to forming lock joints using a drawer-lock router bit, you can join the drawers together using rabbet joints cut with your table saw or dovetails.

3 Chuck a drawer-lock bit in your table-mounted router. (See **Sources** for the bit.) Set the bit height and position the router fence where shown on **Drawing 6a**. Then, rout the ends on the *inside* faces of the fronts (V), backs (X), and sides (W), where shown on **Drawing 6b**, positioning the parts on the table and against the fence in the orientations shown on **Drawing 6a**.

4 Using your table saw, cut a $\frac{1}{4}$ " groove $\frac{1}{4}$ " deep and $\frac{3}{4}$ " from the bottom edge of the fronts (V) and sides (W) for the $\frac{1}{2}$ " plywood bottoms (Y), where shown. Then, glue and clamp the fronts, sides, and backs (X) together, checking for square. When the glue dries, slide the bottoms (Y) into place, and nail them to the bottom of the backs, where shown. Now, glue and clamp the drawer-slide spacers (Z) to the bottoms, centered side-to-side and tight against the fronts. Sand the drawers smooth.

5 Draw centerlines along the length of the spacers (Z). Separate the 17" center-mount drawer slides. Then, center the smaller drawer-slide members on the spacers' marked centerlines with the slides' slotted-hole ends tight against the fronts (V). Drill pilot holes, and drive the supplied screws, where shown on **Drawing 6**.

6 Mark the center of the drawer openings in the face frame. Aligning a framing

square with the marks, draw lines across the width of the center shelf (I). Then, center the larger cabinet-slide members on the lines with the slides' front ends (the ends with two slotted holes) located $\frac{3}{4}$ " back from the outside face of the face frame. Now, mount the slides, as shown in **Photo F**. (The rear mounting brackets supplied with the slides are not used.)

7 To prevent the drawers from rocking, install plastic-headed glide tacks (supplied with the slides), where shown on **Drawing 7**. Drive the tacks into the joint between the face frame and center shelf (I) using a hammer. Then, mount the drawer pulls, install the drawers, and verify they operate smoothly. If you need to adjust a drawer, loosen the cabinet slide's screws, reposition the slide, and tighten the screws.

Now, the shelves and top

1 Cut the outside shelves (AA), inside shelves (BB), outside shelf edging (CC), and inside shelf edging (DD) to the sizes listed. Glue and clamp the edging to the shelves, where shown on **Drawing 7**, keeping the edging flush with the shelves' faces and ends. When the glue dries, sand the shelves smooth, and set them aside.

2 Edge-join enough $\frac{3}{4}$ "-thick boards to make a 20x56" workpiece for the top (EE). When the glue dries, crosscut and then rip the top to the finished size. To secure the crest (FF) later, drill countersunk shank holes in the bottom face of the top along its back edge, where shown.

3 Cut the crest (FF) to size. Mark the ends and center of the arch, where dimensioned. Then, bend a fairing stick to these points, and draw the arch. (For a free fairing stick plan, go to www.woodmagazine.com/wbprojects.) Bandsaw and sand the arch to shape.

6b DRAWER TOP VIEW

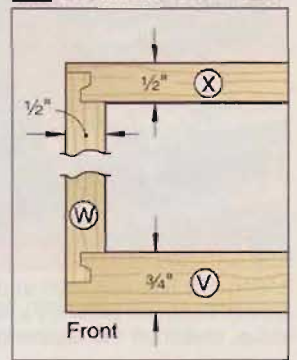

6a DRAWER-LOCK JOINT

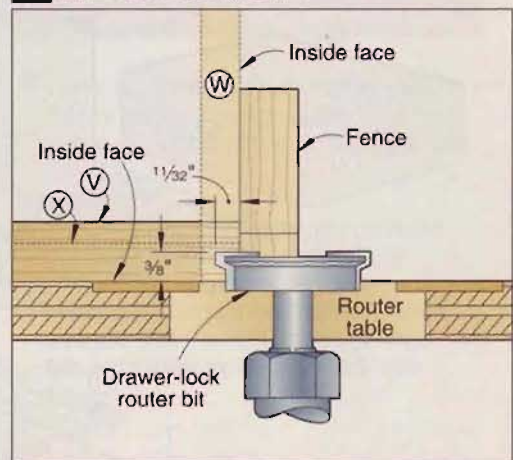

F MOUNT THE CABINET SLIDE

Using a small awl or nail, make pilot holes for mounting the cabinet-slide member. Drive the screws using a short screwdriver.

4 From $\frac{3}{4}$ "-thick stock, cut two $1\frac{3}{4}$ x8" pieces to form the end trim (GG). Laminate the pieces to make a $\frac{1}{2}$ "-thick blank. Then, crosscut two $2\frac{3}{4}$ "-long end-trim pieces from the blank.

5 To cut slots for #10 biscuits for joining the end trim (GG) to the crest (FF), where shown on **Drawing 7**, first mark the slots' centerlines on the parts' faces $\frac{3}{4}$ " from their bottoms. Then, adjust your biscuit-joiner fence to center the slot cutter on the

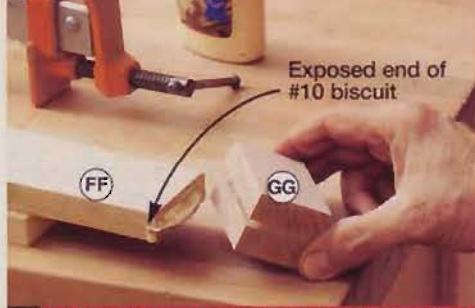

Exposed end of #10 biscuit

G GLUE THE END TRIM TO THE CREST

Using #10 biscuits, glue and clamp the end trim (GG) to the crest (FF). When the glue dries, chisel off the exposed biscuit ends.

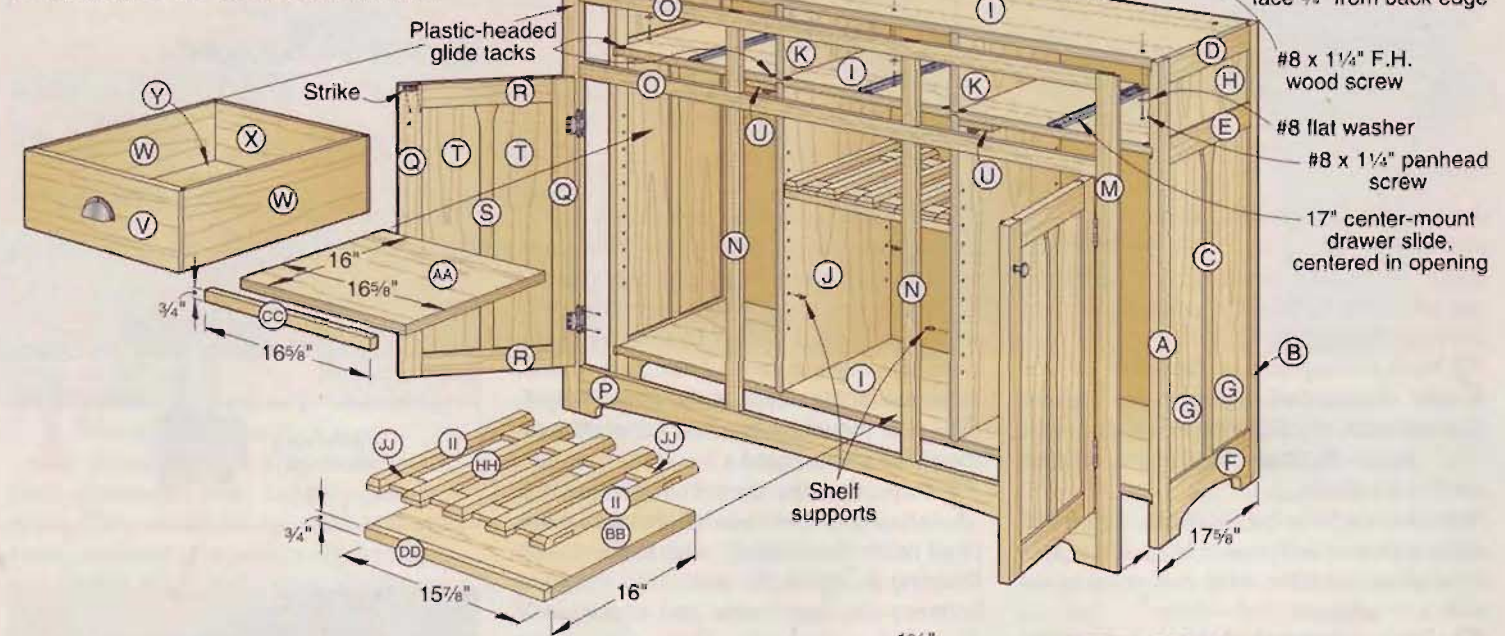

3/4"-thick crest, and plunge the slots in its ends. Readjust the fence to center the cutter on the 1 1/2"-thick end trim. With the trim pieces held in your vise, plunge the mating slots in their edges.

6 Using a 45° chamfer bit in your hand-held router, rout 1/8" chamfers on the top (EE), crest (FF), and end trim (GG), where shown. Sand the parts smooth.

7 Keeping their bottoms flush, glue and clamp the end trim (GG) to the crest (FF), as shown in **Photo G**. When the glue dries, glue and clamp the crest/end trim assembly to the top (EE), centering the assembly side-to-side and aligning the end trim back faces flush with the top's back edge. Then, centering on the countersunk shank holes in the top, drill pilot holes into the crest, and drive the screws.

8 Position the top assembly (EE/FF/GG) on the case, centering the assembly side-to-side with the back edges of the top (EE) and rear stiles (B) flush. Then, attach the assembly with panhead screws and flat washers from inside the drawer cavities, where shown.

Add the wine racks (optional)

1 Cut the center supports (HH), outer supports (II), and rails (JJ) to size.

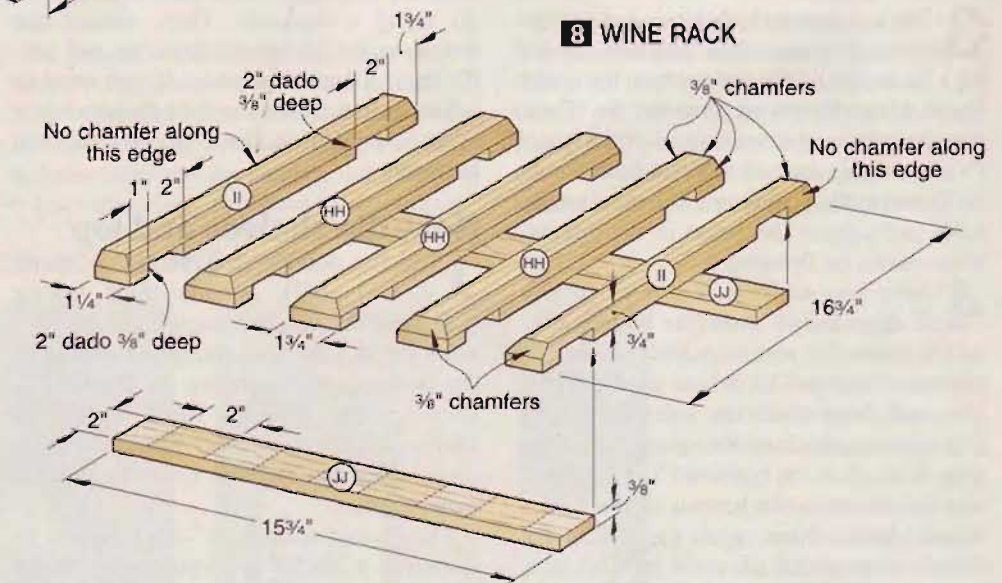

Using your router and chamfer bit, rout 3/8" chamfers along the ends, then edges, of the supports, where shown on **Drawing 8**. Then, using your tablesaw and dado blade, cut 2" dadoses 3/8" deep in the supports' bottom faces, where dimensioned, to fit the rails.

2 From 3/4"-thick scrap, cut four 2x4" spacers. Then, glue and clamp the supports and rails together, inserting the spacers in the center of the rack to position the supports 2" apart while keeping the outer supports (II)

flush with the ends of the rails (JJ). When the glue dries, sand the racks smooth.

Finish up

1 Remove the drawers, doors, and hardware. Sand any areas that need it with 220-grit sandpaper, and remove the dust. If you nailed the face frame to the case, fill the nail holes with a stainable wood putty.

2 Stain the sideboard, if you wish. (We used Zar Oil-Based Stain, no. 110,

Materials List

Side assemblies	FINISHED SIZE			Mati.	Qty.	
	T	W	L			
A	front stiles	¾"	1¾"	37¼"	O	2
B	rear stiles	¾"	1¾"	37¼"	O	2
C	center stiles	¾"	2"	25½"	O	2
D	top rails	¾"	2"	15"	O	2
E	center rails	¾"	2"	15"	O	2
F	bottom rails	¾"	4¾"	15"	O	2
G	lower panels	¼"	7½"	25½"	OP	4
H	upper panels	¼"	15"	4¾"	OP	2
Case						
I	top, center shelf, and bottom	¾"	17"	51½"	OP	3
J	lower dividers	¾"	17"	26¾"	OP	2
K	upper dividers	¾"	17"	6¾"	OP	2
L	back	¼"	34"	51¼"	OP	1
Face frame						
M	outer stiles	¾"	1¾"	37¼"	O	2
N	inner stile blanks	¾"	1¼"	37¼"	O	2
O	top and center rails	¾"	1¼"	52½"	O	2
P	bottom rail	¾"	4"	52½"	O	1
Doors (two)						
Q	stiles	¾"	2"	25¼"	O	4
R	rails	¾"	2"	11¾"	O	4
S	center stiles	¾"	2"	21¼"	O	2
T	panels	¼"	5½"	21¼"	OP	4
U	mounting blocks	½"	1¼"	3"	O	2

Drawers (three)						
V	fronts	¾"	5¼"	15½"	O	3
W	sides	½"	5¼"	17½"	O	6
X	backs	½"	4¼"	15½"	O	3
Y	bottoms	¼"	14½"	17½"	OP	3
Z	drawer-slide spacers	7/8"	1½"	16½"	O	3
Shelves						
AA	outside shelves	¾"	16"	16½"	OP	4
BB	inside shelves	¾"	16"	15½"	OP	3
CC	outside shelf edging	¾"	¾"	16½"	O	4
DD	inside shelf edging	¾"	¾"	15½"	O	3
Top assembly						
EE*	top	¾"	19¼"	55"	EO	1
FF	crest	¾"	3"	49"	O	1
GG*	end trim	1½"	1¾"	2¼"	LO	2
Wine racks (optional)						
HH	center supports	¾"	1¾"	16¼"	O	9
II	outer supports	¾"	1¼"	16¼"	O	6
JJ	rails	¾"	2"	15¼"	O	6

*Parts initially cut oversize. See the instructions.

Materials key: O—oak, OP—oak plywood, EO—edge-joined oak, LO—laminated oak.

Supplies: Spray adhesive, #8×1¼" panhead screws (6), #8 flat washers (6), #8×1¼" flathead wood screws (5), #10 biscuits (2), #17×1" wire nails. For optional face-nailing of the face frame to the case: 6d finish nails, stainable wood putty.

Blades and bits: Dado-blade set, 45° chamfer and drawer-lock router bits.

Sources

Hardware kit for sideboard. Includes 2¼" full-wrap inset hinges, no. 01H30.42 (4); 25mm knobs, no. 01X40.11 (2); drawer pulls, no. 01A57.85 (3); 1¼" spring catches with strikes, no. 00W11.02 (2); 17" center-mount drawer slides with plastic-headed glide tacks and screws, no. 02K14.17 (3); ¼" shelf supports, no. 63Z06.04, package of 20 (2 packages). Kit no. 05D15.15, \$58.00. Price reflects a discount for WOOD® magazine readers. Call Lee Valley 800/871-8158, or go to www.leevalley.com.

Hardware kit for sideboard and optional center door. Includes all hardware listed above plus 2¼" partial-wrap inset hinges, no. 01H31.42 (2); an additional 25mm knob no. 01X40.11; an additional 1¼" spring catch with strike, no. 00W11.02. Kit no. 05D15.16, \$66.00. Price reflects a discount for WOOD magazine readers. Lee Valley—phone and Web address above.

Router bit. Drawer-lock router bit (½"-diameter shank), no. WL-1435, \$35.00. Call Woodline 800/472-6950, or go to www.woodline.com.

Cutting Diagram

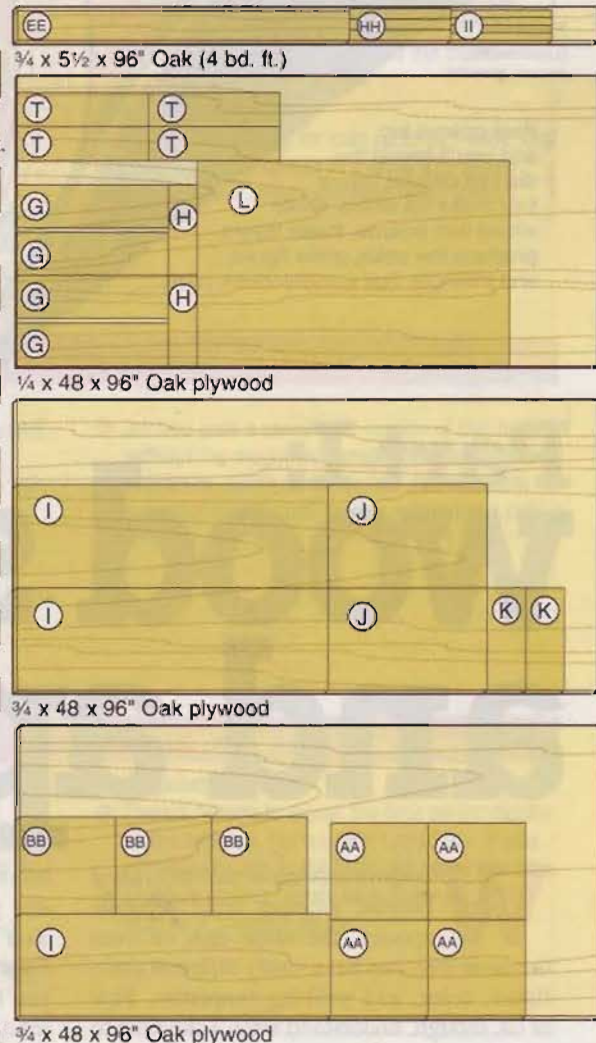
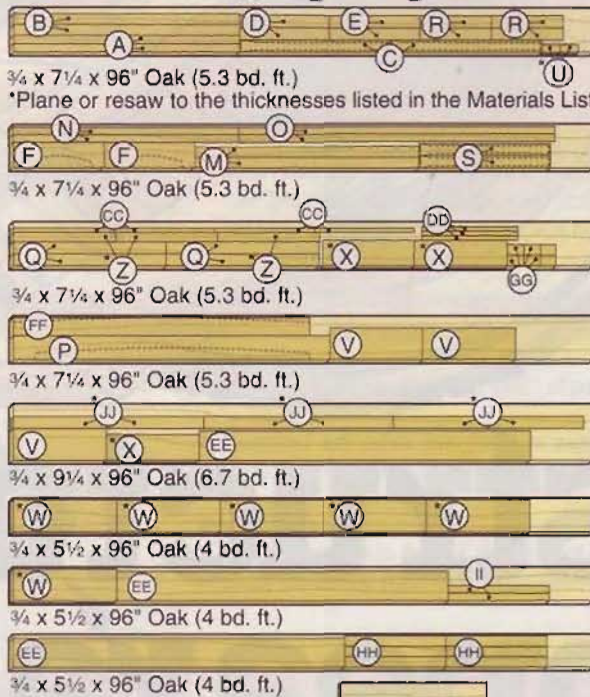

color Salem Maple.) Then, apply three coats of a clear finish. (We used AquaZar Water-Based Clear Satin Polyurethane, sanding to 320 grit between coats.)

3 Remount the hardware, and install the doors and drawers. Then, position the back (L) in the rabbets in the rear stiles (B) and tight against the top (EE). Nail the back to the case, where shown on **Drawing 3**.

4 Finally, install the inside and outside shelves where you wish using ¼" shelf supports, and place any wine racks in position. Now, move this beautiful piece to your dining room, and fill it with your finest china and special wines. ♣

Written by **Owen Duvall** with **Chuck Hedlund**
 Project design: **Kevin Boyle**
 Illustrations: **Roxanne LeMoine**

The more you know about wood, the better able you'll be to master it. In this series, we'll lay the foundation by making you familiar with wood's composition. In the next issue (156) we'll talk about moisture and wood drying. In subsequent issues, you'll learn how wood's properties affect machining, staining, and finishing.

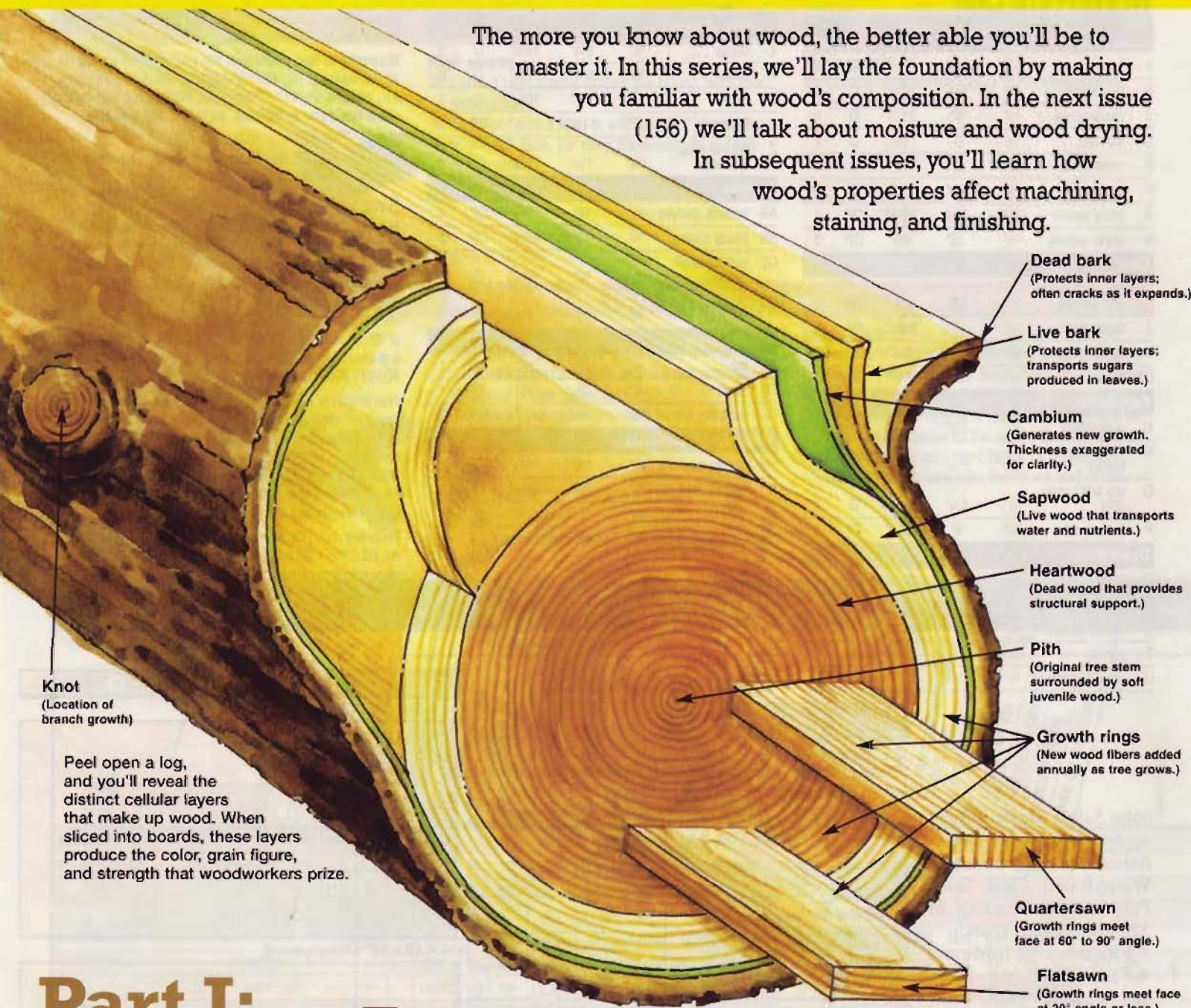

Knot
(Location of branch growth)

Peel open a log, and you'll reveal the distinct cellular layers that make up wood. When sliced into boards, these layers produce the color, grain figure, and strength that woodworkers prize.

Dead bark
(Protects inner layers; often cracks as it expands.)

Live bark
(Protects inner layers; transports sugars produced in leaves.)

Cambium
(Generates new growth. Thickness exaggerated for clarity.)

Sapwood
(Live wood that transports water and nutrients.)

Heartwood
(Dead wood that provides structural support.)

Pith
(Original tree stem surrounded by soft juvenile wood.)

Growth rings
(New wood fibers added annually as tree grows.)

Quartersawn
(Growth rings meet face at 60° to 90° angle.)

Flatsawn
(Growth rings meet face at 30° angle or less.)

Part I: wood structure and appearance

Woodworkers know that individual boards, whether from separate species, the same one, or even the same tree, can have vastly different grain figure, color, and working properties. Few of us, though, understand why. Take time to

become familiar wood as a material, though, and you'll reap rewards by the truckload. You'll better select, machine, assemble, and finish wood for the projects you build. And you'll understand how completed projects react to weather and temperature variables.

Thankfully, you don't have to decipher wood's cellular makeup. We've done that for you in this and upcoming articles, and will make it easy for you to understand what you need to know about wood. Let's start with the basics of how a tree grows.

Growth rings give clues to the tree's age, growth rate, and whether the trunk grew straight or crooked, on flat ground or a slope. Uneven ring distribution can indicate unstable wood.

The growth cycle

Trees, whether hardwood or softwood, all grow pretty much the same way. A narrow stem sprouts from a seed, and reaches for sunlight. But that stem—call it the trunk—doesn't just get longer. Instead, it adds layer upon layer of new material like coats of paint, causing it to increase in both height and diameter as it grows upward.

The **cambium**, a thin layer just beneath the **live bark**, serves as the driving force

behind this growth. Each year, it produces new sapwood on the inner side, and a bit more live bark on the outside.

As they grow, trees sprout branches, which all originate from the stem, now called the **pith**. Branches grow in diameter and length, like the trunk, by adding new cells each season. Slice through the base of the branch at the trunk, and you'll see the telltale remnants of a branch: a **knot**.

Once enough layers accumulate, they show up as **growth rings**, seen in the drawing on *page 74*, and the photo, *above*. In some species, the rings are readily visible. In others, they are difficult to see. This depends, to a large degree, on the types of cells the tree contains, as well as and how they're distributed. Read "An up-close look at wood cells" *below*, to learn more about wood structure.

An up-close look at wood cells

Hardwoods and softwoods share similar cellular makeup, as shown *below right*. Softwoods are simpler, containing two major cell types; hardwoods have four.

In both types of trees, the old analogy of wood as a bundle of straws glued together remains reasonably accurate. Most cells, though, aren't continuous tubes. They have sealed ends.

In softwoods, about 95 percent of cells are **tracheids** (commonly called **fibers**) that are aligned vertically. They carry liquids (sap) through the tree and offer structural support. Horizontally arranged **rays** (the other 5 percent of cells) radiate out from the pith like spokes in a wheel. Rays transfer and store nutrients in the sapwood. In softwoods, rays are usually small and difficult to see.

All of these cells are stuck together by a glue-like substance called lignin.

Hardwoods also contain tracheids and rays. The rays are often larger than those in softwood, and are grouped in bigger bundles, making them readily visible, especially in quartersawn stock, as shown *above right*. Some hardwoods have **vertical parenchyma** cells that are similar to rays, but run up and down.

Hardwoods also feature specialized cells called **vessels** that transport sap. These vessels lose their ends as they form, creating continuous ducts. Looking at a hardwood board in end view, you often can see the open ends of the vessels, which are commonly called **pores**.

Because of this, hardwoods are referred to as "porous" woods. If the

vessel diameters differ greatly in the earlywood and latewood, then the wood is classified as ring porous. Examples include oak, ash, and elm. If, on the other hand, the vessels are uniform in the earlywood and latewood, then the wood is dubbed diffuse porous. Maple, poplar, mahogany, and cherry fall into this category. (A few woods, such as walnut, bridge the gap and are called semi-ring porous.)



Ray cells radiate outward from the tree's center, so they only show up clearly in quartersawn stock. White oak (shown here), red oak, and sycamore are renowned for the distinct "ray fleck" figure that quartersawing exposes.

Hardwood at 100 times magnification

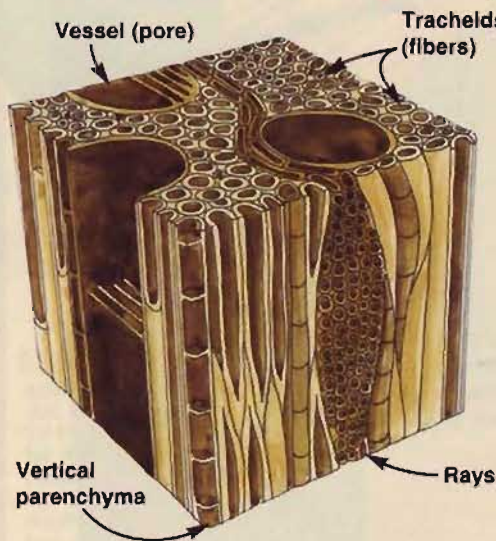

Softwood at 100 times magnification

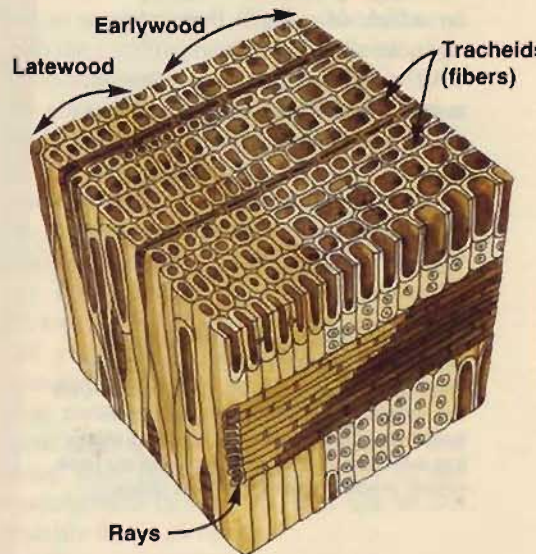

When magnified, "solid" wood shows its true nature: separate fibers joined together. A 1x1" cube may contain as many as 5,000,000 individual fibers.



Both southern yellow pine, above, and red oak, right, produce distinctive rings. In the pine, the latewood appears darker. In oak, the opposite holds true. These woods can prove challenging to machine consistently and stain evenly.

Basswood, above, and ponderosa pine, right, don't have distinct grain lines because their earlywood and latewood cells grow in similar densities.

Ponderosa pine

Growth rings are visible because, in temperate climates, trees grow in an annual cycle. In spring and early summer, the tree produces **earlywood**. From then through fall, the tree makes **latewood**. These two layers form one growth ring.

In some trees, the cells in earlywood and latewood are distinctly different in diameter, wall thickness, and distribution, as seen, *above left*. These woods have very visible growth rings that yield distinct figure when sawn into boards.

Earlywood and latewood cells in other tree species are similar in size and shape, as seen *above right*, resulting in woods that have less-distinct grain figure. Examples include such woods as maple, basswood, poplar, and ponderosa pine.

How rings influence the way wood looks

Why are growth rings important? They matter because slicing a log into lumber through the rings creates patterns on the wood that we call grain figure. And figure stands as one of the most important determiners of wood's beauty. What the resulting figure looks like depends on which of a log's three planes, *right*, we slice through.

As woodworkers know, though, many more types of figure exist than shown in this sample. Figure can form wild patterns that play with the light, creating highly desirable boards. (Read "Fanciful figures," *far right*, to learn more.)

Milling a log to expose the radial surface on the face produces a board with quartersawn figure. One that shows the tangential surface on the face is said to be flatsawn. Crosscutting the log exposes the cross-sectional surface, which woodworkers call end grain.

3 planes of a board

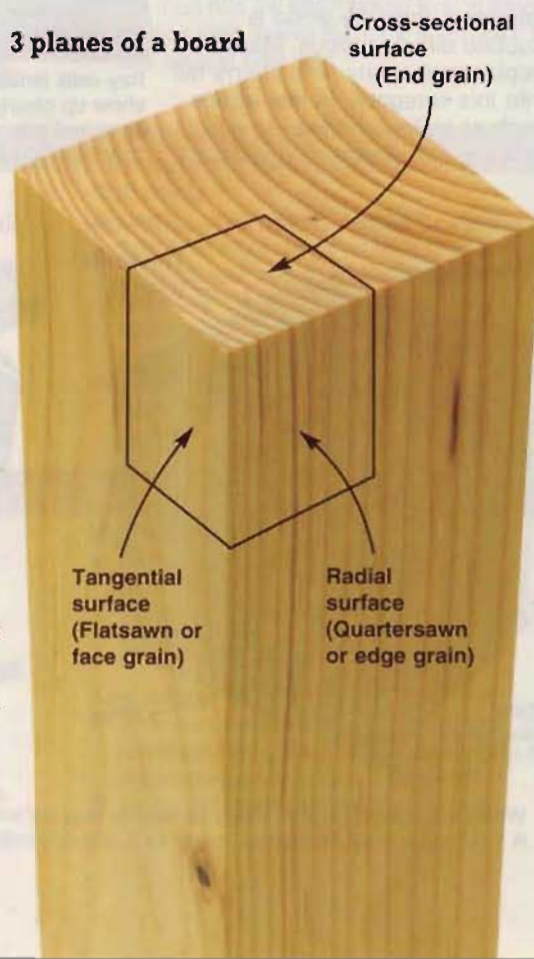

Knots are remnants of branches. While the branch lives, its growth rings are intergrown with those in the trunk. These knots remain firmly attached. When a limb dies but doesn't fall off, growth layers encase it, producing a loose knot. You'll see bark or dark lines surrounding these loose knots. If a branch breaks off, new growth layers eventually cover the wound, but a knot remains behind.

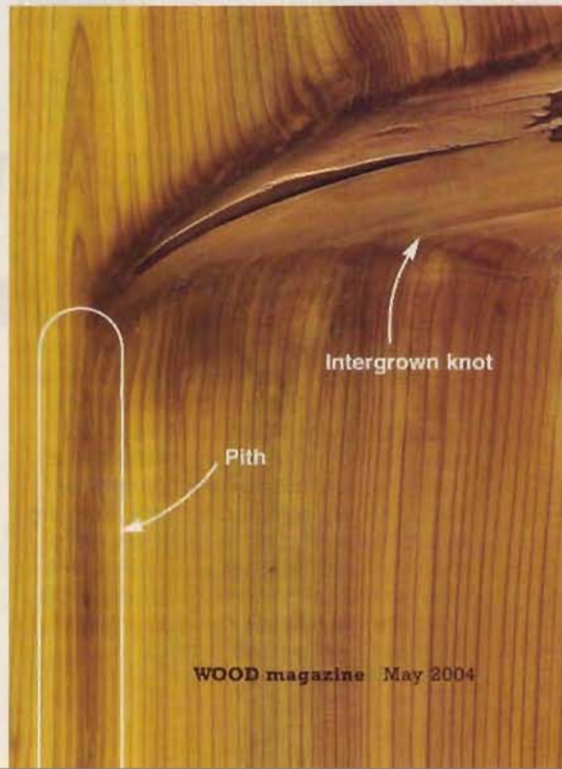

The color connection: heartwood vs. sapwood

As growth rings form around the outside perimeter of a tree, they produce **sapwood**. This outer layer, which often sets itself apart with a white to light tan color, varies in thickness among species. It carries sap (water plus any minerals present in the soil) from the roots up to the leaves. Sugars produced in the leaves flow back down through the live bark to feed the cambium.

Cells residing in the tree's inner layers die as sapwood layers accumulate. At this time, they become **heartwood**, which provides structural support for the tree. During this process, the cell walls take on materials called extractives. Tints in the extractives give many woods, especially hardwoods, their distinctive colors.

Woodworkers value heartwood in most species because of its color and greater natural durability. Some exceptions exist, though. Most prefer the appearance of the consistently light-colored sapwood found in

both maple and poplar, for example, over the darker heartwood.

Extractives in some species add more than color. Those in cedar and redwood make the heartwood resist decay. This explains why the sapwood rots more quickly in these popular outdoor woods.

Heartwood cells often resist the absorption of liquids better than sapwood, too, because the extractives block the tiny pits in cell walls that normally allow liquid movement. As a result, makers of treated lumber for outdoor use choose woods with a high percentage of sapwood, such as southern yellow pine. The sapwood accepts the chemicals and the heartwood does not. So, in this man-altered wood product, the heartwood becomes more susceptible to decay than the sapwood.

The moral of the story: Avoid treated boards with heartwood, especially if those boards will be in contact with the ground.

The transition to heartwood brings other changes to wood cells. As the extractives fill the cell walls, they often become harder and make the heartwood more durable.

In some species, bubble-like membranes called tyloses form in the vessels. These block the flow of water through the vessels. White oak, for example, contains these structures that suit the wood well for crafting wine barrels that won't leak.

Now that you know why wood looks the way it does, you'll be better equipped to find lumber with the right appearance for your next project. Of course, great stock needs more than good looks. In the next issue we'll examine the next key to understanding wood: moisture. While critical to sustaining a tree's life, if not controlled or removed properly from lumber, moisture spells trouble for woodworking projects. ♣

Written by **David Stone**

Illustrations: **Eric Flynn**; original cell art by Les Jozsa

Fanciful figures

Most wood fibers run vertically, but they don't necessarily grow straight up and down. Sometimes, they take on a wavy pattern, twist together (interlock), or spiral.

Combinations of these variables produce intriguing grain lines and cause uneven light reflection. Woodworkers prize boards bearing these properties, *below*, and refer to them as highly figured.

Wavy grain produces curly figure, sometimes referred to as striped or tiger grain. Violinmakers often use tight curly grain known as fiddleback.

When the fibers form localized swirls, the result becomes bird's eye figure, most commonly exhibited in sugar (hard) maple.

At tree crotches (where branches intersect the trunk), wood fibers become

entangled, yielding figures of many types. Most common among them are patterns called crotch and flame. On occasion, trees develop growths called burls that produce wildly figured grain.

Unfortunately, reading what grain figure exists within a tree trunk proves difficult. But finding out what lies within remains one of the joys of cutting logs into lumber.





dolphins-at-play kid's room ensemble

Dress up a child's bedroom or playroom with any one or all of these fanciful accessories. (Note that you can build the chalkboard as a tackboard, too.) The lucky recipient of your handiwork will love showing off his or her favorite awards, pictures, and other prized possessions, and the parents will certainly

appreciate the storage and organization these pieces bring to youthful spaces.

Each project is designed with simple screw-and-plug joinery and routed edge profiles made with common bits so you'll be able to turn out the whole set in a weekend. That's a promise. To help speed things along, see the **Shop Tip**, below.



SHOP TIP

Organize your work to save time

Looking over the drawings for the three pieces of this set, you'll find some of the same machining operations repeated in each one. For example, all the parts A have routed coves, all the parts B have round-overs, and parts B and C in the shelf and chalkboard/tackboard have rabbets along their edges. To save time when making all three projects, avoid repeat setups by first cutting all the parts to size. Keep track of them by labeling their ends, as shown at *right*. (We labeled ours CR for the clothes rack, WS for the wall-hung shelf, and CB for the chalkboard/tackboard, followed by the part letter, -A, -B, etc.) Then select the parts with the same machining operations from each pile, and process them together.



Four-peg clothes rack

1 Cut the top (A) and rails (B) to the sizes listed in the **Materials List**. Chuck a $\frac{3}{8}$ " cove bit in your table-mounted router, and rout the ends and front edge of the top, where shown on **Drawing 1**. Change to a $\frac{1}{4}$ " round-over bit, and rout one edge of the upper rail and two edges of the lower rail, where shown. Then drill $\frac{1}{2}$ " holes for the Shaker pegs in the lower rail.

2 Cut the sides (C) to size. Make two copies of the side on the **WOOD Patterns** insert, and adhere them to the sides

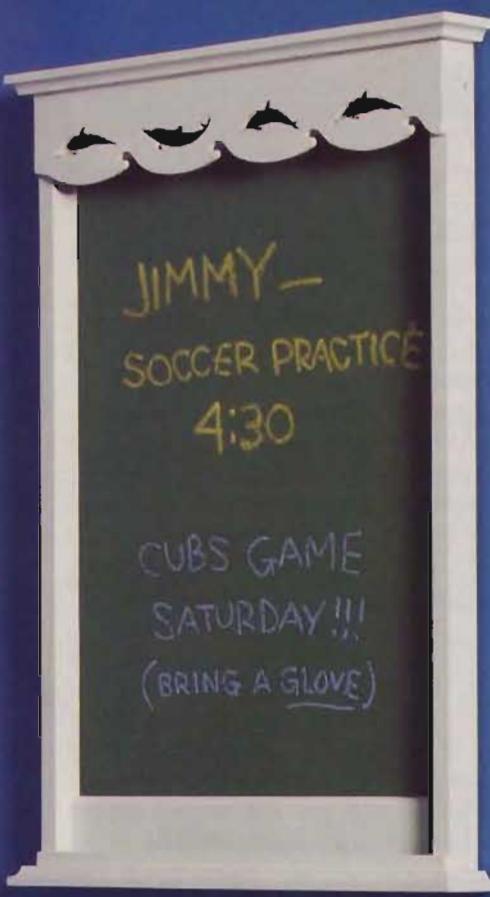

Using the same plans and instructions, you can build the chalkboard shown above, or the tackboard shown on page 81. Or build one of each.

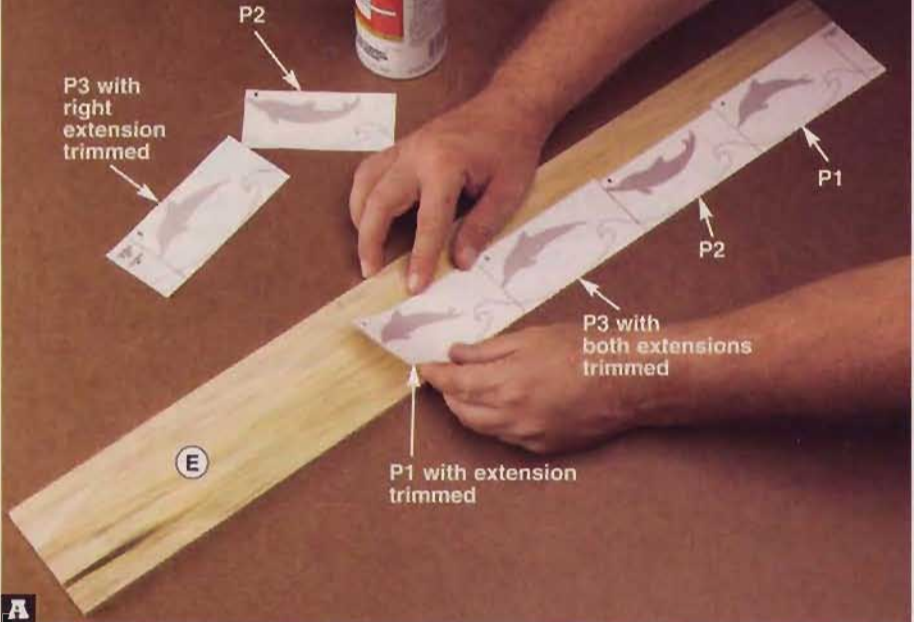

A Apply the patterns to the frieze (E) in the following order: P1, P2, P3 with both extensions trimmed, P1 with its extension trimmed, P2, P3 with its right extension trimmed.

sides (C). Make certain the cleat does not bow in or out.
5 Plug all the counterbores with short pieces of $\frac{3}{8}$ " dowel. To do this, place glue in the counterbore and tap in the end of the dowel. Use a handsaw to trim the dowel slightly above the surface, and then sand it flush. Fill any imperfections with wood filler and when dry, sand it smooth. Glue the Shaker pegs in place.

6 Resaw and plane stock to $\frac{1}{4}$ " thick, and cut the frieze (E) to size. Then make two copies of each of the dolphin-and-wave patterns P1, P2, and P3. Starting from the right end of the frieze and aligning the patterns with its bottom edge, trim the patterns and apply them with spray adhesive, as shown in **Photo A**. Drill a $\frac{1}{8}$ " start hole in each dolphin, and using a #2R blade, scrollsaw the cutouts. Remove the patterns, and finish-sand the frieze. Now glue and clamp it to the sides (C) and cleat (D).

with spray adhesive. Drill the counterbored screw holes where indicated on the pattern. The sides are mirror images, so you'll transfer the counterbored hole locations on one of the sides to the face *without* the pattern. Scrollsaw or bandsaw, and then sand the sides to shape.

3 Finish-sand the parts. Now clamp the rails (B) between the sides (C). Using the holes in the sides as guides, drill pilot holes into the rails, and drive the screws. Then clamp the top (A) in place, flush with the back edges of the sides and centered side-to-side. Drill counterbored screw holes, and drive the screws.

4 Cut the cleat (D) to size, and finish-sand it. Glue and clamp the cleat to the top (A) with its front face flush with the front edges of the

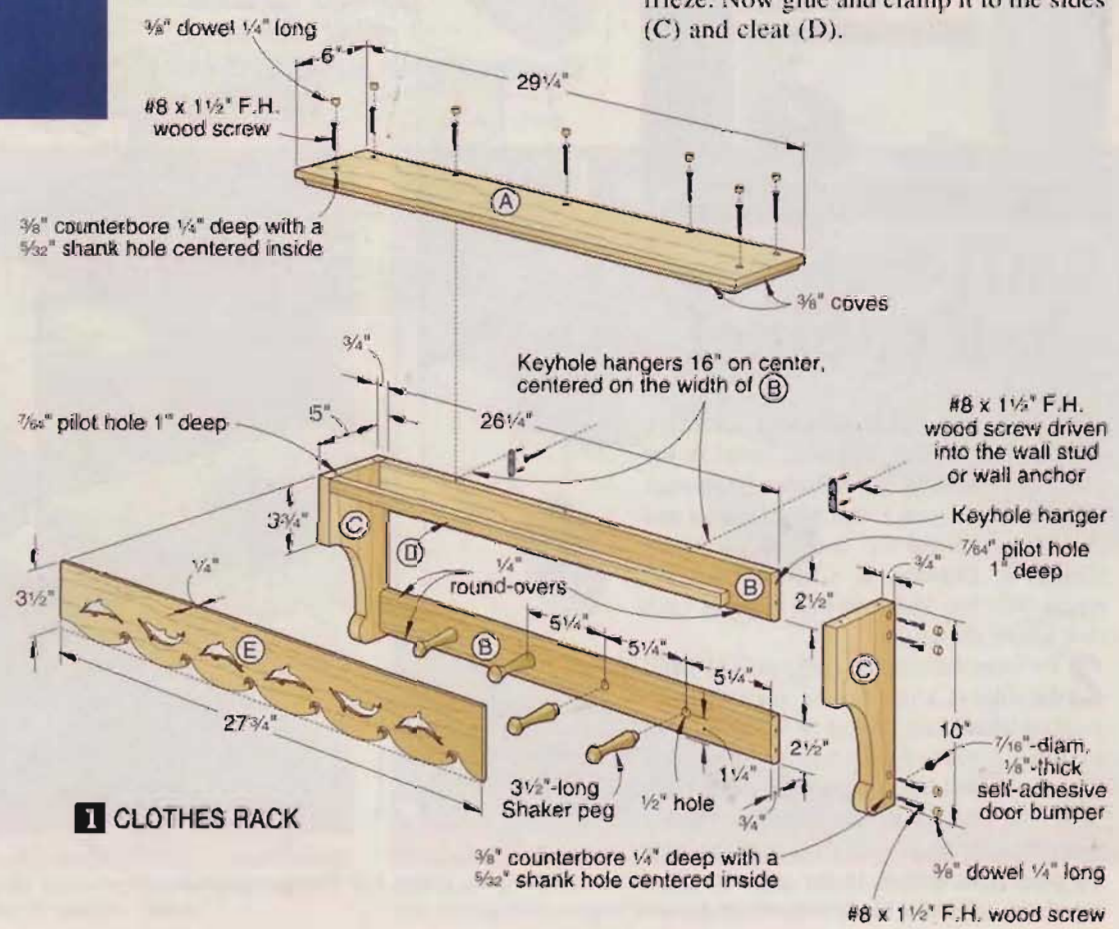

1 CLOTHES RACK

7 Prime and paint the clothes rack. (We used Rust-Oleum Painter's Touch sandable white primer, and topcoated with Rust-Oleum Painter's Touch flat white.)

8 With the paint dry, drill pilot holes, and screw a pair of keyhole hangers to the back of the upper rail (B), where shown on **Drawing 1**. Stick a pair of self-

adhesive bumpers to the back edges of the sides (C), where shown.

9 To hang the clothes rack, drive two #8x1½" flathead wood screws into wall studs or wall anchors, letting the heads protrude ⅛". Make sure the screws are exactly 16" apart and level. Position the rack with the keyhole hangers over the screwheads, and slide it down onto them.

Cutting Diagram

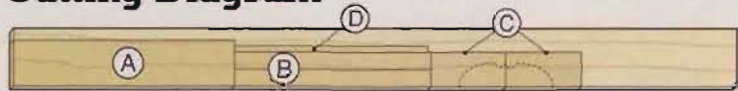

¾ x 7¼ x 96" Poplar (5.3 bd. ft.)



¾ x 5½ x 36" Poplar (1.5 bd. ft.)

*Plane or resaw to the thickness listed in the Materials List.

Materials List

Clothes rack	FINISHED SIZE			Matl. Qty.
	T	W	L	
A top	¾"	6"	29½"	P 1
B rails	¾"	2½"	26¼"	P 2
C sides	¾"	5"	10"	P 2
D cleat	¾"	¾"	26¼"	P 1
E frieze	¾"	3½"	27¼"	P 1

Material key: P—poplar.

Supplies: #8x1½" flathead wood screws, ⅜" dowel, spray adhesive.

Blades and bits: ¼" round-over and ⅜" cove router bits, #2R scrollsaw blades.

Sources

Hardware. Shaker pegs no. 04E51, \$3.50 for a package of 10; single-hole keyhole hangers no. 125505, \$99 for a package of two; self-adhesive door bumpers no. 02S82, \$6.50 for a sheet of 56. Woodcraft. Call 800/225-1153, or go to www.woodcraft.com.



Wall-hung shelf cabinet

1 Cut the top and bottom (A), rails (B), and sides (C) to the sizes listed in the **Materials List**. Chuck a ⅜" cove bit in your table-mounted router, and rout the ends and front edges of the top and bottom, where shown on **Drawing 2**. Change to a ¼" round-over bit, and rout one edge of each rail, where shown.

2 To form the rabbets in the rails (B) and the sides (C), install a ¼" dado blade in your tablesaw, and raise it to ⅜". Attach an auxiliary fence to the rip fence and position it so the dado blade just grazes its surface. Now cut rabbets in the rails by passing them over the blade with their backs against the fence. Cut rabbets in the sides by passing them over the blade with their inside

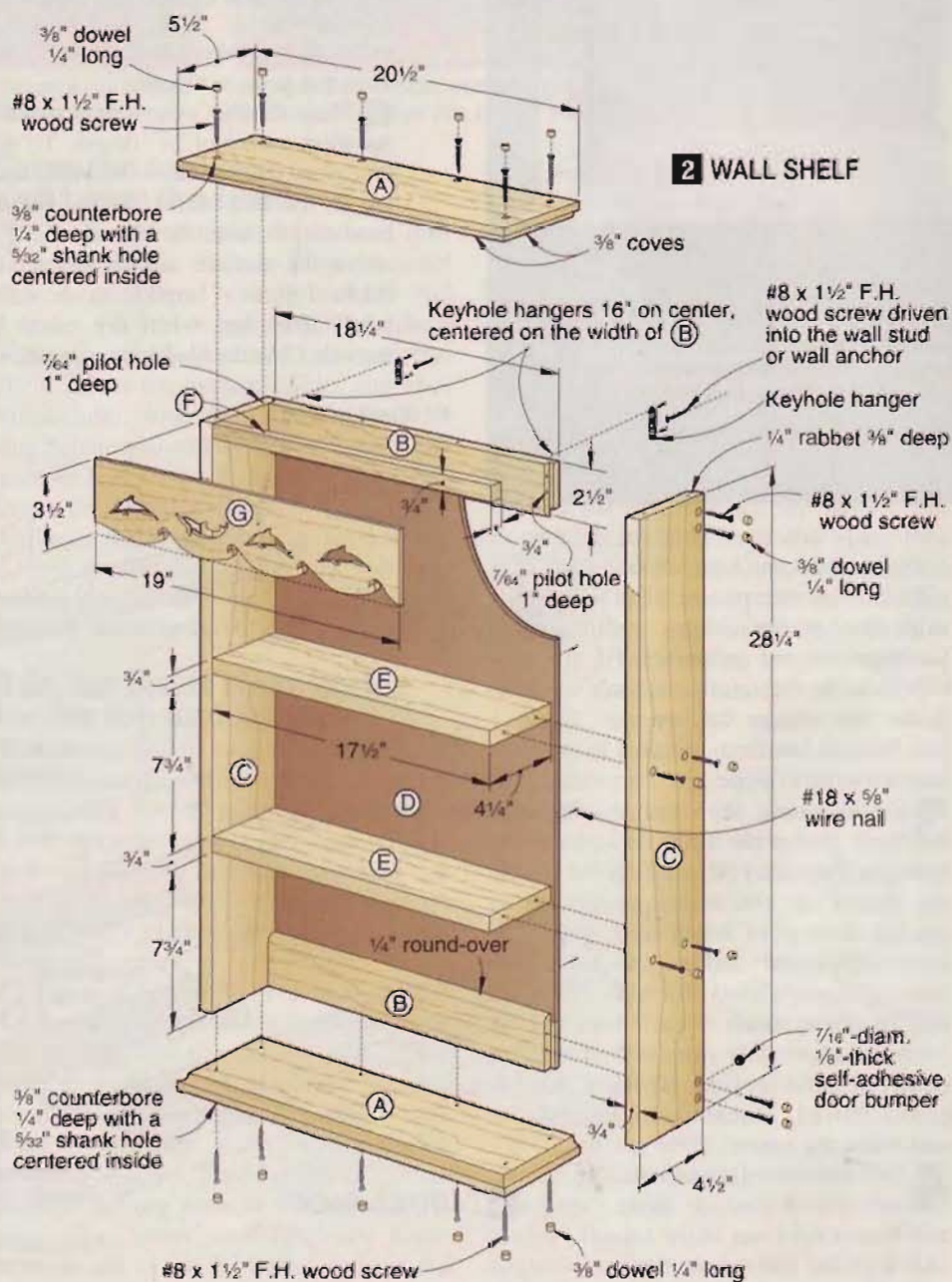

2 WALL SHELF

2a WALL SHELF RAIL DETAIL

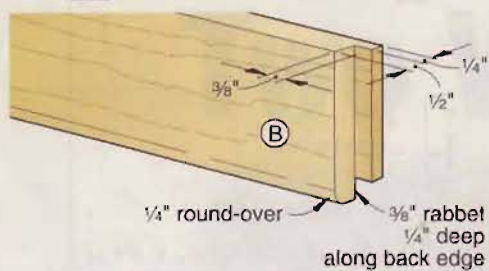

faces against the table. Then cut $\frac{3}{8}$ " rabbets $\frac{1}{2}$ " deep on the ends of the rails, where shown on **Drawing 2a**, forming $\frac{1}{4}$ " tongues $\frac{3}{8}$ " long to fit in the side rabbets.

3 Finish-sand the parts. Now clamp the rails (B) between the sides (C). Drill counterbored screw holes through the sides and into the rails, and drive the screws. Then clamp the top and bottom (A) in place, flush with the back edges of the sides and centered side-to-side. Drill counterbored screw holes, and drive the screws.

4 Cut a piece of $\frac{1}{4}$ " tempered hardboard to size for the back (D), and glue and nail it in place.

5 Cut the shelves (E) to size and finish-sand them. Then install the shelves, as shown in **Photo B**. Drive nails through the back (D) and into the shelves.

6 Cut the cleat (F) to size and finish-sand it. Glue and clamp the cleat to the top (A) with its front face flush with the front edges of the sides (C).

7 Plug and fill the counterbores as directed in **Step 5** of the clothes rack on page 79.

8 Resaw and plane stock to $\frac{1}{4}$ " thick, and cut the frieze (G) to size. Then make one copy each of the dolphin-and-wave patterns P1 and P2, and two copies of P3.

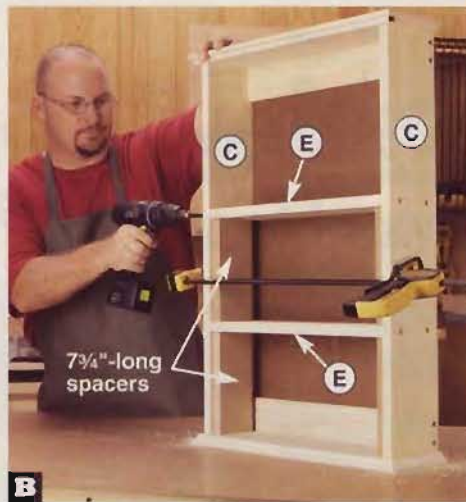

B Inserting $7\frac{3}{4}$ "-long scrap spacers, position the shelves (E) between the sides (C). Drill counterbored screw holes centered on the shelves' thickness, and drive the screws.

Materials List

Shelf cabinet	FINISHED SIZE			Mtl.	Qty.
	T	W	L		
A top and bottom	$\frac{3}{4}$ "	$5\frac{1}{2}$ "	$20\frac{1}{2}$ "	P	2
B rails	$\frac{3}{4}$ "	$2\frac{1}{2}$ "	$18\frac{1}{4}$ "	P	2
C sides	$\frac{3}{4}$ "	$4\frac{1}{2}$ "	$28\frac{1}{4}$ "	P	2
D back	$\frac{1}{4}$ "	$18\frac{1}{4}$ "	24"	H	1
E shelves	$\frac{3}{4}$ "	$4\frac{1}{4}$ "	$17\frac{1}{2}$ "	P	2
F cleat	$\frac{3}{4}$ "	$\frac{3}{4}$ "	$17\frac{1}{2}$ "	P	1
G frieze	$\frac{1}{4}$ "	$3\frac{1}{2}$ "	19"	P	1

Materials key: P—poplar, H—tempered hardboard.

Supplies: #8x $1\frac{1}{2}$ " flathead wood screws, #18x $\frac{3}{8}$ " wire nails, $\frac{3}{8}$ " dowel, spray adhesive.

Blades and bits: $\frac{1}{4}$ " round-over and $\frac{3}{8}$ " cove router bits, stack dado set, #2R scrollsaw blades.

Sources

Hardware. Single-hole keyhole hangers no. 125505, \$.99 for a package of two; self-adhesive door bumpers no. 02S82, \$6.50 for a sheet of 56. Woodcraft. Call 800/225-1153, or go to www.woodcraft.com.

Cutting Diagram

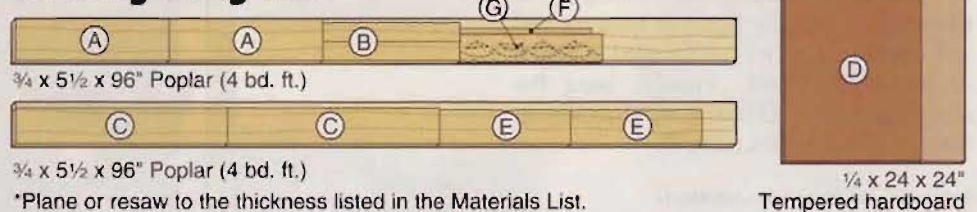

$\frac{3}{4}$ x $5\frac{1}{2}$ x 96" Poplar (4 bd. ft.)

$\frac{3}{4}$ x $5\frac{1}{2}$ x 96" Poplar (4 bd. ft.)

*Plane or resaw to the thickness listed in the Materials List.

$\frac{1}{4}$ x 24 x 24" Tempered hardboard

Starting from the right end of the frieze and aligning the patterns with its bottom edge, apply the patterns to the frieze in the following order: P3 with the left extension trimmed, P1 with its extension trimmed, P2, and P3 with its right extension trimmed. Drill a $\frac{1}{8}$ " start hole in each dolphin, and using a #2R blade, scrollsaw the cutouts. Remove the patterns, and finish-sand the

frieze. Now glue and clamp it to the sides (C) and cleat (F).

9 Prime and paint the shelf as directed in **Step 7** of the clothes rack on page 80. Then referring to **Drawing 2**, add the keyhole hangers and self-adhesive bumpers, as directed in **Step 8** of the clothes rack. Finally, hang the shelf on the wall as directed in **Step 9** of the clothes rack.



A simple modification turns the chalkboard into a cork-surfaced tackboard.

Chalkboard/tackboard

1 Cut the top and bottom (A), rails (B), and sides (C) to the sizes listed in the **Materials List**. Chuck a $\frac{3}{8}$ " cove bit in your table-mounted router, and rout the ends and front edges of the top and bottom, where shown on **Drawing 3**. Change to a $\frac{1}{4}$ " round-over bit, and rout the edges of the rails, where shown.

2 To house the chalkboard, cut rabbets along the back edges of the rails (B) and sides (C), as directed in **Step 2** of the wall-hung shelf on page 80. To house the tackboard, cut the rail and side rabbets in the same manner, but use a $\frac{1}{2}$ " dado blade. Then for the chalkboard, rabbet the ends of the rails, where shown on **Drawing 2a**, forming $\frac{1}{4}$ " tongues $\frac{3}{8}$ " long to fit in the sides' rabbets. For the tackboard, cut rab-

bets where shown on **Drawing 3a**, forming $\frac{1}{2}$ " tongues $\frac{3}{8}$ " long.

3 Finish-sand the parts. Now clamp the rails (B) between the sides (C). Drill counterbored screw holes through the sides and into the rails, and drive the screws. Then clamp the top and bottom (A) in place, flush with the back edges of the sides and centered side-to-side. Drill counterbored screw holes, and drive the screws.

4 Cut the cleat (D) and the lip (E) to size and finish-sand them. Glue and clamp the cleat to the top (A) with its front face flush with the front edges of the sides (C). Glue and clamp the lip to the bottom (A) and the front edges of the sides (C). Make sure parts D and E do not bow in or out.

5 Plug and fill the counterbores as directed in **Step 5** of the clothes rack on page 79.

6 Resaw and plane stock to 1/4" thick, and cut the frieze (F) to size. Then follow the instructions for copying, adhering, and scrollsawing the dolphin patterns in **Step 8** of the wall shelf on page 81. Remove the patterns, and finish-sand the frieze. Now glue and clamp it to the sides (C) and cleat (D).

7 Cut the back (G) to size. To make the chalkboard, paint the back with chalkboard paint. (We used Rust-Oleum Painter's Touch green aerosol chalkboard finish, following the directions on the can.) To make the tackboard, adhere self-adhesive 1/4"-thick sheet cork to the back.

8 Prime and paint the frame, as directed in **Step 7** of the clothes rack on page 80. With the paint dry, install the chalkboard or tackboard, nailing it in place. Now add the keyhole hangers and self-adhesive bumpers, as directed in **Step 8** of the clothes rack. Finally, hang the chalkboard or tackboard as directed in **Step 9** of the clothes rack. 🐿

Written by **Jan Svec** with **Jeff Mertz**
Project design: **Kevin Boyle**
Illustrations: **Mike Mittermeier**

Materials List

Chalk/tackboard	FINISHED SIZE			Matl.	Qty.
	T	W	L		
A top and bottom	3/4"	2 1/2"	20 1/2"	P	2
B rails	3/4"	2 1/2"	18 1/4"	P	2
C sides	3/4"	1 1/2"	28 1/4"	P	2
D cleat	3/4"	3/4"	17 1/2"	P	1
E lip	1/4"	1/2"	19"	P	1
F frieze	1/4"	3 1/2"	19"	P	1
G back	1/4"	18 1/4"	24"	H	1

Materials key: P—poplar, H—tempered hardboard.

Supplies: #8x1 1/2" flathead wood screws, 3/8" dowel, #18x3/8" wire nails for the chalkboard or #17x1" wire nails for the tackboard, spray adhesive.

Blades and bits: 1/4" round-over and 3/8" cove router bits, stack dado set, #2R scrollsaw blades.

Sources

Hardware. Single-hole keyhole hangers no. 125505, \$.99 for a package of two; self-adhesive door bumpers no. 02S82, \$6.50 for a sheet of 56. Woodcraft. Call 800/225-1153, or go to www.woodcraft.com.

Cork. 24x36" self-adhesive cork sheet 6mm (approx. 1/4") thick, \$14.90. The Corkstore. Call 800/959-0995 or go to www.corkstore.com. Under Product Listing, click Cork Rolls and Sheets, and then click PSA-Backed Composition Cork Sheets.

Cutting Diagram

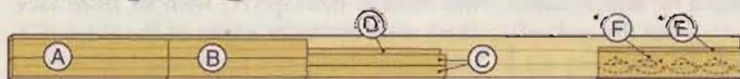

3/4 x 5 1/2 x 96" Poplar (4 bd. ft.)

*Plane or resaw to the thickness listed in the Materials List.

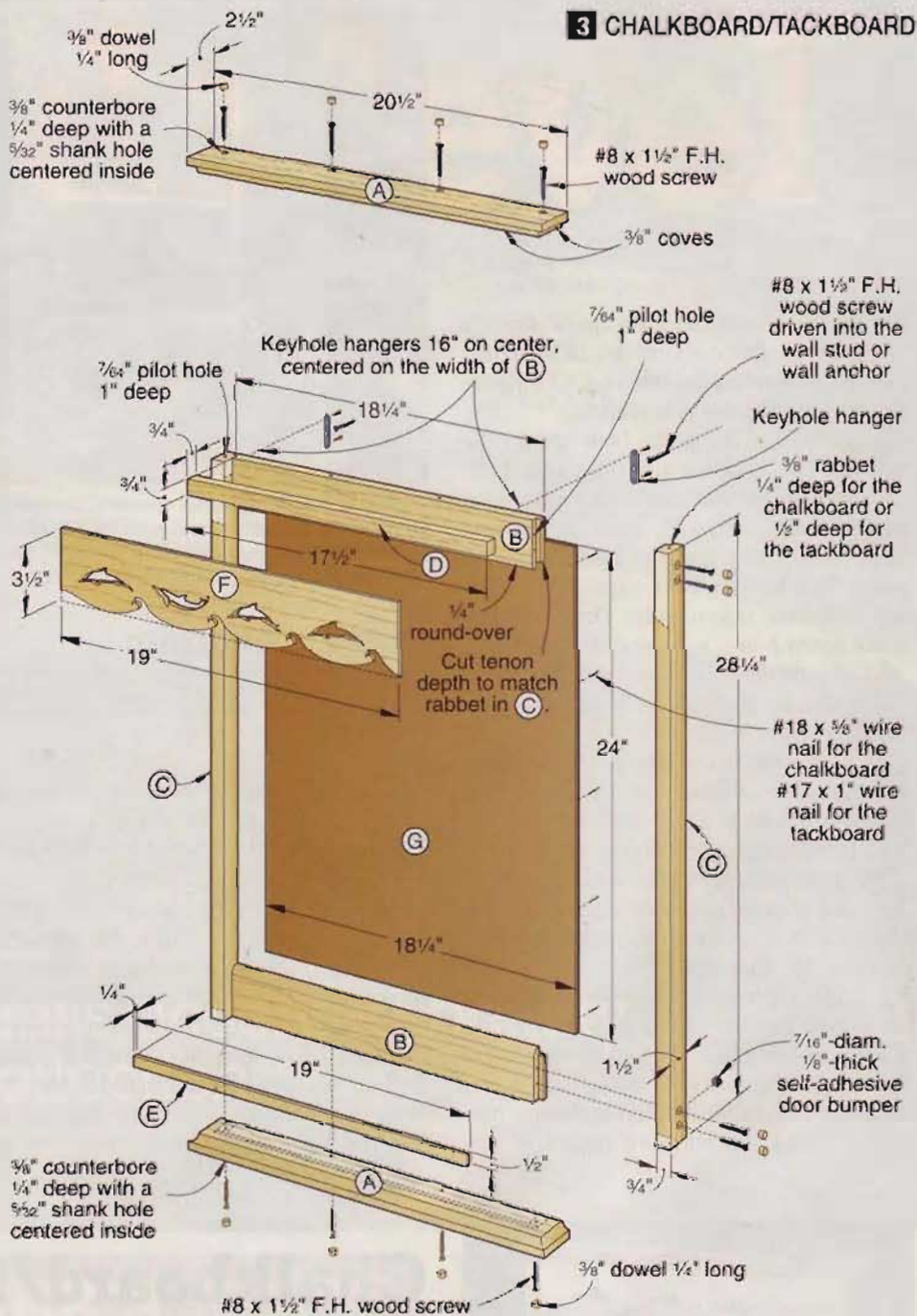

3 CHALKBOARD/TACKBOARD

3a TACKBOARD RAIL DETAIL

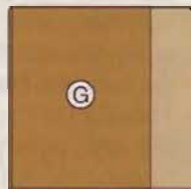
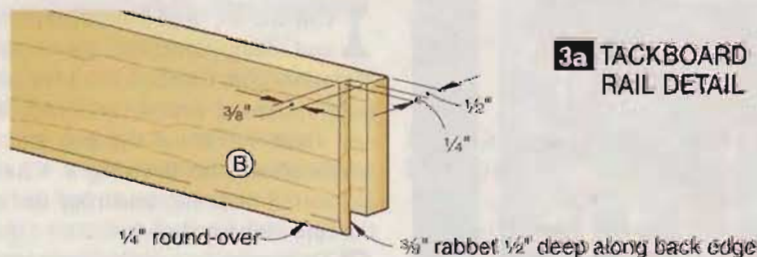

1/4 x 24 x 24" Tempered hardboard

Find more great projects for kids at woodmagazine.com/kids



workshop revival

Innovative shop teachers are fighting for programs to teach the next generation of woodworkers. Here's what they're up to, and what you can do to help.

As schools face budget shortfalls, they're often forced to eliminate "nonessential" classes and programs. As a result, saws fall silent, shop doors get padlocked, and a generation of students lose the opportunity so many of us once took for granted—discovering the joys of working with wood. Yet evidence exists

for resurrecting woodworking in schools and proving that these programs remain vital to providing a well-rounded education.

Where's the proof? We sought out successful high school woodworking programs around the nation, and we gladly report that many don't just survive, they thrive. Here, we'll share the stories of a few.

If you're a teacher, listen to what these educators have to say. Even if you're not, you'll want to pass their counsel on to your local schools. There are other ways you can ensure the survival of woodworking programs, as well. (See "Here's how YOU can help." page 86)

Unstoppable shops keep going, and going, and...

Moffat County High, Craig, Colorado

Back in 1985, the town of Craig, Colorado, almost lost its woodworking program due to lack of funding. Then part-time teacher Craig Conrad stepped in, turning the program into a huge success and a full-time job. By 1996, when we wrote about Craig in issue 89, he had transformed the program by developing what he calls "unstoppable shops." The system still thrives today and can be put into action anywhere.

The idea behind unstoppable shops is simple: If the program needs funding, raise it. To do so, students mass produce and sell a product every year. They run the whole affair as a business by keeping the books, marketing their wares, and fulfilling orders. Their reward? The students keep 75 percent of sales profits, and the shop program gets 25 percent. With hundreds of projects sold each year, that money funds some serious equipment, *center right*.

Students also conduct an annual "Santa's Workshop," producing toys for local kids. Then they remake the shop into the North Pole for a day when they give away the toys.

If the thought of a paycheck and practical business experience weren't enough to attract students, Craig's recruiting techniques alone, *below right*, would make his shop classes tough to resist. Craig even teaches "woodworking for scaredy-cats," a course designed to draw girls, plus boys who might be intimidated by more-experienced classmates.

The unstoppable shops program has worked so well that Craig began sharing his information with other teachers, and even conducts seminars to help spread the gospel of unstoppable shops to woodworking teachers from around the country. To receive information on how to make your shop, or one in your area, unstoppable, send a self-addressed, stamped envelope to: Craig Conrad, Moffat County High School, 900 Finley Lane, Craig, CO 81625.



Students raised enough money with profits from one of their project sales to buy this \$3,900 radial-arm saw for their shop.



"Got Wood" posters attract new kids by showing current students with their projects and other cool hobbies. Shirts and certificates reward excellence.

Students and shop teachers unite to achieve excellence.

Pinkerton Academy, Derry, New Hampshire

As a winner in our mentoring competition (issue 153), we knew Jack Grube had a knack for inspiring students. His regional high school offers half a dozen woodworking courses at four levels, and fills them all to capacity each year. In fact, Jack has to turn away interested students, even though his courses accommodate 320 kids!

To bring in so many students, Jack works hard at recruiting kids who might not normally consider enrolling in "career and technology education" classes (the modern term for vocational courses). For example, he structured one of his introductory-level courses, Woodworking Design and Creation, to fulfill an art-education requirement necessary for graduation. Students who take this course often come back for advanced-level courses once they discover wood as an interesting medium for their artistic abilities.

Though Jack knows most of his students will more likely grow into hobbyists and not professional woodworkers, he also teaches The Business of Woodworking.

In this class, students learn the basics of small business operation. Jack's kids undertake local service projects as well that teach them the high value of community involvement.

Jack remains dedicated to the business of teaching shop, too, and demonstrates his passion for woodworking education beyond the bounds of his school. In 2001, he started the New England Association of Woodworking Teachers, with the hope of getting a dozen colleagues together for brainstorming. Now the association boasts 100 members in 60 schools. Currently, Jack wants to find or help establish similar groups in other areas.



Jack Grube brings in woodworkers with special skills, such as Peter LeClair, a member of a local carving club, to mentor his students and expand their woodworking knowledge.

If you're interested, drop him an e-mail at jackgrube@aol.com. He'd love to help you or the schools in your area.

Letting students chart the course.

Jefferson Township High, Hopatcong, New Jersey

To get students enthused about woodworking, Rolf Warncke lets them create the curriculum by deciding what projects they want to build. And the students come up with some ambitious projects, ranging from traditional chests and tables to elaborate computer and entertainment centers.

Most often, Rolf helps the kids develop original designs by working with them on concept illustrations and simple plans drawn up on graph paper. He then caters his teaching to the techniques and joinery required by the projects.

So, does this strategy work? You bet! In a school of 1,000 students, a full 10 percent pass through the four levels of woodworking offered. And those kids share their interest with others, putting woodworking courses in high demand and, consequently, in high esteem within the district. In addition to creating beautiful projects and acquiring new skills, Rolf's students get the chance to show off their abilities by displaying their work at the school and at local and regional exhibitions of high-school art and technology projects.



Students acquire woodworking skills and learn the benefits of cooperation by working together to build the projects they design.

Producing top-flight projects and award-winning woodworkers.

Cedar Ridge High School, Hillsborough, North Carolina

If you need more proof that kids are capable of amazing woodworking feats, look no farther than Keith Yow's shop at Cedar Ridge High School. Year after year, his students produce awe-inspiring original designs that rival professional furniture-makers. And they consistently win awards from a prestigious annual student-design competition—sponsored by the Association of Woodworking and Furnishings Suppliers (AWFS)—that highlights top talent among high-school and collegiate woodworkers around the nation. Students who make the final round of judging travel with their projects to the competition, which is held in conjunction with one of the nation's largest woodworking-equipment trade shows.

In 2003 alone, young men and women from Cedar Ridge took away multiple awards, including several first place, honorable mention, and finalist designations. One student, Ashley Nicole Hilton, earned the People's Choice Award, besting 49 other entries from high-school and college woodworkers. (See issue 153, page 22).

How does Keith inspire his students to produce such high-caliber projects? First, he gets excited about woodworking, which rubs off on his students. He also helps them understand all the fields of learning that woodworking involves, such as physics, applied mathematics, and life sciences. Then, he encourages students to grow their skills, expand their understanding, and reach for goals they might not initially expect to achieve.

With these kinds of successes, it might seem easy for Keith to keep his shop program alive. But he doesn't take any chances. He constantly promotes his program at school by showing students' projects in the library and other areas. He makes the pro-

Student projects often involve more than just wood, as demonstrated by this finely crafted upholstered chaise.



Cedar Ridge students show their projects in the school and community, and some students, such as these, go on to national competition.

gram visible within his own community, and nationally, by having students enter the AWFS competition.

This exposure helps Keith build relationships with equipment suppliers who may donate tools to the school. He solicits donations locally, too, for money and supplies that help keep his shop running.

Keith strives to continually prove the shop's value to his school district by producing service projects. These include podiums for classrooms, and desks and cabinetry for the school board's reception area.

And, though most of Keith's kids are strictly recreational woodworkers, his program is affiliated with a relatively new national program called WoodLinks. It

partners the woodworking industry with high schools to develop the skilled workforce the furniture industry needs. This helps Keith find additional sources for funding and equipment, and assists such students as Ashley, who aspires to become a professional furnituremaker after college, in making contacts within the industry. You can learn more about the program by visiting www.woodlinks.com.

Finally, Keith recruits good students. That doesn't mean the kids with the highest grades (though valedictorians have passed through his shop), or those who are the most popular in the school. Simply, he looks for folks with creativity, drive, and a desire to learn. You know, woodworkers. ♣

Here's how YOU can help

- **Volunteer:** Spend a few hours each week as a shop assistant at your local school. You can answer students' questions, demonstrate techniques, and monitor safety.
- **Donate:** Many programs can cover the cost of materials but find it hard to scrape up cash for new equipment. If you have extras of anything or if you'd like a nice tax deduction, donate new or used tools to a school in your area.
- **Support:** When you hear of a shop program in danger of closing, don't just wish it weren't so. Attend school board meetings, rally support, and make others see the importance of woodworking programs in schools. Get involved. You'll be glad you did.



With just three years of woodworking experience, Aaron Burns built this walnut china cabinet that earned national honors.

make a splash with a “waterfall” joint

Two quick cuts on the tablesaw are all it takes to create an eye-catching long miter joint, but be prepared—admirers will ask how you did it for years to come.

Careful grain-matching always makes a project look better, and that applies to miter joints too. When you set out to form an edge-joined miter with boards or plywood containing cathedral grain, consider the waterfall joint. It’s quick and easy to make and, as you see in the sample at right, it adds an impressive highlight to your project.

You don’t need to spend much time making a waterfall joint, and the only tool you need is a tablesaw equipped with a combination or rip blade. Bevel-rip two adjacent pieces from one board or sheet, removing only the width of a saw kerf between them, following the cuts shown below. When you assemble the pieces to make the miter joint, using one of the methods shown in the

Matched grain lines cascade over a mitered corner in a waterfall joint.

photos at bottom, match up the grain lines along the joint. The end result is sure to please the eye. ♣

How to bevel-rip a waterfall joint

If you have a piece of stock with cathedral grain that suits the rest of your project, plan your joint line to run through the middle of the best part. Set your tablesaw blade at 45°, and place your workpiece with the joint’s top faces up.

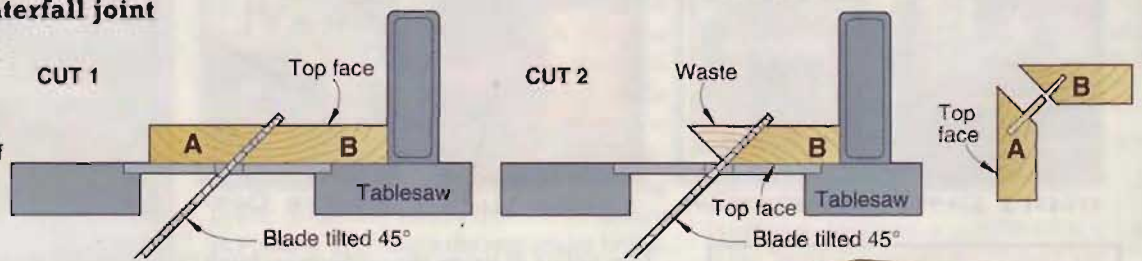

Two ways to reinforce a waterfall joint



Splines

Edge-joined miter joints go together easily with the addition of a spline. Set your tablesaw blade to 45°, and adjust its height to cut approximately 1/2" into the workpiece. Cut a groove in each piece, and then rip a 1/8 x 1 3/16" spline from plywood or hardboard. Crosscut it to the needed length. To assemble the joint, apply glue in the grooves, slide the spline into place, and clamp across the joint in both directions.



Biscuits

Here’s an alternative to spline joinery: If you have a biscuit joiner, set its fence for a 45° cut and form slots as shown on this piece of red oak. Make matching marks on both mating pieces at regular intervals (we used 9" spacing in this case), and set your biscuit joiner to cut slots about 1/4" from the inside face to avoid plunging completely through the workpiece.

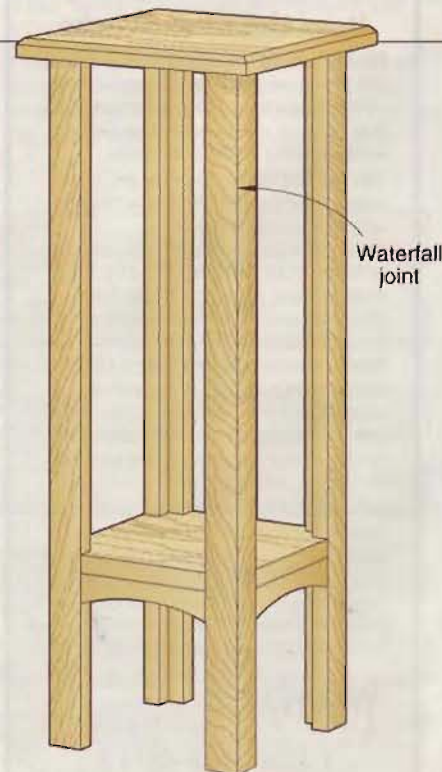

Waterfall joint

shop tips

Helping you work faster, smarter, and safer

Cove-cutting guide is sturdy and secure

Cutting large coves on a tablesaw is simple enough in principle—you set up a diagonal guide and pass the board over the blade. In practice, however, I found that clamping the guide at the correct angle to the blade and the right distance from it took a lot of fiddling and was often not secure. I came up with the jig, shown below, that fastens securely to the saw table and adjusts quickly and easily.

I made the fixture as shown from hardwood and 1/4" Baltic birch plywood for rigidity. The hardwood guide bar fits snugly into the miter-gauge slot and sits in a groove in the fixture base so the T-slot bolts and threaded knobs can clamp the fixture tightly against the saw table.

To use the guide, I draw the cove profile on the end of the stock with a red fine-line marker. I set the blade depth, then, with the stock against the guide fence, I sight along the guide and adjust its position. After tightening the knobs to lock the guide in position, I'm ready to cut.

—Barrie L. Leeser, Whitehall, Pa.

FENCE CROSS SECTION

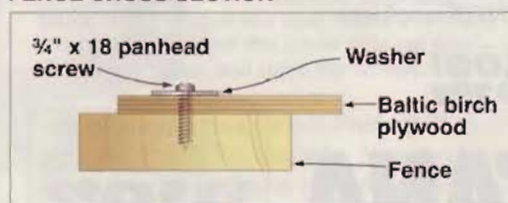

top shop tip

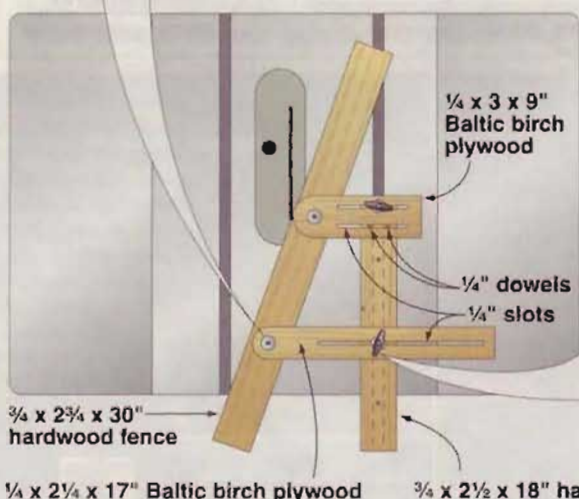

GUIDE CROSS SECTION

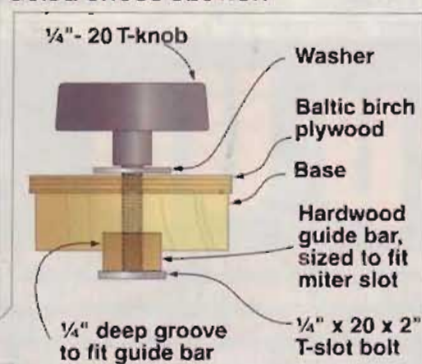

Our Winner



Top Shop Tip winner Barrie Leeser was

working in the kitchen when he came up with his prize-winning cove-cutting fixture (shown in the photo above). He wasn't cooking, though: He was remodeling. Irked by makeshift guides, Barrie came up with a better way, described at left. His fixture helped him finish the kitchen job and he has since used it to make moldings for other projects, including a stereo cabinet.



Barrie Leeser's Top Shop Tip earns him a Mast-R-Lift router lift (router and bit not included) from JessEm Tools. Thanks, Barrie!

Top tips win tools!

Describe how you've solved a workshop dilemma, and you'll earn \$75 if it appears here. And, if your tip earns Top Shop Tip honors, you'll also win a tool prize worth at least \$250.

Send your best tips, along with photos or illustrations and your daytime telephone number, to: **Shop Tips, WOOD® Magazine, 1716 Locust St., GA-310, Des Moines, IA 50309-3023.** Or e-mail tips to: shoptips@woodmagazine.com. Remember to include your contact info in the e-mail as well.

Because we try to publish only original tips, please send your tips only to WOOD magazine. Sorry: submitted materials can't be returned.

Continued on page 94

Router Bits and Shaper Cutters

WOODLINE USA

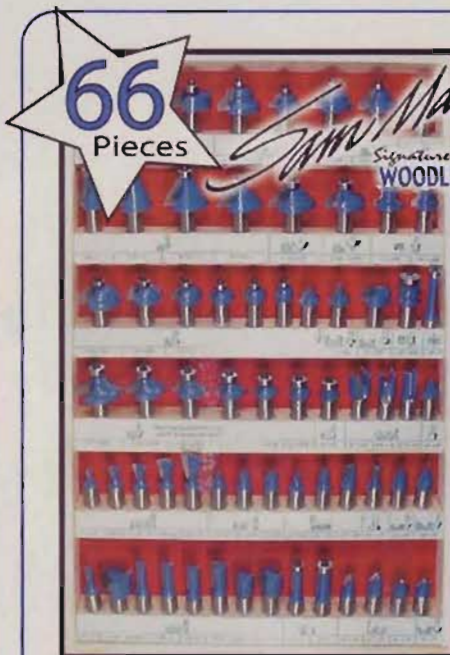

66
Pieces

Signature Series by
WOODLINE USA

Master Craftsman
Woodworking
Collection

Only \$189 set

Includes Deluxe
Wall-Mountable
Wooden Case

- | | |
|------------------------------|-----------------------------|
| 8 Straight Bits | 1 Double Roman Ogee W/ Cove |
| 5 Dovetail Bits | 1 Plunging Roundover |
| 3 Core Box Bits | 1 Stepped Cove |
| 3 Roundnose Bits | 2 Edge Beading Bits |
| 2 Flush Trim Bits | 1 Multibeaded Bit |
| 3 Mortising Bits | 1 Bowl & Tray Bit |
| 1 Plunging Panel Bit | 1 Key Hole Bit |
| 1 Laminate Trim Bit | 1 Double Roman Ogee |
| 1 Bevel Bit | 1 Classic Double Roundover |
| 3 90° V-Groove Bits | 1 Flat Bottom 60° V-Groove |
| 2 Roman Ogee Bits | 1 Standard 60° V-Groove |
| 6 Roundover Bits | 3 Rabbeting / Slot Cutters |
| 1 Point Cutting Roundover | 4 Chamfer Bits |
| 1 Ogee With Fillet | 6 Cove Bits |
| 1 Plunging Roundover W/ Bead | |

WL 2066 For 1/2" Shank

WL 2065 For 1/4" Shank

ANNOUNCING

Your Favorite Source For Router Bits And Shaper Cutters Has Teamed Up With Americas Favorite Master Craftsman To Bring You...

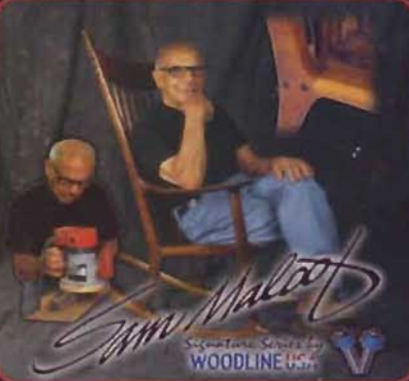

...A Premium Line Of Professional Tools From Our Workbench To Yours!

WL-2008 \$189 VALUE
OUR PRICE ONLY \$75 set

8 Pcs PICTURE FRAME SET
Perfect for making great looking picture frames. Bits can be combined to form complex mouldings or decorative frames.

MOULDING SET
5 Incredible Profiles
OUR PRICE ONLY \$99 set
1/2" Shank Router Bits **WL-2011 \$175 VALUE**

3 Piece CABINET DOOR SET
1/2" Shank Router Bits
2-pc Roman Ogee Rail & Stile
3 1/4" Panel Raiser
WL-2019-1 \$129 VALUE
OUR PRICE ONLY \$69 set Other Profiles Available

MOUNTED LASER CUTTING GUIDE
Quality made. Precision cutting accuracy. Economical battery operated. (included) Versatile, easily mounts to your chop saw, compound miter saw, radial arm saw, or drill press.
Quality • Precise • Economical • Versatile

6 Piece CABINET DOOR SET
1/2" Shank Router Bits
• 2-pc Rail & Stile (Roman Ogee) • Drawer Lock
• 3 1/4" D Panel Raiser (Ogee) • Door Lip • Glue Joint
WL-2020-1 \$175 VALUE
OUR PRICE ONLY \$119 set

WOODLINE USA

GREAT ROUTER BITS AND SHAPER CUTTERS
BEST SELECTION / BEST PRICE!

ORDER TOLL FREE **1-800-472-6950**
WOODLINE USA • 111 WHEELER ST • LA VERGNE, TN 37086

Visit us at our Web site: **WOODBITS.COM**
E-mail: woodline@woodbits.com

PREMIUM CARBIDE
• Euro Anti-Kickback Design
• Super-Slick Non-Slick Finish
• Super Low Prices
QUALITY Guaranteed

• INDIVIDUAL BITS ALSO AVAILABLE • ALL MAJOR CREDIT CARDS • SAME DAY SHIPPING •

shop tips

Hinge makes continuous sanding easier

While sanding a series of flutes in a project recently, my fingers got severely cramped while holding the sandpaper around a dowel. I knew there had to be a better way! A short length of continuous hinge leftover from a previous project provided the solution, as shown in the drawings below.

I wrapped sandpaper loosely around the open hinge, and then closed the hinge, pulling the sandpaper taut. A binder clip keeps the whole assembly together. Flipping the hinge over and moving the binder clip to the barrel side of the hinge also gives you a nice square edge for sanding into the corners of dadoes and grooves.

—Tom Peters, Midland, Mich.

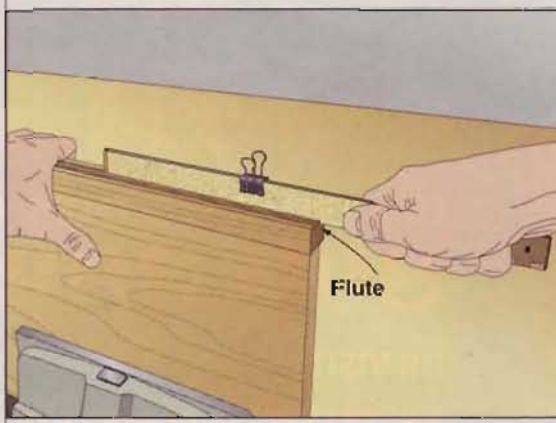
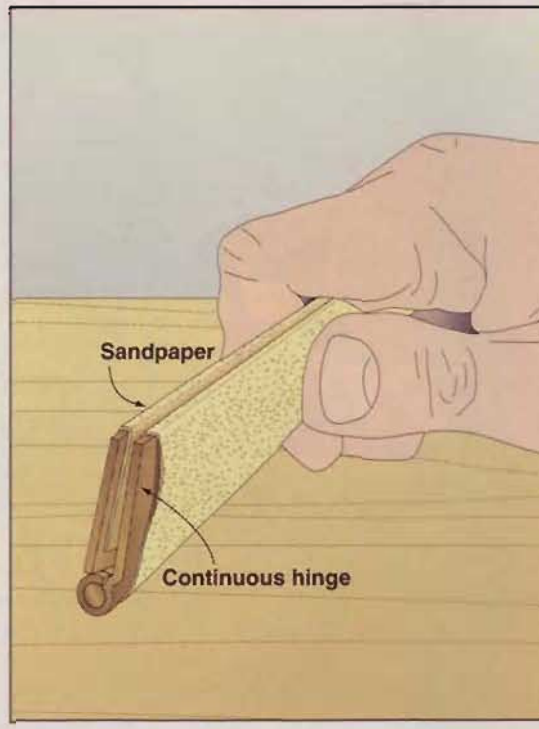

Continued on page 96

Drill gauge stops bits and clears the chips

Shop made drill-depth gauges made from a block of hardwood aren't anything new—you guys have shown them in *WOOD* magazine for years. But I made a simple modification that keeps me from having to pull the drill out of the hole repeatedly to clear out the chips. The change is the addition of an arch in the block bottom.

To make such a gauge, chuck a twist drill the size of the needed hole in your drill. Measure from the chuck nose to the twist-drill point ($2\frac{7}{8}$ ", for example). From that dimension, subtract the depth of the hole

(say, $\frac{1}{2}$ "). The result ($2\frac{3}{8}$ ", in this example) is the height of the jig, as shown in the illustration. Drill the hole in the gauge blank, then bandsaw or scrollsaw the arch. Besides improving chip clearance, I also can see where to place the drill on the hole center.

—Nathan Dixon,
Fort Fairfield, Maine

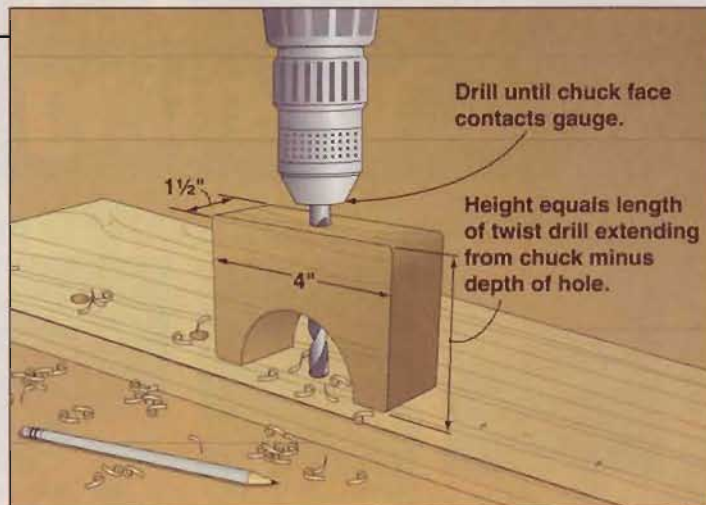

TOOL DOCK

The Modular Workshop

Serious woodworking calls for a lot of tools and shop space. That's why you need Tool Dock™. You can use a variety of mounted tools on a single workstation, saving counter and floor space – leaving room to work. Choose from nine add-on workstations plus accessories.

Find out why customers say getting TOOL DOCK™ was "the best thing I've ever done."

— Roger R., Colorado Springs, Co.

INNOVATIVE SPACE-SAVING DESIGN –
Just pre-mount tools onto interchangeable inserts and store them in the Tool Rack. Slide the tool out and lock the insert down onto a workstation.

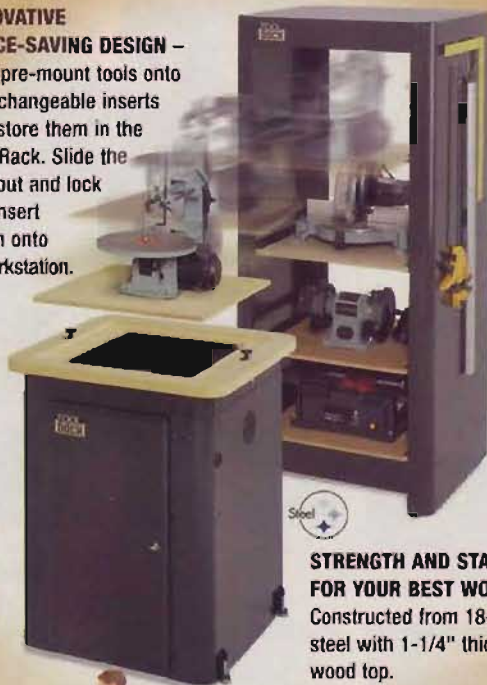

STRENGTH AND STABILITY FOR YOUR BEST WORK –
Constructed from 18-gauge steel with 1-1/4" thick wood top.

Units priced from \$129 to \$329.*



Tools not included.

* Prices are Manufacturer's Suggested Retail Price.

Circle No. 2091

To learn more or find an outlet near you:
1-866-866-5362 www.tooldock.com

Patent pending. ©2004 Waterloo Industries, Inc., Waterloo, Iowa, USA. Tool Dock™ is a trademark of Waterloo Industries, Inc.

Sanded ends show that table is square

When I adjust my disc-sander table at a right angle to the disc, I verify the setting quickly—and precisely—with a couple of 1×2 scrap pieces. I just place the two pieces side-by-side on the table and sand the ends square, as shown below.

Keeping the same edges on the table, I then bring the sanded ends together. If they mate perfectly, I know that the table is square to the disk. Otherwise, I readjust the table and try again. You also can use the same process to ensure your bandsaw table is square to the blade, by cutting two pieces on the same side of the blade.

—Denny Scharringa, Culver City, Calif.

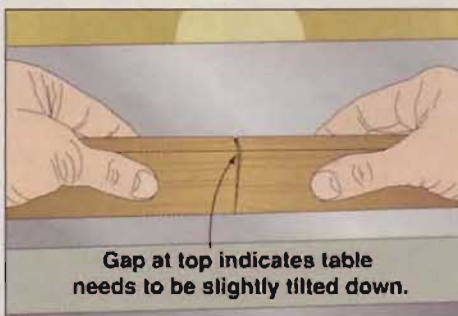
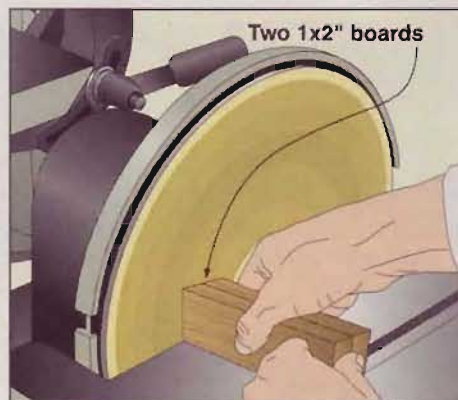

Solid-wood grommets hide plywood edges

Holes in hardwood plywood shelves and countertops that allow cords to pass through show the plywood layers and diminish the appearance of a project. To hide the raw edges, I make custom solid-wood grommets in place. I start by drilling a hole through the top that's larger than necessary for the cable and connectors to pass through—say 1½" in diameter. Then with a circle cutter I cut a plug the same diameter from solid hardwood that matches the plywood veneer.

I glue it into the hole, making it flush with the face of the plywood. When the glue has cured, I enlarge the center hole to the appropriate size for the cord and rout a ¼" round-over around the hole.

—James E. Hoff Sr., Bosque Farms, N.M.

Duct tape prevents chasing plugs

After shaping a number of plugs with a drill-press-mounted plug cutter, it comes time to set those rascals free by slicing them off at the bandsaw. Trouble is, the plugs tend to fly all over the place as they fall free. To avoid this, apply a strip of duct tape over the plugs before going to the bandsaw. That way, when you saw them away from the blank, they stay neatly attached to the tape until you're ready to use them.

—Joe Godfrey, Forest City, N.C.

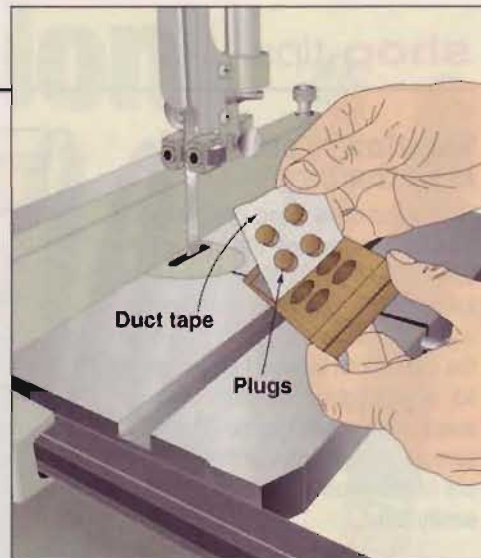

Continued on page 98

Drill 1½" hole in workpiece; glue in 1½" hardwood plug.



Drill 1" hole in plug; round over with ¼" round-over bit.



WANT THIS?

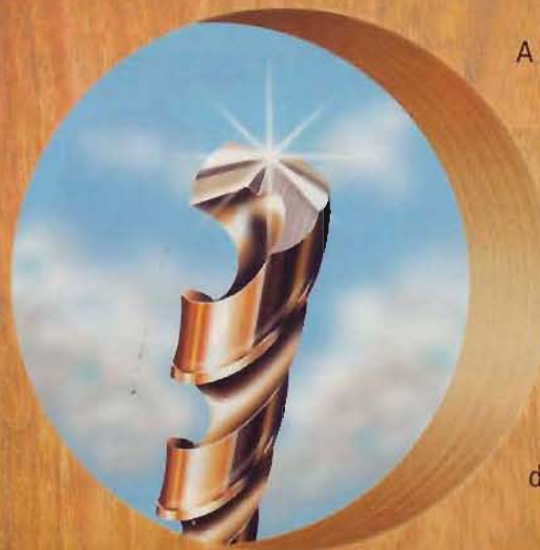

A clean, sharp hole every time. No chips, no splits, no errors. It takes skill and a sharp drill bit. And *that* takes the **Drill Doctor®** drill bit sharpener.

GET THIS.

- Restores bits to factory sharp
- Fast and easy to use
- Sharpens most twist bits—even split point
- Diamond sharpening wheel
- Powerful 20,000 rpm motor

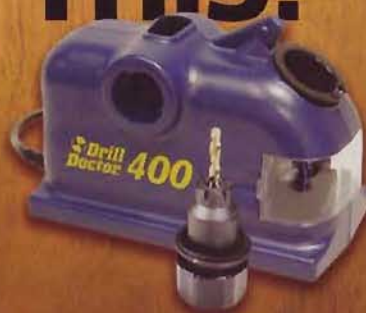

Drill Doctor®
The Drill Bit Sharpener

"I have never recommended a product that was so easy to use and so effective. This is one of the best tools I've ever purchased."

—Stephen Bierhorst
Patterson, Louisiana

Drill bits are meant to be sharpened

Available at Home Depot, Lowe's, Sears and wherever fine tools are sold

www.DrillDoctor.com • 1-888-MYDRILL

Solution to stuck lids is in the bag

Screw-top cans keep oil finishes fresh, but removing the cap is usually a struggle after the can sits for awhile. I avoid the problem by laying a plastic shopping bag over the can spout before I screw on the lid. After I tighten the lid, I trim away the excess plastic. The lid screws on tightly over the two layers of thin plastic, and twists off easily later.

—John W. Bennett, Shelton, Wash.



Rubber band turns pliers into a clamp...

A surgical clamp would have been handy when I started attaching lines to the Child's Mobile in *WOOD* magazine issue 151, but I didn't have one handy. Instead, I wrapped a rubber band around the jaws of small needle-nose pliers, as shown below, for easy one-hand clamping. You can regulate clamping pressure by adjusting how tightly you wrap the rubber band around the jaws.

—Jack Heron, Myrtle Beach, S.C.

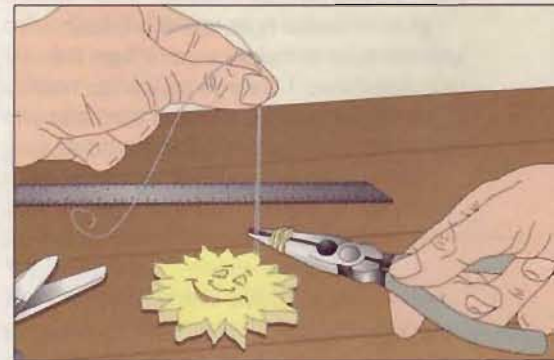

Dust-Free Sanding

Eliminate hazardous dust **BEFORE** it becomes airborne

Airborne dust is now being recognized as a major health hazard. Imagine sanding in a dust-free environment, where 98% of the dust created by sanding is contained.



How It Works

Dust produced by sanding is immediately sucked away through holes located in the sandpaper, the bottom of the sanding pad, AND around the outside edge of the pad (a FEIN exclusive). The extracted dust is contained by a powerful vacuum.

Unbeatable Finishes

When you sand with normal sanders, your sander ends up riding on a bed of dust and broken abrasive. With the FEIN Sanding System, this "bed" of dust doesn't exist. Your paper cuts faster, cleaner, and lasts up to 10 times longer.

Automatic Vacuum

When you turn your FEIN sander on, the vacuum starts. When you switch your sander off, the vacuum stops....automatically. The FEIN Turbo II Vacuum is built to handle large amounts of super-fine dust.

Circle No. 1953



For more information and a dealer near you, call 1-800-441-9878 or visit us on the web at www.feinus.com

...and makes a standard bar clamp a snap to use

I like to use the little F-style bar clamps, but sometimes it takes two hands to get them to grab. For one-hand clamping, I stretch a large rubber band around the jaws as shown, then pull the clamp open and hold the sliding jaw with my thumb. When I'm ready to clamp, I lift my thumb a bit and the jaw slides shut. A quick twist or two of the handle is all it takes to tighten the clamp.

—Malcolm Brennan, Edisto Island, S.C.

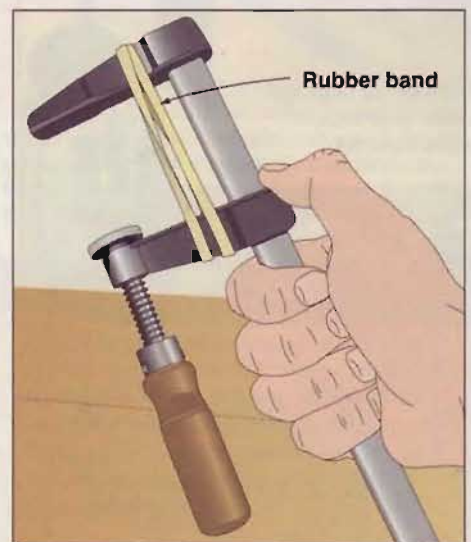

Keep that pesky arbor nut on a string to prevent loss

It's easy to lose control of the arbor nut when changing tablesaw blades. That often means crawling under the saw or trying to reach far into the cabinet—unless you plan ahead.

To prevent an arbor-nut hunt, epoxy the ends of a piece of string to a pair of ½"-diameter magnets. (Powerful rare-earth magnets work well.) Before you remove the arbor nut, stick one of the magnets on the end of the saw arbor and the other to the saw table. If you spin the nut off the end of the arbor, it will slide onto the string loop. When you reinstall the blade, stick one magnet to the end of the arbor again, then slide the nut down the string and onto the arbor for fuss-free fastening.

—Bob Hoffmann, Atlanta

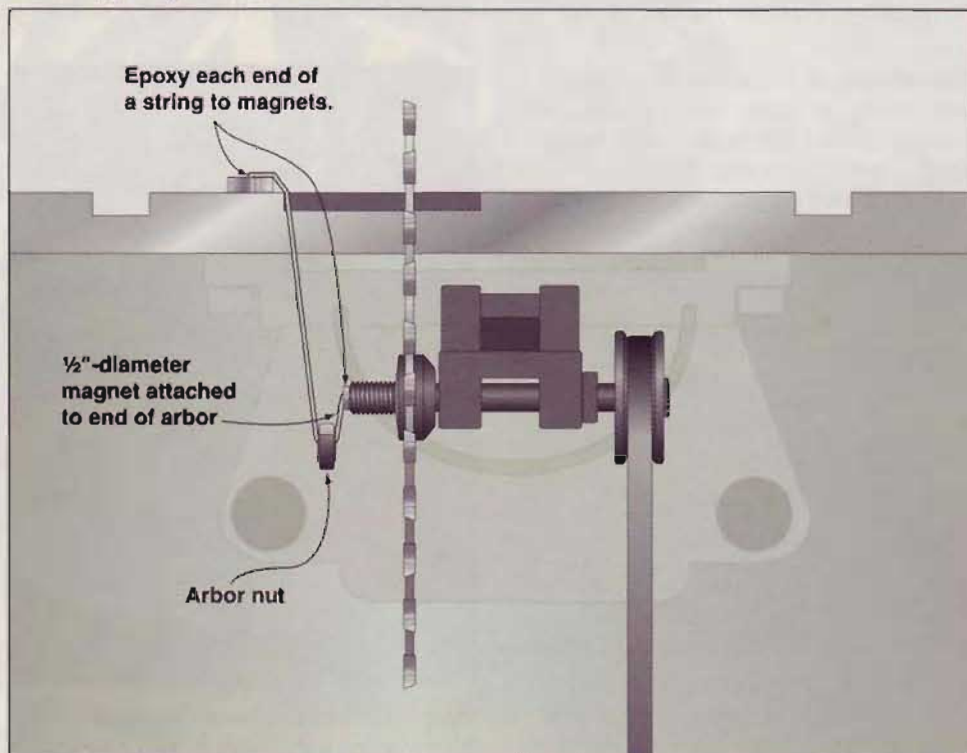

See a new

Shop Tip
of the Day at

woodmagazine.com/tips



www.woodmagazine.com

99

KLINGSPOR'S WOODWORKING SHOP

"Quality Tools and Supplies for the Woodworker"



KLINGSPOR'S WOODWORKING SHOP

15 Year Anniversary Truck Giveaway

Join us in our celebration as we give one of our special customers something to carry their woodworking projects around in - **A BRAND NEW FORD F150!**

Come to one of our 4 stores or check the website for full details.



Whether you shop thru our catalog, our website or one of our four retail stores you will find all your woodworking tools and supplies in one convenient location.

1,000'S OF PRODUCTS AVAILABLE ONLINE
1-800-228-0000 • www.woodworkingshop.com

Circle No. 629

Refinish Your Future.



Own your own business.

Let your passion for furniture lead you into a new business with a Furniture Medic franchise. We're a complete on-site repair and restoration-refinishing business servicing homes and companies as well as handling moving and insurance claims. We offer extensive training and support with a low initial investment and manageable overhead. Financing is available to qualified candidates and franchises are offered nationwide. Call today to brush up on the details.



FURNITURE MEDIC
THE #1 FRANCHISE FOR FURNITURE RESTORATION

www.furnituremedicfranchise.com

1-800-RUN YOURS

Circle No. 895

wood words

A quick guide to must-know terms used throughout *WOOD* magazine

Centerline: A layout line drawn at the center of the thickness, width, or length of a workpiece and sometimes marked with the C symbol. Typically, the centerline marking is used without an accompanying dimensional measurement.

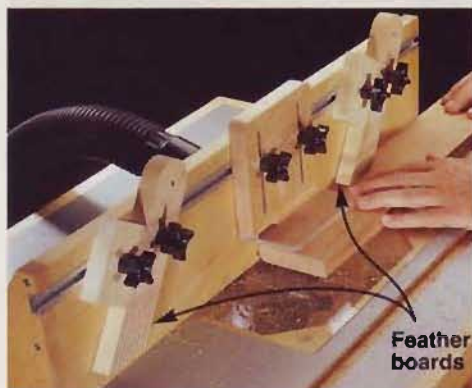

Feather board: A device made up of a series of narrow fingers that hold a workpiece firmly in position against a machine's table surface or fence. A feather board helps increase accuracy and improves safety. You can make your own or purchase plastic versions.



Chip-out: Splinters of wood that break away from a workpiece during a cutting or shaping process. Combat chip-out by using sharp blades and bits, backer boards (see below), and slower feed rates.

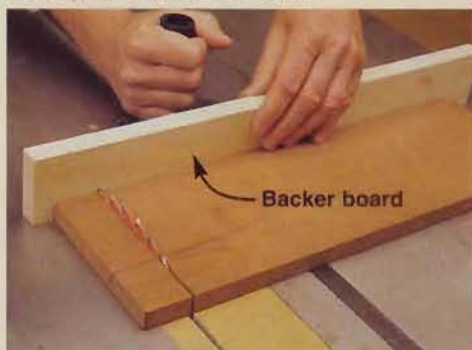

Backer board: A sacrificial board placed behind a workpiece during a cutting or shaping process. The backer board supports the wood to prevent chip-out as the blade or cutter exits the workpiece.



Hand screw: A traditional clamp with two long wooden jaws joined by two threaded rods. The rods adjust independently by turning the handles, which allows you to position the jaws parallel or at angles to one another. Handscrews come in a variety of sizes, based on the length of the jaws (4" to 12"). Throat depth equals half of jaw length.

Kickback: The dangerous mishap that occurs if a spinning blade or bit catches a workpiece and throws it toward the machine operator.



Pushstick: A safety device used to push a workpiece past a blade or bit during a machining operation while keeping your hands out of harm's way. Make your own or buy commercially made versions.

Self-centering bit: A specialized drill bit designed to bore perfectly centered pilot holes for hinge-mounting screws. The bit uses a standard twist drill inside a retractable spring-loaded sleeve. A tapered end on the sleeve fits into the countersink on a hinge screw hole to automatically center the bit when you press the sleeve against the hinge. Commonly referred to as "Vix" bits (the brand name of the original version), self-centering bits come in various sizes to accommodate different screw gauges.

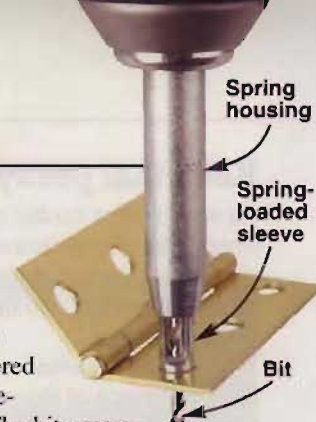

Spray-mount adhesive:

An aerosol glue often used to adhere paper patterns to workpieces. Many types exist; for woodworking, choose the artist's variety, which temporarily bonds well and allows the pattern to peel away. Always spray the adhesive on the pattern, not the wood.



Thickness planer: A machine used to reduce the thickness of boards. It features a horizontal rotating cutterhead equipped with knives that shave wood away from the face as the stock passes beneath, driven by infeed and outfeed rollers. The cutterhead and rollers adjust up and down to accommodate different board thicknesses and cutting depths. Stationary thickness planers usually have 15" width capacity. Portable benchtop planers handle boards up to 13" wide. ♣

short cuts

News and notes from the woodworking world

One way to get kids started in woodworking

Ever wonder why so many kids show little interest in woodworking? You ask them to help with those dining chairs you're making in the shop, and they suddenly disappear. Well, it could be the wrong project. They don't see anything in it for them. But what if the project proved to be way cool?

Sociall Skateboards of Cochrane, Alberta, the largest maker of skateboards in Canada, has developed a simple project that's ideal for entry-level woodworkers, and off the charts insofar as kids' interests are concerned. It involves cutting, shaping, and finishing a skateboard wafer blank, followed by adding steel wheel assemblies. To make it all possible, the company sells everything needed to get the job done, from the laminated maple wafer blanks seen at *right* to all the hardware components (two trucks, four wheels, eight bearings, grip tape, nuts, and bolts). The total cost for the package: \$94.60, plus shipping.

Sociall Skateboards regularly pitches its program to industrial arts teachers. The



WOOD magazine's Products Editor Dave Campbell teams up with son Colby to bandsaw a skateboard wafer from a wafer blank, following the factory-drawn outline.

company also has captured the attention of Junior Achievement groups and other clubs involving boys and girls.



To make a skateboard from the kit, cut the wafer blank to size. Next, sand to the outline and round over the edges with rasps, files, and sandpaper. Apply finish (center). Then add the wheels to the trucks, and secure them to the wafer using the factory-drilled holes and fasteners.

To contact Sociall Skateboards, call 866/390-3325, or e-mail them at sociall@telusplanet.net.

Woodworking class gets A+

Ever wanted to enroll in a woodworking class but didn't, fearing the cost in time and money? With that question in mind, we sent *WOOD* magazine Design Editor Jeff Mertz to Franklin, Indiana, to attend a joinery "bootcamp" at the Marc Adams School of Woodworking.

How'd he get along? "Attending the five-day workshop was definitely worth it," Jeff said. (Incidentally, the class cost \$700 and includes lunch; transportation, lodging, and other meals are up to you). "Not once was I bored. I spent full days and some evenings working in the shop. During two evenings, I attended bonus classes on adhesives, and project presentations by the instructors. When you can hang out with other woodworkers and quality instructors, you come away inspired and energized. The instructors proved to be top-notch and well-informed, regardless of the topic.

"So, can a guy like me who earns his living designing and building projects for the biggest woodworking magazine learn anything from such a place? Absolutely. I was



Instructor Marc Adams (left) and *WOOD* magazine Design Editor Jeff Mertz look up from their discussion on angled mortise-and-tenon joinery. Each workshop student was provided with his or her own bench and project material, in this case, poplar.

raised to believe that power tools were everything. Yet here I learned the importance of crafting wood with hand tools. The workshop took the mystery out of sharpening a chisel and using a scraper."

To find out more about the availability and variety of woodworking classes at the Marc Adams School of Woodworking, call 317/535-4013, or visit marcadams.com.

Continued on page 104

The bus stops here

Kudos to Mark Gordon of Columbus, Ohio, for his First Place effort in the miniatures class at the 2003 Ohio State Fair. His entry: a handsome 21H×12W×41L" model of a 1952 English double-decker bus with a novel redesigned R.V. interior. In effect, it's a two-story home on wheels.

Details include brass fixtures, a solid surface countertop, glass windows, 41 light bulbs, and several furniture pieces. Add it all up and you have 50 pounds of pure, meticulous craftsmanship in a dream vehicle whose time has come.

Photographs: J. Tomasi



It took Mark Gordon 11 months and \$800 to build this 1½"-to-1" scale model of a double-decker bus, left. Interior decor (above) include miniature furniture and cabinets, wiring, and plumbing.

Test your workshop smarts

Looking for a few fun challenges in your life? Give these woodworking brain teasers a go. Find the answers in the next issue of *WOOD* magazine's Short Cuts, or visit woodmagazine.com/editorial to see them now.

■ Can you name five woodworking tools that hail from the Stone Age?

■ What's the common term for the woodworking process known as pyrography?

■ How do you figure the length of a bandsaw blade that you intend to buy for your machine?

Answers to the questions found in issue 154:

■ What's the difference between water-resistant and waterproof glue? Truly waterproof glues, such as epoxy and resorcinol, maintain their bonding strength below waterline (as when submerged) and in structural applications. They also can stand up to heat. A glue



Waterproof epoxy works well above and below water. Boatbuilders use it because of its durability and gap-filling quality.

such as Titebond II is labeled "water resistant" because water will not affect its bonding ability when used in furniture and other outdoor projects made from wood. And though occasional rain will not cause it to fail, it should never be used for such heavy-duty structural applications as making laminated beams, or for building seaworthy wooden boats.

■ What makes a better power-tool table, cast iron or aluminum?

Tom Murrh, a technical support manager at Delta Machinery, says that aluminum is used primarily in smaller tool tables and table wings. Cast iron offers advantages for larger tables, including "flameless, stability,

less, and are more portable, but they can flex and bend in larger tables."

■ Can you guess the diameter of the largest turned wooden bowl?

According to Guinness World Records 2004, the largest wooden bowl—turned in 1997—measures 10' in diameter and weighs approximately 1,600 lbs. It was made by Frank and Hugh Patrick of Patrick's Turning Point in Barnesville, Georgia. It was a commissioned piece for a concrete company that wanted a mold for creating a fiberglass and rubber form. From this they make concrete bowls that are used for landscaping purposes.

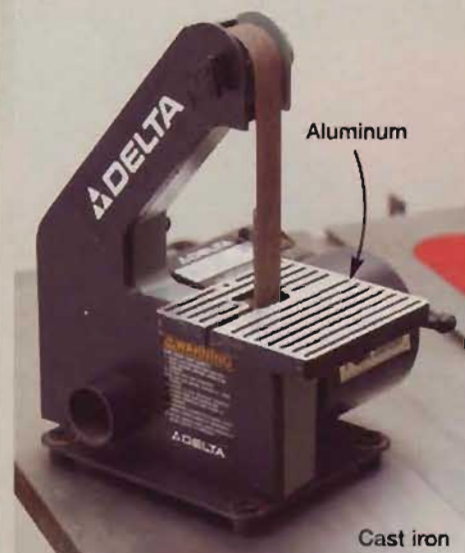

Manufacturers use aluminum when making tables for smaller, more portable tools, such as scrollsaws, mitersaws, and this sander. Rigid cast iron works better for larger tables.

and a more precise machining for miter slots. Being heavier, it also dampens tool vibration as well, though you will need to protect it from rusting." By contrast, says Tom, "lightweight aluminum tabletops cost



A worker at Patrick's Turning Point takes this world-record poplar bowl for a spin. It took six weeks to glue-up, turn, and sand.

Continued on page 106

Toolmaker, woodworker, and artist

Though you might think that the president of a major woodworking tool manufacturer has little time to indulge in the craft itself, that's not the case with multi-talented Shiraz Balolia, founder and president of Grizzly Industrial. A skilled metalworker and woodworker having two fully-loaded shops (one for each interest), Balolia has steered his passion in a new direction—that of luthier, a stringed musical instrument maker.

Using his CNC router, wide-belt sander, and other favorite tools, he was able to exact the fine dimensions called for in his steel-stringed acoustic guitar designs, which are based on smooth-flowing classical guitar shapes. The guitar sounding boards, backs, and sides, for instance, required fine thicknesses measured in thousandths of an inch. Jigs he created helped him bend the sides, execute delicate glue-ups, and shape the tricky contoured neck.

To make the intricate inlays in the fretboard, the rosette surrounding the sounding board opening, and in the guitar's back, Balolia took precise measurements and had

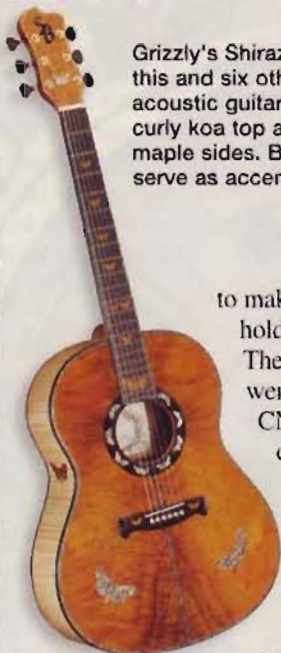

Grizzly's Shiraz Balolia designed this and six other steelstring acoustic guitars. It contains a curly koa top and back with curly maple sides. Butterfly inlays serve as accents.

to make specific jigs for holding them in place. The inlay pockets were cut out using the CNC router and the corresponding male parts were sized .002" smaller for a perfect fit. Holding the small parts for precision cutting was particularly challenging and many of the antennae for the butterflies, *above*, broke (they are 20-thousandths of an inch thick).

To finish his fine musical instruments so they present a "gleaming wet look," Balolia applied two coats of sealer, sanding to 320-



Gracing the back of another Balolia guitar is this 11" tall King Tut inlay. The two shell materials in the headdress and neck area create eye-catching contrast and depth.

grit. He then sprayed on eight thin coats of nitro-cellulose lacquer, sanding with 400-grit between coats. Finally, he sanded down to 2,000 grit before buffing the surface with Menzerna buffing compound. ♣

Talented Creator. Skilled Hobbyist.

BUSINESS OWNER.

You're already two. With Guardsman FurniturePro®, you can become all three!

Guardsman FurniturePro is a network of franchises specializing in furniture-related services. Guardsman FurniturePro has available territories throughout North America.

TRAINING AND SUPPORT PROGRAMS:

- Comprehensive initial training
- Ongoing regional workshops
- Web-based support programs
- 24-hour technical assistance
- Access to fellow FurniturePro franchisees

GUARDSMAN FURNITUREPRO CUSTOMERS:

- Homeowners
- Furniture retailers

- Restaurants and Hotels
- Professional office buildings
- Moving and storage companies

NOT TO MENTION:

- Protected territories
- Affiliation with the most established and respected name and presence in the marketplace
- The support of a \$2.2 billion company, and the largest manufacturer of furniture finishes in the world.
- Affordable franchise entry fees, as low as \$9,500
- Home based with low overhead!



For Franchise Information Call
800.496.6377
www.guardsmanfurniturepro.com.

GUARDSMAN
FurniturePro
The most trusted name in furniture repair

Profit Centers



Furniture Repair - gouges, scratches, burns, water marks, dents and more



Leather Cleaning and Repair - stain removal, recoloring, and more



Upholstery Services - spot cleaning, panel replacement, seat re-upholstering



Cabinet Refurbishing - cleaning, degreasing, repairing and polishing



Refinishing - complete stripping and refinishing using an eco-friendly, water-based system

above-par putters

Russ Fisher's carefully crafted clubs look like a million bucks and putt like a dream.

A few years back, veteran woodshop teacher and avid golfer Russ Fisher went shopping for a new putter. Unable to find one that he liked, he decided to make his own. "Ten days later I had 10 prototype putters," Russ says. "Then, for a year, I experimented with different designs, weighting, and construction techniques, building about 150 club heads."

Today, Russ has retired after 26 years in the high-school shop, and he works full time crafting his Timbered Putter line of custom clubs. He'll sell some 400 clubs this year, with prices that start at \$170. So far, his clubs reside in most every state and in several foreign countries.

All of the putters feature heads made of domestic and exotic hardwoods, combined with such other materials as brass and solid-surfacing countertop material. Although the clubs are beautiful, they aren't just art. Each one conforms to United States Golf Association (USGA) rules and is designed to see action on the links.

As shown in **Photo A**, the process of building a club head starts by gluing up a block of several contrasting woods. Russ weights the largest block to give the club proper heft, feel, and action for striking the ball. "These clubs are face balanced and weighted to provide a sweet spot and accurate aiming," he says.

After the epoxy adhesive sets, Russ uses various templates to outline the head's profile on the blank, as shown in **Photo B**. He cuts freehand at the bandsaw to produce a rough head. Then Russ uses a belt/disc sander, as well as several spindle sanders and pneumatic-drum sanders, to shape the head. "It's all free-hand work, based on my experience," he says.

Next, Russ drills a hole to receive the shaft. He then fine-tunes the shape, as shown in **Photo C**. From here, each head gets sanded up to 2,000 grit before receiving the first coat of a tough epoxy finish. Each club goes into a laser engraver, where aiming lines and the logo get added. Russ often adorns the clubs further with the buyer's name or a special logo. He fills the laser-cut lines with gold epoxy, then adds several more coats of clear epoxy finish to complete the head. Russ mates the head to a shaft, and then adds a leather grip to complete his creation. He offers steel or metal-alloy shafts, but is fondest of his bent-wood versions, *left*. They offer a traditional look and play just as well, he says.

Of course, Russ knows how to stay on top of the putter game. In addition to countless shop hours, he spends many days on the golf course working on "research and development." To see the many club styles Russ offers, check out his full line at www.timberedputtergolf.com. ♣



Russ Fisher epoxies a sole and face to a weighted block to create an oversize blank. He adds other pieces to create one of several different head shapes.



Templates guide freehand cutting at the bandsaw to give the head rough shape. Russ then sands the head to its final profile.



To fine tune the club head's contours, Russ relies on a flap sander. This process readies the head for final hand-sanding and finishing.



success with sanding sealers

Want to make sure your finish application gets off to a smooth start? Let these products help you sand away first-coat roughness in a jiffy.

The first coat of any finish leaves the wood feeling rough, and you have to sand it smooth to make the best base for successive coats of finish. The easiest way to manage this step is by using a sanding sealer.

Sanding sealers come in many forms, as represented by the samples *below*. Although they are often described as products that seal the wood, the first coat of any finish effectively plugs open pores, so you don't need a special product for that job. What you do get from sanding sealers is better sanding results because of the soap-like lubricants they contain.

If you apply lacquer or oil-based varnish as a first coat, your sandpaper gums up as

you work to smooth that coat. Start with a sanding sealer instead, and the resulting mix of wood fiber and dried sanding sealer turns to powder without clogging your sandpaper as you sand.

That's the main benefit of sanding sealers, and we'll also describe how they solve another finishing problem. Applied properly, they fill the grain in medium-grained wood, such as walnut and mahogany, creating a smooth base for your finish.

Do you need sanding sealers in your workshop? For most projects, you can ease sanding by using a thinned application of your final finish for the first coat—we'll discuss that shortly—or fill pores with paste filler or sanding slurry, as described in issue

152, page 96. But if you finish with lacquer or varnish, give sanding sealers a try for the convenience they offer, especially on large projects, such as a set of kitchen cabinets.

Make rough fibers vanish

Different topcoats call for different strategies when it comes to sanding sealers. Here's your guide:

■ **Lacquer and oil-based varnish:** Simply choose a sanding sealer that contains the same material as your topcoat, brush or roll on a liberal coat, and allow it to dry. Then, sand with the grain using 320-grit sandpaper to produce a powdery residue to produce a powder like that shown *below*. Wipe away the powder with a cloth—dampened with



Apply sanding sealer on raw wood or over stain. Let the sealer dry, sand off the rough wood fibers with minimal effort, and add a smooth, clear topcoat.

4 WAYS TO BUY SANDING SEALER



From left to right: lacquer-based sealer in a spray can (\$5.99 for 12 ounces), sealer made with mineral spirits (\$8.20 per quart), water-based sealer (\$12.99), and brushable lacquer-based sealer (\$14.99).

SEALERS MAKE SANDING EASIER



We brushed lacquer-based sanding sealer onto this walnut sample board and let it dry. Light sanding produced a powdery residue that didn't clog the 320-grit sandpaper.

FOR POLYS, MIX YOUR OWN SEALER



Before applying polyurethane, make a sanding sealer by mixing equal parts of poly and mineral spirits (paint thinner). The same ratio, with appropriate thinner, works for oil-based varnish or lacquer.

mineral spirits (paint thinner) if the topcoat is varnish or polyurethane—or vacuum it off. As an alternative, use a thinned coat of lacquer or oil-based var-

nish as the first coat. Mix lacquer 50/50 with lacquer thinner, or mix varnish 50/50 with mineral spirits.

■ **Oil-based polyurethane:** This popular finish doesn't bond well to sanding sealers, so it's a prime candidate for the "thinned first coat" approach. Thin it as shown at *left*, brush or roll it on, and you'll sand the first coat smooth with little effort.

■ **Water-base:** Water-based sanding sealer works fine, but provides relatively small benefit because the finish itself sands easily when applied full-strength. Don't thin water-base; you're likely to have problems due to its complex chemistry.

Fill the grain

Sanding sealers have a higher proportion of solids than typical topcoats. This makes them useful as grain fillers, because when you sand, you remove material from the high areas and leave solids in the low spots, creating a smooth surface. Unfortunately, it's hard to know when to stop sanding, so try this method: Apply a full-strength coat of finish to the bare wood, let it dry, then add sanding sealer. When this coat dries, sand with 320 grit until the sandpaper begins to grab, indicating that you have reached the finish. At this point, you have removed the sanding sealer from the flat surface, but some remains in the low spots. You might have to do this more than once to make the entire surface level.

Shellac puts a lid on oils, resins, and waxes

Dewaxed shellac works as a sanding sealer under any topcoat—but doesn't sand as easily as the products made specifically for this purpose. However, it's a great choice when you need a barrier coat over substances that keep the topcoat from forming a strong bond with the wood.

For example, teak and other exotic woods contain natural oils; pine knots can ooze resin; and you might leave oil, silicone, or wax on the wood during a refinishing project. Brush a coat of dewaxed shellac over any of those substances to create an excellent base for your topcoat.



Seal Coat, which is dewaxed shellac, costs about \$7.99 per quart at home centers. The manufacturer guarantees each can to remain usable for three years, but check the made-on date on the bottom and buy the freshest available. 🐿

3 sanding sealers at a glance

Type	Use it when ...	Be careful because ...	You also should know ...
Lacquer sealer, mineral spirits-based or water-based sealer	you're working on a large surface.	polyurethane doesn't bond well to sanding sealer.	two coats is the limit; a thicker layer leads to a soft, easily damaged finish.
50/50 mix of topcoat and thinner	you're finishing a small project.	it's easy to sand through this thin coat to the stain coat or bare wood.	this is a good method to use with polyurethane.
Shellac	you need a barrier coat between the topcoat and substances that inhibit good adhesion (see sidebar at <i>right</i>).	a heavy first coat of lacquer can dissolve through shellac.	shellac containing wax can cause adhesion problems; always buy a container that's labeled wax-free.

what you need to know about

Polyurethane Glue

If it's not in your adhesive arsenal yet, give it a try. Here's how to get top-notch results.

Polyurethane glue creates a strong, rigid bond and adheres to metal, ceramic, plastic, and other materials in addition to wood. Also, because poly glue is water-resistant, it serves as a great choice for outdoor projects. But its application contrasts with that of yellow or white glue, so you need to learn the right procedures to get lasting results.

Putting poly to work

■ **Protect yourself.** Polyurethane glue contains a chemical compound that can cause harmful reactions in some people, through respiration or skin contact. For this reason,

ensure adequate ventilation while gluing, don an appropriate respirator if you feel any reaction to the fumes, and always wear disposable gloves. In addition to preventing skin rashes, gloves keep the glue from creating a long-lasting stain on your skin.

■ **Mind the moisture.** If the material to be bonded has less than 8 percent moisture content, dampen one or both surfaces with water, as shown *below left*. Skip this step when building with lumber that's already moist, such as new pressure-treated lumber. Poly also needs temperatures above 50° F to cure.

■ **Ease up.** With poly, you need less adhesive per square inch than with yellow or white

glue. Apply a thin bead and then use a plastic spreader to coat the surface, as shown in the photo *above*.

■ **Take your time.** You have about 20 minutes to apply poly and align parts before clamping, a longer open time than you get with yellow glue. That's a great advantage with large or complicated glue-ups. Apply firm clamping pressure and leave the clamps in place for an hour or longer.

■ **Remove the foam-out.** Polyurethane glue expands as it cures, producing foam-out along each glue line. Don't smear the foam-out by wiping when it's wet; instead, slice it off with a chisel after it dries, as shown *below right*.

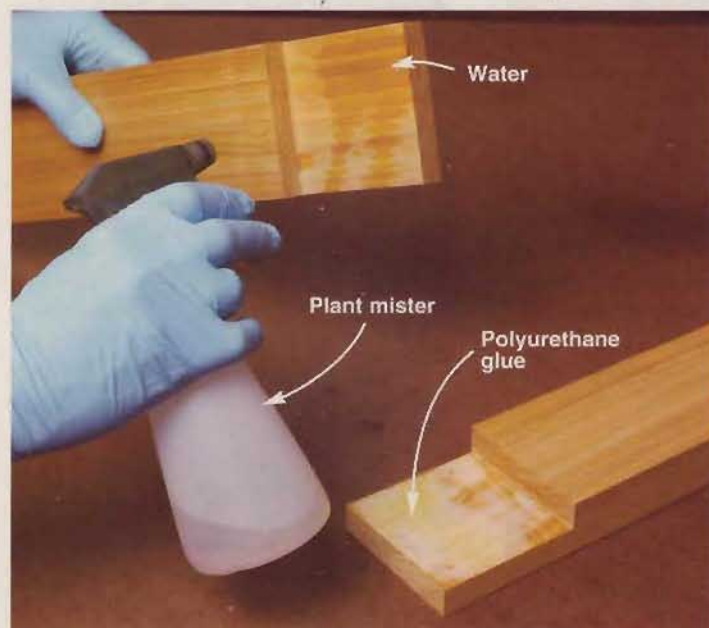

Go easy on both the moisture and the polyurethane glue when preparing a joint. Apply just a light mist of water and wait a minute to allow evaporation before assembly.



The foam produced by polyurethane glue easily fills gaps, but it doesn't produce any strength. Make sure the joints fit tightly before you glue them together.

Continued on page 114



What exactly is polyurethane glue?

Polyurethane glue consists almost entirely of resin solids. By contrast, yellow or white glue contains about half solids and half water. In the presence of water vapor, poly resins undergo a chemical reaction that forms an adhesive film. This reaction also gives off carbon dioxide, leading to the foam-out along the outside of a joint.

Storing it properly

Poly glues remain usable for one to three years unopened, but the shelf life drops to as little as six months after you open the container because moisture in the air triggers curing inside. Here's how to minimize waste:

■ **Think small.** When you buy a bottle of polyurethane glue, look for the smallest one that will serve your needs over the next few months.

■ **Give it a squeeze.** After each use, squeeze the bottle until the glue rises to the tip, forcing out all of the air. Replace the cap, and then store the bottle upside down so that any hardening takes place at the bottom and doesn't hinder the flow of glue from the tip. See the photo at right for a simple storage method. ♣

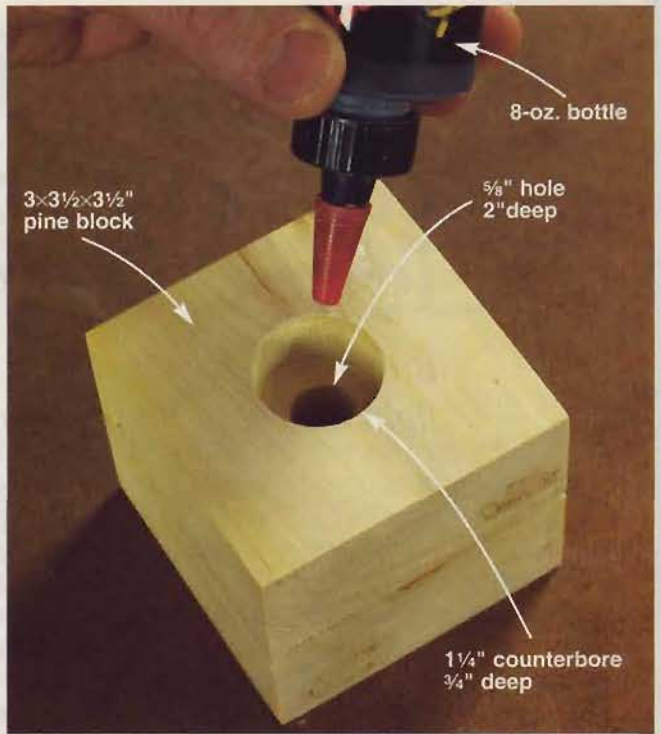

Build a glue bottle holder with two scraps of 2x4 lumber, as shown, to keep usable glue at the tip for a long time. Drill the counterbore to accept the cap of your glue bottle and then drill the smaller hole deep enough for the tip.



8116 Highway 123 North
Toccoa, GA 30577
www.islandlegs.com

KITCHEN ISLAND



- 1484**
Spiro
3 1/2 x 34 1/2
- 1463**
Island Hutch
3 1/2 x 35
- 1453**
Massive Rope
6 x 35
- 1490**
Atlanta
4 x 34 1/2
- 1495**
Barley Twist
3 1/2 x 34 1/2

Request our **NEW** catalog: 1-800-746-3233 • Order line: 1-800-849-8876

Circle No. 1849

The Difference Between Good and Great

JessEm manufactures a variety of products for a great router table to fit your woodworking style. Choose from complete systems or individual components to configure your own custom solution. Our Mast-R-Fence™ has the thickest aluminum frame on the market. All JessEm table tops are machined from solid Phenolic for a strong, stable top that's guaranteed not to warp, sag or swell like MDF tops.

Make it great with production grade routing solutions from the Inventor and #1 Maker of Router Lifts.



See JessEm products in use at
www.woodshopdemos.com

Visit us at www.jessem.com
Or call 866-272-7492
Distributor Inquiries Are Highly Recommended

JessEm
Tool Company

Barrie, Ontario
Canada, North America

Circle No. 1979

shop-proven products

These woodworking wares passed our shop trials

Vac starts and cleans itself automatically

It may not technically qualify as "artificial intelligence," but Bosch's Airsweep 3931 Wet/Dry Vacuum is certainly one of the smartest shop vacuums I've ever seen. Like other tool-triggered vacuums, this quiet unit turns on by itself when you switch on a tool (such as a router or random-orbit sander) that's plugged into the vac's onboard power outlet.

When you turn off the tool, the Airsweep 3931 sucks for a few seconds more to clear the hose of debris, which, again, isn't all that unusual. But then, like a dog at the end of a bath, the vac rumbles for a few seconds more as built-in shakers loosen most of the accumulated debris from the two pleated cartridge filters.

This self-cleaning feature works remarkably well, dumping about 80 percent of the caked-on dust from the filter. I hooked the Airsweep 3931 to my random-orbit sander and sanded for most of an afternoon with no apparent loss of suction. (The filter is rated to capture over 99 percent of dust

particles down to 3 microns.) Every time I took a break, the vac cleaned itself for the next round of sanding.

I'm also impressed with how well this vacuum performs its main duty: sucking up shop debris. Used with its brush attachment, it gathered even the fine dust from the wood pores after my final sanding before applying finish. When I connected the Airsweep 3931 to the dust port on my router, it gathered about 90 percent of chips I generated.

For the occasional wet job, this vacuum proved pretty smart as well. A sensor inside shuts off the motor when the 13-gallon tank is full to prevent motor and filter damage.

—Tested by John Cebuhar

Bosch Airsweep 3931 Wet/Dry Vacuum

Performance	★★★★★
Price	\$400

The Robert Bosch Co.
877/267-2499, www.boschtools.com



Belt sander gets in close, stands up for sanding

DeWalt engineers resurrected a concept from a decades-old Black & Decker model to create a portable belt sander with three rollers instead of two. The smaller radius rollers at the front of the DW433 sander allow the abrasive to nose-up to objects closer than a typical two-roller machine can.

For example, using this sander to flatten a built-in benchtop, I sanded to within 2¼" of the wall when the nose bumped the wall. With other belt sanders I own, I can't get much closer than 3½". I did find during this test that the tight space around the top roller caused my super-coarse 36-grit belt to drag slightly against the body of the sander (but 60-grit and higher belts worked fine).

The DW433's platen and slip plate—the two pieces that define how flat a belt sander sands—showed about average flatness with a slight crown from front to rear. In spite of this I was satisfied with the results I got, especially when used with the included sanding frame. That frame installs easily with only one thumbscrew to secure, and didn't allow the DW433 to gouge my workpiece, indicating that the sander and

frame aligned perfectly. Add a couple of brackets (included with the kit I tested) to the sanding frame and it stands up to become a vertical sander. Or put the brackets on the end of the frame and it lays on its side to make an edge sander.

With all of these good things, it's a shame that the blower-assisted dust-collection system doesn't live up to the rest of the sander. I like that I can switch the fan on or off (to prevent sparks from entering the dust bag when sanding materials with embedded nails or staples), but after only a little sanding, there was as much dust outside the bag as inside it. (After learning of this, a DeWalt engineer traced the dust leak to a seal on that fan switch and told us the problem would be corrected on future DW433 sanders.) Also, because of the location of the dust port, you can't use the bag with the sander mounted in the vertical frame. And the rectangular port doesn't easily attach to a vacuum hose.

Dust issues aside, the overall feel of this sander is very good, with nice, big handles,

outstanding tracking, and a low center of gravity. The DW433 feels to me a little heavier on its left side, but it isn't unbalanced enough to cause control problems.

—Tested by George Granseth



DeWalt DW433KT 3×21" Belt Sander

Performance	★★★★☆
Price	\$220 (includes frame and carrying case)

DeWalt Industrial Tool
800/433-9258, www.dewalt.com

Continued on page 118

Safety glasses put bright light wherever you look

As a woodworker and homeowner, it seems as if I spend a lot of time in areas with inadequate light—working inside a cabinet or wiring a light fixture, for example.

Unfortunately, incandescent work lights create heat and often don't put light where it's needed; battery-powered headlamps are uncomfortable and eat batteries like crazy.

So imagine my delight trying out Craftsman's Lighted Safety Glasses. Super-bright LED lights on their frames run cool and are so comfortable to wear you'll forget you have them on. Although they're bright enough that I could see from one end of my dark 20'-long shop to the other, their forte is lighting within arm's length.

The light created is somewhat blue in color, which takes getting used to. In that light, I found it difficult to distinguish between black and some blues: Consider that if wearing them to do electrical wiring.

Curious about how long the four button-style batteries (about \$2 each to replace) could provide that bright light, I turned on a pair and left them on until they dimmed.



The brightness fell below a useful level after about 52 hours.

The safety glasses fit well over my prescription glasses, and Craftsman also sells the lights and frames without lenses. The lensless version fits better, and costs the same.

—Tested by Paul McClannahan

Craftsman Lighted Glasses

Performance	★★★★★
Price	Lighted Safety Glasses (#93338) or Lighted Frames (#93339), \$20

Sears
www.sears.com/craftsman

Design Breakthrough!

It's the ultimate workbench!
It's a downdraft table!
It's a complete air filtration system!



Deluxe + 30" x 77"

- Generous Maple Worktops
- Powerful 1600, 2100, or NEW 2550 CPM Motor
- GFI Convenience Outlet
- Three Stage Filtering to 0.5 Micron

Ultra Grand 33" x 95"

Call now to find out about our Specials



WOODMARK

P.O. Box 211434 • Bedford, TX 76095

1-800-845-4400

Visa • Mastercard • Amex • FREE CATALOG!

SEIKO MINI INSERT CLOCKS



238S-RWhite



238S-RGold



238S-AWhite



238S-AGold

FEATURES:

- Glass crystal
- Metal case
- Stainless steel back
- 1-7/16" diameter – fits in 1-3/8" hole

SPECIAL OFFER!

5 for \$29.95
postpaid
Retail value \$12.95 each

NEW!
Stainless Steel Back with Rubber Battery Hatch
"The easiest way to change a battery in the industry."

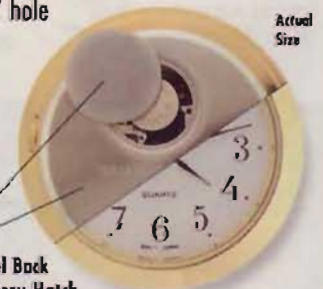

Actual Size

We accept:



Credit cards only.



24120 Detroit Road, Westlake, OH 44145
Phone: 1-800-899-1314 • Fax: 1-440-835-9060

Don't screw that joint, pin it with a Miller Dowel

The unique stepped dowels of the Miller Dowel system provide a large glue surface area to make a strong pinned joint, yet they drive easier than a nail. Straight-sided dowels—even those with glue-relief grooves—require a lot of pounding to drive them more than 2½" deep. To get that much holding power with a Miller Dowel, you have to tap it only about ½" deep.

Choose the species of dowel that suits your project (at press time, you could get them in birch, red oak, cherry, and walnut, with more coming soon), clamp the joint together, and then drill the stepped hole with the Miller Quick-Drill bit. After applying glue to the ribbed middle sections of the dowel, push the dowel into the hole, then tap it home with a hammer or mallet.

I found I could push the dowel about three-fourths of the way into the hole with finger pressure alone, and I never felt the glue's hydraulic pressure fight me as with typical doweled joints. Also, glue didn't squeeze out and make a mess. Yet the fit of the head in the hole was perfect. Even fully

seated, a portion of the dowel head still protruded, but I just cut it off with a flush-trim saw and sanded it flush.

Naturally, the Miller Dowel leaves a plugged look, which you can use to your decorative advantage by choosing a contrasting species of dowel. Miller Dowels come in three sizes: 1X dowels are 2¾" long with ¾"-diameter



heads; 2X dowels (3¾" long) have ½" heads; Mini-X (1¾" long) have ¼" heads.

—Tested by Paul McClannahan

Miller Dowel System

Performance	★★★★★
Price	1X kit (bit and 50 birch dowels), \$25; 2X kit, \$30; Mini-X kit (with 100 dowels), \$23; dowel packs range from \$9 to \$20, depending on size, quantity, and species.

Miller Dowel Company
866/966-3734, www.millerdowel.com

About our product tests

We test hundreds of tools and accessories, but only those that earn at least three stars for performance make the final cut and appear in this section. Testers this issue include: former high-school woodworking teachers **John Cebuhar** and **Paul McClannahan**; and **George Granseth**, who heads the architectural millwork department at a community college. All are avid woodworkers.

www.woodmagazine.com

119

Compare the Air!



Our 2hp Commercial was rated top Dust Collector by Wood Magazine 2003.

"The Oneida 2 Commercial has the most impressive overall performance of all the cyclones in the test, with the highest peak SCFM readings and the ability to sustain that airflow well above 6" of static pressure. This, plus effective fine-dust filtration and fast, easy clean-out earned this sucker Top Tool honors."

WOOD Magazine, Vol. 20, No. 7, Issue 153,
Pg. 98 Twister Test by Michael Morris,
Dave Campbell & Jeff Hall

1.5 - 25hp Systems

- ▶ Test rated filter media captures 0.2 - 2.0 microns @ 11 FPM face velocity
- ▶ 100% Made in USA
- ▶ FREE Catalog
- ▶ Accurate Airflow Ratings
- ▶ Easy Maintenance
- ▶ Ductwork Design Service



Call Us Today!

1-800-732-4065

Now Online Ordering!
www.oneida-air.com



1.5 - 2hp Component

Source Code W504

Oneida Air Systems, Inc. 1001 W. Fayette St., Syracuse, NY 13204

Circle No. 2039

PROXXON

TOOLS WITH CHARACTER

The perfect table saw - quiet, precise and powerful!

For model-building, picture-framing and other intricate projects. With electronically adjustable speeds for working on various materials, all wood types, non-ferrous metals, plastics, rubber, cork and much more.



Table saw
FKS/E

The powerful motor allows for accurate straight cuts and miter cuts up to 45°. It comes equipped with a TCT blade.

The PROXXON line is the assortment for the serious model builder. Every machine one could wish for the delicate project. More than

50 tools, all in a compact size, thus lightweight and easy manageable without ever compromising performance.

High quality German engineered power tools - no matter which project is next on your list, we have the right tool for you!

More information on the line and PROXXON dealers:

— www.proxxon.com/us —

PROX-Tech, Inc., P.O. Box 1909, Hickory, NC, 28603-1909
Toll free 1-877-PROXXON, sales@prox-tech.com

Circle No. 1668



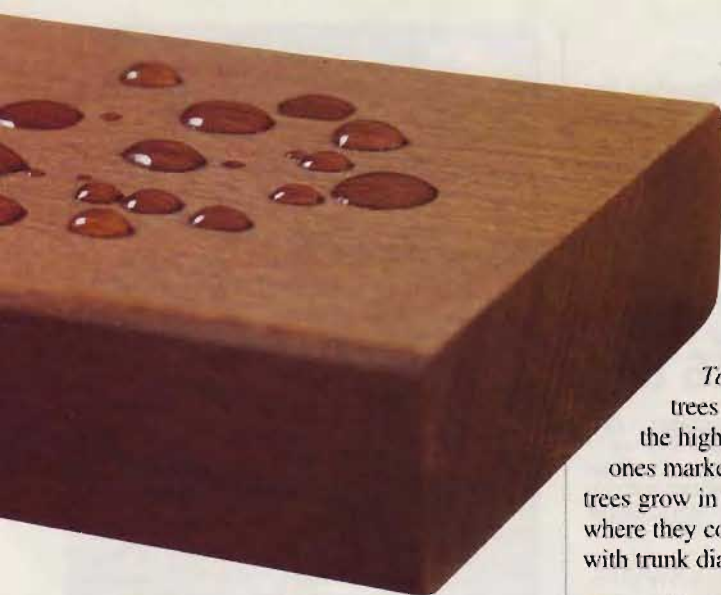

Ipé

A tropical beauty that can withstand the weather.

Tropical hardwoods don't usually spring to mind when considering woods for outdoor projects. But one called ipé (pronounced ee-pay) proves a great choice for such structures because of its incredible resistance to decay and insect infestation. Without any chemical treatment or even a top coat the wood lasts for years outdoors.



Oil finishes give ipé a deep, reddish-brown tone, inhibit fading, and hide the yellow pores.

Photo courtesy of Thompson Mulholland Co., edeck.com

Many woods share one name

Several species of wood fall under the ipé name, but all come from the genus

Tabebuia. Within the species, the trees from the *lapacho* family carry the highest decay resistance and are the ones marketed and sold here as ipé. The trees grow in Central and South America, where they commonly reach 100' heights with trunk diameters of 24" to 36".

Boards filled with beauty and brawn

The rich walnut-color hue of ipé heartwood proves the species' most striking visual characteristic. Fine, interlocking grain also draws your attention, as do tiny deposits of a sulphur-yellow substance called lapachol in the pores. Most retailers stock heartwood only, though you may find some boards bearing narrow band of yellowish-white to tan sapwood, *below right*.

Naturally oily, ipé offers excellent resistance to water penetration, as demonstrated, *above left*. This also means the wood can be left unfinished. Doing so hardly diminishes its durability, but allows the wood to age to a silver tone. To preserve the dark color, apply an exterior oil finish containing ultraviolet inhibitors. See the photo, *below left*.

Ipé resists rot, fungus, and insects (including termites) so well that manufacturers often warrant the wood for 20 to 25 years, even in direct ground contact. This matches the performance of pressure-treated pine without controversial chemicals. Western red cedar and redwood are well-suited to outdoor use as well, though both require finishing and regular upkeep for longevity.

Ipé's durability also results from its high density and heavy weight, at 69 to 80 pounds per cubic foot (pcf). In comparison, redwood and Western red cedar weigh just 27 pcf and 23 pcf, respectively. Comparing the weight of pressure-treated pine proves difficult, because water-based chemicals often account for much of the weight in freshly treated stock.

With almost twice the bending strength and five times the hardness of treated pine, ipé also proves strong. As evidence, 5/4 (1 1/16") ipé deck boards can span 24", while the same size pine board handles only a 16" span. Once dried (to a moisture content of 15- to 18-percent), the wood remains stable.

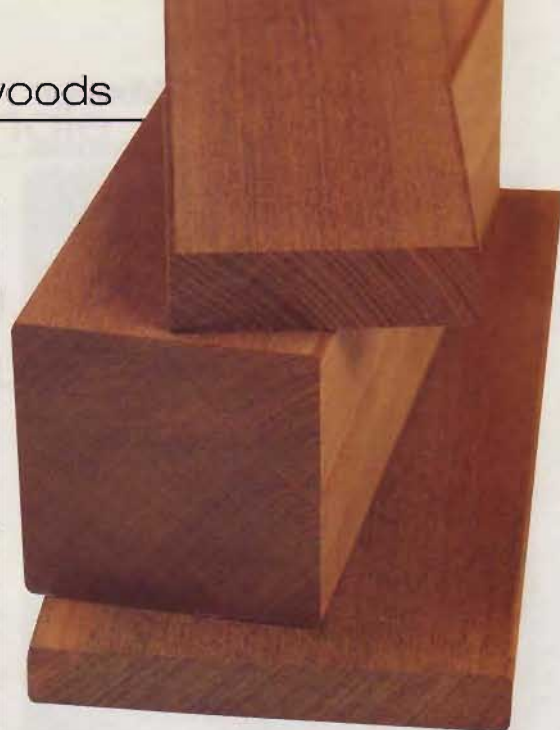

Retailers commonly stock 1x4, 1x6, and 4x4 ipé stock. Some also carry 2x2 and 2x4 stock for deck railings.

Expect to pay more

With so much going for it, you may wonder why ipé isn't used more widely. First, the wood can be difficult to find. To get it, you'll have to go to a specialty hardwood dealer. They place a high price on the wood due to its scarcity as well as the high cost of importing the heavy stock. Some price ipé by the linear foot because the wood is most often milled to the standard dimensional sizes, *above*, used in deck construction. Many dealers, though, price these boards and timbers by the board foot. In our area, costs run about \$5.25 per board foot.

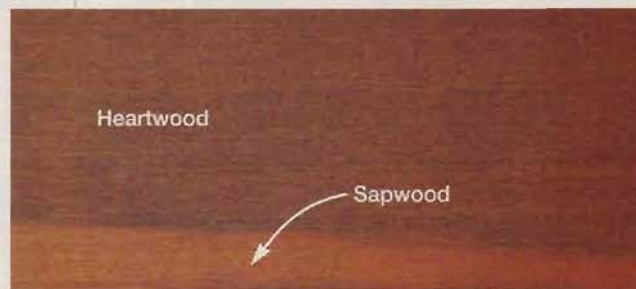

Ipé sapwood carries a white to tan color and proves less resistant to decay than the darker heartwood.

Machining ipé: A dull story

In addition to its legendary performance, ipé has a well-earned reputation for quickly dulling cutting tools. If you've worked with such dense hardwoods as maple, though, you won't be surprised by ipé's affect on bits and blades. You will have to predrill for screws or nails. The wood won't split; it simply will refuse fasteners unless you first drill a pilot hole. ♣

what's ahead

A sneak peek at just some of the articles in the June/July issue (on sale May 19)

FEATURED PROJECT

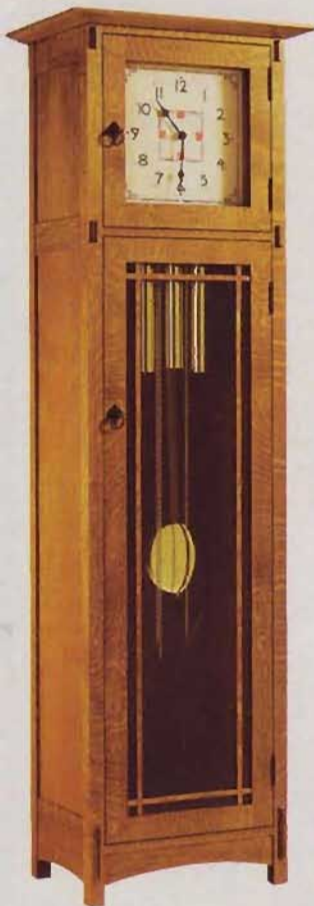

Mission tall clock

Your investment of time and talent in this project will reward you with a prized family heirloom.

For your home, garden, and workshop



Garden bench

Add elegance to your outdoor spaces with this durable, easy-to-make seat.



Woodturning doubleheader

Find plans for turning a rock-solid mallet as well as an article on choosing and using today's best 4-jaw chucks.



Soup up your drill press

Increase the accuracy, convenience, and work capacity of your drill press with this shop-made table and fence system. Goodies include micro-adjustable stop, hold-downs, and replaceable table insert.



Wind chimes

Build this soothing sound-maker and learn how to rout your own dowels in the process.

More great features

TOOL TEST



Benchtop mortisers

Making mortises just got easier with one of the seven machines reviewed and rated here.



Varnish flaws be gone!

Rid your projects of runs, lap marks, dust nibs, and other finish boo-boos by following these tips.



Tool-storage winners

See the reader projects that earned top honors in the WOOD®/Chevy Rugged 'N' Ready tool-storage contest.



Sam Maloof: master chairmaker

Few woodworkers can fetch \$10,000 for a rocking chair. Discover the tricks of this renowned designer and craftsman.