

Build an ARTS & CRAFTS TALL CLOCK p.38

JUNE/JULY 2004 ISSUE 156

Better Homes and Gardens

BRUSH ON  
A PERFECT  
VARNISH FINISH p.92

# WOOD

mortise & tenon joints made *very* easy

3 goofproof ways show you how p.68

8 MUST-MAKE PROJECTS for your home, yard, & shop

**BONUS POSTER**  
YOUR GUIDE TO  
WORKSHOP  
GLUES p.59



# WOOD

June/July 2004, Issue 156

## PROJECTS

- 22 portable glue/paper towel center
- 38 heirloom tall clock
- 52 feature-packed drill-press table
- 65 letter opener
- 74 build-in-a-weekend garden bench
- 94 wind chimes
- 96 classic turned mallet

## TECHNIQUES

- 28 epoxy: a pro's tips
- 32 how to show off quartersawn oak  
Discover the tricks for playing up eye-grabbing ray-fleck figure in project parts.
- 48 building chairs with Sam Maloof  
See how a renowned master craftsman designs and assembles his signature furniture pieces.
- 66 how to deal with wood moisture
- 68 master the mortise-and-tenon joint  
From low-tech to dedicated machines, get to know three ways for making snug-fitting parts.
- 84 get a grip on four-jaw chucks  
Learn the advantages and use of this problem-solving lathe accessory.
- 92 brush on a flawless varnish finish

## TOOLS & MATERIALS

- 14 wise buys: Japanese pull saws
- 59 **BONUS POSTER:**  
guide to woodworking glues
- 78 shop-tested benchtop mortisers  
Seven moderately priced models compete to earn our prestigious "top tool" rating.
- 88 2004 tool storage contest winners  
Check out 13 of the best shop projects from around the nation.
- 100 hollow mortise chisels  
Get maximum performance from your cutters with these pointers on use and care.
- 115 rated: three shop-proven products

## DEPARTMENTS

- 8 editor's angle
- 10 sounding board
- 16 sanding-drum dust collector
- 18 short cuts
- 24 ask WOOD
- 36 wood words
- 104 shop tips
- 110 curious craftsman
- 120 what's ahead

## SPECIAL SECTION

### Mortise-and-Tenon Joinery

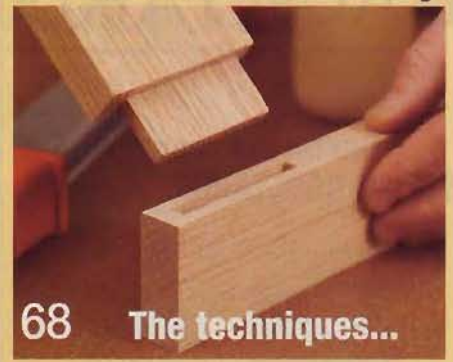

68 The techniques...

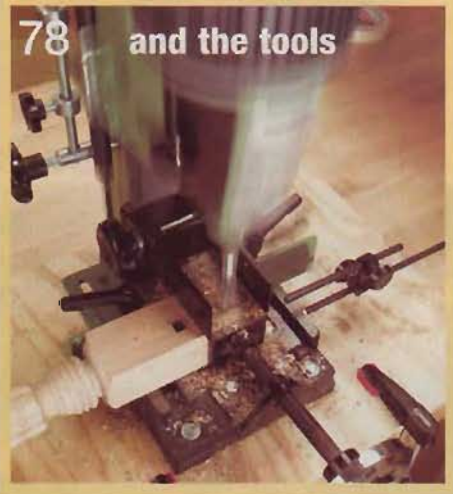

78 and the tools



88

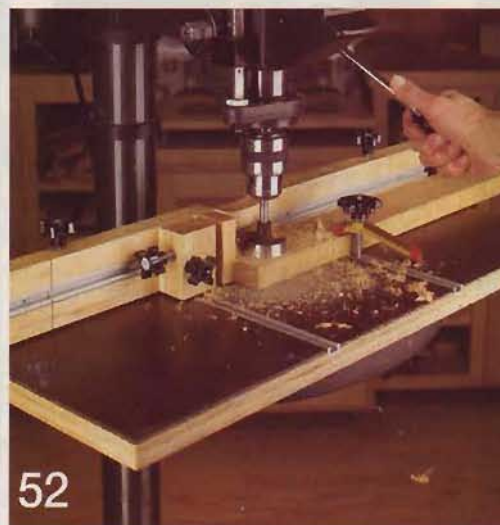

52



38



14



74



This seal is your assurance that we build every project, verify every fact, and test every reviewed tool in our workshop to guarantee your success and complete satisfaction.

# GREAT AMERICAN BACKYARD

contest

## DECK OUT YOUR YARD WITH A \$10,000 BACKYARD MAKEOVER

Using a natural palette and textured finishes, you too can transform timeworn patio furniture and accessories into a stylish outdoor living space.

Send a 100 word or less creative essay telling us why your backyard is the ideal candidate for a makeover. Include a color photo of your yard.



Every entrant receives a free Dream Spaces decorating booklet that will help you create your own makeover. The winner gets a \$10,000 backyard makeover complete with a professional design consultant.



**RUST-OLEUM**

stopping rust is just the start.™

No purchase necessary. Contest is open from 5/15/2004 — 7/31/2004 to homeowners age 21 and over who are legal US residents. Enter online at [great-american-backyard.com](http://great-american-backyard.com) or mail photo and essay with full name, date of birth, address (with zip code) and telephone number to: Rust-Oleum Great American Backyard Contest, c/o ARS, 43 N. Canal Street, Chicago IL 60606. Entries must be postmarked July 31, 2004. Void where prohibited. For official rules and judging criteria, visit [great-american-backyard.com](http://great-american-backyard.com), or send a self-addressed stamped envelope to: Rust-Oleum Great American Backyard Contest, c/o ARS, 43 N. Canal Street, Chicago IL 60606.

© 2004 Rust-Oleum Corporation

# Better Homes and Gardens® WOOD®

June/July 2004

Vol. 21, No. 3

Issue No. 156

EDITOR-IN-CHIEF  
BILL KRIER

Executive Editor **JIM HARROLD**      Managing Editor **MARLEN KEMMET**

Senior Design Editor **KEVIN BOYLE**      Products Editor **DAVE CAMPBELL**

Techniques Editor **JIM POLLOCK**      Features Editor **DAVID STONE**

Projects Editor **OWEN DUVAL**      Projects Editor **JAN SVEC**

Design Editor **JEFF MERTZ**      Master Craftsman **CHUCK HEHLUND**

Art Director **KARL EHLERS**

Associate Art Director **GREG SELLERS**

Assistant Art Director **CHERYL A. CIBULA**

Production/Office Manager **MARGARET CLOSNER**

Administrative Assistant **SHERYL MUNYON**

Photographers

**MARTY BALDWIN, SCOTT LITTLE, BLAINE MOATS, JAY WILDE**

Illustrators

**TIM CAHILL, LORNA JOHNSON, ROXANNE LeMOINE, MIKE MITTERMEIER**

Technical Consultants

**JOHN CEBUHAR, DEAN FIENE, JEFF HALL, GARRY SMITH**

Contributing Craftsman

**JIM HEAVEY**

Proofreaders

**BARBARA KLEIN, JIM SANDERS, MARGARET SMITH**

Publisher **MARK HAGEN**

ADVERTISING OFFICE: 333 N. Michigan Ave., Suite 1500, Chicago, IL 60601

Phone: 312/853-2890 Fax: 312/580-7906

Sales and Marketing Assistant **NEILLE MORRIS**

Account Executive **JACK A. CHRISTIANSEN**

Direct Response Manager **CAROLYN DAKIS**

Direct Response Sales Representative **SANDY ROBINSON**

Account Executive **JOHN THORNBURGH** Detroit,

Phone: 248/356-1149 Fax: 248/356-8930

Account Executive **PATRICK R. TOMLINSON, SR.** Northeast,

Phone: 212/551-7043 Fax: 212/551-7192

**Southeast:** Lagonarsino, Dempsey & Dennis, Inc.

2951 Piedmont Rd. NE, Suite 100, Atlanta, GA 30305

Phone: 404/261-5400 Fax: 404/261-5404

Group Marketing Director **CATHY E. SMITH**

Senior Marketing Services Manager **MARY M. WRIGHT**

Senior Promotion Designer **SARAH MASSIMO**

Group Publisher **STEPHEN B. LEVINSON**

Associate Business Director **CRAIG FEAR**

Consumer Marketing Director **ROBIN HUTCHINSON**

Consumer Marketing Manager **LESLIE SHAEFFER**

Newsstand Product Manager **LISA TROM**

Advertising Operations Manager **PAT HENDERSHOTT**

Sr. Production Manager **MICHAELA LESTER**

Vice President/Publishing Director **WILLIAM R. REED**

**MEREDITH PUBLISHING GROUP**

President **STEPHEN M. LACY**

President, Magazine Group **JACK GRIFFIN**

Corporate Solutions **MICHAEL BROWNSTEIN**

Creative Services **ELLEN DELATHOUDER**

Manufacturing **BRUCE HESTON**

Consumer Marketing **KARLA JEFFRIES**

Finance and Administration **MAX RUNCIMAN**

**Meredith**  
CORPORATION

**WILLIAM T. KERR**, Chairman and Chief Executive Officer

In Memoriam — **E. T. Meredith III (1933-2003)**

©Copyright Meredith Corporation 2004  
All rights reserved. Printed in the U.S.A.



Dave made three guitar stands like this one for Christmas presents.



Mark created this kneeler and screen for the confessional of his church.



Mary and Cathy built the keepsake box from issue 143.

# The Toughest Glue On Planet Earth



**Bonds:**  
Wood, Stone, Metal,  
Ceramic, & More!

Gorilla Glue is the versatile, interior/exterior adhesive ideal for most household fixes and building projects: furniture repair, crafts, woodworking, and general repairs around the house. Bonds wood, stone, metal, ceramic & more! Incredibly strong and 100% waterproof.



**REQUEST YOUR FREE  
INFORMATION KIT!**

[www.gorillaglu.com](http://www.gorillaglu.com)

1-800-966-3458

Circle No. 50

## editor's angle

# air-dried wood: just as good as kiln-dried?

There's a common woodworking myth that air-dried wood is more prone to warping, shrinking, or expanding than kiln-dried wood. Don't believe it—doing so could cost you serious dough when buying boards.

**I**t happened 15 years ago, but I still vividly remember the day I passed up the best lumber deal of my life. It was at a farm auction where the entire contents of a small shed were up for sale. That shed was stuffed to its rafters with a thousand or so board feet of beautiful walnut planks. They had been carefully stacked and stickered, appeared completely dry and flat, and, according to the auctioneer, had been sitting there for at least 25 years. All day long I hadn't found anything at that auction I wanted, but this pile of walnut was different. I yearned for it.

As the bidding began, I told my companions (both experienced woodworkers) that I was ready to make a purchase.

"Be careful," one of them advised. "You don't know what you'll get with that air-dried stuff. It might split or warp months after you build something with it."

"Heck," the other friend said, "I built a coffee table with air-dried stock and it *exploded* right there in my living room!"

I had my doubts about their claims. For centuries our ancestors made beautiful, long-lasting furniture from air-dried stock, and that *explosion* was probably due to faulty joinery. But I decided not to take a chance, and put my auction number card back into my coat pocket. Big mistake.

The auctioneer started off asking \$150 for that wood: about 15 cents per board foot. And no one would pay it! Apparently, I was not the only victim who chose to give in to the myth and avoid taking a chance on air-dried stock. Eventually, some lucky soul paid \$75 for the entire lode.

Since that day, I've wised up in my wood-buying ways, and all of my research tells me that air-dried lumber is no worse



This pile of air-dried oak (parked where my wife used to put her van) has supplied the stock for dozens of projects over the past couple of years.

than kiln-dried stock, and often better. It's less likely to have "honeycombing" or the other defects that can result from hasty kiln drying, as described in Features Editor David Stone's report on *page 66*.

Of course air-drying takes time, typically 6–12 months for each inch of thickness. You need to dry the wood outside, then restack it inside for the final dry-down. You'll need a moisture meter to make sure the wood's moisture content reaches equilibrium with the relative humidity level in your shop and home (6–11 percent moisture content depending on where you live).

So why do lumber producers spend big money on kilns and the energy to run them? Because time is money and commercial kilns cut total drying time to about 6 weeks. Fortunately, few of us hobbyists are under such time pressures to produce lumber.

To learn more about air-dried stock, see issue number 59, pages 40–41, or go to [woodmagazine.com/airdry](http://woodmagazine.com/airdry). You'll find everything you need to air-dry your own stock, or buy it with confidence from someone else. Wish I had that information 15 years ago.

*Bill Krier*

# sounding board

Our bulletin board for letters, comments, and timely updates

## Bigger magazines need upsized storage

Thanks for growing the magazine by  $\frac{3}{8}$ " in width and height (starting with issue 153) to make space for even more information.

Anyone who stores their back issues in the magazine boxes shown in issue 108 (page 50), though, has discovered the bigger issues are just a hair too tall to fit the box design. When readers make more storage boxes, they'll need to enlarge them accordingly.

Ralph Jones, London, Ohio

Here's an updated drawing. If you'd like the complete free plan, go to [woodmagazine.com/magbox](http://woodmagazine.com/magbox).

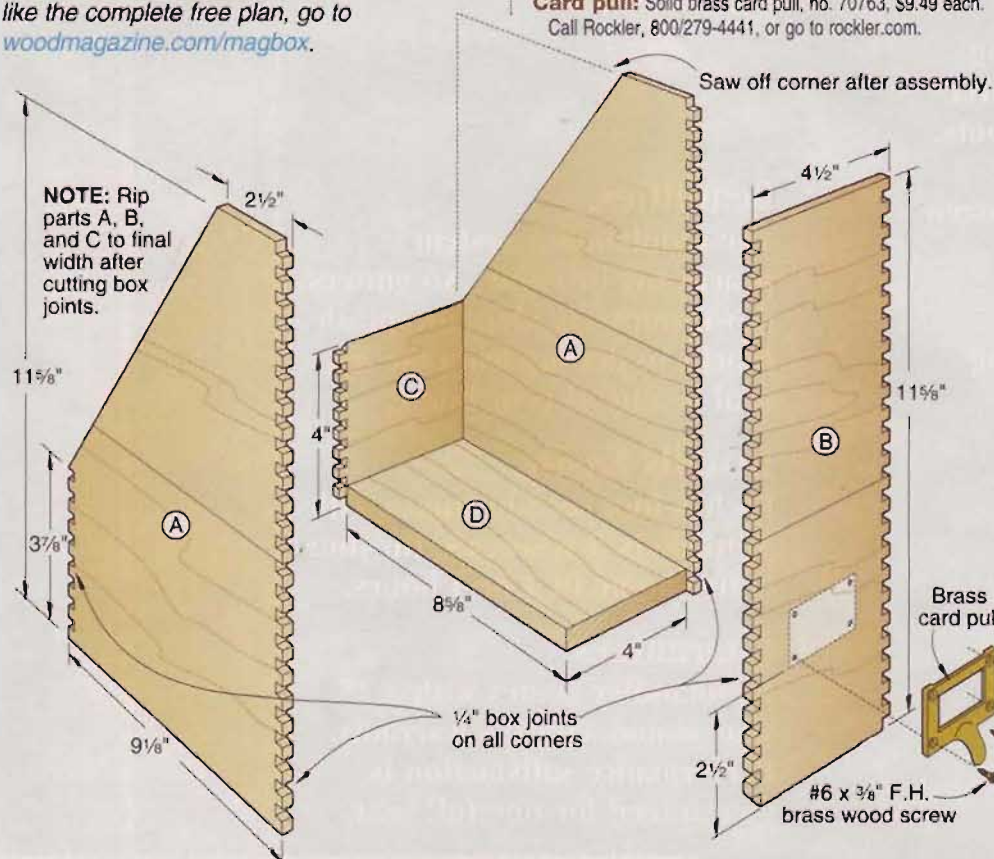

## Materials List

Part	FINISHED SIZE			Matl.	Qty.
	T	W	L		
A* sides	$\frac{1}{4}$ "	$11\frac{5}{8}$ "	$9\frac{1}{8}$ "	M	2
B* back	$\frac{1}{4}$ "	$11\frac{5}{8}$ "	$4\frac{1}{2}$ "	M	1
C* front	$\frac{1}{4}$ "	4"	$4\frac{1}{2}$ "	M	1
D bottom	$\frac{1}{2}$ "	4"	$8\frac{5}{8}$ "	M	1

\*Parts initially cut oversize, then ripped to finished width after cutting box joints. See the instructions.

Materials key: M—mahogany

## Sources

Card pull: Solid brass card pull, no. 70763, \$9.49 each. Call Rockler, 800/279-4441, or go to [rockler.com](http://rockler.com).

## Article updates

**Cat's meow scrollsawn plaque** (issue 154, page 96): Locate the hole for the cutout block  $2\frac{3}{16}$ " from the left edge of the plaque.

**Super-flexible shop storage** (issue 152, page 86): Locate the top three storage-bin mounting brackets in the Hardware Cabinet (Drawing 9) with  $4\frac{1}{4}$ " spacing in between, as shown, below. ⬆



## HOW TO REACH US

### ■ Editorial questions and feedback:

E-mail [woodmail@woodmagazine.com](mailto:woodmail@woodmagazine.com); call 800/374-9663 and press option 2; or write to WOOD magazine, 1716 Locust St., GA-310, Des Moines, IA 50309-3023.

### ■ Subscription assistance:

To notify us of an address change or to get help with your subscription, go to [woodmagazine.com/service](http://woodmagazine.com/service); call 800/374-9663 and press option 1; or write to: WOOD magazine, P.O. Box 37439,

Boone, IA 50037-0439. Please enclose your address label from a recent magazine issue.

### ■ To find past articles:

Go to our continuously updated online index at [woodmagazine.com/index](http://woodmagazine.com/index).

### ■ To order past issues and articles:

Order past issues of WOOD magazine and our newsstand special issues at [woodstore.woodmail.com](http://woodstore.woodmail.com) or by calling 800/346-9663. Be aware that many early issues

are sold out. For reprints, send \$5 per article (no phone orders), including the article name and issue number, to: WOOD Article Reprint Service, P.O. Box 349, Kalona, IA 52247; make check or money order payable to WOOD magazine.

### ■ Updates to previously published projects:

For a complete list of known changes in dimensions and buying guide sources from issue 1 through today, go to [woodmagazine.com/editorial](http://woodmagazine.com/editorial).

our editors test

# Japanese pull saws

## Why buy?

Unlike Western-style handsaws—the style most of us grew up with—a Japanese handsaw cuts on the pull stroke instead of the push. That makes the saw accurate (it's easier to pull a blade straight than to push it) and efficient (the thin blade removes less material). It also allows the manufacturers to harden the cutting teeth more than on a Western-style saw (whose teeth must be softer to withstand the impact of a "catch"), meaning they stay sharp longer. When the saw gets dull, simply replace the blade. We find three styles of pull saws most useful to woodworkers: For crosscuts, *dozuki* (doh-ZOO-kee) saws sport a stiffener to keep their super-thin blades from buckling during the return stroke; the slightly thicker blades of double-edged *ryoba* (ree-OH-buh) saws have fine crosscut teeth on one edge and coarser ripping teeth on the other; and the teeth of a *kugihiki* (koo-gee-HEE-kee) saw cut flush to the adjacent workpiece without marring it.

Type Brand, Price

Dozuki Rockler Dozuki Dovetail Saw, \$42



### Editor test-drive:

This saw features a fine 25-teeth-per-inch (tpi) pitch, and produces a pencil-thin kerf (less than  $\frac{1}{16}$ " thick). With its rigid back, it tracks true, although the stiffener limits the depth of cut to about 2". (When crosscutting, though, I doubled that capacity by cutting  $\frac{1}{4}$ " deep on all four sides of a thick workpiece, as if defining the shoulders of a tenon, then completed with full-depth cuts.)

I hand-cut a few drawer dovetails using the Rockler Dozuki Dovetail Saw and it easily

stayed on my layout lines, even cutting diagonal to the grain without wandering. When used to fine-tune the fit of some interior millwork, this saw excelled in both crosscutting and ripping. And I found I could cut close-fitting notches in the molding more accurately—and in less time—than I could using my power jigsaw.

—Tested by David Stone, Features Editor

To learn more:  
800/279-4441, rockler.com

Ryoba Japan Woodworker 19.605.0, \$26

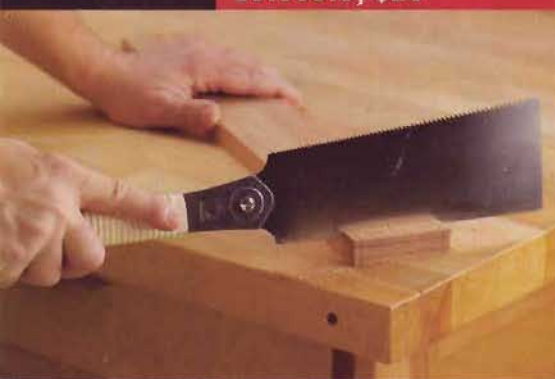

### Editor test-drive:

I've used Japanese-style saws for many years, and frankly, wouldn't own any other kind of handsaw. This ryoba was extremely sharp out of the box and, using the 17-teeth-per-inch crosscut edge, I crosscut a slab of  $\frac{3}{4}$ "x4" hard maple cleaner and in about one-fourth fewer strokes than with a fine-tooth miterbox saw. And, cutting on the pull stroke, I found it much easier to accurately start the cut with the ryoba. Likewise with using the 8-tpi rip edge: faster, cleaner, and more accurate.

The handle on the Japan Woodworker ryoba pivots where it joins the blade so you can swing it to a more comfortable working position if you like, or use the saw in a tight spot. Even if you used only the crosscut edge, this saw would be well worth its \$26 price; the rip edge is just icing on the cake. A razor-sharp replacement blade costs only \$15.

—Tested by Kevin Boyle, Senior Design Editor

To learn more:  
800/537-7820, thejapanwoodworker.com

Kugihiki Veritas Double-Edge Flush Saw, \$17



### Editor test-drive:

I confess that I've had little luck when using the kugihiki saw in the *WOOD*® magazine shop. In fact, I'd pretty much written off the "no-marring" concept of a zero-set saw as overrated until I tried the Veritas Double-Edge Flush Saw. Its stiffer blade resists distorting during the cut, but still flexes enough to press flat against the workpiece. And the top-set teeth (the blade warns: "this side up") cut aggressively to prevent binding—another problem with other flush saws.

To test this saw, I drilled and dowel-plugged several holes in easy-to-scratch obeche ply-

wood. I quickly trimmed a dozen dowels without marring the surrounding surface. Impressed, I pulled a piece of polyurethane-finished red oak from my scrap bin and repeated the test, again without leaving so much as a scratch in the finish. This saw cuts equally well left- or right-handed and far exceeded my expectations. And although its blade isn't removable, the low price makes it easy to replace the whole saw.

—Tested by Jan Svec, Projects Editor

To learn more:  
800/871-8158, leevalley.com

# sanding-drum dust collector

Looking to add even more functionality to the add-on drill-press table featured on page 52? Consider this integral dust-collecting system that channels fine dust to a vacuum hose during sanding-drum operations.

**W**hether you add sanding-drum dust collection to the add-on drill-press table in this issue, or to some other table, here's the lowdown on how to do it. Before applying the finish and installing the mini-track, lay out a 2½"-wide stopped channel that intersects the 3½"x3½" cutout in the table, where shown on the drawing, *below*. (Lay out the channel to the right or left of the center cutout, depending on the most convenient location for your shop vacuum.) Then adhere scrapwood guides to the table with double-faced tape, aligning them with the layout lines. Now rout a ⅝"-deep channel, as shown at *middle right*.

**Note:** If your table doesn't have a cutout and insert, drill ⅜" corner holes, and jig-saw a cutout. Then rout a ⅜" rabbet ¼" deep around its edges for a ¼"-thick insert.

Change to a ⅜" rabbeting bit, and rout a ⅜"-deep rabbet along the edges of the center cutout and the channel, as shown at *bottom right*. Stop the rabbet where dimensioned on the drawing, *below*. Cut two ⅜" hardboard covers to fit the rabbeted openings, and glue and clamp them in place. Apply a finish, and install the mini-track. Using the holes in the shop-vacuum dust port as guides, drill screw holes, and fasten it in place. ♣

### Source

**Dust port.** Plastic shop vacuum dust port no. 03J61.10, \$2.15. Lee Valley Tools Ltd. Call 800/871-8158 or go to [leevalley.com](http://leevalley.com).

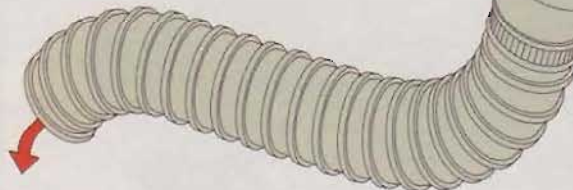
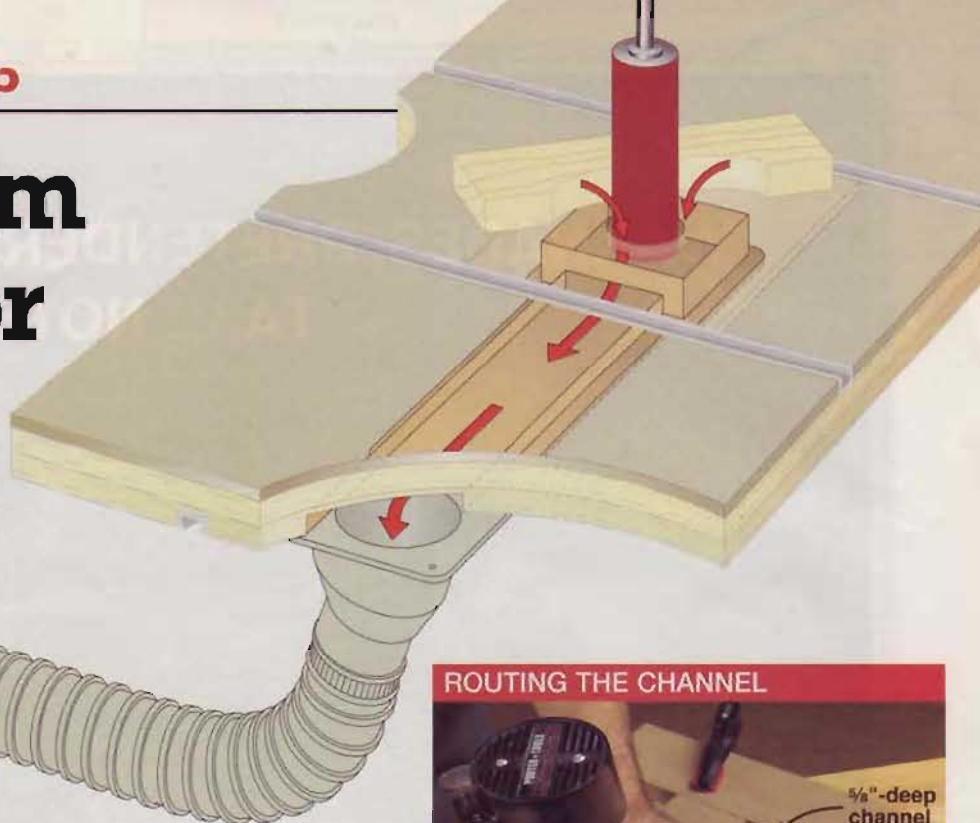

### ROUTING THE CHANNEL

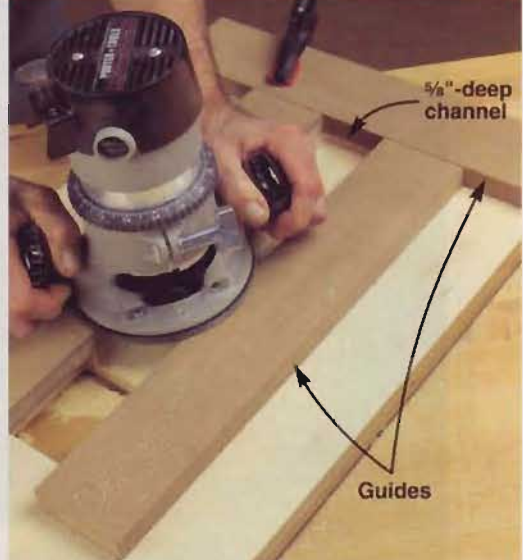

Using a pattern bit guided by scrapwood guides, rout a 2½"-wide stopped channel ⅝" deep in the bottom of the table.

### ROUTING THE RABBET

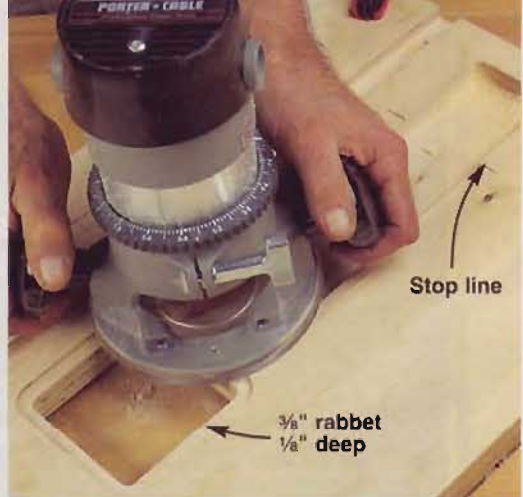

Rout a ⅜" rabbet ⅛" deep along the edges of the 3½"x3½" cutout and the edges of the 2½"-wide channel, stopping 3" from its end.

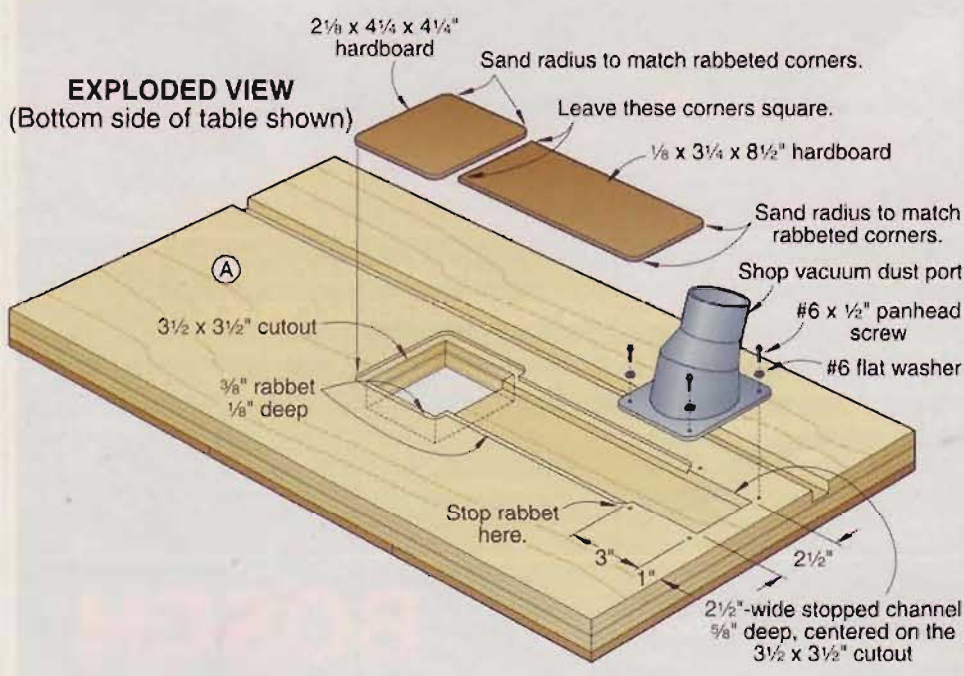

# short cuts

News and notes from the woodworking world

## A hull of a workshop

Just because you live on water doesn't mean you can't work with wood. Simply ask Ron Moreland. His home—a 24×55' houseboat—floats on the tidal waters of the San Francisco Bay in Sausalito, California. After retiring two years ago, Ron built a compact workshop in a 9×15' unfinished bedroom in the boat's hull, placing the shop under water, so to speak. "I found workshop books of little value since none of them dealt with an area this small," claims Ron. "Other than the jointer, I found I was able to put everything in the shop. Each tool has its place and must be put back before using the next one." By "everything" Ron means a tablesaw, a full complement of benchtop power tools, and a total-shop dust-collection system.

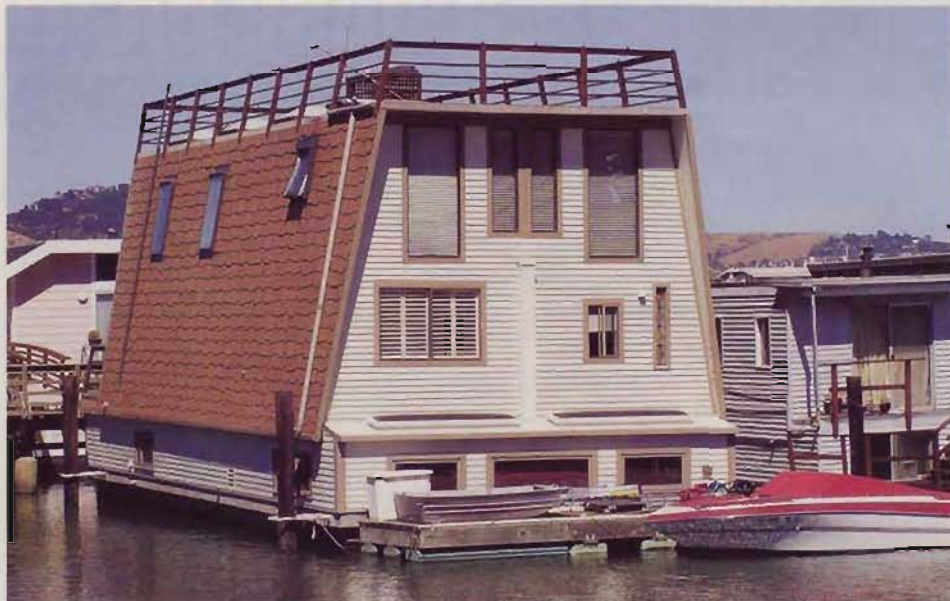

Within the depths of this houseboat lies a fully functional workshop where Ron Moreland builds china cabinets, chests of drawers, and dining tables.

## When wood pulp (almost) ruled the seas

Here's a little-known history lesson from the annals of World War II. Frustrated with the U-boat threat to shipping, Great Britain, under the leadership of Winston Churchill, gave the initial OK to develop a giant unsinkable 2,000'-long aircraft carrier made from ice and wood pulp. Pykrete, the brain-child of Geoffrey Pyke, was a material that could be hammered and sawn and took forever to melt. Because it consisted of 90 percent frozen water, it resisted sinking if hit. And it patched easily, since the ship—slated to be called the HMS Habbakuk—would be

constructed of some 280,000 easily replaceable Pykrete cubes.

Naturally, it would be a cold-water ship, made in Canada by 8,000 workers. Plans called for a hollowed-out interior featuring crew quarters, hangars, and a huge refrigeration plant with 50'-thick walls. Propelling the Habbakuk at a top speed of 10 knots: 26 electric engines powered by a central generating plant. However, the U-boat threat declined due to anti-submarine warfare breakthroughs and codebreaking, melting away any interest in the costly "berg-ship."

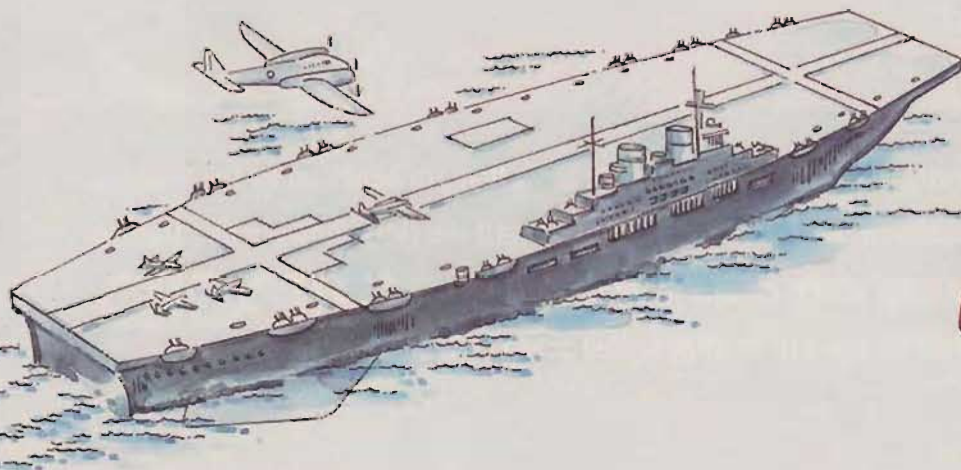

An unsinkable giant aircraft carrier made of ice and wood pulp was once on the planning table to become the pride of the British navy during World War II.

## A bit of a stretch

Ever cut a project part too short or worked hard trying to eke the most from every board foot of some precious hardwood? Of course! It's happened to all of us. Here's how Rod Siminski of Lafayette, Indiana, solved the short-board dilemma. He calls it his "wood stretcher." OK, so it doesn't really work, but it sure looks like it does. Says Rod, "All my woodworking buddies stare at it and conclude, 'I've been looking for one of those.'"

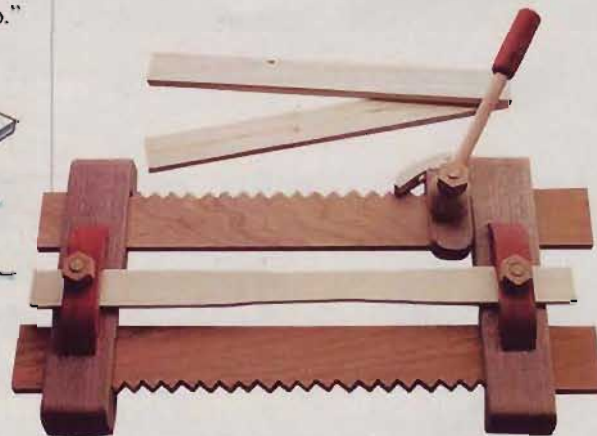

Rod Siminski's ratcheting wood stretcher seldom fails to draw a smile from onlookers. Measuring 18" long, it's made of pine, cherry, walnut, padauk, and maple.

*Continued on page 20*



### Test your workshop smarts

Between projects and looking for some stimulation? Ply your woodworking IQ on these cerebral challenges. For the answers, see the next Short Cuts in *WOOD* magazine, or go online right now to [woodmagazine.com/editorial](http://woodmagazine.com/editorial).

■ For what major workshop tool can we thank the Shakers?

■ What clear woodworking finish among oil or film-forming products holds up best in direct sunlight?

■ Name the wood that for centuries has been the preferred species of violin bow makers.

Answers to the questions in issue 155:

■ Can you name five woodworking tools that hail from the Stone Age?

The knife, chisel, auger, adze, and axe (shown below) were all there at the dawn of woodworking. Unfortunately for those early craftsmen, it wasn't until thousands of years later that *WOOD* magazine arrived on the scene.

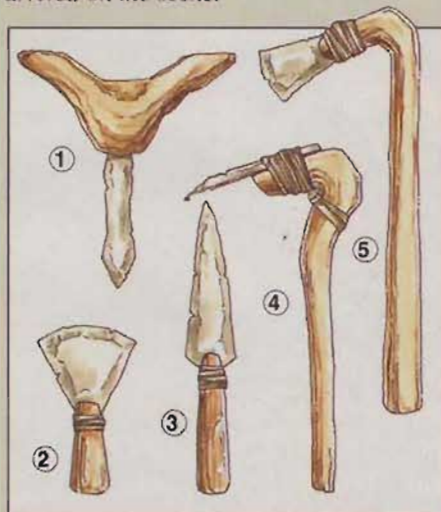

The auger (1), chisel (2), knife (3), adze (4), and axe (5).

■ What's the more common term for the woodworking process known as pyrography?

Woodburning. More precisely, the term pyrography derives from the Greek words *pur* (meaning fire) and *graphos* (meaning writing). Regardless of the name, the artistic process dates back to 17th-century Europe when small woodenware items,

and later furniture, were decorated with fire-heated iron tips. In creative hands the end results can prove quite impressive.

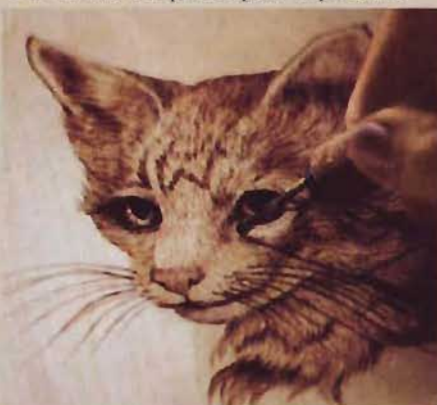

Today, woodburning artists use electrically heated pens and a variety of interchangeable tips to create designs.

■ How do you figure the length for a bandsaw that doesn't have a blade to measure from?

If you lost your bandsaw owner's manual and don't have a blade to measure from, or if you've added riser blocks, put this simple math formula to work to determine your tool's blade length:

$$\text{Blade length} = (2 \times A) + (3.14 \times B)$$

Key:

A = distance in inches between bandsaw wheel centers when the upper wheel is midway in its adjustment range

B = bandsaw wheel diameter

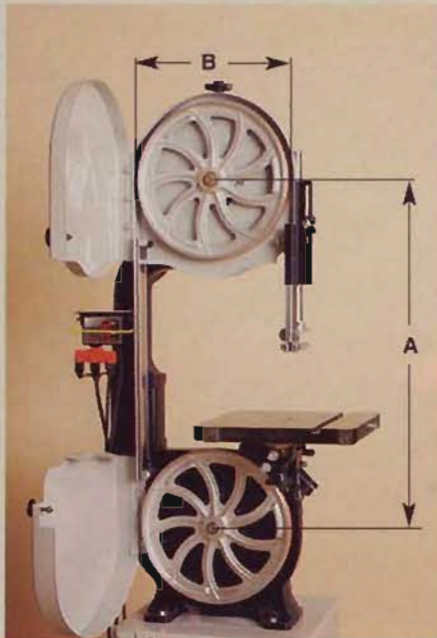

### Woodturners, mark your calendars

On June 10-12, 2004, the Utah Woodturning Symposium will celebrate its 25th anniversary at Brigham Young University in Provo. Its biggest event ever, the UWS plans to include more than 100 demonstrations by world-class turners and an exhibition of work that represents 130 turners from 12 countries. To learn more or register for a workshop, visit [utahwoodturning.com](http://utahwoodturning.com), or call 801/422-2021.

### Buy a tool, get a free education...and plans

Here's a heads-up that woodworkers of all skill levels will like. From June 1 through July 31 of this year, Delta Machinery will run a special promotion for buyers of its tools at Lowe's home centers. With the purchase of any Delta machine, you can buy the new Do-It-Yourself Woodworking Kit for \$19.95, then mail in the tool's rebate and be reimbursed for the Kit's full amount. What is the "Kit"? It's a CD jam-packed with 15 quality project plans from *WOOD* magazine, and loads of tips and techniques by TV's master woodworker Scott Phillips.

In his presentation, Scott works through the machining operations, tune-ups, and safe use of six major workshop machines: the tablesaw, bandsaw, drill press, thickness planer, jointer, and compound mitersaw. He tops that with the step-by-step construction of a Shaker-style bookcase from the March 2004 issue of *WOOD*.

In addition, you'll receive printable drill and screw charts and articles on shop layout, dust-collection, finishing, and more. What if you don't buy a Delta machine? No problem. You can still get the CD for an unrebated \$19.95.



TV's master craftsman Scott Phillips and *WOOD* magazine Editor-in-Chief Bill Krier pause for a photo during the taping of Delta's new Do-It-Yourself Woodworking Kit.

# portable glue/paper towel center

Equally at home mounted on a wall or sitting on your workbench.



## Wall Storage System



**H**ang this handy organizer on the Idea Shop 5 cleat system featured on page 86 of the November 2003 issue of *WOOD* and quickly lift it off and move it wherever you work. It keeps your glue and glue clean-up supplies close at hand. For this shop aid, cut parts A–D from 1/2" plywood, part E from

1/4" hardboard, part F from 1/2" solid stock, and part G from 3/4" stock to the sizes noted on the drawing below. Cut the dowel groove in the supports (D) to shape. Cut the dados, rabbets, and grooves, where illustrated, in parts A, B, and F. Assemble the unit. Cut a 3/4" dowel to fit between the side pieces and into the dowel groove.

To hang the center in a shop without the cleat system, eliminate part G. For use with the Idea Shop 5 cleat system, screw the cleat to the back F with the top edges of F and G flush.

### 1a CLEAT DETAIL



See more of the Idea Shop 5 wall storage system at [woodmagazine.com/IS5](http://woodmagazine.com/IS5)

### 1 EXPLODED VIEW

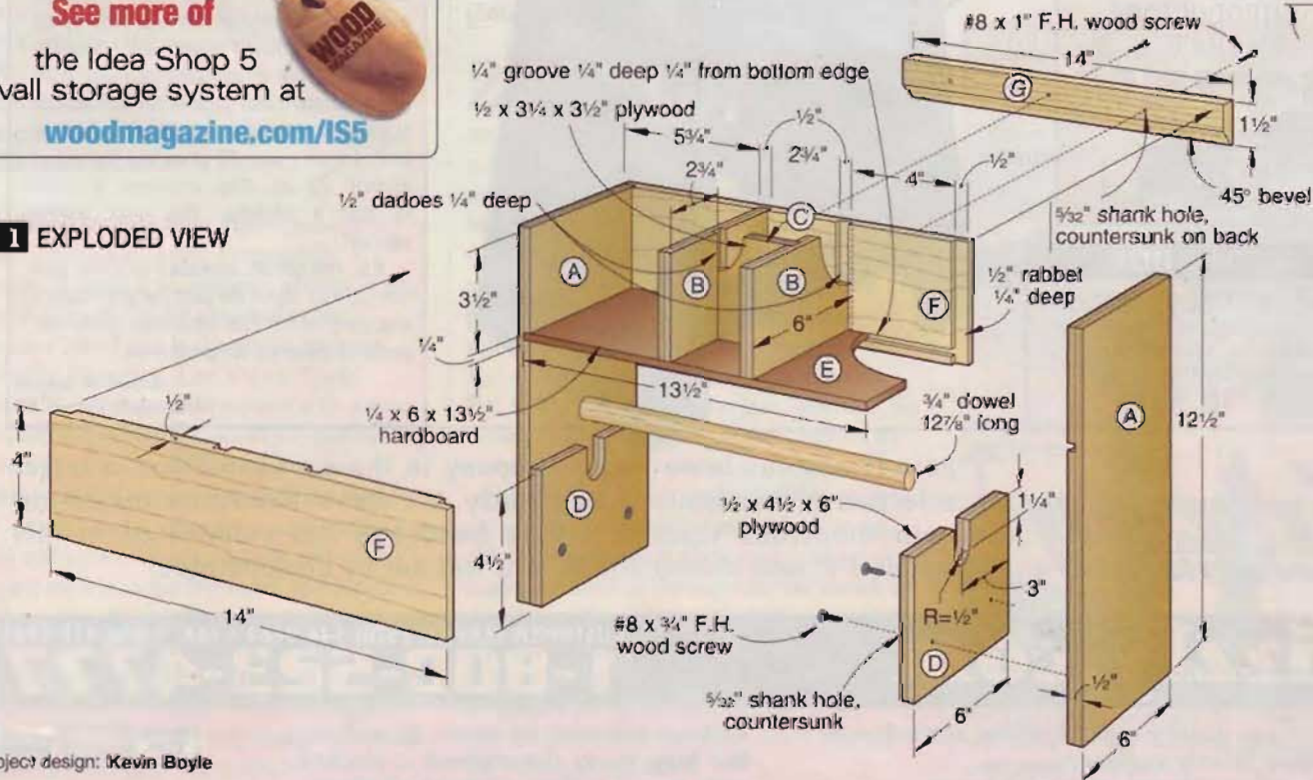

Project design: Kevin Boyle

## How to cut rabbets on a jointer

**Q:** I have a 6" jointer with a rabbeting ledge, but I don't understand how to use it to make rabbets. What's the proper method?

—Stephen Vallery, Yardville, N.J.

**A:** You can make perfect rabbets on your jointer, Stephen, as soon as you take care of a couple of set-up details. First, adjust your jointer knives so they extend  $\frac{1}{32}$ " beyond the front edge of the outfeed table, as shown in **Step 1**; this ensures that your workpiece won't hang up on the outfeed table while sliding across the rabbeting arm and ledge. Second, determine whether your jointer has a depth stop on the

infeed table that limits cuts to  $\frac{1}{8}$ " or less. Most rabbets are deeper than that, so check your owner's manual for information about overriding the depth stop. Many jointers have a spring-loaded pin on the right side. Pull out on the pin to disengage it as you lower the infeed table beyond the normal limit. The rabbeting ledge serves as the maximum stop at a depth of about  $\frac{1}{2}$ ".

To make a rabbet, remove the guard so that it doesn't interfere with the workpiece. *Note: Removal of this guard calls for extra caution during the rabbeting operation.* Set your jointer fence to establish either the width of the rabbet (if you plan to place the workpiece facedown on the jointer, as

shown in **Step 2**) or its depth (with the workpiece on edge, as shown in **Step 3**). A workpiece held on edge rides solely on the infeed and outfeed tables. Laid on its face, it receives extra support from the rabbeting arm, so choose this position when possible. As indicated on the drawings, tear-out is most likely on the surface cut by the ends of the jointer knives.

Finally, adjust the infeed table for a light cut (approximately  $\frac{1}{8}$ " for hardwoods and  $\frac{1}{4}$ " for softwoods), place the workpiece on the infeed table, and make the first pass. Form the rabbet with a series of passes, lowering the infeed table each time and disengaging the depth stop when necessary.

### 3 QUICK STEPS TO JOINTER-MADE RABBETS

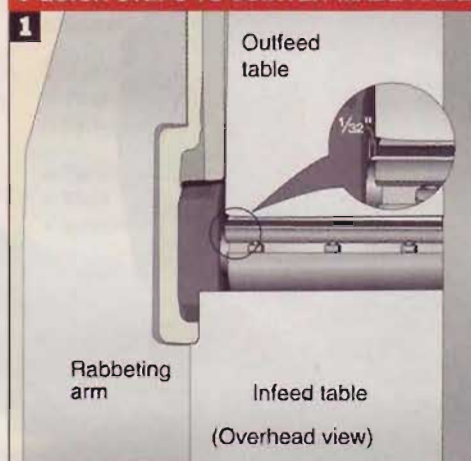

For smooth rabbeting results, set all of your jointer knives so they project  $\frac{1}{32}$ " beyond the outfeed table.

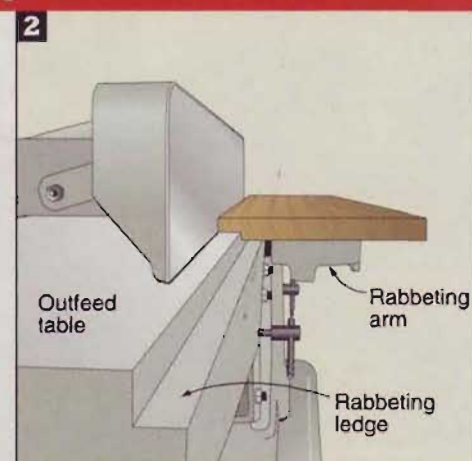

To make a rabbet, hold your workpiece flat on the jointer when possible. The rabbeting arm adds valuable support.

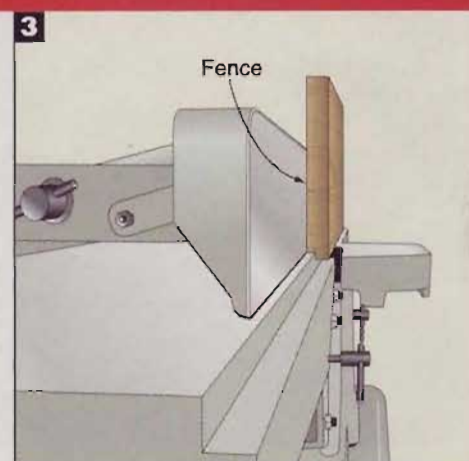

Choose a vertical orientation if you need to avoid tear-out on the workpiece face, created as the knife ends scrape the stock.

## Starting a finish with tung oil spells trouble

**Q:** To finish a solid cherry tabletop, I applied a coat of pure tung oil, let it dry for a day, and then followed with several coats of high-quality water-base. Three days after the final coat went on, white patches began to appear in the finish. What went wrong?

—Tom Lendway, Vadnais Heights, Minn.

**A:** Tom, your problem stems from the tung oil, which needs to cure for several days before it's ready for a topcoat. For that reason, Steve Mickley, host of the

[woodmagazine.com](http://woodmagazine.com) finishing forum, strongly recommends using boiled linseed oil rather than tung oil when you want to accentuate figure before applying a topcoat. After applying boiled linseed oil, and with temperatures of at least 65 degrees F and average indoor humidity, Steve suggests waiting a week before topcoating with varnish, lacquer, polyurethane, or shellac. Lengthen your wait to 10 days before applying a water-based topcoat.



If you apply oil to bare wood and follow too soon with a water-based topcoat, white spots begin to appear within a few days. To repair this situation, strip or sand the piece and start over.

Continued on page 26

# STEVE WALL LUMBER CO.

Quality Hardwoods and Woodworking machinery For The Craftsman and Educational Institutions

Ash	4/4	Select	2.40	\$ 85.00
Basswood	4/4	Select	1.95	\$ 72.00
Birch	4/4	Select	2.75	\$ 89.00
Butternut	4/4	1C	2.30	\$ 77.00
Cherry	4/4	Select	4.90	\$110.00
Hickory - Pecan	4/4	Select	2.85	\$ 89.00
Mahogany (Genuine)	4/4	Select	3.90	\$100.00
Maple (Hard)	4/4	Select	3.15	\$ 96.00
Maple (Soft)	4/4	Select	2.30	\$ 79.00
Poplar	4/4	Select	1.75	\$ 72.00
Red Oak	4/4	Select	2.50	\$ 88.00
Walnut	4/4	Select	4.00	\$100.00
White Oak	4/4	Select	2.50	\$ 88.00
Cedar (Aromatic Red)	4/4	1C+Btr.	1.80	\$ 72.00
Cypress	4/4	Select	2.40	\$ 80.00
White Pine	4/4	F.G.	1.20	\$ 62.00
Yellow Pine	4/4	Clear	2.00	\$ 74.00

Above prices are for 100' quantities of kilndried rough lumber sold by the Bd. Ft. FOB Mayodan, NC. Call for quantity discounts. Other sizes and grades available.

Above prices are 20 bd. ft. bundles of clear kilndried lumber 3"-10" wide x 3'-7' long (Random widths & lengths) Surfaced 2 sides or rough. Delivered UPS prepaid in the Continental U.S.

## \*NOW AVAILABLE\*

### Custom Made Raised Panel Cabinet Doors

4/4 Log Run Walnut  
100 bd. ft. \$160

Also Available Exotic Lumber

### STEVE H. WALL LUMBER CO.

BOX 287  
MAYODAN, N.C. 27027  
336-427-0637  
1-800-633-4062  
FAX 336-427-7588

Email: wood@walllumber.com  
Website: www.walllumber.com

Send \$1.00 For Lumber Catalog  
Prices Subject to Change Without Notice

## UPS Specials

SEE OUR CATALOG ON THE WEB!

Circle No. 856

# WANT THIS?



A clean, sharp hole every time. No chips, no splits, no errors. It takes skill and a sharp drill bit. And *that* takes the **Drill Doctor®** drill bit sharpener.

# GET THIS.

- Restores bits to factory sharp
- Fast and easy to use
- Sharpens most twist bits—even split point
- Diamond sharpening wheel
- Powerful 20,000 rpm motor



**Drill Doctor®**  
The Drill Bit Sharpener

Drill bits are meant to be sharpened

www.DrillDoctor.com • 1-888-MYDRILL

"I have never recommended a product that was so easy to use and so effective. This is one of the best tools I've ever purchased."

—Stephen Bierhorst  
Patterson, Louisiana

Available at Home Depot, Lowe's, Sears and wherever fine tools are sold

Circle No. 1511

## ask wood

### Oil-based stain is OK under a water-based topcoat

**Q:** Will I have problems if I apply a water-based topcoat over an oil-based stain? How about an oil-based finish over water-based stain?

—Bill McTaggart, California City, Calif.

**A:** No problem in either case, Bill, as long as you allow the stain to dry thoroughly. Wait as recommended on the stain and topcoat containers and then put your face next to the surface and sniff. If you smell the stain, give it more time.

Whether you start with oil- or water-based stain, switching to the other type of topcoat actually helps avoid trouble. If you brush or wipe on a topcoat that contains the same solvent as the stain, you might dissolve the stain and cause smearing.



Check the stain and topcoat containers for guidelines about waiting times. The label of this product recommends waiting 48 hours after applying an oil-based stain.

### Got a question?

If you're looking for an answer to a woodworking question, write to Ask WOOD, 1716 Locust St., GA-310, Des Moines, IA 50309-3023 or send us an e-mail at askwood@mdp.com. For immediate feedback from your fellow woodworkers, post your question on one of our woodworking forums at woodmagazine.com.

# epoxy goes mainstream

While most woodworkers shy away from epoxy, furnituremaker Robert Hensarling finds it the adhesive of choice in his workshop, and for good reason.



**F**amed for his mesquite Texas-style rocking chairs (featured in issue 112 of *WOOD*® magazine), Robert Hensarling uses epoxy for just about all his assembly, regardless whether the furniture finds a home in a living or board room. What gives (or doesn't give) with epoxy? We asked Robert about his heavy reliance on it, seeking answers that you too can put to use in your shop.

**Q** ■ Why do you choose epoxy for your joinery?

**A** ■ I like it because it maintains a little resiliency after curing. In other words, it expands and contracts as wood moves. I work mostly with mesquite, but find that epoxy also performs well with other woods I work including quilted maple and black walnut. Another advantage: Compared to yellow glues, it gives me more working time (approximately 15 to 30 minutes) for adjustments before it sets up.

**Q** ■ What do you mix the epoxy in, and how do you apply it?

**A** ■ I mix the epoxy in throwaway plastic cups using wood sticks, such as paint stirrers and tongue depressors. To ensure that the depressors fully contact the cup side and bottom for thorough mixing, I square the round ends on a disc or belt sander. I apply the epoxy using the sticks and disposable glue brushes.

**Q** ■ Epoxy can be messy. How do you deal with squeeze-out?

**A** ■ I assemble everything rough, sanded with nothing finer than 60-grit paper. For a sculpted joint, such as between an arm and a leg, I let the epoxy cure

overnight. Then I remove the squeeze-out with a die grinder, carbide grinding wheel, or a drill with a 60- or 80-grit sanding drum, as shown in the photo, *below*. Because I leave  $\frac{1}{16}$ " to  $\frac{1}{8}$ " extra stock to remove on curved joints for blending purposes after assembly, using a grinder or sanding drum also helps to sculpt the area to final shape. After grinding, I finish-sand the area using a palm sander with progressively finer grits of sandpaper.

For a square-edge butt joint, I remove excess epoxy using a paper towel right after clamping the parts together. When the epoxy cures, I sand the area to remove any remaining adhesive. I don't use acetone or other solvents, which can seep in and weaken joints or clog open wood pores.

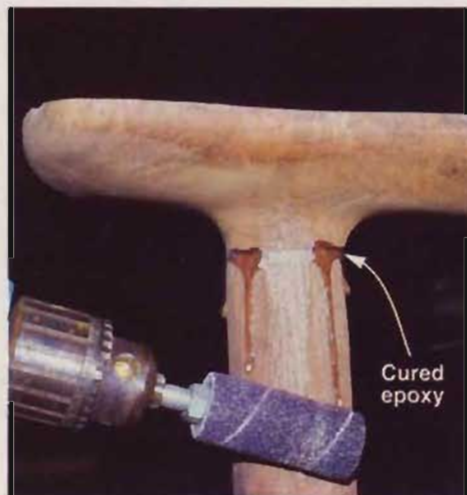

A drill with a sanding drum quickly removes excess cured epoxy and blends the joint between this arm and leg.

**Q** ■ What types of epoxies do you use for joinery?

**A** ■ For most joinery, I use System Three's General Purpose Epoxy. (Call 800/333-5514, or on the Web at [systemthree.com](http://systemthree.com).) It comes with a resin and a choice of three hardeners. In winter weather, I go with their fast hardener; at normal 60 degree to 100 degree temperatures, their medium hardener works well; on really hot Texas days, I use their slow hardener. Using the appropriate hardener gives me the needed open time to spread out, fine-adjust, and clamp joints.

## Solvents and safety

Solvents for epoxy include acetone, lacquer thinner, denatured alcohol, and ordinary white vinegar. These work fine for cleaning tools, but not so well on skin because these thinners can permeate your pores. Robert always wears disposable latex gloves when he mixes, pours, dispenses, spreads, clamps, or cleans up epoxy. Also, work in a well-ventilated space or wear a respirator, he warns. Fumes from epoxies pose health hazards.

*Continued on page 30*

For joints that I leave particularly loose, such as leg joints, I use System Three's T88 Structural Epoxy Adhesive instead of the General Purpose Epoxy because it's thicker and won't run out. (Because I test-fit these joints many times during construction, the loose fit reduces the chance of damaging the parts.) T88 epoxy comes with a resin and one hardener, and it cures in temperatures as low as 35 degrees.

**Q:** To fill gaps on surfaces, do you add sawdust to the epoxy?

**A:** I prefer not to do this, and here's why. I've found that the epoxy color

changes when you add sawdust, particularly with mesquite, which makes a repaired area more noticeable. I've tried adding tints to get a better color match, but found this unsatisfactory too. For me, using just the basic clear amber epoxy works best.

**Q:** How do you repair epoxied joints? By knocking them apart?

**A:** You can't knock an epoxied joint apart as easily as one assembled with water-based glues. What I do instead when chair making is saw off a piece—say a back slat, flush at the seat and head crest. Then I drill out the joints, making the hole in the

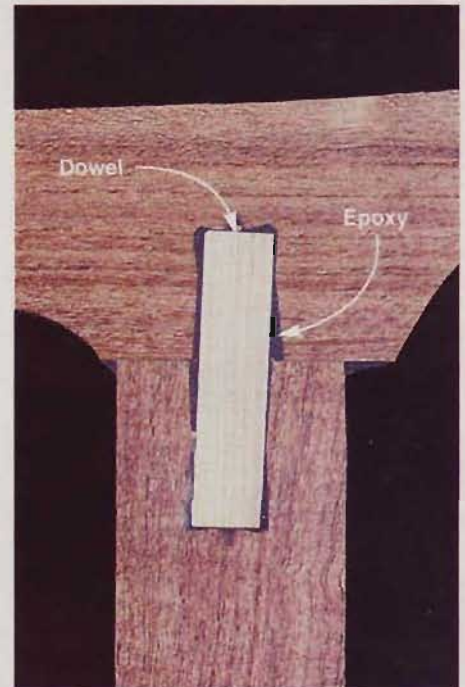

This arm/leg joint cutaway shows how the epoxy encapsulates the dowel in an over-size hole, strengthening the dowel.

head crest twice as deep as the one in the seat, and epoxy a new slat in place. This same technique works for replacing an arm or a leg, but you must be very careful when cutting out the broken part to avoid removing stock at the joint from the adjoining part.

**Q:** Do you prepare a joint for epoxy differently than for yellow glue?

**A:** Yes. One of the things I like about epoxy is that it lets me make what I call "floating dowel" joints. With these, I drill slightly oversize holes so the dowels have a loose fit. Epoxy fills the space around the dowels, as shown in the photo, above, which makes them stronger and lets me make adjustments when clamping the parts together. Another nice feature about epoxy is that it won't swell dowels or biscuits because there's no water in it. ♣

Robert offers four-day seminars on rocking-chair building as well as one-on-one instruction. For more information, write Robert Hensarling, 4326 East Main Street, Uvalde, TX 78801, or visit his Web site: [mesquiterocker.com](http://mesquiterocker.com)

# The First to FINISH WINS!

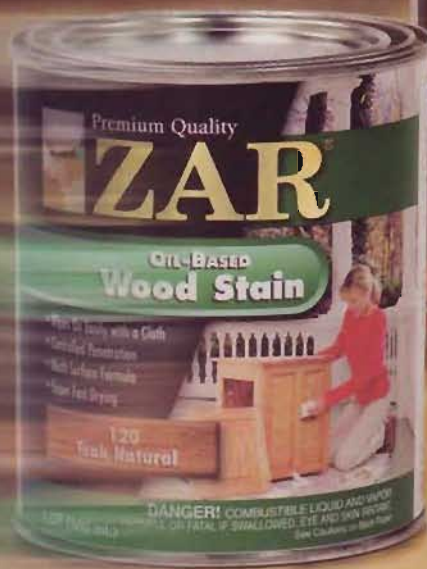

ZAR Premium Quality Oil-Based Wood Stain provides rich uniform color in just 3-hours. This new fast-drying formula is available in 20 popular colors and a tint-base for custom colors.

ZAR ULTRA Fast Drying Polyurethane is an oil-based polyurethane which provides a beautiful



**FAST DRYING**  
FORMULAS

If you want a quality finish and you want it fast, the name to look for is ZAR®.

protective finish that will last in the toughest conditions. It dries and can be recoated in just 2-hours. Available in gloss, semi-gloss, satin and antique flat sheens for the look you want.

ZAR Wood Stain and Clear Finishes, the perfect choice for the fastest finish – Making you the winner.

**ZAR®** The fastest way to a beautiful finish!  
For a free brochure and dealer nearest you, call 1-800-272-3235 or visit [www.ugl.com](http://www.ugl.com)

# put your best face forward

When you build with quartersawn oak, use these simple techniques to display as much beautiful figure as possible.

**T**he distinctive ray flecks of quartersawn white oak play a key role in beautifying the mission tall clock on page 38. When making it, we took extra steps to show as much of that figure as possible—on adjacent faces, for instance. To work similar magic with your projects, try the three techniques here whenever you build with wood that bears beautiful figure on its faces but not on its edges.



For a solid leg with two adjacent show-piece faces, as shown at left, cut and assemble the four pieces you see below.

## Make two display-worthy faces for each leg

The mission clock stands on legs that run full length. If we had laminated 4/4 stock face-to-face to build the legs, each leg would show ordinary-looking edge grain on

two opposite faces and ray fleck on the other faces. Instead, we used a simple technique to place extraordinary figure on both adjacent outside surfaces as shown in the leg above. Here's how to make this splined-miter joint with a filler.

### FIRST CUT THE VISIBLE LEG PIECES AND SPLINE

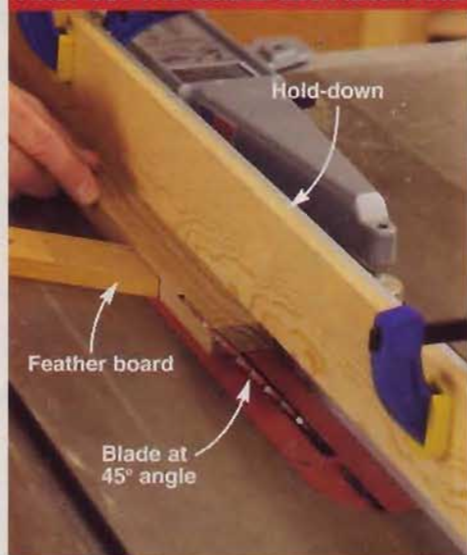

**STEP 1:** Tilt a combination blade away from the tablesaw fence at 45°. (On this right-tilt saw, we moved the fence left of the blade.) Set the fence to cut the upper (outside) face of your 4/4 workpiece  $\frac{1}{16}$ " wider than the leg's final width. Clamp a board to the fence to serve as a hold-down, install a feather board, and bevel-rip to form a leg corner.

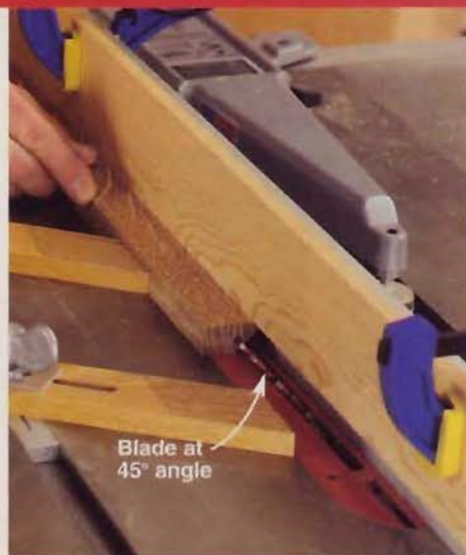

**STEP 2:** Remove the fence to cut spline slots in the bevel-ripped edges where shown, centered  $\frac{1}{4}$ " from the inside corner. Adjust the blade height to cut a kerf  $\frac{1}{4}$ " deep. Replace the feather board and add a second feather board where shown for extra support. Now, using a pushstick, cut a slot on each piece.

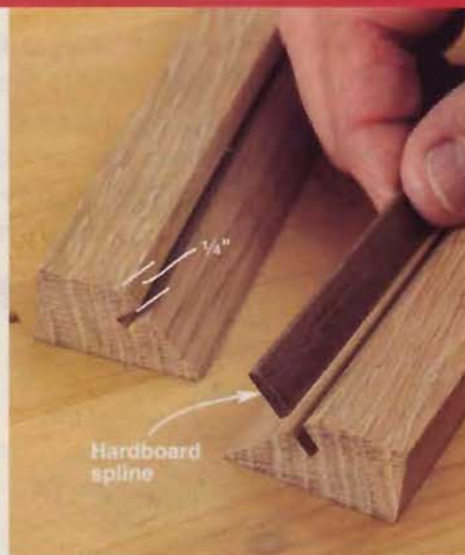

**STEP 3:** On your tablesaw, cut a piece of  $\frac{1}{8}$ " hardboard to make a spline  $\frac{7}{16}$ " wide and the same length as the leg corners. This spline aligns the miter joint during assembly. By keeping the spline slightly narrower than the combined depth of the two kerfs, you ensure that it won't bottom out and cause assembly problems.

*Continued on page 34*

# GARAGE

Sweet

# GARAGE

Turn yours into a dream garage with a **\$10,000 MAKEOVER**

It's America's Ultimate Garage Contest. Win a \$10,000 garage makeover courtesy of Rust-Oleum® EPOXYShield®. Describe what your garage means to you, what makes for an ideal garage, and why you deserve a garage makeover, in 300 words or less. Then, include a color photo of the interior of your garage. The winner will receive "An Ultimate Garage Makeover" from a Home Depot® approved contractor. Included in your new look will be a showroom-quality floor protected with EPOXYShield Garage Floor Coating.

**ONE GRAND PRIZE**  
\$10,000 Garage Makeover

**ONE SECOND PRIZE**  
\$5,000 Garage Makeover

**25 SEMI FINALIST PRIZE PACKAGES**  
EPOXYShield Garage Floor Coating Kits



**RUST-OLEUM®**

stopping rust is just the start.™

No purchase necessary. Contest is open May 15 – August 2, 2004, to legal U.S. and Canada residents ages 18 and over. Enter online at epoxyshield.com, rustoleum.com, homedepot.com, or mail entries, including first and last name, date of birth, address (including zip code), telephone number, color photograph of the interior of your garage and a description, in 300 words or less, of your ideal/ultimate garage and why you are most deserving of your dream garage. Mail entry in a stamped envelope to: America's Ultimate Garage Contest, P.O. Box 39101, Chicago, IL 60639. Entries must be postmarked by Monday, August 2, 2004. Void where prohibited. For official contest rules visit your participating Home Depot, epoxyshield.com or homedepot.com.



You can do it.  
We can help.

## workshop **savvy**

### NOW ASSEMBLE THE LEG

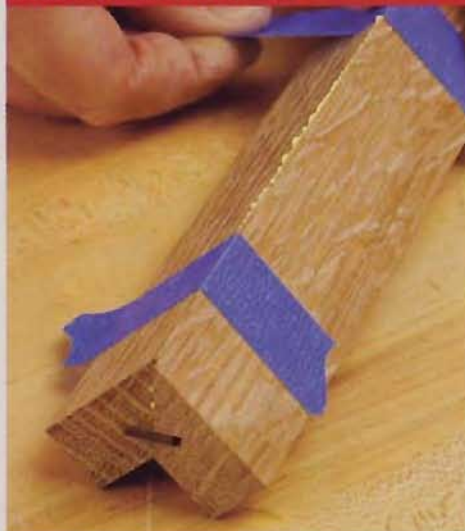

**STEP 1:** Apply glue to both mitered surfaces and the spline. Slip the spline into place, join the two leg corners, and apply masking tape to hold them until the glue dries. Tape across the joint at 6" intervals. Clamp any area that refuses to line up.



**STEP 2:** Rip a filler piece (3/4x3/4" for the clock leg) to fit the L-shape space of the leg assembly and crosscut it to the same length as the leg. Glue and clamp it in place. After the glue dries, reduce the leg to its final dimensions with a jointer or planer.

### Dress up a narrow edge to match your design

The front of the mission clock shows the edge of three divider-frame rails: one at the top of the case, one at the bottom, and one between the doors. A simple step transforms each ordinary edge into an attractive detail complementing the doors and legs.

Select a nicely figured scrap piece as long as the exposed edge and rip a blank as wide as the edge thickness. Now place the blank with its figured face against your tablesaw rip fence and cut a 1/4"-thick strip. Glue this strip on the edge to make the difference shown. Keep this technique in mind when you build shelves too.



Apply a 1/4"-thick strip, which is easy to handle and clamp without gaps. Remember to allow for the thickness of this piece as you plan and build a divider or shelf.

### Cut wide bevels according to the end grain

Finally, here's a specialized technique that applies to wide, shallow bevels like the one on the top trim of the mission clock. As you see, we looked at end grain and chose a workpiece with grain sloping toward one corner. Cut a bevel across the grain, as shown, for the best chance of exposing ray fleck (in oak, ray fleck is most prevalent on surfaces with growth rings that run perpendicular to those surfaces). ♣

End grain tells you where to cut a wide bevel on a white oak or red oak board. Orient the beveled edge so that it's perpendicular to the grain direction.

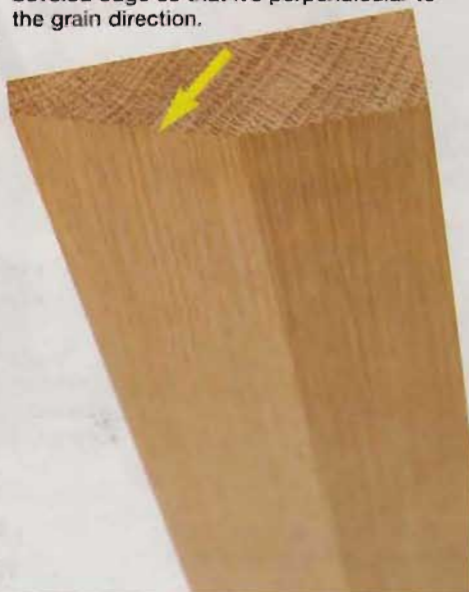



# wood words

A quick guide to must-know terms used throughout *WOOD*® magazine

**Biscuit:** A common name for football-shape wooden “plates” used in joinery. Made from compressed beech, biscuits fit into slots cut with a biscuit joiner (see *bottom*), or a slot-cutting bit in a router. Biscuits increase glue surface in the joint for improved holding power and hold the joint in alignment during clamping. Three traditional sizes (#0, #10, #20) are most common, but several other sizes exist.



Biscuits shown full-size #0



#10



#20

**Biscuit joiner:** A specialized power tool made to cut slots that accept hardwood biscuits. The tool most often resembles an angle grinder with a precision fence and base added on. These parts of the tool work together to align a retractable circular blade that plunges into the mating joint members at the desired slot location. Each plunge creates one half of the biscuit slot.

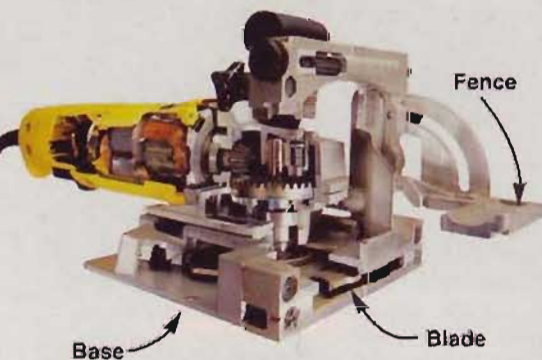

**Materials list:** A chart accompanying a woodworking project that details every part by letter, name, dimensions, material, and quantity. The list may include notes that indicate special cutting instructions.

**Cutting Diagram:** An illustrated guide that depicts the quantities and sizes of boards required for a project as well as where each part should be laid out to minimize waste. While extremely handy for defining lumber needs, cutting diagrams can't account for grain variations in solid wood stock or sheet goods, or for defects in solid stock. So, use a cutting diagram as a guideline only.

### Cutting Diagram

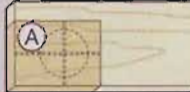

¾ x 5½ x 12" Bird's-eye maple (.5 bd. ft.)

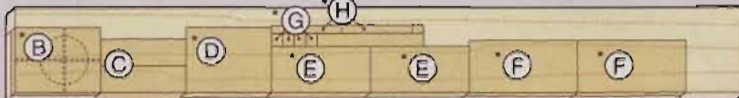

¾ x 5½ x 48" Cherry (2 bd. ft.)

### Materials List

Part	FINISHED SIZE			Matl.	Qty.
	T	W	L		
A face	¾"	4¼"	5½"	BEM	1
B backer	¼"	4¼"	5½"	C	1
C sides	¾"	1¾"	5½"	C	2
D back	½"	4¼"	5½"	C	1
E sub top and bottom	½"	3"	6½"	C	2
F top and bottom	¾"	3¾"	7½"	C	2
G capitals	½"	7⁄8"	¾"	C	4
H pillars	½"	¾"	4½"	C	2

\*Parts initially cut oversize. See the instructions.

**Materials key:** BEM—bird's-eye maple, C—cherry.

### How to stack lumber for air drying

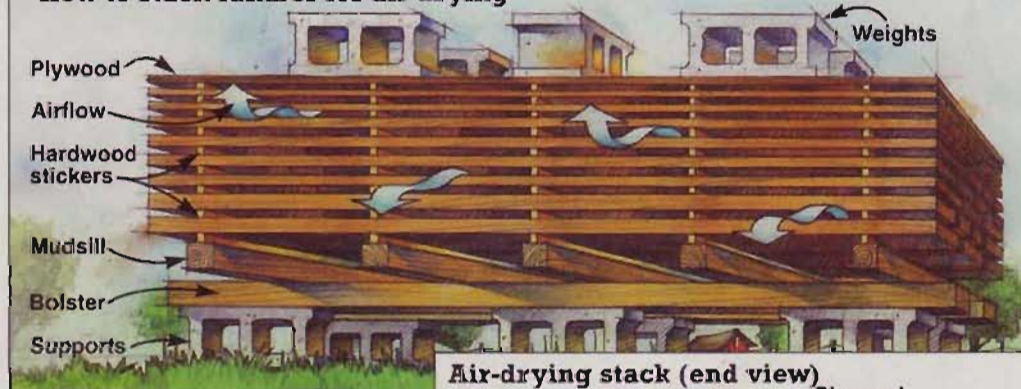

**Air-dried lumber:** Boards that have dried naturally by stacking them in the open air, as shown *above* and *right*. Air flows between the boards, allowing the moisture in the wood to evaporate. Air drying can take as long as one year per inch of board thickness. In all but the driest regions, moisture content rarely falls below 12 to 20 percent without additional drying indoors.

### Air-drying stack (end view)

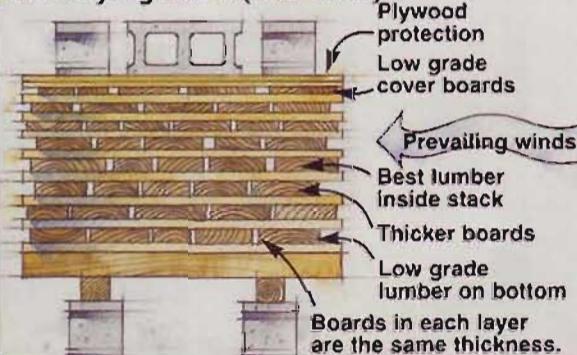

**Kiln-dried lumber:** Stickered boards dried at an accelerated rate by exposure to warm, dry air inside a chamber called a kiln. By controlling airflow, humidity, and temperature, this process reduces moisture content in just days or weeks to desired levels—6 to 10 percent for hardwoods and high-grade softwoods, 12 to 20 percent for construction lumber. ♣

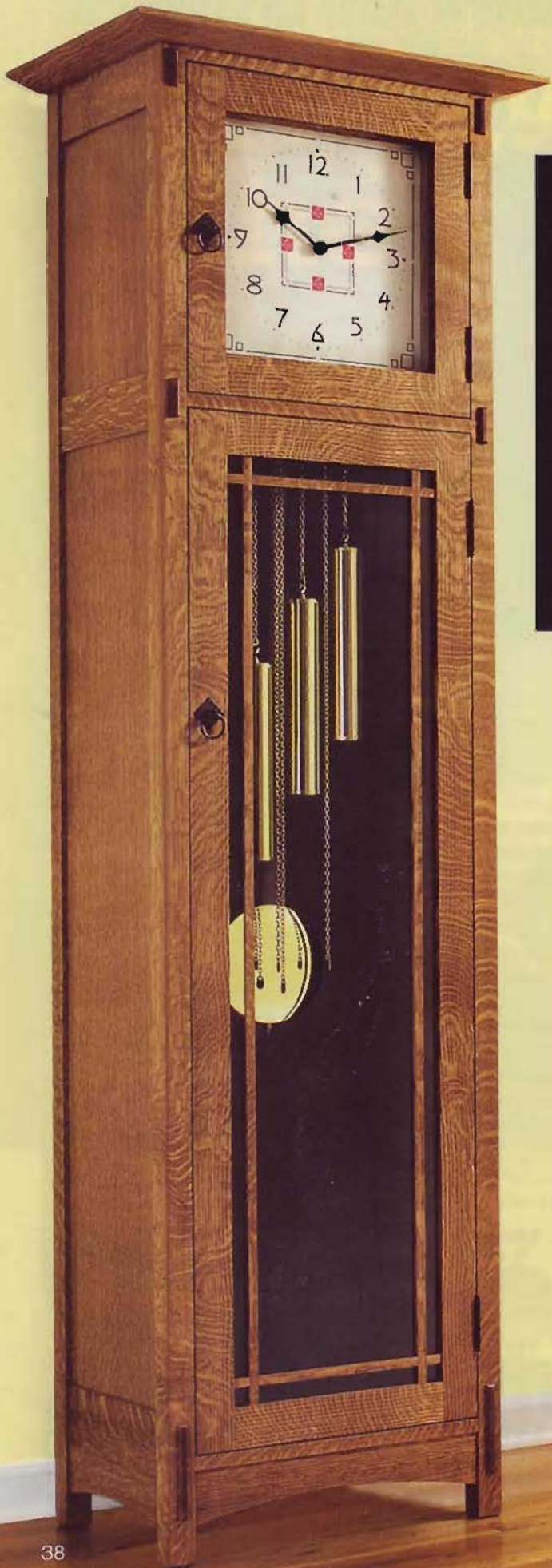

■ ARTS AND CRAFTS ■

# HEIRLOOM TALL CLOCK

Classic clean lines and eye-catching quartersawn oak combine to make this a project that will stay with your family for generations.



**S**triking looks aside, this masterpiece tall clock has several features that reflect simplicity and flexibility in design. For starters, the case uses straightforward stub-tenon-and-groove and mortise-and-tenon joinery. Added to this, easy-to-make leg-mortise plugs give the side rails a time-honored through-tenon look. Also, you have a choice of a mechanical clock movement, as shown *at left*, or a less-expensive battery-powered quartz chiming movement with separate pendulum drive. No matter the movement you select, the case construction remains the same. Finally, if you wish to build the clock using quartersawn white oak, as we did, you'll find the design allows for maximum display of this wood's treasured ray fleck figure.

*Kevin Boyle*  
Senior Design Editor

## 1 SIDE ASSEMBLY (Inside face shown)

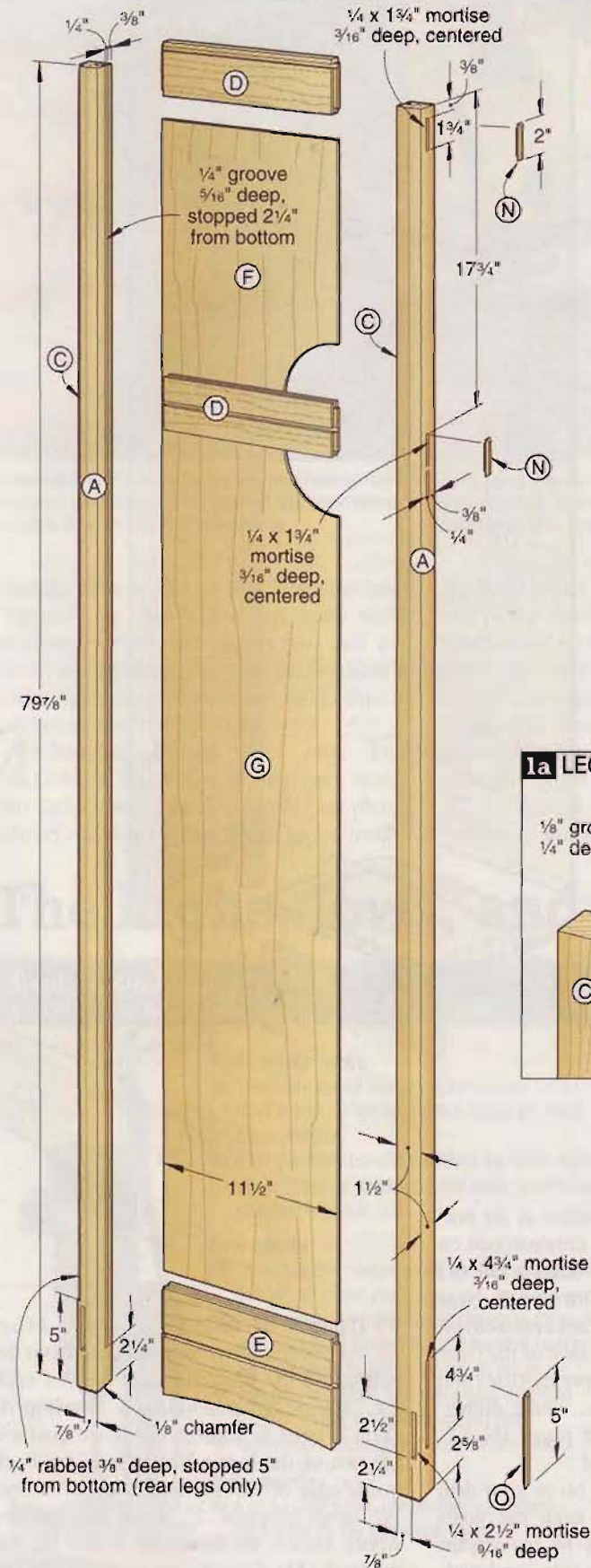

## Make some gorgeous legs

*Note:* To display quartersawn oak ray fleck on adjacent outside faces of the clock's legs, we joined together two corners (A)—showing fleck—with a spline (B), and filler (C) in the configuration shown on **Drawings 1, 1a, and 1b**. If you plan to use unfigured wood, save yourself work by making the legs from solid stock. Cut them to the finished size of  $1\frac{1}{2} \times 1\frac{1}{2} \times 79\frac{7}{8}$ " from  $\frac{3}{4}$ " stock or from laminated  $\frac{1}{4}$ " stock. Then, continue with **Step 4** on page 40.

**1** Cut the corners (A) to  $1\frac{1}{8}$ " wide and 81" long. (You'll trim them to their finished width of  $1\frac{1}{2}$ " and length of  $79\frac{7}{8}$ " after assembly.) Angle your tablesaw blade to a precise  $45^\circ$ , and bevel-rip one edge of each corner piece face-side up, where shown on **Drawing 1a**, leaving the pieces extra wide. Then, lower the blade and cut a  $\frac{1}{8}$ " groove  $\frac{1}{4}$ " deep along the corner pieces' beveled edges, where dimensioned on **Drawing 1b**, to receive the splines (B). For help on cutting and assembling the legs and for techniques to show figure on the edges and bevels of other parts, see page 32.

## AT A GLANCE

- Overall dimensions are  $25\frac{1}{4}$ " wide  $\times$   $16\frac{1}{2}$ " deep  $\times$   $80\frac{7}{8}$ " high.
- For the board feet of lumber, clock/hardware and lumber kits, and other items needed to build this project, see page 46.
- To make it easy for you to install and adjust the clock, we've prepared custom installation instructions that are supplied with the kits.

### 1a LEG ASSEMBLY

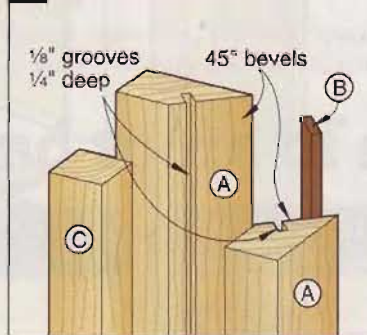

### 1b LEG DETAIL

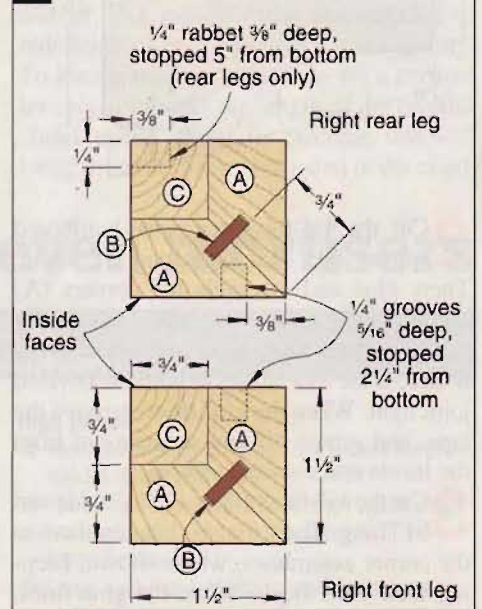

## SHOP TIPS

### How to ensure solid joints and a stunning case

For rock-solid case construction and a showstopping appearance, follow these pointers.

- 1** When cutting grooves and rabbets to fit plywood parts, be sure to match your dado blade to the plywood's thickness.
- 2** For perfect-fitting tenons, save your parts' cutoffs and make test tenons to verify the fit. Then cut the tenons on the parts.
- 3** For a continuous grain flow between adjacent parts, such as the top and bottom side panels (F, G) and top and bottom door stiles (V, W), lay them out in the arrangement shown on the **Cutting Diagram**, page 46.

## 2 SIDE-RAIL TENON DETAILS (Inside face shown)

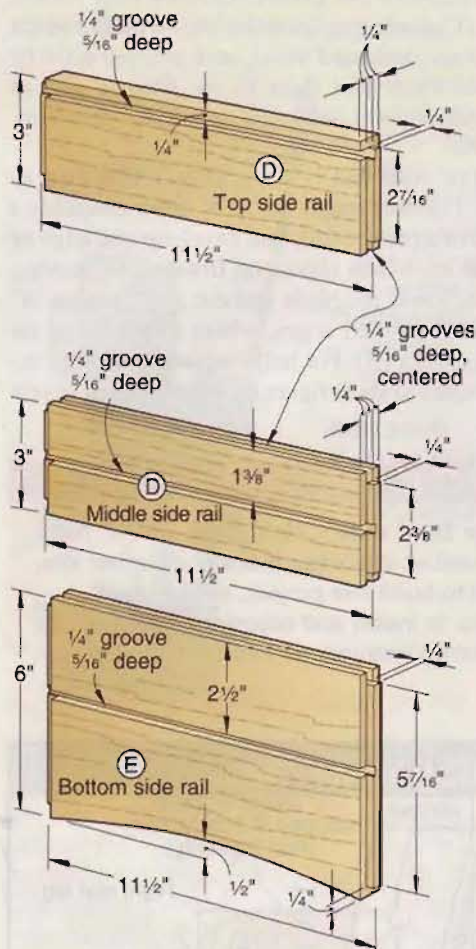

**2** Cut the  $\frac{1}{8}$ "-thick tempered-hardboard splines (B)  $\frac{7}{16}$ " wide and 81" long. Then, glue and assemble the corners (A) and splines, keeping their ends flush. Apply pieces of easy-release painter's tape every 6" across the assemblies to hold the beveled joint tight. When the glue dries, remove the tape, and scrape off any squeeze-out from the inside and outside surfaces.

**3** Cut the  $\frac{3}{4}$ "-thick fillers (C)  $\frac{3}{4}$ " wide and 81" long. Then, glue and clamp them to the corner assemblies, where shown, keeping their ends flush. When the glue dries, scrape off any squeeze-out. Next, using your thickness planer or a horizontal drum sander, plane or sand the corners (A) flush with the fillers, leaving  $1\frac{1}{2}$ "-square legs. Now, cut the legs to the finished length by trimming their ends.

**4** Rout  $\frac{1}{8}$ " chamfers along the legs' bottom edges. To keep the leg locations straight, mark their top ends ("front right," for example). Also, to ensure you machine the legs' mortises, grooves, and rabbets in the correct faces, mark the legs' inside faces, where shown on **Drawing 1b**, keeping in mind the left and right pairs of legs are mirror images.

## 3 CASE ASSEMBLY

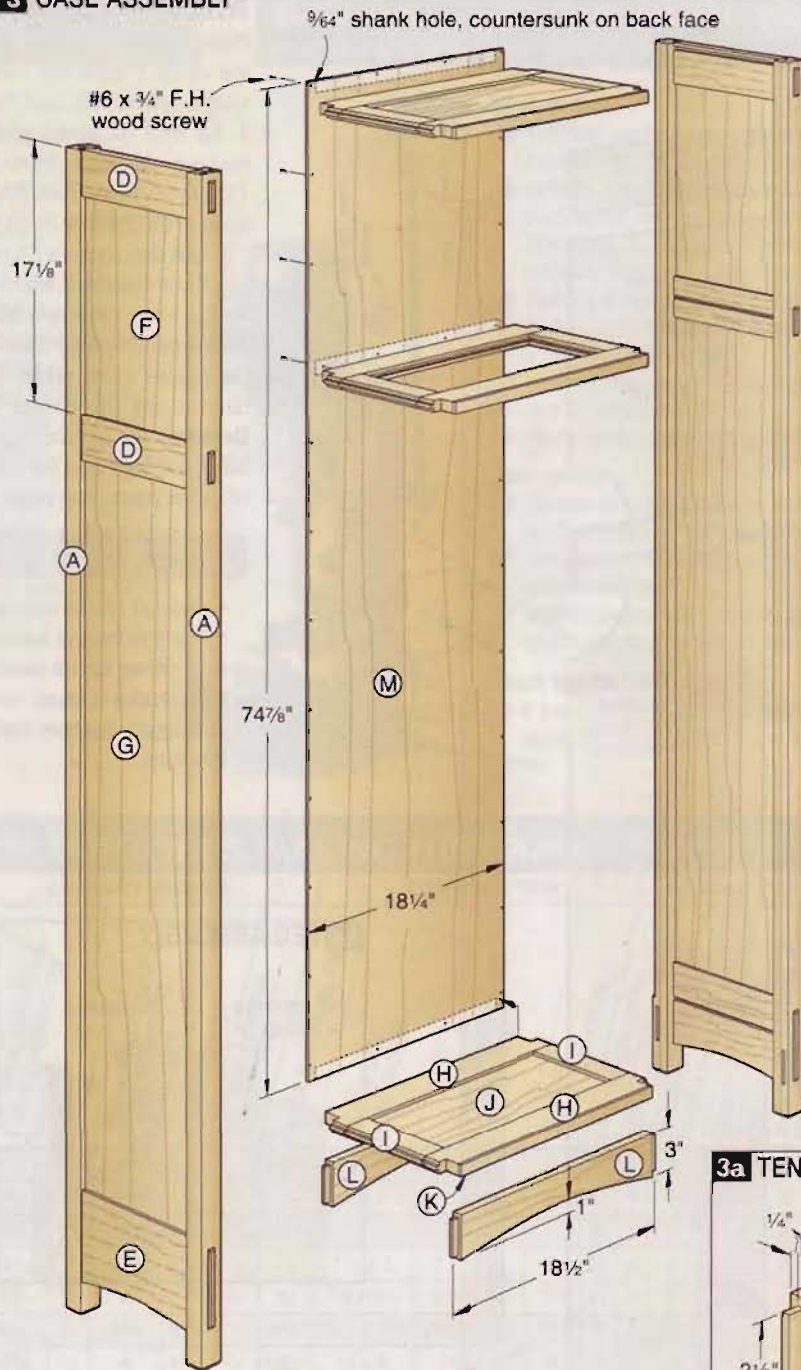

**5** Lay out the  $\frac{1}{4} \times 2\frac{1}{2}$ " mortise at the bottom of each leg, where dimensioned on **Drawing 1**, to receive the bottom rail (L) tenons, where shown on **Drawing 3**. Note that the mortises are *offset* (not centered) on the legs. Then, on the *front* face of the *front* legs, lay out the  $\frac{1}{4} \times 1\frac{3}{4}$ " upper mortises and the  $\frac{1}{4} \times 4\frac{3}{4}$ " lower mortises, where dimensioned, for the leg-mortise plugs (N, O). These mortises are *centered*.

**6** Using a  $\frac{1}{4}$ " brad-point bit in your drill press and a fence to keep the holes aligned, drill the mortises to the depths shown. Then, square their sides and ends with a chisel. For help on cutting mortises and tenons, see *page 68*.

**7** Using a  $\frac{1}{4}$ " dado blade, cut an offset  $\frac{5}{16}$ "-deep groove stopped  $2\frac{1}{4}$ " from the bottom on the marked inside face of each leg, where dimensioned on **Drawing 1**. (You'll need to change the fence position for two of the legs.) Now, along the back inside edge of the *rear* legs, cut a  $\frac{1}{4}$ " rabbet  $\frac{3}{8}$ " deep, stopped 5" from the bottom, where shown on **Drawings 1** and **1b**, for the back (M). For an easy way to form the stopped grooves and rabbets, see the **Shop Tip**, *opposite page, right*.

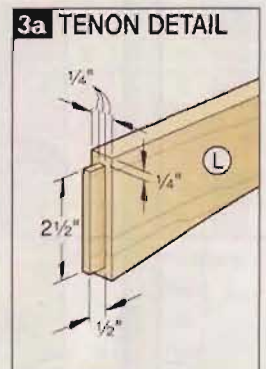

## CUT THE SIDE-RAIL TENONS

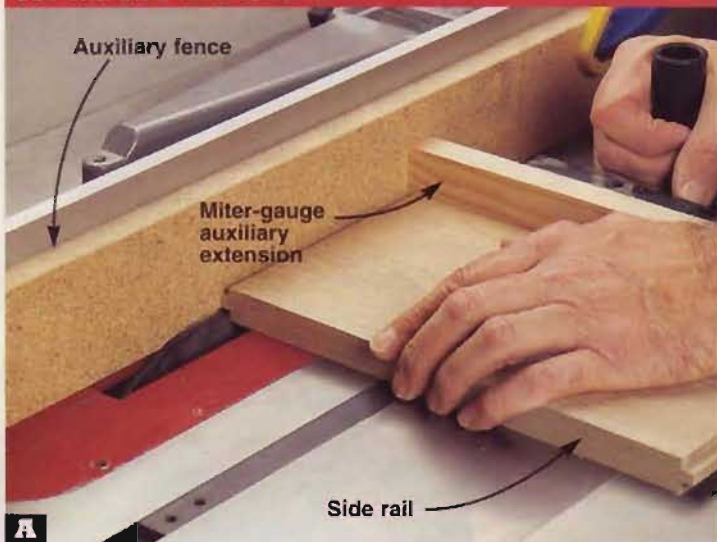

Using an auxiliary fence positioned  $\frac{1}{4}$ " from the outside of the dado blade and a miter-gauge auxiliary extension for backup, cut the tenons on the side rail's ends.

## POSITION THE MIDDLE SIDE RAIL

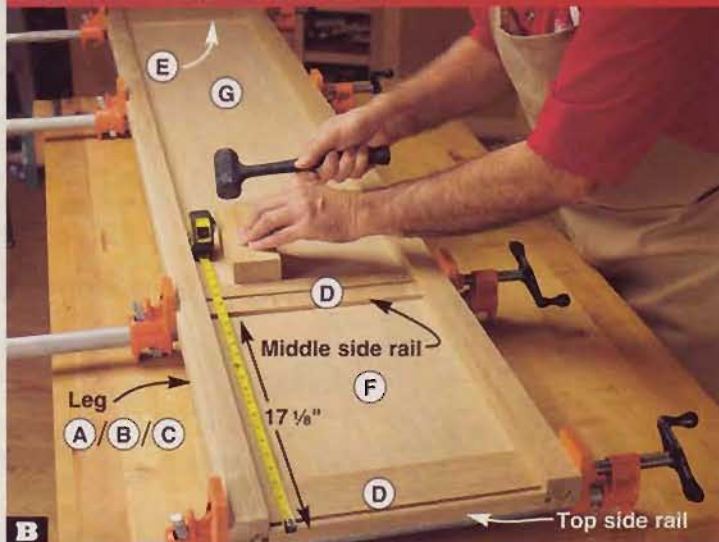

Using a mallet and a scrap wood block, tap the middle side rail (D) to position its top edge  $17\frac{1}{8}$ " from the assembly's top. Mark the rail's location for easy realignment.

*Note: Because both sides of the side panels (F, G) that go in the  $\frac{1}{4}$ " leg grooves are visible in the clock and our quartersawn white oak plywood had only one good side, we veneered these parts to provide two good sides, as explained later. The overall plywood/veneer thickness measured exactly  $\frac{1}{4}$ ".*

## Complete the sides

**1** Cut the top/middle side rails (D), bottom side rails (E), and top and bottom plywood side panels (F, G) to the sizes listed in the **Materials List**. If you wish to veneer the less attractive side of the quartersawn white oak plywood, as we did, see **Sources**. Apply the veneer as directed in the supplied instructions.

**2** Using a  $\frac{1}{4}$ " dado blade, cut a  $\frac{5}{16}$ "-deep groove centered along both edges of the middle side rails (D) and along one edge of the top side rails (D) and bottom side rails (E), where shown on **Drawing 2**.

**3** Adjust your dado blade, if needed, and cut  $\frac{1}{4}$ " grooves  $\frac{5}{16}$ " deep on the *inside* face of the side rails (D, E), where dimensioned, to receive the tongues on the divider frames (H/I/J/K). See **Drawing 3**.

**4** To form tenons on the ends of the side rails, set up your table saw as shown in **Photo A**. Next, cut a  $\frac{1}{4}$ "-long tenon in scrap, and test-fit it in the legs' grooves. Adjust your setup if needed. When satisfied, cut the tenons on the rails' ends. Then, place the top side rails (D) on edge and trim the tenons' width to  $2\frac{1}{16}$ ". Repeat for the bottom side rails (E), where shown, to trim their tenons to  $5\frac{7}{16}$ " wide.

**5** Using a fairing stick, draw the arch on the bottom side rails, where dimensioned on **Drawing 2**. Bandsaw and sand the arches to shape.

**6** Sand the legs (A/B/C), side rails (D, E), and side panels (F, G) with 220-grit sandpaper. Dry-assemble and clamp the parts together to form the two sides, *exactly* positioning the middle side rails (D), as shown in **Photo B**, to ensure that the clock movement and the clock face align later. Then, disassemble and glue and clamp the parts together.

## Add the divider frames

**1** Cut the divider stiles (H), divider rails (I), and plywood divider panels (J) to size to make a top, middle, and bottom divider frame, where shown on **Drawings 3** and **4**. Note that only the top and bottom frames have panels. Then, cut the  $\frac{1}{4}$ " edging (K) to  $\frac{3}{4}$ " wide and  $19\frac{1}{4}$ " long. Cut it so quartersawn figure shows on its face.

**2** Glue and clamp the edging to three stiles (H) for the front. When the glue dries, sand the edging flush.

**3** Using a  $\frac{1}{4}$ " dado blade, cut  $\frac{5}{16}$ "-deep grooves centered on one edge of all of

the stiles (H) and rails (I), where shown on **Drawing 4**. Then, adjust the blade height and cut  $\frac{1}{4}$ " tenons on the rails' ends.

**4** Glue and clamp together the divider frames and panels. When the glue dries, sand them smooth. Then, lay out notches in the stiles (H) to fit around the legs, where dimensioned. Bandsaw the notches.

**5** Cut  $\frac{1}{4}$ " tongues along the notched ends of the frames, where shown, to fit the grooves in the side rails (D, E).

**6** Cut the bottom rails (L) to size. Then, cut  $\frac{1}{4}$ " tenons  $\frac{1}{2}$ " long on the rails' ends, where shown on **Drawings 3** and **3a**, to fit the legs' mortises. Make certain the shoulder-to-shoulder length of the rails exactly matches the  $17\frac{1}{2}$ " notch-to-notch length of the divider frames' front stiles (H), where shown on **Drawing 4**, to ensure that the clock case assembles correctly. Draw, bandsaw, and sand the rails' arches to shape.

**7** Glue and assemble the sides (A through G), divider frames (H/I/J/K), and bot-

## SHOP TIP

### Don't get stumped when cutting stopped grooves or rabbets

Here's an easy way to form stopped grooves or rabbets, such as the ones for the clock's legs (A/B/C). Draw a line on the saw table where a blade tip at the front of the blade passes through the insert, where shown on the drawing, *right*. Then, draw a line on the part where you want to stop the groove or rabbet (for example,  $2\frac{1}{4}$ " from a leg's bottom for the stopped  $\frac{1}{4}$ " groove). Now, cut the groove, stopping when the two marked lines align. The blade will leave a radiused area at the stopped end. Square it with a chisel.

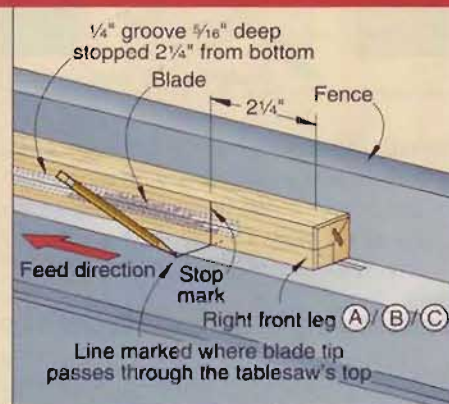

#### 4 DIVIDER FRAMES (3 needed)

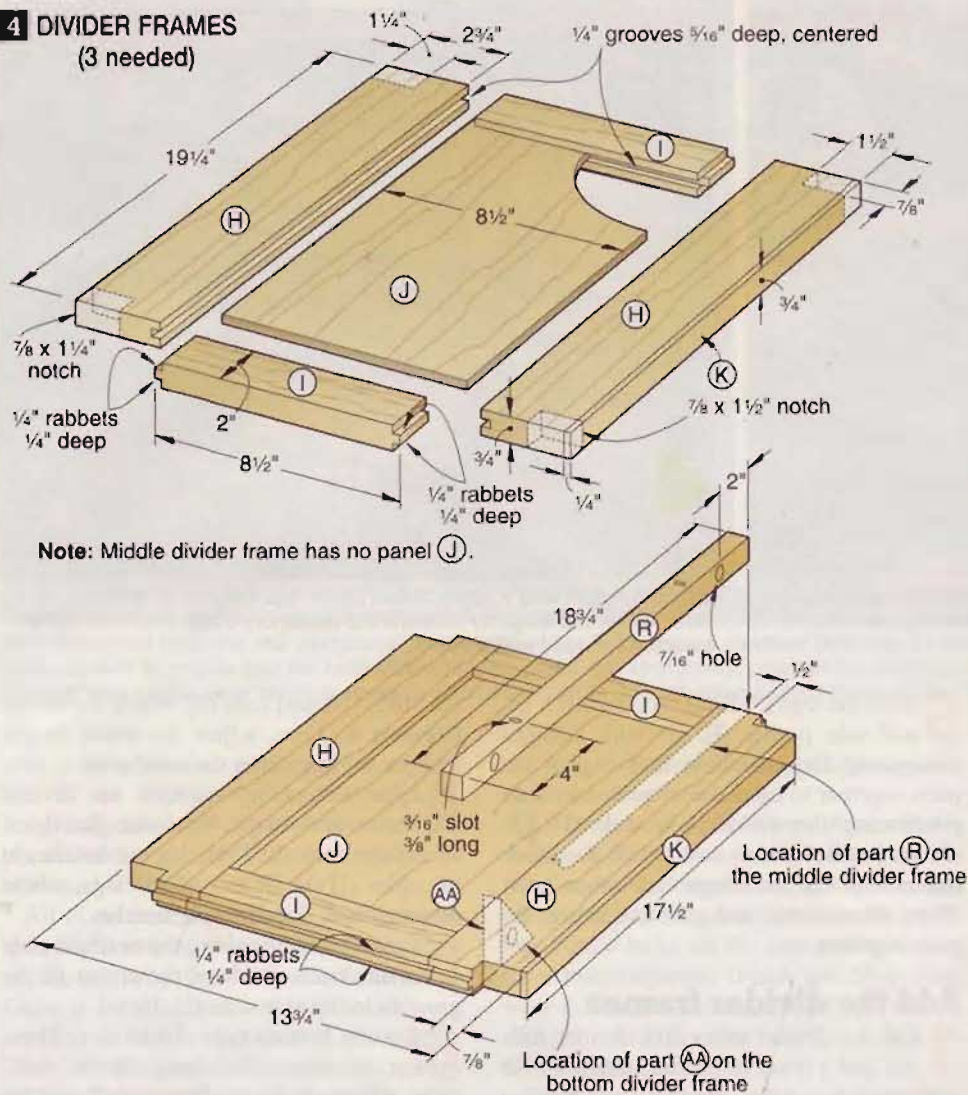

#### 6 CUTTING THE LEG-MORTISE PLUGS

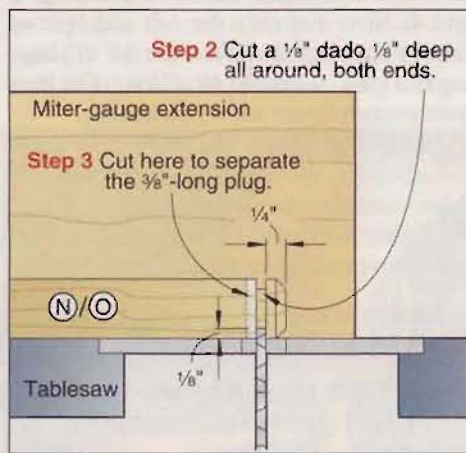
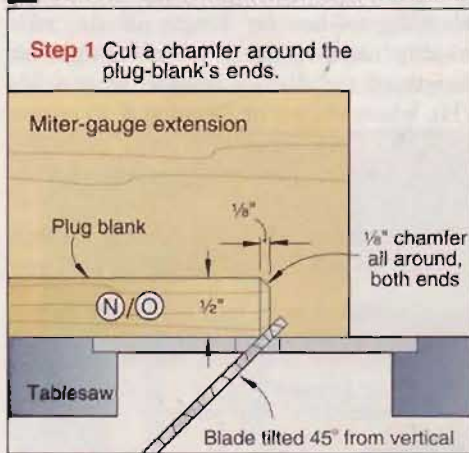

tom rails (L) together, as shown in **Photo C**. Be sure to apply glue to the divider-frame notches to adhere the frames to the legs.

**8** From 1/4" plywood, cut the back (M) to size. Sand it smooth, and set it aside.

#### Next: the plugs and trim

**1** Plane stock to 1/2" thick, and cut two 2x8" blanks to form the upper leg-mortise plugs (N) and a 5x8" blank to

form the lower leg-mortise plugs (O), where shown on **Drawings 1** and **5**. Note that the plugs will show face grain on their sides to give the appearance that the side rails (D, E) have through tenons.

**2** Using your tablesaw, follow the setup and instructions on **Drawing 6**, steps 1 through 3, to form the plugs from the blanks. Sand the plugs smooth. Then, glue them in the legs' mortises.

#### 5 LEG-MORTISE PLUG DETAIL

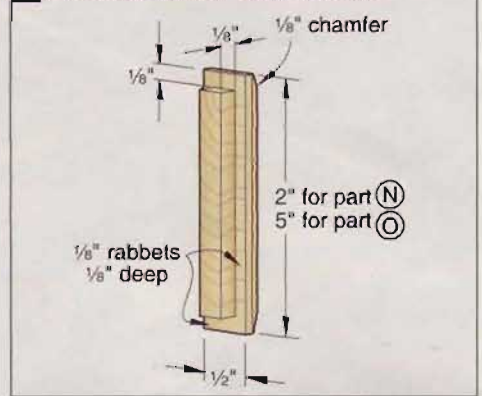

#### ASSEMBLE THE CASE

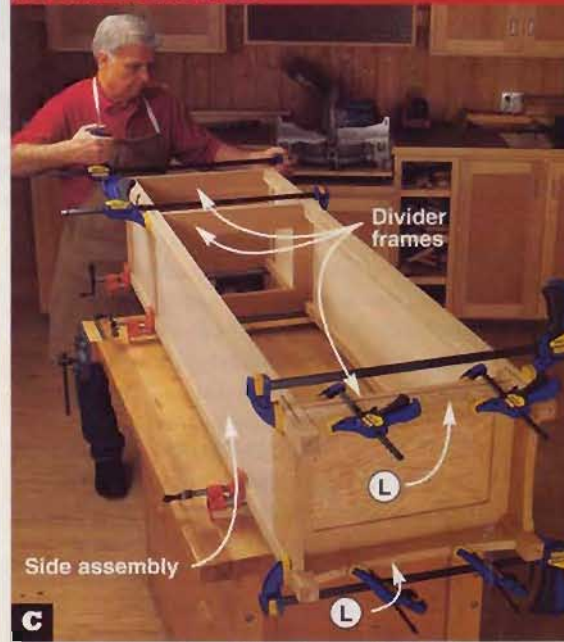

Glue and clamp the divider frames (H/I/J/K) and bottom rails (L) between the side assemblies, making sure to locate the frame without a panel in the middle.

**3** Plane stock to 1" thick, and cut a 4 3/8 x 64" workpiece to form the side and front trim (P, Q) for the top. Angle your tablesaw blade to 18° from vertical, and bevel-rip the workpiece, where dimensioned on **Drawing 7a**. Then, rout a 1/8" chamfer along an edge of the workpiece, where shown. Now, miter-cut the trim to the listed lengths, cutting the pieces in sequence (side, front, side) to maintain a continuous grain flow.

**4** Adjust your biscuit-joiner fence to center the cutter on the trim's thickness. Plunge slots for #20 biscuits in the mitered ends, where shown on **Drawing 7**. Next, drill countersunk shank holes through the top of the trim 3/8" from its back edge, where shown on **Drawings 7** and **7a**. Then, glue and assemble the trim with biscuits. When the glue dries, position the trim on the case, flush with the rear legs' back face and centered side-to-side. Clamp it in

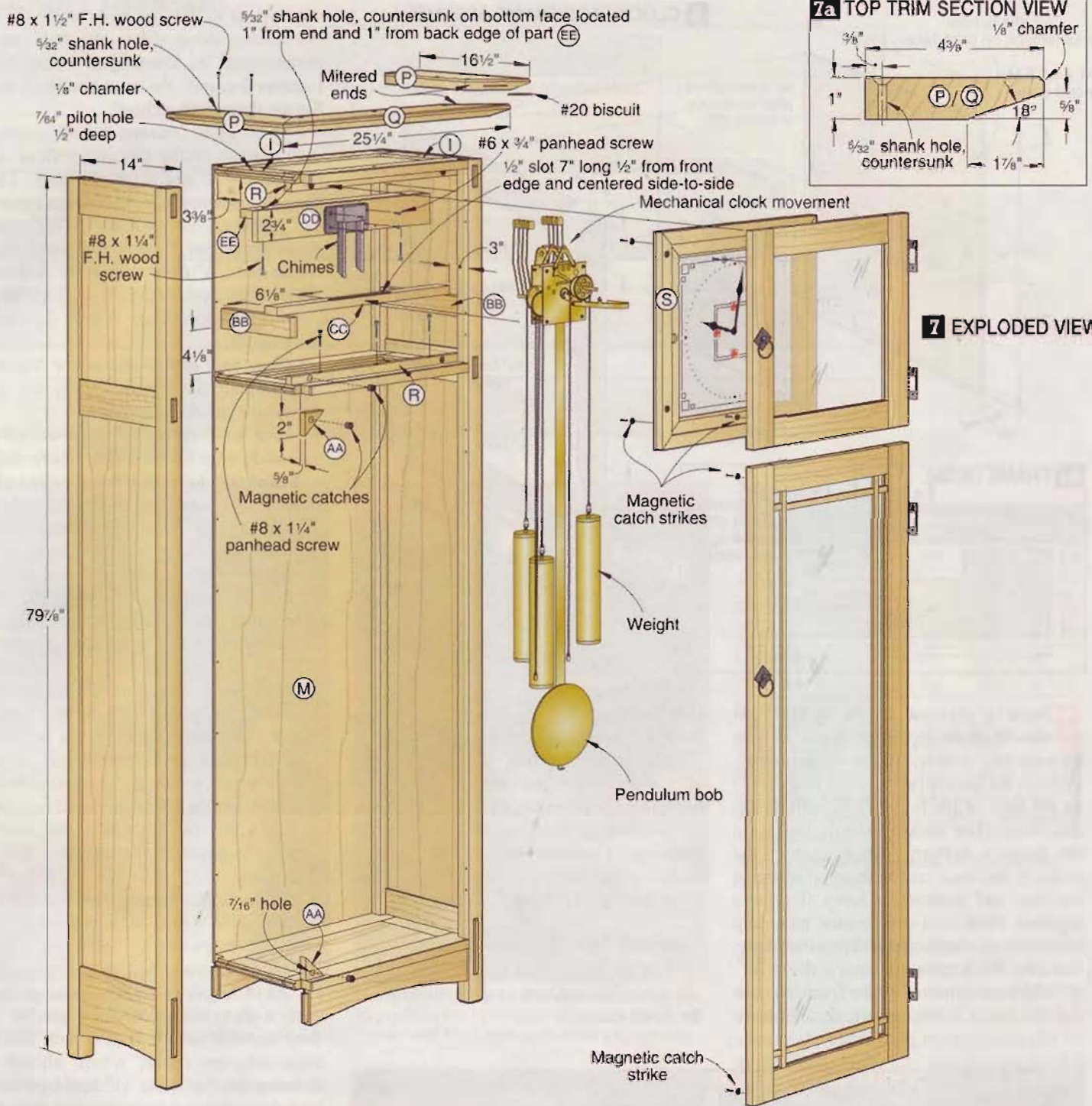

place. Now, drill  $\frac{7}{64}$ " pilot holes  $\frac{1}{2}$ " deep centered in the shank holes into the top divider frame, and drive the screws.

### Put on a beautiful face

**1** Cut the face blocks (R) to size. Then, drill two  $\frac{3}{16}$ " holes through the front edge, where dimensioned on **Drawing 4**, to receive magnetic catches, where shown on **Drawing 7**. (The catches hold the clock-face frame in place.) Now, drill  $\frac{3}{16}$ " holes to form  $\frac{3}{8}$ "-long slots through the top of the blocks, where dimensioned on **Drawing 4**. Using your vise, press magnetic catches into the  $\frac{3}{16}$ " holes.

**2** To mount the face blocks to the top of the middle divider frame's front stile (H) and to the bottom of the top divider frame's front stile, where shown on **Drawing 7**, position the blocks  $\frac{1}{2}$ " back from the stiles' notches (the legs' back face), where dimensioned on **Drawing 4**. Clamp the blocks in place. Now, drill pilot holes, centered in the slots, into the stiles, and drive the panhead screws.

**3** From  $\frac{3}{4}$ "-thick stock, cut a  $2\frac{1}{4} \times 78$ " workpiece for the frame members (S). Using your tablesaw, form a  $1\frac{1}{2}$ " rabbet  $\frac{1}{4}$ " deep on the workpiece's front face, where dimensioned on **Drawing 8a**. Then,

using a 1"-tall auxiliary fence attached to the fence on your table-mounted router and positioning the workpiece on edge with the rabbeted surface against the fence, rout a  $\frac{1}{4}$ " chamfer along the piece, where shown. Sand the workpiece smooth. Now, miter-cut four  $17\frac{3}{8}$ "-long frame members from the piece. Glue, assemble, and clamp the frame together.

**4** Mark centerpoints for two  $\frac{7}{16}$ " holes in the frame for magnetic catches, where dimensioned on **Drawing 8**. (These catches hold the top door closed.) Using a Forstner bit, drill the holes. Now, install the catches.

## 8 CLOCK FACE FRAME ASSEMBLY

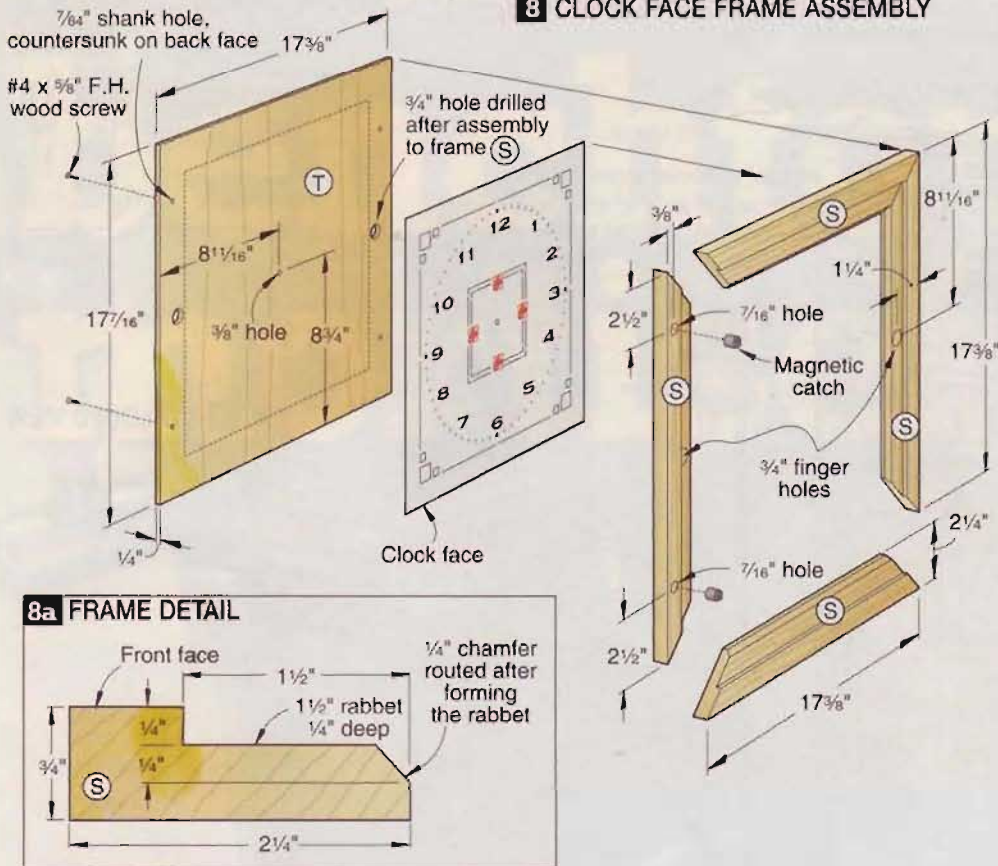

**5** From  $\frac{1}{4}$ " plywood, cut the backer (T) to size. Mark the top. Then, drill a  $\frac{3}{8}$ " hole through the backer, where dimensioned. Position the backer (without the clock face) on the back of the frame flush with its top and sides. (The backer extends  $\frac{1}{16}$ " from the frame's bottom, which centers the frame in the clock case with a  $\frac{1}{16}$ " reveal at the top and bottom.) Clamp the parts together. Now, drill countersunk mounting holes through the backer and into the frame, and drive the screws.

**6** Mark centerpoints on the frame for two  $\frac{3}{4}$ " finger holes, where dimensioned.

Using a Forstner bit in your drill press, bore the holes through the frame and backer.

**7** Match the location of the magnetic catch strikes on the back of the frame/backer assembly (S/T) with those of the catches in the face blocks (R). See **Drawing 7**. Drill pilot holes, and mount the strikes using the supplied screws. Install the assembly in the case.

### Create the prized doors

**1** Cut the top/bottom rails (U), top door stiles (V), and bottom door stiles (W) to the listed sizes.

**2** Lay out  $\frac{1}{4} \times \frac{1}{2}$ " mortises on the top and bottom door stiles (V, W), where dimensioned on **Drawing 9**. Using a  $\frac{1}{4}$ " Forstner bit, drill the mortises  $\frac{1}{16}$ " deep. Square them with a chisel.

**3** Referring to **Drawing 9a**, cut tenons on the ends of the top and bottom door rails (U) to fit the stiles' mortises. Then, mark the locations for the door-pull mounting holes on the stiles (V, W), where dimensioned on **Drawing 9**. Drill a  $\frac{1}{4}$ " counterbore  $\frac{1}{4}$ " deep with a  $\frac{3}{16}$ " hole centered inside through the stiles' front face at the marked locations, where shown on **Drawing 9b**.

**4** Glue and clamp the doors together, checking for square. When the glue dries, sand the doors smooth.

**5** Rout a  $\frac{3}{8}$ " rabbet  $\frac{3}{8}$ " deep around the inside edge of the doors, where shown on **Drawing 9**, to receive the glass and glass stops (X). Square the corners with a chisel.

**6** Mount  $2\frac{1}{2}$ " no-mortise hinges on the door stiles, where dimensioned, using the supplied screws. Then, position each door in its opening, flush with the legs' front face, and centered top to bottom. Check for a uniform reveal all around equal to the hinge-side reveal (approximately  $\frac{3}{32}$ "). Remove the doors and plane their edges, if needed, to achieve the desired reveal. Now, screw the hinges to the legs.

**7** Plane stock to  $\frac{1}{4}$ " thick, and rip two  $\frac{3}{8} \times 96$ " strips for the glass-stop blanks (X). Measure the doors' rabbeted openings, and then cut the horizontal and vertical stops to length to fit the openings. Set the stops aside.

**8** Measure the opening between the bottom door's rails (U) and stiles (W). Then, plane stock to  $\frac{1}{4}$ " thick, and cut the  $\frac{1}{2}$ "-wide horizontal and vertical glass trim (Y, Z) to length to fit the opening. Next, using a dado blade, cut a  $\frac{1}{4}$ " groove  $\frac{1}{16}$ " deep centered on the trim's back face for clear silicone caulk, where shown on **Drawing 9c**. Now, cut  $\frac{1}{2}$ " half-laps in the back face of the vertical trim and front face of the horizontal trim, where dimensioned on **Drawing 9**. Glue and clamp the trim together. When the glue dries, sand the assembly smooth.

**9** Plane stock to  $\frac{3}{8}$ " thick, and cut the door blocks (AA) to size, miter-cutting them, where shown on **Drawing 7**. Next, drill a  $\frac{7}{16}$ " hole through the blocks, where shown. Then, install magnetic catches in the holes. Now, glue and clamp the blocks to the top of the bottom divider frame's front stile (H) and to the bottom of the middle divider frame's front stile, where dimensioned on **Drawing 4**. Match the location of the magnetic catch strikes on

### INSTALL THE CLOCK SEAT AND MOVEMENT

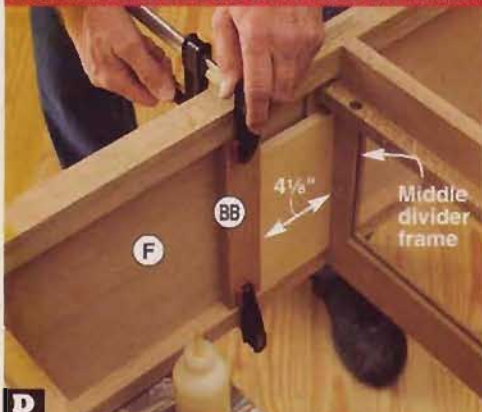

**D** Glue and clamp the cleats (BB) to the top side panels (F) using  $4\frac{1}{2}$ "-wide spacers to position the cleats above the middle divider.

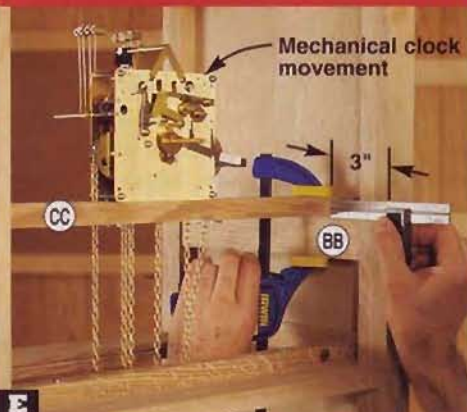

**E** Glue and clamp the clock seat (CC)/movement to the cleats (BB), locating the seat's front edge 3" back from the legs' front face.



the back face of the doors with the catches in the clock-face frame (S) and door blocks, and mount the strikes.

## Time for the clock

**1** Cut the cleats (BB), clock seat (CC), chime mount (DD), and chime-mount support (EE) to the listed sizes. Remove the frame/backer assembly (S/T). Then, install the cleats (BB) in the case against the top side panels (F), where dimensioned on **Drawing 7** and as shown in **Photo D**.

**2** Cut a  $\frac{1}{2}$ " slot 7" long  $\frac{1}{2}$ " from the front edge of the clock seat (CC) and centered side-to-side, where shown. (We formed the slot by drilling  $\frac{1}{2}$ " holes at the ends, and then scrollsawing it to shape.) Then, wearing cotton gloves to protect the brass, mount the mechanical clock movement on the seat, as directed in the instructions supplied with the movement. Now, install the seat/movement in the case, as shown in **Photo E**.

**3** Glue and clamp the chime mount (DD) to the chime-mount support (EE), where shown on **Drawing 7**, keeping the support's top face and the mount's top edge as well as their ends flush. When the glue dries, drill countersunk shank holes through the support's bottom face, where shown.

**4** Install the chimes on the mount (DD), as directed. Then, position the assembly in the case tight against the top divider frame with the back edge of the support (EE)  $3\frac{3}{8}$ " from the back (M), where shown. Using the support's mounting holes as a guide, drill  $\frac{1}{64}$ " pilot holes  $\frac{1}{2}$ " deep into the rails (I). Now, drive the screws.

## Finish up

**1** Remove the doors, clock movement, chimes, and hardware. Then, sand any areas that need it with 220-grit sandpaper. Remove the dust.

**2** Apply a stain, if you wish. (We used Watco Danish Oil Finish, Dark Walnut, lightly sanding it when dry with 320-grit sandpaper.) Top-coat with a clear finish. (We applied three coats of AquaZar Water-Based Clear Satin Polyurethane, sanding to 320 grit between coats.)

*Note: Let the finish dry for seven days before you install the clock movement because fumes will degrade the movement's lubricating oil, causing premature wear and mechanical problems.*

**3** Install the glass and glass stops (X) in the doors, where shown on **Drawing 9**, using #17x $\frac{3}{4}$ " brads. To prevent splitting the stops, drill holes in them using a brad with its head snipped off.

**4** Reinstall all of the hardware. Then, using the supplied screws, mount the

## 9 DOORS (viewed from back)

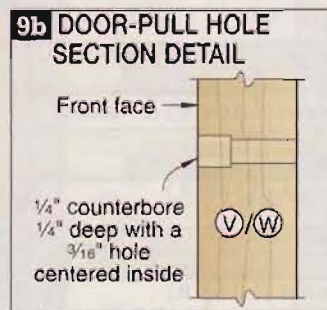
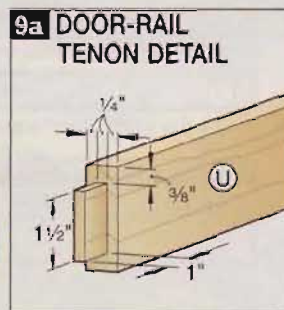
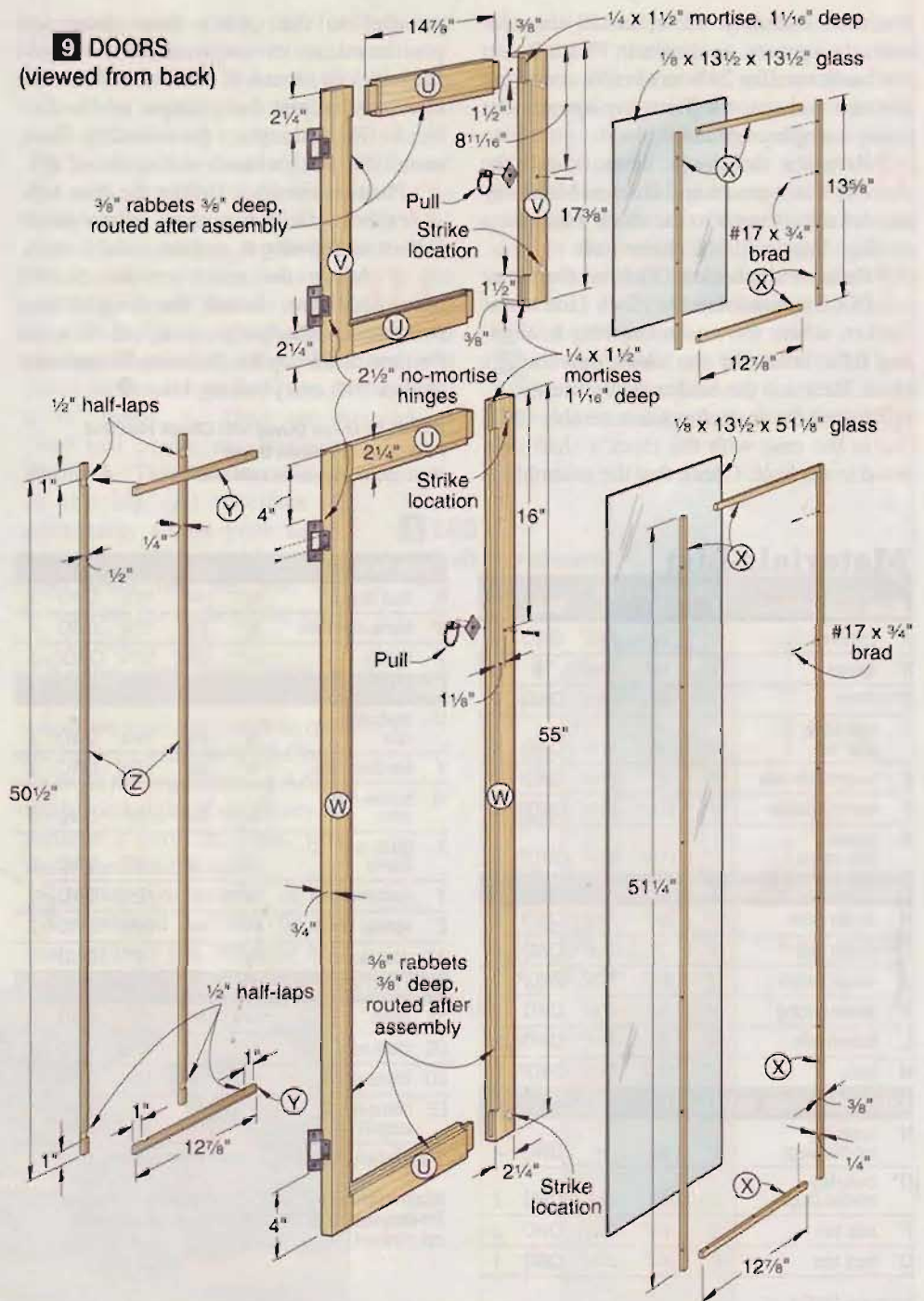

door pulls as shown on **Drawings 7** and **9**. Drive the supplied nails to secure the door-pull escutcheons.

**5** To install the bottom door's trim assembly (Y/Z), first place the door face up on

your workbench. Clean the glass. Then, to keep the long vertical trim (Z) straight, cut two 1x45" strips from  $\frac{1}{8}$ " hardboard for spacers. Next, place a few dabs of clear silicone caulk in the  $\frac{1}{4}$ " grooves in the back of

the trim assembly. Now, install the trim with the spacers, as shown in **Photo F**. Let the caulk cure for 24 hours before removing the tape and spacers. Trim any squeeze-out using a single-edge razor blade.

**6** Remount the doors. Then, install the clock movement and chimes. Make any needed adjustments to the clock's hammers to align them with the chime rods.

**7** Remove the backer (T) from the frame (S). Spray-adhere the clock face to the backer, where shown on **Drawing 8**, aligning their holes for the clock movement's shaft. Reattach the backer to the frame.

**8** Install the frame/backer assembly (S/T) in the case with the clock's shaft centered in the hole. Check that the assembly is

parallel to the case's front face and positioned so its magnetic catches hold the top door closed. If needed, remove the assembly; adjust the position of the face blocks (R); and replace the assembly. Then, install the clock's hands and retaining nut.

**9** Position the back (M) in the rear legs' rabbets. Drill mounting holes, where shown on **Drawing 3**, and drive the screws.

**10** Move the clock to the desired location. Install the weights and pendulum, and adjust as specified. Now, set the time, and enjoy the charming Westminster chimes with every passing hour. 🎵

Written by **Owen Duvall** with **Chuck Hedlund**  
Project design: **Kevin Boyle**  
Illustrations: **Roxanne LeMoine**

## INSTALL THE TRIM ASSEMBLY



With the trim assembly (Y/Z) and spacers held tight against the glass and bottom door stiles (W), apply tape to hold the assembly in place while the caulk cures.

## Materials List

Side assemblies	FINISHED SIZE			Matl.	Qty.
	T	W	L		
A* corners	3/4"	1 1/2"	79 7/8"	QWO	8
B* splines	1/8"	7/16"	79 7/8"	TH	4
C* fillers	3/4"	3/4"	79 7/8"	QWO	4
D top/middle side rails	3/4"	3"	11 1/2"	QWO	4
E bottom side rails	3/4"	6"	11 1/2"	QWO	2
F top side panels	1/4"	11 1/2"	14 3/8"	QWOP	2
G bottom side panels	1/4"	11 1/2"	52 1/4"	QWOP	2
Divider frames, bottom rails, and back					
H divider stiles	3/4"	2 3/4"	19 1/4"	QWO	6
I divider rails	3/4"	2"	8 1/2"	QWO	6
J divider panels	1/4"	8 1/2"	15 3/4"	QWOP	2
K* divider edging	1/4"	3/4"	17 1/2"	QWO	3
L bottom rails	3/4"	3"	18 1/2"	QWO	2
M back	1/4"	18 1/4"	74 7/8"	QWOP	1
Leg-mortise plugs and top trim					
N* upper leg-mortise plugs	1/2"	2"	3/8"	QWO	4
O* lower leg-mortise plugs	1/2"	5"	3/8"	QWO	2
P* side trim	1"	4 3/8"	16 1/2"	QWO	2
Q* front trim	1"	4 3/8"	25 1/4"	QWO	1

Clock face						
R	face blocks	3/4"	3/4"	18 1/4"	QWO	2
S*	frame members	3/4"	2 1/4"	17 3/8"	QWO	4
T	backer	1/4"	17 3/8"	17 1/8"	QWOP	1
Doors						
U	top/bottom rails	3/4"	2 1/4"	14 7/8"	QWO	4
V	top door stiles	3/4"	2 1/4"	17 3/8"	QWO	2
W	bottom door stiles	3/4"	2 1/4"	55"	QWO	2
X	glass-stop blanks	1/4"	3/8"	96"	QWO	2
Y	horizontal trim	1/4"	1/2"	12 7/8"	QWO	2
Z	vertical trim	1/4"	1/2"	50 1/2"	QWO	2
AA	door blocks	5/8"	2"	2"	QWO	2
Clock/chime supports and mounts						
BB	cleats	3/4"	1 3/4"	11"	QWO	2
CC	clock seat	3/4"	1 3/4"	19 1/4"	QWO	1
DD	chime mount	3/4"	2 3/4"	18 1/4"	QWO	1
EE	chime-mount support	3/4"	1 3/4"	18 1/4"	QWO	1

\*Parts initially cut oversize. See the instructions.

**Materials key:** QWO—quartersawn white oak, TH—tempered hardboard, QWOP—quartersawn white oak plywood.

**Supplies:** Easy-release painter's tape; #20 biscuits; #4x5/8", #6x3/4", #8x1 1/4", and #8x1 1/2" flathead wood screws; #6x3/4" and #8x1 1/4" panhead screws; #17x3/4" brads; 1/8x13 1/2x13 1/2" glass (1); 1/8x13 1/2x5 1/8" glass (1); 1/8" hardboard; clear silicone caulk; spray adhesive.

**Blades and bits:** Dado-blade set; 1/4" brad-point bit; 45° chamfer and 3/8" piloted rabbeting router bits; 1/4", 7/16", and 3/4" Forstner bits.

## Sources

**Veneer.** 1/8"-thick pressure-sensitive veneer, white oak quarter sliced, 24x96", no. 61332, \$59.99 (1). Call Rockler Woodworking and Hardware, 800/233-9359, or go to [www.rockler.com](http://www.rockler.com).

**Mechanical clock movement/hardware kit.** Includes mechanical clock movement, chimes, clock face, magnetic catches with strikes and screws (6), door pulls (2), 2 1/2" no-mortise hinges (4). Order kit no. FC-04, \$338.95 ppd. Call Schlaubaugh and Sons Woodworking, 800/346-9663, or go to [www.schsons.com](http://www.schsons.com).

**Quartz clock movement/hardware kit.** Includes battery-operated quartz chiming clock movement, pendulum drive, clock face, magnetic catches with strikes and screws (6), door pulls (2), 2 1/2" no-mortise hinges (4). Order kit no. FC-04Q, \$180.95 ppd. Call Schlaubaugh and Sons Woodworking, 800/346-9663, or go to [www.schsons.com](http://www.schsons.com).

**Lumber kit.** Enough quartersawn white oak stock and plywood and tempered hardboard for one clock, kit no. W156, \$449.95 ppd. Heritage Building Specialties, call 800/524-4184, or go to [www.heritagewood.com](http://www.heritagewood.com).

## Cutting Diagram

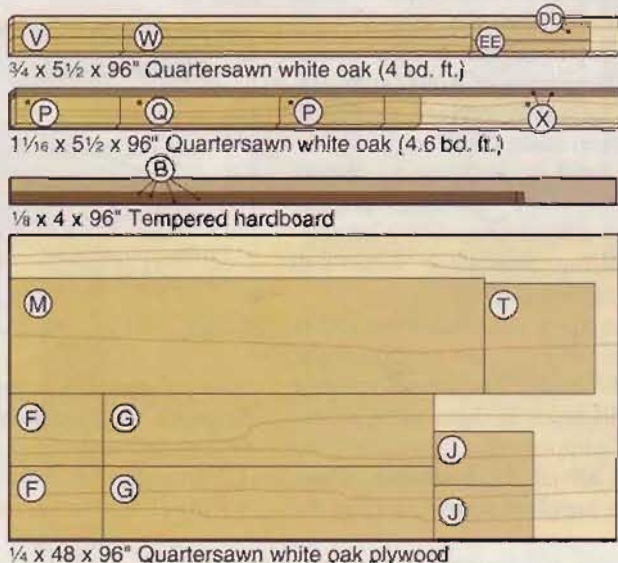
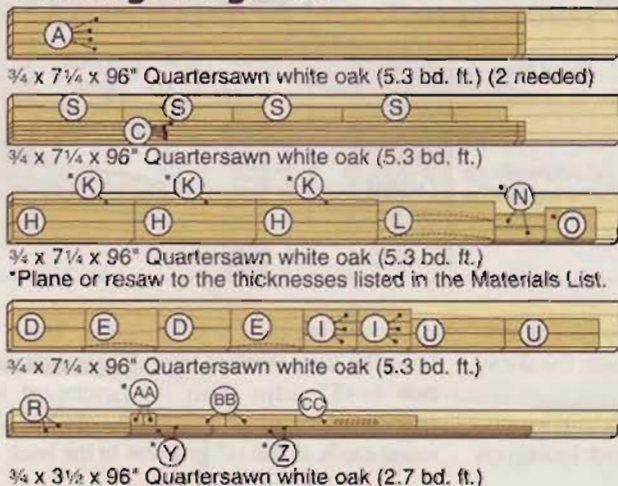

VISIT WITH A MASTER

# Sam Maloof

*"The shape forces you back against the curved slats so the chair supports you from your shoulders all the way to the backs of your knees."*

—Sam Maloof



# Spend a day with America's quintessential chairmaker and learn a few tricks along the way.

**A**n icon of American furnituremaking. An artist. A living legend. All of these words aptly describe Sam Maloof. But Sam shuns fancy labels in favor of a more fitting description. "I'm a woodworker," he says.

Though Sam has crafted more than 500 original furniture designs during five decades as a professional woodworker, his most famous piece remains his elegant, supremely comfortable rocking chair, seen at *left*. His chairs and other pieces are so uniquely original that they don't fit a particular furniture style, but have emerged instead as the "Maloof style."

Recently, we caught up with Sam in his Alta Loma, California, shop to see how this renowned woodworker creates his highly prized rockers that sell for \$20,000 and up. We quickly discovered that trying to derive a plan for one of Sam's chairs is comparable to getting a recipe from a chef that cooks with pinches and dabs: You probably won't be able to exactly re-create what he makes, but you can learn much about the craft by just observing.

## Start with wonderful wood

Like all masters, Sam chooses his woods carefully and knows that beautiful lumber can separate a great piece from a good one. For many years, he built most of his pieces from walnut, which remains one of his favorite species thanks to its great workability and enduring good looks. He also often uses curly maple, zircote, and, on occasion, cherry. Many pieces also feature ebony accents.

Sam always keeps lumber on hand to ensure an adequate supply, and admits that



"I don't have to look for lumber, it finds me," Sam says. As a result, he needs four buildings to store his stash. Luckily, southern California offers ideal storage conditions: low humidity and moderate temperatures.

his passion for good wood may have gotten out of hand, as he now stores a few hundred thousand board feet of his favorites, all separated by species, thickness, and grain pattern, *below left*.

When the time comes to select wood for a chair, Sam carefully matches boards by color, especially when choosing walnut or cherry because they can have widely varying tones. Zircote and maple tend to be more consistent in color, so he selects them by carefully comparing and matching each board's distinctive grain.

Most of Sam's boards are thick, from 8/4 (2") through 16/4 (4"), because he cuts all chair parts except the rockers from solid stock, and many require large curves.

The rockers he creates from 1/4"-thick laminations glued on a form. This gives the rockers consistent shape and strength. Plus, bent lamination allows him to insert con-

trasting wood when desired, such as the ebony accent in the curly maple rocker seen at *left*.

## Templates ensure success

Some woodworkers begin the building process by developing intricate plans for every dimension, part, and detail. Sam does not. Instead, he relies on templates, *below*, to give him the rough shapes needed for such parts as rockers, slats, and arms. Like his designs and techniques, he developed these templates using estimates and experience, not formal training.

"I made my original template for the back slats by cutting cardboard and holding it against my back, then reshaping it until it felt right," Sam says. "I've been using that template for over 30 years now. Everyone tells me how the chairs fit their backs just right, so I guess it works."

You won't find any jigs in Sam's shop, but you can't miss the plywood templates that hang everywhere space allows. Some are decades old, and still see regular use. Many bear the name of the original buyer of that style chair and provide a unique record of his clients.





## BANDSAW SCULPTING WITH A MASTER'S TOUCH

Carefully eyeing his layout lines, Sam begins shaping the blank for a chair arm. He pivots and turns the arm as he works to follow the lines and create compound curves.

After about five minutes, Sam has transformed a rough blank into an arm that is ready for installation. He'll create the mirror image from the other blank, deftly matching the shapes as he works.

## Sculpting the shapes

With his stock and appropriate templates in hand, Sam starts to rough out the parts at the bandsaw, a tool he has mastered like few other woodworkers, *above left*. He's quick to advise, though, that some of his methods "aren't exactly OSHA approved," and he knows better techniques exist. Regardless, he shapes chair parts with amazing agility, more sculpting than cutting. His templates give the rough shape. The rest he creates by eye and feel to make almost perfectly matched parts.

## Forming the seat

To create a chair seat, Sam starts with five pieces of wood. When possible, he cuts them all from the same board to ensure the best color match.

He sculpts the seats to a shape that he believes lies at the heart of his chairs' comfort. "The shape forces you back and places you against the curved slats. This positions you so the chair supports you from your shoulders all the way to the backs of your knees," he says.

Beveling the edges of each seat board creates a contour that yields a more comfortable shape while requiring less shaping. Keeping the edges at 90° simplifies leg joinery.

Before gluing up the seat panel, Sam roughs out some of this sculpted shape at the bandsaw. The seats he makes today feature beveled edges on each of the boards, as seen *below*. This design allows deeper hollowing of the surface than was possible with the flat seat panels he used to make. Though today's chairs look similar to those made decades ago, these subtle refinements point to Sam's drive to constantly improve.

The joint Sam uses to join the seat and legs stands as another of those refinements made over many years. You can see this joint, which he calls the dado-and-rabbet, in the drawing and accompanying photo on the *following page*. "I spent four or five years developing that joint," he notes.

Though the joint offers loads of glue surface, Sam reinforces it with screws after assembling it with standard yellow glue. He's tried many types of screws over the years, and these days chooses ones designed for deck building because of their deep thread purchase. Some woodworkers may scoff and say deck screws aren't appropriate in fine furniture, but Sam sees it differently. He wants to ensure his chairs remain together.

He covers the screws with plugs which he used to make from the same wood as the chair. Now, plugs are often made of ebony. Screws also reinforce the rocker-to-leg joint. Where the arms meet the front legs, blind dowels (no screws) provide strength.

## ANATOMY OF A MALOOF ROCKER SEAT

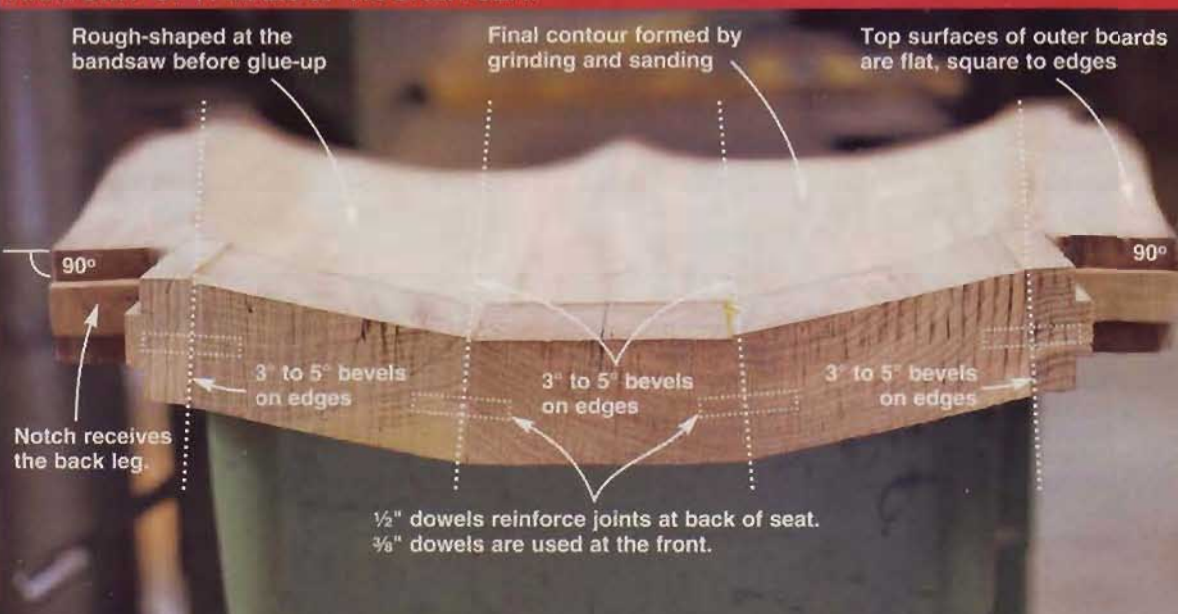

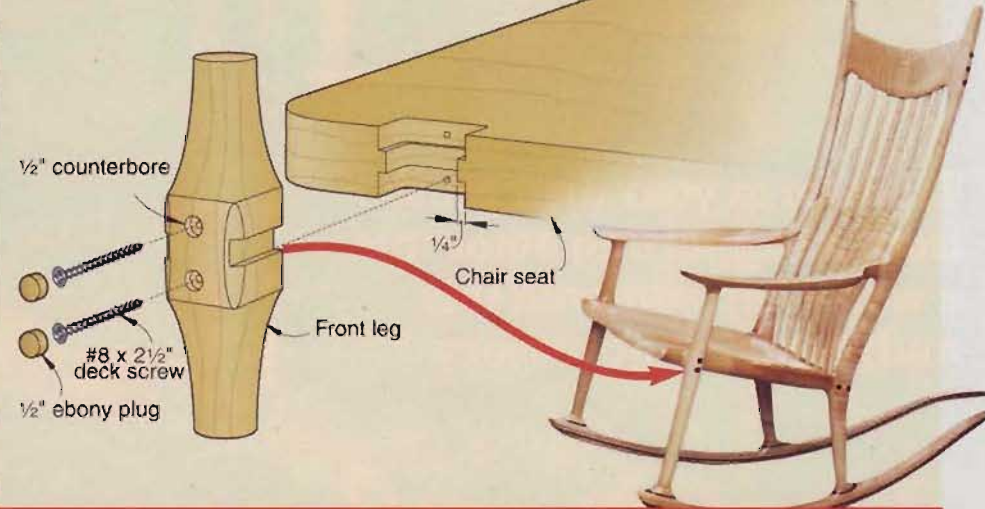

## THE DADO-AND-RABBET JOINT

This unique joint attaches the front and back legs to the seat. The pieces interlock to form a twist-resistant joint with lots of glue surface. A couple of screws, covered by plugs, add strength to withstand long-term use. After assembly, rasps and files blend all the surfaces together.

## Handwork yields final form

For most woodworkers, final assembly of a project means the work is almost complete. With Sam's chairs, though, much work remains. Why? At assembly, all pieces still hold only their rough shape. To create seamless joints and crisp details, Sam relies on hours of painstaking shaping. Pneumatic sanders and grinders speed this process, but most of the work gets done using just traditional hand tools, such as those seen *below*.



Traditional hand tools get a workout in Sam's shop. Sam and the boys commonly use rasps, files, rippers, sandpaper, and scrapers to refine the rough shapes into finished form.

This phase of the process takes many hours, which in the early years meant Sam could produce very few pieces annually. So, Sam employs talented craftsmen who get little of the glory, but play essential roles which Sam readily acknowledges. Seen in the photos, *right*, "the boys," as Sam calls them, are like sons. All three have been with him for at least 15 years.

During this shaping process, the chairs pass continually back and forth among all four guys. Because the process takes much time and because there are usually multiple chairs in process simultaneously, a month may pass before any one chair makes its way from beginning to end.

Once Sam approves the workmanship, a chair is ready for finishing. After sanding to at least 400 grit, a chair gets multiple coats of the finishes Sam developed. The first consists of equal parts boiled linseed oil, tung oil, and polyurethane varnish. Sam applies at least three liberal coats, allowing each to dry for a day. After the third coat, a second mixture of linseed oil, tung oil, and carnauba wax gets applied. Rubbing vigorously ensures that these coats blend thoroughly into those underneath. Again, he applies three coats over three days.

For many years, Sam brewed the finishes himself, but he now has them manufactured. You can purchase Sam's finishes through Rockler Woodworking and Hardware at [www.rockler.com](http://www.rockler.com) or 800/279-4441. A quart of either the poly/oil blend (#58644) or oil/wax blend (#58677) sells for \$15.99.

Finally, each chair receives a couple of coats of furniture wax. The multistep finish imparts a rich glow and adds depth to the grain figure. And, it holds up well, taking on a warm patina over years.

## Sam's legacy and his future

Even at 88 years young, Sam works six days per week designing, cutting out, and assembling every piece of furniture. He also designs a few new pieces each year. "I love being in the shop. It's what I do," he says.

In addition, he established the Sam and Alfreda Maloof Foundation and devised a plan that will pass his business on to the boys; his son, Slimen; new wife, Beverly; and his business manager, Roz Bock.

So, does he have unfulfilled ambitions? Sure, but he keeps it all in perspective: "If I ever make it to the top of the mountain, there will be nowhere to go but back down. So I just keep climbing."

Learn more about Sam by reading *Sam Maloof, Woodworker*, or *The Furniture of Sam Maloof*. Both of these books are available from Amazon.com. Or you can visit [malooffoundation.org](http://malooffoundation.org) where you'll find more information on Sam's business and schedules for public shop tours. ♣

Written by David Stone  
Photographs: Edmund Barr

## THE BOYS: SAM'S PARTNERS IN FURNITUREMAKING HEAVEN

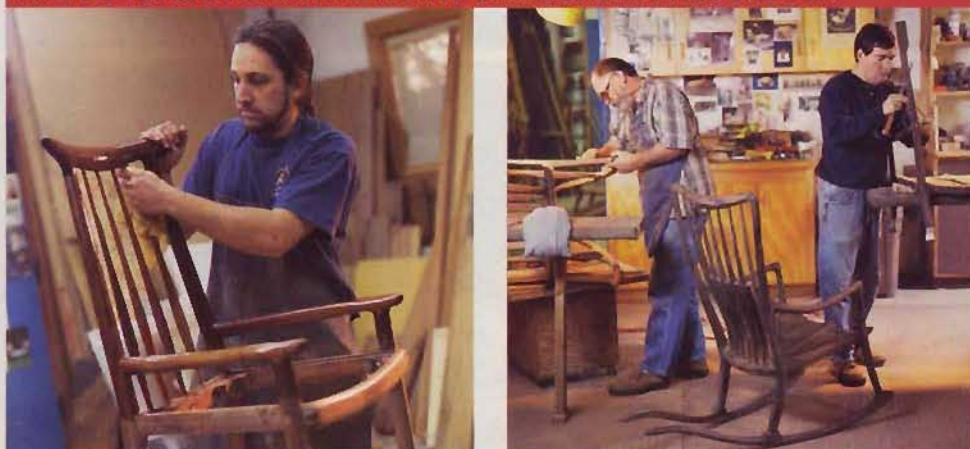

David Wade, *left*, applies Sam's special finish to a decades-old chair sent in for refurbishing, while Larry White, *middle*, and Mike Johnson shape new chairs still under construction.

Transform your drill press from a supporting actor into a workshop star with this multifunction accessory.

Hold-downs quickly and securely clamp workpieces for safe, accurate drilling.

The 3"-high, 32"-long fence slides forward and back, and locks in place in seconds.

A sliding, micro-adjustable stopblock ensures dead-on, repeatable positioning.

Generous 14½"×29½" table eases handling of large workpieces.

# feature-packed drill-press table

## PULL-OUT FENCE EXTENSIONS

Lockable pull-out extensions add 9½" to each end of the fence.

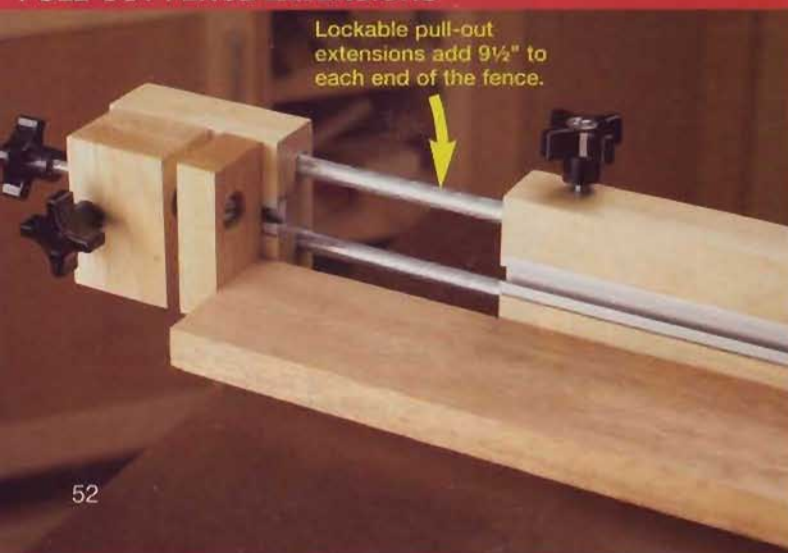

## REPLACEABLE TABLE INSERT

A replaceable insert provides full workpiece support when drilling or sanding.



**A**lthough indispensable in a wood-working shop, most drill presses come equipped with a table more suited to metalworking. This add-on table with fence sets things straight, supplying everything the cast-iron table on your drill press lacks.

## Start with the table

**1** For the base (A), cut two  $14\frac{1}{2} \times 29\frac{1}{2}$ " pieces of  $\frac{1}{2}$ " plywood. (We used Baltic birch plywood for its flatness and absence of voids. You also can use regular birch plywood or medium-density fiberboard.) Glue and clamp the pieces together, keeping their ends and edges flush, where shown on **Drawing 1**.

**2** From  $\frac{1}{4}$ " tempered hardboard, cut the top sides (B), top front (C), and top back (D) to the sizes listed in the **Materials List**. Mark the  $\frac{3}{8}$ "-radius finger notch on the front edge of part D, where shown on **Drawing 1**. Cut and sand it to shape. [The notch makes it easy to remove the insert (E).] Now spread glue on the backs of the hardboard top parts, and glue and clamp them to the 1"-thick plywood base, as shown in **Photo A**.

**3** Draw the  $\frac{3}{4}$ "-radius cutout at the rear of the table, where shown on **Drawing 1**. Bandsaw or jigsaw and sand it to shape.

**4** To locate the  $3\frac{1}{2} \times 3\frac{1}{2}$ " cutout in the drill-press chuck, install a  $\frac{1}{8}$ " bit in the drill-press chuck, center your metal drill-press table under the bit, and lock the table in place. Position the add-on table to center the bit in the recess for the insert (E) created by parts B, C, and D. If the metal drill-press table protrudes beyond the front edge of the add-on table, slide the add-on table forward until the two are flush. Clamp the add-on table in place. Now drill a  $\frac{1}{8}$ " hole all the way through the base (A). Remove the add-on table, and turn it upside down. Mark the  $3\frac{1}{2} \times 3\frac{1}{2}$ " cutout centered on the  $\frac{1}{8}$ " hole. Then drill  $\frac{3}{8}$ " holes at the corners, and cut the opening with a jigsaw. Now cut the insert (E) to the size listed.

**5** For a drill press with slots through its metal table, cut the groove for the mini-track in the bottom of the add-on table where shown on **Drawing 1**.

For a drill press without slots in its metal table, drill two  $\frac{1}{4}$ " mounting holes. Locate the holes about halfway between the center of the table and its rear edge and as far apart as possible. Then clamp the add-on table in place as before, and trace the hole locations on its bottom. Cut the groove for the mini-track so it passes over the hole locations.

**6** Turn the table over, and cut dados for the top mini-tracks, where shown on

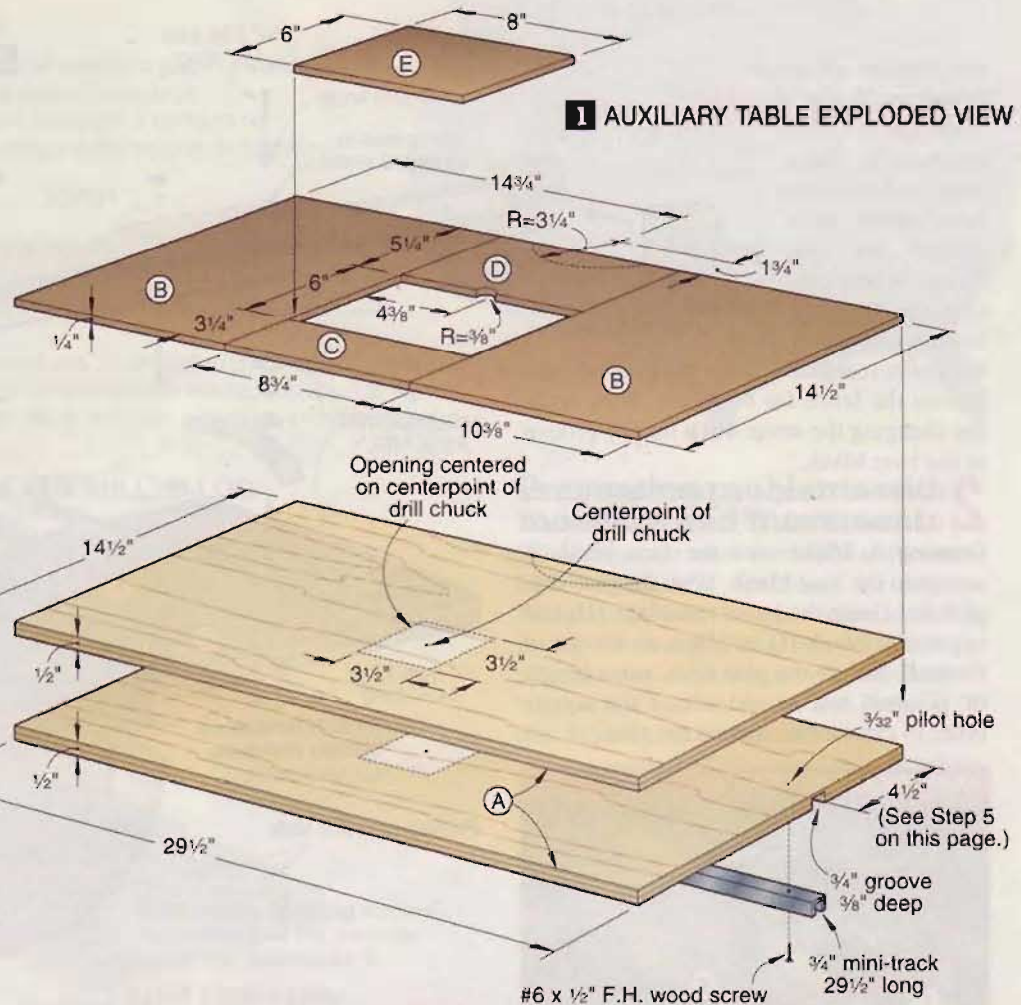

## GLUING UP THE TABLE

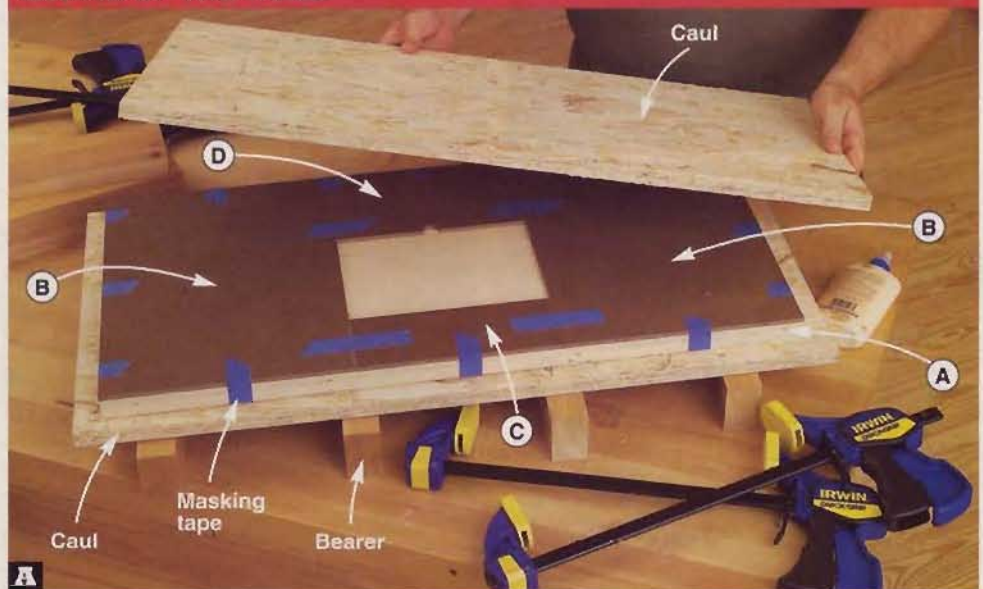

With glue applied to their bottom surfaces, position top parts B, C, and D on the 1"-thick base (A). To keep them from shifting, tape the top parts to each other and to the base with masking tape. Then clamp the top and base between  $\frac{3}{4}$ "-thick cauls and 2x3 bearers.

**Drawing 2.** (The dados are centered on the joint lines between the parts B and the parts C and D.)

**Note:** To add under-table dust collection for the sanding-drum setup shown in the photo, near left, see page 16.

## Now make the fence

**1** Cut the base blank (F), face blank (G), lower rear blank (H), and upper rear blank (I) to size. Install a  $\frac{3}{8}$ " dado blade in your tablesaw and position the fence to cut centered grooves in the thickness of parts H



and I, where shown on **Drawings 3 and 4.**

Then cut  $\frac{3}{16}$ "-deep grooves in these parts, and mark the face that was against the saw fence. When cutting the top and bottom grooves in the lower rear blank, keep the marked face against the fence for both cuts. Now without changing the setup, cut a mating groove in the base blank.

**2** Glue and clamp the face blank (G) to the base blank (F), where shown on **Drawing 4.** Make sure the face blank is square to the base blank. With the glue dry, glue and clamp the lower rear blank (H) and upper rear blank (I) in place, as shown in **Photo B.** Before the glue dries, run a length of  $\frac{3}{8}$ " steel rod in and out of the square holes to clear away any excess glue.

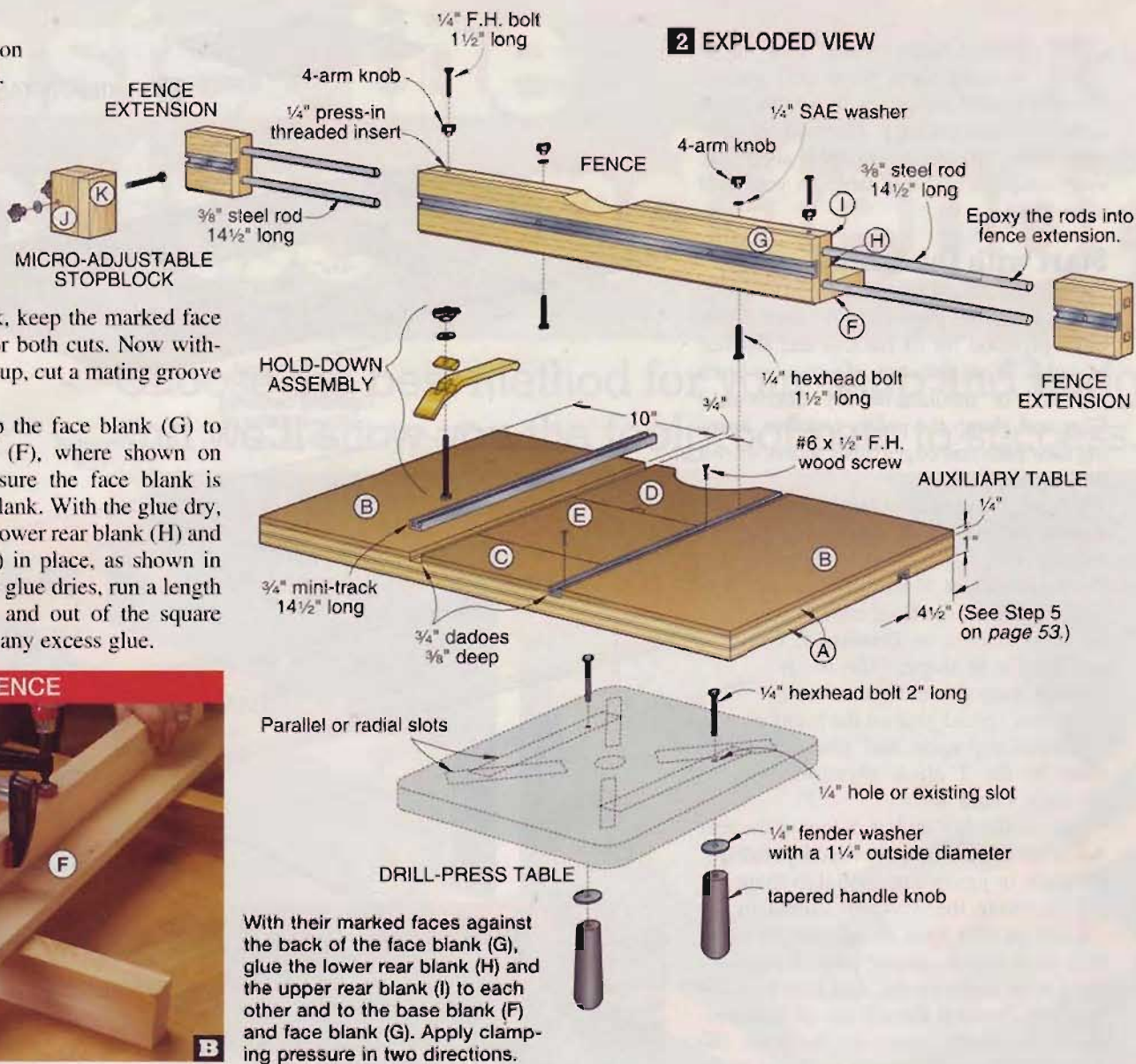

With their marked faces against the back of the face blank (G), glue the lower rear blank (H) and the upper rear blank (I) to each other and to the base blank (F) and face blank (G). Apply clamping pressure in two directions.

### MAKING THE FENCE

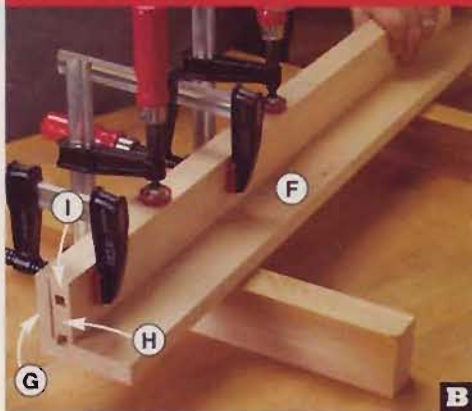

## Tips on using threaded inserts

Shop fixtures and jigs often require the installation of various clamping or adjustment knobs. That's when you'll reach for threaded inserts. Commonly available in sizes from #8-32 (a #8 screw body with 32 threads per inch) to  $\frac{3}{8}$ "-16 (a  $\frac{3}{8}$ " screw body with 16 threads per inch), there are two basic types: thread-in and press-in, shown at *near right*.

Use thread-in inserts in softer woods and plywood where their coarse outside threads cut easily into the surrounding wood. Simply drill a hole sized for the body of the insert, and screw it into place. In very hard woods, such as white oak and maple, or when the insert is close to the edge of a part and screwing it in may split the wood, drill a hole slightly larger than the outside thread diameter, and epoxy the insert in place. To protect the

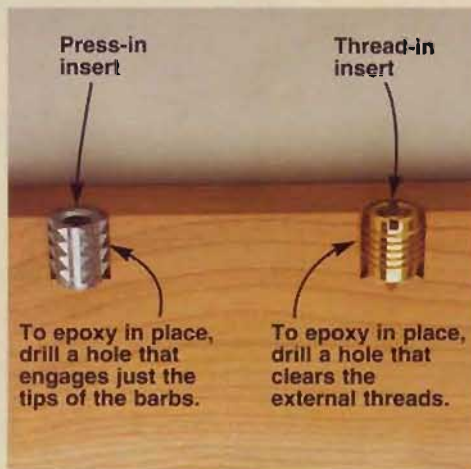

internal threads from epoxy, cover the end of the insert, as shown *above right*.

Press-in inserts, with their barbed exteriors, work well in hard woods, soft woods, and plywood. Drill a hole sized for the body of the insert, and press it into place with a clamp or tap it in with a hammer

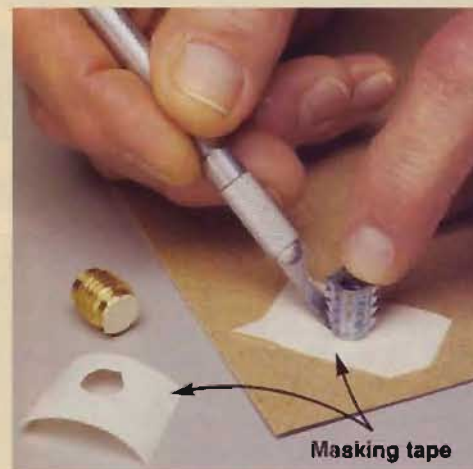

and a block of wood. For applications in which the clamping action tends to push the insert out of the wood, such as the knobs that tighten down on the drill-press fence extension rods, drill a hole that engages just the tips of the insert barbs and epoxy it in place.

**3 FENCE EXPLODED VIEW**

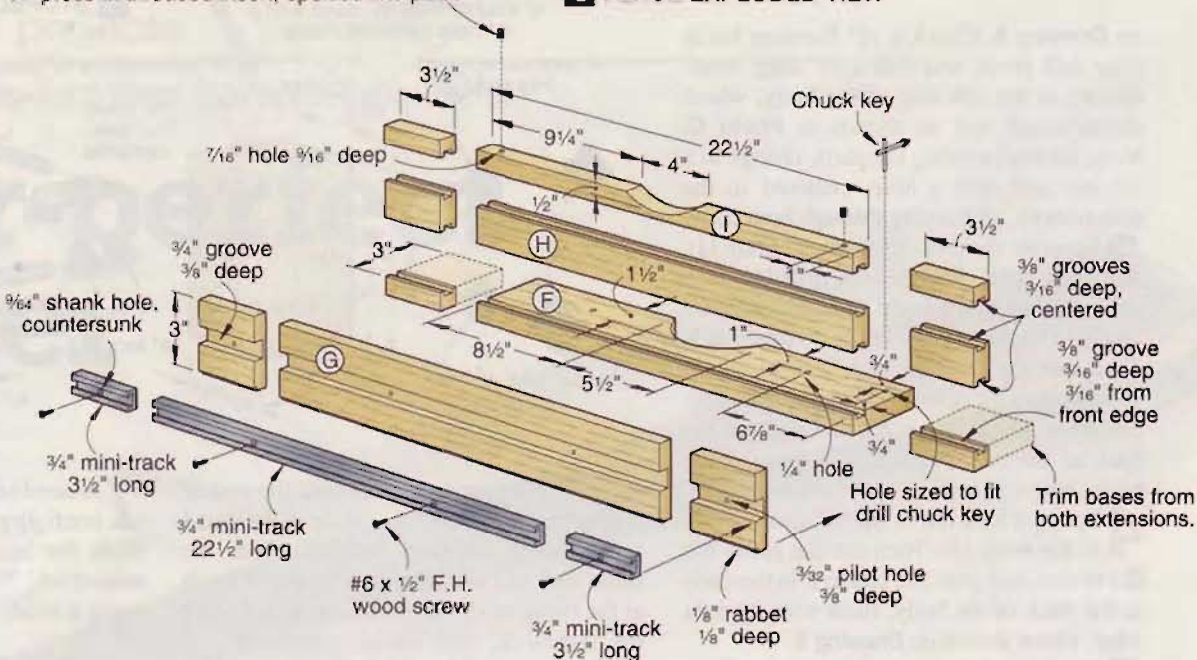

**3** Cut a 3/4" groove 3/8" deep for the mini-track in the fence face (G), where shown on Drawing 4. Then cut a 1/8x1/8" sawdust-relief rabbet along the bottom edge of the fence face.

**4** Trim one end of the assembled fence blank square, and then cut it into three pieces, where shown on Drawing 3, making a 22 1/2"-long fence and two 3 1/2"-long extensions. Now cut off the base portions of the extensions, where shown on Drawing 4.

**5** Bending a fairing strip to join their endpoints and centerpoints, mark the centered radius cutouts on the top of the fence and the back of its base (F), where shown on Drawing 3. Bandsaw or jigsaw, and sand them to shape. Then drill 1/4" holes for the bolts that hold the fence to the table and a hole for the drill-press chuck key in the fence base, where shown.

**6** To install press-in threaded inserts in the fence portion of part I, drill 7/16" holes to intersect the top square hole in the fence, where shown on Drawings 3 and 4. Spread epoxy in the holes, and press the inserts in place. When the epoxy cures, ream out any excess that may have dripped into the extension rod holes with a 3/8" drill bit. For more information on using threaded inserts, see the sidebar, *opposite*.

**Finish and assemble the table and fence**

**1** Cover the bottoms of the grooves and dadoes for the mini-track in the table and fence with masking tape. Now apply a clear finish to all the parts. (We used two coats of satin polyurethane, sanding between coats with 220-grit sandpaper.) When the finish dries, remove the masking tape.

**2** Using the countersunk holes in the mini-track as guides, drill pilot holes into the mating table and fence parts. (The mini-track supplied with the hardware kit listed in Sources on page 56 comes cut to the needed lengths.) Apply epoxy to the bottoms of the grooves and dadoes, and screw and clamp the mini-track in place.

*Note: The mini-track has a small flange along one outside edge, where shown on Drawing 4. To make certain the track in the fence aligns with the track in the extension,*

*orient the flange in the same direction in all three parts.*

**3** Cut four 14 1/2"-long pieces of 3/8" steel rod with a hacksaw. Using 80-grit sandpaper, rough up 3 1/2" at one end of each rod, and epoxy these ends into the square holes in the fence. To hold the rods parallel while the epoxy cures, insert their other ends into the square holes in the fence.

**4** To make knobs for locking the fence extensions in place, refer to Drawing 2, and thread 1 1/2"-long flathead bolts partway into a pair of four-arm knobs. Apply epoxy under the heads, and then seat the bolts in the knobs.

**5** Referring to Drawing 2, slide the heads of two hexhead bolts into the auxiliary table on the drill-press table, dropping the bolts into the slots or holes. Add washers and thread on the tapered handle knobs. *Note: The tapered handle knobs accept about 5/8" of bolt length. You may need to trim the 2"-long hexhead bolts to accommodate the thickness of your drill-press table.*

**6** Slide hexhead bolts into the auxiliary table top mini-tracks. Align the holes in the fence base with the bolts, drop on flat washers, and fasten the fence with four-arm knobs. Slide the extension rods into the fence, and thread in the locking knobs.

**4 FENCE SECTION VIEW**

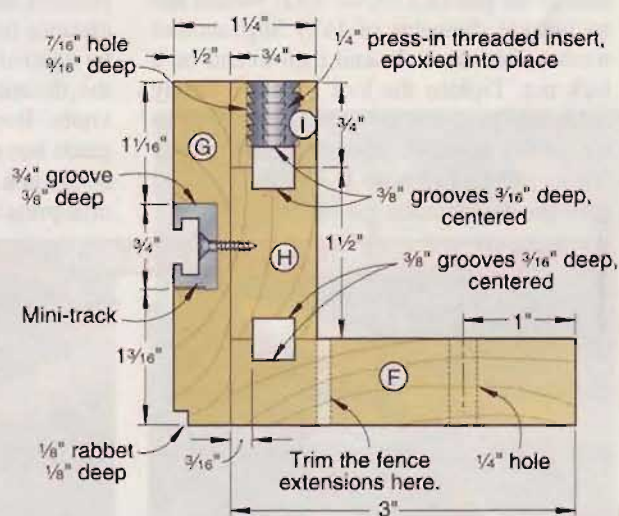

**Add an adjustable stopblock**

**1** To form the body (J), cut two pieces of 3/4" stock to 2x2 3/8", and glue them together face-to-face, keeping their ends and edges flush. With the glue dry, cut a 1/4" dado 3/16" deep centered in the back of the body, where shown on Drawing 5.

**2** Cut the pad (K) to size, and adhere it with double-faced tape to the right side of the body (J) in the configuration shown

on **Drawing 5**. Chuck a  $\frac{1}{2}$ " Forstner bit in your drill press, and drill a  $\frac{3}{8}$ "-deep counterbore in the left side of the body, where dimensioned and as shown in **Photo C**. Now, without moving the parts, change to a  $\frac{1}{4}$ " bit, and drill a hole, centered in the counterbore, all the way through both parts.

**3** Separate the pad (K) from the body (J). Using a  $\frac{3}{4}$ " Forstner bit, drill  $\frac{3}{8}$ "-deep counterbores in the body and pad, centered on the  $\frac{1}{4}$ " holes, where shown on **Drawing 5**. To center the Forstner bit, insert pieces of  $\frac{1}{4}$ " dowel in the holes before drilling. Now, centering a  $\frac{1}{16}$ " bit in the  $\frac{1}{4}$ " dado in the back of the body, drill a hole through the body, where shown.

**4** Epoxy a lock nut in the  $\frac{1}{2}$ " counterbore in the body (J). Then cut the guide bar (L) to size, and glue and clamp it in the dado in the back of the body, flush with its right edge, where shown on **Drawing 5**.

**5** Apply a clear finish to the parts. With the finish dry, slip a  $\frac{1}{4}$ " SAE washer onto the roundhead bolt, and insert it in the hole in the pad (K). (A  $\frac{1}{4}$ " SAE washer has an outside diameter of  $\frac{5}{8}$ ".) Slip another washer onto the bolt, and then thread on a lock nut. Tighten the lock nut so it firmly holds the pad, but still allows the bolt to turn. Now assemble the pad and the body (J), as shown in **Photo D**, driving the bolt until the pad contacts the body.

**6** Epoxy a four-arm knob onto the end of the roundhead bolt. Slide a hexhead bolt through the stop body (J) from the back, and add a washer and four-arm knob at the front, as shown on **Drawing 5**. To use the stopblock, first adjust it to leave  $\frac{1}{2}$ " between the pad (K) and the body. Slide the guide bar and the bolt hexhead into the mini-track, using a ruler or tape measure to position the stopblock close to the desired distance from the drill bit. Clamp it in place by tightening the front knob. Now fine-tune the distance to the bit by turning the end knob. Because the clamping knob and guide bar (L) are centered in the stopblock body, you can use it on either side of the drill-press chuck by simply turning it over.

## 5 STOPBLOCK

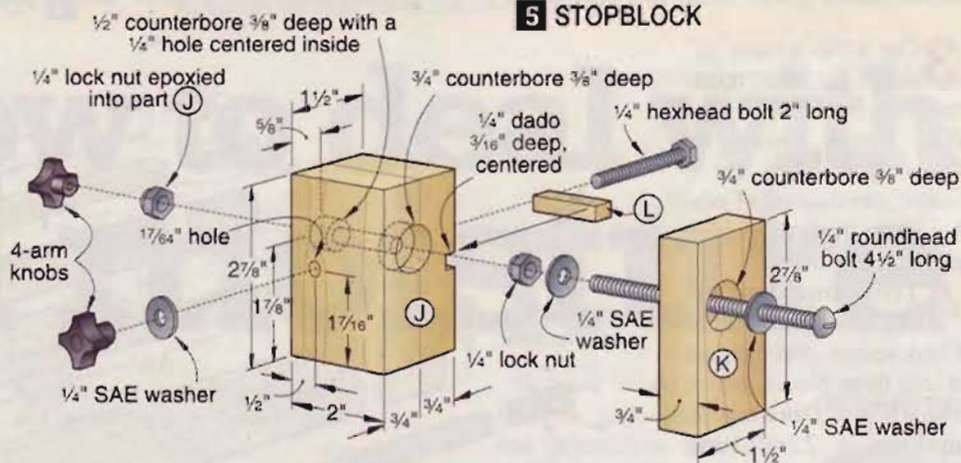

**7** Assemble the hold-down clamps in the configuration shown on **Drawing 2**. Slide the hexheads of their bolts into the mini-track. Now your *woodworking* drill press is ready for action. 📌

Written by Jan Svec  
Project design: Jeff Mertz  
Illustrations: Roxanne LeMoine

## DRILL AND ASSEMBLE THE STOPBLOCK



With the pad (K) down and the dadoed back of the body (J) against the fence, clamp the parts in place, and drill a  $\frac{1}{2}$ " counterbore  $\frac{3}{8}$ " deep in the side of the body.

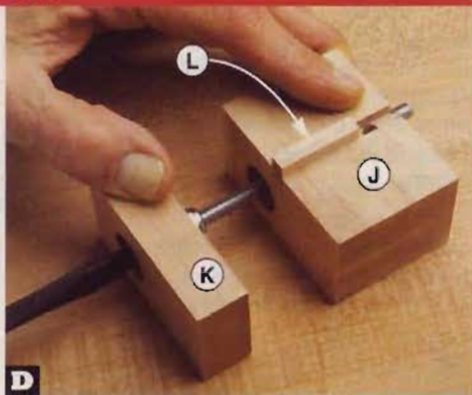

With the pad (K) mounted on the bolt with washers and a lock nut, slide the bolt into the stop body (J), and drive it into the lock nut epoxied in the body.

## Cutting Diagram

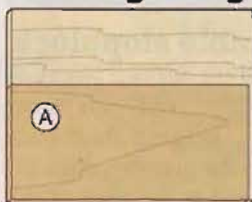

$\frac{1}{2}$  x 24 x 30" Baltic birch plywood (2 needed)

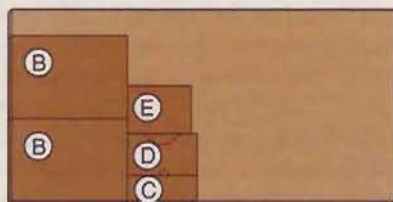

$\frac{1}{4}$  x 24 x 48" Hardboard

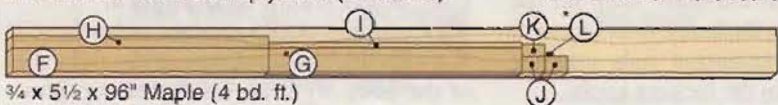

$\frac{3}{4}$  x 5 1/2 x 96" Maple (4 bd. ft.)

\*Resaw and plane to the thicknesses listed in the Materials List.

## Materials List

Table	FINISHED SIZE			Matl. Qty.
	T	W	L	
A base	1"	14 1/2"	29 1/2"	LP 1
B top sides	1/4"	10 3/8"	14 1/2"	H 2
C top front	1/4"	3 1/4"	8 3/4"	H 1
D top back	1/4"	5 1/4"	8 3/4"	H 1
E insert	1/4"	6"	8"	H 1
<b>Fence</b>				
F base blank	3/4"	3"	32"	M 1
G face blank	1/2"	3"	32"	M 1
H lower rear blank	3/4"	1 1/2"	32"	M 1
I upper rear blank	3/4"	3/4"	32"	M 1
<b>Stopblock</b>				
J body	1 1/2"	2"	2 7/8"	LM 1
K pad	3/4"	1 1/2"	2 7/8"	M 1
L guide bar	1/4"	3 1/2"	1 1/8"	M 1

**Materials key:** LP—laminated plywood, H—tempered hardboard, M—maple, LM—laminated maple.

**Supplies:** Masking tape, double-faced tape,  $\frac{1}{4}$ " dowel, epoxy.

**Blades and bits:** Stack dado set;  $\frac{1}{2}$ " and  $\frac{3}{4}$ " Forstner bits.

## Sources

**Hardware kit.** #6x $\frac{1}{2}$ " flathead wood screws (12);  $\frac{3}{4}$ " mini-track: 29 1/2" long (1), 14 1/2" long (2), 22 1/2" long (1), and 3 1/2" long (2);  $\frac{1}{4}$ " press-in threaded inserts (2);  $\frac{3}{8}$ " steel rod 14 1/2" long (4);  $\frac{1}{4}$ " flathead bolts 1 1/2" long (2);  $\frac{1}{4}$ " roundhead bolt 4 1/2" long (1);  $\frac{1}{4}$ " hexhead bolts: 1 1/2" long (2), 2" long (3);  $\frac{1}{4}$ " SAE flat washers (5);  $\frac{1}{4}$ " lock nuts (2); four-arm knobs (6); tapered handle knobs (2);  $\frac{1}{4}$ " IDx $\frac{1}{4}$ " OD fender washers (2); hold-down assemblies (2). Kit no ADP-1, \$42.95 plus \$7.95 shipping. Schlabaugh & Sons Woodworking. Call 800/346-9663, or order online at schsons.com.

**Sheet goods kit.** Two  $\frac{1}{2}$ x $14\frac{1}{2}$ x $29\frac{1}{2}$ " pieces of Baltic birch plywood and one  $\frac{1}{4}$ x $15\frac{3}{4}$ x $31\frac{3}{4}$ " piece of tempered hardboard. Kit no. LP-6, \$15.95 ppd. See above for telephone number and Web address.



# Complete guide to woodworking glues

Just as woodworking tools have changed, so have the glues that hold together your wood projects. If you still rely on just one glue, you've probably overlooked big performance advantages available from the latest generation of adhesives.

Do you know that there are now yellow glues with extended open times that have replaced

traditional white woodworking glues? Or have you heard about water-resistant and waterproof one-part glues for exterior projects?

To help you sort through the many glue choices, we've developed the poster that starts on the next page. Put it up on your shop wall and you'll never have to look far for an answer to your next gluing question.

Still stuck? There are now plenty of resources to help you navigate through glue issues, including the Titebond 800/347-GLUE help line and [titebond.com](http://titebond.com) Web site.

Or, post your gluing question online at [woodmagazine.com/generaforum](http://woodmagazine.com/generaforum).

Woodworkers from far and wide likely will rush to your rescue.

## 4 common gluing mistakes to avoid

**1 Gluing pieces not acclimated to the room temperature and moisture level.** Glues won't set up properly if the boards are at different temperatures. And you'll notice a dimension change (stepped joints) if boards aren't at the same moisture level. So before machining and gluing, allow at least 3 days for all workpieces to adjust.

**2 Overlooking the importance of glue shelf life.** A manufacturing or expiration date should be printed on the glue container. Contact the manufacturer's customer service department if you can't decipher the code. For Titebond products (see example at *right*), the first number represents the final digit of the year in which the glue was produced; it's followed by a letter designating the month. ("A" represents January, "B" February, and so forth, skipping "I"). Ignore the rest of the code, which relates to the particular batch of glue. To know how old is too old, see the "Shelf Life" column on the poster.



**3 Poor procedures in removing glue squeeze-out.** If you don't completely remove glue left on surfaces next to joint lines, your finish will have a splotchy appearance. To avoid problems, allow glue to skin over before removing excess. After glue loses its wet look, remove the squeeze-out with a sharp chisel or scraper. Then soak a clean rag in tap water, squeeze out the excess, and wipe down the joint. Follow with a dry rag.

**4 Not waiting for the glue to cure before machining.** Glue temporarily swells the wood along a glue line (**Drawing A**). If you joint, plane, or sand too quickly and remove the swelled wood, the joint will look good for only a short time (**Drawing B**). But when completely dry, your hastily machined joint will have a valley (**Drawing C**). To avoid problems, let the glue cure for the "Full-Strength Time" listed on the poster. (Effect exaggerated for clarity.)

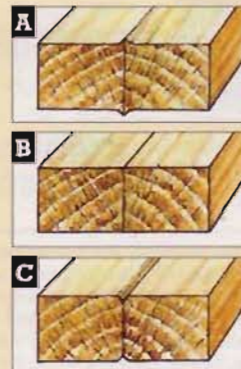

ADHESIVE TYPE	BEST USE	TOTAL ASSEMBLY TIME (1)	MINIMUM CLAMP TIME (2)	FULL-STRENGTH TIME (3)	STRENGTH RATING (4)	WATER RESISTANCE (5)	HEAT RESISTANCE (6)
 <b>YELLOW</b>	Interior woodworking projects.	15 minutes	1/2 hour	24 hours	3,600 psi	G	G
 <b>YELLOW</b> (extended assembly time)	Interior woodworking projects where long open time is desired. Recommended for bent laminations and larger, more involved assemblies.	20–25 minutes	1/2 hour	24 hours	3,510 psi	G	E
 <b>DARK WOOD</b>	Ideal for dark hardwoods, such as walnut and mahogany. Interior use only.	15 minutes	1/2 hour	24 hours	3,600 psi	G	G
 <b>WEATHERPROOF</b>	Exterior woodworking projects where water resistance is important. Interior projects that may come in contact with food and water.	15 minutes	1/2 hour	24 hours	3,750 psi	E	G
 <b>WEATHERPROOF</b> (extended assembly time)	Exterior woodworking projects where long open time is desired. Good choice for gluing bent laminations. Interior projects subjected to water.	20–25 minutes	1/2 hour	24 hours	3,840 psi	E	G
 <b>MOLDING AND TRIM</b>	Ideal for hard-to-clamp joints. Interior use only. Strong initial grip.	15 minutes	1/2 hour	24 hours	3,000 psi	G	P
 <b>WATERPROOF</b>	Exterior projects requiring longer assembly time or lower application temperature than nonextended cross-linking PVAs.	20–25 minutes	1/2 hour	24 hours	4,000 psi	E	G
 <b>POLYURETHANE</b>	Exterior projects requiring long working time and waterproof joinery.	20–25 minutes	2–4 hours	4 hours	3,500 psi	E	E
 <b>POLYURETHANE HOTMELT</b>	Any project requiring quick-setting bonds. Needs little or no clamping. Bonds well when fit is marginal and with end grain. Bonds wide variety of materials.	30 seconds	1–2 minutes	24 hours	1,480 psi	E	E
<b>HIDE GLUE</b>	Ideal for authentic repairs in antiques and musical instruments that you may want to disassemble later. Will expand and contract with wood.	5 minutes*	10 minutes	24 hours	500 psi	P	P
<b>HIDE GLUE-PREMIXED</b>	Ready-to-use formula. Long assembly time. Sensitive to moisture (easy to disassemble later). Latex paint applied over dried glue will provide a crackled paint surface.	20–30 minutes	1 hour	24 hours	3,590 psi	P	E
<b>5-MINUTE EPOXY</b>	Excellent for repairs and joints that don't mate tightly. Cures quickly to any thickness. Fills gaps. Easily colored. Won't shrink. Bonds dissimilar materials.	3 minutes	1 hour	24 hours	5,000 psi	G	G
<b>STRUCTURAL EPOXY</b>	Like 5-minute epoxy but creates waterproof joint that can be used underwater. Easily colored. Won't shrink. Excellent for oily exotic woods.	1 hour	24 hours	7 days	7,500 psi	E+	E
<b>CYANOACRYLATE (instant glue)</b>	Strengthens weak areas and thin, delicate parts. Available in thin and thick (gap-filling) viscosities. Thin CA best used with tight-fitting parts.	**	*	24 hours	2,900 psi	E	P

1 How much time you have from applying glue to clamping the joint.

\* Varies depending on water/glue ratio.

\*\* No open assembly time for thin cyanoacrylates; gap-filling CA glues give you about 5 minutes of open time.

2 Depends on wood species, moisture content, temperature, and humidity.

\* Thin, 15 sec.; gap-filling, 60 sec. For thin-CA joints, mate surfaces, and then apply CA glue.

3 Moisture delays water-based glues; dry conditions delay polyurethane glues.

4 Pressure in pounds per square inch (psi).

Depending on species, most wood will fail before the adhesive.

The high psi for epoxy, for example, reflects bonding strength for non-wood materials.

5 (E+) Excellent plus - Bond not affected by long-term submersion in water.

(E) Excellent - Bond not affected by short-term submersion or soaking in water.

(G) Good - Bond not affected by dampness or high humidity.

(F) Fair - Could be affected by severe humidity or damp conditions.

(P) Poor - Affected by almost any moisture.

# woodworking glues

Sponsored by

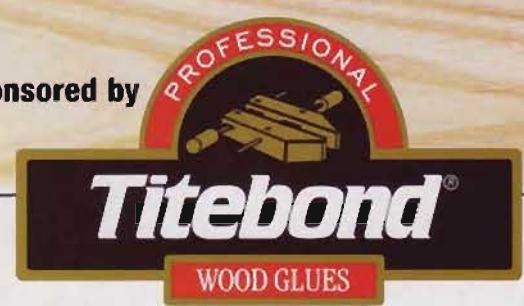

GAP-FILLING (7)	MINIMUM APPLICATION TEMPERATURE	CLEANUP		SHELF LIFE (YEARS)	NON-WOOD MATERIAL IT ALSO BONDS	COST (8)	COMMENTS
		BEFORE SET	AFTER SET				
No	50°F	Water	Scrape or sand	2	Leather, cloth, paper	\$.31/oz.	Fast grab. Best general-purpose interior glue. Least expensive. Good sandability. Long shelf life.
No	40°F	Water	Scrape or sand	1	Leather, cloth, paper	\$.37/oz.	Good sandability.
No	50°F	Water	Scrape or sand	2	Leather, cloth, paper	\$.33/oz.	Minimizes visibility of glue line in dark hardwoods. Dyed version of yellow glue.
No	55°F	Water	Scrape or sand	2	Leather, cloth, paper	\$.37/oz.	Approved for indirect food contact for such projects as cutting boards. Great general-purpose glue. Paintable. Dries and cures through chemical reaction. Long shelf life. Good for wet-use applications.
No	60°F	Water	Scrape or sand	2	Leather, cloth, paper	\$.41/oz.	Approved for indirect food contact for such projects as cutting boards. Paintable. Good for wet-use applications.
Yes	55°F	Water	Scrape or sand	1	Leather, cloth, paper	\$.34/oz.	Thick formula fills some thin gaps. Power sanding not recommended. Doesn't run or drip.
No	47°F	Water	Scrape or sand	1	Leather, cloth, paper	\$.53/oz.	Best option for most outdoor projects. Less messy than polyurethanes or epoxies.
No	50°F	Mineral spirits	Scrape or sand	1	Most materials except some plastics	\$1.08/oz. (12 oz. size)	Triggered by contact with moisture; may be applied to damp surface. Polyurethane adhesives foam up and are tough to remove from hands; wear gloves during application. Relatively long clamping time.
Yes	250°F	Not applicable	Scrape or sand	1	Most materials except some plastics	\$6-\$8 for a 50-gram cartridge	Requires specialty heat gun. WW30 (30-second) sets up quickly; WW60 (60-second) has gap-filling properties; WW75 (75-second) also bonds non-porous materials. Gloves recommended to protect from hot adhesive.
No	120°F	Water	Scrape or sand	Indefinite	Leather, cloth, paper	\$6-\$8 per pound	Dissolves in water. Use in glue pot/warming device (some use Crock-pot) at about 145°F. May be stored in refrigerator between uses. Disassemble joints with steam and heat. Water-based finishes could affect hide glue.
No	50°F	Water	Scrape, sand, or water	1	Leather, cloth, paper	\$.62/oz.	Requires no mixing, heating, or stirring. Has the "crackle" appearance of traditional hide glues.
Yes	35°F	Alcohol or lacquer thinner	Scrape or sand	1	Most materials except some plastics	\$1.00/oz.	Two-part adhesive. Resin and hardener react with each other, producing heat. Bonds many plastics. Gloves recommended. Three different hardeners available for various temperature ranges.
Yes	35°F	Alcohol or lacquer thinner	Scrape or sand	1	Most materials except some plastics	\$.70-\$80 per oz.	Two-part adhesive. Resin and hardener react with each other, producing heat. For bonding oily woods (such as teak), sand, wipe with lacquer thinner, and apply epoxy within 60 minutes. Bonds many plastics. Gloves recommended.
*	Minus 65°F	Not applicable	Scrape, sand, or solvent	1	Most materials except some plastics	\$5.00/oz. for a 2-oz. bottle	Accelerator reduces cure time; 75 percent strength at end of cure. Specialty solvents debond joints. Little glue required; use one drop per square inch. Gloves recommended because it bonds to skin instantly.

6 Applies to power sanding and overheated conditions (for example, enclosed trailer on desert).

(E) **Excellent** - Glue loses little or no strength up to 150 degrees F. No gumming of the sanding belt, even with extensive sanding.

(G) **Good** - Noticeable loss of up to 50 percent of strength at 150 degrees F (substantially weaker joint at 150 degrees). Sands well, but can load up with extensive power sanding.

(P) **Poor** - Dramatic loss of 75 percent of strength at 150 degrees F.

Poor sanding characteristics with any mechanical sanding (even hand-sanding).

7 Ability to bond successfully when materials aren't tightly mated.

\* Thin, no; gap-filling, yes

8 Unless noted, retail cost per ounce in 16-ounce bottle.

Don't toss your scraps—turn them into something useful

# letter-perfect opener

It may not make bills more fun to open, but it will let you enjoy your woodworking firsthand.



**1** Rip and crosscut one piece of a dark wood and two pieces of a light wood (we used wenge and lacewood respectively) to  $\frac{1}{4} \times 1\frac{1}{2} \times 8$ ". With the dark wood in the middle, laminate the pieces face-to-face, with the edges and ends flush.

**2** Make a copy of the Top and Side View patterns from the *WOOD PATTERNS*® insert. Using spray adhesive, adhere the paper Top View pattern to the top of the laminated blank.

**3** Crosscut a piece of 2x4 to about 6" in length. Using cloth-backed double-faced tape, secure the blank to one face of the 2x4. Cutting just outside the marked line, bandsaw the opposite face of the blank to shape, as shown in **Photo A**. Using double-

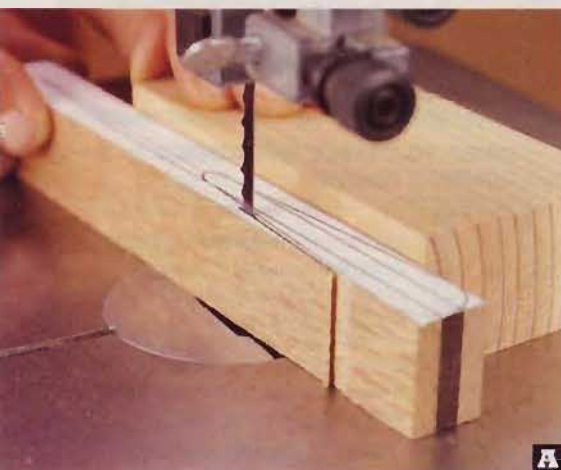

For safety when cutting, adhere the letter opener blank to a section of 2x4.

faced tape, secure the waste back to the face from which it was just cut. Now, secure the 2x4 to that face, and cut the other face of the blank to shape. Tape the second piece of waste back in place. Remove the 2x4 from the blank.

**4** Adhere the Side View pattern to one face of the laminated blank and bandsaw to shape, as shown in **Photo B**.

**5** Remove the patterns and waste from the letter opener blank.

**6** Power-sand or file the edges of the handle portion to shape, working slowly to get comfortable rounded edges. Hone the blade portion of the letter opener, as shown in **Photo C**. Strive for sharp edges and a point for ease in slitting envelopes later.

**7** Finish-sand the letter opener and apply the finish. (We sprayed on three coats of aerosol gloss polyurethane.) Rub lightly with 220-grit sandpaper or 0000 steel wool between coats. ♣

Project design: Will Cummer

## Make the entire set

If you like the looks of this hardwood letter opener, you may want to spend a few more hours crafting the other four pieces of our matching desk set. See the May 2003 issue of *WOOD*® or download the plans online at [woodmagazine.com/gifts](http://woodmagazine.com/gifts)

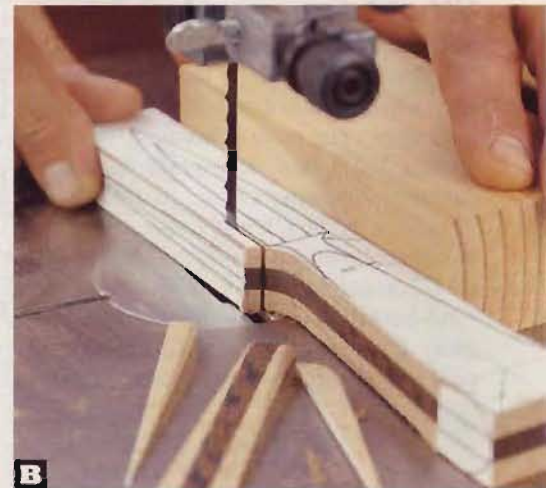

With the waste pieces taped back in place, reattach the 2x4 and finish bandsawing the blank to shape.



Adhere 100-grit sandpaper to a piece of plywood, and chamfer both blade edges.

# Part II: how to deal with wood moisture

**Y**ou probably know that wood has to be dried in order to be useful as lumber. Removing the water makes the material dimensionally stable, predictably machinable, and accepting of glues and finishes.

But have you stopped to consider how water is stored in wood? Do you know how that water is removed, or what happens to wood fibers as they dry?

Knowing the answers to those questions, and understanding what can go wrong if wood gets dried improperly, will make you a smarter buyer and user of this natural resource. Here's the short course on wood moisture and its effects.

## What happens when wood releases water

Whether dried naturally (air dried), or in a kiln, wood dries to a certain percentage, and then stops. The relative humidity of the air around the wood determines this point, called equilibrium moisture content (EMC). This is why you always should let your wood acclimate to the conditions in your shop before beginning a project.

As bound water (see the wood cell cutaway for an explanation) is removed, the cell walls shrink, causing the wood to

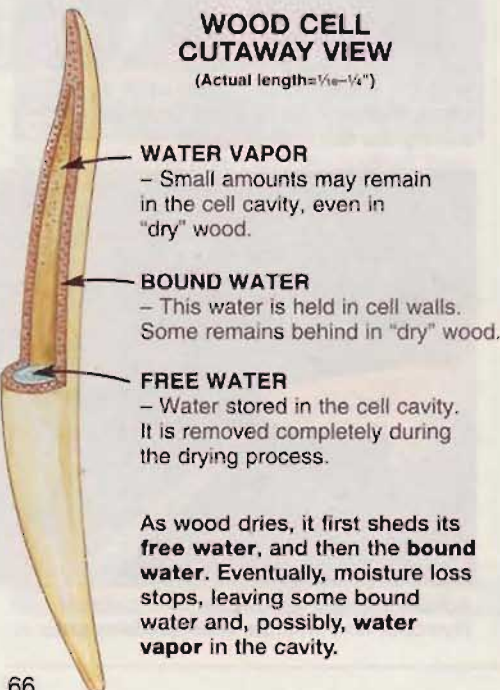

Potential wood movement (inches) caused by an 8 percent change in moisture content:

	Quartersawn	Flatsawn
Cherry	.118	.227
Douglas Fir	.154	.253
Mahogany	.096	.131
Maple (hard)	.154	.317
Pine (white)	.131	.237
Red Oak	.128	.275
Walnut	.176	.250
Western Red Cedar	.077	.160
White Oak	.176	.336

change dimension. Boards shrink most across their tangential plane (face grain), so flatsawn boards shrink more than those that are quartersawn, as shown *above*.

Because wood cells vary in size, density, and orientation, they may shrink unevenly, causing boards to warp in various ways. To minimize these problems, shy away from boards that show wild figure, inconsistent growth-ring spacing, or an off-center pith.



Shrinkage also stresses the wood. If not properly relieved, this tears the fibers apart, as illustrated *below*. You can stop shrinkage by replacing bound water with a stable substance that will remain in the cell walls. Turners do this by soaking blanks in polyethylene glycol (PEG). But this technique remains impractical for use with whole logs or large pieces.

## CAREFUL DRYING RESULTS

Wood dries from the outside in, as the water it contains moves naturally from areas of highest to lowest concentration. This creates uneven pressures in the outer portion (the **shell**) and the inside of the board (the **core**).

### WHEN DRYING GOES WELL

When dried correctly, a dry board appears the same as when wet, only smaller.

#### SCENARIO 1: FRESHLY CUT BOARD

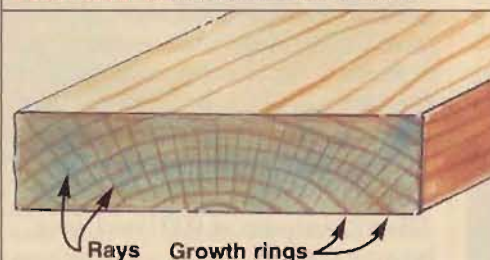

#### SATURATED ("GREEN") WOOD

Most trees arrive at commercial mills and get cut into logs while still fairly wet. That means each board that gets sliced free has a relatively consistent moisture content throughout its thickness and length. At this point, cell walls are fully saturated, and the cell cavities may still be filled completely with water.

#### SCENARIO 2: PROPERLY DRIED BOARD

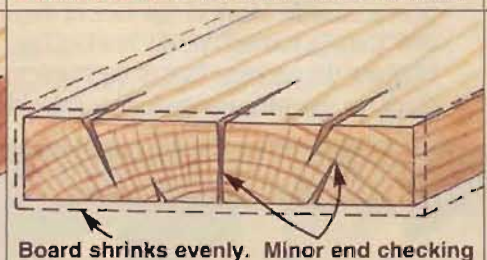

#### DRIED TO USABLE MOISTURE CONTENT (6-11%)



Under good conditions, water exits the wood at a pace that doesn't induce stress. The board shrinks as bound water leaves the cell walls. Ends dry more rapidly, which causes minor stresses that result in some end checks.



# Calculating water content

Moisture content (MC) tells us the ratio of the weight of water in a piece of wood compared to its weight completely dry. We express it as a percentage. To determine MC, first weigh a piece of wood. Then, dry it until it contains no water (determined when weight loss stops). Next, compare the weights as follows:

$$\frac{\text{wet weight} - \text{dry weight}}{\text{dry weight}} = mc$$

For example, if a piece weighs 25 lbs. wet and 20 lbs. dry, its MC equals 25 percent:  
 $(25-20)/20 = 5/20 = .25$  or 25%

Thankfully, you don't have to weigh and dry lumber to determine its MC. A moisture meter does the job for you.

For indoor projects, MC should lie between 6 percent and 11 percent to cope with dehumidified conditions. See the map, right. Construction lumber and outdoor woods, subjected to high humidity levels, should range from 15 to 20 percent MC to minimize expansion and contraction.

MOISTURE CONTENT BY REGION

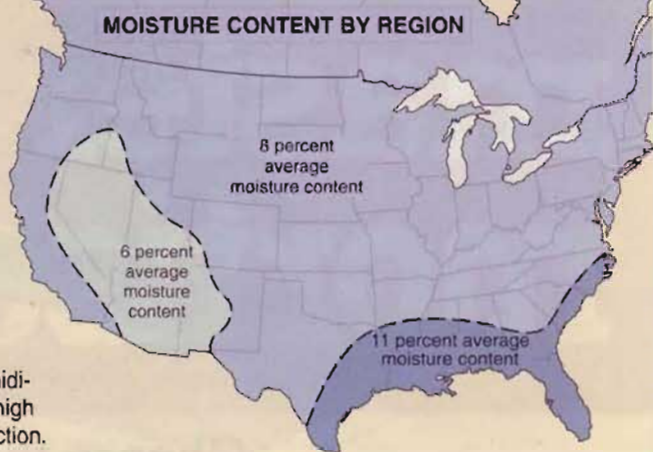

## HOW WOOD WARPS IN A MILLED LOG

As boards dry, natural shrinkage causes them to cup away from the pith. The amount of cupping varies, depending on the board's location in the log.

Good boards may warp if they are dried improperly, as this piece did when dried too quickly.

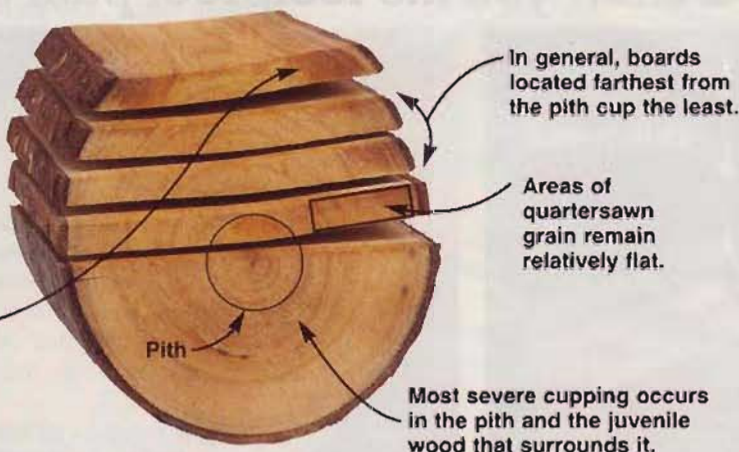

## Preventing problems with moisture and movement

Wood becomes most stable when it reaches EMC, and that's controlled by relative humidity. So what happens when humidity levels fluctuate? Wood is described as hygroscopic, meaning it will continue to take on and shed moisture and, because of this, expand and contract.

You can see how this happens in glued-up panels. At some points during the year, they may be dead flat. At other times, though, panels warp, as shown below. This movement won't cause problems if you build your projects to withstand it, as discussed in issue 150, page 80. Don't have that issue? You can download the article at [woodmagazine.com/woodmovement](http://woodmagazine.com/woodmovement).

To slow down the movement of water vapor into and out of the wood, always apply finish to your completed projects. Apply the same number of coats to all surfaces to equalize the rate of moisture exchange. This helps prevent cupping.

## IN HIGH-QUALITY LUMBER

Lumber producers constantly manipulate the temperature, humidity, and airflow inside the kiln, and cut thin, tuning-fork-shaped cross sections regularly to look for signs of problems before they become too severe to correct.

### WHAT CAN GO WRONG

Drying stresses wood fibers, which can lead to serious defects.

#### SCENARIO 3: REVERSE CASE HARDENING

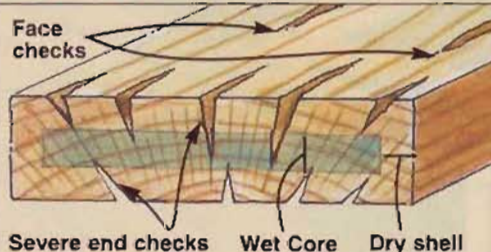

#### PARTIALLY DRIED

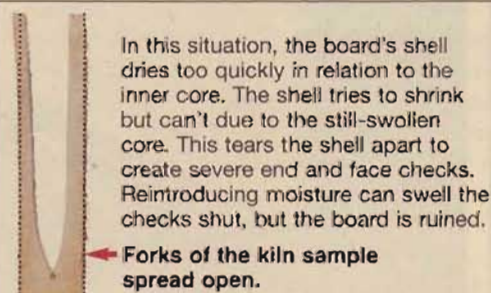

In this situation, the board's shell dries too quickly in relation to the inner core. The shell tries to shrink but can't due to the still-swollen core. This tears the shell apart to create severe end and face checks. Reintroducing moisture can swell the checks shut, but the board is ruined.

#### SCENARIO 4: CASE HARDENING

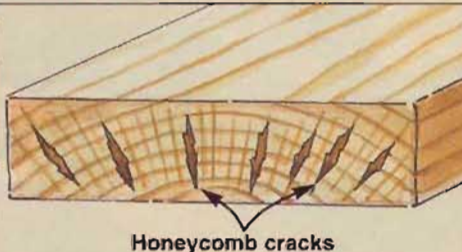

#### FULLY DRIED

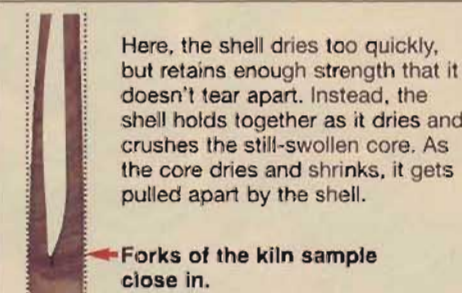

Here, the shell dries too quickly, but retains enough strength that it doesn't tear apart. Instead, the shell holds together as it dries and crushes the still-swollen core. As the core dries and shrinks, it gets pulled apart by the shell.

### WARPING IN GLUED-UP PANELS

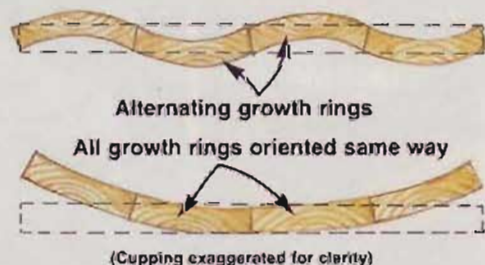

Alternating growth-ring direction creates a panel that stays relatively flat, but wavy. Orienting all rings the same way produces a panel that cups but retains a smooth surface.

## Up next: How wood's anatomy affects machining

In the next issue, we'll examine which wood properties determine success or failure when the time comes to machine your lumber into project parts. ♣

Written by David Stone Illustrations: Eric Flynn

# master the mortise-and-tenon

Choose the best method for your shop and budget, and we'll show you the foolproof path to success.

**Make your mortise in one of three ways**

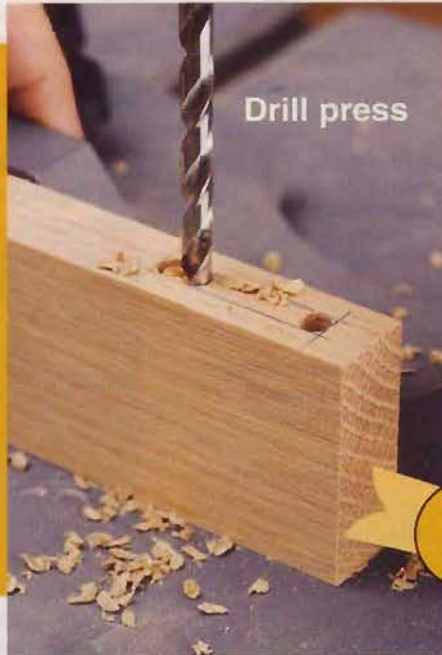

**1**

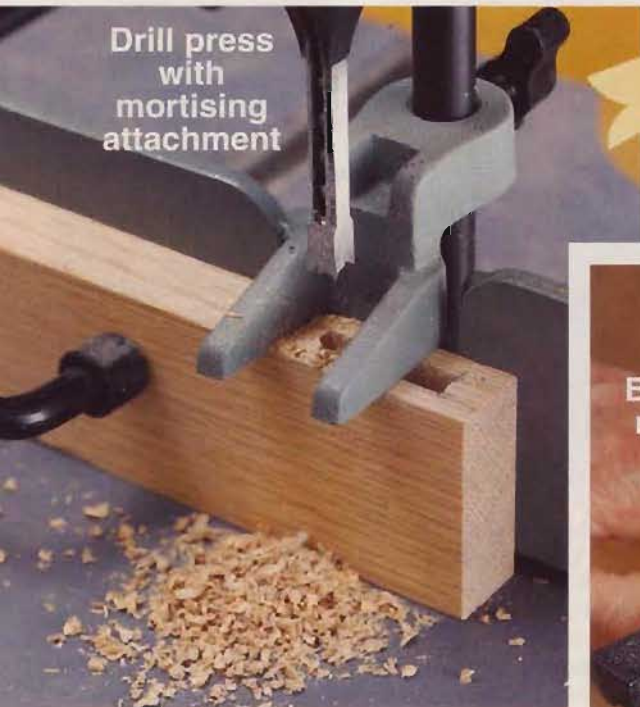
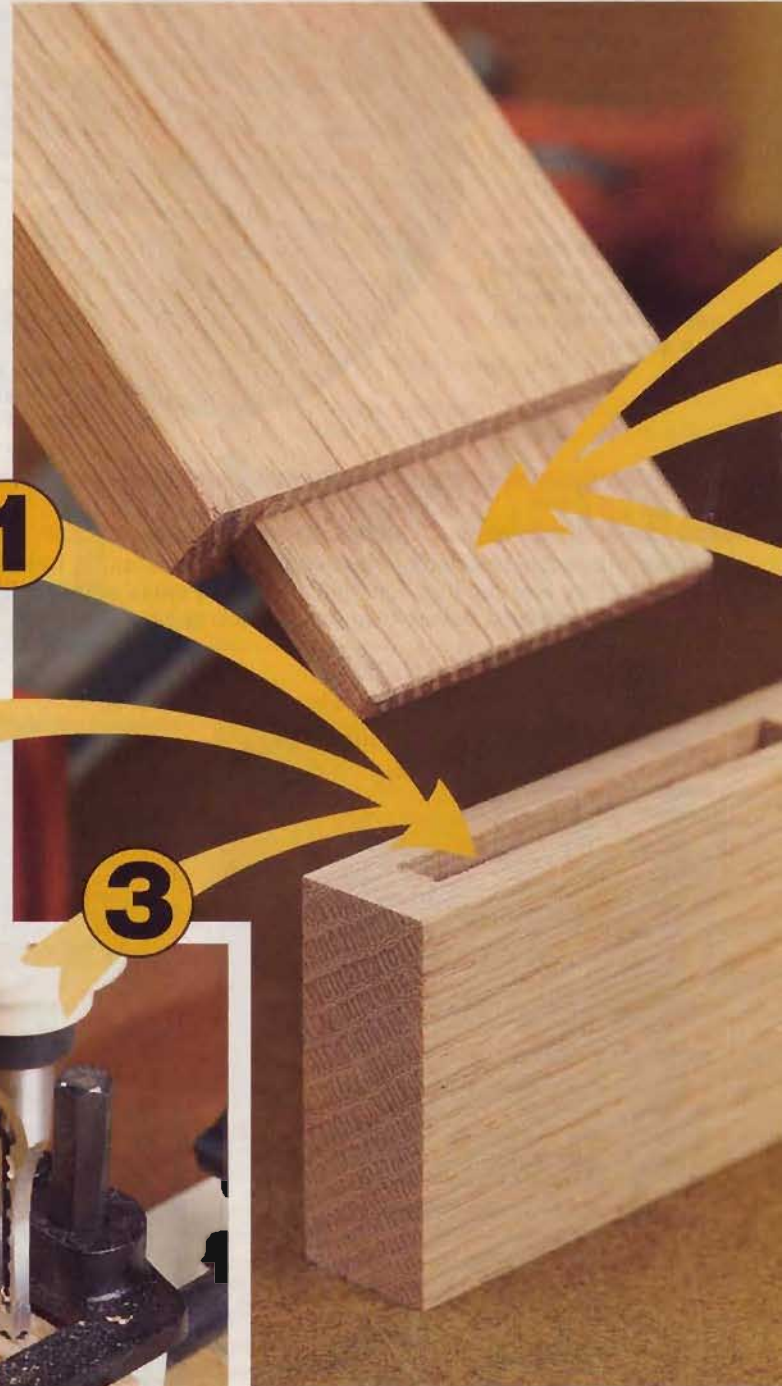

**2**

**3**



# joint

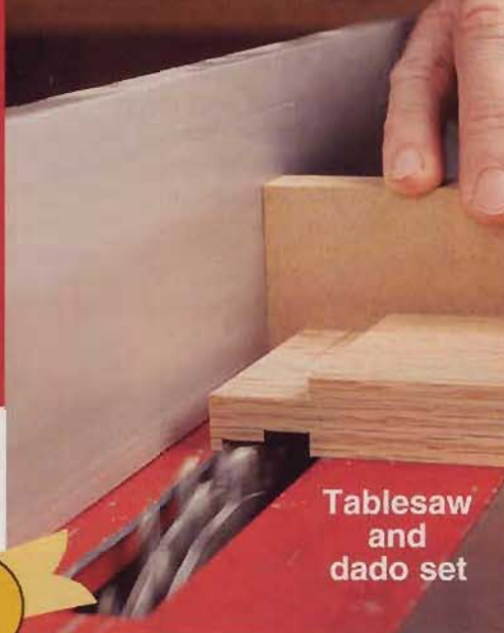

Tablesaw and dado set

1

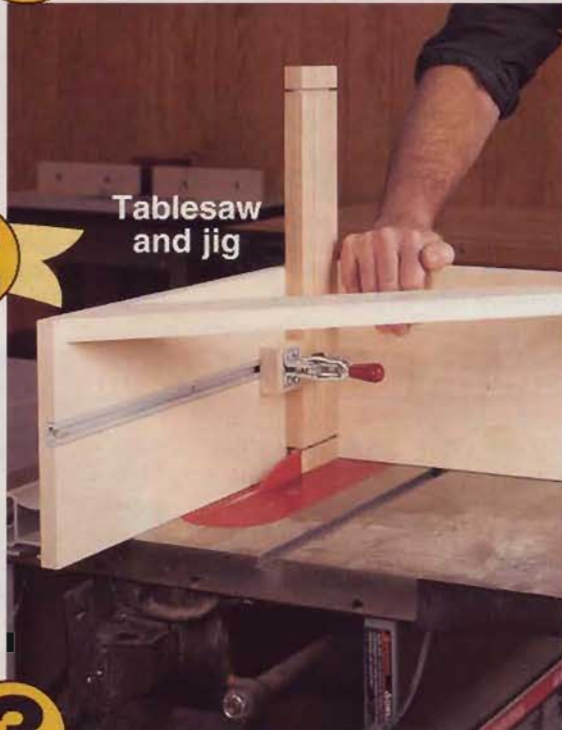

Tablesaw and jig

2



Bandsaw

3

## Cut clean tenons using one of these techniques

**M**astering mortise-and-tenon joinery has always ranked at the top of woodworkers' skill priority lists. That's because its great strength makes it the premier joinery technique for furnituremaking. No wonder our project designers used mortise-and-tenon joinery throughout the mission clock project on page 38.

Machining mortise-and-tenon joint members takes only a moderate amount of time and fuss, provided you have a few basic tools. To help you succeed at the king of joints, we'll walk you through making the blind mortise-and-tenon joint (the most common, where the tenon is completely enclosed in the mortise), letting you choose the options that best suit your tools and preferences. But before we begin, take a minute to review the basic terms and design proportions in the drawing, below.

*Note: Plane your stock to consistent thickness prior to making these joints. (Include a couple of scrap pieces for testing tenoning setups.) This step makes all of your work easier while ensuring accuracy.*

### ANATOMY OF A BLIND MORTISE-AND-TENON JOINT

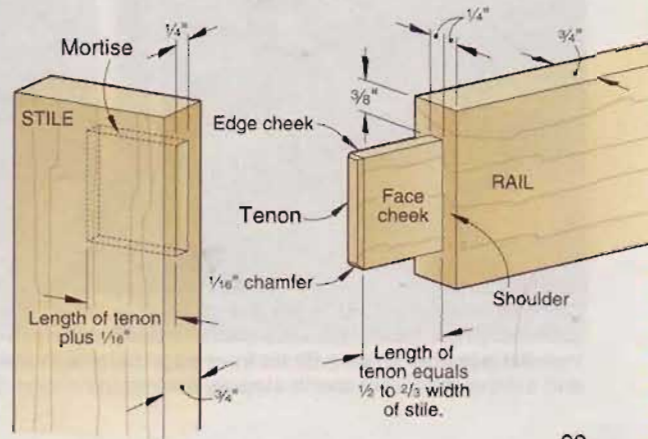

# Start with the mortise

**A**lways cut the mortise first and then size the tenon to fit snugly. It's quicker and easier to adjust the dimensions of a tenon (as we'll show later) than to change a mortise.

Establish the mortise width at one-third of the workpiece thickness. This ratio results in

a joint with plenty of strength in both the tenon and the sidewalls. Most woodworking projects call for 4/4 stock, which measures approximately  $\frac{3}{4}$ " thick after surfacing and sanding, so a  $\frac{1}{4}$ "-wide mortise works well for most of your projects.

Also, avoid mortising less than  $\frac{3}{8}$ " from the end of a workpiece. This prevents splitting as you shape the mortise and assemble the joint. For strength, make the mortise depth approximately one-half to two-thirds the width of the workpiece.

## Mortise method 1: Rely on your drill press

**Pro:** This method requires no expensive or specialized equipment.

**Con:** Cleaning up the mortise with a chisel takes time.

If you have a drill press and chisels, you're ready to mortise. Equip your drill press with a brad-point bit that matches the mortise width; a brad-point bit wanders less than a standard twist bit as you drill overlapping holes to form a mortise.

Now use a sharp pencil or marking knife and a combination square to lay out the mortise opening. Then set the drill-press fence to center the bit between the mortise sides and adjust the depth stop. (See page 52 for instructions on building a precision drill-press fence.) Finally, follow the two-step process shown in the photos at right.

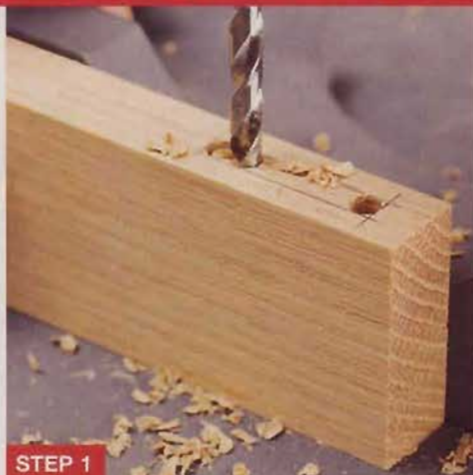

STEP 1

Adjust the fence to center your drill bit in the layout lines. Hold the workpiece against the fence, and form the mortise by drilling to full depth at each end of the layout. Now drill a series of overlapping holes in between.



STEP 2

Clamp the workpiece to your workbench. Place a wide, sharp chisel on the layout line and clean up the mortise walls with hand pressure or by tapping with a mallet. Use a narrow chisel to square the ends.

## Mortise method 2: Add a mortising attachment

**Pro:** A no-chisel way to drill and square the mortise in one step. Moderate price.

**Con:** Installing and removing the mortising attachment takes time, and the drill press can't be used for other tasks with the attachment in place.

To speed up your work, avoid hand chisel work by equipping your drill press with a mortising attachment. Its hollow-chisel design—a drill bit surrounded by a sharp, square sleeve—lets you form a mortise by drilling a series of square holes. We bought a kit that includes hollow chisels in four

sizes for \$70 from Tool Crib at 800/635-5140 ([toolcrib.amazon.com](http://toolcrib.amazon.com)). Before you buy any mortising attachment, check with the dealer or manufacturer to make sure that it fits your drill press. The photos below describe the simple procedure for using this handy accessory.

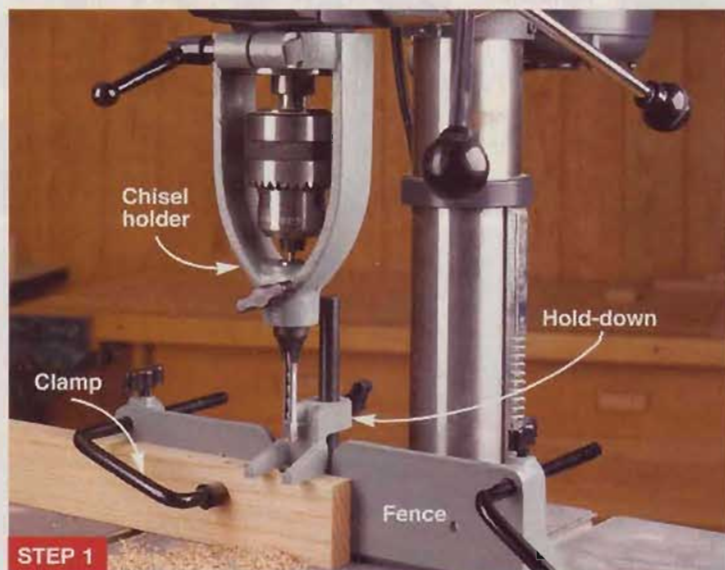

STEP 1

Clamp the chisel holder to the drill-press quill, fasten the fence to your drill-press table, and slide the hold-down onto its support rod. Install the hollow chisel with its front edge parallel to the workpiece and set the drill-press depth stop as desired.



STEP 2

With the hold-down tightened against the workpiece, use moderate pressure on the quill-feed lever to bore a hole at each end of the mortise. Complete the job by drilling a series of slightly overlapping holes in between the end holes.

## Mortise method **3**: Step up to a benchtop mortiser

**Pro:** Yields quick, clean mortises with minimal setup.

**Con:** A benchtop mortiser serves only one purpose in your shop. Entry-level models cost \$200–\$240.

Woodworkers who make a lot of mortises find it handy to own a dedicated machine. A benchtop mortiser works like the drill-press attachment, but it's always ready to use. Refer to the photos at *right* for details and see the tool review on *page 78* for information about the features and performance of several models.

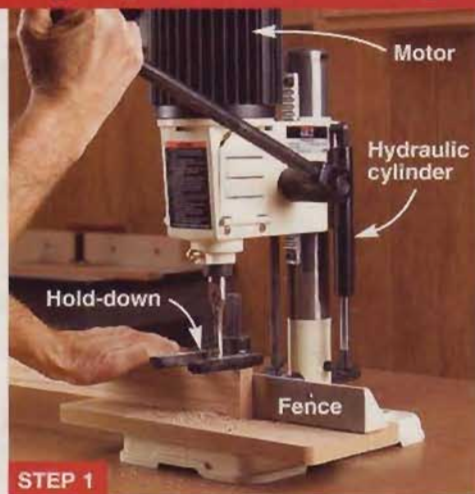

STEP 1

Set the fence of your benchtop mortiser to place the hollow chisel squarely within your mortise layout lines. Then adjust the hold-down to secure your workpiece.



STEP 2

Adjust the depth-stop rod to establish the mortise depth and keep it consistent. Drill a hole at each end of the mortise and a series of slightly overlapping holes in between.

## Now it's tenoning time

**A**fter you finish the mortises, use your scrap test pieces to set up for forming tenons. The ideal tenon slides into its mating mortise with firm hand pressure. Center the tenon on the edge of the workpiece (between

faces) and make it  $\frac{1}{16}$ " shorter than the mortise depth; this hidden gap provides a place for excess glue and guarantees that the tenon won't bottom out in the mortise, spoiling the fit of the joint.

What's the best way to cut the tenons? Match your equipment to one of the operations discussed *below*. If you have it all—dado set, tablesaw, and bandsaw—experiment to discover which method you prefer.

## Tenon method **1**: Keep it simple with your tablesaw and a dado set

**Pro:** No jigs are needed, and you make all cuts with the workpiece completely supported by the table.

**Con:** Some lesser-quality dado sets produce a rough surface and can splinter wood when crosscutting; such surfaces must be sanded. Also, you might find it awkward to handle workpieces over about 4' in length.

In the *WOOD*® magazine shop, we usually choose this method for cutting tenons because it's quick, simple, and reliable. Align your tablesaw rip fence parallel with the dado set and make sure that your miter-gauge fence sits at right angles to the dado set. These steps are critical for making a square, tight-fitting tenon.

You'll also need to install a miter-gauge auxiliary fence that extends to the rip fence. Make this fence by attaching a 2"-wide strip of straight material to the gauge with screws or double-faced tape. Now follow the step-by-step photos at *right*.

If you're in the market for a dado set, see issue 150, page 92, for the results of our tool test or visit [woodmagazine.com/dadodl](http://woodmagazine.com/dadodl) to purchase that article as a printable download. We reviewed 15 models, ranging in price from \$50 to \$260.



Install a dado set and set the rip fence. The distance from the fence to the left side of the dado set equals the tenon length.



Adjust the dado set height to establish the thickness of the tenon. For stock surfaced to  $\frac{3}{4}$ ", set this height at  $\frac{1}{4}$ " and make test cuts.

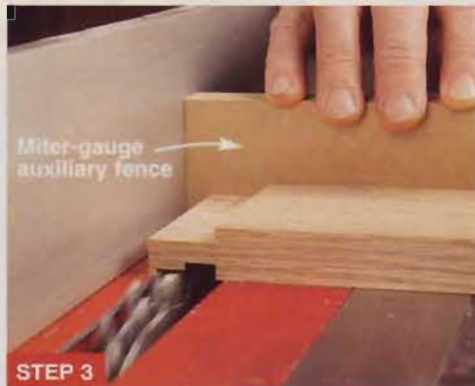

Butt the workpiece end against the rip fence for the first pass. Follow with more passes to form the cheek and then flip and repeat.

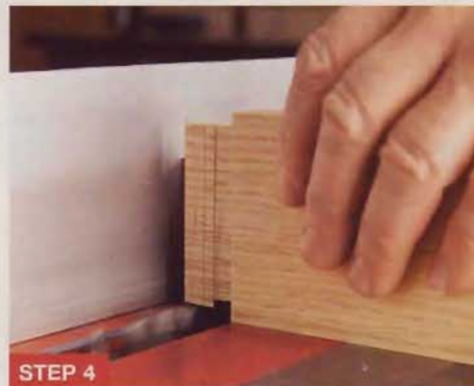

Adjust the dado set height if necessary and cut the tenon edge cheeks with the same methods used for the face cheeks.

## Tenon method 2: Stay with the tablesaw, but add a shop-made jig

**Pro:** Smooth results at little cost.

**Con:** Saw blade's working height limits tenon length; jig takes up storage space in your workshop.

If you're not prepared to pay \$100 or more for a high-quality dado set, cut tenons with the workpiece held vertically on the tablesaw. You need a dependable jig for this operation; the drawing at right shows you how to build one at minimal expense. We designed it to clamp the workpiece in place and ride flush against the rip fence.

Now, mount a combination blade in your tablesaw and add an auxiliary fence to your miter gauge. Also install a zero-clearance throat plate to keep the thin waste pieces from being caught and kicked back. Now proceed as shown below.

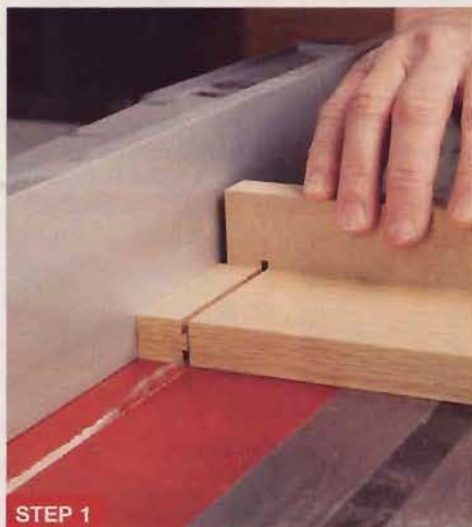
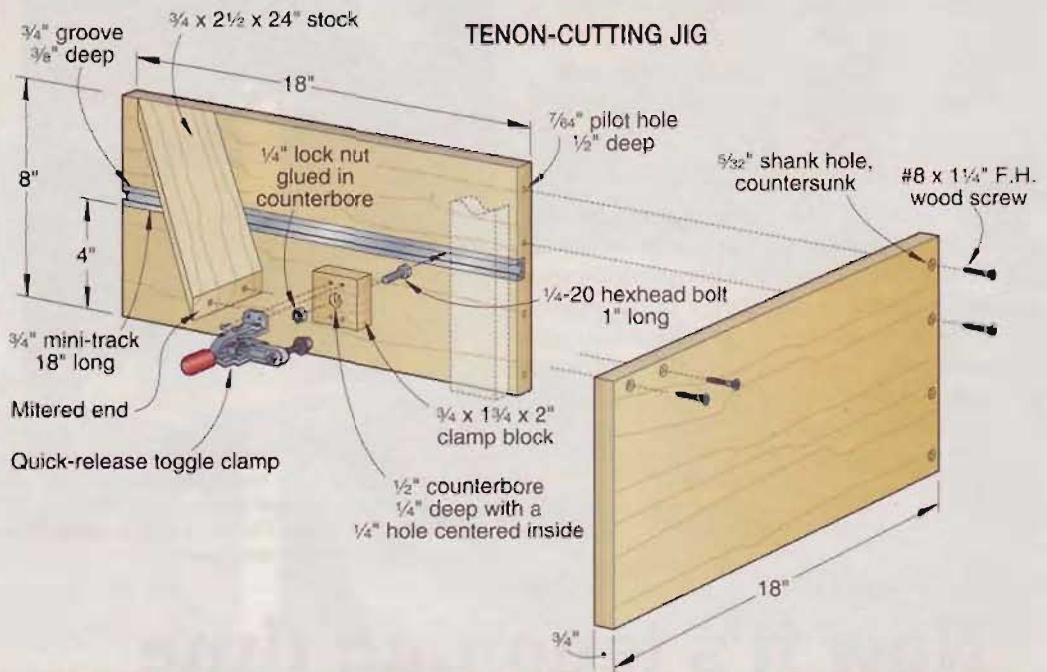

STEP 1

Set the rip fence to establish the length of the tenon and adjust the miter-gauge auxiliary fence so that it nearly touches the rip fence. Set the blade height to establish the tenon thickness. Butt the workpiece against the rip fence and make four passes around the workpiece. Cut a test piece as well.

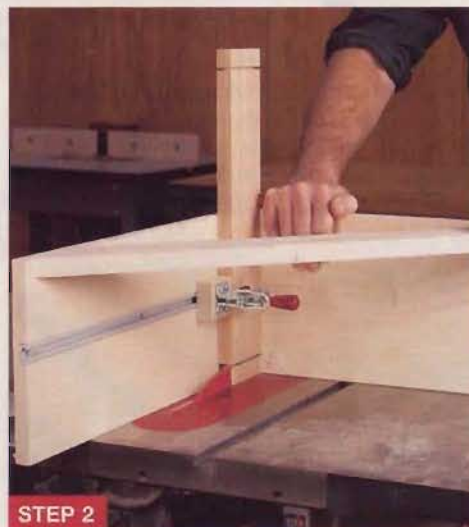

STEP 2

Before cutting the finished piece, use your test piece to set the rip fence. Raise the blade to the kerf's height and set the fence to cut the face cheek on the left side of the blade. Make the cut, flip the workpiece around, cut the other face cheek, and test the result in a completed mortise.



STEP 3

For the edge cheeks, remove the clamp and place a test piece as shown. Adjust the rip fence as necessary, hold the test piece firmly in place, and make the cut. Flip the piece edge for edge, cut the other edge cheek, and test the fit in a mortise. Adjust if needed and then cut the tenon edge cheeks.

## Alternative tenon method 2: Buy a commercial jig

**Pro:** A fine-tuning knob makes this jig easier to adjust than our shop-made version shown above.

**Con:** Not designed to cut edge cheeks. Most jigs cost about \$100.

Would you rather buy a jig than make your own? In issue 152, we tested three similarly priced models and liked them all. A tenoning jig, such as the Delta version shown at right, offers great convenience and accuracy and should last a lifetime.

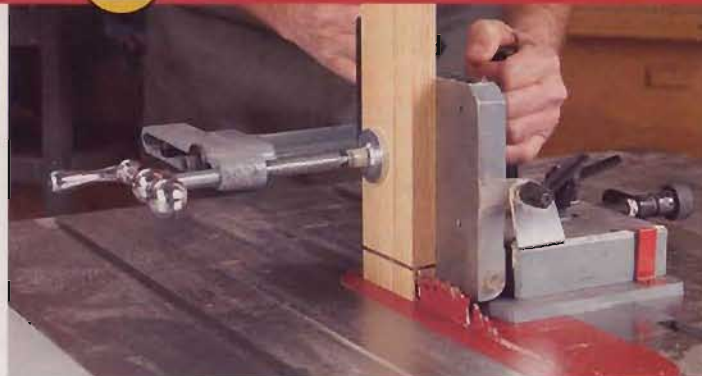

Cutting a tenon with a commercial jig is similar to the process used with our shop-made jig. Cut a kerf around the rail, use a zero-clearance throat plate, and cut on the side away from the jig body. Cut the edge cheeks with a bandsaw, as shown in Tenon Method 3, opposite page, top, or with a crosscut handsaw.

## Tenon method **3**: Try the bandsaw for smooth cuts and versatility

**Pro:** It's easier to handle pieces over 4' long on a bandsaw than on a tablesaw.

**Con:** A dull or poorly tensioned blade results in an uneven face cheek.

None of the tenoning methods discussed so far solve the handling problem you face when cutting oversize workpieces. Rather than hold big pieces vertically on your tablesaw, cut their tenons on your bandsaw, supporting the weight of the rail with a table-height support.

Set up for this technique by installing a blade designed for resawing; a  $\frac{1}{2}$ "-wide blade with three teeth per inch is a good choice. Make test cuts in scrap to determine whether you need to compensate for blade drift by setting your fence at an angle. A bandsaw works just fine for short workpieces, too, and surpasses many dado sets in producing smooth tenon cheeks.

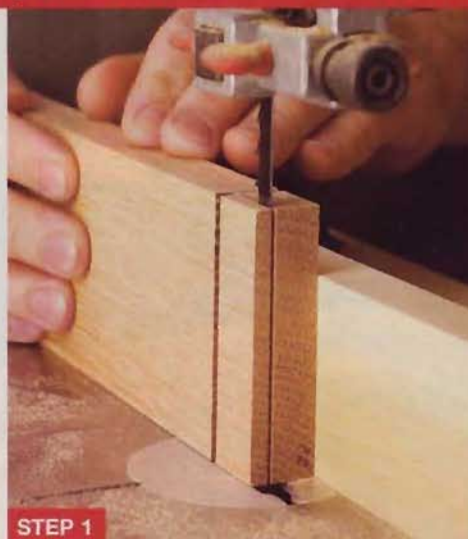

**STEP 1**

Cut a kerf around the workpiece as in Step 1, *opposite page*. Now, clamp a straight fence to the left side of your table to cut the face cheek on the right-hand side of the blade. Flip it edge for edge and cut again.



**STEP 2**

Unclamp and reset the bandsaw fence to cut the edge cheeks, as shown. Again, set up the operation so the waste piece falls away from the blade instead of being trapped against the fence.

## Fine-tune tenons for a good fit

Despite your most careful efforts, sometimes you'll need to make a tenon thinner or thicker to achieve a good fit. Don't count on glue alone to fill gaps—that approach will only weaken the joint.

For a tenon that's slightly oversize, use a sanding block to remove a modest amount of material as shown in the "Sanding" photo. Sandpaper wrapped around a block is likely to ruin the straight line of the shoulder, so use self-adhesive sandpaper on the bottom only. Or, if you prefer, use a rabbeting plane and a light touch, as shown in the "Planing" photo.

Fix a tenon that's too thin by gluing on oversize filler pieces as shown in the "Shimming" photo. Saw, plane, or sand the tenon to final thickness after the glue dries.

Finally, use a sanding block to form a chamfer around the end of each completed tenon, as shown in the "Chamfering" photo. This simple step helps you get the tenon started into its mortise with no fuss at assembly time even if the glue has begun to swell the wood fibers. ♣

Written by **Jim Pollock** with **Kevin Boyle**



**SANDING**

Use 150-grit sandpaper and a sanding block to slightly reduce the thickness of a tenon. Place self-adhesive paper on a block or stick regular sandpaper in place with spray adhesive or double-faced tape.



**PLANING**

A sharp rabbeting plane removes material more quickly than sandpaper. Here you see a low-angle plane (Lie-Nielsen model 60 $\frac{1}{2}$ R), designed to cut efficiently across grain and leave a smooth surface.

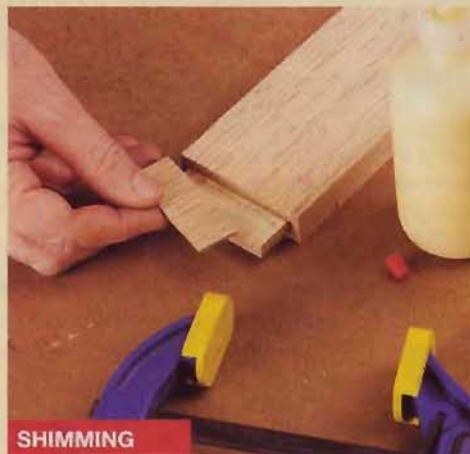

**SHIMMING**

When a tenon proves to be too thin, glue a wood shim on each face cheek to keep the tenon centered. Make the shims thick enough to allow remilling of the tenon.



**CHAMFERING**

Grab your sanding block again to shape a  $\frac{1}{16}$ " chamfer around the tenon end. A chamfered tenon slides more easily into place as you put the joint together.

easy-does-it

# garden bench



**This beauty's so simple to build, you'll be sitting pretty in no time.**

**L**ooking for a weekend project that will yield years of outdoor service? Here it is. This contoured, eye-catching bench derives its durability from rock-solid mortise-and-tenon joinery and decay-resistant cedar. It has just eight different parts, and we've included full-size curved seat rail and support patterns for your convenience.

Better yet, you can build the bench from knotty-grade cedar posts and deck boards, yet achieve the knot-free appearance of clear-grade cedar at a fraction of the cost. To learn how, see the **Builder's Note** from our penny-pinching Design Editor, Jeff Mertz, at *right*.

## BUILDER'S NOTE

### A low-budget way to get clear cedar

If you've tried to buy clear-grade cedar recently, you've discovered that it's a pricey, special-order item. To build this garden bench with premium stock, you would spend about \$245, enough for most of us to say uncle. But, for about one-third of this cost, you can get the same unblemished look that I did using readily available knotty-grade cedar (found at home centers) and working around the knots when laying out the parts, as shown *right*. Of course, you'll need to spend a little time finding the clearest boards (it took me about 15 minutes), and you may need to buy an extra board or two for insurance, as I did. But the savings are significant.

My materials cost about \$85, including the extra boards.

Design Editor



Look over your stock to find the clearest areas. Then, lay out the parts with chalk, as I'm doing here on a 4x4 post for the bench legs (A).



For the lumber and other items needed to build this project, see page 77.

## Start with the legs

**1** From a 4x4 cedar post 8' long, cut four clear 18"-long workpieces for the legs (A). Using your jointer, square two adjacent faces on each piece. Then, cut a 2¼"-square leg from each piece.

**2** Mark the two best faces on each leg for the outside. Then, lay out the ¾x2½" mortises on the legs' inside faces, where dimensioned on **Drawing 1**, making sure you have mirrored pairs of legs. Using a ⅜" Forstner bit in your drill press and a fence to keep the holes aligned, drill the ⅞"-deep mortises. (The mortises are ⅛" deeper than the mating tenons' length to prevent glue squeeze-out and ensure tight-fitting joints.) Now, square their sides and ends with a chisel.

**3** Rout ⅛" round-overs along all of the legs' edges and ends. Then, sand the legs smooth using 180-grit sandpaper.

## Next up: the frame parts

**1** From 5/4 cedar deck boards planed to 1" thick, cut the seat rails (B), bottom side rails (C), and front/back rails (D) to the sizes listed in the **Materials List**. Cut an extra piece with the same

thickness and width for forming test tenons. (Our deck boards measured 1⅛" thick. We planed them to 1" thick by removing equal amounts of material from both faces.)

**2** To form the tenons on the rails' ends, where dimensioned on **Drawing 2a**, fit your tablesaw with a ¾" dado blade, and raise the blade to ⅜". Next, attach an auxiliary fence to the saw's rip fence and an auxiliary extension to the miter gauge as a backer to prevent tear-out. Position the fence so it just touches the dado blade. Now, form a ⅜" tenon ¾" long on the end of your test piece, as shown in **Photo A**. Test the tenon's fit in the leg (A) mortises. If necessary, adjust your setup, and retest. When you're satisfied with the fit, cut the tenons on the ends of the rails (B, C, D).

**3** Raise your dado blade to ½". Then, crosscut both edges on your test piece to trim the tenon's width to 2½". Check its fit in the leg mortises. Adjust the blade height, if necessary, to achieve a good fit. Now, trim the tenons on the rails.

**4** Make four copies of the combined seat rail (B) and seat support (F) full-size half

patterns on the **WOOD Patterns** insert. Set two of the copies aside for a seat support. Then, cut out and spray-adhere the remaining copies to a seat rail, aligning the applicable patterns' ends with the tenons' shoulders. (You'll need to flip one of the patterns over to complete the contour.) Now, bandsaw and sand to the pattern line. Using the rail as a template, mark the contour on the other seat rail, and cut and sand it to shape. Remove the patterns.

**5** Lower your dado blade to ¼". Then, making two passes, cut a 1" dado centered on the inside face of the bottom

**1 LEG**  
(Left rear shown)

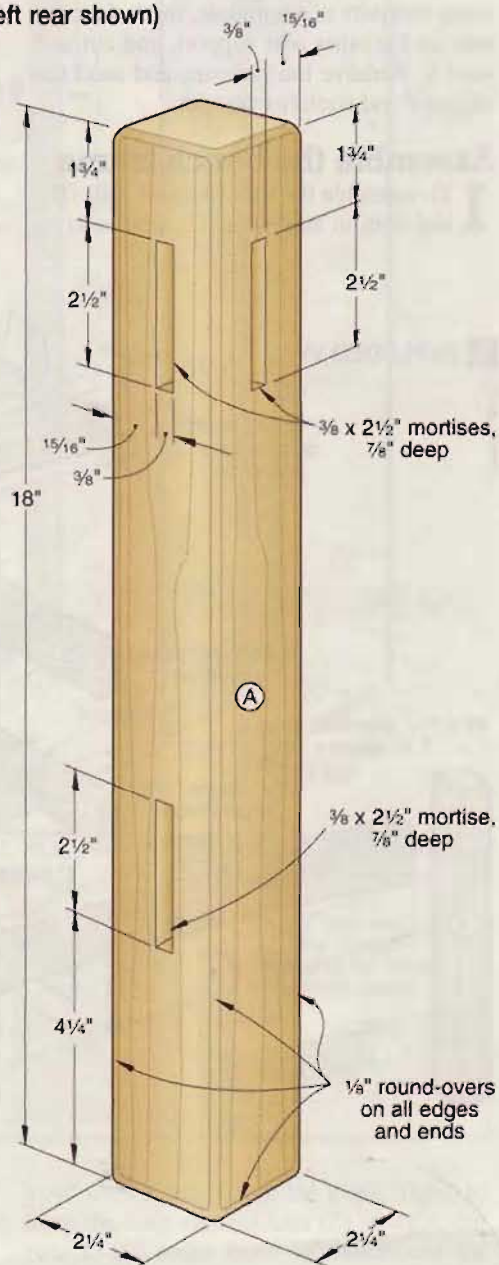

## CUT A TEST TENON



Keeping the end of your test piece tight against the auxiliary fence, crosscut both faces to form a ⅜" tenon ¾" long.

side rails (C), where shown on **Drawing 2**. Now, cut two 1" dados  $\frac{1}{4}$ " deep on the inside face of the front/back rails (D), where dimensioned.

**6** Mark the center of the arches on the bottom side rails (C) and front/back rails (D), where dimensioned. Then, bend a fairing stick to these points, and draw the arches. (For a free fairing stick plan, go to [woodmagazine.com/fairing](http://woodmagazine.com/fairing).) Bandsaw and sand the arches to shape.

**7** Round over the edges of the rails (B, C, D), where shown. Sand the parts smooth.

**8** Cut the stretcher (E) and seat supports (F) to the sizes listed. Then, retrieve the two copies of the seat support half pattern, and spray-adhere them to a seat support, aligning them with the support's ends. Bandsaw and sand them to shape. Now, using this part as a template, mark the contour on the other seat support, and cut and sand it. Remove the patterns, and sand the supports and stretcher smooth.

## Assemble the bench frame

**1** To assemble the legs (A), seat rails (B), and bottom side rails (C), first refer to

**Drawing 2** for the required orientation of the parts. Then, referring to the manufacturer's instructions, apply a thin layer of polyurethane glue in the mortises of two legs, and assemble the legs, a seat rail, and a bottom side rail. Clamp the assembly together, as shown in **Photo B**. (We applied glue only in the mortises to prevent squeeze-out.) Repeat to assemble the other two legs, seat rail, and bottom side rail.

**2** Glue and clamp the seat supports (F) between the front/back rails (D), and check for square. Then, drill countersunk screw holes through the rails, centered in their dados, and into the supports, where shown. Drive the screws. (We bought the stainless steel flathead screws for our project from McFeely's. Call 800/443-7937 or go to [www.McFeelys.com](http://www.McFeelys.com).) Keep the assembly on a flat surface while the glue dries.

**3** Glue and loosely clamp the end assemblies (A/B/C) to the seat



### ASSEMBLE THE ENDS

Using scrap  $\frac{1}{4}$ " hardboard strips to protect the legs (A) from marks, clamp together the legs, seat rail (B), and bottom side rail (C).

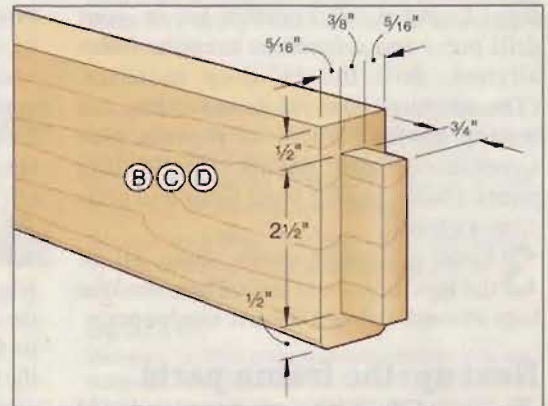

**2a** TENON DETAIL

### 2 EXPLODED VIEW

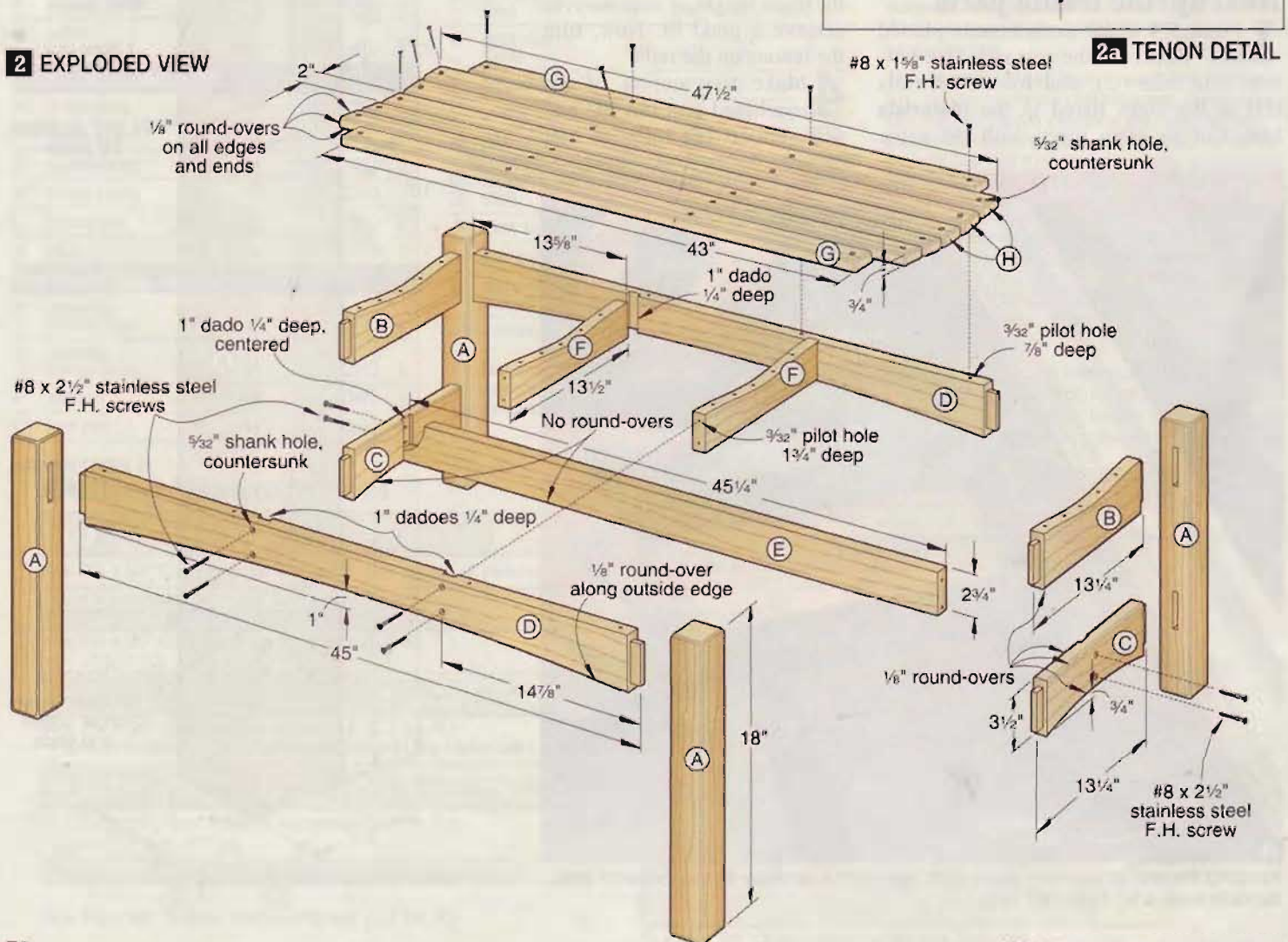

## Cutting Diagram

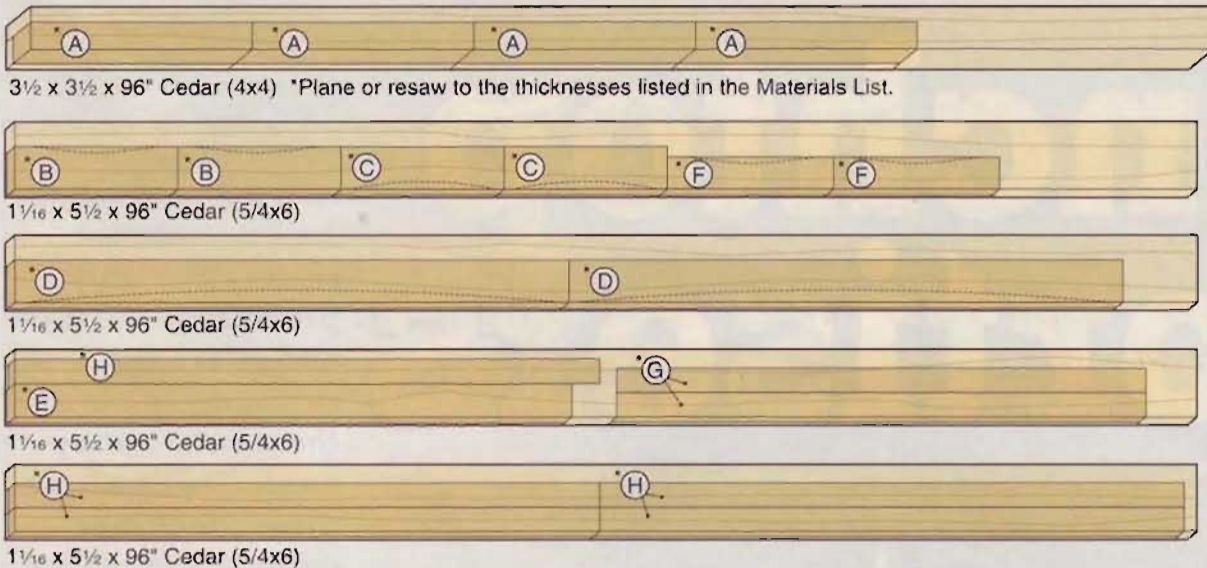

3 1/2 x 3 1/2 x 96" Cedar (4x4) \*Plane or resaw to the thicknesses listed in the Materials List.

1 1/16 x 5 1/2 x 96" Cedar (5/4x6)

1 1/16 x 5 1/2 x 96" Cedar (5/4x6)

1 1/16 x 5 1/2 x 96" Cedar (5/4x6)

1 1/16 x 5 1/2 x 96" Cedar (5/4x6)

### COMPLETE THE FRAME



With the seat support assembly (D/F) on 1 1/2"-tall spacers, glue and clamp the end assemblies (A/B/C) to the front/back rails (D).

support assembly (D/F), as shown in **Photo C**. You can avoid using extra-long clamps by clamping from the seat rails (B) to the seat supports (F), as shown. Then, glue the stretcher (E) in place between the bottom side rails (C), and tighten the clamps. Drill countersunk screw holes through the bottom side rails, centered over their dados, and into the stretcher. Now, drive the screws.

### Add the slats and finish

**1** Plane 5/4 cedar deck boards to 3/4" thick. Cut the front/back seat slats (G) and center seat slats (H) to size. Round over the slats' edges and ends, where shown on **Drawing 2**. Sand the slats smooth.

### MOUNT THE SEAT SLATS

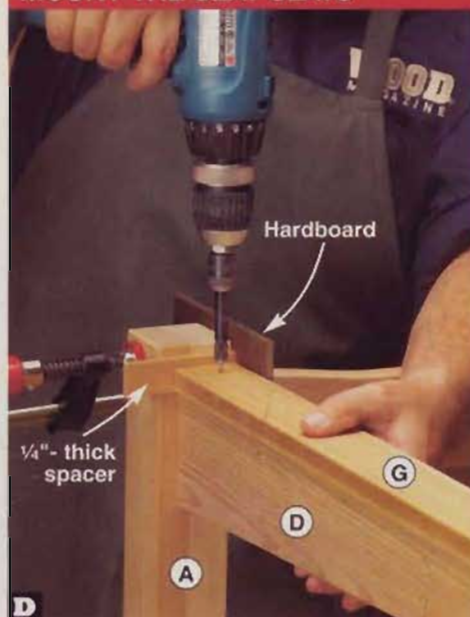

Using 1/4"-thick spacers and hardboard scraps to position the front/back seat slats (G) on the frame, drill the holes, and drive the screws.

**2** Before mounting the slats, apply a coat of waterproof penetrating oil wood sealer to the bench frame and slats. (We used Behr Premium Clear Weatherproofing Wood Sealer & Finish, available at Home Depot.) To give the bottoms of the legs (A) extra protection, soak them in sealer in a disposable pie pan.

**3** When the sealer dries, position the front/back seat slats (G) on the bench frame with their ends 1/4" from the legs (A) and their inside edge flush with the legs' inside face, as shown in **Photo D**. Then, drill countersunk screw holes through the slats and into the front/back rails (D), where shown on **Drawing 2**, and drive the screws.

## Materials List

Part	FINISHED SIZE			Matl.	Qty.
	T	W	L		
A legs	2 1/4"	2 1/4"	18"	C	4
B seat rails	1"	3 1/2"	13 1/4"	C	2
C bottom side rails	1"	3 1/2"	13 1/4"	C	2
D front/back rails	1"	3 1/2"	45"	C	2
E stretcher	1"	2 1/4"	45 1/4"	C	1
F seat supports	1"	2 5/8"	13 1/2"	C	2
G front/back seat slats	3/4"	2"	43"	C	2
H center seat slats	3/4"	2"	47 1/2"	C	5

**Materials key:** C—choice of cedar, redwood, or cypress.

**Supplies:** Spray adhesive, polyurethane glue, #8x2 1/2" stainless steel flathead screws (12), #8x1 3/8" stainless steel flathead screws (28).

**Blades and bits:** Dado-blade set, 1/8" round-over router bit, 3/8" Forstner bit.

**4** Position the center seat slats (H) on the bench frame, inserting 1/4"-thick spacers (not hardboard) between them and the front/back seat slats (G). Center the seat slats so they overhang the seat rails (B) 3/8" at each end. Make any adjustments needed for uniform spacing. Then, drill countersunk screw holes through the seat slats and into the seat rails and seat supports (F), where shown, and drive the screws. Now, move the bench to your garden, kick back, and take some time to smell the roses. 🌹

Written by **Owen Duvall**  
Project design: **Jeff Mertz**  
Illustrations: **Roxanne LeMoine**

Find more  
great outdoor  
projects at  
[woodmagazine.com/outdoor](http://woodmagazine.com/outdoor)

SHOP-TESTED

# benchtop mortisers

Few woodworking joints rival a mortise-and-tenon for strength and beauty. The only problem is the time and effort required to precisely cut *all those mortises* by hand. That's where these machines come to the rescue. Read on to learn which of seven machines bore best.



## Are you ready for a benchtop mortiser?

The article on page 68 shows three options for making mortises, and your need for speed may motivate you to buy a dedicated machine. Benchtop mortisers (sometimes called "hollow-chisel mortisers") cut mortises faster—and cleaner—than drilling a row of holes and cleaning up the mortise with a chisel. Drill-press attachments work fine for occasional use or for mortises smaller than  $\frac{3}{8}$ ", but most drill presses aren't designed to provide the pressure and leverage required to plunge a larger bit and chisel into hardwoods.

Be aware, though, that benchtop mortisers (and drill-press attachments) fall short when it comes to boring through-mortises. Despite our best efforts to control tear-out as the chisel/bit exits the wood, we've found the results unacceptably rough. Often, though, that tear-out will be hidden by the shoulders of the mating tenon.

## 5 key buying considerations

**1 Motor speed.** All of the machines in our test displayed ample power to cut mortises, but some do the job faster than others. The reason: Five units spin the bit at speeds of about 1,720 rpm, while the Bridgewood HM-11 and Shop Fox W1671 run about twice as fast, with speeds of 3,400 and 3,450 rpm. Some woodworkers disdain high-speed machines, arguing that the auger bit overheats easier, causing it to lose its temper and not hold a sharp edge. In our shop tests, though, we measured little difference in auger-bit temperatures between high-speed and low-speed machines after boring a 4"-long mortise, as shown at right.

We did find a significant difference, however, in the amount of time it took to make that same mortise with each of the machines. In hardwoods, the high-speed mortisers did the job in about half the time of the slow-speed machines. We noticed, too, that the slow machines were more prone to stalling in hardwoods, often caused by an errant wood chip getting trapped between the bit and chisel.

## How a mortiser drills square holes

Yes, you can drill a square hole with a round bit. Here's how: An auger-type drill bit spins inside a hollow four-sided chisel secured to the mortiser. The bit itself locks into a drill chuck inside the head of the machine. When you pull down on the mortiser's feed lever, the bit and chisel plunge simultaneously into your workpiece.

Like all drill bits, the auger bit bores a hole and ejects the chips. Meanwhile, the four sharp edges of the chisel pare the wood around the bored hole into a square shape. The auger bit removes this waste, as well, through a chip ejection slot in the chisel. To learn more about bit/chisel sets and how to get the most out of them, see "5 things you need to know about hollow mortise chisels" on page 100.

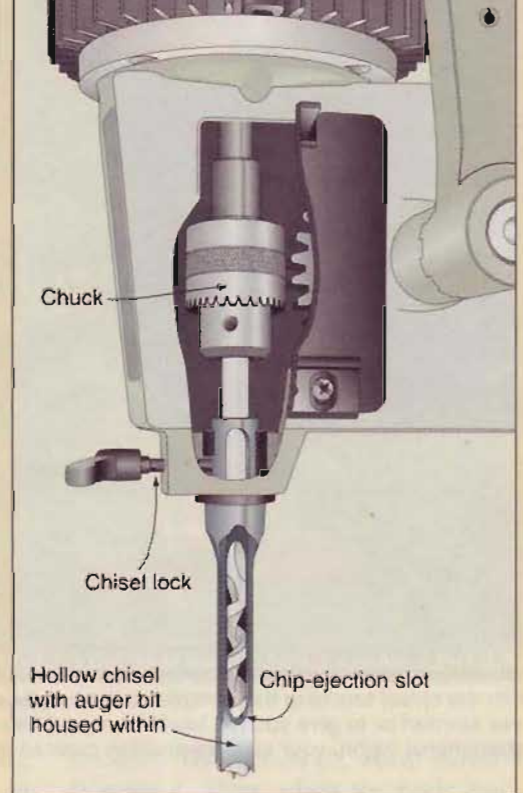

**2 Plunging action.** Here's where the benchtop mortisers have it all over drill-press-mounted attachments. A long handle means more leverage, and Shop Fox's 22" handle is the longest in the test, followed by the 21" handles on the General International

machines. These three mortisers also have a horizontal "L" grip (shown on the next page), making them easier to operate through their full range of motion.

We also prefer multi-position handles that you reposition to gain a more comfort-

## 3,450 RPM MOTORS WORK FASTER, BUT NOT NECESSARILY HOTTER THAN 1,725 RPM MOTORS

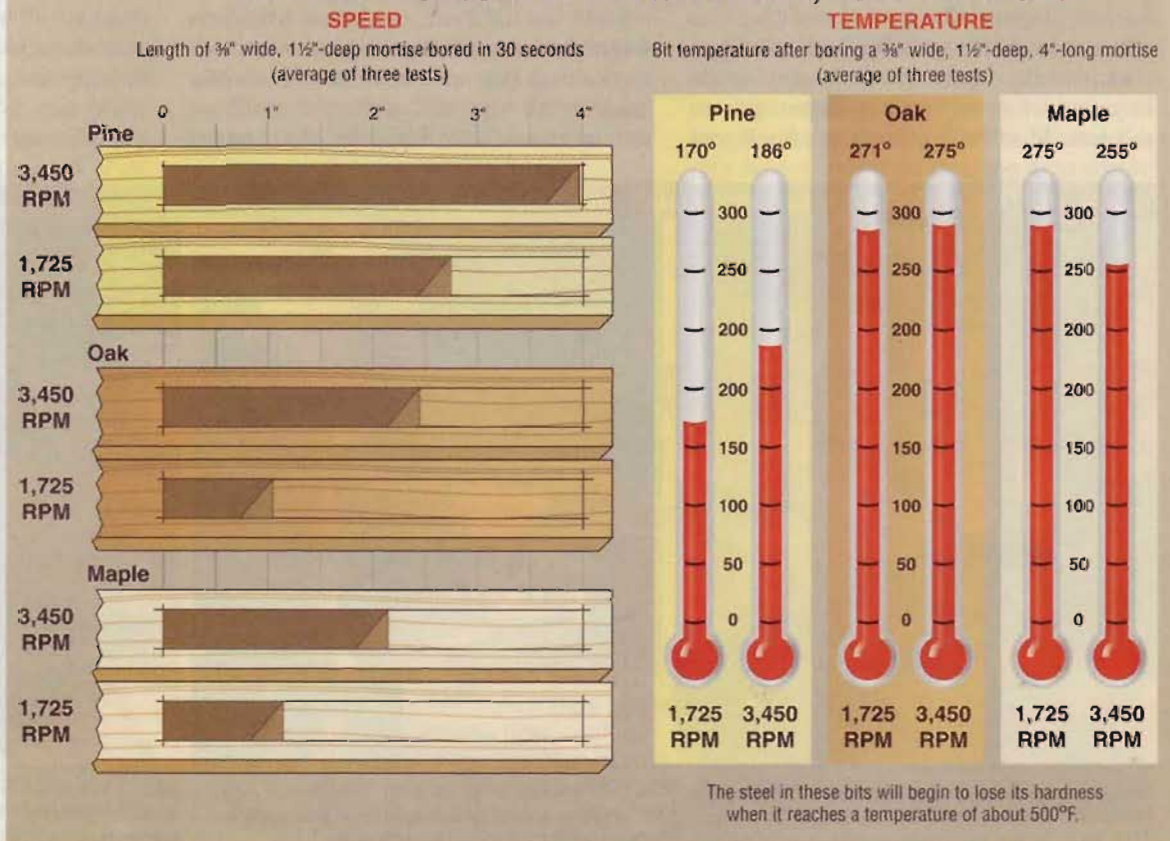

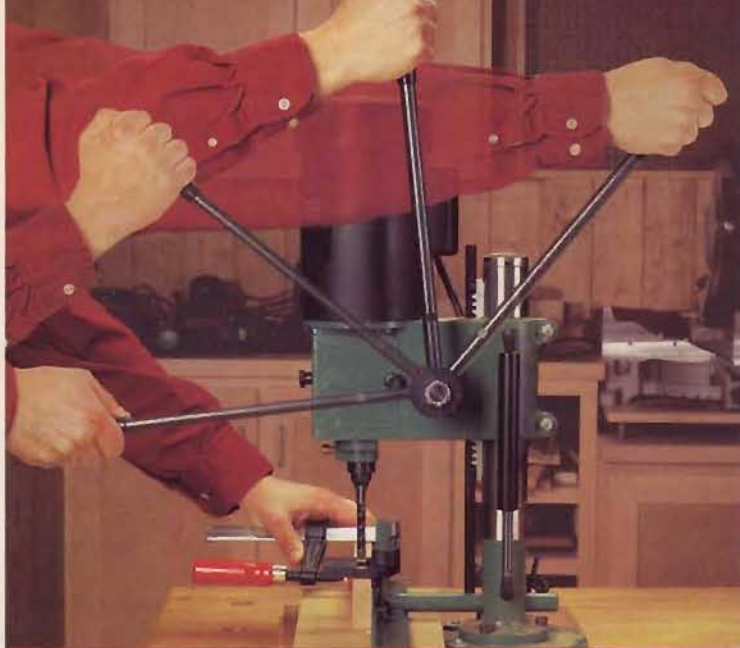

**MULTIPLE HANDLE POSITIONS MAXIMIZE LEVERAGE**

With the chisel touching the workpiece, the handle of the Bridgewood mortiser (left) can be placed in any of four positions (every 45°) to suit your comfort or to give you the best leverage. (We prefer the straight-up position for starting.) With the two-position handle of the General International (right), your starting-position choices are limited to reaching behind the machine or making only a shallow cut.

able or advantageous starting point, regardless of the thickness of your workpiece, length of chisel, or depth of mortise. The photos above demonstrate the importance of these handles.

All of the tested mortisers employ a reliable depth stop to ensure consistent cutting depth, but only three (the Fisch and both General International models) also have a top stop to limit upward travel of the head. That feature saves you both time and energy because the mortiser head doesn't have to return to its full height after each cut.

Incidentally, don't get too hung up on buying the longest stroke (plunge depth) in the test. Most hollow mortise chisels can

cut only 4–5" deep, so any stroke capacity more than that is overkill.

**3 Fences and hold-downs.** A mortiser's fence fixes the distance between the mortise and the edge of the workpiece, and all proved reliable and square to the tabletop. Fence locks on the two machines that have microadjusters (Fisch and Shop Fox) were difficult to access, while Delta's rack-and-pinion mechanism offers fast, but not fine, fence adjustments.

The taller the fence, the better it supports when you're mortising the edge of a wide workpiece. (Because a mortise is usually made in the edge of a workpiece, we'll use the term *width* to describe the vertical

dimension.) However, in most cases, the fence height also dictates the minimum width of workpiece you can mortise. Only the recessed fences on the Delta (shown below center) and General International mortisers allow the hold-down to go lower than the top of the fence.

Workpiece hold-downs on nearly all of the mortisers we tested are made of cast iron, a sometimes rough surface that can mar your workpiece. (Setting the hold-down two thicknesses of paper higher than your workpiece virtually eliminates the marring and still allows you to slide the workpiece as you lengthen the mortise.) The General International machines stand

**GOOD, BETTER, AND BEST: THREE WORKPIECE-HOLDING SYSTEMS**

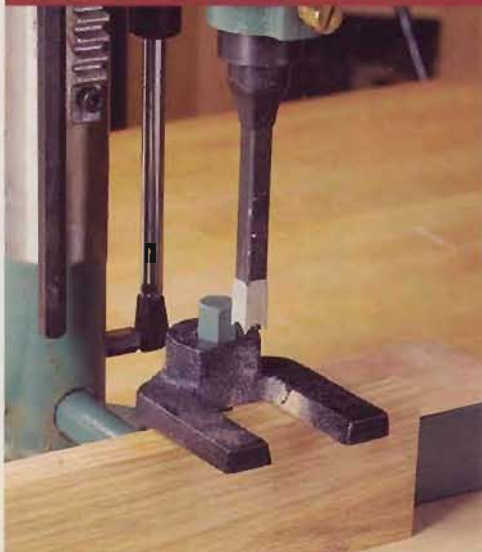

**GOOD:** Bridgewood's stock hold-down requires a hex wrench to secure it. And its 1½"-high fence provides average support.



**BETTER:** Delta's fence stands nearly 3" tall for extra support, yet the stock hold-down works with material as narrow as 1".

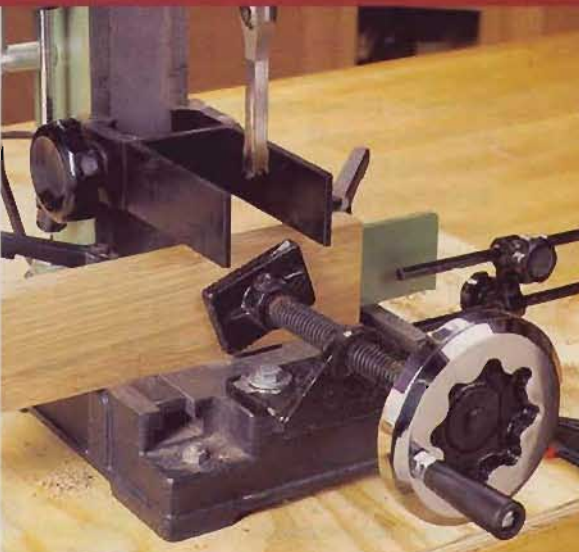

**BEST:** We liked General International's holding system because of its column-mounted hold-down, large locking knob, and handwheel stock clamp.



General International's handy ratcheting lock secures the chisel. The rest of the mortisers require a wrench or screwdriver.



Jet's long chuck key and wide-open access to the drill chuck (left) make it easy to secure bits. By contrast, Bridgewood's chuck (right) can only be operated from the right or front of the machine, and the handle of the chuck key hits the cover knob.



out here for a couple reasons. First, the long "fingers" on the hold-down keep wide workpieces from twisting as you pull the chisel out of them. Second, the hold-down locks with a large handwheel rather than a ratcheting knob or hexhead screw.

**4 Changing chisels and bits.** The General International mortisers make this task as tool-free as possible (see photo above), requiring only a chuck key to install

the bit. Delta's hexhead wrench is on one end of the chuck key, making that the only tool needed for bit and chisel changes. Jet's chuck key (shown above) is the longest, reaching easily inside the mortiser's head to tighten and loosen the chuck; Bridgewood's (top right photo) is the shortest, and a real knuckle-banger.

**5 Workpiece capacities.** The true capacities of these machines are tough to nail

down, because hollow-mortise chisel lengths vary from size to size and brand to brand. The "Maximum Distance From Bushing to Table" column in the chart at the end of this article gives a comparative indication of each mortiser's true capacity. To learn a machine's capacity for a particular chisel, subtract the length of the mortise chisel (our  $\frac{3}{8}$ " chisel, for example, was  $4\frac{1}{4}$ " long) from the dimension listed in the chart.

## The highs, lows, and more of seven mortisers

**Bridgewood HM-11, \$190**  
800/235-2100, wilkemach.com

### High points

- ◆ The high-speed motor cuts mortises faster than the slow-speed motors found on most other models.
- ◆ Four possible handle positions for each mortise allow the user to choose the most comfortable or advantageous one.

### Low points

- ▼ Short handle means more muscle is required to cut  $\frac{1}{2}$ " or wider mortises.
- ▼ Short chuck key makes bit changing difficult, and access is limited for left-handed users.
- ▼ No chisels included in purchase price.
- ▼ The only mortiser that requires a hexhead wrench to set the cutting-depth stop.
- ▼ No onboard storage for adjustment tools.

### More points

- ◆ A good performer, but strictly barebones compared to the other machines.



**Delta 14-651, \$230**  
800/438-2486, deltamachinery.com



### High points

- ◆ Hexhead wrench on chuck key makes for one-tool bit/chisel changes.
- ◆ The unique rack-and-pinion fence mechanism makes for silky-smooth adjustments to the fence location.
- ◆ Large cast-iron table/base provides a broad, stable work surface, enabling you to mortise into the face of wide workpieces.
- ◆ Cutout in fence allows the hold-down to work with pieces as narrow as 1".
- ◆ Head rotates to mortise off the table.
- ◆ Onboard storage for all adjustment tools.
- ◆ Four chisels included in purchase price.

### Low points

- ▼ Straight handle grip is not as ergonomic as horizontal grip found on some machines.

### More points

- ◆ Included riser block and extra-long hold-down post add  $1\frac{3}{4}$ " of workpiece capacity when you need it, but defeats the rack-and-pinion fence adjuster when installed.





**High points**

- ◆ Top stop on depth stop limits upward travel of the head, saving you both time and energy.
- ◆ Onboard storage for all adjustment tools.

**Low points**

- ◆ Straight handle grip is not as ergonomic as horizontal grip on some other machines.
- ◆ Strong head-return spring works against you, especially when cutting deep or wide mortises.

**More points**

- ◆ Microadjustable fence makes it easy to fine-tune a mortise location, but the locking knob is awkward to use.



**High points**

- ◆ The best workholding system in the test, with a substantial hold-down and a screw clamp.
- ◆ Cutouts in fence allow hold-down to secure workpieces narrower than the fence is tall. The fence also features a scale showing its distance from the center of the mortise.
- ◆ Besides a depth-of-cut stop and a top stop to limit upward head travel, this machine also has a mortise-length stop.
- ◆ Long handle for better leverage and horizontal grip for operator comfort.
- ◆ Four chisels included in purchase price.

**Low points**

- ◆ Two-position handle limits your choice of starting points to optimize leverage.
- ◆ Onboard storage for chuck key, but not for adjustment tools.
- ◆ Instruction manual is vague, assuming too much knowledge on the part of the user.

**More points**

- ◆ If you don't need to make angled mortises, or work off the table, this is the best in the bunch.

**SEVEN BENCHTOP MORTISERS, MAKING THE GRADE**

BRAND	MODEL	MOTOR		CAPACITY (INCHES)							CONSTRUCTION				HANDLE	PERFORMANCE GRADES (7)						
		HP	SPEED	MINIMUM WORKPIECE WIDTH UNDER HOLDDOWN	MAXIMUM DISTANCE FROM BUSHING TO TABLE (1)	CHUCK	MAXIMUM DISTANCE FROM FENCE TO CHISEL CENTER	STROKE (2)	MAXIMUM CHISEL SHANK SIZE	TABLE MATERIAL (3)	TABLE SIZE (LxW, INCHES)	BASE DIMENSIONS (DxW, INCHES)	COLUMN CONFIGURATION (4)	LENGTH (INCHES)		STYLE (5)	NUMBER OF POSITIONS (6)	CHUCK ACCESS	CHISEL CHANGING EASE	DEPTH STOP EFFECTIVENESS	HOLDDOWN EFFECTIVENESS	HOLDDOWN ADJUSTMENT
BRIDGEWOOD	HM-11	1/2	3,400	1 5/8	8 1/8	3/8	3 1/2	4 1/2	5/8	MDF	13 1/2 x 6	7 1/2 x 12	F	16	S	4	C	B-	B-	B+	B	C+
DELTA	14-651	1/2	1,725	1	8 3/8	3/8	3 3/4	4 5/8	1/2	CI	12 1/4 x 8 1/4	13 1/2 x 16 1/4	R	18	S	3	A	B+	B	B+	B+	A-
FISCH	BTM99-44252	3/4	1,725	1 1/2	7 3/4	1/2	2 3/4	4 3/8	1/2	MDF	13 1/2 x 6	7 3/4 x 10 1/4	F	18	S	3	A	B	A	B+	B	A
GENERAL INTERNATIONAL	75-050 M1	1/2	1,720	1	10 1/8	1/2	3	6	3/4	CI	7 1/2 x 5	7 x 11 1/2	F	21	H	2	A-	A	A-	A-	A-	B+
	75-050 T	1/2	1,720	1 3/8	10	1/2	3	6 3/4	3/4	CI	8 x 8	8 3/4 x 14	TR	21	H	2	A-	A	A-	A-	A-	B+
JET	JBM-5	1/2	1,720	1 3/4	8 1/8	3/8	3 1/8	4 5/8	1/2	MDF	12 1/4 x 7 1/2	7 5/8 x 12 1/2	R	16	S	3	B+	B-	B	B	B+	C+
SHOP FOX	W1671	3/4	3,450	2 1/8	13 1/8	1/2	4	4 3/4	3/4	MDF	16 x 6	11 x 14	R	22	H	3	A	B	B	B	B	A

**NOTES:** 1. Subtract the length of the mortise chisel from this dimension to determine the mortiser's capacity. Chisel lengths vary by diameter and manufacturer.  
 2. Maximum plunging distance of the chisel.  
 3. (CI) Cast iron (MDF) Medium-density fiberboard  
 4. (F) Fixed column (R) Column rotates (TR) Column tilts and rotates  
 5. (H) Horizontal grip (S) Straight grip  
 6. Within the range of the user's reach.  
 7. A Excellent B Good C Fair D Poor

**These machines mortise to the max**

Although we prefer fast-cutting high-speed mortisers, we found the rugged construction and user-friendliness of the General International 75-050 T impossible to resist, so it's our Top Tool. True, it's the most expensive machine in the test, and it lacks a multi-position handle. But the solid hold-down, fence

scale, front-mounted clamp, length stop, and tilting head are features normally found only on industrial-grade mortisers that cost twice as much. And, aside from chucking the auger bit, every routine adjustment on this machine is performed without the use of a single tool. Don't need the tilting, rotating head? The General International 75-050

M1 is nearly the same machine, except for those functions, for \$40 less.

Our choice for Top Value was tougher, with a virtual tie between the Delta 14-651 and the Shop Fox W1671. We like Shop Fox's powerful high-speed motor, with which we bored cleanly—and quickly—into oak and maple without stalling. Figure



## General International 75-050 T, \$340

514/326-1161, general.ca



### High points

- ◆ This machine has all the great features found on the 75-050 M1: excellent stock hold-downs and fence; depth, top, and length stops; and a long handle with horizontal grip.
- ◆ The head of this mortiser tilts to make angled mortises, such as those in chair legs and back splats. It also rotates (without using tools) for off-the-table mortising.
- ◆ Large cast-iron base provides a broad, stable work surface.
- ◆ Four chisels included in purchase price.

### Low points

- ◆ Same low points as General International 75-050 M1.

### More points

- ◆ This mortiser can do it all, and do it well, so it's our choice for Top Tool.

## Jet JBM-5, \$200

800/274-6848, wmhtoolgroup.com



### High points

- ◆ No tools needed to secure fence and hold-down.
- ◆ Long chuck key makes tightening and loosening the drill chuck easy.
- ◆ 3"-long fingers on hold-down are about 1" longer than most to better stabilize thick workpieces.

### Low points

- ◆ Short handle means more muscle is required to cut 1/2" or wider mortises.
- ◆ Straight handle grip is not as ergonomic as the horizontal grip found on some machines.
- ◆ Onboard storage for chuck key, but not for adjustment tools.

### More points

- ◆ Head rotates to mortise off the table, but the machine must be unbolted from the bench to do so.
- ◆ Optional riser block (\$20) boosts workpiece capacity by 2".

## Shop Fox W1671, \$230

800/840-8420, shopfox.biz



### High points

- ◆ The high-speed motor cuts mortises faster than the slow-speed motors found on most other models.
- ◆ Long handle for better leverage, and horizontal grip for operator comfort.
- ◆ Big-capacity machine: Bores to the center of an 8" workpiece, and the head and hold-down can be quickly reconfigured to mortise pieces about that wide (both best in the test).
- ◆ Large cast-iron base provides a stable work surface.

### Low points

- ◆ Only one chisel included in purchase price.

### More points

- ◆ Microadjustable fence makes it easy to fine-tune a mortise location, but the locking knob is awkward to use.
- ◆ Head rotates to mortise off the table, but the machine must be unbolted from the bench to do so.

TABLE/FENCE SQUARENESS		TOOL STORAGE		OVERALL EASE OF USE		QUALITY OF MANUAL		CHISELS INCLUDED (INCHES)	STANDARD	OPTIONAL	CORD LENGTH	WARRANTY (YEARS)	COUNTRY OF ASSEMBLY (9)	WEIGHT (POUNDS)	SELLING PRICE (10)
A-	D	B	B+	A-	A	A-	A								
A	D	B	B+	A-	A	A-	A	1/4, 5/16, 3/8, 1/2	H, R, SX, T		6'	1	T	50	\$190
A	A-	A-	A-	A-	A	A-	A	1/4, 3/8, 1/2			6'	2	C	55	230
A-	A	B+	B	A-	A	A-	A	1/4, 3/8, 1/2			6'	2	C	66	240
A	C	A-	C	A-	A	A-	A	1/4, 5/16, 3/8, 1/2	B, S		5'6"	2	T	76	300
A	C	A-	C	A-	A	A-	A	1/4, 5/16, 3/8, 1/2	B, S		5'6"	2	T	98	340
A-	C	B	B	A-	A	A-	A	1/4, 3/8, 1/2	B, SX, T	R	6'	2	T	53	200
A-	B+	B+	A-	A-	A	A-	A	1/2	B, H, T		9'6"	2	C	92	230
8.		(B)	Bushing for 3/4" chisel	9.		(C)	China								
		(H)	Hold-down extension			(T)	Taiwan								
		(R)	Riser block	10.		Prices current at time of articles production and do not include shipping, where applicable.									
		(S)	Length stop												
		(SX)	Spindle extension												
		(T)	Tool caddy												

on adding another \$40 or so to the price to get a full set of chisels, though. Delta includes all the chisels you're likely to need, comes nicely appointed with a rack-and-pinion fence and riser block, and all routine adjustments are made with the chuck key. If you don't mind its slower speed, this mortiser is a great value. ♣

Written by Dave Campbell with Jeff Hall

### Share your opinion

of these mortisers in our Interactive Tool Review at

[woodmagazine.com/mortisers](http://woodmagazine.com/mortisers)



# getting a grip on **four-jaw lathe chucks**

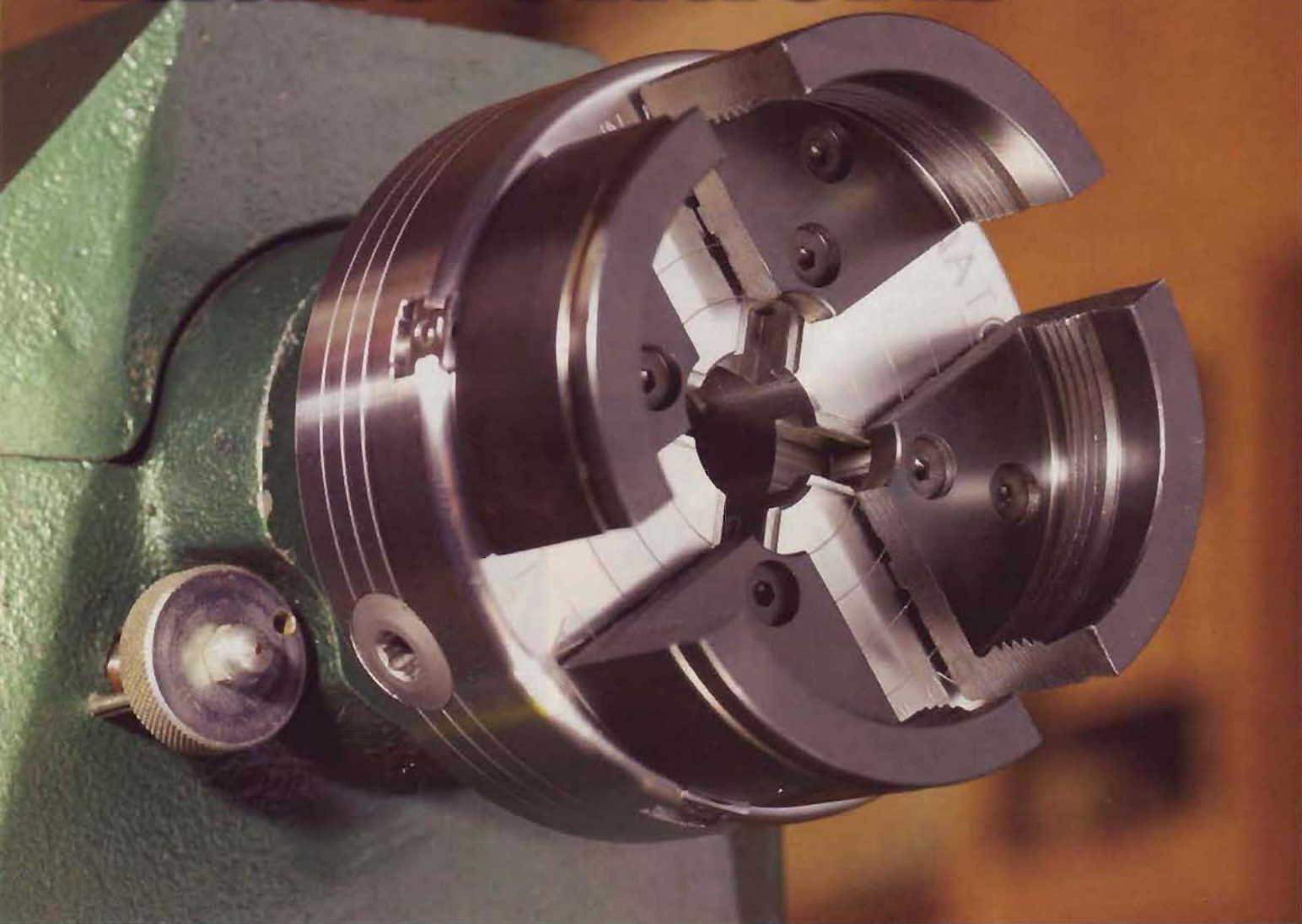

Teknatool of New Zealand started the woodturning chuck revolution in 1988. Shown above is the business end of its Nova Titan chuck.

When first introduced, four-jaw chucks were viewed by many as a luxury just for professional turners. But they offer so many advantages that anyone from novice level on up would benefit from owning one.

**W**ith prices ranging from about \$35 up to \$280, you're probably asking yourself why you should buy a four-jaw chuck for your lathe. Here are some of the best reasons:

- Chucks provide quick, accurate, and positive centering of bowl blanks and standard turning squares.
- There's no need to glue a waste block to your turning blank or give up bowl-blank thickness to accommodate the screws needed to fasten it to a faceplate.

■ When using a chuck to turn a bowl from green stock, you can rough it out, remove it from the lathe, and then later remount it with greater ease and convenience than with faceplate mounting.

■ Accessory chuck jaws are available to hold work as small as a 1/4"-diameter tenon on a miniature vessel and as large as the rim of an 18"-diameter platter.

■ You can turn a bowl and finish it inside and out with little or no trace of how it was held on the lathe.

## HOW FAR YOU OPEN A CHUCK AFFECTS ITS GRIPPING POWER

(Chuck viewed straight on looking toward the headstock)

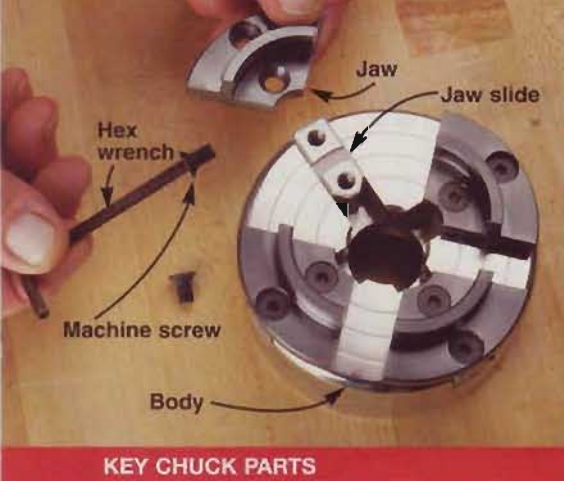

### KEY CHUCK PARTS

The chuck jaws attach to the jaw slides with machine screws, allowing the use of a wide variety of specialized accessory jaws.

### How a chuck works

A chuck consists of a **body**, **jaw slides**, and **jaws**, as shown *above*. Internal spiral gearing moves all four jaws simultaneously, keeping them equidistant from the center of the chuck body. The jaws operate with twin levers or a single key. Lever action requires either the simultaneous use of both hands, or temporarily locking the lathe spindle to adjust the chuck with one lever. Single-key chucks offer the advantage of one-hand operation without the necessity of locking the lathe spindle. One-hand tightening or loosening leaves the other hand free to control stock when mounting it or a finished piece when removing it from the chuck.

### Jaw design

There are two basic jaw designs, dovetail and serrated, as shown *below*. Most jaws for Vicmarc and Axminster chucks are of the dovetail design. The flanged SuperNova jaws are a variation of this design. Serrated jaws are most common on Oneway chucks.

### JAWS NEAR MINIMUM OPENING PROVIDE MAXIMUM GRIP

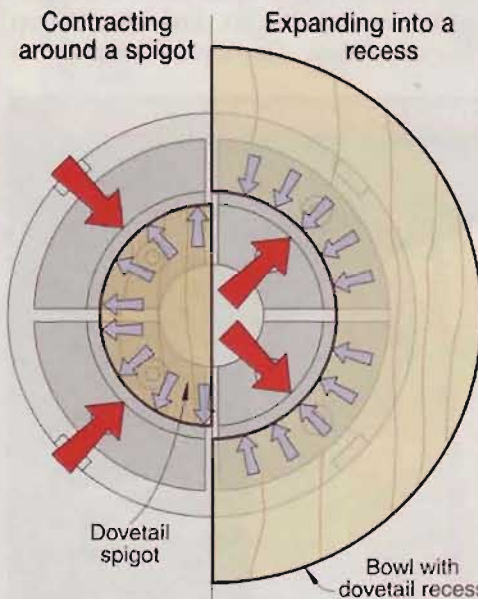

### JAWS NEAR MAXIMUM OPENING PROVIDE LESS GRIP

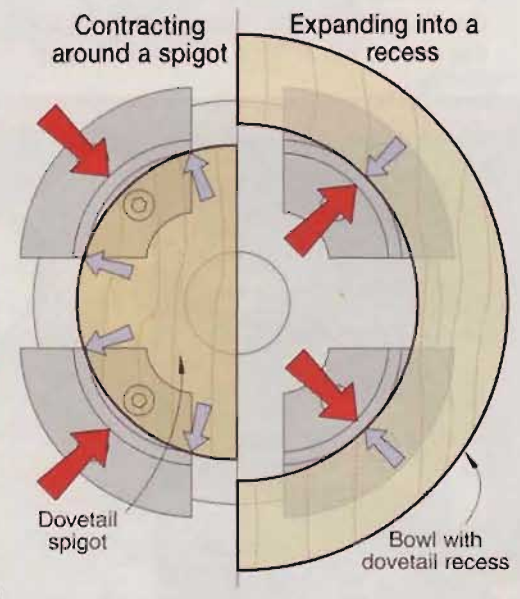

➔ Jaw motion ➔ Workpiece point of contact

### How a chuck grips

Chuck jaws either contract around a turned spigot (round tenon) or expand into a hollowed-out recess. In contracting mode, the jaws commonly supplied with chucks grip spigots from 1½" to 3" in diameter. These same jaws expand into turned recesses from 2" to 3½" in diameter.

Because chuck jaws form a circle when completely closed, they make continuous contact when contracting around a spigot or expanding into a recess that is just slightly larger than the diameter of the circle, as shown *above*. This provides the greatest

holding power and safest operation. As the jaws approach their maximum open position they make only point contact with the workpiece, as shown *above*. Gripping only at these points (eight in contracting mode, or four in expanding mode) is less secure and risks marring the wood. Manufacturers offer accessory jaws to cover a wide range of gripping diameters.

When turning, be careful of chuck jaws adjusted near their maximum diameter. The farther open the jaws, the more they extend beyond the chuck body, and if touched, the more likely they are to cause injury.

### TWO JAW TYPES GIVE YOU DIFFERENT ADVANTAGES

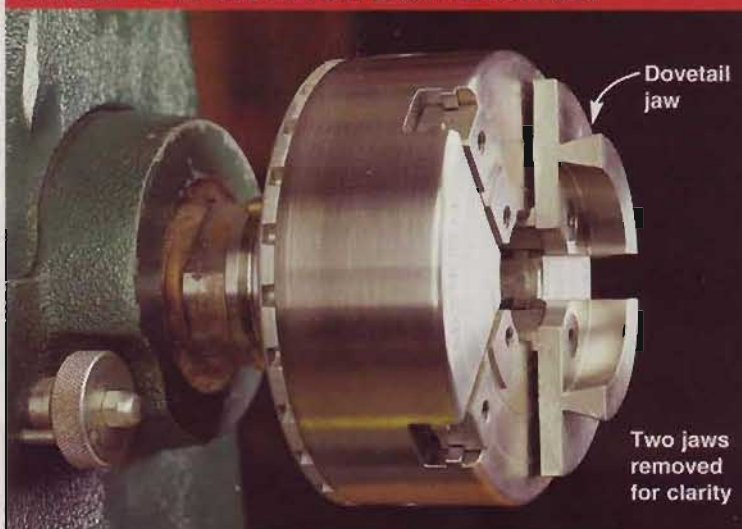

**Dovetail jaws** usually leave minimal or no marking on the finished vessel, reducing the need to remount it to remove any marks.



**Serrated jaws** have great holding power, particularly when gripping end-grain stock, but leave marks that must be removed.

# Turning a bowl with a four-jaw chuck

## Start on the outside

For mounting side-grain bowl blanks, many chucks come with a screw center. To use this center, install it in the chuck by grip-

ping it with the jaws. Drill a hole equal in diameter to the root of the screw and slightly deeper than its length, centered on the top face of the blank. Then thread the blank onto

the screw. Engage the lathe tail center for additional support while turning the rough shape of the bowl. Now turn the outside of the bowl, shaping its bottom to be held by the chuck jaws, as shown in the photo at left. Screw-center mounting allows for easy removal and remounting of the blank while maintaining its centered position.

FIRST, MOUNT THE BLANK ON A SCREW CENTER, AND SHAPE THE OUTSIDE

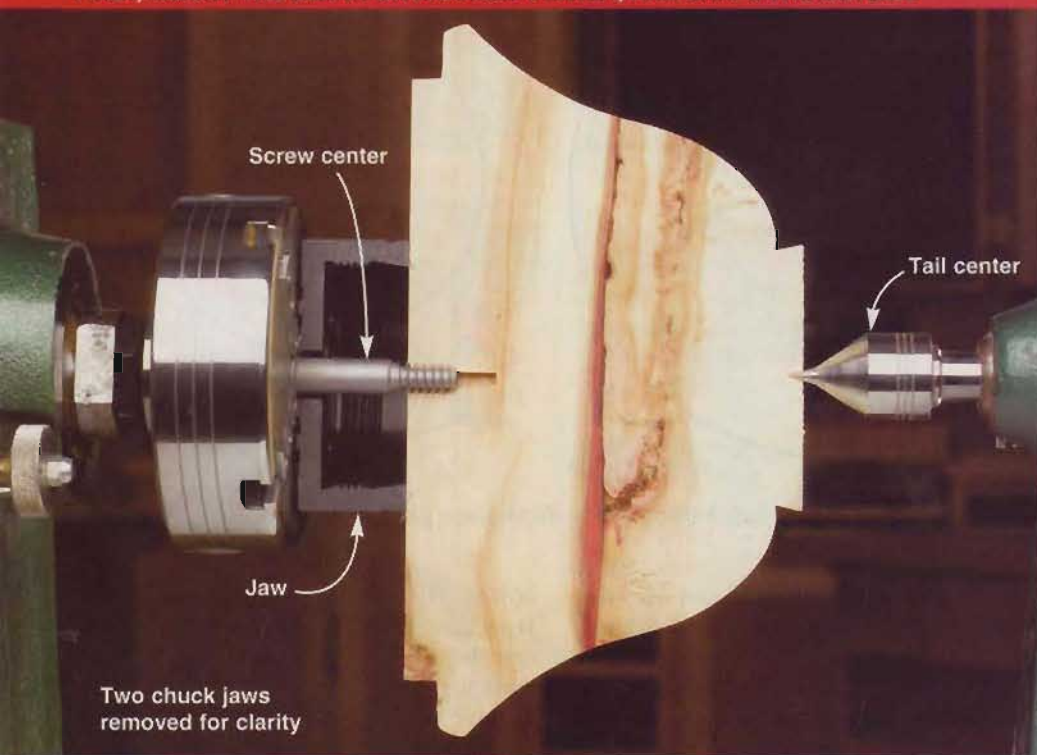

With its exterior shaped, this partially formed bowl was cut in half to show how the screw center secures it to the chuck.

## Shape the bottom

When shaping the outside of a bowl, form its bottom to fit your chuck jaws so you can reverse the blank, grip it with the chuck, and form the inside. For contracting dovetail jaws, form a dovetail spigot as shown below left. Cut the inside corner where the spigot meets the bowl body crisp and clean to provide a positive gripping corner for the chuck jaws. Leave a flat bearing surface for the jaw ends. Because the jaws pull in on the spigot as well as squeezing it, make the spigot slightly shorter than the jaw depth, so it does not bottom out. Sand and finish as much of the outside of the bowl as possible.

The same jaws that contract onto a spigot also will expand into a recess hollowed out in the bottom of a bowl, as shown below. When planning the shape of your bowl, leave extra thickness in its bottom to accommodate this recess. Make it about 1/8-1/4" deep, cleanly cut, and with its edge following the shape of the jaws. Leave sufficient

THEN, GRIP THE BOWL BOTTOM IN ONE OF TWO WAYS, AND FORM THE INSIDE



**Dovetail jaws contracting around a spigot:** When forming a spigot at the bottom of a bowl, match the angle of the outside edge of the spigot to the angle of the jaws.

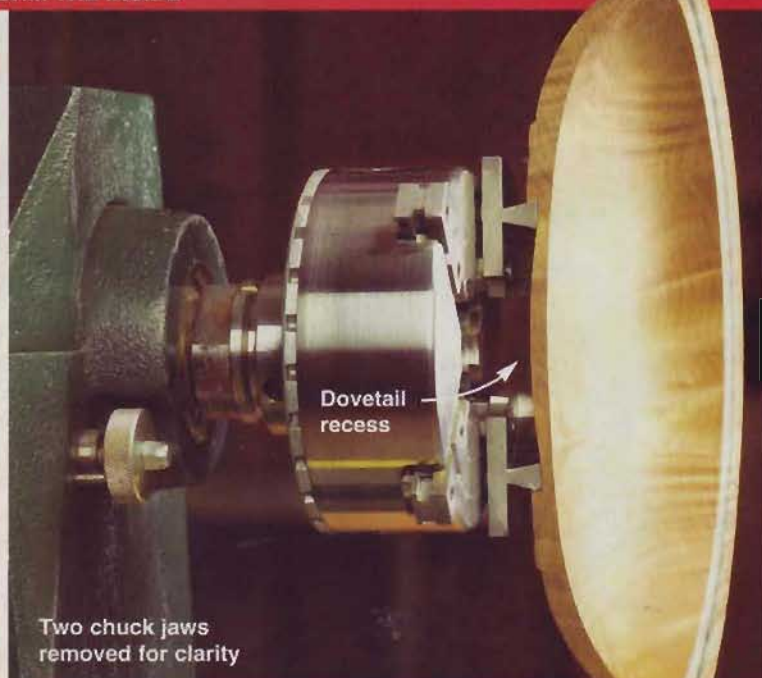

**Dovetail jaws expanding into a recess:** When forming a recess in the bottom of a bowl, match the angle of the inside rim of the recess to the angle of the jaws.

## BOWL JAWS MAKE IT EASY TO REMOVE A SPIGOT

wood around the recess to support the outward force exerted by the expanding jaws. Gripping the bowl in this manner allows you to completely form the outside, including its bottom. With the outside of the bowl formed, sand it and apply a finish.

Generally speaking, contracting into a spigot provides the greatest holding power. However, for turnings of large diameter but shallow depth, such as a large platter, expanding into a recess gives better results. Regardless of how the chuck holds the workpiece, be sure to periodically check its tightness.

### Now form the inside

With the outside of the bowl complete, remove it from the screw center, and remove the screw center from the chuck. To hollow the inside of the bowl, remount it as shown, *opposite page, bottom*. When turning the inside, take care not to catch the tool. Chucks do not hold turning stock as securely as a standard faceplate where several screws secure the blank. A bad catch can dislodge the bowl from the chuck. Once the final inside shape and wall thickness of the bowl have been achieved, sand it and apply the finish. For a bowl gripped in a recess, simply remove it from the chuck.



Although each manufacturer has a different name for this chuck accessory, adjustable bowl jaws all work the same. Resilient grippers hold the bowl rim to the chuck jaws. Sets cost from \$50 to \$140.

### Back to the bottom

For a bowl gripped by a spigot, reverse-chuck it, gripping the rim with a shop-made jam chuck or accessory adjustable bowl jaws, as shown *above*. Then turn away the spigot, and form a slight recess in the bottom of the bowl. Whether using a jam chuck or a four-jaw chuck fitted with bowl jaws, support the workpiece with the tail center for as long as possible. Finish-sand the turned area, and apply a finish. ♣

### Sources

#### Woodturning chucks.

Packard Woodworks. Call 800/683-8876, or go to [packardwoodworks.com](http://packardwoodworks.com).

Grizzly Industrial. Call 800/523-4777, or go to [grizzly.com](http://grizzly.com).

Penn State Industries. Call 800/377-7297, or go to [pennstateind.com](http://pennstateind.com).

Craft Supplies, USA. Call 800/551-8876, or go to [woodturnerscatalog.com](http://woodturnerscatalog.com).

**Coming in issue 159.** See Wise Buys in this upcoming issue for reviews of four chucks priced from about \$35 to \$235.

### A chuck also grips square stock

Chucks also can grip most common sizes of turning squares. Because square stock cannot be held as securely as round stock, hold it with the chuck and support it with a tail center, as shown at *right*. Then turn a round spigot on the tailstock end. Now flip the square end for end, and grip the spigot in the chuck, once again supporting it with the tail center. When you cut square stock for mounting in a chuck, make accuracy a priority; out-of-square stock is difficult to grip securely. The slightly rounded jaw corners of Oneway chucks offer the best design for gripping square stock.

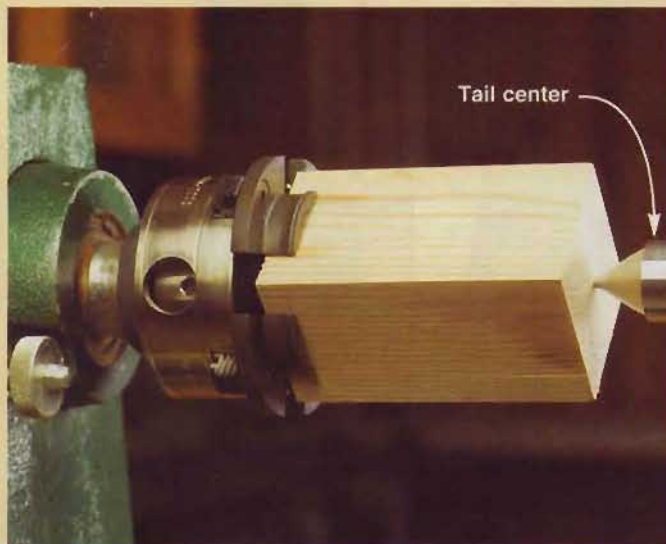

### Meet the authors

This article was produced with the help of Kip Christensen and Rex Burningham. Kip teaches furniture design and prototyping at Brigham Young University in Provo, Utah. He frequently demonstrates turning techniques at national symposia and workshops.



**Kip Christensen**



**Rex Burningham**

Rex teaches turning at Craft Supplies USA, also in Provo. He exhibits his work in galleries and craft shows, and has assisted such legendary turners as Richard Raffin, Rude Osolnik, Dale Nish, and Ray Key.

Illustrations: Roxanne LeMoine

# Here they are, the WINNERS in our 2004

## rugged 'n' ready TOOL STORAGE CONTEST

Readers roll out their most inventive solutions for controlling clutter.

**W**e teamed with Chevy Silverado and DeWalt Tools to rustle up the best storage ideas in the nation during our 2004 "Rugged 'n' Ready Tool Storage Contest." After pouring through the many deserving entries, the judges (Bill Krier, editor-in-chief; Marlen

Kemmet, managing editor; Kevin Boyle, senior design editor; and Jan Svec, projects editor) chose 13 winners: 1 grand prize, 2 runners-up, and ten judges' choice awards. Some are pretty, others just practical, but all offer creative solutions for workshop storage.



★ GRAND PRIZE ★ \$2,500 cash from Chevy Silverado

### Tag-along tool tote

Kevin Hall of Tremonton, Utah, drew inspiration from a rolling carry-on suitcase to create on-the-go storage for the tools and supplies he needs for household repairs and chores outside the shop. Just like the airline version, his features sturdy wheels and a retractable handle. The lid flips up and L-shape sides swing open wide to brace the tote and provide access to the tools and accessories inside. Custom holders keep everything in place while on the roll, and a removable tray holds screws and hardware.

We liked Kevin's idea so much that we'll bring you complete plans for our version in the next issue.



Open the tote wide for easy access to tools and accessories ...



... latch the lid and doors for secure transport ...



... and slide down the locking handle for compact storage.

★ **FIRST RUNNER-UP** ★  
\$1,500 cash from Chevy Silverado

**Flip-up platforms for benchtop tools**

Randy Kough's 12x16' shop in Deltona, Florida, quickly became cramped when outfitted with a full complement of benchtop tools. To save space, he made hinged platforms that hold the machines upside down and out of the way under the bench. When flipped up, a single leg mounted to a strap hinge supports each plywood platform. Sometimes simple is best, and that's why Randy's low-cost solution caught our judges' attention.

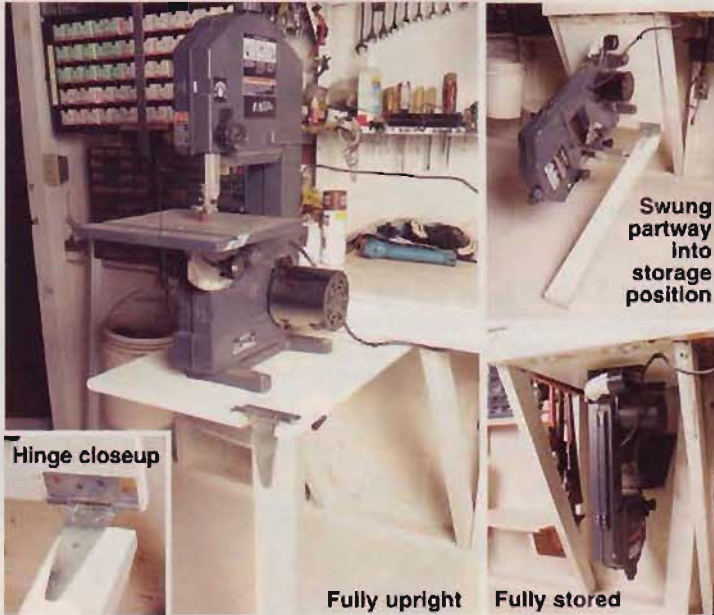

★ **SECOND RUNNER-UP** ★  
\$1,000 cash from Chevy Silverado

**Four-door clamshell corner cabinet**

Dick Carlson of Ridgefield, Washington, wanted to keep the dust off his shelves, so he added a door. Then his creativity kicked in, and he designed four doors. Each holds tools on hooks, and every door is narrower than the next. They're mounted to a stair-step-shape block so each opens to a full 90°. He categorized the tools on the doors, making them easy to find. Over 250 tools now reside in this cabinet that takes almost no shop space at all.

★ **JUDGES' CHOICE AWARDS** ★

We knew we couldn't narrow the field to just three winners, so our judges awarded prizes to the 10 next best. Each of these lucky woodworkers gets to find storage space for about \$500 worth of DeWalt tools.



DW735 thickness planer OR DW433KT belt sander + DW618B3 router kit

**Bench-side tool chest**

Jeff Bradford added loads of storage space alongside the bench in his Seabrook, Texas, shop. But he didn't stop there. Using carving and intarsia, he turned the chest into a thing of beauty. Made mostly of mahogany (solid and plywood), the chest sports a 1½" maple butcher-block top. Jeff even included a tote box that he can use to carry tools needed for jobs outside the shop.



Photograph: Terry Maloney

**Multi-task tool organizer**

Bob Reid got tired of chasing tools and accessories all over his Savage, Minnesota, workshop, so he corralled them in this cabinet. Drawers offer ample storage while cubbies accommodate portable power tools. Bob wheels the organizer to any of his tools needing its built-in stock support roller.



Photograph: Monica Chimbury

**No-spill screw box**

Larry Miller of Olympia, Washington, keeps his corded and cordless drills, bits, and an ample supply of screws in one portable box that measures less than 10x13x17". Made mostly from scrap wood, the box houses two trays that rise on aluminum arms. The top tray nests on the lower unit and features a hinged lid to prevent screw spills.



Photograph: Stan Patterson

*Continued on page 90*

### Right-height work table

Russell Zirngible of Owatonna, Minnesota, built his rolling "do-it-all table" to provide storage, an assembly surface, and outfeed support in one compact package.

The tops supports are marked with various heights for quick outfeed setup at various machines. Slide-out trays store tools behind hardboard doors, and electrical outlets put power close at hand.



Photograph: Mike Oldenburg

### Mobile tablesaw center

This heavy-duty saw station enables Daniel Rabinovitz of Murrysville, Pennsylvania, to wheel his tablesaw and accessories onto his gravel driveway, where he does most of his woodworking. The large pneumatic tires make it easy to roll while 15 storage drawers and compartments place needed tools within reach. Daniel even incorporated dust collection and a fold-away outfeed support into the design.



Photograph: K and G Enterprises

### Race-ready tool transport

Machinist Frank Buddell of Lansing, Illinois, created this racy looking toolbox for his son, Mike, to store his own machinists' tools at work. It has 21 drawers on heavy-duty slides, a bin underneath, and a butcher-block top. Go-kart suspension parts create the high-performance wheelset.



Photograph: Bill Swain

### Expandable workbench

Buddy Rosene of San Antonio combined a cast-off card file cabinet, a couple of pieces of old benchtop, and dining-table equalizer slides into a heavy-duty bench chock-full of functional storage. When he needs a bit more work space, Buddy simply adds one or two more leaves. The whole works rides on a mobile base.



Photograph: Michael Connolly

### Rolling tool tower

Marc Aronson of Chatsworth, California, fit a shopful of small items into a 2'-diameter, 54"-tall tower. Tools and supplies mount on all four outer sides while one side hinges open to reveal slide-out trays. On these, Marc stores bits, blades, tool cases, and more. The tower features a lazy Susan that locks onto the caster-equipped base.



Photograph: Scott Quintard

### Standing tool cabinet

John Boldt of San Antonio built this cabinet to house his hand tools plus some that belonged to his father and grandfather. He used ten different hardwoods to create the cabinet and the custom-fitted holders within. One surprise: This cabinet rolls on heavy-duty casters.



Photograph: Michael Connolly

### Traditional tool chest

Paul Ganther of Stephenville, Texas, designed and built this chest to hold a treasure trove of hand tools inherited from his grandfathers. The chest resembles ones that carpenters once used to house their tools and showcase their craft. Paul's features six removable boxes (known as tills) that hold smaller items, plus large-tool storage below. There's even a recessed compartment in the lid. All are covered with veneers and inlays.



Photograph: Andy Raab



# brush on a flawless varnish finish

**M**ost of us brush on oil-based varnish or polyurethane to beautify and protect our projects. (For the purposes of this article, we refer to oil-based varnish and oil-based polyurethane as varnish.) However, we also know the frustration of seeing dust nibs, brush marks, and runs in those finishes. Rather than accept these flaws as part of finishing with varnish, adopt the following tips. They'll pay off with a finish that feels smooth and looks terrific—guaranteed!



Seeking the key to silky-smooth results?  
Just follow these guidelines.

## 1 Before you begin ...

In most circumstances, varnish dries slowly, providing a wet, sticky gathering place for dust. When the weather turns cold, drying time really stretches out, so warm your finishing area to 70 degrees F prior to finishing.

Reduce the amount of dust in the air by making your finishing area as clean as possible. Work in a room that's separate from your workshop, if possible. Clean the floor with a wet mop, place paper under your project, and then clean the project with a shop vacuum and a store-bought tack rag or a cloth moistened with mineral spirits or naphtha. (Wear appropriate gloves when handling solvents, and ensure the space is well ventilated.)

Choose a high-quality brush with natural bristles and flagged (split) ends. Flagging increases the number of contact points, resulting in a smoother application. The bristle end of the brush should have a V shape when viewed from the side.

Make sure you can see exactly what you're doing. Place a light source nearby, at a low angle to the surface, as shown at *right*.

Build your finish with two or three coats of glossy varnish. For the final coat, apply a varnish with the desired sheen, whether satin or glossy. By following this procedure, you avoid the cloudiness produced by several layers of satin varnish.



It's easy to miss a spot or overlook a flaw as you brush on finish under typical workshop lighting. Correct the situation by placing a lamp or worklight to bounce light across the project toward you. Reflecting light illuminates glare from wet finish and highlights runs, dust nibs, and other boo-boos.

## 2 As you brush ...

To keep your finishing material as clean as possible, pour a small amount of varnish from the can into a jar that's wide enough for your brush. For the first coat, add an equal amount of mineral spirits (paint thinner). This mixture produces a thin coat that dries harder than unthinned varnish, making it easier to sand away the first-coat roughness without clogging the sandpaper.

The second and third coats can be slightly thinned or applied full strength.

However, when the temperature is 90 degrees or higher, fast drying becomes a problem. As a result, air bubbles solidify instead of popping, leaving bumps in the finish. Use a mix of 20 percent mineral spirits and 80 percent varnish for each coat to slow the drying and let the bubbles pop.

Now, brush on the varnish as shown in the sequence of photos *opposite, top*. After each coat dries, sand lightly with 320-grit sandpaper to remove nibs and level the

surface. If you don't see significant flaws, rub with 0000 steel wool to improve bonding of the next coat. (Substitute a synthetic pad if finishing with water-base.) Moisten a cloth with mineral spirits or naphtha and wipe the surface to remove the residue.

Apply three or more coats to a tabletop or any surface that will get lots of hard use. Other surfaces need only two coats, and intricately detailed areas look best with just two coats of a 50/50 mix.

### 3 secrets to beautifully brushed varnish



On a tabletop or other flat horizontal surface, brush varnish from one end to the other in overlapping strips. Begin each strip about 3" from one end, as shown above, and brush to that end. Then return to the starting point and brush to the opposite end.



Eliminate ridges and bubbles by tipping off. First, press the bristles against the jar edge, or squeeze them with a paper towel to remove most of the varnish. Then hold the brush straight up and draw the bristle tips lightly over the wet surface with the grain.

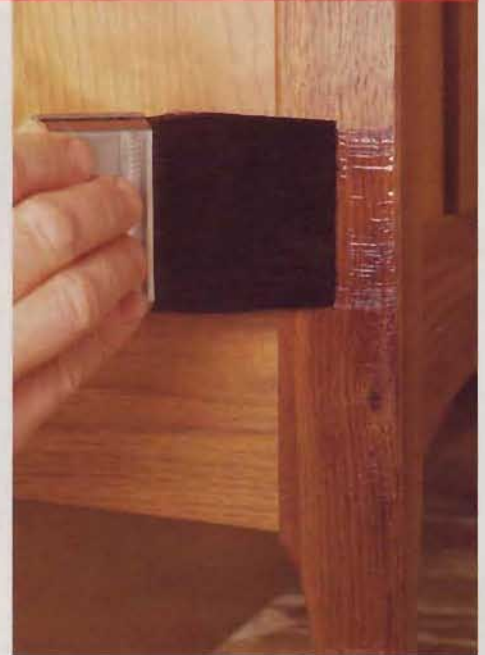

If you can't reposition a vertical surface to lie flat, use cross-brushing to minimize runs. Load less varnish into the brush, start at the bottom and work up, brushing horizontally toward each edge from the middle. Tip off with vertical strokes from bottom to top.

## 3 After the finish cures . . .

For a professional-quality finish, take another step after applying the final coat of varnish. Allow the varnish to cure in normal conditions for at least two weeks, and then rub it out as demonstrated in the sequence of photos below.

Rubbing eliminates any remaining flaws, creates an even sheen, and makes it possible to adjust the sheen of either satin or glossy varnish from flat to satin to somewhat glossy—it's difficult to rub most varnish finishes to a high gloss.

Do a thorough job of rubbing on tabletops and other flat horizontal surfaces that are highly visible and often touched. The other areas of your project, such as legs, require only careful sanding or modest rubbing with 0000 steel wool. ♣

### 3 steps to a professional-looking rubbed finish



After the final coat cures, sand again as you did between coats, using 320-grit steared sandpaper alone or 320-grit wet/dry sandpaper plus mineral spirits as a lubricant. Sand just enough to level the imperfections and wipe off the residue with a cloth.



After sanding, use 0000 steel wool to create a soft satin sheen. Press a thick piece of steel wool flat with your hand and rub firmly in long, straight strokes with the grain. Wipe off the residue on the workpiece with a cloth dampened with mineral spirits or naphtha.



For a higher sheen, rub in a fine rubbing compound, such as those found at an auto-supply store. The lamb's wool applicator shown here lets you use two hands and apply even pressure. Pick one up at a home center or hardware store.

# music in the air wind chimes

**P**leasing to the eye and soothing to the ear, this project assembles so easily, you'll want to build one for yourself and several more as gifts. We provide a source for the chime kit, and even show how you can make your own dowels.

## Form the body

**1** For the body (A), cut a 7½"-long piece of 1"-diameter dowel of a weather-resistant species, such as cedar, cypress (shown), mahogany, redwood, walnut, or white oak. (Can't find dowels in these species? Check out the sidebar, *opposite*.) Drill a centered ⅝" hole ⅜" deep in each end of the dowel.

**2** Make a V-block at least 7½" long out of ¾"-thick material, and draw a template alignment line along the length of the dowel, as shown in the photo, *right*. Then make a copy of the hole drilling template in the *WOOD Patterns*® insert, and cut it along the lines. Now apply spray adhesive to the template and spiral it around the dowel, where shown on *Drawing 1*.

**3** Chuck a ⅜" Forstner or brad-point bit in your drill press, and adjust the fence to center the V-block underneath the bit. Place the dowel in the block, and drill ½"-deep holes at each of the nine template locations.

**4** Install a 90° V-groove bit in your table-mounted router, and adjust the fence ½" away from its center. Clamp a stopblock to the fence, where shown on *Drawing 2*, and chamfer both ends of the dowel. Then move the stopblock, and rout V-grooves, where dimensioned. Finish-sand the dowel.

## Add the arms and finish

**1** Cut nine pieces of ⅜" dowel 3" long of the same species as the body (A) for the arms (B). (To make the ⅜" dowel, see the sidebar, *opposite*.) Using the V-block to center the arms under the bit, drill a ⅛" hole located ¾" from the end in four arms, and ¼" from the end in five arms, where shown on *Drawing 3*.

**Note:** For a very hard wood, such as white oak, drill ⅝" holes.

**2** Sand ⅛" chamfers on one end of each dowel, and then finish-sand them. Glue the arms in the holes in the body. Make sure the dowels with the ⅛" holes located ¾" from the end go in the upper four holes, and

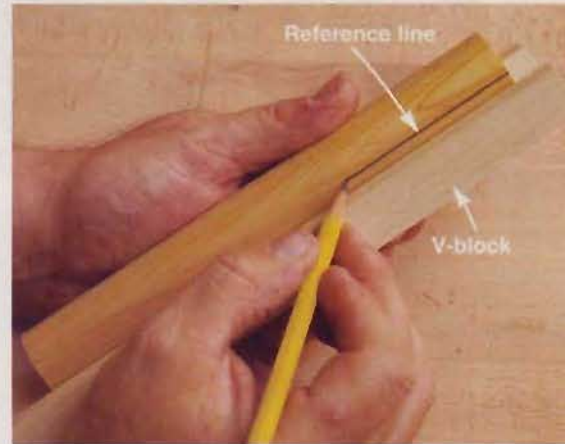

Holding the dowel in a V-block, guide your pencil along its edge to draw a template reference line on the dowel.

those with ⅛" holes located ¼" from the end go in the lower five holes.

**3** With the glue dry, install ⅝" screw eyes, where shown on *Drawing 3*. Then apply several coats of an exterior oil finish. (We chose Watco Exterior Wood Finish.)

## String up the chimes

**1** Hang the body assembly at a convenient working height. Starting with the longest chime and the topmost arm (B), thread the end of the stainless-steel cable (included with the chime kit) down through the hole in the arm, through the chime, and then back up through the arm. Adjust the cable loop to position the top of the chime 1½" below the bottom of the body. Press a #18×⅜" brass escutcheon pin into the hole, wedging the cable in place. Stop when the head protrudes about ⅛", and twist the cable around it twice. Press the pin in flush, and trim the cable. Repeat with the other eight chimes, hanging them in order of decreasing length.

**2** Slide the windbattler grommet over the cable attached to the wind catcher, where shown on *Drawing 4*, resting it on the small ferrule already crimped in place. Add the clapper. Then thread the cable through a large ferrule, through the lower screw eye, and then back through the ferrule. Adjust the length of the cable so the clapper hangs about 6" below the body (A), and crimp the ferrule with pliers. Hang the chimes, and relax to their soothing melody. ♣

## 1 TEMPLATE PLACEMENT

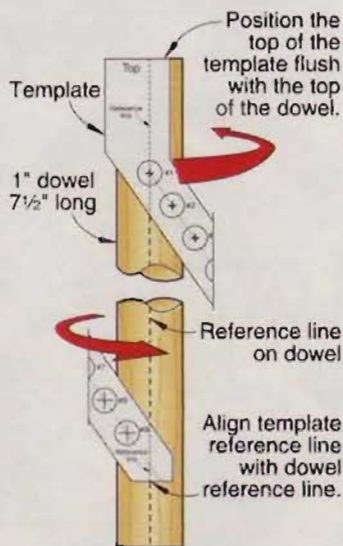

## 2 CHAMFERING THE BODY

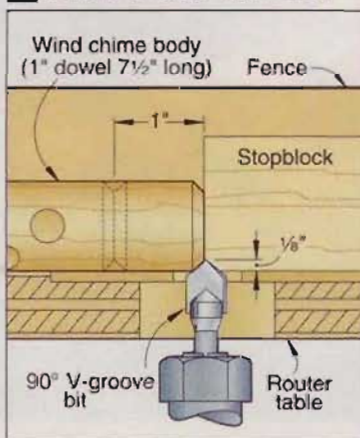

Written by **Jan Svec**  
Project design: **Jeff Mertz**  
Illustrations: **Roxanne LeMoine**

## 3 EXPLODED VIEW

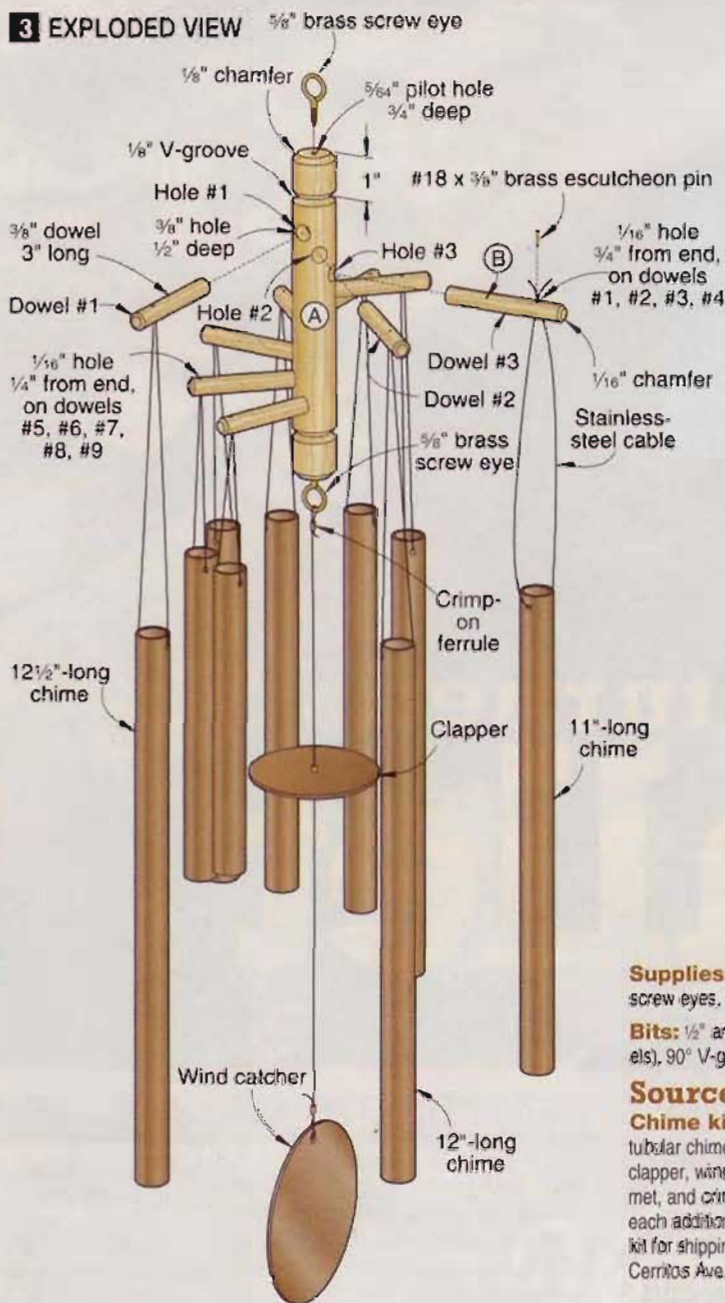

## 4 ASSEMBLY DETAIL

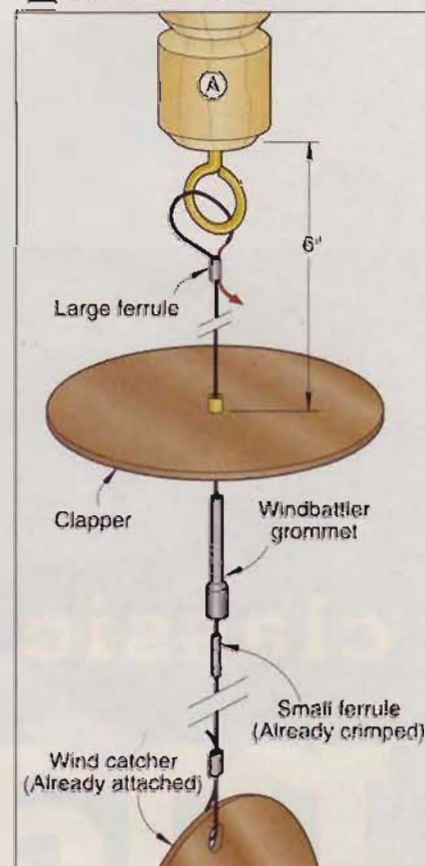

**Supplies:** 1" dowel, 3/8" dowel, spray adhesive, 5/8" brass screw eyes, #18x3/8" brass escutcheon pins.

**Bits:** ½" and 3/16" round-over router bits (for matching stop-blocks), 90° V-groove router bit, 1/16" Forstner or brad-point bit.

### Source

**Chime kit.** Set of nine 3/4"-diam powder-coated tubular chimes, 1/4' of three-strand stainless steel cable, clapper, wind catcher with attached cable, windbattler grommet, and crimp-on ferrule. Kit no. KWT, \$25. Add \$20 for each additional kit. Shipping via UPS included, add \$5 per kit for shipping via USPS. Jacobs Musical Chimes, 378.2 Cerritos Ave., Los Alamitos, CA 90720. Call 800/627-5840.

## Make your own dowels on a router table

Often when building a project, you'll need just a few short lengths of dowel, or a dowel of a species that isn't commercially available. The first case hardly justifies a special trip to the hardware store, and the second leaves you high and dry. Don't worry. With wood scraps, round-over bits, and a table-mounted router, you can make your own. Here's how.

Cut stock 3" longer than the dowel length needed, plus 6" for a test piece. (If the length-plus-3" dimension is more than one-half the length of your router-table fence, clamp on a longer auxiliary fence.) Joint and plane the stock into a square the same dimension as the diameter of the dowel needed. Cut off the 6" test piece.

Install in the router a round-over bit whose radius is one-half the diameter of the intended dowel. (For the 1" and 3/8" dowels needed in this project, use ½" and 3/16" round-over bits.) Position the bit with the pilot bearing flush with the fence and the bottom of the radius flush with the table. Rout 1" in on each edge of the test piece, and check its fit in a hole of the desired diameter drilled in scrap. Adjust your setup as needed.

Stick masking tape on the table, and draw a start line 1" to the left and a stop line 1" to the right of the bit center. Now with the left end of the stock at the start line, and the right end against the fence, use a pushstick to plunge the stock into the router bit, as shown at right. Feed the

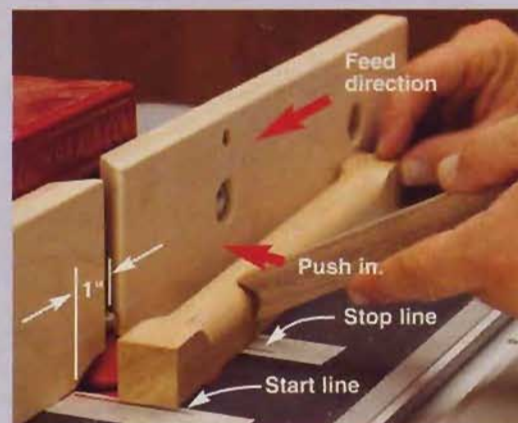

stock past the bit until the trailing end reaches the stop line. Then pivot the trailing end away from the bit. Repeat on the other three edges. Cut the dowel to length, trimming both ends.

WOOD MAGAZINE  
COLLECTOR'S  
SERIES  
HAND TOOLS

# classic turned mallet

After a simple glue-up and a quick turn between centers, you'll have one strikingly beautiful tool in no time. And with its supple ash handle and super-dense morado (Bolivian rosewood) head, you can expect a lifetime of service.

## 1 Build the blank

Joint and plane a 2×2×12" ash turning square to 1½×1½". Then joint one edge of a 3×30" piece of 5/4 dense hardwood. (We used morado.) Plane this piece to 7/8" thick, rip it to 2½" wide, and cut it into four 7" lengths. Glue and clamp the four pieces to the ash, in the configuration shown at right.

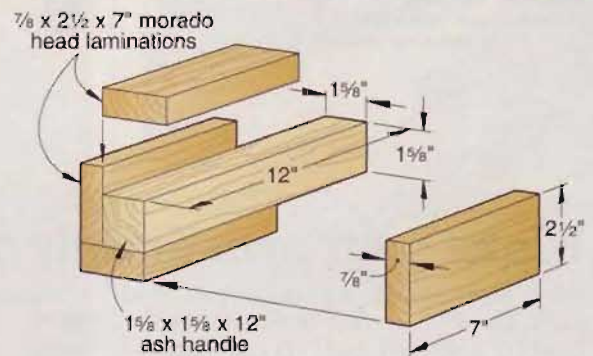

## How to glue resinous woods

Gluing resinous woods, such as bubinga, cocobolo, teak, and the morado used for the mallet head, poses a dilemma. Due to their oily surfaces should you use regular woodworking glue or epoxy?

As it turns out, both suit the need. Although epoxy is foolproof and fills gaps, it's messy and more expensive. We chose Tightbond II for our mallet. With the glue surfaces of the four morado blocks jointed and planed, we wiped them with a clean rag and lacquer thinner. Then we immediately sanded their surfaces with 80-grit sandpaper, taking care not to round the edges, and glued and clamped the assembly, as shown, *above right*. After letting the glue dry overnight, we turned the mallet. We subjected it to five days of smacking chisels while cutting dovetails, mortises, and other joints at a woodworking class, followed by six months of routine shop use. The glue joints show no sign of failing.

See more  
WOOD magazine  
collector's series  
hand tools at  
[woodmagazine.com/handtools](http://woodmagazine.com/handtools)

## 2 Create the template

Make a copy of the mallet full-size template pattern on the *WOOD Patterns* insert. Adhere the pattern to a piece of 1/8" hardboard with spray adhesive. Then bandsaw or scrollsaw and sand the template to shape.

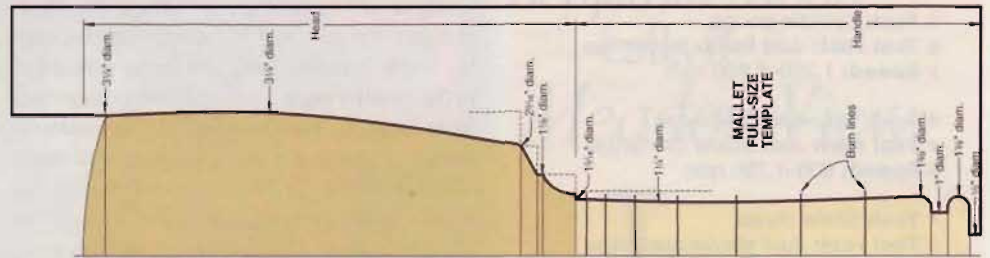

## 3 True the head and make gauging cuts

- **Tool:** Roughing gouge
- **Tool rest:** At centerline
- **Speed:** 600–800 rpm

- **Tool:** Parting tool
- **Tool rest:** At centerline
- **Speed:** 800–1,200 rpm

Find the centers by drawing diagonals on both ends of the blank, and mount it between centers on your lathe. Use a 3/4"

roughing gouge to turn the mallet head to a 3 3/8"-diameter cylinder.

Lay the template on the mallet head with the top of the template even with the top of the blank. Mark the locations of the head critical diameters. (The 1 5/16"-diameter gauging cut marks the bottom of the head, even though some morado will remain to the right of this mark.) Using a parting tool and outside calipers, make gauging cuts to

the diameters indicated on the template, as shown *below*. Do not make a gauging cut on the mallet head to the left of the 3 3/4" diameter shown on the template and the drawing, *below left*.

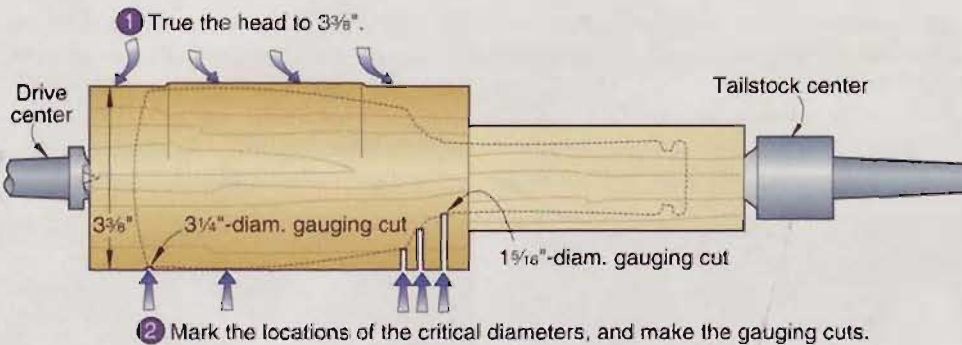

## 4 True the handle and make gauging cuts

- **Tool:** Roughing gouge
- **Tool rest:** At centerline
- **Speed:** 600–800 rpm

- **Tool:** Parting tool
- **Tool rest:** At centerline
- **Speed:** 800–1,200 rpm

Use a 3/4" roughing gouge to turn the handle to a 1 1/2"-diameter cylinder, working as

close as possible to the morado portion of the blank. Remove the morado to the right of the 1 5/16"-diameter gauging cut with a parting tool, extending the 1 1/2" diameter of the handle to the bottom of the cove. Form the stairstep shoulders at the bottom of the head, where shown on the template and as shown *at right*. Align the template and mark the handle critical diameters. Make gauging cuts with a parting tool.

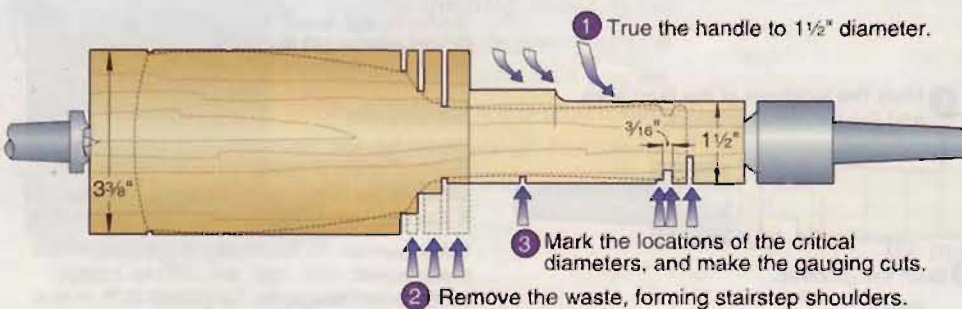

## 5 Form the profiles

- **Tool:** Spindle gouge
- **Tool rest:** Just below centerline
- **Speed:** 1,200–1,600 rpm
- **Tool:** Roundnose scraper
- **Tool rest:** Just below centerline
- **Speed:** 800–1,200 rpm
- **Tool:** Skew chisel
- **Tool rest:** Just above centerline
- **Speed:** 800–1,200 rpm

Using a  $\frac{3}{8}$ " spindle gouge, shape the head and then the handle. On each part of the mallet, work downhill from the larger diameters to the smaller ones. At the stairstep transition from head to handle, use a  $\frac{1}{2}$ " roundnose scraper to form the cove, as shown at *right*. Make light cuts to avoid tear-out. Widen the  $\frac{1}{2}$ "-diameter gauging cut at the end of the handle for more working room, and use a  $\frac{3}{4}$ " skew chisel to form the bead.

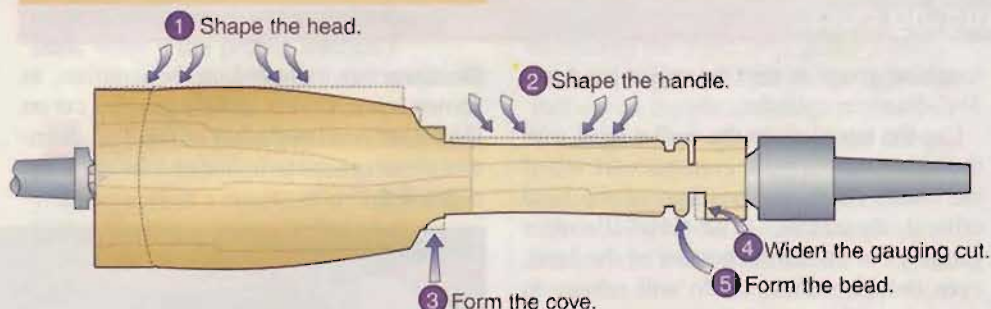

## 6 Sand, burn, and finish

- **Tool:** Skew chisel
- **Tool rest:** Just above centerline
- **Speed:** 800–1,200 rpm
- **Tool:** Parting tool
- **Tool rest:** At centerline
- **Speed:** 800–1,200 rpm
- **Tool:** Spindle gouge
- **Tool rest:** Just below centerline
- **Speed:** 1,200–1,600 rpm

*hold the ends between your thumb and forefinger. Do not wrap the wire around your fingers or hand.*

Remove the waste at the top of the mallet with a parting tool, leaving a  $\frac{1}{2}$ "-diameter tenon connecting it to the spur center. Form

the domed top of the mallet with a  $\frac{3}{8}$ " spindle gouge. Remove the mallet from your lathe, and trim away the waste with a fine-tooth handsaw. Finish-sand the ends with a random-orbit sander, and apply several coats of an oil finish. ♣

Sand the finished portions of the mallet, progressing from 120-grit to 400-grit sandpaper. Using your template, mark the locations of the burn lines on the handle with a pencil. Cut  $\frac{1}{32}$ "-deep grooves at each mark with the point of a  $\frac{3}{4}$ " skew chisel, as shown at *near right*. Now, with the lathe running, hold a piece of 22-gauge wire or a .026" wire burner in each groove until it is singed black, as shown at *far right*. (For wire burners with wood ball handles like the one shown in the photo, see **Sources**.) Sand over the grooves with 400-grit sandpaper.

**Caution:** When using ordinary wire to burn the grooves, cut a piece about 8" long and

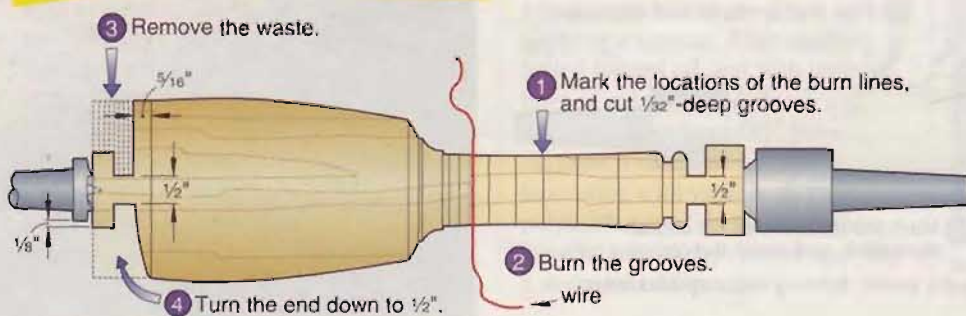

Written by **Jan Svec**  
Project design: **Jeff Mertz**  
Illustrations: **Roxanne LeMoine**

### Sources

**Wood kit.** One  $1\frac{1}{2} \times 1\frac{1}{2} \times 12$ " piece of ash and four  $\frac{7}{8} \times 2\frac{1}{2} \times 7$ " pieces of morado. Kit no. W-156, \$22.95 ppd. or five kits for \$89.95 ppd. Heritage Building Specialties, 205 N. Cascade, Fergus Falls, MN 56537. Call 800/524-4184.

**Wire burner.** KC Spindle Wire Burners (set of three 6"-long burners, .016", .026", and .039") no. 115302, \$9.95. Packard Woodworks. Call 800/683-8876, or go to [www.packardwoodworks.com](http://www.packardwoodworks.com).

# 5 things you need to know about hollow mortise chisels

**N**o matter how much you spend on a hollow-chisel mortiser—whether it's a benchtop model like those on page 78, a low-dough drill-press-mounted device, or a monstrous stationary mortising machine—you'll get the best results with the right hollow mortise chisel, properly installed and used.

A hollow mortise chisel consists of an auger bit nested inside a four-sided chisel. As you plunge this drilling duo into your workpiece, the auger removes most of the waste while the chisel pares away the corners and squares up the hole, pushing the waste into the auger, where it is ejected. After years of experience working with them in the *WOOD*® magazine shop, here's what we've learned about getting the most from these square-hole cutters.

**1 Sharpen the chisel before you start; then keep it sharp.** Fortunately, a couple of special accessories, shown in the photo at right, make sharpening the concave bevel inside the chisel opening virtually foolproof. Lee Valley Tools (800/871-8158, leevalley.com) sells a pair of diamond grinding stones (\$7, part no. 77J81.20) for sharpening most makes of hollow chisels. After removing the auger bit, chuck the 51° cone into your cordless drill and turn it slowly into the end of the chisel; switch to the 50° cone, and repeat to make a microbevel. This process creates a slight burr on the outside of the chisel, which we removed by lapping all four sides with 800-grit sandpaper adhered to glass. (As a bonus, this final step makes the chisel easier to pull out of the wood.)

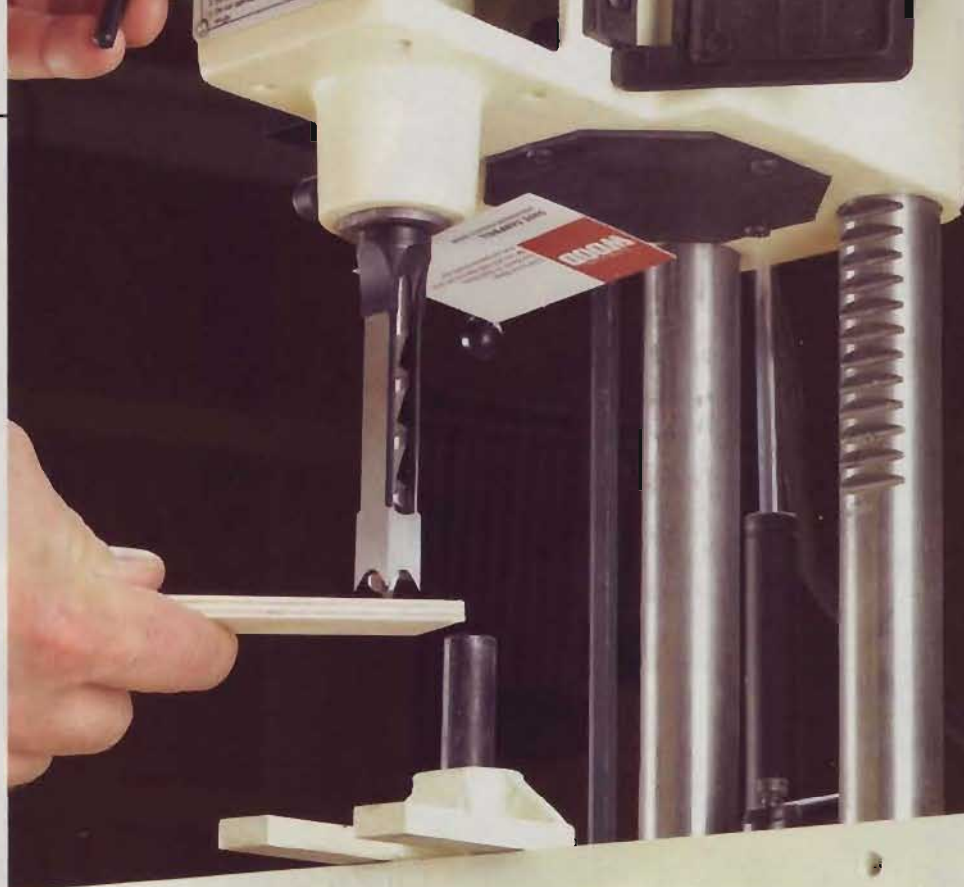

A business card between the chisel and mortiser head establishes the proper bit clearance during installation. The wood scrap protects your fingers from the chisel's sharp points.

English-made Clico hollow mortise chisels are ground to a different angle, so you'll need that company's sharpener for those. The replaceable bushing on the end of the Clico sharpener guides it into the chisel. Garrett Wade (800/221-2942, garrettwade.com) sells both the chisels (\$66–\$70 each) and the sharpener (\$89).

**2 Give the bit a tiny head start.** The height relationship between the auger and chisel is crucial to the set's performance. If the auger leads the chisel too much, it can stray, prematurely wearing the bit and—in extreme cases—causing the bit to break; if the bit leads too little, the chisel cuts before the bit, requiring more force to plunge into the mortise. Mortiser manufacturers recommend anywhere from 1/16" to 3/16" clearance between the bit and chisel. But in our experience, the less clearance the better, so long as the bit doesn't rub on the chisel in which it's seated.

Here's how we set up our hollow mortise chisels for minimal clearance: Mount the chisel, sandwiching a business card between it and the head of the mortiser, as shown in the photo above. Now chuck the auger bit into the mortiser, holding it snug against the bottom of the chisel. With the auger secured, loosen the chisel, remove the business card, then seat the chisel against the head and tighten it.

**3 Your bits need time to chill.** Heat is the enemy of any high-speed steel cutter, such as these auger bits, because overheated bits don't hold a cutting edge well. If you have a lot of mortises to cut, go grab a cup of coffee every third or fourth mortise, and

*Continued on page 102*

## IF YOU'RE GONNA OWN 'EM, HONE 'EM

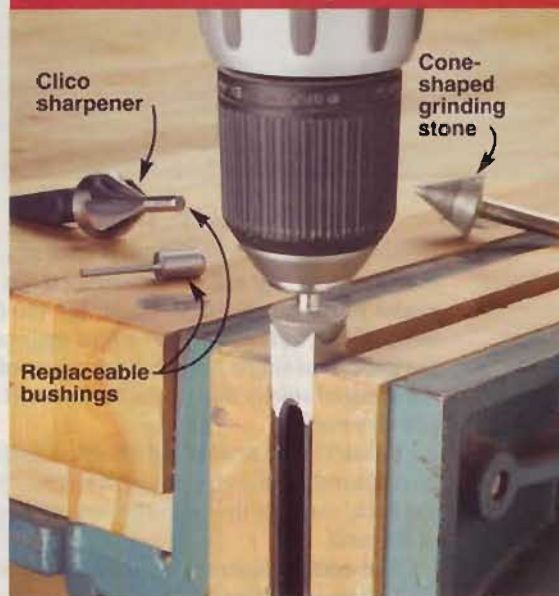

Cone-shaped grinding wheels put a sharp edge on the business end of a hollow mortise chisel held in a vise. The fluted Clico sharpener (at left in photo) works only on that brand of chisels.



# Router Bits and Shaper Cutters

# WOODLINE USA

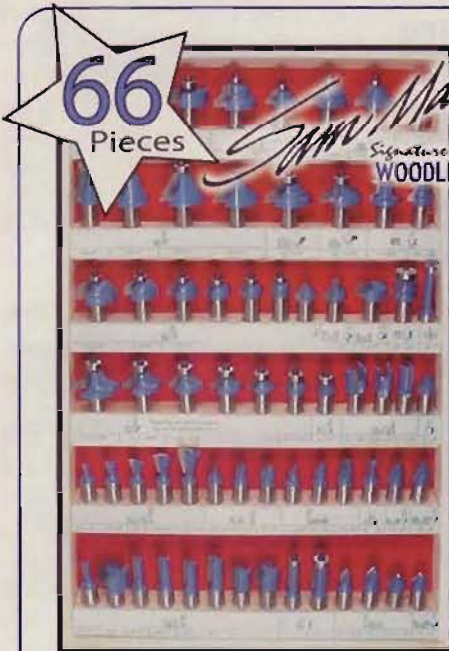

66 Pieces

*Signature Series by*  
WOODLINE USA

## Master Craftsman Woodworking Collection

Only \$189 set

Includes Deluxe Wall-Mountable Wooden Case

- |                              |                             |
|------------------------------|-----------------------------|
| 8 Straight Bits              | 1 Double Roman Ogee W/ Cove |
| 5 Dovetail Bits              | 1 Plunging Roundover        |
| 3 Core Box Bits              | 1 Stepped Cove              |
| 3 Roundnose Bits             | 2 Edge Beading Bits         |
| 2 Flush Trim Bits            | 1 Multibeading Bit          |
| 3 Mortising Bits             | 1 Bowl & Tray Bit           |
| 1 Plunging Panel Bit         | 1 Key Hole Bit              |
| 1 Laminate Trim Bit          | 1 Double Roman Ogee         |
| 1 Bevel Bit                  | 1 Classic Double Roundover  |
| 3 90° V-Groove Bits          | 1 Flat Bottom 60° V-Groove  |
| 2 Roman Ogee Bits            | 1 Standard 60° V-Groove     |
| 6 Roundover Bits             | 3 Rabbeting / Slot Cutters  |
| 1 Point Cutting Roundover    | 4 Chamfer Bits              |
| 1 Ogee With Fillet           | 6 Cove Bits                 |
| 1 Plunging Roundover W/ Bead |                             |

WL 2066 For 1/2" Shank

WL 2065 For 1/4" Shank

## blades and bits

allow the bit to cool in between. While the bit is still warm (but not hot), dip the end in paraffin wax, which will travel up the flutes with your next cut and aid with ejection of the waste chips.

**4** Take full cuts at both ends and partial cuts in between. Bore the ends of your mortise first, and then make a series of barely overlapping cuts in between to clear the remaining material, as shown in the Mortise Boring Sequence drawing, below. Removing much less than a full bite can increase side-to-side deflection and the likelihood of auger-bit breakage, especially in 1/4" chisels, so take as much waste as you can with each cut.

### MORTISE BORING SEQUENCE



These holes slightly overlap Mortise location

We find this slight-overlap method about 50 percent faster than the common practice of taking a series of nonoverlapping cuts, and then boring out the material in between. The latter method does, however, result in virtually zero side-to-side deflection, and we'll sometimes use it for 1/4" mortises. Regardless of which method you use, when the main cutting is complete, go back and clean up the mortise with a closely spaced series of full-depth cuts.

**5** Put your money where it makes the most sense. Not surprisingly, we've found that premium-priced hollow mortise chisels perform better than lower-cost ones. But, at about \$70 per chisel, you can quickly spend more on chisels than you spend for the mortising machine itself. Pay the premium if you'll make a lot of one size of mortise, or if you routinely cut 1/4" mortises. Machining mortises puts a lot of stress on smaller bits, and the less-expensive bits break more easily. (We've even seen a 1/4" auger bit unravel in the middle of a cut.)

If you make mortises only occasionally, buy an inexpensive 3/8" hollow mortise chisel for \$9-\$30. It should serve you well if you're careful to keep it sharp and not overheat the bit. Buying hollow mortise chisels in a small set further lowers your per-chisel cost. ♣

## ANNOUNCING

Your Favorite Source For Router Bits And Shaper Cutters Has Teamed Up With Americas Favorite Master Craftsman To Bring You...

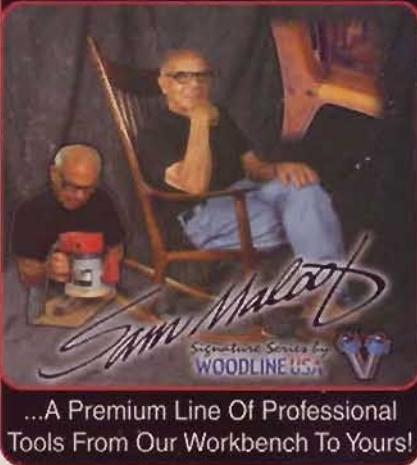

...A Premium Line Of Professional Tools From Our Workbench To Yours!

WL-2008 \$189 VALUE  
OUR PRICE  
ONLY \$75 set

**8 Pcs** Perfect for making great looking picture frames. Bits can be combined to form complex mouldings or decorative frames.

**PICTURE FRAME SET**

**MOULDING SET**  
5 Incredible Profiles  
OUR PRICE ONLY \$99 set  
1/2" Shank Router Bits WL-2011 \$175 VALUE

**3 Piece CABINET DOOR SET**  
1/2" Shank Router Bits  
2-pc Roman Ogee Rail & Stile  
3 1/4" Panel Raiser  
WL-2019-1 \$129 VALUE  
OUR PRICE ONLY \$69 set Other Profiles Available

**MOUNTED LASER CUTTING GUIDE**  
Quality made. Precision cutting accuracy. Economical battery operated. (included) Versatile, easily mounts to your chop saw, compound miter saw, radial arm saw, or drill press.  
Quality • Precise • Economical • Versatile

**6 Piece CABINET DOOR SET**  
1/2" Shank Router Bits  
• 2-pc Rail & Stile (Roman Ogee) • Drawer Lock  
• 3 1/4" D Panel Raiser (Ogee) • Door Lip • Glue Joint  
WL-2020-1 \$175 VALUE  
OUR PRICE ONLY \$119 set

# WOODLINE USA

GREAT ROUTER BITS AND SHAPER CUTTERS  
BEST SELECTION / BEST PRICE!

ORDER TOLL FREE 1-800-472-6950

WOODLINE USA • 111 WHEELER ST • LA VERGNE, TN 37086

Visit us at our Web site: **WOODBITS.COM**  
E-mail: woodline@woodbits.com

**PREMIUM CARBIDE**  
• Euro Anti-Kickback Design  
• Super-Slick Non-Stick Finish  
• Super Low Prices  
**QUALITY Guaranteed**

• INDIVIDUAL BITS ALSO AVAILABLE • ALL MAJOR CREDIT CARDS • SAME DAY SHIPPING •

# shop tips

Helping you work faster, smarter, and safer

## Convert spiderweb place to storage space

I discovered a simple way to make use of the space underneath my workbench top and behind the skirt without re-engineering the base for drawer boxes. To use the space, I built drop-down storage compartments, as shown at *right*, to hold small tools and to organize my fasteners.

The hinges attached between the back apron and the plywood base allow the compartments to drop down. Chains, secured to the benchtop and the box sides with screw eyes, limit the depth of the drop. A locking hasp firmly secures the storage units out of the way.

—Dan Opper,  
Lawrence, Kan.

### top shop tip

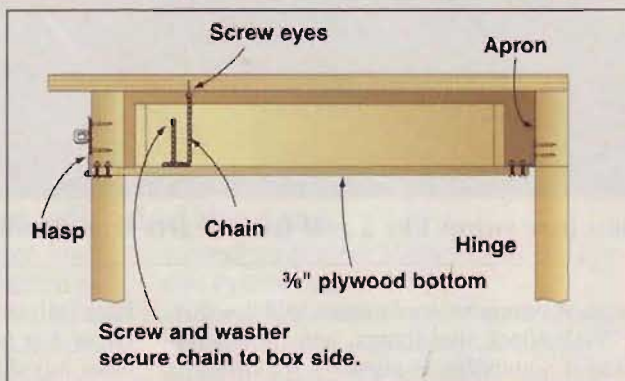

## How to ground flying reindeer

I made several of *WOOD*® magazine's reindeer lawn ornaments but had trouble with them trying to take flight and join Santa's sleigh whenever a strong wind blew. To put a stop to their aerial ambitions, I anchored 5' lengths of 3/4" rigid electrical conduit to their hooves.

For each outdoor ornament, buy one 10' length of conduit and cut it in half. (Spray-paint the pipe if you want it to blend into the surface it's sitting on.) Next, drill small holes through your reindeer's hooves and secure the conduit with plastic cable ties or wire. These pipes will keep your reindeer firmly grounded in even the strongest winds and the method is much easier than driving stakes into frozen ground.

—Richard Hedges, Woodstock, Ill.

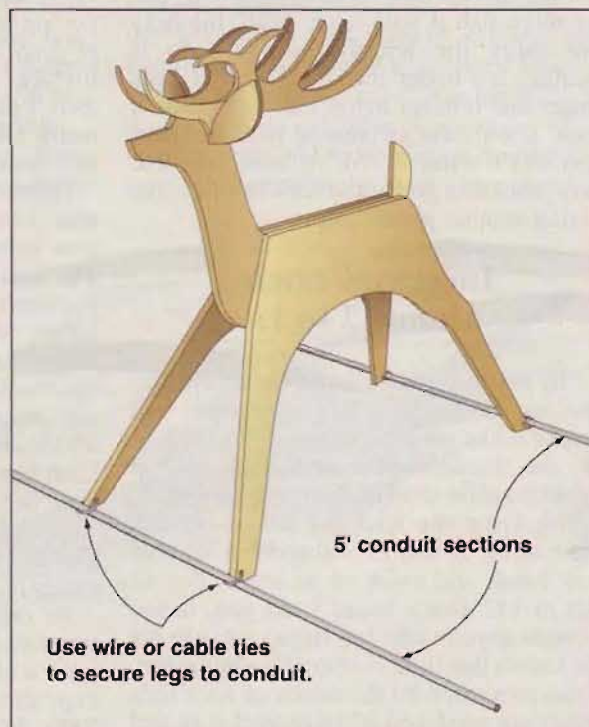

Continued on page 106

## Our Winner



Like most of us—regardless of the size of our shops—Dan Opper wanted to squeeze every bit of storage from his space. “One day, I was looking at my bench,” says the retired telephone engineer, “and I thought, there’s wasted space under this benchtop. What can I do with it?” After a little pondering, Dan came up with the idea at *left*, and we think it’s a dandy. We named it our Top Shop Tip for this issue.



Dan will have to clear more room in his shop for the Makita LS1220 12" mitersaw we're sending his way.

## Top tips win tools!

Describe how you've solved a workshop dilemma, and you'll get \$75 if it appears here. And, if your tip earns Top Shop Tip honors, you'll also win a tool prize worth at least \$250.

Send your best tips, along with photos or illustrations and your daytime telephone number, to: **Shop Tips, WOOD Magazine, 1716 Locust St., GA-310, Des Moines, IA 50309-3023.** Or e-mail tips to: [shoptips@woodmagazine.com](mailto:shoptips@woodmagazine.com). Remember to include your contact info in the e-mail as well.

Because we try to publish only original tips, please send your tips only to *WOOD* magazine. Sorry, but submitted materials can't be returned.

## Contain the shower of lathe shavings with a curtain

Turning wood in my small shop presented me with a few problems. I was forever wiping wood shavings off my shelves, nearby bench tools, and out of nail bins. Also, because I turn green or semi-green wood, my other tools ended up getting a rust-making shower from the wet shavings.

My solution was to hang shower curtains from the ceiling joists and around the lathe. I screwed J-hooks into the bottom of the ceiling joists to hold the curtain rods and to make it easy to take down my little tent. The curtains contain the water spatter and force the shavings to drop to the floor, making cleanup easier and protecting my other tools.

—Kip Stratton, Otego, N.Y.

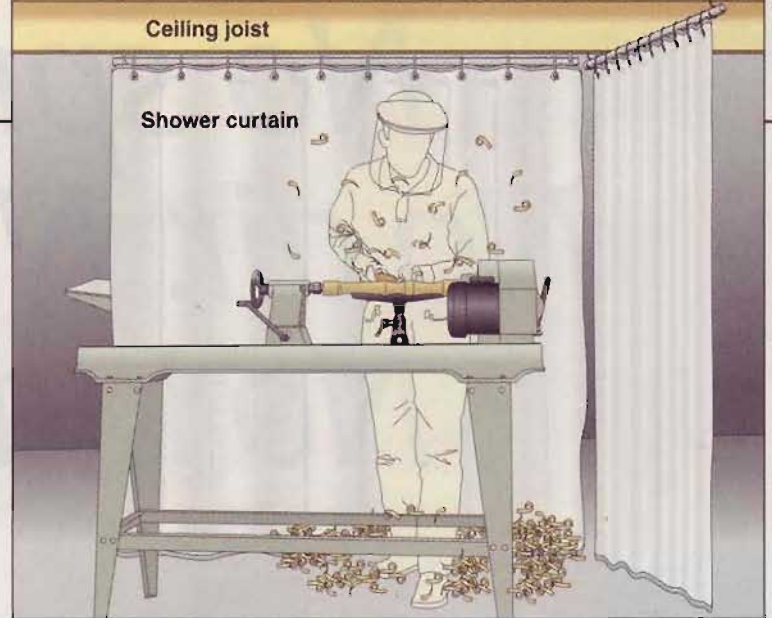

## Effective router dust collector for just pennies

Although most of my tools have good dust collection, capturing debris from a router while making edge cuts was a big problem. To make my router dust-free, I created a dust-collection hose adapter using hose clamps and two 10" aluminum ring-shank gutter spikes.

First, I slightly bent the spikes about 3" from the end. Then I inserted them in the edge-guide holes of the router base, secured them with screws, and used the hose clamps to strap on a 4" flexible hose that connects to my dust collector. With the hose end positioned about 1" from the router bit, this setup grabs almost all the dust generated.

—Roger Schoenhals, Lake Orion, Mich.

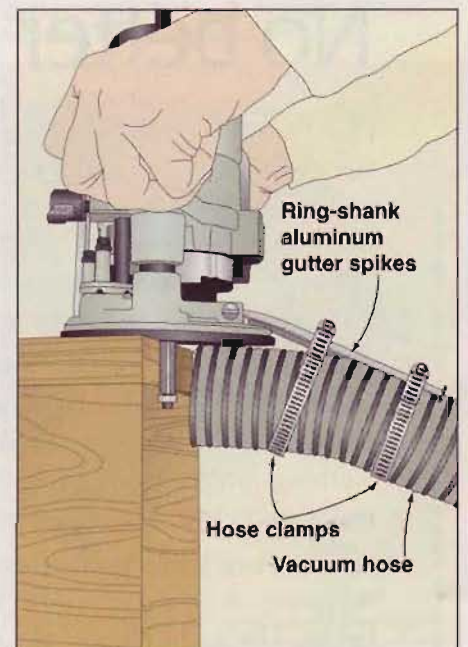

## DRIVES 4 SIZES OF NAILS WITH NO EFFORT

■ Comfortable Ergonomic Styling with Cushioned Non-Slip Grip.

■ Trigger and Surface Safety Locks.

■ Non-Marring Bumper.

DRIVES 4 DIFFERENT SIZE BRAD NAILS UP TO 1 1/4" LONG

14 AMP'S

■ New Heavy Duty Nail Driving Power with Built-in 10' Cord.



Available at home centers, lumber yards and hardware stores, wherever fine tools are sold.



Arrow Fastener Co., Inc., 271 Mayhill Street, Saddle Brook, New Jersey 07663  
 Canada: Jardel Distributors, Inc., 6505 Metropolitan Blvd. East, Montreal, Quebec H1P 1X9  
 United Kingdom: Arrow Fastener (U.K.) Ltd., Unit 5 ZK Park, 23 Commerce Way, Croydon CR0 4ZS, Surrey  
 www.arrowfastener.com Rev.1002

## It takes a thick skin to hide your boo-boos

While building oak kitchen-cabinet doors, I jiggered up my drill press to bore the 35mm hinge holes in the door stiles and started drilling away. After the second door, I suddenly realized that it matched the first door a little too well—I'd just drilled them as if they were two left doors, instead of left and right! With no extra parts, and no way to plug the holes and have the doors look right, I racked my brain until I came up with this solution.

First, from a piece of oak the same dimensions as the botched stile, I resawed a slightly over-thick patch and sanded it to exactly  $\frac{1}{8}$ "-thick using my drum sander. Next, I set up my tablesaw to cut  $\frac{1}{8}$ " deep, positioned the fence to cut along the rail-and-stile joint line, and made the cut. Finally, I reset the blade height to the width of the stile, and moved the fence to take  $\frac{1}{8}$ " off the back of the stile, and again, made the cut, this time with the door on edge and a tall auxiliary face mounted to my fence. These steps resulted in a  $\frac{1}{8}$ "-

deep rabbet in the back of the door as wide as the stile—a perfect match for the patch I made earlier.

After gluing the patch into place, I ran the door through the drum sander again to clean up the joint. With the misplaced holes now well-hidden, I again bored the hinge holes—this time in the correct side of the door!

—Ray Wallon, via e-mail

### CREATING A PLACE FOR THE PATCH

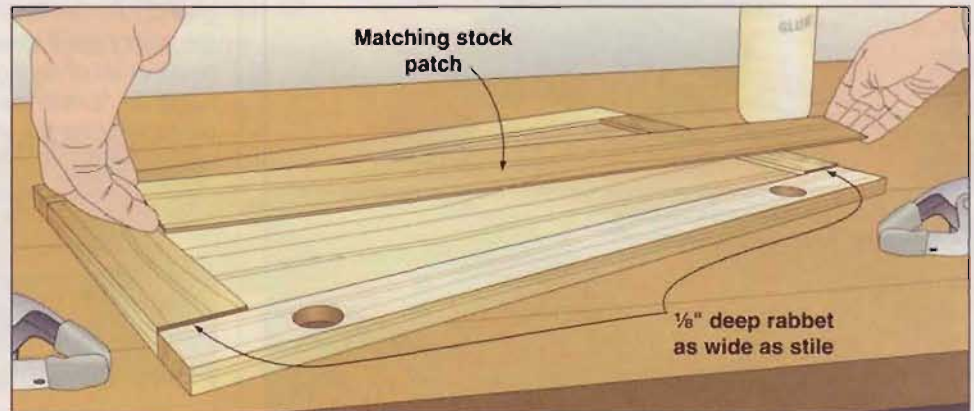
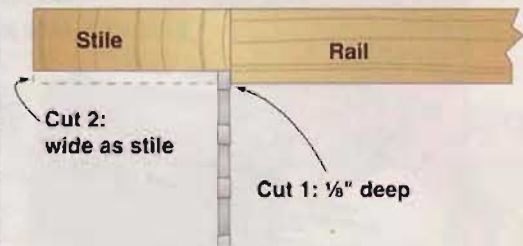

Continued on page 108

107

woodmagazine.com

# LAGUNA TOOLS

www.lagunatools.com

**Call for FREE Video!**  
**1.800.234.1976**

The new Laguna TS table saw is setting a new high standard by which all others will be measured.

The X31 multi-task machine has a lineage second to none. This third-generation combination machine is a best seller, with updated fences and increased cutting capacity.

Meet our latest award-winning machine, the LT 14 bandsaw. Packed with outstanding features for powerful performance. 1.7 HP motor - 13 1/4" throat - 1/16" to 1" blade - 8" resaw.

Circle No. 640

The **BLUE** Mark of Quality.



**POCKET HOLE SYSTEMS™**

Quality tools, education, service and value.

Expect this and more from **KREG**, the leader in Pocket Hole technology.



Kreg jig® ProPack

**A better way to join wood.**

**Faster...** No waiting for the glue to dry.  
**Stronger...** Screws put unmatched clamp pressure on the joint line.  
**Simpler...** Drill pocket holes in only one workpiece. Align for assembly with a single clamp.  
**Better!** Faster assembly, stronger joints, fewer headaches. Give it a try today!

Two simple steps to wood joinery...



Drill pocket holes.



Drive screws.

[www.kregtool.com](http://www.kregtool.com)



800.447.8638

Circle No. 802



8116 Highway 123 North  
 Toccoa, GA 30577  
[www.osbornewood.com](http://www.osbornewood.com)

**DINING TABLE**



- 1130**  
Country Squire  
5 x 29
- 1113**  
Heritage  
2½ x 29
- 1114**  
Portsmouth  
4 x 29
- 1122**  
Old World  
3½ x 29
- 1153**  
Tapered Rope  
5 x 29

Request our **NEW** catalog: 1-800-746-3233 • Order line: 1-800-849-8876

Circle No. 1849

**shop tips**

**Hotmelt veneer adhesive out of a bottle**

You can make your own hotmelt veneer by coating both your workpiece and a piece of veneer with a good quality woodworking glue. (I use Titebond II.) Let it dry completely, then iron it on like you would with normal hotmelt wood tape. It works amazingly well, and allows you to veneer areas larger than you can with veneer tape.

—Don West, Phoenix, Ariz.

Don, we checked out your tip with Dale Zimmerman at Franklin International (maker of Titebond woodworking glues), and he says you're right on the money. Dale told us that you can let the glue dry for "as long as a couple of days, but the longer it dries, the more heat it takes to reactivate the adhesive." He says five hours or so of drying is about right for Titebond II. Dale suggests using the "cotton" setting on your iron, and keep it moving to prevent scorching the veneer.

—WOOD® magazine

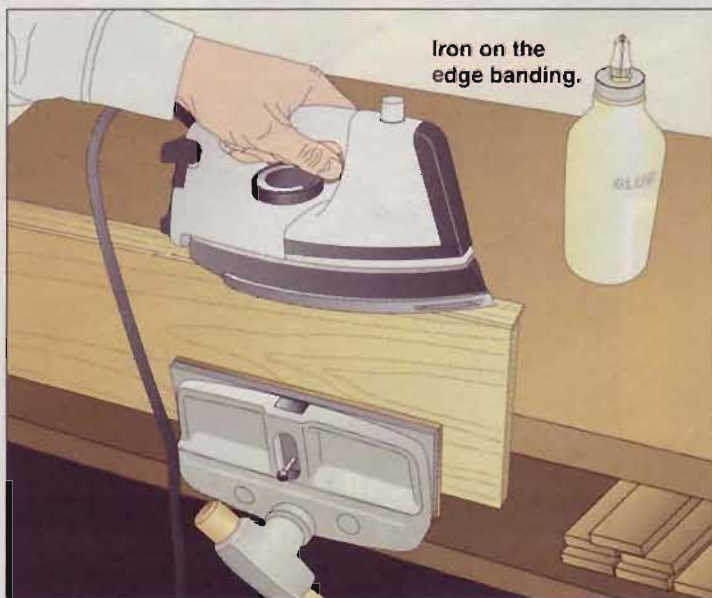

## Tip your hat to this pivoting outfeed table

Having a roller stand in the shop is almost like having another person around to help you work with long and cumbersome

material, but roller stands also have a frustrating flaw: If the material is warped or droopy, you'll probably knock over the stand before you get help from it. The tilting plywood platform, shown at right, virtually eliminates this problem.

To use it with your tablesaw, set the level platform height to match your table-saw top, and then tilt the platform toward the saw. When you feed the board through, it catches the platform and

levels it out, and the roller stand will remain standing.

—J. D. Stanley, Cleveland Heights, Ohio

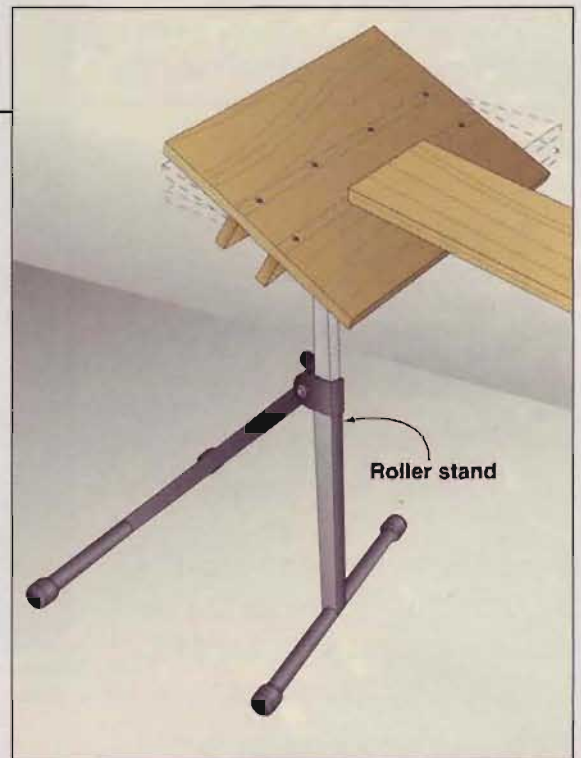
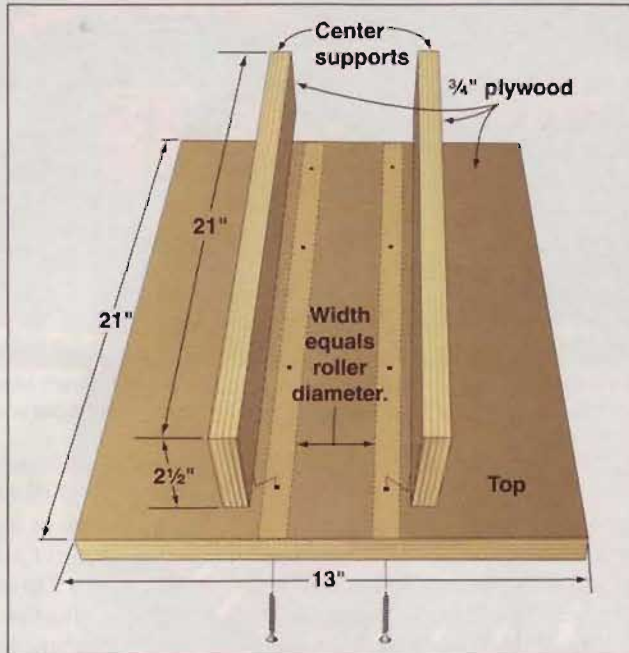

See a new

Shop Tip of the Day at

[woodmagazine.com/tips](http://woodmagazine.com/tips)



**GENERAL INTERNATIONAL**

**IWF 2004**

August 26-29, 2004  
Atlanta, Georgia USA  
Georgia World Congress Center  
[www.iwf2004.com](http://www.iwf2004.com)  
Booth 6263 Hall B

**WWW.GENERAL.CA**

**ROCKLER**  
WOODWORKING AND HARDWARE

THE WORLD'S  
**BEST**  
SELECTION  
OF HINGES

50 years  
1954-2004

Call or go online to get your **FREE** catalog today! Code 14033

1-800-403-9736 or [rockler.com/go/V4335](http://rockler.com/go/V4335)

# just playing around

San Francisco woodworker Barbara Butler creates the stuff of kids' dreams with her fun, colorful play structures.

**B**arbara Butler got into the deck-building business to help pay the bills during her starving-artist days. A skilled craftsperson, she also created carved furniture in vibrant colors. Before long, she combined her talents to develop unique playhouses and backyard structures that attract kids like candy.

Today, Barbara, *below*, and her crew of 10 design and build about 40 of these backyard-adventure structures per year. The themed, multi-level masterpieces fetch from \$6,000 to six-digits, and they are shipped and installed all over the country.

## Creating fantasy worlds

Barbara begins the process of building a custom structure by meeting with the prospective buyer, surveying the site, and



Barbara demands quality materials and construction to create safe, lasting structures.



All photographs: Teena Albert

Bold colors, fanciful designs, and complex shapes take Barbara's play structures several steps beyond the ordinary. Each custom piece exhibits its own personality.

sketching the design. Careful measurements ensure the structures will conform to changing terrain and fit well among other landscape elements.

Barbara and her team entirely build each structure in her shop. "I use second-growth redwood from certified sustainable forests," she says. "It's beautiful, great to work with, and lasts for years without chemical preservatives." She uses jigs to simplify creating complex shapes and insists on tight tolerances and furniture-grade workmanship.

With construction complete, the parts get numbered then disassembled for staining and finishing. During this time, Barbara adds such details as cutouts and carvings.

Next, the crew rebuilds the structure to double-check workmanship, then preps it for shipping. These processes eat man hours—a playhouse may take 70 hours to build—and the attention to detail shows.

## Building to last

Craftsmanship remains apparent in such details as fasteners and hardware. "I use stainless-steel screws and bolts to withstand the weather and prevent rust stains on the wood," says Barbara. All steel parts feature a tough baked-on finish that seals them against the elements and softens any sharp edges.

Good materials help the structure last, and careful finishing preserves color. Every piece receives exterior tung oil stain, usually in several of the 50 custom colors Barbara

blends (base colors come from Woodburst stains: 425/433-0899; woodburst.com). Applying three or four coats of clear exterior tung oil finish seals in the color. See the **Shop Tip** on page 112 for more exterior staining tips.

Finally, Barbara ensures the structures go together properly on site by either installing them herself, supervising, or providing written instructions to a qualified contractor.

## The debate over doing more

Barbara's business keeps her pace hectic, with 80-hour weeks a norm, but she shuns getting less involved or mass-producing products. "We could have our stock pieces built overseas, sell them cheaper, and sell more, but that's a hassle and not the way I

*Continued on page 114*



Barbara's structures often intermingle closely with trees, sometimes even tying them directly into the design.

want to do business," she says. "We have recently begun offering plans for a few playhouses, and may produce more." Even with her busy schedule, she finds time for

other woodworking, *below*. And she simply enjoys producing projects that help drive kids' imaginations. To learn more, visit [barbarabutler.com](http://barbarabutler.com) or call 415/864-6840. ♣

## SHOP TIP

### Keep outdoor colors bright

Barbara Butler tells her clients that they may have to sand and restain their structures every four years. But many don't feel the need for seven or eight years. Here's her advice for creating exterior finishes that last:

- Apply stain liberally to outdoor projects. The stain will weather to an attractive appearance after a year or two of exposure, and then continue to look good for another couple of years before needing to be restained.
- Clean the structure at least twice each year by scrubbing with a stiff bristle brush dipped in a mixture of biodegradable soap and water.
- Protect the stain by refreshing the topcoat every year or two. Use a clear, penetrating-oil exterior finish that contains ultraviolet (UV) light inhibitors.

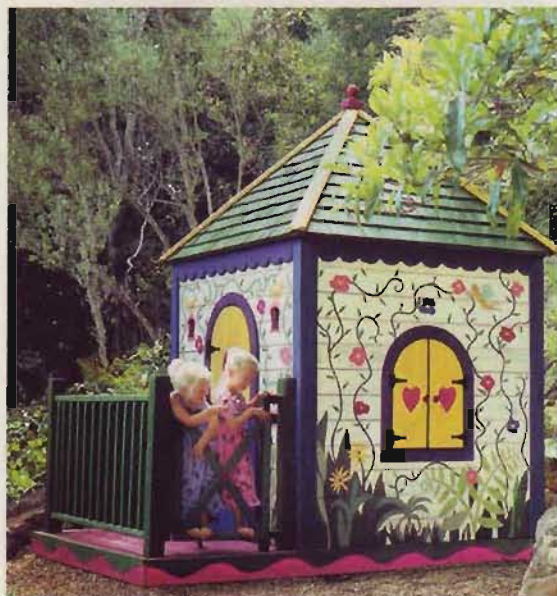

Walls of the Country Cottage playhouse bear Barbara's whimsical flowers and vines along with birds, bugs, and even a few fairies.



Barbara returns to her roots by crafting about 10 custom furniture pieces per year. "That's my art now, my escape," she says.

*Talented Creator. Skilled Hobbyist.*

## BUSINESS OWNER.

You're already two. With Guardsman FurniturePro®, you can become all three!

*Guardsman FurniturePro is a network of franchises specializing in furniture-related services. Guardsman FurniturePro has available territories throughout North America.*

### TRAINING AND SUPPORT PROGRAMS:

- Comprehensive initial training
- Ongoing regional workshops
- Web-based support programs
- 24-hour technical assistance
- Access to fellow FurniturePro franchisees

### GUARDSMAN FURNITUREPRO CUSTOMERS:

- Homeowners
- Furniture retailers

- Restaurants and Hotels
- Professional office buildings
- Moving and storage companies

### NOT TO MENTION:

- Protected territories
- Affiliation with the most established and respected name and presence in the marketplace
- The support of a \$2.2 billion company, and the largest manufacturer of furniture finishes in the world.
- Affordable franchise entry fees, as low as \$9,500
- Home based with low overhead!



For Franchise Information Call  
800.496.6377  
[www.guardsmanfurniturepro.com](http://www.guardsmanfurniturepro.com).

**GUARDSMAN**  
**FurniturePro**  
*The most trusted name in furniture repair*

## Profit Centers



**Furniture Repair** - gouges, scratches, burns, water marks, dents and more



**Leather Cleaning and Repair** - stain removal, recoloring, and more



**Upholstery Services** - spot cleaning, panel replacement, seat re-upholstering



**Cabinet Refurbishing** - cleaning, degreasing, repairing and polishing



**Refinishing** - complete stripping and refinishing using an eco-friendly, water-based system



# shop-proven products

These woodworking wares passed our shop trials

## Change router bits in a snap, without tools

For years, router and accessory makers have searched for the Holy Grail of routerdom: a safe and effective collet requiring no wrenches. Craftsman finally unearths the answer with the QuikRout System.

The system consists of a quick-release connector and adapters that mount on 1/4"- or 1/2"-shank router bits. Align the red index marks on the connector and adapter, and with a little pressure the adapter snaps into place. Pull back on the connector's collar, and the bit pops out. The mechanism was a little stiff when I first started testing, but it broke in nicely.

Although the adapters use two different methods to hold the bit (the 1/2" adapters have a collet similar to the one the connector replaces; the 1/4" version grips the bit with set screws), both sizes fit into the 1/2" connector. That means you can switch from a 1/2" bit to a 1/4" bit—and back—in an instant. I also found I could set up matched bits, such as a rail-and-stile set, and swap those bits back and forth without having to test-cut and height-adjust each time.

Installing the QuikRout connector couldn't be easier. Simply remove the nut



and collet from your Craftsman router (there's one version for current models, another for pre-2003 machines, and a third version for Porter-Cable routers), then thread on the connector where the collet nut used to be. It takes just seconds.

Because moving the individual adapters from bit to bit defeats the purpose of the system, I'll keep a set of QuikRout adapters on my most-used bits. (The 1/2" kit comes with four 1/2"-bit adapters, and additional adapters cost \$10 for a set of three.) For



rarely used bits, I'll either keep an extra adapter on hand, or temporarily replace the connector with the router's factory collet.

The only downside I found is that the 1/2" QuikRout System adds about 3/8" of cutting depth to the router, which can be a problem with long bits. For example, with a 2 1/4"-long straight bit in my fixed-base P-C 690, I couldn't cut any shallower than 3/16". With the 690 in its plunge base, however, that bit retracted completely.

—Tested by John Cebuhar

### Craftsman 1/2" QuikRout System

Performance	★★★★☆
Price	\$30

At Sears stores or craftsman.com

## Bridgewood cabinet saw boasts beefiness

At first glance, Bridgewood's BW-10LTS 3-hp, left-tilting, cabinet-style table saw didn't look like anything special. But one glance under the table told me this saw provides a lot of meat for the money.

It appears that Bridgewood's designers married the massive box trunnions of a Powermatic 66 with the stout trunnion-mounting brackets of a Delta Unisaw. The result is a powerful, vibration-free saw, whose fence scale remains accurate throughout the full bevel range. (Most table saws vary in blade-to-fence distance as you tilt the blade from 0° to 45°.) Out of the crate, the miter slot of the BW-10LTS was within .0015" of perfectly parallel to the blade, which is excellent. And I would rate the cut quality as above average.

The front-locking Biesemeyer-style fence fell short of the rest of the saw, however. It deflected an acceptable .008" at the arbor



location when ripping a hefty sheet of medium-density fiberboard (MDF), and I found it easy to make the left face parallel to the tabletop using the two top-mounted hexhead screws. But with the left face perpendicular, the right face tilted 1/16" out at the top. And the left face showed signs of scoring from where it was machined at the factory.

If you're a safety nut like me, you'll like the BW-10LTS's power switch: Once the saw has been shut off, you must rotate the switch one-half turn before you can turn it back on.

—Tested by John Cebuhar

### Bridgewood BW-10LTS

Performance	★★★★☆
Price	3 hp with 50" fence, \$1,300; optional laminate extension table & legs (shown), \$100

Wilke Machinery  
800/235-2100, wilkemach.com

Continued on page 116

**REBATE!**  
\$2 OFF on our POCK'IT JIG KIT

**(a great buy Just got better)**

THROUGH DEALERS ONLY  
**\$39.95**  
(less \$2 rebate)

**THE KIT INCLUDES:**

- Pocket Jig with Clamp
- 3/8" Steel Step Drill Bit
- Adjustable Stop Collar for Drill Bit
- Hex Wrench for Drill Bit Collar
- A Supply of Square Drive Screws
- 6" Steel Square Drive Bit

PAT. # 6,254,320

You can use this versatile pocket jig kit to make numerous types of joints.

Heavy-duty aluminum extrusion with hardened steel drill bushings.

Shown in use the clamp holds the wood firmly in place for accurate drilling.

The POCK'IT JIG™ KIT is available at these dealers:

- AMAZON.COM 800-635-5140 • EAGLE AMERICA 800-872-2511
- HARTVILLE TOOLS 800-345-2396 • WOODWORKERS SUPPLY 800-645-9292
- McFEELY'S 800-443-7937 • WOODWORKERS WAREHOUSE 800-767-9999
- PRICECUTTER 888-288-2487 • WOODWORKERS CHOICE 800-892-4866
- WOODCRAFT SUPPLY 800-225-1153 • ROCKLER TOOLS 800-279-4441

To receive your rebate, clip & mail us this ad with proof of purchase. (Your sales slip or package bar code will do the trick)

**SIMP'L PRODUCTS Inc.** 21 Bertel Avenue, Mount Vernon, NY 10550  
Web Site: woodjigs.com E-Mail: info@woodjigs.com WM 6-704

Circle No. 665

## Blast gates automatically fire up your dust collector

If you have a central dust-collection system, you know the value of blast gates ("valves" on the ductwork that you open or close to direct suction to the tool in use). After a long day in the shop, you probably do the "blast-gate boogie" in your sleep: Open the gate, walk to the dust collector, turn it on, walk to the tool, make the cut, walk to the collector, shut it off, walk to the tool, close the gate, and so on.

Penn State's Long Ranger MultiGate Switch System saves you steps because every time you open a blast gate on the system, your dust collector comes on automatically. When you close the gate, the collector powers down. No weak suction from gates left open; no hunting for a remote control.

The aluminum gates themselves are spring loaded, so they slam closed when released. That loud "snap!" is disconcerting at first but didn't appear to cause any damage. When you open a gate, you must shift it slightly sideways in its track to engage a stopping pin. The first few times I operated a gate, I jammed it by either pulling too far or shifting it too much, but I quickly got the hang of it.

Installation of the MultiGate system proved super-simple, and I mounted and wired four blast gates on my 4" PVC-pipe system in less than an hour. The gate assemblies nicely fit both the PVC and the 4" flexible hose between the gate and tool. Oddly, there are no keyhole slots or mounting tabs on the relay box to which all the gates are wired, so you're on your own for where to put the thing. I used some self-stick hook-and-loop strips to attach the box to the wall near my collector.

For \$50, you get one MultiGate blast gate, 100' of low-voltage wire, a bag of wire connectors, and the relay box. Additional blast gates (part no. LRGATE) cost only \$11 each, so I did my whole shop for under \$100.

When you order, be sure to specify whether your dust collector operates on 110 or 220 volts.

—Tested by Owen Duvall

### Long Ranger MultiGate Switch System

Performance	★★★★☆
Price	\$50
Penn State Industries 800/377-7297, pennstateind.com	



## Voted BEST Dust Collector!



"Hands down, this machine tested best, so we named it our Top Tool."  
WOOD Magazine, Dec. 2003

2hp Commercial

"It's hard to believe there is no dust in my shop. I love to sand now!"  
J.G. - Fairfield, IL

- ▶ 1.5 - 25hp Systems
- ▶ Made in USA
- ▶ Duct Design Service
- ▶ Superior Customer Service

Order On-Line!  
www.oneida-air.com

Call Us Today! It's FREE!  
**1.800.732.4065**

Oneida Air Systems, Inc. 1001 W. Fayette St., Syracuse, NY 13204



Circle No. 2039

## About our product tests

We test hundreds of tools and accessories, but only those that earn at least three stars for performance make the final cut and appear in this section. Our testers this issue include: retired high-school woodworking teacher **John Cebuhar** and WOOD® magazine projects editor **Owen Duvall**. Both are avid woodworkers. 🪵

# what's ahead

Come celebrate our *20th anniversary* in this special September issue (on sale **July 20**)

## Projects to build over several weeks or just a weekend

### FEATURED PROJECT



#### Modular entertainment center . . . and more

Here it is: Our special 20th-anniversary project! You can build and arrange the furniture pieces in this collection to suit a TV of nearly any size and shape. Better still, its base doubles as a coffee table, and you'll find matching end tables, too.



#### Jewelry box

Although you can build this project in no time, it is sure to be treasured by its recipient for all time.



#### Business card holder

Propped open on a desk, or folded up inside a shirt pocket, this slim carrier delivers your calling cards in style.



#### Flower aquarium base

Watch your garden bloom again in this water-filled globe supported by your shop-made base.

## Tools, Tips, and Techniques

### GLUE TEST



#### Sticky situation

See how 16 glues perform in our tests of strength, open time, and water resistance, among other things.



#### Save money on tools

Want to buy top tools at rock-bottom prices? Of course! Products editor Dave Campbell shows you how.



#### Guide to air-tight joints

Uncover the secrets to precise machine- or hand-cut joinery, as well as simple fixes for common flaws.

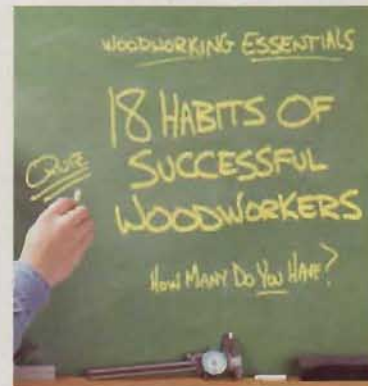

#### Improve your woodworking

Take this fun quiz to learn how many habits of successful woodworkers you have and how to master those you don't.