

Better Homes and Gardens®

# WOOD

The Shop-Proven Woodworking Magazine

create a  
better finish p.52

build this fully loaded

## router-table fence

achieve new levels  
of precision p.40

special  
router  
issue

4 must-have  
jigs p.44

ARTS & CRAFTS CLASSIC



build as a nightstand  
or end table p.62

ISSUE 159  
NOVEMBER 2004

Display until November 23, 2004

U.S.A. \$6.99



Made-in-a-day  
Holiday Gifts

● p.59 ● p.74 ● p.82



# WOOD

November 2004, Issue 159

## SPECIAL ROUTER COVERAGE

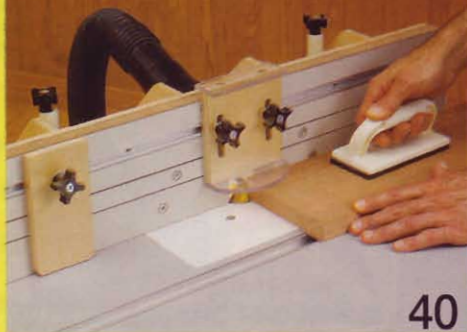

40

build a do-it-all router-table fence



12

DIY vs. pro routers: what's the difference?



16

avoiding router burns on wood

*plus*

38 forming perfect slots with your router

88 how to wisely choose a router table



68

tested: multi-base router kits

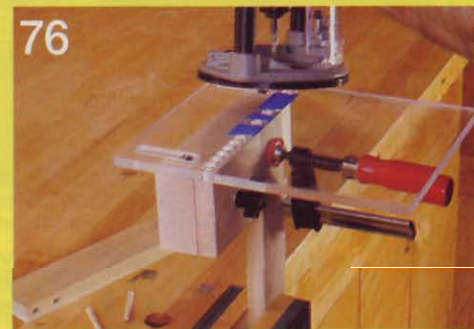

76

4 router jigs from 3 experts



62

### PROJECTS

20 easy-access drill/driver organizer

48 turned salad bowls

59 picture-perfect bookends

62 Arts & Crafts nightstand/end table

74 easy-to-make desk clock

82 kids' lap desk



59

### TECHNIQUES

22 say good-bye to power-sanding snafus

52 build a better finish with solvents

### TOOLS & MATERIALS

10 wise buys: mitersaw lasers

92 bright ideas for workshop lighting

100 4 shop-proven products



74

### DEPARTMENTS

6 editor's angle

8 sounding board

28 short cuts

36 ask WOOD

96 shop tips

112 what's ahead



This seal is your assurance that we build every project, verify every fact, and test every reviewed tool in our workshop to guarantee your success and complete satisfaction.



48



# Hungry for more shop plans for routers?

Created by the editors of **WOOD** magazine



Mobile Sawing & Routing Center Plan  
DP-00271



Benchtop Router Table Plan  
DP-00151



Tilt-Top Router Table Plan  
DP-00064



Heavy-Duty Router Table Plan  
WP-WT-1002

Download any of the above plans starting at just **\$6.95**, or have them mailed directly to you with prices starting at **\$9.95**.

To download the information yourself or to preview over 400 other plans and articles, go to

**woodmagazine.com/plans.**

Call **toll free 1-888-636-4478**

for paper-plans credit card orders.

WD1104

# Better Homes and Gardens® WOOD®

November 2004

Vol. 21, No. 6

Issue No. 159

EDITOR-IN-CHIEF  
BILL KRIER

Executive Editor  
JIM HARROLD

Managing Editor  
MARLEN KEMMET

Senior Design Editor  
KEVIN BOYLE

Tool Editor  
DAVE CAMPBELL

Techniques Editor  
BOB WILSON

Projects Editor  
OWEN DUVAL

Projects Editor  
JAN SVEC

Design Editor  
JEFF MERTZ

Master Craftsman  
CHUCK HELDUND

Art Director  
KARL EHLERS

Associate Art Director  
GREG SELLERS

Assistant Art Director  
CHERYL A. CIBULA

Production/Office Manager  
MARGARET CLOSNER

Administrative Assistant  
SHERYL MUNYON

Photographers  
MARTY BALDWIN, SCOTT LITTLE, BLAINE MOATS, JAY WILDE

Illustrators  
TIM CAHILL, LORNA JOHNSON, ROXANNE LeMOINE, MIKE MITTERMEIER

Technical Consultants  
JOHN CEBUHAR, DEAN FIENE, JEFF HALL

Contributing Craftsman  
JIM HEAVEY

Proofreaders  
BARBARA KLEIN, JIM SANDERS, MARGARET SMITH

Senior Vice President **BOB MATE**

Vice President **WILLIAM R. REED**

Group Publisher **STEPHEN B. LEVINSON**

Publisher **MARK HAGEN**

ADVERTISING OFFICE: 333 N. Michigan Ave., Suite 1500, Chicago, IL 60601

Phone: 312/853-2890 Fax: 312/580-7906

Sales and Marketing Assistant **GAYLE CHEJN**

Sales and Marketing Assistant **LISA GREENWOOD**

Account Executive **JACK A. CHRISTIANSEN**

Direct Response Manager **CAROLYN DAKIS**

Direct Response Sales Representative **SANDY ROBINSON**

Account Executive **PATRICK R. TOMLINSON, SR.**

Northeast, Phone: 212/551-7043 Fax: 212/551-7192

Detroit: RPM Associates,

29350 Southfield Road, Suite 31, Southfield, MI 48076

Phone: 248/557-7490 Fax: 248/557-7499

Southeast: Lagomarsino, Dempsey & Dennis, Inc.

2951 Piedmont Rd. NE, Suite 100, Atlanta, GA 30305

Phone: 404/261-5400 Fax: 404/261-5404

Group Marketing Director **CATHY E. SMITH**

Vice President, General Manager **TOM HARTY**

Promotion Art Director **SARAH MASSIMO**

Associate Business Director **CRAIG FEAR**

Consumer Marketing Director **ROBIN HUTCHINSON**

Consumer Marketing Manager **LESLIE SHAEFFER**

Newsstand Product Manager **LISA TROM**

Advertising Operations Manager **PAT HENDERSHOTT**

Production Manager **STEVE KRIDER**

**MEREDITH PUBLISHING GROUP**

President **JACK GRIFFIN**

Corporate Sales **TOM HARTY**

Creative Services **ELLEN DELATHOUDER**

Interactive Media/Brand Licensing **DOUG OLSON**

Manufacturing **BRUCE HESTON**

Finance and Administration **MAX RUNCIMAN**

Consumer Marketing **KARLA JEFFRIES**

**Meredith**  
CORPORATION

**WILLIAM T. KERR**, Chairman and Chief Executive Officer

**STEPHEN M. LACY**, President and Chief Operating Officer

In Memoriam — **E.T. Meredith III (1933-2003)**

©Copyright Meredith Corporation 2004  
All rights reserved. Printed in the U.S.A.

For subscription and editorial inquiries, see "How to Reach Us" on page 8.



Kevin designed and built this four-piece set to serve as end tables or a coffee table.



Marlen made this dresser and mirror in his favorite furniture style, Greene and Greene.



Chuck's new front door includes matching sidelights.





TURN OFF  
THE LIGHTS.  
TURN ON  
THE SUN.

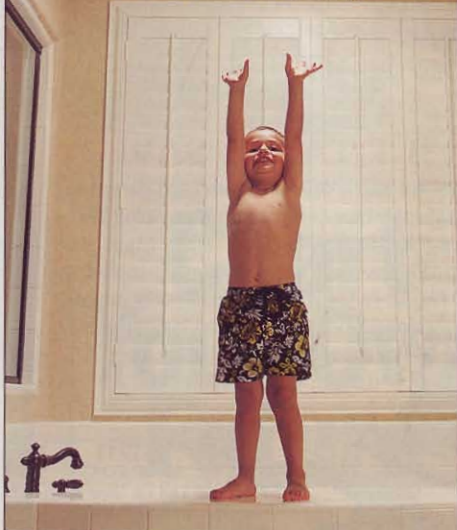

It's the ultimate light switch. By installing Solatubes in your home, you'll be able to capture and redirect sunlight to the areas that need it most.

Let Solatube fill your home with beautiful, natural daylight. Switch to the sun. Call for free information or a dealer near you. Code 1076.

1 - 8 0 0 - 9 6 6 - 7 6 5 2

www.solatube.com



— Dealer Inquiries Welcome —

## editor's angle

# Router rules to live by

Perhaps no tool is more loved by woodworkers than the router. Small wonder. From cutting edge joints to jointing edges, the versatile router does it all. That's why we've devoted much of this issue to it. And despite the router's many attributes, it's essentially a very simple machine, as are the rules for choosing and using one. Here are some of our favorites.



Three guys who definitely know their stuff when it comes to routers: (from left) Kevin Boyle, Chuck Hedlund, and Jeff Mertz.

**I** know three guys who spend every day playing with woodworking tools and building projects. In between, they talk shop with woodworkers near and far. And for this they get paid. Nice work if you can find it, don't you think?

I'm talking about Chuck Hedlund, our resident master craftsman; Kevin Boyle, senior design editor; and Jeff Mertz, design editor. Collectively, these guys have tried nearly every router, jig, and bit ever put on the market. There's not a router technique they haven't experienced. So, to mine their store of knowledge, I sat down with them recently to uncover their best rules for router use. Here's what they said:

**1 Choose a basic router.** Don't put a lot of emphasis on exotic features when buying a router. Our resident router whizzes prefer no-nonsense tools, such as the venerable Porter-Cable 690. Nothing fancy, just an easy-to-adjust, accurate, and low-maintenance machine. Their favorite versions come with a D-handle.

**2 Pick a laminate trimmer for your second router.** Big is not necessarily better when it comes to routers. In the *WOOD*® shop we reach for a laminate trimmer when using 1/4"-or-smaller round-over and chamfer bits. You just can't beat the one-handed control this tool offers.

**3 Use a router table.** We do about 80 percent of our routing work on a table. Why? A table provides a high degree of

control, accuracy, and safety, especially with big bits. It also enables the use of adjustable fences, hold-downs, stop blocks, and dust-collection ports.

By the way, neither Chuck, Kevin, nor Jeff has found the ideal router for a router table. "The perfect router for table use has yet to be invented," according to Chuck. "Right now, if I had \$1,000 to invest in a router table, I'd buy a shaper."

**4 Select specialty bits carefully.** The bits that get used again and again in the *WOOD* magazine shop are pretty basic: 1/4" and 3/8" round-overs, a chamfer bit, and a rabbeting bit with bearing set. Chuck and Kevin admit a fondness for two specialty bits though. "I really like solid carbide spiral bits over straight bits because they slice wood instead of chopping it," concedes Chuck. And Kevin loves his locking-rabbit set for sturdy, quickly made drawers.

**5 Get a handle on feed rate.** To get smooth, burn-free cuts, move the router or your workpiece at a steady feed rate. And listen to the router. If it slows, take lighter, multiple cuts.



Happy routing!

Bill Krier



# sounding board

Our bulletin board for letters, comments, and timely updates

## Glues: revisiting a sticky subject

Because of manufacturer and reader inquiries regarding the woodworking glues test in the September 2004 issue (no. 157, pages 80–85), we took a second look at the test methodology and results and found the following:

- An error occurred in creating the chart titled “A Few Glues Excel in Edge-Grain to End-Grain Joints.” The glue bead for Titebond III should have extended off the chart because the wood failed before the glue in all of the test samples.

- The sample size for the strength test mentioned above and the water-resistance test on page 84 were restricted to three and two samples, respectively. In samplings this limited, the degree of accuracy may not be sufficient to ensure the certainty of results due to the variability in the wood grain structure of the test pieces. Variations in grain orientation and wood density, even within the same board, can have dramatic effects on glue integrity.

For example, Titebond III bonds broke under an average of 208 PSI in our 24-hour submersion test, but an independent test conducted by Teco, a lab in Eugene, Oregon, reveals that Titebond III passes the industry standard ANSI (American National Standard Institute) / HPVA (Hardwood Plywood Veneer Association) Type 1 test, HPVA's most stringent test for water resistance. In the Teco test, three veneers of 1/16x1x3" birch were glued face to face with Titebond III to form 3/16x1x3" plywood samples (20 total). Those samples were submerged in boiling water for four hours and then dried for

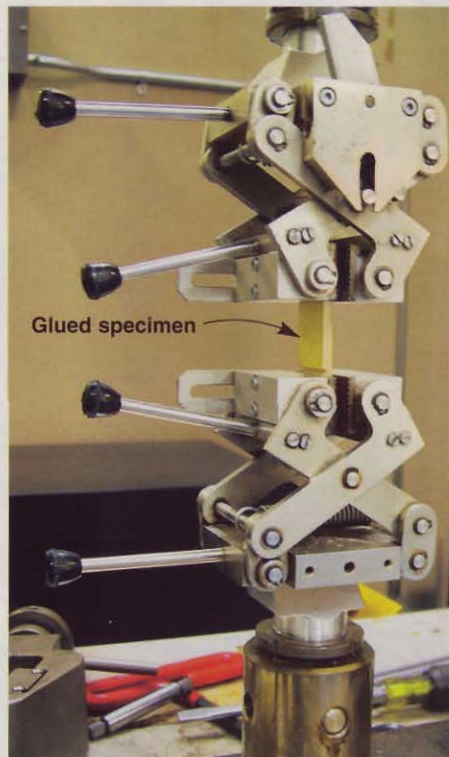

In Type 1 water-resistance testing, a glued specimen in wet and dry states is locked in jaws and subjected to shearing force.

20 hours. The specimens were boiled again for four hours, cooled in tap water, then 10 of them were tested wet for shear strength at a rate of 600–1,000 PSI. The other half of the samples were dried and subjected to the same shear test.

The bottom line: No other one-part glue that we know of has passed Type 1 test-

ing. Would we use Titebond III for exterior projects? Yes—its squeezeout is a breeze to manage and clean up compared to a polyurethane glue. If you're looking to bond wood with a nonwood material, then pick a poly. As with any exterior glue, we suggest securing joints on outdoor projects with stainless steel fasteners or other proper reinforcement.

- In the chart on page 85 we graded “speed of set” by giving the fastest glues the highest grades. However, in complex glue-ups, a longer open time (slower speed of set) proves to be an advantage. Viewed that way, the slower-setting glues would receive the higher grades.

- Speaking of open time, the article lists different open times for Titebond III on pages 84 and 85. The actual open time in our tests of this product was 20 minutes (a figure that will vary depending on the humidity and temperature of your shop).

- In light of these findings, we feel it is only fair to designate Titebond III as the top overall woodworking glue. It passes Type 1 water-resistance testing, it's easy to clean up, performed without failure in our severe edge-grain to end-grain strength test, and has ample open time for complicated glue-ups. You can use it for interior and exterior projects with confidence. You'll pay a price higher than other PVA glues but much lower than polyurethane glues.



—WOOD magazine editors

## HOW TO REACH US

### Editorial questions and feedback:

- E-mail [woodmail@woodmagazine.com](mailto:woodmail@woodmagazine.com); call 800/374-9663 and press option 2; or write to WOOD magazine, 1716 Locust St., GA-310, Des Moines, IA 50309-3023.

### Subscription assistance:

- To notify us of an address change, or to get help with your subscription, go to [woodmagazine.com/service](http://woodmagazine.com/service); call 800/374-9663 and press option 1. Outside the U.S., call 515/247-2981. Or write to:

WOOD magazine, P.O. Box 37439, Boone, IA 50037-0439. Please enclose your address label from a recent magazine issue.

### To find past articles:

Go to our continuously updated online index at [woodmagazine.com/index](http://woodmagazine.com/index).

### To order past issues and articles:

Order past issues of WOOD magazine and our special issues at [woodmagazine.com/store](http://woodmagazine.com/store), or by calling 800/346-9663. Be aware that many early

issues are sold out. For reprints, send \$5 per article (no phone orders), including the article name and issue number, to: WOOD Article Reprint Service, P.O. Box 349, Kalona, IA 52247; make check or money order payable to WOOD magazine.

### Updates to previously published projects:

For an up-to-date listing of changes in dimensions and buying-guide sources from issue 1 through today, go to [woodmagazine.com/editorial](http://woodmagazine.com/editorial).



our editors test

# mitersaw lasers

## Why buy?

Looking for a way to add speed, convenience, and accuracy to your miter saw and radial-arm saw cuts? An aftermarket laser shoots a bright red light across your workpiece showing the precise path of the blade, so you don't have to extend your mark across the piece with a square or tediously align the blade's teeth with the marked line. You simply mark your workpiece, align the mark with the laser line, and make the cut. We tested each of these lasers on a miter saw, but you'll find similar versions of each for use on a radial-arm saw.

### Bladepoint, \$80

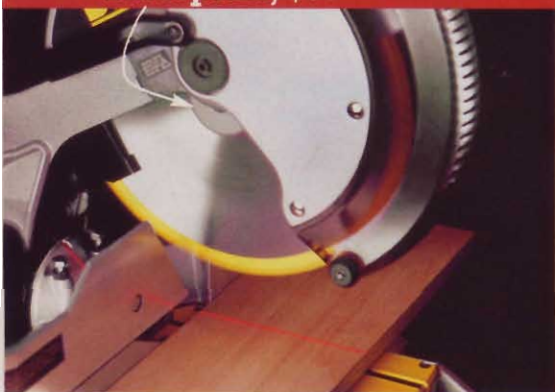

#### Editor test-drive:

Bladepoint mounts to your saw in place of the factory-supplied blade washer and casts a laser line straight along the left side of the blade and onto the workpiece. An internal centrifugal switch automatically turns on the button-battery-powered laser as the blade speeds up, and turns it off as it slows, maximizing battery life. I got about 2 hours of continuous run time from the batteries; start-and-stop cutting will make them last much longer in actual use.

To use Bladepoint, I place my workpiece on the left (waste on the right), start the saw to light the

laser, then move my workpiece to the right until the cut line just "kisses" the right edge of the laser line. Whether making miters, bevels, or compound cuts, Bladepoint proves reliably and repeatably dead-on. However, because it marks only the left edge of the blade, it's little help for cuts made with your keeper piece on the right, as sometimes happens when cutting crown molding at its "installed" angle between the fence and tabletop.

—Tested by Jim Harrold, Executive Editor

#### To learn more:

617/770-4575; bladepoint.com

### Laserkerf, \$83

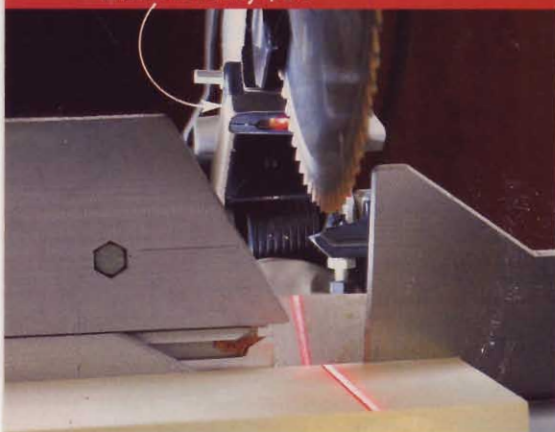

#### Editor test-drive:

Unlike other miter saw lasers I've seen, Laserkerf shows the entire kerf. The model 125, with its  $\frac{1}{8}$ " wide laser line, matched my blade's width so well I could consistently split a pencil line regardless of which side of the blade I sawed on, even in bevel and compound cuts. I did find it easy to bump and would always test its alignment before any work session to prevent miscutting a valuable piece of stock. Fortunately, alignment knobs let me make those adjustments fairly easily.

Installation is different for nearly every miter saw, and the Laserkerf Web site gives you some idea of

what's involved for your saw, although those instructions—like the general instructions that come with the laser—are sometimes unclear. The laser unit mounts behind the blade and you attach its manual power switch near the saw handle. Both mount solidly with strong adhesive strips.

I tested the 110-volt version, and a AA-battery-powered model also is available. Both also come in a thin-kerf configuration with a narrower laser.

—Tested by Bill Krier, Editor-In-Chief

#### To learn more:

859/494-0790; laserkerf.com

### Laser Line Cutting Guide, \$40

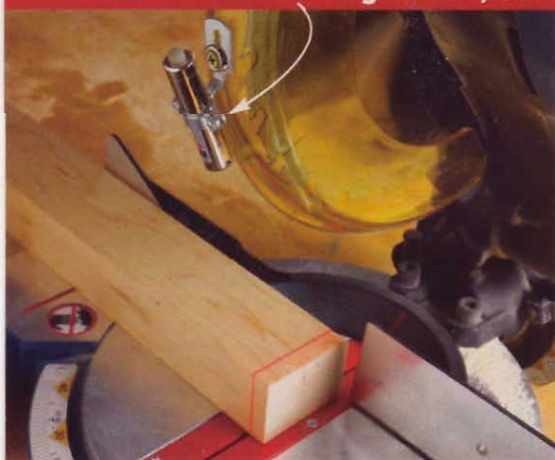

#### Editor test-drive:

The Laser Line Cutting Guide (model LLINEMS) from Penn State Industries installs on the miter saw's blade guard, which has never impressed me as a terribly stable mounting surface. However, for the most part, I was surprised at how accurately it shows the cutting line. For miter cuts, it was dead-on or within  $\frac{1}{32}$ ". I can't recommend it for bevel or compound cuts though: As the saw head tilts, the guard droops, and with it the laser line, causing cuts to be off as much as  $\frac{3}{32}$ ".

Installation took me about 20 minutes, mostly because I moved the laser unit farther up on the guard than shown in the instructions so it would cast its line across the front edge and width of a

6"-wide board. Unlike blade-washer-style lasers, you can align the Laser Line Cutting Guide to show either the right or left edge of the blade, or even switch from one side to the other between cuts if you like. The adjustments are easy, requiring only one test cut.

Periodic realignment is advised, especially if you move your saw frequently. (Mine bumped my leg in transit and got knocked out of whack.) And remember to manually turn off the unit after every cut to extend the life of the button-style batteries.

—Tested by Owen Duvall, Project Editor

#### To learn more:

800/377-7297; pennstateind.com



# Buying a router: need you go pro?

What's the real difference between a router costing \$100 and another costing twice that? The answer might surprise you.



We chopped up two perfectly good routers in our quest to learn the differences between low-dough and top-price routers.

**S**hopping for a router at the home center, you see two router kits side by side: Both boast plunge and fixed bases, 2 horses under the hood, 1/2" and 1/4" collets, similar features, and lengthy warranties. Yet one sells for \$99 and the other for \$240. There must be *some* difference between the machines, but should you *pay* the difference? That depends on how—and how much—you'll use that tool.

## The class system for power tools: DIY and pro

Power-tool manufacturers typically design, build, and market their machines to suit one of two types of users: the do-it-yourself (DIY) user or the professional. (See "What Kind of Router User Are You?" at right.) Both have different needs and place different demands on their tools.

For example, the DIY user may have less experience with power tools (this may be his first router), so such ergonomic touches as large soft-grip handles and a trigger-style power switch give him confidence to operate the tool safely and effectively while growing his skills. Function trumps finesse for this user with depth-setting systems that operate intuitively, sometimes at the sacrifice of fine adjustability. The DIYer uses the tool less frequently, for shorter periods of time, and is more likely to replace the router than repair it, so serviceability means less to him.

The pro, on the other hand, may use the tool all day, every day and is more concerned with power, performance, and precision than ergonomics. In fact, a pro may not use the handles at all, opting to grip the tool around the motor if that best suits the job at the time. He's also more inclined to perform routine maintenance,

so the router design he chooses should promote ease of self-service with such features as externally replaceable motor brushes. Although those profiles appear to be black-and-white, in truth there are many "grey" users. For instance, an up-and-coming woodworker may buy a pro router because he doesn't want to mess with buying a step-up router later. And we've seen DIY-level routers in pro shops (typically dedicated to a specific occasional task) alongside the pro routers assigned to tougher daily assignments.

## Pro routers outperform DIY when the heat is on

You can't judge a router by its outward appearance, so we went undercover to see what separates DIY and pro routers, disassembling and cutting away 2-hp routers from Bosch and Skil (both manufactured by the Robert Bosch Tool Company). After tearing into the tools, we showed them to Lance Stonehocker, the top router service technician at Puckett Tools & Equipment, a local Skil/Bosch authorized service center.

### WHAT KIND OF ROUTER USER ARE YOU?

| DIY  | Professional  |
|--|---|
| <ul style="list-style-type: none"> <li>Self-trained and buys tools as needed for projects.</li> </ul>                  | <ul style="list-style-type: none"> <li>Earns a living with tools, and needs to have high-quality tools at hand.</li> </ul>                |
| <ul style="list-style-type: none"> <li>Less informed about what is available in the market.</li> </ul>                 | <ul style="list-style-type: none"> <li>Choice of brand reflects years of experience and expectations of quality and precision.</li> </ul> |
| <ul style="list-style-type: none"> <li>Likely to buy tools from home center or mass retailer.</li> </ul>               | <ul style="list-style-type: none"> <li>Likely to buy from specialty tool store, catalog, or online.</li> </ul>                            |
| <ul style="list-style-type: none"> <li>Uses a router for short bursts of activity (5–10 minutes at a time).</li> </ul> | <ul style="list-style-type: none"> <li>Turns a router on and leaves it on for 30 minutes or more at a time.</li> </ul>                    |
| <ul style="list-style-type: none"> <li>Uses a router occasionally, perhaps once or twice a month.</li> </ul>           | <ul style="list-style-type: none"> <li>Uses a router regularly, more than once a week.</li> </ul>   |
| <ul style="list-style-type: none"> <li>When router fails, is likely to replace it with another router.</li> </ul>      | <ul style="list-style-type: none"> <li>More likely to repair a router than replace it.</li> </ul>   |
| <ul style="list-style-type: none"> <li>Low price and ease-of-use are top priorities.</li> </ul>                        | <ul style="list-style-type: none"> <li>Precision, power, and durability are top priorities.</li> </ul>                                    |

Continued on page 14



# Hungry for more info. on routers?



Routing techniques and more created by the editors of **WOOD** magazine

## Routing Techniques



Raised-Panel Doors Made Easy  
DS-053a



Five Ways to Get the Most  
Out of Your Router  
DS-037

## Tool Reviews and How To



Mid-Size Plunge Router Review  
TR-013



How To Table-Mount Your Router  
DA-00022

Download any of the techniques or tool reviews starting at just **\$4.95**.

To download the information yourself or to preview over 400 other plans and articles, go to

**woodmagazine.com/store**

WD1104

## router clinic

Stonehocker says a router's number one enemy is heat, which shortens the life of the motor and bearings. The photos, *right*, show how differences in the bearings and armature assemblies of the Skil (DIY) and Bosch (pro) machines impact their heat resistance.

■ **Motor armature:** The armature is the part of the motor that spins, turning the shaft and the collet that holds the bit. The large surface area of Bosch's long narrow armature heats slower and cools faster than the short squat armature on the Skil. It also reduces deflection of the shaft when there's a heavy side load on the bit (such as when routing edge treatments).

■ **Bearings:** Big shielded bearings on both ends of the Bosch armature run cooler and protect the bearings from dust penetration and loss of lubrication better than the smaller sealed bearings on the Skil.

■ **Motor housing.** Bosch's aluminum motor housing acts like a heat sink, drawing heat away from the motor. Skil's plastic housing acts more like an insulator, trapping heat inside the router.

Stonehocker says that the Skil router probably should not be operated full throttle for more than 20 minutes at a time due to motor-damaging heat buildup. And it should be allowed to cool for at least 20 minutes before using it again. The Bosch router, he says, could probably run 60 minutes continuously before heat begins to take its toll. It's ready to get back to work in only 10–15 minutes. He speculates that under identical working conditions, the Bosch motor would last two to three times as long as the Skil.

## IT'S WHAT'S INSIDE THAT COUNTS

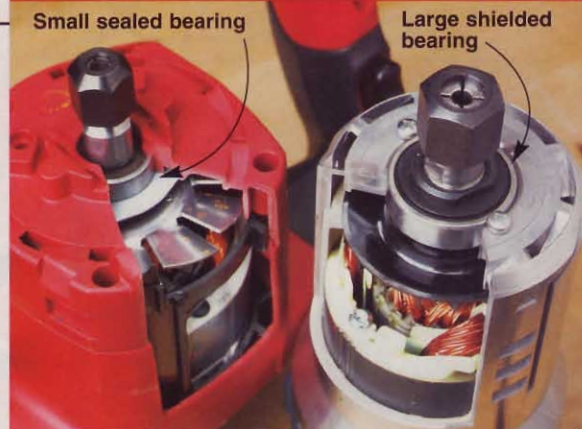

Skil 1825

Bosch 1617

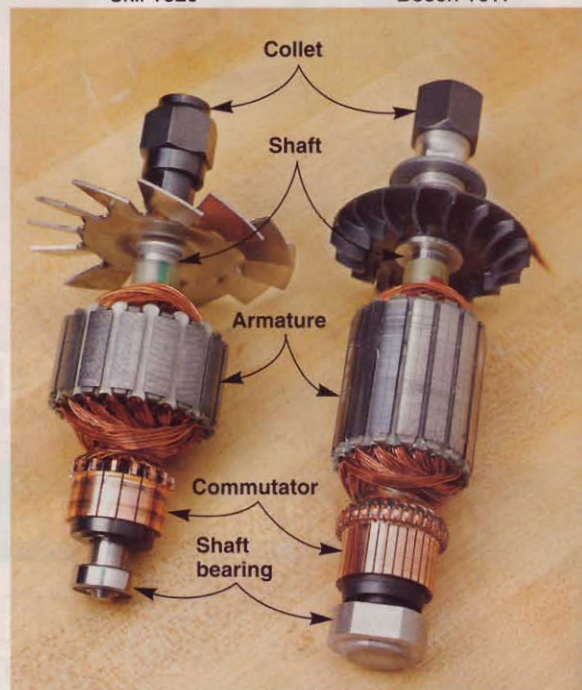

Skil's small shaft bearing heats up faster than Bosch's larger bearing, making it less durable. In a similar fashion, Bosch's 32-segment commutator runs cooler than the 16-segment commutator on the Skil router and allows it to better withstand overload conditions without failure.

## SO, WHAT DOES ALL THIS MEAN TO YOU?

First off, from the outside of the tool, it's hard to tell a DIY router from a pro model. Price and brand name are your best indicators: Black & Decker, Craftsman, Ryobi, and Skil represent the DIY category, while Bosch, Craftsman Professional, DeWalt, Hitachi, Makita, Milwaukee, and Porter-Cable typically build to pro standards.

If you honestly assess yourself using the user profiles shown in the chart, you may find that you can save money by buying a DIY router, and still have a tool that will last your lifetime. Or you may

discover that your level of usage warrants spending the extra money on a pro-level router, with bigger savings over the long haul.

At the prices of most DIY-level routers, we think that most woodworkers will benefit from having both kinds in their shop: Keep a pro-level tool on hand for the toughest routing tasks, and a DIY model or two dedicated to specific bits or tasks. The time savings alone from not having to change and set up bits quickly makes up for the extra money you'll spend. 🌲



# learn not to burn

Don't let router bits get you or your workpiece overheated.

**W**ant to prevent those annoying burn marks that leave your routed edges black and your face red? Keep cool by putting the following tips to work.

## Keep it clean

Ideally, you should wipe your bits clean after each use. Most of us, though, just drop them back in their holders and walk away. Unfortunately, resins and dust build up that cause bits to get hotter faster, making them more likely to burn the wood.

If your bits are covered with sawdust, wipe them with a dry cloth. Remove the stubborn build-up with a blade-and-bit cleaner. The benefit: Clean bits stay sharp longer because excessive heat breaks down carbide cutters.

## Stay sharp

A dull bit cuts poorly and builds up heat doing so. If you can run the cutter over your fingernail without shearing off a shaving, then your bit needs sharpening.

To freshen up router bit cutting edges with diamond lapping stones, hone only the flat surfaces. Count your strokes to make sure you remove the same amount of



Remove pitch to keep bits cool. Diamond lapping stones (about \$7 each) keep a keen edge between professional sharpenings.

material from each cutter to keep the bit balanced. It only takes a half-dozen or so strokes with each stone. If that doesn't restore cutting ability, have the bit sharpened by a pro or replace it.

## Set speed limits

Router bits spin up to 24,000 revolutions per minute (rpm). And most bits have two cutters, so they take up to 48,000 bites every minute. Think of it that way and you see why bits and wood heat up in a hurry.

To keep things cool, set your router speed according to the chart, *above right*. If your router doesn't have variable speed, you can get a plug-in controller for less than \$25. (Check your local retailer or contact MLCS at 800/533-9298; mlcswoodworking.com.)

You can keep heat in check too by controlling how fast you feed the bit into the workpiece. A slow feed rate generates more heat. Use a fast and consistent feed rate to keep the bit and wood cool.

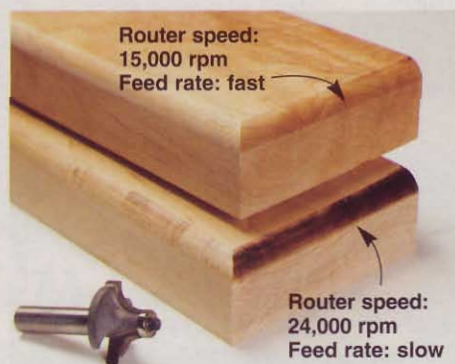

We used the same router and dull bit to round over these maple pieces (cut from the same board). The results are quite different.



## MAXIMUM ROUTER SPEED

| Bit diameter | Max. Speed (rpm) |
|--------------|------------------|
| Up to 1"     | Up to 24,000     |
| 1 to 1¼"     | 16,000 to 18,000 |
| 1¼ to 2¼"    | 12,000 to 16,000 |
| 2¼ to 3½"    | 12,000           |

## Watch your woods

Some woods, such as oak, don't easily burn. Maple and cherry burn notoriously because of their density and the oils and extractives they contain. Among softwoods, pine can be troublesome in areas that contain pitch pockets. With these species, slow the router and increase feed rate to minimize burning.

## Take it one step at a time

Powerful routers and sharp carbide-tipped bits are capable of hogging out large cuts in even the hardest of woods. But doing so stresses the bit, causes tear-out, and leads to burning. When removing more than ¼" of material, make multiple shallow passes, as shown *below*.

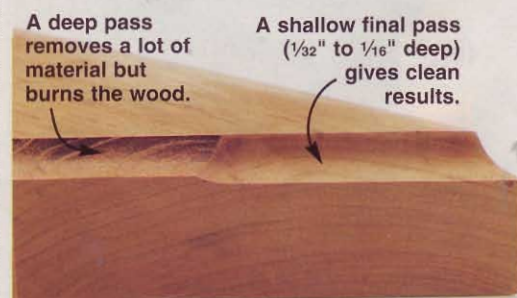

Even in burn-prone woods, such as cherry, making a shallow final pass keeps the bit and wood cool to eliminate most burns.



# multitiered drill/driver organizer

Build the box, then apply the quick-reference chart to match the right bit instantly to the right screw.



To achieve maximum holding power when using screws, drilling the correct pilot- and shank-hole sizes are a must. And, knowing what combination pilot/countersink bit to use for each screw size can be a "bit" confusing. Then there's the problem we all face of keeping our many drilling bits, plug cutters, and driving bits organized. To solve these dilemmas, build this super organized project. You'll even find a color-coded chart to make selecting the correct bit a no-brainer. Extra tiers provide plenty of room for all the bits you'll need to drive a wide assortment of screws.

To build one, use the drawing at right and the full-size patterns on the *WOOD Patterns* insert to cut pieces A-F to size. Use 1/4" hardboard for parts A and 3/4" solid stock for everything else. For the tiers (F), cut a 3/4"-thick piece of stock to 2x26". Mark the hole centerpoints and kerf locations for crosscutting the pieces to length. Drill the holes, bevel-rip the bottom edge with a pair of 45° cuts, then crosscut the tiers to finished length. When assembling the project, allow the lid to rotate on the two #8x3/4" flathead screws. We sanded the edge of the lid to rotate smoothly between the sides (A).

Use model airplane gloss-enamel paint or nail polish

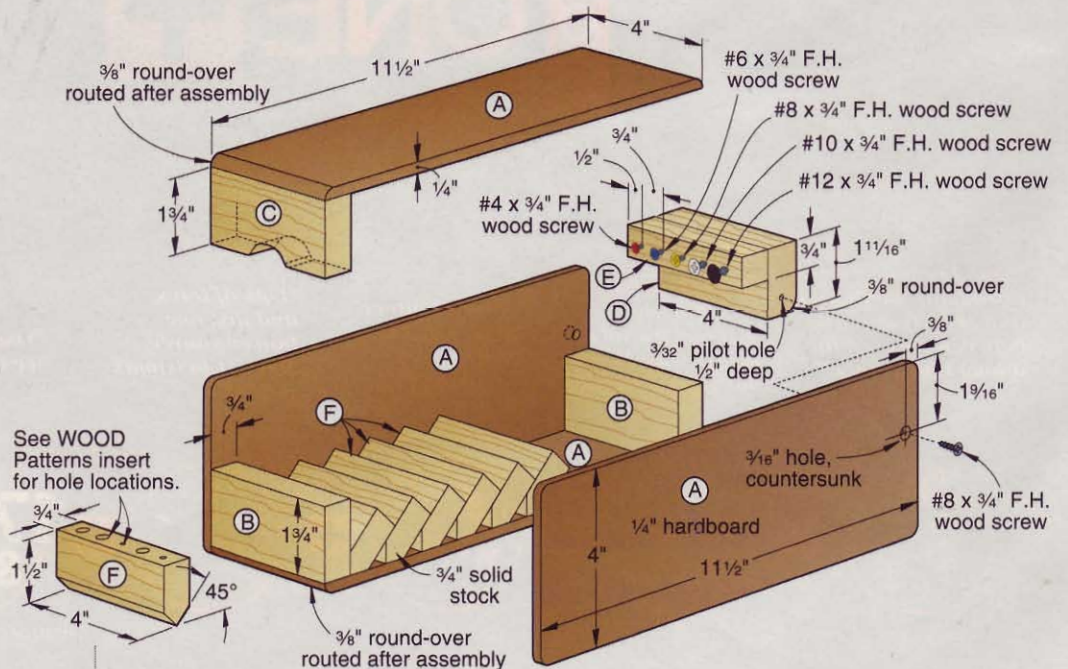



# WOOD

MAGAZINE

## Guide to pilot holes, countersinks, plug cutters, and drivers

For wood screws of this size

| Screw size | #4 | #6 | #8 | #10 | #12 |
|------------|----|----|----|-----|-----|
|------------|----|----|----|-----|-----|

Use the following accessories and hole sizes

|                          |        |       |        |        |       |
|--------------------------|--------|-------|--------|--------|-------|
| Vix/Self-centering bit   | #3     | #5    | #5     | #9     | #9    |
| Pilot/Countersink bit    | 5/64"  | 3/32" | 7/64"  | 1/8"   | 9/64" |
| Plug cutter              | 3/8"   | 3/8"  | 3/8"   | 3/8"   | 1/2"  |
| Square driver            | #0     | #1    | #2     | #2     | #3    |
| Phillips driver          | #0     | #2    | #2     | #2     | #3    |
| Slotted driver           | 4-6    | 6-8   | 6-8    | 10-12  | 10-12 |
| Head bore size           | 15/64" | 9/32" | 11/32" | 25/64" | 7/16" |
| Shank hole size          | 7/64"  | 9/64" | 5/32"  | 3/16"  | 7/32" |
| Hardwood pilot hole size | 5/64"  | 3/32" | 7/64"  | 1/8"   | 9/64" |
| Softwood pilot hole size | 1/16"  | 5/64" | 3/32"  | 7/64"  | 1/8"  |

to mark portions of the bits to match the color-coded chart. Cut out the color chart or make a color photocopy of it. Using spray adhesive, adhere the chart to the inside of the box, where shown in the photo on page 20. Then, when you need to drill a hole,

note the size of the screw on the chart. If you're not sure, match its head size to the tier of screws permanently mounted in part E. Match the color on the chart for that particular size to the color coded bit. ♣

Project design: Jeff Mertz

# The Toughest Glue On Planet Earth



**Bonds:**  
Wood, Stone, Metal,  
Ceramic, & More!

Gorilla Glue is the versatile, interior/exterior adhesive ideal for most household fixes and building projects: furniture repair, crafts, woodworking, and general repairs around the house.

**Bonds wood, stone, metal, ceramic & more!**  
Incredibly strong and 100% waterproof.



**REQUEST YOUR FREE INFORMATION KIT!**

[www.gorillaglu.com](http://www.gorillaglu.com)

1-800-966-3458



# avoid these power-sanding slip ups

Sanders can be your shortcut to success or a source of hasty headaches. Here's how to avoid the most common sanding mistakes.

**D**one right, power sanding speeds your way to a silky surface. Done wrong, your impatience will haunt you with every flat spot, gouge, and burn mark your tools leave behind. Here's how to avoid sanding's biggest risks.

## Match Grit to Grain

**Potential problem:** Figuring that fine-grained hardwoods, such as walnut or cherry, require a fine sandpaper grit, you add a fresh 220-grit to your drill press sanding drum or disk sander and give your workpiece a firm push to remove saw marks around the edges. Suddenly, there's the scent of burnt wood in the air. Like the only slightly exaggerated example shown above, your project is now firewood.

**Safeguards:** Avoid this problem by using a coarser sandpaper—such as 80-grit—for your disk or oscillating spindle sander. Let the machine do the work and use soft pressure when pushing the workpiece against the sander, especially on end grain. Keep your sander or your workpiece in constant motion to prevent heat build-up.

Oscillating spindle sanders work great for dense hardwoods. The up-and-down motion of the spindle spreads sanding-generated heat over a greater area than a sanding drum on a drill press, although you still need to keep your workpiece in motion.

If you're sanding a workpiece down to a pattern line, first cut it to within  $\frac{1}{32}$ " of the final shape to eliminate as much sanding as possible.



## SAFEGUARD



## Scuff-Sand by Hand

**Potential problem:** You're sanding down your sealer coat of clear finish with 220-grit paper when your sander cuts through both the finish coat and the stained surface beneath. Odds are you'll need to sand down to bare wood and restain the entire surface of the damaged face.

**Safeguards:** This time, rethink the need to sand between the first and second coats. Finishes such as lacquer partially dissolve the earlier coat, and require no between-coat sanding. With polyurethane finishes, apply a second coat without sanding the first sealer coat, which often dries rougher than following coats. After the second coat, use 320-grit sandpaper on a hand-held pad to scuff-sand a bondable surface for the next coat. Commercial sanding sealers require especially mild sanding.

## PROBLEM: UNFINISHED BUSINESS



## SAFEGUARD



Continued on page 24



### Copy the Contour

**Potential problem:** You've just fed a workpiece with a long, sweeping curve through your oscillating spindle sander when you stop to admire your work and discover that your long curve has become a string of bumps and dips.

**Safeguards:** We exaggerated a bit here to make a point: Always use the largest diameter drum that fits within the radius of the

curved edge. A hand-sanding alternative uses the curved scrap created when your curved workpiece was cut. Rough-sand the saw marks from the curved edge of the scrap piece without altering its profile. Then cut and attach strips of adhesive-backed sandpaper in progressively finer grits, starting with 60-grit and ending with 180- or 220-grit, turning the scrap into a custom-contoured sanding block.

#### PROBLEM: RUFFLES WITH RIDGES



#### SAFEGUARD

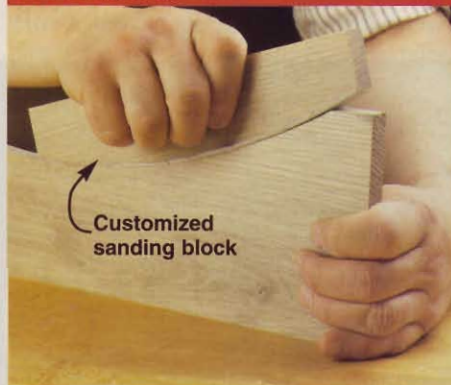

### Skip the Dips

**Potential problem:** When edge-joining pieces of exact thickness, it's tricky to glue panels with perfectly even joints. So you cruise your power sander up and down the problem seams, and the situation goes from bad to worse: Your uneven joints turn into noticeable dips.

**Safeguards:** Sanders make poor thicknessing tools, especially belt sanders. When gluing up sections, inspect for workpiece slips at joint lines, and correct imperfections well before the glue sets.

If a problem still surfaces, visualize an area about twice the width of your sanding pad on either side of the joint and work gradually from the edges to the center to avoid abrupt surface changes directly over the joint.

#### PROBLEM: THE BIG DIPPER

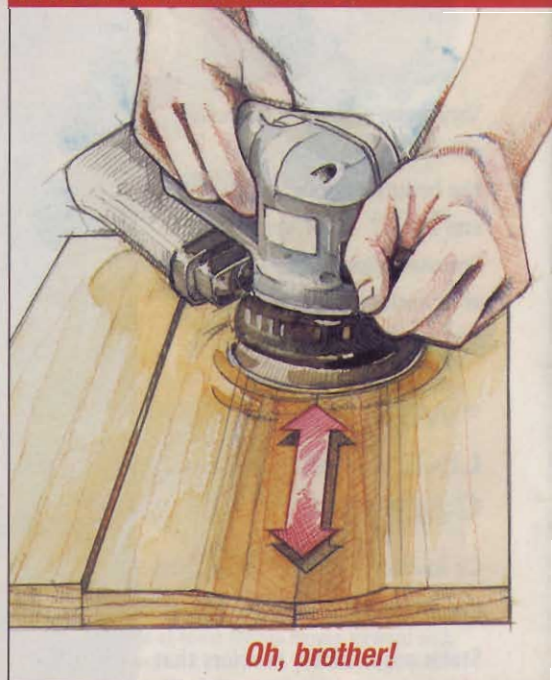

### Sand Veneer with Care

**Potential problem:** Edge-banding a sheet of hardwood plywood with matching veneer often leaves overlaps where the edging protrudes above the surface of the face, so you pick up your sander and lean it over to even out the excess. On one especially stubborn portion, the plywood hardwood veneer disappears along with the edging, exposing the layer beneath.

**Safeguards:** Don't tilt your sander as you cross the edge or you'll remove both veneer and edging. If you're still concerned about cutting through the veneer, sand the overlaps by hand with 220-grit paper or higher.

You can also trim veneer using a chisel with the bevel side up and the back flat against the face of the plywood. Finish by lightly hand-sanding with 220-grit paper or higher.

#### PROBLEM: LIVING ON THE EDGE



#### SAFEGUARD



#### SAFEGUARD

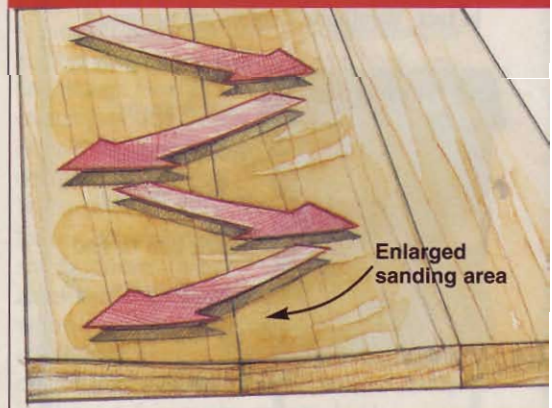

Enlarged sanding area

Continued on page 26



## Losing Your Edge

**Potential problem:** You figure that if you hold your pad or random-orbit sander just right, you can reach into the nooks and crannies of a profiled edge. Unfortunately, the profile loses its crisp lines and curves become flattened.

### PROBLEM: CRIMINAL PROFILE



**Safeguards:** For simple shapes, such as the one *below*, make a contoured sanding block by bandsawing a chunk of rigid polystyrene foam to match the edge profile and cover it with adhesive-backed sandpaper. (Spray adhesive dissolves foam.)

Here's another option for matching your

### SAFEGUARD 1



### SAFEGUARD 2



# The Next Level...

# LAGUNA TOOLS

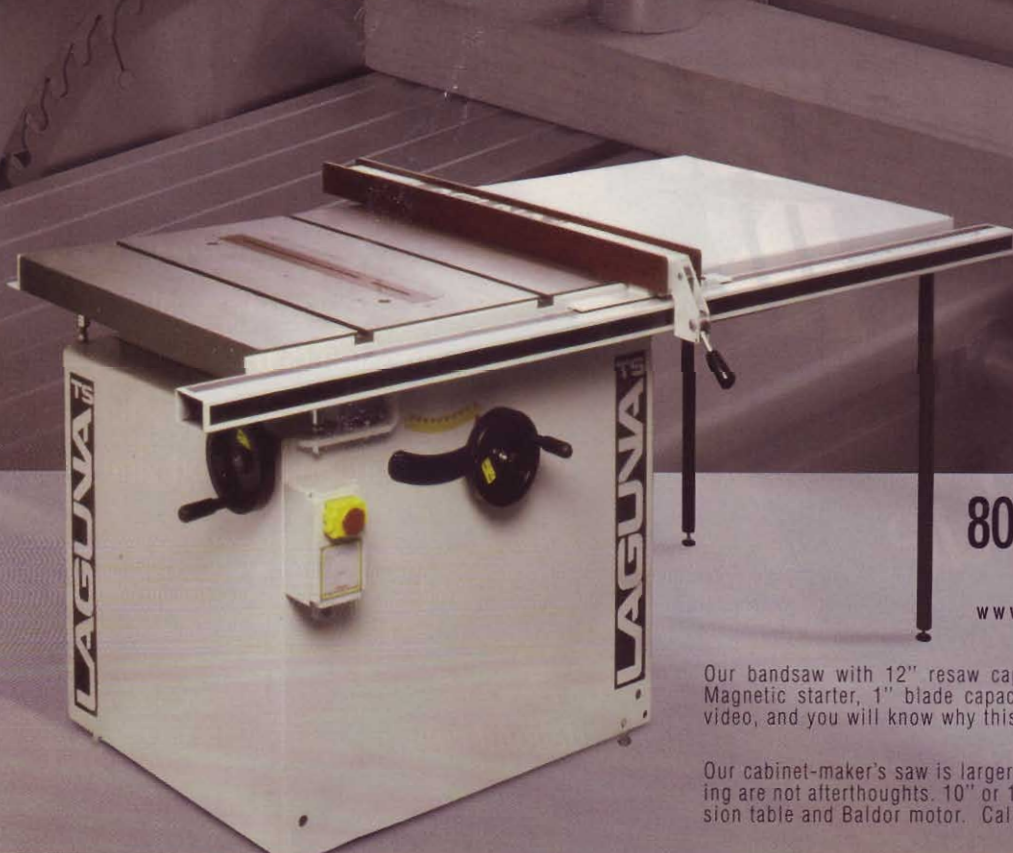

800.234.1976

[www.lagunatools.com](http://www.lagunatools.com)

Circle No. 640

Our bandsaw with 12" resaw capacity, cast-iron flywheels, ceramic Laguna Guides, Magnetic starter, 1" blade capacity with and Baldor motor. Call now for your free video, and you will know why this machine is consistently rated # 1..

Our cabinet-maker's saw is larger and heavier. Options such as sliding table and scoring are not afterthoughts. 10" or 12" blade capacity euro-style riving knife, steel extension table and Baldor motor. Call now for your free video.



# short cuts

News and notes from the woodworking world

## Cordless drill to the rescue

Though most people don't need another hole in their head, that wasn't the case for 29-year-old Ben King, a Hailey, Idaho, resident. While visiting a friend, King fell down a flight of stairs and hit his head on a concrete floor, rendering him unconscious. Internally, blood welled up in his skull, creating potentially fatal pressure on his brain.

Due to the severity of the case, doctors decided to transfer King from their small local hospital, the St. Lukes Wood River Medical Center at Ketchum, to a larger one, St. Alphonsus Regional Medical Center in Boise. But because of a snowstorm outside, getting him there proved a challenge. It required an ambulance ride to a rendezvous point where a LifeFlight heli-

copter would move King to the larger facility.

With King's condition worsening by the minute, a concerned radiologist who studied the brain scans told the Center's emergency physician, Keith Sivertson, that he didn't think King would survive the transit.

In need of a solution, Dr. Sivertson grabbed a 14.4-volt cordless Makita drill and bits from the hospital's maintenance shop and drove off to catch up with King at the rendezvous. Arriving at the moment of transfer, the doctor then drilled a  $\frac{3}{8}$ " hole in King's skull to relieve the pressure. The unorthodox procedure did the



At a ceremony in his honor, Dr. Sivertson presents former patient Ben King with a T-shirt showing the Makita drill that he used to save King's life.

Photograph: Courtesy of St. Lukes Wood River Medical Center

trick, pulling the patient through, and making this one more legendary day in the wild and woolly West.

## Test your workshop smarts

Answers to the questions in issue 158:

### ■ What woods did makers use in the construction of Civil War era canteens?

According to Stephen W. Silvia, author of *Civil War Canteens*, canteen makers used cedar, cherry, and maple. Cedar was the least preferred as it tainted the flavor of the water. Canteen construction, as depicted by the Confederate wood drum model left, consisted of a pair of flat, round faceplates spanned by several short staves serving as the sides. Like a wooden barrel, these were held tightly in place by metal bands. Added to this were a cylindrical wood mouthpiece and a cork that stopped the container.



Civil War-era wood drum canteens typically measured  $2\frac{3}{8}$  X  $7\frac{1}{2}$ " and carried one quart of water.

### ■ Can you name this unique Victorian-era hand tool and describe its use?

Carpenters working on late Victorian houses over a century ago might recognize this cast-iron handheld miter box or "miter gauge." Fitted with an adjustable spring-activated lock that allowed the head to be fixed at the desired sawing angle, the device could be used by a workman on a roof or ladder to cut boards without having to return to the

To use the miter gauge, a carpenter locked its head at the desired angle, rested the rail against the board's edge, and, with a handsaw or backsaw inserted through the jaws, made the cut.

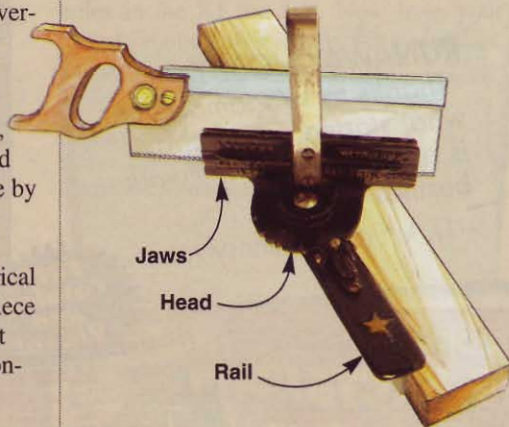

ground to perform the task. Because wood parts of Victorian houses required numerous angle cuts, the miter gauge was designed to save time, though it never garnered widespread interest in the trades.

### ■ What's the origin of "penny," the word used to define nail sizes?

The "d" abbreviation for penny dates back to Roman times and the coin called denarius. The "penny" system of nail designations, however, stems from the English pence. At no time did a 6d nail cost sixpence, but records show that 100 6d nails had once cost that amount, and that 100 8d nails had simultaneously cost eightpence.

Today, the "d" designation pertains more to length than cost. A 2d nail used with wood measures 1" long. Each 1d increment equals a  $\frac{1}{4}$ " nail-length increase up to 16d. Above 16d, nail-length increases come in  $\frac{1}{2}$ " increments. That explains why a 10d nail is 3", and a 20d nail, the next size jump above 16d, measures 4".



Continued on page 30



### Why are bluebirds so darn happy?

The answer's easy: It's because of all the free housing generated by Flathead Wildlife Incorporated in Kalispell, Montana, and a local woodworker/conservationist named Warren Lamoreux. The story begins 12 years ago when the president of a conservation club teamed up with Warren to make and sell bluebird houses. The club purchased the wood, Warren cut out the parts, and some 20 conservation club members dutifully assembled them.

That first year the club sold a whopping 500 houses, making \$1,800 for a wildlife habitat fund. Encouraged by its success, the club and Warren's busy saw have since built more than 5,400 bluebird houses, netting the fund some \$19,000. The 81-year-old industrious Warren was honored by the Montana Wildlife Federation in 2000 as "volunteer of the year."



Photograph: Robert E. Cole

Montanan Warren Lamoreux has cut out the parts for over 5,400 bluebird houses, working out of his small woodstove-heated shop.

### George Washington tree limb falls into good hands

When hurricane Isabel ravaged Virginia and the Chesapeake Bay area in September 2003, it left massive amounts of deadfall in its wake. And while most of it was carted off to the dump or cut into firewood, one very special piece was saved for posterity—a limb from a 219-year-old Mount Vernon white ash tree planted by none other than George Washington in 1785.

Consequently, the limb wood was sawn into blanks and given to selected woodturners to make something special. One such turner, Bruce Hoover from Virginia's Eastern Shore, took his assignment to heart, and turned the exquisite statement of patriotic fervor you see below. Of all the turnings, his alone will be on permanent display at Mount Vernon, Washington's home. 🌲



Photograph: Courtesy of Bruce Hoover

Woodturner Bruce Hoover embellished his vessel with a woodburned and dyed American eagle and 13-star flag.

# WANT THIS?



A clean, sharp hole every time. No chips, no splits, no errors. It takes skill and a sharp drill bit. And *that* takes the **Drill Doctor®** drill bit sharpener.

# GET THIS.

- Restores bits to factory sharp
- Fast and easy to use
- Sharpens most twist bits—even split point
- Diamond sharpening wheel
- Powerful 20,000 rpm motor



**Drill Doctor®**  
The Drill Bit Sharpener

Drill bits are meant to be sharpened

www.DrillDoctor.com • 1-888-MYDRILL

*"I have never recommended a product that was so easy to use and so effective. This is one of the best tools I've ever purchased."*

—Stephen Bierhorst  
Patterson, Louisiana

Available at Home Depot, Lowe's, Sears and wherever fine tools are sold

### Position opening at **WOOD® Magazine**

The staff position of Woodworking Techniques Editor is currently open at **WOOD Magazine** in Des Moines, Iowa. Work includes producing technique articles for the magazine, traveling as needed to complete assignments, and planning and directing photography and illustrations to complement articles.

Qualified applicants, please send cover letter and resume to:

**D. Neumann**  
Meredith Corporation  
HR/Publishing Group, Dept #34526  
1716 Locust Street  
Des Moines, Iowa 50309  
Fax: 515-284-2958 EOE



# Bring on the Air Force

Look at all you can do with an air-powered brad nailer or narrow-crown stapler!

If you've always wanted a brad nailer or narrow-crown stapler, the time is perfect to make your dream a reality. No longer are these tools exclusively for production shops and tradesmen. Today's air-powered tools fit nicely into the home woodworker's arsenal. Consider these advantages:

- Prices have come down in recent years, moving high-quality nailers into your home-shop budget. Nowadays, you can buy a nailer and compressor packaged together at one low price. An added bonus: The compressor often arrives with a kit for household tasks, including a needle to inflate athletic balls, valves for air mattresses, and adapters for auto and bike tires.
- Nailers, staplers, and compressors are smaller, lighter, and more compact than ever. Once you've cleared a corner of your workbench for air tools, you'll be amazed at how often you put them to use. And because some compressors weigh as little as 20 pounds, you can easily move them from place to place.
- Today's air-powered nailers and staplers are reliable and nearly maintenance-free. Some require no lubrication; others need just an occasional drop of oil.
- New technology makes air-powered tools virtually jam-free. An easy-access front gate on the tool makes it a breeze to extract the rare jammed staple or brad.
- Combination models allow you to buy one gun that shoots brads and staples.

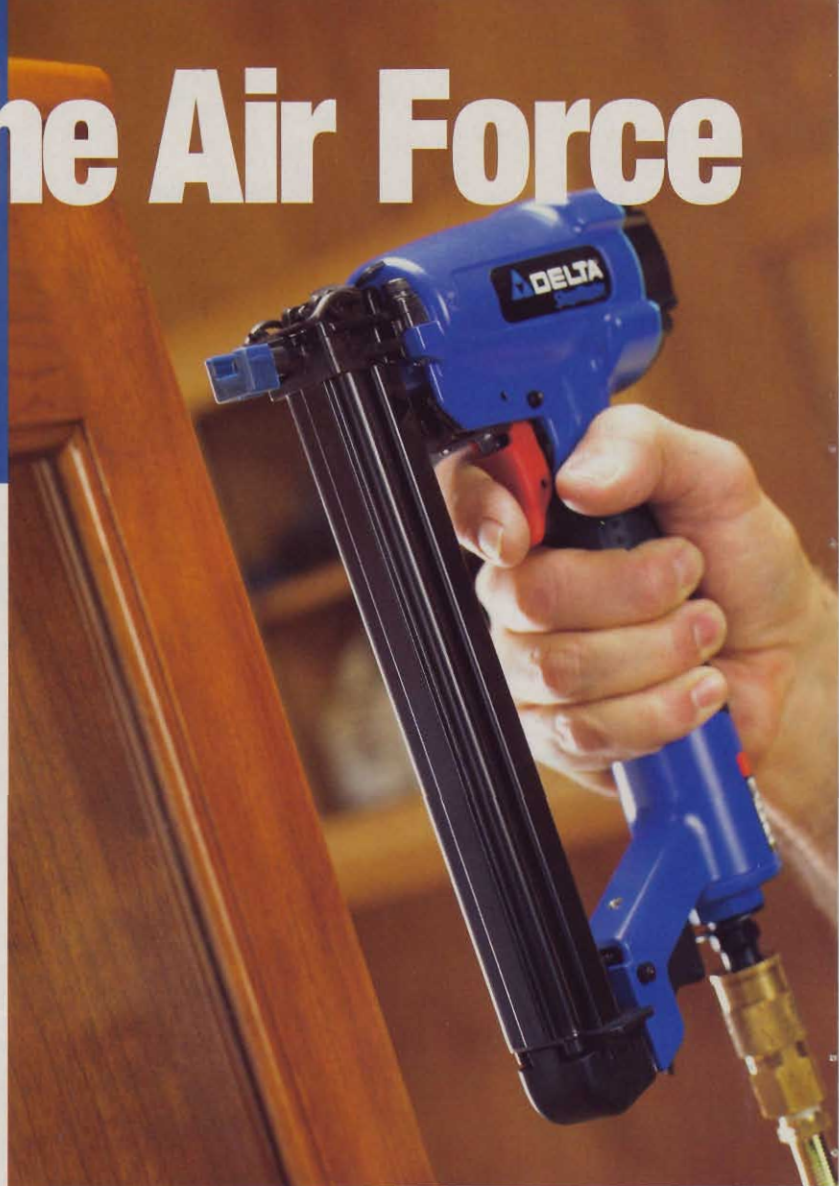

A narrow-crown stapler is the ideal way to effortlessly install a 1/4" plywood back.

## 12 ways to use an air-powered fastening tool to improve your woodworking



### 1. Clampless glue-ups

Instead of waiting for glue to dry, keep working on your project. You'll save money by buying fewer clamps.



### 2. Less splitting

There's not a better way to fasten fragile materials, such as glass stops. There's less chance of shattering glass—and you won't have to pre-drill holes. Whatever delicate hardwood molding you select, you're unlikely to split it with a pneumatic brad.





### 3. Easier project-part handling

One person can easily accomplish tasks—like installing crown molding—that traditionally takes three hands to hammer, nail, and apply joint pressure.

**4. Accuracy** You'll enjoy more accurate assembly because slippery glued parts won't slide under clamping pressure. With this 2½-pound tool, fatigued forearms are a thing of the past—and so are bashed fingers.

**5. Speed** Air-powered tools drive fasteners many times faster than a hammer. When you add in the extra time required for setting finish nails, there's just no contest.

**6. Quality** Eliminate divots (hammer tracks) from your hammering oops. The rubber nose cushion prevents marring.

**7. Quickly make jigs and fixtures** Nailers and staplers make short order of assembling your workshop helpers.



**8. Manageable miters** A nailer performs efficient, reliable joining of mitered corners, including picture frames.



### 9. Quick stack-cutting

Speed up production cutting (and accuracy) at your bandsaw or scroll-saw by firing nails into waste areas of stacked workpieces. The alternative—double-faced tape—is slower and messier.

**10. Stronger joints** Each time your hammer strikes a nail, you loosen the joint. Or worse, you run the risk of bending the nail.

**11. Forgiving** Accidentally sawing through a brad or staple causes negligible damage to a saw blade compared to hitting a screw or finish nail.

**12. Neat, space-saving fastener storage** The compact boxes of fasteners replace bulky cans and bags of nails and screws.

## Tips for nailers and staplers

■ **Follow common-sense safety pointers** included in the instruction manual. And always wear safety glasses.

■ **Test fire** Before rushing into a project, shoot fasteners into scrap stock to test the depth of the drive. (This is especially important with staples and thin stock.) With the adjustment knob, it's easy to dial in the precise pressure setting to match the size of the fastener and the material hardness. Setting a brad 1/16" below the surface is adequate for most fillers.

■ **Watch hand position** Brad and staples follow grain lines and could exit on the side where your fingers are positioned.

■ **Check the fastener supply frequently** Most nailers have a window that indicates the remaining supply of fasteners. However, if you realize you've been shooting blanks, grab a stud finder to track down the last properly secured hole.



■ **Reduce reliance on long bar clamps** by toenailing dadoed shelves. This technique secures the carcass while the glue dries.

## When is a narrow-crown staple a better choice than a brad?

Some of the fastening tasks that are best suited for a narrow-crown stapler:

■ **¼" or thinner material** With a stapler, you'll have better holding power in thin plywood. An added bonus: fast!

■ **Upholstery** Staples are perfect for smoothly securing fabric and other flexible, thin project materials.

■ **Underlayment** The next time you get involved in a remodeling project, forget about spending the day stooped over with a hammer and nails. Your knees will appreciate the quick completion with a stapler. Plus you'll have a perfectly smooth surface for the finish layer of flooring.



Rely on staplers to install glue blocks in no time flat.

Brought to you by **DELTA**  
Your achievement. Our tools.



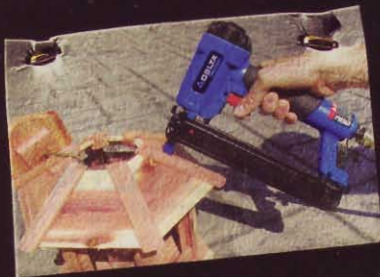



## Tune a tablesaw for high performance

**Q:** In a woodworking catalog, I've seen tablesaw tune-up kits with a link belt and new pulleys. Do these items and changes make a difference? Are they worth the money and effort?

—Frank Siudowski, Wilmington, Del.

**A:** We wondered the same thing, Frank, so we got a kit and installed it on a Delta contractor-style tablesaw. The rationale behind the product makes sense: Machined pulleys are better balanced, so they run more smoothly than stamped ones. A link belt eliminates the problem of belt set—that's what happens when an ordinary belt sits for an extended period and forms humps matching the shape of the pulleys. When you turn on the saw, the humps in the running belt bounce over the pulleys and create vibration.

To see whether the products work, we removed the old stamped pulleys on the saw arbor and motor and replaced them with the

machined and balanced pulleys. We used a straightedge to make certain the edges of the pulleys aligned with each other before tightening them. It was easy to add or remove links from the drive belt so it matched the length of the old V-belt. After replacing the belt guard, we switched on the saw and managed to balance a 1.35mm-thick dime on edge on the table while spinning a ¾" stacked dado blade. Even months after the upgrade, the saw still purrs along. For our money (about \$50 postage paid from In-Line Industries, 800/533-6709 or [in-lineindustries.com](http://in-lineindustries.com)), these upgrades proved worthwhile.

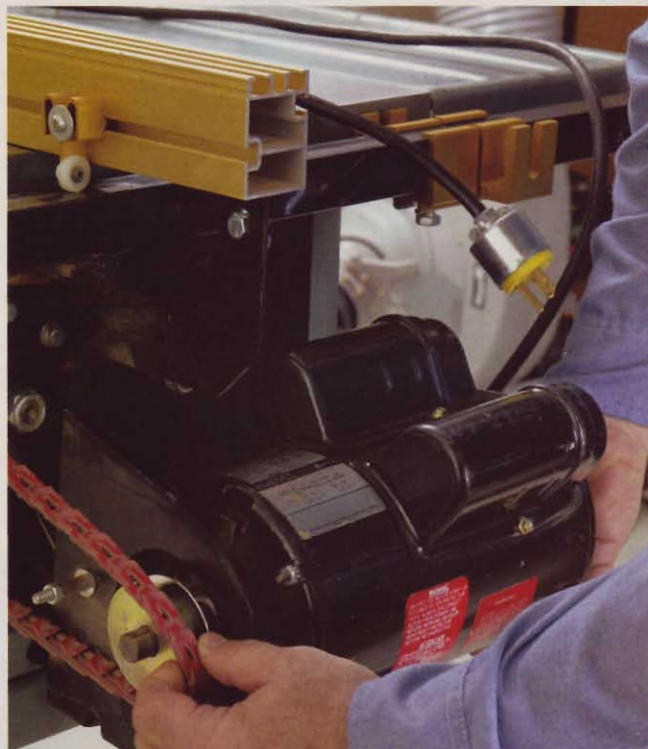

When installing a tablesaw tuneup kit, carefully align and tighten the machined pulleys. The flexible drive belt of interlocking segments keeps vibration to a minimum.

## Becoming an HVLP convert

**Q:** I've heard that an HVLP (high volume/low pressure) spray-finishing system offers benefits over traditional spray guns, but I'd like a further explanation. Also, can I convert my existing gun, or do I have to junk it? And do I need to replace my compressor with a turbine?

—Dick Guinan, Omaha, Neb.

**A:** HVLP systems use large amounts of air delivered at low pressures at the air cap (10 psi or less) to reduce bounce-back and overspray, Jeff, so more finish ends up on your project instead of being wasted. That improves the air quality in your shop and cuts costs.

Forget converting an older conventional spray gun to HVLP operation. Replacement parts can be hard to find, and worse, conversions only marginally improve an older gun. That's because turning up the pressure high enough to pull the finish out of the old gun's cup increases the delivery pressure, so you're back where you started.

Your best alternative for a compressor-driven HVLP is probably a gravity-feed gun like the one in the photo, right. (It's a DeVilbiss model FLG-635-316, with a retail price of about \$150.) Optional plastic cup liners dramatically reduce cleanup time, and they let you spray with the gun upside down to coat hard-to-reach places.

HVLP guns require plenty of air, so you may have to buy a larger compressor. The manufacturer of the gun shown recommends a minimum of a 3-hp compressor with a 20-gallon tank. Although this is an added investment, you can use the compressor to power other tools. An HVLP turbine, on the other hand, has a single function.

Most manufacturers of turbine-driven HVLP sprayers market a complete system to ensure compatibility of the components. And even though the cup is under the gun like a conventional sprayer, some air is piped into the container to pressurize the contents. We found complete HVLP systems at prices ranging from \$100 to \$700. Just an HVLP spray gun designed to work with a 3-hp air compressor is about \$180.



When using an HVLP sprayer, you'll get the best results by adjusting the incoming air pressure to the minimum setting that still fully atomizes the finish. An in-line pressure valve simplifies this process.



## Drilling holes in dowels

**Q:** Whenever I need to drill a hole through a dowel, the bit wants to skate around and choose its own starting point. How do I get clean holes positioned where I want them?

—Chris Harrison, Inglewood, Ont.

**A:** A V-block is the traditional way to hold round stock for drilling, Chris, but it sometimes yields less than perfect results, particularly if you use a twist bit. We suggest the jig shown below because it's easy to make and yields dependable results. The hole in the side of the block should match the diameter of your dowel, and the hole centered in the top helps to accurately steer your bit.



Make this simple jig to drill holes in dowels. You'll get accurate results, even in small-diameter stock.

## Got a question?

If you're looking for an answer to a woodworking question, write to Ask WOOD, 1716 Locust St., GA-310, Des Moines, IA 50309-3023 or send us an e-mail at [askwood@mdp.com](mailto:askwood@mdp.com). For immediate feedback from your fellow woodworkers, post your question on one of our woodworking forums at [www.woodmagazine.com/forums](http://www.woodmagazine.com/forums)

## HELPING YOU BUILD LIKE A PRO!! BY USING WHAT THE PROS USE!!

### Professional 6pc Cabinetry Set

With Woodline's 6-piece cabinet set, everything you need to create raised panel doors for your cabinetry and fine furniture projects. This set includes an ogee raised panel with matching 2-piece rail and stile, reversible glue joint and drawer lock bit to build strong drawers. Also includes a door lip which adds a finger-pull style profile to doors or drawers. This set also includes an undercutter on the panel raiser which produces a true 1/4" tongue automatically in any thickness of material.



WL 2020-1  
1/2" Shank.....

**\$109**

- WOODLINE USA**
- ★ Finest Quality Carbide Tips
  - ★ Full Anti-Kickback
  - ★ Ultimate Lifetime Warranty
  - ★ Unsurpassed Customer Service
  - ★ Complete Selection of Individual Bits
  - ★ Custom Designed Bits Made Affordable

LOG ONTO WWW. **WOODLINE.COM** OR CALL TOLL-FREE 1-800-472-6950

### 66pc Master Woodworking Router Bit Collection



- |                      |                              |                            |
|----------------------|------------------------------|----------------------------|
| 8 Straight Bits      | 6 Roundover Bits             | 1 Multibead Bit            |
| 5 Dovetail Bits      | 1 Point Cutting Roundover    | 1 Bowl & Tray Bit          |
| 3 Core Box Bits      | 1 Ogee With Fillet           | 1 Key Hole Bit             |
| 3 Roundnose Bits     | 1 Plunging Roundover W/ Bead | 1 Double Roman Ogee        |
| 2 Flush Trim Bits    | 1 Double Roman Ogee W/ Cove  | 1 Classic Double Roundover |
| 3 Mortising Bits     | 1 Plunging Roundover         | 1 Flat Bottom 60 V-Groove  |
| 1 Plunging Panel Bit | 1 Stepped Cove               | 1 Standard 60 V-Groove     |
| 1 Laminate Trim Bit  | 2 Edge Beading Bits          | 3 Rabbeting / Slot Cutters |
| 1 Bevel Bit          |                              | 4 Chamfer Bits             |
| 3 90 V-Groove Bits   |                              | 6 Cove Bits                |
| 2 Roman Ogee Bits    |                              |                            |

Woodline USA's most comprehensive carbide tipped bit collection features 66 carefully chosen profiles in a fully labeled wooden wall mountable case!

WL 2066  
1/2" Shank..... **\$189**  
WL 2065  
1/4" Shank..... **\$189**

### 3pc Offset Tongue and Groove

When looking for a good glue joint system that makes heirloom quality cabinets and furniture in half the time then you need Woodline's New Offset Tongue and Groove System. This unique set creates perfect 1/4" offset T&G joints. Great for cabinetry frames and furniture construction with strength & beauty.

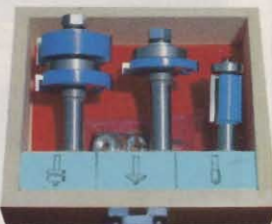

WL 2038  
1/2" Shank..... **\$79**

### 8pc Picture Frame Set

This set features everything needed to make beautiful custom frames. These 8 bits can be combined in thousands of different ways to produce unique mouldings.



WL 2008  
1/2" Shank..... **\$75**  
WL 2007  
1/4" Shank..... **\$75**

Ad Sale Code: WOOD03  
Prices Good Through 01/01/05

# WOODLINE USA

CALL 1-800-472-6950 OR LOG ONTO WOODLINE.COM TODAY! TO ORDER OR TO RECEIVE A FREE CATALOG - WOODLINE USA • 111 Wheeler St • La Vergne, TN 37086



# forming perfect slots

For arrow-straight slots with crisp, clean ends and edges, let your router table, a few shop-made accessories, and a little know-how help you produce on-target results.

**D**rilling end holes and sawing out the waste between them is one way to form a slot. Appearance depends on your unwavering ability to follow the straight cutlines connecting the end holes with a scrollsaw or jigsaw. Here's a better method that eliminates the risk of wandering off course.



**1 LAY OUT THE SLOT**  
Draw slot boundary lines on the part, extending the end lines to the edges.

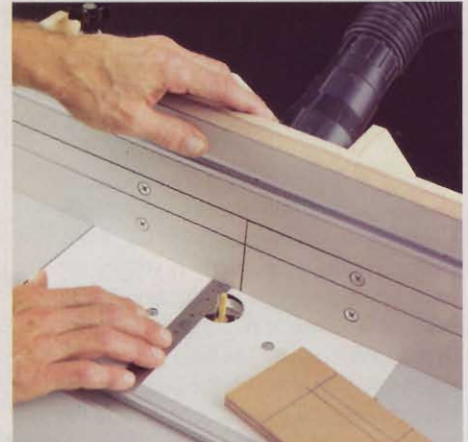

**2 POSITION THE FENCE**  
Chuck a slot-size bit in the router. Position the fence to center the bit in the slot.

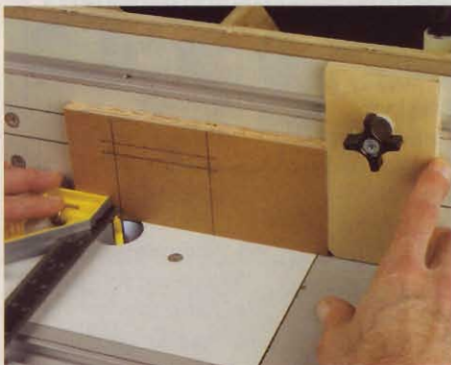

**3 SET THE RIGHT STOP**  
Align the slot left end line with the left edge of the bit. Position and secure the right stop.

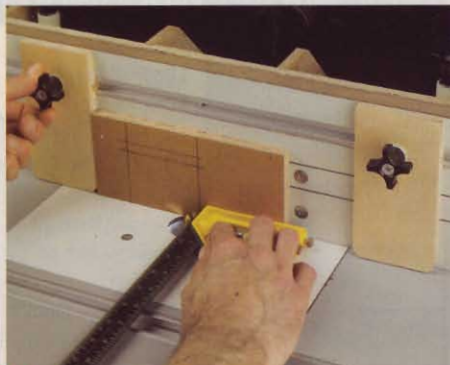

**4 SET THE LEFT STOP**  
Align the slot right end line with the right edge of the bit. Position and secure the stop.

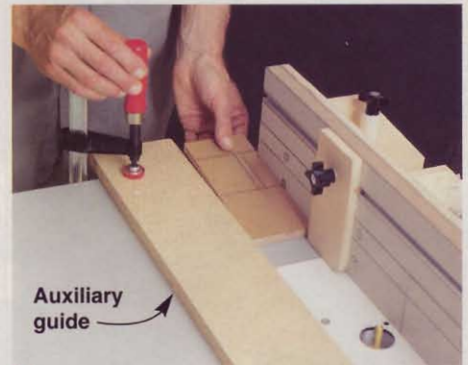

**5 ADD AN AUXILIARY GUIDE**  
Using the part width to gauge the distance, clamp an auxiliary guide parallel to the fence.  
*Note: The part should slide easily between the guide and fence without excess play.*



**6 DRILL OUT THE WASTE**  
Using a bit  $\frac{1}{8}$ " smaller than the slot width, drill overlapping holes inside the layout lines.  
*Note: Creating a slightly undersized rough slot with a drill bit lets you rout a clean finished size slot in one easy pass.*

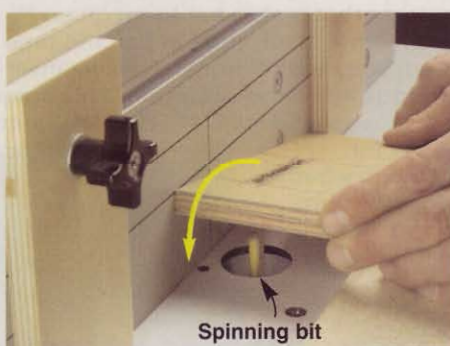

**7 MAKE A PLUNGE CUT**  
With the right end of the workpiece touching the right stop, lower it onto the spinning bit.

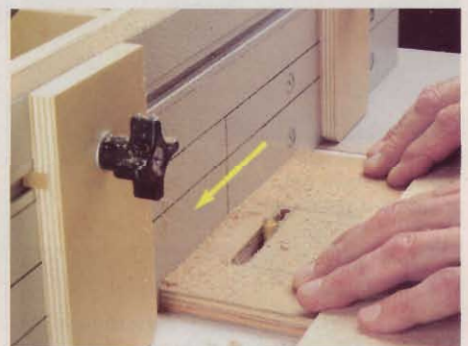

**8 ROUT THE SLOT**  
Feed the part to the left until it hits the stop. The auxiliary guide keeps the part in line.



# do-it-all router-table fence

This full-featured fence and a team of accessories make an unbeatable workshop combination.

Extensions put the fence-adjustment knobs at your fingertips.

Dust collection port helps keep your shop clean and you breathing easy.

Aluminum T-track makes attaching accessories a snap.

Easy-to-build bit guard and other accessories, see pages 44–46.

Stopblock locks in place for precision cuts, see page 45.

Segmented fence face accommodates all sizes of bits.



The 2"-high lower portion of the fence opens to house the majority of your bits.

To accommodate tall bits, such as this crown molding cutter, open the 1"-tall center portion.



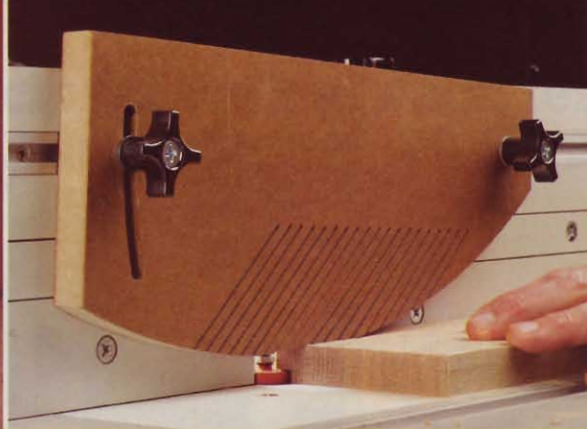

Feather board, see page 46

A one-piece feather board firmly holds down workpieces for consistent profiles.



Jointer, see page 44

A jointer face quickly straightens edges or removes saw marks for edge-gluing.

**I**s an ordinary fence limiting the performance of your table-mounted router? Now you can move your routing into the big leagues with this feature-packed upgrade. To add flexibility, the fence is designed to attach to a router table in just about every imaginable way. Use threaded inserts, T-track, or simply clamp the ends to your router table. If the fence is for a router table built into your tablesaw extension, an optional cleat enables you to clamp it to the tablesaw rip fence.

### Start with the fence body

**1** From 1/2" plywood (we used Baltic birch), cut the upright (A) and base (B) to the sizes listed on the **Materials List**. Adjust a dado blade to the thickness of your 1/2" plywood, and cut 1/8"-deep dados across the widths of the parts, where shown on **Drawing 1**.

**Note:** If your router table already has threaded inserts or T-track for mounting and securing a fence, make sure the location of the braces does not interfere with it.

Because these dados house the braces (C) [see page 42], they must align perfectly. Position the tablesaw rip fence as a stop 4" from the blade and, using the miter gauge to steady the parts, cut all four of the outside dados. Reposition the fence 11" from the blade and cut the four inside dados. Now cut the 1/2" rabbet along the bottom edge of the upright.



Mounting options for all situations



Optional fence cleat (E)

Fence-mounting options include threaded inserts, T-track, and clamps. For a saw-table-mounted router, clamp it to the rip fence.

### 1 FENCE BODY PARTS

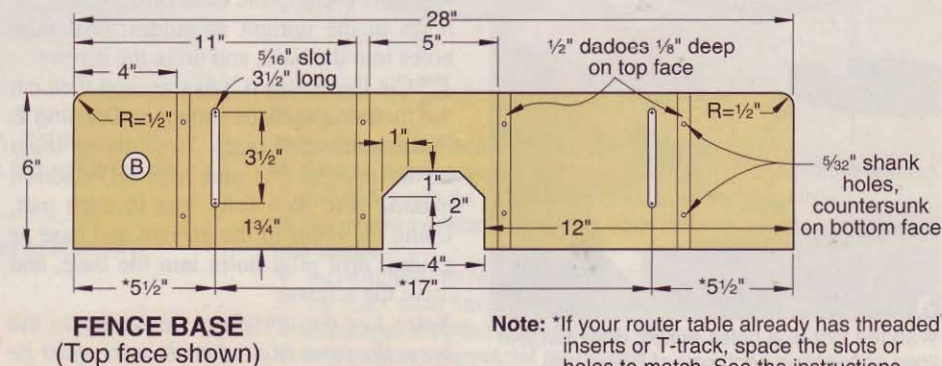
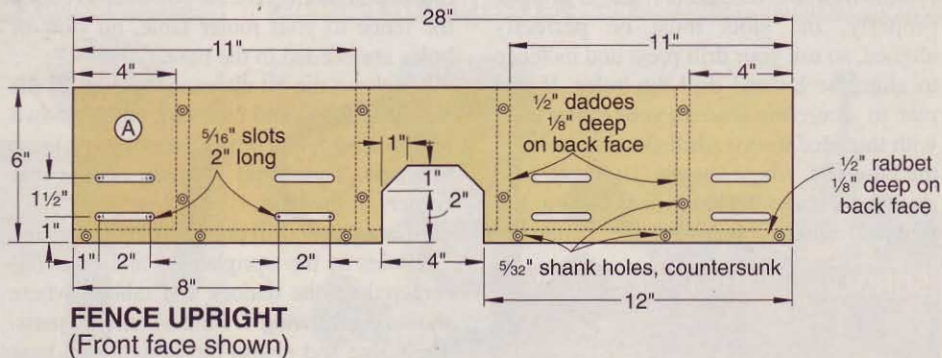

**Note:** \*If your router table already has threaded inserts or T-track, space the slots or holes to match. See the instructions.



## 2 EXPLODED VIEW

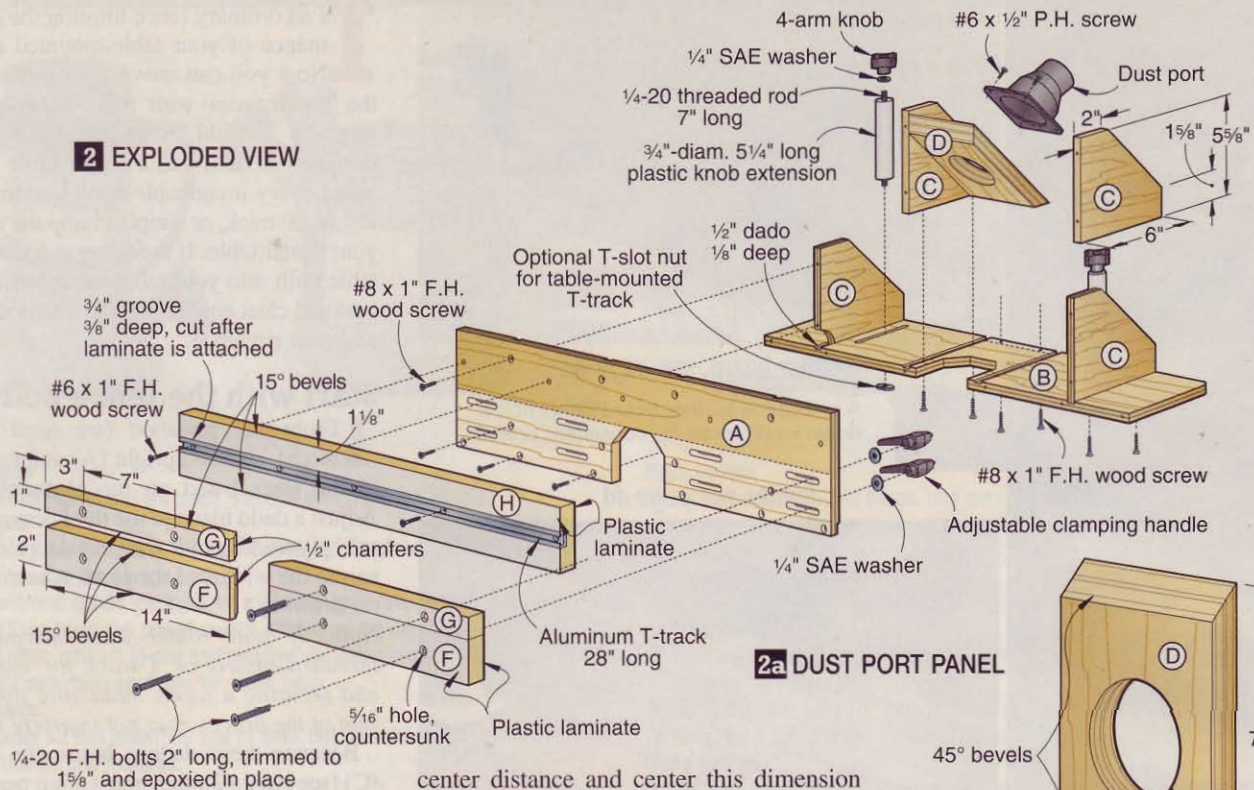

**Note:** For the upright to be square to the base after assembly, the dados and rabbet must be uniform in depth. Make two passes over the blade to make certain the bottoms of your cuts are completely cleaned out.

**2** Lay out the centers of the  $\frac{5}{16}$ " holes that form the ends of the slots in the upright (A), where shown on **Drawing 1**. For the movable face parts F and G to work properly, the slots must be perfectly aligned, so use your drill press and its fence to align the bit and drill the holes. If you plan to secure the fence to your router table with threaded inserts, drill slot-end holes in the base (B), where shown. To locate base slots for a router-table top that already has threaded inserts, measure the center-to-

center distance and center this dimension on the base. Now form the slots, as shown in **Photo A**. To machine perfect slots with a table-mounted router, see page 38.

If you plan to install T-track in your router-table top, drill only the slot-end holes closest to the front edge of the base (B). To locate base holes for a router-table top that already has T-track, measure the center-to-center distance and center this dimension on the base. If you plan to clamp the fence to your router table, no slots or holes are needed in the base.

**3** Lay out the bit clearance cutouts in the upright (A) and base (B), where shown on **Drawing 1**, and scrollsaw or jigsaw them to shape. Then sand  $\frac{1}{2}$ "-radii on the rear corners of the base.

**4** Using your drill press, drill countersunk holes in the upright (A) and base (B) centered on the dados and rabbet, where shown on **Drawing 1**. Finish-sand the parts. Then glue and clamp the upright and base together, keeping the ends flush. Using the holes in the upright as guides, drill pilot holes into the base, and drive the screws.

**5** Cut the braces (C) to size, and then cut them to the shape shown on **Drawing 2**. Finish-sand the braces. Now clamp them in the upright (A) and base (B) dados, making sure they fully seat in each part. Using the holes in the upright and base as guides, drill pilot holes into the base, and drive the screws.

**Note:** For the upright to be square to the base, the front edge of each brace must be square to its bottom edge.

## 2a DUST PORT PANEL

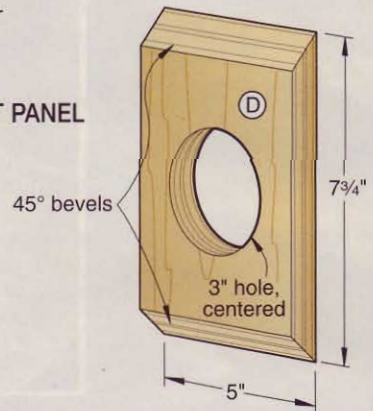

**6** Check the distance between the center braces (C), and cut the dust port panel (D) to size. Then cut  $45^\circ$  bevels on the ends, where shown on **Drawing 2a**. Center and draw a 3"-diameter circle on the panel with a compass, drill a blade start hole inside the circle, and saw out the hole. Finish-sand the panel. Now apply glue to the bevels and clamp the panel in place between the braces, with its top edge flush with the top edge of the upright (A).

## SCROLLSAW THE FENCE BODY

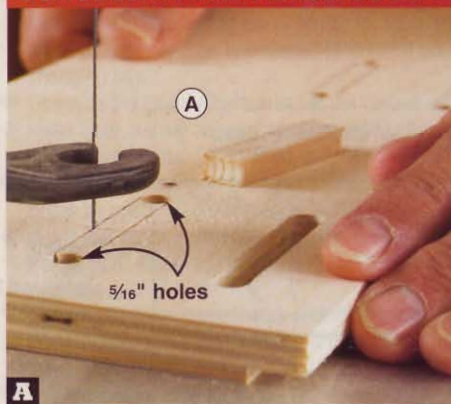

**A** With the slot-end holes drilled, draw tangent lines connecting each pair of holes, and scrollsaw the slots.

## SECURE THE FENCE



**B** For a tablesaw-extension mounted router, adding the optional cleat (E) allows you to clamp the fence to the tablesaw rip fence.



**7** If you will clamp the fence to your table saw rip fence for use with an extension-table mounted router, as shown in **Photo B**, measure the height of the rip fence, cut the optional fence cleat (E) to size, and finish-sand it. Clamp the cleat to the braces (C), where shown on **Drawing 3**. Drill countersunk holes through the cleat and into the braces, and drive the screws.

## Make the segmented face

**1** For the fence faces (F, G, H), cut two pieces of plastic laminate and a piece of  $\frac{3}{4}$ " medium-density fiberboard (MDF) to  $7 \times 29$ ". (We used Formica brand laminate in no. 464 Graystone color.) Adhere the laminate to both sides of the MDF with contact adhesive. True one edge and one end of the laminated blank on your table saw. Then cut the lower face (F), center face (G), and upper face (H) to size. Using a  $15^\circ$  bevel laminate trimming router bit, bevel the ends and edges of the parts.

**2** Cut  $\frac{1}{2}$ " chamfers on the inside ends of the lower face (F) and center face (G), where shown on **Drawing 2**. Then drill  $\frac{5}{16}$ " holes in the parts. Countersink the holes so the head of a  $\frac{1}{4}$ " flathead bolt is slightly below the laminate surface.

*Note: The holes are oversize to allow room for epoxy when permanently mounting the bolts in the faces (F, G).*

**3** Install a  $\frac{3}{4}$ " dado blade in your table saw and cut a  $\frac{3}{8}$ "-deep groove for the aluminum T-track in the upper face (H). Fit the track in the groove, ends flush with the upper face ends. Using the predrilled holes in the track as guides, drill shank holes through the upper face.

## Apply finish and assemble

**1** Cover the plastic laminate surfaces with masking tape. Then apply a clear finish to all the parts. (To adequately seal the MDF edges of the fence faces, we brushed on four coats of satin polyurethane, sanding with 220-grit sandpaper between coats. We finished the fence body with two coats of aerosol satin polyurethane, sanding between coats.) Remove the masking tape.

**2** Cut 2"-long flathead bolts to  $1\frac{5}{8}$ ", as indicated on **Drawing 2**. To protect the plastic laminate from excess epoxy, cover the holes in the faces (F, G) with plastic packing tape. Cut around the countersinks with a utility knife. Epoxy the bolts in the holes, as shown in **Photo C**. When the epoxy cures, remove the tape. Use a chisel to pare away any excess epoxy that protrudes beyond the plastic laminate surface.

**3** Clamp the fence body to a flat surface. Insert the lower face (F) and center face (G) bolts in the slots in the upright (A).

## 3 OPTIONAL TABLESAW FENCE CLEAT

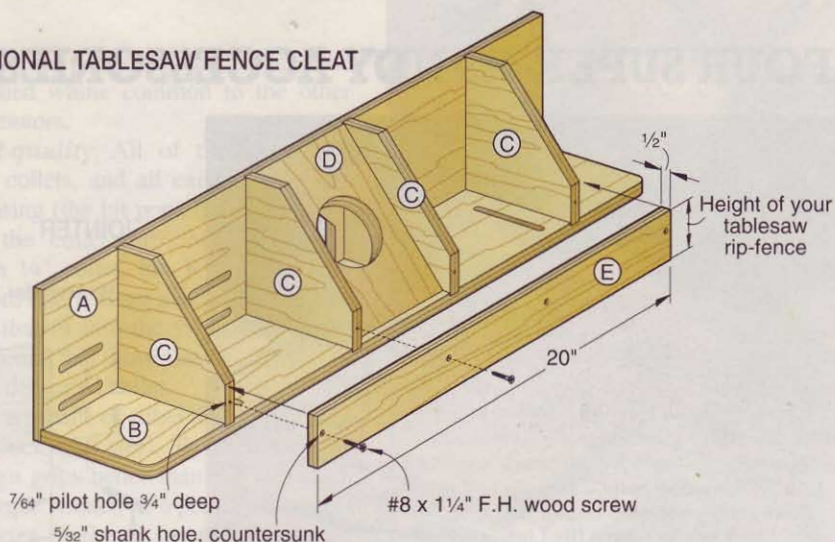

Insert business or playing cards between them as spacers, as shown in **Photo D**, and secure the faces with washers and adjustable clamping handles, shown on **Drawing 2**. Now position the upper face (H) on the center face, and insert card spacers between them. Make sure the ends of the upper face and upright are flush, and clamp the face to the upright. Fasten the upper face to the upright, as shown in **Photo D**.

**4** Position the dust port over the hole in the dust port panel (D). Using the holes in the port as guides, drill pilot holes into the panel, and screw the dust port in place.

**5** If needed, install T-track or  $\frac{1}{4}$ -20 threaded inserts in your router table top, where shown on **Drawing 4**.

**6** To clamp the fence to a router table equipped with T-track or threaded inserts, first cut two pieces of  $\frac{1}{4}$ -20 threaded rod 7"-long. For T-track, thread the rods into the raised-collar side of T-slot nuts so  $\frac{1}{16}$ " protrudes from the bottom of the nut. Then slide the nuts into the tracks, and drop the fence down over the rods. Slip the plastic knob extensions onto the rod and add

washers and four-arm knobs, as shown on **Drawing 2**. Tighten the knobs enough to secure the fence. Now fill the knob recesses with epoxy, fixing the threaded rods in place. For threaded inserts, thread the rods  $\frac{3}{8}$ " into the inserts. As you did with the T-track, add the fence, knob extensions, washers, and knobs. Tighten the knobs and add epoxy.

## 4 INSTALLING T-TRACK OR THREADED INSERTS

$\frac{3}{4}$ " groove  
 $\frac{3}{8}$ " deep for  
aluminum T-track

$\frac{7}{16}$ " hole  $\frac{1}{2}$ " deep for  
 $\frac{1}{4}$ -20 threaded insert  
epoxied in place

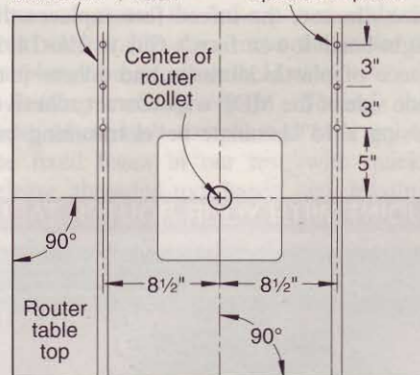

## EPOXY BOLTS TO THE FACES AND ASSEMBLE THE FENCE



Apply epoxy to the bolt shanks, and insert them into the holes. Snug the bolts in place with washers and nuts, making sure they are perpendicular to the surface. When the epoxy cures, remove the nuts and washers.

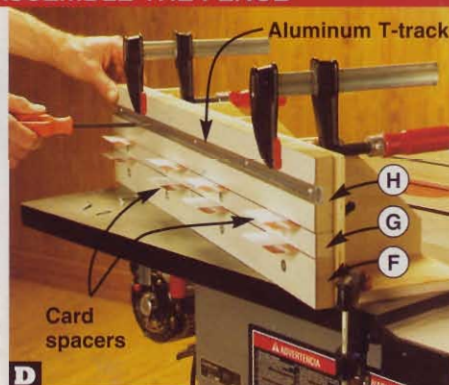

With card spacers between the fence faces (F, G, H), install the T-track in the upper face (H). Using the holes in the track and face as guides, drill pilot holes into the upright (A), and drive the screws.



# FOUR SUPER-HANDY ACCESSORIES FOR YOUR NEW FENCE



## JOINTER

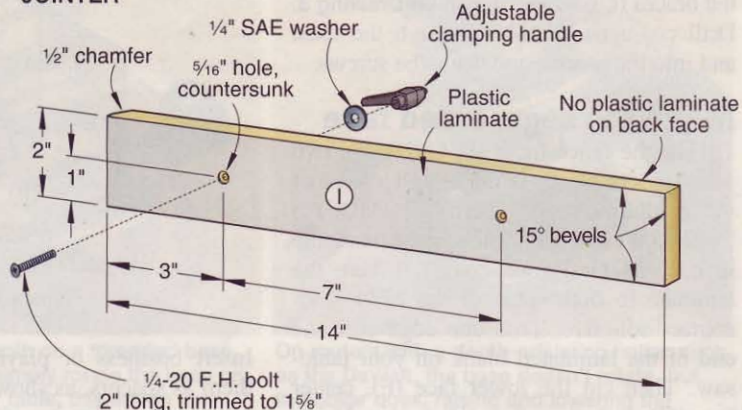

## 1 Jointer insert helps you straighten edges

### Make the infeed face

From  $\frac{3}{4}$ " MDF cut the infeed face (I) to size. (In use, the infeed face replaces the right-hand lower face.) Cut a  $2\frac{1}{2} \times 14\frac{1}{2}$ " piece of plastic laminate and adhere it to one side of the MDF with contact adhesive. Using a  $15^\circ$  laminate bevel trimming bit,

trim the excess laminate. Cut a  $\frac{1}{2}$ " chamfer on one end of the infeed face, where shown on the drawing above.

As you did when making the lower faces, drill  $\frac{5}{16}$ " countersunk holes in the infeed face. Mask the laminate and apply polyurethane. Then trim two 2"-long flathead bolts to  $1\frac{5}{8}$ " and epoxy them in place.

### Jointing with your fence

To joint an edge on your router table, remove the right-hand lower fence face (F)

and replace it with the infeed face (I). Then chuck a straight router bit in the router and align the left-hand lower fence face (F) with the bit, as shown below left. Now slide the infeed face (I) to within  $\frac{1}{8}$ " of the bit and secure it with washers and adjustable clamping handles. Make test cuts and fine-tune the fence position by loosening one end and lightly tapping it forward or backward with a mallet to precisely align the bit with the outfeed face. Joint your stock, as shown below.

## JOINT WITH YOUR ROUTER TABLE FENCE

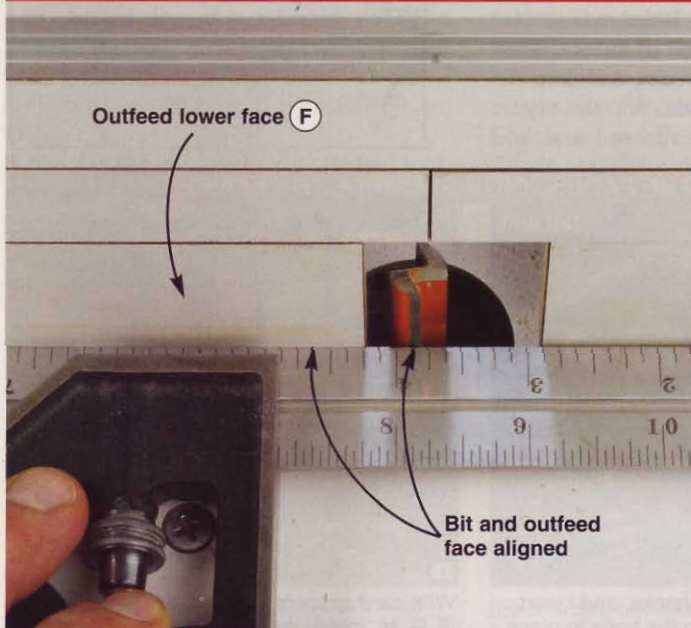

Position the left-hand (outfeed) lower fence face (F)  $\frac{1}{8}$ " from the cutting edge of the bit. Using a straightedge and moving the fence, align the fence face with the bit. Then clamp the fence in place.

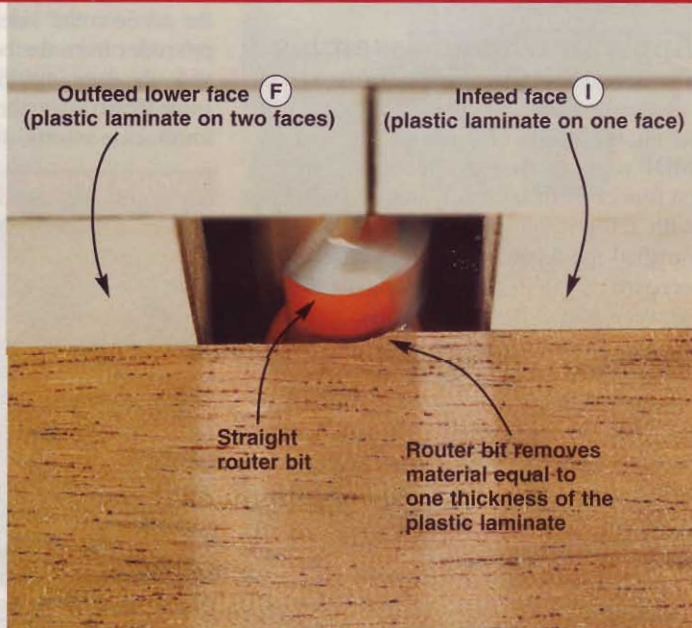

Slide your stock along the infeed face and into the bit. Because the jointer has plastic laminate on only one side, the bit removes stock equal to the thickness of the laminate.



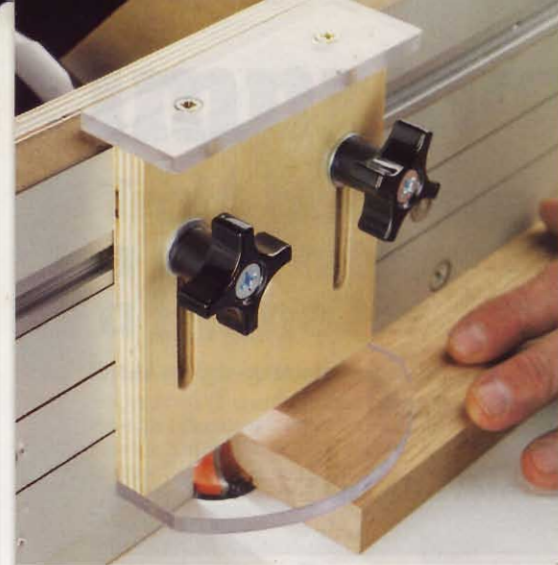

## 2 Adjustable bit guard protects fingers and deflects chips

### Cut and assemble the parts

Cut the guard body to size. As you did when slotting the fence upright (A), drill  $\frac{5}{16}$ " holes, as shown on the drawing at right. Then connect the holes with tangent lines and saw out the slots. Finish-sand the body and apply a clear finish.

From  $\frac{1}{4}$ " clear acrylic cut a  $1\frac{1}{2} \times 4\frac{1}{2}$ " piece for the handle and a  $2\frac{1}{4} \times 4\frac{1}{2}$ " piece

for the shield. Make a copy of the shield pattern on the *WOOD Patterns*® insert, and adhere it to the shield blank with spray adhesive. Bandsaw and sand the curve. Then drill countersunk holes in the handle and shield, where shown. (The holes are oversize to prevent cracking the acrylic.) Sand the edges of both parts smooth.

Centering the handle on the body, and aligning the straight edge of the shield flush with the back face of the body, use the holes as guides and drill pilot holes. Remove the masking sheet from the acrylic, and screw the parts to the body.

Thread two  $1\frac{3}{4}$ "-long flathead bolts into two 4-arm knobs, leaving the bolt heads protruding  $\frac{1}{2}$ " from the top of each knob. Then apply epoxy under the bolt heads and drive them the rest of the way. With the epoxy cured, slip washers on the bolts, insert them in the slots, and thread on T-slot nuts with the raised collars toward the knob.

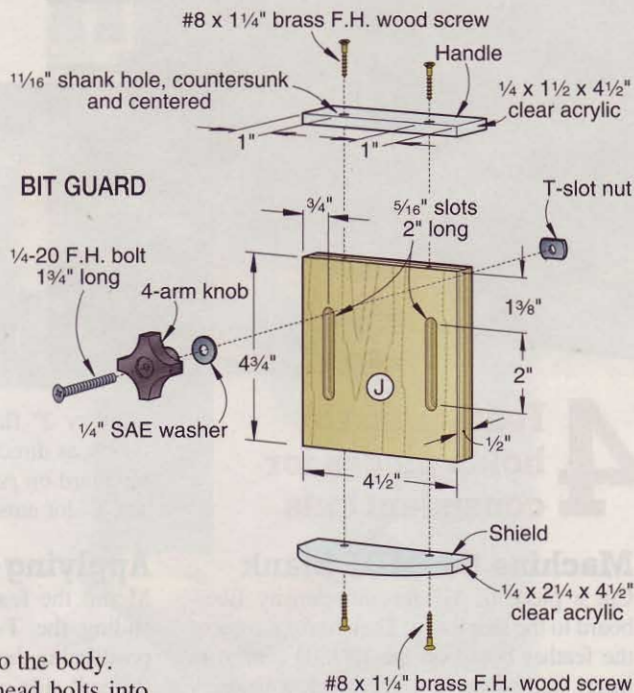

### Keeping your fingers safe

To use the bit guard, slide the T-slot nuts into the T-track, and center the shield over the bit. Grasp the guard by the  $\frac{1}{4}$ " acrylic handle, adjust its height to clear the stock you will be routing, and tighten the knobs.



## 3 Locking stopblocks enable precise stopped cuts

### Make the bodies and cleats

Cut two stop bodies (K) to size. Then cut a  $\frac{5}{16}$ " dado  $\frac{1}{4}$ " deep in the back of each one,

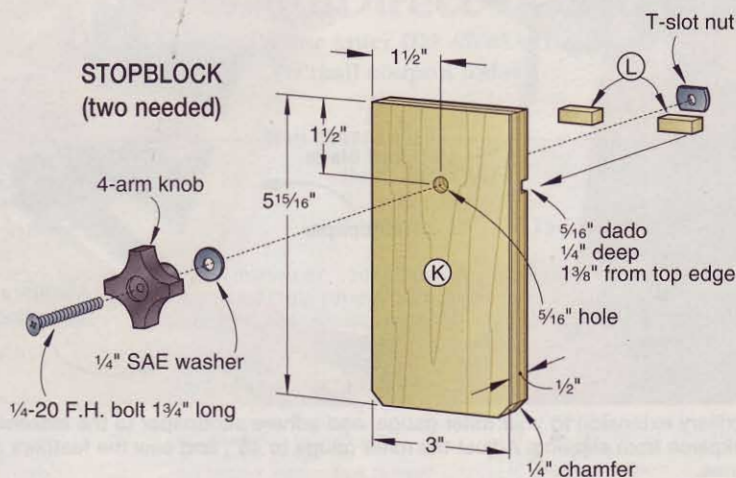

where shown on the drawing above. Drill a  $\frac{5}{16}$ " hole centered in the dados and on the width of the bodies. Now cut  $\frac{1}{4}$ " sawdust-relief chamfers on the bottom corners. Finish-sand the bodies.

Resaw and plane a  $\frac{5}{16} \times \frac{1}{2} \times 10$ " blank for the cleats (L), checking its fit in the stop body dados. Cut the cleats to length, and glue and clamp them in the dados with the ends flush with the edges of the stop body. Apply a clear finish.

Epoxy  $1\frac{3}{4}$ " flathead bolts into two 4-arm knobs. Install the knobs and washers in the stopblocks and add T-slot nuts.

### Making stopped cuts

To use the stopblocks, slide the cleats (L) and T-slot nuts into the T-track. Using a ruler, position the stopblocks the required distance from the bit, and tighten the knobs. For a good example of these stopblocks in action, see the article on page 38.



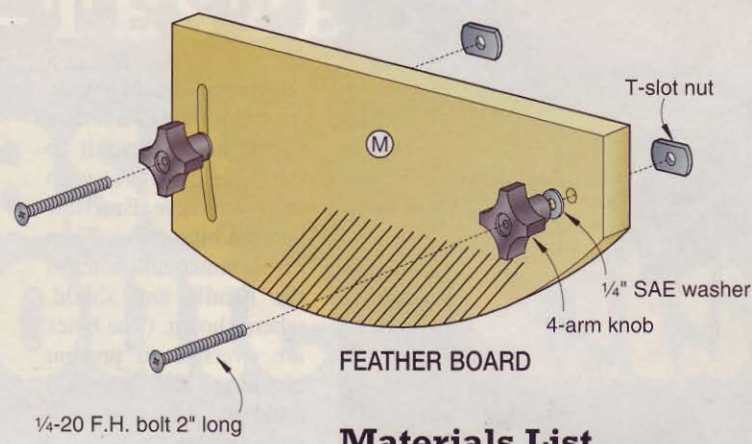
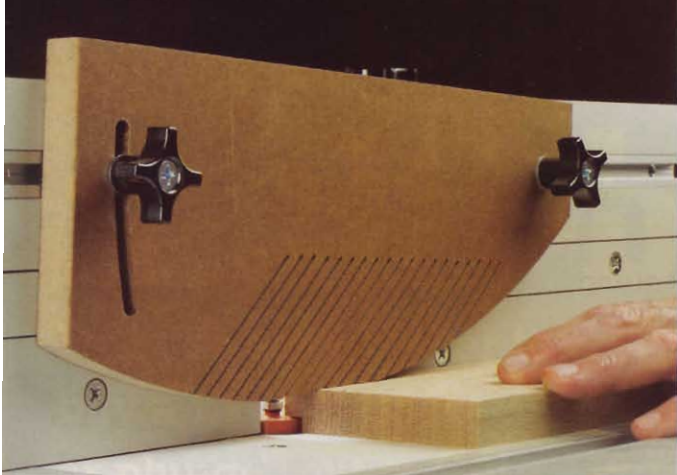

# 4 Feather board holds pieces for consistent cuts

## Machine the MDF blank

Cut a piece of 3/4" medium-density fiberboard to the size listed. Then make a copy of the feather board on the *WOOD Patterns*® insert, and adhere it to the blank with spray adhesive. Install a blade in your bandsaw that cuts a 1/16" kerf. (We used a 1/2" resawing blade.) Cut the feathers, as shown below. Chuck a 5/16" bit in your drill press and drill the pivot hole and the holes at the ends of the curved slot. Then scrollsaw the slot. Now bandsaw the curved edge of the feather board. Apply a clear finish.

Epoxy 2" flathead bolts into two 4-arm knobs, as directed in the instructions for the bit guard on page 45. Install the knobs and add T-slot nuts, where shown above.

## Applying the pressure

Mount the feather board on the fence by sliding the T-slot nuts into the T-track, positioning the pivot hole on the right-hand (infeed) side of the bit and the curved slot on the left-hand (outfeed) side. Center the feather board over the bit and snug the knobs. Slide a piece of the stock to be routed under the feather board, and press the feather board down on the stock so the feathers flex but the stock moves easily. Tighten the knobs. Hold the stock against the fence, and feed it past the bit.

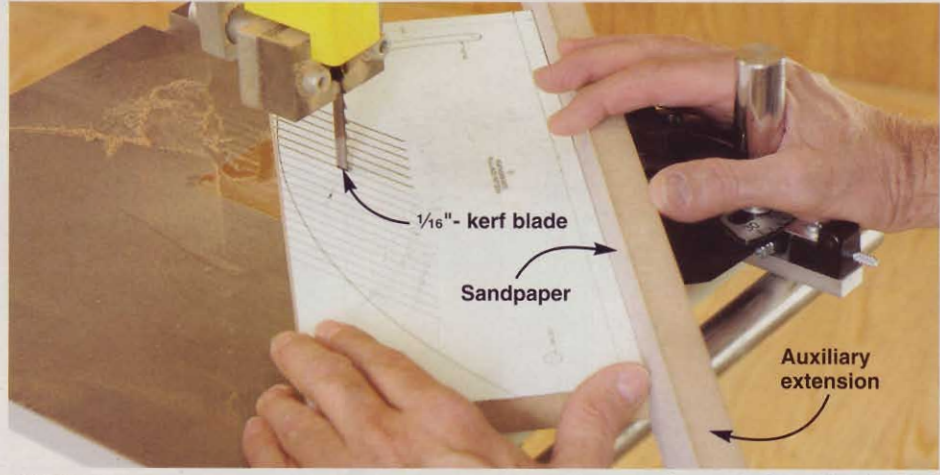

Attach an auxiliary extension to your miter gauge, and adhere sandpaper to the extension to keep the workpiece from slipping. Adjust the miter gauge to 45°, and saw the feathers along the pattern lines.

## Cutting Diagram

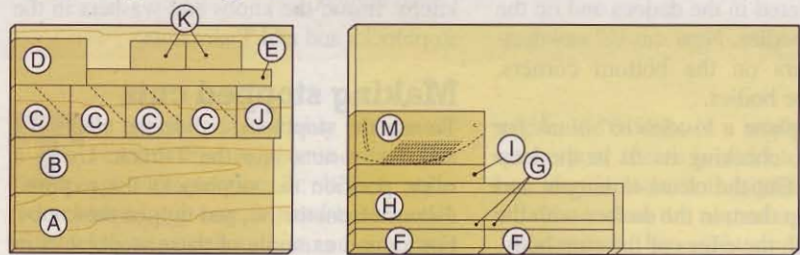

1/2 x 24 x 30" Baltic birch plywood    3/4 x 24 x 48" Medium-density fiberboard

## Materials List

| Fence                  | FINISHED SIZE |        |          | Mati. | Qty. |
|------------------------|---------------|--------|----------|-------|------|
|                        | T             | W      | L        |       |      |
| A upright              | 1/2"          | 6"     | 28"      | BP    | 1    |
| B base                 | 1/2"          | 6"     | 28"      | BP    | 1    |
| C braces               | 1/2"          | 5 5/8" | 6"       | BP    | 4    |
| D dust port panel      | 1/2"          | 5"     | 7 3/4"   | BP    | 1    |
| E optional fence cleat | 1/2"          | †      | 20"      | BP    | 1    |
| F* lower faces         | 3/4"          | 2"     | 14"      | MDF   | 2    |
| G* center faces        | 3/4"          | 1"     | 14"      | MDF   | 2    |
| H* upper face          | 3/4"          | 3"     | 28"      | MDF   | 1    |
| <b>Jointer</b>         |               |        |          |       |      |
| I infeed face          | 3/4"          | 2"     | 14"      | MDF   | 1    |
| <b>Bit guard</b>       |               |        |          |       |      |
| J guard body           | 1/2"          | 4 1/2" | 4 3/4"   | BP    | 1    |
| <b>Stopblocks</b>      |               |        |          |       |      |
| K stop bodies          | 1/2"          | 3"     | 5 15/16" | BP    | 2    |
| L* cleats              | 5/16"         | 1/2"   | 3/4"     | M     | 4    |
| <b>Feather board</b>   |               |        |          |       |      |
| M feather board        | 3/4"          | 5 3/4" | 14"      | MDF   | 1    |

†Height of your table saw rip fence. See the instructions.  
\*Parts initially cut oversize. See the instructions.

**Materials key:** BP-Baltic birch plywood, MDF-medium-density fiberboard, M-maple.  
**Supplies:** Contact cement, epoxy, spray adhesive.  
**Blades and bits:** Stack dado set, 15° bevel laminate-trimming router bit.

## Buying Guide

**Hardware kit.** 24x30" plastic laminate, 1/4" clear acrylic, 1/4-20 four-arm knobs (8), 1/4" SAE flat washers (16), 1/4-20 flathead bolts 2" long (12), 1/4-20 flathead bolts 1 3/4" long (4), T-slot nuts (8), #6x1/2" panhead screws (4), #6x1" flathead wood screws (5), #8x1" flathead wood screws (26), #8x1 1/4" brass flathead wood screws (4), 3/4" T-track 28" long (1), 3/4"-diameter 5 1/4"-long plastic knob extensions (2), 1/4-20 threaded rod 7" long (2), dust port (1). Kit no. RFT, \$124.95 ppd. Schlabaugh and Sons, 720 14th St., Kalona, IA 52247. Call 800/346-9663 or go to schsons.com.

**Wood kit.** All the 1/2" Baltic birch plywood, 3/4" medium-density fiberboard, and maple needed to build the router table fence and accessories. Kit no. LP-11 \$19.95 ppd. Schlabaugh and Sons, see above.

Written by **Jan Svec** with **Chuck Hedlund**  
Project design: **Jeff Mertz**  
Illustrations: **Roxanne LeMoine**

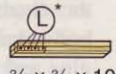

3/4 x 3/4 x 10" Maple  
\*Plane or resaw to the thickness listed in the Materials List.



# salad bowls

an easy way to turn them quickly

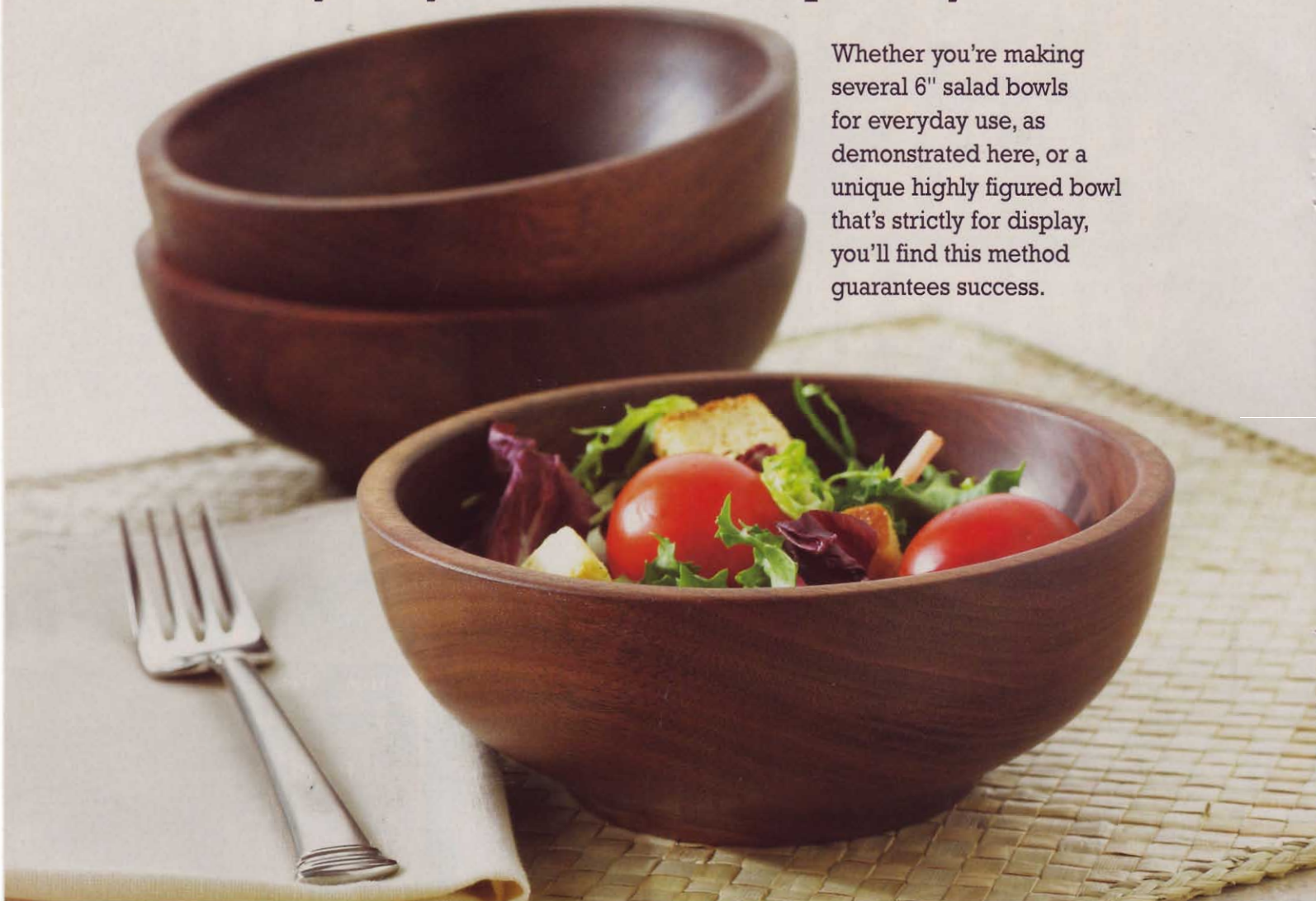

Whether you're making several 6" salad bowls for everyday use, as demonstrated here, or a unique highly figured bowl that's strictly for display, you'll find this method guarantees success.

**W**hen you turn multiple salad bowls, you want the process to go quickly and efficiently. The question: Is there a method that's faster than gluing a waste block to each bowl blank and mounting it on a face plate?

The answer: Use a four-jaw chuck to quickly mount, dismount, and remount your bowl-in-the-making. This lathe accessory used to be pricey, but we found one that does the job and includes a screw center for less than \$50.

## 1 Create the templates

Make a copy of the three templates on the *WOOD Patterns*® insert, and adhere them with spray adhesive to 1/8" tempered hardboard. Cut the templates to shape.



Ash



Hackberry



Cherry



Red Elm



Walnut

In case you don't have a ready supply of bowl blanks, we've lined up a supplier of reasonably priced ones in the species used to make these five bowls. See Sources on page 51.

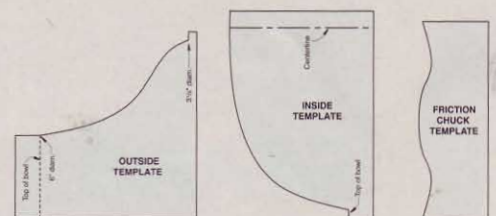



## 2 Mount and true the blank

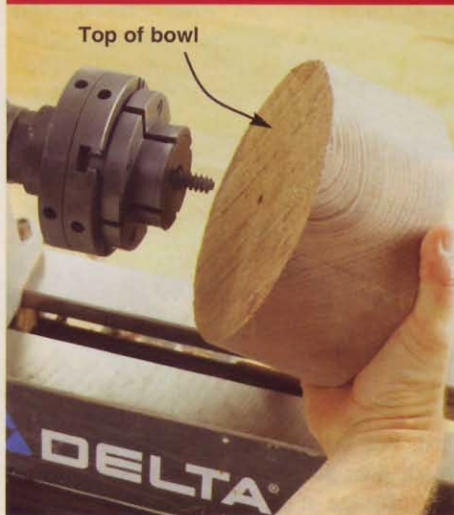

- **Tool:** 1/2" bowl gouge
- **Tool rest:** Slightly below center
- **Speed:** 600–800 rpm

Find the center of each 2 3/4 x 6 1/2 x 6 1/2" bowl blank by drawing its diagonals, and use a compass to draw a 6 1/4"-diameter circle. Bandsaw the blanks round, and then drill a centered 1/4" hole 1" deep in the top of each one. Grip the screw center with the chuck, and thread it into a blank, as shown above.



**Note:** Dimensions given for the screw center hole and spigot diameter and length are for the chuck shown.

True the bottom of the blank with your bowl gouge, removing just enough to make it flat, as shown above. Then use your gouge to true the outside edge, as shown above right, turning it to a 6 1/8"-diameter cylinder.

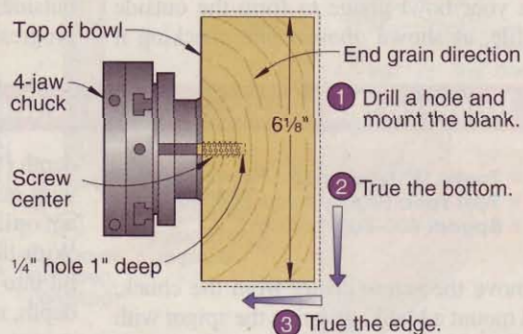

## 3 Turn a spigot for shaping the inside later



- **Tools:** 1/2" bowl gouge, 3/4" skew chisel
- **Tool rest:** Gouge, slightly below center; skew, slightly above center.
- **Speed:** 800–1,200 rpm

First, for remounting the bowl later, use the tail center to mark the center of the bottom. Then with a pencil, mark the diameters of the spigot and the bowl base on the bottom of the blank, as shown above. Use your bowl gouge to remove 1/4" from the blank

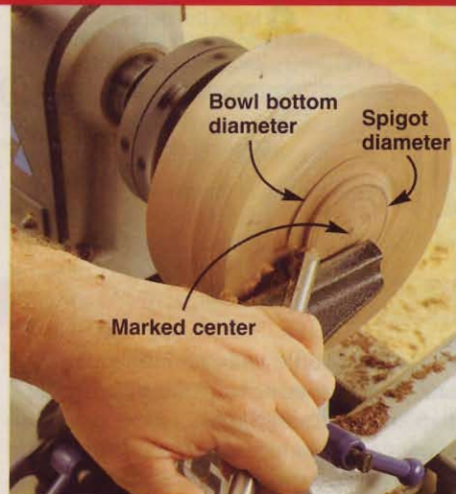

edge to the line marking the diameter of the bowl base. Now remove 3/16" from the area between the base diameter and the spigot diameter line, as shown above. You now have a 3/16"-long spigot and a 1/16" step that marks the diameter of the bowl base. Finally, use your skew chisel as a scraper to undercut the spigot edge, matching the angle of the dovetail jaws, as shown above right.

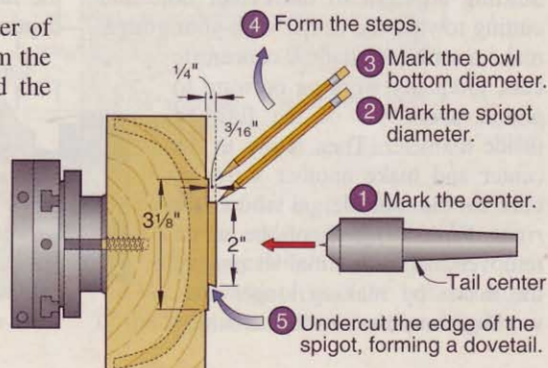



## 4 Form the outside profile

- **Tool:** 1/2" bowl gouge
- **Tool rest:** Slightly below center
- **Speed:** Gouge, 1,200–1,600 rpm; sanding, 800–1,200 rpm

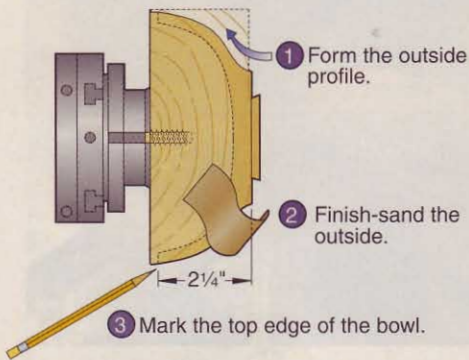

Use your bowl gouge to form the outside profile, as shown *above right*, checking it



with the template. With the lathe running, mark high areas with a pencil for removal, as shown *above right*. With the profile complete, slow the lathe and finish-sand the outside. (Start with 80-grit sandpaper and progress through 120, 180, 220, and 320



grit. For best results, increase grit by no more than 50 percent at each step.) Mark the top edge of the bowl. Remove the bowl blank from the screw center. Mount the remaining blanks, true the ends and edges, form spigots, and turn the outsides.

## 5 Reverse the blank, and mark the depth

- **Tools:** 1/2" bowl gouge, 5/16" drill bit
- **Tool rest:** Slightly below centerline
- **Speed:** 600–800 rpm

Remove the screw center from the chuck, and mount a blank, gripping the spigot with the jaws. Make sure the flat bottom of the blank is tight against the ends of the chuck jaws. Use your bowl gouge to true the top of the blank, turning it to the 2 1/4" finished height of the bowl. To provide a depth indication when hollowing the inside of the bowl, mark a 1 1/2"

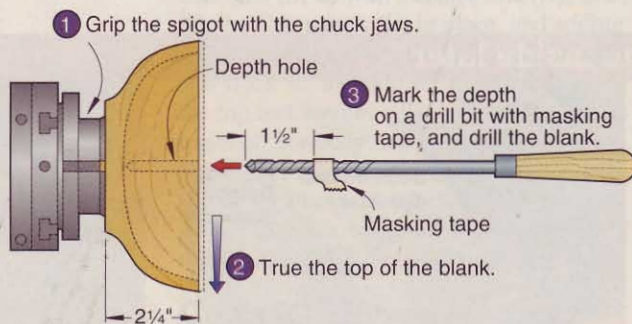

depth (1/4" less than the 1 3/4" finished depth) with masking tape on a handled drill bit or an ordinary bit chucked in the tailstock. With the lathe running, carefully push the bit into the screw chuck hole to the marked depth, as shown at *right*.

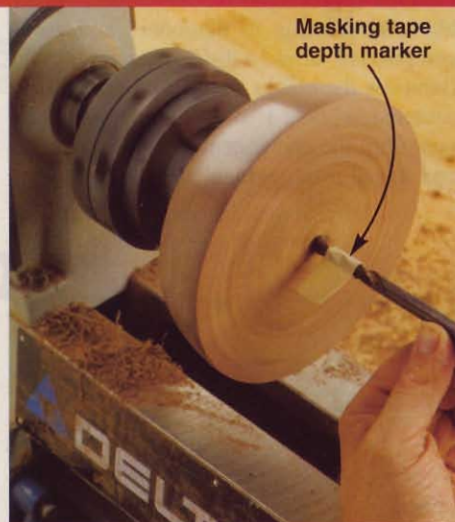

## 6 Hollow the inside

- **Tool:** 1/2" bowl gouge
- **Tool rest:** Slightly below center
- **Speed:** 1,200–1,600 rpm

Use your bowl gouge to hollow the bowl. Starting adjacent to the center hole and cutting toward the center with your gouge, make a series of shallow concentric cuts, gradually working outward to within about 1/8" of the finished inside diameter. Then return to the center and make another series of cuts to the outside, as shown at *right*. With the bulk of the waste removed, begin the final shaping of the inside by making longer cuts, working from the rim to the center.

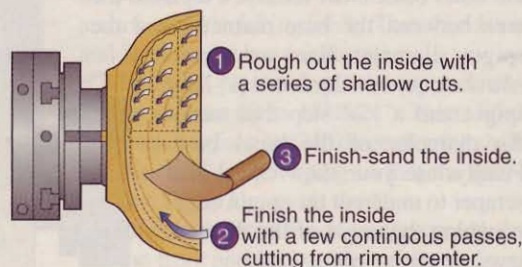

Check the profile with the inside template, and finish the inside by making steady, continuous cuts from the rim to the center, as shown *opposite top*. Finish-sand the inside. Remove the bowl from the chuck. Chuck the remaining blanks, true the tops, mark depths, and hollow and sand the insides.

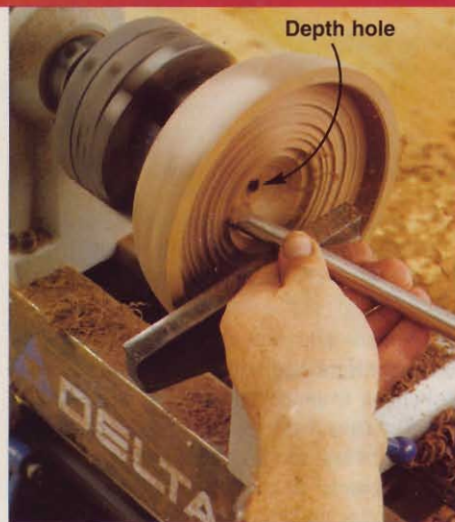



## 6 Hollow the inside (cont.)



Starting at the bowl rim...



...swing the tool handle to the left...



...and push the tip to the center.

## 7 Make a friction chuck, and finish the foot

- **Tool:**  $\frac{3}{8}$ " bowl gouge
- **Tool rest:** Slightly below center
- **Speed:** 800–1,200 rpm

Grip the screw center in the chuck. Use a compass to draw a  $3\frac{1}{2}$ "-diameter circle on a  $1\frac{1}{2}$ "-thick piece of softwood scrap, and bandsaw a disc. Drill a centered pilot hole, and mount it on the screw center. Use your bowl gouge to true the disc to a  $3\frac{1}{4}$ " diameter, and then shape the end to match the friction chuck template. Mount the bowl, placing a folded paper towel between it and the friction chuck, as shown at *right*. Apply moderate pressure to the center of the spigot with the lathe tail center. Rotate the bowl at slow speed, adjusting its position on the friction chuck until it is centered. Making very light cuts, use your bowl gouge to remove the spigot and create a slight hollow in the bowl foot. Work as close to the tail center as possible without completely cutting away the spigot, as shown at *far right*. Remove the bowl from the lathe, and pare away the remaining spigot with a chisel. Mount the other blanks on the friction chuck, and finish the feet.

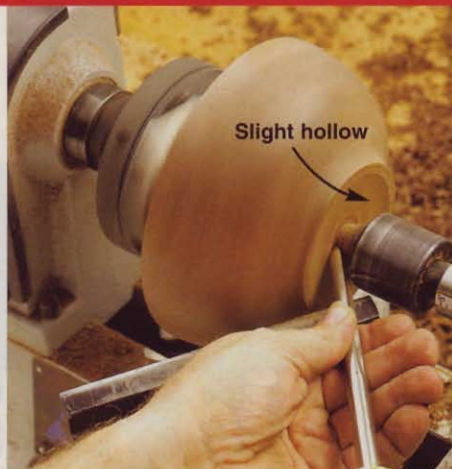
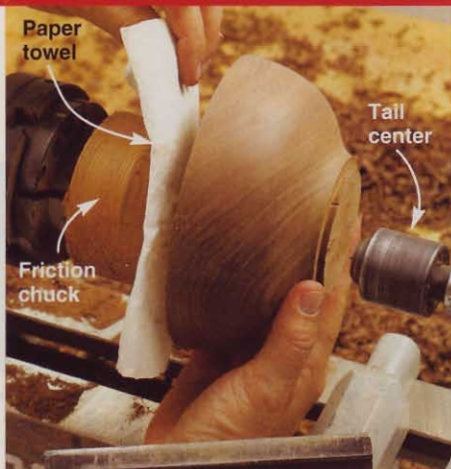

- 1 Mount a piece of softwood scrap on the screw center and form a friction chuck.

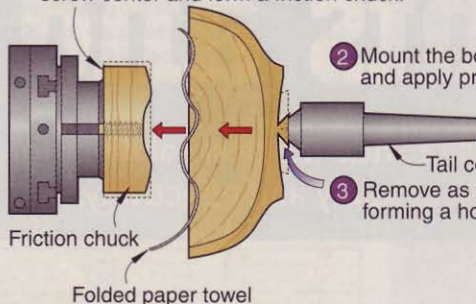

- 2 Mount the bowl on the friction chuck, and apply pressure with the tail center.

- 3 Remove as much of the spigot as possible, forming a hollow in the bowl foot.

## 8 Finish the bowls

Apply a food-safe finish to the bowls. (We used Behlen Salad Bowl Finish, following the directions on the container.) Now at your next meal, serve salad in bowls you'll be proud to place on the table. 🍴

Written by Jan Svec  
Project design: Jeff Mertz  
Illustrations: Roxanne LeMoine

### Sources

**Lathe chuck.** Four-jaw utility lathe chuck, includes a screw center and adapters for  $\frac{3}{4}$ "x16tpi and 1"x8tpi spindles, no. C3418, \$46.95. Penn State Industries. Call 800/377-7297, or go to pennstateind.com.

**Bowl blanks.**  $2\frac{3}{4}$ x $6\frac{1}{2}$ x $6\frac{1}{2}$ " bowl blanks in your choice of ash, cherry, hackberry, red elm, or walnut. 6 bowl blanks for \$21, 12 for \$42, or 18 for \$63. Supply of some species may be limited. Call Johnson Wood Products, 563/933-6504 for availability and shipping charges.

**Finish.** Behlen Salad Bowl Finish no. 125701 (pint) or no. 125702 (quart). Packard Woodworks. Call 800/683-8876, or go to packardwoodworks.com for prices.

See more  
shop-tested  
woodworking skills  
at  
[woodmagazine.com/shopskills](http://woodmagazine.com/shopskills)







Thinned 50 percent

Thinned 20 percent

Full-strength polyurethane

# build a better finish using solvents and thinners

Discover which products provide the best solutions for a wide range of finishing challenges. Then learn how to use them safely and effectively.

**G**athering dust on many workshop shelves are cans of solvent used mostly to clean a brush or wipe up a splatter. Between the odors and the warning labels, you may be afraid to use solvents for much else. That's too bad because those cans hold the answers to many common finishing problems.

First, let's sort out why some products can be called a solvent one time and a thinner the next. Solvents dissolve solids, turning them into a liquids. Thinners dilute fin-

ishes, letting you apply lighter coats. For example, the mixtures *above* show oil-based polyurethane thinned with 50 percent mineral spirits for use as a wiping finish or sealer coat over bare wood and thinned 20 percent to help brush marks level out of subsequent coats.

Some products dissolve as well as thin a finish: Alcohol thins and dissolves shellac, for example. Mineral spirits can dissolve or thin varnish while the finish is wet, but does neither once the finish cures.

## Your solvent toolbox

Solvent needs vary with the finishes you use. To alter oil-based finishes, you'll need mineral spirits—also called paint thinner—and naphtha. Both are extracted from petroleum, but they're as different as gasoline and motor oil in how quickly they evaporate. Because naphtha vaporizes quickly, use it sparingly to shorten the drying time of oil-based finishes. Mineral spirits evaporate slowly, giving the finish time for brush marks time to disappear.



When you work with shellac, keep plenty of denatured alcohol on hand. Some types of alcohol are labeled “shellac thinner,” but any denatured alcohol—ethanol with methanol added to make it undrinkable—containing little or no water will work.

Lacquer thinner’s mix of chemicals both dissolves and dilutes lacquer, but can also affect its drying time. (See “Lacquer’s Chemical Cocktail” on page 54.) Latent solvents in the mix slow the evaporation rate and give the finish time to level, while primary solvents, such as acetone, speed up the drying process. Most lacquer thinners are blended for moderate drying speed. For other solvents, see “Common Solvents/Thinners at a Glance,” below.

### The skinny on thinning

Although oil-based finish labels warn “Do Not Thin,” many finishing pros thin varnish or polyurethane by as much as 50 percent. Thinning oil-based finishes reduces the thickness of the coat without damaging the finish, says chemist Paul Fishbein, a woodworker and member of the

## Discover the Thinner Difference

Here are three ways thinned finishes can help you create a more attractive project:

- Mix shellac at the rate of 1 ounce of flakes per 5.3 fluid ounces of alcohol (a 1½-pound cut) to create a seal coat. “I’ll stain wood and seal it with shellac,” chemist Paul Fishbein says. Any topcoat will bond to the shellac and, he adds, “I don’t worry about what’s on top interacting with the stain.”
- Add up to 25 percent mineral spirits to polyurethane to create a brushable finish with added drying time for brush marks and bubbles to level out and disappear.
- Thin polyurethane with 10 percent mineral spirits for a thick top coat that still has enough drying time to level.

International Professional Finishers Group.

Manufacturers discourage thinning because federal rules limit finishes’ volatile organic compound (VOC) content—the fumes you smell from an open can. More factory-added solvents would push finishes beyond legal VOC limits, but that doesn’t prevent you from adding thinners at home.

Unlike varnish and polyurethane, penetrating oil finishes, such as tung oil, can be

tricky to thin. As thinned oil finishes cure, added solvent may produce enough warmth to push the finish from the pores of the wood. “The solvent or the oil itself will bleed out of the wood,” Fishbein says.

Shellac, thinned to as much as 1 ounce of flakes to 16 fluid ounces of alcohol, is a versatile and durable sealing coat. Thinned shellac dries quickly without bubbling, making it a smooth surface for many types

## Common Solvents/Thinners at a Glance

|                              |      |  |  |  |  |  |  |  |
|------------------------------|---|---|---|---|--|---|---|---|
|                              | Acetone   | Brush cleaner   | Denatured alcohol   | Lacquer thinner   | Methyl ethyl ketone  | Mineral spirits   | Naphtha   | Toluene/Xylene (Xylo)   |
| Dissolves                    | Lacquer; removes epoxy and contact cement   | Oil and latex paint, varnish  | Shellac; crystallizes hide glue   | Lacquer, shellac, and water-based finishes  | Lacquer  | Wax   | Wax (also cleans off silicones and oil)   | Grease, oil; softens water-based finishes   |
| Thins                        | Lacquer and polyester resins  | Not recommended for thinning  | Shellac   | Lacquer, shellac, and catalyzed lacquer   | Lacquer  | Wax, varnish, and oil-based finishes such as polyurethane                             | Oil-based paints and varnishes  | Anti-rust coatings  |
| Safety and handling factors* | Use a charcoal filter respirator and neoprene or natural-rubber gloves                  | Not for general cleaning because of fire risk                                       | Denatured alcohol is poisonous  | Toluene content known to cause birth defects  | Extremely flammable  | Use odorless types with fewer aromatic ingredients                                    | More volatile than mineral spirits  | Handle with polyvinyl alcohol (PVA) or nitrile gloves                                 |
| Comments, other uses         | Cleans fiber-glass resins; speeds finish drying; shelf life is six months after opening | A blend of petroleum distillates and alcohol plus other solvents                    | Don’t use alcohol containing water to dissolve shellac                              | Most have medium drying times; retarder can be added to slow drying                 | Creates a moderate drying time for lacquer; not as fast as acetone                   | Also called paint thinner; slows drying time for some oil-based finishes              | Speeds up drying (but not curing) time for spraying and brushing finishes             | Toluene evaporates faster than xylene   |

\* See “Solvent Safety” on the following page for general safety and handling tips for all solvents and thinners.



## Lacquer's Chemical Cocktail

Paul Fishbein describes lacquer and lacquer thinner as a "witch's brew." That's because the delicate balance between the ingredients spells the difference between a flawless finish and one marred by brush strokes or a sticky surface.

To help you understand what's going on in this brew, here's the story behind the most significant groups of ingredients listed on lacquer labels:

- N-butyl acetate, methyl isobutyl ketone, acetone, methyl isobutyl ketone (MIBK), methyl ethyl ketone (MEK), propylene glycol monomethyl ether, ethyl acetate, ethylene glycol, and monobutyl ether are *primary* solvents. They dissolve the nitrocellulose in lacquer that forms the finish.

- Methanol, n-butanol, and isopropyl alcohol are called *latent* solvents. The latter two evaporate slower than the primary solvents and give the finish time to level out and eliminate bubbles or brush marks.

- Toluene and xylene dilute the mix. They also lessen shrinkage of the finish to stop cracking, help the film to bond harder, and reduce yellowing.

of topcoats. "Thinned shellac makes a seal coat to minimize or eliminate fish-eye (bubbles trapped in a fast-drying finish) so you don't have to worry about applying your topcoats," Fishbein says. "I always use it to seal in glaze coats or toner coats (colors applied after a sealer coat and before a topcoat). It's cheap, fast, and works very well."

For tips on thinning polyurethane and shellac, see "Discover the Thinner Difference" on the *previous page*.

By comparison, thinning lacquer is tricky because different types of additives alter lacquer in different ways. For example, a *lacquer retarder* slows down lacquer's rapid drying time enough for it to be brushed on. Typical lacquer thinner contains an assortment of solvents, many affecting the drying time or leveling ability of the finish without making it significantly thinner. That's why Fishbein recommends thinning lacquer no more than 10 percent with premixed lacquer thinners.

The most difficult finish to alter uses the safest thinner: water. Unlike oil-based counterparts, water-based finishes can only be thinned about 10 percent. Adding more

## Warming Up Your Water-Based Finish



If water-based finishes are the future, they'll need to win over woodworkers accustomed to the warm amber tones of oil-based finishes. A few drops of concentrated, water-soluble dye can help water-based finishes mimic the subtle amber tones of oil-based finishes. Dye is especially helpful for water-based finishes applied to darker woods, such as the oak shown *above*, and on walnut.

water than that spaces out the resins in the finish until they're unable to dry into an even, solid coating.

### Future finishes

Environmental safety and consumers' health concerns are driving research to create durable water-based finishes. More than a decade ago, manufacturers were given an economic incentive to develop water-based alternatives when California banned the sale of most oil-based finishes. Add to that market a host of woodworkers eager to avoid filling their houses and shops with solvent odors.

Oil-based finishes will survive, but they aren't the category where finish manufacturers are investing their research dollars, Fishbein says. Their research goal is a water-based finish with the durability, ease of application, and warm tone of oil-based finishes. (See "Warming Up Your Water-Based Finish" *above*.)

"There'll be a phase-in for water-based finishes, and we're at the beginning of that," Fishbein says. "I think you'll always be able to buy an oil-based finish, but it'll become a specialty item."

## Solvent Safety

To work safely with solvents, keep them away from your skin and eyes, avoid inhaling them, and eliminate the possibility of accidental fires. The safety gloves, goggles, and respirators you'll need to do this are available from hardware stores and home centers. Vapor filtration masks, powered respirators, and other specialty products can be ordered by mail from suppliers such as Rockler Woodworking and Hardware (800/279-4441 or [rockler.com](http://rockler.com)) and Lee Valley Tools (800/871-8158 or [leevalley.com](http://leevalley.com)).



Choosing the right gloves to wear depends on the solvent or thinner you use. Reusable or disposable neoprene gloves are an all-around safety precaution against acetone, naphtha, and methyl alcohol, but provide less protection against toluene, xylene/xylol, methyl ethyl ketone, or turpentine. Readily available nitrile gloves, or harder to find and expensive polyvinyl alcohol (PVA) gloves, provide better protection from those chemicals. Latex gloves will not protect against most solvents.



There's no definition of the "well-ventilated area" cited on product labels, but a good guide is that when you smell a solvent, you're at risk. Don't use solvents where the fumes could be touched off by a pilot light or accidental spark, as from an electric motor. If you use a fan to bring fresh air into your workshop or finishing room, position it so that fresh air passes through the blades and blows solvent away from the spark of the fan motor. In addition to venting your workspace, wear a respirator designed to filter out solvent fumes. Surgical-style dust masks won't do that. Make sure the respirator fits snugly and has charcoal filter cartridges that absorb VOCs.



For more protection than safety glasses can provide, wear splash-resistant goggles. Look for eye protection that fits tight against your face and has vents that block splashed liquids.



Solvent-soaked rags in confined spaces, such as a trash can, become a fire hazard when oils react with oxygen in the air and generate heat until the rags burst into flames. Hang unfolded rags in a well-ventilated area where they can dry before being discarded. (They're dry when you no longer smell solvent odors.) You can also drape them over the rim of a metal bucket or fireproof object until they dry. ♣





# picture-perfect bookends

Frame favorite photos and support good reading with this pair of easily made bookends.

**H**ere's a project you can build in an evening or two with just a few shop scraps. Sized to hold standard 4x6" vertical format photos, you won't have to cut a single joint to assemble the stack-laminated frames. A simple jig guarantees perfect results.

**Note:** The quantities shown on the **Materials List** make one bookend. See **Source** for a mail-order kit of supplies and planed-to-thickness wood.

## First build the frame

**1** For the rails and stiles (A, B, C, D) cut a  $\frac{3}{4}$ "-thick board to  $1\frac{1}{4}$  x 48". Resaw it in half and plane the halves to  $\frac{1}{4}$ " thick. For a safe method of resawing on your tablesaw, see the sidebar on page 61. Now cut the rails (A) and stiles (B) to the lengths listed on the **Materials List**. Then rip the remaining stock to  $\frac{1}{8}$ " wide, and

cut the center rail (C) to length. Now cut a  $2\frac{3}{4}$ "-long rail spacer. Rip the remaining stock to  $\frac{1}{16}$ " wide, and cut the center stiles (D) to length. Finally cut  $\frac{1}{8}$ " glue-relief grooves  $\frac{1}{16}$ " deep in both sides of parts C and D, where shown on **Drawing 1**.

**2** To ensure quick and accurate assembly of the frame, make the jig shown in **Drawing 2**. (We used MDF.) Cut the  $\frac{3}{16}$ " and  $\frac{1}{8}$ " dowel spacers shown to keep the  $\frac{1}{8}$ "-wide center rail (C) and  $\frac{1}{16}$ "-wide center stiles (D) flush at the outside edges with the  $\frac{1}{4}$ "-wide rails (A) and stiles (B). Then assemble the frame members (A, B, C, D), as shown in **Photos A, B, and C**.

**Note:** Be sure to plane, saw, or sand the center cleat to  $\frac{1}{16}$ " thick to allow the caul to apply even pressure to the frame. Cover the base, cleat, and clamp blocks with plastic packing tape to prevent excess glue from sticking to the jig parts.

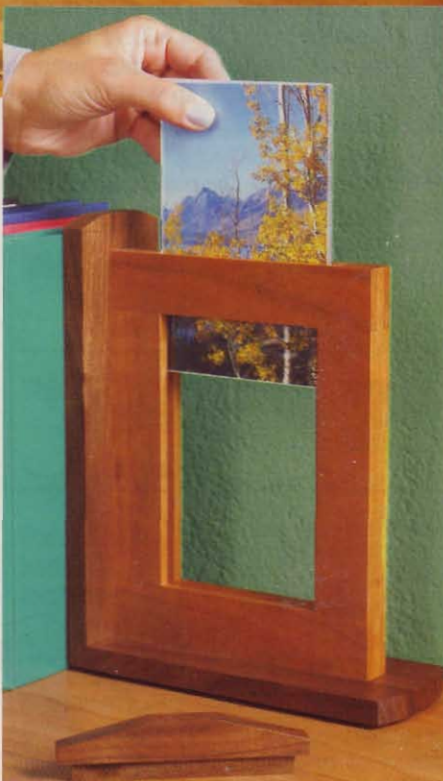

To quickly change photos, simply lift off the walnut cap and pull up the acrylic panes/photo sandwich.



A SIMPLE JIG MAKES PERFECTLY FLAT AND SQUARE FRAMES A SNAP

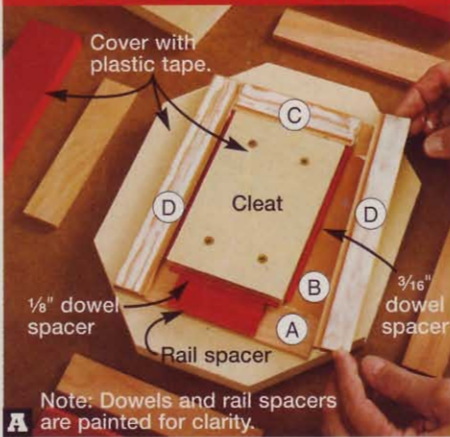

Position two rails (A) and two stiles (B) around the cleft. Then place dowel spacers next to the cleft and add the rail spacer. Apply glue to both sides of the center rail (C) and center stiles (D) and lay them in place.

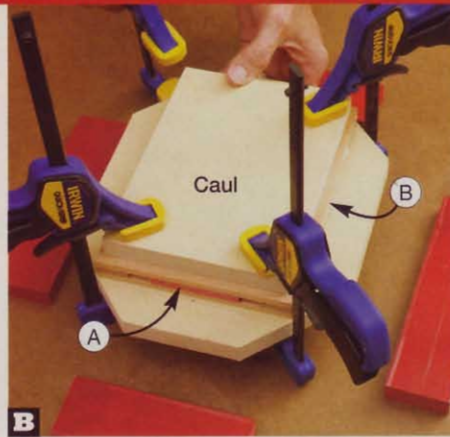

Position the second set of rails (A) and stiles (B) around the cleft. Place the caul on top of the stack, centered, and clamp it in place at the corners, applying light pressure. Wipe off any excess glue with a damp cloth.

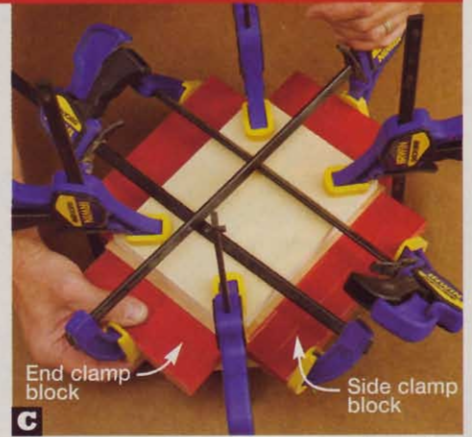

Clamp the side clamp blocks then the end clamp blocks in place, applying light pressure. Alternating among the side clamp block, end clamp block, and caul clamps, gradually increase the clamping pressure.

1 EXPLODED VIEW

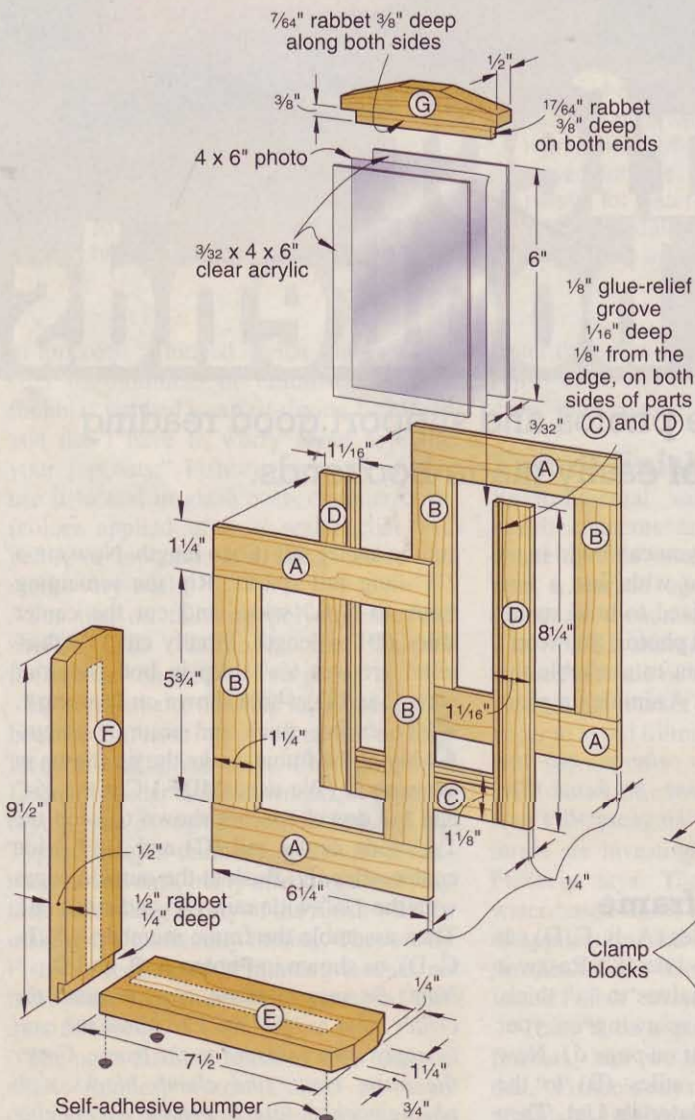

Add base, upright, and cap

- 1 With the glue dry, remove the frame from the jig, and finish-sand it. Take care not to round the edges or ends.
- 2 From 1/2" stock, cut the base (E) and upright (F) to size. Mark the angled corners, where shown on **Drawing 1**, and bandsaw and sand them to shape. Then rabbet the bottom end of the upright, where shown. Finish-sand the parts.
- 3 Glue and clamp the base (E) and upright (F) together, checking them for square. When the glue dries, glue, center, and clamp the frame (A/B/C/D) in place.
- 4 From 1/2" stock, cut the cap (G) to size. Make a copy of the cap pattern on the *WOOD Patterns*® insert, and adhere it to the part with spray adhesive. Then install a zero-clearance insert in your tablesaw. Now, housing a dado blade in an auxiliary fence attached to your tablesaw rip fence, rabbet the cap, as shown in **Photos D and E** on the next page.
- 5 Bandsaw and sand the cap (G) tapers to the pattern lines. Then finish-sand the entire cap.

2 CLAMPING JIG

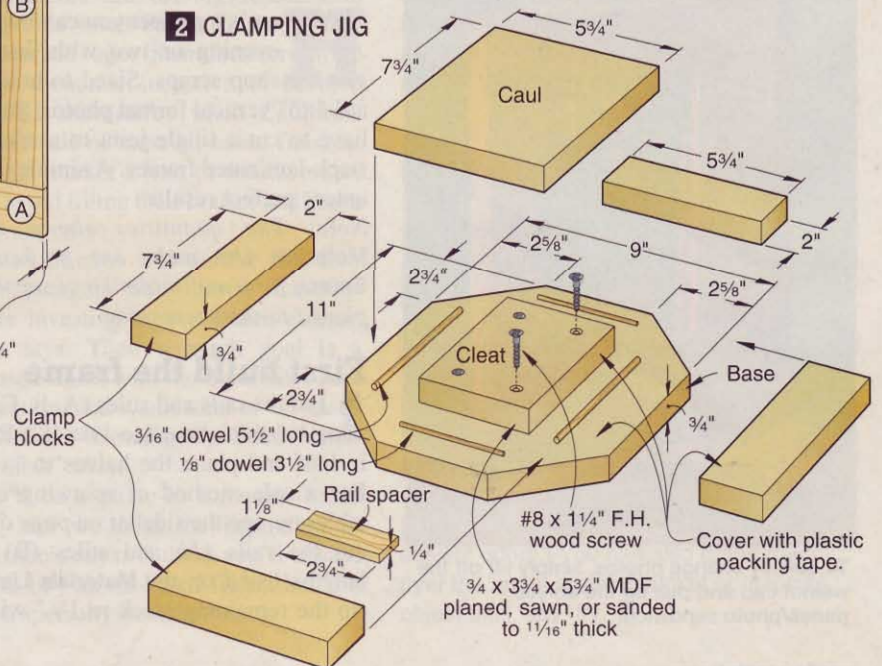



## RABBET THE CAP FOR A SNUG FIT

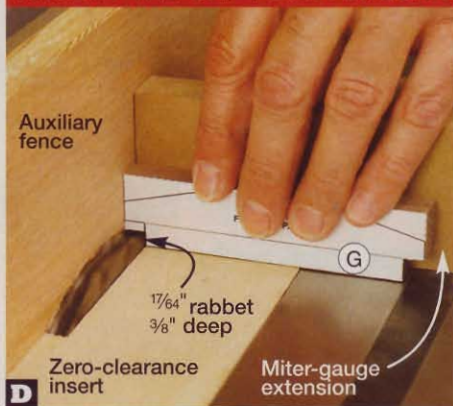

With  $\frac{1}{64}$ " of the dado blade exposed, cut  $\frac{3}{8}$ "-deep rabbets in the cap (G) ends.

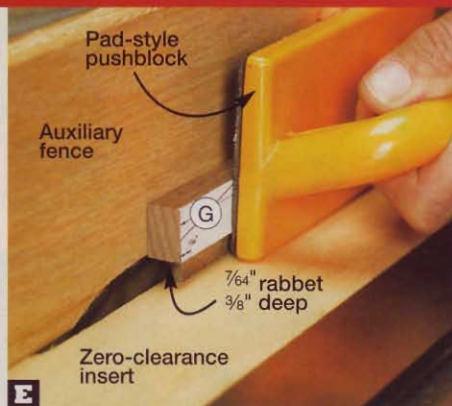

Repositioning the fence to expose  $\frac{7}{64}$ " of the blade, rabbet the edges of the cap (G).

## Now finish and assemble

1 Check over the bookend, and resaw areas that need it. Slightly chamfer any sharp edges with a sanding block. Apply a clear finish. (We applied two coats of an aerosol satin polyurethane, sanding with 220-grit sandpaper between coats.)

2 Stick four self-adhesive bumpers to the bottom corners of the base. Then cut two  $\frac{3}{32}$ "-thick clear acrylic panes to 4x6". (We used a 50-tooth combination blade. For an alternate method, see the **Shop Tip**, below.) Smooth the sharp edges with a sanding block, and remove the protective covering. Sandwich a photograph between the panes, slide it into the frame, and add the cap (G). (For a bookend visible from both sides, sandwich two photos back-to-back between the panes.) Now put a picturesque end to your bookshelf.

Written by **Jan Svec** with **Chuck Hedlund**  
Project design: **Steve Levine**, Dayton, N.J.  
Illustrations: **Roxanne LeMoine**

## Cutting Diagram



$\frac{1}{2}$  x 3 $\frac{1}{2}$  x 24" Walnut (.3 bd. ft.)

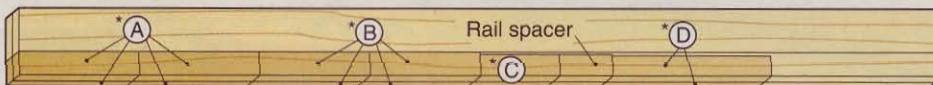

$\frac{3}{4}$  x 3 $\frac{1}{2}$  x 48" Cherry (1.3 bd. ft.)

## Materials List

| Part             | FINISHED SIZE   |                   |                   | Matl. Qty. |
|------------------|-----------------|-------------------|-------------------|------------|
|                  | T               | W                 | L                 |            |
| A* rails         | $\frac{1}{4}$ " | $1\frac{1}{4}$ "  | 6 $\frac{1}{4}$ " | C 4        |
| B* stiles        | $\frac{1}{4}$ " | $1\frac{1}{4}$ "  | 5 $\frac{3}{4}$ " | C 4        |
| C* center rail   | $\frac{1}{4}$ " | $1\frac{1}{8}$ "  | 4 $\frac{1}{8}$ " | C 1        |
| D* center stiles | $\frac{1}{4}$ " | $1\frac{1}{16}$ " | 8 $\frac{1}{4}$ " | C 2        |
| E base           | $\frac{1}{2}$ " | 2 $\frac{3}{4}$ " | 7 $\frac{1}{2}$ " | W 1        |
| F upright        | $\frac{1}{2}$ " | 2 $\frac{3}{4}$ " | 9 $\frac{1}{2}$ " | W 1        |
| G cap            | $\frac{1}{2}$ " | $1\frac{1}{8}$ "  | 4 $\frac{5}{8}$ " | W 1        |

\*Parts initially cut oversize. See the instructions.

**Materials key:** C—cherry, W—walnut.

**Supplies:**  $\frac{3}{4}$ " medium-density fiberboard, #8x $1\frac{1}{4}$ " flat-head wood screws,  $\frac{1}{8}$ " and  $\frac{3}{16}$ " dowel, and plastic packing tape for the frame clamping jig; self-adhesive bumpers;  $\frac{3}{32}$ " clear acrylic; spray adhesive.

**Blade:** Stack dado set.

## Source

**Wood and supplies kit.** Cherry and walnut planed to the finished thicknesses for the parts listed above,  $\frac{3}{32}$ " clear acrylic, self-adhesive bumpers, MDF and dowels for one clamping jig with each order. Order kit no. W-159 and indicate one of the following quantities: one pair of bookends, \$32.95 ppd., two pairs of bookends, \$59.95 ppd., five pairs of bookends, \$129.95 ppd. Heritage Building Specialties. Call 800/524-4184, or go to heritagewood.com.

\* Resaw in half and plane both pieces to the finished thickness. See the instructions.

## Safe resawing on a tablesaw

When it's time to resaw lumber for thin stock, a bandsaw usually comes to mind. But in many situations, such as preparing the  $\frac{1}{4}$ "-thick stock for the frame parts in this project, you can do it on your tablesaw. Most 10" tablesaws easily resaw boards up to 5 $\frac{1}{2}$ " wide. The photos, below, show how.

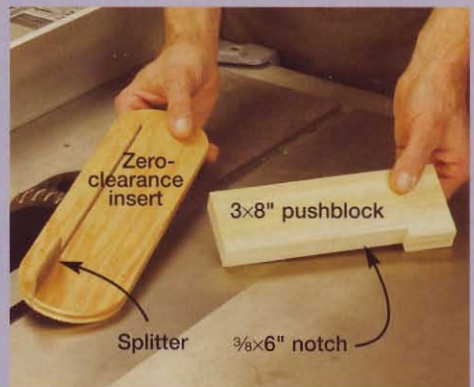

Outfit your tablesaw with a zero-clearance insert equipped with a  $\frac{1}{8}$ " hardboard splitter that protrudes  $\frac{3}{4}$ " above the surface of the insert. Then make a 3x8" pushblock with a  $\frac{3}{8}$ " notch 6" long from stock at least as thick as the stock to be resawn.



Adjust the blade height to  $\frac{13}{16}$ " to clear the splitter, center the stock on the blade, and make the first cut. Then make additional cuts, raising the blade each time until the depth of the cut is just over half the width of the stock you are resawing.

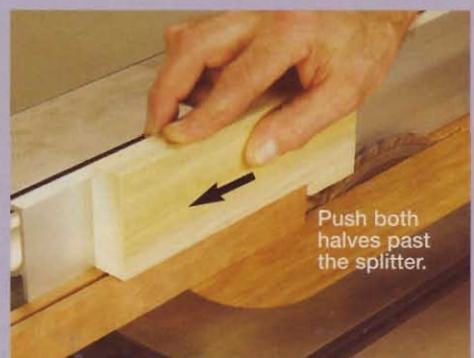

Flip the stock end-for-end, and keeping the same side against the fence, repeat the previous cutting sequence in the other edge until the stock is sawn in half. Push both pieces of the resawn stock all the way past the splitter with the pushblock.

## SHOP TIP

### Rout away rough cuts in acrylic

If you get too much chipping when cutting the acrylic panes on your tablesaw, here's a way around the problem: Using the finest-tooth blade you have, cut 4 $\frac{1}{4}$ x6 $\frac{1}{4}$ " blanks. Then cut a piece of  $\frac{3}{4}$ "-thick scrap to 4x6". One at a time, adhere the blanks to the scrap with double-faced tape, centering the blank on the scrap. Chuck a flush-trim bit in your table-mounted router and trim the blanks to finished size, as shown at right.





more than a

# nightstand

You'll find  
this beauty  
at home  
just about  
anywhere.

**M**ade to complement our heirloom-quality Arts & Crafts bed in the previous issue, this solid-oak nightstand features matching corbels and arched rails in addition to ample drawer and open storage. Don't need a nightstand? This piece also can serve as a lamp table, as shown at *right*. Either way, you'll find the project well-suited for any home.

Thanks to its simply stated design, you can place this multipurpose piece next to an easy chair or sofa, keeping your favorite reading materials handy.





## AT A GLANCE

■ Overall dimensions are 28" wide × 20<sup>1</sup>/<sub>8</sub>" deep × 30<sup>1</sup>/<sub>2</sub>" high.

■ For the board feet of lumber and other items needed to build this project, see page 66.

### Let's start with the sides

**1** From <sup>3</sup>/<sub>4</sub>" stock, cut the legs (A), top side rails (B), bottom side rails (C), and center stiles (D) to the sizes listed in the **Materials List**. Save the rail cutoffs to make test tenons.

**2** From <sup>3</sup>/<sub>4</sub>" stock planed to <sup>3</sup>/<sub>8</sub>" thick, cut the side panels (E) to size. Sand the panels to 220 grit, and remove the dust. Then stain both faces. (We used Watco Danish Oil Finish, Dark Walnut.)

**3** Using a dado blade in your tablesaw that matches the thickness of the side panels, cut a centered <sup>3</sup>/<sub>8</sub>" groove <sup>5</sup>/<sub>16</sub>" deep along the inside edges of the legs (A) and top and bottom side rails (B, C) and along both edges of the center stiles (D), where shown on **Drawing 1**.

**4** To form tenons on the rails (B, C) and stiles (D), where shown on **Drawings 1** and **1a**, attach an auxiliary fence to your saw fence and an auxiliary extension to the miter gauge. Then cut a <sup>3</sup>/<sub>8</sub>" tenon <sup>1</sup>/<sub>4</sub>" long on a rail cutoff. Test-fit the tenon in the grooves in the rails. Adjust your setup, if needed, and cut the tenons on the rails.

**5** Place the legs (A) *inside* face up on your workbench, and pair them together with the grooved edges on the inside and the ends flush. Next, lay out the locations for the <sup>3</sup>/<sub>4</sub>" rabbet, two <sup>3</sup>/<sub>4</sub>" dados, and <sup>3</sup>/<sub>8</sub>" mortises on each pair of legs, where dimensioned on **Drawing 2**, making sure you have mirror-image pairs. Extend the lines for the rabbets and dados onto the leg edges. The rabbets and dados will receive the top

### INSTALL THE LEG FILLERS

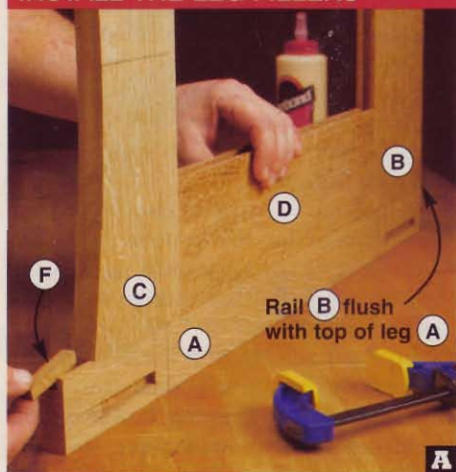

Dry-assemble a leg (A), top and bottom side rails (B, C), and center stile (D). With rail B flush with the top of the leg, glue and clamp a filler (F) in the leg groove tight to rail C.

### 1 SIDE ASSEMBLY

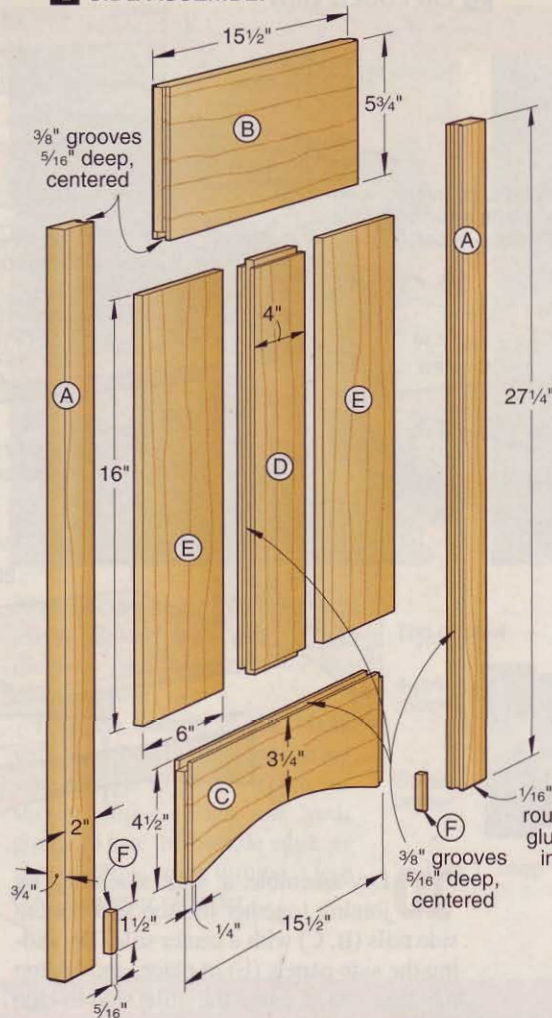

### 1a TENON DETAILS

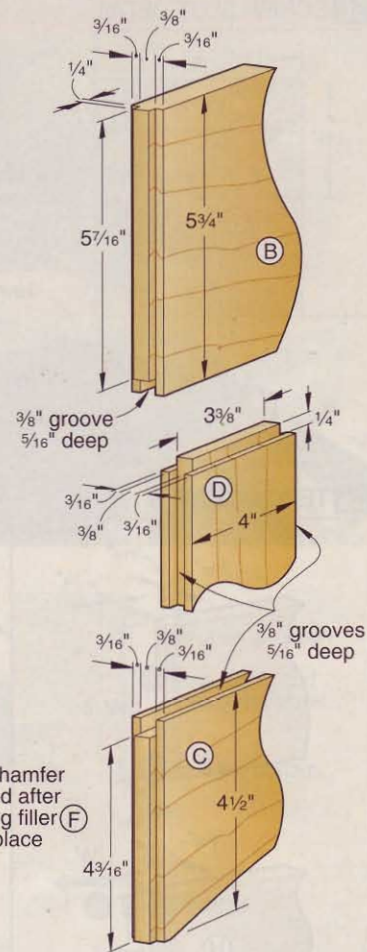

and center shelves (I) and bottom shelf (K), and the mortises will accept the tenons on the top back rail (G) and bottom rails (H), where shown on **Drawing 3**.

**6** Using a <sup>3</sup>/<sub>8</sub>" brad-point bit in your drill press and a fence to keep the holes aligned, drill the <sup>3</sup>/<sub>8</sub>" leg mortises <sup>3</sup>/<sub>16</sub>" deep. Then square the sides and ends with a chisel.

**7** Mark the ends and center of the arch on the bottom side rails (C), where dimensioned on **Drawing 1**. Bending a fairing stick to these points, draw the arches. Then bandsaw and sand them to shape. (For a free fairing stick plan, go to [woodmagazine.com/fairing](http://woodmagazine.com/fairing).)

**8** To make the leg fillers (F), rip a <sup>5</sup>/<sub>16</sub>"-wide strip from a piece of <sup>3</sup>/<sub>8</sub>×12" stock. Crosscut four 2"-long fillers from the piece. Glue and clamp a filler in the bottom of the groove in each leg (A), as shown in **Photo A**. Let the glue dry overnight. Then trim the fillers flush with

### 2 LEFT SIDE ASSEMBLY (Inside face shown)

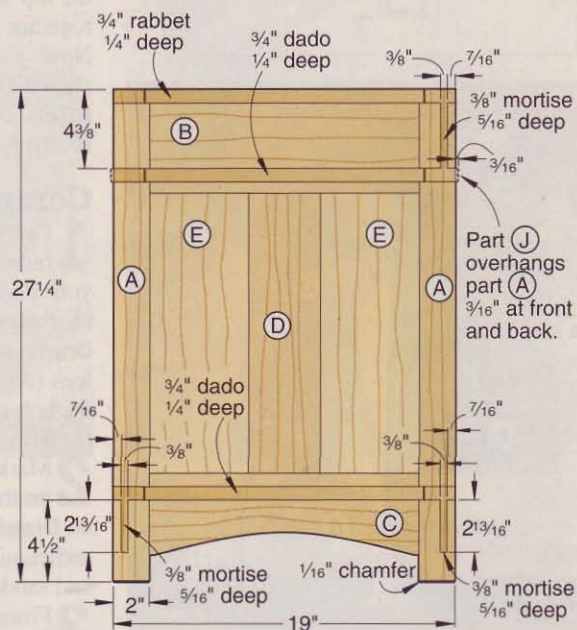

the bottoms of the legs, and sand the fillers flush with the ends and edges of the legs.

**9** Using your table-mounted router, rout a <sup>1</sup>/<sub>16</sub>" chamfer around the bottom edges of the legs, where shown on **Drawing 2**.



### 3b SCREW SLOT DETAIL

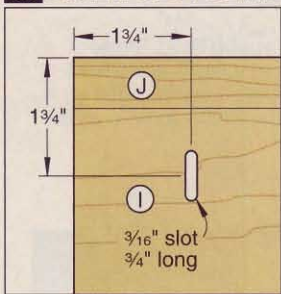

### 3 EXPLODED VIEW

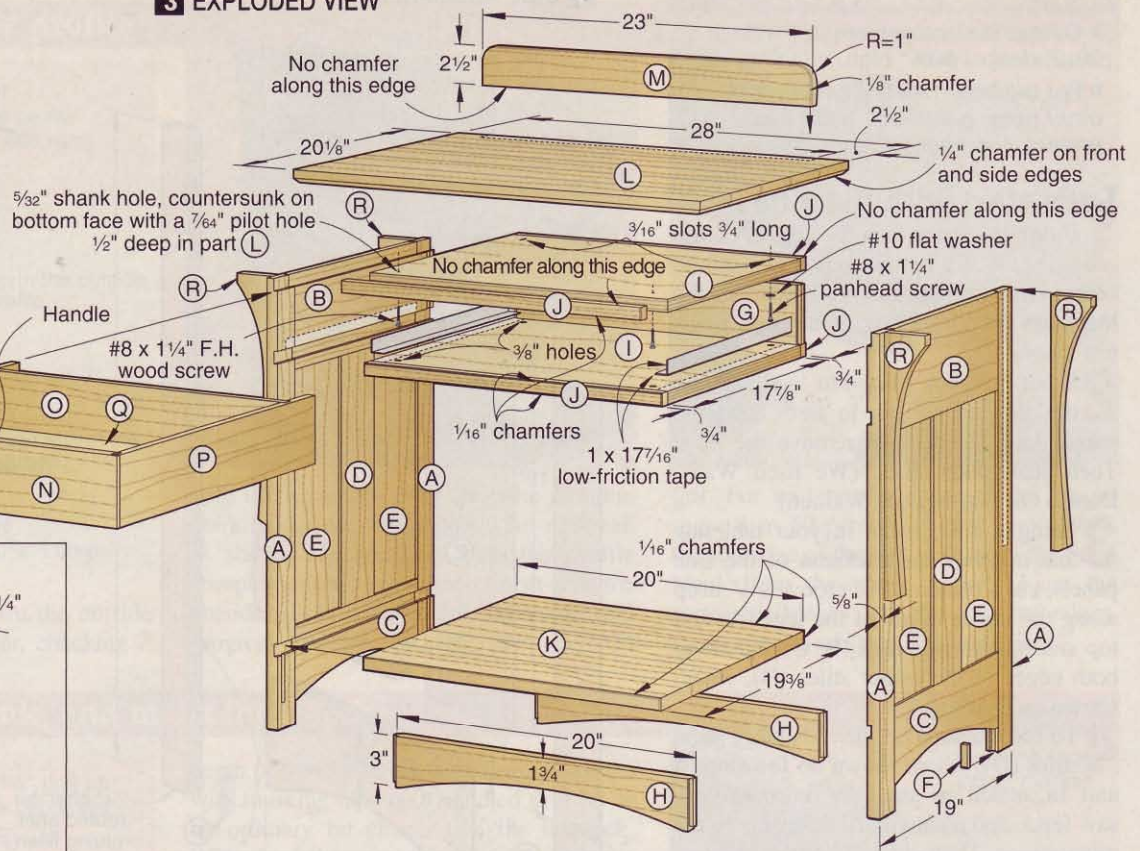

### 3a TENON DETAILS

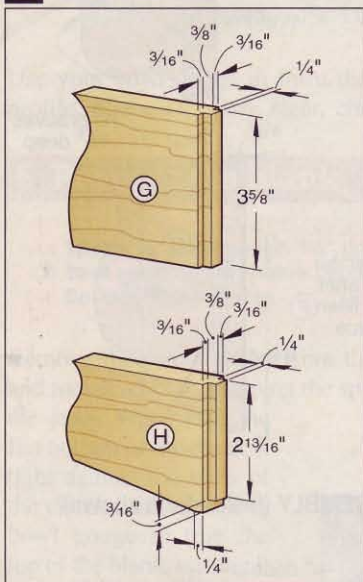

### GLUE THE SIDE TOGETHER

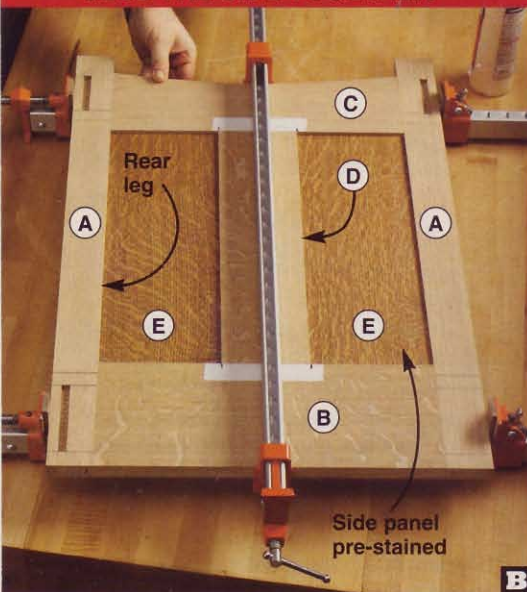

Assemble a side by gluing and clamping together two legs (A), top and bottom rails (B, C), center stile (D), and side panels (E), aligning the stile with the tape marks.

**10** Dry-assemble a side assembly by joining together the top and bottom side rails (B, C) with a center stile (D), sliding the side panels (E) in place, and adding the legs (A). Center the stile side-to-side and mark its location on masking tape on the top and bottom rails. Verify all parts fit together correctly, and then disassemble. Now glue and clamp them together, as shown in **Photo B**. (We did not glue the panels in place to allow for wood movement.) Repeat for the other side assembly.

### Complete the case parts

**1** Cut the top back rail (G) and bottom rails (H) to the sizes listed. Then, using your dado blade, form  $\frac{3}{8}$ " tenons  $\frac{1}{4}$ " long on the ends of the rails, where shown on **Drawings 3** and **3a**, to fit the mortises in the legs (A). Next, with the bottom rails set on the bottom edge, trim  $\frac{3}{16}$ " from their tenons for a final tenon length of  $2\frac{13}{16}$ ".

**2** Mark the ends and center of the arch on the bottom rails, where dimensioned on **Drawings 3** and **3a**. As before, draw the arches using a fairing stick. Then bandsaw and sand the arches to shape.

**3** From  $\frac{3}{4}$ " plywood, cut the top and center shelves (I) to  $17\frac{7}{8}$ " $\times$  $21$ ". Then, from  $\frac{3}{4}$ " stock, cut four  $\frac{3}{4}$ " $\times$  $21$ " pieces for the shelf edging (J). Cut the edging so that the quartersawn figure shows on the face.

**4** Glue and clamp the edging, centered, on the front and back edges of the shelves.

After the glue dries, sand the edging flush with the shelf faces. Then crosscut the shelves to the finished length of 20".

**5** To drill mounting holes and slots through the shelves, where shown on **Drawings 3** and **3b**, for attaching the top (L) later, first align the top shelf on the bottom shelf and clamp them together. Then, on the top shelf, mark a centerpoint  $1\frac{3}{4}$ " in from each corner. Now drill  $\frac{1}{16}$ " holes through the shelves at the centerpoints. Separate the shelves.

**6** Using a  $\frac{3}{8}$ " twist bit, redrill each of the holes in the center shelf. (These provide clearance for a screwdriver when attaching the top.) Next, centering on the front pair of holes in the top shelf, drill countersunk  $\frac{5}{32}$ " shank holes in the bottom face. Switch to a  $\frac{3}{16}$ " bit. Now redrill the rear pair of holes in the front shelf, and then drill additional holes to form  $\frac{3}{16}$ " slots  $\frac{3}{4}$ " long, where shown on **Drawing 3b**.

**7** Edge-join  $\frac{3}{4}$ " stock to form a  $20$ " $\times$  $21$ " workpiece for the bottom shelf (K). After the glue dries, crosscut and rip the shelf to  $19\frac{3}{8}$ " $\times$  $20$ ". Then, using your table-mounted router, rout  $\frac{1}{16}$ " chamfers along the front and back edges of the shelf and the edging (J) on the top and center shelves (I), where shown on **Drawing 3**. Hand-sand chamfers on the ends of the parts.

**8** Using a dado blade that matches the thickness of the bottom shelf (K) and aligning the blade with your layout marks, cut a  $\frac{3}{4}$ " dado  $\frac{1}{4}$ " deep in each side assem-



bly, where shown on **Drawing 3** and as shown in the **Shop Tip**, right.

**9** Adjust the dado blade to match the thickness of the shelves (I/J). Repositioning your fence as needed, cut a  $\frac{3}{4}$ " dado and rabbet  $\frac{1}{4}$ " deep for the shelves in each side assembly at your marks. Now sand the assemblies, top back rail (G), bottom rails (H), and shelves (I/J, K) to 220 grit.

## Assemble the case

**1** Dry-assemble the side assemblies, top back rail (G), bottom rails (H), top and center shelves (I/J), and bottom shelf (K). Verify that all parts fit together correctly, and disassemble.

**2** Using squaring braces, glue and loosely clamp together the left side assembly, top back rail (G), and top and center shelves (I/J), as shown in **Photo C**, centering the shelves front-to-back with a  $\frac{3}{16}$ " overhang. Then, to align the top back rail, place the bottom rails (H) and right side assembly (no glue) in position, as shown, making sure the tenon on the top back rail engages the mortise in the right side assembly. Now tighten the clamps.

**3** Later, remove the right side assembly and bottom rails. Then glue and clamp these parts and the bottom shelf (K) in place, as shown in **Photo D**. Apply glue to only the front 6" of the bottom shelf ends to allow for expansion and contraction.

## Add the top

**1** Edge-join  $\frac{3}{4}$ "-thick stock to form a 21x29" workpiece for the top (L). After the glue dries, crosscut and rip the top to 20 $\frac{1}{8}$ x28". Then rout a  $\frac{1}{4}$ " chamfer along the bottom edges, where shown on **Drawing 3**.

**2** Cut the crest (M) to size. Then mark the 1" radii, where shown. Bandsaw and sand the radii to shape. Next rout a  $\frac{1}{8}$ " chamfer along the front edge. Now glue and clamp the crest to the top (L), flush with the back edge and centered side-to-side.

**3** Position the top assembly (L/M) on the case, flush with the back edge of the top shelf (I/J) and centered side-to-side. Reaching inside the case, use a 4d finishing nail to mark the centers of the mounting holes and slots through the shelf (I) on the bottom side of the top (L). Remove the top, and drill  $\frac{7}{64}$ " pilot holes  $\frac{1}{2}$ " deep at the marked locations. Reposition the top, and drive the screws to secure it in place.

## Make the drawer

**1** Cut the drawer front (N), back (O), and sides (P) to size. From  $\frac{1}{4}$ " plywood, cut the drawer bottom (Q) to size.

**2** Referring to **Drawings 4** and **4a** and the three-step **Drawing 5** on the next page, cut the grooves in the drawer front (N) and

## SHOP TIP

### Use a guide to safely cut dados

To cut dados in case assemblies, such as the ones that hold the bottom shelf (K), attach a  $\frac{3}{4}$ x2x22" guide to the bottom of the assembly legs (A), as shown at right. The guide keeps the assembly in continuous contact with the fence throughout the cut. Attach the guide to the legs by drilling mounting holes and driving #8x1 $\frac{1}{2}$ " flathead wood screws into the bottom of the legs. Also, to avoid tear-out, adhere a backer to the assembly using double-faced tape.



sides (P) for the bottom (Q), the dados in the sides (P) for the front (N), and the locking joint on the ends of the front (N). Then cut the dados in the sides (P) for the back (O), where dimensioned on **Drawing 4**.

**3** Carefully mark the centerpoints and drill two  $\frac{5}{16}$ " holes through the drawer front (N) for the handle, where dimensioned. Then glue and assemble the front, sides (P), back (O), and bottom (Q). Clamp the assembly, and check for square. Now drill mounting holes through the bottom and into the back, where shown, and drive the screws.

## Finish up

**1** Cut the corbels (R) to size. Then photocopy the full-size corbel pattern from the **WOOD Patterns** insert. Spray-adhere the pattern to a corbel. Now bandsaw the corbel to shape, cutting just outside the pattern line. Sand to the line using a 120-grit

sanding drum. Using this piece as a template, mark the contour on the other corbels. Cut and sand them to shape.

**2** Apply glue to the back edges of the corbels. Then clamp them in place on the legs (A) under the top (L), positioning them  $\frac{5}{8}$ " from the leg outside edges, where shown on **Drawing 3**.

**3** Touch up any areas that need it with 220-grit sandpaper, and remove the dust. Then apply stain. After the stain dries, top-coat with a clear finish. (We applied three coats of AquaZar Water-Based Clear Satin Polyurethane, sanding to 320 grit between coats.)

**4** To ensure the drawer slides easily, cut four 17 $\frac{7}{16}$ "-long pieces from a roll of 1"-wide low-friction tape. Apply two of the pieces to the center shelf (I/J) and the other two pieces to the top side rails (B), where shown, positioning the strips tight against the top back rail (G). Next, referring to

## FOR EASY ASSEMBLY, GLUE UP THE CASE IN TWO STAGES

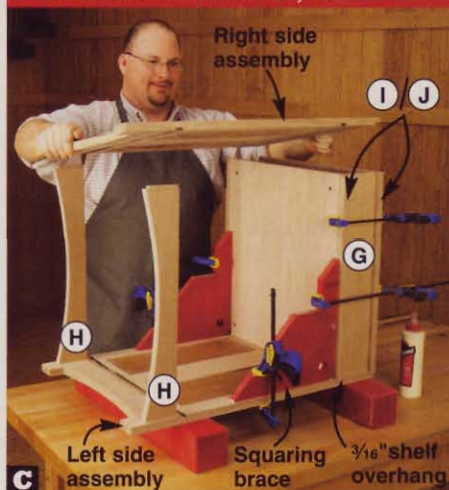

Glue and clamp together the left side assembly, top and center shelves (I/J), and top back rail (G). Add the bottom rails (H) and right side assembly to align rail G.

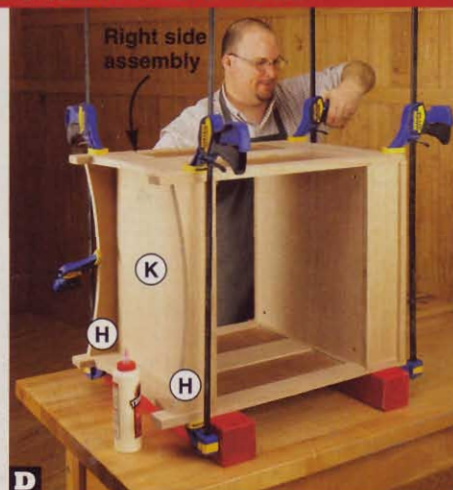

Complete the case by gluing and clamping together the bottom rails (H), bottom shelf (K), and right side assembly, centering the shelf front-to-back.



#### 4 DRAWER

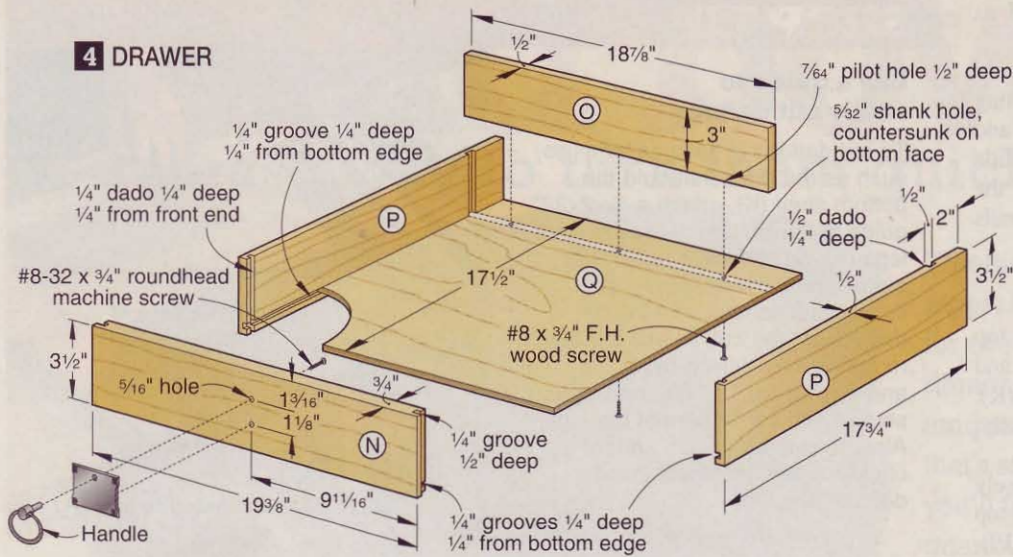

#### 4a DRAWER JOINT DETAIL

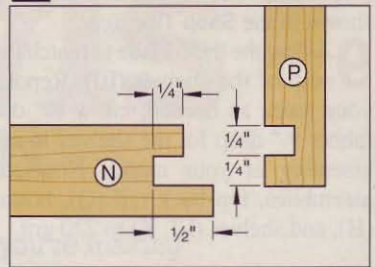

#### 4b DRAWER HANDLE DETAIL SECTION VIEW

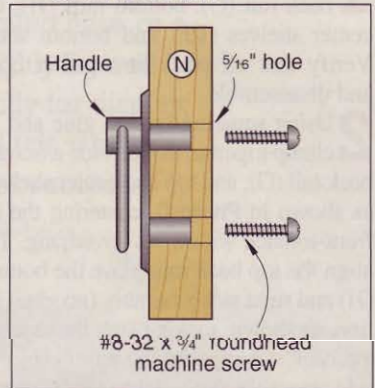

#### 5 MACHINING THE DRAWER FRONT AND SIDES

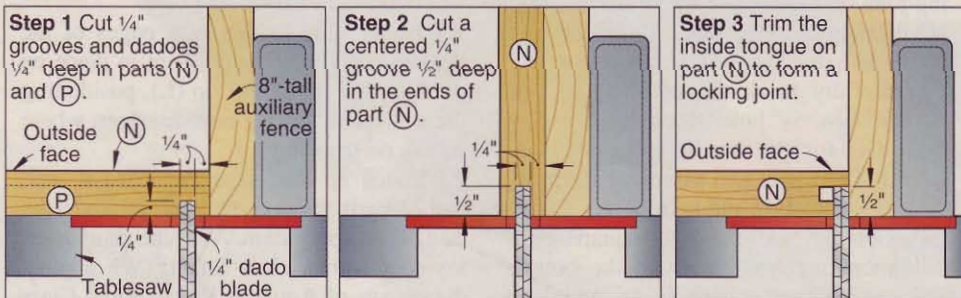

**Drawing 4b**, attach the drawer handle using #8-32x3/4" roundhead machine screws. (The 1" screws supplied with the handle are too

long.) Then slide the drawer in place. Now place the nightstand next to your bed, and rest a spell to admire your craftsmanship. 🌟

Written by **Owen Duvall** with **Jeff Mertz** Project design: **Kevin Boyle** Illustrations: **Roxanne LeMoine**

#### Materials List

| Case                      | FINISHED SIZE |         |         | Matl. | Qty. |
|---------------------------|---------------|---------|---------|-------|------|
|                           | T             | W       | L       |       |      |
| A legs                    | 3/4"          | 2"      | 27 1/4" | QO    | 4    |
| B top side rails          | 3/4"          | 5 3/4"  | 15 1/2" | QO    | 2    |
| C bottom side rails       | 3/4"          | 4 1/2"  | 15 1/2" | QO    | 2    |
| D center stiles           | 3/4"          | 4"      | 16"     | QO    | 2    |
| E side panels             | 3/8"          | 6"      | 16"     | QO    | 4    |
| F* leg fillers            | 5/16"         | 3/8"    | 1 1/2"  | QO    | 4    |
| G top back rail           | 3/4"          | 3 5/8"  | 20"     | QO    | 1    |
| H bottom rails            | 3/4"          | 3"      | 20"     | QO    | 2    |
| I* top and center shelves | 3/4"          | 17 7/8" | 20"     | OP    | 2    |
| J* shelf edging           | 3/4"          | 3/4"    | 20"     | QO    | 4    |
| K* bottom shelf           | 3/4"          | 19 3/8" | 20"     | EQO   | 1    |
| L* top                    | 3/4"          | 20 1/8" | 28"     | EQO   | 1    |
| M crest                   | 3/4"          | 2 1/2"  | 23"     | QO    | 1    |

#### Drawer and corbels

|                 |      |         |         |    |   |
|-----------------|------|---------|---------|----|---|
| N drawer front  | 3/4" | 31 1/2" | 19 3/8" | QO | 1 |
| O drawer back   | 1/2" | 3"      | 18 7/8" | QO | 1 |
| P drawer sides  | 1/2" | 31 1/2" | 17 3/4" | QO | 2 |
| Q drawer bottom | 1/4" | 17 1/2" | 18 7/8" | OP | 1 |
| R corbels       | 3/4" | 2 3/4"  | 20"     | QO | 4 |

\*Parts initially cut oversize. See the instructions.

**Materials key:** QO—quartersawn white oak, OP—oak plywood, EQO—edge-joined quartersawn white oak.

**Supplies:** Double-faced tape, spray adhesive, #8x3/4" flathead wood screws (3), 4d finishing nail, #8x1 1/4" flathead wood screws (2), #8x1 1/4" panhead screws (2), #10 flat washers (2), #8-32x3/4" roundhead machine screws (2).

**Blades and bits:** Dado-blade set, 3/8" brad-point bit, 45° chamfer router bit.

#### Sources

**Low-friction tape.** Low-friction (UHMW) tape no. 25U04.01, 1"x18" roll, \$9.95. Call Lee Valley, 800/871-8158; leevalley.com.

**Drawer handle.** Mission-style 2 3/4" black handle no. 01W32.11, \$2.10. Telephone and Web address above.

#### Cutting Diagram

**A** 3/4 x 5 1/2 x 96" Quartersawn white oak (4 bd. ft.)

**B** 3/4 x 7 1/4 x 96" Quartersawn white oak (5.3 bd. ft.)  
\*Plane or resaw to the thicknesses listed in the Materials List.

**F** 3/4 x 7 1/4 x 96" Quartersawn white oak (5.3 bd. ft.)

**K** 3/4 x 7 1/4 x 96" Quartersawn white oak (5.3 bd. ft.)

**L** 3/4 x 5 1/2 x 96" Quartersawn white oak (4 bd. ft.)

**L** 3/4 x 5 1/2 x 96" Quartersawn white oak (4 bd. ft.)

**N** 3/4 x 7 1/4 x 48" Quartersawn white oak (2.7 bd. ft.)

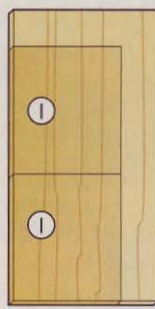

3/4 x 24 x 48" Oak plywood

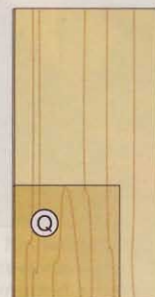

1/4 x 24 x 48" Oak plywood



SHOP-TESTED

# multi-base router kits

Don't sweat whether to buy a fixed-base or plunge router. Get both with any of eight versatile kits.



Plunge base

Fixed base

**T**he router is arguably the most versatile tool in your shop, but the age-old question is: Which style router should you buy, a fixed-base model with depth adjustments fast and accurate, or a plunge router for cuts that start and

stop in the middle of a workpiece? Fortunately, your choice is easier today thanks to kits that include both styles of base for little more than the cost of one router.

We rounded up eight multi-base router kits ranging in price from \$100 to \$270 and

put them through the paces in both fixed and plunge modes to show you the key differences between kits. Because each kit has three basic components—the motor, the fixed base, and the plunge base—we'll break down our report along those lines.



## Part 1: The motor

In this section, we'll talk about the power plants of these kits, including their collets, and how easy it is to switch the motor from one base to another.

■ **Power.** Because of the variety of hand-held and router-table work a router kit must handle, power ranks high. The rated horsepower of these tools range from 1¾ hp to 2¼ hp, but we found little difference in actual power. While plowing ¼" deep dadoes in oak-veneer plywood with a ½" straight bit at a speedy 12 feet per minute, all of the routers handled the cuts easily. But the tools without electronic feedback—Porter-Cable 694VK, Ryobi 1803BK, and Skil 1825—took longer to recover when the bit first entered the wood.

With all that power in hand, we greatly appreciated soft-start motors that gradually come up to full speed. Only the Skil lacks soft start, but its trigger-style switch helped us keep good control of the tool at start-up.

■ **Switch placement.** Mistakes and accidents can occur when you have to remove one hand from the router to operate the on/off switch. We find a handle-mounted trigger switch, like that on the Skil router shown *below*, more convenient than motor-mounted switches. The switches on most of the rest are within easy reach of a finger or thumb, but the Makita RF1101KIT2's top-mounted toggle switch can't be reached without letting go of one handle.

■ **Noise level.** We measured noise levels at the motor's highest to lowest speeds, and the Noise Level column in the chart at the *end of the article* shows the average readings at high speed. Makita's motor is noticeably quietest at both the highest and

lowest speeds, partly because it lacks the high-pitched whine common to the other routers' motors.

■ **Collet quality.** All of the kits come with ½" collets, and all except Skil's are self-releasing (the bit pops free after a full turn of the collet nut). Most kits also include a ¼" collet, but Ryobi and Skil instead provide reducer sleeves (see photo at *right*) that fit into the ½" collet. In our tests we found that those sleeves grip just as well as a dedicated collet.

Collets are made of either thin-wall spring steel or thick-wall steel. To learn whether one design grips better than the other, we used a torque wrench on a precision-ground ½"-diameter steel rod inserted into each collet to measure how easily a bit shank would slip. Our finding: Spring-steel collets, such as on the Bosch 1617EVSPK, Craftsman 26620, DeWalt DW618PK, and Ryobi routers, held best. However, in real use, none of the collets slipped when we cut solid oak with a ⅝" cove bit.

We measured collet runout (wobble) 2¼" from the subbase—the far end of the cutting depth for most router bits. Any deviation of less than .003" runout is acceptable, and the Bosch, Craftsman, DeWalt and Makita met this standard on both collets; Skil passed on its ½" collet, but not its ¼" sleeve.

■ **Base changes.** Because changing the motor between bases is an inherit task with these kits, the process should take as little effort as possible. All of the motors slide into and out of their fixed bases easily (but not so easily that they'll drop to the floor if installed in a router table). We found the spindle lock on the Ryobi a bit of a nuisance because it always seemed to be in the way.

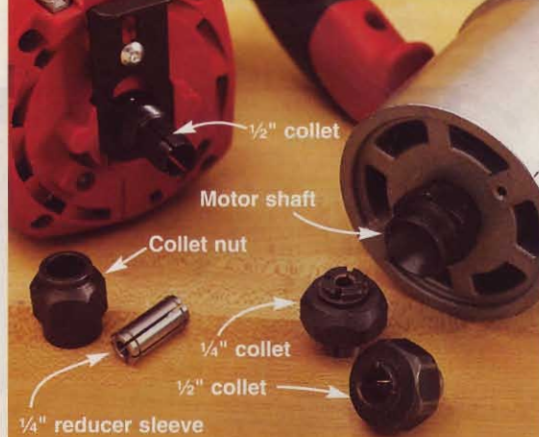

## COLLET COMPARISON

The Porter-Cable 694VK (right) typifies collets on this class of router: separate ½" and ¼" collets that thread onto the motor shaft. Skil's ½" collet (left) is part of the shaft, and to use ¼"-shank bits, you insert a reducer sleeve into it.

Most motors install just as easily into their plunge bases. However, on the DeWalt, you must first remove the depth-adjusting collar (it threads off and on); and both the Makita and Porter-Cable 694VK require a tool to lock the motor into the plunge base.

## Part 2: The fixed base

Besides the simple, quick depth adjustments that are the hallmark of a fixed base router, kits provide an additional advantage: You can mount the base permanently in your router table, then move the motor to the plunge base for hand-held work.

■ **Setting cutting depth.** Setting the depth of cut isn't complicated with any of the fixed bases in our test, with quick-release threaded-rod bases and rotating bases (photos on the *next page*) about equal in speed and adjustability. A rotating collar

## START-UP CONVENIENCE DEPENDS ON HOW MUCH WALKING YOUR FINGERS HAVE TO DO



Skil's trigger switch stays at your fingertips so your hands never have to leave the handles to power up the router.

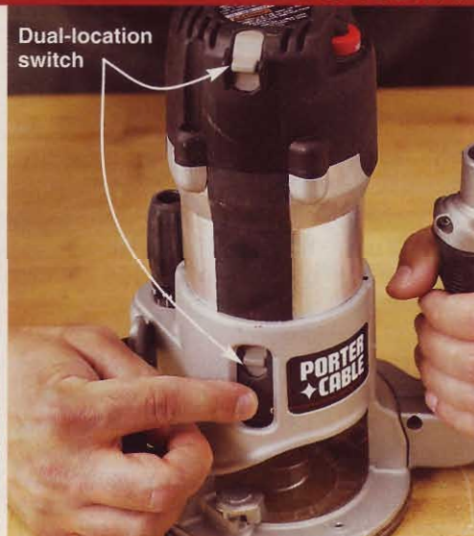

The Porter-Cable 895PK switch operates from two locations: at the base for handheld use, and at the motor top when table mounted.



You can't reach the top-mounted toggle switch on the Makita without removing one hand from a handle.



## THREE DEPTH-SETTING SYSTEMS



We like quick-release bases with a spring-loaded lever that frees the motor for large depth changes. Releasing the lever engages the threaded fine-adjustment mechanism.



To change cutting depth on a threaded base, such as the Makita, simply rotate the base on the motor. In a router table, this action changes the power-switch location.



On routers with a depth-adjusting collar, such as the DeWalt, the base doesn't rotate, but the collar does, raising and lowering the motor in the base.

adjusts cutting depth on the DeWalt and Ryobi (the DeWalt requires fewer turns and so goes up and down faster than the Ryobi). Skil's threaded-rod system is accurate, but slow when making large depth changes.

We're glad to see that almost all router manufacturers have made the switch to levers to lock the cutting depth on their fixed bases. Only Ryobi still uses a T-bolt, which can be difficult to release if over-tightened.

■ **Dust collection.** In this age of dust awareness, we were surprised to find that only one of the fixed bases—Ryobi—comes with a dust-collection shroud. Of the optional systems, Bosch's dust shroud and port bested the Porter-Cable 895PK's through-the-handle collector, which tended to clog with large shavings. Fixed-base dust collection isn't an option on the Craftsman, DeWalt, and P-C 694VK.

■ **Router table capability.** Things look and function a little differently when you hang them upside down. Makita's top-mounted power switch, awkwardly located for handheld use, is perfectly placed with the router table-mounted. The controls on the Bosch and Craftsman routers also lend themselves well to router-table use. At the other extreme, Skil's handle-mounted trigger switch proved hard to engage and the variable-speed setting is difficult to see. For bit changes, we recommend a tool with a motor that can be quickly removed from its fixed base; Bosch, Craftsman, DeWalt, and the Porter-Cable 895PK are a snap to dismount when table-mounted.

The Craftsman and P-C 895PK have a leg up on the competition with an above-table adjustment system: A hex shank inserted

through the tabletop engages the threaded-rod depth-setting system. Both systems work well, but you must still reach under the table to lock the Craftsman.

### Part 3: The plunge base

A router equipped with a plunge base can do everything a fixed base can do, but adds the ability to start and stop a cut in the middle of a workpiece. These "field" cuts include stopped flutes and dadoes, as well as router-carved recesses in signs.

■ **Depth adjustments.** To set the cutting depth or make a series of progressively deeper cuts with a plunge base, two mechanisms work in tandem: depth-stop rods and turrets. The depth-stop rod "zeroes" the bit to the material; from there, you use the tool's scale to set the cutting depth.

Tweaking the cutting depth on the Bosch, Craftsman, and DeWalt (shown at right) is simple. Makita's threaded-rod stop has a quick-release for large changes; but when fine-tuning the depth, the cursor moves with the adjustment so it's unclear exactly how much you've adjusted the cut. Skil has an innovative spring-loaded rod: After zeroing out to the material, you simply pull down the height-adjustment rod to the desired depth, and then tighten it.

For progressively deeper cuts, a stepped, rotating turret on most plunge bases controls the depth of each cut in the sequence. Bosch and Craftsman use an eight-tier turret with  $\frac{1}{8}$ " increments; the DeWalt, Makita, and both Porter-Cable units have fewer steps, but some are adjustable. Ryobi has no steps, only the base itself as the stop.

Most depth scales read easily, but Ryobi and the P-C 895PK lose points because

their cursor stands  $\frac{1}{4}$ " away from the scale, which causes inaccurate readings. Also, the 895PK's scale is small and hard to read. DeWalt's scale is mostly hidden behind the depth-stop rod.

■ **Dust control.** Only DeWalt provides dust collection on its plunge base, and its through-the-handle collection proved both convenient and effective. You can't buy dust collection accessories for the Craftsman, Porter-Cable 694VK, and Ryobi routers.

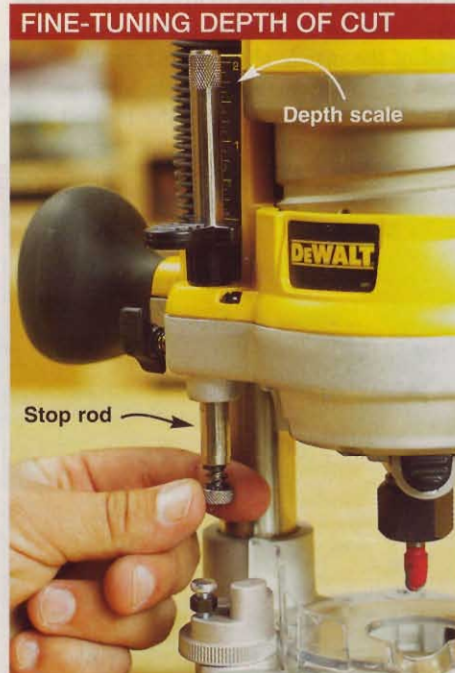

The end of the stop rod threads in and out to make minute adjustments on the Bosch, Craftsman, and DeWalt (shown above) plunge bases. However, the rod obscures the depth scale on the DeWalt.



# Let's take a closer look at each tested kit

**Bosch 1617EVSPK, \$195** 877/267-2499, boschtools.com



### High points

- ◆ Plunge and fixed bases quickly adjust for large depth changes, yet also offer simple microadjustments.
- ◆ On/off switch remains near the handles, even when the depth-of-cut is changed.
- ◆ Low vibration and collet runout.
- ◆ Tied with the Porter-Cable 895PK for the fastest and easiest base changes in the test.

### Low points

- ▼ Dust collection is optional for either base.

### More points

- ◆ Storage case is ruggedly made and well organized, but it can't store the optional dust-collection accessory or edge guide.
- ◆ Kit includes a toolless quick-change adapter that fits Porter-Cable-style guide bushings.

**DeWalt DW618PK, \$240** 800/433-9258, dewalt.com



### High points

- ◆ On/off switch remains near the handles, even when the depth-of-cut is changed.
- ◆ Through-the-handle dust collection on the plunge base was the most effective in the test.
- ◆ Detachable power cord makes for easy switch to optional D-handle fixed base or for disconnecting power to motor before changing bits.
- ◆ Clear subbases on both bases improve bit visibility, and included concentricity tool ensures that the subbase opening is centered on the collet.

### Low points

- ▼ Depth-adjusting collar must be removed from motor when switching to plunge base and reinstalled when switching back.
- ▼ On the plunge base, the depth-stop rod blocks the scale from view.
- ▼ The variable speed control is very close to the plunge column, making it awkward to use.

### More points

- ◆ Unlike most of the tested plunge bases, the locking lever operates in the normally free mode; it must be pulled to lock the cutting depth.

**Craftsman 26620, \$220** Visit Sears or craftsman.com



### High points

- ◆ Same high points as the nearly identical Bosch 1617EVSPK.
- ◆ In a router table, depth-adjustments can be made from above the table using the included hexhead wrench.

### Low points

- ▼ No dust collection provided for either base, even as an accessory.

**Makita RF1101KIT2, \$250** 800/462-5482, makitatools.com



### High points

- ◆ Has the quietest motor of all the tested routers.
- ◆ Subbase readily accepts P-C-style guide bushings, and an extra subbase that comes with the kit accommodates larger-diameter bits.
- ◆ Top-mounted switch is convenient when router is mounted in a table.

### Low points

- ▼ You must take one hand off a handle to flip the on/off switch.
- ▼ The motor easily installs into both bases, but requires a Phillips screwdriver to tighten into the plunge base.
- ▼ Dust collection accessories are optional.





**High points**

- ◆ Depth-stop turret has six steps, three of which are adjustable.

**Low points**

- ◆ The motor easily installs into both bases, but requires a hexhead wrench to tighten into the plunge base.
- ◆ No electronic speed feedback on motor, so feed-rate control is important.
- ◆ In the fixed base, the power switch rotates as the depth setting changes, so it's often difficult to see and requires removing one hand from the tool.
- ◆ No dust collection available for either base.

**More points**

- ◆ This router kit has stood the test of time, but most kits now surpass it in performance and features.



**High points**

- ◆ Dual-position power switch on fixed base can be activated near handles for handheld use and at top of motor for router-table use. It also locks out when the spindle lock is engaged to prevent accidental startup when changing bits.
- ◆ Ties with the Bosch/Craftsman for the fastest and easiest base changes.
- ◆ Fixed base quickly adjusts for large depth changes, yet also offers simple microadjustments.
- ◆ Two clear subbases (one that accepts guide bushings and the other with a larger bit opening) provide good bit visibility.
- ◆ In a router table, depth-adjustments can be made and the cutting depth locked from above the table using the included extension knob.

**Low points**

- ◆ The spindle lock doesn't work with the optional dust shroud or the guide-bushing subbase, making it difficult to change bits when using these accessories.
- ◆ The most expensive kit in the test.
- ◆ Dust collection accessories are optional. We tested the optional through-the-handle system for the fixed base and it tended to clog with chips.



**High points**

- ◆ Kit includes two fixed bases, one with a D-handle, five plastic guide bushings, an edge-guide fence, and dust-collection adapter.
- ◆ Well-designed and comfortable hand grips.

**Low points**

- ◆ No electronic feedback on motor, and the low-end speed is 15,000 rpm—too fast for large-diameter bits.
- ◆ Dust collection shroud covers the spindle lock; you must remove the adapter each time you change bits.
- ◆ No depth-stop turret on plunge base, and the depth-of-cut cursor is far from the scale, making it difficult to read reliably.

**More points**

- ◆ Unlike most of the tested plunge bases, the locking lever operates in the normally free mode; it must be pulled to lock the cutting depth.
- ◆ Comes in a soft-sided fabric bag (instead of a plastic case), which we found difficult to keep organized.

**ROUTER-KIT ROUNDUP:**

| BRAND        | MODEL      | AMPS | MOTOR             |                              |                     |                      | COLLET                |                          |                                   |                              |
|--------------|------------|------|-------------------|------------------------------|---------------------|----------------------|-----------------------|--------------------------|-----------------------------------|------------------------------|
|              |            |      | SPEED RANGE (RPM) | ELECTRONIC FEEDBACK (YES/NO) | SOFT START (YES/NO) | 1/2" COLLET TYPE (1) | TIGHTENING METHOD (2) | SUBBASE OPENING (INCHES) | BASE OPENING W/O SUBBASE (INCHES) | CUTTING DEPTH RANGE (INCHES) |
| BOSCH        | 1617EVSPK  | 12   | 8,000-25,000      | Y                            | Y                   | SS                   | 2W                    | 2 1/16                   | 3 3/4                             | 1 5/8                        |
| CRAFTSMAN    | 26620      | 12   | 8,000-25,000      | Y                            | Y                   | SS                   | 2W                    | 1 3/4                    | 3 3/4                             | 1 5/8                        |
| DEWALT       | DW618PK    | 12   | 8,000-24,000      | Y                            | Y                   | SS                   | PB                    | 1 1/4                    | 3 3/4                             | 1 1/2                        |
| MAKITA       | RF1101KIT2 | 11   | 8,000-25,000      | Y                            | Y                   | S                    | 2W                    | 1 3/16                   | 3 3/8                             | 1 1/2                        |
| PORTER-CABLE | 694VK      | 11   | 10,000-27,000     | N                            | Y                   | S                    | 2W                    | 1 3/16                   | 3 3/4                             | 1 1/4                        |
|              | 895PK      | 12   | 10,000-23,000     | Y                            | Y                   | S                    | PB                    | 1 3/16                   | 3 3/4                             | 1 1/4                        |
| RYOBI        | RE1803BK   | 10   | 15,000-25,000     | N                            | Y                   | SS*                  | PB                    | 2 1/2                    | 4 1/8                             | 1 1/2                        |
| SKIL         | 1825       | 11   | 8,000-25,000      | N                            | N                   | SN*                  | SB                    | 2 1/16                   | 4 1/8                             | 1 1/2                        |

**NOTES:**

- (S) Steel, self-releasing  
(SN) Spring steel, non-self-releasing  
(SS) Spring steel, self-releasing  
(\*) Reducer sleeve for 1/4" bits
- (2W) Two wrenches  
(PB) Push-button spindle lock and wrench  
(SB) Sliding bracket spindle lock and wrench
- (C) Collar  
(QR) Threaded rod with quick release  
(RM) Rotating motor  
(TR) Threaded rod
- (R) Round  
(F) Round with flat edge





**High points**

- ▲ Has a built-in LED work light that effectively illuminates the cutting area.
- ▲ Trigger switch in the handle means you never have to let go of a handle to start the tool and compensates for not having a soft-start motor.
- ▲ Lowest-priced kit in test.

**Low points**

- ▼ No electronic feedback nor soft start on motor.
- ▼ The fixed base threaded-rod depth adjustment lacks a quick release, so large cutting depth changes are tedious.
- ▼ The plunge base on our test unit tended to stick at the bottom of its travel.
- ▼ No dust collection provided for either base.
- ▼ Non-self-releasing collet is affixed to the motor shaft; if a bit should get stuck in the collet, there's no easy way to remove it.
- ▼ Inverted in a router table, the power switch is difficult to lock "on," and the variable-speed dial equally hard to read.

**Crowning the router-kit king**

The quick and accurate depth-adjustment system is a major reason the Bosch 1617 EVSPK earns Top Tool honors. The plunge base has pistol-grip handles, giving you the greatest control; and the plunge action is silky smooth. (The sub-\$200 price point helps too.) In table use, the router performed well, but an extension knob would improve the unit's small fine-adjustment knob. If you plan to use the fixed-base portion mostly in your router table, opt instead for the nearly identical Craftsman 26620 with its through-the-tabletop height adjustments. We also liked the DeWalt DW618PK, which came in a close second to the Bosch/Craftsman overall, and would be our first choice if we intended to add a D-handle base later on.

For Top Value, the Skil 1825 has good features and decent performance at a cost (\$100) less than half of most of the other kits. The on-board work light and soft-grip pistol handles lend an extra level of accuracy, control, and balance. Although it costs \$80 more, the Ryobi RE1803BK comes with nearly everything you need, including a D-handle base. ♣

Written by Joe Truini with Jeff Hall

**Share your opinion**  
of these router kits  
in our Interactive Tool  
Review at  
[woodmagazine.com/rtrkits](http://woodmagazine.com/rtrkits)

**EIGHT QUICK-CHANGE ARTISTS GRADED AND RATED**

|                          | BASE CONSTRUCTION     |                       |                          |                                   | PERFORMANCE RATINGS (5) |                |                     |                |                   |                           |                   |      |                   |               |                         |                 |                  |                  | ACCESSORIES (8)   |                 |                       |                  |                    |                  |                         |                     |                    |                      |    |       |
|--------------------------|-----------------------|-----------------------|--------------------------|-----------------------------------|-------------------------|----------------|---------------------|----------------|-------------------|---------------------------|-------------------|------|-------------------|---------------|-------------------------|-----------------|------------------|------------------|-------------------|-----------------|-----------------------|------------------|--------------------|------------------|-------------------------|---------------------|--------------------|----------------------|----|-------|
|                          | PLUNGE                |                       |                          |                                   | GENERAL USE             |                |                     |                | FIXED BASE USE    |                           |                   |      | PLUNGE BASE USE   |               |                         |                 |                  |                  | STANDARD          |                 | OPTIONAL              |                  | CORD LENGTH (FEET) | WARRANTY (YEARS) | COUNTRY OF ASSEMBLY (9) | KIT WEIGHT (POUNDS) | SELLING PRICE (11) |                      |    |       |
| ADJUSTMENT MECHANISM (3) | NUMBER OF DEPTH STOPS | PLUNGE RANGE (INCHES) | SUBBASE OPENING (INCHES) | BASE OPENING W/O SUBBASE (INCHES) | BASE SHAPE (4)          | OBSERVED POWER | BALANCE AND CONTROL | LACK OF RUNOUT | LACK OF VIBRATION | GUIDE BUSHING EASE OF USE | BIT CHANGING EASE | EASE | CASE ORGANIZATION | SETTING DEPTH | DEPTH SCALE READABILITY | SWITCH LOCATION | DUST CONTROL (6) | ROUTER TABLE USE | PLUNGE SMOOTHNESS | SWITCH LOCATION | DEPTH STOP ADJUSTMENT | DUST CONTROL (6) |                    |                  |                         |                     |                    | NOISE LEVEL (db) (7) |    |       |
| QR                       | 8                     | 2 1/4                 | 2 1/16                   | 3 5/16                            | F                       | A              | A-                  | A              | A                 | A                         | B+                | A    | B-                | A             | A                       | A               | A*               | B+               | A                 | B               | A                     | A*               | 91                 | GA               | A, C, E, F, G, X        | 10                  | 1                  | U                    | 18 | \$195 |
| QR                       | 8                     | 2 1/4                 | 1 3/4                    | 3 5/16                            | F                       | A              | A-                  | A              | A                 | A                         | B+                | A    | B-                | A             | A                       | A               | N/A              | A                | A                 | B               | A                     | N/A              | 91                 | S, T             | G                       | 10                  | 1                  | U                    | 18 | 220   |
| C                        | 5                     | 2 1/4                 | 1 1/4                    | 3 1/2                             | F                       | A              | A-                  | B              | A                 | B                         | A-                | B+   | A                 | A-            | B+                      | B               | N/A              | B                | A                 | B               | B                     | A                | 93                 | A, C, S          | D, E, F, G              | 8                   | 3                  | M                    | 22 | 240   |
| RM                       | 3                     | 2 1/2                 | 1 3/16                   | 3 3/8                             | R                       | A              | A-                  | A              | A-                | B                         | B+                | C-   | A                 | A             | B                       | C               | A*               | B                | A                 | D               | B                     | A*               | 88                 | S                | A, D, F, G              | 8                   | 1                  | U                    | 21 | 250   |
| RM                       | 6                     | 2 1/2                 | 1 3/16                   | 3 3/4                             | R                       | A-             | B+                  | C              | A-                | B                         | B+                | C    | B-                | A-            | B+                      | C               | N/A              | A                | B                 | B               | A-                    | N/A              | 93                 |                  | D, F, G                 | 7                   | 1                  | U                    | 18 | 200   |
| QR                       | 4                     | 2 1/4                 | 1 3/16                   | 3 3/4                             | R                       | A              | A-                  | C              | A                 | B                         | B                 | A    | B-                | A             | A                       | A*              | A                | B                | B                 | C-              | B                     | B*               | 89                 | T                | A, F, G                 | 10                  | 1                  | U                    | 22 | 270   |
| C                        | 1                     | 2                     | 2 1/2                    | 3 3/4                             | R                       | A-             | B                   | B              | B+                | C                         | B                 | C    | C                 | C             | B+                      | C+              | B+               | C                | B                 | B               | D                     | N/A              | 94                 | A, D, F, G       |                         | 10                  | 2                  | U                    | 20 | 180   |
| TR                       | 2                     | 1 7/8                 | 2 1/16                   | 3 1/2                             | F                       | A-             | A                   | A              | B+                | C                         | B                 | B    | C                 | C             | A                       | A               | A*               | D                | C                 | A               | B                     | A*               | 95                 | L                | A, F, G                 | 8                   | 2                  | U                    | 17 | 100   |

5. **A** Excellent  
**B** Above average  
**C** Average  
**D** Below average

6. **\*** Tested with optional dust shroud installed.  
**N/A** No dust collection available for this base

7. Measured 2' from motor running under no load at top speed.

8. (A) Above base dust collection  
(C) Subbase centering cone  
(D) D-handle base  
(E) Edge-guide dust collection  
(F) Edge guide fence  
(G) Guide bushings  
(GA) Guide bushing adapter  
(L) Work light  
(S) Clear subbase  
(T) Through-the-table height adjuster  
(X) Height-adjustment extension knob

9. (M) Mexico  
(U) United States  
10. Prices current at time of article's production and do not include shipping, where applicable.



# easy-to-make desk clock

**W**ith just five simple parts and a pattern for cutting the arch, you can build this handsome time-piece in a couple of hours. You need only a small amount of wood, two screws, and an inexpensive clock movement.

## Let's prepare the parts

**1** From  $1\frac{1}{2}$ " or laminated  $\frac{3}{4}$ " stock, cut the body (A) to the size listed in the **Materials List**. Make a copy of the body full-size pattern on the *WOOD Patterns*® insert. Spray-adhere the pattern to the body.

**2** Using your bandsaw with a  $\frac{1}{4}$ " blade or scrollsaw with a no. 9 blade, form the body's arch by cutting close to the pattern line. Then sand to the line using a 1"-diameter 120-grit sanding drum. Next, using a  $2\frac{3}{8}$ " Forstner bit in your drill press, bore a  $\frac{7}{8}$ "-deep hole in the body, where shown.

**3** From a  $\frac{3}{4}\times 1\frac{3}{4}\times 12$ " piece of stock planed to  $\frac{1}{8}$ " thick, crosscut two 1"-long pieces for the plates (B), saving the cutoff. (To minimize material waste, we resawed  $\frac{3}{4}$ " stock, and then planed a  $\frac{3}{8}$ " resawn piece to  $\frac{1}{8}$ ".) For a safe way to plane thin stock, see the **Shop Tip**, below. Crosscut the cutoff in half for use as spacers during assembly.



**4** From a  $\frac{3}{4}\times 1\frac{1}{2}\times 12$ " piece of stock, crosscut two  $\frac{3}{4}$ "-long pieces for the pillars (C). Then, from a  $\frac{3}{4}\times 2\frac{1}{4}\times 12$ " piece of stock planed to  $\frac{1}{2}$ " thick, crosscut two  $4\frac{1}{4}$ "-long pieces for the top and bottom (D). Using a  $\frac{1}{4}$ " cove bit in your table-mounted router and a pushblock, rout along the edges on one face of the top and bottom, where shown on **Drawing 1**. Now, from a  $\frac{3}{4}\times 2\frac{1}{4}\times 12$ " piece of stock planed to  $\frac{1}{4}$ "

thick, crosscut two  $1\frac{1}{8}$ "-long pieces for the feet (E).

**5** Finish-sand all of the parts with 220-grit sandpaper, being careful not to round over any edges.

## Now assemble the clock

**1** Apply glue to the feet of the arch on the body (A). Then place the body faceup on a  $\frac{1}{8}$ " spacer on your workbench. Now

## SHOP TIP

### An easy and safe way to plane thin stock

For safety, many manufacturers of thickness planers do not recommend planing stock less than  $\frac{1}{2}$ " thick and 12" long. How, then, do you plane thin material, such as for the desk clock's  $\frac{1}{8}$ "-thick plates (B)? Simply adhere the jointed face of your stock to a flat  $\frac{3}{4}$ "-thick carrier board with double-faced tape, as shown at *right*, and then plane to the needed thickness. You can safely plane to a thickness of  $\frac{1}{16}$ " using this technique. Make sure the carrier board is at least as wide as and a couple inches longer than your stock. To remove the planed piece from the carrier, gently pry it off using a putty knife. If the piece resists prying, dissolve the tape adhesive with lacquer thinner.

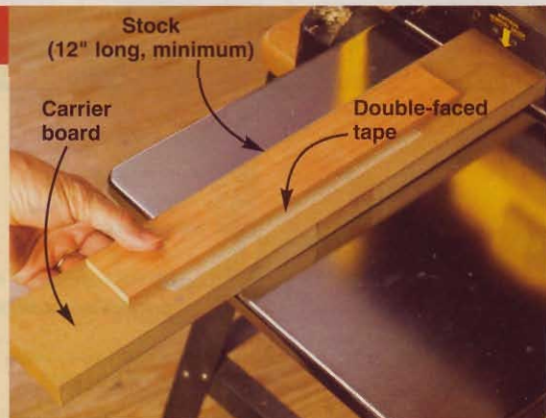



## SPACERS HOLD THE KEY TO QUICK, ACCURATE GLUE-UPS

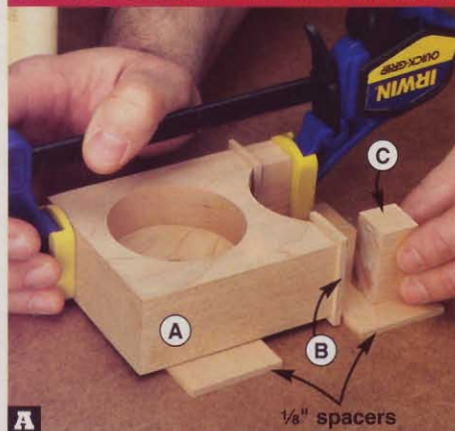

**A** Using  $\frac{1}{8}$ " spacers under the body (A) and pillars (C), center the pillars side-to-side on the plates (B), and clamp them in place.

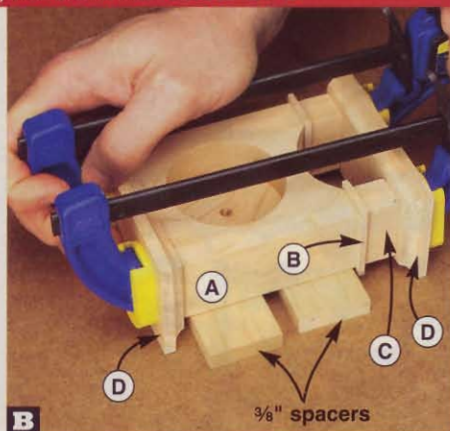

**B** With the body (A) on  $\frac{3}{8}$ " spacers, center the top and bottom (D) on the body side-to-side with a  $\frac{3}{8}$ " overhang, and clamp in place.

## DRILL THE MOUNTING HOLES

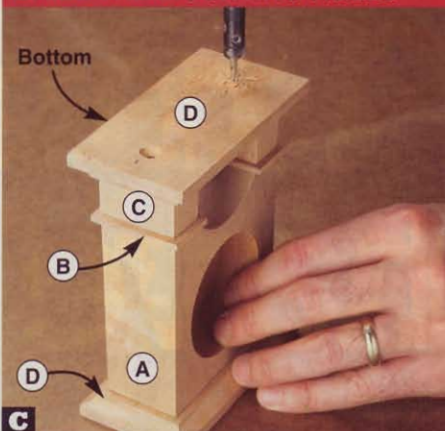

**C** Drill countersunk  $\frac{9}{64}$ " shank holes with  $\frac{3}{32}$ " pilot holes  $1\frac{1}{4}$ " deep through the bottom (D), pillars (C), and plates (B) into the body (A).

## 1 EXPLODED VIEW

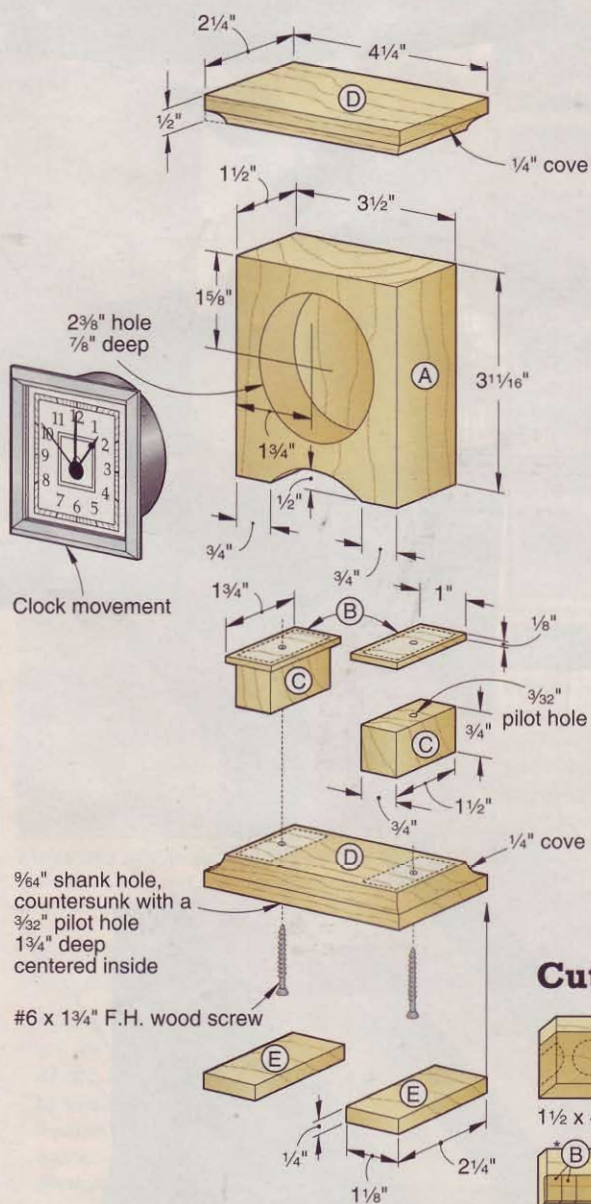

position and clamp the plates (B) to the feet, centering the plates side-to-side with a  $\frac{1}{8}$ " overhang. Remove glue squeeze-out on all edges.

**2** After the glue dries, apply glue to the top of the pillars (C). Clamp the pillars to the plates (B), as shown in **Photo A**. Then apply glue to the bottom of the pillars and top of the body (A). Now clamp the top and bottom (D) in place, as shown in **Photo B**.

**3** Mark the centerpoints for two mounting holes on the bottom (D), where dimensioned on **Drawing 1a**. Then drill the holes, as shown in **Photo C**, and drive the screws. (We used a combination drill bit and countersink to drill the

holes.) Now glue and clamp the feet (E) to the bottom, flush with the front and back edges and ends. Sand the edges of the feet flush with the bottom.

**4** Touch up any areas that need it with 220-grit sandpaper, and remove the dust. Apply a stain, if you wish. (We applied Zar Oil-Based Wood Stain no. 116 Cherry, and then top-coated with a satin lacquer aerosol finish.)

**5** Finally, install an N-size battery in the clock, set the time, and press the clock into the hole in the body. Now set your masterpiece on a desk where you can admire it by the hour. 🕒

Written by **Owen Duvall**  
Project design: **Kevin Boyle**  
Illustrations: **Mike Mittermeier**

## Materials List

| Part              | FINISHED SIZE |        |         | Matl. Qty. |
|-------------------|---------------|--------|---------|------------|
|                   | T             | W      | L       |            |
| A body            | 1 1/2"        | 3 1/2" | 3 1/16" | C 1        |
| B* plates         | 1 1/8"        | 1 3/4" | 1"      | C 2        |
| C* pillars        | 3/4"          | 1 1/2" | 3/4"    | C 2        |
| D* top and bottom | 1/2"          | 2 1/4" | 4 1/4"  | C 2        |
| E* feet           | 1/4"          | 2 1/4" | 1 1/8"  | C 2        |

\*Parts initially cut oversize. See the instructions.

**Material key:** C—cherry.

**Supplies:** Spray adhesive, double-faced tape, #6x1 1/4" flathead wood screws (2), N-size battery.

**Blades and bits:** 1/4" bandsaw blade or no. 9 scroll-saw blade, 1/4" cove router bit, 2 3/8" Forstner bit.

## Sources

**Clock movement.** 2 3/8"-diameter press-in clock movement (1), no. 200915-S, \$13.90 ppd. Add \$9.95 for each additional movement. Schlaubaugh and Sons Woodworking, 720 14th Street, Kalona, IA 52247. Call 800/346-9663; schsons.com.

**Bit.** 2 3/8" Forstner bit, kit no. 400901, \$18.95 ppd. Addresses and telephone number above.

## 1a SCREW LOCATION DETAIL

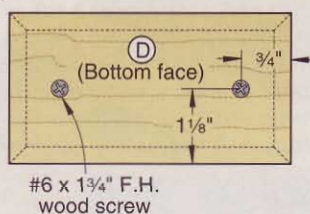

## Cutting Diagram

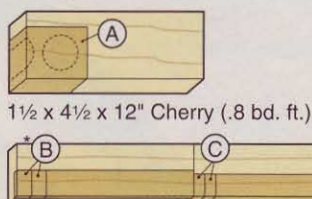

1/4 x 3 1/2 x 60" Cherry (1.7 bd. ft.)

\*Plane or resaw to the thicknesses listed in the Materials List.



# 4 must-have jigs *from* 3 router experts

For this special issue on routers, we asked a trio of seasoned router experts to share shop-made jigs they have found super handy over the years. We'll provide the plans for each, and also show how they're used. Add to that a healthy dose of expert wisdom along the way.



# Pat Warner's Two-Part Dado Jig



Photograph: Wild Rose Photography

EXACT-WIDTH  
DADO JIG

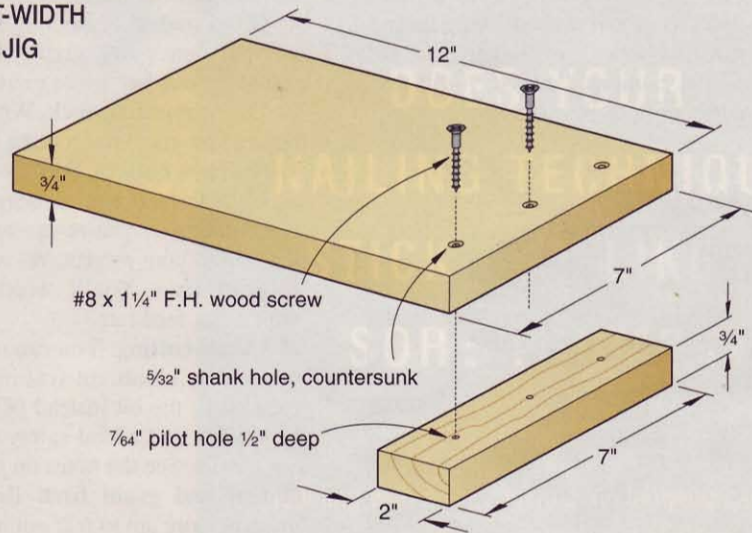

**I**n addition to writing four router books, Pat Warner has designed specialty router bits and is currently developing a collection of inexpensive, disposable, single-flute mortising bits.

## Why you need this jig

“Accuracy in routing requires attention to detail—and not much sophistication,” Pat notes. This Californian’s simple jig helps match dado width to shelf thickness. Using Pat’s two-part jig, we set up to cut a dado in less time than it takes to equip a tablesaw with a dado set.

## How to build Pat’s jig

You’ll need to assemble two of the jigs, shown *above*. (We cut two pairs of jigs, one from 3/4"-thick plywood and another using medium-density fiberboard (MDF). If you plan to make dados 10" or longer, build additional pairs with the top pieces at least 12" long or more.

## Put the two-part jig to use

Before you begin cutting dados, you’ll need a sample of the stock that the dado will ultimately hold in your project. Here’s one key to a snug dado: Go through each sand-

ing step you plan to follow until your sample piece reaches its finished thickness.

For this example, we’re cutting a dado in the side of a cabinet for a shelf. Position the two-part jig where you plan to cut the dado; then snug the sanded shelf scrap between the parts, as shown in the photo *below left*. Next, clamp both parts firmly in place at the edges away from the gap to keep the clamps from interfering with the router.

After removing the sample (save this piece for future reference), set your router cutting depth equal to the thickness of the jig parts plus the depth of cut you want.

## PERFECT DADOES: BEFORE AND AFTER



After locating the dado position, place a piece of finish-sanded scrap between the jig’s two parts. Then clamp the parts to the workpiece.

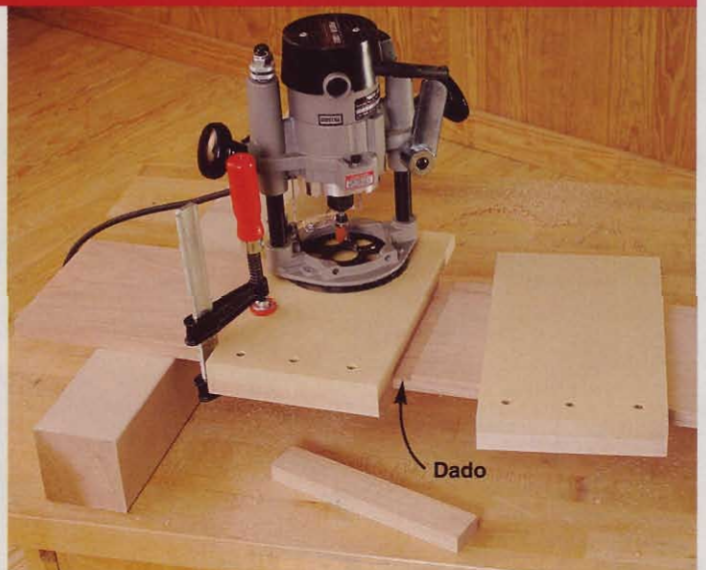

If the dado is too snug (sometimes caused by a pattern-cutting bit that’s smaller than the bearing), shim out the shelf scrap with a sheet or two of paper, adjust the jig parts, and rout again.



Then rout a dado using a pattern-cutting bit (also sold as a shank-bearing guided trimmer). The bearing of this bit rides along the edge of the jig parts and produces a crisp, square dado, as shown in the drawing *below*.

"Be sure the cutter isn't larger than the bearing," Pat cautions, "or else you'll tear up the edges of your jig parts."

#### DADO JIG SIDE VIEW

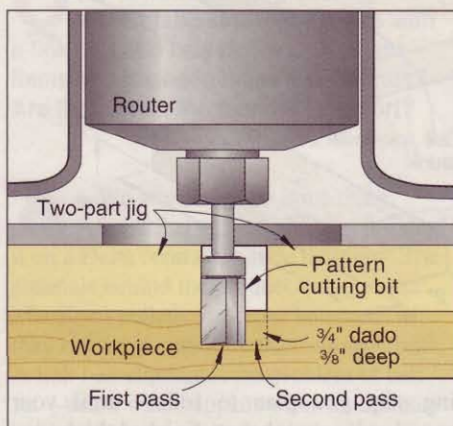

### Keys to avoiding tear-out

To avoid tearing out the edge of your workpiece as you finish your cut, as shown *below*, clamp a sacrificial piece of scrapwood to the edge of your work. Here are other tactics Pat recommends to reduce tear-out:

- **Good material.** Routing straight-grained, properly seasoned hardwood reduces tear-out. Interesting grain patterns, including bird's-eye and quilted maple, have visual appeal, but create more routing challenges.
- **Well-prepared stock.** Wherever possible, eliminate cups and bows in your stock before you get to the routing steps.
- **Sharpen cutters.** Well-honed bits produce less tear-out.
- **Light cuts.** If you cut deeper than  $\frac{3}{8}$ " with one pass, you're apt to introduce tear-out to your project.  $\frac{1}{8}$ " is ideal.
- **Feed rate.** You'll worsen tear-out with a fast feed rate.
- **Climb-cutting.** You can reduce tear-out with a climb cut (cutting with the rotation of the bit instead of against it). Light cuts and added safety procedures are a must. See the notes on *page 80*.
- **Cut end grain first.** Because end grain is more apt to tear out, rout it first. Then rout edge grain and clean up any tear-out.



## Patrick Spielman's Multi-Hole Doweling Jig

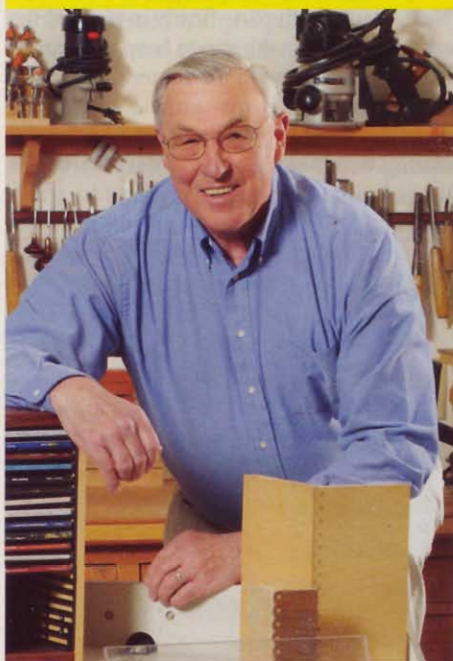

Photograph: Harman Studios/Sturgeson Bay

**P**atrick Spielman of Fish Creek, Wisconsin, has authored more than 75 woodworking books. His original *Router Handbook* sold more than a million copies, and his revised *New Router Handbook* remains one of Sterling Publishing's best-selling woodworking titles. Patrick shares with us his multi-hole doweling jig.

### Why you need this jig

In addition to positioning dowels for most doweling joints (we found the jig particularly useful for face-frame joinery), this is a great jig for aligning shelf-support pins.

"The dowel joint makes a lot of sense to me," the former schoolteacher says. Dowels provide extra mechanical strength when joining end to edge grain, but they're quicker to make than hand-cut dovetails.

"The dowel joint is pretty much fool-proof, and with this jig, you can take the joint further and have the dowels come through the other side."

The 2" counterbored slots in the  $\frac{3}{8}$ "-thick plastic jig make Patrick's jig versatile. The adjustable, removable stop will help you precisely position face stock.

### How to build Patrick's jig

Follow the drawing, *opposite top*, to build the jig. Lay out and drill the  $\frac{5}{8}$ " holes as accurately as possible in the plastic. (We used a drill press for this step.)



Two-piece guide bushings easily attach to your router's base.

### Put the jig to use

With a guide bushing in your router, dowel holes always line up regardless of how accurately you spaced the  $\frac{5}{8}$ " holes for your jig. For this type of plunge routing, use upcut spiral bits like the one shown to the *left*.

To position the jig and router to make identically spaced dowel holes in face frame stiles and rails, see the two illustrations *opposite bottom*.



Upcut spiral router bit



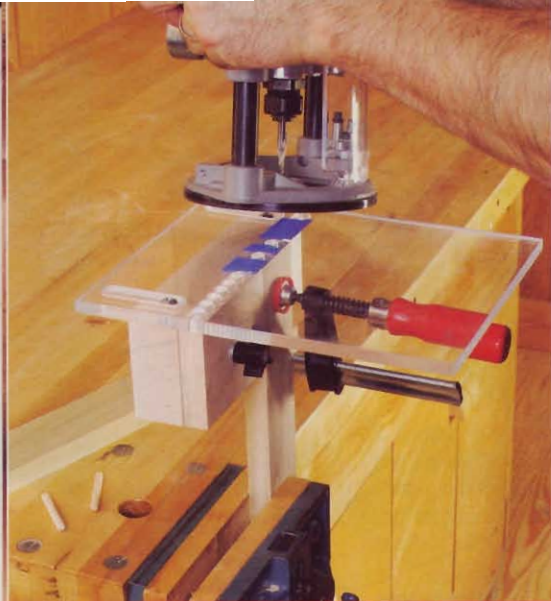

### ROUTING FACE-FRAME HOLES

Patrick Spielman's doweling jig makes quick work of doweling tasks, including the face frame joinery (end to edge grain) above. The  $\frac{5}{8}$ " guide-bushing hole is compatible with  $\frac{1}{4}$ ",  $\frac{5}{16}$ ", or  $\frac{3}{8}$ " dowel pins. The positioning block ensures quick, accurate alignment of the stock. Illustrations, below right, show routing dowel-pin holes in the rail and stile.

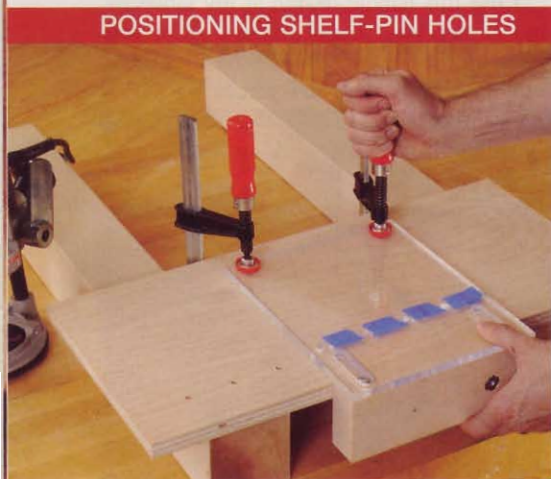

### POSITIONING SHELF-PIN HOLES

Originally designed for doweling, this jig also helps you make evenly spaced holes for shelf pins. To avoid goofs, tape over holes you won't use, as shown above. (Spacing of  $1\frac{1}{4}$ – $2$ " between holes works well in most applications.)

### SLOT DETAIL

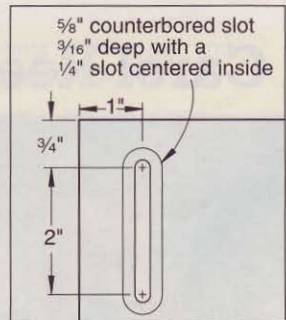

### DOWELING JIG

$\frac{5}{8}$ " counterbored slot  
 $\frac{3}{16}$ " deep with a  
 $\frac{1}{4}$ " slot centered inside

$\frac{1}{4}$ -20 x 3" panhead  
machine screw

$\frac{1}{4}$ " lock washer

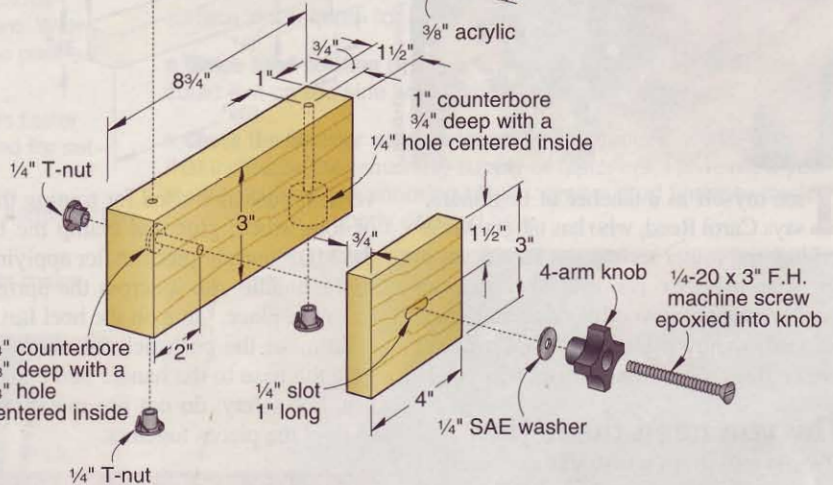
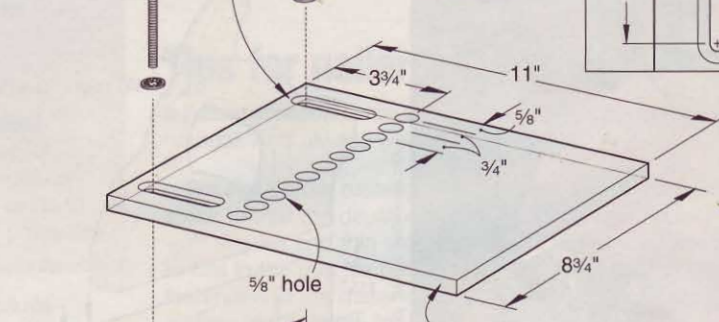

### CUTTING HOLES ON STILE EDGES

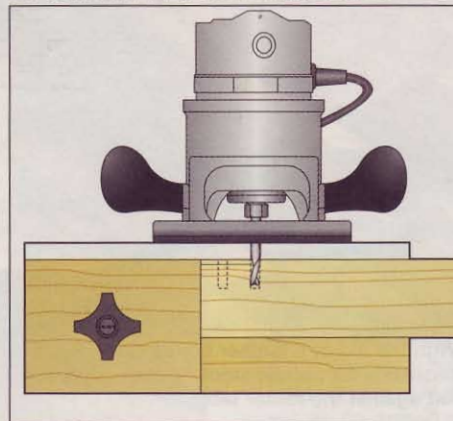

### CUTTING HOLES ON RAIL ENDS

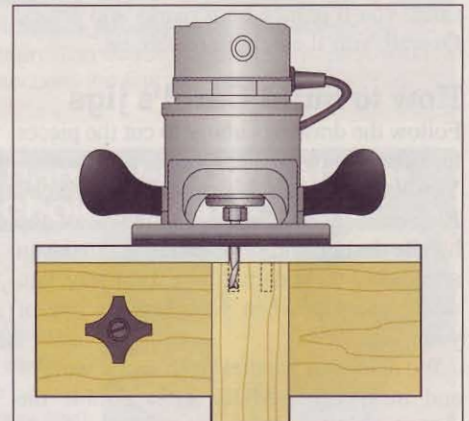

## The plastic world

With more than 35 years experience with routers, Patrick has designed several jigs incorporating plastic parts. We built Patrick's jig from  $\frac{3}{8}$ " polycarbonate because it's commonly available at hardware stores and home centers. However, he prefers  $\frac{1}{2}$ " polycarbonate, a thickness that's tougher to find.

"If you can find  $\frac{1}{2}$ " plastic," Patrick says, "you have fewer problems with guide bushings being too long for the router bits.

Plus, thicker plastic makes it easier to rout adjustable slots."

"I avoid acrylic plastic because it's brittle," Patrick adds. "I've had fewer problems with polycarbonate plastic cracking or breaking around a hole or near the edge."

We found a local polycarbonate supplier under "plastics" in the phone directory. The local price was about \$2.90 per square foot for  $\frac{3}{8}$ "-thick polycarbonate cut to order.



# Carol Reed's Finger-Saving Success Devices



Photograph: Courtesy of Sendor Nagyszalanczy

## NARROW STOCK PUSHSTICK

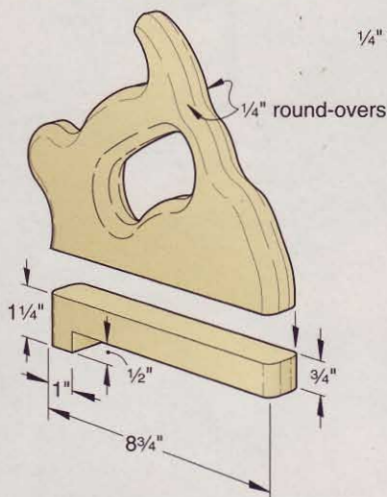

## VERTICAL STOCK PUSHSTICK

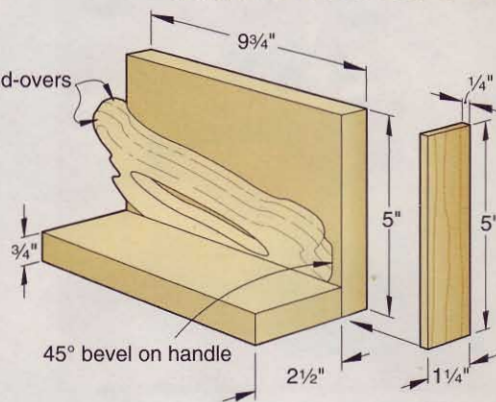

## Put the pushsticks to use

Paired with a feather board, Carol's narrow stock pushstick, *below left*, helps you control small pieces. The vertical pushstick, *below right*, supports the ends of tall pieces.

"I use this handle design at my tablesaw and jointer, too," Carol advises. After you chew up the sole and heel, send it through the jointer and attach new pieces.

"And don't think of just 3/4"-thick material. I have safely routed with 3/8" pushsticks and a little heel." 🌲

Written by Carl Voss Illustrations: Roxanne LeMoine

"I see myself as a teacher of beginners," says Carol Reed, who has taught woodworking and router techniques for 20 years. This Phoenix-area resident also demonstrates her talents at woodworking and home and garden shows. Her first book, *Router Joinery Workshop*, was published in 2003.

## Why you need these jigs

"I like to call these pushsticks my 'success devices,'" Carol says. "The real reason to use pushsticks is that, not only will you be safer, you'll reduce burn marks and errors. Overall, you'll enjoy more success."

## How to build Carol's jigs

Follow the drawings *above* to cut the pieces for Carol's two router table accessories. You'll find the handle pattern in the *WOOD Patterns*® insert. Create a template of the handle design, she says, and then "make an armload of these darn things. That way, you won't feel bad when you chew up one of your jigs."

We made our handles from easily worked and inexpensive MDF. To assemble the

vertical pushstick used for routing the ends of long stock, glue and clamp the base to the MDF upright piece. After applying glue to the handle, rub it across the upright and clamp in place. Glue on the heel last.

To make the pushstick for narrow stock, glue the base to the handle and clamp until dry. For safety, do not use metal fasteners to hold the pieces together.

## PUTTING PROBLEM-SOLVING PUSHSTICKS TO WORK



With the aid of a feather board, Carol Reed's pushstick for narrow stock keeps workpieces flat against the router table.

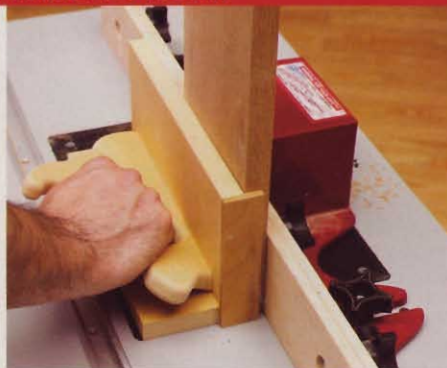

Carol's vertical pushstick, with a replaceable 1/4" plywood heel, helps you press tall pieces firmly against your router table fence.

## Climb-cut safely

Carol advises woodworkers to approach climb-cutting with added caution. (Although this method of clockwise cutting with a handheld router produces less splintering than the traditional counter-clockwise direction, the router tends to pull itself away from the operator.) With climb-cutting, you can remove burn marks or clean up tear-out, making only a 1/64" pass with a handheld router.

"But I don't advocate any climb-cutting at a router table," Carol adds. "Think of it this way: A router table was designed to

cut wood narrower than the handheld router base. If you introduce wood to the backside of a cutter at a router table, you essentially drop your stock onto a moving sidewalk. And if you're trying to control a small piece, where will your fingers go? Right into the bit."

"For safety, I encourage all my students to draw big bit rotation arrows with a Sharpie marker on their router bases and motors." The arrows provide a constant and readily visible reminder of which direction the bit is turning.



# on-the-go lap desk

Whether at home or on the road, kids will enjoy writing and drawing on this portable slant-top desk. It keeps their art supplies organized and handy whenever inspiration strikes!



Built from lightweight pine, the lap desk weighs 4½ pounds, making it easy for youngsters to tote around.

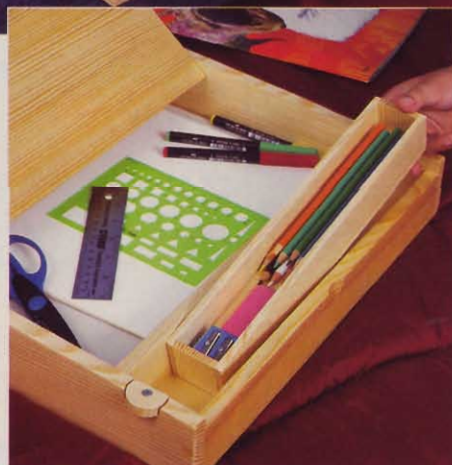

A divider forms separate areas for paper and a lift-out pencil box. The box bottom has magnets to hold it in place on the desk.

**H**ere's a project sure to stir a youth to action in the shop. It features easy-to-make parts and super simple glue-and-screw butt joinery. Now team up with a youngster, as Managing Editor Marlen Kemmet did with his enthusiastic 8-year-old son, Carter, and build—along with the project—great memories.

*Note: After preparing the parts as explained in the first section of this article, have your partner join forces to complete the machining and assembly starting with the section identified by the adult/child icon on page 84.*







## ASSEMBLE THE CASE



**A** Glue and clamp the right side (A) and back (B) together with a squaring brace. Then drill pilot holes through the side into the back.

## RABBET THE CASE BOTTOM



**B** With the rabbeting bit's bearing riding along the inside of the case, rout a  $\frac{3}{8}$ " rabbet  $\frac{1}{4}$ " deep around the bottom inside edges.

## DRILL HOLES FOR THE LID PINS



**C** Flip the case. Holding the lid (E) in place and positioned by spacers, drill holes through the side into the lid for the brass hinge pins.

**6** Using your table-mounted router with a  $\frac{1}{8}$ " round-over bit, rout along the top front edge of the lid rest (D), where shown on **Drawing 1**. Then switch to a  $\frac{1}{4}$ " round-over bit, and rout along the top back edge of the lid (E). Now mark centerpoints for two #6x $\frac{3}{8}$ " flathead wood screws in the top face of the lid rest, where dimensioned. (The screws align with magnets you'll install in the bottom of the pencil box later.) Drill the countersunk pilot holes at the centerpoints.

**7** To form a finger recess on the front (C), first lay out a  $1 \times \frac{5}{8}$ " area centered on the front, where dimensioned on **Drawing 1**. Then chuck a  $1\frac{1}{2}$ "-diameter sanding drum with a 150-grit sleeve in your drill press. Holding the front against the drum at approximately  $20^\circ$ , sand the recess.

**8** From  $\frac{1}{4}$ " plywood, cut the bottom (F) to size. Then, from  $\frac{3}{4}$ " stock planed to  $\frac{1}{2}$ ", cut the divider (G) to size.

**9** To form the turn buttons (H), plane  $\frac{3}{4}$ " stock to  $\frac{3}{8}$ ". Then cut a  $2 \times 6$ " workpiece. Make two copies of the full-size turn button pattern, **Drawing 3**. Spray-adhere the patterns to the workpiece, aligning the

straight edges with an edge of the workpiece. Drill countersunk shank holes through the buttons. Next, using your scrollsaw with a no. 3 blade, cut the buttons to shape. Using the sanding drum in your drill press, sand the edges smooth. Now hand-sand a  $\frac{1}{16}$ " round-over along the top rounded edges.

**10** From  $\frac{3}{4}$ " stock resawn and planed to  $\frac{1}{4}$ ", cut the front/back (I) and ends (J) to size for the pencil box. Then, from stock planed to  $\frac{1}{2}$ ", cut the bottom (K) to size. (Your partner will drill the holes in the bottom for the magnets later.)

## Assemble the lap desk

**1** Glue and clamp together the right side (A) and back (B), as shown in **Photo A**. Then have your partner drill  $\frac{3}{32}$ " pilot holes, centered in the side counterbores, through the bottom of the counterbores and  $\frac{3}{4}$ " deep into the back, as shown. (We

wrapped a piece of masking tape around the bit for a depth stop, locating the tape  $1\frac{1}{4}$ " from the end of the bit to allow for the  $\frac{1}{2}$ "-thick side and  $\frac{3}{4}$ " pilot-hole depth.) Drive the screws. Repeat to attach the left side (A) and front (C) to assembly A/B.

**2** Assisting your partner, as needed, apply glue to the top edge of the back (B) and to the ends of the lid rest (D). Clamp the lid rest in position on the beveled top edge of the back, where shown on **Drawing 1**, making sure the rounded edge of the rest is faceup and to the inside of the case. Now drill pilot holes, centered in the side counterbores, into the rest, and drive the screws. Remove the glue squeeze-out.

**3** Chuck a  $\frac{3}{8}$ " rabbeting bit in your table-mounted router. Then rout a  $\frac{1}{4}$ "-deep rabbet around the inside bottom edges of the case to receive the bottom (F), where shown on **Drawing 1** and as shown in **Photo B**. (We recommend the adult do this.)

**4** To attach the lid (E), lay the case with the bottom up on a flat work surface. Then place the lid in the case bottom face up, making sure that the rounded edge of

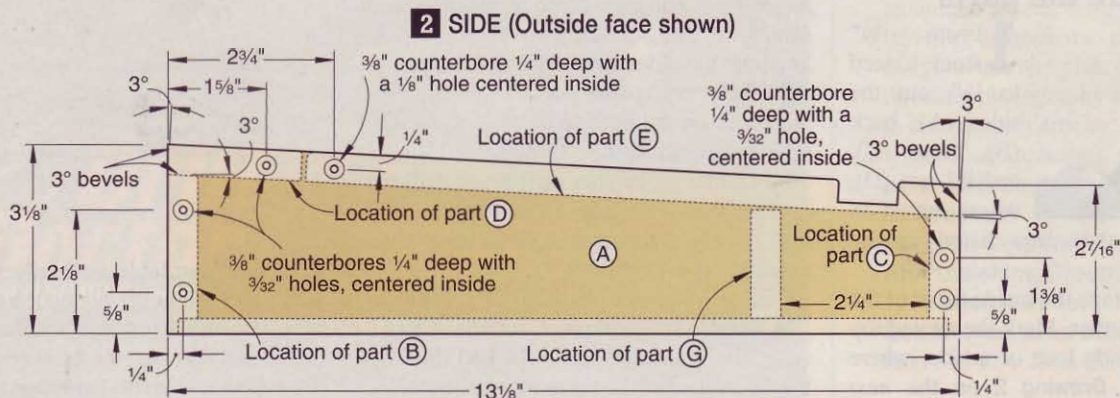



### DRIVE PINS INTO THE LID

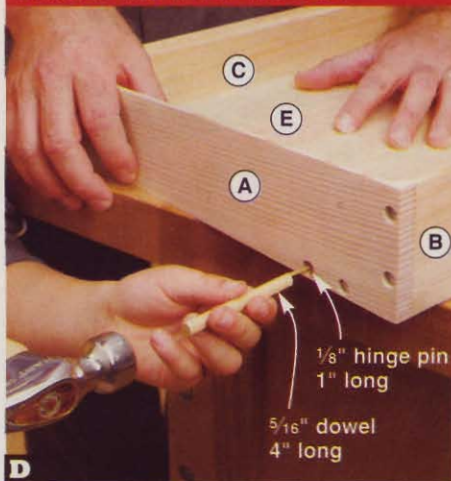

Using a 4"-long piece of  $\frac{5}{16}$ " dowel as a pin punch, drive the lid hinge pin flush with the bottom of the counterbore in the side (A).

### TRIM THE COUNTERBORE PLUGS



Trim the plugs flush with the sides (A) using a flush-trim saw. Keep the saw blade flat against the sides to ensure a straight cut.

### BORE FOR THE TURN BUTTONS

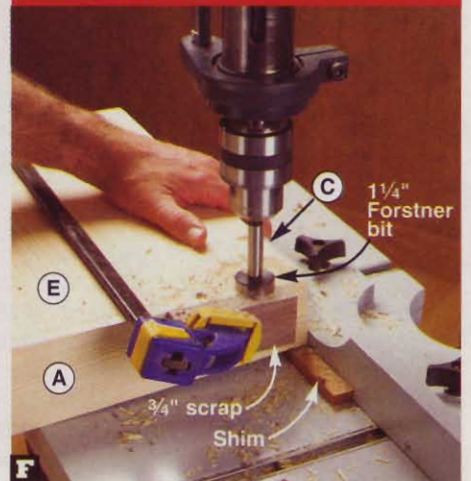

With the lap desk shimmed level and a  $\frac{3}{4}$ " scrap clamped to the side (A) to prevent tear-out, bore the turn-button recess.

the lid is facedown and adjacent to the lid rest (D). Next, position the beveled front edge of the lid flush with the front (C) by inserting scrap  $\frac{1}{8}$ "-thick spacers between the lid and the lid rest, and center the lid side-to-side by inserting  $\frac{1}{32}$ " spacers (we used card stock) between it and the sides

(A), as shown in **Photo C**. Now drill  $\frac{1}{8}$ " holes  $\frac{3}{4}$ " deep, centered in the side counterbores, into the lid for the brass hinge pins, as shown. Remove the spacers.

**5** From a  $\frac{1}{8}$ " brass rod 6" long, hacksaw two 1"-long pieces for the hinge pins. To install a pin, position the case vertically

on a side (A), holding the lid (E) in place. With the hinge-pin holes aligned, slip a #8 brass flat washer between the lid and the side, center the washer with the holes, and insert a pin into the holes as far as you can. Then, holding the pin and lid in place, lay the assembly bottom up on your work surface. Now seat the pin, as shown in **Photo D**. Repeat to install the other pin.

**6** Have your helper make plugs for the 12 counterbores, as explained in the **Shop Tip**, left. Then glue the plugs in place, aligning the plug grain with that of the sides (A). Let the glue dry overnight. Then trim the plugs, as shown in **Photo E**.

**7** Using a 150-grit sanding drum in your drill press or a disc sander, let your partner sand radii on the corners of the bottom (F) to fit it in the rabbeted recess in the case. Then glue and clamp the bottom in place.

**8** Apply glue to the bottom edge of the divider (G). Then clamp it to the bottom (F), where dimensioned on **Drawing 1**.

**9** Mark centerpoints on the top edges of the sides (A) for  $\frac{1}{4}$ "-diameter recesses for the turn buttons (H), where dimensioned on **Drawing 1a**. Next, chuck a  $\frac{1}{4}$ " Forstner

## SHOP TIP

### Perfect plugs made easy

To plug screw-hole counterbores, such as those in the sides (A) of the lap desk, you want the plugs to fit snugly and match the tone and grain pattern of the surrounding wood. Make virtually invisible plugs using a tapered plug cutter and a cutoff from the part that needs plugs. Drill the plugs, as shown *below left*, making the length equal to the depth of the counterbore plus  $\frac{1}{8}$ " and leaving about  $\frac{1}{4}$ " of space between them. Cut a few more plugs than needed so you can choose ones that match best. Pry the plugs from the cutoff using a straight-blade screwdriver, as shown *below right*. A  $\frac{3}{8}$ " tapered plug cutter needed for the lap desk sells for less than \$12 at Lee Valley, 800/871-8158; leevalley.com.



### 3 FULL-SIZE TURN BUTTON PATTERN

$\frac{1}{16}$ " round-over, hand-sanded

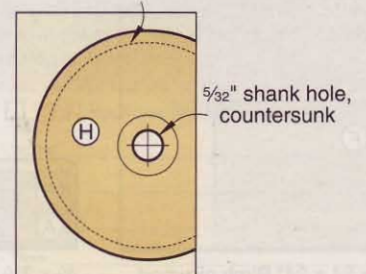



## An 18th-century idea for 21st-century kids

President Thomas Jefferson discovered the practicality of a lap desk more than 225 years ago. To increase productivity during 200-mile coach rides between his Monticello home in Charlottesville, Virginia, and the Continental Congress in Philadelphia, Jefferson designed the lap desk, *right*. The desk stored his supplies and give him a surface for reading and writing, including the penning of the Declaration of Independence in 1776. Though the concept is not new, our simplified child's lap desk offers equal convenience and utility for today's creative on-the-go kids.



Photograph: Richard Strauss, Smithsonian

bit in your drill press. Place the lap desk on the drill-press table with the front (C) against the fence. Then insert a shim of the needed thickness under the front of the desk, as shown in **Photo F**, to make the top level. To prevent tear-out, clamp a small piece of  $\frac{3}{4}$ " scrap to the side (A), as shown. Now bore a  $\frac{3}{8}$ "-deep hole. Repeat to bore a hole in the other side. Using the centers of the counterbores as guides, drill  $\frac{5}{64}$ " holes  $1\frac{1}{8}$ " deep for the turn-button mounting screws.

**10** Lending your partner a hand, glue and clamp together the pencil-box front/back (I), ends (J), and bottom (K), noting that the front/back pieces overlap the ends. After the glue dries, drill two holes for magnets in the bottom, where dimensioned on **Drawing 1b**. (Using a Forstner bit, we drilled  $\frac{3}{8}$ " holes  $\frac{3}{16}$ " deep to fit  $\frac{3}{8}$ "-diameter magnets  $\frac{3}{16}$ " long from a hardware store.) Then install the magnets using 5-minute epoxy.

### Cutting Diagram

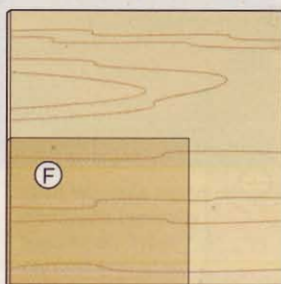

$\frac{1}{4}$  x 24 x 24" Birch plywood

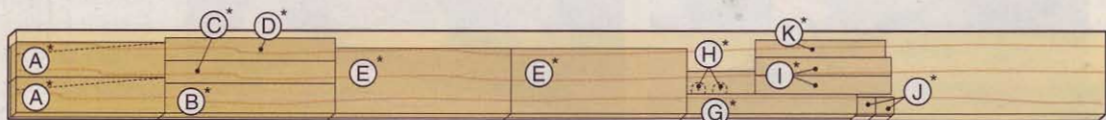

$\frac{3}{4}$  x  $7\frac{1}{4}$  x 96" Pine (5.3 bd. ft.) \*Plane or resaw to the thicknesses listed in the Materials List.

### Time to finish up

**1** Carefully mark centerpoints for  $\frac{3}{16}$ " holes on the outside face of the back (B) for attaching a 3" wire pull, where dimensioned on **Drawing 1**. Drill the holes.

**2** Sand the lap desk and pencil box with 220-grit sandpaper. Ease the edges of the sides (A) and lid (E), where shown. Remove the dust. Then apply three coats of a clear finish. (We used a satin polyurethane, sanding to 220 grit between coats.) For health reasons, we recommend that the adult do this in a well-ventilated area.

**3** Finally, screw the wire pull to the back (B) and the turn buttons (H) to the sides (A). Rotate the turn buttons, and check that you can raise the lid (E). If not, slightly sand the straight edges of the buttons for the needed clearance for the lid. Drive two #6x $\frac{3}{8}$ " flathead wood screws that align with the magnets in the pencil box into the holes in the lid rest (D). Now have your partner round up some drawing supplies, and let the artistry begin! 🌲

Written by **Owen Duvall** with **Jeff Mertz**  
Project design: **Kevin Boyle**  
Illustrations: **Roxanne LeMoine**

### Materials List

| Lap desk        | FINISHED SIZE   |                         |                     | Matl. | Qty. |
|-----------------|-----------------|-------------------------|---------------------|-------|------|
|                 | T               | W                       | L                   |       |      |
| A sides         | $\frac{1}{2}$ " | $3\frac{1}{8}$ "        | $13\frac{1}{8}$ "   | P     | 2    |
| B back          | $\frac{1}{2}$ " | $2\frac{5}{8}$ "        | 15"                 | P     | 1    |
| C front         | $\frac{1}{2}$ " | 2"                      | 15"                 | P     | 1    |
| D lid rest      | $\frac{1}{2}$ " | 2"                      | 15"                 | P     | 1    |
| E* lid          | $\frac{1}{2}$ " | 11"                     | $14\frac{15}{16}$ " | EP    | 1    |
| F bottom        | $\frac{1}{4}$ " | $12\frac{7}{8}$ "       | $15\frac{3}{4}$ "   | BP    | 1    |
| G divider       | $\frac{1}{2}$ " | $1\frac{3}{4}$ "        | 15"                 | P     | 1    |
| H* turn buttons | $\frac{3}{8}$ " | $1\frac{3}{16}$ " diam. |                     | P     | 2    |
| Pencil box      |                 |                         |                     |       |      |
| I front/back    | $\frac{1}{4}$ " | $1\frac{5}{8}$ "        | 12"                 | P     | 2    |
| J ends          | $\frac{1}{4}$ " | $1\frac{1}{2}$ "        | $1\frac{5}{8}$ "    | P     | 2    |
| K bottom        | $\frac{1}{2}$ " | $1\frac{1}{2}$ "        | $11\frac{1}{2}$ "   | P     | 1    |

\*Parts initially cut oversize. See the instructions.

**Materials key:** P—pine, EP—edge-joined pine, BP—birch plywood.

**Supplies:** Double-faced tape, spray adhesive,  $\frac{1}{8}$ " brass rod 6" long, #8 brass flat washers (2),  $\frac{3}{16}$ " dowel 4" long, #6x $\frac{3}{8}$ " flathead wood screws (2), #6x $1\frac{1}{2}$ " flathead wood screws (2), #8x1" roundhead screws (10), #8-32x1" round-head machine screws (2), 5-minute epoxy,  $\frac{3}{8}$ "-diameter magnets  $\frac{3}{16}$ " long (2), 3" wire pull.

**Blades and bits:**  $\frac{3}{8}$ " and  $1\frac{1}{4}$ " Forstner bits,  $\frac{1}{8}$ " and  $\frac{1}{4}$ " round-over and  $\frac{3}{8}$ " rabbeting router bits, no. 3 scrollsaw blade,  $\frac{3}{8}$ " tapered plug cutter.



# from simple to deluxe — how to choose a router table

Options and accessories abound for table-mounted routers. We'll sort out what matters most to help you pick the table setup that best suits your needs.

## SIMPLE

Free from scrap bin



## BUDGET

Less than \$60



## STANDARD

About \$200 complete

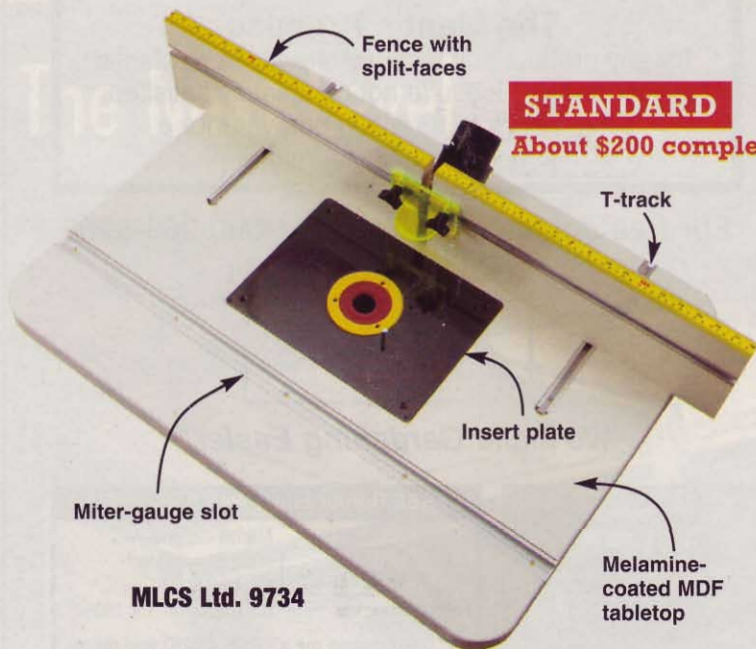

## DELUXE

About \$1,000 complete



**W**oodworkers love their router tables. And we have good reason. These highly useful accessories give us cabinet-shop capability. For profiling an edge or cutting many types of joints, they make the tasks easy, accurate, and safe.

Not surprisingly, a slew of manufacturers have responded to woodworkers' insatiable appetite for router tables and accessories with a mind-boggling array of products. Vendors sell everything from basic tables to tricked-out machines with the features of a

full-fledged spindle shaper. We've tried nearly all of them. To help you benefit from that experience, we've pooled together our best advice on the subject so you can find and outfit a router table ideally suited to your shop size, routing needs, and budget.



# 7 choices that make a difference

## Choice 1: Get your work-surface needs on the table

Which router table to use—stand-alone, benchtop, or tablesaw-mounted—should be your first decision. Thankfully, you no longer need to choose a stand-alone model in order to get a full-featured router table. Today's benchtop and tablesaw-mounted versions offer all the bells and whistles you could ever want, as shown *at right*.

It makes sense to replace your tablesaw's extension table with a router table, as shown *at far right*, if you're tight on shop space. If your projects take you outside the shop, or if you'll only use a router table on occasion, go for a benchtop unit. You can stow it away or hang it on a wall to save space.

If space allows, a stand-alone table provides the most versatility. Place the table on wheels and position it wherever you



Bench Dog  
ProTop  
Contractor

This benchtop model offers an enclosed cabinet, multi-function fence, and an inset plate predrilled to fit almost any router.



Bench Dog  
ProMAX

This tablesaw-mounted router table shares all the amenities found on the manufacturer's stand-alone model.

want. A stand-alone (or benchtop) table can be set up for an operation and left without interfering with other tool operations.

**Bottom Line:** Space and portability may dictate your decision here, but if you have

the room, opt for a stand-alone table. Besides maximizing your flexibility, a stand-alone table usually offers the widest range of tabletop sizes and the most storage and dust collection options.

## Choice 2: What's what in tabletop materials

Manufacturers make tabletops in a variety of materials. Most consist of a core made of medium-density fiberboard (MDF) covered with either plastic laminate or melamine. This combination produces a table that's flat, economical, and durable.

Because channels cut into MDF will wear, manufacturers often equip these tables with aluminum tracks to guide the miter gauge and fence. Know also that MDF can absorb moisture and swell if placed in particularly damp environments. Seal any exposed MDF to prevent such absorption.

Several manufacturers now offer tabletops made of phenolic resin, a rock-hard, stiff, and durable plastic. These tables come dead flat and boast immunity to moisture changes. Phenolic machines well, meaning you can mill a miter-gauge slot or slots for T-tracks or fence mounts directly into the tabletop. On the downside, phenolic tabletops cost 10 to 20 percent more than MDF.

If you prefer heavy metal, your tabletop options include aluminum, plate steel, and cast iron. These tables are ground smooth and flat, and are very durable. Typically, they're equipped with miter-gauge slots.



MLCS Ltd.  
#9459 Cast-  
Iron Table

The cast-iron router table (left) resembles a tablesaw top. The plate-steel version (right) offers similar traits of flatness and heft, but has no miter-gauge slot.

Note that you'll have to keep rust off steel and iron versions. Aluminum tables won't rust, but can corrode. And uncoated aluminum may leave marks on wood.

**Bottom Line:** MDF ranks as our top choice for tabletops. These are priced right, durable, and sold in a variety of sizes. Plus, you easily can cut and machine MDF if you want to modify the tabletop.



Veritas Router Table  
Top #05J20.01  
fence #05J21.01

## Choice 3: Gauge your miter-gauge preferences

Router tables, by design, perform best at machining the edges of workpieces. So what if you need to rout across the end of a board? Most tables accomplish this with a built-in track that guides a standard

miter gauge (which you supply). This slot often doubles as a handy place to mount accessories, such as feather boards.

Some router-table users prefer instead to use a shop-built miter sled that rides against the fence. With a sled, the workpiece stays square to the fence face whether or not the

fence sits perfectly parallel to the miter-gauge slot.

**Bottom Line:** A miter-gauge maximizes flexibility, allowing you to dado and cut slots, even at an angle, such as when splining a mitered joint. A sled may raise the workpiece beyond the bit's cutting height.



## Choice 4: Select from a full plate of insert options

Most tabletops come with an insert plate that fits into a rabbeted opening. The router bolts to the plate—which is typically made of phenolic, aluminum, or polycarbonate—using existing holes in the router base. You also can buy insert plates separately and fit them to your tabletop.

A removable insert plate offers two advantages over bolting the router directly to a solid tabletop. First, at 1/4" to 3/8" thick, a plate allows greater cutting height than if the bit had to reach through a 1" or thicker tabletop. Second, a plate makes the router easily removable. You'll appreciate this when you need to change bits, *below*.

The insert plate must sit flat and flush with the table surface. If it doesn't, your workpiece may catch on protruding edges.

Phenolic



Polycarbonate



Aluminum



These three types of insert plates hold the router base firmly in place, remove easily for bit changing, and are thin enough to allow full cutting capacity. Each is made of material that resists sagging with weighty routers.

Make sure that either the tabletop or plate has jack screws or another leveling system to flush the plate with the tabletop.

Some manufacturers design a slight crown into the plate. If the router's weight flexes the plate, it forces the plate flat rather than create a concave surface.

Because router bits range from less than 1/4" to more than 3" in diameter, choose an

insert with interchangeable reducer rings to adjust the bit opening, as shown *below*.

**Bottom Line:** What plate material you choose holds less importance than getting one with reducer rings and a leveling system. You'll pay more for these features, but will be glad you did. For the ultimate router plate, get one that's equipped with a lift. (See "Router lifts" on the *next page*).

### IT'S EASIER TO CHANGE BITS FROM ABOVE THAN BELOW



Lifting the router and insert plate out of the table (left) simplifies bit changing by allowing full access. If the router bolts directly to the table (right), a tilting top facilitates bit changes.

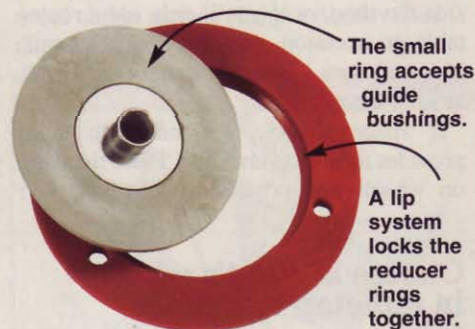

Reducer rings fit into the insert plate to support stock, increase safety, and reduce tear-out.

## Choice 5: Find a reliable feature-filled fence

Unless you're using a bearing-guided bit, most router-table operations require a fence to guide the workpiece. To work properly, a fence has to, at a minimum, measure flat from end to end, hold the faces square to the tabletop, and adjust easily.

Split faces that open and close to change the size of the gap around the bit, as shown

*below*, perform best. By allowing you to offset one face, the split faces on some fences allow you to joint board edges, as shown at *right*. This feature comes in handy if you don't have a jointer.

Beyond these basic functions, find a fence with T-tracks or other mounting points for such accessories as feather boards and stop-blocks, bit guards, and auxiliary jigs. If the fence doesn't come with a port to accept



The outfeed side of some fences moves forward with spacers or adjustment screws so you can edge-joint boards with a straight bit.

### SLIDING FENCE FACES ADJUST TO SUIT ANY SIZE BIT

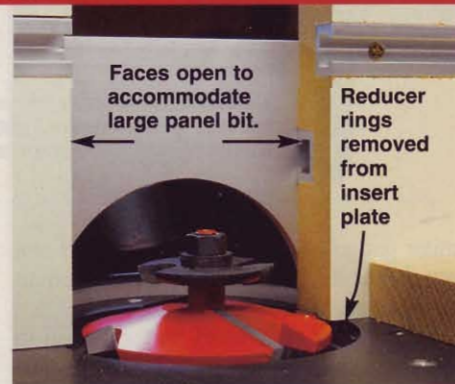
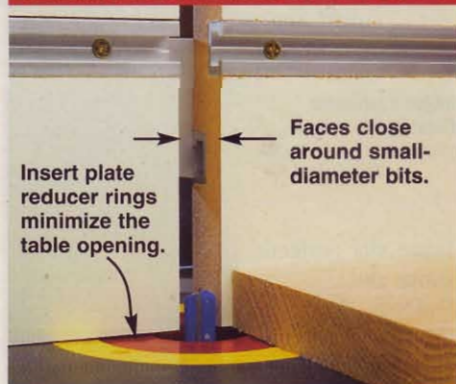

You can adjust sliding fence faces to fully support the workpiece on the infeed and outfeed sides of the cut, no matter what size bit you use. To get the best performance, always set the smallest gap possible around the bit.

a vacuum hose, get one. By connecting to a shop vacuum or dust-collector hose, you can collect most of the dust and chips your router produces. Most commercial fences offer these features, as does the fence we designed on *page 40*.

**Bottom Line:** The best fences offer split faces, accessory-holding tracks, and a sturdy frame (usually made of extruded aluminum). Choose one that's at least as wide as your tabletop, and check the attachment system. Some require that you mount tracks in the tabletop; others clamp in place. A few can be mounted either way.



## Choice 6: Define your minimum stand standards

After you have chosen your tabletop and accessories, you still need to decide on a stand. The big question: Should the stand be enclosed or open? Both approaches have advantages and disadvantages.

An open stand allows easy access to the router, letting you adjust settings or change bits by reaching under the table. Plus, an open design allows unlimited ventilation to cool the router. On the other hand, an open

stand does nothing to contain noise or dust, and offers no storage space.

An enclosed stand, such as the model shown at *right*, keeps noise and dust contained, and may offer storage space for bits and accessories. However, this style will likely cost more than an open stand.

**Bottom Line:** An enclosed stand offers the most versatility. When selecting one, make sure it allows quick router access and ventilation to keep your router motor running cool.

**Woodhaven #365 Stand with phenolic tabletop and fence**



An enclosed cabinet keeps your router workstation tidy by providing storage space for bits and router accessories.

## Choice 7: Consider a shop-built solution

With so many router tables available, why would you want to build one yourself? Because you can customize it to meet your exact needs rather than having to mix and match components or purchase a package deal. You'll find plans for two top-notch

tables, shown *below*, on our Web site at [woodmagazine.com/toolplans](http://woodmagazine.com/toolplans).

Thankfully, many of the same vendors that sell complete tables also stock about every component and accessory you'll need to customize your table. You'll find some of our favorite sources for router-tables and gear listed *bottom right*.

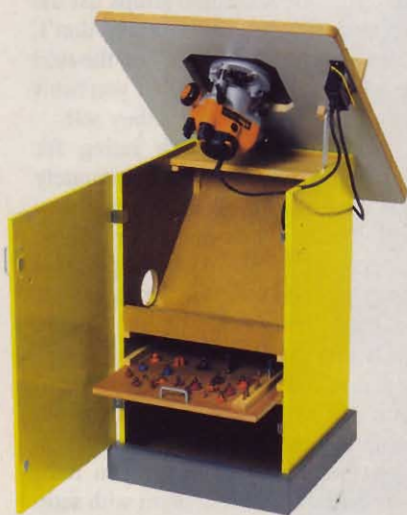

Our downloadable router-table plans allow you to build your own hard-working setup. The tilt-top model (left) offers storage, dust collection, and a large tabletop. The benchtop model boasts big features in a compact size.

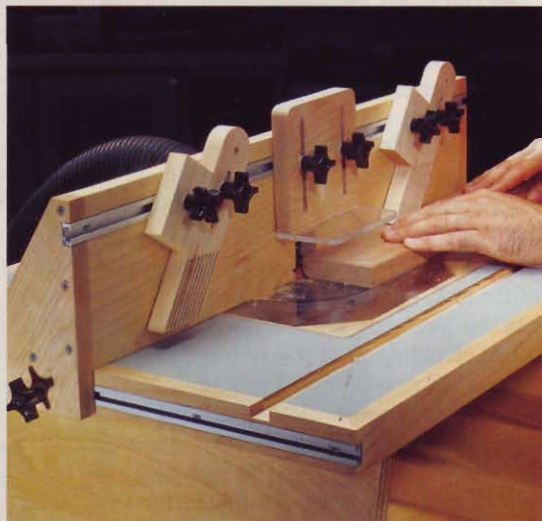

You can buy router-table components that would prove too difficult to build in the shop. These include insert plates and levelers, miter-gauge and T-tracks, dust-collection fittings, and many safety devices.

**Bottom Line:** Building your own router table offers the ultimate opportunity for customization. You choose which features you want, including table size, insert-plate location, and stand type. You decide which parts to build and which to buy. If you don't want to fuss with the precision required to build a fence, for example, purchase one and build the rest yourself. ♣

## Router lifts

A router lift holds the router motor in a carriage that rides up and down on a pair of guide posts that are attached to an insert plate. By turning a cranking mechanism above the table, you can adjust the cutting height of the router bit accurately without having to reach under the tabletop.

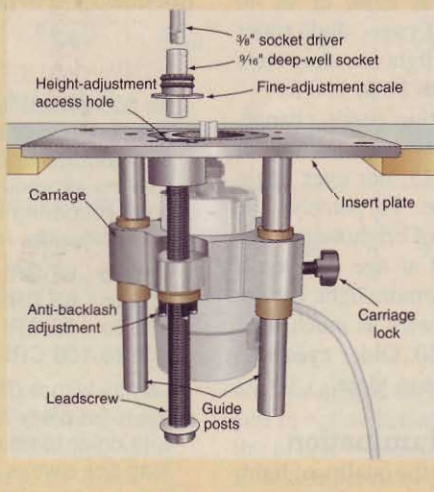

Written by **David Stone** Illustration: **Tim Cahill**

## A few of our favorite sources

**Bench Dog** Complete router tables, components, router lifts, accessories. 800/786-8902; [benchdog.com](http://benchdog.com)

**Grizzly Industrial, Inc.** Complete router tables, accessories. 800/523-4777; [grizzly.com](http://grizzly.com)

**JessEm Tool Co.** Complete router tables, fences, router lifts, accessories. 866/272-7492; [jessem.com](http://jessem.com)

**MLCS Ltd.** Complete router tables, components, fences, accessories. 800/533-9298; [mlcswoodworking.com](http://mlcswoodworking.com)

**Rockler Woodworking and Hardware** Complete router tables, fences, components, insert plates, stands, accessories. 800/279-4441; [rockler.com](http://rockler.com)

**Rousseau Co.** Complete router tables, fences, components, insert plates, accessories. 800/635-3416; [rousseauco.com](http://rousseauco.com)

**Woodhaven** Complete router tables, fences, components, insert plates, router lifts, accessories. 800/344-6657; [woodhaven.com](http://woodhaven.com)



# bright ideas for workshop lighting

See the difference with these surefire strategies.

## Strategy 1: Take a two-fold approach to proper lighting

When setting up shop, most of us pay too little attention to lighting. We hang a few fixtures where convenient and hope the light produced fits our needs. Without good illumination, though, the fine details needed for top-notch woodworking and shop safety disappear.

As you'll see, our eyes perceive not just the quantity of light, but its quality, as well. To get the quantity and quality of light you need, consider the following:

### Light it bright

Lighting quantity—the amount of light reaching a surface—is measured in foot-candles (fc). The quantity of light needed for any task increases with the complexity of the task. For example, household chores can be accomplished comfortably with 30 fc. Reading requires 50 fc. Precision tasks, such as woodworking, require more.

How much more? We asked lighting expert Doreen LeMay-Madden.

She chairs the residential lighting committee for the Illuminating Engineering Society of North America, and is president of Lux Lighting Design in Belmont, Massachusetts. She suggests that those of us 40 years of age and older should light our shops to a uniform 80 to 100 fc.

Lighting needs change, too, as we age. Starting at about age 15, our eyes begin to deteriorate. To perceive the same amount of brightness at age 40 as you did at age 20, you'll need 50 percent more light. By age 70, you'll need twice as much light as you did at age 40. Older eyes also become more sensitive to glare.

### Provide quality illumination

Three factors determine the quality of light. These are color temperature, color rendering, and glare.

**Color temperature:** All lamps (bulbs to us laymen) receive a rating based on the color of light they produce. The rating is expressed as a temperature in degrees Kelvin (K). Manufacturers assign names to the temperatures, such as "soft white" (3,000° K), "cool white" (4,100° K), or "daylight" (6,500° K). Some lamps list the name or temperature, while others don't. See "Fluorescent Lamp Basics" on the *next page*, or ask the retailer for help if you can't decipher which types of lamps they sell.

**Color rendering:** Another rating for lamps indicates their ability to accurately represent the colors of the items they illuminate. For an explanation, see "Show your true colors," *below*. We often perceive bulbs that reproduce color better to be brighter, even though they don't actually put out a higher quantity of light.

**Glare:** If a surface is too reflective or contrasts with those around it, glare will result. LeMay-Madden suggests painting shop in flat or eggshell-sheen white. If you have natural-wood cabinets, coat them with satin finish, rather than gloss. And what about all those cast-iron surfaces on woodworking machines? Wax these surfaces or coat them with such commercial protectants as Boeshield T-9 to prevent excess reflection.

### Show your true colors

All fluorescent lamps are rated by how accurately they show the color of objects they illuminate. Lighting experts express this ability with a color rendering index (CRI) rating that measures from 0 to 100.

- 0 to 55 CRI = poor accuracy
- 55 to 65 CRI = fair accuracy
- 65 to 75 CRI = good accuracy
- 75 to 100 CRI = excellent accuracy

Lamps with a CRI of at least 65 offer the most pleasing light in a shop. As with color temperature, these ratings may not always be listed on lamps, but you can obtain them from retailers or manufacturers.



## Strategy 2: Use fluorescents for overall lighting

Fluorescent lights have a bad reputation among some woodworkers who say they won't start in cold weather and that they hum, flicker, and make colors look odd. But if you use the proper fixtures and lamps, you can prevent those problems.

Fluorescent fixtures are a smart choice because they're three to four times more efficient than incandescent bulbs and last about 10 times longer. Fluorescent fixtures have become downright cheap to purchase, too. And you'll find a wide variety of styles suited to shop environments. The most common types are shown in the "Fixture Basics" chart, *below*.

### Find the right ballast

All fluorescent light fixtures use a device called a ballast to supply the high initial voltage necessary to start the lamps and to regulate the voltage lamps receive while operating. This prevents flickering. You'll find two types: magnetic and electronic, shown *above right*.

Magnetic ballasts cost about half the price of electronic versions, but often generate more noise (producing that telltale hum). Magnetic ballasts also may cause annoying flickering and perform poorly—or not at all—at temperatures below 50° Fahrenheit. Electronic ballasts are quiet, stable, and operate at temperatures as low as -10° F.

### Install the correct lamp

Once you choose fixtures, you'll need lamps to bring them to life. Home centers stock a large array. Use the "Fluorescent Lamp Basics" chart, *below*, to cut through the confusion and make sure you pick the correct type for your needs.

Lamps with higher temperature and CRI ratings cost more than run-of-the-mill cool white versions, but perform better. To see the difference in the light produced by these



Look at ballast labels for two important ratings: Minimum starting temperature, shown in degrees, and noise rating, where A ranks quietest.

## SHOP TIP

### Protect lamps from impacts

If your shop ceiling height is less than 10', you may know what happens when a board meets a fluorescent lamp. Plastic protectors (about \$2 to \$3 at home centers) provide cheap insurance against showers of broken glass.



## FIXTURE BASICS

You'll find fluorescent fixtures in many sizes and shapes. For shop use, look for the following types:

### Standard Strip

- Best use: General lighting
- Construction: Two or four open lamps located below a metal housing
- Location: Mount directly to a finished ceiling
- Styles: 4' and 8' long, plug-in or hard-wire
- Price: \$10 and up (less-expensive models use magnetic ballast)

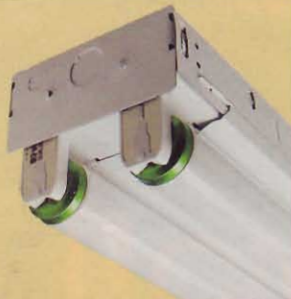

### Industrial

- Best use: General lighting
- Construction: Similar to a standard strip, but flanked by reflectors. Some feature protective screening (shown).
- Location: Suspend below a high or unfinished ceiling
- Styles: 4' and 8' long, plug-in or hardwired
- Price: \$10 and up



### Under Cabinet

- Best use: Task lighting
- Construction: Single lamp inside a metal housing with an opaque diffusing cover
- Location: Mount under a cabinet or shelf
- Styles: 13 to 48" long, plug-in or hardwired
- Price: \$8 and up



## FLUORESCENT LAMP BASICS

Looking to buy fluorescent lamps for your shop? Here's what you need to know:

- **Sizes:** Lamps for ceiling-mount fixtures come in 4' and 8' lengths. Two diameters are common: T8 (1") and T12 (1½").
- **Power:** Full-wattage 4' T12s are rated at 40 watts, 8' versions at 75 watts. Ratings for economy versions are 34 and 60 watts, respectively.

- **Common names:** While more varieties exist, look for the following for shop use:

### Cool White

- Color temperature: 4,100° K
- Approximate CRI rating: 70
- Cost (4'): \$1.50+
- Acceptable for overall shop lighting



### Natural Sunshine

- Color temperature: 5,000° K
- Approximate CRI rating: 90
- Cost (4'): \$1.50+
- Great for overall shop lighting



### Spec 35/Full Spectrum

- Color temperature: 3,500-5,000° K
- Approximate CRI rating: 90
- Cost (4'): \$4.00+
- A good choice for finishing areas



### Daylight Deluxe

- Color temperature: 6,500° K
- Approx. CRI rating: 85
- Cost (4'): \$5.00+
- Good for those who need more light





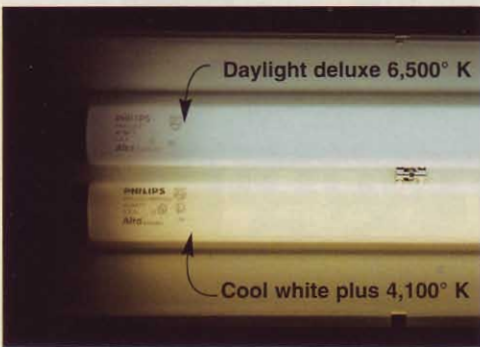

A cool-white lamp (bottom) seems bright, but a higher-temperature "daylight" lamp gives more perceived light and better color.

lamps, check out the photo, above. Higher-priced lamps last longer as well.

### Locate fixtures for best lighting

As the final step in lighting your shop, you need to decide where to put the fixtures. To get the most from your lighting layout, locate fluorescent lights using the guidelines in "Perfect fixture positioning made simple," right.

### Perfect fixture positioning made simple

To ensure adequate illumination without shadows or dark spots, use these formulas to determine fixture locations. *Note: These formulas assume the use of continuous rows of two-lamp fluorescent fixtures.*

- Measure (A), the distance from your main work surfaces to the ceiling (or to the desired height of suspended fixtures—usually 8' to 10' above the floor).
- The distance between fixtures (B), should be equal to or no more than 1.5 times (A).
- The distance between a fixture and the wall (C) should be no more than one third to one half (B).

Let's translate that to a typical two-car garage shop that measures 24x24' with a 9' ceiling and work surfaces 36" high. We'll use 16'-long rows of fixtures (either two 8' or four 4' placed end-to-end):

A=72" or 6'  
 B=72"×1.5=108" or 9'  
 C=108"×.5=54" or 4½'

If we place two rows of fixtures 9' apart (B), they'll each be 7½' (C) from the side walls—way more than the 4½' maximum. The sides of the shop will be too dark.

If we center one row, then add two more rows spaced 8' apart (B=8), then the outer rows will be 4' (C=4) from the walls. This layout lights the shop well.

### Strategy 3: Examine options for supplementary lighting

Well-placed fluorescents provide great overall lighting. But you'll want additional light over such places as your workbench, band-saw, and finishing area.

#### Get task-light right

Standard incandescent bulbs work well for task lighting, LeMay-Madden says. They cast more shadows, which can highlight contrasts and make blades and layout lines more visible.

To get better lighting quality, replace an incandescent with a "halogena" lamp.

Compact fluorescent lamps work in any fixture that takes a standard screw-in bulb. They operate more economically, but don't offer quite as much contrast as an incandescent or halogena.

We recently discovered a new halogen fixture that offers promise for shop lighting, above far right. It's a cinch to install thanks to adhesive backing on the power strip. The fixtures clip onto the strip so you can move them to exactly where you need lighting.

#### Automate your lights

For the ultimate in lighting convenience, add motion sensors, such as those at right.



You can replace an incandescent bulb with a compact fluorescent, which costs less to run, or a screw-in "halogena" that lasts longer.

Use one to simply turn on a single light to illuminate your path when you enter the shop, or to flip on all of the lights. Try putting one over your lumber rack so you can better examine boards, or above your mitersaw station. You'll have light every time you cut, without having to flip a switch. 🌱

Written by David Stone  
 Illustration: Mike Mittermeier

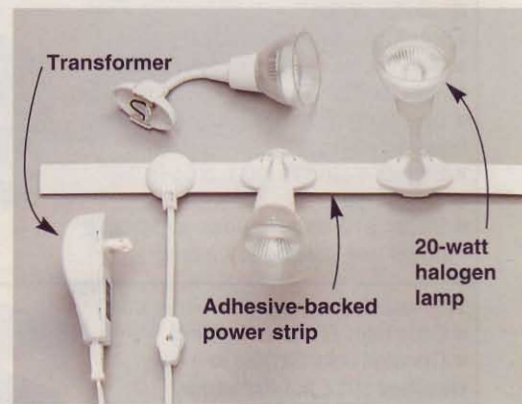

This \$30 setup from Lights Now (800/945-4837; lightsnow.com) includes three clip-on lamps that mount along its 48" power strip.

### GOING THROUGH THE MOTIONS



This floodlight (\$40) has a wireless remote sensor to allow mounting options.

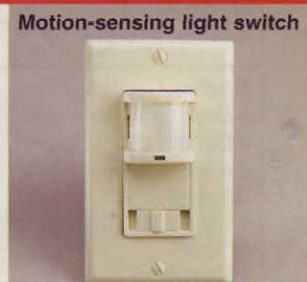

Motion-detecting switches can turn on overhead fixtures when you walk in the room.



# shop tips

Helping you work faster, smarter, and safer

## Gauging your wood's appetite for biscuits

Ever wonder whether your biscuit slots are sized right for the width of your workpiece or whether you can squeeze in two instead of one? This jig takes the guesswork out of spacing biscuits in narrow rails.

Make the jig by cutting biscuit slots of three sizes (#0, #10, and #20) in a piece of  $\frac{3}{4}$ " material. Cut a pair of slots of each size in the jig sides and leave  $\frac{1}{8}$ " between slots. To use the jig, set the butt end of a rail against the jig side to determine the size and number of biscuits to insert in the joint.

—Stu Klausner, Hilton Head, S.C.

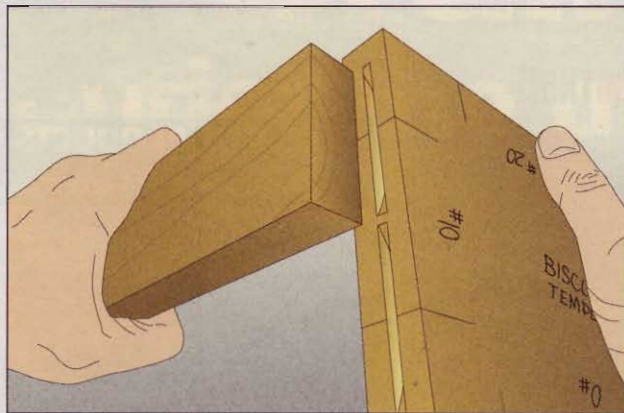
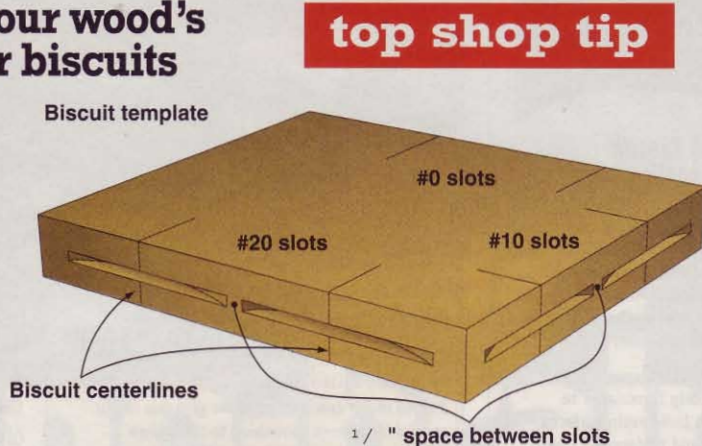

## Reversed drill bits a step forward for safe storage

Sometimes when I drill, the bit spins briefly in the chuck, creating a ring-like burr on the shank, which becomes a problem for bits stored in metal storage cases. As I put the bit away, the burr often hangs up in the tight metal holes of the case, sometimes cutting my finger or causing the case of bits to spill. The same happens when I try to remove the bit from the case.

To avoid this frustration, I turn the bits over so the smooth shank sticks out. Now I can remove and replace bits without hangups, and view

the solid shank, making it easier to select the correct bit size.

—Dave Dunlap, Kingman, Ariz.

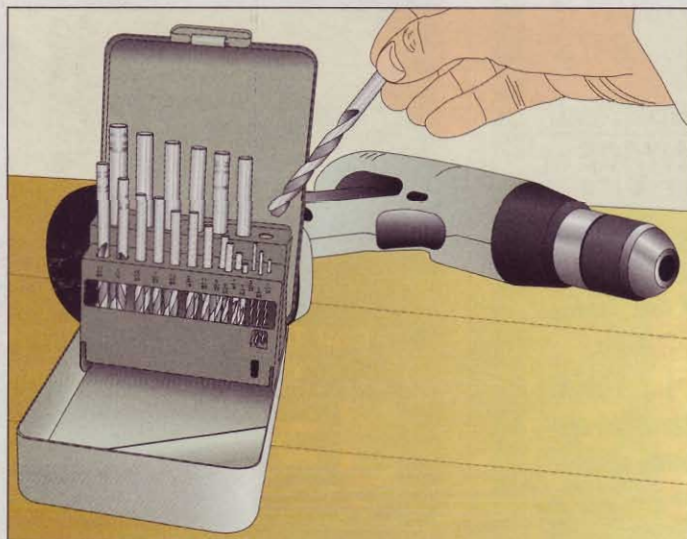

## Our Winner



Scott Moody, Pro Photo Inc.

After retiring from Cornell University about seven years ago, Stu Klausner and his wife moved to Hilton Head, South Carolina, where he started a computer consulting business. Life is good, he says. "I'm five minutes from the ocean. I work two days, I fish two days, I build furniture two days. On the seventh day, I rest." Recently, Stu wrestled a 68-pound cobia into his boat. Now, our Top Shop Tip winner gets free tools. Some guys have all the luck.



Stu Klausner wins a Bosch 14.4-volt cordless tool kit (92614DJP) for submitting the Top Shop Tip. Congratulations, Stu!

## Top tips win tools!

Describe how you've solved a workshop dilemma, and you'll earn \$75 if it appears here. And, if your tip garners Top Shop Tip honors, you'll also win a tool prize worth at least \$250.

Send your best tips, along with photos or illustrations and your daytime phone number, to: **Shop Tips, WOOD Magazine, 1716 Locust St., GA-310, Des Moines, IA 50309-3023.** Or e-mail tips to: [shoptips@woodmagazine.com](mailto:shoptips@woodmagazine.com). Remember to include your contact info in the e-mail as well.

Because we try to publish only original tips, please send your tips only to WOOD magazine. Sorry, submitted materials can't be returned.



## Clean calculator is in the bag

My workshop calculator doesn't react well with the flying dust, splashing solvents, and moisture changes that take place in the shop. After ruining a few calculators, I started storing my current one in a plastic zipper-type storage bag and hanging it on the pegboard. I also discovered I can use the calculator while it's still in the bag, so I never have to expose the sensitive electronics to the shop environment.

—Mike Herberger, East Rochester, N.Y.

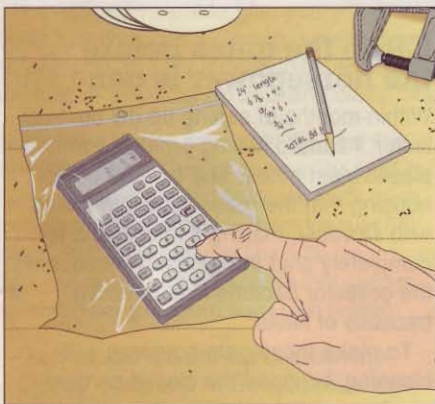

## Taming tangled cords with office supplies

Wrapping power tool cords around the tool for storage has often been a source of aggravation for me. More often than not, the cord comes loose while I'm putting the tool away or "cord gremlins" tangle it together with other cords during storage. To confidently tame those cords, use a binder clip to clamp the cord to itself for storage. When the tool is in use, keep the clip handy by clamping it to the cord.

—Minuand Jordan, Ransom Canyon, Texas

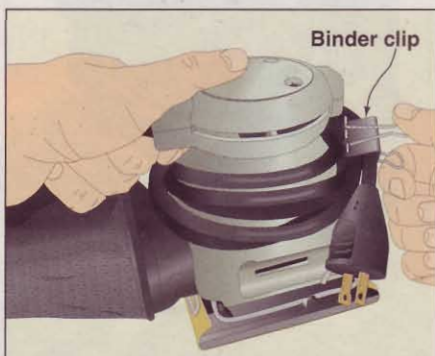

Continued on page 98

## YOU'RE PROBABLY JUST AS AMBITIOUS.



Whether you are a do-it-yourselfer, a professional woodworker or somewhere in between, you have a world full of projects in the home or in the shop that will be easier and more enjoyable to complete when you use quality clamps, bench vises and miter boxes/saws from the Adjustable Clamp Company. Look for them under the Jorgensen, Adjustable and Pony brand names wherever fine tools are sold.

Circle No. 733

**Adjustable™ "Jorgensen" "Pony"®**

Made in the USA by the Adjustable Clamp Co.,  
433 North Ashland Ave., Chicago, IL 60622,

[www.adjustableclamp.com](http://www.adjustableclamp.com)



## DULUTH TRADING & E



Holy Cow! Bucket Master™ is better than a tool box!  
You could say that again... if we had a bigger ad



We stock wonderful, useful Equipment and Goods designed and tested by Tradesmen for Builders and ardent Do-It-Yourselfers. Get a Free Catalog at 800-505-8888 or order on line - [www.DuluthTrading.com](http://www.DuluthTrading.com)



## Quick-reference label demystifies jig's origins

Over the years, I have accumulated quite a few shop-made jigs. Occasionally, I forget some of the finer points of the jig's operation and need a refresher course. The problem is that finding the jig's origins sometimes feels like an archeological expedition as I dig through my woodworking library.

My solution: Label each jig with enough information (title of magazine, date or issue number, and page number) to identify the original source. The clear self-sticking address labels (available at office supply stores) work well, and I can print them with a computer. Attach the label to the jig in a place that won't interfere with its operation, and cover the label with clear tape to keep the printing intact.

—Richard Rudisill, Harrisburg, Pa.



## Close the gates before the horsepower is gone

Within months of setting up my dust collector, I started having problems with the plastic blast gates. The corners of the housing that the gates slide into fouled with sawdust, making it impossible to completely shut the gates. Consequently, the collector became less effective because of leaks.

To make these gate housings self-cleaning, I clipped the closed corners, as shown, to give the dust a means of escape. The slight draft through the corner holes when the gate is open doesn't noticeably take away from the collector's power.

—Val Ingraham, Norcross, Ga.





# Triple Force



**ET2025™**

**3 in 1 Electric Staple & Nail Gun**

- Shoots 4 size flat crown & 4 size round crown staples
- Drives 5/8" brad nails
- Unique wire fastening attachment flips over to accommodate a variety of wire sizes
- Drive power adjustment dial



**ETFX50™**

**Heavy-Duty Professional Electric Staple & Nail Gun**

- Shoots 6 size T50® staples
- Drives 5/8" brad nails
- 10 foot cord • 14 amps
- Exclusive on/off safety trigger lock
- One-piece solid steel base construction
- Ergonomic cushioned grip for comfort
- Patented jam-proof mechanism



**ET200™**

**Nail Master™ 2 Heavy-Duty Electric Nail Gun**

- Drives 4 size brad nails up to 1-1/4"!
- Comfortable ergonomic design
- Surface contact and trigger safety lock
- Non-marring bumper
- 10 foot cord • 14 amps

## The Power of Arrow is Electrifying



www.arrowfastener.com

Arrow Fastener Co., Inc., 271 Mayhill Street, Saddle Brook, New Jersey 07663  
 Canada: Jardel Distributors, Inc., 6505 Metropolitan Blvd. East, Montreal, Quebec H1P 1X9  
 United Kingdom: Arrow Fastener (U.K.) Ltd., Unit 5, ZK Park, 23 Commerce Way, Croydon CR0 4ZS, Surrey



## Set an accurate miter gauge as simple as 1-2-3

I enjoyed the tablesaw tune-up article in the November 2003 *WOOD*® magazine (issue 152), and it inspired me to share a simple and accurate way I use to true my miter gauge to 90°. Begin with a scrap of ¾" sheet goods—I prefer medium-density fiberboard (MDF)—at least 8×8" that has one perfectly straight edge. Mark this edge as 1. Label the other edges 2, 3, and 4 in a counterclockwise direction, as shown in the drawing.

Place edge 1 against your miter gauge set at 90° and cut edge 2, then rotate the piece clockwise and repeat for edges 3 and 4. The three cuts will cause any angular error to be magnified by three because each cut adds to the error of the previous cut. Using an accurate square, check the angle between edges 1 and 4 for square. If a gap shows on the inside elbow of the framing square, adjust the miter gauge counterclockwise; if the gap is at the top of the test piece, adjust the gauge clockwise.

—Dave Willis, Murray, Utah

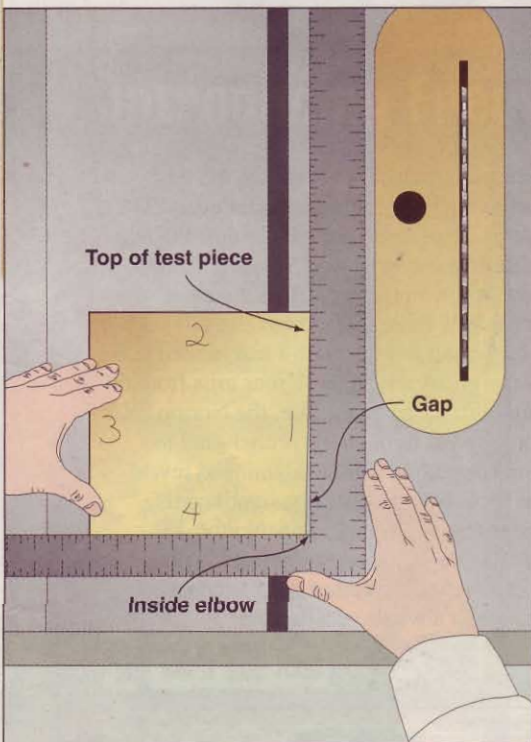

See a new

Shop Tip  
of the Day at

[woodmagazine.com/tips](http://woodmagazine.com/tips)



## Quality Pen Kits and Other Turning Kits



- Designers & Manufacturers
- Wholesale & Retail

**THE BereaHardWoods** CO. Inc.

Manufacturer of quality writing instruments, components and kits.

CALL FOR FREE CATALOG

18745 Sheldon Road • Middleburg, Ohio 44130 U.S.A.  
Ph: (216)898-8956 • Fax: (216)898-8962 • [bereahard@aol.com](mailto:bereahard@aol.com)

Circle No. 2127

Great art that doesn't require an artist's touch!

## CMT's exclusive new 3D Router Carver™ System

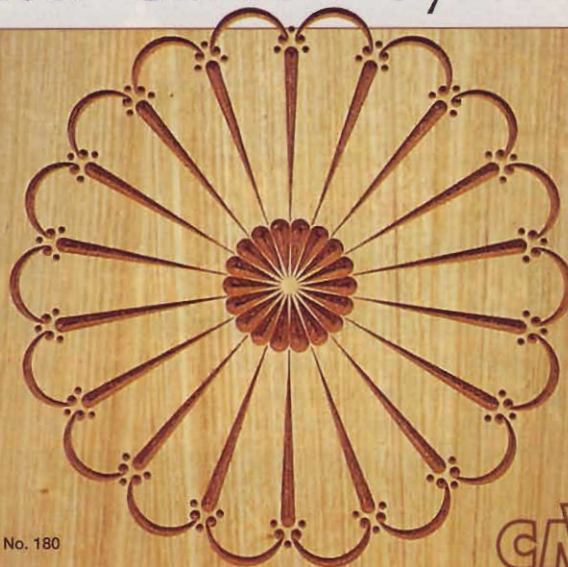

Circle No. 180

**CMT**

Available only from your CMT Distributor



Who says that intricate woodcarving requires an artist's touch or the skill of a traditional woodcarver? Thanks to the patented 3D Router Carver System, anyone with a 1/2" collet plunge router can create dozens of beautiful designs easily, accurately and with complete repeatability. Rout true 3-dimensional carvings on doors, drawers, cabinets, furniture or just about any flat wooden surface in minutes. Ask for your free 2004 - 2005 CMT catalog for details, then visit your CMT Distributor to get in on the fun!



Ask for a free catalog & a distributor in your area  
**888-268-2487 • [www.cmtusa.com](http://www.cmtusa.com)**  
CMT USA, Inc. • 307-F Pomona Drive • Greensboro, NC 27407



The 3D Router Carver System is protected by U.S. Patent No. 5,146,965



# shop-proven products

These woodworking wares passed our shop trials

## This 14" bandsaw comes loaded

I'd heard good things about Powermatic's PWBS-14CS bandsaw, and my test-drive proved this is one solid machine. After assembling the bandsaw (including its fixed 5"-wide extension table that fills the gap between the spacious 15×15" tilting table and the column), I turned it on. Instead of making the usual start-up noises—a rattling door, the blade rubbing on a guide, etc.—the PWBS-14CS purred like a kitten. In fact, it was so smooth, I stood two nickels on edge then ripped and crosscut a piece of 2×2×8" red oak. To my surprise, both nickels stood for the whole procedure.

Next, using the included T-square-style fence with its resawing guide attached, I resawed several 6"-wide pieces of red oak and maple, the maximum for this saw without an optional riser block, and the PWBS-14CS didn't miss a beat, thanks to its 1½-hp motor. Same story when I stack-sawed three pieces of 4/4 maple. And through all the cutting, the well-positioned

4" dust port (connected to my dust collector) helped catch almost everything.

Like many newer bandsaws, the PWBS-14CS has a quick-release blade tensioner, and this one comes from Carter—the people who invented the bandsaw quick-release and sell it as a \$150 add-on. With three handle positions, you can have the blade fully tensioned, completely detensioned, or tensioned enough to adjust blade tracking.

Microadjustable ball-bearing blade guides proved easy to set and lock, even on the ⅛"-wide blade I used for scroll-cutting a bandsawn box. Other standard equipment accessories include a gooseneck lamp and dust blower that keep the cutline visible.

—Tested by Pat Lowry

### PWBS-14CS 14" bandsaw (1791216K)

|             |       |
|-------------|-------|
| Performance | ★★★★★ |
| Price       | \$900 |

Powermatic  
800/274-6848; wmhoolgroup.com



## Norton 3X sandpaper cuts and cleans like crazy

The manufacturer of Norton 3X sandpaper claims that it cuts three times faster and lasts three times longer than conventional

sandpaper. Although I couldn't verify the "three times" claims in my tests, this abrasive definitely cuts faster and cleans easier than other sandpapers I compared it to.

Using the rig shown at left, I tested 60-grit Norton 3X sheets side-by-side against another widely sold 60-grit sandpaper with 5 lbs of weight on each. The workpiece is melamine-coated particleboard sprayed with primer, and after just a few back-and-forth cycles, I noticed white dust quickly piling up at the ends of the stroke on the Norton 3X, where the other paper had little.

To make sure the papers didn't load up with dust and affect

their performance, I vacuumed the test surface and both abrasives after every 50 cycles. Here I noticed that the dust buildup released easily from the Norton 3X on the first pass with the vac, while the other brand took more agitation to clean.

I repeated this test until I had sanded 500 cycles with each paper in four grits from 60 through 220. In every case, the Norton 3X abrasive cut through the primer (and in some cases, the white melamine to reveal the particleboard beneath) significantly faster than the competition. Norton 3X comes in nine different grits and is priced about the same as other sheet sandpaper, making it a whale of a bargain.

—Tested by Dean Fiene

### 3X Sandpaper

|             |   |
|-------------|---|
| Performance | ★★★★★   |
| Price       | \$14, 20-sheet packages of 60- through 150-grit; \$10, for grits 180 through 400. |

Norton Abrasives  
800/551-4415; nortonabrasives.com

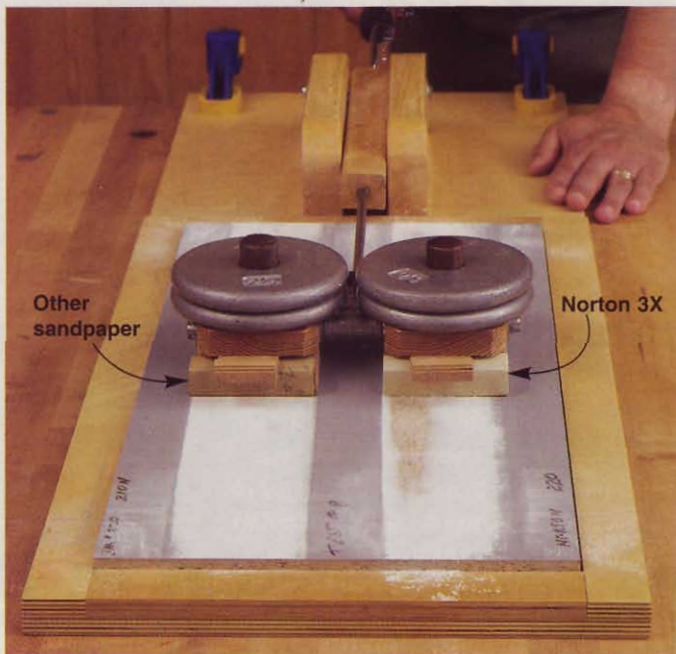



## DeWalt vac: Not your mother's Dustbuster

When I received DeWalt's DC500 battery-powered Wet-Dry Vacuum, my first thought was, "Why do I want a cordless vac to carry around the shop?" Now that I've used it for a few weeks, I'm more inclined to think, "Why not?"

First, unlike vacs for the home that run on their internal batteries for only a few short minutes, I vacuumed with the DC500 continuously for 12-13 minutes using an 18-volt battery pack before suction began to suffer. The unit also operates on DeWalt's 14.4- and 12-volt packs; the 14.4-volt battery yielded only 7-8 minutes of run-time. And, when the battery did run low, I simply unwrapped the AC cord, plugged it into a wall socket, and got back to work.

And work it does. Under battery power, I found little, if any, difference between the suction of the DC500 and my big 12-gallon corded shop vacuum. Hooked to the dust-collection port on my router, this vac gobbled up virtually all of the chips from a 1/2" round-over.

The 1 1/2"-diameter hose proved plenty flexible in my tests, and I like that it twists into the canister, so I don't have to

worry about it disconnecting. Another nice bonus: You don't have to remove the washable Gore-Tex filter for wet jobs (although you should empty dust from the tank first).

If the \$100 price tag seems low, remember that doesn't include a battery pack, which could nearly double the price unless you already own a DeWalt cordless tool. That basic price includes onboard storage of the hose, wide nozzle, crevice tool, and AC power cord. And I found myself wishing that I could charge the drained battery on the vacuum, as with DeWalt's job-site radio, but the DC500 just isn't set up for that.

—Tested by Randy Zimmerman

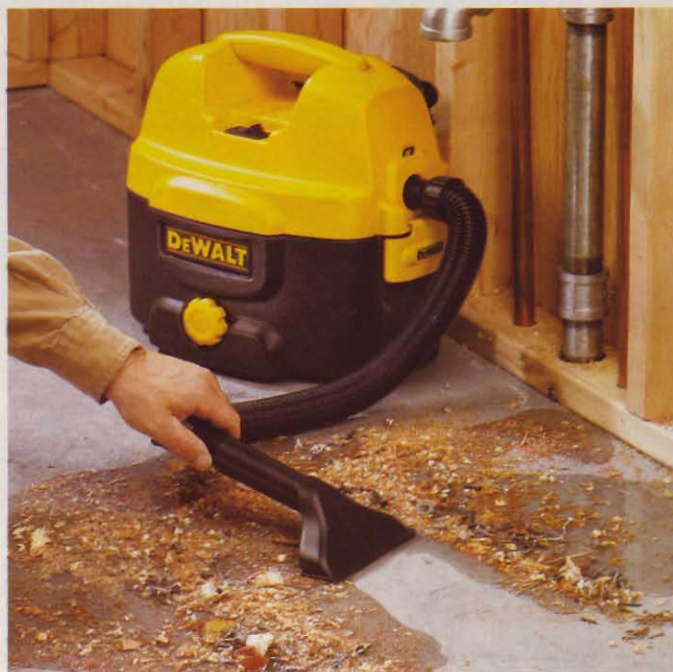

### DC500 Wet-Dry Vacuum

Performance ★★★★☆  
Price \$100 (battery not included)

DeWalt Industrial Tool Co.  
800/433-9258, dewalt.com

## Design Breakthrough!

It's the ultimate **workbench!**  
It's a **downdraft table!**  
It's a complete **air filtration system!**



### Deluxe + 30" x 77"

- Generous Maple Worktops
- Powerful 1600, 2100, or NEW 2550 CFM Motor
- GFI Convenience Outlet
- Three Stage Filtering to 0.5 Micron



### Ultra Grand 33" x 95"

Call now to find out  
about our Specials

# WOODMARK

P.O. Box 211434 • Bedford, TX 76095

## 1-800-845-4400

Visa • Mastercard • Amex • **FREE CATALOG!**

## Prevent power surge at air compressor startup

I'll admit it: My garage workshop is underpowered, working off a single 110-volt circuit breaker in the house. Working alone, I only use one power tool at a time, so it's rarely a problem. But my portable air compressor, plugged into the outlet farthest from the breaker box, overloads that breaker almost every time it starts. That's because a compressor draws its highest current at startup. SmartStart lessens this initial draw, although it has nothing to do with the compressor's electrical system.

SmartStart replaces the air filter on virtually any electric air compressor (it contains its own filter), and installs in less than five minutes. When the compressor is running, it allows air to pass normally; but when the compressor stops, a valve inside closes to add resistance when the compressor kicks in again. At that point, the valve slowly opens, allowing the motor to reach operating speed before it starts compressing air.

My SmartStart-accessorized compressor fired up without so much as dimming the lights. I even used the compressor on a 25' extension cord with no ill effect, proving SmartStart to be an inexpensive fix to a nagging problem. 🌲

—Tested by Jim Harrold



### SmartStart Inlet Control for Air Compressors

Performance ★★★★★  
Price \$15 (plus shipping)

R. Conrader Company  
814/898-2727; conrader.com



# what's ahead

A preview of some of the articles in the December issue (on sale November 23)

## Projects for your home and holiday gift giving



### FEATURED PROJECT

#### Shaker clock

This timely project is beautiful on a wall, mantel, or shelf. We built two to show how you might combine different woods for the case/door frame and bookmatched panel.



#### Media storage

At last! A classy cabinet big enough to hold every CD, DVD, and video tape in your collection.



#### Intarsia angel

Here's another fun Judy Gale Roberts design you can make using just your scrollsaw, drill, and a few abrasives.



#### Mission dresser

The matching bedroom set that began with the bed (October issue), and includes the nightstand on page 62, continues with this stylish and practical addition.

### SPECIAL SECTION



#### 4 must-master hand tools

Many workshop tasks are still best done with hand tools. Here, learn to use and sharpen chisels, block planes, a marking knife, and scrapers. Instructions for building your own marking knife and how to buy the best low-angle block plane round out the section.

## More tips & tools for better woodworking



#### Hot new tools for 2005

Our editors uncover the latest and greatest innovations in woodworking equipment and accessories.



#### Shop storage solutions

Find three organizer projects for your workshop: a wall rack for boards, a scrap sorter, and a sheetgoods holder.



#### Dust-free finishing

Improve your finishes by keeping the surrounding air clean with this low-cost, five-minute, pop-up tent.



#### Matching stain colors

To imitate an existing stain color, you need to work in the right light. We show you how.