

# WOOD®

The Shop-Proven Woodworking Magazine

## heirloom cupboard

*It's easy to customize!*

(see page 42)

Build a  
rock-solid, low-cost  
**Workbench**  
trick it out **6** ways

(pages 14 and 60)

**Plus —**

- Best mid-priced tablesaws
- Simply-made arched trellis
- 5 gluing goofs to avoid

**SPECIAL**  
**3** COUNTRY PROJECTS  
**4** COUNTRY FINISHES

Check out the super-smooth sliding doors! (see page 47)





# WOOD

June/July, Issue 163

## PROJECTS

14 low-dough, rock-solid workbench

38 paper-towel holder with drawer

### COVER STORY

42 versatile sliding-door cupboard

Build it as a deep, stacked, display cabinet; a buffet; a bookcase; or a step-back hutch.

60 worthy workbench upgrades

- tool-tote trio
- a bank of shallow tool drawers
- added weight for super bench stability
- glue-up clamp holder

67 matching bathroom wall cabinets

82 elegant arched trellis

Make an attractive home for clinging plants, letting the latticed design double as a privacy screen.

## TECHNIQUES

18 add strength and style to miter joints

51 how to build flawlessly flat panels

74 a rich country finish in seven steps

88 Curtis Buchanan's time-tested finishes

Discover the process for creating lasting beauty using an oil/varnish mix or milk paint.

94 designers notebook: cupboard options

96 gluing woes: prevention and cure

## TOOLS & MATERIALS

10 edge plywood with special router bits

22 tool update: lithium-ion batteries

See why this latest in cordless tool technology offers advantages over other batteries.

76 mid-priced tablesaws

We test and rate 11 portable and contractor-style saws costing between \$500 and \$700.

100 four shop-proven products

## DEPARTMENTS

6 editor's angle

8 sounding board

26 ask WOOD

30 shop tips

112 what's ahead



This seal is your assurance that we build every project, verify every fact, and test every reviewed tool in our workshop to guarantee your success and complete satisfaction.



42



38



14, 60



82



67



74



88



51

10



76

18





Jeff shows off the Greene & Greene-style tables he designed and built for his home.

**EDITOR-IN-CHIEF**  
**BILL KRIER**

Executive Editor **JIM HARROLD**      Managing Editor **MARLEN KEMMET**

Senior Design Editor **KEVIN BOYLE**      Tools Editor **DAVE CAMPBELL**

Techniques Editor **BOB WILSON**      Techniques Editor **PAT LOWRY**

Projects Editor **OWEN DUVALL**      Projects Editor **JAN SVEC**

Design Editor **JEFF MERTZ**      Master Craftsman **CHUCK HEDLUND**



Jan designed and built these cabinets for his church. They're used to store name badges.

Art Director **KARL EHLERS**      Associate Art Director **GREG SELLERS**      Assistant Art Director **CHERYL A. CIBULA**

Production/Office Manager **MARGARET CLOSNER**      Administrative Assistant **SHERYL MUNYON**

Photographers  
**MARTY BALDWIN, SCOTT LITTLE, BLAINE MOATS, JAY WILDE**

Illustrators  
**TIM CAHILL, LORNA JOHNSON, ROXANNE LeMOINE**

Technical Consultants  
**DEAN FIENE, JEFF HALL**

Contributing Craftsman  
**JIM HEAVEY**

Proofreaders  
**BARBARA KLEIN, IRA LACHER, JIM SANDERS**

**CUSTOMER SERVICE: 800/374-9663**

For more ways to reach us about specific matters, see *page 8*.

**ADVERTISING**

Publisher **MARK HAGEN**

**CHICAGO OFFICE:** 333 N. Michigan Ave., Suite 1500, Chicago, IL 60601  
 Phone: 312/853-2890 Fax: 312/580-7906

Sales and Marketing Assistant **GAYLE CHEJN**  
 Sales and Marketing Assistant **LISA GREENWOOD**  
 Account Executive **JACK A. CHRISTIANSEN**  
 Direct Response Manager **CAROLYN DAKIS**  
 Direct Response Sales Representative **SANDY ROBINSON**

**NEW YORK:** Phone: 212/551-7043 Fax: 212/551-7192  
 Account Executive **PATRICK R. TOMLINSON, SR.**

**DETROIT:** RPM Associates,  
 29350 Southfield Road, Suite 31, Southfield, MI 48076  
 Phone: 248/557-7490 Fax: 248/557-7499

**ATLANTA:** Navigate Media,  
 1875 Old Alabama Road, Suite 1320, Roswell, GA 30076  
 Phone: 678/507-0110 Fax: 678-507-0118

Director, Corporate Sales **RICH BERENSON**  
 Director, Corporate Research **BRITTA C. WARE**  
 Business Manager **JOEL ETIENNE**  
 Consumer Marketing Director **ROBIN HUTCHINSON**  
 Consumer Marketing Manager **LESLIE SHAEFFER**  
 Advertising Operations Manager **PAT HENDERSHOTT**  
 Production Manager **STEVE KRIDER**

Executive Vice President **BOB MATE**

**MEREDITH PUBLISHING GROUP**  
 President **JACK GRIFFIN**  
 General Manager **TOM HARTY**  
 Brand Licensing/Operations **DOUG OLSON**  
 Consumer Marketing/Finance **KARLA JEFFRIES**  
 Manufacturing **BRUCE HESTON**  
 Creative Services **ELLEN DELATHOUDER**



Chairman and Chief Executive Officer **WILLIAM T. KERR**  
 President and Chief Operating Officer **STEPHEN M. LACY**

**In Memoriam — E.T. Meredith III (1933–2003)**





## Have it your way

We woodworkers have many reasons for building furniture instead of buying it. For one thing, we want furnishings customized to our personal tastes, needs, and spaces. At *WOOD*® magazine we keep that in mind when designing *your* projects.

**F**rom the project snapshots that so many of you send us, we know that you like to customize the project plans you find in this magazine. Sometimes you simply change the wood species or perhaps a molding profile. You may take our idea and alter its look completely to suit your personal tastes. I think that's great—all of us like to surround ourselves with furnishings that fit our personality, style, and surroundings.

With that in mind, our staff has worked hard to design projects that give you as much flexibility as possible in how you build them. For example, you can construct the sliding-door cupboard exactly as shown on the cover of this issue (two identical cases stacked up). Or, as shown on *page 42*, you can build a single case with a tabletop to function as a buffet. If you prefer the project to work as a bookcase or step-back hutch, see *page 94*.

You'll find other examples of this designed-to-suit flexibility in this issue, including the paper towel holder on *page 38*. You can mount it under an upper cabinet or simply set it on a countertop. In the next issue you'll find a computer desk that changes to fit your work requirements and available space. (See *page 112*.)

And remember to keep sending us pictures of your completed projects. We post them on a large bulletin board for all of the staff to see. Your craftsmanship and creativity inspire us every day.

### Meet the new guy

One thing I hope to do from time to time in this column is to help you better know the people who create this great magazine. We have a dedicated and passionate team here, with tons of woodworking experience and some pretty interesting backgrounds.

Take, for example, our newest staffer, Techniques Editor Pat Lowry. For 22 years Pat ran his own construction and woodworking shops. In 1990 he renamed his business "Wood-N-Water." Now, you might be wondering what water has to do with wood. "I was in a small town, and some of the locals urged me to sell bait and tackle in addition to my cabinets and furniture," Pat chuckles. "I can tell you there is not a lot of money in selling worms."



When Pat Lowry's not in the woodshop, he's often trying his luck with a fishing pole.

In recent years, Pat managed a woodworking store, an experience that taught him a lot about tools and the needs of average woodworkers. Because of his extensive background, about a year ago we asked him to do some tool tests. We found his work insightful, fair, and professionally prepared, so it was an easy decision to hire him full-time when a position came open.

When Pat's not making sawdust, he likes to relax in his fishing boat—although now he *buys* bait instead of selling it. I think you'll enjoy his upcoming articles.

*Bill Krier*





# sounding board

Our bulletin board for letters, comments, and timely updates

## An inventive twist to the pine hutch

Just a note of thanks for your article on the heirloom hutch in the March 2004 issue. My wife was tired of looking at the old wood box next to our wood stove, so I installed file drawer slides and a big drawer in the bottom of the hutch for firewood. The hutch (with the lower back removed) backs up to the wall dividing our living room from the cellar stairs, so I built a hatch in the wall behind the hutch. (See photo below.) Now I can bring firewood from the cellar and place it into the wood box without tracking through the living room.

Mike Johnsen, Dalton, N.Y.



Photographer: James Hanselman

## Battery shelf life

I learned a lot of useful information from the article "Get the Most from Your Tool Batteries" in the February/March 2005 issue. One question still remains for me. Your article states that all batteries have a shelf life of about 3–5 years. My concern: In many stores, a cordless tool or replacement battery may sit on a shelf for six months, a year, or more before it sells. Does this shelf time shorten the "shelf life" of the battery? I know that regular flashlight batteries have an "expiration" date; does the same hold true for cordless tool batteries?

I don't use cordless tools every day, so I'm concerned that the batteries may constantly deteriorate without ever being used.

Brian McCabe, Youngsville, N.Y.

*Good questions, Brian. We contacted Cas Adams, Vice President of Sanyo Energy (USA) Corp., one of the top Ni-Cad battery manufacturers in the world. Says Adams: "Shelf life depends on the quality of the battery cells. There is typically a significant difference in the quality of cells used in do-it-yourself (DIY) tools and those in professional tools. Because DIY tools are designed to handle lighter load and use applications, toolmakers typically equip them with less-robust batteries than those meant for professional tools. So, to answer your question, yes, the useful life of the battery is reduced by the length of time it's in the distribution chain."*

*"Flashlight batteries have an expiration date because they cannot be recharged. This isn't true for rechargeable batteries, as they can accept a charge and deliver energy sometimes after many years of use or non-use. A person who uses tools rarely will have difficulty economically justifying cordless tools."*



## 14.4-volt drill feedback

I just read the 14.4-volt drill/driver article in the February/March 2005 issue and want to express my appreciation for the way you go about these articles. I've seen how others beat around the bush so much that you have no idea what they are saying. You say what you mean and mean what you say. You evaluate rigorously, document the data well, and write in a way that is easily understood. I cannot tell you how refreshing that is.

Dan Little, Wheeling, Ill.

## Article updates

### December/January 2004/2005, issue 160

- The large drawer illustration on page 68 shows the hardware placed 8 $\frac{3}{4}$ " from the end of the drawer. That measurement should be 7 $\frac{1}{4}$ ".

### February/March 2005, issue 161

- The illustration at the bottom of page 24 "create super-strong bridle joints" should read "30° bevel on handle."
- In the chart on page 71, the Bosch model numbers are reversed. Model numbers 33614 and 32614 should switch places.

## HOW TO REACH US

### ■ Editorial questions and feedback:

E-mail [woodmail@woodmagazine.com](mailto:woodmail@woodmagazine.com); call 800/374-9663 and press option 2; or write to *WOOD* magazine, 1716 Locust St., GA-310, Des Moines, IA 50309-3023.

### ■ Subscription assistance:

To notify us of an address change, or to get help with your subscription, go to [woodmagazine.com/service](http://woodmagazine.com/service); call 800/374-9663 and press option 1. Outside the U.S., call 515/247-2981. Or write to:

*WOOD* magazine, P.O. Box 37439, Boone, IA 50037-0439. Please enclose your address label from a recent magazine issue.

### ■ To find past articles:

Go to our continuously updated online index at [woodmagazine.com/index](http://woodmagazine.com/index).

### ■ To order past issues and articles:

Order past issues of *WOOD* magazine and our special issues at [woodmagazine.com/store](http://woodmagazine.com/store), or by calling 800/346-9663. Be aware that

many early issues are sold out. For reprints, send \$5 per article (no phone orders), including the article name and issue number, to: *WOOD* Article Reprint Service, P.O. Box 349, Kalona, IA 52247; make check or money order payable to *WOOD* magazine.

### ■ Updates to previously published projects:

For an up-to-date listing of changes in dimensions and buying-guide sources from issue 1 through today, go to [woodmagazine.com/editorial](http://woodmagazine.com/editorial).

# plywood edging bits

These router bits help you dress up exposed plywood edges.



**H**ardwood-veneer plywood may be a woodworker's best friend: Dimensionally stable, it won't swell and shrink like solid wood when humidity levels change; it costs less than solid wood; and you can find it readily at home centers in several common species. Of course, this workshop standard has an ugly side—or more accurately, an ugly *edge*.

The thin layers (or *plys*) of wood that make up plywood show themselves as an unattractive striping best hidden on your projects. Woodworkers sometimes glue and/or tack on a thin band of solid wood to mask the plys, but a mismatch in grain or color can belie

the fix. Thin iron-on strips of veneer banding provide a less noticeable remedy; however, the heat-activated glue sometimes weakens over the long haul, and you can't add an edge treatment, such as a round-over.

Looking for a better way to treat plywood edges (and those of other hardwood-veneer sheet goods, such as MDF), we found three bits or bit sets designed specifically to improve—though not necessarily make easier—the task of edge-banding  $\frac{3}{4}$ " plywood. (Similar bits also work with  $\frac{1}{2}$ " plywood.) After testing them in our shop, we're ready to reveal the pros and cons of each.

## Burgess Edge Set, \$130

802/233-1489, burgessedge.com



The Burgess Edge Set consists of two mating cutters—one to machine a curved recess in the edge of the plywood, and another to shape the solid-wood banding that fits into that recess. To use them, cut your plywood panel to finished size, and then rout the recess. Next, rout the bullnose on a blank of the same thickness as your panel, and glue it into the recess. Finally, trim your panel to finished size, removing the excess banding. The banding nests between the outer veneers of the plywood, virtually eliminating any sign of a joint line.

### Pros

- ◆ The banding looks as seamless as iron-on veneer tape, but its  $\frac{1}{4}$ " thickness and larger glue surface area make it more durable than tape.
- ◆ If you prefer a routed edge, you can leave the banding, say,  $\frac{1}{8}$ " proud of the veneer, and then rout a  $\frac{1}{8}$ " round-over.
- ◆ Banding can't slip up or down on the edge of the plywood during glue-up and clamping.

### Cons

- ◆ Tolerances are so tight with this system that minor thickness variances in a single sheet of plywood can leave veneer near the edge fragile and prone to chipping.
- ◆ We had to shim the bits to get them to match both the plywood thickness and each other. Several test cuts were needed to get the correct thickness and cutting height, like a rail-and-stile router-bit set.
- ◆ Because of the captured nature of the banding, we found it difficult to measure for mitered corners when wrapping all four edges of a panel.
- ◆ Despite the manufacturer's suggestion that the banding thickness needn't match the plywood thickness, we found it easier to machine the banding when the thicknesses matched exactly.
- ◆ High cost.

### Other

- ◆ Both bits have bearings to guide the workpiece, but we achieved our best results by setting our router-table fence flush with those bearings.
- ◆ Also available for use with  $\frac{1}{2}$ " plywood (\$120), and a shaper (\$400).

*continued on page 12*



## Edge V-groove bits, \$80

800/872-2511, eagle-america.com



Think of this bit set as a low-tech, lower-priced version of the Burgess Edge Set. Instead of a cove and bullnose, however, these bits create a V-shape groove and solid-wood piece of banding to match.

### Pros

- ▲ Same “pros” as Burgess Edge Set.
- ▲ No shimming is needed to adjust for differences in plywood thickness.
- ▲ The V-groove leaves a little more plywood supporting the veneer—and a little more gluing surface—than the cove made by the Burgess bit.
- ▲ Works equally well with ½" and ¾" plywood.

### Cons

- ▼ Same “cons” as Burgess Edge set, except for the cost.
- ▼ These bits are less forgiving than the Burgess set. When trimming the panel to its final size with the banding installed, overcutting it by a mere ¼" reveals the plies and ruins the panel.

## PlyPrep, \$15

888/838-8988, collinstool.com



adjust your fence so the top edge of the plywood just intersects the cutter. This allows the bit to remove little (if any) of the plywood’s outer veneers. Solid-wood banding can now be glued to the freshly cut edge.

### Pros

- ▲ Because the plies swell to meet the banding, we found we could successfully “clamp” the banding onto the plywood with only masking tape, yet still achieve a tight seam between the banding and plywood.
- ▲ Fast setup: You prepare the joints with one bit—no bit changes or fussy height adjustments needed.
- ▲ You can rout an edge treatment, such as a chamfer, bullnose, or round-over, on the solid-wood banding.
- ▲ The dimensions of the plywood panel equal the “short” (heel-to-heel) dimensions of the banding for making mitered corners when banding all four edges.

### Cons

- ▼ Color and grain differences between the plywood veneer and the solid-wood banding can detract from the seamless look.
- ▼ Panels must be cut undersize to account for the thickness of the banding.
- ▼ If you don’t center the bit properly on the plywood’s thickness, the bit may remove too much material at the top or bottom edge, causing your banding to tilt slightly up or down.
- ▼ Not available for ½" plywood.

Unlike the other edge-banding bit sets we looked at, the barrel-shaped PlyPrep bit doesn’t create male and female workpieces. Instead, it cuts a shallow cove into the edge of a plywood panel. Because of the cove, you can “clamp” the banding with mere masking tape: Glue causes the panel’s interior plies to swell to meet the banding, creating a tight-fitting joint.

To use the bit, set it up in your router table so the groove in the center of the bit aligns with the center ply of the plywood. Then,

## The bottom line on edge-banding bits

If you’re looking for a fast, clampless way to band panels, the PlyPrep bit does the job, and for not a lot of money. It’s also the best option for panels that you want to wrap completely in banding and show no end grain. Gotta have that seamless look? Then opt for a set of Edge V-groove bits. Remember, though, that these bits work best on shelving and other workpieces where you want banding on only one edge or two opposite edges because mitering corners is a hit-or-miss process. 🌲

# low-dough, rock-solid workbench

Build this workshop workhorse in a weekend, and add features as you need them. See some great options on page 60.



## Begin with the base

Start by selecting clean, straight dimensional lumber (2x2s, 2x4s and 2x6s) for the base. You'll need two 2x2s 8' long, five 2x4s 8' long, and two 2x6s 8' long. The drier the stock you can select, the less chance of troublesome warpage. If the stock is wet, let it dry as long as possible in your shop before machining. Rip and crosscut all the parts to the sizes listed in the **Materials List** on page 16. When cutting the pieces to width, we ripped *both* edges to remove the round-overs found on all dimensional lumber.

If you plan on using the workbench behind your table saw as an outfeed table, adjust the overall height dimensions so that the tabletop sits about 1/4" lower than your table saw top.

Also, we built our workbench for someone about 5' 10" tall to work comfortably. If you'd like your workbench shorter or taller, simply adjust leg parts I and K accordingly.

*continued on page 16*

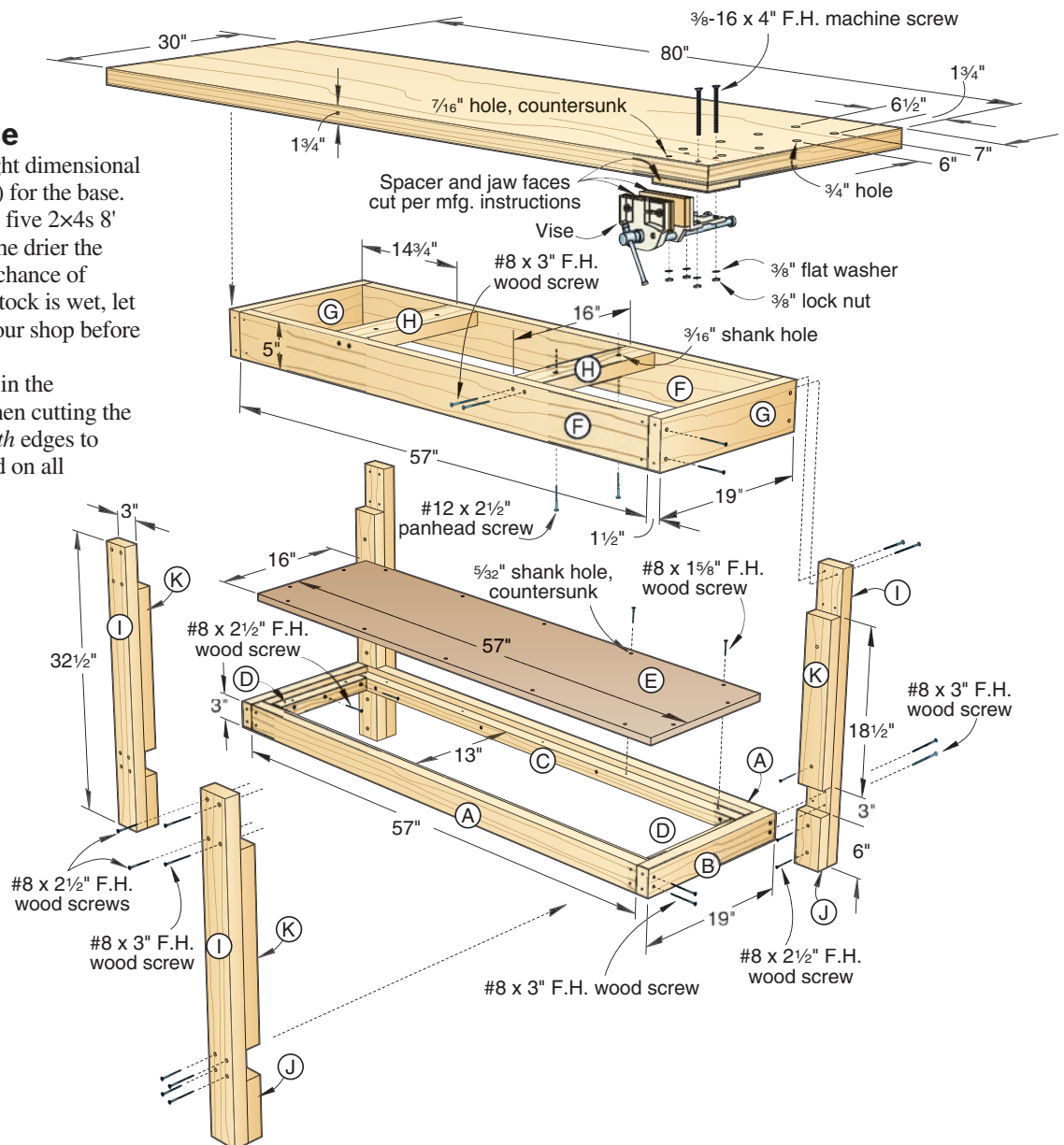



Using the drawing on page 14 for reference, glue and screw the base together. Cut the lower shelf (E) to fit in the opening, drill the mounting holes, and screw it in place.

### Add the sturdy top

You can laminate stock to form the top, or do as we did and purchase a solid-core door. Slightly damaged doors often can be

purchased at a substantial discount from home centers and other outlets. Using the previously drilled shank holes in the cleats (H), secure the top to the base.

### Want to customize your workbench?

See "6 Ways to Beef Up a Workbench" on page 60.



Project Design: Jeff Mertz

## Materials List

Part		FINISHED SIZE			Matl.	Qty.
		T	W	L		
A	lower rails	1½"	3"	57"	C	2
B	lower end rails	1½"	3"	19"	C	2
C	lower shelf long cleats	1½"	1½"	57"	C	2
D	lower shelf short cleats	1½"	1½"	13"	C	2
E	lower shelf	¾"	16"	57"	SG	1
F	upper rails	1½"	5"	57"	C	2
G	upper end rails	1½"	5"	19"	C	2
H	cross cleats	1½"	3"	16"	C	2
I	legs	1½"	3"	32½"	C	4
J	lower dividers	1½"	3"	6"	C	4
K	upper dividers	1½"	3"	18½"	C	4

**Materials key:** C—choice of spruce, pine, or fir; SG—choice of sheet goods (We used MDF).

**Supplies:** #8x1½" flathead wood screws, #8x2½" flathead wood screws, #8x3" flathead wood screws, #12x2½" panhead wood screws, ⅜-16x4" flathead machine screws, ⅜" flat washers, ⅜" lock nuts.

**Hardware:** G9851 Shop Fox Quick-Release Vise, 9" jaw, \$69.95, Call Grizzly Industrial, 800/523-4777 or go to grizzly.com.

**See more**  
shop project  
plans at

[woodmagazine.com/shoptools](http://woodmagazine.com/shoptools)



# add strength and style to miter joints

Dress up mitered picture frames with face keys and you'll open up a world of creative possibilities.



Once you master the precision needed to make tight, flawless miter joints, you're ready to explore ways to embellish them with face keys of contrasting woods that break up the predictable appearance of a standard frame.

This sophisticated look is simple to create. For starters, you can make both the key stock and corner rabbets on the tablesaw where you cut the miters. For an easy-to-make jig that steadies a mitered frame at the correct angle for cutting corner rabbets on both faces, see the plans shown below. The sample frame corners, shown at right, use readily available 3/4" stock cut 2" wide.

## CORNER RABBETING JIG

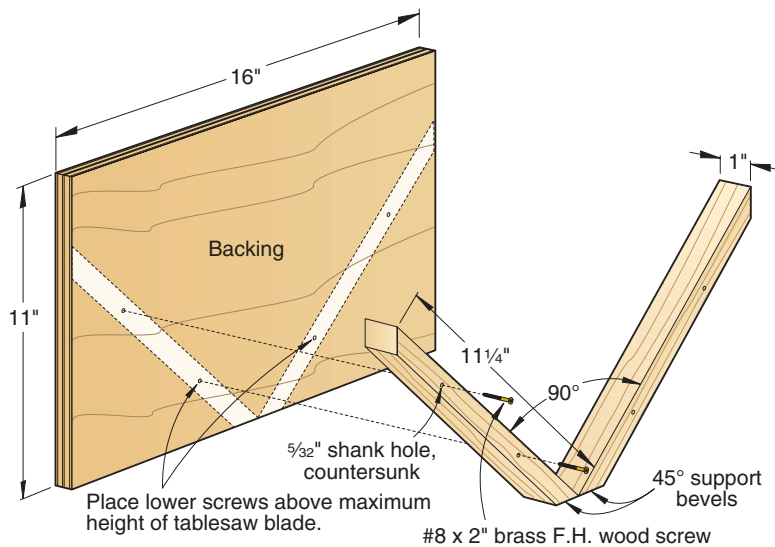

Assemble the corner rabbeting jig so that the support bevels and the bottom edge of the backing rest flat on your tablesaw. Place the lower pair of screws at least 3 1/2" above the lower edge of the backing and base to avoid accidental contact with your saw blade.

## Variations on a Theme

Experiment with different combinations of species for frames, keys, and decorative pins, or try some of the looks shown below.

### Potential key combinations include:

1. Walnut and mahogany keys on mahogany

2. Walnut keys and cherry pins on cherry

3. Oak keys and cherry pins on cherry

4. Cherry keys and maple pins on maple

5. Mahogany keys on maple



Continued on page 20



## Let's make a face-keyed miter joint

In preparation, build a corner rabbeting jig using  $\frac{3}{4} \times 1$ " supports and a piece of MDF overlay plywood,  $\frac{3}{4}$ " Baltic birch plywood, or MDF. You'll also need assembled frames plus scrapwood frame corners for practice.

To make key stock that works with the 2"-wide frame parts shown, resaw a piece of  $\frac{3}{4}$ " stock that's  $4\frac{1}{2}$ " wide by roughly 8" long to create two 2"-wide pieces of key stock. The blank can be a single piece of wood or an edge-glued combination of woods. Raise your saw blade to 2" and set your fence to cut a slot the distance from the face of the blank slightly thicker than your saw kerf will cut in your frames. Use a feather board and pushstick for added control. Flip the piece end for end and cut a second slot, as shown in **Photo A**, leaving a  $\frac{1}{2}$ " bridge in the middle to connect the key stock to the blank. Then, by hand or on a bandsaw, cut the key stock free from the blank.

### Cut the corner rabbets

Set your tablesaw blade height to 2" for corners on 2"-wide stock. Make test cuts in scrap miters to fine-tune your cutting depth and position. Secure the mitered frame in the jig, and set the fence so that the blade will cut a kerf-deep rabbet into the workpiece corner, as shown *opposite top*. By cutting the rabbet on the frame face pressed tight against

### CUT THE KEY STOCK

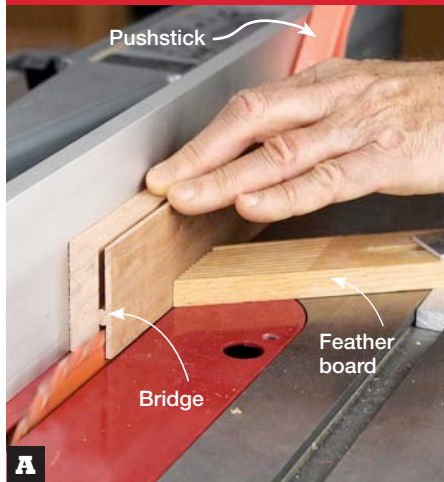

**A** Between the kerfs, leave a bridge about  $\frac{1}{2}$ " wide. The bridge can be removed later with a bandsaw or handsaw.

the jig, you'll minimize tear-out. For keys on both sides of the frame, rotate the workpiece and make a second cut.

### Attach the keys

If necessary after sawing the keys, plane them to just thicker than the depth of your rabbet. Glue and clamp the key stock to the corners on the front, back, or both faces of the frame, as shown in **Photo B**.

Bandsaw the excess key stock from the edges of the frame, as shown in **Photo C**. Flush-sand the edges and faces of the keys with the edges and faces of the frame.

### GLUE AND CLAMP THE FACE KEYS



**B** These face keys have been planed to about  $\frac{1}{32}$ " thicker than the depth of the key rabbets in the frame stock.

### SAW KEYS FLUSH WITH FRAME



**C** Remove excess key stock with a bandsaw, then sand the face and edges flush using a random-orbit sander.

## How to further decorate this joint

Face keys alone give you dozens of possible wood combinations, but your imagination needn't stop there. Adding dowels or plugs to the keys, as shown at *right*, gives them even more character.

Begin by marking the locations of the plugs on the keys, as shown in **Photo D**. We placed these  $\frac{3}{8}$ " plugs  $\frac{1}{2}$ " from the long edge of the key, spacing them 1" apart and equal distances from the shorter edges of the keys. For your plugs, use either the frame wood species or introduce a third species to the joints.

These plugs extend through the key and into the frame without emerging through the face on the other side. Orient the grain of the plugs with that of the keys to allow for wood movement.

Glue and seat the plugs, leaving about  $\frac{1}{8}$ " above the surface. Remove the excess with a flush-cutting saw, as shown in **Photo E**.

Finish by sanding the plugs flush with the frame's face. 🪵

Written by **Bob Wilson**

### FIRST, LAY OUT THE PLUG LOCATIONS



**D** Space the plugs an equal distance from the miter joint line. Plug locations can be adjusted to suit your key and frame sizes.

### FINALLY, CUT THE PLUGS FLUSH



**E** When using a flush-cutting saw to remove plug stock above the key, cut parallel to the direction of the key grain.



# Lithium-Ion batteries

What you need to know about the latest in cordless-tool technology

**C**ordless-tool batteries have continually stepped up in voltage since they were invented nearly 50 years ago, but with each boost in power came added weight. In fact, a 24-volt nickel-cadmium (NiCd) or nickel-metal hydride (NiMH) drill can weigh nearly 8 pounds—about the same as a gallon of milk—and who wants to lug that around the shop or job site all day?

Responding to that criticism, Milwaukee Electric Tool introduced a line of 28-volt cordless tools at the International Builders Show in January. The lithium-ion (Li-Ion) chemistry used in these batteries provides more power for less weight than NiCd or NiMH cells, meaning an 18-volt drill of the

future could weigh as little as today's 12-volt drill. Also, Milwaukee engineers say Li-Ion batteries could one day make more power-hungry tools (such as big routers and benchtop planers) cordless.

## Li-Ion's share: Shifting from cell phone to shop

Although the lithium-ion name may be unfamiliar to you, chances are good that you've used a Li-Ion powered device in the past few days. That's because this rechargeable battery chemistry is the power source of choice for cellular phones, digital cameras, and laptop computers. Those applications draw a small amount of energy from the battery over long periods of time,

which has traditionally been considered the forte of Li-Ion cells.

However, Gary Meyer, head of the team that developed Milwaukee's "V28" battery platform, says they've cracked the code to make Li-Ion work in high-drain applications, such as professional power tools. "Our batteries aren't the ultimate in energy delivery [which translates into run time]," he says, "but they're good enough [on run time] while vastly improving on power." How good is "good enough?" A Milwaukee representative shared with us the results of independent lab testing that showed their V28 batteries ran about twice as long as 18-volt NiCd batteries.

*continued on page 24*



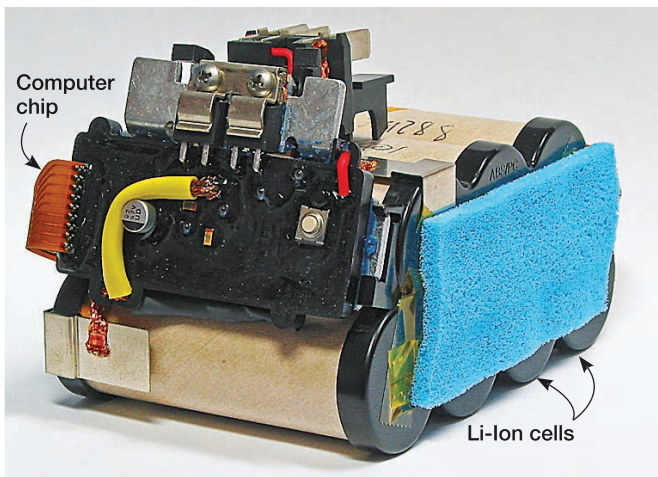

Besides managing the inflow and outflow of power, a computer chip inside Milwaukee's V28 "smart" battery pack also tracks charge/discharge patterns and the date of first use for service and warranty purposes.

Part of that boost, naturally, comes from an almost 50 percent increase in voltage over an 18-volt battery pack, regardless of chemistry. But the Li-Ion cells, coupled with a computer chip inside the battery pack (shown at *left*) that regulates both the charging and discharging of the pack, also get credit for improved

run time. Milwaukee's Dave Selby, manager of new product development, puts it this way: "The voltage of a NiCd battery steadily falls off as the battery discharges, giving you less power to do the job. Our batteries deliver the same power from the first pull of the trigger to the last. When the voltage falls below a certain threshold, the chip simply shuts the battery down." Engineers added a "fuel gauge" on the battery to help users tell when the pack is nearing depletion.

### More power, long run time—what's not to like?

In a nutshell, cost. Prices on Li-Ion tools weren't available as this issue went to press, but Selby estimates their 28-volt tools will cost about 40 percent more than pro-level 18-volt NiCd tools. "The raw materials to make Li-Ion batteries are actually less expensive than NiCd, but the higher volume of production of NiCd batteries helps keep their cost lower," he says.

Another concern could be in *cycle life* (the number of recharge cycles over the life of the battery). Although Selby says Li-Ion's cycle life about equals that of NiCd, other portable-tool manufacturers say their evaluations of lithium manganese (the formula used in Milwaukee's batteries) suggest its cycle life is shorter than that of NiCd technology, particularly in heavy-use applications.

### Looking ahead: Is Li-Ion in your tool future?

We can't fathom when we'd need a 28-volt drill in a woodworking shop; there's always an outlet and corded drill nearby for those demanding jobs. Still, we tried the Milwaukee V28 6½" circular saw in our shop, and it cut like a corded saw, without the entanglements.

We asked Dave Selby if he expects Li-Ion to trickle down to lower-voltage tools, giving consumers more power at lighter weight. "That is very much a possibility," he responded. "At this point, though, we're looking to apply it to make now-corded tools cordless." He wouldn't elaborate for competitive reasons, but says that this technology pours out up to 700 watts of power, more than twice the 300-watt cap typified by NiCd and NiMH. "That means just about any tool requiring 25 amps, up to possibly 40 amps, is a candidate." Could a cordless tablesaw be on the horizon? ♣

# ask wood

Answers to your questions from letters, e-mails, and WOOD Online®

## Make jigs for template routing

**Q:** I'm making speaker cabinets that require several round and rectangular holes. I plan to use templates, guide bushings, and my router to do the work. There's only one problem: How do I figure out what size to make the templates?

—James Sullivan, Columbus, Ohio

**A:** Get a pattern-cutting bit with a top-mounted bearing, James, and you'll eliminate the need for any math. This bit will duplicate the same-size hole in your stock as that in your template. Just clamp your pattern where you want the holes and let the bearing ride the inside edges of the pattern while the bit does the cutting. If you still want to use a bushing and straight bit, subtract the bit diameter from the outside diameter of the bushing, and add half the difference to each dimension of the template. For example, if you have a 1/2"-diameter bushing and a 3/8" bit, half the difference is 1/16". So you'd make a template opening 5 1/16" x 7 1/16" for a 5 x 7" opening.



A pattern-cutting bit with a top-mounted bearing simplifies the sizing of templates. Rout counter-clockwise inside the pattern.

## The veneer has two faces

**Q:** I visited a specialty hardwood dealer to buy some oak plywood, and he asked me whether I wanted rotary-cut or bookmatched face veneer. What's the difference?

—George Keller, Fort Wayne, Ind.

**A:** You're fortunate to have such a well-stocked lumber supplier, George. Many dealers choose only one type of face veneer per plywood thickness.

The differences between the veneers come down to appearance, which depends on how they were cut at the mill. To produce rotary-cut veneer, the mill mounts a log between centers—imagine a massive lathe—and spins it against a long knife that slowly advances. Veneer peels off in a continuous sheet, like unrolling a giant roll of paper towels. Rotary cutting is economical because there's little waste, but it produces whirling grain patterns that sometimes appear exaggerated and unnatural.

A more labor-intensive method slices individual sheets of veneer, then joins them side-by-side. Arranging each pair of successive slices like identical pages of a book to create a mirror image effect is called bookmatching. Slicing sheets from a different angle on the log produces quarter-sawn veneer. Either way, each veneer slice has the natural appearance of a cut board. Compared to the dramatic grain pattern of

rotary-cut veneer, bookmatched and quarter-sawn veneers look more natural and formal. Because of the extra labor involved, bookmatched veneer plywood may cost more than rotary-cut. For example, one supplier we contacted quoted roughly the same price for both varieties of oak plywood but a difference of 50 cents to \$1 per square foot higher for bookmatched maple over plywood with rotary-cut maple veneer.

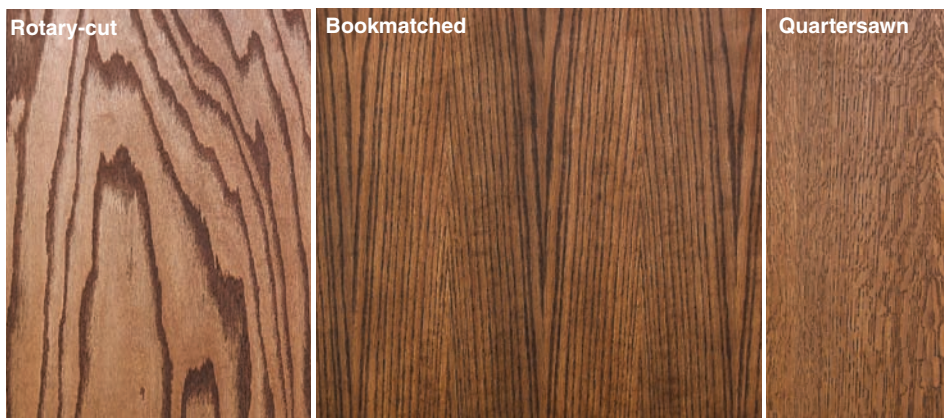

continued on page 28



## No “nourishment” needed

**Q:** The makers of a lot of woodfinishing products describe how they “nourish the wood” or “replace natural oils.” Are these accurate statements or hokum?

—Joe Brickner, Lima, Ohio

**A:** As much as we woodworkers like to romanticize wood’s mysterious qualities, Joe, the plain fact is that wood is composed of dead cells and a small percentage of water. Only a few types of wood species have more than a trace of natural oil in them. For this reason it’s not possible to replace oil when the wood didn’t have it in the first place. And even woods that have natural oils don’t require special feeding or oil changes any more than dried flowers need fertilizer.



Wood finishes serve a variety of useful purposes (such as protection), but no finish supplies useful nutrients to the wood.

## Fine-tune shop-made throat plates with a router

**Q:** I used ½" Baltic birch plywood to make a zero-clearance throat plate for my tablesaw, only to find out that it protrudes slightly above the table. I’d like to find a simple, safe way to make it flush.

—Dan Clemons, Columbus, Ohio

**A:** Dan, you only need to cut two very shallow rabbets on the bottom face. If you have a router table, install a straight bit, and raise it to trim off the excess material. Set the fence for a ⅝"-wide cut to receive the throat-plate supports on a typical tablesaw. Then, form a pair of rabbets, and check the results on your saw. If you don’t have a router table, cut the rabbets with a dado set on your tablesaw.

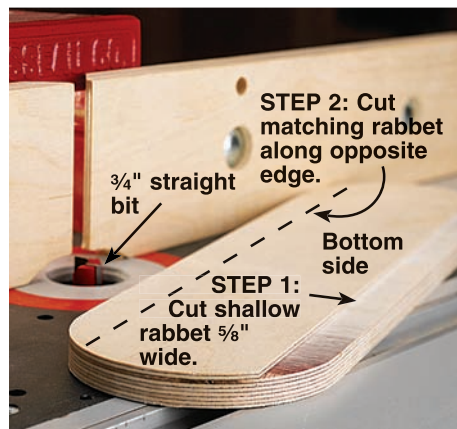

## Got a question?

If you’re looking for an answer to a woodworking question, write to Ask WOOD, 1716 Locust St., GA-310, Des Moines, IA 50309-3023 or send us an e-mail at [askwood@mdp.com](mailto:askwood@mdp.com). For immediate feedback from your fellow woodworkers, post your question on one of our woodworking forums at [www.woodmagazine.com](http://www.woodmagazine.com).

# shop tips

Helping you work faster, smarter, and safer

## Wider is better for resaw feather boards

As a maker of guitars, I do a great deal of resawing to create the thin slices of material I need for my work, frequently with very expensive woods like ebony and rosewood. When resawing, it's very important to keep the workpiece firmly against the fence. If it moves away from the fence, even a little, the blade will make an ugly cut that will cost me money in wasted material.

To maintain the necessary pressure, I created this "amped-up" version of a feather board that applies pressure across a wide area. The jig is essentially two feather boards separated by a lift box. I made the box from  $\frac{3}{4}$ " birch plywood, and screwed the feather boards to its top and bottom. You could make the box taller for workpieces wider than 6".

—Joel Nowland, West Point, Utah

*Editor's note: Joel used the "4-in-1" combination feather boards from Eagle America, and removed the level and scale from each feather board's center. (Item has been discontinued. Other sources are available.)*

### top shop tip

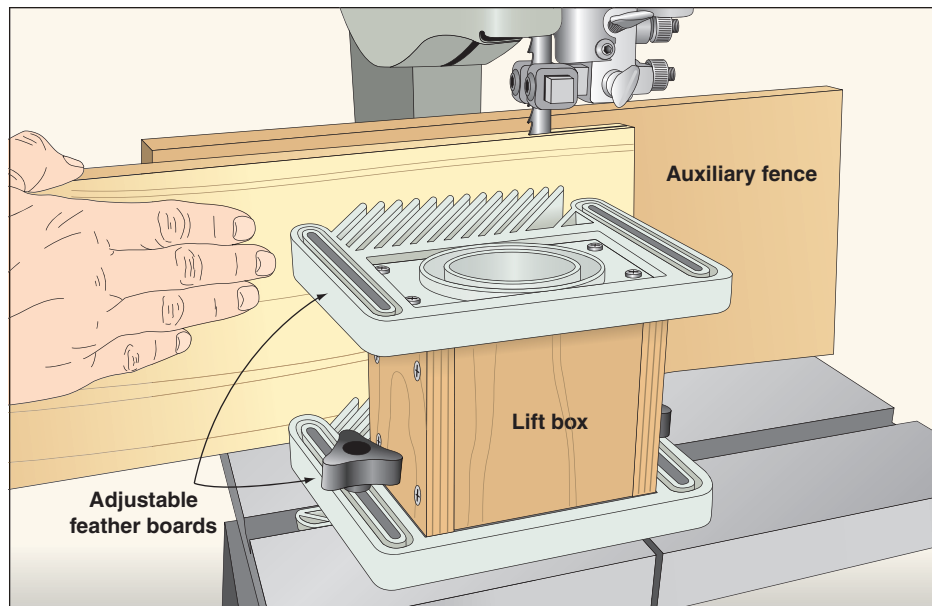
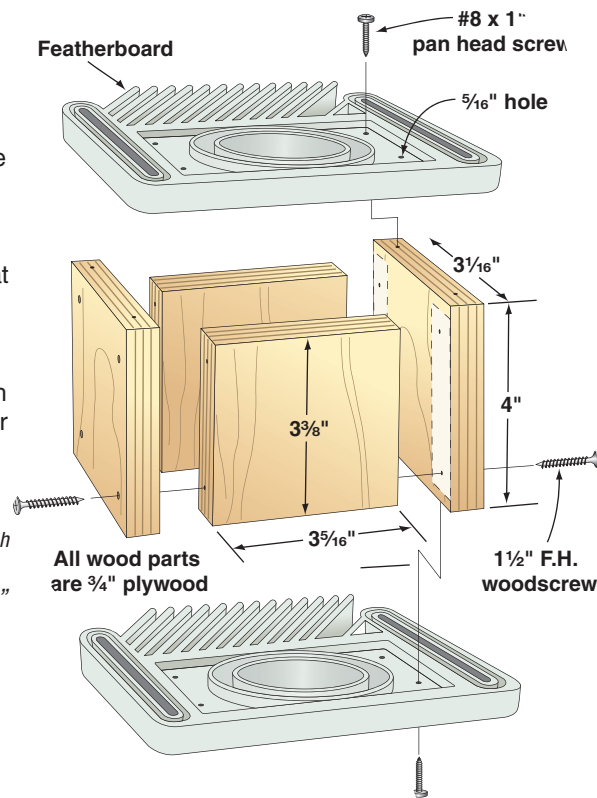

## Our Winner



Photo: Shannon Dabbling

Hooked on woodworking since building furniture in high school, Joel Nowland watched a fellow on TV making a cello and decided to try his hand at building a guitar. About five years ago, that avocation became Joel's vocation and he started building them full-time in his 1,400-sq. ft. basement shop. These days, our Top Shop Tip winner's guitars—some named after his wife and sons—command up to \$5,000 apiece.



For sending this issue's Top Shop Tip, Joel Nowland wins a Fein 14.4-volt cordless drill and bit set. Congrats, Joel!

## Top tips win tools!

Describe how you've solved a workshop dilemma, and you'll earn \$75 if it appears here. And, if your tip garners Top Shop Tip honors, you'll also win a tool prize worth at least \$250.

Send your best tips, along with photos or illustrations and your daytime phone number, to: **Shop Tips, WOOD Magazine, 1716 Locust St., GA-310, Des Moines, IA 50309-3023.** Or e-mail tips to: [shoptips@woodmagazine.com](mailto:shoptips@woodmagazine.com). Remember to include your contact info in the e-mail as well.

Because we try to publish only original tips, please send your tips only to **WOOD®** magazine. Sorry, submitted materials can't be returned.

continued on page 32



## Air filter masquerades as a mobile work table

My basement workshop has a low ceiling, so I can't effectively mount an air-filtration system overhead. Rather than having the cleaner in a fixed and inconvenient location, I decided to make it part of a mobile workbench, as shown *below*.

The air cleaner sits on top of a sheet of  $\frac{3}{4}$ " rigid foam to absorb sound and vibration. I also added a power strip to the bench for extra versatility. It works especially well as a sanding and finishing table, but I avoid using the bench for heavy pounding because that might damage the cleaner.

—Richard Herst, Lake Villa, Ill.

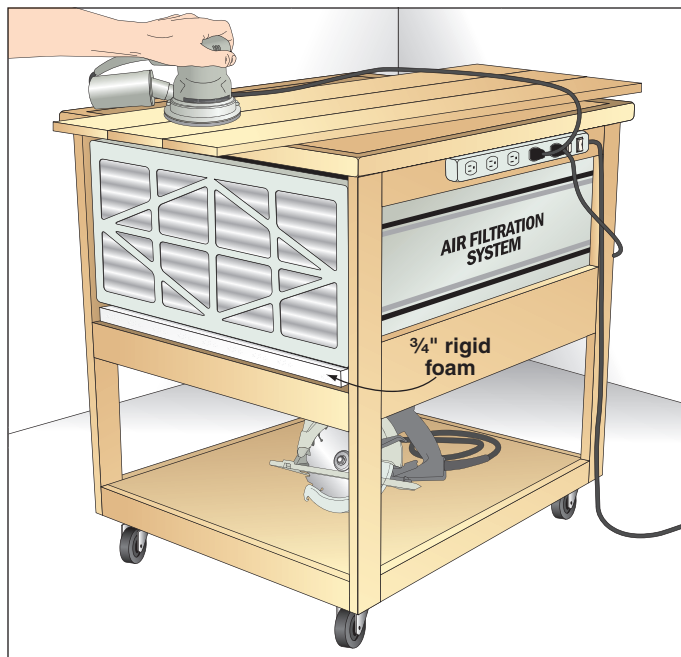

## Wire shelving for storage-bin support

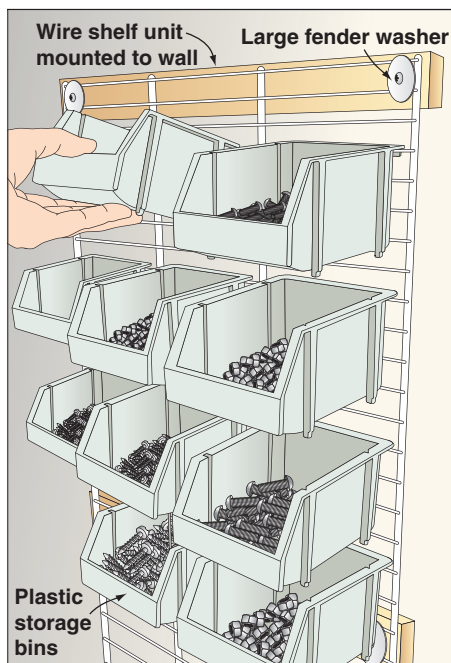

I have numerous plastic storage bins that were designed to hang on a wall-mounted rail. Much to my surprise, each rail cost almost \$7 and would only hold three bins. Fortunately, I found an economical solution when I discovered the bins would hang securely on metal wire shelving.

I mounted the shelving vertically to furring strips with fender washers. A single piece of wire shelving securely holds dozens of bins of various sizes and offers much more flexibility than individual rails.

—Paul Boutin, Kelowna, B.C.

## Quick-stick cleats divide and conquer drawers

When I add a divider to one of my tool drawers, I use cleats made from  $\frac{1}{4}$ " tempered hardboard attached to the drawer with  $\frac{3}{4}$ "-wide, cloth-backed, double-faced tape. I make the cleats about 1" wide and a bit shorter than the inside height of the drawer box. After carefully wiping all dust from the drawer box and cleats, I attach the tape to the smooth side of the cleats. I position the first cleat, set the divider in place, and then install the cleat's mate on the other side.

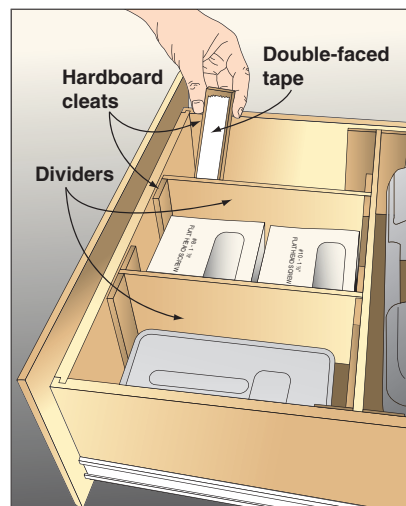

These cleats offer a quick and inexpensive way to organize parts and tools. And they last—I've had them in my unheated barn shop for more than two years, and they still hold fast.

—Bill Esposito, Rindge, N.H.

## Steady turned parts for accurate boring

Recently, I faced the daunting task of drilling a straight, accurate hole through the center of a turned handle. To make it possible, I constructed a clamping jig from two 6"-long blocks of 4x4. First, I squared the faces of the blocks on the jointer, and then I cut the ends to length and perfectly square using my mitersaw. Next, I notched a V-shaped groove in one side of each block using my tablesaw with the blade bevel set at 45°. Finally, I vertically mounted one of the V-blocks to a scrap piece of  $\frac{3}{4}$ " plywood.

To use the clamping jig, I place my turned part in the groove of the mounted V-block, and then clamp the other V-block to the first, as shown *above*. With the workpiece secured in the jig, I center the workpiece underneath the drill bit and clamp the jig base to the drill press table. By only fixing one of the two V-blocks to the base, the jig can firmly hold a variety of different-sized pieces, either square or round.

—Michael Millerick, Ridgefield, Conn.

*continued on page 36*

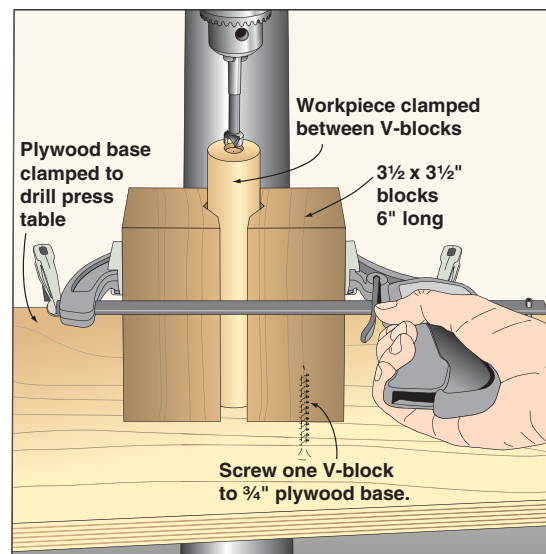

## Conquering the final frontier of dust collection

My stationary belt sander was one of the few tools I had without a dust-collection port. This was a big-time problem because fine sanding dust remains suspended in the air for a long time. To tackle this challenge, I devised a dust-collection hood out of 3" PVC pipe.

I began by cutting a collection slot into the 3" pipe and glued a PVC test cap on the end. I then mounted the pipe to a slab of medium-density fiberboard (MDF) attached to the belt sander stand at the outfeed end of the belt. After a few wraps of duct tape around the free end of the PVC to increase its diameter, a 4" dust-collection hose slips over the pipe and is held in place with a band clamp.

—Roy Davis, Phoenix

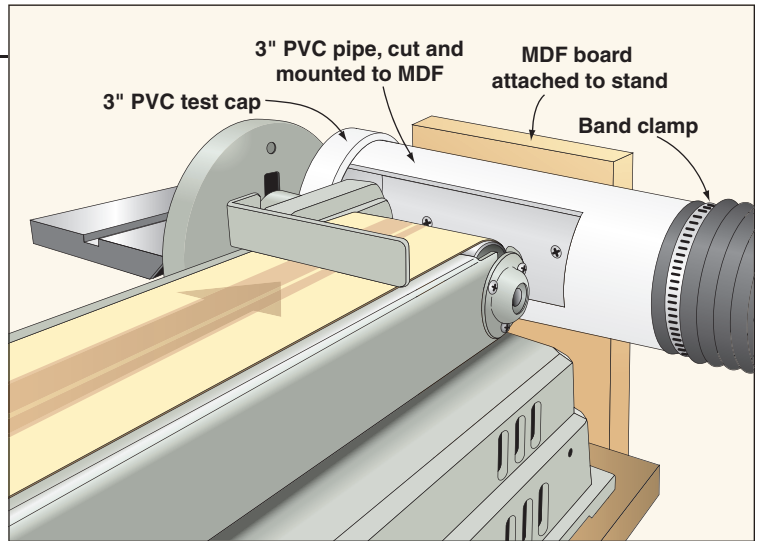

## Make a worn star-drive tip shine again

My screwdrivers with star-drive, or Torx, tips tend to slip over time because the sharp, small points are easily damaged. To revive a worn-out tip, I just grind off the damaged end with a 1" belt sander or my bench grinder. In a late-night, stores-are-closed, what-am-I-gonna-do pinch, I've even sanded into the flared part of the tip, making it fit the next larger size of star-drive screw.

—Pat Lowry, WOOD® magazine Techniques Editor

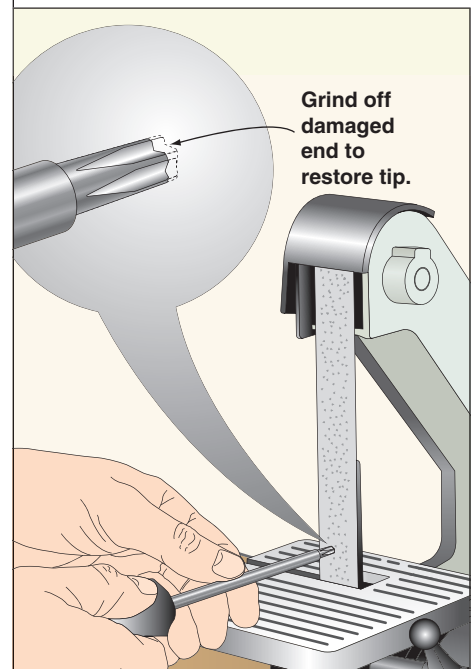

See a new  
Shop Tip  
of the Day at  
[woodmagazine.com/tips](http://woodmagazine.com/tips)





# double-duty paper-towel holder

Mount this handy kitchen accessory under a cabinet or simply set it on a countertop.



**N**eed to unwind and have only a few hours to spend in the shop? That's all you need to build this simple project. And you don't need much in the way of materials—just a small piece of oak (or a wood to match your cabinets), a 1" dowel, and a few supplies from your local home center or hardware store.

## Start with the holder

**1** Edge-join  $\frac{3}{4}$ "-thick oak to form two  $8 \times 9$ " blanks for the sides (A) and two  $8 \times 11\frac{3}{4}$ " blanks for the top and bottom (B). Plane all of the pieces to  $\frac{1}{2}$ " thick. Then double-face-tape the blanks for the sides (A) together with the best faces (for the outside) facing out and the edges flush.

**2** Make a copy of the full-size side pattern from the *WOOD Patterns*® insert. Spray-adhere the pattern to one of the side pieces.

**3** Chuck a 1" Forstner bit in your drill press. Then set the depth stop to bore a hole through one piece for the right side (A) and a  $\frac{1}{4}$ "-deep hole into the other piece for the left side, where shown on the pattern and **Draw-**

**ing 1.** Clamp the parts to the drill-press table. Then bore the hole. Now drill a countersunk shank hole centered inside the  $\frac{1}{4}$ "-deep hole in the left side.

**4** With the sides still taped together, cut them to shape, as shown in **Photo A**. Then sand to the marked pattern lines using a 2"-diameter, 120-grit sanding drum.



For countertop use, leave off the optional mounting cleats (D), and flip over the drawer.

## SHAPE THE SIDES



**A** Bandsaw or scrollsaw the sides (A) to shape, cutting just outside the pattern lines. Then sand to the lines.

**5** Separate the parts, and remove the tape. For a stubborn fit, use lacquer thinner to soften the tape adhesive. Using a  $\frac{1}{4}$ " dado blade in your tablesaw, cut two  $\frac{1}{4}$ "-deep dadoes on the *inside* faces of both side pieces, where dimensioned on **Drawing 1** and shown on the pattern, to receive  $\frac{1}{4}$ " tongues on the top and bottom (B). Remove the pattern using a cloth moistened with lacquer thinner.

**6** Attach an auxiliary fence to your tablesaw fence and an auxiliary extension to the miter gauge. Reposition the saw fence with the auxiliary fence adjacent to the dado blade. Then cut  $\frac{1}{4}$ " rabbets  $\frac{1}{4}$ " deep on both ends of the top and bottom (B) to form  $\frac{1}{4}$ " tongues to fit the dadoes in the sides (A).

## CLAMP THE HOLDER TOGETHER

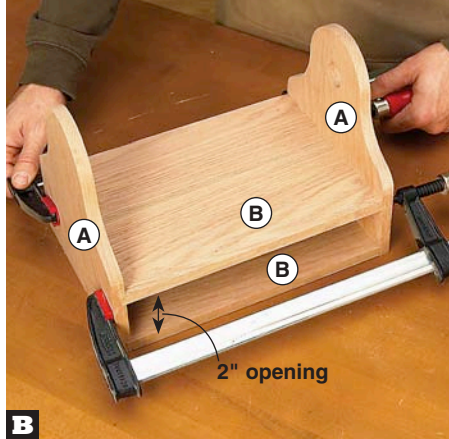

**B** Glue, assemble, and clamp the sides (A) and top and bottom (B) together, keeping the outer edges of the parts flush.

**7** Apply glue to the rabbets on the top and bottom (B). Then assemble the holder, as shown in **Photo B**, ensuring the rabbets face in the directions shown on **Drawing 1**.

**8** From a 1"-diameter oak dowel, crosscut a 12"-long piece for the towel rod (C). Mark centerpoints on the dowel ends using an awl. Clamp the dowel in your vise with an end up. Using your portable drill and a twist bit, drill a centered  $\frac{5}{32}$ " hole  $\frac{5}{8}$ " deep in one end of the dowel for a dowel screw. Switch to a  $\frac{1}{2}$ " Forstner bit. Then bore a centered hole  $\frac{1}{8}$ " deep in the other end. (We marked the drilling depth on the bit with a fine-point felt-tipped pen.) Now install a  $\frac{1}{2}$ "-diameter magnet  $\frac{3}{16}$ " thick (found at hardware stores)

in the hole using five-minute epoxy. Note that the magnet extends  $\frac{1}{16}$ " from the dowel end to ensure contact with the head of the knob-attaching screw for the left side (A).

**9** If you plan to mount the holder to a cabinet bottom, cut the mounting cleats (D) to the size listed in the **Materials List**. (Note that the  $\frac{1}{2}$ " width of the cleats accommodates cabinets with a face-frame overhang up to 1". If your overhang exceeds 1", increase the width of the cleats as needed.) Now glue and clamp the cleats to the holder, where shown on **Drawing 1**, flush with the front and back edges and ends.

## Add the handy drawer

**1** From  $\frac{3}{4}$ "-thick stock planed to  $\frac{1}{2}$ " thick, cut the drawer sides (E), front and back (F), and false front (G) to the sizes listed. From  $\frac{1}{8}$ " hardboard, cut the drawer bottom (H) to size.

**2** Referring to **Drawing 1** and the two-step **Drawing 2** on page 40 for the machining setups, cut  $\frac{1}{4}$ " dadoes  $\frac{1}{4}$ " deep  $\frac{1}{4}$ " from both ends of the sides (E) and  $\frac{1}{4}$ " rabbets  $\frac{1}{4}$ " deep in both ends of the front and back (F) to form the locking joints, where shown. Switch to a standard blade in your tablesaw. Then cut a  $\frac{1}{8}$ " groove  $\frac{1}{4}$ " deep  $\frac{1}{8}$ " from the bottom edges of the sides, front, and back to receive the bottom (H). Sand all of the parts, except the bottom, to 220 grit.

**3** Glue, assemble, and clamp the drawer together with the bottom captured in the grooves in the sides, front, and back. Check for square.

## 1 EXPLODED VIEW

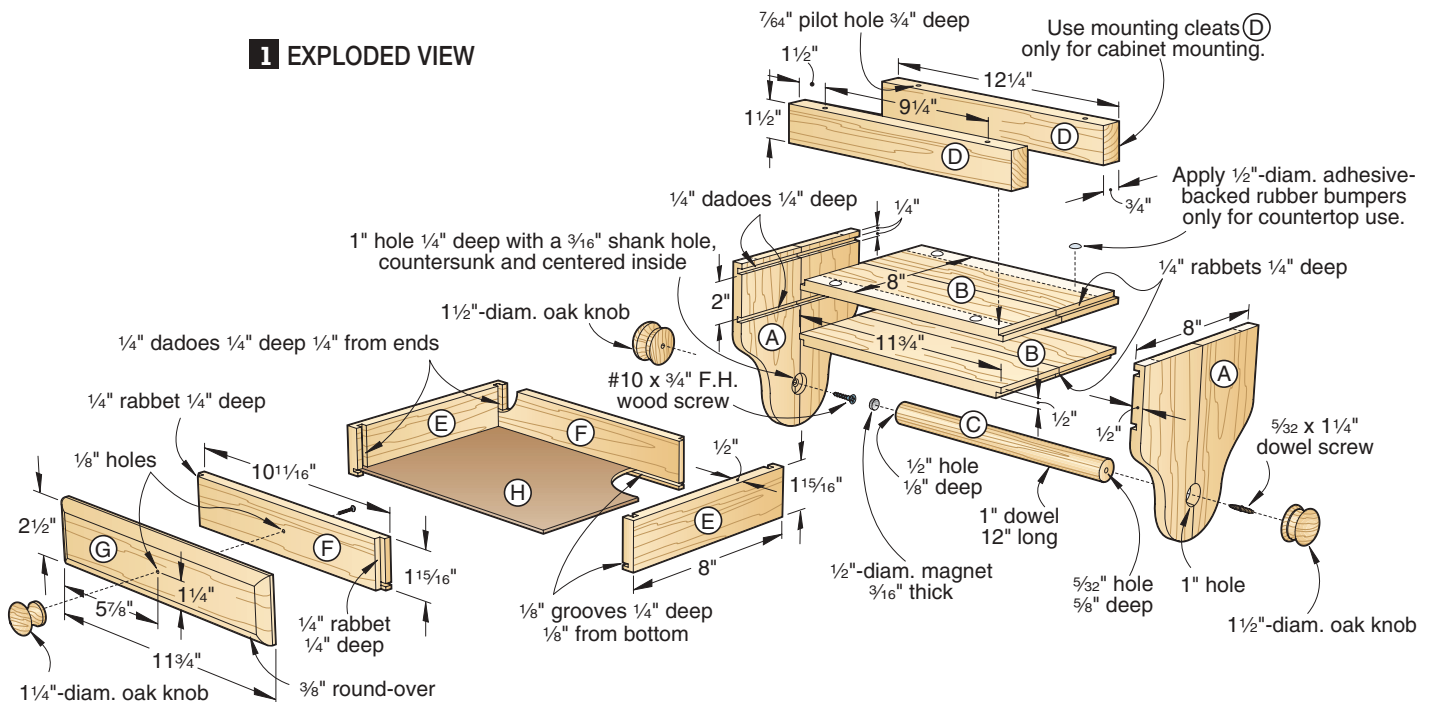



## 2 MACHINING THE DRAWER SIDES, FRONT, AND BACK

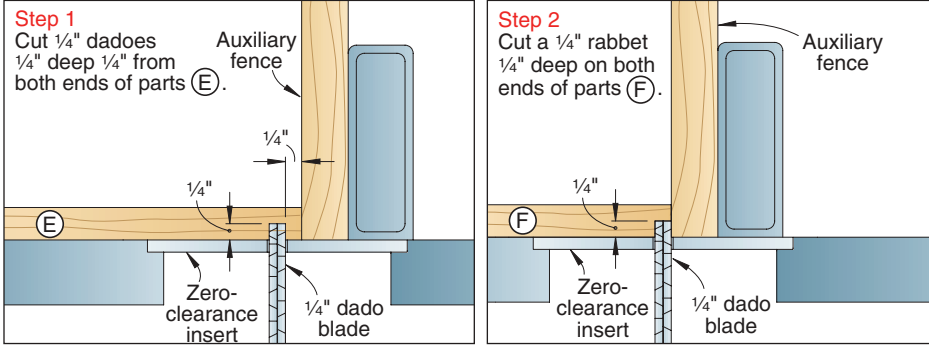

**4** Using a  $\frac{3}{8}$ " round-over bit in your table-mounted router and a pushblock for safety, rout the ends and then the edges on the front of the false front (G). Next, mark a centerpoint on the front of the false front for screw-mounting a  $\frac{1}{4}$ "-diameter oak knob, where dimensioned on **Drawing 1**. Glue and clamp the false front to the drawer front (F) with the false front centered side-to-side and top-to-bottom. Now drill a  $\frac{1}{8}$ " hole through the false front and drawer front at the marked centerpoint.

## 3 CABINET-MOUNTING SECTION VIEW

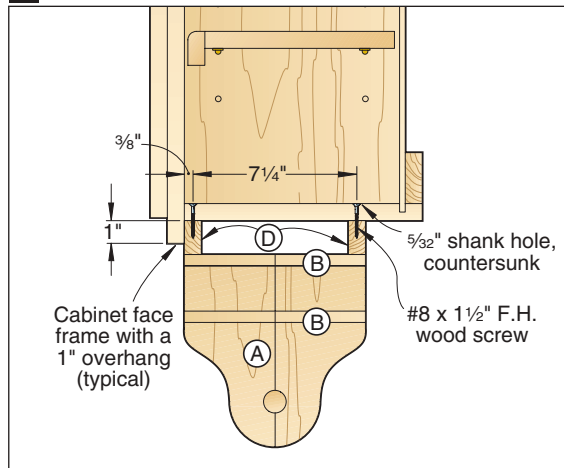

## Finish up

**1** Sand a  $\frac{1}{4}$ "-diameter store-bought oak knob for the false front (G), two  $\frac{1}{2}$ "-diameter oak knobs for the holder, towel rod (C), and any areas of the holder and drawer that need it to 220 grit. Remove the dust. Apply a stain, if you wish, and two coats of a clear finish. (We applied Varathane Premium Wood Stain, Summer Oak No. 206, and topcoated with Varathane aerosol Diamond Wood Finish, semigloss.)

**2** Attach the  $\frac{1}{4}$ "-diameter oak knob to the false front (G) using the screw supplied with the knob. Next, attach a  $\frac{1}{2}$ "-diameter oak knob to the left side (A), where shown on **Drawing 1**, using a  $\#10 \times \frac{3}{4}$ " flathead wood screw. Now mount the remaining  $\frac{1}{2}$ "-diameter oak knob to the predrilled end of the towel rod (C) with a  $\frac{5}{32} \times \frac{1}{4}$ " dowel screw.

**3** For cabinet mounting, position the holder under a cabinet, as shown in **Photo C**. Using a combination square, mark mounting-hole centerpoints inside the cabinet on the bottom for driving two screws into each mounting cleat (D), where dimensioned on **Drawings 1** and **3**. If necessary, remove the cabinet shelf to provide room for your drill. Then drill the holes through the cabinet bottom and into the cleats, and drive the screws. Countersink the holes so that the screwheads sink slightly below the shelf surface to avoid nicking glassware and dishes.

**4** For countertop use, apply four  $\frac{1}{2}$ "-diameter adhesive-backed rubber bumpers to the bottom (B), where shown on **Drawing 1**. The bumpers provide friction to keep the holder from sliding when tearing off the paper towels.

**5** Finally, slide the drawer into the holder, and tuck away some kitchen items in it, such as hot pads, knives, or napkins. Then position a roll of paper towels in the holder, and insert the magnetic end of the towel rod (C) through the 1" hole in the right side (A), the center of the paper-towel roll, and into the stopped 1" hole in the left side (A). Need a towel? Give it a rip. 🌲

Written by **Owen Duvall**  
Project design: **Kevin Boyle**  
Illustrations: **Roxanne LeMoine**

## Cutting Diagram

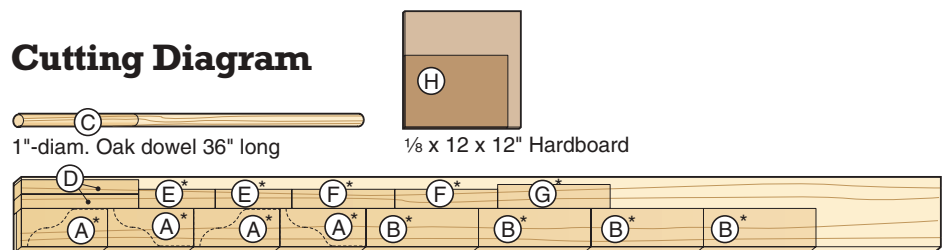

$\frac{3}{4} \times 7\frac{1}{4} \times 96$ " Oak (5.3 bd. ft.)  
\*Plane or resaw to the thickness listed in the Materials List.

## CABINET-MOUNT THE HOLDER



**C** Clamp the holder to the cabinet bottom with the front mounting cleat (D) tight against the face frame. Drill the mounting holes.

## Materials List

Holder	FINISHED SIZE			Matl.	Qty.
	T	W	L		
A* sides	$\frac{1}{2}$ "	8"	$8\frac{1}{2}$ "	EO	2
B top and bottom	$\frac{1}{2}$ "	8"	$11\frac{3}{4}$ "	EO	2
C towel rod	1" diam.		12"	O	1
D mounting cleats (optional)	$\frac{3}{4}$ "	$1\frac{1}{2}$ "†	$12\frac{1}{4}$ "	O	2
Drawer					
E sides	$\frac{1}{2}$ "	$11\frac{5}{16}$ "	8"	O	2
F front and back	$\frac{1}{2}$ "	$11\frac{5}{16}$ "	$10\frac{11}{16}$ "	O	2
G false front	$\frac{1}{2}$ "	$2\frac{1}{2}$ "	$11\frac{3}{4}$ "	O	1
H bottom	$\frac{1}{8}$ "	$7\frac{1}{2}$ "	$10\frac{11}{16}$ "	H	1

\*Parts initially cut oversize. See the instructions.  
†Cleat width of  $1\frac{1}{2}$ " fits cabinets with a face-frame overhang of up to 1". For an overhang greater than 1", increase the cleat width as needed.

**Materials key:** EO—edge-joined oak, O—oak, H—hardboard.  
**Supplies:** Cloth-backed double-faced tape, spray adhesive,  $\frac{1}{2}$ "-diameter magnet  $\frac{3}{16}$ " thick, five-minute epoxy,  $\frac{1}{4}$ "-diameter oak knob,  $\frac{1}{2}$ "-diameter oak knobs (2),  $\#10 \times \frac{3}{4}$ " flathead wood screw,  $\frac{5}{32} \times \frac{1}{4}$ " dowel screw,  $\#8 \times 1\frac{1}{2}$ " flathead wood screws (4) for cabinet mounting only,  $\frac{1}{2}$ "-diameter adhesive-backed rubber bumpers (4) for countertop use only.

**Blades and bits:** Dado-blade set,  $\frac{1}{2}$ " and 1" Forstner bits,  $\frac{3}{8}$ " round-over router bit.



# stack-up or stand-alone sliding-door cupboard

Divided glass panes and traditional moldings give these stacked cabinets a stately look, while wide sides create deep, ample display room.



**W**hether you make two cabinets, as shown *left*, or build one to serve as a base cabinet with counter space, you'll appreciate the efficient building approach used here. The sliding doors also let you locate the cabinet in places where swing-out doors would pose a problem.

The **Materials List** on *page 49* shows the number of parts needed to make the two-cabinet configuration. To make the single-cabinet version shown in the photo *below*, reduce the number of case and door parts (parts A through J and P through U) by one-half and omit the crown assembly (parts V through CC).



For a spacious sideboard, build just one case. To view this project as a bookcase and a step-back hutch, see *page 94*.





# 1 CASE PARTS

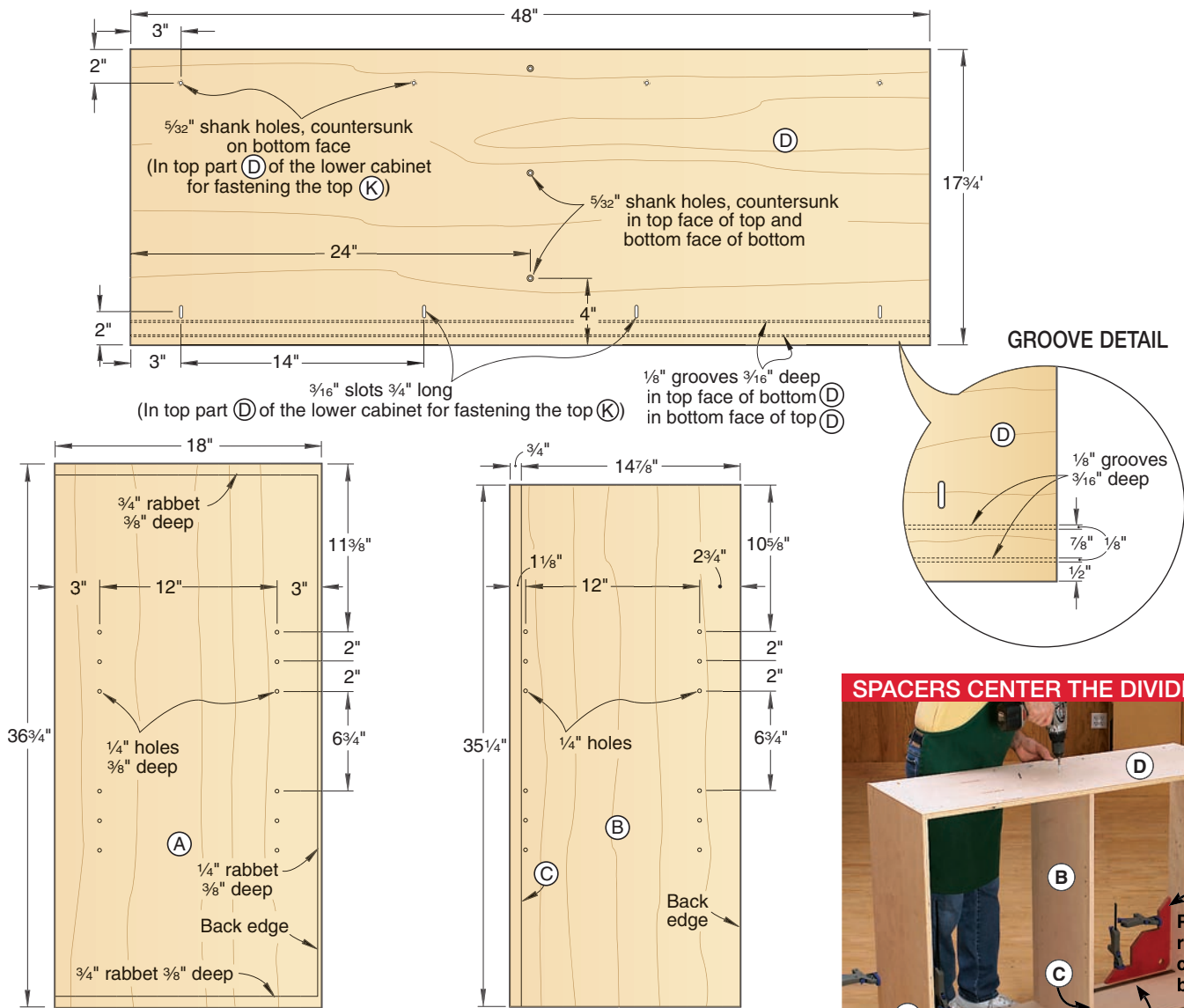

## AT A GLANCE

- Overall dimensions: 52 1/4" wide x 19 7/8" deep x 81 3/4" high.
- For the board feet of lumber and other items needed to build this project, see page 49.

### Start with the case

**1** From 3/4" plywood, cut the sides (A) to the size listed on the **Materials List**. Then cut rabbets on the inside faces along the top and bottom ends and back edges, where shown on **Drawing 1**.

**2** Cut the dividers (B) to size. The length should be the same as the top rabbet shoulder to bottom rabbet shoulder dimension of the sides (A). Cut the divider bands (C) to size, and glue and clamp them to the dividers. With the glue dry, sand the bands flush with the dividers.

**3** To ensure proper orientation during assembly, mark the top edges of the sides

(A) and dividers (B) and lay out shelf-pin hole centers, where dimensioned on **Drawing 1**. Then chuck a 1/4" brad-point bit in your drill press, and drill 3/8"-deep holes in the sides and holes all the way through the dividers. Finish-sand the parts.

**4** Cut the case tops and bottoms (D) to size. With a 1/8"-kerf blade in your tablesaw, cut 3/16"-deep grooves in the *bottom* faces of the case tops and the *top* faces of the case bottoms, where shown in the **Groove Detail** on **Drawing 1**. Then drill 5/32" shank holes countersunk on the top faces of the case tops and the bottom faces of the case bottoms for fastening the dividers (B). Finally, for fastening the top (K) to the lower cabinet only, drill 5/32" shank holes countersunk on the bottom face of the case top and form 3/16" slots 3/4" long, where shown. Finish-sand the parts.

**5** With the parts flush at the front, glue and clamp the case tops and bottoms (D) between the sides (A). Make sure the marked

## SPACERS CENTER THE DIVIDER

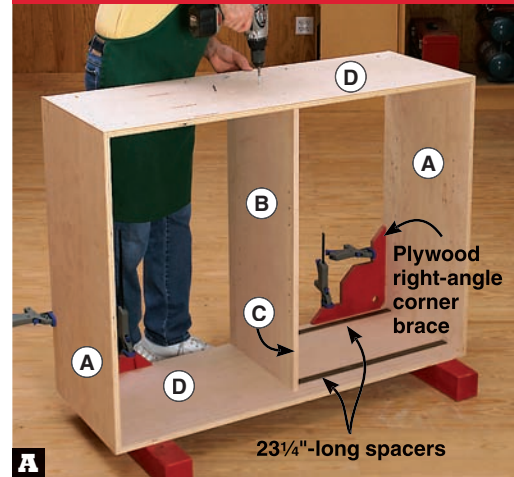

**A** Align the divider (B) with spacers. Using the holes in the case top and bottom (D) as guides, drill pilot holes and drive the screws.

ends of the sides face up. To keep the cases square, use shop-made plywood right-angle corner braces, as shown in **Photo A**.

**6** Center the dividers between the sides (A) flush with the rear edges of the case tops and bottoms (D). Fasten them in place, as shown in **Photo A**. Now sand the ends of the sides flush with the case tops and bottoms.

**7** Cut the backs (E) to size from 1/4" plywood, finish-sand, and set them aside.

**8** From 3/4" plywood, cut the shelves (F) to size. Then cut the shelf bands (G) to size, and glue and clamp them to the shelves. With the glue dry, sand the bands flush with the shelves, and then finish-sand the parts.

**2 CASE**  
(Top Cabinet Shown)

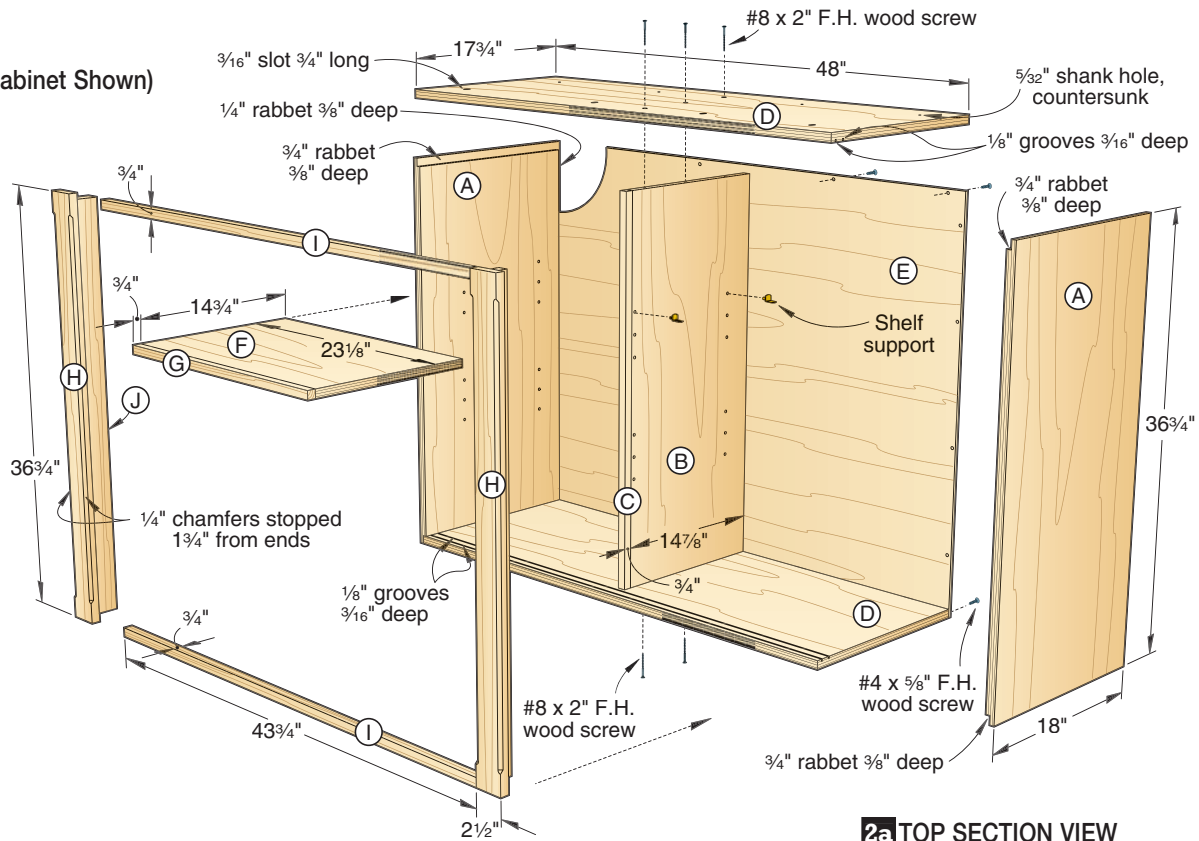

**Add a face frame and top**

**1** First checking the length of the sides (A), cut the stiles (H) to size. Rout stopped chamfers on the stiles, where shown on **Drawing 2**. For a method of routing stopped edge profiles, see the sidebar, *below*.

**2** Finish-sand the stiles (H). Glue and clamp them to the sides (A) with the ends and outside edges flush, where shown on **Drawing 2a**.

**3** First checking the distance between the stiles (H), cut the rails (I) to size. Glue and clamp the rails to the case tops and bottoms (D). Sand the rails flush with the tops and bottoms, and then finish-sand the parts.

**4** Cut the door stops (J) to size and finish-sand them. Glue and clamp the stops to the stiles (H), as shown in **Photo D**, setting them back  $\frac{1}{8}$ " from the stile edges, where dimensioned on **Drawing 2a**.

**2a TOP SECTION VIEW**

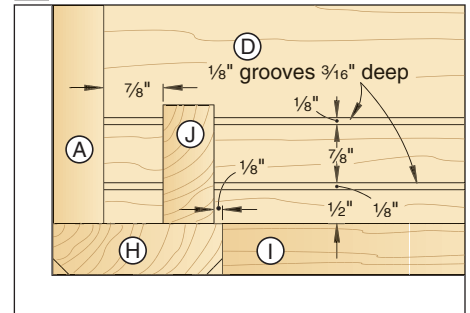

**Simple jigs guarantee precise stopped chamfers**

Sometimes, routing a stopped edge profile is as simple as clamping a stopblock to the workpiece and routing up to it. But what do you do when the position of the stopped profile puts the stopblock off the end of the workpiece? Here's how to solve this problem when routing the  $\frac{1}{4}$ " stopped chamfers on the stiles (H).

First, chuck a chamfer bit into your hand-held router and adjust it to rout a  $\frac{1}{4}$ " chamfer. Then from  $\frac{3}{4}$ "-thick medium-density fiberboard, particleboard or plywood, build a pair

of the router stops shown on **Drawing 3**. To find the stopblock setback indicated on the drawing, measure the distance from the bit to the edge of the router base, as shown in **Photo B**. Subtract  $1\frac{1}{4}$ " (the distance the chamfer stops from the end of the stile) from this measurement. The remainder is the

setback. (On our router, the bit-to-edge distance is  $2\frac{3}{8}$ ". Subtracting  $1\frac{1}{4}$ " leaves  $\frac{5}{8}$ ", so our stop setback is  $\frac{5}{8}$ ".) Now capture the stiles (H) between the stops and rout the chamfers, as shown in **Photo C**. Start and stop routing with the router base against the stopblock, as shown in the inset photo.

**3 ROUTER STOP**  
(Two needed)

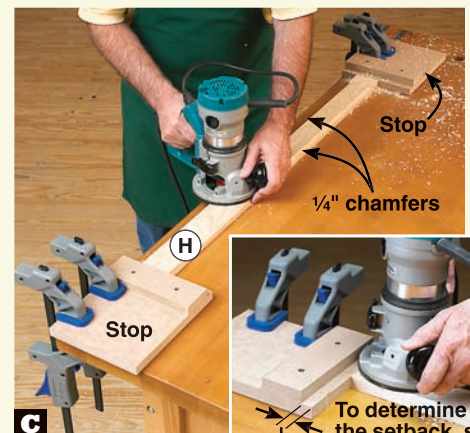
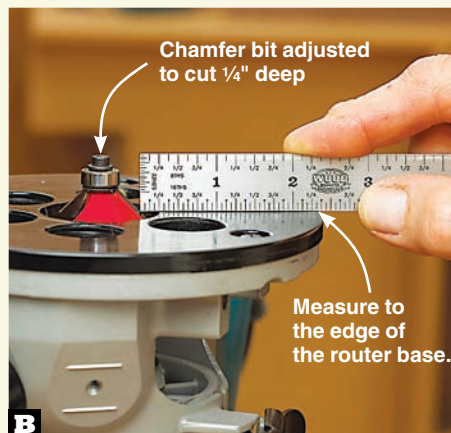
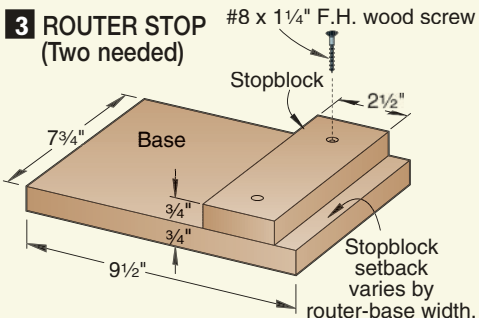



**USE SPACERS FOR EASY POSITIONING**

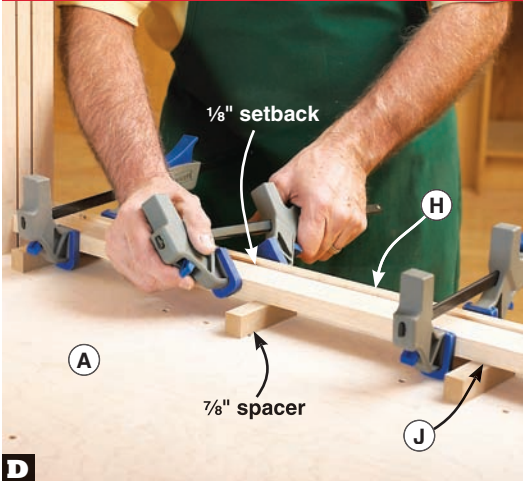

**D** For a uniform 1/8" setback between the stiles (H) and door stops (J), insert 7/8" spacers between the sides (A) and the door stops.

**5** Edge-join boards to make an oversize blank for the top (K). With the glue dry, trim the top to finished size. Chuck a 3/8" round-over bit in your hand-held router, and adjust it as shown on **Drawing 4a**. Then rout the top ends and front edge,

where shown on **Drawing 4**. Switch to a 1/8" round-over bit, and rout the bottom ends and front edge of the top. Finish-sand the top. For a lumber-saving alternative to a solid-wood top, see the **Shop Tip**, on the *next page*.

**4a TOP EDGE VIEW**

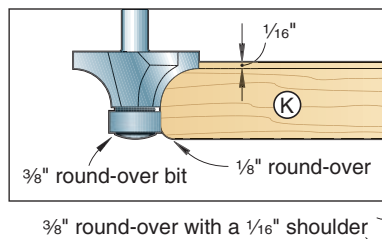

**4 EXPLODED VIEW**

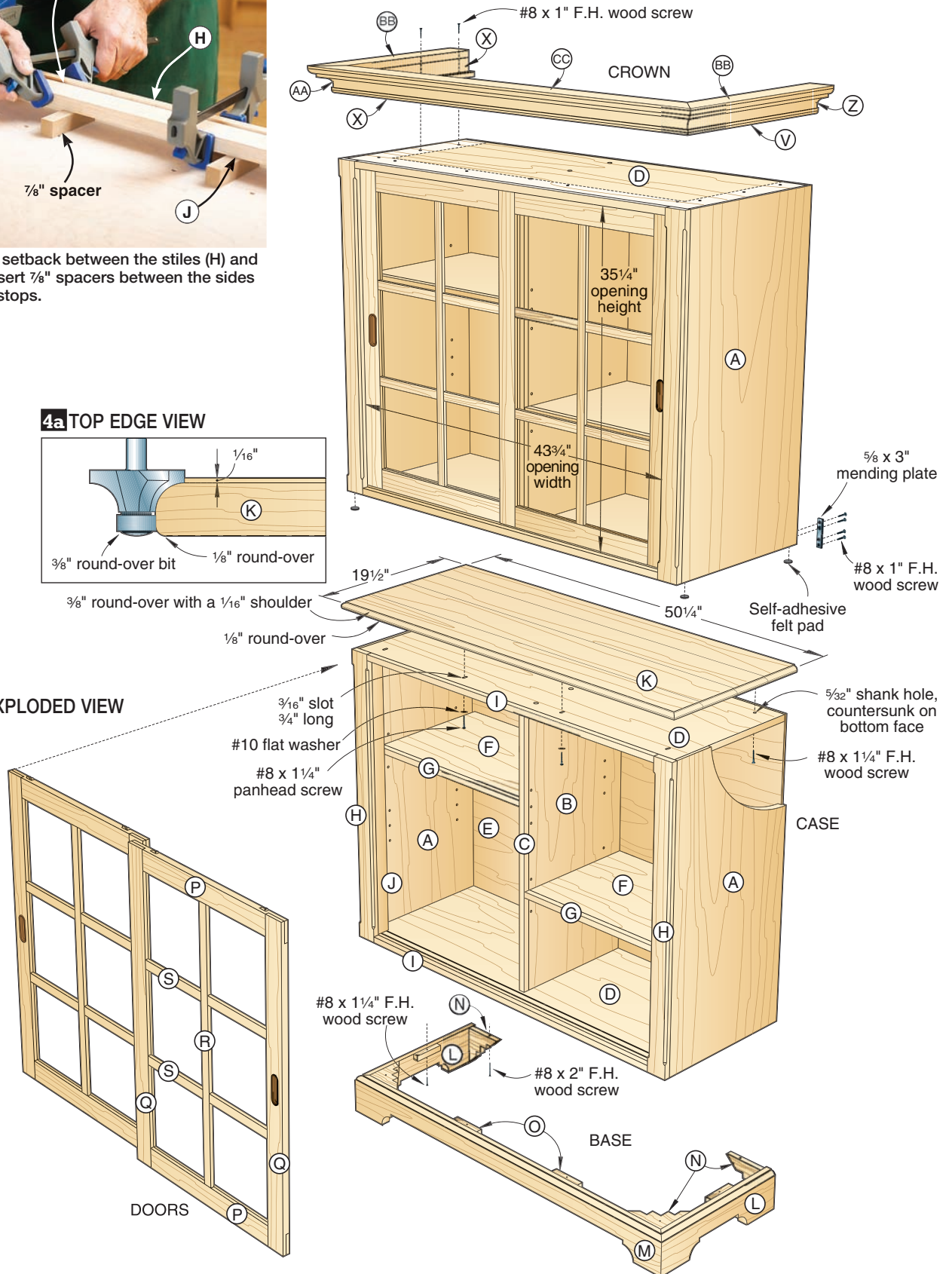

# SHOP TIP

## Small change saves lumber

It's a little more work, but because the top (K) is largely covered by the upper cabinet, you can save on lumber by substituting a wood-edged panel for the solid-wood top, shown on **Drawing 4**. And because of the stability of engineered sheet goods, you won't have to form wood-movement slots in the top (D) of the lower case. Here's how to make the switch.

First, cut a 17½×46¼" panel from ¾" plywood, particleboard, or MDF. Then from maple, cut a ¾×2×52" piece for the front edging and two ¾×2×22" pieces for the side edging. Miter-cut the front edging to length and glue and clamp it to the panel. Miter-cut the front ends of the side edging, dry-fit them, and mark the lengths flush with the rear edge of the panel. Trim the side edging to

length, and glue and clamp them in place. Sand the edging flush with the panel. Now, following the directions for the solid top, rout the round-overs along the ends and edges.

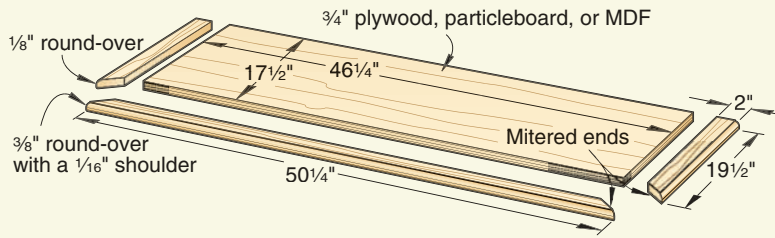

## Now make the base

**1** Laminate ¾"- and ½"-thick stock for the base sides (L) and base front (M). Cut the parts to width and 1" longer than the length listed. Chuck a ½" bead bit in your handheld router. With the ¾" part of the laminated pieces face up, rout beads along the top edges of the parts, where shown on **Drawing 5**. Now miter-cut the parts to finished length.

**2** Make three photocopies of the base cut-out patterns on the *WOOD Patterns*® insert. Adhere them to the base sides (L) and base front (M) with spray adhesive, where shown on **Drawing 5a**. Draw lines connecting the right- and left-hand patterns, where indicated on the patterns. Then bandsaw and sand the cutouts.

**3** Adjust your biscuit joiner fence to 45° and cut slots for #20 biscuits in the base miters, where dimensioned on **Drawing 5**.

**4** Cut the corner blocks (N) to the shape shown on **Drawing 5b** and drill the 5/32" countersunk shank holes.

**5** Glue and clamp two corner blocks (N) to the base front (M), flush at the top and

aligning the corners of the corner blocks with the heels of the miters. Test the corner block positions by dry-fitting the base sides (L) to the base front. Screw the corner blocks in place, as shown in **Photo E**. Now biscuit and glue the miters and clamp the base sides in place. Make sure the base sits flat, and then drill pilot holes and screw the corner blocks to the base sides. Let the glue dry.

**6** Glue, clamp, and screw the corner blocks (N) ¼" from the rear ends of the base sides (L), where shown on **Drawing 5**. Cut the cleats (O) to size and glue them in place, centered on the length of the base sides and evenly spaced across the length of the base front (M). With the glue dry, drill centered, angled 5/32" countersunk shank holes through the cleats. Now finish-sand the base.

**7** Retrieve the top (K), and lay it top down on a pair of sawhorses. Turn the lower case upside down and position it on the top, flush at the back and centered side-to-side. Using the holes and the centers of the slots in the case top (D) as guides, drill pilot holes into the top. Fasten the top to the case with screws at the front and washers at the back, where shown on **Drawing 4**.

**8** Clamp the base to the bottom of the upturned case, centered side-to-side and

## BRACES ENSURE SQUARE CORNERS

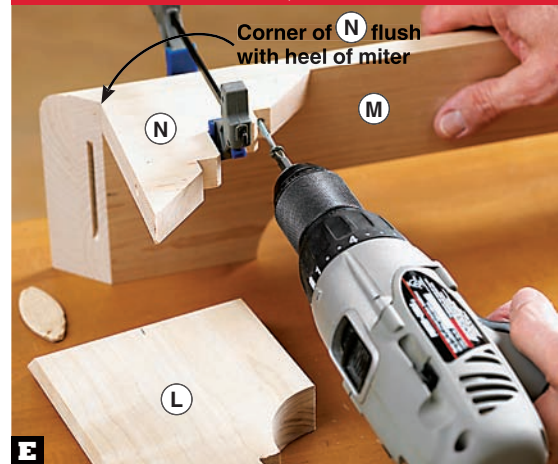

**E** Using the screw holes in the corner blocks (N) as guides, drill pilot holes into the base front (M), and drive the screws.

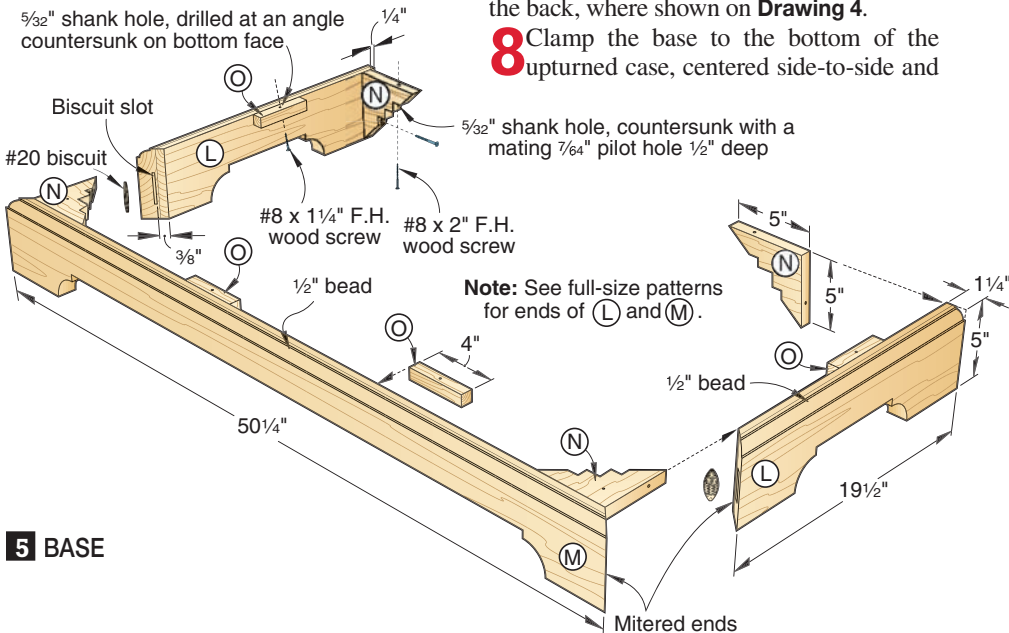

**5** BASE

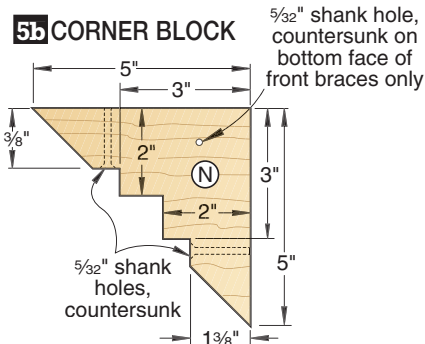

**5a** PATTERN LOCATION (Left-hand pattern shown)

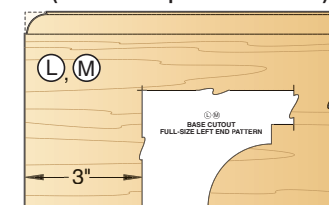



## 6 LEFT DOOR (Viewed from the back)

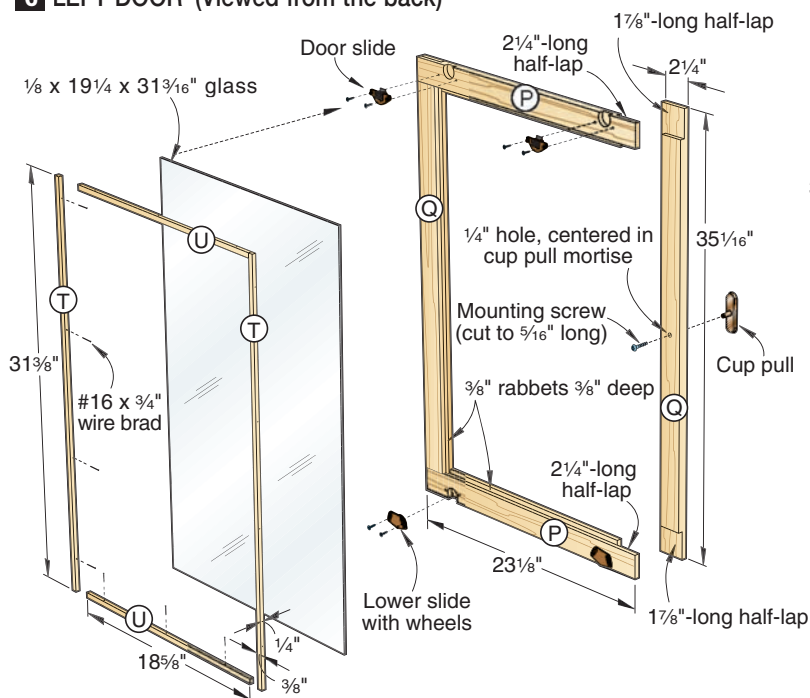

## 6c MULLION DETAIL

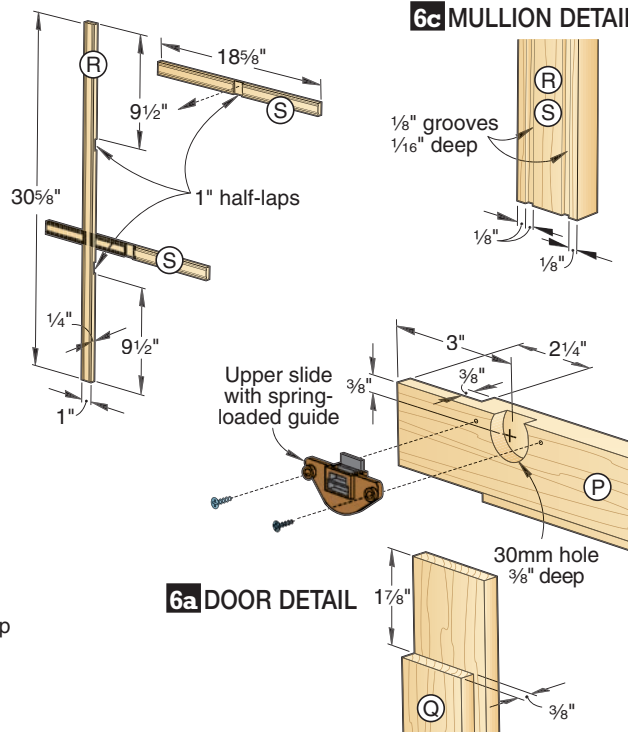

## Build the sliding doors

**1** Check the dimensions of your cabinet front openings against those shown on **Drawing 4**. The doors will accommodate a slight variance in opening width, but for the door slides to work, the doors must be  $\frac{3}{16}$ " shorter than the opening height. Making any necessary adjustments to the part lengths, cut the rails (P) and stiles (Q) to size.

**2** Lay out the door parts in their final configuration, and mark their positions for assembly after machining. For installing the cup pulls later, mark the fronts of the left door left stiles and

## 6b CUP PULL MORTISE

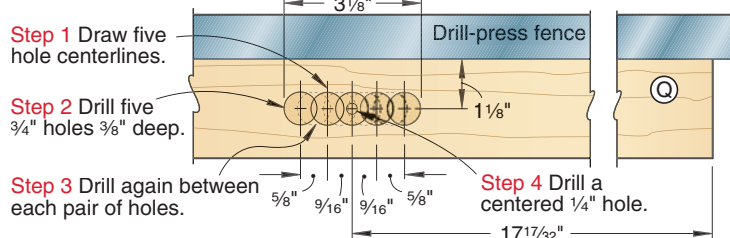

## The best sliding-door hardware

Many types of sliding door hardware require rollers mortised into the bottom edge of the door and unsightly track. For this project we found door slides that fit into single-hole mortises drilled into the backs of the rails (P). Instead of track, the slides ride in unobtrusive  $\frac{1}{8}$ " saw kerfs, and adjustment couldn't be easier. Here's how to install this hardware.

Before assembling the case, cut  $\frac{1}{8}$ " saw kerfs  $\frac{7}{8}$ " apart (for  $\frac{3}{4}$ "-thick doors) in the case top and bottom. (You did this in **Step 4** on *page 43*. See the **Groove Detail** for part D on **Drawing 1**.) To install the slides in the doors, chuck a 30mm Forstner bit into your drill press and drill  $\frac{3}{8}$ "-deep holes in the back faces of the rails (P), where shown on **Drawings 6** and **6a**.

Install the upper slides with the spring-loaded guides in the top rail mortises, as shown in **Photo F**, and the wheeled lower slides in the bottom rail mortises, as shown in **Photo G**. Drill pilot holes, and screw the upper slides in place. Drill pilot holes centered in the lower slide slots, and screw them in place. To install the doors, place the bottom slide fixed guides in the case bottom (D) grooves, retract the upper slide spring-loaded guides, and tilt the door into place, as shown in **Photo H**. Align the upper guides with the case top (D) grooves and release them. To adjust the doors, loosen the lower guide mounting screws, rotate the guide to raise or lower the door as needed, and retighten the screws.

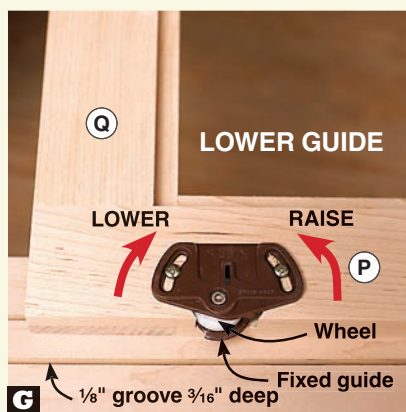

the right door right stiles. Then mark the rear inside edges of each part. Chuck a  $\frac{3}{8}$ " rabbet bit in your table-mounted router and rout  $\frac{3}{8}$ " deep rabbets along the marked edges.

**3** To form the door-frame half-laps shown on **Drawings 6** and **6a**, install a  $\frac{3}{4}$ " dado blade in your tablesaw, and adjust it to cut  $\frac{3}{8}$ " deep. To back the cuts, attach an auxiliary extension to the miter gauge, extending it about 1" beyond the dado blade. For a stop, position the rip fence  $2\frac{1}{4}$ " from the left side of the blade, and cut laps in the front faces of the rails (P). Reposition the fence  $1\frac{7}{8}$ " from the left side of the blade, and cut laps in the back faces of the stiles (Q).

**4** To mount the cup pulls, retrieve the marked stiles (Q), and chuck a  $\frac{3}{4}$ " Forstner bit in your drill press. Then follow the four steps shown on **Drawing 6b**. Check the fit of the pull and if necessary, straighten the mortise edges with a chisel.

**5** Glue and clamp the doors. Check them for square by measuring the diagonals. (Equal diagonals mean square doors.) Set the doors on a flat surface to dry.

**6** To install the door slides, where shown on **Drawing 6**, see the sidebar on page 47. With the installation complete, remove the doors from the case and the hardware from the doors, and finish-sand them.

**7** First checking the inside dimensions of the doors, plane stock to  $\frac{1}{4}$ " thick and cut the vertical mullions (R) and horizontal mullions (S) to size. Cut half-lap joints, where shown on **Drawing 6**. Then to prevent the silicone caulk you will use to attach the mullions to the glass from squeezing out, cut the grooves shown on **Drawing 6c** in the backs of the mullions. Finish-sand the mullions, and glue and clamp them together.

**8** First checking the dimensions of the door rabbeted openings, plane stock to  $\frac{1}{4}$ " thick and cut the vertical glass stops (T) and horizontal glass stops (U) to size. Clip the head off a #16 wire brad, and use it to drill pilot holes in the stops, where shown on **Drawing 6**. Finish-sand the stops.

## Build up a crown

**1** Cut a  $\frac{1}{2}\times 2\times 48$ " blank for the side bases (V) and a  $\frac{1}{2}\times 2\times 56$ " blank for the front base (W). With a  $\frac{3}{4}$ " dado blade in your tablesaw, cut a  $\frac{1}{8}$ "-deep groove in each blank, where shown on **Drawing 7a**. Then chuck a  $\frac{1}{4}$ " round-over bit in your table-mounted router, and rout the lower front edges of both

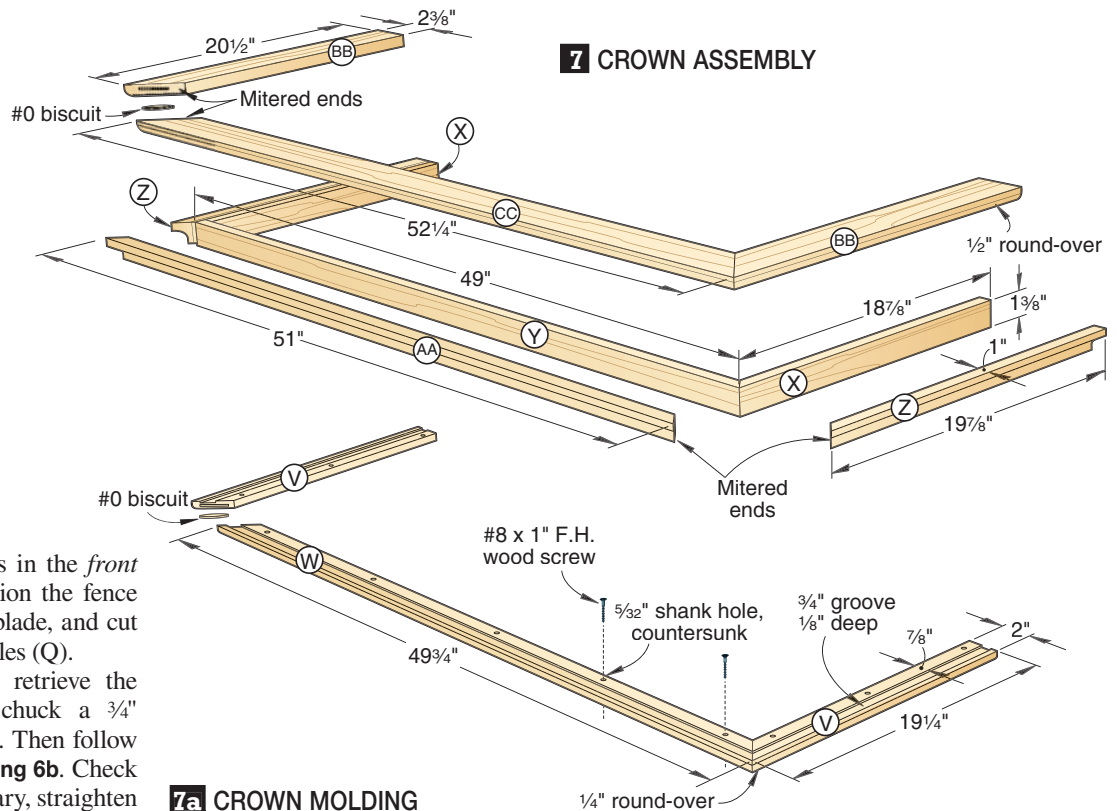

**7a** CROWN MOLDING SECTION VIEW

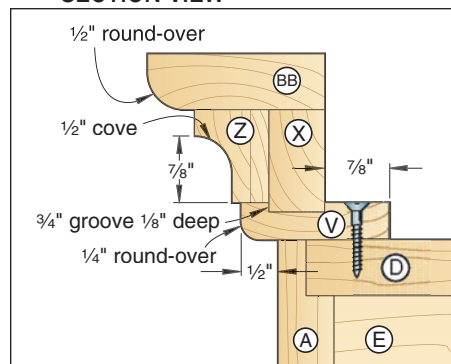

**7b** FORMING THE COVES

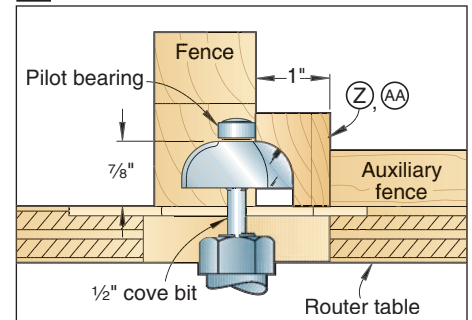

blanks. Finish-sand the portions that will be exposed in the final assembly.

**2** Cut a  $\frac{3}{4}\times 1\frac{3}{8}\times 48$ " blank for the side fillers (X) and a  $\frac{3}{4}\times 1\frac{3}{8}\times 56$ " blank for the front filler (Y). Glue and clamp the fillers into the grooves in the base blanks, where shown on **Drawing 7a**.

**3** From  $\frac{1}{4}$ "- and  $\frac{3}{4}$ "-thick stock, laminate  $1$ "-thick stock for the side coves (Z) and front cove (AA). Then cut a  $1\times 1\frac{1}{4}\times 48$ " blank for the side coves and a  $1\times 1\frac{1}{4}\times 56$ " blank for the front cove.

**4** Chuck a  $\frac{1}{2}$ " cove bit in your table-mounted router, and position the fence flush with the pilot bearing. Adjust the bit to cut  $\frac{1}{4}$ " deep. Then clamp a  $\frac{3}{4}$ "-thick scrapwood auxiliary fence to the table, where shown on **Drawing 7b**. Pressing straight down on the cove blanks with a pair of pad-style pushblocks, make the first cut. Then make additional cuts, raising the bit about  $\frac{1}{8}$ " with each pass. When the bottom of the

bit is just below the table, switch to  $\frac{1}{16}$ "-deep cuts until the full  $\frac{7}{8}$ " depth is reached.

**5** Finish-sand the cove blanks, and glue and clamp them to the base/filler blank assemblies, where shown on **Drawing 7a**. Sand the tops of the coves and fillers flush.

**6** Cut a  $\frac{3}{4}\times 2\frac{3}{8}\times 48$ " blank for the side caps (BB) and a  $\frac{3}{4}\times 2\frac{3}{8}\times 56$ " blank for the front cap (CC). Then chuck a  $\frac{1}{2}$ " round-over bit in your table-mounted router, and rout the lower front edges of both cap blanks, where shown on **Drawing 7a**. Finish-sand the cap blanks, and glue and clamp them to the base/filler/cove blank assemblies.

**7** Miter-cut the 56"-long glued-up blank assembly to length for the front crown (W/Y/AA/CC). Cut #0 biscuit slots centered in the mitered ends of the front base (W) and front cap (CC), where shown on **Drawing 7**. Position the front crown on the case so the front base (W) overhangs  $\frac{1}{2}$ " at the front and sides, and clamp it in place. Drill counter-





### DRY-FIT FOR PERFECT LENGTH

Inserting biscuits in the mitered end, clamp the side crown assembly in place. Mark the length flush with the rear edge of the side (A).

sunk screw holes through the base and into the case top (D), where shown on **Drawings 4 and 7**, and drive the screws.

**8** Cut the 48"-long blank assembly in half for the side crowns (V/X/Z/BB). Miter-cut the front ends of each assembly. Then cut #0 biscuit slots centered in the mitered ends of the side bases (V) and side caps (BB), where shown on **Drawing 7**. Dry-fit and mark the finished length of the side crowns, as shown in **Photo 1**. Remove the side crowns and biscuits, and cut the crowns to length.

**9** Glue and biscuit the crown miters and clamp the side crowns in place. Drill countersunk screw holes through the side bases (V) and into the case top (D), where shown on **Drawings 7 and 7a**. Drive the screws. With the glue dry, finish-sand the miters.

## Apply finish and assemble

**1** Inspect all the parts and assemblies and finish-sand where needed. Then apply finish as desired. (We applied two coats of Varathane Traditional Pecan stain. After the stain dried for 24 hours, we sprayed on three coats of AquaZar satin water-based polyurethane, sanding with 220-grit sandpaper between coats.)

**2** Clamp the backs (E) to the cases. Then drill countersunk screw holes through the backs and into the sides (A), dividers (B), and tops and bottoms (D), where shown on **Drawing 2**. Screw the backs to the cases.

**3** Install the door slides. Hacksaw the cup pull screws to  $\frac{3}{16}$ " long and install the cup pulls. Have single-strength glass cut about  $\frac{1}{8}$ " smaller in height and width than the door rabbeted openings. Lay the glass in the doors and fasten the glass stops with #16x $\frac{3}{4}$ " wire brads. Set the brads and fill the holes with a matching putty stick. Apply a *thin* bead of clear silicone caulk to the backs of the mullions and press them into place. Allow the silicone to cure overnight.

**4** Set the lower cabinet away from the wall. Apply self-adhesive felt pads to the bottom of the upper cabinet, and place it on the lower cabinet, flush at the rear and centered side-to-side. Position  $\frac{5}{8}$ x3" mending plates, where shown on **Drawing 4**, drill pilot holes, and fasten the cabinets together. Move the cabinets against the wall. Install the shelf supports and shelves. Install the doors. Now roll the doors open and roll in the goods. 🌲

## Materials List

Case	FINISHED SIZE				Matl.	Qty.
	T	W	L			
A	sides	$\frac{3}{4}$ "	18"	36 $\frac{3}{4}$ "	BP	4
B	dividers	$\frac{3}{4}$ "	14 $\frac{7}{8}$ "	35 $\frac{1}{4}$ "	BP	2
C	divider bands	$\frac{3}{4}$ "	$\frac{3}{4}$ "	35 $\frac{1}{4}$ "	M	2
D	tops/bottoms	$\frac{3}{4}$ "	17 $\frac{3}{4}$ "	48"	BP	4
E	backs	$\frac{1}{4}$ "	36 $\frac{3}{4}$ "	48"	BP	2
F	shelves	$\frac{3}{4}$ "	14 $\frac{3}{4}$ "	23 $\frac{1}{8}$ "	BP	8
G	shelf bands	$\frac{3}{4}$ "	$\frac{3}{4}$ "	23 $\frac{1}{8}$ "	M	8
H	stiles	$\frac{3}{4}$ "	2 $\frac{1}{2}$ "	36 $\frac{3}{4}$ "	M	4
I	rails	$\frac{3}{4}$ "	$\frac{3}{4}$ "	43 $\frac{3}{4}$ "	M	4
J	door stops	$\frac{3}{4}$ "	1 $\frac{1}{4}$ "	35 $\frac{1}{4}$ "	M	4
K*	top	$\frac{3}{4}$ "	19 $\frac{1}{2}$ "	50 $\frac{1}{4}$ "	EM	1
<b>Base</b>						
L*	base sides	$\frac{1}{4}$ "	5"	19 $\frac{1}{2}$ "	LM	2
M*	base front	$\frac{1}{4}$ "	5"	50 $\frac{1}{4}$ "	LM	1
N	corner blocks	$\frac{3}{4}$ "	5"	5"	M	4
O	cleats	$\frac{3}{4}$ "	$\frac{3}{4}$ "	4"	M	4
<b>Doors</b>						
P	rails	$\frac{3}{4}$ "	2 $\frac{1}{4}$ "	23 $\frac{1}{8}$ "	M	8
Q	stiles	$\frac{3}{4}$ "	2 $\frac{1}{4}$ "	35 $\frac{1}{8}$ "	M	8
R	vertical mullions	$\frac{1}{4}$ "	1"	30 $\frac{5}{8}$ "	M	4
S	horizontal mullions	$\frac{1}{4}$ "	1"	18 $\frac{5}{8}$ "	M	8
T	vertical glass stops	$\frac{1}{4}$ "	$\frac{3}{8}$ "	31 $\frac{3}{8}$ "	M	8
U	horizontal glass stops	$\frac{1}{4}$ "	$\frac{3}{8}$ "	18 $\frac{5}{8}$ "	M	8
<b>Crown</b>						
V*	side bases	$\frac{1}{2}$ "	2"	19 $\frac{1}{4}$ "	M	2
W*	front base	$\frac{1}{2}$ "	2"	49 $\frac{3}{4}$ "	M	1
X*	side fillers	$\frac{3}{4}$ "	1 $\frac{3}{8}$ "	18 $\frac{7}{8}$ "	M	2
Y*	front filler	$\frac{3}{4}$ "	1 $\frac{3}{8}$ "	49"	M	1
Z*	side coves	1"	1 $\frac{1}{4}$ "	19 $\frac{7}{8}$ "	LM	2
AA*	front cove	1"	1 $\frac{1}{4}$ "	51"	LM	1
BB*	side caps	$\frac{3}{4}$ "	2 $\frac{3}{8}$ "	20 $\frac{1}{2}$ "	M	2
CC*	front cap	$\frac{3}{4}$ "	2 $\frac{3}{8}$ "	52 $\frac{1}{4}$ "	M	1

\*Parts initially cut oversize. See the instructions.

**Materials key:** BP—birch plywood, M—maple, EM—edge-joined maple, LM—laminated maple.

**Supplies:** #4x $\frac{5}{8}$ ", #8x1", #8x1 $\frac{1}{4}$ ", and #8x2" flathead wood screws; #8x1 $\frac{1}{4}$ " panhead screws; #10 flat washers; #0 and #20 biscuits; spray adhesive; single-strength glass; #16x $\frac{3}{4}$ " wire brads; putty stick to match the finish; clear silicone caulk;  $\frac{5}{8}$ x3" mending plates.

**Blades and bits:** Stack dado set;  $\frac{1}{4}$ " brad-point drill bit;  $\frac{3}{4}$ " and 30mm Forstner bits; 45° chamfer,  $\frac{1}{8}$ " round-over,  $\frac{1}{4}$ " round-over,  $\frac{3}{8}$ " round-over,  $\frac{1}{2}$ " round-over,  $\frac{1}{2}$ " bead,  $\frac{3}{8}$ " rabbet, and  $\frac{1}{2}$ " cove router bits.

## Source

**Hardware:** Shelf supports no. 63Z06.04, \$4.95 for a pack of 20 (one pack for each cabinet); sliding door hardware no. 00B10.26, \$11.50 per set (two sets for each cabinet); cup pulls no. 00A92.85, \$4.15 ea. (two for each cabinet); self-adhesive felt pads no. 93K87.01, \$1.20 for a sheet of 60 (one sheet); 30mm Forstner bit no. 06J12.30, \$5.60. Lee Valley Hardware. Call 800/871-8158, or go to [leevalley.com](http://leevalley.com).

Written by **Jan Svec** with **Chuck Hedlund**

Project design: **Kevin Boyle**

Illustrations: **Roxanne LeMoine**

## Cutting Diagram

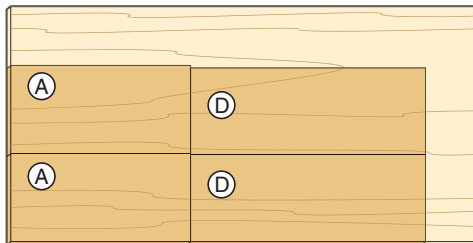
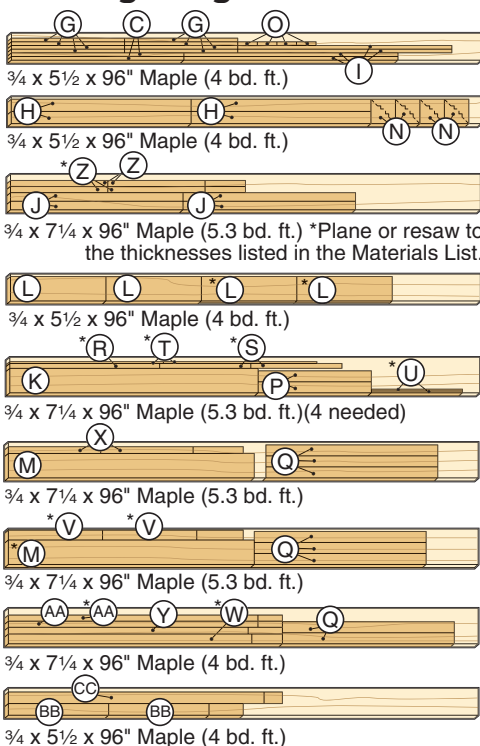

$\frac{3}{4}$  x 48 x 96" Birch plywood (2 needed)

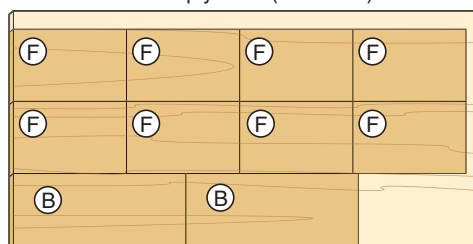

$\frac{3}{4}$  x 48 x 96" Birch plywood

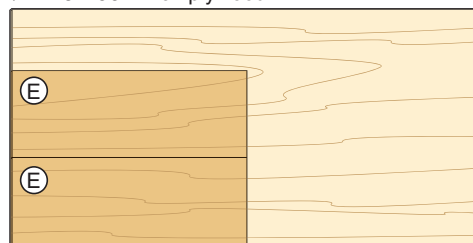

$\frac{1}{4}$  x 48 x 96" Birch plywood

# build flawlessly flat panels

(and keep them that way)

Making flat, stable panels from edge-jointed stock requires careful preparation and clamping. Even after the glue dries, there's work to be done.

Joining boards into a flat, wide panel seems trickier than herding cats when each piece acts determined to stray a different direction. Follow these steps, though, and you can tame even the stickiest glue-ups.

## Start with good wood

Begin with stock that's both straight-grained and consistent in its grain patterns, width, and moisture content. Avoid pieces already showing signs of twisting or cupping, and buy all of your wood in one trip to the lumberyard. That's the best way to mix and match complementary grain patterns and, when pieces are pulled from the same bundle,

ensure uniform moisture content. Bring a moisture meter to the store to check that the moisture content is 6–8 percent for hardwoods and 12–15 percent for softwoods.

Shop for boards with grain best suited for panels. When buying oak, for example, avoid flatsawn boards in favor of more stable, riftsawn or quartersawn lumber. The roughly parallel growth rings in riftsawn and quartersawn boards are less prone to cupping.

Culling through stacks of 6", 8", or even wider lumber in the store, it's tempting to buy wide boards for fewer joints. Don't. Wide boards conceal internal stresses that eventually will be released once your finished panel is exposed to changing humidity. Instead, buy boards in the 3–5" range, or rip wider boards to those widths.

Lumber fresh from the store needs to acclimate in your shop to adjust to the humidity and temperature there. So store dry lumber in your shop or home for more than three days before you machine it.

Start with stock that's about 1/8" thicker than needed

for your finished panel. You'll also want enough stock to lose 1/2" per board in width and an extra 2" long so the panel ends can be cut straight and square.

**Note:** When you dimension stock for extra-wide panels you'll assemble in stages, leave an extra 1/16" thickness for planing the individual sections (in addition to the extra 1/8" mentioned earlier).

## Machine the stock

Make the faces and edges of individual boards straight, square, and parallel with each other using this four-step approach:

- 1 Flatten one face using your jointer.
- 2 Use a thickness planer to make the opposite face parallel to the jointed face. Reduce the board to the desired thickness.
- 3 Returning to your jointer, square and straighten one edge.
- 4 At your tablesaw, rip a parallel edge. If necessary, smooth it with a light pass through your jointer.

Machine the stock and build the panel in one session, whenever possible. Glue-up delays allow freshly machined stock time to warp as newly exposed surfaces absorb or release moisture.





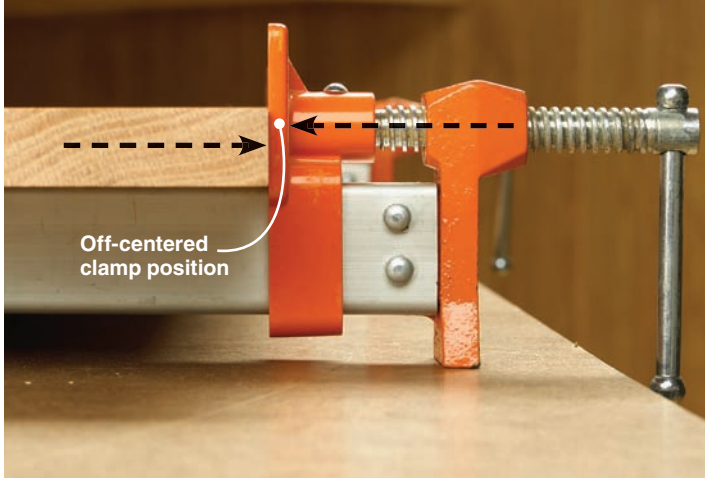

**THE PROBLEM: MISALIGNED CLAMP PRESSURE**

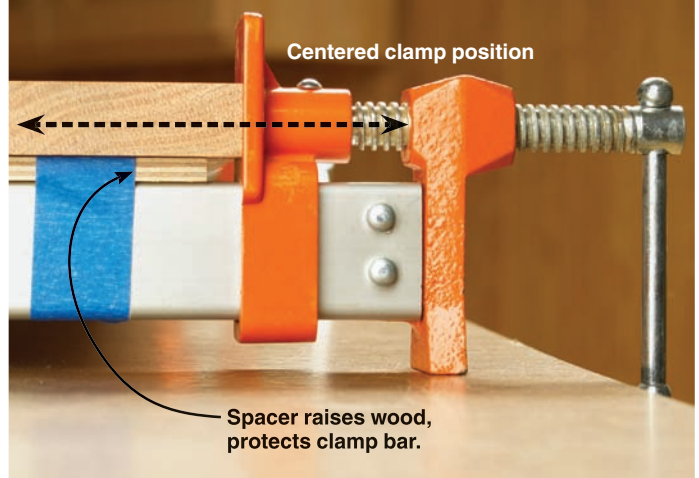

**THE SOLUTION: CENTER CLAMPING PRESSURE**

## Prepare to clamp

Boost your chances of success by starting with plenty of clamps and a flat, solid work surface. If you use clamps that support the workpiece on the clamp bars, you still need to align the clamping screws so they're centered on the thickness of the boards.

To fix the misalignment, cut spacers 1" wide and nearly as long as the panel width. Cover the top of the spacers with packing or masking tape so squeeze-out won't stick to the spacers, and attach them to every bar or pipe clamp, as shown *above right*. Squeeze-

out won't bond to metal parts, but it can cause some metals to discolor wood. If you don't need spacers, run a strip of tape along the clamp to keep glue from sticking to it. (Pull off this tape when you're finished.)

Are your boards still unwieldy? Consider one of the edge joints in "Popular Edge-Alignment Joints for Flat Panels" on *page 54* to bring them under control.

Joining too many boards too quickly causes problems. In the following steps, we're building a 19"-wide panel in one glue-up of four

boards. When building a wider panel or working with more than six joints, break the glue-up into stages. Edge-gue two to four boards into a blank. Repeat the process until you have enough blanks for the panel. Keep each blank narrow enough to fit through your thickness planer, and skim both faces of the sections to remove minor unevenness at the joints.

With your sections glued and planed, edge-gue them together to form the complete panel.

# A 5-step clamping plan to squeeze out errors

**1 Apply glue and begin clamping.** Ideally, all clamps would elevate your boards the same distance off your benchtop and apply uniform pressure. Most real-world workshops, however, house a hodgepodge of clamp sizes and styles. That's a problem when these clamps have jaws that sit at different heights above your benchtop.

One solution is to support your stock on squared blocks, as shown *below left*. Then raise or lower clamps individually to apply

pressure to the center of your stock's edge. Clamps of various types also produce different clamping pressures along the glue-up. Solve this problem by applying glue evenly along the joints and gauge clamping pressure according to the amount of squeeze-out.

Now you're ready to position clamps 20" apart beneath your stock, and double-check the grain alignment or assembly order of your pieces. Spread yellow glue evenly on

the edges to be joined. If you apply glue to just one edge, slide the boards back and forth to distribute the glue on both pieces. Press the boards together and tighten the end horizontal pipe or bar clamp until snug, but not too tight. Place small sliding-head clamps vertically on each joint line at that end, as shown *below right*, and tighten them to hold the boards flush. Return to the horizontal clamp closest to the vertical clamps and tighten it with moderate pressure.

## RAISE YOUR WORK WITH SQUARED BLOCKS

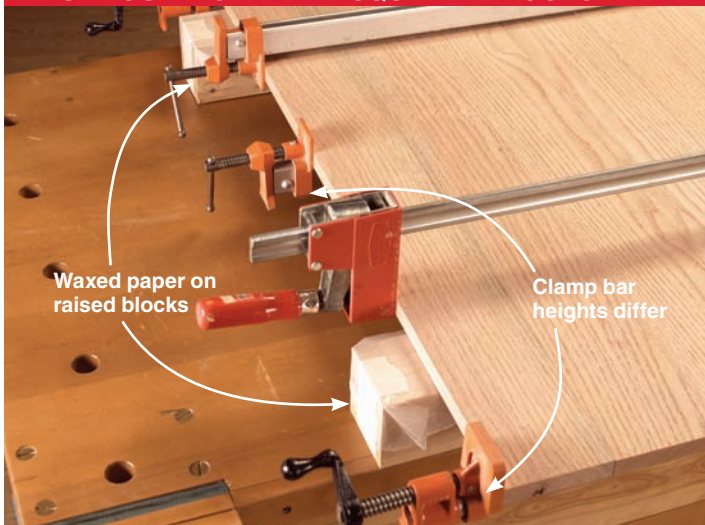

## CLAMPS HOLD JOINTS FLAT AT ENDS

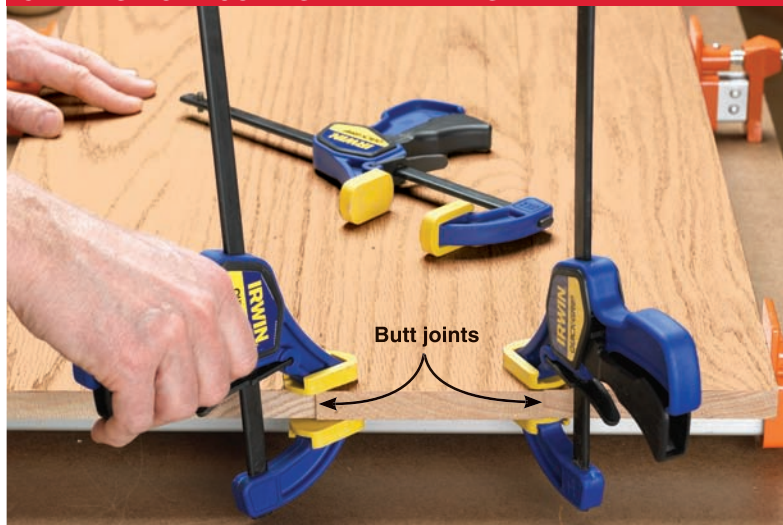





**SPACE HORIZONTAL CLAMPS 10" APART**

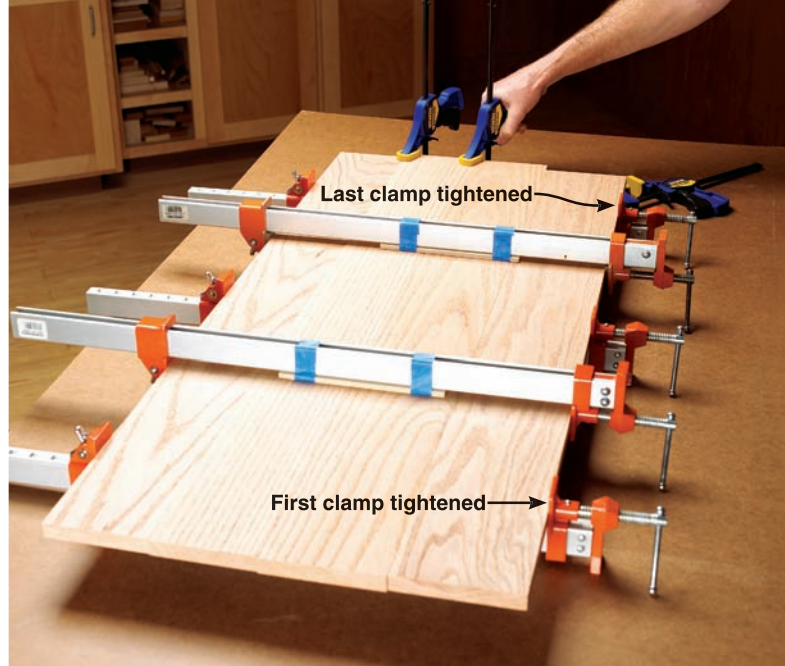

**MOVE JOINT CLAMPS TO THE OPPOSITE END**

**2 Alternate clamp position.**

Move 10" down the panel and place a horizontal clamp on top of the glue-up, as shown *above left*, to compensate for any slight off-center pressure from the clamp heads. Feel the joint lines between this horizontal clamp and the first one to make certain the board surfaces are flush and flat. Force high spots down using hand pressure or taps from a non-marring dead-blow mallet and then tighten the clamp. Proceed down the length of the panel, adding clamps at regular intervals, tightening each top or bottom clamp in order.

**3 Align the other end.**

Horizontal clamp pressure now holds the starting end in place, so move the sliding-head clamps to the joint lines at the

opposite end of the panel, as shown *above right*. Tighten the final bar clamp.

After five minutes, remove the sliding-head clamps to let the glue dry in those spots. After the squeeze-out becomes rubbery (usually within a half hour), remove it from both faces with a sharp paint scraper or putty knife. Leave the horizontal clamps in place for at least an hour.

**4 Keep panel centers aligned.**

If edge joints at the center of your panel prove tough to keep flat, add wooden straightedges, as shown *below left*. Apply clear plastic packing tape on edges touching the panel. Now check for flatness with a metal straightedge.

**5 Sand and cut to size.**

After the glue dries, remove the clamps

and double-check the joint lines. If you find any slightly uneven spots, smooth them with a cabinet scraper or a random-orbit sander equipped with 80-grit abrasive, as shown *below right*. Work the panel's entire surface, not just the trouble spot, to avoid creating low areas that show up after finishing. Finally, rip the panel to final width and crosscut it to length. For best results, use a crosscutting sled on your tablesaw.

For panels more than 24" wide, trim the ends with a circular saw and a straightedge guide instead of making an awkward cut on the tablesaw. If your circular saw leaves an unacceptably rough edge, clean it up using the straightedge and a router-mounted straight bit, taking a light cut.

**USE STRAIGHTEDGES TO ENSURE FLAT PANELS**

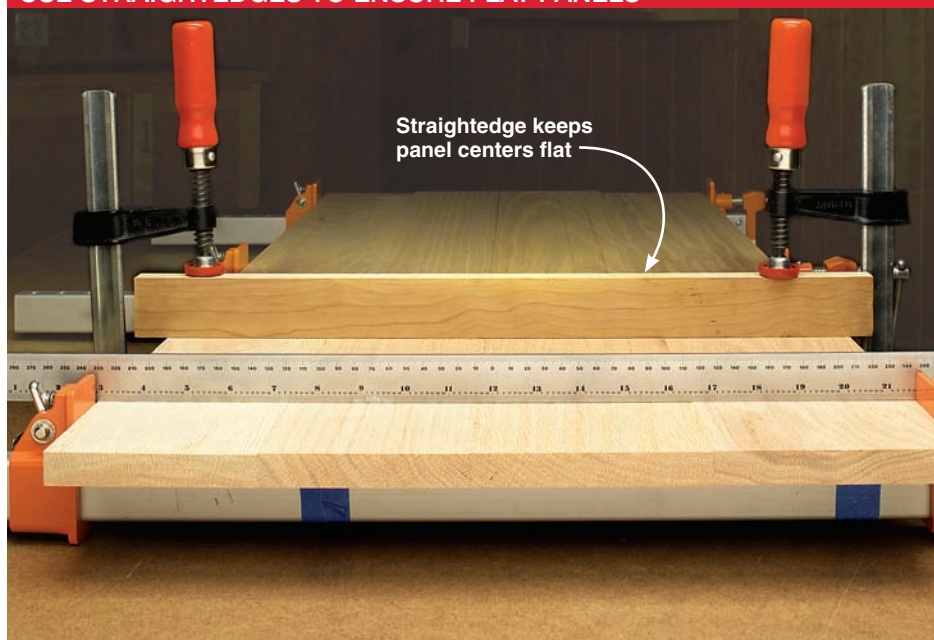

**SANDING FLATTENS MINOR ERRORS**





# Popular Edge-Alignment Joints for Flat Panels

joint type	biscuit	dowel	spline	tongue-and-groove	V-joint
what's involved	Biscuits hold pieces in position during glue-up and reinforce joints for added strength. Placing the biscuit slots accurately is easy. Allow glued joints to dry thoroughly before sanding.	Dowels inserted at regular intervals align surfaces for glue-up. Use spiral or fluted dowels to expel glue and trapped air that could push joints apart. Dowels must be aligned dead-on for pieces to slip together.	This easy-to-make joint requires just a tablesaw to make both the splines and grooves. Splines can be left visible on the ends, or stopped short of the end to conceal the joint (requires a stopped spline cut).	Create this simple joint using a tablesaw with a dado set or a table-mounted router with a straight or spiral bit. Use feather boards on your saw or router table to control long pieces and make consistent cuts.	A V-joint router bit creates ridges that increase the glue bonding surface and keep joints flat. Use feather boards to control long pieces. Don't use this on a raised panel—you'll wind up with wavy lines at the joints.

## Now keep them flat

Just because you've created an absolutely flat panel doesn't mean it will stay that way if it's not incorporated into your project correctly.

For the same reasons that raised panels aren't glued in place in a door frame, solid wood panels used in other applications need freedom to expand and contract when temperature and humidity change. In the case of our stacking cabinet on *page 42*, for example, the panel created to form the top is screwed firmly in place along one side. On the other side, though, the screws holding the panel to the carcass ride in a slot, as shown at *right, top left*.

To keep panels stable and warp-free for the long haul, try these solutions:

- When attaching cleats to wood panels that will be in motion—the lid of a blanket chest, for example—use a simple trick, shown at *far right, top*, for an assembly that looks solid but allows wood to move. Screws should be just tight enough to hold the cleat against the panel. Don't glue cleats directly to the panel.

- Fasten wide panels in place using hardware that allows the panel to move, as shown at *right*. Figure-8 connectors rotate slightly within their recess as the wood moves, while expansion washers (*far right*) create a smooth surface on which the mounting screw can slide. You can find both at Lee Valley Tools (800/871-8158 or [leevalley.com](http://leevalley.com)).

- Consider where your project will be used. A cabinet in a steamy bathroom must endure greater humidity extremes than a blanket chest in an adjoining bedroom. Doubling the thickness of your film finish won't totally block this moisture, but it will help moderate the humidity's impact on wood.

## 4 WAYS TO ALLOW FOR EXPANSION IN SOLID WOOD TOPS

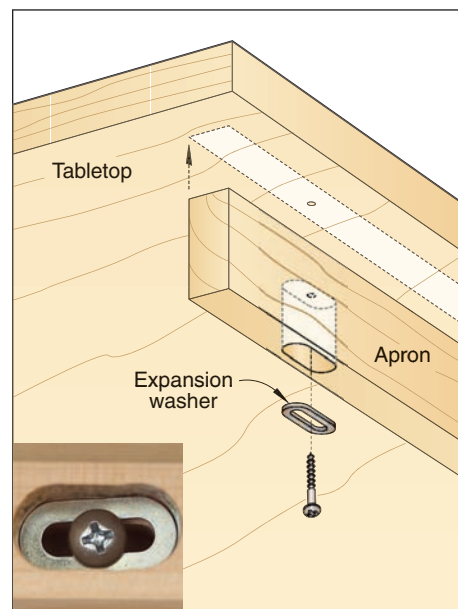
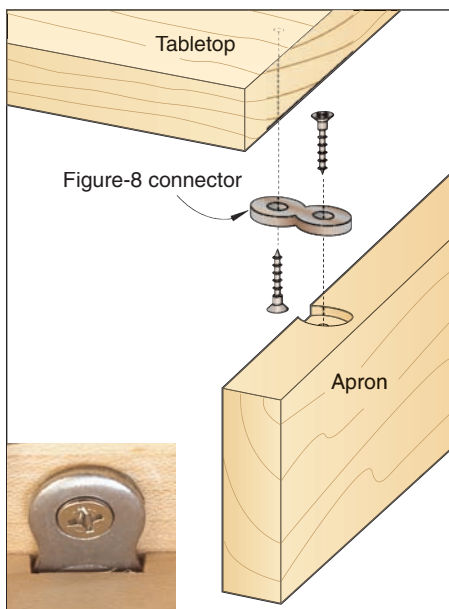
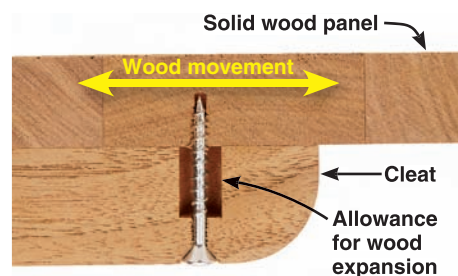
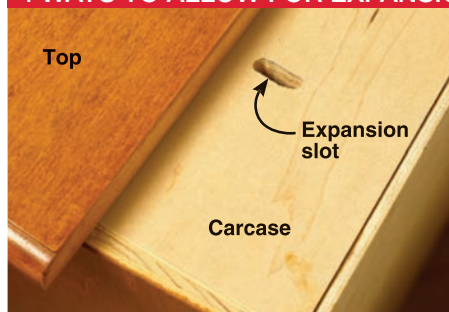

- Finish both faces of a panel plus the ends and edges. This is especially important with film-forming finishes, such as polyurethane, which do a better job of repelling moisture than oil finishes. Otherwise, a panel gains

moisture more quickly from one side than the other, causing it to warp. Only extremely thick finishes, such as two-part, poured-on bartop or countertop finishes, completely block moisture. 🌳

# WOOD PATTERNS®

June/July 2005

Issue 163

Paper-Towel Holder, Page 38  
Sliding-Door Cupboard, Page 42  
Bathroom Cabinets, Page 67  
Arched Trellis, Page 82

Dear Reader: As a service to you, we've included full-size patterns on this insert for irregular shaped and intricate project parts. You can machine all other project parts using the Materials List and the drawings accompanying the project you're building.

© Copyright Meredith Corporation, 2005. All rights reserved. Printed in the U.S.A. Meredith Corp., the publisher of *WOOD Patterns*® allows the purchaser of this pattern insert to photocopy these patterns solely for his/her own personal use. Any other reproduction of these patterns is strictly prohibited.

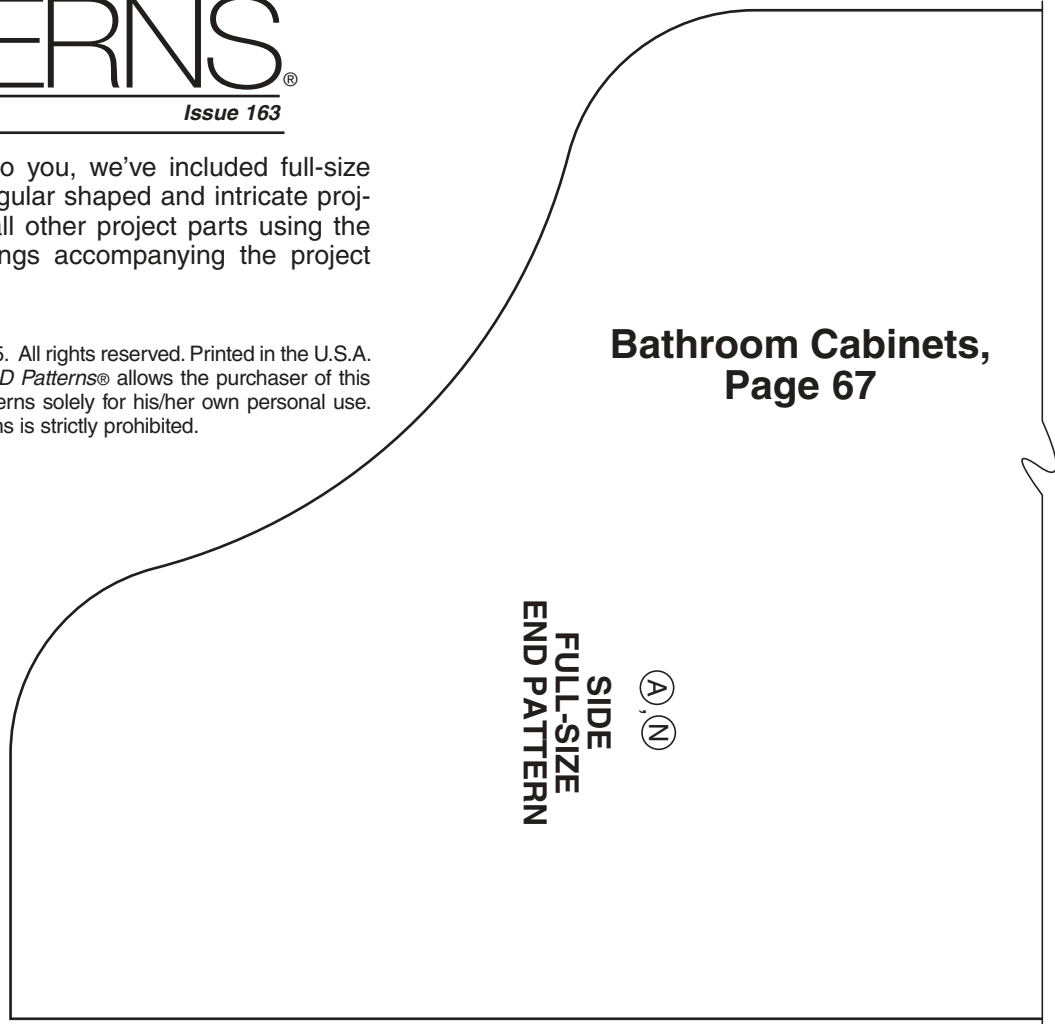

## Sliding-Door Cupboard, Page 42

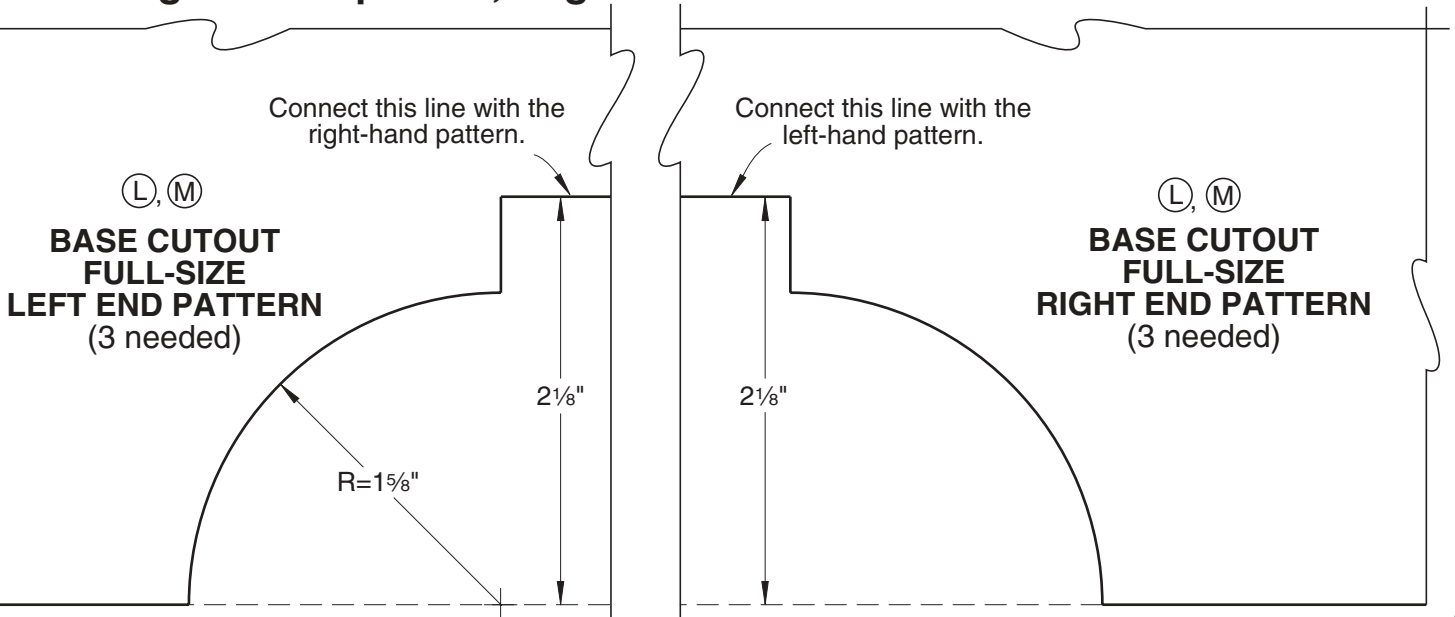



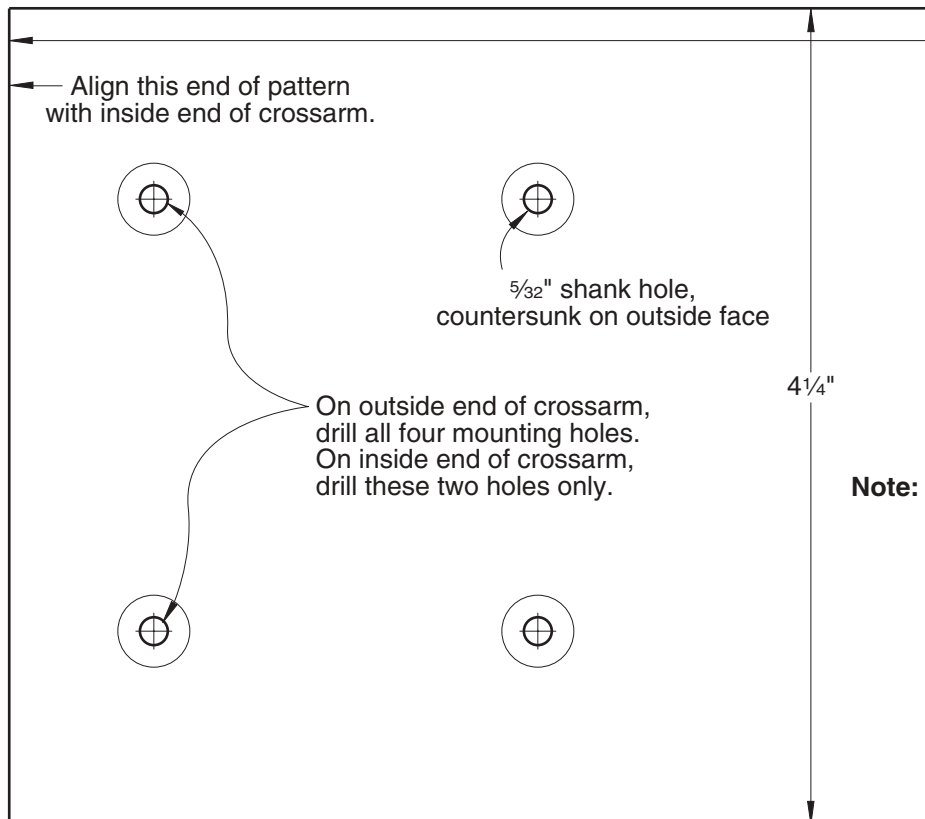
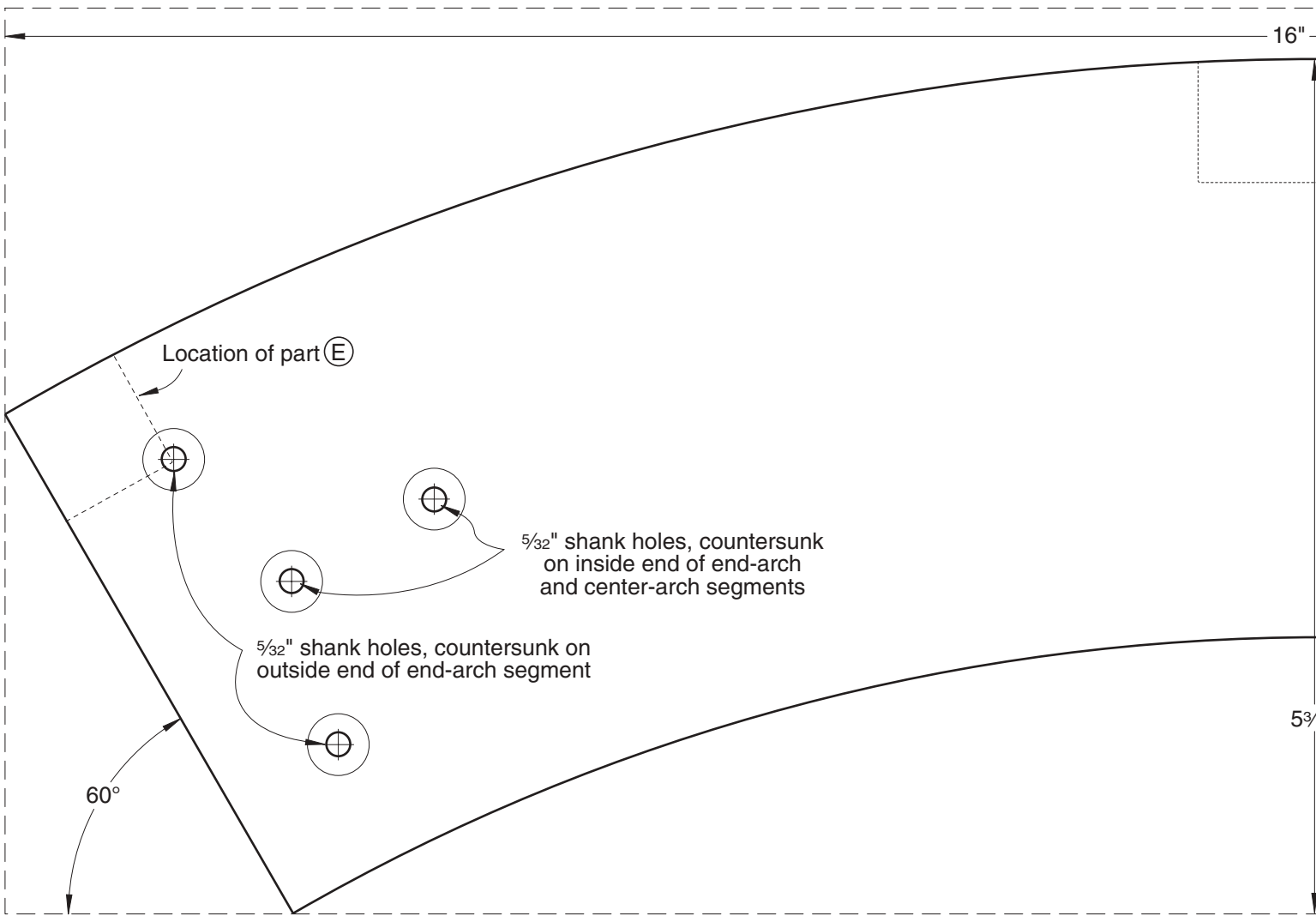

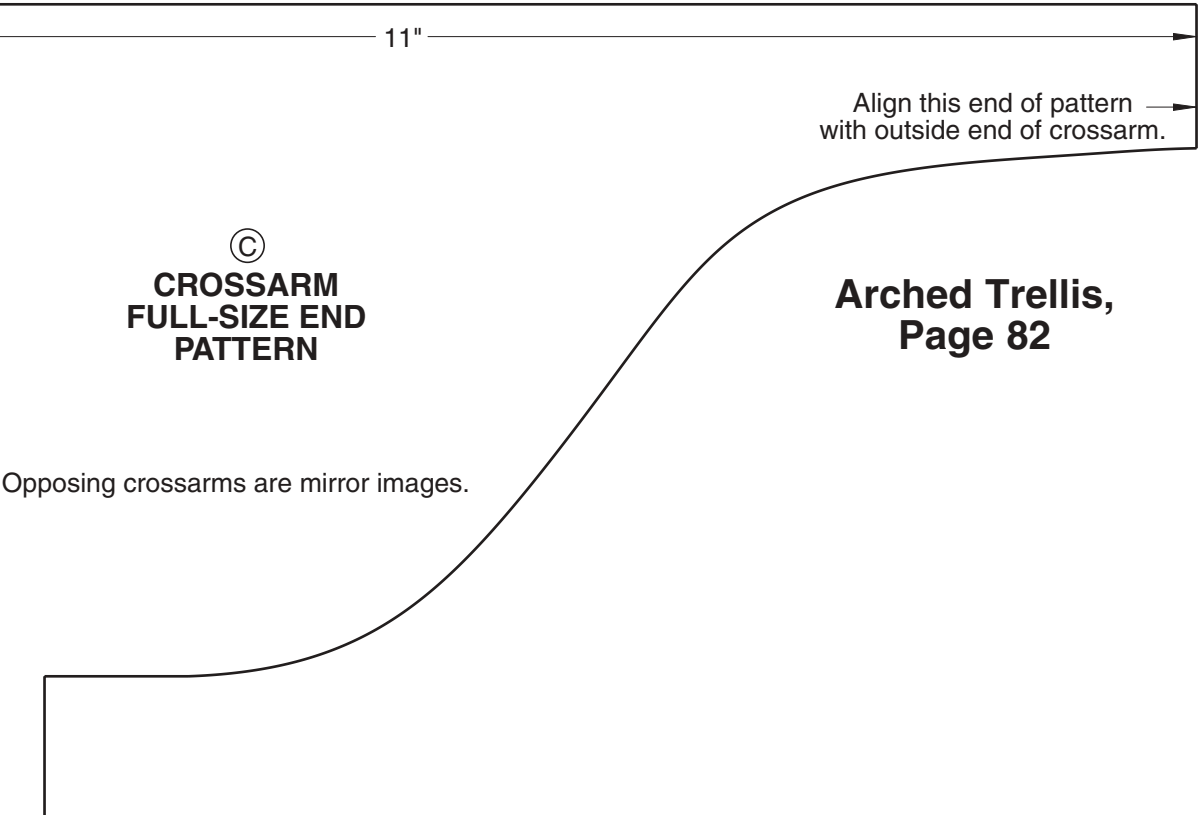
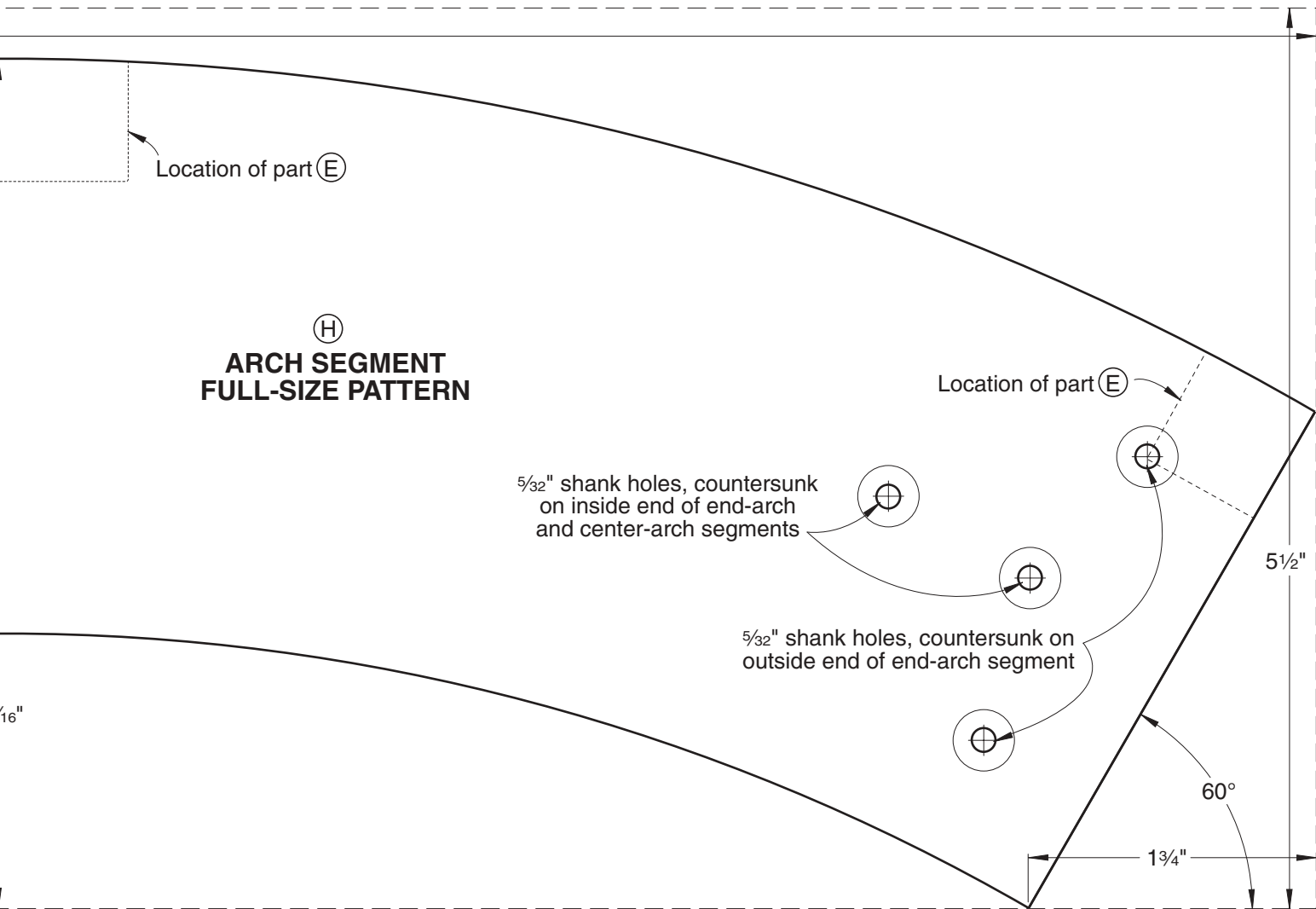

Opposing crossarms are mirror images.

**Arched Trellis,  
Page 82**



Paper-Towel Holder,  
Page 38

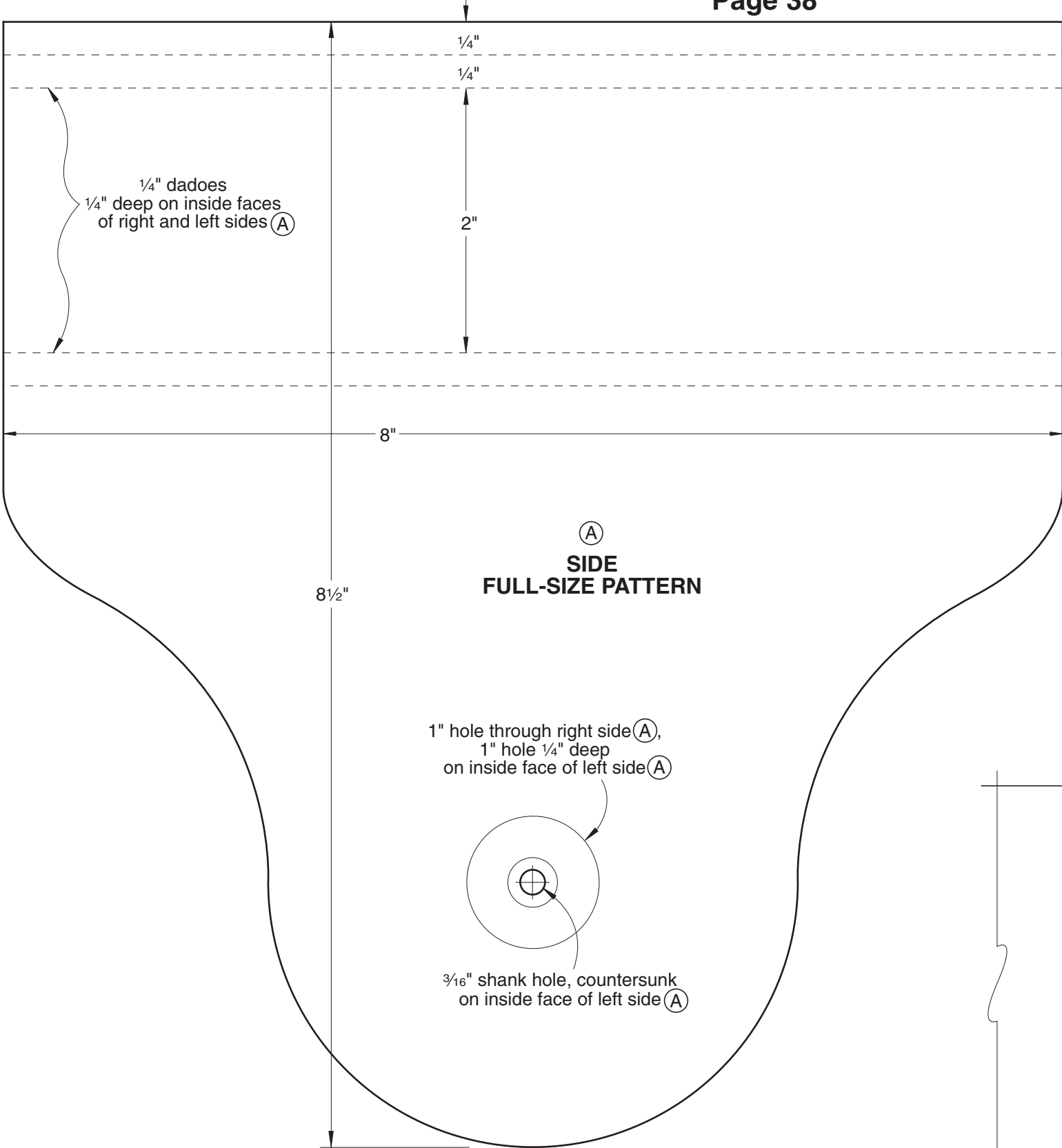

# 6 ways to beef up a workbench

Few workshop items hold as much raw potential as your bench. Here's how to tap into its full usefulness.

## Six-pack of upgrades

- 1 50 pounds of added weight for stability
- 2 Three tool totes
- 3 Three wide drawers for tools and plans
- 4 Paper roll holder for protecting the top from finish spills.
- 5 Surge protector power strip for tools and plans
- 6 Glue-up clamp holder

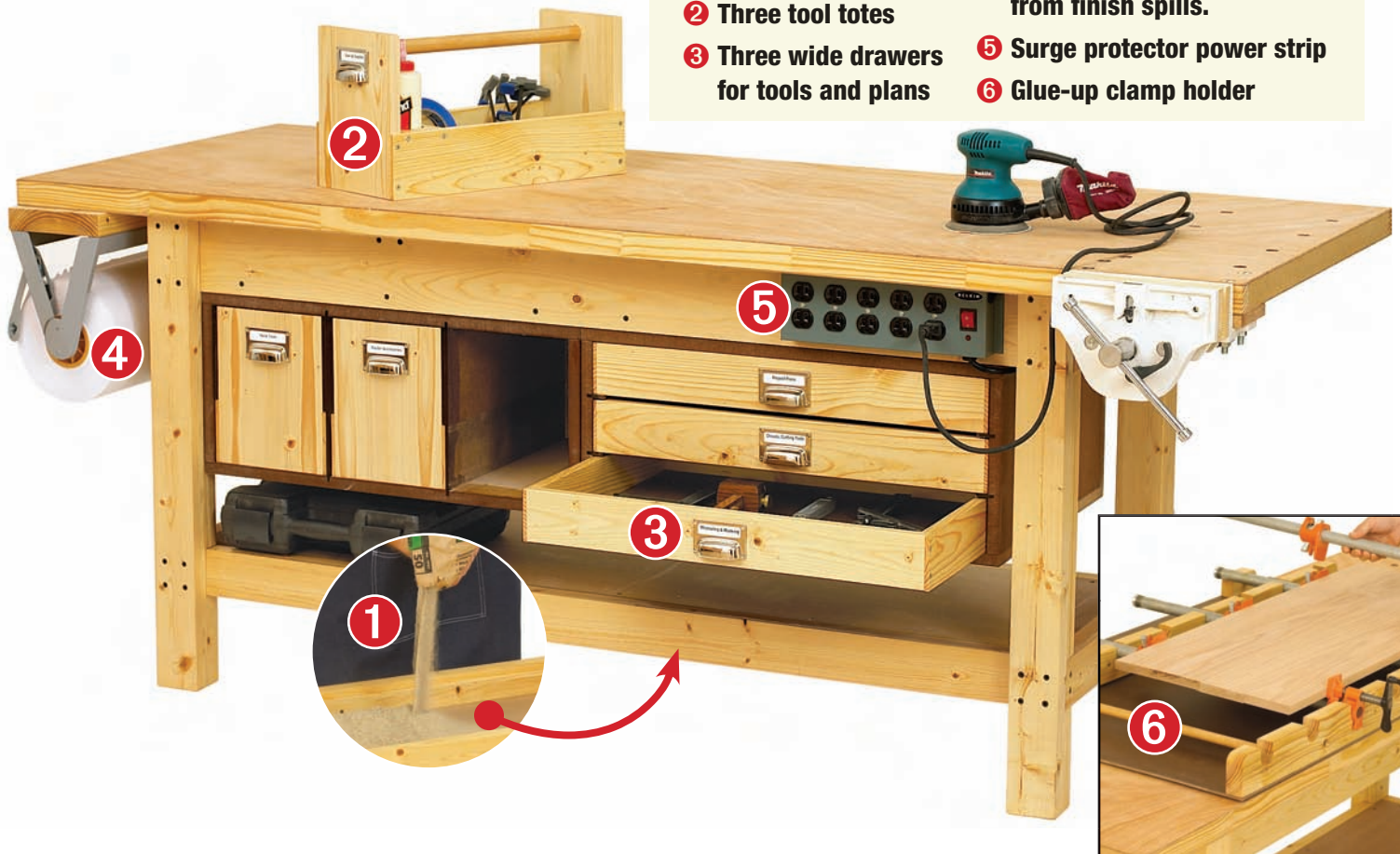

**L**ike a tablesaw without a dado blade, sliding cutoff table, or other helpful add-ons, a bare-bones workbench is a workshop staple that becomes several times more helpful after you accessorize it. So you can understand why we couldn't let our basic workbench, shown at *right* and detailed on *page 14*, stay basic for long.

For starters, we supplemented the base with a hefty, solid-core door top and an affordable 9" quick-release vise. We drilled

holes into the top for bench dogs to increase the vise's holding capacity.

That still left plenty of ways to make our bench more accommodating, versatile, and solid. After all, workbenches earn their place at the heart of your shop because they're multipurpose tools for everything from gripping a delicate carving to providing a level slab for assembling furniture. With these add-ons, you'll make your bench ready for nearly anything.

## START WITH A BASIC BENCH



See construction plans on *page 14*.



## Upgrade 1: Add weight for stability

Maybe you've been there: With a workpiece clamped in your vise, you muscle a plane down a board edge, causing the bench to go for a little walk.

Workbenches, unlike woodworkers, can't be too weighty when push comes to shove. True, the MDF lower shelf and solid-core benchtop add heft, but more weight means more stability. For the price of a 50-pound bag of sand and a second piece of  $\frac{3}{4}$ " MDF cut to  $16 \times 57$ ", you can turn a bantam bench base into a heavyweight.

The cleats inside the lower rail that support the shelf also brace the second MDF sheet holding your ballast in place. To make the job easier, remove the benchtop before you turn the frame upside down. Then pour the sand into the shallow tray formed by the shelf and lower rail cleats, as shown at *right*. Spread the sand evenly, keeping it off the tops of the cleats.

Test-fit the shelf bottom to ensure a leak-free fit. Then drill and countersink screw holes. Run a thick bead of glue along the top of the cleats, lay the shelf bottom within the frame and secure it with  $\#8 \times 1\frac{1}{8}$ " wood screws. Allow the glue to dry before turning the bench back on its legs.

The cavity beneath the shelf holds an entire 50-pound bag of sand. Adding weight down low helps keep the bench from becoming top-heavy.



## Pick a benchtop that meets your needs

Because of its hardness and weight, a shop-made maple butcher-block top is the ultimate work surface, but it's also costly and time-consuming to make. Here are some sturdy, time-saving options:

**Solid-core door.** The door used atop the bench at *left* has a  $1\frac{1}{2}$ " medium-density fiberboard (MDF) core between  $\frac{1}{8}$ " lauan skins. With pine trim strips on the sides, though not the ends, the door is 30" wide by 80" long. Doors save time because they come cut to size and ready to finish. We bought this one at a home center for \$43. You also can find discounted returns and seconds at lumberyards and millwork stores.

### Medium-density fiberboard.

Glue together two pieces of  $\frac{3}{4}$ " MDF, and trim the edges flush. To avoid damaging the edges, glue maple trim strips to all four. By making the trim strips  $\frac{1}{4}$ " higher than the top surface of the panels, you can lay a sheet of  $\frac{1}{4}$ " tempered hardboard atop the MDF to create a durable, easy-to-replace work surface. Drill a 1"

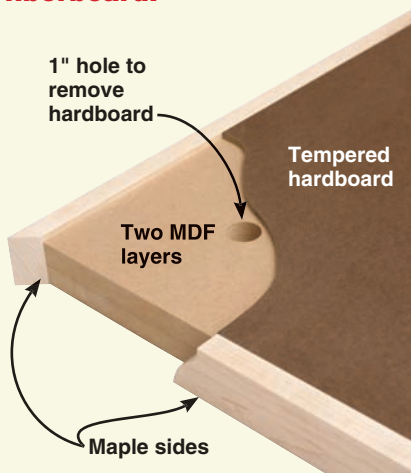

hole into the MDF to push the hardboard away from the benchtop before dropping in a fresh piece. A 30"-wide top can't be made from a single  $48 \times 96$ " sheet, which cost us about \$23 locally, but you can use the leftover pieces from two sheets to make the  $16 \times 57$ " lower shelf and a cap for adding sand to anchor the bench. An advantage of this material is that it provides a dead-flat surface and plenty of much-needed weight. However, it doesn't have plywood's resistance to breaking, especially if weight is applied to the overhanging areas of the benchtop.

**Plywood.** Glue two  $\frac{3}{4}$ "-thick pieces together, and trim the edges square with the surface. Then add trim strips and a tempered hardboard top, as with the MDF. You'll need two sheets of plywood to make this top. One  $4 \times 8$ ' sheet of  $\frac{3}{4}$ " BC pine plywood cost us \$25. Plywood is a durable choice, but is not as consistently flat as MDF.

### Manufactured butcher block.

Want the butcher-block look without the work? Buy a prefabricated maple top. A  $1\frac{3}{4} \times 30 \times 96$ " top that can be trimmed to fit this bench is \$235, plus \$58 shipping, from Grizzly Industrial, 800/523-4777 or grizzly.com.



## Upgrade 2: Tool totes that stow or go

If a project can't come to your tools, take your tools to the project in these easy-on, easy-off tool totes.

### Build the tool tote case

**1** From  $\frac{3}{4}$ " MDF, cut the top and bottom (A), sides (B), and back (C) to the dimensions on the **Materials List**. (The tool totes share the same size cases as the drawers on page 63. If you plan to build both, save time now by doubling the number of tops, bottoms, sides, and backs that you cut.)

**2** Cut two pieces of  $1\frac{1}{2}$ " square stock (D) to a length of  $26\frac{3}{8}$ " to hang the case from the workbench frame. Next, make the dividers (E) and retainers (F) from  $\frac{1}{4}$ " hardboard. Use hardboard that's smooth on two sides, or you can substitute  $\frac{1}{4}$ " MDF.

**3** Cut  $\frac{1}{4}$ " grooves  $\frac{3}{8}$ " deep, where shown in the top and bottom (A).

**4** From a scrap of  $\frac{3}{4}$ " MDF, cut a strip that's  $\frac{3}{4}$ " wide by 18". Cut a  $\frac{1}{4}$ " groove  $\frac{3}{8}$ " deep along one face to use as a guide. Place the guide on the top edge of the dividers (E) to serve as a  $\frac{3}{8}$ " spacer. Now, glue and



Temporary support blocks

### Tool Tote and Case Materials List

Case	FINISHED SIZE			Matl.	Qty.
	T	W	L		
A bottom/top	$\frac{3}{4}$ "	19"	$26\frac{3}{8}$ "	MDF	2
B sides	$\frac{3}{4}$ "	$10\frac{1}{16}$ "	$18\frac{1}{4}$ "	MDF	2
C back	$\frac{3}{4}$ "	$10\frac{1}{16}$ "	$26\frac{3}{8}$ "	MDF	1
D cleats	$1\frac{1}{2}$ "	$1\frac{1}{2}$ "	$26\frac{3}{8}$ "	C	2
E dividers	$\frac{1}{4}$ "	$10\frac{3}{16}$ "	$18\frac{1}{4}$ "	HB	2
F retainers	$\frac{1}{4}$ "	6"	$18\frac{1}{4}$ "	HB	6
<b>Tool totes (3)</b>					
G tool tote ends	$\frac{3}{4}$ "	$7\frac{1}{2}$ "	10"	C	6
H tool tote sides	$\frac{3}{4}$ "	4"	$18\frac{1}{4}$ "	C	6
I tool tote handles	1" diam.	$17\frac{3}{4}$ "		B	3
J tool tote bottoms	$\frac{1}{4}$ "	7"	$17\frac{1}{4}$ "	HB	3
K glue divider	$\frac{3}{4}$ "	4"	$6\frac{1}{2}$ "	C	1†

†Quantity will vary with your glue storage needs.

**Materials key:** MDF—medium density fiberboard; HB—hardboard; B—birch; C—choice of spruce, pine, or fir.

**Supplies:** #8x $1\frac{1}{2}$ ", #8x2", #8x $2\frac{1}{2}$ " flathead wood screws.

**Blades & Bits:** Stack dado set,  $2\frac{1}{2}$ " and  $\frac{3}{4}$ " drill bits

**Hardware:**  $3\frac{1}{4}$ x2" card-frame pull (01A5765 (3), \$4.30 each; Lee Valley Tools, 800/871-8158 or leevalley.com

clamp on the retainers (F) to the dividers where shown. Glue the retainers (F) to the cabinet sides (B), aligning them flush on each end and flush on the top edges.

**5** Attach the cleats (D) to the top of the tool tote case, where shown in the drawing.

**6** Glue and screw the case together. We finished the case and totes with Watco Danish Oil. When attaching the case to the bench, use blocks like those shown above to support the case while driving screws through the bench and into the cleats.

### TOOL TOTES AND CASE

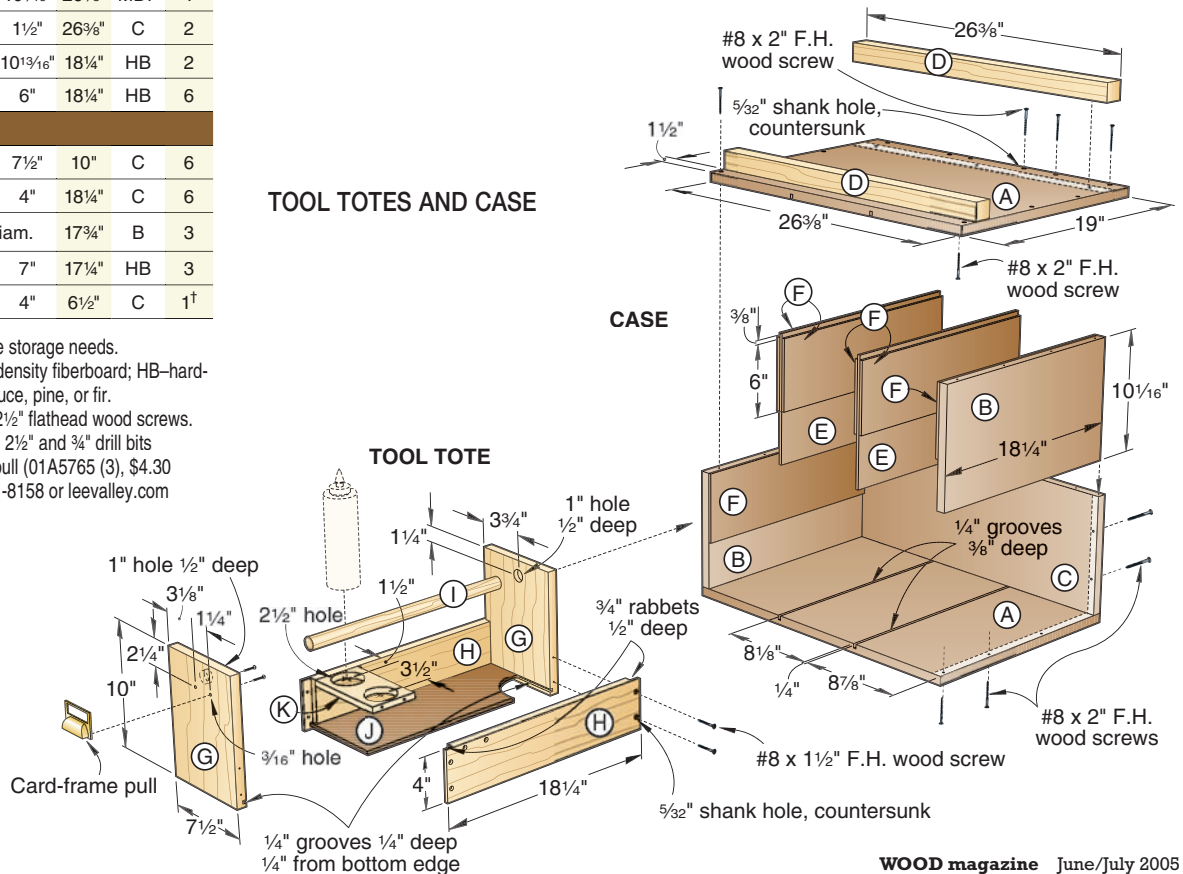



## On to the tool totes

**1** From  $\frac{3}{4}$ "-thick pine, cut the tool tote ends (G) and sides (H) to the dimensions in the **Materials List** on page 62. Cut  $\frac{1}{4}$ " grooves  $\frac{1}{4}$ " deep and  $\frac{1}{4}$ " from the bottom edge of the sides and ends to hold the drawer bottoms (J). Cut the bottoms to size.

**2** Cut  $\frac{3}{4}$ "-wide rabbets  $\frac{1}{2}$ " deep on each end of the sides. For the tote to fit the case, its width should be  $\frac{1}{16}$ " narrower than the case opening, and the sides should be  $\frac{1}{16}$ " less than the openings between the case

bottom (A) and the lower edges of the drawer retainers (F).

**3** Drill a 1"-diameter hole where shown for the handle (I) on each of the tote ends. Now, glue and screw the tool totes together, as shown in the drawing.

**4** For the optional glue dividers (K), cut the number desired to the dimensions shown, and drill holes to fit the bottles. (The  $2\frac{1}{2}$ "-diameter holes fit the diameter of common 16-ounce glue bottles.) Attach the glue dividers as shown.



**5** Sand all parts to 150 grit, and apply two coats of Watco Danish Oil. Then drill two  $\frac{3}{16}$ " holes where shown, and attach the drawer pulls, as seen above.

## Upgrade **3**: Stacking drawers for special storage

These stacking drawers store tools you need to protect but still use every day: measuring instruments and chisels to name a few.

### Build a tool drawer case

**1** Cut  $\frac{3}{4}$ " MDF to the dimensions given in the **Materials List** to make the top and bottom (A), sides (B), and back (C).

**2** Cut  $\frac{1}{4}$ " grooves  $\frac{3}{8}$ " deep on the sides (B), where shown.

**3** Now cut  $\frac{1}{4}$ " hardboard glides (D) to size. Glue and clamp the drawer glides to the sides (B) so that the ends are flush.

**4** Next, glue and screw the case together, as shown in the drawing.

**5** Attach the cleats (E) to the top of the case, as shown.



Tool drawers can be built with a single open space or divided into compartments.

### Assemble the three drawers

**1** From  $\frac{3}{4}$ " pine, cut the drawer fronts and backs (F) and sides (G) to size. Cut a  $\frac{1}{4}$ " groove  $\frac{1}{4}$ " deep, where shown.

**2** Cut  $\frac{3}{4}$ " rabbets  $\frac{1}{2}$ " deep on both ends of the drawer sides. Drill  $\frac{5}{32}$ " countersunk

pilot holes  $\frac{3}{4}$ " from the edges where shown.

**3** Cut the drawer bottoms (H) from  $\frac{1}{4}$ " hardboard. Glue and screw the drawers together, as shown in the drawing. Allow the drawer bottom to float loose within the slots.

**4** Sand all parts to 150 grit, and apply two coats of Watco Danish Oil finish.

**5** Drill two  $\frac{3}{16}$ " holes into the fronts (F), and attach the drawer pulls.

**6** Attach the completed case to the underside of the bench rails using  $2\frac{1}{2}$ " wood screws, similar to the way the toolbox case was installed on page 62.

### THREE-DRAWER CASE

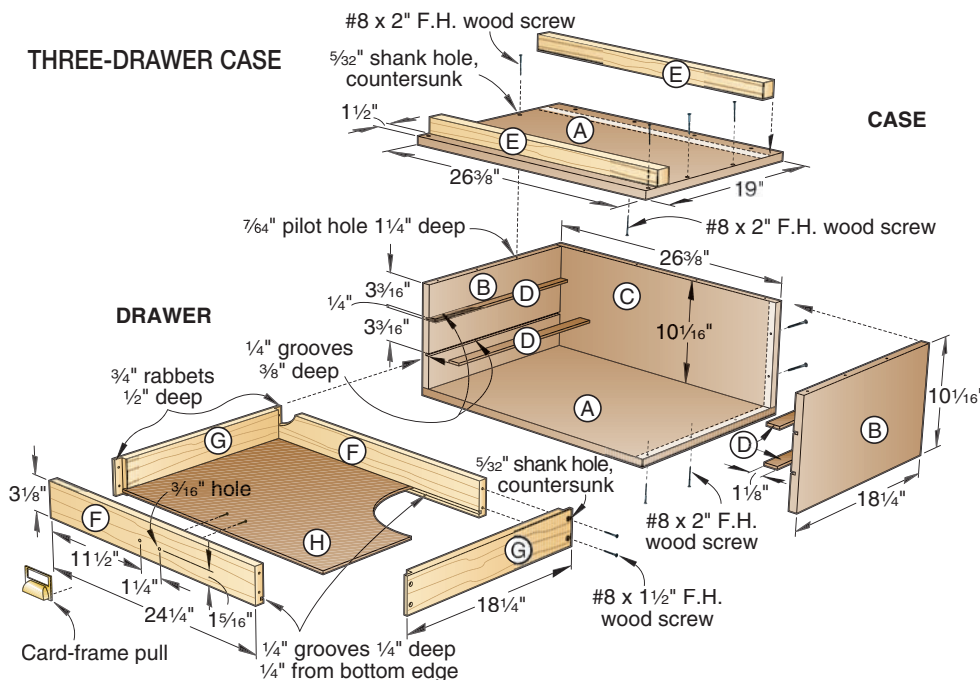

### Three-Drawer Case Materials List

Case	FINISHED SIZE			Matl.	Qty.
	T	W	L		
A bottom/tops	3/4"	19"	26 3/8"	MDF	2
B sides	3/4"	10 1/16"	18 1/4"	MDF	2
C back	3/4"	10 1/16"	26 3/8"	MDF	1
D glides	1/4"	1 1/8"	18 1/4"	HB	4
E cleats	1 1/2"	1 1/2"	26 3/8"	C	2
<b>Drawers (3)</b>					
F drawer fronts/back	3/4"	3 1/8"	24 1/4"	C	6
G drawer sides	3/4"	3 1/8"	18 1/4"	C	6
H drawer bottoms	1/4"	17 3/4"	23 3/4"	HB	3

\*Parts initially cut oversize. See the instructions.

**Materials key:** MDF—medium density fiberboard, HB—hardboard, C—choice of spruce, pine, or fir.

**Supplies:** #8x1 1/2", #8x2", #8x2 1/2" flathead wood screws.

**Blades & Bits:** Stack dado set.

**Hardware:** 3/4x2" card-frame pulls (3) (01A5765, \$4.30; call Lee Valley Tools, 800/871-8158 or go to [leevalley.com](http://leevalley.com)).

## Upgrade 4: Add benchtop protection

Seeking a way to protect your bench during finishing work? Add the 30"-wide paper roll holder, shown at *right*, to the underside of your overhanging benchtop.

The only part you need to make is a block to mount the metal roll holder (see Sources) to the bench. We cut ours from a 2x8 with the factory edges removed, as shown in the drawing. After sanding the block to 150 grit, apply two coats of Watco Danish Oil.

Now, center the roll holder on the mounting block, and attach it using #8x1¼" panhead screws. Drill countersunk pilot holes in the mounting block. Then center and attach the paper roll holder to the bench. Expect the mounting block to extend about 1" past the edge of the workbench on the front and back. Insert the paper roll as directed in the manufacturer's instructions.

### PAPER ROLL HOLDER

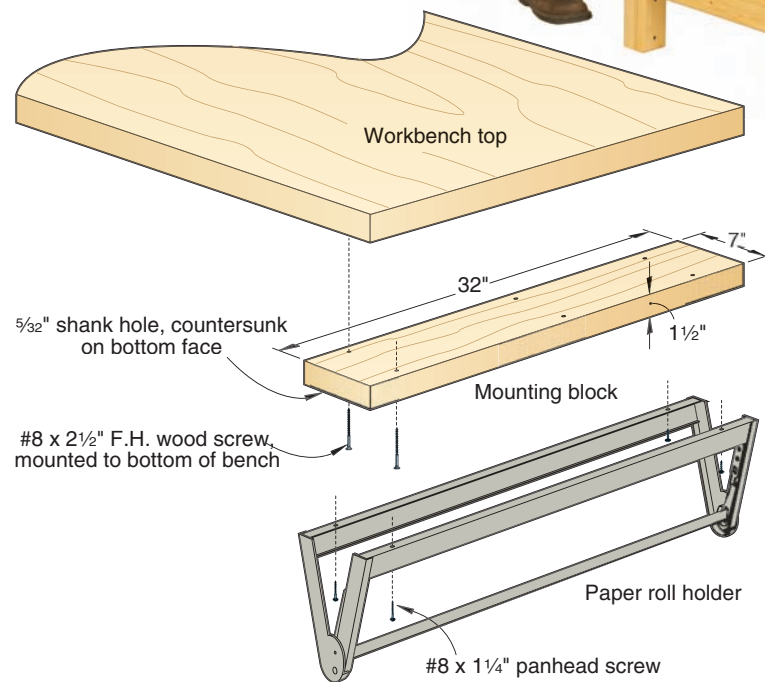

## Workbench extras

In addition to workbench accessories you make, there's a host of helpful items you can buy. Check these out:

**Bench dogs.** No mortising is required with the ¾" brass bench dogs shown *below*. Simply drill ¾" holes for them to sit in. A spring clip holds them in place, and plastic pads are available for delicate work. Adjustable bench dogs, as shown *below*, provide clamping power used with or without the bench vise.

**Hold-downs.** These provide vertical clamping pressure to secure workpieces anywhere on the bench where there's a ¾" hole.

**Wheels.** Our bench lacks wheels because we wanted a solid stance more than mobility. Where tight space requires a movable bench, opt for locking casters with a 150-pound capacity (each) and rubber 4"-diameter tires that grip the floor.

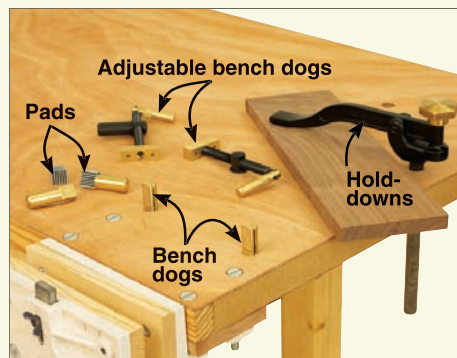

## Sources

**Vise.** Shop Fox quick-release, 9" vise, #G9851, \$69.95. Call Grizzly Industrial, 800/523-4777; grizzly.com.

**Bench dogs, hold-down accessories.** 4¾" (#05G04.02, \$18.50/pair) and 2¾" (#05G04.04, \$14.95/pair) round bench dogs; adjustable bench dogs (#05G10.02, \$22.50; #05G10.03, \$26.95); hold-down, (#05G14.01, \$54.50); bench dog pads, (#05G04.10, \$1.95/pair), Lee Valley Tools. Call 800/871-8158; leevalley.com.

**Paper roll holder and paper.** 30" Butcher Paper Dispenser (18100-A500, \$29.95) and 30"x800' roll of 50# butcher paper (\$37.95), from POSpaper.com, 877/469-7655.

**Surge protector.** 10-outlet SurgeMaster (F5H-300-EXT, \$33.99), Belkin Corp., 800/223-5546 or belkin.com.

## Upgrade 5: Plug into convenience

Add a heavy-duty power center to your workbench, and eliminate the inconvenience and danger of tripping over multiple extension cords on your shop floor.

Select a power strip with a metal case for impact resistance, such as the one shown at *right* (see Sources), and a cord long enough to reach a wall outlet in the least traveled part of your shop. This model's surge-blocking ability protects the electronics in today's battery chargers, and its 10 outlets accommodate multiple tools and a recharger or two.

Most power strips have mounting holes in the back panel. Select sheet-metal screws to fit these holes. We positioned this one so it could be lifted free for replacement. Carefully route the cord under the bench to avoid the drawers, if added, or possible damage caused while you work at the bench.

Periodically check the power strip outlets and cord for wear or damage. Always plug three-prong cords into grounded three-prong wall outlets. Follow any local electrical code restrictions that may apply.





# Upgrade **6**: Turn your bench into a glue-up station

Nobody enjoys scraping glue globs off a workbench. Save time and hassles with this pipe clamp glue-up table designed specifically to fit our 30x80" door. The hardboard base catches the drips, while the rack steadies up to eight clamps spaced 6" apart. Holes in the base allow you to hang it on a wall between glue-ups.

We designed this glue table to use 3/4" pipe clamps like those shown at right. To hold other types of clamps, modify the shape of the notches accordingly.

## Build the glue-up station

**1** From 2x4s and 1/4" hardboard, cut the parts to the sizes listed in the **Materials List** and the drawings. Rip both edges of the 2x4s to remove the factory edges and square the stock.

**2** To make the notches in the fixed rail (A) as shown in the parts view, first drill a series of 1 1/2" holes 3/4" from the top edge of the workpiece. We set up a fence and drilled them on the drill press for greater consistency. Turn the holes into notches, as shown, using a jigsaw or handsaw.

**3** To house the dowels, drill a pair of 3/4" holes 3/4" deep in the fixed rail, where shown. Drill 7/8" holes through the sliding rail (B).

**4** Drill and cut notches in the sliding rail (B) using the dimensions shown.

**5** Cut the glides (C) from 1/4" hardboard, and round over the edges. Glue them to the lower edge of the sliding clamp support, centering them under the dowel holes.



The glue-up station's sliding rail supports clamps close to the workpiece, allowing you to size clamp lengths to suit the project.

**6** Cut out the glide supports (D), as shown. Then cut two pieces of 3/4" dowel to 28 1/2" long for the guide bars (E).

**7** Cut a piece of 1/4" hardboard to the dimensions indicated to make the base (F). Drill two 1" holes, where shown, to hang the rack on the wall.

**8** Sand wooden parts to 150 grit. Finish them with two coats of Watco Danish Oil.

**9** Assemble the unit as shown, taking care to avoid gluing the sliding clamp support to the dowels. 🌿

Written by **Bob Wilson**  
Project design: **Jeff Mertz**  
Illustrations: **Roxanne LeMoine**

## PARTS VIEW

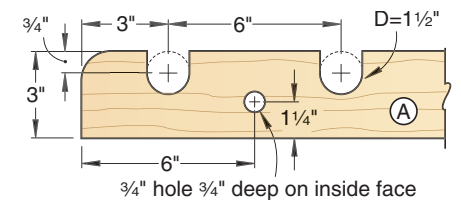
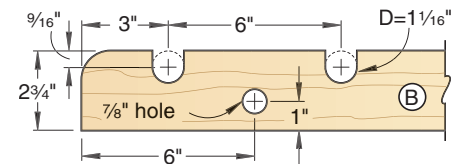

## PORTABLE GLUE-UP STATION

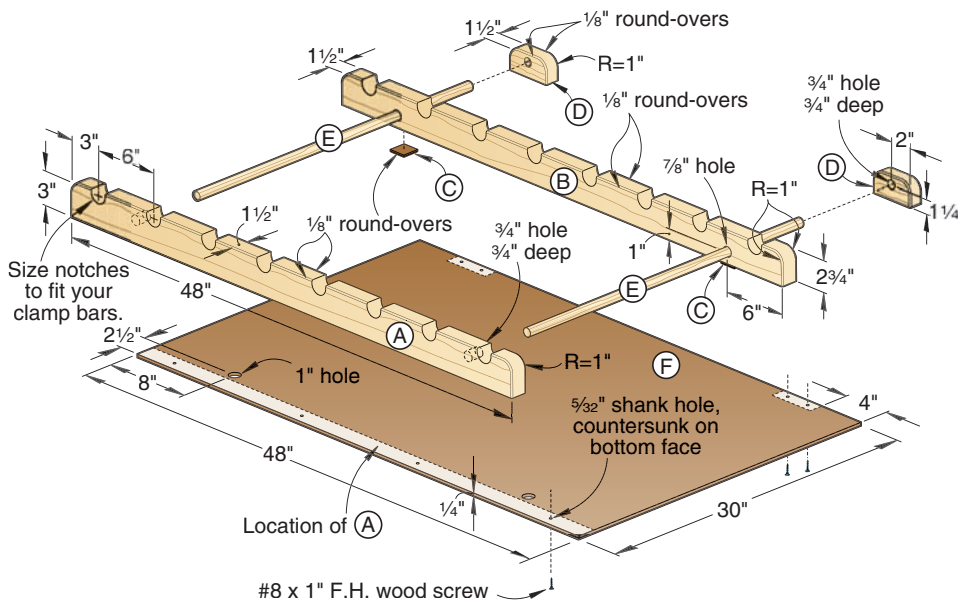

## Glue-Up Station Materials List

Part	FINISHED SIZE	FINISHED SIZE			Matl.	Qty.
		T	W	L		
A	fixed rail	1 1/2"	3"	48"	C	1
B	sliding rail	1 1/2"	2 3/4"	48"	C	1
C	glides	1/4"	1 1/2"	1 1/2"	HB	2
D	glide supports	1 1/2"	2"	4"	C	2
E	guide bars	3/4" diam.		28 1/2"	P	2
F	base	1/4"	30"	48"	HB	1

**Materials key:** HB—hardboard, P—poplar, C—choice of spruce, pine, or fir.

**Supplies:** #8x1", flathead wood screws.

**Blades & Bits:** Stack dado set; 1/8" round-over bit; 1 1/2", 7/8", and 3/4" drill bits.



## a perfect pair matching bathroom cabinets

Combine storage and style with these easy-to-build projects.

If you don't need a mirror, give the medicine cabinet a different look by substituting patterned glass, such as the fluted glass shown here.



**D**on't let appearances fool you. Underneath the dark, luxurious finish lies inexpensive poplar and simple biscuit joinery. Because these two pieces share almost identical construction, you easily can build both in a weekend. We'll start with the medicine cabinet; you'll find the open-shelf cabinet on [page 71](#).

### Medicine cabinet Start with the case

**1** From  $\frac{3}{4}$ " stock (we used poplar), cut the sides (A), bottom (B), and rail (C) to the sizes listed on the **Materials List**. Draw biscuit slot centerlines on the sides (A), where shown on **Drawing 1**. Then draw mating centerlines on the ends of the bottom (B) and rail (C). Cut #0 biscuit slots in the parts, as shown in **Steps 1** through **4** in the sidebar, on [page 69](#). Make sure the sides are mirror images.

**2** Mark the back edges and bottom ends, and fasten the sides (A) together in mir-

ror-image orientation with double-faced tape. Make a photocopy of the side end pattern on the *WOOD Patterns*® insert and adhere it to one side, flush at the edges and bottom end. Jigsaw or bandsaw and sand the sides to the pattern line. Separate the parts.

**3** Lay out the shelf support hole centers on the sides (A), where dimensioned on **Drawing 1**. Chuck a  $\frac{1}{4}$ " brad-point bit in your drill press, position the fence  $1\frac{3}{8}$ " from the center of the bit, and drill the holes.

**4** Finish-sand the sides (A), bottom (B), and rail (C). Glue, biscuit, and clamp the case together in the configuration shown on **Drawing 2**. Check the case for square by measuring the diagonals. (When the diagonals are equal, the case is square.)

**5** Cut a  $\frac{3}{4}$ "x $1\frac{1}{4}$ "x52" blank for the bottom bead (D), vertical beads (J), and horizontal beads (K). Chuck a  $\frac{1}{4}$ " beading bit in your table-mounted router, and rout beads along both edges of the blank, as shown in **Step 1**





shoulder on the ends and front edge, where shown on **Drawing 2**. For a tip on preventing tear-out, see the **Shop Tip** at *right*.

**4** Finish-sand the cap (G). Glue and clamp it to the top (F), flush at the back and centered side-to-side.

## Now build the door

**1** Cut the stiles (H) and rails (I) to size. With a 1/4" dado blade in your tablesaw cut 3/8"-deep grooves in the inside edges of the parts, where shown on **Drawing 4**.

**2** Adjust the dado blade to cut 1/4" deep, and cut 3/8"-long tenons on the rails (I), where dimensioned on **Drawing 4a**, to fit the stile (H) grooves. Glue and clamp the stiles and rails together, checking for square by measuring the diagonals. Set the door frame on a flat surface to dry. Finish-sand the frame.

**3** Retrieve the bead strips, and miter-cut the vertical beads (J) and horizontal beads (K) to length. Glue and clamp them to the door frame, where shown on **Drawing 4**. Finish-sand the beads.

**4** Chuck a 3/8" rabbeting bit into your table-mounted router. Place the door frame *inside face down* on the router table, and adjust the bit so the pilot bearing rolls on the outside lip of the 1/4" groove while the cutter removes the inside lip to form a 3/8" rabbet 1/2" deep. Rout away the inside lip and square the corners of the rabbet with a chisel.

**5** Cut the vertical stops (L) and horizontal stops (M) to size. Cut the head off a #18x3/4" wire brad, and use it to drill nail pilot holes through the stops, where shown on **Drawing 4**. Finish-sand the stops.

**6** Place the hinges on the door, where dimensioned on **Drawing 4**. Using the *slotted* holes in the hinges as guides, drill centered pilot holes. Then place the hinges on the side (A), where shown on **Drawing 1**. With

## SHOP TIP

### Use a follower block for smoother routing

When routing across end grain, small chips of wood often tear from the trailing edge as the bit exits the workpiece. To prevent this, push the workpiece past the bit with a scrap follower block, as shown at *right*. The block supports the edge grain, preventing it from tearing out. Using a follower block also steadies a long, narrow workpiece, such as the cap (G), for smoother routing. To make a follower block easier to handle, cut a 6" length of 1" dowel, drill a centered 1" hole in the block, and insert the dowel.



## Biscuit joiner tricks for case construction

When using a biscuit joiner you usually position the slot by adjusting the fence. But for some operations, such as biscuit-joining the bottom (B) and rail (C) to the sides (A), you'll use the base of the tool to position the slot. Most biscuit joiners

center the slot cutter 3/8" from the bottom, which is perfect for 3/4"-thick stock. Even if the distance isn't exact, orienting the bottom of the biscuit joiner in the same direction on each part guarantees perfect alignment. The photos, *below*, show how.

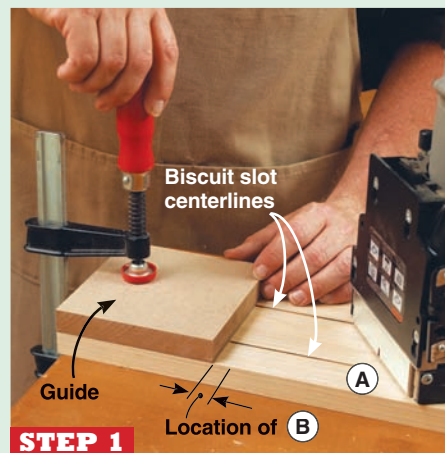

**STEP 1** Mark biscuit slot centerlines for the bottom (B) on the side (A). Clamp a scrap guide to the side with one edge aligned with the position of the bottom face of the bottom (B).



**STEP 2** With the bottom of the biscuit joiner against the scrap guide, align the biscuit joiner centerline with the marked centerlines and cut the two biscuit slots.



**STEP 3** Mark a biscuit slot centerline for the rail (C) on the side (A). Clamp a guide to the side back edge. With the joiner against the guide and aligned with the centerline, cut the slot.



**STEP 4** Clamp the bottom (B) bottom-down to your workbench. Mark biscuit centerlines. Align the joiner with the lines, and cut the slots. Clamp the rail (C) back-down and repeat.

## DEAD-ON CATCH POSITIONING



**B** Lay the cabinet catch-side-down on your workbench. Engage the strike in the catch rollers. Mark the slotted holes, remove the catch, and drill centered pilot holes.



## 4 DOOR (Viewed from back)

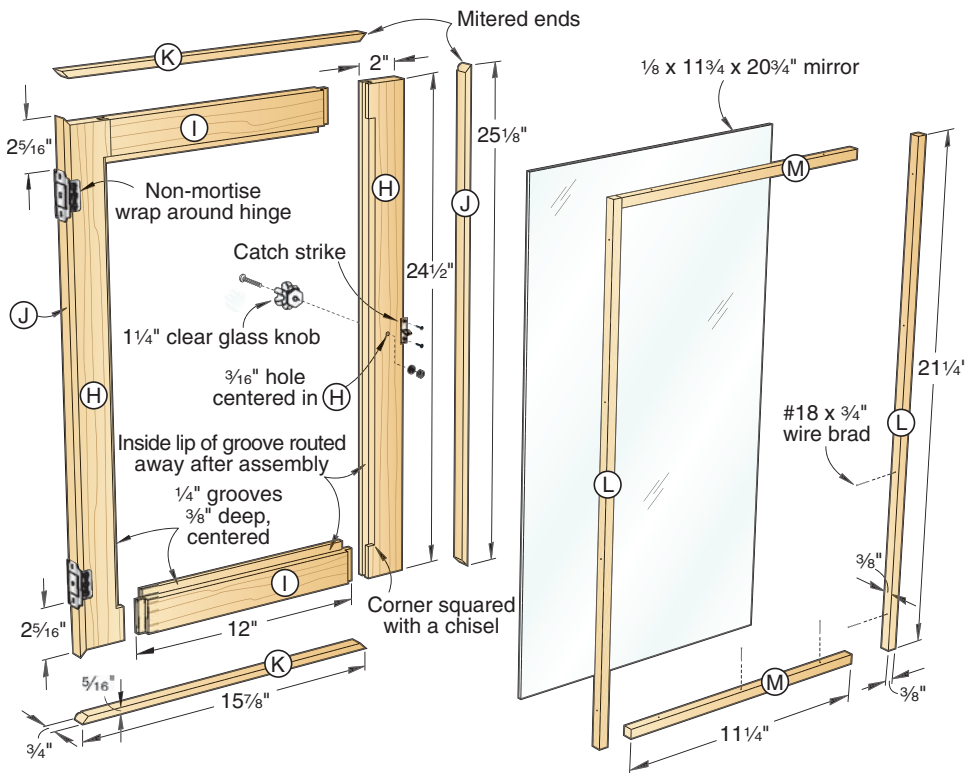

the hinge knuckles clearing the front edge of the side by  $\frac{1}{16}$ " , drill pilot holes centered in the slotted holes. Drill a  $\frac{3}{16}$ " hole in the door stile (H) for the knob. Now screw the hinges to the door, position it in the case opening, and screw the hinges to the side. Using the slotted holes in the hinges, adjust the door for an even gap all around.

**7** Position the catch strike on the door, centered vertically and  $\frac{1}{8}$ " from the edge. Drill pilot holes and screw the strike to the door. Now install the roller catch, as shown in **Photo B**.

### Apply finish and assemble

**1** Remove all the hardware. Inspect the parts, and resand any areas that need it. Apply a finish of your choice. To reproduce the finish shown on *page 67*, see the article on *page 74*.

**2** Have a glass shop cut a piece of  $\frac{1}{8}$ " mirror to fit your door and three shelves to the size shown on **Drawing 2**. For a finished look, order the shelf front edges ground with a "pencil" edge.

**3** Lay the door facedown, place the mirror in the rabbeted opening, and nail the stops in place with #18x $\frac{3}{4}$ " wire brads. To avoid scratching the back of the mirror while installing the stops, cover it with a piece of thin cardboard. Attach the hinges and the catch strike to the door. Install the glass knob

and mark the length of the knob bolt needed. Remove the knob and cut the bolt to length with a hacksaw. Remove any burr with a file and reinstall the knob.

**4** Nail the back (E) in place with #18x $\frac{3}{4}$ " wire nails. Attach flush-mount wall hangers (see the **Shop Tip** on *page 72*) to the wall with #4x1 $\frac{1}{4}$ " flathead wood screws by screwing into studs or using wall anchors. Attach flush-mount wall hangers to the rail (C) with #4x $\frac{1}{2}$ " flathead wood screws so they align with those on the wall. Adhere self-adhesive bumpers to the lower rear edges of the sides (A), where shown on **Drawing 2**. Install the roller catch, and hang the door in the case. As before, use the slotted screw holes in the hinges to align the door. Hang the cabinet on the wall, interlocking the flush-mount wall hangers, and install the shelf supports and shelves. Now check yourself in the mirror to see if you need to shave before dinner. 🍷

### Cutting Diagram

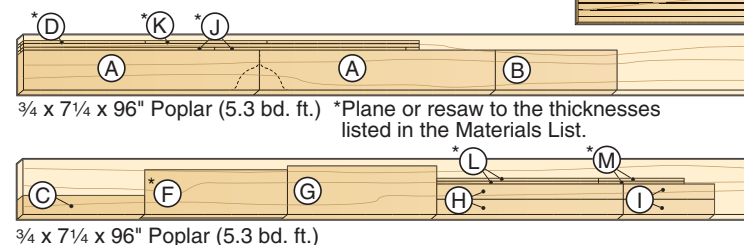

## 4a TENON DETAIL (Viewed from back)

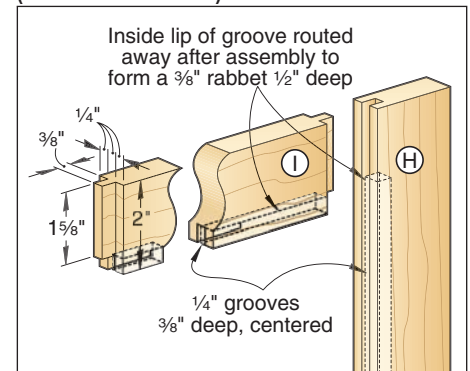

### Materials List

MEDICINE CABINET		FINISHED SIZE				
Case		T	W	L	Matl.	Qty.
A	sides	3/4"	5 1/4"	31"	P	2
B	bottom	3/4"	5 1/4"	16"	P	1
C	rail	3/4"	2 1/2"	16"	P	1
D*	bottom bead	5/16"	3/4"	16"	P	1
E	back	1/4"	16 3/4"	23 1/2"	BBP	1
F	top	1/2"	5 7/8"	18 3/4"	P	1
G	cap	3/4"	6 5/16"	19 5/8"	P	1
<b>Door</b>						
H	stiles	3/4"	2"	24 1/2"	P	2
I	rails	3/4"	2"	12"	P	2
J*	vertical bead	5/16"	3/4"	25 1/8"	P	2
K*	horizontal bead	5/16"	3/4"	15 7/8"	P	2
L	vertical stop	3/8"	3/8"	21 1/4"	P	2
M	horizontal stop	3/8"	3/8"	11 1/4"	P	2

\*Parts initially cut oversize. See the instructions.

**Materials Key:** P—poplar, BBP—beaded birch plywood.

**Supplies:** Double-faced tape, #0 biscuits; #4x $\frac{1}{2}$ " , #4x1 $\frac{1}{4}$ " , and #8x1 $\frac{1}{2}$ " flathead wood screws; #18x $\frac{3}{4}$ " wire nails; #18x $\frac{3}{4}$ " wire brads;  $\frac{1}{8}$ " mirror;  $\frac{1}{4}$ " glass for shelves.

**Blades and bits:** Stack dado set;  $\frac{1}{4}$ " brad-point drill bit;  $\frac{1}{4}$ " beading,  $\frac{3}{8}$ " cove,  $\frac{3}{8}$ " round-over, and  $\frac{3}{8}$ " rabbet router bits.

### Source

**Hardware.** Brushed-nickel non-mortise ball-tip wrap-around hinge no. 31508, \$6.39 pr. (1 pair); double roller catch no. 29785, \$3.39 for a pack of 4 (1 pack);  $\frac{1}{4}$ "-diameter clear glass knob no. 71965, \$4.99 ea. (1); extra-thin flush mounts no. 29983, \$2.49 pr. (2 pairs);  $\frac{1}{2}$ " self-adhesive bumpers no. 34926, \$2.99 for a pack of 25 (1 pack); shelf supports for  $\frac{1}{4}$ " glass shelves no. 34082, \$3.49 for a pack of 16 (1 pack). Rockler Woodworking and Hardware. Call 800/279-4441, or go to rockler.com.



1/4 x 24 x 48"  
Beaded  
birch  
plywood



**C**omplete your bathroom face lift by adding an open-shelf cabinet with a convenient towel rod that perfectly matches the medicine cabinet on page 67. Because the cabinets share construction methods and similar parts, you can eliminate repeat setups by machining similar parts at the same time.

## Open-shelf cabinet Start with the case

**1** From  $\frac{3}{4}$ " stock (we used poplar), cut the sides (N), bottom (O), and rails (P) to the sizes listed on the **Materials List** on page 72. **1** raw biscuit slot centerlines on the sides (N), where shown on **Drawing 5**. Then draw mating centerlines on the ends of the bottom (O) and rails (P). Cut #0 biscuit slots in the parts as shown in the sidebar Steps 1–4 for the medicine cabinet on page 69.

**2** Mark the back edges and bottom ends, and fasten the sides (N) together in mir-

ror-image orientation with double-faced tape. Make a photocopy of the side end pattern on the *WOOD Patterns*® insert, and adhere it to one side, flush at the edges and bottom end. Jigsaw or bandsaw and sand the sides to the pattern line. Separate the parts.

**3** Lay out the towel bar hole centers on the facing surfaces of the sides (N), where dimensioned on **Drawing 5**. Chuck a 1" Forstner bit in your drill press, and drill  $\frac{3}{8}$ "-deep holes in both sides.

**4** Cut a  $\frac{3}{4} \times 1 \times 23\frac{1}{4}$ " blank for the bottom bead (Q). Chuck a  $\frac{1}{4}$ " beading bit in your table-mounted router and rout a bead along one edge of the blank and one edge of the front rail (P), in the same manner shown on Step 1 of **Drawing 3** on page 68. Then rip the bottom bead from the blank in the same manner shown on Step 2. Use a pushblock to push the bead and waste all the way through the blade.

**5** Cut the towel bar (R) to length from 1"-diameter dowel. Finish-sand the sides

(N), bottom (O), rails (P), and towel bar. Glue, biscuit, and clamp the case together in the configuration shown on **Drawing 6**, capturing the towel bar in the 1" holes. Check for square by measuring the case diagonals. (When the diagonals are equal, the case is square.) With the glue dry, glue and clamp the bottom bead (Q) to the bottom.

**6** Rout a rabbet for the back (S) in the back edges of the case in the same manner shown in **Photo A** on page 68.

**7** From  $\frac{1}{4}$ " beaded birch plywood, cut the back (S) to size. Saw and sand radii on the corners to match the round corners of the case rabbet. Set the back aside.

## Add the top and cap

**1** Plane stock to  $\frac{1}{2}$ " thick for the top (T), and cut it to size. Chuck a  $\frac{3}{8}$ " cove bit in your table-mounted router and rout coves along the ends and front edge, where shown on **Drawing 6**. Finish-sand the top.

**2** Clamp the top (T) to the case, flush at the back and centered side-to-side. Drill countersunk screw holes through the top, and into the sides (N) and rails (P), where shown on **Drawing 6**. Drive the screws.

**3** Cut the cap (U) to size. Following the procedure in Step 3 on page 68, rout round-overs with  $\frac{1}{16}$ " shoulders on the ends and front edge, where shown on **Drawing 6**.

**4** Finish-sand the cap (U). Glue and clamp it to the top (T), flush at the back and centered side-to-side.

## Apply finish and assemble

**1** Inspect the parts and resand any areas that need it. Apply a finish of your choice. To reproduce the finish shown on page 67, see the article on page 74.

**2** Nail the back (S) in place with #18 $\times\frac{3}{4}$ " wire nails. Attach flush-mount wall hangers (see the **Shop Tip**, opposite) to the wall with #4 $\times\frac{1}{4}$ " flathead wood screws by screwing into studs or using wall anchors. Attach flush-mount wall hangers to the rear rail (P) with #4 $\times\frac{1}{2}$ " flathead wood screws so they align with those on the wall. Adhere  $\frac{1}{2}$ " self-adhesive bumpers to the lower rear edges of the sides (N), where shown on **Drawing 6**. Hang the cabinet on the wall, interlocking the flush-mount wall hangers. Now collect all the magic potions that crowd the rim of the sink and arrange them on the shelf.



# SHOP TIP

## Handy hardware for sturdy hanging

Adding only a 1/8" space between the cabinet and the wall, flush-mount wall hangers provide rock-solid mounting. Each half of an interlocking pair is identical, so there's no need to keep track of which half goes on the wall or cabinet. And because they require no mortising, they install in a jiffy. Just fasten a pair of mounts to the wall "fingers up," as shown at *right*, by screwing into studs or using wall anchors. Make sure the mounts are level with each other. Then screw another pair "fingers down" to the back of the cabinet, positioning them so they align with the mounts on the wall. Hang the cabinet by interlocking the mounts. Need to repaint? Simply lift the cabinet off the mounts screwed to the wall.

Fasten to cabinet with #4x1/2" flathead wood screws.

Fasten to wall with #4x1 1/4" flathead wood screws.

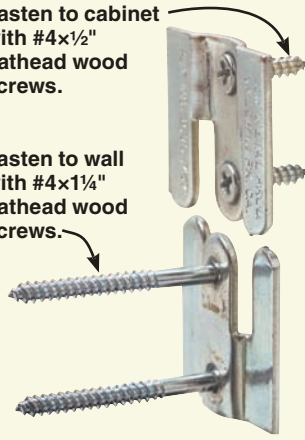

## Materials List

OPEN CABINET	FINISHED SIZE			Matl.	Qty.
	T	W	L		
N sides	3/4"	5 1/4"	21"	P	2
O bottom	3/4"	5 1/4"	23 1/4"	P	1
P rails	3/4"	2 1/2"	23 1/4"	P	2
Q* bottom bead	5/16"	3/4"	23 1/4"	P	1
R towel bar	1" diam.		24"	B	1
S back	1/4"	24"	11 1/4"	BBP	1
T top	1/2"	5 7/8"	26"	P	1
U cap	3/4"	6 5/16"	26 7/8"	P	1

\*Parts initially cut oversize. See the instructions.

**Materials key:** P—poplar, BBP—beaded birch plywood, B—birch.

**Supplies:** Double-faced tape, #0 biscuits; #4x1/2", #4x1 1/4", and #8x1 1/2" flathead wood screws; #18x3/4" wire nails.

**Bits:** 1" Forstner bit; 1/4" beading, 3/8" cove, 3/8" round-over, and 3/8" rabbet router bits.

## Source

**Hardware.** Extra-thin flush mounts no. 29983, \$2.49 pr. (2 pairs); 1/2" self-adhesive bumpers no. 34926, \$2.99 for a pack of 25 (1 pack). Rockler Woodworking and Hardware. Call 800/279-4441, or go to rockler.com.

Written by Jan Svec

Project design: Jeff Mertz

Illustrations: Roxanne LeMoine

## 6 OPEN CABINET EXPLODED VIEW

### 5 WALL CABINET SIDE

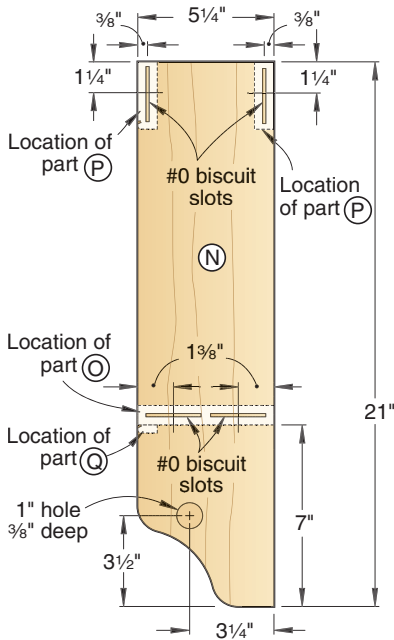

## Cutting Diagram

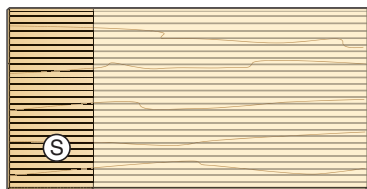

1/4 x 24 x 48" Beaded birch plywood

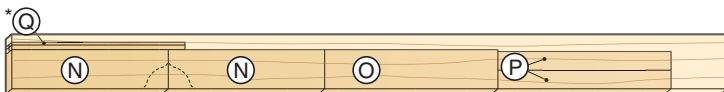

3/4 x 7 1/4 x 96" Poplar (5.3 bd. ft.) \*Plane or resaw to the thicknesses listed in the Materials List.



3/4 x 7 1/4 x 60" Poplar (3.3 bd. ft.)

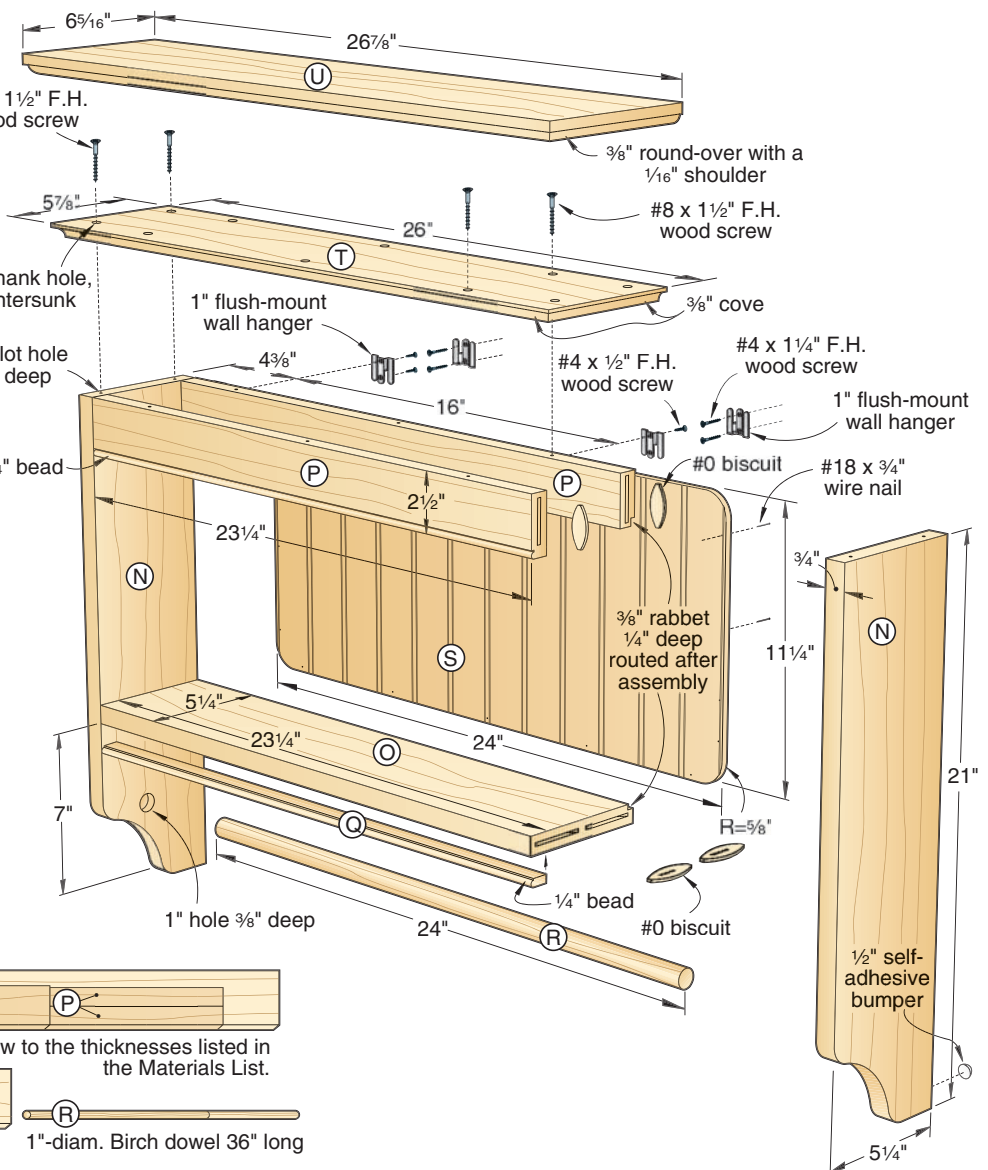



create a  
deep, rich

# country finish

You don't get this sort of  
creamy chocolate color  
from a can.

You'll need *two* cans.

## COUNTRY FINISH SEQUENCE

Sanded bare poplar

Ebony dye

American walnut stain  
(one coat)

Wipe-on poly finish  
(polyurethane thinned  
50 percent)

**D**on't be afraid of the dark—dark finishes, that is. They're a great way to complement today's informal furnishings, and they allow you to conceal inexpensive woods, such as poplar. With only one additional coloring step, you'll master this finishing technique in no time.

This isn't like the distressed pine or faux painted country finishes of the past. With its dark tones allowing muted wood grain patterns to show through, this contemporary country look feels both casual and refined.

Begin by sanding your bare wood to 180 grit, using 220-grit paper on the end grain. Careful sanding takes on added importance with dark finishes. That's because deep colors can bring out planer and jointer marks along with minor scratches and gouges.

We'll start by applying a water-based dye, so prepare the wood by first wiping it with a water-dampened rag to raise the grain, as shown in **Photo A**. These passes can expose minor sanding goofs you'll need to fix before dyeing the wood. Light, quick passes with

220-grit paper will remove the raised nibs.

To darken the wood, first wipe it with a rag soaked in ebony dye (W.D. Lockwood & Co., 866/293-8913 or [wdlockwood.com](http://wdlockwood.com)). Let the dye soak in evenly, as shown in **Photo B**, and wipe off the excess with a dry rag. Work from moistened areas into dry ones to avoid streaks or blotching. To prevent over-dyeing end grain as you work, wipe the sanded ends with a water-dampened rag, followed quickly by an application of dye.

Allow the wood to dry thoroughly before checking it for consistent color. You want an even, charcoal gray shade that doesn't obscure the grain with blotches. To darken light spots, wipe those areas with a second coat of dye, as shown in **Photo C**. Where the wood has become too dark, first try reducing the amount of dye by wiping the area with a water-soaked rag. Immediately remove any excess water with a dry rag, which also removes some unwanted dye.

Sanding also will eliminate excess dye, but with a catch: By making the sanded area



smoother than surrounding wood, less walnut stain will lodge in the fine scratches, lightening the stain color once you reach that stage. If 400-grit sanding is required after applying dye, carefully wipe off all excess dye and dust, as shown in **Photo D**.

Once you have an even, dry application of ebony dye on all surfaces, wipe on the first coat of stain, as shown in **Photo E**. We used Varathane's American walnut stain to create a dark chocolate-brown color. Allow the first coat to dry and apply a second one, darkening light areas as needed. Check for even color on all surfaces, but don't worry that the surface looks dark and flat at this stage.

### Make a wipe-on finish

Brushing on a coat of polyurethane straight from the can provides a durable finish, but a blend-it-yourself wipe-on varnish combines the advantage of a streak-free surface with the application ease of a gel varnish.

It's easy: Just mix equal amounts of oil-based polyurethane finish and low-odor mineral spirits until you have enough finish for your project. Later, experiment with increasing the amount of polyurethane in the mix. You can continue to add finish until the mixture becomes difficult to wipe on smoothly. If you use a satin finish, such as the one shown here, mix the thinned finish often during application to keep the dulling agent suspended.

Using a clean rag, wipe on your thinned finish in long strokes, as shown in **Photo F**. Until the finish dries, avoid wiping additional finish onto areas you've just covered. The first coat of varnish will seem to transform dark finishes, adding sheen to flat areas and bringing out subtle shading of the stained areas against the dark background.

Wipe-on finish dries faster than a full-strength application, reducing the amount of dust that accumulates on the finish. A thinned wipe-on finish is also less prone to runs. However, you'll need at least twice as many applications to equal the same thickness you'd achieve using full-strength, brushed-on coatings. Whether wiped or brushed on, scuff-sand lightly between coats using 400-grit abrasive.

After your final coat of finish, buff in a coat of wax, as shown in **Photo G**, to bring out that deep, dark color seen in **Photo H**. 🌲

MOISTEN SANDED PIECES



A

APPLY EBONY DYE



B

TOUCH UP LIGHT SPOTS



C

WIPE OFF EXCESS DYE AND DUST



D

APPLY WALNUT STAIN



E

FINISH WITH WIPE-ON POLY



F

RUB ON WAX



G

FINISHED AND LOOKING GREAT



H

Learn more  
wood-finishing  
techniques  
for free at

[woodmagazine.com/finishes](http://woodmagazine.com/finishes)





**SHOP TESTED**

# mid-priced tablesaws

For \$500 to \$700, you can choose from a lot of tablesaws (we tested 11 for this article). So how do you decide on one? To find out, we put them through a series of tests cutting hardwoods.



**W**ith tablesaws ranging in price from \$200 to more than \$2,000, you can pay as much or as little as you want for this workshop centerpiece. The lowest-priced tablesaws are lightweights both figuratively (with anemic motors) and literally (small and light enough to stow on a shelf). And at the other end of the price range you'll find cabinet saws: heavy, closed-stand stationary tools with powerful 3-hp motors.

Smack in the middle of the price range—with enough power to cut hardwoods and not break the bank—are the 11 tablesaws we tested for this article. They fall into two basic saw styles: contractor-style (belt-driven stationary tools with open leg stands) and lighter portable saws (collapsible-stand saws with direct-drive motors).

To test the power of each saw, we timed how long it took the tool to rip a 2' length of hard maple. We used new, identical full-kerf carbide-toothed blades in each saw, and moved the hardwood through the blade on a sled pulled by 20 pounds of weight.



## Contractor-style vs. portable: the differences that matter

This chart shows some of the differences we discovered in our tests of the two different types of saws. Some findings surprised us. For example, we expected the portable saws (weighing less than 125 pounds) to vibrate more than the heavier contractor-style saws (weighing 234 pounds and up). However, we could stand a nickel

on the tabletop of all of the saws with their motors running. Weight does impact stability, though: Portables showed more tendency to tip when ripping sheet goods. And, we expected to find the noisy universal motors on the portable saws annoying, but the sound of the blade cutting wood drowned out any motor noise.

	CONSTRUCTION	POWER TRAIN	RIPPING/ FENCE SYSTEM	CROSSCUTTING/ MITER GAUGE	PORTABILITY
CONTRACTOR- STYLE	Cast-iron main table with iron or steel extension wings. Typical table size including wings: 40×27" (L×W). Stable leg stand.	Induction motor; belt-driven blade arbor (with pulleys on motor and blade arbor).	30–36" capacity; front-locking T-square-style fence (typical) with permanent rails. (One tested saw, though, locks at both front and rear.)	Cast-iron miter-gauge head. T-slot miter bar. Area in front of blade allows for crosscutting pieces up to 13" wide with miter-gauge head still on table.	200–400 lbs with no built-in mobility on most models. Requires a rather large footprint (13–14 sq.ft.) due to 6' length of fence rails.
PORTABLE	Cast-aluminum table with no extension wings. Typical table size: 29×20". Less-sturdy leg stand than contractor-style saw.	Universal motor; direct-drive arbor (blade arbor connects to motor shaft by gears).	24–25" rip capacity. Rails extend to accommodate maximum rips. Fence locks at front and rear. Scales can be confusing.	Plastic miter-gauge head. Narrow area between front of table and front of blade limits crosscuts to workpieces 5–8" wide with miter gauge still on table.	55–125 lbs with collapsible wheel stand (typical). Stored on end, requires 4–6 sq.ft. of floor space.
WHY IT MATTERS	The large surface of a contractor-style saw provides more workpiece support, especially helpful for cutting sheet goods.	Little difference in cutting power between the two motor types. Induction motors run cooler; belt drive reduces arbor play, improving cut quality.	Portable-saw fence rails retract to take up less room in the shop. Contractor-style saw fences allow wider rips.	If you frequently crosscut pieces wider than about 6", you'll be frustrated with a portable saw.	If space is at a premium, or you take your wood-working on the road, you can't beat a portable saw.

### Key tests of any tablesaw, regardless of price

• **Power.** Ripping thick hardwood with a full-kerf (1/8") combination blade requires substantial power, and it's a demand you're likely to make of your tablesaw. To evaluate the power of the tested tools, we ripped 2"-thick hard maple using the setup shown at left. The chart below shows the results of our tests, averaging the cut times of five rips each with full-kerf and thin-kerf blades.

Contractor-style saws turned in both the best and worst times. The Jet JWTS-10JF cut fastest, averaging just under 12 seconds per rip. Times for the portable saws were as mixed as contractor-style saws, with the

portable Ridgid TS2400 cutting faster than most of the stationary saws.

When we repeated the tests with thin-kerf blades, all of the saws demonstrated more apparent power and the disparity between them lessened, but the Jet still ripped fastest. And, contrary to conventional wisdom, we observed no appreciable difference in the cut quality between full- and thin-kerf blades.

• **Cut quality.** We evaluated cut quality using the samples from our power test as well as a series of controlled crosscuts, looking for signs of blade scoring. Here we found that portable saws produced more pronounced scoring than contractor-style saws, although none of the cuts were ready for glue

### MORE POWER MEANS FASTER CUTTING TIMES

We clocked how long it took each tablesaw to make a 24" rip through 2"-thick hard maple using identical blades and feed pressure. Shorter bars on this chart indicate faster cutting, and thus more power.

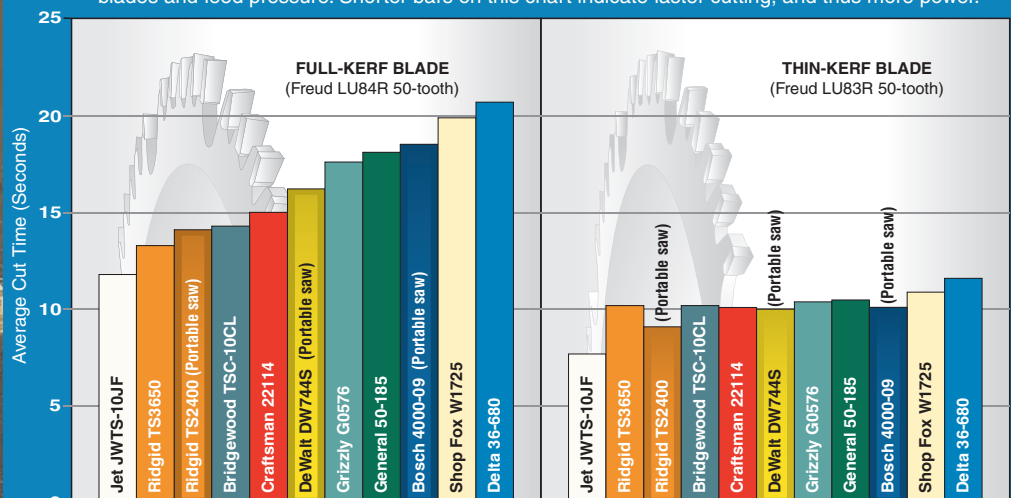

## PORTABLE SAWS SCORE MORE

Ridgid TS3650  
(contractor-style)

Ridgid TS2400  
(portable)

Blade scoring, revealed by blue chalk, varied from the consistent surface shown in the top photo, to deep and spotty (bottom photo).

joints straight from the saw—all would need dressing on a jointer. (See the photos, above.) Because the blade arbor of a portable saw attaches to its motor shaft by gears, any play in that connection transfers to the blade, leading to the increased scoring we observed. Portable saws aside, the saws with slower blade speeds (3,000–3,200 rpm) tended to cut cleaner than those with the highest speeds (around 4,200 rpm).

• **Fence quality.** The Ridgid TS3650 offers best-in-test rip capacity (36"), and a front-and-rear locking fence that deflected the least (.002" at the arbor with 20 lbs of sideways pull at the rear of the fence). The portable-saw fences also lock at the front and rear and, in our tests, locked dead-on parallel to the blade every time. All of the fence faces were sufficiently flat, and most provide T-slots for attaching accessories, such as feather boards or hold-downs.

Despite their compact size, portable saws achieve 24+\" rip capacities thanks to telescoping fence rails, as shown at top right. This leads to some creative solutions for the fence scales, and we found Bosch's (photo, above right) to be a bit user-unfriendly. On the contractor-style saws, we found the scales on the Craftsman 22114, Grizzly G0576, Jet, and Ridgid TS3650 easiest to read.

• **Tabletops.** All of the saws in our test were within .004\" of perfectly flat across the diagonals and along the blade path. The difference in crosscutting capacities, though, is markedly different from a high of 13\" on the Ridgid TS3650 to a low of 5\" on the DeWalt DW744S. Why so little on the DeWalt? There's only that much tabletop in front of the blade, and this saw's miter gauge lacks a T-bar that would extend it by even a few inches. Even the widest-cutting portable saw maxes out at much less than a contractor-style saw. (See comparison photos, at right.)

• **Blade adjustments.** Blade height adjustments on all of the saws are made by cranking a handwheel. None are difficult to use, but the Bosch, DeWalt, and Ridgid

## PORTABLE-SAW FENCES EXTEND FOR WIDER RIPS



DeWalt's rack-and-pinion fence rails extend to a 24½\" rip capacity. A flip-down stock support on the fence keeps the edge of the workpiece at the same height as the tabletop.

## TWO-STEP FENCE SCALES CAN CONFUSE THE USER



For rips wider than 13\" on the Bosch 4000-09, you lock the fence at 13\" (right cursor), then extend the table until the left cursor points to the width of the cut. That scale reads right-to-left (14½\" rip shown).

TS3650 required about twice as many tedious turns of the crank to put the blade at full height. For adjusting the blade tilt, most saws use the familiar handwheel adjustment. The Bosch and DeWalt portable saws, on the other hand, tilt freely: Just loosen the lock, tilt the blade assembly by hand, and then tighten the lock. The system is fast, and easy-reading scales make it pretty accurate; however, it's tough to make fine adjustments.

• **Dust collection.** Except for the Delta 36-680 (which makes no provision at all for dust collection) and the Ridgid TS3650, the contractor-style saws all sport 4\" dust ports. We found the most effective dust collection on the Craftsman, thanks to its fully enclosed cabinet. The Bosch, DeWalt, and both Ridgid tablesaws proved nearly as efficient with a 2½\" dust port on a blade shroud that surrounds the lower half of the blade.

## CONTRACTOR-STYLE SAWS WORK WIDER

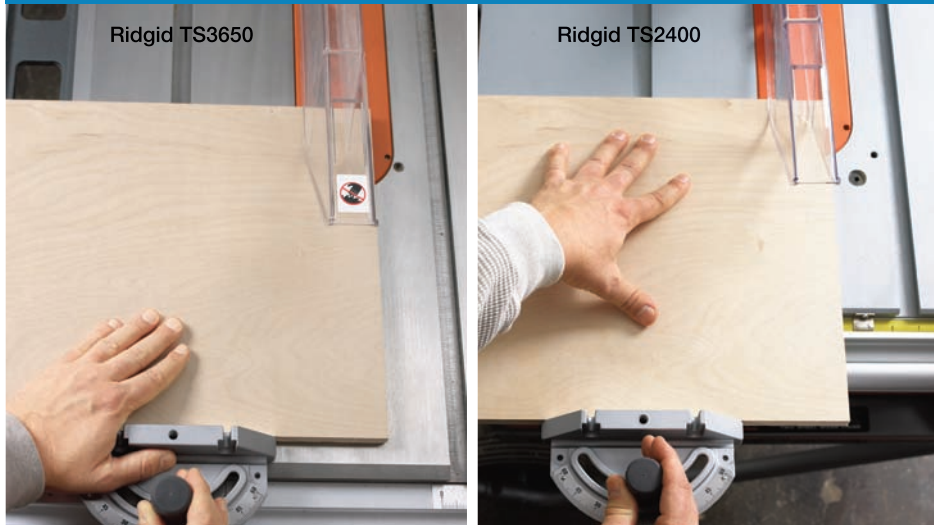

Most contractor-style saws (left) handle this 12\"-wide crosscut with no problems: The miter gauge sits flat on the table with the bar fully in the miter slot. The widest-cutting portable saw (right) leaves about 4\" of the workpiece (as well as the miter-gauge) hanging.



# a model-by-model look at mid-priced tablesaws



**Bridgewood TSC-10CL, \$550**  
800/235-2100, wilkemach.com

#### High points

- ▲ The lowest-priced contractor-style saw in the test, and a very good performer.
- ▲ Turned drive pulleys and link belt reduce vibration and come as standard equipment with this saw.
- ▲ Fence has adjustment screws for bringing it parallel to the blade and perpendicular to the tabletop.

#### Low points

- ▼ The 1/8" and 1/4" hash marks on the fence scale are the same length, making them difficult to differentiate.

#### More points

- ▶ You can make your own right wing, or Wilke Machinery sells a full-length laminate extension table with legs (\$100) or a cast-iron wing (\$70).
- ▶ As this issue went to press, we learned that this saw has been upgraded with a new motor, although the model number has not changed.



**Craftsman 22114, \$650**  
Visit Sears store or craftsman.com

#### High points

- ▲ Cabinet-saw-like design: Large, sturdy trunnions, removable table for easy blade alignment, and enclosed cabinet for superior dust collection.
- ▲ Bevel stops adjust through the tabletop.
- ▲ Splitter/guard assembly mounts and dismounts with a few turns of a knob.
- ▲ The auxiliary fence face can move forward to support long workpieces or to serve as a crosscut gauge.

#### Low points

- ▼ Right-rip capacity of 25 1/2" is the smallest of the contractor-style saws.
- ▼ The large miter-gauge extension, and its length stop, require a hexhead wrench to adjust.

#### More points

- ▶ For \$120 less, Craftsman model 22104 is the same saw except it has stamped-steel wings and lacks the auxiliary fence face, miter-gauge extension, and a dust port.



**Delta 36-680, \$600**  
800/438-2486, deltamachinery.com

#### High points

- ▲ Bevel stops adjust through the tabletop.
- ▲ Fence has adjustment screws for bringing it parallel to blade and perpendicular to tabletop.
- ▲ Miter-gauge bar adjusts to fit miter slot.

#### Low points

- ▼ Slowest cut in our test.
- ▼ No dust collection.

#### More points

- ▶ Blade tilts right.
- ▶ Also available with stamped-steel wings (model 36-675) for \$500.



**General International 50-185, \$700**  
514/326-1161, general.ca

#### High points

- ▲ Adjustable, spring-loaded ball plungers in miter-gauge bar fit it perfectly to the slot.
- ▲ Substantial handwheels make blade adjustments smooth and easy.
- ▲ On-tool storage for the miter gauge and fence.

#### Low points

- ▼ No T-slots on fence for attaching jigs and/or hold-downs.
- ▼ Small markings and a fine hairline cursor make the fence scale somewhat difficult to read.
- ▼ Owner's manual needs updating and would be hard to follow for a first-time saw owner.



**Grizzly G0576, \$615**  
800/523-4777, grizzly.com

#### High points

- ▲ Substantial handwheels make blade adjustments smooth and easy.
- ▲ Large, clear markings and a magnified cursor make fence scale easy to read.
- ▲ Fence has adjustment screws for bringing it parallel to blade and perpendicular to tabletop.
- ▲ Miter-gauge bar adjusts to fit miter slot.

#### More points

- ▶ This is the only saw in the test that comes from the factory wired for 220 volts. You'll need to add your own plug, even if you rewire for 110-volt use.



**Jet JWTS-10JE, \$650**  
800/274-6848, [wmhtoolgroup.com](http://wmhtoolgroup.com)

**High points**

- ▲ The fastest-cutting saw in the test, completing a 24" full-kerf rip in maple in about half the time of the slowest saws.
- ▲ Large, clear markings and a magnified cursor make the fence scale easy to read.

**Low points**

- ▼ Miter bar fits loosely in the miter slot, and with no adjustment mechanism in the bar, we had to peen it for a good fit.

**More points**

- ◆ Blade tilts right.
- ◆ One of two saws in our test with stamped-steel extension wings.
- ◆ For about \$100 more, you can get this same saw with cast-iron wings (model JWTS-10CW2-JF).



**Ridgid TS3650, \$570**  
800/474-3443, [ridgid.com](http://ridgid.com)

**High points**

- ▲ A large tabletop, good power, and minimal blade scoring on the cuts.
- ▲ Fence locks at front and rear, reducing deflection to .002". Its 36" rip capacity is the widest by 6".
- ▲ Splitter/guard assembly mounts and dismounts with a few turns of a thumbscrew—easy enough to make this safety device convenient.
- ▲ Built-in mobile base with four swivel casters goes any direction. It locks and unlocks with a pedal.
- ▲ Slots in cast-iron wings simplify clamping feather boards and jigs to tabletop.
- ▲ "Eccentric lever" at rear of saw dials in blade-to-miter-slot alignment without a mallet.

**Low points**

- ▼ It takes 33½ turns of the crank to raise the blade to full height—nearly three times as many as most other contractor-style saws in our test.



**Shop Fox W1725, \$650**  
800/840-8420, [shopfox.biz](http://shopfox.biz)

**High points**

- ▲ This is the only saw we tested with a magnetic switch that prevents the saw from turning back on should power be interrupted.
- ▲ Large, clear markings and a magnified cursor make fence scale easy to read.
- ▲ Fence has adjustment screws for bringing it parallel to blade and perpendicular to tabletop.
- ▲ Miter-gauge bar adjusts to fit miter slot.

**Low points**

- ▼ One of the slowest cutting saws in our test.

**More points**

- ◆ The "off" button must be rotated before turning on the saw (a safety feature to prevent accidental startup), which takes some getting used to.
- ◆ One of two saws in our test with stamped-steel extension wings.



**Bosch 4000-09, \$550**  
877/267-2499, [boschtools.com](http://boschtools.com)

**High points**

- ▲ Low fence deflection, thanks to a fence that locks front and rear.
- ▲ Blade-arbor lock makes changing blades a one-wrench task.
- ▲ "Gravity Rise" stand collapses with little more than a twist of the locking handle for storage and transporting.
- ▲ On-tool storage for wrenches and extra blades.

**Low points**

- ▼ For rips wider than 13", you must lock the fence at 13", extend the right wing, and then read a different fence scale. It can be confusing.
- ▼ Blade must be raised to full height before you can remove the throat-plate insert.



**DeWalt DW744S, \$500**  
800/433-9258, [dewalt.com](http://dewalt.com)

**High points**

- ▲ Large knob and rack-and-pinion system for extending the fence to rip wider than 13" makes fine adjustments a breeze.
- ▲ Low fence deflection, thanks to a fence that locks front and rear.
- ▲ On-tool storage for wrenches and extra blades.

**Low points**

- ▼ Miter gauge fits sloppily in the miter gauge slot. Without a T-shaped miter slot, crosscutting workpieces wider than about 5" is tricky.
- ▼ Stand lacks wheels for mobility, won't easily fit through doorways, and saw must be removed before you can collapse it for storage.
- ▼ No T-slots in fence for attaching accessories.



**Ridgid TS2400, \$500**  
800/474-3443, [ridgid.com](http://ridgid.com)

**High points**

- ▲ Low fence deflection: a test-best .002", thanks to a fence that locks front and rear.
- ▲ The second-fastest cutting saw in the test.
- ▲ Wheeled base collapses easily for mobility.
- ▲ On-tool storage for fence, miter gauge, wrenches, and extra blades.
- ▲ This saw is almost ready to go to work right out of the box. You only need to install the splitter/guard (requiring only a knob) and the blade.

**Low points**

- ▼ Excessive play in the arbor assembly resulted in noticeable scoring on cuts.
- ▼ Magnifier on fence scale can distort the scale, making it difficult to read.

**More points**

- ◆ If space and portability are more important to you than cut quality, the TS2400 heads the list of portable tablesaws.



# MID-PRICED TABLESAWS: HOW MODELS PRICED FROM \$500 TO \$700 MADE THE CUT

BRAND	MODEL	POWER TRAIN				TABLE				PERFORMANCE RATING (6)										ACCESSORIES (9)								
		MOTOR VOLTAGE (1)	(BELT OR DIRECT DRIVE)	BLADE SPEED (RPM)(2)	BLADE TILT (LEFT OR RIGHT TO FULL BLADE HEIGHT)	SIZE INCLUDING EXTENSION WINGS (WXL, INCHES)	MATERIAL (3)	RIP CAPACITY (INCHES) (4)	MAXIMUM CROSSCUT (INCHES) (5)	MAXIMUM CUTTING DEPTH (INCHES) (5)	POWER (7)	QUALITY OF CUT	LACK OF FENCE DEFLECTION	READABILITY OF FENCE SCALE	MITER GAUGE FIT	EASE OF ADJUSTING BLADE	SPLITTER AND GUARD QUALITY	DUST COLLECTION EFFICIENCY (6)	CLARITY OF OWNER'S MANUAL	CORD LENGTH	STANDARD	OPTIONAL	WARRANTY (YEARS)	COUNTRY OF ASSEMBLY (10)	WEIGHT (POUNDS)	SELLING PRICE (11)		
CONTRACTOR-STYLE	BRIDGEWOOD	TSC-10CL	110/220	B	3,966	L	12¼	30x27	CI	30	11¼	3	A-	A-	A	A-	A	A	C	B	A	6'	D	CI	1	T	308	\$550
	CRAFTSMAN	22114	110/220	B	3,599	L	19½	40x27	CI	25½	12¼	3¾	A-	A-	B	A	A	A-	B+	A	A	8'	C	D	1	C	385	\$650
	DELTA	36-680	110/220	B	3,046	R	18½	40½x27	CI	31	12½	3½	B-	B-	B	A	A	A	C	N/A	B	8'	C	B,D,M	2	C	234	\$600
	GENERAL INTERNATIONAL	50-185	110/220	B	4,228	L	12½	40x27	CI	30	11¼	3	B	A-	B	B	A	A	C	B	D	6'	D		2	T	300	\$700
	GRIZZLY	G0576	110/220*	B	4,247	L	12½	39¾x27	CI	30	11¼	3¾	B	A-	A-	A	A	A	C	B	A	11'	C,D		1	T	298	\$615
	JET	JWTS-10JF	110/220	B	4,179	R	13½	40x27	CI/SS	30	11¼	3½	A	B+	B	A	B	A	C	B	A	6'2"		CI,D,M	2	T	260	\$650
	RIDGID	TS3650	110/220	B	3,172	L	33½	44x27	CI	36	13	3¾	A-	A	A	A	A	A-	B+	A-	A	10'	C,M		3	T	287	\$570
SHOP FOX	W1725	110/220	B	4,243	L	12½	39½x27	CI/SS	28	11	3¾	B-	A-	A-	A	A	A-	C	B	A	10'	D	C,M	2	T	285	\$650	
PORTABLE	BOSCH	4000-09	110	D	3,024	L	26½	29x21½	AL	25	6¾	3½	B	B-	A	C	A-	B	C	A-	A	10'	C,W		1	T	56	\$550
	DeWALT	DW744S	110	D	3,862	L	26	26½x19½	AL	24½	5	3½	B+	B-	A	B-	C	B	C	A-	B	8	C,S		3	M	58	\$500
	RIDGID	TS2400	110	D	4,222	L	17	30x21	AL	25	8½	3½	A-	C+	A	B-	A-	B	B	A-	A	10'	C,W		3	T	122	\$500

- NOTES:**
- (\*) Wired from the factory for 220V. All others wired for 110V.
  - Measured with phototachometer under no load.
  - (AL) Cast aluminum  
(CI) Cast iron  
(CI/SS) Cast-iron main table with stamped-steel extension wings
  - All tested saws can rip up to approx. 12" left of the blade, except the Craftsman 22114, with 24½" capacity left of the blade.
  - Measured with miter-gauge head on table.
  - |   |           |
|---|-----------|
| A | Excellent |
| B | Good      |
| C | Fair      |
| D | Poor      |
  - Using full-kerf combination blade.
  - [N/A] No dust-collection port on this model.
  - (C) Carbide-tipped saw blade  
(CI) Cast-iron extension wing(s)  
(D) Dado throat-plate  
(M) Mobile base  
(S) Stand  
(W) Stand with wheels
  - (C) China  
(M) Mexico  
(T) Taiwan
  - Prices current at time of article production and do not include shipping where applicable.

## PALS: A table saw owner's best friend

One of the most difficult adjustments to make on almost any contractor-style saw is aligning the blade to the miter slot. The task often involves lying under the saw and tapping the trunnions into alignment with a mallet—not a very fine adjustment. The easy-to-install Precision Alignment and Locking System (PALS) from In-Line Industries eliminates much of the woe.

PALS consists of a pair of threaded studs and aluminum angle that replace your

contractor-style saw's rear trunnion bolts. By turning a hexhead wrench in the angle-mounted socket-head cap screws, you can gently nudge the trunnion assembly into perfect alignment. Once you've paralleled the blade and miter slot, simply tighten the locking nut against the aluminum angle to help keep the trunnions aligned by restricting their movement. PALS costs \$20. For more info, call or click: 800/533-6709 or in-lineindustries.com

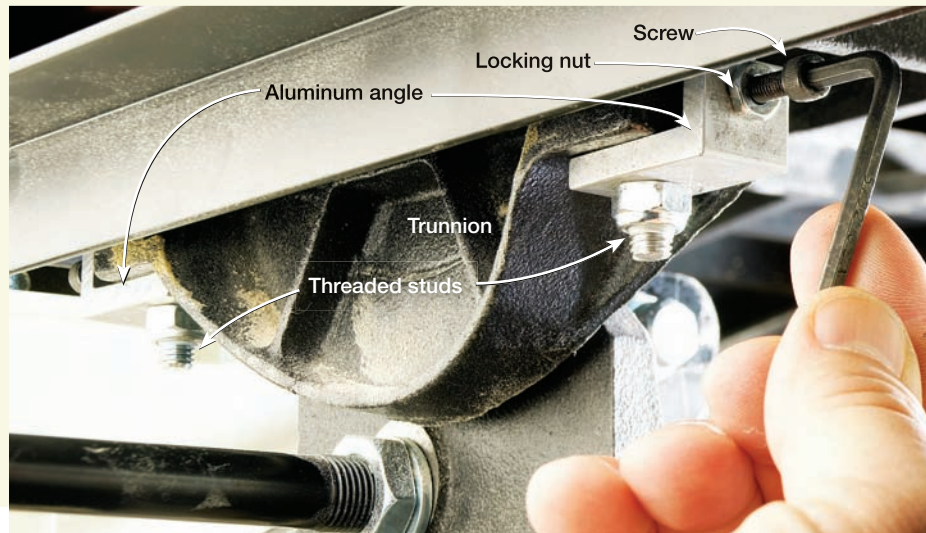

## These tools are tops among the mid-priced table saws

Performance-wise, the Bridgewood TSC-10CL and Ridgid TS3650 were at the top and running neck-and-neck until the very end. Even their prices are close. But we have to give the Ridgid our nod for Top Tool because of its extra rip capacity and firm-locking fence, and because it comes with two cast-iron wings, a nifty built-in mobile base, and carbide-tipped saw blade.

We can't really recommend any of the portable saws when compared head-to-head with the contractor-style saws, unless mobility and floor space top your priority list. If that's the case, we'd recommend the Ridgid TS2400. It has the most power of the portable saws and lots of nice features, but we found its cut quality subpar. 🌲

Written by Dave Campbell with Pat Lowry

**Share your opinion** of these table saws in our Interactive Tool Review at [woodmagazine.com/tableaws](http://woodmagazine.com/tableaws)



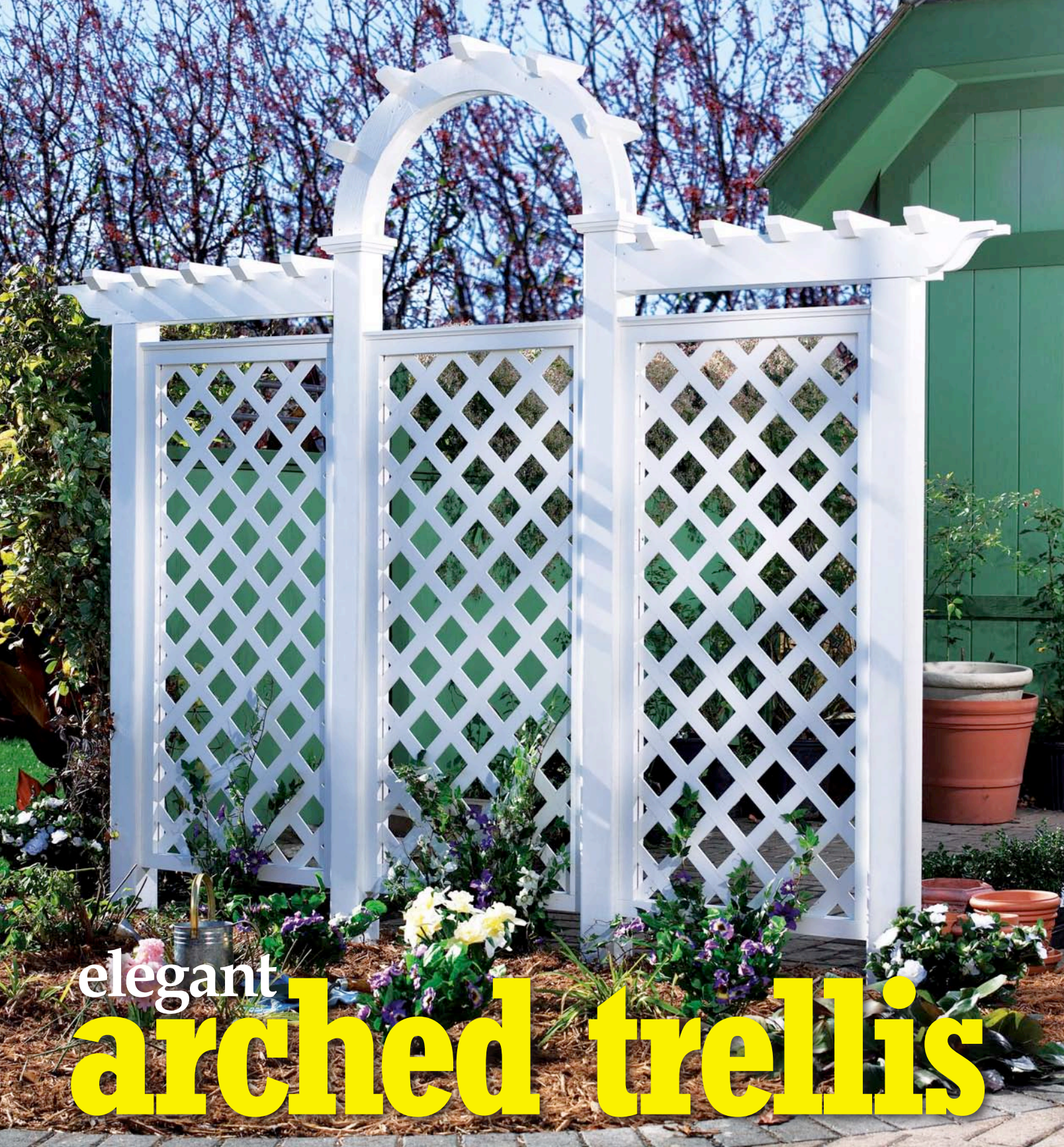

elegant

# arched trellis

Whether used as a home for climbing plants or a privacy screen for a deck or patio, expect this latticed beauty to capture the envious eyes of neighbors.

### AT A GLANCE

- Overall dimensions are 104" wide x 8" deep x 86½" high.
- PVC lattice never needs painting.
- For the board feet of lumber and other items needed to build this project, see *page 87*.



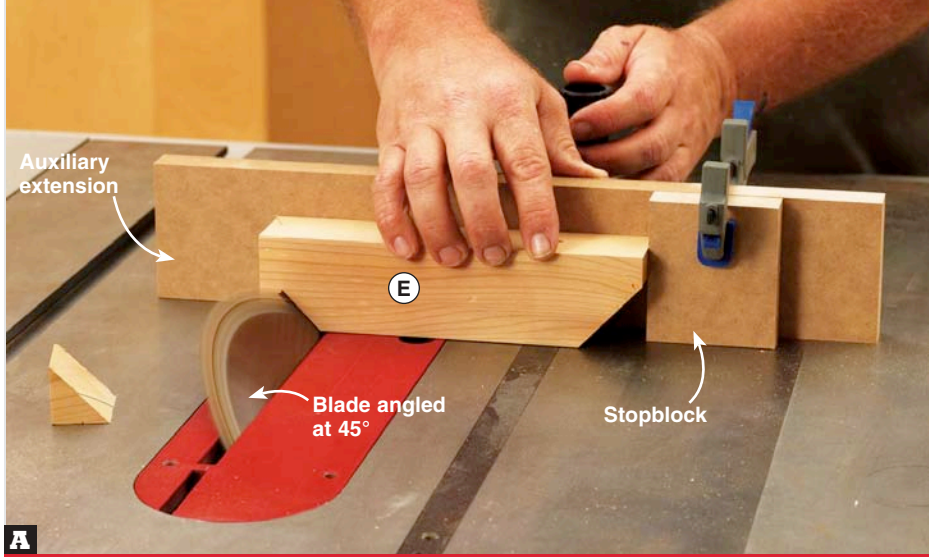

**A** **BEVEL-CUT THE CLEAT ENDS**

Using an auxiliary extension with a stopblock on your miter gauge, bevel-cut an end of the cleat (E). Flip the cleat, and cut the other end.

**D**on't let the impressive looks of this project fool you. You need only basic skills, portable power tools, and common construction materials available at your local home center to build it. With super-simple butt joinery, full-size patterns to easily form the curved parts, and measurements no finer than 1/4", you'll find this beautiful yard accessory the perfect weekend project.

### Start with the posts and crossarms

**1** From the straightest pressure-treated 4x4 (3 1/2 x 3 1/2" actual) posts you can find, crosscut the end posts (A) and center posts (B) to the needed lengths to reach the frost line for your area. (Check with your local building department for the frost-line depth.) The minimum lengths are 90 1/2" for the end posts and 91 3/4" for the center posts, where shown on **Drawing 1** on page 84. These lengths include a below-grade length of 24" for safe support of the structure.

**2** Using your portable circular saw, cut 4 1/4" rabbets 3/4" deep on the front and back faces of the end posts (A) at the crosscut ends, where shown on **Drawing 1**. For help on doing this, see the **Shop Tip**, right.

**3** From 1x6 (3/4" thick actual) cedar, cut the crossarms (C) to the size listed in the **Materials List**. To make a template for marking the crossarm shaped ends and locations for the mounting holes, cut a 4 1/4 x 11" piece from 1/4" hardboard. Photocopy the full-size crossarm end pattern from the **WOOD Patterns** insert. Spray-adhere the pattern to the hardboard. Bandsaw or jigsaw and sand the template to the pattern lines. Then drill a small hole (ours was 1/8"), sized to accept an awl or a nail for marking purposes, through the template at the centerpoints for the four mounting holes.

**4** Noting that the crossarms at each end of the trellis are mirror-image pairs, align the shaped end of the template with the *outside* end of a crossarm. Draw the shape and mark centerpoints for the four mounting holes. Then align the other end of the template with the *inside* end of the crossarm, and mark centerpoints for only two mounting holes, where shown. Repeat for the other crossarms. (For two of the crossarms, you'll need to flip over the template for marking.)

**5** Using a bandsaw or jigsaw, cut the ends of the crossarms to shape. Then drill countersunk shank holes through the crossarms, where marked.

**6** From 2x6 (1 1/2" thick actual) cedar, cut the two crossarm mounting blocks (D) and 15 cleats (E) to the sizes listed. Drill countersunk mounting holes through the face of the mounting blocks, where dimensioned on **Drawing 1a**. Set the blocks aside.

**7** On one cleat (E), mark the 45° beveled ends, where dimensioned on **Drawing 2**. Angle your tablesaw blade to 45° and bevel-cut the ends of the cleat, as shown in **Photo A**. (You also can use a miter saw to cut the bev-els.) Repeat for the remaining cleats.

**8** Mark on one cleat the locations for the two 3/4" dados 3/4" deep to fit the crossarms (C) and arch segments (H). Refit your tablesaw with a 3/4" dado blade set at 90°. Then reposition the stopblock to align a marked dado location on the cleat with the blade. Using the same cut-and-flip process, cut the 3/4"-deep dados in the cleat. (You also can cut the dados using a jigsaw.) Repeat for the other cleats.

**9** Position five cleats (E) on each pair of crossarms (C), where dimensioned on **Drawing 1**. Then nail the cleats to the crossarms. (To prevent splitting the soft cedar, we drilled 1/16" pilot holes before driving the nails.) Set the remaining five cleats aside.

## SHOP TIP

### 3 easy steps for safely cutting large rabbets in long stock

To cut the 4 1/4" rabbets 3/4" deep in the ends of the trellis 4x4 end posts (A), use a square to lay out the rabbets. Then clamp the posts onto sawhorses. Adjust your portable circular saw for a 3/4"-deep cut. Now form the rabbets, as shown.

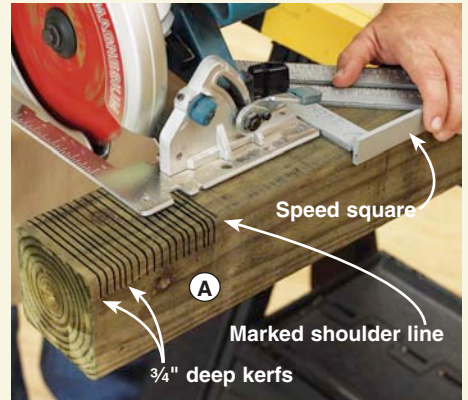

**Step 1:** Using a guide, such as a speed square, cut a series of kerfs approximately 1/8" apart across the width of the marked rabbet, stopping at the shoulder line.



**Step 2:** Break away the remaining thin pieces from the rabbet with a hammer. Using moderate force, you'll need to take a couple of swings to break all of the pieces.



**Step 3:** Using a mallet and a chisel at least 1" wide, pare away the remaining material to smooth the rabbet. To avoid dig-ins, hold the chisel with the bevel facedown.





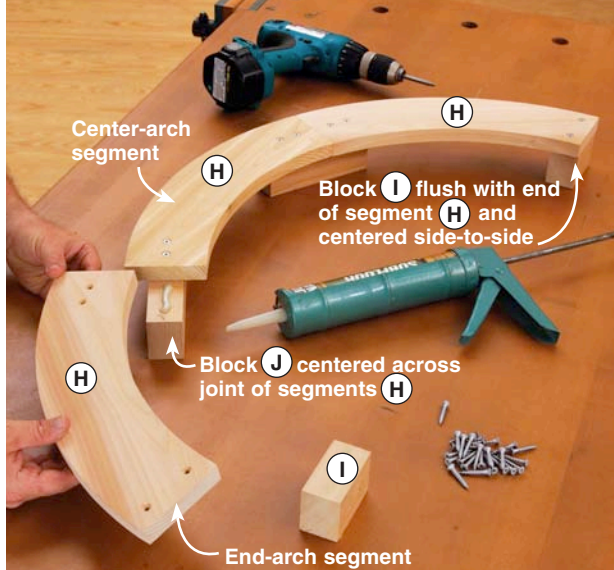

**B**  
**FORM THE SEGMENTED ARCH**  
Fasten two end-arch segments (H) and a center-arch segment to the mounting blocks (I, J), positioning the blocks as shown.

### 3 CAPS AND ARCH MOUNTING DETAIL

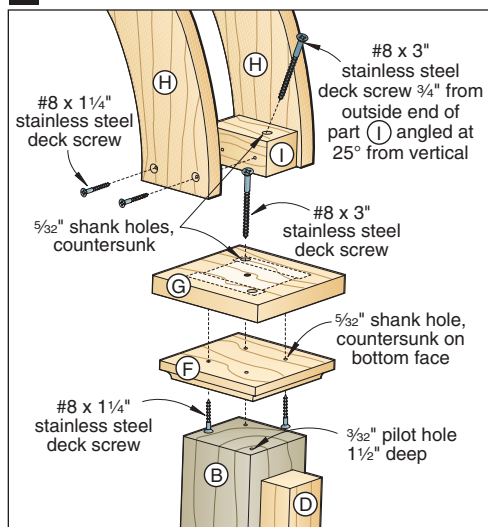

### 4 LATTICE-FRAME MOUNTING TOP SECTION VIEW

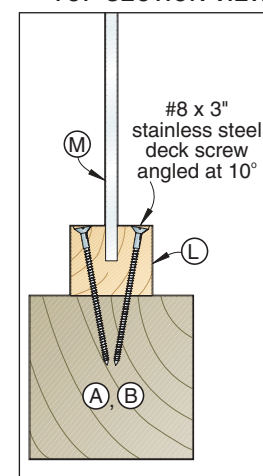

## On to the post caps and arch assembly

**1** From  $\frac{3}{4}$ "-thick stock, cut the sub caps (F) and caps (G) for the center posts (B) to the sizes listed. Then, using your router table and a pushblock for safety, rout a  $\frac{3}{8}$ " cove along the bottom edges of the sub caps, where shown on **Drawing 1**.

**2** Using a construction adhesive (we used Liquid Nails Subfloors and Decks Adhesive, LN-602), adhere the sub caps, centered, to the bottom of the caps. Then drill two countersunk mounting holes through the bottom face of the sub caps into the caps, where shown on **Drawing 3**, and drive the #8x1 $\frac{1}{4}$ " deck screws. Now drill two mounting holes through the top face of the caps for attaching the assemblies to the posts.

**Note:** We used corrosion-resistant stainless steel screws, suitable for use with the cedar and pressure-treated lumber, to assemble the trellis. To reduce cost, you also can use double hot-dipped galvanized screws, but you may get staining around them in the cedar from the tannic acid.

**3** From  $\frac{3}{4}$ "-thick stock, cut six 5 $\frac{1}{2}$ x16" pieces to form the arch segments (H). Then, from  $\frac{1}{4}$ " hardboard, cut a same-size piece to make a template for drawing the arch-segment shape and marking the mounting-hole locations. Photocopy the full-size arch-segment pattern from the insert. Spray-adhere the pattern to the hardboard. Bandsaw or jigsaw to shape, and sand to the pattern lines. Now drill a  $\frac{1}{8}$ " (or suitable size) hole for marking through the template at the centerpoints of the eight mounting holes.

**4** Position the template on an arch segment (H) with the bottom edges aligned. Draw the shape on the segment. Then mark the locations of the appropriate pair of mounting holes (for an inside or outside end) on both

ends, where shown on the pattern and **Drawing 1**. Repeat for the remaining segments.

**5** Bandsaw or jigsaw and sand the arch segments to shape. Then drill the countersunk mounting holes.

**6** From  $\frac{1}{2}$ "-thick stock, cut the end-arch mounting blocks (I) and the two center-arch mounting blocks (J) to the sizes listed.

**7** To assemble the arch, fasten two end-arch segments (H) and a center-arch segment to the end-arch mounting blocks (I) and center-arch mounting blocks (J), where shown on **Drawing 1** and in **Photo B**. Secure the parts with construction adhesive and #8x1 $\frac{1}{4}$ " deck screws. Next, turn the assembly over, and attach the remaining three arch segments to the blocks. Now nail the five cleats (E) that you set aside earlier to the arch assembly, positioning the cleats where shown on **Drawing 1** and the arch-segment pattern.

## Now let's make the lattice-frame parts

**1** From  $\frac{1}{2}$ "-thick stock, cut the lattice-frame rails (K) and stiles (L) to the sizes listed. Using a  $\frac{1}{4}$ " dado blade in your tablesaw or a  $\frac{1}{4}$ " straight bit in your router with an edge guide, cut a centered groove  $\frac{3}{4}$ " deep along the *inside* face of the rails and stiles, where shown on **Drawing 1**, to fit your  $\frac{1}{4}$ " lattice parts (M).

**2** To allow water drainage, drill  $\frac{1}{4}$ " holes spaced 2" apart in the grooves in the three bottom rails (K), where shown. Then drill countersunk mounting holes angled at 10° on the inside faces of the stiles (L), where shown on **Drawings 1** and **4**, for attaching the lattice frames to the posts (A, B) later.

**3** Using your tablesaw or jigsaw, cut the  $\frac{1}{4}$ " PVC lattice (M) to size. The lattice flexes easily, so use a support stand or a helper to keep it flat while you cut it.

**4** From  $\frac{3}{4}$ "-thick stock, cut the lattice-frame caps (N) to size. Then rout a  $\frac{3}{8}$ " cove along the front and back edges of the caps on the bottom face, where shown. Set the caps aside.

## Time to prime and paint, and assemble the frames

**1** Prime and paint all of the parts, except for the lattice. (We applied one coat of Behr Plus 10 Oil-Based Primer Sealer No. 94 followed by two coats of Behr Premium Plus Porch & Patio Floor Paint, Low-Lustre Ultra Pure White No. 6050.)

**2** Assemble and clamp together (no glue) the three lattice frames with the lattice (M) captured in the grooves in the rails (K) and stiles (L) and the ends of the rails flush with the outside faces of the stiles, where shown on **Drawing 1**. Drill a pair of countersunk mounting holes through the top and bottom rails at both ends into the stiles, centered on the  $\frac{1}{2}$ " thickness, where shown. Now drive the #8x3" deck screws.

**3** With the coves facing down, position the lattice-frame caps (N) on the top rails (K), flush with the rail ends and centered front-to-back. (The top rails do not have the drainage holes.) Drill three pairs of countersunk mounting holes through the caps and into the rails, where shown. Then drive the #8x1 $\frac{1}{4}$ " deck screws.

## Plant the posts, and mount the lattice frames

**Caution:** Before you dig the postholes, call the "One Call" phone number for your state or province, and ask to have the buried pipes and wires on your property located and marked. If you can't find the number, call the North American One Call Referral System at 888/258-0808.



### ATTACH AND LEVEL A 2x6 AS A GUIDE FOR EASY ALIGNMENT OF THE POSTS

**C** With the end post (A) plumb and braced with 1x3s, attach an 8'-long 2x6 to the post with the top edge aligned with the top tape.

**D** Holding the free end of the 2x6 level with the front face 1/4" back from the center of the postholes, screw the 2x6 to a 1x3 stake.

**1** On a flat area, mark the center locations for the four holes for the posts (A, B) spaced 28 1/2" on center, where dimensioned on **Drawing 1**.

**2** Referring to **Drawing 5** and using a post-hole digger or an auger, dig 10"-diameter holes, centered on the marked locations, to the needed depth to reach your frost line plus another 6" for a gravel base. Pour 6" of gravel in the holes.

**3** To make it easy to set the posts at the correct height and to position the lattice frames (K/L/M/N) between the posts, draw alignment lines around the posts. Referring to **Drawing 1** and measuring from the top ends, mark lines for grade level at 66 1/2" for end posts (A) and 67 3/4" for center posts (B). Then mark lines 7" above these lines on all

of the posts for aligning the bottoms of the lattice frames. For better visibility, wrap blue easy-release painter's tape around the posts, aligning the top of the tape with the marked lines at the two locations.

**4** Place an end post (A) centered in an outer hole with the rabbets in the top positioned where shown on **Drawing 1**. Check that the top edge of the bottom tape is even with grade level. Add or remove gravel as needed to adjust the post height.

**5** Plumb the post using a level. Then brace it using 1x3s fastened with #8x1 1/4" deck screws, as shown in **Photo C**. To establish a level reference to easily position and align the remaining posts, attach one end of an 8'-long 2x6 to the back face of the post with a #8x3" deck screw and the other end to a 1x3

stake with a #8x1 1/4" deck screw, as shown in **Photos C and D**.

**6** Position a lattice frame (K/L/M/N), with the bottom rail (K) that has drainage holes down, on the end post (A) with the bottom face of the rail even with the top edge of the top tape and the frame centered front-to-back. Clamp the frame to the post, and drive the screws through the predrilled angled holes in the stiles (L) into the post, as shown in **Photo E**. To give clearance for the drill chuck, use a long screwdriver bit. (We used a 6"-long Phillips bit, available at home centers.)

**7** Place a center post (B) in the adjacent hole tight against the lattice frame attached to the end post (A). Add or remove gravel to align the top tape on the post with the top edge of the 2x6. Drive #8x3" deck

### 5 POSTHOLE SECTION VIEW

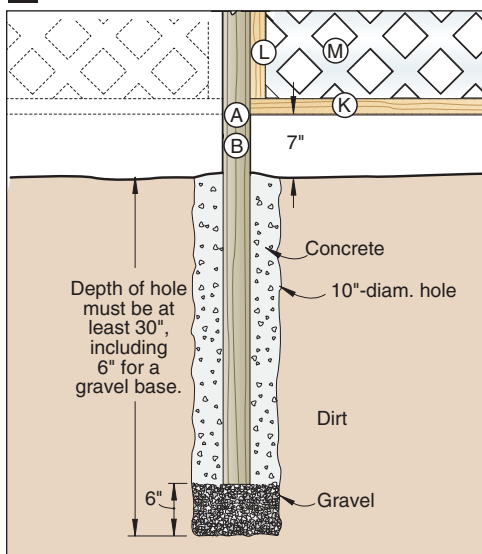

### Cutting Diagram

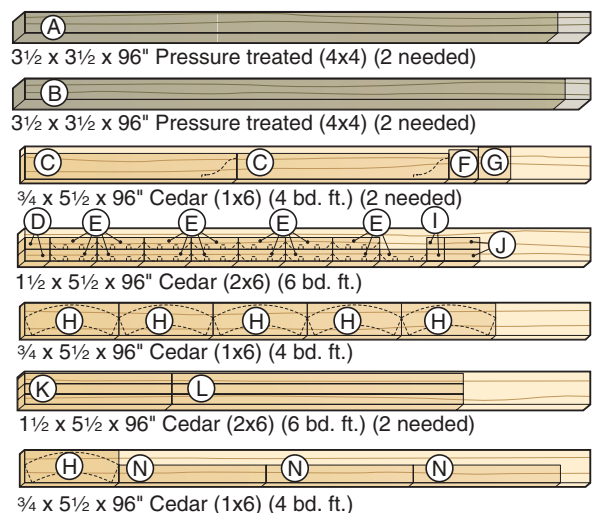





### ATTACH THE LATTICE FRAME

With the lattice frame (K/L/M/N) clamped in position to the end post (A), drive #8x3" deck screws through the stiles (L) into the post.

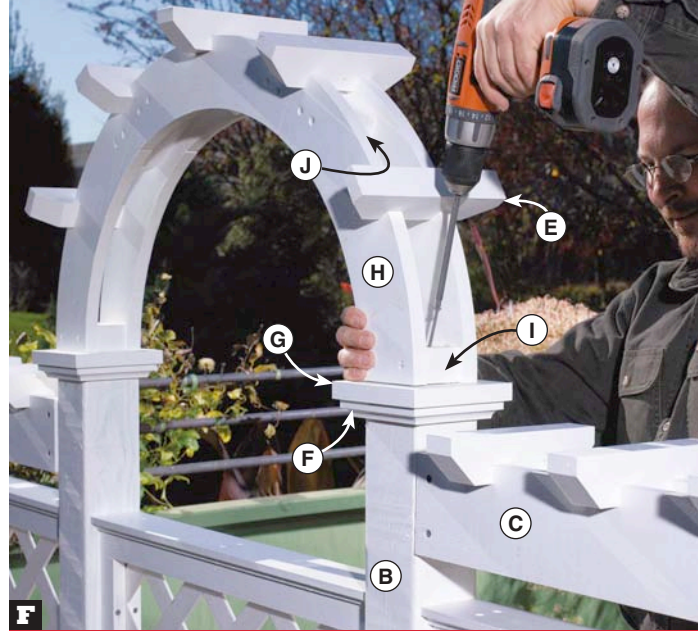

### MOUNT THE CROWNING ARCH

With the arch assembly (E/H/I/J) centered on the caps (G), drive a #8x3" deck screw through each block (I) into the cap.

screws through the 2x6 into the post to hold it in position. As before, center the lattice frame front-to-back on the center post and screw it to the post. Repeat the process to install the remaining center and end posts and lattice frames. Then fill the holes with concrete, where shown on **Drawing 5**.

### Add the crossarm and arch assemblies

**1** Screw the crossarm mounting blocks (D), centered front-to-back, to the sides of the center posts (B), where dimensioned on **Drawing 1**. Then slide a crossarm assembly (C/E) into position over the rabbeted end of an end post (A), where shown, with the bottoms of the crossarms (C) and mounting block flush. Drive the screws through the

predrilled holes in the crossarms into the end post and mounting block. Repeat for the other assembly.

**2** Center the cap assemblies (F/G) on the center posts (B), and secure them with #8x3" deck screws, where shown on **Drawing 3**. Then center the ends of the arch assembly (E/H/I/J) on the caps (G). Drill an angled mounting hole through each end-arch mounting block (I), where shown, and drive the screws, as shown in **Photo F**.

**3** After the concrete cures, remove the 1x3 bracing. Fill the screw holes with acrylic caulk, and touch up with paint. Now, plant some flowers and climbing plants, and rest awhile to admire your handiwork. 🌿

Written by **Owen Duvall** with **Jeff Mertz**  
Project design: **Kevin Boyle**  
Illustrations: **Roxanne LeMoine**

### Materials List

Part		FINISHED SIZE			Mati.	Qty.
		T	W	L		
A	end posts	3½"	3½"	†	PT	2
B	center posts	3½"	3½"	†	PT	2
C	crossarms	¾"	4¼"	36"	C	4
D	crossarm mounting blocks	1½"	2"	4¼"	C	2
E	cleats	1½"	2"	8"	C	15
F	sub caps	¾"	5"	5"	C	2
G	caps	¾"	5½"	5½"	C	2
H*	arch segments	¾"	5¾"	16"	C	6
I	end-arch mounting blocks	1½"	2"	3"	C	2
J	center-arch mounting blocks	1½"	2"	6"	C	2
K	lattice-frame rails	1½"	1¾"	25"	C	6
L	lattice-frame stiles	1½"	1¾"	49½"	C	6
M	lattice	¼"	23½"	51"	L	3
N	lattice-frame caps	¾"	3"	25"	C	3

\*Parts initially cut oversize. See the instructions.

†The minimum lengths are 90½" for end posts (A) and 91¾" for center posts (B). This includes a below-grade length of 24" for safe support of the structure. Increase lengths of posts as needed to reach your local frost-line depth.

**Materials key:** PT—pressure-treated, C—cedar, L—diagonal-pattern PVC lattice.

**Supplies:** Spray adhesive, construction adhesive, 8d galvanized finish nails, #8x1¼" and #8x3" stainless steel deck screws, easy-release painter's tape, 50-pound bags of gravel (4), concrete (one 60-pound bag per 12" depth of posthole), acrylic caulk.

**Blades and bits:** Dado-blade set, ¾" cove and ¼" straight router bits, 6"-long Phillips bit.

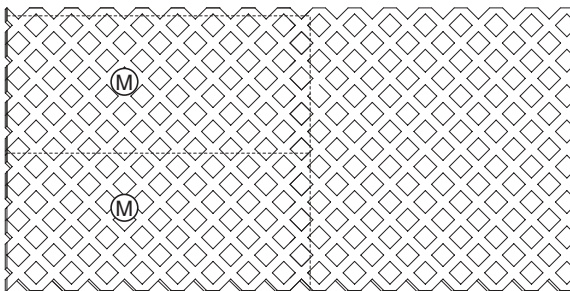

¼ x 48 x 96" PVC lattice

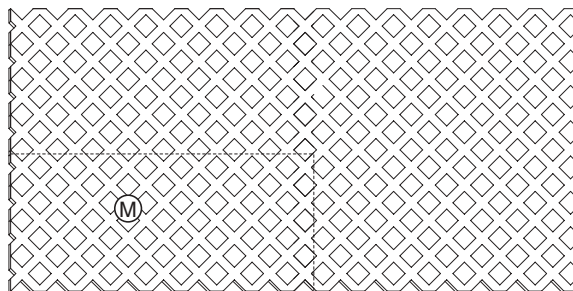

¼ x 48 x 96" PVC lattice

**Find more**  
great outdoor  
projects at  
[woodmagazine.com/outdoor](http://woodmagazine.com/outdoor)



VISIT WITH A MASTER CHAIR-MAKER

# Curtis Buchanan's 3 showstopping finishes





**O**ftentimes, the word “country” describes a furniture style that’s simple, unrefined, and maybe even a little rough around the edges. That falls woefully short in characterizing the chairs made by Curtis Buchanan, who plies his trade in the shadow of the Smoky Mountains. A professional chair-maker for more than 20 years, Curtis’s work marries strength with

beauty. How else could an eight-pound Windsor chair support 200 pounds every day for generations? But according to Curtis, the tapered mortises and spokeshaved spindles aren’t what first attracts his non-woodworking clientele—it’s the finish.

Curtis’ finishing techniques are country, too—country simple, that is. Although they take time to lay down, they don’t require a

high level of skill, aren’t dust sensitive, and guarantee good results even on your very first attempt.

We visited Curtis at his shop in Jonesboro, Tennessee, to see how he applies his three favorite finishes: a homemade oil/varnish, a simple one-color milk paint, and a pleasing multi-layered milk paint finish. Give one a try on your next country project.

## 1 A Buchanan Favorite: Homemade Oil/Varnish Finish

“There’s not much to my wiping finish,” says Curtis, almost apologetically. But in truth, his simple blend of oil, varnish, and thinner compares well to other pre-mixed finishes—for less than half the price. And once you stir up a batch or two for yourself, you’ll learn how to make small changes to the mix to better suit your project or working style.

### Mixing it up

You don’t need a degree in chemistry to make your own wiping varnish. Pour equal amounts of mineral spirits, boiled linseed oil, and spar varnish into a glass jar and stir them together. (See the photo *below*.) According to Curtis, the boiled linseed oil accentuates the grain, the spar varnish provides water protection and gives the finish a sheen, and the mineral spirits thins the mix so that you can wipe it on easily with a rag. (Curtis hasn’t observed any difference between expensive marine-grade spar and the cheaper store-brand varnishes. Use whatever you have on hand.) Like most finishes, this blend will start to cure as soon as it’s exposed to air. For that reason, store it in a tightly sealed container, and mix up only the amount you might need for a particular project.

“By knowing what goes into the finish, it’s easy to adjust the mix to suit your working style or to deal with changes in the weather,” says Curtis. For example, adding more varnish makes a finish that dries faster and builds quicker, which is an advantage if you’re in a hurry to get a project out of the shop, but it’s harder to wipe down between coats. On the other extreme, during the summer or when working on a large piece, adding more mineral spirits makes a blend that’s easier to wipe on and off, although because it’s thinner, you’ll probably need to apply a few extra coats.



Start by mixing up equal parts of spar varnish, boiled linseed oil, and mineral spirits in a sealable container.



Curtis likes an oil-varnish finish because it not only protects the wood but it also highlights beautiful grain like that found in the stool’s seat.

### Preparing the wood

Because wiping varnish leaves such a thin film, you need to pay careful attention to the wood. “What you see is what you’ll get,” claims Curtis. After planing and scraping, Curtis carefully hand-sands all surfaces up to 320-grit. After sanding, he recommends wiping down the project with a rag dampened in mineral spirits. Doing this will show up imperfections, such as dents, or spots of dried glue.





### Step 1

Project prep for applying an oil/varnish blend requires sanding all surfaces up to 320 grit, and then wiping up the dust.

### Wiping on that special look

Curtis begins by sanding the wood as shown in **Step 1**. When wiping on the first coat (**Step 2**), he recommends putting on as much finish as the wood can absorb before the varnish starts to harden and seals the pores of the wood. “Pay extra attention to the end grain,” says Curtis. “It tends to wick up finish like a sponge.”

After about 15 minutes, wipe off the excess finish with a rag. (If the coat tacks up before it can be wiped off, add more finish and wipe it off immediately.) Allow the project to dry for at least a day before continuing. Any more and you could create problems with the underlying coat. If you need to smooth rough patches, Curtis says you can sand lightly between coats, but try not to overdo it.



### Step 3

Coarse burlap is perfect for knocking off dust nibs and burnishing the surface. Follow up with a wax top coat to produce a nice, even sheen.



### Step 2

As Curtis wipes on the first coat, the butternut springs to life. Apply more finish to those spots that quickly absorb finish.

“Remember, the point is to build up a finish,” he says. Repeat the wipe on/rub off process for two or three more applications, or until you achieve the level of “build” you’re after. To arrive at a quality look, examine every inch of the piece to ensure an even application.

### Finishing touches

Your next step is to show patience. Depending on the number of coats applied, and other factors such as temperature, humidity, and your particular oil/varnish blend, it may take a few days, or as long as a week, for the finish to cure completely. “When in doubt, wait an extra day,” says Curtis.

Once the surface dries, Curtis lightly buffs it with coarse burlap cloth to knock off any dust nibs as shown in **Step 3**, and then applies a coat of paste wax with 0000 steel wool. “The wax offers a little extra protection, but what I really like is the sheen it gives to the wood,” he explains.

## SAFETY WARNING

As it cures, linseed oil generates enough heat to ignite rags or papers, even without a flame, spark, or heat from another source. This reaction is called spontaneous combustion. To avoid the danger of fire, oil-soaked rags, newspapers, or other waste should be placed in a sealed water-filled container immediately after use. Another alternative is to spread the rags outdoors on a non-combustible surface, away from buildings, until they are thoroughly dry. After the finish has completely cured, the stiff rags can be discarded with regular trash.



## 2 A Time-Tested Milk-Paint Finish

Most of Curtis's chairs aren't made from eye-popping hardwoods, but from a blend of hardwoods and softwoods, chosen for certain attributes, such as strength, flexibility, or workability. To visually tie everything together, Curtis applies a finish long used by country woodworkers who wanted to add splashes of color to otherwise drab rooms—milk paint. "Milk paint matches the chair," he says. "It adds color, but you can still feel the wood. It's about as close to raw wood as it gets."

### What's in your milk paint?

Milk paint consists of lime, casein (milk protein), clay, and pigment. Woodworkers have mixed their own for centuries. Today, it's available in 16 premixed colors. All you do is add water (See **Sources** on page 93 and the photo below).

"Milk paint is about the least toxic paint out there," says Curtis. Unlike other finishes, it contains no VOCs, driers, or other toxins. However, Curtis warns that it contains some hydrated lime, which can dry out your skin. "You'll want to wear a mask when rubbing it down," he says.

Because it contains no preservatives, milk paint can gel up. For that reason, mix only as much as you need. You can extend the working time of mixed paint 2–3 days by storing it in the refrigerator, and adding extra water in the mixture to keep it from gelling. When kept in a tightly sealed container, the dry mix remains useable indefinitely.

What really makes milk paint stand out is its distinctive look. Wood absorbs the thin-bodied paint more like a stain. Unlike other paints, the coat will not chip or peel, but will wear away to reveal wood or colors beneath. (On the next page, you'll learn how to take advantage of that quality using a multi-layered finish.)

Milk paint isn't perfect. For starters, it doesn't bond well to previously painted wood. Because it stains easily, it needs to be protected with a wiping varnish, and then a coat of wax. The total treatment takes almost a week to do, but, "When you watch how people are drawn to the finish, you'll agree that it was worth it," says Curtis.

### Mixing it up

The directions on the bag say to use equal amounts of water and dry mix, but Curtis says to consider that as a guide. "It's like making bread; you can't say exactly how much water, because it depends on how much moisture is in the air or already in the powder." Curtis starts with equal parts of warm water and dry mix, and then adds



Here's what you need to mix up a batch of milk paint. You can borrow many of these items from the kitchen, as long as you remember to clean everything off before the paint dries.



A quality milk-paint finish requires protective coats of varnish and wax.

more water—a few drops at a time—until he gets a mix that's smooth enough to spread, but still thick enough to cover the wood.

Mix the paint (Curtis uses an eggbeater as shown in the inset below), and then let it sit for 30 minutes. This is about the time needed to do the prep work (see page 89). After that, scoop off any foam that has risen to the top of the mix. Now pour the paint through cheesecloth to filter out any large particles. See **Step 1** below.



After mixing your milk paint (Curtis uses an eggbeater), pour it through cheesecloth to filter out any unmixed chunks that would stick out like boulders on the surface of the wood.



## Step 2

Curtis applies the first coat with a dabbing/stroking motion. The object isn't to be perfect, but to lay it on before it dries.

### Prep makes perfect

Milk paint lays on the wood like a second skin, which means that you'll need to be meticulous when preparing the surface of the wood. First, fill all dents, nail holes, even minuscule-sized knots with latex filler. "When you apply the first coat, even the smallest spots will jump out at you," says Curtis.

Because milk paint contains water, it raises the grain of the wood. To prevent this, Curtis sands the surface with 150-grit sandpaper, and then wipes everything down with a damp sponge. As soon as it dries, he lightly sands the surface with 150 grit, "just enough to

knock off the whiskers," he says. Don't sand too much, or else you may cut into the wood and expose more fibers.

### Giving milk paint a go

Because of milk paint's thinness and quick absorption, apply it more like a stain than a paint. Using a combination of dabbing and brushing strokes, lay on a thin, even coat as shown in **Step 2** at left. Don't worry if it doesn't look even at this point; the goal is simply to avoid leaving any drips or puddles on the wood. Stir the paint periodically to keep the solids from settling out. The first coat will dry to the touch in minutes, but you'll want to wait at least 4 hours between coats. Once it's dry, the first coat will look blotchy, but don't worry. The paint will start to show its true colors by the second coat. Because less will be absorbed by the wood, it also will prove a lot easier to brush.

Some lighter woods, such as maple, may look fine with two coats, but pine (because it absorbs so much) and oak may benefit from a third coat. At this point, visible brush strokes are okay, but Curtis suggests developing a painting sequence to ensure that everything gets the same amount of paint. "And don't answer the phone in the middle of a coat," warns Curtis. "It's almost impossible to tell where one coat stops and another starts."

*Note: If you're interested in the one-color treatment like the red chair shown on the previous page, jump ahead to the rubbing out and oiling instructions on the next page.*

## 3 Layering Milk Paint for a High-End Look



What makes milk paint unique is the way it wears to reveal colors hiding beneath. Some craftsmen layer several colors and then distress certain areas to simulate generations of use. Curtis' approach—one requested by most of his clients—involves brushing on a thin "wash" of black over a base coat, such as red, then rubbing down the piece until the underlying red appears to float to the surface. "It's much more interesting than plain black," says Curtis. "It can make pine look almost like antique mahogany or rosewood."

### Making and applying a wash coat

Because the objective is for a hint of red to show through the black, Curtis mixes up what he calls a "wash coat." This paint is mixed and strained just as before, except that you use two parts water for every one part of paint. Again, this isn't a hard and fast recipe. Test the paint on a sample board. Add a few more drops of warm water if you can't see a hint of red through the wet paint.

Once mixed, apply the wash coat as quickly and evenly as possible, as shown in **Step 1**, opposite top. Avoid touching up previously painted spots or you'll lay down too much paint. Be extra careful not to leave any puddles. When dry, those black blobs will crack down to the base coat and leave a telltale red spot.

After applying the first coat of black, Curtis brushes on a second, even lighter, coat that adds grain and depth to the finish. To do this,



This detail (above) of the Windsor chair (left) showcases the rich, aged look resulting from a multi-layered milk-paint finish.





**Step 1**

Curtis brushes a thin coat of black on top of three coats of barn red. Thin the black so that you can still see a hint of the red underneath.



**Step 2**

Apply an even lighter second coat of black. The tips of the bristles should leave streaks across the surface of the piece.



**Step 3**

Burnishing milk paint with #0000 steel wool is dusty work, but gives the otherwise flat finish a metallic sheen as shown in the inset.

he dips the brush into the paint and then runs it over the wood so that the bristle tips just graze the surface. Aim for a slightly streaky or grainy-looking appearance, as shown in **Step 2**.

**Rubbing and oil bring milk paint to life**

Whether you've stopped at one color or are going for the layered look, your milk-painted project may not look terribly impressive at this point. But the best is soon to come.

Starting with a maroon (medium-grit) synthetic wool pad, rub down every square inch of your project. (See **Step 3**.) The paint will turn chalky white. To develop a shiny, burnished look, Curtis suggests switching over to #0000 steel wool and "sanding until your fingers ache." As you can see in the far right bottom sample on the pine board *below*, if you rub hard enough, the paint will develop an almost metallic luster.

But wait, you're not finished quite yet. To top it all off, Curtis applies his oil/varnish blend, as shown in **Step 4**. Two to three coats

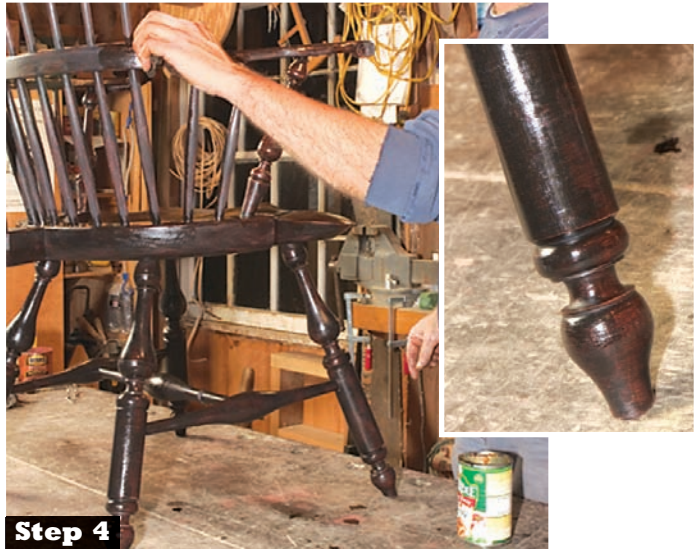

**Step 4**

An oil/gloss varnish topcoat protects the milk paint from staining and creates a richer look, as seen in the inset. Finish with a coat of wax.

of the wiping finish offer protection and give the milk paint an even richer look. After the oil finish dries, apply a coat of wax for an incredibly rich sheen (**Step 4 inset**).

The burnishing and oil give the finish a solid start, but many people believe that milk paint looks even better as it ages. "Clients ask me to match a chair that I built for them years ago," says Curtis. "I can duplicate the original finish, but what they really love—the shading and character—I have to leave that up to Father Time." 🌲

**Source**

The Old Fashioned Milk Paint Co., Inc.  
 P.O. Box 222  
 Groton, MA 01450  
 (866) 350-6455  
 www.milkpaint.com  
 pint, \$8.95, plus shipping

Written by Joe Hurst-Wajszczuk; photographs: Tom Raymond



A safe way to see the results of your milk-paint finish before committing it to a furniture piece is to create a sample board out of the same wood and work through the steps from a sanded bare surface to the final look.

# one design, two variations

Suit special storage needs with a few dimensional changes.

**A** good idea is contagious. That's certainly true about the sliding door cabinet on page 42. Originally conceived as a display cabinet, it didn't take us long to think of a few more uses. You can transform the piece into the bookcase, shown *below left*, by reducing the depth of the cases, the widths of the shelves and top, and the lengths of the base and crown sides

by 4½". On the shortened base sides, omit the cutouts.

Or make the step-back hutch, shown *below right*, by reducing the depth of just the upper case and placing it on a full-depth lower case. No matter what you decide, follow the instructions on page 43, referring to the **Materials List** at right, for the dimensions of the bookcase-depth parts. 🌲

## Materials List

Case	FINISHED SIZE			Matl.	Qty.
	T	W	L		
A sides	¾"	13½"	36¾"	BP	4
B dividers	¾"	10⅞"	35¼"	BP	2
D case tops/bottoms	¾"	13¼"	48"	BP	4
F shelves	¾"	10¼"	23⅞"	BP	8
K* top	¾"	15"	50¼"	EM	1
<b>Base</b>					
L* base sides	1¼"	5"	15"	LM	2
<b>Crown</b>					
V* side bases	½"	2"	14¾"	M	2
X* side fillers	¾"	1⅞"	14⅞"	M	2
Z* side coves	1"	1¼"	15⅞"	LM	2
BB* side caps	¾"	2⅜"	16"	M	2

\*Parts initially cut oversize. See the instructions.

**Materials key:** BP—birch plywood, M—maple, EM—edge-joined maple, LM—laminated maple.

Dimensions altered to make bookcase-depth parts.

Depth of cases reduced by 4½"



Bookcase

Omit the cutout in the base sides.

Reduced-depth upper case



Step-back hutch

Full-depth lower case



# 5 gluing woes: prevention and cure

Adhesive problems don't have to make you come unglued. Follow these tips to avoid sticky situations.

**G**lue that's used properly can be one of a woodworker's best friends, producing joints that are literally stronger than the wood itself. As a result, you'll have great-looking projects that will be sturdy for generations.

As with many problems, prevention is a better strategy than repair work. Before you

reach for the glue bottle, dry-fit each joint; then proceed with the glue-up. Apply the glue with care. Otherwise, you can have the worst of two worlds: hidden weaknesses that can make joints fail prematurely, plus highly visible surface defects.

As you'll see in the following tips, a thin bead of glue squeeze-out along the joint line

is a good thing. It indicates that the joint contains sufficient glue and that you've applied even, adequate clamping pressure. How much clamping pressure is enough? Stop as soon as you see squeeze-out along the entire joint line. If you have to bear down on the clamp screws to see squeeze-out, the joint may need to be re-cut.



## EXCESS SQUEEZE-OUT: AVOID IT

For a strong joint, brush a thin, even coat of woodworkers glue onto both mating surfaces. (Polyurethane glue requires only one surface coated with glue and the other dampened with water.) Don't go overboard on clamping pressure because you'll "starve" the joint by driving out most of the glue.

## CORNER SQUEEZE-OUT: CONTAIN IT



For best protection, seal off adjoining joint surfaces from squeeze-out with masking tape. Apply the tape during the dry-fitting, taking care not to get the tape so close to the edge that it gets pinched into the joint, ruining its fit. After gluing-up the joint, scoop up any squeeze-out, then peel up the tape to complete the cleanup.

## NORMAL SQUEEZE-OUT: SCOOP, DON'T SMEAR



After the glue congeals, scoop it up without smearing it. Use a flexible putty knife for this, one with the corners ground round to prevent the tool from digging into the surface. Complete the glue removal by lightly wiping the surface with a damp cloth. Continue wiping with a fresh portion of the damp cloth until no visible glue remains.

*continued on page 98*

## avoiding **workshop goofs**

### DRIED-ON GLUE: SAND IT AWAY



We've all done it: forgotten to scoop up glue while it's still soft. If you're faced with dried glue beads, hand-sanding is the best cure. To get started, put a piece of coarse abrasive on a sanding block, and attack the dried glue with long, steady strokes. After you've removed the dried glue beads, you can switch to a power sander to complete the sanding process.

### GLUE RESIDUE: UNCOVER IT WITH NAPHTHA



Before staining, wipe your project with a cloth dampened with naphtha to reveal any areas where glue still resides. Sand any problem surfaces and repeat the naphtha test. To avoid this problem altogether, try staining adjoining surfaces before initially gluing them. Mask mating joint surfaces, protecting them from stain, and apply glue to raw wood only. 🌲



# shop-proven products

These woodworking wares passed our shop trials.

## 12" compound mitersaw plays by the numbers

With every passing birthday my eyesight seems to get a little worse, making it more and more difficult to read the tiny increments on tool scales. Just as I was about to get stronger glasses, I spotted Hitachi's C12LCH 12" compound mitersaw at the tool store and decided to check it out.

Two features caught my eye. The first is the up-front digital LCD display (*inset photo*) that shows the miter and bevel angles to the nearest 1/2°. The cuts I made at a variety of miter and bevel angles were dead-on. I found the cast-in scale about as easy to read as the digital display, but I really appreciated the bevel-angle readout because a typical bevel scale at the back of the saw is notoriously small and hard to read. Hitachi engineers also added a fine-adjustment knob to tweak the bevel angle without the saw head getting away from me.

My second favorite thing about the C12LCH is its laser cutline, which, unlike the blade-retainer-washer lasers on many mitersaws, resides on the saw housing. That means the laser line doesn't stray from the cutline as the blade plunges toward the workpiece, and I can fire up the laser and line up my cut without spinning the blade.

The saw-mounted laser has a couple of other advantages, as well. With a few turns

of a hexhead wrench, I found that I could align the laser line with either side of the blade, depending on whether I wanted the waste piece on the left or right. And because the laser draws its power directly from the saw, I'll never have to buy or replace batteries.

Gadgets aside, the rest of the C12LCH is nicely appointed as well: It mitters up to 52° both left and right, with stops at 15°, 22.5°, 31.6°, and 45°; its 5"-tall left fence supports tall stock, but flips out of the way for bevel cutting; it comes with a decent 32-tooth carbide blade; and it has plenty of power for any cut I throw at it.

—Tested by Dean Fiene



### Hitachi C12LCH 12" compound mitersaw

Performance	★★★★★
Price	\$370

Hitachi Power Tools  
800/829-4752; hitachipowertools.com



## Add one more tape to your shop for good measure

Over the years, I've accumulated more than my share of retractable tape measures, so it takes something special to make me buy another tape. FastCap's Pro Carpenter 16' Flatback tape is just such an animal.

Although there's nothing earth-shattering about this tape measure, lots of little things add up to make it really handy. For example, the tape locks with one of two buttons: a temporary catch-and-release button on the bottom of the case, or a more typical sliding lock on the front. I also like the erasable writing surface on the case where I jot down measurements so I won't forget them.

But the thing that makes the Flatback unusual is the tape itself. Instead of being cupped to make it rigid for long standouts, the tape is flat and flexible. That means I don't have to rock the tape to bring an edge down on a workpiece to mark a dimension

accurately. And it means I can measure curved surfaces precisely without the tape buckling in the middle. (Downside: The tape has no standout at all, drooping immediately as it comes out of the case.)

The face of the flexible tape has a blank writing area along one edge for using it like a story stick. So, instead of having to remember that the hinges on the cabinets need to be 3 5/16" from the bottom of the door, I just pencil a mark at 3 5/16" on the tape surface and write "bottom hinge." The marks erase easily.

And, did I mention the built-in pencil sharpener? Many of the features on the Flatback are found on other FastCap tapes



as well. Check the company's Web site to find the model with the features you want.

—Tested by Dean Fiene

### Pro Carpenter 16' Flatback Measuring Tape (PSSP-FLAT16)

Performance	★★★★★
Price	\$7

FastCap  
888/443-3748; fastcap.com

continued on page 102

## Pushblocks know when to hold (and when to fold)

I have half a dozen push blocks in my shop that I've made for various tablesaw, jointer, and router-table tasks, but none are as all-around handy as Joy-Blocks. The protruding "heel" on the bottom of each block hooks over the end of a board, as shown in the photo, to provide positive pushing power.

That alone is no big deal—anybody can make a push block with a heel. However, when you press a Joy-Block down in the middle of a board, such as when hand-over-hand feeding a long board on the jointer, the springy heel retracts into the block. With the heel retracted, the rubbery surface on the bottom of each Joy-Block provides a tenacious grip on the wood, even when dusty.

If you're worried about damaging a cutter if you accidentally catch the heel in a knife or router bit, don't. The heel itself is made of the same plastic as the rest of the Joy-Block, and there are no metal springs or hardware.

—Tested by Dave Campbell, Tools Editor

### Joy-Block Push Blocks (124-205)

Performance ★★★★★  
Price \$11 each

Woodworker's Supply  
800/645-9292; woodworker.com



## Nontacky tack cloth picks up dust like a vacuum

We've all used those sticky, varnish-impregnated tack cloths to remove sanding dust before applying a finish. But I've never liked them because they can contaminate my finish, dry out quickly, and are useless if dropped on a dusty floor. The days of the sticky tack cloth may be numbered, however, thanks to an impressive replacement.

Micro Fiber Dry Tack Cloth is woven from a fabric made of fibers thinner than a human hair. Each fiber is split 16 times, and the V created by each split makes the cloth super soft while letting it trap the tiniest dust particles.

Before finishing a cherry cabinet, I sanded it to 220-grit, and then wiped it down with the Micro Fiber Dry Tack Cloth. Although the wood felt smooth to the touch, in making the pass with the cloth I could sense tiny snags as the microfibers dug down into the wood pores. After sanding between coats of water-based polyurethane finish on another project, the cloth performed equally well, leaving not a trace of residue behind.

The 16×16" cloth can be washed in soapy water—water alone won't release dirt from its microscopic clutches—and reused hundreds of times without affecting its performance. One caution, though: If you wash it with lint-producing fabrics, the Micro Fiber Dry Tack Cloth will absorb the lint and become useless.

—Tested by Pat Lowry, Techniques Editor



### Micro Fiber Dry Tack Cloth

Performance ★★★★★  
Price \$4 (plus shipping)

Norton Abrasives  
800/551-4415; nortonabrasives.com  
Available from toolsforworkingwood.com



# what's ahead

Your special preview of the September issue (on sale July 19)

## Projects big and small



### FEATURED PROJECT



#### Home office desk system

Mix and match any number of these components—corner desk, straight desk, and up-top storage cabinet—to suit your needs and available space.



#### Salt and pepper mills

A modest-sized lathe, a few scraps of wood, and inexpensive grinding mechanisms are all you need to make these.



#### Stackable serving tray

Here's just the thing for get-togethers, TV snacking, or breakfast in bed for someone special. A cork tray surface prevents slipping and cleans up fast.



#### All-purpose abrasives cabinet

Keep your sanding sheets and discs flat and quickly accessible in this storage piece that also has room for belts, drums, and blocks.

## Tools and techniques

### TOOL TEST

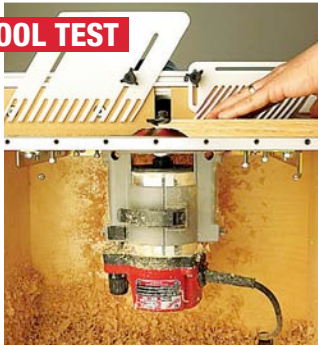

#### 15-amp big-boy routers

Looking for a router powerful enough to drive the burliest bits? Check out our ratings of 11 models.



#### Master jewelry-box maker

Here's your chance to meet and learn from Al Ladd, a precision woodworker extraordinaire.



#### Raised panels two ways

Discover the most effective methods for cutting raised panels with a tablesaw or table-mounted router.



#### Installing cabinet doors

Fit and hang precisely aligned doors with minimal fuss using the hardware and shop-proven tricks described here.