

**BONUS**  
★ 7 Shop Projects ★  
See center insert

# WOOD

## made-to-please **cheval mirror**

easy-to-follow plans inside p.38

plus  
**25**  
must-know  
tips & skills

- **HOT NEW TOOLS for 2006** p.80
- **6 GREAT FINISHES for Cherry, Maple, and Oak** p.50
- **LAST-MINUTE HOLIDAY GIFT IDEAS** p.8 and p.84
- **SAVE BIG BUYING USED TOOLS** p.44

### FEATURE-FILLED GAME TABLE



with special  
flip-over top  
p.88



# WOOD

December/January 2005/2006, Issue 167

## PROJECTS

- 8 bandsawn wine-bottle holder
- 14 taco holders in two sizes
- 28 rolling workshop storage cabinet
- 38 classic cheval mirror
- 62 kid's room wall-hung organizer
- 71 multipurpose router jig
- 76 keep-it-tidy play center
- 84 adjustable photo-display easel
- 88 accommodating game table

What's your pleasure? Poker? Monopoly? This clever design will meet your needs, featuring a reversible top, storage, and out-of-the-way beverage holders.

## TECHNIQUES

- 10 wipe out project tool marks
- 50 great finishes for cherry, maple, and oak  
Try one or more of six easy-on finishes for three of America's favorite woodworking woods.
- 68 work smarter with pro Jeffrey Lohr  
Develop habits that let you make the most out of every minute and ensure your woodworking success.
- 96 applying a felt game-table surface

## TOOLS & MATERIALS

- 16 wise buys: doweling jigs
- 44 buying used machines  
Snag a bargain... or two... or three, following the failsafe tool-evaluation formula laid out here.
- 80 hot new tools for 2006
- 102 three shop-proven products

## DEPARTMENTS

- 6 editor's angle
- 8 sounding board
- 18 ask WOOD
- 30 shop tips
- 116 what's ahead



This seal is your assurance that we build every project, verify every fact, and test every reviewed tool in our workshop to guarantee your success and complete satisfaction.



62



88



76



38



84



68

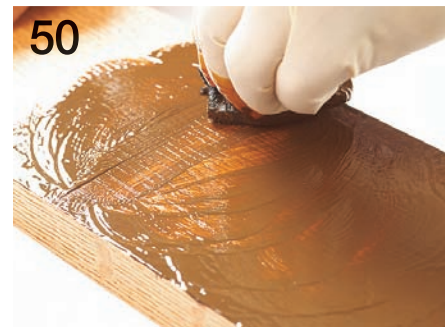

50

## HOT NEW TOOLS pg. 80



Better Homes and Gardens®  
**WOOD**®

December/January 2005/2006

Vol. 22, No. 7

Issue No. 167

**We asked our staff:**

What's your favorite sanding shortcut?

By cutting sandpaper sheets ahead of time, you'll speed up the sanding process.



Turn a craft stick into a mini sanding board. Mark the grit on the end of the handle.



EDITOR-IN-CHIEF  
**BILL KRIER**

Executive Editor **JIM HARROLD**     Managing Editor **MARLEN KEMMET**

Editorial Manager, Tools and Techniques  
**DAVE CAMPBELL**

Senior Design Editor **KEVIN BOYLE**     Techniques Editor **BOB WILSON**

Projects Editor **OWEN DUVALL**     Projects Editor **JAN SVEC**

Design Editor **JEFF MERTZ**     Master Craftsman **CHUCK HEDLUND**

Art Director **KARL EHLERS**     Associate Art Director **GREG SELLERS**     Assistant Art Director **CHERYL A. CIBULA**

Production/Office Manager **MARGARET CLOSNER**     Administrative Assistant **SHERYL MUNYON**

Photographers **MARTY BALDWIN, SCOTT LITTLE, BLAINE MOATS, JAY WILDE**

Illustrators **TIM CAHILL, LORNA JOHNSON, ROXANNE LeMOINE**

Technical Consultants **JEFF HALL, DEAN FIENE**

Contributing Craftsman **JIM HEAVEY**

Proofreaders **BARBARA KLEIN, IRA LACHER, JIM SANDERS**

**CUSTOMER SERVICE: 800/374-9663**

For more ways to reach us about specific matters, see page 8.

Vice President/Publishing Director **DOUG OLSON**

Publisher **MARK HAGEN**

**ADVERTISING**

**CHICAGO OFFICE:** 333 N. Michigan Ave., Suite 1500, Chicago, IL 60601

Phone: 312/580-7956 Fax: 312/580-7906

Account Executive **JACK A. CHRISTIANSEN**

Direct Response Manager **CAROLYN DAKIS**

Direct Response Sales Representative **SANDY ROBINSON**

Marketing Manager **AMANDA SALHOOT**

Sales and Marketing Assistant **GAYLE CHEJN**

**DETROIT:** RPM Associates

29350 Southfield Rd., Suite 31, Southfield, MI 48076

Phone: 248/557-7490 Fax: 248/557-7499

**ATLANTA:** Navigate Media

1875 Old Alabama Rd., Suite 1320, Roswell, GA 30076

Phone: 678/507-0110 Fax: 678/507-0118

Business Manager **JOEL ETIENNE**

Consumer Marketing Director **ROBIN HUTCHINSON**

Assistant Consumer Marketing Manager **BILL WOOD**

Associate Director of Marketing-Newsstand **TOM DEERING**

Production Manager **STEVE KRIDER**

Advertising Operations Manager **LIBBY EHMKE**

**MEREDITH PUBLISHING GROUP**

President **JACK GRIFFIN**

General Manager **TOM HARTY**

Finance & Administration **KARLA JEFFRIES**

Consumer Marketing **DAVID BALL**

Manufacturing **BRUCE HESTON**

Creative Services **ELLEN DE LATHOUDER**

Interactive Media **LAUREN WIENER**

Corporate Sales **JACK BAMBERGER**

Group Marketing **NANCY WEBER**

Director, Corporate Sales **DORENE BAIR**

Executive Director, Corporate Research **BRITTA C. WARE**



Chairman and Chief Executive Officer **WILLIAM T. KERR**

President and Chief Operating Officer **STEPHEN M. LACY**

In Memoriam — E.T. Meredith III (1933–2003)

Stop sanding at 120 or 150 grit on unstained (natural) surfaces. Sanding scratches on clear-coated surfaces won't show.



Sandpaper backed with a foam pad absorbs the heat when sanding on a lathe.



Use all the available grits between your rough and finish papers for fast and consistent results.



# Let the games begin

Unless you spend all of your time in the shop, you've probably noticed the current poker craze. Our response to this phenomenon: Design a table you can build that's appropriate for poker *and* board games *and* general day-in, day-out use.



**O**kay, I admit it, I'm not a poker player. I went to Vegas a few months ago for a big woodworking trade show and didn't invest a single dollar at the poker tables. Even my pocket change was safe from the omnipresent video poker machines. So I may be decidedly uncool when it comes to card games, but I know a craze when I see one, and we're in the midst of full-blown poker mania. As a result, we decided awhile back to design a poker table for you, but with a few twists on more-typical designs.

First, we simplified things. Those eight-sided poker tables on a pedestal base look nice, but how many of you want to spend months making one? We're guessing a scant few. So we designed one you can make in only a couple of weekends.

And, because most of us don't have floor space in our homes to devote to a table with just one use, the table shown *above* features a reversible top: one side with a felt covering for card games (my card-playing buddies tell me the felt stops dealt cards from sliding off the table and into the abyss), and another wood side for board games and everyday use. Yes, you can stay up half the night playing poker on this table, and then eat your Wheaties on it come morning.

But my favorite parts of the table are the cup holders that form the tops of the legs. They're not only functional in keeping

drinks clear of the playing surface, they also give this project its own special character. It's usually the first thing visitors to our shop comment on when they see the table.

I have to admit that during the table's construction I was a bit concerned about the hollow, tapered legs. Would the average guy be able to cut the four leg sides—each with mitered and tapered edges—accurately enough to make the joints between them tight and attractive? Well, as usual, our Master Craftsman, Chuck Hedlund, put my mind at ease by coming up with a tablesaw sled for cutting the leg sides. It's everything we aim for when designing workshop jigs: The sled simplifies a potentially difficult task; it ensures accuracy; it's easy to make so you can spend your time building projects, not the jigs to make them; and it increases your margin of safety by keeping your digits well clear of the saw blade.

Another design benefit: The legs don't require tricky clamping setups. Just tape them together. The rest of the construction is straightforward, including the method for attaching the felt surface.

The completed table looks so nice I might have to build one for myself...and learn how to play poker.



Bill Krier

# sounding board

Our bulletin board for letters, comments, and timely updates

## Show the world your workshop

The editors at *WOOD*® magazine are searching for America's greatest home woodworking shops. Does yours fit the mold? If so, we may photograph your shop for the education and enjoyment of woodworkers everywhere. Here's what we're looking for:

- The shop must be hardworking, organized, and full of problem-solving ideas; these could be storage projects, special jigs, or some other solution.
- For starters, we'd especially like to see shops in these areas: Los Angeles/San Diego, Chicago/Milwaukee, and New York City/New Jersey/Eastern Pennsylvania/Delaware. (Don't let this stop you from

submitting if you live in another location and have an outstanding shop loaded with ideas.)

- Yes, it's okay to nominate a friend's shop (with their permission).
- To participate, send us the following:
- 3 to 5 overall photos of your shop
  - 5 to 10 close-ups of dedicated machining or storage areas, and problem-solving shop projects that successfully fill a need
  - a rough floor plan (with overall shop dimensions)
  - a one-page write-up of what makes your shop great and how it serves your woodworking interests.



E-mail your submission with photos to [workshops@meredith.com](mailto:workshops@meredith.com), or mail to: Great American Workshops *WOOD* magazine, 1716 Locust St. LS-221 Des Moines, IA 50309-3023

**The deadline is January 2, 2006.**

—*WOOD* magazine

## More than one way to hold a wine bottle

In the 2005 November issue of *WOOD* magazine, professional woodworker Carl Stammerjohn provided a nifty way to use up scrapwood by making wedge-shaped wine bottle holders. While in Hawaii recently, I found a different design, a C-shape holder made from mango wood, shown below, that serves the same purpose. To bandsaw this project, use



the full-size pattern in the *WOOD Patterns*® insert. Begin with a block of wood dimensioned as shown in the drawing below. (You may need to laminate thinner stock and plane the lamination to size.) Then draw a reference line across the block where shown. Adhere the pattern to the block, aligning the hole centerline with the

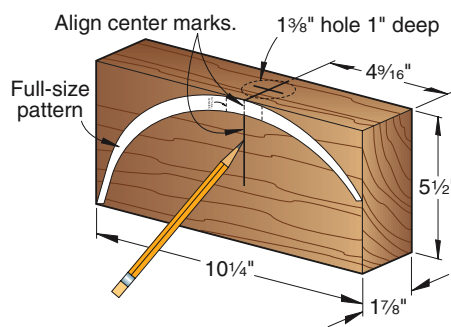

reference line. Now drill the centered 1 3/8" hole. Cut the holder to shape, working just outside the pattern's outline. Next, sand the holder to the line. A disc sander works best for sanding the outside or convex surface; an oscillating spindle sander for the inside or concave surface. Finish-sand the holder through 220 grit, and apply finish.

—*Jim Harrold, Executive Editor*

## Article updates

**October 2005, issue 165**

■ On page 62, the caption for Photo 1b should read "Align the chuck with progressively harder taps against its lower portion using a piece of scrap and hammer."

■ In the chart on page 73, the price for the Converter Router Trolley should say that the model is sold with a pair of 48" rails.

## HOW TO REACH US

### ■ Woodworking advice:

Post your woodworking questions (joinery, finishing, tools, turning, general woodworking, etc.) on one of 20+ online forums at [woodmagazine.com/forums](http://woodmagazine.com/forums).

### ■ Editorial feedback:

Send your comments via e-mail to [woodmail@woodmagazine.com](mailto:woodmail@woodmagazine.com); or call 800/374-9663 and press option 2; or write to *WOOD* magazine, 1716 Locust St., Des Moines, IA 50309-3023.

### ■ Subscription assistance:

To notify us of an address change, or to get help with your subscription, go to [woodmagazine.com/service](http://woodmagazine.com/service); or call 800/374-9663 and press option 1. Outside the U.S., call 515/247-2981. Or write to *WOOD* magazine, P.O. Box 37439, Boone, IA 50037-0439. Please enclose your address label from a recent issue.

### ■ To find past articles:

See our index at [woodmagazine.com/index](http://woodmagazine.com/index).

### ■ Past issues and articles:

Order past issues of *WOOD* magazine, our special issues, or downloadable articles from issue 100 to present. Visit our online store at [woodmagazine.com/store](http://woodmagazine.com/store), or call 888/636-4478. Some issues are sold out.

### ■ Updates to previously published articles:

For an up-to-date listing of changes in dimensions and buying-guide sources from issue 1 through today, go to [woodmagazine.com/editorial](http://woodmagazine.com/editorial).

# wipe out project tool marks

When staining and finishing, nobody likes surprises. But snipe, chatter marks, and more can show up to mar your finest craftsmanship.

**I**t happens to the best of us, but by following a few simple precautions, you can remove the goofs before they pose a problem. Begin with sound machining, assembly, and prep practices, relying on the handy Tool-Mark Problem Solver on page 12 for specific fixes.

## The tool-mark legacy

Tool marks leave an uneven surface on the wood, change its color, and alter the way it absorbs a stain or finish. Once a stain or finish goes on, most tool marks are pretty much there to stay, unless you sand back down to bare wood. The ultimate strategy for eliminating tool marks is prevention, with final touch-ups serving as backup.

## An ounce of prevention

Preventing tool marks starts by using only sharp and clean bits, blades, and other cutters on your machines, and running these at the proper speed. Align your tablesaw fence parallel to the blade. Also, mill all pieces of stock slightly oversize, observing how well the wood machines, and adjusting feed rates and direction to get the best cut. Finally, “sneak up” on the final cut, taking off just a small amount of material. Doing this will clean up existing tool marks without creating new ones.

## Sanding smarts

Many believe power-sanding cures a world of ills, and it can. But it also can cause its own set of tool-mark problems. Take care here or you’ll risk the hard work you spent building the project.

First, wipe down all the surfaces you plan to sand with a tack rag to remove sawdust and other debris that can make scratches when they are picked up by the sander. Then, move up through the sandpaper grits in small steps from coarse to fine and let the sander do the work, wiping down the piece between each grit change.

Next, use a soft cloth to apply mineral spirits to all the areas you sanded. The “mineral spirits rubdown,” shown *below right*, offers three benefits—it gives you an idea what the wood will look like under a clear finish, shows up glue stains you may have missed, and highlights any remaining tool marks, including notoriously hard-to-see sanding swirls. Note the spots that need more work and go back to them after the mineral spirits dries. This trick also can be used prior to assembly or during dry-fitting to find problems that would be difficult to repair after assembly.

## Reaching the finish line

For the ultimate surface, complete the process with a final hand-sanding at 220grit (or up to one step higher than your last machine grade), following the direction of the wood’s grain. Despite advances in sanding technology, nothing produces a mar-free surface

## Dealing with dents and scratches

Though not typically caused by tools, dents and scratches in wood also can show up at finish time like uninvited guests. And while sanding removes surface scratches, dents require a different tack. First, moisten the dented area by placing a damp cloth over the depression, and then running a hot household iron over the cloth, as shown *right*. The steam generated will swell the compressed wood fibers, letting you sand them flush once they dry.

Sometimes, the easiest and best fix for tool marks is to mill a replacement part, or better yet, to machine extra stock for spares in the beginning. Another option includes using tool-marked stock in areas where it won’t be seen.



Your latest masterpiece is almost complete. But as the finish goes on, you discover ugly tool marks that spoil the moment.

like patient hand-sanding under an attentive eye. And one last check with mineral spirits will ensure no surprises at finish time. What should you do if you apply a stain or finish and a tool mark bids hello? Simple: Reach for the sandpaper once more and a hefty can of elbow grease. 🌲



The best way to detect machine marks on a project is to rub it down with mineral spirits, using a clean, soft cloth.



A household iron, a dampened towel, and sandpaper team up to help you make dents disappear.

# Tool-Mark Problem Solver

The Damage		Causes	Solutions
	<b>Sanding Swirls</b> Cross-grain grit scratches on the stock's surface	<ul style="list-style-type: none"> <li>■ Improper sanding technique</li> <li>■ Damaged sandpaper</li> <li>■ Grit schedule not followed through</li> </ul> <p><b>Culprits:</b> power-sanders, cross-grain hand-sanding</p>	<p>Solutions in ■ green help avoid tool marks, and those in ■ red guide in fixing them.</p> <ul style="list-style-type: none"> <li>■ Gradually move from coarse to fine sandpaper grades.</li> <li>■ Let the sander do the work; avoid undue pressure.</li> <li>■ Keep firm control over the sander.</li> <li>■ Replace damaged sandpaper.</li> <li>■ <b>Hand-sand following the stock's grain.</b></li> </ul>
	<b>Scoring</b> Lines made in stock by cutters	<ul style="list-style-type: none"> <li>■ Cutters not tracking properly or fences misaligned</li> <li>■ Poor-quality tooling</li> </ul> <p><b>Culprits:</b> saw, router, planer, jointer, hand plane</p>	<ul style="list-style-type: none"> <li>■ Repair or replace damaged cutters.</li> <li>■ Ensure cutters/saw teeth are properly set.</li> <li>■ Purchase only high-quality blades/bits.</li> <li>■ Align fences.</li> <li>■ <b>Sand, hand-scrape, or re-mill stock, depending on the number and depth of score marks.</b></li> </ul>
	<b>Ridges</b> Raised lines made in milled stock	<ul style="list-style-type: none"> <li>■ Cutters nicked or not tracking properly</li> </ul> <p><b>Culprits:</b> planer, jointer, router, hand plane</p>	<ul style="list-style-type: none"> <li>■ Repair or replace damaged cutters.</li> <li>■ Shift cutters so nicks do not align from one cutter to the next.</li> <li>■ <b>Sand or hand-scrape stock.</b></li> </ul>
	<b>Gouges</b> Chunks torn from the stock	<ul style="list-style-type: none"> <li>■ Highly figured or very hard/brittle stock</li> <li>■ Cutting against the grain</li> </ul> <p><b>Culprits:</b> planer, jointer, hand plane, router, saw</p>	<ul style="list-style-type: none"> <li>■ Dampen surface of figured stock before milling.</li> <li>■ Take light cuts.</li> <li>■ Use slower feed rate/higher cutter speed.</li> <li>■ Reverse feed direction.</li> <li>■ Send stock through at an angle.</li> <li>■ <b>Re-mill stock.</b></li> </ul>
	<b>Chatter</b> Stock removed unevenly, resulting in closely spaced scallops, like waves on water.	<ul style="list-style-type: none"> <li>■ Stock bouncing away from and into cutters as it is fed</li> <li>■ Cutters deflecting from and rebounding into stock</li> <li>■ Feed rate too fast</li> </ul> <p><b>Culprits:</b> jointer, planer, router, hand plane</p>	<ul style="list-style-type: none"> <li>■ Properly support and restrain stock.</li> <li>■ Ensure cutters are sharp and properly set.</li> <li>■ Move stock through cutters at the appropriate speed.</li> <li>■ Take lighter cuts on stock.</li> <li>■ <b>Sand, hand-scrape, or re-mill stock, depending on the extent of the chatter.</b></li> </ul>
	<b>Snipe</b> Stock slightly scooped at its end(s)	<ul style="list-style-type: none"> <li>■ Stock not properly supported</li> <li>■ Infeed roller dropping off end of stock</li> <li>■ Misaligned jointer tables</li> <li>■ Flexibility in planer mechanism</li> </ul> <p><b>Culprits:</b> planer, jointer, router</p>	<ul style="list-style-type: none"> <li>■ Adjust jointer infeed/outfeed tables.</li> <li>■ Use additional supports for long stock.</li> <li>■ Feed scrap stock through planer following workpiece.</li> <li>■ Take lighter final cuts on stock.</li> <li>■ Upgrade to a more robust planer.</li> <li>■ <b>Mill pieces long and cut off snipe.</b></li> </ul>
	<b>Fuzzing</b> Raised wood fibers resembling peach fuzz	<ul style="list-style-type: none"> <li>■ Cutters not cleanly slicing wood fibers</li> <li>■ Damp or wet wood</li> </ul> <p><b>Culprit:</b> router</p>	<ul style="list-style-type: none"> <li>■ Sharpen or replace cutters.</li> <li>■ Take lighter final cut on stock.</li> <li>■ Use only air- or kiln-dried wood, 6–8% moisture content for hardwoods, and under 12% for softwoods.</li> <li>■ <b>Hand-sand/hand-scrape fibers.</b></li> </ul>
	<b>Burns</b> Stock's surface carbonized by heat build-up	<ul style="list-style-type: none"> <li>■ Heat from cutters not dissipated</li> <li>■ Excessive heat generated by binding stock or dull cutters</li> <li>■ Resinous stock with low combustion temperature</li> </ul> <p><b>Culprits:</b> saw, router, mortise machine, drill</p>	<ul style="list-style-type: none"> <li>■ Operate cutters at an appropriate speed.</li> <li>■ Keep stock moving through cutters.</li> <li>■ Sharpen or replace cutters.</li> <li>■ Properly align fences and cutters.</li> <li>■ Take light final cut on problem stock.</li> <li>■ <b>Hand-sand/hand-scrape stock.</b></li> </ul>
	<b>Scratches</b> Narrow scrapes on the stock's surface	<ul style="list-style-type: none"> <li>■ Sharp debris on stock or tool/workbench surfaces</li> <li>■ Careless tool or project handling</li> </ul> <p><b>Culprit:</b> any hard, pointed object that contacts the work</p>	<ul style="list-style-type: none"> <li>■ Keep materials, tools, and work area clean.</li> <li>■ <b>Sand, hand-scrape, or re-mill stock, depending on the number and depth of the scratches.</b></li> </ul>
	<b>Dents</b> Crushed wood fibers	<ul style="list-style-type: none"> <li>■ Excessive clamping pressure</li> <li>■ Careless blows from hammers or other tools</li> </ul> <p><b>Culprits:</b> clamps, hammers, any hard, blunt surface</p>	<ul style="list-style-type: none"> <li>■ Apply appropriate clamping pressure.</li> <li>■ Employ clamping pads to spread pressure.</li> <li>■ Use softwood blocks to cushion hammer blows.</li> <li>■ Assemble projects with padded hammers.</li> <li>■ <b>Raise dent with steam; then hand-sand and hand-scrape.</b></li> </ul>

Written by Schuyler Grace Photography: David Cruz at Most Wanted Photos

# no-tip taco holder



Fill 'em up. This simple serving accessory holds your taco shells upright so you can put (and keep) the fixins where they belong.

**C**ut a piece of 1/2"-thick hardwood (we used cherry) to 3/4" wide and the desired length to make the base (A). To determine the length, allow 1 1/2" for each taco, and then subtract 3/4" from the total. For example, our small holder cradles four tacos, so the base measures 5 1/4" ( $4 \times 1 1/2" = 6" - 3/4" = 5 1/4"$ ).

After you cut the base to size, rout or sand 1/8" round-overs on all four edges, but not the ends.

Next, install a 3/4" dado blade in your tablesaw, and dado the base, where dimensioned, to receive the dividers.

With the base complete, reinstall your standard saw blade and cut two 4"-wide blanks from 3/4" stock (maple in our case) to make the dividers (B) and ends (C). If you're making the small holder, cut both of these blanks 12" long. You'll have some waste, but these oversize pieces prove safer to handle during machining steps.

To make a longer holder, determine the length of the divider (B) blank by divid-

ing the length of the jumbo taco holder blank by 4 1/4". For example, the length of the jumbo taco holder blank equals 25 1/2" ( $12/2 = 6 \times 4 1/4" = 25 1/2"$ ).

With the divider and end blanks cut, tilt your tablesaw blade 15° from vertical and bevel all four edges of the divider (B) blank, where shown in **Drawing 1**. Then bevel just two edges of the end (C) blank.

Reset the blade to 0°, adjust the fence, and rip the dividers to 1 1/4" by making one pass on each edge of the blank. Adjust the fence again, and rip the ends to 1 1/2" tall. Next, crosscut the ends and dividers to length. Rout or sand 1/8" round-overs on the ends and dividers where shown. Then sand all the pieces to 220 grit.

Now glue the dividers in place so they overhang the base equally on each side. Also glue and clamp the ends in place. After

the glue dries, drill holes through the ends and into the base where shown. Cut and glue 1/4" cherry dowels into the holes, then trim them flush.

Protect the wood with three coats of a food-safe topcoat, such as mineral oil, and allow the finish to cure before using the taco holder at your next fiesta. 🌮

Project Design: Jeff Mertz

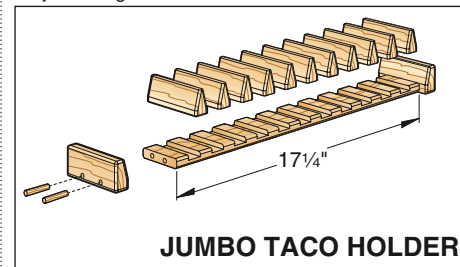

JUMBO TACO HOLDER

## 1 TRIMMING THE DIVIDERS

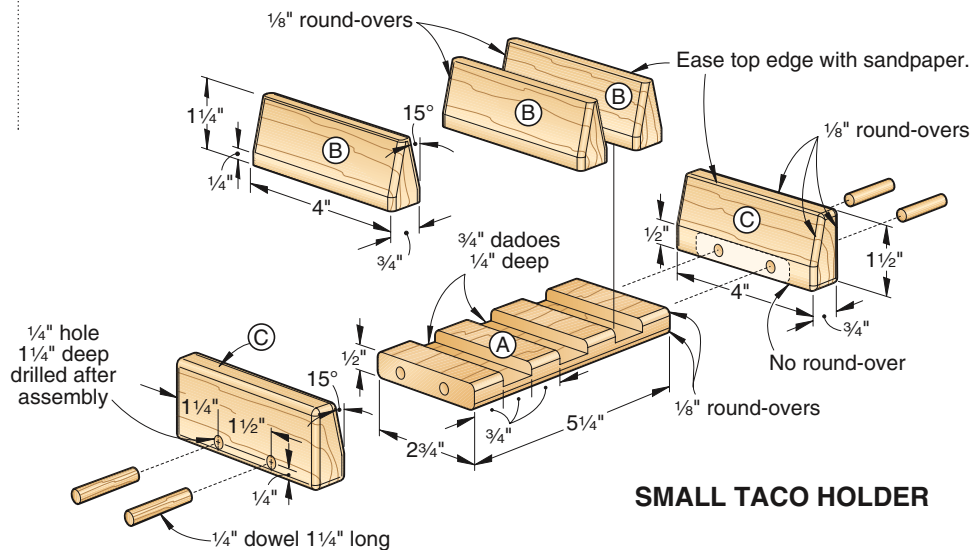
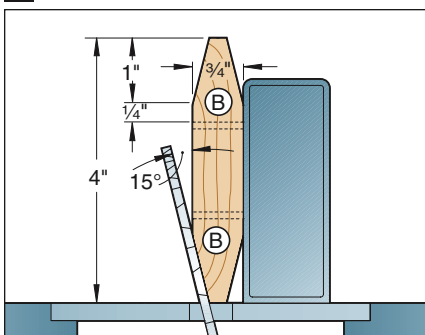

SMALL TACO HOLDER



our editors test

# doweling jigs

## Why buy?

Dowel pins add mechanical strength and glue surface area to almost any joint, and aid in aligning parts during assembly. Dowel joinery is unforgiving, though: If dowel holes don't line up, or aren't perfectly perpendicular to the surface of the workpieces, forgetaboutit! A good doweling jig—coupled with a sharp brad-point bit—helps you bore precisely mating holes, minimizing both your frustration and the need to sand or plane to a seamless joint. We tested five doweling jigs ranging from \$40 to \$230 in edge-to-edge joints, corner butt joints, T-joints, and more. Here are the three jigs we like best.

### Wolfcraft DowelPro, \$40

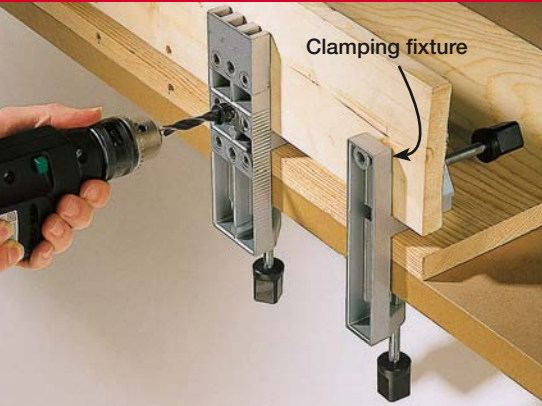

#### Editor test-drive:

The DowelPro kit (model #3751) is so intuitive, I made several edge-to-edge and edge-to-end joints in  $\frac{3}{4}$ " stock before even cracking open the instruction manual. To test it, I clamped the mating workpieces back-to-back in the jig, and drilled matching  $\frac{1}{4}$ ",  $\frac{5}{16}$ ", and  $\frac{3}{8}$ " dowel holes in both pieces. DowelPro centers holes in  $\frac{3}{4}$ " stock, making it great for face-frame work, but for thinner and thicker (up to  $1\frac{1}{4}$ " stock, I had to make shims or leave the holes off-center. The jig is also capable

of edge-to-face or end-to-face joints in the middle of a board, as when doweling shelves into a bookcase or shadow box.

For long workpieces, the included clamping fixture supports the top workpiece while sliding the drilling jig down the line, as shown at *left*. Occasionally, a workpiece I drilled with DowelPro slipped unintentionally—a little non-skid tape on the clamp jaws would help here.

—Tested by Jeff Mertz, Design Editor

#### To learn more:

630/458-4000; wolfcraft.com

### Veritas 05J08.01, \$67

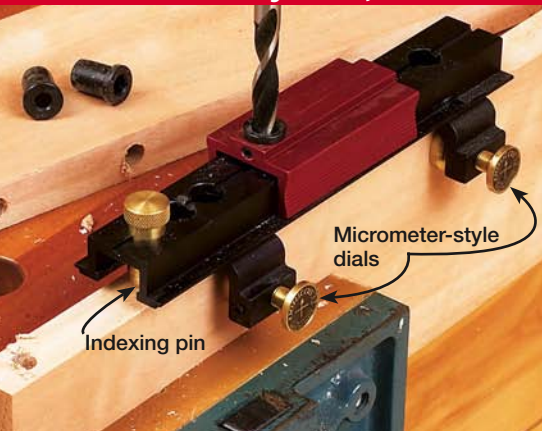

#### Editor test-drive:

It's been several years since I'd used a doweling jig, but I remember them being inaccurate and the clamps unreliable. So when the Veritas 05J08.01 landed on my desk, I was surprised at the sturdy and precise (yet affordable) extruded-aluminum jig that came out of that box.

The Veritas jig references off one face, so any difference in workpiece thickness won't show up on the good face of the joint. You can intentionally offset a workpiece up to  $\frac{1}{4}$ " by rotating the micrometer-style dials, which move that reference face  $\frac{1}{32}$ " for each full turn. And

the brass indexing pin allows you to step-and-repeat your way down the edge of a long board by dropping the pin through the jig into a previously drilled hole. Three drill guides—for  $\frac{1}{4}$ ",  $\frac{5}{16}$ ", and  $\frac{3}{8}$ " dowels—come with the jig.

Two limitations: The Veritas jig can't be used to join the end or edge of a board to the face of another board, such as when pinning shelves into a case. And second, its maximum 1" capacity prevents work in thick stock.

—Tested by Dave Campbell, Tools Editor

#### To learn more:

800/267-8735; leevalley.com

### Dowelmax, \$230



#### Editor test-drive:

Don't let the price scare you: In my tests, this finely built jig proved more accurate than a biscuit joiner, and at least as versatile. The spacing of the five  $\frac{3}{8}$ " drill guides ( $\frac{1}{4}$ " guides are optional) and the ends of the jig is so precise, you can reverse the jig, and the joints still fit like an old shoe.

For offset joinery, such as where a table apron meets a leg, index marks on Dowelmax ensure correct workpiece orientation before drilling. Mark the face of the joint, and then insert each workpiece with the marked face against the check mark on the jig. Using the spacers that come with

Dowelmax, I found I could seamlessly join virtually any combination of material thicknesses from  $\frac{1}{2}$ " to 4", flush or offset, edge-to-edge or edge-to-face.

As with the Veritas jig, Dowelmax's indexing pin makes joining long workpieces foolproof. If you prefer more distance between the dowels, simply install the distance gauge (shown in the photo at *left*) on the jig and space the dowel holes up to 9" apart as you step down the edge of the workpiece.

—Tested by Kevin Boyle, Senior Design Editor

#### To learn more:

877/986-9400; dowelmax.com

# ask wood

Answers to your questions from letters, e-mails, and WOOD Online®



**A:** If the spindles have come unfastened, but you can't slide them out to apply fresh glue, try using a glue injector (no. 836-702, \$26 from Woodworker's Supply, 800/645-9292 or woodworker.com). With this tool, you drill a  $\frac{1}{16}$ " hole from an inconspicuous place near the spindle to the inside of the joint. To reglue a seat spindle, for example, drill into the underside of the seat to reach the spindle. Using the glue injector, force yellow glue through the hole and into the joint. Allow the glue to dry thoroughly; then cover the hole with wood putty or filler.

If you can pull the joint apart far enough to expose a small gap

between the spindle and the sides of the hole, add glue using a less expensive glue syringe, such as the one shown at *left* (no. 178-001, \$4 from Woodworker's Supply).

Avoid using yellow glue to fill gaps; it will leave voids as it dries. Epoxy glue is a better choice where there's little wood-to-wood contact and it dries clear. For severe gaps, mix fine sawdust of the same wood species with the epoxy to conceal the gap.

## Fill the void in chair repair

**Q:** We have a 20-year-old dining room set that was in climate-controlled storage for more than five years. Now, after two heating seasons in Maine, we have a few loose spindles on a couple of the chairs. What are the easiest and most effective methods of repair?

—Peter Bossé, South Portland, Maine

## Make shallow pattern cuts to avoid chip-out

**Q:** I'm making a pedestal shaped like an hourglass. I traced the pattern to the oak workpiece, cut it with my jigsaw to within  $\frac{1}{8}$ " of the line and screwed the piece to a template. As my router nears the end of the piece, I'm routing

diagonal to the grain and the corner breaks off. Should I step up from a  $\frac{1}{2}$ " to a  $\frac{3}{4}$ " pattern bit?

—Dean Davis, Moosup, Conn.

**A:** Instead of a larger pattern bit, Dean, consider trying a bit with a slanted cutting edge, such as the one at *left*, or a spiral flush-trim bit, like the one shown at *right*. Use an upcut spiral for table-mounted routers or a downcut spiral for handheld work. Either can be ordered from MLCS (800/533-9298 or mlcswoodworking.com). Both the slanted and spiral bits cut with a shearing action rather than the chopping action of a straight cut, leaving a smoother surface and reducing chip-out.

Next, make less work for your bit. Rough-saw your workpiece to within  $\frac{1}{16}$ – $\frac{1}{32}$ " of your pattern to stop splintering and tear-out.



## Try alternative (tri-)angles

**Q:** I'm building a triangle to go above an outside gate and need to cut 60° bevels on the ends of 2x6 boards. I can't figure out how to do this with my tablesaw, compound mitersaw, or portable circular saw. All of them are limited to 45° cuts. Can you please explain how to do it?

—Kevin Courtney, Happy Valley, Ore.

**A:** Most saws like the ones you describe don't tilt 60°, partly because the blades won't extend far into the wood at such a steep pitch. You could design a jig to angle the workpiece on your saw table, but there may be an easier way to create an equilateral triangle.

Cut the three identical pieces of your triangle the same length using 30° bevels on each end, as shown *above*. Assemble the pieces with a beveled end of each board butting the face of the next piece, as shown *below*. Combined, the two 30° bevels will produce a 60° angle at each corner.



continued on page 22

## Let air-dried lumber sit in the shop before milling

**Q** ■ I recently purchased rough-sawn lumber that was air-dried for a year. How long should it acclimate in my shop before I can use it?

—George Poljak, Port Vue, Pa.

The short answer, George, is that you should stack and sticker the lumber for at least a week in a controlled-temperature room if the lumber is an inch or less in thickness. If thicker, it most likely needs more outdoor air-drying.

The best way to put your mind at ease is to rely on a moisture meter. These devices cost between \$35 and \$285, and instantly show you the moisture content of lumber as a percentage, comparing the weight of water in a piece of wood to the weight of that wood when completely dry. Air-dried wood in your part of the country usually settles at 12–15 percent, which is satisfactory for outdoor projects. Ideally, hardwoods should dry to 9 percent or less for interior projects.

If a week in your shop doesn't get the lumber to that level, help the process along with a low-tech drying setup. Stack and sticker the lumber on a sheet of plastic, the bottom layer of lumber a few inches off the floor. Set a dehumidifier and fan on the plastic beside the stack, and cover the whole arrangement with more plastic. Regularly check the moisture content with a meter. When it reaches the target level, turn off the dehumidifier. Keep the fan running for two more days to let the entire stack stabilize at that moisture content.



A moisture meter eliminates the guesswork about lumber condition. At 8.6 percent, this board is ready to use.

## Sheets of veneer benefit from TLC

**Q** ■ I bought some sliced veneer (no paper backing) at a woodworking show, but I'm not sure how to store it. Any advice?

—Raymond Vohrman, Indianapolis

**A** ■ A few simple steps are all you need, Ray. First, when dealing with rolled-up veneer, open the package carefully so the veneer doesn't spring open and crack. Next, whether the veneer was rolled or flat, apply masking tape across each end of each sheet to prevent splits and to keep small splits from growing.

Then place rolled veneer on a flat surface, curled ends up; it will begin to straighten naturally. To help it along, place books near the center of the piece, gradually sliding them closer to the ends over the course of a day or two. If the veneer was very tightly rolled or is wavy or buckled, add moisture to increase flexibility. Spray a light mist of water on the veneer or sprinkle a few drops of water and wipe them across the surface; then cover the veneer overnight with a board. Remove the board the next day, and allow air to circulate around both sides of the veneer to dry it completely. Finally, store veneer horizontally on a flat surface in a cool, dry, well-ventilated area. Keep it away from direct light and cover it with cloth to prevent fading.



Delicate unbacked veneer tends to split along grain lines as it's handled, so apply tape to give the ends support.

*continued on page 26*

## Router speed controls

**Q:** I have two routers, a Porter-Cable and a DeWalt, plus a separate speed-control unit. Both companies told me not to use separate speed controls because they'll damage the routers. Why?

—Leonard Ambruso, Los Osos, Calif.

**A:** Back when routers were mostly just high-speed motors and a chuck, a simple rheostat-type speed control regulated motor speed by varying the amount of electrical current. Though imprecise, they allowed you to reduce your router speed to work safely with bits of different diameters, as indicated at *bottom*.

With today's routers, even single-speed models use electronics for soft starts and to maintain a constant speed under load.

While a rheostat-type speed control may not damage your router's electronics, it could stall the router by robbing it of current. A representative for Porter-Cable went a step further, adding that some tool manufacturers will void the warranty of router owners who modify their tools with after-market devices the tool was not designed to accept.



Unlike this variable-speed router, add-on rheostat or electronic speed controls don't allow you to set precise router speeds.

## Safe router bit speeds

Diameter	Speed (RPM)*
<1"	22,000–24,000
1–1¼"	18,000
1¼–2¼"	16,000
2¼–3½"	8,000–12,000

\* Complex bit profiles or dense woods may require lower speeds than those shown. For carbide profiles exceeding 1½", drop router speeds to 16,000 RPM or slower and make multiple passes. Check your router manual for additional speed and maximum bit diameter recommendations.

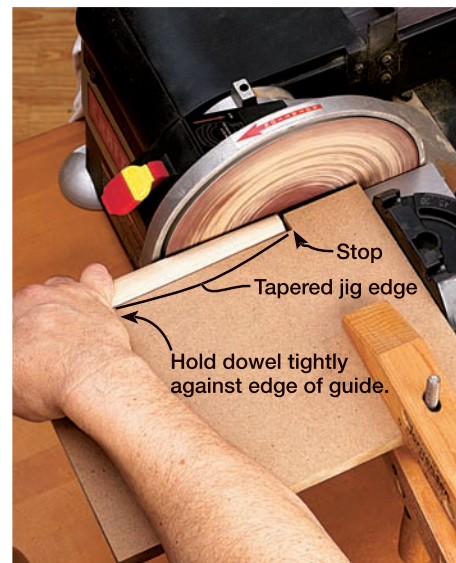

## Sanding handle tapers

**Q:** Please tell me the most efficient way to cut or sand the correct taper on a wooden handle for a rake or squeegee. What is the best machine to use?

—Mark Thorsell, Golden Valley, Minn.

**A:** We used a disk sander with a guide block clamped to the sander table, Mark. To make the guide block, cut an angled notch along roughly three-quarters of the longest edge of a 9×12" scrap. The notch is cut at a taper equal to the taper needed for your handle. Clamp this guide block to the table of your disk sander with the stop at the end of the tapered edge parallel to the face of the sanding disk. Make certain to position the stop to the left of the disk's center. Experiment with the distance between the block and the disk to achieve the length of handle taper you want for the diameter of the stock you're sanding, then mark that location.

With the handle held firmly against the edge of the guide, as shown *above*, slowly feed the workpiece into the moving disk while rotating it to create an even taper. Continue pushing the stock toward the stop on the guide until you sand up to the mark.

## Got a question?

If you're looking for an answer to a woodworking question, write to **ASK WOOD**, 1716 Locust St., LS-221, Des Moines, IA 50309-3023 or send us an e-mail at [askwood@meredith.com](mailto:askwood@meredith.com). For immediate feedback from fellow woodworkers, post your questions on our woodworking forums at [woodmagazine.com/forums](http://woodmagazine.com/forums).

# rolling workshop storage

**T**his unit was designed and built to bring order out of the chaos in my workshop," explained reader Bernard Monneau of Calgary, Alberta, in his letter to us. We liked his idea of mixing plastic tubs and shelves so much, we built one for the *WOOD*® magazine shop and invite you to construct one for your work area as well.

The design centers around plastic storage tubs of the type sold in home centers and large discount stores. Our unit houses Rubbermaid Roughneck Storage Tote 3-gallon/11.3-liter containers. Adjust the project dimensions accordingly if you use a different size tub.

The entire project, minus the optional shelves and cleats, is built out of two sheets

of MDF (¾" birch plywood would also work well). See the Cutting Diagram for optimal sheet-goods usage.

To build the project, cut the parts to the sizes noted on the drawing below. Rout a ⅛" round-over along the one exposed edge of each 1½x1½" cleat and along the top edge of each ¾x¾" cleat where shown. (The round-over on the interior cleats allows the tubs to slide easier.) Then, drill the countersunk mounting holes through all parts where noted. Glue and screw the two dividers between the two sides. Next, attach the top, bottom, center partitions, and cleats. Mount the interior support cleats allowing just an inch or two of clearance, top to bottom, between containers. Attach the casters. ♣

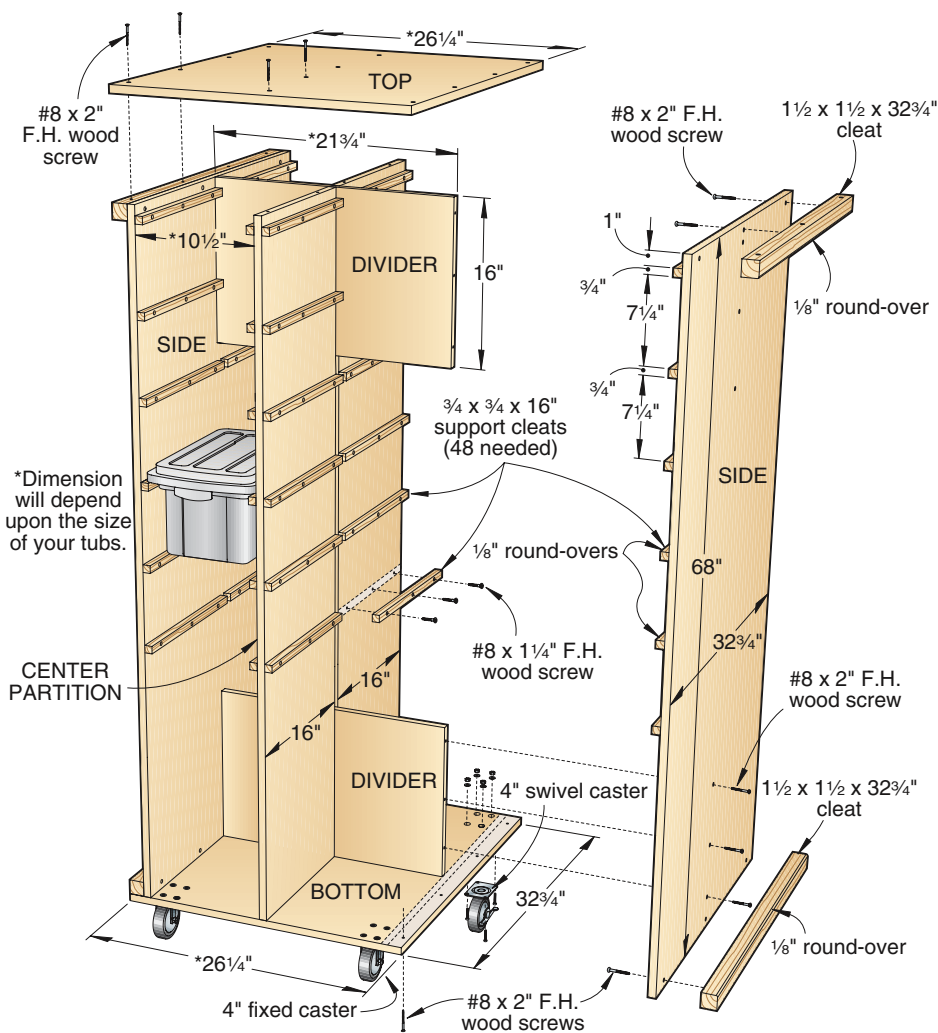

As an option, use 10½x16" shelves in place of some or all of the tubs.



## Cutting Diagram

Center partition	Divider
Side	Top/bottom

¾ x 49 x 97" Medium-density fiberboard (MDF) (2 needed)

Outside cleats  
1½ x 3½ x 72" Pine (4 bd. ft.)

Inside cleats  
¾ x 5½ x 96" Pine (4 bd. ft.)

Inside cleats  
¾ x 3½ x 96" Pine (2.7 bd. ft.)

# shop tips

Helping you work faster, smarter, and safer

## Our Winner

### top shop tip

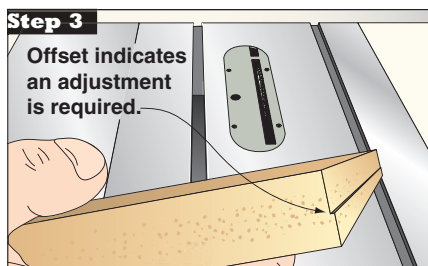
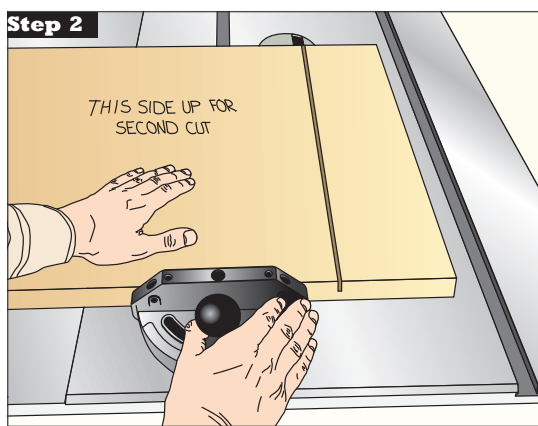
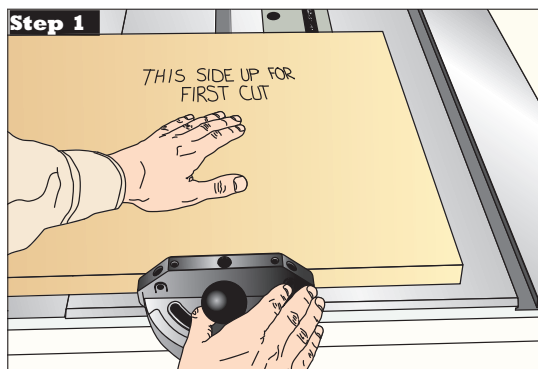

## Square up that miter gauge easily

Like many woodworkers, I've generally perceived my tablesaw's miter gauge as a nonprecision instrument—that is, until I discovered a simple way to accurately set it for 90° cuts. In truth, it's more difficult to describe my process than to actually do it.

Start by preparing a test piece—MDF works great—about 2' long and as wide as the maximum crosscut capacity of your saw (typically about 13" for a contractor-style saw). Make sure the long edges of the test piece are absolutely parallel by ripping them on your tablesaw.

Set the miter gauge to 90° and the blade height to just a hair over half the test-piece thickness. Mark one face of the test piece “this side up for first cut” and make the first cut. Turn off the saw and flip the piece so the formerly far edge is now against the miter gauge, and the marked face is down against the table.

Mark the second face as shown and carefully align the kerf from the first cut with the blade, then make the second pass. The edge of the test piece shows whether your miter gauge needs an adjustment. If the half-kerfs diverge, make tiny adjustments to the miter gauge and repeat the test until the pair of cuts line up perfectly.

—Jonathan Leavy, Newton, Mass.



Photo: Leo Gozbebian

An accountant by trade, Jonathan Leavy knows the best way to relax after a week of crunching numbers is on a five-sail sloop on the Atlantic Ocean. Although our Top Shop Tip winner sold his boat *Defiance* a few years ago, working on the 22' wooden vessel rekindled his love of woodworking. Since selling the sailer, Jonathan spends more time at the lathe turning a different kind of vessel, as shown above.

Jonathan Leavy wins a Freud Dial-A-Width dado set for sending this issue's Top Shop Tip. We appreciate your help, Jonathan!



## Top tips win tools!

Describe how you've solved a workshop problem, and you'll earn \$75 if it appears here. And, if your tip garners Top Shop Tip honors, you'll also win a tool prize worth at least \$250.

Send your best tips, along with photos or illustrations and your daytime phone number, to: **Shop Tips, WOOD Magazine, 1716 Locust St., LS-221, Des Moines, IA 50309-3023.** Or e-mail tips to: [shoptips@woodmagazine.com](mailto:shoptips@woodmagazine.com). Remember to include your contact info in the e-mail as well.

Because we try to publish original tips, please send your tips only to **WOOD®** magazine. Sorry, submitted materials can't be returned.

## Easy-made mortises for keyhole hangers

Keyhole hangers provide a strong, stable mount for frames, plaques, and shelving, but to make the fixture mount flush to the wall, the hanger needs to be mortised into the back of the shelf or frame. To do this, you need a two-level mortise: one to recess the hanger itself and a deeper one inside it for the screwhead that slides into the hanger.

The quickest, most effective way to make the two-level recess is to drill concentric mortises with two sizes of Forstner bits, as shown in the drawing at right. The result is a wall-hugging plaque or picture frame.

—Leonard Estrada, Gladstone, Va.

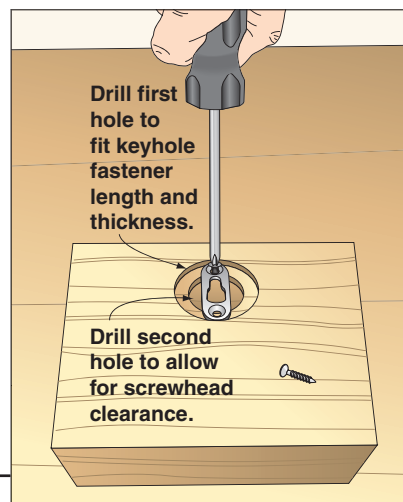

continued on page 32

## Tailor-made sanding discs from sheets

Random-orbit sanders have no equal for quickly and effectively sanding a surface; however, it's sometimes hard to find discs finer than 320 grit. Because I wanted to use my random-orbit sander to smooth finishes, I began making my own hook-and-loop abrasive discs from sandpaper sheets, which are available in much finer grits. The simple process is shown in the drawing. (I use worn 220-grit discs, and make the dust-collection holes with a hole punch.)

With this technique, my grit choices are almost limitless. I've even made terrific buffing pads from old flannel shirts and fleece sweatshirts. When a buffing pad becomes worn, I simply add a new one on top of it with spray adhesive.

—Mark Blomster, Plymouth, Minn.

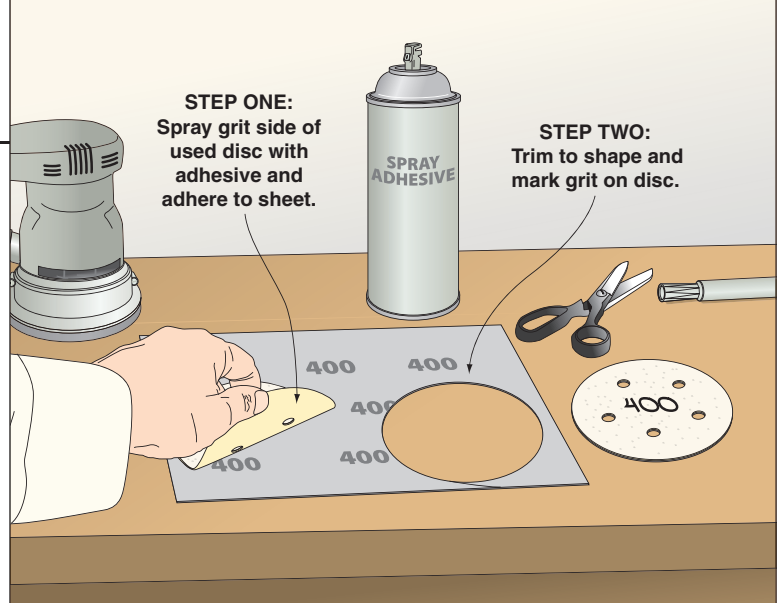

## Magnets and metal lend a helping hand in a pinch

Engineers and welders have long known about a wonderful little tool—the magnetic base. Unlike other magnets, these bases (about \$8–\$10) are magnetic only when you turn them on. Although typically used with swivel-arm clamps and dial indicators, they also work well by themselves all around the shop, for example to hold a workpiece against a fence like a feather board, as shown *below*. Once activated, they will stick to your cast-iron table or any other ferrous surface almost like they're bolted in place.

—Warren Perkins Jr., Millington, Mich.

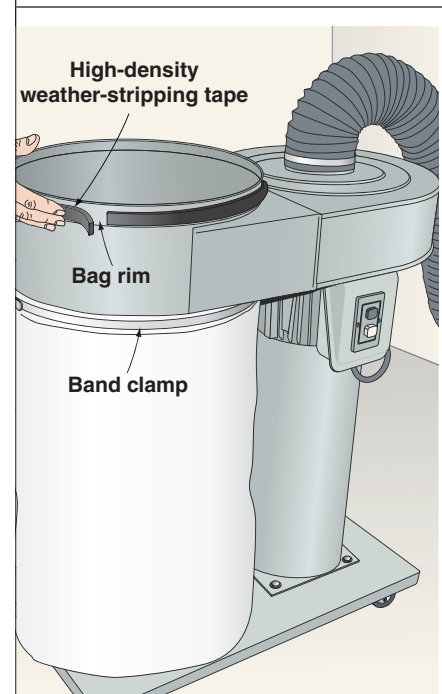

continued on page 34

## Filled cavities help in clamping to tables

The ribs on the bottom of cast-iron tool tables help stiffen them, but also make it difficult to clamp on jigs, fences, and other accessories. I solved this problem by adhering filler blocks on the underside of the table using silicone caulk. The solution was so simple that I filled the cavities on the underside of my drill-press, bandsaw, and disc-sander tables.

—David Stradtman, Kewaskum, Wis.

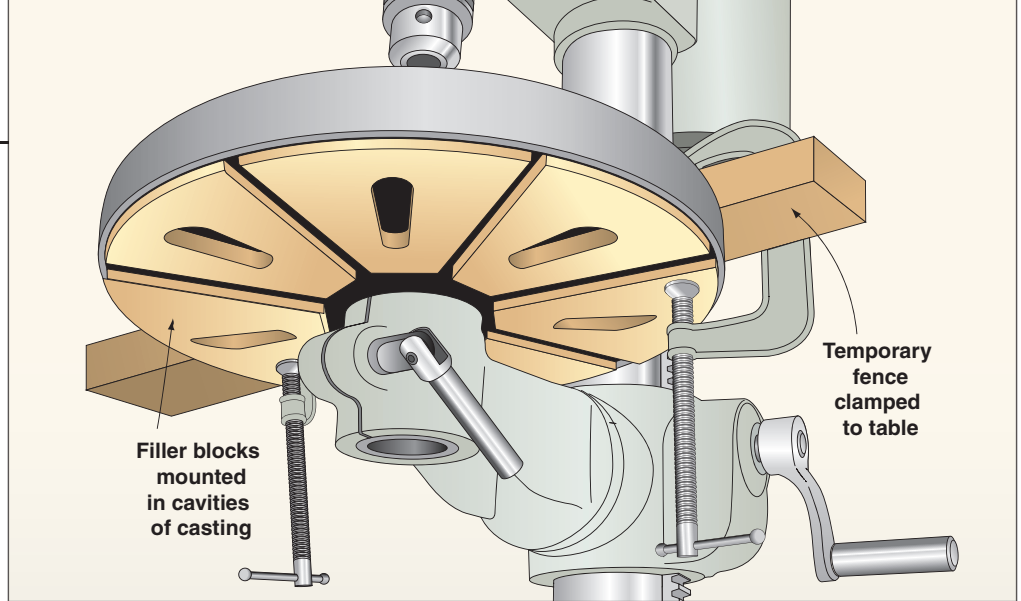

## “Tight as a drum” dust collector

My dust collector grabs woodworking debris like there’s no tomorrow, but after emptying the bag, I always had a hard time getting the band clamps tight enough. They let dust puff out from puckers in the bag material by the bands. I solved the dusty problem by applying high-density weather-stripping tape (1/4" thick x 1/2" wide) around the steel rims of the dust collector, as shown *below*. To apply the weather stripping, remove the bags and bands and wipe the rim clean with alcohol. Let the rim dry and apply the stripping.

—Richard Pinks, Gainesville, Fla.



*continued on page 36*



## The wonderful world of wedges and woodworking

For those occasions when you need a stable way to hold a board on its edge, turn to a tool that's as old as woodworking itself—the wedge. I fashioned the wedge stands shown at *right* from scraps of 2×6 and a 3/8×6" bolt and nut.

To make the stand, cut a 7"-long chunk from the 2×6 and drill a 1/2" hole centered 2 1/4" from the edge and 1 3/4" up from the bottom. This hole reduces the likelihood of the stand splitting once the wedge is cut out. Mark the cutlines for the wedge as shown in the illustration, and then cut it to shape with

a bandsaw. For a more attractive wedge, round the nose off with a sander. Finally, strengthen the stand by installing the bolt through its base. (This prevents the base from splitting when you drive the wedge.)

For extra convenience, you can connect the wedge to the stand with a length of lightweight cord so the parts don't become separated. When tightening the wedges, be sure to use a rubber mallet or dead-blow hammer to prevent unnecessary damage to the wedge.

—Anthony Weiss, Dover, Del.

36

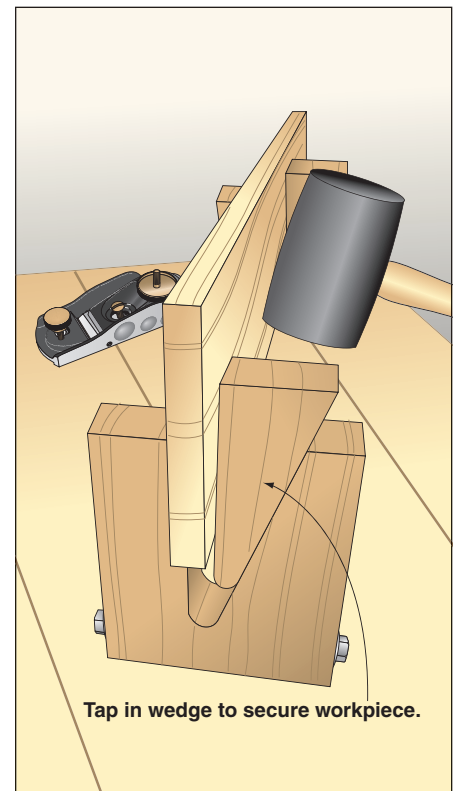
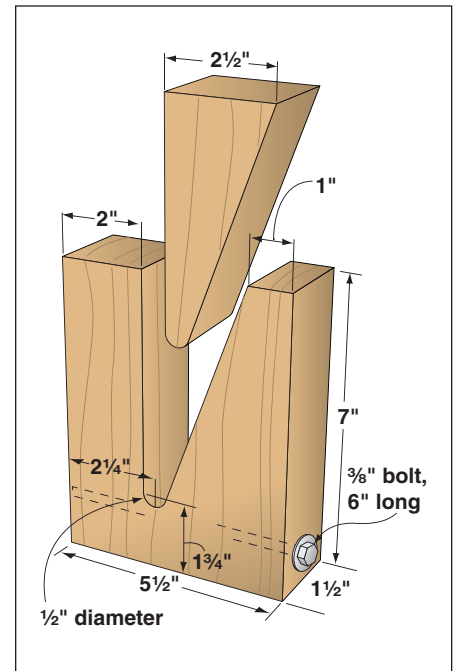

See a new  
Shop Tip  
of the Day at  
[woodmagazine.com/tips](http://woodmagazine.com/tips)



# a mirror to admire



This cheval masterpiece reflects well on your craftsmanship.

**W**ith this freestanding mirror, you can see yourself from head to toe to make sure every detail's just right. The latest member of our popular maple-and-cherry bedroom suite, this project shares the raised-panel and curved-leg features of the other pieces. For ease of machining the panels and to keep cost down, you'll bevel-rip them with your tablesaw instead of using a raised-panel router bit.

## Start with the mirror frame

**1** From 3/4"-thick stock (we used maple), cut the center stile (A), top rail (B),

center rail (C), bottom rail (D), and outer stiles (E) to the sizes listed in the **Materials List**. Then, from a 3/4"-thick contrasting wood planed to 1/2" thick (we used cherry), cut the panels (F) to size.

**2** Using a dado blade, cut a 1/4" groove 1/2" deep, centered, along *both* edges of the center stile (A) and center rail (C) and along the *inside* edges of the top rail (B), bottom rail (D), and outer stiles (E), where shown on **Drawings 1** and **1a** through **1e**.

**3** Again, using your dado blade and an auxiliary extension on your miter gauge for backup, cut the 1/4"-thick, 7/16"-long tenons on both ends of the center

### 1a CENTER-STILE TENON DETAIL

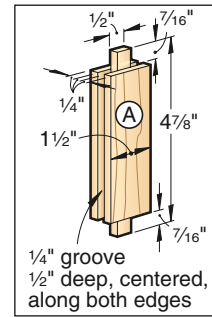

### 1b TOP-RAIL TENON DETAIL

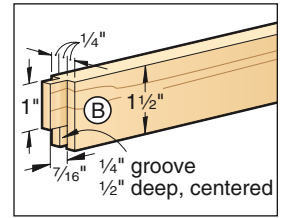

### 1c CENTER-RAIL TENON DETAIL (Viewed from back)

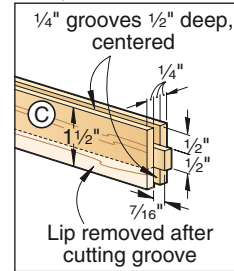

### 1d BOTTOM-RAIL TENON DETAIL (Viewed from back)

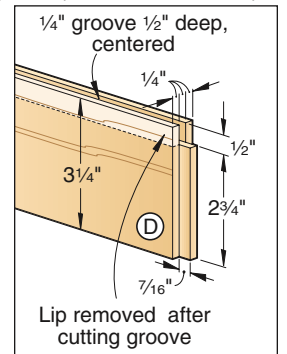

### 1e OUTER-STILE DETAIL (Viewed from back)

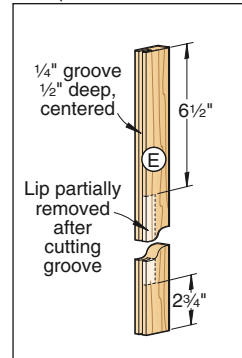

### 1f LEG BEVEL DETAIL

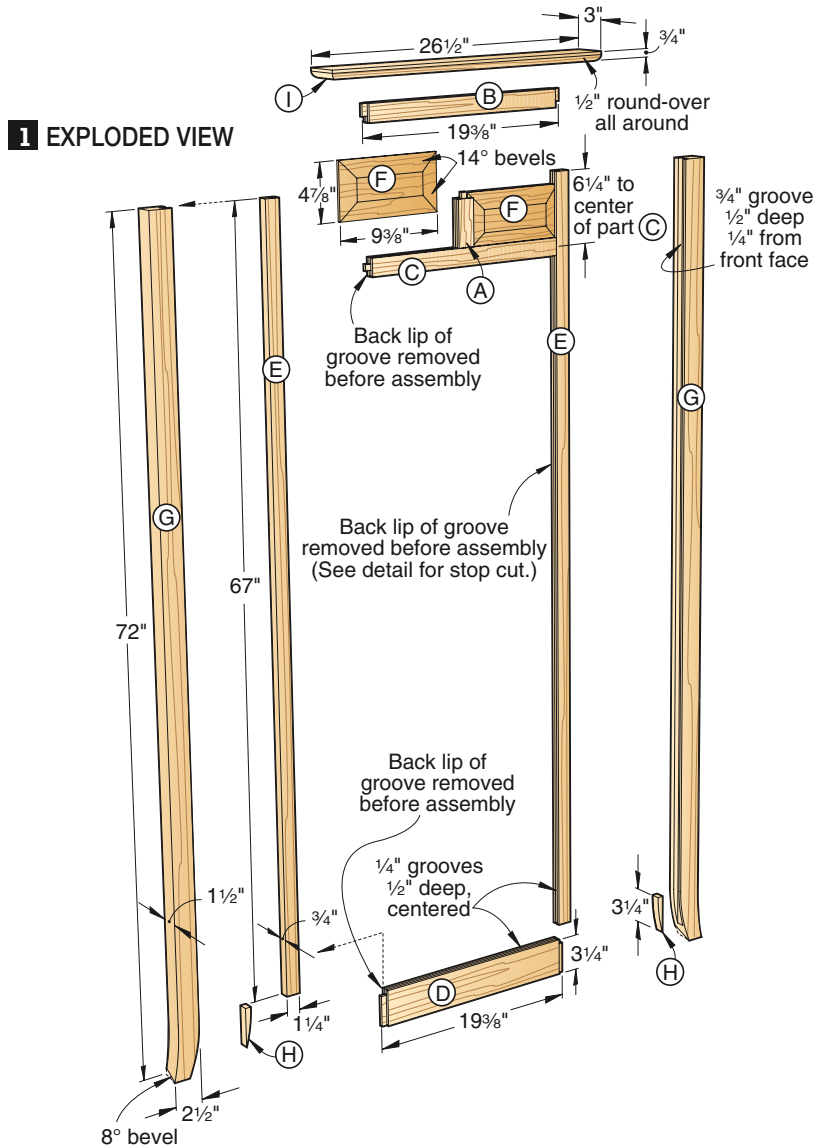
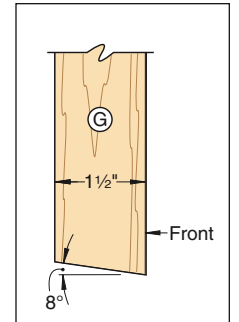

## 2 BEVEL-RIPPING THE PANELS

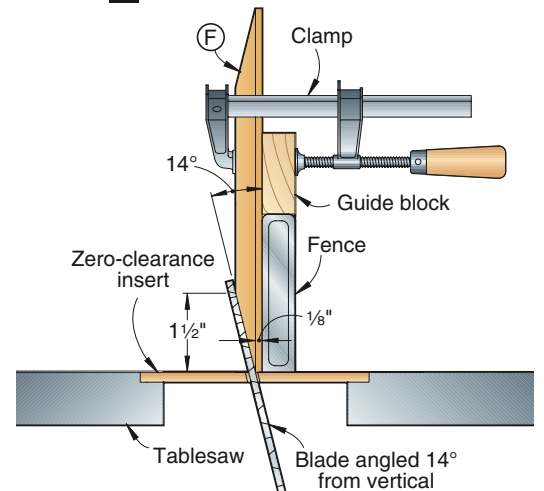

## What is a cheval mirror?

A cheval mirror (also called "cheval glass") is a full-length mirror mounted in a frame that allows tilting. In some mirrors, the glass pivots in the frame. In others, a hinged back lets you angle the frame. For our project, Design Editor Jeff Mertz went with a hinged back, which enabled use of a long mirror that fits a person of any height without need for adjustment.

## SHOP TIP

### Make stopped cuts in 3 easy steps

When using your tablesaw to make stopped cuts, such as to remove the back lips of the  $\frac{1}{4}$ " grooves in the outer stiles (E), you need a simple process that prevents overcutting. Here's how to make the hidden cuts so they end a little shy of the dimensioned stops, allowing you to easily remove the remaining material with a chisel.

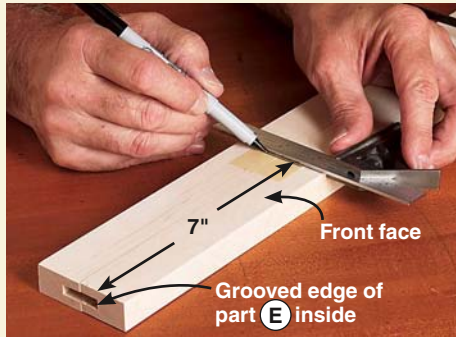

**Step 1:** Clamp together the outer stiles (E) with the front faces up and grooved edges inside. To prevent overcutting, add  $\frac{1}{2}$ " to the finished stop dimensions of  $6\frac{1}{2}$ " and  $2\frac{3}{4}$ ", and draw lines 7" from the top and  $3\frac{3}{4}$ " from the bottom on the front faces of the stiles.

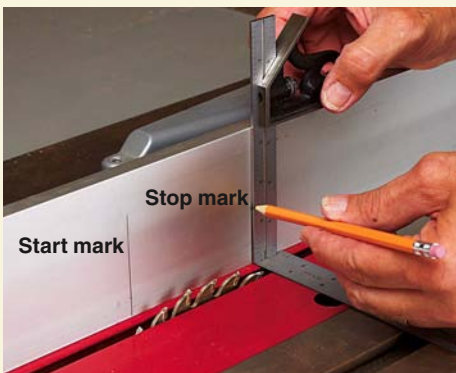

**Step 2:** Raise your tablesaw blade  $\frac{3}{8}$ ", and position the rip fence  $\frac{1}{2}$ " from the face of the teeth furthest from the fence. Using a steel rule and a combination square, draw start and stop marks on the fence aligned with the front and back of the blade at the intersection with the tabletop.



**Step 3:** Position a stile above the blade with the grooved edge against the fence and start marks aligned, as shown. Start the saw and slowly lower the stile so the blade cuts through the lip. Continue cutting until the stop marks align. Stop the saw. Repeat this step for the other stile.

### FORM THE TENONS

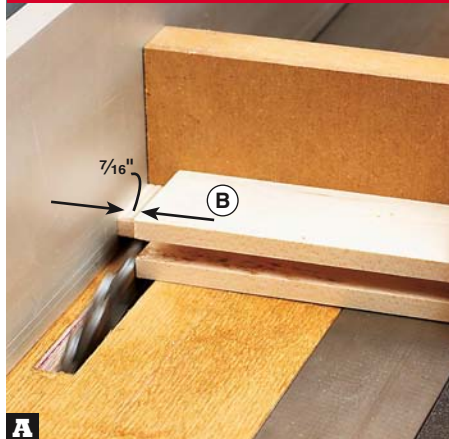

**A** Cut the tenons on the center stile (A) and rails (B, C, D) in several passes, starting at the ends and moving the parts toward the fence.

stile (A), top rail (B), center rail (C), and bottom rail (D), where shown on **Drawings 1** and **1a** through **1d** and as shown in **Photo A**. (We cut a tenon on a rail cutoff first to verify a snug fit in the mating  $\frac{1}{4}$ " grooves in the rails and stiles.)

**4** To cut  $14^\circ$  bevels on the panels (F), where shown on **Drawings 1** and **2**, switch to a standard blade in your tablesaw, and install a zero-clearance insert. Holding a panel (F) on an end, clamped to a guide block on top of your rip fence for support, bevel-rip the panel, as shown in **Photo B**. Rotate the panel, and bevel-rip the other end. Then bevel-rip the edges. Repeat for the other panel.

**5** Finish-sand the panels (F) to 220 grit, easing the sharp edges at the bevel/field transitions. To prevent unfinished areas of the panels from showing during seasonal wood shrinkage, apply a coat of clear finish to the panels. (We used Zar Water-Based Satin Polyurethane.) After the finish dries, lightly sand the panels.

**6** To remove the back lips of the  $\frac{1}{4}$ " grooves in the center rail (C) and bottom rail (D), where shown on **Drawings 1, 1c**, and **1d**, replace the tablesaw insert, and return the blade to vertical. Raise the blade  $\frac{3}{8}$ ", and position the fence  $\frac{1}{2}$ " from the *outside* face of the blade. Next, position the center rail (C) back face down with the *bottom* edge against the fence. Cut off the bottom back lip. Then place the bottom rail (D) back face down with the *top* edge against the fence, and cut off the back top lip.

**7** To partially remove the back lips of the  $\frac{1}{4}$ " grooves in the outer stiles (E), where dimensioned on **Drawing 1e**, make stopped cuts with your tablesaw, as explained in the **Shop Tip, left**. You'll remove the remaining material at the ends of the cuts with a chisel after assembling the mirror frame.

### BEVEL-RIP THE PANELS

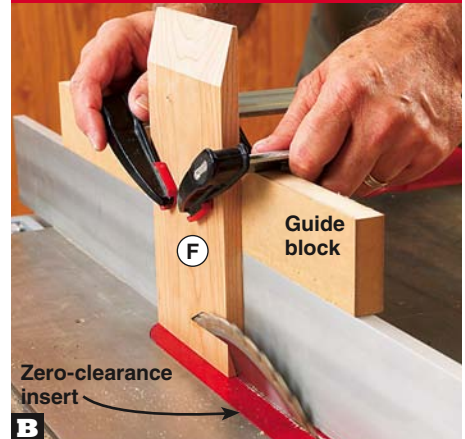

**B** With the panel (F) supported on a zero-clearance insert and clamped to a guide block on your fence, bevel-rip the ends.

**8** On the front faces of the center stile (A), top rail (B), and center rail (C), draw centerlines for aligning the stile between the rails. Then glue and clamp the parts together, as shown in **Photo C**.

**9** To assemble the mirror frame, draw centerlines on masking tape at both ends of the center rail (C) and mating alignment lines across the width of both outer stiles (E)  $6\frac{1}{4}$ " from the top ends, where dimensioned on **Drawing 1**. Next, with the beveled sides facing the front, slide the raised panels (F) into the grooves in the center stile/rail assembly (A/B/C). Then assemble (no glue) this assembly, the bottom rail (D), and outer stiles (E) together, keeping the top rail (B) and bottom rail (D) flush with the ends of the outer stiles and aligning the marked lines on the center rail (C) and outer stiles. Verify that the parts fit together correctly. Make any needed adjustments. Now glue and clamp the frame together.

**10** Using a mallet and a sharp chisel, remove the remaining lip material from the stopped cuts in the outer stiles (E) to complete the opening for the mirror. Then sand the frame smooth.

### Complete the frame

**1** From  $1\frac{1}{2}$ "-thick stock (we used maple for all of the remaining parts) or laminated  $\frac{3}{4}$ "-thick stock, cut the legs (G) to size.

**2** Using your dado blade, cut a  $\frac{3}{4}$ " groove  $\frac{1}{2}$ " deep  $\frac{1}{4}$ " from the *front* face of each leg along the *inside* edges to fit the outer stiles (E), where shown on **Drawing 1**. Identify the fronts of the legs to ensure correct orientation during assembly.

**3** From  $\frac{3}{4}$ "-thick stock, cut two  $\frac{1}{2} \times 5$ " blanks for the leg fillers (H) to fit snug in the leg grooves. Glue the fillers in place, flush with the leg bottoms. After the glue

### GLUE THE CENTER STILE

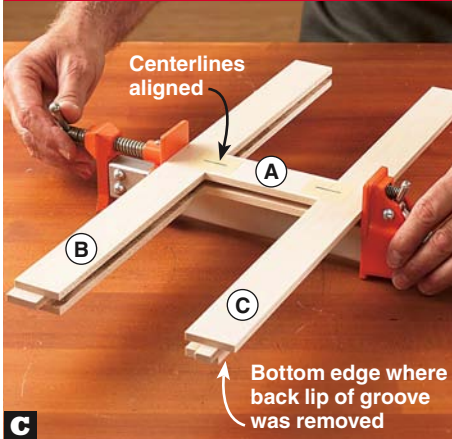

**C** Aligning the marked centerlines, glue and clamp the center stile (A) between the top rail (B) and center rail (C).  
Centerlines aligned  
Bottom edge where back lip of groove was removed

### BANDSAW THE LEG TO SHAPE



**D** Using the fence as a guide, bandsaw the *outside* edge of the *left* leg (G) to shape, rotating the leg, as shown, to cut the bottom curve.  
Fence 2" from inside of blade  
Rotate leg counterclockwise to cut bottom curve.

### SQUARE THE LEG MORTISES



**E** Clean up the *ends* of the leg (L) mortises using a 1/4" chisel. Then pare the *sides* using a chisel at least 3/4" wide.

dries, bevel-cut the leg bottoms at 8°, where shown on **Drawing 1f**.

**4** Photocopy the left and right leg full-size patterns from the *WOOD Patterns*® insert. Cut the patterns apart, where shown. Then spray-adhere the pattern pieces to the *front* faces of the legs, aligning the pieces with the tops and bottoms of the legs. Draw lines along the outside edges of the legs to connect the patterns.

### 3 BRACE ASSEMBLY

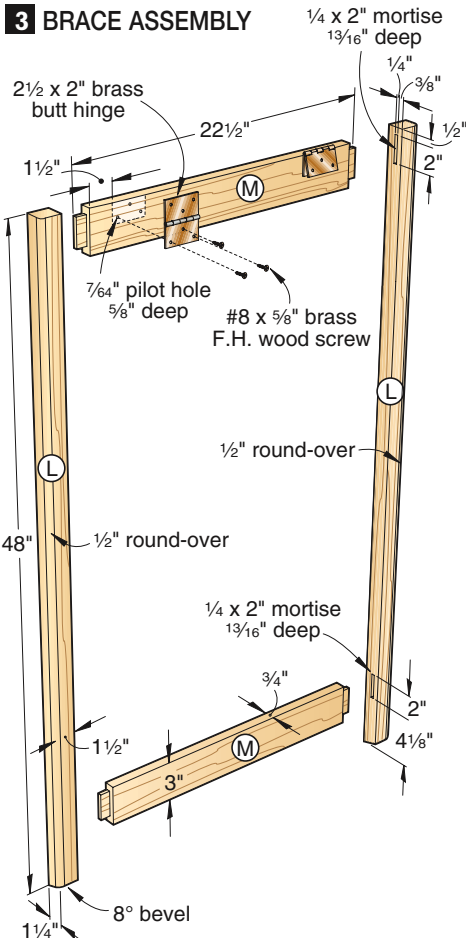

**5** Bandsaw the curve on the *inside* edges of the legs (G) at the bottom to the pattern lines. (Cutting the inside edges first gives you clearance to rotate the legs when cutting the outside edges to shape.) Next, position your fence 2" from the *inside* of the blade. Then, using a support stand, bandsaw the *outside* edge of the *left* leg to shape, as shown in **Photo D**. Reposition the fence 2" from the *inside* of the blade on the opposite side. Now bandsaw the *outside* edge of the *right* leg to the pattern line. Sand the legs smooth. Remove the patterns with a cloth moistened with paint thinner.

**6** Noting the marked front faces for correct orientation, glue and clamp the legs (G) to the mirror frame with the top ends of the legs and outer stiles (E) flush.

**7** From 3/4"-thick stock, cut the crown (I) to size. Then, using your table-mounted router, rout a 1/2" round-over along the ends and then the edges on the *bottom* face of the crown, where shown on **Drawing 1**.

**8** Glue and clamp the crown to the top of the mirror frame, centered side-to-side and front-to-back.

**9** From 3/4"-thick stock resawn or planed to 1/4" thick, cut the vertical stops (J) and horizontal stops (K) to the sizes listed to fit the opening in the back of the mirror frame.

(The horizontal stops fit between the vertical stops.) Set the stops aside.

### On to the brace assembly

**1** From 1/2"-thick stock (or laminated 3/4"-thick stock) planed to 1/4" thick, cut the legs (L) for the brace assembly to the size listed, bevel-cutting the bottoms at 8°, where shown on **Drawings 3** and **3a**. Then, from 3/4"-thick stock, cut the rails (M) to size.

**2** Lay out two 1/4x2" mortises on the *inside* edges of the legs (L), where dimensioned on **Drawing 3**, noting the mortises are offset 3/8" from the *front* faces. Using a 7/32" brad-point bit in your drill press and a fence, drill overlapping holes 1 3/16" deep, centered along the length of the marked mortises. Then clean up the ends and sides of the mortises with chisels, as shown in **Photo E**.

**3** Using the 1/2" round-over bit in your table-mounted router, round over the front outer edge of each leg (L), where shown.

**4** Refit your tablesaw with a dado blade. Then cut offset tenons, 1/4" thick and 3/4" long, on both ends of the rails (M), where dimensioned on **Drawing 3b**, to fit snug in the leg mortises.

**5** Glue and clamp the legs (L) and rails (M) together with the front faces flush. Check for square. Sand the assembly smooth.

### 3a LEG BEVEL DETAIL

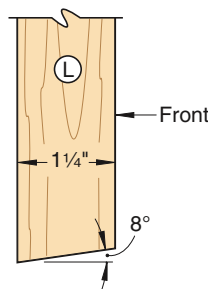

### 3b TENON DETAIL

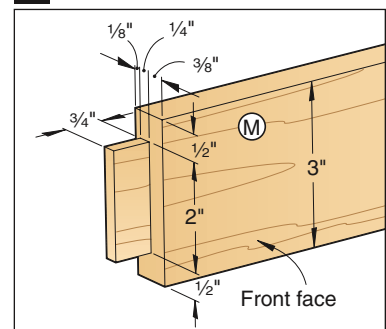

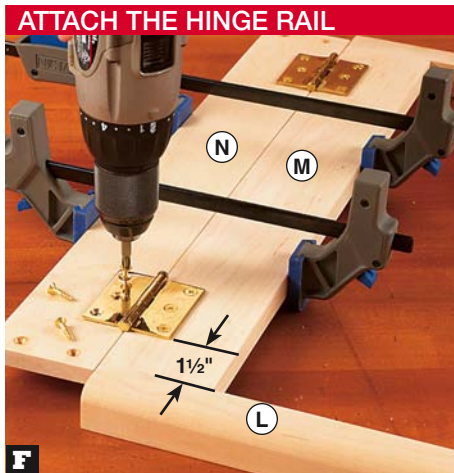

**F** Position 2½x2" brass butt hinges on the top rail (M) and hinge rail (N), where shown. Drill pilot holes, and drive the screws.

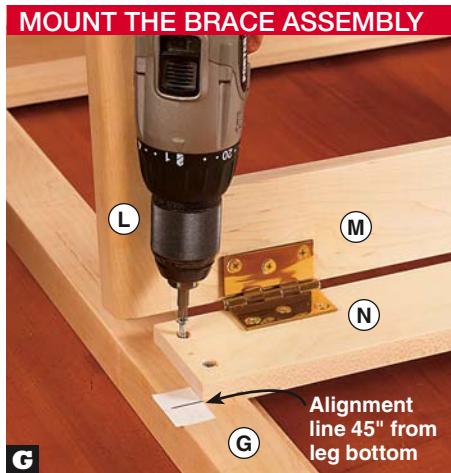

**G** Holding the brace assembly up, align the bottom edge of the hinge rail (N) with the marked lines. Drill pilot holes, and drive the screws.



**H** Install the vertical and horizontal stops (J, K) using brad nails or an air nailer. Protect the mirror with a piece of poster board.

**6** From ¾"-thick stock, cut the hinge rail (N), support arm (O), and support stops (P) to the sizes listed.

**7** Using your dado blade, cut 1" rabbets ¼" deep on the *front* face of the hinge rail (N), where shown on **Drawing 4**. Then, on the *back* face, drill countersunk shank holes, where dimensioned on **Drawing 4a**.

**8** Switch to a 45° chamfer bit in your table-mounted router. Using a handscrew to hold each support stop (P) for safety, rout ⅛" chamfers along the ends and edges of the stop on the *bottom* face, where shown on **Drawing 4b**. Then drill two countersunk shank holes in the *bottom* faces of the stops, where dimensioned.

**9** Position the support stops (P) on the bottom face of the support arm (O), where dimensioned. Using the shank holes in the

stops as guides, drill pilot holes into the support arm. Now drive the screws.

### Complete the assembly

**1** Place the brace assembly (L/M) on your workbench with the *front* face up. Then clamp the hinge rail (N), with the *back* (non-rabbeted) face up, tight against the top rail (M) and centered side-to-side, as shown in **Photo F**. Next, position 2½x2" brass butt hinges 1½" from the joints between the top rail (M) and legs (L), where dimensioned on **Drawing 3**, with the knuckles centered over the joint between the clamped rails. Drill the mounting holes, and drive the screws.

**2** To mount the brace assembly (L/M/N) to the mirror frame, draw lines on the back face of the legs (G) 45" from the bottoms, where dimensioned on **Drawing 4**. Align the

bottom edge of the hinge rail (N) with the marked lines, as shown in **Photo G**. Using the shank holes in the rail as guides, drill pilot holes into the legs. Drive the screws.

**3** To attach the support arm/stop assembly (O/P) to the bottom rail (D), position a 2½x2" brass butt hinge, centered side-to-side, on the top face of the support arm (O), where shown. Drill pilot holes, and drive the screws. Then mount the hinge to the bottom rail, centered side-to-side and ¼" below the top edge, where dimensioned.

### Finish up

**1** Remove all of the hinges and hinge rail (N). Sand any areas that need it to 220 grit. Remove the dust.

**2** Apply three coats of a clear finish, sanding to 220 grit between coats.

## Check out the matching pieces

Interested in building an ensemble or selected pieces that complement the cheval mirror? You'll find the plans for the sleigh bed in issue 135, nightstand in issue 136, armoire/TV

entertainment center in issue 137, and dresser with mirror in issue 138. If you don't have these back issues, see *page 8* for ordering them, or see **Source** at the end of this article to order the plans.



#### 4a MOUNTING HOLE DETAIL

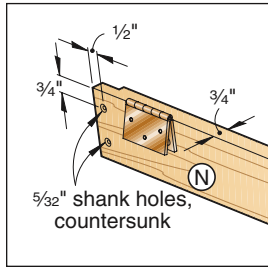

#### 4 EXPLODED VIEW (Viewed from back)

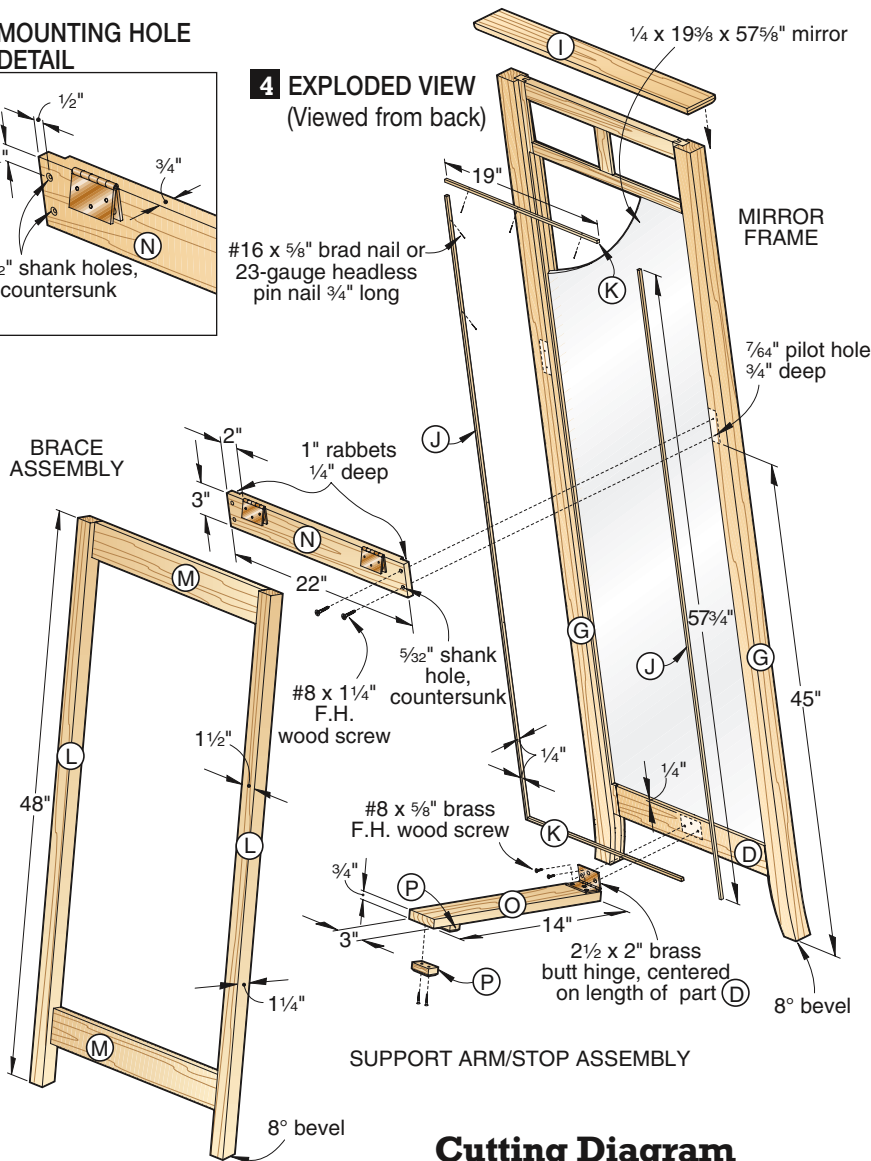

#### 4b SUPPORT STOP DETAIL (Viewed from bottom)

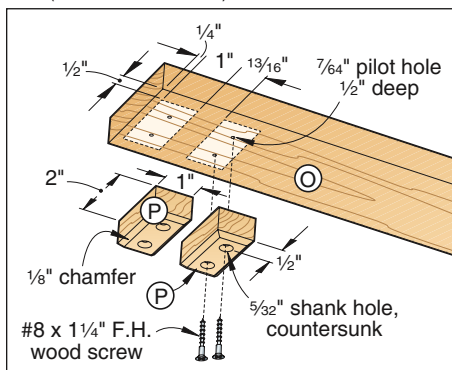

**3** Have a piece of 1/4" mirror cut 1/8" smaller in length and width than the opening. (Our mirror measured 19 3/8 x 57 5/8") Clean the mirror, and set it in the opening. Using a piece of poster board to protect the mirror, as shown in **Photo H**, install the vertical and horizontal stops (J, K) using a tack hammer and #16 x 5/8" brad nails or an 18-gauge brad

nailed with 3/4"-long brads or 23-gauge headless pin nailer with 3/4"-long pin nails. To prevent splitting the stops when using a hammer and brads, drill holes through the stops using a #16 x 1" brad with the head cut off.

**4** Finally, reinstall the hinges to attach the brace and support arm assemblies. Place the mirror where desired. Then angle the

## Materials List

Mirror frame	FINISHED SIZE			Matl.	Qty.
	T	W	L		
A center stile	3/4"	1 1/2"	47 5/8"	M	1
B top rail	3/4"	1 1/2"	19 3/8"	M	1
C center rail	3/4"	1 1/2"	19 3/8"	M	1
D bottom rail	3/4"	3 1/4"	19 3/8"	M	1
E outer stiles	3/4"	1 1/4"	67"	M	2
F panels	1/2"	4 7/8"	9 3/8"	C	2
G legs	1 1/2"	2 1/2"	72"	M	2
H* leg fillers	3/4"	1/2"	3 1/4"	M	2
I crown	3/4"	3"	26 1/2"	M	1
J vertical stops	1/4"	1/4"	57 3/4"	M	2
K horizontal stops	1/4"	1/4"	19"	M	2
<b>Brace assembly</b>					
L legs	1 1/4"	1 1/2"	48"	M	2
M rails	3/4"	3"	22 1/2"	M	2
N hinge rail	3/4"	3"	22"	M	1
O support arm	3/4"	3"	14"	M	1
P support stops	3/4"	1"	2"	M	2

\*Part initially cut oversize. See the instructions.

**Materials key:** M—maple, C—cherry.

**Supplies:** Spray adhesive, 2 1/2 x 2" brass butt hinges (3), #8 x 5/8" brass flathead wood screws (18), #8 x 1 1/4" flathead wood screws (8), #16 x 5/8" and #16 x 1" brad nails (or 18-gauge brads 3/4" long or 23-gauge headless pins 3/4" long when using an air nailer), 1/4 x 19 3/8 x 57 5/8" mirror.

**Blade and bits:** Dado-blade set, 1/2" round-over and 45° chamfer router bits, 7/32" brad-point bit.

## Source

**Plans.** To purchase the paper plans for the matching pieces, call 888/636-4478, and ask for the sleigh bed, MD-00174; nightstand, MD-00175; dresser, MD-00172; mirror, MD-00173; or armoire/TV entertainment center, MD-00171. Or, to purchase downloadable plans for any of the items except the sleigh bed, go to [woodmagazine.com/sleighbed](http://woodmagazine.com/sleighbed). Prices range from \$9.95 to \$14.95 for the paper plans and \$6.95 to \$9.95 for the downloadable plans.

## Cutting Diagram

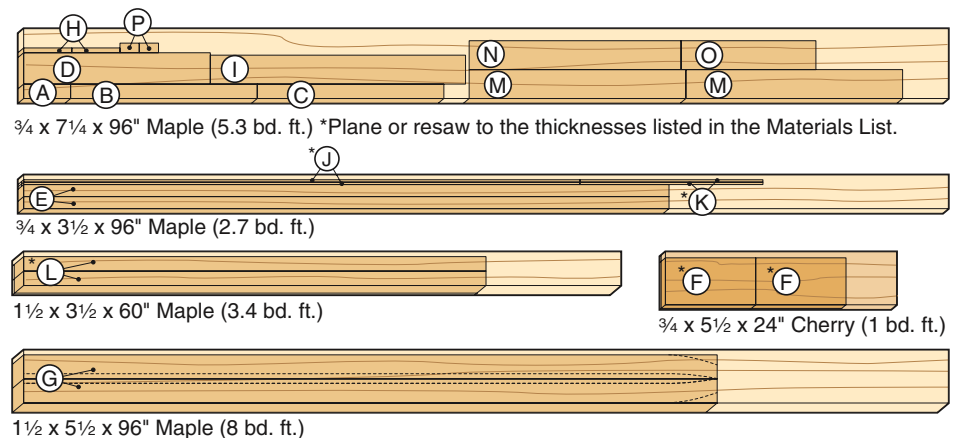

back brace away from the mirror frame until the bottom rail (M) is captured between the support stops (P). Now step in front of your masterpiece, and check out the view! 🐿

Written by **Owen Duvall** with **Chuck Hedlund** and **Dave Grieve**

Project design: **Jeff Mertz**

Illustrations: **Roxanne LeMoine; Lorna Johnson**

# buying used machines

## How to tell the gems from the junk



**W**hether you're just getting into woodworking or hoping to step up to bigger and better machinery, every woodworker quickly learns the cruel science of tool economics—the battle between unlimited wants and limited resources. To save money, you could spend hours studying the classifieds, surveying every garage sale, even sitting in at a few auctions, with the hope of snagging some screaming deal. But the real trick isn't finding used machinery—it's ferreting out the bargains from the boat anchors. And that's what you'll learn here.

### Buying old vs. buying new

Before venturing into the world of old iron, compare the advantages and disadvantages of buying used machinery. As you'll see, spending more up front sometimes can make sense—and cents—in the long run.

#### **Advantages of buying old:**

■ Just like new cars, woodworking machinery starts to depreciate as soon as you roll it out of the store. Although prices vary from one area of the country to another, it's not uncommon to find old machines going for much less than half the cost of a new model. A few years of neglect, a missing part or two, and a seller's general lack of interest in woodworking can translate into an even sweeter purchase.

■ Machines built in the '30s and '40s, sometimes referred to as the

"Golden Age of American Machinery," were built to last. Even today, those large table-saws, jointers, and bandsaws designed for abusive production-shop environments can still take on any project you might imagine without even a shudder.

Surprisingly, even the smaller benchtop tools (a fairly new market at that time) were built almost as solidly as their bigger brothers. These little machines didn't come cheap; a 12" Walker-Turner bandsaw advertised for \$29.95 in 1936 would cost about \$420 today; a 9" DeWalt radial-arm saw selling for \$229 in 1956 would run more than \$1,500 in today's dollars. Considering how much they cost in their day, it's little wonder that so many still make sawdust.

#### **Disadvantages of buying old:**

■ Despite these machines' well-earned reputations, belts, bearings, switches, wires, and motors eventually wear out even under the best conditions. Anticipate a few repairs.

■ Expect some missing parts. Machinery manufacturers—those still in business—may be able to service older equipment. (For example, Delta carries parts for their oldest Unisaws.) Other old-machine collectors can be an excellent resource, but don't expect the level of assistance you'd get from a manufacturer's 800 number. Should you need to hire a machine shop to repair or fabricate a part, the cost can exceed the price of a new tool.

#### **Advantages of buying new:**

Although it will mean paying more up front, buying new has its advantages.

■ New equipment often arrives factory-adjusted and (with some minor assembly) pretty much ready to run. This can be a big advantage if you're more interested in making sawdust than in tuning and tinkering with an old machine.

■ Most new equipment comes with a warranty; with secondhand equipment you're usually on your own.

■ In terms of safety, new machinery comes with motor brakes, blade

Written by Joe Hurst-Wajszczuk with Dave Campbell  
Photos: Del Brown Photography



guards, and splitters to bring it up to current safety standards. With old iron, this equipment was not around, or may have been dismantled and discarded years ago.

■ Another important consideration is time. If you're eager to start wood-working and need a tablesaw, view that as a red flag. You don't want to walk into your first auction with a fistful of cash ready to buy the first tool you see. (For a better alternative, see "Buying From a Dealer," on the *next page*.)

### Be prepared: Assemble a shopper's tool kit

When you start looking at old machines, expect to get dirty. In addition to a flashlight and rag, toss in a few extra items to create a tool shopper's kit. (See the photo, *above right*.) Keep it simple. In most cases, you won't have time to fuss with fancy testing equipment. (If a seller sees too much gear, he may realize how good the machine still is, and you may lose your ability to make a deal.) Use the simple assessment chart on the following pages to decide whether or not the machine is a good deal for you.

After buying the machine, the next trick is getting it back to your shop. For that, you'll need a second set of tools (see photo, at *right*) to help break down your purchase into transportable parts. Be sure to label disassembled parts carefully (or take a few photos) so you can reassemble the machine when you get home. Even when stripped of fences and motors, cast-iron beds easily can weigh several hundred pounds. Make sure you, your helper, and your vehicle are able to safely handle the load.



#### SHOPPER'S TOOL KIT

#### HELPERS BEFORE YOU HAUL IT HOME



## 3 Rules of buying old machinery

- 1. Know your limitations.** A used machine probably will need some work; plus, there's always the risk of buying irretrievable junk. If you're not ready for either, you may be better off buying new.
- 2. Do your homework.** Compare the cost with a new machine. If you can find a model number, learn all you can about the manufacturer and try to obtain a copy of the original manual, finding out if replacement parts are still available.

Online support groups, such as the *WOOD* Online® Old Tools and Machinery forum ([woodmagazine.com/oldmachinery](http://woodmagazine.com/oldmachinery)), and Old Woodworking Machines ([www.owwm.com](http://www.owwm.com)) often can be a big help.

- 3. Be patient.** According to professional rust hunters, you don't find old tools; they find you...when you're ready. Focus on Rules 1 and 2 so you can strike when a deal comes along.

## Buying from a dealer

Although you will pay more than if you snagged a machine yourself at an estate sale or auction, buying used equipment from a dealer is a safer bet, and almost as convenient as buying brand-new.

Like you, used-machinery dealers scout estate sales and auctions. But they have years of experience when it comes to assessing the condition (and value) of a machine. Most have stockpiles of parts and the necessary equipment to make short work of seemingly deal-killing repairs. These shops check and repair the machines (some refurbish them to like-new condition) before reselling.

Generally, dealers sell used machines for 60–75 percent of the cost of a new tool, and should anything go wrong, most offer 30–90-day warranties. They typically focus on big machines, such as 16" jointers and 24" planers. But you can sometimes find deals on cabinet-style tablesaws and smaller machines, such as 6" jointers or 9" radial-arm saws, that were bought with a lot of other equipment.

Another way to save money is to ask to buy a machine after it's been looked over, but before the dealer has invested any time cleaning or doing a soup-to-nuts overhaul. To find a used-machinery dealer near you, check your Yellow Pages under "Machinery."

**Generally, dealers sell used machines for 60–75 percent of the cost of a new tool...**

## Step by step: How to evaluate used machines

- GO FOR IT
- PROCEED WITH CAUTION
- DEAL KILLER

### Step 1: Assess Yourself First

You enjoy the thrill of the hunt, are willing and able to make some repairs, and are willing to accept the risk.

YES

NO

There's no shame in buying new.

### Step 2: First Contact

Big purchases start (or stop) with a phone call. As soon as you find an advertised tool, ask the seller a few simple questions.

#### Who made the machine, and how old is it?

**Brand name, less than 30 years old, still running strong.**

**Lesser-known name, older than 30 years.** You may have a hard time finding parts, so proceed carefully. Try to find out more about the manufacturer, and maybe snag a copy of an old manual.

**Long-retired relic.** Have you ever heard of babbitt bearings and leather belt drives? If you haven't, and don't plan to start another hobby, keep looking.

#### Is it still running/being used?

"Yes, I just used it for..."

"I don't know." If they're not a woodworker, they may not know. You might find a bargain or a bucket of bolts.

"It's been collecting dust in the corner." Ask why. Aside from rust, realize that bearings, belts, and tires dry out in a few years. You may have a project on your hands.

#### How Much?

**Asking 50 percent or less of new tool cost.**

**Asking 50–75 percent of new.** OK if in good shape or tricked out with accessories. Check it out. Closer inspection may reveal it to be a good deal, or you may be able to settle on a lower price.

**Asking more than 75 percent of new.** Unless this sale comes with a warranty (or the seller is your father-in-law), you'd be better off buying a new machine.

### THREE-PHASE MOTORS: MOST HOME SHOPS CAN'T HANDLE THEM

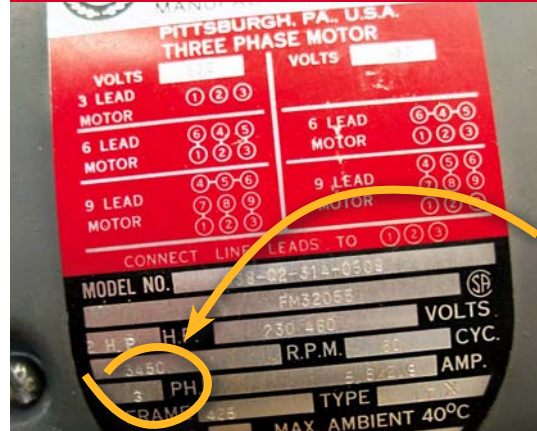

Although the industrial world runs on 3-phase power because of its efficiency and reliability, you'll rarely find it in residential or rural areas. The motor plate on this old Rockwell table saw clearly spells out its nature with the words "three phase motor" in big letters. All motor plates, however, should be stamped with a numeral 1 (for single phase) or 3, as shown here, to indicate the phase requirement.

### Step 3: First Glance

You'll know whether to stay or go in the first few minutes. Learn to trust your gut. Use surrounding clues to determine the "big picture."

**Clean, shiny, and intact—**all parts appear to be there

#### Rust and dust

**A little.** That's to be expected. Brush off what you can and take a closer look.

**Severe rust.** A ring around the base may indicate that the machine was in a flood. Having a professional machine shop smooth a severely pitted top will cost about as much as a new machine.

#### Missing parts

**Some are missing.** If loose parts come in a separate box, odds are good that a few are missing. Roughly calculate the replacement costs with the estimates provided on pages 48–49; then decide whether or not you can find replacements or do without.

**Missing a bunch of parts.** Unless you're looking for a second machine for parts, look elsewhere.

#### Cracked casting or jury-rigged repairs

**Minor cracks.** Accidents happen. Careful welds suggest professional repairs.

**Major cracks.** If this is the abuse you can see, what about the stuff you can't?

#### Check the motor

**Single-phase.**

**No motor, or 3-phase with belt drive.** You might be able to refit the machine with a single-phase motor. Factor in the cost of a new motor. Don't forget the starter, cords, and plugs.

**Direct-drive 3-phase.** You'll need a 220V circuit and a phase converter to run this machine. Otherwise, no sale.

### Step 4: Closer Inspection

With the machine off and unplugged, see if you can adjust the knobs, guides, guards, etc. Manually turn the shafts, cutterhead, belts, and pulleys, and check for any loose or clicking bearings. **IMPORTANT: Turn the cutterhead or blade one complete revolution to make sure it won't hit anything before attempting to turn on any machine. If any part appears loose, or if hardware is missing, don't flip the switch.**

**Everything moves as it should.**

**Some stiffness or clicking.** It could be bad bearings, or maybe just a stiff belt and some rust. Try to find the root of the problem and estimate the cost of buying replacement parts.

**It's frozen tight.** Game over.

### Step 5: Power Up to Check Performance

Ask if you can turn the machine on, and if you can see it under load. (In some cases, you may be able to temporarily remove the belt to make at least a rough assessment of the motor.) Wait a few minutes before turning the machine off; then put your hand on the motor.

**Low hum, little or no vibration. Motor is cool to touch.** You've got a winner!

**Some vibration.** Try to identify the problem (maybe it's just a bad belt or poorly welded bandsaw blade). If it appears fixable, make your best offer, but be ready to roll up your sleeves.

**Motor feels hot.** If it's too hot for you to touch, then you should plan to buy a replacement.

**Nothing happens.** Double-check the switch, outlet, and circuit. Walk away if you can't identify the problem, and pay no dough for a no-go.

### Step 6: Seal the Deal

If you're a good listener, you may learn a lot about the history of the machine to confirm your own observations. (You might also glean some of this information from the ad or your first contact.)

#### Where was it used?

**Home shop.** Probably well-taken care of and not pushed to the breaking point. If everything looks good, make an offer.

#### Professional woodworker.

Although used hard, it should be well-maintained. Before signing the check, you may want to ask about the machine's maintenance schedule and why it's being replaced.

**School shop.** You can find some excellent older tools there, but expect to correct many years' worth of neglect. Make your offer accordingly.

**Surplus sale.** Some machines are sold only after they've been run into the ground. Unless you don't mind the idea of a complete overhaul, put your hands deep into your pockets and back away slowly.

### Step 7: Final details

Can you get it home? All bets are off if you can't transport the machine or maneuver it into your shop. Realize that moving a big machine can cost as much as transporting a car that doesn't run.

# What to look for in a used jointer, bandsaw, and tablesaw

These three woodworking machines represent the best candidates to buy secondhand because there are so many of them out there. Each machine shows wear in different ways. Here are the most common weaknesses to look for in each.

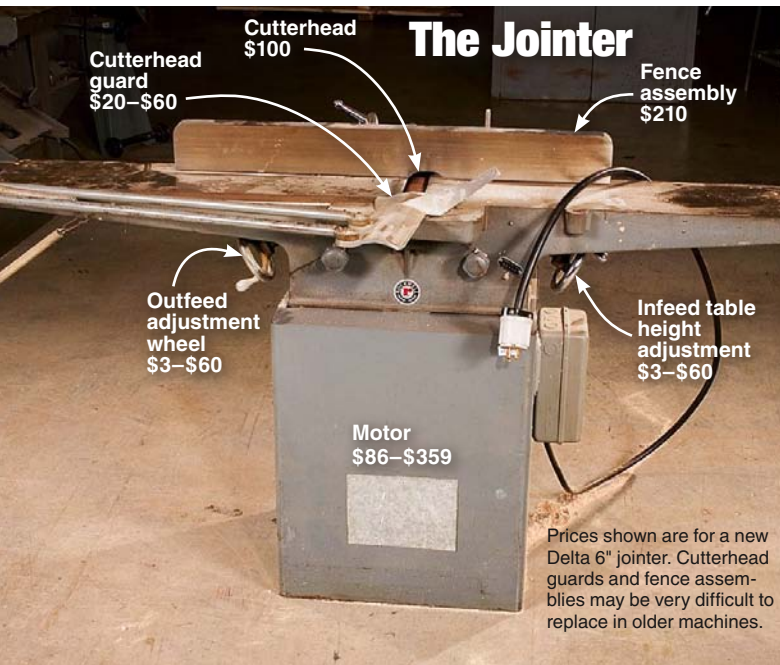

## ✓ Spots to Check

❑ **Bearings.** Rotate the cutterhead a couple of times by hand. Listen and feel for any roughness or clicking that might indicate that the bearings are loose or worn. The heavy coat of rust on the cutterhead suggests that this machine hasn't seen use in a while.



❑ **Tables.** Make sure the infeed and outfeed tables haven't rusted tight, and still move up and down on their dovetailed slides. The surfaces of both tables should be clean and free of major pitting that would prevent you from sliding a board across the top. You also may need to remove one or both cast-iron tables to move the machine.



❑ **Fence.** Using a square, check the fence across the length of the table. A twist could cause the wood to rotate, resulting in an out-of-square edge.

**T**he mechanics of a jointer are fairly simple, but maintaining and tuning this tool can be a challenge. If the table or fence measures even a few thousandths of an inch off, you may not be able to produce straight, flat, square-edged stock—the starting point for successful woodworking. Don't settle for a 4" or 6" jointer unless it's good to go. Larger (8" and up) jointers cost thousands of dollars new; for the right price, an older machine might warrant the extra work.

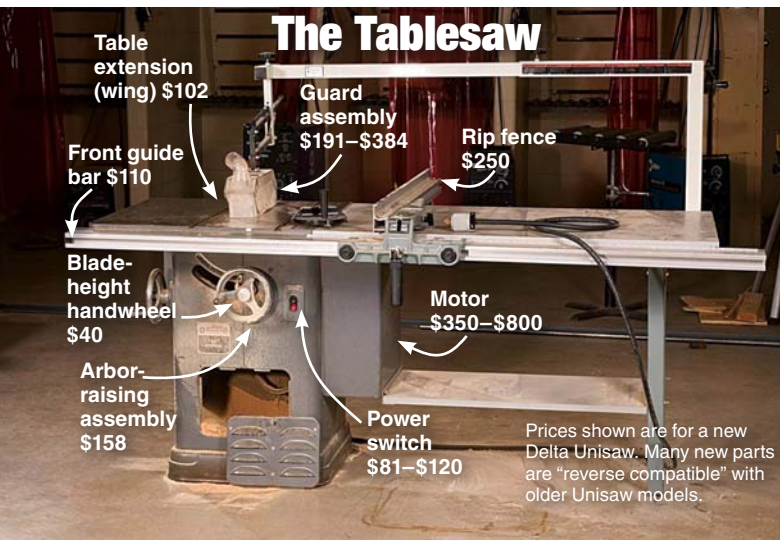

## ✓ Spots to Check

❑ **Arbor.** Any wear or looseness will cause the blade to wobble. With the saw unplugged and blade removed, rotate the arbor, and then gently pull up and down to check for play in the shaft. Any clicking or play indicates worn bearings.



❑ **Gears and pivot.** Expect the internal mechanisms that control blade tilt and elevation to be caked in sawdust. Brush off the dust; then check for cracked or missing teeth. Raise and lower the blade, crank the bevel adjustment, and check for smooth movement.

❑ **Belts.** Unexplained vibration could be due to mismatched belts. If one looks good, and the other appears cracked or frayed, the load will be carried by the better belt. Replace all the belts at once.

**T**he tablesaw makes up the heart of most woodworking shops, but the cost of a new cabinet-style saw keeps this machine out of reach for many. Fortunately, if you're willing to make minor repairs or order replacement parts, it's not too hard to find a reasonably priced used machine. When scouting out cabinet saws, stick with the major brands just in case you need to replace missing parts. Some woodworkers/mechanics find it cheaper to buy a second "parts" saw than buying everything new.

# The Bandsaw

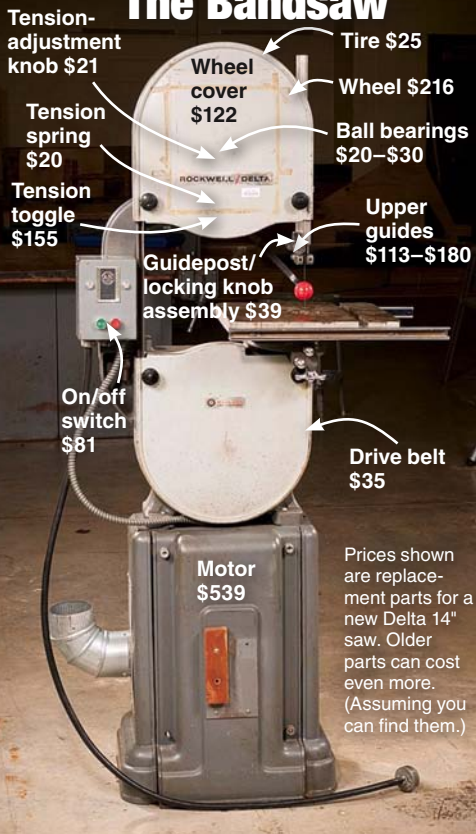

Prices shown are replacement parts for a new Delta 14" saw. Older parts can cost even more. (Assuming you can find them.)

**B**andsaws are fairly complex machines and can be unforgiving when misaligned and poorly maintained. The good news is that if all the parts are there, setting up and tuning this machine is somewhat straightforward. Check the condition of the blade guides, the tensioning system, and the tracking-adjustment knob before assuming the machine needs a complete overhaul.

Because small- to medium-size saws (14" and smaller) are found all over the place, consider one only if it looks to be in good shape. A larger saw may be worth some extra work on your part.

## ✓ Spots to Check

❑ **Wheels.** Turn each wheel, and then grasp it by its sides and try to rock it. If there's a clicking sound or any rocking, the bearings probably are shot. Replacement isn't terribly difficult, provided you can still find parts.

❑ **Tires and Belts.** When cracked or worn, these parts can contribute to a bumping sensation or wandering cuts. Plan on replacing them.

❑ **Guide post.** The blade guides should stay in the same relative position to the blade regardless of the cutting height. With the guide post lowered to the table, move the side bearings or blocks until they almost touch the blade. Raise the post to its highest setting, and recheck the clearances.



## Bandsaw case study: Tune-up or extreme makeover?



This 14" Rockwell/Delta bandsaw is a good example of what you might find at an auction or estate sale. This particular machine has been "ridden hard and put away wet" by high school shop students for more than 50 years. Tom Caccia, the shop instructor at Platteville (Wis.) High School, says the saw "can still make the cut," but it's at a point where another shop might consider replacement over repairs.

At an auction, a saw like this might sell for \$300–\$450. Compared with the cost of a new saw (about \$400–\$1,000), this deal might sound like a steal, but is it really?

Knowing that this machine still runs is a good sign that the motor and bearings still work reasonably well (don't forget to rock the wheels) and that it's not missing any major parts. However, a closer inspection reveals common signs of neglect: a crushed compression spring, cracked tires, and a frayed drive belt. Replacing just those parts will set you back about \$125. (See the photos, at right.)

To put it on par with a new saw, you may consider adding a blade-tension quick-release, as we did here, for \$155. This upgrade makes it easy to change the blade, and reduces wear on the bearings, blade, and tires. The old blade guide assembly was functional, but well-worn. You should probably expect to shell out an additional \$160 for a replacement in the near future.

In short, you could make this saw work as well as (or maybe better than) ever for about \$440 (not including labor or the price you paid for the saw). It's important to note that the total cost can exceed the price of a

new tool, but without a warranty. Should the bearings seize or motor fail, you'll be even more dollars behind. All told, this "bargain" saw may not have been the steal it first appeared to be, and was probably best left where we found it. ♣

## SOURCE

14" urethane band saw tires, \$25 ea.; Cobra Coil bandsaw tension spring replacement, \$20; Quick Release tension toggle, \$150; bandsaw conversion kit (guides), \$150–\$180. **Carter Products Company.** Call 888/622-7837, or go to [carterproducts.com](http://carterproducts.com).

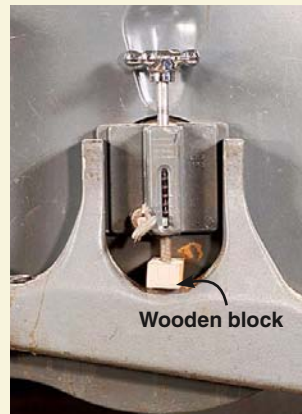

The wooden block under the tension-adjustment screw (above) and cracked tires suggest neglect that might mean additional problems you won't find right away.



Springs wear out. Luckily, replacement is a simple chore. Adding a tension quick-release spares the blade, tires, and bearings from needless wear.



New urethane tires slip easily onto the old wheels with hot, soapy water. Unless the bandsaw is nearly new, expect to replace the tires and drive belt.

# 6 great finishes for ...

## cherry ...

Beat blotchiness as you bring out cherry's complex figure to achieve either a warm, natural finish or one that mimics a 100-year-old antique.



Natural glow



Antique elegance

## maple ...

Make curly maple figure dance, or simply add visual dimension to this pale wood using an easy-to-make white glaze.



Fantastic figure



Glazed grain

## & oak

Dye produces a mission finish you can make as dark as you like. Or give your projects a sophisticated look by filling oak's deep pores for a silky-smooth surface.

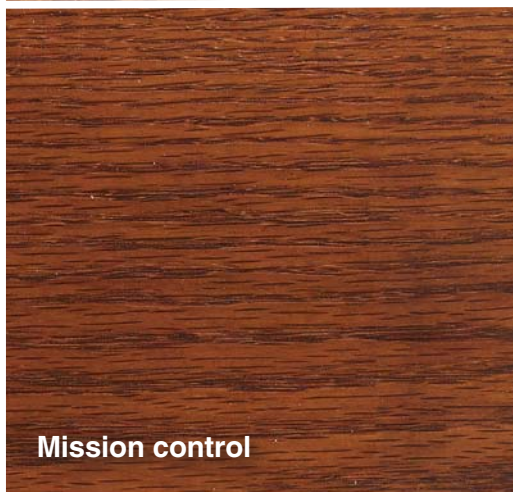

Mission control



Level best

## Cherry: Natural glow

Sometimes, cherry just needs a little encouragement to show off its color and figure. This easy-to-apply finish heightens cherry's natural color and grain, even as the wood darkens with age.

**Ingredients:** Boiled linseed oil, 2-lb. cut shellac (your choice of shade, as shown below), and satin finish alkyd-resin varnish (see Sources on page 56).

**Directions:** Sand the surface to 220 grit and apply a liberal coat of boiled linseed oil, allowing it to soak in for 30 minutes before wiping off the excess. Buff the surface with a clean, dry cloth to remove the surplus oil. Weather conditions will affect how quickly the oil cures, but the wood should be ready to continue finishing after a week. Next, apply a single coat of shellac in a 2-lb. cut. The grade of shellac will determine how much color you add to the wood. Super-blonde will add a slight amount of color while garnet creates a reddish-brown tone. Shellac can serve as your topcoat, but alkyd-resin varnish over shellac provides a more durable option. (See "All about alkyds," below.) If that's your preference, add two coats of alkyd-resin varnish, sanding between coats.

### All about alkyds

Polyurethane has taken over the varnish shelves of most stores, but it's not your only varnish option. Alkyd-resin varnishes don't resist abrasion as well as polyurethane, but that can work to your advantage by making an alkyd-resin finish easier to rub out for an even sheen.

Alkyd resins form by combining alcohol and acid. The word "alkyd" is a modified contraction of these two ingredients. Cooking these resins with oil forms varnish, but one particular type of oil takes advantage of alkyd resins' light color. Check the varnish label for soya (soybean-based) oils. These not only go on lighter than linseed oil, they darken less with time.

### Shades of shellac

Going back centuries before the 1700s, shellac was valued as a reddish-purple dye color, not as a wood finish. That color remains important when applying a shellac wood finish. We applied shellac to white foam-core boards, shown *below left*, to emphasize the colors of the following types:

**Garnet** describes the darkest of the commonly available shellac flakes. It lends darker woods an even richer tone, but should be applied carefully to lighter woods to avoid streaking.

**Amber** shellac dries slightly lighter, but still dark enough to become a toner for light woods.

**Blonde** shellac passes through an activated carbon filter that removes most of its color. This light shade gives woods a slight amber glow.

**Super-Blonde** shellac adds almost no color at all to any but the lightest woods. Only the less common **Ultra-Blonde** grade is lighter.

The concentration, or cut, of the mixture influences the color, too. Increasing the quantity of shellac flakes without increasing the amount of denatured alcohol in a mix increases the concentration and darkens the color. Expect that color to remain consistent with time; it's a misconception that shellac darkens with age as do oil-based varnishes and lacquer.



Garnet

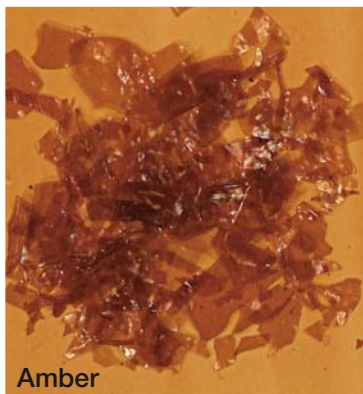

Amber

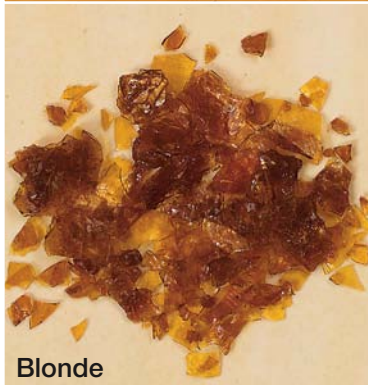

Blonde

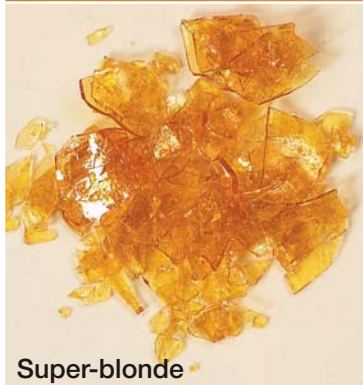

Super-blond

Sand to 220 grit

Apply boiled  
linseed oil

Seal with shellac

Add two coats  
of varnish

## Cherry: Antique elegance

Finishing expert Steve Mickley uses this recipe when he's asked to create a dark cherry finish that resembles those found on antiques dating back hundreds of years. In the past, he used lye to darken the wood. But the method described here provides safer, more predictable results that can be reversed somewhat if necessary, unlike lye.

**Ingredients:** English brown mahogany dye, rosewood dye, distilled water, boiled linseed oil, and alkyd-resin varnish (see Sources on page 56).

**Directions:** Sand all surfaces to 220 grit. From your dye concentrates (see "Color control using concentrated dye," on page 55), mix two parts of English brown mahogany and one part rosewood in nine parts of distilled water. Soak the wood surface evenly with dye using a synthetic sponge. Then wring out the sponge, and use it to wipe away any excess. Should the color turn darker than you like, use a wet sponge to redissolve and wipe off some of the dye. Allow the dye to dry thoroughly before saturating the surface with boiled linseed oil and wiping away any excess. Let a week pass for the oil to cure, then apply three coats of alkyd-resin varnish, sanding between coats.

### Mix shellac to suit your needs

Mixing shellac from flakes (see Sources) lets you control the concentration, or "cut," and shade of the finish. Dry shellac performs best when stored in a cool place and used within 6 months after mixing, so make just enough for your immediate needs.

Use the chart, *below right*, to determine the amount of solid shellac flakes to mix with alcohol. Begin by breaking up the brittle shellac flakes, as shown *below*. Add the correct amount of denatured alcohol to a sealable plastic or glass container and pour in the shellac.

Stir the mixture frequently during the next few hours, covering the container when not in use. Once the shellac dissolves, pour it through a paint strainer to remove any undissolved material and impurities. Label the mixture with the grade of shellac, the cut, and date it was mixed.

For the finishes here, you'll use 2-lb. cuts of shellac because this concentration lays down a layer of finish that can be lightly

sanded without cutting through to stained or dyed wood underneath.

A 1-lb. cut can be used over bare, unstained wood. It also serves as a sealer when there's no need to sand between the sealer and the topcoat, as when you want to add a coat of shellac for its color before applying coats of varnish.

Use a ½-lb. cut as a pre-stain coating to reduce blotching on such woods as pine. Just apply a coat and sand lightly to smooth the surface before staining.

### Shellac mixing ratios

Cut	Amount	Shellac	Alcohol
½-lb.	Pint	1 oz.	16 oz.
	Quart	2 oz.	32 oz.
	Gallon	8 oz.	128 oz.
¾-lb.	Pint	1½ oz.	16 oz.
	Quart	3 oz.	32 oz.
	Gallon	12 oz.	128 oz.
1-lb.	Pint	2 oz.	16 oz.
	Quart	4 oz.	32 oz.
	Gallon	16 oz.	128 oz.
1½-lb.	Pint	3 oz.	16 oz.
	Quart	6 oz.	32 oz.
	Gallon	24 oz.	128 oz.
2-lb.	Pint	4 oz.	16 oz.
	Quart	8 oz.	32 oz.
	Gallon	32 oz.	128 oz.



Breaking up shellac flakes in a blade-type coffee grinder helps them dissolve more quickly and evenly in alcohol.

Sand to 220 grit

Color with dye

Add boiled linseed oil

Apply alkyd-resin varnish



## Maple: Fantastic figure

Figured, or curly, maple displays exquisite visual texture if you stay away from most pigmented and penetrating stains that can leave the surface looking blotchy and mask subtle figure. Here's one way to achieve the best of both: dramatic figure and rich color.

**Ingredients:** Early American maple dye concentrate, distilled water, boiled linseed oil, and optional alkyd-resin varnish (see Sources on *page 56*). An optional step requires either amber or garnet shellac in a 2-lb. cut.

**Directions:** Sand all surfaces to 220 grit. Dilute one part of early American dye concentrate with three parts distilled water. Flood the surface with dye using a synthetic sponge. Then wring out the sponge, and use it to wipe away the excess. This will color wood more evenly than pigments or oil-soluble penetrating stains without obscuring the curly figure. Allow the wood to dry thoroughly before saturating the surface with boiled linseed oil, allowing it to soak into the wood for about 30 minutes. Wipe away the excess oil, buff the surface, and allow the oil to cure for one week. As an optional step, apply amber or garnet shellac in a 2-lb. cut to add even more depth to the future. Protect the surface with three coats of alkyd-resin varnish.



For added contrast between the figured areas and the rest of the surface, wet-sand the boiled linseed oil with 220-grit abrasive to produce a dyed slurry that packs the open grain of the figured areas. Then wipe away the excess working perpendicular to the grain.

### Boiled linseed oil: a finish that's just the start

Boiled linseed oil is among the thinnest, least durable finishes. But saturating wood with just one coat is enough to highlight figure that would look muted beneath the surface of sturdier film finishes.

That's because linseed oil, and tung oil as well, work from the inside out. They penetrate deep into the wood where they react with oxygen and harden. Just as some parts of a

board's surface soak up more stain than others to produce blotching, linseed oil penetrates some areas more thoroughly than others. This produces color contrasts that seem to pull your eye beneath the wood's surface. Add a film finish after allowing the boiled linseed oil to dry thoroughly, and you get the best of both worlds: contrasting wood tones beneath a durable surface.



# Maple: Glazed grain

If you want to preserve or even enhance maple's pale color while highlighting the details on routed profiles and trim, here's a way to do both.

**Ingredients:** Super-blonde shellac, white oil-based paint, mineral spirits, and alkyd-resin varnish. A cellulose acetate butyrate acrylic (CAB) lacquer (see Sources on page 56) or water-borne finish may be substituted as a topcoat for less yellowing.

**Directions:** Sand to 220 grit and seal the wood with super-blonde shellac. Lightly sand the sealed surface with 320 grit without cutting through the finish. Make a glaze by adding one part white oil-based paint to four parts mineral spirits, and stir until it reaches an even consistency. Wipe the thinned paint onto the sealed surfaces, working it into any recessed corners and crevices in the wood. Wipe away most of this glaze from the flat surfaces using a clean rag, and use a dry brush to remove or spread remaining glaze in the recesses. If you remove too much, reapply and spread the glaze where needed. After the glaze dries thoroughly, seal the surface with alkyd-resin varnish if a light amber tone suits your needs. Use CAB acrylic lacquer or water-borne finishes for a clear topcoat.



Sand to 220 grit

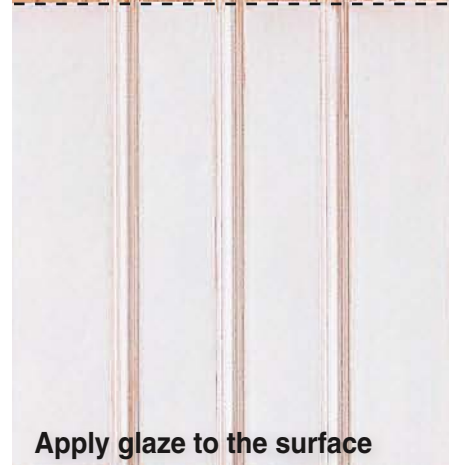

Apply glaze to the surface



Remove most of the glaze



Seal with lacquer or varnish

## STEP 1: APPLY THE GLAZE



Don't worry about applying glaze with painted finish precision. It's more important to apply it quickly so that the surplus can be removed before drying.

## STEP 2: DRY BRUSH GLAZE



A dry, synthetic-bristle brush lets you control the amount of glaze you leave. Frequently wipe the surplus on a clean rag to avoid just moving the glaze around the surface.

## STEP 3: APPLY VARNISH



A pale wood to begin with, maple can be further lightened and moldings accented using a white glaze. For this door, we restored warmth to the wood using varnish.

## FILM FINISHES ADD COLOR

Oil-based polyurethane	CAB acrylic lacquer	Water-borne finish
Unfinished wood		

Not all "clear" topcoats are clear. On this sample piece of maple, the oil-based polyurethane on the left leaves behind a definite amber color that will darken with age. CAB acrylic lacquer in the center sample dries nearly as colorless as the water-borne finish on the right, but may yellow more with age. Nitrocellulose lacquer (not shown) goes on darker than CAB acrylic lacquer and will darken still further with age. Both CAB acrylic lacquer and water-borne finish come close to the natural color of the unfinished wood.

# Oak:

## Mission control

Original mission furniture was once produced in a host of shades, ranging from natural oak to ebony. Using a finishing technique that relies on concentrated dye, you can make your project's mission finish as dark as you like.

**Ingredients:** Light or dark fumed oak dye, as shown *below*; super-blond shellac; a dark gel stain (we used Varathane's mission oak stain); mineral spirits; and alkyd-resin varnish in a satin or semigloss sheen (see Sources on *page 56*).

**Directions:** Sand the surface to 220 grit, and apply either a light or dark fumed oak dye diluted to one part concentrate in three parts water. For an extra-dark surface, reduce the dilution of the dark fumed oak concentrate. After the dye dries, seal the surface with super-blond shellac to keep subsequent steps from altering the color of the dye. Lightly sand the shellac with 320 grit, taking care to avoid cutting through the sealer. Next, apply dark gel stain across the grain. Immediately wipe across the grain to remove any stain that doesn't lodge in the pores. Wait a few minutes, and then wipe across the grain again with a paper shop towel dampened with mineral spirits. This removes stain left on the surface, leaving stain only in the pores. Finish with three coats of alkyd-resin varnish.

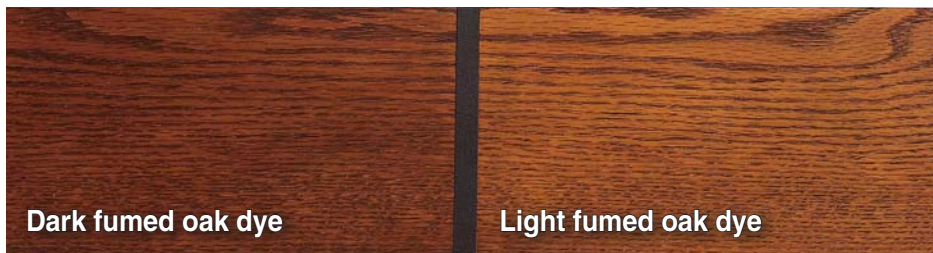

## Color control using concentrated dye

Uniformly coloring the dense ray flecks and open-pore grain of quartersawn oak presents a finishing challenge. In our October 2004 issue (#158), we showed how to create a rich mission finish using one part non-fibered roofing asphalt to four parts Minwax red oak or golden oak oil-based stain. This mix adds depth to the finish while coloring quartersawn oak ray flecks that tend to repel stain.

There was just one problem. For the deepest, darkest mission colors, coats of the stain/asphalt mix had to be sprayed on and allowed to dry for built-up color, not something most woodworkers are equipped to do. This also can obscure the grain.

For deep color just shy of ebonizing, you'll need to do more than switch dye colors. Instead, apply a highly concentrated dye like that shown at *right*. Mixed at the ratio of 1 ounce of dye to 1 pint of water, this produces uniform, easily controlled color that can go on as dark as you like.

To make a dye concentrate, disregard the usual mixing instructions. For example, some dye suppliers recommend mixing 1 ounce of dry powder with up to 4 pints of water. You could dilute the dye further still for a lighter shade, but you can't extract water to create a darker finish.

Instead, Steve Mickley mixes 1 ounce of dye powder with just 1 pint of hot (but not boiled) distilled water. Later, additional water can be added to lighten the dye to the desired shade, or you can use it at full strength for a super-dark finish. The color of the wet, freshly dyed surface gives you a preview of the dye color after applying a topcoat.



Sponged generously onto the surface, dark fumed oak dye concentrate evenly tints both the flecks and the surrounding wood.

Sand to 220 grit

Apply light fumed oak dye

Seal dye with shellac

Fill pores with dark stain

Finish with alkyd-resin varnish

# Oak:

## Level best

Oak's many deep pores can leave behind an uneven surface, no matter how carefully you sand and finish the wood. By filling those pores, however, you help level the wood surface and lay the base for an even sheen. Your choice of filler also lets you control how much the pores match or contrast with the surrounding wood.

**Ingredients:** Super-blonde shellac, paste wood filler (we used Wood-Kote Wood-Perfect in walnut), and alkyd-resin varnish (see Sources below).

**Directions:** Sand to 220 grit, and seal the wood with super-blonde shellac. The shellac doesn't fill the wood pores, but protects the surface from being stained by the wood filler paste. Carefully sand the shellac with 320 grit to avoid cutting through the sealer coat. Next, cover the surface with paste wood filler, and use a plastic scraper worked perpendicular to the grain to force the filler into the pores. Take special care to fill the wood near the edges and corners. Again scraping across the grain, remove as much of the filler as possible. Allow the filler to dry until it produces a dull haze, and then wipe the surface across the grain with a clean, coarse cloth, such as burlap, to remove the last of the excess filler. After the filler dries in the pores, finish with three coats of alkyd-resin varnish.

Sand to 220 grit

Seal with super-blonde shellac

Wipe on and scrape off wood filler

Finish with alkyd-resin varnish

### STEP 1: APPLY THE FILLER



Wipe on the pore filler, drawing it back and forth across the grain to leave a generous amount on the surface.

### STEP 2: PUSH FILLER INTO PORES



By pulling a plastic scraper across the surface with a firm downward pressure, you force the filler into the grain while removing most of the excess.

### STEP 3: SEAL WITH VARNISH



The darkest areas indicate pores filled with the walnut-tint, grain-filling paste. 🌳

### Sources

**Dye:** Woodcrafters' Water-Soluble Dye in light and dark fumed oak, English brown mahogany, early American maple, and rosewood; Paxton Woodcrafters' Store, 7455 Dawson Road, Cincinnati, OH 45243; 877/648-3752 or paxtonwood.com.

**Alkyd-resin varnish:** Pratt & Lambert 38 clear varnish; Pratt & Lambert, 800/289-7728 or prattandlambert.com. An alternative is McCloskey Heirloom oil-based varnish, McCloskey Division of Valspar Corp., 800/345-4530.

**Cellulose acetate butyrate (CAB) acrylic lacquer:** Sher-Wood CAB Acrylic Lacquer, Sherwin-Williams, 800/474-3794 or sherwin.com.

**Shellac flakes:** Woodcrafters' Shellac, Paxton Woodcrafters' Store, 877/648-3752 or paxtonwood.com.

**Wood filler:** WoodPerfect in walnut (No. 704); Wood Kote Products, 800/843-7666 or woodkote.com. An alternative is Pore-O-Pac grain filler in medium brown walnut; H. Behlen & Bro., 866/785-7781 or HBehlen@.com.

Written by **Robert Wilson** with **Steve Mickley**

# WOOD PATTERNS

December/January 2005/2006

Issue 167

Dear Reader: As a service to you, we've included full-size patterns on this insert for irregular shaped and intricate project parts. You can machine all other project parts using the Materials List and the drawings accompanying the project you're building.

© Copyright Meredith Corporation, 2005. All rights reserved. Printed in the U.S.A. Meredith Corp., the publisher of *WOOD Patterns*® allows the purchaser of this pattern insert to photocopy these patterns solely for his/her own personal use. Any other reproduction of these patterns is strictly prohibited.

- Wine Bottle Holder, Page 8
- Cheval Mirror, Page 38
- Showcase for Kids, Page 62
- Play Center, Page 76
- Photo-Display Easel, Page 84
- Game Table, Page 88

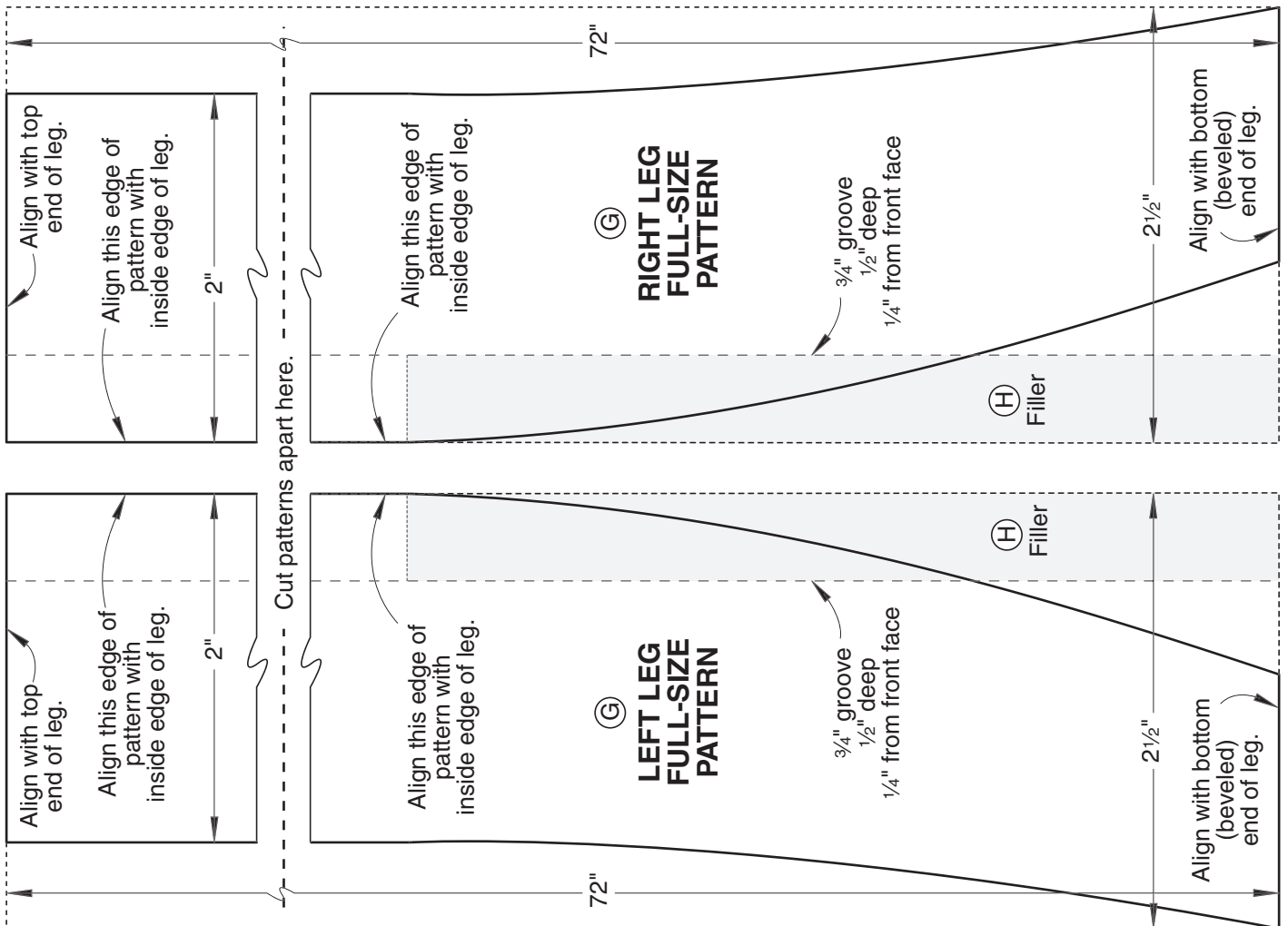

Cheval Mirror, Page 38

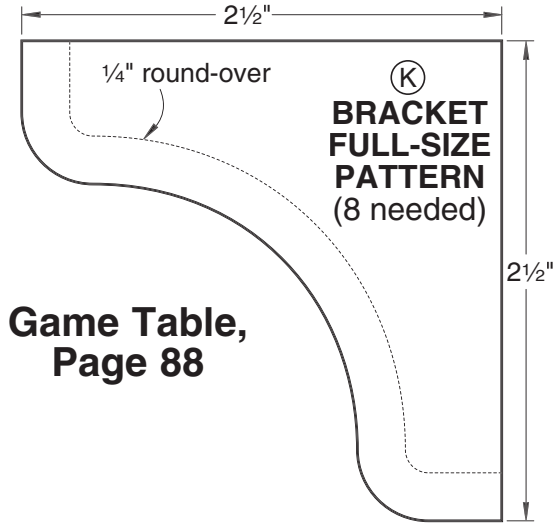

**Game Table,  
Page 88**

**Play Center,  
Page 76**

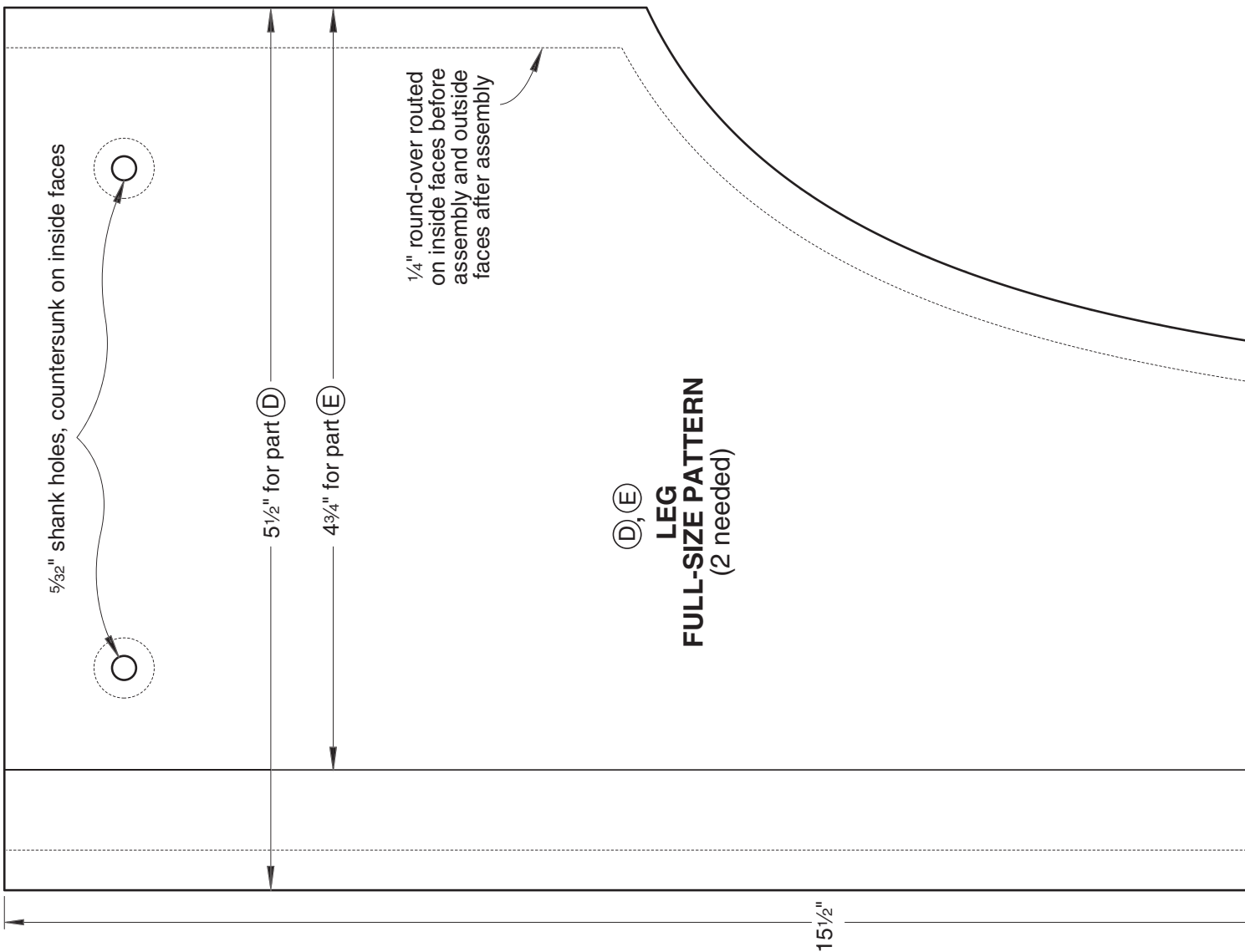

**Photo-Display  
Easel,  
Page 84**

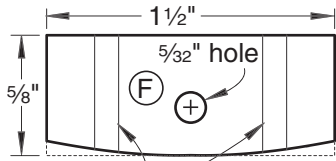

1/8" dados 1/8" deep

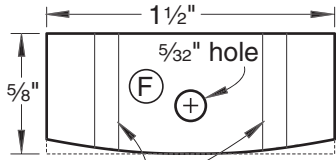

1/8" dados 1/8" deep

**FULL-SIZE  
CLAMP PATTERNS**  
(Front view)

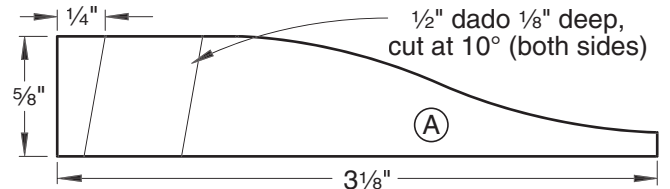

**FULL-SIZE BRACE PATTERN**

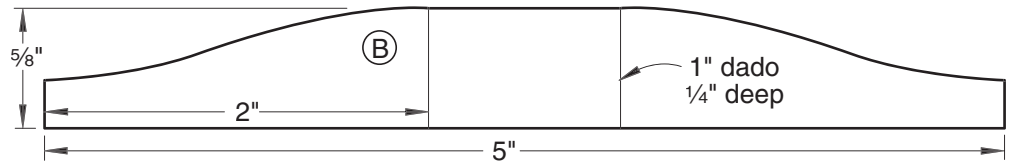

**FULL-SIZE FOOT PATTERN**  
(Back face)

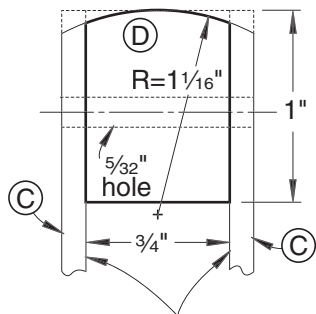

1/8 x 1/2" aluminum bars  
10 3/8" long

**FULL-SIZE  
CAP PATTERN**

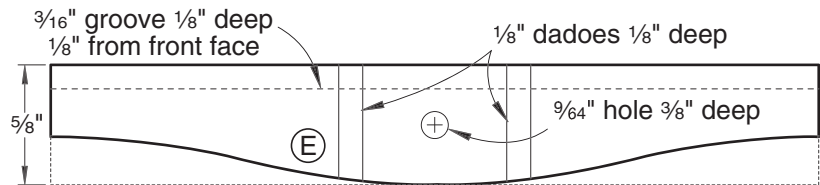
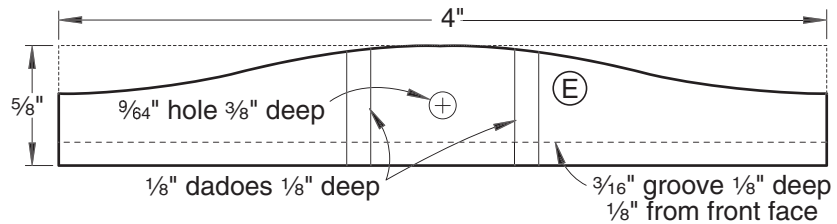

**FULL-SIZE GRIPPER PATTERNS**  
(Back faces)

Showcase for Kids,  
Page 62

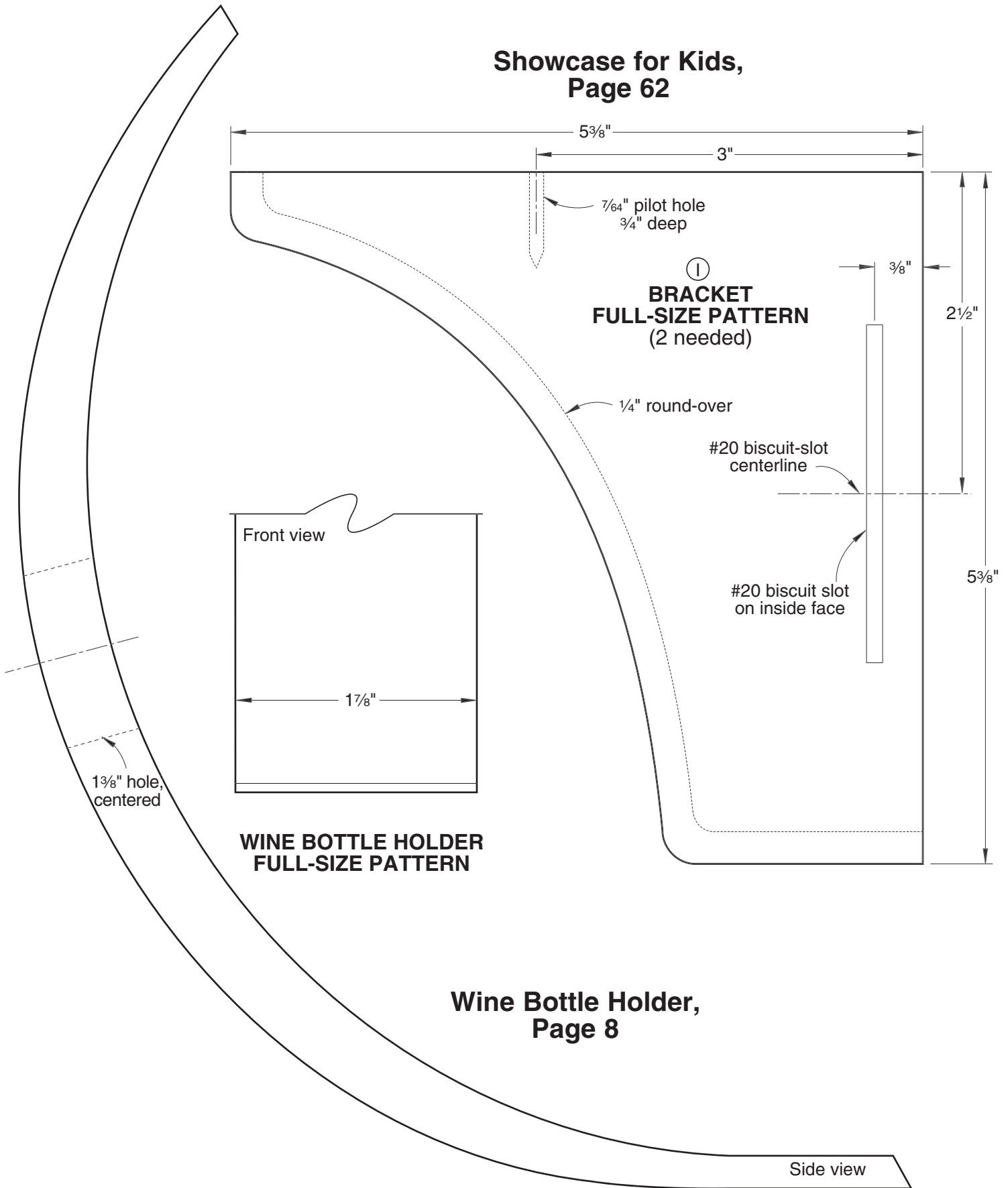



# winner's circle showcase for kids

Help a child organize and display his or her cherished awards and mementos with this combination shelving, corkboard, and Shaker-peg wall unit.



**H**ere's an easy-to-build project sure to delight any young person. What's more, you can give him or her a hand in making it. After you prepare the parts, have your partner join in the fun and complete the

assembly. That's what Design Editor Jeff Mertz and his 13-year-old daughter, Madie, did for this article. Follow the adult and adult/child icons to see who does what.

## Let's prepare the parts



**1** From  $\frac{3}{4}$ "-thick stock (we used red oak), cut the outer case sides (A), inner case sides (B), case tops and bottoms (C), shelves (D), case spacers (E), top (F), bottom (G), and peg rail (H) to the sizes

listed in the **Materials List**. Then cut two  $\frac{3}{4} \times 5\frac{3}{8} \times 5\frac{3}{8}$ " blanks for the brackets (I).

**2** Using a dado blade, cut a  $\frac{3}{4}$ " rabbet  $\frac{1}{2}$ " deep along the back edge of the outer case sides (A) on the *inside* face, where shown on **Drawing 1**. Next, cut a  $\frac{1}{4}$ " rabbet  $\frac{1}{4}$ " deep along the back edge of the inner case sides (B) on the *outside* face, where shown on **Drawings 1 and 2**.

**3** Mark six centerpoints on the front face of the peg rail (H) for  $\frac{1}{2}$ " holes to receive the tenons on  $3\frac{1}{2}$ " Shaker pegs, where dimensioned on **Drawing 3**. Chuck a  $\frac{1}{2}$ "

## 1 CASE (Left case shown)

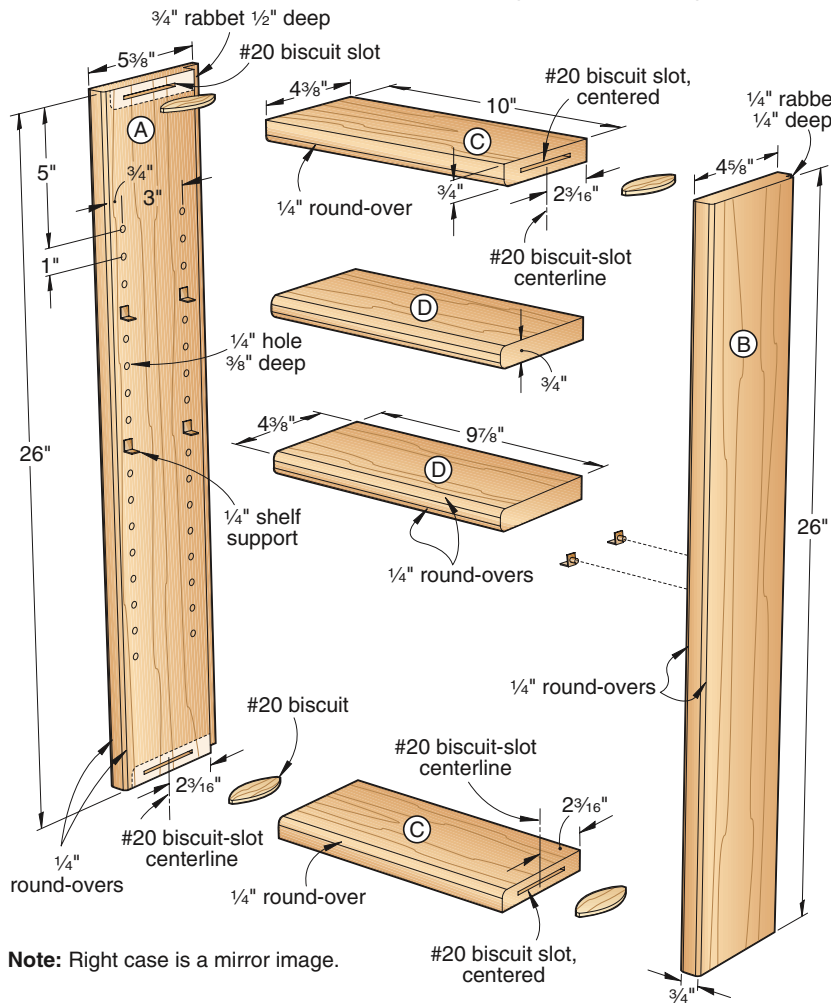

Note: Right case is a mirror image.

## 2 PARTS VIEW

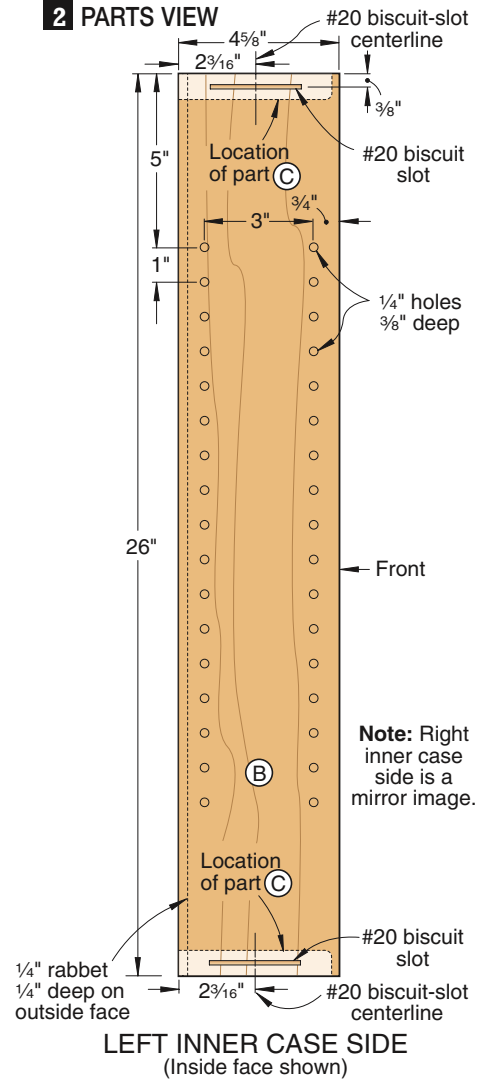

LEFT INNER CASE SIDE  
(Inside face shown)

## DRILL THE SHELF-PIN HOLES



Clamp the hole-drilling jig to an outer case side (A), as shown. Using a depth stop on your drill bit, drill the holes for shelf supports.

Forstner bit in your drill press. Using a fence for consistency, drill 5/8"-deep holes at the marked locations.

**4** Make two copies of the bracket full-size pattern from the *WOOD Patterns*® insert. Spray-adhere a pattern to each blank for the brackets (I). Bandsaw and sand the brackets

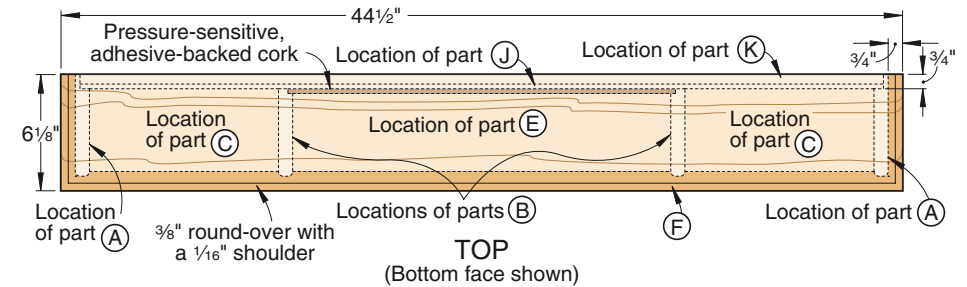

to shape. Next, using a 1/4" round-over bit in your table-mounted router and a starter pin for guidance and safety, round over the edges of the brackets on both faces, where shown on the patterns. (Do not remove the patterns. Your partner will need them later when plunging biscuit slots.)

**5** From 1/4" red oak plywood, cut the back (J) to the size listed.

**6** From 3/4"-thick stock planed to 1/2" thick, cut the mounting cleats (K) to size. Bevel-rip one edge of each cleat at 45°, leaving a 1/8" flat, where shown on **Drawing 4**. Set the cleats aside.

**7** For your partner to easily drill perfectly spaced 1/4" holes for shelf supports in the outer case sides (A) and inner case sides (B),

make the simple hole-drilling jig shown on **Drawing 5**. To ensure correct hole placement, apply masking tape to the perforated hard-board, where shown, leaving exposed two rows of 17 holes spaced 3" apart.

## Machine the details



**1** Position the hole-drilling jig on the *inside* face of an outer case side (A), flush at the ends with the jig cleat tight against the *front* edge. Clamp the assembly to your workbench. Then have your partner drill 1/4" holes 3/8" deep for shelf pins, where dimensioned on **Drawing 1** and as shown in **Photo A**. Repeat for the remaining

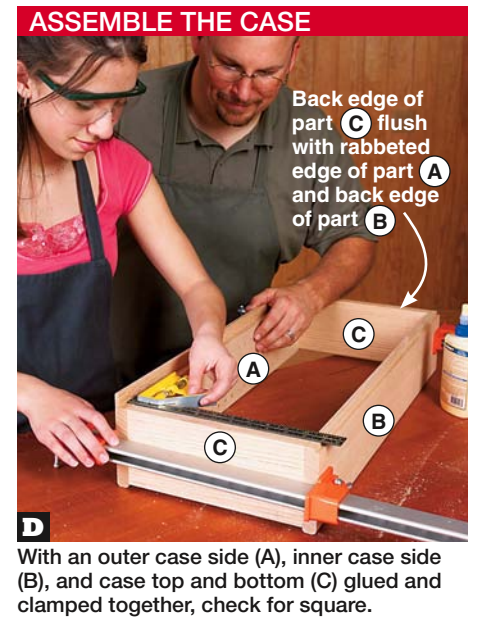
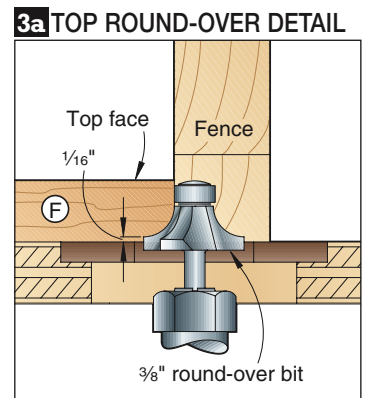
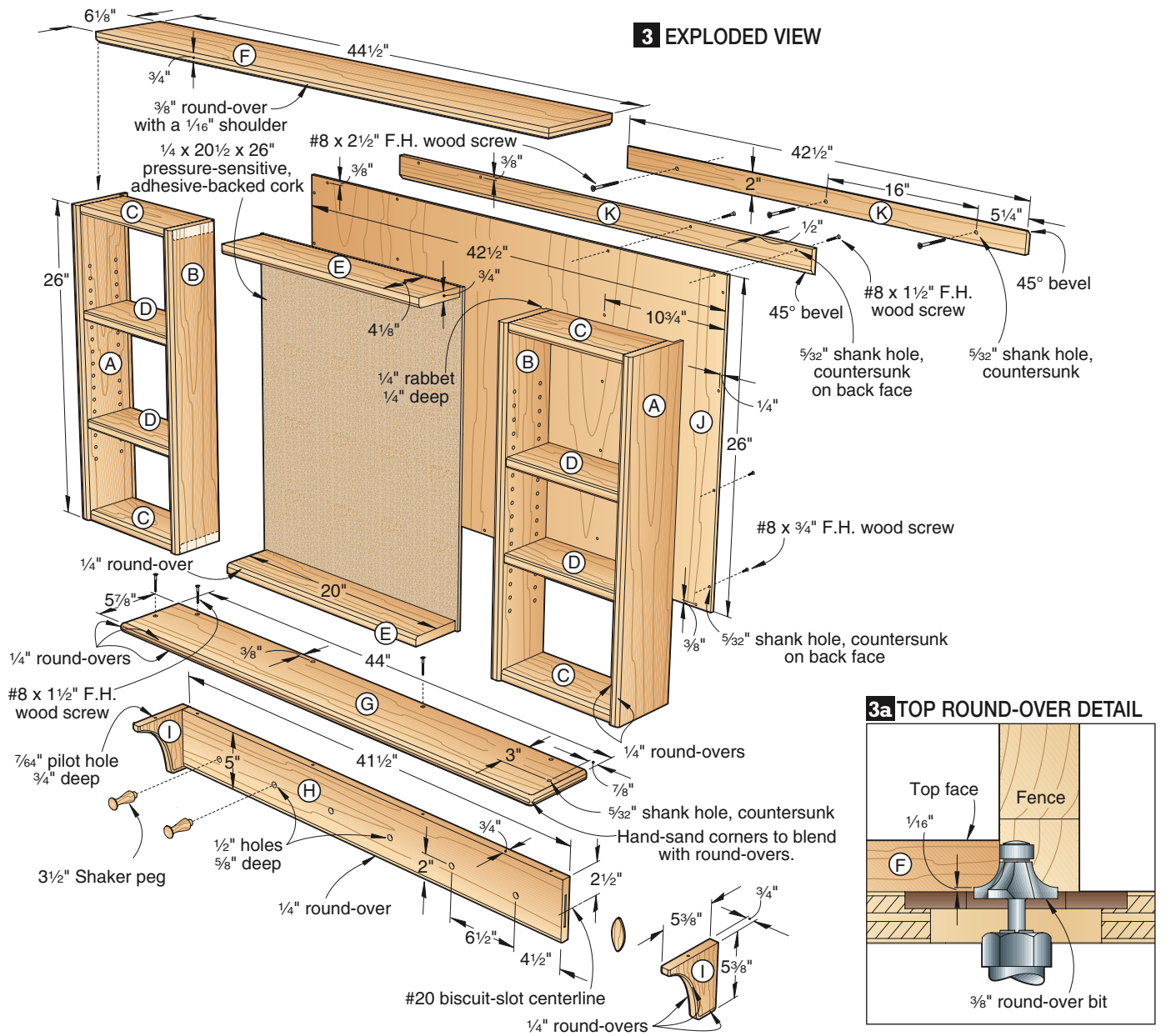

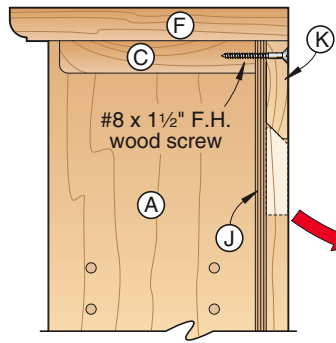

**4 CASE SECTION VIEW**  
(Left case shown)

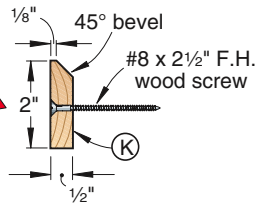

outer case side (A). Positioning the jig in the same way, drill the holes in the inner case sides (B), where dimensioned on **Drawing 2**.

**2** With the  $\frac{1}{4}$ " round-over bit still in your table-mounted router and the starter pin removed, align the fence flush with the bit bearing. Then, assisting or taking over for your helper, as appropriate, rout round-overs along the front edge of the outer case sides (A) on *both* faces, where shown on **Drawing 1** and as shown in **Photo B**. Repeat for the inner case sides (B) and shelves (D).

Next, round over the front edges of the case tops and bottoms (C) and case spacers (E) on the *inside* faces only, and the bottom front edge of the peg rail (H), where shown on **Drawings 1** and **3**. Now round over the ends and front edge of the bottom (G) on *both* faces, where shown on **Drawing 3**, using a miter gauge to safely guide the part when machining the ends. Round the front corners of the bottom to blend with the round-overs using a 120-grit sanding block.

**3** To form a  $\frac{3}{8}$ " round-over with a  $\frac{1}{16}$ " shoulder on the top (F), where shown on **Drawings 3** and **3a**, switch to a  $\frac{3}{8}$ " round-over bit in your table-mounted router. Now have

your partner round over the ends and then the front edge of the top on the *bottom* face.

**4** Draw centerlines for plunging #20 biscuit slots at both ends of the outer case sides (A), inner case sides (B), and case tops and bottoms (C) on the *inside* faces, where dimensioned on **Drawings 1** and **2**. Note that the  $\frac{2\frac{3}{16}}$ " dimension to the biscuit-slot centerlines is from the rabbeted edges of parts A and back edges of parts B and C. Then draw the biscuit-slot centerlines at both ends of the peg rail (H) on the *front* face, where dimensioned on **Drawing 3**.

**5** Clamp the case tops and bottoms (C) and peg rail (H) to your workbench with the marked biscuit-slot centerlines facing up. Using your biscuit joiner, plunge slots in the case side at the marked locations, as shown in **Photo C**. Repeat for the inner case sides (B). In the same way, hold each bracket (I), back edge down, against an end of a clamped part, and plunge a slot in the bracket, where shown on the pattern.

**5 HOLE-DRILLING JIG**

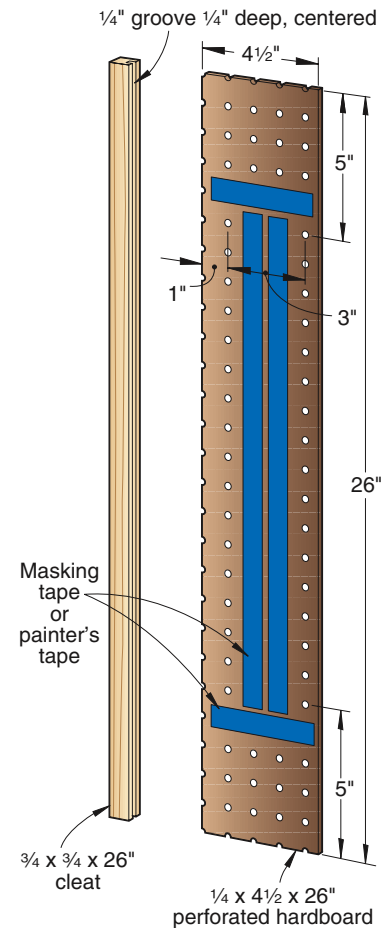

**6** Remove the patterns from the brackets (I) using a cloth moistened with paint thinner. Then sand all of the parts to 220 grit.

**Begin the assembly**

**1** With the front edges down, help your partner glue, biscuit, and clamp together an outer case side (A), inner case side (B), and case top and bottom (C), in the configuration shown on **Drawings 1** and **3** and as shown in **Photo D**. Keep the back edges of the case top and bottom (C) flush with the rabbeted edge of the outer case side (A) and back edge of the inner case side (B). Check for square. Repeat to assemble the remaining case.

**2** Glue, biscuit, and clamp the brackets (I) and peg rail (H) together with the top edges flush. Next, glue and clamp the bracket/peg-rail assembly (H/I) to the bottom (G), where shown on **Drawing 3**, keeping the assembly flush with the back edge of the bottom and centered end-to-end. Then drill mounting holes through the bottom into the bracket/peg-rail assembly, where dimensioned, and drive the screws. Now glue  $3\frac{1}{2}$ " oak Shaker pegs in the  $\frac{1}{2}$ " holes in the peg rail. (We found the Shaker pegs at a local home center.)

**GLUE AND CLAMP TOGETHER THE SHOWCASE IN TWO STAGES**

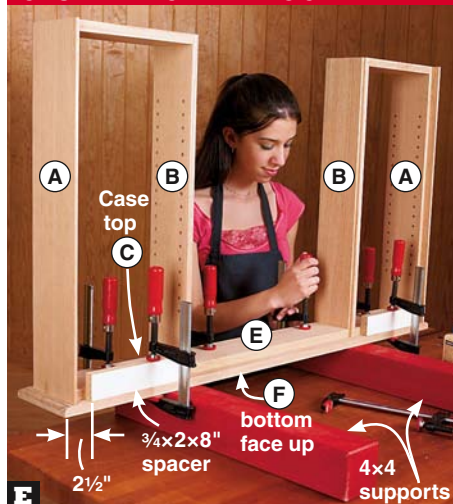

Glue and clamp the cases and a case spacer (E) to the top (F), keeping the case tops (C) tight against  $\frac{3}{4}$ " spacers clamped to the top.

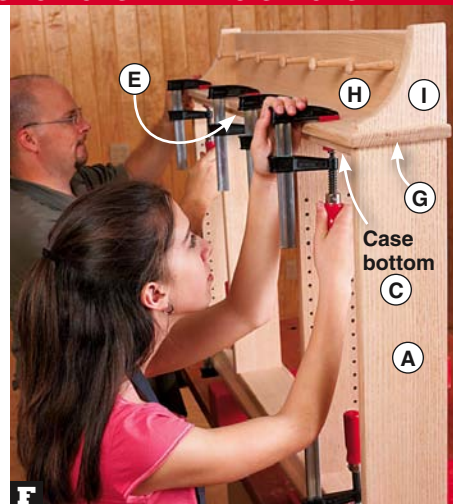

Then glue and clamp the peg-rail assembly (G/H/I) and remaining case spacer (E) in place, aligning them as shown.

### APPLY THE CORK TO THE BACK



Holding the cork by the edges, align it with the bottom edge of the back (J) and the unfinished area. Then lay the cork in place.

**3** Position the top (F) bottom face up on 4x4 supports (for clamp clearance), as shown in **Photo E** on page 65. To easily align the cases with the case tops (C)  $\frac{3}{4}$ " from the back edge of the top, where dimensioned on **Drawing 2**, clamp a  $\frac{3}{4}$ x2x8" spacer on edge  $2\frac{1}{2}$ " from each end of the top along the back edge, as shown.

Apply glue to the case tops and *outside* face of a case spacer (E). Then clamp the cases and case spacer, centered end-to-end, to the top, as shown in **Photo E**, keeping the case tops tight against the  $\frac{3}{4}$ " spacers and aligning the back (nonrounded) edge of the case spacer with the rabbeted edges of the inner case sides (B).

**4** Apply glue to the case bottoms (C) and the *outside* face of the remaining case spacer (E). Then, assisting your partner, clamp the peg-rail assembly (G/H/I) and the case spacer (E) in place, where shown on **Drawing 3** and as shown in **Photo F**. Center the peg-rail assembly end-to-end with the back edges of the bottom (G) and outer case sides (A) flush. Align the case spacer with the inner case sides (B) as before.

### Cutting Diagram

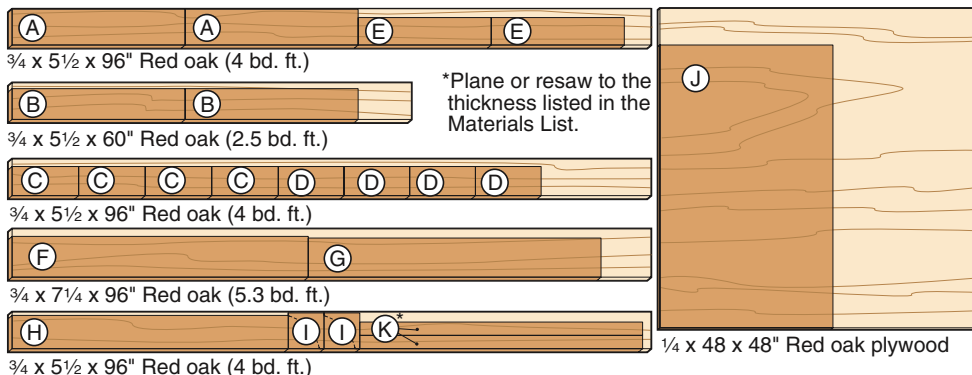

### INSTALL THE MOUNTING CLEAT



With a mounting cleat (K) tight against the top (F) and the bevel positioned as shown, drill mounting holes at the marked locations.

### Finish up

**1** From a  $\frac{1}{4}$ x24x36" sheet of pressure-sensitive, adhesive-backed cork, cut a  $20\frac{1}{2}$ x26" piece to fit between the rabbeted edges of the inner case sides (B), where shown on **Drawing 3**. (We recommend the adult do this using a sharp utility knife and a straightedge.) Then on the front of the plywood back (J), mask a  $20\frac{1}{2}$ "-wide area centered end-to-end for the cork.

**2** Sand any areas that need it to 220 grit, and remove the dust. Then apply a clear finish. (We applied three coats of AquaZar Water-Based Clear Satin Polyurethane, sanding to 320 grit between coats.)

**3** Place the back (J) on your workbench, front face up, with the masked area uncovered. Remove the protective backing from the cork. Then, assisting your partner, apply the cork to the back, as shown in **Photo G**. Now firmly adhere the cork using a 3" rubber J roller or a kitchen rolling pin.

**4** Position the showcase on your workbench with the front down. Place the back (J) in the rabbets in the outer case sides (A), ensuring the cork fits in the rabbeted edges of the inner

case sides (B). Mark centerpoints for countersunk mounting holes for #8x $\frac{3}{4}$ " flathead wood screws along the ends and bottom edge of the back, where dimensioned on **Drawing 3**. Drill the holes, and drive the screws.

**5** Position a mounting cleat (K) on the back (J), tight against the top (F), as shown in **Photo H**. Mark centerpoints for countersunk mounting holes for #8x $1\frac{1}{2}$ " flathead wood screws, where dimensioned on **Drawing 3**. Drill the holes, and drive the screws.

**6** Finally, hold the remaining mounting cleat (K) level on your wall with the beveled edge positioned where shown on **Drawing 3**. Drill countersunk mounting holes through the cleat into the wall studs, and fasten with #8x $2\frac{1}{2}$ " flathead wood screws. With your partner's help, hang the unit. Install the four shelves (D), where desired, using  $\frac{1}{4}$ " shelf supports. Now have the lucky recipient of the showcase round up his or her treasured ribbons, trophies, and other memorabilia, and arrange them on the unit where they can be admired every day. 🌟

Written by **Owen Duvall**  
Project design: **Jeff Mertz**  
Illustrations: **Roxanne LeMoine**

### Materials List

Part		FINISHED SIZE			Matl.	Qty.
		T	W	L		
A	outer case sides	$\frac{3}{4}$ "	$5\frac{3}{8}$ "	26"	O	2
B	inner case sides	$\frac{3}{4}$ "	$4\frac{5}{8}$ "	26"	O	2
C	case tops and bottoms	$\frac{3}{4}$ "	$4\frac{3}{8}$ "	10"	O	4
D	shelves	$\frac{3}{4}$ "	$4\frac{3}{8}$ "	$9\frac{7}{8}$ "	O	4
E	case spacers	$\frac{3}{4}$ "	$4\frac{1}{8}$ "	20"	O	2
F	top	$\frac{3}{4}$ "	$6\frac{1}{8}$ "	$44\frac{1}{2}$ "	O	1
G	bottom	$\frac{3}{4}$ "	$5\frac{7}{8}$ "	44"	O	1
H	peg rail	$\frac{3}{4}$ "	5"	$41\frac{1}{2}$ "	O	1
I	brackets	$\frac{3}{4}$ "	$5\frac{3}{8}$ "	$5\frac{3}{8}$ "	O	2
J	back	$\frac{1}{4}$ "	$42\frac{1}{2}$ "	26"	OP	1
K	mounting cleats	$\frac{1}{2}$ "	2"	$42\frac{1}{2}$ "	O	2

**Materials key:** O—red oak, OP—red oak plywood.  
**Supplies:** Spray adhesive, #20 biscuits (10),  $3\frac{1}{2}$ " oak Shaker pegs (6), #8x $\frac{3}{4}$ " flathead wood screws (21), #8x $1\frac{1}{2}$ " flathead wood screws (10), #8x $2\frac{1}{2}$ " flathead wood screws (3),  $\frac{1}{4}$ " shelf supports (16).  
**Blade and bits:** Dado-blade set,  $\frac{1}{4}$ " and  $\frac{3}{8}$ " round-over router bits,  $\frac{1}{2}$ " Forstner bit.

### Source

**Cork:**  $\frac{1}{4}$ x24x36" pressure-sensitive, adhesive-backed cork, \$23.70 plus shipping. Call Jelinek Cork Group at 800/959-0995, or click [corkstore.com](http://corkstore.com).

Find more  
great projects  
for kids at

[woodmagazine.com/kids](http://woodmagazine.com/kids)



# woodworking smarter, not harder



**Master Woodworker Jeffrey Lohr shares his professional strategies for saving time, money, and wood.**

Jeffrey Lohr and his dog, Toby, take a short break after test-assembling the walnut and quartersawn oak cabinets he's built for his own kitchen.

**A**t first glance, Jeffrey Lohr's shop doesn't look much different than many home shops, until you look at the quantity and quality of his work. Starting out at Conestoga Valley High School's outstanding woodshop program in Pennsylvania, Jeffrey has spent the last 30 years mastering his craft. In that time, he's distinguished himself as nationally known Arts & Crafts furnituremaker and has helped train hundreds of aspiring woodworkers.

What makes Jeffrey unique is not only his signature furniture styling, but also the practical production methods and inventive jigs that enable him to make a decent living from his craft. Jeffrey's combination of careful craftsmanship and efficient techniques has allowed his business to move from an unheated one-car garage to a farm with a barn-sized shop, large enough to build 5x14' slabwood dining room tables, or comfortably house a class of eight students. He also

employs a full-time apprentice to help manage his workload.

According to Jeffrey, the difference between pros and amateurs isn't their tools or shop size, but how they use them. "I enjoy woodworking, but I don't play at it. For success, I have to work quickly and efficiently, while still making furniture of superior quality and looks." What secrets does he use to streamline his work? To find out, we visited his shop in Schwenksville, Pennsylvania.

# Work from the rough for polished results

Jeffrey's practical approach starts from the moment the wood leaves the mill. Regardless of what you're building, woodworking smart begins with knowing how to select good boards; developing a methodical milling procedure to ensure that workpieces are flat, straight, and square; and learning how to carefully store milled parts until you're ready to assemble them.

"The first rule to remember is that wood moves. Period," says Jeffrey. "Unsealed wood freely absorbs or releases moisture. Depending on the grain, the wood's moisture content, and humidity levels, a straight board may warp or twist hours after it's been cut." For that reason, Jeffrey encourages students to invest in a jointer and planer right away, so that they use rough-sawn stock. "Rough stock has room to move," he says. "The extra material can be jointed and/or planed away when you're ready to work. On the other hand, when a pre-milled board moves, re-flattening it can result in a board that's thinner than your plan calls for." Jeffrey also points out that it's not only cheaper to buy rough wood, but also easier to find matching

boards because most sawyers stack wood as it's sliced from the log. (Local sawyers aren't that tough to find. Start by checking your Yellow Pages under "Lumber" or "Sawmills," or the classified section of your local newspaper. You can also perform an online search at [woodfinder.com](http://woodfinder.com).)

Working with rough wood starts by looking for stock slightly larger than what's listed on your materials list. Jeffrey suggests selecting boards that are at least  $\frac{3}{16}$ " thicker,  $\frac{3}{8}$ " wider, and 1" longer than what you need. "If careful, you can reduce the minimum allowances a little to squeeze out an extra piece, but larger allowances just waste wood," he says.

Although you might think it difficult to do with rough-sawn stock, Jeffrey performs most of his inspecting and matching long before turning on his jointer. After pulling a few promising boards from his rack, Jeffrey slices off the sealed end with his radial-arm saw. In addition to exposing the end grain, the thin slice is a good way to test for checks that could run through the board. (See **Photo A**.) "You want to cut back to good wood," he says. "For deep checks you can save wood by

ripping through the check and gluing the two pieces back together."

Because the best way to assemble panels with even grain and color is by using boards cut from the same tree, Jeffrey surveys the stack to find sequentially cut boards. "Rough boards are easier to read than smooth stock because they aren't chopped into standard lengths. If two rough boards are the same length, they more than likely were cut from the same log." After arranging the boards by length, Jeffrey uses the end grain to stack the boards as they were cut from the log. In this case, the bark left on the edges of these boards is a dead giveaway. (See **Photo B**.)

At this point, many woodworkers would start jointing and planing their stock. Jeffrey points out that doing this with the cupped and bowed board in **Photo B** would mean a lot of wasted wood. Still using his extra wood allowances, Jeffrey decides what smaller pieces he can make from the board. He then crosscuts the board to lessen the bow and rips the board to reduce the cup.

After each crosscut, Jeffrey marks a line across the end grain of the wood—one line

## FINDING CHECKS IN THE MIX



**A**

Start your search for the right board by sawing a thin slice off the best end. By flexing the strip as shown, checks once hidden by the paint will pop out with little effort.

## SALVAGING CUPPED BOARDS



**B**

The matching end grain and bark left on the bottom waney-edged boards show that they were cut sequentially. Salvage cupped boards, such as the one on top, by ripping them into narrower pieces.

at the end of the first board, two lines at the second, etc. (See **Photo C.**) This enables him to easily keep track of where the shorter boards came from. Using the end-grain “map” marks, Jeffry quickly can fold two adjacent strips together to make a book-matched lamination, or glue one with the next one down the line to make a slip-match. “Glancing at the lines is much easier and faster than trying to match grain by staring at the boards,” he says. (See “Slicing and arranging wood for effect” on *page 71* for an understanding of these terms.)

Jeffry came up with another “line trick” to help him track boards at the planer so he doesn’t have to holler over the machine to his apprentice. (See **Photo D.**) Through the planing process, Jeffry feeds the boards into the machine, while his apprentice catches them at the other end. As soon as the boards come out, they are chalked with one of three marks: a straight line to indicate when a board is being planed in the right direction, an arrow to specify that the board should be fed through in the opposite direction, or “gd” (good) to show that a board is being fed through correctly, even though it appears to be the wrong way. “You’d be surprised to know how often boards plane better when fed against the grain,” he says.

Jeffry tries to preserve all of his map marks on the boards through the milling process. “Slice off the end grain lines at the very end. In this case, the marker lines on the

ends help quickly arrange boards for glue-up without having to stare at the face grain. I remove the end grain marks when I cut to final length,” he says. The chalk lines, made while planing, stick around a little longer. “I try to assemble wood panels according to the chalk so that they can be planed together following the glue-up,” he says. If it’s not planed off, the chalk will disappear when sanding.

Milling may be only the beginning of the building process. With that said, Jeffry emphasizes just how important it is to handle stock carefully, whether you plan to continue working the next day or the next weekend. “Left carelessly on your bench, even the straightest boards can, and will, warp.” he says.

To ensure frustration-free woodworking, Jeffry suggests safekeeping milled stock on a series of identically thickened spacers, or

stickers, about 1 to 2’ apart. (See **Photo E.**) Starting with your longest, heaviest boards, continue building the stacks in layers, placing boards over each new series of spaced stickers until all your parts are stacked. “The wood will still move,” he says, “but as long as air can get at all the faces, the boards stay fairly stable.”

## MARK BOARDS FOR PAST TRACKING

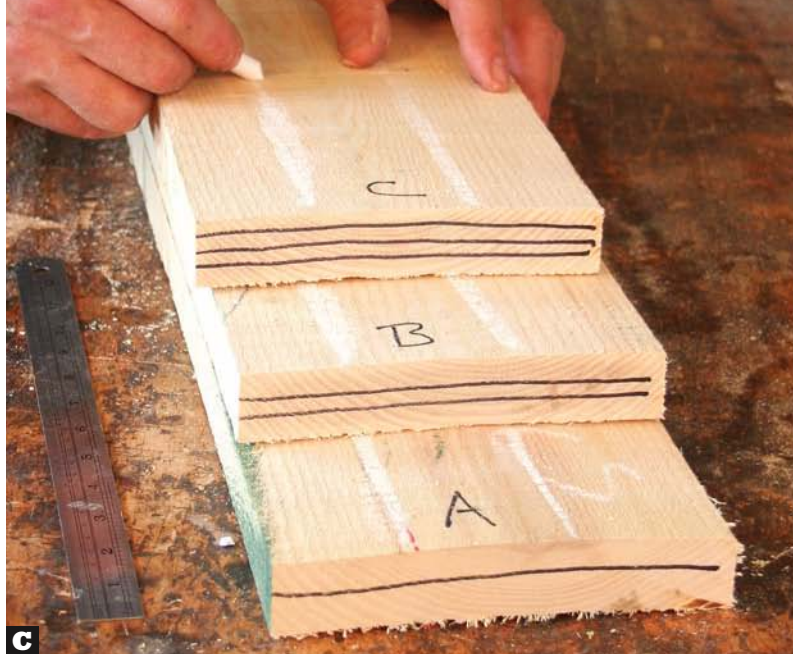

**C** Before chalking rough rip cuts, use a black marker to indicate how the board was cut to length. By “mapping” the end grain, you can easily reposition book- or slip-matched strips even after jointing and planing.

## MARK BOARDS FOR BETTER MACHINING



**D** Jeffry uses chalk lines to mark boards that plane without problems, arrows to remind him to reverse the feed direction on difficult-grained boards, and “gd” for boards that plane better against the grain.

## CONTROL WOOD MOVEMENT WITH WOOD STICKENING

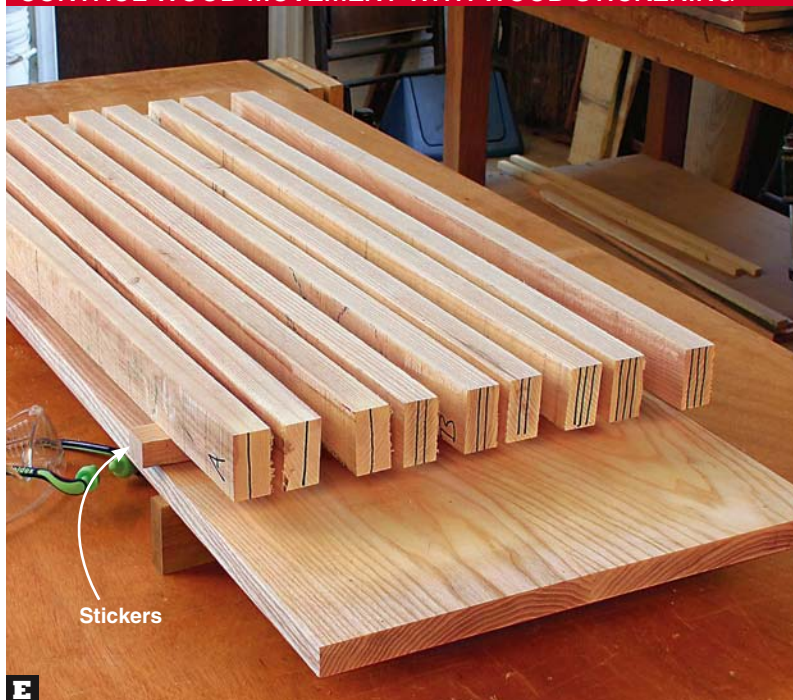

**E** Carelessly stacked parts can warp days after milling. Stack and sticker pieces on your bench so air can get at all the faces. Note how the end grain marks make it easy to arrange pieces for a pleasing grain match.



# Slicing and arranging wood for effect

Though you can randomly select boards and glue-join them into panels, you can achieve a more interesting or consistent look by either book-matching or slip-matching the pieces together. As shown *below*, book-matching describes successively cut pieces of veneer or resawn boards that—when arranged side by side—will resemble a mirror image while displaying opposing wood grain faces B and C.

By contrast, one version of slip-matched panels displays joined pieces of veneer or resawn boards, arranged so that same-face

sides (B, D or A, C) are joined to create a repeating pattern. An alternate slip-matched version (*below right*) involves cutting consecutive pieces from the same boards and slipping the same faces (A, A) alongside one another to produce a uniform color and respectable grain matching, though it is not as perfect as book-matching.

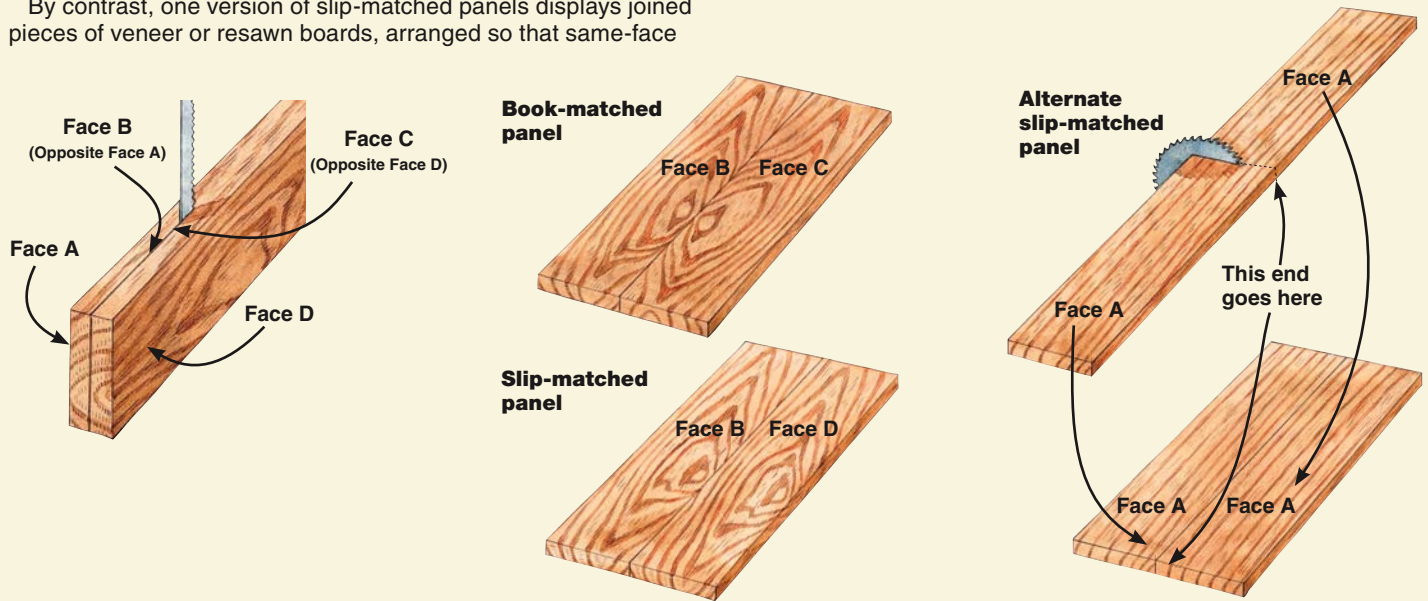

# Make your jigs multitaskers

Jigs and fixtures are important ingredients to Jeffry's success. "If I can do it on a machine, I don't use a hand tool," he says. "Carbide cutters, routers, and jigs can do fine work, and help me to pay the mortgage." While Jeffry admits that he "gets a kick out of creating inventive jigs and fixtures," he never forgets that jigs take time to build and take up space when not in use. For that reason, he tries to keep his jigs simple and flexible enough so they can serve multiple operations. A good example: Jeffry's hardworking routing jig.

## Multipurpose routing jig

This versatile jig serves not only as a reliable platform for rounding over the edges of long boards (without having to stop to reposition a clamp), but also for rounding over the edges and ends of small stock. By adding the mortising guide with its adjustable stops, the jig helps you mortise the legs of tables, chairs, and more. Better still, you can make most of it from the scrap sheet goods and hardwood sitting around the shop.

To build the jig, Jeffry used a leftover strip of 3/4" plywood for the base (see the drawing at *right*), but you can use whatever stock you have on hand, such as hardwood plywood, or

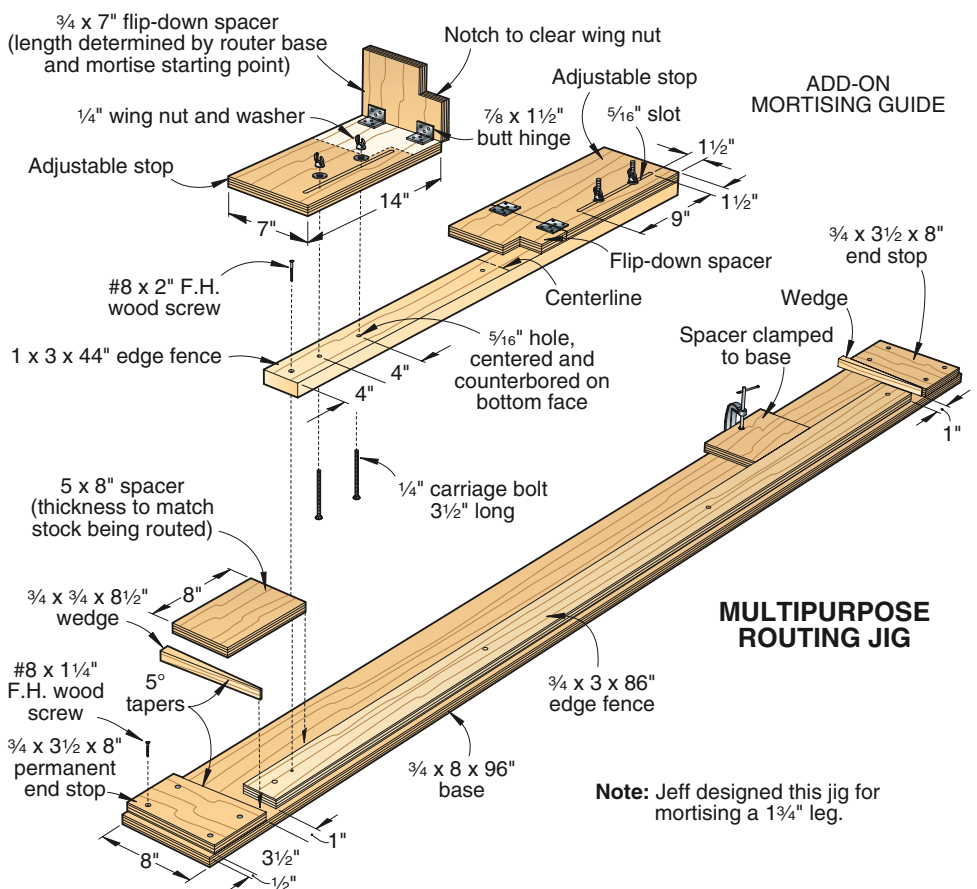



**F USE THIS JIG FOR ROUTING LONG EDGES ...**

To rout long edges without stopping to reposition clamps, make spacers the same thickness as the workpiece. Clamp one to the free end. At the other end, use a wedge and spacer to secure the workpiece.

**G ... FOR MILLING SMALL PIECES SAFELY ...**

For routing small pieces like these pulls, Jeffrey's jig is faster and safer than routing them one by one on a router table. He simply aligns and gangs the pieces together, and then routs them all at the same time.

even a strip of MDF (medium-density fiberboard). Similarly, you can alter the dimensions of the fence, end stops, and spacers to use scrap material.

To use the jig to rout workpiece edges (see **Photo F**), Jeffrey employs temporary spacers that measure the same thickness as the stock he's routing. He clamps one spacer to his bench (not seen here), and uses a wedge to snug the other spacer against the jig's permanent end stop. These spacers let him run the router over the entire board edge in one smooth movement while not tipping over the tool at the end of a cut.

The spacer-and-wedge system also works when routing small pieces, such as the ends of these cabinet pulls (see **Photo G**). Rather than setting up his table-mounted router and adjusting the bit to match the edge profile, he arranges the pieces face to face, and then secures them to the jig with a few mallet taps on the wedge. By doing this, he can shape the ends of all the pulls in just four passes, instead of passing each piece over a table-mounted router and bit four times.

As shown in **Photo H**, the jig can help rout dead-on mortises. In this case, Jeffrey designed the guide to fit a 1 3/4" square leg. He used wing nuts to lock down the adjustable stops, and cut slots in the stops so they can slide back and forth to establish the length of the mortises. Jeffrey positions and adjusts his router's edge guide along the outside edge of the legs to establish the location of the mortise. In addition, Jeffrey outfitted both stops with flip-down

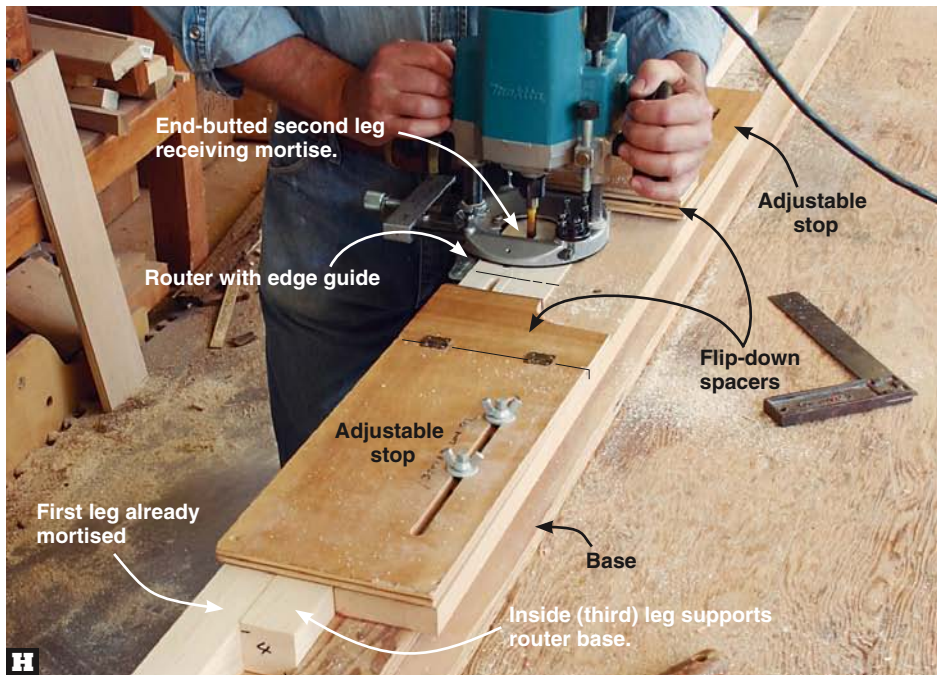

**H ... AND FOR PLUNGE-ROUTING MORTISES**

To use the jig, Jeffrey attaches the mortising guide to establish the location of his mortises on two end-butted legs. During machining, he flips down one spacer to stop his router at the top end of one mortise. He lifts that spacer and flips down the other to rout the second leg.

spacers. "Because I make so many legs, I devised this jig so that I can mortise two legs at once with their top ends butted against one another," he explains. (Note that the second leg extends beneath Jeffrey's left arm. The inside leg supports the router base.) Build the flip-down spacers to match your router and desired mortise lengths.

To rout two mortises consecutively, Jeffrey aligns the top ends of both legs on the centerline. Then he sets the mortising guide stops to cut the lower end of each leg mortise. When flipped down, the spacers provide stopping points for the top ends. After mortising the first leg, he raises one spacer, flips down the other, and mortising the second.

# Try wedges instead of clamps

**A**t last count, Jeffrey estimates that he has more than a hundred different clamps, a surprisingly small number considering the size of his shop and the quantity of work. Unlike most other woodworkers, that number is more than enough. Instead of investing in thousands of dollars worth of specialty clamps, he's designed most of his jigs and fixtures to work with wedges made from scrap. "Making a wedge to match a jig saves the time that would be wasted searching for a regular clamp," he says. What's more, Jeffrey points out that he can saw or rout up to a wedge without worrying about damaging the blade or bit. "If I hit a wedge, it's no big deal. You can always make another. Hitting a metal clamp is a far more dangerous and expensive accident."

**Photos I, J, and K** demonstrate three ways that Jeffrey uses wedges instead of store-bought clamps. He says the fastest way to start incorporating his "wedge method" is to keep offcuts, such as the pointed pieces left from cutting a set of tapered legs, close at hand. When cutting wedges from square scrap, set your saw to cut just a 4° to 6° angle. "You can always glue two scraps together for a steeper pitch," he says. Remember to cut stopblocks at angles that complement those of your wedge. That way, when you tap the wedge with a mallet, you direct force straight



**I**

## ESTABLISH DRAWER SPACING WITH THIN WEDGES

Small wedges (cutoffs from other projects) help you quickly position doors and drawers precisely into a cabinet frame.

into the workpiece, keeping it snugly secured to the jig.

Unlike a clamp, releasing a wedge only takes a tug or tilt to free the wedge's grip. For his leg-tapering jig in **Photo K**, Jeffrey glued hardwood blocks to the fat ends of the

wedges. "Adding the knobs makes the wedges easier to tap in and out with a mallet," he says. The bigger striking target also makes it less likely that he (or his students) would accidentally dent a leg tapping a wedge into position to secure a workpiece.

## LARGE WEDGES HELP SECURE JEFF'S JIGS



**J**

Because it's cut from the same stock, this wedge is sure to fit under the mortising template Jeffrey uses to rout the half-moon cutout on his dining room chairs. The scrap "clamp" stays with the jig.

## SCRAP HOLD-DOWNS AND WEDGES FIX THE WORKPIECE



**K**

Jeffrey devised the hold-downs on his taper jig to secure workpieces with wedges from previously made tapered legs. The knobs on one end of the wedges make them easier to tighten and remove with a mallet.



**L**

### USE SANDING STICKS FOR NOOKS AND CORNERS

Sanding sticks help knock down edges or smooth spots where power-sanders can't reach. Cut a slight bevel along the stick's edge to sand into the corners. Spray-adhere the paper to the hardboard strip.



**M**

### SENSIBLE SANDING THAT SAVES TIME

Jeffrey's skip-grit sanding system saves time while producing a showroom finish. Use 80 grit for removing machine marks and leveling uneven joints. Stop at 220 grit for a film-forming finish; 320 grit for oil.

## Finish faster, better, with less effort

"Perhaps it's because they remember their days in shop class, where half of the semester was spent building, and the other half sanding with a 'jitterbug' sander, but most of my students waste too much time sanding," says Jeffrey. Today, random-orbit sanders are the fastest way to go, for everything from smoothing big panels to flushing the lip on a face frame. The sander's spinning and oscillating motion not only finishes in a fraction of the time, but also leaves a finish smoother than the grit suggests. "Stepping up from one grit to the next finer grit is a waste of time and money," he says. "I'll match my skip-grit finish up with anybody's."

The key to sanding speed is to know where to start, when to switch grits, and when to stop. (See "Jeffrey's 4-step skip-grit finish," at right.) Before reaching for a machine, Jeffrey uses sanding sticks to knock down sharp corners and smooth places where a pad sander can't reach, as shown in **Photo L**. From there the work goes quickly. Jeffrey spot-sands with 80-grit discs to rub out machine marks or to flatten seams where wood may have shifted during assembly. "Use 80 grit sparingly, and keep the sander moving," he says. "It doesn't take much to sand through thin plywood veneer." (See **Photo M**.)

As soon as the marks are rubbed out, Jeffrey gives the whole piece a quick hit with 120- and then 180-grit discs. When applying a stain, Jeffrey stops at 180 grit because "stain needs something to stick to." For clear, film-forming finishes, such as polyurethane or wiping varnish, he recommends sanding up to 220 grit

with the sander, and then topping things off with a light hand-sanding. "Random-orbit sanders aren't perfect. Sanding with the grain erases any swirls left by the machine."

Spray finishing may rank as the fastest finishing method for production shops, but Jeffrey believes that wipe-on finishes are a smarter choice for home woodworkers. "It's tough to justify the cost of spraying and safety equipment, not to mention the space required for a spray booth," he says. By contrast, Jeffrey points out that wipe-ons can be applied with some rags in a dusty shop, but still produce a fine finished surface.

Jeffrey's time-tested two-step finish uses oil and varnish to their best advantage. First, he brushes on a generous coat of boiled linseed oil, and then wipes off the excess with a rag. (See **Photo N**, below.) While Jeffrey likes the way oil brings out the color of the wood, he warns that it's not a finish by itself. "Linseed oil will continue to darken until it's sealed under a coat of varnish," he says. For that reason, he suggests oiling everything at

the same time; otherwise one part may oxidize darker than the other pieces.

In 3 to 5 days, Jeffrey seals the oiled wood with a coat of wiping varnish. It avoids collecting dust nibs the way a brushed-on varnish does. He applies a coat per day for 3 days, and then lightly burnishes with 0000 steel wool for a protective satin finish. 🌲

Written by **Joe Hurst-Wajszczuk**  
Photography: **Paul Anthony**  
Illustrations: **Roxanne LeMoine** and **Thomas Rosborough**

### Jeffrey's 4-step skip-grit finish

According to Jeffrey, the dual action of a random-orbit sander not only removes stock in a hurry but it also leaves a finish fine enough for you to skip grits. If you're applying a film-forming finish, such as lacquer or polyurethane, sanding a piece in four steps—80, 120, 180, and 220 grit, and skipping 100 and 150 grit saves time and sandpaper, and produces a finish-ready surface. Here's the nitty-gritty:

**80 grit** For erasing machine marks and leveling edges; stop as soon as marks disappear.

**120 grit** For initial smoothing on all surfaces.

**180 grit** Stop here when staining; wood needs "tooth" to hold pigment.

**220 grit** Fine enough; rub out the small swirl marks left by the machine sanding by hand-sanding with a used 220-grit disc, going with the grain.

### MAKING STAIN COME ALIVE



**N**

Boiled linseed oil is an easy way to "pop" the color and grain. Seal oiled wood with a film-forming finish to stop oil from oxidizing and overdarkening the wood.

For more about Jeffrey Lohr's furniture and woodworking classes, check out [jdlohrwood.com](http://jdlohrwood.com).

# keep-it-tidy play center

This over/under, play/storage project will keep kids and moms happy.



A pair of roll-around toy boxes tucks neatly underneath the play table when not in use.



Slide-in hardboard panels painted with chalkboard paint make changing box labels easy.

**Y**oungsters will love the smooth flat tabletop for building a transcontinental railroad, assembling a block structure, or putting together a 1000-piece puzzle. Moms will appreciate the tray-like top that keeps small parts corralled and the roll-out boxes for stowing toys at cleanup time. Dads, too, get a break because this project requires only basic tools, moderate skill, and a weekend to complete.

## First make a tray

**1** From  $\frac{3}{4}$ "-thick stock, cut the short sides (A) and long sides (B) to the sizes listed on the **Materials List**. (We used oak.) Then install a  $\frac{1}{2}$ " dado blade in your tablesaw and cut a  $\frac{1}{2}$ " groove  $\frac{3}{8}$ " deep in each side, where indicated on **Drawing 1**. Now, without changing the depth of cut, support the parts with the miter gauge and make two passes to cut  $\frac{3}{4}$ " rabbets in the ends of the long sides.

**2** Cut the bottom (C) to size. (We used birch plywood.) Dry-fit the tray parts and make any necessary adjustments. Then apply glue to the bottom of the side (A, B) grooves and the rabbets in the ends of the long sides. Clamp the tray (A/B/C) together, check it for square by measuring the diagonals (equal diagonals means a square assembly), and set it aside to dry.

**3** Chuck a  $\frac{1}{4}$ " round-over bit in your hand-held router and rout all the inside and outside tray edges and the outside corners, where indicated on **Drawing 1**. To steady your router when routing the inside edges of the sides (A, B), see the **Shop Tip**, *opposite page, top right*. Finish-sand the tray.

## AT A GLANCE

- Overall dimensions: Table, 36" wide x 48" long x 19" high; toy boxes, 16" wide x 30 $\frac{3}{4}$ " long x 12 $\frac{1}{2}$ " high.
- For the board feet of lumber and other items needed to build this project, see *page 78*.

## Now add the legs

**1** Cut the wide leg halves (D) and narrow leg halves (E) to size. Make two copies of the leg pattern on the *WOOD Patterns*® insert and cut them to shape, trimming one to the width indicated for part D and the other for part E. Use spray adhesive to adhere each pattern to one respective part. Then jigsaw and sand the two leg halves to shape. Use these leg halves to draw the curves on the remaining pieces and jigsaw and sand them to shape. For a time-saving way to form the leg curves, see the **Shop Tip** at right.

**2** Drill  $\frac{5}{32}$ " shank holes, countersunk on the inside faces, in the leg halves (D, E), where indicated on the patterns. Then on the leg-half inside faces, rout  $\frac{1}{4}$ " round-overs along the bottom end and curved edges. Glue and clamp the wide leg halves (D) to the narrow leg halves (E) to form four legs. With the glue dry, rout  $\frac{1}{4}$ " round-overs along the outside edges and bottom ends, where shown on **Drawing 1**. Finish-sand the legs and glue and clamp them to the inside corners of the tray. Now using the shank holes as guides, drill  $\frac{1}{2}$ "-deep pilot holes into the sides (A, B) and drive the screws.

## Build the mobile toy boxes

**1** From  $\frac{1}{2}$ " plywood, cut the sides (F) and fronts and backs (G) to size. Then with a dado blade in your tablesaw, cut  $\frac{1}{2}$ " rabbets  $\frac{1}{4}$ " deep along the inside bottom edges of the sides, fronts, and backs, and along the ends of the fronts and backs, where shown on **Drawing 2**. Now cut the bottoms (H) to size. Finish-sand the parts, apply glue to the rabbets, and clamp the boxes.

**2** Cut the side trim (I) and front and back trim (J) to size. With a dado blade in your tablesaw, cut  $\frac{1}{2}$ " rabbets  $\frac{3}{8}$ " deep in the ends of the trim to form half-lap joints, where shown on **Drawing 2**. Glue and clamp the two trim frames, checking them for square.

**3** Chuck a  $\frac{1}{4}$ " round-over bit into your table-mounted router, and rout the lower trim frame (I/J) outside edges and all the edges of the upper trim frame. Finish-sand

## SHOP TIP

### Enjoy wobble-free routing even on narrow edges

Routing round-overs along the outside edges and corners of the tray assembly is easy. You can stand the tray on edge so the router base has plenty of surface to support it where shown *below*. But

when routing the inside edges, you'll have only the  $\frac{3}{4}$ " thickness of the sides on which to balance the router. To avoid this shaky situation, clamp a piece of 2x4 to the side of the tray.

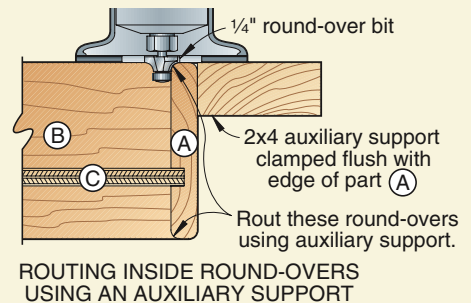
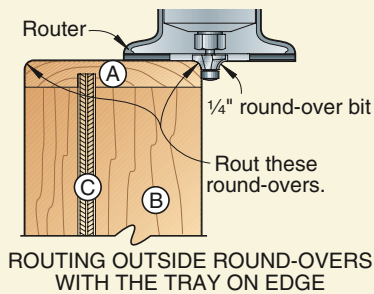

## SHOP TIP

### Duplicate parts perfectly with a table-mounted router

After using jigsaw and sanded leg halves (D, E) as templates to trace the curves onto the remaining leg-half blanks, rough-cut the parts with your jigsaw, staying to the waste side of the lines. Then chuck a flush-trim bit into your table-mounted router. Adhere a rough-cut part to the corresponding finished part with cloth-backed double-faced tape. Now with the bit pilot bearing riding on the edge of the finished part, flush-trim the curved edge of the rough-cut part to shape, as shown.

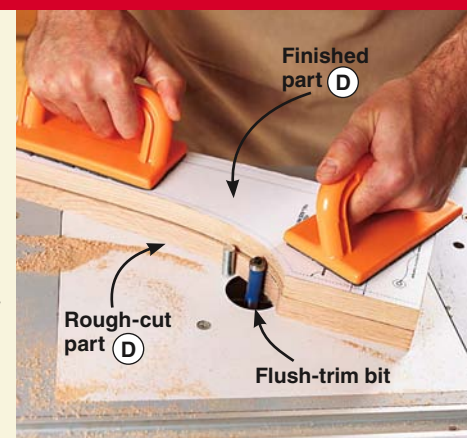

the frames. Then, one at a time, glue and clamp them to the boxes, centering the frames on the boxes so they protrude  $\frac{3}{8}$ ", where shown on **Drawing 2a**.

**4** Turn the boxes upside down and using the holes in the caster mounting plates as guides, drill  $\frac{7}{64}$ " pilot holes into the lower frame. Screw the casters in place.

## Make the box labels

**1** For the side cleats (K) and top and bottom cleats (L), resaw a  $\frac{3}{4}$ "x2x28" piece of stock to  $\frac{1}{2}$ " thick. Install a  $\frac{1}{4}$ " dado blade in your tablesaw and adjust it to cut  $\frac{1}{4}$ " deep. Attach a wood auxiliary fence to the rip fence, position it so the dado blade just grazes the face of the auxiliary fence, and cut a  $\frac{1}{4}$ "

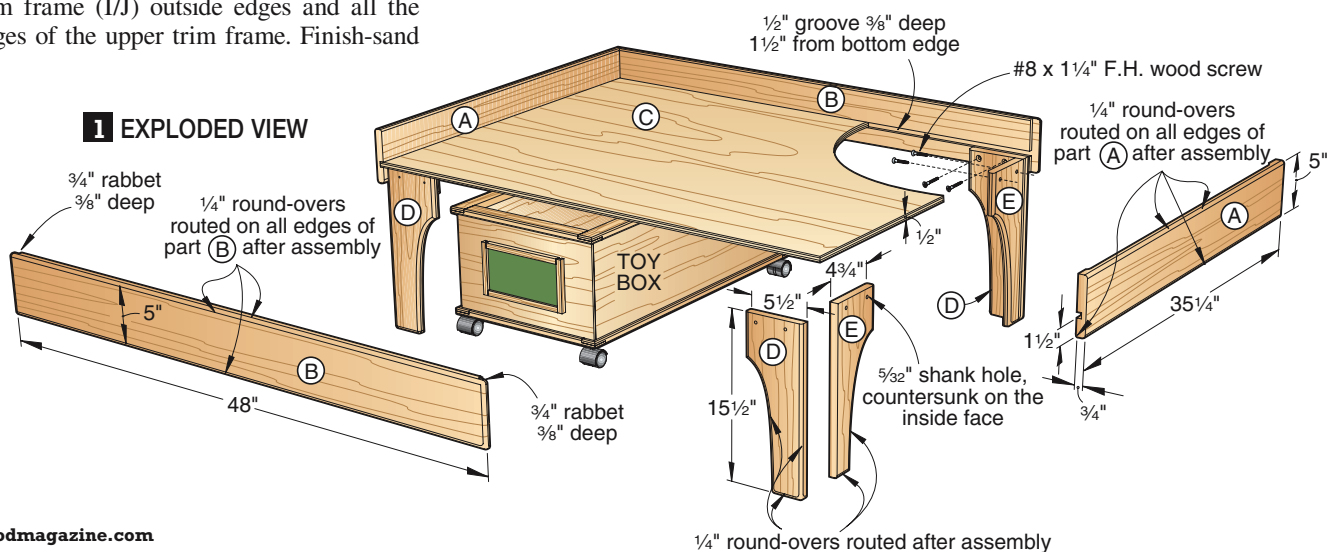

## SPACERS PROVIDE FOOLPROOF CLEAT POSITIONING

rabbet 1/4" deep in both edges of the 1/2"-thick stock. Then rip a 1/2"-wide rabbeted blank from each edge. Cut two each of parts K and L from each blank. Finish-sand the cleats.

**2** From 1/4" tempered hardboard, cut the panels (M) to size and glue and clamp a side cleat (K) to one end of each panel, centered. With the glue dry, cover the cleat with masking tape and paint the front faces of the panels with green chalkboard paint. (We used Rust-Oleum Chalkboard spray paint.)

**3** To position the cleats (K, L) on the front (G) of each box, cut one 1/4x3 1/8x9" and two 1/4x2x7 1/2" spacers. With the panel (M) captured between the top and bottom cleats (L) and the spacers adhered to the front with double-faced tape, glue and clamp the cleats in place, as shown in **Photos A and B**.

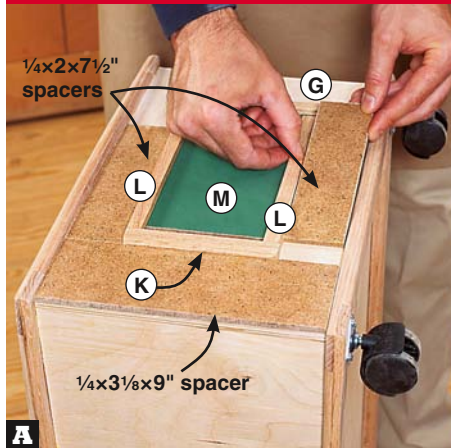

**A** Apply glue to one side cleat (K) and top and bottom cleats (L) and use spacers and the panel (M) to position them on the front (G).

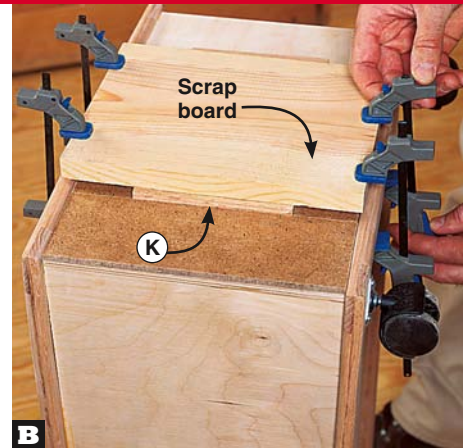

**B** Place a scrap board on the cleats (K, L) and apply pressure with clamps. Remove the side cleat/panel assembly (K/M).

## 2 TOY BOX (two needed)

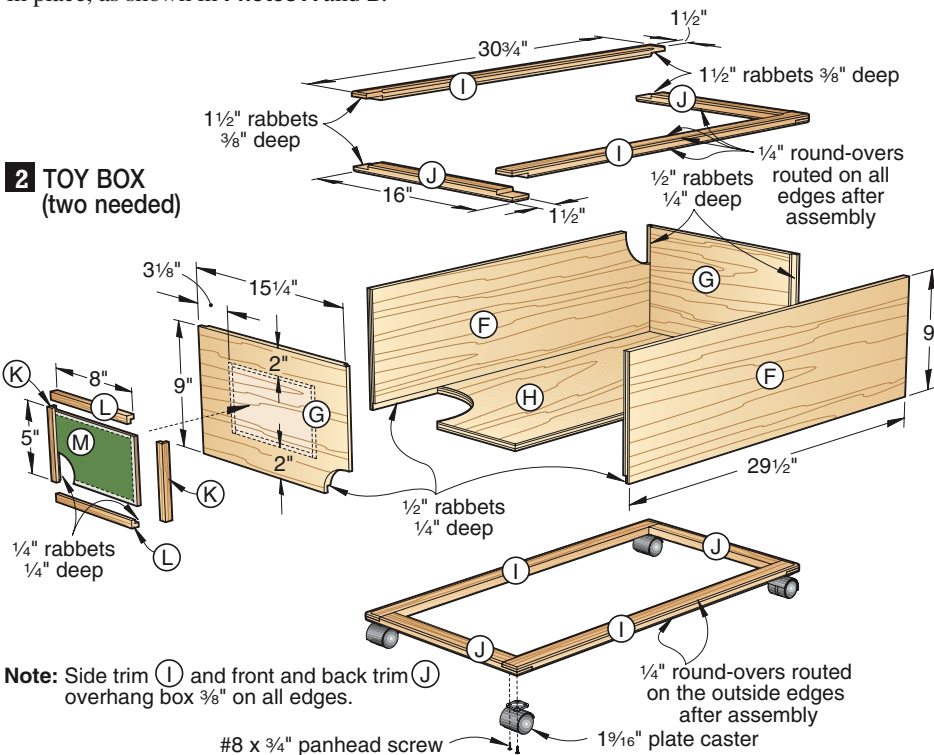

### 2a TRIM DETAIL

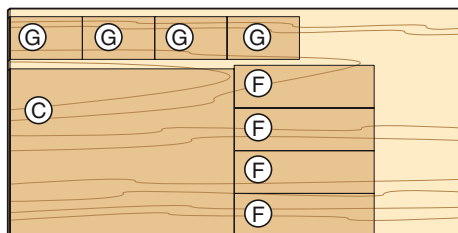
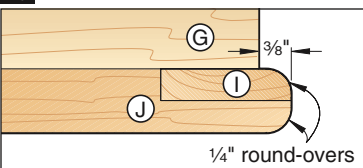

### Cutting Diagram

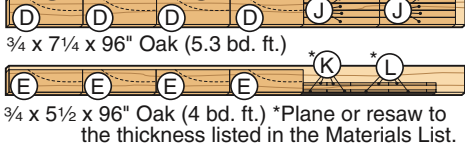
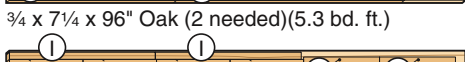
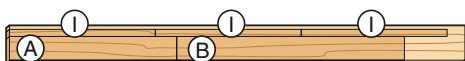

1/2 x 48 x 96" Birch plywood

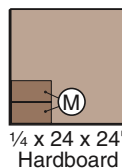
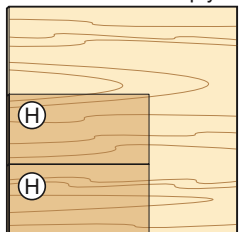

## Apply finish and assemble

**1** Remove the casters. Inspect all the parts and finish-sand where needed. Mask the painted panels (M). Then apply a clear finish to all the parts. (We applied two coats of water-based satin polyurethane, sanding with 220-grit sandpaper between coats.)

**2** With the finish dry, reinstall the casters. Place the table in the desired location and roll the toy boxes underneath. Write the intended contents of each toy box on the panels (M) with chalk and slide the cleat/panel assemblies (K/M) into place. Now have the kids gather all their Legos and let the playing begin. 🎮

Written by Jan Svec with Charlie Bartlett

Project design: Kevin Boyle

Illustrations: Roxanne LeMoine

## Materials List

Table		FINISHED SIZE			Matl.	Qty.
		T	W	L		
A	short sides	3/4"	5"	35 1/4"	O	2
B	long sides	3/4"	5"	48"	O	2
C	bottom	1/2"	35 1/4"	47 1/4"	BP	1
D	wide leg halves	3/4"	5 1/2"	15 1/2"	O	4
E	narrow leg halves	3/4"	4 3/4"	15 1/2"	O	4
<b>Toy boxes</b>						
F	sides	1/2"	9"	29 1/2"	BP	4
G	fronts and backs	1/2"	9"	15 1/4"	BP	4
H	bottoms	1/2"	14 3/4"	29 1/2"	BP	2
I	side trim	3/4"	1 1/2"	30 3/4"	O	8
J	front and back trim	3/4"	1 1/2"	16"	O	8
K*	side cleats	1/2"	1/2"	5"	O	4
L*	top and bottom cleats	1/2"	1/2"	8"	O	4
M	panels	1/4"	4 1/2"	8 1/2"	H	2

\*Parts initially cut oversize. See the instructions.

**Materials key:** O—oak, BP—birch plywood, H—tempered hardboard.

**Supplies:** #8x1 1/4" flathead wood screws, #8x3/4" panhead screws, 1 1/16" plate casters (8), spray adhesive, double-faced tape, chalkboard paint.

**Blade and bit:** Stack dado set, 1/4" round-over router bit.

# hot new tools for 2006

**WOOD®** magazine editors comb the woodworking market to uncover the tools and accessories that'll have you burning rubber to the tool store in the coming year. Many of these products were in the prototype stage when we snuck a peek at them, and have yet to undergo full-scale testing. Let us know which ones you want tested first by voting for your favorite five at [woodmagazine.com/hottools](http://woodmagazine.com/hottools).

## K3 MASTER SYSTEM: ULTIMATE POCKET-HOLE JIG

The Kreg boys went back to the drawing board and eliminated most of the nuisances associated with pocket-hole joinery. They moved the K3's clamp handle out front for convenient operation and added a spring on the jaw to account for minor differences in workpiece thickness. The dust-collection port eliminates the need to constantly clear chips. And the drill guide switches from the benchtop base to the completely portable base (at left in photo) in just seconds.

**Price: \$150**  
800/447-8638, [kregtool.com](http://kregtool.com)



## BENCHTOP DRUM SANDER SAVES MONEY, SPACE

Grizzly downsized an industrial-style drum sander into a benchtop version and made it affordable. (The G0459 is just a bit bigger than a benchtop planer.) We like its rubbery feed belt better than the abrasive belts found on other drum sanders. The closed-end design

eliminates drum deflection, but limits the G0459 to pieces 12" or narrower. Because we rarely sand anything wider than that in the *WOOD* magazine shop, we'll gladly take the lesser capacity for the lower price.

**Price: \$395**  
800/523-4777,  
[grizzly.com](http://grizzly.com)



## POWDER-COATING SYSTEM "PAINTS" WITH PLASTIC

Okay, so it's not exactly a woodworking tool, but Craftsman's nifty Powder Coat System (17288) is just too cool to leave out of this article. It puts a durable paintlike finish (similar to that found on kitchen appliances) on any metal object that will fit inside an oven. The system electrostatically applies a thin layer of fine powder to the object, which is then baked for 20–30 minutes at 400°F to cure the finish. That means you can dress up hinges and pulls with any of the five colors that come with the system (gold, green, satin black, red, or white) or the 15 optional powder colors. Each container of powder covers about the same area as a can of aerosol spray paint, and the overspray can be collected and reused.

**Price: \$190; \$6 for each additional powder color**  
800/377-7414, [craftsman.com](http://craftsman.com)





## INNOVATIVE MORTISER IS FULL OF USEFUL IMPROVEMENTS

Powermatic engineers designed so many great things into the Model 701 mortiser, we can only scratch the surface: an anti-racking depth stop; a can't-slip threaded hold-down and wheels that hold stock snug against the fence; and a smooth-gliding rack-and-pinion fence adjustment. But the 701 goes from "very cool" to "genius" with its built-in bit and chisel spacer (no more inserting a coin when installing the chisels), reversible feed handle (mount it on the left, if you like), and onboard sharpening cone to keep those chisels honed.

**Price: \$400 (stock no. 1791310)**  
800/248-0144,  
wmhtoolgroup.com



## BIG-FEATURED BANDSAW FOR A SMALL PRICE

Don't be fooled by the \$300 price tag: With welded-steel construction, microadjustable ball-bearing guides, a blade-tracking window, dual dust ports, and a cast-iron table measuring nearly 20x16", the two-speed Craftsman 22400 12" bandsaw specs more like an 18" saw. Its 7" resaw capacity bests—by an inch—most 14" bandsaws without a riser block. Throw in the drift-adjustable fence and built-in worklight, and this may be as much bandsaw as you'll ever need.

**Price: \$300**  
**Available at Sears stores or craftsman.com**



## MOTORIZED ROUTER LIFT ELIMINATES ENDLESS CRANKING

We're awfully impressed with the accuracy of Jointech's SmartLift Digital router lift. (See our review on page 102.) Now, they've built that same lift into a solid phenolic router tabletop and added a motor and control unit for height adjustments. Two speeds both up and down mean you can make coarse adjustments quickly, yet still fine-tune bit height. Working area is generous, with two 27x36" models—one centered, and one for offset systems like Jointech and Incra—and a massive 27x48" version.

**Expected price: \$750**  
800/619-1288, jointech.com

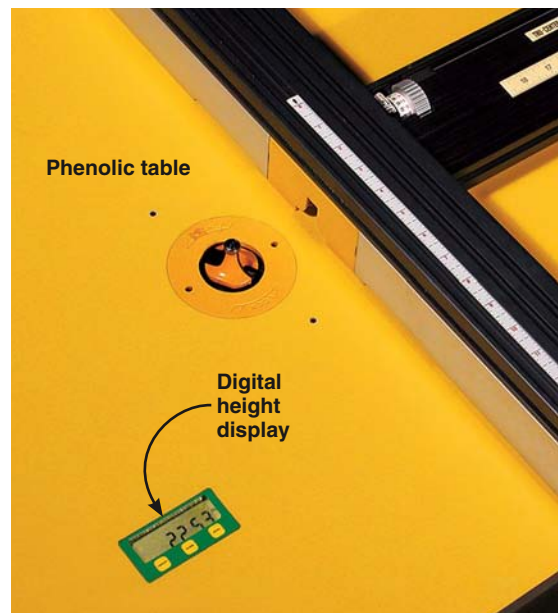

## COMPACT SLIDING MITERSAWS SAVE ON SHOP SPACE

Here's a trend we can get behind—literally. Two new 12" dual-bevel sliding mitersaws promise to deliver wide crosscuts without the usual 40 acres of clearance behind the tool. You can butt the 36 $\frac{5}{8}$ "-deep Hitachi C12LSH up against the wall and still crosscut a 4x12 at 90°. And it sports an adjustable laser line, LCD digital readout of both the bevel and miter settings, and a microadjustable tilt mechanism.

**Price: \$650**  
800/829-4752, hitachipowertools.com



DeWalt's DW718 requires 6" behind the saw (2 $\frac{1}{4}$ " less than their previous 12" slider) for a total depth of 36", but crosscuts a whopping 2x16 at 90° thanks to a unique fence setback system. It also cuts 6 $\frac{1}{2}$ "-tall molding stood on edge. And you can completely override its miter stops for fine-tuning an angle near a stop.

**Price: \$660**  
800/433-9258, dewalt.com



## 13" PORTABLE PLANER FOR POCKET CHANGE

Portable planers keep getting wider, with their prices growing as well (13" planers start around \$330 and go above \$500). Now Ryobi shatters that price barrier with the AP1301, a 13" model for \$200. For that price, you get quick-change knives, a full 6" thickness capacity, and a two-year warranty. The AP1301 also sports a unique dust hood that allows you to let the chips fall where they may, or instantly redirect them to your shop vac through a fan-assisted 2¼" port. Without infeed and outfeed tables, snipe may be an issue on workpieces longer than a couple of feet.

**Price: \$200, exclusively at Home Depot**  
800/525-2579, ryobitools.com



## "COLT" ROUTER: A WORKHORSE IN THE PALM OF YOUR HAND

The laminate trimmer has finally come of age with Bosch's 1-hp "Colt." The variable-speed PR20EVSK runs from 16,000 to 35,000 rpm, and includes such big-router amenities as electronic speed control, a self-releasing ¼" collet, and two-stage cutting-height adjustments. (Slide the base for coarse changes, and then fine-tune with the microadjust dial.) The kit includes an edge-guide fence and case; it's also packaged with other specialty bases and accessories (PR20EVSNK, \$200), and in a single-speed version (PR10E, \$100).

**Price: \$120**  
877/267-2499, boschtools.com



## A FOUR-JAW LATHE CHUCK PRICED TO BOWL YOU OVER

When the turners on our staff saw Penn State Industries' Barracuda2 four-jaw lathe-chuck set (CSC3000C) priced at just over \$150, their jaws hit the floor. The self-centering chuck comes with #1 step jaws, #2 and #3 round jaws, pin jaws, and a screw center. (Jumbo flat jaws are also available for \$25 extra.) With its square-drive T-handle key you can tighten the jaws with one hand while supporting the workpiece with the other. Barracuda2 includes adapters for 1"x8tpi and ¾"x16tpi headstocks.

**Price: \$155**  
800/377-7297, pennstateind.com



## ONE-SIZE-FITS-ALL WRENCH GRIPS BY FLATS, NOT CORNERS

No more chasing down the right size open-end or box wrench (or guessing between English or metric) with Bionic Wrench from Loggerhead Tools. When you squeeze its handles, this steel-laminate tool self-sizes to fit any bolt or nut from 7/16" to ¾". And should you ever accidentally round off the corners of a nut or bolt with another wrench, Bionic Wrench comes to the rescue again: Its six spring-loaded "jaws" act on the flat sides rather than the corners.

**Price: \$30**  
888/564-4374, loggerheadtools.com



## NEW ONE-HANDED CLAMPS SQUEEZE TIGHTER, COST LESS

Does the world really need any more one-handed bar clamps? You might not think so, but Jorgensen's ISD Bar Clamps (top) apply up to 40 percent more clamping force than Quick-Grip clamps. That means they have more than enough pressure for glue-ups, and slip less easily when clamping a fence to a drill-press table, for example. As if that's not enough, they cost about 20 percent less than the leading brand. The companion Pony ISD Hand Clamps (bottom) are built to resist the jaw-twisting that can happen with other hand clamps.

**Price: 6"-36" bar clamps, \$14-\$25;**  
**1½"-4" hand clamps, \$3-\$6**  
312/666-0640,  
adjustableclamp.com



## A PLUG CUTTER THAT WORKS IN HAND DRILLS

The lack of a center point makes most plug cutters impossible to use in a handheld drill. Montana Brand Tools' self-centering plug cutters use a retracting center point that keeps the cutter from wandering before it contacts the workpiece. As a bonus, the small pinhole left by the center point makes it easy to identify the narrow end of the tapered plug without a magnifying glass. The cutters come in 5/16", 7/16", and 3/8" diameters, and their ¼" hex shanks snap into any standard drill quick-connect system.

**Price: \$14-\$18 each, or \$45 for a set of three**  
888/809-5673, montanabrandtools.com



Written by Dave Campbell

last-minute holiday gift idea

# photo-display easel

If your brush is a camera and your canvas a snapshot, try displaying your photos like works of art.



Instead of applying a clear finish, you can spray-paint the easel any color you wish, like this one in classic black.



**I**nspired by the design of a full-size painter's easel, this miniature version easily adjusts to display a favorite 5×7" photo either horizontally or vertically. You'll find the wood scraps you need in your shop and all the other parts at hardware stores or home centers.

## First make the base

**1** From 5/8"-thick stock, cut a 1×9" blank for the brace (A). (We used maple.) To cut the angled dadoes, where shown on the drawing, *opposite top*, install a zero-clearance insert and a 1/2" dado blade in your table saw and adjust it to cut 1/8" deep. Make a cut in scrap stock, test the fit of the 1/8×1/2" aluminum bar for the uprights (C), and make any necessary adjustments. (Our bar was

slightly oversize in thickness and width.) Now position the rip fence 1/4" from the dado blade, angle the miter gauge, and cut dadoes in the brace, as shown in **Photos A** and **B**. To make certain the angled dadoes are perfectly parallel, see the top **Shop Tip**, on page 86.

**Note:** *The brace blank is long enough for two braces. If you wish to make two easels, cut angled dadoes in both ends of the blank.*

**2** Make a photocopy of the brace pattern on the *WOOD Patterns*® insert and adhere it to the brace (A) blank with spray adhesive, aligning the dado indicated on the pattern with the dado in the blank. Crosscut the brace to length, and then bandsaw and sand it to shape. Finish-sand the part.

**3** From 5/8"-thick stock, cut the foot (B) to size. Make a photocopy of the foot pat-

tern on the insert and adhere it to the foot with spray adhesive. Then with a dado blade in your table saw, cut the centered 1/4"-deep dado where indicated on the pattern, testing it with the brace (A) for a snug fit. Bandsaw and sand the foot to shape, and then finish-sand the part.

**4** Install a 60-tooth carbide-tipped blade and a zero-clearance insert in your table saw. Then for the uprights (C), cut two 10 1/2"-long pieces of 1/8×1/2" aluminum bar, making a 10° cut at the bottom end of each piece. You'll file the uprights to finished length after installing the cap (D).

**5** Dry-clip the uprights (C) into the brace (A) dadoes. Cut the cap (D) to size. To ensure that the uprights stay parallel, test the fit of the cap between the uprights just above

the brace. Finish-sand the cap. Now using quick-setting epoxy, glue and clamp the uprights into the brace dadoes and the cap between the uprights. Keep the ends of the uprights flush with the bottom of the brace and the top of the cap, and the front and back surfaces of the cap flush with the edges of the uprights. Using a clean rag dampened with acetone, remove any excess epoxy before it cures.

**6** With the epoxy cured, make a photocopy of the cap (D) pattern on the insert and adhere it to the cap and uprights (C). Chuck a  $\frac{5}{32}$ " bit into your drill press and drill a centered hole through the uprights and cap, where indicated on the pattern. Hacksaw a #6-32 $\times$ 1 $\frac{1}{2}$ " roundhead machine screw to 1 $\frac{1}{4}$ " long, removing the head. Insert the threaded stud into the hole, and secure it with nickel-plated cap nuts.

**7** Clamp the uprights (C) in your bench vise and file and sand the top ends of the uprights and cap (D), as shown in **Photo C**.

**Note:** To avoid heating the aluminum and softening the epoxy, do not power-sand the uprights (C) and cap (D) to shape.

**8** Join the brace/uprights/cap assembly (A/C/D) to the foot (B) by gluing and clamping the brace into the dado in the foot. Keep the bottoms flush.

## Add the photo holders

**1** From  $\frac{5}{8}$ "-thick stock, cut two  $\frac{5}{8}\times 9$ " blanks for the grippers (E) and the clamps (F). Making two passes over your tablesaw blade, cut a  $\frac{3}{16}$ "-wide groove  $\frac{1}{8}$ " deep  $\frac{1}{8}$ " from the front face of only the gripper blank. Then make a photocopy of the two gripper patterns on the pattern insert. Orienting the  $\frac{3}{16}$ " groove  $\frac{1}{8}$ " deep indicated on the patterns with the groove cut in the gripper blank, align one end of each pattern with one end of

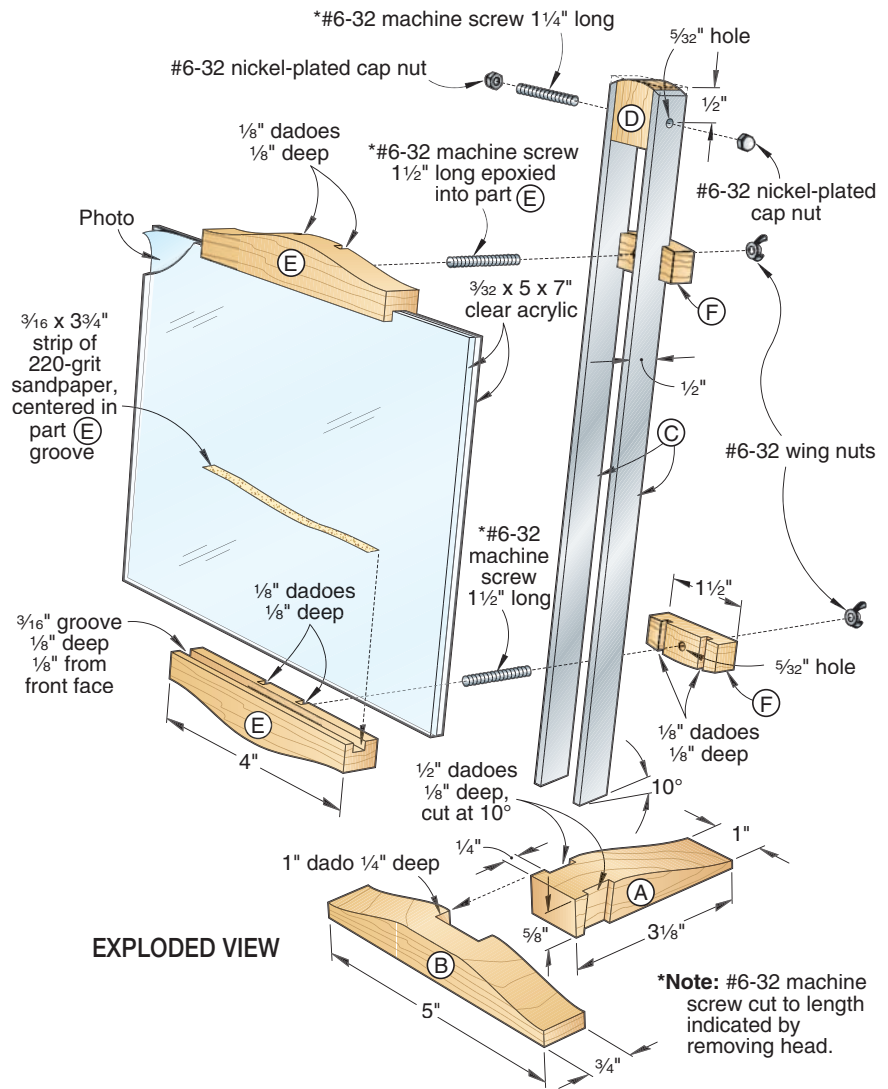

the blank, and adhere the patterns to the *back* face of the blank with spray adhesive.

**2** To cut mating dadoes in the grippers (E) and clamps (F) for the uprights (C), install a  $\frac{1}{8}$ "-kerf blade in your tablesaw and

adjust it to cut  $\frac{1}{8}$ " deep. Then attach an extension to the miter gauge so it extends about 4" to the right of the blade. Clamp a stopblock to the extension and cut two dadoes in the gripper blank and two in the clamp

### CUT ANGLED DADOES IN THE BRACE

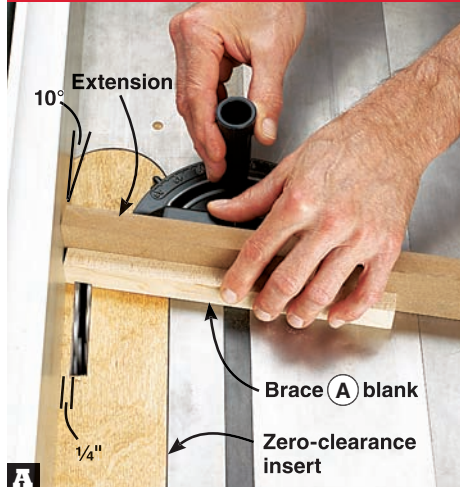

Angle the miter gauge 10° to the right and attach an extension. With the brace (A) blank corner touching the fence, cut the first dado.



Angle the miter gauge 10° to the left. Turn the brace (A) blank over, and again with the corner touching the fence, cut the second dado.

### FORM THE UPRIGHTS AND CAP

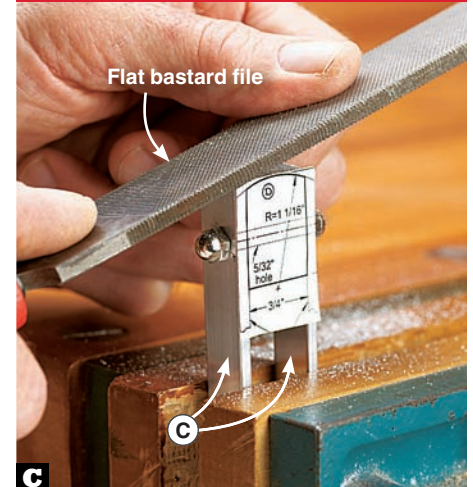

Rough-form the curved top of the uprights (C) and cap (D) with a flat bastard file. Then finish-sand with sandpaper to 220 grit.

blank, as shown in **Photos D** and **E**. Before repositioning the stop to cut the second set of dados, cut a dado in a piece of scrap and test the fit of an upright. If necessary, widen the dado. To do this without moving the stopblock, see the **Shop Tip**, *below right*. Now reposition the stopblock by aligning the blade with the second dado on the pattern, and cut two more dados in the gripper blank and two more in the clamp blank.

**3** Make a photocopy of the two clamp (F) patterns on the insert. Adhere the patterns to the clamp blanks, aligning the 1/8" dados indicated on the patterns with the dados in the clamp blank. Then drill 5/32" holes through the clamp blank and 9/64" holes 3/8" deep into the gripper (E) blank, where indicated on the patterns. Now, following the pattern lines, crosscut the grippers and clamps to length, and bandsaw and sand them to shape. Finish-sand the parts.

### Apply finish and assemble

**1** Mask the aluminum uprights (C) and apply a clear finish to all the parts. (We sprayed on three coats of satin lacquer.)

**2** Hacksaw two #6-32x2" roundhead machine screws to 1 1/2" long, removing the heads. Spread quick-setting epoxy in the gripper (E) holes, and insert the threaded studs. Let the epoxy cure. Then cut two 3/16x3 3/4" strips of 220-grit sandpaper and adhere them in the bottoms of the gripper grooves with spray adhesive, centered end-to-end, where shown on the drawing on page 85.

**3** Capturing the uprights (C) between them, insert the threaded studs of the grippers (E) into the holes in the clamps (F), and thread on wing nuts. Tighten the lower

## SHOP TIP

### Angle setup guide ensures perfectly parallel dados

When cutting the dados in the brace (A), you have to adjust the miter gauge first 10° to the right, and then 10° to the left. A small difference in setting the angles may be noticeable at the top ends of the 10 3/8"-long uprights (C). Rather than trust the markings on your miter gauge to set the angles, make a setup guide by cutting the end of a 4"-wide piece of scrap at 10°. Place the angled end of the guide against the fence and set the miter gauge to it, as shown *right*. To set the opposite angle, flip the guide over, and repeat. Now, even if the angle isn't exactly 10°, the two cuts will be parallel.



## SHOP TIP

### Widen a dado without moving the stopblock

When widening the 1/8" dados in the grippers (E) and clamps (F) of the easel, you'll want to retain the original stopblock position to make repeat cuts. Or when using a stack dado set, you may want to widen a dado without having to remove the tablesaw insert, remove the arbor nut, unstack the dado blade, and add a shim. In both cases, a spacer placed between the stopblock and the workpiece, as shown at *right*, does the trick. Use more playing cards for just the right thickness.

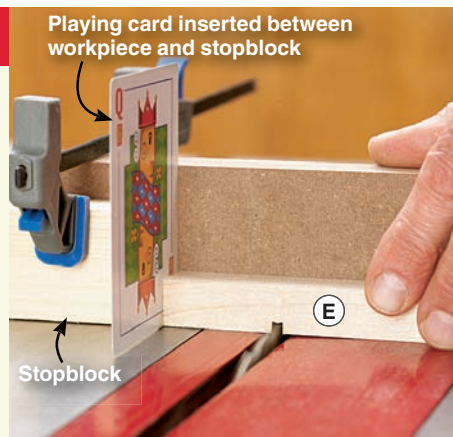

photo holder in place and leave the upper holder loose.

**4** Cut two 5x7" pieces of 3/32"-thick clear acrylic. (For optimum chip-free cuts, use an 80-tooth triple-chip carbide-tipped blade. As an alternate, we had good results with a sharp 40-tooth carbide-tipped combination

blade.) Sand away the saw marks and remove the sharp edges with 220-grit sandpaper. Then sandwich your photo between the two pieces of acrylic, capture the sandwich in the gripper (E) grooves, and tighten the upper holder wing nut. 🌲

Written by **Jan Svec** with **Erv Roberts**  
Project design: **Jeff Mertz**  
Illustrations: **Roxanne LeMoine**

## MATCH BLADE TO PATTERN FOR PERFECTLY ALIGNED CUTS

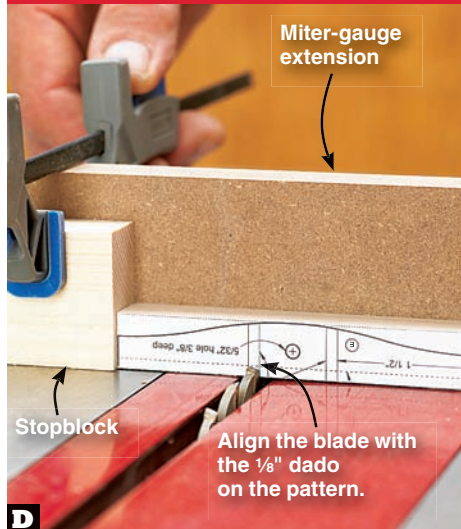

**D** Align the blade with the 1/8" dado shown on the gripper (E) pattern. Clamp a stopblock to the miter-gauge extension.

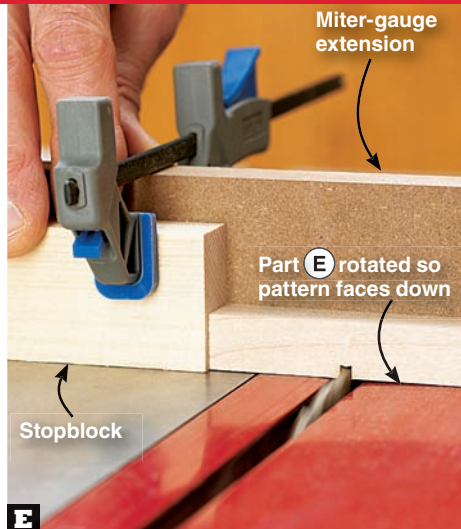

**E** Rotate the gripper (E) blank so the pattern faces down and cut the dado. Then turn the blank end-for-end and dado the other end.

## Materials List

Part	FINISHED SIZE			Matl.	Qty.
	T	W	L		
A* brace	5/8"	1"	3 1/8"	M	1
B foot	5/8"	3/4"	5"	M	1
C* uprights	1/8"	1/2"	10 3/8"	A	2
D cap	1/2"	3/4"	1"	M	1
E* grippers	5/8"	5/8"	4"	M	2
F* clamps	5/8"	5/8"	1 1/2"	M	2

\*Parts initially cut oversize. See the instructions.

**Materials key:** M—maple, A—aluminum.

**Supplies:** Spray adhesive, 1/8x1/2" aluminum bar, quick-set epoxy, #6-32x2" roundhead machine screws (3), #6-32 nickel-plated cap nuts (2), #6-32 wing nuts (2), 3/32" clear acrylic.

**Blades:** Stack dado set, 60-tooth carbide blade (for cutting aluminum), 80-tooth triple-chip carbide or 40-tooth carbide combination blade (for cutting acrylic).

# win-win game table

These guys seem to know my hand as well as I do.

My luck's about to change.

This should help me get that new router.

Try your luck building this reversible-top fun center. With these easy-to-follow plans, how can you lose?



The three gentlemen who collaborated on this project—(from left) project designer Kevin Boyle, writer Jan Svec, and project builder Chuck Hedlund—try it out. The tabletop flips to a wood surface for board games and other uses.



## 1 LEG ASSEMBLY

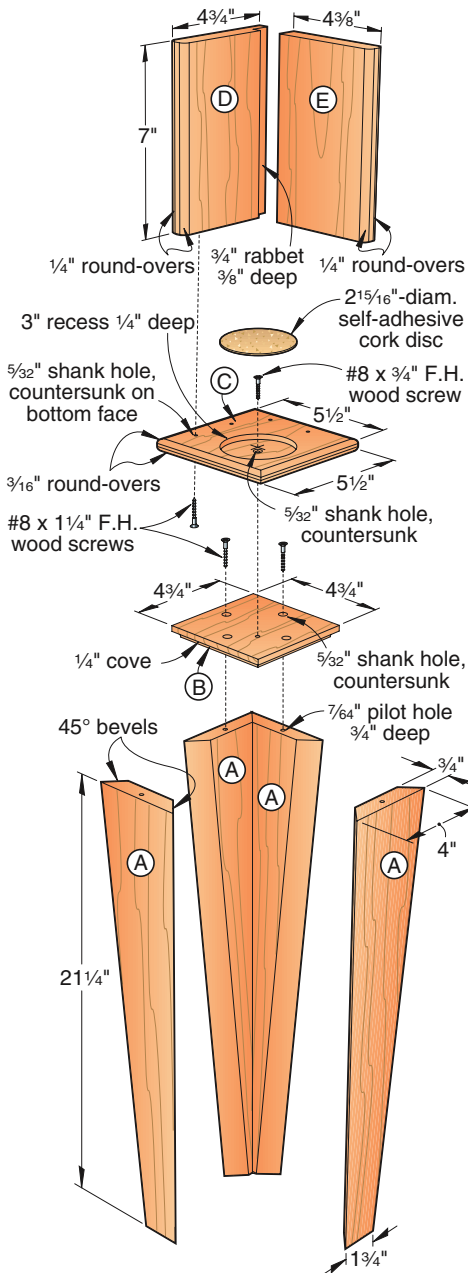

## 1a LEG BEVEL DETAIL

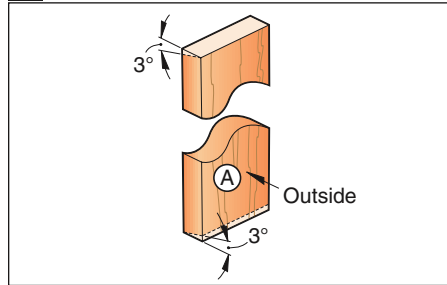

## 1b LEG CAP

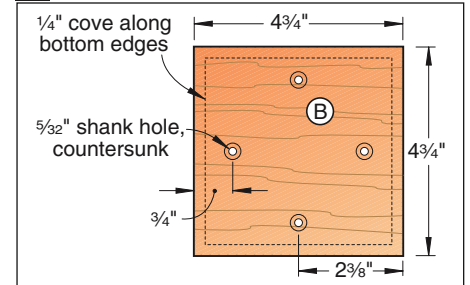

## 1c CUP HOLDER

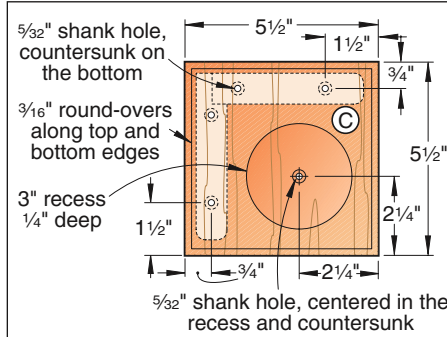

## 1d CUP HOLDER ASSEMBLY

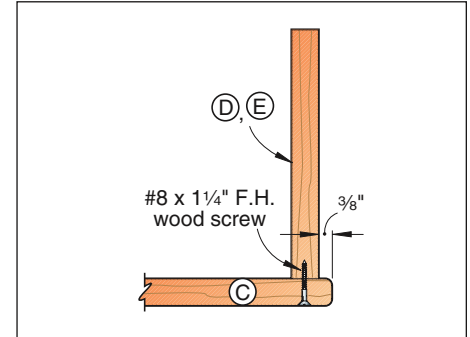

## 2 LEG SIDE TAPERING JIG

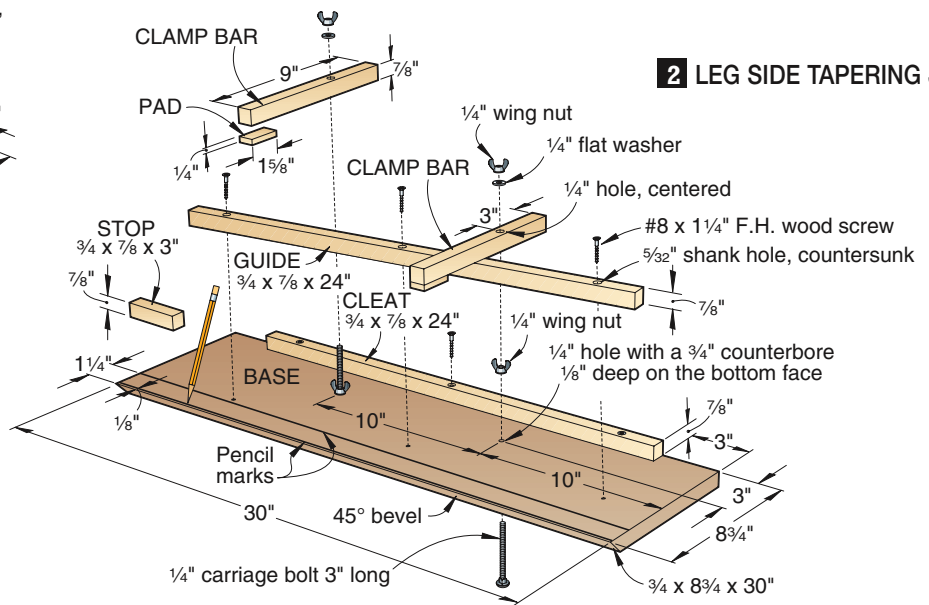

**H**ere's a felt-surfaced table that plays equally well to an intense evening of Texas Hold 'Em, a rousing game of Parcheesi, or a drawn-out siege of Risk. The traditional green felt top eliminates glare, reduces the sound and bounce of dice and poker chips, and gives dealt cards just enough glide to get to their destination without skittering off the edge of the table. An ingenious cork-lined drink holder at the top of each leg keeps the playing surface clear when the action gets hot. When the games conclude, protect the felt surface by simply flipping the top to expose a varnished wood panel, and set the table for a round of snacks. Don't worry about where to stash game boards, poker chips, and cards. A 3/4"-deep compartment underneath the tabletop provides ample storage.

## AT A GLANCE

- Overall dimensions: 36 1/16" wide x 36 1/16" long x 30 3/8" high.
- For the board feet of lumber and other items needed to build this project, see page 94.

## Make the tapering jig

**1** To simultaneously taper and bevel the leg sides (A), where shown on **Drawing 1**, first make the leg side tapering jig shown on **Drawing 2**. To make the jig, cut a 3/4x9x30" blank for the base. (We used medium-density fiberboard.) Bore two 3/4" counterbores 1/8" deep in the bottom face and drill 1/4" centered holes, where shown. Then tilt your tablesaw blade to 45° and bevel-rip the base to the 8 3/4" width shown.

**2** Cut three pieces of stock to 3/4x7/8x24" for the cleat, guide, stop, and clamps. For the cleat and guide, drill countersunk shank holes in two of the pieces, where shown. Then cut the stop and two clamp bars to length from the third piece. Drill 1/4" holes in the clamp bars, where dimensioned. Now cut two 1/4"-thick pads to size and glue and clamp them to the clamp bars.

**3** Draw two pencil lines parallel to the edge of the base, 1/8" and 1/4" from the beveled edge. Then position the cleat flush with the base edge. Using the holes in the cleat as guides, drill pilot holes into the base and drive the screws. Insert 1/4" carriage bolts 3" long in the base holes, and secure them with wing nuts. Slide the clamps over the carriage bolts and secure them with washers and wing nuts. You'll position the guide and stop later.

## ONE JIG AND SIX EASY STEPS TO PERFECTLY TAPERED AND BEVELED LEG SIDES

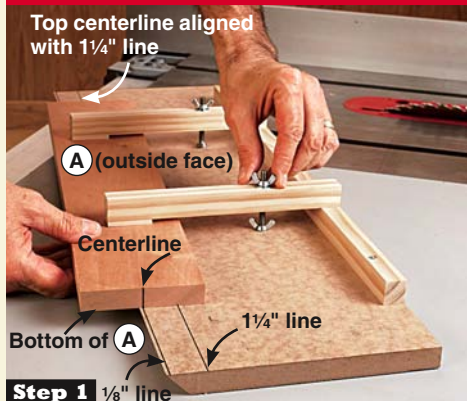

**Step 1** 1/8" line

Align the leg side (A) bottom centerline with the 1/8" line at the front of the jig and the top centerline with the 1/4" line at the rear.



**Step 2**

With the leg side (A) clamped in place, position the jig guide against it. Drill pilot holes into the base, and drive the screws.

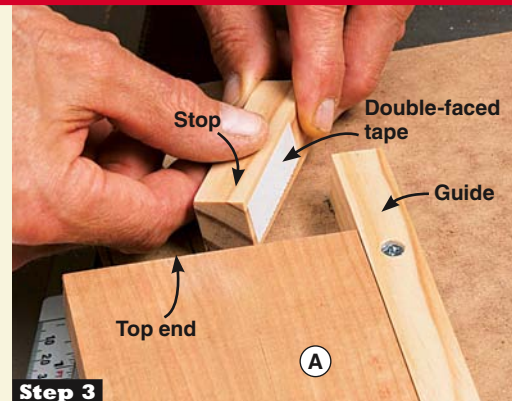

**Step 3**

Use double-faced tape to adhere a stop to the guide at the rear of the jig, positioning the stop against the top end of the leg side (A).

### Cut the leg sides to shape

**1** Cut the leg sides (A) to the size listed on the **Materials List**. Then make a reference mark on the inside face of each leg side at the top. Now tilt your tablesaw blade 3° and cut a bevel on both ends of each leg side, where shown on **Drawing 1a**.

**2** To set up the leg side tapering jig for tapering and beveling the first edge of the leg sides (A), make one of the leg sides the setup part by marking centerlines on both ends. Then use this part to position the jig guide and stop, as shown in **Steps 1, 2, and 3** above. Now bevel-rip the first edge of all 16 leg sides, as shown in **Step 4**.

**3** Remove the guide and stop from the base. Then retrieve the setup part and reposition it on the jig, as shown in **Step 5**. Now reset the guide and stop and bevel-rip the second edge of all the leg sides, as shown in **Step 6**.

### Assemble the legs

**1** With both edges of all 16 leg sides (A) bevel-ripped, assemble the four legs, as shown in **Steps 1, 2, 3, and 4** at right.

**Note:** After assembling the legs, there should be a slight gap between adjacent sides (A) at the heels of the bevels. This guarantees that the points of the bevels close tightly for a flawless appearance.

**2** With the glue dry, remove the masking tape. Sand away any excess glue. Chuck a 1/4" round-over bit into your table-mounted router, and rout the corners and bottom ends of each leg. Finish-sand the legs.

**3** From 1/2"-thick stock, cut the leg caps (B) and cup holders (C) to size. Chuck a 1/4" cove bit into your table-mounted router and rout the bottom edges of the leg caps, where shown on **Drawing 1**. Switch to a 3/16" round-over bit, and rout the top and bottom edges of the cup holders.

**4** Drill four 5/32" countersunk shank holes in each leg cap (B), where shown on **Drawing 1** and dimensioned on **Drawing 1b**. Now glue and clamp the leg caps to the legs, centered. Using the holes in the leg caps as guides, drill pilot holes into the leg sides (A), and drive the screws.

**5** Chuck a 3" Forstner bit into your drill press, and bore a 1/4"-deep recess in each cup holder (C), where dimensioned on **Drawing 1c**. Then drill a 5/32" shank hole in the center of each recess. Now drill four more 5/32" shank holes in each cup holder, countersunk on the bottom, where dimensioned.

### 4 QUICK STEPS TURN FLAT SIDES INTO HOLLOW TAPERED LEGS

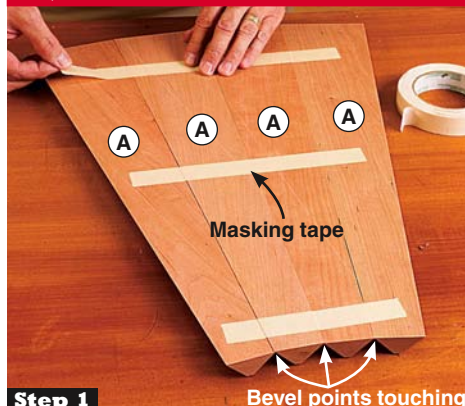

**Step 1**

Lay out four leg sides (A) with the outside faces up, the bevel points touching, and the ends flush. Join them with masking tape.

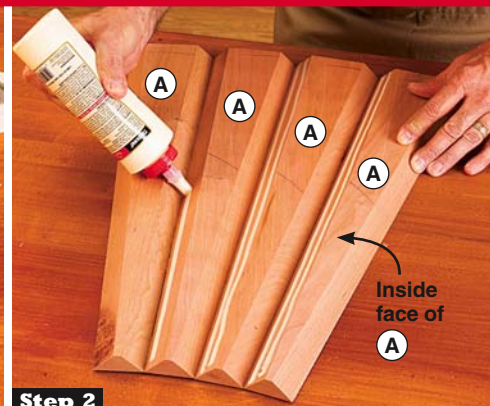

**Step 2**

Carefully turn the taped-together legs over, and apply two beads of glue to one bevel of each leg side (A).

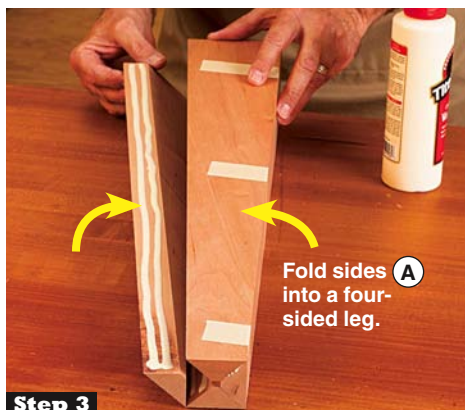

**Step 3**

Fold the taped-together leg sides (A) into a four-sided leg, align the ends of the first and last sides, and secure the corner with tape.

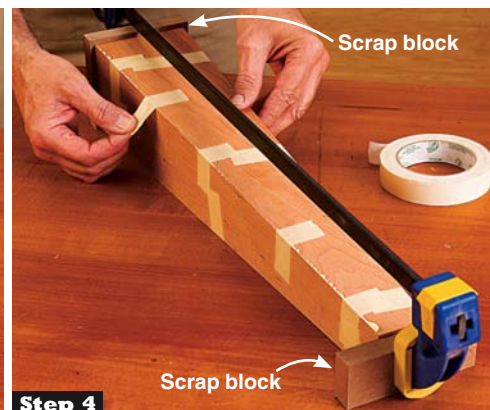

**Step 4**

To align the leg side ends, clamp scrap blocks against the top and bottom of the leg. Add more tape at the corners, where needed.



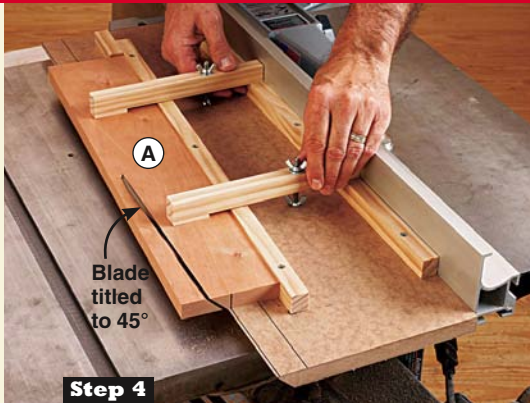

**Step 4**

With the tablesaw blade tilted to 45° and the rip fence positioned to align the blade with the edge of the base, bevel-rip the first edge.

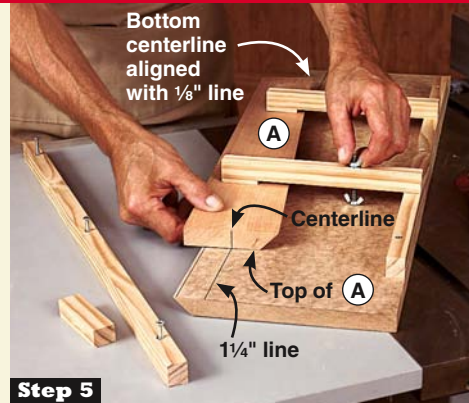

**Step 5**

Realign the leg side (A) top centerline with the 1/4" line at the front of the jig and the bottom centerline with the 1/8" line at the rear.

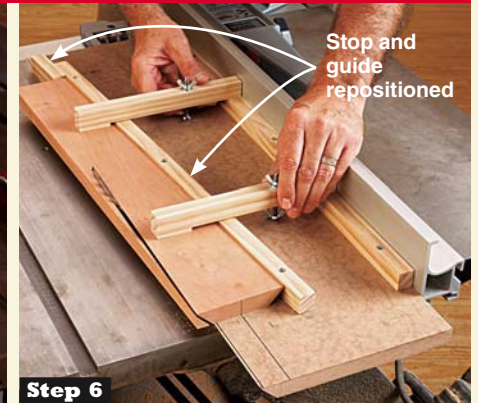

**Step 6**

With the jig guide repositioned against the edge of the leg side (A) and the stop against the bottom end, bevel-rip the second edge.

Finish-sand the cup holders. To form the cup-holder recesses with your handheld router, see the **Shop Tip** below.

**6** Cut the cup-holder wide sides (D) and cup-holder narrow sides (E) to size. With a dado blade in your tablesaw, cut a 3/4" rabbet 3/8" deep along the back edge of each wide side, where shown on **Drawing 1**. Then chuck a 1/4" round-over bit into your table-mounted router and rout the front edges of each side. Finish-sand the cup-holder sides and glue and clamp them together, making sure the corners are square.

**7** Glue and clamp the cup-holder side assemblies (D/E) to the cup holders (C), positioning the sides on the holders where

shown on **Drawing 1d**. Then using the countersunk shank holes in the cup holders as guides, drill pilot holes into the sides and drive the screws.

**8** Apply glue to the leg caps (B). Centering the cup holders (C) on the leg caps, clamp the cup-holder assemblies (C/D/E) to the leg assemblies (A/B). Then using the shank hole centered in each cup-holder recess as a guide, drill pilot holes into the leg caps and drive the screws.

### Build the apron assembly

**1** Cut the aprons (F), long leg supports (G), and short leg supports (H) to size. With a dado blade in your tablesaw, cut 3/4" rabbets

1/2" deep in both ends of each apron and one end of each long leg support, where shown on **Drawing 3**. Then cut a 1/2" rabbet 1/2" deep along the bottom edge of each apron for the bottom (I). Now drill 5/32" countersunk shank holes in the leg supports, where shown on **Drawing 3a**. Finish-sand the aprons.

**2** Glue and clamp the long leg supports (G) and short leg supports (H) in the configuration shown on **Drawing 3**. Then using the shank hole in each long support as a guide, drill a pilot hole into each short support and drive the screw. Finish-sand the leg support assemblies (G/H).

**3** Glue and clamp the four aprons (F) to the four leg support assemblies (G/H), where

## SHOP TIP

### Form large-diameter, flat-bottom recesses with your handheld router

Sets of Forstner bits usually top out at 2 1/8", with larger bits acquired as the need arises. Drilling the 3"-diameter recesses in the cup holders (C) with a Forstner bit

requires an \$18–\$26 investment and a trip to a woodworking specialty store or a wait of several days and the additional expense of shipping for a mail-order delivery. The

three steps *below* show how to form the cup-holder recesses with an adjustable circle cutter, a handheld router, and a 1"-long pattern bit.

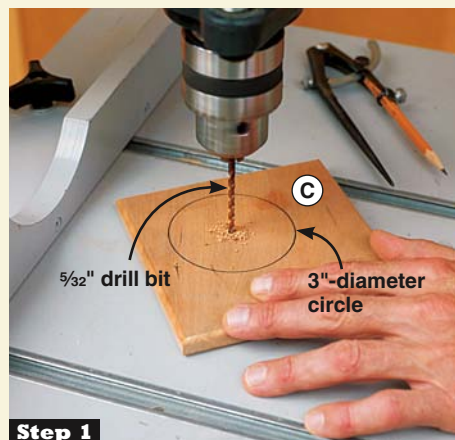

**Step 1**

Draw a 3"-diameter circle on the cup holder (C) with a compass, and then drill a 5/32" shank hole at the center of the circle.

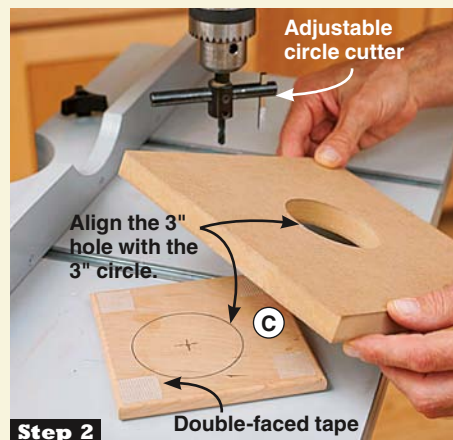

**Step 2**

Cut a 3"-diameter hole in a 3/4x9x9" piece of scrap with an adjustable circle cutter. Adhere it to the cup holder with double-faced tape.

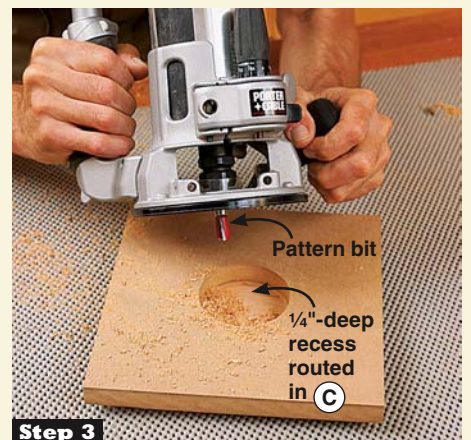

**Step 3**

Chuck a pattern bit into your handheld router, and adjust it to protrude 1" (3/4" scrap thickness plus 1/4" recess depth). Rout the recess.

### 3 APRON ASSEMBLY

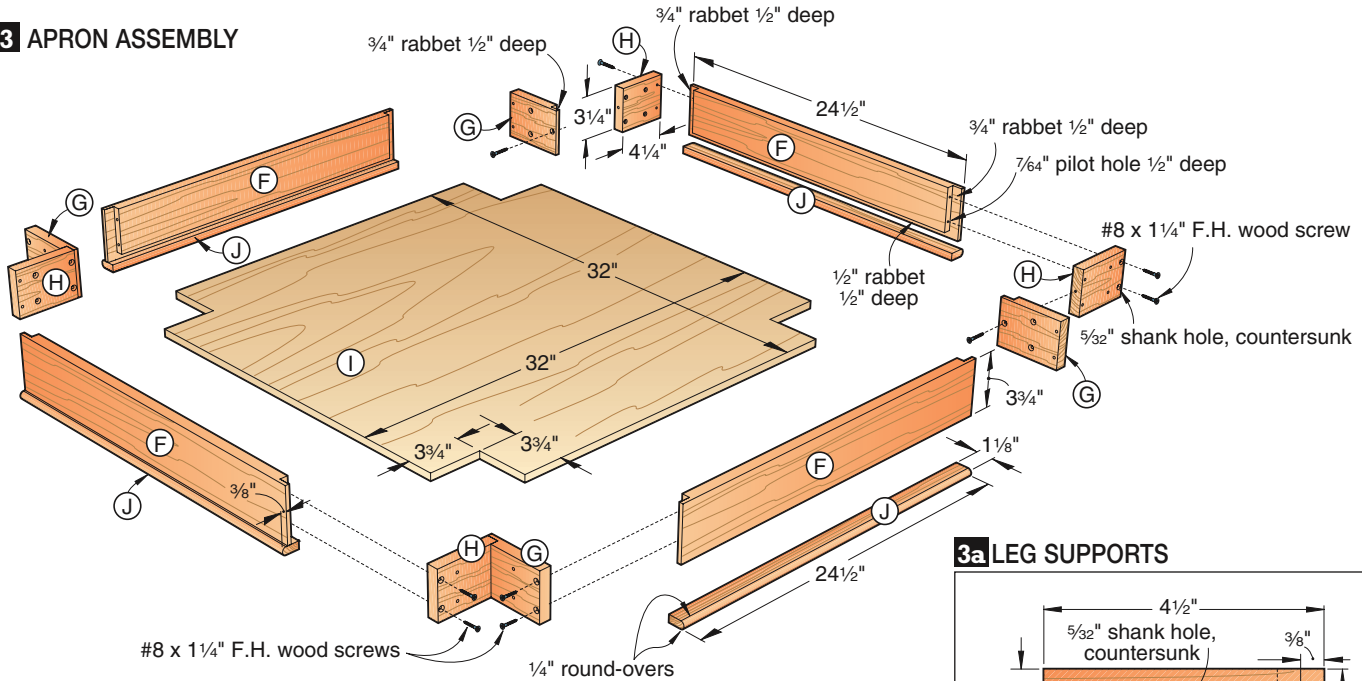

shown on **Drawing 3**. Keep the top edges flush. Then using the shank holes in the leg supports as guides, drill pilot holes into the aprons and drive the screws.

**4** Cut the bottom (I) to size from  $\frac{1}{2}$ " plywood. Lay out the corner notches, where shown on **Drawing 3**, and cut them out with a jigsaw. With the apron assembly (F/G/H) upside down, spread glue in the apron rabbets and on the bottoms of the leg supports and clamp the bottom in place. Make sure the assembly is square.

**5** Plane stock to  $\frac{1}{2}$ " thick and cut the apron trim (J) to size. With the  $\frac{1}{4}$ " round-over bit in your table-mounted router, rout the outside edges of the trim, where shown on **Drawings 3** and **4**. Glue and clamp the trim to the aprons (F) and bottom (I).

### JOIN THE LEGS TO THE APRONS



**A** Glue and clamp the cup holder sides (D, E) to the leg supports (G, H) with the tops flush. Drill pilot holes, and drive the screws.

### Assemble the table

**1** Join the leg assemblies to the apron assembly, where shown on **Drawing 5** and as shown in **Photo A**.

**2** For the brackets (K), cut two  $\frac{3}{4} \times 2\frac{1}{2} \times 16$ " pieces of stock. Then to orient the grain diagonally on the finished parts, cut four triangular blanks from each piece for a total of eight blanks, as shown in **Photos B** and **C** and the **Cutting Diagram**.

**3** Make eight photocopies of the bracket (K) pattern on the *WOOD Patterns*® insert. Adhere a pattern to each bracket blank with spray adhesive. Bandsaw and drum-sand the brackets to shape. Then rout  $\frac{1}{4}$ " round-overs along the edges, as shown in **Photos D** and **E**. Finish-sand the brackets, and glue and clamp them to the apron trim (J) and cup holder sides (D, E), where shown on **Drawings 4** and **5**.

### Make a reversible top

**1** Plane stock to  $\frac{3}{8}$ " thick and cut the cove trim (L) to the width listed and oversize to 37" long. Chuck a  $\frac{1}{4}$ " cove bit into your table-mounted router, and rout the lower outside edges, where shown on **Drawings 4** and **5**. Finish-sand the cove trim.

**2** Cut the panel surrounds (M) to the width listed and oversize to 37" long. Then chuck a  $\frac{1}{4}$ " round-over bit into your table-mounted router, and rout the lower outside edges of the surrounds, where shown on **Drawings 4** and **5**. Switch to a  $\frac{3}{8}$ " round-over bit, and rout the upper outside edges. Now switch to a rabbet bit and rout a  $\frac{1}{8}$ " rabbet  $\frac{1}{8}$ " deep along the upper inside edges. Finish-sand the surrounds.

### 3a LEG SUPPORTS

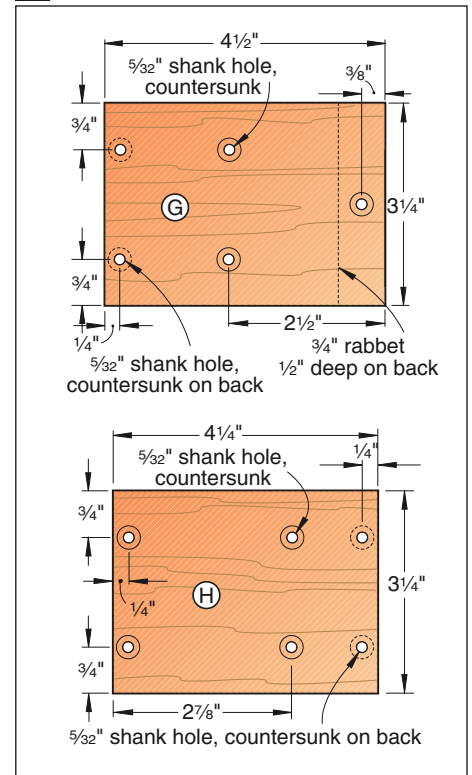

**3** To form the top frame sides, glue and clamp the cove trim (L) to the panel surrounds (M) with the ends flush and the inside edges of the cove trim protruding  $\frac{1}{2}$ " beyond the inside edges of the surrounds, where shown on **Drawing 4**.

**4** Miter-cut the top frame sides (L/M) to the length listed in the **Materials List** and shown on **Drawing 5** for part M. To ensure a square frame, make sure all the frame sides are exactly the same length. Then cut slots for #20 biscuits centered in the mitered ends of the panel surrounds (M). Now glue, biscuit, and clamp the top frame, checking it for square. With the glue dry, sand the corner joints smooth.

**5** To align the top frame (L/M) when gluing it to the aprons (F), cut four 1¾×1¾×8" alignment blocks. Then using double-faced tape to hold the blocks in place, position them in the corners of the cup holder side assemblies (D/E) so the blocks protrude 2" beyond the tops of the cup holder sides. Test the top frame for a wobble-free fit over the blocks. Now glue and clamp the top frame in place, as shown in **Photo F**.

**6** Cut the panel (N) to size and finish-sand the good face. Then cut the panel trim (O) to the width and 1" longer than the length listed. With a dado blade in your tablesaw, cut a ¼" rabbet ¼" deep along the top inside edge of each trim piece, where shown on **Drawing 4**. Miter-cut the panel trim to fit around the panel. Now drill centered ⅝" countersunk shank holes through the panel trim, where shown on **Drawings 4 and 5**.

**Note:** For a close fit between the panel assembly and the top frame that still allows for easy removal, make sure the opening in the top frame is 30/16×30/16". If the dimensions of your opening are different, make the necessary adjustments to the sizes of the panel (N) and the panel trim (O).

### Add the finishing touches

**1** Inspect all the parts and assemblies and finish-sand where needed. If desired, apply a stain, and then apply a clear finish. On the panel (N), finish only the good face. (We applied Minwax Cherrywood 607 gel stain and let it dry for 24 hours. Then we sprayed on two coats of water-based satin polyurethane, lightly sanding with 220-grit sandpaper between coats.)

### 4 TOP/APRON SECTION VIEW

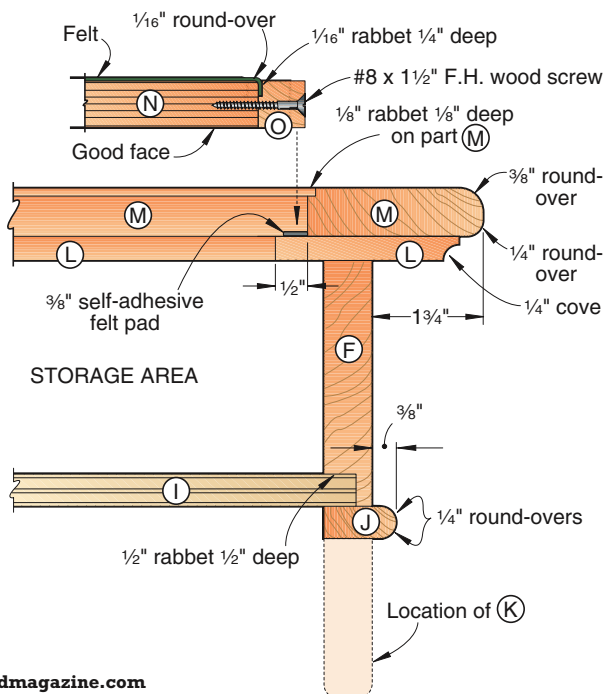

### MAKING THE DIAGONAL-GRAIN BRACKET BLANKS

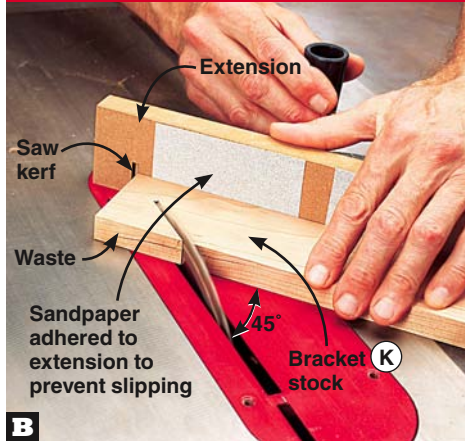

**B** Angle your miter gauge to 45°, attach an extension, and cut a saw kerf through the extension. Trim the end of the bracket stock.

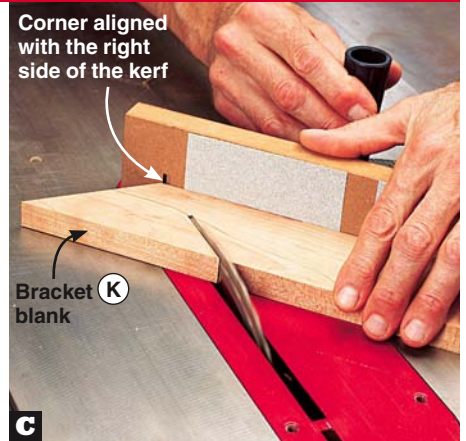

**C** Turn the bracket stock over. Align the corner with the right side of the saw kerf, and cut off a bracket blank. Repeat to make four blanks.

### A CARRIER BOARD IS KEY TO SAFELY ROUTING THE BRACKETS



**D** To safely hold the brackets (K) while routing the round-overs, cut a 2½×2½" notch in an 8½×8½" piece of ¾"-thick stock.



**E** Holding each bracket in the carrier board notch, rout the round-overs. Start and finish routing along the edge of the carrier.

### ALIGNMENT BLOCKS ENSURE A NO-MESS GLUE-UP

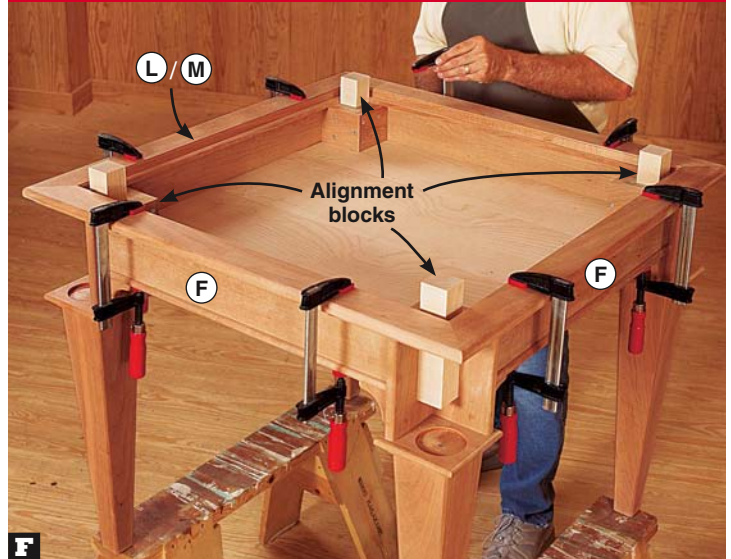

**F** Apply a thin bead of glue to the top edges of the aprons (F). Lower the top frame (L/M) over the alignment blocks, and clamp it in place.

## 5 EXPLODED VIEW

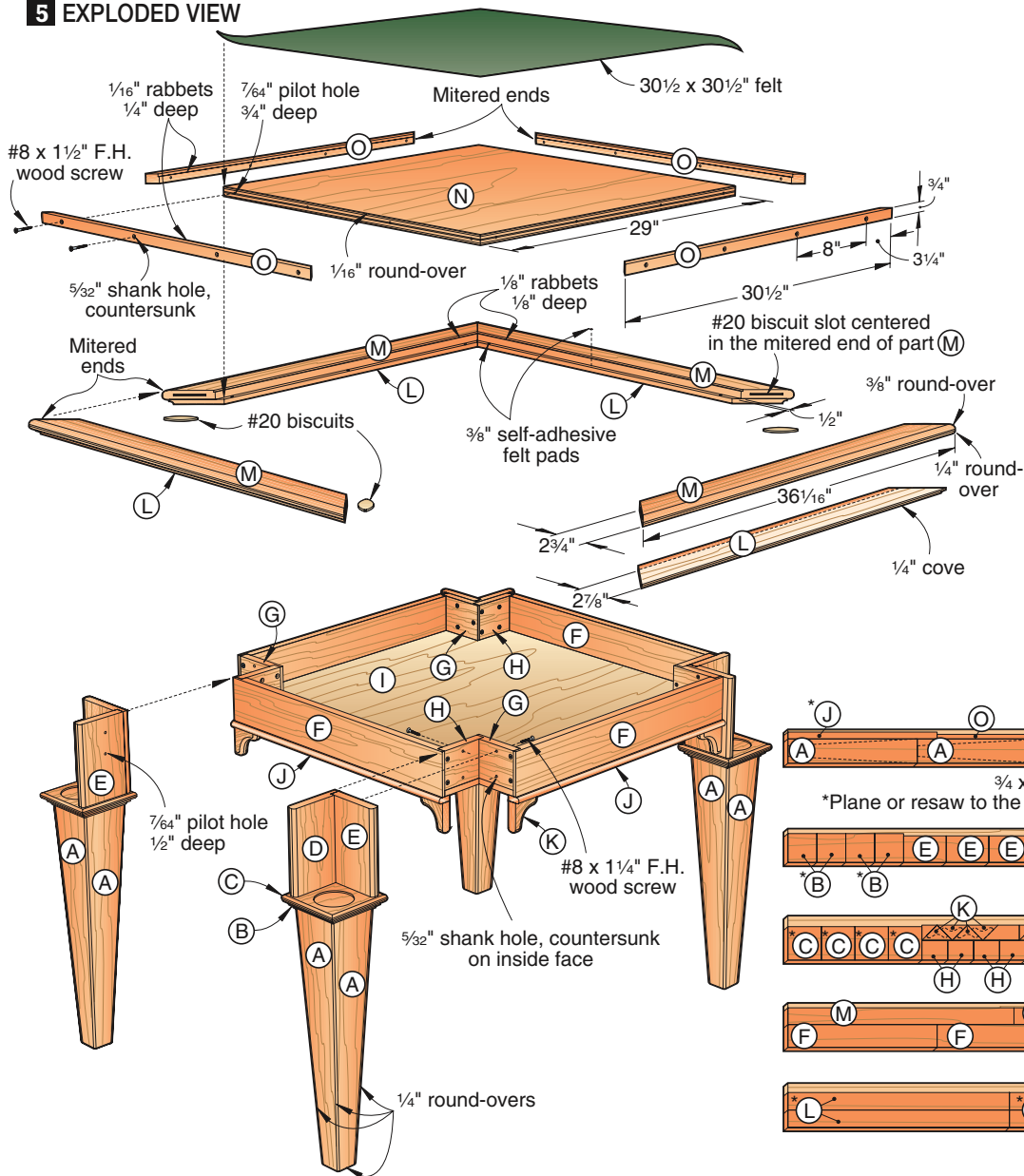

## Cutting Diagram

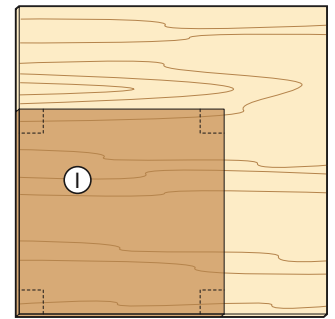

1/2 x 48 x 48" Birch plywood

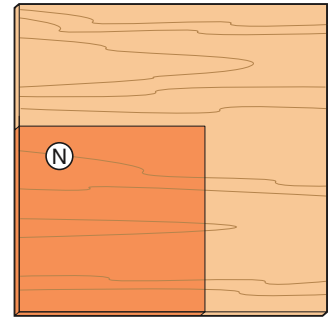

3/4 x 48 x 48" Cherry plywood

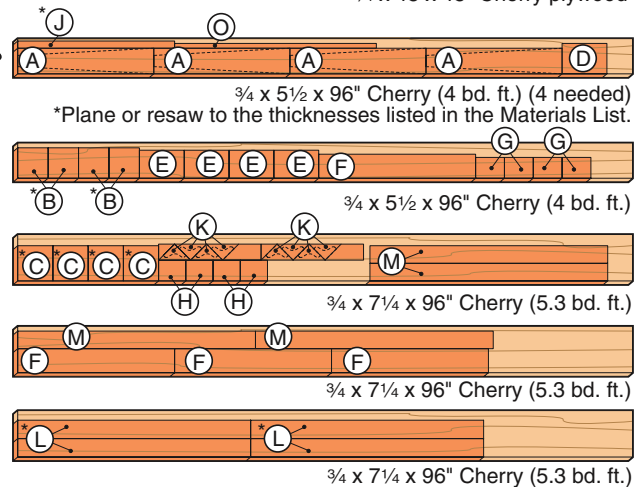

3/4 x 5 1/2 x 96" Cherry (4 bd. ft.) (4 needed)  
\*Plane or resaw to the thicknesses listed in the Materials List.

3/4 x 5 1/2 x 96" Cherry (4 bd. ft.)

3/4 x 7 1/4 x 96" Cherry (5.3 bd. ft.)

3/4 x 7 1/4 x 96" Cherry (5.3 bd. ft.)

3/4 x 7 1/4 x 96" Cherry (5.3 bd. ft.)

**2** Adhere 2<sup>15/16</sup>" self-adhesive cork discs in the recesses in the cup holders (C). Then apply self-adhesive felt discs to the cove trim (L), where shown on **Drawings 4 and 5**.

**3** To add a felt playing surface to the back face of the panel (N) and apply the panel trim (O), see the article on *page 96*. With the felt and panel trim installed, position the top assembly (N/O) in the top frame (L/M) opening, resting it on the protruding lip of the cove trim (L). To remove or flip the top assembly, push it up from underneath by inserting a finger in one of the openings in the upper inside corners of the cup holders. Now find three other card sharks, serve up cold drinks, and deal the cards. 🍀

Written by **Jan Svec** with **Chuck Hedlund**

Project design: **Kevin Boyle**

Illustrations: **Roxanne LeMoine; Lorna Johnson**

## Materials List

Legs	FINISHED SIZE			Matl.	Qty.
	T	W	L		
A sides	3/4"	4"	21 1/4"	C	16
B caps	1/2"	4 3/4"	4 3/4"	C	4
C cup holders	1/2"	5 1/2"	5 1/2"	C	4
D cup holder wide sides	3/4"	4 3/4"	7"	C	4
E cup holder narrow sides	3/4"	4 3/8"	7"	C	4
<b>Apron assembly</b>					
F aprons	3/4"	3 3/4"	24 1/2"	C	4
G long leg supports	3/4"	3 1/4"	4 1/2"	C	4
H short leg supports	3/4"	3 1/4"	4 1/4"	C	4
I bottom	1/2"	32"	32"	BP	1
J apron trim	1/2"	1 1/8"	24 1/2"	C	4
K* brackets	3/4"	2 1/2"	2 1/2"	C	8

Top					
L* cove trim	3/8"	2 7/8"	35 5/16"	C	4
M* panel surrounds	3/4"	2 3/4"	36 1/16"	C	4
N panel	3/4"	29"	29"	CP	1
O* panel trim	3/4"	3/4"	30 1/2"	C	4

\*Parts initially cut oversize. See the instructions.

**Materials key:** C—cherry, BP—birch plywood, CP—cherry plywood.  
**Supplies:** #8x3/4", #8x1 1/4", #8x1 1/2" flathead wood screws; spray adhesive; double-faced tape; #20 biscuits; 30 1/2x30 1/2" green felt.

**Blades and bits:** Stack dado; 3/16" round-over, 1/4" round-over, 3/8" round-over, rabbet, 1/4" cove router bits; 3" Forstner bit or adjustable circle cutter and 1"-long pattern router bit.

## Source

**Cork and felt.** 1/8"-thick x 2 15/16"-diam. self-adhesive cork discs no. 832, \$3.75 (pack of 8); 3/8"-diameter self-adhesive felt pads no. 7357, \$3.99 (100). Meisel Hardware Specialties. Call 800/441-9870, or go to [meiselwoodhobby.com](http://meiselwoodhobby.com).

# put on a (felt) game face

Easy to cut and apply, felt is the perfect material for a game-table top. Just follow this five-step process.

**T**hink you need the skills of a seamstress to apply felt? Hardly. Using spray adhesive, a few simple tools, a shop-made edge-trimming guide, and the sure-bet process *below*, you can install a precise-fitting, wrinkle-free overlay sure to draw admiring players to the table. For an example, we'll cover the top panel (N) for the game table on *page 88*.

## 1 Prepare the panel

To protect the felt from sharp corners, rout  $\frac{1}{16}$ " round-overs along the edges on the



unfinished face of the game-table top panel (N). Sand the edges smooth using 220-grit sandpaper. Then, to ensure clean surfaces for adhering the fabric, remove all of the dust from the face and edges with a vacuum or tack cloth.

## 2 Cut and iron the felt

Using sharp scissors, cut a  $30\frac{1}{2}\times 30\frac{1}{2}$ " piece of felt for the  $29\times 29$ " panel. (The oversize felt allows for wrapping and trimming along the panel edges.) Place the

felt on a clean piece of cardboard or medium-density fiberboard a little larger than the felt. Using an iron on the "wool" setting, remove all wrinkles from the felt.

## 3 Now, adhere the felt

Apply an even coat of spray adhesive, such as 3M Spray Mount Artist's Adhesive, to the felt. Let the adhesive dry for one minute. Then, using a helper, center and lay the panel, finished face up, on the felt, as shown in **Photo A**. Now turn the panel over, and firmly adhere the felt to the face and edges using a 3" rubber J roller.

## 4 Trim the excess fabric

Pinch the felt together at the corners and cut off the excess, as shown in **Photo B**. Then, to trim the felt along the edges, leav-

*continued on page 98*



ing a 1/4" overhang, make an edge-trimming guide by cutting a 1/4" rabbet 1/2" deep in a 3/4x3/4x6" wood block. Using the guide and a sharp utility knife, cut off the excess felt along the edges, as shown in **Photo C**.

## 5 Install the panel trim

Turn the panel over. Then, with the panel trim (O) oriented with the rabbets down, where shown on the drawing *right*, clamp the trim to the panel, flush with the finished face. (To allow removal of the trim for future felt replacement, omit glue.) Using the mounting holes in the trim as guides, drill pilot holes, and drive the screws, as shown in **Photo D**. 🌲

Illustration: Roxanne LeMoine

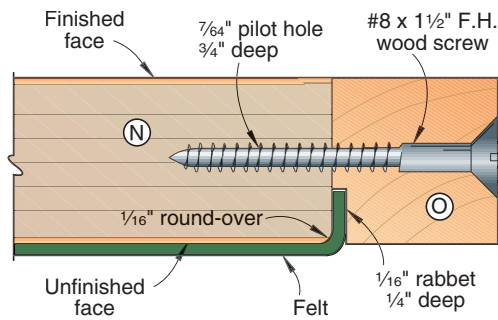
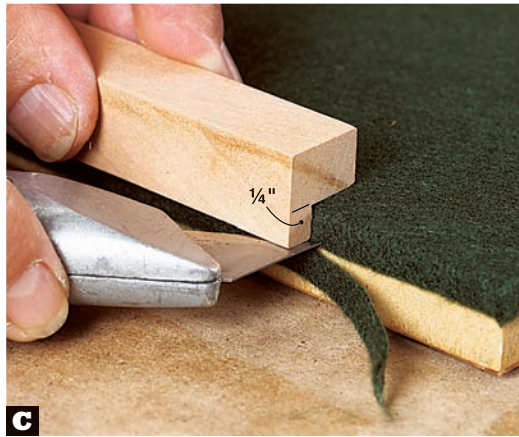

# shop-proven products

These woodworking wares passed our shop trials.

## One word for this digital router lift: Wow!

Router lifts have grown in popularity with woodworkers for the past several years because they make it easy to adjust bit height from above the router table. But as more router manufacturers build through-table height adjustment mechanisms into their routers, lifts may become as obsolete as brace-and-bit drills. Now, along comes Jointech's SmartLift Digital router lift that goes beyond where any built-in height adjuster can currently go.

Like most lifts, SmartLift Digital consists of an insert plate and a crank-driven mechanism that raises and lowers a router motor mounted in the carriage below the insert plate. That's pretty much where the similarities end.

Let's start with SmartLift's digital display that shows the bit's cutting height in either inches or millimeters, accurate to .001". To



102

test its accuracy, I set the top of my rail-cutting bit flush with the tabletop and zeroed the digital display. I then raised the bit, machined the rails, and noted the reading—in this case, 1.250". Next, I set up my stile-cutting bit, again zeroing the top of the cutter to the tabletop, made test cuts to match the rail, and noted the reading on the display (1.175").

To test SmartLift Digital's repeatability and reliability, I then removed both the bit from the router (any bit can be changed from above the table) and the router from the table. I then reinstalled them, again raising the stile-cutting bit to 1.175". No matter how many times I removed and remounted the bit and the router, I always made a precisely matching stile cut, as long as I first zeroed the bit to the tabletop.

Another unique feature of SmartLift Digital is the planetary gear system that drives the lift, rather than the chains or belts found on other lifts. This gear system—completely enclosed to protect it from dust—virtually eliminates backlash. (That's the mechanical slack found in other router lifts that makes you question whether a full turn of the elevation crank really results in a 1/16" or 1/32" change in cutting height.)

SmartLift Digital accepts the motor from a Porter-Cable 7518 or 7519 3-hp router out of the box, but optional adapters (\$30) fit some 2-hp routers: Bosch 1617/1618 series; DeWalt DW610, DW616, or DW618; P-C 690 or 890 series; and Makita 1101. It's also available without the digital readout (SmartLift Pro, \$270). Jointech plans to introduce a motorized version of the SmartLift built into a solid phenolic tabletop in 2006.

—Tested by Pat Lowry

### SmartLift Digital router lift

Performance ★★★★★  
Price \$400

Jointech  
800/619-1288; jointech.com

## **Saw-Jaw protects you and your tablesaw blades**

I've more than once "donated" blood while changing blades on my tablesaw. It seems like the wrenches put my hands in perfect position to get bitten by the blade teeth when the arbor nut breaks loose. Saw-Jaw wraps around your tablesaw blade like an oil-filter wrench, capturing the teeth inside its protective plastic jaws.

To use Saw-Jaw, I remove my saw's throat plate, clamp the Jaw around the blade (it locks closed) and remove the arbor nut. Then I use the Jaw's long handle to slide it and the blade off the arbor. That sure beats trying to pull the blade and my hand out of the throat.

If you buy an extra Saw-Jaw or two, you'll never need to handle a tablesaw blade by its teeth again, because this device also stores the blade. The manufacturer left a nice space on the back of the handle for you to label the blade contained within.

Saw-Jaw doesn't work on my 10" miter saw or radial-arm saw. The manufacturer also warns that it won't fit into most portable (sometimes called benchtop or job-site) saws. But for contractor- and cabinet-style tablesaws, left- or right-tilt, it works wonders.

—Tested by *Charlie Bartlett*



### **Saw-Jaw**

Performance	★★★★★
Price	\$17

HIQOL L.C.  
800/729-9366; saw-jaw.com



## Replacement subbase accepts big bits, bushings

Here's a solution to the long-standing problem about the bit openings in router bases. The dilemma: If the hole is small enough to hold a Porter-Cable-style guide bushing, it won't accommodate large-diameter bits; if it has a larger opening, it won't accept P-C bushings. Some routers come with two subbases—one for bushings and one for larger bits—but it can be a pain to change and recenter them on the collet.

The TurnLock Base Plate solves these problems, and a couple more. I replaced the subbase on my P-C 690 with the 6" model (there's also a 7" version; check [milescraft.com](http://milescraft.com) for a list of routers that each Base Plate fits) and centered it on the collet using the included cone and 3/4" guide bushing. The oversize bit opening accepts bits up to 1 7/8" in diameter. When you need a guide bushing, simply insert a TurnLock bushing, rotate it 1/8 turn, and it locks in place.

Skeptical about the durability of the plastic TurnLock bushings, I rubbed one against the rough edge of 3/4" plywood for 15 minutes. I became a believer: The bushing held up without a scratch. Don't want to give up your metal bushings? You also get an adapter for P-C-style guide bushings with the Base Plate.

Like the bit opening, the outer rim of the TurnLock Base Plate is shaped to accept other accessories, such as a circle-cutting trammel and an offset base. With this inexpensive add-on, you're not just buying a gadget, you're investing in an easy-to-use, multifaceted system. ♣

—Tested by Pat Lowry



### TurnLock Base Plate and Bushing Set

Performance ★★★★★

Price Base plate, \$15; Bushing set, \$10

Milescraft  
815/874-2400; [milescraft.com](http://milescraft.com)

# what's ahead

Articles you'll find in the February/March issue (on sale January 17)

## Projects for throughout the house

### FEATURED PROJECT



#### Chimney cupboard

Build this classic from ready-made pine panels, and then clear-finish or paint it to complement its surroundings.



#### Mantel clock

Looking for a make-in-a-weekend project that's destined to be a family heirloom? This mission-influenced timepiece fills the bill.



#### Magazine rack

Bring order to your reading materials while creating a convenient spot for your beverage or TV remote.



#### Turned platter

Basic lathe skills are all you need to shape this beauty. You'll find an economical and convenient source for the eye-catching burl stock.



#### Treasure chest

Elegant design makes this simple-to-build box stand apart. Use mail-order-sourced exotic woods or scrap pieces you've set aside for that special project.

## Tools and techniques

### TOOL TEST



#### 8" jointers

Always wanted a machine that can handle big boards? We tested eight models, including several with spiral cutterheads.



#### A professional's finish

Learn how finishing wiz Jeff Jewitt brushes on a rich painted finish and ages it with a coat of glazing.



#### Hand-cut dovetails

With a little practice and patience you can use but a few modest tools to cut this traditional joint.



#### 4 tablesaw jigs

Zane Powell shares his favorite jigs for cutting box joints, machining tenons, and ripping thin strips.