

WOOD®

**NEW
LOWER
PRICE!**

Build this Bookcase

and learn valuable new skills ...

- Back-to-basics case construction
- Cabriole legs for first-timers
- Simple sliding-dovetail drawers

plus

- Tabletop Curio Case p.54
- Cut Crisp, Clean Dadoes p.65
- Get More From Your Clamps p.92
- Keys to a Perfect Poly Finish p.89
- Rated: 11 Time-saving Router Lifts p.74

HAND-TOOL SKILLS



Display until August 29, 2006
D 9>



U.S.A. \$6.99

WOOD

September 2006, Issue 171

PROJECTS

- 8 wine-bottle holder
 - 30 orbital sander rest
 - 36 frame-clamping jigs
 - 38 heirloom bookcase
 - 54 tabletop curio case
 - 60 intarsia eagle wall hanging
 - 70 workshop extension tables
- Support workpieces when using your miter saw or mortising machine with this three-part fixture.

TECHNIQUES

- 12 cut sliding dovetails for drawers
- 48 cabriole legs the simple way
- 52 custom color your finishes
- 65 master dados, grooves, and rabbets
Learn the best and cleanest ways to saw or rout woodworking's most common joinery cuts.
- 80 hand-tool skills for power-tool guys
- 89 picture-perfect poly
Follow these techniques for a flawless finish.
- 92 make your clamps work harder
Discover eight tips for successful assembly.
- 101 cutting tenons to a T
Using a tablesaw and mortising machine, see how to mill snug-fitting mortise-and-tenon joints.

TOOLS & MATERIALS

- 34 wise buys: self-sizing dado guides
- 74 tool review: insert-based router lifts
Add accuracy and convenience to your router table.
- 94 three shop-proven products

DEPARTMENTS

- 6 editor's angle
- 8 sounding board
- 16 ask WOOD
- 20 shop tips
- 112 what's ahead



This seal is your assurance that we build every project, verify every fact, and test every reviewed tool in our workshop to guarantee your success and complete satisfaction.



52



70

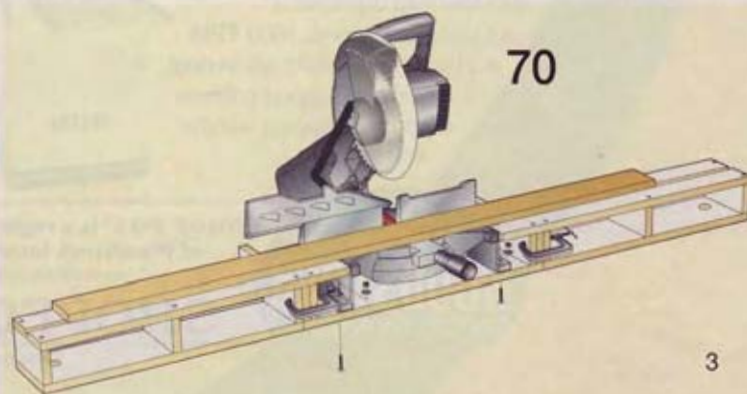

We asked our staff:
What is your favorite joinery method?

The dovetail lap joint lends style to a project. Making one with a router and straight bit is faster than doing it with a hand chisel.



Hand-cut dovetails are strong, flexible in size, and give a piece character. Making them can test one's skill and patience.



Editorial Manager, Tools and Techniques

Executive Editor
JIM HARROLD

Managing Editor
MARLEN KEMMET

Senior Design Editor
KEVIN BOYLE

Techniques Editor
BOB WILSON

Techniques Editor
BOB HUNTER

Projects Editor
OWEN DUVALL

Projects Editor
JAN SVEC

Design Editor
JEFF MERTZ

Master Craftsman
CHUCK HEDLUND

Art Director
KARL EHLERS

Associate Art Director
GREG SELLERS

Assistant Art Director
CHERYL A. CIBULA

Production/Office Manager
MARGARET CLOSNER

Administrative Assistant
SHERYL MUNYON

Photographers **MARTY BALDWIN, SCOTT LITTLE, BLAINE MOATS, JAY WILDE**

Illustrators **TIM CAHILL, LORNA JOHNSON, ROXANNE LeMOINE**

Technical Consultants **JEFF HALL, DEAN FIENE, PAT LOWRY**

Contributing Craftsman **JIM HEAVEY**

Proofreaders **BARBARA KLEIN, IRA LACHER, JIM SANDERS**

CUSTOMER SERVICE: 800/374-9663

For more ways to reach us about specific matters, see page 10.

Publisher **MARK L. HAGEN**

ADVERTISING AND MARKETING

CHICAGO: 333 N. Michigan Ave., Suite 1500, Chicago, IL 60601

Phone: 312/580-7956 Fax: 312/580-7906

Marketing Manager **AMANDA SALHOOT**

Advertising Managers **JACK CHRISTIANSEN, CAROLYN DAKIS**

Direct Response Advertising Representative **RYAN INTERLAND**

Assistants **GAYLE CHEJN, JENNIFER RUGGIERI**

ATLANTA: Navigate Media

1875 Old Alabama Rd., Suite 1320, Roswell, GA 30076

Phone: 678/507-0110 Fax: 678/507-0118

DETROIT: RPM Associates

29350 Southfield Rd., Suite 31, Southfield, MI 48076

Phone: 248/557-7490 Fax: 248/557-7499

BUSINESS DEVELOPMENT

NEW YORK: Concepts Media Group

52 Truesdale Dr., Croton On Hudson, NY 10520

Phone: 914/239-3483 Fax: 914/239-3493

LOS ANGELES: Southcoast Projects

12682 Pacato Circle North, San Diego, CA 92128

Phone: 858/673-0921 Fax: 360/246-5661

Business Manager **JOEL ETIENNE**

Consumer Marketing Director **ROBIN HUTCHINSON**

Assistant Consumer Marketing Manager **BILL WOOD**

Associate Director of Marketing-Newsstand **TOM DEERING**

Production Manager **TIM STOUFFER**

Advertising Operations Manager **LIBBY EHMKE**

Senior Vice President/Publishing Director **DOUG OLSON**

Group Publisher **TOM DAVIS**

MEREDITH PUBLISHING GROUP

President **JACK GRIFFIN**

Finance & Administration **KARLA JEFFRIES**

Manufacturing **BRUCE HESTON**

Consumer Marketing **DAVID BALL**

Creative Services **ELLEN de LATHOUDER**

Corporate Sales **JACK BAMBERGER**

Interactive Media **LAUREN WIENER**

Corporate Marketing **NANCY WEBER**

Meredith
CORPORATION

President and Chief Executive Officer **STEPHEN M. LACY**

Chairman of the Board **WILLIAM T. KERR**

In Memoriam — E.T. Meredith III (1933–2003)

© Copyright Meredith Corporation 2006. All rights reserved. Printed in the U.S.A.



The Toughest Glue On Planet Earth.



I use biscuits wherever appropriate. They're quick and easy to install, strong enough for most applications, and invisible.



Pocket-hole joints take little time and are as easy as boring a hole. You don't need a lot of measuring—just a drill, dedicated jig, a clamp or two, and screws.



Bonds hundreds of materials including wood, stone, metal, ceramic & more! Incredibly strong & 100% waterproof!



1-800-966-3458 • www.gorillaglu.com

The Toughest Tape On Planet Earth.



Extra Thick. Extra Stick.
New Gorilla Tape sticks to things ordinary tapes simply can't.

1-800-966-3458 • www.gorillatape.com

Polyseamseal. As a caulk, it's durable, paintable and stays flexible after drying. Perfect for bathtubs, windows and cabinets. You name it, it'll seal it. Oh, and it's also a great adhesive. See bottom.

It's a caulk.



It's an adhesive.

Polyseamseal. As an adhesive, it's strong, easy to use, and, of course, permanent. It bonds virtually any materials together, permanently. Oh, and one more thing, it's also a great caulk. See top.

editor's angle

Build a project; save your life and another

We woodworkers don't typically think of what we do as a life-saving activity. But by participating in our Build-A-Gift contest, you can extend lives.



WOOD
MAGAZINE

BUILD-A-GIFT
CONTEST

This hasn't been proven in a medical journal yet, but I'm fairly convinced that every hour we spend in the shop extends our lifespans by at least three hours. After all, what's more therapeutic than escaping to our workshops? And while I must admit there are shop moments that actually may deduct a few minutes from our lives—miscalculating a part or applying a finish that doesn't turn out come to mind—these incidents are the exception, not the rule. By and large, shop time melts away any stresses we're experiencing. At least that's my theory, and I'm sticking with it.

But have you ever stopped to consider that you also can extend another person's life by putting in shop time? What's cooler than that? Here's how: Build a gift and enter it in the Build-A-Gift Contest detailed on pages 28 and 29. Your project may win you some great tools or woodworking supplies. And here's where you can help save other lives. After the judging, your project will be sold at auction to raise funds for St. Jude's Children's Research Hospital. Every single dime of the auction proceeds go directly to St. Jude to treat and find cures for childhood illnesses. No family ever pays St. Jude for medical treatment.

To find out more about this worthy charity go to its Web site: stjude.org. For a full list of prizes (the \$5,000 top prize from Peachtree Woodworking Supply, for example, consists of too many items to show in the ad) go to woodmagazine.com/contest. There are 25 ways for you to win.

Start building today

Your entry is due to us November 1, but I encourage you to get into the shop now. From my experience as a judge in past

contests like this one, I know that the top entries were well-planned and carefully built, with a well-cured finish that took several days or weeks to apply.

Here are some more tips to keep in mind: There are separate prizes for projects from *original designs* and projects from *existing plans*. For the originally designed projects, the judges will be looking for creativity, pleasing style, and functionality. If you build a project from an existing plan, make sure it's a well-thought-out one, and then execute it to your best ability. The judges look for well-fitted joints, good grain matching, and—no surprise here—a gift they would like to receive or give themselves. Just remember that your project has to fit into a box no larger than 2x2x3'.

In years past I've been amazed by the outpouring of incredible projects that readers built for *WOOD* magazine contests, and this year I'm sure you'll come through for the kids at St. Jude. We'll showcase all of the winning projects in the February/March 2007 issue.

Best of luck. I can't wait to see what you send in.

Bill Kier



sounding board

Our bulletin board for letters, comments, and timely updates

Holy mackerel, another wine bottle holder

We keep coming across interesting wine bottle holders. Here's one more, designed by Eric Jorgensen of Chesapeake, Virginia. Eric asks that you only make a few for gifts using his design. (He sells a full line of functional wood items through the Abacus gallery in Portland, Maine; 800/206-2166, or visit abacusgallery.com.)

Begin with a $\frac{3}{4} \times 4 \times 12$ " piece of scrap. (Eric likes to use exotic woods; the one pictured at *right* is made from gonzalo alves.) Apply the pattern from the *WOOD* Patterns® insert. Now, drill the $\frac{1}{2}$ " through-hole, and the $\frac{3}{16}$ " hole $\frac{3}{8}$ " deep on

the top side for the eye. (Order the yellow eye no. 8865, \$.79 for two eyes, from Meisel Hardware Specialties, 800/441-9870, or go to meiselwoodhobby.com.)

Next, rout a $\frac{3}{16}$ " chamfer around the large hole on both sides. Cut the 45° bevel at the end of the tail. Except for the mouth, scrollsaw the fish to shape. On your router table, rout the $\frac{3}{16}$ " round-over on the edges of the fish. Follow that by cutting the mouth, sanding, and finishing. Friction-fit the eye in place.

—WOOD editors



Article update

Issue 166 (November 2005)

• If you're building the hall table on pages 60–64 and using one of the alternate joinery methods, cut the four aprons (B, C) $1\frac{1}{2}$ " shorter than specified in the plans. (Essentially, you would be cutting off the tenons.) Be sure to cut to length before laying out the arc. All other measurements and steps remain the same.

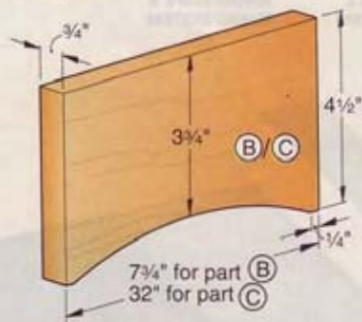

Think inside the box for Build-A-Gift contest

Projects created for the Build-A-Gift contest should fit into a box no bigger than $2 \times 2 \times 3$ ". An announcement in issue 170 (June/July 2006) incorrectly stated " $2 \times 2 \times 3$ in." The Build-A-Gift contest, sponsored by *WOOD*® magazine, will auction off all project entries to raise money for St. Jude Children's Research Hospital, and prizes will be awarded in 24 categories, including \$5,000 of tools and accessories for the Grand Prize. For more information, see *page 28*.

Felt-good story of the year

Your article on working with felt in issue 167 (December 2005/January 2006) page 96, caught my interest. I submit that scissors—no matter how sharp—are a poor choice for cutting felt. After much trial and error, I stumbled onto using my wife's rotary fabric knife (available at any fabric store). As shown at *right*, it works great when used alongside a thick straightedge. No more stretching the felt out of shape, or uneven cuts.

—Norm Streeter, Waldport, Ore.

To trim felt or other fabric (such as velvet used to line jewelry boxes) with a rotary cutter, lay the material on a blade-absorbing rotary cutting mat. Mark where you want to make your cut, and then line up your straightedge over the marks. (We used a thick, wide acrylic ruler found at fabric stores.) Now, with the exposed blade face flush to the straightedge and just off the



fabric, press on the handle to protrude the sharp cutting edge. Run the wheel along the straightedge, severing the fabric.

—WOOD editors

Close ceiling with shortcut

I read the Shop Tip for enclosing a basement ceiling in issue 168 (February/March 2006), but found a quicker way to do it. I enclosed my basement ceiling by nailing 3"-wide strips of hardboard to the bottom edge of the floor joists, leaving $\frac{3}{4}$ " extended on each side. Then I placed acoustic ceiling tiles on the top side of the strips for an attractive ceiling that won't need paint.

—Adeline Koebel, Manitowoc, Wis.

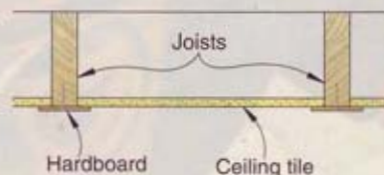

continued on page 10



Bored physicist “turns” into woodworker

I'm a 78-year-old retired physicist who decided to get into woodturning because I became bored with retired life. The first project on my new mini-lathe was the holiday ornament from issue 166 (November 2005), page 52.

Making them out of walnut and chestnut, I combine carving and painting,

my other favorite hobbies, with turning to make them more decorative and unique. So far I have made 17 ornaments, but change each one slightly. I have added a

second pine tree to some, an angel on top of one, and three with a cross inside in place of the tree.

—Paul Long, Friendsville, Tenn.

An attractive solution

Many of you have told us that you can't find the magnetic bases featured in the Shop Tip of issue 167 (December 2005/January 2006), page 32. No longer! You can buy them at Woodcraft for \$21 each, no. 128398. Call 800/225-1153, or visit woodcraft.com.

—WOOD editors



Reader improves Top Tip

I liked Jonathan Leavy's Top Shop Tip on how to square your miter gauge in issue 167 (December 2005/January 2006), page 30, but it will only work if the edges on your test piece are perfectly parallel. I found a quicker way. To be accurate, the test cuts need to be referenced from the same

straight edge of the workpiece, as shown below. The best way to do this is to make the first cut—with the blade's height equal to half the board's thickness—in the middle of a test piece; then flip the board end for end instead of edge for edge. Finally, make the second cut to check for square.

—Reinhold Weindel, Taylor, Pa.

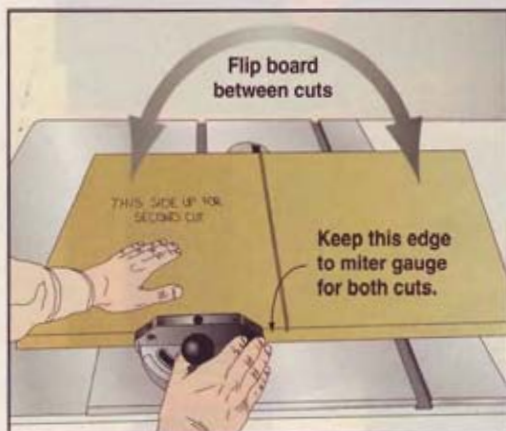

HOW TO REACH US

■ For woodworking advice:

Post your woodworking questions (joinery, finishing, tools, turning, general woodworking, etc.) on one of 20+ online forums at woodmagazine.com/forums.

■ To contact our editors:

Send your comments via E-mail to woodmail@woodmagazine.com; or call 800/374-9663 and press option 2; or write to WOOD magazine, 1716 Locust St., LS-221, Des Moines, IA 50309.

■ Subscription assistance:

To notify us of an address change, or to get help with your subscription, go to woodmagazine.com/service; call 800/374-9663 and press option 1. Outside the U.S., call 515/247-2981. Or write to WOOD magazine, P.O. Box 37439, Boone, IA 50037-0439. Please enclose your address label from a recent magazine issue.

■ To find past articles:

See our index at woodmagazine.com/index.

■ To order past issues and articles:

Order past issues of WOOD magazine, our special issues, or downloadable articles from issue 100 to present: Visit our online store at woodmagazine.com/store, or call 888/636-4478. Some issues are sold out.

■ Updates to previously published projects:

For an up-to-date listing of changes in dimensions and buying-guide sources from issue 1 through today, go to woodmagazine.com/editorial.

cut sliding dovetails for durable drawers

Dovetail construction symbolizes quality woodworking for good reason: Its locking parts produce a mechanically strong joint built to last. By adding sliding dovetails to your drawers, you achieve that strength while sidestepping the time and experience needed to hand-cut through dovetails or the jigs needed to machine half-blind dovetails.

To guide you through the steps for cutting sliding dovetails in your own projects, we'll use the drawers from the bookcase on page 38 as an example. You also can use this joint for applications as varied as locking the ends of shelves to the sides of a bookcase or partitioning a box.

First, organize your cuts

When cutting the drawer front, back, and sides, make the sides $\frac{1}{8}$ " wider than their final width. This extra margin allows you to remove any router-bit tear-out on the sides prior to assembling the drawers. Save scraps the thickness of the sides and fronts to test your router table settings.

Start by labeling your drawer front, sides, and back, as shown below, plus the inside surfaces and top edges on each

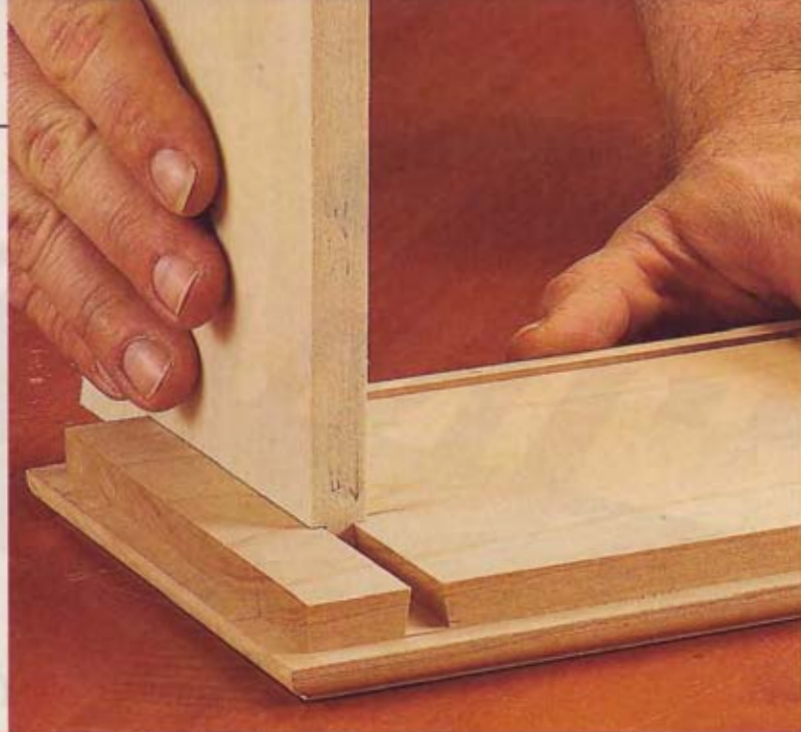
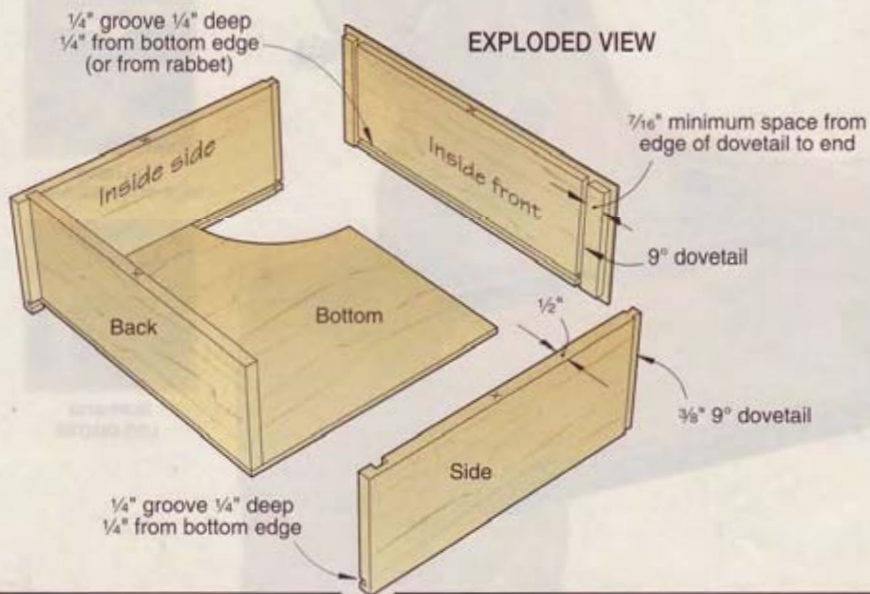

piece. Then mark the dovetail centerlines on the back of each drawer front.

Give your bit a little relief

Ease the strain on the dovetail bit, and keep chips from packing into the dovetail slot, by first cutting a relief kerf at the dovetail slot centerline, as shown in **Photo A**.

Set the blade height to $\frac{3}{16}$ " for a $\frac{3}{8}$ "-deep dovetail in $\frac{3}{4}$ " stock. For thicker drawer fronts, dovetail depths can be cut up to half the thickness of the part. Back up your relief cut with a sacrificial pushblock.

Speed up your setup

Now you're ready to rout the dovetails. First, divide the maximum width of the dovetail bit in half. Then subtract that from the distance between the dovetail center-

lines and the drawer ends to determine the distance from the fence to the edge of the dovetail bit.

On the bookcase drawers, for example, half the width of the $\frac{3}{8}$ " dovetail bit would be $\frac{3}{16}$ ". Subtract $\frac{3}{16}$ " from the centerlines marked $\frac{1}{4}$ " from the drawer end, and set your router table fence $\frac{1}{16}$ " from the outer edge of the bit, as shown in **Photo B**. As a rule of thumb, leave at least $\frac{7}{16}$ " between the edge of the dovetail and the end of the



continued on page 14

SLOW PASSES LET CHIPS ESCAPE

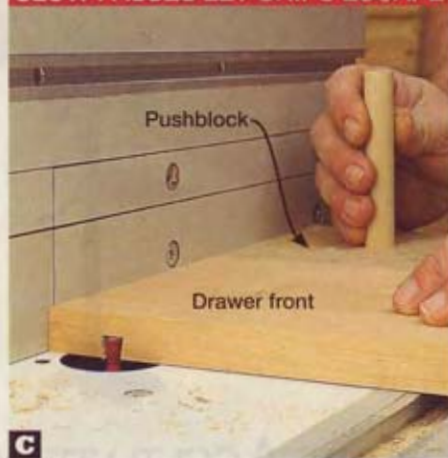

C

CUT DOVETAILED IN THE SIDES



D

drawer front to allow enough stock to reinforce the dovetail.

Again, use a pushblock to stop tear-out when the dovetail bit emerges, as shown in **Photo C**. Slow the feed rate to allow chips to escape through the relief kerf, and use a second clean-up pass if needed.

Now, rout no-fail tails

Leaving the dovetail bit height unchanged, adjust the router table fence so the bit will cut into the face of the drawer sides, as shown in **Photo D**. (You'll sneak up on a perfect fit using scrap.) If the fence has an adjustable bit opening, move both sides as close as safely possible to the bit.

Test your fence setting on scrap the same thickness as your drawer sides. If the dovetail is too thick to fit the dovetail slot, nudge the fence away from the bit by *half* the difference. Make additional test cuts until the dovetail fits snugly within the dovetail slot. Using a push pad and block, cut the dovetail on the front ends of your drawer sides.

SHOP TIP

Cut long sliding dovetail jobs down to size

Sliding dovetails, like those you might cut into the ends of a shelf 12" wide or wider, can produce so much friction during glue-up and assembly that they catch in the dovetail slot. For problem-free assembly, reduce this friction by cutting notches in long dovetails, as shown at *right*, using a bandsaw or coping saw. The notches also capture excess glue to reduce squeeze-out. Leave $\frac{1}{32}$ " of the dovetail to avoid the chance of cutting into the surface.



Make the remaining cuts

To cut a drawer bottom groove between the dovetail slots on the inside of the front piece, first chuck a straight bit in your table-mounted router that's wide enough to accommodate the thickness of the drawer bottom. Then adjust the fence to leave at least $\frac{1}{4}$ " of material between the edge of the groove and bottom edges of the drawer sides and front.

To make a stopped drawer-bottom groove in a drawer front, first mark the location of the bit on a piece of masking tape, as shown in **Photo E**. Lower the drawer front onto the bit so the dovetail slot centers over the two lines, rout the groove, and raise the other end after cutting to the other dovetail slot.

Next, cut grooves the full length of both side pieces to hold the drawer bottom. For our sample drawer, we also cut dados in the sides to accommodate the drawer back. The top edges of the drawer sides can now be trimmed to the parts' final width.

Finally, cut the drawer back piece to a width matching the distance from the edge of the drawer-bottom groove to the top of the sides. If you cut the drawer bottom from plywood, make it $\frac{1}{32}$ " smaller than the maximum dimension between the grooves to allow for expansion. If you make the drawer bottom from solid wood, cut the panel to a snug fit, and orient the grain to run from side-to-side as shown at *right*, not front-to-back.

Glue and assemble the front and sides before adding the drawer bottom and then the back. The solid wood drawer bottom shown in **Photo F** will be glued to the front, but not the sides. A screw through an expansion slot in the drawer bottom attaches it to the back. ⚡

MARK THE BIT LOCATION ON TAPE

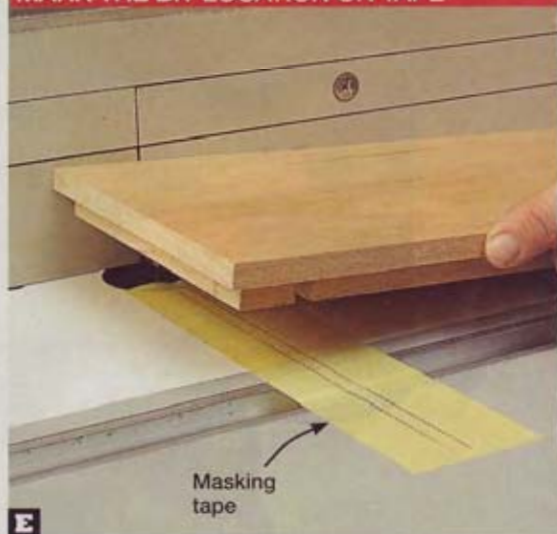

E

SLIDE IN THE DRAWER BOTTOM



F

ask wood

Answers to your questions from letters, e-mails, and *WOOD* Online®

Got a question?

If you're looking for an answer to a woodworking question, write to **ASK WOOD**, 1716 Locust St., LS-221, Des Moines, IA 50309-3023 or send us an e-mail at askwood@woodmagazine.com. For immediate feedback from your fellow woodworkers, post your questions on one of our woodworking forums at woodmagazine.com/forums.

Hide sapwood with dye

Q: I'm working with a wide piece of walnut that has sapwood on one edge. Is there a good way to stain the sapwood to match the heartwood?

—Ken Johnson, Lancaster, Pa.

A: Use dye instead of stain to equalize heartwood and sapwood color differences, Ken. Unlike most stains, dye doesn't have pigments that settle into wood pores, thus emphasizing them. You can easily lighten or darken dye for a close color match. For the walnut part shown at right, we used TransTint dark walnut dye (Woodcraft no. 128485, \$17, 800/225-1153 or woodcraft.com), but you also can use brown mahogany (no. 819064). Mix 1 teaspoon of dye in 1 cup of water, then test your dye color on sanded pieces of scrap sapwood. Add water or dye to the mix to lighten or darken the color until you get a match close to the color of heartwood moistened with a damp cloth. Don't worry about making a perfect color match; wood naturally has slight color variations.

Now, on your workpiece, moisten the adjoining heartwood to preview the color the wood will turn once it's finished. This



also blocks the dye from bleeding into the heartwood. Then moisten a towel with dye and press out the excess. Wipe the dye onto the sapwood, working with the grain. To

blend the edges of the dyed area with the heartwood, wipe them with a moist cloth. A light sanding with 220-grit abrasive will knock down raised grain.

Dinnertime dilemma

Q: I get so grossed out with working in my garage workshop that I sometimes miss a hot supper when my wife calls and I can't hear her. I tried a wireless doorbell, but that's not loud enough. Is there a way to make a wireless remote light?

—Bob Parsons, Maplewood, Minn.

A: When the sound of the tablesaw drowns out the growling of your stomach, let a wireless switch connected to a lamp in your shop call you to dinner, Bob. Among those available are two through Amazon.com (no. B00008X5D5, \$16, or no. B0006GYCIO, \$40). Both work up to 100 feet, depending on the number of walls and metal obstructions between the transmitter and receiver.

Plug a lamp into the receiver and the receiver into the workshop wall outlet closest to your house. Then place the lamp where its light will be noticed. By pressing the on and off buttons on the keychain

transmitter, your wife can send you a supper signal. Or to really get your attention, plug in a rotating beacon such as the one shown below, or a strobe light. Both are available at novelty stores.



The skinny on plywood

Q: I am looking for true 1/4" birch plywood for some flat-panel doors I'm making. My rail bit cuts a slot that's exactly 1/4" wide, and undersize plywood moves around in the slot. Can anyone direct me to dealers who supply true 1/4" plywood?

—Tony Leone, Wesley Chapel, Fla.

A: Part of your difficulty is that your bit was meant to cut dados for solid wood panels sized to 1/4" thick, Tony, not for plywood. If you work with plywood frequently, consider supplementing your two-bit stile-and-rail set with a bit that cuts just the rail and stile profiles, and a set of straight bits sized to common plywood thicknesses for cutting panel slots. The profiling bits require added setup time, but allow you to control the distance from the profile to the slot and the width of the panel slot.

You're unlikely to find true 1/4" birch plywood because commonly available imports come in metric sizes. A 6mm thickness comes close to 1/4" at .2362". However, some suppliers also market 5mm plywood, or .1969", as 1/4" plywood. In our shop, 1/2" Baltic birch measures about 12mm, or .4724".

For construction-grade plywood, the following sizes are common: 3/8, 7/16, 15/32, 19/32, and 23/32". For these sizes, straight bits like the one shown below can cut dados for plywood in such sizes as 7/32 or 15/64 (for 1/4" plywood), 11/32 (for 3/8"), 15/32 or 31/64 (for 1/2"), and 23/32 (for 3/4").

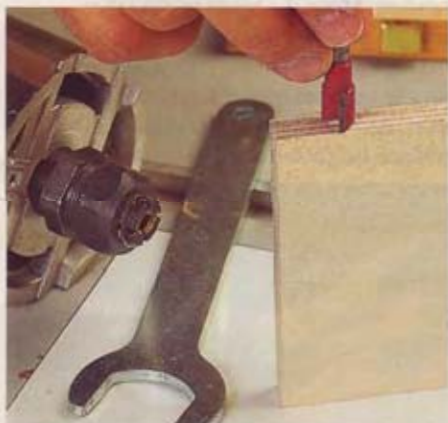

Plywood bits cut dado widths that match common plywood thicknesses. Freud offers a set of four with 1/4" (#90-106) or 1/2" (#89-650) shanks; 800/334-4107 or freudtools.com.

continued on page 18

The Ultimate Dust Collectors!

BALDOR
MOTORS • DRIVERS • GENERATORS
Pro 2000



Shown with Optional Angle Iron Stand & 55 Gal. Drum.

New! **Pro Series 1500 & 2000**

Oneida redesigned their award-winning 2 & 3hp Commercial systems into the new and more powerful Pro Series 1500 & 2000!

- ▶ More CFM
- ▶ Heavier Gauge Barrel
- ▶ Filter Efficiency Gauge
- ▶ Magnetic Starter
- ▶ Square-to-Round Inlet
- ▶ Heavy-Duty Wall Bracket
- ▶ 5-Year Warranty
- ▶ Internal Silencer

2 & 3hp Dust Gorillas

See CFM test results on our website.

Editor's Pick

American Woodworker - Jan. 2006

"Its new Gorilla line delivers top performance at a competitive price."

Our 3hp Gorilla tested in a class by itself with the most airflow (CFM). Our 2hp Gorilla tested with more CFM than the 3, 2.5 and 2hp competitors except for one 3hp unit.



BALDOR
MOTORS • DRIVERS • GENERATORS
3hp Super Gorilla

Patent Pending Internal Silencer

Shown with Optional Angle Iron Stand.

See Us at
IWF 2006
Booth 6765
Aug. 23 - 26

- ▶ 1.5 - 30hp Systems
- ▶ Ready-to-Ship Ductwork
- ▶ Ductwork Design Service
- ▶ Outstanding Filtration
- ▶ Superior Customer Service
- ▶ Dust Collection Since 1993

D-I-Y unit and hose packages available.



Sander, Hoses and Shop Vacuum not included.

Patent Pending

Dust Deputy™

Turns your shop vacuum into a cyclonic vacuum. Sand for hours without having to clean your filter!

Order On-Line!

www.oneida-air.com

Call Today for **FREE** Brochure!

1.800.732.4065

Keep batteries at their peak

Q: Our sons have given me a number of cordless tools, but when I want to use one of them, the batteries soon run low because they've lost their charge sitting on a shelf. Is there a way I could plug the chargers into a power strip, and then plug the strip into a timer to charge the batteries, say for 30 minutes every day? Or would that harm the batteries?

—Robert Jesse, Moweaqua, Ill.

A: That approach is a crude version of what some tool battery chargers do automatically, Robert, and it could work if left on long enough each day to fully recharge the battery. Leaving a battery in an unplugged charger shouldn't create problems for either the battery or charger.

However, a check of your tool owner's manual may make all of this unnecessary. More expensive cordless tools usually come with high-end features, such as chargers like the one shown at right, that bring a battery up to full charge and feed it a maintenance, or "trickle," charge as needed.

Other tool manufacturers discourage leaving batteries in unattended chargers for long periods. A charger malfunction could result in the battery going into continuous overcharge and becoming overheated. Only the owner's manual for your tools can specify whether continuous charging is right for you.



The ARROW[®] Machine ETFX50™

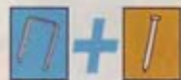

XTRA HEAVY DUTY
Professional

XCEPTIONAL COMFORT
Cushioned Grip

XPERT PERFORMANCE
Drives 6 Different Size
Staples+Nails

XTRAORDINARY POWER
14 Amps of Surge Power

XCITING DESIGN
New Ergonomic Styling



... It's what
you've come to
XPECT from Arrow!



Keeping America Strong

Available at home centers, lumberyards, and fine hardware stores wherever professional tools are sold!



Arrow Fastener Co., Inc., 271 Mayhill Street, Saddle Brook, New Jersey 07663
Canada: Jardel Distributors, Inc., 6505 Metropolitan Blvd. East, Montreal, Quebec H1P 1X9
Arrow Fastener (UK) Ltd., Unit 5 ZK Park, 23 Commerce Way, Croydon CR0 4ZS, Surrey, United Kingdom
www.arrowfastener.com ©2002 Arrow Fastener Co., Inc. Rev 102

Hinges hit a sour note

Q: Installing a long piano hinge generally frustrates me. Surely there's a simple, surefire method that will ensure the hinged parts are aligned so the surfaces of both pieces are level with each other. Got any suggestions?

—Charles Cottingham, Columbia, Mo.

A: The hinge itself can solve your alignment problems, Charles. To start, mark both workpieces where one end of the hinge will be located. Then open the hinge so its barrel is on the outside of an L formed by the two leaves. Lay the hinge on a workpiece with one end against your hinge-end mark and a leaf resting along the edge, as shown below. Press the other leaf flat against the top surface and clamp the hinge firmly in place. Place the tip of a self-centering Vix drill bit in the hinge leaf holes, and drill pilot holes at each screw location. Move the hinge to the other workpiece where it will later be mounted, and repeat the process. This way, the two outside surfaces mount level with each other, and the hinge barrel rides at a uniform height between both parts.

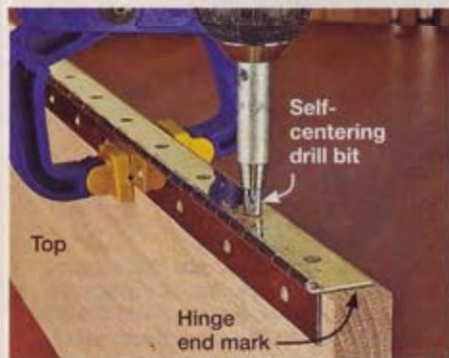

Remove the twist when cutting half-round molding

Q: I'd like to slice some dowels in half lengthwise to make half-round molding. But when I tried a test cut at the bandsaw, the stock wanted to twist. How can I get a clean cut?

—Felipe Juarez, Houston

A: As you've discovered, Felipe, the trick is guiding the dowel without twisting. The jig shown here is easy to make and serves as both a splitter and stabilizer behind the blade. Simply screw a piece of metal slightly thinner than the blade to a wooden block, and clamp it to the bandsaw's rip fence. To place the metal plate in line with the blade, make the thickness of the block just under half the diameter of the dowel you're cutting.

A nailing plate attached to a wood strip keeps dowel stock from twisting as you slice it lengthwise.



woodmagazine.com

19

SUBSCRIBERS: PLEASE NOTE!

Many of our customers are mail-order buyers. These consumers are interested in receiving offers for other products and services from our company (Meredith Corporation) and for products and services offered by other reputable companies.

In order to promote our other products, we retain your name and address in a prospective customer file. We also provide that name and address to other reputable companies who offer products we consider to be of value and interest to our customers.

However, we also respect the rights of those customers who prefer not to receive additional mail-order offers.

Should you prefer to have your name restricted, please fill out the coupon (below), clip it out, and mail it to the address shown. Please be sure to indicate whether you wish to restrict all offers or just those from other companies.

- I will accept offers from Meredith Corporation only.
- I prefer not to receive any offers.

Include a current magazine address label with this coupon, and mail your request to:

Magazine Customer Service
P.O. Box 10263
Des Moines, IA 50336-0263

YOU'RE PROBABLY JUST AS AMBITIOUS.



Circle No. 733

Adjustable "Jorgensen" "Pony"

Made in the USA by the Adjustable Clamp Co.,
433 North Ashland Ave., Chicago, IL 60622.

www.adjustableclamp.com

Whether you are a do-it-yourselfer, a professional woodworker or somewhere in between, you have a world full of projects in the home or in the shop that will be easier and more enjoyable to complete when you use quality clamps, bench vises and miter boxes/saws from the Adjustable Clamp Company. Look for them under the Jorgensen, Adjustable and Pony brand names wherever fine tools are sold.



Circle No. 733

shop tips

Helping you work faster, smarter, and safer

Steady-as-she-goes biscuit-joiner jig

I love the convenience of my biscuit joiner for mounting face frames on cabinets. But I always found it awkward to keep its fence flat on the workpiece while plunging the cutter. I solved both problems by adding an oversized base with a handhold, as shown below. With the base installed, I use my left hand to keep the biscuit joiner aligned, and my right hand to plunge the cutter. For smaller workpieces, I mount the base upside down in my bench vise.

I sized the base shown for my DeWalt biscuit joiner. You may have to change the width and location of the joiner

mounting holes to suit your tool. To avoid splinters, be sure to ease the edges of the plywood bed and handhold.

—Earl Eliason, Pagosa Springs, Colo.

Most biscuit joiners have mounting holes predrilled in the bed. If yours doesn't, find two flat spots on the bed where a raised bolt-head won't interfere with the joiner's operation. Locate your bolt positions on the bottom of the bed and dimple both locations with a punch to limit drill-bit travel. As you drill the holes, lubricate the bit frequently with light machine oil. Before you drill, remember that altering the tool may void your warranty.

—WOOD Editors

top shop tip

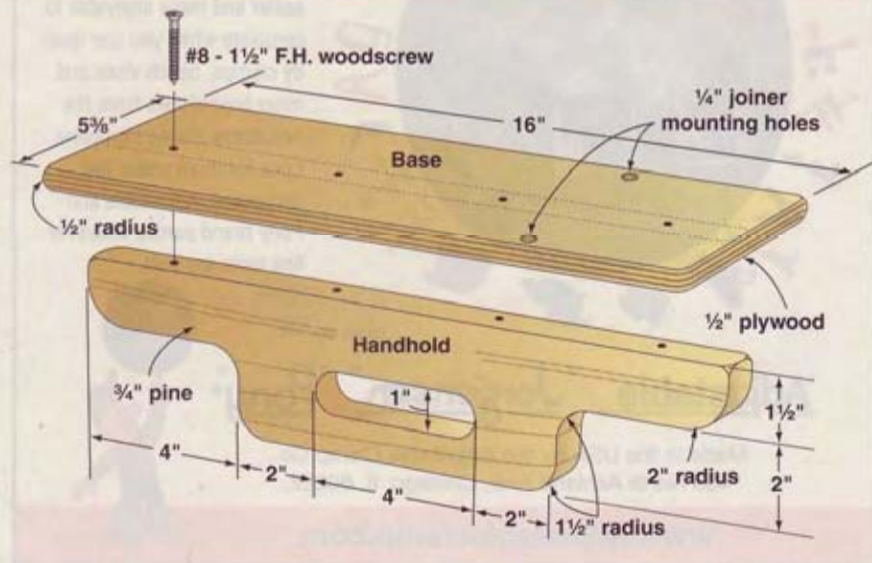
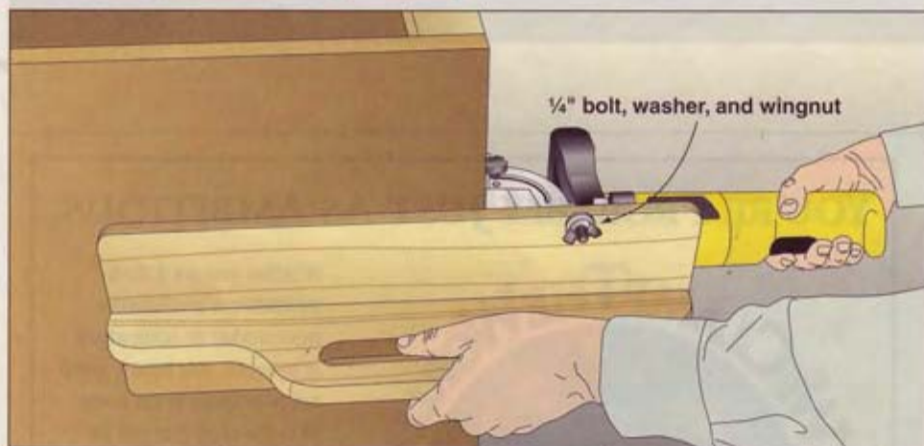

continued on page 23

The Top Tipster



Photo: Art Franz

Between careers in the military and electronics, Earl Eliason figures he's lived in 27 different places during his lifetime. For the past eight years, though, our Top Shop Tip winner has set up shop in a log cabin in tiny Pagosa Springs, Colorado. "I can see the Continental Divide from my front window, and there's great fishing just a quarter-mile away," he boasts. Through all the moves, Earl has held onto his first woodworking project: a smoking stand (shown above) he made when he was 14 years old.



For submitting the best Shop Tip of this issue, Earl Eliason earns a Grizzly G0459 12" benchtop drum sander. Excellent, Earl!

Top tips earn tools!

Describe how you've solved a workshop stumper, and you'll get \$75 if we print it. And, if your tip garners Top Shop Tip honors, we'll also reward you with tool treasures worth at least \$250.

Send your best tips, along with photos or illustrations and your daytime phone number, to: **Shop Tips, WOOD Magazine, 1716 Locust St., LS-221, Des Moines, IA 50309-3023.** Or e-mail tips to: shoptips@woodmagazine.com. Remember to include your contact info in the e-mail as well.

Because we publish only original tips, please send your tips only to **WOOD** magazine. Sorry, submitted materials can't be returned.

Positive stop for a squirrely sanding table

I make small toy parts that require a great deal of accurate sanding. For that accuracy, I use a 1"-belt/6"-disc sander that, unfortunately, uses small, hard-to-tighten wing nuts to secure the table. If a nut works loose, which happens frequently, the table slips down. To solve the problem, I created a carriage-bolt support post for the table, as shown below, that keeps the table perpendicular to the disc.

To make the support post, cut a 1" wide strip of scrap wood about as long as the table to house the post. Install a 5/16" T-nut in the bottom of the strip, as shown, and add the bolt, wing nut, and washer. Finally, glue and screw the strip to the sander's base.

After locking the table square to the disc, turn the carriage bolt until it rests on the underside of the table. Then, lock it in place by tightening the wing nut against the washer and strip.

—John Shaw, Falmouth, Mich.

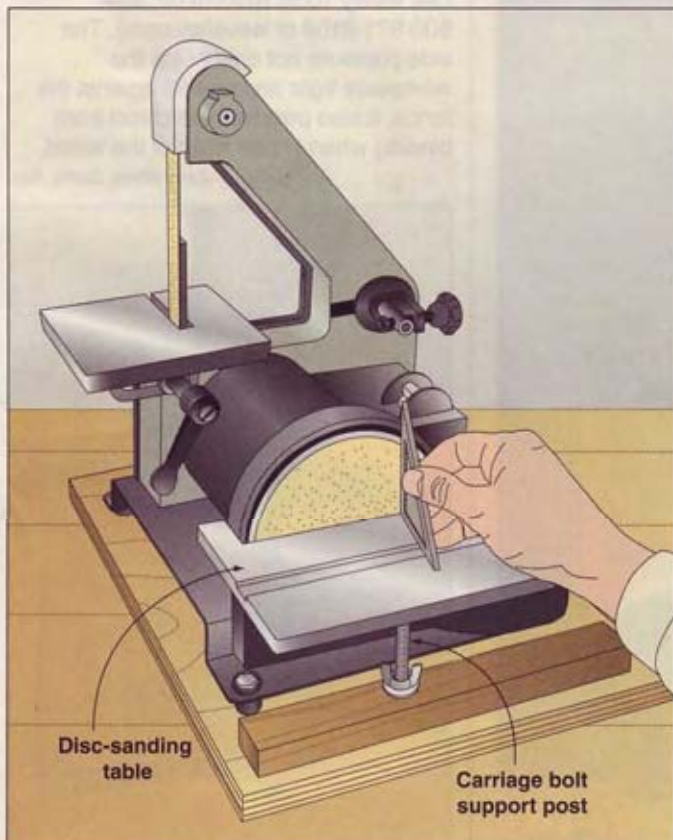
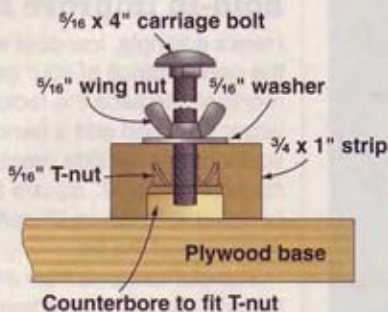

continued on page 24

GENERAL INTERNATIONAL
3/4 HP Dust Collector
#10-060
Designed specifically for smaller shops.
Wall mounted unit frees up valuable shop floor space.
Compact design with built-in 1 micron filter.
Clear re-usable collector bag.
Quick-release bag clamp for easy bag replacement with no tools or other help required.
Optional Hook-up kit Item # 10-065
WWW.GENERAL.CA
Circle No. 1954

BED POSTS & FINIALS

Osborne Wood Products, Inc. offers a variety of bed posts and a selection attractive finials to top them off.

#2600NC Rice Post
#2600 Carved Rice Post
#2500 Pencil Post
#2000 Cannonball
#2001 Cannonball
Heritage Finial
Shaker Finial
Fence Post Top
Mirror Top

CALL FOR A CATALOG:
1.800.481.2307
ORDER LINE:
1.800.849.8876
www.osbornewood.com
4620 GA Highway 123 • Toccoa, GA 30577 • Email: turn@alltel.net

No hang-ups with this shop-vacuum hoop skirt

I got tired of my shop vacuum catching on every machine in my shop as I pulled it across the floor. Frequently, the hose would pop loose and add to the frustration. So I took a lesson from amusement park bumper cars and constructed a hoop around the casters. Now the vac bounces off obstructions. Build the three-ply hoop, as shown, and screw or bolt it to the caster housings. Then take your newly remodeled vacuum out for a spin around the shop.

—Jack Hirtlinger, Davidsonville, Md.

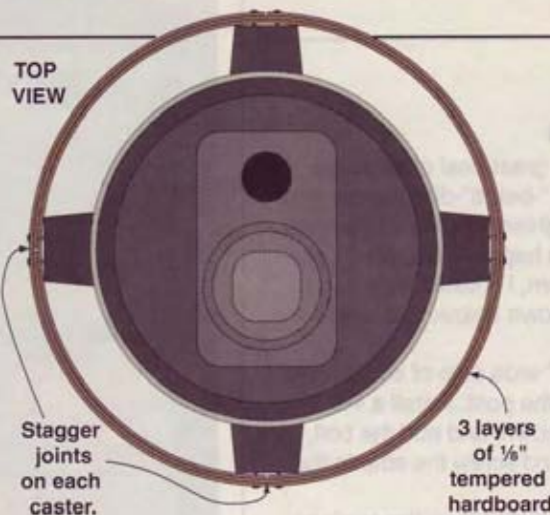

EXPERT SHARPENING

Woodworkers know how important a sharp drill bit is for keeping projects split, chip, and error-free. And when you Work Smart, you know the best way to Work Sharp is with the Drill Doctor drill bit sharpener.

In addition to all its other features, Drill Doctor's exclusive Quad Cut™ split point not only helps you cut faster than with standard bits, it also prevents drill bit "wandering" to keep your materials in pristine condition. Better sharpening means better projects. Every time.

- ✗ Sharpens 3/32"–1/2" standard-twist bits
- ✗ Sharpens high-speed steel, masonry, carbide, cobalt, and TiN-coated bits
- ✗ Sharpens and creates Quad Cut™ split-point bits for faster penetration and less drill bit "wandering"
- ✗ **NEW!** Simplified alignment and sharpening procedures
- ✗ **NEW!** Variable Alignment lets you adjust chisel and relief angles
- ✗ User-replaceable diamond sharpening wheel
- ✗ Durable construction

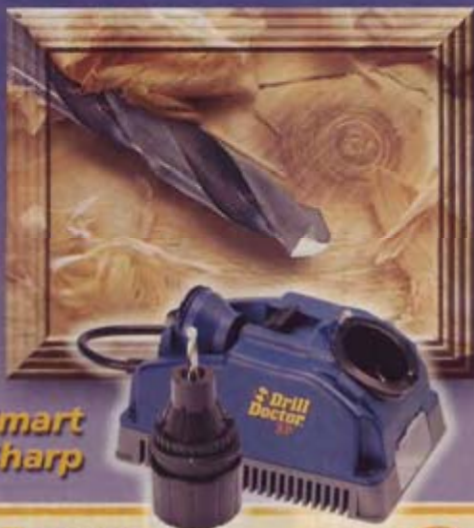

(Features apply to model XP shown)

**Work Smart
Work Sharp**

OVER
2
MILLION
SOLD

Drill Doctor
The Drill Bit Sharpener

Full
THREE 3 YEAR
WARRANTY

Look for the Drill Doctor at Sears, The Home Depot, Lowes, Ace, Woodcraft, Rockler, and wherever you buy your tools.

1-888-MYDRILL (693-7455) • www.DrillDoctor.com

Circle No. 1511

Oversize table and hold-in improve mortiser

Here's a simple, low-cost way to improve the performance of your benchtop mortiser. Replace the factory table with a larger one, and add a bench-dog type screw clamp for side pressure. I made my MDF table 12" square and drilled the bench dog holes on 2" centers on the centerline of the bit.

The clamp came from my mitersaw, but you can get something similar from Lee Valley Tools (05G10.02, \$24, 800/871-8158 or leevalley.com). The side pressure not only holds the workpiece tight and square against the fence, it also prevents the chisel from binding when I raise it out of the wood.

—Larry Hayes, Olathe, Kan.

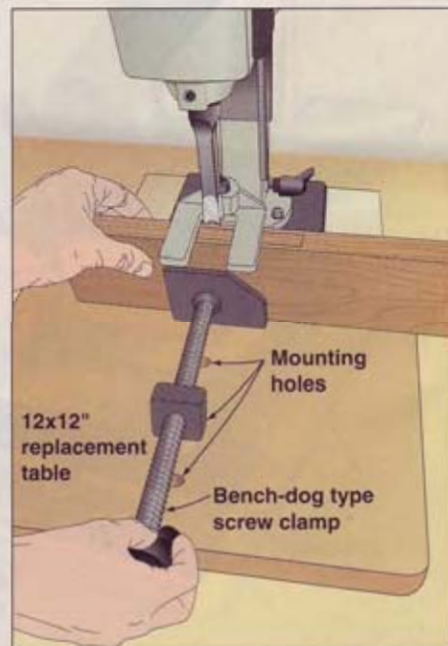

continued on page 26

Self-cleaning lathe tool storage

I like to have my lathe tools close at hand, so I found a way to mount 12"-wide wire closet shelving to my lathe stand. The plastic-coated stuff is available at every home center, and when installed upside down, it keeps lathe chisels from rolling off the shelf.

After finding where the front-to-rear splay of the legs of my stand equals 11½"—the distance between the outer bars of the shelving—I marked that height on all four legs. Then I cut the shelving to the length between those marks, leaving an extra 1" or so of edge bar and shelf-base bar on each end. On most lathes you'll probably have to loosen at least one leg on the stand to slip the shelving into place. After that, gravity and the splayed legs keep the shelf in place.

On lathe stands without splayed legs, you could drill holes in the stand just underneath where the shelf will rest, and then insert ⅜x1" hex head bolts, nuts, and lock washers. The bolt heads will support the shelf ends. ♣

—Bob Zajicek, Marietta, Ga.

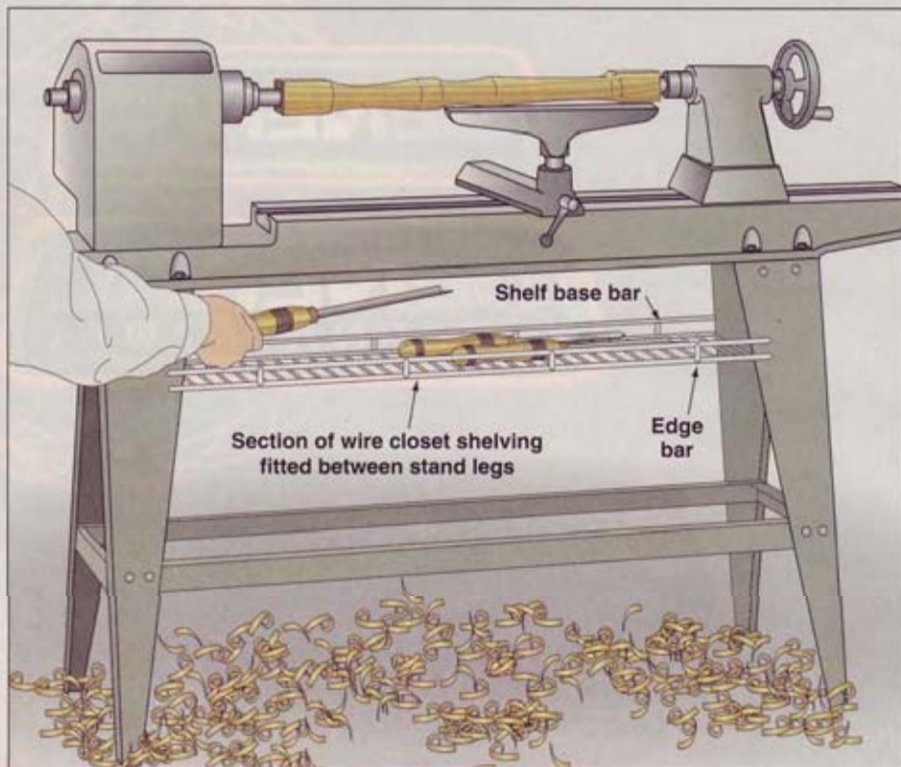

Starting at \$9,995!

Unmatched Quality, Performance, and Reliability.

CO₂ Laser Engraving, Cutting, and Marking Systems

Adding engraving capabilities to your business has never been more affordable. Engrave and cut photos, clipart, logos and more - and it's as easy to operate as a printer. Call us today at toll free 888-437-4564 to receive a free brochure, sample kit, and CD demo of the system in action!

Epilog Laser Product Line



Contact Information:
 16371 Table Mountain Pkwy.
 Golden, CO 80403
 Toll Free: 1.888.437.4564
 Phone: 303.277.1188
 sales@epiloglaser.com
 www.epiloglaser.com/bhg.htm

orbital sander rest

Customize our basic design to support your sander.

For Chuck Hedlund, *WOOD*® magazine's Master Craftsman, time is always of the essence. Even the precious few seconds he wastes holding a 5" random-orbital sander until its pad quits spinning add up. And even if you're not in a rush, isn't it a pain waiting for that pad to stop twirling around?

To remedy this situation, Chuck designed and built this benchtop sander rest. After powering down his sander, he immediately places it in the rest. After much testing in the *WOOD* magazine shop, Chuck chamfered the bottom edge of the hole in the top to trap the sander in the opening. Then, he added an upright to catch the sander's dust port and keep the sander from spinning. For sanders with a vacuum attachment (see smaller photo), add the optional support. This holds up the vacuum hose while keeping the sander from tipping over. Use the 1" hole in the base to hang the rest when not in use. 🛠️

Project design: **Chuck Hedlund**
Illustration: **Roxanne LeMoine**



FOR SANDERS WITH DUST BAGS

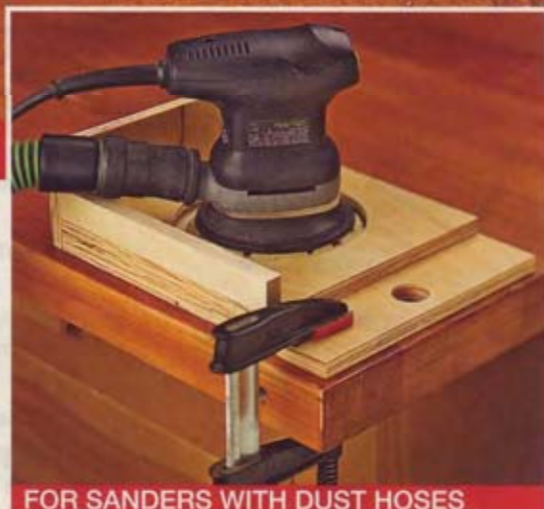

FOR SANDERS WITH DUST HOSES

The optional support at right, works well for the vacuum hose to rest on, preventing the sander from tipping over.

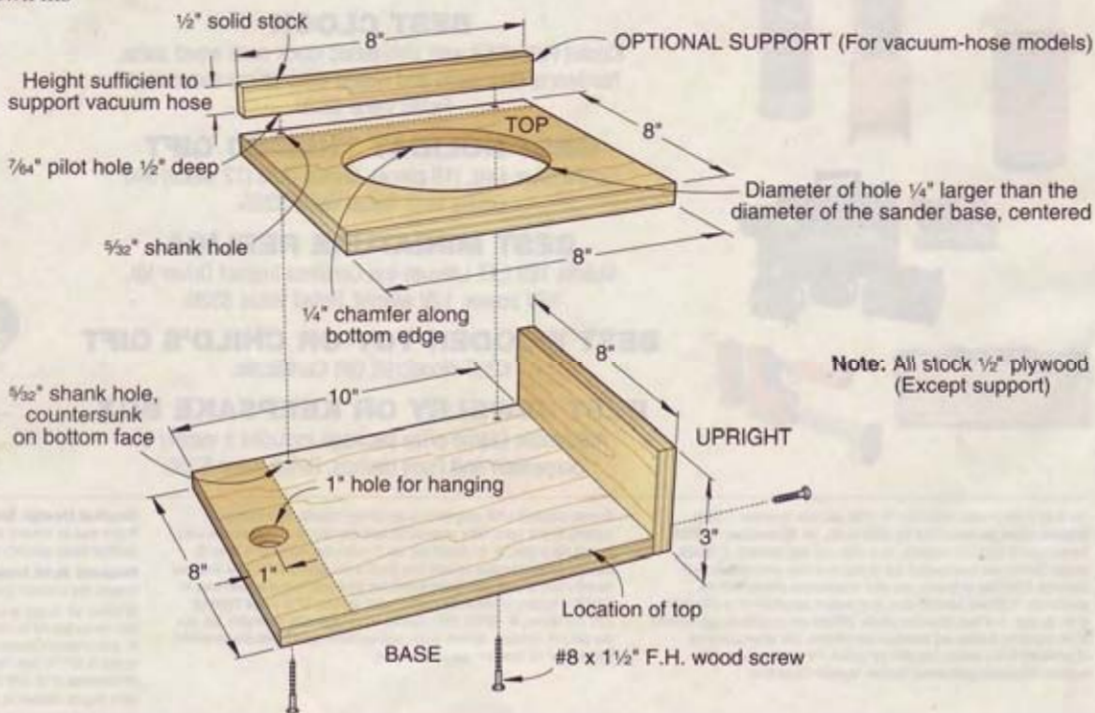

our editors test

self-sizing dado guides

Why buy?

Because plywoods typically measure thinner than their 1/4", 1/2", or 3/4" stated thicknesses, you usually have to rout dados in two passes using a smaller straight bit. (So-called "plywood bits" get you close but can't account for sheet-to-sheet variances.) Routing the first pass is pretty routine: Clamp on a straightedge and rout one edge of the dado. The second pass gets trickier, though. Measuring the difference accurately, moving the straightedge precisely, and keeping it parallel can drive a woodworker half nuts. These router dado guides use a scrap of the plywood to align that second cut precisely without moving the straightedge.

Accurate Guide, \$50

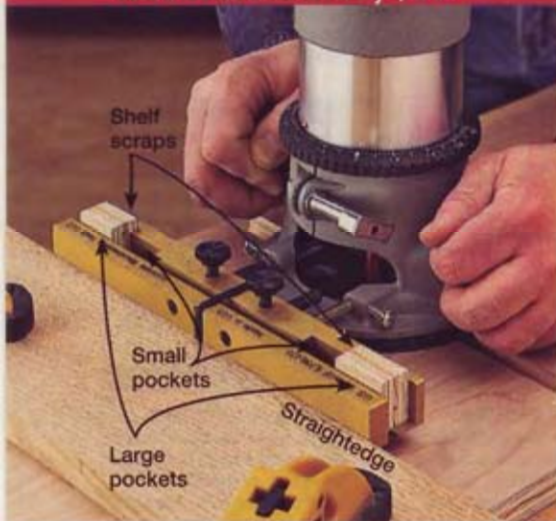

Editor test-drive:

The Accurate Guide uses two small scraps of the plywood shelf to automatically set the spacing between the first and second router passes for a perfect-fitting dado. And the Guide works the way you're probably already routing dados: by simply running your router against a straightedge.

While building a bookshelf for my daughter, I installed the Guide using the fence-rod holes on my router. After positioning my straightedge to account for the distance between the bit and the Guide's fence (no scrap spacer yet), I routed the first pass for the 3/4"-ish plywood shelf with a 1/2" straight bit. Next, I simply inserted two pieces of shelf scrap into the Guide's large pocket-

ets, as shown at left, and routed along the straightedge again, widening the dado. (For dados wider than 1/2", you insert the scrap pieces into the large pockets, as shown; for 1/4"- to 1/2"-wide dados, use the small pockets.)

After making the second cut, I found that the shelf fit the dado almost too well, with no room for glue, so I simply shimmed each scrap piece with a "sticky note" and was satisfied with the fit. Even if you rout dados only a few times a year, Accurate Guide is well worth it, selling for just \$50.

—Tested by Jeff Mertz, Design Editor

To learn more:

920/589-4010; accuratewoodtools.com

DadoWiz, \$160

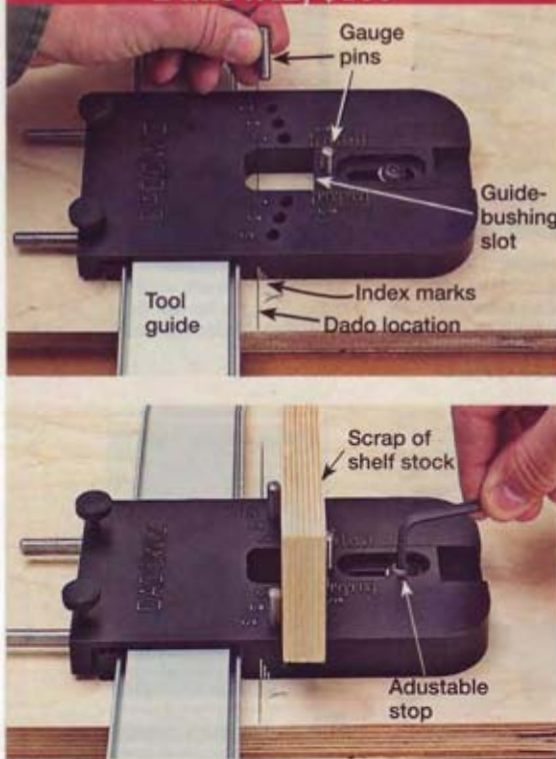

Editor test-drive:

It takes three basic steps to make well-fitting dados with DadoWiz, as I did when building a plywood shelving unit for my garage. First, I fit the jig on my 2 1/8"-wide clamp-on tool guide (it adjusts to fit other clamp-on guides as well) and clamped the guide to my case side. Next, I aligned the dado location to an index mark on the side of DadoWiz—to the long index mark for routing with a 1/2" bit, the middle one for a 3/8" bit, or the short mark for a 1/4" bit. I loved not having to measure from the bit to the edge of the router subbase to position the straightedge.

After installing the three gauge pins on the jig—again, the bit size determines the gauge-pin location—I set the adjustable stop that establishes the width of the dado. To do this, I sandwiched a scrap of the shelf stock between the index pins, locked the stop, and then removed the scrap and pins.

Finally, I installed the supplied 1" Porter-Cable-style guide bushing on my router, and set a straight bit to cut the depth of the dado. With the bushing

See these guides
in action

by visiting our
Web site at
woodmagazine.com/dadojigs



inserted and tight against the left end of the guide-bushing slot, I routed a partial-width dado. Next, I slid the router to the right end of the slot and routed another pass, widening the dado to fit my plywood shelf perfectly.

I also used DadoWiz to cut dead-on dados that fit solid stock I planed to a random thickness. It made no difference whether I used a 1/4", 3/8", or 1/2" bit, as long as the bit was wider than half the thickness of the mating workpiece. The \$160 price tag may seem high, but I can't imagine a faster, more foolproof way to rout perfect-fitting dados.

—Tested by Bob Wilson, Techniques Editor

To learn more:

800/472-6950; woodline.com

no-slip helpers for clamping frames

Avoid a four-clamp juggling act by utilizing two pieces of scrapwood.

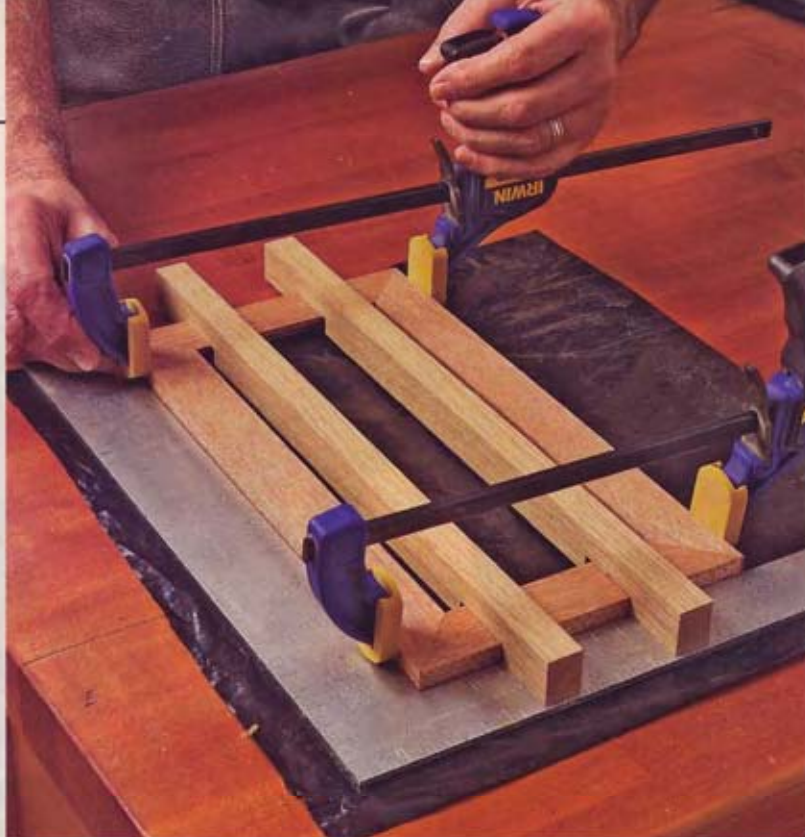

Without a special clamp, gluing up a mitered frame can be an exercise in frustration. First, you'll need four clamps applying just the right amount of pressure in two directions. Then if you squeeze the sides too much, the miters slip, and the ends push out. Now before you can push the ends back into alignment, you'll have to release the side clamps. Back them off too much, and out go the sides. You know the routine.

When gluing up the seven frames that make up the tabletop display case on page 54, Master Craftsman Chuck Hedlund assembled them with ease by making a pair of simple glue-up jigs like the ones shown here. You can make your own to fit any size frame. Here's how.

First, from $\frac{3}{4}$ "-thick scrap, cut two pieces $\frac{1}{2}$ " wider than the thickness of the frame members and 3" longer than the frame sides, as shown at right. Then install a $\frac{3}{4}$ " dado blade in your tablesaw, fasten an extension to your miter gauge, and clamp on a stopblock $1\frac{1}{2}$ " from the blade. Adjust the blade to cut a dado of the depth shown. Now with the jig pieces on edge, cut two dados $\frac{1}{8}$ " wider than the width of the frame members in each piece.

To use the jig pair, apply glue to the frame miters and assemble the frame flat on your workbench, aligning the parts with a framing square. (To protect the workbench, we covered it with a piece of plastic cut from a trash bag.) Then position the jig pieces close to the inside corners,

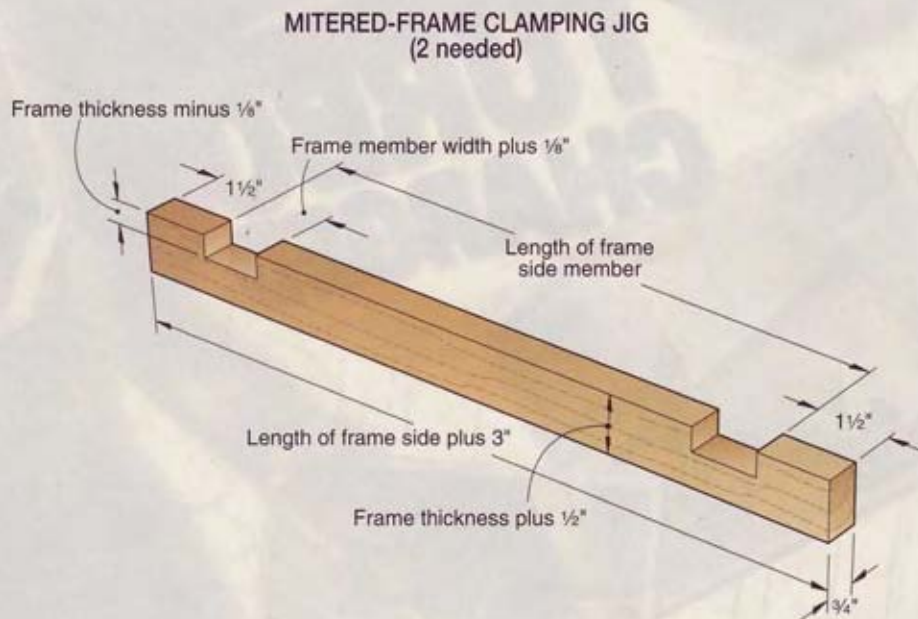

capturing the frame end members in the dados. Now apply clamping pressure to the frame sides. The frame ends, restrained by the jig dados, can't push out of place. And because the dados were cut using the same stopblock position, the frame ends stay perfectly parallel. Let the glue set long enough to grab, and then wipe away any excess from both sides of the frame with a damp cloth. ♣

See more shop project plans at woodmagazine.com/shoptools

heirloom bookcase

Put your treasured books, collectibles, and craftsmanship on display with this stylish case-on-case project that's surprisingly easy to build.

Though this handsome piece looks sophisticated, you don't need the skills of a master craftsman to build it. You'll find the case construction straightforward, using biscuit, dado, rabbet, and groove joinery. The drawers assemble with sliding dovetail joints that you'll easily form on your router table. And, whether you've ever made cabriole legs before or not, you'll discover the process for shaping them—using only a bandsaw, rasp, hand-saw, and mill file—amazingly simple. From start to finish, we'll guide you step-by-step. Let's do it!

Begin with the bottom case

1 From $\frac{3}{4}$ " cherry plywood, cut the bottom-case sides (A) to the size listed in the **Materials List**. Then, from $\frac{3}{4}$ " birch plywood, cut the top, middle, and bottom panels (B) and the divider (C) to the sizes listed.

2 To lay out the curved bottom edges on the case sides (A), where dimensioned on **Drawing 1**, cut a piece of card stock to $2\frac{1}{4} \times 5\frac{5}{16}$ " to make a half-template. Draw lines to mark the start and top of the curve, as shown in **Photo A**. Draw the curve, as explained in the **Shop Tip**, below. Cut the template to shape.

3 Position the half-template on the *outside* face of a side (A), aligned with the *left* edge and bottom. Draw the curve. Now flip the template, align it with the *right* edge and bottom, and draw another curve to complete the layout, as shown in **Photo B**. Repeat for the other side. Now bandsaw and drum-sand the bottom edge of each side to shape.

4 Using a dado blade in your tablesaw that matches the thickness of the plywood panels (B), cut two $\frac{3}{8}$ "-deep dados on the *inside* face of each side (A), where dimensioned on **Drawing 1**. Next, attach an auxiliary fence to the rip fence, and position the fence adjacent to the blade. Now cut a $\frac{3}{8}$ "-deep rabbet across the top end of each side on the *inside* face.

5 To cut $\frac{7}{8} \times 1\frac{1}{4}$ " notches in the back corners of the three panels (B), where shown on **Drawings 1** and **2**, raise the dado blade to $1\frac{1}{4}$ ". Attach a $\frac{3}{4} \times 6 \times 36$ " extension to the miter gauge and clamp a stopblock to the extension, positioned $\frac{7}{8}$ " from the *outside* of the blade, as shown in **Photo C**. Now cut each notch in two passes, as shown.

SHOP TIP

A quick way to draw smooth curves

A flexible curve is easier to use than a French curve for drawing a perfectly smooth shape. Simply bend the curve to the marks and trace the shape, as shown. The rubber-coated 24" flexible curve we used costs about \$5 (see **Sources**), and has a lead core with spring steel on both sides that allows the curve to flex easily and hold its shape. You can bend the curve to a radius as small as $\frac{1}{2}$ ".



MAKE A HALF-TEMPLATE

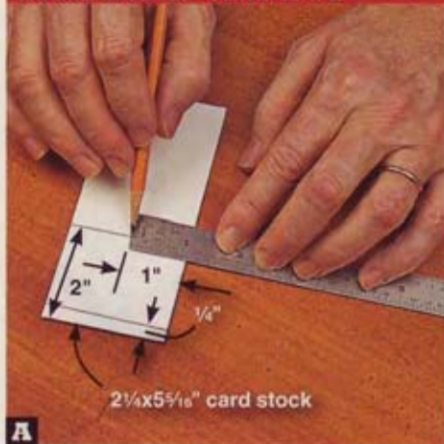

A To make a half-template for drawing the curved bottom edges on the case sides (A), draw lines to lay out the curve, where shown.

MARK THE SIDE BOTTOM EDGE

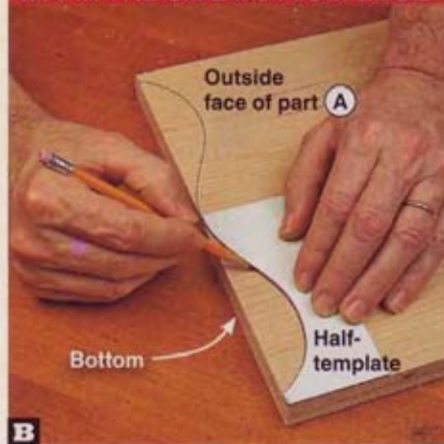

B After drawing a curve along the bottom edge of a side (A), flip the half-template and draw another curve to complete the shape.

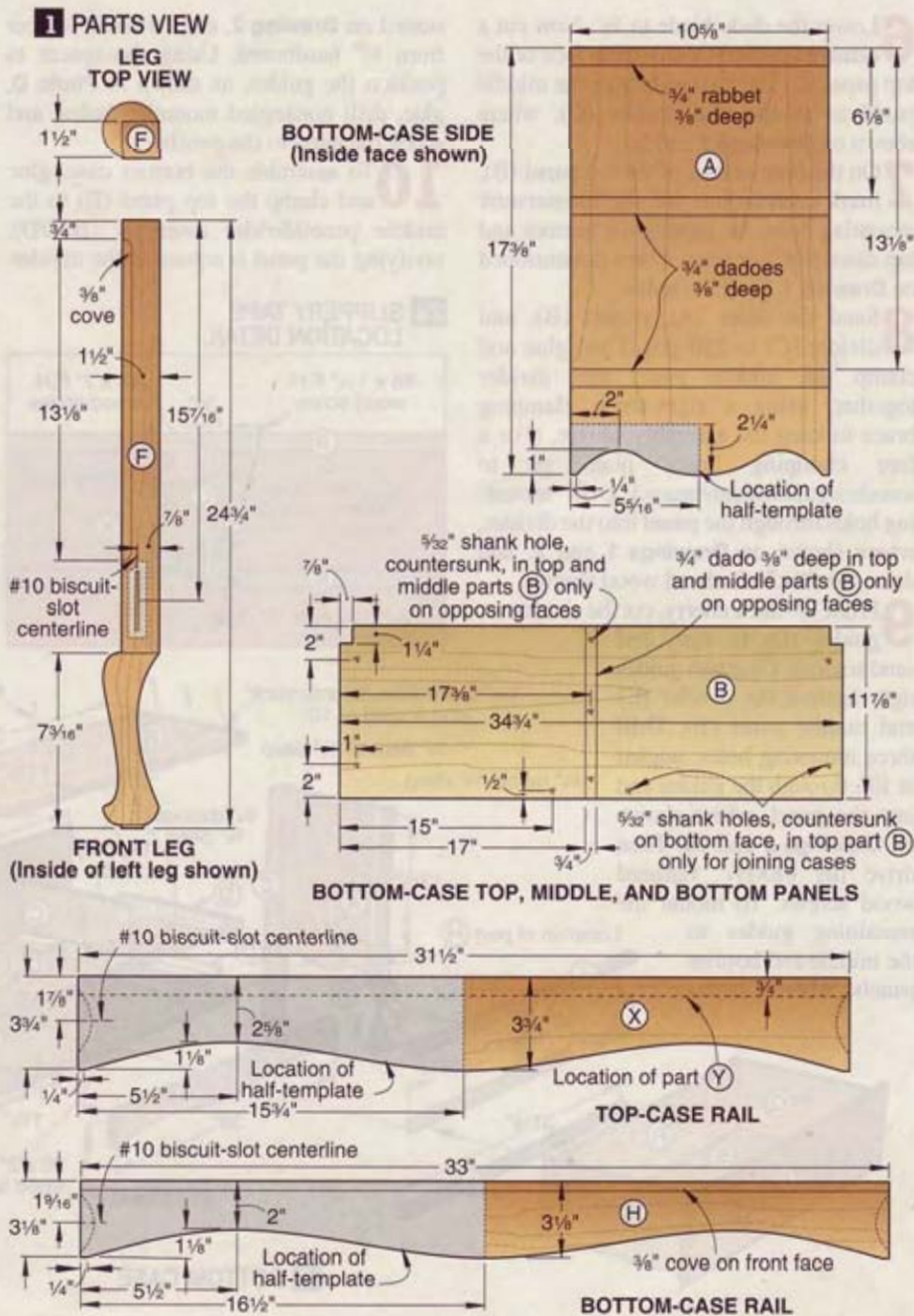

CUT THE PANEL NOTCHES

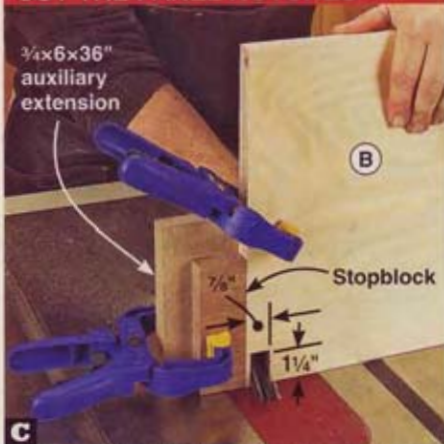

With a panel (B) tight against the stopblock, cut through the panel. Shift the panel. Then cut it again to complete the $\frac{7}{8} \times \frac{1}{4}$ " notch.

MOUNT THE DRAWER GUIDES



Using a spacer to position the drawer guides (D), glue and screw the guides $1\frac{1}{8}$ " from the ends of the middle and bottom panels (B).

ASSEMBLE THE BOTTOM CASE



Glue and clamp the sides (A), panel/divider assembly (B/C/D), and bottom panel (B/D) together. Drill the mounting holes at 10° .

6 Lower the dado blade to $\frac{3}{8}$ ". Now cut a centered dado on the *bottom* face of the top panel (B) and the *top* face of the middle panel to receive the divider (C), where shown on **Drawings 1 and 2**.

7 On the *bottom* face of the top panel (B), mark centerpoints for six countersunk mounting holes for joining the bottom and top cases together later, where dimensioned on **Drawing 1**. Drill the holes.

8 Sand the sides (A), panels (B), and divider (C) to 220 grit. Then glue and clamp the middle panel and divider together, using a right-angle clamping brace to keep the assembly square. (For a free clamping brace plan, go to woodmagazine.com/brace.) Drill mounting holes through the panel into the divider, where shown on **Drawings 1 and 2**, and drive the $\#8 \times 2$ " flathead wood screws.

9 From $\frac{3}{4}$ "-thick cherry, cut the six drawer guides (D) to size, and sand smooth. Glue two guides tight against the divider (C) and middle panel (B). Drill three mounting holes, angled at 10° , through the guides and into the panel, where shown on **Drawings 2 and 2a**. Then drive the $\#8 \times 1\frac{1}{4}$ " flathead wood screws. To mount the remaining guides to the middle and bottom panels, where dimen-

sioned on **Drawing 2**, cut a $1\frac{1}{2} \times 10$ " spacer from $\frac{1}{4}$ " hardboard. Using the spacer to position the guides, as shown in **Photo D**, glue, drill nonangled mounting holes, and screw the parts to the panels.

10 To assemble the bottom case, glue and clamp the top panel (B) to the middle panel/divider assembly (B/C/D), verifying the panel is square to the divider.

2a SLIPPERY TAPE LOCATION DETAIL

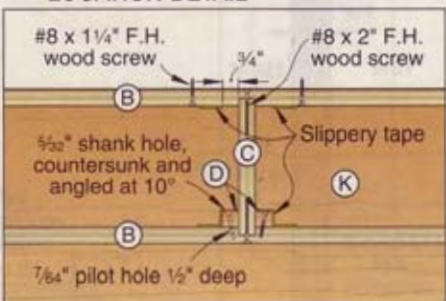

2b FRONT-LEG LOCATION DETAIL (Left leg viewed from top)

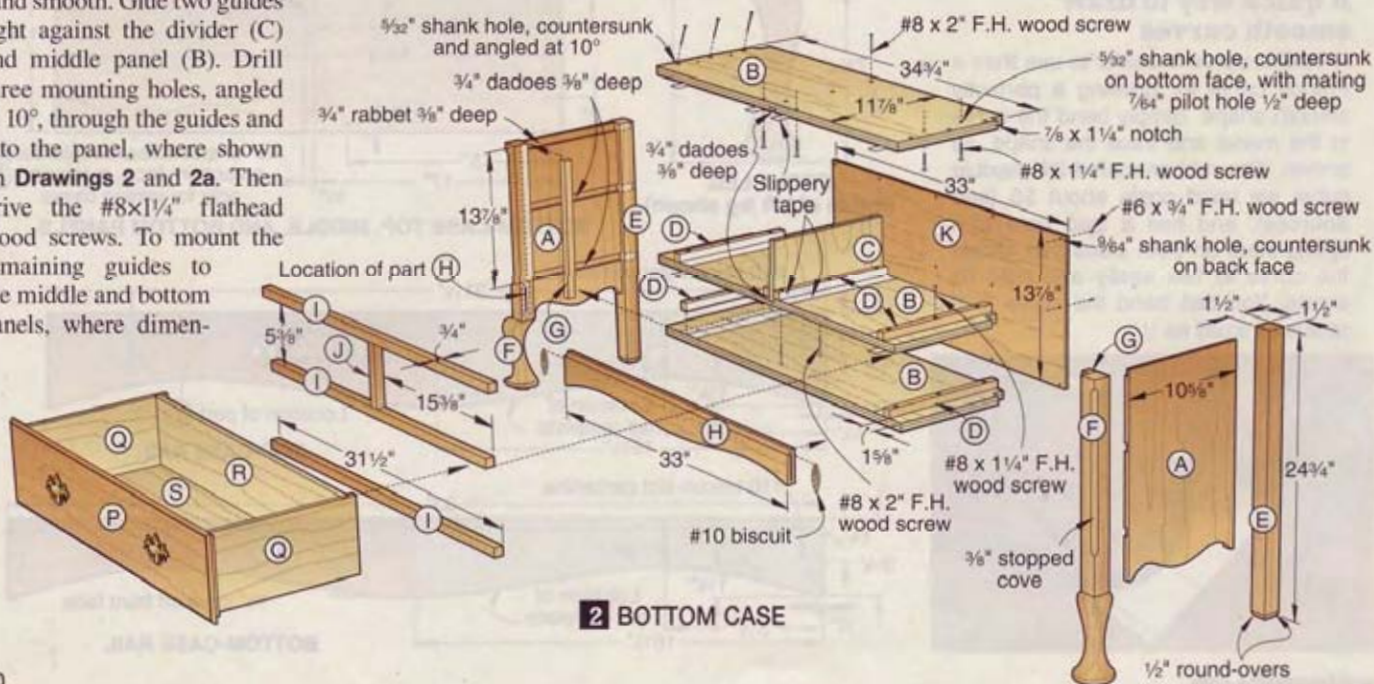
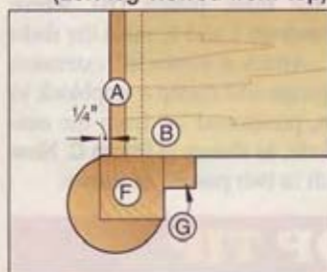

2 BOTTOM CASE

COVE THE FRONT LEGS



With the start lines aligned, angle a front leg (F) into the bit. Rout the cove, rotating the leg away from the bit when the stop lines align.

Now fashion the legs

1 From 1½"-thick cherry (or laminated ¾" stock), cut four 1½"x24¾" pieces—two for the back legs (E) and two for the front legs (F). After cutting a stopped cove in the front legs, you'll glue additional pieces to each leg for shaping the foot.

2 Using a ½" round-over bit in your table-mounted router and a backer attached to the miter gauge for support, round over the bottom edges of the back legs (E), where shown on **Drawing 2**. To prevent tear-out and burning of the cherry, rout the edges in three passes, raising the bit after each pass. Sand the legs smooth.

3 To rout a ⅜" stopped cove on each front leg (F), draw start and stop lines for the cove on a face of each leg, where dimensioned on **Drawing 3**. Refit your table-mounted router with a ⅜" cove bit, raised ⅜". Then draw start and stop lines on the fence, aligned with the bit cutting edges. Lower the bit to about ⅜". Now rout the cove in each leg, as shown in **Photo F**. Raise the bit to ⅜", and rout each leg again.

4 From ¾"-thick cherry, cut two 1½"x7⅜" pieces and two 2¼"x7⅜" pieces to complete the blanks for forming the feet on the front legs (F). Now glue and clamp the pieces to the legs, flush at the bottom, in the configuration shown on **Drawing 3**. Now shape the feet using the easy-to-follow process on *page 48*.

Complete the bottom case

1 Glue and clamp the back legs (E) in the notches in the top, middle, and bottom panels (B), flush with the top panel. Note that the legs overhang the back edges of the panels and outside faces of the sides (A) ¼".

2 From ¾"-thick cherry, cut the side edging (G) to size. Sand smooth. Then glue and clamp an edging piece to the *inside* face of each front leg (F), flush with the top and

MARK THE BOTTOM-CASE RAIL

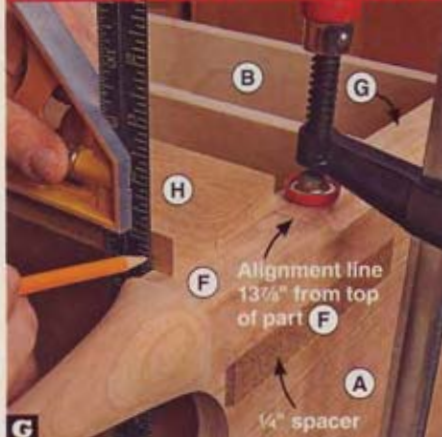

Position the rail (H) tight against the left front leg (F), overlapping the right leg, and aligned with the lines. Mark the final rail length.

back, where shown on **Drawings 2** and **2b**. You'll cut the remaining edging (I, J) to size to fit the case after assembling the front legs and rail (H) to the case.

3 From ¾"-thick cherry, cut the rail (H) to the size listed except ½" longer to allow for precise fitting between the front legs (F). Dry-clamp the legs to the case, flush with the top and overhanging the sides (A) ¼", where shown on **Drawing 2b**. To easily position the legs, adhere ¼" hardboard spacers to the sides, as shown in **Photo G**, using double-faced tape, and align the legs flush with the spacers. Draw a line across the front face of each leg 13⅞" from the top, where dimensioned on **Drawing 2**, for aligning the top of the rail. Place the rail in position and mark the exact length, as shown. Now crosscut the rail at the marked line.

4 Remove the front legs (F/G), leaving the spacers in place. To cut slots for #10 biscuits for joining the rail (H) to the legs, where shown on **Drawing 2**, draw centerlines at the ends of the rail on the *front* face, where dimensioned on **Drawing 1**. Then draw centerlines on the *front* faces of the legs, where dimensioned. Adjust your biscuit-joiner fence to center the cutter on the ¾" thickness of the rail. Plunge a slot in each end. Do not change the fence position. Now, using a ½"-thick spacer under your joiner, which centers the cutter ⅞" from the back face of the legs, plunge a slot in the *inside* face of each leg at the marked centerline, as shown in **Photo H**.

5 As you did for the sides (A), make a half-template from a 3⅞"x16½" piece of card stock to lay out the curved bottom edge on the rail (H), where dimensioned on **Drawing 1**. Position the half-template on the *outside* face of the rail, aligned with the *left* end and bottom. Draw the curve on the rail, flipping the template to complete the shape. Now bandsaw and drum-sand the rail to shape.

CUT THE LEG BISCUIT SLOT



With your biscuit joiner on a ½" spacer and aligned with the marked centerline on a front leg (F), plunge a slot in the *inside* face.

6 Using your table-mounted router, rout a ⅜" cove along the *top* edge of the rail on the *front* face. Sand smooth.

7 Glue and clamp the right front leg (F/G) to the case, again aligning the leg flush with the ¼" spacer. Then glue and biscuit the rail (H) to the leg, placing two ½" spacers under the rail to correctly position it from the front edges of the panels (B), as

3 FRONT LEG BLANK (Left leg shown)

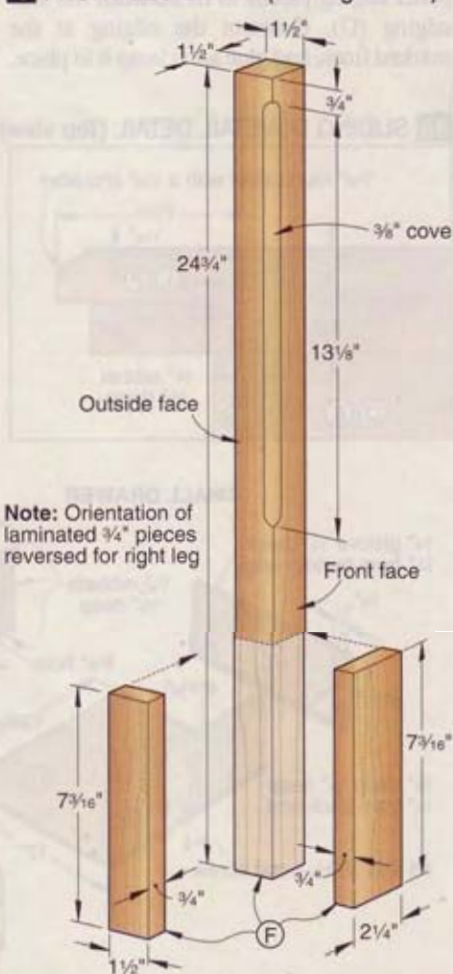

MOUNT THE LEGS AND RAIL

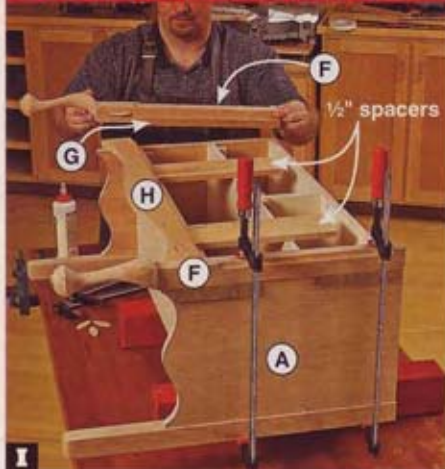

Glue and biscuit the rail (H), positioned on 1/2" spacers, to the right front leg (F/G). Then glue, biscuit, and clamp the left leg in place.

shown in **Photo I**. Now glue, biscuit, and clamp the left front leg in place, as shown. Remove all of the spacers.

8 From 3/4"-thick cherry planed to match the thickness of the plywood panels (B) and divider (C), cut the panel edging (I) and divider edging (J) to the sizes listed except 1/2" longer. Sand the edging smooth. Next, position and mark the exact length of the panel edging pieces to fit between the side edging (G). Crosscut the edging at the marked lines, and glue and clamp it in place,

4a SLIDING DOVETAIL DETAIL (Top view)

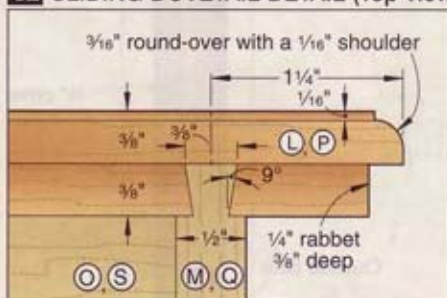

RABBET THE DRAWER FRONTS

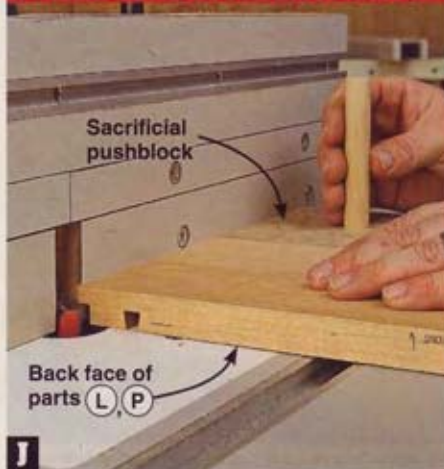

Backing up the fronts (L, P) with a sacrificial pushblock, rout a 1/4" rabbet 3/8" deep across the ends and edges on the back face.

flush with the panel faces. In the same way, crosscut the divider edging to the finished length, and glue and clamp it in place.

9 From 1/4" cherry plywood, cut the back (K) to size to fit the case opening. Sand

MARK THE DRAWER SIDES

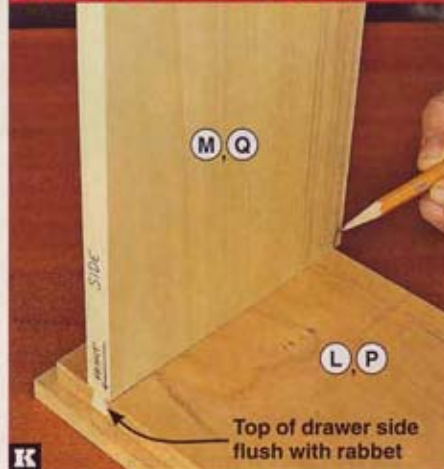

Align the top of each drawer side (M, Q) with the rabbets in the fronts (L, P). Mark the final width of the sides at the bottom.

smooth. Glue the back in place. Then drill countersunk mounting holes through the back and into the panels (B), where shown on **Drawing 2**. Drive the #6x3/4" flathead wood screws.

LARGE DRAWER

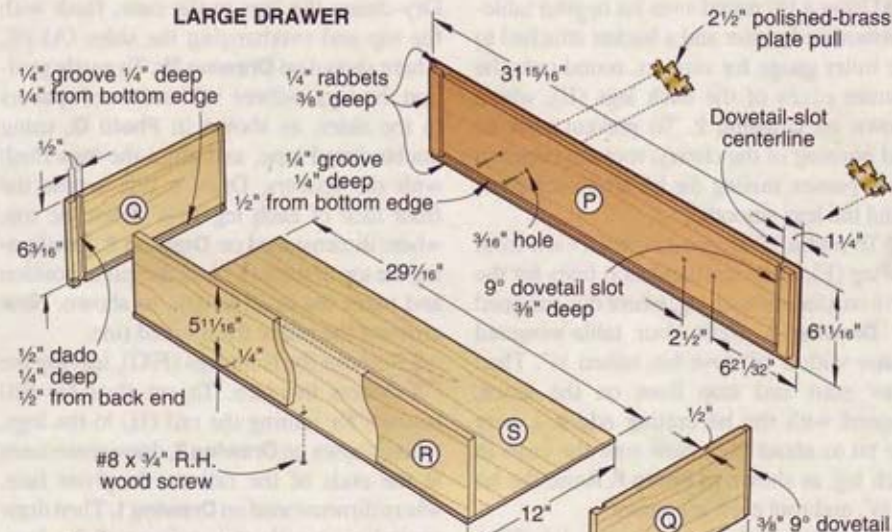

4 DRAWERS (Back view)

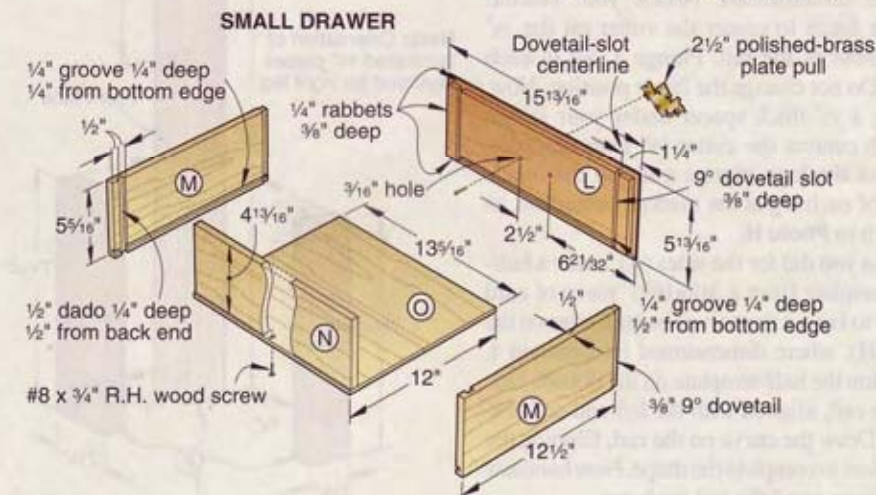

4b DRAWER BOTTOM DETAIL (Top view)

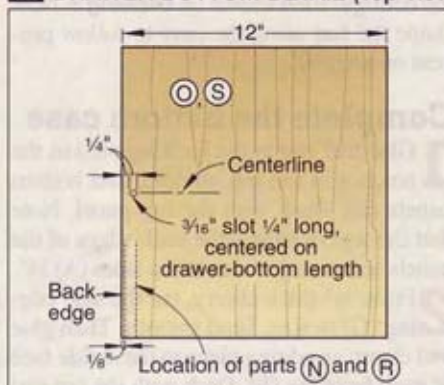

Slide over to the drawers

1 From $\frac{3}{4}$ "-thick cherry, cut the fronts (L, P) for the small and large drawers to the sizes listed. Then, from $\frac{3}{4}$ "-thick poplar planed to $\frac{1}{2}$ " thick, cut the sides (M, Q) and backs (N, R) to the sizes listed except rip the sides $\frac{1}{8}$ " wider to allow for precise fitting during assembly of the drawers. Now, from $\frac{3}{4}$ "-thick edge-joined poplar planed to $\frac{1}{4}$ ", cut the bottoms (O, S) to the sizes listed. Sand the parts smooth.

2 Using a 9° dovetail bit in your table-mounted router and sacrificial pushblock to avoid tear-out, rout a $\frac{3}{8}$ "-deep slot centered $\frac{1}{4}$ " from each end of the fronts (L, P) on the *back* faces, where dimensioned on **Drawings 4** and **4a**. Then rout the mating tails on the front end of each side (M, Q) to form a snug joint in the drawer fronts. For help with machining the sliding dovetail joints, see the article on *page 12*.

3 Switch to a $\frac{3}{4}$ " straight or rabbeting bit in your router. Then rout a $\frac{1}{4}$ " rabbet $\frac{3}{8}$ " deep across the ends and then along the edges of the fronts (L, P) on the *back* faces, as shown in **Photo J**.

4 To trim the sides (M, Q) to final width, mate the dovetailed sides to the fronts (L, P) with the top edges of the sides flush with the rabbets in the fronts. Mark the excess on the sides, as shown in **Photo K**. Then rip the sides at the marked lines.

5 To rout grooves to fit the bottoms (O, S), refit your router with a $\frac{1}{4}$ " straight bit. Then rout a $\frac{1}{4}$ " groove $\frac{1}{4}$ " deep $\frac{1}{4}$ " from the bottom edges of the sides (M, Q) on the *inside* faces, where dimensioned. Reposition the fence as needed. Now rout a $\frac{1}{4}$ " groove $\frac{1}{4}$ " deep $\frac{1}{2}$ " from the bottom edges of the fronts (L, P) on the *back* faces, noting the groove stops at the dovetail slots. For help with routing the stopped grooves, see *page 14*.

6 Rechuck with a $\frac{3}{16}$ " round-over bit, positioned to form a $\frac{1}{16}$ " shoulder, where dimensioned on **Drawing 4a**. Then round over the ends and edges of the fronts (L, P) on the *front* faces.

7 Using a dado blade in your tablesaw, cut a $\frac{1}{2}$ " dado $\frac{1}{4}$ " deep $\frac{1}{2}$ " from the back end of each side (M, Q) on the *inside* face, where dimensioned on **Drawing 4**, to receive the backs (N, R).

8 Lay out the location for a $\frac{3}{16}$ " slot $\frac{1}{4}$ " long, centered along the back edges of the bottoms (O, S), where dimensioned on **Drawing 4b**. Using a $\frac{3}{16}$ " twist bit and drilling overlapping holes, form the slots. (The slots allow the solid-stock bottoms to move freely with seasonal changes.)

9 Glue and assemble the fronts (L, P) and sides (M, Q). Then slide the bottoms (O, S), *without* glue, in place, as shown in

INSTALL THE DRAWER BOTTOMS

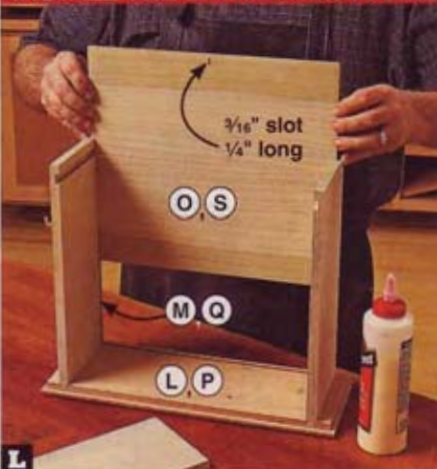

With the bottoms (O, S) positioned as shown, slide them (*without* glue) into the $\frac{1}{4}$ " grooves in the sides (M, Q) and fronts (L, P).

Photo L. Next, glue and slide the backs (N, R) into the dados in the sides, tight against the bottoms. Now drill a pilot hole, centered in the slot in each bottom, into the back. Drive a $\#8 \times \frac{3}{4}$ " roundhead wood screw to secure each bottom.

10 Mark centerpoints on the *front* face of each front (L, P) for $\frac{3}{16}$ " holes to mount $2\frac{1}{2}$ " polished-brass plate pulls, where dimensioned on **Drawing 4**. (The pulls on the small drawers are centered; those on the large drawer are positioned to vertically align with the pulls on the small drawers.) Drill the holes. Set the drawers aside.

Move up to the top case

1 From $\frac{1}{4}$ " cherry plywood, cut the top-case sides (T) and top/bottom (U) to the sizes listed.

2 Drill $\frac{1}{4}$ " holes $\frac{3}{8}$ " deep for brass paddle supports for the shelves on the *inside* face of each side (T), where dimensioned on **Drawing 5** on *page 44*. (For quick and precise drilling of the 1"-spaced holes, we used a simple jig made from $\frac{1}{4}$ " perforated hardboard with a cleat to locate the holes $\frac{1}{4}$ " from the front and back edges of the sides.) For consistent drilling depth, wrap a piece of masking tape around the bit for a visual stop.

3 Using a dado blade in your tablesaw that matches the thickness of the $\frac{3}{4}$ " plywood top/bottom (U), cut a $\frac{3}{8}$ "-deep rabbet across the top and bottom of each side (T) on the *inside* face, where shown. Now cut a $\frac{1}{4}$ " rabbet $\frac{3}{8}$ " deep along the *back* edges of the sides (T) and top/bottom (U) on the *inside* faces to house the back (V).

4 Glue and clamp together the sides (T) and top/bottom (U), using right-angle clamping braces, as shown in **Photo M**. Drill mounting holes angled at 10° through the top and bottom and into the sides, where

SCREW THE TOP CASE TOGETHER

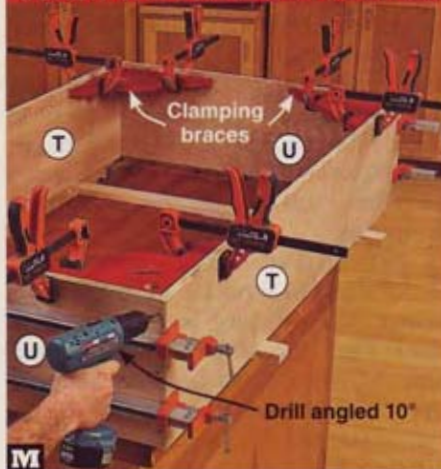

With the top case assembled and square, drill mounting holes angled at 10° through the top/bottom (U) and into the sides (T).

shown on **Drawing 5**. Then drive the $\#8 \times 2$ " flathead wood screws.

5 From $\frac{1}{4}$ " cherry plywood, cut the back (V) to size to fit the case opening. Sand smooth. Glue the back in place. Then drill countersunk mounting holes through the back and into the sides (T) and top/bottom (U). Drive the $\#6 \times \frac{3}{4}$ " flathead wood screws.

6 From $1\frac{1}{2}$ "-thick cherry (or laminated $\frac{3}{4}$ " stock), cut the pillars (W) to size. As you did for the bottom-case front legs (F), rout a $\frac{3}{8}$ " stopped cove on each pillar, where dimensioned on **Drawing 5**.

7 From $\frac{3}{4}$ "-thick cherry, cut the rail (X) to the size listed except $\frac{1}{2}$ " longer to allow for precise fitting between the pillars (W). To position the pillars on the top case, overhanging the sides (T) $\frac{1}{4}$ ", where dimensioned on **Drawing 5a**, adhere $\frac{1}{4}$ " hardboard spacers to the sides with double-faced tape, as you did when positioning the front legs (F/G) on the bottom case. Dry-clamp the pillars in place, flush with the spacers and case top and bottom. Position the rail tight against the left pillar and flush with the top (U). Mark the rail where it overlaps the right pillar. Now crosscut the rail at the marked line.

8 Remove the pillars (W), leaving the spacers in place. To cut slots for #10 biscuits for joining the rail (X) to the pillars, where shown on **Drawing 5**, draw centerlines at the ends of the rail on the *front* face, where dimensioned on **Drawing 1**. Then draw centerlines on the opposing *inside* faces of the pillars, where dimensioned on **Drawing 5**. With your biscuit-joiner fence positioned to center the cutter on the $\frac{3}{4}$ " thickness of the rail, plunge a slot in each end. Do not change the fence position. Now, with the biscuit joiner and back face of the pillars flush on your worksurface, plunge a slot in the *inside* face of each pillar at the marked centerlines.

9 Make a half-template from a $3\frac{3}{4} \times 15\frac{3}{4}$ " piece of card stock to lay out the curved bottom edge on the rail (X), where dimensioned on **Drawing 1**. Draw the curve on the rail. Bandsaw and drum-sand the rail to shape. Now glue, biscuit, and clamp the pillars (W) and rail to the case, again aligning the pillars flush with the spacers. Remove the spacers.

10 From $\frac{3}{4}$ "-thick cherry, cut a $1\frac{1}{4} \times 33$ " blank to form the cove trim (Y). Rout a $\frac{3}{8}$ " cove along both edges of the blank. Then rip a $\frac{3}{8}$ "-wide strip from each edge. Mark the exact length of the trim pieces to fit between the pillars (W) on the bottom (U) and rail (X), where shown on **Drawing 5**. Crosscut the pieces at the marked lines. Now glue and clamp them in place.

Trim out the top case

1 From $\frac{3}{4}$ "-thick cherry, cut two 3×70 " blanks to form the top/bottom front and side trim (Z, AA) and a 3×32 " blank for the bottom back trim (BB). Chuck a thumbnail table-edge bit in your table-mounted router. Making three passes and raising the bit with each pass, rout the profile shown on **Drawing 5b** along one edge of the two 3×70 " blanks. Sand the three blanks smooth.

2 From the two 3×70 " blanks, miter-cut the top/bottom front-trim pieces (Z) to the finished length of 37", where shown on **Drawing 5**. Then miter-cut the side-trim pieces (AA) to $14\frac{1}{2}$ " long ($\frac{1}{2}$ " longer than the finished length) to allow for precise fitting on the case.

3 Draw lines for locating the trim (Z, AA, BB) on the top and bottom (U), where dimensioned on **Drawing 5c** and indicated by dashed lines. Position the top case on your workbench with the back down. Apply glue to the top (U) in the mating area for the front-trim piece (Z). Now clamp the trim in place, centered side-to-side and aligned with the marked line. Repeat to mount the front trim on the bottom (U).

4 Place a side-trim piece (AA) in position on the top (U), aligned with the marked line and tight against the mitered front trim (Z). Mark the finished length of the side trim, as shown in **Photo N**. Crosscut the trim along the marked line. Next, apply glue to the top (U) and the mating mitered ends of the front and side trim. Clamp the side trim in place. Drill mounting holes, where shown on **Drawing 5**, and drive the $\#8 \times 1\frac{1}{4}$ " flathead wood screws. (We reinforced the side-trim attachment with screws to avoid the use of long clamps.) Repeat to mount the remaining side-trim pieces.

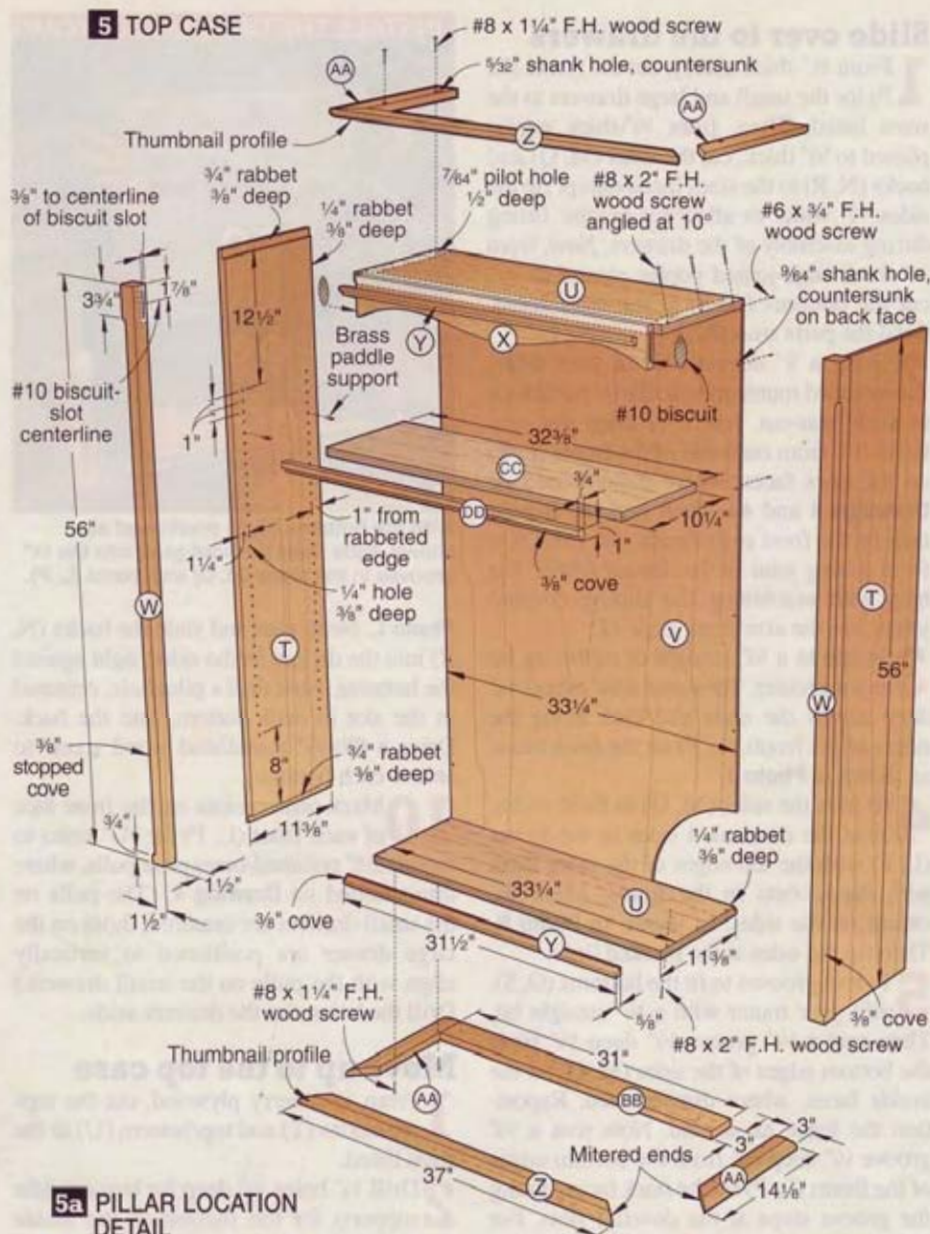

5a PILLAR LOCATION DETAIL (Viewed from top)

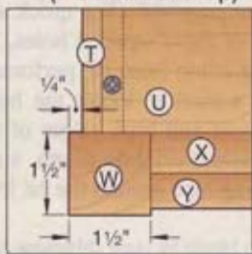

5b TRIM THUMBNAIL DETAIL

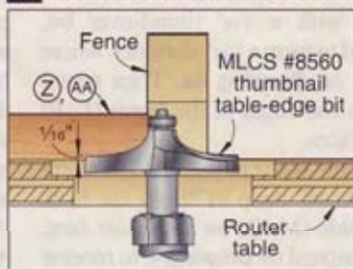

5c TRIM LOCATION DETAIL (Viewed from top)

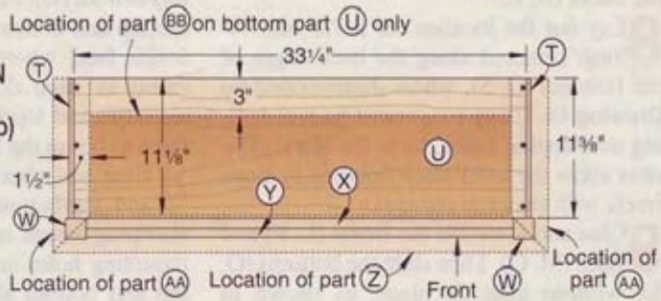

MARK THE SIDE-TRIM LENGTH



N Holding the side trim (AA) in position on the top (U), mark the final length of the trim at the back edge of the top.

5 Mark and crosscut the 3x32" blank for the bottom back trim (BB) to length to fit snugly between the side trim (AA). Glue and screw the trim in place.

Add the shelves

1 From 3/4" cherry plywood, cut the shelves (CC) to size. Then, from 3/4"-thick cherry, cut a 4x33" blank to form the shelf edging (DD). Rout a 3/8" cove along both edges of the blank. Then rip a 1"-wide strip from each edge. Cove and rip the blank to make one more edging strip.

2 Glue and clamp the edging to the shelves, flush with the top faces and centered end to end. (The edging overhangs the bottom faces of the shelves 1/4".) Then trim the edging flush with the ends of the shelves. Sand the shelves smooth.

Finish up

1 Using a helper, position the top case on the bottom case, flush at the back and centered side-to-side, with the bottom side trim (AA) overhanging the back and front

JOIN THE CASES TOGETHER



O Using a 12d nail, mark centerpoints through the mounting holes in the bottom-case top panel (B) on the top-case bottom trim (Z, AA).

6a SECTION VIEW DETAIL

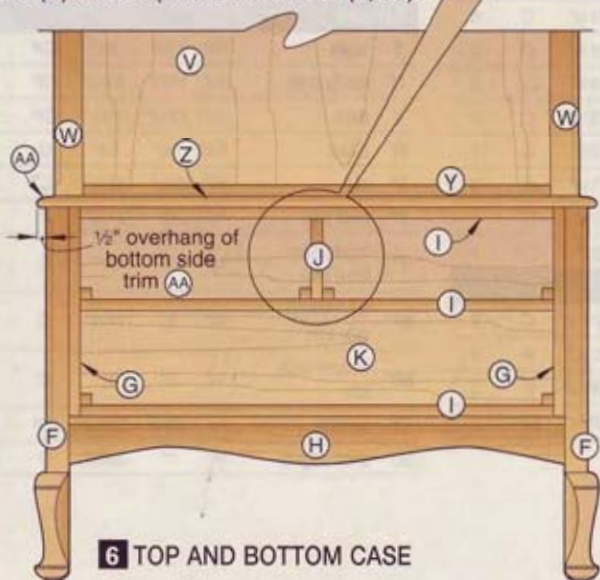
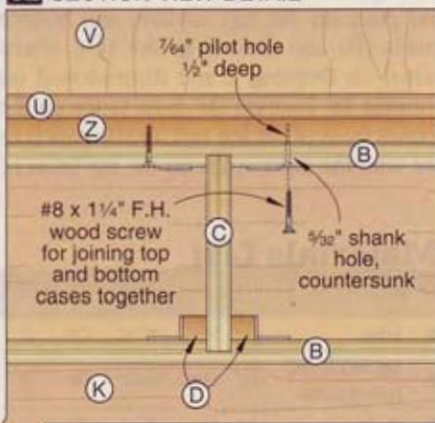

6 TOP AND BOTTOM CASE

legs (E, F) 1/2", where dimensioned on **Drawing 6**. Reach inside the bottom case and, using the mounting holes in the top panel (B) as guides, mark centerpoints for pilot holes on the bottom front trim (Z) and side trim,

as shown in **Photo O**. Now remove the top case, and drill 7/64" pilot holes 1/2" deep at the marked centerpoints.

2 Sand any areas of the bottom case, top case, drawers, and shelves that need it to 220 grit, and remove the dust.

3 Apply a stain and clear finish of your choice. (We applied a blend of two oil-based stains to our project, followed by two coats of water-based satin polyurethane. For more on blending stains, see

"Get the color you *really* want by blending stains," *below*.)

4 Mount 2 1/2" polished-brass plate pulls on the drawers, where shown on **Drawing 4**, using the screws supplied with the pulls.

SHOP TIP

Get the color you really want by blending stains

Ever tested a couple of close-colored stains on scrap before finishing a project and wished for a tone somewhere between? Here's how to get that between color.

Using the *same type* of stains from the *same manufacturer*, add a small amount of one stain (we used 3 ounces) to a graduated container. Now estimate the appropriate amount of the second stain, add it, and stir the mixture. Apply the mix to scrap, making note of the ratio. Repeat to test various ratios. For best results, let the stain samples dry and topcoat with the finish you plan to use. For the bookcase, we selected a 50/50 mix of Varathane Premium Wood Stains no. 263 Mission Oak and no. 233 Golden Mahogany.



From bottom up, 25/75, 50/50, and 75/25 mixes of Mission Oak/Golden Mahogany

5 For smooth-sliding drawers, cut 18 pieces of slippery tape 11 $\frac{7}{8}$ " long from a 1" x 18" roll. (See **Sources**.) Remove the protective backing from the strips. Then press the strips into place on the top, middle, and bottom panels (B) and drawer guides (D), where shown on **Drawing 2** and dimensioned on **Drawing 2a**. Position the outer strips on the *bottom* faces of the top and middle panels in line with the outer strips on the *top* faces of

the middle and bottom panels. Using a sharp utility knife, trim the tape on the $\frac{3}{4}$ "-tall drawer guides flush with the top faces.

6 Finally, using your helper again, move the cases, drawers, and shelves where you wish to locate the bookcase. Reposition the top case on the bottom case, and drive #8 x 1 $\frac{1}{4}$ " flathead wood screws through the mounting holes in the bottom-case top panel (B) into the top case using a small screw-

driver. Slide in the drawers. Then position the shelves where desired, using $\frac{1}{4}$ " brass paddle supports, where shown on **Drawing 5**. Now round up your favorite books, magazines, and collectibles, and place them in your masterpiece with pride. ♣

Written by **Owen Duvall**

Project design: **Jeff Mertz**

Illustrations: **Roxanne LeMoine; Lorna Johnson**

*Parts initially cut oversize. See the instructions.

†Each front leg (F) is formed by laminating $\frac{3}{4}$ x 1 $\frac{1}{2}$ x 7 $\frac{3}{4}$ " and $\frac{3}{4}$ x 2 $\frac{1}{4}$ x 7 $\frac{3}{4}$ " pieces to the bottom of a 1 $\frac{1}{2}$ x 1 $\frac{1}{2}$ x 24 $\frac{1}{2}$ "-long piece, as explained in the article.

Materials key: CP—cherry plywood, BP—birch plywood, C—cherry, LC—laminated cherry, P—poplar, EP—edge-joined poplar.

Supplies: #6 x $\frac{3}{4}$ ", #8 x 1 $\frac{1}{4}$ ", and #8 x 2" flathead wood screws; double-faced tape; #10 biscuits; #8 x $\frac{3}{4}$ " roundhead wood screws for assembly of drawers; 12d nail.

Blade and bits: Dado-blade set; $\frac{1}{2}$ " round-over, $\frac{3}{8}$ " cove, and thumbnail table-edge router bits. For machining of drawers: 9° dovetail, $\frac{3}{4}$ " straight or rabbeting, $\frac{3}{8}$ " round-over, and $\frac{1}{4}$ " straight router bits.

Sources

Hardware and tape: $\frac{1}{4}$ " brass paddle supports no. 63Z06.04, \$5.25 pkg. of 20 (1 pkg.); 2 $\frac{1}{2}$ " polished-brass plate pulls no. 01G02.02, \$9.60 ea. (4); 1" x 18" slippery tape no. 25U04.04, \$9.50. Call or click Lee Valley, 800/871-8158; leevalley.com.

Flexible curve: 24" flexible curve no. 07K01.01, \$4.95. Phone number and Web address above.

Table-edge router bit: Thumbnail table-edge router bit with $\frac{1}{8}$ " shank no. 8560, \$31.00. Call or click MLCS, 800/533-9298; mlcswoodworking.com.

Materials List

Bottom case	FINISHED SIZE			Matl.	Qty.
	T	W	L		
A sides	$\frac{3}{4}$ "	10 $\frac{1}{4}$ "	17 $\frac{3}{4}$ "	CP	2
B top, middle, and bottom panels	$\frac{3}{4}$ "	11 $\frac{7}{8}$ "	34 $\frac{3}{4}$ "	BP	3
C divider	$\frac{3}{4}$ "	11 $\frac{7}{8}$ "	6 $\frac{1}{8}$ "	BP	1
D drawer guides	$\frac{3}{4}$ "	$\frac{3}{4}$ "	11 $\frac{7}{8}$ "	C	6
E back legs	1 $\frac{1}{2}$ "	1 $\frac{1}{2}$ "	24 $\frac{3}{4}$ "	C	2
F front legs†	2 $\frac{1}{4}$ "	2 $\frac{1}{4}$ "	24 $\frac{3}{4}$ "	LC	2
G side edging	$\frac{3}{4}$ "	$\frac{3}{4}$ "	13 $\frac{7}{8}$ "	C	2
H* rail	$\frac{3}{4}$ "	3 $\frac{1}{8}$ "	33"	C	1
I* panel edging	$\frac{3}{4}$ "	$\frac{3}{4}$ "	31 $\frac{1}{2}$ "	C	3
J* divider edging	$\frac{3}{4}$ "	$\frac{3}{4}$ "	5 $\frac{3}{8}$ "	C	1
K back	$\frac{1}{4}$ "	13 $\frac{7}{8}$ "	33"	CP	1
Small drawers (2 needed)					
L fronts	$\frac{3}{4}$ "	5 $\frac{1}{16}$ "	15 $\frac{1}{16}$ "	C	2
M* sides	$\frac{1}{2}$ "	5 $\frac{1}{16}$ "	12 $\frac{1}{2}$ "	P	4
N backs	$\frac{1}{2}$ "	4 $\frac{1}{16}$ "	13 $\frac{1}{16}$ "	P	2
O bottoms	$\frac{1}{4}$ "	12"	13 $\frac{1}{16}$ "	EP	2

Large drawer					
P front	$\frac{3}{4}$ "	6 $\frac{1}{16}$ "	31 $\frac{1}{16}$ "	C	1
Q* sides	$\frac{1}{2}$ "	6 $\frac{3}{16}$ "	12 $\frac{1}{2}$ "	P	2
R back	$\frac{1}{2}$ "	5 $\frac{1}{16}$ "	29 $\frac{7}{16}$ "	P	1
S bottom	$\frac{1}{4}$ "	12"	29 $\frac{7}{16}$ "	EP	1
Top case					
T sides	$\frac{3}{4}$ "	11 $\frac{7}{8}$ "	56"	CP	2
U top/bottom	$\frac{3}{4}$ "	11 $\frac{7}{8}$ "	33 $\frac{1}{4}$ "	CP	2
V back	$\frac{1}{4}$ "	33 $\frac{1}{4}$ "	55 $\frac{1}{4}$ "	CP	1
W pillars	1 $\frac{1}{2}$ "	1 $\frac{1}{2}$ "	56"	C	2
X* rail	$\frac{3}{4}$ "	3 $\frac{3}{4}$ "	31 $\frac{1}{2}$ "	C	1
Y* cove trim	$\frac{3}{4}$ "	$\frac{5}{8}$ "	31 $\frac{1}{2}$ "	C	2
Z* top/bottom front trim	$\frac{3}{4}$ "	3"	37"	C	2
AA* top/bottom side trim	$\frac{3}{4}$ "	3"	14 $\frac{1}{8}$ "	C	4
BB* bottom back trim	$\frac{3}{4}$ "	3"	31"	C	1
CC shelves	$\frac{3}{4}$ "	10 $\frac{1}{4}$ "	32 $\frac{3}{8}$ "	CP	3
DD* shelf edging	$\frac{3}{4}$ "	1"	32 $\frac{3}{8}$ "	C	3

Cutting Diagram

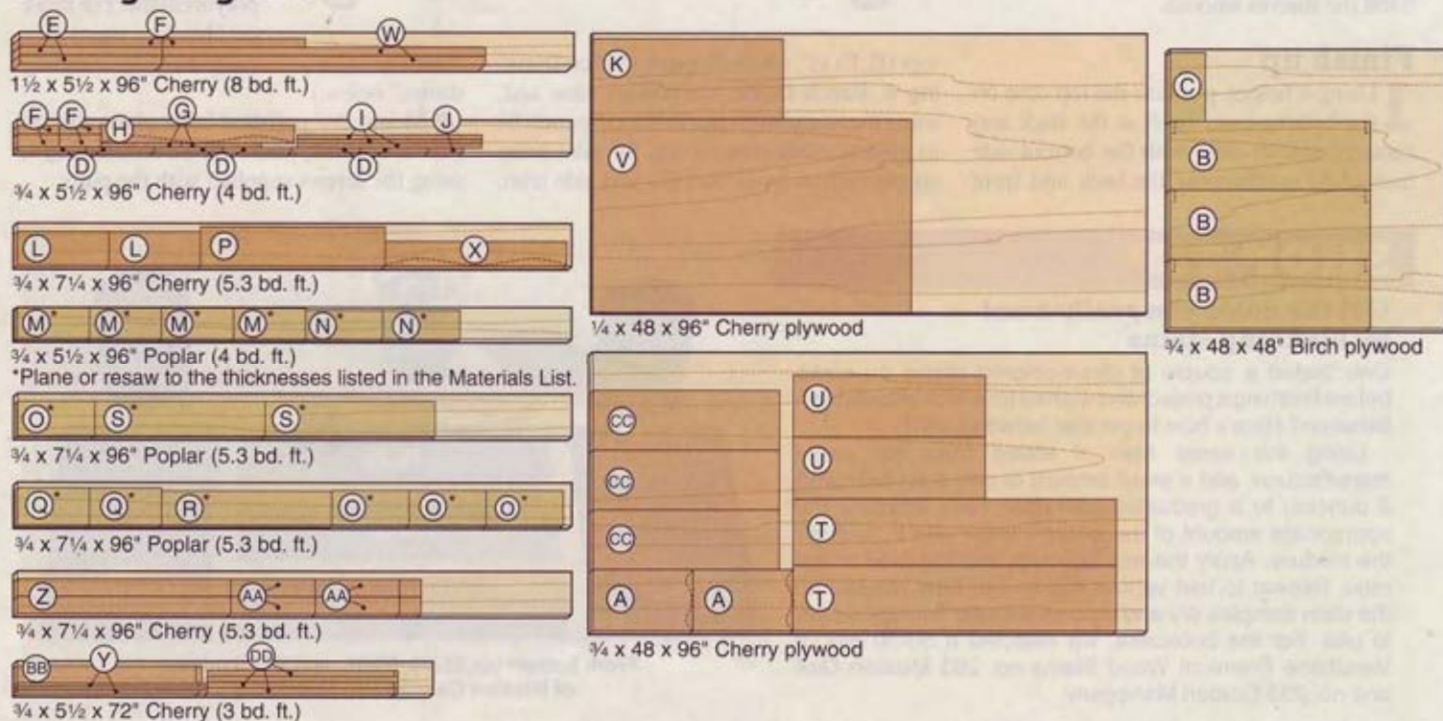

how to shape cabriole legs in easy, little steps

Form this classic-styled leg in just one hour using four tools and a super-simple process.

Think that shaping a cabriole leg is difficult? So did Design Editor Jeff Mertz—until he developed a simple method for making the front legs for the bookcase featured on page 38. His straightforward procedure lets you quickly craft a leg using only a bandsaw, rasp, handsaw, and mill file. “Even with no previous experience, you’ll be amazed at how easy it is,” Jeff says.

For best shaping results, use a tight-grained hardwood, such as cherry, walnut, or mahogany. Also, when contouring the leg after bandsawing it to rough shape, use a half-round rasp with *hand-cut* instead of *machine-cut* teeth. Although both types do a fine job removing material, the random tooth pattern of the hand-cut rasp leaves a much smoother surface that needs less sanding. (We used an 8" hand-cut half-round rasp, no. 62W25.08, which costs about \$20 at Lee Valley; 800/871-8158; leevalley.com.) Even better, if your budget permits, consider the *crème de la crème* of rasps—a #49 pattern maker’s rasp, costing around \$40. The hand-cut teeth of this tool produce the least chatter, a more even cut, and the smoothest surface.

If you’ve never made a cabriole leg, practice rounding over edges and shaping areas on a scrap of the same wood type with your rasp to get used to the cutting action. When

you’re comfortable controlling the rasp, you’re ready to shape a leg. Using a laminated blank for making a front leg (F) for the bookcase, here’s how to do it.

1 LEG BANDSAWING SEQUENCE (Right leg shown)

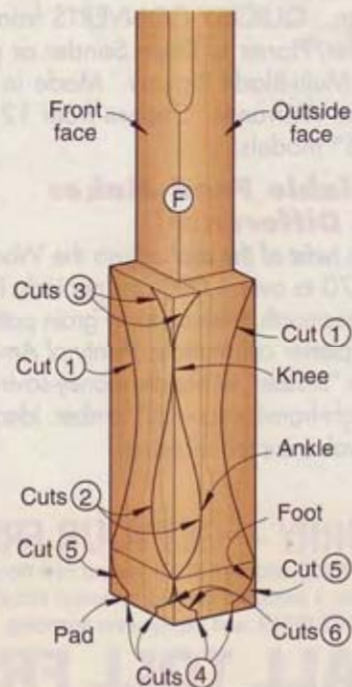

“Even with no previous experience, you’ll be amazed at how easy it is.”

Make a template, and draw the shape on the leg

① Cut a piece of card stock to 2¼×9" to make a template for marking the shape. Photocopy the full-size cabriole leg pattern from the *WOOD Patterns*® insert. Spray-adhere the pattern to the card stock. Then cut the template to shape along the pattern lines with a sharp crafts knife.

For a right leg, position the template with the pattern side up on the *outside* face of the leg, aligned with the bottom, edges, and upper 1½"-square portion of the leg. Draw the shape. Flip the template over (pattern side down) on the *front* face of the leg, and draw the shape again, as shown at *right*. **For a left leg,** position the template with the pattern side up on the *front* face of the leg, aligned with the bottom, edges, and upper 1½"-square portion of the leg. Draw the shape. Flip the template over (pattern side down) on the *outside* face of the leg, and draw the shape again.

Bandsaw the leg using an easy series of cuts

② Using your bandsaw with a ¼" blade, make Cut 1 along the *outside* face of the leg and then along the *inside* face, where shown on *Drawing 1*, to remove the material between the foot and top of the leg.

③ Make Cut 2 on the *outside* face of the leg, where shown, removing the material between the foot and knee of the leg. Save the cutoff. Do not make Cut 2 on the *front* face of the leg until *Step 6*.

④ Make Cut 3 on the *outside* face of the leg to remove the material between the knee and top of the leg. Again, save the cutoff.

⑤ Adhere the cutoffs from *Steps 3* and *4* to the leg using double-faced tape.

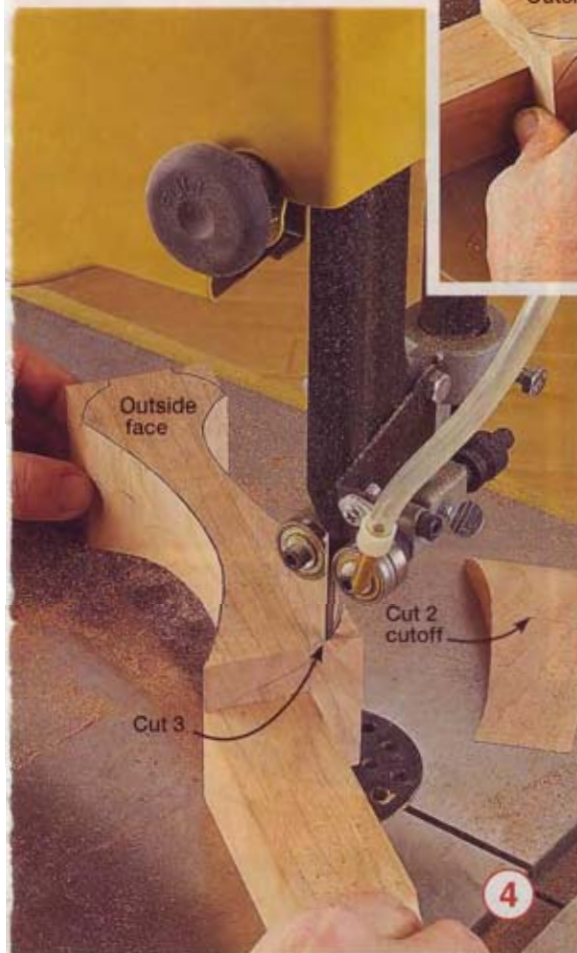
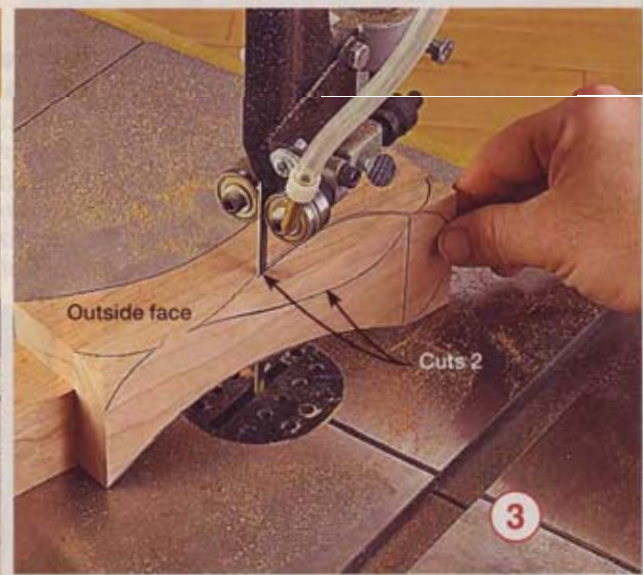
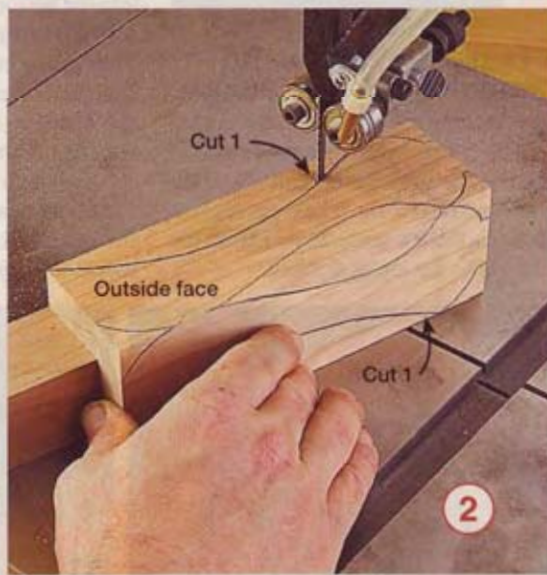
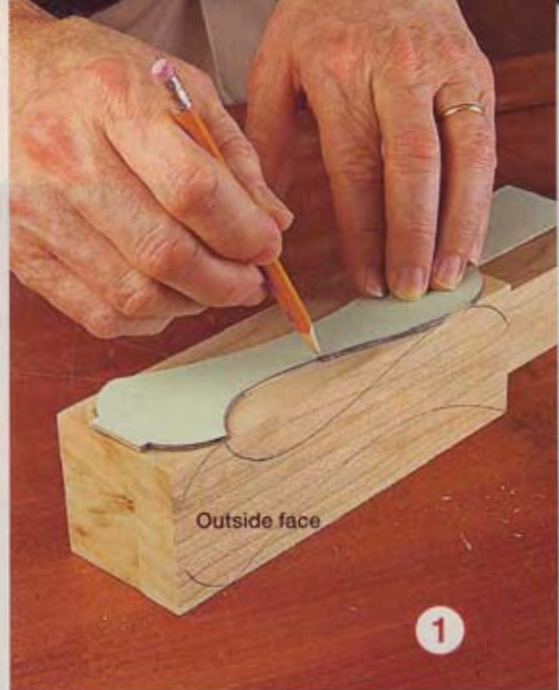

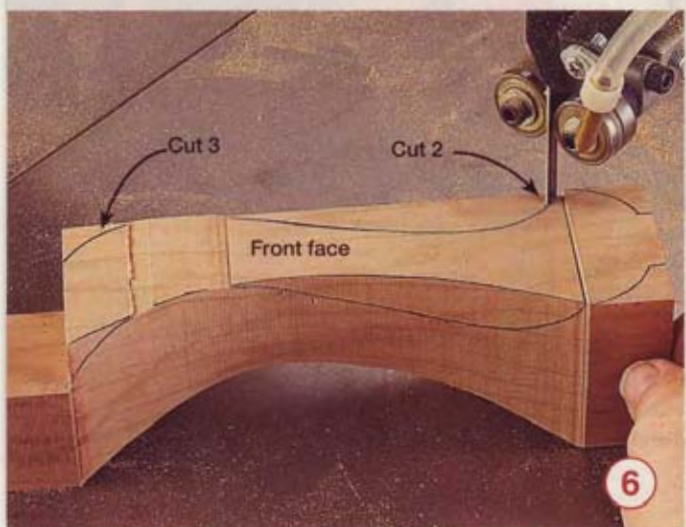

6

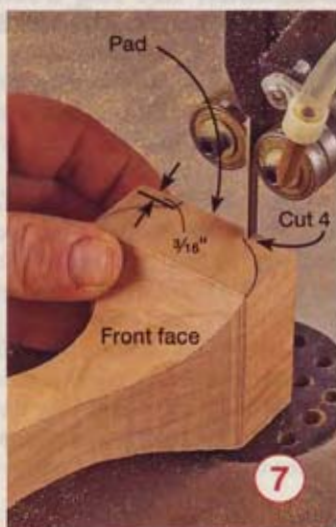

7

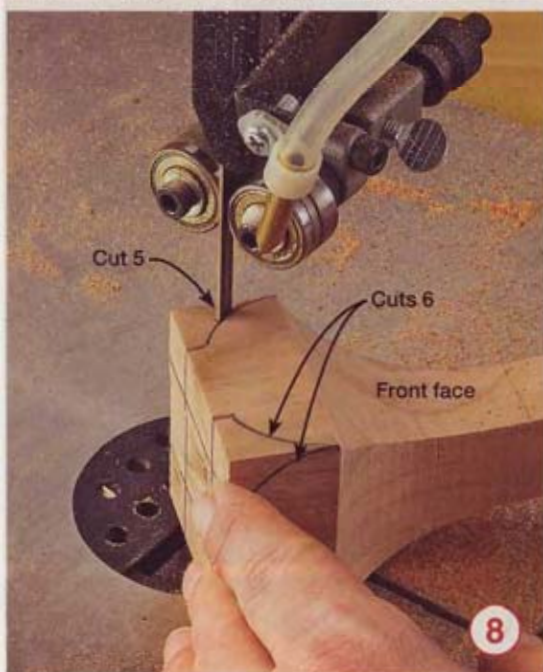

8

Now rasp, file, and sand to a smooth, flowing shape

9 To protect the leg from damage during rasping and filing, wrap several layers of masking tape around the bottom 2" of the square portion of the leg. Then, on each of the four faces, draw a centered line from the top of the leg to the top of the foot.

10 Clamp the leg in a vise. Using the flat side of a half-round rasp and an arcing motion, round over an edge of the leg between the marked centerlines, working from the top of the leg to the ankle, where the edge transitions from a convex to concave shape. Round the edge to the centerlines. If you accidentally remove any of the lines, redraw them. Don't worry about the rasp marks. They'll clean up quickly later.

11 Switch to the round side of the rasp. Now complete rounding of the edge to the top of the foot. Repeat Steps 10 and 11 to round each of the remaining edges.

12 On the bottom of the leg, draw a centered 1" circle. To remove the corners of the pad, make 3/16"-deep cuts, close to the circle, into the bottom of the pad, using a fine-tooth saw. Make sure you don't cut into the foot. Then make cuts into the sides of the pad to free the corner pieces.

13 Using a square-edged mill file, round the edge of the pad.

14 Switch to your rasp. Using the flat side, round over each corner of the foot between the centerlines. Blend as needed to form a round foot approximately 2 1/4" in diameter.



9

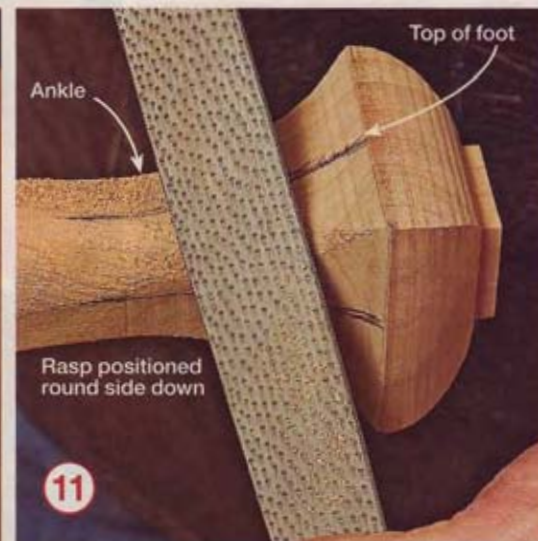

11

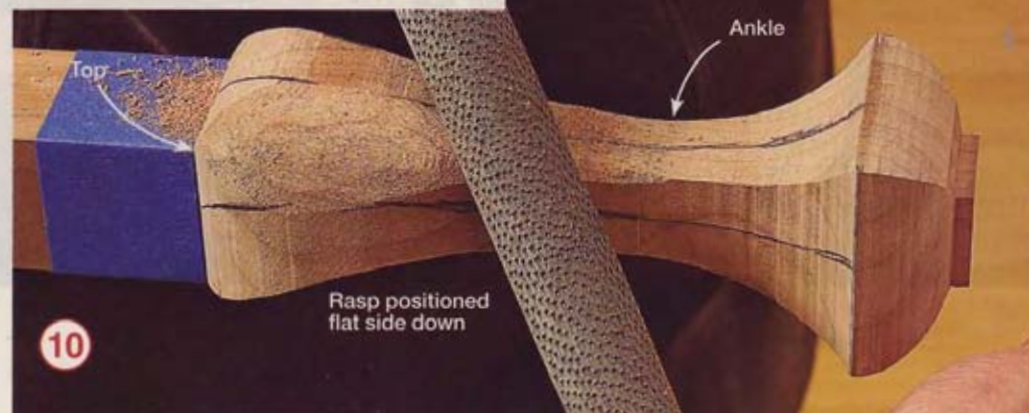

10

6 Repeat Steps 3 and 4 on the front face of the leg. Remove the cutoffs.

7 To define the area for the 1"-diameter pad, make two straight cuts—Cuts 4—1/16" deep into the bottom of the leg on the front and then outside faces.

8 With the front face of the leg up, make Cut 5 from the top of the foot to the straight cut at the bottom to remove the bottom portion of the foot along the inside face. Then, with the outside face of the leg up, repeat the cut to remove the bottom portion of the foot at the back. Now make Cuts 6 to remove the remaining bottom portions of the foot. After making the first Cut 6, tape the cutoff in place to make the second Cut 6. Discard the cutoffs.

You may find it helpful to check the roundness using a compass with the point centered on the pad.

15 To complete shaping the foot, draw a line around the circumference 1" from the bottom of the pad.

16 Using the flat side of the rasp, round over each of the corners of the foot from the marked line to the pad, again blending the areas together to create a round shape.

17 To complete the shaping, use the round side of the rasp to round over the top of the foot from the ankle to the circumference line, leaving a crisp and uniform edge.

18 Finally, examine and feel the leg for any ridges, facets, and deep rasp marks. Blend the areas, taking light strokes with the rasp. Then sand the leg smooth. Start with 80 grit, which quickly removes the remaining rasp marks, and progress through 120, 150, 180, and 220 grits. Now polish off your shapely masterpiece with a stain and clear finish of your choice. ♣

Illustration: **Roxanne LeMoine; Lorna Johnson**

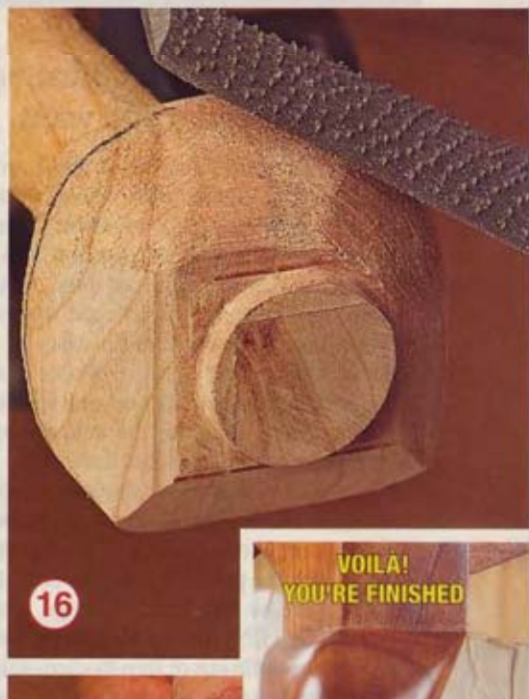



custom color your finishes

A new product helps you tweak stains or film finishes for the exact tint you want.

When matching wood finish colors, sometimes “close” isn’t close enough. Now there’s a versatile colorant to help you do that job: Mixol tinting paste. Unlike stains or dyes, Mixol contains no binder, so you can add it to oil- or water-based stains or film finishes.

As with dyes, you can mix two or more colors for additional shades beyond Mixol’s 32 stock colors. Because the colors come from pigments, they fade less than dyes.

Mixol has limitations, though. Colors cannot be used alone without a binder. (Binders are a component in stains that serve to lock the pigment particles onto the wood surface so they don’t dislodge when you brush on a film finish.) Mixol’s pigment particles can settle out of thin-bodied stains and finishes (such as lacquers and thinned shellac), so stir the solution thoroughly before and during use.

Four ways to use Mixol in your workshop

1 Fine-tune stain colors

Whether you’re matching existing furnishings or stained millwork, color matches don’t always come straight from a can. You may need to add more red, green, or yellow, or perhaps darken the original stain color.

The four red oak sample boards at right show the results of adding 1 teaspoon of Mixol pigment to a half-cup of Varathane pecan stain. Add bold Mixol colors, such as red (10) and maize yellow (6), for the most dramatic changes. For subtle stain color changes, use earth shades, such as Mixol umber (2), brown (3), red (4), yellow (5), chestnut (20), and dark brown (23).

To match an existing finish, start with a stain that’s closest to matching the color you want. Pour enough of this stain to coat your project into a separate container. Then either lighten this base color by thinning it with mineral spirits or darken it by adding black Mixol (1) or darker browns such as tobacco (22) and dark brown (23).

TINT STAIN FOR A COLOR MATCH



Starting with straight Varathane pecan stain (upper left), we added 1 teaspoon of Mixol in various colors to half-cups of stain to change its tint.

Pick a pigment

Mixol pigments range from earth tones to bright primary colors. Some of Mixol’s 32 colors are shown. Oxide pigments(*) resist fading from exposure to sunlight.



CUSTOM-COLOR A DANISH OIL FINISH



Make one can of Danish oil finish do the work of six. To create these five custom-colors, we mixed a quarter-teaspoon of different Mixol shades in quarter-cups of finish.

Practice your color matches on project scrap that's sanded to the final grit used on the wood. To start, apply the stain to the scrap and compare it with the color you're matching. Working under the same type of lighting as where the finished project will be displayed, determine which shades need to be added, usually red, green, or yellow. Add just 10 drops of colorant at a time per cup of stain to build toward a match. Compare scrap samples, as shown at the top of page 52, with the target color while the stain is still moist to estimate how the color will look beneath a film finish.

2 Make a brush-on toner

Add Mixol to any clear film finish to create a toner. A toner is a tinted layer of film finish applied between layers of clear finish to reduce color differences among different boards. Unlike a pigment stain, it doesn't enhance color contrasts between earlywood and latewood in the grain. On quartersawn oak, it equalizes the color between ray flecks and the surrounding surface.

You can make toner from any clear finish, but we decided on $\frac{1}{2}$ -pound cut ultra-blonde shellac because it dries quickly, bonds with most other finishes, and can be

removed with denatured alcohol if you're not satisfied with the color. To create the toner shown below, we first mixed $\frac{1}{4}$ -ounce of shellac flakes with 4 ounces ($\frac{1}{2}$ -cup) of denatured alcohol. To that, we added one teaspoon of dark brown (23) Mixol. This thin coating produced an even color over both the grain and flecks in quarter-sawn oak that had earlier been sealed with thinned lacquer.

MAKE TONER FROM SHELLAC



Shellac tinted with Mixol creates a toner that leaves a uniform color on this quartersawn oak board.

3 Customize an oil finish

Oil-varnish finishes, such as Danish oil, give wood a muted, natural finish, but their color ranges are limited. Adding Mixol to clear or "natural" Danish oil steers the wood color in the direction you want. The oil in the finish helps distribute the pigment, while the small amount of varnish dries to lock it in place.

As shown at left, Mixol colors can increase the amount of red, green, or yellow within a shade of brown. Control the color by starting light and building up darker colors using multiple coats.

CAUTION

Pigment doesn't reduce the flammability of rags soaked in Danish oil. To prevent spontaneous combustion, allow oily rags to dry thoroughly before discarding.

4 Tint water-based finishes

Add bright Mixol colors to water-based finishes to create a translucent topcoat for projects such as toys. Mixol can be added directly to the finish, unlike powdered dyes that first must be dissolved in water to avoid reacting with the finish and forming clumps. Experiment with different colors by starting with one teaspoon of Mixol in a half-cup of water-based finish.

In addition to the violet (11) shown below, choose from primary colors; pink, greens, and oranges; or mix pigments to come up with your own shades. ♣

CREATE FUN FINISHES



Combine Mixol with a water-based clear finish to create a colorful translucent coating that won't yellow with age.

Sources

Mixol: \$4.99 for 20 ml (just over 4 teaspoons), Woodcraft, 800/225-1153, or visit woodcraft.com.



full-view tabletop display case



Add glass shelves or remove them altogether to suit your collection.

Spend a few minutes fine-tuning your tablesaw miter gauge to exactly 45°, and you'll breeze through this project. Along the way, you'll pick up valuable tips on cutting and gluing mitered frames. When you're finished, let the size of the items in your collection determine the number of glass shelves. We'll show you how to finish the edges of the glass shelves right in your own shop. You can easily access the shelves and collectibles through a side door.

Build the case parts

1 From ½"-thick stock, cut the stiles (A), side rails (B), end rails (C), top sides (D), and top ends (E) to the widths and 1" longer than the lengths listed on the **Materials List**. Then with a ⅛"-kerf blade in your tablesaw, cut ⅜"-deep grooves in all the parts, where shown in **Step 1** of **Drawing 1**. Now switch to a ¼" dado blade, and cut ¼" rabbets ⅜" deep, where shown in **Step 2**.

1 FORM THE FRAME PARTS

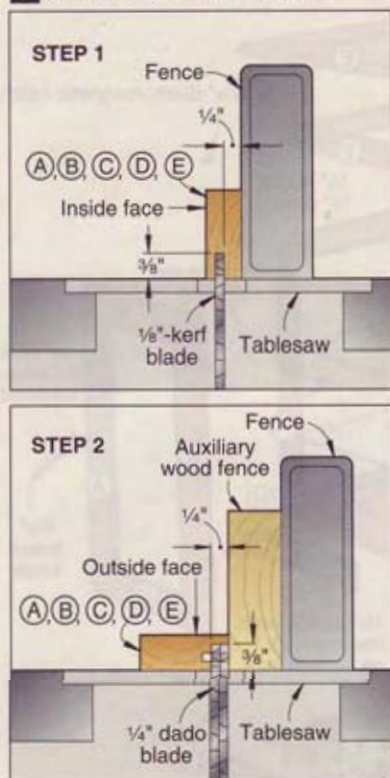

2 CASE FRAMES

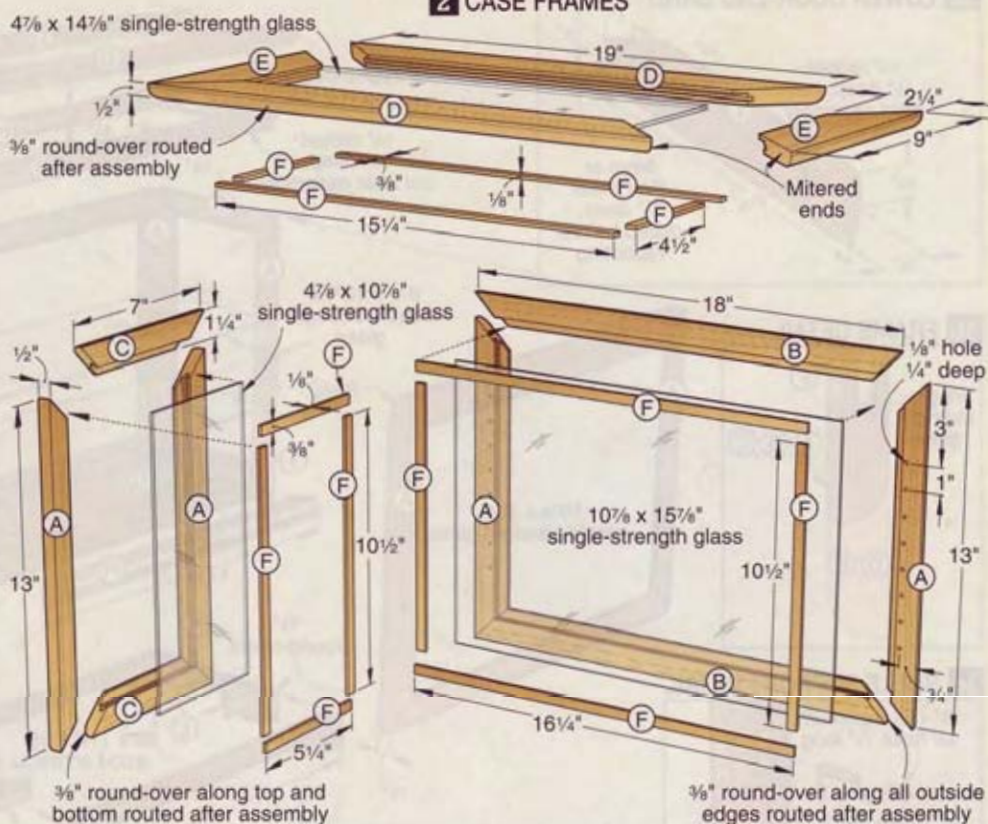

A MITERED STOPBLOCK GUARANTEES ACCURATE PART LENGTHS

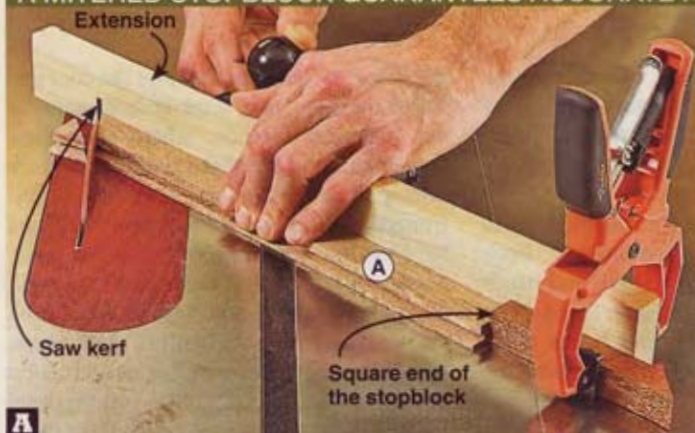

Align one end of a stile (A) with the extension saw kerf. Clamp the stopblock against the other end, and miter the stile.

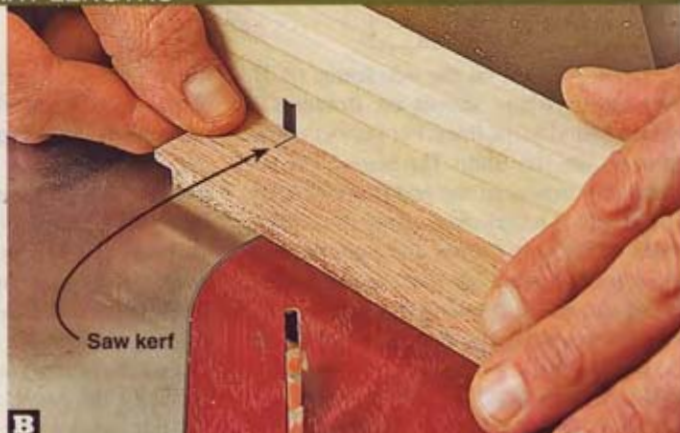

Mark the finished length on the stile (A), and align the mark with the saw kerf. Position the stopblock against the mitered end.

2 To miter the stiles (A) to length, first attach an extension to your table saw miter gauge. Then cut a 45° miter on one end of a stopblock, cutting a saw kerf through the extension. Now miter all the stiles to length, as shown in Photos A, B, and C. Repeat with the side rails (B), end rails (C), top sides (D), and top ends (E).

3 Glue and clamp the side frames (A/B), end frames (A/C), and top frame (D/E) in the arrangement shown on Drawing 2, making sure the frames are flat and square. To simplify your glue-ups, see page 36. With the glue dry, sand the miters smooth.

4 To mark the side frame stiles (A) for shelf support holes, first apply masking tape to the inside faces of the stiles, and mark the top ends. Then lay out the hole centers on the tape, where dimensioned on Drawing 2. Now chuck a 1/8" brad-point bit into your drill press, position the fence 3/4" from the bit center, and drill 1/4"-deep holes. Finish-sand the inside faces of the frames.



With the mitered end of the stile (A) captured by the mitered end of the stopblock, miter the stile to finished length.

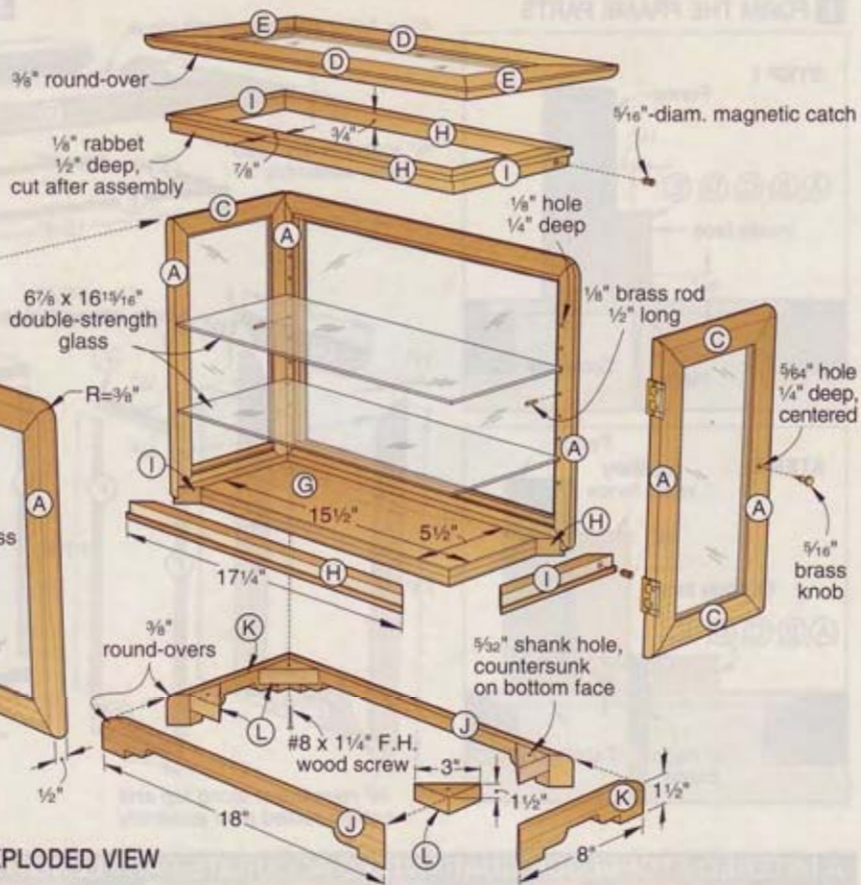
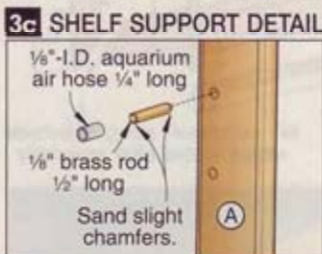
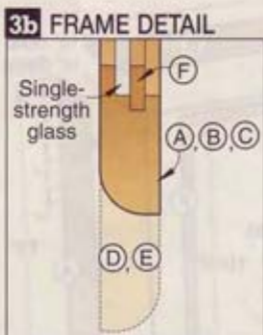
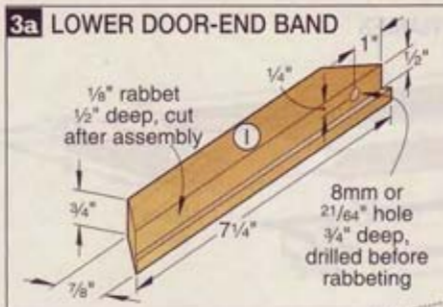

5 Draw $\frac{3}{8}$ " radii on the side frame (A/B) corners, where shown on **Drawing 3**, and disc-sand to the lines. For perfect radius corners, see the **Shop Tip** below. Do not round the corners of the end frames (A/C). Then rout $\frac{3}{8}$ " round-overs along the outside edges of the side frames and *only the outside top and bottom edges* of the end frames, where shown on **Drawing 2**. Now rout $\frac{3}{8}$ " round-overs along the bottom edges of the top frame (D/E).

6 Plane stock to $\frac{1}{8}$ " thick for the glass stop blanks (F), checking for a snug fit in the

frame saw-kerf grooves. Then cut the blanks to size and finish-sand them. Now referring to **Drawing 2**, cut the individual stops to length, and test fit them. Remove the stops and set them aside.

7 From $\frac{3}{4}$ " birch plywood, cut the bottom panel (G) to size. Then from $\frac{3}{4}$ "-thick stock, cut the side bands (H) and end bands (I) to width and 1" longer than listed. Now miter two side and two end bands to fit around the bottom panel. When cutting the bands for the panel, cut the remaining end and side bands to the same lengths.

8 Select two end bands (I) for the door end of the case, and mark hole centers for the magnetic catches, where shown on **Drawings 3** and **3a**. Make sure the parts are mirror images, with the hole centers $\frac{1}{4}$ " from the *bottom* edge of the upper band and $\frac{1}{4}$ " from the *top* edge of the lower band. Mark one "top" and the other "bottom." Then chuck an 8mm or $\frac{21}{64}$ " brad-point bit into your drill press and drill $\frac{3}{4}$ "-deep holes. Now, referring to **Drawing 3**, glue and clamp one set of bands (H, I) to the bottom panel (G) and make an open frame from the other set of bands, keeping the door-end bands in mirror-image orientation.

9 To rabbet the top outside edges of the bottom (G/H/I) and the bottom outside edges of the band frame (H/I), where shown on **Drawing 3**, attach an auxiliary fence to your table saw and position it so a $\frac{1}{8}$ "-kerf saw blade just grazes the surface. Adjust the blade to cut $\frac{1}{2}$ " deep and cut the rabbets.

Note: Before cutting the rabbets, dry-assemble the side frames (A/B) and end frames (A/C). Make sure the frames are flush at the ends. Measure the inside width and length of the case. These dimensions should be $\frac{1}{4}$ " less than the width and length of the bottom and band frame. If your dimensions are different, make the necessary adjustments to the rabbet widths.

SHOP TIP

How to rout perfectly round corners

Disc-sanding to a pencil line is the easiest way to round a corner. But for the corner to look good, you have to carefully sand to the layout line. To round the corners of the side frames (A/B) in this project, you'll have to duplicate that first corner seven more times. Here's an easier way.

First, chuck a round-over bit ($\frac{3}{8}$ " for this project) into your table-mounted router, and position the fence flush with the bit pilot bearing. To prevent chip out and keep the frame square to the fence and the router-table top, clamp it to a 2x4 follower block, as shown at *right*.



Make the base

1 From $\frac{3}{4}$ "-thick stock, cut the base sides (J) and base ends (K) to the width and 1" longer than the lengths listed. Then chuck a $\frac{3}{8}$ " round-over bit into your table-mounted router, and rout the top outside edge of each part. Miter the parts to length.

2 Make four photocopies of the **Base End Patterns** on the *WOOD Patterns*® insert. Adhere them with spray adhesive to the base parts J and K. Then bandsaw and sand the parts to shape.

3 Cut a $\frac{3}{4} \times 1\frac{1}{2} \times 12$ " blank for the corner blocks (L), and cut four blocks, as shown in **Photos D and E**. Then drill a $\frac{5}{32}$ " countersunk shank hole, centered in each block, where shown on **Drawing 3**.

4 Glue and clamp the base sides (J) and base ends (K) in the arrangement shown on **Drawing 3**. Then glue and clamp the corner blocks (L) with the countersinks on the bottom. With the glue dry, finish-sand the base.

Assemble the case

1 Place the bottom (G/H/I) on your workbench. Apply a thin bead of glue to the

FOR CORNER BLOCKS, MITER, FLIP, MITER, AND REPEAT

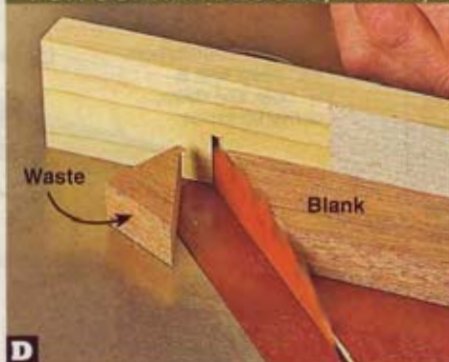

D Align the end of the blank for the corner blocks (L) with the saw kerf in the extension, and cut off a waste triangle.



E Flip the blank, align the end of the first cut with the saw kerf, and cut a corner block (L). Flip and cut three more times.

side of one side band rabbet and the rabbet in the end band *without* the hole for the magnetic catch. Then apply glue to the edge of one stile (A) of an end frame (A/C). Now assemble the end frame, side frame (A/B), and bottom, as shown in **Photo F**. Make sure the frames are fully seated in the bottom rabbet. Next add the band frame (H/I) as shown in **Photo G**. Finally, glue and clamp the second side frame in place, as shown in

Photo H. To make sure the case is square at the door end, dry-fit the second end frame (the door) in the opening.

2 With the glue dry, finish-sand the outside of the case. Then remove the dry-fit end frame (A/C). Now placing the top (D/E) upside down on riser blocks for clamp head clearance, glue the case to the top, as shown in **Photo I**. Next add the base (J/K/L), as shown in **Photo J**.

STEP-BY-STEP CASE ASSEMBLY

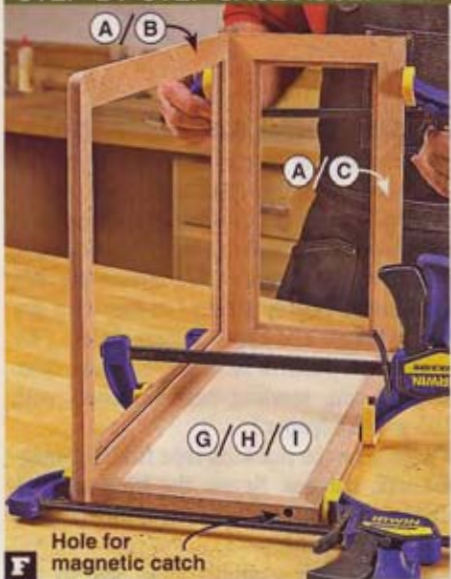

F Glue and clamp a side frame (A/B) and an end frame (A/C) to each other, flush at the outside corner, and to the bottom (G/H/I).

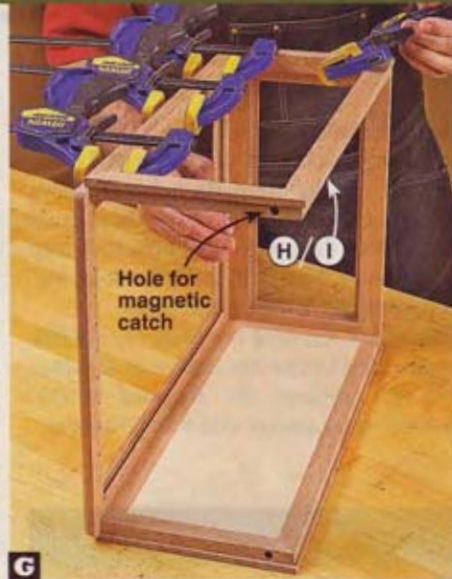

G Apply glue to the side band and end band rabbets and clamp the band frame (H/I) to the side frame (A/B) and end frame (A/C).



H Apply glue to the edge of the end frame stile (A) and the side band (H) rabbets, and clamp the side frame (A/B) in place.



I Squeeze a thin bead of glue onto the top of the band frame (H/I), center the case on the top (D/E), and clamp the case in place.

J Clamp the base, centered, to the case. Using the corner block (L) holes as guides, drill pilot holes and screw the base in place.



4 BEVELING THE DOOR EDGES

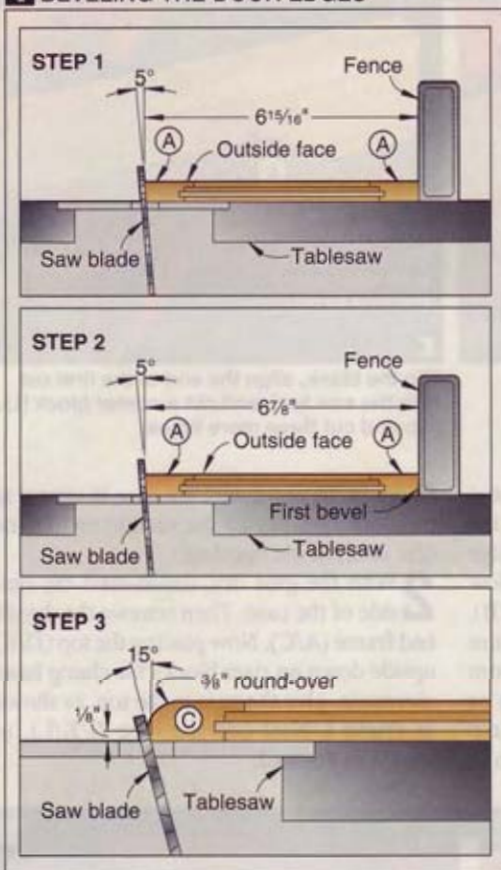

5 DOOR (Inside face shown)

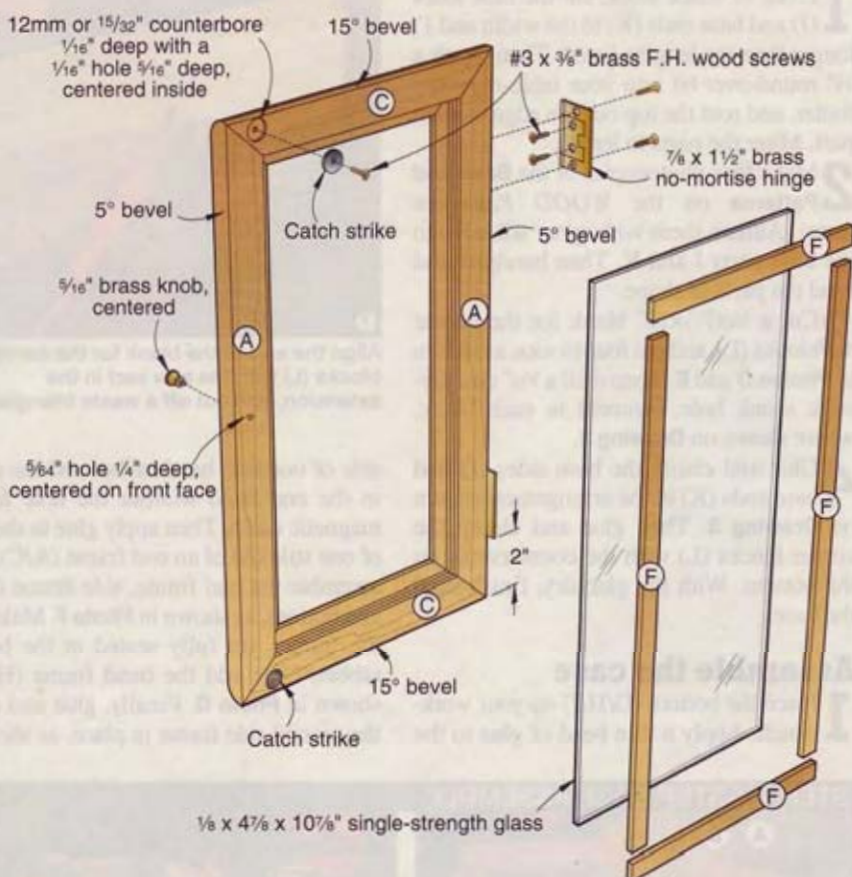

Fit the door

1 Retrieve the door (A/C) and bevel-rip one stile (A), where shown in **Step 1** of **Drawing 4**. Then bevel the door to finished width, as shown in **Step 2**. Now bevel the top and bottom door rails (C), where shown in **Step 3**. Next drill a $\frac{3}{64}$ " hole $\frac{1}{4}$ " deep for the knob, where shown on **Drawing 3**.

2 Install the hinges on the door, where shown on **Drawing 5**, and hang it in the case opening. Press the magnetic catches

into the holes in the end bands (I). Then to mark the positions of the catch strikes on the door, see the **Shop Tip** below. Remove the door, chuck a 12mm or $\frac{15}{32}$ " brad-point bit into your drill press, and drill $\frac{1}{16}$ "-deep counterbores. Now drill $\frac{1}{16}$ " pilot holes $\frac{5}{16}$ " deep, centered in the counterbores.

Note: When screwing the hinges to the side frame stile (A) and the strikes to the door rails (C), replace the supplied $\#3 \times \frac{5}{8}$ " flathead wood screws with $\#3 \times \frac{3}{8}$ " screws.

Apply finish and assemble

1 Remove the hinges from the door and finish-sand the case and door, where needed. Cover the magnetic catches with small circles of masking tape. Apply a stain if desired. (We applied Varathane no. 245 Traditional Cherry stain.) Let the stain dry for 24 hours, and apply a clear finish. (We applied two coats of satin polyurethane from a spray can, sanding between coats with 220-grit sandpaper.)

2 Remove the masking tape from the magnetic catches. Screw the hinges, catch strikes, and knob to the door. Hang the door in the case opening.

3 Have single-strength glass cut to the sizes shown on **Drawings 2** and **5** for the case sides, end, door, and top. Have double-strength glass cut to the size shown on **Drawing 3** for the shelves. To remove the sharp edges from the shelves and give them a finished look, see the **Shop Tip** opposite page, top. Install the glass and glass stops (F), where shown on **Drawing 3b**, and as shown in **Photo K**.

Note: Before ordering glass for the shelves, carefully measure the inside length of the bottom (G/H/I), and order shelves with a length $\frac{1}{16}$ " less than this dimension.

SHOP TIP

Catch strike location made easy and dead-on

When locating the catch strikes on the door in this project, you'll want to make sure they align with the magnets and clear the edge of the rabbets in the end bands (I). Here's how to ensure exact placement.

With the magnetic catches in place, insert the strike screws in the strikes and position them on the catches, $\frac{1}{16}$ " from the rabbet bottom, as shown at right. Then close the door, pressing it onto the screw tips. The screws mark the centers of the strike counterbores and pilot holes.

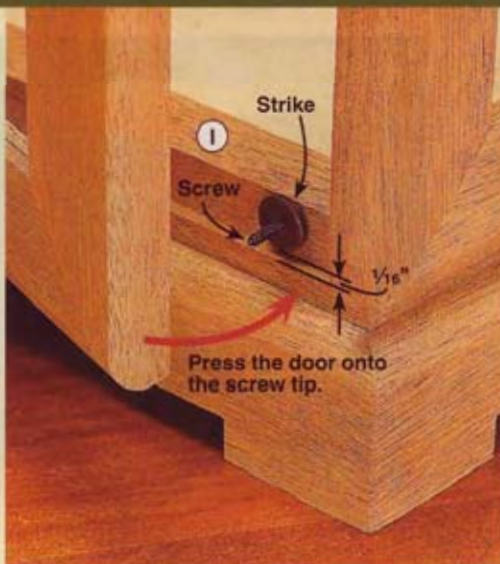

SHOP TIP

A little extra effort yields finished glass edges

Quickly removing the sharp edges from the glass shelves in this project with fine sandpaper and a sanding block makes them safe to handle. But with just a little extra work, you can give them a smooth, uniform, good-looking ground edge. Here's how.

First, adhere 220-grit wet/dry sandpaper to a smooth, flat, water-resistant substrate with spray adhesive. (We used a piece of $\frac{3}{4}$ "-thick melamine-coated particleboard.) To accommodate the length of the shelves, use two sheets in the arrangement shown at right. Then dribble water onto the sandpaper. Wearing leather gloves to protect your hands, work one edge of the shelf back and forth, using moderate pressure and long even strokes. Keep the sandpaper wet. Periodically inspect the edge by wiping it with a dry cloth. When all shiny spots have been replaced by a dull sheen, tilt the shelf 45° one way and then the other, giving it a few strokes in each position to remove the sharp edges. Repeat on the other three edges.



INSTALL THE GLASS AND STOPS

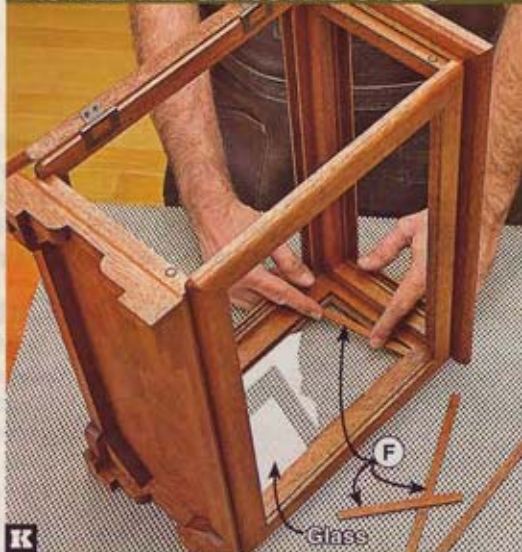

Laying each case face flat on your workbench, position the glass in the frame and press the glass stops (F) into the grooves.

4 From $\frac{1}{8}$ " brass rod, cut eight $\frac{1}{2}$ "-long shelf supports with a hacksaw. File or sand a slight chamfer on both ends of each support, where shown on **Drawing 3c**. Press the shelf supports into the holes in the side frame stiles (A). Then cut $\frac{1}{4}$ "-long pieces of $\frac{1}{8}$ " plastic aquarium air hose and slide them over the supports. Install the shelves. Now give the display case a prominent piece of tabletop real estate and proudly display a few of your favorite things. 🍀

Written by Jan Svec with Chuck Hedlund
Project design: Kevin Boyle
Illustrations: Roxanne LeMoine; Lorna Johnson

Materials List

Case	FINISHED SIZE			Matl.	Qty.
	T	W	L		
A* stiles	$\frac{1}{2}$ "	$1\frac{1}{4}$ "	13"	M	8
B* side rails	$\frac{1}{2}$ "	$1\frac{1}{4}$ "	18"	M	4
C* end rails	$\frac{1}{2}$ "	$1\frac{1}{4}$ "	7"	M	4
D* top sides	$\frac{1}{2}$ "	$2\frac{1}{4}$ "	19"	M	2
E* top ends	$\frac{1}{2}$ "	$2\frac{1}{4}$ "	9"	M	2
F glass stop blanks	$\frac{1}{8}$ "	$\frac{3}{8}$ "	18"	M	14
G bottom panel	$\frac{3}{4}$ "	$5\frac{1}{2}$ "	$15\frac{1}{2}$ "	BP	1
H* side bands	$\frac{3}{4}$ "	$\frac{7}{8}$ "	$17\frac{1}{4}$ "	M	4
I* end bands	$\frac{3}{4}$ "	$\frac{7}{8}$ "	$7\frac{1}{4}$ "	M	4
Base					
J* sides	$\frac{3}{4}$ "	$1\frac{1}{2}$ "	18"	M	2
K* ends	$\frac{3}{4}$ "	$1\frac{1}{2}$ "	8"	M	2
L* corner blocks	$\frac{3}{4}$ "	$1\frac{1}{2}$ "	3"	M	4

*Parts initially cut oversize. See the instructions.

Materials key: M—mahogany, BP—birch plywood.
Supplies: #8x $1\frac{1}{4}$ " flathead wood screws, #3x $\frac{3}{8}$ " brass flathead wood screws (6), spray adhesive, single-strength glass, double-strength glass, $\frac{1}{8}$ "-diameter brass rod, $\frac{1}{8}$ "-inside-diameter plastic aquarium air hose.
Blade and bits: Stack dado set, $\frac{3}{8}$ " round-over router bit, $\frac{1}{8}$ " brad-point bit, 8mm or $\frac{3}{16}$ " brad-point bit, 12mm or $\frac{1}{2}$ " brad-point bit.

Source

Hardware: $\frac{3}{8}$ x $1\frac{1}{2}$ " statuary bronze no-mortise hinges no. 28670, \$1.79 pr.; $\frac{3}{16}$ "-diameter magnetic catches no. 29272, \$5.79 pack of four; #3x $\frac{3}{8}$ " brass flathead wood screws no. 30482, \$2.49 pack of 25; $\frac{3}{16}$ " brass knobs no. 27748, \$2.29 pack of 2. Call Rockler at 800/279-4441, or go to rockler.com.

Cutting Diagram



$\frac{1}{2}$ x $7\frac{1}{4}$ x 96" Mahogany (2.7 bd. ft.) *Plane or resaw to the thickness listed in the Materials List.



$\frac{3}{4}$ x $5\frac{1}{4}$ x 60" Mahogany (2.5 bd. ft.)



$\frac{3}{4}$ x 12 x 24" Birch plywood

an intarsia showpiece regal eagle

Your patriotism and creativity will soar with this majestic wall hanging, designed by incomparable intarsia artist Judy Gale Roberts.



Never tried intarsia? Here's a perfect opportunity to spread your wings and build a masterpiece right out of the chute. Though this project appears to have numerous feather parts and complex

wing contours, it's simpler than it looks. By scrollsawing just 11 parts total for the bottom of the wings and tail and grooving them with a small gouge or rotary tool, you'll achieve the look of 62 feathers across the

wingspan. Also, because many of the parts have a continuous contour across them, you'll find it easy to shape them as groups. Let's dive in!



The eagle has a 24" wingspan. If you wish to make a larger one up to 50" long, it's simple. See the sidebar "How to create a bigger eagle" on page 64.

Cut out the parts

1 Make five copies of the full-size eagle patterns from the *WOOD Patterns*® insert. Tape together one set of the patterns, joining them where shown. Set this pattern aside as a master for reference.

2 From the remaining copies, cut the pattern pieces, identified by the *solid* (primary scrollsaw) lines. There are three pieces near the top of each wing that have long dashed (secondary scrollsaw) lines on them. For continuous grain flow, cut them out along the solid lines. Later, you'll scrollsaw them apart along the dashed lines.

3 Round up enough stock of the needed types and thicknesses for the project. Each pattern piece has a letter on it identifying the wood type, an arrow showing the grain direction, and an initial thickness. Judy used walnut for the dark-toned wings, body, and legs; aspen for the white tail and head, and yellowheart for the beak and feet.



CUT THE PARTS TO SHAPE



A Using a #2 reverse-tooth blade to minimize bottom tear-out, scrollsaw the parts to shape, cutting along the center of each line.

Feel free to use other wood species with similar colors. As an alternative to yellow-heart, you can use yellow cedar, canary wood, or pine colored with a yellow dye. In place of aspen, consider holly.

4 For each pattern piece, align the arrow on the pattern with the grain on the wood, and move the pattern around until you find the area with the best color and most interesting grain. Adhere the patterns using spray adhesive. Then drill a $\frac{1}{8}$ " hole through the head to receive a dowel for the eye, where shown on the pattern and Drawing 1.

5 Fit your scrollsaw with a #2 reverse-tooth blade, and make sure that it's square to the table. Then cut the parts, as shown in Photo A. Also, cut apart the upper wing pieces along the dashed lines. Sand off splinters with 120 grit.

6 Cut the full-size spacer pattern for the left leg and foot from one of your copies. Spray-adhere the pattern to a piece of $\frac{1}{4}$ " hardboard. Then scrollsaw the spacer to shape, and set it aside.

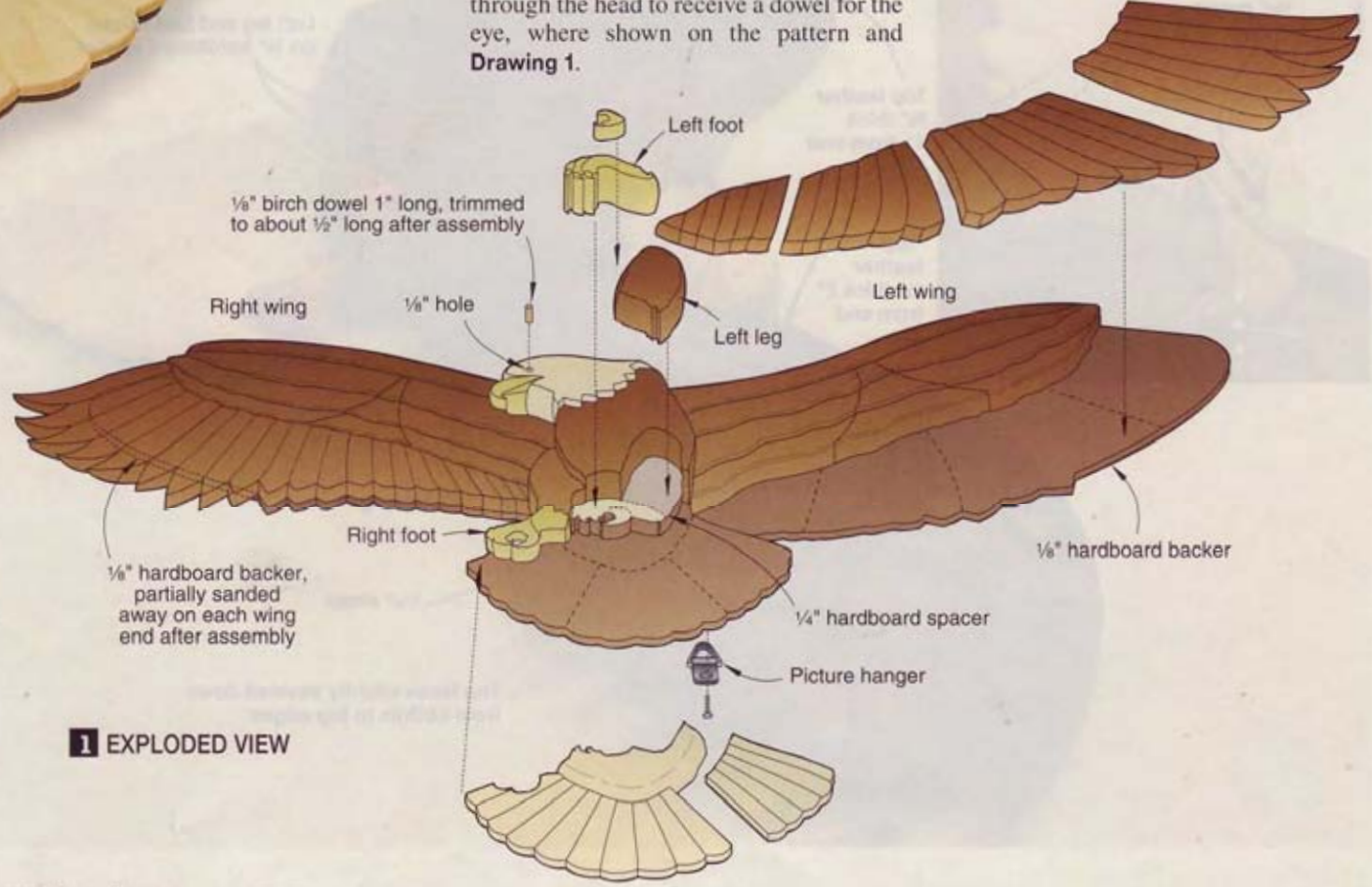

1 EXPLODED VIEW

Sand the parts to shape

1 Starting with the top feather piece of the right wing and referring to the **Contouring Guide** below, sand the part to shape, as shown in **Photo B**, removing the pattern as you sand. We used a 3"-diameter pneumatic sanding drum (see **Sources**), inflated to 5 psi, with a 120-grit sleeve to shape the parts. An oscillating spindle sander or sanding drum in your drill press also will work.

Note: Do not sand completely around the edges of parts to the back face, which will leave gaps between the parts.

2 To contour the three rows of feathers below the part you just shaped, adhere the three parts of each row to a piece of scrap using double-faced tape, as shown in **Photo C**. Noting the approximate $\frac{1}{16}$ " steps between the rows and the top feather part, where shown on the **Contouring Guide**, sand the parts to shape, angling the top faces down slightly from the bottom to top edges, and lightly rounding the edges. Position the parts you're shaping against the previously

BEGIN THE CONTOURING



B Taper the top feather of the right wing from a thickness of $\frac{1}{2}$ ", 2" from the left end, to $\frac{1}{4}$ " at each end. Round over the front edge.

PREPARE FOR GROUP SANDING

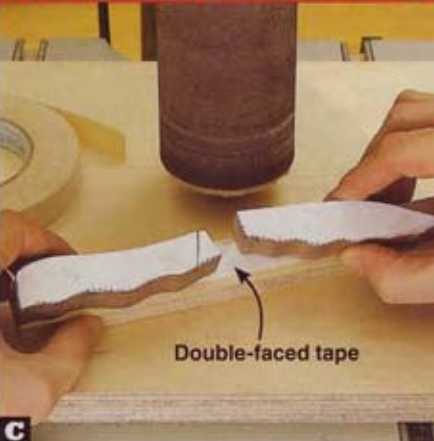

C To save time, sand parts that have a continuous contour as a group. Adhere the parts to scrap using double-faced tape.

contoured parts, as needed, to check your sanding progress. Remove the parts from the scraps.

3 In the same way, contour the three feather parts at the bottom as a group to

meet about $\frac{1}{16}$ " below the top face of the parts above.

4 Using a white or light-colored pencil, draw lines on the bottom feather parts, where shown on the pattern by the dotted

Contouring Guide

HEAD DETAIL

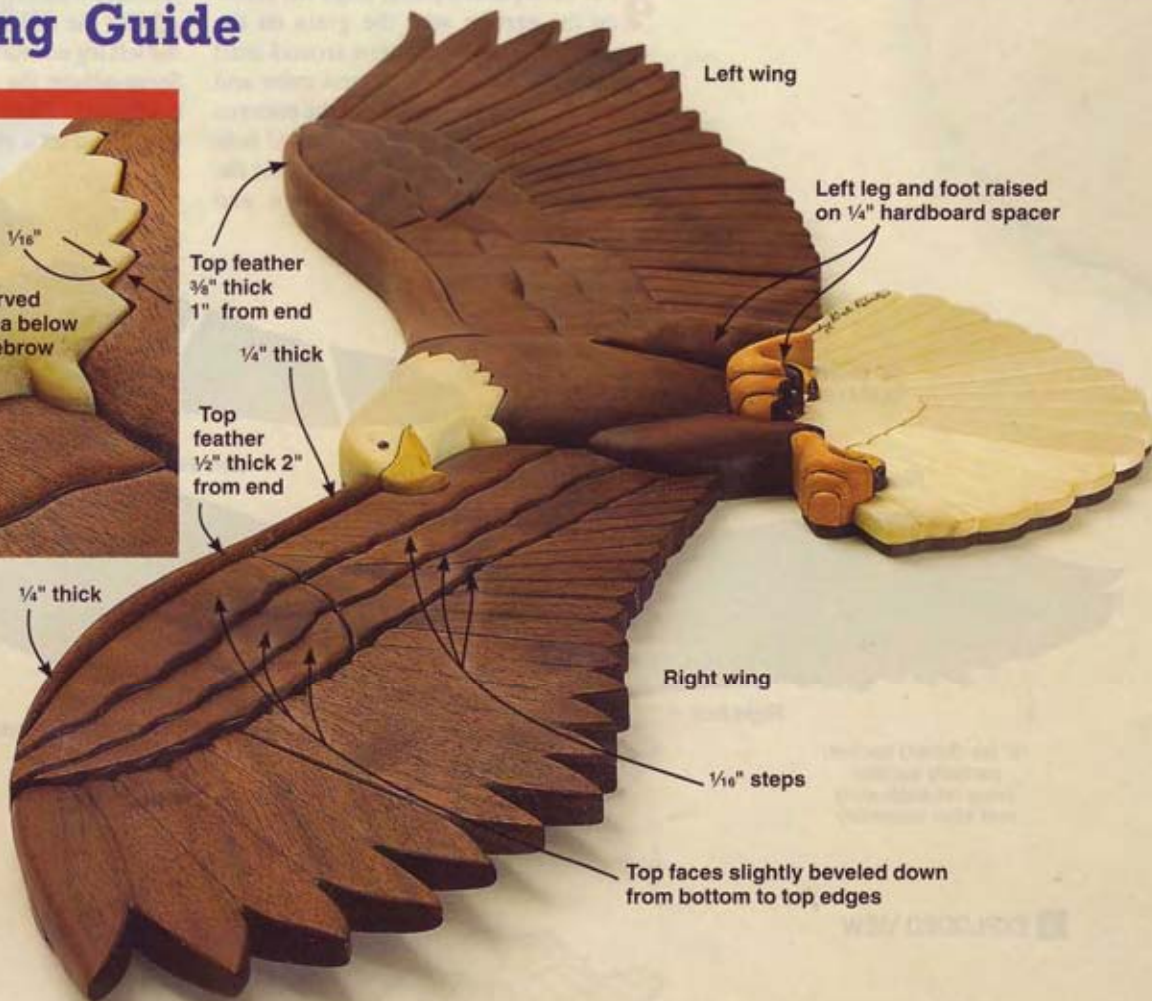
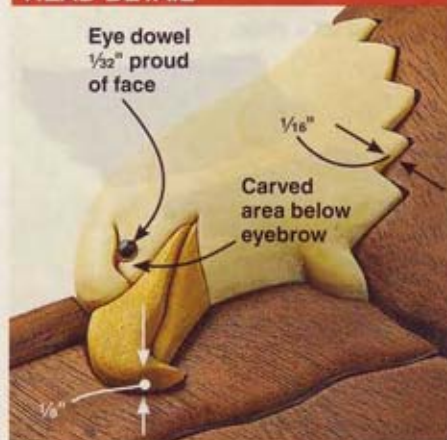

LAY OUT AND EASILY FORM THE GROOVED FEATHER DETAILS

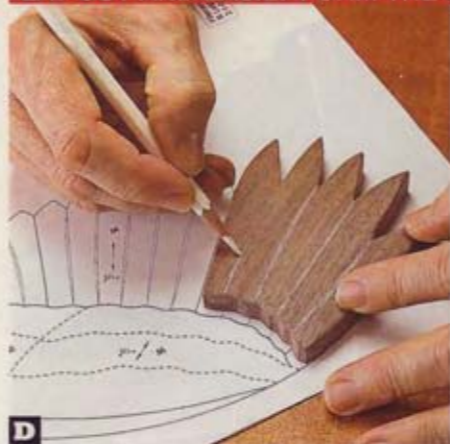

D Positioning each bottom feather part on the pattern as shown, draw lines for the feather details, where indicated by the dotted lines.



E Using a small V-parting carving gouge, cut grooves along the marked lines, increasing in depth to about $\frac{1}{16}$ " at the center.

lines, and as shown in **Photo D**, for creating the feather details. Then, using a small V-parting carving gouge, cut grooves along the marked lines, as shown in **Photo E**. As an alternative, you can groove the pieces

using a V-groove router bit in a rotary tool, or scrollsaw the individual feathers apart and lightly chamfer the edges by sanding.

5 Using the same process as for the right wing, contour the left-wing parts to

SHAPE THE POWERFUL FEET

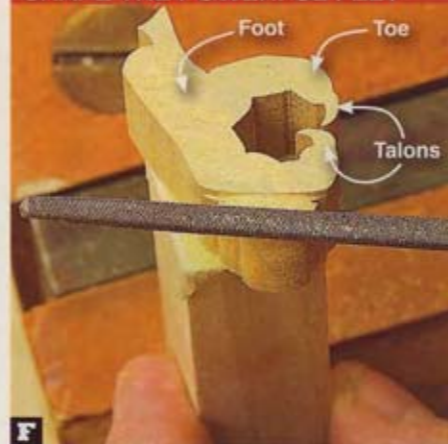

F Round over the edges of each foot and shape the toes and talons using a small square file. Sand to remove the file marks.

shape, except taper the $\frac{1}{2}$ "-thick top feather part to about $\frac{3}{8}$ " thick at the right end, starting 1" from the end.

6 Adhere the three large bottom tail feather parts and the small tail piece, located in the right foot, to a scrap with double-faced tape. Sand the parts to a slightly concave shape with thicknesses of about $\frac{3}{16}$ " at the sides and $\frac{1}{8}$ " at the center. Note that the right piece stands about $\frac{1}{16}$ " proud of the adjacent wing part, where shown on the **Contouring Guide**. As before, draw lines for the feather details, and form the grooves.

7 To complete the tail, position the three large bottom pieces against the large top part. Mark the contour of the bottom pieces along the bottom edge of the top part. Now adhere the top part and the small piece above it, located in the left foot, to a scrap. Sand the pieces to a thickness of about $\frac{1}{2}$ ", and then round over the large piece, staying just above the marked line on the bottom edge.

8 Using the contoured wing and tail parts as reference points, and referring to the **Contouring Guide**, mark and sand the legs, feet, body, head, and beak to shape. (For the feet, we found it easiest to sand them to approximately $\frac{3}{8}$ " thick, and then shape them with a file, as explained in the next section.) Make sure you place the left leg and foot on the $\frac{1}{4}$ " hardboard spacer before marking the contour lines on these parts. Sand the head and body together. Then, to make the head feathers stand out, remove the head and sand the top of the body so it meets about $\frac{1}{16}$ " below the head.

Add the simple details

1 Adhere each foot to a small wood scrap in your vise with double-faced tape. Then, referring to the **Contouring Guide** and pattern, shape the feet, toes, and talons using a file, as shown in **Photo F**.

FOOT AND TALON DETAIL



TAIL DETAIL



GIVE THE EYE SOME RELIEF



Using a straight carving gouge or small chisel, remove a little material below the eyebrow to create a shadow area.

2 To create a shadow area below the eyebrow, shave away a little material, as shown in **Photo G**.

3 Cut a 1"-long piece from a 1/8"-diameter birch dowel for the eye. Sand one end of the dowel round. Then glue the dowel in the 1/8" hole in the head with the round end projecting about 1/32" above the chiseled surface on the face, where shown on the **Contouring Guide**. After the glue dries, trim the dowel flush at the back.

4 Using a dark-brown permanent marker or woodburner, color the talons, where shown on the **Contouring Guide** and as shown in **Photo H**. Then color the end of the eye dowel.

Finish up

1 Using 180-grit sandpaper followed by 220-grit, hand-sand the parts with the grain to remove any scratches or roughness. Then remove the dust.

2 Apply three coats of a wiping varnish to the parts, including the bottoms, using a 1" foam brush. (We used Bartley Gel Varnish, Clear Satin.) Following the time schedule on the can, wipe off the excess and buff the parts with soft paper towels or clean

TINT THE TALONS



Color the talons and the joints between the toes using a medium-point, dark-brown permanent marker.

rag until they're nearly dry to the touch. Let each coat dry for 6 hours.

3 From 1/8" tempered hardboard, cut a 12x26" piece for a backer. Assemble the eagle, centered, on the backer. Check the fit and transition between all of the parts, and make any final adjustments, as needed. Then trace around the eagle. When tracing along the bottom of the wings, you do not need to go in and out of the V-shaped openings along an approximately 5"-long area at the ends. Simply draw a line along the tips of the feathers in these areas. (You'll partially sand away the backer along these lengths after gluing the eagle in place.) Carefully slide the parts off the hardboard, keeping the pieces together. Cut the backer to shape, scrollsawing just inside the marked line. Sand the edges smooth.

4 Center the eagle on the backer so there's an even overlap all around. Then glue each piece to the backer using a couple of drops of yellow woodworking glue.

5 Finally, to give the wings an upswept appearance at the ends, partially sand away the backer and taper the trailing feathers toward the tips, where shown in **Photo I**, using a 10" disc sander, stationary belt

GIVE THE WINGS SOME LIFT



Sand away the backer and taper the trailing feathers at the end of each wing over the area shown to create an upswept look.

sander, or portable belt sander clamped upside down in your vise. Sand to 220 grit. Then apply finish to the sanded surfaces of the feathers. Now attach a picture hanger to the backer, where shown on the pattern, hang your winged treasure where you wish, and admire it and your artistry with pride. ♣

Written by **Owen Duvall** with **Kevin Boyle**
Project design: **Judy Gale Roberts**
Illustration: **Roxanne LeMoine; Lorna Johnson**

Supplies: Spray adhesive; double-faced tape; 1/8"x12x26" tempered hardboard; 1/8"-diameter birch dowel 1" long; medium-point, dark-brown permanent marker; picture hanger.

Blade and bit: #2 reverse-tooth scrollsaw blade, V-groove router bit when using a rotary tool to cut grooves in the bottom feather parts.

Source

Pneumatic sanding drum and adapter. 3x8" pneumatic drum no. FF43080, \$49.95; drill-press drum adapter no. FF43081, \$16.95; 120-grit 3x8" sanding sleeve no. PU00752, \$2.75. Call or click Klingspor's, 800/228-0000; woodworkingshop.com.

See more
Intarsia Patterns
at
woodmagazine.com/intarsia



How to create a bigger eagle

By simply enlarging the patterns and making a few minor parts changes, you can scale up the eagle. Here's how.

■ Have the full-size patterns in the insert enlarged to the desired size and copied in the needed quantities. For example, to increase the eagle from approximately 24" long to 36" long, enlarge the patterns 150%. Although you can have the patterns enlarged at a local print center, we found it more economical to buy enlarged patterns from Judy Gale Roberts. Call 800/316-9010 (865/428-8875 if outside the

U.S.); or click intarsia.com. Judy has patterns available for 37"- and 50"-long eagles.

■ To maintain the three-dimensional look for the enlarged eagles, increase the initial and final thicknesses of all parts 1/4".

■ To provide increased stiffness to prevent loosening of parts, use 1/4" instead of 1/8" hardboard for the backer that you'll glue the shaped parts to, where shown on **Drawing 1**. Also, go with a 3/16" dowel in place of a 1/8" dowel for the eye.



how to master dadoes, grooves, and rabbets

These common cuts can prove uncommonly difficult in joint-making. Sloppy fits, uneven edges, and splintered wood point to poor execution. All you need are tools already in your shop.

Dadoes, grooves, and rabbets form the backbone of so many woodworking projects, from a simple picture frame to the cherry bookcase on page 38. Fundamentally and structurally sound, they're reliable standards in case construction and any project that features shelves, drawers, or dividers. We'll walk you step-by-step through the techniques so you can produce flawless, tight-fitting joints on your projects.

Select your tools of choice

The tools and method you choose to cut dadoes, grooves, and rabbets will vary based on which tools you own and whether the resulting joint will be seen in your final project. (For a comparison of the pros and

cons of these tools, see the chart on page 66.) Keep in mind that you can cover up some joints with face frames, or make a

merely good dado better with special cleanup tools. (See "Dado-cleanup bits remove table saw blemishes," page 69.)

DADOES, GROOVES, AND RABBETS: WHAT'S THE DIFFERENCE?

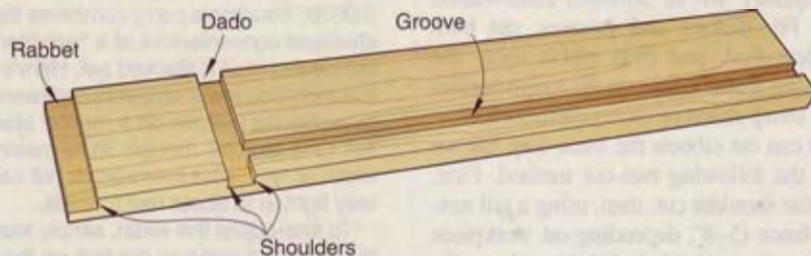

Although similar in structure, these cuts differ due to their placement within a board. Rabbets form an L-shaped recess along an edge or end. Dadoes have two shoulders and run across the grain. Grooves also have two shoulders, but run with the grain.

COMPARING FIVE WAYS TO CUT DADOES, GROOVES, AND RABBETS

Tool	Performance results		Cost	Other uses
Stacked dado set	Pros: Cleanest cut of saw blades; can be shimmed to exacting widths.	Cons: Leaves triangular grooves in bottom corners; needs backer board to avoid tear-out across grain.	\$80-\$250.	Cutting tenons, box joints, half-laps, shiplaps, and tongue-and-groove joints.
Adjustable dado blade	Pros: Quick and easy to adjust width; inexpensive.	Cons: Uneven bottoms; needs backer board to prevent tear-out across grain.	\$50-\$80.	Cutting tenons, half-laps, and shiplaps, but quality suffers.
40- or 50-tooth combination blade	Pros: No need to purchase or install dado set; creates clean rabbets when machining in perpendicular cuts.	Cons: Repeated passes could create inaccurate widths; saw marks need to be cleaned up; time-consuming; needs backer board to prevent tear-out across grain.	\$10-\$80.	Ripping and crosscutting in regular use of tablesaw.
Straight router bit	Pros: Clean cuts with square shoulders; accurate when bit size matches channel size.	Cons: Deep cuts require time-consuming multiple passes; needs backer board to avoid tear-out across grain.	\$5-\$20 for a single bit; \$30-\$100 for a set of 6-9 bits.	Mortising, plunge cuts, template routing, and flattening rough stock.
Rabbeting router bit	Pros: Machines clean rabbets, in router table or hand-held router; quicker setup than straight router bit.	Cons: Deep cuts require time-consuming multiple passes; needs backer board to avoid tear-out across grain; lifts veneer on sheet goods.	\$10-\$40 for a single bit; \$20-\$60 for multi-bearing sets.	No other uses recommended.

Tablesaw delivers quick, accurate channels

In the *WOOD*® magazine shop we turn first to the tablesaw for cutting dadoes, grooves, and rabbets. Typically, it takes less time to install and adjust a dado set than it does to prep a router. And, we prefer the tablesaw's ability to quickly cut channels and handle most sizes of boards or panels.

You have two options in dado sets: stacked or adjustable. The stacked sets—which we prefer—reliably deliver a square, clean cut. Of course, higher-priced sets typically produce the cleanest cuts with flat bottoms and square, no-tear-out shoulders. Most stacked dado sets, however, leave tiny, triangular “ear marks” in the bottom corners caused by the beveled teeth of the outer blades.

Adjustable dado blades (sometimes called “wobbler” blades) tempt you with low prices and quick setup. But these sets come with serious drawbacks: They create concave or ridged bottoms and unsquare corners that need considerable cleanup.

You also can make all three cuts with a good quality 40- or 50-tooth combination blade. For dadoes and grooves, cut both shoulders first, and then nibble away the remaining waste. Clean up the rough bottom with a sharp chisel or router cleanout bit.

You can cut rabbets the same way, but we prefer the following two-cut method. First, make the shoulder cut; then, using a tall auxiliary fence (5–8", depending on workpiece height), adjust the blade height and cut the bottom perpendicular to the shoulder. To avoid kickback, be certain the waste side is not trapped between the fence and the blade.

Tips for top-notch tablesaw results

■ Tip 1: Adjust your saw for clean, accurate cuts.

To ensure accuracy and squareness before making any cuts, first make sure you have your tablesaw set up correctly. The miter slots and rip fence must be perfectly paral-

lel to the blade, and the miter gauge must be set perpendicular to the blade. Even the slightest deviation will affect the fit and finish of the joint.

■ Tip 2: Choose a good dado set for best results.

Stacked dado sets contain two outside blades, several chippers, and metal or plastic shims. (If your set does not include shims, make your own from thin paper or card stock.) Determine the width of your channel; then add the requisite number of chippers between the outer blades (see illustration, right) on the arbor and tighten. Don't worry if the arbor washer won't fit—leave it off. It's more important to get the arbor nut tightened to full threads.

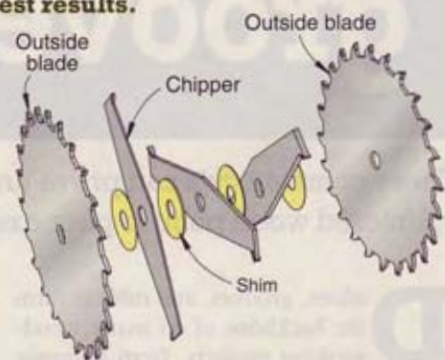

Freud bridges gap between stacked sets and wobblers

Freud's Dial-A-Width dado set (model SD608; freudtools.com) combines the shimless conveniences of a “wobbler” with the clean cut of a stacked set. Here's how it works: You stack chippers between the outer blades just like on a regular stacked set. One caution, though: At its maximum width of 1 3/16", your saw's arbor nut can only tighten to about half threads.

To fine-adjust the width, simply loosen the arbor nut and turn the hub on the outer blade, as shown at right. Each “click” on the hub changes the width by .004", much like inserting an actual shim.



■ **Tip 3: Test and adjust your dado set for dead-on cuts.**

For dados and grooves, cut a test scrap piece to check for fit. Adjust the fit by adding or removing shims and chippers. We like to cut dados and grooves slightly undersized (within a few hundredths of an inch); then sand the inserted workpiece until it fits snugly. Be sure to sand the entire workpiece to the same grit, or your finish will reveal where you stopped sanding. Be careful not to sand through the veneer face on plywood.

■ **Tip 4: Use a zero-clearance insert for tear-out free cuts.**

Here's how to make a zero-clearance insert plate for your saw's blade throat. With the dado set adjusted to exact width and lowered below the table, install a planed and shaped wood insert flush with the table surface. Clamp a board to the saw table across the length of the insert—to one side of the blade—to hold it in place. Turn your saw on and slowly raise the blade, cutting through the insert, until it reaches the approximate height to match the depth of your joint. Turn the saw off and check the blade height. For help in making insert blanks, see woodmagazine.com/zeroclearance.

■ **Tip 5: Resharpen your entire stacked dado set.**

The carbide teeth of stacked dado sets dull over time and need resharpening. When having a set sharpened, always include each blade and chipper—even those you've never used—so the teeth remain identical in height. If the teeth don't match exactly, some chippers will cut deeper than the rest.

■ **Tip 6: Prevent veneer chip-out with tape.**

When making cuts in veneered sheet goods, chip-out always looms as a possibility. To keep a veneer face from chipping, apply painter's tape over the cutline—and at the opposite end to maintain a level surface when machining. Make a shallow scoring pass first; then, with the tape still on, raise the blade and finish with a cut to final depth, as shown at *right*. Slow your feed rate accordingly when removing a large amount of material.

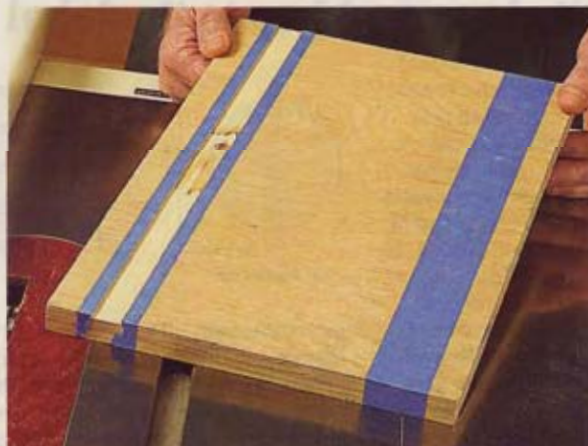

Scoring $\frac{1}{16}$ " deep cleanly shears the veneer, (*left*). After cutting the channel to depth, peel away the tape gently to avoid lifting the wood fibers and reveal a flawless veneer face (*right*).

■ **Tip 7: Defeat end-grain tear-out with backer boards.**

Machining cross-grain joints on a tablesaw results in tear-out when the blade exits the wood, as shown at *right*, unless you take some precautions. Install a wood extension to the miter gauge to back up the cut, as shown in the photo for Tip 8, or hold a back-up piece between the workpiece and miter gauge.



We cut these $\frac{3}{4}$ " dados in red oak with a scrap board to back up the cut (*left*) and then without (*right*). The backer board eliminates tear-out.

■ **Tip 8: Use a rip fence as a stop.**

For dados and end-grain rabbets, use the rip fence and miter gauge in conjunction with each other, as shown at *right*. Because you're not cutting entirely through the board, it will not pinch and kick back. Add an auxiliary fence for rabbets to keep the blades from touching the rip fence.

For a quick auxiliary fence, mount it to the rip fence with double-faced tape. Set up the dado stack wider than your intended rabbet. Cut an opening for the blade in the auxiliary fence (see illustration, *below*). Adjust the fence to the desired width of the rabbet and cut the workpiece.



When cutting across grain, use the rip fence as a stopblock and a wood extension to reduce tear-out. Sandpaper grips the workpiece.

STEP 1
Securely clamp auxiliary fence to tablesaw rip fence.

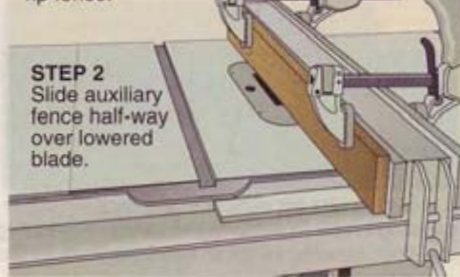

STEP 2
Slide auxiliary fence half-way over lowered blade.

STEP 3
Slowly raise blade to cut opening in auxiliary fence.

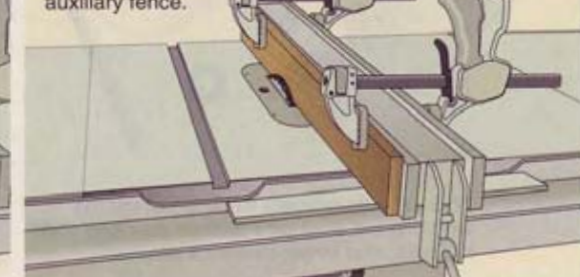

Router offers versatility, cleaner channels

For joints that will be seen on the finished project, you can't beat a router, because it cuts square, clean, flat-bottomed dados, grooves, and rabbets. Whether using your router by hand or in a router table, you'll get great results either way. And routers excel at machining stopped channels (those that do not exit the workpiece on one or both ends of the channel). With a router, you can see the start and stop marks as well as the bit. On a tablesaw, however, the blade is hidden beneath the board, making it more challenging to start and stop precisely at a mark.

Rout great rabbets by hand or in a router table

You can use rabbeting, straight, or spiral bits to machine perfect rabbets. Purchase

rabbeting bits individually or in a set with multiple bearing sizes (see photo, *below left*) to achieve different widths. When routing a rabbet by hand, move the router counterclockwise around the outside edges of a workpiece. Keep one handle over the workpiece to maintain a level cut. To avoid tear-out when approaching a corner on end grain, use a backer board or stop an inch short and rout it carefully from the corner backwards (known as climb-cutting).

When routing in sheet goods, rabbeting bits fray end-grain veneer rather than shear it cleanly, as shown, *below*. To handle this, first rout the rabbet to correct width and depth. Then, using a square-edged sanding block, sand with the grain toward the rabbet to knock down the frayed grain.

Rabbeting bits also work great in a router table, which offers a distinct advantage over rabbets cut with a handheld router: You don't need to change bearings to vary the cut width. You can adjust the table's fence so it aligns with the front edge of the bearing for full-width cuts, or bring the fence forward for a shallower cut. When you allow the bearing alone to guide the cut, a rabbeting bit follows the exact contour of the workpiece edge—even imperfections—and duplicates that on the joint.

If you don't have a rabbeting bit set, straight bits and spiral bits also machine great rabbets. Use them with the fence on a router table, or with an edge guide on a handheld router. Avoid dull bits that burn the wood or cause it to "fuzz" instead of cutting cleanly.

CUT VARIED SIZES WITH A SET



This set cuts rabbets to different widths with one bit. Smaller bearings produce wide rabbets, and larger bearings shallow.

HOW TO CLEAN THE "HAIRS" OFF RABBETED VENEER



Rabbeting bits lift veneer when cutting rather than shear it cleanly (*left*), so we rely on a sanding block to remove the stringy fibers (*right*). If any fibers bend into the rabbet, simply use your sanding block to sand the vertical face of the cut. Take care to not round the edge.

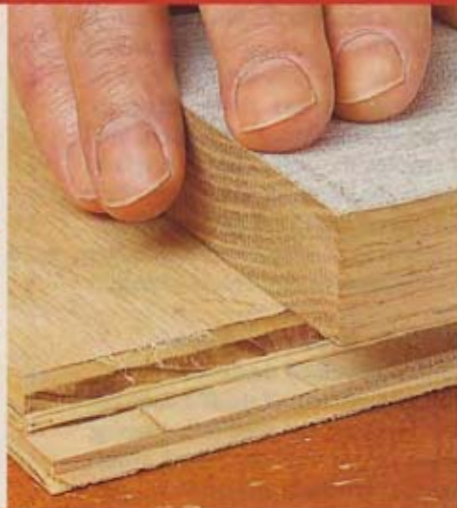

Sheet goods sizes don't always add up to the label

Sheet goods, such as plywood or medium-density fiberboard (MDF), almost always come up short of their stated thickness. For example, a sheet of $\frac{3}{4}$ " plywood typically measures only $\frac{23}{32}$ " thick (*right*). So what does this mean? Well, if you plan to cut dados, grooves, or rabbets in sheet goods, you'd better measure everything first. Thicknesses can vary even in sheets from the same stack. Always make a test cut and check the fit. Use specially sized plywood router bits that come in cutting diameters such as $\frac{15}{64}$ ", $\frac{9}{32}$ ", $\frac{15}{32}$ ", $\frac{17}{32}$ ", $\frac{23}{32}$ ", and $\frac{25}{32}$ ".

Or, to get truly dead-on results, use straight or spiral bits narrower than the thickness of the plywood and make two cutting passes with shop-made or manufactured jigs. See three purchased jigs in *Wise Buys* on page 34. To make your own, find three free jig plans at woodmagazine.com/dadojigs.

If you're like us, however, and prefer to use your tablesaw with a stacked dado set, here's a helpful trick. First, label all your shims (such as A, B, C, etc.) with a permanent marker or



$\frac{3}{4}$ " router bit

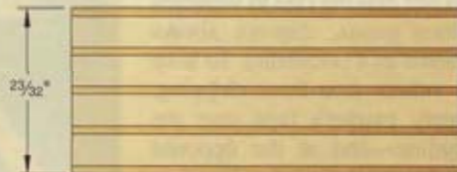

$\frac{3}{4}$ " plywood

etch them with an engraver. Now set up your saw with the appropriate blades, chippers, and shims to get a precise cut. When you remove the stack, make a note indicating which chippers and shims you used. The next time you need to cut a joint for that size sheet, just put together the same combination. Once again, though, don't trust it completely. Test your cut first.

Dado-cleanout bits remove tablesaw blemishes

Dado-cleanout bits do just what they say: They shave imperfections from the bottom of a flawed cut to leave a perfectly flat, square joint, as shown *below*.

Here's how to use them: First, machine your cut to width on the tablesaw, but leave the blade height about $\frac{1}{16}$ " short of the final depth. Machine all your channels.

TRIM BACK THOSE EARS

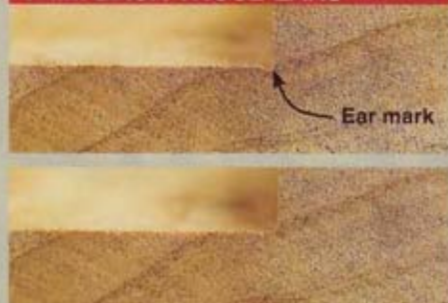

The outside blades of stacked dado sets leave tiny ear marks in the corners (*top*). A cleanout bit removes those blemishes (*bottom*).

Chuck the dado-cleanout bit into your hand-held router, and set it to machine to the finished depth. Run the router bit through the channel, with the bearing riding against one shoulder and then the other, as shown *below*.

Don't confuse these bits with similar-looking mortising bits, which have taller

DOWN AND BACK FINISHES JOB

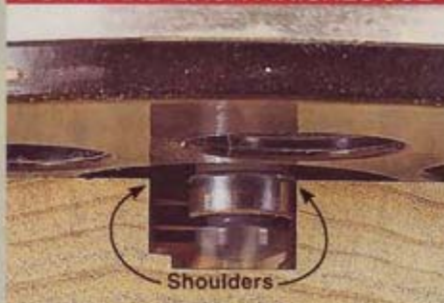

Dado-cleanout bits pare away the final $\frac{1}{16}$ " of channel depth to bring the joint to its final, flawless state.

cutters ($\frac{3}{8}$ – $\frac{1}{2}$ " tall). This puts the bearing above the shoulders of a $\frac{3}{8}$ "-deep channel, requiring a guide board or straightedge. Woodline's cleanout bit (800/472-6950; woodline.com) has just a $\frac{1}{8}$ " cutter height, and MLCS bits (800/533-9298; mlcswoodworking.com) feature $\frac{3}{16}$ "-tall cutters, as shown *below*.

CAN'T-MISS CLEANERS



These dado-cleanout bits excelled in our shop because they cut well and their cutter and bearing fit into a $\frac{3}{8}$ "-deep groove.

Take advantage of a router table's benefits when routing dadoes, grooves, and rabbets

For router-made channels, we'll choose the router table over a handheld router in most instances because of the additional safety and control offered by the table's accessories, such as a fence, feather boards, miter gauge, and dust collection.

For best results, know the limitations of your router and bit. Routing $\frac{3}{4}$ " grooves $\frac{3}{8}$ " deep in red oak puts a lot of strain on your router and speeds dulling of the bit. So make the cut in two passes, cutting away half the depth on the first pass.

Sometimes, chips build up in the joint or get under a board and lift it slightly, creating an uneven cut. After you've routed the full

channel, blow the dust and chips off the table and workpiece, and make one more pass—without making any changes—to ensure a clean joint.

Downcut spiral bits, like the one at *right*, can cause lifting when routing grooves and dadoes on a table. These solid-carbide bits perform best when making through-cuts, where the debris falls through the opening created. Upcut spiral bits, conversely, pull debris out of the groove, but also can lift the veneer slightly on plywood. Our advice: Use an upcut spiral bit anywhere you'd use a straight bit, and use a downcut bit only when your cut has an open side or bottom.

CHIPS FIND NO ESCAPE



Downcut spiral bits cut great but pack the waste into the groove rather than eject it. Remove the debris and make another pass.

Rely on straightedge guides when routing dadoes and grooves by hand

Channels located too far from the workpiece edge for your router table fence call for hand-held routing. You've got three good options at this point: Run the router base along a straightedge, use a bearing-guided pattern bit and straightedge, or use a router-mounted fence.

For the first option, chuck a straight or upcut spiral bit into the router and set the depth. Measure the distance from the router base edge to the nearest point of the cutter. Clamp your straightedge that exact distance from the marked channel, and align it as needed. Run your router against the straightedge to machine the channel, as shown at *near right*.

Pattern bits—option two—save you the hassle of setting the straightedge-to-cutter distance because they have a bearing on the shaft above the cutterhead that rides

against the straightedge. This means you clamp the guide right at your cut line, *below right*.

When your workpiece's dimensions prove too cumbersome for the router table, use a router-mounted fence to help you create a

DON'T SPIN THE ROUTER



For a straight and consistent channel, maintain the same point of contact between your router base and straightedge.

channel that parallels the workpiece edge—up to the maximum reach of the fence: typically 8". Use straight bits or upcut spiral bits for best results. 🌲

Written by **Bob Hunter** with **Chuck Hedlund**
Illustrations by **Roxanne LeMoine** and **Tim Cahill**

PATTERN BITS CUT TO THE LINE



Because the cutter aligns with the bearing, you clamp the guide right on the line of the joint, eliminating offset measurements.

space-saving extension tables for miterersaws ...

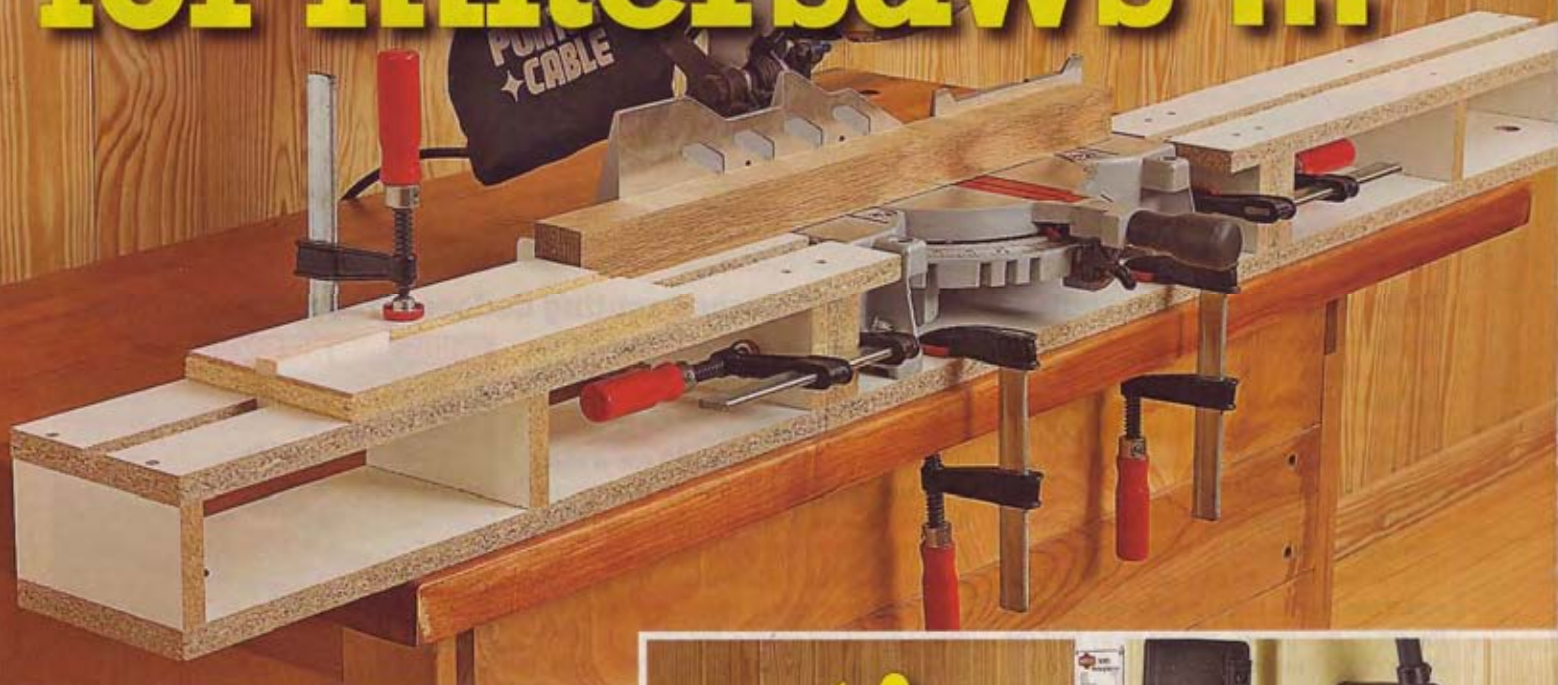

... or mortisers

Outfit either tool with easy-to-build extensions that provide workpiece support and feature a sliding stop.

AT A GLANCE

- The tool platform and extensions easily adapt to any miter saw or mortiser. If you own both a miter saw *and* mortiser you can build one pair of extensions to serve both machines.
- Ideal for small shops with limited space, the tool platform and extensions quickly clamp to your workbench and stow out of the way when not in use.
- One sliding stop for each machine fits both right- and left-hand extensions. Stop distance from the center of the tool ranges from about 36" to 60".



1 Build the tool platform

Measure the depth and width of the base of your miter saw or mortiser. If the tool table protrudes beyond the sides of the tool base, measure the table for the width. Add $1\frac{1}{2}$ " to the depth and 7" to the width dimension for the width and length of the tool platform bottom (A), as indicated at right. Then cut the bottom to size from $\frac{3}{4}$ "-thick melamine-coated particleboard, medium-density fiberboard (MDF), or plywood.

Measure the height of the tool table, and subtract $\frac{3}{4}$ " from this dimension for the width of the tool platform risers (B). Then cut two risers to this width and a length equal to the width of the bottom (A). Now clamp the risers to the bottom, drill countersunk screw holes through the bottom and into the risers, and drive the screws. To configure tool platforms so a miter saw and mortiser share one set of extensions, measure the height of both tool tables. Subtract $\frac{3}{4}$ " from the larger dimension for the width of the risers for both tool platforms.

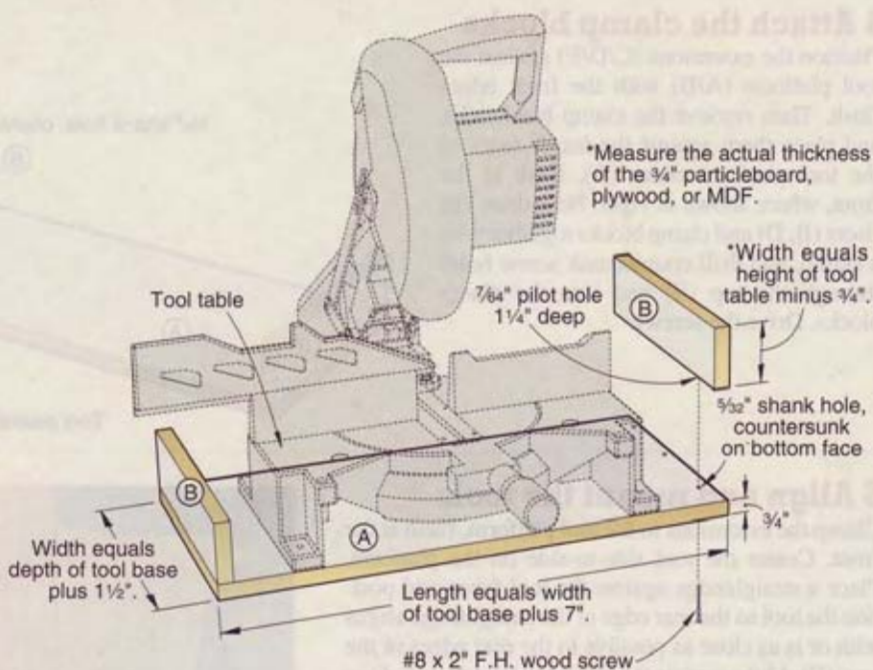

2 Build the extensions

Cut two extension bottoms (C) from $\frac{3}{4}$ "-thick material to the size shown at right. (You can vary the length of the extensions depending on your needs and space.) To hang the extensions while not in use, drill a 1" hole in each bottom, where shown. Then cut six 6"-long extension risers (D) to the same width as the tool platform risers (B). Cut two additional pieces to the same size for the clamp blocks (F), and set them aside. (You'll attach the clamp blocks to the extensions in Step 4.) Now clamp the risers to the bottoms, centering the middle risers on the length of the bottoms. Drill countersunk screw holes through the bottoms and into the risers, and drive the screws.

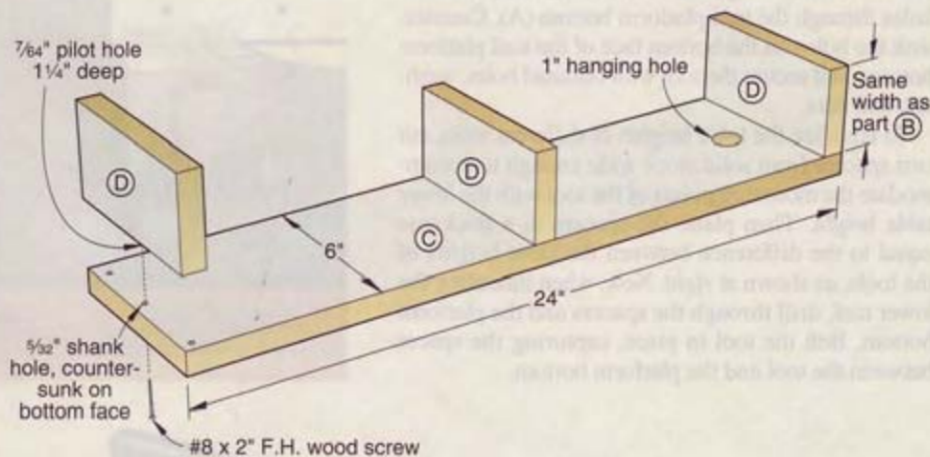

3 Add the tops

Place the tool platform on your workbench, and center the tool on it. Position one extension against the tool platform, where shown at right. Then measure the distance from the outside face of the end riser (D) to the edge of the tool table. Cut two 6"-wide tops (E) to this length. To make the extensions fit two tools, measure the riser-to-table lengths for both tools, and cut the tops to the shorter dimension.

Now with a $\frac{3}{4}$ " dado blade in your tablesaw, cut centered $\frac{3}{8}$ "-deep grooves in each top. Clamp the tops to the extensions (C/D), drill countersunk screw holes through the tops and into the risers, and drive the screws.

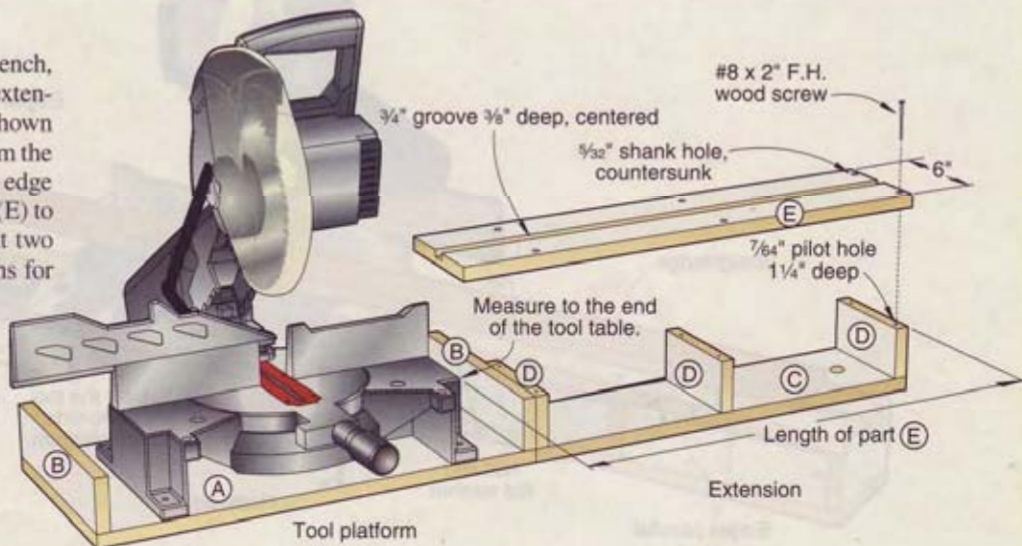

4 Attach the clamp blocks

Position the extensions (C/D/E) against the tool platform (A/B) with the front edges flush. Then retrieve the clamp blocks (F), and place them against the *inside* faces of the tool platform risers (B), flush at the front, where shown at *right*. Now draw the risers (B, D) and clamp blocks together with a clamp, and drill countersunk screw holes through the top (E) and into the clamp blocks. Drive the screws.

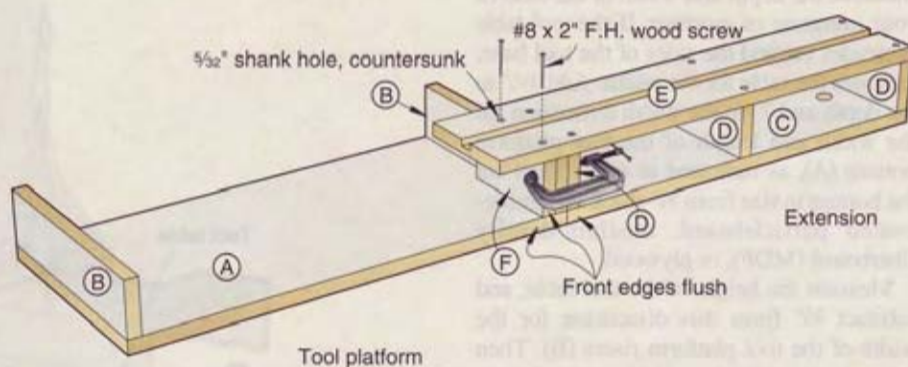

5 Align and mount the tools

Clamp the extensions to the tool platform, flush at the front. Center the tool side-to-side on the platform. Place a straightedge against the tool fence and position the tool so the rear edge of the straightedge aligns with or is as close as possible to the rear edges of the tops (E). Make certain the straightedge edges and top edges are parallel, as shown *below*. Now remove the straightedge and the extensions. Mark the locations of the tool mounting holes, remove the tool, and drill holes through the tool platform bottom (A). Countersink the holes on the bottom face of the tool platform bottom, and secure the tool with flathead bolts, washers, and nuts.

To equalize the table heights of different tools, cut two spacers from solid stock wide enough to accommodate the mounting points of the tool with the *lower* table height. Then plane the spacers to a thickness equal to the difference between the table heights of the tools, as shown at *right*. Now, when mounting the lower tool, drill through the spacers and the platform bottom. Bolt the tool in place, capturing the spacer between the tool and the platform bottom.

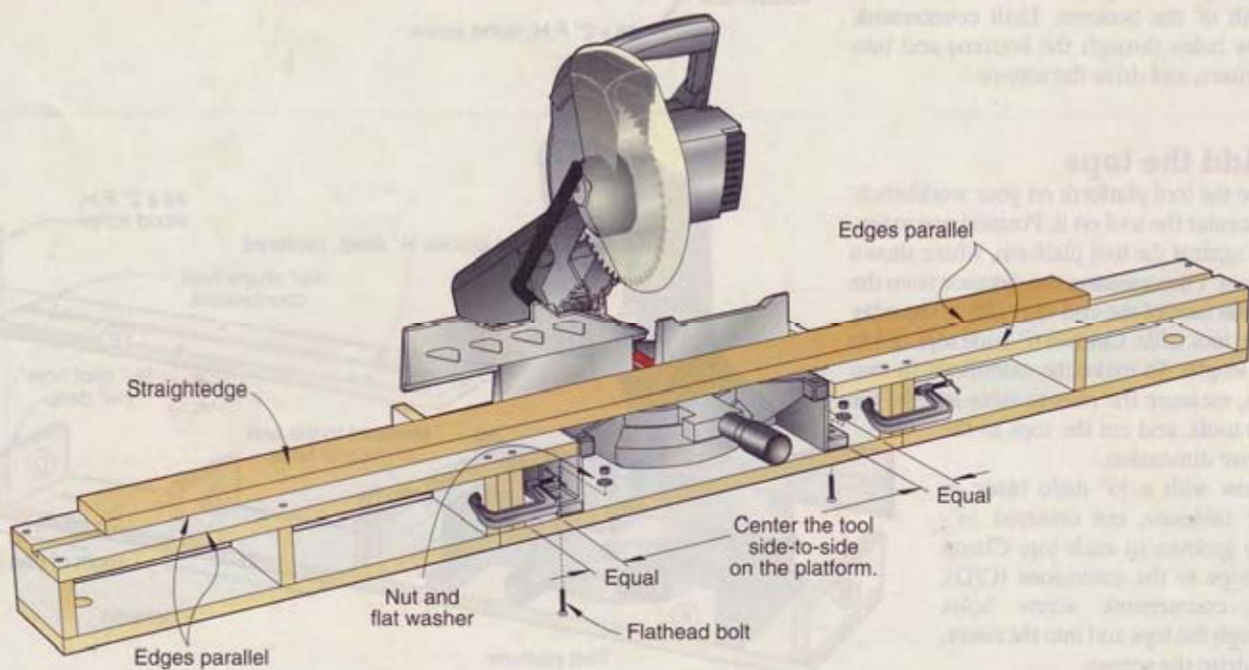
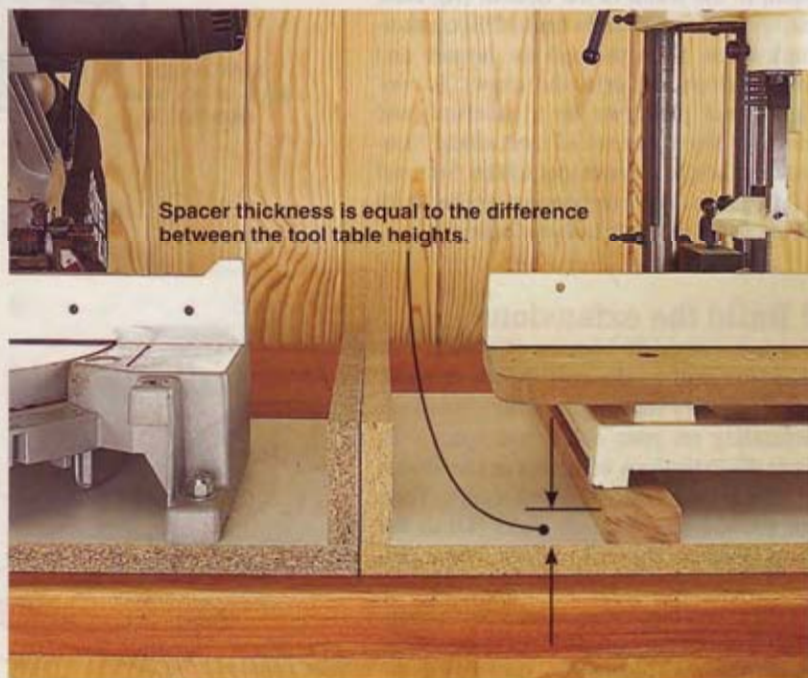

6 Make the stops

To determine the width of the miter saw stop body (G), measure the distance from the front edge of one extension to the front face of the miter saw fence, where shown *below*. For the width of the mortiser stop body (H), measure the distance from the front edge of the extension to the *center* of the mortising bit, where shown *below right*. For the lengths of the stops, measure the distance from the *inside* face of the extension riser (D) closest to the tool platform to the center of the tool table. Cut pieces of $\frac{3}{4}$ "-thick stock to these sizes. Then with a $\frac{3}{4}$ " dado blade in your tablesaw, cut $\frac{1}{8}$ "-deep grooves in the top and bottom faces of each body $2\frac{3}{8}$ " from the front edge and $\frac{1}{8} \times \frac{1}{8}$ " sawdust relief rabbets in the top and bottom faces of both ends, where shown at *right*. Now resaw and plane two 12"-long pieces of stock to $\frac{7}{16} \times \frac{3}{4}$ " for the guide bars (I). Measure the distance from the *inside* face of the extension riser (D) closest to the tool platform to the overhanging end of the top (E). Cut the guide bars to this length,

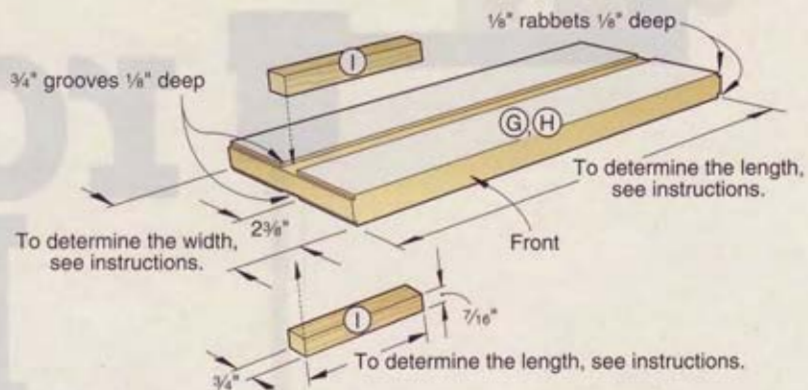

and glue and clamp them into the stop body grooves, flush with the shoulders of the $\frac{1}{8} \times \frac{1}{8}$ " rabbets at one end.

Note: On a mortiser with a front-mounted workpiece clamp, you may have to cut the stop body to fit around the clamp.

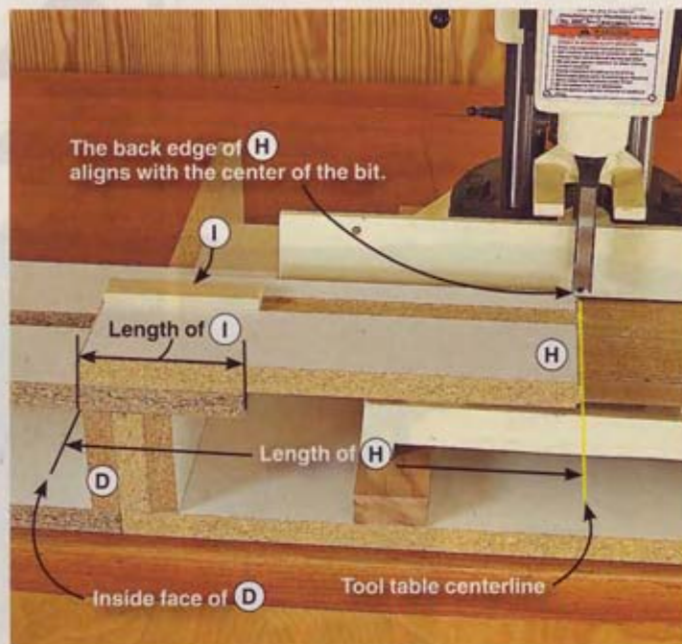
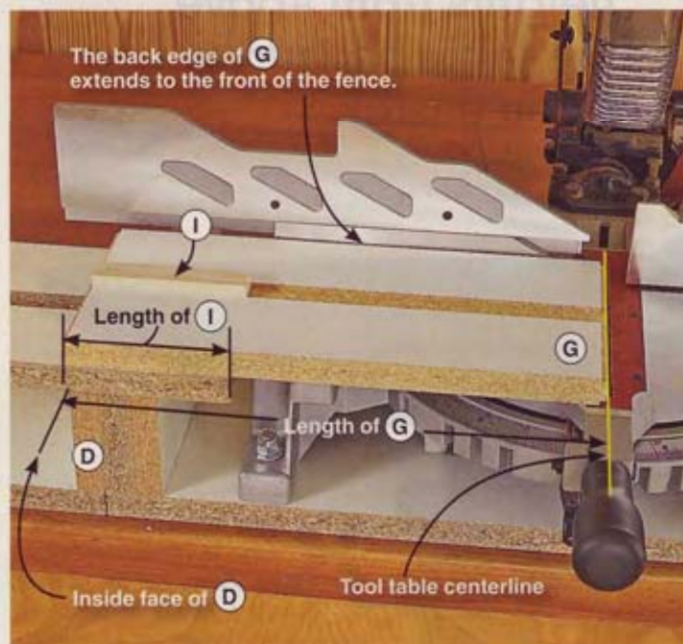

7 Using the extensions

First, clamp the tool platform (with the tool attached) to your workbench. Then position the extensions on both sides, flush at the front, capturing the tool platform risers (B) between the extension risers (D) and clamp blocks (F). Clamp the extensions to the tool platform. To increase the stop distance, clamp both extensions end to end on one side, as shown at *right*. (On our setup with the extensions flanking the tool, the stop distance is $35\frac{1}{2}$ ". With both extensions on one side, the stop distance increases to $63\frac{3}{4}$ ".) To use the stops, simply insert the guide bar (I) into the extension top (E) groove, slide it to the desired position, and secure it to the top with a clamp. For the maximum stop distance, let the end of the stop *without* the guide bar protrude beyond the end of the extension. To switch the stop from right to left, simply flip it over. 📌

Written by Jan Svec
Project design: Chuck Hedlund
Illustrations: Roxanne LeMoine



router lifts

Changing bits and bit heights from above the table has never been easier.

Carriage

Lead screw

Guide post

Router tables have become a staple in home woodworking shops. But for most of us, it's still a hassle to raise and lower cutter height as we fumble around below the table to make time-eating adjustments.

That began to change about seven years ago when Darrin Smith at JessEm Tools introduced Rout-R-Lift—the first device that brought through-the-table height adjustability to router tables. Smith's insert plate replacement spawned a raft of imitators, and even inspired router makers to rethink height adjustments on their tools. (See "Three more options in router-raising," on page 77.)

Today there are no less than a dozen router lifts on the market. And the price range has broadened as well, with lifts costing from \$170 to \$430. So what do you need to know before you drop that kind of dough? Read on.

How a lift does its router-raising thing

Boiled down to its basics, a router lift consists of two primary parts: the elevation mechanism and the insert plate. On the typical elevation mechanism (at left), the motor from a fixed-base router mounts in a carriage that travels up and down a lead screw (or screws) when a removable crank is turned from above the table. Guide posts keep the carriage tracking true throughout its full range of travel.

When shopping for a lift, you must first ask yourself two questions: Will my router fit into the lift? And, will the lift fit into my router table?

To answer the first question, the chart at right shows that nearly all of the tested lifts accept midsize fixed-base routers from Bosch, DeWalt, Makita, and Porter-Cable. Many of those require an adapter (\$25–\$40), which can be removed to install the 3-hp Porter-Cable 7518. This option lets you mount a midsize router now, and later upgrade to a 3-hp model without buying a new lift. JessEm's Rout-R-Lift and Woodpeckers' Unilift both fit a large number of routers.

As for the question about fitting the lift to your table, if your current insert plate measures 9¼×11¼", eight of the lifts will fit out of the box. JessEm's Rout-R-Lift has the largest plate; Bench Dog's ProLift, the smallest. (See the chart at the end of the article for specific sizes.)

Carriages: Machined masterpieces

Regardless of whether a lift uses gear drive (Jointech SmartLift), chain drive (Woodpeckers Precision Router Lift and Unilift), belt drive (JessEm Rout-R-Lift), or direct screw drive (all the rest), they all operated smoothly and reliably. We even hand-packed sawdust into the threads of the lead screws and ran the carriages up and down to see whether the threads would gum up. Nope.

Nor are guide posts a point of difference. All of the lifts strayed a few thousandths of an inch from perpendicular through 2" of vertical travel. But in actual use, those variances had no impact on the cuts we made.

One key difference between the lifts is the thread pitch of the lead screw (or screws), which determines how much the carriage

height changes with every turn of the crank. An 8-threads-per-inch (tpi) lead screw, for example, raises the router 1/8" for each crank rotation; a 32-tpi screw changes the height 1/32" per rotation. (See photos, below.) Those

finer threads make it easier to eyeball a tiny adjustment.

Thread pitch is a reliable way to calculate height changes—until you change directions. Whenever you reverse the rotation of

FIND A LIFT THAT MATCHES YOUR ROUTER

A model number in **black** fits this router out-of-the-box. A **red** number shows the adapter required to install that router in the lift for the Porter-Cable 7518/7519. A dash indicates incompatibility.

	ROUTER LIFT										
	Bench Dog ProLift	JessEm Mast-R-Lift	JessEm Rout-R-Lift	JessEm Rout-R-Lift FX	Jointech SmartLift Digital	Rousseau Router Lift LS	Woodhaven EZ Lift	Woodpeckers PlungeLift	Woodpeckers Precision Router Lift	Woodpeckers Quick-Lift	Woodpeckers Unilift
Fixed-base routers											
Bosch 1617/1618	40-002	02111	02001	02302	SL-A1	3002	1431	—	adap690	QL350A	ulifbxx
DeWalt 610	40-002	02111	02001	02302	SL-A1	3002	1431	—	adap690	QL350A	ulifbxx
DeWalt 616/618	40-002	02111	02001	02302	SL-A1	3002	1431	—	adap690	QL350A	ulifbxx
Hitachi M12VC	40-078	02115	02001	02305	—	—	1425R3	—	adapM12VC	—	—
Makita RF1100/1101	40-003	02113	02001	02303	SL-A2	3003	1425R2	—	adap1101	—	ulifbxx
Milwaukee 5615/5616/5619	—	02118	02001	02304	—	3004	—	—	—	—	ulifbxx
Milwaukee 5625	—	02116	02001	—	—	—	1430S	—	—	QL414A	ulifbxx
Porter-Cable 690/890	40-002	02111	02001	02302	SL-A1	3002	1431	—	adap690	QL350A	ulifbxx
Porter-Cable 7518/7519	40-016	02101	02001	—	SL-D1	—	1432	—	PRL32	QL420A	—
Ridgid R2930	—	—	02001	—	—	—	—	—	—	—	—
Plunge routers											
Bosch 1613	—	—	02001	—	—	—	—	—	—	—	ulifbxx
Bosch 1615	—	—	02001	—	—	—	—	—	—	—	ulifbxx
Bosch 1619	—	—	02001	—	—	—	—	pl1619	—	—	—
DeWalt DW621	—	—	02001	—	—	—	—	pldw621	—	—	ulifbxx
DeWalt DW625	—	—	02001	—	—	—	—	pldw625	—	—	ulifbxx
Fein RT1800	—	—	02001	—	—	—	—	—	—	—	ulifbxx
Freud FT2000	—	—	02001	—	—	—	—	plft2k	—	—	ulifbxx
Hitachi M12V	—	—	02001	—	—	—	—	plm12v	—	—	ulifbxx
Makita 3612C	—	—	02001	—	—	—	—	pl3612c	—	—	ulifbxx
Porter-Cable 7529	—	—	02001	—	—	—	—	plpc7529	—	—	ulifbxx
Porter-Cable 7536	—	—	02001	—	—	—	—	—	—	—	ulifbxx
Porter-Cable 7539	—	—	02001	—	—	—	—	plpc7539	—	—	ulifbxx
Porter-Cable 8529	—	—	02001	—	—	—	—	—	—	—	ulifbxx
Triton TRC-001	—	—	02001	—	—	—	—	—	—	—	ulifbxx

THREE LEAD-SCREW THREADS FROM FAST TO SLOW

An 8-tpi lead screw (left) makes large height changes quickly; handy for changing bits, but fine adjustments can be hit-or-miss. A 16-tpi screw (center) adds precision. A 32-tpi screw (right) helps make fine adjustments, but gets tedious when raising the router to change bits.

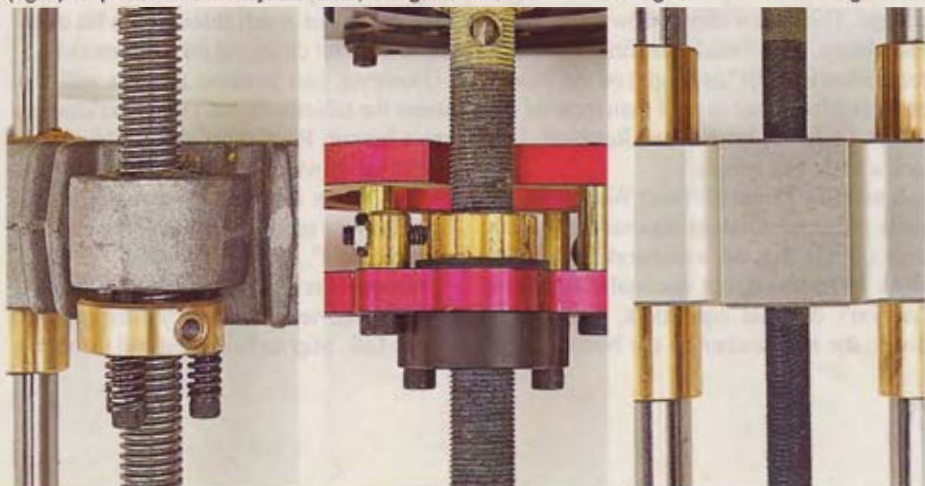



Jointech's liquid-crystal display (left) shows the bit's height with .001" accuracy, and zeroes with a simple push of a button to show only the amount of change. High-contrast, fractional markings make Bench Dog's scale (center) one of the easiest to read. At the low end of the range, Woodhaven's molded scale (right) ranks low for both readability and comprehension. (What does the "3" mean? $\frac{3}{16}$? $\frac{3}{32}$? .003"?)

the lead screw, slack between the threads has to be taken up. The resulting loss of height change—called *backlash*—means you can't rely solely on a lift's scale. We tested for backlash on each lift by first routing the stile of a rail-and-stile joint, and then a perfectly mating rail. After lowering the bit exactly five rotations and then raising it five rotations, we cut a new rail. None of the new joints fit perfectly, but all were within .004–.008".

Next, we repeated the test, this time lowering the bit five turns, then raising it $5\frac{1}{2}$ turns, and finally lowering it again $\frac{1}{2}$ turn. The new joints, in all cases, fit as well as the originals, so that extra half-turn effectively countered the backlash on all of the lifts. Strictly speaking, we observed backlash in SmartLift Digital, but, because it measures and displays the actual height change of the carriage, as shown above left, backlash is irrelevant.

Now that we've defeated backlash, we prefer a scale that reads easily and can be zeroed to show only the amount of height change. The photos above show the range of readability. We found the fine markings (each showing .001" of height) on the Woodpeckers lifts harder to read than most of the others. Only the JessEm and Rousseau lifts lack a scale that zeroes.

Some lifts (SmartLift and Woodpeckers) show measurements in thousandths of an inch (.001"), but we woodworkers tend to think in fractions, not decimals. To find a fraction's decimal equivalent, you simply divide the top number by the bottom num-

ber ($\frac{1}{8} = 1$ divided by 8, or .125"). To save you the hassle of scrounging up a calculator every time you make an adjustment, we've put a handy conversion chart on our Web site at woodmagazine.com/convert.

Changing bits from above: A big plus

All but three of the tested lifts raise the collet high enough to change any bit from above the tabletop. On those three (JessEm Rout-R-Lift, and Woodpeckers PlungeLift and Unilift) you install the router with its

The new joints, in all cases, fit as well as the originals, so that extra half-turn effectively countered the backlash on all of the lifts.

base, so the machine itself limits the collet height. Woodpeckers sells offset wrenches (\$12 each) that reach through the bit opening to ease bit changing on these models.

However, just because a collet will rise above the tabletop doesn't mean bit changes are a breeze. Remember that 32-tpi thread pitch that provides superfine height adjustments? When it comes to changing router bits, that now means 32 turns of the crank to raise the bit 1".

Woodpeckers found the ultimate solution to this speed-versus-accuracy dilemma with Quick-Lift. Slip an L-shaped rod through a

hole in the insert, twist it a quarter turn, and the carriage disengages from the lead screw. Lift the rod, and the router comes all the way to the top of its travel, exposing the collet for bit changing. Lower the rod to put the bit at its approximate cutting height, and then dial-in the precise bit height with the 32-tpi crank.

Insert plates: Setting the table

Router lift or not, a good router-table insert plate should have adjustments for making the plate flush with the tabletop. All of the Woodpeckers lifts earned high marks because you can make insert-height adjustments from above the table. In addition, each Woodpeckers plate sports "snuggers" (adjustable ball bearings in the edge of the plate) that take up minor slop in the fit between plate and table. JessEm's Rout-R-Lift FX is the only other lift with levelers that adjust from above the table.

With bit openings $3\frac{3}{8}$ " or larger in these inserts, that leaves quite a chasm around a $\frac{1}{2}$ " straight bit. Not all of the lifts come with reducer rings that fit into the bit opening and close that gap. The chart on page 78 shows what comes with each lift.

Mounting concerns: Can I use my router handheld?

In most cases, installing a router in a lift is no more or less difficult than mounting a router to an ordinary router table insert plate. So you may want to dedicate a router to your lift and leave it there. But three

MOTOR MOUNTS (AND DISMOUNTS) IN A SNAP



Installing a motor doesn't get any easier than this: Open the cam-style locking lever, insert the motor, and then close the lever.

lifts—JessEm Rout-R-Lift FX, Rousseau, and Woodhaven EZ Lift—have toolless quick-release mounts (see photo, above) that allow you to move a router motor from the lift to a handheld base as easily as it swaps between handheld bases. At the other end of the scale, installing Woodpeckers Plunge-Lift may require removing some router parts, which would have to be replaced when returning to handheld mode.

Three more options in router-raising

If you like the idea of through-the-table height adjustments, here are some other options:

1 RouterRaizer. (\$90, 866/266-1293, routertechnologies.com) Already have a plunge router in your table? This is the least expensive way to add tabletop height adjustments. Installation involves drilling a hole in your router's base and may include adding and removing other parts of your router, but the crank works even when handheld. As with any lift that uses a plunge router, you typically can't change bits from above the table without offset wrenches or a collet extension.

2 Lift-equipped routers. Router manufacturers quickly figured out ways to build through-the-base adjustments into their machines. Most of these

routers, selling for \$180–\$270, also allow above-table bit changes. You'll find built-in lifts on the Bosch 1617/1618, Craftsman 26620, Freud FT1700VCE, Milwaukee 5615/5616, Porter-Cable 890, Ridgid R2930, and Triton MOF001.

3 Lift-equipped router tables. Woodhaven sells its EZ Lift built into a solid phenolic tabletop (\$320), and JessEm also offers a phenolic router table with Mast-R-Lift built-in (Mast-R-Lift Excel, \$450). Neither requires an insert plate. A permanent crank makes the JessEm arrangement even more like a shaper. Jointech plans to take the concept one step further next year with a motorized lift built into a router tabletop. The price for this convenience, called SmartLift Professional: \$700–\$750.



A quick spin through the eleven tested router lifts

Bench Dog ProLift, \$325 800/786-8902, benchdog.com

High points

- ◆ With its nickel-plated steel insert plate, cast-aluminum carriage, and stout lead screw, this built-like-a-tank lift should last a lifetime.

- ◆ The intuitive, easy-to-read scale slips onto the included $\frac{9}{16}$ " socket, and zeroes with a simple twist on the socket.

Low points

- ◆ Steel reducer rings must be leveled to the insert plate and fastened with screws (unlike the simple twist-to-lock rings on other lifts), and can damage a bit that comes into contact.
- ◆ Insert plate lacks a leveling system.



JessEm Mast-R-Lift, \$290 866/272-7492, jesse.com

High points

- ◆ 16-tpi thread pitch on the lead screw provides a nice compromise between fine adjustments and speed of bit height changes.

- ◆ Well-marked scale is easy to read and intuitive.

Low points

- ◆ Only one $1\frac{1}{2}$ " reducer ring comes with the lift, which leaves a serious gap around a $\frac{1}{2}$ " straight bit, yet was too small for our rail-and-stile bits.

- ◆ Scale cannot be zeroed, so figuring bit height changes requires some math.

More points

- ◆ Identical to Rockler 22788 (800/233-9359, rockler.com). Inca version (972/242-9975, inca.biz) has nifty magnetic reducer rings.



JessEm Rout-R-Lift, \$215 866/272-7492, jesse.com

High points

- ◆ Fits almost any router; may be your only choice if you want to install your current router in a lift.

- ◆ Oversize insert plate can be retrofitted to almost any router table.

Low points

- ◆ Offset wrenches or collet extender are needed for above-table bit changes.

- ◆ One full turn of the crank changes bit height by $\frac{1}{32}$ ", which we found confusing for small adjustments. Scale cannot be zeroed.

More points

- ◆ Total vertical travel is shortest in test ($2\frac{1}{2}$ "), but further adjustments can be made on the installed router.
- ◆ Jet's XACTA-Lift (\$280; 800/274-6848, jettools.com), an accessory to Jet tablesaws, is identical to Rout-R-Lift, except for its aluminum insert plate.



JessEm Rout-R-Lift FX, \$180

866/272-7492, jessem.com



High points

◆ Quick-release mounting mechanism makes it simple to return an installed midsize router motor to its handheld base.

◆ Has same easy-to-read scale and 16-tpi thread pitch as the Mast-R-Lift.

◆ Plate leveling adjustments are made from above the table.

◆ Low price and good performance make it a Top Value for a midsize router.

Low points

◆ Scale cannot be zeroed, so figuring bit height changes requires some math.

More points

◆ JessEm makes this lift for Rockler (model 27956, \$180) but the plate size is 8x11".



Jointech SmartLift Digital, \$430

800/619-1288, jointech.com



High points

◆ Sophisticated electronics measure the actual height change of the router, eliminating the need for backlash counter-measures. We found we could return precisely to any height setting if we first zeroed the bit to insert level.

◆ Auto-off feature saves batteries and remembers last height setting when reactivated.

More points

◆ We noticed dust inside the digital display, but Jointech's Kevin Kirkman assured us that current displays are sealed against dust penetration, and that ours would be replaced under warranty.

◆ Also available without the digital display (SmartLift Analog, \$270), but the bare-bones scale on that model left us guessing about changes to bit height.



Rousseau Router Lift LS, \$170

800/635-3416, rousseauco.com

High points

◆ This lift is identical to JessEm's Rout-R-Lift FX, except for the insert plate, which is sized to match Rousseau's router insert plates.

Low points

◆ Instead of JessEm's above-the-table levelers, this lift comes with Rousseau's plate-leveling and -fitting system, which installs on your router table and adjusts from below.



THE UPS AND DOWNS OF 11 ROUTER LIFTS

BRAND	MODEL	MATERIAL (1)	SIZE (LxW, INCHES) (2)	INSERT PLATE			MATERIAL (1)	HEIGHT CHANGE PER CRANK ROTATION (INCHES) (3)	CARRIAGE			PERFORMANCE RATINGS (5)				ACCESSORIES (8)			WARRANTY (YEARS)	COUNTRY OF ASSEMBLY (9)	SELLING PRICE (10)
				PRIMARY THICKNESS (INCHES)	MAXIMUM BIT OPENING (INCHES)	REDUCER RING DIAMETERS (INCHES)			TOTAL VERTICAL TRAVEL (INCHES) (4)	BIT-HEIGHT ADJUSTMENT EASE	SCALE READABILITY	EASE OF ZEROING SCALE (7)	EASE OF INSTALLING AND REMOVING ROUTER	STANDARD	OPTIONAL	WARRANTY (YEARS)	COUNTRY OF ASSEMBLY (9)	SELLING PRICE (10)			
BENCH DOG	ProLift	S	8 1/4 x 11 3/4	1/2	4 1/4	2, 2 1/2, 3 1/4	A	1/8	6	A-	B	A	A	C	B	C, R, S	A, G, P, Z	2	U	\$325	
JESSEM	Mast-R-Lift	A	9 1/4 x 11 3/4	1 1/16	3 3/8	1 1/2	A	1/16	3 1/2	B+	B	A	N/A	B+	B	C, S	A, R	1	C	\$290	
	Rout-R-Lift	A	11 3/4 x 14 3/4	3/16	3 3/8	1 1/2	A	1/20	2 1/2	B	C	B	N/A	B	C	S	R	1	C	\$215	
	Rout-R-Lift FX	P	9 1/4 x 11 3/4	3/4	3 3/8	1 1/2	A	1/16	3	B+	B	A	N/A	B	A	C, S	R	1	C	\$180	
JOINTECH	SmartLift Digital	A	9 1/4 x 11 3/4	3/8	3 3/8	1/2, 1 3/8, 2 1/2	Z	1/16	4 1/8	A	B	A	A	B+	B	C, S	A, R	2	U	\$430	
ROUSSEAU	Router Lift LS	P	9x12	3/4	3 13/16	1 1/16, 2 1/8	A	1/16	3	B+	B	A	N/A	B-	A	C, S	R	LIFE	C	\$170	
WOODHAVEN	EZ Lift	P	9 1/4 x 11 3/4	3/8	3 3/8	2	P	1/16	3 3/8	B+	B	C	A-	C	A	R, S	A	LIFE	U	\$165	
WOODPECKERS	PlungeLift	A	9 1/4 x 11 3/4	3/8	3 3/8	1, 1 1/16, 2 1/8	NC	1/32	*	B	C*	B-	A	A	B	C, R, S		LIFE	U	\$170	
	Precision Router Lift	A	9 1/4 x 11 3/4	3/8	3 3/8	1, 1 1/16, 2 1/8	A	1/16*	4	B	B	B-	B	A	B	C, R, S	A	LIFE	U	\$300	
	Quick-Lift (QL420A)	A	9 1/4 x 11 3/4*	3/8	3 3/8	1, 1 1/16, 2 1/8	A	1/32	3 3/8	A	A	B-	A	A	B	C, R, S		LIFE	U	\$230*	
	Unilift	A	9 1/4 x 11 3/4	3/8	3 3/8	1, 1 1/16, 2 1/8	A	1/16*	3 3/4	B	C	B-	A	A	B-	C, R, S		LIFE	U	\$270	

NOTES:

- (A) Aluminum
(P) Phenolic
(S) Steel
(Z) Zinc
(NC) No carriage
- (*) Also available with 8 1/4 x 11 3/4" plate to fit Bench Dog tables.
- (*) Also available with 1/32" thread pitch.
- (*) Limited by plunge depth of installed router.
- | | |
|---|-----------|
| A | Excellent |
| B | Good |
| C | Fair |
- (*) Varies depending on router installed in lift.
- (N/A) Scale cannot be zeroed.
- (A) Adapter collar for midsize, fixed-base routers
(C) Extended-height crank
(G) Freehand routing guard with d.c. port
- (P) Porter-Cable guide-bushing adapter
(R) Reducer ring set
(S) Starter pin for freehand routing
(Z) Zero-clearance insert
- (C) Canada
(U) United States
- Prices current at time of article production and do not include shipping, where applicable.
(*) Fits Porter-Cable 7518. Model QL350A for midsize routers sells for \$200.

Woodhaven EZ Lift, \$165
800/344-6657, woodhaven.com

High points

◆ Despite being made almost entirely of phenolic—even the carriage and guides are made of the stuff—this lift proved as accurate, with adjustments as smooth, as any lift in the test.

◆ The only lift in our test with a quick-release mount for the Porter-Cable 7518 router motor.

Low points

◆ No wrench or crank comes with the lift; you must supply a 9/16" socket and wrench.

◆ Scale is difficult to read and confusing, simply marked with "0," "1," "2," and "3."

◆ No plate-leveling adjustments.

More points

◆ Model 1431 fits popular 2-hp routers out of the box; or buy model 1432 with an adapter if you think you'll someday upgrade to a Porter-Cable 7518.



Woodpeckers PlungeLift, \$170
800/752-0725, woodpeck.com

High points

◆ Adjustable "snuggers" in the edges of the insert help it fit snugly in the table opening. Plate-leveling adjustments are made from above the table.

Low points

◆ You can't change bits from above the table without a collet extender or offset wrenches.

◆ Mounting a router may involve partial disassembly, so you'll want to dedicate a router to this lift.

More points

◆ 32-tpi thread pitch makes bit height adjustments slow, but precise.



Woodpeckers Precision Router Lift, \$300
800/752-0725, woodpeck.com

High points

◆ Same plate-fitting system as PlungeLift.

More points

◆ 32-tpi thread pitch of lead screw takes a lot of cranking to change bits from above the table, but you also can order this lift with a 16-tpi lead screw for the best combination of speed and precision.



Woodpeckers Quick-Lift, \$230
800/752-0725, woodpeck.com

High points

◆ The best and fastest bit-changing in the test: Slip a rod through the insert plate and twist it to release the carriage from the lead screw, and then instantly lift the router to full height. Lower the bit to approximate cutting height, lock the carriage, and then dial in the precise bit height with the crank.

◆ Has the same plate-fitting system as other Woodpeckers lifts.

More points

◆ Options abound on this lift, with two different plate materials (aluminum or phenolic) in two sizes. We tested the QL420 (\$230) for the P-C 7518. Model QL350A (\$200) fits 2-hp router motors.

◆ The fast height adjustments and affordable price make the large version of this lift (QL420) our Top Value for the Porter-Cable 7518 motor.



Woodpeckers Unilift, \$270
800/752-0725, woodpeck.com

High points

◆ Fits many popular routers on the market today (though not as many as JessEm's Rout-R-Lift), thanks to its "universal" router-mounting plate.

◆ Uses the same plate-fitting system as the other Woodpeckers lifts.

Low points

◆ Offset wrenches or collet extender are needed for above-table bit changes.

More points

◆ 32-tpi thread pitch of lead screw takes a lot of cranking for large height changes, but you also can order this lift with a 16-tpi lead screw.



The tops of the lifts

The router lift you choose may depend largely on the machine you plan to install in it, so that may narrow the field for you considerably. Find the models that fit; then review the model-by-model summaries to make your best choice.

Because many of the lifts fit the Porter-Cable 7518; the Bosch/DeWalt/Makita/P-C midsize, fixed-base routers; or both, we think a recommendation is in order for those machines. Without question, Jointech's SmartLift Digital earns Top Tool honors for the routers listed above. It's well built, easy to understand, and provides reliable repeatability that no other lift can match. And, if you buy it with an adapter for your midsize router now, you can remove the adapter later to upgrade to the Porter-Cable 7518.

If SmartLift's \$430 price tag is out of reach, our Top Value for use with the P-C 7518 is the Woodpeckers Quick-Lift QL420. And for the midsize, fixed-base router bunch listed above, we named both JessEm's Rout-R-Lift FX and Woodpeckers' Quick-Lift QL350A as Top Values. ♣

Download more
tool reviews
at

woodmagazine.com/toolreviews



Written by Dave Campbell with Pat Lowry



hand-tool skills

for the power-tool woodworker

In many cases, hand tools cut cleaner and faster than their motorized cousins. We'll show you when and why to reach for the first cordless tools.

"Although I appreciate the raw muscle and speed of power tools, I'm ambivalent about them. Hand tools...remind me of their music at every turn. Pick up a well-used and loved plane, one with a history of being cared for.... Listen to the distinctive whisper it makes as shavings spiral smoothly from its throat. Those shavings are the individual notes a plane makes in its song."

—Ross Laird,
Grain of Truth: The Ancient Lessons of Craft

"Yeah, well, who has time for that?!?"
—Kevin Boyle, *WOOD* magazine senior design editor

The American political system has nothing on woodworkers. Get a group of us together and we're likely to divide along party lines: those who swear by their hand tools, and those who swear at them. And just as in politics, the most effective way to get the job done often lies with both parties working together.

Although we do the majority of our work in the *WOOD* magazine shop using power tools, we still keep a select group of precision hand tools at our disposal because they do some jobs better and faster than motorized tools. Here's how to get the most from the three we use often—a block plane, rabbeting plane, and flush-cutting saw.

Best plane on the block

Traditionally, hand planes are used for everything from rough-shaping (scrub

plane) to putting a final surface on your project (smoothing plane). But the most used plane in our shop is a low-angle block plane, the "baby" of the jack-plane family.

Capable of removing a nearly transparent shaving when tuned, a block plane cuts as well across the grain as with it. Learn to super-tune your plane in *WOOD* magazine issue 160 (Dec./Jan. 2004/2005), or download it at woodmagazine.com/blockplanes. Here's what this tool can do for you:

- **Adjust reveals on inset doors.** A slightly out-of-square door leaves an unequal (and unsightly) gap between the face frame and the door. Starting where the gap is narrowest, trim the door by making progressively longer strokes with a block plane to taper the door and equalize the reveal. When fitting the top or bottom of a rail-and-stile door, clamp a scrapwood backer at the

CURB BLOWOUT WITH A BACKER BOARD



When planing end grain, attach a piece of scrapwood to prevent blowing out the grain as the blade exits the workpiece. The scrap tears out instead of your project.

end of the cut to avoid blow-out, as shown in the photo above.

• Soften sharp edges on solid stock.

Before you can say "Where's my router and chamfering bit?" you can break those edges with a block plane. And, a block plane can do things a router bit can't, such as cutting tapered or off-center chamfers. For those unusual features, define and mark the limits of the chamfer on the workpiece, and then plane down to your lines.

• **Clean up edges before gluing.** A tablesaw blade can score or burn the edge of a workpiece; a jointer leaves a straight, but scalloped edge. Neither is perfect, but a few strokes from a block plane can make them nearly so.

For short workpieces, assemble a simple bench hook, such as the one shown above right, and place your workpiece on it, with one end against the fence. Now, lay your block plane on its side and "shoot" a smooth edge on the workpiece, as shown at right. You can even joint end grain with this method—something you should *never* attempt with a power jointer.

To tidy up a workpiece too long for the bench hook, clamp it in your bench vise. Press the front of the plane flat onto the workpiece edge with your thumb on the knob, and your fingers below the sole acting as a fence against the workpiece face, as shown at left. Now push the plane along the edge of the workpiece, making a continuous cut from one end to the other. A few passes should be all it takes to remove the imperfections.

Rabbet plane cuts corners

Before there were tablesaws and routers, rabbets (the step cut along the edge or end of a workpiece) were cut with a simple plane like that shown at right, whose blade extends to the edge of its sole. Although we wouldn't dream of cutting rabbets by hand today, in

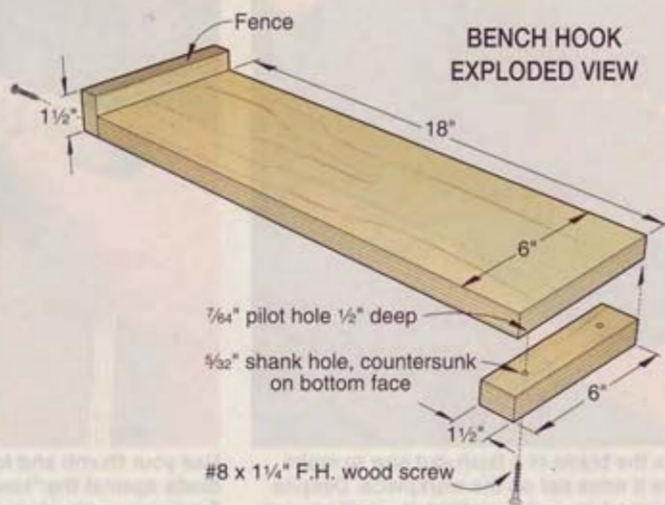

the power-tool era, we frequently reach for a rabbet plane to clean up a workpiece after machining. Those times include:

• **Flattening rabbets.** To paraphrase the old potato chip commercial, "Rabbets have ridges," especially when cut with a stacked dado set on the tablesaw, as shown below. Those irregularities weaken the glue joint. The cure? Set the rabbet plane blade just proud of the sole, hold the plane body square against the wall of the rabbet, and take a few strokes to flatten those ridges.

• **Tightening tenons.** You could use a sanding block or a block plane to trim a tenon down to perfect size, but neither tool can get tightly into the corner between the cheek and shoulder like a rabbet plane can. With the plane body against the shoulder, and the sole flat on the cheek, as shown below right, pare down the cheek with a few shallow passes.

SHOOT CLEAN EDGES WITH A BENCH HOOK

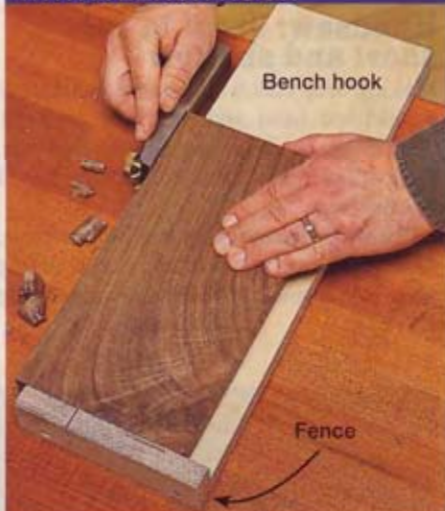

A bench hook makes it easy to smooth edges. The sole and side of a block plane form a right angle to ensure a square cut.

REMOVE RIDGES EFFORTLESSLY WITH A RABBET PLANE



A rabbet plane rapidly and cleanly pares away the ridges left in the bottom of a rabbet (left) cut with a stacked dado set. Because the blade gets tightly into corners, we often use one to trim a tenon to perfectly fit its mortise (right).

CUT PLUGS FAST AND FLUSH



Flex the blade of a flush-cut saw to make sure it rides flat on the workpiece. Despite the wood-to-metal contact, it won't scratch the surrounding surface.

COMPLETE THE CUT BY HAND



Use your thumb and forefinger to guide the blade against the "keeper" side of the kerf. For large waste pieces, straddle the start of the kerf with a clamp to prevent binding.

BENCH HOOK = MINI MITER BOX



Besides holding a workpiece while planing, a bench hook can double as a miter box for small workpieces. A thin kerf cut in the fence precisely guides the saw blade.

Handsaw: Use it to cut short and shallow

Making deep cuts with a handsaw requires a practiced hand and plenty of patience. (But it can be done; see *below*.) However, there are plenty of other tasks better suited to a handsaw:

• **Flush trimming.** Some project parts, such as through-tenons and screw-hiding plugs, are intentionally left too long during

assembly, and then trimmed flush later. The teeth on a flush-cut saw won't mar the surrounding surface while slicing through the plug or tenon, as shown *above left*. The flexible blade also permits trimming parts in the middle of a large workpiece.

• **Finishing "inside" cuts.** A round saw blade can't cut completely inside the elbow of an L-shaped workpiece. Complete the cut with a handsaw. Support both the

keeper and waste piece during the cut to prevent premature breakage, and use the machine-cut kerf as a guide for your saw.

• **Cutting small parts.** For small moldings and dowels, a fine-tooth handsaw cuts cleaner and safer than a fast-spinning tablesaw or miter saw blade. Cut kerfs in the fence of your bench hook, as shown *above*, at common cut angles, and use it like an old-fashioned miter box.

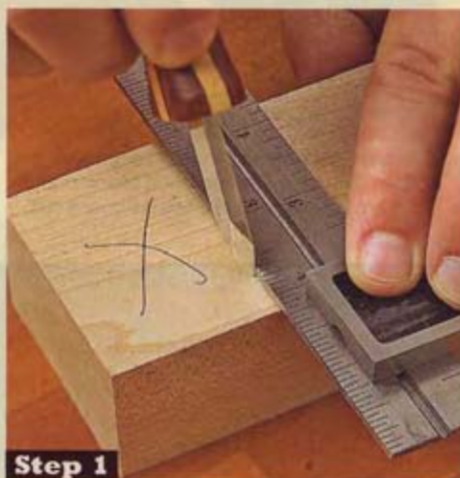

Step 1

The secrets to sawing straight

Most of us can't cut a straight line with a handsaw to save our souls. The trick to sawing straight, according to hand tool authority Graham Blackburn, is to *start* straight. Here's how:

First, score the cut line on the face of the workpiece with the beveled edge of your marking knife on the waste side (**Step 1**). Transfer the cutline to the adjacent edge or edges of your workpiece, as shown in the Shop Tip, at *right*. Then bevel-cut back to the scored line (again, on the waste side) to create a small channel (**Step 2**) for the saw blade.

Regardless of whether you use a Western-style (push) saw or Japanese-style (pull) saw, start your cut by placing the blade in the top channel (**Step 3**) and gently drawing the saw toward you for a few strokes. Lift the saw out of the cut between strokes. Now, saw back and forth, keeping the teeth cutting along both cut lines at once (**Step 4**). For the cleanest, straightest cut, use the full length of the blade and let the saw do the work—don't force it through the wood.



Step 2



Step 3



Step 4

Two more super-handly hand tools

• **Marking knife.** Besides creating a line finer and more consistent than any pencil you can dream of, a marking knife adds another distinct benefit: It slices through the top layer of wood grain to reduce tear-out, even in machine-cut crosscuts. That scoring also comes in handy when transferring a line around a workpiece, such as when lay-

ing out the shoulder lines of a tenon, as shown in the Shop Tip, below.

You don't have to buy an expensive stainless steel knife to enjoy this benefit, though. Make your own from the plans in *WOOD* magazine issue 160 (or at woodmagazine.com/markingknife), or from a scrap of steel, ground or filed to a bevel edge.

• **Chisels.** A power-tool woodworker cuts mortises with a drill press or benchtop mor-

tising machine. However, both methods can leave excess material on the walls of the mortise that will weaken the glue joint. That's where a sharp chisel works wonders. Hold the chisel—using the widest one that fits comfortably in the mortise—with its back (the non-beveled side) against the mortise wall, as shown in the photo below. Then plunge it down along the wall using only hand pressure.

SHOP TIP

Mark four sides fast and accurately

Ever try to carefully mark a line around four faces of a workpiece and not have the last line meet up with the first? Here's a foolproof way to get it perfect: Score the top face on your cut line with a square and a marking knife. Now place the marking knife blade in the score at one edge of the workpiece, as shown at right; slide your square up to it; and score the second face. Repeat the process for the opposite end of the first cut and again to connect the scores on the bottom of the workpiece.

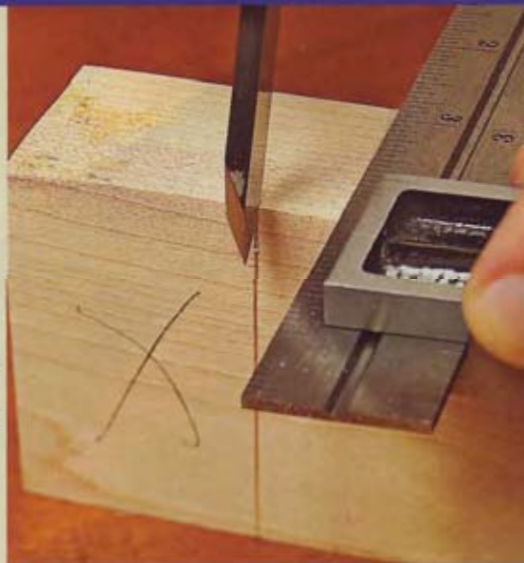

MAKE ROUND HOLES SQUARE



A sharp bench chisel shears off the waste left behind by the drill bit to flatten the walls of the mortise.

Blackburn's Principles of Efficient Furnituremaking

While working with Graham Blackburn on this article, he shared with us his four rules that every woodworker should live by. They apply as much to power-tool woodworking as to hand-tool use, so you'll find them helpful whether you make that crosscut with a Dzuki or a DeWalt.

1 Whenever you put two or more pieces together, mark them.

Whether you're edge-joining a tabletop or assembling a face frame with pocket-hole joinery, mark a triangle or series of hash marks across the joint lines before you start any cutting. These index marks help ensure that the pieces go back together in exactly the way you intended. Use chalk or pencil, and be sure to mark the workpieces in a location that won't get planed, sawed, or sanded away before assembly.

2 **Don't measure.** Of course, you have to start with some measurements, but as much as possible, use the first workpiece to measure the second one. For example, a 1/4" tenon fits into a 1/4" mortise, but mismeasuring by a fraction of an inch results in a too-tight, too-loose, or misaligned joint. If you cut the mortise first

and then use it to mark the location of the tenon, you'll increase accuracy without actually measuring.

3 **Mark your waste.** Careful layout means squat if you cut sockets where you meant to leave pins in a dovetail joint or sawed on the wrong side of the cut line, making it too short (another good argument for principle #2). Get in the habit of marking an "X" in the waste area to prevent miscuts.

4 **The strongest joint results when you remove the least material from both workpieces.** Remember to keep things in balance. In similar-sized workpieces, a small mortise keeps that part of the joint strong, but the thin tenon you must cut to fit it weakens the overall joint. In 3/4"-thick stock, use the rule of thirds: Make your tenon 1/4" thick (or one-third the thickness of the workpiece).



About our expert

Graham Blackburn teaches hand-tool skills and elements of design as a faculty member at the Marc Adams School of Woodworking in Franklin, Indiana (317/535-4013, marcadams.com). He has written a number of books, including *The Illustrated Encyclopedia of Woodworking Handtools* and *Traditional Woodworking Handtools* (Blackburn Books, 845/679-4990, blackburnbooks.com).

Written by Dave Campbell with Graham Blackburn and Kevin Boyle

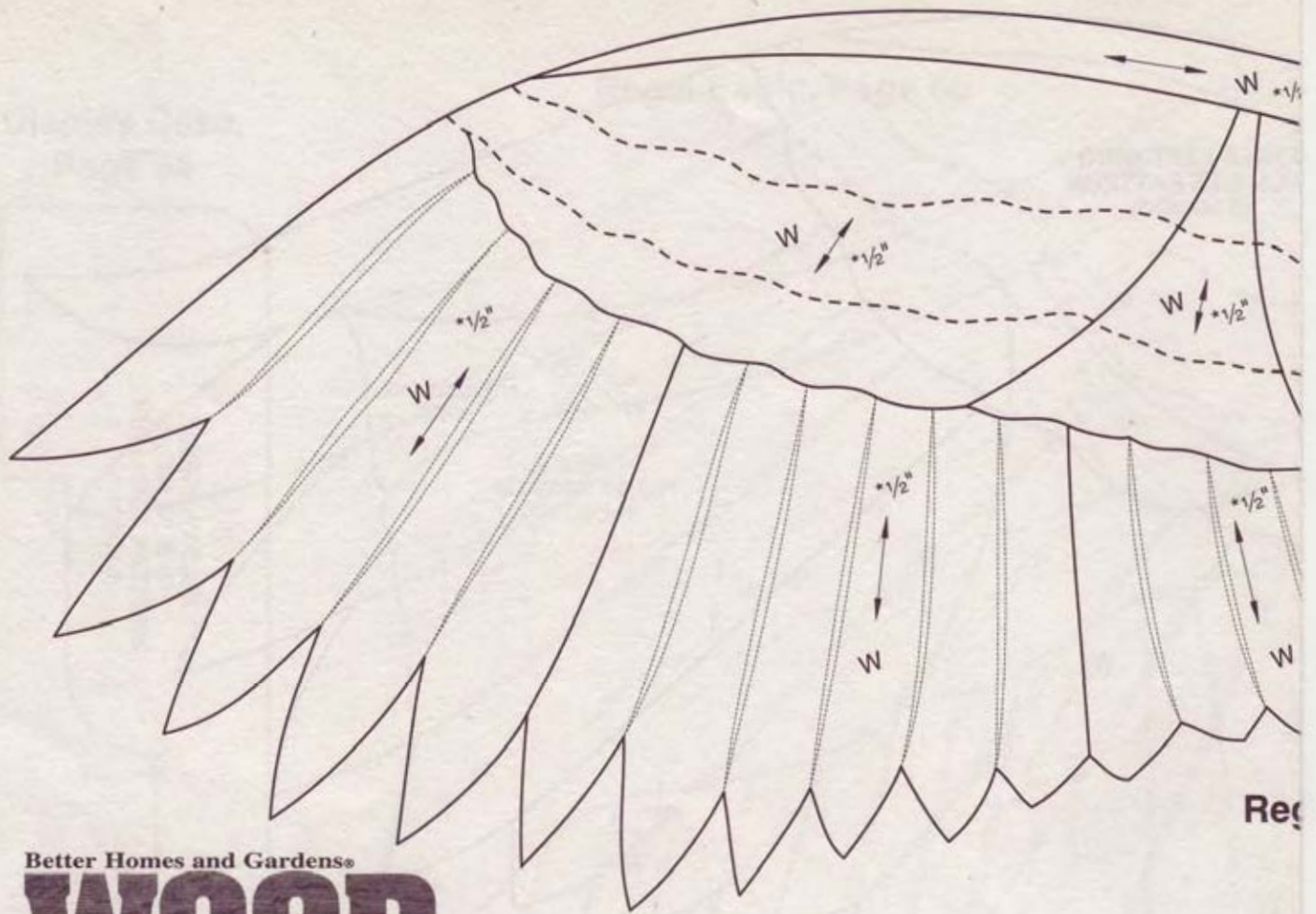

Better Homes and Gardens®

WOOD PATTERNS

September 2006

Issue 171

- Wine Bottle Holder, Page 8**
- Heirloom Bookcase, Page 38**
- Display Case, Page 54**
- Regal Eagle, Page 60**

Dear Reader: As a service to you, we've included full-size patterns on this insert for irregular shaped and intricate project parts. You can machine all other project parts using the Materials List and the drawings accompanying the project you're building.

© Copyright Meredith Corporation, 2006. All rights reserved. Printed in the U.S.A. Meredith Corp., the publisher of *WOOD Patterns*® allows the purchaser of this pattern insert to photocopy these patterns solely for his/her own personal use. Any other reproduction of these patterns is strictly prohibited.

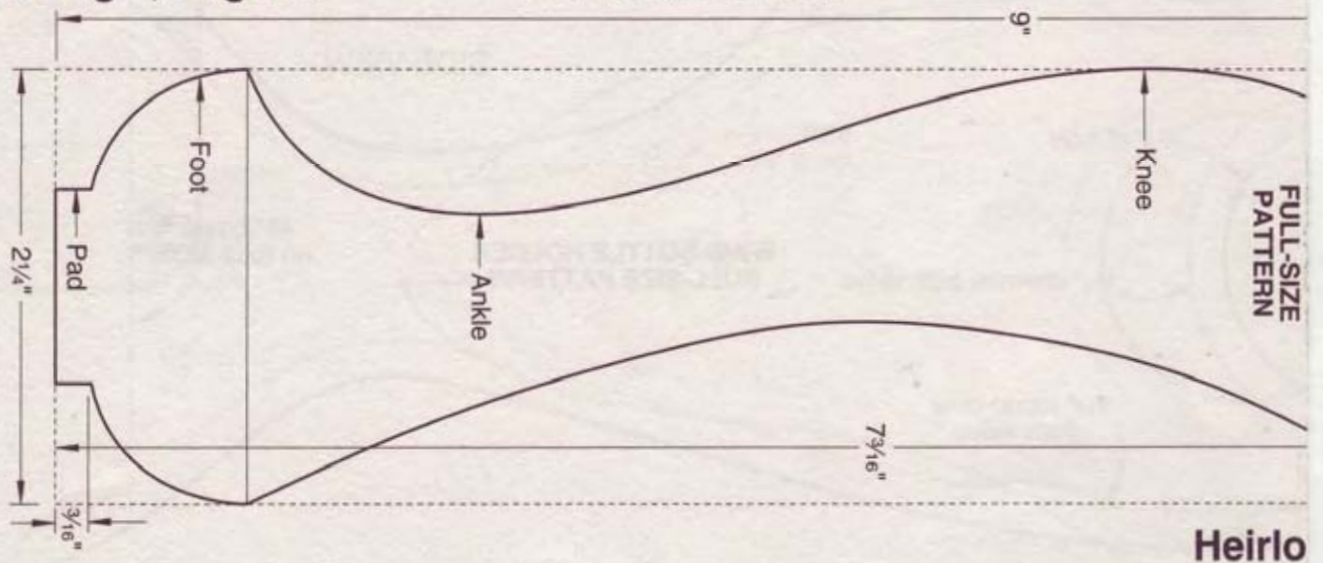

Heirlo

Regal Eagle, Page 60

Display Case, Page 54

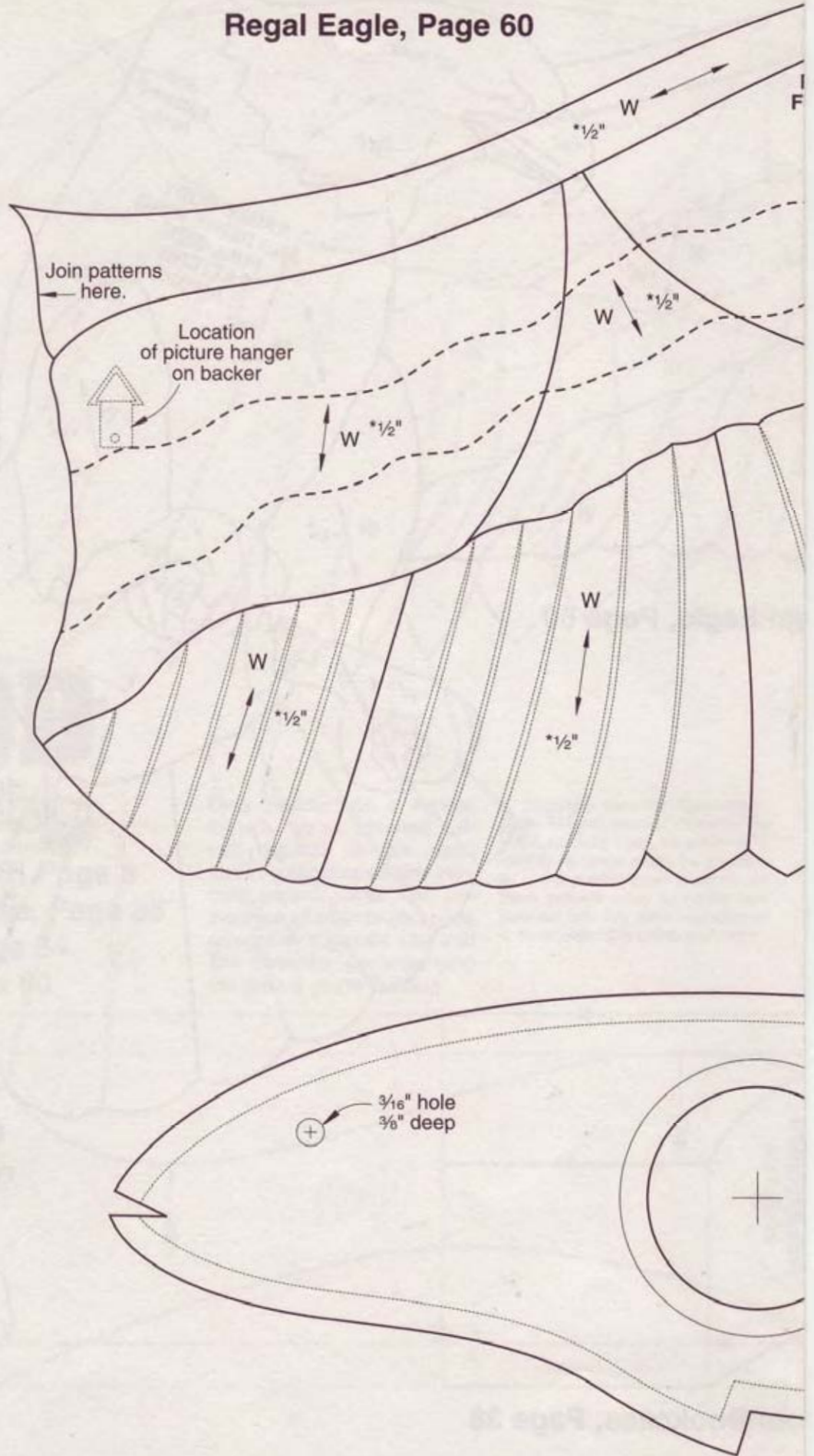
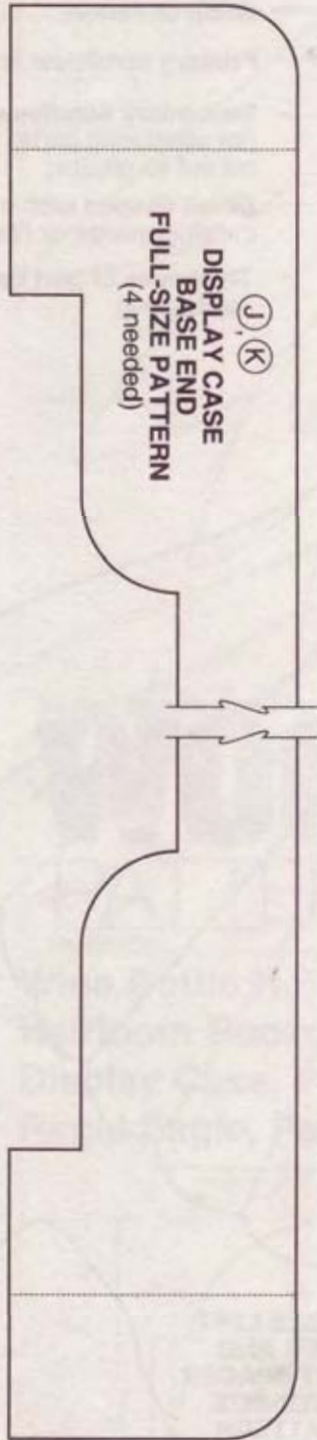

**EAGLE LEFT WING
FULL-SIZE PATTERN**
(5 needed)

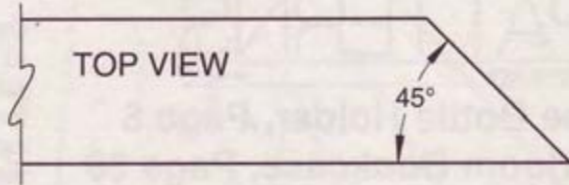
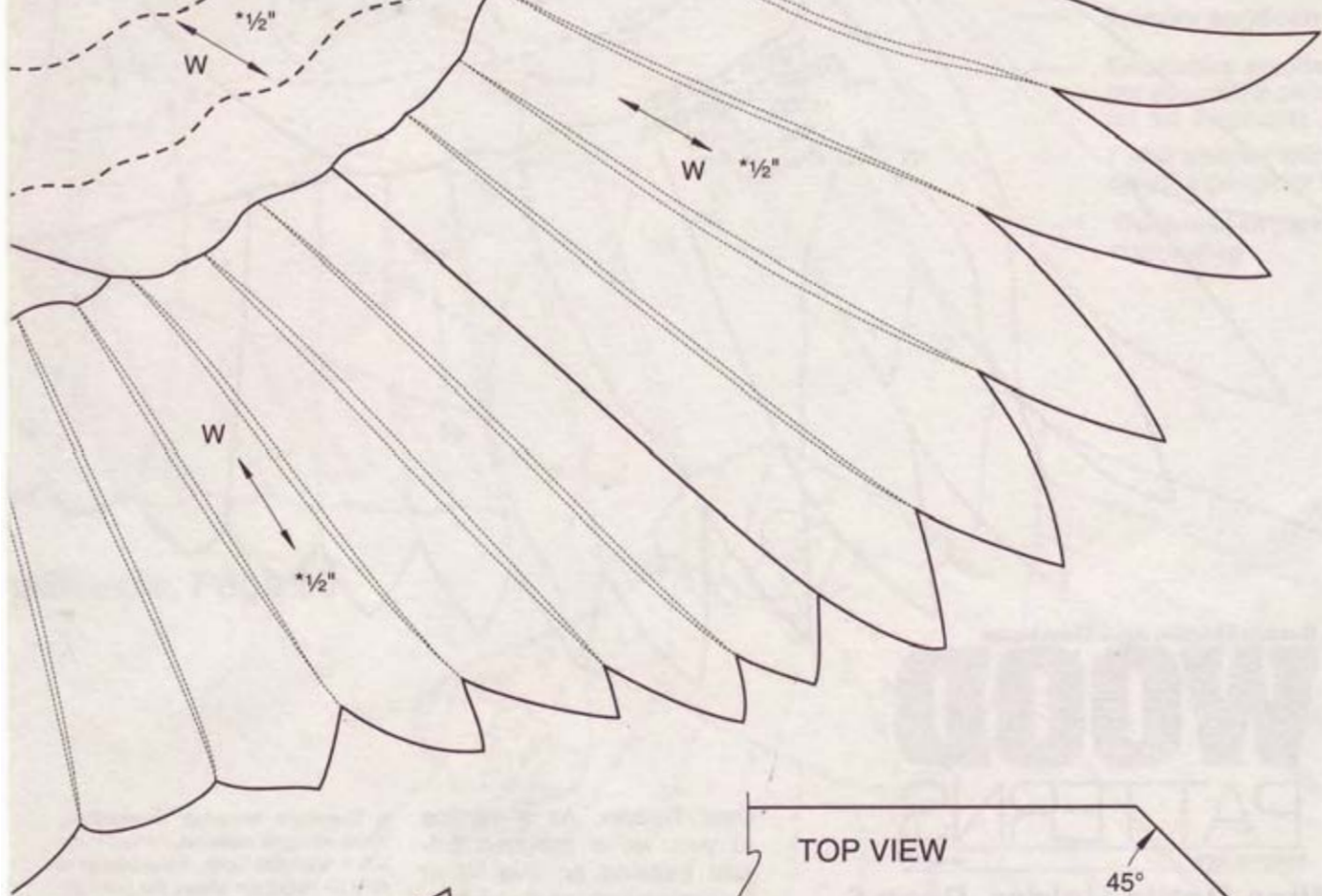

Wine Bottle Holder, Page 8

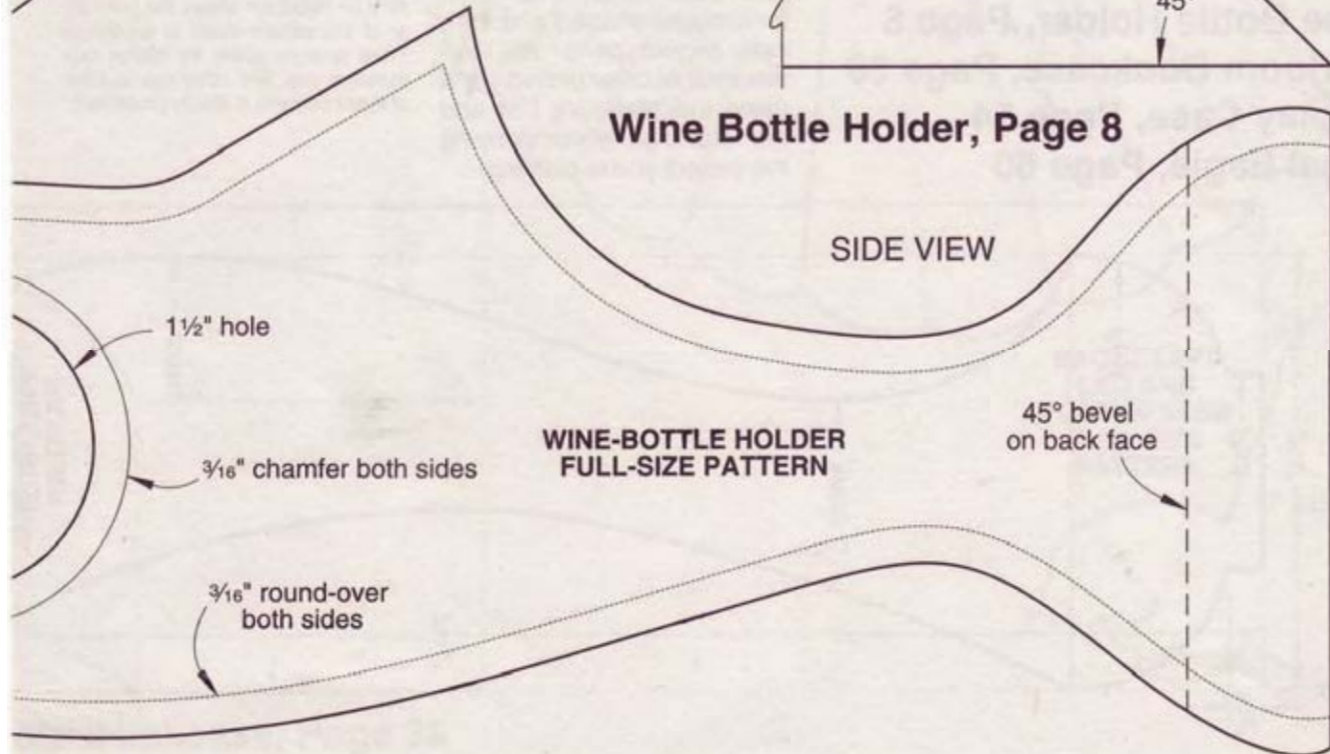

KEY

W - Walnut
 Y - Yellowheart
 A - Aspen

- ↔ Grain direction
- Primary scrollsaw line
- - - Secondary scrollsaw line (for separating parts cut out as groups)
- ⋯ Detail shaped with a carving gouge or file
- * Thickness of part before contouring

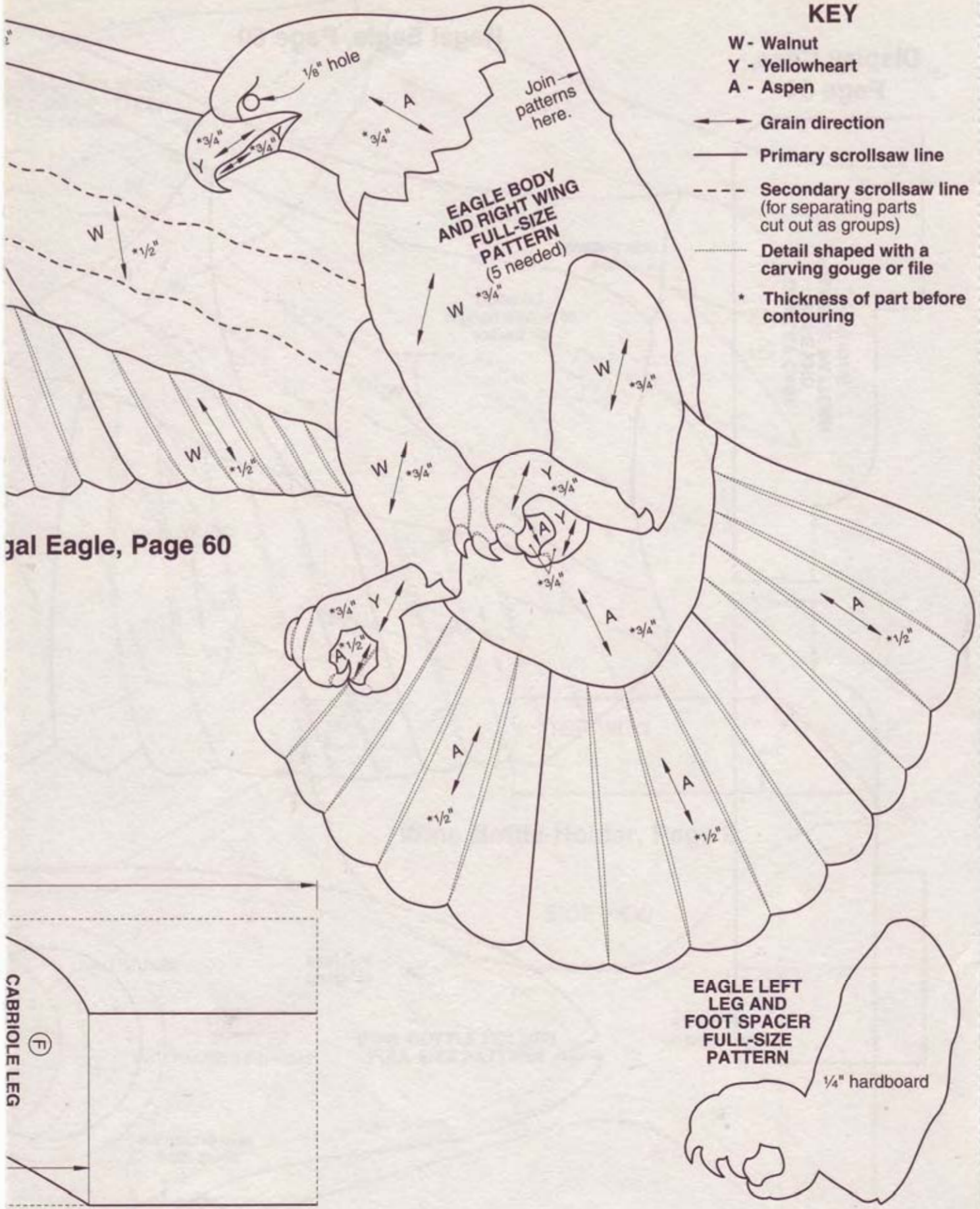

EAGLE BODY AND RIGHT WING FULL-SIZE PATTERN
 (5 needed)

EAGLE LEFT LEG AND FOOT SPACER FULL-SIZE PATTERN

1/4" hardboard

gal Eagle, Page 60

CARRIOLE LEG (F)

om Bookcase, Page 38

picture-perfect poly

Master the steps to transform a polyurethane finish from plastic to fantastic.

Aggressively marketed and widely available, polyurethane isn't just the favored finish of many woodworkers; it's their only finish. True, there's a lot to like about poly. The long drying time makes brushing a breeze, and once dry, the tough finish resists moisture and abrasion.

Oil-based poly isn't perfect, though. That long drying time allows plenty of dust nibs to collect on the tacky surface, and bubbles left by brushing flaw the finish. Once dry, gloss poly can look too shiny, like the tabletop shown *below*. (Even satin poly finishes

can call attention to surface flaws unless you rub them out.) You'll also need to carefully scuff-sand each coat to ensure proper adhesion. If polyurethane remains your first choice, master these strategies for working around its shortcomings.

Prevent poly problems

You can't fix problems you can't see, so shine a bright light on the work surface at an angle that emphasizes drips, surface debris, and bubbles. Other accessories you'll need include a natural-bristle or fine synthetic bristle brush (see "Pick a Brush that Gets Your Finish Off to a Smooth Start"), an angled (or sash) brush of the same type for working finish into inside corners, a separate container for holding finish, and a supply of shop rags.

Prepare the wood by sanding to 120 grit for unstained wood or 180 grit for surfaces to be stained. Any added smoothness from sanding to higher grit at this stage disappears after you apply the finish. Hand-sand at the final grit with a flat, lightly padded block. First, vacuum the wood surface thoroughly, and then wipe it clean using a rag soaked in mineral spirits.

For fewer dust flaws, start with a clean work area. First, vacuum the dust from overhead lights and surfaces within your finishing area. Then vacuum and damp-

mop the floor to avoid kicking up dust while you finish. After any airborne dust settles, run your hand across the wood just prior to applying a finish. The oils on your skin will pick up the last bits of dust on the surface.

Start with a sealer coat

Avoid the frustration of digging a stray brush bristle out of a dried coat of polyurethane. First, slap the bristles against your palm to detect any strays. Just before you apply the finish, completely dip the bristles into mineral spirits and blot or shake away the excess. Check again for loose bristles.

Polyurethane doesn't bond well with other surfaces, especially itself, if you don't scuff-sand it.

Apply finish directly from the original can and you risk contaminating the polyurethane with debris picked up by your brush. Instead, pour enough finish for the project into a separate container. If you're using a previously opened can, strain the polyurethane through a paper paint filter to remove debris and globs of partially dried finish.

ALL GLOSS AND NO GLOW

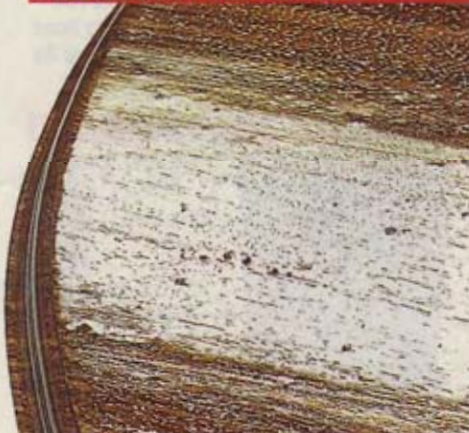

If you don't rub out a gloss poly finish, glare highlights dust nibs and drips, while the surface feels rough.

ANGLED LIGHTS SHOW SAGS



Polyurethane's slow drying time can allow sags to form. Use an angled light source to spot excess finish you'll need to brush off.

Whether you thin the first coat of finish or apply it at full strength may depend on whether you're covering a stained surface. A thicker, full-strength sealer coat provides added protection against accidentally sanding through both polyurethane and stain to bare wood. If you're finishing unstained wood, however, polyurethane thinned 50 percent with mineral spirits creates a thin but fast-drying sealer coat.

Apply finish to horizontal surfaces whenever possible, even if that means tilting your project on edge. Where the work surface must remain vertical, use the angled light source to check for drips, as shown *above*. Do this as you work and after coating the surface but before the finish skins over.

SCUFF-SAND OR SUFFER



We scored 100 squares in topcoat applied to an unscuffed layer, and covered them with packaging tape. Finish pulled loose from 92 squares as the tape was removed.

Grip the brush by the metal ferrule between your thumb and fingers, and dip the bristles about a third of their length into the finish. Gently drag the bristles against the container's edge to remove the excess.

Begin brushing with the grain from the center of the project surface to the ends, reloading your brush as needed. Apply a complete strip of finish from end to end before starting the next strip at the wet edge of the previous one. Work as quickly as your brush can release each load of finish.

You can't avoid leaving a few air bubbles in the finish, and polyurethane's slow drying time can produce unexpected sags. Reduce the number of bubbles and drips by "tipping off" each strip of finish. To do this,

hold the brush perpendicular to the work surface and lightly pull the brush tip the length of the strip. To drain the brush of excess finish picked up while tipping off, wipe it against an empty container.

Add top-quality topcoats

Once the sealer coat dries, use 220-grit abrasive and a flat sanding block to knock down dust nibs and surface flaws. You may need to sand more after the sealer coat than you will between topcoats, but avoid cutting through to the wood below. Sand molded details using your fingers and a gentle touch. You're most likely to sand through the finish at crisp edges. Afterward, carefully vacuum the surface and wipe away sanding dust with a soft cloth.

Polyurethane doesn't bond well with other surfaces, especially itself, as shown *above left*. You'll need to lightly scuff-sand the surface between coats with 220-grit abrasive to create tiny grooves where the next coat can grip the previous one. Wipe away all sanding dust between coats.

Avoid the temptation to apply too thick a coat, which can allow drips or sags to form. Polyurethane hardens by reacting with oxygen, so even a surface that's dry to the touch may still be hardening. If you plan to rub out the finish, apply a full-strength final coat.

When should you thin topcoats? Some polyurethane formulas do a better job than others of leveling off brush marks. If you've done everything possible to brush on a smooth finish and you still get brush marks or unpopped bubbles, sand that layer and thin your finish about 10 percent before applying the next coat.

Pick a brush that gets your finish off to a smooth start

Just about any brush will transport poly onto your project. The right brush, however, will lay down finish that's smooth enough to cut your sanding time while leveling the finish prior to rubbing it out.

Natural China-bristle brushes have long been popular for applying polyurethane, and for good reason. They're fine enough to flex as you brush on a finish without producing grooves, as stiffer nylon bristles might do. Some synthetic bristles, such as Purdy's Syntox (Purdy, 503/286-8217 or purdycorp.com), rival natural bristles for bristle size and flexibility. So here's what to look for, regardless of the bristle type you choose.

Flagging. Think of these as split ends on the hairs of your brush. Each flagged tip provides an even finer applicator than the body of the finest bristle. The result: Finish flows from the brush to the surface of the wood without leaving ridges.

Chiseled tip. Don't confuse this term with the sharply defined point of a foam brush. "Chiseled" describes how some of the bristles stop short of reaching the end, forming a slight wedge shape that lays down a smooth finish as you draw the brush along at an angle.

Tapered bristles. Picture how a fishing rod flexes more at the tip than at its base. The slight taper of individual bristles from the ferrule to the flagged tip can be hard to see, but it allows the brush to hold a firm shape while remaining flexible at its tip to apply a smooth finish.

NYLON BRISTLES: TOO COARSE



NATURAL BRISTLES: JUST RIGHT



Rub topcoats to perfection

Polyurethane finish labels don't stress rubbing out the last coat of finish, but this is what produces a velvet-smooth surface that shows off grain. Rubbing out a finish accomplishes three things: You remove the last crop of dust nibs, brush marks, and partially popped bubbles. You keep the surface from reflecting light in patches of glare. And you produce a surface that's so smooth, your fingertips glide across it. Simply follow these four easy steps:

1 After the finish dries for two weeks (it takes that long for polyurethane to cure hard), wet-sand the finish with a rubber- or felt-backed sanding block starting at 320 or 400 grit. Using mineral oil as a lubricant, as shown *below*, slows the sanding process more than sanding with mineral spirits, produces fewer odors, and helps avoid accidental sand-through.

Sand until you have a uniform layer of scratches across the entire surface. Gloss finish helps you spot gaps in your sanding easier than using satin finish.

Sanding completely through part of the topcoat and into the one beneath can leave irregular rings. To remove them, wipe away all sanding residue and mineral oil using

GIVE FINISHES YOUR LEVEL BEST



An angled light source helps you check the consistency of your sanding as you level the last coat of finish.

mineral spirits. Then lightly scuff-sand with 220-grit abrasive for a good bond, apply another topcoat, and allow it to harden.

2 It's time to choose a sheen for your final finish. If you want a satin finish, sand through 600 grit before going to Step 3. If you want a semigloss or glossy surface, work through silicon carbide sanding grits 600, 800, 1,000, 1,200, and 2,000; and then go to Step 3. Either way, clean the surface thoroughly between grits using mineral spirits to prevent accidental scratches.

Because you're sanding finish, not wood, you can sand against the grain with every other grit to tell when you've removed the scratches from the previous grit. Sand with the grain for the final grit. When both fine-sanding and, later, rubbing out a finish, develop a routine to avoid missing spots. Start by working the edges—the most overlooked areas—before sanding and polishing the center from side to side.

RUB FINISHES THE RIGHT WAY



Mix mineral oil or paraffin oil into the pumice or rottenstone directly on the wood surface.

3 Now you're ready for the rubbing compounds. For a satin surface, use pumice in 2F and 4F grades. To achieve a semigloss surface, use rottenstone (powdered limestone). Use one or the other, not both, or the coarser pumice will leave coarser scratches than the 2,000-grit abrasives.

Pour mineral oil or paraffin oil onto the surface, and sprinkle it with pumice or rottenstone to form a slurry, as shown *above*.

Wipe-on poly wipes out finish flaws

If your best efforts don't prevent brush marks, drips, and sags, you can still achieve a polyurethane finish with the application ease of a Danish oil finish.

Wipe-on varnish and gel varnish do away with brushing. To make your own wipe-on varnish, just thin your existing varnish 25 percent or more with mineral spirits. Apply each coat with a soft rag, and immediately remove the excess with a separate clean rag. Gel varnish goes on much the same way.

In both cases, the finish will dry faster than brushed-on, full-strength poly. The trade-off: Thinner layers require two or three times as many coats for the same thickness as a full-strength coat. Still, if you bristle at the thought of brushing, either wipe-on or gel poly creates a film that rivals spray finishes for smoothness.

Using a piece of scrapwood with a felt pad attached to the bottom, work the pumice or rottenstone slurry with the grain. Don't rub out the finish any more than necessary to achieve the look you want.

Polyurethane finish labels don't stress rubbing out the last coat of finish, but this is what produces a velvet-smooth surface that shows off grain.

4 To fill in the last of the fine scratches, apply a coat of paste wax and buff it to an even shine, like that shown *below*. You can also use spray wax, such as Pledge, if that's how you maintain your furniture finishes. ♣

Written by **Bob Wilson** with **Bob Flexner**

Choose the resin that best matches your needs

"Polyurethane" may be a synonym for varnish to some woodworkers, but the word really only describes one of three varnish resins: phenolic, alkyd, and uralkyd. Varnish makers mix one or a combination of the following resins with oil under heat. The types of resins in the mix partly determine a finish's abrasion resistance, clarity, and cost.

Phenolic resins grew out of the early 20th-century's plastics industry. Phenol extracted from coal tar was mixed with formaldehyde and combined with oil such as tung oil. Though a durable replacement for shellac at the time, its ingredients tended to yellow more than later varnish

resins. Phenolic resins still find their way into high-end marine varnishes, such as McCloskey Boat-Koat Spar Varnish and Pettit Paint's Bak-V-Spar Varnish.

Alkyd resins made by mixing alcohol and acid proved less costly than phenolic resins while producing less yellowing. That cost savings continues to make them a main ingredient in many varnishes labeled as polyurethane. Alkyds can be purchased unblended in varnishes, such as Pratt & Lambert 38 and McCloskey Heirloom.

Uralkyd resin best describes the type of polyurethane most woodworkers use. These

combine alkyd and urethane resins to gain the strengths of both: alcohol resistance from alkyds, for example, and scuff resistance from urethanes.

so many clamps...



...so little budget

If you haven't said it, you've heard it: You can never have too many clamps. But let's face it: Few of us can tie up a truckload of money in clamps. Here are eight tips and shortcuts for saving money and getting the most from the clamps you already have on hand.

TIP ①

Save money with pipe clamps.

Pipe clamps have long been popular because they deliver incredible clamping strength and durability at an affordable price. Clamp fixtures (a sliding jaw and fixed headstock that threads onto $\frac{1}{2}$ " or $\frac{3}{4}$ " steel pipe) sell for \$4–15 per set.

You can make pipe clamps any length you want, as long as one end of the pipe is threaded to mount the headstock. The fix-

tures can be removed easily and put on other lengths of pipe, saving you money because pipe is cheap. Our advice: Buy 4–8 sets of fixtures, and keep on hand a variety of pipe lengths. Store them out of your way when not in use.

You can buy threaded pipe from any home-improvement center or plumbing supply store. Choices include black or galvanized, with each having advantages and disadvantages. Fixtures slide better on black pipe, which sells for about \$1 per foot, a third less than galvanized. Galvanized pipe's chief advantage, rust protection, works only on the pipe surface, not its threads. However, black pipe will leave dark stains on your workpiece if it comes into contact with glue during a glue-up.

(Use waxed paper as a protectant, or make sleeves for the pipe from PVC.)

Long lengths of pipe can bow under clamping pressure. To prevent this, use the more rigid $\frac{3}{4}$ "-diameter pipe. Protect exposed threads on both pipe types with slip-on plastic caps.

TIP ②

Keep clamps clean.

Maintain your clamps just as you do your tools. Clean the jaws, pads, and bars after a glue-up because hard, dried glue can dent workpieces and interfere with the jaw movement. And, once glue builds up, it is difficult to remove. To prevent this, put waxed paper between the clamp and workpiece. Or, apply



Headstock

①

Tailstock

92



②

a light coat of paste wax or paraffin wax to the clamp components to resist glue sticking. Add wax on the clamp screws for smoother turning. Do not use silicone- or oil-based lubricants: They can stain your workpiece and interfere with your finish.

TIP ③

Rely on cauls.

To create even clamping pressure across a wide joint, use a hardwood caul, a sturdy board that distributes clamping pressure across a wide area. Simply insert a 2"-3" wide board—cut to match the length of the joint—between the clamps and the workpiece. Add a little cloth-backed, double-faced tape to hold the caul in place while you tighten the clamps.

TIP ④

Close the gap with shims.

Sometimes you can't get a clamp where you need one, such as the middle of this case. At

those times, rely on a caul to do the job. Loosely clamp this caul with one edge against the case, and then add thin wedges or shims in the middle. When you tighten the clamps, this exerts equal pressure against the middle of the joint and the ends.

TIP ⑤

Make short clamps longer.

When you're gluing up a large case and don't have enough long clamps, make short pipe clamps act like long ones. Join two short pipe clamps with a coupler. (They cost less than a buck.)

TIP ⑥

Look for shortcuts.

Another way to make short clamps work like long clamps: Take advantage of what the project offers you. Use a divider or shelf (secured in a dado) for leverage and pull from it with a short clamp.

TIP ⑦

Create your own leverage.

If your project doesn't have a built-in leverage surface, make one. Clamp or screw a temporary cleat to the workpiece edges—but only if the holes will later be covered by a face frame, edge band, or back panel—and use a short clamp to draw parts together.

TIP ⑧

Correct unsquare corners.

Gluing up a large case proves difficult enough, but trying to keep it square adds another complication. Before fretting about it being square, first clamp up the assembly. Before the glue sets, place a bar or pipe clamp askew on the long axis. Tightening this clamp changes the corner angles. Use a measuring tape to check diagonally—front and back—across the corners until both read the same. If the case moves the wrong way, reverse the orientation of the clamp. ♣

Written by Bob Hunter with Kevin Boyle

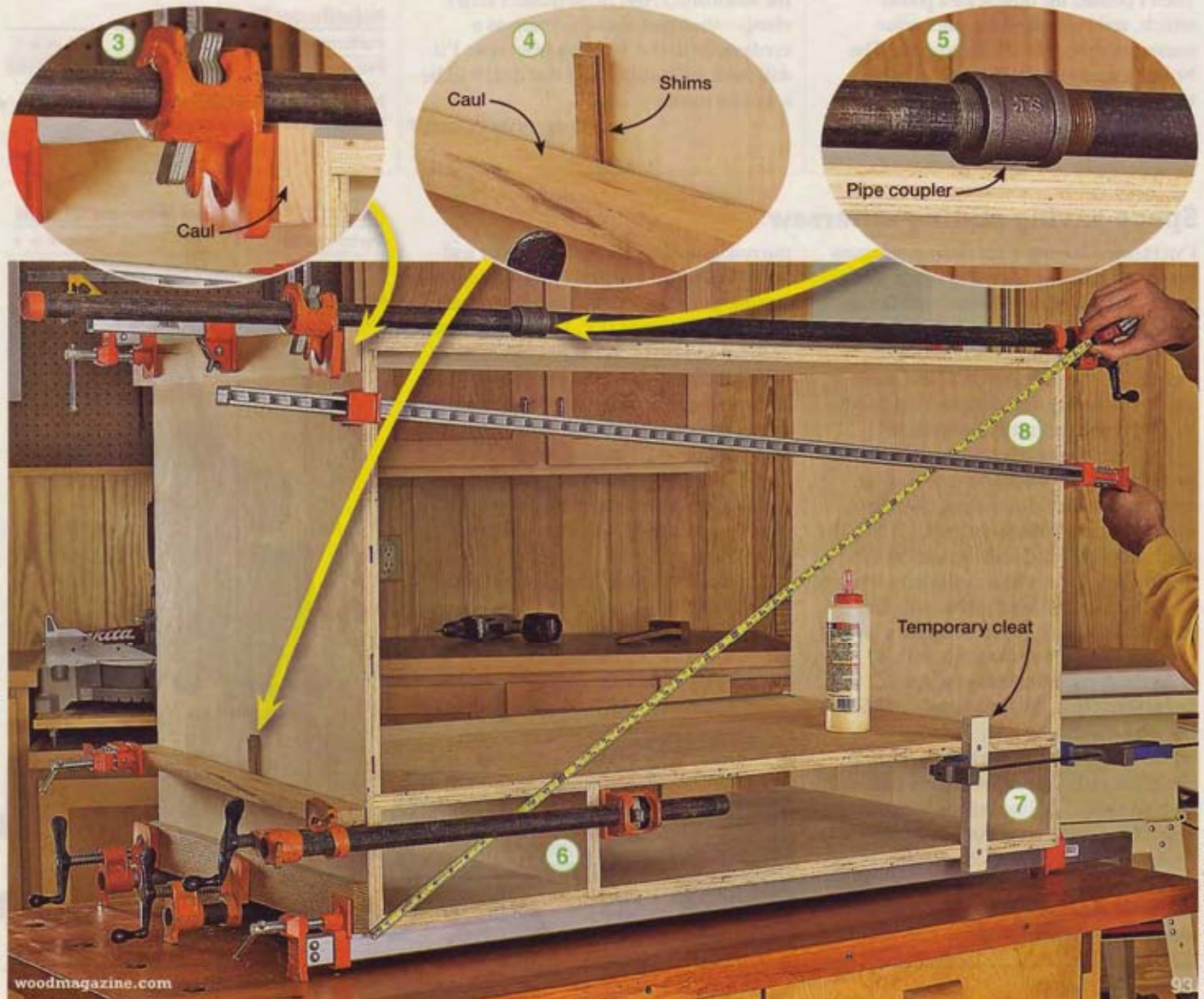

shop-proven products

These woodworking wares passed our shop trials.

Hearing protection that cancels shop noise

It's no wonder noise-canceling headphones are popular among travelers. These new gadgets "hear" environmental noise (such as the constant drone of aircraft engines) and generate a frequency that cancels out the drone. Now the same technology has come to the wood shop in the form of NoiseBuster Safety Earmuffs.

The day the muffs arrived, I headed straight to my portable planer, slipped the NoiseBusters over my ears, and fired up that loud machine. With their power switch off, they worked about as well as my other muff-style hearing protection, but didn't cut the sound as well as my usual in-ear plugs. Then I pushed the dust-sealed power switch, and instantly the planer noise seemed to drop by half. Impressive. The NoiseBusters yielded the same results when used with outdoor power equipment, including a mower, chipper, and chainsaw.

There's no radio on the NoiseBusters, but a stereo headphone jack allows you to plug in a portable radio or MP3 player (and not run it louder than an unhealthy 85dB). A buddy took my NoiseBusters to a NASCAR race and plugged a scanner into the jack. He eavesdropped on the conversations between the pit crews and drivers while shutting out most of the track noise.

The manufacturer says you'll get about 65 hours of use from the single AA battery that powers NoiseBusters. That's probably about right. (I left mine on by accident a few times because the power indicator LED isn't very bright and it hides behind the headband.) And NoiseBusters aren't cheap—they cost about as much as a cordless drill. But 20 years from now, I'll still have my hearing, and that drill will be a distant memory.

—Tested by Dave Campbell

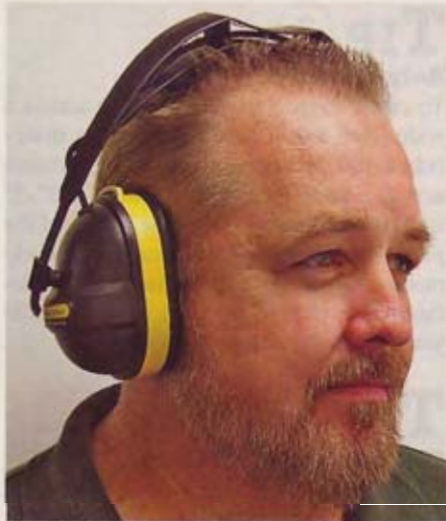

NoiseBuster PA4000

Performance ★★★★★
Price \$150

Pro Tech Communications
877/226-1944; noisebuster.net

Space-saving sliding mitersaw

I've resisted buying a 12" sliding mitersaw because it takes up almost as much space as a contractor-style tablesaw, and fits up against a wall about as well. But Hitachi's C12LSH gives a full 12"+ of crosscut capacity, yet requires only 25" of bench depth. (Including the miter-locking handle, its total depth measures just over 36".)

The secret to its compact footprint? The head (motor and blade) on most sliding mitersaws is fixed to a pair of rails that slide in the saw's base. On the C12LSH, the head slides on fixed rails, similar to the way the head slides on a radial-arm saw. (You can lock the head on the rails and have the rails slide in the base like a typical saw, but I found no advantage in that.)

As the premier mitersaw in the toolmaker's line, the dual-bevel C12LSH has a base-mounted laser (no need to turn on the saw to see the line) that adjusts to the left or right side of the blade in seconds without tools. The line proved accurate throughout my testing, but I didn't haul it to a jobsite to see how well it held after being banged around.

The C12LSH also sports two features unique to Hitachi mitersaws:

microadjustments for both the miter and bevel angle, and a digital LCD display on a flexible gooseneck that shows both angle settings, accurate to 0.5°. I made a number of miter and bevel cuts at random angles, noting the reading on the display, and then compared that reading to the measurement on my protractor. The cuts were dead-on every time. Next, I made several inside and outside compound cuts in 5" crown molding while trimming out a room and crowning a cabinet. The fit on all joints proved tight.

The \$650 price tag may give you pause, but it's not out of line for a 12" dual-bevel slider. Hitachi also sells a version of this saw without the digital display (model C12RSH) for \$50 less.

—Tested by Pat Lowry

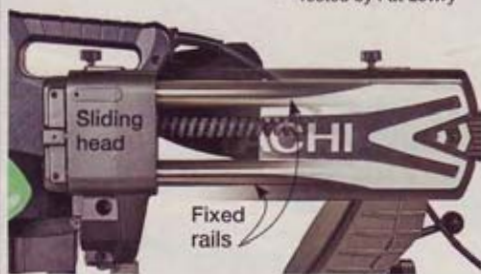

Hitachi 12" Compound Miter Saw C12LSH

Performance ★★★★★
Price \$650

Hitachi Power Tools
800/829-4752; hitachipowertools.com



continued on page 99

Slim pushblock keeps hands safe in two ways

If you use a tablesaw, router table, or jointer, you need pushsticks or pushblocks to move the workpiece when the cutter gets too close to your fingers for comfort. Bench Dog's Push-Loc pushblock adds an extra measure of safety not found in other commercial or shop-made pushsticks.

First, the tail hook and a stiff rubbery pad along the sole of Push-Loc's 9"-long body grip the workpiece beneath it, so I always felt completely in control of any workpiece. And second, the 3/16"-thick body and comfortable offset handle allowed me to keep my tablesaw's blade guard on for rips as narrow as 1" without interference. (Depending on your saw's guard, your narrowest workpiece may be wider or narrower.)

To keep Push-Loc always within reach, it comes with a "docking station" that mounts to your fence's body with double-stick tape. At 2 1/2" wide, it fit easily in the recess between the faces on top of my commercial Biesemeyer-style fence, but proved a little too wide for the home-shop

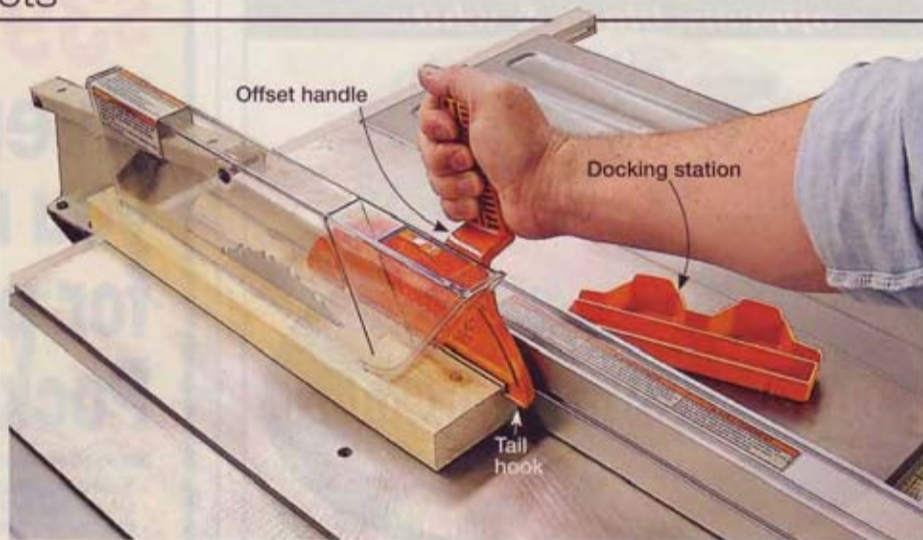

version of the same fence. It also can be mounted on the back side of your fence or left freestanding.

A molded pocket on the docking station holds pencils nicely, but the two tape-measure pockets didn't fit any tape I could find, unless I hung them on the outside. And then, the raised edges of the fence faces interfered. (This won't be a problem on non-Biesemeyer-style fences.)

Here's the bottom line on Push-Loc: I could take or leave the docking station, but I love the pushblock, even at \$20.

—Tested by Randy Zimmerman

Push-Loc

Performance	★★★★☆
Price	\$20
Bench Dog, Inc. 800/786-8902; benchdog.com	

Everything You Need For Pocket Hole Joinery!

When it comes to your next woodworking project, look no further than Kreg. We proudly offer a complete line of Pocket Hole tools and accessories that will have you building faster, stronger and better than you could have ever imagined.



Foreman Pocket Hole Machine

Did you know that we also manufacture Pocket Hole machines? Our semi-automatic Foreman is priced right and drills a Pocket Hole in less than a second!



800.447.8638 | www.kregtool.com

See these products in action on our website!

cutting tenons to a T

Don't be afraid of mortise-and-tenon joinery. We'll show you two goof-proof ways to machine tenons that match your mortises.

There's no need to run for the biscuit joiner or pocket-hole jig every time a project calls for edge- to end-grain joints. Mortise-and-tenon joinery, a centuries-old favorite, specializes in that situation, offering incredible strength.

An ideal mortise-and-tenon joint takes only mild hand pressure to assemble. If you cut a tenon too small—even $\frac{1}{32}$ "—the joint weakens because of a poor glue bond. When you leave a tenon too big and have to force it into the mortise, it can starve the joint of glue, or even worse, expand or split the workpiece. Still, achieving a perfect fit proves little consolation if the finished joint is misaligned. Fortunately, knowing a few tricks makes it easy to avoid measuring, marking, and machining errors.

Good tenons start with good mortises

Before you do anything, machine all of your workpieces to the final dimensions, including several extras for test cuts. Starting with stock of equal thickness and width helps ensure accuracy. Planning the joint so all the shoulders measure the same depth (see illustration, page 102) saves you time later because you can machine the shoulders at the same blade height on your tablesaw.

In the *WOOD*® magazine shop we cut the mortises first, then fit the tenons to them

because it proves much easier to fine-tune a tenon than a mortise. You can machine a mortise in many ways. We prefer a benchtop mortising machine for its accuracy and squareness and, once set up correctly, its ability to make repeated and precise cuts. But you also can do the job with a drill-press mortising attachment or by drilling a series of holes and chiseling out the waste. Machine-cut mortises require only light cleanup with a sharp chisel. (See issue #156,

pages 68–71 for three detailed techniques on cutting mortises.)

Before machining, lay out the mortise on a test piece, as well as the workpieces, with a sharp pencil or marking gauge. Make test cuts on the practice piece until the mortise is centered, as shown, *below*. Once you've centered the mortise, machine the final workpieces. Use stopblocks secured to the mortiser's fence to fix the starting and ending points for each mortise.

HOW TO CUT PERFECTLY-CENTERED MORTISES

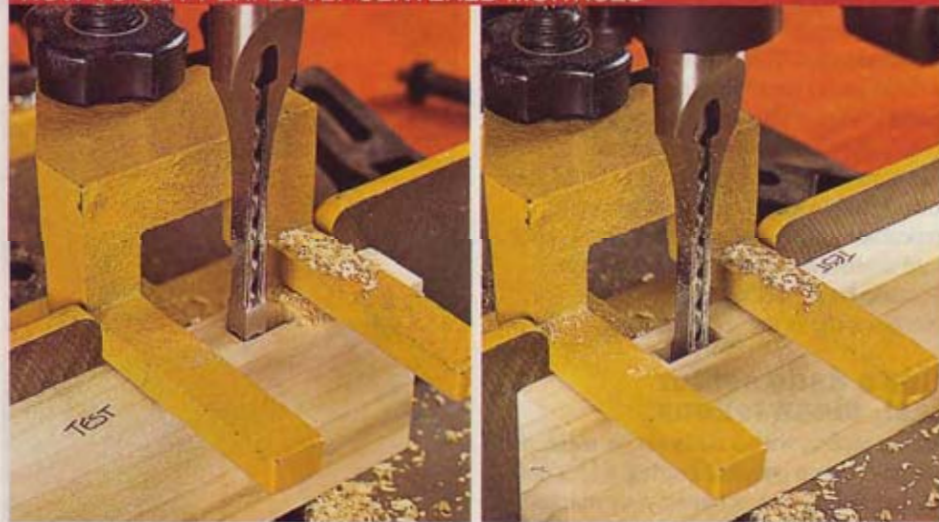

To test your setup, plunge two cuts into a test piece (*left*). Place the opposite face against the fence and gently plunge the chisel—with the motor off—into the mortise (*right*). If it catches on the mortise, adjust the fence and repeat until it enters from both sides without catching.

continued on page 102

ANATOMY OF A MORTISE-AND-TENON JOINT

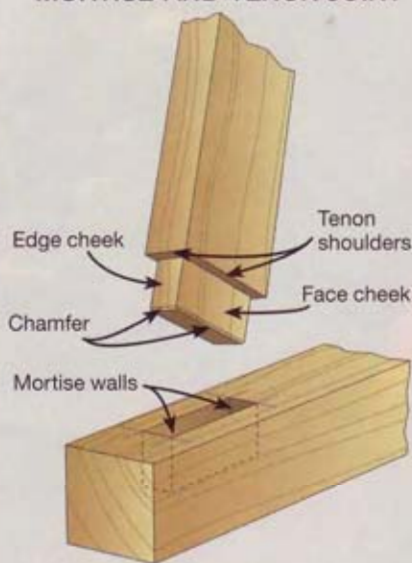

Because each joint will have subtle variations in size and fit, mark each matching pair with numbers to keep them paired. With all your mortises finished, you're now ready to machine the tenons.

Tenons, anyone?

Trying to achieve a perfect-fitting tenon with your tablesaw blade leads to a pile of scrap pieces. Instead we cut tenons $\frac{1}{64}$ " proud in width and thickness, and then trim them to fit the mortise. And, we cut them $\frac{1}{16}$ " shorter than the depth of the mortise to allow room for excess glue.

As with mortises, you can cut tenons in multiple ways, each with advantages and disadvantages. You can machine them with a dado set on your tablesaw or with a commercial or shop-built tenoning jig. (See pages 58-59 in issue #168, or visit woodmagazine.com/tenonjigs to build your own.) Both methods produce accurate, repeatable, clean tenons. Oftentimes, stock size determines which method we use because larger stock proves more cumbersome in the tenoning jig.

Use a dado set for fast, clean tenons

To cut tenons with a dado set, at *right*, use the maximum possible cutting width and set the height to just below your marked tenon. After aligning the shoulder lines with the blade, slide the rip fence to the end of the tenon. Attach an extension to

Comparing two ways to saw tenons

	Tenoning Jig	Dado Blade Set
Cost	\$65-\$125	\$85-\$250
Other Uses	None	• Cutting dados, grooves, rabbets, half-laps, shiplaps, tongue & grooves
Pros	<ul style="list-style-type: none"> • Safe—hands stay well clear of blade • Clean cut (with sharp blade) • Excels on angled tenons • Don't need to change saw blades • Less tear-out 	<ul style="list-style-type: none"> • Cuts shoulders and cheeks with same setup • Most woodworkers use this often, so setting up to cut tenons proves almost second nature • Handles stock size too big for tenoning jig • Easy to store
Cons	<ul style="list-style-type: none"> • Jigs might not work on some saws due to miter-slot distance from blade • Heavy and cumbersome to handle • Awkward to store • Could be difficult to remember setup and operation if used infrequently • Limits to stock being cut (typically 3" for width and 3'-4' for length) 	<ul style="list-style-type: none"> • Saw marks need more cleanup • Tear-out more likely across the grain • Benchtop saws might not accept dado set • Resharpening is expensive • Time-consuming to change blades

the miter gauge to avoid tear-out, and make certain you have your rip fence parallel with the blade, and the miter gauge perpendicular to the blade.

Making test cuts on scrap pieces, "sneak up" on the tenon thickness, raising the

blade in slight increments after testing the fit each time in the mortise. Remember, each adjustment *doubles* the amount of material removed because whatever you machine on one side will be duplicated on the opposite side.

CUT QUICK, CLEAN TENONS WITH A DADO SET

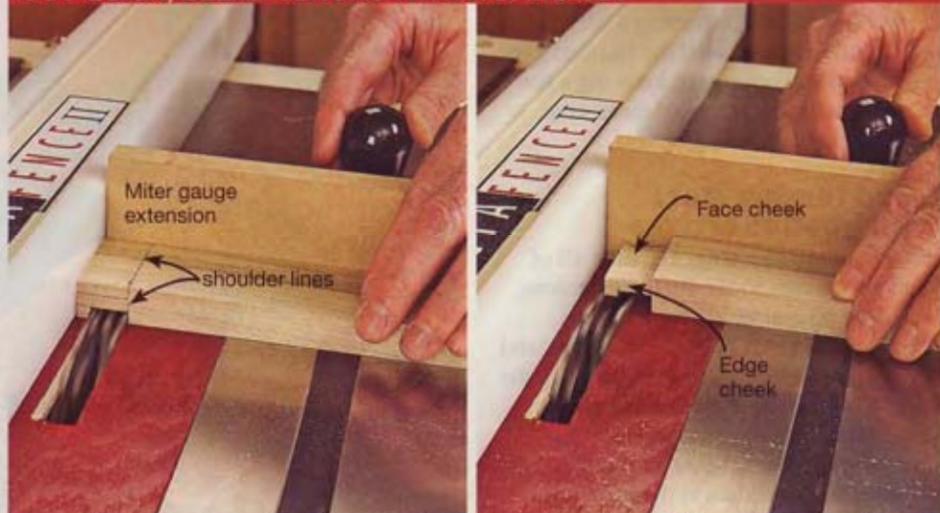

Line up the dado set to cut the cheeks at the shoulder lines first (*left*). Cut all four shoulders (faces first, then edges), and then slide the board down and nibble away the remaining waste (*right*) on all cheeks.

continued on page 104

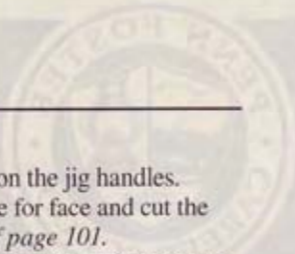

HOW TO GET TOP-NOTCH RESULTS WITH A TENONING JIG



A Cutting the shoulders first results in crisp edges. Use the rip fence as a stopblock and a miter-gauge extension to prevent tear-out.



B Adjust the jig square to the table and parallel to the blade, so your tenons will be square and perfectly match your mortises.



C Clamp your workpiece in the jig and line up the outside cheek. Use the fine adjustment knob (far right) to align the mark with the blade.



D Cut cheeks so scrap falls away from the blade, avoiding kickback. After making a cut, pull the jig back through the blade rather than lifting it.

Cutting tenons with a jig

One advantage to using a tenoning jig: You don't need to change saw blades. A quality 40- or 50-tooth combination blade, used in conjunction with a zero-clearance insert, will work great. To get the cleanest tenons, first cut the shoulders to depth with a miter gauge on the tablesaw. Make all four cuts,

faces followed by edges, with a backer board, as shown in **Photo A**.

Now grab your tenoning jig and make sure it sits square to the saw table, **Photo B**. Line up the tenon face cheek closest to the blade for the first cut, **Photo C**. Set the blade height to intersect the shoulder cut, and cut the first cheek, as shown in **Photo D**.

keeping both hands on the jig handles. Rotate the board face for face and cut the second cheek, *top of page 101*.

Test the fit in your mortise. If it's too big, adjust the jig and shave a little more off each cheek. Always cut opposing cheeks after making a change to ensure that the tenon stays centered. Stop cutting when it's close to sliding into the mortise.

We do not recommend cutting edge cheeks with a commercial tenoning jig because the fence and support system might allow boards to deviate from square. Instead, cut the edge cheeks on the bandsaw, as shown, *bottom left*, because it's quick and accurate. Clean any nibs left in the corners with a sharp chisel.

Hone tenons to a perfect fit

Now your tenon almost fits into its mortise. Don't force it. Instead, make a hardwood sanding block, as shown, *bottom center*, with crisp, square edges. (We made ours from 1/4" oak with self-adhesive 150-grit sandpaper.) Sand the cheeks lightly until the tenon slides in smoothly. You also can use a rabbet plane, making light passes.

We like to sand a small chamfer on the ends, which helps to keep the glue adhered to the mortise wall—a sharp end would scrape the glue to the bottom of the mortise. To keep from starving the glue joint, cut a few small grooves along the grain of the tenon face cheeks, as shown, *below*. Like flutes on dowels, this provides channels for excess glue to travel as the mortise and tenon are clamped together.

To get the best glue bonds, follow the principle that "glue won't stick where glue ain't." Using a glue brush, coat the mortise walls with glue, and also brush a thin layer on the tenon. Don't worry about putting glue on the shoulders; it will not provide a strong bond, and will just squeeze out. ♣

BANDSAW-CUT EDGE CHEEKS



Set the fence to cut the farthest edge, avoiding pinching the cut-off piece. Be careful not to cut into the shoulders—or your fingers.

FINE-TUNE TENONS TO FIT



Use a sanding block to reduce the tenon's thickness. Keep the block square to the cheek and shoulder to avoid tapering the tenon.

CUT GROOVES FOR GLUE TRAVEL



Using a carving tool or V-chisel, cut shallow grooves toward the end of the tenon to avoid an errant cut into the shoulder.

what's ahead

Check out the articles in the October issue (on sale August 29)

For your home and shop

FEATURED PROJECT

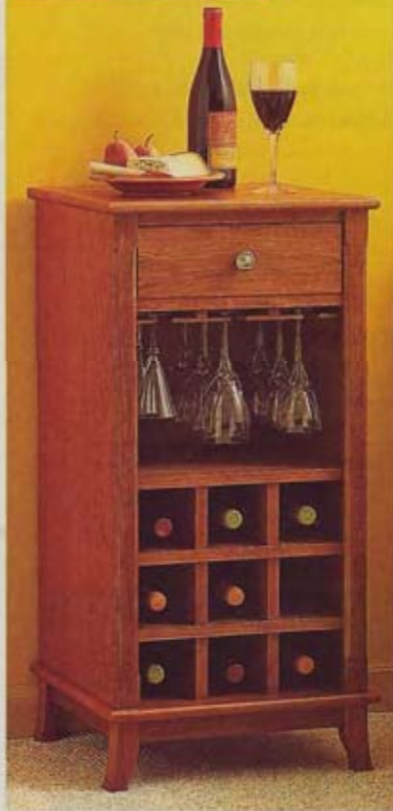

Wine server

Keep your favorite wines, stemware, and serving accessories handy in this modest-sized cabinet.



End-grain cutting board

Learn the nifty cutting and clamping tricks that help turn scraps into pleasing geometric patterns.



Bow-front table

A kerf-bent apron and curved, tapered legs give this wall-hugging project its graceful beauty.



Accommodating tool cabinet

This four-door cabinet occupies just 7 square feet of wall space yet delivers 26 square feet of tool storage on its Pegboard alone!

Tools and skill-builders

TOOL TEST



Air-filtration systems

You'll breathe easier after choosing a model from our comparison of 10 store-bought units and one homemade option.



33 shop-stretching pointers

Find adaptable ideas for squeezing the most storage and work space from even the smallest of shops.



Bandsaw perfection

No one can make a bandsaw "sing" better than pro Michael Fortune. Here are his top tips.



How to straighten anything

Woodworking begins with straight edges. Discover how to cut them on even the unrullest workpieces.