

WOOD

Easy-to-make

Wine Cabinet

NEW
LOWER
PRICE!

Add to Your Skills

- Cut Perfectly Straight Edges p.76
- Tune Up your Bandsaw p.52
- Kerf-Bend Plywood p.32

Improve Your Shop

- Space-saving Tool Storage p.46
- 10 Air Cleaners Tested p.70

END-GRAIN CUTTING BOARD



Display until October 10, 2006



21 Workshop Clutter Busters

p.90

WOOD

October 2006, Issue 172

PROJECTS

- 28 router-bit holder
- 32 kerfing jig for bending plywood
- 38 ready-to-serve wine cabinet
- 46 amazing-space tool cabinet
This four-door cabinet occupies just 7 square feet of wall yet delivers 26 square feet of tool storage.
- 58 tones-of-fun tongue drum
- 62 graceful bowfront table
- 82 end-grain cutting board
- 98 more cutting-board designs

TECHNIQUES

- 34 put an end to measuring mistakes
- 52 make any bandsaw a peak performer
Master woodworker Michael Fortune shows how to tune-up and use this key shop tool.
- 68 making curved and tapered legs
- 76 cut straight edges on anything
Know your machining options for taking the crook out of less-than-perfect stock.
- 90 pack more workshop into less space
Discover 21 storage-savvy ways to address the mess in your favorite hangout.
- 106 try gauge blocks for fast set-ups
Cut profiles of your router bits and use them for quick adjustment when making these cuts again.

TOOLS & MATERIALS

- 70 shop tested: air-filtration systems
Purify your shop's air with one of these 10 models.
- 100 five shop-proven products

DEPARTMENTS

- 6 editor's angle
- 8 sounding board
- 12 ask WOOD
- 20 shop tips
- 112 what's ahead



62



46



70



This seal is your assurance that we build every project, verify every fact, and test every reviewed tool in our workshop to guarantee your success and complete satisfaction.

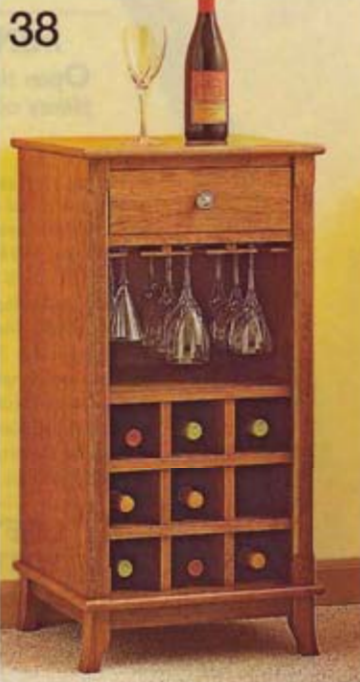

38



82



52



58



76

EDITOR-IN-CHIEF
BILL KRIER

Executive Editor **JIM HARROLD** Managing Editor **MARLEN KEMMET**

Editorial Manager, Tools and Techniques
DAVE CAMPBELL

Senior Design Editor
KEVIN BOYLE

Techniques Editor
BOB WILSON

Techniques Editor
BOB HUNTER

Projects Editor
OWEN DUVALL

Projects Editor
JAN SVEC

Design Editor
JEFF MERTZ

Master Craftsman
CHUCK HEDLUND

Art Director
KARL EHLERS

Associate Art Director
GREG SELLERS

Assistant Art Director
CHERYL A. CIBULA

Production/Office Manager
MARGARET CLOSNER

Administrative Assistant
SHERYL MUNYON

Photographers **MARTY BALDWIN, SCOTT LITTLE, BLAINE MOATS, JAY WILDE**

Illustrators **TIM CAHILL, LORNA JOHNSON, ROXANNE LeMOINE**

Technical Consultants **JEFF HALL, DEAN FIENE, PAT LOWRY**

Contributing Craftsman **JIM HEAVEY**

Proofreaders **BARBARA KLEIN, IRA LACHER, JIM SANDERS**

CUSTOMER SERVICE: 800/374-9663

For more ways to reach us about specific matters, see page 10.

Publisher **MARK L. HAGEN**

ADVERTISING AND MARKETING

CHICAGO: 333 N. Michigan Ave., Suite 1500, Chicago, IL 60601

Phone: 312/580-7956 Fax: 312/580-7906

Marketing Manager **AMANDA SALHOOT**

Advertising Managers **JACK CHRISTIANSEN, CAROLYN DAKIS**

Direct Response Advertising Representative **RYAN INTERLAND**

Assistants **GAYLE CHEJN, JENNIFER RUGGIERI**

ATLANTA: Navigate Media

1875 Old Alabama Rd., Suite 1320, Roswell, GA 30076

Phone: 678/507-0110 Fax: 678/507-0118

DETROIT: RPM Associates

29350 Southfield Rd., Suite 31, Southfield, MI 48076

Phone: 248/557-7490 Fax: 248/557-7499

BUSINESS DEVELOPMENT

NEW YORK: Concepts Media Group

52 Truesdale Dr., Croton On Hudson, NY 10520

Phone: 914/239-3483 Fax: 914/239-3493

LOS ANGELES: Southcoast Projects

12682 Pacato Circle North, San Diego, CA 92128

Phone: 858/673-0921 Fax: 360/246-5661

Business Manager **JOEL ETIENNE**

Consumer Marketing Director **ROBIN HUTCHINSON**

Assistant Consumer Marketing Manager **BILL WOOD**

Associate Director of Marketing-Newsstand **TOM DEERING**

Production Manager **TIM STOUFFER**

Advertising Operations Manager **LIBBY EHMKE**

Senior Vice President/Publishing Director **DOUG OLSON**

Group Publisher **TOM DAVIS**

MEREDITH PUBLISHING GROUP

President **JACK GRIFFIN**

Finance & Administration **KARLA JEFFRIES**

Manufacturing **BRUCE HESTON**

Consumer Marketing **DAVID BALL**

Creative Services **ELLEN de LATHOUER**

Corporate Sales **JACK BAMBERGER**

Interactive Media **LAUREN WIENER**

Corporate Marketing **NANCY WEBER**

Research **BRITTA WARE**

Meredith
CORPORATION

President and Chief Executive Officer **STEPHEN M. LACY**

Chairman of the Board **WILLIAM T. KERR**

In Memoriam — E.T. Meredith III (1933-2003)

© Copyright Meredith Corporation 2006. All rights reserved. Printed in the U.S.A.



Owen constructed this quartersawn white oak cradle for a friend.



As a gift for her mother, Sheryl made the garden arbor from issue 98.



Karl built this clock from issue 170 for his parents' 50th wedding anniversary.

The Toughest Glue On Planet Earth.

Bonds hundreds of materials including wood, stone, metal, ceramic & more! Incredibly strong & 100% waterproof!

1-800-966-3458 • www.gorillaglu.com

The Toughest Tape On Planet Earth.

Extra Thick. Extra Stick. New Gorilla Tape sticks to things ordinary tapes simply can't.

1-800-966-3458 • www.gorillatape.com





NEW!
Never-before
published
plans!

32
Outstanding
Project Plans
for your Home,
Yard, and Holidays!

- Build any design in a weekend or less
- Save money with off-the-shelf lumber
- Use only basic power and hand tools

Available on newsstands September 12 or order online at woodmagazine.com/publications

editor' angle

High school wood shop: alive and well (in places)

It's no secret: Wood shop is disappearing from schools everywhere. But there are innovative teachers who manage to buck the trend. Here are two of them.



I caught up with Jeff Hall (right) during a bandsaw-blade test.

If you read the tool reviews in every issue of this magazine, you already know of Jeff Hall. He's been doing independent tool tests for us—and doing a first-rate job of it—for the past several years. What you may not know is that when Jeff's not torturing tools, he's teaching cabinetmaking at East High School here in Des Moines. Recently, Jeff was honored with the 2006 Teacher of the Year Award for Des Moines schools.

Like a lot of great teachers, Jeff cares deeply about his students and is someone they confide in. Plus, he expects quality work from them. He actively keeps himself, his students, and his program visible at the school and in the community. For example, when East High recently underwent renovations, his students built donor plaques and constructed new display cases. He exposes his pupils to expert woodworkers and set up a program for his students to become mentors in instructing children and adults in pen turning.

Another "teacher of the year," for Yavapai County, Arizona, is Tom Bockman of Prescott. His program is exploding in popularity with 91 students in 2003–04, 172 students in 2004–05, and 201 students in 2005–06. For the first time, he had to turn advanced students away this school year, while adding another beginning class.

How does he do it? Tom chalks up his success to several things. First, he developed an interactive CD for 8th-grade students. It gets the kids (and their parents) excited about high school shop class by showcasing in-class and job-site activities.

Second, the Prescott students conduct attention-getting community projects such



Tom Bockman (left) invited internationally acclaimed woodturner Richard Raffan to demonstrate for his woodshop class.

as a wishing well for the Make-A-Wish Foundation. For these projects Tom is tireless in pursuing publicity—another key to the popularity of his program. Finally, his students have the opportunity to make a little money by selling projects to libraries, furniture stores, private citizens, and the school board. Their most ambitious project: a school board conference table fully wired for electrical outlets, interfaces for laptop computers, and lighting.

Of course I don't have enough space here to mention all of the outstanding teachers helping to pass along woodworking skills to a generation less exposed to them than ever before. But for several more examples of young woodworkers doing great work, see page 8.

To all of you who are mentoring tomorrow's woodworkers, in a classroom or your home shop, keep up the good work!

Bill Krier

sounding board

Our bulletin board for letters, comments, and timely updates

Woodworking lives on with today's youth

Although many high schools are cutting back on vocational classes, there are still some out there instructing students in

hands-on skills—such as woodworking—that could lead to either a career or hobby. At *WOOD*® magazine we applaud those

adults who teach the next generation, as well as those young people who are eager to learn the craft.

Students work together to build and expand *WOOD*'s game table



Photo: Tony Payne

Juniata Valley students, from left, seniors Tyler Hall, Matt Boone, and Corey Lightner, sophomore Corey Boone, and junior Nate Paterson, reengineered and built this game table.

Five of my high school woodshop students recently built a modified version of the game table you featured in issue 167 (December/January 2005/2006). They wanted to make it bigger to seat more friends, so they doubled its length, added two legs to support the middle, and expanded the size of the cup holders. Using cherry, they finished the table with a natural cherry stain and four coats of polyurethane.

The group usually follows a magazine project's plans as closely as possible, but after researching casino-style game tables on the Internet, they elected to change the playing surface. They recessed the top $\frac{1}{4}$ " to keep cards from sliding off; added a layer of $\frac{1}{8}$ " closed-cell foam under the surface for padding; and used velveteen fabric, rather than felt, because it's less likely to "pill" (develop tiny balls of fabric that result from wear).

It took the group three weeks to make the table, working two hours a day in class. (Incidentally, students in another class made the four-seat game table as shown in your magazine.) Thanks for the project and plans.

—Tony Payne, Industrial Arts and Technology teacher,
Juniata Valley High School, Alexandria, Pa.

High schoolers fulfill their mission to craft dining chairs

Two students in our cabinetmaking class recently built 12 mission-style dining chairs from the design you published in issue 154 (March 2004). Dovi Hirsch, 18, and Ian Marsan, 17, worked together to build the chairs from cherry for their senior project. (Last year they built a cherry dining table.)

The only difference in their chairs is the seat: Ian wanted red fabric upholstery on his six, while Dovi preferred black vinyl for his. Because Ian's dad works as an upholsterer, he helped out with that aspect. Working about four hours each day, the guys completed the chairs in about seven weeks. Dovi, who graduated as valedictorian in his class, also operates his own Web site business, dhpens.com. There he sells custom-turned pens as well as other office and kitchen accessories.

—Joe Markt and Roland Bessette, cabinetmaking instructors,
Southeastern Regional Vocational Technical High School, South Easton, Mass.



Photo: Marcia Dolgin

Dovi Hirsch, left, and Ian Marsan built a dozen dining chairs for their senior project.

Father tutors daughter with Tudor birdhouse

My 10-year-old daughter, Anna, likes to look through *WOOD*® magazine and has been asking me to build something with her for some time. The Tudor birdhouse plans in issue 169 (April/May 2006) seemed like the right project, so I decided to set aside some time with her and build it.

We made some changes because she didn't want to wait for delivery of the copper foil for the roof. I had cedar shakes lying around, so we used them for the roof. She did all the painting, nailing, and design changes, with help from me on the power tools. She is so proud of the birdhouse and looks out the window every morning in hopes of seeing its first tenants.



Photo: Laurie Timmerberg

Anna and Paul Timmerberg show off their version of the Tudor birdhouse.

—Paul Timmerberg, St. Louis
continued on page 10

Pegboard sides add extra tool storage to cart

I loved your design for the rolling workshop storage unit in issue 167 (December/January 2005/2006). I made it even more useful by adding perforated hardboard to the two sides from which I hang tools. I simply cut $\frac{1}{4}$ " grooves in the top and bottom 2x2 cleats, and added extra 2x2 cleats with grooves vertically to hold the $\frac{1}{4}$ " perforated hardboard.

—Steve Voldal, Eden Prairie, Minn.

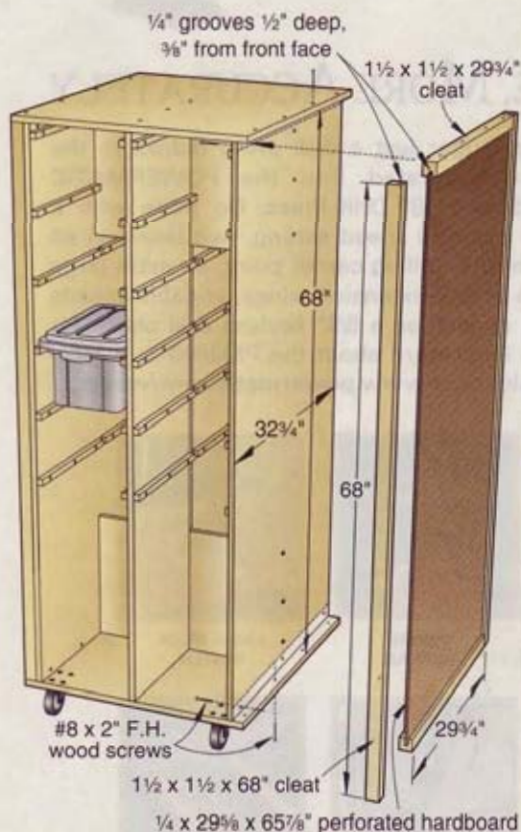

Putting reclaimed wood back to work—in a bench

After many years of intending to build a workbench for my shop, I recently built your workbench from issue 166 (November 2005). I particularly liked the use of top stretchers, which makes for a stiffer frame.

I built mine almost entirely of reclaimed wood. I made the top from salvaged maple flooring boards set on edge, with the tongues and grooves cut off, using the equivalent of 60 square feet of flooring.



The rest of the bench I made from pine reclaimed from old buildings. I turned the vise handle from a salvaged piece of maple. The maple for the vise jaws turned out to be the only new wood in the project.

—Duey Marthaller, Mandan, N.D.

“Log” on to this Web site

After reading your article on master woodworker Jeffrey Lohr in issue 167 (December/January 2005/2006), I wanted to share a Web site devoted to those who enjoy wood in its rougher stages. Jeffrey suggests finding a local sawyer to obtain rough lumber or to have your logs custom sawn, and folks can do

that by going to forestryforum.com and using the locator link to find what they need. There are more than 3,000 members on this Web site discussing forestry, sawmilling, drying, construction, safety, and many other woodworking-related areas.

—Dave Klish, Oneida, N.Y.

Article updates

Issue 169 (April/May 2006)

■ The article “Fasteners for a lasting, firm hold” on pages 64–65 described our finishing trim screw as a decking screw; however, it’s designed for finish carpentry applications. We recommend our R4 multi-purpose screw and RT trim-head screw for fastening deck boards. Second, a photo referred to a competitor’s screw as a “W-Cut,” which is a trademark of GRK Fasteners and refers to one of many patents owned by GRK. For more information on our product line please visit grkfasteners.com.

—Dr. Mirco Walther, president & co-owner, GRK Fasteners, Thunder Bay, Ont.

Issue 169 (April/May 2006)

■ If you’re building the planter box on pages 56–59, you’ve probably noticed a few missing dimensions from the stretcher (part O). The correct dimensions are shown, below.

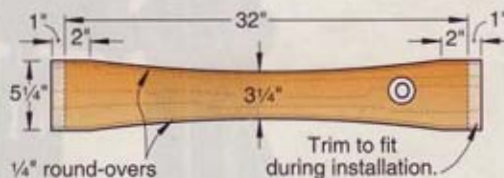

HOW TO REACH US

For woodworking advice:

Post your woodworking questions (joinery, finishing, tools, turning, general woodworking, etc.) on one of 20+ online forums at woodmagazine.com/forums.

To contact our editors:

Send your comments via E-mail to woodmail@woodmagazine.com; or call 800/374-9663 and press option 2; or write to WOOD magazine, 1716 Locust St., LS-221, Des Moines, IA 50309.

Subscription assistance:

To notify us of an address change, or to get help with your subscription, go to woodmagazine.com/service; call 800/374-9663 and press option 1. Outside the U.S., call 515/247-2981. Or write to WOOD magazine, P.O. Box 37439, Boone, IA 50037-0439. Please enclose your address label from a recent magazine issue.

To find past articles:

See our index at woodmagazine.com/index.

To order past issues and articles:

Order past issues of WOOD magazine, our special issues, or downloadable articles from issue 100 to present: Visit our online store at woodmagazine.com/store, or call 888/636-4478. Some issues are sold out.

Updates to previously published projects:

For an up-to-date listing of changes in dimensions and buying-guide sources from issue 1 through today, go to woodmagazine.com/editorial.

ask wood

Answers to your questions from letters, e-mails, and WOOD Online®

Got a question?

If you're looking for an answer to a woodworking question, write to **ASK WOOD**, 1716 Locust St., LS-221, Des Moines, IA 50309-3023, or send us an e-mail at askwood@woodmagazine.com. For immediate feedback from your fellow woodworkers, post your questions on one of our woodworking forums at woodmagazine.com/forums.

Sorting out a maple mix-up

Q: I was given some maple boards, but how can I tell if they are hard or soft maple? Also, what's the best finish for each?

—Robert King, High Ridge, Mo.

A: Color and grain similarities make hard maples—sometimes called sugar, rock, sweet, or black maple—tough to distinguish from soft maples, which include red, silver, or swamp maple. For a simple test to tell the difference, Robert, mix two tablespoons of ferrous sulfate (iron sulfate) in one cup of water and shake until dissolved. (You can find ferrous sulfate at many lawn and garden stores.) Wipe the solution onto a piece of the unknown lumber and wait a minute for the wood to change color. Soft maple will turn a translucent blue-black color. On hard maple, the surface turns greenish gray.

Whether you have hard or soft maple, the “best finish” is just the one that suits your

project and personal preferences. To preserve maple's light color, apply a non-yellowing, water-based finish. To bring out the pattern in bird's-eye or curly maple while giving it a light amber color, apply boiled linseed oil and allow it to dry for a week before applying a clear film finish.

If you want darker colors, though, use a dye instead of a pigmented stain. Maple's small pores don't trap enough pigment to produce an even color without blotching. Unlike stain



Ferrous sulfate solution applied to these sample boards turns the soft maple (left) a blue-black, and the hard maple greenish gray.

pigments, dye will fade with age, however, so apply a darker surface than you want for the long term.

Patching a nuisance nail

Q: I didn't angle my air-powered brad nailer right, and the fastener blew out the side of my project. Can I pull the brad through, or do you have a better idea?

—Shawn Smith, Bridgeport, Ohio

A: You can pull the brad through, Shawn, if the wood is soft enough, the brad head is small enough, and you have enough room to attach a pair of locking pliers to pull or pry it out.

Another option, shown at *upper right*, is to break off the brad beneath the surface and patch the hole. In this instance, bending the loose end of the brad back and forth broke it off just below the wood surface. Should the nail break off slightly above the surface, use a hammer and nail set to drive the exposed portion beneath the surface. After lightly sanding the damaged area, fill the hole with putty, as shown at *lower right*, to match the finished color of the wood.

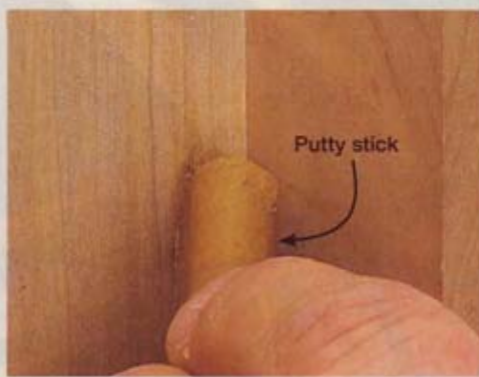

Kid-size table heights

Q: I want to build a 3x5' table for kids to use, but I'm not sure what height to make it. Any advice?

—Shannon Duff, Vancouver, Wash.

A: Here's a good way to measure table height for kids, regardless of their age, Shannon. Seat the child on a chair or stool they'll use at the table. Measure from a point just below their ribs to the floor, and use that dimension as the table-top height. Adding a couple of inches will help the table adapt to kids as they grow.



This play center from issue 167 (December/January 2005/2006), page 76, stands 19" high at the sides and 16" high at the table top.

continued on page 14

It's Here



Portable
Quiet
Small
Clean
Elegant

1000+ CFM
Approx. 5' Tall
Pat. Pend.
Buy Online



www.oneida-air.com 800.732.4065

Circle No. 2039

ask wood

Wipe out stain streaks

Q: I built an oak sideboard from **WOOD** magazine plans in issue 155, page 66. When applying the stain, I accidentally left a streak of stain across the grain. Now, I can see that wipe mark. What can I do about it?

—Dave Parrish, Youngsville, N.C.

A: You have three opportunities to remove such flaws, Dave. An accidental stain droplet or wiping mark on a freshly stained surface can be masked by applying enough stain to that area to penetrate the wood as deeply as the droplet or wiping mark. Then remove the surplus stain, making your final passes with the grain using a clean cloth. If the resulting color is too dark, lightly wipe the whole surface with a rag saturated in mineral spirits.

As the binder in the stain dries, you can still remove unwanted stain using mineral spirits and a soft rag, as shown *below*. Wipe the streaked area firmly.

Once the binder in the stain has dried and locked the pigment in place, however, you'll need to remove the mark with sandpaper of the highest grit used for the rest of the project. Then restain until you match the color of the surrounding wood.

To lessen the impact of accidental stain streaks and spots, apply stain working from the bottom to the top of each surface. That way, any accidental drips fall on previously stained surfaces, where they're less likely to show up if you wipe them away while still wet. Wipe away excess stain before it begins to dry, and work on one face at a time to avoid leaving accidental streaks on adjoining surfaces.



Holding together memories

Q: I have a question about the scrapbook project in *WOOD* magazine issue 166, page 72. Do you have a recommendation for gluing leather to wood?

—Dudley Williams, Wichita, Kan.

A: Any white or yellow wood glue will bond most raw leather to wood, Dudley. According to technical specialist Dale Zimmerman at Franklin International, that company's original Titebond glue once was used to connect the

ends of leather drive belts for heavy machinery in factories.

A scrapbook binding, such as the one shown at *right*, won't face the same stresses, but you'll need to take a few precautions. Some leather treatments or colorings reduce any glue's bonding ability, so test the bond by gluing a leather scrap to a wood scrap and giving it a light tug. Also, yellow glue won't discolor most leathers, but check for color transfer when gluing thin or light-colored leather. If there's a problem, switch to a clear-drying white glue.



continued on page 16

Shrinking a saw blade arbor hole opens up options

Q: After recently buying a 12" miter saw, I discovered the blade that came with the saw has a $\frac{5}{8}$ " arbor hole. I am trying to find a replacement blade, but they're all made for a 1" arbor. Where can I get a 12" blade with a $\frac{5}{8}$ " hole, or a 1"-to- $\frac{5}{8}$ " bushing?

—Bill Fisher, Vancouver, Wash.

A: A bushing will expand the blade options for your saw, Bill. These bushings, which look like carefully machined washers, slip into the 1" arbor hole on a 12" blade, as shown *below*. That reduces the hole size to fit your saw's $\frac{5}{8}$ " arbor. Freud makes a bushing (no. BL71MCE9) for downsizing 1" blade holes to fit your saw. Make certain the saw's blade mounting washers and arbor nut place pressure against the blade body, not the bushing, to keep the blade from spinning loosely on the arbor. Before you buy a bushing, though, make certain the saw didn't come with a bushing that's jammed onto the original blade or arbor.



"Ouch."

That's gotta hurt.

But you can prevent this kind of pain by sharpening your drill bits with Drill Doctor—the drill bit sharpener. Sharpen with Drill Doctor and you're never more than 60 seconds away from a precision-sharp drill bit. Working sharp is working smart—your bits will be sharp, and so will your projects. If you're looking for precise results every time, work with the drill bit sharpening expert—Drill Doctor.

**Work Smart
Work Sharp**



(Features apply to model XP shown)

Drill Doctor
The Drill Bit Sharpener

Look for the Drill Doctor at Sears, The Home Depot, Lowes, Ace, Woodcraft, Rockler, and wherever you buy your tools.

1-888-MYDRILL (693-7455) • www.DrillDoctor.com



• Fast and easy to operate



• Sharpens in less than 60 seconds



• Sharpens $\frac{3}{32}$ "– $\frac{1}{2}$ " bits—HSS, masonry, cobalt, carbide, TiN-coated



• Sharpens and creates QuadCut™ split-point bits for faster penetration and less drill bit "wandering"



Upping the amps

Q: When my 14.4-volt cordless drill batteries gave out, I found I could buy a new cordless drill with two batteries and a charger for about the same price as two replacement batteries, so that's what I did. The new batteries were marked 2.6 Ah, while my old drill's batteries were marked 2 Ah. The salesman said I could use the 2.6-Ah batteries in my old drill. Is this correct?

—John Watkins, Ozark, Ark.

A: So long as the new batteries fit into the old drill and are the same voltage, they'll work just fine, John. Batteries with higher ampere-hour (Ah) ratings store more energy than batteries with lower Ah ratings. Your old drill will run roughly 30

percent longer with your new 2.6-Ah batteries than with the old ones.



One good turn...

Q: I'm satisfied with my bandsaw, except for the blade tensioning knob. The 2½" diameter knob is too small for my hands and it's too close to the housing. Has anyone found a larger knob, handle, or crank that makes tension adjustment easier?

—Bob Rufener, Hartford, Wis.

A: You'll need only five minutes to replace that knob with an easy-to-turn crank, Bob. That's how long it took us to install the Quik-Crank bandsaw tensioner (Rockler no. 20410, \$35, 800/279-4441 or rockler.com), which works on most 14" bandsaws. Just unscrew the original threaded tensioning rod and knob, add the replacement rod and nut, and attach the crank using the set screw and allen wrench provided, as shown below.

If you need a more heavy-duty option, install a Spinner 3 tensioning crank (Highland Hardware no. 189102, \$60, 800/241-6748 or tools-for-woodworking.com). This retrofit uses a 5" chromed cast-iron crank wheel attached to a ¾" acme-threaded rod and bronze nut designed to keep the tension setting from slipping. Both types fit most brands of 14" bandsaws. ♣



The WOOD MASTER[®] Plus AFS 1100
CORN-PELLET FUEL FURNACE

offering owners an independent and self-sufficient lifestyle.

Reasons to Heat with Natural Energy™

- Save money with economic, stable heating costs
- Environmentally friendly virtually no smoke
- Supports local economy
- User-friendly automated feed system
- Uses renewable/sustainable fuels
- Decreases dependence on imported fuels

Patent Pending

NATURAL ENERGY

UL LISTED

1-800-932-3629
www.woodmasterplus.com

Dealer inquiries welcome
 © copyright 2006

shop tips

Helping you work faster, smarter, and safer

No-brainer setups for feather boards

Feather boards add both safety and consistency to many cuts on the router table and tablesaw. But there's a fine line between too much and too little pressure, and finding that line used to drive me half nuts. That was before I made a few feather-board setup sticks from scraps of hardwood.

After perfecting the feather-board tension for a $\frac{3}{4}$ "-thick workpiece, I made a setup stick by planing down a scrap of stock a little at a time until it just slid easily under that feather board. Then, I labeled the stick so I'd know which thickness of material it works for.

Now, when I need to set the feather board, I simply slide the appropriate

top shop tip

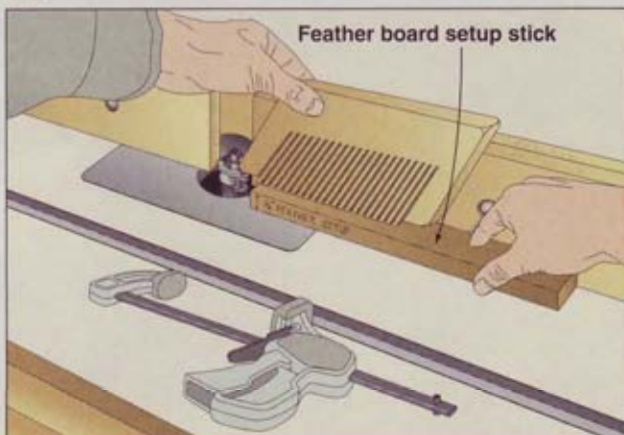

setup stick against the fence, stand the feather board on top of it, as shown above, and clamp the feather board to the fence. The setup stick also ensures that the feather board stays parallel to the table top, applying uniform pressure along its length.

—John Ducey, Lawrence, Kan.

Microadjust your fence with a turnbuckle

Making superfine adjustments to my router table fence was hit-or-miss until I came up with my own microadjustment system, shown below. With this system, I simply clamp one end of the fence and make fine adjustments to the other end, fore or aft, with the turnbuckle.

To add a turnbuckle to your fence, use the hardware shown to add a pivot bolt to both the fence and the starting block. Use a turnbuckle with eyes large enough to fit snugly over the bolts. If the eyes are too large, fill them with epoxy, let it cure, and then drill out the epoxy to fit the bolts. Use a washer on either side of the eye, and tighten the assembly together.

The turnbuckle works best on the "push" stroke, so always make final adjustments by driving the fence away from the starting block to take out any slack in the threads. To ensure

that the fence doesn't move once you've got it perfect, clamp the turnbuckle end of the fence down. When not in use, you can leave the pivot bolt and eyes in place and remove the turnbuckle. Then store the fence and the starting block.

—Wayne Donovan, Kansas City, Mo.

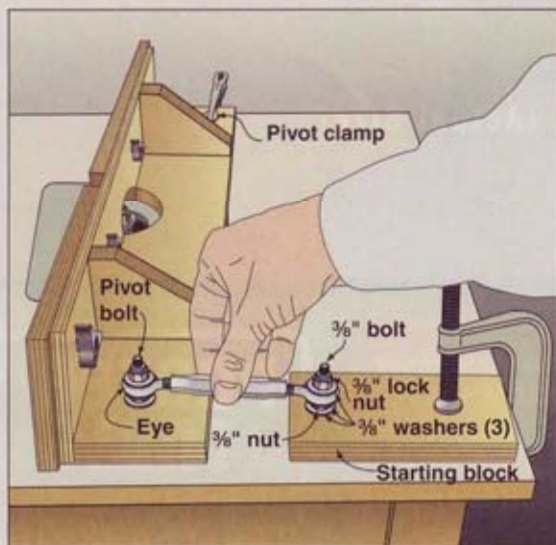

The Top Tipster



A recent newcomer to woodworking, John Ducey is just starting to set up his shop. Other than his tablesaw, he owns a router that he received for Christmas a year ago. He then built the router table, shown above, that inspired this issue's Top Shop Tip.



For sending the Top Shop Tip of this issue, we're doubling the number of routers in John Ducey's shop by shipping to him a Porter-Cable 895PK 2-hp router kit. Attaboy, John!

Top tips earn tools!

Describe how you've solved a workshop stumper, and you'll get \$75 if we print it. And, if your tip garners Top Shop Tip honors, we'll also reward you with tool treasures worth at least \$250.

Send your best tips, along with photos or illustrations and your daytime phone number, to: **Shop Tips, WOOD Magazine, 1716 Locust St., LS-221, Des Moines, IA 50309-3023.** Or e-mail tips to: shoptips@woodmagazine.com. Remember to include your contact info in the e-mail as well.

Because we publish only original tips, please send your tips only to **WOOD** magazine. Sorry, submitted materials can't be returned.

continued on page 22

Laid-back sander sharpens knives and chisels

As a wood carver, I spend a little more time sharpening my knives and chisels than most woodworkers. And while I could justify spending up to \$500 on a dedicated sharpening system, a few dollars and a little ingenuity allowed me to turn my strip sander into one of the best sharpening systems I've ever used.

Begin by building the dual sander base, as shown in the drawing. Be sure to add hardwood feet to the sharpening base to create a space for the tool rest hardware. Next, mount the sander to the

base. Finally, build the tool rest, as shown, from $\frac{3}{8}$ " threaded rod and a piece of 1x1" aluminum angle.

The base allows you to tip the sander onto its back so the belt will travel horizontally and away from you. This position is ideal for sharpening tools. Fine sanding belts of 400 to 600 grit will work for many sharpening chores. For more versatility, a leather belt is also available that, when treated with an abrasive, will do an excellent job of stropping gouges and chisels.

—Gene Carey, Cicero, N.Y.

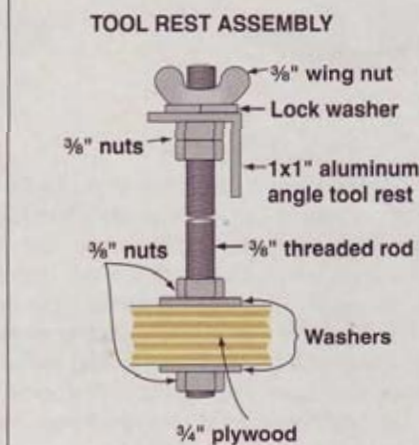
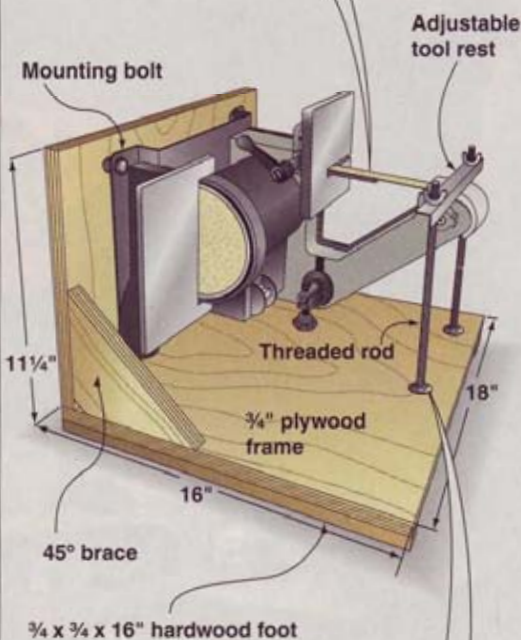
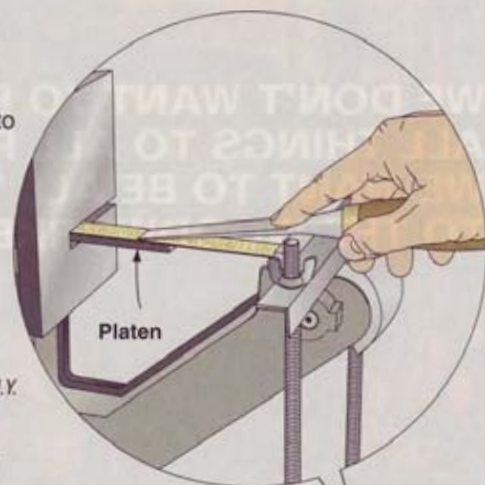

The ARROW[®] Machine ETFX50[™]

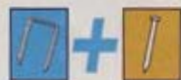

XTRA HEAVY DUTY
Professional

XCEPTIONAL COMFORT
Cushioned Grip

XPERT PERFORMANCE
Drives 6 Different Size
Staples + Nails

XTRAORDINARY POWER
14 Amps of Surge Power

XCITING DESIGN
New Ergonomic Styling



... It's what
you've come to
XPECT from Arrow!



Keeping America Strong

Available at home centers, lumberyards, and fine hardware stores wherever professional tools are sold!



Arrow Fastener Co., Inc., 271 Mayhill Street, Saddle Brook, New Jersey 07663
Canada: Jardel Distributors, Inc., 6505 Metropolitan Blvd. East, Montreal, Quebec H1P 1X9
Arrow Fastener (U.K.) Ltd., Unit 5 2K Park, 23 Commerce Way, Craydon CR0 4ZS, Surrey, United Kingdom
www.arrowfastener.com ©2002 Arrow Fastener Co., Inc. Rev 702

A slick solution for portable-tool bases

When cutting soft woods with my jigsaw, the steel shoe (base) always left unsightly marks on the workpiece. So I bought some self-adhesive polyester film (such as Mylar) at a crafts and hobby shop, and fit a piece to my saw's shoe. After thoroughly cleaning the shoe with alcohol to remove any oil or grease, I applied the sheet to the shoe, being careful not to trap any air bubbles.

Now my jigsaw glides on the workpiece without marring it. You could use the same material on your circular saw's shoe to protect the wood underneath.

—Rusty Ingram, Cedar Grove, N.J.



continued on page 26

Suspended storage saves steps

Workbenches work best when they're in the middle of the shop so you can move around the project. The problem: Your tools are usually stored around the perimeter of the shop. The solution: the tool storage shelf, shown below. It not only makes use of vacant overhead space—it saves time and labor. Shaped like a stirrup and mounted to the ceiling joists, you can configure it to your needs to hold small hand tools, clamps, screwdrivers, and whatever else you want to keep handy.

—Bud Beck, Jr., Land O' Lakes, Fla.

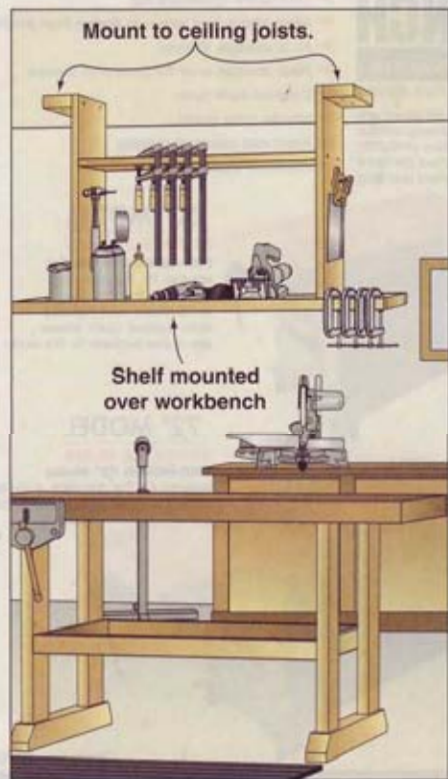

Quality Pen Kits and Other Turning Kits



- Designers & Manufacturers
- Wholesale & Retail

THE BEREAHARDWOODS CO. INC.

Manufacturer of quality writing instruments, components and kits.

Visit Our New Web Site: www.penkits.com

18745 Sheldon Rd. • Middleburg Hts., Ohio 44130 U.S.A.

Ph: 216-898-8956 • Fax: 216-898-8962 • E-mail: bereahard@aol.com

Circle No. 840

YOU'RE PROBABLY JUST AS AMBITIOUS.

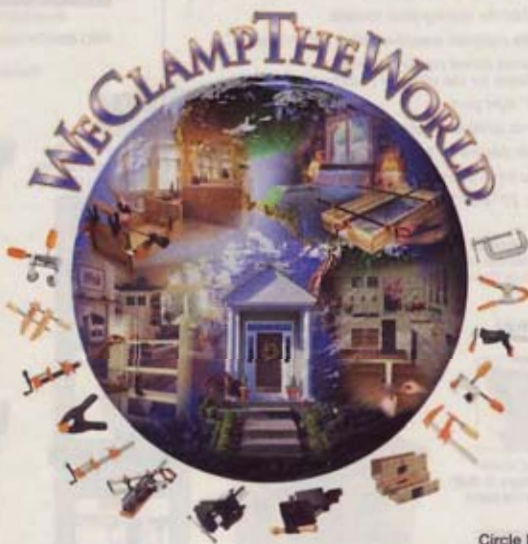

Whether you are a do-it-yourselfer, a professional woodworker or somewhere in between, you have a world full of projects in the home or in the shop that will be easier and more enjoyable to complete when you use quality clamps, bench vises and miter boxes/saws from the Adjustable Clamp Company. Look for them under the Jorgensen, Adjustable and Pony brand names wherever fine tools are sold.

Circle No. 733

Adjustable™ **"Jorgensen"**™ **"Pony"**™

Made in the USA by the Adjustable Clamp Co.,
433 North Ashland Ave., Chicago, IL 60622,

www.adjustableclamp.com



Supports for dust-collection ductwork

I needed a good way to install the main duct runs of my dust-collection system, and I wasn't looking forward to the prospect of trying to raise a network of pipes to the ceiling by myself. The system shown at right, using 50" cable "zip" ties and furring strips, provided the solution.

I started by screwing furring strips to the joists along the path I wanted the ducts to take. I then laid the zip ties across the notches in the furring strips and zipped the ties into large loops. Next, I fed the duct parts through the loops and joined them. With the ductwork still hanging low, I had no problem sealing all the way around the joints. Once the duct was joined and sealed, I raised the entire labyrinth up to the ceiling by slowly ratcheting up the zip ties. 🐾

—Bill Goggin, Alma, Mich.

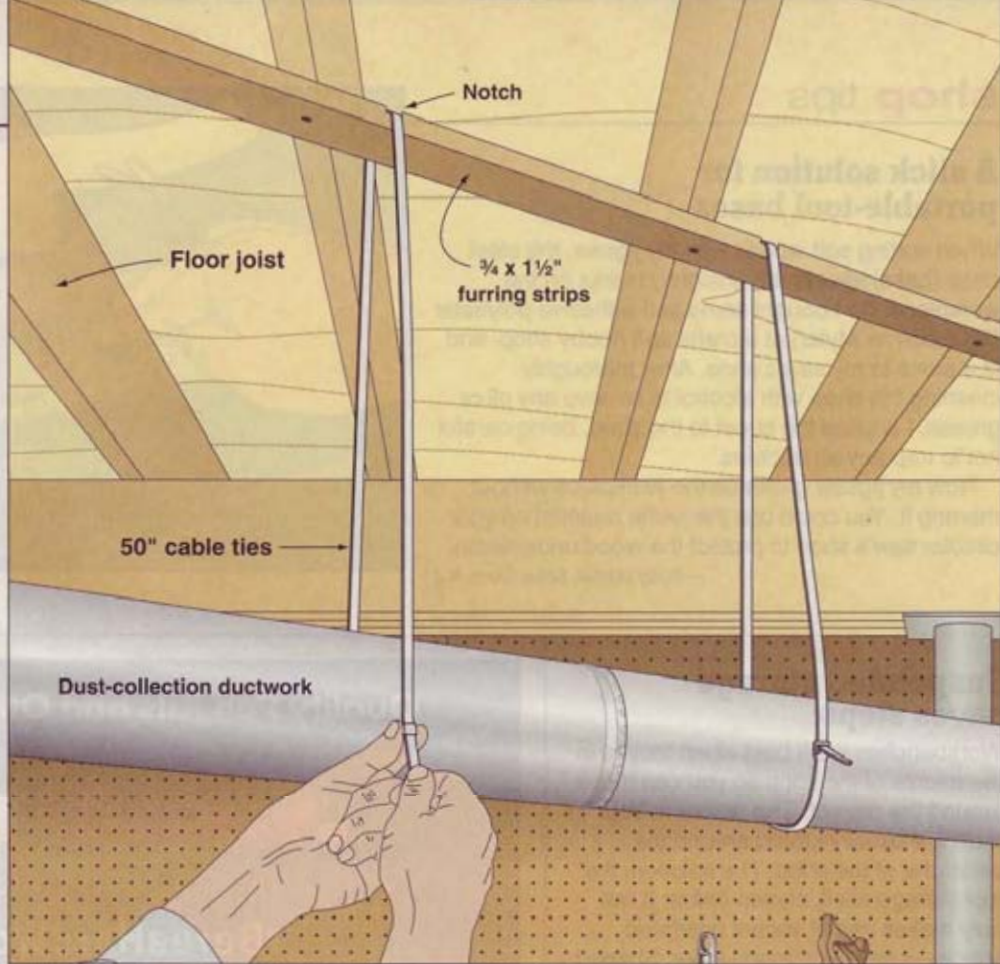

New Bench Dog Products Available in Fall 2006.

PRO WOODWORKER ProMAX[™] Complete Router Table

Available Fall 2006
STOCK NO. 40-087
ProMAX Complete Router Table comes with ProMAX cast iron router table (#40-031), ProMAX End Cap (#40-044), ProMAX Professional Cabinet (#40-074).

- ▶ Only full-size cast iron router table in the marketplace.
- ▶ Integrated router bit storage with pull-out shelves.
- ▶ Drawer option with full extension ball bearing slides.
- ▶ Fence and cabinet made in USA.
- ▶ Unique cubby for storing your routers.
- ▶ Router table includes award-winning 28" ProFence.
- ▶ Bolt and cross dowel construction and steel hardware for the ultimate in strength.
- ▶ Includes 4" dust port.
- ▶ Components available separately.
- ▶ Curved side panels for better ergonomics.
- ▶ Solid Baltic birch panel construction.
- ▶ Table size: 27" x 20", height: 35 1/2".



ProMAX Complete Router Table shown with optional Cab-Loc mobile base. No ProMAX products include Cab-Loc mobile base.

PROMAX PROFESSIONAL CABINET FEATURES



Center router bay allows easy access and great dust collection.

Pull-out router bit storage is fast and convenient.

Lower cubby is perfect for spare router storage.

Comes with 4" dust port.

ProMAX Complete Router Table shown with the following options: Cab-loc mobile base (#40-008), Door Pack (#40-084) and Drawer Pack (#40-083)



CABINET OPTIONS

Compatible with both ProMAX Professional Cabinets and PRO-BENCH Cabinets.



DOOR PACK #40-084



DRAWER PACK #40-083



CAB-LOC #40-008

PRO WOODWORKER PRO-BENCH[™] Premium Workbenches

Available late Fall 2006
PRO-BENCH models below are shown with the following options: Cab-loc mobile base (#40-008), Door Pack (#40-084), Drawer Pack (#40-083)

- ▶ Unfinished sycamore top
- ▶ More stable and easier to flatten than maple
- ▶ Hi-lo storage shelves
- ▶ Rear storage area for tools and clamps
- ▶ Cabinet-style base
- ▶ Mobile base ready
- ▶ Front row bench dog holes
- ▶ Premium vises



50" MODEL

STOCK NO. 40-085
PRO-BENCH 50" Model includes 50" Top (#40-088), 3" Cabinet (#40-089), and two Standard vises (40-090). Note: Optional Quick release vise is also available for this model.



72" MODEL

STOCK NO. 40-086
PRO-BENCH 72" Model includes 72" Top (#40-092), 4" Cabinet (#40-093), Quick release vise (#40-091), and Standard vise (#40-090).

MADE IN USA



For more product information visit our website at

www.benchdog.com

router-bit holder and profile display

The best edge treatment is but a glance away.

See instantly what profile each of your router bits create by building this handy bit display with matching profiles. You can sit the bit support on your workbench or build the optional wall mount and secure it to a vertical surface. The bit support shown at right measures 8" long, but can be lengthened to hold more bits and profiles. Add 1/2" for each additional bit you wish to add. For large-diameter bits, such as a panel raiser, you'll need to lengthen it even more. For smaller-diameter bits, an extra inch per bit should suffice. We built our wall mount extra long for adding more bit supports in the future.

To form the angled bit support, start with a piece of 1 1/2 x 2 1/4 x 8" stock. Using a pushstick for safety, bevel-rip it at 18°, and

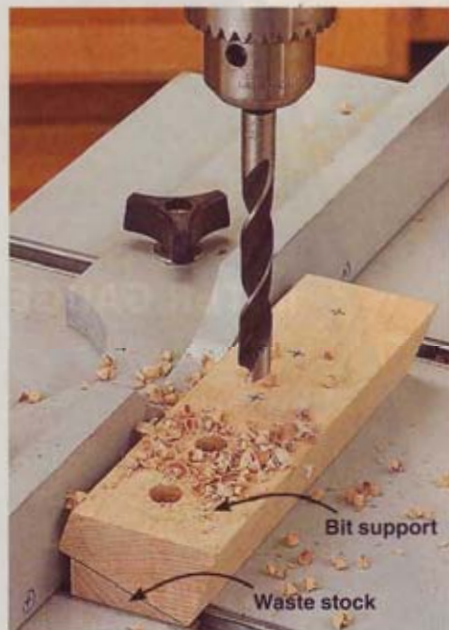
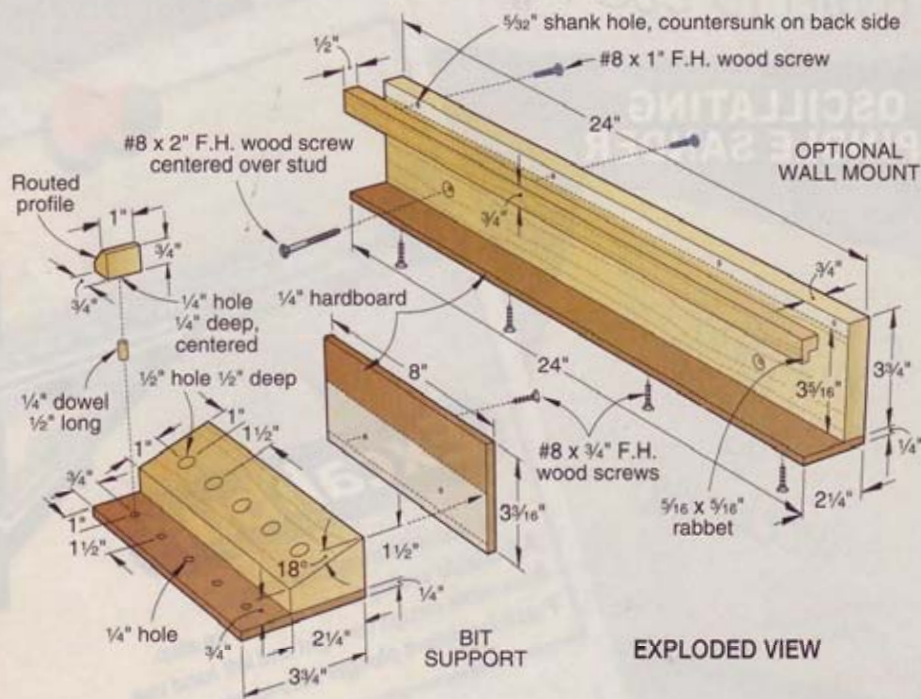

Stick the waste stock to the bit support, and drill the 1/2" holes.

use cloth-backed, double-faced tape to stick the two pieces together in the configuration shown in the photo at left. Then drill 1/2" holes 1/2" deep into the support, and separate the support from the scrap.

To create a profile for each bit you'll house in the bit support, cut blanks 8" long, and drill a 1/4" hole centered side to side and 1/2" from one end. Now, rout each 8"-long

blank with a different bit. Crosscut a 1"-long section from each blank, and glue in a piece of 1/4" dowel 1/2" long in the previously drilled hole. The profiles can be removed from the base so you can hold them up to an edge needing routing. It also gives you the flexibility to replace bits and move them as future needs dictate. ♣

Project design: Kevin Boyle

kerfing jig

To bend plywood or solid stock you need to saw many uniformly spaced kerfs. You'll quickly plow through them with this simple jig.

Cutting closely spaced kerfs into the back of a piece of stock and leaving a thin web of wood on the front allows the workpiece to bend—ideal for forming a curved part. (For a kerf-bending anatomy, see the photo at right.) Whether bending solid stock or plywood, uniform kerf spacing guarantees the best results. Here's how to make a jig for your tablesaw miter gauge that'll accomplish the job with speed and accuracy.

First, from plywood, particleboard, or MDF, cut a $\frac{3}{4} \times 2\frac{1}{4} \times 16$ " miter-gauge extension. Then cut a $\frac{1}{8}$ " saw kerf $\frac{1}{4}$ " deep centered in the extension, where shown at right. Now rip a $\frac{1}{8}$ "-wide strip from the edge of a $\frac{1}{4}$ "-thick piece of stock, cut a $1\frac{1}{2}$ "-long piece, glue it into the extension kerf, and sand chamfers, where shown at right. (Centering the pin in the extension provides ample support on both the "infeed" and "outfeed" sides of the pin when kerfing a long strip of wood.)

Put the jig to work

To prevent chip-out at the back edge of the workpiece, fit your tablesaw with a zero-

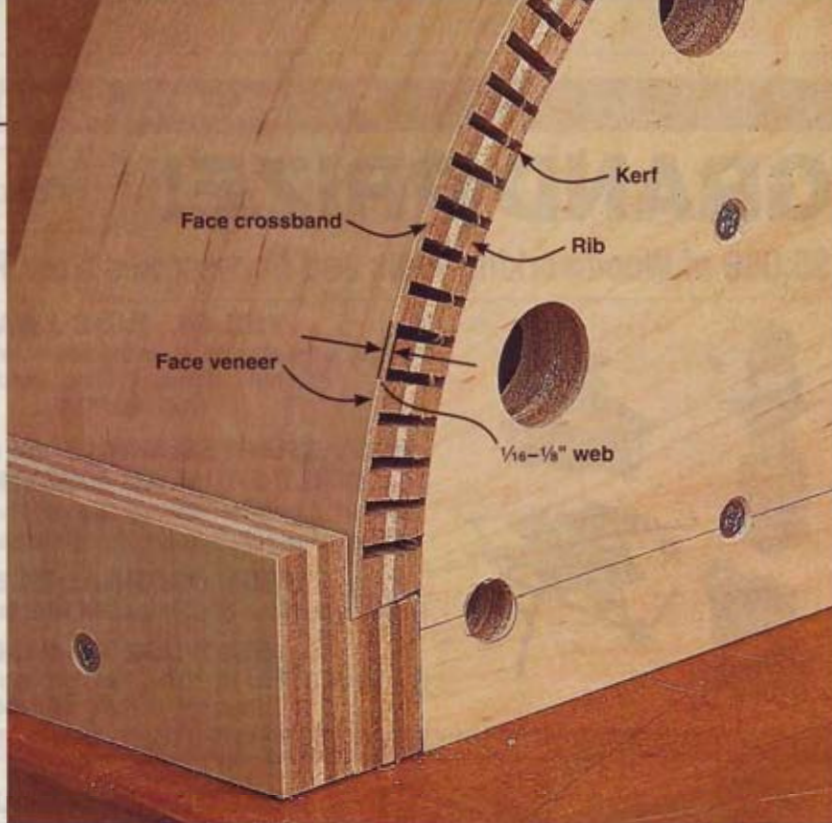

clearance insert. Then adjust the cutting height of the blade. For solid stock, adjust the blade so the cut leaves a $\frac{1}{8}$ "-thick web. For plywood, adjust the blade so it slightly cuts into the crossband directly under the face veneer, leaving a $\frac{1}{16}$ – $\frac{1}{8}$ "-thick web.

Now set the kerf spacing and cut the kerfs, as shown in the photos below. [The photos show setting up and cutting $\frac{1}{4}$ "-spaced kerfs for the aprons (F) of the bow-front table on page 62.]

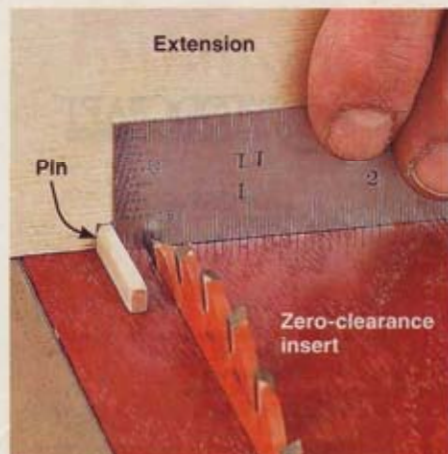
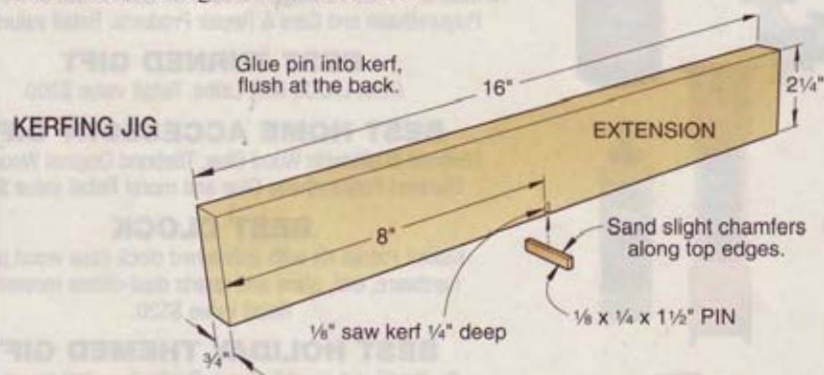

Position the pin $\frac{1}{4}$ " from the blade, and fasten the extension to the miter gauge.

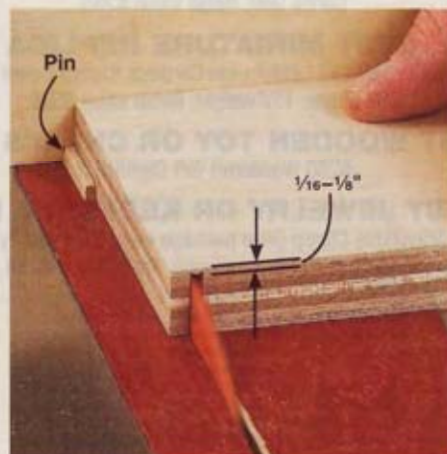

Place one end of the workpiece against the pin, and cut the first saw kerf.



Dropping each successive saw kerf over the pin, kerf the entire length of the workpiece.

put the kibosh on measuring mistakes

Accuracy in woodworking often boils down to measuring correctly before machining anything. The following five tips should help you avoid common measuring goofs. First, though, we offer a few nuggets that apply to all work in your shop:

- Double-check measurements before cutting.
- Use the same measuring tape throughout your project, when possible, because minor inconsistencies from tape to tape can add up to major headaches. Sometimes, however, you might need specialty tapes, such as for center-finding or left-right reading. We'll show you these tapes and tell you where to find them.
- Before you do any cutting, check and adjust machines and accessories to make sure they are square.
- Dry-fit your project before glue-up. That way you'll get a chance to find and correct assembly problems without being pressured by drying glue.

FIND TRUE CENTER WITHOUT STRAINING YOUR BRAIN

Mistake: You've miscalculated while trying to find a workpiece's center.
Solution: Eliminate the chance for errors in math by using a measuring tape with a half-scale on the lower level. This board measures $29\frac{3}{8}$ " in length, *top*. The bottom row on the tape indicates that the halfway point is $14\frac{1}{16}$ ". To mark the midpoint, go back to the top row, find $14\frac{1}{16}$ " and make your mark, *bottom*.

MeasurePro 16' centering tape, \$15, PriceCutter.com; 888/288-2487

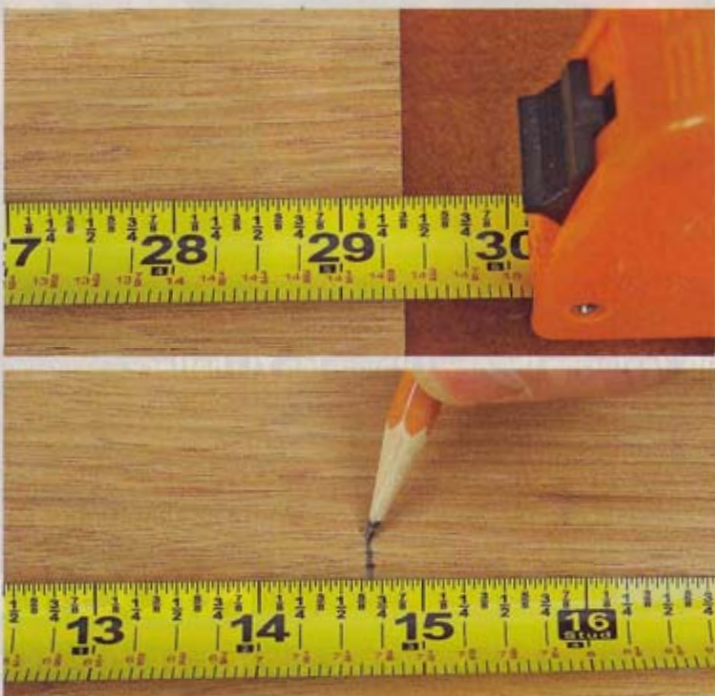

DON'T GET BURNED BY TAPE'S FIRST INCH

Mistake: You measured from the 1" mark ("burning" the first inch), then forgot to add an inch when marking.

Solution: First, use a steel rule or folding rule that doesn't have the play of a retractable tape's hook. Second, if you must burn that inch, make your mark, *top*, then double-check it by measuring again using the hook, *bottom*. This example shows how burning that inch resulted in greater accuracy, as the bottom measurement is $\frac{1}{64}$ " shorter than the tape indicates.

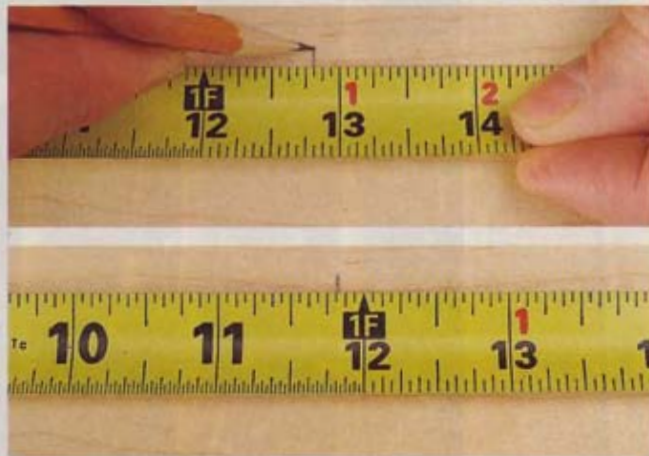

USE LEFT/RIGHT TAPE FOR INVERTED MARKING

Mistake: When you hold the tape in your left hand so you can mark with your right hand, the numbers on most tapes read upside down. That can lead to confusion, especially for unmarked fractions.

Solution: Rather than try to figure out which mark is $\frac{3}{8}$ and which is $\frac{5}{8}$ for example, get a left-reading measuring tape or one that reads from both sides, as shown below.

FastCap 16' Lefty/Righty, \$6, Amazon.com

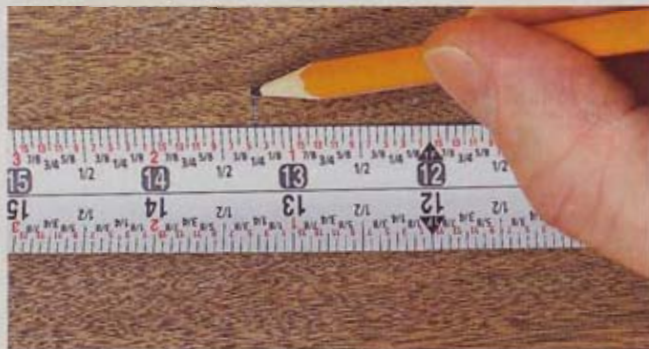

continued on page 36

avoiding **workshop goofs**

DON'T DOUBLE THE CORRECTION; HALVE IT

Mistake: You removed double the intended amount when fine-tuning a tenon to fit a mortise, instead of half from each side.
Solution: To avoid cutting too much off a tenon when making microadjustments, leave reminders where they will be seen. Write the word "half" on the tenon cheeks and also on a piece of tape near the fine adjustment knob of your tenoning jig, as shown. Then split the difference between both sides when you need to remove more. Similar errors can happen when machining half-laps, and the solution works the same.

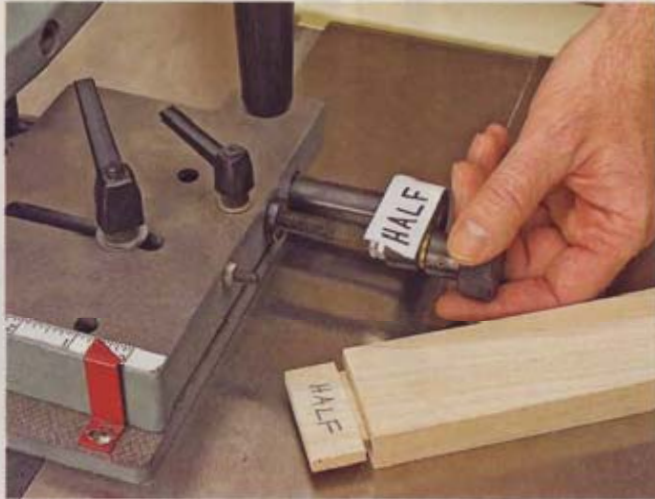

36

USE STOPBLOCKS TO MAKE REPETITIVE CUTS

Mistake: Individually measuring and cutting each one of multiple, matching workpieces (picture frame sides, for example), leaving slight discrepancies in actual dimensions.
Solution: Eliminate cutting each piece to a pencil mark. Instead, use a stopblock clamped to a fence or miter gauge, as shown, to ensure each workpiece will be exactly the same length. ♣



WOOD magazine October 2006

FESTOOL FANATICS



- Tech Support that Knows FESTOOL Products
- 3 Year Factory Warranty on ALL Festool Tools
- McFeely's Honors All FESTOOL Specials
- Top rated Tools that Work as a SYSTEM

On Any Festool Order **FREE** Shipping & Handling Over \$150 From McFeely's

Write for **FREE** Catalog!

McFEELY'S

SQUARE DRIVE SCREWS

PO Box 11169 • Dept WDMGK • Lynchburg • VA • 24506
 Toll Free 1-800-443-7937 or at www.mcfeelys.com

Circle No. 648

WOW!

LOOK WHAT A TYPICAL TABLE SAW CAN DO.

Convert your table saw into a molder with the Magic Molder.



MAGIC MOLDER™



818.782.0226

A Division of:



9250 Independence Ave. Chatsworth, CA 91311 818.782.0226 or FAX 818.909.7602
 Email: sales@lrhent.com Website: www.lrhent.com

Circle No. 238

ready-to-serve
wine cabinet

Keep your favorite wines, stemware, and serving accessories handy in this stylish unit.



Don't let the sophisticated look of this project fool you. With straightforward case and drawer construction, a full-size pattern for forming the feet, and easy-to-shape wineglass holders, you'll complete it in a jiffy and have plenty of reasons to toast your success.

Start with the case

1 From $\frac{3}{4}$ " cherry plywood, cut the sides (A), sub-top and shelf (B), and bottom (C) to the sizes listed in the **Materials List**.

2 Cut a $\frac{3}{4}$ " dado and rabbet $\frac{3}{8}$ " deep across the *inside* face of each side (A), where dimensioned on **Drawing 1**, to fit

the sub-top and shelf (B). Then, on the same face of each side, cut a $\frac{1}{4}$ " rabbet $\frac{3}{8}$ " deep along the *back* edge to house the plywood back (I).

3 From $\frac{3}{4}$ "-thick cherry, cut the stiles (D) to size. Then rout $\frac{1}{4}$ " chamfers, stopped 2" from the ends, along both edges on the *front* faces of the stiles, where shown. For an easy way to do this without tear-out, see the **Shop Tip**, page 40, top.

4 Glue and clamp the stiles (D) to the sides (A), where shown on **Drawing 1**, flush with the ends and *outside* faces of the sides. After the glue dries, sand the assemblies to 220 grit.

1a RAIL-TENON DETAIL

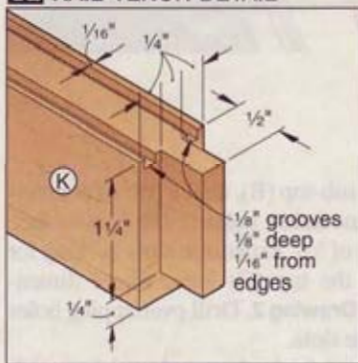

1 EXPLODED VIEW

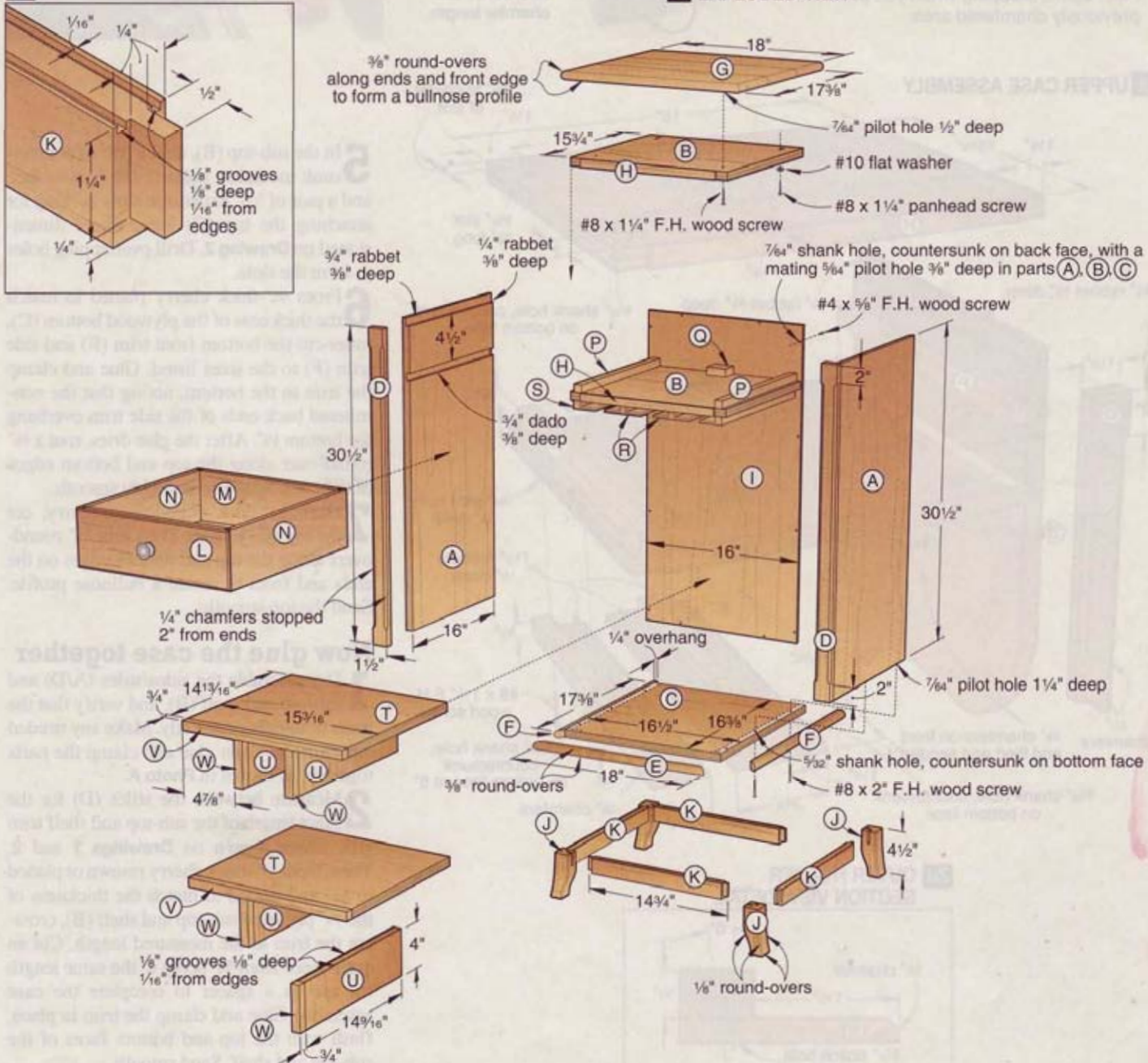

SHOP TIP

Don't get burned routing stopped chamfers

Ever experienced tear-out or burning when routing a stopped chamfer? Tear-out can happen if you rout the entire chamfer in one pass. Burning occurs if the spinning bit lingers in one spot, so you need to quickly pull the part away from the bit at the end of the chamfer. Here's an easy way to avoid these problems. With the part on *edge* and against a stopblock, rotate the part into the bit, as shown at *right*. Without hesitating, rout about two-thirds the length of the chamfer. Then flip the part end-for-end and reposition it against the stopblock with the face down and partially chamfered edge toward the fence. Rout again, stopping when you pass the previously chamfered area.

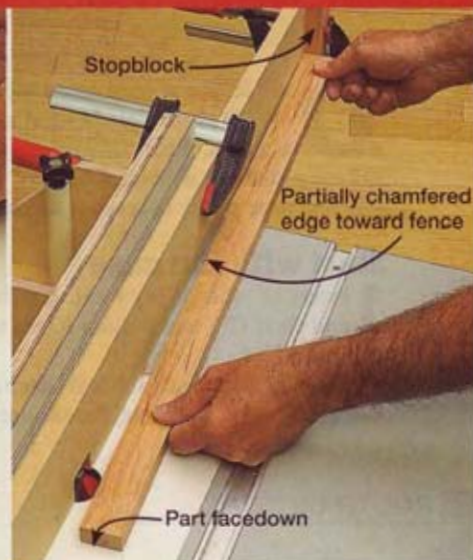
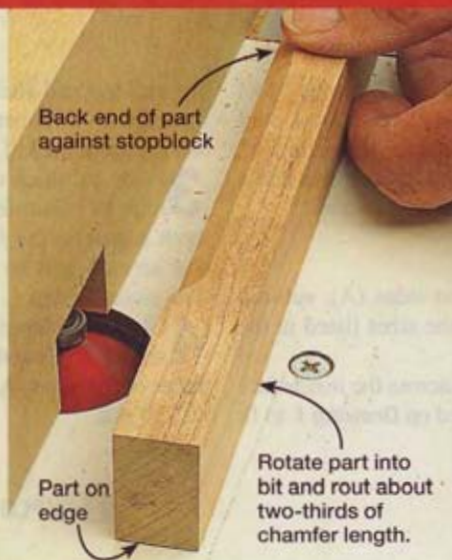

2 UPPER CASE ASSEMBLY

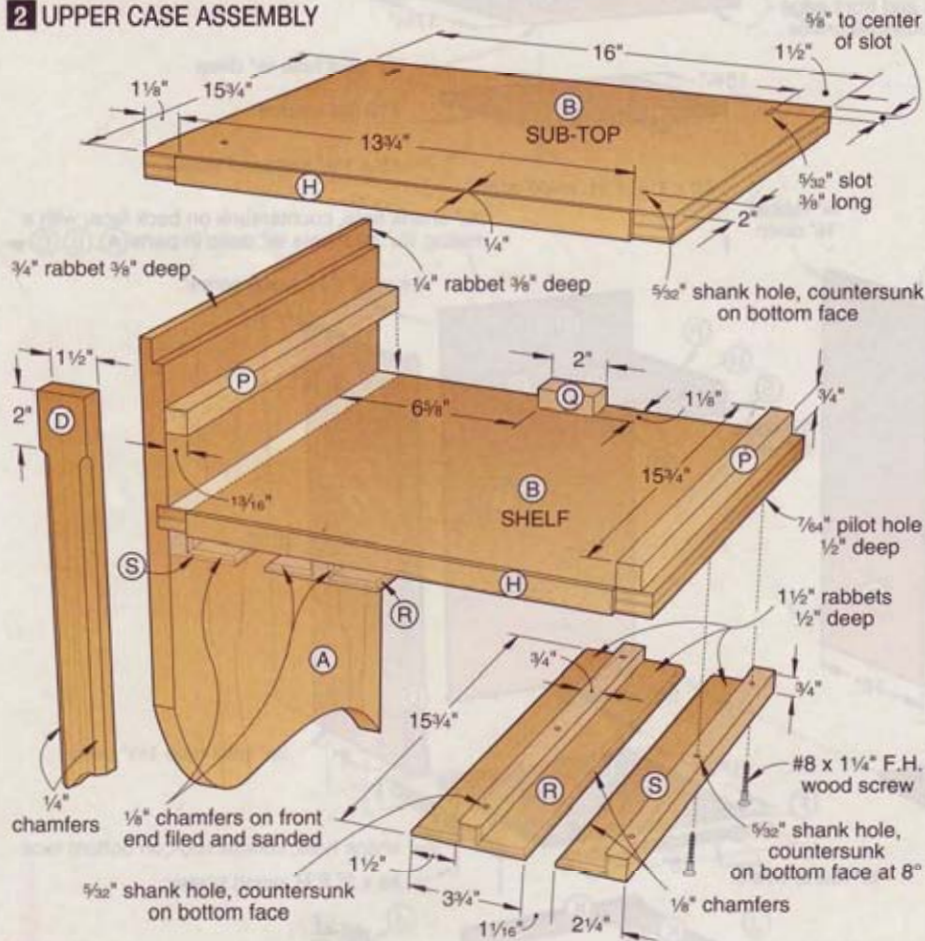

2a OUTER HOLDER SECTION VIEW DETAIL



5 In the sub-top (B), drill a pair of countersunk mounting holes in the *bottom* face and a pair of $\frac{5}{32}$ " expansion slots $\frac{3}{8}$ " long for attaching the top (G) later, where dimensioned on **Drawing 2**. Drill overlapping holes to form the slots.

6 From $\frac{3}{4}$ "-thick cherry planed to match the thickness of the plywood bottom (C), miter-cut the bottom front trim (E) and side trim (F) to the sizes listed. Glue and clamp the trim to the bottom, noting that the non-mitered back ends of the side trim overhang the bottom $\frac{1}{4}$ ". After the glue dries, rout a $\frac{3}{8}$ " round-over along the top and bottom edges of the trim. Sand the assembly smooth.

7 From $\frac{3}{4}$ "-thick edge-jointed cherry, cut the top (G) to size. Then rout $\frac{3}{8}$ " round-overs along the top and bottom edges on the ends and front to create a bullnose profile. Sand the top smooth.

Now glue the case together

1 Dry-assemble the sides/stiles (A/D) and sub-top and shelf (B), and verify that the parts fit together correctly. Make any needed adjustments. Then glue and clamp the parts together, as shown in **Photo A**.

2 Measure between the stiles (D) for the exact length of the sub-top and shelf trim (H), where shown on **Drawings 1** and **2**. Then, from $\frac{3}{4}$ "-thick cherry resawn or planed to $\frac{1}{4}$ " and ripped to match the thickness of the $\frac{3}{4}$ " plywood sub-top and shelf (B), cross-cut the trim to the measured length. Cut an extra piece from $\frac{3}{4}$ " scrap to the same length for use as a spacer to complete the case assembly. Glue and clamp the trim in place, flush with the top and bottom faces of the sub-top and shelf. Sand smooth.



ASSEMBLE THE CASE

Glue and clamp the case together, ensuring that the sub-top and shelf (B) are flush with the rabbeted back edges of the sides (A).

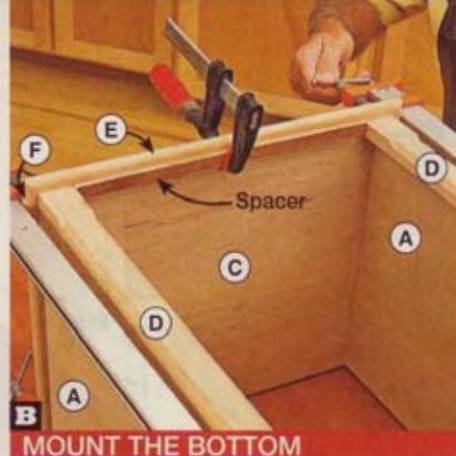

MOUNT THE BOTTOM

Clamp the bottom/trim assembly (C/E/F), centered side-to-side, to the case, with the spacer tight between the stiles (D).

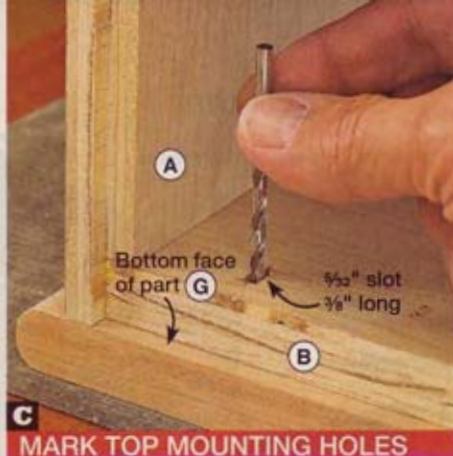

MARK TOP MOUNTING HOLES

Using a $\frac{5}{32}$ " brad-point bit, mark the centers of the mounting holes and slots in the sub-top (B) on the bottom face of the top (G).

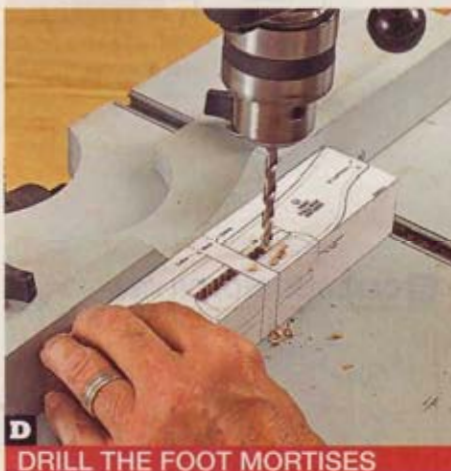

DRILL THE FOOT MORTISES

Drill overlapping holes to form $1\frac{1}{4}$ " mortises $\frac{3}{16}$ " deep in the face and edge of the foot blank, where shown on the pattern.

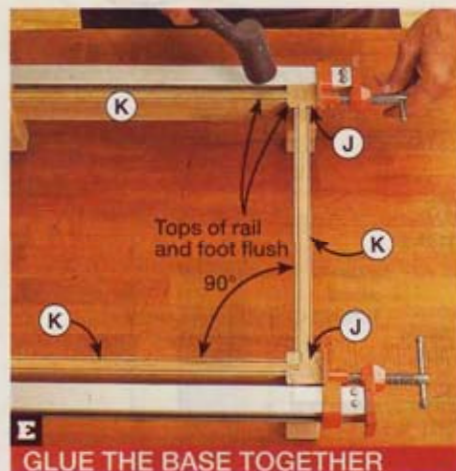

GLUE THE BASE TOGETHER

Glue and clamp the feet (J) and rails (K) together, keeping the top surfaces flush. Measure the diagonals to verify square.



ADD THE BASE TO THE CASE

Glue and clamp the base (J/K) to the case bottom (C/E/F), with the base centered side-to-side, and the feet (J) flush with the back.

3 Position the case with the back down. Using the spacer to maintain the correct distance between the stiles (D) at the bottom, clamp (do not glue) the bottom/trim assembly (C/E/F) and spacer to the case, as shown in Photo B. Then drill mounting holes through the bottom (C) and centered into the sides (A), where shown on Drawing 1. Drive the #8x2" flathead wood screws.

4 To mount the top (G), position it with the bottom face up on your workbench. Then place the case, with the sub-top (B) down, on the top, centered side-to-side and flush at the back. Mark the centers of the mounting holes and slots in the sub-top on the top, as shown in Photo C. Remove the case, and drill pilot holes into the top at the marked centerpoints. Reposition the case. Now, using a short screwdriver, fasten the top with #8x1 1/4" flathead wood screws and #8x1 1/4" panhead screws with #10 flat washers, where shown on Drawing 1.

5 From 1/4" cherry plywood, cut the back (I) to size to fit the rabbeted opening in the case. Position the back in the case, tight against the top (G). Drill mounting holes through the back and into the case, where

shown. Then remove the back, sand it smooth, and set it aside.

Move down to the base

1 From laminated 3/4"-thick cherry (or 1 1/2"-thick stock), cut two 2x9 1/2" blanks to form the feet (J). You'll get two feet from each blank.

2 Make two copies of the full-size foot pattern from the WOOD Patterns® insert. Spray-adhere a pattern to each blank, folding the pattern where shown. Using a 1/4" brad-point bit in your drill press, drill 1 1/4" mortises 3/16" deep in the face and edge of each blank, where shown on the pattern and as shown in Photo D. Then, using sharp chisels, square the ends and sides of the mortises.

3 Bandsaw and drum-sand each blank to the pattern lines, but do not separate the feet. Using a 1/8" round-over bit in your table-mounted router, round over the edges and ends of the blanks on both faces, where shown on the pattern and Drawing 1. Sand the routed edges smooth.

4 Using an extension on your table saw, cut a miter gauge for support, and a stopblock to ensure identical lengths, crosscut two

4 1/2"-long feet from each blank, where shown on the pattern.

5 Cut the rails (K) to size. Using a dado blade in your table saw, form a 1/4" tenon 1/2" long at each end of the rails, where shown on Drawings 1 and 1a, to fit snugly into the foot mortises. (We made test-cuts in cutoffs to verify our setup before cutting the rail tenons.) After cutting the tenon cheeks, set the rails on the bottom edges and cut the ends again to trim the 1 1/2"-wide tenons to 1 1/4".

6 Refit your table saw with a standard 1/8"-kerf blade. Then cut a pair of 1/8"-deep grooves 1/16" from each face of the rails along the top edges, where dimensioned on Drawing 1a. The grooves capture glue squeeze-out when mounting the base to the case. Sand the rails smooth.

7 Dry-assemble the feet (J) and rails (K), and verify that the parts fit together correctly. Then glue and clamp the base together, as shown in Photo E.

8 Place the case on the floor with the bottom up. Apply glue to the area on the rails (K) between the 1/8" grooves. Now position and clamp the base (J/K) to the bottom of the case, as shown in Photo F.

3 DRAWER

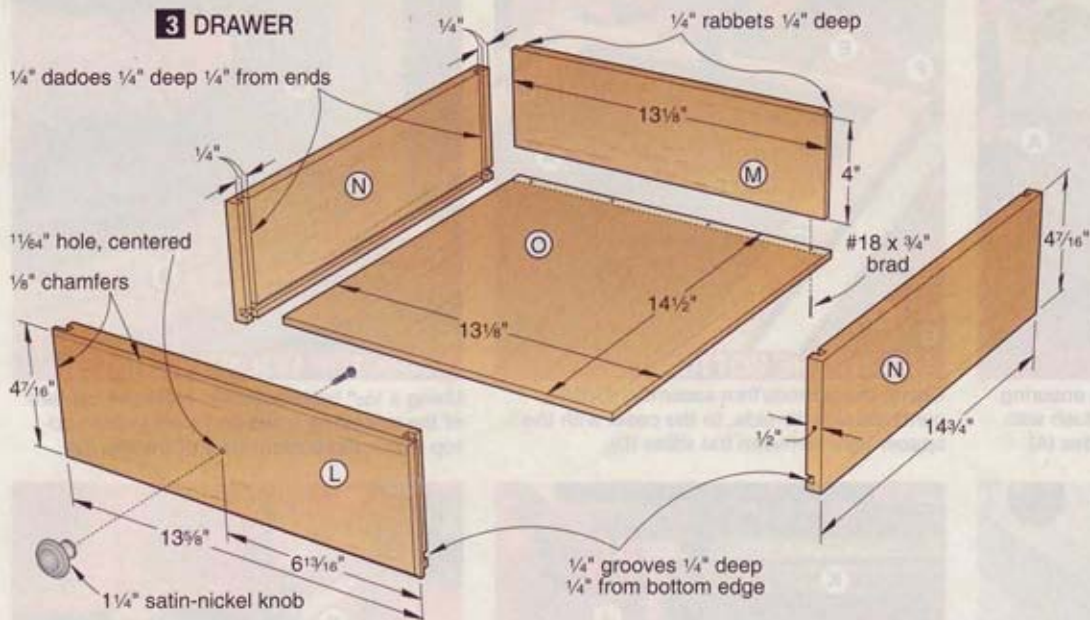

3a DRAWER-JOINT DETAIL

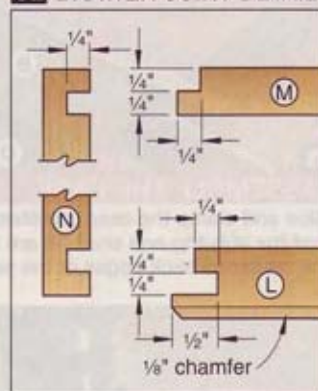

4 MACHINING THE DRAWER PARTS

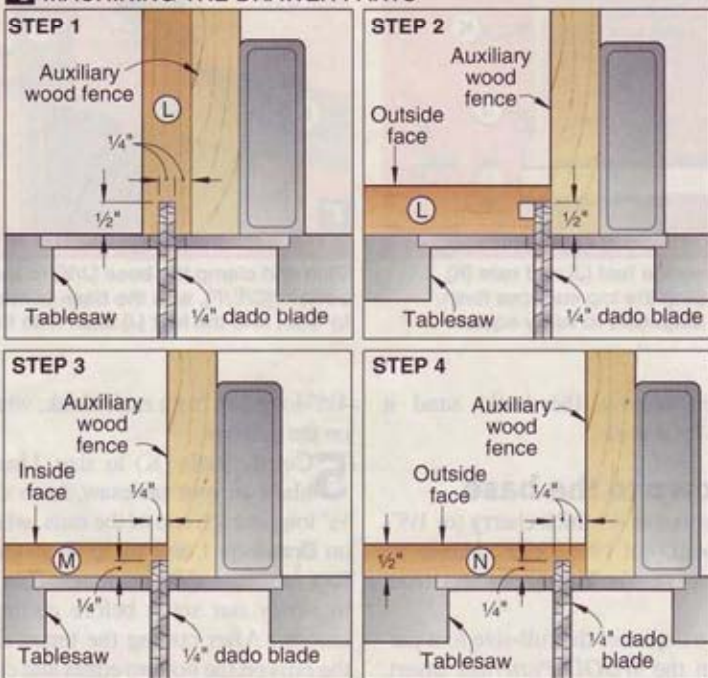

5 CASE SIDE SECTION VIEW

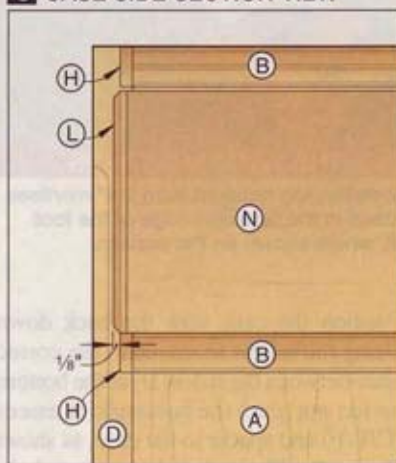

Now head up to the drawer

1 From 3/4"-thick cherry, cut the drawer front (L) to size. Then, from 3/4" stock planed to 1/2", cut the back (M) and sides (N) to size.

2 Fit your tablesaw with a 1/4" dado blade. Then, referring to **Drawings 3** and **3a** and the four-step **Drawing 4**, machine the grooves, rabbets, and dadoes in the drawer parts. When cutting the 1/4"-deep grooves 1/4" from the bottom edges in the front (L) and sides (N) to receive the 1/4" plywood bottom (O), switch to a standard 1/8"-kerf blade and cut the grooves to width in two passes to snugly fit your plywood.

3 Using a 45° chamfer bit in your table-mounted router, rout a 1/8" chamfer across the ends and along the edges of the drawer front (L) on the *front* face, where shown on **Drawing 3**. Then drill an 1 1/4" hole, centered, through the front for screw-mounting a 1 1/4" knob later.

4 From 1/4" cherry plywood, cut the bottom (O) to size. Sand all of the drawer parts smooth. Then glue and clamp the front (L), back (M), and sides (N) together, keeping the top edges of the back and sides flush. Check for square. Now slide the bottom (do not glue) in place, and secure it to the back with #18x3/4" brads.

5 From 3/4"-thick cherry, cut the drawer cleats (P) and stop (Q) to the sizes listed. Position the cleats (without glue) in the case, tight against the sides (A) and stiles (D). Slide the drawer into place, and verify that it moves smoothly. If tight, remove the drawer, and plane or sand the cleats as needed to achieve the desired fit. Then glue and clamp the cleats into position.

6 Dry-clamp the stop (Q) to the shelf (B), centered side-to-side and flush at the back. Slide the drawer into the case until it contacts the stop. Verify that the front (L) overhangs the shelf trim (H) 1/8", where shown on **Drawing 5**. If the overhang is greater than 1/8", trim the stop width, as needed. If the overhang is less than 1/8", position the drawer with a 1/8" overhang, and glue and clamp the block to the shelf, tight against the drawer back (M). Remove the drawer.

Shape the wineglass holders in 4 quick steps

It's easy to cut the rabbets in the wineglass holders and chamfer the edges using a standard blade in your tablesaw. Here's how.

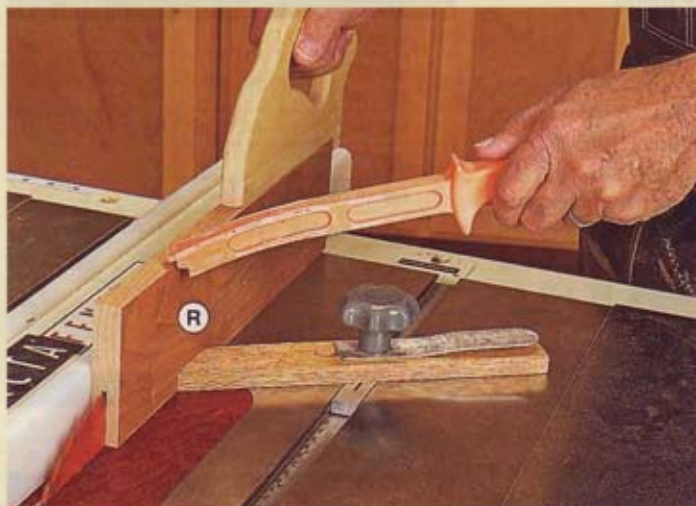

STEP 1 Raise your blade 1½" above a zero-clearance insert, and position the fence ¼" from the *inside* of the blade. Using a pushblock, pushstick, and feather board for safety, rip the outer holders (S) along *one* edge and inner holders (R) along *both* edges, keeping the same face against the fence.

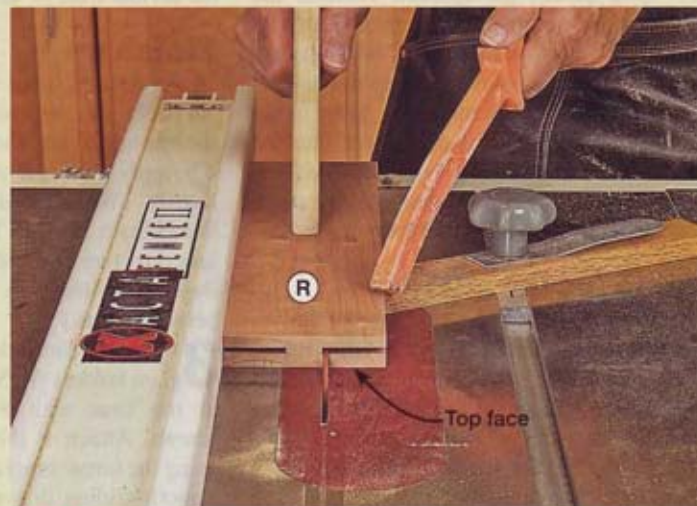

STEP 2 Lower the blade to ½", and reposition the fence 2¼" from the inside of the blade. With the *top face* of an inner holder (R) down, cut the piece, turn it end-for-end, and cut it again to complete the rabbets. **For stability, keep the pushblock centered on the holder.** Repeat for the other inner holder.

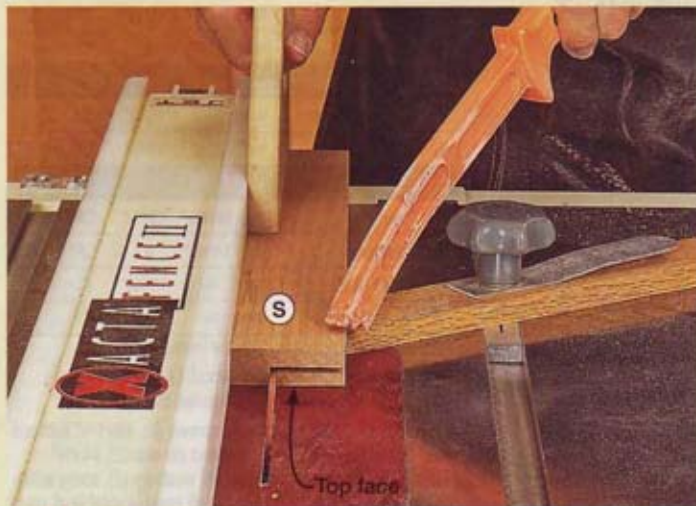

STEP 3 With the blade height still at ½", reposition the fence ¾" from the inside of the blade. Keeping an outer holder (S) tight against the fence with the *top face* down, cut the piece to complete the rabbet. Hold the pushblock snug to the fence to keep the part stable. Repeat for the other holder.

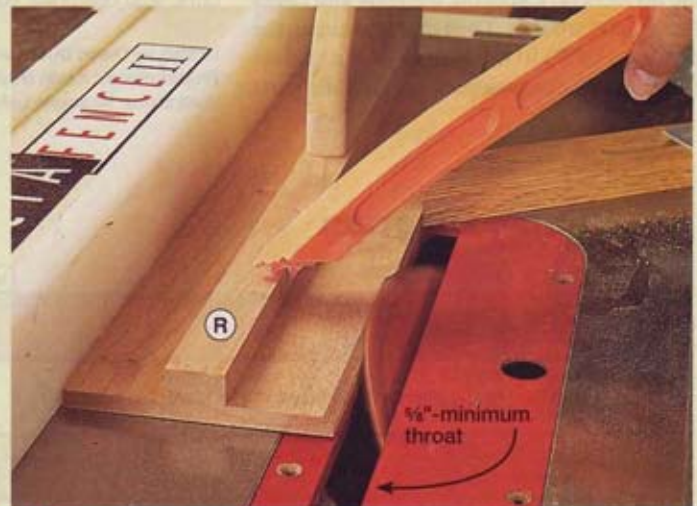

STEP 4 To chamfer the edges of the holders, switch to your standard blade insert. Tilt the blade to 45°, and raise it ¾". Position the fence, as shown, and cut a ⅛" chamfer along *both* edges of the inner holders (R). Then reposition the fence, and chamfer the *inside* edge of the outer holders (S).

Add the wineglass holders

1 From ¾"-thick cherry, cut the wineglass inner and outer holders (R, S) to the sizes listed. Using a standard blade in your tablesaw, cut 1½" rabbets ½" deep in the holders, where shown on **Drawing 2**, making two cuts to form each rabbet. Then bevel-rip a ⅛" chamfer along the *edges* (not *ends*) of the holders, where shown. For help with cutting the rabbets and chamfers, see the sidebar, "Shape the wineglass holders in 4 quick steps," *above*.

2 Using a wood or cabinet file, form a ⅛" chamfer on the front ends of the inner

and outer holders (R, S), where shown on **Drawing 2**.

3 Drill countersunk mounting holes in the bottom faces of the holders (R, S), angling the holes in the outer holders (S) at 8°, where shown on **Drawing 2a**. Sand the holders.

4 To mount the holders (R, S) in the case, position the case with the top (G) down and supported on 4×4 spacers for clamp clearance, as shown in **Photo G**. From ¾"

With the inner and outer holders (R, S) clamped in position with 1/16"-wide spacers between them, drill pilot holes into the shelf (B) and drive the screws.

INSTALL THE HOLDERS

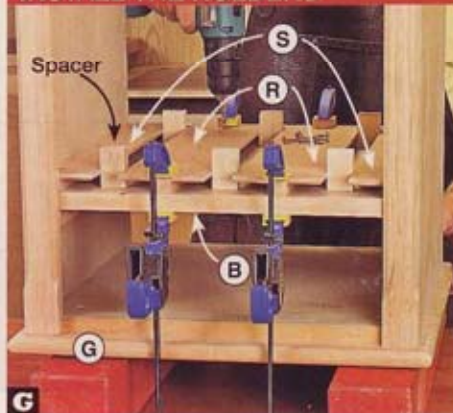

scrap, cut a 1 1/16 x 12" piece. Then crosscut six 1 3/4"-long pieces for spacers. Position the holders (*without* glue) on the shelf (B), flush at the back edge, with the 1 1/16"-wide spacers between them, as shown. Clamp the holders into place. Using the mounting holes in the holders as guides, drill pilot holes into the shelf. Drive the screws. For easy finishing later, remove the screws and holders, mark the holder locations, and set them aside.

Time for the shelves

1 From 3/4" cherry plywood, cut the shelves (T) and dividers (U) to the sizes listed. Then, from 3/4"-thick cherry planed to match the plywood thickness, cut the shelf trim (V) and divider trim (W) to the given sizes.

2 As you did for the base rails (K), cut a pair of 3/8" glue-relief grooves along the top edges of the dividers (U), where shown on **Drawing 1**.

3 Glue and clamp the shelf trim (V) to the shelves (T), and the divider trim (W) to the dividers (U), keeping the ends and edges flush. Sand smooth. Then glue and clamp the dividers (U/W) to the bottom of the shelves (T/V) where dimensioned, keeping the parts

flush at the back. (The shelf trim overhangs the divider trim 1/4" at the front.)

Finish up

1 As needed, sand any areas of the case, back, drawer, wineglass holders, and shelves to 220 grit and remove the dust.

2 Apply a stain, if you wish, and clear finish. (We applied Varathane Premium Wood Stain No. 245 Traditional Cherry, followed by two coats of satin AquaZar Water-Based Polyurethane, sanding to 320 grit between coats.)

3 When the finish dries, remount the wineglass holders (R, S). Then fasten the back to the case with #4 x 3/8" flathead wood screws. Attach a 1 1/4" knob to the drawer using the screw supplied with the knob. For a smooth-gliding drawer, apply paraffin wax to the cleats (P) and bottom edges of the sides (N). Install the drawer and shelves in the case. Now fill the cabinet with your favorite wines, wineglasses, and accessories, pop a cork, and celebrate your fine work! 🍷

Written by **Owen Duvall** with **Chuck Hedlund**
Project design: **Kevin Boyle**
Illustrations: **Roxanne LeMoine**; **Lorna Johnson**

Materials List

Case	FINISHED SIZE			Matl.	Qty.
	T	W	L		
A sides	3/4"	16"	30 1/2"	CP	2
B sub-top and shelf	3/4"	15 3/4"	16"	CP	2
C bottom	3/4"	16 1/8"	16 1/2"	CP	1
D stiles	3/4"	1 1/2"	30 1/2"	C	2
E bottom front trim	3/4"	3/4"	18"	C	1
F bottom side trim	3/4"	3/4"	17 1/2"	C	2
G top	3/4"	17 3/4"	18"	EC	1
H sub-top and shelf trim	1/4"	3/4"	13 3/4"	C	2
I back	1/4"	16"	31 1/4"	CP	1
Base					
J* feet	1 1/2"	2"	4 1/2"	LC	4
K rails	3/4"	1 1/2"	14 1/4"	C	4
Drawer					
L front	3/4"	4 7/8"	13 3/8"	C	1
M back	1/2"	4"	13 1/8"	C	1
N sides	1/8"	4 7/8"	14 1/4"	C	2
O bottom	1/4"	13 1/8"	14 1/4"	CP	1
P cleats	3/4"	1 1/8"	15 1/4"	C	2
Q stop	3/4"	1 1/8"	2"	C	1
Wineglass holders					
R inner holders	3/4"	3 3/4"	15 1/4"	C	2
S outer holders	3/4"	2 1/4"	15 1/4"	C	2
Shelves					
T shelves	3/4"	14 3/8"	15 3/8"	CP	3
U dividers	3/4"	14 3/8"	4"	CP	6
V shelf trim	3/4"	3/4"	15 3/8"	C	3
W divider trim	3/4"	3/4"	4"	C	6

Cutting Diagram

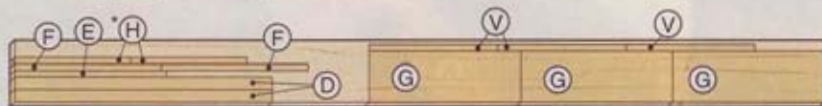

3/4 x 7 1/4 x 96" Cherry (5.3 bd. ft.)

*Plane or resaw to the thicknesses listed in the Materials List.

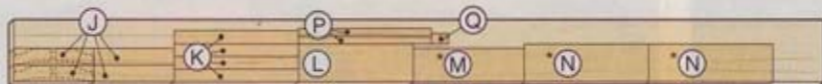

3/4 x 7 1/4 x 96" Cherry (5.3 bd. ft.)

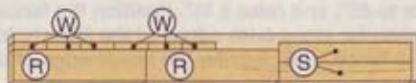

3/4 x 5 1/2 x 48" Cherry (2 bd. ft.)

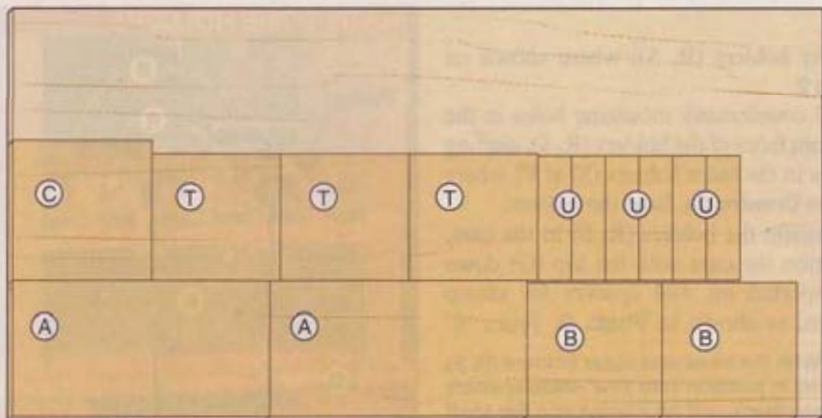

3/4 x 48 x 96" Cherry plywood

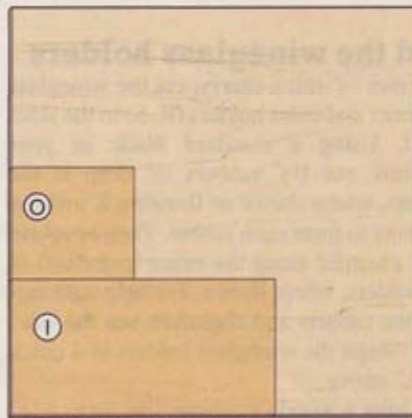

1/4 x 48 x 48" Cherry plywood

shop-in-a-box tool cabinet



Keep tools, hardware, and supplies organized in this space-saving, 4-door cabinet. Though it occupies little more than 7 square feet of wall area, it offers a full 26 square feet of storage on the perforated-hardboard panels alone!



Looking for an easy-to-build project that makes a really big impact on reducing shop clutter and improving work efficiency? Here it is. With identical case and door construction using simple rabbet-and-groove joinery, you can make this cabinet in a few evenings or a weekend. For materials, you need only a 4x8 sheet each of $\frac{1}{4}$ " perforated hardboard and $\frac{3}{4}$ " plywood, plus a quarter-sheet of $\frac{1}{4}$ " hardboard.

Start with the case

1 From $\frac{3}{4}$ " plywood, cut the sides (A) and top and bottom (B) to the sizes listed in the **Materials List**. (We used Baltic birch plywood, which we found at a local home center, and applied a clear finish. If you plan to paint the unit, you can use less-expensive type AC or BC plywood.) Because the thickness of plywood varies, you may need

to slightly adjust the sizes of some parts and the mating dadoes and rabbets.

2 Mark centerpoints for $\frac{1}{4}$ " holes $\frac{3}{8}$ " deep for shelf supports on the *inside* faces of the sides (A), where dimensioned on **Drawing 1**. Drill the holes using a brad-point bit in your drill press. Adjust the depth stop for consistent drilling depth.

3 Fit your tablesaw with an auxiliary fence and dado blade that matches the thickness of your $\frac{3}{4}$ " plywood. Then cut a $\frac{3}{8}$ "-deep rabbet across the *inside* faces of the sides (A) at each end, as shown in **Photo A**.

4 To cut a $\frac{1}{4}$ " groove $\frac{3}{8}$ " deep in the sides (A) and top and bottom (B) to fit your $\frac{1}{4}$ " perforated hardboard for the back (C), where dimensioned on **Drawings 1** and **2**, switch to a standard $\frac{1}{8}$ "-kerf blade in your tablesaw. Position the fence $\frac{3}{4}$ " from the *inside* of the blade. Then cut a groove along



Though the case measures just $12\frac{3}{8}$ " deep, it houses all four doors when closed.

RABBET THE SIDES

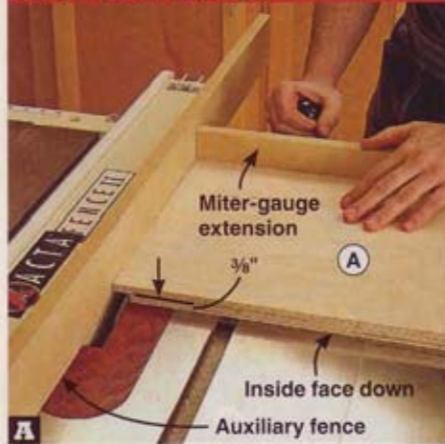

Keeping a side (A) tight against an auxiliary fence and miter-gauge extension, cut a rabbet across each end on the *inside* face.

SCREW-MOUNT THE SHELF

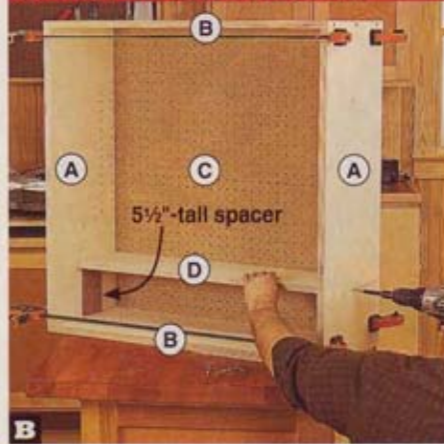

With the shelf (D) on 5 1/2"-tall spacers and tight against the back (C), drill mounting holes through the sides (A) into the shelf.

the back edges of the sides, top, and bottom on the *inside* faces. Now reposition the fence, as needed, and cut the grooves to final width to snugly fit the hardboard. Sand the parts smooth to 180 grit.

5 From 1/4" perforated hardboard, cut a 31 3/4"-square piece for the back (C). Then dry-assemble the sides (A), top and bottom (B), and back, and check that the parts fit together correctly. Make any needed adjustments. Now glue and clamp the case together, measuring for equal diagonals to verify square. Drill mounting holes through the sides and into the top and bottom, where shown on **Drawing 2**, and drive the screws.

6 From 3/4" birch plywood, cut the shelf (D) to size. Then, from your 1/4" perforated-hardboard cutoffs, cut two 4x5 1/2" spacers. Position the shelf in the case on the 5 1/2"-tall spacers, as shown in **Photo B**. Drill the mounting holes, where dimensioned on **Drawing 1**, and drive the screws.

7 From 3/4" plywood, cut the mounting cleats (E) and spacer (F) to 1 1/2"x31". Bevel-rip one edge of each cleat at 45°, leaving a 1/8" flat, where shown on **Drawing 2a**.

8 Position the case on your workbench with the back (C) up. Then glue and clamp a mounting cleat (E) in place on the back, tight against the top (B), in the orientation shown on **Drawing 2a**. From inside the case, drill mounting holes, centered in the holes in the perforated-hardboard back, into the mounting cleat, where shown on **Drawing 2**, and drive the #8x3/4" flathead wood screws to further strengthen the attachment. In the

1 CASE SIDE (Inside face of left side shown)

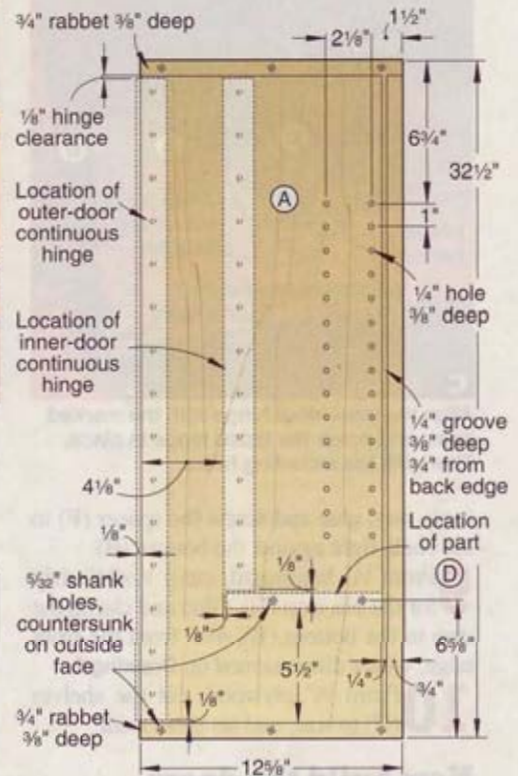

Note: Right side (A) is a mirror image.

2a CLEAT MOUNTING DETAIL



2 CASE

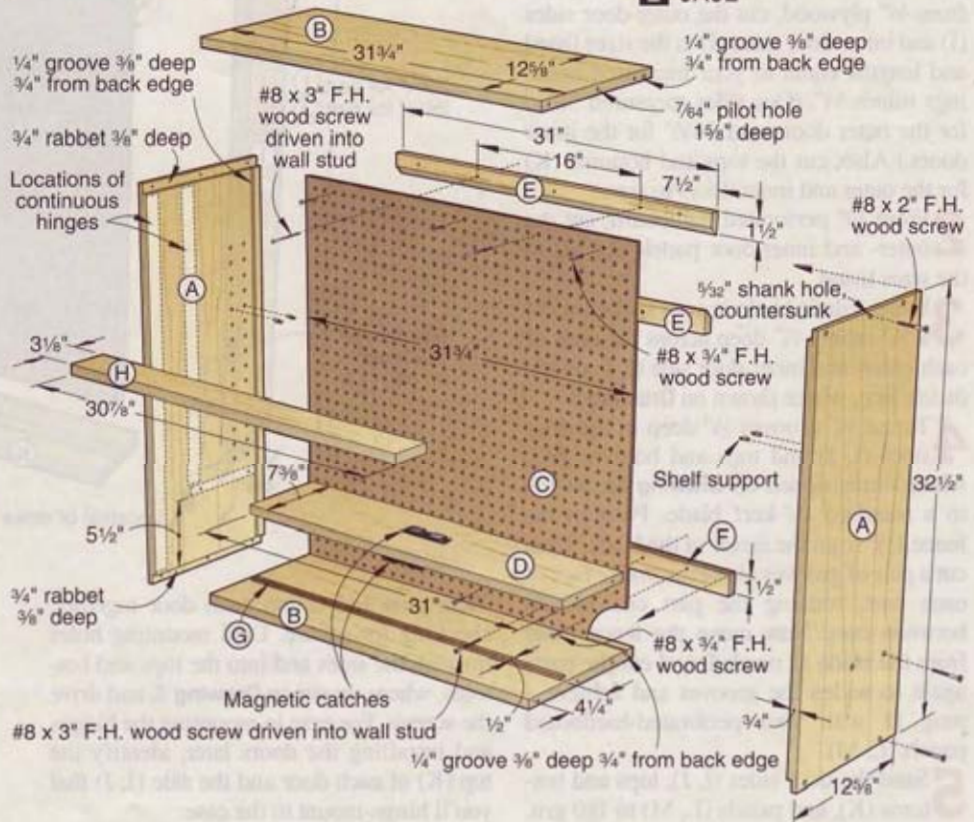

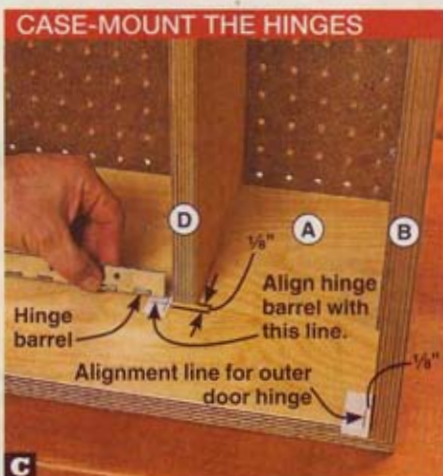

C Align the inner-door hinge with the marked lines, and press the taped hinge in place. Then drill the mounting holes.

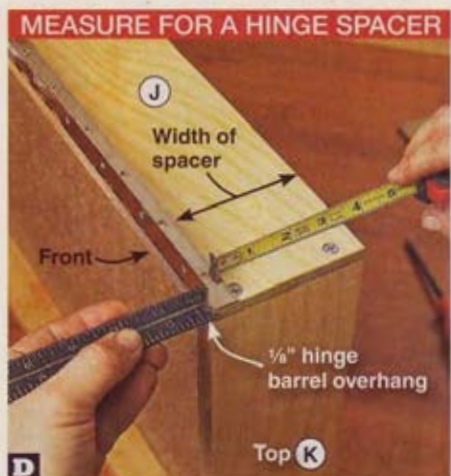

D Position a hinge on an inner-door side (J) with a $\frac{1}{8}$ " overhang. Measure from the back to the hinge to find the spacer width.

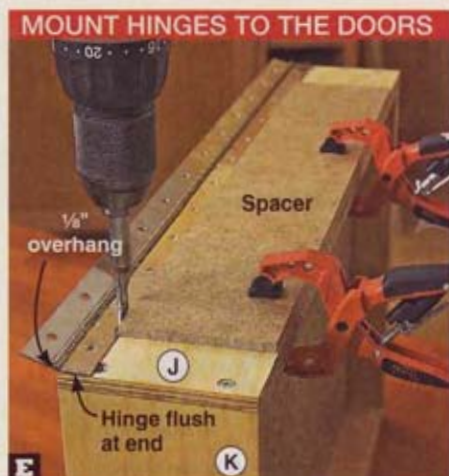

E Clamp the spacer to the door, flush with the back edge. With the hinge tight against the spacer, drill the mounting holes.

same way, glue and screw the spacer (F) to the back, tight against the bottom (B).

9 From $\frac{1}{4}$ " hardboard, cut a $\frac{1}{2} \times 31$ " strip for the bin stop (G). Glue and clamp the stop to the bottom (B), $\frac{1}{4}$ " from the front edge, where dimensioned on **Drawing 2**.

10 From $\frac{3}{4}$ " plywood, cut the shelves (H) to size, and set them aside.

Now build the doors

1 To ensure that the outer and inner doors fit into the case with $\frac{1}{8}$ " clearance at the top and bottom, where shown on **Drawing 1**, measure the openings between the top and bottom (B) for the outer doors and the top and shelf (D) for the inner doors. Then, from $\frac{3}{4}$ " plywood, cut the outer-door sides (I) and inner-door sides (J) to the sizes listed and lengths equal to your measured openings minus $\frac{1}{4}$ ". (Our sides measured $30\frac{3}{4}$ " for the outer doors and $24\frac{1}{2}$ " for the inner doors.) Also, cut the tops and bottoms (K) for the outer and inner doors to size.

2 From $\frac{1}{4}$ " perforated hardboard, cut the outer- and inner-door panels (L, M) to the sizes listed.

3 Using a dado blade in your tablesaw, cut a $\frac{3}{4}$ " rabbet $\frac{3}{8}$ " deep across the ends of each outer- and inner-door side (I, J) on the *inside* face, where shown on **Drawing 3**.

4 To cut $\frac{1}{4}$ " grooves $\frac{3}{8}$ " deep in the door sides (I, J) and tops and bottoms (K), where dimensioned on **Drawing 3a**, switch to a standard $\frac{1}{8}$ "-kerf blade. Position the fence $1\frac{1}{2}$ " from the *inside* of the blade. Then cut a pair of grooves along the *inside* face of each part, rotating the part end to end between cuts. Now move the fence away from the blade as needed, and cut the parts again to widen the grooves and achieve a snug fit with your perforated-hardboard panels (L, M).

5 Sand the door sides (I, J), tops and bottoms (K), and panels (L, M) to 180 grit.

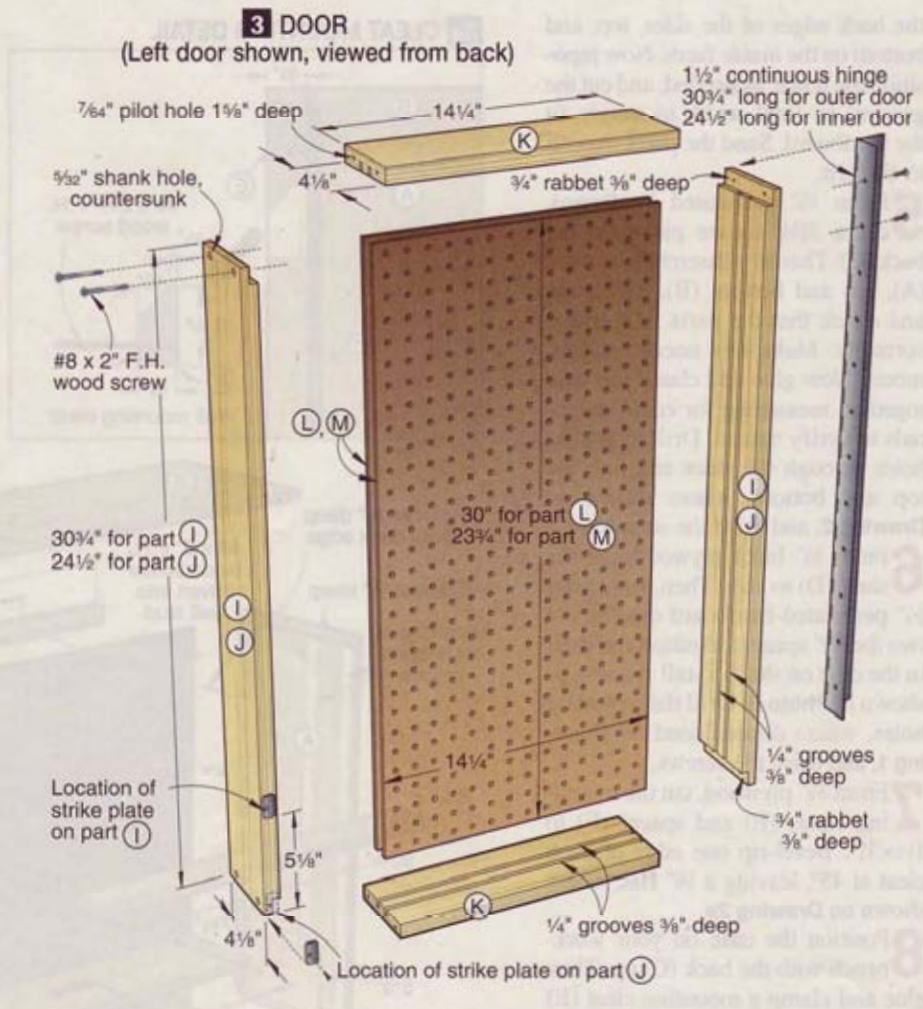

Then glue and clamp each door together, checking for square. Drill mounting holes through the sides and into the tops and bottoms, where shown on **Drawing 3**, and drive the screws. For ease in mounting the hinges and installing the doors later, identify the top (K) of each door and the side (I, J) that you'll hinge-mount to the case.

3a DOOR GROOVE DETAIL

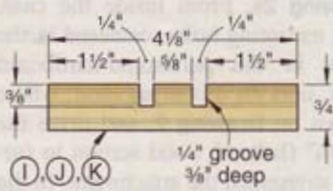

MOUNT THE DOORS

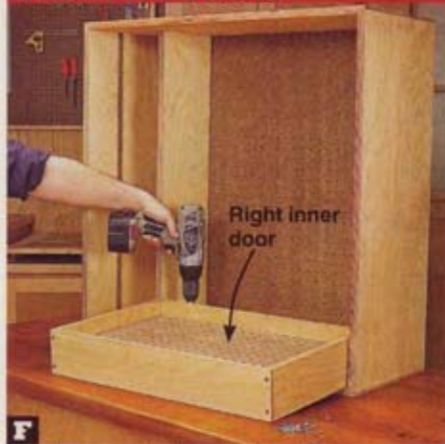

F Position the right inner door in the case, aligning the hinge with the previously drilled mounting holes. Drive the screws.

Add the easy-to-make bins

1 From $\frac{3}{4}$ " plywood, cut the fronts (N) and backs (O) for the eight bins to the sizes listed. Then, from $\frac{1}{4}$ " hardboard, cut the sides (P) and bottoms (Q) to size.

2 Lay out the angled edge on a side (P), where dimensioned on **Drawing 4**. Bandsaw or scrollsaw to the marked line, and sand smooth. Using this piece as a template, mark the angle on the remaining side pieces, and cut and sand them to shape.

3 Sand the fronts (N), backs (O), sides (P), and bottoms (Q) to 180 grit. Then glue and clamp the parts together in the configuration shown.

Sand, then apply the finish

1 If needed, fill any voids in the plywood edges with a paintable wood putty, and sand smooth when dry. Then sand any areas of the case, doors, shelves, and bins that need it to 180 grit, and ease any sharp edges. Remove the dust.

2 Apply two coats of a clear finish, sanding between coats. (We applied Varathane Diamond Water-Based Polyurethane, satin finish, sanding to 320 grit between coats.)

Complete the assembly

1 Measure the lengths of the outer- and inner-door sides (I, J). Then, from two $1\frac{1}{2}$ "x48" continuous hinges for the outer doors and two $1\frac{1}{2}$ "x30" hinges for the inner doors, hacksaw the pieces to the measured lengths. To maintain the correct orientation of the hinges during assembly, mark the manufactured (uncut) ends "top."

2 To position the hinges on the case sides (A), where dimensioned on **Drawing 1**, place the case on the left side. Draw alignment lines on masking tape $\frac{1}{8}$ " from the top and bottom (B) for the outer-door hinge and

POSITION THE CATCHES

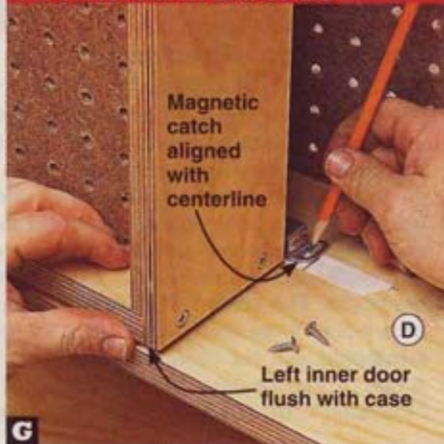

G Align the mounting flange of the magnetic catch with the marked centerline on the shelf (D). Mark the centers of the slots.

$\frac{1}{8}$ " from the top and shelf (D) for the inner-door hinge to center the hinges top-to-bottom. Then, to position the barrel of the inner-door hinge $\frac{1}{8}$ " from the front of the shelf so the door closes flush with the shelf, adjust a combination square to the distance from the front edge of the side to the shelf less $\frac{1}{8}$ ". (We set our square to $4\frac{1}{8}$ ".) Now mark intersecting lines using the square.

3 To mount the inner-door hinge, apply a few small pieces of cloth-backed double-faced tape to the case-side hinge leaf. With the hinge leaves positioned at 90° and the marked top end of the hinge correctly oriented, align the hinge with the marks, as shown in **Photo C**, and press it in place. Using a self-centering bit, drill the mounting holes. Drive the screws, supplied with the hinge, in the two top and bottom holes to prethread them for easier mounting of the door later. Then remove the screws, hinge, and tape.

In the same way, mount the outer-door hinge, except position it so that the barrel overhangs the front edge of the case $\frac{1}{8}$ ". Use a combination square or a $\frac{3}{4}$ "-wide strip of $\frac{1}{8}$ " hardboard as an alignment aid to set the hinge overhang. Now reposition the case on the right side (A), and repeat the hinge marking and mounting process.

4 BIN

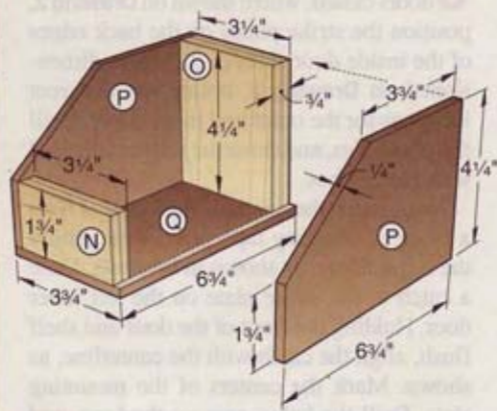

4 To mount the hinges on the doors, where shown on **Drawing 5**, place a hinge for an inner door along the *front* edge of the side (J) identified for hinge-mounting to the case. With the hinge leaves positioned at 90° , the top of the hinge at the top of the door, and the ends flush, align the hinge so that the barrel overhangs the edge $\frac{1}{8}$ ".

Next, to easily keep the hinge aligned, measure from the back of the door to the hinge for a spacer, as shown in **Photo D**. (We measured $3\frac{3}{8}$ ".) Then, from $\frac{1}{4}$ " hardboard, cut a 20"-long piece to your measured width. Now clamp the spacer to the door and mount the hinge, as shown in **Photo E**, driving all of the screws. Repeat for the other doors.

5 Position the case on the right side (A), and screw-mount the right inner door, as shown in **Photo F**. Raise the door to the closed position. Then mount the right outer door. Using a helper, reposition the case on the left side. Mount the remaining doors.

5 CABINET

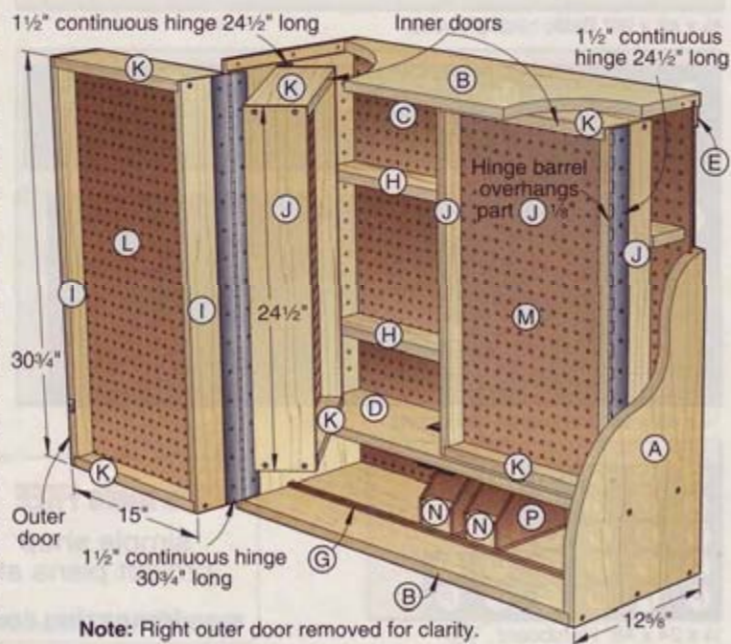

Note: Right outer door removed for clarity.

6 To mount magnetic catches to hold the doors closed, where shown on **Drawing 2**, position the strike plates on the back edges of the inside door sides (I, J), where dimensioned on **Drawing 3**, noting the different locations for the outer and inner doors. Drill the pilot holes, and drive the screws supplied with the catches.

Next, mark the center of the shelf (D) on a piece of masking tape positioned behind the inner doors, as shown in **Photo G**. Mate a catch to the strike plate on the left inner door. Holding the front of the door and shelf flush, align the catch with the centerline, as shown. Mark the centers of the mounting slots. Drill the holes, remove the tape, and screw-mount the catch. In the same way, mount the catch for the right inner door, tight against the left-door catch. Then mark the center of the shelf (D) on the *bottom* face at the front edge. Now mount the catches for the outer doors, aligning the catches with the centerline.

7 To mount the unit, hold the remaining mounting cleat (E) level on your wall with the beveled edge positioned where shown on **Drawings 2** and **2a**. Drill counter-

SHOP TIP

Lock hooks to perforated hardboard in a snap

Here's a simple and inexpensive way to secure standard, nonlocking hooks to perforated hardboard so they won't come out. Strap them in place with M-style hook holders. Just center a holder over the hook shank, and press the barbed ends into an adjacent pair of holes, as shown. You easily can release the holders to reposition the hooks. The holders fit standard 9-gauge and heavy-duty 5-gauge hooks used in $\frac{1}{8}$ " and $\frac{1}{4}$ " hardboard with $\frac{3}{16}$ " or $\frac{9}{32}$ " holes spaced 1" apart. A bag of 50 clips, no. 1169A85, costs \$11.89 from McMaster-Carr, 404/346-7000, mcmaster.com.



sunk mounting holes through the cleat into the wall studs, and fasten with #8x2½" flat-head wood screws. Using a helper, hang the unit. Then, from inside the cabinet, drill mounting holes, centered in holes in the back (C), through the case mounting cleat (E) and spacer (F) into the studs to anchor the assembly to the wall.

8 Finally, install the shelves (H), where you wish, using ¼" shelf supports. Place the bins in the cabinet behind the bin stop

(G), where shown on **Drawing 5**. Now tidy up your shop by filling the cabinet with tools, hardware, and supplies, hanging items on the perforated-hardboard panels using suitable ¼" metal hooks, available at your local home center or hardware store. For a simple way to keep hooks securely in place, see the sidebar, *above*.

Written by **Owen Duvall**
Project design: **Jeff Mertz**
Illustrations: **Roxanne LeMoine, Lorna Johnson**

Cutting Diagram

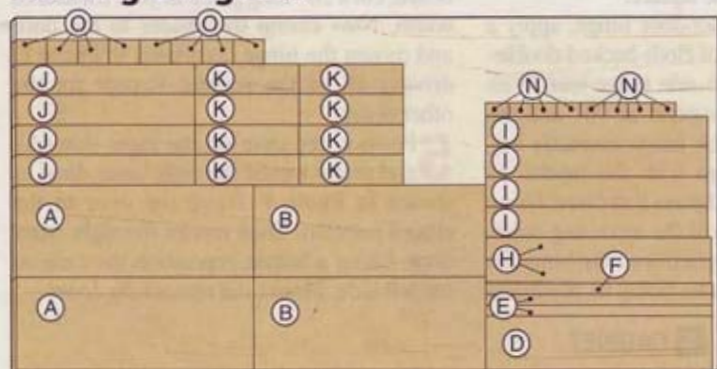

¾" x 48" x 96" Baltic birch plywood

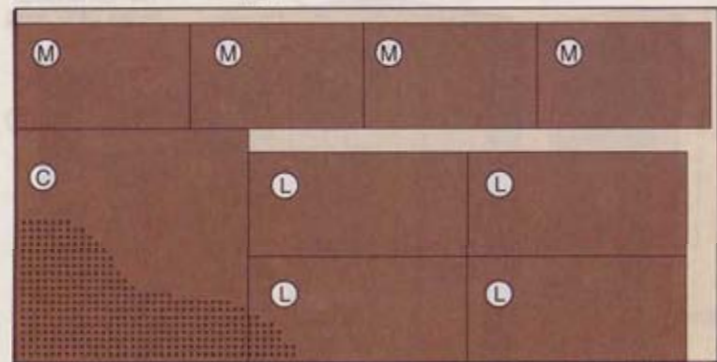

¾" x 48" x 96" Perforated hardboard

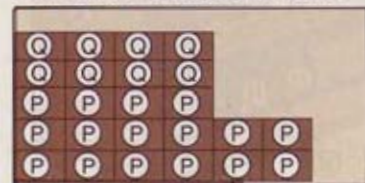

¼" x 24" x 48" Hardboard **G**

See more **FREE**
simple shop
project plans at

woodmagazine.com/wbprojects



Materials List

Case	FINISHED SIZE			Matl.	Qty.
	T	W	L		
A sides	¾"	12¾"	32½"	BP	2
B top and bottom	¾"	12¾"	31¾"	BP	2
C back	¼"	31¾"	31¾"	PH	1
D shelf	¾"	7¾"	31"	BP	1
E mounting cleats	¾"	1½"	31"	BP	2
F spacer	¾"	1½"	31"	BP	1
G bin stop	¼"	½"	31"	H	1
H shelves	¾"	3¾"	30¾"	BP	2
Doors (2 outer and 2 inner needed)					
I outer-door sides	¾"	4½"	30¾"	BP	4
J inner-door sides	¾"	4½"	24½"	BP	4
K tops and bottoms	¾"	4½"	14½"	BP	8
L outer-door panels	¼"	14¾"	30"	PH	4
M inner-door panels	¼"	14¾"	23¾"	PH	4
Bins (8 needed)					
N fronts	¾"	1¾"	3¼"	BP	8
O backs	¾"	3¼"	4¼"	BP	8
P sides	¼"	4¼"	6¼"	H	16
Q bottoms	¼"	3¾"	6¼"	H	8

Materials key: BP—Baltic birch plywood, PH—perforated hardboard, H—hardboard.

Supplies: #8x¾" flathead wood screws (6); #8x2" flathead wood screws (48); #8x2½" flathead wood screws (2); #8x3" flathead wood screws (4); cloth-backed, double-faced tape; 1½x48" continuous hinges (2) and 1½x30" continuous hinges (2); paintable wood putty; magnetic catches (4); ¼" shelf supports (8); ¼" perforated-hardboard hooks.

Blade and bit: Dado-blade set, ¼" brad-point bit.

make any bandsaw a peak performer

with
Michael Fortune

Learn how to set up your saw from a pro, and how to perfect the four most common cuts.

Michael Fortune resaws with precision on his perfectly tuned and modestly priced Ridgid bandsaw.

Okay, so maybe you couldn't afford that \$1,000 bandsaw. Perhaps you had to settle for an el cheapo that you hide in a dark corner of your shop when your woodworking buddies come calling. No need to feel shame—with the right TLC and a few clever add-ons, you can tune up and trick

out a low-cost tool and make it deliver clean, precise cuts with every flick of the switch.

How's that possible? We let one of North America's premier master craftsmen, Michael Fortune, tackle that question. (See more on Michael, *above right*.) During a recent visit to his workshop in Lakefield, Ontario,

Michael introduced us to one of the stars of his tool lineup, a modest 14" Ridgid bandsaw, model BS14000, with a ¾-hp, 110-volt motor, purchased for around \$350. "That's plenty of saw for a one-man shop," he says, "provided you set it up properly." Now, you can do the same with your low-dough bandsaw.

More on the expert

Artist, award-winning furniture designer, teacher, accomplished woodworker—Michael Fortune fits all of these descriptions. His designs have appeared in museums and exhibitions worldwide and can be seen on his Web site at michaelfortune.com. In addition, Michael teaches design workshops at universities and woodworking schools throughout North America. You can catch him teaching bandsaw and other woodworking-related workshops at The Woodworking Shows and the Marc Adams School of Woodworking. For more on the Marc Adams School, call 317/535-4013; or go to marcadams.com.

Made from Macassar ebony with silver and mother-of-pearl inlay, Michael's signature chairs consist of steam-bent and laminated parts, held together by mortise-and-tenon joinery. They command a price that only the affluent can fork up.



Begin with a good basic tool

Michael has five bandsaws in his shop, all rigged similarly to the two shown here—his Ridgid and a more expensive 14" General International (GI) (about \$800). He isolates five key ingredients that a top-performing cutting machine should include:

■ **Rock-solid base.** A vibration-free bandsaw, Michael says, "starts with a solid base that sits firmly on the floor." He does not rest his bandsaws on wheeled mobile bases. Instead, he installed a piece of plywood with rounded-over edges beneath the GI. Beneath it, he attached four Teflon sliders (sometimes call furniture movers) that he purchased at a local hardware store. These give the tool full contact with the floor and let him slide it around with relative ease. The legs on his Ridgid and several other stationary tools also have sliders beneath them for quick and occasional relocation. End result: The solution is dirt cheap, and it meets the woodworker's needs!

■ **Dust disposal.** An efficient machine provides one or more dust-collection ports attached to a vacuum to keep the wheel housing from filling up with sawdust and interfering with the saw's operation. Michael especially likes the built-in dust collection of the GI because it eliminates having to work around a shop vacuum or large dust-collector hose.

■ **Adequate power.** "A ½-hp bandsaw motor works fine for most workshop jobs," Michael says. But he agrees that a bigger motor handles

big assignments faster, as when resawing 4" or wider hardwood boards, for example.

■ **Top-quality blade.** According to Michael, "New saws typically come with bad blades that need to be replaced." That's the first thing he does. And while he's tried all kinds of blades, he always comes back to his favorite—a ½" skip-tooth, carbon steel, coarse blade having three teeth per inch and a large gullet. "I found a fine-tooth blade isn't really better than a coarse blade for clean, straight cuts," he says. Equally important is the quality of the weld. "For trueness

and durability of their welds, I rely on BC Saw & Tool, Inc. [call 888/251-2236, or visit bcsaw.com] for all the bandsaw blades in my shop."

■ **Stock support.** Finally, due to the small size of bandsaw tables, Michael engineered a simple adjustable work support system that includes an inexpensive ball-bearing roller stand (minus one leg), a wood support rail attached to the saw's base, and a lockable, adjustable wood arm that connects the stand to the saw. With this add-on he can saw boards 10' long.

A PAIR OF PEAK PERFORMERS IN MICHAEL'S SHOP



Tricked out and tuned up, Michael's 14" Ridgid (left) and 14" General International bandsaws are equals when it comes to precision cutting, though the General International costs hundreds of dollars more.

Set up your saw for success

Accurate bandsaw adjustments make all the difference between a so-so cut and one that requires little cleanup. Here are Michael's secrets for achieving great results.

■ **Center the blade for centered cuts.** First, with the saw's power off, spin the upper wheel by hand to ensure the blade stays on the tire, turning the top-wheel adjustment knob as shown. Then, with the cover slightly ajar—enough to see the wheel and blade—turn on the saw and fine-tune the wheel angle to center the blade perfectly on the crown of the tire. This will cause the blade to center on the lower tire as well, provided the bearing and guide blocks are correctly adjusted. (Michael never adjusts the lower wheel.) Make a test cut in scrap, and then compare it to the drawing at right to determine if your blade is centered.



HOW TO TELL IF YOUR BLADE IS CENTERED

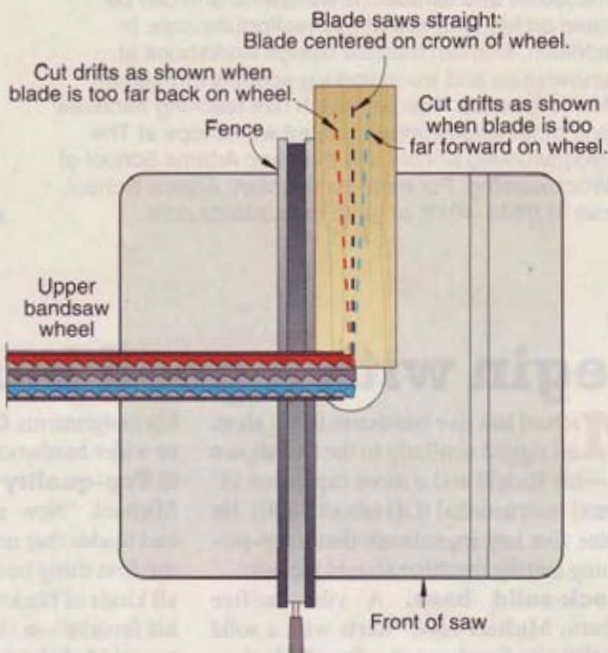

■ **Apply the right blade tensioning.** Michael applies just enough tension to allow him to deflect the blade $\frac{1}{4}$ " with finger pressure as shown. "When tensioning the blade, I get better results by adjusting it lower than the settings marked on the saw," he says. "For a $\frac{1}{2}$ " blade, for instance, I adjust the tension to the $\frac{3}{8}$ " setting." After sawing, Michael releases the blade tension to avoid creating a tire-damaging track and forming a bend in the blade that could stress the weld over time.



■ **Use a wheel brush for a clean sweep.** Too much sawdust buildup on the wheel could move the blade off the crown, affecting cut quality. A simple brush located on the lower wheel keeps sawdust from compacting on the tire. On one bandsaw in Michael's

shop, he fastened a small piece of wooden push broom inside the lower housing, letting the stiff bristles do the dirty work. Another option: Purchase a wheel brush from Rockler, no. 28299, \$5.99 plus shipping. (Call 800/279-4441, or visit rockler.com.)



■ **Set low-tolerance guide blocks.**

The ideal setting for guide blocks, according to Michael, removes any side-to-side play in the blade without rubbing constantly on it. "I fold a thin piece of tracing paper that measures $\frac{1}{1000}$ " thick around the back edge of the blade to establish the needed clearance," he advises. "Too much play could let the blade twist and score the blocks when cutting tight curves."



■ **Adjust the thrust bearing.**

Michael slips a 6" metal rule that measures $\frac{1}{32}$ " thick between the back edge of the blade and the thrust bearing, as shown at right, to establish proper clearance. He then locks the setting in place with a few turns on the hexhead with a wrench. Make the same adjustment below the saw table. Spin the wheel by hand and do a visual check to ensure the correct clearance is established at both locations.



■ **Trick the table and true the fence.**

Michael offers a neat trick that simplifies leveling the table. First, he reverses the 0° table stop bolt underneath the table, threading it from the bottom up instead of the typical top down. He then bores a $\frac{3}{16}$ "-diameter hole 1" deep in a $\frac{1}{2}$ " length of $\frac{1}{2}$ " brass or aluminum rod, and sands the solid end flat. Next, he slips this "cap" over the bolt's threaded end, as shown at right, and adjusts the now easily accessible locking nut and bolt head, far right, until the square shows the blade at 90° to the table. This lets him tilt the table to the left by removing the cap, and return it to 90° by adding the cap.

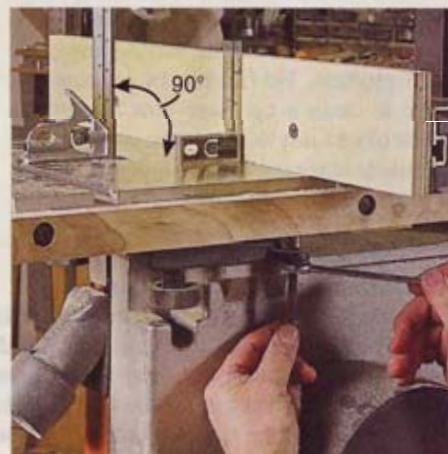
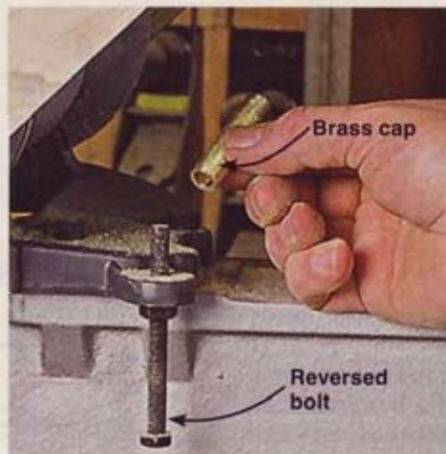

■ **A good fence = good cuts.**

Michael always keeps an auxiliary wood fence attached to his bandsaw's metal fence. Why? So the blade doesn't abrade the metal fence, to support wider stock when resawing, and because it is so much faster to square an auxiliary fence to the table. To adjust the wood fence, Michael simply removes it and adheres one or more lengths of masking tape along either the bottom or top edge of the saw's metal fence, as shown below.

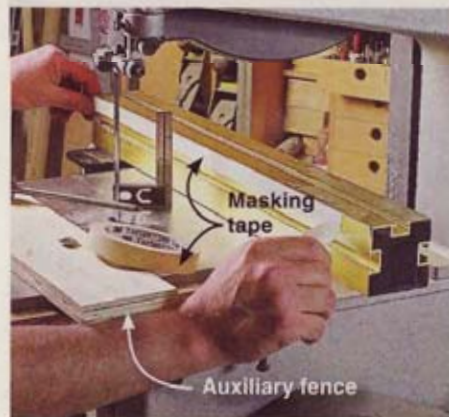

■ **Tighten your belt.**

Here's another idea for some bandsaw models. To ensure a well-tensioned belt between the motor and saw, Michael loosens the bolts holding the motor down, and then drives opposing wedges between the motor and saw base, as shown below. With the slack removed, he retightens the motor's bolts. This results in a belt that delivers maximum power and doesn't slip. Note also the 1"-thick plywood added to the steel base to reduce vibration.

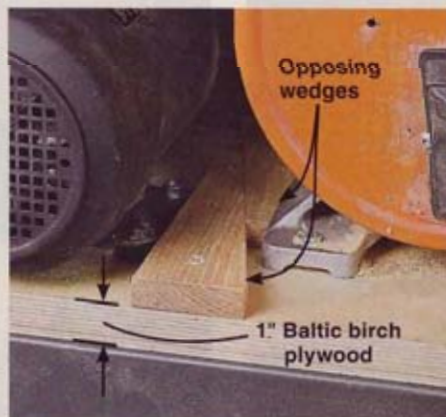

■ **Keep tools within easy reach.**

Michael likes his tools close at hand. For quick adjustments, he employs a pair of rare-earth magnets to hold a wrench to the upper wheel metal housing. (From Rockler: $\frac{1}{8}$ "-thick magnets, $\frac{1}{2}$ " diam., no. 30810, \$6.69 for 10, plus shipping; call 800/279-4441, or visit rockler.com.)

A hole in his pushstick keeps it hanging at arm's reach on the upper housing knob, where shown below.



4 common bandsaw cuts made easy

With your bandsaw tuned up and ready for action, follow Michael's lead and try these basic cuts. They tune up your sawing skills as well.

1 Right-on rip cuts

Michael prepares a length of rough-cut lumber by ripping it to size on his bandsaw. "I haven't used a tablesaw to rip boards to width for at least 30 years. I do it all on the bandsaw," he says. "It's more efficient because it creates less waste while using less energy." He first freehand cuts one rough-sawn edge working closely along a marked outline. He then joints that edge.

Next, he places the jointed edge against the fence and trims off the remaining rough edge, as shown *near right*. The cut remains true for the entire length, barring any blade drift problem. He finishes by jointing this edge to clean it up. Note how he sets the guide blocks just $\frac{1}{4}$ " above the workpiece to eliminate blade movement from side to side, and to maximize control.

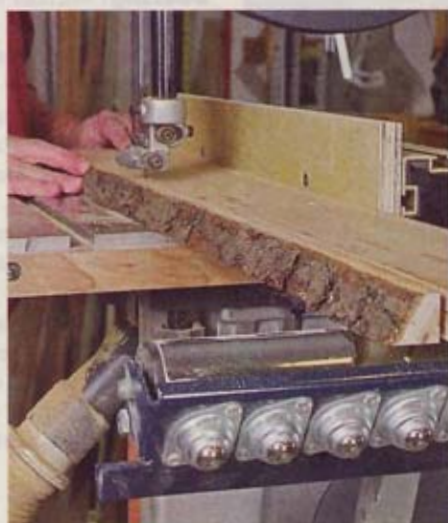

"I haven't used a tablesaw to rip boards to width for at least 30 years."

2 Straight-up resawing

With his saw set up as described earlier, Michael can resaw with perfection, using the most inexpensive bandsaw in his shop, as shown *below* and on *page 52*. Here, he switches to a taller auxiliary fence to provide full support as he moves the blade through the workpiece. He keeps his pushstick handy to safely complete the cut.



3 Cut curves with confidence

For curves or freehand cutting, Michael starts the saw blade just $\frac{1}{32}$ " to $\frac{1}{64}$ " outside the cutline, maintaining that distance throughout. (If your cut requires turning a sharp radius, be sure you use the correct blade width, as shown in the drawing at *right*.) For best control, the trick lies in applying side pressure on the workpiece and blade from the concave side of the cutline, where indicated by the arrows in the photo *below*. Later, Michael staples a strip of sandpaper to the curved cutoff and uses it to sand the curved edge on the workpiece, as shown *below right*.

CHOOSING THE RIGHT BLADE FOR CUTTING CURVES

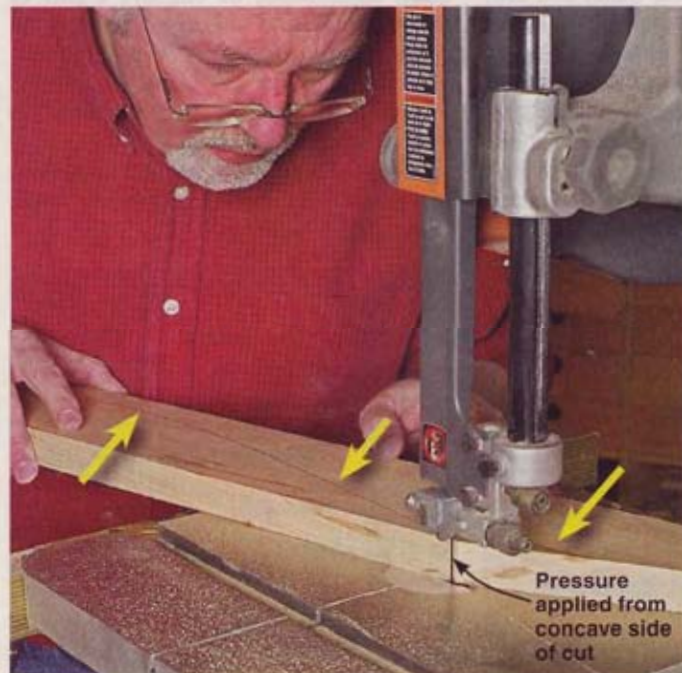
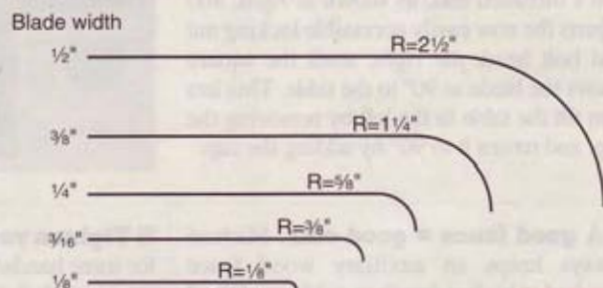

4 Jig up to cut in the round

Michael's circle-cutting jig consists of a piece of $\frac{1}{2}$ " plywood with a dovetailed key glued into a centered dado. Into the dovetailed slot slides a matching dovetailed key with a dowel pivot pin at one end as shown in the drawing below.

To use the jig, determine the radius of the circle you want. Then, with the jig clamped to the bandsaw table, move the dovetail key until the distance between the right-hand tooth of the blade and the center of the pivot pin equals that radius. Clamp a stopblock on the key at the end of the dovetail slot, as shown at right. Drill a $\frac{1}{4}$ " hole centered on the underside of the workpiece. Slide the key back, and fit the workpiece onto the pivot pin. Turn on the saw, and slide the dovetail key and workpiece toward the blade. Rotate the workpiece clockwise into the blade, applying slight side and forward pressure until the stopblock abuts the end of the dovetail slot. At this point you will begin cutting a perfectly round circle, with the side and forward pressure keeping the dovetail key in place for the duration of the cut.



Written by Jim Harrold
Illustrations: Roxanne LeMoine; Lorna Johnson

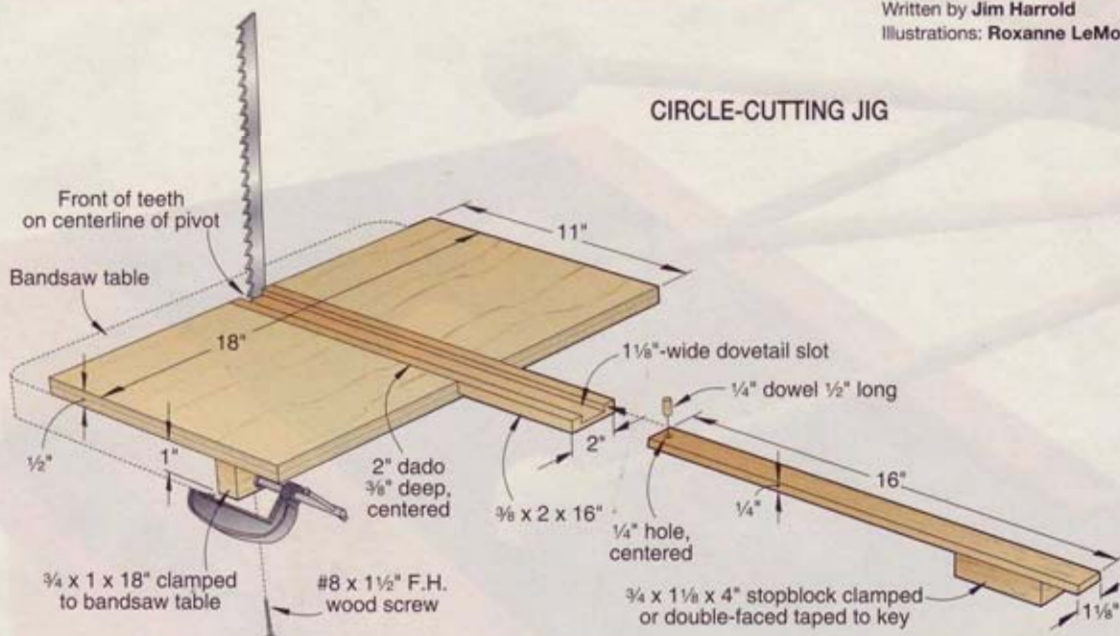

CIRCLE-CUTTING JIG

Simple but effective shop-made T-fence

Many times the new (or used) bandsaw you buy does not come with a fence. That was the case with this small benchtop model in Michael's shop. The solution: Make a simple T-fence using two pieces of straight plywood scrap. (Here, Michael used Baltic birch plywood.) He saws $\frac{1}{16}$ " kerfs into the ends of the edge guide to quickly clamp the T-fence to the table using a pair of spring clamps. Then he glues and screws the two pieces together at a right angle to form the T.

To use the T-fence, just locate it the needed distance from the blade. Remove one jaw cover from each clamp, and slip the uncovered jaws into the kerfs when securing the fence to the front edge of the saw table, as shown at right.

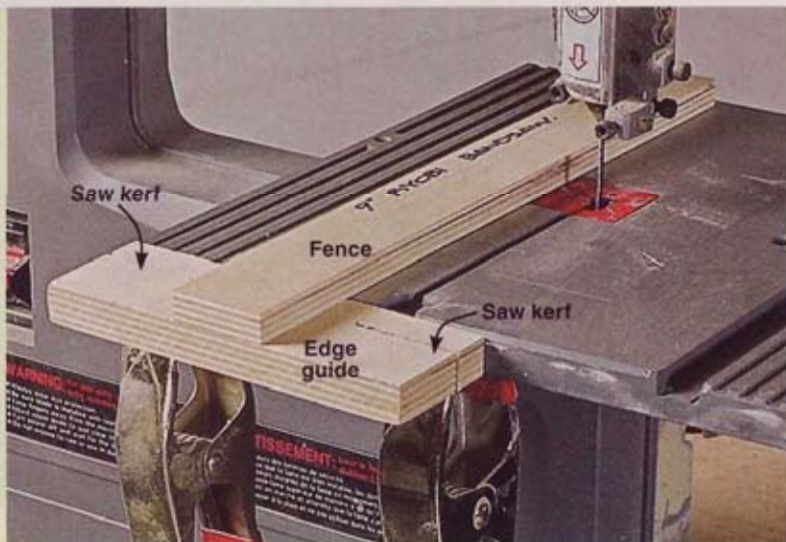

tones-of-fun tongue drum

Make beautiful sounds by striking the slitted top of this six-note, easy-to-build instrument.

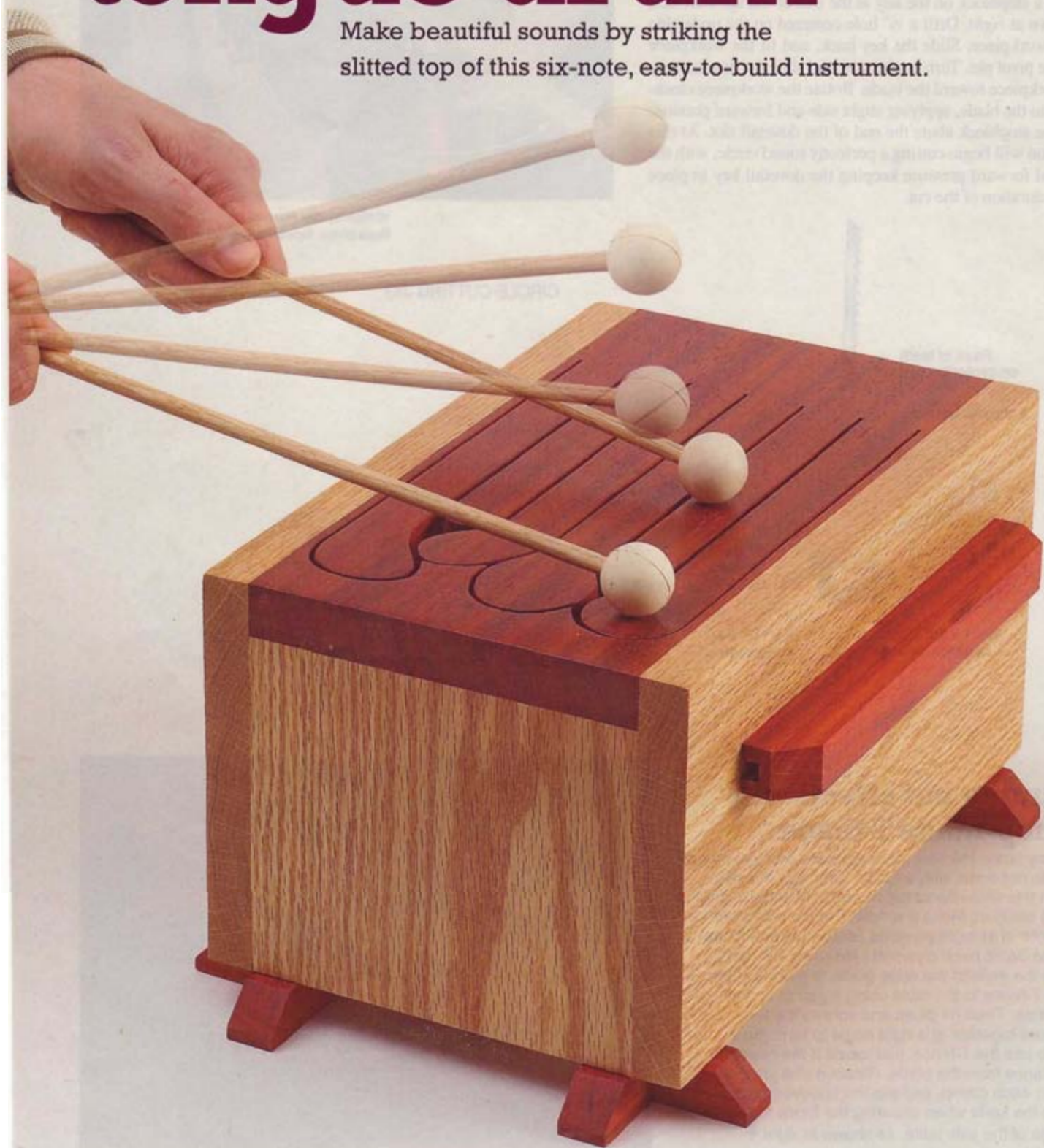

In a few hours and using just a tablesaw, jigsaw, and drill press, you can build this modern version of an ancient instrument. The project—designed by craftsman and musician Steve Roberts of Chico, California—uses simple butt joinery and assembles with glue only. The tone quality of each drum is unique. See the sidebar, “About tongue drums,” page 61, to learn more about them, and go to tonguedrum.com to hear what one sounds like and see video clips.

Start with the drum parts

1 From a $\frac{3}{4}$ "-thick hardwood free of knots, cracks, and checking, cut the top (A) to the size listed in the **Materials List**. (We used padauk and red oak for the project. Other suitable woods are purpleheart, mahogany, rosewood, birch, and maple. If you wish, you can make all of the drum parts from one type of wood.)



A DRILL START HOLES IN THE TOP

With the top (A) on a backer board to prevent tear-out, drill two $\frac{3}{8}$ " start holes for your jigsaw through the top, where shown on the pattern.

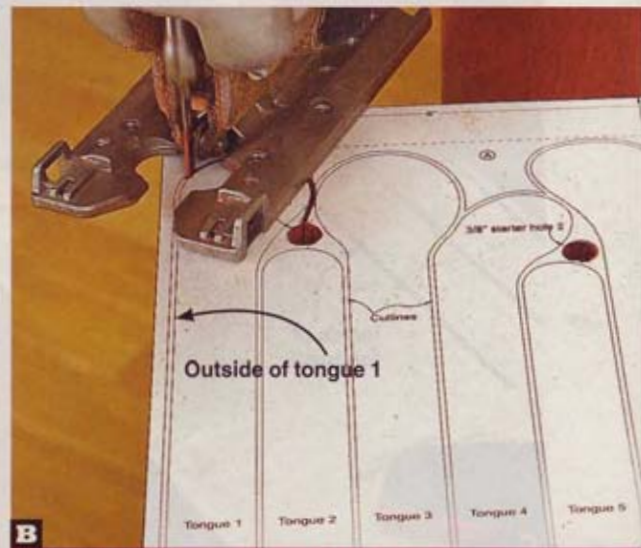

B JIGSAW TONGUE 1 TO SHAPE

From start hole 1, jigsaw along the round end and outside of tongue 1. Then, from the round end, cut along the inside of the tongue.

2 Photocopy the full-size top pattern from the *WOOD PATTERNS*® insert. Spray-adhere the pattern to the top. Using a twist bit in your drill press or portable drill, drill two $\frac{3}{8}$ " start holes for your jigsaw through the top, where shown on the pattern and as shown in **Photo A**.

3 To form the tongues in the top, fit your jigsaw with a blade that has 20 teeth per inch for a smooth curve cut. Beginning at start hole #1 and following the pattern lines, cut around tongue 1, as shown in **Photo B**. Then cut around tongues 2 and 3, as shown

1 EXPLODED VIEW

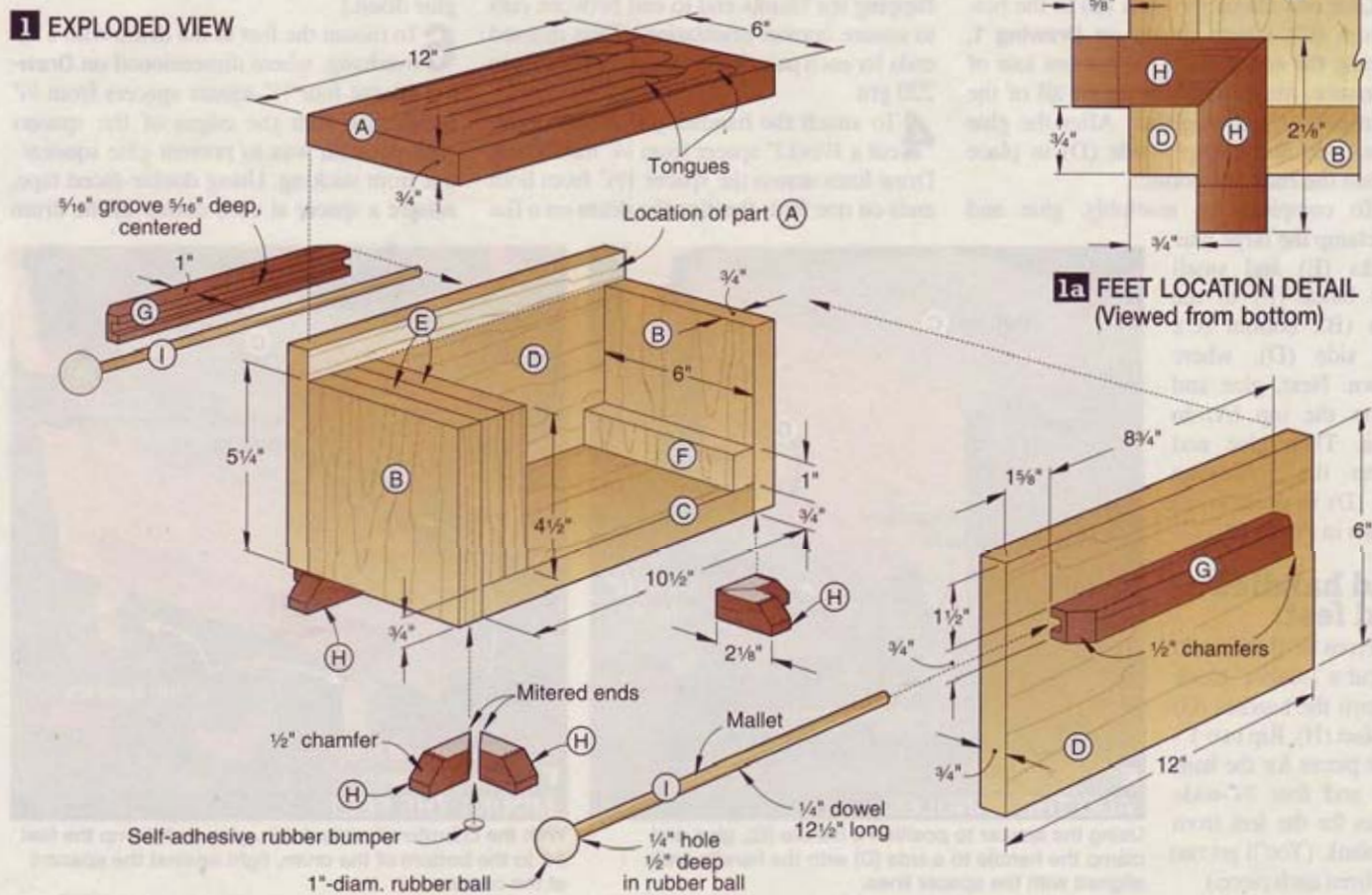

1a FEET LOCATION DETAIL (Viewed from bottom)

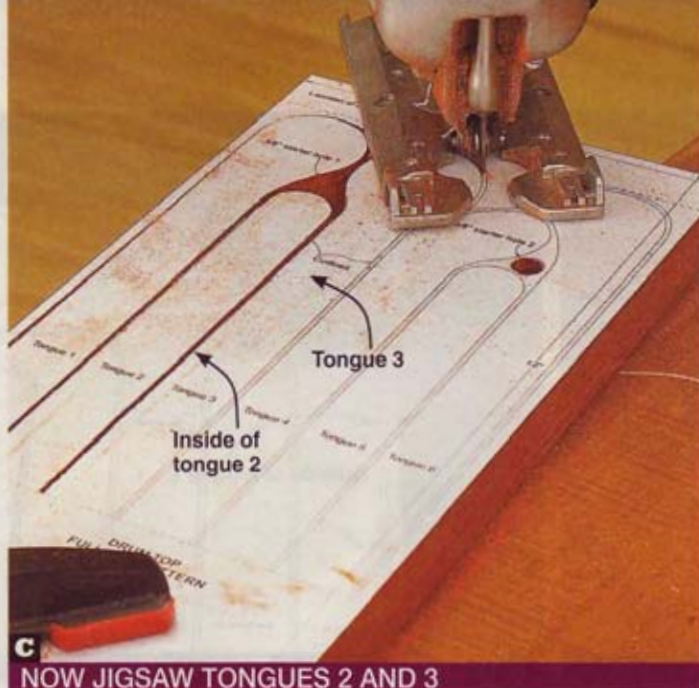

C NOW JIGSAW TONGUES 2 AND 3

After jigsawing tongue 1 to shape, cut around the top and along the inside of tongue 2. Then cut around tongue 3.

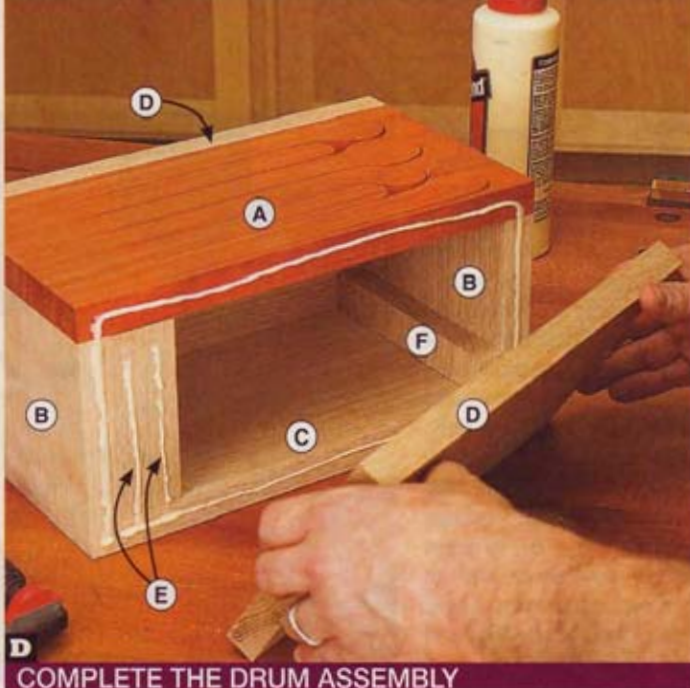

D COMPLETE THE DRUM ASSEMBLY

Apply glue to the exposed edges of the drum, and clamp the remaining side (D) in place to complete the assembly.

in Photo C. Now switch to start hole #2, and cut tongues 6, 5, and 4 in the same way.

4 From $\frac{3}{4}$ "-thick, defect-free stock, cut the ends (B), bottom (C), sides (D), large glue blocks (E), and small glue block (F) to the sizes listed.

Now assemble the drum

1 Glue and clamp the ends (B) to the bottom (C), where shown on Drawing 1, keeping the edges flush. To prevent loss of resonance, make sure you clamp all of the drum parts tightly together. After the glue dries, glue and clamp a side (D) in place against the ends and bottom.

2 To complete the assembly, glue and clamp the large glue blocks (E) and small glue block (F) to the ends (B), bottom (C), and side (D), where shown. Next, glue and clamp the top (A) in place. Then glue and clamp the remaining side (D) in position, as shown in Photo D.

Add handles and feet

1 From $\frac{3}{4}$ "-thick stock, cut a $7\frac{1}{4} \times 8\frac{3}{4}$ " blank to form the handles (G) and feet (H). Rip two 1"-wide pieces for the handles and four $\frac{3}{4}$ "-wide pieces for the feet from the blank. (You'll get two feet from each piece.)

2 Cut a $\frac{5}{16}$ " groove $\frac{3}{16}$ " deep, centered, along an edge of each handle (G), where shown on Drawing 1, to receive the mallet handles (I) for storage.

3 Miter-cut a $\frac{1}{2}$ " chamfer on each end of the handles (G) and the four blanks for the feet (H), where shown. Then miter-cut a $2\frac{1}{8}$ "-long foot from each end of the blanks, flipping the blanks end to end between cuts to ensure correct orientation of the mitered ends for each pair of feet. Sand the handles to 220 grit.

4 To attach the handles (G) to the drum, cut a $1\frac{1}{2} \times 12$ " spacer from $\frac{1}{4}$ " hardboard. Draw lines across the spacer $1\frac{5}{8}$ " from both ends on one face. Position the drum on a flat

surface with the bottom (C) up. Using the spacer, glue and clamp a handle to a side (D), as shown in Photo E. Repeat to glue the remaining handle to the other side.

5 Glue together four pairs of feet (H) in the configuration shown on Drawing 1. (We wrapped masking tape around each pair of feet to keep the mitered corner tight until the glue dried.)

6 To mount the feet to the drum with a $\frac{5}{8}$ " overhang, where dimensioned on Drawing 1a, cut four $\frac{3}{4}$ "-square spacers from $\frac{1}{4}$ " hardboard. Rub the edges of the spacers with paraffin wax to prevent glue squeeze-out from sticking. Using double-faced tape, adhere a spacer at each corner of the drum

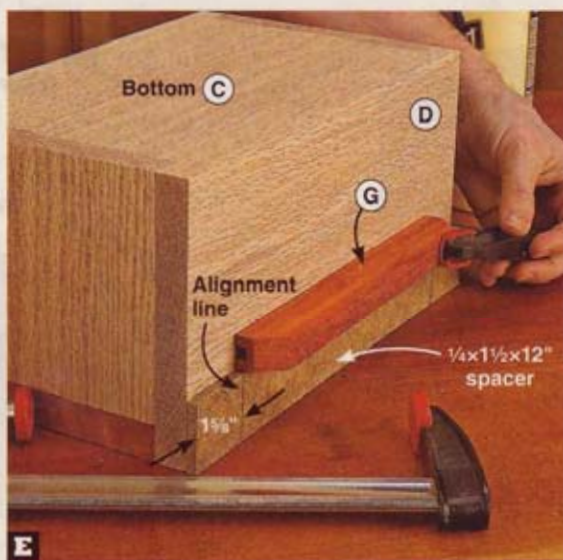

E ADD THE HANDLES

Using the spacer to position a handle (G), glue and clamp the handle to a side (D) with the handle ends aligned with the spacer lines.

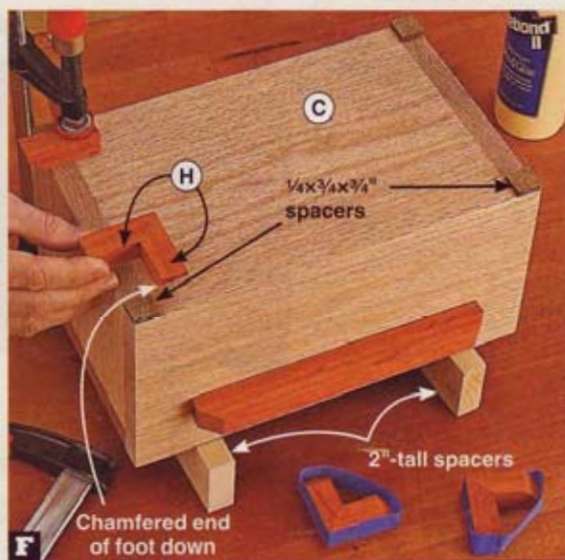

F MOUNT THE FEET

With the chamfered ends down, glue and clamp the feet (H) to the bottom of the drum, tight against the spacers at the corners.

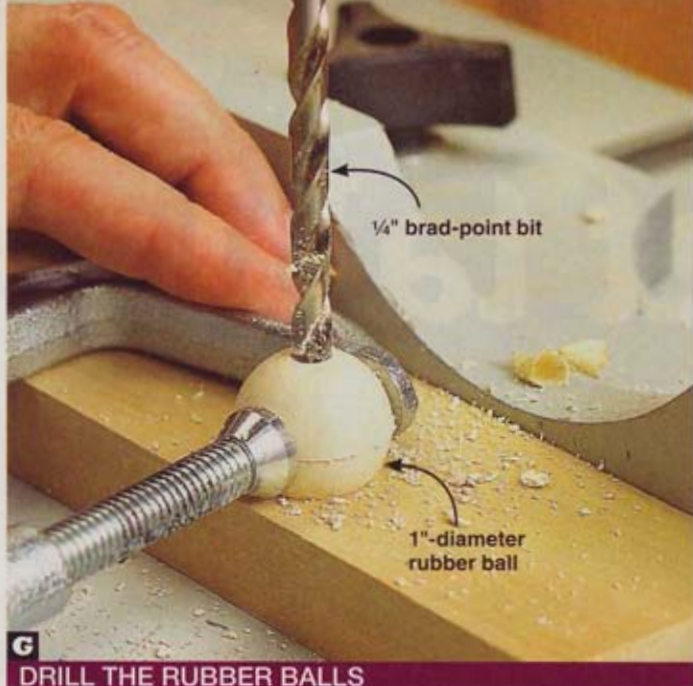

G DRILL THE RUBBER BALLS

With each rubber ball positioned in a 3/4" hole in scrap and held with a clamp, drill a 1/4" hole 1/2" deep in the ball.

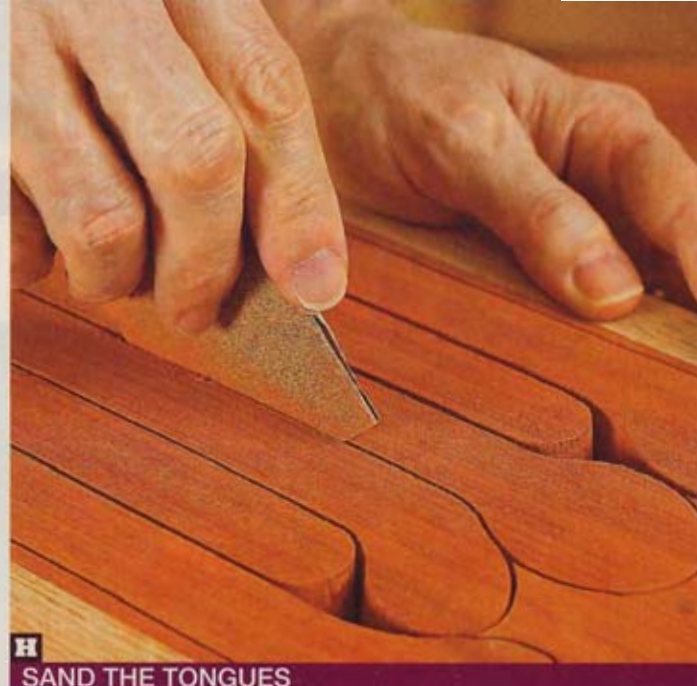

H SAND THE TONGUES

Using sandpaper folded into thirds, sand the kerfs and openings between the tongues, progressing from 120 to 150 and 180 grit.

on the bottom, flush with the edges. Sand the feet smooth. Then, with the drum placed on 2"-tall spacers to provide clamp clearance, glue the feet to the drum, as shown in Photo F.

Time for the mallets

1 From a 1/4"-diameter oak dowel 36" long, cut two 12 1/2"-long pieces for the mallet handles (I).

2 To drill centered holes in 1"-diameter rubber balls for mounting on the ends of the mallet handles (I), where shown on Drawing 1, chuck a 3/4" Forstner bit in your drill press. Clamp a piece of 3/4" scrap to the table, and bore a hole through the scrap to position each ball for drilling. Reclamp with a 1/4" brad-point bit. Then, holding each ball in the 3/4" hole, drill a 1/2"-deep hole in the ball, as shown in Photo G. Use medium-hard rubber balls, such as SuperBalls®, available at your

local toy, hobby, or crafts supply store. Now glue the balls to the mallet handles with rubber cement.

Finish up

1 Scrape off any glue squeeze-out. Then finish-sand the drum to 220 grit, removing any sharp edges.

2 To remove splinters that can inhibit free movement of the tongues and to create clean edges for the best appearance, sand the saw kerfs and openings between the tongues, as shown in Photo H.

3 Finally, remove the dust. Then apply three coats of a clear finish. (We applied satin polyurethane, sanding to 220 grit between coats.) To prevent slippage of the drum and adjacent surfaces from vibrating, install self-adhesive rubber bumpers on the feet (H), where shown on Drawing 1. Now grab your mallets, and check out the drum's amazing sounds. ♣

Cutting Diagram

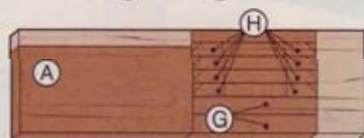

3/4 x 7 1/4 x 24" Padauk (1.3 bd. ft.)

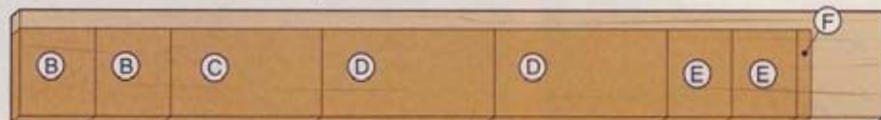

3/4 x 7 1/4 x 60" Oak (3.3 bd. ft.)

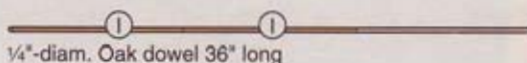

1/4"-diam. Oak dowel 36" long

Written by Owen Duvall
Project design: Steve Roberts
Illustrations: Roxanne LeMoine; Lorna Johnson

About tongue drums

Tongue drums—also known as slit, log, and xylo drums—have been used in African, Asian, and North and South American cultures for hundreds of years for communication, ceremonial, and other purposes. Though originally made from a hollowed-out log with a narrow opening (slit) in the top or side, modern tongue drums consist of a wood enclosure with a slitted top, typically having from 4 to 14 tongues. When struck, a tongue vibrates, and the tone that's produced resonates in the enclosure. The tone quality and frequency depend on the length, width, and thickness of the tongue, the density of the wood, and the size of the enclosure.

Materials List

Part	FINISHED SIZE			Matl.	Qty.
	T	W	L		
A top	3/4"	6"	12"	P	1
B ends	3/4"	6"	5 1/4"	O	2
C bottom	3/4"	6"	10 1/2"	O	1
D sides	3/4"	6"	12"	O	2
E large glue blocks	3/4"	6"	4 1/2"	O	2
F small glue block	3/4"	6"	1"	O	1
*G handles	3/4"	1"	8 3/4"	P	2
*H feet	3/4"	3/4"	2 1/8"	P	8
I mallet handles	1/4"-diam.	12 1/2"	OD	Oak	2

*Parts initially cut oversize. See the instructions.

Materials key: P—padauk, O—red oak, OD—oak dowel.

Supplies: Spray adhesive; double-faced tape; paraffin wax; 1"-diameter medium-hard rubber balls (2), available at toy, hobby, and crafts supply stores; rubber cement; self-adhesive rubber bumpers (4).

Blades and bits: Jigsaw blade with 20 teeth per inch, dado-blade set, 3/4" Forstner and 1/4" brad-point bits.

A wooden bowfront table with a dark wood top and light wood body, holding a candle holder and a vase of roses.

simply graceful

bowfront table

A classic design combined with simple construction methods equals a project you can complete in minimum time for maximum compliments.

AT A GLANCE

■ Overall dimensions are $35\frac{3}{4}$ " wide \times $12\frac{7}{8}$ " deep \times $32\frac{3}{4}$ " high.

■ For the board feet of lumber and other items needed to build this project, see *page 66*.

The delicately curved legs and elliptical shape of this table make it a real attention-grabber. And the wall-hugging design fits easily into any entry or hallway. Build it and you'll learn how easy it is to make the curved and tapered legs and kerf-bent plywood aprons. You'll also discover how to lay out an ellipse of any size.

Start with the legs

From $1\frac{3}{4}$ " stock, cut three 3×32 " blanks for the legs (A), and plane them to $1\frac{1}{2}$ " thick. (We used maple.) You also can laminate the leg blanks from $\frac{3}{4}$ " stock. To form the legs, see *page 68*.

Build the table body

For the body panels (B), cut a $\frac{3}{4}\times 24\times 32$ " plywood blank. Then cut the short ribs (C),

1 LEG SPACERS

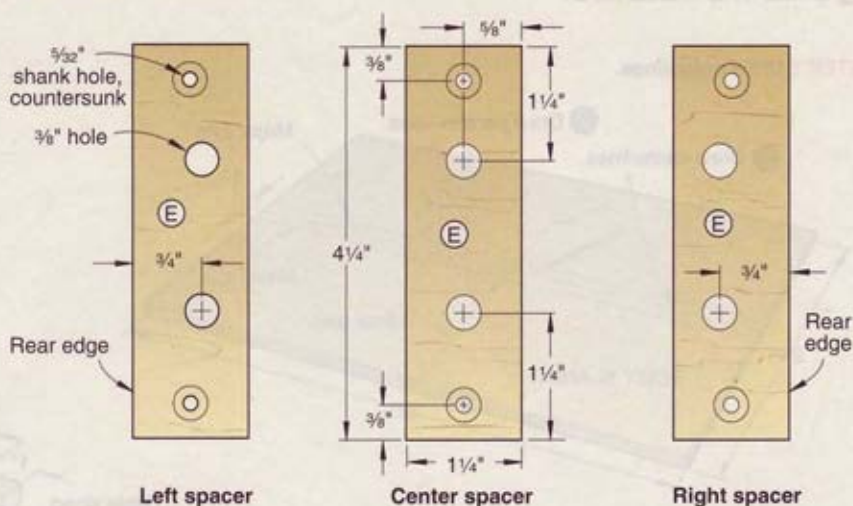

long ribs (D), and leg spacers (E) to the sizes listed on the **Materials List** on *page 66*. Drill $\frac{3}{32}$ " countersunk shank holes and $\frac{3}{8}$ " holes in the leg spacers, where dimensioned on **Drawing 1**. Make sure the right and left spacers are mirror images with the $\frac{3}{8}$ " holes

offset from center, as shown. Mark the rear edges of these two spacers. Now lay out, cut, sand, and drill the body panels, and assemble the body, as shown in **Steps 1–8** of **Drawing 2**. To lay out an ellipse of any size, see the **Shop Tip** below.

SHOP TIP

Draw ellipses the easy way, one-quarter at a time

Here's how to draw an ellipse of any size, using a scrap of wood, a pencil, two nails, and a framing square (or a piece of plywood with a square corner).

Lay out the major axis and minor axis of the ellipse on the workpiece, where shown *below*. Then to make an ellipse trammel, cut a $\frac{1}{2}\times\frac{3}{4}$ " scrapwood strip to the length indicated at *bottom*. Mark a hole center for a pencil and points A and B for two nails, where shown. Drill a snug hole for the pencil, and drive the nails through the strip. File or grind away the points

of the nails. Next align the outside edges of a framing square with the major and minor axes drawn on the workpiece, and secure it with double-faced tape. Place nail A at the corner of the square and nail B against the edge of the square aligned with the major axis. Now rotate the trammel, moving nail A along the edge of the square aligned with the minor axis and nail B along the edge aligned with the major axis, and draw the ellipse in quarters, as shown *below*. To see a video clip of how to draw an ellipse, go to woodmagazine.com/ellipse.

ELLIPSE LAYOUT

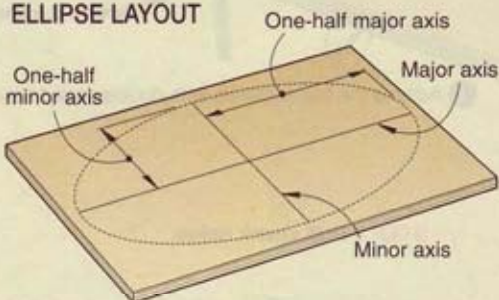

ELLIPSE TRAMMEL

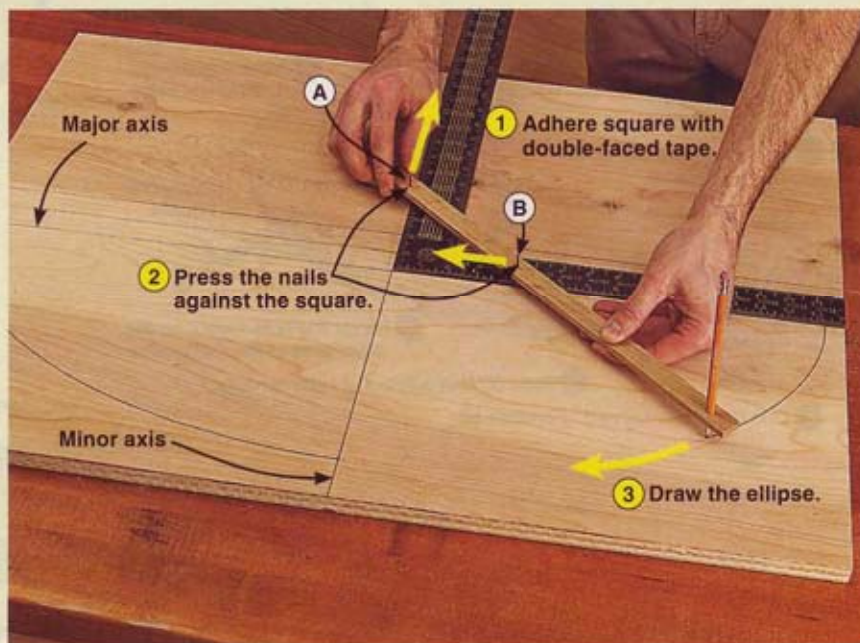
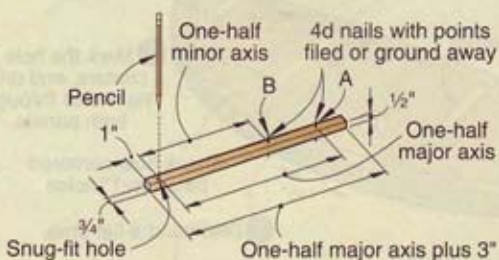

2 BUILD THE TABLE BODY

STEP 1 Draw guidelines.

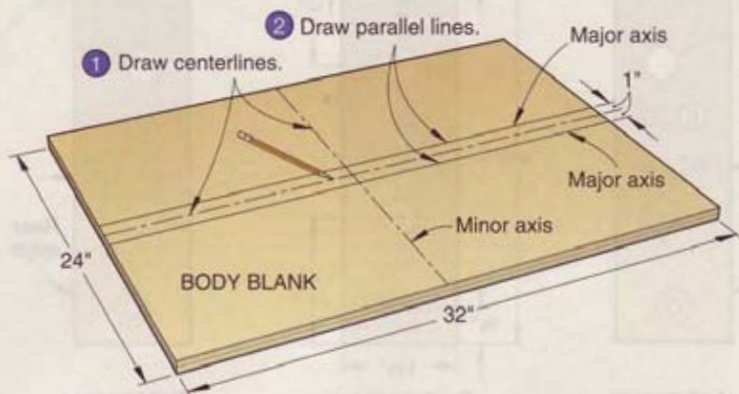

STEP 2 Make an ellipse trammel.

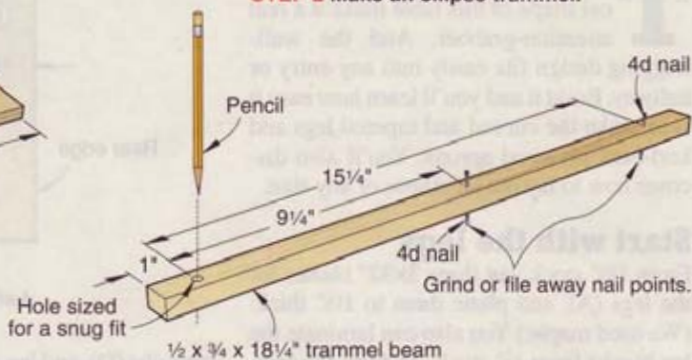

STEP 3 Lay out a half ellipse.

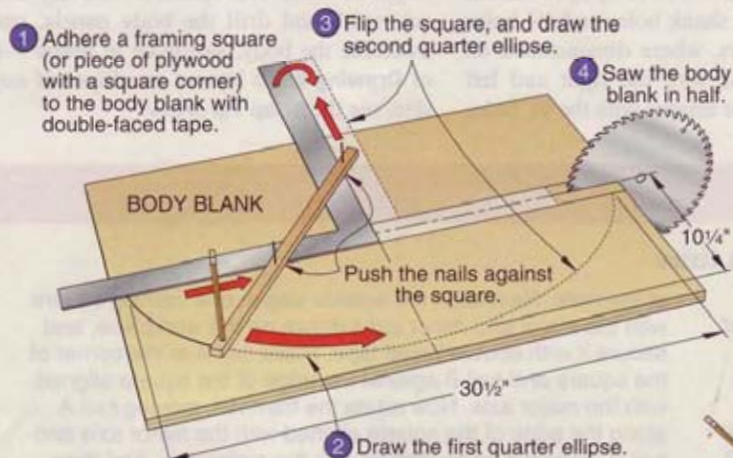

STEP 4 Bandsaw the body panels.

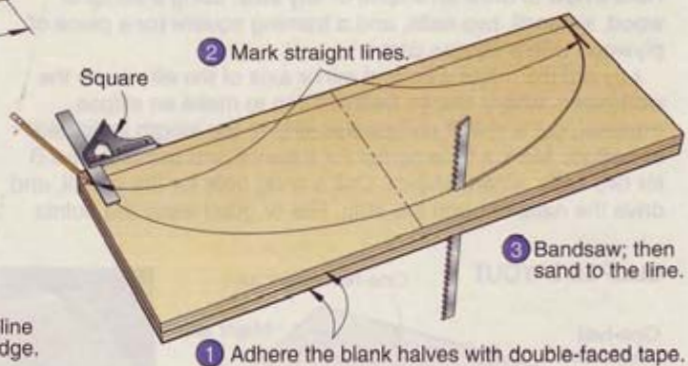

STEP 5 Lay out and drill clamp head holes.

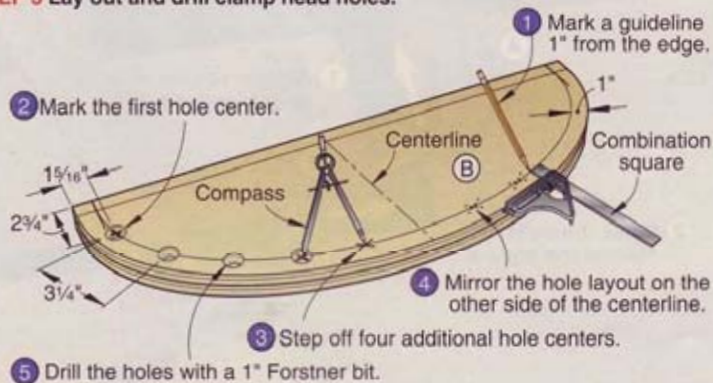

STEP 6 Drill shank holes.

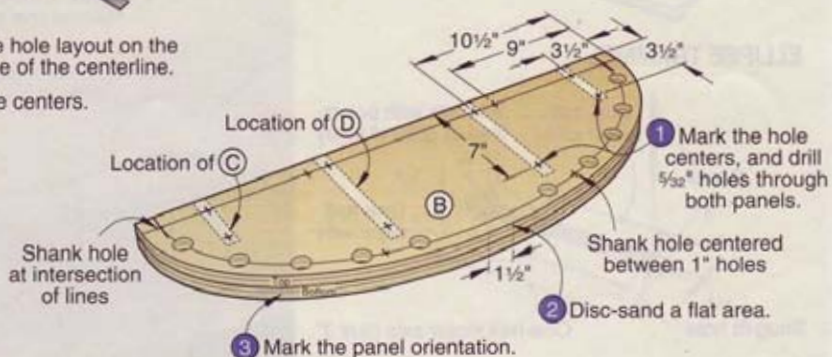

STEP 7 Countersink the shank holes, and drill screw-access holes.

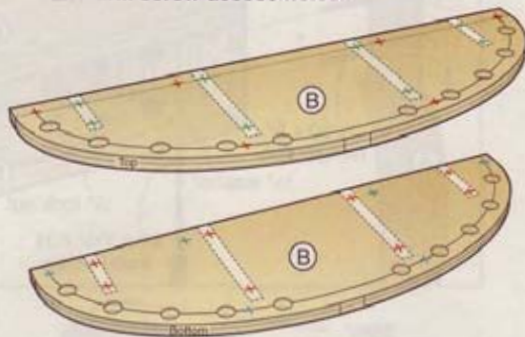

GREEN: Countersink on top face.
RED: Countersink on bottom face.
BLUE: Enlarge hole to 1/2" for screw access.

STEP 8 Assemble the body.

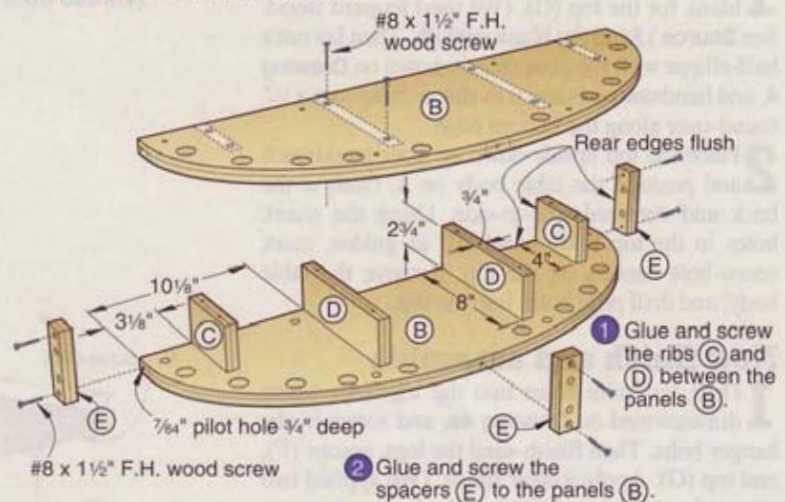

1 Glue and screw the ribs (C) and (D) between the panels (B).

2 Glue and screw the spacers (E) to the panels (B).

Add the kerf-bent aprons

1 For the aprons (F), cut a 3/4x4 1/4x40" plywood blank. Then, for a tight fit against the right and left leg spacers (E), cut 10° bevels on each end, where shown on **Drawing 3**. Now, measuring from the beveled ends, cut the two aprons to finished length. To maintain continuous grain orientation when attaching the aprons to the table body, mark the top edge of each apron.

Note: Although a kerfed maple board conforms to the broad front curve of the table, it is too stiff to bend around the tight curves at the ends. Because birch plywood becomes very flexible when kerfed, and closely matches the color and grain of the maple legs, we chose it for the table aprons.

2 To make a simple jig for kerfing the aprons (F) on your tablesaw, see page 32. Then adjust the cutting depth so the saw blade just begins to cut into the crossband directly under the face veneer. (Depending

3 APRONS (Top view)

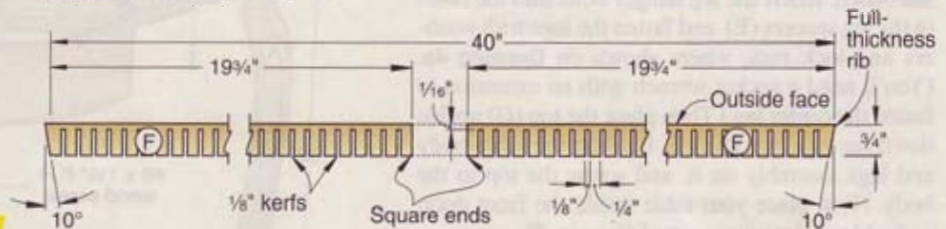

on the number of plies in your plywood, you'll cut within 1/16-1/8" of the outside face of the plywood aprons.) Now, starting at the square-cut end of each apron, cut 1/4"-spaced saw kerfs. Be sure to leave a full-thickness plywood rib at each beveled end.

3 Cut three 3/4x4 1/4x2" scrap plywood cleats, and drill a centered 3/32" countersunk hole in each one. Screw the cleats to the leg spacers (E), as shown in **Photo A**.

Then test-fit the aprons (F), as shown in **Photo B**. Leave no more than a 1/16" gap at each end between the aprons and leg spacers. To ensure uniform clamp pressure, rip four 1/8x3/4x19" hardwood strips and dry-clamp the aprons to the body, as shown in **Photo C**. When you are satisfied with the fit, apply glue to the edges of the body panels (B), and clamp the aprons in place. With the glue dry, remove the clamps and cleats.

GLUE THE APRONS TO THE BODY



A With the cleat overhanging the leg spacer (E), drill a pilot hole into the spacer and screw the cleat in place.

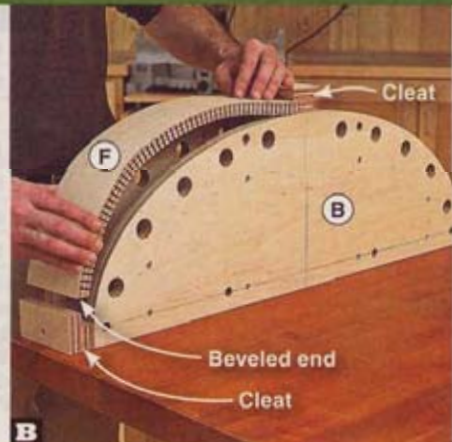

B Orienting the beveled end of the apron (F) as shown, tuck the ends under the overhanging edges of the cleats.



C Using hardwood strips to distribute clamp pressure and working from the center to the ends, clamp the aprons (F) in place.

Make the top

1 Edge-join $\frac{3}{4}$ "-thick stock to make an oversize blank for the top (G). (We used leopard wood. See **Source**.) Sand the blank smooth. Then lay out a half-ellipse with the dimensions shown on **Drawing 4**, and bandsaw and sand it to shape. Now rout a $\frac{1}{4}$ " round-over along the bottom edge.

2 Place the top upside down on your workbench and position the table body on it, flush at the back and centered side-to-side. Using the shank holes in the top body panel (B) as guides, mark screw-hole centers on the top. Remove the table body, and drill pilot holes into the top.

Now finish and assemble

1 Drill $\frac{3}{16}$ " pilot holes into the legs (A), where dimensioned on **Drawing 4a**, and screw in the hanger bolts. Then finish-sand the legs, aprons (F), and top (G). Apply a clear finish. (We applied two coats of satin polyurethane to the legs and aprons and three coats to the top, lightly sanding with 220-grit sandpaper between coats.)

2 Place the table body upside down on your workbench. Insert the leg hanger bolts into the holes in the leg spacers (E) and fasten the legs with washers and lock nuts, where shown on **Drawing 4a**. (You'll need a socket wrench with an extension to fasten the center leg.) Then place the top (G) upside down on your workbench. Position the table body and legs assembly on it, and screw the top to the body. Now, place your table inside the front door, and add a welcoming vase of flowers. 🌸

Written by **Jan Svec** with **Kevin Boyle**

Project design: **Jeff Mertz**

Illustrations: **Roxanne LeMoine**; **Lorna Johnson**

Cutting Diagram



$1\frac{1}{4}$ x $3\frac{1}{2}$ x 72" Maple (4 bd. ft.)

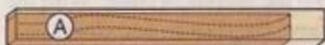

$1\frac{1}{4}$ x $3\frac{1}{2}$ x 48" Maple (2.7 bd. ft.)



$\frac{3}{4}$ x $5\frac{1}{2}$ x 48" Leopard wood (2 bd. ft.)

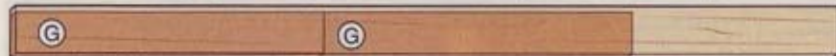

$\frac{3}{4}$ x $5\frac{1}{2}$ x 96" Leopard wood (4 bd. ft.)

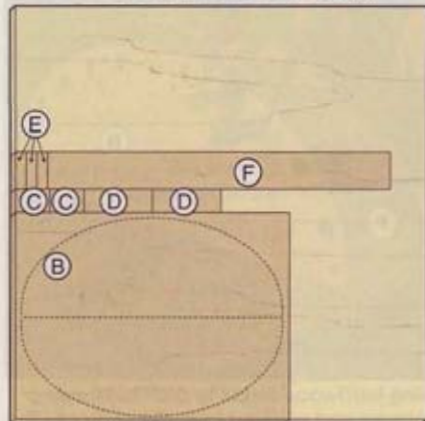

$\frac{3}{4}$ x 48 x 48" Birch plywood

4a LEG AND TABLETOP MOUNTING DETAIL (Viewed from back)

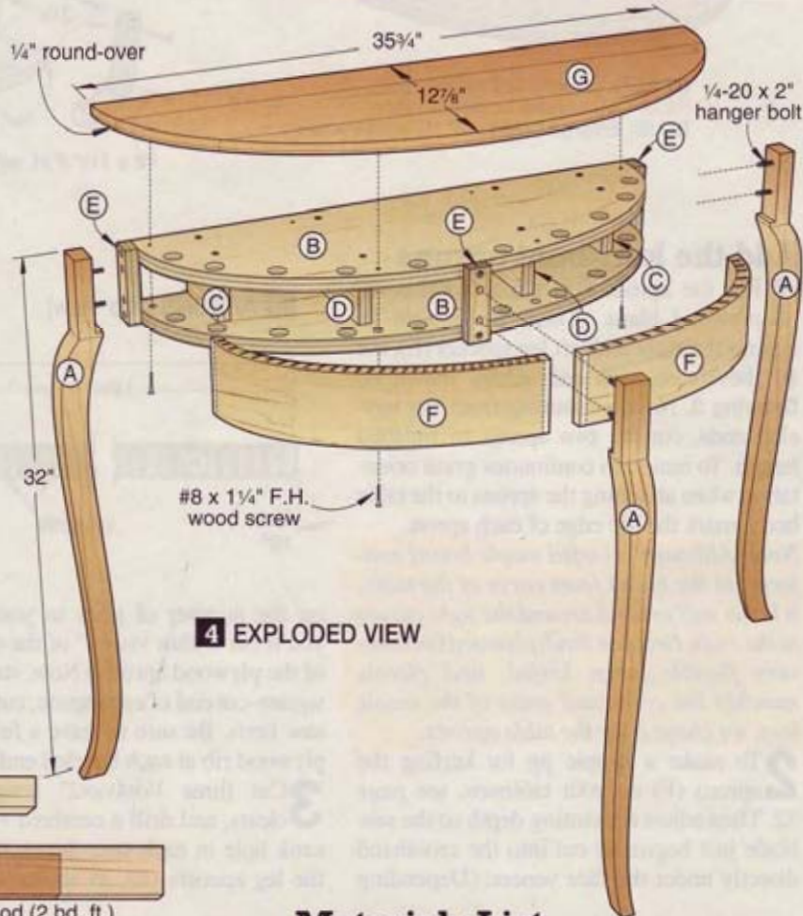
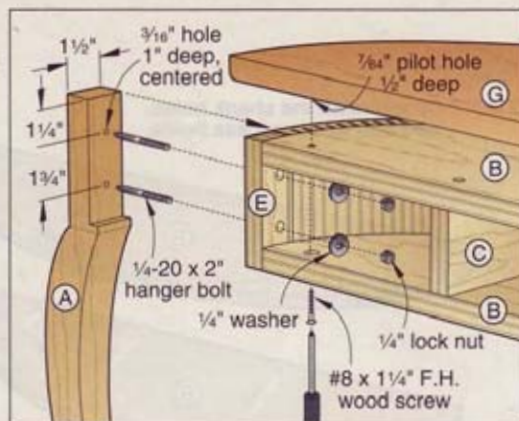

4 EXPLODED VIEW

Materials List

Part	FINISHED SIZE			Matl.	Qty.
	T	W	L		
A* legs	$1\frac{1}{2}$ "	$2\frac{1}{2}$ "	32"	M	3
B* body panels	$\frac{3}{4}$ "	$10\frac{1}{4}$ "	$30\frac{1}{2}$ "	BP	2
C short ribs	$\frac{3}{4}$ "	$2\frac{3}{4}$ "	4"	BP	2
D long ribs	$\frac{3}{4}$ "	$2\frac{3}{4}$ "	8"	BP	2
E leg spacers	$\frac{3}{4}$ "	$4\frac{1}{4}$ "	$1\frac{1}{4}$ "	BP	3
F* aprons	$\frac{3}{4}$ "	$4\frac{1}{4}$ "	$19\frac{1}{4}$ "	BP	2
G* top	$\frac{3}{4}$ "	$12\frac{7}{8}$ "	$35\frac{3}{4}$ "	EL	1

*Parts initially cut oversize. See the instructions.

Materials key: M—maple, BP—birch plywood,

EL—edge-joined leopard wood.

Supplies: #8x $1\frac{1}{4}$ " and #8x $1\frac{1}{2}$ " flathead wood screws, $\frac{1}{4}$ -20x2" hanger bolts (6), $\frac{1}{4}$ " washers (6), $\frac{1}{4}$ " lock nuts (6).

Bit: $\frac{1}{4}$ " round-over router bit.

Source

Leopard wood. To check the price and availability of leopard wood, go to woodworkerssource.net.

"nice legs"

Learn how to make curved and tapered table legs; then prepare to be complimented.

When so much about woodworking involves straight and square cuts, the sinuous shape of curved and tapered legs always grabs people's attention. Nonwoodworkers admire them for their grace, while woodworkers wonder, *How'd you do that?* It's easy.

Design guidelines

When designing a curved and tapered table leg, use your personal preferences and the project's overall style to guide the shape and dimension of the legs. Traditional furniture styles, such as Queen Anne, have design rules of thumb for cabriole legs that you can adapt to curved and tapered legs. For example, Queen Anne-style legs form a continuous S-curve with little or no straight section in the middle of the leg. Examples of these and other design rules can be found in books such as *American Furniture of the 18th Century*.

The curved and tapered leg shown here and on the bowfront table on page 62 uses a gradual taper from 1½" square just below the block to ¾x1" at the foot. There's also a straight section at the center.

There's no formula for sizing a blank when creating your own designs, as long as the completed

MATCH GRAIN FOR THICK STOCK

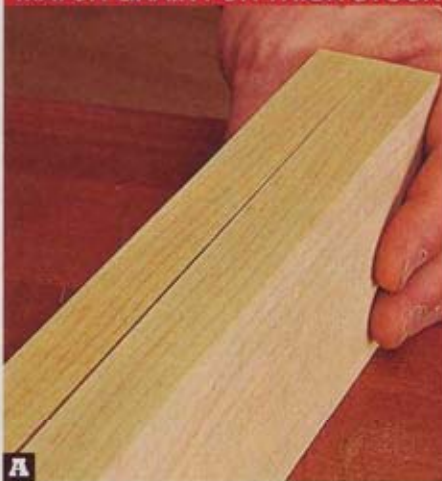

MARK TAPERS ON THE EDGES

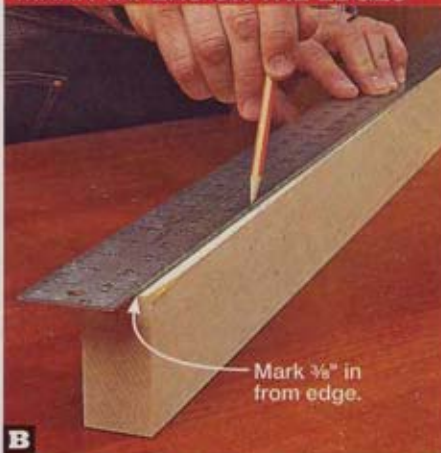

Mark ⅜" in from edge.

BANDSAW TAPERS AS MARKED

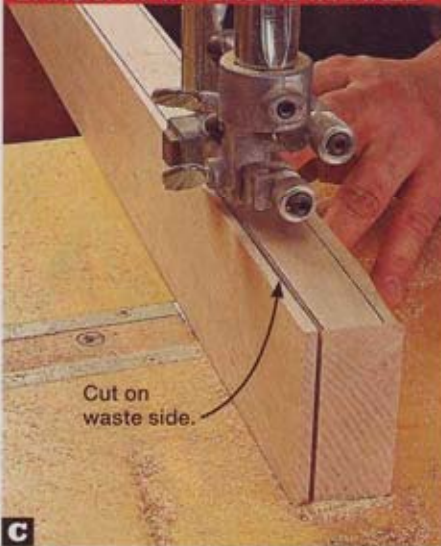

Cut on waste side.

leg complements your project dimensions. For example, the block on the leg we'll make here measures about 4½" long, or three times its width. The block width equals twice the thickness of a ¾" table top. If you have a project that calls for a specific look, research and measure examples of such furniture before drawing a pattern.

Let's make a leg

We'll use the legs from the bowfront table to show how to create a curved and tapered leg, so start by machining a 1½x3x32" blank. If you can't find 1½"-thick stock, make your own by first ripping ¾x6¼" stock down its center. Find the most attractive grain match and glue the two halves together, as shown in **Photo A**. Then plane the glue-up to size.

Mark the length of the block atop the leg blank, and extend the line around both its faces and sides. (Find dimensions and a pattern for this leg on page 85.)

Lay out the taper on both faces of the blank at the foot end by marking in from each edge. In this case, we placed two marks ⅜" in from each edge. Repeat this on the opposite face, and then draw lines on both faces from your end marks to the marks defining the block, as shown in **Photo B**, as guides for both bandsawing and beltsanding the tapers.

Bandsaw on the waste sides of the taper lines, as shown in **Photo C**, and avoid cutting into the lines defining the block. To sand the taper, first secure the blank between two dogs made from ½" or

Block
Notch 1¼" 1½"

Knee

Side Face

Ankle

Foot

thinner scrap clamped to your workbench, as shown in **Photo D**. Then mark wavy pencil lines on the side to be sanded to visually gauge your progress. Belt-sand until the taper reaches the pencil lines on both faces, as shown in **Photo E**. Flip the blank over and repeat this process on the other edge.

Bandsaw the curves

Whether you use our pattern or one of your own design, transferring it to a hardboard template helps ensure all your legs will look the same. To copy the pattern on page 85, create a 1" grid on the hardboard and reproduce the leg design in the same proportions as the smaller paper pattern's grid. Then cut and sand the pattern to your pencil lines. Using your template, transfer the leg shape to one side of your tapered blank, as shown in **Photo F**.

Then make the straight cuts that define the block. To counteract the effects of the taper and create a vertical kerf, press the block against the bandsaw table as you make the straight cut, as shown in **Photo G**. Stop at the start of the curve. Now cut the notch on the opposite face of the block.

MARK CURVES WITH A TEMPLATE



BANDSAW THE TOPS FIRST

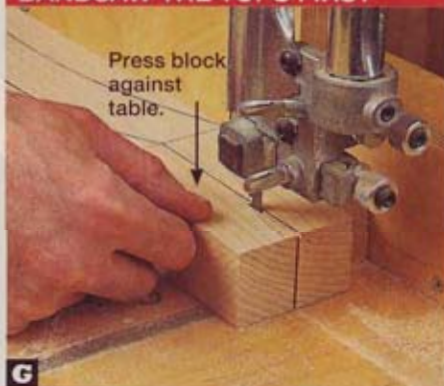

From the foot end, begin bandsawing the curves with the taper pressed flat against the saw table. The slight angle of the cut will not affect the curves until you reach the straight cut made earlier. As you approach the end of the curved cut, press the block firmly against the table, and then complete the cut. Repeat for the opposite curved cut, as shown in **Photos H** and **I**.

Next, remove saw marks by hand-sanding with 80-, 100-, and 120-grit abrasives. If you use a random-orbit sander, as shown in **Photo J**, center the pad over the curve and sand with light pressure on the edges of the disc. Keep the sander moving to avoid gouges or flat spots. As with the tapers, a wavy pencil line helps you gauge your sanding progress.

Hand-sand the curved surfaces with the grain for your final grit. For the block, hand-sand with a flat pad to hold a crisp edge where the block meets the curve, as shown in **Photo K**.

Written by Bob Wilson with Kevin Boyle

SECURE PARTS FOR SANDING

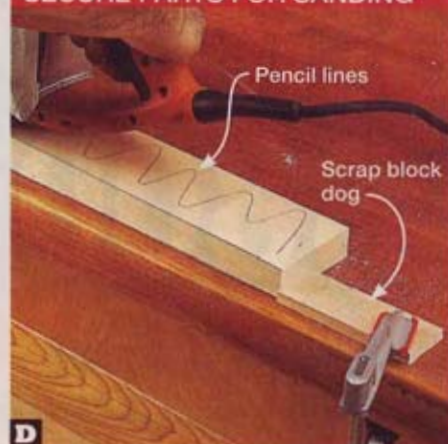

CUT CURVES AT THE LINES

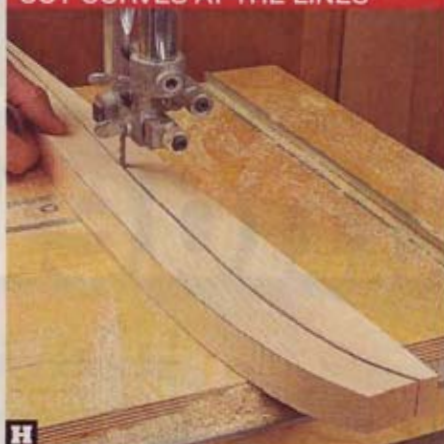

SAND AWAY SAW MARKS



SAND TAPERS TO LINES



STRAIGHTEN THE KERF ON TOP

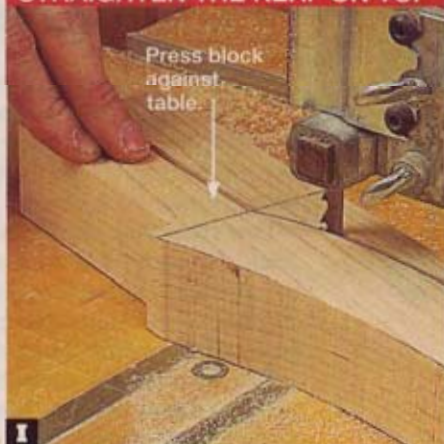

HAND-SAND THE BLOCK





air scrubbers under \$300

An air-filtration system grabs the tiny airborne dust that escapes your dust collector. Do you need one? Which one? Let's find out.

In the war against workshop dust, gathering debris directly from the tool with a dust collector or shop vacuum should be your first line of defense. You can win that battle but lose the war if those tiny but dangerous airborne particles escape, so you also need air support. That's where a ceiling-hung filtration unit comes in.

Here's how these simple machines work. Each has a steel box with a blower inside that sucks dust-laden air into the filters and exhausts clean air out the other end. The *prefilter* (which looks like a common furnace filter) catches the bulk of the larger dust particles. Smaller particles get trapped in the *high-efficiency filter* behind the prefilter.

With most of these machines costing more than \$200, we wondered if they were much more effective than a simple box fan with a filter taped to the front. So we ran that option through our tests, too.

Airflow: Does bigger mean better?

At a minimum, the air-filtration system you choose should be able to recirculate the air in your shop every 10 minutes. To find out how much airflow you need, first figure the cubic footage of your shop (length × width × ceiling height, in feet), and then divide that number by 10. The resulting number shows the minimum air flow you need in cubic feet per minute (cfm). For example, a 14×18' shop with an 8½' ceiling holds 2,142 cubic feet of air. Divide that by 10, and that shop's filtration system should pull at least 215 cfm of air.

Because manufacturers use different testing methods to arrive at their airflow specs, we evened the playing field by testing all of the units using a single method. (Our numbers may not agree with theirs, but they provide a fair head-to-head assessment.) We measured the airflow of each system in our test using a hot-wire anemometer at 25 specific points across the face of the prefilter, and then averaged those airflow readings.

The results of our test are shown in the chart, at right. As you can see, seven systems charted airflows between 547 and 650 cfm, with the Grizzly G0572, JDS 750-ER, Shop Fox W1690, and Jet AFS-1000B all bunched up from 630 to 650 cfm. Penn State Industries' AC620 and Jet's AFS-500 pulled only a little more air than the box fan and filter setup.

How well do these machines gather dust?

Although a good second line of defense, an air-filtration system may still let through small dust particles that can lodge in your lungs. (See "Particle size and your health," at right). For complete protection from air-

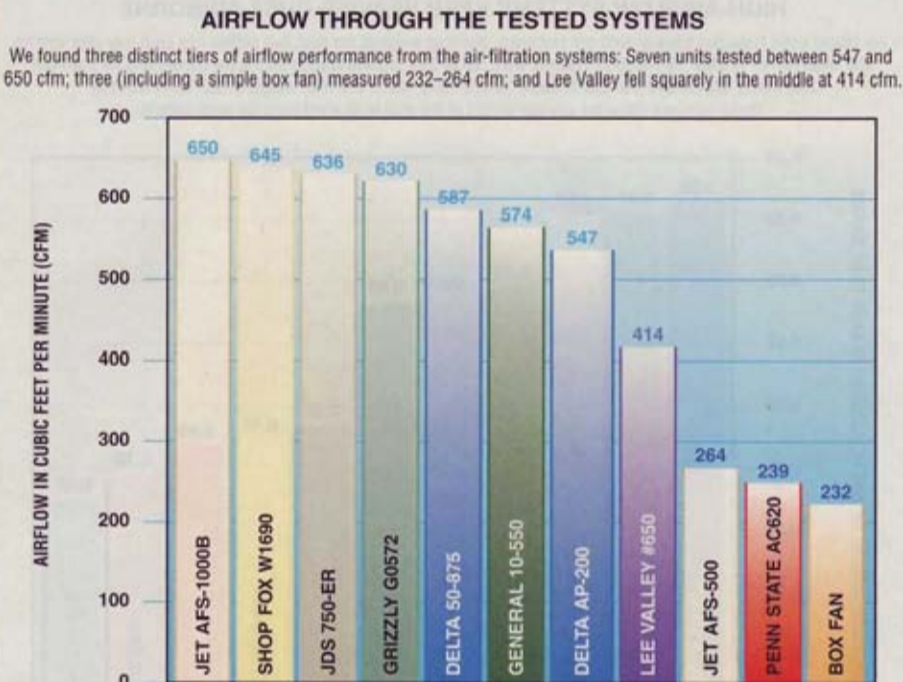

Airflow measured with hot-wire anemometer at 25 distinct points 1¼' from the prefilter face. To test real-world airflow, filters were loaded under identical circumstances, and then tapped clean before airflow measurements were taken. Numbers shown are an average of three tests.

borne dust, you should wear a snug-fitting mask or respirator. We focused our tests of these units on the nuisance dust that seems to settle on everything in the shop.

After sealing off our 14×18' test shop in a shroud of heavy-duty plastic sheeting, we hung an air-filtration system from the ceiling and placed eight collection trays in various locations around the shop, as shown below left. Next, we plugged the system into a timer that would turn it off after exactly 65 minutes, and then turned it on at its highest speed. Our respirator-equipped tester then cut 160' of MDF and exited the shop. Six

hours later (five hours after the air-filtration system turned off), we returned and weighed the amount of dust in each tray. The results of this test are shown on the next page.

Surprisingly, almost all of the high-cfm units allowed more dust to settle around the

Particle size and your health

Dust-collection and filtration-equipment manufacturers often explain the effectiveness of their filters by stating the smallest particle size (in microns) that their filter will catch. But how big, exactly, is a micron?



Well, there are 24,500 microns in 1", or about 380 microns per ¼". A 10-micron particle can be seen with the naked eye; a 1-micron particle requires a microscope.

Dust particles larger than 10 microns settle to the floor quickly, so they don't pose a significant breathing hazard. Our body's natural filtering systems (nose hairs, etc.) do a pretty good job of filtering out dust in the 4–5-micron range, and particles smaller than 0.3 micron behave like a gas, so we tend to inhale and exhale those without harm. Particles between 0.3 and 5 microns pose the biggest health risks because they slip past our natural defenses and can lodge in the lung passages. (Tobacco smoke particles range from about .01 to 1 micron in size.)

COLLECTION TRAY LOCATIONS



DUST SETTLERS WEIGH IN



We weighed the dust that settled out of the air using a microbalance—a supersensitive scale accurate to 0.01 of a gram.

HIGH-AIRFLOW SYSTEMS KEEP HEAVIER DUST AIRBORNE

We placed eight collection trays around our test shop, and then weighed the dust that settled into each tray after cutting 160 lineal feet of ¾" MDF. Air-filtration systems were run at their highest speeds during the cutting and for one hour afterwards. We allowed the dust to settle for five more hours, and then weighed each collection tray. These numbers show the average weight of the dust in all eight trays for each system.

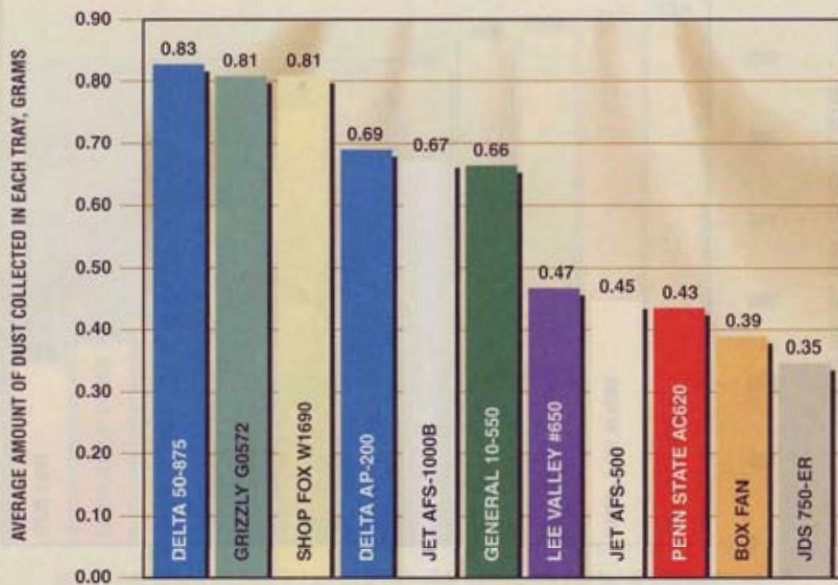

Tests conducted in a sealed 14x18x8½" test shop. No dust collection was used during this test. Average of three tests.

DUST COLLECTION AND AIR FILTRATION WORK BETTER IN TANDEM

To see how using on-tool dust collection would affect the performance of these air filters, we took one high-CFM air-filtration unit and reran the dust-settling test, this time with a typical two-bag dust collector connected to the tablesaw. The difference was dramatic. Just dialing down the speed of the air-filtration motor to a rate more appropriate for the size of the shop lessened the settling dust by about one-third.

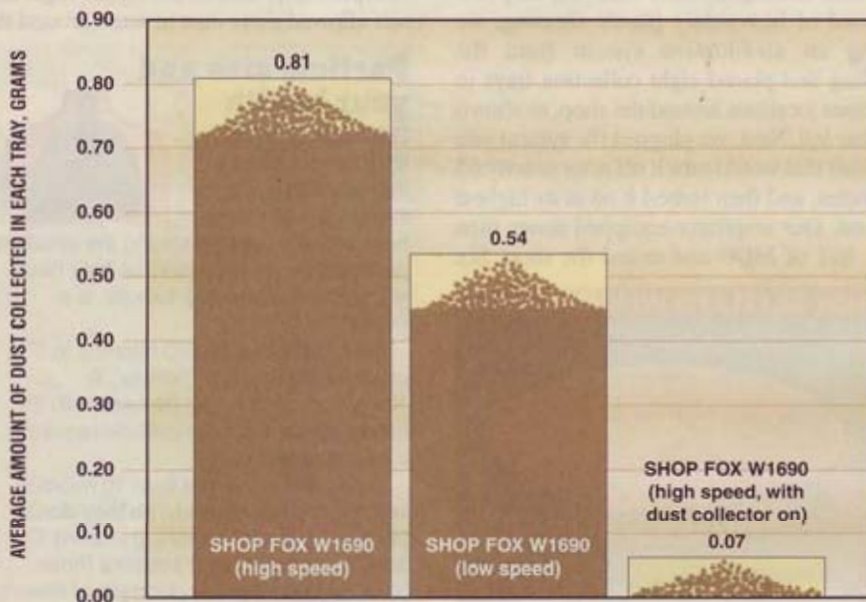

Tests conducted in sealed 14x18x8½" test shop. Average of three tests.

Meet MERV

When you replace a high-efficiency filter, how do you know you're getting a good one? According to Al Veeck, executive director of the National Air Filtration Association (NAFA, nafahq.org), all replacement particulate filters should have a Minimum Efficiency Reporting Value (MERV) marked on them.

He suggests that woodworkers get a filter rated at no less than MERV13, which filters out more than 75 percent of the particles sized 0.3 micron. And for woods like cedar and walnut that can trigger respiratory reactions, go no lower than MERV15 and wear a respirator. A MERV16 filter catches 95 percent of all particles sized 0.3 micron and larger, but Al says such superfine filtration has its price: Every step up the MERV ladder costs a 10–12 percent drop in cfm.

the airflow without affecting the *volume* of air, keeping airborne dust closer to the filter inlet. All other air-filtration systems in our test have a smaller exhaust outlet that increases air velocity.

We repeated this test with the multi-speed Shop Fox set at its lowest speed, and again at high speed with the tablesaw connected to a dust collector. Slowing the blower resulted in one-third less dust fallout; adding dust collection to the mix cut the amount of dust settling around the shop by a whopping 87 percent, as shown at *left*.

Fine points on filters

The prefilter protects the high-efficiency filter from larger particles that would quickly render it inefficient. The washable prefilters on the JDS and Lee Valley may seem more economical than disposable prefilters, but in our tests, washable filters allowed more dust through to the high-efficiency filter, as shown *opposite page, top*. A disposable prefilter can be tapped out several times before you have to replace it.

We also found two different kinds of high-efficiency filters on the tested units. Most use a super-fine mesh bag filter, but the Jet AFS-500 uses a disposable pleated paper filter instead. This style of filter has a much smaller surface area than a bag filter, so it will load faster and need to be cleaned and replaced more often. Among the bag filters, Penn State and Shop Fox have the largest surface area—about 30 percent more than typical. That should give you more time between cleanings.

As for how well those filters actually work at snatching dust, filter efficiency rat-

shop than the lower-cfm models. After sharing our results with several airflow and filtration experts, we concluded that the high airflow (about three times what's needed for a shop this size) likely carried heavier particles out to the perimeter of the shop before they slowed enough to fall. A

low-cfm model—or no air-filtration system at all—allowed those heavier particles to fall harmlessly to the floor.

So why didn't the JDS suffer the same heavier fallout as the other powerful units? Its diffused exhaust, spread out over the entire rear of the box, reduces the *velocity* of

BAG FILTERS FARE BETTER BEHIND DISPOSABLE PREFILTERS



Bag filter shown after removing washable prefilter



Bag filter shown after removing disposable prefilter

With the prefilters removed, we see how well they do their job. The bag filter behind a washable prefilter (*left*) is caked with dust that should have been caught by the prefilter. The bag filter behind a disposable prefilter (*right*) shows that far less dust slipped through.

ings should indicate *both* the minimum particle size and the percentage of those particles it captures. (Particle size alone isn't enough because even a burlap bag will trap

some 0.5-micron dust.) Higher percentages are better, obviously.

The manufacturers' specs for filtration efficiency are shown in the chart on *the next*

page, but we were unable to verify these numbers in our testing. In fact, two manufacturers, Grizzly and Shop Fox, couldn't provide us with their filters' efficiencies.

Thinking outside the box: Other meaningful features worth having

■ **Off-timer.** Just because you're done working in the shop for the day doesn't mean your air-filtration system should be. An off-timer allows you to set the system to run from 30 minutes to eight hours and then shut itself off.

■ **Remote control.** Because these units typically hang high overhead, it's nice to be able to turn them on and off, select the blower speed, and set the off-timer without having to get out a ladder. Except for the Delta AP-200, Jet AFS-500, and Lee Valley

#650, all of the tested units come with remote controls. Kudos to JDS and Penn State Industries here: Their remotes display the fan speed and off-timer settings, as shown *below*. (With the other five, you still have to be able to see the display on the filtration unit itself.)

Like your TV remote control, most of these systems use infrared (IR) remotes that require line-of-sight to the filtration unit. That sometimes means walking around behind the unit to start and stop it. Penn

State Industries' radio frequency (RF) remote can be used anywhere within about 40' of the unit—about twice the maximum range of IR remotes.

■ **Airflow gauge.** Over time, dust buildup in the filters starts to impede airflow, rendering the system less effective. The process is so gradual, you may not even realize it until you're looking through a dusty haze. Only the Delta 50-875 has a built-in airflow gauge to give you an at-a-glance indication of when it's time to clean or replace the filters.

LOOKING FOR A SELF-STOPPER



Units with a built-in off-timer automatically power down after one of several preset times, so you can set it to clear the air when you're not around.

THE LONG AND SHORT OF REMOTES



Jet's compact remote tucks nicely into an apron pocket. Although larger, JDS's control comes with a wall-mounting bracket, and shows timer and fan settings.

ALMOST TIME TO CLEAN THE FILTER

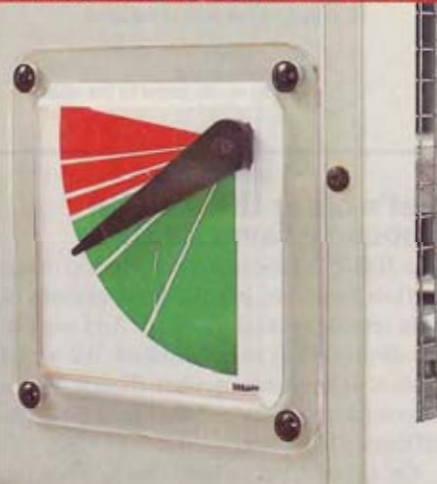

A vane in the exhaust of the Delta 50-875 shows that airflow is still sufficient for effective filtering. When the needle hits the red area, filters need cleaning.

■ **Filter seals.** You gotta love the blower's work ethic: It keeps trying to pull the same volume of air regardless of whether the filter is packed or not. And if it can't suck dust-laden air *through* the filter, it might just pull it *around* the filter. Fortunately, almost all of the units we tested (except Lee Valley) have seals at the high-efficiency filter to prevent dust blow-by. We prefer box-mounted seals to filter-mounted seals, as shown at *right*, because they make filter replacement easier, although both proved effective.



TWO WAYS TO SEAL THE DEAL

Seals mounted on the flange behind the filters (*left*) work as well as a spongy foam seal (*right*) that wraps around the perimeter of the bag filter. The foam seals pinch and bulge during installation, though, which can affect the fit of the prefilter.

TEN AIR-FILTRATION SYSTEMS, BY THE NUMBERS

BRAND	MODEL	DIMENSIONS (HxWxL, INCHES)(1)	NUMBER OF BLOWER SPEEDS (2)	AIRFLOW AT HIGHEST SPEED (CFM)	OFF-TIMER SETTINGS (HOURS) (3)	REMOTE CONTROL TYPE (4)	BLOWER			FILTERS			PERF. GRADES			FOR MORE INFO:					
							IR	RC	N	CFM	IR	RC	N	CFM	IR	RC	N	CFM	IR	RC	N
DELTA	AP-200	12x24x28	1	547	N/A	N	D	2,700	99%	96%	A-	B	C	E,H	U	50	2	T	\$230	800/438-2486	deltamachinery.com
	50-875	12x24x28	3	587	1/2,1,2,4	IR	W	2,700	99%	96%	A-	C	B	A,E,R,H	U	50	2	T	\$280		
GENERAL INTERNATIONAL	10-550	12x24x28	1	574	2,4,8	IR	D	2,700	98%	85%	A-	B	B	E,R,H	U	68	2	T	\$230	888/949-1161	general.ca
GRIZZLY	G0572	15x19x26	3	630	1,2,4	IR	D	2,500	—	—	A	C	B	E,R	U	55	1	CH	\$200	800/523-4777	grizzly.com
JDS COMPANY	750-ER	12x24x34	3	636	1,2,3,4	IR	W	2,700	99%	91%	A	A	A-	E,R	U	70	5	CH	\$300	800/480-7269	jdstools.com
JET	AFS-500	12x24x15	3**	264	N/A	N	D	1,200	98%	85%	C	A-	C	H	U	33	5	T	\$180	800/274-6848	jettools.com
	AFS-1000B	12x24x30	3	650	2,4,8	IR	D	2,600	98%	85%	A	B	B	E,R,H	U	54	5	T	\$275		
LEE VALLEY/WORKSHOP	#650	11x20x25	2**	414	N/A	N	W	2,900	98%	94%	B	A-	B	E	U	40	3	CA	\$265	800/871-8158	leevalley.com
PENN STATE INDUSTRIES	AC620	12x24x30	5*	239	2,4,6,8	RC	W	3,700	96%	65%	C	A-	A	E,R,H	U	42	2*	T	\$220	800/377-7297	pennstateind.com
SHOP FOX	W1690	12x24x30	3	645	1,2,4	IR	D	4,000	—	—	A	C	B	E,R,H	U	55	2	CH	\$220	800/840-8420	shopfox.biz

NOTES: 1. Prefilter size is first two dimensions.
2. Speed can be changed on box and by remote control unless otherwise noted.
(*) Controlled only by remote
(**) Controlled only on box
3. (N/A) No off-timer on this model.
4. (IR) Infrared
(RC) Radio control
(N) No remote control for this model.
5. (D) Disposable
(W) Washable
6. Rating provided by manufacturer. Percentage of particles of this size caught by the filter, according to American Society of Heating, Refrigerating and Air-Conditioning Engineers standard 52.2.
(—) Unable to obtain rating from manufacturer.
7. **A** Excellent
B Good
C Fair
8. (A) Airflow gauge
(E) Eyebolts
(H) Handles for carrying
(R) Remote control
(U) Upgrade/replacement filters
9. (*) Extendable to five years for \$15.
10. (T) Taiwan
(CH) China
(CA) Canada
11. Prices current at time of article production and do not include shipping, where applicable.

Let's clear the air and choose a favorite filter

The JDS 750-ER ranked near the top in our airflow tests, yet left the least amount of dust settling around the shop. And we like the display on its remote control. We would replace its washable prefilter, though, with a disposable one to extend the life of the high-efficiency bag filter.

On a shoestring budget? Our \$20 box fan with a furnace filter duct-taped over it tested as well in airflow and dust settling as systems priced 10 times more. It's not as easy to tap out or replace the filters, and you

Written by Dave Campbell with Jeff Hall

won't get a fancy off-timer or remote control, but it did the job pretty well. This simple setup might hold you over until you can save enough money for a larger unit. 🍄

how to cut a straight

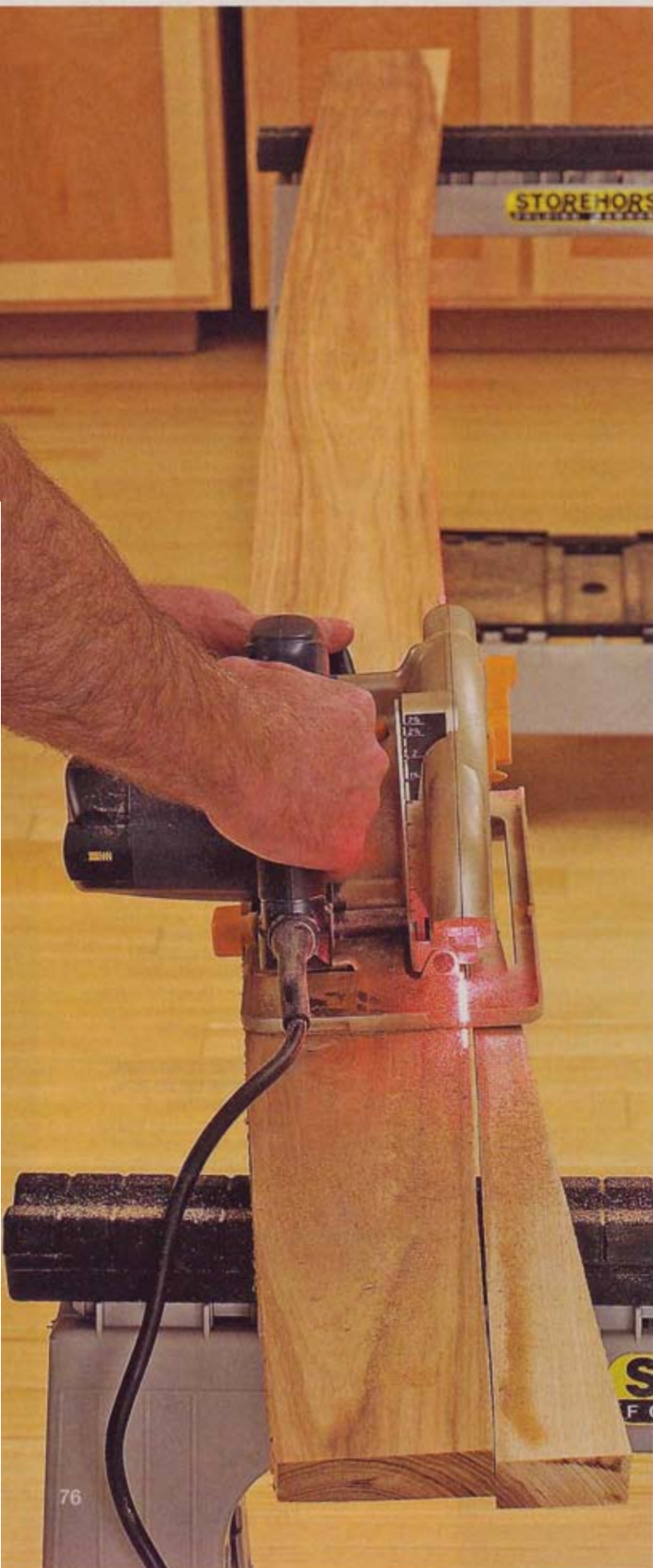

Before you can turn rough lumber into a project you're proud of, you need to start with one straight edge.

In a perfect world, the hardwoods you buy for your projects would come with laser-straight edges. Unfortunately, that perfect "factory" edge is the exception rather than the rule. In this article, we'll show you how you can create that ideal edge on less-than-ideal lumber.

Straight edges start at the lumber store

When shopping for lumber, choose the best boards available, paying special attention to the grain and how it will appear on your finished project. You can buy lumber in rough condition with no sides surfaced, or with only the faces planed (S2S), or surfaced on both faces and both edges (S4S). Choosing the latter, while more costly, often eliminates the headaches of cutting a straight edge. However, even S4S lumber can warp.

Warped boards, although more difficult to work with, can still be put to good use. A board with flat faces but crooked edges, like the one shown at *left*, can be machined easily to create straight edges, as shown in the decision map on *page 78*.

Don't work with more than you need

After you've selected your boards and allowed them a few days to acclimate to your shop's temperature and humidity levels, cut them to rough length before doing anything else. The longer the board, the more stock you'll waste trying to straighten it. Leave a few inches to allow for waste.

To plane or not depends on your tools

Once the stock has acclimated to your shop, you can go one of two directions. Either joint and plane the faces of your board flat, and then work on straightening an edge, or straighten an edge with the stock faces in their rough condition. We recommend the first course of action because some of the prep methods work best with clean workpiece faces.

But the option you choose may be determined by the limitations of your tools. For example, you can't face-joint an 8"-wide board on a 6" jointer. And, cleaning both faces on your planer does not guarantee they will be flat, only parallel. In this case, straighten one edge, rip it to width on the tablesaw, joint one face, and then plane to thickness. If you need the final workpiece wider than the knives on your jointer, simply rip it into two or three pieces, joint and plane the faces, joint the edges, and then edge-glue them back together once they're square and true.

Read what your board's edges tell you

Now eyeball along the length of your board's edges to determine your next move. If it has one reasonably straight edge, you'll have no trouble making it perfectly straight. A small amount of crook takes a little more work, but can be straightened quickly. Even if your board has a substantial crook, you'll be able to put a straight edge onto it in a couple of steps. Here's how to get a straight edge, from best- to worst-case scenarios.

edge on anything

Jointer: The essential straightening machine

If you work with rough lumber, you really should own a good jointer. It's the best tool for cutting a square, clean, straight edge, as shown at *right*, as well as for cleaning and flattening a board's face. Although a 6" jointer performs well, consider stepping up to an 8" jointer, which not only machines wider stock, but also has longer infeed and outfeed tables to better support long workpieces.

We don't recommend using auxiliary stands to add infeed and outfeed support to jointers because boards with rough or crooked edges can sometimes knock stands over and possibly cause the jointer's knives to gouge the board.



Rely on your jointer to machine a straight, square edge on a relatively straight board in just a pass or two.

Best case: No crook

Consider yourself ahead of the game if your workpiece falls into this category. Regardless of length, you should be able to machine a straight edge quickly with a jointer, *above*. If you don't own a jointer, use your table saw to cut away the rough edges, as shown *below*.

A router will also help you machine a straight edge onto this type of board. If it has a rough-sawn face, use a guide board with a smooth face and a straight edge on top of your workpiece, as shown *bottom, left*. Use a top-bearing pattern bit in the router. Set the guide slightly back from the

workpiece edge and equal to the amount you want to remove. Make two passes if necessary.

With boards that have smooth faces, clamp a straightedge (this can be a board, shop-made guide, or commercial accessory) onto your workpiece so the router—as it runs along the guide—removes no more than $\frac{1}{16}$ " with each pass, as shown *bottom, center*. Make as many passes as needed to straighten the edge.

You also can cut a straight edge at your router table, but it takes a little more setup. First, chuck a straight or spiral bit in your table-mounted router and set the height for just a little more than the thickness of the workpiece. Set the infeed fence so it will remove no more than $\frac{1}{16}$ ". Align the outfeed fence flush with the front edge of the cutter. If you don't have a split fence, simply clamp or double-face-tape a piece of plastic laminate, equal to the amount of material you want to remove, to the outfeed side of the fence, as shown *below*.

RIP AWAY ROUGH EDGES ON THE TABLESAW



When cutting with this method, run the straightest edge against the rip fence to avoid potential kickback. Cut away the opposing rough edge (*left*), adjust the fence, flip the board so the new edge is against the fence, and rip the other rough edge (*right*).

USE A STRAIGHTEDGE TO CREATE A STRAIGHT EDGE

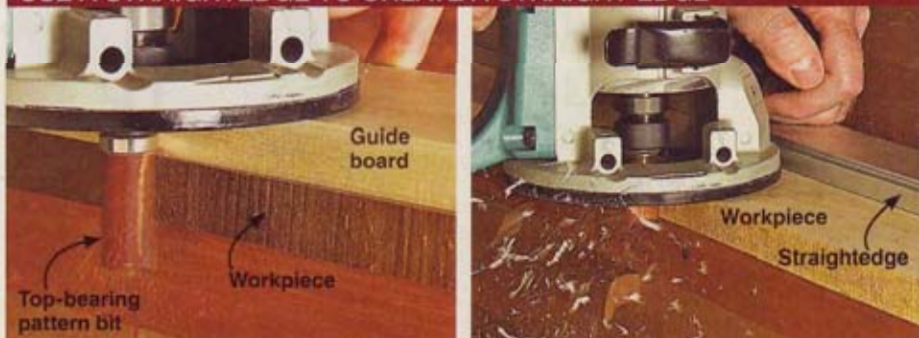

Rest your router subbase on top of the guide board and run the bearing against its edge. Trim no more than $\frac{1}{16}$ " per pass.

For this method, use either an upcut or downcut spiral bit or a straight bit that is longer than the board's thickness.

TURN YOUR ROUTER TABLE INTO A JOINTER



Sand a slight chamfer on the end of the laminate nearest the bit so the workpiece won't catch as you feed it through.

For a straight edge, go straight to the best tool

The tools and methods you use to straighten a board's crooked edges vary depending on the severity of the crook and the length of the board. Use this decision map to determine the best tools and methods to use for each situation. For more options, read on.

START HERE: Cut your board to rough length; then assess the edges of the board.

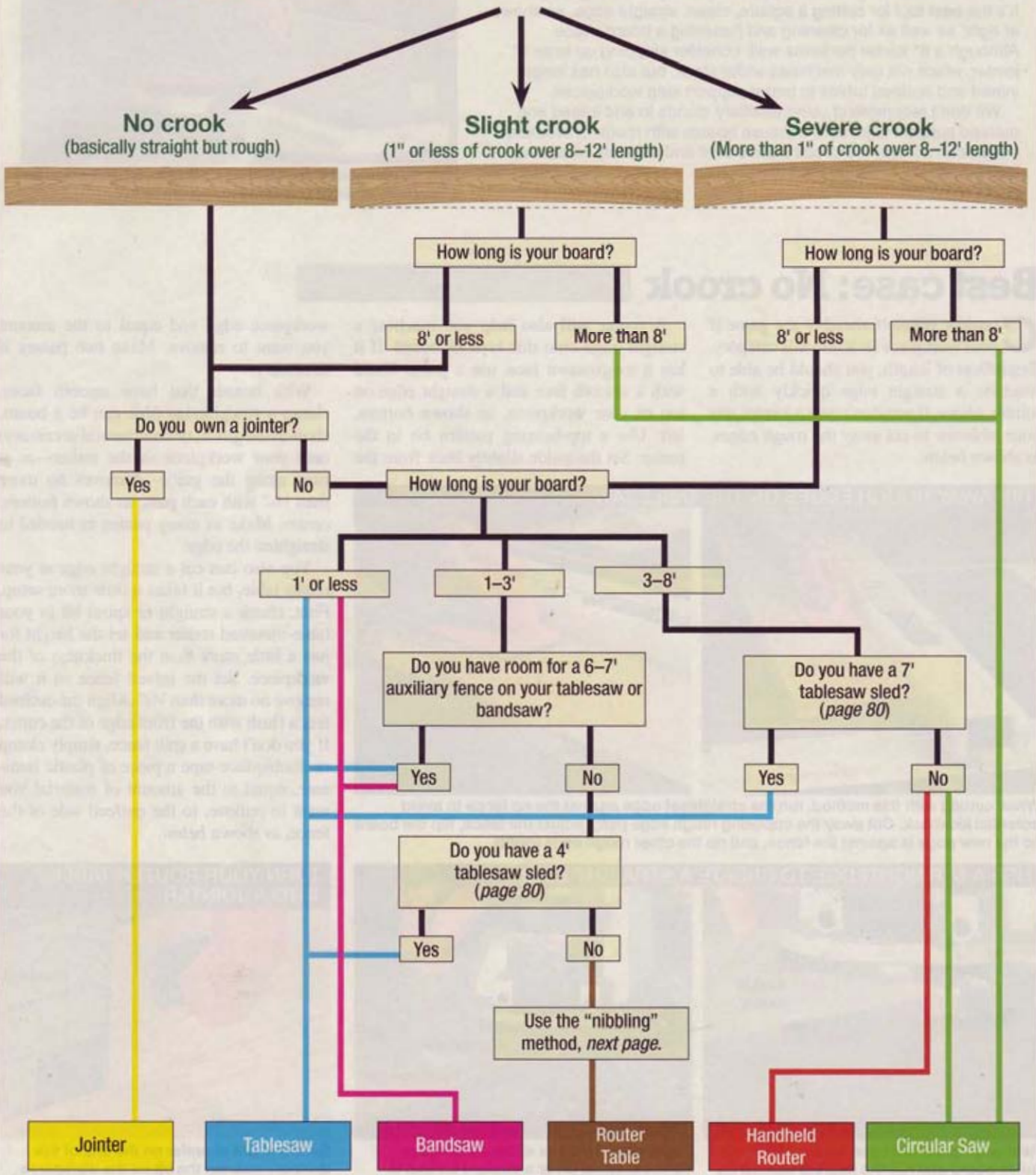

Typical case: Slight crook

(1" or less of crook over 8–12' length)

Many boards fall into this category when they warp as they swell or shrink acclimating to the environment around them. Plan your straight edge to give the board the best grain direction in the project. Boards in this category will be machined in different ways, depending upon their length.

Make quick work of boards 1' long or less

For short boards try the simplest options first: jointer, tablesaw, or bandsaw. The jointer proves quickest, even if it takes a few passes to straighten an edge. You'll use the same technique for the tablesaw and bandsaw: ripping with the concave edge against the rip fence. Edges cut on the bandsaw or tablesaw, although straight, will have saw marks that clean up with one quick pass at the jointer. The router table option leaves a jointer-smooth edge, but takes more time setting up than a jointer.

Choose from many options for boards 1–3' long

Boards of these lengths offer you the most options of any size stock. At the jointer you've got two ways to handle these boards. First, joint the edge as usual, concave edge down, taking off a little more with each subsequent pass until flat. Or, "nibble" several passes on one end before spinning the board to do the same for the other end, as shown at *left*. Repeat until the crook is nearly gone, then joint the entire length.

The tablesaw and bandsaw again provide good options, but with one important change. For boards longer than 1', add a long auxiliary fence to maintain contact between the end points of the board's concave edge and the fence, as shown *below, left*. Make your auxiliary fence twice as long as the workpiece, plus an extra 6" at each end, and center it with the blade. Clamp it to the rip fence, or adhere it with cloth-backed, double-faced tape.

To use your router table for this length of board, combine the extra-long auxiliary fence of the tablesaw method with the nibbling action of the jointer, as shown *below, center*. Use a sharp straight or spiral bit (upcut or downcut). Using a handheld router and straightedge will take several passes, but requires little space, an attractive solution for shops tight on elbow room.

Cutting a straight edge proves easy when using a carrier or sled, such as the one shown *below, on the tablesaw*. To use this sled, place your board so either edge hangs over the edge of the sled, aligning the board to cut the most attractive grain pattern. Secure it with the hold-downs, or use screws at the ends. Raise the blade so it cuts through the piggybacked workpiece. Build this sled from the plans on *page 80*.

MAKE NIBBLING CUTS TO REMOVE CROOK

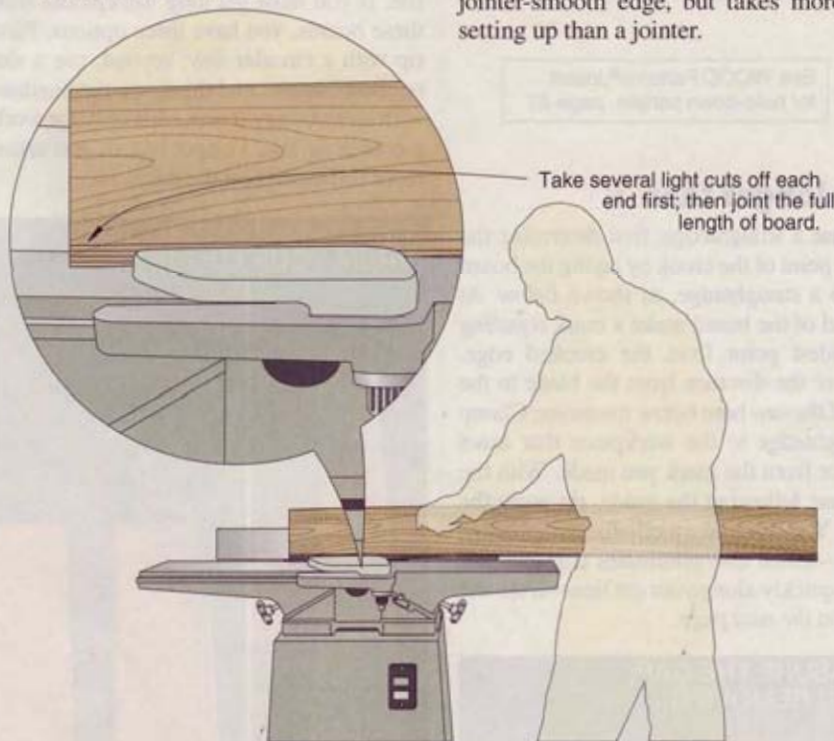

AUXILIARY FENCES ADD REACH FOR REMOVING CROOK

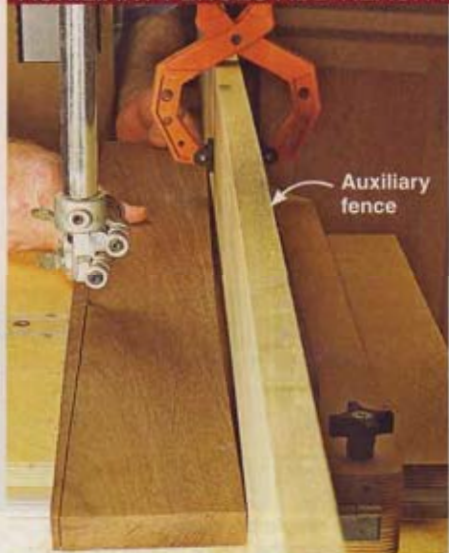

An auxiliary fence allows the workpiece to follow a straight path, and the bandsaw to cut a straight edge.



For an auxiliary fence on your router table, cut an opening in the center, along an edge, for the bit to spin freely.

LET A SLED SHOULDERS THE LOAD



The hold-downs can grip either the sides or ends of a workpiece. Hold the sled flat on the table when ripping.

CARRIAGE BOLT HEAD DETAIL

1/4-20 carriage bolt
3 1/2" long



File head of carriage bolt flat on two sides.

TABLESAW RIPPING SLED



See *WOOD Patterns*® insert for hold-down pattern, page 87.

Don't sweat straightening boards longer than 3'

You have four options with these boards: jointer, router with a straightedge, circular saw, or a table saw sled. If you have a 6" jointer, use the "nibbling" method; if you have an 8" jointer, you'll be okay to use either method because of the support from the longer tables.

Your circular saw provides yet another way to cut a straight edge. You can do this by using a straightedge, or by snapping a chalk line to map out the cut, and then ripping along that line, as shown *below*. Laser guides, available on some saws, make it easy to track a chalked or drawn line.

To use a straightedge, first determine the widest point of the crook by laying the board next to a straightedge, as shown *below*. At one end of the board make a mark equaling the widest point from the crooked edge. Measure the distance from the blade to the edge of the saw base below the motor. Clamp a straightedge to the workpiece that exact distance from the mark you made. With the saw base following the guide, rip away the crook. You can make a reliable straightedge guide—which also eliminates chip-out and aligns quickly along your cut line—from the plans on *the next page*.

CUT SAFELY ON THE FLOOR WITH NO WORRIES



Rigid foam insulation makes a great sacrificial cutting surface. Set the blade depth so the saw cuts slightly into the foam.

MEASURE THE GAP; THEN REMOVE IT



With your crooked edge lying against a straightedge, measure the widest gap to determine the path you want the saw to cut.

Worst case: Severe crook

(More than 1" of crook over 8-12' length)

Before machining a board like this, first determine how it can best be used. Removing the crook from a 10'-long board means wasting a great deal of wood, as shown *below*. If you really need a long board, try to find one with a straighter profile. If you must get long workpieces from these boards, you have three options: First, rip with a circular saw; second, use a sled on the table saw; and third, use the bandsaw with an auxiliary fence—but only for workpieces 3' or less. Longer boards just create more difficulties on the bandsaw.

GET MAXIMUM USE FROM YOUR LUMBER

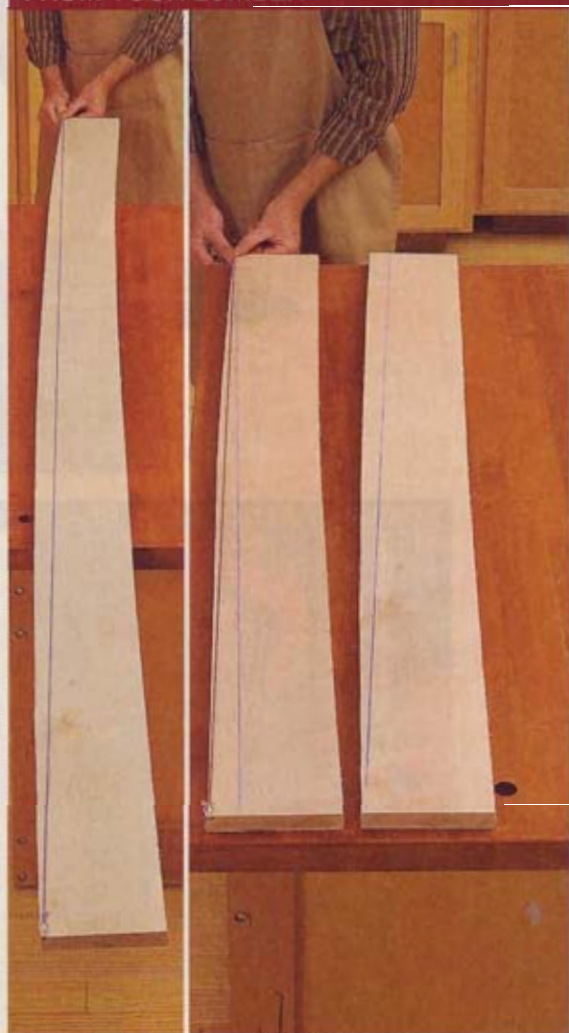

Cutting this maple board, *left*, to remove the crook along the entire length wastes wood and leaves a narrow workpiece. Instead, cut it into two pieces, *right*, to maximize its width.

Make your own zero-clearance cut-off guide

You can construct two cut-off guides, a 4- and 8-footer, for use on different workpiece lengths. Made to custom-fit your circular saw and router, both guides can be constructed from one sheet of $\frac{1}{2}$ " plywood. (We recommend a sheet with sanded faces.) Here's how:

■ Begin by snapping a chalk line along the entire length of the sheet 11" from the edge. Using your circular saw, rip along that line.

■ Use the factory edge of the cut-off piece as a guide for your circular saw to make the rest of the cuts. From the remaining plywood piece, rip two strips 2" wide, two strips 8" wide, and one strip 11" wide.

■ Cut the strips to the lengths shown in the illustration at right, and assemble the sleds, removing any glue squeeze-out.

■ Once dry, secure each sled to your workbench, allowing clearance for the saw blade. Using your circular saw with the blade you would commonly use, rip the edge on the wider side opposite the fence, as shown below. Do the same for the other side with your router.

Whichever diameter router bit you use will be the size you should use in the future for making cut-offs. ♣

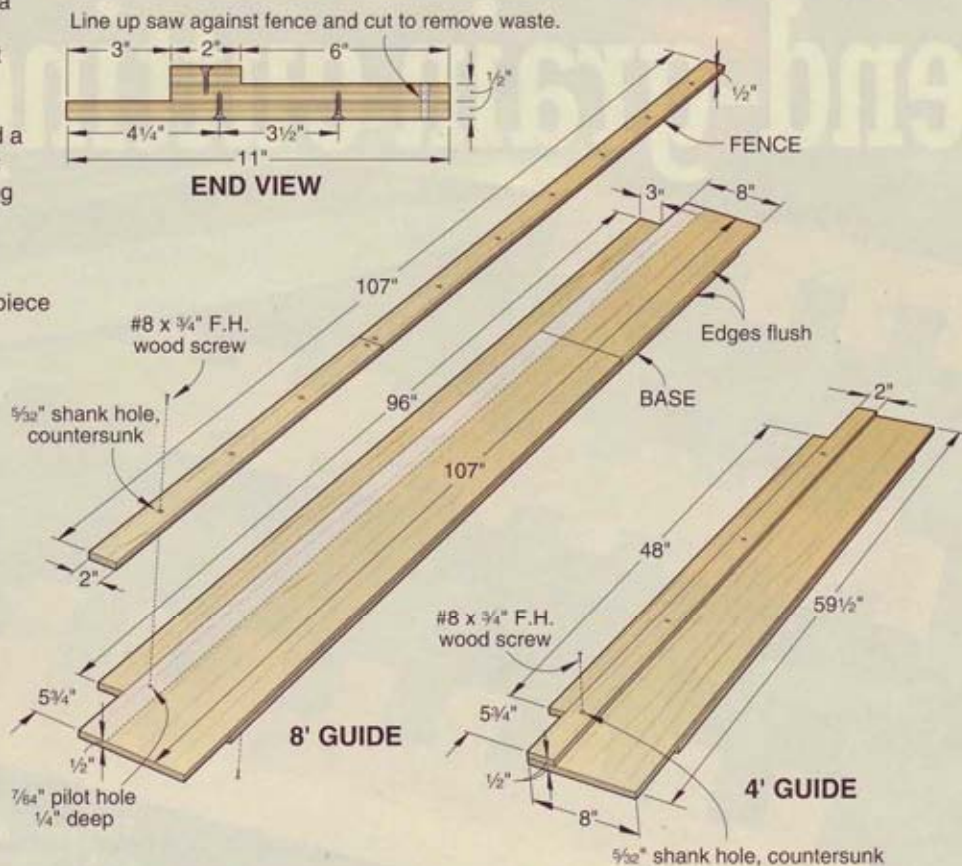

CUSTOM-FIT GUIDE HELPS ELIMINATE CHIP-OUT

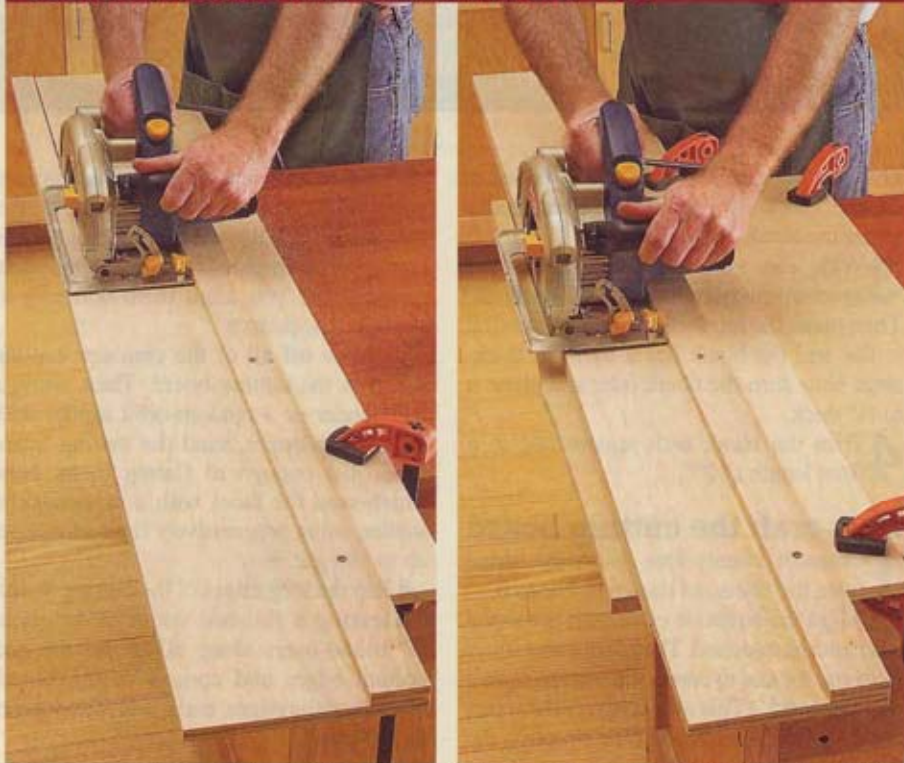

With your circular saw's base riding against the fence, rip the waste off each guide (left). To use the guide, clamp it to a workpiece with the cut-off edge aligned on your mark. Set the saw blade to the appropriate depth and make the cut (right).

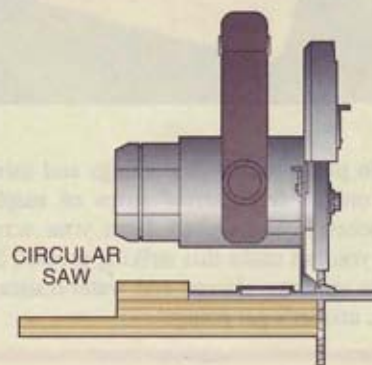

CIRCULAR SAW

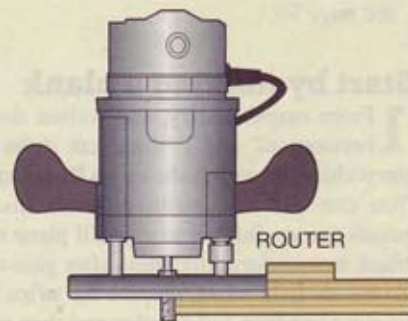

ROUTER

Written by Bob Hunter with Jeff Mertz
Illustrations by Tim Cahill and Roxanne LeMoine

slice 'n' dice end-grain cutting board



This eye-catching kitchen accessory may look challenging, but it's amazingly easy to make thanks to a simple trick for creating the lively geometric pattern. And this project provides one tough cutting surface: its end-grain top holds up well to your sharpest utensils.

In just a couple of evenings and using only a few narrow strips of maple, cherry, and walnut from your scrap bin, you can make this striking project. So rustle up some clamps and water-resistant glue, and let's get going.

For two more cutting-board designs, see page 98.

Start by making a blank

1 From maple, cherry, and walnut stock between $\frac{3}{4}$ " and 1" thick, cut strips to the widths and length shown on **Drawing 1**. You can use stock with different thicknesses (as we did) because you'll plane the blank to a uniform thickness after glue-up. To ensure tight joints, prepare the strips by jointing one face and an edge and then ripping them to the needed widths.

2 Edge-glue the strips with the jointed faces down in the arrangement shown on **Drawing 1** and in **Photo A**. To keep the

glue-up flat, center the clamping pressure on the blank by positioning riser blocks under the blank, as shown.

3 With the glue dry, scrape off the squeeze-out from the faces of the blank. Then plane the top face of the blank until it is flat and the blank has a uniform thickness. Now turn the blank over and plane it to $\frac{5}{8}$ " thick.

4 Trim the blank ends square and to a final length of 35".

Now craft the cutting board

1 Crosscut twenty-four $\frac{1}{4}$ "-wide strips from the blank, as shown in **Photo B**.

2 Align the strips on edge with the wood patterns matched. Then turn every other strip end for end to create the pattern shown on **Drawing 2**. (This also staggers the joints for a super-strong board.) To simplify the glue-up, separate the strips into three groups of eight pieces. Now glue and clamp the pieces in each group together, as shown in **Photo C**. (To prevent the cauls from

sticking to the strips, either place waxed paper behind the cauls or remove them after the glue sets.) After the glue dries, glue and clamp the three groups into one lamination, making sure you align them correctly to continue the pattern.

3 Scrape off all of the glue squeeze-out from the cutting board. Then, using a belt sander or a random-orbit sander with 80-grit sandpaper, sand the cutting board faces just enough to flatten them. Now finish-sand the faces with a random-orbit sander, using progressively finer sandpaper up to 180 grit.

4 Rip the long edges of the cutting board, leaving a finished width of 11". Rout $\frac{3}{8}$ " round-overs along all of the top and bottom edges and corners of the board. Now sand the edges, ends, and round-overs to 180 grit.

5 Apply a food-safe finish of your choice. (We applied three coats of mineral oil, let each coat penetrate for five minutes, and then wiped off the excess.) For other finish

THE ABCs OF MAKING A CUTTING BOARD: EDGE-GLUE, CROSSCUT, AND FACE-GLUE THE STRIPS

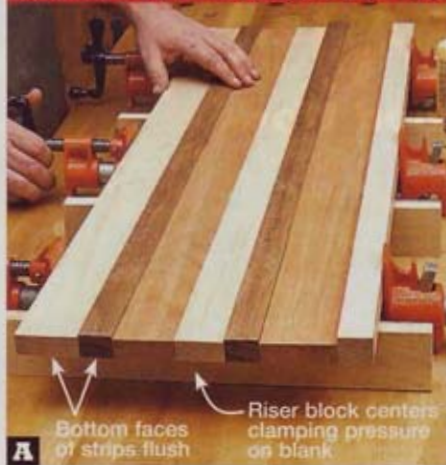

A Glue and clamp the contrasting wood strips together in order, keeping the bottom faces and ends flush.



B Using a stopblock attached to an auxiliary extension on your tablesaw miter gauge, crosscut 1 1/4"-wide strips from the blank.

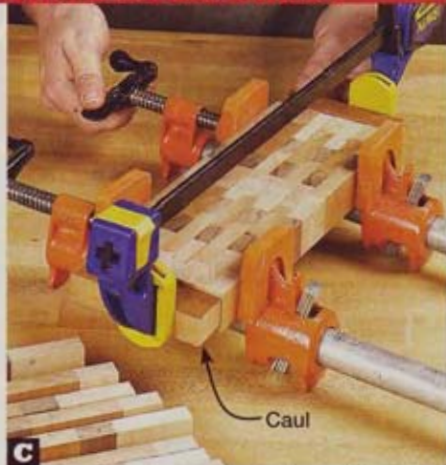

C Face-glue and clamp together eight strips at a time. Keep the top and bottom edges flush and the ends aligned with cauls.

options, see the article "Is your finish food-safe?" at woodmagazine.com/foodsafef.

6 To prevent the board from slipping during use and to allow air underneath it for drying, drill pilot holes and screw six 3/4"-diameter rubber bumpers to its bottom, where shown on **Drawing 2**. Now gather up some fresh vegetables, and start slicing and dicing! 🍴

Written by **Owen Duvall**
Project design: **Jeff Mertz**
Illustrations: **Mike Mittermeier**

3 tips for taking care of your cutting board

- 1** After use, hand-wash the cutting board in warm soapy water, rinse it clean, and wipe it dry. Never let it soak in water.
- 2** At least every three months or whenever the wood looks dry, reapply a protective oil finish, such as

mineral oil, to prevent water from penetrating and damaging the wood.

- 3** When the cutting surface becomes heavily scored, sand it with a random-orbit sander, starting with 80-grit and progressing to 180-grit sandpaper. Then reapply the finish.

Supplies: Waxed paper, mineral oil, 3/4" rubber bumpers with screws (6). We found the oil and bumpers at a hardware store.

Bit: 3/8" round-over router bit.

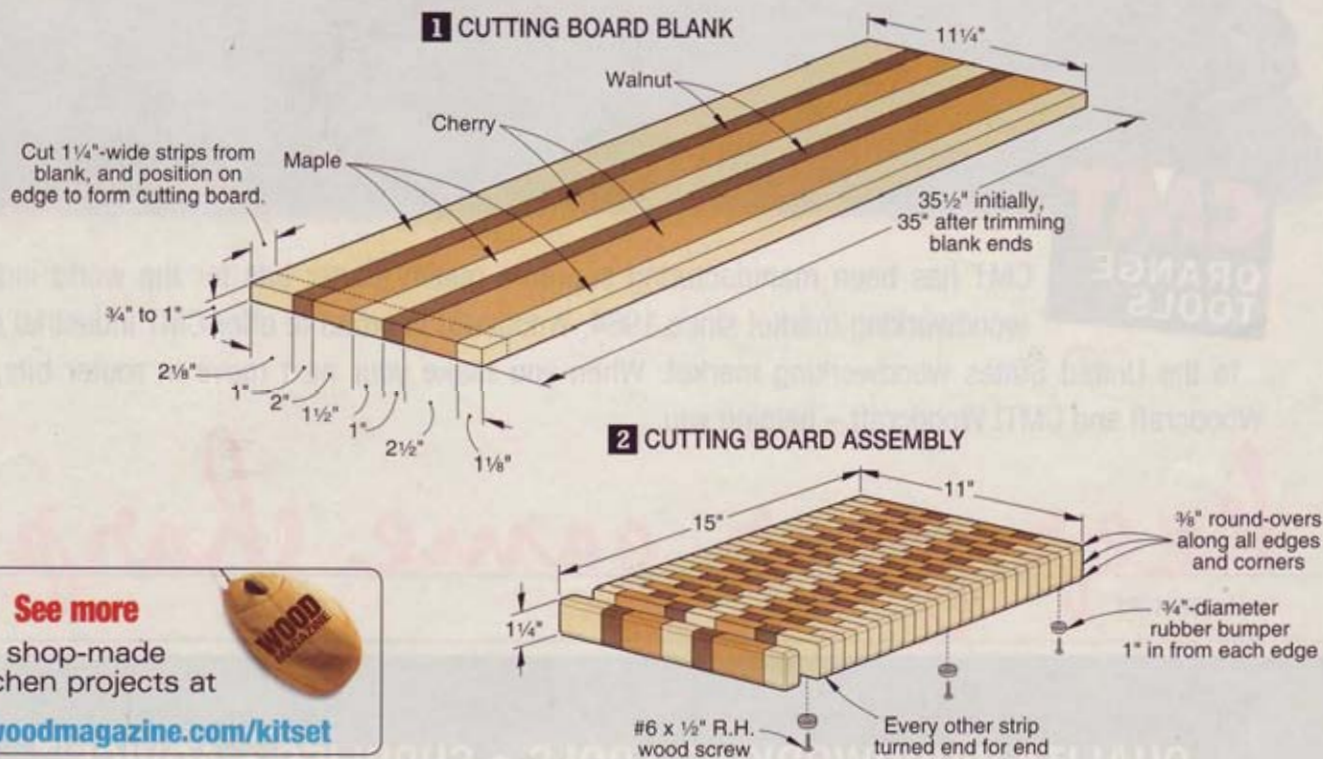

See more shop-made kitchen projects at woodmagazine.com/kitset

Better Homes and Gardens®

WOOD PATTERNS®

October 2006

Issue 172

Dear Reader: As a service to you, we've included full-size patterns on this insert for irregular shaped and intricate project parts. You can machine all other project parts using the Materials List and the drawings accompanying the project you're building.

©Copyright Meredith Corporation, 2006. All rights reserved. Printed in the U.S.A. Meredith Corp., the publisher of *WOOD Patterns*® allows the purchaser of this pattern insert to photocopy these patterns solely for his/her own personal use. Any other reproduction of these patterns is strictly prohibited.

Wine Cabinet, Page 38

Tongue Drum, Page 58

Bow Front Table, Page 62

How to cut a straight edge, Page 76



Wine Cabinet, Page 38



Bow Front Table, Page 62

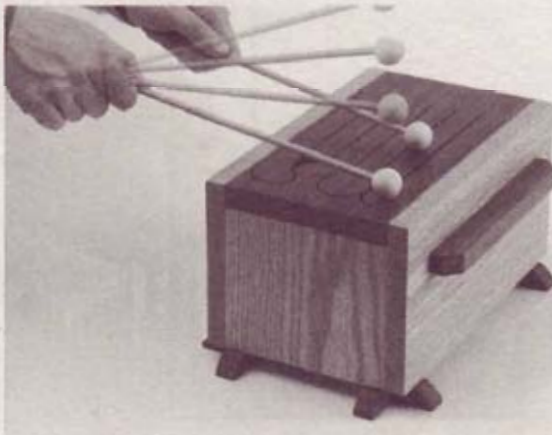

Tongue Drum, Page 58



How to cut a straight edge, Page 76

Bow Front Table, Page 62

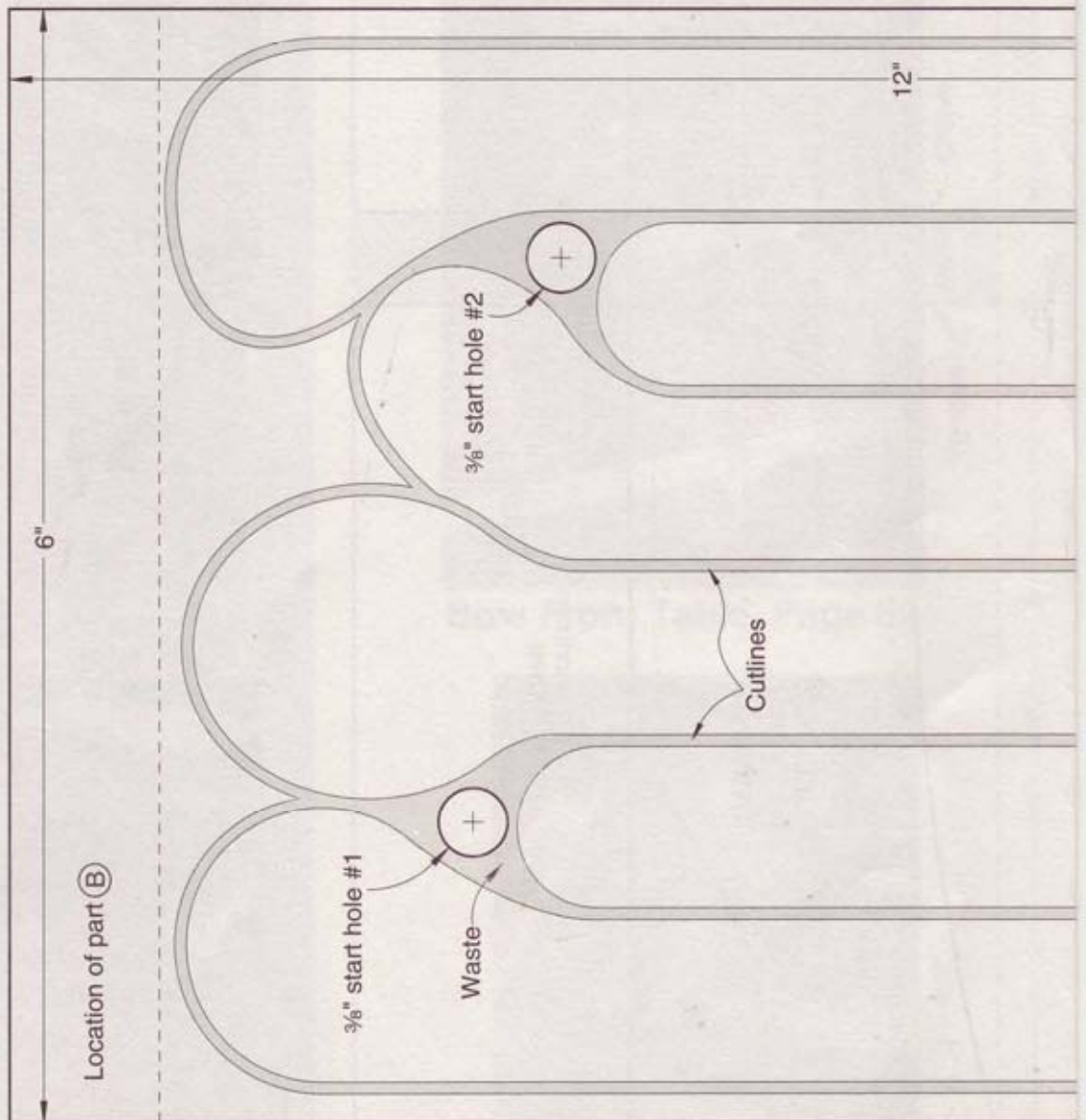
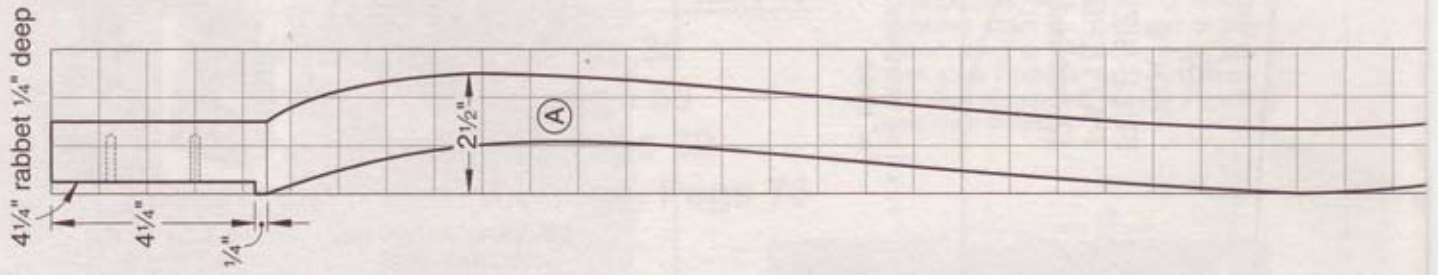

LEG
FRONT
VIEW

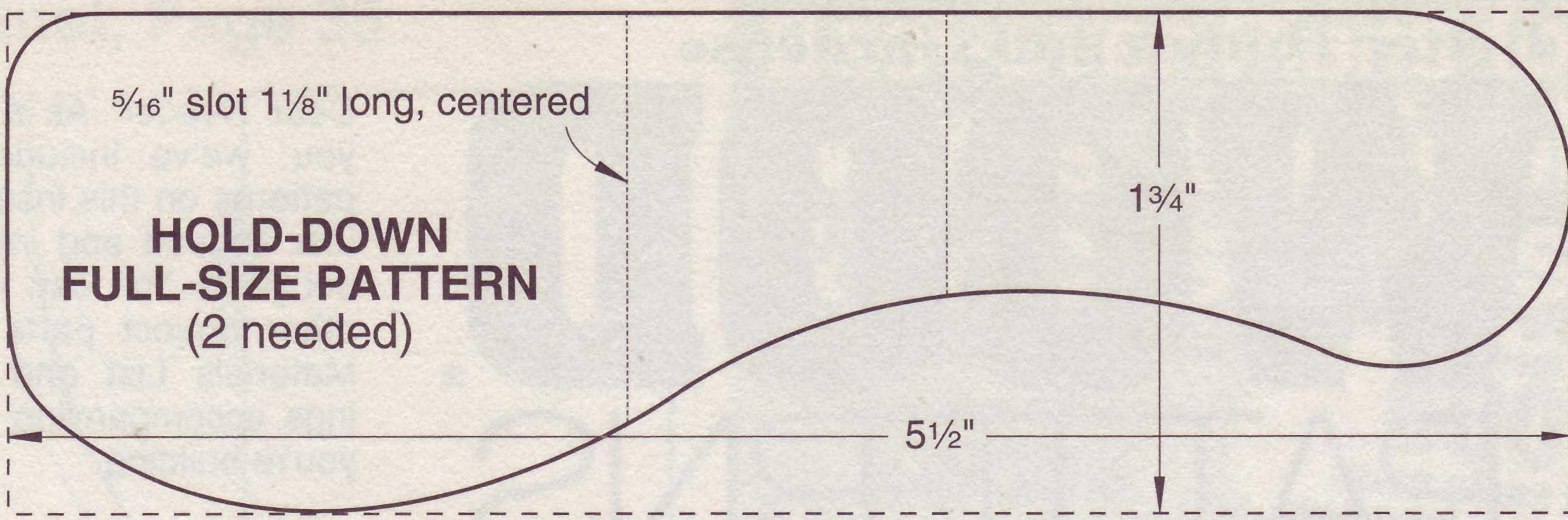
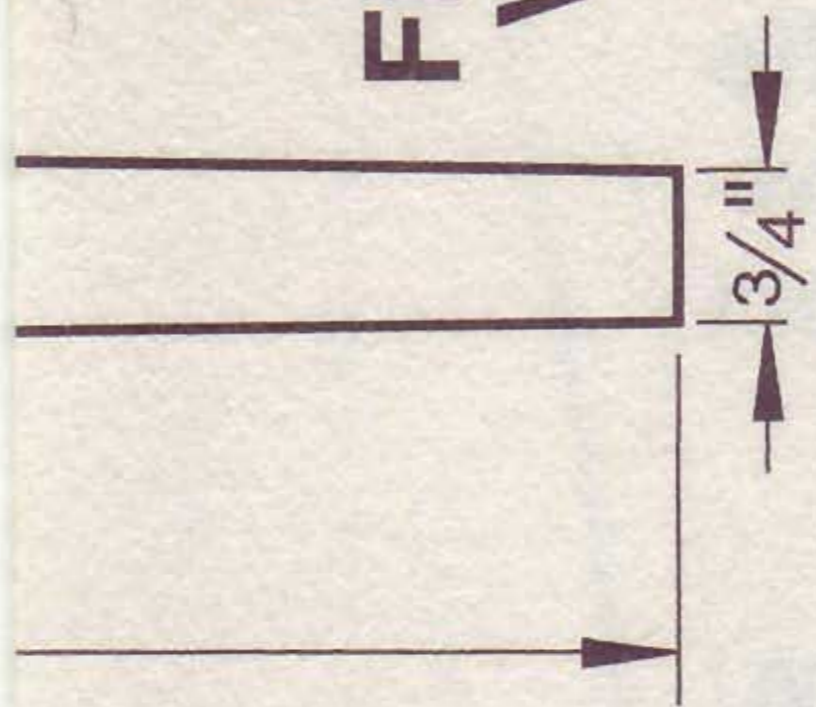

How to cut a straight edge (Hold-down), Page 76

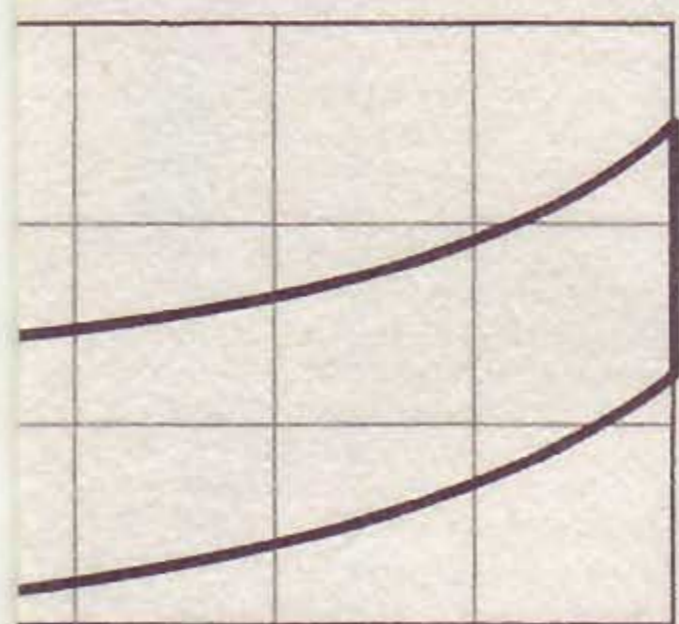

One square = 1"
Enlarge 400%
for full-size pattern.

LEG GRIDDED
PATTERN

Tongue Drum, Page 58

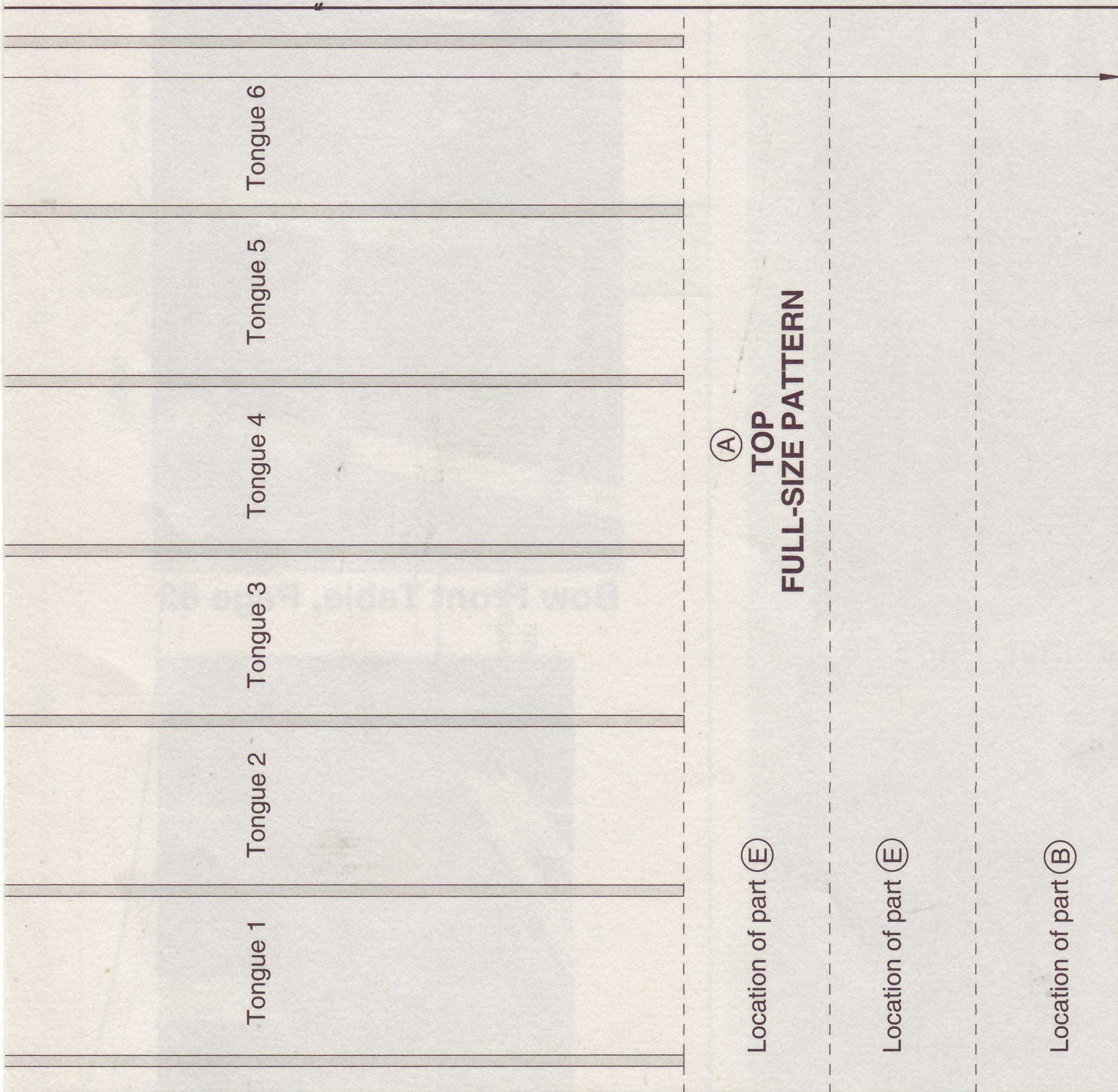

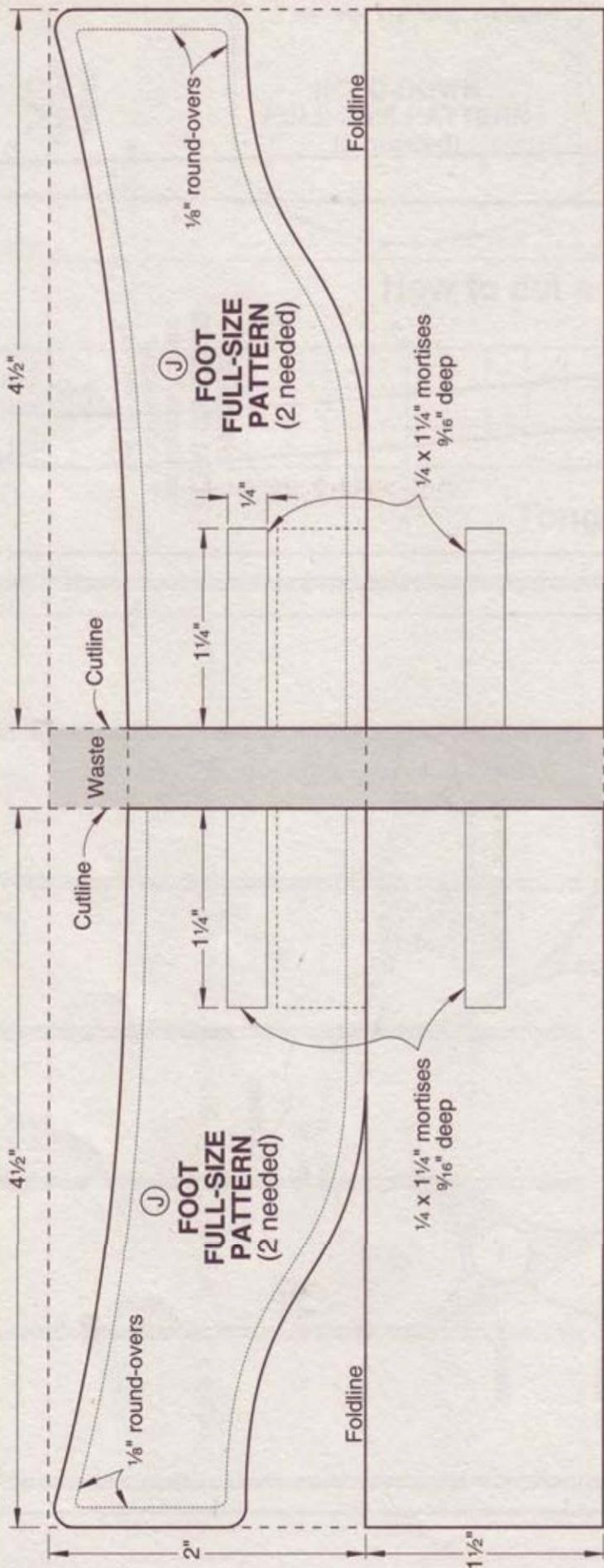

Best-Ever Plans for Workshop Tools & Accessories

from the editors
of **WOOD**
magazine

View over
600
more plans at
woodmagazine.com/plans



Roll-Around Tool Base Plan
DP-00061 \$6.95



Swivel-Topped
Tool Cabinet Plan
DP-00063 \$8.95

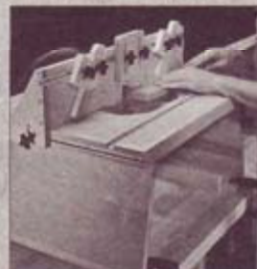

Benchtop Router Table Plan
DP-00151 \$7.95



Universal Wall Cabinet Plan
DP-00140 \$8.95



Space-Saving
Work Center Plan
DP-00168 \$6.95



Lumber Storage Rack Plan
DP-00135 \$7.95



Simple-To-Build
Workbench Plan
DP-00134 \$7.95



Mobile Sawing & Routing
Center Plan
DP-00271 \$7.95

Download any of these woodworking plans at the prices listed above, or have them mailed directly to you for an additional \$3 each. To download a plan or to view a larger image, go to woodmagazine.com/plans. Call toll free 1-888-636-4478 for paper-plan credit card orders.

pack more workshop

If clutter and cramped floor space best describe your workshop, fight back and win with these space-saving ideas.

Nobody plans to mess up the shop; it gets messy for lack of a plan. If you're close to owning an unworkable workshop, devise an organization strategy and take action.

Every woodworker's clutter cure is unique, so pick and choose the ideas shown here that suit your situation. Whichever solutions you go with, you'll first need to do three things:

■ **Define the boundaries of your shop** to determine how much space you actually have. Remember to think vertically, too, not just within your shop's width and length.

■ **Decide what needs to be kept within the shop** and what could be moved elsewhere. Then list the tools you need to accommodate immediately and envision locations for tools you'll own eventually.

■ **Make the same space hold more** or serve multiple purposes. Search out areas with untapped storage potential.

Bust up the clutter

You can't organize your shop until you get rid of needless stuff, so play "moving day." What would you keep or toss if you had to pack everything and move next week? Send everything that's not a keeper to the trash or to the secondhand store. Turn unused tools and loose hardware into someone else's clutter by boxing them up for the next garage sale. Then take nearly empty cans of paint in forgotten colors to your local hazardous waste disposal site.

As you sort, distinguish between tools and supplies for home repairs and those for woodworking. Box up plumbing and electrical specialty tools and fixtures you'll seldom use. Then store them on high shelves or outside the shop.

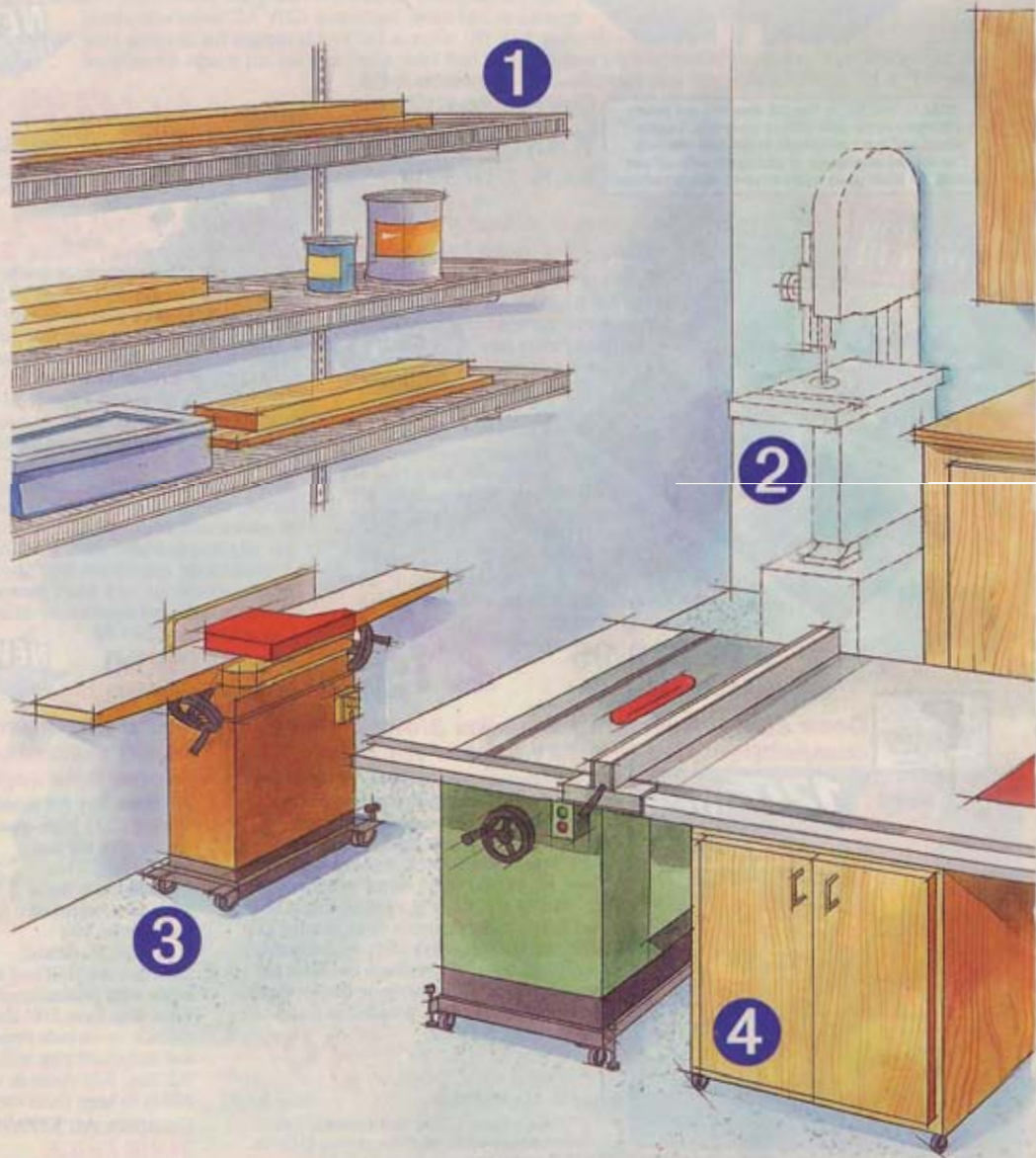

Lay out space for flexibility

When reorganizing your workshop, plan for changing equipment or different woodworking interests, such as woodturning. A single area within your shop can serve both existing and future uses, but only if you design it with that flexibility. Here are 10 ways to make smarter use of the space you have:

1 Adjustable shelving adapts to change better than fixed shelving, especially for storing lumber. The wire mesh shelves

used here provide ventilation for lumber and are readily available at most home centers. Run shelves all the way to the ceiling to use every cubic foot of space.

2 Plan for the equipment you expect to add along with what you already own. That could mean leaving a corner empty until you can afford that bandsaw you've been eyeing, for example. If you're creating

into less space

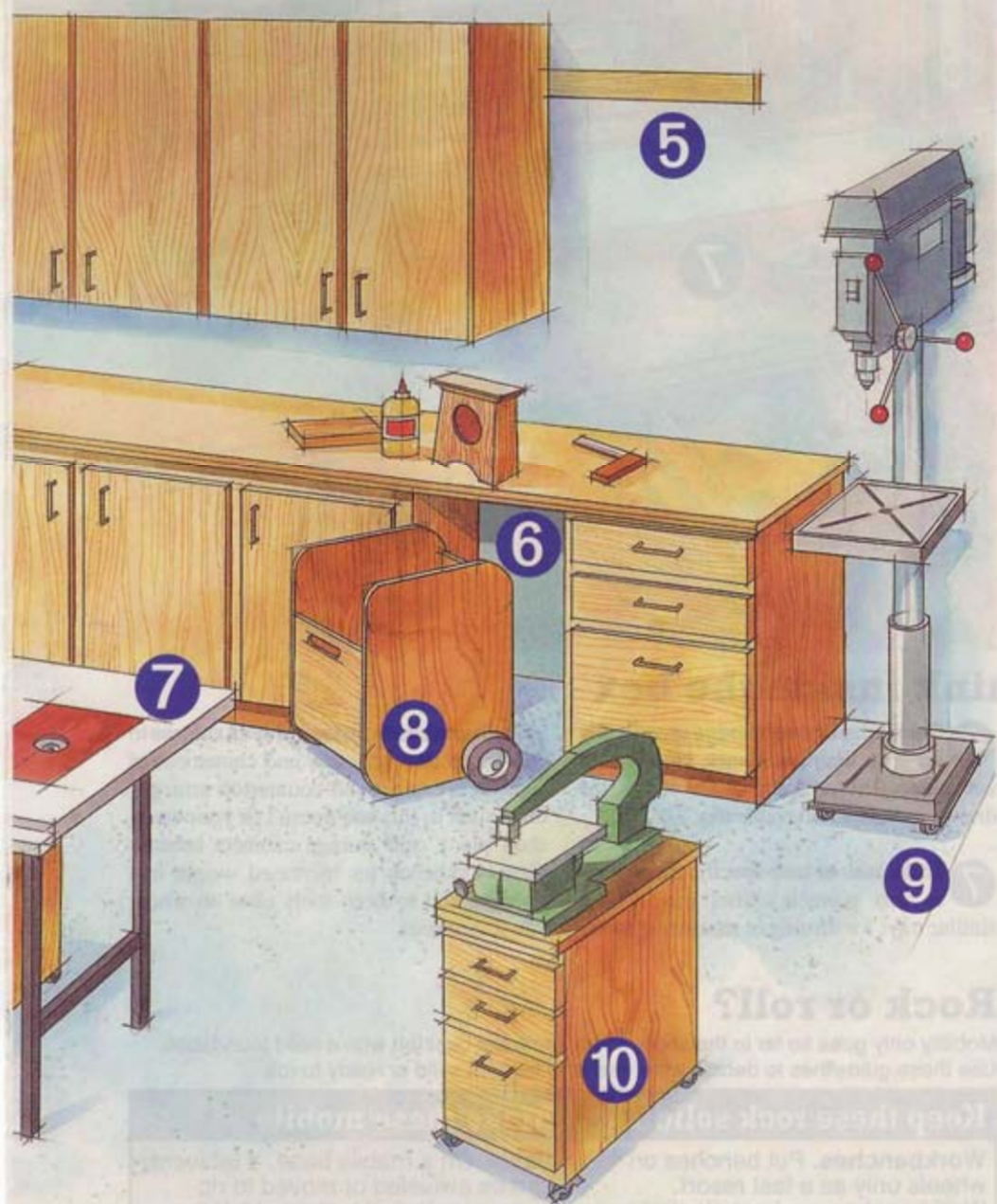

a shop from scratch, add 220-volt outlets to power step-up machinery without the hassle of extension cords or rewiring.

3 Mobility = flexibility. Even if you don't have to accommodate parking in a garage shop, put equipment and storage cabinets on casters and mobile bases. That lets you use the same floor space for more than one task, speeds cleanup, and makes it

easier to accommodate new equipment as your shop expands.

4 Look for neglected spaces to add storage. A cabinet on wheels can be stored beneath a tablesaw extension and rolled out to double as an assembly table. Also, store loose parts in stacking bins beneath jointer tables, between the legs of a lathe, or below a drill press table.

5 Add wall cleats for a more flexible layout. Wall cleats give you the freedom to add or rearrange wall cabinets as your needs change. They also make it easier to build or buy additional cabinets gradually instead of all at once. In addition to cabinets, cleats can hold specialized storage, such as clamp racks and tool boards.

6 Create space where you can sit and work. Between cabinets under a countertop, leave a knee space wide and deep enough to store a mobile storage cabinet or scrap bin. If your countertop stands higher than your tablesaw top, build a rolling storage cabinet short enough to fit into the knee space but tall enough to double as an outfeed support for the saw or other major tools around the shop.

7 Double-duty design uses half the space. Instead of a separate router table that takes up more floor space, drop a router table insert plate into the tablesaw extension. This arrangement lets you use the same fence for two tools.

8 Make a place for wood scraps. For pieces too large for the trash but too small to store with your lumber, build a mobile scrap bin. That way, you create a source for small project parts, scraps for testing blade or bit settings, or just material for building jigs.

9 Fit tall tools into corners. Use gaps between benches or cabinets and walls to store tall, narrow tools, such as a drill press. Mobile bases make it easy to move tools into these tight spaces.

10 Replace steel leg stands with mobile cabinets. This keeps accessories close to the tools that use them, creates a heftier tool base for greater stability, and relieves some of the storage burden on your other cabinets and drawers.

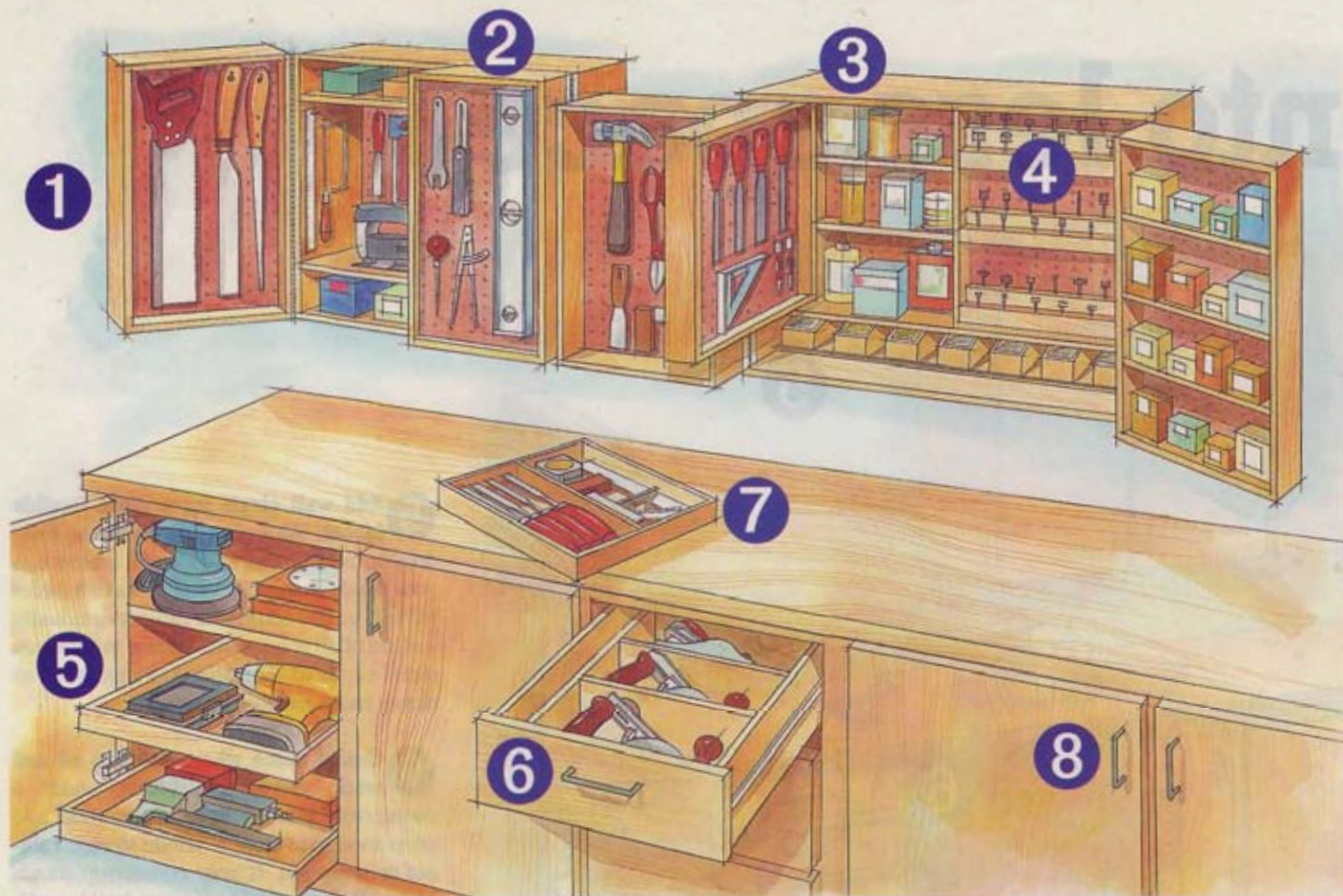

Custom cabinets: Think inside the box

1 **Bump up wall cabinet capacity** by fitting them with clamshell doors. Use the inside cavity to hang tools, or fit it with shelves to organize fasteners and loose hardware. Then customize the outside of the door for hanging storage.

2 **Add dimension to storage.** Perforated hardboard provides easy-to-install storage, but alternative methods use space more efficiently. Instead, buy or build cabinets that hold more tools in less wall space.

3 **Add cabinets that create storage within storage** to hang tools and organize accessories. The accordion cabinet (*page 46*) uses two interior doors with perforated hardboard for layers of hanging storage.

4 **Replace space-eating drill and router bit packages** with a storage cabinet that holds everything you need, including wrenches, collets, and accessories.

5 **Use slide-out trays in base cabinets** to provide access to the contents with less bending or kneeling. For a simpler alternative, fit cabinets with adjustable shelves to keep tools and supplies from being heaped on each other.

6 **Customize drawer storage** specifically for such items as planes, chisels, and saw blades. Allow space at the top of the drawer to hold a removable tray.

7 **Make tool- or task-specific trays**, such as this portable chisel tray. Create similar trays for turning or measuring tools.

8 **Use cabinets instead of open shelves** to keep dust off tools and clutter out of sight. If a cabinet and countertop arrangement such as this one doesn't fit your workshop plans, add storage cabinets beneath your workbench for increased weight and stability and to keep tools close to where you'll use them.

Rock or roll?

Mobility only goes so far in the shop; some items are best left with a solid foundation. Use these guidelines to decide what needs to be rock solid or ready to roll.

Keep these rock solid	Make these mobile
<p>Workbenches. Put benches on wheels only as a last resort. Workbenches are best planted in one spot for greater stability.</p>	<p>Saws. On a mobile base, a tablesaw can be swiveled or moved to rip large panels and tucked out of the way when not in use.</p>
<p>Lathes. The vibration of a lathe makes it a poor candidate for mobile bases and casters. If you need mobility, use wheels that retract completely or low, removable rolling dollies.</p>	<p>Drill press. A mobile base allows you to wheel this tool into a corner of the shop when not in use.</p>
	<p>Router tables. Shaping long stock is as easy as wheeling your router table into a wide-open work area.</p>
	<p>Jointers/planers. Jointers can be mounted on bases with retractable wheels. Planers can be attached to cabinets with locking casters.</p>

Space-stretching tips just for garage shops

1 No space goes to waste. Put that area above your garage door to work by suspending a platform beneath the ceiling. It's a handy spot for lumber, tool cases, and household items you moved aside to make room for your shop. Just make certain you've firmly connected the framework to the ceiling joists.

Need temporary storage for a couple of long pieces of lumber? Rest them on the garage floor centered between the wheels of your car. Raise the boards off the floor using scrapwood supports, and cover them to guard against vehicle leaks.

2 Up against the wall. Sheet goods leaning against a wall waste space and tend to warp. Solve both problems with a simple bungee cord. Mount eye hooks into the wall studs more than 8' apart, center the panels between the hooks, and pull them tightly against the wall with a pair of bungee cords hooked at the middle. Most panels are 4' wide or less, leaving plenty of room for shelves above your sheet goods.

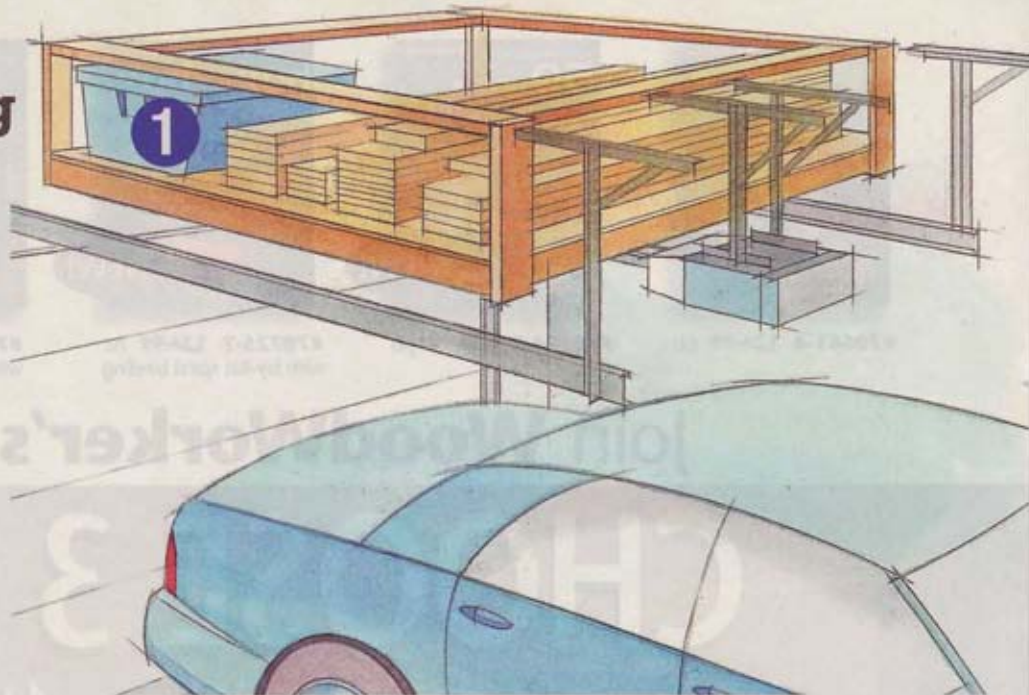

3 Put high walls to work. Not all storage needs to be within easy reach. Use the high walls in your garage to add one additional layer of storage for items you'll use infrequently. Mount cabinets in the space above your car hood. You'll add storage without sacrificing parking space. 📌

Written by **Robert Wilson**
Illustrations: **Brian Jensen**

Use every cubic foot of your shop

Even little changes can add up to big space savings. Here are five more ways to stretch your shop:

■ In basement shops, drive nails or pegs into the overhead joists to hang clamps conveniently close to your workbench.

■ If you can't foresee when you'll have time to build shop cabinets, don't wait. Get started with inexpensive, ready-to-assemble cabinets from a local home center. Then customize these basic boxes with add-ons, such as router-bit holders, tool racks, and additional shelves.

■ Handle every incoming item only once. For example, don't leave that new box of screws you just bought resting on your workbench just because you're in a hurry. Take the extra 15 seconds to store it now and you'll save yourself 15 minutes of clearing accumulated clutter later.

■ Don't stop with your shop. Add or improve storage throughout your house to create places for items that don't belong in the workshop.

■ Create a limbo box for all those doodads you toss into your shop when you're in a hurry thinking they're too handy to pitch but not ready to store. When the box fills up, it's judgment day: time to sort the trash from the treasures.

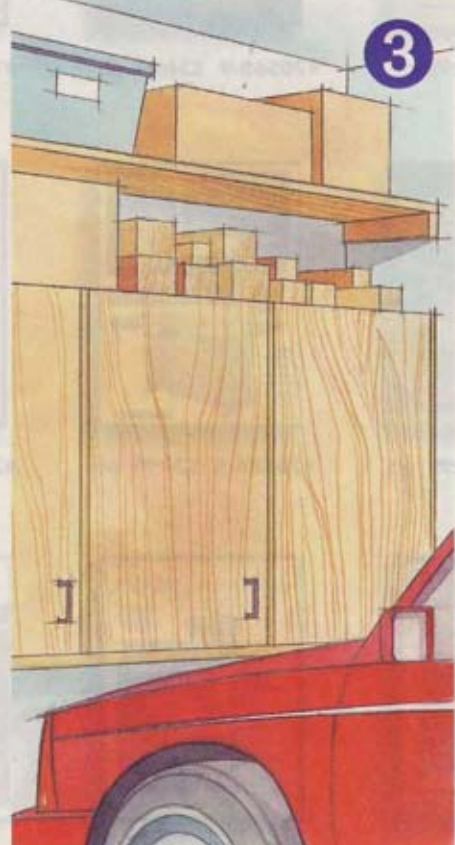
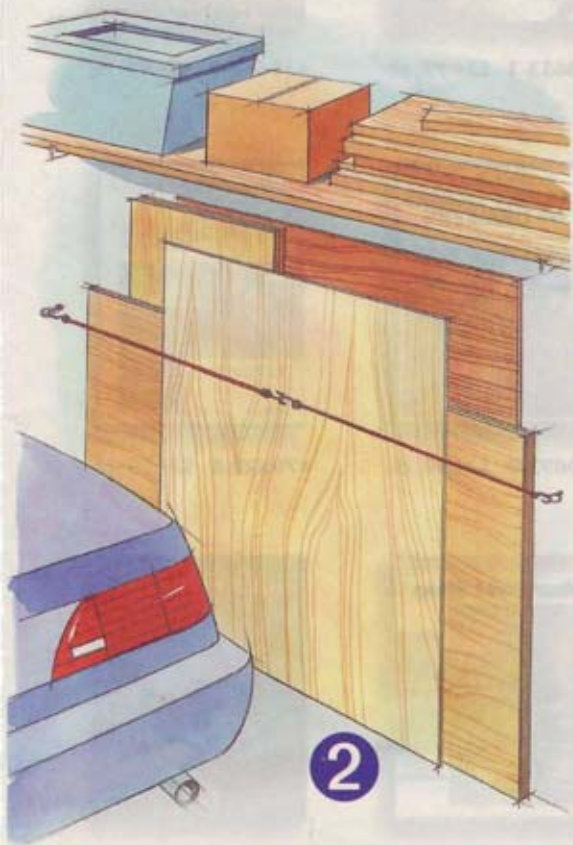

mix-and-match

cutting-board designs

Simply alter the blank for fresh new looks.

I enjoyed coming up with the design for the cutting board featured on page 82 so much that I created these additional designs for you to try. To produce the patterns, combine contrasting wood strips of different widths to form the cutting board blanks shown below, making sure that the blank wood patterns—when reversed—off-

set all of the joint lines by at least $\frac{1}{4}$ ". Although there's no rule for the strip widths, I kept them between $\frac{1}{2}$ " and $2\frac{1}{2}$ " to take advantage of narrow scrap-bin rippings.

To make either of these cutting boards, follow the instructions in the referenced article, cutting the blank strips to the widths

shown below. Or if you feel adventurous, try your hand at a new design, now that you know the offset secret.

Jeff Merty

Design Editor

Design Option 1

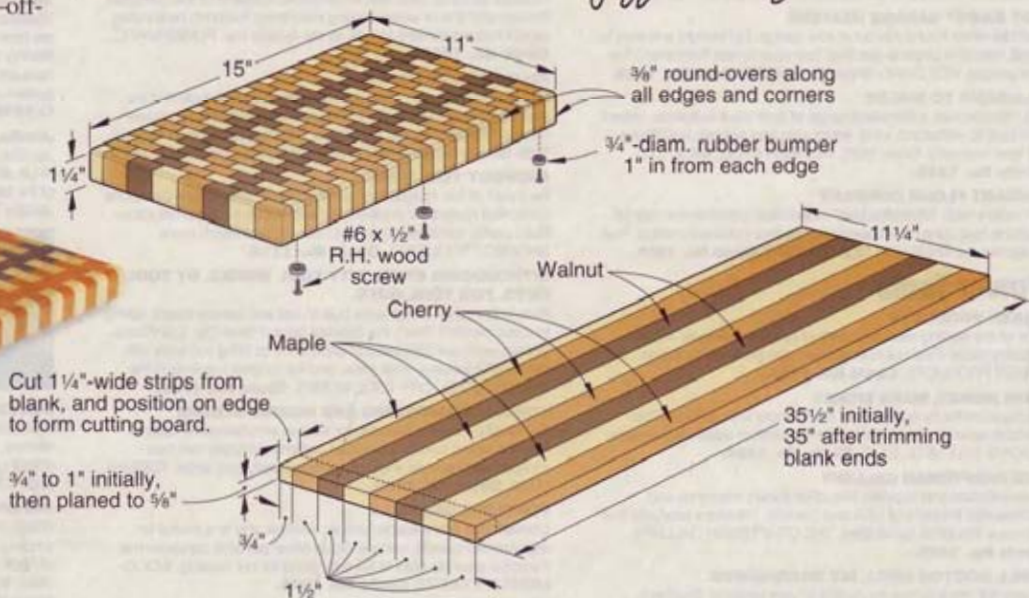

Design Option 2

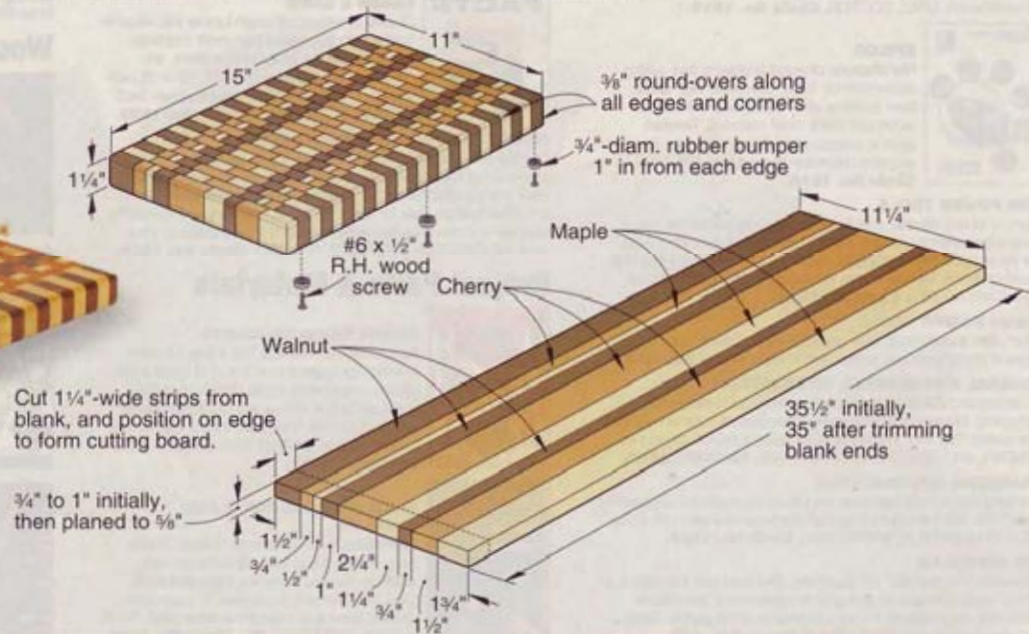

shop-proven products

These woodworking wares passed our shop trials.

Planer-size drum sander leaves a smooth surface and saves you money, too

Anything that eliminates the drudgery of hand-sanding is okay in my book—that's why I use a drum sander. Like most home-shop drum sanders, mine features one open end that permits sanding pieces up to twice as wide as the drum. It thickens as reliably as a planer (but slower), and leaves a finer finish on my workpieces. From a space standpoint, though, a drum sander is just one more big stationary tool I have to walk around.

But Grizzly's G0459 Baby Drum Sander, with its 12×22" footprint, takes up only a little more room than a typical benchtop planer. (Although, at 150 pounds, it weighs about twice as much.) And, like industrial-scale drum sanders, both ends of the G0459 are closed. That means two things: There's no deflection of the drum, as you sometimes can find on open-ended sanders; and you can't sand anything wider than 12". I'll bet that 90 percent of the pieces I shove through my drum sander measure less than 12" wide, so that capacity is plenty for me.

Another feature that separates the G0459 from other drum sanders: its conveyor belt that pulls wood through the machine. Most machines use an abrasive belt, but this sander's rubbery belt (again, borrowed from industrial drum sanders) seems to grip better. And it tracked true right out of the box.

You won't waste any time getting to work, because the sander comes completely assembled, save for installing the crank handle and dust port. I was surprised to see only a 2½" dust port on the G0459, but when I hooked it up to my shop vacuum and then sanded 10"-wide walnut boards, little or no dust escaped.

Hook-and-loop sanding strips, 3" wide, make changing worn abrasives a breeze. The ends of the abrasive strips tape down with strapping tape, which isn't as sexy as fancy clips, but equally effective.

—Tested by Pat Lowry



Baby Drum Sander G0459

Performance	★★★★★
Price	\$425
Grizzly Industrial 800/523-4777; grizzly.com	

Full-on clamping pressure with a flick of a lever

Remember the days when every clamping operation was a chore because you had to twist a handle or crank to tighten the jaws? Pistol-grip style bar clamps made the job easier, but VersaClamp simplifies clamping even more with a lever-activated cam to apply pressure. Like a clamp-on tool guide, you simply slide the movable jaw so that both jaws touch the assembly you want to clamp, and then push the lever down. Instantly, 400 psi of pressure is applied to the joint. (By comparison, pistol-grip bar clamps deliver about 200–250 psi; a threaded-jaw clamp can go to 1,000 psi.)

Mount a VersaClamp to the front edge of your bench (or sawhorses, as shown at right) using the optional brackets, and it acts like a tail vise and bench dog to secure a workpiece while you work it. You can still easily remove the clamp for handheld use, but the protruding brackets left behind tended to catch on my pockets. I wound up leaving a clamp in the brackets most of the time to prevent that.

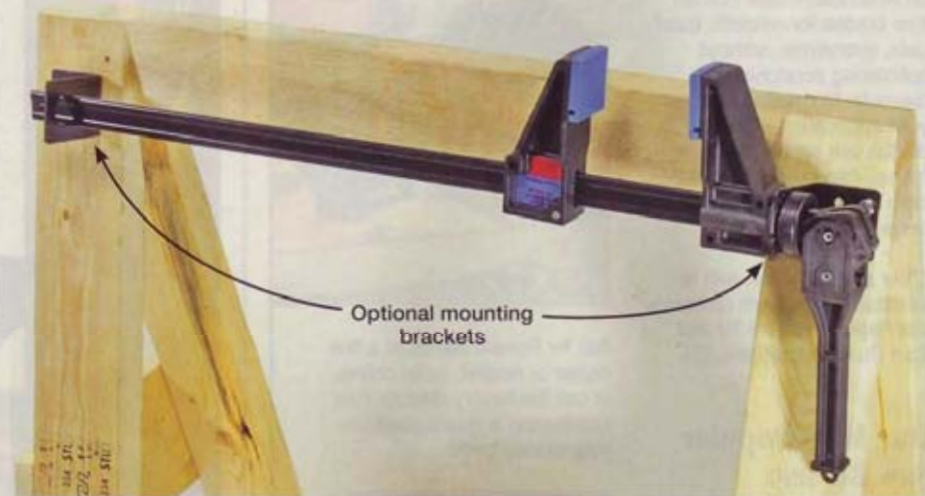

The only other downside is the price. A 20"-capacity VersaClamp runs \$35—about the same price as a 24" Bessey K-Body clamp that boasts large, parallel jaw faces and more clamping pressure.

—Tested by Randy Zimmerman

VersaClamp

Performance	★★★★★
Price	\$35; mounting brackets, \$5/pair
T.S. Tool Co. 812/933-5421; tstoolco.com	

Stop bleeding: Nip workshop nicks fast

When you told your wife you were going to the shop to stain a project, you probably didn't mean with your own blood. But any time you work with cutting tools, there's always a chance that you'll cut yourself. QR powder—the same stuff used by sports teams and physicians to stop bleeding—is available for your shop and home.

Recently, a bench chisel "bit" me on the finger when I instinctively reached for the tool as it fell off the bench. The cut was deep enough that I would have had to stop what I was doing, and go in the house to hunt for the antiseptic and a bandage. Total downtime: maybe 10 minutes.

Instead of a bandage, though, this time I cracked open a plastic bubble of QR powder, painlessly poured it over the open cut, and tamped it down with my finger. Within about 15 seconds, an artificial scab had formed. I shook off the excess powder and went back to work.

QR doesn't contain antiseptic, so you still have to cleanse the wound from dirt and contaminants to prevent infection. I forgot to, but the next day I noticed that the cut area wasn't red, tender, or swollen, so the "instant scab" works as advertised, allowing the healing to begin quicker.

—Tested by Jeff Mertz



QR Quick Relief

Performance ★★★★★
Price \$6 (four single-use applications)
Biolife
800/722-7559; biolife.com

continued on page 102

Handle the Suits

In the ruggedly handsome,
stain and rain shedding,
pockets-for-everything
PRESENTATION JACKET!

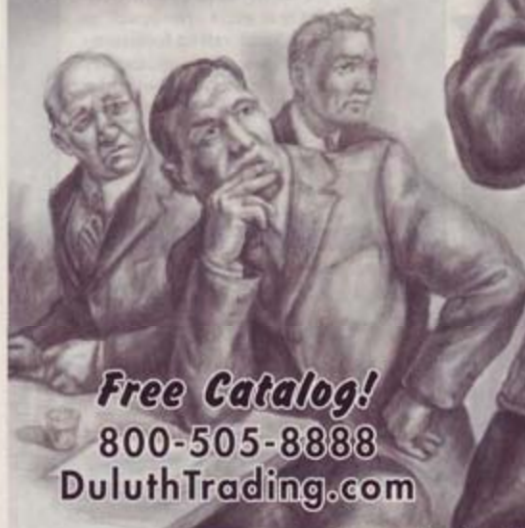

Free Catalog!
800-505-8888
DuluthTrading.com

DULUTH
TRADING & CO.
G&H

Circle No. 573

Circle No. 1301

Warm to the comfort of radiant heat

RADIANT

Floor Company

Efficient, Quiet, Reliable

It's never been easier to do it yourself

compatible
with any fuel source:
GAS, PROPANE
SOLAR, OIL, WOOD
ELECTRIC,
GEOTHERMAL



VISIT OUR WEBSITE
CALL FOR A FREE QUOTE
www.radiantcompany.com

Barton, Vermont
(toll free) 1.866.WARM-TOES (927.6863)

Circle No. 1301

**LOWEST PRICES
UNBEATABLE QUALITY**

**PRO CABINETMAKER
6 pc Door Set**

- 1/2" Shank Router Bits
- 2-pc Rail & Stile (Roman Ogee)
- Drawer Lock
- 3 1/4" D Panel Raiser (Ogee) w/ UnderCutter
- Door Lip
- Reversible Glue Joint

ONLY \$119 set
\$175 VALUE WL-2020-1



CARBIDE



BLOWOUT
OEGEE CLASSICAL COLLECTION!
Add that extra little touch to your handcrafted furniture, table edges, moldings, drawers, picture frames, cabinet doors and so much more!
ONLY \$85
REG \$99 - WL-2016

800-472-6950
ORDER 24/7
WOODLINE.COM

FREE STRAP CLAMP

8 Piece PICTURE FRAME SET
Perfect for making great looking picture frames. Bits can be combined to form complex moldings or simple decorative frames.

OUR PRICE ONLY \$75 set
WL-2008
\$189 VALUE

CARBIDE

66 Piece Master Woodworking Router Bit Collection

This may not be every bit you'll ever need, but it's close! Use this set to complete your collection!

WL 2066 1/2" Shank..... **\$189**
WL 2065 1/4" Shank..... **\$189**

CARBIDE



FREE!

WORKHORSE ROUTER TABLES

PALAMINO Router Table

3-1/4" HP ROUTER WHILE SUPPLIES LAST

- Portable design for ease of use
- Quiet deluxe cabinet base
- Laminated 12 ply birch 1-3/16" ultra flat top
- Deluxe fence system
- Fits all routers with up to 3-1/2" diam. bits

ONLY \$249
REG \$295 + \$169 Router- WL-TAB2

FREE CATALOG 1-800-472-6950 **WOODLINE USA**
111 Wheeler St, LaVergne TN, 37086

shop-proven products

Remove damaged screws with GraBit

In 30 years of woodworking, I've damaged more screwheads than I can remember. Soft brass screws are the most susceptible, but even the heads of today's inexpensive steel screws tend to shred under the influence of a cordless drill/driver. Once damaged, you can't drive 'em in, and often can't back 'em out. But GraBit screw extractors give me a way to back 'em out.

Each end of the GraBit bit has a different function: The burnishing tip bores and smooths a shallow dimple in the messed-up screwhead. Flip the bit around to expose the reverse-spiral extracting tip; then use your drill/driver, *slowly*, in reverse. The spiral bites into the dimple, and out comes the screw. The key, I found, is to create a smooth dimple for that spiral to seat in.

To test GraBit, I intentionally bunged up a Phillips-head brass hinge screw so badly, I couldn't even see where the drive slots had been. To my surprise, the burnishing/extracting process worked exactly as advertised. In fact, no matter what kind of screw I tried it on—steel screws, drywall screws, brass screws, Phillips, slotted or square drive—GraBit worked in them all.

The 2-piece set works on screws from size #6 to #14, and should be in every woodworker's toolbox. The manufacturer suggests not using GraBit on screws longer than 2". Such screws provide more resistance than the extracting tip can overcome.

—Tested by Pat Lowry

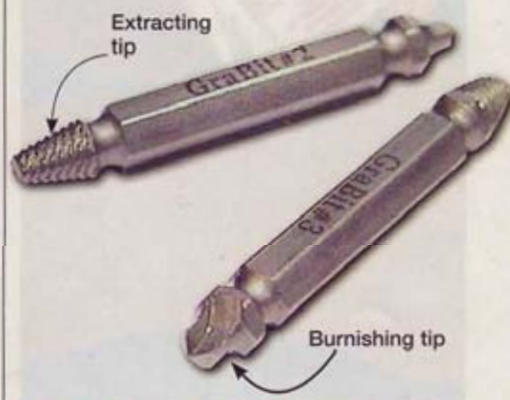

GraBit Damaged Screw Remover

Performance **★★★★★**
Price \$18 (#820P two-piece set)

Alden Corporation
800/832-5336; aldn.com

continued on page 104

Dust Deputy puts the cuffs on sanding dust

A dust collector gobbles up debris created by machines such as a table saw, planer, or jointer. But for portable power tools with small dust ports, a shop vacuum works more effectively—that is, until the vac's filter becomes choked with fine dust. If only someone would come up with a device to keep my vac performing at its peak by preventing that dust pack.

Oneida's Dust Deputy does just that. Connected inline between the tool and the vacuum, this heavy steel cyclone separator acts like a full-size cyclone, allowing only the smallest particles to get into the vac's

tub. I'll admit I was skeptical, but my tests made me a believer.

After washing out my vacuum's tub, I connected its hose to Dust Deputy's 2" top outlet. Next, I hooked up another hose (an optional hose kit from Oneida) between the Deputy's 1/2" side inlet and my random-orbit sander. Finally, I hogged away a scrap of hard maple with 80-grit paper. After 10 minutes of sanding, I stopped and popped off the vacuum's lid. Only when I wiped the inside of the vac tub did I see a trace of dust. On the other hand, a quick check of Dust Deputy's 10-gallon steel drum

showed the interior completely coated with fine maple dust.

Thinking I hadn't challenged this mini-cyclone enough, I thoroughly cleaned the vac tub and the drum, hooked up my big drum sander to the inlet, and again fired up the vacuum. This time,

I continuously fed 10"-wide maple and walnut boards, stopping only long enough to lower the sanding drum slightly between passes. After abrading more than 40 lineal feet of wide stock, I checked the tub and drum and found the same result: very little dust in the vacuum, and a deep, swirly dune of dust in the

bottom of Dust Deputy's drum. It really performed well. But then it should for \$200 (not including the optional \$30 hose that runs between the tool and the Deputy; you could also use your own).

You can cut your cost in half, though, if you buy the DIY Package that mounts on your own 5-gallon bucket. I assembled this model with a scrap of plywood, gasket material (I used an old router pad), and a few bolts in less than 30 minutes. It worked every bit as well as the Complete system. ♣

—Tested by Pat Lowry



CO₂ Laser Engraving,
Cutting and Marking Systems
Starting at \$9,995!

Unmatched Quality, Performance and Reliability.



Adding engraving capabilities to your business has never been more affordable. Engrave and cut photos, clipart, logos and more - and it's as easy to operate as a printer. Call us today toll free at 888-437-4564 to receive a free brochure, sample kit and a CD demo of the system in action!



16371 Table Mountain Pkwy. • Golden, CO 80403
Toll Free: 1.888.437.4564 • Phone: 303.277.1188
sales@epiloglaser.com • www.epiloglaser.com/bhg.htm

Dust Deputy

Performance ★★★★★
Price \$200, Complete; \$130, DIY Package

try gauge blocks for fast set-ups

Once you've fussed over setting the perfect height for a table-mounted router bit, make a gauge block so next time you can skip the hassle.

Which bits need blocks?

Creating gauge blocks for the following router bits makes good sense:

- Matching pairs, such as cope-and-stick bits, used to make rails and stiles on doors and windows, or tongue-and-groove bits.
- Bits requiring precise alignment, such as those designed for cutting finger joints or raised panels.
- Any bits that you use to match existing profiles, such as on molding or trim.

Build blocks that will last

Machine your gauge blocks from hard, tight-grained wood, such as maple, cherry, or walnut, or medium-density fiberboard (MDF). If you think changing humidity might cause wood blocks to swell or shrink, make them out of ultra-high molecular-weight polyethylene (UHMW), as shown *below*.

Start with a blank at least 4" wide and 6–8" long. Plane blanks to the same thickness as the workpieces you would ultimately use on a project. For example, if your rails and stiles for raised-panel doors typically measure 3/4" thick, make your gauge blocks to match.

WOOD OR UHMW: YOUR CHOICE



UHMW, at right, machines just as easily as wood and won't change size or shape with seasonal variations in humidity.

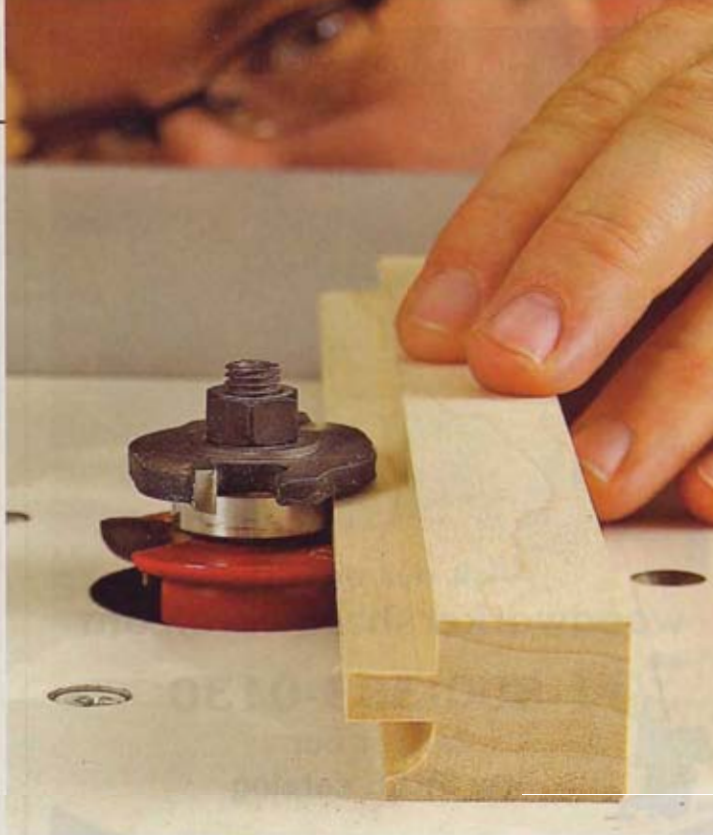

Now set up the bit in the router table as you would for a project part. Make test cuts on scrap to perfect the settings; then rout the profile onto the blank, as shown *below*. Repeat the process for the mating bit (if any), and then machine the opposite edge of the blank. Finally, rip the gauge blocks to about 1/2" in width. Sand away any splinters or rough areas, being careful not to alter the profile.

How to use gauge blocks

To set up a bit, first raise it to the approximate height. Make sure the router is unplugged. Place your matching gauge block—centered on the bit—with the profile against the bit. Raise or lower the bit until it slides perfectly into the routed profile on your block, as shown at *right*,

ROUT; THEN RIP



Cutting a gauge-block profile on wider stock, before ripping to width, proves safer than routing narrower pieces.

and lock in the height. Now set up your fence or miter gauge as needed. Note: While gauge blocks are helpful in set-up, always rout a test piece first to confirm the accuracy.

Store your gauge blocks near your router bits or router table, either in a cabinet or drawer. Or, drill a hole near one end, to hang them on a nail or hook. To avoid confusion later, write on your gauge blocks which router bits they match. ♣

Source

UHMW: 3/4x4x48" \$20, plus shipping and handling, Amazon.com.

MATCH THE BIT TO THE BLOCK

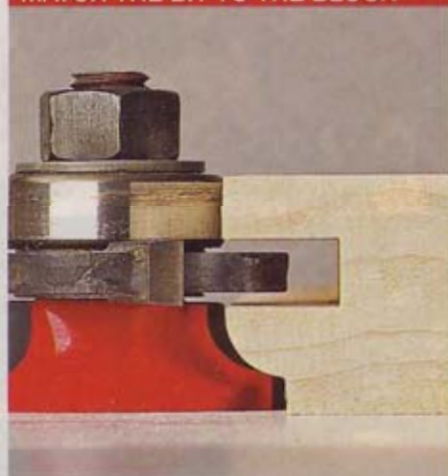

With the router unplugged and the bit tightened into the collet, lock in its height when the bit aligns with the gauge block.

what's ahead

A sneak peek inside the November issue (on sale October 10)

Get a head start on holiday gifts

FEATURED PROJECT



Accommodating 3-in-1 Bed

At last! A bed that stays with a child from infancy to the teenage years and beyond. It changes from a baby crib to a toddler bed to a full-size bed. Simple fasteners make it easy to swap out the sides and footboard.



Magic-wand kaleidoscope

Here's a way to dazzle kids that doesn't require batteries, computer chips, or software. And it's simple to assemble.



Tile-topped keepsake box

Build it in a weekend, add an eye-catching tile, and you'll have a present sure to please anyone on your list.

Make the most of your time in the shop

TOOL TEST



Benchtop planers

Don't buy your next thicknesser until you check out this comparison of today's top 10 machines.



Planer tips and tricks

This tool can do a lot more than plane boards to thickness. Here's how to expand its job description.



Oil vs. film finishes

Woodworkers tend to swear by one of these finishes. Some of us swear at both. Learn to get the best results from each.



Wood-joint torture test

What's the strongest way to join two workpieces? How strong is strong enough? Our scientific trials tell all.