

14 PROJECTS FOR YOUR HOME AND SHOP!

ISSUE 175 MARCH 2007

Better Homes and Gardens®

BONUS!  
FULL-SIZE  
PATTERNS

# WOOD

## 39 Must-have Tips & Skills

- Fast Fixes for Misplaced Holes p.104
- Secrets for Steam-bending Wood p.105
- Choosing Wood for Top Results p.62
- Join Frames without Fussy Miters p.82

## Build this Super-Easy BLANKET CHEST p.40

### TOOL TEST

Rejoice!  
Through-  
dovetail jigs  
are now  
idiot-proof

p.77

Make a Miter Saw  
Stand from One  
Sheet of Plywood p.68

Discover a  
"no-sweat" way to  
install cedar lining

Display until March 30, 2007

0 3 >



9 2567 14072 5

56 99 U.S. / \$7.99 CAN





# in this issue



72

68



58



## PROJECTS

- 22 easy-access drill-bit carousel
- 40 cedar-lined blanket chest  
Install store-bought cedar strips to give your chest's interior an authentic look and aroma.
- 48 turned top with a textured surface
- 56 steam-bending chamber and form  
Use these simple shop projects to bend wood.
- 58 simply graceful plant stand  
Only six pieces make up this table, including three curved, steam-bent legs.
- 68 expandable miter saw platform
- 72 three full-length wall mirrors  
Choose the style option that best suits your home.
- 86 four whimsical keepsake boxes  
Scrollsaw and assemble the dolphin, duck, teddy

## TECHNIQUES

- 50 chatter turnings for a textured look
- 52 how to steam-bend wood  
See a master woodworker use an ages-old method to bow project parts for a special design element.
- 62 let grain reign  
Discover the tricks for choosing and using the right piece of wood for every project.
- 82 no-fuss dowel and half-lap joints
- 94 how to prevent miter saw kickback
- 104 make misplaced drill holes vanish
- 106 steps to center your router's subbase

- 26 build-a-gift contest winners  
View 24 well-crafted (many original) entries sent in by participants from across the country.

## TOOLS & MATERIALS

- 77 through-dovetail jigs under \$350  
We tested 10 router-assisted jigs and picked winners in three price ranges.
- 96 three shop-proven products

## DEPARTMENTS

- 6 editor's angle
- 12 sounding board
- 14 ask *WOOD*
- 30 shop tips
- 116 what's ahead



77



40



52



This seal is your assurance that we build every project, verify every fact, and test every reviewed tool in our workshop to guarantee your success and complete satisfaction.





96



## WATCH WOOD BEND!

Steam-bent wood adds a graceful, "how'd-you-do-that?" element to projects like the Plant Stand on *page 58*. You'll be amazed at how flexible hardwood can become when you watch our free two-minute video on steam-bending at [woodmagazine.com/videos](http://woodmagazine.com/videos).

### MORE FREE VIDEOS

- How to turn and apply "chatter" to the Turned Top project on *page 48*.
- Quick and easy sharpening
- How to lay out an ellipse



## GET EXTRA HELP ON THE CHEST



If you plan to build the cedar-lined Blanket Chest on *page 40*, check out the free step-by-step slide show of that project going together in the *WOOD* magazine shop at [woodmagazine.com/slides](http://woodmagazine.com/slides).

### MORE SLIDE SHOWS

- Wedged-tenon bench (issue 174)
- Highlights from the International Woodworking Fair
- Tour the *WOOD* magazine workshop

62



## FAST ANSWERS TO YOUR QUESTIONS

Next time you have a woodworking-related question, go to [woodmagazine.com/forums](http://woodmagazine.com/forums), where you'll find fellow woodworkers willing to help in 14 topical forums ranging from Arts & Crafts Furniture to Finishing. Or, if you have just a few minutes to kill while the glue dries, check out the most interesting discussions near the top of our home page at [woodmagazine.com](http://woodmagazine.com).



82



## EXPERIMENT OUTSIDE YOUR SPECIES



Stuck in an oak and pine rut? Each month in our Woodworking Woods forum ([woodmagazine.com/woods](http://woodmagazine.com/woods)), host and expert Keith Stevens describes the working characteristics of a different hardwood in a post titled "Wood Conversation." January's wood is ash; in February, learn all about mesquite, shown at *left*.



## We asked our staff: What is the one tool in your shop you can't live without?

I bought a drum sander on a lark and have used it on nearly every project since.



My Starrett combination square. It's an equipment setup tool, layout tool, and precision ruler.



Editorial Manager, Tools and Techniques  
**DAVE CAMPBELL**

Executive Editor  
**JIM HARROLD**

Techniques Editor  
**BOB WILSON**

Projects Editor  
**OWEN DUVALL**

Design Editor  
**JEFF MERTZ**

Art Director  
**KARL EHLERS**

Production/Office Manager  
**MARGARET CLOSNER**

EDITOR-IN-CHIEF  
**BILL KRIER**

Managing Editor  
**MARLEN KEMMET**

Senior Design Editor  
**KEVIN BOYLE**

Techniques Editor  
**BOB HUNTER**

Projects Editor  
**JAN SVEC**

Master Craftsman  
**CHUCK HEDLUND**

Assistant Art Director  
**CHERYL A. CIBULA**

Administrative Assistant  
**SHERYL MUNYON**

Photographers

**MARTY BALDWIN, JASON DONNELLY, DEAN SCHOEPNER, JAY WILDE**

Illustrators **TIM CAHILL, LORNA JOHNSON, ROXANNE LeMOINE**

Technical Consultants **JEFF HALL, DEAN FIENE, PAT LOWRY**

Contributing Craftsman **JIM HEAVEY**

Proofreaders **BARBARA KLEIN, IRA LACHER, JIM SANDERS**

**CUSTOMER SERVICE: 800/374-9663**

For more ways to reach us about specific matters, see page 12.

Publisher **MARK L. HAGEN**

**ADVERTISING AND MARKETING**

**CHICAGO:** 333 N. Michigan Ave., Suite 1500, Chicago, IL 60601

Phone: 312/580-7956 Fax: 312/580-7906

Marketing Manager **AMANDA SALHOOT**

Advertising Managers **JACK CHRISTIANSEN, CAROLYN DAKIS**

Direct Response Advertising Representative **RYAN INTERLAND**

Assistants **GAYLE CHEJN, JACI LESKO**

**ATLANTA:** Navigate Media

1875 Old Alabama Rd., Suite 1320, Roswell, GA 30076

Phone: 678/507-0110 Fax: 678/507-0118

**DETROIT:** RPM Associates

29350 Southfield Rd., Suite 31, Southfield, MI 48076

Phone: 248/557-7490 Fax: 248/557-7499

**BUSINESS DEVELOPMENT**

**NEW YORK:** Concepts Media Group

52 Truesdale Dr., Croton On Hudson, NY 10520

Phone: 914/239-3483 Fax: 914/239-3493

**LOS ANGELES:** Southcoast Projects

12682 Pacato Circle North, San Diego, CA 92128

Phone: 858/673-0921 Fax: 360/246-5661

Business Manager **JEFF STILES**

Consumer Marketing Director **ROBIN HUTCHINSON**

Associate Consumer Marketing Director **DAN HOLLAND**

Associate Director of Marketing-Newsstand **TOM DEERING**

Production Manager **TIM STOFFER**

Advertising Operations Manager **JIM NELSON**

Senior Vice President/Publishing Director **DOUG OLSON**

Group Publisher **TOM DAVIS**

**MEREDITH PUBLISHING GROUP**

President **JACK GRIFFIN**

Editorial Director **MIKE LAFATORE**

Finance & Administration **KARLA JEFFRIES**

Manufacturing **BRUCE HESTON**

Consumer Marketing **DAVID BALL**

Creative Services **ELLEN de LATHOUDER**

Corporate Sales **JACK BAMBERGER**

Interactive Media **LAUREN WIENER**

Corporate Marketing **NANCY WEBER**

Research **BRITTA WARE**



President and Chief Executive Officer **STEPHEN M. LACY**

Chairman of the Board **WILLIAM T. KERR**

In Memoriam — E.T. Meredith III (1933–2003)

© Copyright Meredith Corporation 2007. All rights reserved. Printed in the U.S.A.

I'm not willing to do the hand-sanding that my random-orbit sander saves me.



My 14.4-volt DeWalt cordless drill/drivers. They have more than enough power to do everything I ask of them.



# High Performance Power Tools

## Need the BEST Abrasives

Norton makes sanding easier with 3 times the total performance over conventional products. Ask your woodworking supplier for Norton 3X discs and sheets.



**NORTON**

THE MUSCLE BEHIND THE MACHINE™







# IT WAS LIKE HIS NEIGHBOR'S SHOVEL WAS NEVER BROKEN

LEAVING HIM FREE TO KEEP BORROWING HIS TOOLS.

When the shovelhead fell to the ground, all he could think of was the face of his neighbor who owned the tool. Not wanting to risk losing access to his well-stocked garage, he tried Gorilla Glue. Two years later, his neighbor still hasn't noticed.



FOR THE TOUGHEST JOBS ON PLANET EARTH.™

1-800-966-3458 • GORILLAGLUE.COM

© 2006 The Gorilla Glue Company. G3SV

Circle No. 50

# editor's angle

## lobbying manufacturers for good deals on tools

In every issue we publish tool tests to help you buy the best wood-working products at the best price. What you may not know, however, is that during each test, we work one-on-one with manufacturers to improve their products or make them more price-competitive.

It's not "good enough" to simply report the results of how well tools perform after we test them in our shop? Those findings prove crucial to you when making smart buying decisions. But we like to go a step further, being your advocate with manufacturers. For example, when we tested the through dovetail jigs on page 77, Tools and Techniques editor Bob Hunter and tester Pat Lowry effected the following tool improvements or price reductions:

■ Hartville Tool lowered the price of its model GFK1800 by nearly \$100 after Bob pointed out how many necessary items, including templates, bits, and bushings, had to be bought separately from the jig in order to cut through dovetails. Those accessories pushed the price to \$342, considerably higher than similarly featured jigs. Now, you can buy Hartville's jig with everything needed for half-blind and through dovetails (but not box joints), for \$250.

■ Bob pointed out to MLCS that an optional \$10 guide bushing was necessary to use the jig for through dovetails. MLCS now includes the bushing as a standard item while holding the jig's \$50 price.

■ After Bob alerted Woodline that its jig compared unfavorably because it cut through dovetails in stock only up to 3/8" thick, the company created an optional set of templates and bits for 3/4" stock.

■ When Rockler learned from Bob that its jig's bits with longest-in-test 1/4" shanks were chatter-prone, company officials got to work. Now Rockler includes 8mm shanks—which chatter less—and a collet reducer for 1/2" collets.



Tools and Techniques Editor Bob Hunter worked the phone with manufacturers following the through-dovetail jig testing.

■ Keller and MLCS improved the clarity of their instruction manuals after Bob and Pat said they were hard to understand.

■ The Craftsman jig requires a proprietary guide bushing that fits only Craftsman router bases or a universal subbase you purchase for routers of other brands. When Bob learned that Sears was dropping the universal subbase, he pointed out the problem this would create for owners of non-Craftsman routers. Sears put the universal subbase back into its product lineup and also added a set of Porter-Cable style guide bushings as another alternative.

This small sampling reflects what we've been doing for years, and I'm always encouraged by how quickly manufacturers respond to our recommendations. After all, they want the same thing we all do—products that sell well because they're a great value!



Bill Krier



# sounding board

Our bulletin board for letters, comments, and timely updates

## Go to school with a **WOOD®** staffer

Interested in improving your woodworking skills and having a fun time in the process? Here's your chance to learn one-on-one with a **WOOD** magazine craftsman this summer at the Marc Adams School of Woodworking in Franklin, Ind. Contributing Craftsman Jim Heavey will teach "Making a Wine Cabinet," June 11-15, with the help of his brother, Mike. Students will build the wine cabinet, shown *near right*, from issue 172 (October 2006), and learn tips and techniques that apply to many other woodworking projects.

Design Editor Jeff Mertz will lead "Build an Arts and Crafts Morris Chair" Aug. 6-10. Students start with a pile of rough lumber and end with a finished chair.

Following that class, Jeff will teach a two-day course Aug. 11-12 titled "A Weekend Bookcase for Two," a great way

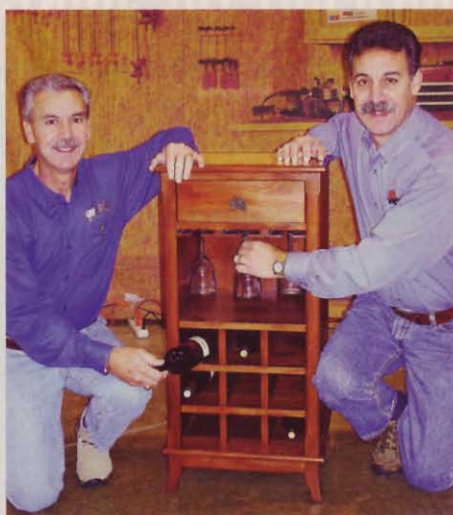

Jim, left, and Mike Heavey show off their version of the wine cabinet.

to get a friend or relative started in woodworking. Students will learn to make the bookcase from issue 154 (March 2004) in their choice of style: Shaker, country,



Jeff Mertz built the mission bookcase, left, and the traditional version in one weekend.

mission, or traditional, as shown *above*. To sign up for these classes or to look at other offerings at the school, go to [marcadams.com](http://marcadams.com) or call 317/535-4013.

## Woodworking, golf lose a real ace

I was so pleased to see the article in your e-mail newsletter (Oct. 15, 2006) about my sweet husband, Byron. He loved woodworking, even though it was much more difficult for him than playing golf. **WOOD** magazine was his favorite of all the magazines he received. Your plans were easier for him to follow, and with **WOOD**'s help, he made hundreds of gifts for family and friends over the 25 years he enjoyed this great hobby. When you ran the photo of Byron in your magazine, he was almost prouder of that than anything he ever did in golf. I thank you for the great tribute to him.

—Mrs. Peggy Nelson, Roanoke, Texas

*Golfing legend Byron Nelson passed away on Sept. 26, 2006 at the age of 94. He first appeared in WOOD magazine, at right, in issue 60 (April 1993).*



Byron Nelson proudly displays the cherry bookcase he made from **WOOD** plans.

—**WOOD** editors

## Article updates

October 2006, issue 172

■ Mounting brackets are included in the \$35 price for the VersaClamp (page 100). Additional brackets can be purchased for \$5 per pair. (812/933-5421 or [tstoolco.com](http://tstoolco.com))

■ Contact information for Oneida Air Systems' Dust Deputy (page 104) is 800/732-4065 and [oneida-air.com](http://oneida-air.com).

## HOW TO REACH US

### ■ For woodworking advice:

Post your woodworking questions (joinery, finishing, tools, turning, general woodworking, etc.) on one of 14 online forums at [woodmagazine.com/forums](http://woodmagazine.com/forums).

### ■ To contact our editors:

Send your comments via e-mail to [woodmail@woodmagazine.com](mailto:woodmail@woodmagazine.com); or call 800/374-9663 and press option 2; or write to **WOOD** magazine, 1716 Locust St., LS-221, Des Moines, IA 50309.

### ■ Subscription assistance:

To notify us of an address change or to get help with your subscription, visit [woodmagazine.com/service](http://woodmagazine.com/service) or call 800/374-9663 and press option 1. Outside the U.S., call 515/247-2981. Or write to **WOOD** magazine, P.O. Box 37439, Boone, IA 50037-0439. Please enclose your address label from a recent magazine issue.

### ■ To find past articles:

See our index at [woodmagazine.com/index](http://woodmagazine.com/index).

### ■ To order past issues and articles:

Order past issues of **WOOD** magazine, our special issues, or downloadable articles from issue 100 to present: Visit our online store at [woodmagazine.com/store](http://woodmagazine.com/store) or call 888/636-4478. Some issues are sold out.

### ■ Updates to previously published projects:

For an up-to-date listing of changes in dimensions and buying-guide sources from issue 1 through today, go to [woodmagazine.com/editorial](http://woodmagazine.com/editorial).



# ask wood

Answers to your questions from letters, e-mails, and WOOD Online®

## Got a question?

For an answer to your woodworking question, write to ASK WOOD, 1716 Locust St., LS-221, Des Moines, IA 50309-3023 or e-mail us at [askwood@woodmagazine.com](mailto:askwood@woodmagazine.com). For immediate feedback from your fellow woodworkers, post your questions on one of our woodworking forums at [woodmagazine.com/forums](http://woodmagazine.com/forums).

### A new angle on sawing panels

**Q:** What's a reliable, safe way to make a long, angled cut lengthwise on a panel for duplicate pieces? I can always use a circular saw and straightedge, but is there a slicker way?

—Jeff Johnston, Rio Rancho, N.M.

**A:** Try this strategy for making more clean, consistent, and repeatable cuts than the method you're using now, Jeff: On one panel with the appearance side down, mark a line precisely where you want your final cut. Using a straightedge and a circular saw or jigsaw with a plywood-cutting blade, cut to within  $\frac{1}{8}$ " of the line on the waste side, as shown at right. Then reposition your straightedge, and use a router with a top-bearing straight bit to trim the panel to your marked line. This piece now becomes the template for the remaining parts.

Place this first piece atop other panels—again with the appearance side down—and mark lines about  $\frac{1}{8}$ " from the angled edge. Then rough-cut the panels to these lines. Instead of a straightedge, though, use the template piece atop the remaining pieces to guide your top-bearing straight bit and trim the rough edges to their final dimensions.

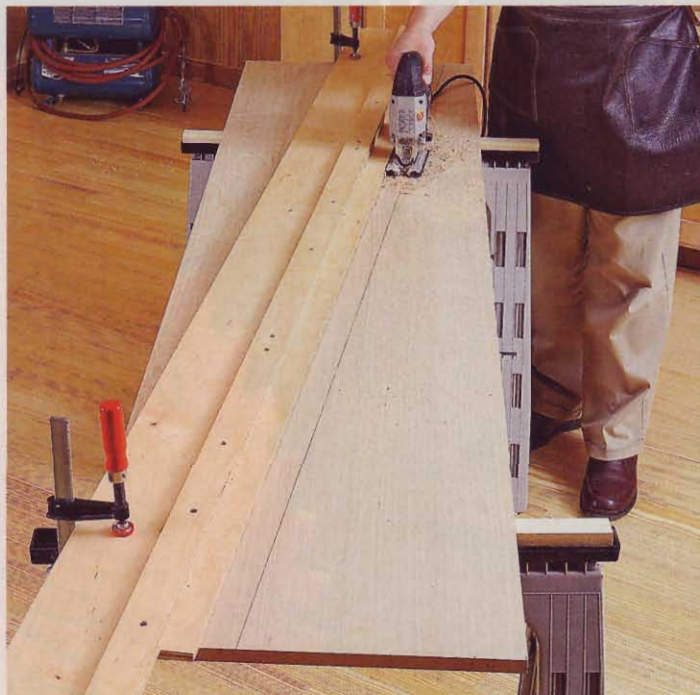

### Compound miters can confound glue-ups

**Q:** Is there a clamp or glue-up method to fasten compound miter joints for a frame? No regular frame clamp will work.

—John H. Bolden, Dallas

**A:** You can try two possible clamping techniques for these awkward frame parts, John. To grip the angled shape of the molding, use the pinch clamps shown below. (Clamp-All starter set no.

H3703, \$36 from Grizzly Industrial, 800/523-4777 or [grizzly.com](http://grizzly.com).) Flip the frame parts upside down, add glue, and then use the clamp spreader to attach the clamps to the back side of the frame. This method has two disadvantages. The clamps leave small indentations on the back side that you'll need to putty before finishing the frame. Second, by working from the back side, it's more difficult to confirm that the pieces are aligned accurately.

Another option is to use stretchable tape to hold the pieces together. (Scotch Stretchy Tape, \$6 with dispenser, 3M, [ScotchBrand.com](http://ScotchBrand.com).) Again, with the pieces upside down, apply glue and stretch tape between the pieces, as shown below center. Although you assemble the frame upside down with this method, too, it's easy to turn the assembly back over, as shown below, to check the joints without the risk of a clamp coming loose.

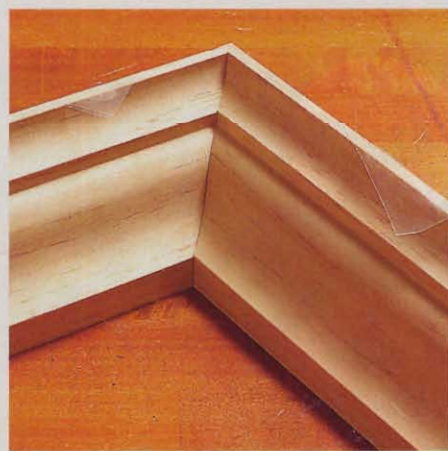
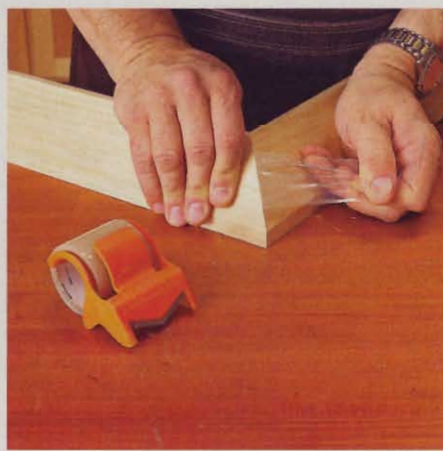

continued on page 16



## 6pc Cabinet Set

Everything you need to create raised panel doors for your cabinetry and fine furniture projects. Includes a 3-1/4" ogee raised panel with matching 2-piece rail & stile, reversible glue joint, drawer lock bit to build strong drawers and a door lip which adds a finger-pull style profile to doors or drawers. This set also includes an undercutter on the panel raiser which produces a true 1/4" tongue automatically.

ONLY \$109<sup>95</sup>

WL-2020-1 : 1/2" Shank

**WOODLINE USA**

- ★ Finest Quality Carbide Tips
- ★ Full Anti-Kickback
- ★ Ultimate Lifetime Warranty
- ★ Unsurpassed Customer Service
- ★ Complete Selection of Individual Bits
- ★ Dedicated To Providing Affordable Solutions



**66 Piece Master Wood Working Router Bit Set**

Woodline USA's most comprehensive carbide tipped bit collection features 66 carefully chosen profiles in a fully labeled wooden case. The perfect set to start or complete every woodworker's collection of bits.

ONLY \$189<sup>95</sup>

WL-2066 : 1/2" Shank  
WL-2065 : 1/4" Shank

MULTIPLE DECORATIVE DOVETAIL DESIGNS INCLUDED

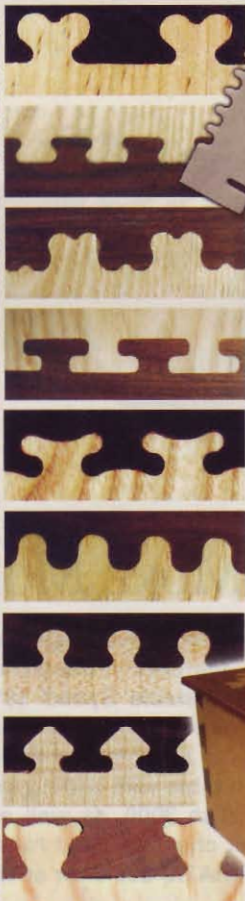

## Route -R- Joint

As seen on DIY Network! This simple system uses interchangeable guide templates to produce an ever growing number of beautiful decorative dovetails for drawers, boxes and furniture in no time at all. Amateurs, children and professional woodworkers will enjoy the ease of use, safety and simplicity of this system while making magnificent joints!

ONLY \$219<sup>95</sup>

WL-RJT-11



## Wood Gear Clock Kit

Create this fabulous working work of art with Woodline's Wooden Gear Clock Kit with Pin router attachment. The kit comes with full size gear templates, hardware kit, spiral bit, and full instructions on CD and DVD. The included wood kit includes 6 pieces of specialty gear plywood in your choice of walnut or cherry. You supply the other wood needed from your scrap box. Includes the Woodline Pin Router Table Attachment perfect for many different projects. Additional gear plywood and hardware kits available.

ONLY \$239<sup>95</sup>

WL-WCK-DPC : Cherry Kit  
WL-WCK-DPW : Walnut Kit



Pin Router Accessory Included

## ask wood

### Baked maple's off the menu

**Q:** When a friend cut a large maple log in half for firewood, the inside was beautifully spalted throughout. He cut it into 4x12" pieces 18" long for me. Can I dry these pieces in the oven, or would it be better to air-dry them? (I'm eager to start on a mantel clock I want to make from a *WOOD* magazine plan.)

—Mark Ball, Duluth, Minn.

**A:** Oven-drying or microwaving wood could be a recipe for trouble, Mark. Drying those 4"-thick pieces in a kitchen appliance invites splits and warps, warns Richard Bergman, research chemical engineer for the USDA Forest Products Laboratory. Instead, coat the freshly cut ends with polyurethane finish, and allow the pieces to air-dry in a place protected from rain and snow.

"Air-drying and sheltering the pieces while allowing air flow would be the best method, unless you know of a small custom kiln dryer, preferably a vacuum kiln, which would be quite expensive," Bergman says. "Air-drying the pieces would take a couple of years, but allows a gradual drying to minimize drying stresses for thick lumber."

The good news is that the wood may already be dry enough to use, considering that spalting forms in trees that have been dead long enough for the wood to begin decaying. Check the pieces with a moisture meter, as shown below, to see whether they're between 6 and 8 percent. If they're close to that, consider allowing them to air dry the rest of the way.

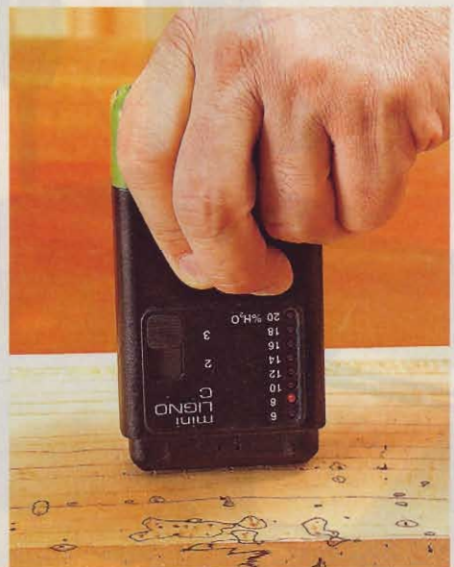

continued on page 18

ORDER TODAY!  
1-800-472-6950

WOODLINE.COM  
**WOODLINE USA**  
111 Wheeler St, LaVergne TN, 37086





**WOODCRAFT**  
Helping You Make Wood Work®

For A Free Catalog Or To Find Your Local Woodcraft Store, Visit [www.woodcraft.com](http://www.woodcraft.com) Or Call 800-542-9115.



**E**very detail of these Pinnacle™ tools was engineered with one thing in mind; provide woodworkers with tools that empower them to craft higher quality, more professional cabinetry and furniture. Pinnacle™ tools are available exclusively at Woodcraft.



**Pinnacle  
4" Box Clamp**

Quickly square up and secure the pieces of any box structure with a thickness between 1/4" to 1"!  
147529 (1) \$34.99

To learn more about Pinnacle™ tools visit [www.woodcraft.com/pinnacle.aspx](http://www.woodcraft.com/pinnacle.aspx)

Dept: 06WD11P5

QUALITY WOODWORKING TOOLS • SUPPLIES • ADVICE™

Circle No. 700

*Enjoy All the Creature Comforts  
with Radiant Floor Heating*

*Compatible with any fuel source:*

GAS PROPANE SOLAR OIL WOOD ELECTRIC GEOTHERMAL

VISIT OUR WEBSITE

CALL FOR A FREE QUOTE

[www.radiantcompany.com](http://www.radiantcompany.com)

Barton, Vermont

(toll free) 1.866.WARM-TOES (927.6863)

**RADIANT**  
Floor Company



Circle No. 1301

**ask wood**

**Cutting clean in melamine**

**Q:** When I routed 1/2"-wide dados in 3/4" melamine, the result was burned steel and carbide bits. Would a dado set in a tablesaw be the better way to go?

—Bob Underwood, Winter Park, Fla.

**A:** We'd go with the tablesaw instead of a router, Bob. When sharp, a dado set cuts clean, chip-free dados in melamine-covered particleboard. For the best results, first make a 1/16"-deep scoring cut, as shown *below*, to remove the melamine layer and a small amount of substrate without producing tear-out. Then reset the blade to your finished dado depth and complete the cut.

If you're still more comfortable routing your dados, use a down-cut spiral bit instead of a straight bit and make two or more shallow passes instead of one deep cut to avoid burned bits. The spiral cutting action compresses the melamine against the particleboard as it cuts, resulting in less chip-out. A down-cut bit like the one at *bottom* doesn't clear chips as effectively as a straight-cut bit, but particleboard chips are usually drier than those from wood.

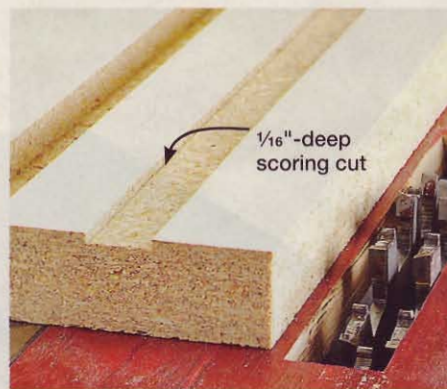

*continued on page 20*



# Dust Collection. Only Oneida.

## Ask Us...



... why we have over  
20 models of dust  
collectors?

... why we have third  
party ASHRAE filter  
testing?

*\*Complete tests on our website.*

... why we have won  
every independent  
Top Tool comparison  
award?

... about our shop  
plan design service!

Complete Ready-to-Ship  
Ductwork

FREE Shipping, \$100+.  
48 States. Restrictions  
Apply.



- ▶ 1.5 - 40hp Systems
- ▶ Since 1993
- ▶ Dust Collection is Our Only Business

Shop Our NEW Online Store!

[www.oneida-air.com](http://www.oneida-air.com) **1.800.732.4065**

Call Today for FREE Brochure!

Circle No. 2039

ask wood

### Erase mildew stains

**Q:** I started making a china cabinet out of ash, and put it aside. I knew it would be a long time before I worked on it again, so I covered it with a nylon tarp and set it up on 4x4s in my garage. Six months later, I found a greenish mold or mildew had formed over the lower third of the unfinished wood. How can I get that off without ruining the wood or driving the mold deeper into the grain?

—Andy Hunter, Adams, Ind.

**A:** Mildew stains look bad, Andy, but it's easy to give this fungus the brush-off using readily available products around your house. Start by mixing up a solution of 1 part dishwashing liquid or detergent to 10 parts household bleach and 30 parts warm water.

Wearing rubber gloves and working in a ventilated area, use the solution and a cloth or soft-bristle brush to gently scrub away the surface mildew, including any that's reached into the grain of the wood. Finish by rinsing the cleaned area with fresh water, and wipe the surface dry with a soft towel. Wait for the wood to dry thoroughly before working it further, then sand off any raised grain.

When future projects need to be put on hold and you can't store them indoors, cover them with an old sheet or blanket that allows air to circulate and won't trap moisture, as will a waterproof tarp.





## Straight scoop on drilling post ends

**Q:** I am refinishing an 1870s bed, but the bottom 9" of the turned posts were beyond repair. I cut off the damaged areas and turned new matching sections that I'll attach using 1" dowels. However, the 4' posts are too long for my drill press. How can I drill a perfectly perpendicular dowel hole in the ends using a hand-held drill?

—Jim Kinder, Unicoi, Tenn.

**A:** A shop-made drilling guide should solve your problems, Jim. Glue together sufficient scrap to create a guide block about 3" thick and 6" square. On your drill press, chuck a Forstner bit the diameter of your post end and bore a 1"-deep hole into the block. Without moving the block, bore a 1"-diameter hole through the rest of the block.

Seat the end of the post into the bottom of the guide block. Then use the 1" hole to guide the bit in your hand-held drill, as shown below. Drill as deeply as you can using the guide; then remove the guide and use the hole itself to keep your bit straight, should you need to deepen the dowel hole farther.

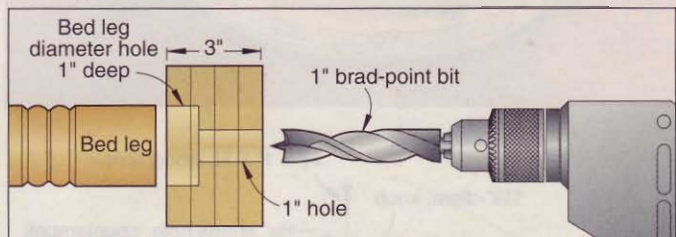

## Keep plywood grounded

**Q:** Recently, I was ripping a 12"-wide piece of 1/4" oak plywood on my tablesaw. As I was just about finished, the plywood climbed up the blade, turned to the left, and became a missile, injuring my left hand. What did I do wrong? Are there any hold-downs that would have avoided this?

—Roy Tiefisher, Coeur d'Alene, Idaho

**A:** First, eliminate saw misalignment as the problem, Roy. Double-check that the fence runs parallel with your saw blade to prevent binding. Next, if you're not using your saw's blade guard and splitter, reinstall them to further prevent binding. (Ours is omitted for photography purposes.) Also, avoid using the fence in combination with a miter gauge.

As another precaution, clamp a hold-down strip to the fence about 1/8" above the panel, allowing it to slide freely, as shown at right. Then set the blade to no higher than 3/8" above the surface of the plywood. Finally, use a pushblock designed to ride on top of the wood with a heel on its base to push the plywood through the cut. ♣

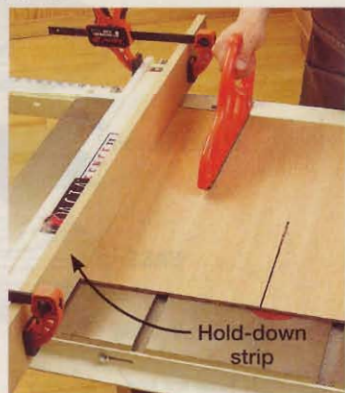

# EXPECT THE BEST!

For over 50 years, Old Masters has provided craftsmen with superior quality stains & finishes to protect and enhance their wood projects in which they've invested their time and precision.



Contact us at 800-747-3436 for a free product guide or visit [www.oldmasters.com](http://www.oldmasters.com) to locate a dealer near you.

Circle No. 95

## Size Matters.



No matter what your need, RIKON has the size.



# easy-access drill bit carousel

A rotating organizer you can take wherever necessary

**W**ant to keep large drill bits and other hole-boring accessories close at hand and easy to find? This compact carousel holds a multitude of specialty bits, such as holesaws and Forstner bits, and swivels on a lazy Susan bearing for quick access.

To build one, use a compass to mark three 5"-radius circles on  $\frac{3}{4}$ " plywood. Bandsaw and sand the discs to shape. For the top, use the Top Detail drawing below to mark the nine curved slot locations. Drill  $\frac{5}{8}$ " start holes for the outside and middle slots where shown. Drill  $\frac{3}{8}$ " start holes for each inside slot. Scrollsaw or jigsaw between the holes to form the slots. Drill  $\frac{5}{8}$ "-deep holes in the shelf to fit the shanks of your bits and accessories. Drill a  $\frac{1}{2}$ " hole through the base for screw access.

Crosscut the dowels to length. Create a collar with a  $\frac{3}{4}$ " hole in it. Assemble the unit in the configuration shown at right, attach the bearing to the base, and then use the  $\frac{1}{2}$ " hole in the base for access to drive the screws into the shelf.

Project design: Jim Harrold

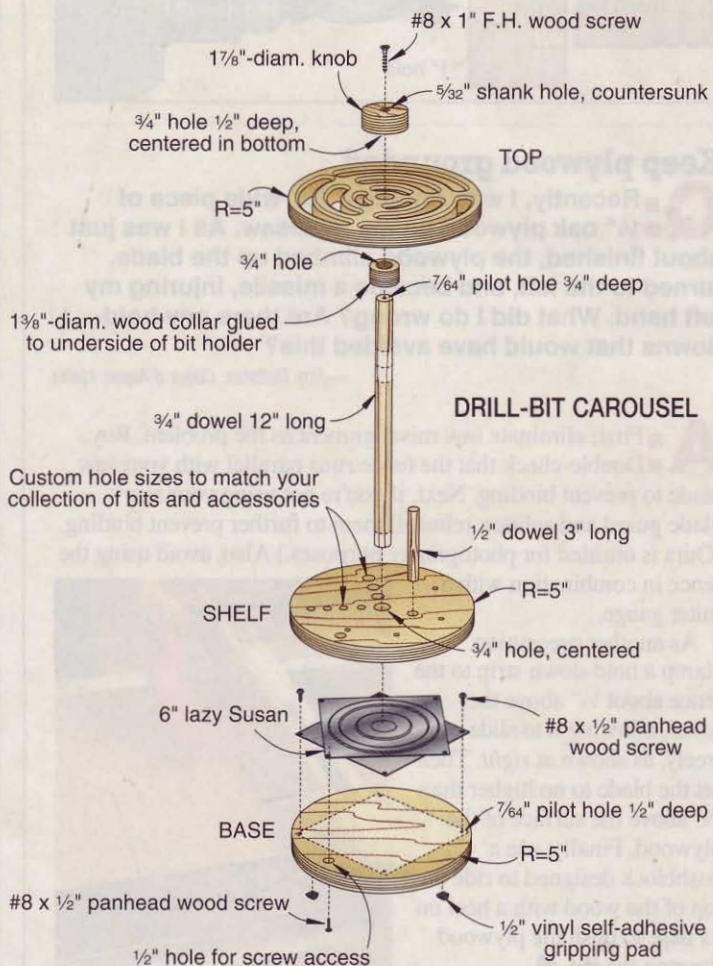
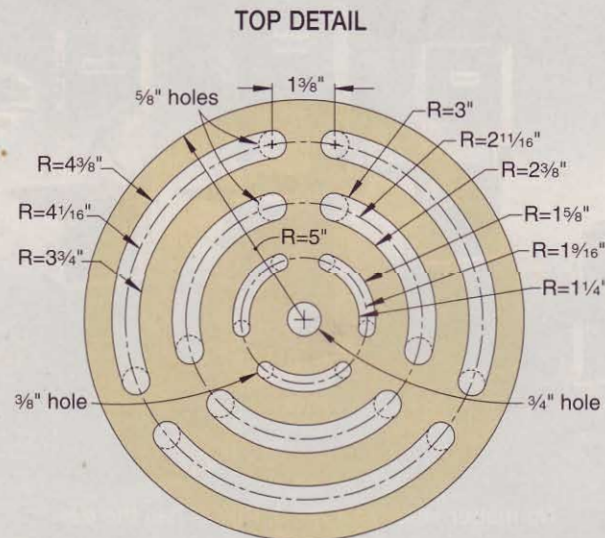
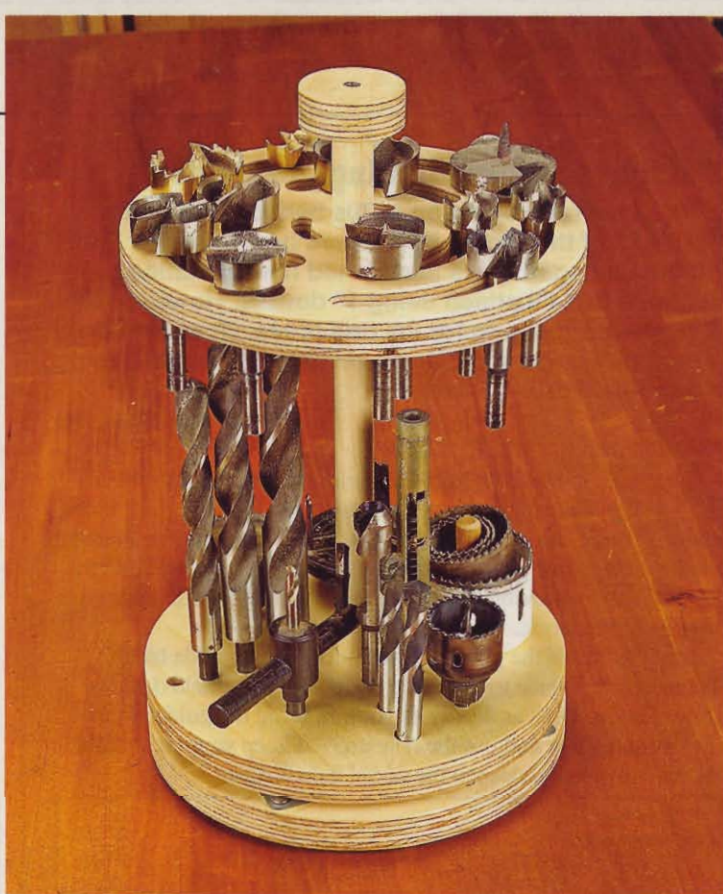





**WOOD**  
MAGAZINE

# BUILD-A-GIFT

CONTEST

# WINNERS

**W**hen we announced the *WOOD*® magazine Build-A-Gift contest in the September 2006 issue, we had no idea what to expect. Then, when the entries came pouring in—WOW! We found creativity and craftsmanship alive and well in all 20 contest categories. With 226 total gift items, the trio of judges had their hands full...but admitted that they enjoyed every minute of it. The judges included Editor-in-Chief Bill Krier, Senior Design Editor Kevin Boyle, and Design Editor Jeff Mertz.

Of course, the biggest winner is St Jude Children's Research Hospital, which will receive all proceeds from auction sales of the entries. This money, in turn, will help St. Jude find cures for catastrophic childhood illnesses through research efforts and treatment.

Finally, we'd like to extend a special thanks to all of the woodworkers who took the time to build the gift entries, and to our sponsors who provided a wide range of great prizes. To all the prizewinners, congratulations!



### GRAND PRIZE

**Winner:** Wayne Holder, Brooksville, Fla.  
**Entry:** Old-time locomotive and coal car  
**Prize:** \$5,000 of tools and accessories from Peachtree Woodworking Supply Inc.



To see group photos of many of the entries during the judging, go to [woodmagazine.com/buildagift](http://woodmagazine.com/buildagift)

### BEST USE OF A ROUTER

**Prize for each:** Freud 2¼ hp, variable-speed, fixed-base router and portable router table.  
**Value:** \$380



### (Original Design)

**Winner:** Dan McGrady, Spring Hill, Fla.  
**Entry:** Burl-topped, dovetailed jewelry box



### (From Existing Plan)

**Winner:** Charles Krauss, Augusta, Kan.  
**Entry:** Recipe card box and cookbook holder with dovetailed joints



### BEST USE OF WOOD

**Winner:** Bill Stavros, Des Plaines, Ill.  
**Entry:** Overland stagecoach  
**Prize:** Hitachi 10" Sliding Dual Compound Mittersaw. Value: \$500

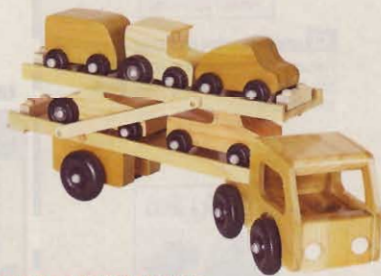

### BEST CRAFTSMANSHIP IN PROJECT BUILT FROM AN EXISTING PLAN

**Winner:** Mark Stinson, Casper, Wyo.  
**Entry:** Car-hauling truck  
**Prize:** Bosch 10" Dual-Bevel Sliding Mittersaw with saw blades. Value: \$900



### BEST ORIGINAL DESIGN

**Winner:** Dallas Solum, Layton, Utah  
**Entry:** Backhoe truck  
**Prize:** General International Jobsite Tablesaw. Value: \$680



**BEST JOINERY**

Prize for each:  
Porter-Cable Omnijig. Value: \$300



**(Original Design)**

Winner: Michael Hahn, Ashton, Ill.  
Entry: Locking toolbox with drawers



**(From Existing Plan)**

Winner: Vincent Krzyzanowski,  
Palm Coast, Fla.  
Entry: Pine cradle

**BEST FINISH**

Prize for each: Varathane stains, polyurethane,  
and care and repair products. Value: \$250



**(Original Design)**

Winner: Daniel Collins, Battle Ground, Wash.  
Entry: Jewelry box with wooden hinges



**(From Existing Plan)**

Winner: Bob Dragosavac, Meadville, Pa.  
Entry: Picture easel

**BEST CLOCK**

Prize for each: Klockit Patriot Kit with tall clock  
case, movement, and hardware.  
Value: \$520



**(Original Design)**

Winner: Lee Bridge, Holland, Ind.  
Entry: Curved, textured clock

**BEST TURNED GIFT**

Prize for each: Delta Midi Lathe. Value: \$300



**(Original Design)**

Winner: John Carlson, Beloit, Wis.  
Entry: Segmented bowl



**(From Existing Plan)**

Winner: Robert White, Canon City, Colo.  
Entry: Segmented bowl with flag design

**BEST HOME ACCESSORY GIFT**

Prize for each: Titebond glues.  
Value: \$300



**(Original Design)**

Winner: Neil Lamens, Brookhaven, N.Y.  
Entry: Knock-down, wedge-pin cradle



**(From Existing Plan)**

Winner: Paul Brockman, Sibley, Mo.  
Entry: Shaker boxes



**(From Existing Plan)**

Winner: Martin Cutler, Jr., Raleigh, N.C.  
Entry: Exposed wooden movement clock



**BEST HOLIDAY-THEMED GIFT**

Prize for each: Gorilla Glue glues and tapes.  
Value: \$285



**(Original Design)**

Winner: Robert Lund, Lakeview, Ore.  
Entry: Turned-birdhouses decoration



**(From Existing Plan)**

Winner: Kenneth Groth, Waterford, Mich.  
Entry: Violin

**BEST MINIATURE REPLICA**

Prize for each: Makita 18-volt impact drill/driver kit with charger. Value: \$320

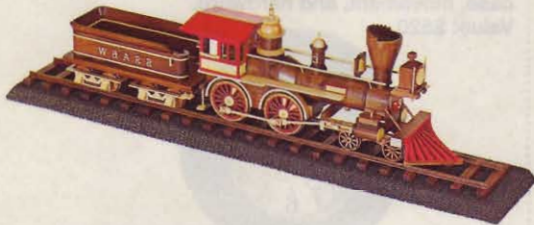

**(Original Design)**

Winner: Wayne Holder, Brooksville, Fla.  
Entry: Old-time locomotive and coal car



**(From Existing Plan)**

Winner: Ralph Sonnier, Sulphur, La.  
Entry: Duesenberg SSJ antique car

**BEST WOOD TOY OR CHILD'S GIFT**

Prize for each: Woodcraft gift certificate. Value: \$250



Winner: Howard Clements, Knox, Pa.  
Entry: Toy truck



**(From Existing Plan)**

Winner: Charles Svajgl, Papillion, Neb.  
Entry: Articulated crab

**BEST JEWELRY OR KEEPSAKE BOX**

Prize for each: Jorgensen Pony adjustable-clamp assortment. Value: \$250



**(Original Design)**

Winner: Dan McGrady, Spring Hill, Fla.  
Entry: Burl-topped, dovetailed jewelry box



**(From Existing Plan)**

Winner: Tommy Farmer, Easley, S.C.  
Entry: Elevated jewelry box

**HONORABLE MENTIONS**

Marwin Feldman, Amherst, N.Y.  
Turned jewelry goblet



Carl Boop, Lewittown, Pa.  
Fire truck with ladder



Don Fry, Charlottesville, Va.  
Cradle with ball, glove, and bats



Rod Hildahl, Brooklyn Park, Minn.  
Rubber-band boat on stand



Eugene Emanuel, Fayetteville, Tenn.  
Dinosaur puzzle



Written by Jim Harrold



# shop tips

Helping you work faster, smarter, and safer

## Shed a little light wherever you need it

My old scrollsaw still works like it's 1989; unfortunately, my eyes don't. To brighten my work space, I built a small task light from a block of wood, a couple of rare-earth magnets, a keychain-size LED flashlight, and a length of #6 copper grounding wire, as shown *below*.

On the scrollsaw, I use it to light my outline or from below—an angle perfect for threading delicate fretwork blades. I also find it indispensable during machine repairs. (The side magnet prevents small screws and parts from rolling away.)

—Raj Chaudhry, New York

### top shop tip

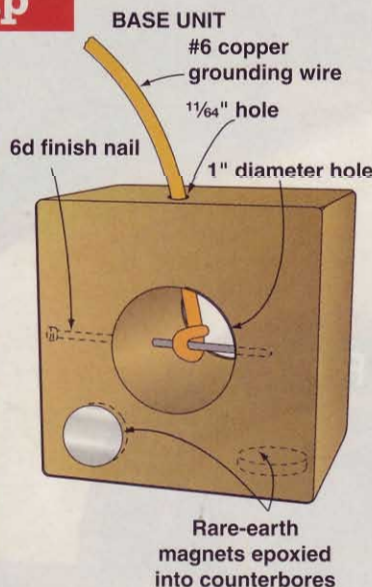
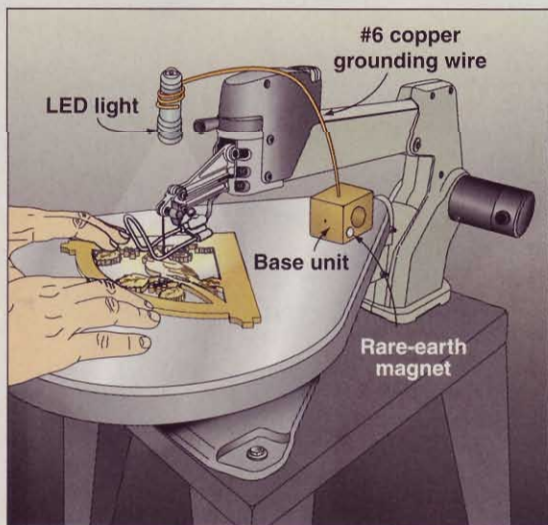

## Remove the fear factor when making inserts

The scary part of cutting the slot in a zero-clearance tablesaw throat-plate insert is raising that spinning 10" blade through the uncut plate. For a bit of confidence and security when you make the cut, try this simple technique.

First, install one of the outer blades from your dado set on your tablesaw. (Because of its smaller circumference, this blade doesn't have to work as hard to cut through the insert.)

Next, clamp a scrap board over the new insert, as shown *above right*, and raise the spinning dado blade through the insert to its maximum height. Finally, replace the dado blade with your 10" blade and repeat the procedure.

—Chris Penkala, Seattle

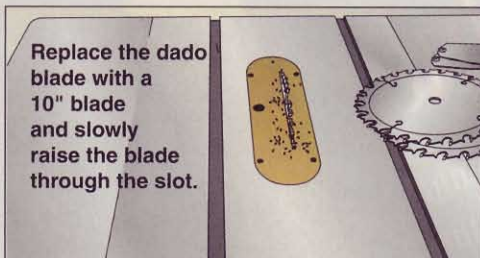
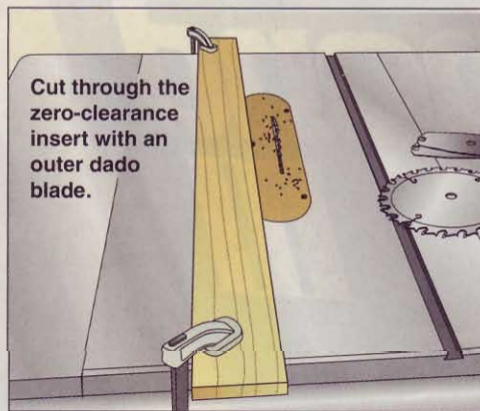

## The Top Tipster

Photo: Steven C. Trachtman

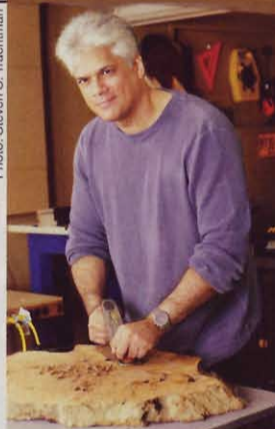

So you think your shop is small? Raj Chaudhry builds projects in his Manhattan

apartment. "I have a tiny lathe I use when I need to get my woodworking fix," Raj says. "I do a little carving there, too." Otherwise, it's a 35-minute train ride out to Long Island, where he likes to build rustic lodge-style furniture in his family's full-size shop. Raj came up with the big idea, at *left*, that earned him this issue's Top Shop Tip honors.



Raj Chaudhry should have no trouble fitting the Fein MultiMaster into either shop. We're sending him one for submitting this issue's Top Shop Top. Right on, Raj!

## Top tips earn tools!

Describe how you've solved a workshop stumper and you'll get \$75 if we print it. And, if your idea garners Top Shop Tip honors, we'll also reward you with tool treasures worth at least \$250.

Send your best shop solutions, along with photos or illustrations and your daytime telephone number, to: **Shop Tips, WOOD Magazine, 1716 Locust St., LS-221, Des Moines, IA 50309-3023**. Or you can e-mail them to us at [shoptips@woodmagazine.com](mailto:shoptips@woodmagazine.com). Include your contact info in the e-mail as well.

Because we publish only original tips, please send your pointers only to *WOOD* magazine. Sorry, submitted materials can't be returned.

continued on page 32



### Proper grit ready in a pinch

When shaping spindles or other projects on my lathe, I use small pieces of sand-paper of various grits while finishing. To keep the small sheets handy and sorted out, I glued wooden clothespins onto a thin strip of plywood and mounted the hanger to the side of the lathe stand. On the clothespins, I marked the grit of each abrasive.

—Rick Mercado, Colorado Springs, Colo.

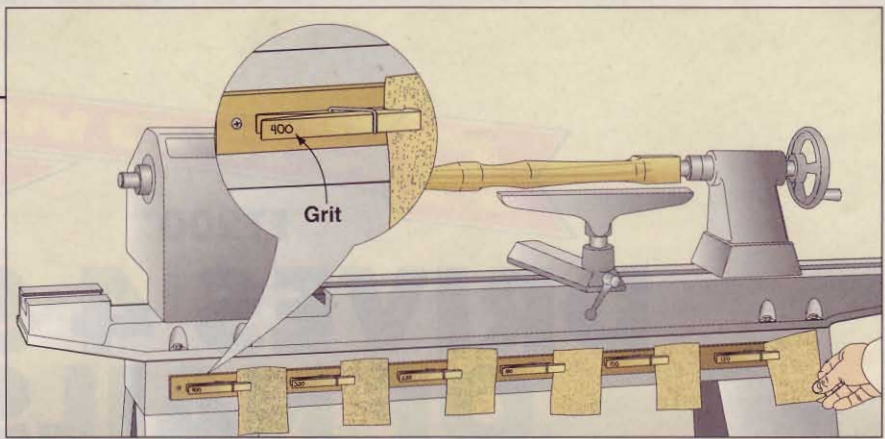

### Spacers calibrate thin-strip cutting

I've developed a safe way to quickly cut thin strips of equal thickness on a tablesaw. First, plane a piece of scrap that equals the thickness of the strips you need plus the thickness of the saw blade kerf. Cut the scrap piece into short blocks and position the fence so the board you're ripping just grazes the inside edge of the saw blade.

Next, attach a stopblock to your fence rail with a clamp so the block touches the fence's rail bracket. Finally, loosen the fence and add a spacer between the stop block and fence, as shown. Install your feather board and make the first rip. Each added spacer will correctly position the fence for the next rip—no measuring required.

—Robert Wilde, Welling, Alberta

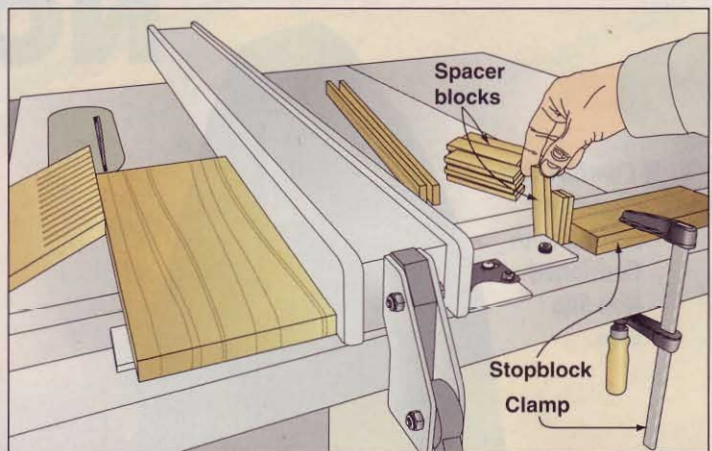

continued on page 35

# “Ouch.”

That's gotta hurt.

But you can prevent this kind of pain by sharpening your drill bits with Drill Doctor, The Drill Bit Sharpener. With Drill Doctor, you can restore most bits to precision sharp in less than 60 seconds. Working sharp is working smart. Your bits will be sharp, and so will your projects. If you're looking for precise results every time, work with the drill bit sharpening expert—Drill Doctor.

Circle No. 1511



- Sharpens most bits in less than 60 seconds



- Sharpens 3/32"-1/2" bits—HSS, masonry, cobalt, carbide, TiN-coated



- Sharpens and creates BACK-CUT™ split-point bits for faster penetration and less drill bit “wandering”

Work Smart  
Work Sharp

(Features apply to model XP shown)



**Drill Doctor**  
The Drill Bit Sharpener

Look for the Drill Doctor at Sears, The Home Depot, Lowes, Ace, Northern Tool, and wherever you buy your tools.

**\$15 MAIL-IN REBATE**  
on any Drill Doctor model except 300 & 350X

To receive your rebate, just send this coupon with your name, address, phone number, and which model you purchased, along with the original UPC from the box and a copy of your original sales receipt as proof of purchase, to:

Rebate Code  
**WD**

Dept. 32, Offer OPFT00002  
P.O. Box 10005-32  
Douglas, AZ 85655-1105

For details and to get a rebate form online, visit [www.DrillDoctor.com](http://www.DrillDoctor.com) or call 1-800-741-1365

Rebate offer good on purchases made Jan. 1-Apr. 30, 2007. Rebate cannot be combined with any other offer from manufacturer.



### Sanding-disc server for woodturners

As a woodturner, I use a variety of 2" hook-and-loop abrasive discs for my sanding tool. However, those small discs are hard to keep sorted and inconvenient to store. To solve both problems, I made this sanding-disc server that looks like a tray to hold poker chips.

Because I use eight different grits, I drilled eight 2" holes through a scrap of MDF, and then glued on a hardboard base, as shown. Using my tablesaw, I then trimmed the front off the server—enough to create an opening about a thumb's width—to provide easy access to the discs.

The server holds quite a few discs, and I can load my tool and align the disc by simply dipping the tool's pad into the hole. To make things even easier, I boldly mark the grit of each disc on its back before storing it in the server.

—Bill Esposito, Rindge, N.H.

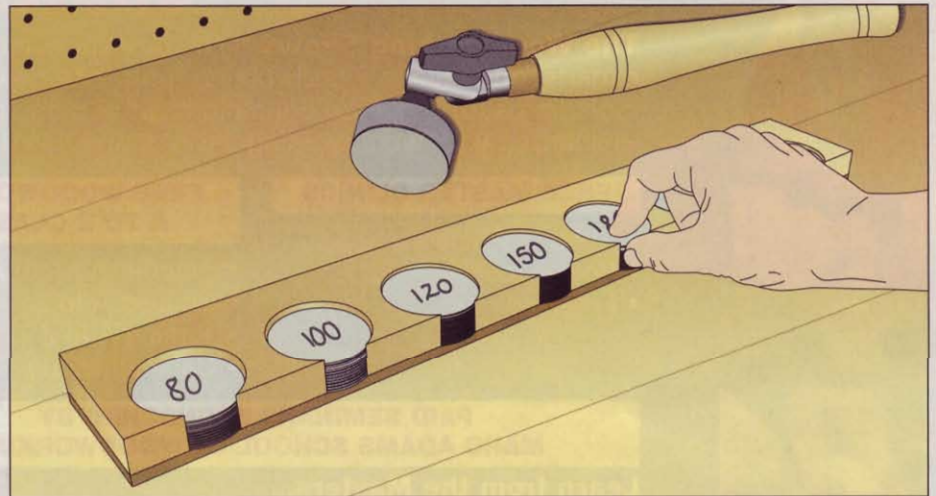
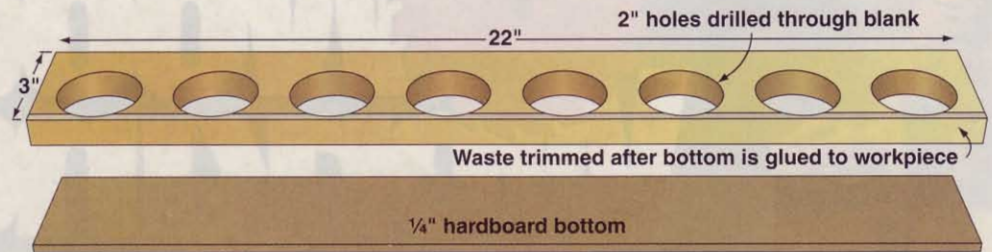

continued on page 37

### Rock-hard foundation for insert-plate leveling

I have a router table with a shop-made top of MDF and plastic laminate. Over time, I had trouble with my router lift's plate-leveling screws digging into the MDF, causing the plate to no longer lie flush with the table's surface. To create a solid foundation for the leveling screws, I drove small, flathead wood screws into the baseplate recess at the leveling screws' points of contact. Problem solved!

—Dave Falkenstein, Cave Creek, Ariz.

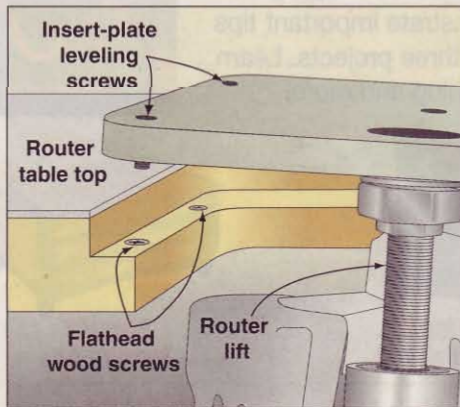

## Enter for your chance to WIN this POWERMATIC workshop!\*



Rockler Woodworking and Hardware is now your best source for Powermatic power tools. Enter for your chance to win one of 4 Powermatic workshops!

Enter daily online at [www.rockler.com/powermatic](http://www.rockler.com/powermatic) or visit a Rockler Woodworking and Hardware store near you. To call the store nearest you, dial 1-877-ROCKLER



Create with Confidence™



\*NO PURCHASE NECESSARY TO ENTER. A PURCHASE WILL NOT INCREASE YOUR CHANCES OF WINNING. Open and offered to legal residents of the 50 U.S. and DC, except FL, who are age 18 or older at time of entry. Void in FL and where prohibited by law. Sweepstakes starts at 12:00:01 AM CT on 9/26/06 and ends at 11:59:59 PM CT on 4/30/07. Subject to full Official Rules, available at [www.rockler.com/powermatic](http://www.rockler.com/powermatic). Sponsor: Rockler Companies, Inc., Medina, MN 55340.



## Mend more than furniture with your pocket-hole jig

For years we lived with creaky and squeaky floors. At one time these creaks were useful when they helped us detect when our teenagers were late for curfew, but with the kids grown, the squeaks are merely annoying.

To silence the squeaks, I used a portable mini pocket-hole jig that's intended for furniture repair. I simply locate the squeaky spot by having my wife walk around on the floor until I have it pinpointed. Then I use the jig to install screws to pull the subfloor tight to the floor joist, as shown below.

For extra insurance, I squirt a bit of woodworking glue into the gap before driving the screws. Also, I drive several screws along the gap to make sure it's fully closed.

—Pete Eisinger, Laingsburg, Mich.

*Subflooring can vary in thickness from 3/4" to more than 2". Before using this technique, it's important to know its thickness so you can choose the correct screw length. Usually, you can find this thickness by pulling out a floor heat/air vent and looking at the cutout edge. Be certain you don't drive screws all the way through, where sharp hidden screw points can lie in wait under the carpet.*

—WOOD® magazine

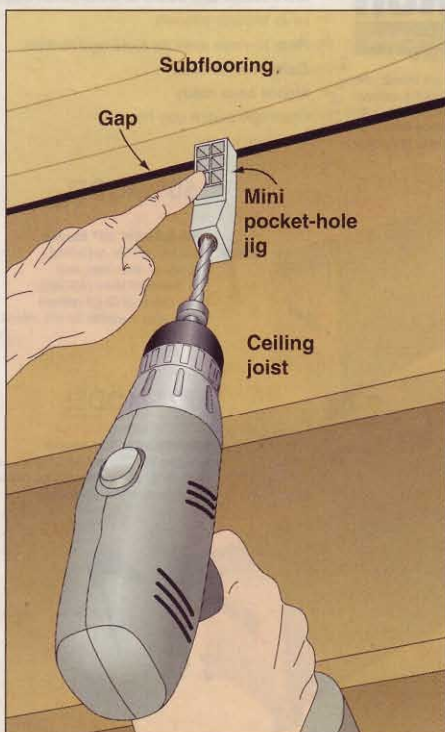

continued on page 38

## Quality Pen Kits and Other Turning Kits



- Designers & Manufacturers
- Wholesale & Retail

**THE BereaHardWoods** CO. Inc.

Manufacturer of quality writing instruments, components and kits.

Visit Our New Web Site: [www.penkits.com](http://www.penkits.com)

18745 Sheldon Rd. • Middleburg Hts., Ohio 44130 U.S.A.

Ph: 216-898-8956 • Fax: 216-898-8962 • E-mail: [bereahard@aol.com](mailto:bereahard@aol.com)

Circle No. 2127

## Introducing ZAR® ULTRA Max

### Waterborne Oil Modified Polyurethane



ZAR ULTRA Max comes in quart and gallon sizes. It is available in gloss, semi-gloss and satin sheens.

**ULTRA Max is an environmentally safe, revolutionary dual drying polyurethane. It dries by coalescing & oxygen cross-linking for a harder "through cure."**

- Self-leveling, smooth finish
- Ideal for floors, cabinets, furniture and woodwork
- Outstanding wear and durability
- Super fast drying-low odor formula
- Exotic hardwoods approved

**DualDrying**  
TECHNOLOGY  
DRIES HARDER FASTER

UGI  
**75**  
YEARS

For more information and a dealer near you call 1-800-272-3235 or visit us at [www.ugi.com](http://www.ugi.com).

Circle No. 154



## Sheet material rides safely on vehicle roof

I couldn't load 4x8 sheet goods inside my SUV and those sheets just didn't sit securely on the curved crossrails of the factory-supplied roof rack. To haul whole sheets home safely and easily, I built the carrier shown at right.

The 2x4 structure fits over the roof rack, which keeps it from sliding and protects the vehicle paint. The 1x6 front stop prevents the load from sliding forward when I brake. (I don't load panels any higher than the front stop.) The rear stop flips down for loading, and up before driving so panels won't slide off the back.

Make sure the weight of the carrier and the material on it doesn't exceed the weight capacity of your vehicle's roof carrier (shown in the owner's manual). After loading, run a ratchet tie-down strap through the front doors (not the windows) and over the load. Run another strap under the factory roof rack rails and over the load at the back. Then, drive home on city streets to avoid high speeds. 🌲

—Kevin McLaughlin, Helena, Ala.

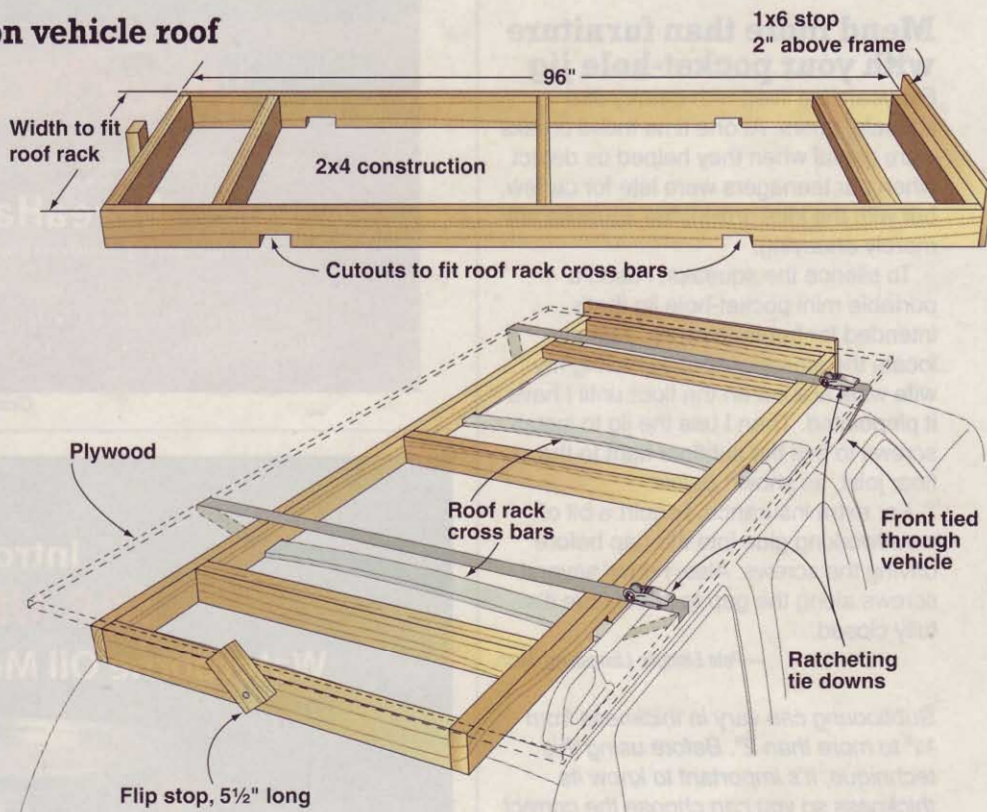

## New Bench Dog Products.

### PRO WOODWORKER ProMAX<sup>SM</sup> Complete Router Table

STOCK NO. 40-087

ProMAX Complete Router Table comes with ProMAX cast iron router table (#40-031), ProMAX End Cap (#40-044), ProMAX Professional Cabinet (#40-074).



- ▶ Only full-size cast iron router table in the marketplace.
- ▶ Integrated router bit storage with pull-out shelves.
- ▶ Drawer option with full extension ball bearing slides.
- ▶ Fence and cabinet made in USA.
- ▶ Unique cubby for storing your routers.
- ▶ Router table includes award-winning 28" ProFence.
- ▶ Bolt and cross dowel construction and steel hardware for the ultimate in strength.
- ▶ Includes 4" dust port.
- ▶ Components available separately.
- ▶ Curved side panels for better ergonomics.
- ▶ Solid Baltic birch panel construction.
- ▶ Table size: 27" x 20", height: 35 1/2".

**ProMAX Complete Router Table**  
shown with optional Cab-Loc mobile base. No ProMAX products include Cab-Loc mobile base.

#### PROMAX PROFESSIONAL CABINET FEATURES



Center router bay allows easy access and great dust collection.



Pull-out router bit storage is fast and convenient.



Lower cubby is perfect for spare router storage.



Comes with 4" dust port.

**ProMAX Complete Router Table**  
shown with the following options:  
Cab-loc mobile base (#40-008),  
Door Pack (#40-084) and  
Drawer Pack (#40-083)



### PRO WOODWORKER PRO-BENCH<sup>TM</sup> Premium Workbenches

PRO-BENCH models below are shown with the following options:  
Cab-loc mobile base (#40-008),  
Door Pack (#40-084)  
Drawer Pack (#40-083)

- ▶ Unfinished sycamore top
- ▶ More stable and easier to flatten than maple
- ▶ Hi-lo storage shelves
- ▶ Rear storage area for tools and clamps
- ▶ Cabinet-style base
- ▶ Mobile base ready
- ▶ Front row bench dog holes
- ▶ Premium vises

#### 50" MODEL

STOCK NO. 40-085

**PRO-BENCH 50" Model**  
includes 50" Top (#40-088),  
3" Cabinet (#40-089), and  
two Standard vises (40-090).  
Note: Optional Quick release  
vise is also available for this model.



#### 72" MODEL

STOCK NO. 40-086

**PRO-BENCH 72" Model**  
includes 72" Top (#40-092), 4" Cabinet  
(#40-093), Quick release vise (#40-091),  
and Standard vise (#40-090).



#### CABINET OPTIONS

Compatible with both ProMAX Professional Cabinets and PRO-BENCH Cabinets.



**DOOR PACK**  
#40-084



**DRAWER PACK**  
#40-083



**CAB-LOC**  
#40-008

MADE IN  
USA



For more product information visit our website at

[www.benchdog.com](http://www.benchdog.com)



# cedar-lined blanket chest

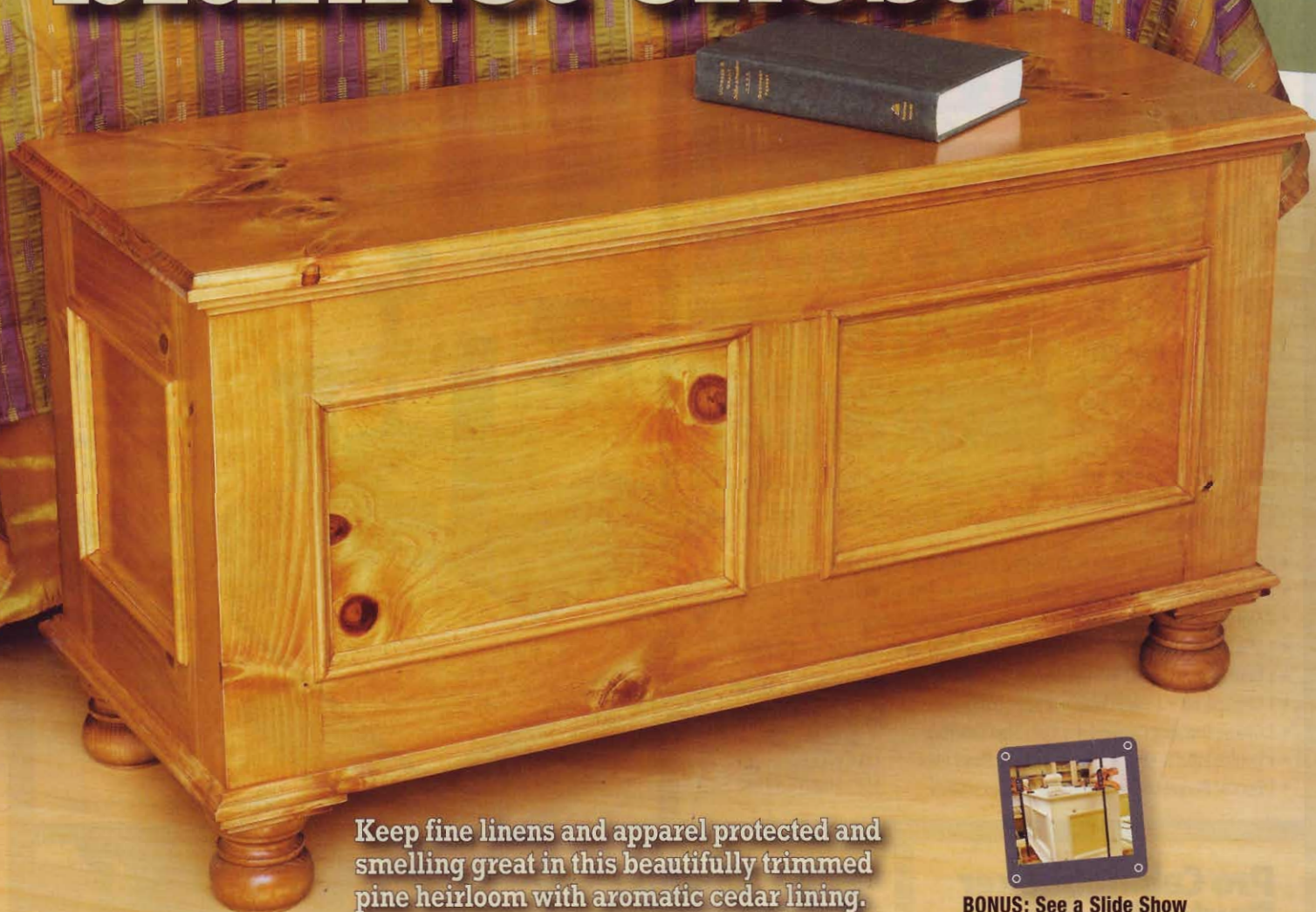

Keep fine linens and apparel protected and smelling great in this beautifully trimmed pine heirloom with aromatic cedar lining.



**BONUS:** See a Slide Show of the project assembly at: [woodmagazine.com/slides](http://woodmagazine.com/slides)



Place off-used items in a handy tray that slides on the top lining retainers.

## AT A GLANCE

- Overall dimensions are 39 $\frac{1}{4}$ " wide x 16 $\frac{3}{4}$ " deep x 21 $\frac{7}{8}$ " high.
- Materials used: Pine, birch plywood, and cedar closet lining.
- If you wish to build the chest without the lining and tray, simply omit parts Q through W.
- The attractive trim profiles are made using common cove, round-over, and straight router bits.
- The chest front/back and side panels assemble with straightforward stub-tenon-and-groove joinery.
- Looking to save time and money? Order the hardware kit containing the continuous hinge, lid stays, and bun feet from the **Source** on page 46. Prefer to turn the feet? See the full-size foot pattern in the *WOOD patterns*® insert.

## Start with the panels

**1** Cut the front/back stiles (A), side stiles (B), front/back rails (C), side rails (D), and front/back center stiles (E) to the sizes listed [Materials List, page 46]. Save the rail cutoffs for making test tenons.

**2** Using a dado blade in your tablesaw, cut a centered  $\frac{1}{4}$ " groove  $\frac{3}{8}$ " deep along the *inside* edge of the front/back stiles (A), side stiles (B), front/back rails (C), and side rails (D), and along *both* edges of the center stiles (E) [Drawings 1 and 2].

**3** Again using your dado blade, form a  $\frac{1}{4}$ " tenon  $\frac{3}{8}$ " long on both ends of the front/back rails (C), side rails (D), and front/back center stiles (E) [Drawings 1 and 2, Photo A] to fit snugly in the grooves in the rails and stiles. (We cut a test tenon on a rail cutoff to verify our setup before cutting the tenons.)



## 1 FRONT/BACK AND SIDE PANELS

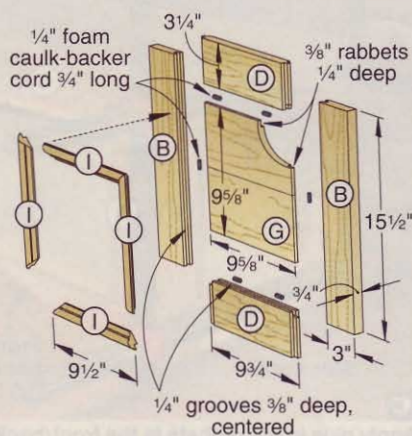

SIDE ASSEMBLY

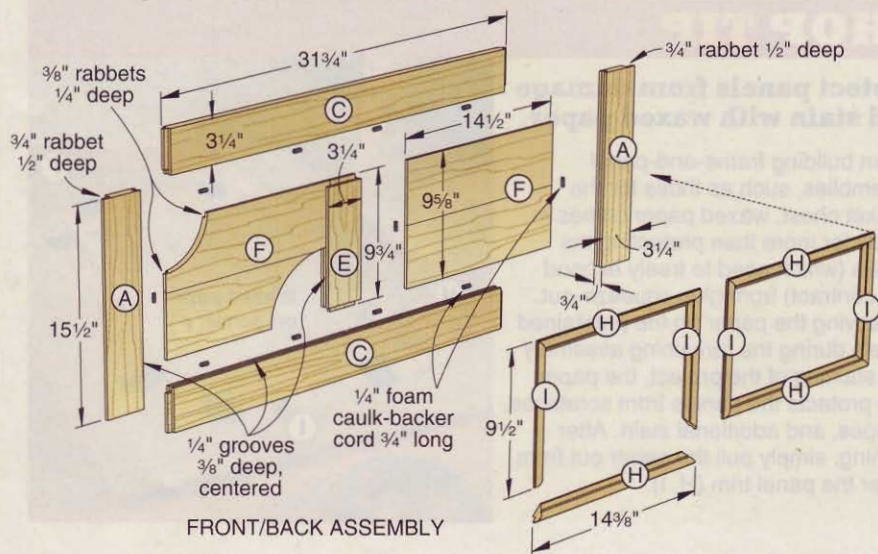

FRONT/BACK ASSEMBLY

**4** Adjust your tablesaw setup. Then cut a  $\frac{3}{4}$ " rabbet  $\frac{1}{2}$ " deep along the *outside* edge of the front/back stiles (A) on the *inside* face to receive the side stiles (B) [Drawings 1 and 2].

**5** From edge-joined stock, cut the front/back panels (F) and side panels (G) to the sizes listed. (Note that the panels are  $\frac{1}{8}$ " shorter in width and length than the openings to allow for seasonal movement.) Then cut a  $\frac{3}{8}$ " rabbet  $\frac{1}{4}$ " deep around each panel on the *inside* face to form a  $\frac{1}{4}$ "-thick lip that fits snugly in the grooves in the rails and stiles [Drawing 1].

**6** Sand all of the parts to 220 grit, and remove the dust from the panels (F, G). Stain the panels. Staining them now prevents unfinished edges from showing when the panels expand and contract. (We stained the panels and chest with Varathane no. 218 Traditional Pecan Stain, first applying Varathane Premium Wood Conditioner to prevent blotching of the stain on the pine.) If you plan to install cedar lining in the chest, stain only the *outside* faces of the panels, as explained in "A finishing no-no for cedar-lined chests," *above right*.

**7** To assemble the front/back panels, mark centerlines on masking tape on the rails (C) and center stiles (E) on the *outside* faces for aligning the stiles. Then, to keep the front/back and side panels (F, G) centered in the openings, cut from  $\frac{1}{4}$ " foam caulk-backer cord (available at home centers) 36 pieces  $\frac{3}{4}$ " long for spacers.

**8** Insert the foam spacers into the grooves in the front/back stiles (A), rails (C), and center stiles (E) [Drawing 1]. Then glue and clamp together the stiles, rails, and center stiles with panels (F) captured in the grooves and the center stile/rail centerlines aligned [Photo B]. Apply glue only to the rail and center-stile tenons (no glue on the panels or in the grooves). To prevent damage to the

## 2 RAIL AND STILE DETAILS

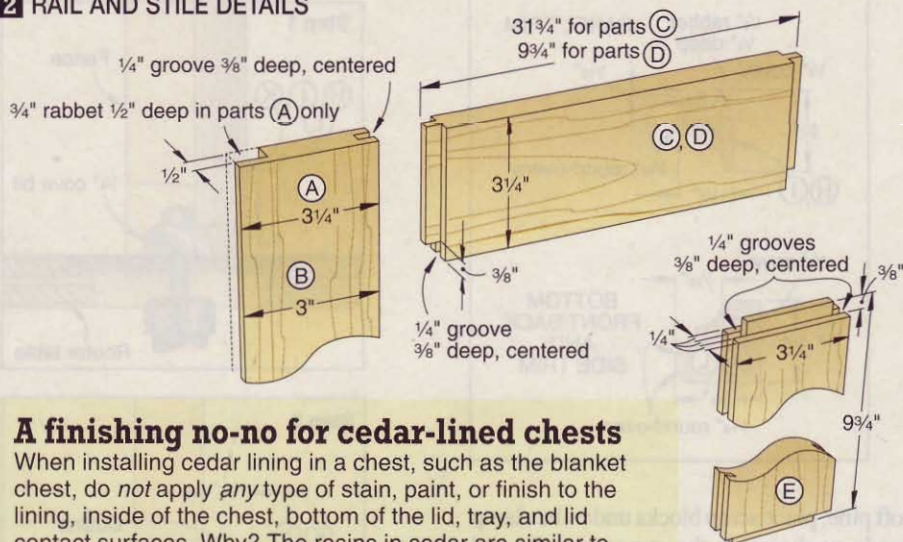

### A finishing no-no for cedar-lined chests

When installing cedar lining in a chest, such as the blanket chest, do *not* apply *any* type of stain, paint, or finish to the lining, inside of the chest, bottom of the lid, tray, and lid contact surfaces. Why? The resins in cedar are similar to those in turpentine, so the oil vapors will soften oil- and water-based stains, paints, and finishes (including lacquer), causing clothes and the lid to stick.

### CUT THE RAIL AND STILE TENONS



**A** Using a miter-gauge extension for backup, form a  $\frac{1}{4}$ " tenon  $\frac{3}{8}$ " long on each end of the rails (C, D) and center stiles (E).

### ASSEMBLE THE PANELS

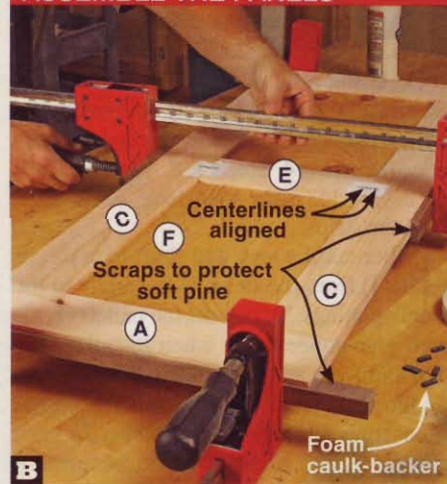

**B** Glue and clamp together the front/back stiles (A), rails (C), center stiles (E), and panels (F) with the center stiles aligned.



## SHOP TIP

### Protect panels from damage and stain with waxed paper

When building frame-and-panel assemblies, such as those for the blanket chest, waxed paper comes in handy for more than protecting the panels (which need to freely expand and contract) from glue squeeze-out. By leaving the paper on the prestained panels during the remaining assembly and staining of the project, the paper also protects the panels from scratches, scrapes, and additional stain. After staining, simply pull the paper out from under the panel trim (H, I).



## GLUE AND CLAMP THE CHEST

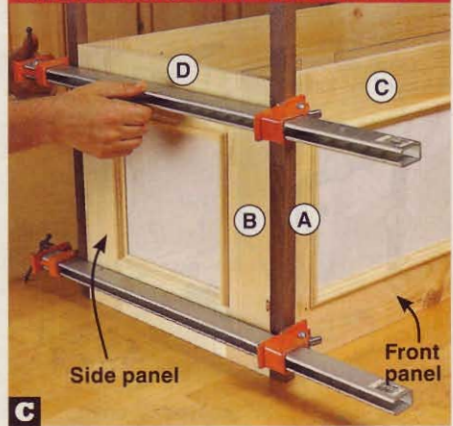

Apply glue in the rabbets in the front/back stiles (A), and assemble and clamp the front/back and side panels together.

### 3 TRIM PROFILES

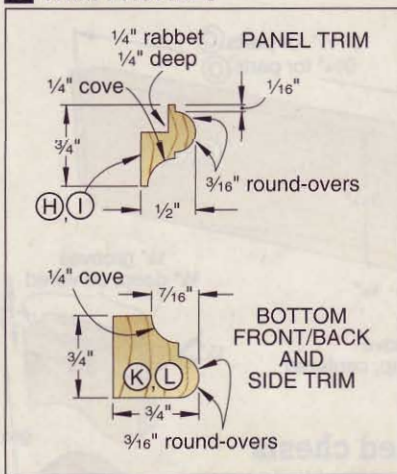

soft pine, place scrap blocks under the clamp heads, as shown. In the same way, glue and clamp together the side stiles (B), rails (D), and panels (G) to form the side panels, again inserting the foam spacers in the grooves.

### Trim and glue up the chest

**1** To form the long and short panel trim (H, I), cut four 2x48" pieces from 3/4" stock. Using a 1/4" cove bit, 3/16" round-over bit, and a 1/4" straight bit, rout the profile [Drawing 3] along both edges of each piece [Drawing 4, Steps 1, 2, 4 and 5]. Then rip a 1/2"-wide trim strip from each edge. Sand the strips.

**2** Miter-cut the long and short trim pieces (H, I) from the strips to fit snugly in the panel openings. To protect the panels (F, G) from glue squeeze-out when installing the trim and from additional stain when finishing the chest later, see the **Shop Tip**, above. Then apply glue along the rabbet in each trim piece, and install the trim, securing it to the rails and stiles with masking tape.

**3** Glue and clamp together the front/back panels (A/C/E/F/H/I) and side panels

### 4 ROUTING THE TRIM PROFILES

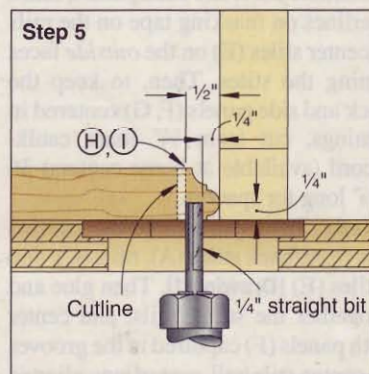
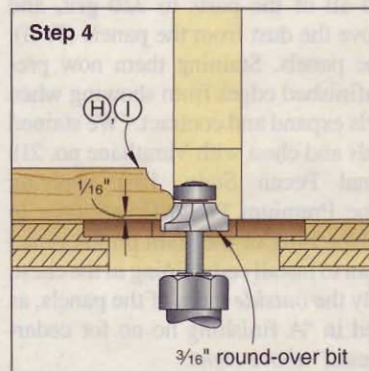
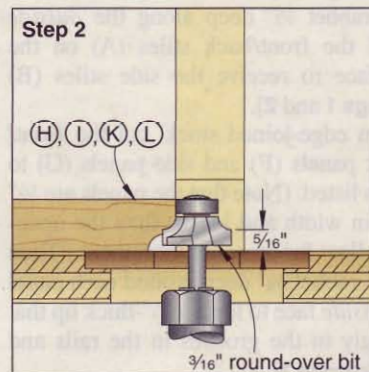
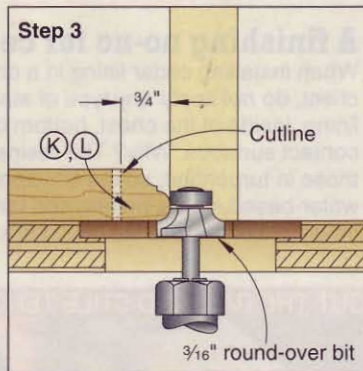
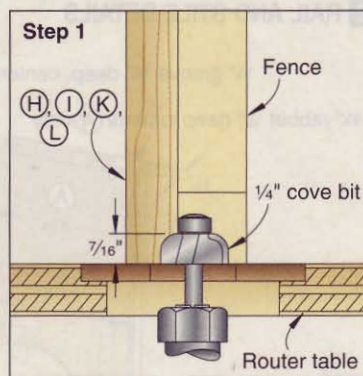

(B/D/G/I), measuring for equal diagonals to verify square [Photo C].

### Add the bottom and feet

**1** Cut the bottom (J) to size. Then, from 3/4" stock planed to match the thickness of the plywood bottom, cut two 2x40" pieces to form the front/back trim (K) and side trim (L). Using 1/4" cove and 3/16" round-over bits, rout the profile [Drawing 3] along both edges of one piece and one edge of the other [Drawing 4, Steps 1, 2, and 3]. Then rip a 3/4"-wide trim strip from each edge. Sand the strips. Now miter-cut the trim pieces to length to fit the bottom, and glue and clamp them in place, verifying tight corners.



## 5 EXPLODED VIEW

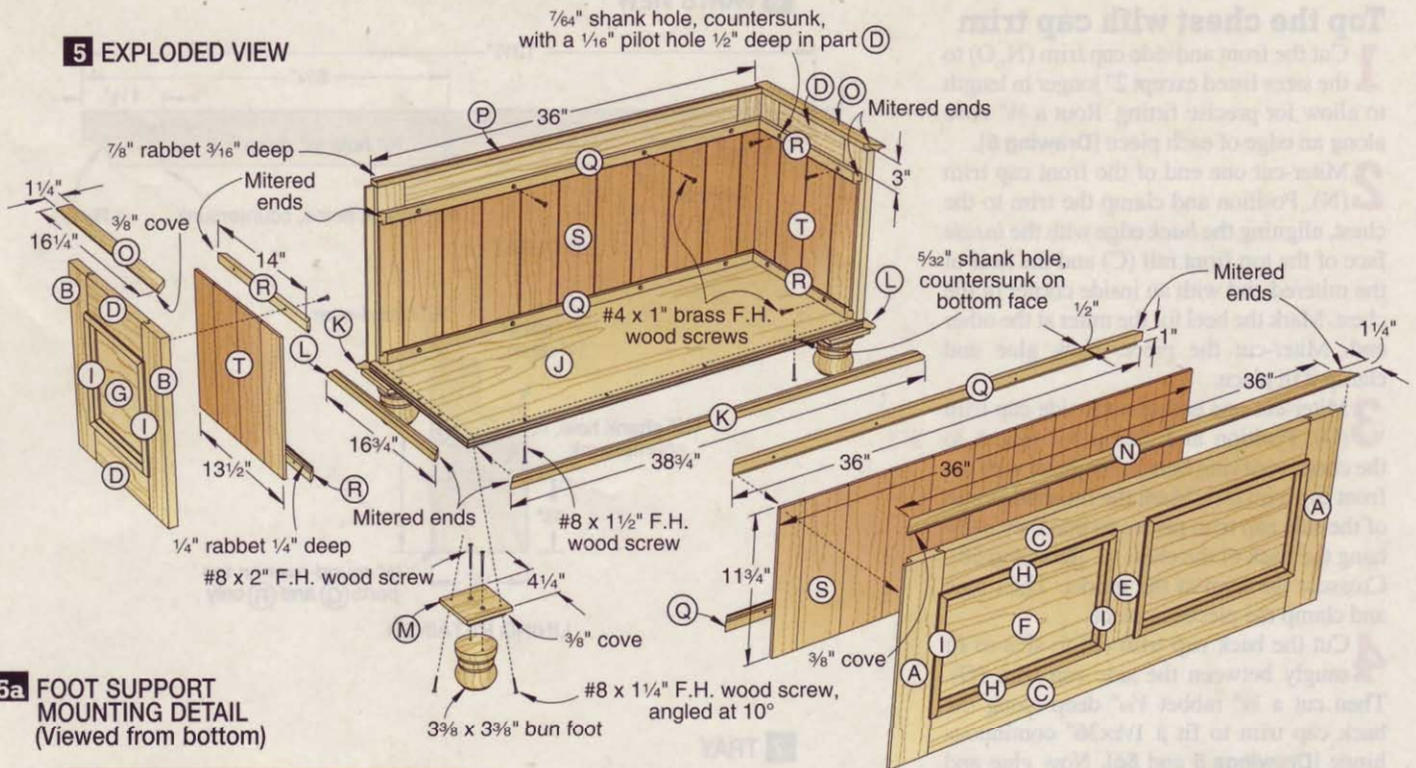

**5a FOOT SUPPORT MOUNTING DETAIL (Viewed from bottom)**

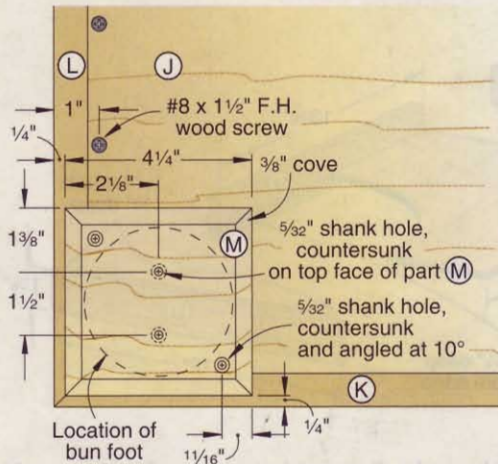

**5b END VIEW DETAIL**

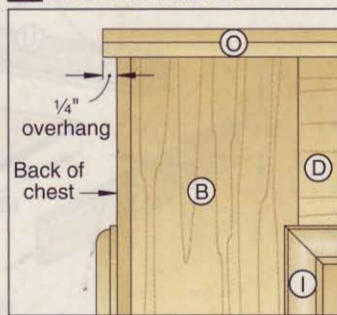

**5c BACK CAP TRIM SECTION DETAIL**

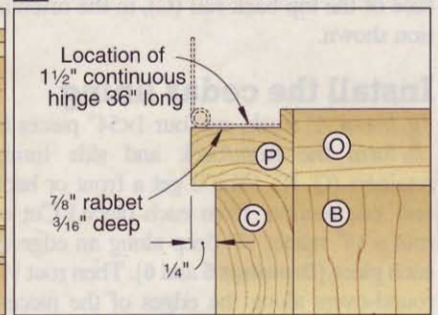

**2** Cut the foot supports (M) to size. Then rout a  $\frac{3}{8}$ " cove around the bottom edges of each support [Drawing 5]. Glue a  $3\frac{3}{8} \times 3\frac{3}{8}$ " bun foot, centered, to the bottom (coved face) of each support. Now drill two mounting holes through the top of each support into the centered foot [Drawing 5a], and drive the screws.

**3** With the *bottom* face of the bottom panel (J/K/L) up, glue and screw the foot support (M) assemblies to the panel, positioning the supports  $\frac{1}{4}$ " from the outside edges of the front/back and side trim (K, L) [Drawing 5a, Photo D].

**4** Position the chest with the bottom up. Then center the bottom panel assembly (J/K/L/M) on the chest. Drill mounting holes through the bottom (J) and centered into the front/back and side rails (C, D), where dimensioned [Drawing 5a, Photo E]. Drive the screws.

## MOUNT THE FEET AND BOTTOM ASSEMBLY TO THE CHEST



**D** Glue each foot support (M) assembly to the bottom panel (J/K/L). Drill mounting holes angled at  $10^\circ$ , and drive the screws.

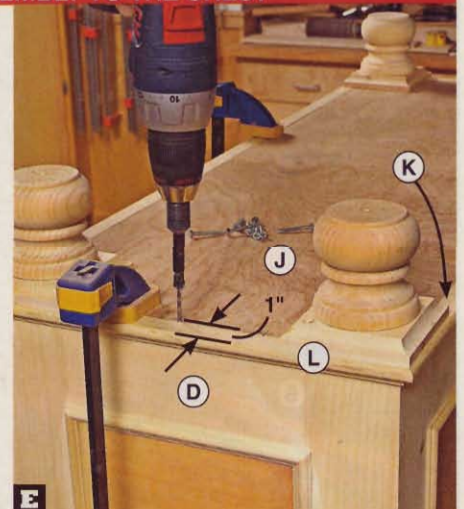

**E** Drill mounting holes 1" from the outside edges of the front/back and side trim (K, L) to mount the bottom assembly to the chest.



## Top the chest with cap trim

**1** Cut the front and side cap trim (N, O) to the sizes listed except 2" longer in length to allow for precise fitting. Rout a  $\frac{3}{8}$ " cove along an edge of each piece [Drawing 5].

**2** Miter-cut one end of the front cap trim (N). Position and clamp the trim to the chest, aligning the *back* edge with the *inside* face of the top front rail (C) and the heel of the mitered end with an inside corner of the chest. Mark the heel for the miter at the other end. Miter-cut the piece. Now glue and clamp it in place.

**3** Miter-cut one end of each side cap trim (O). Position and clamp the pieces to the chest, verifying tight miter joints with the front cap trim (N). Mark the finished length of the side cap trim pieces so that they overhang the back of the chest  $\frac{1}{4}$ " [Drawing 5b]. Crosscut the trim at the marks. Then glue and clamp the pieces in place.

**4** Cut the back cap trim (P) to size to fit snugly between the side cap trim (O). Then cut a  $\frac{7}{8}$ " rabbet  $\frac{3}{16}$ " deep along the back cap trim to fit a  $1\frac{1}{2} \times 36$ " continuous hinge [Drawings 5 and 5c]. Now glue and clamp the trim in place, flush with the *inside* face of the top back rail (C), in the orientation shown.

## Install the cedar lining

**1** From  $\frac{1}{2}$ " stock, cut four  $1 \times 54$ " pieces to form the front/back and side lining retainers (Q, R). (You'll get a front or back and side retainer from each piece.) Cut or rout a  $\frac{1}{4}$ " rabbet  $\frac{1}{4}$ " deep along an edge of each piece [Drawings 5 and 6]. Then rout  $\frac{1}{8}$ " round-overs along the edges of the pieces, where shown, omitting the round-over along the bottom edge of the two pieces that you'll use for the bottom retainers.

### INSTALL THE CEDAR LINING

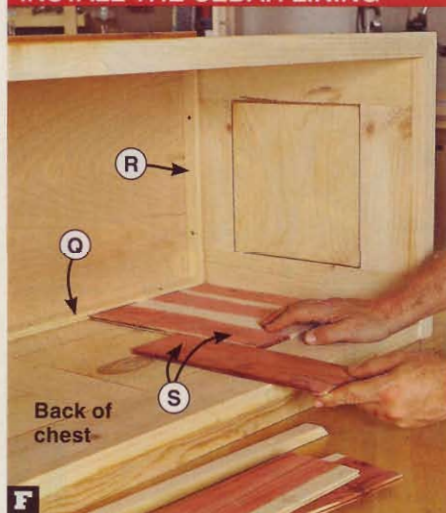

**F** Slide each piece of the back lining (S) into the rabbet in the bottom back lining retainer (Q), keeping the lining joints tight.

## 6 PARTS VIEW

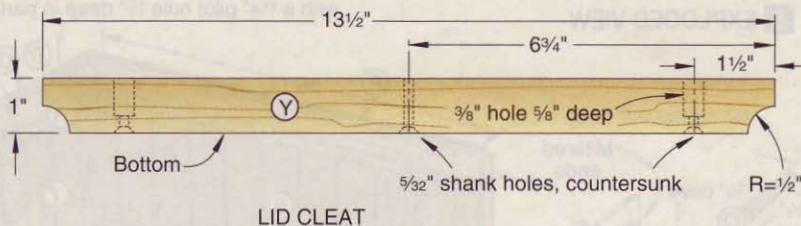

LID CLEAT

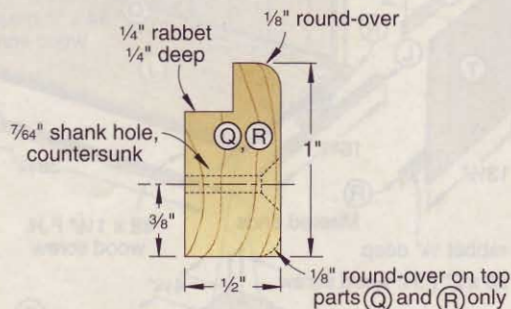

LINING RETAINER

## 7 TRAY

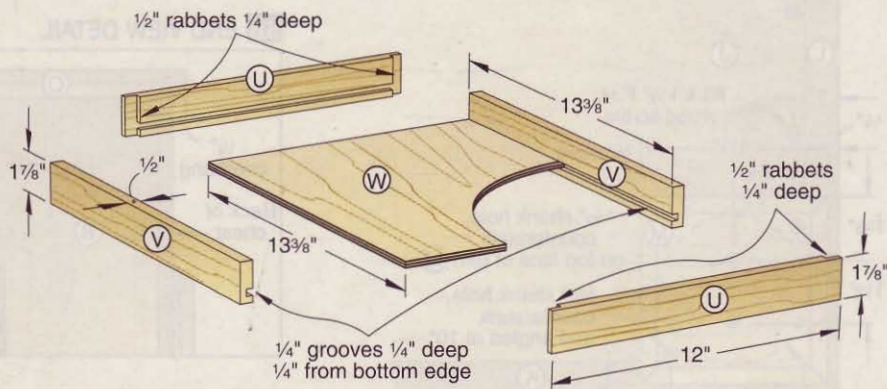

**2** Miter-cut the front/back and side retainers (Q, R) from the pieces to fit snugly in the chest. Drill mounting holes through the retainers, where shown. Sand smooth.

**3** Position the front/back and side retainers for the bottom (the ones without round-overs on the bottom edges) in the chest. Using the mounting holes in the retainers as guides, drill pilot holes into the chest. Then drive the screws.

**4** To form the front/back lining (S) and side lining (T), cut thirty  $11\frac{1}{4}$ "-long pieces from  $\frac{1}{4} \times 3\frac{3}{4}$ " cedar closet lining. (We found a 15-board-foot package of 48"-long lining at a local home center—enough material for the chest.)

**5** Lay out 11 pieces each for the front/back lining (S), and fit the tongues and grooves tightly together. Measure the length of the chest on the inside. Center this measurement on each lining assembly. Then trim equal amounts off the outside edges of

the first and last pieces of each assembly. Sand the lining smooth.

**6** Position the chest with the back down. Install the back lining (S) [Drawing 5, Photo F]. Screw-mount the top back lining retainer (Q) in place to secure the lining. Now reposition the chest with the front down. In the same way, install the front lining and top front retainer (Q).

**7** From the remaining lining pieces, lay out and fit together four pieces each for the side lining (T). Measure between the front/back lining (S) for the exact width of the side lining. As before, center the measurement on each lining assembly, and cut off the ends. Sand the lining smooth. Now install the lining and remaining side lining retainers (R).

## Build the tray

**1** Cut the front/back (U), sides (V), and bottom (W) to the sizes listed.



## 8 LID ASSEMBLY

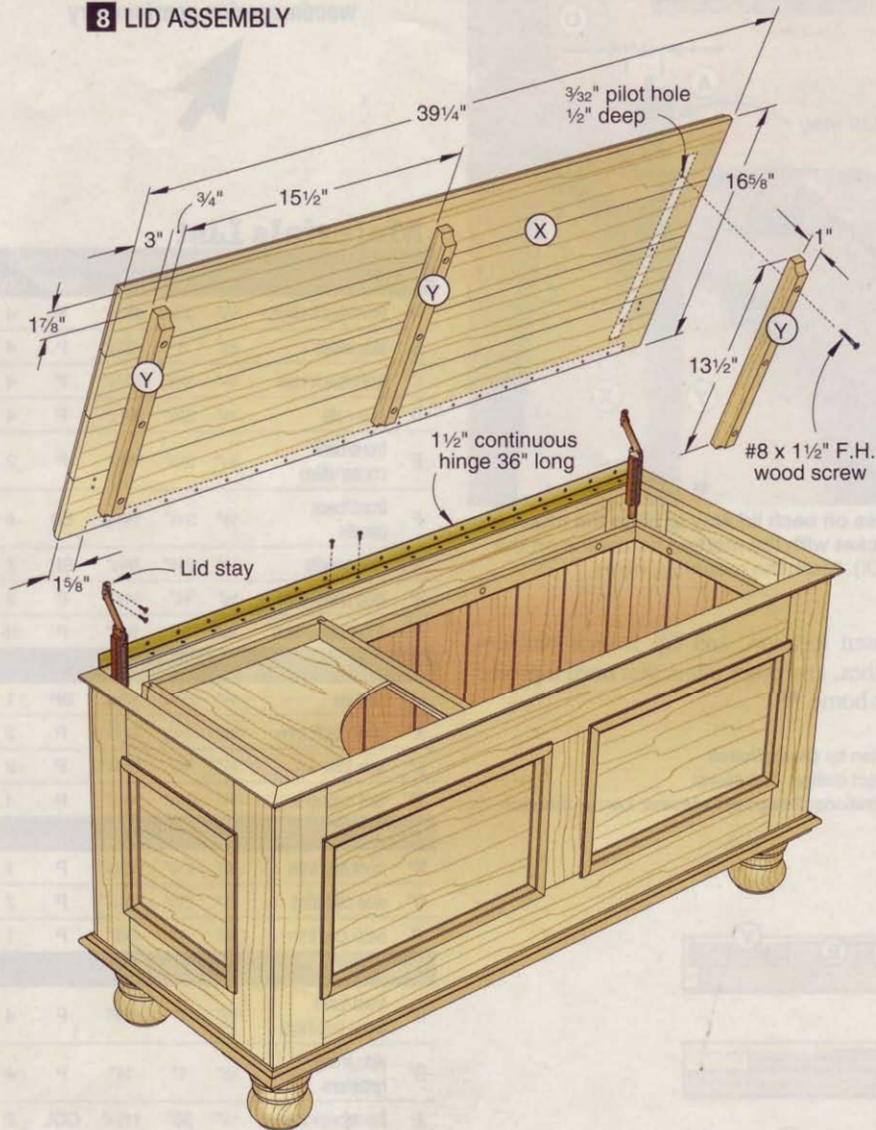

### 8a LID PROFILE DETAIL

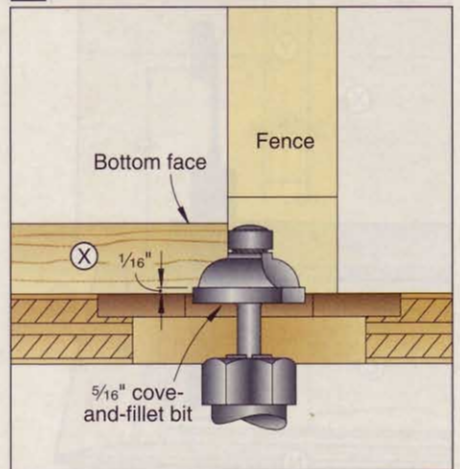

### HINGE THE LID

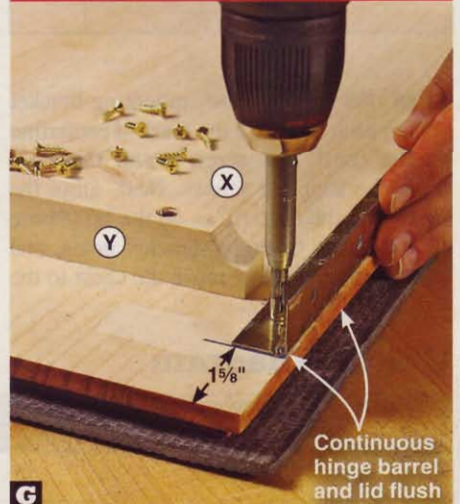

**G** With the continuous hinge aligned with the marks on the lid and the hinge barrel flush with the back edge, drill the mounting holes.

**2** Using a dado blade, cut  $\frac{1}{2}$ " rabbets  $\frac{1}{4}$ " deep across the ends of the front/back (U) on the inside faces [Drawing 7]. Then cut a  $\frac{1}{4}$ " groove  $\frac{1}{4}$ " deep  $\frac{1}{4}$ " from the bottom edges of the front/back and sides (V) to fit the plywood bottom (W). Sand smooth.

**3** Glue and clamp the tray together. Measure for equal diagonals to verify square.

### Time for the lid

**1** Edge-join  $\frac{3}{4}$ " stock to form a  $17 \times 40$ " blank for the lid (X). Then crosscut and rip the lid to the finished size of  $16\frac{5}{8} \times 39\frac{1}{4}$ ". Using a  $\frac{5}{16}$ " cove-and-fillet router bit, rout the profile [Drawing 8a] along the ends and edges of the lid. (We used a Freud no. 38-282 router bit.) As an alternative to the cove-and-fillet profile, you can rout a  $\frac{3}{8}$ " cove on the lid. Sand the lid.

**2** Cut the cleats (Y) to size. Draw the radius at each end of the cleats [Drawing 6]. Bandsaw and sand to shape. Next, drill

three countersunk shank holes through the cleats on the bottom edge, where dimensioned. Now drill a  $\frac{3}{8}$ " hole  $\frac{5}{8}$ " deep in the outer holes (to accommodate lid movement) in the top edge.

**3** With the bottom face of the lid (X) up, position (without glue) the cleats (Y), where dimensioned [Drawing 8]. Using the shank holes in the cleats as guides, drill pilot holes into the lid. Now drive the screws.

### Let's wrap things up

**1** Sand any areas that need it to 220 grit, and remove the dust. With the waxed paper still in place on the panels (F, G), apply wood conditioner and stain to the chest and lid. If you installed the cedar lining, do not stain the inside of the chest, bottom of the lid (X/Y), the top faces of the cap trim (N, O, P), and the tray (U/V/W) as explained previously. Remove the waxed paper. Then apply a finish to the stained

areas only. (We applied two coats of Varathane Diamond Water-Based Polyurethane, sanding to 320 grit between coats.)

**2** To mount the lid (X/Y), position a  $1\frac{1}{2}$ " continuous hinge 36" long in the rabbeted back cap trim (P) [Drawings 5c and 8]. Drill the mounting holes, but do not drive the screws. Remove the hinge.

Next, position the lid with the bottom face up. Mark alignment lines for the hinge on masking tape  $1\frac{3}{8}$ " from the ends of the lid at the back edge. With the hinge leaves at 90°, position the hinge on the lid, aligning the ends with the marked lines, and drill the mounting holes [Photo G]. Remove the hinge and tape. Now screw-mount the hinge to the lid and back cap trim using the screws supplied with the hinge.

**3** To mount the lid stays, position the chest on its back with the lid open at 90°. Mark centerlines for mounting holes on the chest and lid, where dimensioned [Drawing 9].



## 9 MOUNTING THE LID STAYS

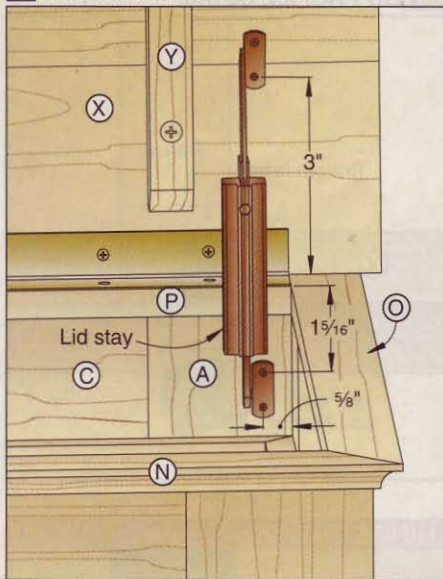

Align the appropriate mounting-bracket hole in each stay with the marked centerline on the chest, and screw-mount the stays using the supplied screws. Next, align the stays with the centerlines on the lid [Photo H], mark the mounting-bracket holes, and attach the stays. Now move the chest to the

## MARK THE LID STAY HOLES

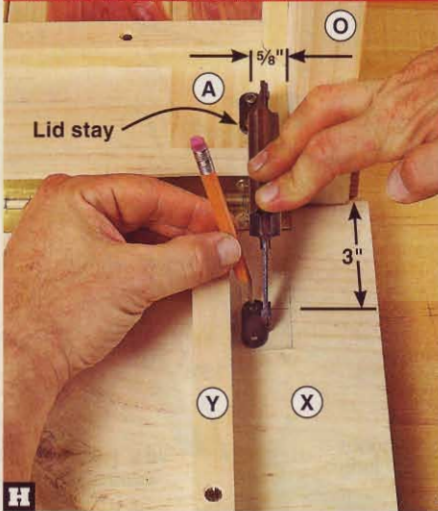

Press on each lid stay to align the mounting bracket with the marked centerline on the lid (X). Mark the mounting holes.

chosen location, and fill it with woolens, clothes, and other items that need a protective home. 🐿

Written by **Owen Duvall**  
Project design: **Jeff Mertz**  
Illustrations: **Roxanne LeMoine; Lorna Johnson**

Find more Country Furniture plans at:  
[woodmagazine.com/country](http://woodmagazine.com/country)



## Materials List

Chest panels	FINISHED SIZE			Matl.	Qty.
	T	W	L		
A front/back stiles	3/4"	3 1/4"	15 1/2"	P	4
B side stiles	3/4"	3"	15 1/2"	P	4
C front/back rails	3/4"	3 1/4"	31 3/4"	P	4
D side rails	3/4"	3 1/4"	9 3/4"	P	4
E front/back center stiles	3/4"	3 1/4"	9 3/4"	P	2
F front/back panels	1/2"	9 5/8"	14 1/2"	EP	4
G side panels	1/2"	9 5/8"	9 5/8"	EP	2
H* long panel trim	1/2"	3/4"	14 3/8"	P	8
I* short panel trim	1/2"	3/4"	9 1/2"	P	16
<b>Bottom</b>					
J bottom	3/4"	15 1/4"	37 1/4"	BP	1
K* front/back trim	3/4"	3/4"	38 3/4"	P	2
L* side trim	3/4"	3/4"	16 3/4"	P	2
M foot supports	3/4"	4 1/4"	4 1/4"	P	4
<b>Cap trim</b>					
N* front cap trim	3/4"	1 1/4"	38 1/2"	P	1
O* side cap trim	3/4"	1 1/4"	16 1/4"	P	2
P back cap trim	3/4"	1"	36"	P	1
<b>Cedar lining</b>					
Q* front/back lining retainers	1/2"	1"	36"	P	4
R* side lining retainers	1/2"	1"	14"	P	4
S front/back lining	1/4"	36"	11 1/4"	CCL	2
T side lining	1/4"	13 1/2"	11 1/4"	CCL	2
<b>Tray</b>					
U front/back	1/2"	1 7/8"	12"	P	2
V sides	1/2"	1 7/8"	13 3/8"	P	2
W bottom	1/4"	11 1/2"	13 3/8"	BP	1
<b>Lid assembly</b>					
X* lid	3/4"	16 5/8"	39 1/4"	EP	1
Y cleats	3/4"	1"	13 1/2"	P	3

\*Parts initially cut oversize. See the instructions.

**Materials key:** P—pine, EP—edge-joined pine, BP—birch plywood, CCL—cedar closet lining.

**Supplies:** 1/4" foam caulk-backer cord, #8x2" flathead wood screws (8), #8x1 1/4" flathead wood screws (8), #8x1 1/2" flathead wood screws (23), #4x1" brass flathead wood screws (24), 1 1/2" continuous hinge 36" long, lid stays (1 pr.), 3 3/8x3 3/8" bun feet (4).

**Blade and bits:** Dado-blade set; 1/4" and 3/8" cove, 3/16" round-over, 1/4" straight, and 3/16" cove-and-fillet router bits.

## Source

**Hardware kit.** Contains a 1 1/2" continuous hinge 36" long, lid stays (1 pr.), and 3 3/8x3 3/8" bun feet (4). Order kit no. 3017, \$42.95 plus shipping and handling. Call or click Meisel Hardware Specialties; 800/441-9870; [meiselwoodhobby.com](http://meiselwoodhobby.com).

## Cutting Diagram

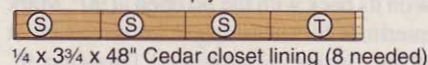
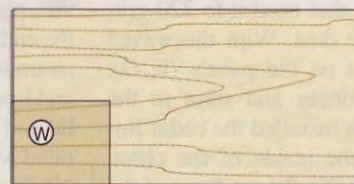
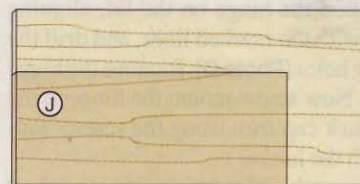
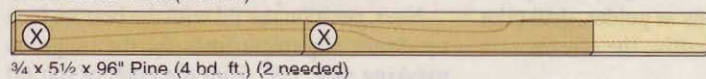
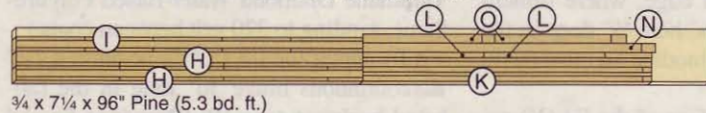
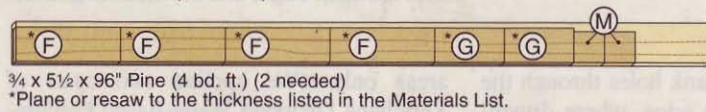
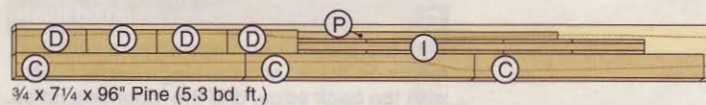
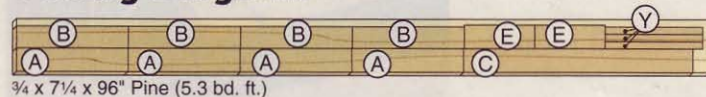



# give a top a whirl

Special hardware and chattering give this turning a whole new spin.

**H**ere's a turning you can churn out quickly for gift giving. Or, if you're a wood collector, turn a bunch with the following technique to display a variety of cherished wood species. You'll learn to decorate the top with a chatter texture, using a low-cost tool you can make in your shop with parts from the hardware store.



Watch a FREE 6-minute video on turning a chatter-decorated top at: [woodmagazine.com/videos](http://woodmagazine.com/videos)

## 1 Gather the materials

For this project, you need the supplies shown at *right*, which include a 2x2x2 1/4" turning blank. (We used hard maple; for a long-wearing spinning point, the harder the wood, the better. For the screw mandrel, top hardware, and an inexpensive drill chuck, see **Sources** on page 50.) To find the center of the turning blank, draw diagonals on one end. Then drill an 1 1/64" hole 7/8" deep where the lines intersect. To make the template, photocopy the top pattern on the *WOOD Patterns*® insert, adhere it to cardboard with spray adhesive, and cut it to shape with a crafts knife.

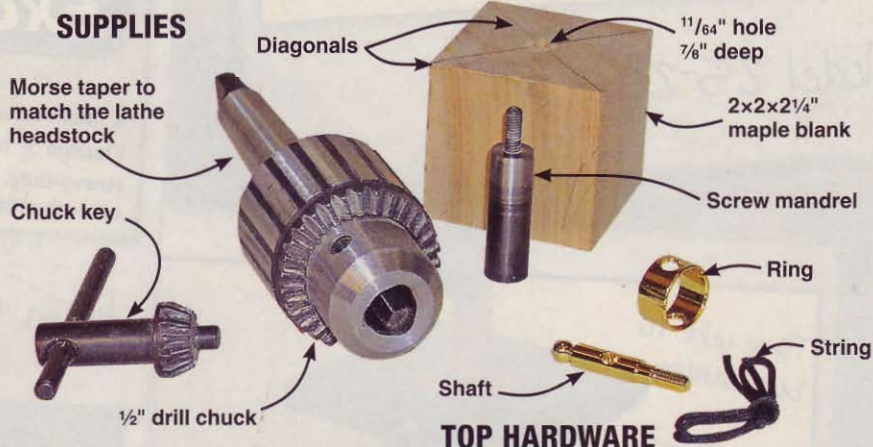

## 2 Mount the blank and rough-turn the top

**Tool:** 3/4" roughing gouge.  
**Tool rest:** At center.  
**Speed:** 2,000 rpm.

Install a drill chuck in the headstock of your lathe. Adjust the threaded shaft of the screw mandrel to protrude 3/8", and chuck the mandrel into the drill chuck. Then screw the blank onto the threaded shaft. (If the threaded shaft turns in the mandrel body when you thread on the turning blank, remove the shaft from the mandrel body, and apply thread locker, such as Loctite, to the threads. Insert the shaft, and let the thread locker dry.) Support the blank with the tailstock live center. Next, use a roughing gouge to turn the blank to a cylinder. Now, making light downhill cuts, use the same tool to rough-turn the top to shape, as shown at *right*.

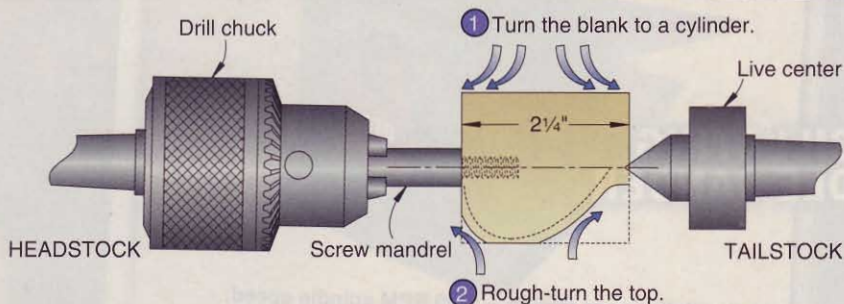





### 3 Refine the shape

**Tool:**  $\frac{3}{8}$ " spindle gouge.  
**Tool rest:** Slightly below center.  
**Speed:** 2,000 rpm.

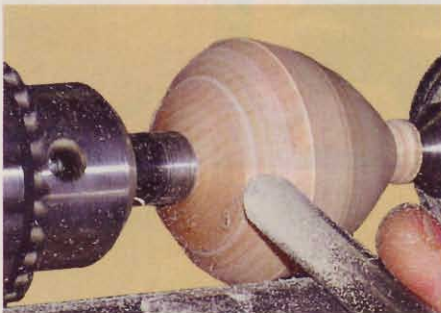

Using the template to check your progress, pick up a spindle gouge to turn the top to finished shape, as shown *above*. Work right up to the screw mandrel at the top and leave

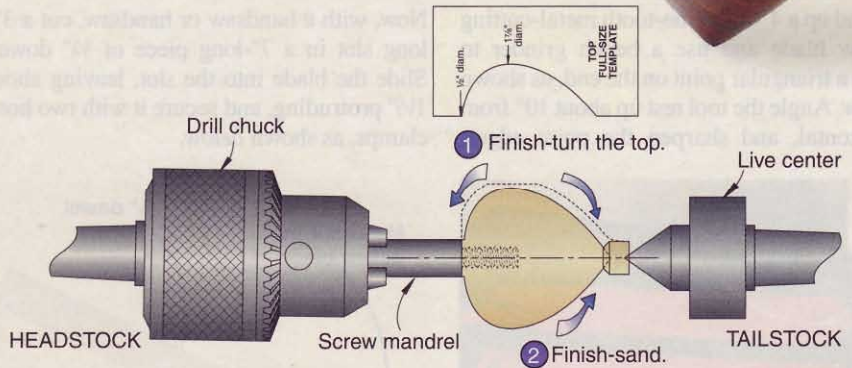

enough wood at the point to engage the live center for support when sanding and applying the chatter decoration. Then finish-sand the top with a progression of 120-, 180-,

220-, and 320-grit sandpaper. To apply chatter decoration to the top, see the instructions on the *following page*.

### 4 Part and finish the top, and add the hardware

Use a skew chisel to part the top from the live center and complete the point, as shown *below*. Back off the live center and lightly finish-sand the point. Remove the top from the mandrel. If you chattered and colored your top, let the marker ink dry for 24 hours, and apply a clear lacquer finish. Assemble the hardware, as shown *below right*.

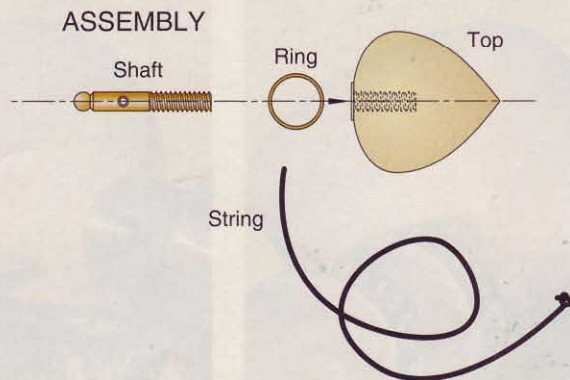
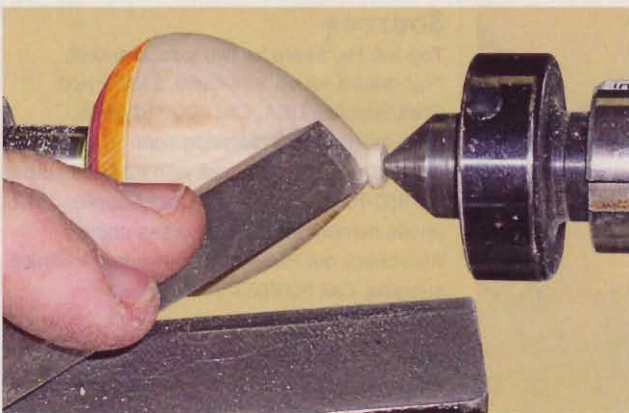
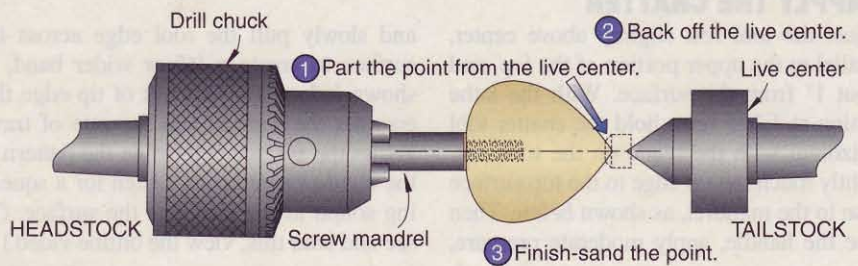



# CHATTERING SHORT COURSE

The art of applying decoration to a spinning vessel has deep roots, stemming from the early days of pot making. To do it, you use a chatter tool, which is simply a flexible blade with a handle. When drawn across a rotating surface, the blade vibrates and skips, gouging the surface in a repetitive pattern. Here's how to make and use your own inexpensive chatter tool.



## 1 MAKE THE TOOL

Round up a 4"-long fine-tooth metal-cutting jigsaw blade and use a bench grinder to form a triangular point on the end, as shown *below*. Angle the tool rest up about 10° from horizontal, and sharpen the point edges.

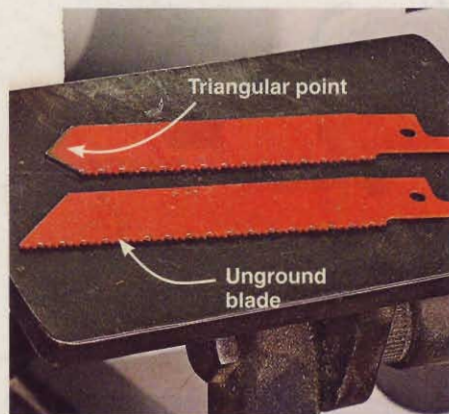

Now, with a bandsaw or handsaw, cut a 3"-long slot in a 7"-long piece of 3/4" dowel. Slide the blade into the slot, leaving about 1 1/2" protruding, and secure it with two hose clamps, as shown *below*.

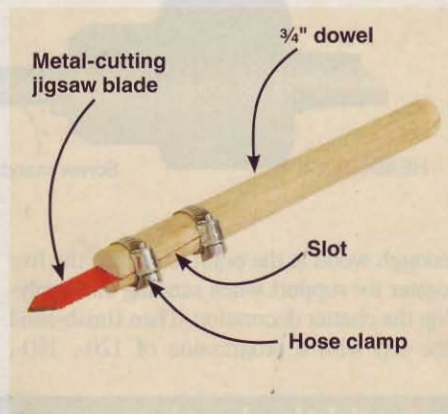

## 2 APPLY THE CHATTER

Adjust the tool rest slightly above center, parallel to the upper portion of the top, and about 1" from the surface. With the lathe turning at 1,200 rpm, hold the chatter tool horizontal with the blade on the tool rest. Lightly touch the tip edge to the top surface close to the mandrel, as shown *below*. Then raise the handle, apply moderate pressure,

and slowly pull the tool edge across the surface to create a 1/4" or wider band, as shown *below*. The amount of tip edge that engages the surface and the rate of travel across the surface determine the pattern of the band of chattering. Listen for a squealing sound as the tool cuts the surface. (To see and hear this, view the online video.)

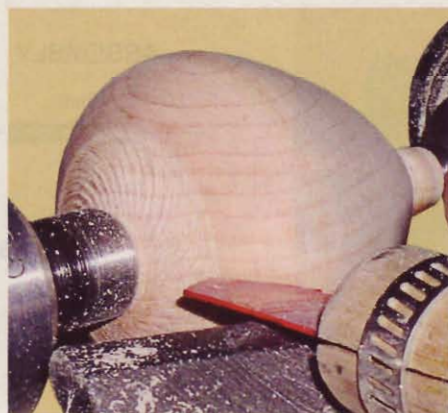
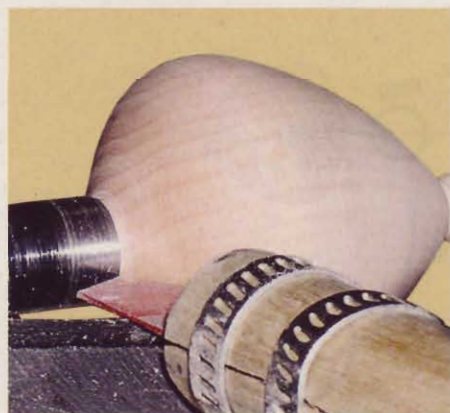

## 3 COLOR AND GROOVE THE BANDS

Keeping the tool rest parallel to the upper portion of the top, position it at center and about 1/2" from the surface. Then, with the lathe turning at 1,200 rpm, lightly touch a medium-tip permanent marker to the surface. Work from the outside toward the center, changing colors with each band of chattering, as shown *below*. Next, to sharpen the boundaries between the chatter bands, raise the tool rest slightly above center, and increase the lathe speed to 2,000 rpm. Form small grooves with the tip of a skew chisel, as shown at *bottom*.



## CHATTER TIPS

- Chattering works best on end grain, and the harder the wood, the better the chatter.
- A chatter tool dulls just like any other tool. Resharpener the edges on a grinder.
- Experiment! Patterns vary with lathe speed, tool angle, the rate you draw the tool across the surface, and the distance the tool blade overhangs the tool rest. ♣

## Sources

**Top kit.** Hardware for two tops, mandrel, 11/64" drill bit, kit no. 964-6999, \$10.99 ppd. Craft Supplies USA. Call 800/551-8876, or go to [woodturnerscatalog.com](http://woodturnerscatalog.com).

**Drill chuck.** 1/2" drill chuck with #2 Morse taper no. 850-7051, \$24.99 ppd. Craft Supplies USA, phone number and Web address *above*. Also check out Packard Woodworks for turning supplies. Call 800/683-8876, or visit [packardwoodworks.com](http://packardwoodworks.com).

Written by Jan Svec with Phil Brennon  
Project design, photographs: Phil Brennon  
Illustrations: Roxanne LeMoine; Lorna Johnson



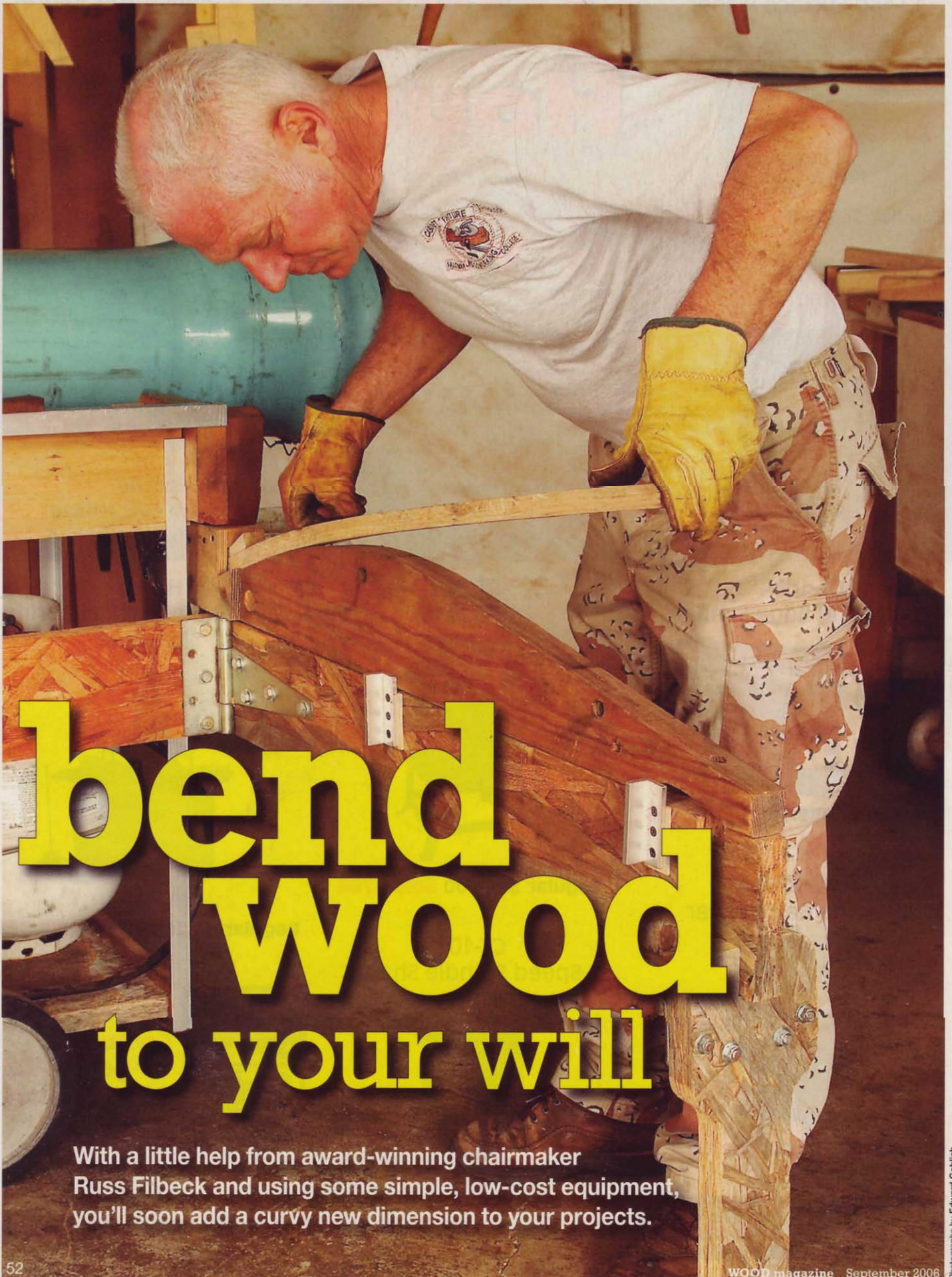

# bend wood to your will

With a little help from award-winning chairmaker Russ Filbeck and using some simple, low-cost equipment, you'll soon add a curvy new dimension to your projects.





Watch a FREE 2-minute video on Steam Bending at: [woodmagazine.com/videos](http://woodmagazine.com/videos)

Of all the ways to reshape and transform wood, steam bending seems the most mysterious. Wood goes into the steaming chamber stiff as, well, a board and comes out pliable enough to bend into an all-new shape.

Some of that mystery disappears once you understand what happens to steamed wood, as shown *below*. Each cell of the wood is covered in lignin, a glue-like chemical that also binds cells together at normal temperatures. Heat transmitted by steaming softens the lignin, allowing the cells to rearrange as some are compressed and others stretched. When the wood cools and the lignin rehardens, the cells bond together again. By fastening heated wood to a bending form before it cools, the rehardened lignin locks these cells into a new shape.

Lignin can be heated too much, though. When that happens, lignin goes from soft to brittle, making the wood easier to break. Because different species of trees have different cell structures, some woods tolerate steam-bending better than others. (See *Best Bending Woods, below*.)

### Best Bending Woods

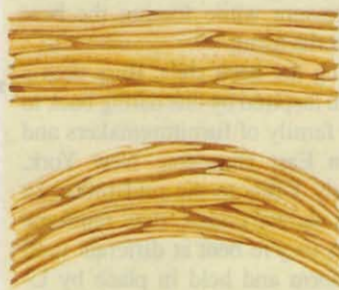

Bendable	Avoid
ash	dense, oily
beech	tropicals and
birch	softwoods
cherry	(spruce, pine, fir)
elm	mahogany
hackberry	
hickory (green)	
soft/hard maple	
red oak	
walnut	
white oak	

Lignin (represented by the dark areas) surrounds wood cells, as shown above. When steamed wood is bent, softened lignin allows cells to shift position. Cells on the outer curve stretch, while cells on the inside curve compress.

### Throwing wood a curve

Russ Filbeck uses this science to craft his award-winning chairs and as an associate professor in the Cabinet and Furniture Technology Department at Palomar Community College in San Marcos, California. For Russ, the process starts with an annual pilgrimage to Kentucky to hand-select and harvest freshly cut oak logs to make his chair parts. For the straightest possible grain, Russ prefers to hand-rive blanks from these green logs. Blanks then air-dry to about 20 percent moisture content for shaping and steam-bending. (See "Straight talk on riving wood" on page 55.)

Why air-dried? Kiln-dried lumber can be steam-bent, but it resists softening because kiln-drying hardens lignin too much for steaming. When Russ bends kiln-dried lumber as a demonstration or out of necessity, he buys pieces with the straightest grain available and then soaks parts in a PVC pipe filled with water and liquid fabric softener for at least a week before steaming them.

Once steam-bending time arrives, Russ wheels out a customized steamer, shown *above right*, that uses a PVC pipe just long enough to hold pieces for the back legs and slats of his chairs. A cart also



*Opposite page:* Russ inserts one end of workpiece into a hold-down built into one end of a form and secures it with a wooden wedge. *Above:* The steam chamber, water tank, heat source, and form holder ride on a cart for easy setup and storage.

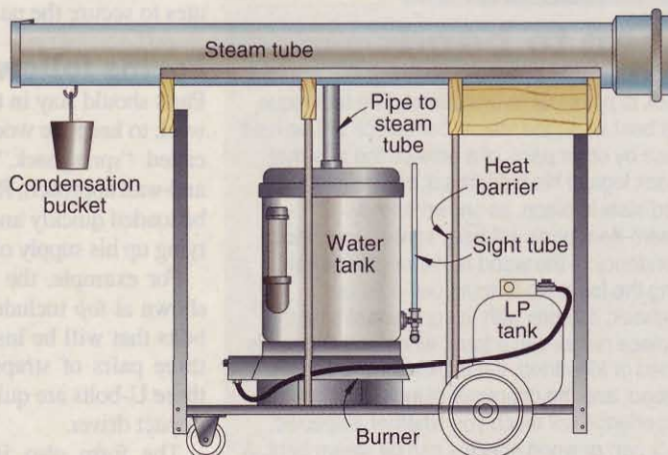

Russ's steamer uses a 22-quart water tank from a recycled steel pressure cooker to avoid refills while steaming.

holds the water tank made from a converted 22-quart, stainless-steel pressure cooker and a burner, plus a swing-out stand (see photo *opposite*) that supports his bending forms to save precious time getting wood from the steamer to the form.



# Steam bending forms and their parts

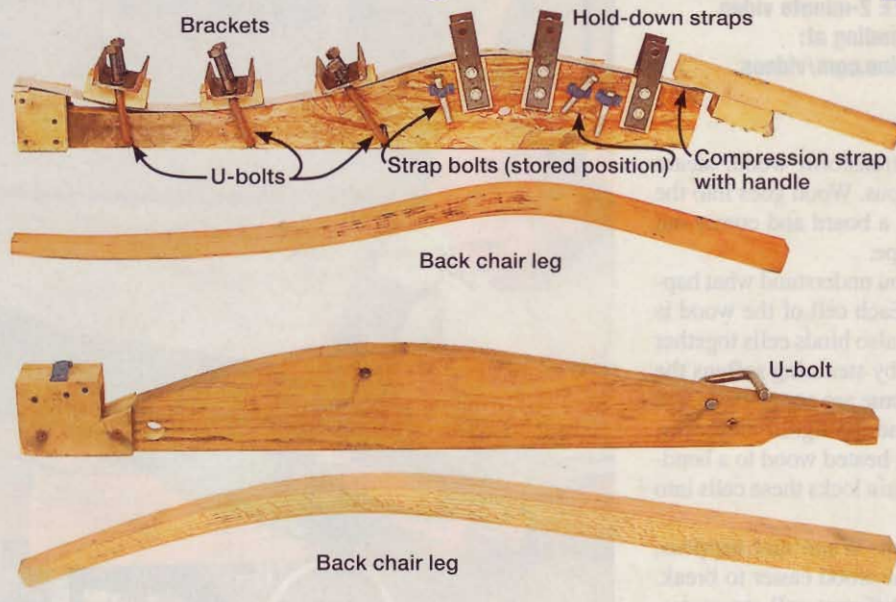

The top form makes compound curves using a mix of screw-down brackets and straps plus a compression strap. The right end of the form holds the compression strap handle in place. The lower form creates a simple curve, using two U-bolts and wedges. The maple and walnut slat form at right is modeled after one used in the middle to late 1700s.

Russ inserts parts into a cool steamer and lights the burner. Once puffs of 212° steam emerge from the vent holes, he starts the countdown. As a rule of thumb, Russ steams wood at the rate of one hour for every inch of wood thickness. Wood that refuses to yield to the bending form can be returned to the steamer for an extra 15–30 minutes before trying again.

Once wood leaves the steamer, Russ has to work quickly. Lignin immediately begins to reharden, giving him fewer than 5 minutes to secure the part in a form.

## Forms follow function

Parts should stay in their forms for at least a week to keep the wood from restraightening, called “springback.” Given this hurry-up-and-wait approach, Russ designs his forms to be loaded quickly and then left to sit without tying up his supply of clamps.

For example, the compound curve form shown at top includes elastic bands to hold bolts that will be inserted into holes on the three pairs of straps. The brackets on the three U-bolts are quickly tightened using an impact driver.

The form also includes a compression strap: a flexible, stainless-steel band attached to the form on one end and extending to a handle on the other. The strap disperses bending stresses on the wood’s outside fibers to reduce the chance of cracks.

Russ prefers U-bolts and wedges over tying up an assortment of clamps for days at a time. The wedges also help spread out the

clamping pressure while forcing the bent wood against the form.

For bending the back slats, Russ uses a bending form inspired by one dating back to the Dominy family of furnituremakers and craftsmen in East Hampton, New York, from the early 1700s to the mid-1800s. In the example shown above, slats reinforce each other as they’re bent at different radii against the form and held in place by U-bolts and wedges stored in elastic loops on the base of the form. Both sides lock in place using a top piece forced down by a wedge. None of the forms carry a finish that could be harmed by the heated wood or block the wood from drying.



## When to bend

Though an expert on steam bending, Russ is quick to point out its limitations. The technique works best when the steam-bent piece will be held in place by other parts of a project, the way that the back legs of his ladderback chairs hold the curved slats in place, as shown above.

Steam-bent parts will have some springback, the tendency of the wood to restraighten after leaving the form. No formula can predict springback; it varies with the amount of time the bent piece remains in a form, whether the wood is air-dried or kiln-dried, the thickness and species of the wood, and the character of individual boards.

Experience will teach you whether a specific project part or wood species can be steam bent. A ¼"-thick piece of oak or ash may bend around a 3" radius just short of cracking while a strip of mulberry twice as thick could make the same bend. To test steamed parts, Russ created a pyramid of seven plywood disks—each ¾" thick—that starts at 24" diameter and tapers to 12" diameter in 2" increments. He wraps test parts around progressively smaller disks until the wood reaches its breaking point.

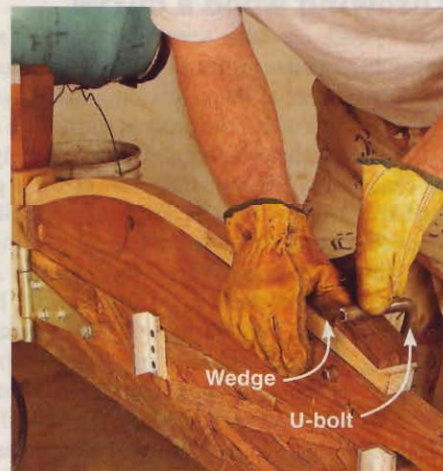

If bent quickly after being pulled from the steam chamber, this workpiece will easily wrap across the form.



# Straight talk on riving wood

Project parts with straight grain better withstand the stress of bending than wood where the grain emerges from either surface. That's why Russ hand-splits, or rives, his own parts from green logs cut slightly longer than the length of such finished project parts as ladderback chair slats.

Riving requires simple tools, some of them hundreds of years old: a hammer, a wedge (like that used for splitting firewood), a froe (see **Sources**), and a wood mallet for striking the froe. Always wear safety glasses, especially when striking the splitting wedge with a metal hammer. Here's how the process works:



## 1. Split the log into sections

Hold the wedge perpendicular to a log's growth rings, using any checking as a starting place. Hammer the wedge in until the wood splits along its length; then repeat to divide the log into sections, as shown above. Split pieces of oak reveal ray flecks in the grain, as shown at right.



## 2. Split parts from sections

Hold the froe against the end of a split section so the blade parallels the rings of the wood. Using a hardwood mallet, drive the froe into the wood to start the split, as shown above.



## 3. Complete the split

As the split develops, tilt the froe handle, as shown above, to split off a piece. This split also will follow the wood grain, as shown at right.



## 4. Work parts to size

Riven pieces now can be cut to length and shaped by hand, as Russ demonstrates at left, or machined. Straight grain makes them easy to plane and steam bend.



## Hot tips on steam bending

Years of experience have taught Russ a few steam-bending secrets:

- **Soften up hardwoods.** Soaking air-dried hardwood parts for a week helps prepare the lignin for bending. To help the water penetrate the wood, add ½ cup of fabric softener as a surfactant. Add water daily so long as the wood absorbs it. Once the wood is bent and sanded, the softener won't interfere with stains or finishes.
- **Minimize wood thickness.** When bending parts that will have a taper, Russ tapers the wood before steaming to reduce its resistance to bending. On parts where he'll round over two edges along the inside face of a bend, he chamfers those edges

before steaming to reduce the amount of wood to be compressed during bending.

- **Learn from experiments.** While steam-bending parts for a project, fill any leftover space in your steamer with various sizes of practice pieces to test their bending ability for future projects.

- **Pre-bend tight turns.** Before chair slats go into their forms, Russ starts the bends by pressing parts against the outside curve of a 16" PVC pipe. This makes it easier to slip short pieces into the forms.

### Sources

**Froe:** 15" Basic American Pattern no. 685-0015, \$40. Traditional Woodworker. Call 800/509-0081, or click on [traditionalwoodworker.com](http://traditionalwoodworker.com)



# Build your own steam-bending chamber



deep grooves on one side and  $\frac{3}{8}$ " rabbets on the other to simplify assembly. Six pieces of PVC pipe held in place by the sides support the wood above water that collects in the bottom of the box during steaming and make it easy to slide project parts into and out of the chamber. Where the insides of the doors meet the ends of the box, add foam weatherstripping for a tight seal.

We sized the chamber for the 40"-long legs of the plant stand. For projects requiring shorter parts, downsize the box as much as possible to conserve steam and distribute it more evenly.

Drainage holes on the bottom of the box also prevent pressure from building up. Steam under pressure can cause severe burns instantly.

To power our steam-bending chamber, we used an electric kettle and extension pipe from Lee Valley Tools (no. 05F14.01, \$37.50; 800/871-8158 or leevalley.com). An oval slot on the underside of the box accommodates the angle of the pipe, while the two legs hold the box at the correct height. We were able to keep the chamber steamed for an hour by refilling the kettle just once.

Now it's your turn to try steam bending. If you plan to build the plant stand on page 58, here's what you'll need to bend its three curved legs. Start by assembling the steam box shown in **Drawing 1**.

We constructed it from one sheet of  $\frac{3}{4}$ " exterior plywood, purchased locally for \$25. Leave the plywood unfinished inside and out to let it absorb and release moisture. The four 48"-long box parts have identical  $\frac{3}{8}$ "-

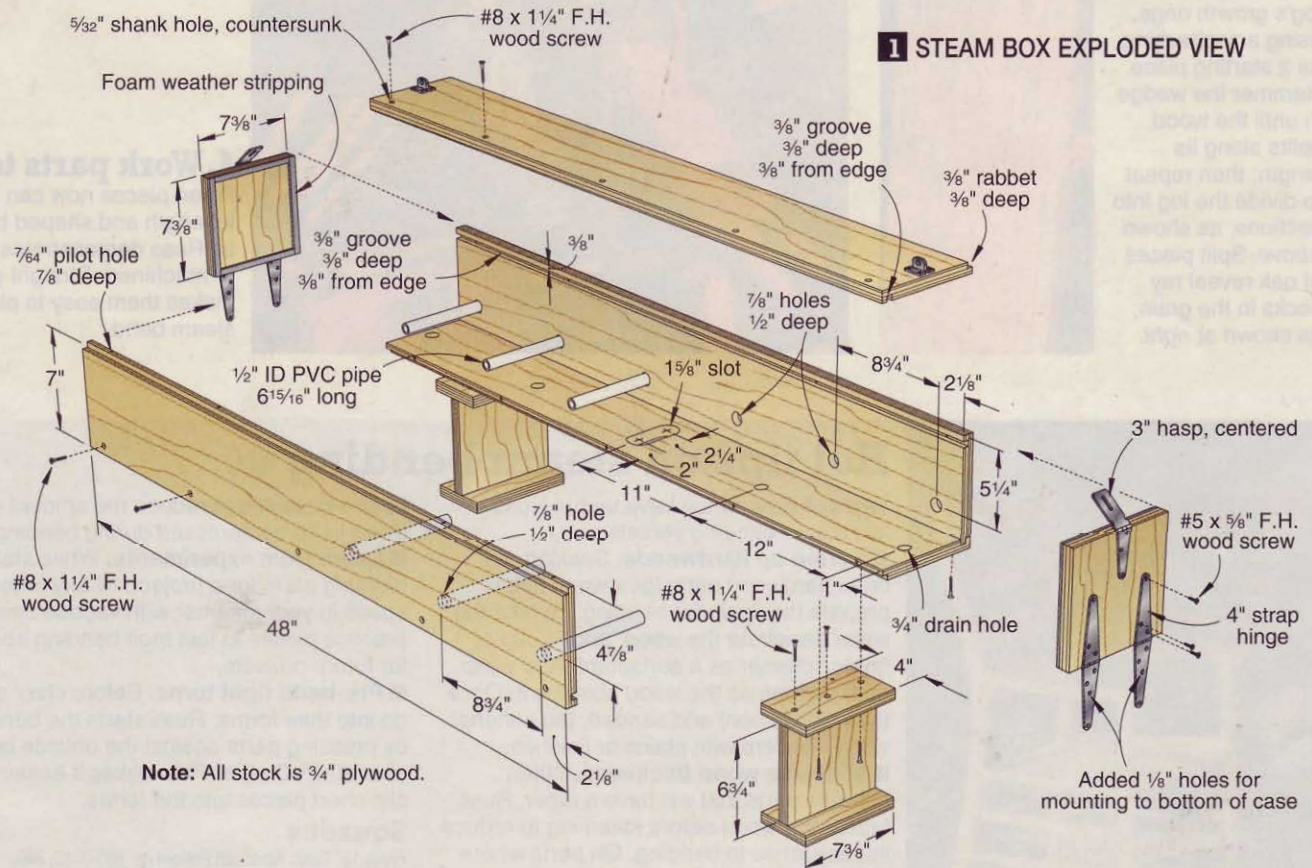





## Putting Russ's lessons in action

We brought home the steam-bending lessons from Russ Filbeck's workshop to create a trio of curved legs for the plant stand on page 58.

To start, use  $\frac{3}{4}$ " plywood to assemble three of the forms shown in **Drawings 2** and **3**. Prepare the necessary hardware by sawing off the threaded portions of six 2" square U-bolts, and cut six wedges roughly  $4\frac{1}{2}$ " long and  $\frac{5}{8}$ " thick at one end. In addition to the steaming box and steam source, you'll need heat-resistant cups to catch condensate from the vent holes, a waterproof tarp to protect your workbench, and towels to mop up spills. For safety, always wear sturdy leather gloves when handling heated wood.

Cut three workpieces for steaming, plus a backup piece or two should a flaw in the wood create an accidental split. Although we used air-dried oak lumber for the plant stand, we also experimented with kiln-dried workpieces soaked for one week in 3" PVC pipes filled with water and  $\frac{1}{2}$  cup of fabric softener. These steamed and bent as well as the air-dried pieces, with little springback.

Plan to steam the  $\frac{3}{4}$ "-thick pieces for one hour after the first puffs of steam emerge

from the vent holes. The steaming time remains the same whether you use air-dried or soaked kiln-dried lumber. Check your steam source periodically to ensure it doesn't run out of water and overheat. While waiting as the wood steams, position your forms, U-bolts, and wedges on a work surface near the steamer.

### Forming the wood

Open the box door carefully and keep your hands away from the escaping steam. Remove one workpiece at a time, and immediately insert one end of it into the hold-down at the end of the form, as shown in **Photo A**. Force that end tight against the form by inserting a wedge.

With one hand, press the wood down firmly against the form and use your other hand to insert the U-bolts loosely into the form, as shown in **Photo B**.

To hold the part firmly against the form, tap wedges beneath the top leg of each U-bolt, as shown in **Photo C**.

Leave the parts secured to the forms for at least one week to minimize springback. Then tap the wedges sideways to release them and free the part. Before sanding, finishing, or using these workpieces in your project, allow them to sit overnight to release most of their springback. 🌿

Written by **Bob Wilson** with **Russ Filbeck**  
Illustrations: **Roxanne LeMoine**; **Lorna Johnson**

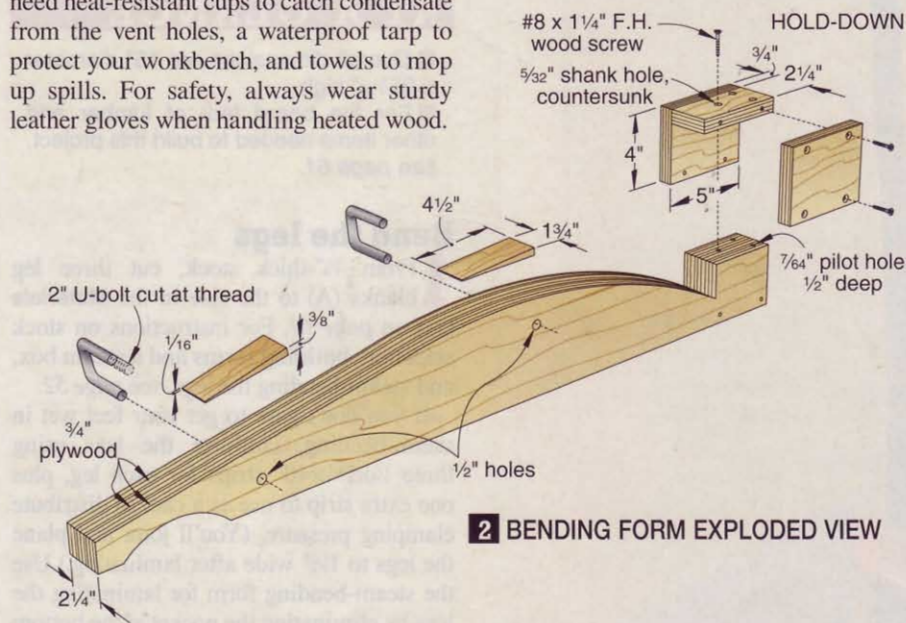

**2** BENDING FORM EXPLODED VIEW

**3** BENDING FORM SIDE VIEW

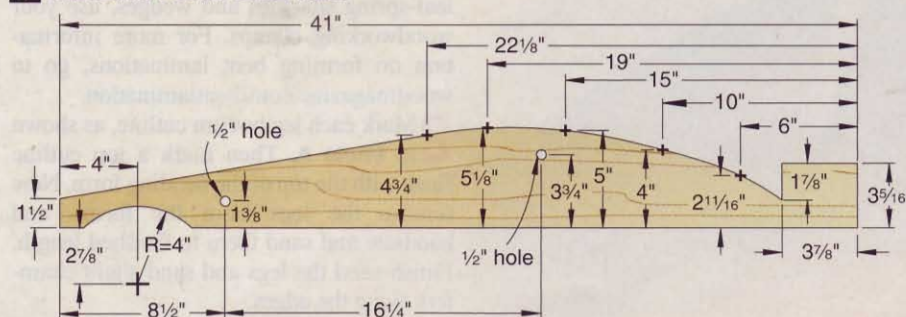





# simply graceful plant stand

Two discs supported by three curving legs equals a stunning pedestal for a flower-filled vase.

**H**ere's the perfect project for learning the basics of steam-bending. Once you curve the legs, you're just three parts and a few wood screws from completing this eye-catching home accent.

## AT A GLANCE

- Overall dimensions are 15" diameter x 35<sup>7</sup>/<sub>16</sub>" high.
- For the board feet of lumber and other items needed to build this project, see page 61.

## Bend the legs

**1** From <sup>3</sup>/<sub>4</sub>"-thick stock, cut three leg blanks (A) to the size in the **Materials List** on page 61. For instructions on stock selection, building forms and a steam box, and steam-bending the legs, see page 52.

If you don't care to get your feet wet in steam-bending, laminate the legs using three <sup>1</sup>/<sub>4</sub>x1<sup>3</sup>/<sub>4</sub>x40" strips for each leg, plus one extra strip to use as a caul to distribute clamping pressure. (You'll joint and plane the legs to 1<sup>1</sup>/<sub>2</sub>" wide after laminating.) Use the steam-bending form for laminating the legs by eliminating the pocket at the bottom end. Then, instead of securing the leg with leaf-spring shackles and wedges, use your woodworking clamps. For more information on forming bent laminations, go to [woodmagazine.com/bentlamination](http://woodmagazine.com/bentlamination).

**2** Mark each leg bottom cutline, as shown in **Photo A**. Then mark a top cutline flush with the top of the bending form. Now remove the legs from the forms, and bandsaw and sand them to finished length. Finish-sand the legs and sand slight chamfers along the edges.



## MARK THE LEG BOTTOM

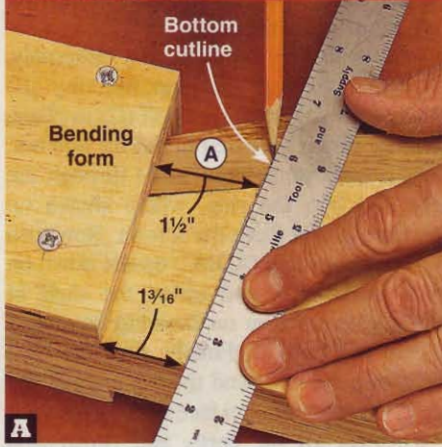

Before removing each leg (A) from the bending form, angle a straightedge as shown and draw the bottom cutline.

## CUT THE SHELF FROM THE RING

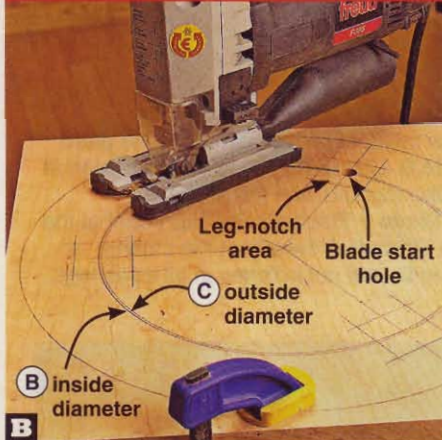

Centering the jigsaw blade between the ring (B) inside diameter line and the shelf (C) outside diameter line, cut out the shelf.

## Make the ring, shelf, and top

**1** Edge-join  $\frac{3}{4}$ "-thick stock to make an oversize blank for the ring (B). You'll make the shelf (C) from the waste cut from

## 1 LAY OUT THE RING AND SHELF IN 4 STEPS

**STEP 1** Draw the radii for the parts.

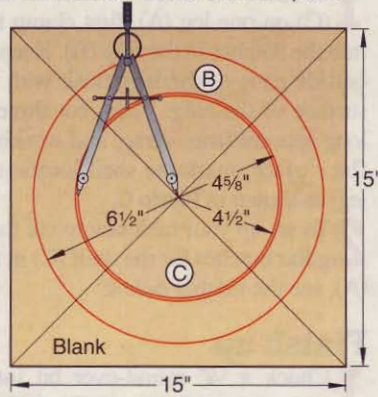

**STEP 2** Draw the first leg-notch centerline.

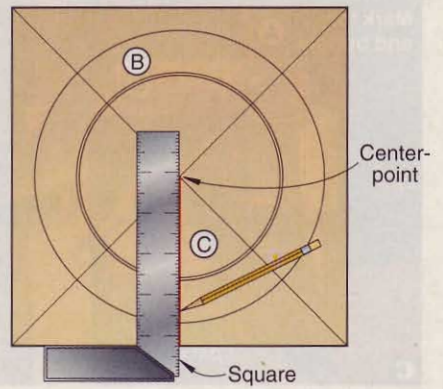

**STEP 3** Draw the second and third notch centerlines.

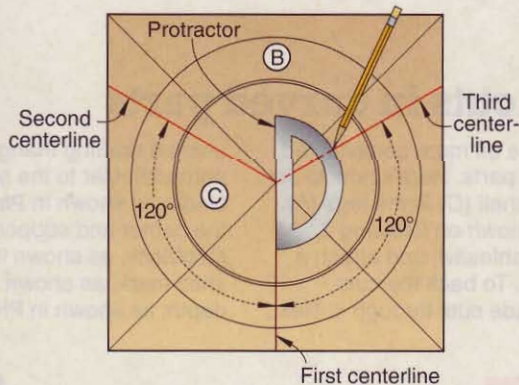

**STEP 4** Draw the leg notches and drill shank holes.

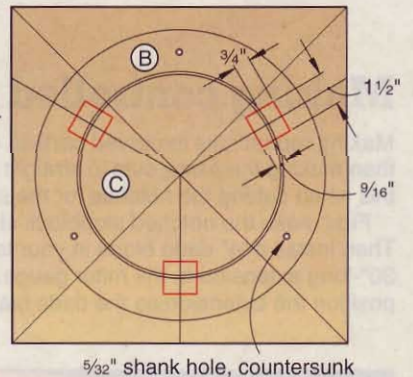

the center of the ring. Edge-join a second oversize blank for the top (D). (We used cherry for both blanks.) With the glue dry, sand both blanks smooth.

**2** Find the centers of both blanks by drawing diagonals on the bottom faces. Then lay out the ring (B) and shelf (C), as shown in **Steps 1, 2, 3, and 4 of Drawing 1**.

**Note:** When it's time for assembly, you can pocket-screw the shelf to the legs, using a pocket-hole jig. We chose another method

that uses an ordinary Forstner bit. See the **Shop Tip** below.

**3** Drill a blade start hole in one of the leg-notch areas, and jigsaw the shelf (C) from the blank, as shown in **Photo B**. Then jigsaw the outer diameter of the ring (B). Now disc-sand the outside diameters of both parts to the lines, and drum-sand the inside of the ring to the line. Finally, jigsaw the notches in the ring and shelf, testing the fit with a leg (A).

## SHOP TIP

### How to pocket-screw without a jig

In this project, when fastening the shelf (C) to the legs (A), you'll want to avoid plugged screw holes on the faces of the legs. Pocket-screwing from the back is the perfect solution, and here's a way to do it if you can't justify buying a pocket-hole jig.

First, with a Forstner bit, drill  $\frac{3}{4}$ " holes  $\frac{1}{4}$ " deep in the bottom of the shelf where shown at *near right*. Then, placing the tip of a  $\frac{5}{32}$ " bit in the corner of each hole, drill a shank hole at a  $35^\circ$  angle. To guide the bit, bandsaw a bevel on a piece of scrap, as shown at *far right*. At assembly time, drill pilot holes and fasten the shelf to the legs with ordinary flathead wood screws.

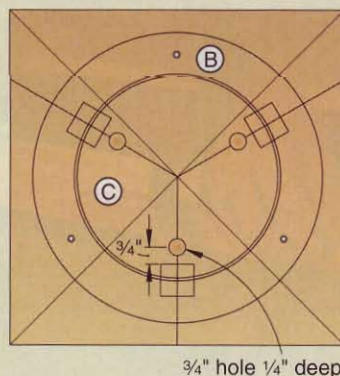

$\frac{3}{4}$ " hole  $\frac{1}{4}$ " deep





## MARK THE SHELF LOCATION

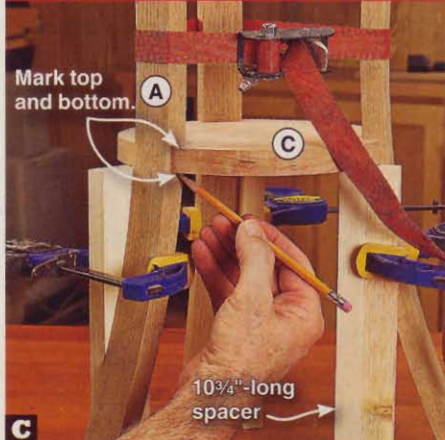

**C** Clamp the legs (A) into the shelf (C) notches, positioning the shelf with 10 3/4"-long spacers. Mark the shelf top and bottom on one leg.

## Notch the legs for the shelf

**1** To mark the notch location for the shelf (C) on one leg (A), first clamp the legs into the notches in the ring (B). Keep the top outside ends of the legs flush with the top surface of the ring. Then, cut three 10 3/4"-long spacers from scrap, and working on a flat surface, mark the shelf location on the leg, as shown in **Photo C**.

**2** To set up your table saw to cut the triangular notches for the shelf (C) in the legs (A), see the sidebar *below*.

## Finish up

**1** Chuck a 1/4" round-over bit into your table-mounted router, and rout the edges of the shelf (C) and top (D), where shown on **Drawing 3**. Then switch to a 1/2" round-over

bit, and rout just the *bottom* edge of the ring (B). Finish-sand the parts.

**2** As with the previous dry assembly, clamp the legs (A) into the ring (B) notches. Then clamp the shelf (C) in place, making sure it is seated in the leg notches. Drill countersunk screw holes through the legs and into the ring, where shown on **Drawing 3**, and drive the screws. Now turn the base assembly (A/B/C) upside down on your workbench, and fasten the shelf in place, where shown on **Drawing 3a** and as shown in **Photo G**. Finally, turn the base right side up, and sand the top ends of the legs flush with the top face of the ring.

**3** Inspect all the parts, and finish-sand where needed. Apply a clear finish. [We brushed two coats of satin polyurethane

## Making controlled cuts in curved parts

Making repeat cuts in curved parts is a bit more complicated than making the same cuts in straight parts. Here's how to do this when cutting the notches for the shelf (C) in the legs (A).

First make the notched stopblock shown on **Drawing 2**. Then install a 3/4" dado blade in your table saw, and attach a 30"-long extension to the miter gauge. To back the cuts, position the extension so the dado blade cuts through it. Next,

using a drafting triangle to position the shelf top mark perpendicular to the saw table, align the mark with the dado blade, as shown in **Photo D**. Clamp the leg to the extension at the center and support the top end with the notched stopblock, as shown in **Photo F**. Recheck the alignment of the shelf mark, as shown in **Photo E**. Now adjust the cutting depth, as shown in **Photo D**, and cut notches in all three legs.

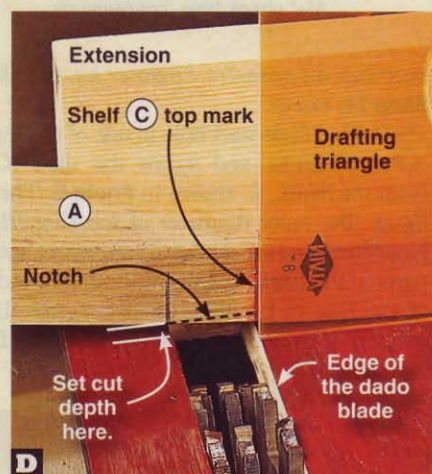

## 2 NOTCHED STOPBLOCK

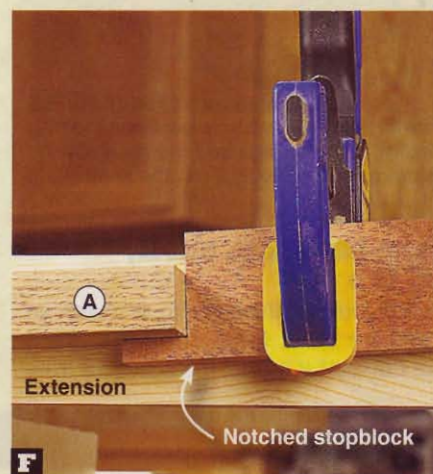
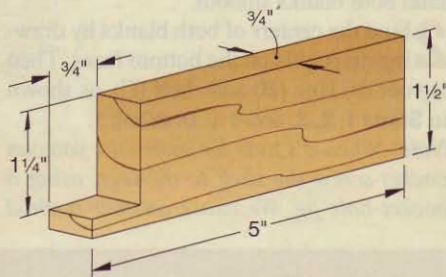



onto the base assembly and three coats onto the top (D), sanding with 220-grit sandpaper between coats.]

**4** Place the top (D) bottom face up on your workbench. Center the ring (B) on the top. Using the shank holes in the ring as guides, drill pilot holes into the top, and drive the screws. Now turn the plant stand right side up, and complete your project with a vase of freshly cut flowers. 🌸

Written by **Jan Svec** with **Chuck Hedlund**  
Project design: **Kevin Boyle**  
Illustrations: **Roxanne LeMoine; Lorna Johnson**

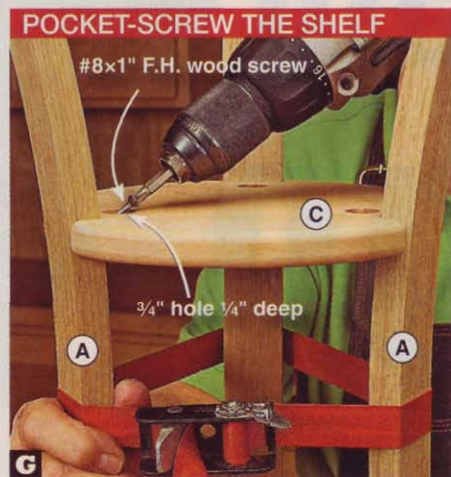

**G** First, using the shelf (C) shank holes as guides, drill pilot holes into the legs (A); then drive the screws.

### 3a POCKET SCREW DETAIL

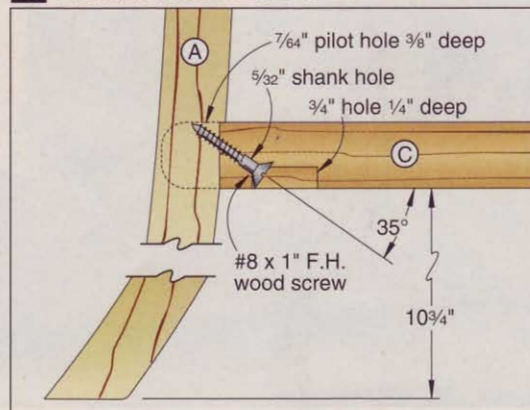

## Materials List

Part	FINISHED SIZE			Matl.	Qty.
	T	W	L		
A	3/4"	1 1/2"	40"	WO	3
B*	3/4"	13" diam.	EC		1
C*	3/4"	9" diam.	EC		1
D*	3/4"	15" diam.	EC		1

\*Parts initially cut oversize. See the instructions.

**Materials key:** WO—white oak, EC—edge-jointed cherry.  
**Supplies:** #8x1", #8x1 1/4", and #8x1 1/2" flathead wood screws.

**Blade and bits:** Stack dado set, 1/4" and 1/2" round-over router bits, 3/4" Forstner bit.

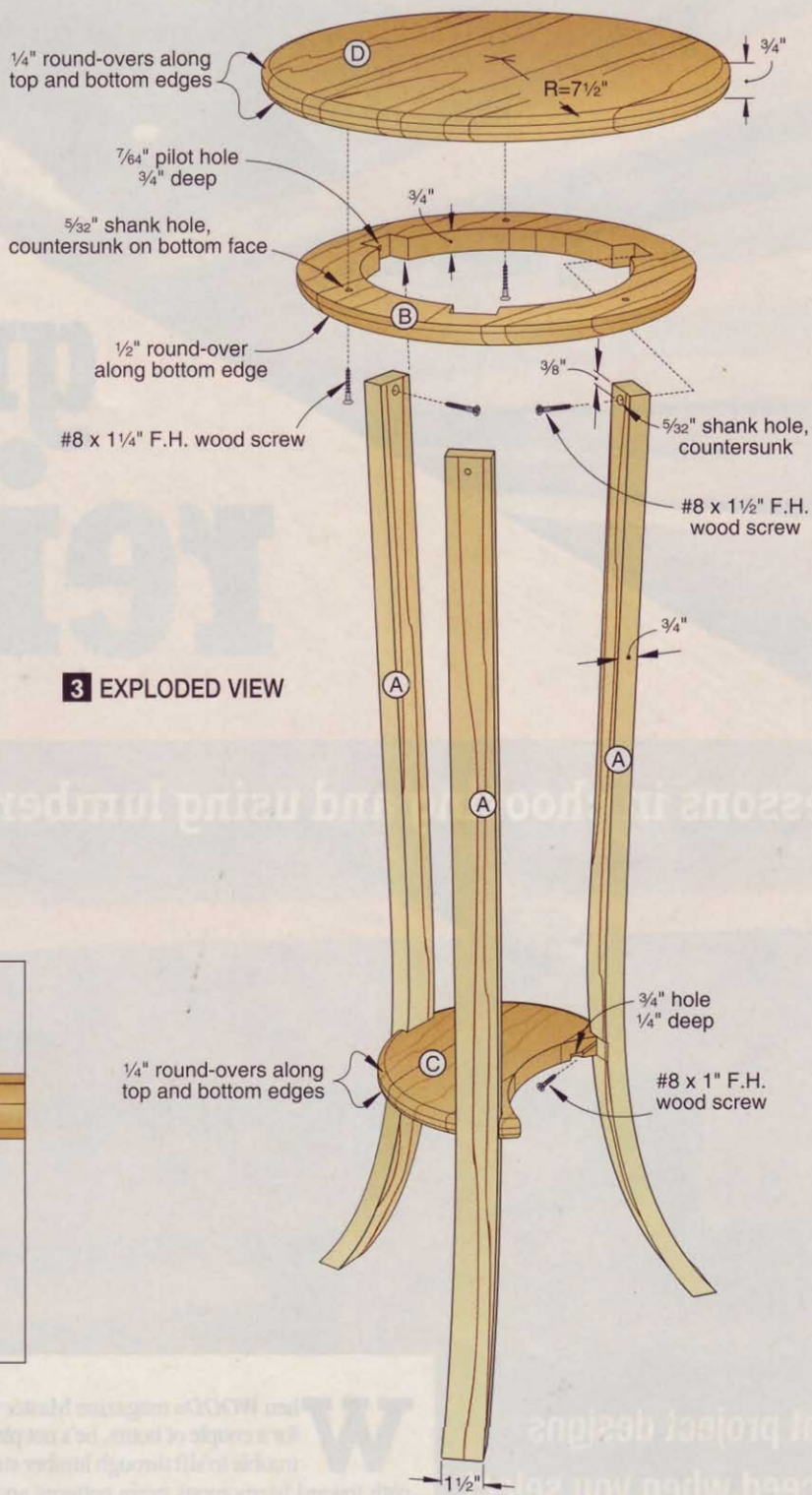

## Cutting Diagram

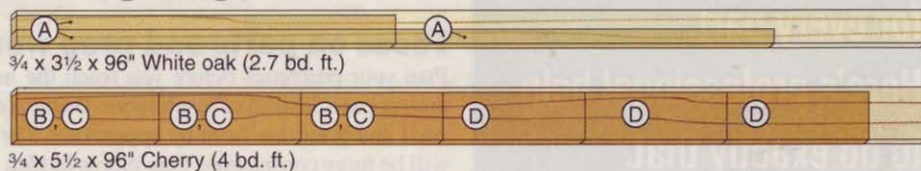





# let grain reign

lessons in choosing and using lumber for top results

**Great project designs  
succeed when you select  
the right piece of wood  
for every part.  
Here's professional help  
to do exactly that.**

**W**hen *WOOD*® magazine Master Craftsman Chuck Hedlund heads to the lumberyard for a couple of hours, he's not playing hooky. Just the opposite: By investing time and trouble to sift through lumber stacks for just the right stock, he sets his projects on the path toward harmonious grain patterns and matching wood tones. These early efforts may go unrewarded until after Chuck applies the last coat of finish, but even the best finish can't create attractive grain that's lacking within the wood. Invisible glue lines and cabinet frames where the wood colors blend together even without stain don't just happen by chance, either.

### **Focus on parts and prep work**

Plan your purchases before you reach the lumber supplier by thinking in terms of buying project parts instead of just lumber. Using your project parts list, examine what pieces you'll need and prioritize them by appearance. For example, the visible components of a tabletop will be more conspicuous than pieces hidden within a carcass.



## time can reveal color differences



2001: Boards in cherry panels match



2007: Same boards, different colors

The all-heartwood cherry boards in these bed panels appeared a good match when first built in 2001. But the boards darkened at varying rates over time, now giving the headboard a mismatched appearance.

Whenever possible, build solid-wood panels and tabletops from a single board, or boards you know came from the same log. Your panel pieces will stand a better chance of matching in both the short and long term, as you can see by the cherry panels created for the sleigh bed in our September 2001 issue (#135), shown *above*. In just six years, the once color-matched pieces of cherry used in these panels darkened differently, something not apparent when the bed was built. If you simply can't find enough stock from the same board or log, apply stain during the finishing process to help even out color differences now and in the future.

### Cut parts with the grain in mind

Cutting diagrams help you make the most of your lumber purchases, but they can't tell you how to make the most of wood grain. Instead of studying boards to see how many parts can be cut from the least amount of wood, consider what grain works the best for each part.

For example, the cutting diagram for the Arts & Crafts nightstand (November 2004, #159), shown at *right*, is based on getting the most project parts from hypothetical board sizes. It shows parts A and C cut from a different board than parts B and D to make the



For the best figure and color match, cut all five parts of the side panel, shown *above*, from a single board or two boards from the same log.



side panel. So you either need two boards from one log or one board long enough to cut all five parts for each side. Remember, a cutting diagram is just a guide, not a mandate, for how to cut parts from boards.

If one project part in particular provides an opportunity to show off an attractive grain pattern, knot, or other grain feature—the top rail of a headboard, for example—note that on your shopping list. To preview how a piece will look on the finished project, cut the part's shape out of a piece of paper and bring this “window” to the store with you to position on different boards. Back in your shop, use the window, or a more rugged cardboard duplicate, to rough-plan the final cut, as shown at *right*.

Other items to bring along on your shopping trip include a tape measure and chalk for marking which parts you'll cut from each board. If your lumber dealer sells rough-cut or skip-planed stock, bring along a sharp block plane, a bottle of water, and a rag to check for grain details and color.

### Let's go lumber shopping

Once at the store, start by weeding out warped or twisted boards that will only get worse with age and humidity changes. Don't pass up rough-cut pieces with a slight taper along the edges; these boards just follow the shape of the tree.

Now you're ready to sort the most promising boards by grain and color. That can be tricky when saw marks and debris partially obscure the surface. If the lumberyard owner allows, here's where your block plane comes in handy. For a look at what's beneath the rough-sawn surface, lightly plane the board to reveal grain details beneath the saw marks, as shown *above, far right*.

Now that you have a better idea of what's below the surface, choose the dominant grain pattern for your project from the types illustrated at *right, center*. Quartersawn stock will yield straight-grain surfaces, an easy pattern to match and one that's more dimensionally stable than flatsawn lumber. Flatsawn boards, on the other hand, produce a more dramatic grain pattern and are often less expensive because this sawing method makes more efficient use of each log.

Whether you choose quartersawn, riftsawn, or flatsawn figure, determine which parts need to be consistent with each other. You may want to cut table legs from quartersawn stock, for example, but make the tabletop from riftsawn lumber.



Paper windows let you rough out the position of cuts for a balanced pattern.

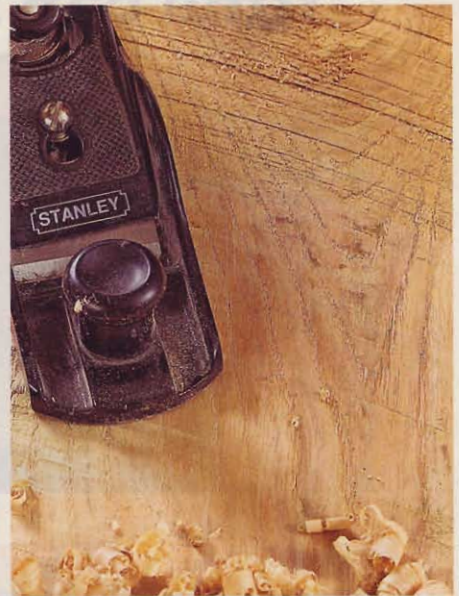

Planing a small portion of rough-sawn lumber can reveal figure surprises.

### Different cuts yield different figures

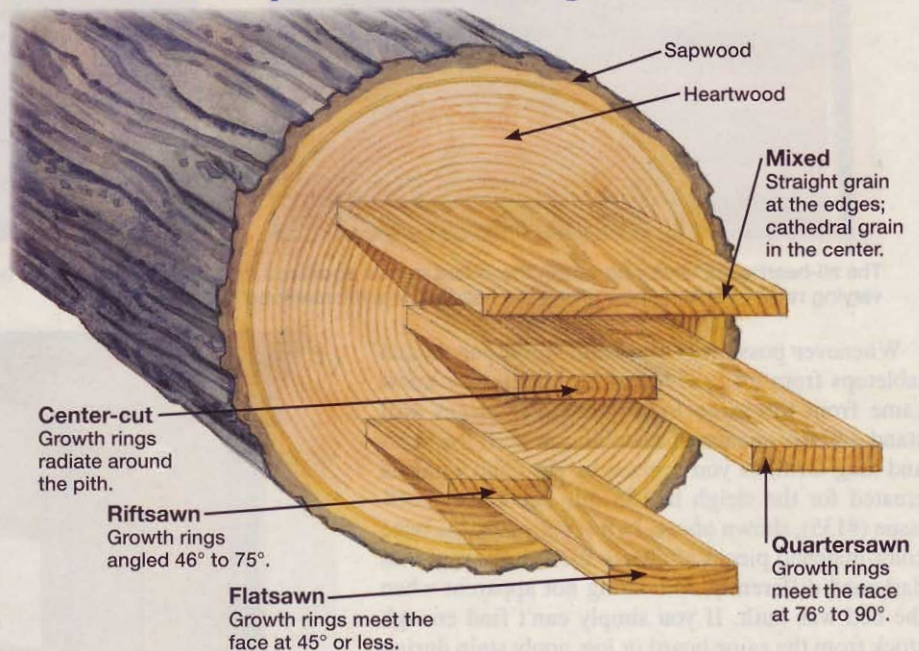

A moist cloth reveals grain and color as it will appear after finish is applied.



If you need more than one board for a glue-up, wipe a water-soaked rag across the surface, as shown on the *previous page*, for a preview of how well they'll match after you apply a finish. Back in the shop, you can do the same thing using mineral spirits.

With your choice boards set aside, organize cuts around the features of specific boards. Some boards are wide enough to contribute more than one part. By splitting an extra-wide board, like the one shown at *right*, you can create straight-grained stock for stiles and rails and use the cathedral grain at the center to form parts of the center panel in a raised-panel door.

### Transform rough stock into contributing parts

Double-check your in-store observations by planing or jointing rough-sawn lumber to study all of the grain—including any surprises, such as the curly figure in the piece of ash shown *below near right*. Once you can see what each board has to offer, map out which parts to cut from specific boards.

As you're laying out your cuts, you may discover that the best patterns don't always follow the edge of the board. If necessary, mark and rough-cut pieces at an angle to follow the best grain flow.

Not all parts benefit from this approach. The top pair of drawers in the cabinet shown at *right, center*, for example, were cut from contiguous pieces of the same board, as were the bottom pair. Study the fronts on both pairs and you'll see that the grain flows almost uninterrupted from the drawer faces on the left to the ones on the right.

Grain flow is equally important for large and small projects where corners wrap around, such as the jewelry box shown at *far right*. After cutting your four pieces slightly oversize from the same board, number each piece in order and indicate the front surface and top. Then make your 45° miter cuts at each corner, removing as little stock as possible. As you prepare to glue the sides together, order them in the same sequence they were cut from the stock, with surfaces facing out and up as marked. The result will be grain lines that seem to flow from one side to the next at three of the four corners.

Learn more Woodworking Skills at:  
[woodmagazine.com/skills](http://woodmagazine.com/skills)

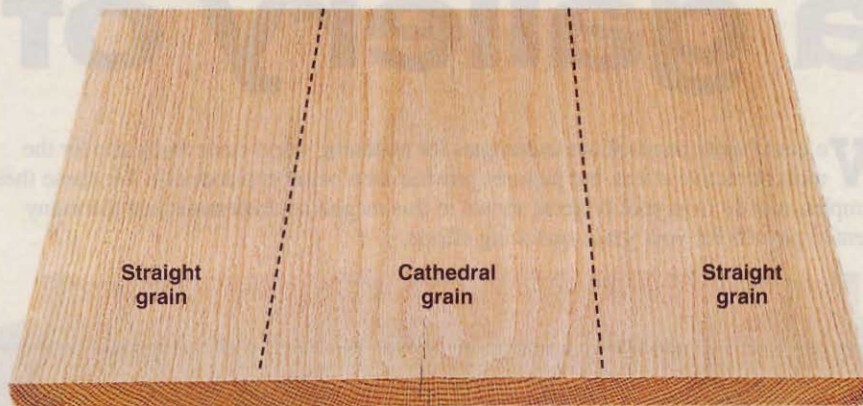

Extra-wide boards may extend from one side of a log to the other, creating a mix of grains.

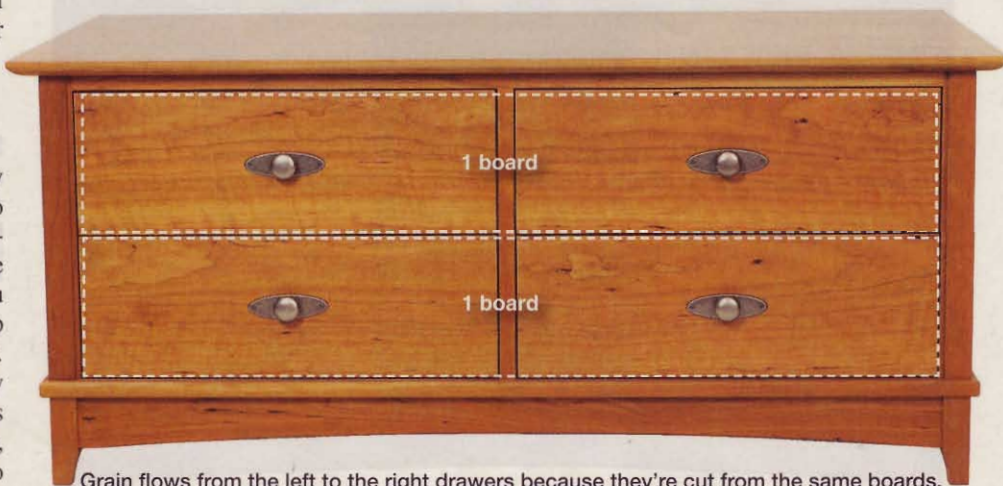

Grain flows from the left to the right drawers because they're cut from the same boards.

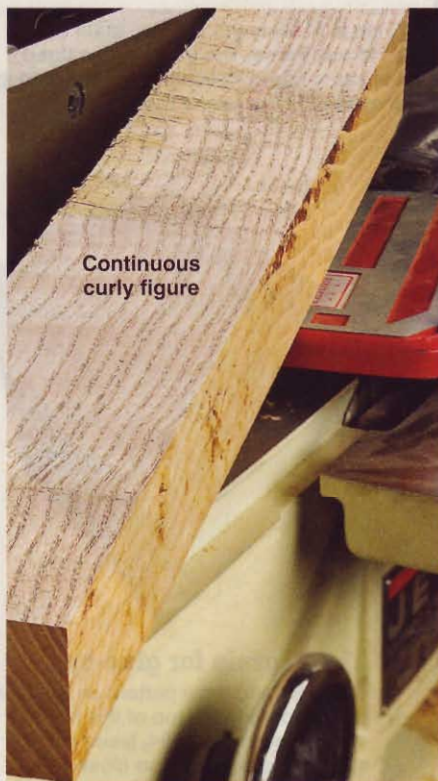

Just one pass on the jointer exposes curly grain that adds character to a project.

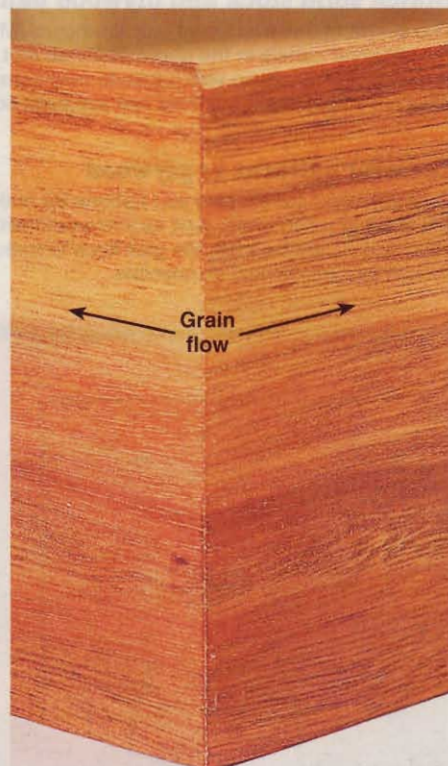

Cutting four box pieces from a single board lets the grain flow around the corners.



# a gallery of great g

**W**e could write pages about techniques for matching wood color and grain for the most attractive effect, but pictures provide even better explanations. We chose these examples, mostly from past projects shown in this magazine, to demonstrate the many potential payoffs for your grain-matching efforts.



## Match solid stock and plywood panels

The secret of this traditional oak sideboard (May 2004, issue #155) is the way the grain of the plywood panels in the doors matches that of the solid oak frame. The fronts of the three drawers coordinate so well because they came from the same board—even though the cutting diagram shows them cut from two separate boards for more efficient use of the lumber.

## Look for patterns in plywood

Even plywood panels give you options for making the most of wood grain. Just as you would with a solid wood panel, center the glue lines to make the design as symmetrical as possible.



## Match grain for glue-ups

The color and grain pattern on the four pieces forming the top of this night stand (November 2004, issue #159), shown above, match so closely that the panel seems made from a single board. The most dramatic swirls are at the front where they're sure to be noticed.



## Showcase the wood's character

Show off unusual features in the wood, such as the cluster of knots on the top rail of this pine bookshelf (March 2004, issue #154). Use a paper cutout of the rail shape to center the feature on your part, as shown on page 106.



## Resaw for book-matched parts

Although there's a mix of grain patterns in this dresser (December 2004, issue #160), the swirling grain of the inset panels seems to flow together. That's because they were resawn from a single board.





### Dramatic grain requires added planning

There's nothing wrong with vivid grain patterns like those on the desktop at *right*—if that's the effect you want. Coordinating dramatic patterns into a desktop can be challenging, however. Straight-grain stock used for the student desk *above* (November 2002, issue #145) makes it easier to coordinate pieces and creates a more refined look for your project.



### Center panel patterns

When working with book-matched plywood panels or veneers, center the most prominent figure, as on the side of this sofa table.



### Luck favors the prepared woodworker

While purchasing knotty pine stock for the base of this hutch (March 2003, issue # 147), Master Craftsman Chuck Hedlund discovered two boards cut from the same log with the same arrangement of knots. He then glued up two raised panels with mirroring knot patterns.



# a cut-above mitersaw platform



A free-sliding inner rest on each extension lets you instantly position extra support where needed.

Flip-up stopblock enables on-the-money repetitive cuts.

Cut boards up to 10' long with the outer rests fully extended.

Easy-grip four-arm knobs lock the pipe extensions and stopblocks into position.

Cleats spaced to straddle your sawhorse rails create a rock-solid workstation.

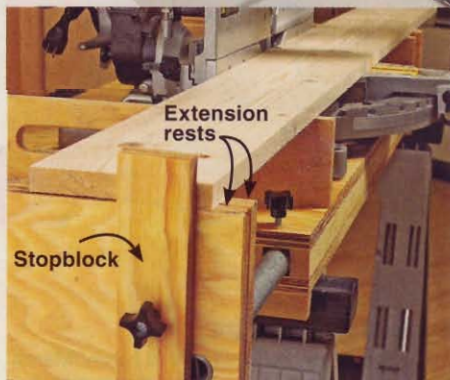

The stopblock on each outer extension rest makes precise repetitive cuts a snap.



## 1 EXPLODED VIEW

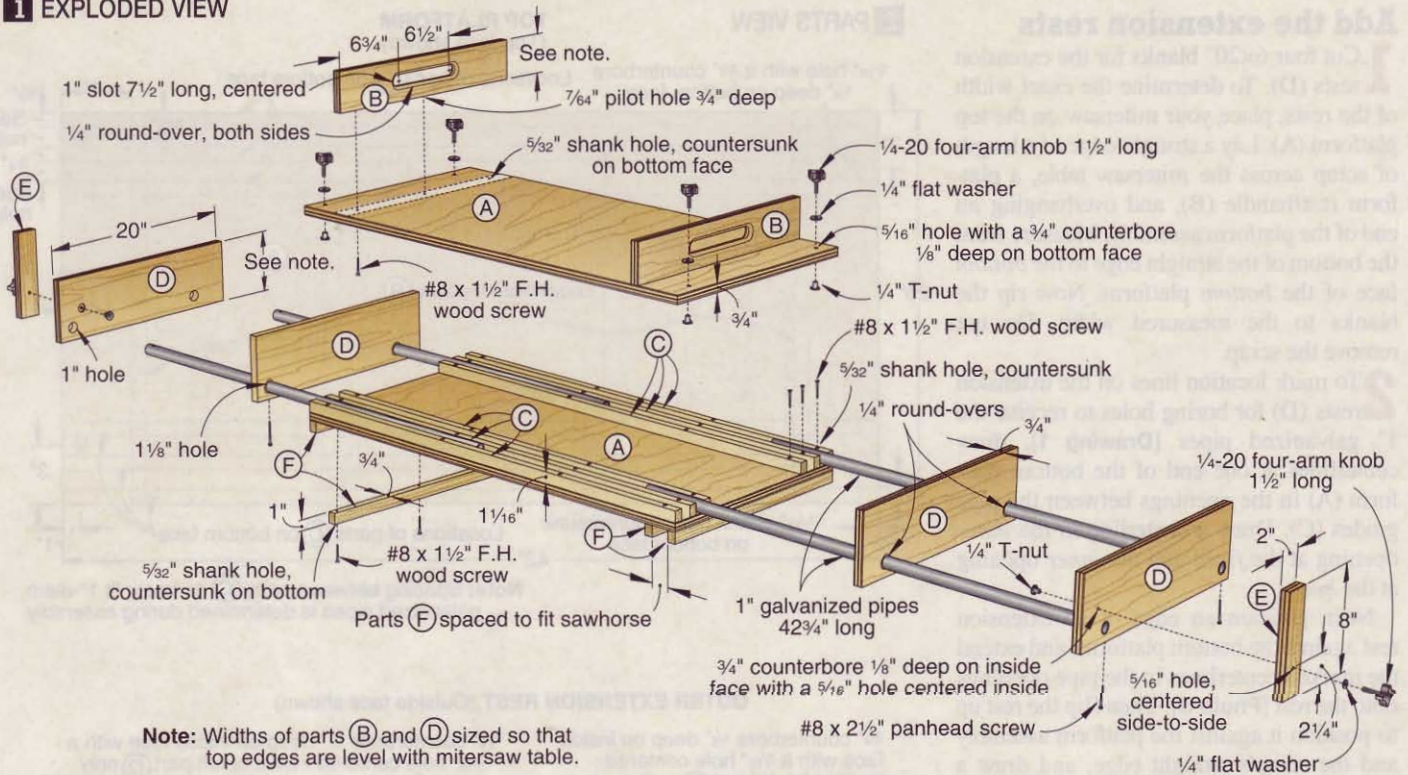

## AT A GLANCE

- Overall dimensions are 48 1/8" wide (121" wide fully extended) x 20" deep x 6 1/2" high.
- Approximate weight: 57 pounds
- Materials needed: One 4x8 sheet of 3/4" plywood, one 1x6 (3/4x5 1/2") maple board 8' long, and four 1" galvanized pipes 42 3/4" long, all found at your local home center or hardware store.
- The stand assembles quickly with glue and screws.

tear-out. Complete the slots using your jigsaw. Then rout a 1/4" round-over along both edges of the slots.

**4** Glue the platform rests/handles (B) to the top face of the top platform (A), where dimensioned [Drawing 2]. Drill the mounting holes, and drive the screws.

**5** Cut the pipe guides (C) to size. Glue and clamp the two outer pipe guides to the top face of the bottom platform (A), flush with the edges and ends [Drawing 1]. Drill the mounting holes, and drive the screws.

To attach the center and inner guides, hack-saw four pieces of 1" galvanized pipe (for the extensions) to 42 3/4" long. Using the pipes and business cards as spacers, position and mount the center guides [Photo B]. Repeat to mount the inner guides. The business cards provide clearance to ensure that the pipes slide freely between the guides.

**6** Apply glue to the top edges of the pipe guides (C). Then clamp the top platform (A/B) to the bottom platform (A/C), keeping the edges of the platforms aligned.

## Start with the platforms

**1** Cut the top/bottom platforms (A) to the size listed [Materials List, page 71]. Mark centerpoints for four counterbored holes for 1/4" T-nuts on the bottom face of the top platform, where dimensioned [Drawings 1 and 2]. Drill and counterbore the holes. Then install the T-nuts.

**2** To determine the width of the platform rests/handles (B), measure the height of your miter saw table [Photo A]. (Our saw table measured 3 3/16".) Then cut the rests/handles to the size listed, and the width equal to your measurement.

**3** To form a centered 1" slot 7 1/2" long in the platform rests/handles (B), mark centerpoints 6 1/2" apart for 1" holes, where dimensioned [Drawing 1]. Bore the holes using a Forstner bit and backer to prevent

## SIZE THE HANDLES TO MATCH YOUR SAW'S TABLE HEIGHT



**A** Using a combination square, measure from a flat surface to your miter saw table to find the width of the platform rests/handles (B).

## MOUNT THE CENTER PIPE GUIDES



**B** With a business card bent around a 1" pipe at each end for a spacer, mount the center pipe guides (C) to the bottom platform (A).



## Add the extension rests

**1** Cut four 6x20" blanks for the extension rests (D). To determine the exact width of the rests, place your mitersaw on the top platform (A). Lay a straight edge of a length of scrap across the mitersaw table, a platform rest/handle (B), and overhanging an end of the platform assembly. Measure from the bottom of the straight edge to the *bottom* face of the *bottom* platform. Now rip the blanks to the measured width. Do not remove the scrap.

**2** To mark location lines on the extension rests (D) for boring holes to receive the 1" galvanized pipes [Drawing 1], draw centerlines at one end of the bottom platform (A) in the openings between the pipe guides (C). Draw a centerline in the *outer* opening at the *front* and the *inner* opening at the *back*.

Next, position an edge of an extension rest against the bottom platform, and extend the marked centerlines in the pipe openings onto the rest [Photo C]. Then flip the rest up to position it against the platform assembly and the scrap's straight edge, and draw a line on the end of the rest at the *bottom* of the *top* platform [Photo D]. (This line locates the *top* of the pipe holes to position the tops of the rests even with the mitersaw table.) Now, using a square, draw intersecting lines from the marked locations on the rest for the hole at each end. Transfer the marks and lines onto the remaining rests.

**3** For the two outer extension rests (D), bore holes at the marked locations using a 1" Forstner bit [Photo E]. Identify the outer rests. Switch to a 1 1/8" Forstner bit, and reposition the fence so that the bit aligns with the

## 2 PARTS VIEW

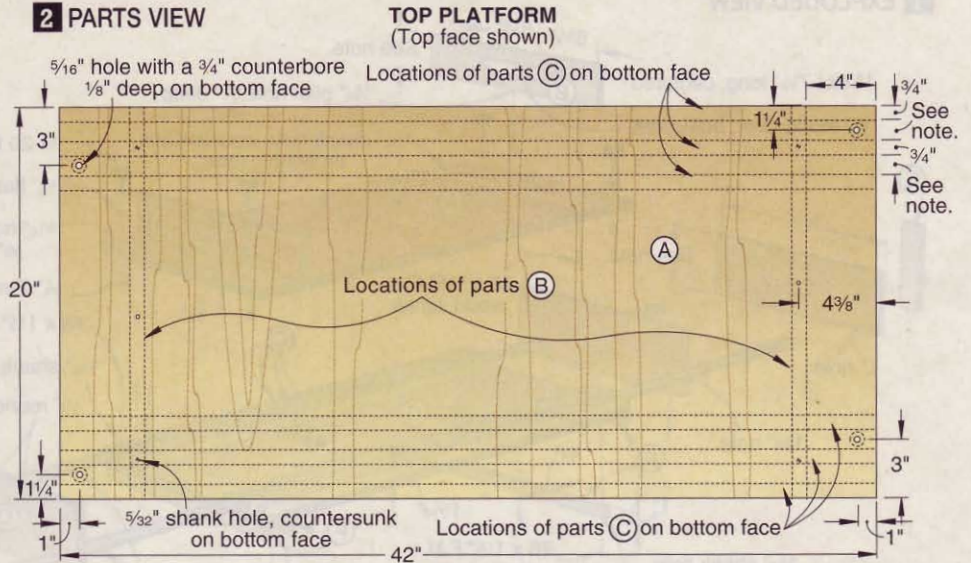

**Note:** Spacing between parts (C) to freely fit 1"-diam. galvanized pipes is determined during assembly.

## OUTER EXTENSION REST (Outside face shown)

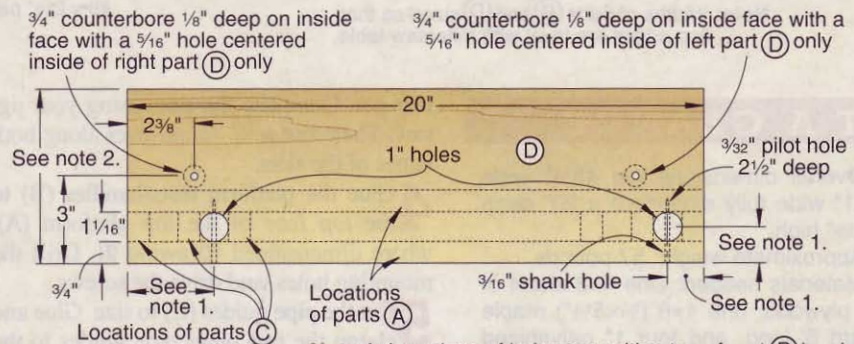

**Note 1:** Locations of holes to position top of part (D) level with mitersaw table are determined during assembly.

**Note 2:** Width sized so that top edge is level with mitersaw table.

## MARK THE EXTENSION-REST HOLE LOCATIONS IN TWO EASY STEPS

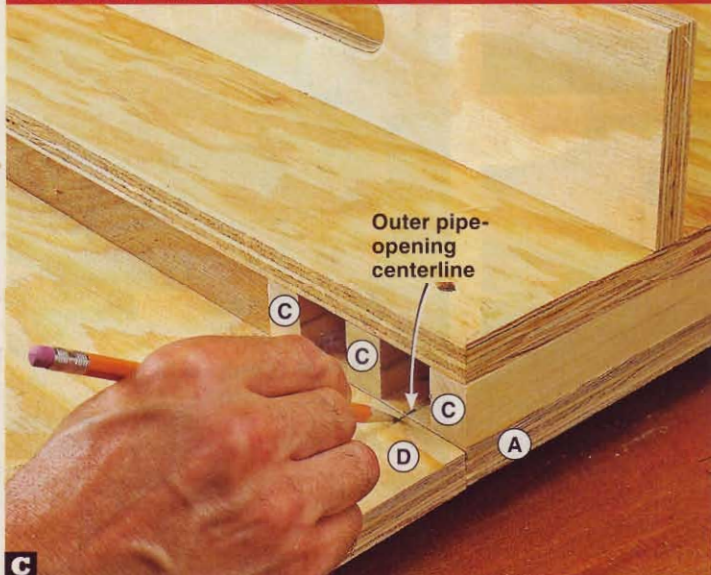

**C** With the ends of an extension rest (D) aligned with the bottom platform (A), extend the centerlines from the pipe openings.

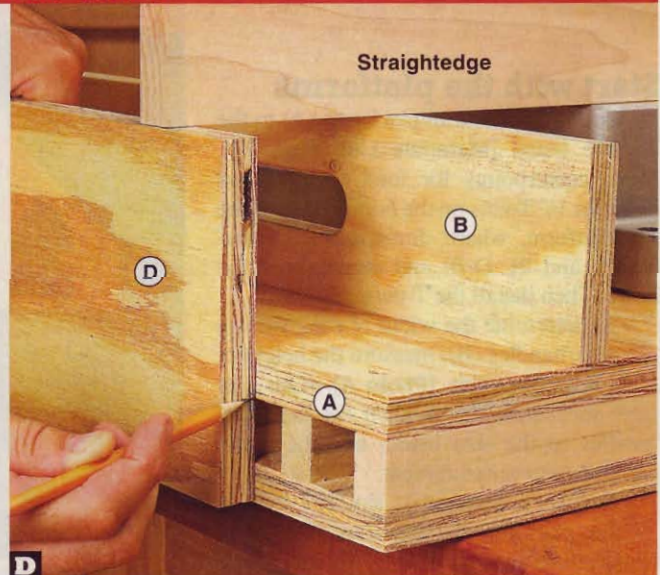

**D** Flip the rest up 90°. Then mark the location of the *bottom* of the top platform (A) on the end of the rest.



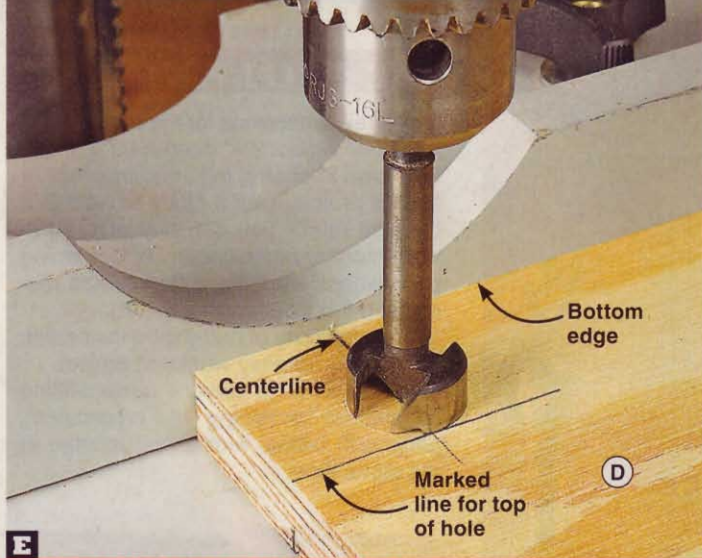

**E** **BORE THE EXTENSION RESTS**

Align the Forstner bit with the marked lines on the extension rests (D). Bore 1" holes in the outer rests and 1½" holes in the inner rests.

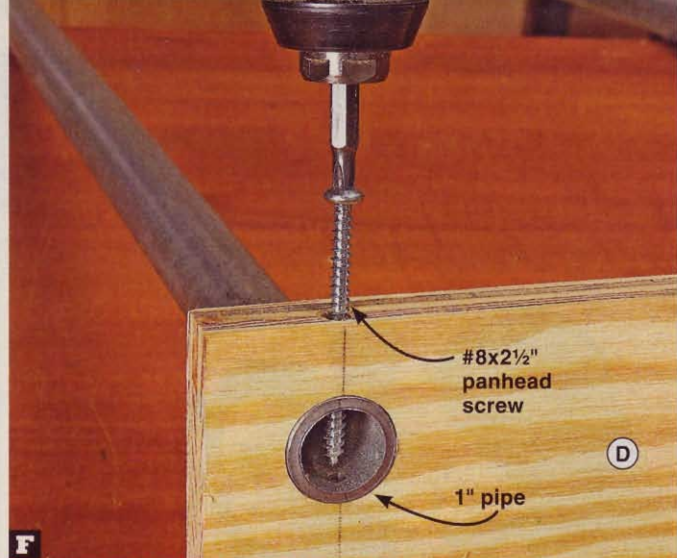

**F** **SCREW-MOUNT THE OUTER RESTS**

Drill mounting holes centered into the edge of the two outer extension rests (D) and through the 1" pipes. Drive the screws.

marked line for the top of the hole. Then bore the holes through the two inner rests. (The larger holes let the rests slide freely on the pipes.) Note that the hole spacings are the same in all of the rests. To accommodate the offset pair of pipes at each end of the platform assembly [Drawing 1], you'll flip a pair of rests at one end.

**4** Rout a ¼" round-over around both edges of the 1½" holes in the inner extension rests (D) [Drawing 1]. Next, check the fit of the 1" pipes in the holes in the outer rests. Using a round file, ¾"-diameter 120-grit sanding drum in your portable drill, or an oscillating spindle sander, enlarge the holes, as needed, to snugly fit the pipes. To maintain the correct location of the top edges of the extension rests, do not file or sand the tops of the holes. With the ends of the pipes flush with the outside face of the extensions, drill mounting holes to secure the pipes, and drive the screws [Drawing 2, Photo F].

**5** Cut the stopblocks (E) to size. Then drill a 5/16" hole through the stopblocks, where dimensioned [Drawing 1].

**6** To attach the stopblocks to the outer extension rests (D), mark a centerpoint on the inside face of each rest, where dimensioned [Drawing 2]. Note the different hole locations for the right and left extensions to place the holes at the front of the platform assembly. Drill and counterbore the holes. Then install a ¼" T-nut in each counterbore.

### Finish up

**1** Cut the sawhorse cleats (F) to size. Glue and screw the cleats, spaced to straddle the top rails of your sawhorses, to the bottom platform (A) at the ends [Drawing 1].

**2** Sand all parts to 180 grit and ease any sharp or rough edges. Remove the dust. If you wish, apply a clear finish (recommended for outdoor use). (We applied two coats of spar varnish.)

**3** Attach the stopblocks (E) to the outer extension rests (D) with ¼-20 four-arm knobs 1½" long and ¼" flat washers [Drawing 1]. Using a permanent marker, draw a line on the top of each pipe 3" from the end to identify the maximum extension for safety. Next, slide the inner extension rests (D) over the pipes in the orientations shown [Drawing 1]. Then, guide the pipes into the appropriate openings in the platform. Secure the pipes with the same-size four-arm knobs and flat washers.

**4** Finally, place the stand on sawhorses, and center your miter saw on the top platform. Drill mounting holes, where needed, and secure the saw with suitable fasteners. Now dig into a project, and safely chop away! 🪚

Written by Owen Duvall  
Project design: Kevin Boyle  
Illustrations: Roxanne LeMoine; Lorna Johnson

### Cutting Diagram

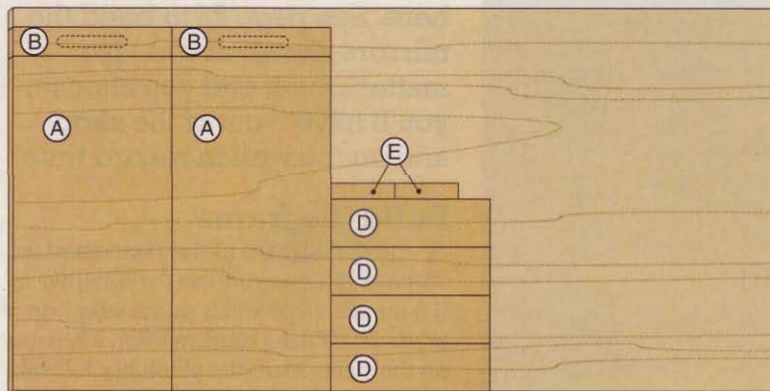

¾ x 48 x 96" Plywood

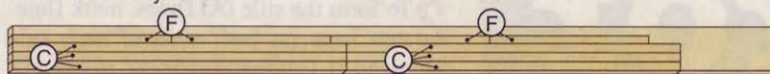

¾ x 5½ x 96" Maple (4 bd. ft.)

### Materials List

Part	FINISHED SIZE			Matl.	Qty.
	T	W	L		
A	¾"	42"	20"	P	2
B	¾"	†	20"	P	2
C	¾"	1½"	42"	M	6
D*	¾"	†	20"	P	4
E	¾"	2"	8"	P	2
F	¾"	1"	20"	M	4

\*Parts initially cut oversize. See the instructions.

† Finished widths of platform rests/handles (B) and extension rests (D) are determined by measurements during assembly.

**Materials key:** P—plywood, M—maple.

**Supplies:** ¼" T-nuts (6), #8x1½" flathead wood screws (42), 1" galvanized pipes 42¾" long (4), #8x2½" panhead screws (4), ¼" flat washers (6), ¼-20 four-arm knobs 1½" long (6).

**Bits:** ¾", 1", and 1½" Forstner bits; ¼" round-over router bit.





full-length  
**mirror**  
 in three pleasing designs

**AT A GLANCE**

- Overall dimensions for the mirror at *left* are 22 $\frac{3}{8}$ " wide x 2 $\frac{5}{8}$ " deep x 69 $\frac{7}{8}$ " high.
- Shown in cherry, oak, and maple.
- This project uses a stock-size 16x60" beveled mirror you can buy at a hardware store or home center. To determine part dimensions for a different-size mirror, see the sidebar on *page 75*.
- The simplicity of butt-joint construction makes this an easy weekend project.
- Learn how to ensure perfect-fitting assemblies by ripping and crosscutting parts with critical widths and lengths at the same time.

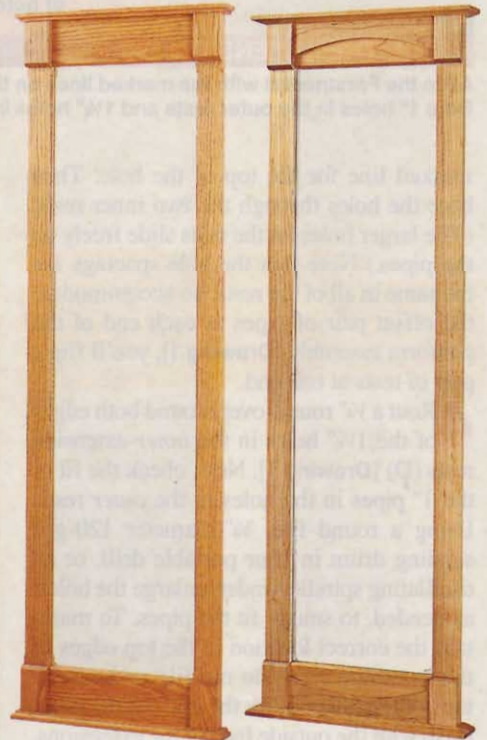

Three distinct styles share the same simple construction. (We'll build the version at *left* here. See *page 76* to build the mirrors shown *above*.) No matter which one you choose, you'll have it out of the shop and on the wall in record time.

**Build the frame**

**1** Cut the stiles (A) to size [Materials List, *page 75*]. To ensure that the plinth blocks (D) are the same width as the stiles, rip a  $\frac{3}{4}$ "-thick, 20"-long blank to width when you rip the stiles. Mark the plinth block blank, and set it aside.

**2** To form the stile (A) flutes, mark flute-stop lines on both ends of each stile [Drawing 1]. Cut four  $\frac{3}{4}$ x2x2 $\frac{3}{4}$ " stopblocks from scrap. Then chuck a  $\frac{1}{4}$ " round-nose bit



## 1 FLUTE DETAIL

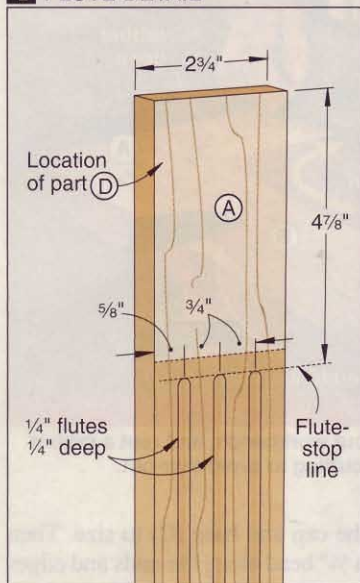

## FORM STOPPED FLUTES IN THE STILES

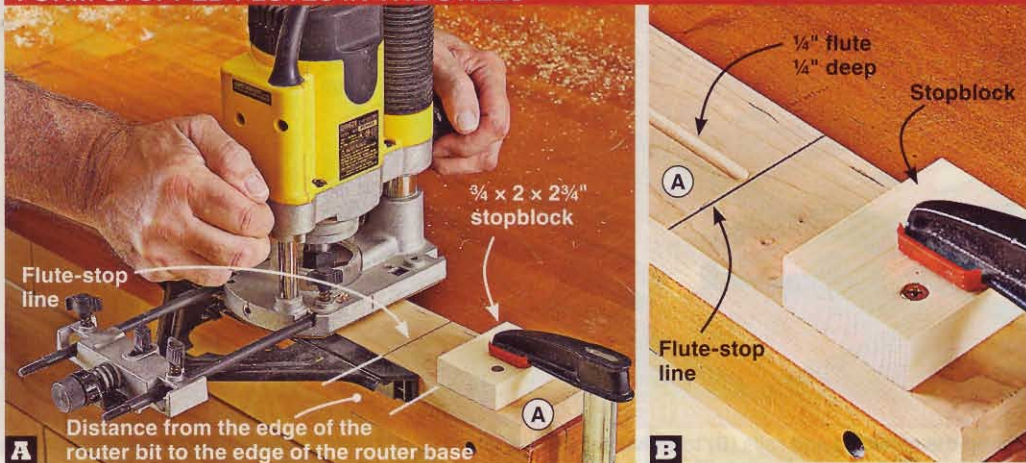

Clamp a stile (A) with attached stopblocks to your workbench. Adjust a plunge router edge guide to center a 1/4" round-nose bit on the stile. Position the base against the first stopblock. Plunge the bit into the stile, and move the router along the length [above left]. To avoid burning, quickly move the router away from the first stopblock after plunging, and immediately retract the bit when the router base contacts the second stopblock. The flute begins and ends at the stop lines [above right].

into a plunge router, and adjust it to cut 1/4" deep. Measure the distance from the edge of the bit to the edge of the router base. Position the stopblocks the measured distance from the flute-stop lines, and screw them to the stiles. Rout center flutes on each stile [Photos A and B]. Readjust the edge guide, and rout the outside flutes.

**3** To ensure that the rails (B), dentil moldings (E), and beads (F) are the same length, first cut two 3/4x4 1/2x16" blanks for the rails, a 3/8x2 3/4x16" blank for the dentil moldings, and a 1/4x1 1/4x16" blank for the beads. (You'll rip two dentil moldings and two beads from each respective blank.) Then attach an extension to your miter

gauge, clamp a stopblock to the extension, and cut the four blanks to the 15 3/8" finished length. Mark the dentil molding and bead blanks and set them aside.

**4** Use a pocket-hole jig to drill pocket holes in the backs of the rails (B) [Drawing 2a]. Then rout chamfers along one edge of each rail [Drawing 2]. Assemble the mir-

## 2 EXPLODED VIEW

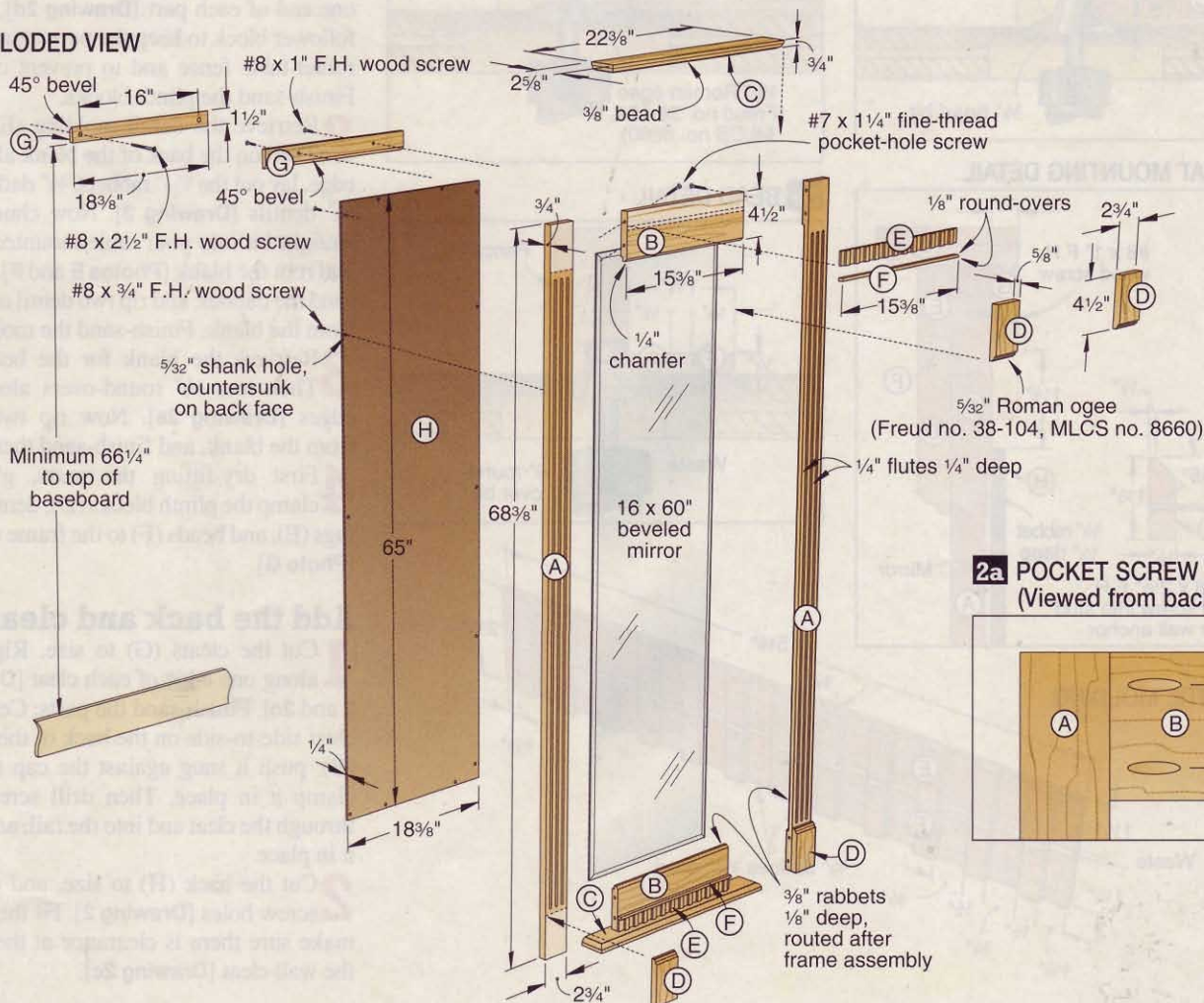

### 2a POCKET SCREW DETAIL (Viewed from back)

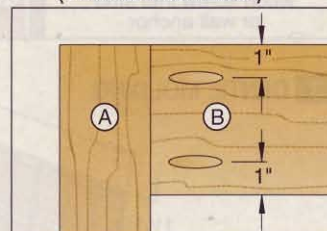





## ASSEMBLE AND RABBET THE FRAME

Clamp the stiles (A) and rails (B) together facedown, aligning the parts with a piece of scrap. Then drive the pocket screws.

Clamp the frame securely to your workbench, and rout a rabbet along the inside edges, climb-cutting to avoid tear-out.

ror frame (A/B) [Photo C]. Now chuck a  $\frac{3}{8}$ " rabbet bit into a handheld router and rout a rabbet to accept the mirror [Photo D]. Square the corners of the rabbet with a chisel, and finish-sand the frame.

**Note:** The bevel width on stock mirrors varies, and some stock mirrors have no bevel. Before rabbeting the frame make test cuts in scrap, adjusting the depth of cut so the backs of the mirror and frame are flush.

5 Cut the cap and base (C) to size. Then rout a  $\frac{3}{8}$ " bead along the ends and edges of each part [Drawing 2b]. Finish-sand the cap and base. Now glue and clamp the parts to the rails (B), with the back edges overhanging the back faces of the rails  $\frac{1}{2}$ " [Drawing 2c], and centered side-to-side.

### 2b BEAD DETAIL

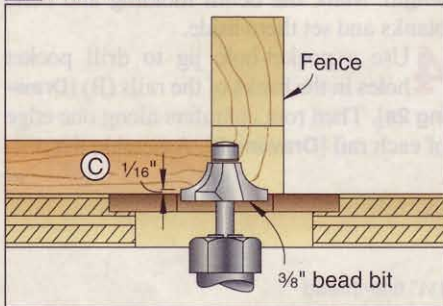

### 2d OGEE DETAIL

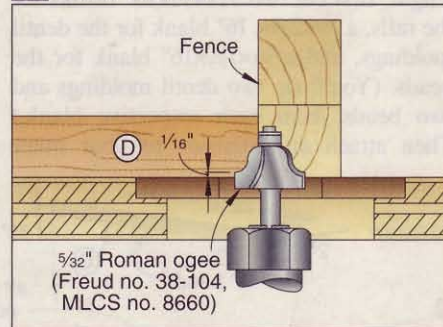

### 2c CLEAT MOUNTING DETAIL

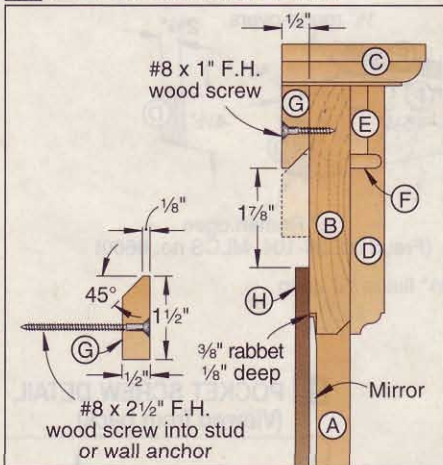

### 2e BEAD DETAIL

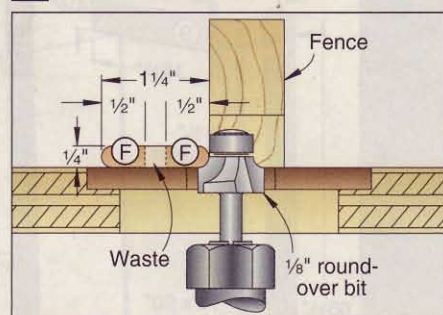

### 3 DENTIL MOLDING

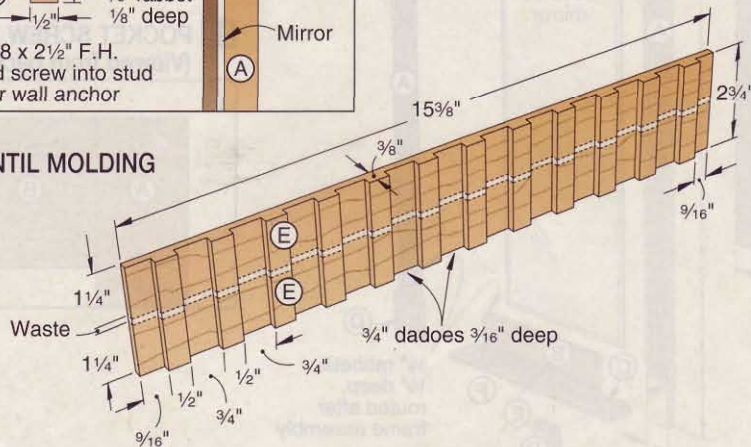

## Apply the moldings

1 Retrieve the blank for the plinth blocks (D), plane it to  $\frac{5}{8}$ " thick, and cut the blocks to length. Rout an ogee profile along one end of each part [Drawing 2d], using a follower block to keep the part square to the router-table fence and to prevent chip-out. Finish-sand the plinth blocks.

2 Retrieve the dentil molding (E) blank. Then on the back of the blank along one edge, lay out the  $\frac{9}{16}$ " rabbets,  $\frac{3}{4}$ " dadoes, and  $\frac{1}{2}$ " dentils [Drawing 3]. Now chuck a  $\frac{3}{4}$ " straight bit into your table-mounted router, and rout the blank [Photos E and F]. Finish-sand the dadoes, and rip two dentil moldings from the blank. Finish-sand the moldings.

3 Retrieve the blank for the beads (F). Then rout  $\frac{1}{8}$ " round-overs along both edges [Drawing 2e]. Now rip two beads from the blank, and finish-sand them.

4 First dry-fit the parts, glue and clamp the plinth blocks (D), dentil moldings (E), and beads (F) to the frame (A/B/C) [Photo G].

## Add the back and cleats

1 Cut the cleats (G) to size. Rip bevels along one edge of each cleat [Drawings 2 and 2c]. Finish-sand the parts. Center one cleat side-to-side on the back of the top rail (B), push it snug against the cap (C), and clamp it in place. Then drill screw holes through the cleat and into the rail, and screw it in place.

2 Cut the back (H) to size, and drill the screw holes [Drawing 2]. Fit the back to make sure there is clearance at the top for the wall cleat [Drawing 2c].



## MAKING THE DENTIL MOLDINGS



**E** With a  $\frac{3}{4}$ " straight bit, rout a  $\frac{3}{16}$ "-deep notch in the miter-gauge extension. Then mark the notch edges on the extension.

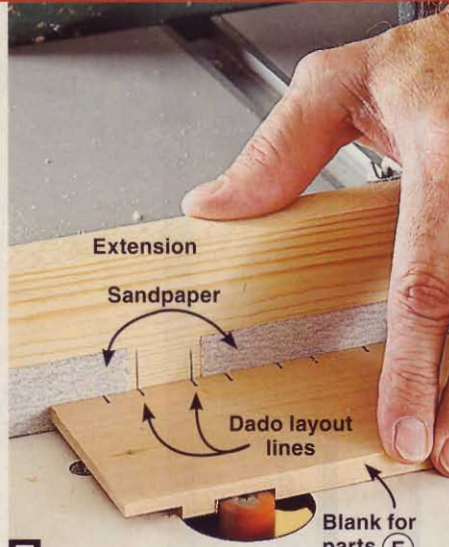

**F** To keep the blank from slipping, apply sandpaper to the extension. Align the layout and extension marks, and rout the dados.

## Apply finish and assemble

**1** Inspect all parts and finish-sand, where needed. Apply a stain, if you desire, and then apply a clear finish. (We applied Varathane Traditional Cherry no. 245 stain and sprayed on two coats of satin lacquer.)

**2** With the finish dry, lay the frame face-down and insert the mirror. (To center our beveled mirror, we inserted thin spacers between the mirror and frame.) Lay the

back (H) in place, and using the holes in the back as guides, drill pilot holes into the frame. Drive the screws.

**3** Attach the wall cleat (G) to the wall by driving screws into studs or using wall anchors. (We recommend anchoring to at least one stud.) Make sure the cleat is level, and leave at least  $66\frac{1}{4}$ " between the bottom of the cleat and the top of the baseboard. Hang the mirror by interlocking the frame and wall cleats. Now step back and see who's fairest of them all.

## APPLY THE MOLDINGS TO THE FRAME

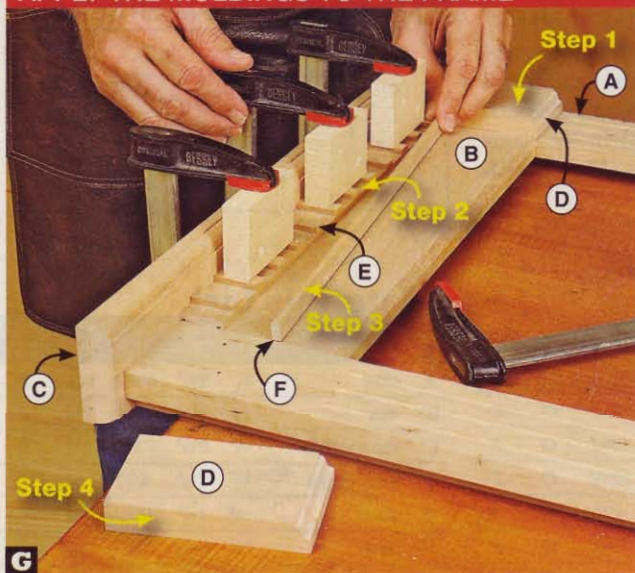

**Step 1** Glue and clamp the first plinth block (D) to the stile (A), flush at the outside edge, and snug against the cap (C).

**Step 2** Glue and clamp a dentil molding (E) to the rail (B), snug against the plinth block and the cap.

**Step 3** Glue and clamp a bead (F) to the dentil and rail, snug against the plinth block.

**Step 4** Glue and clamp the second plinth block to the stile, snug against the cap, dentil, and bead. Repeat at the base end.

## How to resize your parts for a different-size mirror

If your hardware store or home center carries a mirror slightly different from the  $16 \times 60$ " one we used, here's how to adjust your part dimensions. First, measure the width and length of the mirror. Then make the following calculations:

**Length of A** Add  $8\frac{3}{8}$ " to mirror length.

**Length of B, E, F** Subtract  $\frac{5}{8}$ " from mirror width.

**Length of C** Add  $6\frac{3}{8}$ " to mirror width.

**Length of G** Add  $2\frac{3}{8}$ " to mirror width.

**Width of H** Add  $2\frac{3}{8}$ " to mirror width.

**Length of H** Add 5" to length of mirror.

**Note:** Changing the length of the dentil molding (E) will require adjusting the widths and spacing of the rabbets and dados.

## Materials List

Traditional mirror	FINISHED SIZE				Qty.
	T	W	L	Matl.	
A stiles	$\frac{3}{4}$ "	$2\frac{3}{4}$ "	$68\frac{3}{8}$ "	C	2
B* rails	$\frac{3}{4}$ "	$4\frac{1}{2}$ "	$15\frac{3}{8}$ "	C	2
C cap and base	$\frac{3}{4}$ "	$2\frac{5}{8}$ "	$22\frac{3}{8}$ "	C	2
D* plinth blocks	$\frac{5}{8}$ "	$2\frac{3}{4}$ "	$4\frac{1}{2}$ "	C	4
E* dentil moldings	$\frac{3}{8}$ "	$1\frac{1}{4}$ "	$15\frac{3}{8}$ "	C	2
F* beads	$\frac{1}{4}$ "	$\frac{1}{2}$ "	$15\frac{3}{8}$ "	C	2
G cleats	$\frac{1}{2}$ "	$1\frac{1}{2}$ "	$18\frac{3}{8}$ "	C	2
H back	$\frac{1}{4}$ "	$18\frac{3}{8}$ "	65"	HB	1

\*Parts initially cut oversize. See the instructions.

**Materials key:** C—cherry, HB—tempered hardboard.

**Supplies:** #8 $\times\frac{3}{4}$ ", #8 $\times$ 1", and #8 $\times$ 2 $\frac{1}{2}$ " flathead wood screws; #7 $\times$ 1 $\frac{1}{4}$ " fine-thread pocket-hole screws; 16 $\times$ 60" beveled mirror.

**Bits:**  $\frac{1}{4}$ " round-nose, 45° chamfer,  $\frac{3}{8}$ " rabbet,  $\frac{3}{8}$ " bead,  $\frac{5}{32}$ " Roman ogee,  $\frac{3}{4}$ " straight,  $\frac{1}{8}$ " round-over router bits.

Written by Jan Svec with Chuck Hedlund

Project design: Jeff Mertz

Illustrations: Roxanne LeMoine; Lorna Johnson

## Cutting Diagram

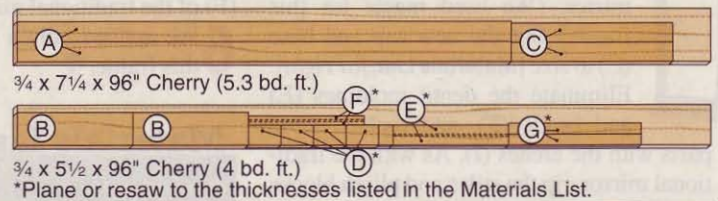

\*Plane or resaw to the thicknesses listed in the Materials List.

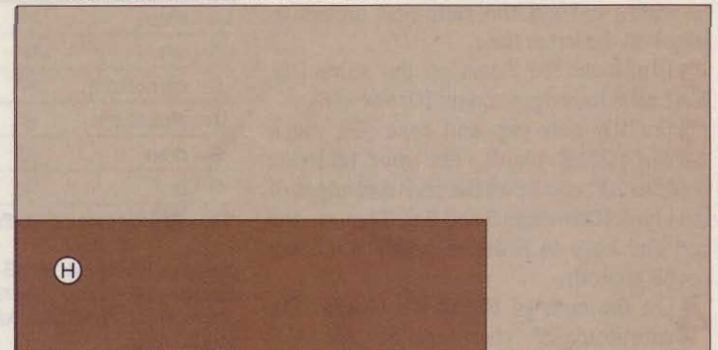

$\frac{1}{4}$  x 48 x 96" Hardboard



## Mirror design options

Simple changes to the traditional-style mirror on page 72 give you a choice of two additional designs that are even easier to build. To make the mirror frames shown here, just follow the instructions for the traditional mirror, making the following changes.



### Classic oak style

**1** For this design, cut the stiles (A), rails (B), cap and base (C), plinth blocks (D), cleats (G), and back (H) to the same sizes as those for the traditional mirror. Eliminate the dentil moldings (E) and beads (F). As with the traditional mirror, rip the stiles and plinth blocks to width at the same time. With no other part to cut to the same length, simply cut the rails to finished length.

**2** Eliminate the flutes on the stiles (A). Instead, rout stopped coves along the edges [Drawing 4].

**3** On the ends and edges of the cap and base (C), eliminate the  $\frac{3}{8}$ " beads, and rout  $\frac{3}{8}$ " coves instead.

**4** On the plinth blocks (D), substitute  $\frac{3}{8}$ " chamfers for the Roman ogees.

**5** We stained this frame with Varathane Summer Oak no. 206, and applied a clear satin finish.



### Shaker style

**1** For this design, cut the stiles (A), rails (B), plinth blocks (D), cleats (G), and back (H) to the same sizes as those for the traditional mirror. (We used maple for this frame.) Cut the new cap and base (C) to size [Materials List, far right]. Eliminate the dentil moldings (E) and beads (F), and replace these parts with the arches (I). As with the traditional mirror, rip the stiles and plinth blocks to width and cut the rails and arches to length at the same time.

**2** Eliminate the flutes on the stiles (A). Leave the edges square [Drawing 5].

**3** For the new cap and base (C), cut a  $\frac{3}{4} \times 7 \times 23\frac{3}{8}$ " blank. Tilt your tablesaw blade to  $20^\circ$ , and bevel the ends and edges of the blank [Drawings 5 and 5a]. Then rip the cap and base to finished width. Sand the bevels smooth.

**4** On the ends of the plinth blocks (D), substitute  $\frac{3}{8}$ " chamfers for the  $\frac{5}{32}$ " Roman ogees.

### 4 CLASSIC OAK STYLE

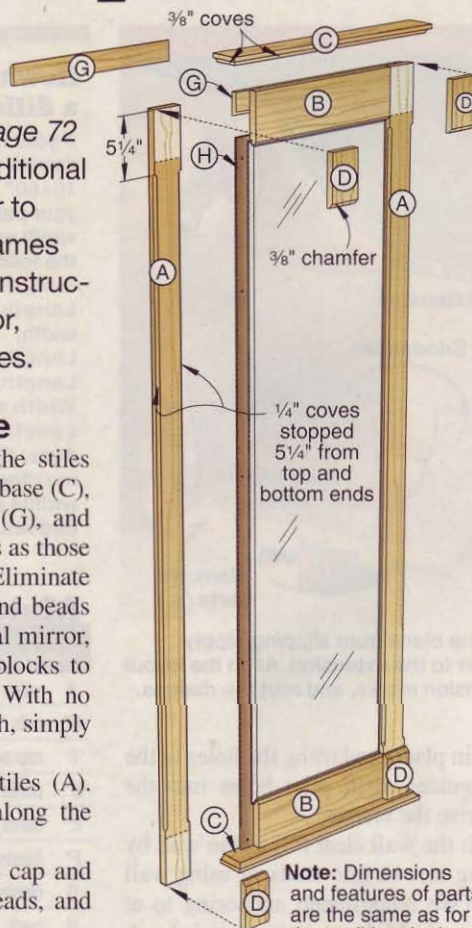

**Note:** Dimensions and features of parts are the same as for the traditional mirror (Drawing 2) except where shown.

### 5 SHAKER STYLE

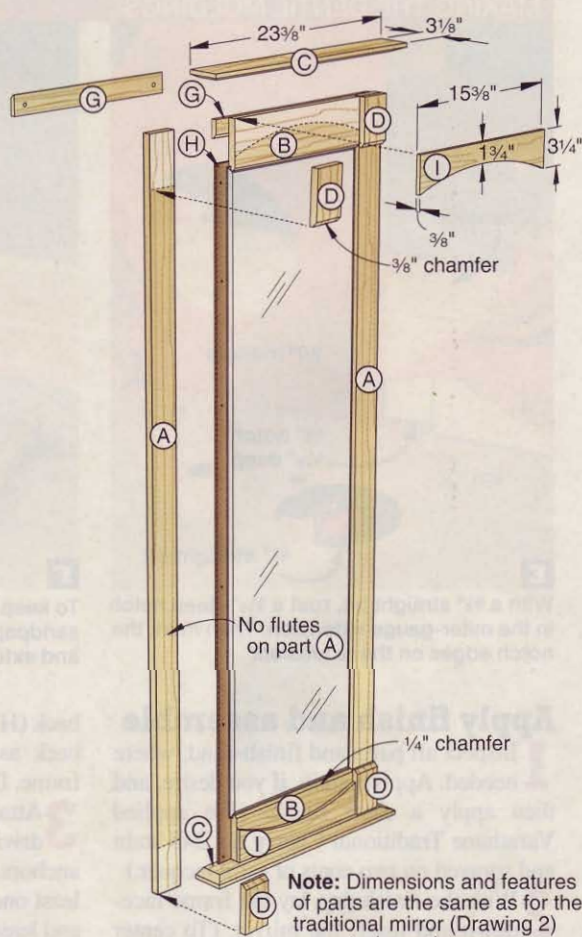

**Note:** Dimensions and features of parts are the same as for the traditional mirror (Drawing 2) except where shown.

**5** Lay out the endpoints and midpoint of the curve on each arch (I) [Drawing 5]. Connect the points with a fairing stick, and draw the curves. Bandsaw and sand to the lines. Finish-sand the arches and glue and clamp them to the rails (B) in the same manner as the dentil moldings (E) and beads (F) of the traditional mirror.

**6** We applied only a clear satin finish to this frame. ♣

### 5a TOP/BOTTOM CHAMFER DETAIL

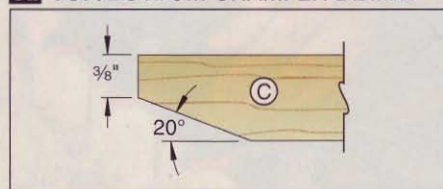

## Materials List

Classic oak mirror	FINISHED SIZE			Matl.	Qty.
	T	W	L		
A stiles	$\frac{3}{4}$ "	$2\frac{3}{4}$ "	$68\frac{3}{8}$ "	O	2
B rails	$\frac{3}{4}$ "	$4\frac{1}{2}$ "	$15\frac{3}{8}$ "	O	2
C cap and base	$\frac{3}{4}$ "	$2\frac{5}{8}$ "	$22\frac{3}{8}$ "	O	2
D* plinth blocks	$\frac{5}{8}$ "	$2\frac{3}{4}$ "	$4\frac{1}{2}$ "	O	4
G cleats	$\frac{1}{2}$ "	$1\frac{1}{2}$ "	$18\frac{3}{8}$ "	O	2
H back	$\frac{1}{4}$ "	$18\frac{3}{8}$ "	65"	HB	1

\*Part initially cut oversize. See the instructions.

**Materials key:** O—red oak, HB—tempered hardboard.  
**Supplies:** #8x $\frac{3}{4}$ ", #8x1", and #8x2 $\frac{1}{2}$ " flathead wood screws; #7x1 $\frac{1}{4}$ " fine-thread pocket-hole screws; 16x60" beveled mirror.  
**Bits:** 45° chamfer,  $\frac{3}{8}$ " rabbet,  $\frac{1}{4}$ " and  $\frac{3}{8}$ " cove router bits.

## Materials List

Shaker mirror	FINISHED SIZE			Matl.	Qty.
	T	W	L		
A stiles	$\frac{3}{4}$ "	$2\frac{3}{4}$ "	$68\frac{3}{8}$ "	M	2
B* rails	$\frac{3}{4}$ "	$4\frac{1}{2}$ "	$15\frac{3}{8}$ "	M	2
C* cap and base	$\frac{3}{4}$ "	$3\frac{1}{8}$ "	$23\frac{3}{8}$ "	M	2
D* plinth blocks	$\frac{5}{8}$ "	$2\frac{3}{4}$ "	$4\frac{1}{2}$ "	M	4
G cleats	$\frac{1}{2}$ "	$1\frac{1}{2}$ "	$18\frac{3}{8}$ "	M	2
H back	$\frac{1}{4}$ "	$18\frac{3}{8}$ "	65"	HB	1
I* arches	$\frac{3}{8}$ "	$3\frac{1}{4}$ "	$15\frac{3}{8}$ "	M	2

\*Parts initially cut oversize. See the instructions.

**Materials key:** M—maple, HB—tempered hardboard.  
**Supplies:** #8x $\frac{3}{4}$ ", #8x1", and #8x2 $\frac{1}{2}$ " flathead wood screws; #7x1 $\frac{1}{4}$ " fine-thread pocket-hole screws; 16x60" beveled mirror.  
**Bits:** 45° chamfer,  $\frac{3}{8}$ " rabbet router bits.



# Through-dovetail jigs under \$350

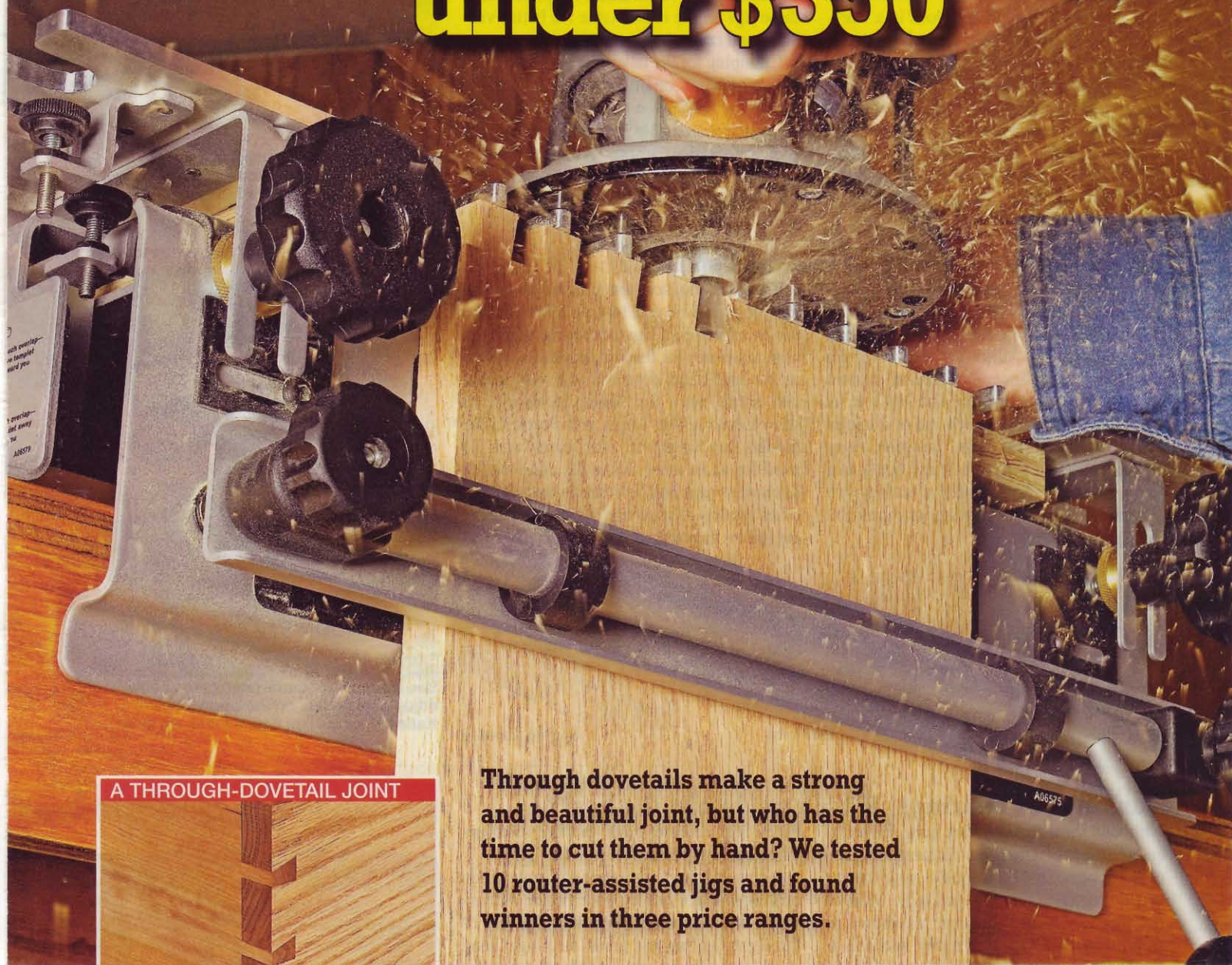

A THROUGH-DOVETAIL JOINT

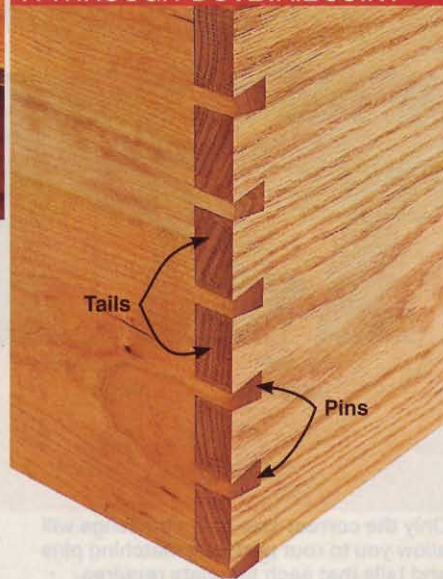

Through dovetails make a strong and beautiful joint, but who has the time to cut them by hand? We tested 10 router-assisted jigs and found winners in three price ranges.

**F**ew things say more about the quality of a project than through-dovetail joinery. Attractive looks aside, the joint's interlocking pins and tails have proven their strength and reliability in joining boards end to end for more than 5,000 years. Some woodworkers get misty-eyed when they romanticize about cutting dovetails with hand tools, but you can use a router and a commercial jig to do the job in a fraction of the time—and typically with more precision and airtight fit.

Dovetail jigs have a reputation for being overpriced and overcomplicated, but is that a fair characterization? To find out we rounded up 10 jigs capable of producing through dovetails, with prices ranging from \$50 to \$330. Three jigs (the CMT300, Craftsman 25455, and Woodline WL-RJT) require buying accessory equipment to make this joint, thus inflating their base prices. After running each jig through rigorous testing and letting the dust settle, here's what we found.



## Despite unique features, jigs fit one of two styles

Although the 10 jigs we tested achieve the same end result—tight-fitting through-dovetail joints—these work-savers certainly don't look the same. You use routers to cut the pins and tails by following templates, but that's where the similarities end. Six of the jigs must be mounted or clamped to a benchtop or workstand. You lock in a workpiece with the jig's built-in clamping system, then run the router on top of the jig, as shown on the *previous page*. All six feature either cam-clamping bars or threaded knobs on bars, and proved adequate in our test.

The other four jigs consist of templates mounted to either a wood block or plate, with the workpiece clamped to the jig. Of

these, the Katie Jig, Keller, and MLCS jigs can be used in a vise or on a benchtop for handheld routing, or you can use them upside down on a router table, as shown with the Keller at *right*. Woodline's jig consists of a phenolic and plywood base, and works only on a router table. We prefer using these jigs on the router table for better visibility and control.

Clamping for the latter jigs proves so easy: Just a pair of one-handed clamps safely secure the workpiece to the jig. When routing on the router table, grip the jig body at its ends rather than gripping the workpiece. Katie Jig and Keller offer optional clamping kits, but you can get by without them.

### THE UPSIDE OF UPSIDE DOWN



Visibility of the cutter improves and the chips blow away from you when routing tails and pins on a router table.

## How do you like your pins and tails spaced?

Most of the tested jigs use a one-piece template to space dovetails equally along the width of the workpiece. But two—the Katie Jig and the Leigh—allow you to arrange the template guide fingers to create custom spacing. This same feature also lets you set up perfect half-pins on each end of the joint and then space the pins between them equally. We like this versatility. One-piece templates offer no variability unless you skip some slots when routing, or reposition the jig after cutting.

Consider, too, how much function you get for your hard-earned tool dollars: We like the extra value of jigs that come equipped with templates for through dovetails as well as for half-blind dovetails and box joints, and some even for sliding dovetails, as shown *below*. The Leigh and Porter-Cable models can create all four joints with no need for accessories. Hartville and Rockler jigs cut through and half-blind dovetails. All other models require optional equipment to cut joints other than through dovetails.

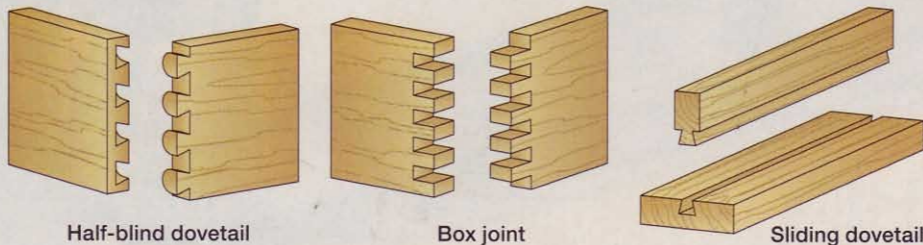

### YOU'LL LIKE MOVABLE FINGERS

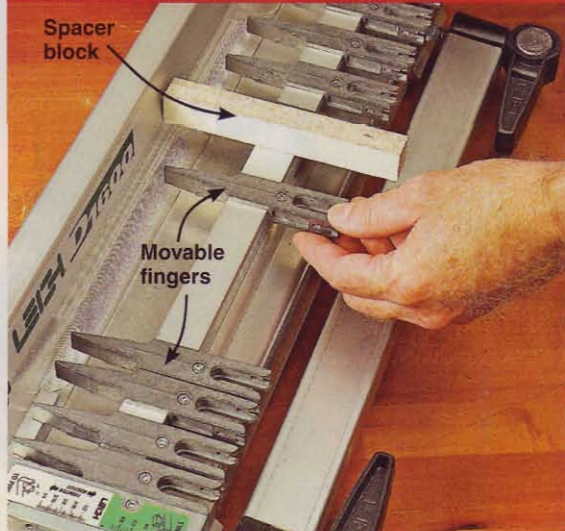

Use a spacer for equal positioning of the adjustable fingers on the Leigh (shown) or Katie Jig, or eyeball it for a hand-cut look.

## Bushings or bearings: Which guide bits the best?

Although these jigs can look quite different, each consists of a multiple-fingered template or templates that you guide your router around to shape the pins and tails. Most of the jigs use guide bushings, as shown at *right*, that mount to your router subbase or router-table insert, but the Katie Jig and Keller 1500 rely on bearing-guided bits, as shown *top right*. With these, you simply run the bearing along the template fingers. Ease of setup proves the chief advantage with these jigs because you don't have to install a guide bushing. The downside: Replacement bits can sometimes be difficult to find.

A guide bushing offers the advantage of working with any replacement bit that matches the dimensions the jig requires. But even a slight variance in bushing diameter can affect the fit of the joint. And five of the

tested jigs require guide-bushing changes when changing bits.

Another thing to be aware of: Some guide bushings might not fit your router. Porter-Cable-style bushings (included with five of the eight jigs that use guide bushings) need an adapter for routers outfitted for other bushing styles such as Bosch. Also, the CMT's bushings require using its optional subbase (\$40), or you can use your own bushings as long as the outer diameters match and you shorten their length to fit the  $\frac{3}{16}$ "-thick template. Craftsman's bushing for cutting pins measures .400", an odd size. But it's made to mount only on Craftsman routers. For other routers you'll need to buy, from Sears, a universal subbase (\$13) or a set of Porter-Cable-style bushings that includes the odd size.

### BUSHINGS FOLLOW TEMPLATE'S PATH

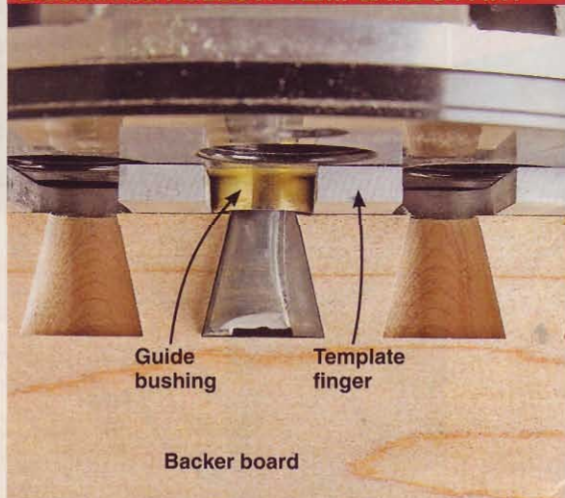

Only the correct-size guide bushings will allow you to rout perfectly matching pins and tails that each template requires.



## It's not "Dovetails for Idiots," but help is nearby

Some manufacturers create shortcuts for the user by putting tips and helpful markings on their templates. Porter-Cable has numerous tips etched into its aluminum template, as shown *far right*. Craftsman also has molded bit-depth settings on its jig body. The Leigh features color-coded settings to ensure that you're setting up for the right joint, and it also has a precision scale for accurate and easy adjustments.

Hartville's GFK1800 has a centering mark on its template, shown *near right*, that allows you to align your workpiece by simply finding its center. No need for edge stops. We tried this on other unmarked templates by making our own mark and found it worked great as well. If you don't want centered and symmetrical pins and tails, either use a jig with adjustable fingers or design your workpieces to have the desired positioning.

## LINEUP TIP SAVES YOU TIME

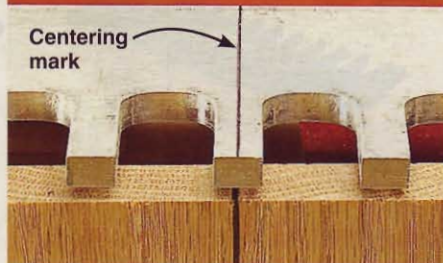

Eliminate the worry of getting perfectly symmetrical pins and tails by centering your workpiece to the template.

CMT's color-coded edge guides help you line up your workpiece in the jig to correctly position the pins and tails. The brown and violet guides serve as workpiece stops for through dovetails in  $\frac{1}{2}$ " and  $\frac{3}{4}$ " stock, respectively, on the jig's face, as indicated in the manual. (The other colored stops work for half-blind dovetails and box joints.) With

## QUICK AND EASY POSITIONING

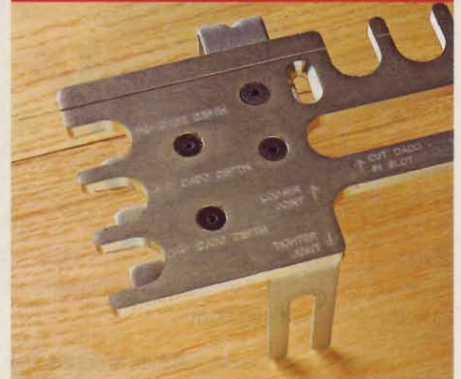

Porter-Cable's templates feature depth settings for bits, width settings for guide bushings, and fine-tuning directions.

these you simply position your board's edge against the stop, put its end against the template, and lock the clamp. Rockler, Katie Jig, and Craftsman feature similar styles, although not color-coded.

## Tame tear-out and bit chatter for better results

Tear-out (see photo *right*) proved troublesome on both workpiece faces with all the jigs and in all materials unless we sandwiched the workpiece between sacrificial backer boards. (We cut dovetail joints in red oak, pine, Baltic birch plywood, and MDF.) Some jigs only have room for a  $\frac{1}{4}$ " front board, but we found that was enough to help eliminate tear-out.

Although cut quality proved a nonissue, we found that  $\frac{1}{4}$ "-shank bits chattered far more than  $\frac{1}{2}$ "-shank bits. Leigh's 8mm bit (equivalent to  $\frac{5}{16}$ " ) chattered some, but not as much as smaller shanks. Chatter stresses the bit and creates discomfort and annoyance for the user. Porter-Cable includes  $\frac{1}{2}$ "-shank bits; they're optional for CMT and MLCS.

## JUST SAY "NO" TO TEAR-OUT



Note the effect on tear-out when using a backer board on both faces (left) and only one on the back face (right).

## MEET THE CONTENDERS

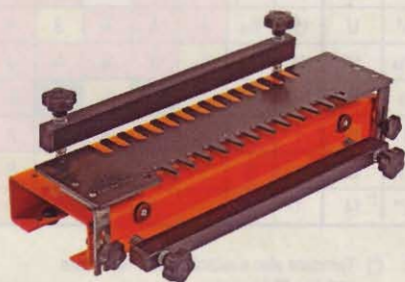

**CMT300, \$130 (\$250 fully equipped for through dovetails)**  
888/268-2487; cmtusa.com

We found that the color-coded edge stops—which help position your workpiece quickly and accurately—make setup a snap. The backer boards needed to prevent tear-out must be  $\frac{1}{4}$ " thicker than the workpiece to keep the bits from cutting into the jig. It has lots of small parts (edge stops, template screws) that could easily get lost. The two manuals (one with illustrations and one with written instructions that refer you to the illustrations) proved awkward; we'd prefer one manual.

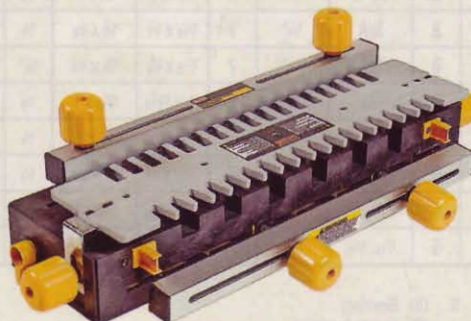

**Craftsman 25455, \$200 (\$240 fully equipped for through dovetails)**  
800/549-4505; sears.com

With quick setup and an easy-to-understand manual, we cut perfect joints on this jig in practically no time. The jig body and templates consist of high-impact polystyrene. The molded bit stops speed up the setup process, with only a little fine-tuning needed. It's one of two jigs that can work on 1"-thick stock. But the hassle of using two guide bushings (one an odd size) that fit only Craftsman routers or the optional subbase detracts from an otherwise quality product.

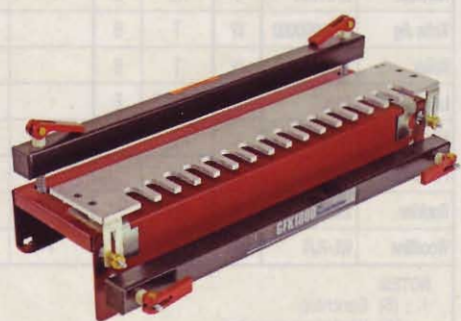

**Hartville GFK1800, \$250, fully equipped for through dovetails**  
800/345-2396; hartvilletool.com

This 18" jig's assembly time took the longest in our test, just over one hour. Similar to older stamped steel jigs, this one features better clamping, with square tubing and cam-action levers, and a powder-coated body to resist slippage. The manual says little about through dovetails, so we learned by intuition and trial and error. The GFK1800 is available as a half-blind jig only for \$150. Hartville also has a 12"-long model (GFK1200, \$100 base price, plus \$145 in through-dovetail accessories).



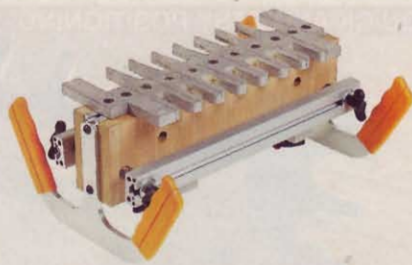

**Katie Jig KJ12000002, \$260, fully equipped for through dovetails**  
317/881-8601; katiejig.com

It took longer to read the manual than to cut the first dovetail with this unit. It came out of the box fully assembled, with backer board installed, and we completed a joint in only seven minutes, with no need to adjust for a perfect fit. The edge stops work great at positioning the workpiece, and it required a 5/32" Allen wrench (included) to remove the 1" spacers. The optional handles for router-table use seem unnecessary, since you can hold it by its body.

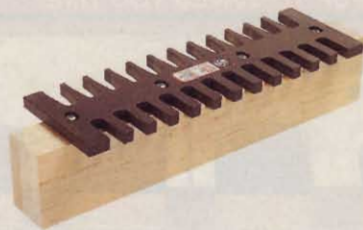

**Keller 1500 Journeyman, \$160, fully equipped for through dovetails**  
800/995-2456; kellerdovetail.com

Cutting through dovetails doesn't get much simpler than with this 15" jig. There's very little setup, and only slight adjustments the first time you use it. You also can cut dovetails for angled joints with this jig. Buy the optional small-bit set (\$65) to create scaled-down through dovetails, or the box-joint bit set (\$32) for traditional box joints—both with the same Journeyman template. The only downside to this jig is it won't cut half-blinds.



**Leigh D1600, \$330, fully equipped for through dovetails**  
800/663-8932; leighjigs.com

Although it looks complicated, this jig proved easy to understand and use, thanks to the best manual in the field and the included DVD. Assembly took 27 minutes, with just another 9 minutes needed to turn out a tight joint. An included reducer allows you to use the 8mm-shank bits in a 1/2" collet. Also available as options are finger-joint templates (\$200) and Leigh's Isoloc template set (\$340) for hearts, clovers, bears, keys, waves, and ellipses.

## THROUGH-DOVETAIL JIGS UNDER \$350

BRAND	MODEL	JIG STYLE (1)		OUT-OF-BOX		WITH OPTIONAL ACCESSORIES		ADDITIONAL ACCESSORIES REQUIRED FOR THROUGH DOVETAILS (3)		TEMPLATE MATERIAL (4)		ROUTER GUIDING SYSTEM (5)		GUIDE BUSHING DIAMETER (FOR PINS) (INCHES) (6)		SHANK SIZE (7)		THROUGH-DOVETAIL ROUTER BITS			CAPACITIES (INCHES)			PERFORMANCE GRADES (13)							
																		DOVETAIL ANGLE (DEGREES)	DOVETAIL BIT SIZE (DxH, INCHES)	STRAIGHT BIT SIZE (DxH, INCHES) (8)	MINIMUM THICKNESS (9)	MAXIMUM THICKNESS (10)	MAXIMUM WIDTH (11)	WORKPIECE		PINS (12)	EASE OF INITIAL SETUP	EASE OF CHANGING SETUP	EASE OF TUNING FIT OF JOINT (14)	MANUAL CLARITY	EASE OF USE
																								MINIMUM SPACING (ON CENTER)	MINIMUM WIDTH						
CMT	CMT300	B	H	B,T	D,G,S,T	S	G	3/8, 7/16	1/4***	8	1/2 X 1	5/16 X 1	5/16	25/32	11 3/4	1	1/2	B	B+	B	C	B									
Craftsman	25455	B	H	B,T	D,S	PS	G	1/2, 400	1/4"	7 1/2"	3/16 X 1	1/4 X 1	3/8	1	16	1	9/16	B	B	B	B	B									
Hartville	GFK1800	B	H,T	B		A	G	3/4, 5/8	1/4"	7	3/4 X 7/8	1/4 X 1	3/8	3/4	18	1 1/8	3/4	B	B	B	B	B									
Katie Jig	KJ12000002	W	T	B		A	B	N/A	1/4"	7	7/16 X 3/4	5/8 X 3/4	1/4	3/4	U	1 3/8	7/16	A	A-	N/A	A	A									
Keller	1500	W	T	B		P	B	N/A	1/4"	7	7/16 X 3/4	5/8 X 3/4	1/4"	3/4"	U	1 1/8	7/16	A-	A	A	B	A									
Leigh	D1600	B	B,H,S,T	E		Z	G	7/16	8mm*	8	1/2 X 1 3/16	5/16 X 1	1/8	1 3/16	16	7/8	1/4	B+	A	A	A	A									
MLCS	8712	W	T			A	G	5/8	1/2**	14	3/4 X 7/8	3/8 X 1	1/4	7/8	U	1 1/8*	3/4"	B	C	B+	C	A-									
Porter-Cable	4212	B	B,H,S,T			A	G	3/4, 5/8	1/2"	7	17/32 X 3/4	1 3/32 X 1	1/4	1	12	1	17/32	A	A-	A	A-	A									
Rockler	23882	B	H,T			P	G	7/16	1/4"	8	1/2 X 1 3/16	5/16 X 1	3/8	3/4	12	1	1/2	B	B	B	B	B									
Woodline	WL-RJT	W	E	H,T	T	H	G	7/16, 5/16	1/4"	14	1/2 X 1/2	3/16 X 3/4*	1/4	3/8**	14	1	1/2	B	A	A-	B	B-									

### NOTES:

1. (B) Benchtop  
(W) Workpiece-mounted

2. (B) Box joints  
(E) Exotic joints  
(H) Half-blind dovetails  
(S) Sliding dovetails  
(T) Through dovetails

3. (D) Dovetail bit  
(G) Guide bushing  
(S) Straight bit  
(T) Template

4. (A) Aluminum  
(H) High-density polyethylene  
(P) Phenolic  
(PS) High-impact polystyrene  
(S) Steel  
(Z) Zinc alloy

5. (B) Bearing  
(G) Guide bushing

6. (N/A) Uses bearing-guided bits, not guide bushings.

7. (\*) 1/4" bits also available  
(\*\*) 1/2" bits also available

8. (\*) Spiral bit

9. (\*) 1/8" minimum thickness when using optional small bit set

10. (\*) 1" with rabbeted pins  
(\*\*) Manufacturer plans to offer templates and bits that will machine through dovetails in 3/4" stock.

11. (U) Unlimited

12. (\*) Template also available with 1"-wide tails and pins 2" on center.

13. **A** Excellent  
**B** Good  
**C** Fair

14. (N/A) Preset by manufacturer. No front or back adjustments available.

15. (AB) Alternate bits  
(B) Box-joint template  
(C) Clamp kit  
(E) Exotic joint templates  
(G) Guide bushings  
(H) Handles for router-table use  
(HB) Half-blind dovetail bit  
(HT) Half-blind dovetail template  
(R) Collet reducer  
(S) Router subbase





**MLCS 8712, \$50, fully equipped for through dovetails**

800/533-9298; mlcswoodworking.com

Similar to the Keller in its design, this jig proved more difficult to set up and fine-tune, taking three test cuts to get it right. Nevertheless, once we zeroed it in, it turned out great-fitting joints. The instruction sheet could be better illustrated. If you prefer wider tails and pins, choose MLCS model 8713 for the same price, or get either model with 1/4"-shank bits. Pretty simple once tuned in, and an unbeatable price.



**Porter-Cable 4212, \$160, fully equipped for through dovetails**

888/848-5175; porter-cable.com

Essentially a revamped half-blind jig, this model excels at all joints. With so many helpful hints etched onto the templates and jig body, you almost don't need the manual (which proves very good as well). It's one of only two jigs that will machine stock up to 1" thick. Replacements for the unusual-dimension bits (\$16 for the 13/32" straight bit; \$22 for the 17/32" dovetail bit) will prove difficult to find from sources other than the manufacturer.

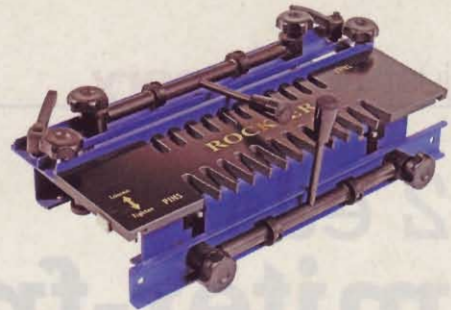

**Rockler 23882, \$140, fully equipped for through dovetails**

800/279-4441; rockler.com

This jig includes everything you need to cut half-blinds and through dovetails. It features sturdy cam-clamping power and adjusts easily when fine-tuning the fit of a joint. Rockler's bits had the longest shanks in the test, resulting in the most chatter. (Rockler's Steve Krohmer told us they will be replacing in the first quarter of 2007 their 1/4"-shank bits with 8mm shanks, which should reduce chatter. A reducer for 1/2" collets will be included.)

ACCESSORIES (15)				
STANDARD	OPTIONAL	COUNTRY OF ASSEMBLY (16)	WARRANTY, YEARS (17)	BASE UNIT SELLING PRICE (18)
G,HB,HT	AB,B,S,SB,T,TB	I	L	\$130
B,G,HB,HT,T	G,S,SB,TB	U	L	\$200
G,HB,HT,SB,T,TB	B	U	1	\$250*
SB,TB	B,C,H	U	1	\$260
SB,T,TB	AB, C	U	1	\$160
G,HB,R,SB,TB	AB,E,V	CA	5	\$330
G,SB,T,TB		CH	1	\$50
B,G,HB,HT,SB,T,TB		CH	1	\$160
G,HB,HT,SB,T,TB		T	1	\$140
E,G,HB,SB,TB	AB,E,HT, T	U	L	\$180

- (SB) Straight bit
- (T) Through-dovetail template
- (TB) Through-dovetail bit
- (V) Vacuum attachment

- 16. (CA) Canada
- (CH) China
- (I) Italy
- (T) Taiwan
- (U) United States

17. (L) Lifetime

18. (\*) Hartville kit #30073TD  
Prices current at time of article production and do not include shipping, where applicable.

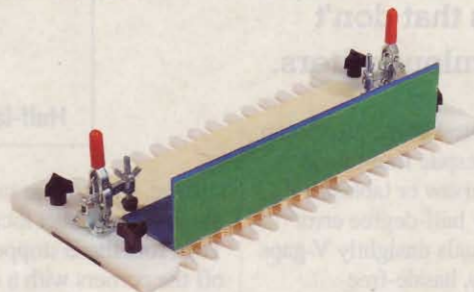

**Woodline WL-RJT, \$180 (\$207 fully equipped for through dovetails)**

800/472-6950; woodline.com

Originally designed to cut decorative (hearts, keys) and box joints in small boxes, this jig has grown into a fully functional multi-joint unit. The through dovetails we cut with it needed very little fine-tuning. You get a lot of versatility with this jig by being able to add new templates from the many

available. You also get a DVD to help guide you. Two downsides: You have to buy the optional half-blind (for the pins) and through templates, and those limit you to 3/8"-thick stock. (Woodline's Wayne Sutter told us they will have templates and bits for 3/4" stock available by January 2007.)

**If it were for our shop, we'd go with a versatile jig**

Before buying one of these jigs, consider what you want to do with it. Given that all the jigs create good joints and all but one of the jigs cost \$130 or more, we recommend that you get the most bang for your buck: Buy a jig that makes more joints than just through dovetails. (A separate half-blind dovetail jig will cost you another \$100 or more.) Also, get a jig that will be just as easy to remember and use even if you let it sit idle for a year.

That kind of versatility, coupled with exceptional performance, is what grabs Top Tool honors for the Leigh DI600. Although the priciest, nonetheless it executed clean, snug-fitting dovetails on accommodating 16" templates. And though we'd prefer bearing-guided bits instead of its guide bushings, the DI600's set of standard and optional

templates made it impressively useful for a variety of joints.

The Porter-Cable 4212 follows closely behind the Leigh in performance—selling for \$170 less but lacking variable spacing, and earning a Top Value award. Keller's 1500 cuts through dovetails simply, quickly, and accurately, but for the same money lacks the Porter-Cable's versatility.

The MLCS 8712 shares Top Value honors with the Porter-Cable. Despite a couple of minor inconveniences and the fact that it only turns out through dovetails, the 8712 does a respectable job for only \$50.

Written by Bob Hunter with Pat Lowry  
Illustrations by Roxanne LeMoine

See more Tool Reviews at:  
[woodmagazine.com/reviews](http://woodmagazine.com/reviews)



# 2 easy miter-free frame joints

Turn to these two techniques for striking, sturdy corners that don't demand meticulous miters.

**M**iscut mitered frame pieces can happen despite fine-tuning your mitersaw or tablesaw miter gauge. A measly half-degree error multiplied by eight equals unsightly V-gaps all around. Thankfully, hassle-free alternatives exist. Our no-miter mirror on page 72 shows one approach using pocket-hole screws. Here are two more: doweled butt joints and half-lap joints. Both eliminate the need for angle-cuts, add strength for heavy-duty framing jobs, and offer eye-catching good looks.

## Decorate with dowels

Although doweled joints also demand precision, careful layout and a decent doweling jig quickly solve this problem. (See Sources.) In addition to reinforcing butt joints, dowels add an artful touch to frame sides when left exposed. Another advantage of doweled butt joints over miters: you can join rails and stiles of different widths [Photo A].

Start by cutting the stiles and rails to their finished dimensions. Then label the parts, and letter each joint on both pieces. With the end of the stile flush with the rail edge, use a square and fine pencil to mark lines across the joint where you want each dowel [Photo B]. (If you use a jig with preset dowel spacing, mark just one line per joint for the dowel closest to the end.)

If your finished frame requires a rabbet along the back inside edges to hold glass and artwork or a mirror, first rabbet the rails along their entire lengths. Dry-assemble the frame upside down on a flat

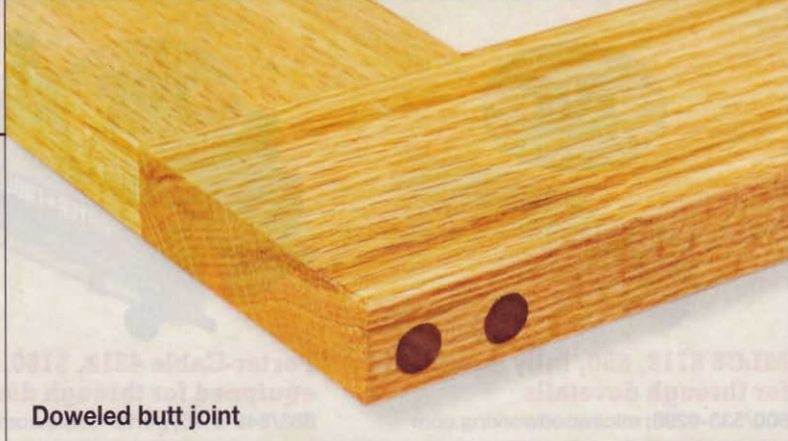

Doweled butt joint



Half-lap joint

surface, and use the rail rabbets to mark the stopped rabbet locations on the stiles. Then rout those stopped rabbets, squaring off the corners with a chisel.

Secure a stile in your wood vise. Position the doweling jig to center a dowel hole on one of your marks, and drill a hole just longer than half the depth of the dowel pin's length [Photo C]. Repeat for

remaining dowel locations on both the stiles and the ends of the rails.

To extend dowels through the stiles to expose the dowel ends for a decorative effect, remove the jig and use the holes as guides to drill through each stile. Add a scrapwood backer block to prevent tear-out [Photo D]. Cut dowels about 1/2" longer

*continued on page 84*

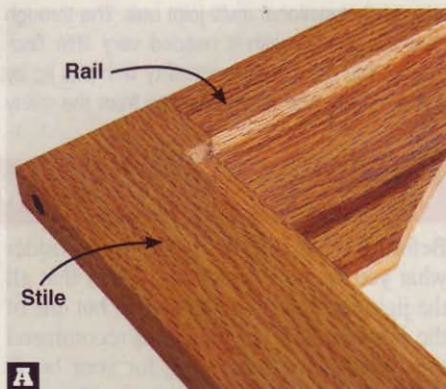

**A**



**B**

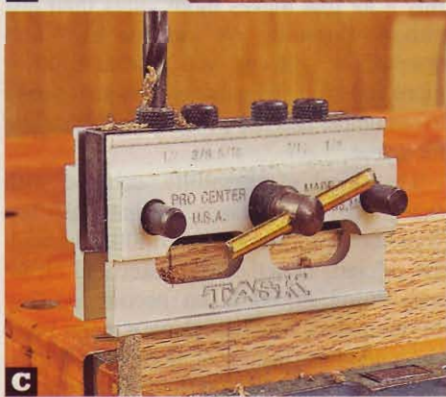

**C**



**D**



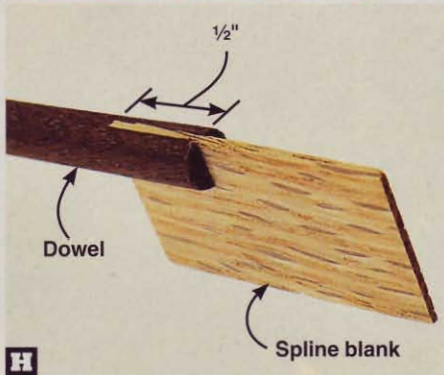

than the combined depth of the hole in the rail and the width of the stile.

Allow air and excess glue to escape as you tap in the dowel by using the corner of a chisel or a saw to cut a glue-relief groove to within 1" of one end [Photo E]. Drip enough glue into the holes to cover the sides by spreading it with a nail or screw [Photo F], and apply glue to the ends to be joined. Then immediately tap the dowels into place through the stile and into the rail, grooved end first [Photo G].

After two hours, saw the dowels flush with the edges. To enhance the contrast between dowels and the surrounding wood (see opening photo on page 82), wipe on boiled linseed oil or Danish oil before applying a film finish.

For a decorative variation on this dowel joint top right, add splines to the dowel tips. Cut dowels  $\frac{1}{4}$ " longer than the holes in both pieces, and add glue-relief grooves. Bandsaw a notch  $\frac{1}{2}$ " deep into the top end. Next, bandsaw a spline blank of contrasting wood and sand it to fit within the notch to form a slight wedge [Photo H]. Glue the wedge in place and trim off the excess. Then glue and drive the dowels into place with the splines running parallel with each other and parallel or perpendicular to the grain. Allow two hours for the glue to dry, then flush-cut the splined dowels.

## Rout half-lap joints

Half-laps lack the mechanical connection of a doweled butt joint, but they make up for it through the strength of their face-to-face glue bond that usually outlasts the surrounding wood under stress. We'll make

this simple joint on a router table with a 1" straight bit for clean, flat, joint faces seldom possible using a tablesaw dado blade.

Dimension the stiles and rails to a uniform thickness and width before cutting them to length. Save the cut-offs to test your router bit settings later. Then, chuck a straight bit into your router and set its height to half the thickness of your frame pieces. Make test cuts and adjust the bit height until the faces of the two cut-offs are flush with each other [Photo I].

Now set aside your scrap pieces and rout several shallow passes on your workpieces. To do this, repeatedly step back your router-table fence [Photo J] until the length of the half-lap comes to within  $\frac{1}{4}$ " of the mating workpiece width. Before routing the final pass, place and offset the mating workpieces along the fence to set the exact fence distance from the edge of the bit [Photo K]. Then make your final passes on both ends of each piece [Photo L] using a backer block to eliminate tear-out.

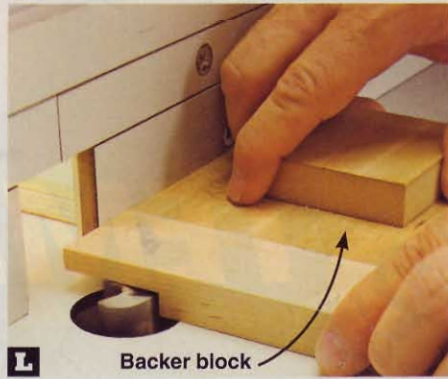
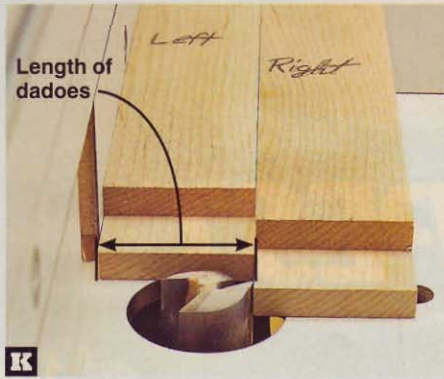
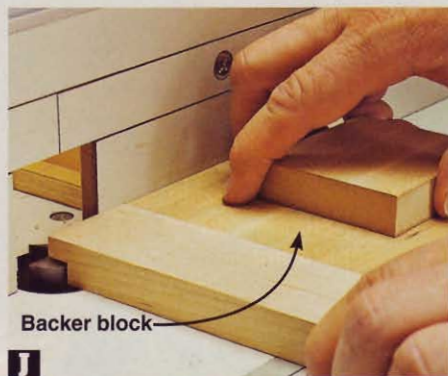
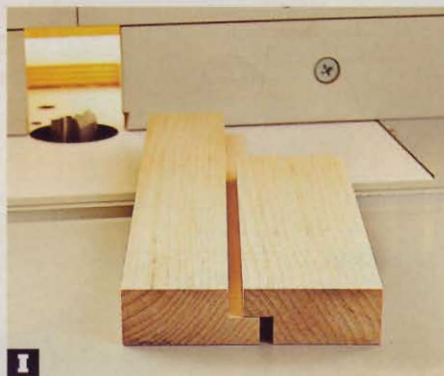



Dry-assemble the frame pieces on a flat surface to check for a tight fit [Photo M]. If you plan to rabbet the back for art and glass or mirror, start by routing rabbets no deeper than half the thickness of your workpieces along the entire length of the rails. Make at least two passes to reduce tear-out. Then dry-assemble the pieces and

use the rabbets to mark the stops for rabbeting the stiles. Make the stopped rabbets [Photo N] and square the rounded corners using a chisel.

Next, glue and clamp the pieces. Half-laps help pieces square with each other, but check all four corners of your glue-up with a square to ensure 90° corners. ♣

## Sources

**Doweling jigs.** Premium Doweling Jig no. 124315, \$60 (Woodcraft, 800/225-1153 or woodcraft.com). Dowelmax kit with 3/8" drill guides, \$239 (Dowelmax, 877/986-9400 or dowelmax.com). Edge-to-Edge Doweling Jig no. 109-142, \$22 (Woodworker's Supply, 800/645-9292 or woodworker.com).

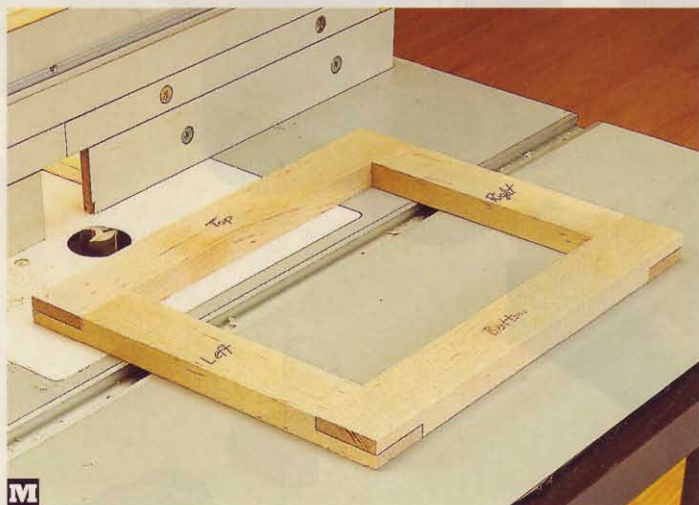

M

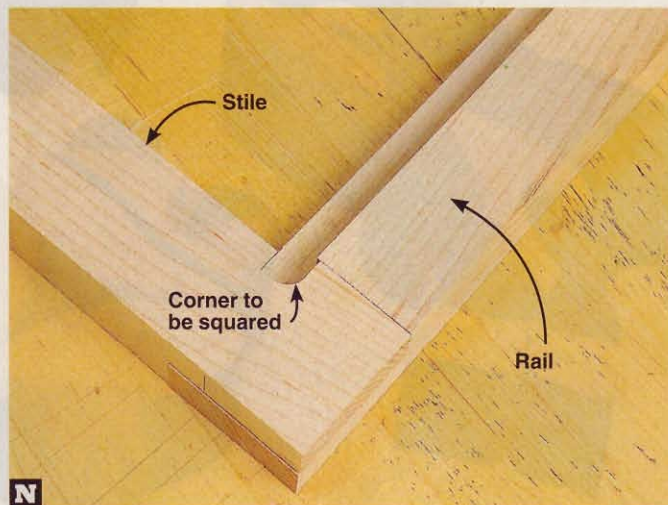

N

woodmagazine.com

85

## Refinish Your Future.



### Own your own business.

Let your passion for furniture lead you into a new business with a Furniture Medic franchise. We're a complete on-site repair and restoration-refinishing business servicing homes and companies as well as handling moving and insurance claims. We offer extensive training and support with a low initial investment and manageable overhead. Financing is available to qualified candidates and franchises are offered nationwide. Call today to brush up on the details.



**FURNITURE MEDIC**  
"The go-to solution for damaged furniture"

www.furnituremedicfranchise.com

1-800-RUN YOURS

## The World's Best 16" Dovetail Jig.



- perfect through, half-blind and sliding dovetails • fully adjustable spacing of pins and tails
- includes three bits and one guidebush • optional templates for box and Isoloc joints



**FREE DVD & CATALOG!**  
Call Now 800-663-8932  
www.leighjigs.com

**LEIGH**  
Leigh Router Joinery Jigs



# keepsake boxes



Turn your scrap into great gifts.

**T**o begin, make five copies of one of the animal figures from the *WOOD Patterns*® insert on page 89. Select a species of wood or use those we did. Contrasting colors or complementary species (for example, similar tight-grained woods like maple, cherry, and aspen) produce the best appearances for the intarsia tops.

## Cut out the boxes first

For each box you'll need four 4½×4½" blanks (the orca, however, requires 4½×6" blanks) in these thicknesses: lid and bottom, ⅜"; box, ¾"; and the backer for attaching the intarsia pieces, ⅛" plywood. (For best color match, cut blanks for the lid, box, and bottom from the same board.) See the drawing at right for reference on assembling the layers.

Using double-faced tape, adhere the lid blank to one face of the box blank, and attach one pattern with spray adhesive to the other face of the box blank. Drill a ⅛" hole inside the dotted line in a corner, then cut along that dotted line using a #5 blade in your scrollsaw. Leave the pattern attached to the box blank, but remove the lid and set it aside.

Now glue and clamp the bottom blank to the bottom of the box. After the glue dries, attach the ⅛"-thick plywood blank to the bottom blank with double-faced tape. Scrollsaw the outer shape along the solid lines on the pattern. Remove the plywood. Sand away any imperfections on the box sides using a small file and fine-grit sandpaper.

## Now for the intarsia parts

Cut out each of the intarsia parts from the patterns, staying about ¼" outside the lines. Attach each pattern piece to your stock with spray adhesive, then cut them out on the scrollsaw about ½" larger than the pattern line. (We made the bear's snout from ½"-thick stock and its nose from ⅝" stock so they would protrude from the face. The mouth is a saw kerf cut after drilling out the hole for the nose. We also made the bear's inner ears ¼" thick so they would be recessed. All other parts are ⅜" thick.)

Hold the small parts with double-faced tape on a small length of scrapwood. Sand each piece to the line on a 1"-wide strip sander or spindle sander. Dry-assemble the intarsia parts and test their fit on one copy of the pattern.

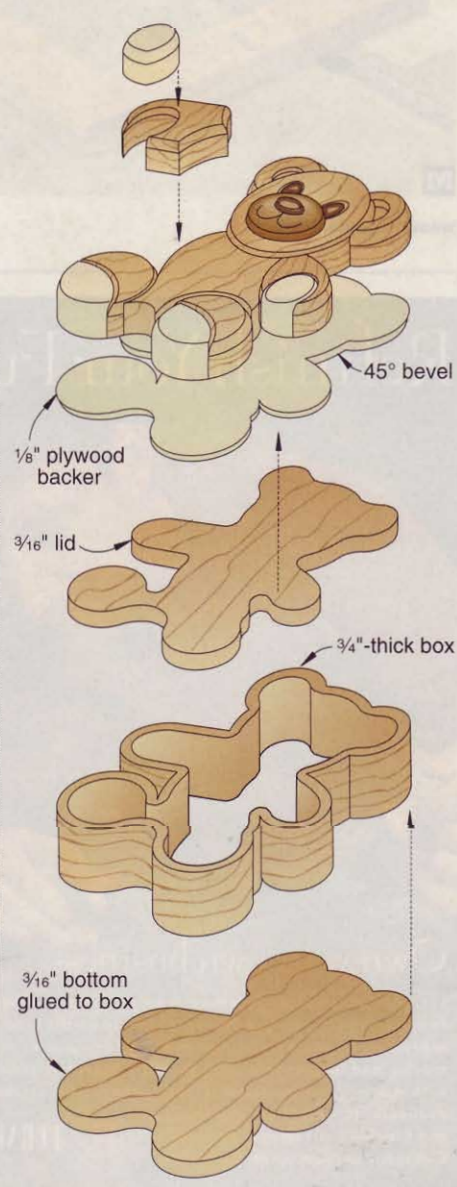



After all the pieces fit together, sand their top edges to the desired contours, as shown *near right*. (The eyes of the frog are cut, fitted, and glued together before contouring.) After contouring all the pieces, glue them to the plywood only while fitting tightly together. Use hand pressure to hold the pieces in place for 1–2 minutes, keeping them tight and aligned.

After the glue dries, sand a 45° bevel on the plywood edge, as shown at *far right*, with a strip sander. Use a small file or emery board to get into tight corners. (This reveal makes it easier to grip and remove the box lid when completed.)

To align and attach the lid to the plywood, first make three spacers to sit inside the box. The tops of these spacers must be 5/8" from the box bottom to allow the recessed lid to rest on them while sitting flush with the box top. Place the lid onto the spacers, spread glue onto the lid, and press the plywood onto the lid. Sand the project with a 320-grit sanding sponge, then remove all dust with compressed air. Finish with three coats of spray lacquer. 🐾

## DETAILED SANDING BRINGS ANIMAL COMPONENTS TO LIFE

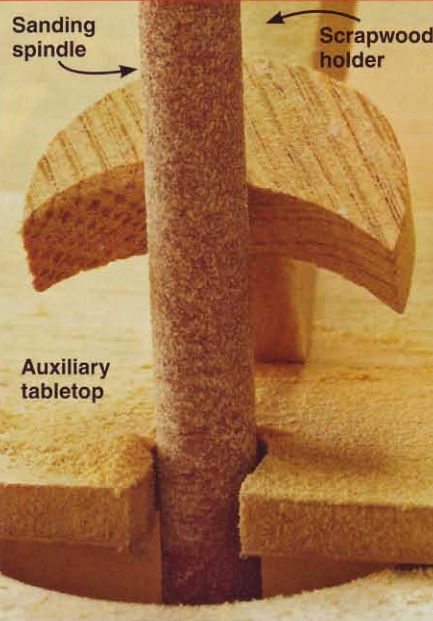

To keep small parts from falling into the throat around the spindle, add an auxiliary tabletop made of hardboard or plywood.

Project design: August Caryl



When beveling the plywood at 45°, avoid sanding the edges of the intarsia pieces. An auxiliary table covers the throat opening.



## Handle Winter Handiwork With Warm Hands.



### Energy Efficient Garage Heaters

- Hush-puppy quiet warmth from natural or propane gas.
- Lightweight, easily installs only 1" from ceiling.
- New separated-combustion units use outside air for:
  - Greater heating efficiency,
  - Increased durability in dusty, dirty or humid workspaces.

You don't have to go fur to find a Hot Dawg. For a free brochure and the location of your nearest Hot Dawg source, fetch your phone and call: **888-288-4991**  
[www.modine.com/hotdawg](http://www.modine.com/hotdawg)





Better Homes and Gardens®

# WOOD PATTERNS®

March 2007

Issue 175

Dear Reader: As a service to you, we've included full-size patterns on this insert for irregular-shaped and intricate project parts. You can machine all other project parts using the Materials List and the drawings accompanying the project you're building.

©Copyright Meredith Corporation, 2007. All rights reserved. Printed in the U.S.A. Meredith Corp., the publisher of *WOOD Patterns*®, allows the purchaser of this pattern insert to photocopy these patterns solely for personal use. Any other reproduction of these patterns is strictly prohibited.



**Cedar-lined Blanket Chest, Page 40**



**Top, Page 48**



**Intarsia Keepsake  
Boxes,  
Page 86**



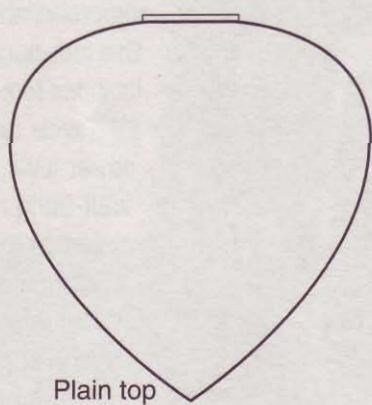
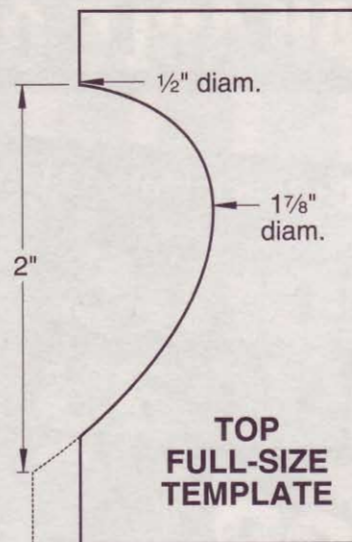
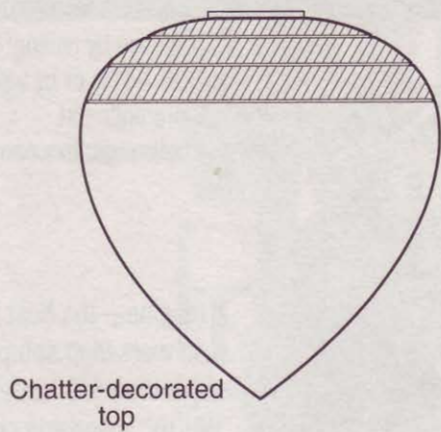

**Top, Page 48**

**Cedar-lined  
Blanket Chest,  
Page 40**

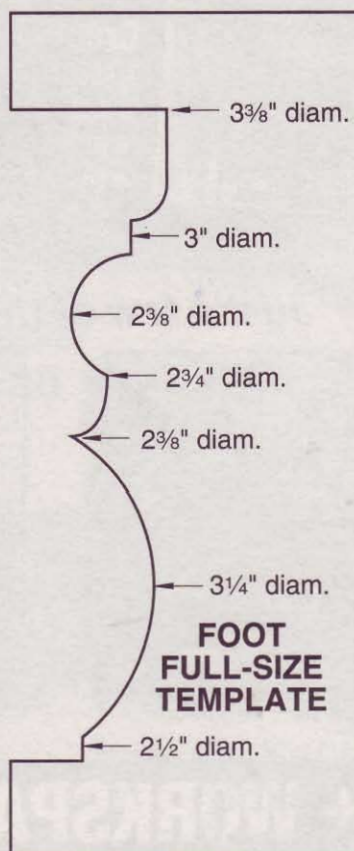



**Intarsia  
Keepsake  
Boxes,  
Page 86**

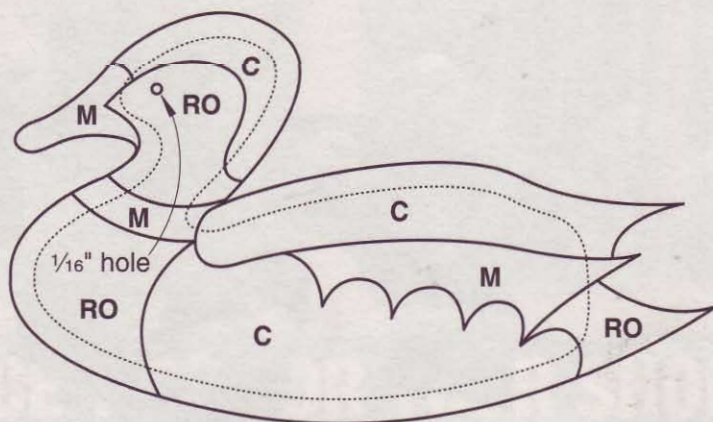
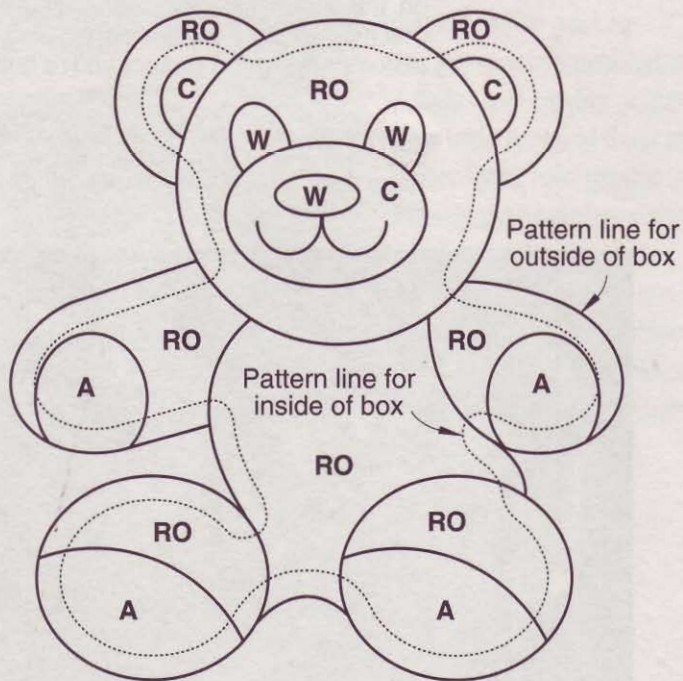
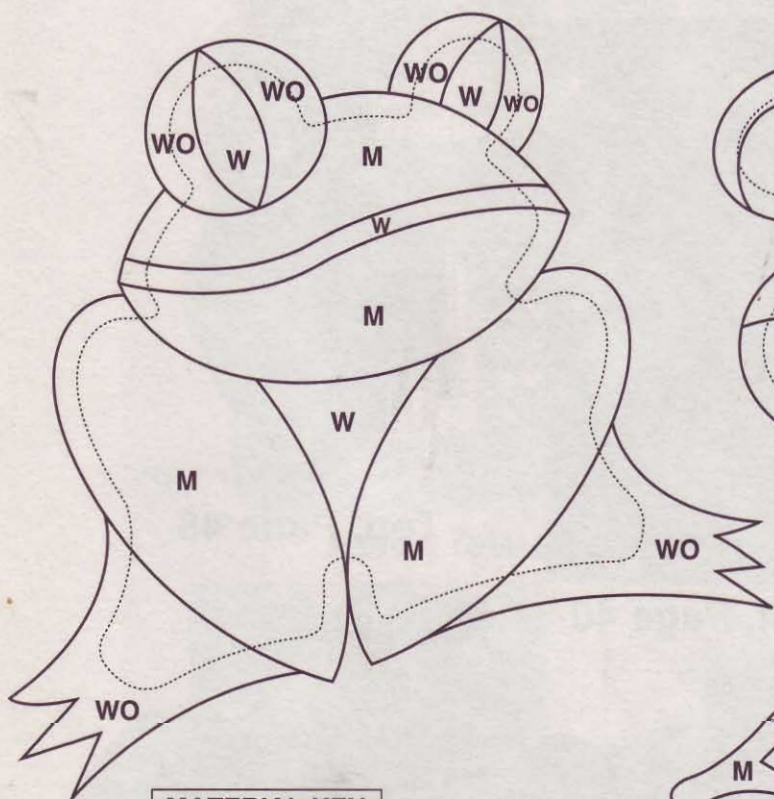
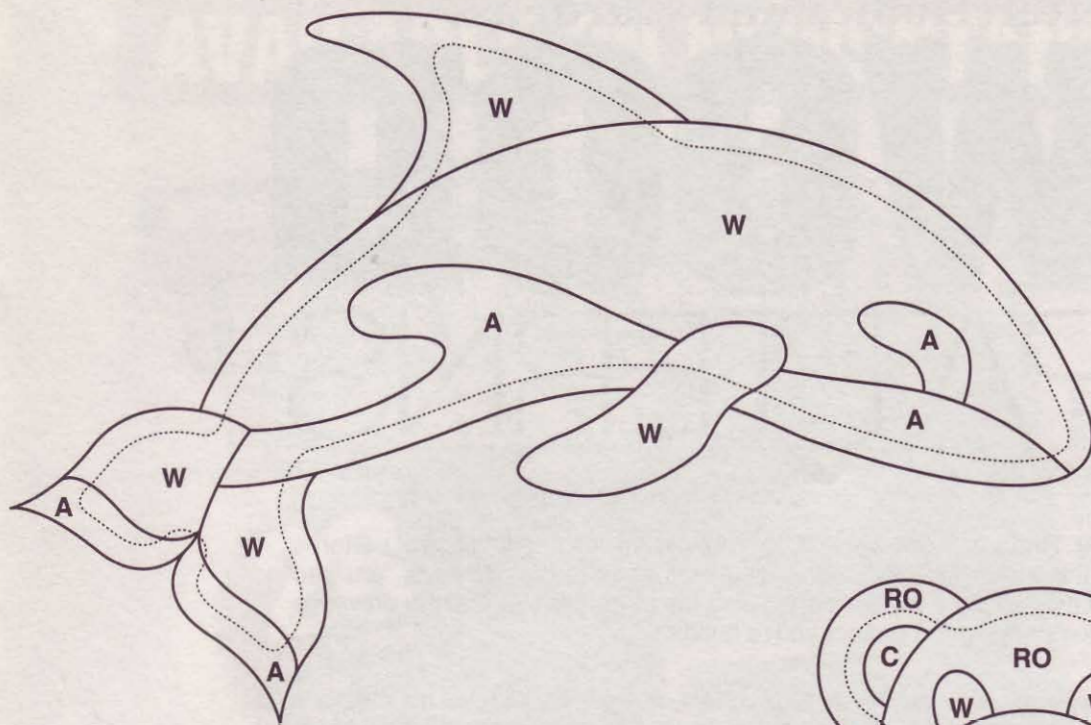

**MATERIAL KEY**

A	aspen
C	cherry
M	maple
RO	red oak
W	walnut
WO	white oak



# how to prevent miter saw kickback

## The incident

**M**y dad was remodeling his bathroom, and I offered to install some crown molding for him. After bevel-cutting a front piece using my compound miter saw, I needed a 2"-long side piece. I bevel-cut one end of a 3"-long piece and marked the other end for a 90° cut. Holding the piece against the saw fence with my right hand, I cut the piece with my left, and immediately raised the saw with the blade spinning—a BIG mistake! The teeth caught the bottom of the piece, resulting in a violent kickback and deep cut halfway along my index finger (the important "trigger" finger in my job as a police officer). I don't know if it was the blade or flying piece that cut me—it happened that fast.

Not wanting to lose time going to the hospital, I stitched the wound myself (something I've done a few times before). Fortunately, my finger healed fine. Unfortunately, I learned an important safety lesson...the hard way.

—Rodney Wolfington, Arlington, Wash.

## The woodworker

Rodney has served as a police officer for 13 years in the Seattle area. To help unwind, he spends time in his shop building cabinets and furniture. He has about nine years of woodworking experience.



## The warning signs

From watching others, Rodney learned the unsafe habit of lifting the miter saw head with the blade running, which creates a risk for kickback. Another factor: He used his hand as a hold-down when cutting a very short workpiece, placing his fingers dangerously close to the blade.

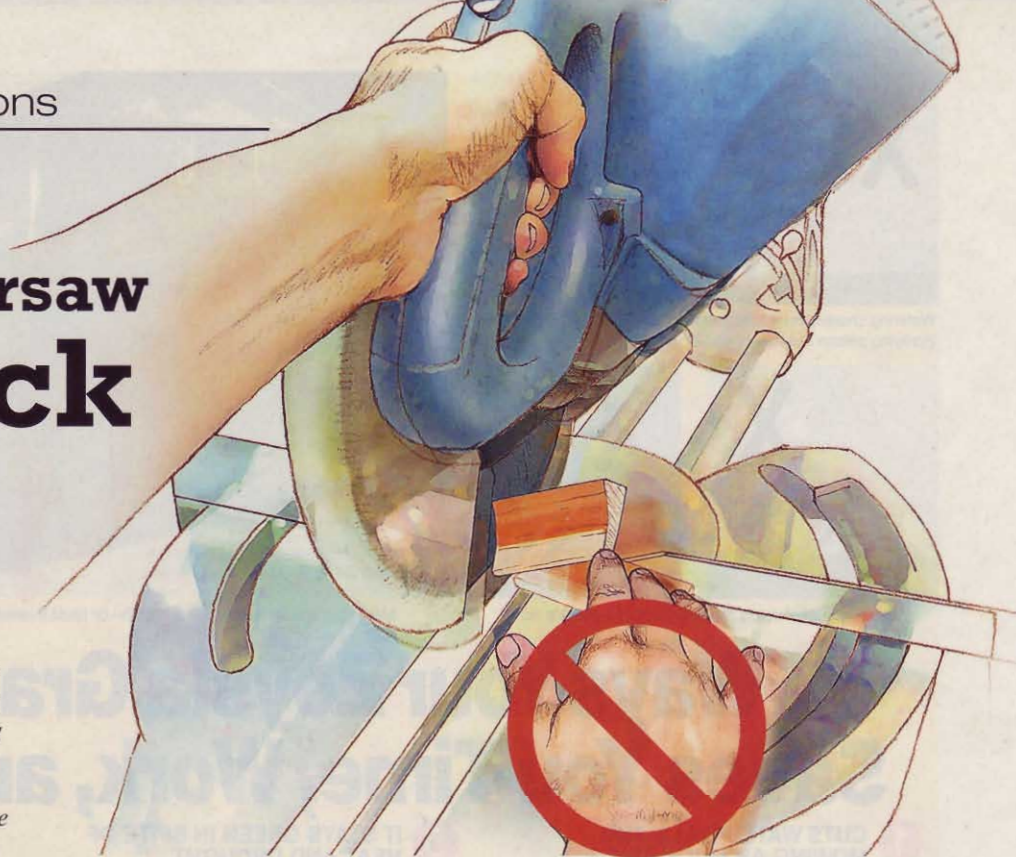

## The lessons

The next time you find yourself at the miter saw, follow these pointers to ensure safe operation:

- When completing a cut, *always* release the power switch and wait for the blade to stop before raising the miter saw head.
- Firmly hold or clamp the workpiece tightly against the saw table and fence.
- *Never* place your hands in the saw's table hazard zone [Photo A].
- If you must cut a short piece, make sure you use clamps to secure it, thereby keeping your hands out of the danger area. When you cannot securely clamp the piece, temporarily adhere it to a carrier board [Photo B].
- Avoid cutting from short pieces. Plan your work so you cut short parts to finished length from longer stock.

■ *Never* assume that other woodworkers whom you've observed know how to safely operate power equipment. Read your tool manuals and safety instructions to make sure you know *all* of the correct operating procedures and rules. ♣

Opening illustration: **Melanie Powell**

## Earn \$100 for your story

Help other readers work safely by sharing a personal shop-related mishap or near miss. Send a detailed description of the incident (about 150 words) along with photos or illustrations and a daytime phone number, to: **Safety: Real Life Lessons, WOOD Magazine**, 1716 Locust St., LS-221, Des Moines, IA 50309-3023. Or e-mail us at [safety@woodmagazine.com](mailto:safety@woodmagazine.com).

### STAY CLEAR OF THE BLADE



**A** Always keep your hands out of the saw's table hazard zone—typically about 6" on either side of the blade. Symbols or lines identify the zone on most saws.

### CUT SMALL PARTS ON A CARRIER



**B** To safely cut a small piece that you cannot easily clamp, adhere it to a carrier board with double-faced tape. Then clamp the carrier board tightly against the table and fence.



# shop-proven products

These woodworking wares passed our shop trials.

## Upgrade your old jointer with a new spiral head

From power tools to computers, nothing irritates me more than saving up to buy a dream machine and then learning of a new technology breakthrough. Shortly after I bought my straight-knife 6" jointer, models started coming with spiral cutterheads that shear the stock for less tear-out on figured woods. Rather than invest in a new machine, I decided to try an aftermarket spiral cutterhead from Sunhill Machinery.

Unlike the spiral cutterheads that come on many 6"- and 8" jointers these days (with dozens of square carbide cutters), the Sunhill spiral cutterhead uses flexible high-speed steel knives that conform to the spiral knife slots. This makes the cutterhead cut with an action more akin to the industrial cutterheads that inspired spiral heads in consumer machines.

Before replacing my straight cutterhead—which had a fresh set of knives—I pulled out a piece of curly white oak and face-jointed it. Not surprisingly, the wild grain tore out badly. (That's why I typically machine this wood with a drum sander, removing a tedious  $\frac{1}{64}$ " at a time).

Next, I swapped out my old cutterhead for the new, about a 20-minute job. I did notice that the pulley on the Sunhill spiral

cutterhead didn't align perfectly with my jointer's drive pulley, but it didn't affect performance. Once again, I face-jointed some curly white oak and, although not completely tear-out-free, the little bit of tear-out that occurred was shallow enough to remove with a few passes on my drum sander. That's a huge improvement.

Replacing the three strip knives takes only 20 minutes, and they self-index into a groove in the cutterhead. I pulled the knives out and then replaced them in a random fashion, and the cut was every bit as smooth as the one before.

The Sunhill spiral cutterhead has economy on its side, too: just \$19 for a set of no-fuss disposable knives, and the cutterhead itself costs about half of what square-insert spiral cutterheads cost. Sunhill also sells replacement spiral cutterheads for 8" jointers, as well as 15" and 20" planers.

—Tested by Jeff Mertz



### Spiral jointer cutterheads

Performance	★★★★★
Price	\$150 for 6" jointers, (replacement knives, \$19); \$230 for 8" jointers, (replacement knives, \$30)

Sunhill Machinery  
800/929-4321; sunhillmachinery.com

## Lee Valley router bits cut lots of screw slots

The typical method of forming expansion slots to allow for seasonal wood movement (drilling a row of holes and then using a file or chisel to remove the material between) offends my sense of craftsmanship, because the slots are always ragged. And when the screw heads must be recessed to allow clearance for, say, a drawer, you have to drill holes for an elongated counterbore, clean it up with a chisel, and then form the slot, centered in the counterbore. It's a lot of mess.

Screw-Slot bits use your plunge router to create slots with a counterbore (model 16J11.70) or a countersink (model 16J11.60) in one smooth operation. Both  $\frac{1}{2}$ "-shank bits fit #8 screws, and each is designed to work in maximum  $\frac{3}{4}$ "-thick material. (You'll get a  $\frac{1}{4}$ "-deep counterbore when plunging through  $\frac{3}{4}$ "-thick material.)

I chucked one of the Screw-Slot bits into my router and set the plunge depth to  $\frac{13}{16}$ ". Guiding the router against a straightedge, I simply plunged the bit into the workpiece and moved it back and forth to form a screw slot. It cut quickly and smoothly without chatter. At first, I plunged the bit completely before moving it to form the length of the slot, but noticed burning at the entry. Working the router back and forth while gradually plunging eliminated burning, and it seemed to cut easier.

Unlike an ordinary straight bit, Screw Slot bit tips are pointed for plunging. A flat washer under the head of a panhead screw, as shown at *right* in the photo, seems to be the most foolproof method of ensuring bind-free movement. So for my \$27.50, I'd get just the counterbore bit.

—Tested by Jan Svec

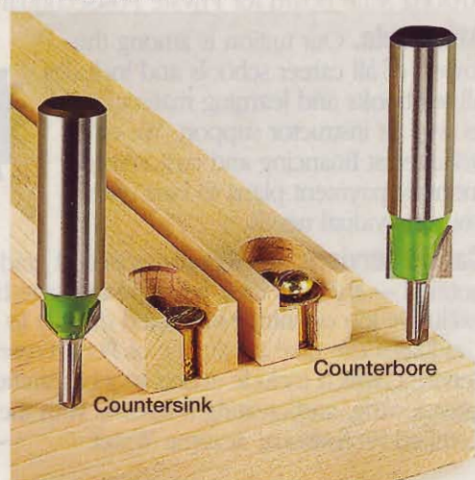

### Screw-Slot bits

Performance	★★★★★
Price	\$27.50

Lee Valley Tools  
800/871-8158; leevalley.com

continued on page 98



# CORBELS

Osborne Wood Products, Inc. introduces an exciting new line of corbels.



**8087**  
12 1/2 x 5 1/2 x 8



**8027**  
12 x 3 1/2 x 8



**8035**  
9 3/4 x 4 1/2 x 5 1/2



**8057**  
10 1/2 x 4 1/2 x 3



**1427**  
36 x 7 x 7 1/2



**8017**  
9 x 3 x 3 1/2



**8003**  
6 x 3 x 2 3/4

Circle No. 1851



ORDER ONLINE:  
**www.ordercorbels5.com**  
ORDER LINE: 1.800.849.8876  
CALL FOR A CATALOG: 1.800.746.3233  
4620 GA Highway 123 • Toccoa, GA 30577  
Email: info@osbornewood.com

## shop-proven products

### First-class mortise-and-tenon joints in seconds

Many woodworkers shy away from mortise-and-tenon joinery because the parts can be time-consuming to cut. And if they don't mate precisely, it requires even more time and effort to correct the fit. Leigh Industries' FMT (Frame Mortise and Tenon) jig helps rout both parts of the joint so easily and accurately, you'll almost forget about its price tag.

At first glance, the FMT looks complicated and intimidating—the owner's manual runs 126 pages long—but it really isn't. The FMT system consists of the tablelike fixture, shown *below right*, that holds the workpiece; a set of #20-biscuit-size interchangeable router guides; and a subbase that mounts to virtually any plunge router. (It took me about 30 minutes to install the subbase on my old Ryobi 1-hp router. But with that done, it takes only seconds to remove or reinstall it, so I still can use my router for other chores.)

That subbase has two guide pins on the bottom. One rides in a permanent slot on top of the fixture; the other runs either in the slot of the router guide (when routing the mortise) or around the perimeter of the guide (when routing the tenon). You use the same upcut spiral bit and cutting depth to machine both parts of the joint.

I like the slide-away centering sight that perfectly aligns the mortise or tenon. The first joint I made with the FMT fit so well that when I pulled it apart, it made a "pop!" like a cork coming out of a bottle. That's a little too perfect for a glue joint, so I tweaked the fit with the on-board adjustment knob that resizes the joint components in .001" increments. A couple of clicks later, I remachined the pieces to a just-right fit.

The FMT comes with five guides that will make more than 20 sizes of mortises and tenons using only the 5/16" spiral bit that comes with the system. You can buy additional guide sets and make different adjustments to stops on the fixture to create an almost infinite variety of mortise-and-tenon joints, including angled joints, in workpieces up to 3" thick and 5 1/2" wide.

In the space allowed for this report, I've only scratched the surface of the FMT's capabilities. I'd encourage you to visit Leigh's Web site to learn more. It may be more jig than many woodworkers need (just as a Mercedes is more car than I need), but what a sweet ride it is. ♣

—Tested by Paul McClannahan

#### FMT Mortise-and-Tenon Jig

Performance ★★★★★  
Price \$800

Leigh Industries  
800/663-8932; leighjigs.com

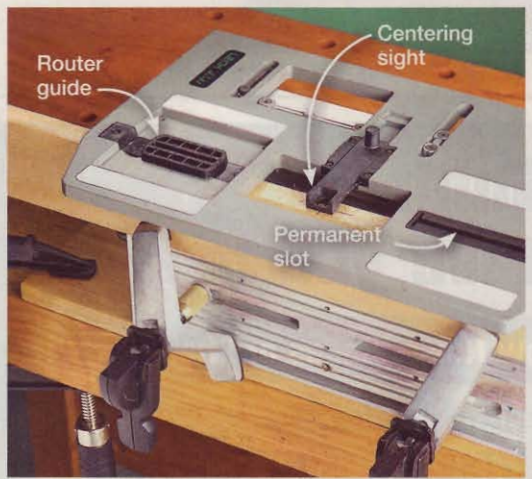





# patching misplaced holes

Although your first reaction might be to scrap a board after boring a hole in the wrong place, try these tips for repairing it first.

**P**erhaps more than any other workshop goof, a hole accidentally drilled in the wrong place proves difficult to repair because a circular patch often creates a stark contrast to the board's grain. But you can make these repairs practically invisible. Here's how.

## Three fixes for partial-depth holes

If you catch the error before you bore through a workpiece, you're in luck. Partial-depth holes, such as those shown *above*, prove less troublesome to repair than through holes. You have the following choices:

**Option 1** Because you've drilled into only one face of your workpiece, you might be able to simply flip it over and make the opposite face your good face, provided it doesn't diminish the project's appearance.

**Option 2** Repair holes by plugging them with matching wood, preferably a cutoff of the board from which you cut your workpiece. Use a plug cutter—one that cuts tapered plugs for a tighter, less-noticeable repair seam—to create a patch, as shown *near right*. You'll find plug cutters in many sizes up to 1" in diameter. While a dowel might patch this same hole tightly, its end grain will contrast with the face grain, especially when it absorbs more finish than the surrounding workpiece grain.

**Option 3** Machine a shallow groove through the goof, wide enough to remove it entirely. Glue in a strip of wood, with matching grain and color, that's slightly thicker than the groove depth, as shown *below right*. Trim it with a hand plane and then sand it smooth. (You also can remove

extra material to make a rabbet, which you then patch in the same manner. This creates one fewer seam on the face but adds one on the edge.) Even if you can't match the grain perfectly, at worst this type of patch will look like boards joined edge to edge in a glued-up panel.

### MAKE PLUGS THAT BLEND IN



Use a cutoff from your workpiece or find a board with closely matching grain, and then cut a plug to fill the errant hole.

### GET IN THE GROOVE

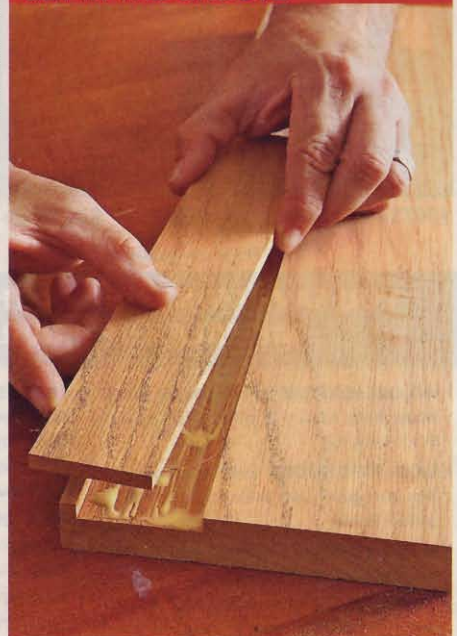

When patching a groove, orient the grain of the filler strip in the same direction as that of the workpiece.







# center your subbase

Eliminate milling mistakes with this fail-safe fix.

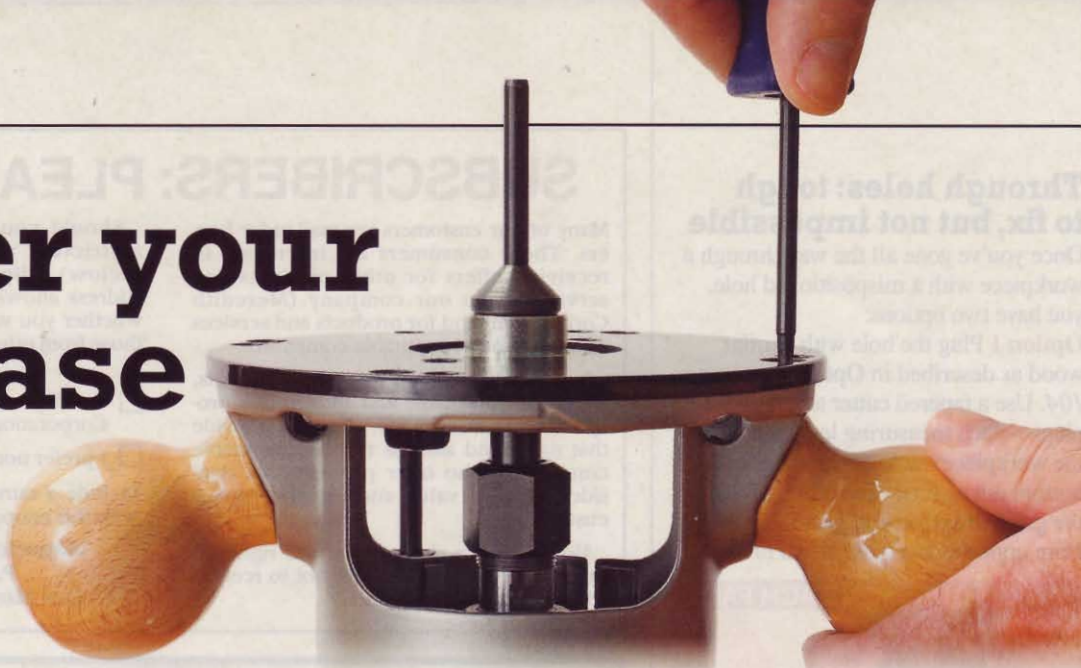

If you don't accurately set up your router's subbase, everything you machine with it may be flawed. Never does this ring true more than when using a guide bushing on your router for precise work, such as routing dovetails on a jig. But by centering your router's subbase to its collet with a centering cone, such as those shown below, you reduce the potential for error. Here's how to do it.

## Use a centering cone for perfect subbase setup

If your router didn't come with a centering cone, you'll first need to get one. Bosch, MLCS, and Bench Dog sell them as accessories. DeWalt's 616 and 618 routers and Ridgid's R2930 include a cone; they are not sold as accessories. All these cones will work in most routers, but some might be tight between the collet and subbase.

Once you have a centering cone, the six simple steps at right will get the job done.

### GET BETTER ROUTER RESULTS WITH THESE SIMPLE STEPS

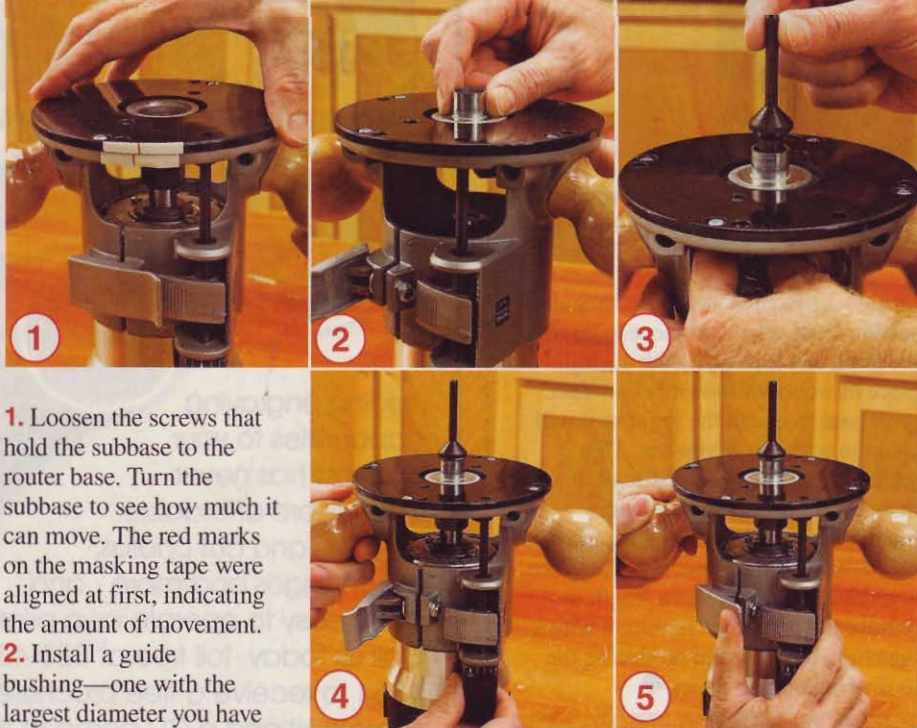

1. Loosen the screws that hold the subbase to the router base. Turn the subbase to see how much it can move. The red marks on the masking tape were aligned at first, indicating the amount of movement.
2. Install a guide bushing—one with the largest diameter you have on hand but not exceeding the size of the cone—into the subbase. Although you can use the larger cones to center the subbase without a guide bushing, there's no guarantee the center opening or the outer circumference of the subbase is perfectly round. Use a bushing to achieve the most accurate setup. Also, when routing along a straightedge after centering the subbase, maintain the same point of contact with the straightedge.
3. Chuck the centering cone into the collet—through the bushing—and snug it by hand. (The MLCS and Bench Dog cones mount below the guide bushing.)
4. Loosen your router's height adjustment, and then raise or lower the motor until the cone makes contact evenly around the guide bushing's rim.
5. Lock the height adjustment.
6. Tighten the subbase screws, as shown in the photo at the top of this page. Remove the centering cone.

### CONES COME IN MANY STYLES



The Ridgid/DeWalt cones are reversible onto their shafts. They, the Bosch, and the MLCS can be used for 1/4" and 1/2" collets. The Bench Dog fits only 1/2" collets.

4. Loosen your router's height adjustment, and then raise or lower the motor until the cone makes contact evenly around the guide bushing's rim.
5. Lock the height adjustment.
6. Tighten the subbase screws, as shown in the photo at the top of this page. Remove the centering cone.

### Sources

Bosch centering cone, model RA1150, \$5, 866/597-3850 or ToolBarn.com.  
 Bench Dog cone with guide bushing adapter, model 40-015, \$22, 877/495-8665 or northwestpowertools.com.  
 MLCS centering cone, part #9054, \$6, 800/533-9298 or mlcswoodworking.com.



# what's ahead

A look inside the May issue (on sale March 20)

## Projects for indoors and out

### FEATURED PROJECT



#### Display shelves

Open design, basic joinery (biscuits and screws), and minimal wood make this project easy on your eyes, time, and checkbook.

#### Pagoda box

A distinctly Asian influence sets apart this small keepsake container. Simple but clever jigs make the lid easy to bandsaw and sand to final shape.



#### Garden structure

Using only portable tools, you can build and install this masterpiece in a weekend. Simple modifications make it an eye-catching privacy screen.



#### Caterpillar pull toy

Kids will delight in tugging about this colorful, wiggly character. A bevy of stock parts makes it a snap to build.

## Get great results and save bucks with these tips

### TOOL REVIEW



#### Trim routers

We tested 11 models and found they do much more than trim laminates. Now, we rank them among the handiest machines in the shop.



#### 4 easy oak finishes

These no-fuss applications—water-based stains and film finishes, a new translucent metallic finish, an oil finish, and ebonizing—give oak extraordinary looks.



#### Free found wood

Own a bandsaw? If so, you can make spectacularly grained boards for next to nothing. Here's how one woodworker does it.